

REPORT NUMBER: TO11-MGA-2002-007

**FULL SCALE SIDE IMPACT POLE TESTS
OF BASELINE VEHICLES
Task Order # T007 / RFP # 0011**

**NISSAN
2000 NISSAN MAXIMA
NHTSA NUMBER: RY5218**

**PREPARED BY:
MGA RESEARCH CORPORATION
5000 WARREN ROAD
BURLINGTON, WI 53105**



OCTOBER 25, 2002

FINAL REPORT

**PREPARED FOR:
U.S. DEPARTMENT OF TRANSPORTATION
VOLPE NATIONAL TRANSPORTATION SYSTEM CENTER
55 BROADWAY, KENDALL SQUARE
CAMBRIDGE, MA 02142**

This final test report was prepared for the U.S. Department of Transportation, Volpe National Transportation System Center, in response to Contract Number DTRS57-98-D-00041.

This document is disseminated under the sponsorship of the U.S. Department of Transportation in the interest of information exchange. The United States Government assumes no liability for its content or use thereof.

Prepared by: _____
David Winkelbauer, Project Engineer

Reviewed by: _____
Gary Strassburg, Project Engineer

Approval Date: _____

Technicians: Wayne Dahlke
Jordan Haynes
Erik Nelson
Chris Nowak
Eric Peschman

Photographic: Tammy Brausch
Chris Kulis

Instrumentation/
Calibration: Jamie Aide
Tim Michnay

Secretary: Susan Kozlowski

FINAL REPORT ACCEPTED BY:

Accepted By: _____
Contract Technical Manager

Acceptance Date: _____

TABLE OF CONTENTS

<u>Section</u>		<u>Page No.</u>
1	Purpose and Test Procedure	1
2	Summary of Side Impact Test	2
3	Side Impact Dummy (ES-2) and Vehicle Test Data	5
4	Occupant and Vehicle Information	11

<u>Data Sheet No.</u>		<u>Page No.</u>
1	General Test and Vehicle Parameter Data	6
2	Test Vehicle Tire Information	9
3	Post Test Observations	10
4	Vehicle Pre-Test and Post Test Measurements	12
5	ES-2 Longitudinal Clearance Dimensions	13
6	ES-2 Lateral Clearance Dimensions	14
7	Vehicle Side Measurements	15
8	Vehicle Exterior Crush Profiles	16
9	Vehicle Damage Profile Distances	18
10	Vehicle Accelerometer Locations and Data Summary	19
11	High Speed Camera Locations and Data	22

<u>Appendix</u>		
A	Photographs	A
B	Dummy and Vehicle Response Data Traces	B
C	ES-2 Configuration and Performance Verification Data	C
D	Test Equipment List and Calibration Information	D
E	Procedure Used for ES-2 Positioning	E
F	Dummy Peak Responses	F

SECTION 1
PURPOSE AND TEST PROCEDURE

This Side Impact test is conducted as part of Contract No. DTRS57-98-D-00041, task order 7, RFP # 0011 sponsored by the U.S. Department of Transportation, Volpe National Transportation System Center. The purpose of this test is to evaluate the responses of the ES-2 with prototype rib extensions and an upgraded back plate in a 2000 Nissan Maxima, when subjected to a rigid pole side impact at 285 degrees.

MGA does not endorse or certify products. The manufacturer's name appears solely for identification purposes.

SECTION 2

SUMMARY OF SIDE IMPACT TEST

A rigid pole side impact test at 285 degrees was performed on a 2000 Nissan Maxima. The subject vehicle was towed into a rigid pole at a velocity of 31.9 km/h. The weight of the vehicle as tested was 1690.5 kg. The test was conducted at MGA Research Corporation in Burlington, Wisconsin, on October 25, 2002. Pre- and post-test photographs of the test vehicle and the dummies are included in Appendix A.

One ES-2 side impact dummy with prototype rib extensions and an upgraded backplate was placed in the left front designated seating position according to instructions specified in the FMVSS 201P Laboratory Test Procedure which is dated April 21, 2000 and Evaluation of Eurosid-1 Positioning Procedure Appendix A dated February 5, 1997. The side impact event was documented by nine high speed cameras. Camera locations and other pertinent camera information can be found in this report.

Appendix B contains the vehicle and dummy response data traces. A summary of the dummy configuration and performance verification test data is shown in Appendix C. Dummy and vehicle calibration data can be found in Appendix D of this report. The positioning procedure for the ES-2 dummy is located in Appendix E. Appendix F contains the dummy peak responses.

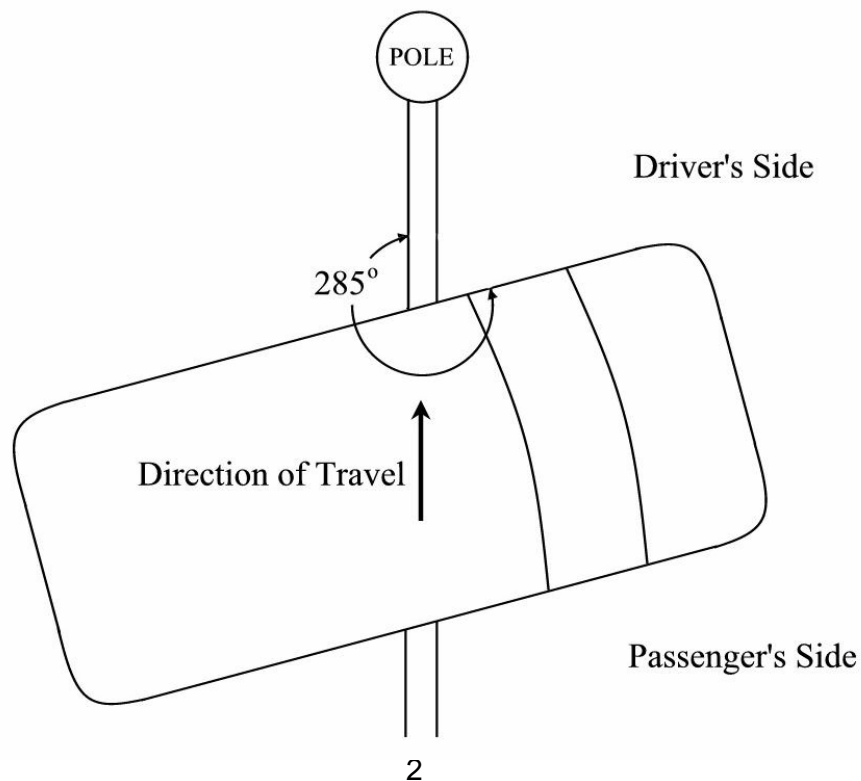

SECTION 2...continued
SUMMARY OF SIDE IMPACT TEST

The following table summarizes the results of the Left Side Impact Test:

Head Performance Criteria		Left Front
<1000	T1 (msec)	57.4
	T2 (msec)	58.1
	HPC	12144
Thorax Performance Criteria		
Chest Deflection <42 mm	Upper Rib Deflection	39.9
	Mid Rib Deflection	36.2
	Lower Rib Deflection	33.9
Viscous Criteria <1.0 (m/sec.)	Upper Rib	0.8
	Mid Rib	0.9
	Lower Rib	0.7
Abdominal Protection Criteria		
Sum < 2500 N	Front Abdominal Force	295
	Mid Abdominal Force	746
	Rear Abdominal Force	1210
	Sum of Abdominal Force	2249
Pelvis Performance Criteria		
< 6000 N	Pubic Symphysis Force	2465

		Left Front
HIC	T1 (msec)	57.4
	T2 (msec)	58.1
	T2 – T1 (msec)	0.7
	HIC	12144

Fir Filtered	Left Front
Upper Rib Y (g's)	102.3
Mid Rib Y (g's)	149.0
Lower Rib Y (g's)	175.9
Upper Spine (g's)	48.2
Lower Spine Y (g's)	80.4
Pelvis Y (g's)	62.9
TTI (g's)	128

Contacts	Left Front
Rib (msec)	36.2
Pelvis (msec)	25.2
Arm (msec)	23.1

TEST NOTES

The following data channels were found to have Questionable Data:

Left Front Door At Arm Y Acceleration - No valid data after 30 msec

The ES-2 contained prototype rib extensions and an upgrade to the backplate area.

SECTION 3
SIDE IMPACT DUMMY (ES-2) AND VEHICLE TEST DATA

DATA SHEET NO. 1

GENERAL TEST AND VEHICLE PARAMETER DATA

Test Vehicle: 2000 Nissan Maxima

Test Date: October 25, 2002

TEST VEHICLE INFORMATION

Make	Nissan
Model	Maxima
Body Style	4 Dr Sedan
VIN	JN1CA31D0YT724197
Color	Painted Orange
Odometer Reading (mile)	72990
Transmission	automatic
Final Drive	front
Number of Cylinders	6
Engine Displacement (L)	3.0
Engine Placement	lateral

TEST VEHICLE OPTIONS

Front Airbag	yes
Side Airbags	no
Power Windows	yes
Power Steering	yes
Power Door	no
Tilt Wheel	yes
Air Conditioning	yes
Power Brakes	yes
Anti-lock Brakes	yes
AM/FM/CD	yes
Cruise Control	yes

DATA FROM CERTIFICATION LABEL

Manufactured By	Nissan	GVWR (kg)	1965.4
Date of Manufacture	8/99	GAWR Front (kg)	1072.8
		GAWR Rear (kg)	901.8

DATA FROM TIRE PLACARD

Measured Parameter	Front	Rear
Maximum Tire Pressure (kPa)	300	300
Cold Pressure (kPa)	231	210
Recommended Tire Size	P215/55R16	P215/55R16
Tire Size on Vehicle	P215/55R16	P215/55R16
Tire Manufacturer	Goodyear	Goodyear

Measured Parameter	Front	Rear	Third	Total
Type of Seats	Bucket	Contour		
Number Of Occupants x 68.04 kg.	136.1	204.1		340.2
Capacity Wt. (VCW) (kg)				400.1
Cargo Wt. (RCLW) (kg)				59.9

DATA SHEET NO. 1... (continued)

GENERAL TEST AND VEHICLE PARAMETER DATA

Test Vehicle: 2000 Nissan Maxima

Test Date: October 25, 2002

TEST VEHICLE WEIGHTS

	Units	As Delivered (UVW) (Axle)			As Tested (ATW) (Axle)		
		Front	Rear	Total	Front	Rear	Total
Left	kg	450.9	284.9		494.4	358.8	
Right	kg	464.9	270.3		506.2	331.1	
Ratio	%	62.3	37.3		59.2	40.8	
Totals	kg	915.8	555.2	1471.0	1000.6	689.9	1690.5

TARGET TEST WEIGHT CALCULATION

Measured Parameter	Units	Value
Calculated Vehicle Target Weight (TVTWT)	kg	1690

TEST VEHICLE ATTITUDES

	Unit	As Delivered	Fully Loaded	Ready for Test
Right Door Sill Angle	Deg	0.1 ND	0.1 BD	0.1 BD
Left Door Sill Angle	Deg	0.0	0.3 BD	0.2 BD
Front Bumper Angle	Deg	0.0	0.3 LD	0.1 LD
Rear Bumper Angle	Deg	0.0	0.2 LD	0.1 LD

ND=Nose down, BD = Back Down, LD = Left Down, RD = Right Down

GENERAL TEST VEHICLE DATA

Measurement Description	Units	Value
Test Vehicle Wheel Base	mm	2760
Total Vehicle Length at Left Side	mm	4140
Total Vehicle Length at Centerline	mm	4808
Total Vehicle Length at Right Side	mm	4140
Total Vehicle Width	mm	1795
Weight of Ballast in Cargo Area	kg	0
Amount of Water in Fuel Tank	liters	61.3

TEST VEHICLE VERTICAL IMPACT LINE DATA

Measurement Description	Units	Value
Actual Impact Point	mm	0

DATA SHEET NO. 1... (continued)

GENERAL TEST AND VEHICLE PARAMETER DATA

Test Vehicle: 2000 Nissan Maxima

Test Date: October 25, 2002

NORMAL DESIGN RIDING POSITION

Driver seat back angle: 11.0 Measured at headrest post

SEAT FORE/AFT POSITIONS

The driver's seat is electronically operated. The fore/aft is set to the middle position for the driver's seat.

Driver seat fore/aft total travel: 240 mm

Driver seat fore/aft position: 120 mm

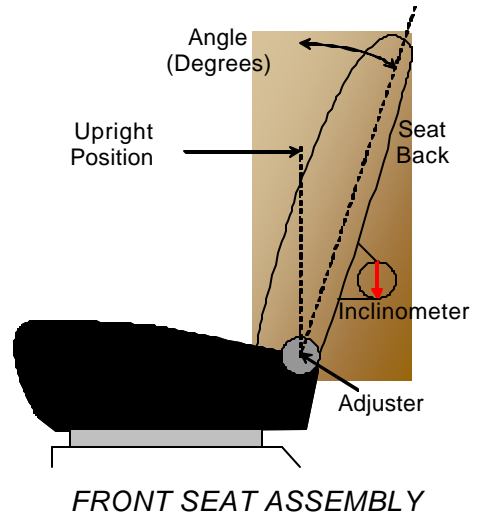

SEAT BELT UPPER ANCHORAGE

The test vehicle "D" ring anchorage for the driver's seat position was placed in the full up position.

STEERING COLUMN ADJUSTMENT

The steering column was placed in the mid position.

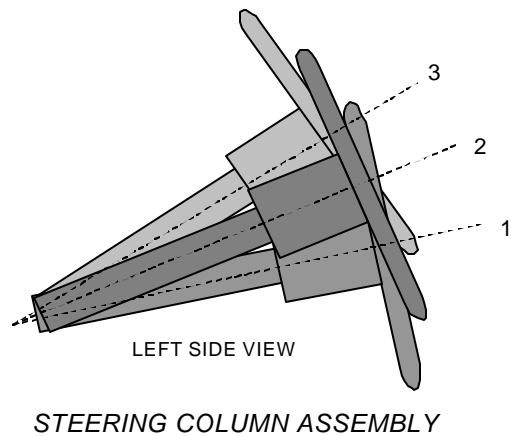

DATASHEET NO. 2
TEST VEHICLE TIRE INFORMATION

Test Vehicle: 2000 Nissan Maxima

Test Date: October 25, 2002

Vehicle Year	2000	Vehicle Make	Nissan
Vin	JN1CA31D0YT724197	Vehicle Model	Maxima

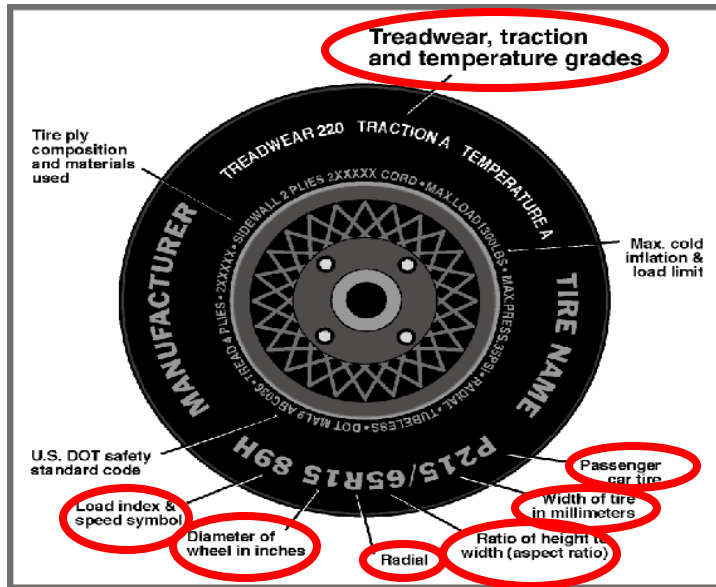

	Front	Rear
Tire Manufacturer	Goodyear	Goodyear
Tire Name	Eagle LS	Eagle LS
Tire Type	Passenger	Passenger
Tire Width (mm)	215	215
Ratio of Height to Width (aspect ratio)	55	55
Radial	Radial	Radial
Wheel Diameter	16	16
Load Index & Speed Symbol	93H	93H
Treadwear	360	360
Traction Grade	A	A
Temperature Grade	A	A

DATA SHEET NO. 3
POST TEST OBSERVATIONS

Test Vehicle: 2000 Nissan Maxima

Test Date: October 25, 2002

TEST DUMMY INFORMATION AND CONTACT POINTS

Description	Left Front
Dummy Type	ES-2
Head Contact	Pole / headrest / D ring
Upper Torso Contact	Upper door
Lower Torso Contact	Mid door
Left Knee Contact	Mid door
Right Knee Contact	Left knee

POST TEST DOOR OPENING

Description	Left Front	Left Rear
Left Side Door Opening	Remained latched and closed	Remained latched and closed
Right Side Door Opening	Remained latched and closed	Remained latched and closed

POST TEST STRUCTURAL OBSERVATIONS

Critical Areas of Performance	Observations and Conclusions
Pillar Performance	No failure
Sill Separation	None
Windshield Damage	Left side cracked
Window Damage	Left side windows down for test
Other Notable Effects	None

AIRBAG DEPLOYMENT

	Driver
Front	No
Side	None
Curtain	None

SECTION 4
OCCUPANT AND VEHICLE INFORMATION

DATA SHEET NO. 4

VEHICLE PRE-TEST AND POST-TEST MEASUREMENTS

Test Vehicle: 2000 Nissan Maxima

Test Date: October 25, 2002

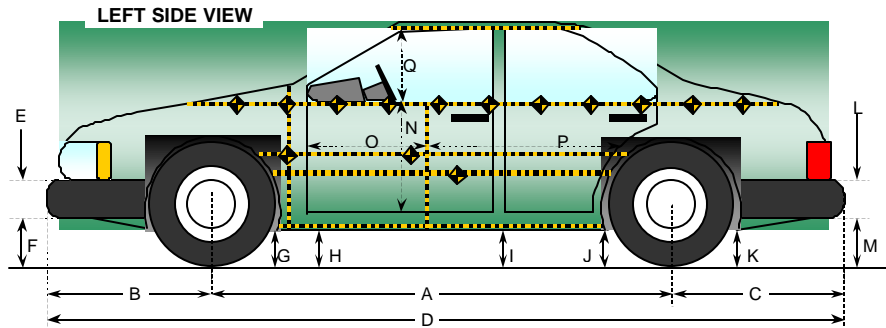

All Measurements in mm

Code	Measurement Description	Pre-Test	Post-Test	Difference
A	Wheelbase	2760	2540	220
B	Front Axle to FSOV	986	966	20
C	Rear Axle to RSOV	1062	1114	-52
D	Total Length at Centerline	4808	4620	188
E	Front Bumper Thickness	140	140	0
F	Front Bumper Bottom to Ground	533	582	-49
G	Sill Height at Front Wheel Well	316	324	-8
H	Sill Height at Front Door Leading Edge	328	339	-11
I	Sill Height at "B" Pillar	326	399	-73
J1	Sill Height at Rear Wheel Well	324	376	-52
J2	Pinch Weld Height at Rear Wheel Well	327	379	-52
K	Sill Height Aft of Rear Wheel Well	377	407	-30
L	Rear Bumper Thickness	215	215	0
M	Rear Bumper Bottom to Ground	505	502	3
N	Sill Height to Window Bottom Sill	620	635	-15
O	Front Door Leading Edge to Impact CL	980	936	44
P	Rear Door Trailing Edge to Impact CL	1035	1049	-14
Q	Front Window Opening	455	404	51
R	Right Side Length	4140	4176	-36
S	Left Side Length	4140	3887	253
T	Vehicle Width at "B" Post	1752	1522	230

DATA SHEET NO. 5
ES-2 LONGITUDINAL CLEARANCE DIMENSIONS

Test Vehicle: 2000 Nissan Maxima

Test Date: October 25, 2002

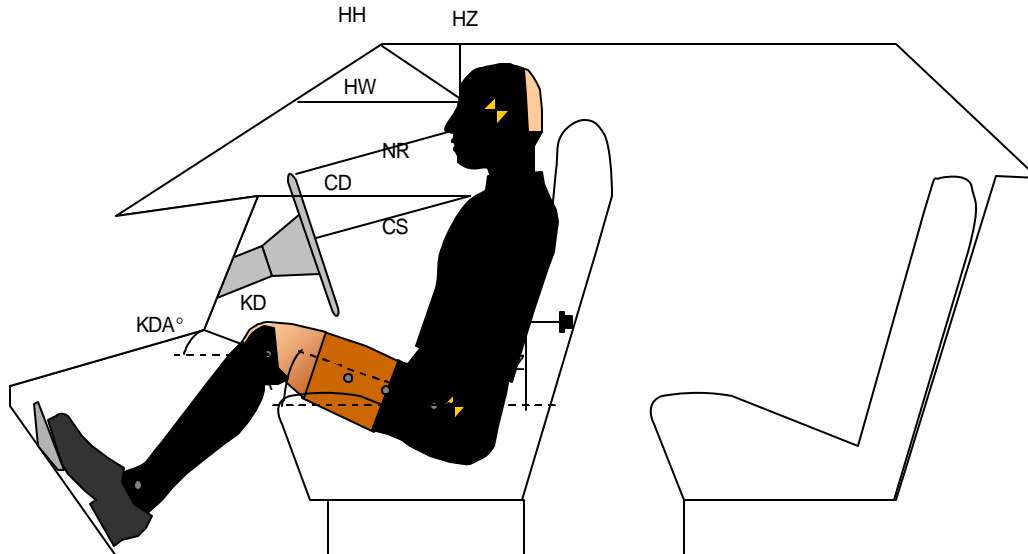

Driver Code	Measurement Description	Left Front	
		Length(mm)	Angle(°)
HH	Head to Header	299	
HW	Head to Windshield	480	
HZ	Head to Roof	127	
NR	Nose to Rim	430	
CD	Chest to Dash	550	
CS	Chest to Steering Wheel	350	
KDL	Left Knee to Dash	236	0
KDR	Right Knee to Dash	219	0
PA	Pelvic Angle (Longitudinal)		23.6
PA	Pelvic Angle (Lateral)		0.6
SA	Spine Angle (Longitudinal)		23.9
SA	Spine Angle (Lateral)		0.8
PHX	H-Point to Striker (X-Axis)	229	
PHZ	H-Point to Striker (Z-Axis)	120	

DATA SHEET NO. 6
ES-2 LATERAL CLEARANCE DIMENSIONS

Test Vehicle: 2000 Nissan Maxima

Test Date: October 25, 2002

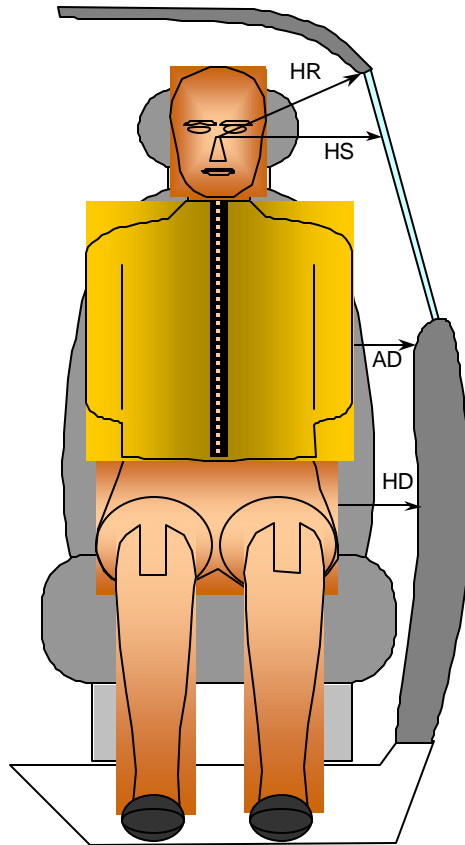

FRONT VIEW OF DUMMY

Code	Measurement Description	Units	Left Front
HR	Head to Side Header	mm	175
HS	Head to Side Window	mm	305
AD	Arm to Door	mm	84
HD	H-Point to Door	mm	141

DATA SHEET NO. 7
VEHICLE SIDE MEASUREMENTS

Test Vehicle: 2000 Nissan Maxima

Test Date: October 25, 2002

PRETEST AND POST TEST EXTERIOR PROFILE MEASUREMENTS

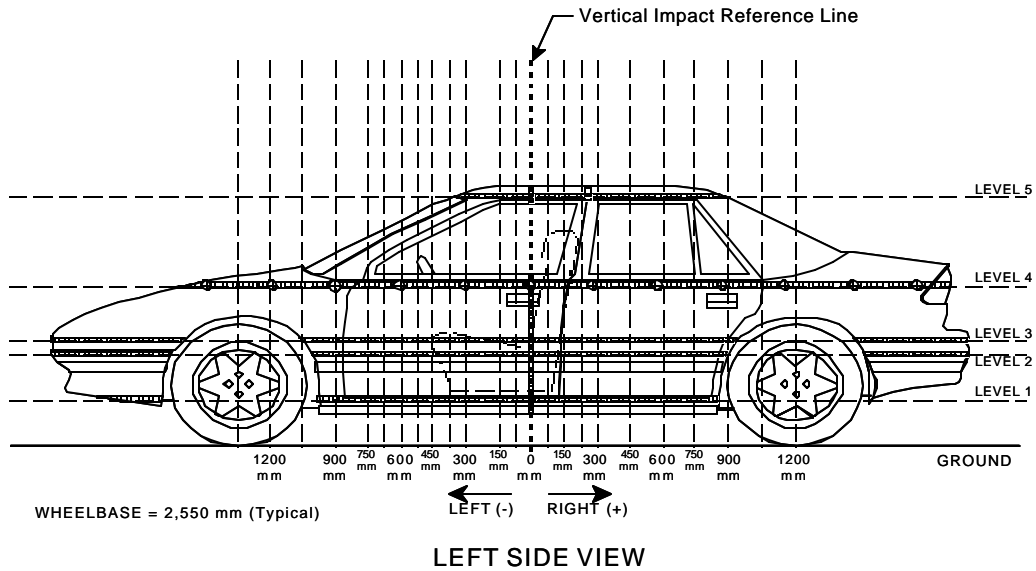

Measurements are taken with vehicle in the as tested condition.
 Measurements along the vertical 0 mm.
 All measurements below in mm.

Level	Measurement Description	Height Above Ground
5	Window	1459
4	Window Sill	1017
3	Mid Door	729
2	Occupant H-Point	627
1	Sill Top	398

DATA SHEET NO. 8
VEHICLE EXTERIOR CRUSH PROFILES

Test Vehicle: 2000 Nissan Maxima

Test Date: October 25, 2002

	Pre-Test					Post-Test					Difference				
	1	2	3	4	5	1	2	3	4	5	1	2	3	4	5
-1800				343					298					-22	
-1650				319					287					-21	
-1500				302					273					-15	
-1350				293					274					-20	
-1200				289					271					-15	
-1050				287					273					-16	
-975	279	236	236	286		290	245	237	273		11	9	1	-13	
-900	284	239	237	286		306	238	235	275		22	-1	-2	-11	
-825	284	239	235	286		318	269	270	273		34	30	35	-13	
-750	283	238	234	287		361	306	400	295		78	68	66	8	
-675	284	237	234	287		390	340	348	324		106	103	114	37	
-600	284	235	232	287		418	377	388	361		134	142	156	74	
-525	284	235	232	287		445	417	427	404		161	182	195	117	
-450	284	234	232	287		476	456	469	447		192	222	237	160	
-375	284	234	232	287		507	495	508	488		223	261	276	201	
-300	284	234	232	287		542	538	550	531		258	304	318	244	
-225	284	234	232	287	517	583	582	590	575	601	299	348	358	288	84
-150	284	234	231	287	511	640	630	630	621	646	356	396	399	334	135
-75	284	234	231	288	511	685	676	678	670	699	401	442	447	382	188
0	284	233	231	288	512	686	686	685	676	696	402	453	454	388	184
75	284	232	231	288	514	652	662	663	659	676	368	430	432	371	162
150	284	232	230	288	517	603	608	603	604	653	319	376	373	316	136
225	284	232	229	289	518	547	518	517	558	624	263	286	288	269	106
300	283	232	229	289	520	413	483	490	519	607	130	251	261	230	87
450	284	232	230	290	518	475	454	468	493	612	191	222	238	203	94
600	285	234	232	290	520	396	494	415	451	577	111	260	183	161	57
750	284	236	234	294	521	320	333	356	405	540	36	97	122	111	19
900	284	238	236	296	522	276	282	304	367	513	-8	44	68	71	-9
1050	279	236	237	298	523	231	218	243	321	503	-48	-18	6	23	-20
1200			222	303	545			220	294	526			-2	-9	-19
1350				308					298					-10	
1500				315					299					-16	
1650				324					303					-21	
1800				334					312					-22	
1950				349					330					-19	
2100				366					349					-17	
2250				391					366					-25	

Reference plane is parallel to test vehicle longitudinal centerline.
Given dimensions = Reference plane to car body.
Measurements in mm.

DATA SHEET NO. 8... (continued)
VEHICLE EXTERIOR CRUSH PROFILES

Test Vehicle: 2000 Nissan Maxima

Test Date: October 25, 2002

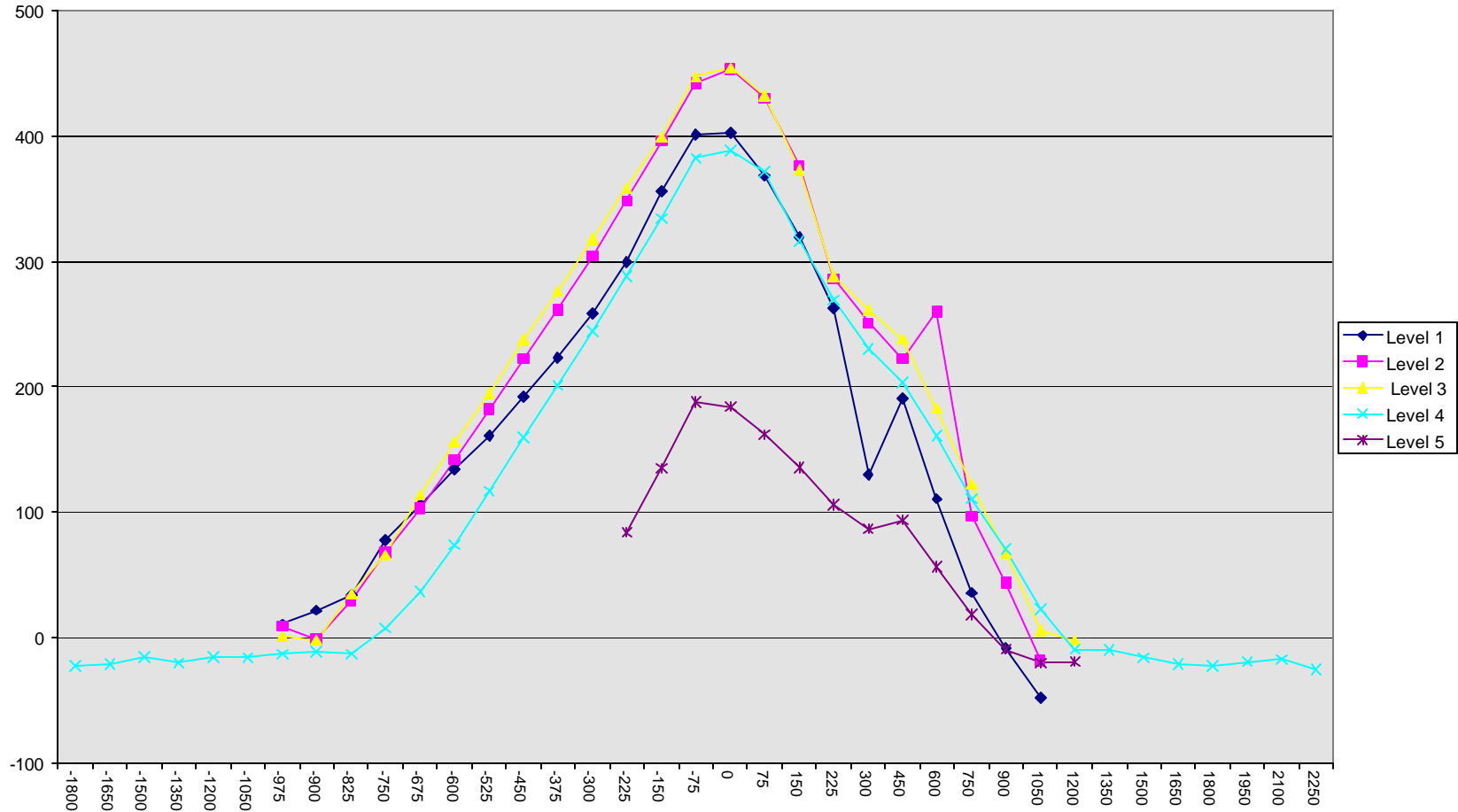

17

Measurement in mm.

DATA SHEET NO. 9
VEHICLE DAMAGE PROFILE DISTANCES

Test Vehicle: 2000 Nissan Maxima

Test Date: October 25, 2002

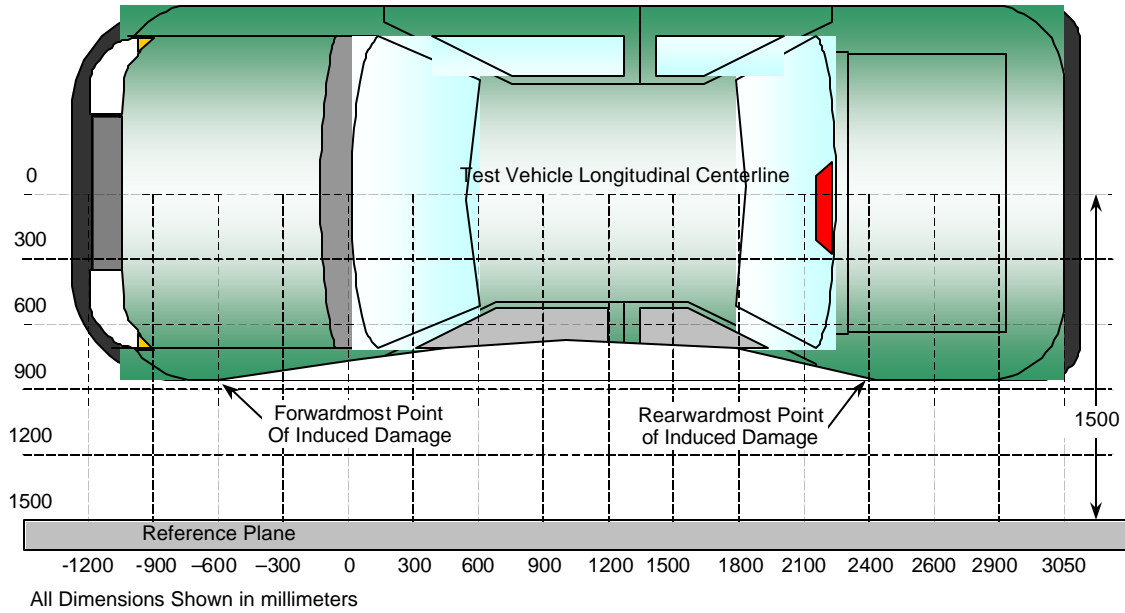

TOP VIEW

Damage Profile Distances

DPD	Distance from Impact Point in mm	Level	Pre-Test (mm)	Post-Test (mm)	Max Static Crush (mm)
1	2100 mm	4	391	395	4
2	1338 mm	4	314	384	70
3	565 mm	4	293	562	269
4	-357 mm	3	287	741	454
5	-1180 mm	4	287	393	106
6	-1950 mm	4	343	364	21

Reference plane is parallel to test vehicle longitudinal centerline.

Given dimensions = Reference plane to car body.

DATA SHEET NO. 10

VEHICLE ACCELEROMETER LOCATIONS AND DATA SUMMARY

Test Vehicle: 2000 Nissan Maxima

Test Date: October 25, 2002

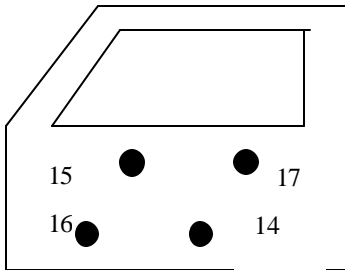
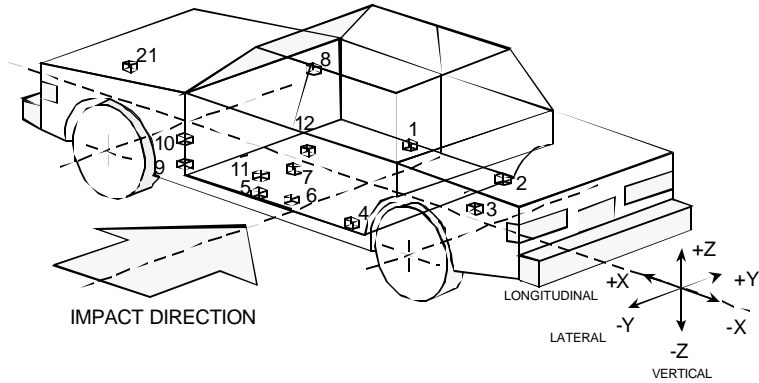

No.	Location
1	Right Side Sill at Front Seat
2	Right Side Sill at Rear Seat
3	Rear Floorpan Above Axle
4	Left Side Sill at Rear Door
5	Left Side Sill at Front Door
6	Left Lower B-Post
7	Left Mid B-Post
8	Left Upper B-Post
9	Left Lower A-Post
10	Left Mid A-Post
11	Driver Seat Track

No.	Location
12	Vehicle CG
13	Left A-Pillar @ Roof
14	Left Front Door @ Pelvis
15	Left Front Door @ Arm
16	Left Front Door @ Knee
17	Left Front Door @ Rib
19	Left Driver Seat Frame
20	Right Driver Seat Frame
21	Lower Center Radiator Support

DATA SHEET NO. 10... (continued)

VEHICLE ACCELEROMETER LOCATION AND DATA SUMMARY

Test Vehicle: 2000 Nissan Maxima

Test Date: October 25, 2002

VEHICLE ACCELEROMETER PEAK DATA AND PRE-TEST LOCATIONS

Loc. No.	Accelerometer Location	Long (X) Maximums (g's) (CFC 60)		Lat. (Y) Maximums (g's) (CFC 60)		Vert. (Z) Maximums (g's) (CFC 60)		Resultant (g's) (CFC 60)
		Pos.	Neg.	Pos.	Neg.	Pos.	Neg.	Max.
1	Right Side Sill at Front Seat	0.4	2.7	10.3	0.2	3.7	4.4	11.0
2	Right Side Sill at Rear Seat	1.2	2.5	10.2	0.1	4.2	5.1	10.7
3	Rear Floorpan Above Axle	4.3	2.6	9.8	0.0	3.4	3.8	9.9
4	Left Side Sill at Rear Door			13.0	2.2			
5	Left Side Sill at Front Door			41.6	12.3			
6	Left Lower B-Post			48.6	9.1			
7	Left Mid B-Post			41.7	17.6			
8	Left Upper B-Post			37.0	20.2			
9	Left Upper A-Post			54.5	11.5			
10	Left Lower A-Post			15.2	1.1			
11	Left Mid A-Post			9.9	4.8			
12	Driver Left Seat Track			53.5	22.1			
13	Vehicle CG	4.1	9.8	29.7	11.1	31.6	10.0	33.8
14	Left Front Door at Pelvis			136.6	146.8			
15	Left Front Door at Arm			142.1	38.3			
16	Left Front Door at Knee			79.3	60.6			
17	Left Front Door at Rib			**	**			
19	Left Driver Seat Frame			59.1	13.3			
20	Right Driver Seat Frame			60.1	12.2			
21	Lower Center Radiator Support	1.1	6.0	8.5	3.0	3.3	3.4	9.1

** = No Valid Data after 30 msec

Sign Convention X - Test Vehicle Rear Bumper (+ forward)
 Y - Test Vehicle Centerline (+ to right)
 Z - Ground Plane (+ down)

DATA SHEET NO. 10... (continued)

VEHICLE ACCELEROMETER LOCATION AND DATA SUMMARY

Test Vehicle: 2000 Nissan Maxima

Test Date: October 25, 2002

VEHICLE ACCELEROMETER COORDINATES

Loc. No.	Description	Coordinates (mm)		
		X	Y	Z
1	Right Side Sill at Front Seat	2944	705	210
2	Right Side Sill at Rear Seat	1929	705	216
3	Rear Floorpan Above Axle	1050	0	480
4	Left Side Sill at Rear Door	1616	-708	218
5	Left Side Sill at Front Door	2760	-705	214
6	Left Lower B-Post	2180	-700	400
7	Left Mid B-Post	2182	-700	892
8	Left Upper B-Post	2100	-496	1345
9	Left Lower A-Post	3233	-685	303
10	Left Mid A-Post	3310	-790	833
11	Driver Left Seat Track	2376	-540	352
12	Vehicle CG	2706	0	316
13	Left A-Pillar @ Roof	2650	-535	1260
14	Left Door @ Pelvis	2429	-760	570
15	Left Door @ Arm	2649	-762	732
16	Left Door @ Knee	2845	-746	658
17	Left Door @ Rib	2429	-760	570
19	Left Driver Seat Frame	2227	-504	684
20	Right Driver Seat Frame	2227	-206	686
21	Lower Center Radiator Support	4560	25	278

Sign Convention X – Rear Bumper (+ forward)
 Y – Vehicle Centerline (+ to right)
 Z – Ground Plane (+ up)

DATA SHEET NO. 11
HIGH SPEED CAMERA LOCATIONS AND DATA

Test Vehicle: 2000 Nissan Maxima

Test Date: October 25, 2002

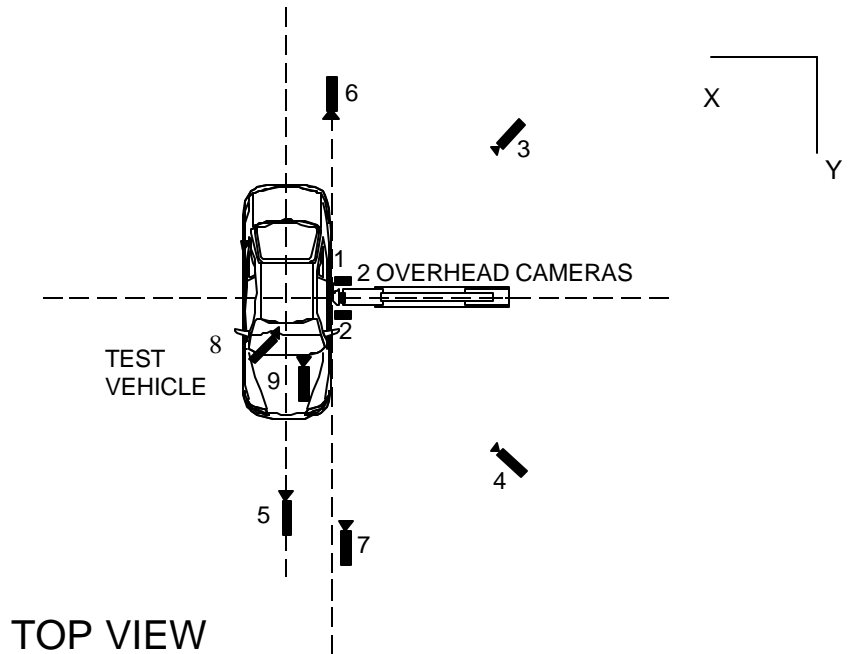

No.	Camera View	Location (mm)			Lens (mm)	Film Speed (fps)
		X	Y	Z		
1	Overhead Overall	600	0	5000	8	1020
2	Overhead Close-up	0	0	5000	13	1010
3	Left Side 45 deg. Rearward Pole View	-3000	-6000	1430	50	1005
4	Left Side 45 deg. Forward Pole View	-3300	5100	1370	50	No marks
5	Real Time					
6	Front Ground Level Vehicle/Pole Impact	750	-9150	1700	25	810
7	Rear Ground Level Vehicle/Pole Impact	-500	9000	1560	25	985
8	Test Vehicle Onboard Hood				13	518
9	Test Vehicle Onboard Driver Hip				13	515
10	Test Vehicle Onboard Driver Head Contact				8	500

Reference Points X - + Forward of Impact
Y - + Right of Impact
Z - + Up from Ground

APPENDIX A
PHOTOGRAPHS

TABLE OF PHOTOGRAPHS

		<u>Page No.</u>
Photo No. A-1	Pre-Test Front View of Test Vehicle	A-1
Photo No. A-2	Post-Test Front View of Test Vehicle	A-2
Photo No. A-3	Pre-Test Rear View of Test Vehicle	A-3
Photo No. A-4	Post-Test Rear View of Test Vehicle	A-4
Photo No. A-5	Pre-Test Left Side View of Test Vehicle	A-5
Photo No. A-6	Post-Test Left Side View of Test Vehicle	A-6
Photo No. A-7	Pre-Test Left $\frac{3}{4}$ Rear View of Test Vehicle	A-7
Photo No. A-8	Post-Test Left $\frac{3}{4}$ Rear View of Test Vehicle	A-8
Photo No. A-9	Pre-Test Vehicle Positioned Against Pole (Left $\frac{3}{4}$ Front)	A-9
Photo No. A-10	Post-Test Pole and Vehicle (Left $\frac{3}{4}$ Front)	A-10
Photo No. A-11	Pre-Test Vehicle Positioned Against Pole (right side)	A-11
Photo No. A-12	Post-Test Pole and Vehicle (right side)	A-12
Photo No. A-13	Pre-Test Vehicle Positioned Against Pole Overhead View	A-13
Photo No. A-14	Post-Test Pole and Vehicle Overhead View	A-14
Photo No. A-15	Pre-Test Driver Dummy Left Side View (Door open)	A-15
Photo No. A-16	Pre-Test Driver Dummy Left Side View	A-16
Photo No. A-17	Pre-Test Driver Dummy Right Side View	A-17
Photo No. A-18	Post-Test Driver Dummy Right Side View	A-18
Photo No. A-19	Pre-Test Driver Dummy Shoulder and Door Top View	A-19
Photo No. A-20	Post-Test Driver Dummy Contact to Pole	A-20
Photo No. A-21	Pre-Test Impact Point on Vehicle	A-21
Photo No. A-22	Post-Test Impact Point on Vehicle	A-22
Photo No. A-23	Impact	A-23
Photo No. A-24	Vehicle Certification Label	A-24

A-1.



Pre-Test Front View of Test Vehicle



Post-Test Front View of Test Vehicle



Pre-Test Rear View of Test Vehicle



Post-Test Rear View of Test Vehicle

A-5.



Pre-Test Left Side View of Test Vehicle

A-6.



Post-Test Left Side View of Test Vehicle



Pre-Test Left $\frac{3}{4}$ Rear View of Test Vehicle



Post-Test Left ¼ Rear View of Test Vehicle

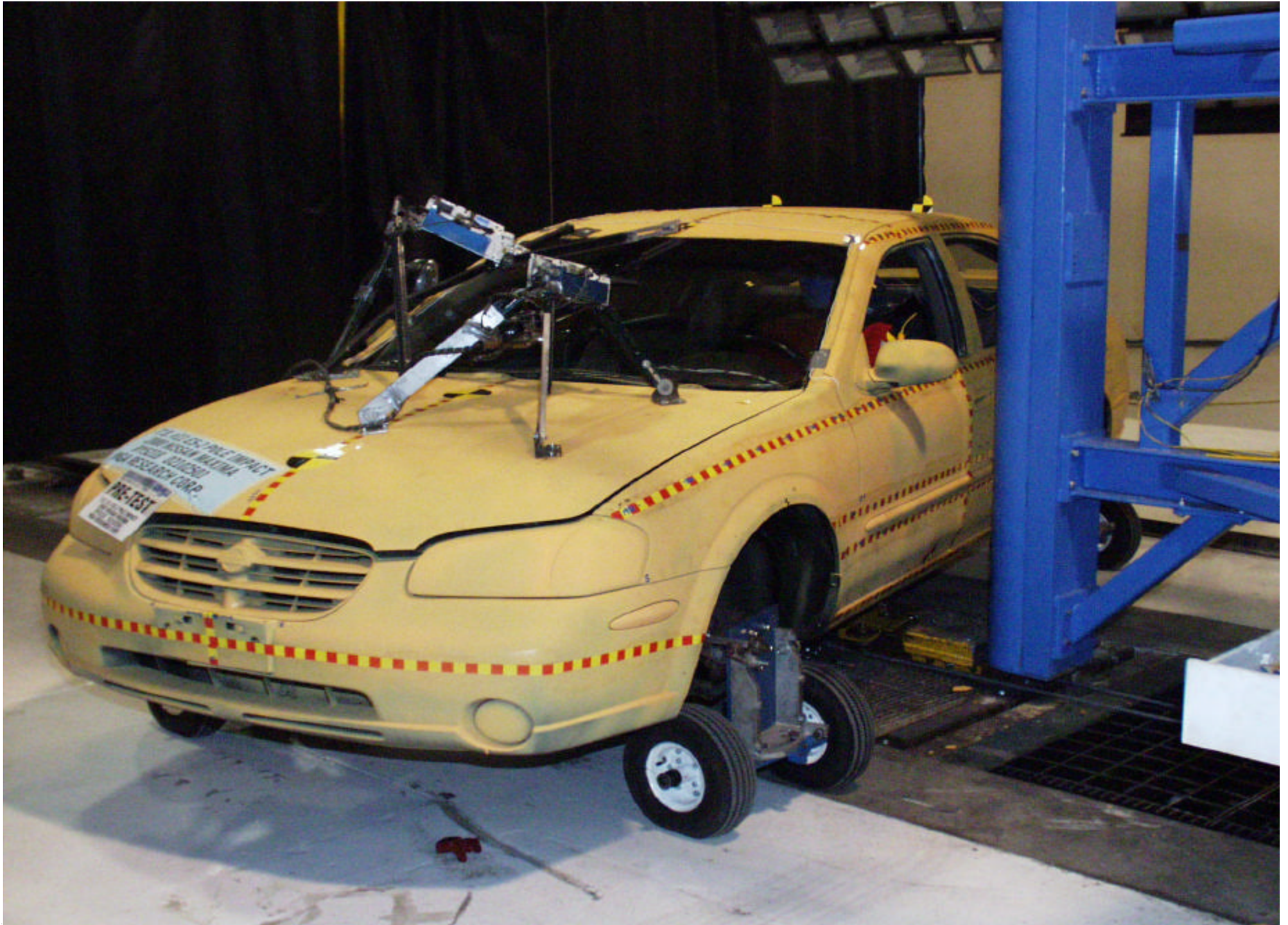

Pre-Test Vehicle Positioned Against Pole (Left ¾ Front)

A-10.



Post-Test Pole and Vehicle (Left $\frac{3}{4}$ Front)

A-11.



Pre-Test Vehicle Positioned Against Pole (right side)



Post-Test Pole and Vehicle (right side)

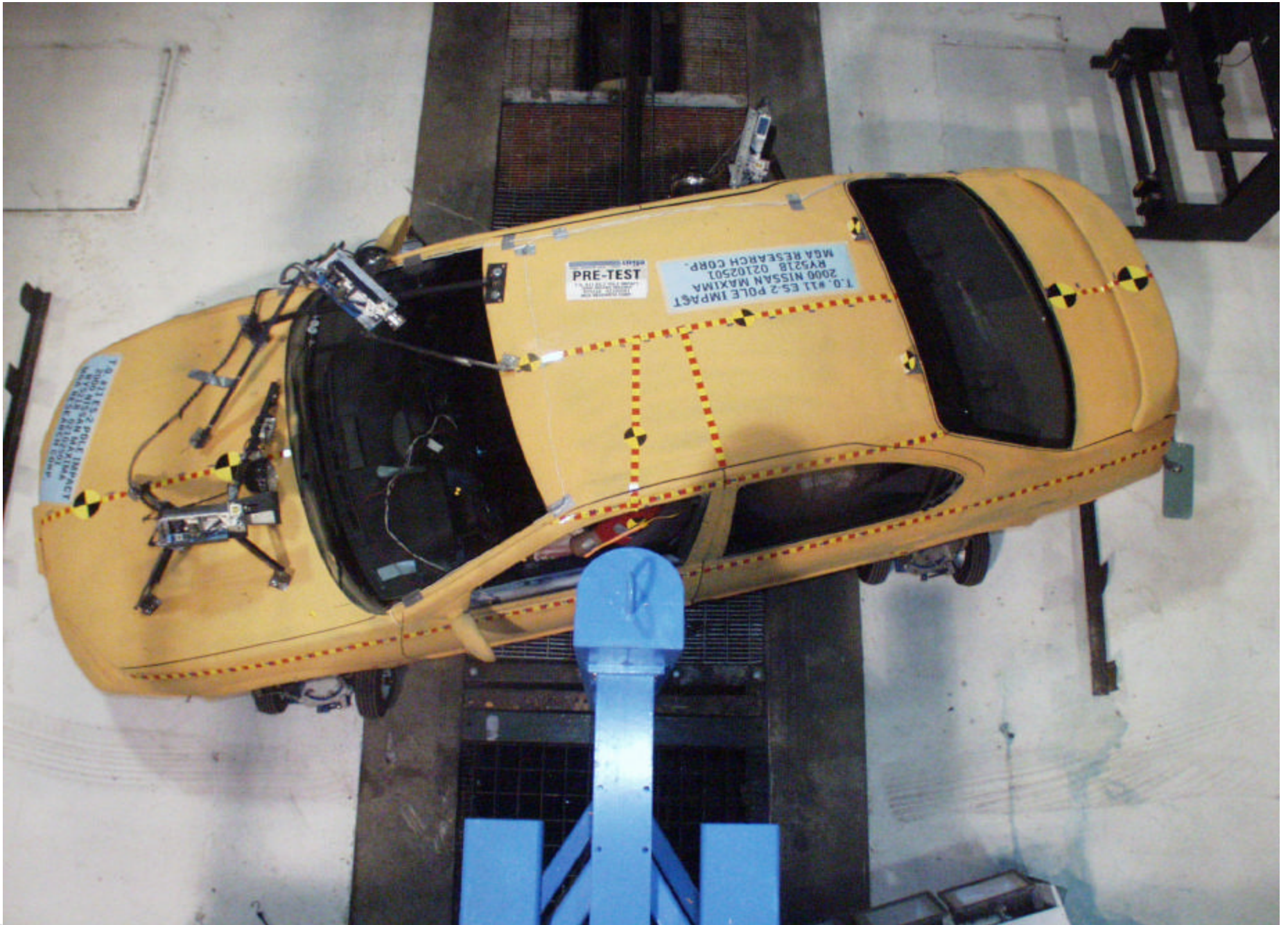

Pre-Test Vehicle Positioned Against Pole Overhead View



Post-Test Pole and Vehicle Overhead View



Pre-Test Driver Dummy Left Side View (Door open)



Pre-Test Driver Dummy Left Side View

A-17.



Pre-Test Driver Dummy Right Side View

A-18.



Post-Test Driver Dummy Right Side View



Pre-Test Driver Dummy Shoulder and Door Top View



Post-Test Driver Dummy Contact to Pole



Pre-Test Impact Point on Vehicle



Post-Test Impact Point on Vehicle



Impact

MFD.BY NISSAN MOTOR CO.,LTD

DATE 08/99

GVWR/PNBV 4333 LBS.

GAWR/PNBE FR. 2365 LBS. RR. 1988 LBS.

THIS VEHICLE CONFORMS TO ALL APPLICABLE FEDERAL
MOTOR VEHICLE SAFETY, BUMPER, AND THEFT PREVENTION
STANDARDS IN EFFECT ON THE DATE OF MANUFACTURE
SHOWN ABOVE.

JN1CA31D0YT724197

PASSENGER CAR/VOITURE DE TOURISME



JN1CA31D0YT724197

APPENDIX B

VEHICLE AND DUMMY RESPONSE DATA TRACES

TABLE OF DATA PLOTS

Figure No. 1	Driver Head X Acceleration vs. Time	B-1
Figure No. 2	Driver Head Y Acceleration vs. Time	B-1
Figure No. 3	Driver Head Z Acceleration vs. Time	B-1
Figure No. 4	Driver Head Resultant Acceleration vs. Time	B-1
Figure No. 5	Driver Head X Velocity vs. Time	B-2
Figure No. 6	Driver Head Y Velocity vs. Time	B-2
Figure No. 7	Driver Head Z Velocity vs. Time	B-2
Figure No. 8	Driver Head Y Front Acceleration vs. Time	B-3
Figure No. 9	Driver Head Z Front Acceleration vs. Time	B-3
Figure No. 10	Driver Head Y Front Velocity vs. Time	B-3
Figure No. 11	Driver Head Z Front Velocity vs. Time	B-3
Figure No. 12	Driver Head X Left Acceleration vs. Time	B-4
Figure No. 13	Driver Head Z Left Acceleration vs. Time	B-4
Figure No. 14	Driver Head X Left Velocity vs. Time	B-4
Figure No. 15	Driver Head Z Left Velocity vs. Time	B-4
Figure No. 16	Driver Head X Upper Acceleration vs. Time	B-5
Figure No. 17	Driver Head Y Upper Acceleration vs. Time	B-5
Figure No. 18	Driver Head X Upper Velocity vs. Time	B-5
Figure No. 19	Driver Head Y Upper Velocity vs. Time	B-5
Figure No. 20	Driver Upper Neck Force X vs. Time	B-6
Figure No. 21	Driver Upper Neck Force Y vs. Time	B-6
Figure No. 22	Driver Upper Neck Force Z vs. Time	B-6
Figure No. 23	Driver Upper Neck Force Resultant vs. Time	B-6
Figure No. 24	Driver Upper Neck Moment X vs. Time	B-7
Figure No. 25	Driver Upper Neck Moment Y vs. Time	B-7
Figure No. 26	Driver Upper Neck Moment Z vs. Time	B-7
Figure No. 27	Driver Upper Neck Moment Resultant vs. Time	B-7
Figure No. 28	Driver Lower Neck Force X vs. Time	B-8
Figure No. 29	Driver Lower Neck Force Y vs. Time	B-8
Figure No. 30	Driver Lower Neck Force Z vs. Time	B-8

Figure No. 31	Driver Lower Neck Force Resultant vs. Time	B-8
Figure No. 32	Driver Lower Neck Moment X vs. Time	B-9
Figure No. 33	Driver Lower Neck Moment Y vs. Time	B-9
Figure No. 34	Driver Lower Neck Moment Z vs. Time	B-9
Figure No. 35	Driver Lower Neck Moment Resultant vs. Time	B-9
Figure No. 36	Driver Shoulder Force X vs. Time	B-10
Figure No. 37	Driver Shoulder Force Y vs. Time	B-10
Figure No. 38	Driver Shoulder Force Z vs. Time	B-10
Figure No. 39	Driver Upper Spine X Acceleration vs. Time	B-11
Figure No. 40	Driver Upper Spine Y Acceleration vs. Time	B-11
Figure No. 41	Driver Upper Spine Z Acceleration vs. Time	B-11
Figure No. 42	Driver Upper Spine Resultant Acceleration vs. Time	B-11
Figure No. 43	Driver Upper Spine X Velocity vs. Time	B-12
Figure No. 44	Driver Upper Spine Y Velocity vs. Time	B-12
Figure No. 45	Driver Upper Spine Z Velocity vs. Time	B-12
Figure No. 46	Driver Upper Rib Y Acceleration vs. Time (CFC 1000)	B-13
Figure No. 47	Driver Mid Rib Y Acceleration vs. Time (CFC 1000)	B-13
Figure No. 48	Driver Lower Rib Y Acceleration vs. Time (CFC 1000)	B-13
Figure No. 49	Driver Upper Rib Y Acceleration vs. Time (CFC 180)	B-14
Figure No. 50	Driver Mid Rib Y Acceleration vs. Time (CFC 180)	B-14
Figure No. 51	Driver Lower Rib Y Acceleration vs. Time (CFC 180)	B-14
Figure No. 52	Driver Upper Rib Y Velocity vs. Time (CFC 180)	B-15
Figure No. 53	Driver Mid Rib Y Velocity vs. Time (CFC 180)	B-15
Figure No. 54	Driver Lower Rib Y Velocity vs. Time (CFC 180)	B-15
Figure No. 55	Driver Upper Rib Displacement vs. Time	B-16
Figure No. 56	Driver Mid Rib Displacement vs. Time	B-16
Figure No. 57	Driver Lower Rib Displacement vs. Time	B-16
Figure No. 58	Driver Upper Rib Viscous Criteria vs. Time	B-17
Figure No. 59	Driver Mid Rib Viscous Criteria vs. Time	B-17
Figure No. 60	Driver Lower Rib Viscous Criteria vs. Time	B-17
Figure No. 61	Driver Lower Spine X Acceleration vs. Time	B-18

Figure No. 62	Driver Lower Spine Y Acceleration vs. Time	B-18
Figure No. 63	Driver Lower Spine Z Acceleration vs. Time	B-18
Figure No. 64	Driver Lower Spine Resultant Acceleration vs. Time	B-18
Figure No. 65	Driver Lower Spine X Velocity vs. Time	B-19
Figure No. 66	Driver Lower Spine Y Velocity vs. Time	B-19
Figure No. 67	Driver Lower Spine Z Velocity vs. Time	B-19
Figure No. 68	Driver Torso Force X vs. Time	B-20
Figure No. 69	Driver Torso Force Y vs. Time	B-20
Figure No. 70	Driver Torso Moment Y vs. Time	B-20
Figure No. 71	Driver Torso Moment Z vs. Time	B-20
Figure No. 72	Driver T-12 Force X vs. Time	B-21
Figure No. 73	Driver T-12 Force Y vs. Time	B-21
Figure No. 74	Driver T-12 Moment X vs. Time	B-21
Figure No. 75	Driver T-12 Moment Y vs. Time	B-21
Figure No. 76	Driver Lumbar Force Y vs. Time	B-22
Figure No. 77	Driver Lumbar Force Z vs. Time	B-22
Figure No. 78	Driver Lumbar Moment X vs. Time	B-22
Figure No. 79	Driver Pubic Symphysis Y vs. Time	B-22
Figure No. 80	Driver Front Abdomen Force Y vs. Time	B-23
Figure No. 81	Driver Mid Abdomen Force Y vs. Time	B-23
Figure No. 82	Driver Rear Abdomen Force Y vs. Time	B-23
Figure No. 83	Driver Summed Abdomen Force vs. Time	B-23
Figure No. 84	Driver Pelvis X Acceleration vs. Time	B-24
Figure No. 85	Driver Pelvis Y Acceleration vs. Time	B-24
Figure No. 86	Driver Pelvis Z Acceleration vs. Time	B-24
Figure No. 87	Driver Pelvis Resultant Acceleration vs. Time	B-24
Figure No. 88	Driver Pelvis X Velocity vs. Time	B-25
Figure No. 89	Driver Pelvis Y Velocity vs. Time	B-25
Figure No. 90	Driver Pelvis Z Velocity vs. Time	B-25
Figure No. 91	Driver Left Femur Force X vs. Time	B-26
Figure No. 92	Driver Left Femur Force Y vs. Time	B-26

Figure No. 93	Driver Left Femur Force Z vs. Time	B-26
Figure No. 94	Driver Left Femur Force Resultant vs. Time	B-26
Figure No. 95	Driver Left Femur Moment X vs. Time	B-27
Figure No. 96	Driver Left Femur Moment Y vs. Time	B-27
Figure No. 97	Driver Left Femur Moment Z vs. Time	B-27
Figure No. 98	Driver Left Femur Moment Resultant vs. Time	B-27
Figure No. 99	Driver Right Femur Force X vs. Time	B-28
Figure No. 100	Driver Right Femur Force Y vs. Time	B-28
Figure No. 101	Driver Right Femur Force Z vs. Time	B-28
Figure No. 102	Driver Right Femur Force Resultant vs. Time	B-28
Figure No. 103	Driver Right Femur Moment X vs. Time	B-29
Figure No. 104	Driver Right Femur Moment Y vs. Time	B-29
Figure No. 105	Driver Right Femur Moment Z vs. Time	B-29
Figure No. 106	Driver Right Femur Moment Resultant vs. Time	B-29
Figure No. 107	Driver Rib Contact	B-30
Figure No. 108	Driver Pelvis Contact	B-30
Figure No. 109	Driver Arm Contact	B-30
Figure No. 110	Right Front Sill X Acceleration vs. Time	B-31
Figure No. 111	Right Front Sill Y Acceleration vs. Time	B-31
Figure No. 112	Right Front Sill Z Acceleration vs. Time	B-31
Figure No. 113	Right Front Sill Resultant Acceleration vs. Time	B-31
Figure No. 114	Right Front Sill X Velocity vs. Time	B-32
Figure No. 115	Right Front Sill Y Velocity vs. Time	B-32
Figure No. 116	Right Front Sill Z Velocity vs. Time	B-32
Figure No. 117	Right Rear Sill X Acceleration vs. Time	B-33
Figure No. 118	Right Rear Sill Y Acceleration vs. Time	B-33
Figure No. 119	Right Rear Sill Z Acceleration vs. Time	B-33
Figure No. 120	Right Rear Sill Resultant Acceleration vs. Time	B-33
Figure No. 121	Right Rear Sill X Velocity vs. Time	B-34
Figure No. 122	Right Rear Sill Y Velocity vs. Time	B-34
Figure No. 123	Right Rear Sill Z Velocity vs. Time	B-34

Figure No. 124	Floorpan @ Rear Axle X Acceleration vs. Time	B-35
Figure No. 125	Floorpan @ Rear Axle Y Acceleration vs. Time	B-35
Figure No. 126	Floorpan @ Rear Axle Z Acceleration vs. Time	B-35
Figure No. 127	Floorpan @ Rear Axle Resultant Acceleration vs. Time	B-35
Figure No. 128	Floorpan @ Rear Axle X Velocity vs. Time	B-36
Figure No. 129	Floorpan @ Rear Axle Y Velocity vs. Time	B-36
Figure No. 130	Floorpan @ Rear Axle Z Velocity vs. Time	B-36
Figure No. 131	Left Front Sill Y Acceleration vs. Time	B-37
Figure No. 132	Left Front Sill Y Velocity vs. Time	B-37
Figure No. 133	Left Rear Sill Y Acceleration vs. Time	B-37
Figure No. 134	Left Rear Sill Y Velocity vs. Time	B-37
Figure No. 135	Left Lower A-Post Y Acceleration vs. Time	B-38
Figure No. 136	Left Lower A-Post Y Velocity vs. Time	B-38
Figure No. 137	Left Mid A-Post Y Acceleration vs. Time	B-38
Figure No. 138	Left Mid A-Post Y Velocity vs. Time	B-38
Figure No. 139	Left A-Post @ Roof Y Acceleration vs. Time	B-39
Figure No. 140	Left A-Post @ Roof Y Velocity vs. Time	B-39
Figure No. 141	Left Upper B-Post Y Acceleration vs. Time	B-39
Figure No. 142	Left Upper B-Post Y Velocity vs. Time	B-39
Figure No. 143	Left Lower B-Post Y Acceleration vs. Time	B-40
Figure No. 144	Left Lower B-Post Y Velocity vs. Time	B-40
Figure No. 145	Left Mid B-Post Y Acceleration vs. Time	B-40
Figure No. 146	Left Mid B-Post Y Velocity vs. Time	B-40
Figure No. 147	Driver Seat Track Y Acceleration vs. Time	B-41
Figure No. 148	Driver Seat Track Y Velocity vs. Time	B-41
Figure No. 149	Driver Left Seat Frame Y Acceleration vs. Time	B-42
Figure No. 150	Driver Left Seat Frame Y Velocity vs. Time	B-42
Figure No. 151	Driver Right Seat Frame Y Acceleration vs. Time	B-42
Figure No. 152	Driver Right Seat Frame Y Velocity vs. Time	B-42
Figure No. 153	Vehicle CG X Acceleration vs. Time	B-43
Figure No. 154	Vehicle CG Y Acceleration vs. Time	B-43

Figure No. 155	Vehicle CG Z Acceleration vs. Time	B-43
Figure No. 156	Vehicle CG Resultant Acceleration vs. Time	B-43
Figure No. 157	Vehicle CG X Velocity vs. Time	B-44
Figure No. 158	Vehicle CG Y Velocity vs. Time	B-44
Figure No. 159	Vehicle CG Z Velocity vs. Time	B-44
Figure No. 160	Left Front Door @ Rib Y Acceleration vs. Time*	B-45
Figure No. 161	Left Front Door @ Arm Y Acceleration vs. Time	B-45
Figure No. 162	Left Front Door @ Pelvis Y Acceleration vs. Time	B-45
Figure No. 163	Left Front Door @ Knee Y Acceleration vs. Time	B-45
Figure No. 164	Left Front Door @ Rib Y Velocity vs. Time*	B-46
Figure No. 165	Left Front Door @ Arm Y Velocity vs. Time	B-46
Figure No. 166	Left Front Door @ Pelvis Y Velocity vs. Time	B-46
Figure No. 167	Left Front Door @ Knee Y Velocity vs. Time	B-46
Figure No. 168	Lower Center Radiator Support X Acceleration vs. Time	B-47
Figure No. 169	Lower Center Radiator Support Y Acceleration vs. Time	B-47
Figure No. 170	Lower Center Radiator Support Z Acceleration vs. Time	B-47
Figure No. 171	LC Radiator Support Resultant Acceleration vs. Time	B-47
Figure No. 172	Lower Center Radiator Support X Velocity vs. Time	B-48
Figure No. 173	Lower Center Radiator Support Y Velocity vs. Time	B-48
Figure No. 174	Lower Center Radiator Support Z Velocity vs. Time	B-48
Figure No. 175	Driver Upper Spine X Acceleration vs. Time (FIR 100)	B-49
Figure No. 176	Driver Upper Spine Y Acceleration vs. Time (FIR 100)	B-49
Figure No. 177	Driver Upper Spine Z Acceleration vs. Time (FIR 100)	B-49
Figure No. 178	Driver Upper Rib Y Acceleration vs. Time (FIR 100)	B-50
Figure No. 179	Driver Mid Rib Y Acceleration vs. Time (FIR 100)	B-50
Figure No. 180	Driver Lower Rib Y Acceleration vs. Time (FIR 100)	B-50
Figure No. 181	Driver Lower Spine X Acceleration vs. Time (FIR 100)	B-51
Figure No. 182	Driver Lower Spine Y Acceleration vs. Time (FIR 100)	B-51
Figure No. 183	Driver Lower Spine Z Acceleration vs. Time (FIR 100)	B-51

* No Valid Data after approximately 30 msec.

Figure No. 184	Driver Pelvis X Acceleration vs. Time (FIR 100)	B-52
Figure No. 185	Driver Pelvis Y Acceleration vs. Time (FIR 100)	B-52
Figure No. 186	Driver Pelvis Z Acceleration vs. Time (FIR 100)	B-52
Figure No. 187	Driver Upper Rib Y Acceleration vs. Time	B-53
Figure No. 188	Driver Upper Rib Y Velocity vs. Time	B-53
Figure No. 189	Driver Upper Rib Y Displacement vs. Time	B-53
Figure No. 190	DUR differentiated velocity vs. Time	B-53
Figure No. 191	Driver Mid Rib Y Acceleration vs. Time	B-54
Figure No. 192	Driver Mid Rib Y Velocity vs. Time	B-54
Figure No. 193	Driver Mid Rib Y Displacement vs. Time	B-54
Figure No. 194	DMR differentiated velocity vs. Time	B-54
Figure No. 195	Driver Lower Rib Y Acceleration vs. Time	B-55
Figure No. 196	Driver Lower Rib Y Velocity vs. Time	B-55
Figure No. 197	Driver Lower Rib Y Displacement vs. Time	B-55
Figure No. 198	DLR differentiated velocity vs. Time	B-55

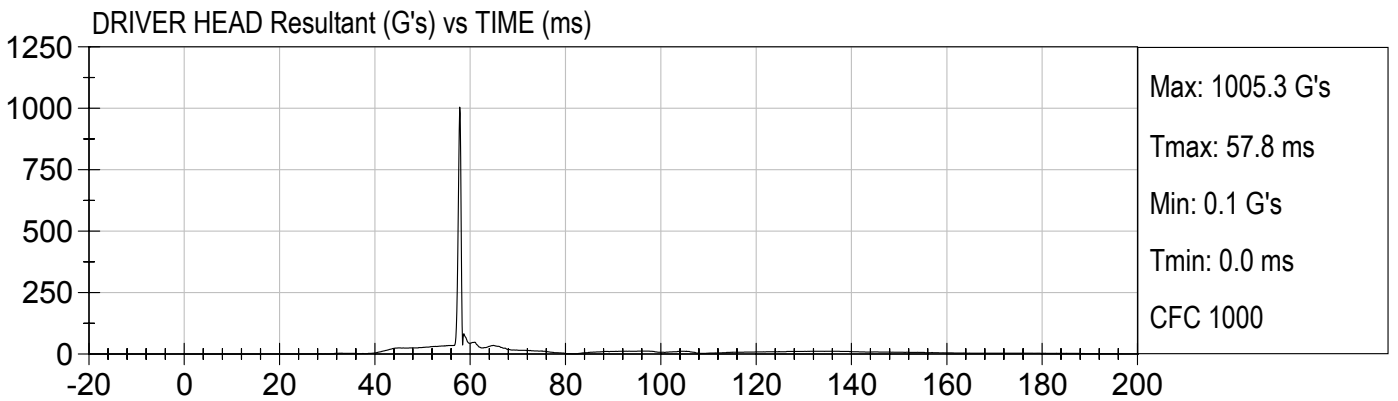
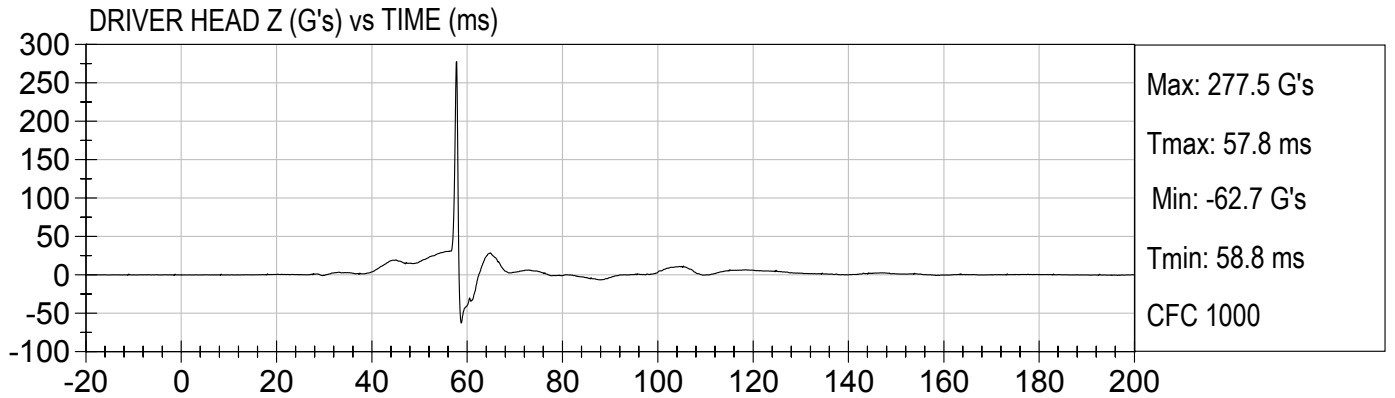
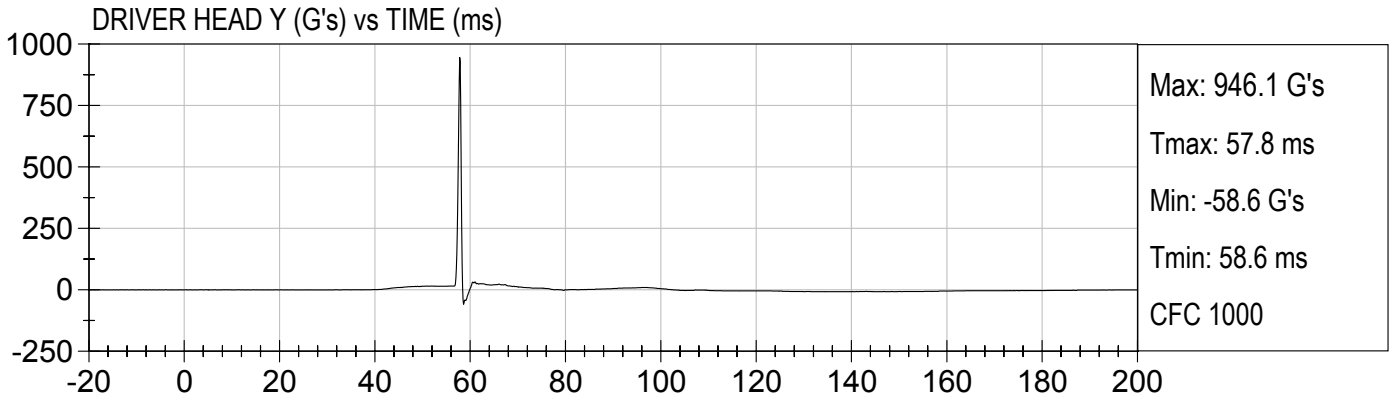
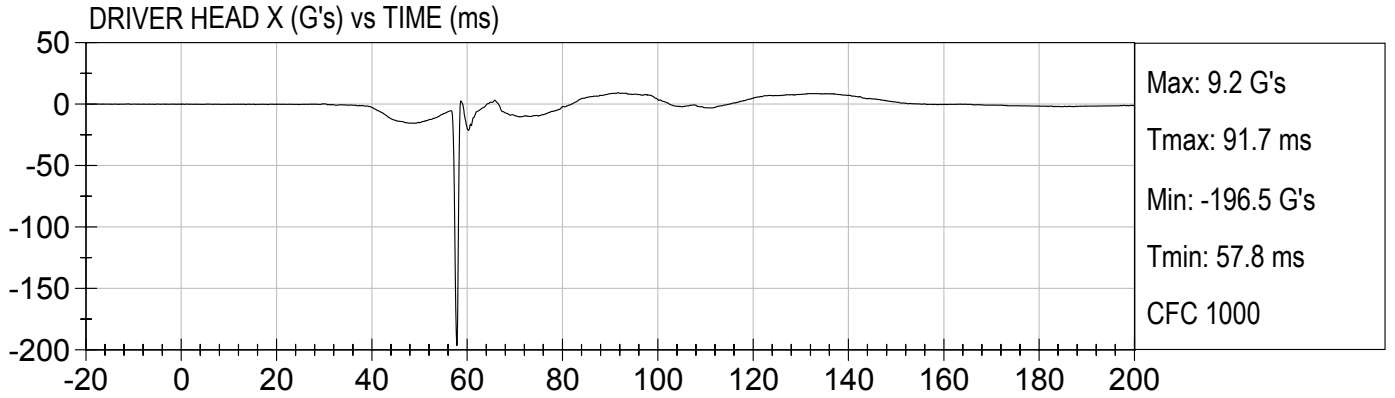

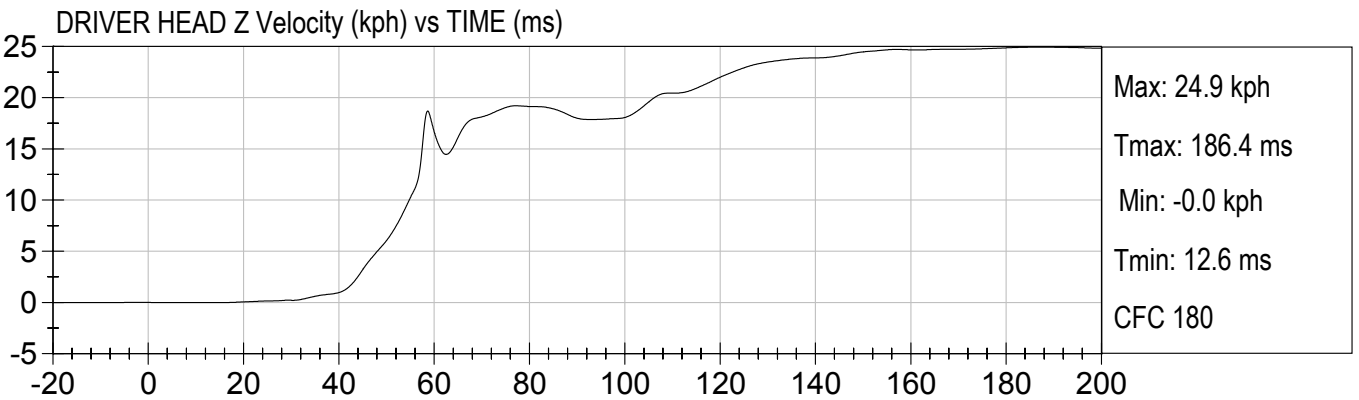
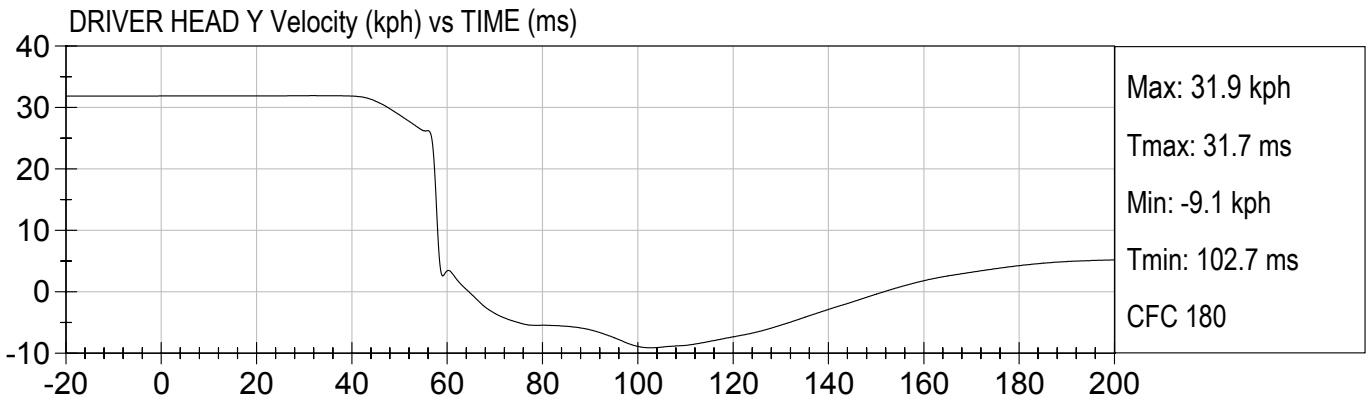
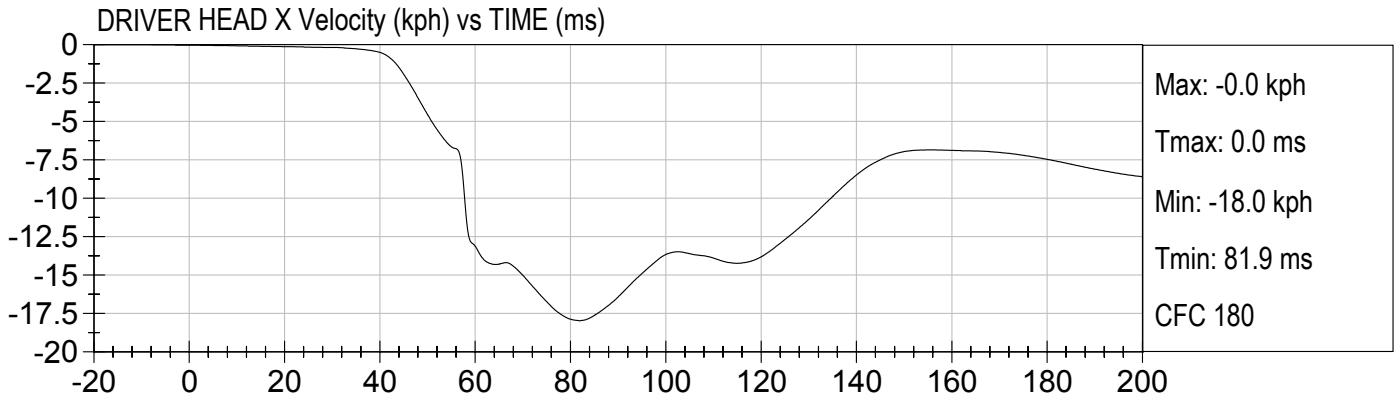

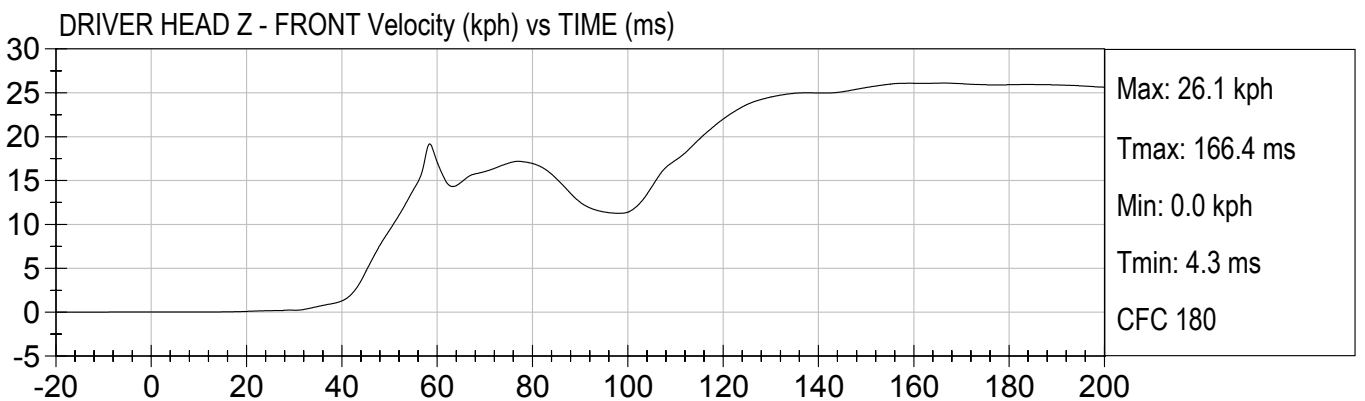
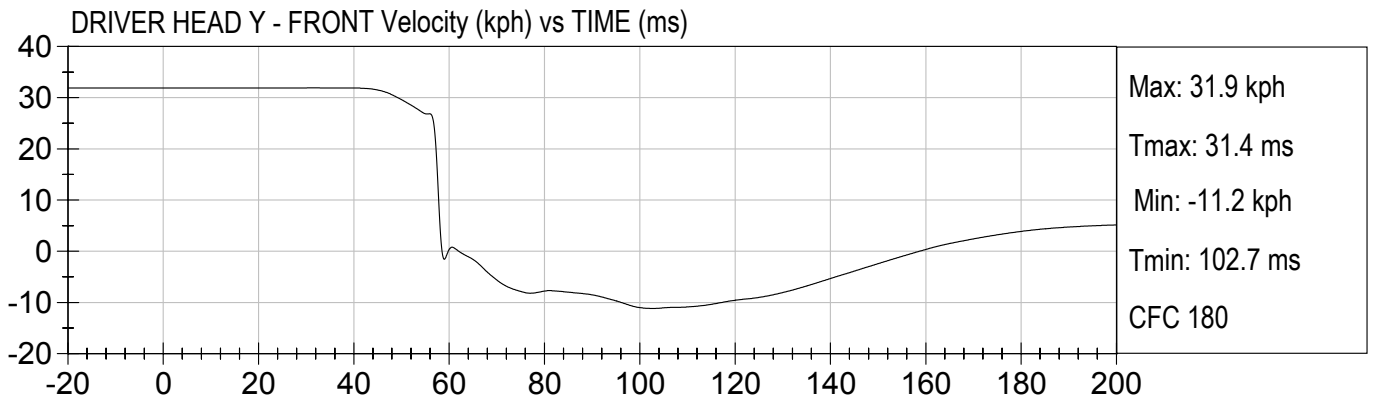
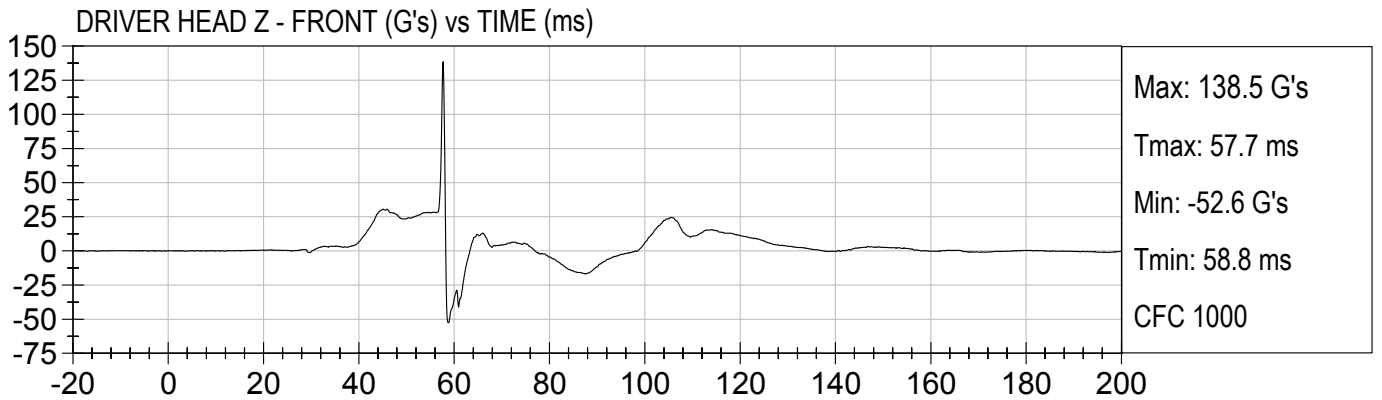
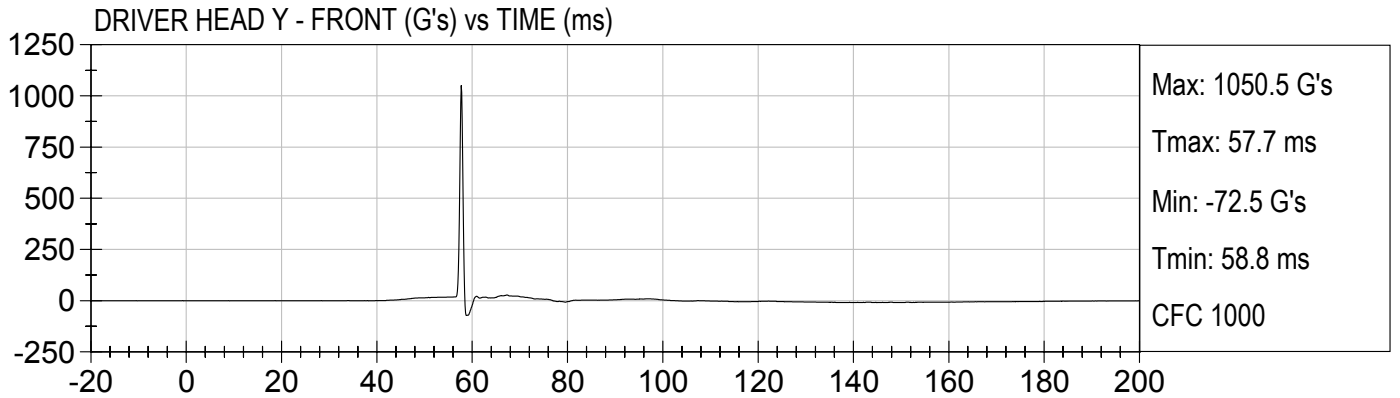

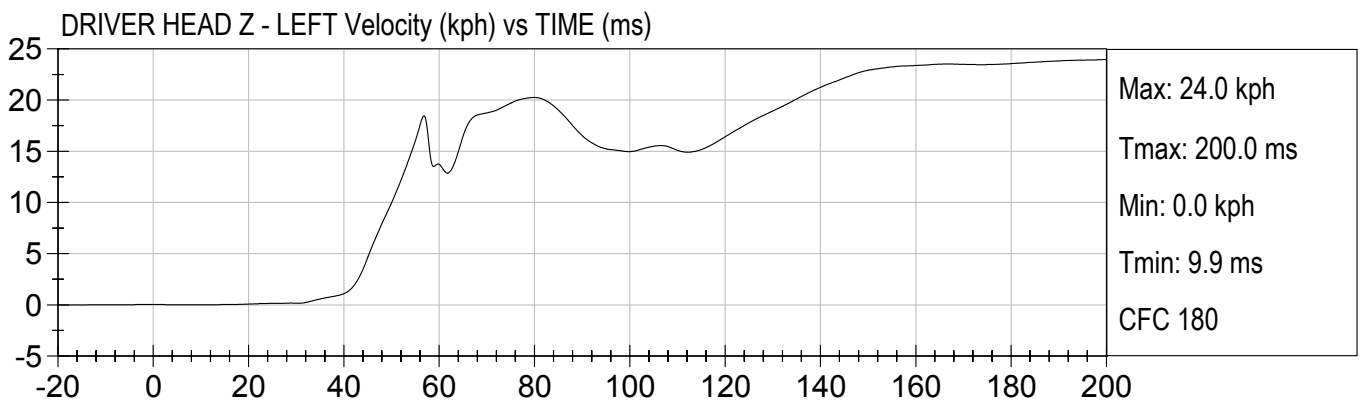
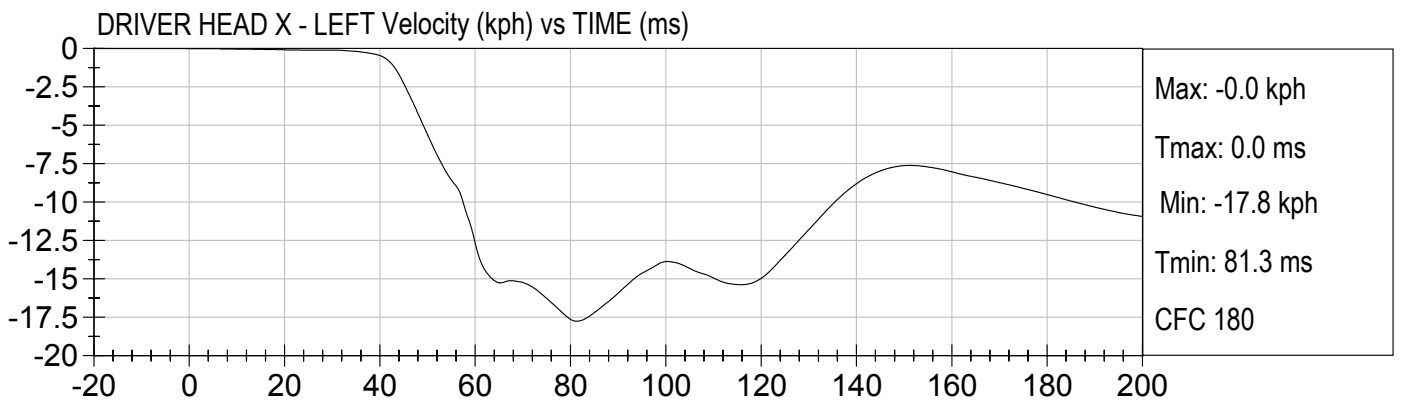
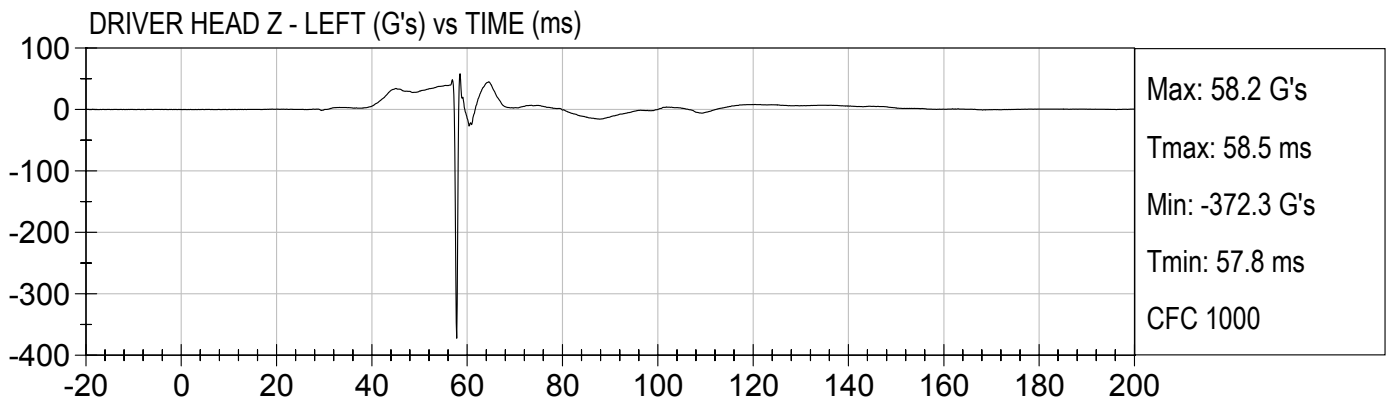
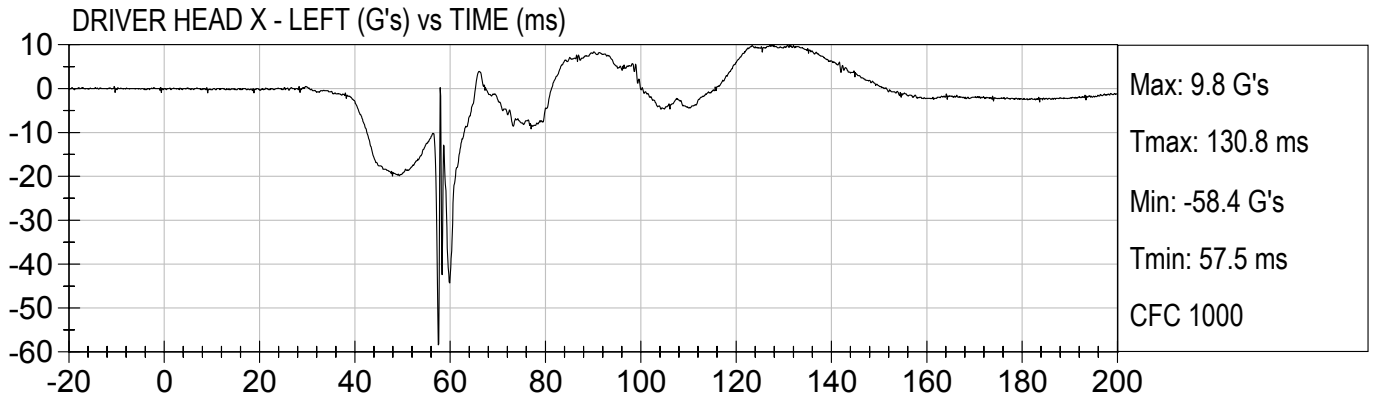

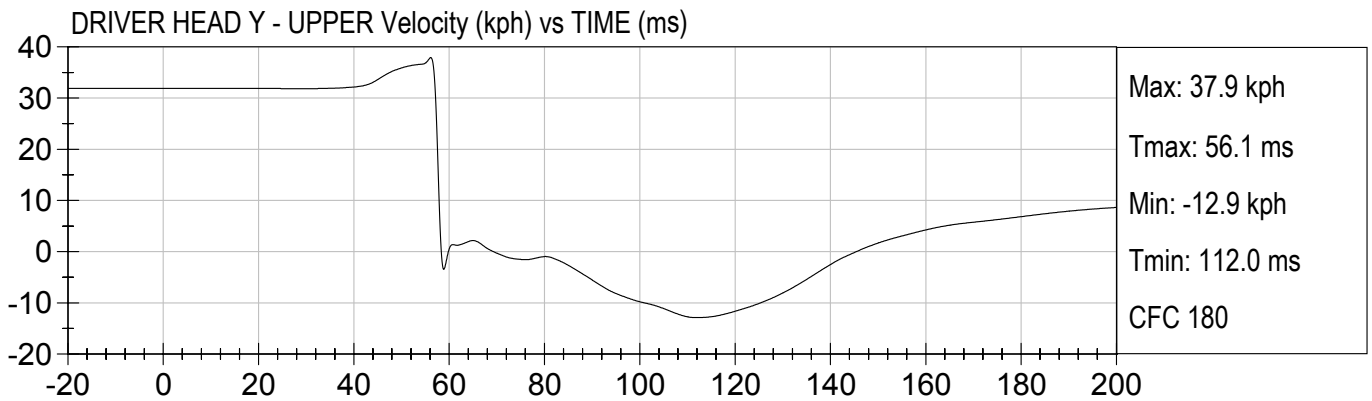
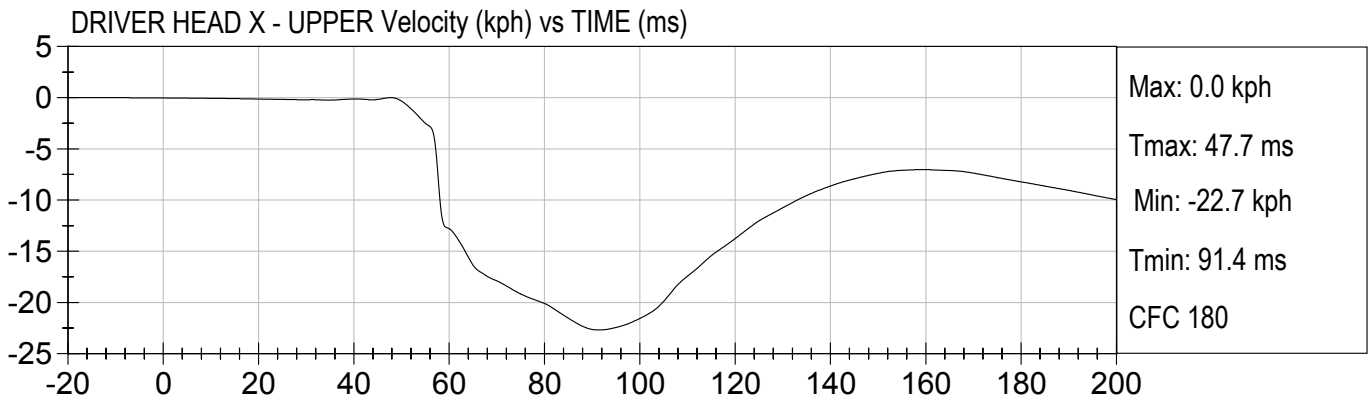
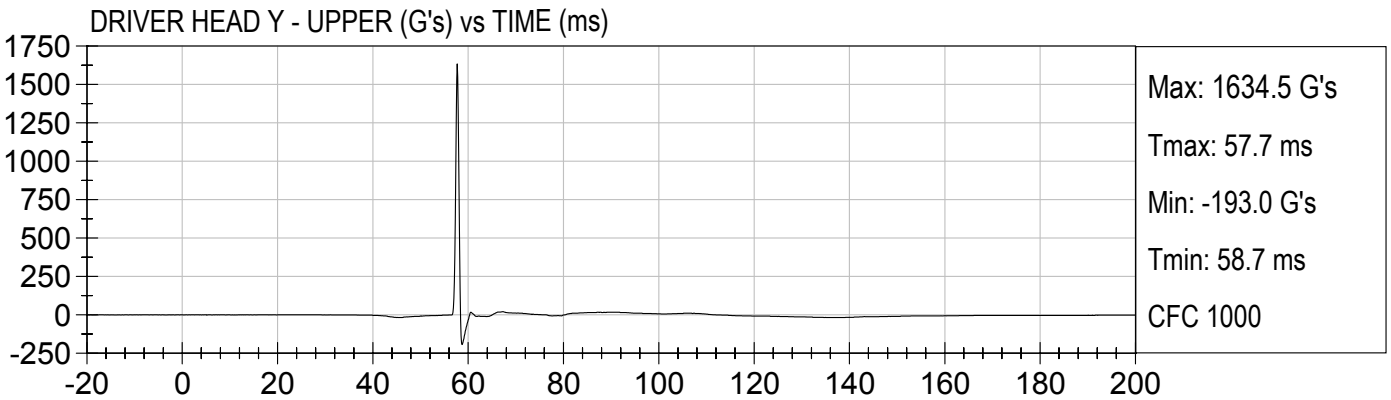
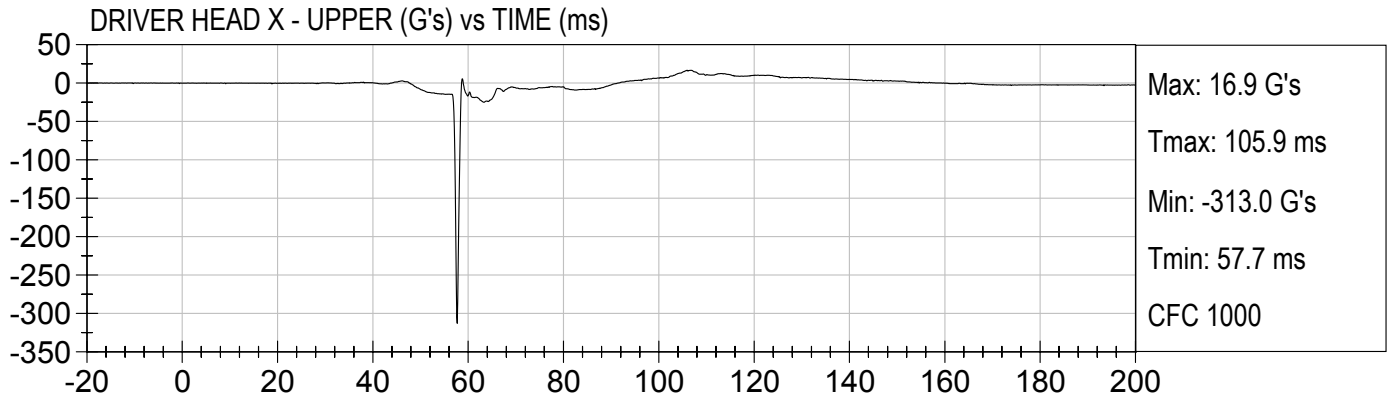

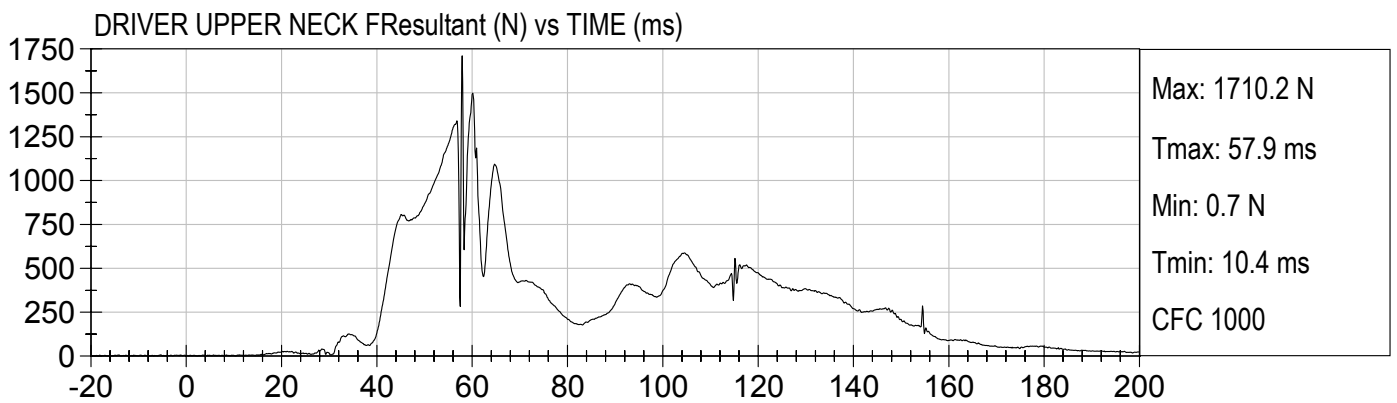
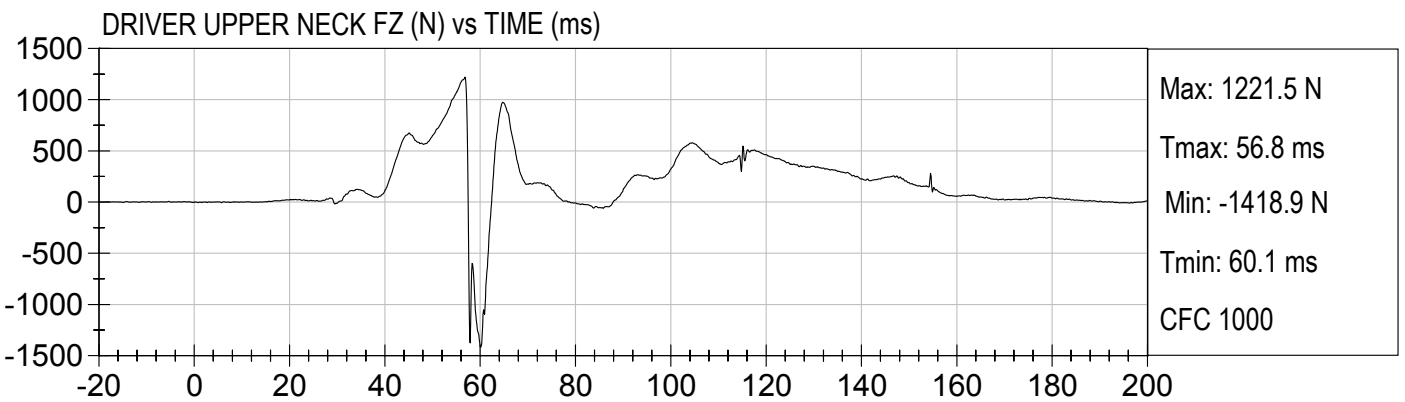
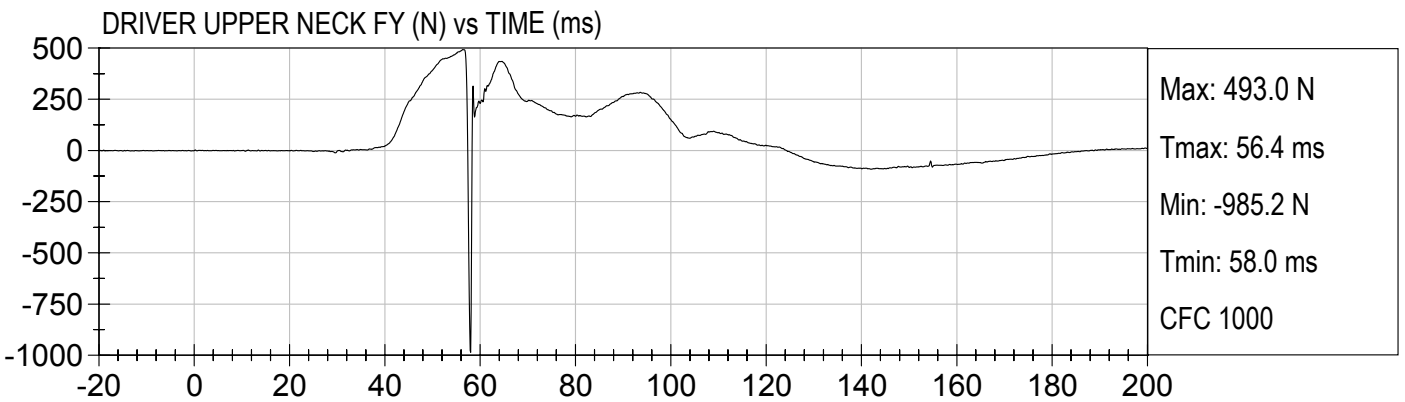
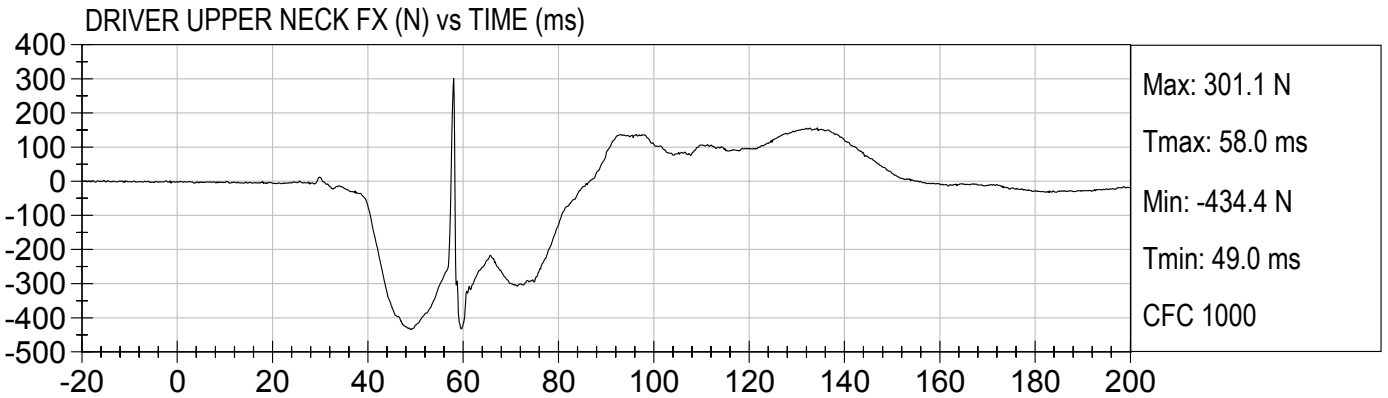

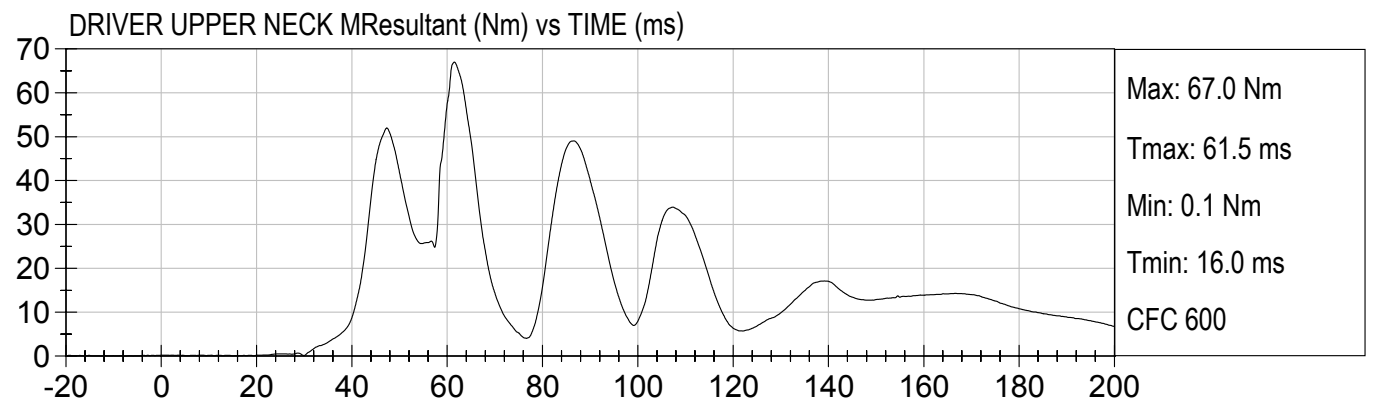
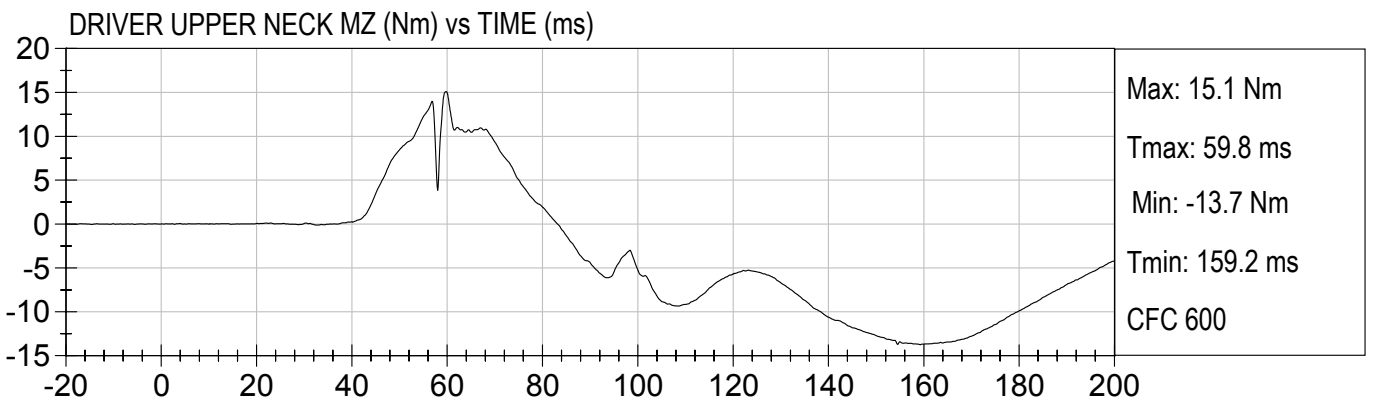
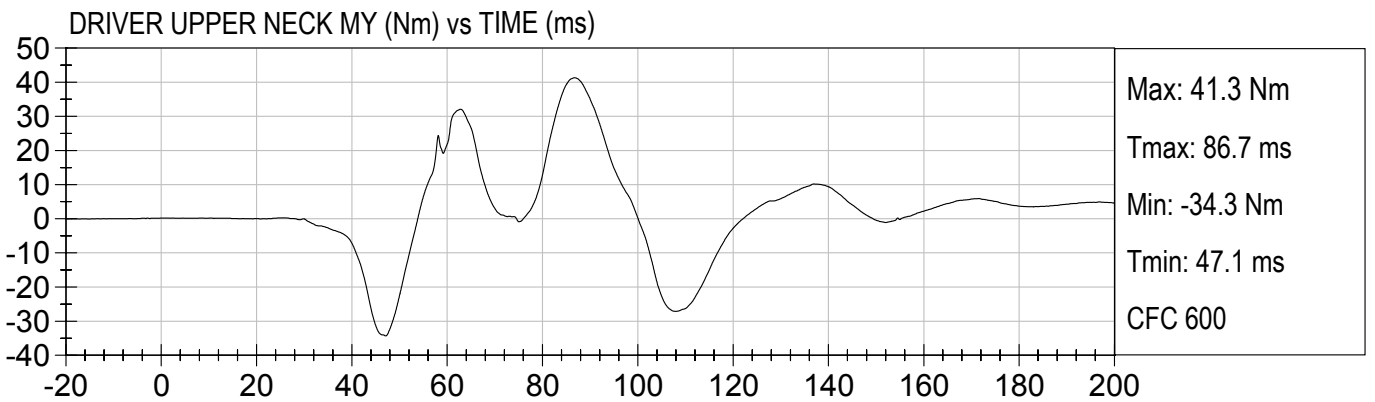
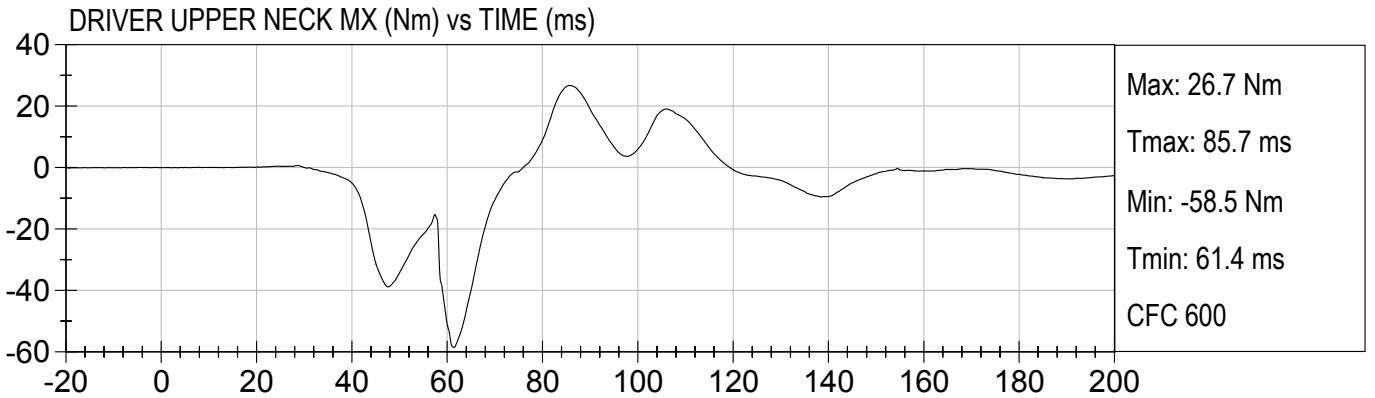

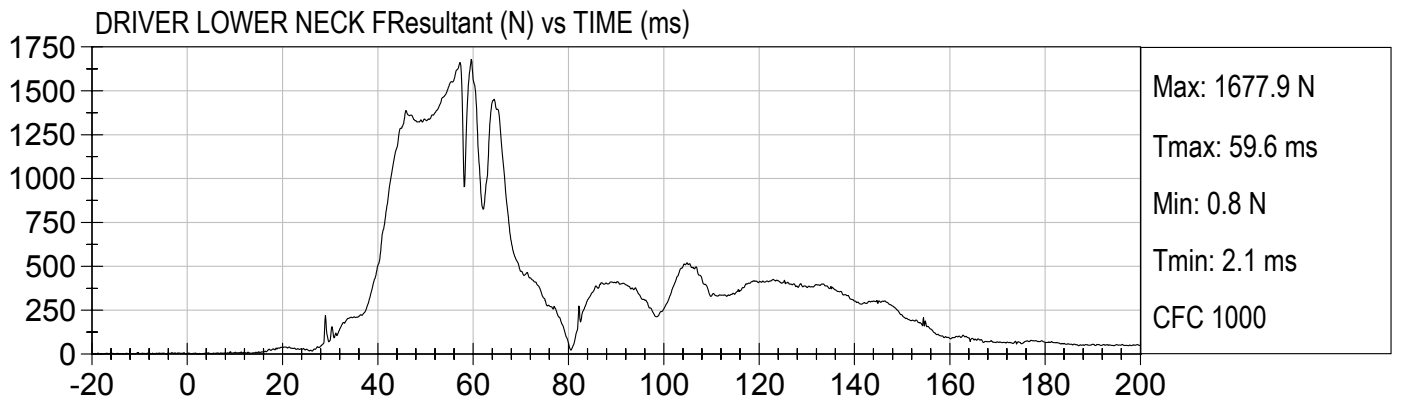
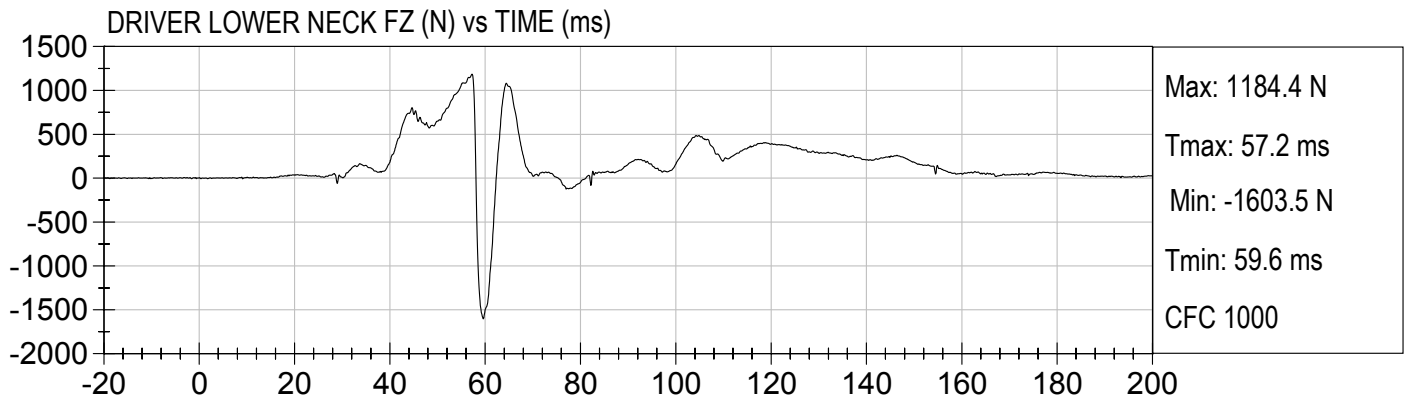
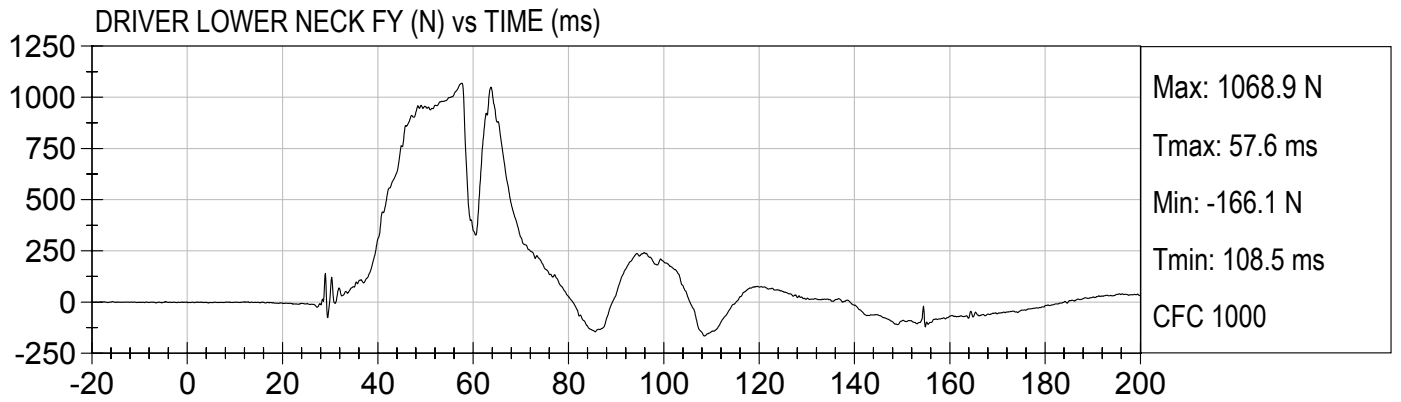
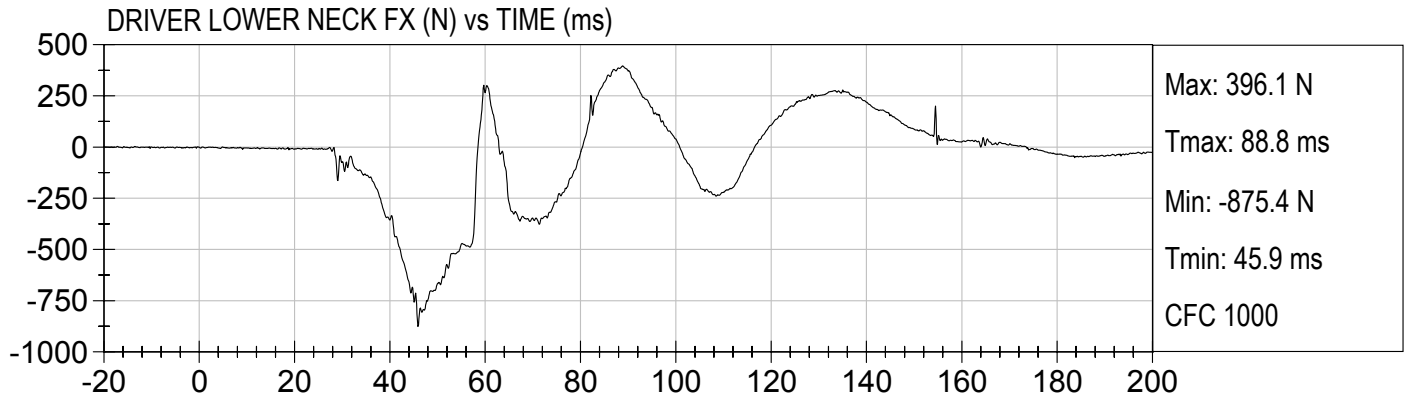

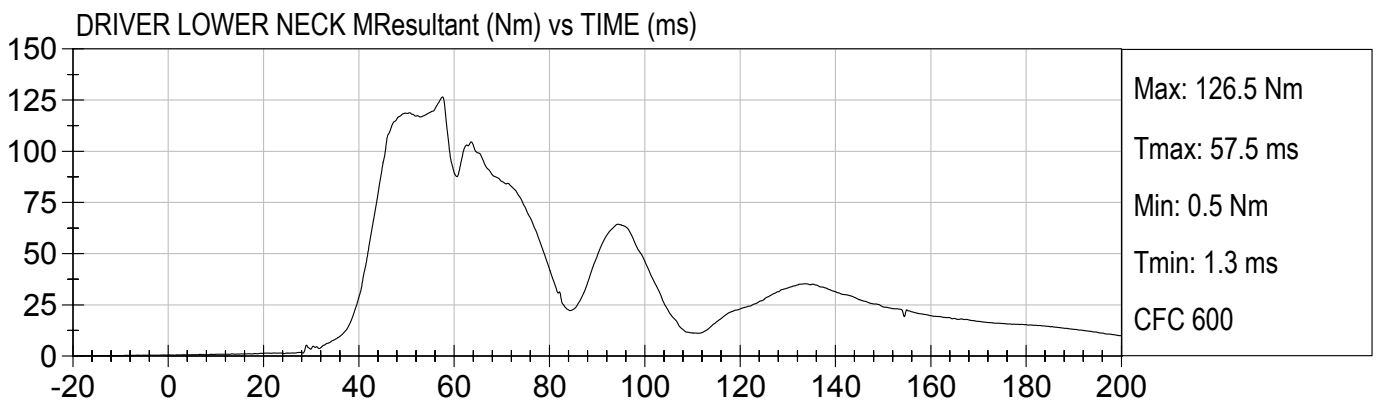
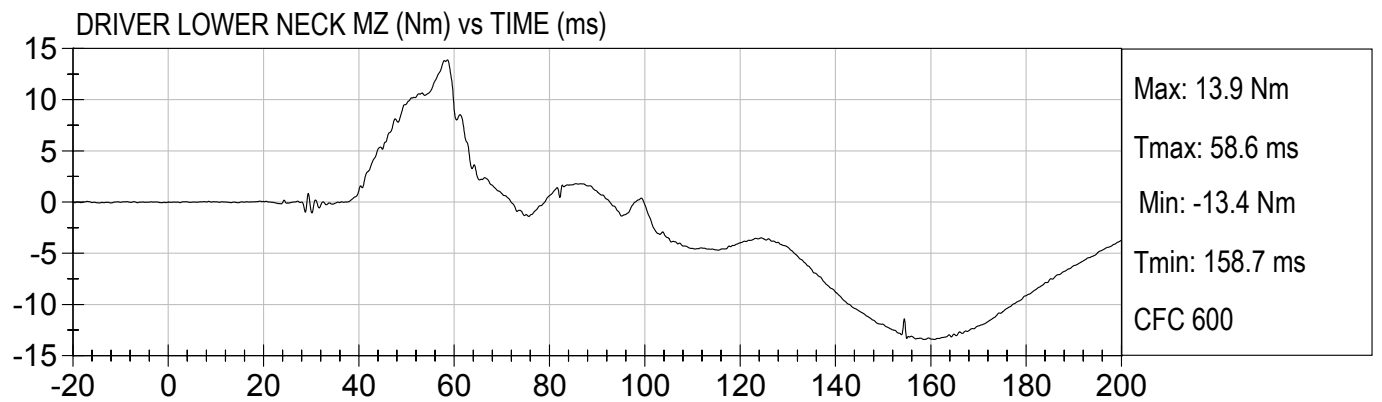
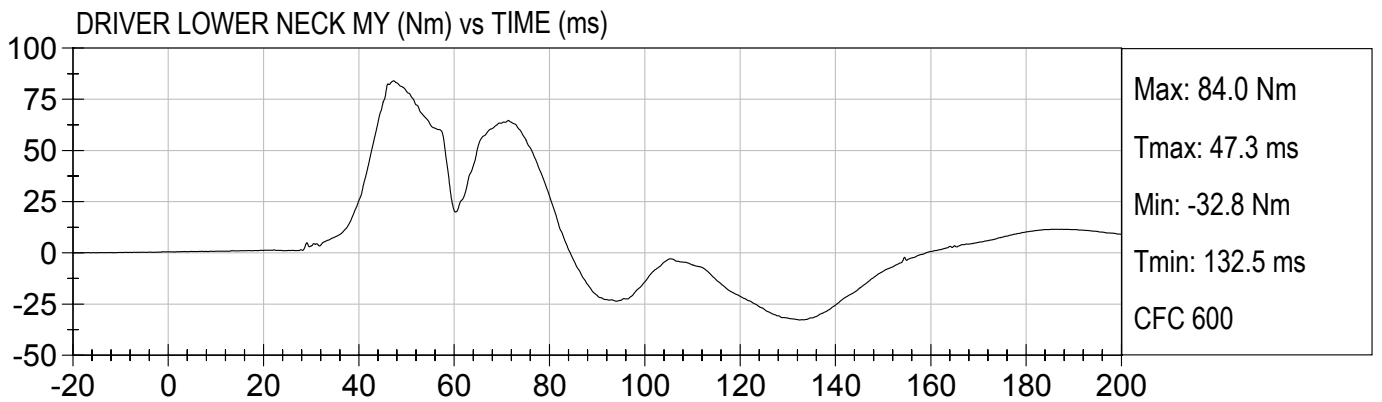
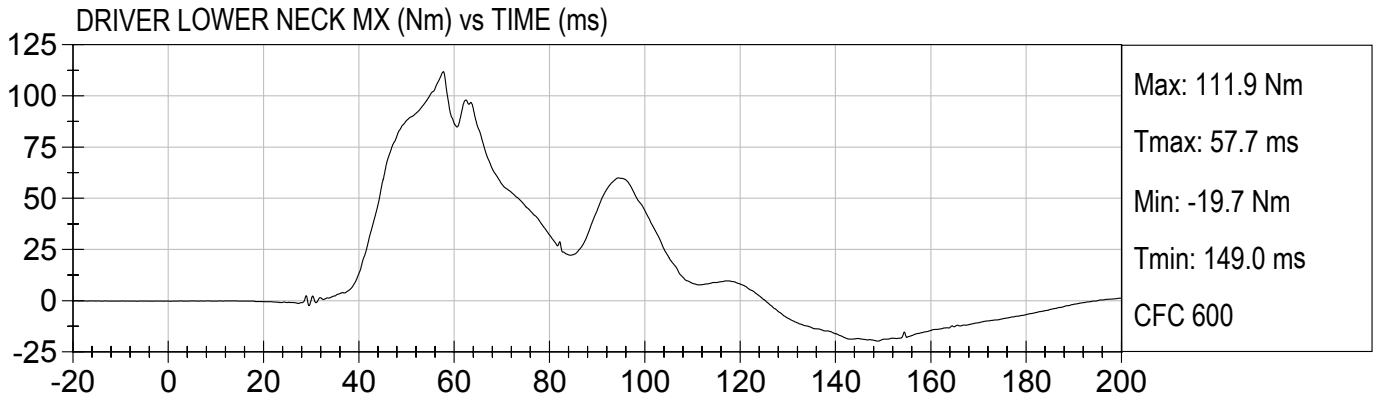

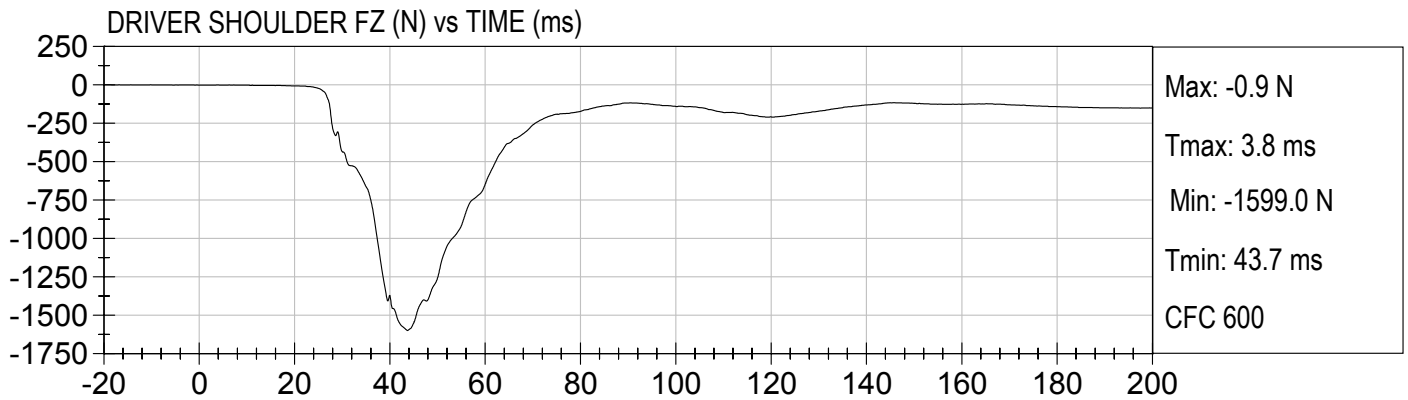
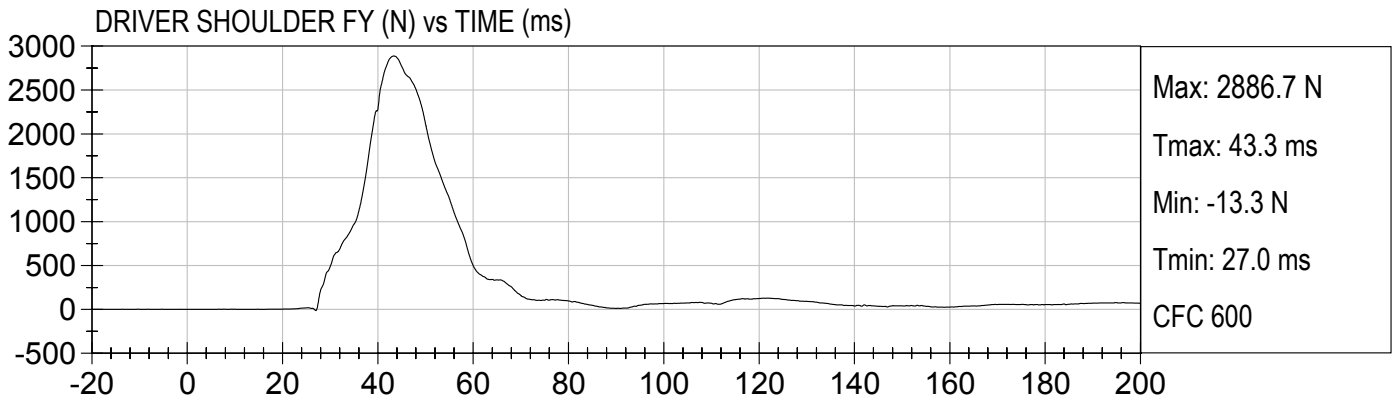
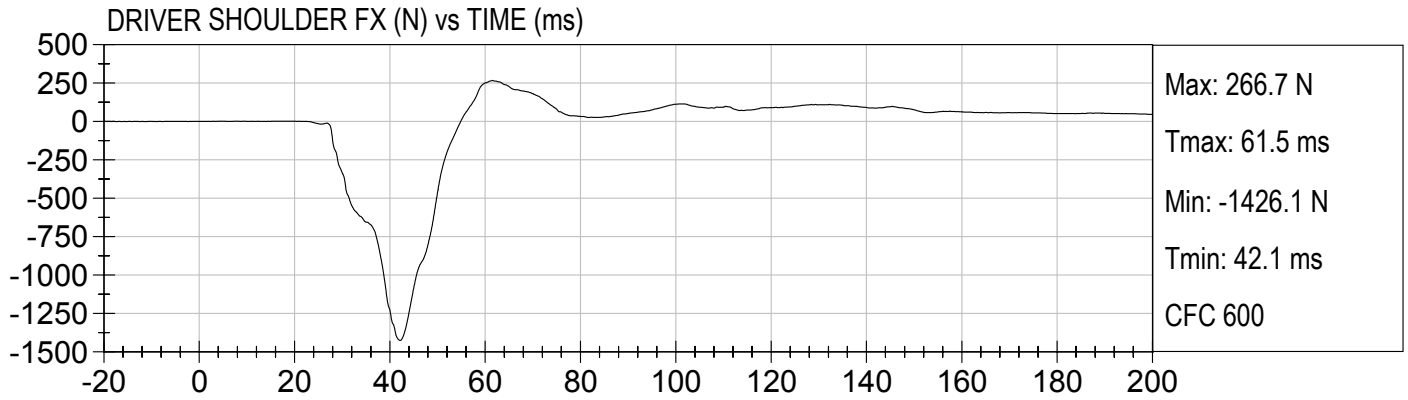

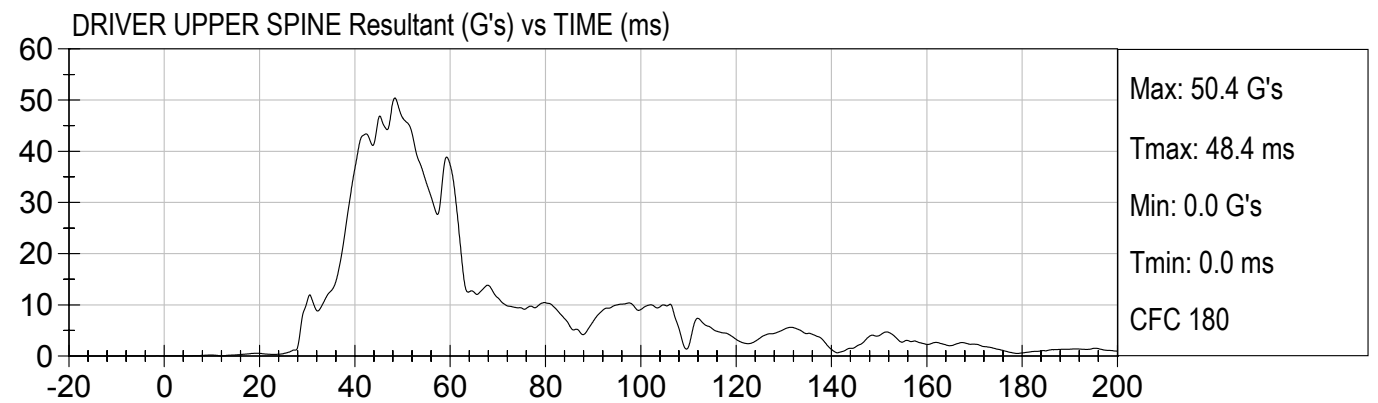
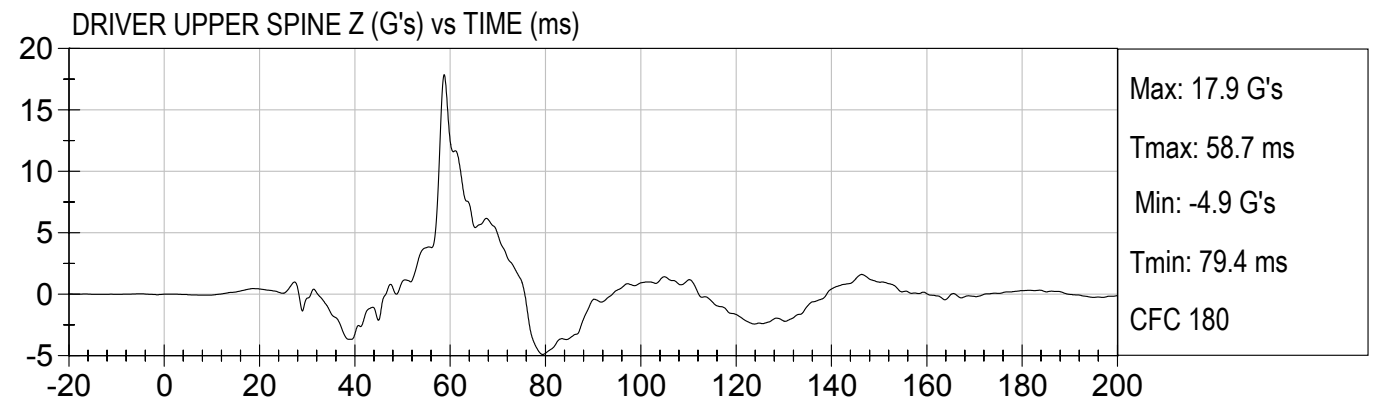
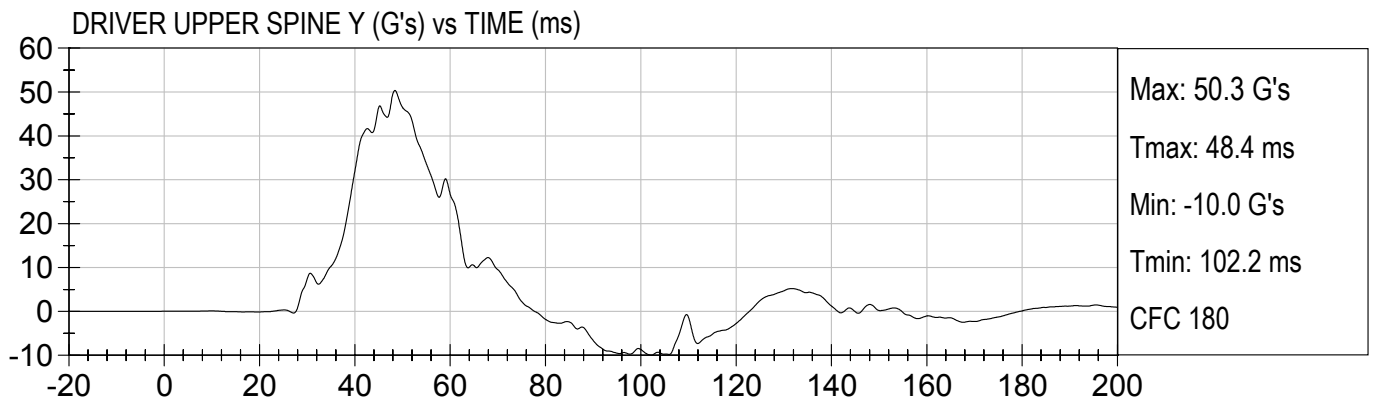
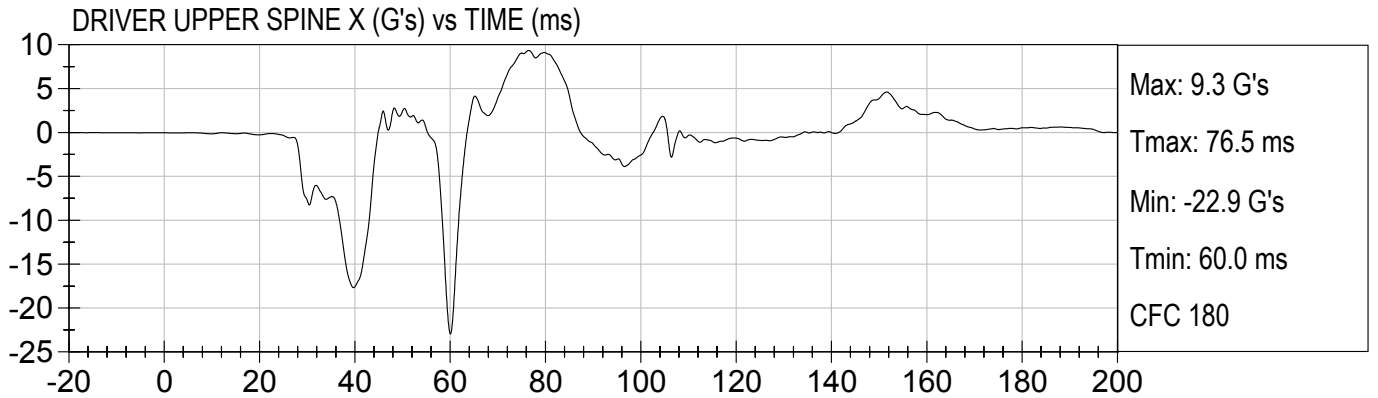

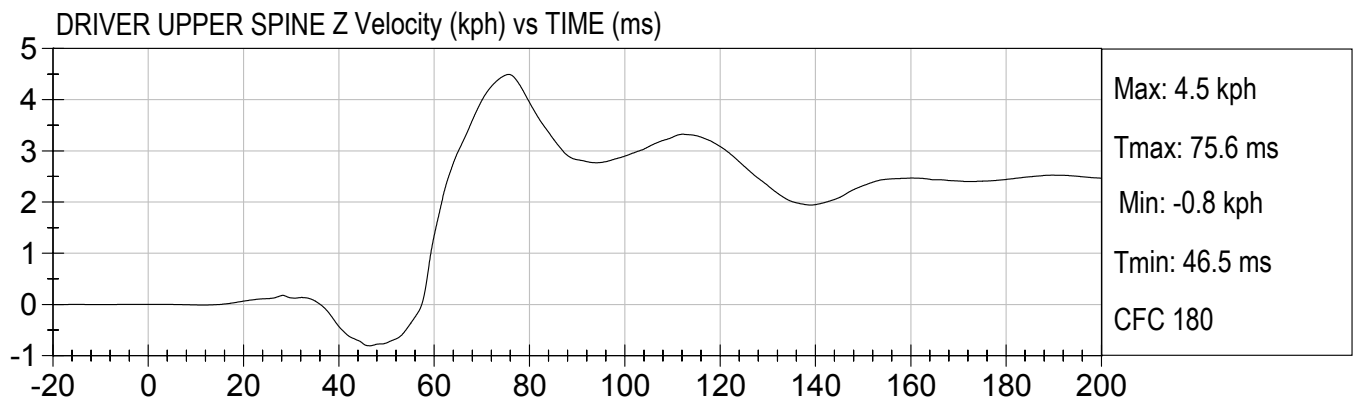
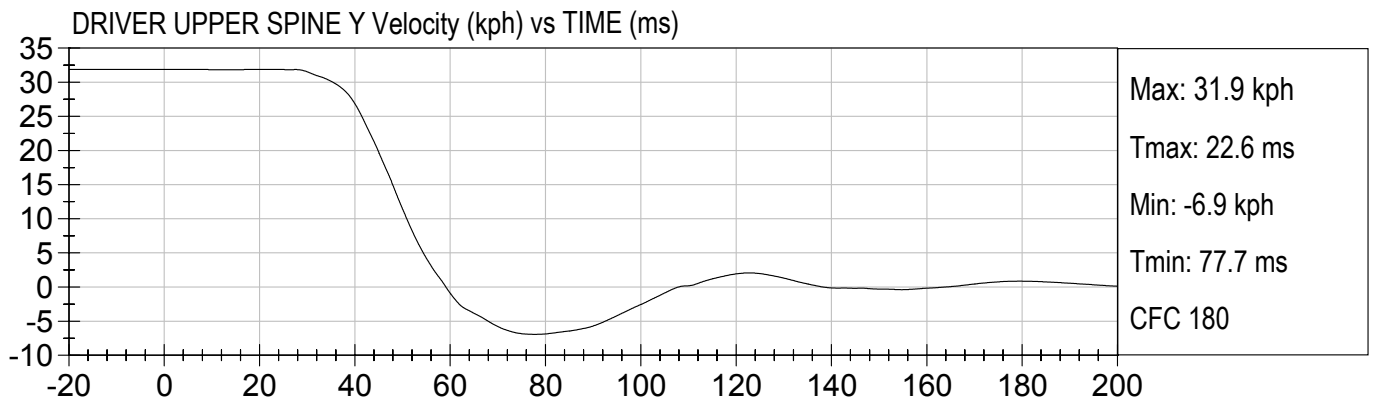
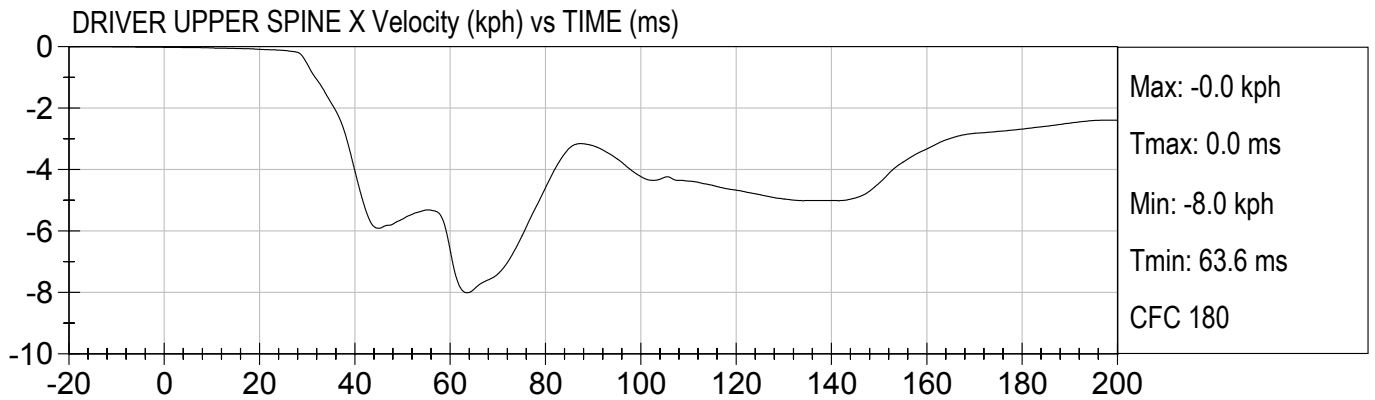

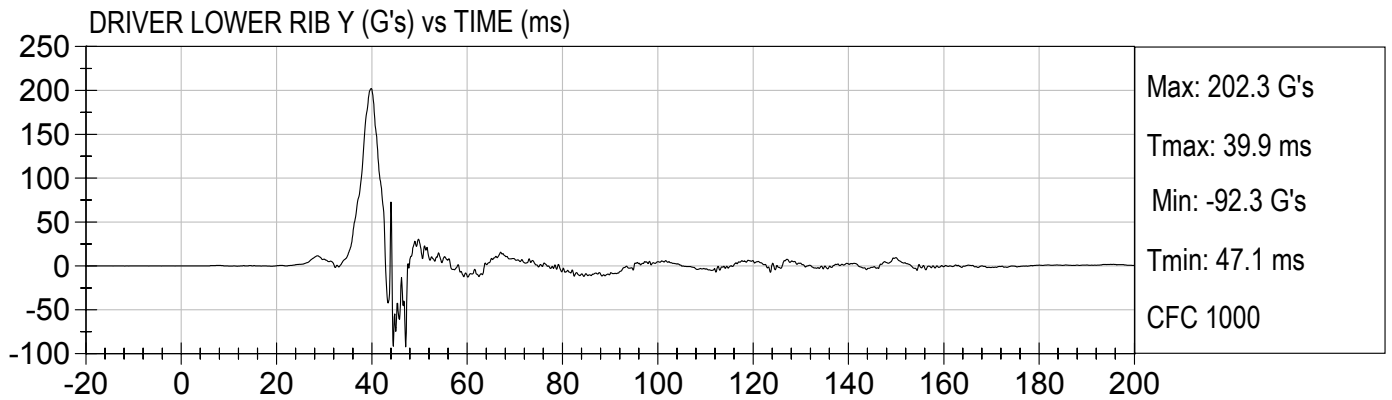
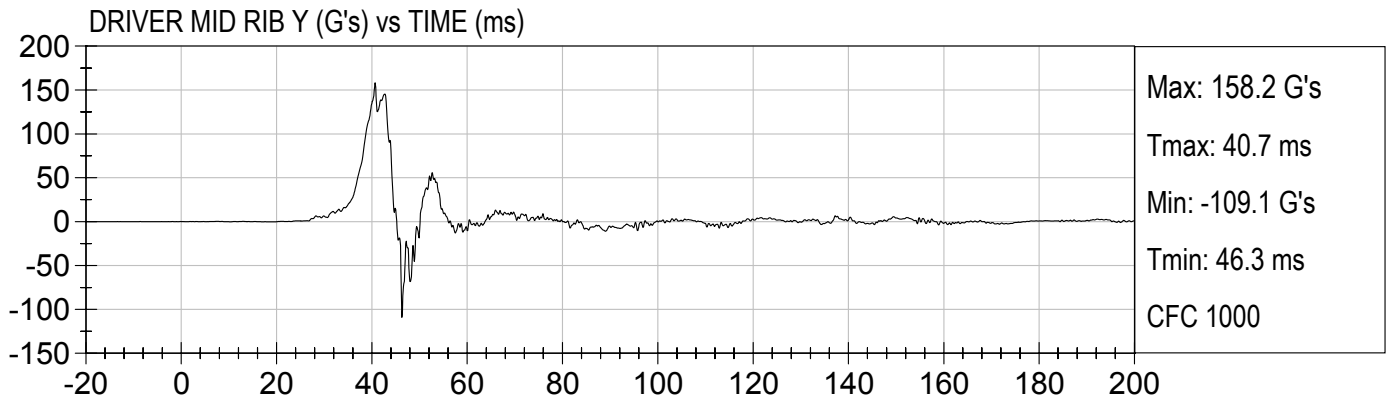
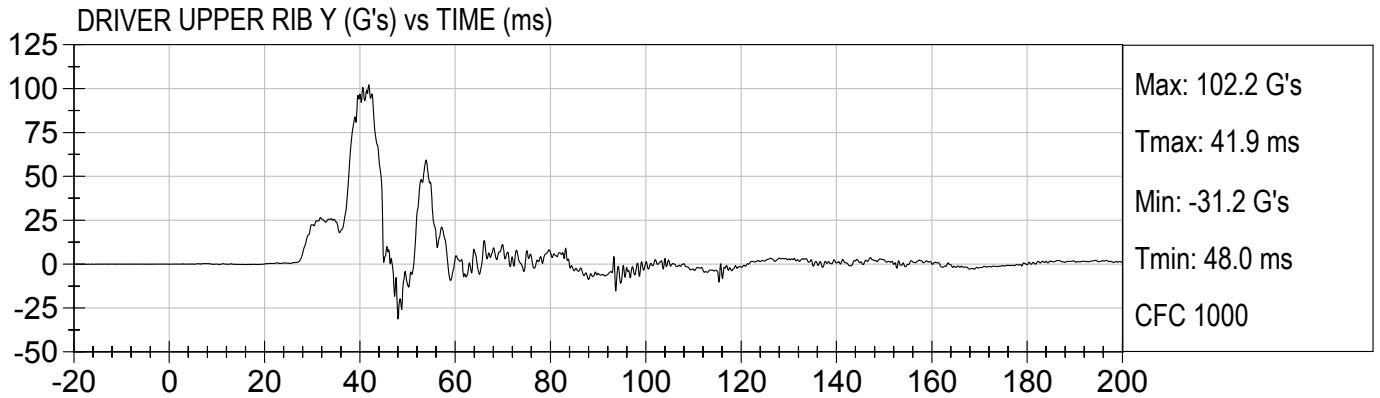

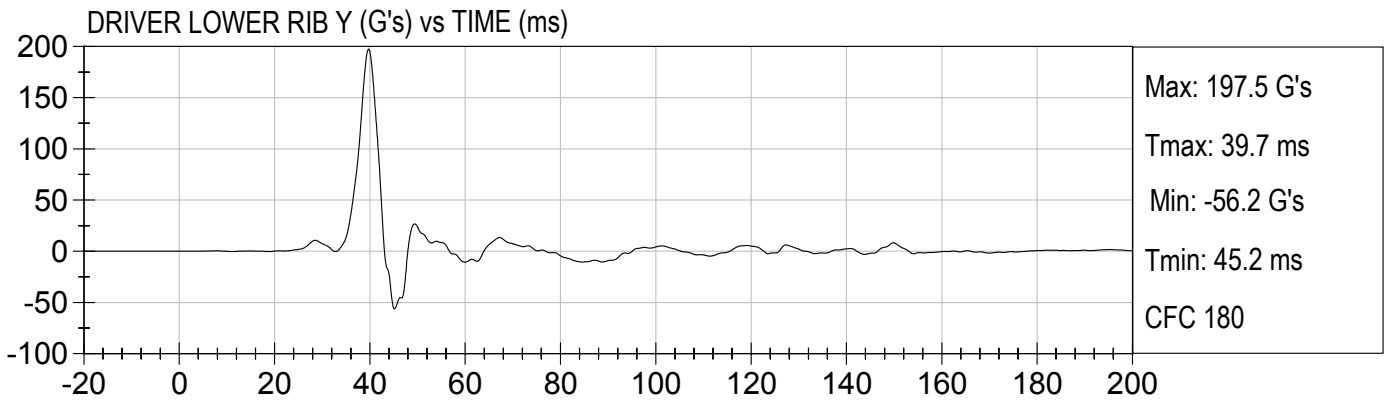
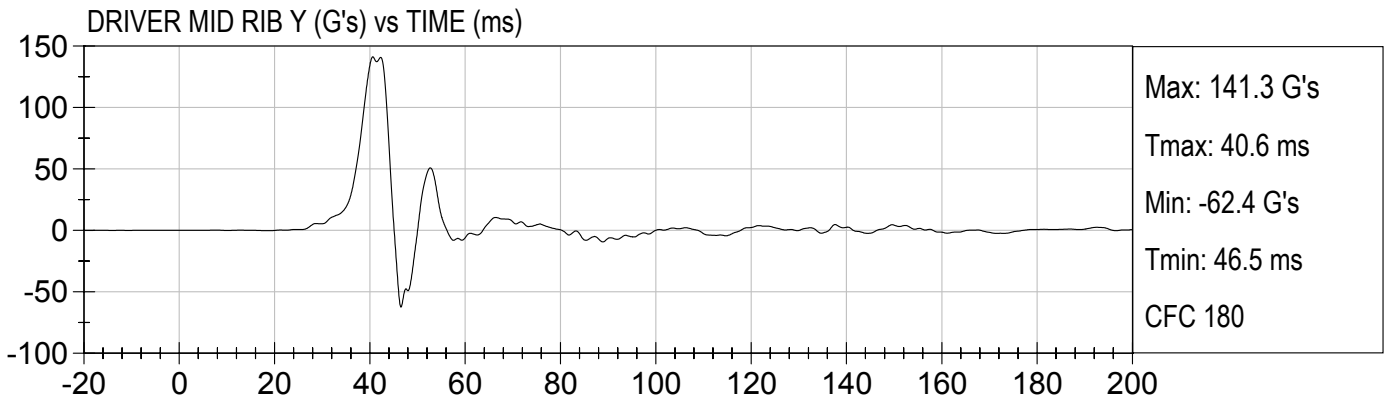
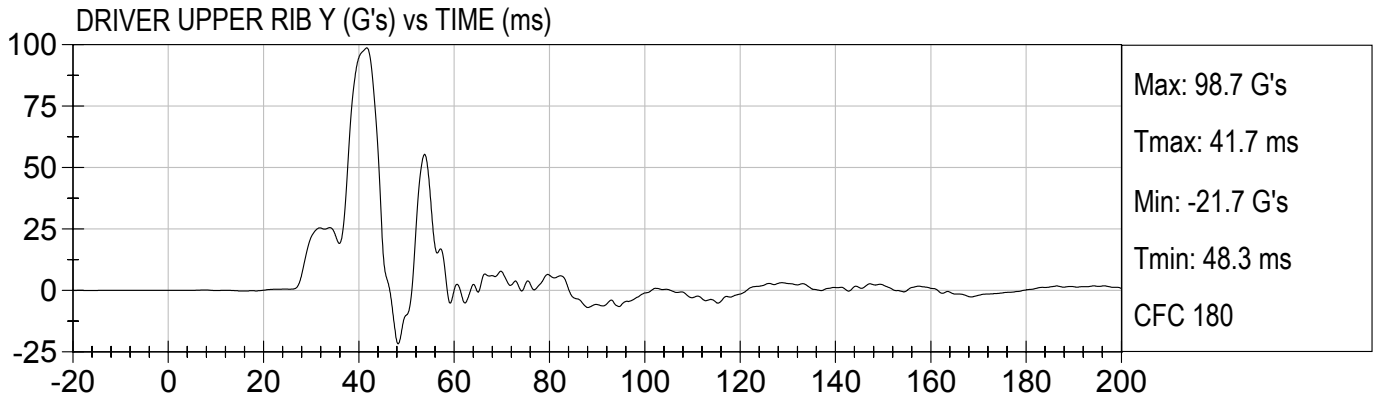

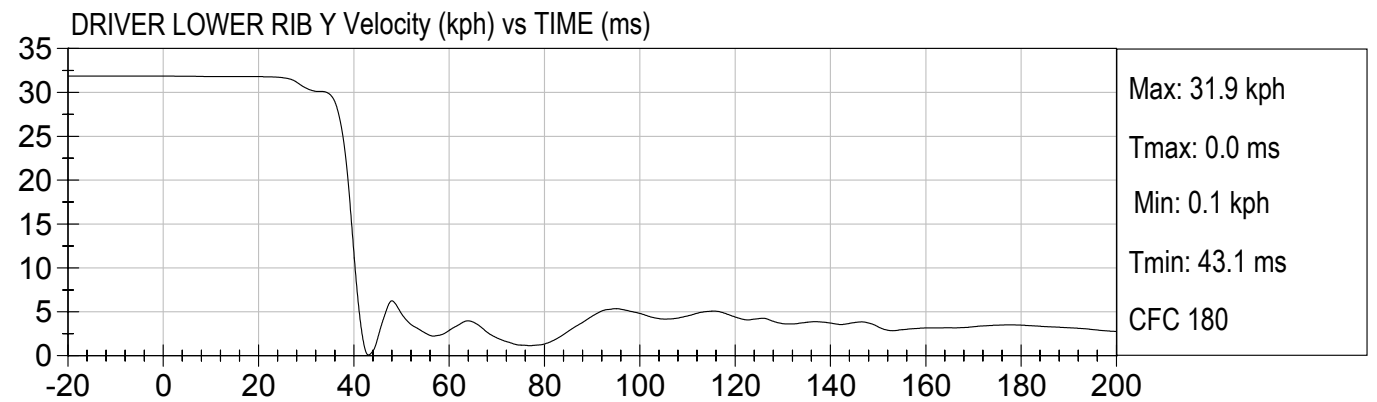
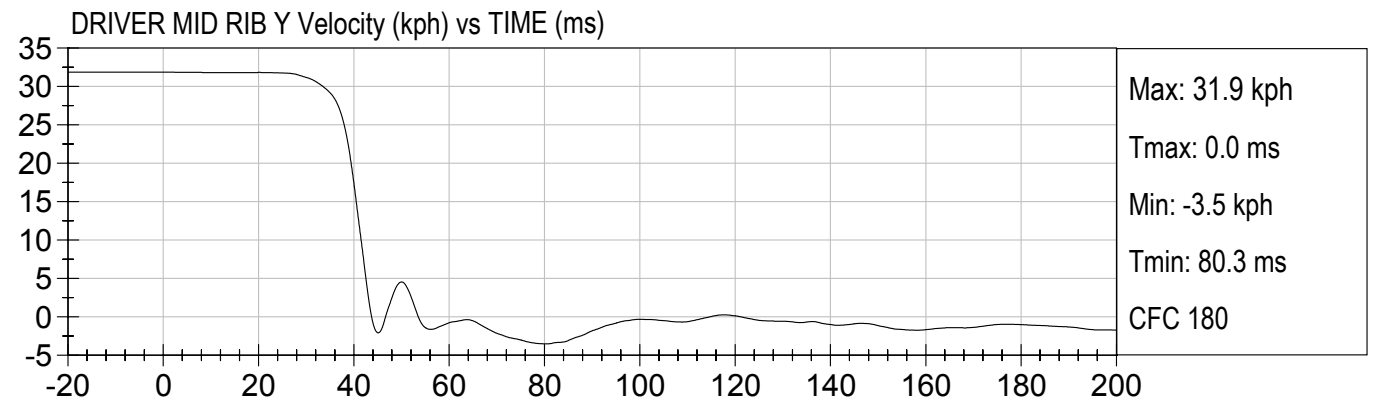
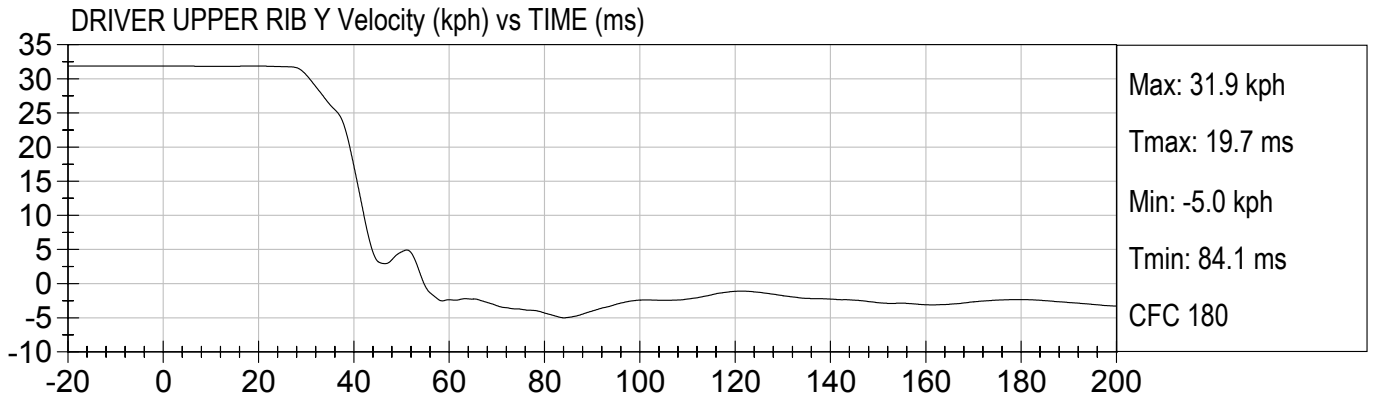



DR UPPER RIB DISPLACEMENT (mm) vs TIME (ms)

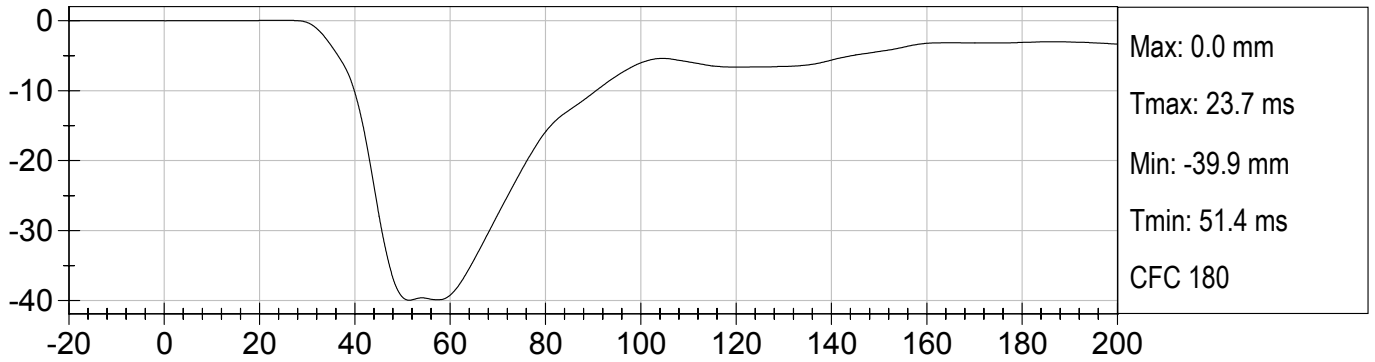

DR MID RIB DISPLACEMENT (mm) vs TIME (ms)

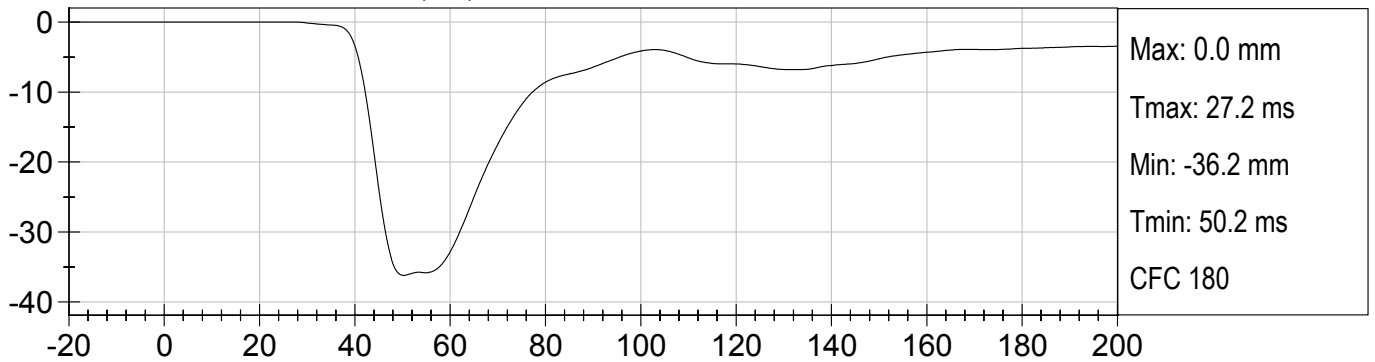

DR LOWER RIB DISPLACEMENT (mm) vs TIME (ms)

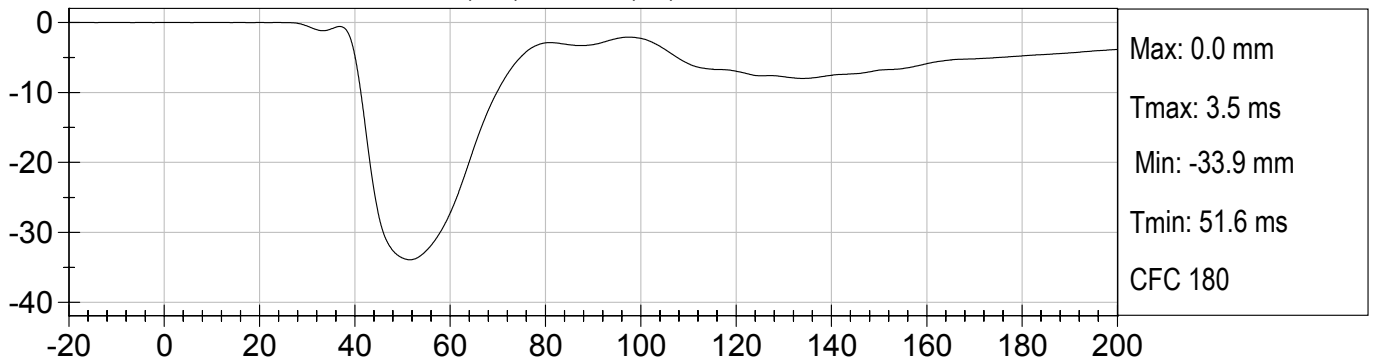

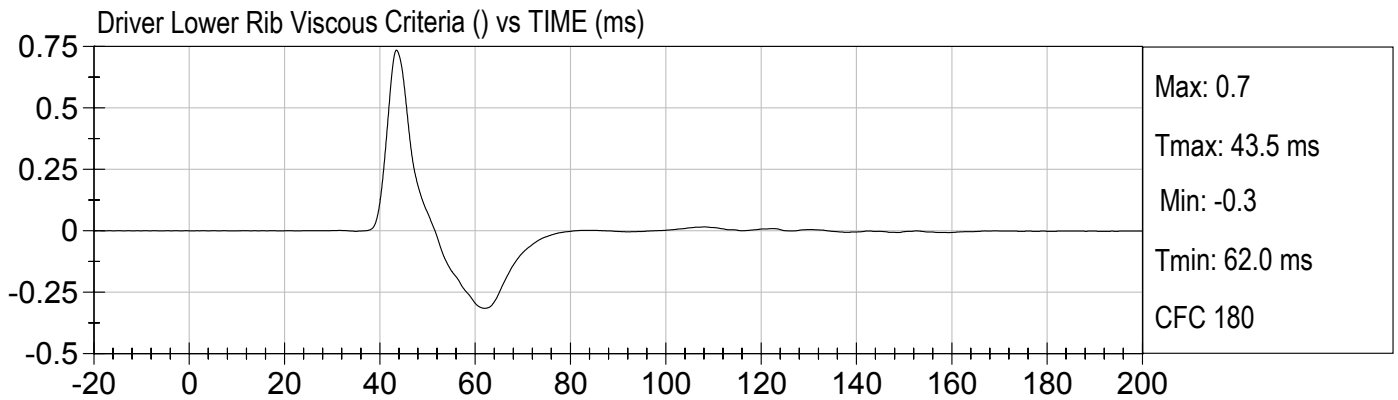
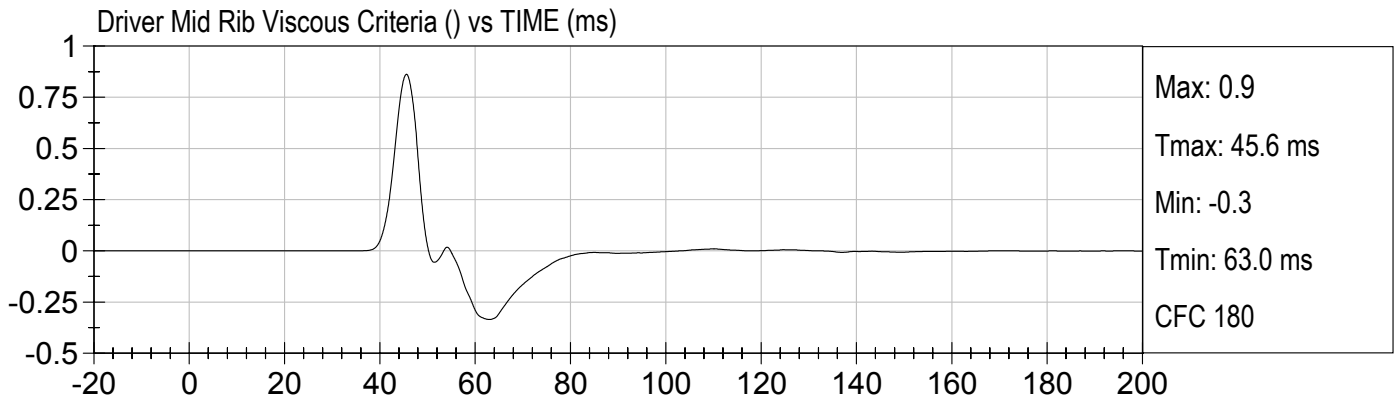
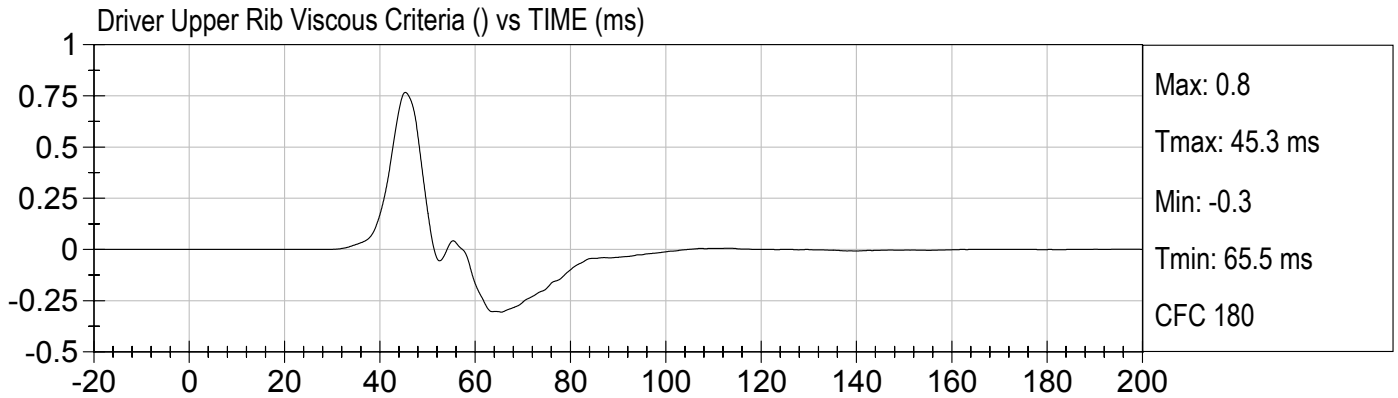

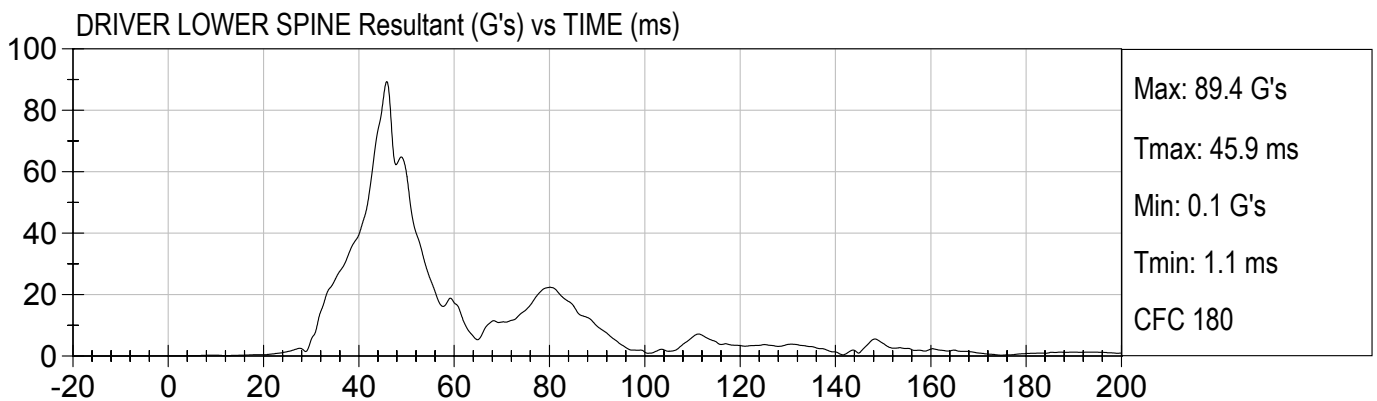
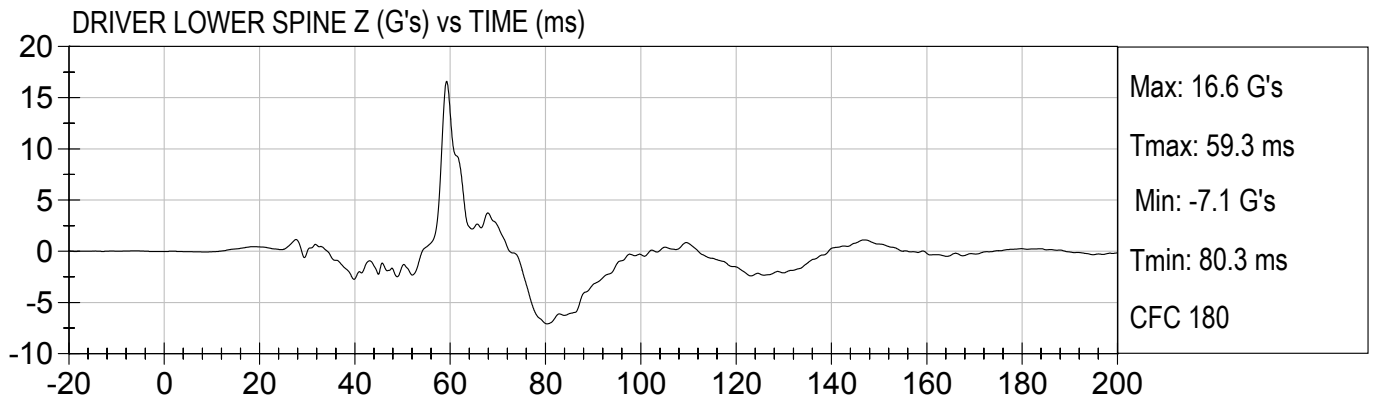
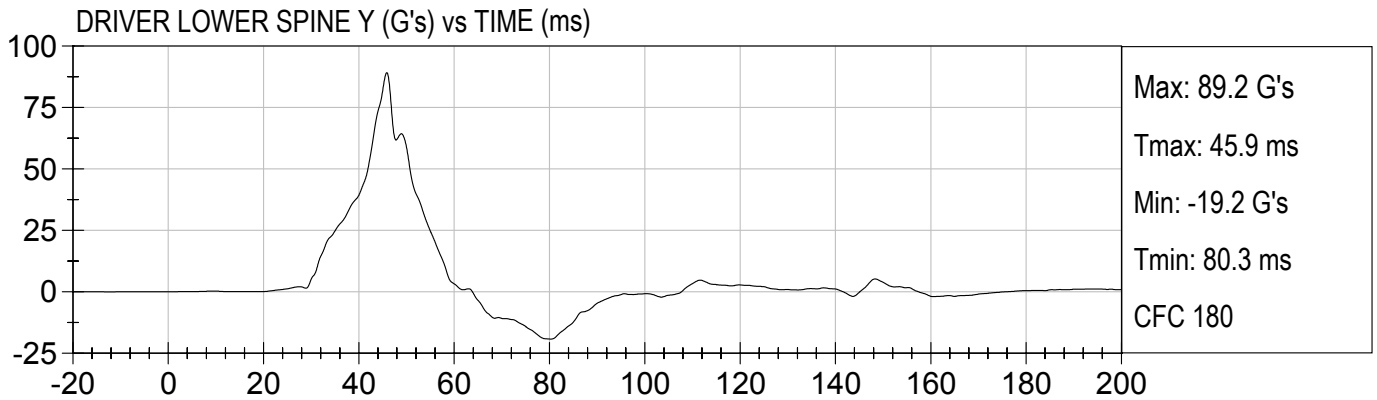
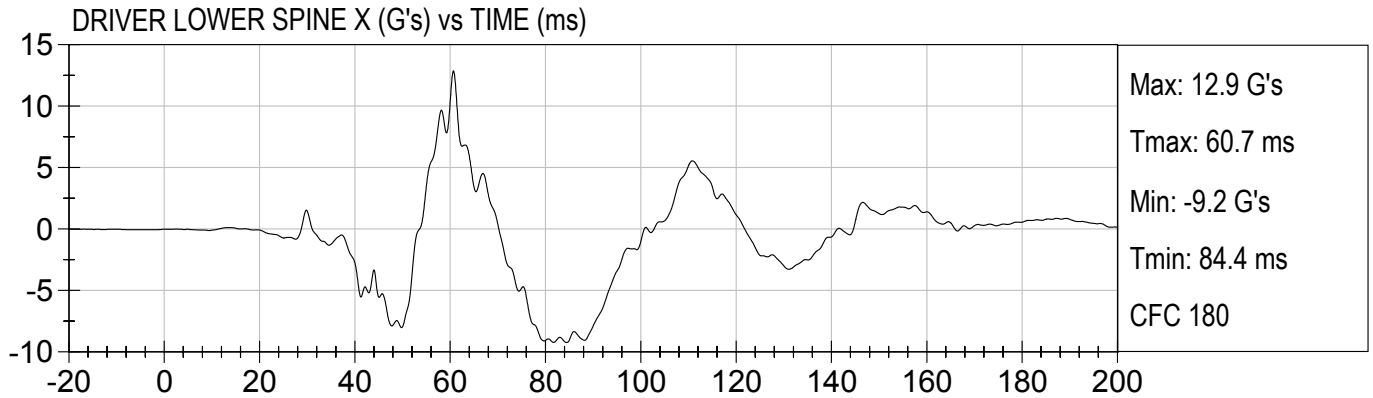

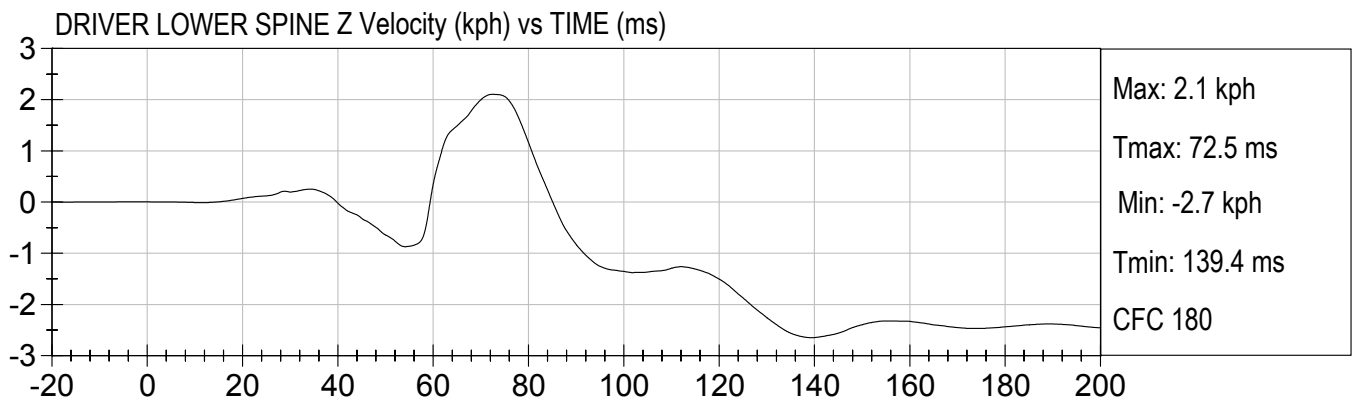
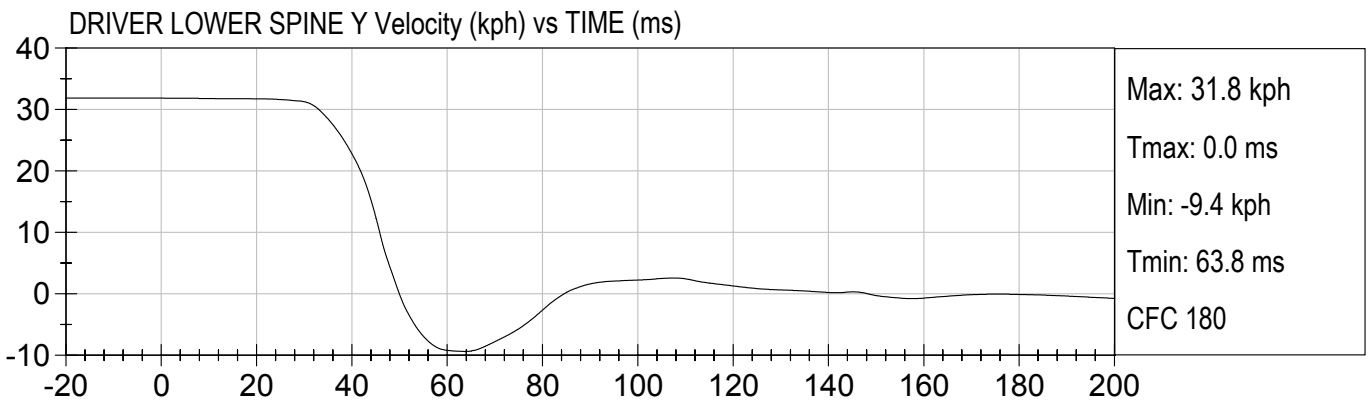
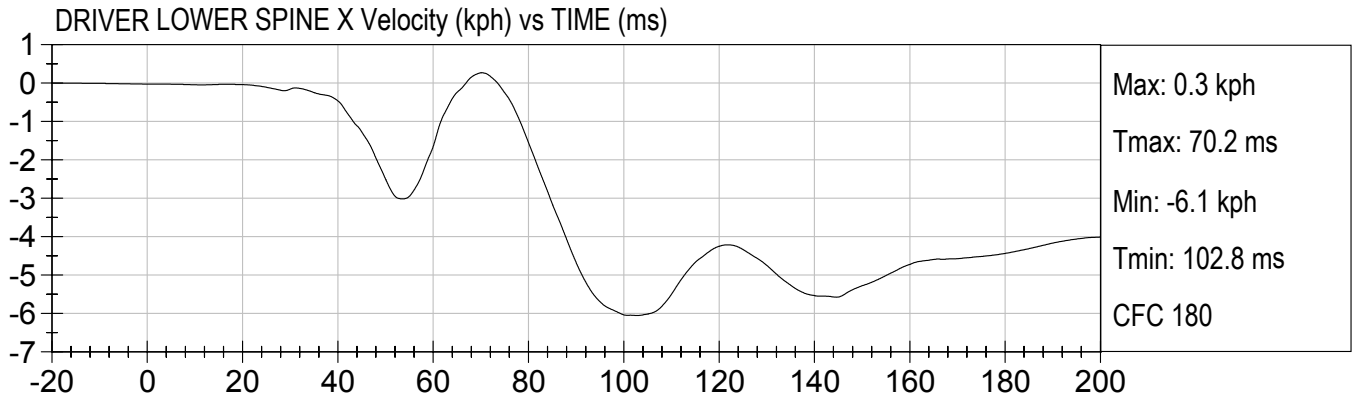

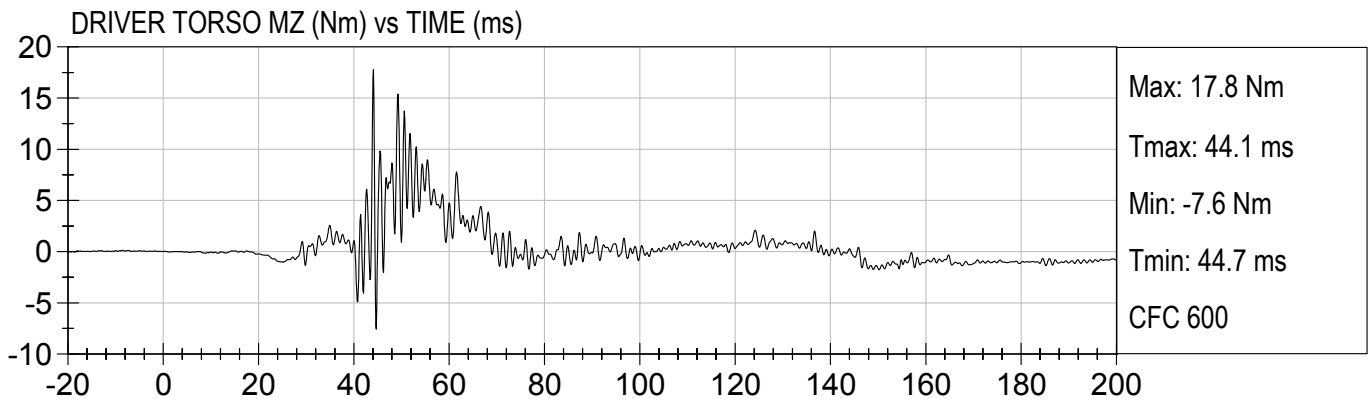
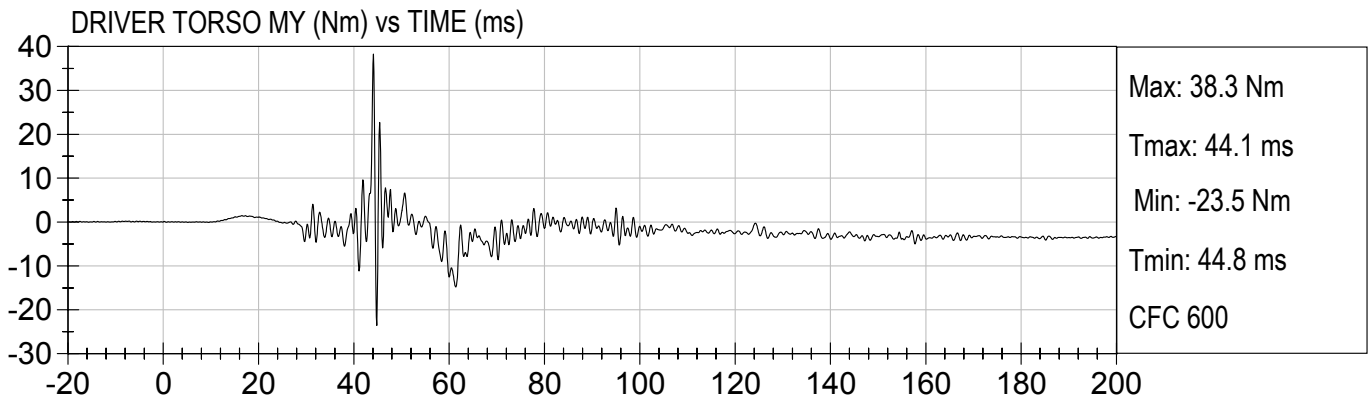
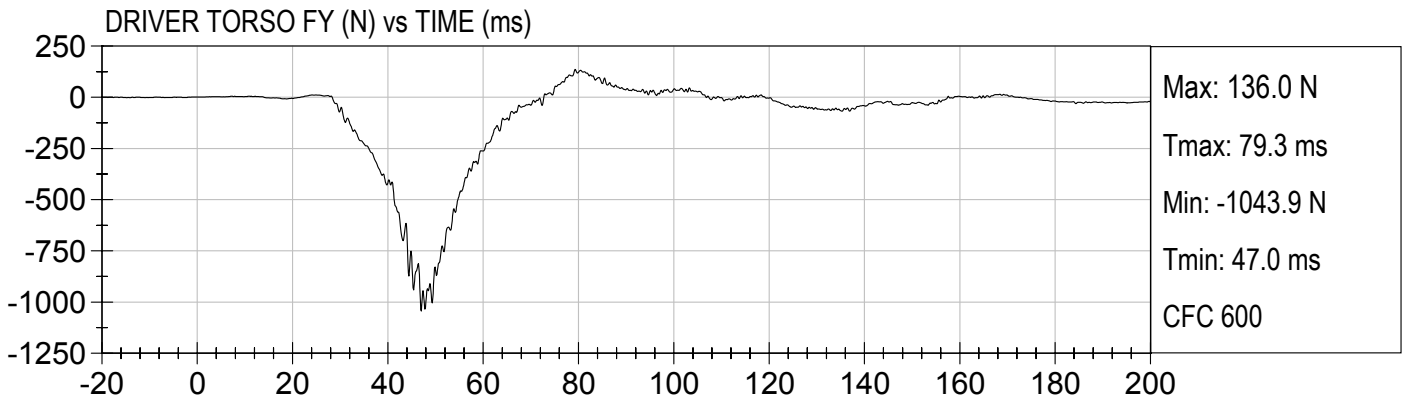
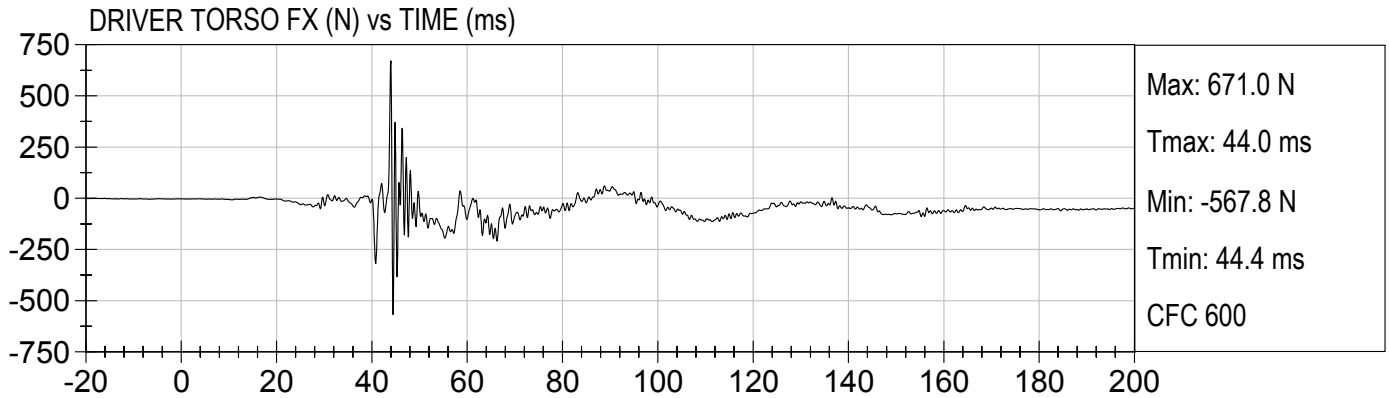



20 MPH SIDE POLE
2000 NISSAN MAXIMA (RY5218)

Test Date: 10/25/2002
Speed: 19.8 mph (31.9 km/h)

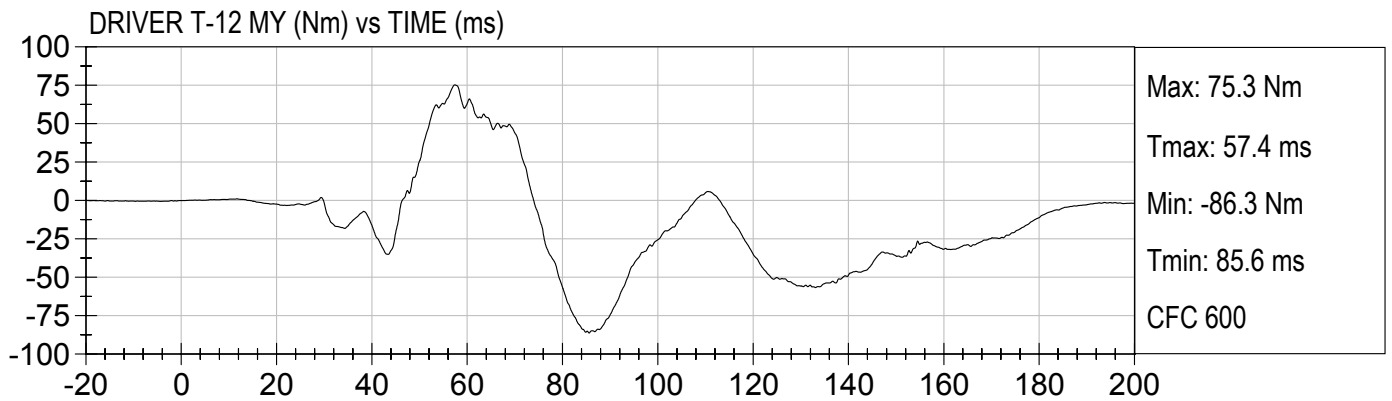
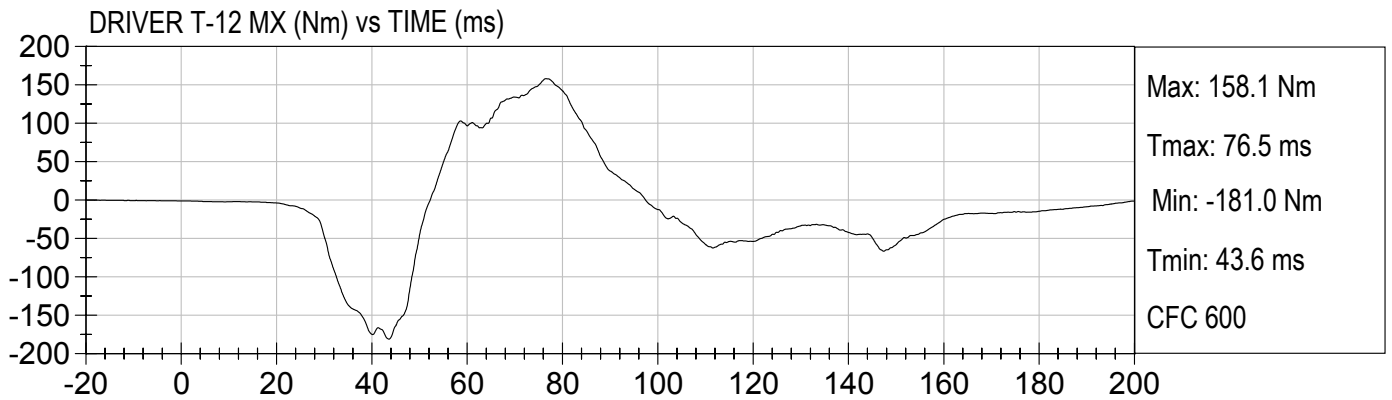
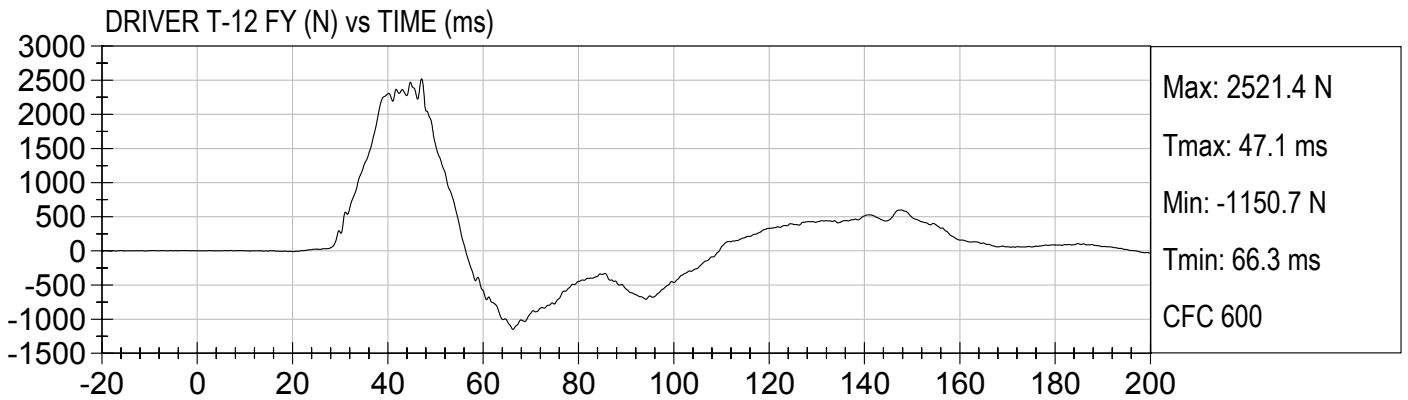
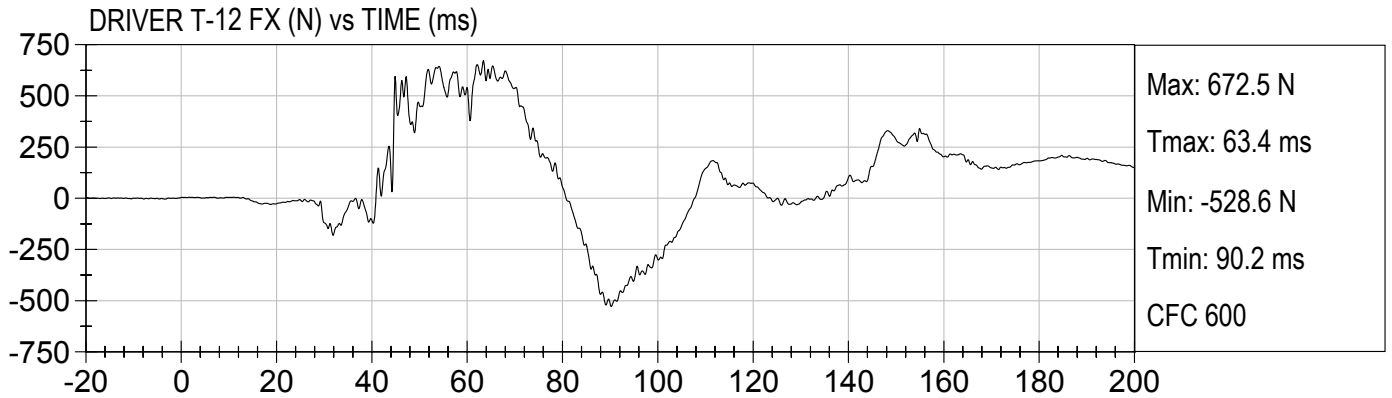

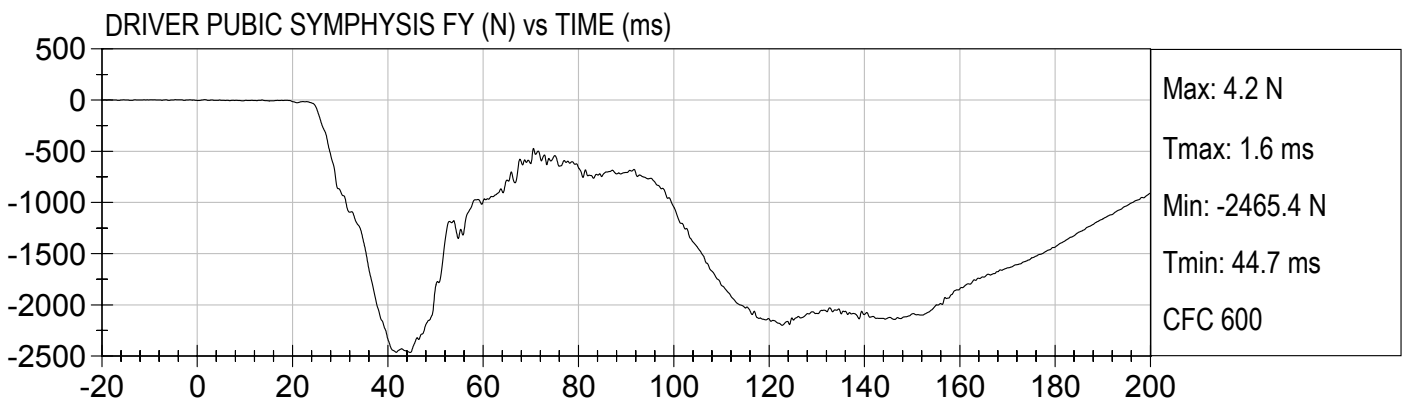
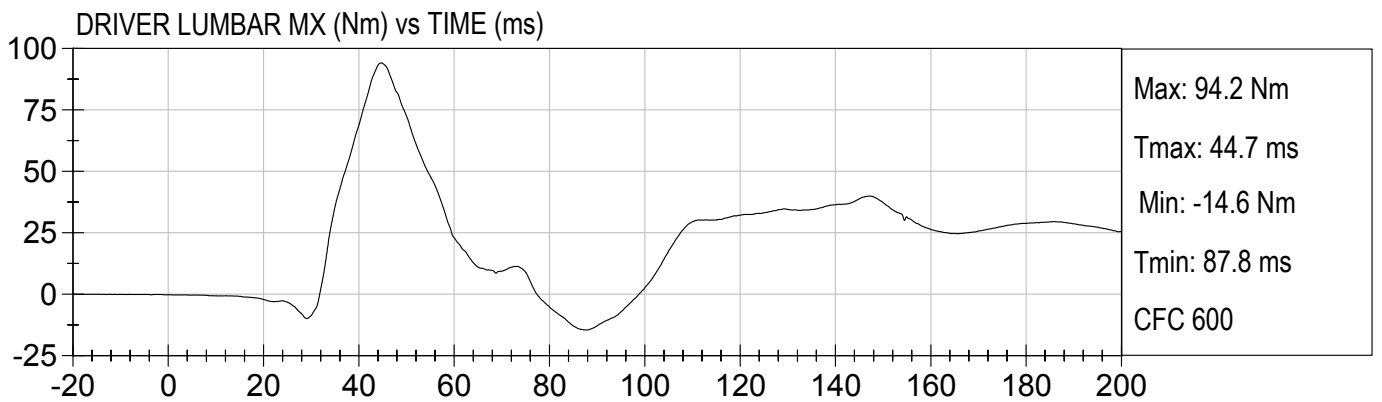
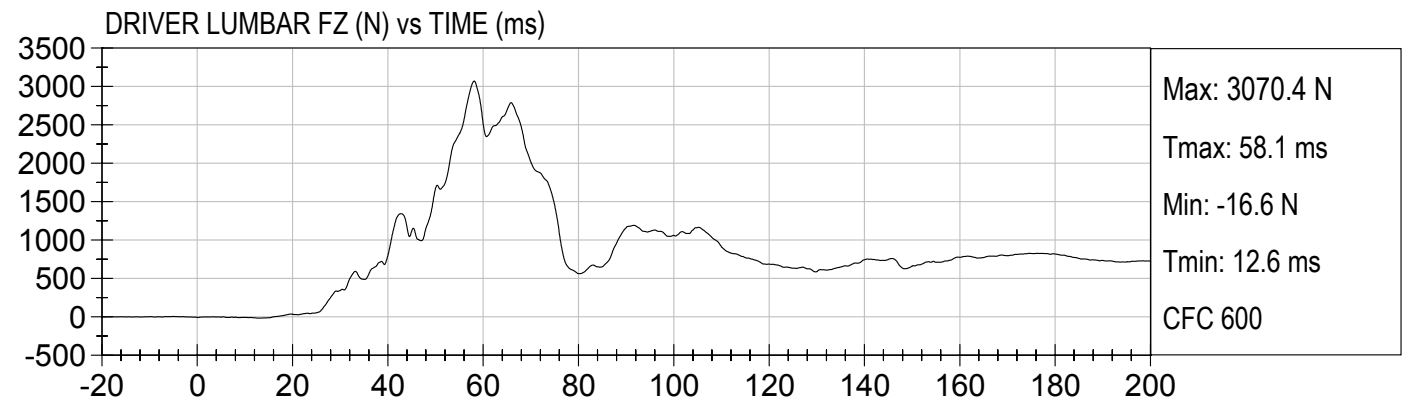
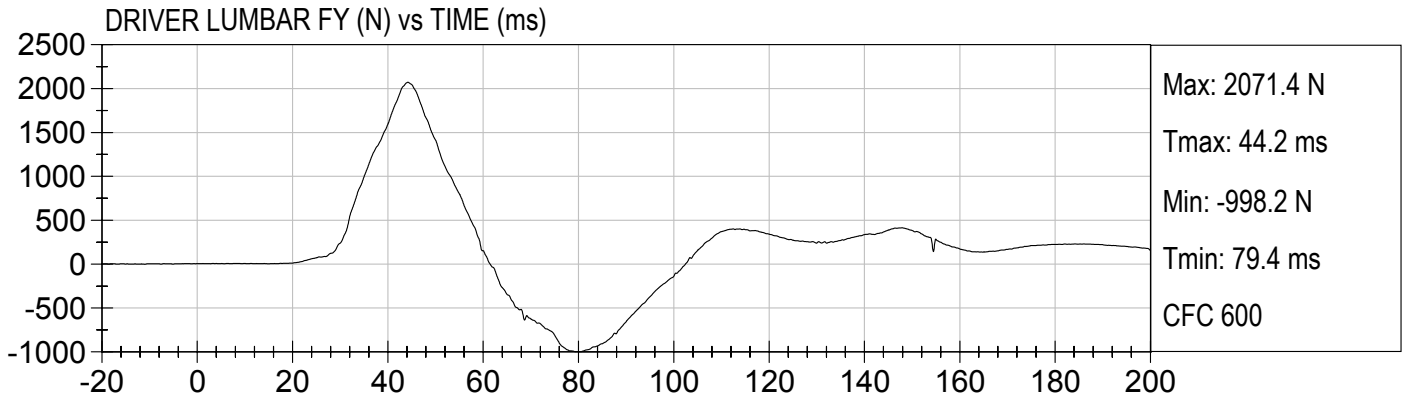

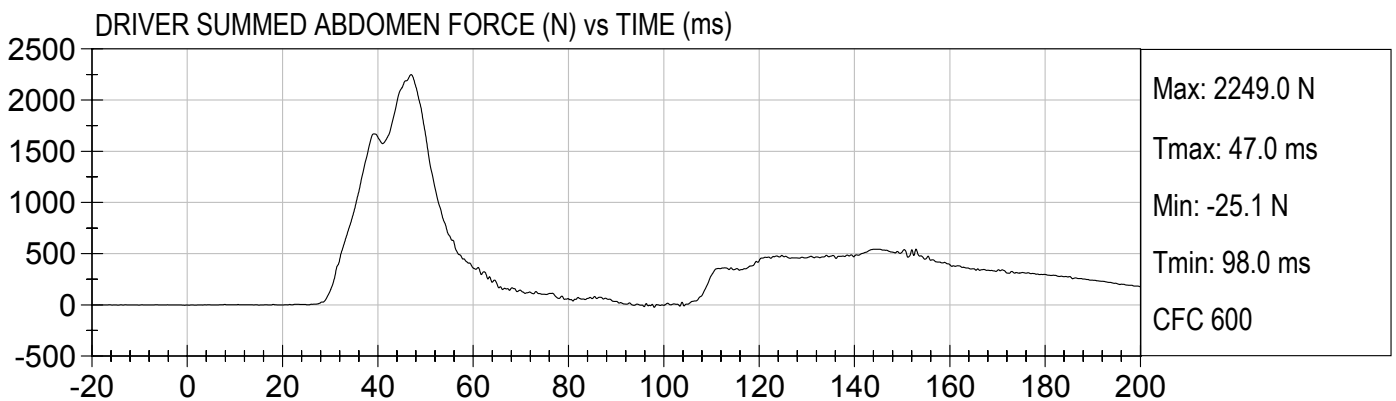
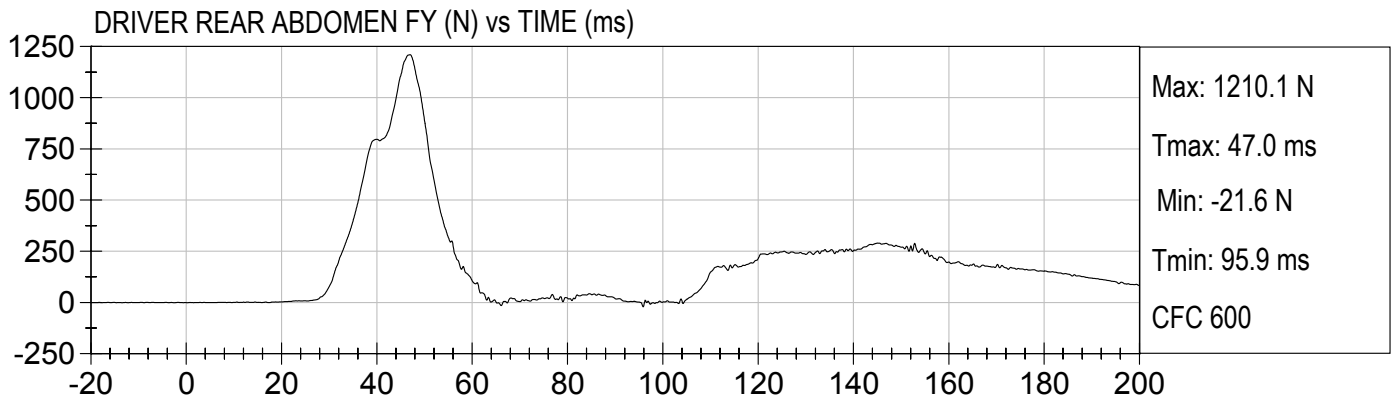
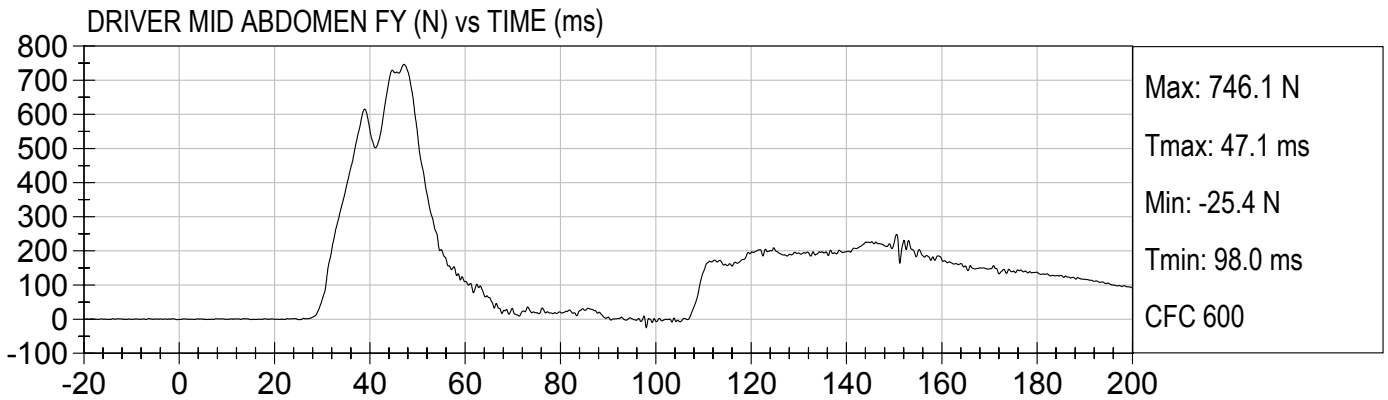
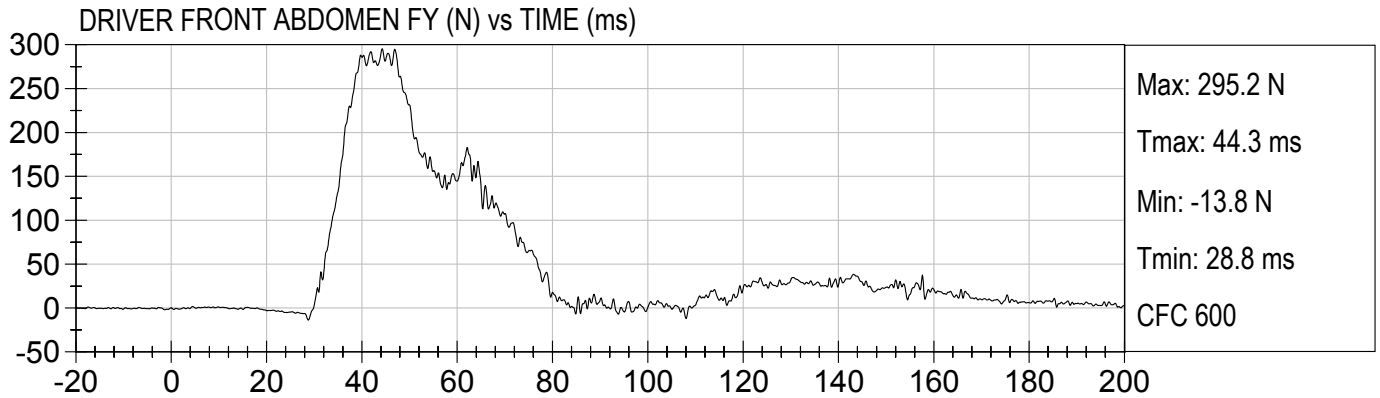

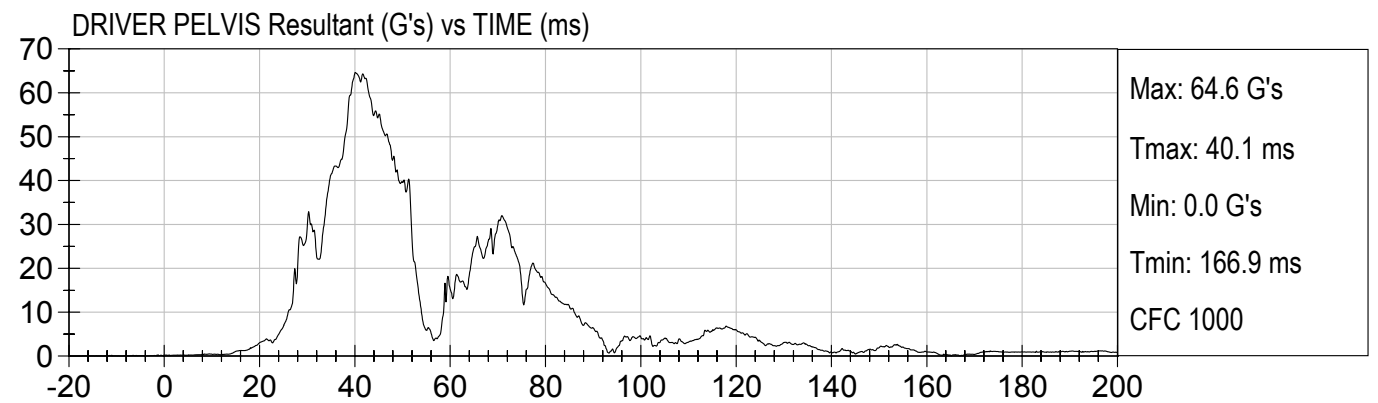
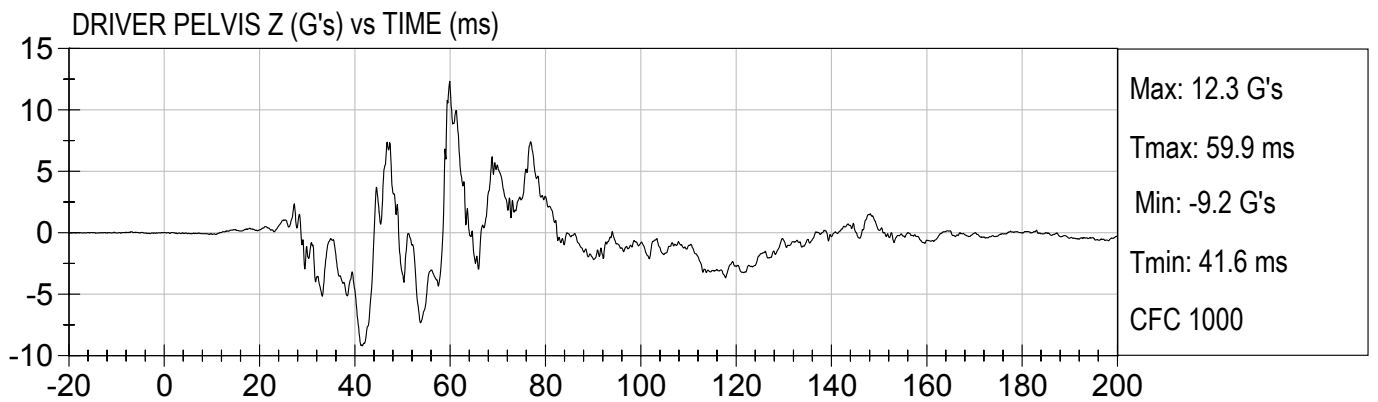
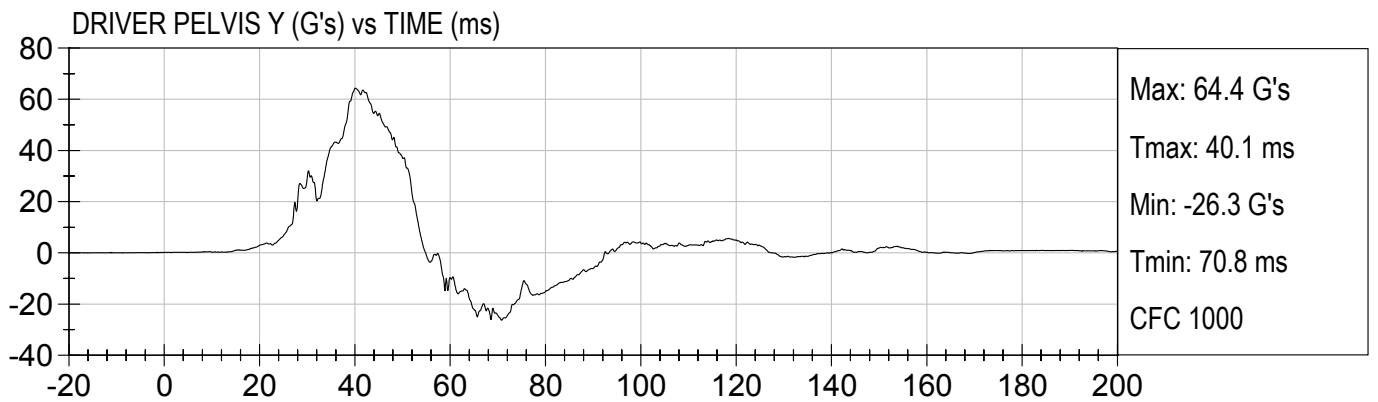
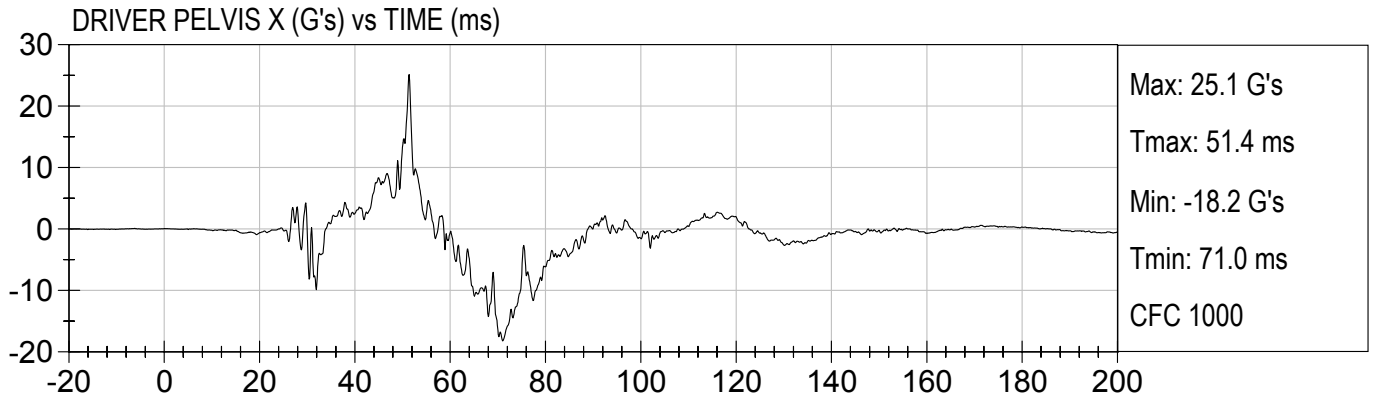



DRIVER PELVIS X Velocity (kph) vs TIME (ms)

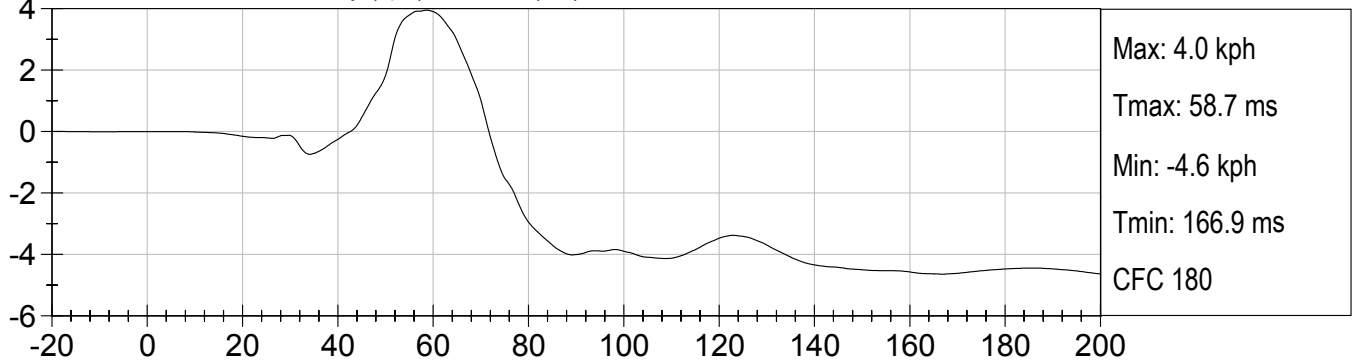

DRIVER PELVIS Y Velocity (kph) vs TIME (ms)

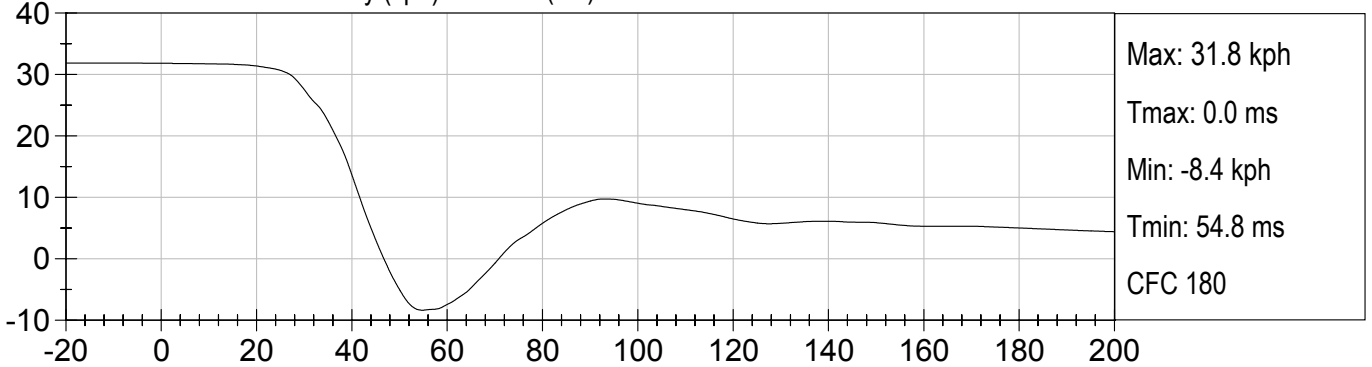

DRIVER PELVIS Z Velocity (kph) vs TIME (ms)

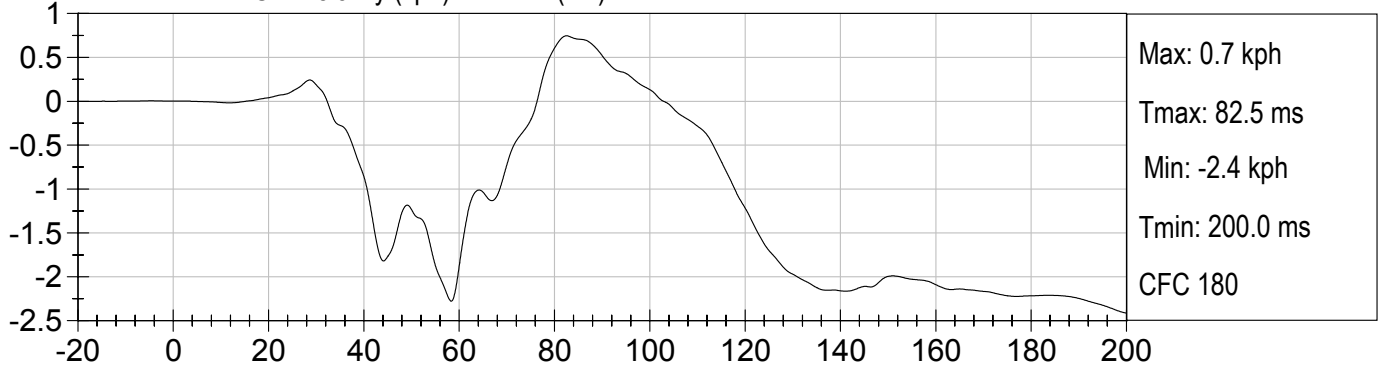

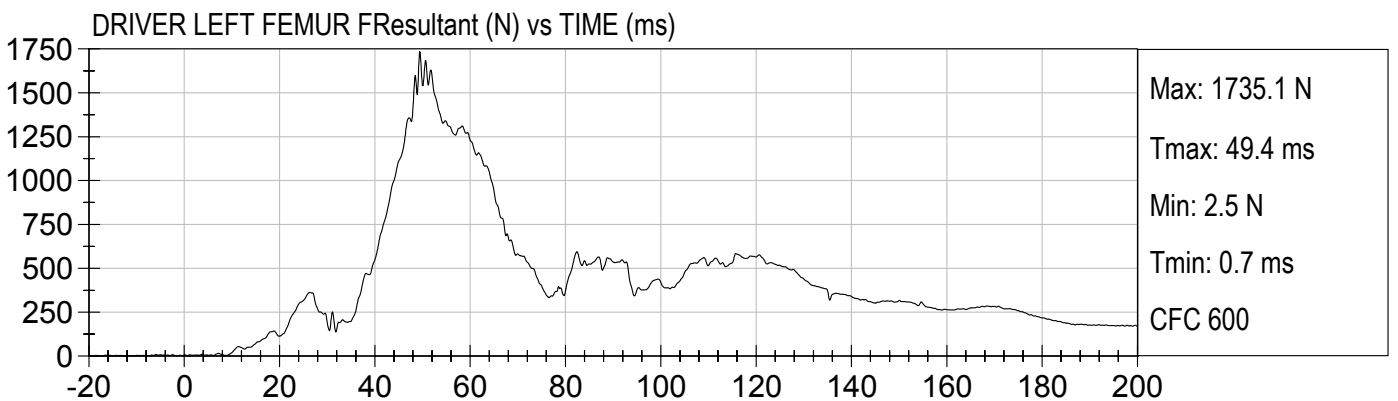
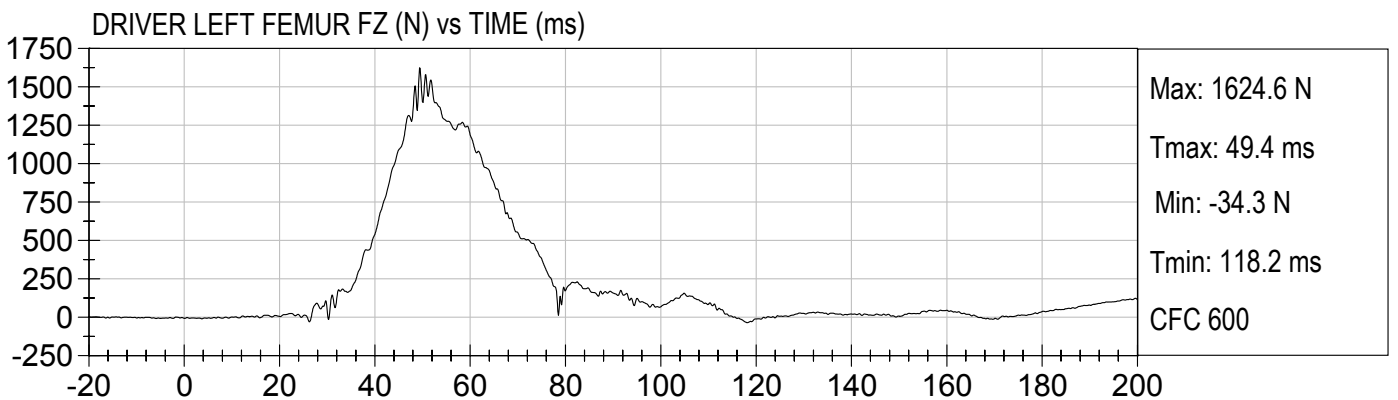
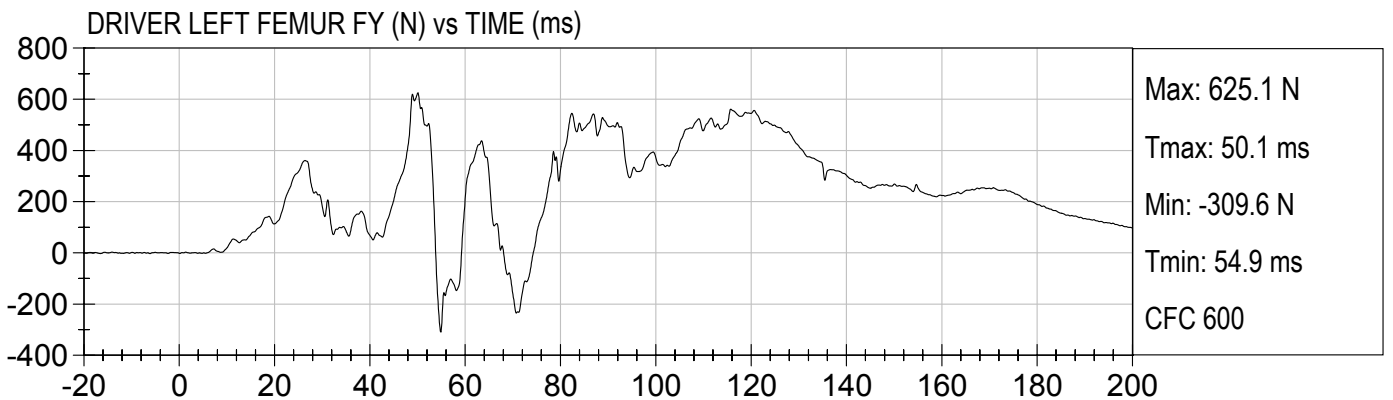
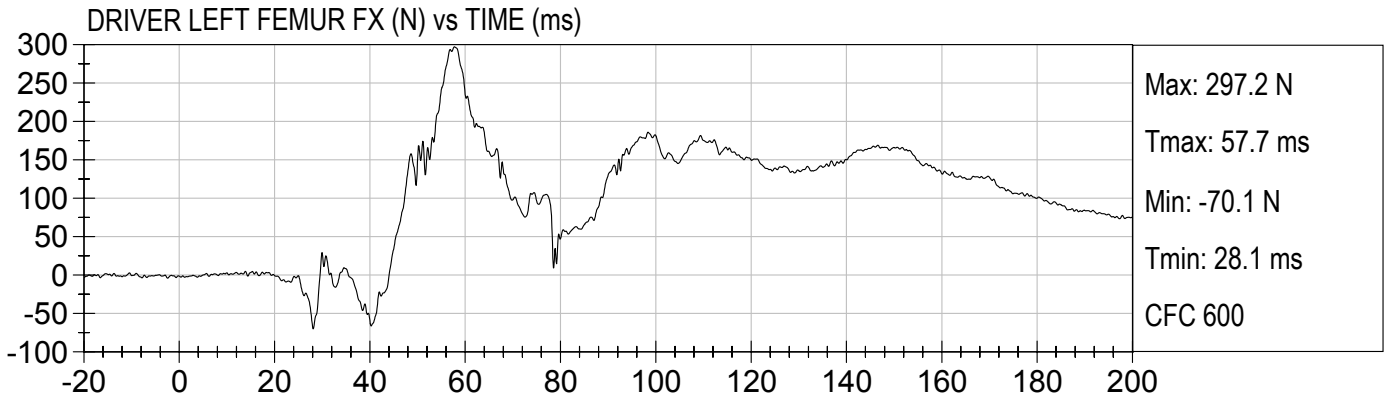

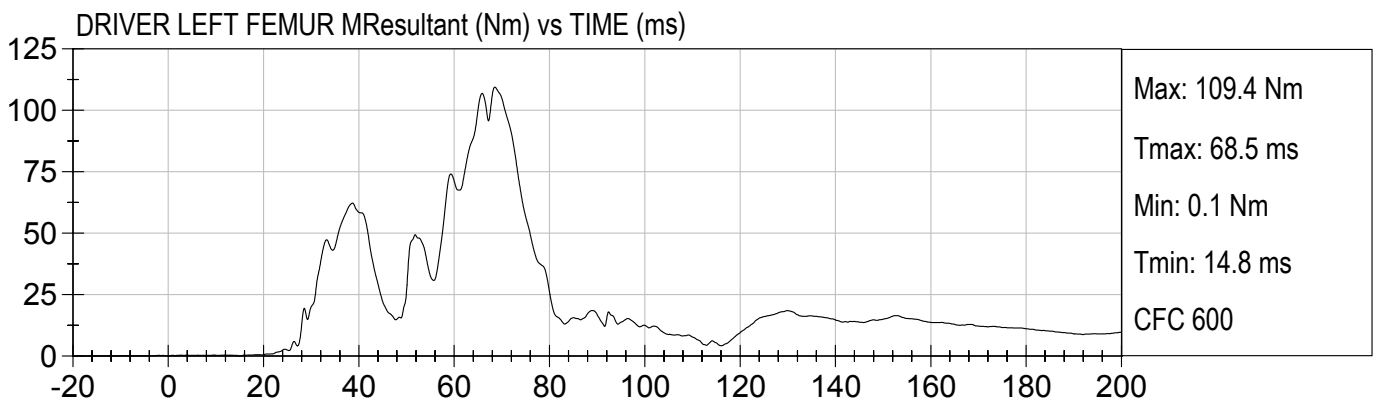
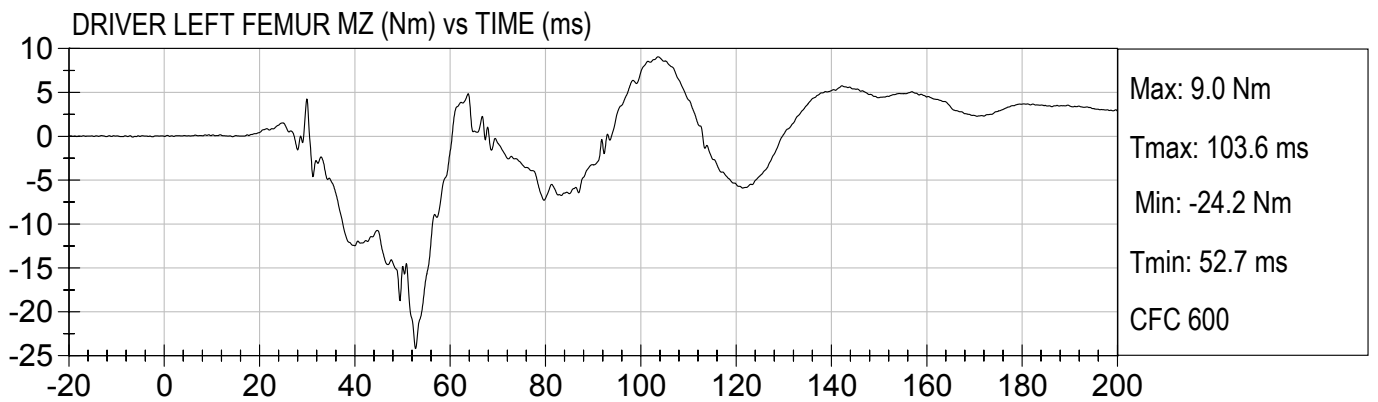
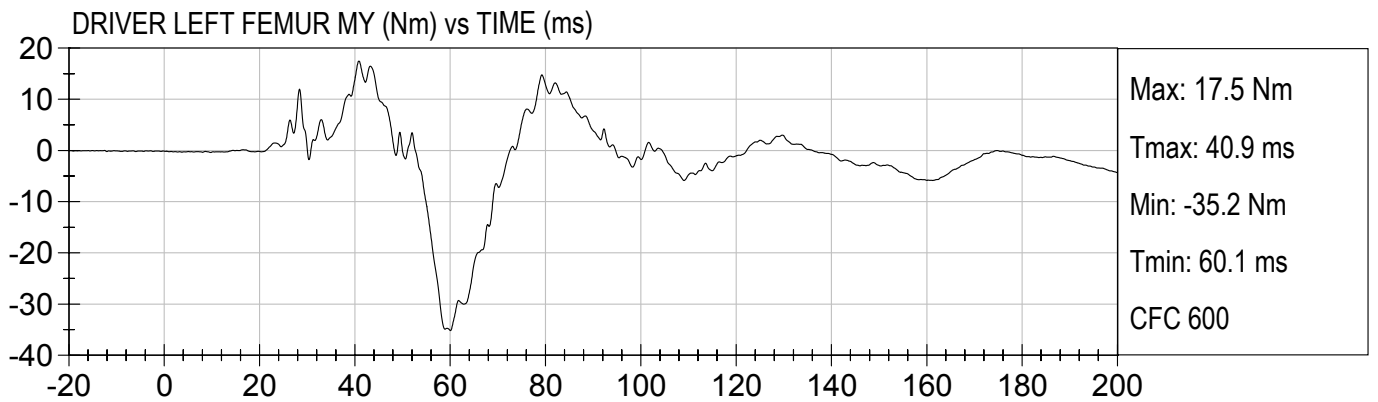
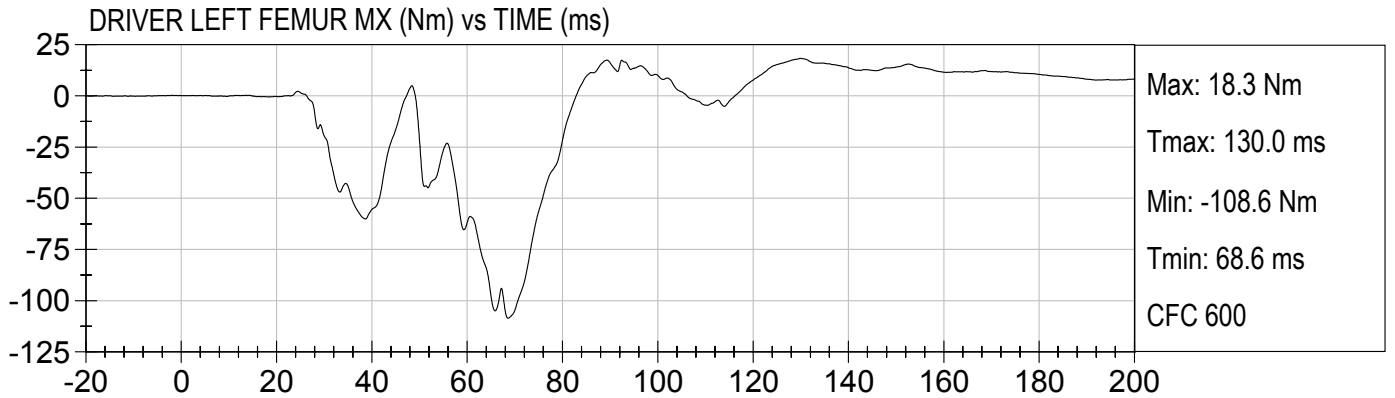

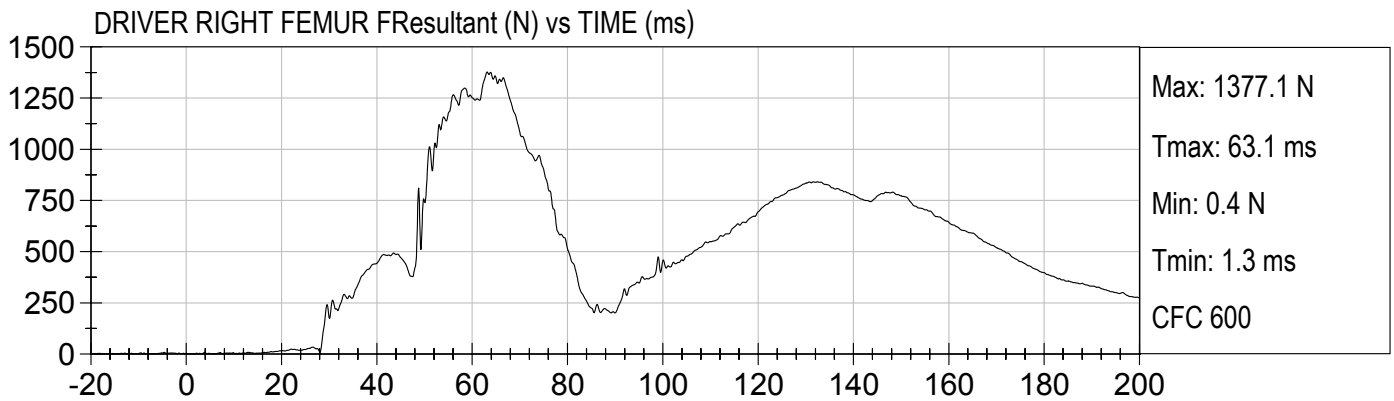
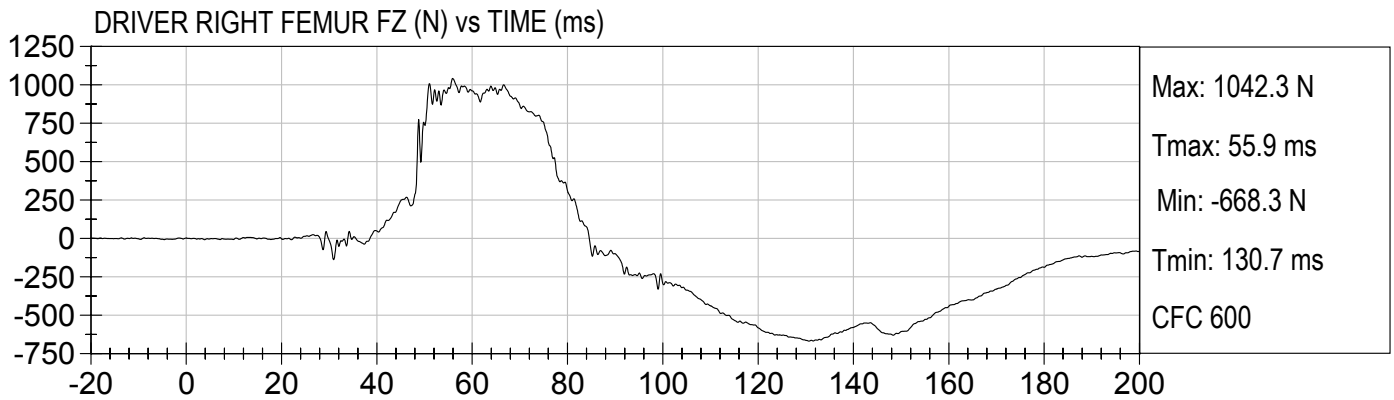
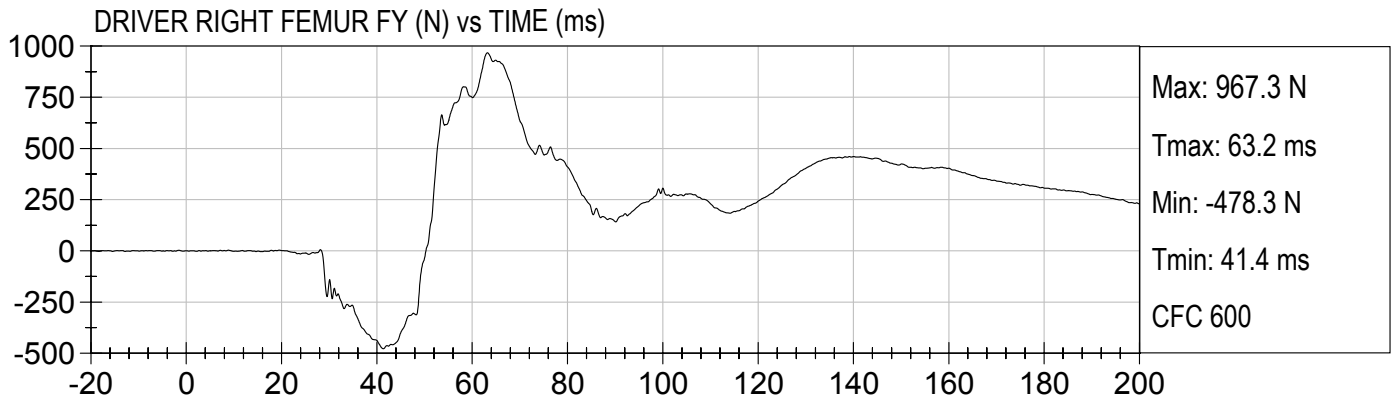
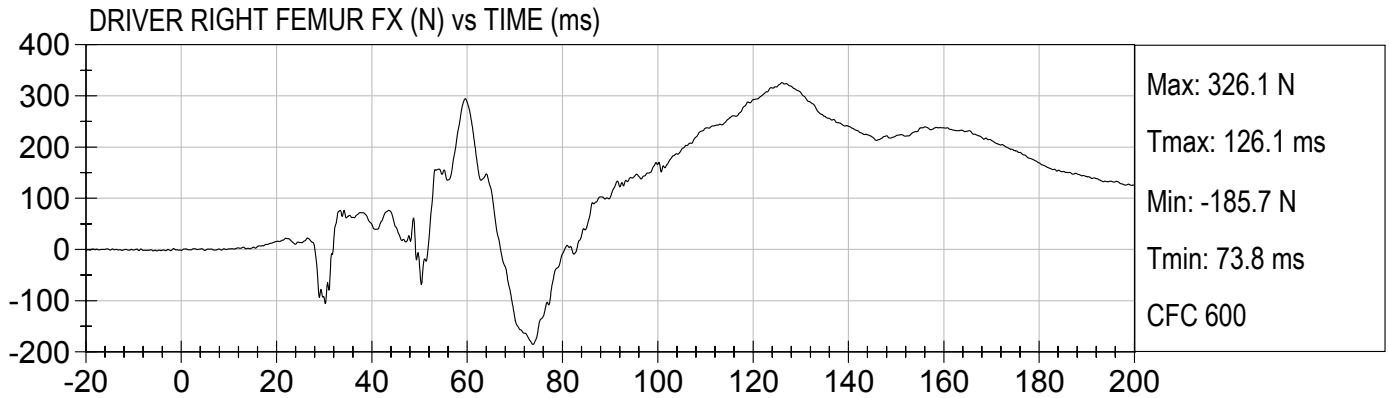

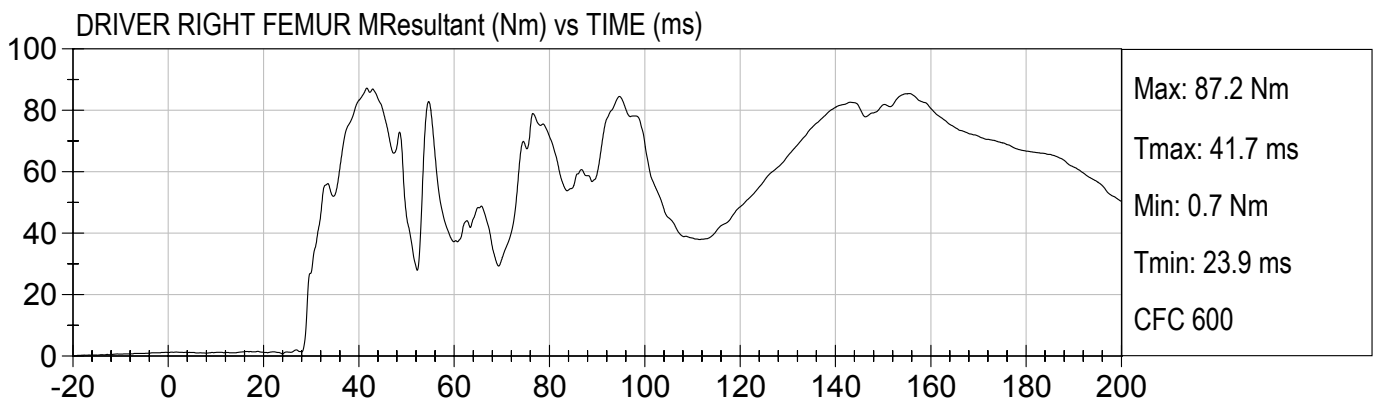
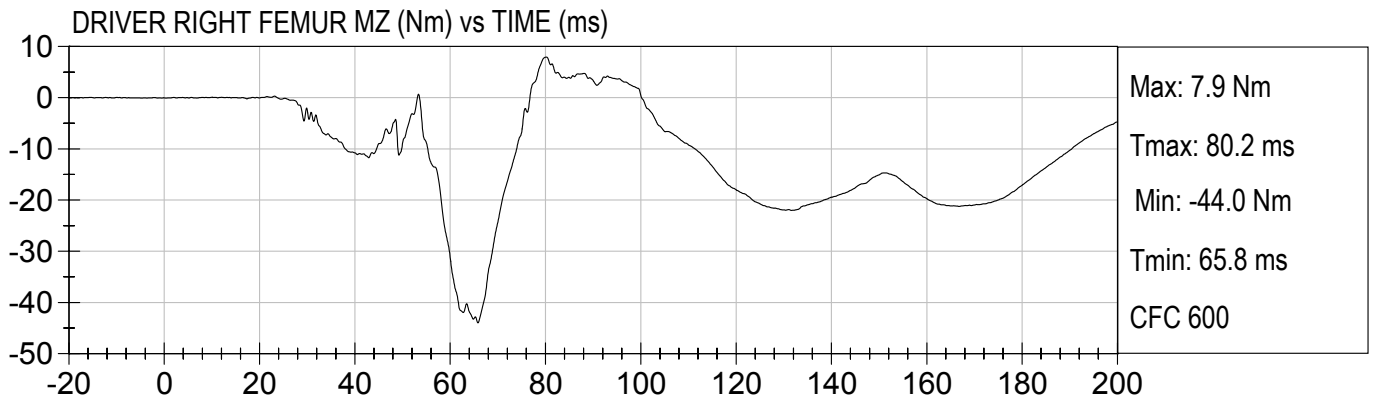
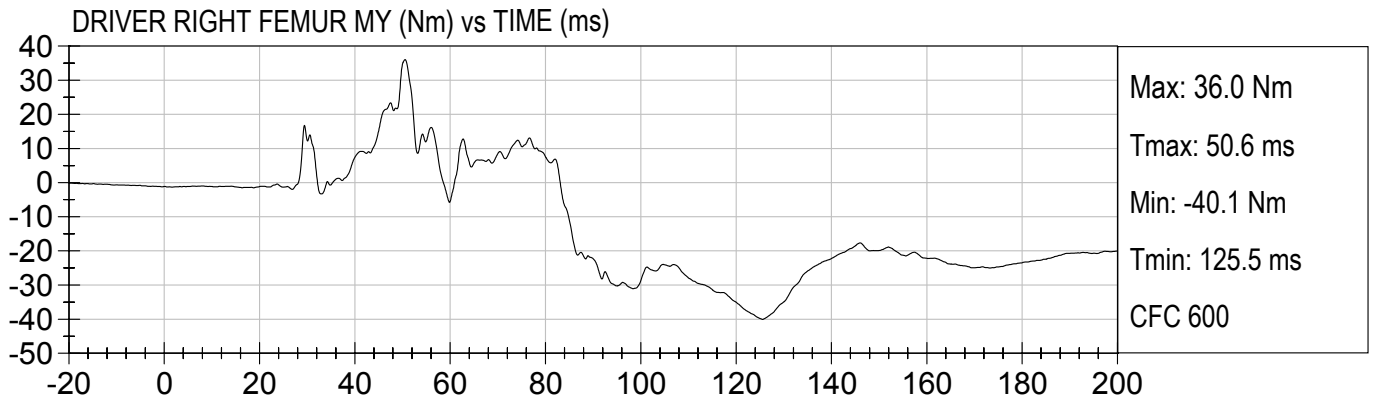
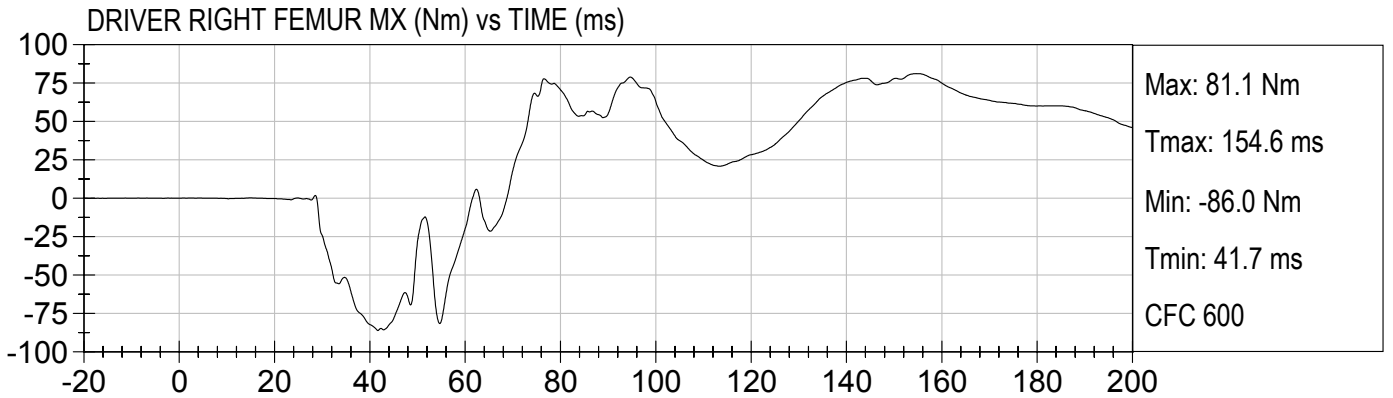

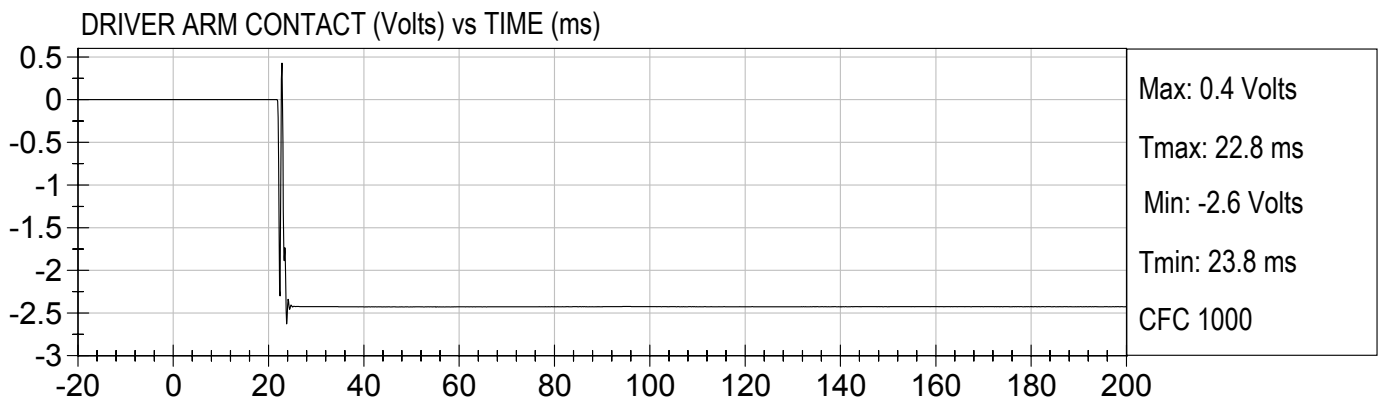
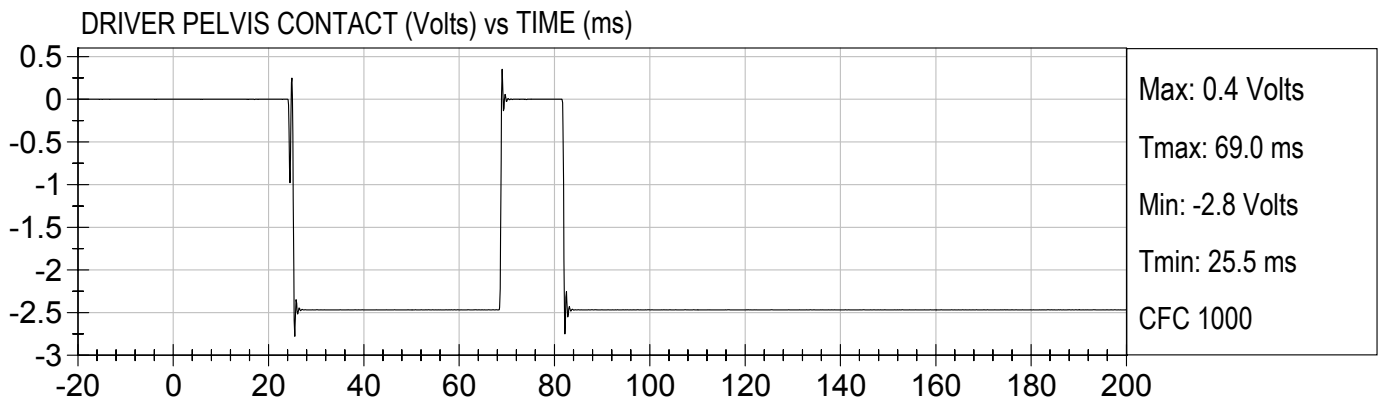
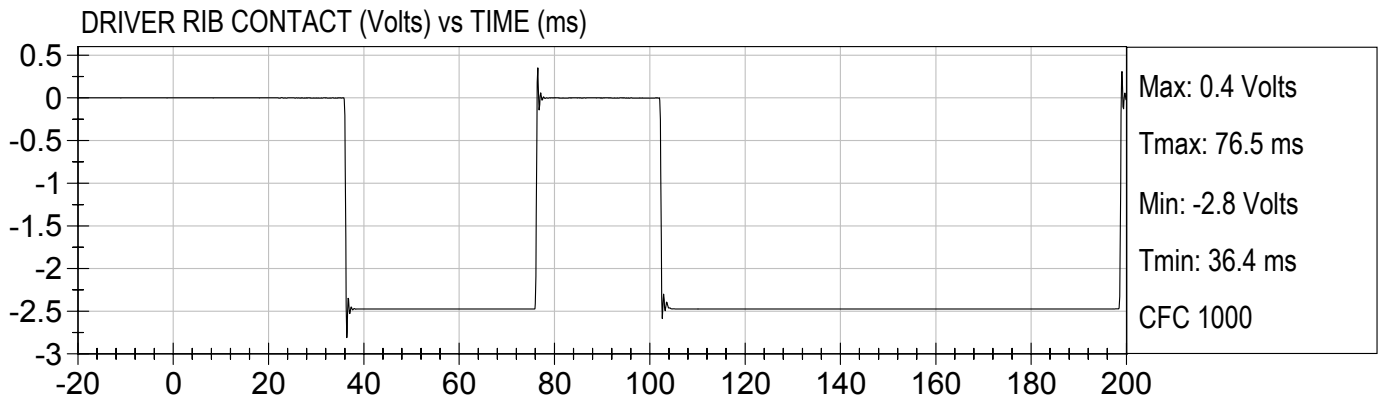

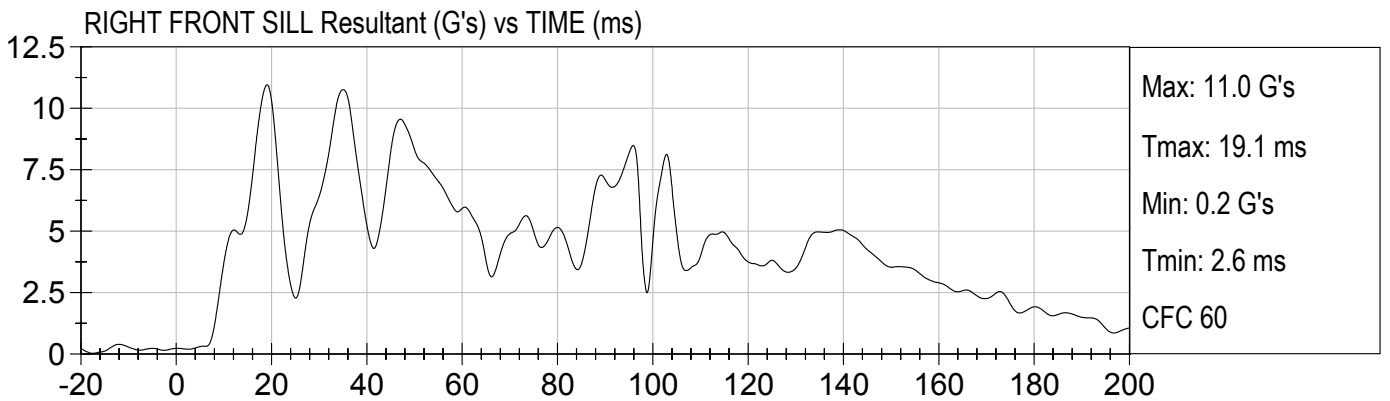
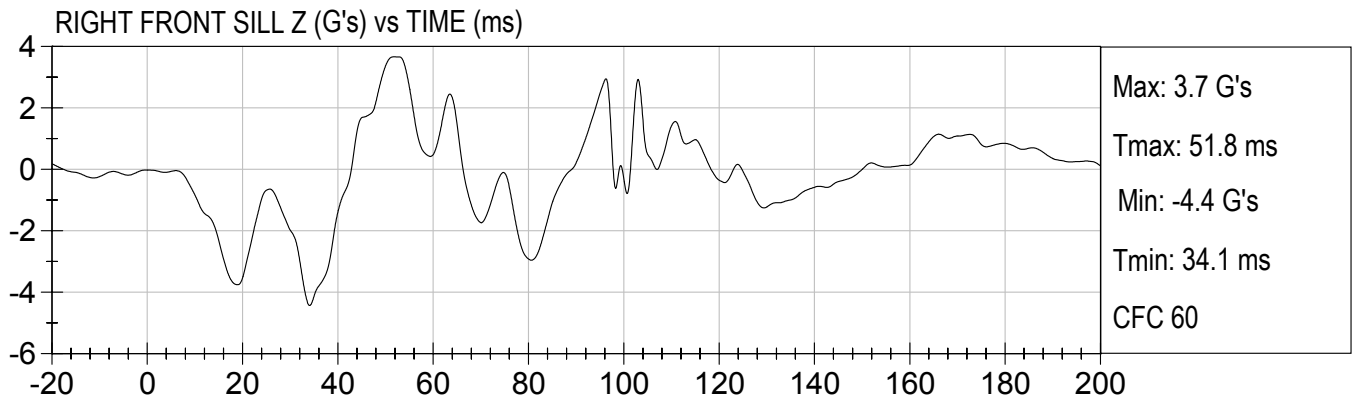
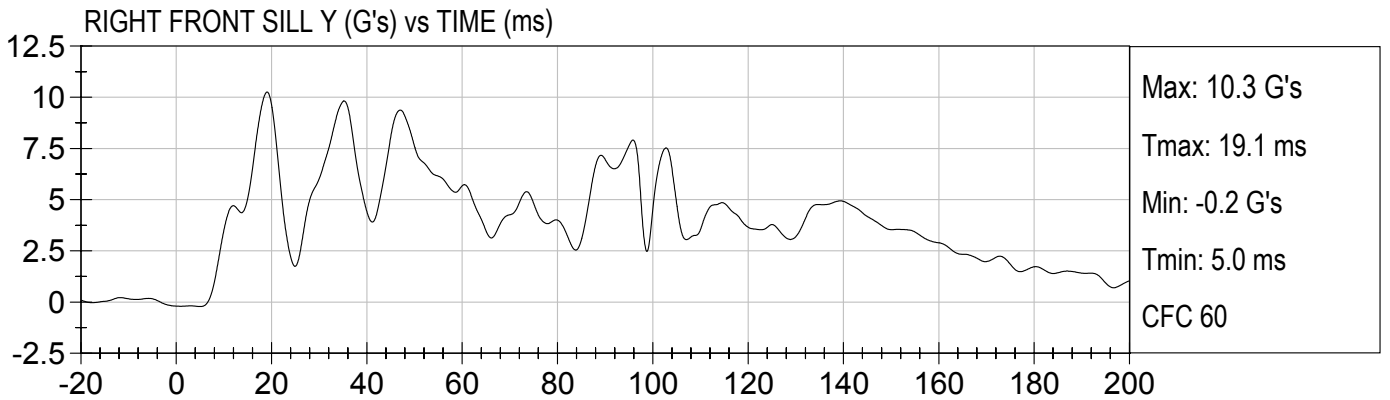
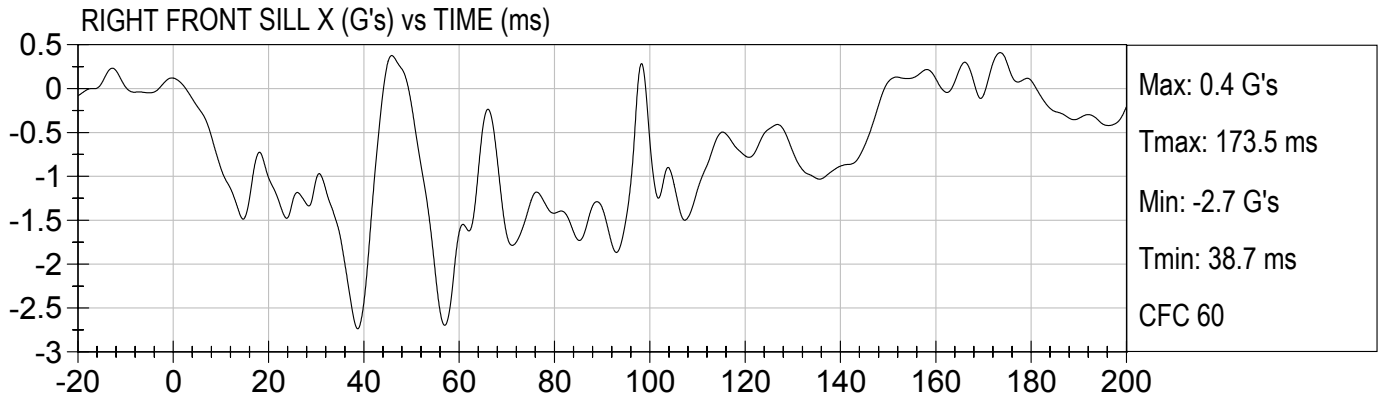



RIGHT FRONT SILL X Velocity (kph) vs TIME (ms)

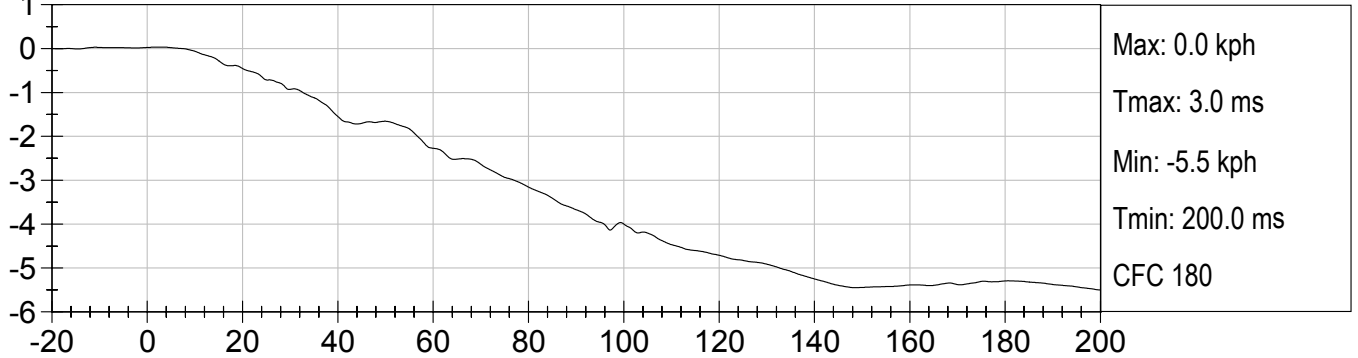

RIGHT FRONT SILL Y Velocity (kph) vs TIME (ms)

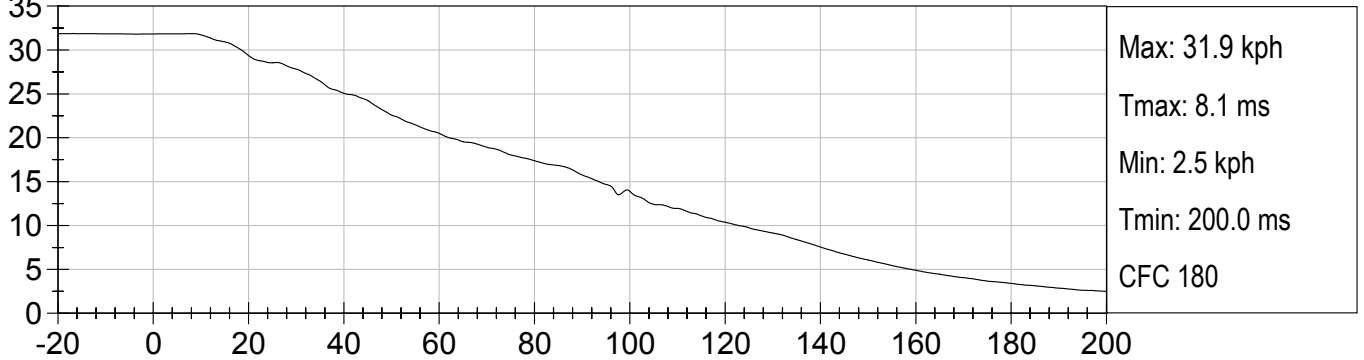

RIGHT FRONT SILL Z Velocity (kph) vs TIME (ms)

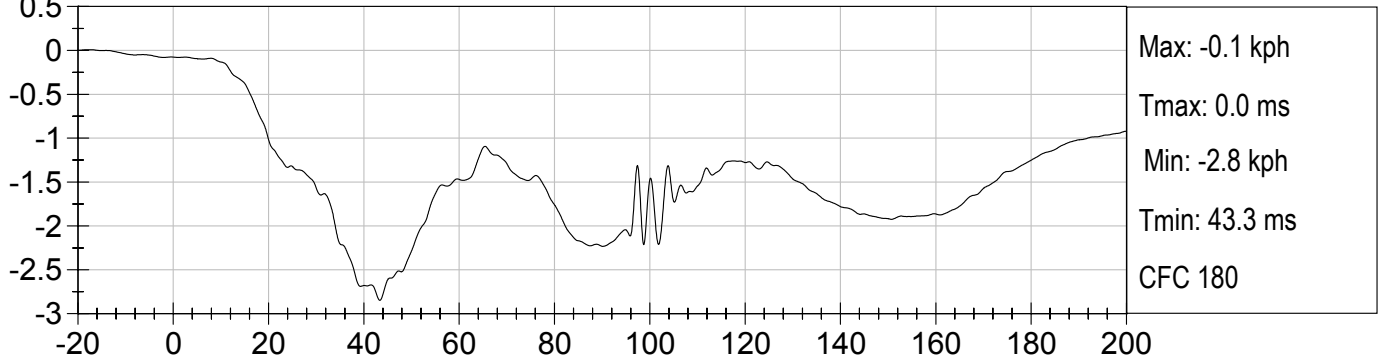

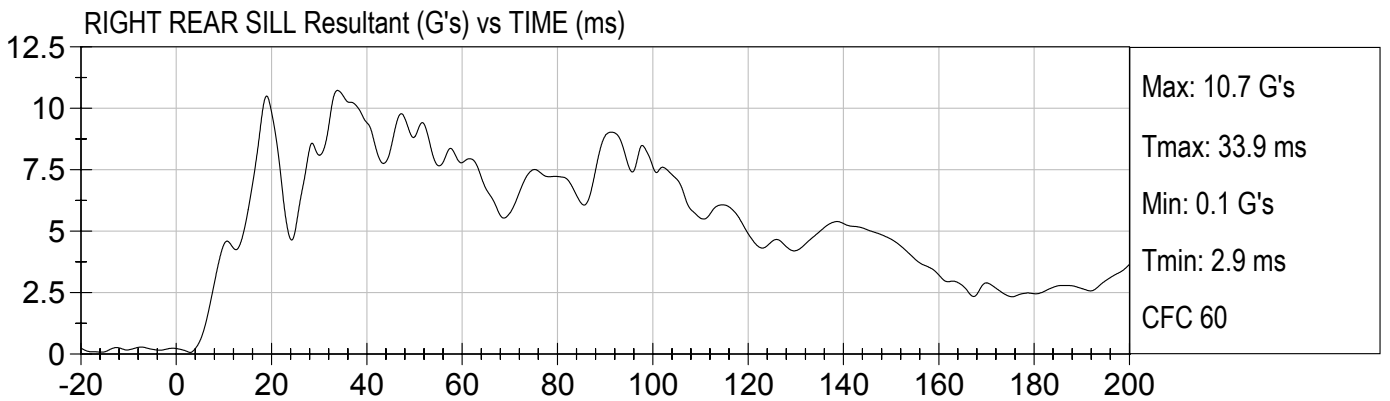
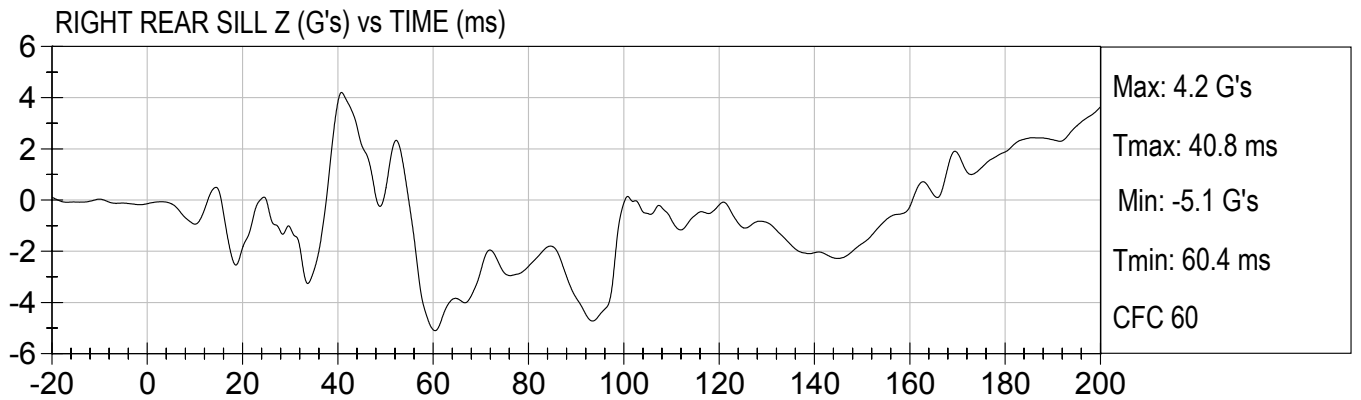
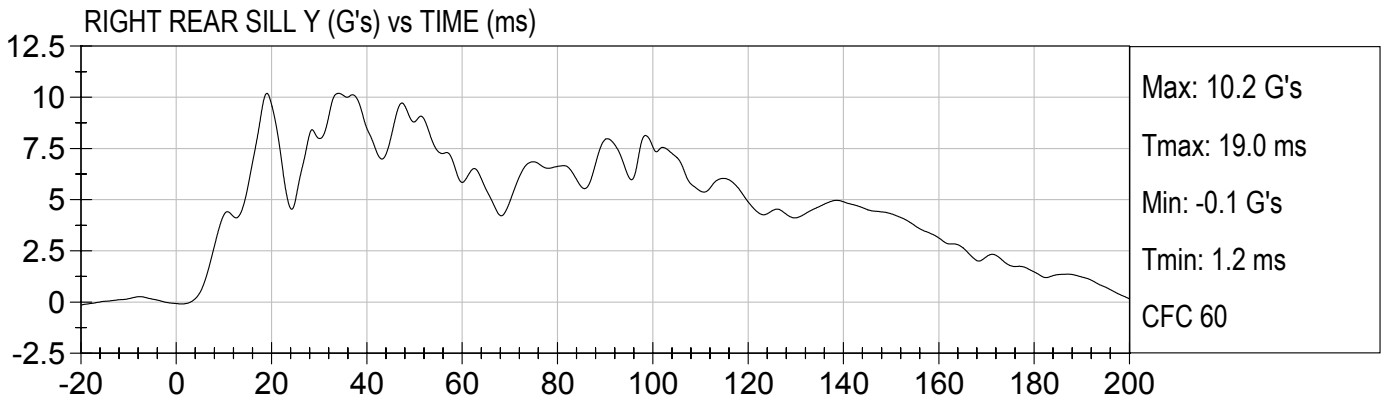
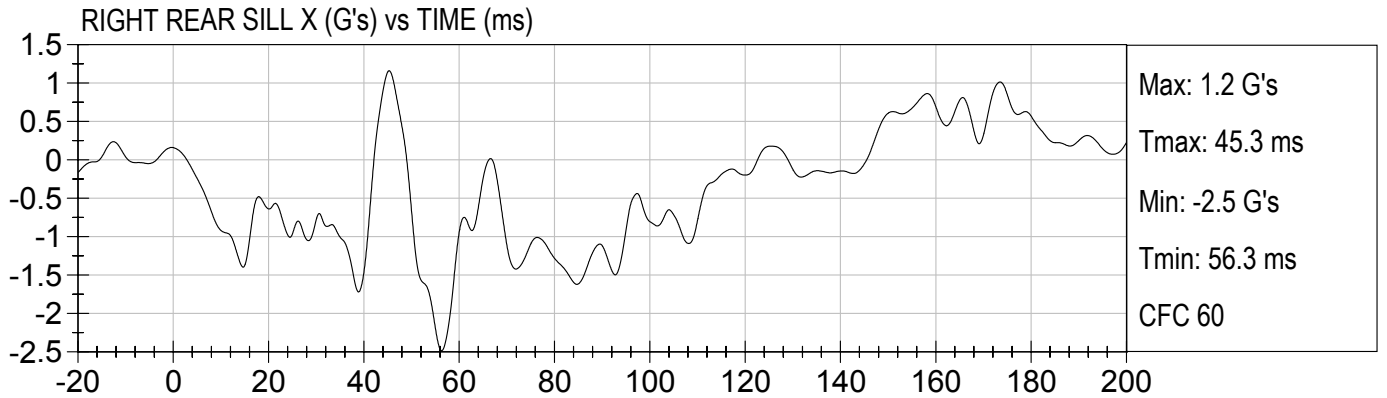

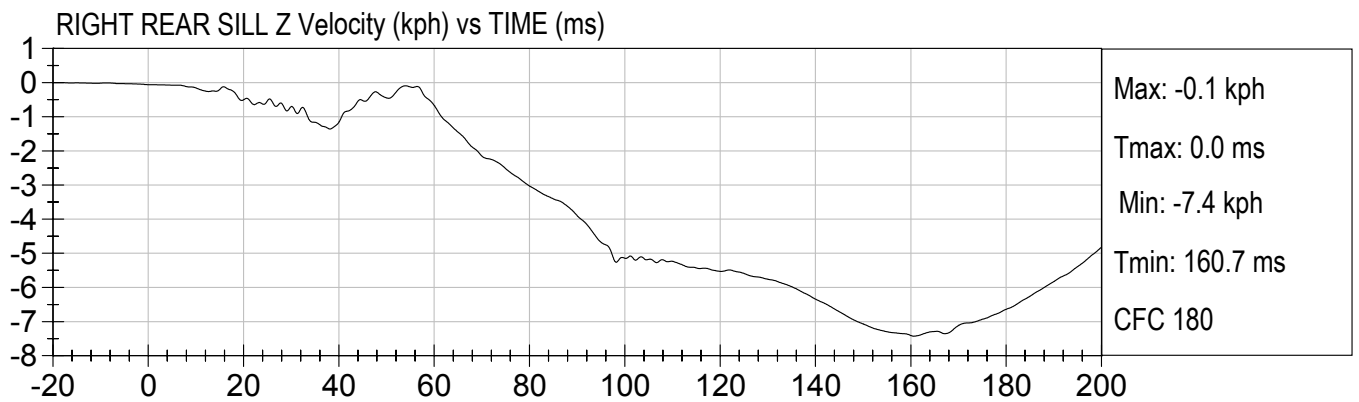
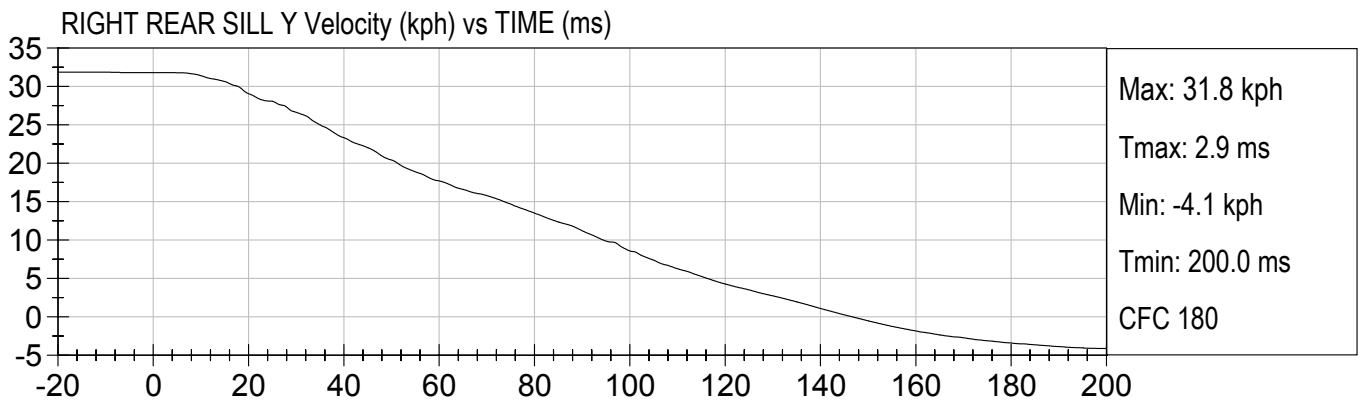
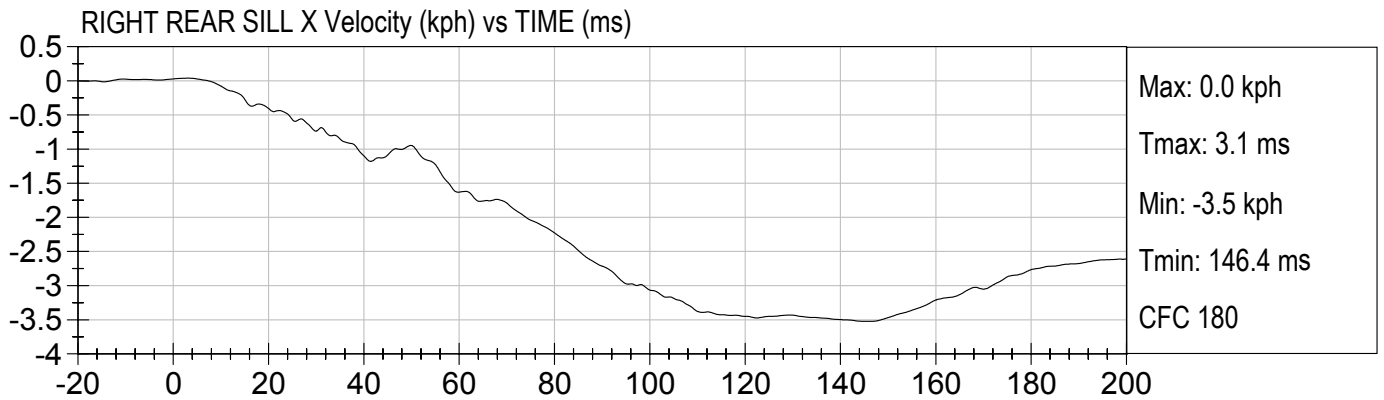

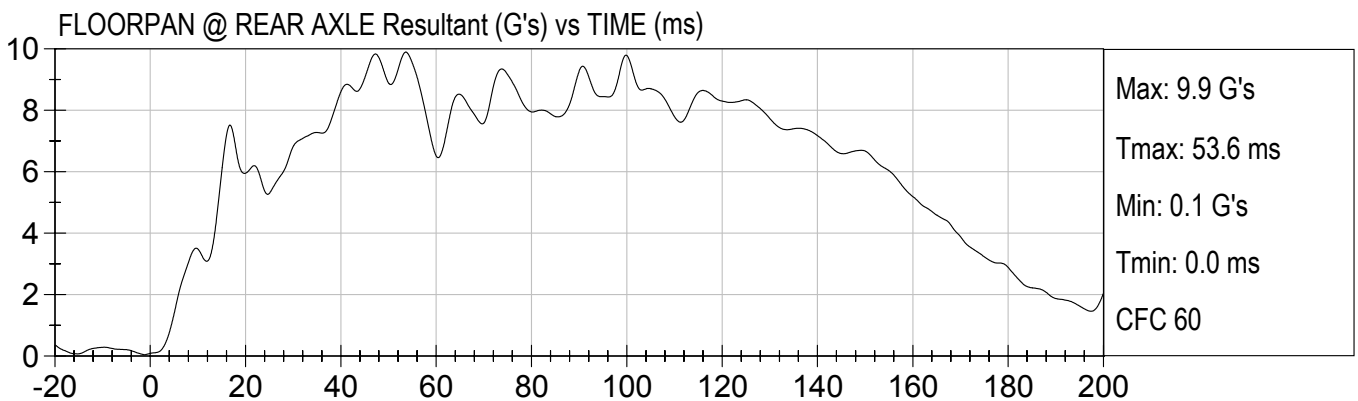
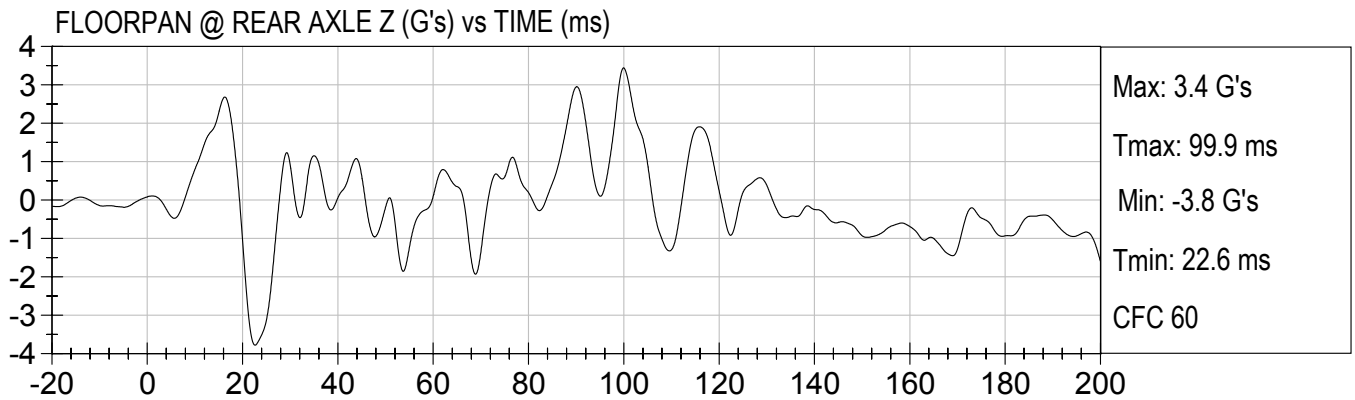
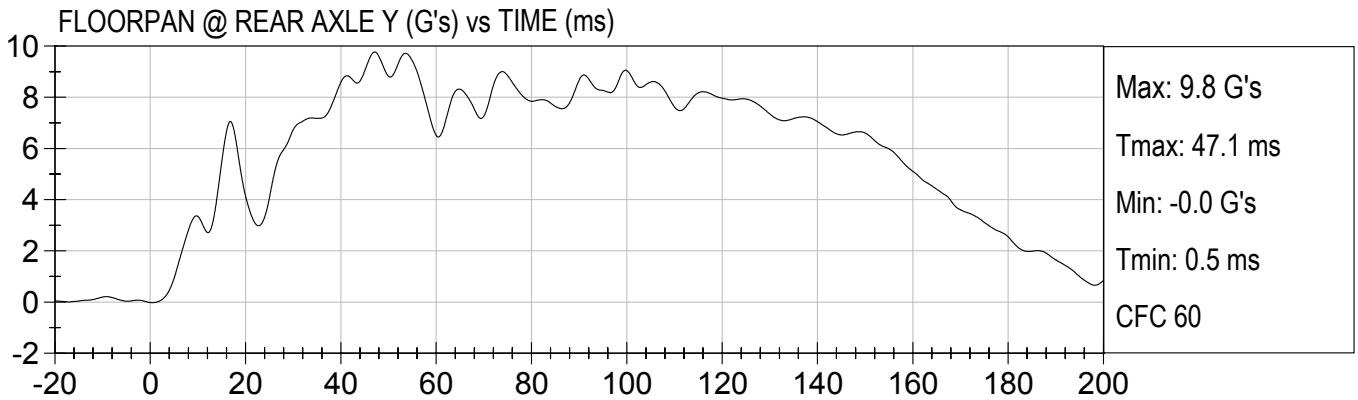
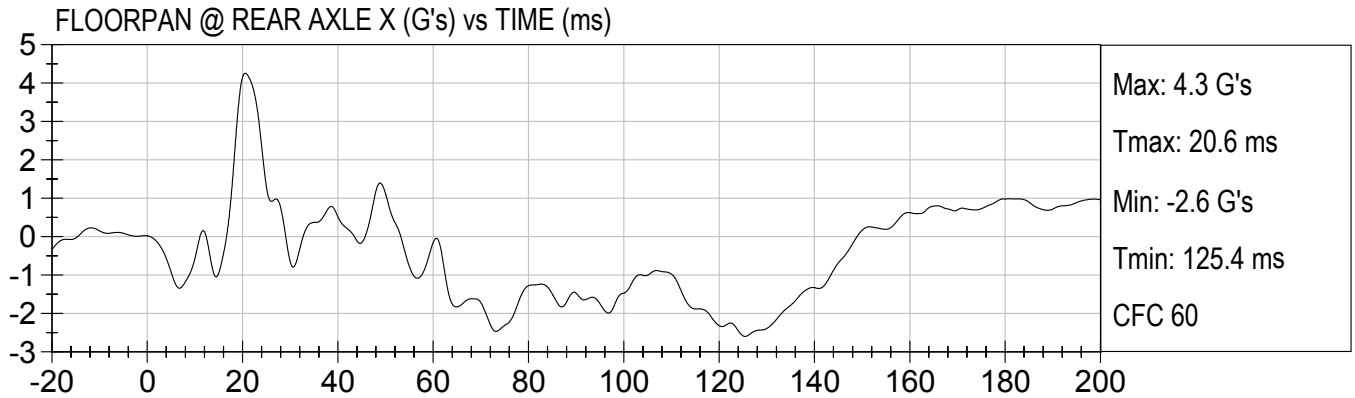



FLOORPAN @ REAR AXLE X Velocity (kph) vs TIME (ms)

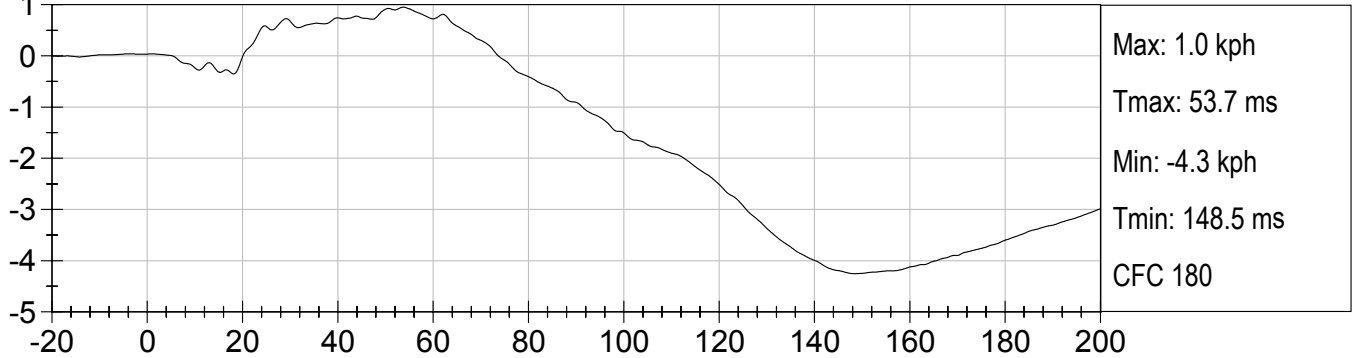

FLOORPAN @ REAR AXLE Y Velocity (kph) vs TIME (ms)

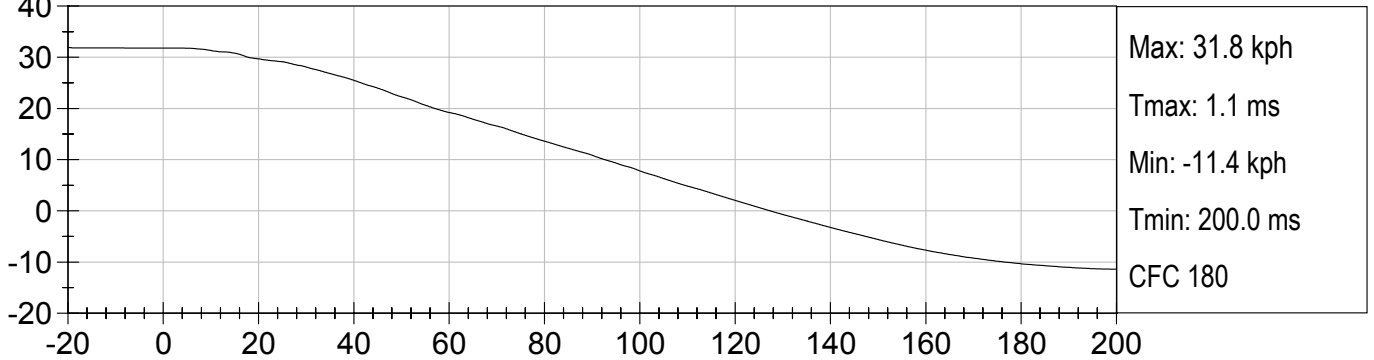

FLOORPAN @ REAR AXLE Z Velocity (kph) vs TIME (ms)

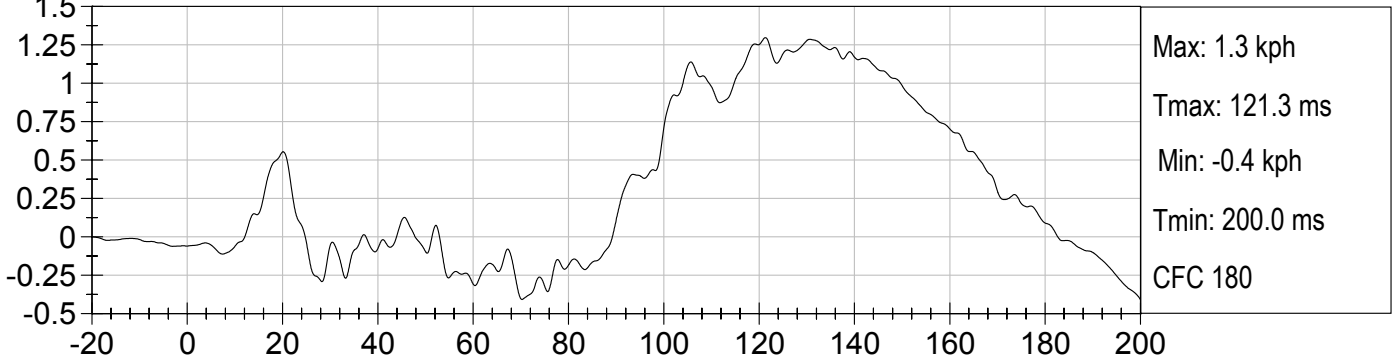

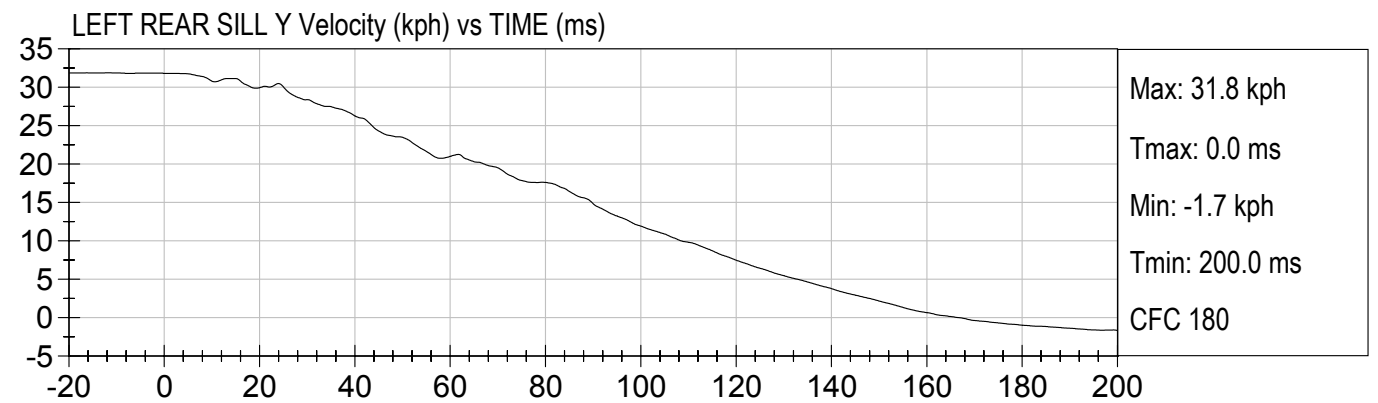
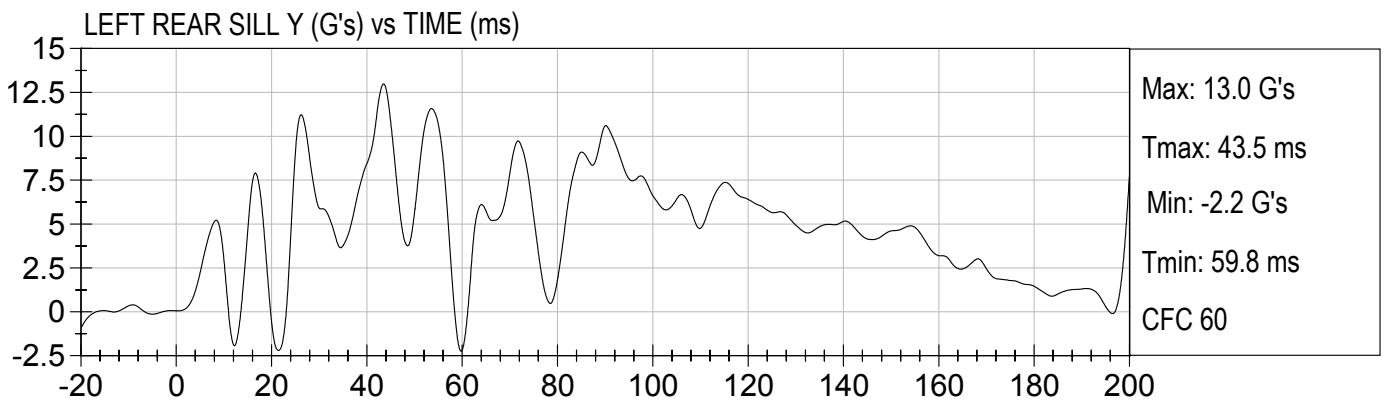
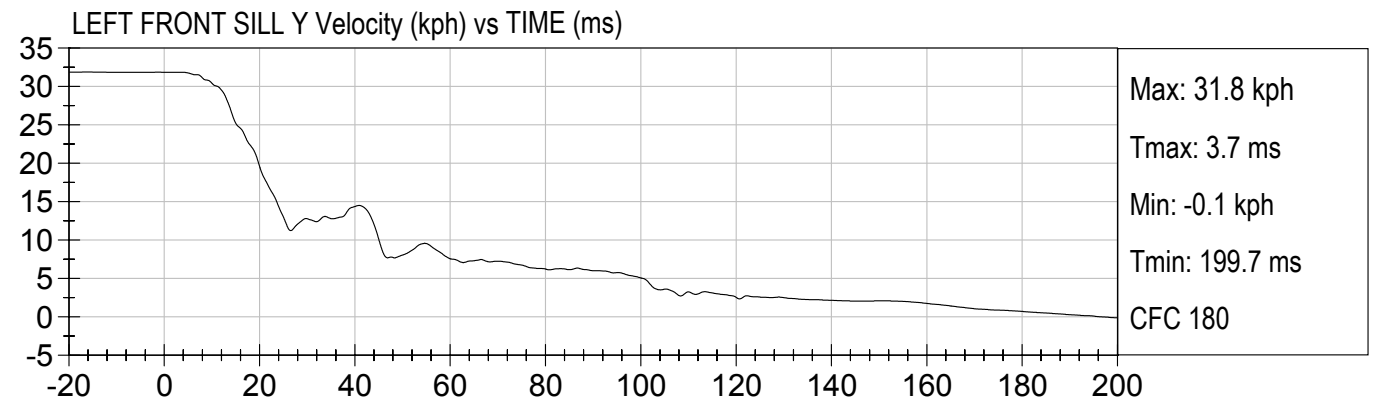
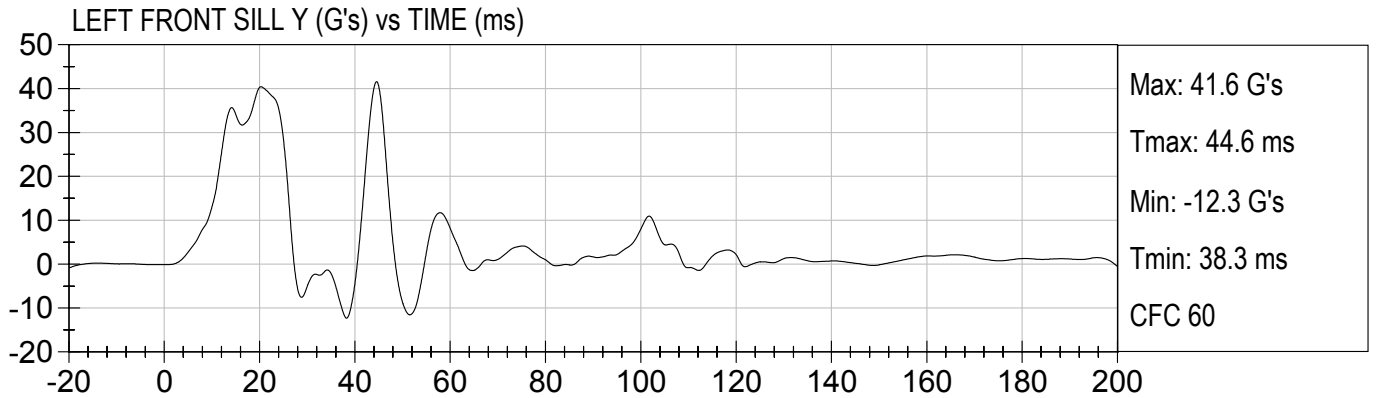

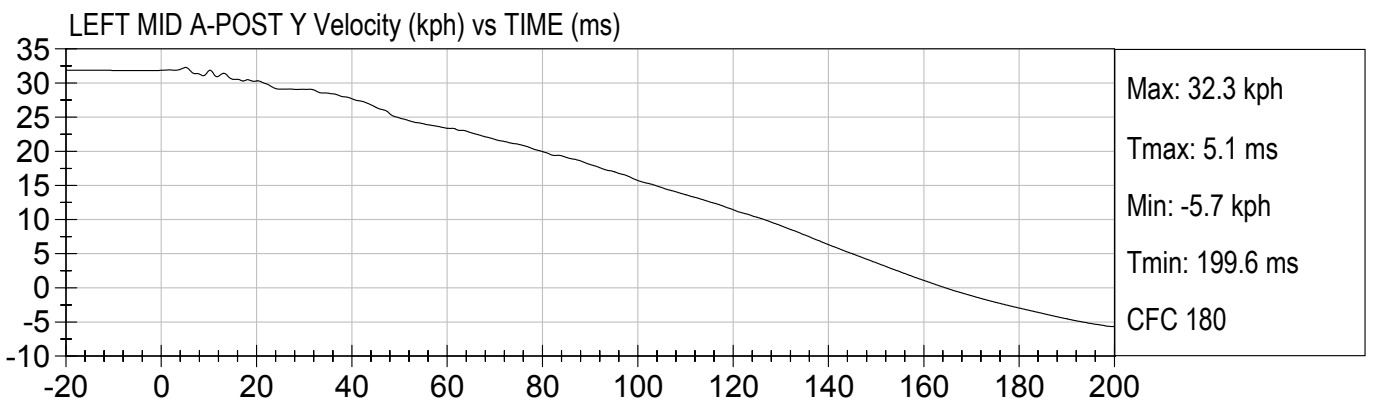
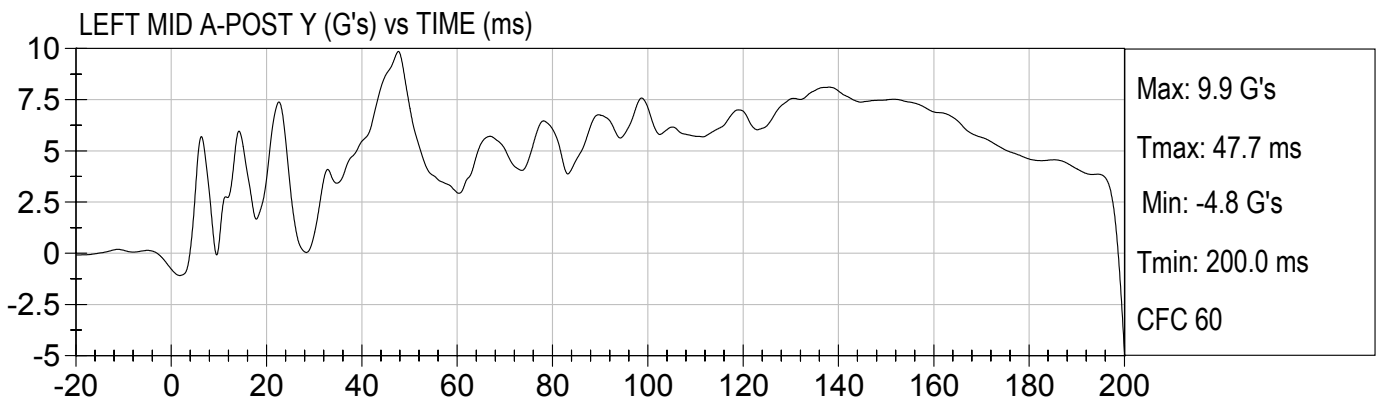
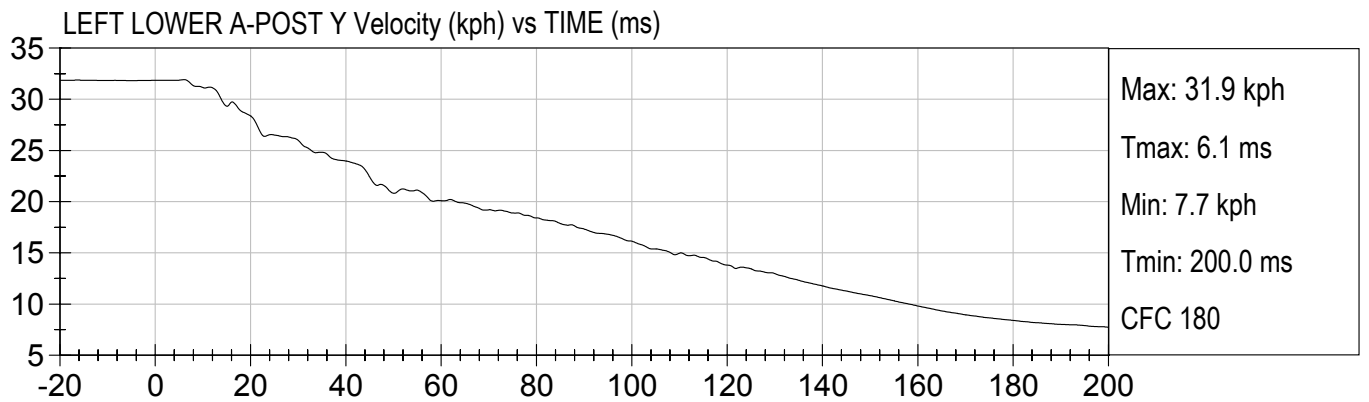
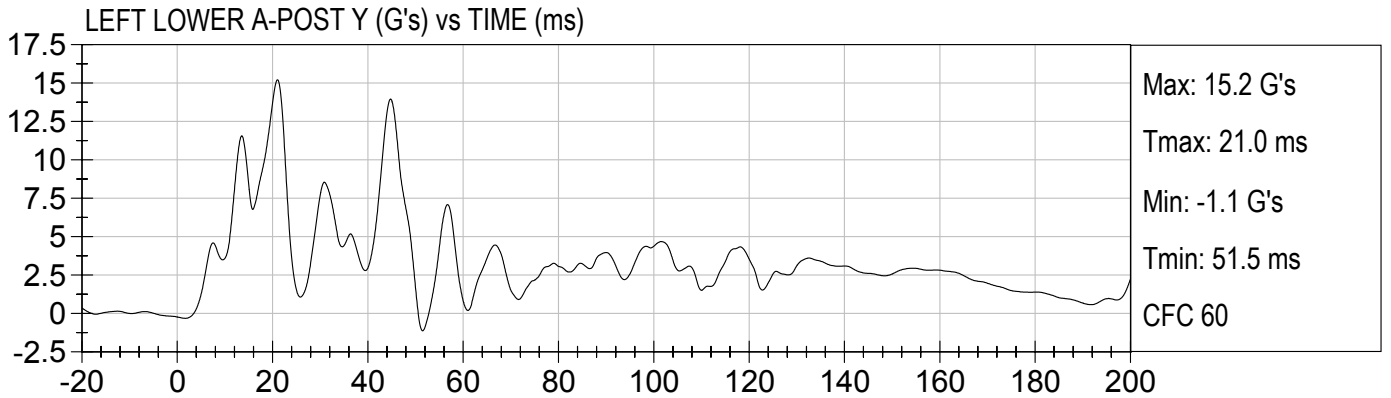

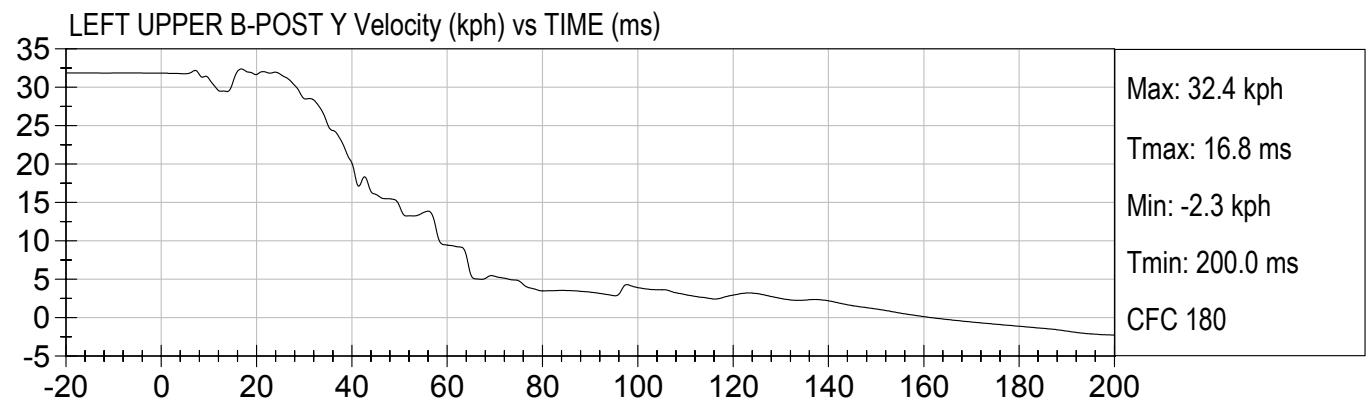
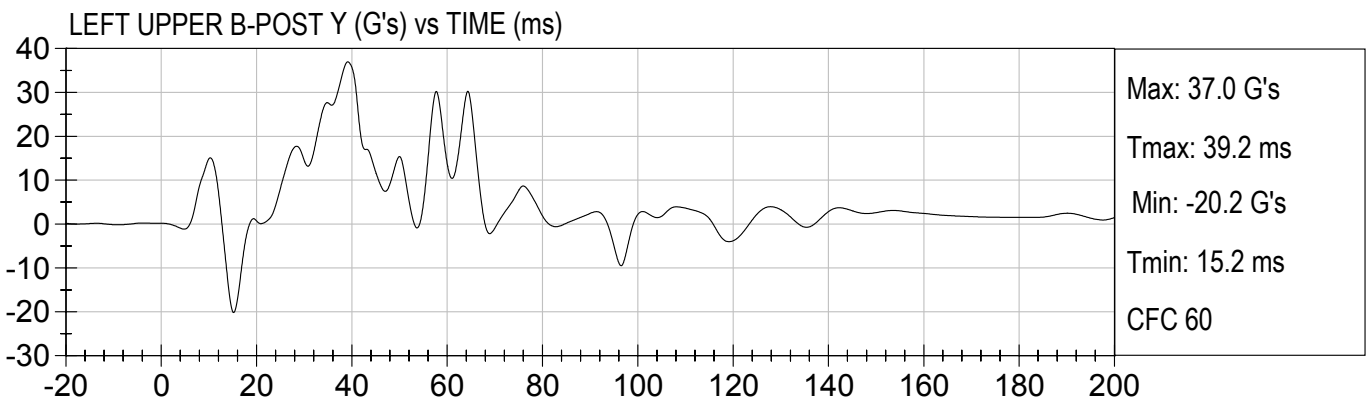
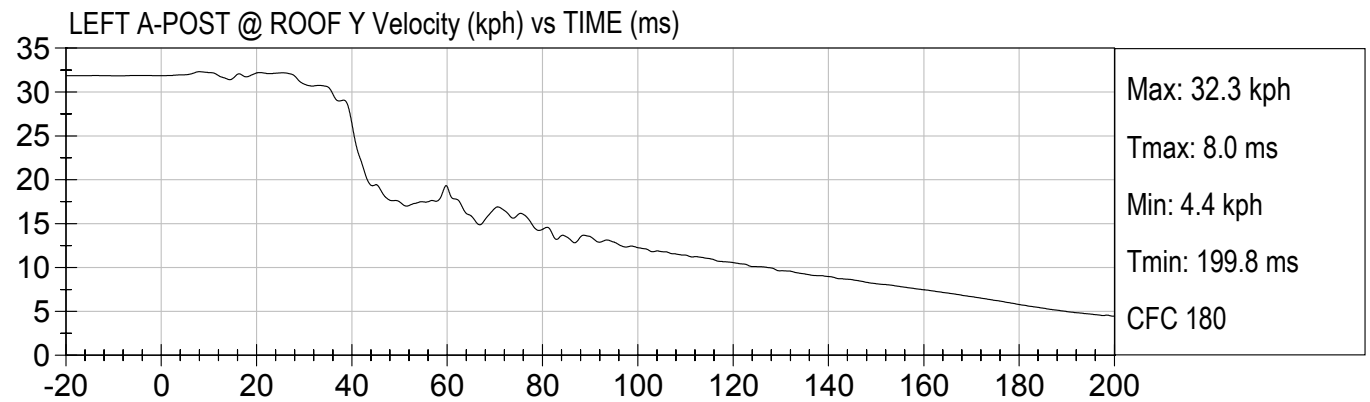
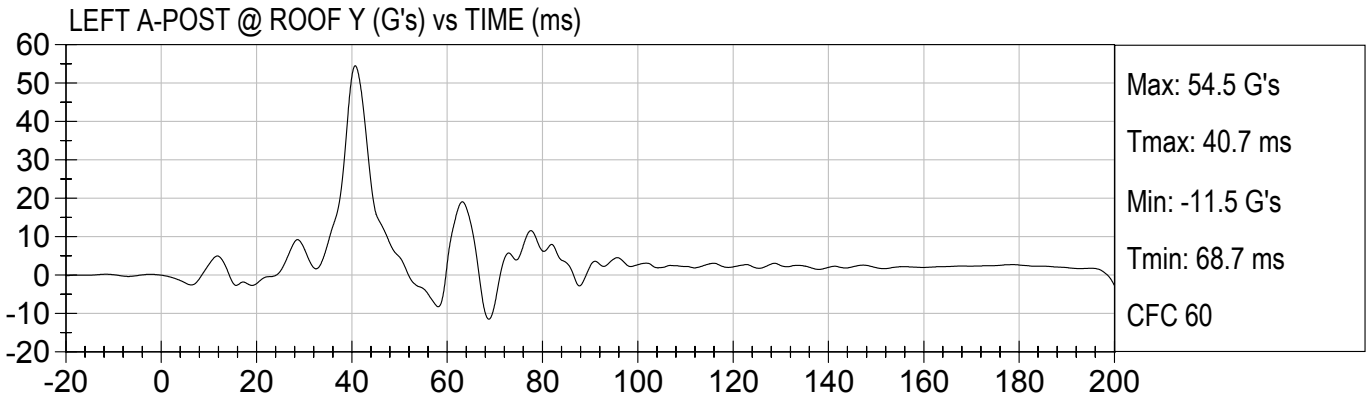

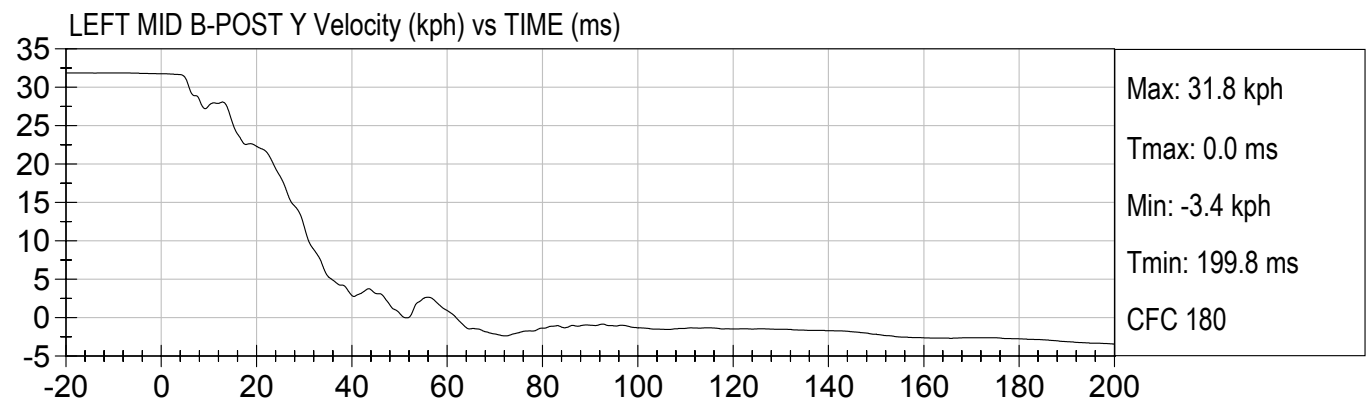
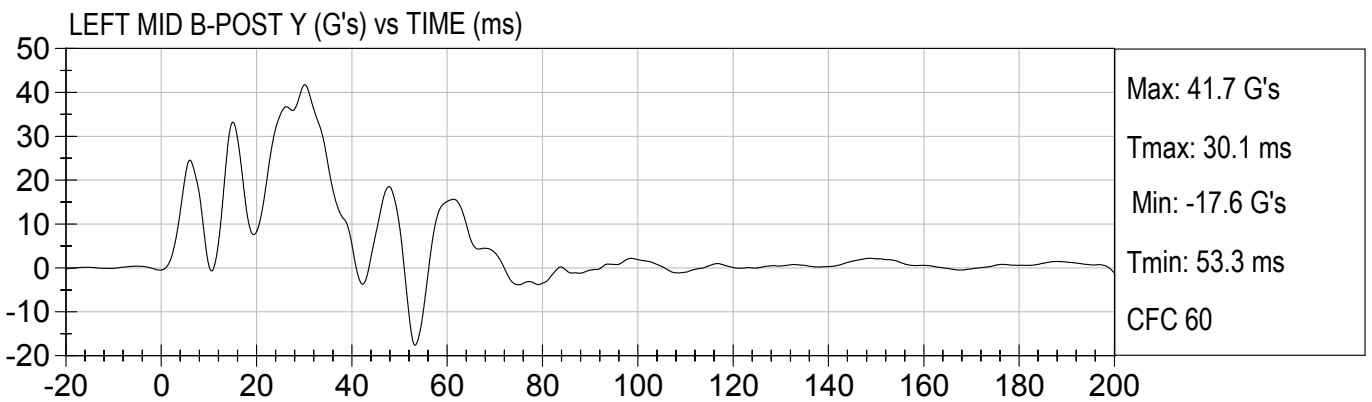
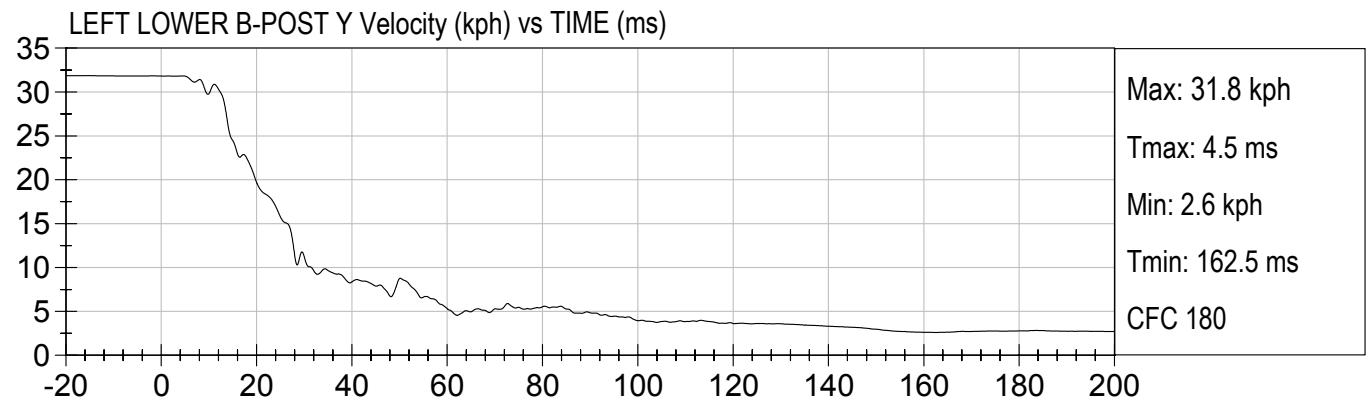
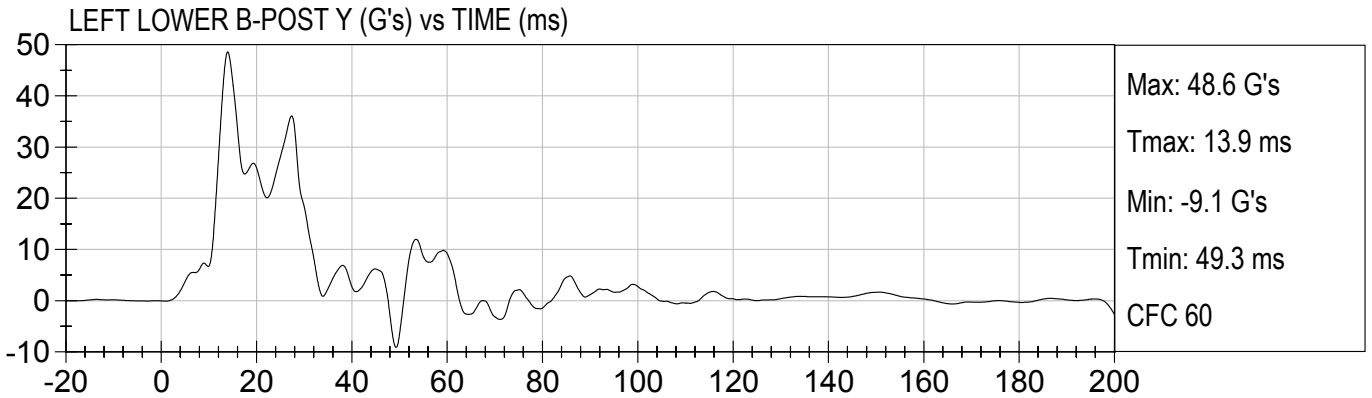

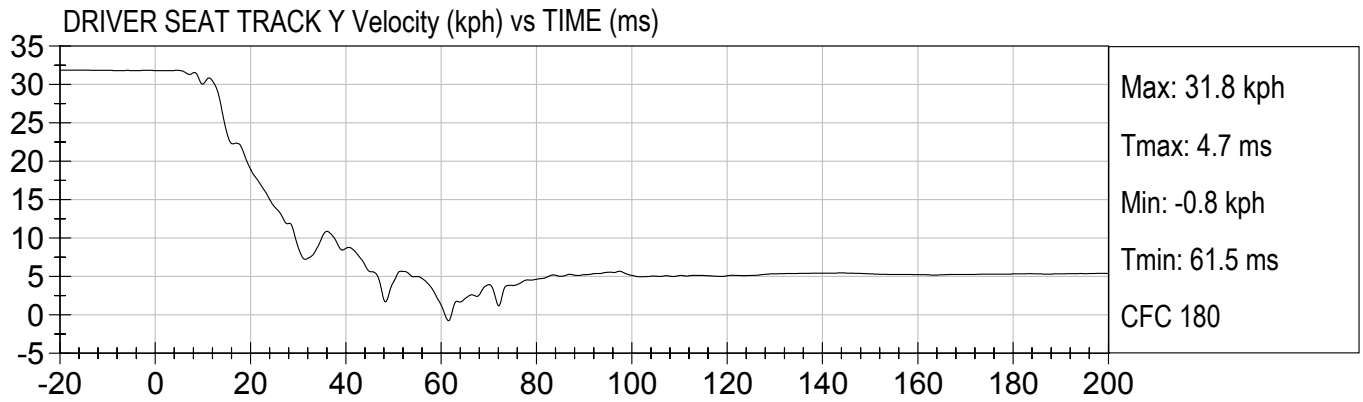
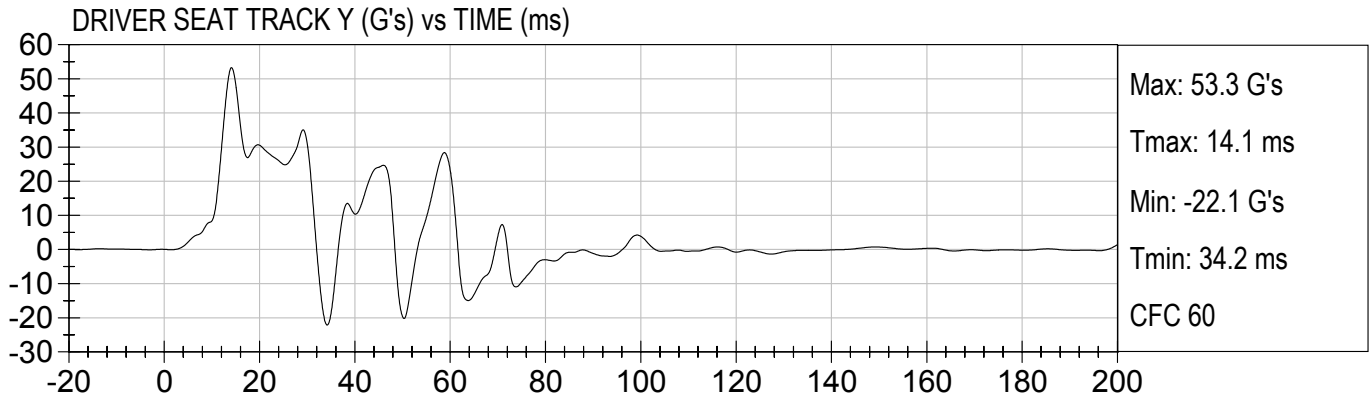

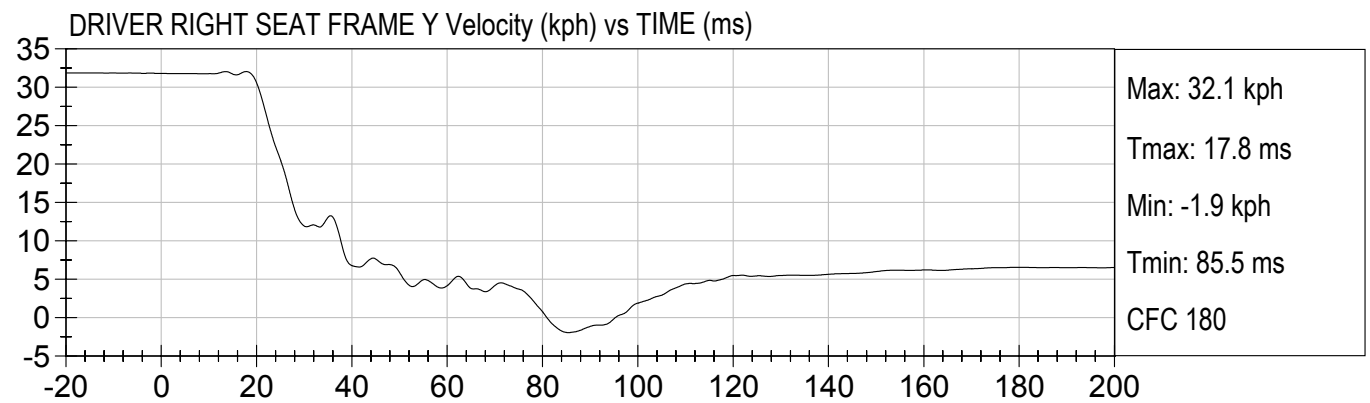
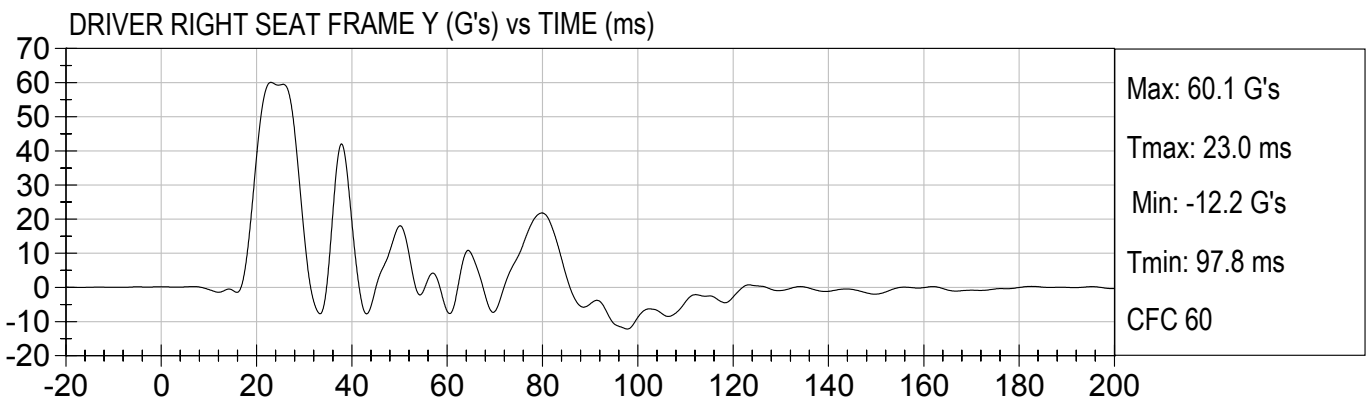
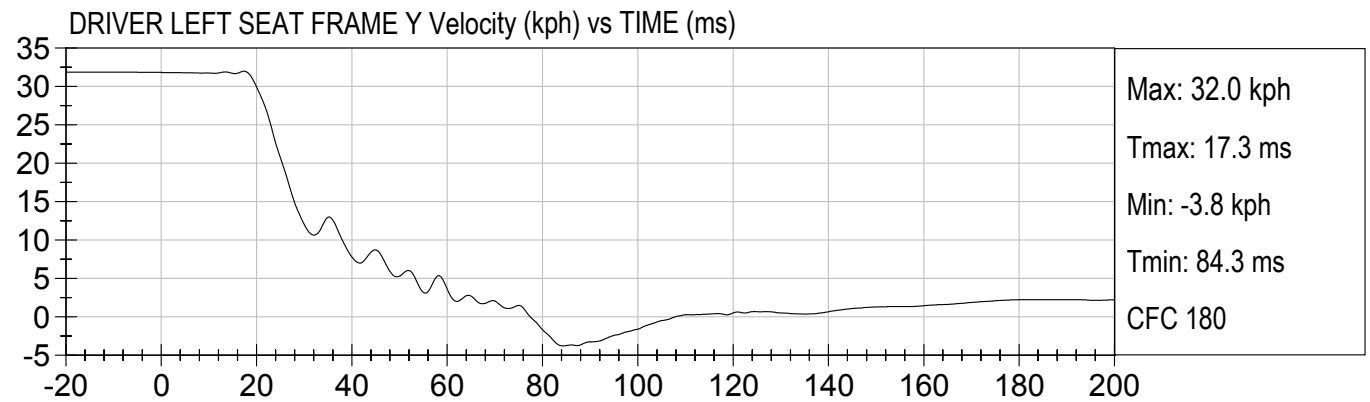
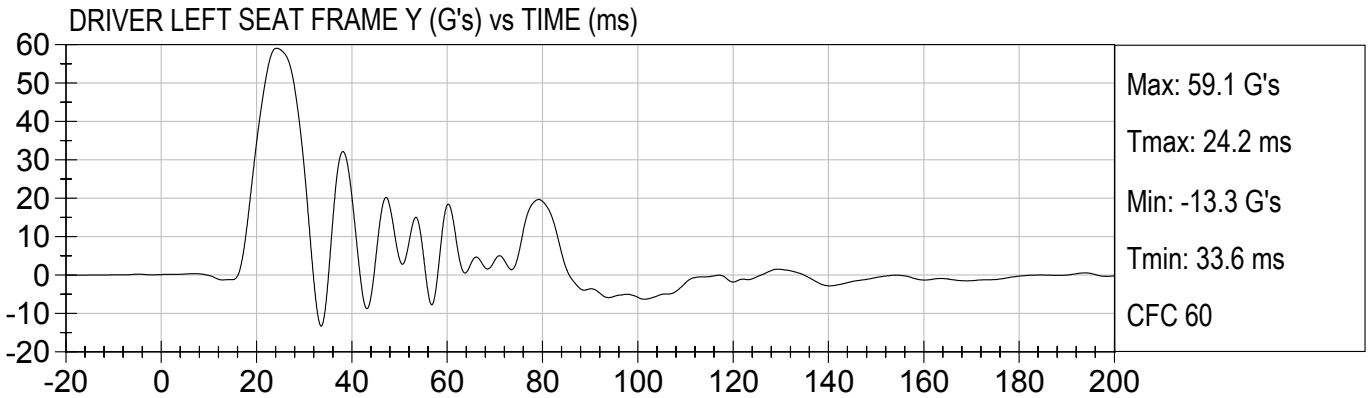



20 MPH SIDE POLE
2000 NISSAN MAXIMA (RY5218)

Test Date: 10/25/2002
Speed: 19.8 mph (31.9 km/h)

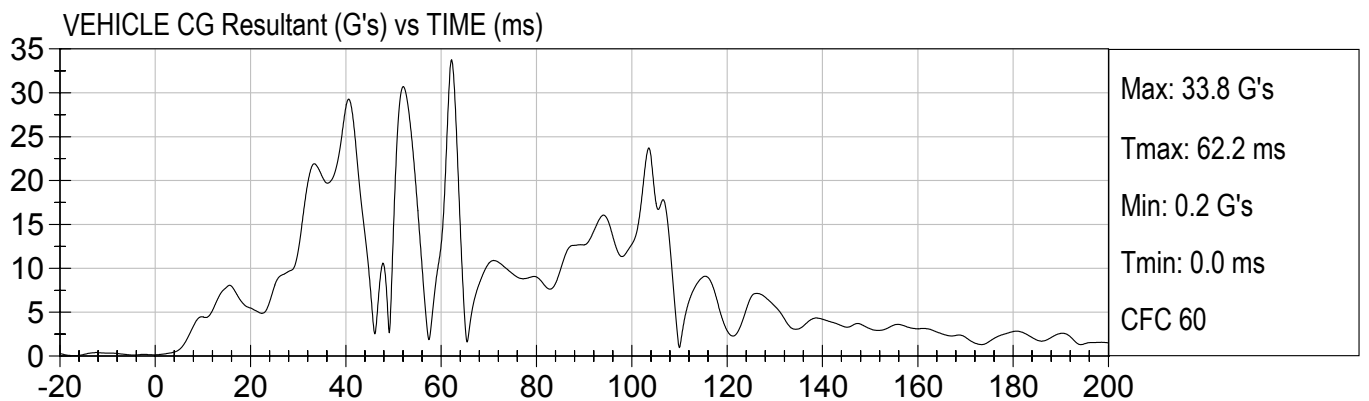
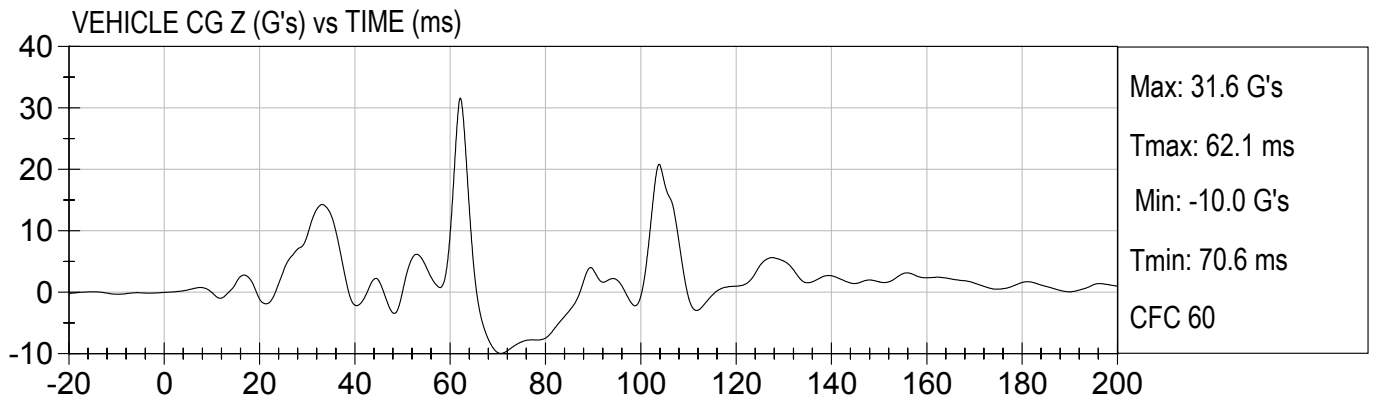
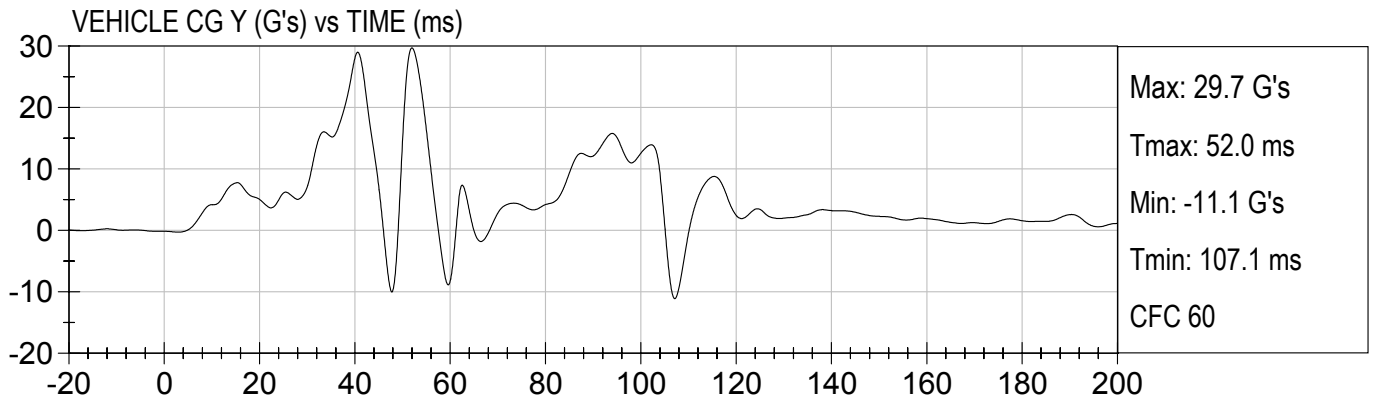
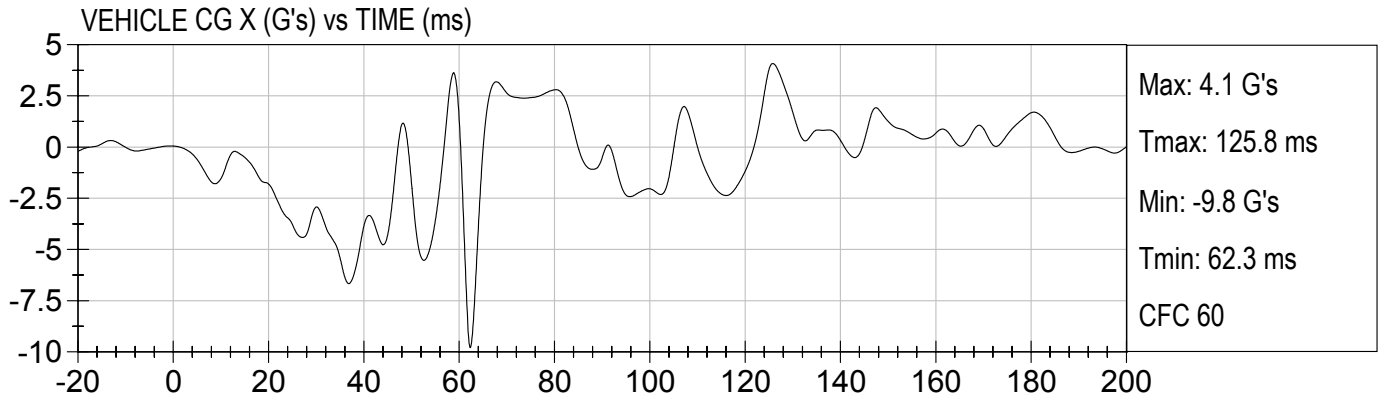



VEHICLE CG X Velocity (kph) vs TIME (ms)

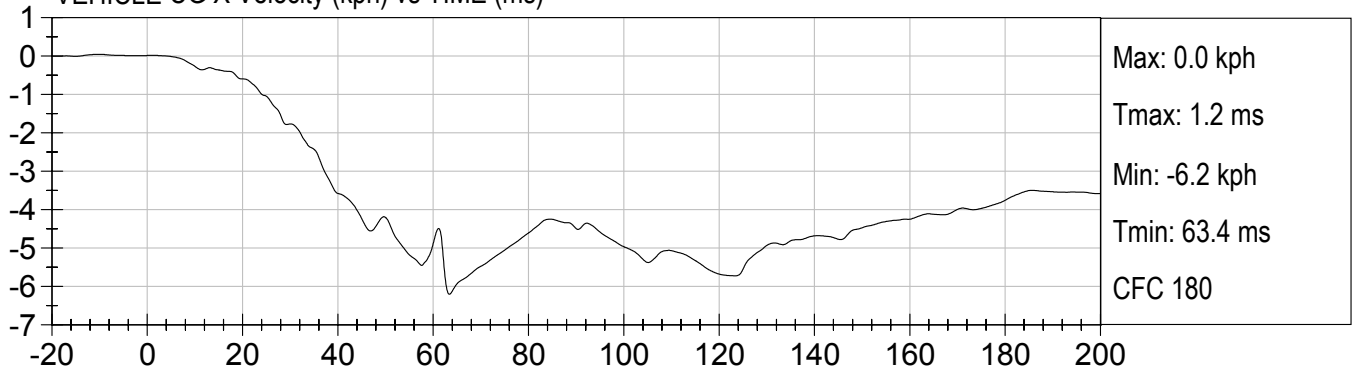

VEHICLE CG Y Velocity (kph) vs TIME (ms)

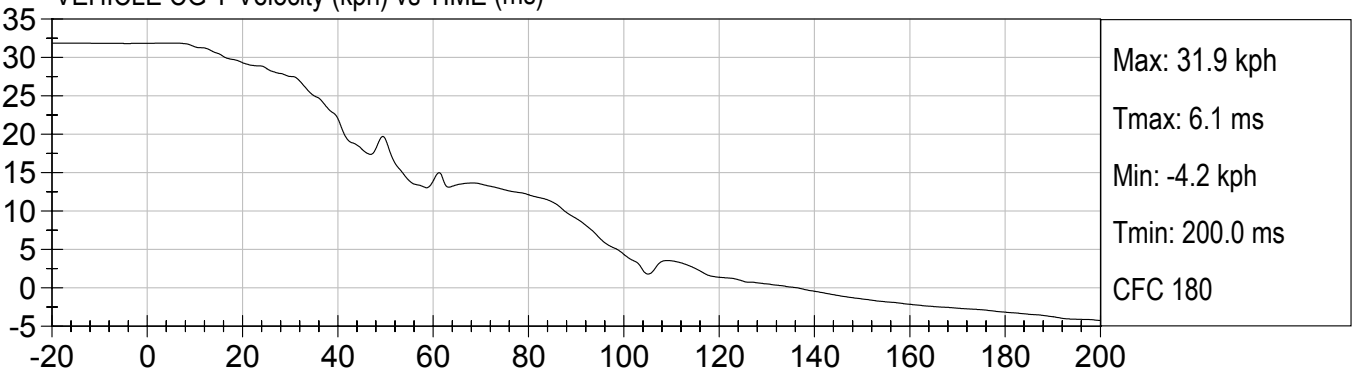

VEHICLE CG Z Velocity (kph) vs TIME (ms)

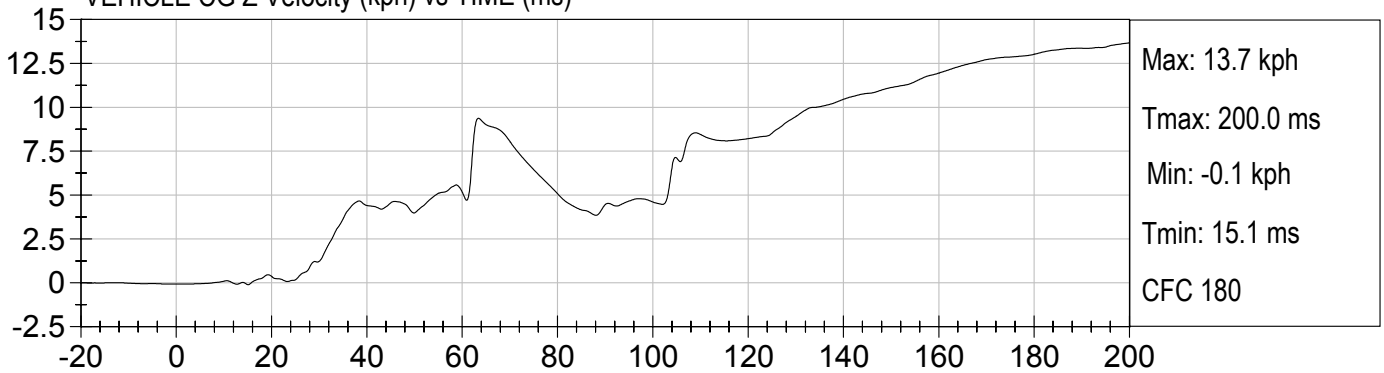

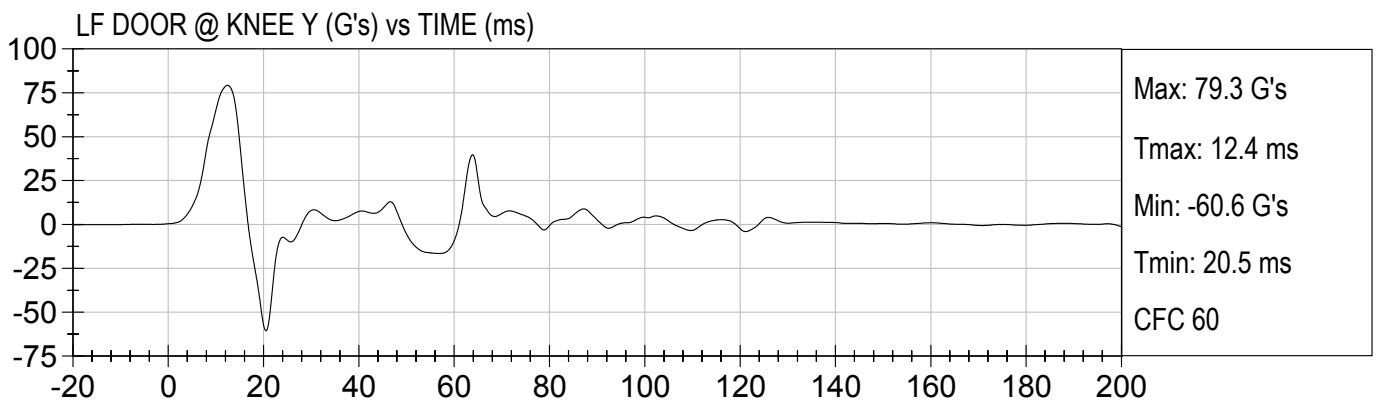
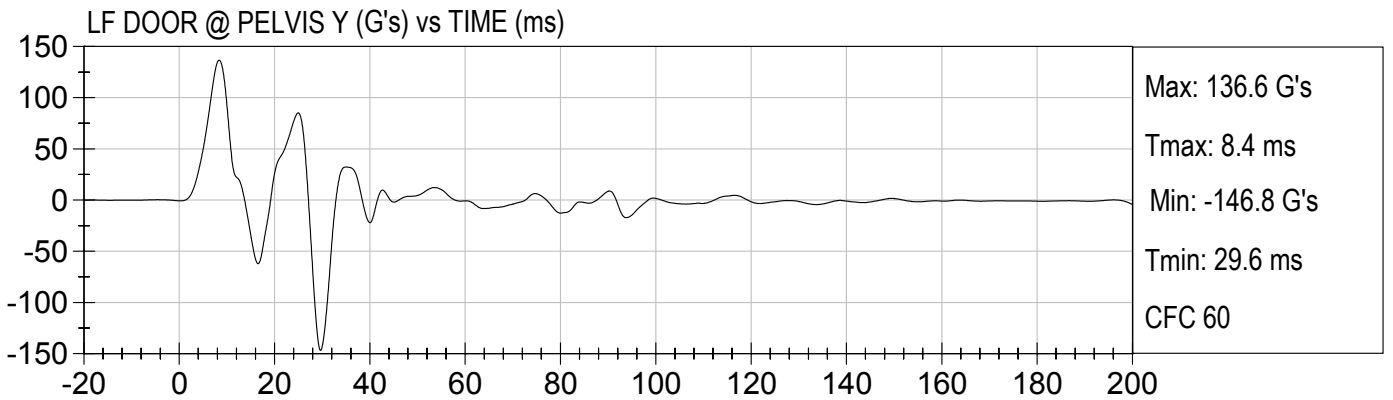
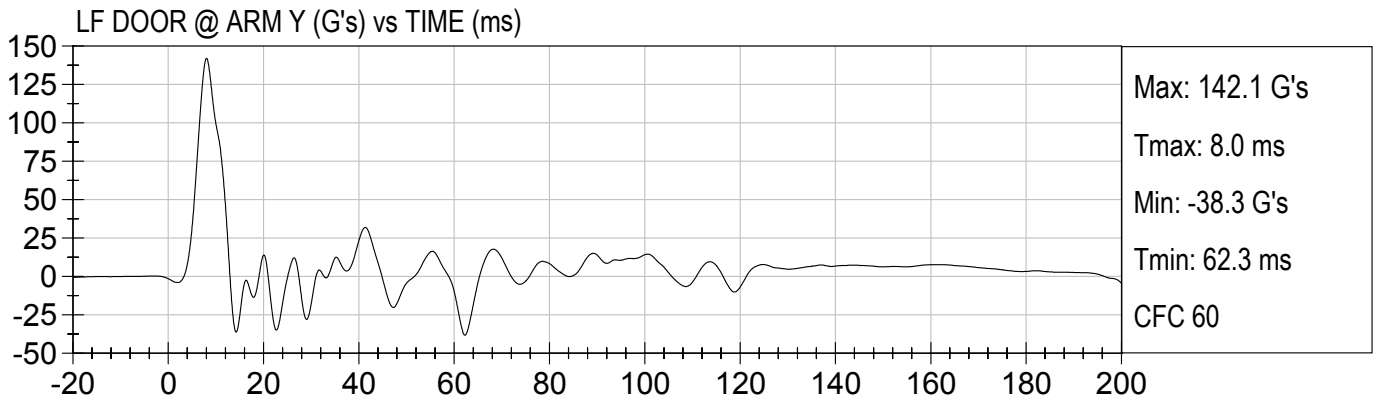
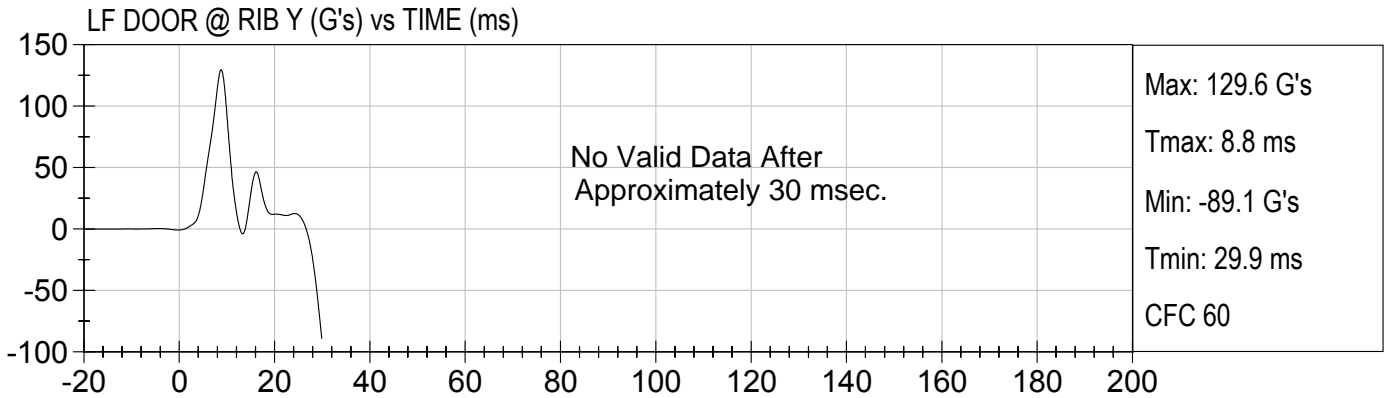



LF DOOR @ RIB Y Velocity (kph) vs TIME (ms)

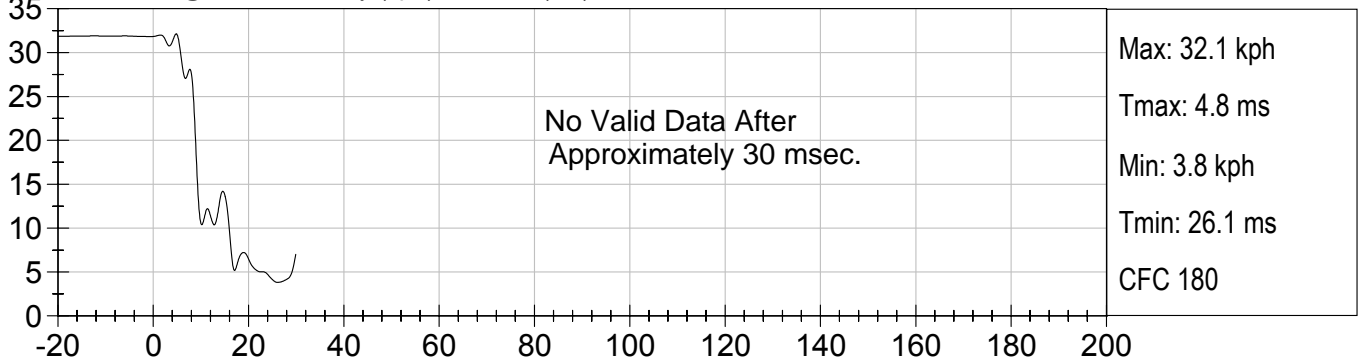

LF DOOR @ ARM Y Velocity (kph) vs TIME (ms)

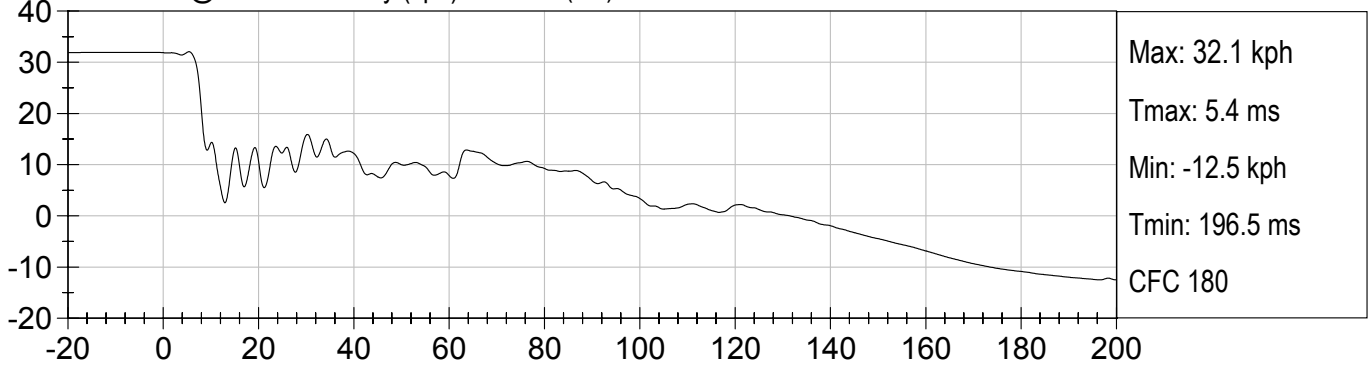

LF DOOR @ PELVIS Y Velocity (kph) vs TIME (ms)

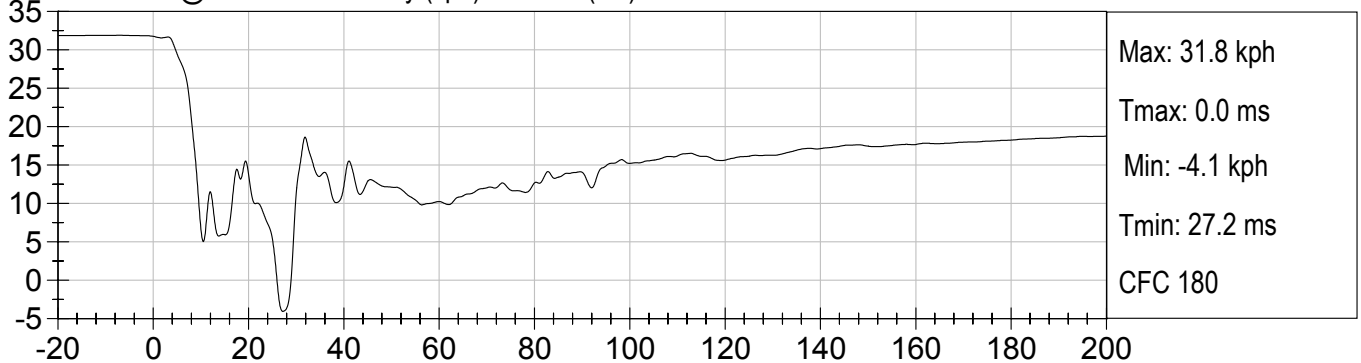

LF DOOR @ KNEE Y Velocity (kph) vs TIME (ms)

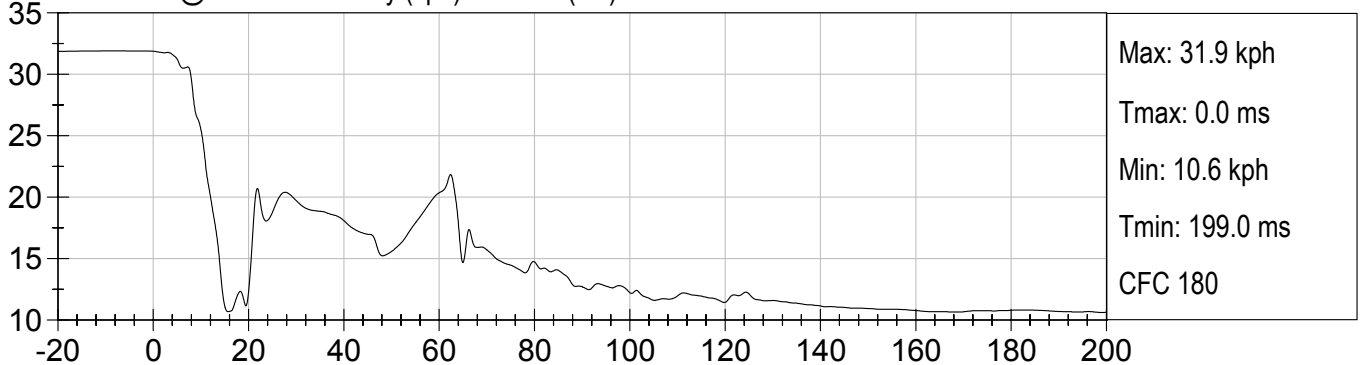



LC RADIATOR SUPPORT X (G's) vs TIME (ms)

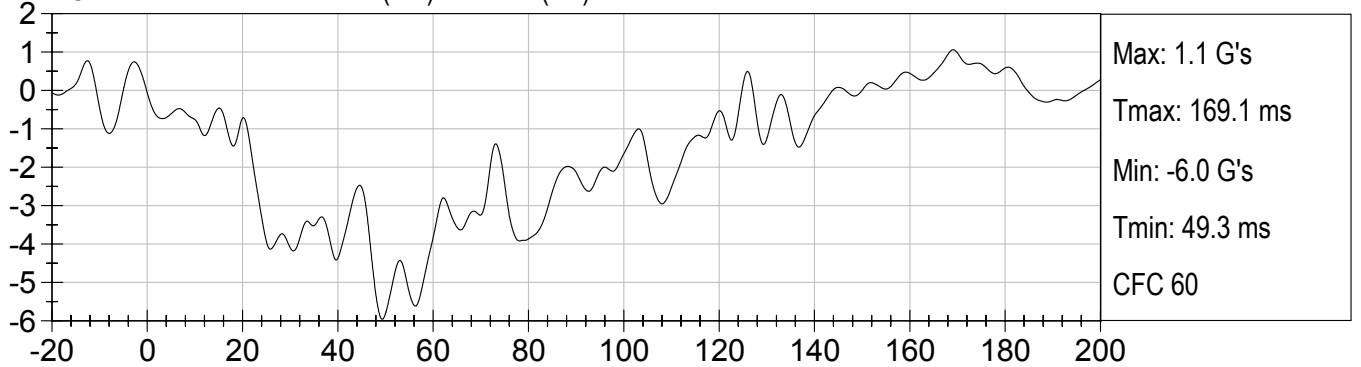

LC RADIATOR SUPPORT Y (G's) vs TIME (ms)

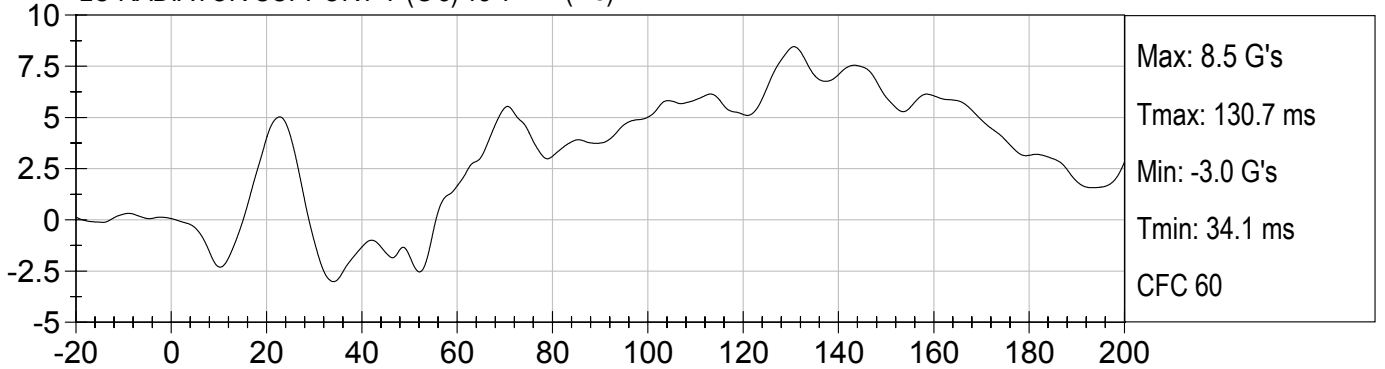

LC RADIATOR SUPPORT Z (G's) vs TIME (ms)

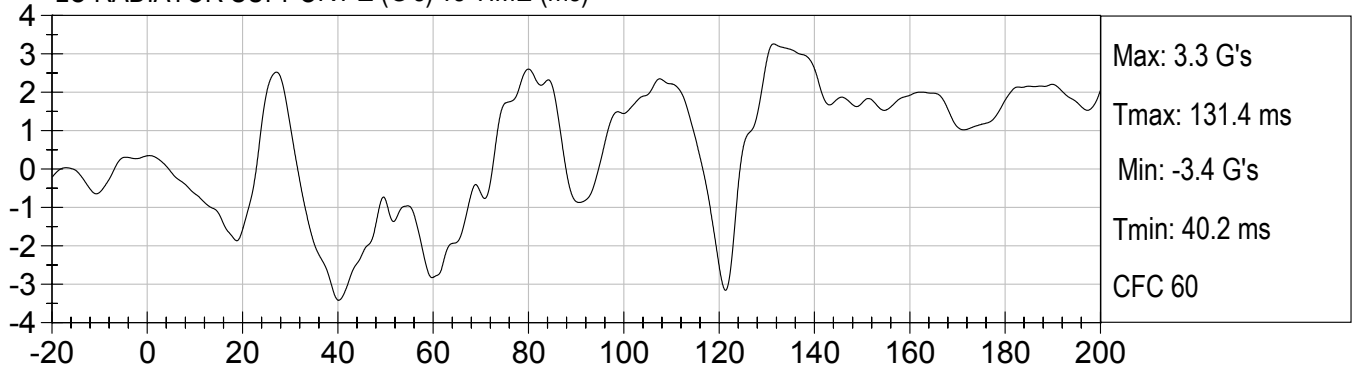

LC RADIATOR SUPPORT Resultant (G's) vs TIME (ms)

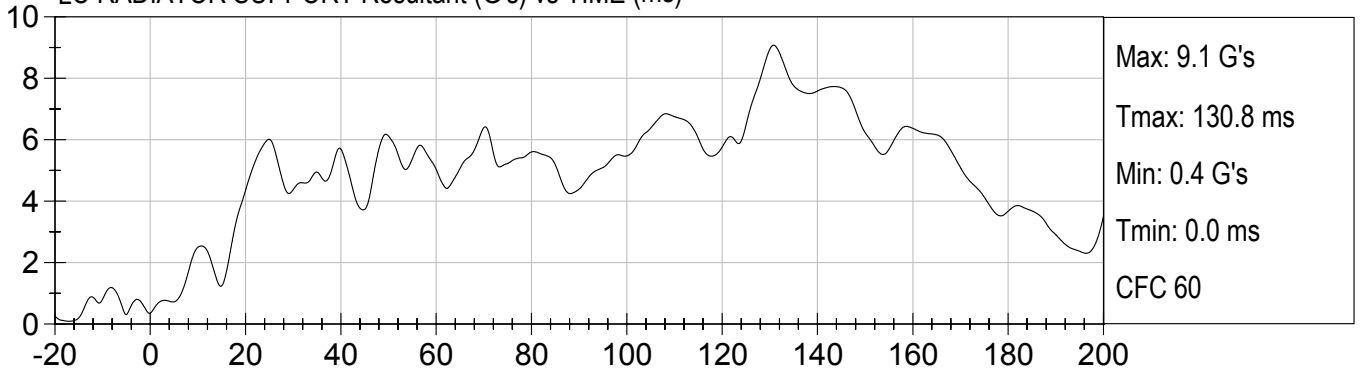

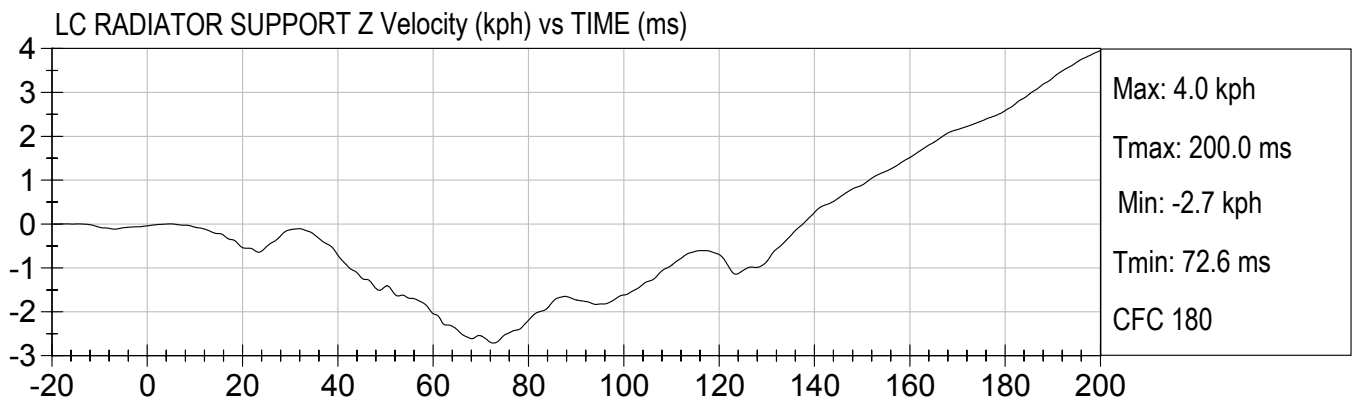
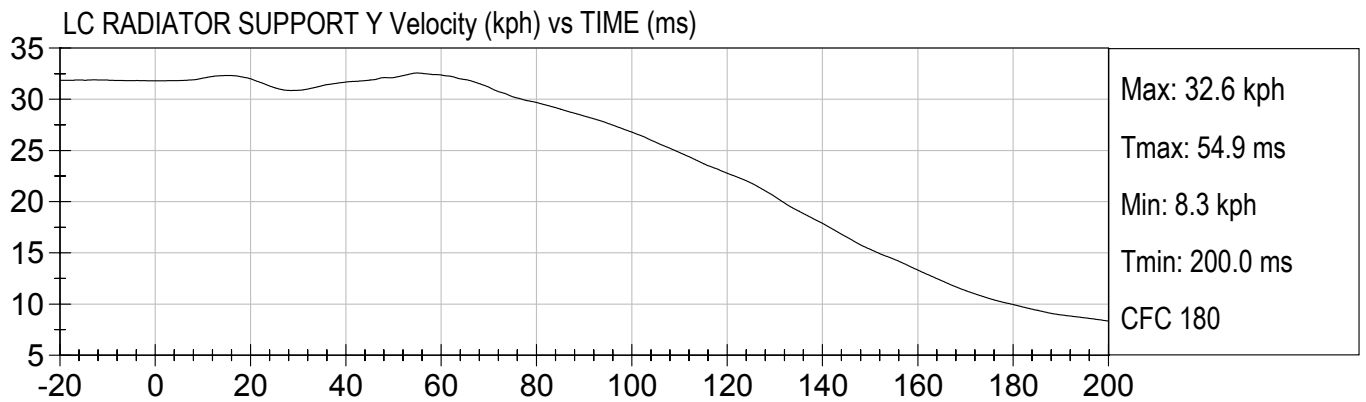
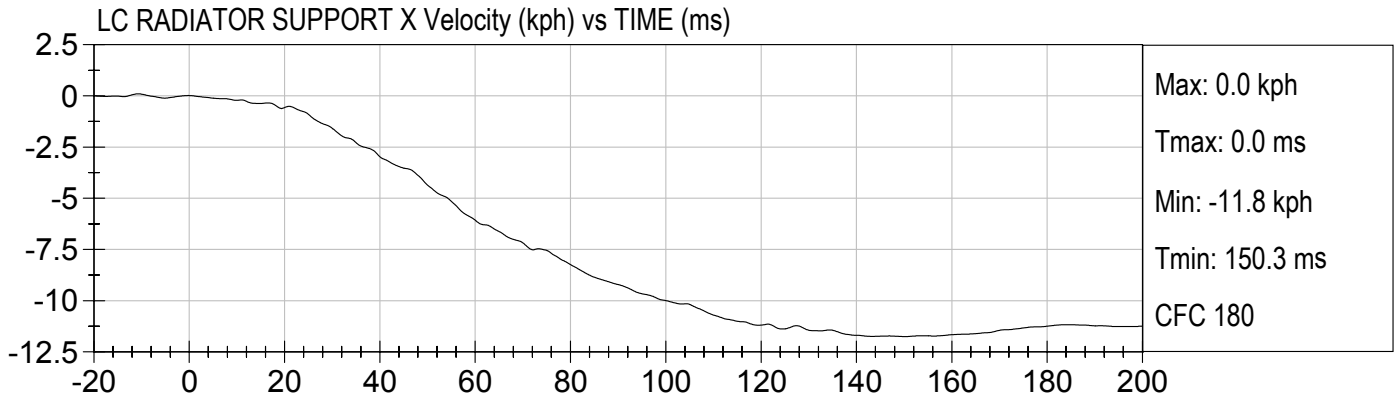

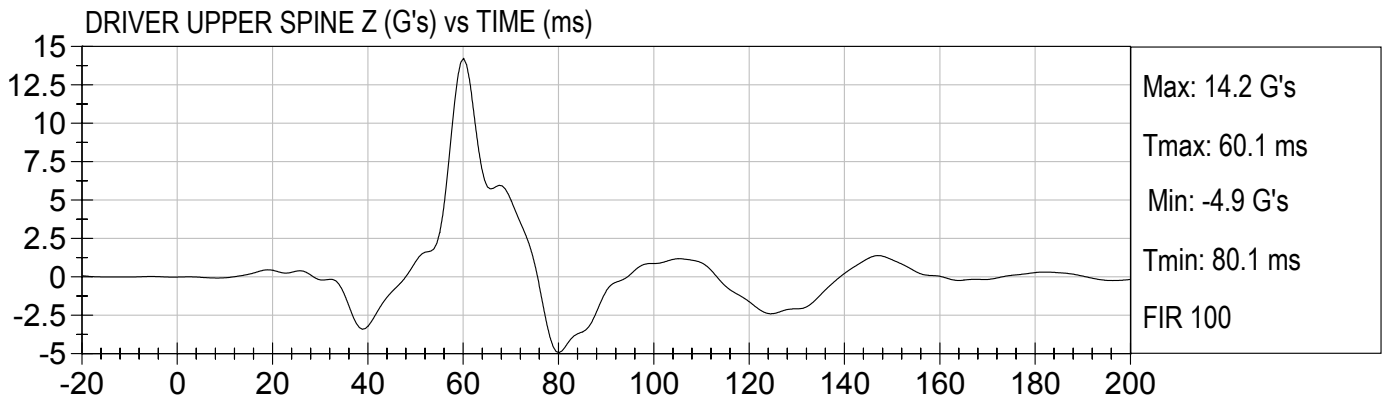
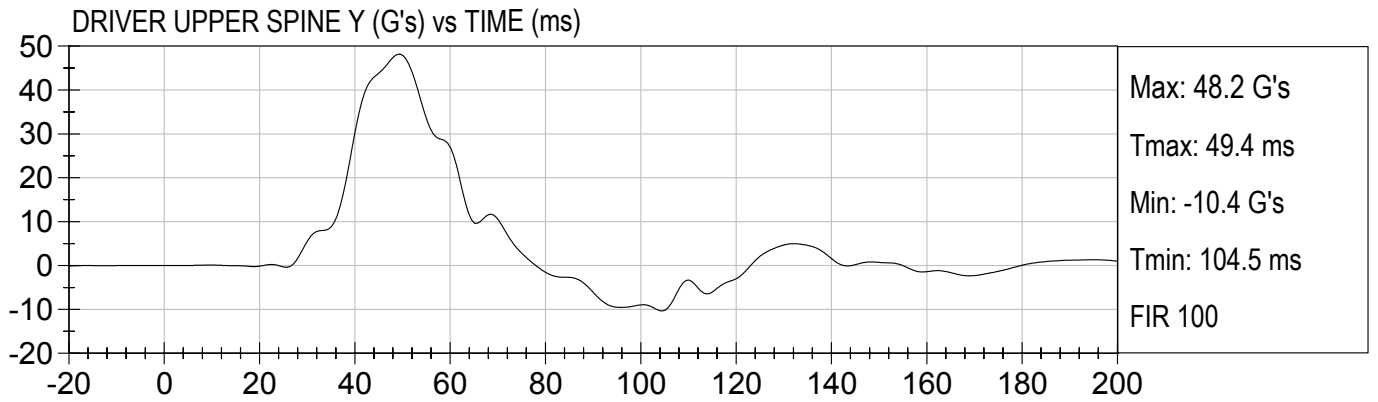
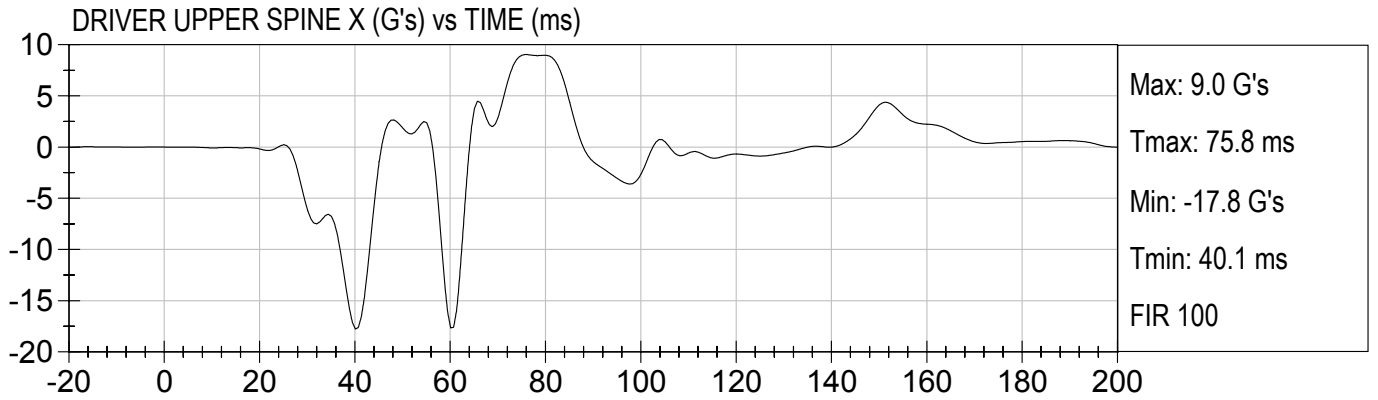

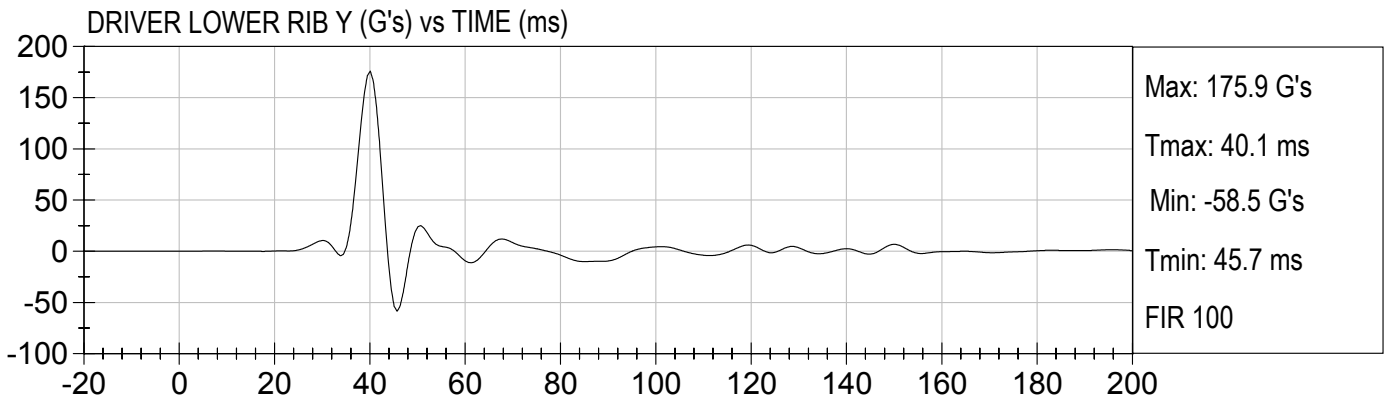
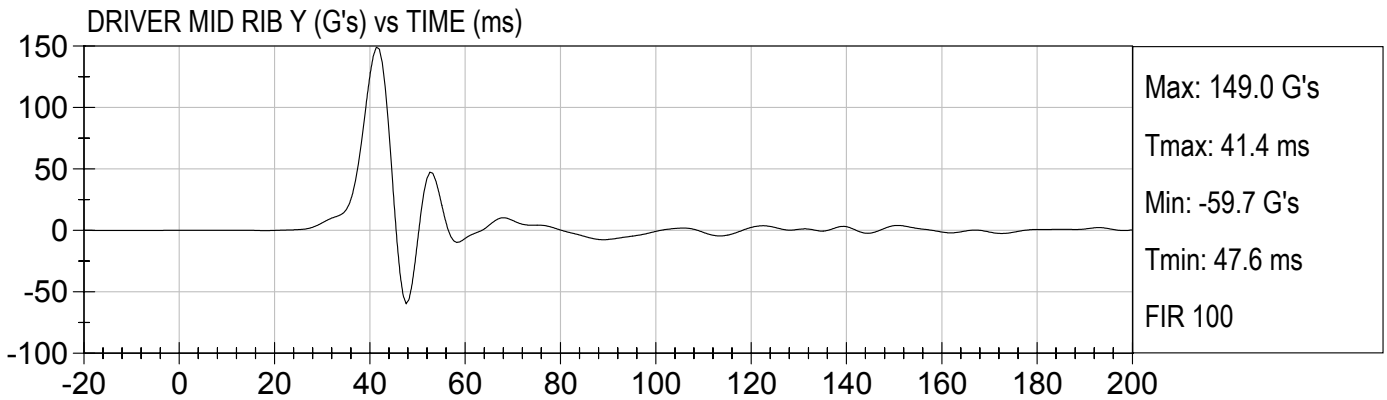
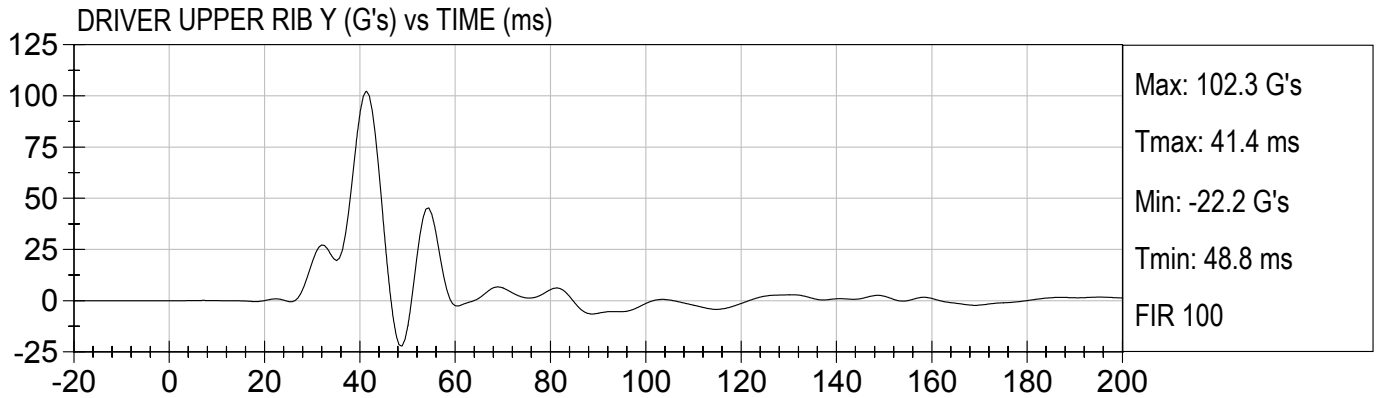

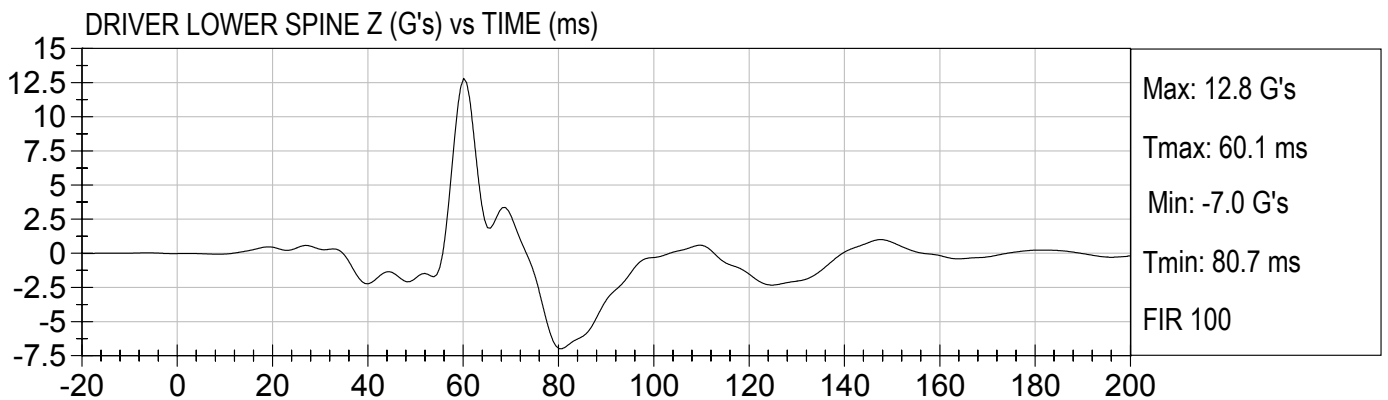
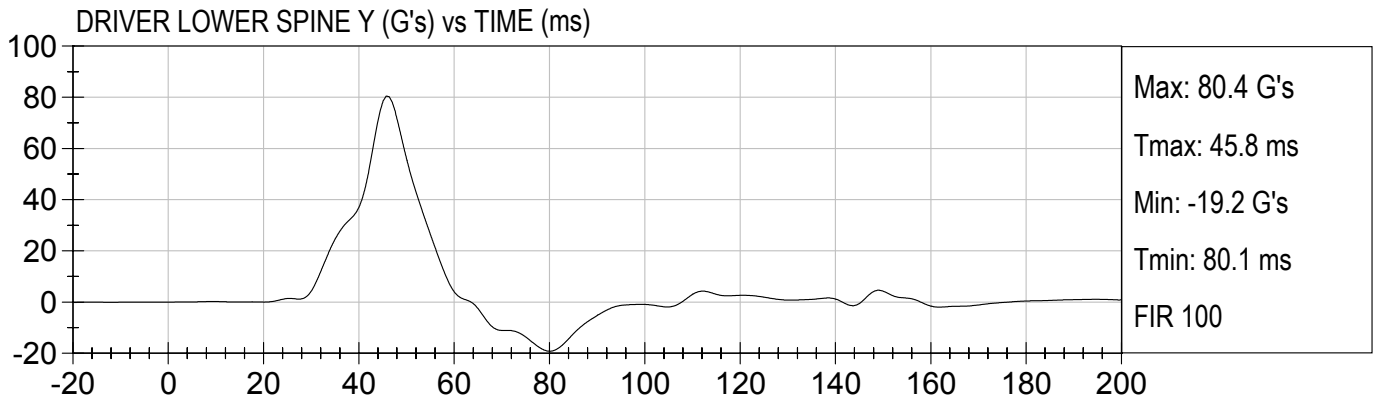
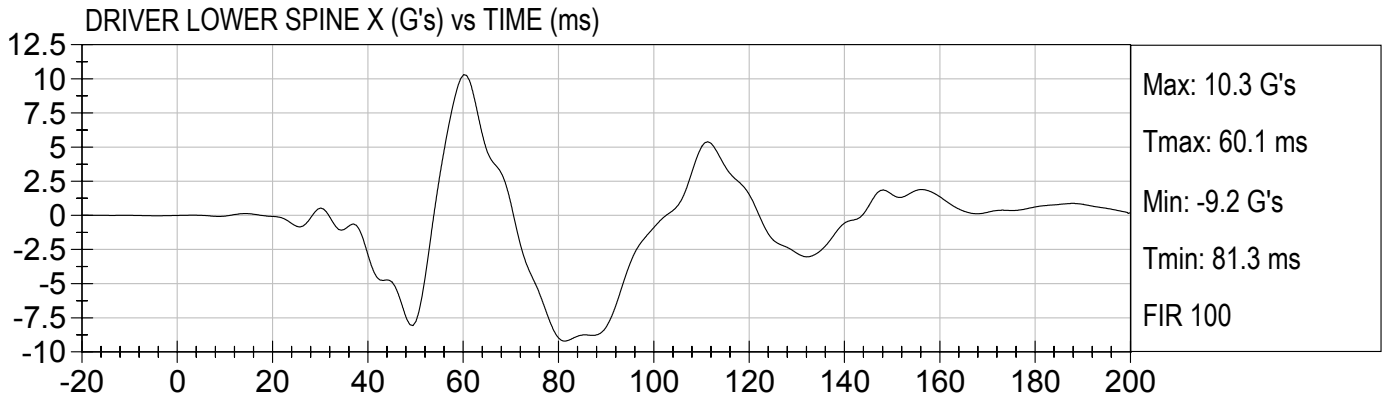

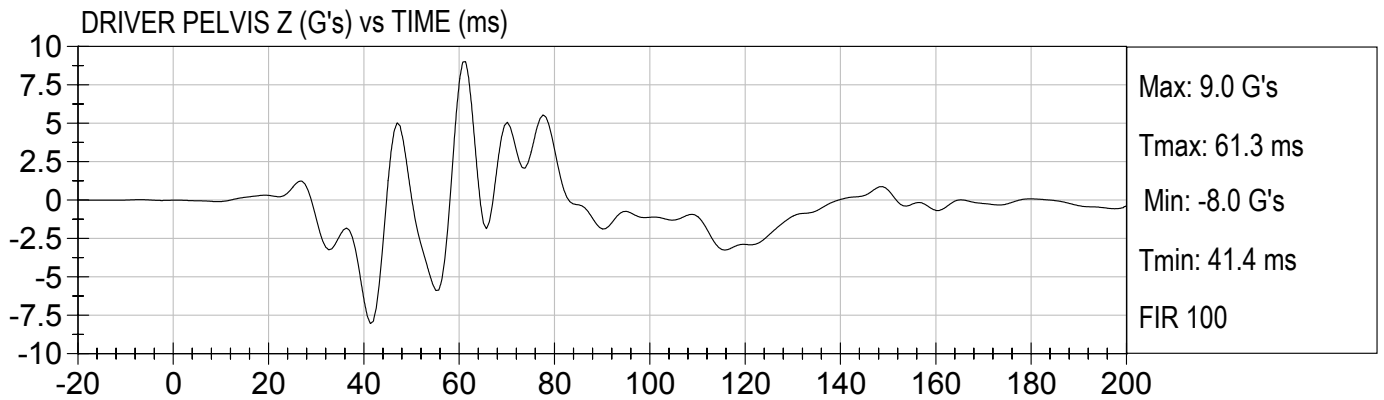
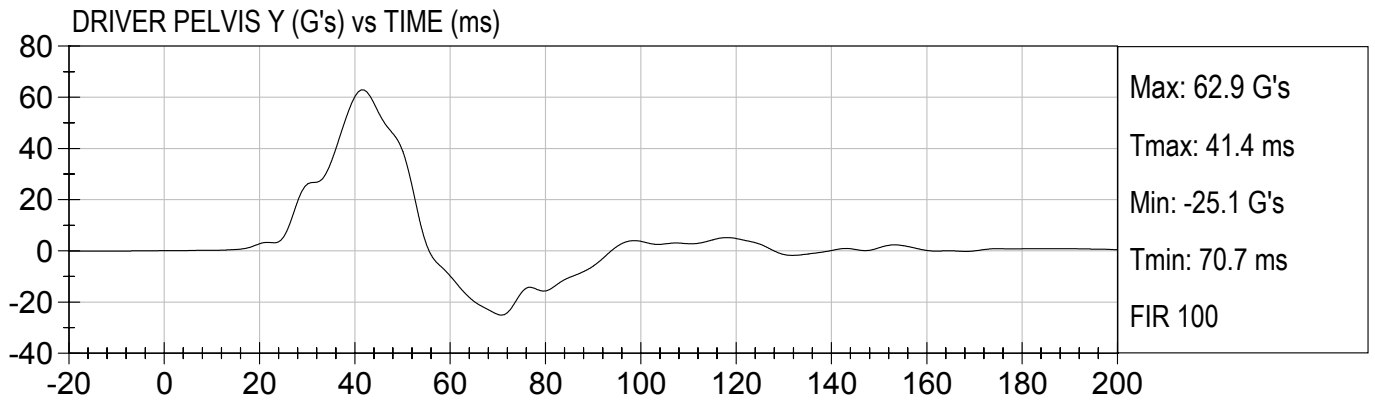
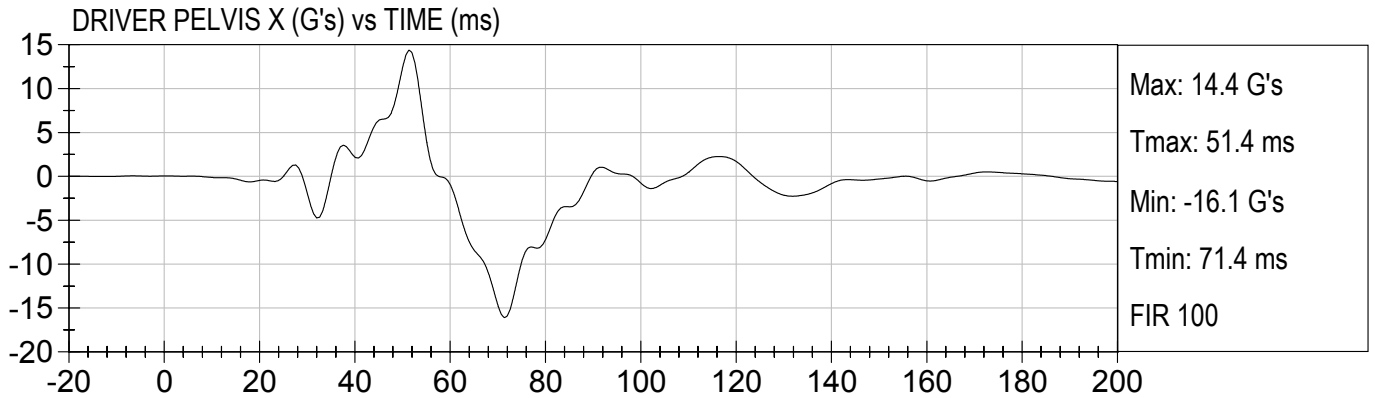

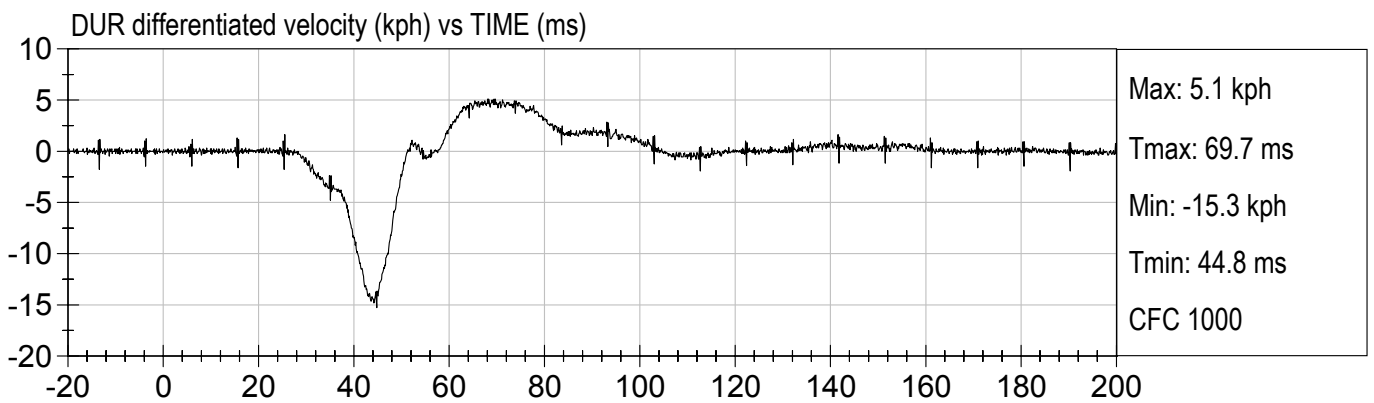
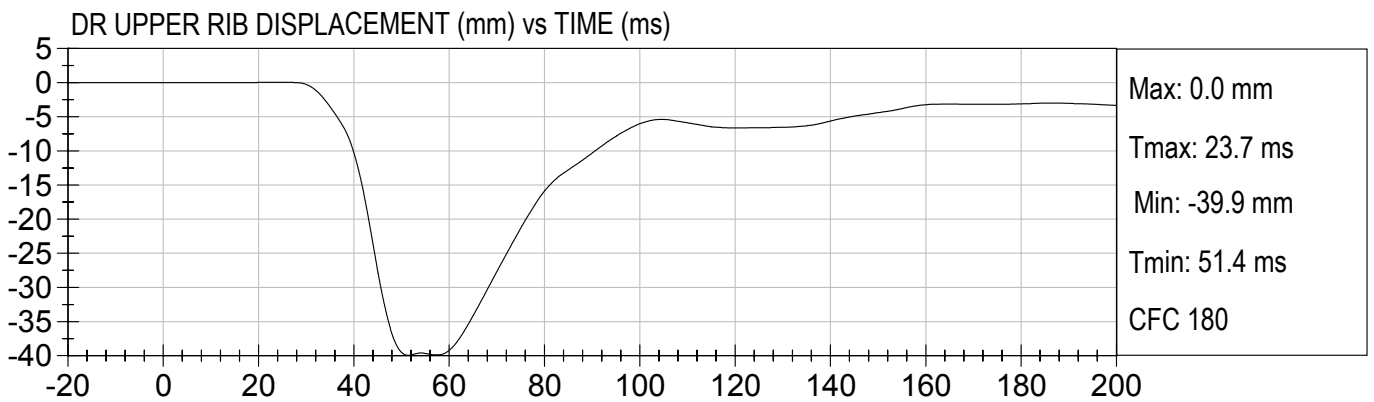
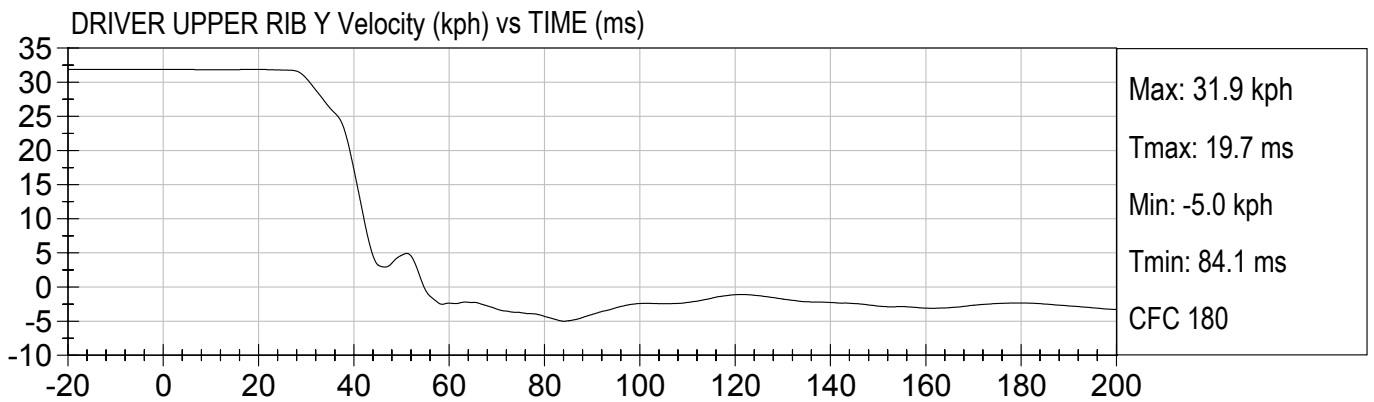
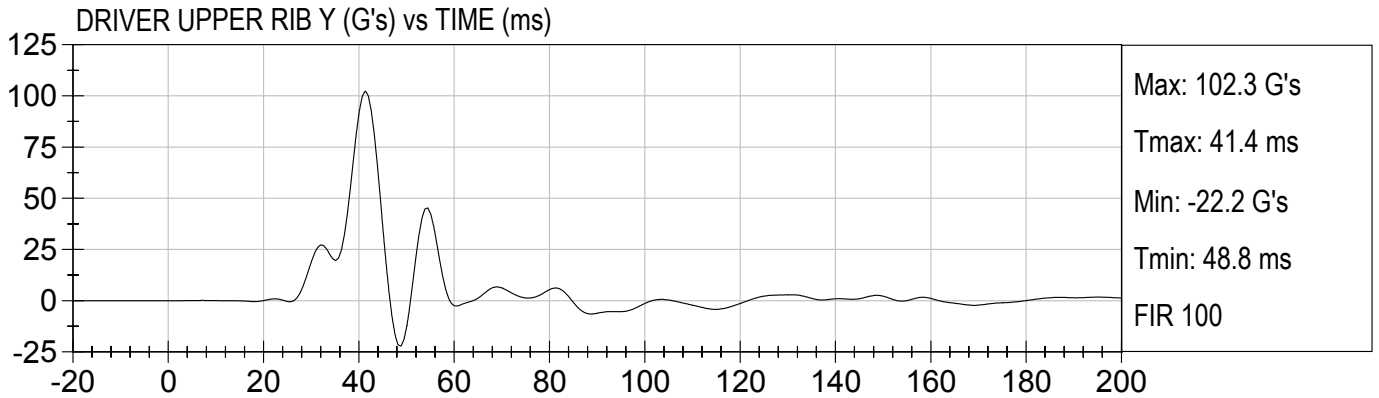

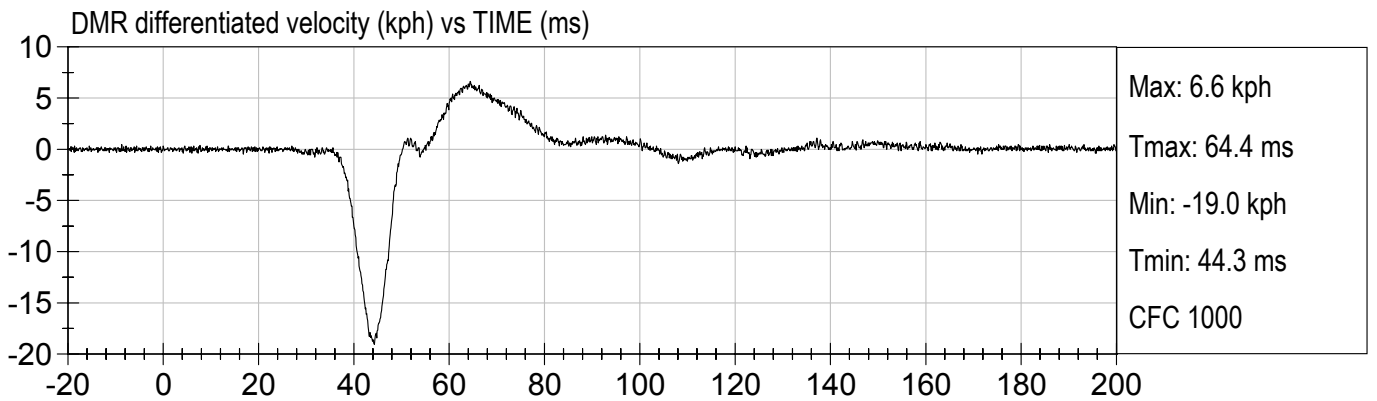
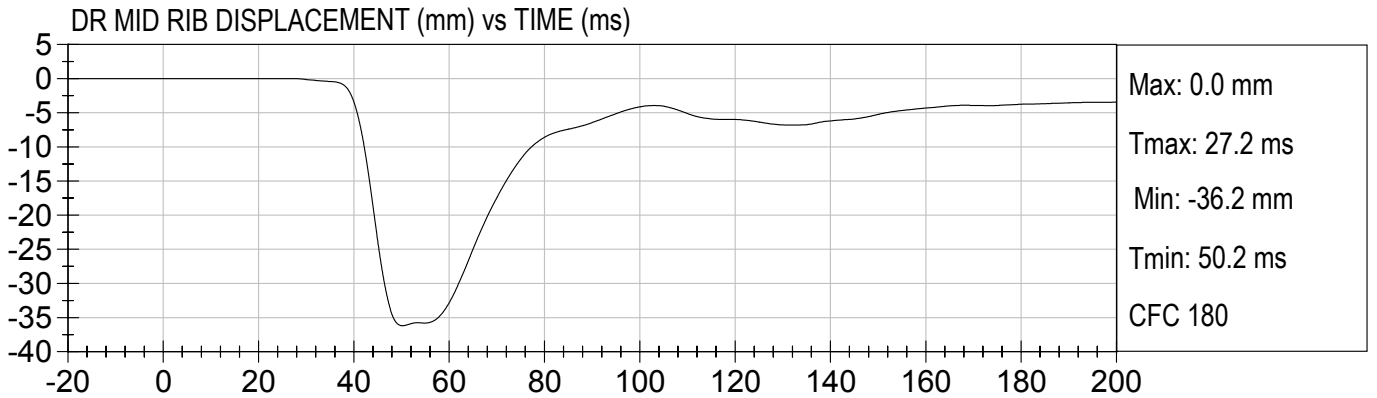
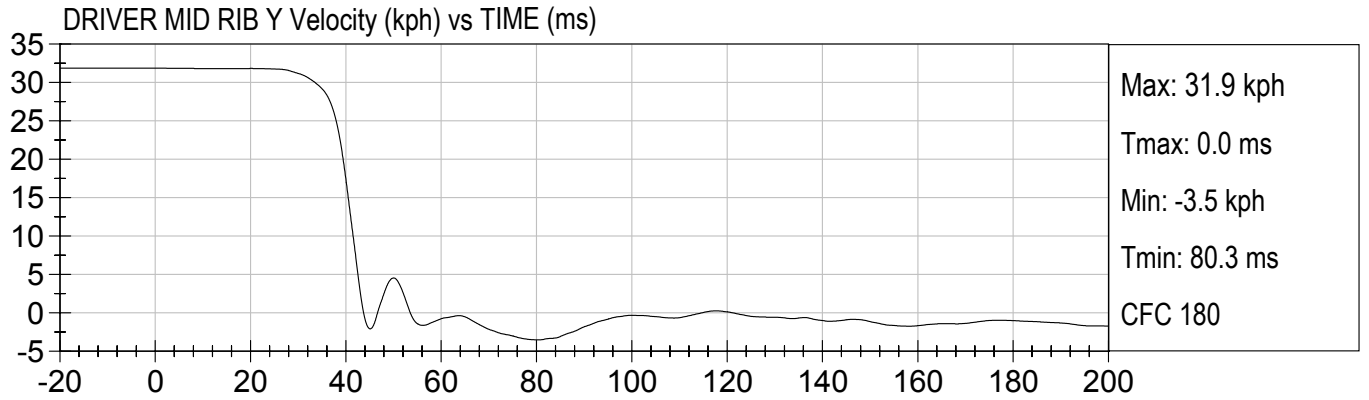
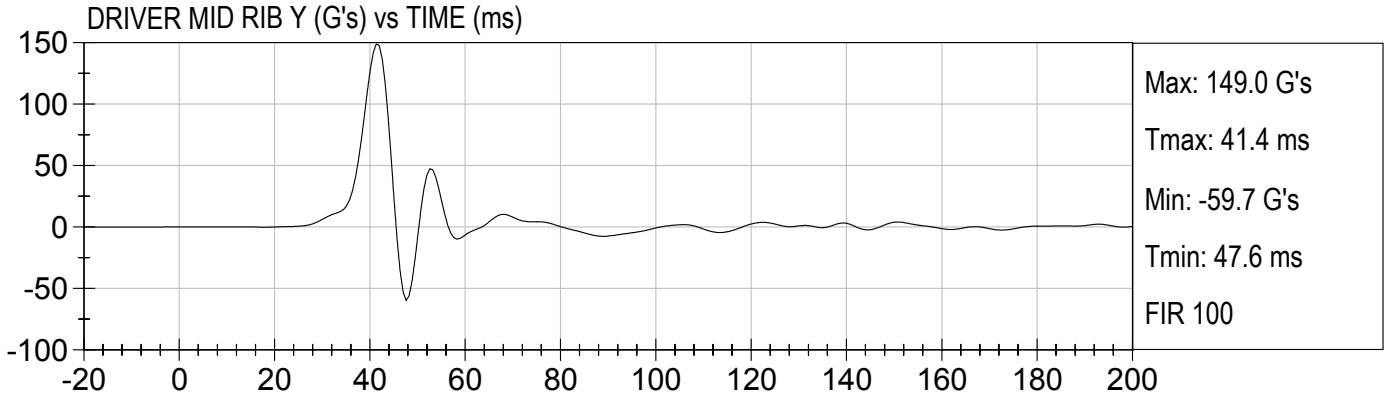

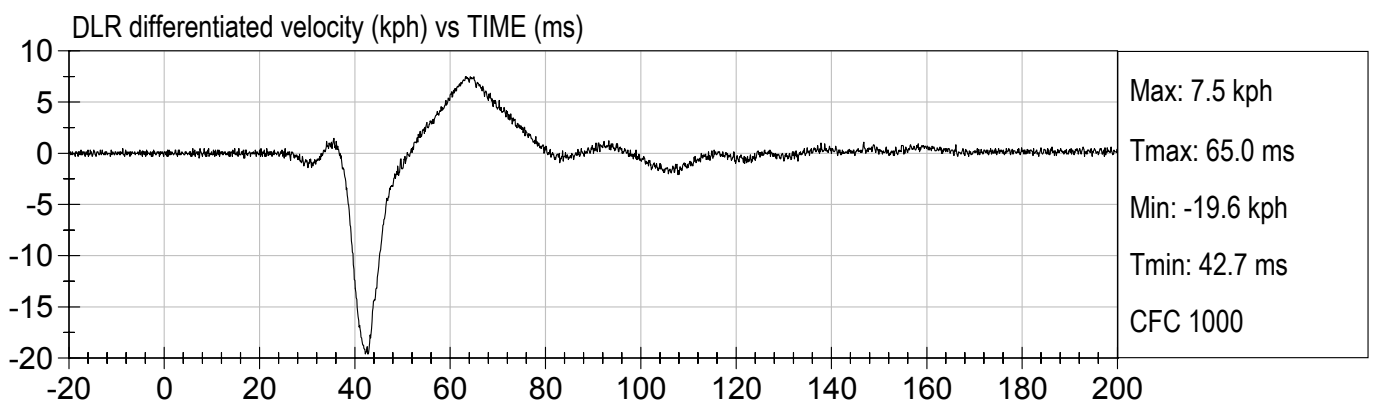
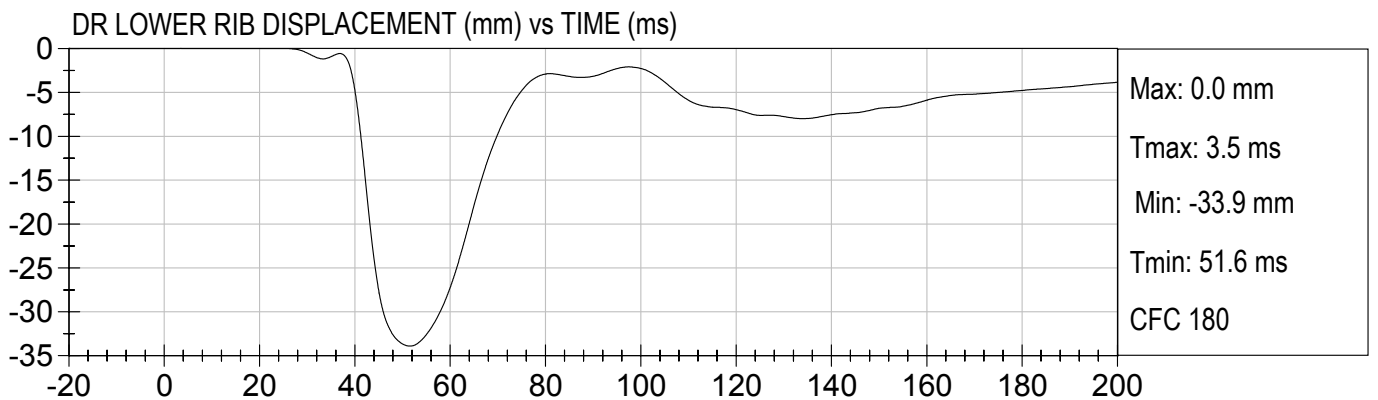
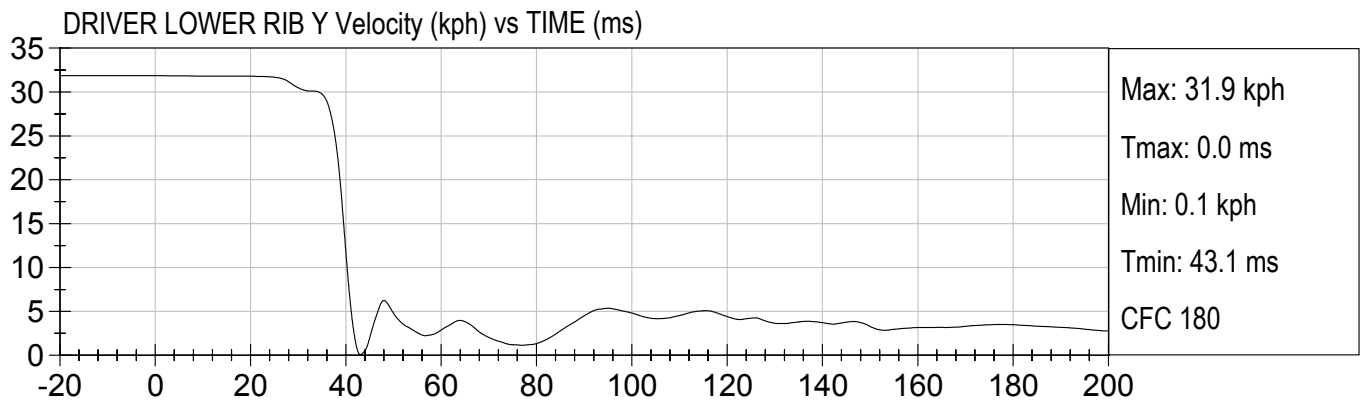
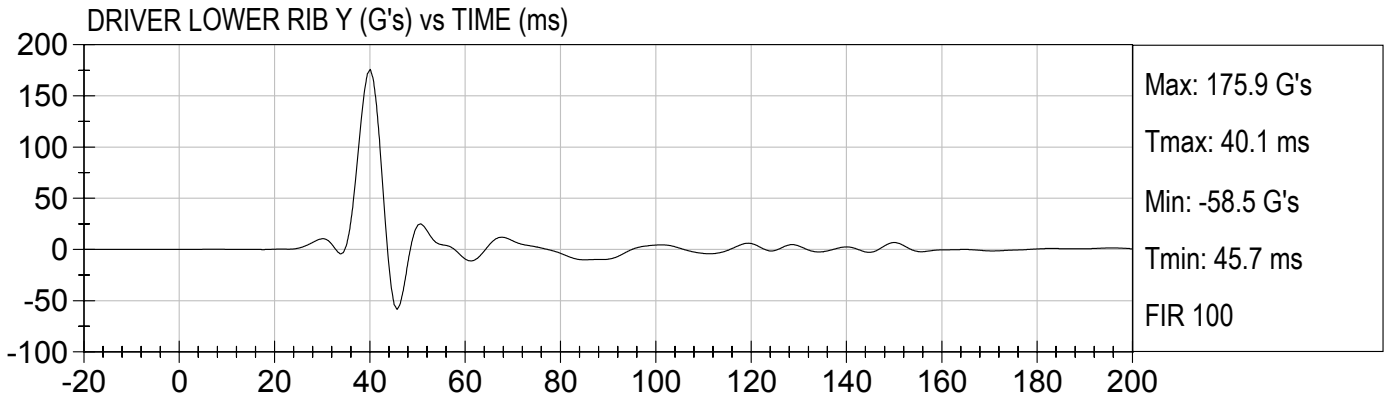

APPENDIX C

ES-2 CONFIGURATION AND PERFORMANCE VERIFICATION DATA

CERTIFICATION DATA

Dummy Serial Number: 009

Calibration Test Results Summary

Dummy Serial Number: 009

Pre-Test Calibration

Head Drop Test:	The head passed all drop test requirements.
Neck Pendulum Test:	The neck passed all impact test requirements.
Shoulder Impact Test:	The shoulder passed all impact test requirements.
Rib Tests:	All ribs passed all impact test requirements.
Abdomen Test:	The abdomen passed all impact test requirements.
Lumbar Spine Test:	The lumbar spine passed all impact test requirements.
Pelvis Test:	The pelvis passed all impact test requirements.

MGA RESEARCH CORPORATION
HEAD DROP TEST
EUROSID 2 DUMMY

Date: 10/22/02

Dummy Serial Number: 009

Test Number: D021341

TEST PARAMETER	SPECIFICATION	TEST RESULTS
Temperature (°C)	18.0 – 22.0	21.4
Relative Humidity (%)	10 – 70	31
Peak Resultant Acceleration	100 – 150 g's	138
Time of Max. Res. Acceleration	msec	2.5

TEST MEETS SPECIFICATIONS

Technician: _____

Approved By: _____



PEAK RESULTANT ACCELERATION

Test Desc.: Head Drop
Component: Dummy #009

Test Date: 10-22-02
Speed: 0.0 fps, 0.00 M/s

Ymin = .14 G'S @ -0.0084 sec., Ymax = 137.84 G'S @ 0.0025 sec.

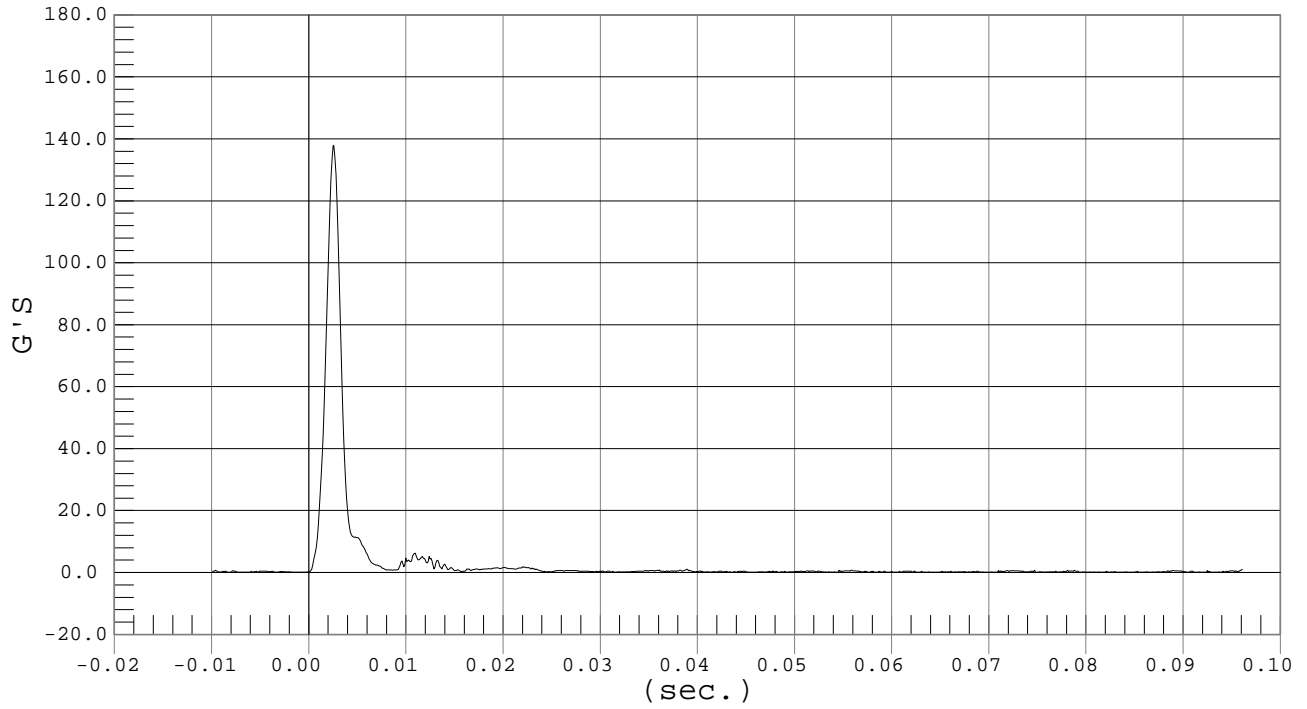

MGA RESEARCH CORPORATION
NECK PENDULUM TEST
EUROSID 2 DUMMY

Date: 10/22/02
 Dummy Serial Number: 002
 Test Number: D021342

TEST PARAMETER		SPECIFICATION	TEST RESULTS
Temperature (°C)		18.0 – 22.0	21.4
Relative Humidity (%)		10 – 70	32
Pendulum Speed		3.3 - 3.5	3.4
Pendulum Deceleration	3 msec	~1.25 - ~1.53 m/sec	-.35
	8 msec	~1.59 - ~2.04 m/sec	-1.75
	14 msec	~3.20 - ~3.85 m/sec	-3.37
Maximum Flexion Angle		49.0 – 59.0 deg	56.1
Time of Max. Flexion Angle		54.0 – 66.0 ms	58.0
Maximum Angle Theta (A)		32.0 – 37.0 deg	34.8
Time of Max. Theta (A)		53.0 – 63.0 ms	58.0
Maximum Angle Theta (B)		29.94 – 32.44 deg	31.2
Time of Max. Theta (B)		54.0 – 64.0 ms	57.7

TEST MEETS SPECIFICATIONS

Technician: _____

Approved By: _____



PENDULUM DECELERATION

Test Desc.: Neck Bending
Component: Dummy #009

Test Date: 10-22-02
Speed: 11.1 fps, 3.39 M/s

Ymin = -4.3 M/SEC @ 0.1862 SEC, Ymax = 0 M/SEC @ 0.0000 SEC

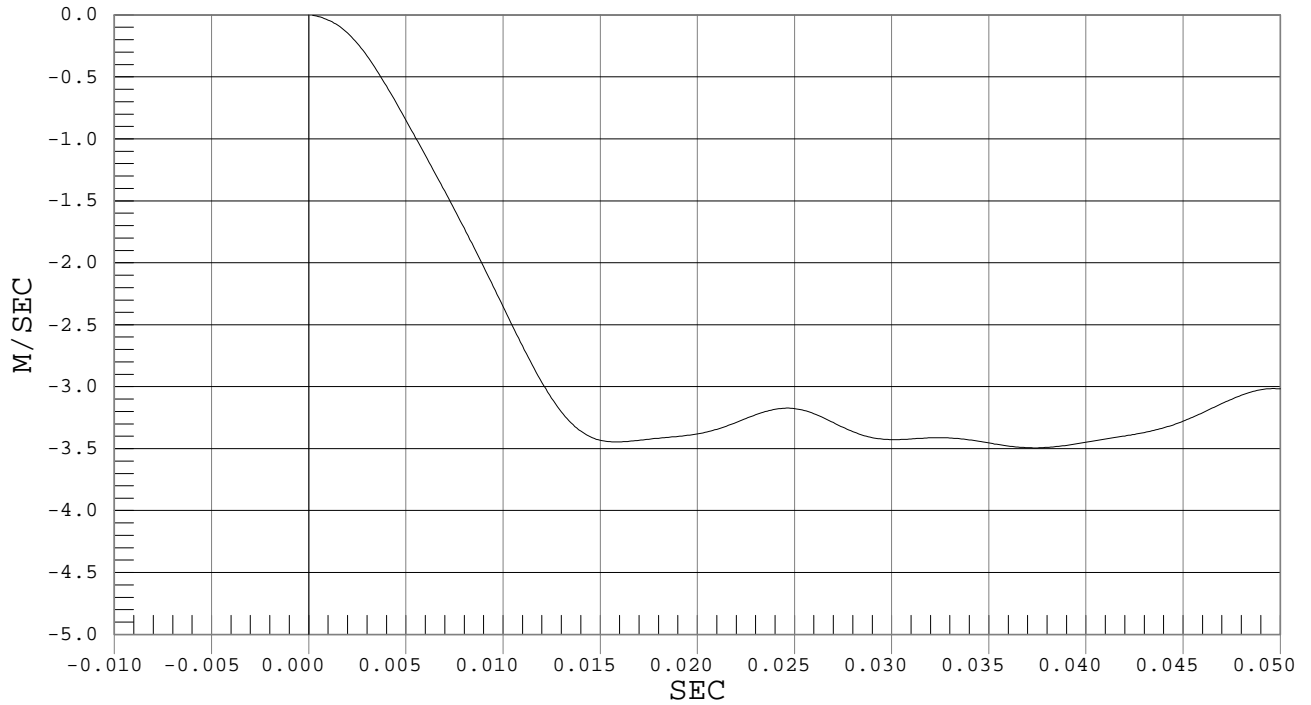

FLEXION ANGLE

Test Desc.: Neck Bending
Component: Dummy #009

Test Date: 10-22-02
Speed: 11.1 fps, 3.39 M/s

Ymin = -26.55 DEG @ 0.1640 sec., Ymax = 56.11 DEG @ 0.0580 sec.

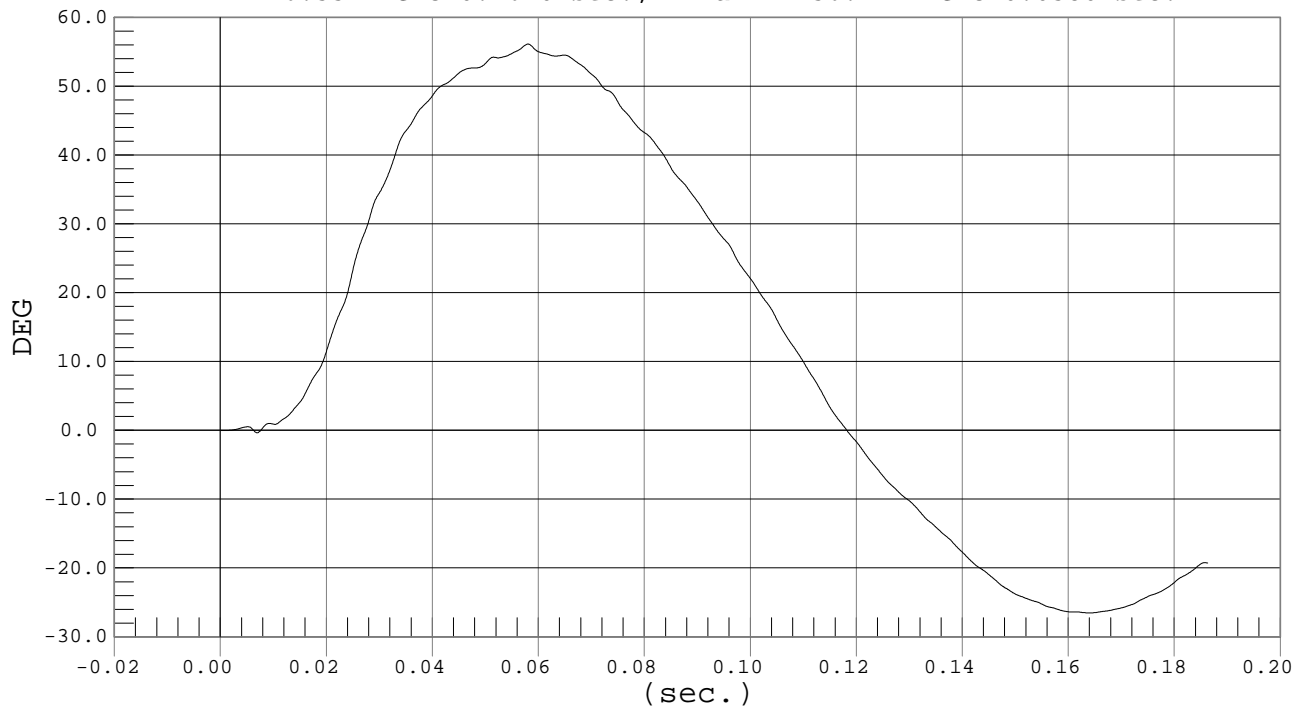



Test Desc.: Neck Bending
Component: Dummy #009

THETA A

Test Date: 10-22-02
Speed: 11.1 fps, 3.39 M/s

Ymin = -16.13 DEG @ 0.1638 sec., Ymax = 34.84 DEG @ 0.0580 sec.

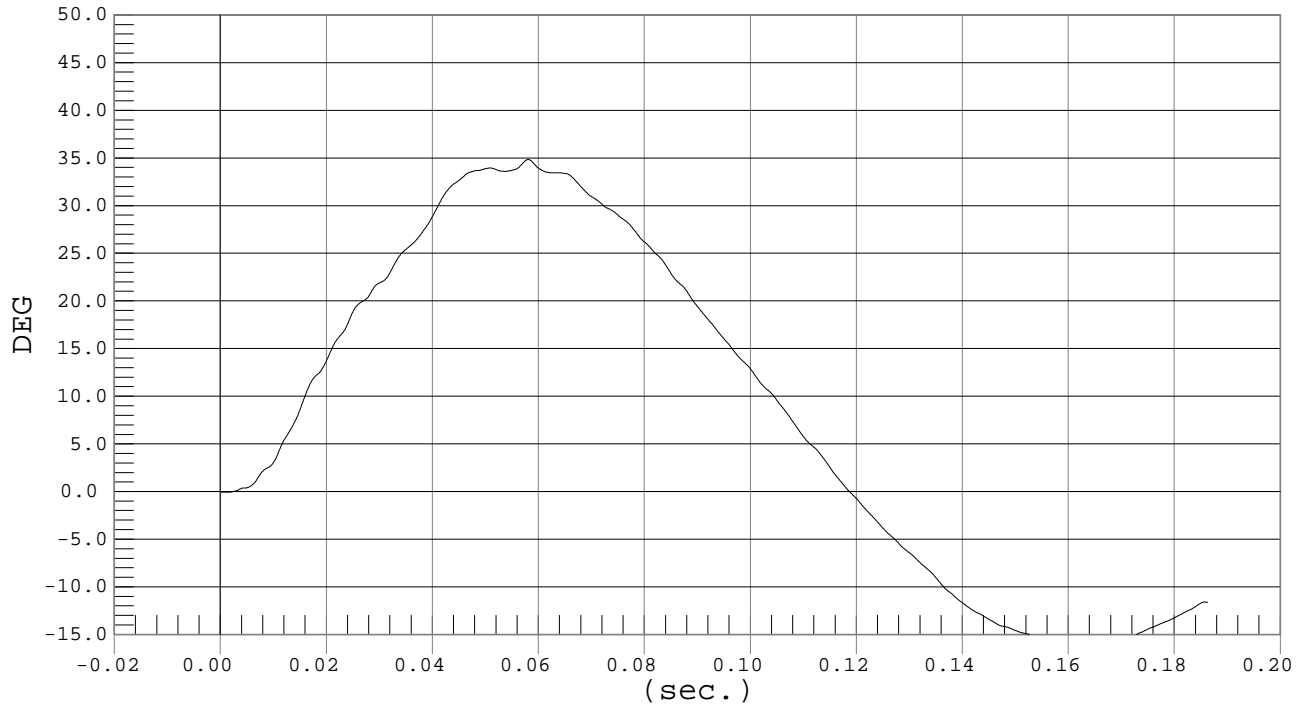

Test Desc.: Neck Bending
Component: Dummy #009

THETA B

Test Date: 10-22-02
Speed: 11.1 fps, 3.39 M/s

Ymin = -17.84 DEG @ 0.1674 sec., Ymax = 31.21 DEG @ 0.0577 sec.

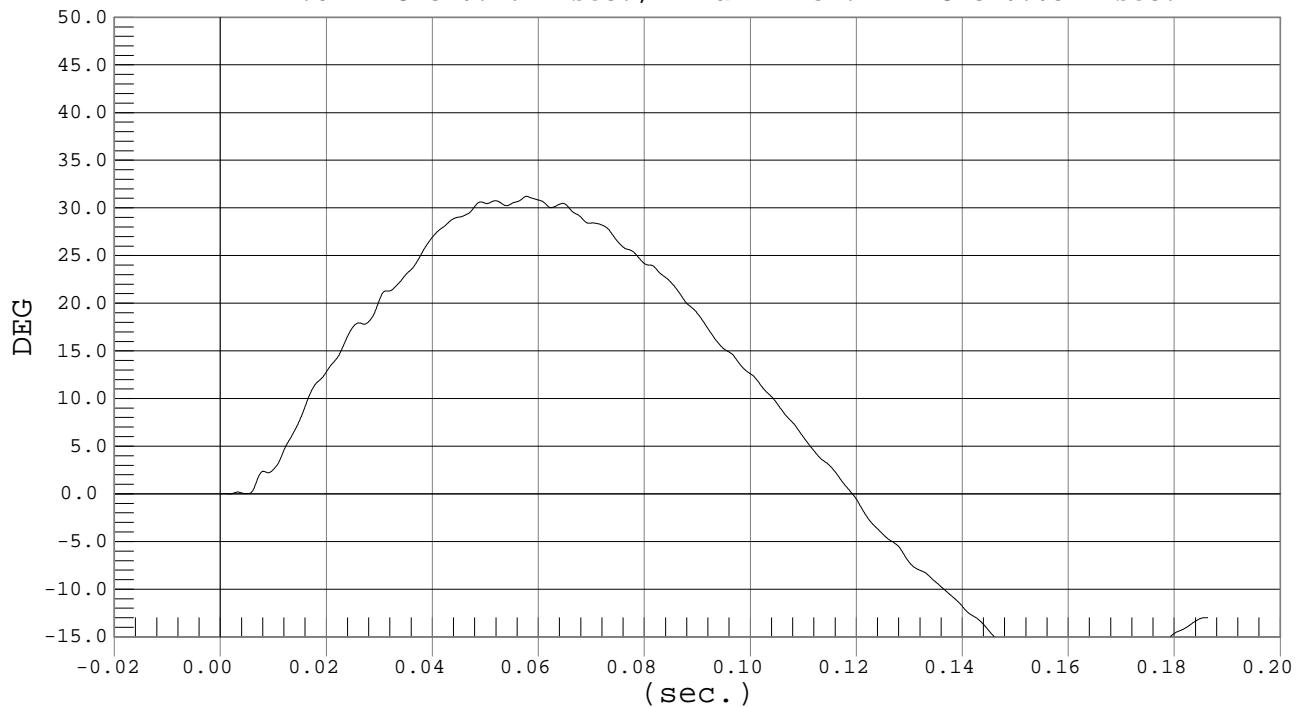

MGA RESEARCH CORPORATION
SHOULDER IMPACT TEST
EUROSID 2 DUMMY

Date: 10/22/02

Dummy Serial Number: 009

Test Number: D021343

TEST PARAMETER	SPECIFICATION	TEST RESULTS
Temperature (°C)	18.0 – 22.0	20.7
Relative Humidity (%)	10 – 70	29
Pendulum Speed	4.2 – 4.4 m/s	4.4
Max. Resultant Acceleration	7.5 – 10.5 g's	10.1
Time of Max. Pendulum Acceleration	msec	11.9

TEST MEETS SPECIFICATIONS

Technician: _____

Approved By: _____



SHOULDER ACCELERATION

Test Desc.: Shoulder Impact
Component: Dummy #009

Test Date: 10-22-02
Speed: 14.3 fps, 4.35 M/s

Ymin = -.48 G'S @ 0.1011 sec., Ymax = 10.07 G'S @ 0.0119 sec.

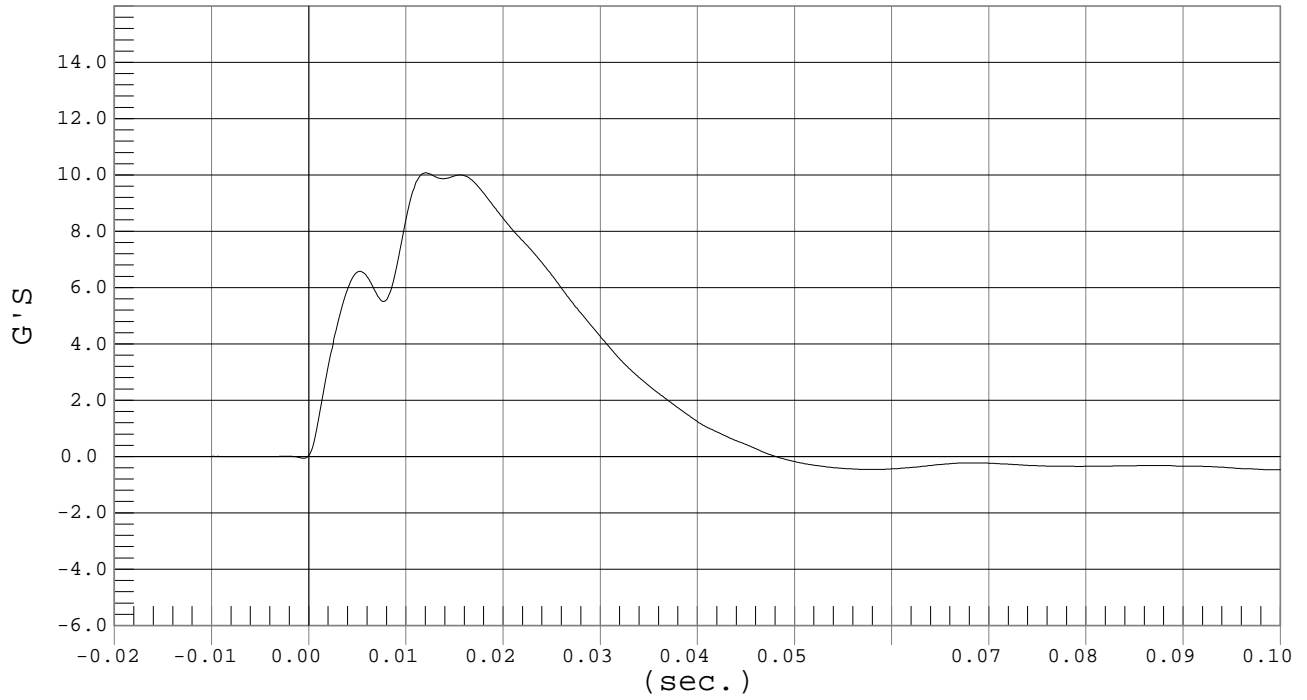

MGA RESEARCH CORPORATION
 UPPER/MIDDLE/LOWER RIB TESTS
 EUROSID 2 DUMMY

Date: 10/22/02
 Dummy Serial Number: 009
 Test Number: D021344/5/6

UPPER RIB - TEST PARAMETER	SPECIFICATION	TEST RESULTS
Temperature (°C)	18.0 – 22.0	21.4
Relative Humidity (%)	10 – 70	30
Displacement at 2 m/s	23.5 – 27.5 mm	27.0
Displacement at 3 m/s	36.0 – 40.0 mm	38.6
Displacement at 4 m/s	46.0 – 51.0 mm	50.6

MIDDLE RIB - TEST PARAMETER	SPECIFICATION	TEST RESULTS
Temperature (°C)	18.0 – 22.0	21.4
Relative Humidity (%)	10 – 70	30
Displacement at 2 m/s	23.5 – 27.5 mm	26.1
Displacement at 3 m/s	36.0 – 40.0 mm	39.8
Displacement at 4 m/s	46.0 – 51.0 mm	50.5

LOWER RIB - TEST PARAMETER	SPECIFICATION	TEST RESULTS
Temperature (°C)	18.0 – 22.0	21.4
Relative Humidity (%)	10 – 70	30
Displacement at 2 m/s	23.5 – 27.5 mm	24.2
Displacement at 3 m/s	36.0 – 40.0 mm	36.6
Displacement at 4 m/s	46.0 – 51.0 mm	48.0

TEST MEETS SPECIFICATIONS

Technician: _____

Approved By: _____



UPPER RIB DISPLACEMENT

Test Desc.: Rib Module
Component: Dummy #009

Test Date: 10-22-02
Speed: 6.6 fps, 2.00 M/s

Ymin = -4.81 mm @ 0.0854 sec., Ymax = 27 mm @ 0.0454 sec.

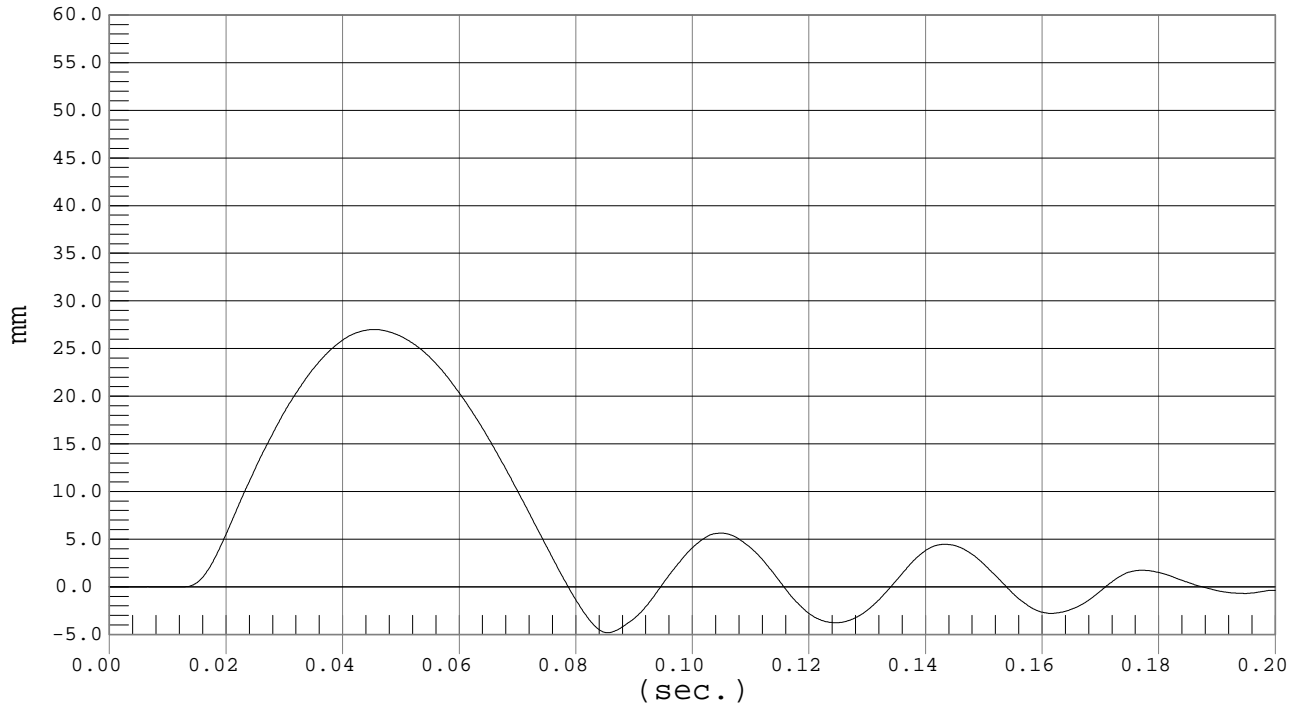

UPPER RIB DISPLACEMENT

Test Desc.: Rib Module
Component: Dummy #009

Test Date: 10-22-02
Speed: 9.8 fps, 3.00 M/s

Ymin = -5.85 mm @ 0.0822 sec., Ymax = 38.56 mm @ 0.0459 sec.

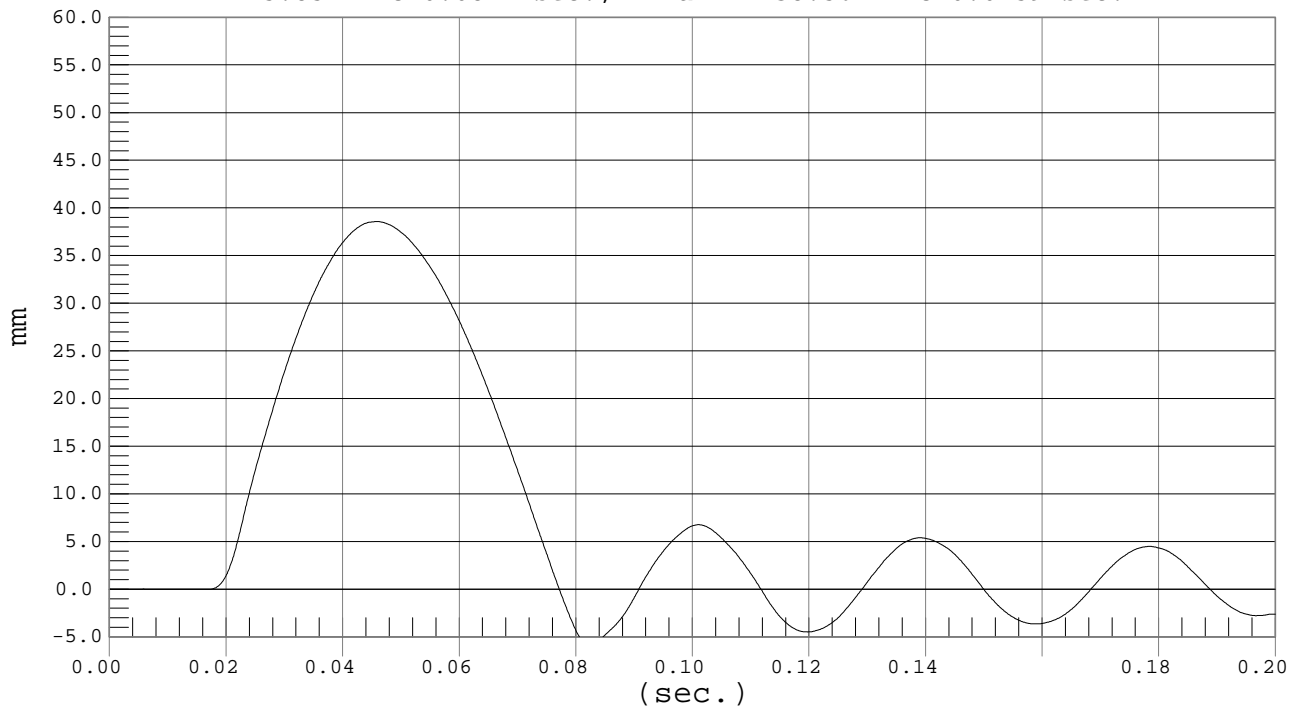



Test Desc.: Rib Module
Component: Dummy #009

UPPER RIB DISPLACEMENT

Test Date: 10-22-02
Speed: 13.1 fps, 4.00 M/s

Ymin = -6.33 mm @ 0.0712 sec., Ymax = 50.55 mm @ 0.0363 sec.

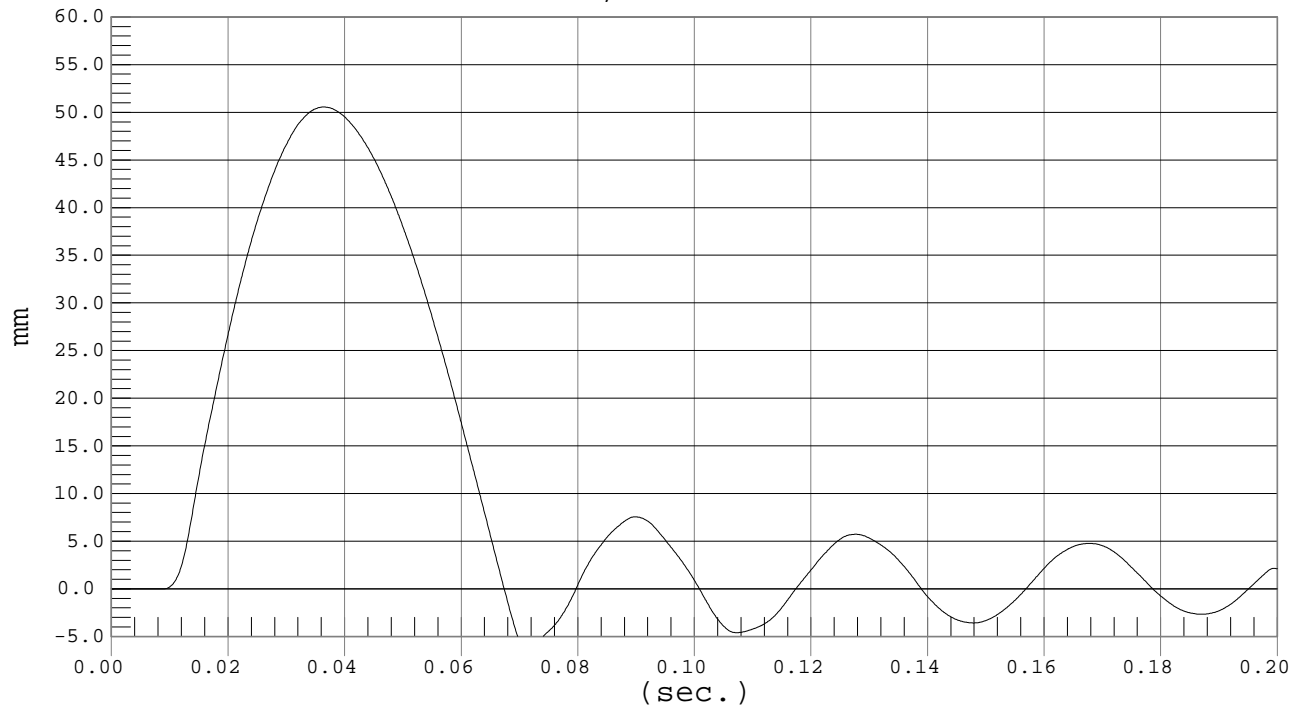



MIDDLE RIB DISPLACEMENT

Test Desc.: Rib Module
Component: Dummy #009

Test Date: 10-22-02
Speed: 6.6 fps, 2.00 M/s

Ymin = -4.56 mm @ 0.0808 sec., Ymax = 26.13 mm @ 0.0414 sec.

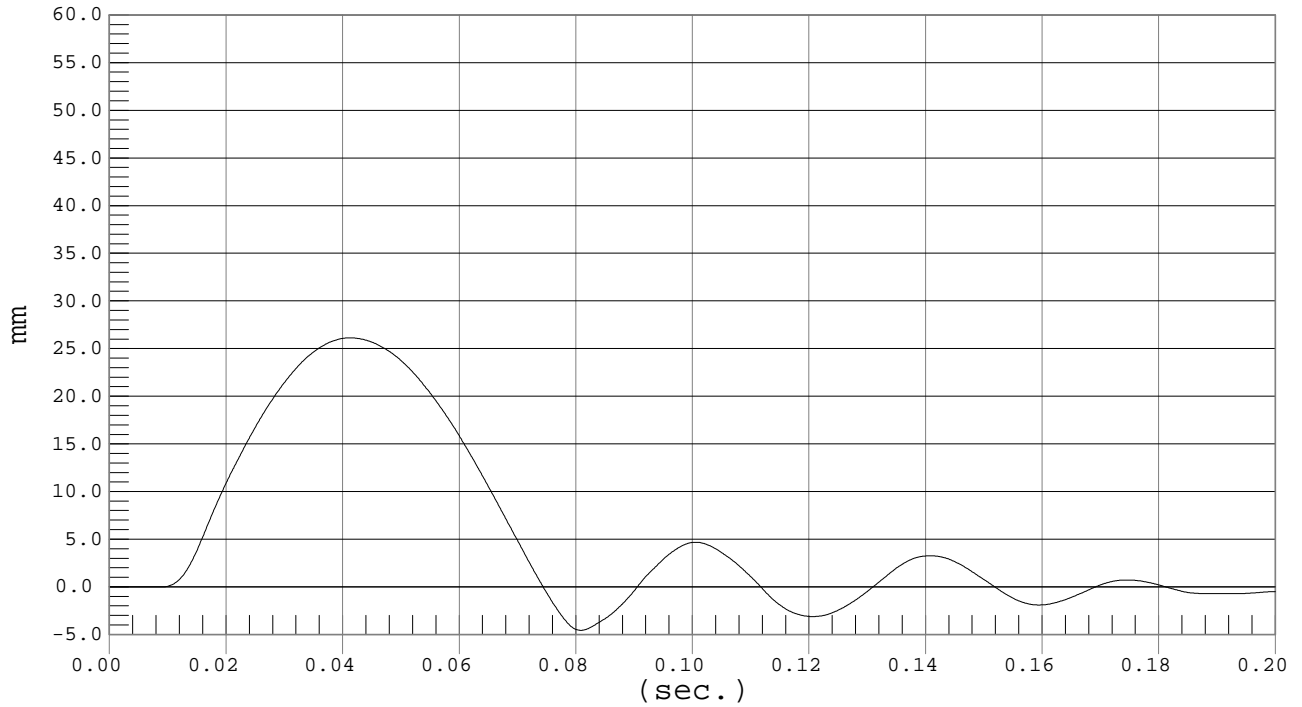

MIDDLE RIB DISPLACEMENT

Test Desc.: Rib Module
Component: Dummy #009

Test Date: 10-22-02
Speed: 9.8 fps, 3.00 M/s

Ymin = -5.5 mm @ 0.0765 sec., Ymax = 39.84 mm @ 0.0404 sec.

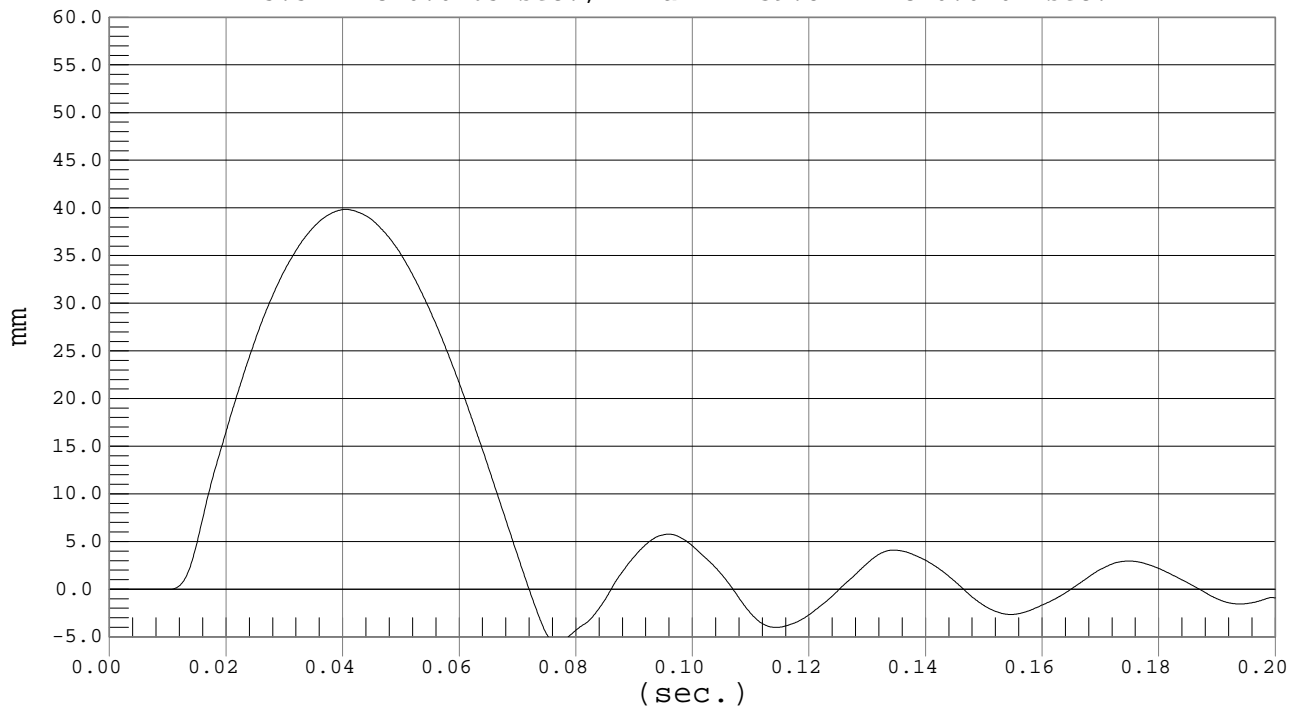



MIDDLE RIB DISPLACEMENT

Test Desc.: Rib Module
Component: Dummy #009

Test Date: 10-22-02
Speed: 13.1 fps, 4.00 M/s

Ymin = -5.45 mm @ 0.0712 sec., Ymax = 50.5 mm @ 0.0366 sec.

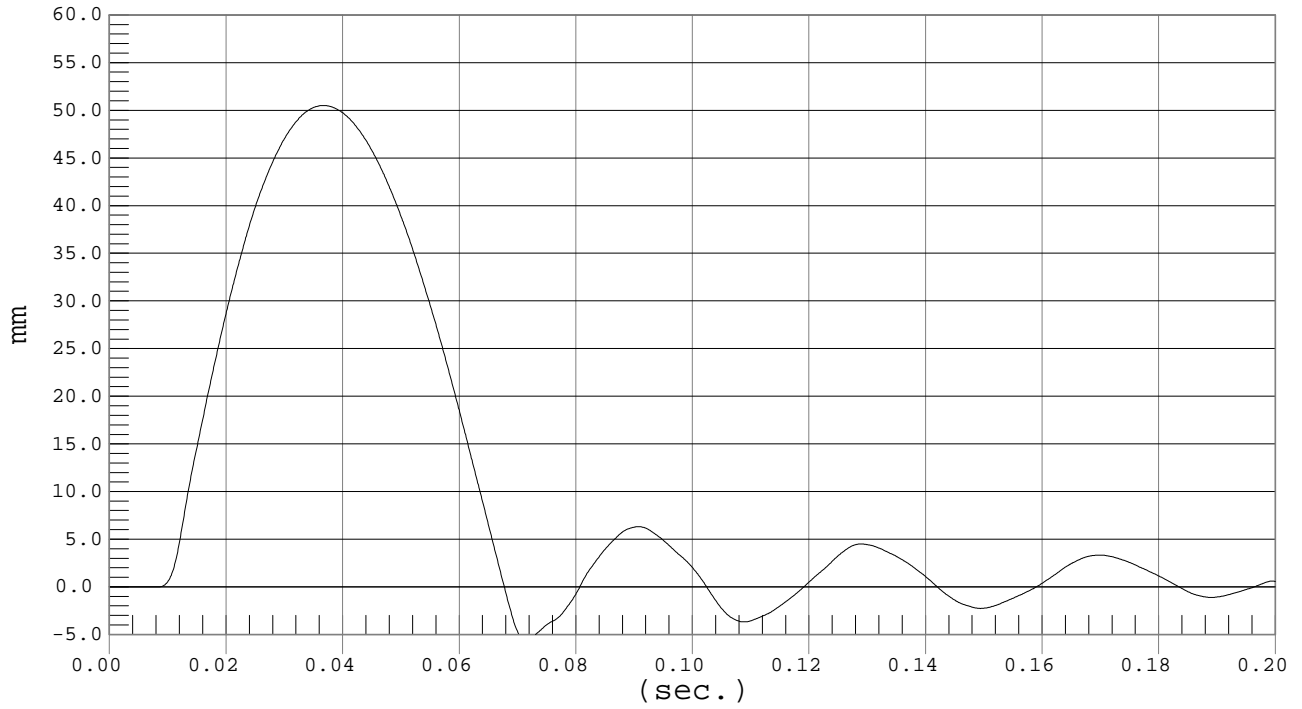



LOWER RIB DISPLACEMENT

Test Desc.: Rib Module
Component: Dummy #009

Test Date: 10-22-02
Speed: 6.6 fps, 2.00 M/s

Ymin = -5.36 mm @ 0.0776 sec., Ymax = 24.19 mm @ 0.0400 sec.

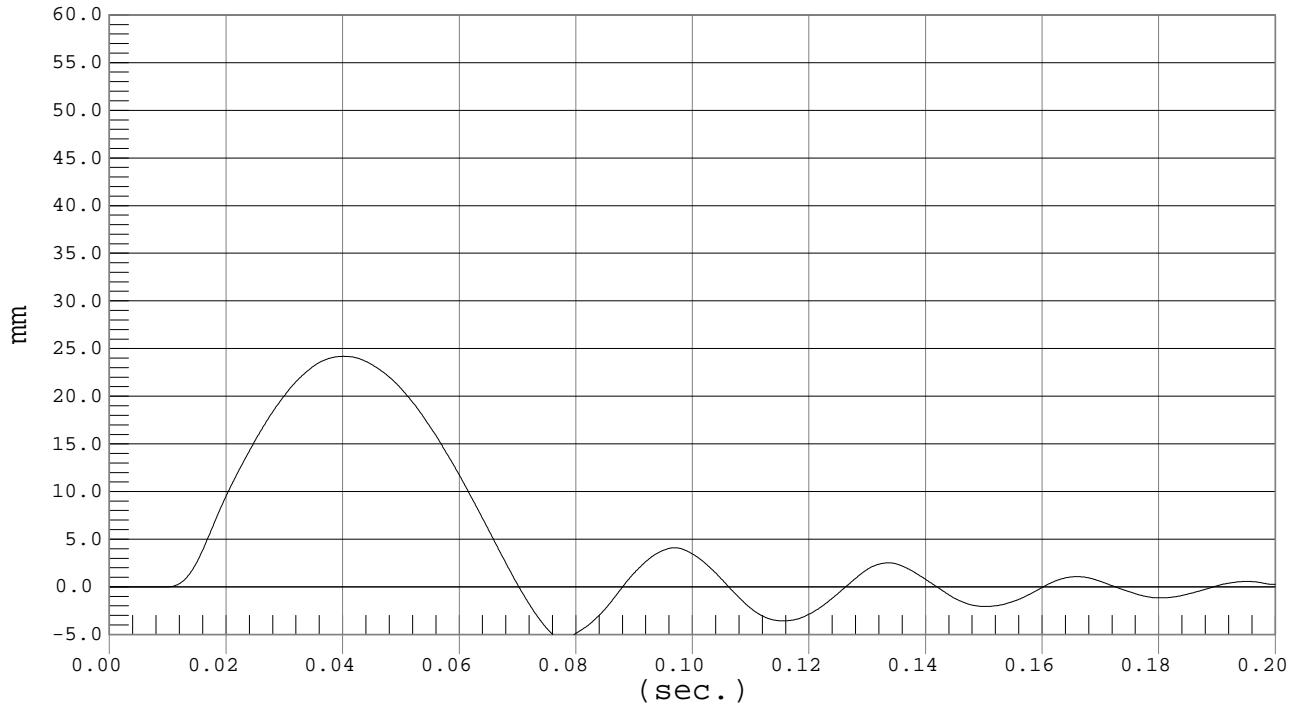

LOWER RIB DISPLACEMENT

Test Desc.: Rib Module
Component: Dummy #009

Test Date: 10-22-02
Speed: 9.8 fps, 3.00 M/s

Ymin = -6.44 mm @ 0.0754 sec., Ymax = 36.56 mm @ 0.0415 sec.

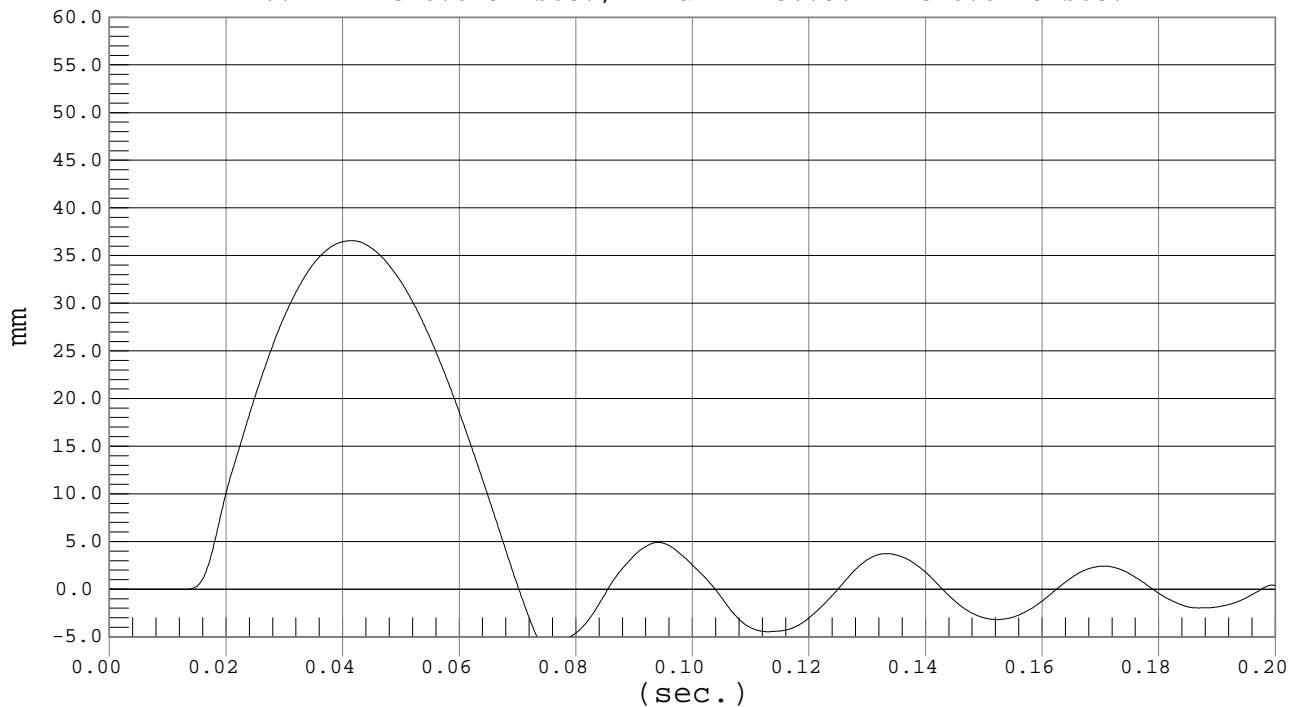



LOWER RIB DISPLACEMENT

Test Desc.: Rib Module
Component: Dummy #009

Test Date: 10-22-02
Speed: 13.1 fps, 4.00 M/s

Ymin = -6.84 mm @ 0.0735 sec., Ymax = 48.09 mm @ 0.0408 sec.

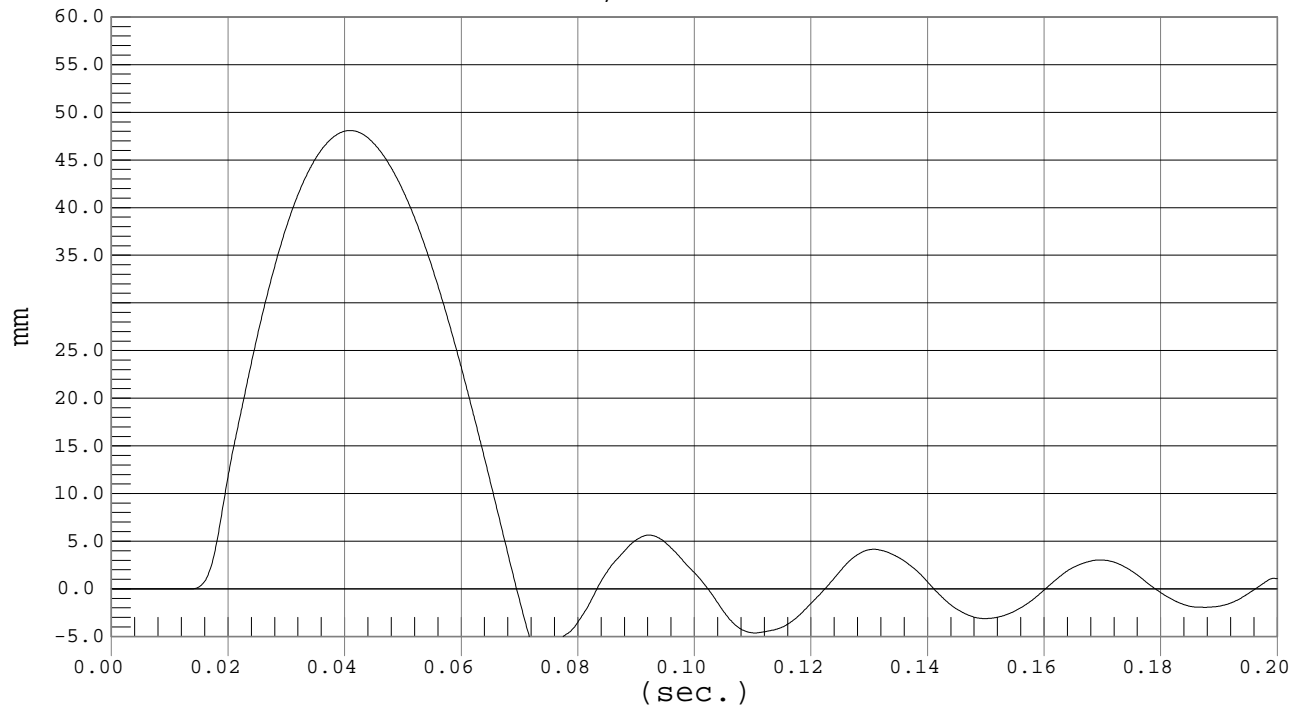

MGA RESEARCH CORPORATION
ABDOMEN TEST
EUROSID 2 DUMMY

Date: 10/22/02

Dummy Serial Number: 009

Test Number: D021347

TEST PARAMETER	SPECIFICATION	TEST RESULTS
Temperature (°C)	18.0 – 22.0	221.1
Relative Humidity (%)	10 – 70	30
Probe Speed (m/s)	3.90 – 4.10	4.01
Maximum Impact Force	4.00 – 4.80 kN	4.55
Time of Maximum Force	10.60 – 13.00 ms	10.70
Maximum Total Abdomen Force	2.20 – 2.70 kN	2.36
Time of Max. Total Force	10.00 – 12.30 ms	10.70

TEST MEETS SPECIFICATIONS

Technician: _____

Approved By: _____

MGA RESEARCH CORPORATION
LUMBAR SPINE TEST
EUROSID 2 DUMMY

Date: 10/22/02
 Dummy Serial Number: 009
 Test Number: D021348

TEST PARAMETER		SPECIFICATION	TEST RESULTS
Temperature (°C)		18.0 – 22.0	21.4
Relative Humidity (%)		10 – 70	31
Pendulum Speed		5.95 – 6.15	6.09
Pendulum Deceleration	10 msec	$\bar{2}.46 - \bar{1}.59$ m/sec	-1.91
	20 msec	$\bar{5}.25 - \bar{4}.07$ m/sec	-4.42
	25 msec	$\bar{6}.64 - \bar{5}.30$ m/sec	-5.59
	30 msec	≥ -6.5 m/sec	-6.17
Maximum Flexion Angle		45.0 – 55.0 deg	47.4
Time of Max. Flexion Angle		39.0 – 53.0 ms	44.1
Maximum Angle Theta (A)		31.0 – 35.0 deg	31.4
Time of Max. Theta (A)		44.0 – 52.0 ms	44.2
Maximum Angle Theta (B)		27.18– 29.68 deg	27.47
Time of Max. Theta (B)		44.0 – 52.0 ms	45.3

TEST MEETS SPECIFICATIONS

Technician: _____

Approved By: _____



PENDULUM DECELERATION

Test Desc.: Lumbar Flexion
Component: Dummy #009

Test Date: 10-22-02
Speed: 20.0 fps, 6.09 M/s

Ymin = -7.45 M/SEC @ 0.1368 SEC, Ymax = 0 M/SEC @ 0.0000 SEC

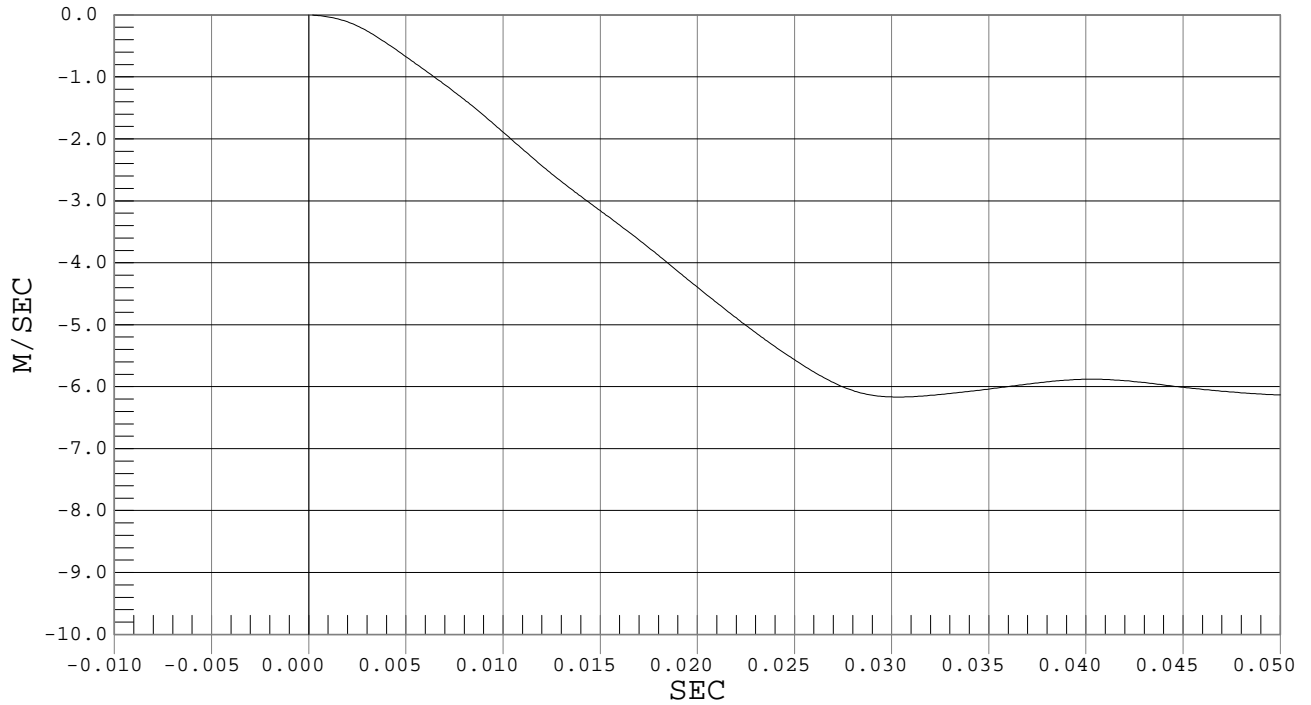

FLEXION ANGLE

Test Desc.: Lumbar Flexion
Component: Dummy #009

Test Date: 10-22-02
Speed: 20.0 fps, 6.09 M/s

Ymin = -14.94 DEG @ 0.1118 sec., Ymax = 47.39 DEG @ 0.0441 sec.

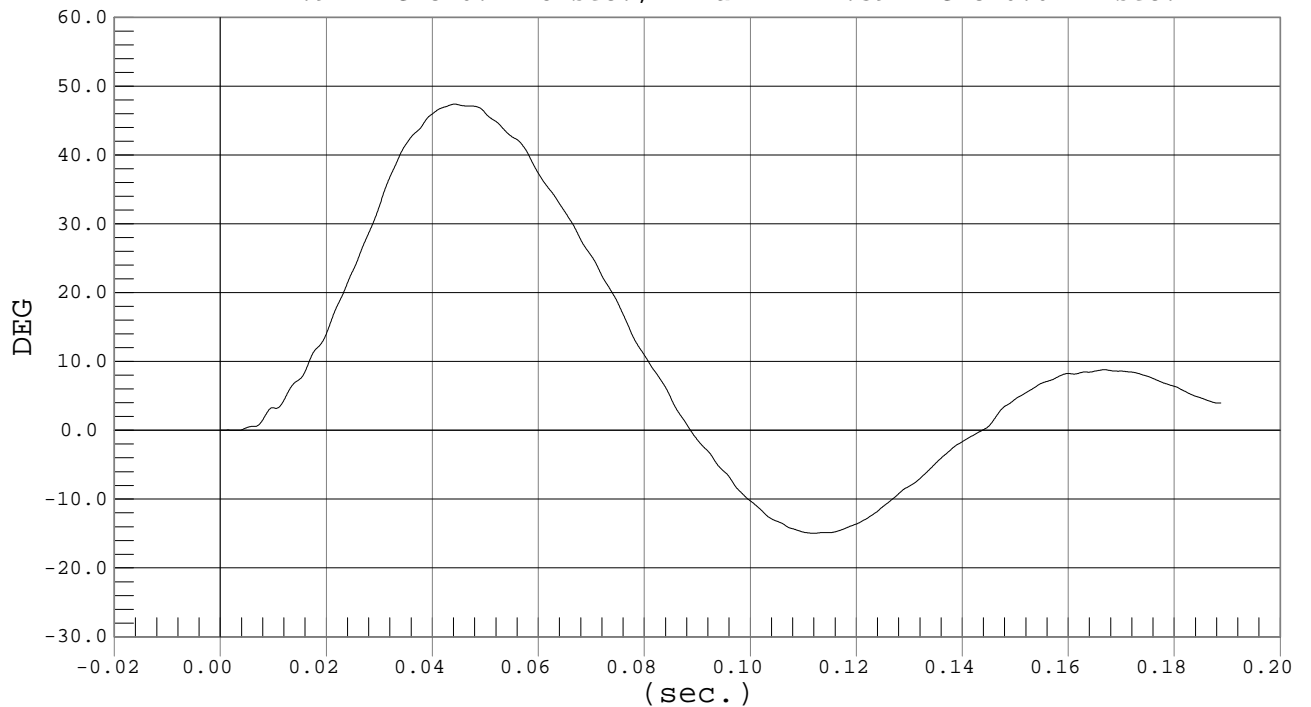



Test Desc.: Lumbar Flexion
Component: Dummy #009

THETA A

Test Date: 10-22-02
Speed: 20.0 fps, 6.09 M/s

Ymin = -9.77 DEG @ 0.1123 sec., Ymax = 31.36 DEG @ 0.0442 sec.

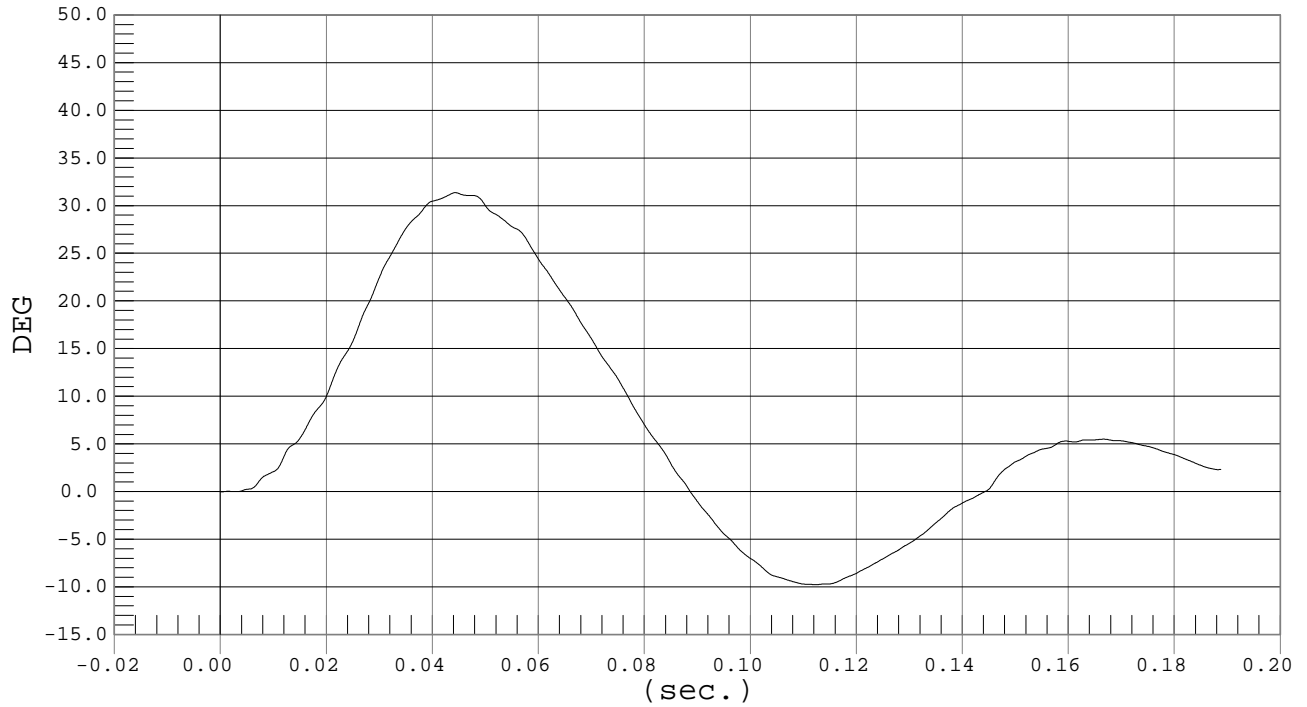

Test Desc.: Lumbar Flexion
Component: Dummy #009

THETA B

Test Date: 10-22-02
Speed: 20.0 fps, 6.09 M/s

Ymin = -10.52 DEG @ 0.1117 sec., Ymax = 27.47 DEG @ 0.0453 sec.

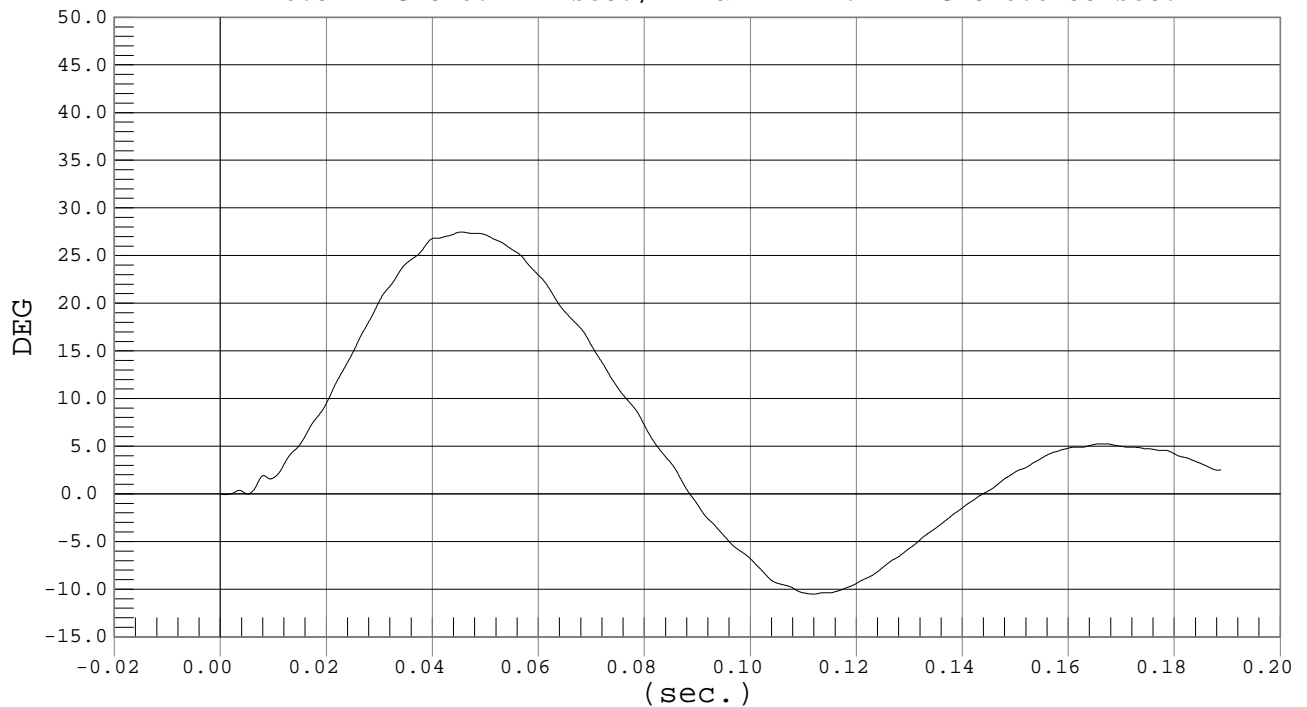

MGA RESEARCH CORPORATION
PELVIS TEST
EUROSID 2 DUMMY

Date: 10/22/02

Dummy Serial Number: 009

Test Number: D021349

TEST PARAMETER	SPECIFICATION	TEST RESULTS
Temperature (°C)	18.0 – 22.0	20.8
Relative Humidity (%)	10 – 70	31
Pendulum Speed	4.20 – 4.40 m/s	4.34
Maximum Impactor Force	4.40 – 5.40 kN	4.88
Time of Max. Impactor Force	10.30 – 15.50 ms	15.10
Maximum Pubic Force	1.04 – 1.64 kN	1.38
Time of Max. Pubic Force	9.90 – 15.90 ms	15.60

TEST MEETS SPECIFICATIONS

Technician: _____

Approved By: _____



IMPACTOR FORCE

Test Desc.: Pelvis Impact
Component: Dummy #009

Test Date: 10-22-02
Speed: 14.2 fps, 4.34 M/s

Ymin = 0 kN @ 0.0776 sec., Ymax = 4.88 kN @ 0.0151 sec.

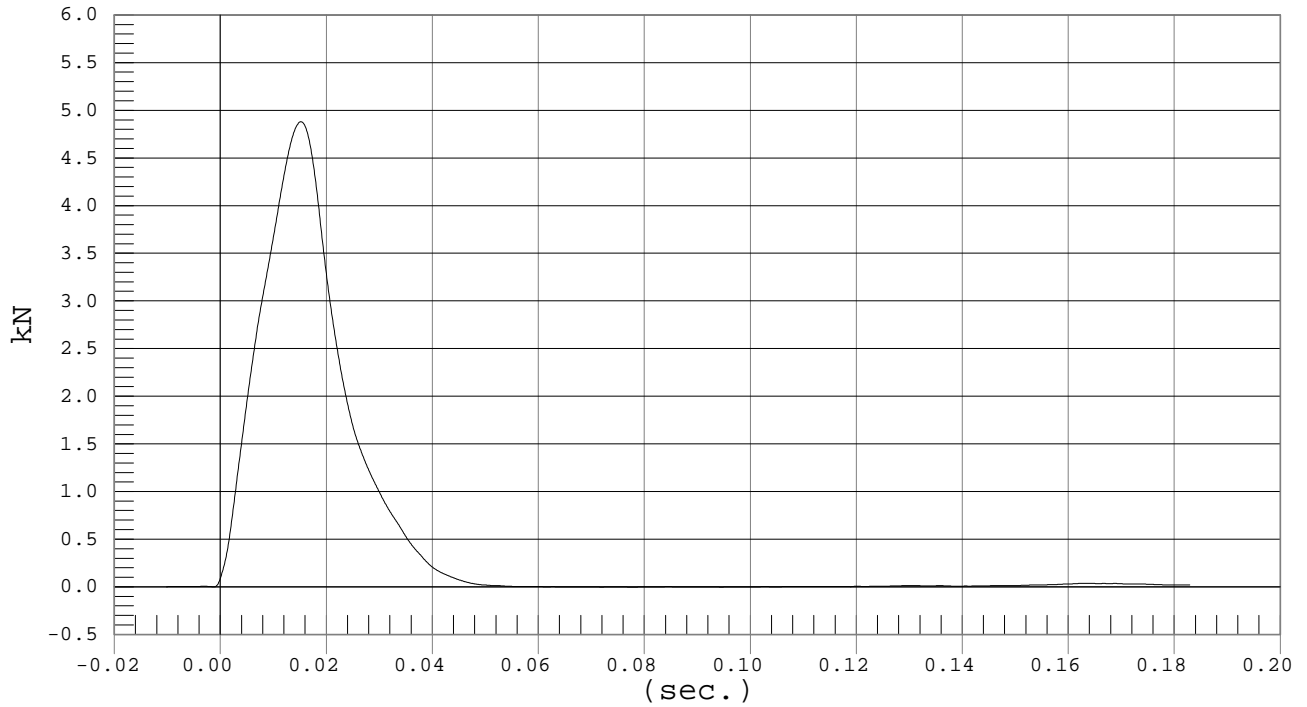

PUBIC FORCE

Test Desc.: Pelvis Impact
Component: Dummy #009

Test Date: 10-22-02
Speed: 14.2 fps, 4.34 M/s

Ymin = -.06 G's @ 0.0459 sec., Ymax = 1.38 G's @ 0.0156 sec.

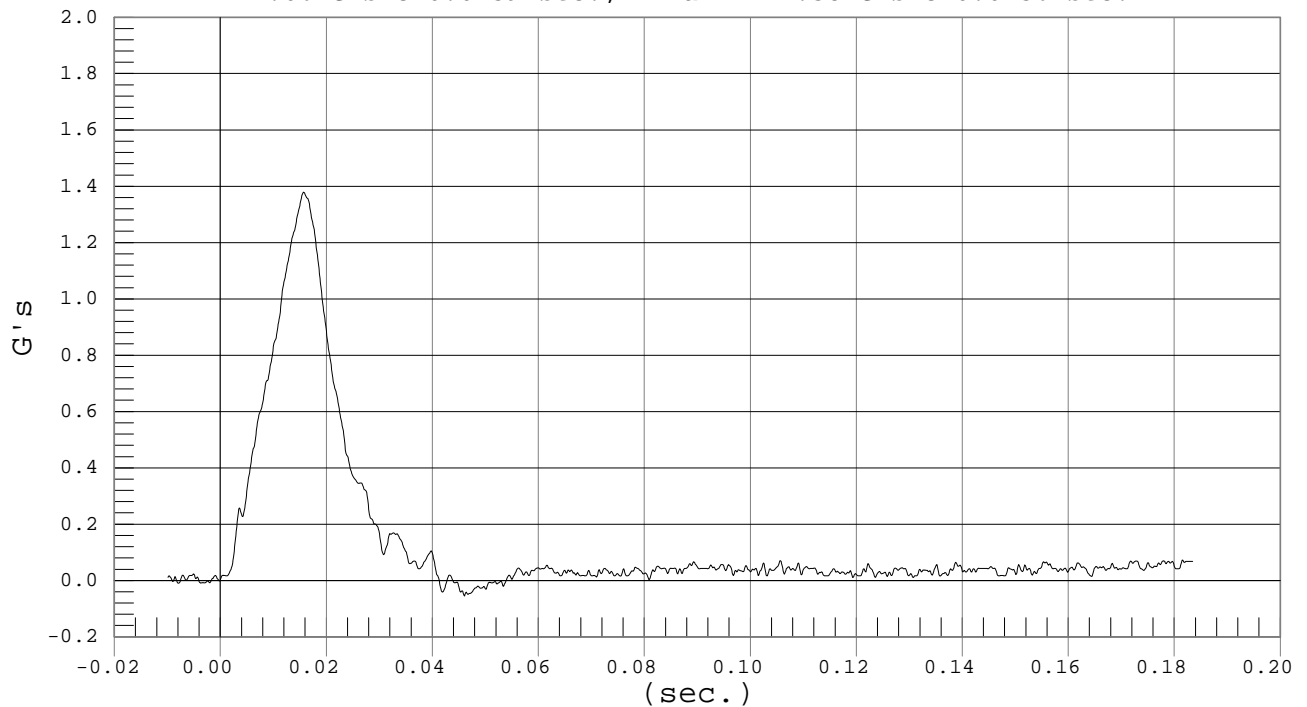

CERTIFICATION DATA

Dummy Serial Number: 009

Calibration Test Results Summary

Dummy Serial Number: 009

Pre-Test Calibration

Head Drop Test:	The head passed all drop test requirements.
Neck Pendulum Test:	The neck passed all impact test requirements.
Shoulder Impact Test:	The shoulder passed all impact test requirements.
Rib Tests:	All ribs passed all impact test requirements.
Abdomen Test:	The abdomen passed all impact test requirements.
Lumbar Spine Test:	The lumbar spine passed all impact test requirements.
Pelvis Test:	The pelvis passed all impact test requirements.

MGA RESEARCH CORPORATION
HEAD DROP TEST
EUROSID 2 DUMMY

Date: 11/4/02
Dummy Serial Number: 009
Test Number: D021421

TEST PARAMETER	SPECIFICATION	TEST RESULTS
Temperature (°C)	18.0 – 22.0	21.9
Relative Humidity (%)	10 – 70	27
Peak Resultant Acceleration	100 – 150 g's	147
Time of Max. Res. Acceleration	msec	2.4

TEST MEETS SPECIFICATIONS

Technician: _____

Approved By: _____



PEAK RESULTANT ACCELERATION

Test Desc.: Head Drop
Component: Dummy #009

Test Date: 11-04-02
Speed: 0.0 fps, 0.00 M/s

Ymin = .04 G'S @ -0.0087 sec., Ymax = 147.3 G'S @ 0.0024 sec.

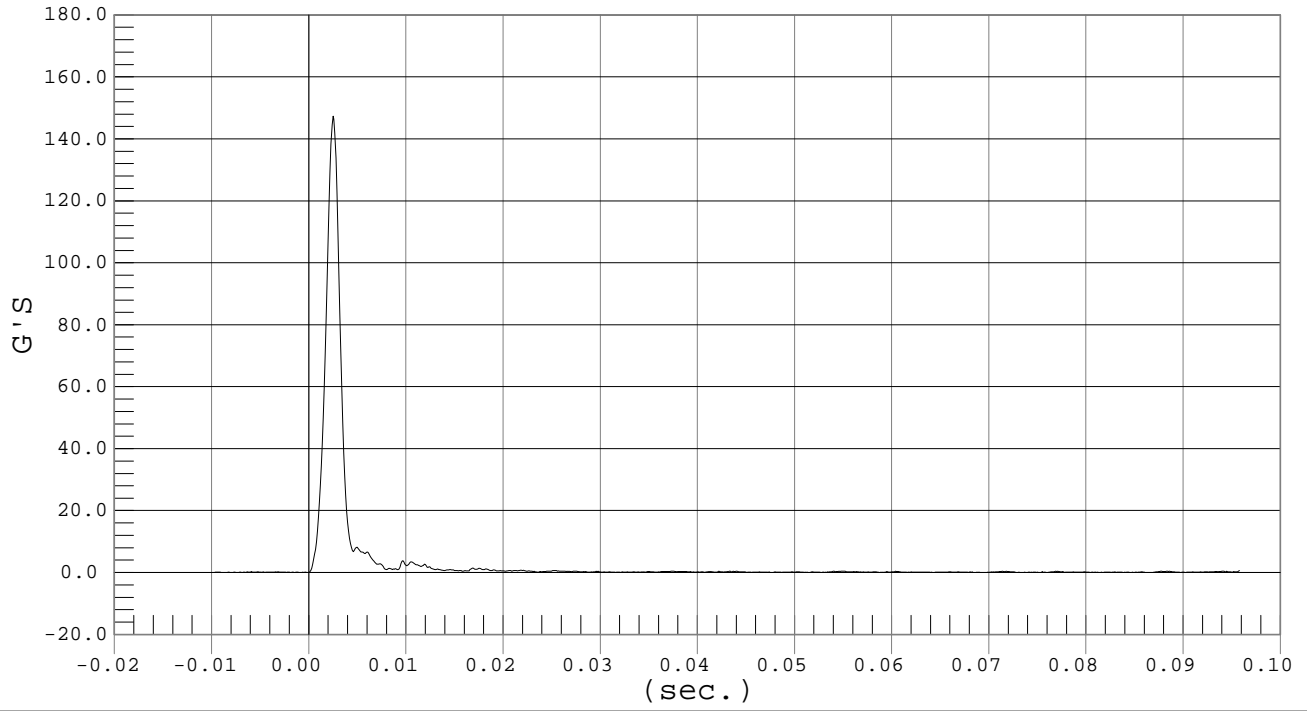

MGA RESEARCH CORPORATION
NECK PENDULUM TEST
EUROSID 2 DUMMY

Date: 11/4/02
 Dummy Serial Number: 009
 Test Number: D021422

TEST PARAMETER		SPECIFICATION	TEST RESULTS
Temperature (°C)		18.0 – 22.0	21.3
Relative Humidity (%)		10 – 70	29
Pendulum Speed		3.3 - 3.5	3.3
Pendulum Deceleration	3 msec	~1.25 - ~1.53 m/sec	-.36
	8 msec	~1.59 - ~2.04 m/sec	-1.85
	14 msec	~3.20 - ~3.85 m/sec	-3.46
Maximum Flexion Angle		49.0 – 59.0 deg	56.0
Time of Max. Flexion Angle		54.0 – 66.0 ms	56.9
Maximum Angle Theta (A)		32.0 – 37.0 deg	34.9
Time of Max. Theta (A)		53.0 – 63.0 ms	56.7
Maximum Angle Theta (B)		30.02 – 32.51 deg	31.7
Time of Max. Theta (B)		54.0 – 64.0 ms	56.7

TEST MEETS SPECIFICATIONS

Technician: _____

Approved By: _____



PENDULUM DECELERATION

Test Desc.: Neck Bending
Component: Dummy #009

Test Date: 11-04-02
Speed: 11.0 fps, 3.34 M/s

Ymin = -4.51 M/SEC @ 0.1890 SEC, Ymax = 0 M/SEC @ 0.0000 SEC

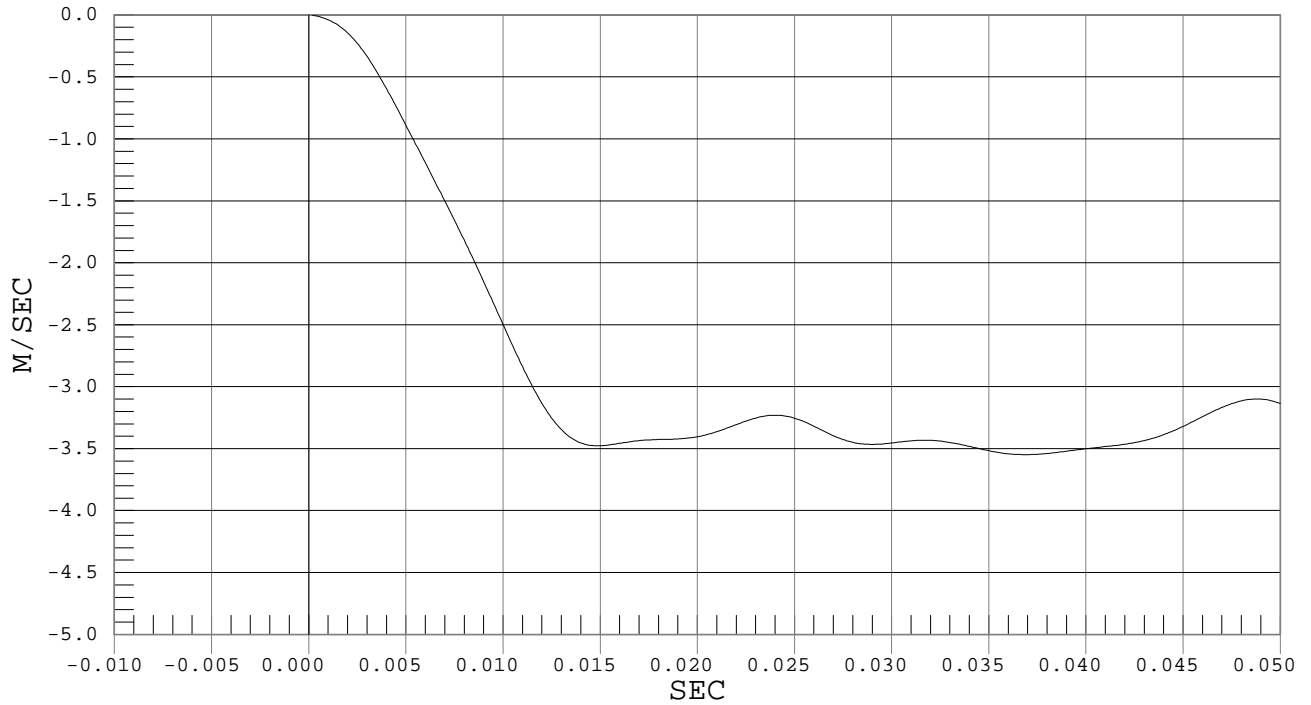

FLEXION ANGLE

Test Desc.: Neck Bending
Component: Dummy #009

Test Date: 11-04-02
Speed: 11.0 fps, 3.34 M/s

Ymin = -26.41 DEG @ 0.1623 sec., Ymax = 55.97 DEG @ 0.0569 sec.

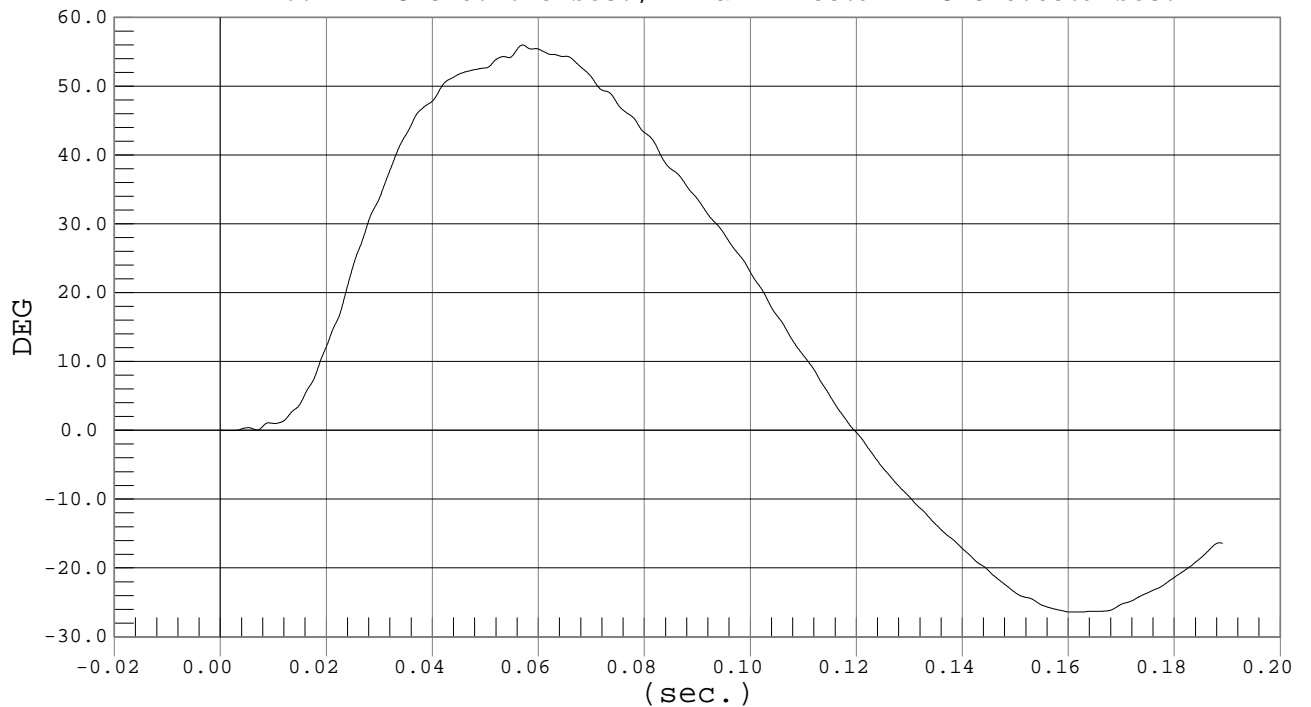



Test Desc.: Neck Bending
Component: Dummy #009

THETA A

Test Date: 11-04-02
Speed: 11.0 fps, 3.34 M/s

Ymin = -16.65 DEG @ 0.1623 sec., Ymax = 34.93 DEG @ 0.0567 sec.

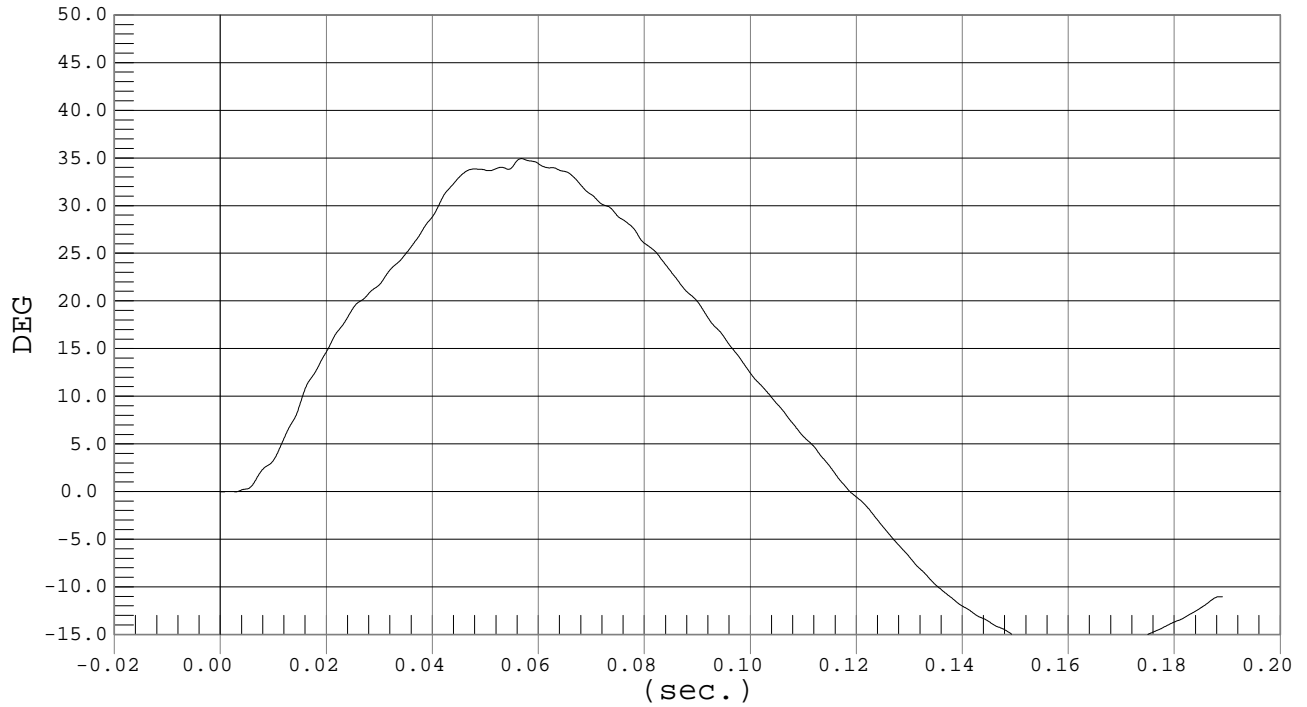

Test Desc.: Neck Bending
Component: Dummy #009

THETA B

Test Date: 11-04-02
Speed: 11.0 fps, 3.34 M/s

Ymin = -18.3 DEG @ 0.1651 sec., Ymax = 31.67 DEG @ 0.0567 sec.

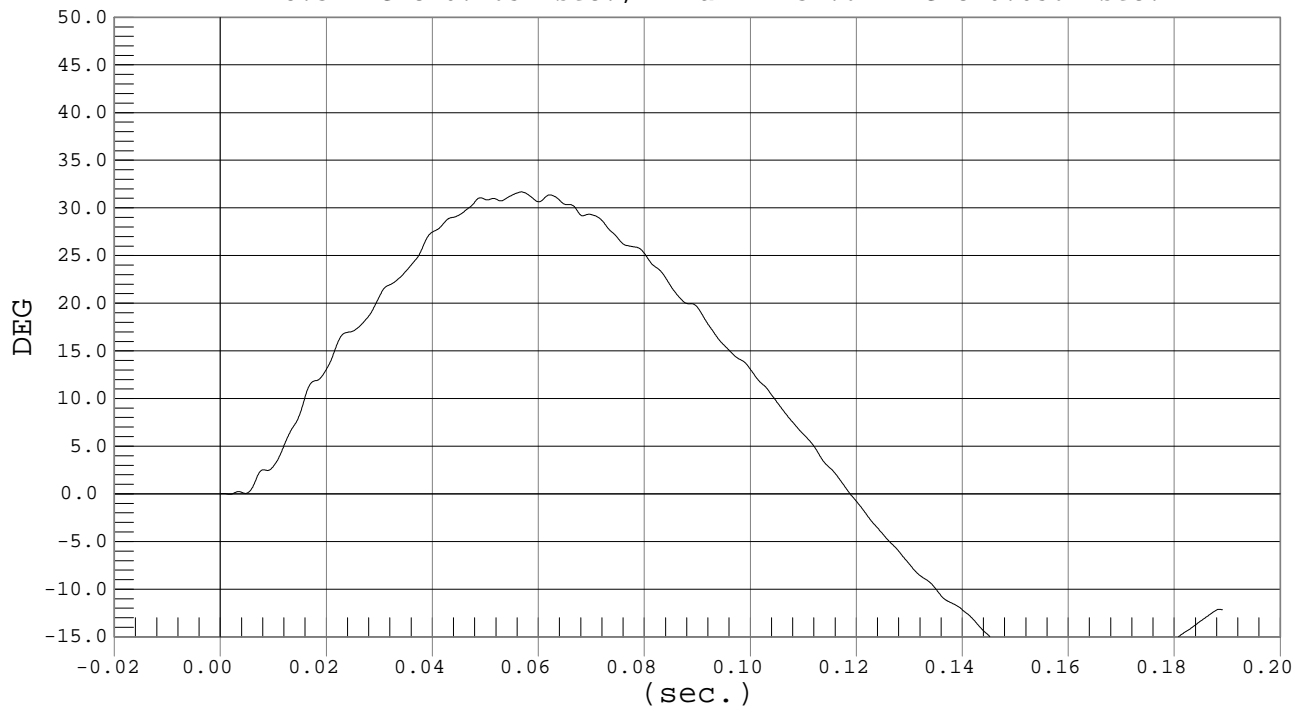

MGA RESEARCH CORPORATION
SHOULDER IMPACT TEST
EUROSID 2 DUMMY

Date: 11/4/02
Dummy Serial Number: 009
Test Number: D021423

TEST PARAMETER	SPECIFICATION	TEST RESULTS
Temperature (°C)	18.0 – 22.0	21.8
Relative Humidity (%)	10 – 70	27
Pendulum Speed	4.2 – 4.4 m/s	4.3
Max. Resultant Acceleration	7.5 – 10.5 g's	9.4
Time of Max. Pendulum Acceleration	msec	11.6

TEST MEETS SPECIFICATIONS

Technician: _____

Approved By: _____



SHOULDER ACCELERATION

Test Desc.: Shoulder Impact
Component: Dummy #009

Test Date: 11-04-02
Speed: 14.2 fps, 4.34 M/s

Ymin = -.58 G'S @ 0.0571 sec., Ymax = 9.42 G'S @ 0.0116 sec.

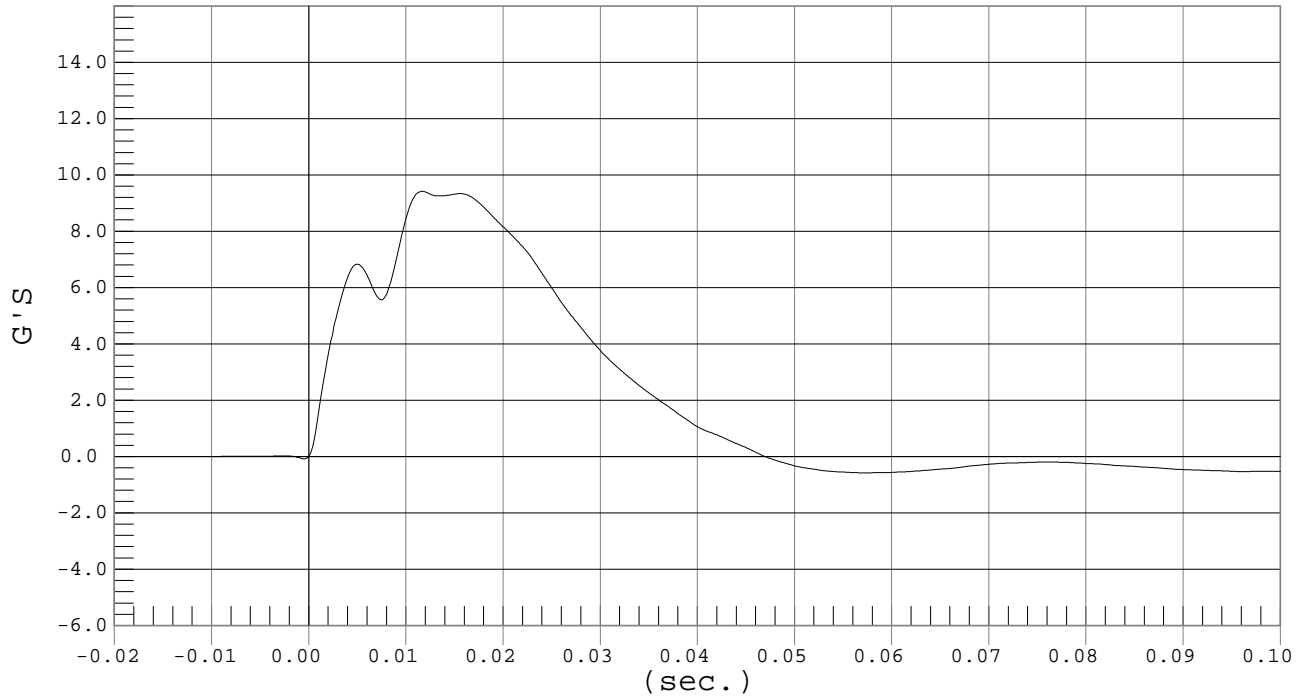

MGA RESEARCH CORPORATION
 UPPER/MIDDLE/LOWER RIB TESTS
 EUROSID 2 DUMMY

Date: 11/5/02
 Dummy Serial Number: 009
 Test Number: D021424/5/6

UPPER RIB - TEST PARAMETER	SPECIFICATION	TEST RESULTS
Temperature (°C)	18.0 – 22.0	21.3
Relative Humidity (%)	10 – 70	31
Displacement at 2 m/s	23.5 – 27.5 mm	27.0
Displacement at 3 m/s	36.0 – 40.0 mm	37.7
Displacement at 4 m/s	46.0 – 51.0 mm	49.5

MIDDLE RIB - TEST PARAMETER	SPECIFICATION	TEST RESULTS
Temperature (°C)	18.0 – 22.0	21.3
Relative Humidity (%)	10 – 70	31
Displacement at 2 m/s	23.5 – 27.5 mm	26.4
Displacement at 3 m/s	36.0 – 40.0 mm	39.6
Displacement at 4 m/s	46.0 – 51.0 mm	50.5

LOWER RIB - TEST PARAMETER	SPECIFICATION	TEST RESULTS
Temperature (°C)	18.0 – 22.0	21.3
Relative Humidity (%)	10 – 70	31
Displacement at 2 m/s	23.5 – 27.5 mm	25.6
Displacement at 3 m/s	36.0 – 40.0 mm	37.2
Displacement at 4 m/s	46.0 – 51.0 mm	47.8

TEST MEETS SPECIFICATIONS

Technician: _____

Approved By: _____



UPPER RIB DISPLACEMENT

Test Desc.: Rib Module
Component: Dummy #009

Test Date: 11-05-02
Speed: 6.6 fps, 2.00 M/s

Ymin = -4.7 mm @ 0.0848 sec., Ymax = 27.01 mm @ 0.0445 sec.

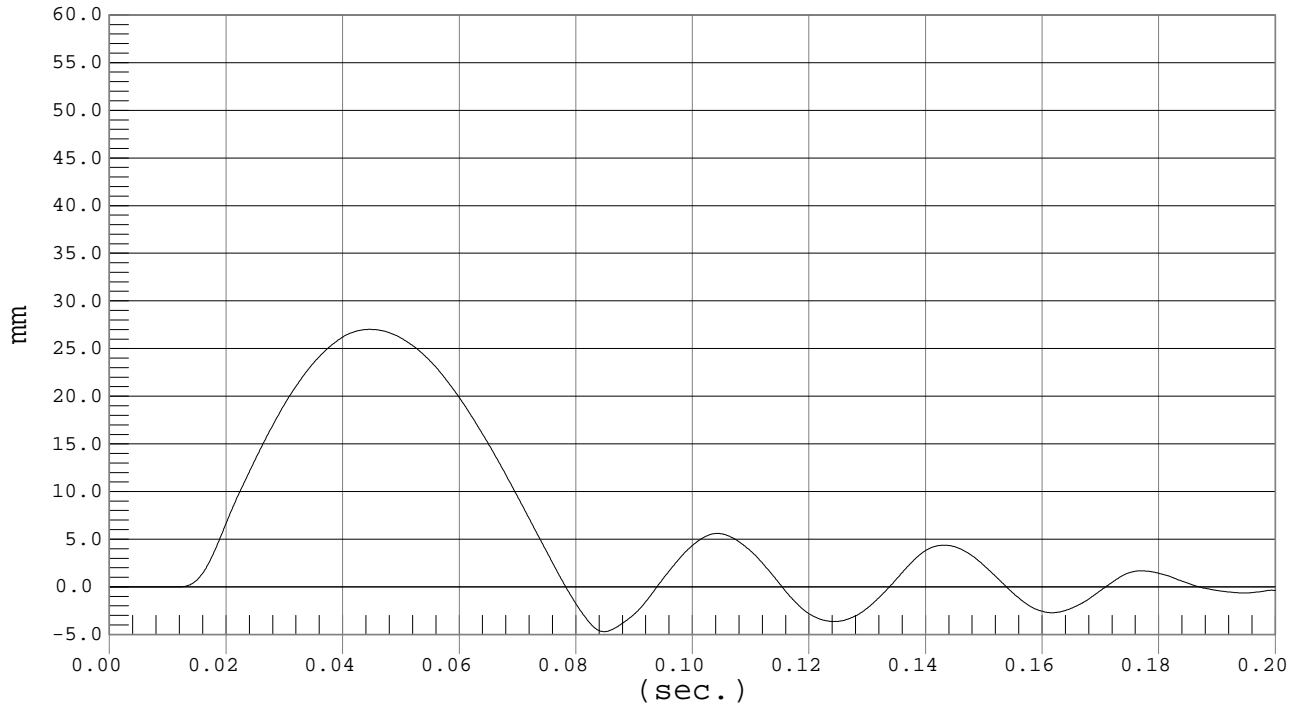

UPPER RIB DISPLACEMENT

Test Desc.: Rib Module
Component: Dummy #009

Test Date: 11-05-02
Speed: 9.8 fps, 3.00 M/s

Ymin = -5.49 mm @ 0.0740 sec., Ymax = 37.71 mm @ 0.0375 sec.

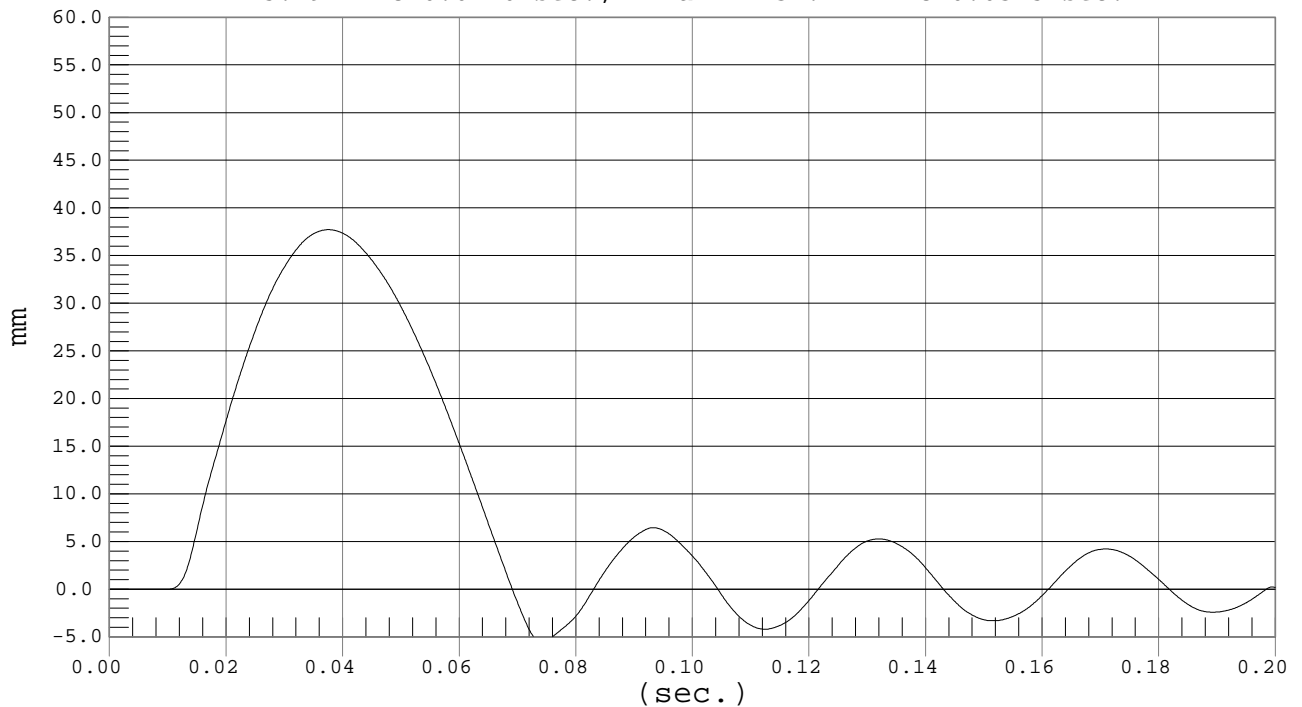



Test Desc.: Rib Module
Component: Dummy #009

UPPER RIB DISPLACEMENT

Test Date: 11-05-02
Speed: 13.1 fps, 4.00 M/s

Ymin = -6.19 mm @ 0.0690 sec., Ymax = 49.54 mm @ 0.0343 sec.

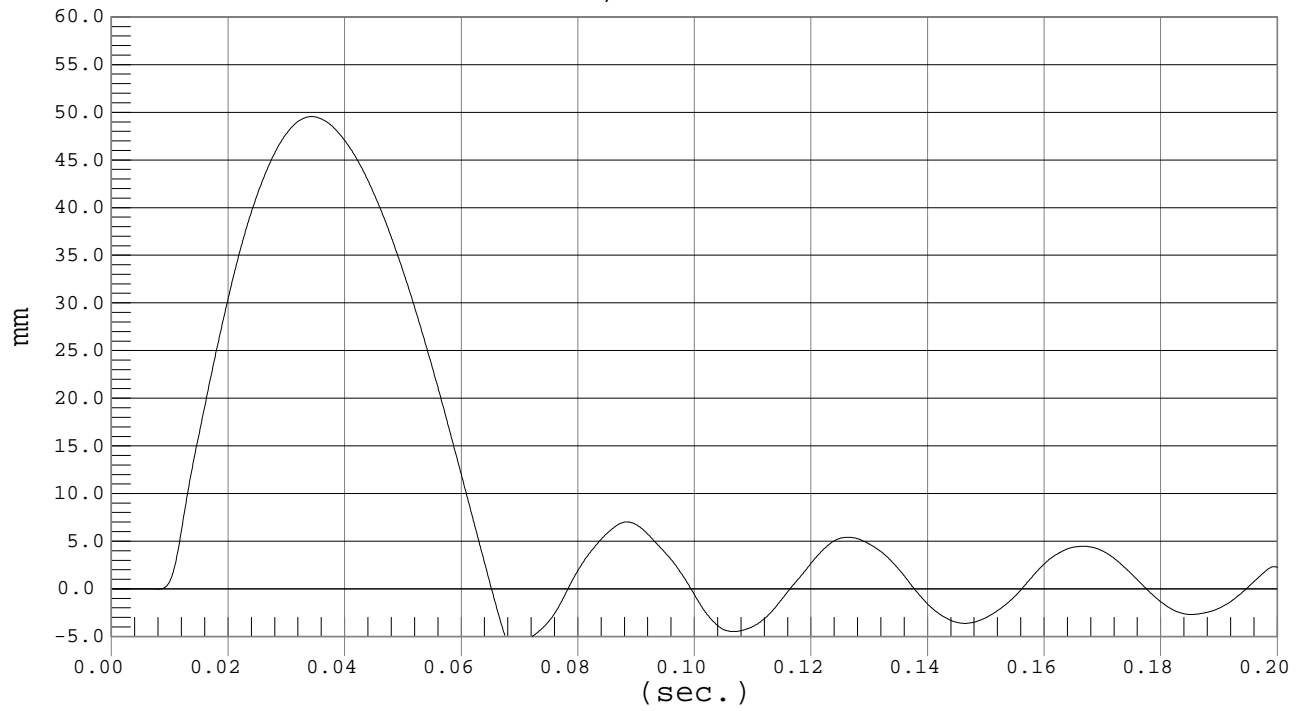



MIDDLE RIB DISPLACEMENT

Test Desc.: Rib Module
Component: Dummy #009

Test Date: 11-05-02
Speed: 6.9 fps, 2.09 M/s

Ymin = -4.39 mm @ 0.1298 sec., Ymax = 26.44 mm @ 0.0916 sec.

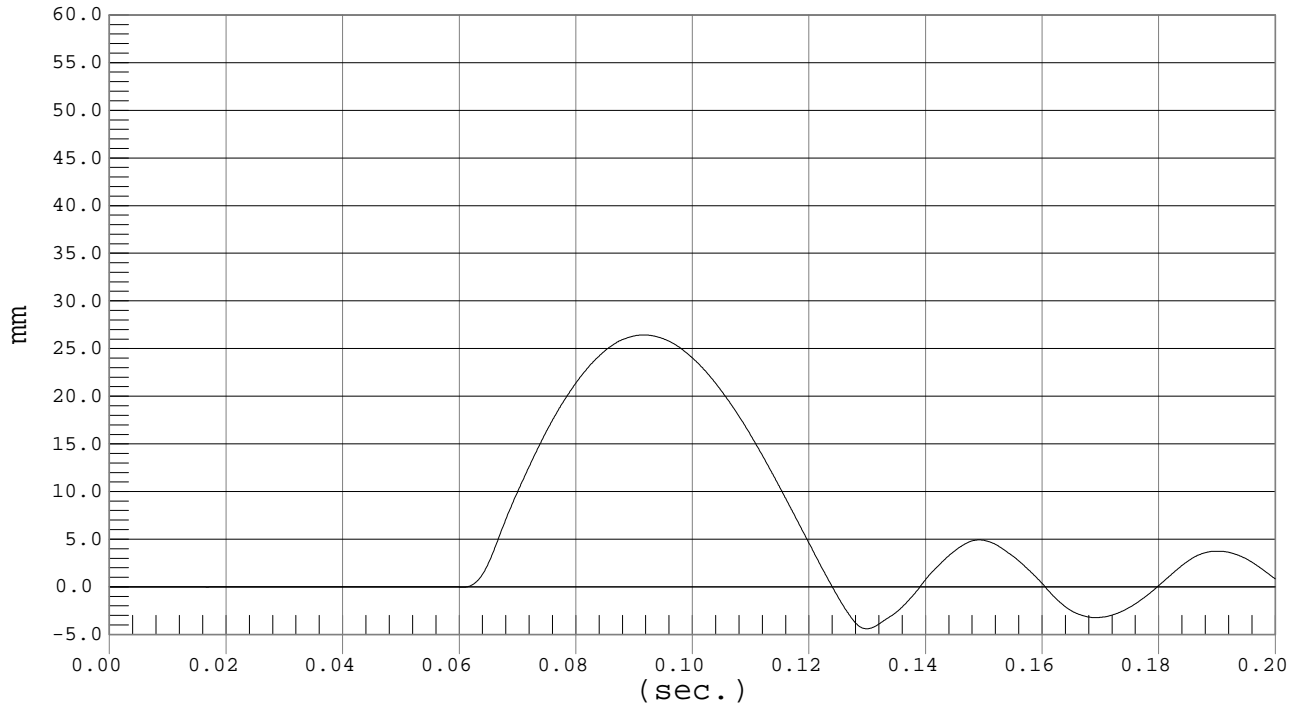

MIDDLE RIB DISPLACEMENT

Test Desc.: Rib Module
Component: Dummy #009

Test Date: 11-05-02
Speed: 9.8 fps, 3.00 M/s

Ymin = -5.46 mm @ 0.0776 sec., Ymax = 39.62 mm @ 0.0413 sec.

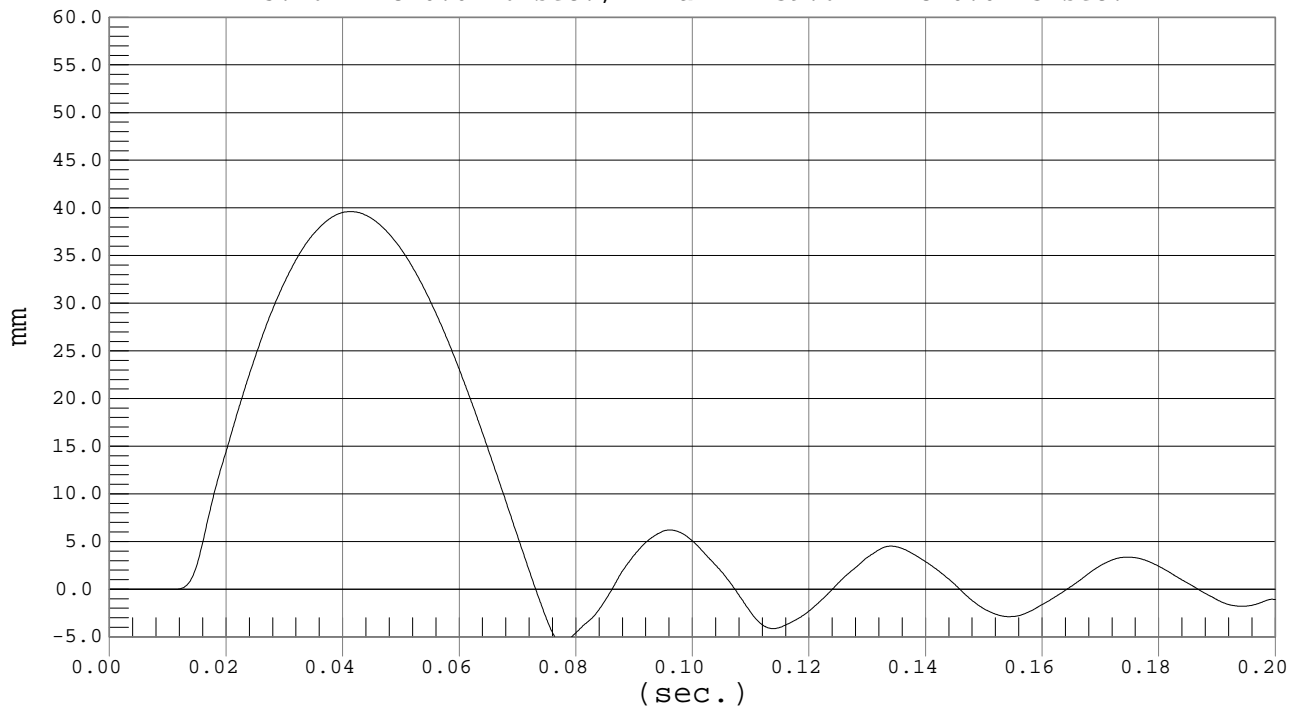



MIDDLE RIB DISPLACEMENT

Test Desc.: Rib Module
Component: Dummy #009

Test Date: 11-05-02
Speed: 13.1 fps, 4.00 M/s

Ymin = -5.34 mm @ 0.0750 sec., Ymax = 50.54 mm @ 0.0402 sec.

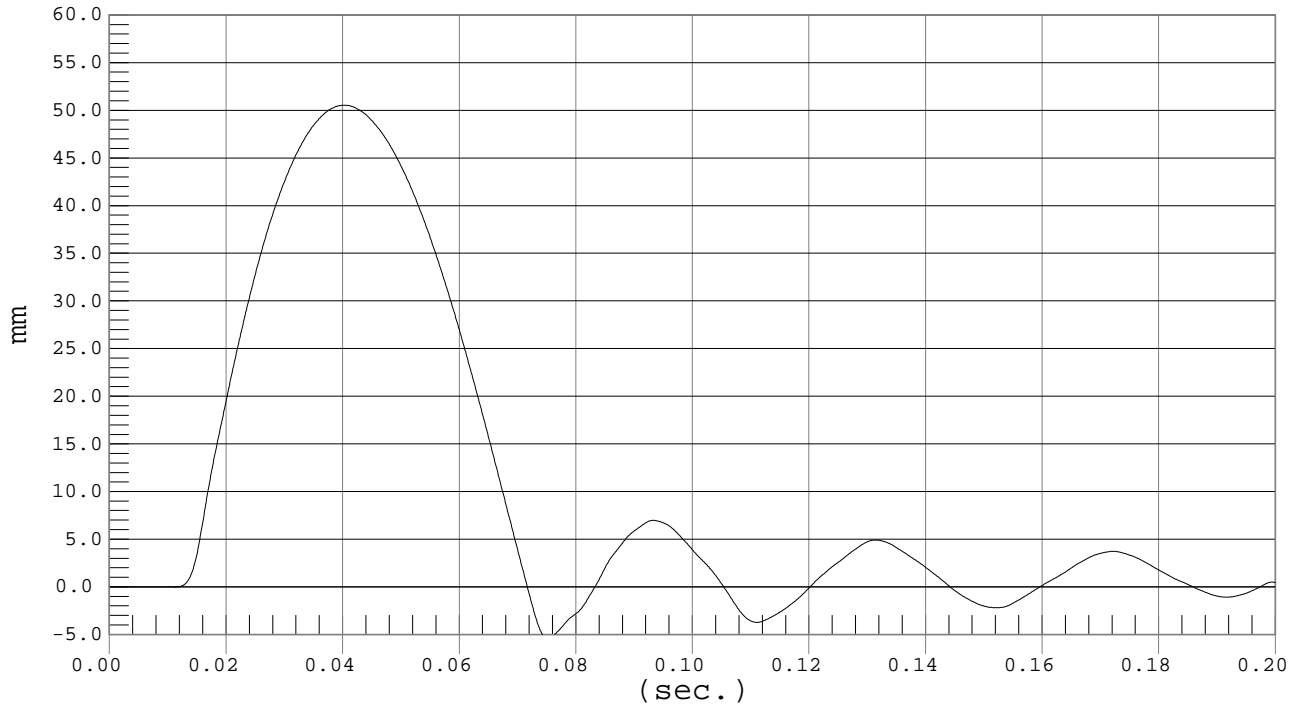



LOWER RIB DISPLACEMENT

Test Desc.: Rib Module
Component: Dummy #009

Test Date: 11-05-02
Speed: 6.6 fps, 2.00 M/s

Ymin = -5.55 mm @ 0.0794 sec., Ymax = 25.59 mm @ 0.0429 sec.

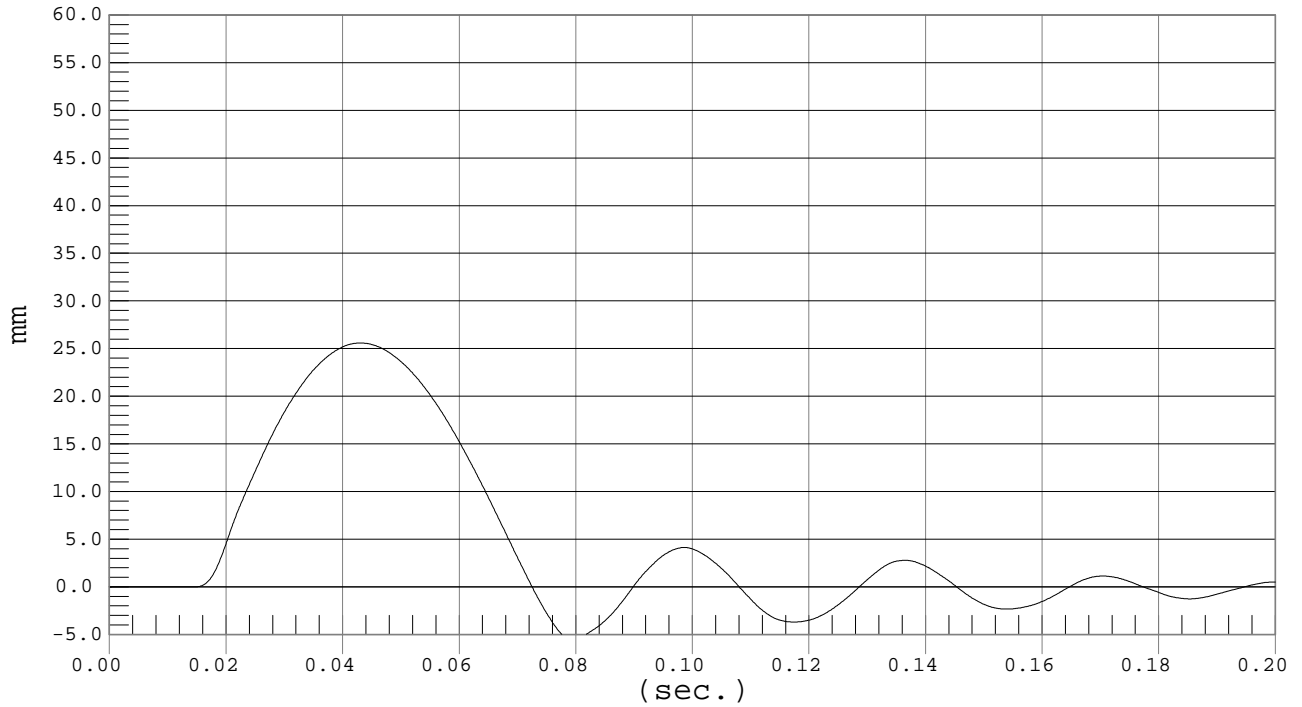

LOWER RIB DISPLACEMENT

Test Desc.: Rib Module
Component: Dummy #009

Test Date: 11-05-02
Speed: 9.8 fps, 3.00 M/s

Ymin = -6.57 mm @ 0.0715 sec., Ymax = 37.16 mm @ 0.0379 sec.

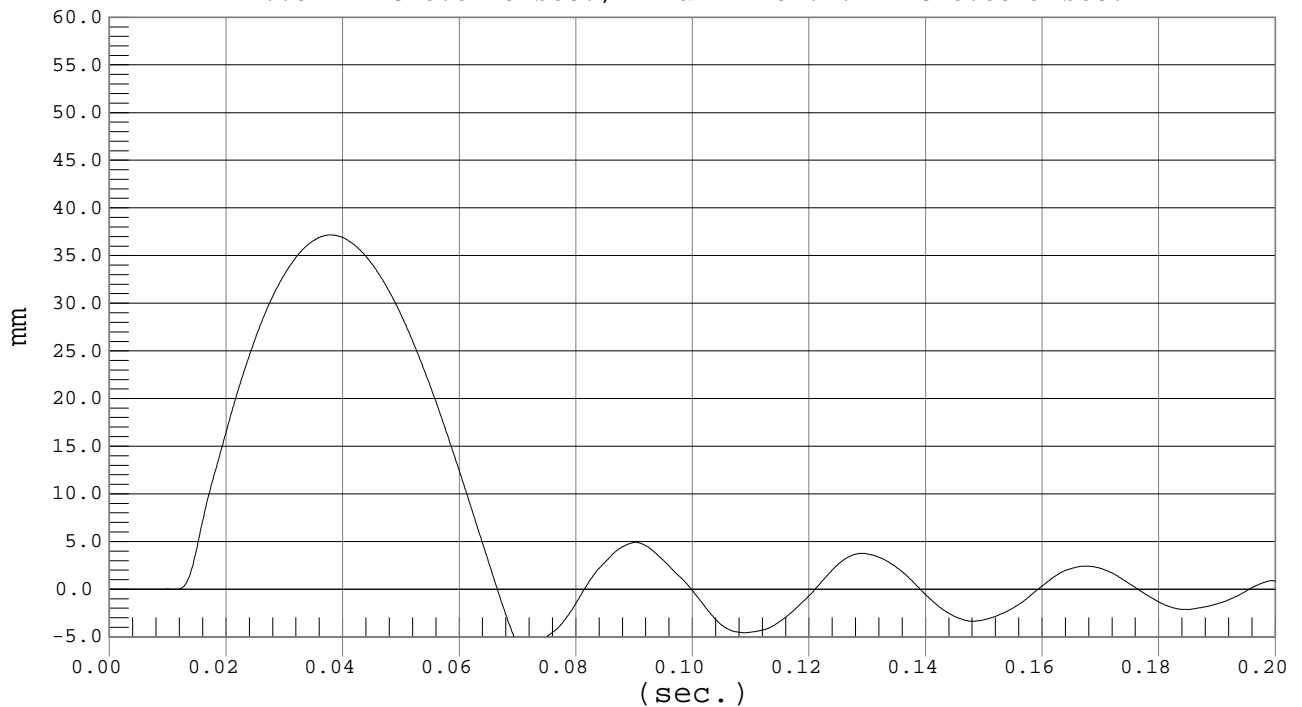



Test Desc.: Rib Module
Component: Dummy #009

LOWER RIB DISPLACEMENT

Test Date: 11-05-02
Speed: 13.1 fps, 4.00 M/s

Ymin = -7.02 mm @ 0.0701 sec., Ymax = 47.79 mm @ 0.0378 sec.

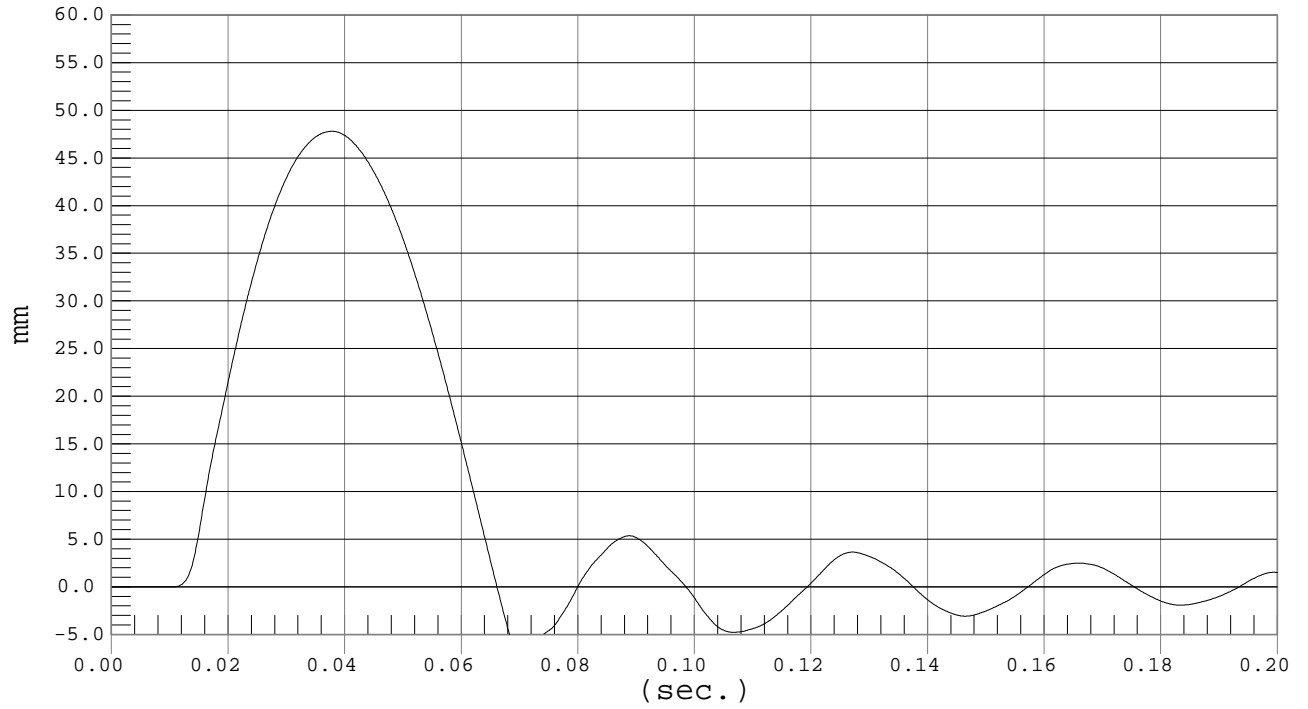



IMPACTOR FORCE

Test Desc.: Abdomen Impact

Test Date: 10-22-02

Ymin = -.07 kN @ -0.0005 sec., Ymax = 4.55 kN @ 0.0107 sec.

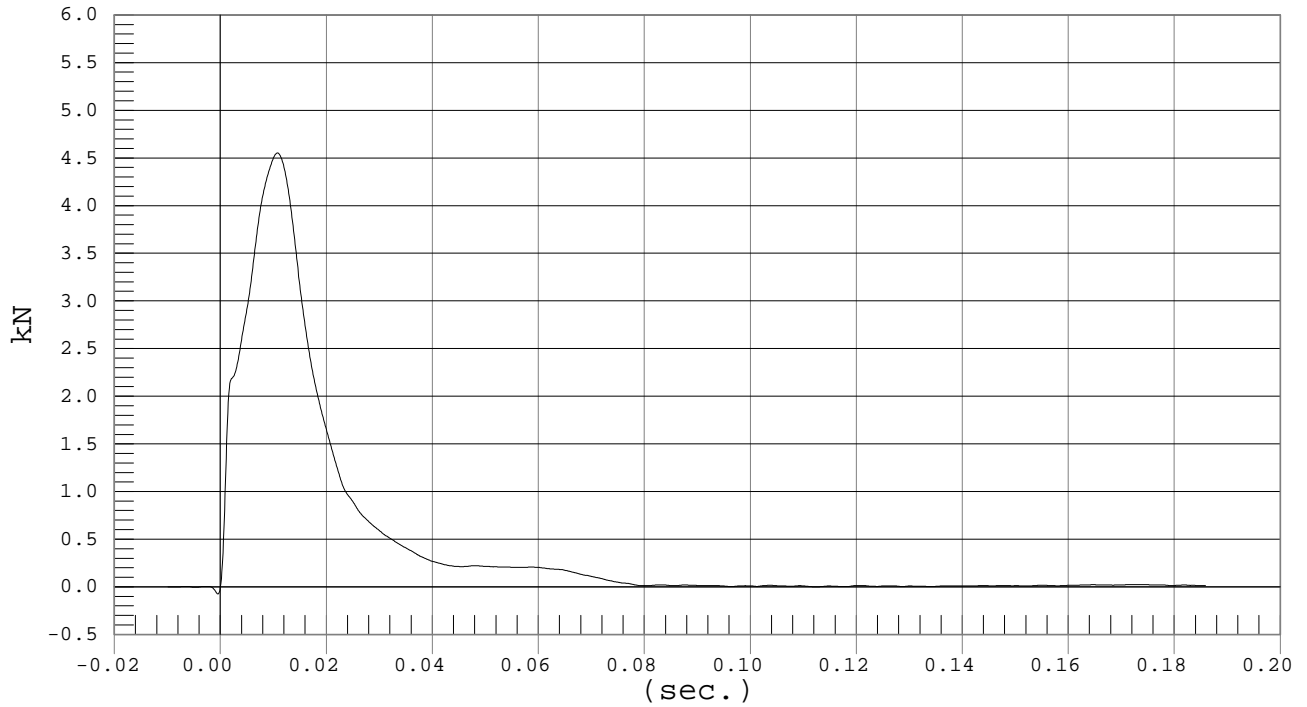

ABDOMEN FORCE

Test Desc.: Abdomen Impact
Component: Dummy #009

Test Date: 10-22-02
Speed: 13.1 fps, 4.01 M/s

Ymin = -.05 kN @ 0.1013 sec., Ymax = 2.36 kN @ 0.0107 sec.

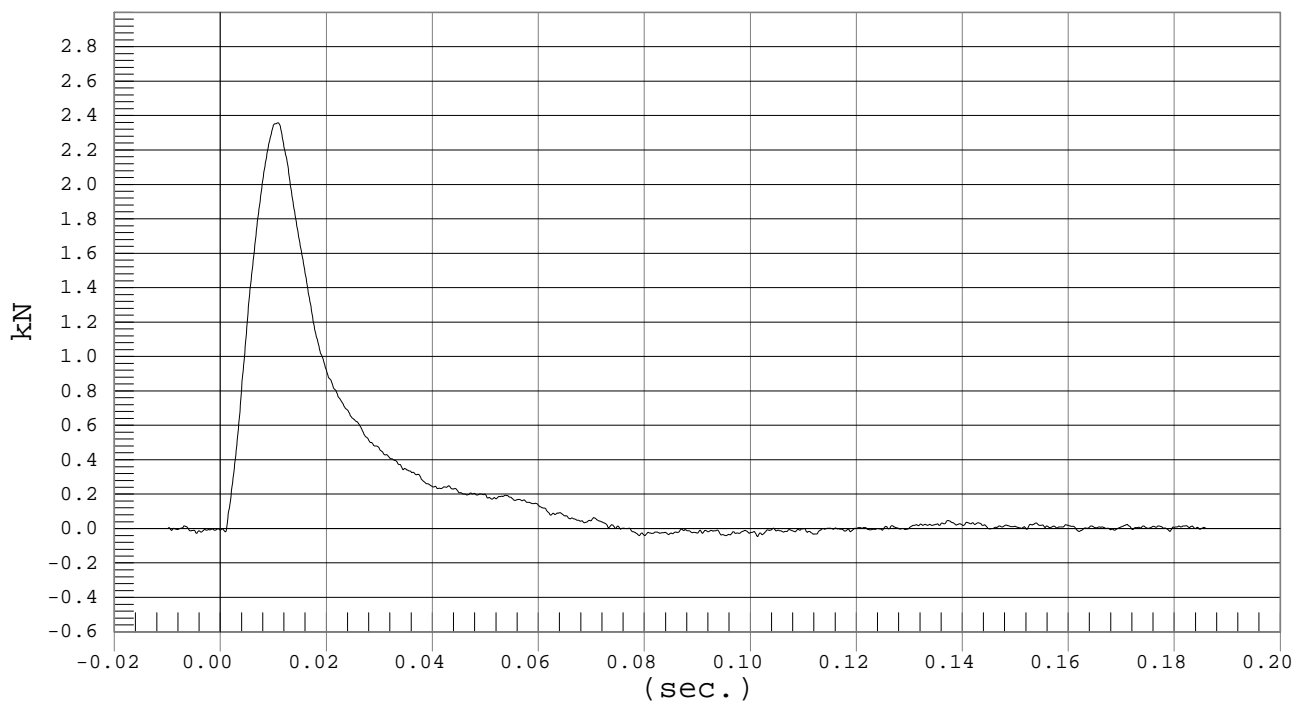

MGA RESEARCH CORPORATION
ABDOMEN TEST
EUROSID 2 DUMMY

Date: 11/4/02
Dummy Serial Number: 009
Test Number: D021427

TEST PARAMETER	SPECIFICATION	TEST RESULTS
Temperature (°C)	18.0 – 22.0	21.8
Relative Humidity (%)	10 – 70	26
Probe Speed (m/s)	3.90 – 4.10	4.03
Maximum Impact Force	4.00 – 4.80 kN	4.58
Time of Maximum Force	10.60 – 13.00 ms	10.70
Maximum Total Abdomen Force	2.20 – 2.70 kN	2.27
Time of Max. Total Force	10.00 – 12.30 ms	10.60

TEST MEETS SPECIFICATIONS

Technician: _____

Approved By: _____



IMPACTOR FORCE

Test Desc.: Abdomen Impact
Component: Dummy #009

Test Date: 11-04-02
Speed: 13.2 fps, 4.03 M/s

Ymin = -.07 kN @ -0.0003 sec., Ymax = 4.58 kN @ 0.0107 sec.

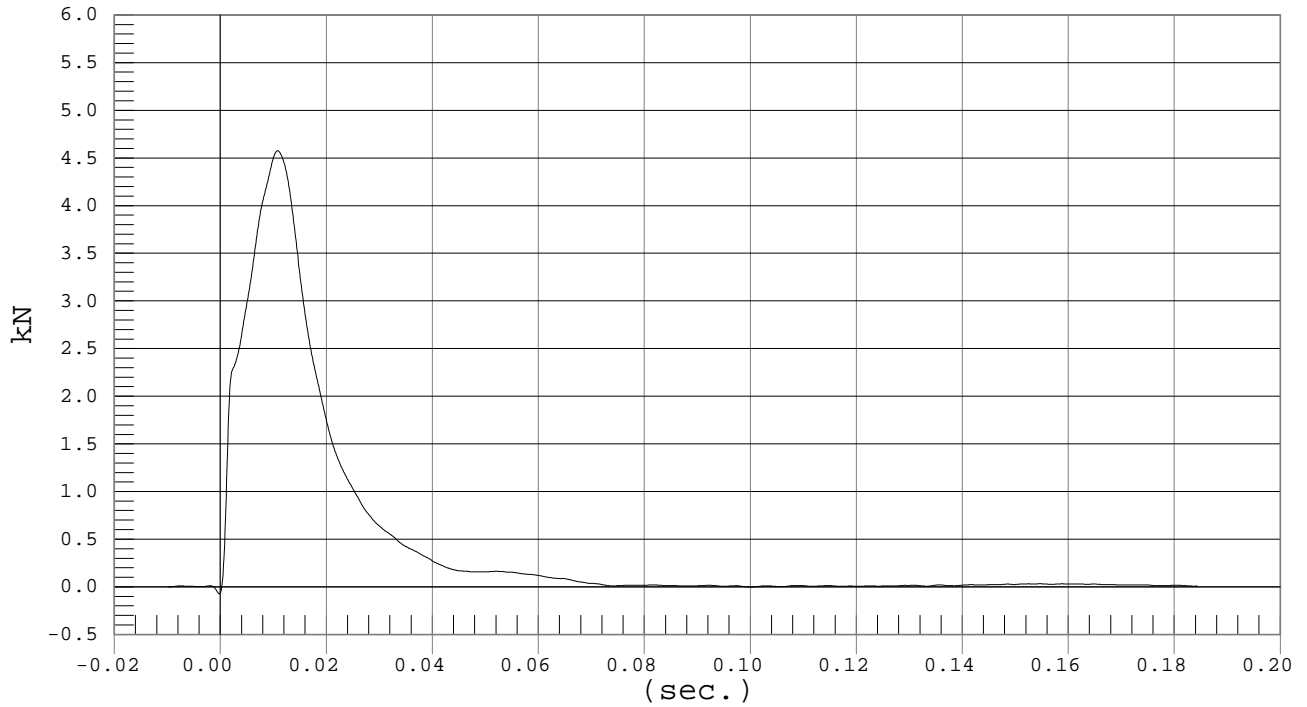

ABDOMEN FORCE

Test Desc.: Abdomen Impact
Component: Dummy #009

Test Date: 11-04-02
Speed: 13.2 fps, 4.03 M/s

Ymin = -.03 kN @ 0.0836 sec., Ymax = 2.27 kN @ 0.0106 sec.

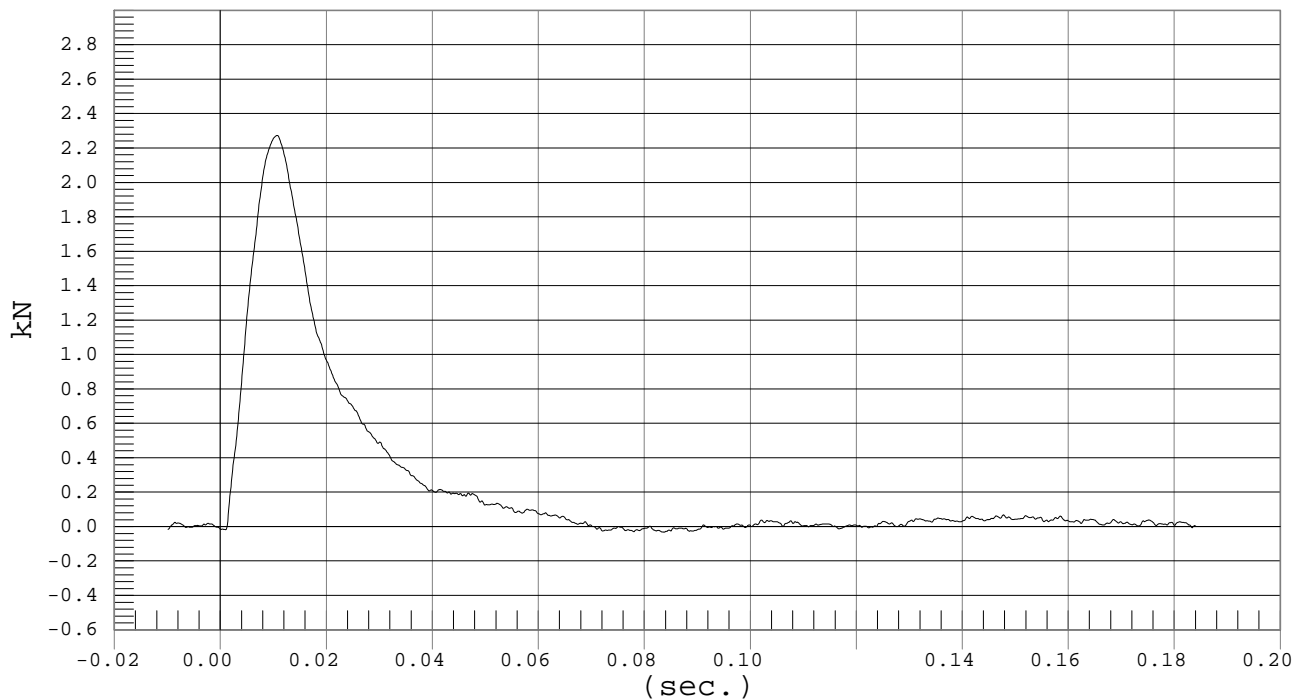

MGA RESEARCH CORPORATION
LUMBAR SPINE TEST
EUROSID 2 DUMMY

Date: 11/4/02
 Dummy Serial Number: 009
 Test Number: D021428

TEST PARAMETER		SPECIFICATION	TEST RESULTS
Temperature (°C)		18.0 – 22.0	21.3
Relative Humidity (%)		10 – 70	29
Pendulum Speed		5.95 – 6.15	6.11
Pendulum Deceleration	10 msec	$\bar{2}.46 - \bar{1}.59$ m/sec	-2.11
	20 msec	$\bar{5}.25 - \bar{4}.07$ m/sec	-4.75
	25 msec	$\bar{6}.64 - \bar{5}.30$ m/sec	-5.82
	30 msec	≥ -6.5 m/sec	-6.23
Maximum Flexion Angle		45.0 – 55.0 deg	46.3
Time of Max. Flexion Angle		39.0 – 53.0 ms	45.0
Maximum Angle Theta (A)		31.0 – 35.0 deg	31.5
Time of Max. Theta (A)		44.0 – 52.0 ms	45.0
Maximum Angle Theta (B)		27.20– 29.70 deg	28.18
Time of Max. Theta (B)		44.0 – 52.0 ms	46.3

TEST MEETS SPECIFICATIONS

Technician: _____

Approved By: _____



PENDULUM DECELERATION

Test Desc.: Lumbar Flexion
Component: Dummy #009

Test Date: 11-04-02
Speed: 20.0 fps, 6.11 M/s

Ymin = -7.58 M/SEC @ 0.1377 SEC, Ymax = 0 M/SEC @ 0.0000 SEC

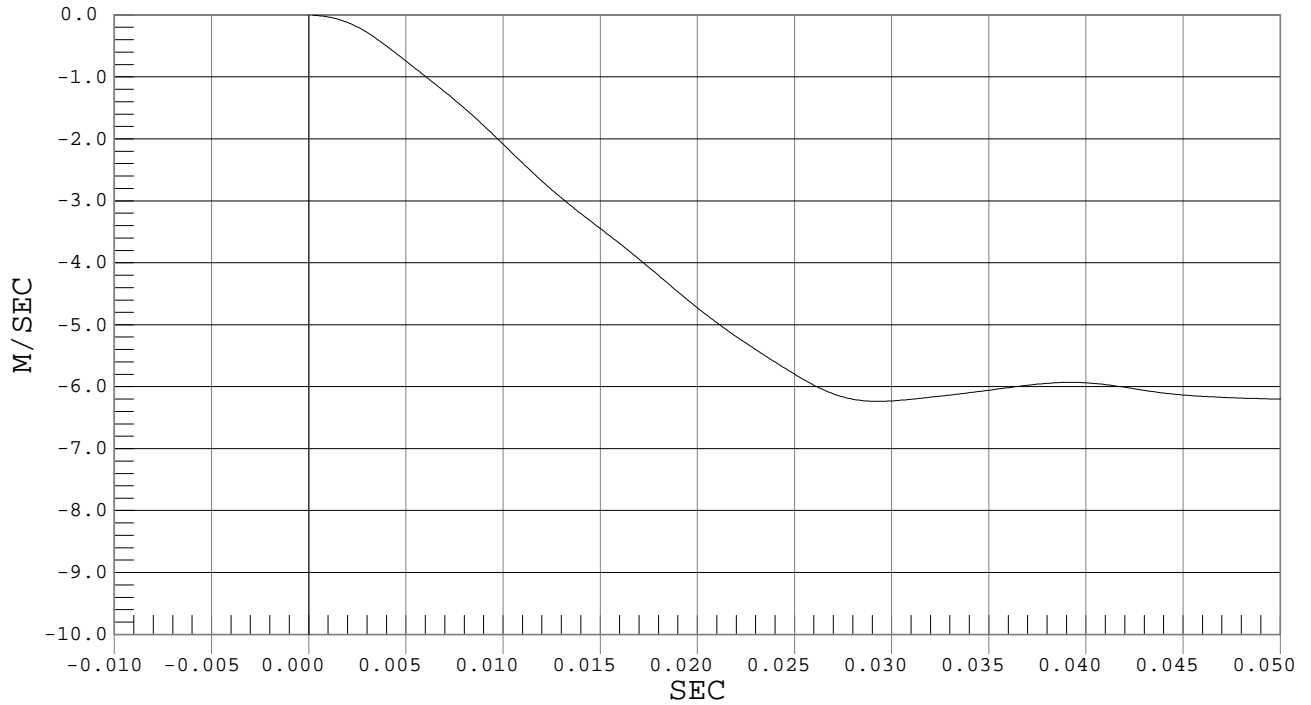

FLEXION ANGLE

Test Desc.: Lumbar Flexion
Component: Dummy #009

Test Date: 11-04-02
Speed: 20.0 fps, 6.11 M/s

Ymin = -17.91 DEG @ 0.1086 sec., Ymax = 46.32 DEG @ 0.0450 sec.

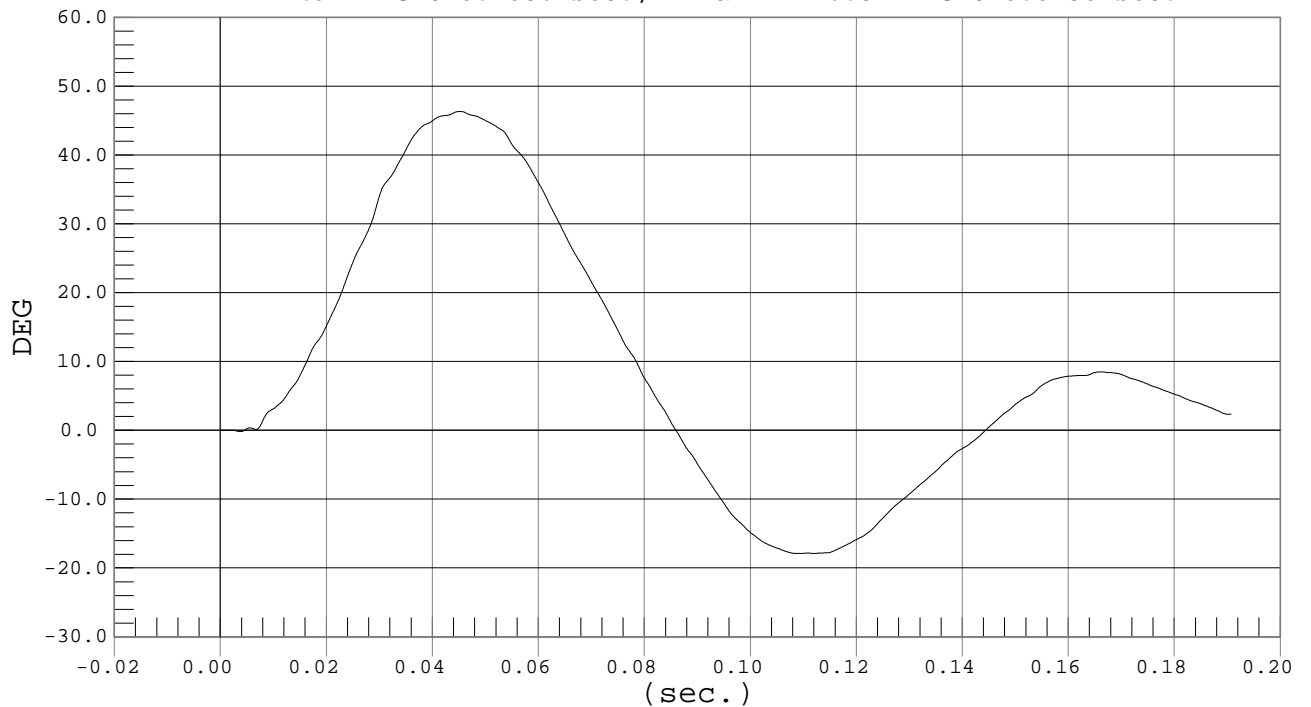



Test Desc.: Lumbar Flexion
Component: Dummy #009

THETA A

Test Date: 11-04-02
Speed: 20.0 fps, 6.11 M/s

Ymin = -11.02 DEG @ 0.1117 sec., Ymax = 31.53 DEG @ 0.0450 sec.

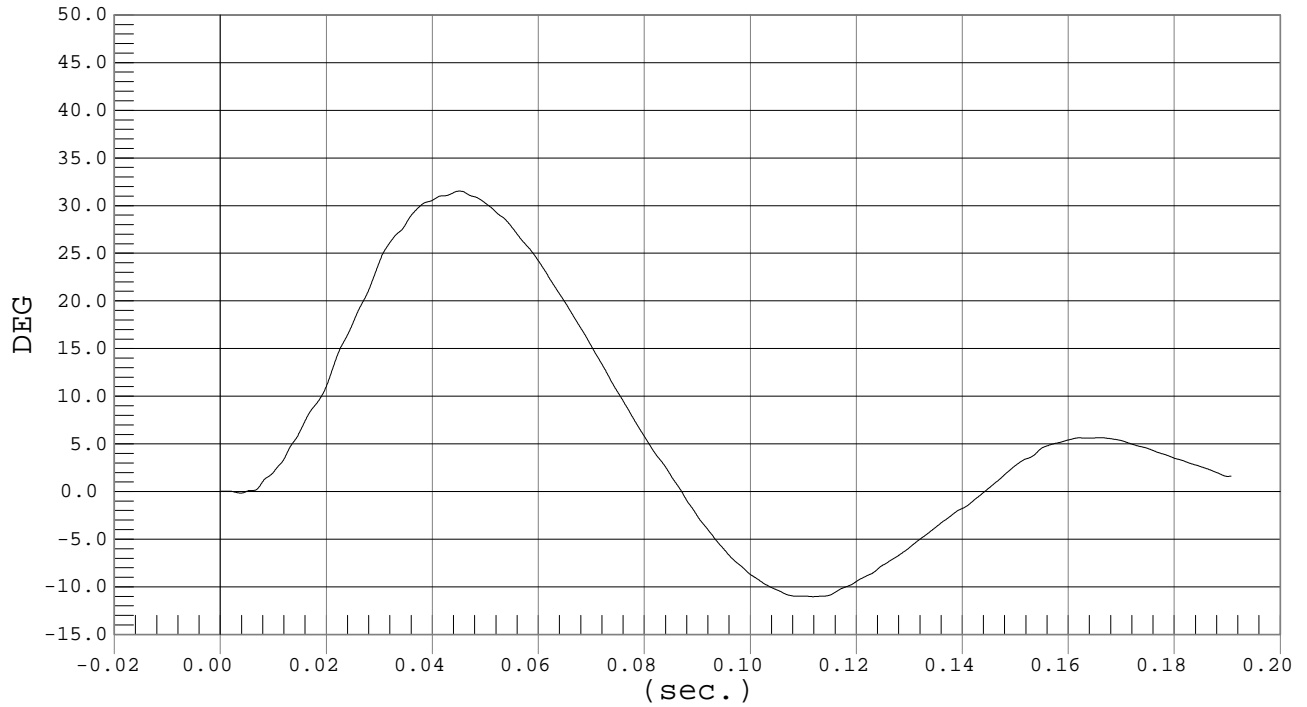

Test Desc.: Lumbar Flexion
Component: Dummy #009

THETA B

Test Date: 11-04-02
Speed: 20.0 fps, 6.11 M/s

Ymin = -11.69 DEG @ 0.1109 sec., Ymax = 28.18 DEG @ 0.0463 sec.

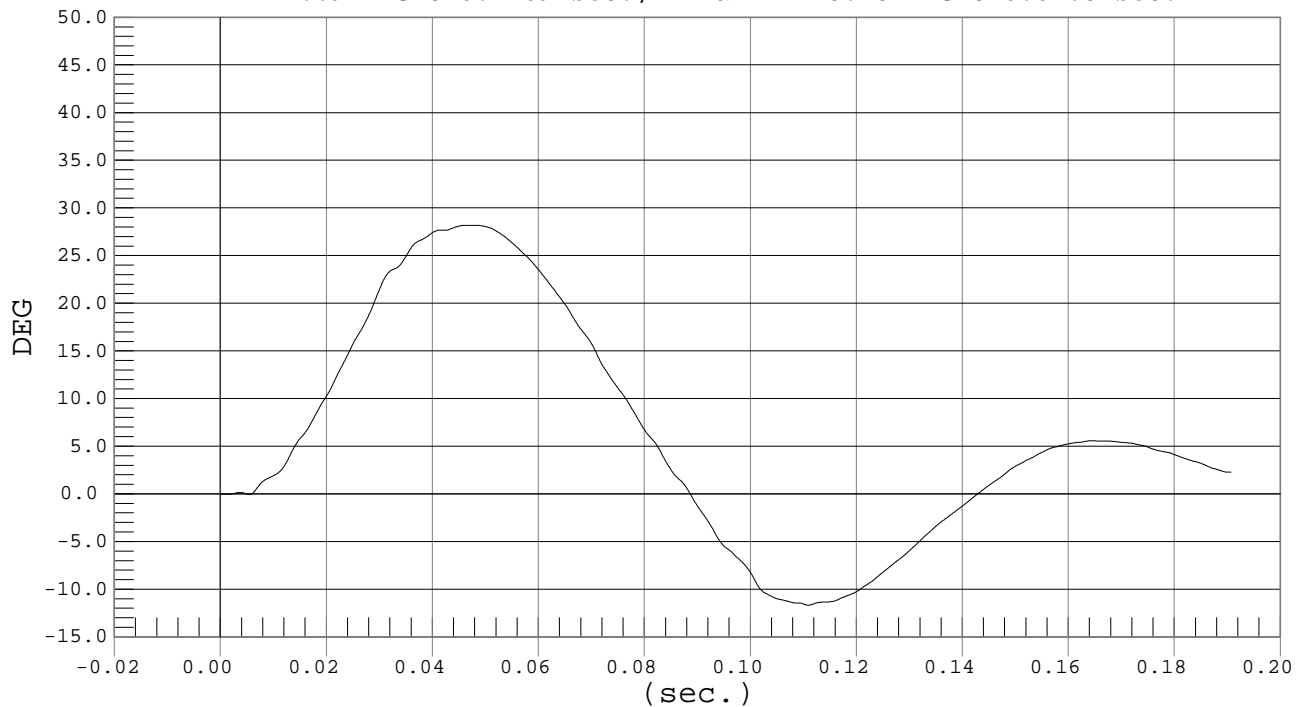

MGA RESEARCH CORPORATION
PELVIS TEST
EUROSID 2 DUMMY

Date: 11/4/02
Dummy Serial Number: 009
Test Number: D021429

TEST PARAMETER	SPECIFICATION	TEST RESULTS
Temperature (°C)	18.0 – 22.0	21.8
Relative Humidity (%)	10 – 70	24
Pendulum Speed	4.20 – 4.40 m/s	4.33
Maximum Impactor Force	4.40 – 5.40 kN	4.96
Time of Max. Impactor Force	10.30 – 15.50 ms	14.30
Maximum Pubic Force	1.04 – 1.64 kN	1.42
Time of Max. Pubic Force	9.90 – 15.90 ms	15.50

TEST MEETS SPECIFICATIONS

Technician: _____

Approved By: _____



Test Desc.: Pelvis Impact
Component: Dummy #009

IMPACTOR FORCE

Test Date: 11-04-02
Speed: 14.2 fps, 4.33 M/s

Ymin = -.02 kN @ -0.0007 sec., Ymax = 4.96 kN @ 0.0143 sec.

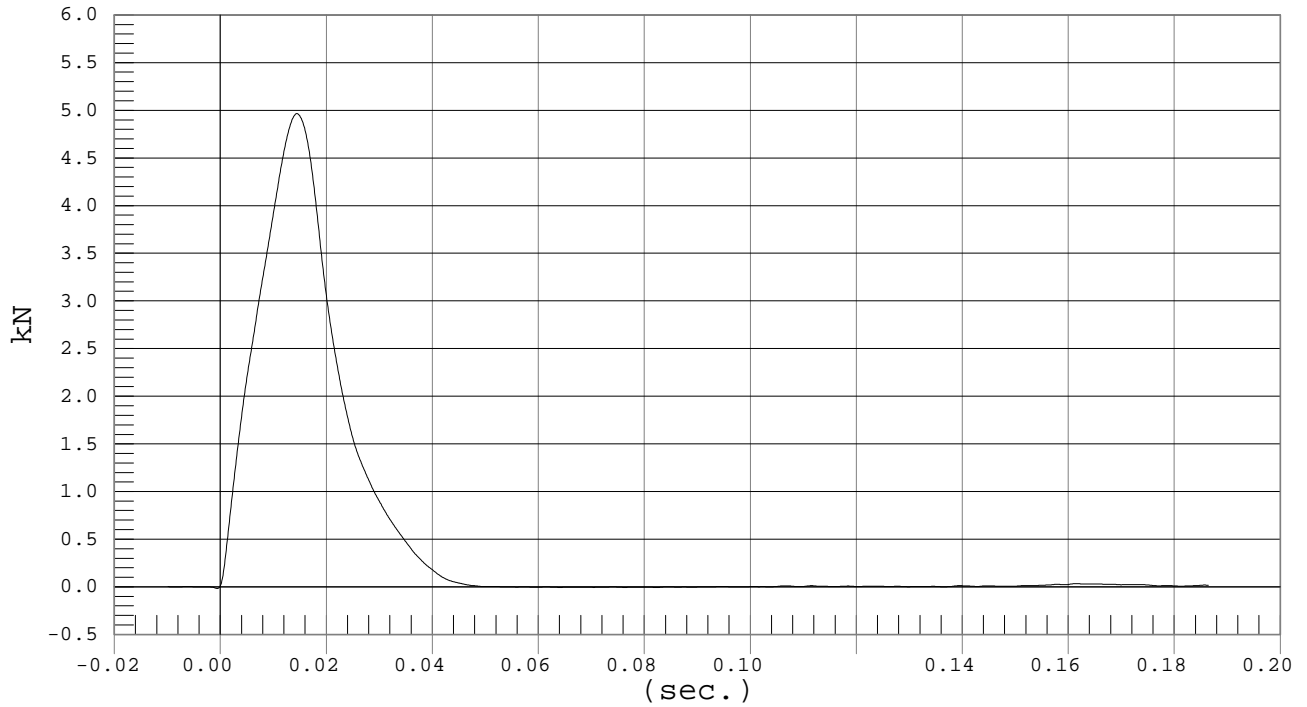

Test Desc.: Pelvis Impact
Component: Dummy #009

PUBIC FORCE

Test Date: 11-04-02
Speed: 14.2 fps, 4.33 M/s

Ymin = -.08 G's @ 0.0457 sec., Ymax = 1.42 G's @ 0.0155 sec.

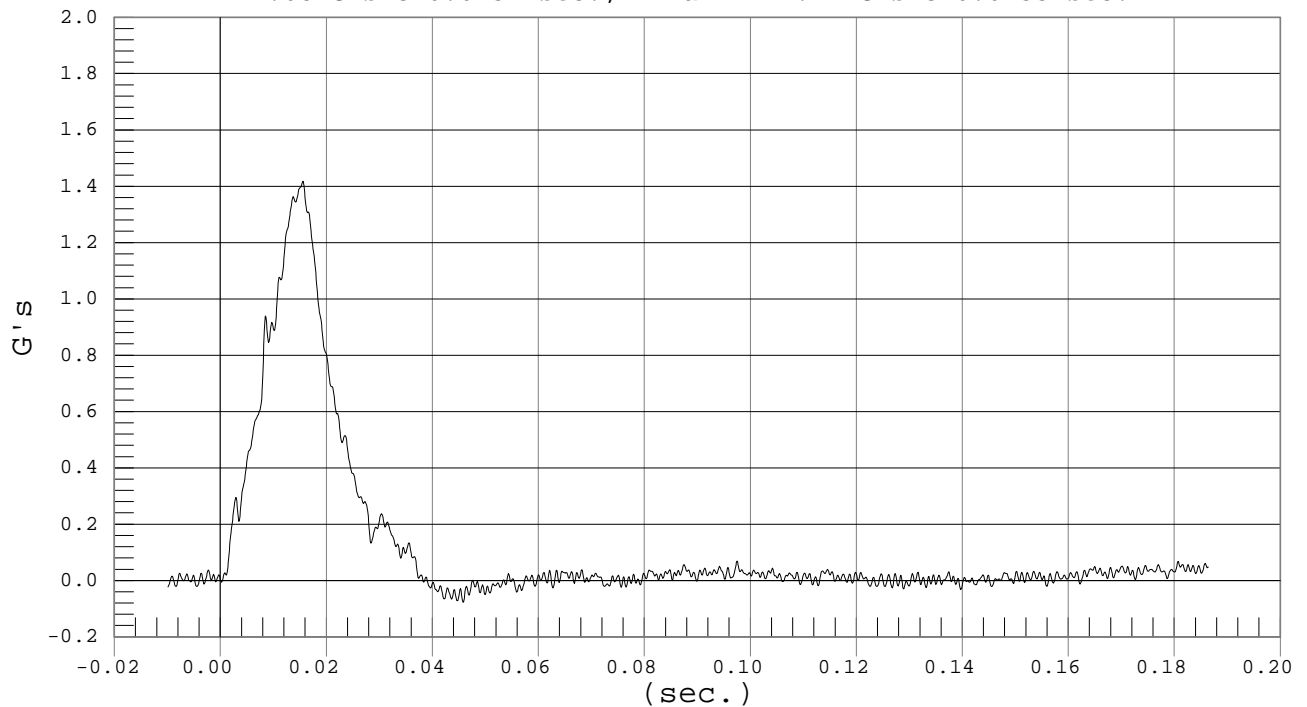

APPENDIX D
TEST EQUIPMENT LIST AND CALIBRATION INFORMATION

DUMMY AND VEHICLE CALIBRATION DATA

	INSTRUMENTS FOR LEFT FRONT DUMMY NO. 010		
	SERIAL NO.	MANUFACTURER	CALIBRATION DATE
Head X Accelerometer	P22180	Endevco	7/23/02
Head Y Accelerometer	P22805	Endevco	7/23/02
Head Z Accelerometer	P23012	Endevco	7/23/02
Head Front Y	P22692	Endevco	7/23/02
Head Front Z	P24260	Endevco	7/23/02
Head Left X	P22190	Endevco	7/23/02
Head Left Z	P24154	Endevco	7/23/02
Head Top X	P22101	Endevco	7/23/02
Head Top Y	P22150	Endevco	7/23/02
Upper Neck Force X Load Cell	N105FX	FTSS	5/13/02
Upper Neck Force Y Load Cell	N105FY	FTSS	5/13/02
Upper Neck Force Z Load Cell	N105FZ	FTSS	5/13/02
Upper Neck Moment X	N105MX	FTSS	5/13/02
Upper Neck Moment Y	N105MY	FTSS	5/13/02
Upper Neck Moment Z	N105MZ	FTSS	5/13/02
Lower Neck Force X Load Cell	N110FX	FTSS	5/16/02
Lower Neck Force Y Load Cell	N110FY	FTSS	5/16/02
Lower Neck Force Z Load Cell	N110FZ	FTSS	5/16/02
Lower Neck Moment X	N110MX	FTSS	5/16/02
Lower Neck Moment Y	N110MY	FTSS	5/16/02
Lower Neck Moment Z	N110MZ	FTSS	5/16/02
Shoulder Force X Load Cell	S119FX	FTSS	5/10/02
Shoulder Force Y Load Cell	S119FY	FTSS	5/10/02
Shoulder Force Z Load Cell	S119FZ	FTSS	5/10/02
Upper Spine X Accelerometer	P24216	Endevco	7/22/02
Upper Spine Y Accelerometer	P24226	Endevco	7/22/02
Upper Spine Z Accelerometer	P23059	Endevco	7/22/02
Upper Rib Y Accelerometer	P22107	Endevco	7/22/02
Mid Rib Y Accelerometer	P22687	Endevco	7/22/02
Lower Rib Y Accelerometer	P22454	Endevco	7/22/02
Upper Rib Displacement	009U	Honeywell	5/22/02
Mid Rib Displacement	009M	Honeywell	5/22/02
Lower Rib Displacement	009L	Honeywell	5/22/02
Lower Spine X Accelerometer	P21352	Endevco	7/22/02
Lower Spine Y Accelerometer	P22695	Endevco	7/22/02
Lower Spine Z Accelerometer	P22659	Endevco	7/22/02
Torso Force X Load Cell	ET100FX	FTSS	10/31/01
Torso Force Y Load Cell	ET100FY	FTSS	10/31/01
Torso Moment Y Load Cell	ET100MY	FTSS	10/31/01
Torso Moment Z Load Cell	ET100MZ	FTSS	10/31/01

	INSTRUMENTS FOR LEFT FRONT DUMMY NO. 010		
	SERIAL NO.	MANUFACTURER	CALIBRATION DATE
T-12 Force X Load Cell	LS103FX	FTSS	5/13/02
T-12 Force Y Load Cell	LS103FY	FTSS	5/13/02
T-12 Moment X Load Cell	LS103MX	FTSS	5/13/02
T-12 Moment Y Load Cell	LS103MY	FTSS	5/13/02
Front Abdomen Load Cell	A122FY	FTSS	5/16/02
Mid Abdomen Load Cell	A123FY	FTSS	5/16/02
Rear Abdomen Load Cell	A124FY	FTSS	5/16/02
Pubic Symphysis Force	P115FY	FTSS	5/13/02
Pelvis X Accelerometer	P22084	Endevco	7/23/02
Pelvis Y Accelerometer	P22099	Endevco	7/23/02
Pelvis Z Accelerometer	P22972	Endevco	7/23/02
Right Femur Force X Load Cell	F135FX	FTSS	5/13/02
Right Femur Force Y Load Cell	F135FY	FTSS	5/13/02
Right Femur Force Z Load Cell	F135FZ	FTSS	5/13/02
Right Femur Moment X	F135MX	FTSS	5/13/02
Right Femur Moment Y	F135MY	FTSS	5/13/02
Right Femur Moment Z	F135MZ	FTSS	5/13/02
Left Femur Force X Load Cell	F136FX	FTSS	5/13/02
Left Femur Force Y Load Cell	F136FY	FTSS	5/13/02
Left Femur Force Z Load Cell	F136FZ	FTSS	5/13/02
Left Femur Moment X	F136MX	FTSS	5/13/02
Left Femur Moment Y	F136MY	FTSS	5/13/02
Left Femur Moment Z	F136MZ	FTSS	5/13/02
Lumbar Force Y Load Cell	L104FY	FTSS	8/15/02
Lumbar Force Z Load Cell	L104FZ	FTSS	8/15/02
Lumbar Moment X Load Cell	L104MX	FTSS	8/15/02

VEHICLE INSTRUMENT CALIBRATION

	VEHICLE ACCELEROMETERS		
	SERIAL NO.	MANUFACTURER	CALIBRATION DATE
Left Mid A-Post Y	G03-N23	ENTRAN	7/24/02
Left Lower A-Post Y	F04-N08	ENTRAN	10/18/02
Left Upper B-Post Y	I25-F08	ENTRAN	10/8/02
Left A-Post @ Roof Y	D11-F05	ENTRAN	9/6/02
Left Mid B-Post Y	L23-A05	ENTRAN	5/30/02
Left Lower B-Post Y	I25-F07	ENTRAN	10/8/02
Rear Floorpan Above Axle X	L23-A02	ENTRAN	5/30/02
Rear Floorpan Above Axle Y	D11-F16	ENTRAN	5/29/02
Rear Floorpan Above Axle Z	L23-A01	ENTRAN	5/30/02
Right Front Sill X	G03-N10	ENTRAN	10/7/02
Right Front Sill Y	G03-N13	ENTRAN	10/7/02
Right Front Sill Z	F04-N04	ENTRAN	10/7/02
Right Rear Sill X	D11-F05	ENTRAN	9/6/02
Right Rear Sill Y	K21-N20	ENTRAN	10/18/02
Right Rear Sill Z	K21-N11	ENTRAN	6/25/02
Left Front Sill Y	K21-N22	ENTRAN	9/13/02
Left Rear Sill Y	G03-N12	ENTRAN	10/7/02
Vehicle CG X	K21-N11	ENTRAN	6/25/02
Vehicle CG Y	H14-N11	ENTRAN	5/30/02
Vehicle CG Z	H14-N07	ENTRAN	5/30/02
Left Front Door @ Pelvis Y	99F272	ENTRAN	6/24/02
Left Front Door @ Arm Y	G01-N09	ENTRAN	7/24/02
Left Front Door @ Knee Y	G01-N14	ENTRAN	7/24/02
Left Front Door @ Rib Y	99F3A5	ENTRAN	6/24/02
Left Driver Seat Frame Y	99F159	ENTRAN	5/13/02
Right Driver Seat Frame Y	K21-N12	ENTRAN	9/6/02
Lower Center Radiator Support X	K21-N31	ENTRAN	10/9/02
Lower Center Radiator Support Y	G01-N06	ENTRAN	7/23/02
Lower Center Radiator Support Z	K21-N27	ENTRAN	10/18/02

Note: All Endevco accelerometers are Model No. 7264-2000
All Entran accelerometers are Model No. EGE-72

APPENDIX E
PROCEDURE USED FOR ES-2 POSITIONING

Installation of the Side Impact Dummy (recommended practice)

1. GENERAL

- 1.1 The dummy to be used for the following installation procedure is described in Annex 6 to this regulation.
- 1.2 Adjust the knee joints so that they just support the leg when it is extended horizontally (1 to 2 g).
- 1.3 Clothe the dummy in form fitting cotton stretch mid-calf length pants. Each foot is equipped with a shoe.

2. INSTALLATION

- 2.1 Place the dummy in the outboard front seat of the impact side as described in the test specifications.
- 2.2 The mid-sagittal plane of the dummy shall coincide with the centerplane of the occupant (as determined according to Annex 3, paragraph 2.8) with a tolerance of 2°.
- 2.3 The pelvis of the dummy shall be positioned according to the following:
 - 2.3.1 The pelvis pitch angle shall be 20.0° +/- 2.5°.
 - 2.3.2 A line passing through the dummy H-points shall pass through an imaginary circle in the mid-sagittal plane of the dummy. This circle has a radius of 10 mm and is located 20 mm horizontally forward and 5 mm vertically above the reference H-point, determined by the 3D H-point machine.
- 2.4 The upper torso of the dummy shall be positioned according to the following:
 - 2.4.1 The upper torso shall be bent forward and then laid back against the seat back. The shoulder of the dummy shall be set fully rearward.
 - 2.4.2 The torso reference line pitch angle shall be 25.0° +/- 2.5°. The torso reference line is defined as the thoracic spine center line.
- 2.5 The arms shall be positioned in such a way that the angle between the projection of the arm centerline on the mid-sagittal plane of the dummy and the torso reference line is 40° +/- 5°.
- 2.6 For the driver's seating position, without inducing pelvis or torso movement, place the right foot of the dummy on the undepressed accelerator pedal with the heel resting as far forward as possible on the floorpan. Set the left foot perpendicular to the lower leg with the heel resting on the floorpan in the same lateral line as the right heel. Set the knees of the dummy such that their outside surfaces are 150 +/- 10mm from the plane of symmetry of the dummy. If possible, within these constraints, place the thighs of the dummy in contact with the seat cushion.
- 2.7 For other seating positions, without inducing pelvis or torso movement, place the heels of the dummy as far forward as possible on the floorpan without compressing the seat cushion more than the compression due to the weight of the leg. Set the knees of the dummy such that their outside surfaces are 150 +/- 10 mm from the plane of symmetry of the dummy.

**APPENDIX F
DUMMY PEAK RESPONSES**

Driver Dummy Peak Responses

Location	Peak Values (G's)								
	Class	Axis	Units	Maxima 6/13/02 ES-2		Maxima 8/29/02 ES-2		Maxima 10/25/02 ES-2	
				Peak	Time	Peak	Time	Peak	Time
Head	1000	X	G	-197.7	58	-249.5	23	-196.5	58
	1000	Y	G	922.7	58	1042.2	56	946.1	58
	1000	Z	G	286.8	58	236.6	56	277.5	58
	1000	Res	G	964.1	58	1089.1	56	1005.3	58
Head injury Criteria (HIC)				11983		15591.0		12144	
T1				57.8		55.5		57.4	
T2				58.5		56.2		58.1	
Upper Neck Force	1000	X	N	-480	60	576	56	-434	49
	1000	Y	N	-977	58	-1367	56	-985	58
	1000	Z	N	-1386	61	-1664	59	-1419	60
	1000	Res	N	1474	60	1868	56	1710	58
Upper Neck Moment	600	X	Nm	-51.0	62	-49.0	92	-58.5	61
	600	Y	Nm	-37.0	47	-31.2	46	41.3	87
	600	Z	Nm	13.6	61	11.9	58	15.1	60
	600	Res	Nm	59.5	63	55.3	60	67	62
Lower Neck Force	1000	X	N	-762	49	-579	45	-875	46
	1000	Y	N	1103	57	965	48	1069	58
	1000	Z	N	-1549	60	-1719	58	-1604	60
	1000	Res	N	1687	57	1759	58	1678	60
Lower Neck Moment	600	X	Nm	115.1	58	88.9	56	111.9	58
	600	Y	Nm	83.9	49	64.5	47	84.0	47
	600	Z	Nm	13.2	58	13.8	56	13.9	59
	600	Res	Nm	130.5	58	103.7	48	126.5	58
Shoulder Force	600	X	N	-968	41	-993	39	-1426	42
	600	Y	N	2425	45	2275	40	2887	43
	600	Z	N	-1503	43	-1277	42	-1599	44
Upper Spine	180	X	G	-21.8	61	23.3	58	-22.9	60
	180	Y	G	51.2	50	50.0	46	50.3	48
	180	Z	G	15.8	59	-13.9	57	17.9	59
	180	Res	G	51.3	50	50.3	46	50.4	48
Lower Spine	180	X	G	-12.1	48	9.2	59	12.9	61
	180	Y	G	82.8	46	84.4	46	89.2	46
	180	Z	G	14.3	60	-12.5	57	16.6	59
	180	Res	G	83.4	46	84.6	46	89.4	46
Upper Rib	180	Y	G	87.1	41	90.6	39	98.7	42
Mid Rib	180	Y	G	114.4	40	123.7	40	141.3	41
Lower Rib	180	Y	G	187.1	40	195.5	39	197.5	40

Driver Dummy Peak Responses

Location	Peak Values (G's)								
	Class	Axis	Units	Maxima 6/13/02 ES-2		Maxima 8/29/02 ES-2		Maxima 10/25/02 ES-2	
				Peak	Time	Peak	Time	Peak	Time
Upper Rib Deflection	180	Y	mm	-41.5	51	-43.7	55	-39.9	51
Mid Rib Deflection	180	Y	mm	-38.6	55	42.1	54	-36.2	50
Lower Rib Deflection	180	Y	mm	-38.4	52	41.3	50	-33.9	52
Upper Rib VC	180	Y	m/sec	0.85	46	0.80	44	0.80	45
Mid Rib VC	180	Y	m/sec	0.85	45	1.00	44	0.90	46
Lower Rib VC	180	Y	m/sec	0.83	44	0.90	42	0.70	44
Torso Force	600	X	N	-147	58	-193	66	671	44
	600	Y	N	-785	47	-691	47	-1044	47
Torso Moment	600	X	Nm	-12.1	60	-11.2	59	38.3	44
	600	Y	Nm	5.8	53	8.9	56	17.8	44
T-12 Force	600	X	N	594	49	675	49	673	63
	600	Y	N	2335	46	1941	47	2521	47
T-12 Moment	600	X	Nm	-187.4	42	-137.3	39	-181.0	44
	600	Y	Nm	-70.0	85	72.1	69	-86.3	86
Abdomen Front Force	600	Y	N	336	45	255	47	295	44
Abdomen Mid Force	600	Y	N	733	46	634	46	746	47
Abdomen Rear Force	600	Y	N	1112	46	1139	46	1210	47
Abdomen Summed Force	600	Y	N	2151	46	2014	46	2249	47
Pubic Symphysis Force	600	Y	N	-2548	44	-2495	44	-2465	45
Right Femur Force	600	X	N	373	134	200	155	326	126
	600	Y	N	840	66	810	91	967	63
	600	Z	N	1062	65	959	89	1042	56
	600	Res	N	1338	65	1215	91	1377	63
Right Femur Moment	600	X	Nm	-91.1	42	-87.4	71	-86.0	42
	600	Y	Nm	38.7	65	-35.4	132	-40.1	126
	600	Z	Nm	-53.4	65	-42.0	91	-44.0	66
	600	Res	Nm	93.0	42	88.5	71	87.2	42

Driver Dummy Peak Responses

Location	Peak Values (G's)								
	Class	Axis	Units	Maxima 6/13/02 ES-2		Maxima 8/29/02 ES-2		Maxima 10/25/02 ES-2	
				Peak	Time	Peak	Time	Peak	Time
Left Femur Force	600	X	N	288	58	179	89	297	58
	600	Y	N	705	53	608	105	625	50
	600	Z	N	1539	51	1436	81	1625	49
	600	Res	N	1651	53	1496	81	1735	49
Left Femur Moment	600	X	Nm	-111.7	54	-107.4	103	-108.6	69
	600	Y	Nm	-25.8	52	-18.9	96	-35.2	60
	600	Z	Nm	-24.3	53	-36.5	84	-24.2	53
	600	Res	Nm	115.7	54	107.6	103	109.4	69
Pelvis	1000	X	G	20.6	52	19.2	52	25.1	51
	1000	Y	G	61.6	41	64.2	42	64.4	40
	1000	Z	G	17.1	75	11.3	58	12.3	60