

REPORT NUMBER TR-P23003-01-NC

**NEW CAR ASSESSMENT PROGRAM
SIDE IMPACT TEST**

**FUJI HEAVY INDUSTRIES
2003 SUBARU FORESTER 2.5X
AWD WAGON**

NHTSA NUMBER: M35500

**Prepared By:
KARCO ENGINEERING, LLC
9270 HOLLY ROAD
ADELANTO, CALIFORNIA 92301**



OCTOBER 29, 2002

FINAL REPORT

**PREPARED FOR:
U.S. DEPARTMENT OF TRANSPORTATION
NATIONAL HIGHWAY TRAFFIC SAFETY ADMINISTRATION
SAFETY PERFORMANCE STANDARDS
OFFICE OF CRASHWORTHINESS STANDARDS
MAIL CODE: NPS-10
400 SEVENTH STREET, SW, ROOM 5313
WASHINGTON, D.C. 20590**

This final test report was prepared for the U.S. Department of Transportation, National Highway Traffic Safety Administration, in response to Contract Number DTNH22-99-D-02041.

This publication is distributed by the U.S. Department of Transportation, National Highway Traffic Safety Administration, in the interest of information exchange. The opinions, findings and conclusions expressed in this publication are those of the author(s) and not necessarily those of the Department of Transportation or the National Highway Traffic Safety Administration. The United States Government assumes no liability for its contents or use thereof. If trade or manufacturers' names or products are mentioned it is only because they are considered essential to the object of the publication and should not be construed as an endorsement. The United States Government does not endorse products or manufacturers.

Prepared by: _____
Mr. James E. Gorth, Project Engineer
KARCO Engineering, LLC

Date: November 13, 2002

Reviewed by: _____
Mr. Jerry L. Kratzke, Director of Operations
KARCO Engineering, LLC

Date: November 13, 2002

Approved by: _____
Mr. Frank D. Richardson, Program Manager
KARCO Engineering, LLC

Date: November 13, 2002

FINAL REPORT ACCEPTED BY:

Manager, Side Impact NCAP

Date of Acceptance

Technical Report Documentation Page

1. Report No. TR-P23003-01-NC	2. Government Accession No.	3. Recipients Catalog No.																			
4. Title and Subtitle Final Report of New Car Assessment Program Testing Side Impact Testing of a 2003 Subaru Forester 2.5X AWD Wagon NHTSA NO. M35500		5. Report Date November 13, 2002																			
		6. Performing Organization Code KAR																			
7. Author(s) Mr. James E Gorth, Project Engineer, Karco Mr. Frank Richardson, Program Manager, Karco		8. Performing Organization Report No. TR-P23003-01-NC																			
		10. Work Unit No.																			
9. Performing Organization Name and Address KARCO Engineering, LLC 9270 Holly Road Adelanto, CA 92301		11. Contract or Grant No. DTNH22-99-D-02041																			
		13. Type of Report and Period Covered Final Test Report Option Year 3																			
12. Sponsoring Agency Name and Address U.S. Department of Transportation National Highway Traffic Safety Administration Safety Performance Standards Office of Crashworthiness Standards Mail Code: NPS-10 400 Seventh Street, SW, Room 5313 Washington, D.C. 20590		14. Sponsoring Agency Code DOT/NHTSA/NRM/OCS																			
		15. Supplementary Notes																			
16. Abstract A 55/28 km/h 90 deg. Moving Deformable Barrier Side Impact NCAP Test was conducted on the subject 2003 Subaru Forester 2.5X AWD Wagon in accordance with the specifications of the Office of Crash Worthiness Standards Test Procedure for the generation of consumer information on vehicle side crash protection. The test was conducted at KARCO Engineering laboratories in Adelanto, California, on October 29, 2002 The impact velocity of the Moving Deformable Barrier was 61.57 km/h, and the outside ambient temperature at the struck (driver's) side of the vehicle was 20.5 deg. C. The target vehicle's maximum post test static crush was 286 mm located at level 2. The test vehicle's occupant performance is as follows:																					
<table border="1" style="width: 100%; border-collapse: collapse;"> <thead> <tr> <th style="width: 30%;">Measurement Description</th> <th style="width: 35%;">Driver SID Hybrid III</th> <th style="width: 35%;">Pass SID Hybrid III</th> </tr> </thead> <tbody> <tr> <td>Left Upper Rib (LUR) G's</td> <td style="text-align: center;">55.7</td> <td style="text-align: center;">40.3</td> </tr> <tr> <td>Left Lower Rib (LLR) G's</td> <td style="text-align: center;">45.5</td> <td style="text-align: center;">46.6</td> </tr> <tr> <td>Lower Spine (T₁₂) G's</td> <td style="text-align: center;">46.4</td> <td style="text-align: center;">41.9</td> </tr> <tr> <td>Thoracic Trauma Index (TTI) G's</td> <td style="text-align: center;">51</td> <td style="text-align: center;">44</td> </tr> <tr> <td>Pelvis (PEV) G's</td> <td style="text-align: center;">64</td> <td style="text-align: center;">52</td> </tr> </tbody> </table>				Measurement Description	Driver SID Hybrid III	Pass SID Hybrid III	Left Upper Rib (LUR) G's	55.7	40.3	Left Lower Rib (LLR) G's	45.5	46.6	Lower Spine (T ₁₂) G's	46.4	41.9	Thoracic Trauma Index (TTI) G's	51	44	Pelvis (PEV) G's	64	52
Measurement Description	Driver SID Hybrid III	Pass SID Hybrid III																			
Left Upper Rib (LUR) G's	55.7	40.3																			
Left Lower Rib (LLR) G's	45.5	46.6																			
Lower Spine (T ₁₂) G's	46.4	41.9																			
Thoracic Trauma Index (TTI) G's	51	44																			
Pelvis (PEV) G's	64	52																			
17. Key Words New Car Assessment Program (NCAP) Side Impact Moving Deformable Barrier (MDB) Side Impact Dummy Hybrid III (SID)		18. Distribution Statement Copies of this report are available from: National Highway Traffic Safety Admin. NHTSA Technical Reference Division 400 Seventh St., SW, Room 5108 Washington, DC 20590																			
19. Security Classification(of this report) UNCLASSIFIED	20. Security Classification(of this page) UNCLASSIFIED	21. No. of Pages 319	22. Price																		

Form DOT F1700.7 (8-72)

TABLE OF CONTENTS

Section		Page
1	Purpose and Test Procedure	1
2	Summary of Side Impact Test	2
3	Side Impact Dummy (SID)/Hybrid III and Vehicle Test Data	3
4	Occupant and Vehicle Information	11

Data Sheet No.		Page
1	General Test and Vehicle Parameter Data	4
2	Test Vehicle Summary of Results	8
3	Moving Deformable Barrier (MDB) Summary of Results	9
4	Post Test Observations	10
5	SID/Hybrid III Injury Criteria and Sensor Data	12
6	Vehicle Pre-Test and Post-Test Measurements	14
7	SID/Hybrid III Longitudinal Clearance Dimensions	15
8	SID/Hybrid III Lateral Clearance Dimensions	16
9	Vehicle Side Measurements	17
10	Vehicle Exterior Crush Profiles	18
11	Vehicle Damage Profile Distances	20
12	Deformable Barrier Honeycomb Face Static Crush	21
13	Vehicle Accelerometer Location and Data Summary	22
14	MDB Accelerometer Location and Data Summary	24
15	High Speed Camera Locations and Data	25
16	FMVSS 301 Fuel System Integrity Post Impact Data	26
17	FMVSS 301 Static Rollover Data Sheet	27

Appendix		
A	Photographs	A
B	SID/Hybrid III, Vehicle, and MDB Response Data	B
C	SID/Hybrid III Configuration and Performance Verification Data	C
D	Test Equipment List and Calibration Information	D

SECTION 1

PURPOSE and TEST PROCEDURE

1.1 PURPOSE

This Side Impact NCAP test is conducted as part of the FY' 2003 test program sponsored by the National Highway Traffic Safety Administration (NHTSA), under contract No. DTNH22-99-D-02041. The purpose of this test is to generate comparative side impact data on a 2003 Subaru Forester 2.5X AWD Wagon manufactured by Fuji Heavy Industries.

1.2 TEST PROCEDURE

The side impact test was conducted in accordance with the current National Highway Traffic Safety Administration (NHTSA), Office of Crashworthiness Standards (OCS), laboratory test procedure NCAP Side Impact Testing, dated July 1997 and the corresponding KARCO Engineering Test Procedure KTP-214D, dated November 18, 1998. The procedures for receiving, inspection, testing, and reporting of test results are described in the test procedures and are not repeated in this report.

SECTION 2

SUMMARY OF SIDE IMPACT TEST

2.1 SUMMARY OF SIDE IMPACT NCAP TEST

A model year 2003 Subaru Forester 2.5X AWD Wagon was impacted on the left (driver's) side by a Moving Deformable Barrier (MDB) which was moving forward in a 27° crabbed position to the tow road guidance system at a velocity of 61.57 km/h. The specified impact velocity range is from 61.1 to 62.7 km/h. The test (target) vehicle was stationary and positioned 63° to the line of forward motion. The weight of the vehicle as tested was 1638 kg and the test weight of the MDB was 1361 kg. The test was conducted at KARCO Engineering, LLC in Adelanto, California, on October 29, 2002.

SUPPLEMENTAL RESTRAINT INFORMATION

Restraint Type	Left Front (Driver)		Left Rear (Passenger)	
	Installed	Operation	Installed	Operation
Front Airbag	Yes	Not Deployed	None	Not Applicable
Side Torso Airbag	Yes	Deployed Properly	None	Not Applicable
Head Curtain Airbag	None	Not Applicable	None	Not Applicable

One (1) real-time motion picture camera and ten (10) high-speed motion picture cameras were used to document the impact event. The pre-test and post-test conditions were recorded by one (1) real-time motion picture camera. Camera locations and pertinent camera information is documented in the data sheets. Pre- and post-test photographs of the vehicle and SID,s/Hybrid III can be found in Appendix A. Two 50th percentile adult male Side Impact Dummy's (SID's)/Hybrid III were placed in the driver's and left rear passenger designated seating positions according to the test procedure. Each SID/Hybrid III is instrumented with contact switches on the pelvis and thorax, and twenty accelerometers in the following locations:

- Left Upper Rib (LUR) uni-axial accelerometer (Y-axis primary and redundant)
- Left Lower Rib (LLR) uni-axial accelerometer (Y-axis primary and redundant)
- Lower Thoracic Spine (T12) uni-axial accelerometer (Y-axis primary and redundant)
- Pelvic (PEV) section uni-axial accelerometer (Y-axis primary and redundant)
- Head Center of Gravity (CG) tri-axial accelerometers (X, Y, and Z axes)

Note: Sid,s are Hybrid III head and neck. 6 neck load cells per dummy.

The test vehicle was instrumented with twenty-five (25) structural accelerometers and the MDB was instrumented with five (5) accelerometers and a one (1) contact switch on the right bumper to compare left side to right side bumper impact timing. All data channels were recorded with a fully self contained on-board Test Data Acquisition System (TDAS). The data was digitally sampled at 10,000 samples per second and processed per Appendix V of the Test Procedure.

2.2 GENERAL COMMENTS

The test vehicle sustained a maximum static crush of 286 mm at level 2, 1650mm rearward of the left vertical impact point. The driver SID Hybrid III, Serial No. 275 and the passenger SID Hybrid III, Serial No. 274 were calibrated just prior to this test. The SID/Hybrid III injury criteria is summarized as follows:

Measurement	Units	Driver	Passenger
Thoracic Trauma Index (TTI)	G's	51	44
Peak Pelvic G's (PEV)	G's	64	52

Tests summaries and post-test observations are presented in Section 3. The vehicle, camera, and occupant measurements are presented in Section 4. Appendix A contains the still photograph prints. Appendix B contains the driver and passenger SID's/Hybrid III, vehicle, and MDB response data traces. Appendix C contains the SID's/Hybrid III Configuration and performance verification data. Appendix D contains the test equipment information.

SECTION 3

SIDE IMPACT DUMMY (SID)/HYBRID III AND VEHICLE TEST DATA

Test Vehicle: 2003 Subaru Forester 2.5X AWD Wagon

NHTSA No. M35500

Test Program: 55/28 km/h 90° Side Impact NCAP

Test Date: 10/29/02

CONVERSION FACTORS USED IN THIS REPORT*

Quantity	Typical Application	Std Units	Metric Unit	Multiply By
Mass	Vehicle Weight	lb	kg	0.4536
Linear Velocity	Impact Velocity	mile/h	km/h	1.609
Length or Distance	Measurements	in	mm	25.4
Volume	Fuel Systems	gal	liter	3.785
Volume	Small Fluids	oz	mL	29.573
Pressure	Tire Pressures	lbf/in ²	kPa	7.0
Volume	Liquid	gal	liter	3.785
Temperature	General Use	°F	°C	$=(tf - 32)/1.8$
Force	Dynamic Forces	lbf	N	4.448
Moment	Torque	lbf/ft	Nm	1.355

* Based on the Recommended Practice in SAE J916, May 85

DATA SHEET NO. 1
GENERAL TEST AND VEHICLE PARAMETER DATA

Test Vehicle: 2003 Subaru Forester 2.5X AWD Wagon

NHTSA No. M35500

Test Program: 55/28 km/h 90° Side Impact NCAP

Test Date: 10/29/02

TEST VEHICLE INFORMATION

Make	Subaru
Model	Forester
Body Style	4- Door
NHTSA No.	M35500
VIN	JF1SG63613G714471
Color	Green
Delivery Date	2002-09-13
Odometer Reading (mile)	69.2
Dealer	Subaru of San Bernardino
Transmission	5-Speed Manual
Final Drive	AWD
Type/Number Cylinders	4
Engine Displacement (L)	2.5
Engine Placement	Transverse

TEST VEHICLE OPTIONS

Driver Front Airbag	Yes
Driver Side Torso Airbag	Yes
Driver Side Head Airbag	No
Rear Pass. Airbag	No
Rear Pass. Torso Airbag	No
Rear Pass. Head Airbag	No
Power Brakes	Yes
Power Steering	Yes
Disc Brakes, Front	Yes
Disc Brakes, Rear	Yes
Anti-lock Brakes	Yes
Tilt Steering Wheel	No
Power Windows	Yes
Power Seats	No

DATA FROM CERTIFICATION LABEL

Manufactured By	FUJI HEAVY IND.	GVWR (kg)	1880
Date of Manufacture	May-02	GAWR Front (kg)	930
		GAWR Rear (kg)	1000

DATA FROM TIRE PLACARD

Measured Parameter	Front	Rear
Maximum Tire Pressure (kPa)	200	250
Cold Pressure (kPa)	200	250
Recommend Tire Size	P215/60R16	P215/60R16
Tire Size on Vehicle	P215/60R16	P215/60R16
Tire Manufacturer	YOKOHAMA	YOKOHAMA

Measured Parameter	Front	Rear	Third	Total
Type of Seats	Bucket	Bench	None	
Number of Occupants	2	3	0	5
Capacity Wt. (VCW) (kg)				464
Cargo Weight (RCLW) (kg)				68

DATA SHEET NO. 1...(CONTINUED)
GENERAL TEST AND VEHICLE PARAMETER DATA

Test Vehicle: 2003 Subaru Forester 2.5X AWD Wagon

NHTSA No. M35500

Test Program: 55/28 km/h 90° Side Impact NCAP

Test Date: 10/29/02

TEST VEHICLE WEIGHTS

	Units	As Delivered (UVW)			As Tested (ATW)		
		Front Axle	Rear Axle	Total	Front Axle	Rear Axle	Total
Left	kg	397	318		439	410	
Right	kg	392	310		411	378	
Ratio	%	55.7	44.3		51.9	48.1	
Totals	kg	789	628	1417	850	788	1638

TARGET TEST WEIGHT CALCULATION*

Measured Parameter	Units	Value
Total Delivered Weight (UVW)	kg	1418
Weight of 2 P572M SID's/Hybrid III Dummies	kg	161
Rated Cargo/Luggage Weight (RCLW)	kg	68
Calculated Vehicle Target Weight (TVTW)	kg	1647

*Actual As Tested Weight (ATW) will be TVTW -5/-10 kg

TEST VEHICLE ATTITUDES AND CG

	Units	LF	RF	LR	RR	CG (aft of front axle)
As Delivered	mm	749	760	753	752	1122
As Tested	mm	735	748	723	732	1218
Fully Loaded	mm	735	756	719	729	

GENERAL TEST VEHICLE DATA

Measurement Description	Units	Value
Test Vehicle Wheel base	mm	2531
Total Vehicle Length at Left Side	mm	3013
Total Vehicle Length at Centerline	mm	4452
Total Vehicle Length at Right Side	mm	3013
Weight of Ballast In Cargo Area	kg	54
Amount of Stoddard Solvent in Fuel Tank	Liters	55.9

TEST VEHICLE VERTICAL IMPACT LINE DATA

Measurement Description	Units	Value
Test Vehicle Wheel base	mm	2531
Target Impact Point Aft of Front Axle	mm	326
Actual Impact Point Aft of Front Axle	mm	309

DATA SHEET NO. 1...(continued)

GENERAL TEST AND VEHICLE PARAMETER DATA

Test Vehicle: 2003 Subaru Forester 2.5X AWD Wagon
Test Program: 55/28 km/h 90° Side Impact NCAP

NHTSA No. M35500
Test Date: 10/29/02

NOMINAL DESIGN RIDING POSITION

The driver's seat back is positioned to the manufacturer's designated angle. The procedure for positioning the seat is as follows: A slit is cut into fabric of the seat at the outboard edge, approximately 10-13 inches above the pivot point to expose the frame of the seat. An inclinometer is firmly placed against the flat portion of the frame surface and the seat back is adjusted to the manufacturers designated angle.

Driver seat back angle: 22° with a seated dummy
Rear seat back angle: 21° fixed

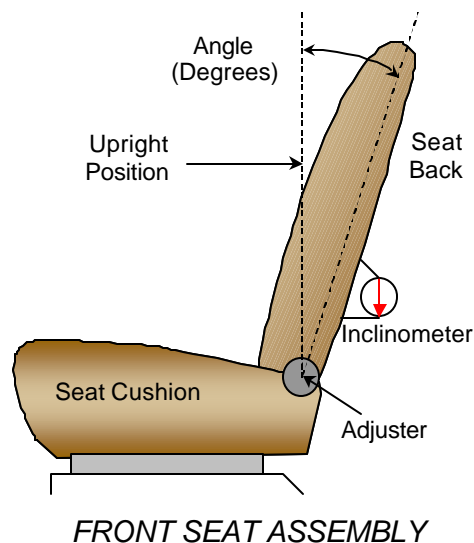

SEAT FORE/AFT POSITIONS

The driver's seat is adjustable. The fore/aft position is set to the middle.

Driver seat fore/aft total travel: 17 seat detents
Rear seat fore/aft total travel: Seat is fixed
Driver seat fore/aft position: Placed in the 9th detent
Rear seat fore/aft position: Seat is fixed

SEAT BELT UPPER ANCHORAGE

Both driver and rear passenger seats are equipped with adjustable upper seat belt anchorages. The driver's "D" ring anchorage has 5 positions and is placed in the 2nd position from the top; the rear passenger seat has 3 positions and is placed in the 2nd position from the top.

DATA SHEET NO. 1...(continued)

GENERAL TEST AND VEHICLE PARAMETER DATA

Test Vehicle: 2003 Subaru Forester 2.5X AWD Wagon

NHTSA No. M35500

Test Program: 55/28 km/h 90° Side Impact NCAP

Test Date: 10/29/02

FUEL TANK CAPACITY DATA

The "Usable Capacity" of the standard equipment fuel tank is: 60.19 liters

The "Usable Capacity" of any optional equipment fuel tank is: N/A liters

92-94% of "Usable Capacity" for certification to FMVSS 301 requirement: 55.34 to 56.55 liters

Actual amount of Stoddard solvent added to vehicle for certification test: 55.95 liters

The test vehicle is equipped with an electric fuel pump. The fuel pump will operate for approximately three (3) seconds with the ignition in the "ON" position, after which the fuel pump automatically shuts off. The fuel filler door is located on the left rear fender.

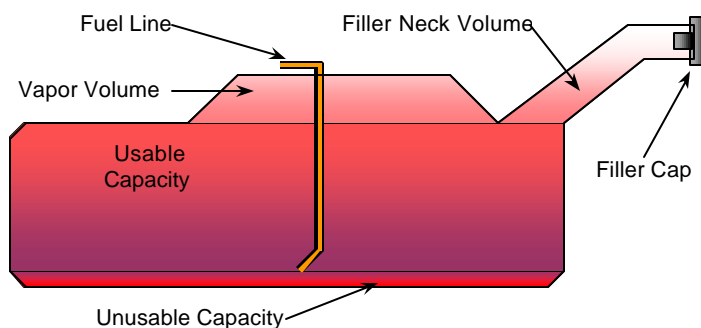

VEHICLE FUEL TANK ASSEMBLY

STEERING COLUMN ADJUSTMENT

Steering wheel and column adjustments are made so that the steering wheel hub is at the geometric center of the locus it describes, when it is moved through its full range of motion. An aluminum plate is placed across the rim of the steering wheel, an inclinometer is placed onto the plate and the angle is measured. The tested vehicle has its steering column set at position 2 as indicated in the drawing at right and the angle below.

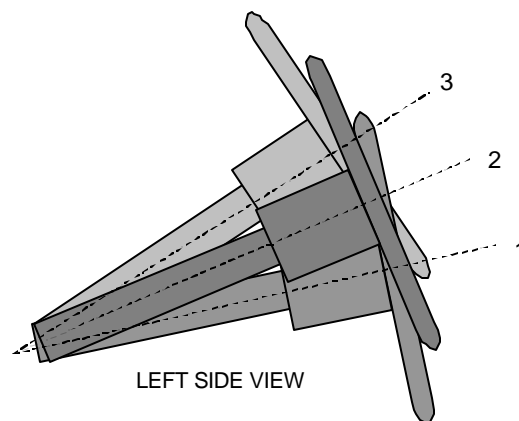

STEERING COLUMN ASSEMBLY

Lowermost, position 1: 22°

Geometric center, position 2: 24°

Uppermost, position 3: 25°

**DATA SHEET NO. 2
TEST VEHICLE SUMMARY OF RESULTS**

Test Vehicle: 2003 Subaru Forester 2.5X AWD Wagon
 Test Program: 55/28 km/h 90° Side Impact NCAP

NHTSA No. M35500
 Test Date: 10/29/02

TEST VEHICLE WEIGHTS

	Units	As Delivered (UVW)			As Tested (ATW)		
		Front Axle	Rear Axle	Total	Front Axle	Rear Axle	Total
Left	kg	397	318		439	410	
Right	kg	392	310		411	378	
Weight Ratio	%	55.7	44.3		51.9	48.1	
Totals	kg	789	628	1417	850	788	1638

MAXIMUM EXTERIOR STATIC CRUSH

Level	Measured Parameter	Units	Maximum Crush	Above Ground
Level 1	Sill Top Height	mm	183	318
Level 2	Occupant H-Point	mm	286	603
Level 3	Mid Door	mm	284	663
Level 4	Window Sill	mm	161	966
Level 5	Window Top	mm	55	1463
N/A	Maximum Penetration	mm	286	

INSTRUMENTATION

Driver SID/Hybrid III Accelerometers	20
Passenger SID/Hybrid III Accelerometers	20
Vehicle Structure Accelerometers	25
MDB Accelerometers	5
Total	70

16mm MOVIE COVERAGE

High Speed, Vehicle On-Board	3
High Speed, Off-Board	5
High Speed, MDB On-Board	2
Real Time, Panning	1
Total	11

DATA SHEET NO. 3
MOVING DEFORMABLE BARRIER (MDB) SUMMARY OF RESULTS

Test Vehicle: 2003 Subaru Forester 2.5X AWD Wagon

NHTSA No. M35500

Test Program: 55/28 km/h 90° Side Impact NCAP

Test Date: 10/29/02

MDB SPECIFICATIONS (mm)

Measurement Description	Length
Overall Width of Framework Carriage	1252
Overall Length Including Honeycomb Face	4115
Wheel base of Framework Carriage	2590
C.G. Location aft of Front Axle	1127

MDB WEIGHTS

	Units	Front Axle	Rear Axle	Total
Left	kg	384	308	
Right	kg	385	284	
Ratio	%	56.5	43.5	
Totals	kg	769	592	1361

SPEED AND IMPACT ANGLE DATA

Measured Parameter	Units	Requirement	Value
Trap No. 1 Velocity (Primary)	km/h	61.1 to 62.7	61.57
Trap No. 2 Velocity (Redn.)	km/h	61.1 to 62.7	61.61
MDB CL to Target Vehicle CL	degrees	88.5 to 91.5	89.5

MAXIMUM STATIC CRUSH OF HONEYCOMB FACE (mm)

Vertical Location			From Centerline		Max Crush
Row	Description	Height	Distance	Direction	
A	Center of Bumper	432	800	Right	173
B	Top of Bumper	533	800	Left	113
C	Mid Level	686	800	Left	119
D	Top of Stack	813	800	Left	178

MDB INSTRUMENTATION AND CAMERAS

Accelerometers	5
Contact Switches	2
High Speed Cameras	2

**DATA SHEET NO. 4
POST TEST OBSERVATIONS**

Test Vehicle: 2003 Subaru Forester 2.5X AWD Wagon

NHTSA No.: M35500

Test Program: 55/28 km/h 90° Side Impact NCAP

Test Date: 10/29/02

Description	Front Seat SID/Hybrid III	Rear Seat SID/Hybrid III
Dummy Type / Serial No.	P572M SID Hybrid III / No. 275	P572M SID Hybrid III / No. 274
Head Contact	Side Bag/B-Pillar	C-Pillar
Upper Torso Contact	Side Bag/Panel	Panel
Lower Torso Contact	Panel	Panel
Left Knee Contact	Panel	Panel
Right Knee Contact	Knee	Knee

POST TEST DOOR OPENING AND SEAT TRACK INFORMATION

Description	Front	Rear
Left Side Door Opening	Remained closed inoperable	Remained closed inoperable
Right Side Door Opening	Remained closed operable	Remained closed operable
Seat Movement	None	None
Seat Back Failure	None	None

POST TEST STRUCTURAL OBSERVATIONS

Critical Areas of Performance	Observations and Conclusions
Pillar Performance	Pillars pushed inward with no apparent failure
Sill Separation	5 3/4 " Separation on Driver/5" Separation on Pass. LR
Windshield Damage	Glazing Cracks on Struck Side Only
Window Damage	Both Left Side Windows Remained Intact.
Other Notable Effects	No significant items to note.

SUPPLEMENTAL RESTRAINT INFORMATION

Restraint Type	Left Front (Driver) Occupant Location 01		Left Rear (Passenger) Occupant Location 04	
	Installed	Operation	Installed	Operation
	Front Airbag	Yes	Not Deployed	None
Side Torso Airbag	Yes	Deployed Properly	None	Not Applicable
Head Curtain Airbag	None	Not Applicable	None	Not Applicable
Seat Belt Pretensioner	None	Not Applicable	None	Not Applicable
Seat Belt Load Limiter	None	Not Applicable	None	Not Applicable

MDB LEFT EDGE IMPACT POINT DATA

Measured Parameter	Units	Requirement	Value
Horizontal Offset	mm	+/- 50	17(left)
Vertical Offset	mm	+/- 20	15(below)

SECTION 4
OCCUPANT AND VEHICLE INFORMATION

DATA SHEET NO. 5
HIII/SID INJURY CRITERIA AND SENSOR DATA

Test Vehicle: 2003 Subaru Forester 2.5X AWD Wagon

NHTSA No.: M35500

Test Program: 55/28 km/h Side Impact NCAP

Test Date: 10/29/02

THORAX AND PELVIS PEAK ACCELERATIONS, PRIMARY (FIR 100 Filtered)

Location	Axis	Units	Driver				Passenger			
			Max	Time	Min	Time	Max	Time	Min	Time
Upper Rib (LUR)	Y	G's	55.7	12.5	-25.4	17.5	40.3	48.1	-9.5	101.9
Lower Rib (LLR)	Y	G's	45.5	11.3	-8.2	6.3	46.6	46.3	-12.5	101.9
Lower Spine (T ₁₂)	Y	G's	46.4	33.8	-7.3	73.1	41.9	40.6	-13.4	76.9
Pelvis (PEV)	Y	G's	64.1	28.8	-10.0	63.8	52.3	31.9	-9.1	85.6

THORACIC TRAUMA INDEX (TTI) AND PELVIC ACCELERATION, PRIMARY (FIR 100 Filtered)

Location	Driver				Passenger			
	LUR	T ₁₂	TTI(g)	PEV(g)	LLR	T ₁₂	TTI(g)	PEV(g)
Primary Rib, Spine, and Pelvis	55.736	46.449	51	64	46.630	41.943	44	52

THORAX AND PELVIS PEAK ACCELERATIONS, REDUNDANT (FIR 100 Filtered)

Location	Axis	Units	Driver				Passenger			
			Max	Time	Min	Time	Max	Time	Min	Time
Upper Rib (LUR)	Y	G's	56.6	12.5	-24.2	17.5	39.9	47.5	-10.2	81.9
Lower Rib (LLR)	Y	G's	47.1	11.3	-8.8	6.3	45.3	46.3	-12.6	101.9
Lower Spine (T ₁₂)	Y	G's	46.5	33.8	-6.7	73.1	42.4	40.6	-14.5	75.6
Pelvis (PEV)	Y	G's	64.1	28.8	-9.9	63.8	51.4	31.9	-10.0	85.6

THORACIC TRAUMA INDEX (TTI) AND PELVIC ACCELERATION, REDUNDANT (FIR 100 Filtered)

Location	Driver				Passenger			
	LUR	T ₁₂	TTI(g)	PEV(g)	LLR	T ₁₂	TTI(g)	PEV(g)
Redundant Rib, Spine, and Pelvis	56.559	46.544	52	64	45.345	42.375	44	51

Positive Acceleration Polarities:

- Longitudinal (X) = Forward
- Lateral (Y) = Right
- Vertical (Z) = Down

DATA SHEET NO. 5...(continued)
HIII/SID INJURY CRITERIA AND SENSOR DATA

Test Vehicle: 2003 Subaru Forester 2.5X AWD Wagon

NHTSA No.: M35500

Test Program: 55/28 km/h Side Impact NCAP

Test Date: 10/29/02

HEAD PRIMARY PEAK ACCELERATIONS (SAE CLASS 1000 Filtered)

Location	Axis	Units	Driver				Passenger			
			Max	Time	Min	Time	Max	Time	Min	Time
Head CG	X	G's	3.7	34.8	-12.3	65.2	11.0	60.7	-6.3	55.4
Head CG	Y	G's	16.0	46.5	-4.7	29.4	121.5	61.4	-12.4	82.6
Head CG	Z	G's	18.3	62.0	-5.0	27.2	20.6	98.2	-25.7	67.2
Head CG Resultant	N/A	G's	23.3	62.0			121.9	61.4		

HEAD PRIMARY INJURY CRITERIA (SAE CLASS 1000 Filtered)

Location	Driver				Passenger			
	HIC	T ¹	T ²	Avg G	HIC	T ¹	T ²	Avg G
Head CG	59.0	44.6	80.5	19.3	600.5	59.1	65.7	95.7

HEAD REDUNDANT PEAK ACCELERATIONS (SAE CLASS 1000 Filtered)

Location	Axis	Units	Driver				Passenger			
			Max	Time	Min	Time	Max	Time	Min	Time
Head CG	X	G's	3.9	35.1	-12.5	62.6	10.7	61.1	-6.1	54.6
Head CG	Y	G's	16.5	52.3	-5.9	29.5	122.1	61.6	-12.3	82.2
Head CG	Z	G's	18.5	61.1	-4.7	27.3	21.1	98.1	-25.2	67.4
Head CG Resultant	N/A	G's	23.9	61.1			122.5	61.6		

HEAD REDUNDANT INJURY CRITERIA (SAE CLASS 1000 Filtered)

Location	Driver				Passenger			
	HIC	T ¹	T ²	Avg G	HIC	T ¹	T ²	Avg G
Head CG	58.5	44.6	80.5	19.3	581.9	59.2	65.6	95.7

UPPER NECK PEAK FORCES AND MOMENTS

Location	Axis	Units	Driver				Passenger			
			Max	Time	Min	Time	Max	Time	Min	Time
Neck Force	X	Newtons	93.0	22.6	-465.0	64.8	494.5	67.4	-350.2	98.1
Neck Force	Y	Newtons	334.0	71.1	-90.5	18.0	189.8	145.0	-938.6	66.6
Neck Force	Z	Newtons	1009.5	61.4	-219.5	27.1	923.7	98.7	-3026.7	64.8
Neck Force Resultant	N/A	Newtons	1119.0	61.4			3162.9	64.8		
Neck Moment	X	N•m	23.6	81.1	-17.3	22.1	18.8	150.4	-72.5	62.9
Neck Moment	Y	N•m	28.7	89.5	-21.5	59.3	23.9	105.2	-45.3	77.8
Neck Moment	Z	N•m	18.6	80.4	-6.9	41.3	36.6	82.1	-9.8	150.1
Neck Moment Resultant	N/A	N•m	38.3	85.9			75.4	62.9		

DATA SHEET NO. 6

VEHICLE PRE-TEST AND POST TEST MEASUREMENTS

Test Vehicle: 2003 Subaru Forester 2.5X AWD Wagon

NHTSA No. M35500

Test Program: 55/28 km/h 90° Side Impact NCAP

Test Date: 10/29/02

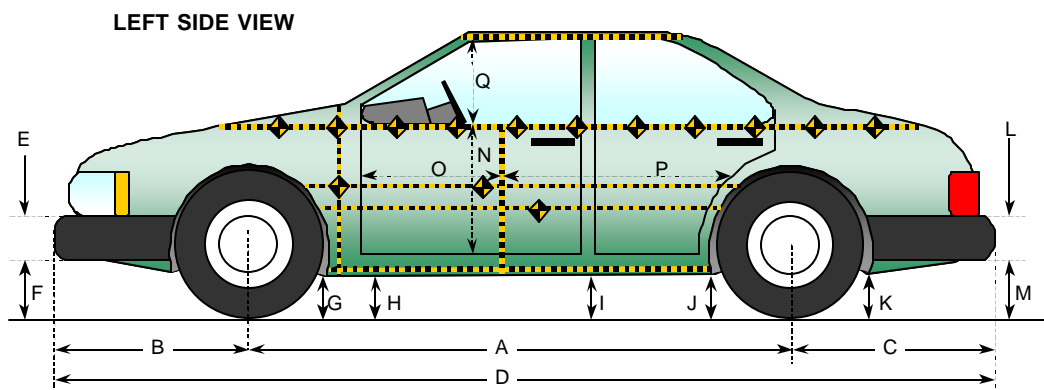

All Measurements in mm

Code	Measurement Description	Pre-Test	Post-Test	Difference
A	Wheelbase	2531	2483	-48
B	Front Axle To FSOV	909	928	19
C	Rear Axle to RSOV	1014	1033	19
D	Total Length at Centerline	4452	4433	-19
E	Front Bumper Thickness	317	317	0
F	Front Bumper Bottom to Ground	302	333	31
G	Sill Height at Front Wheel Well	243	304	61
H	Sill Height at Front Door Leading Edge	256	304	48
I	Sill Height at "B" Pillar	250	316	66
J1	Sill Height at Rear Wheel Well	228	295	67
J2	Pinch Weld Height at Rear Wheel Well	246	309	63
K	Sill Height aft of Rear Wheel Well	266	319	53
L	Rear Bumper Thickness	345	345	0
M	Rear Bumper Bottom to Ground	342	383	41
N	Sill Height to Window Bottom Sill	653	635	-18
O	Front Door Leading Edge to Impact CL	709	708	-1
P	Rear Door Trailing Edge to Impact CL	1272	1215	-57
Q	Front Window Opening	421	445	24
R	Right Side Length	3013	3023	10
S	Left Side Length	3013	2953	-60
T	Vehicle Width at "B" Post	1715	1605	-110

DATA SHEET NO. 7

SID/HYBRID III LONGITUDINAL CLEARANCE DIMENSIONS

Test Vehicle: 2003 Subaru Forester 2.5X AWD Wagon

NHTSA No. M35500

Test Program: 55/28 km/h 90° Side Impact NCAP

Test Date: 10/29/02

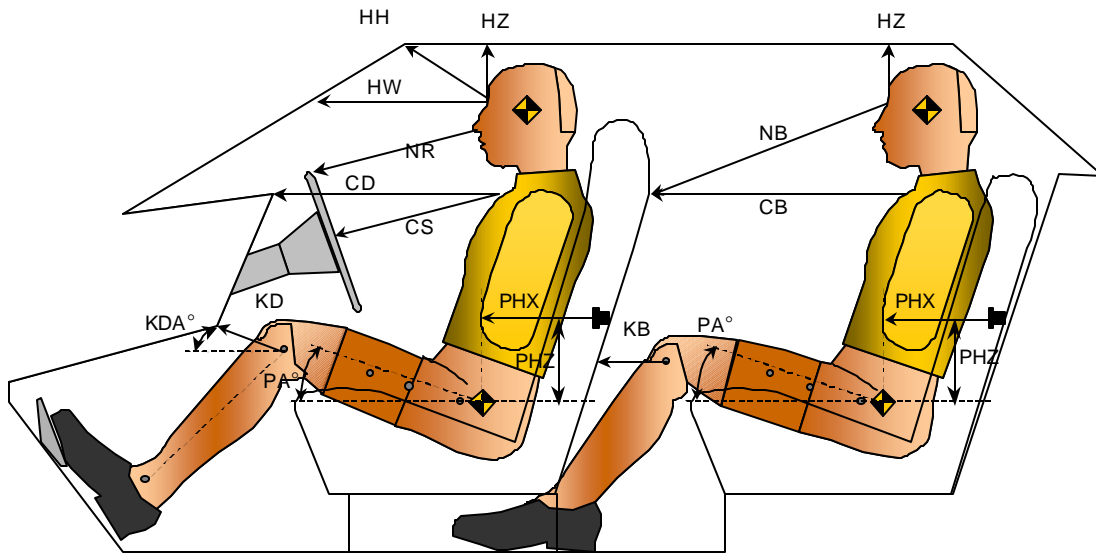

Driver Code	Pass. Code	Measurement Description	Driver		Passenger	
			Length(mm)	Angle(°)	Length(mm)	Angle(°)
HH		Head to Header	500	11		
HW		Head to Windshield	700			
HZ	HZ	Head to Roof	210	90	240	90
NR	NB	Nose to Rim/Nose to Seatback	515	15	520	27
CD	CB	Chest to Dash or Seatback	567	3	450	6
CS		Chest to Steering Wheel	395	16		
KDL	KBL	Left Knee to Dash or Seatback	160	21	150	
KDR	KBR	Right Knee to Dash or Seatback	175		165	
PA	PA	Pelvic Angle	0	24		24
PHX	PHX	H-Point to Striker (X-Axis)	151		230	
PHZ	PHZ	H-Point to Striker (Z-Axis)	75		300	

DATA SHEET NO. 8
SID/HYBRID III LATERAL CLEARANCE DIMENSIONS

Test Vehicle: 2003 Subaru Forester 2.5X AWD Wagon
 Test Program: 55/28 km/h 90° Side Impact NCAP

NHTSA No. M35500
 Test Date: 10/29/02

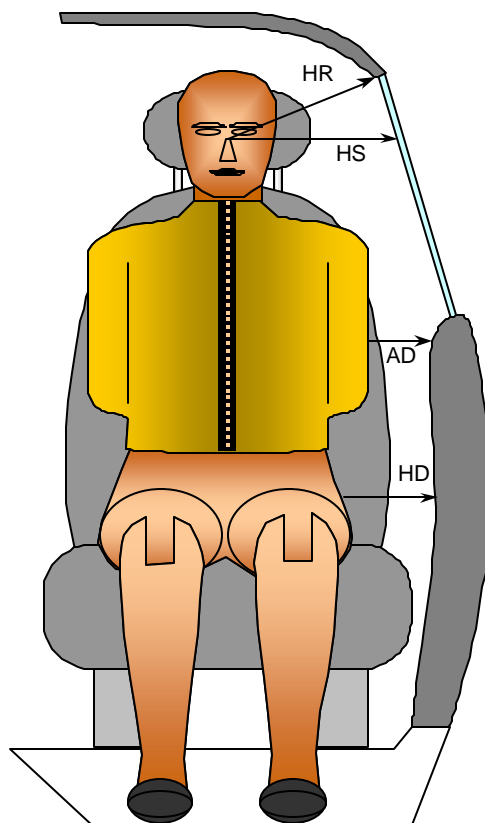

FRONT VIEW OF DUMMY

Code	Measurement Description	Units	Driver	Passenger
HR	Head to Side Header	mm	270	300
HS	Head to Side Window	mm	320	350
AD	Arm to Door	mm	96	106
HD	H-Point to Door	mm	131	131

DATA SHEET NO. 9

VEHICLE SIDE MEASUREMENTS

Test Vehicle: 2003 Subaru Forester 2.5X AWD Wagon

NHTSA No.: M35500

Test Program: 55/28 km/h 90° Side Impact NCAP

Test Date: 10/29/02

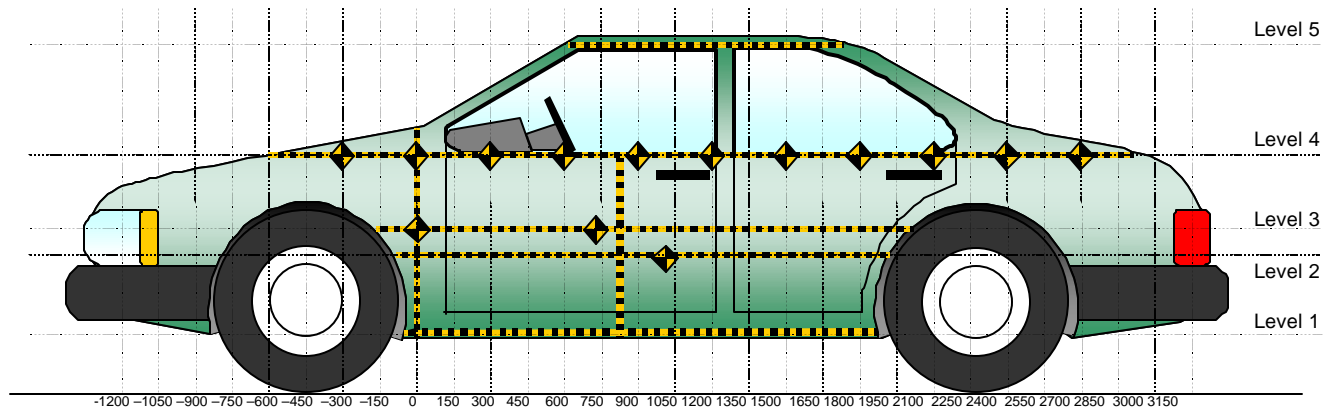

All Measurements Shown in mm

LEFT SIDE VIEW

Measurements are taken with vehicle in the as tested condition.

Measurements taken 900mm right of impact reference.

All measurements below in mm.

Level	Measurement Description	Height Above Ground
5	Window Top	1463
4	Window Sill	966
3	Mid Door	663
2	Occupant H-Point	603
1	Sill Top	318

DATA SHEET NO. 10 – VEHICLE EXTERIOR CRUSH PROFILES

Test Vehicle: 2003 Subaru Forester 2.5X AWD Wagon

NHTSA No.: M35500

Test Program: 55/28 km/h 90° Side Impact NCAP

Test Date: 10/29/02

	Pre-Test					Post-Test					Difference				
	1	2	3	4	5	1	2	3	4	5	1	2	3	4	5
-900															
-750															
-600															
-450															
-300															
-150															
0		631	628	688			726	724	754			95	96	66	
150	694	642	645	690		825	852	837	754		131	210	192	64	
300	725	649	645	685		836	870	853	756		111	221	208	71	
450	726	649	645	677		841	880	869	774		115	231	224	97	
600	727	646	642	679		846	894	876	784		119	248	234	105	
750	726	645	641	675		853	881	881	800		127	236	240	125	
900	727	642	642	674	899	859	877	886	801	943	132	235	244	127	44
1050	727	641	641	671	899	861	880	893	809	949	134	239	252	138	50
1200	727	643	643	672	898	863	899	889	832	953	136	256	246	160	55
1350	726	644	644	671	905	863	916	924	832	953	137	272	280	161	48
1500	726	641	646	672	905	871	916	930	815	947	145	275	284	143	42
1650	722	643	648	673	905	876	929	927	796	946	154	286	279	123	41
1800	700	641	650	674	906	883	834	841	786	939	183	193	191	112	33
1950		637	636	679	905		754	751	766	939		117	115	87	34
2100			631	678	907			724	740	929			93	62	22
2250				682	913				737	924				55	11
2400				685	920				741	929				56	9
2550				696	926				727	929				31	3
2700				706	932				718	931				12	-1
2850				716					719					3	
3000															

Measurements are taken from fixed reference 1000mm from vehicle CL.

DATA SHEET NO. 10...(continued)
VEHICLE EXTERIOR CRUSH PROFILES

Test Vehicle: 2003 Subaru Forester 2.5X AWD Wagon

NHTSA No.: M35500

Test Program: 55/28 km/h 90° Side Impact NCAP

Test Date: 10/29/02

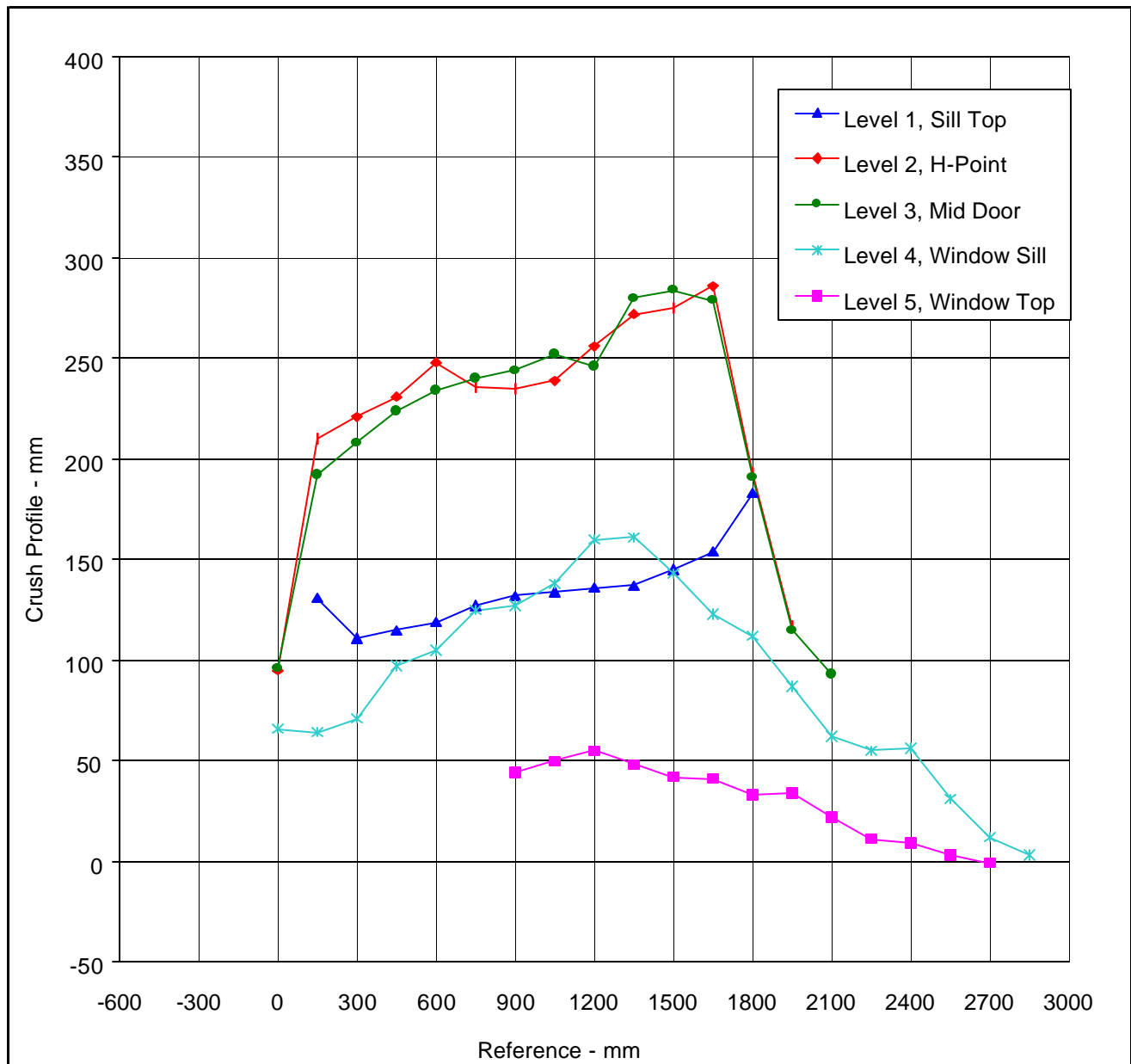

	Units	Level 1	Level 2	Level 3	Level 4	Level 5
Maximum Crush	mm	183	286	284	161	55
Distance from Impact	mm	1800	1650	1500	1350	1200

DATA SHEET NO. 11
VEHICLE DAMAGE PROFILE DISTANCES

Test Vehicle: 2003 Subaru Forester 2.5X AWD Wagon

NHTSA No.: M35500

Test Program: 55/28 km/h 90° Side Impact NCAP

Test Date: 10/29/02

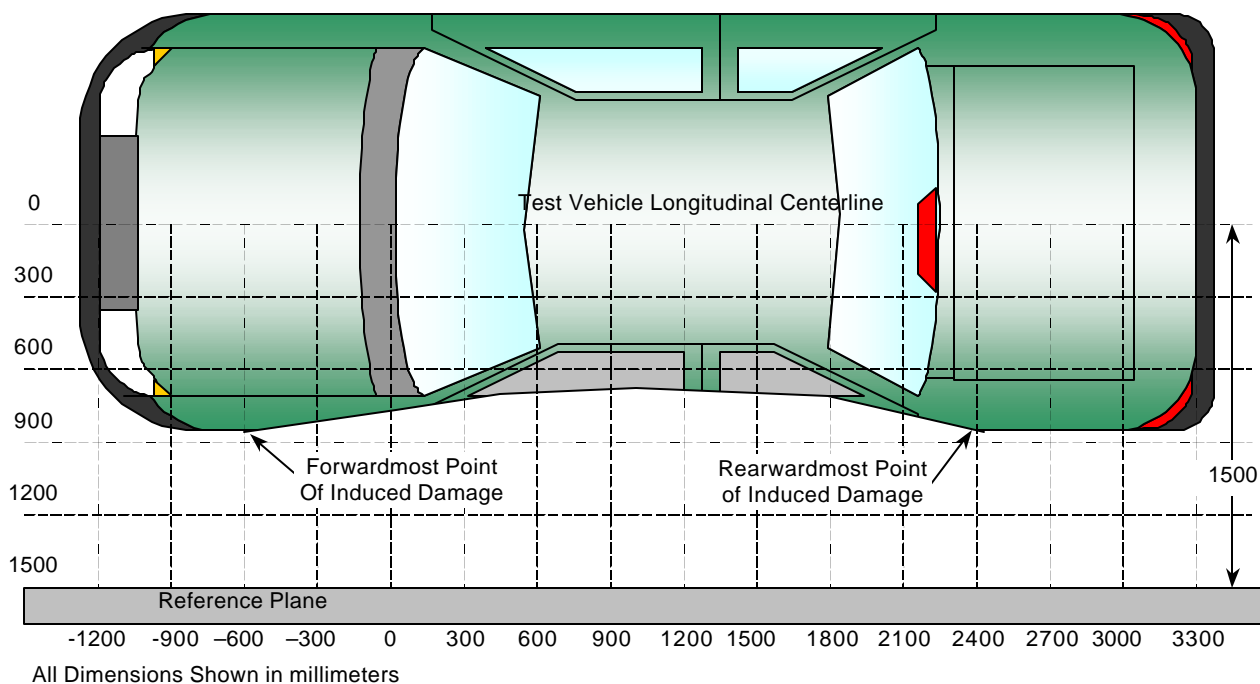

TOP VIEW

Damage Profile Distances

DPD	Distance From Impact Point in mm	Level	Pre-Test (mm)	Post-Test (mm)	Max Static Crush (mm)
1	0	3	628	724	-96
2	600	2	646	894	-248
3	1200	2	643	899	-256
4	1800	2	641	834	-193
5	2400	4	685	741	-56
6	2850	4	716	719	-3

Pre-Test and Post-Test measurements are distance from vehicle centerline.

DATA SHEET NO. 12

DEFORMABLE BARRIER HONEYCOMB FACE STATIC CRUSH

Test Vehicle: 2003 Subaru Forester 2.5X AWD Wagon

NHTSA No.: M35500

Test Program: 55/28 km/h 90° Side Impact NCAP

Test Date: 10/29/02

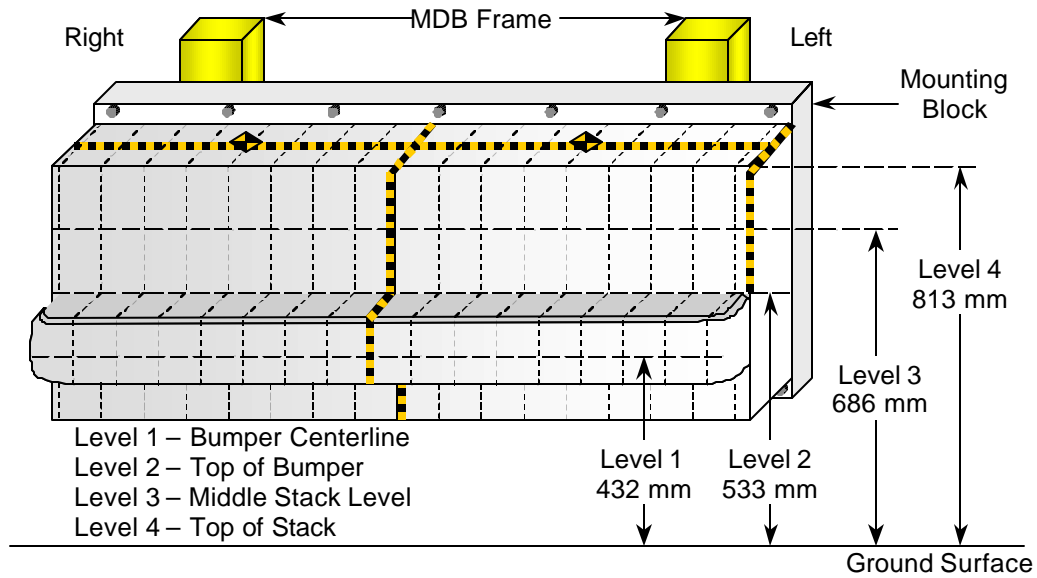

DEFORMABLE BARRIER STATIC CRUSH

Stack	Distance Right of Center								C _L	Distance Left of Center							
	800	700	600	500	400	300	200	100		0	100	200	300	400	500	600	700
1	170	149	136	133	132	132	133	132	133	137	138	140	143	140	143	153	173
2	113	104	101	98	97	89	85	78	72	72	83	83	92	102	112	112	102
3	119	93	72	58	44	34	31	31	36	43	61	44	29	28	28	33	75
4	178	127	86	61	50	43	35	40	48	67	102	79	48	39	48	58	76

All Dimensions in mm

DATA SHEET NO. 13

VEHICLE ACCELEROMETER LOCATION AND DATA SUMMARY

Test Vehicle: 2003 Subaru Forester 2.5X AWD Wagon

NHTSA No.: M35500

Test Program: 55/28 km/h 90° Side Impact NCAP

Test Date: 10/29/02

LEFT SIDE VIEW

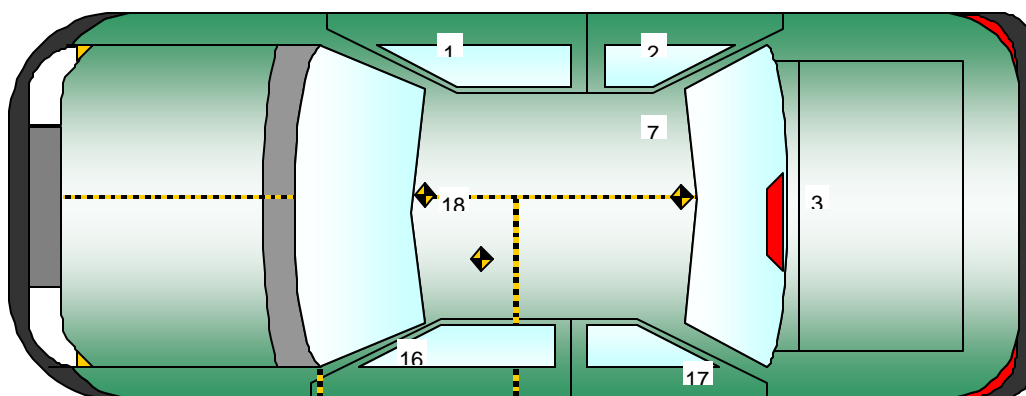
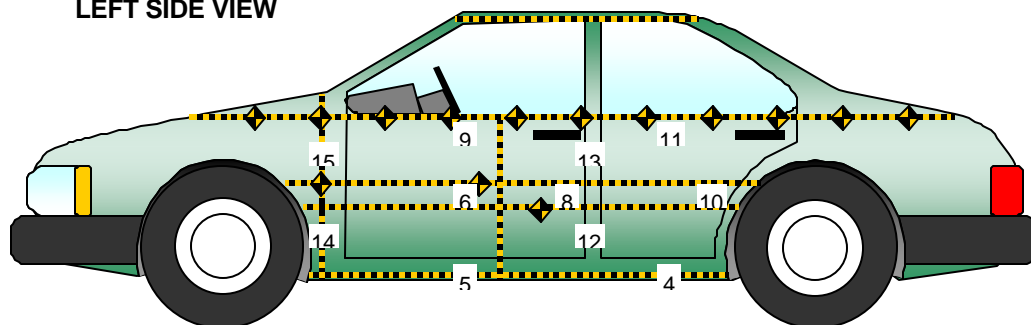

No.	Location
1	Right Sill at Front Seat
2	Right Sill at Rear Seat
3	Rear Floorpan Above Axle
4	Left Sill at Rear Door
5	Left Sill at Front Door
6	Left Front Door Centerline
7	Right Rear Occupant Compartment
8	Left Front Door Mid-Rear
9	Left Front Door Upper Centerline

No.	Location
10	Left Rear Door Mid-Rear
11	Left Rear Door Upper Centerline
12	Left Lower B-Post
13	Left Middle B-Post
14	Left Lower A-Post
15	Left Middle A-Post
16	Front Seat Track
17	Rear Seat Track or Structure
18	Vehicle CG

DATA SHEET NO. 13

VEHICLE ACCELEROMETER LOCATION AND DATA SUMMARY

Test Vehicle: 2003 Subaru Forester 2.5X AWD Wagon

NHTSA No.: M35500

Test Program: 55/28 km/h Side Impact NCAP

Test Date: 10/29/02

VEHICLE ACCELEROMETER PEAK DATA AND PRE-TEST LOCATIONS

Loc. No.	Accelerometer Location	Measurements (mm)			Peak Values (G's)				
		X	Y	Z	Axis	Max	Time	Min	Time
1	Right Sill at Front Seat	2830	610	325	X	2.9	56.0	-6.4	24.3
					Y	24.6	30.4	-2.6	127.5
					Z	8.8	25.8	-12.4	15.4
					RES	25.6	30.5		
2	Right Sill at Rear Seat	1625	670	405	X	3.5	56.9	-3.4	23.6
					Y	23.9	24.2	-3.2	78.3
					Z	6.6	91.5	-5.1	19.5
					RES	24.1	24.1		
3	Rear Floorpan Above Axle	80	80	450	X	9.1	40.4	-15.5	33.1
					Y	34.7	32.7	-4.6	100.0
					Z	20.1	24.2	-29.6	19.6
					RES	38.7	32.9		
4	Left Sill at Rear Door	1780	-660	250	Y	45.1	18.3	-26.4	24.8
5	Left Sill at Front Door	2420	-660	250	Y	45.2	4.9	-2.5	53.5
6	Front Door Centerline	2495	-740	755	Y	0.0	0.0	0.0	0.0
7	Rt. Rear Occ. Compartment	2070	405	300	Y	27.4	24.5	-4.0	78.9
8	Front Door Mid-Rear	2275	-740	710	Y	90.7	12.1	-19.7	49.5
9	Front Door Upper Centerline	2525	-740	925	Y	184.2	15.4	-119.1	21.5
10	Rear Door Mid-Rear	1450	-710	725	Y	93.4	15.8	-70.3	24.9
11	Rear Door Upper Centerline	1590	-710	930	Y	148.4	15.2	-138.2	34.6
12	B-Post Lower	2080	-700	590	Y	166.4	4.1	-31.3	27.8
13	B-Post Middle	2080	-700	820	Y	99.2	4.3	-20.0	28.0
14	A-Post Lower	3050	-760	640	Y	96.9	4.1	-22.1	23.4
15	A-Post Middle	3050	-760	770	Y	60.5	4.0	-26.9	18.0
16	Front Seat Track	2460	-590	430	Y	61.6	12.8	-32.6	24.3
17	Rear Seat Structure				Y				
18	Vehicle CG	1810	0	420	X	4.0	3.9	-7.9	23.7
					Y	26.6	24.9	-2.8	77.8
					Z	17.0	16.1	-20.3	4.9
					RES	29.1	5.3		

¹ Channel failed, no data

² Channel failed at 22.1 msec.

³ Not installed

DATA SHEET NO. 14
MDB ACCELEROMETER LOCATION AND DATA SUMMARY

Test Vehicle: 2003 Subaru Forester 2.5X AWD Wagon
 Test Program: 55/28 km/h Side Impact NCAP

NHTSA No.: M35500
 Test Date: 10/29/02

MDB ACCELEROMETER PEAK DATA AND LOCATIONS

Loc. No.	Accelerometer Location	Measurements (mm)			Peak Values (G's)				
		X	Y	Z	Axis	Max	Time	Min	Time
1	MDB CG	-1195	0	430	X	2.2	122.6	-23.5	36.8
					Y	2.6	74.6	-8.3	21.7
					Z	13.2	18.7	-12.1	70.8
					RES	24.1	36.9		
2	MDB Rear	-2642	-593	608	X	2.5	98.3	-22.3	40.4
					Y	2.3	52.8	-4.6	21.7

Reference Points X - MDB Front Axle Y - MDB Centerline Z - Ground Plane

MDB BUMPER CONTACT SWITCH DATA

Loc. No.	Contact Switch Location	Units	Peak and 50% Crossing Point			
			Max	Time	50%	Time
3	MDB Left Bumper (T=0)	% F.S	100.0	0.0	50.0	0.0
4	MDB Right Bumper	% F.S.	101.1	22.6	50.0	-0.7

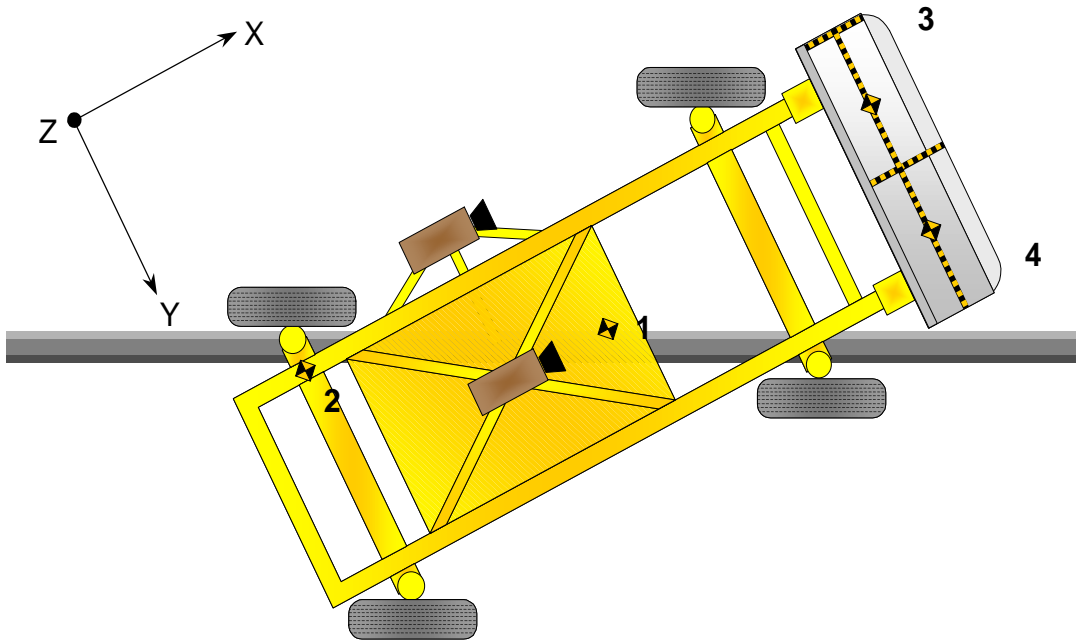

DATA SHEET NO. 15
HIGH SPEED CAMERA LOCATIONS AND DATA

Test Vehicle: 2003 Subaru Forester 2.5X AWD Wagon

NHTSA No.: M35500

Test Program: 55/28 km/h 90° Side Impact NCAP

Test Date: 10/29/02

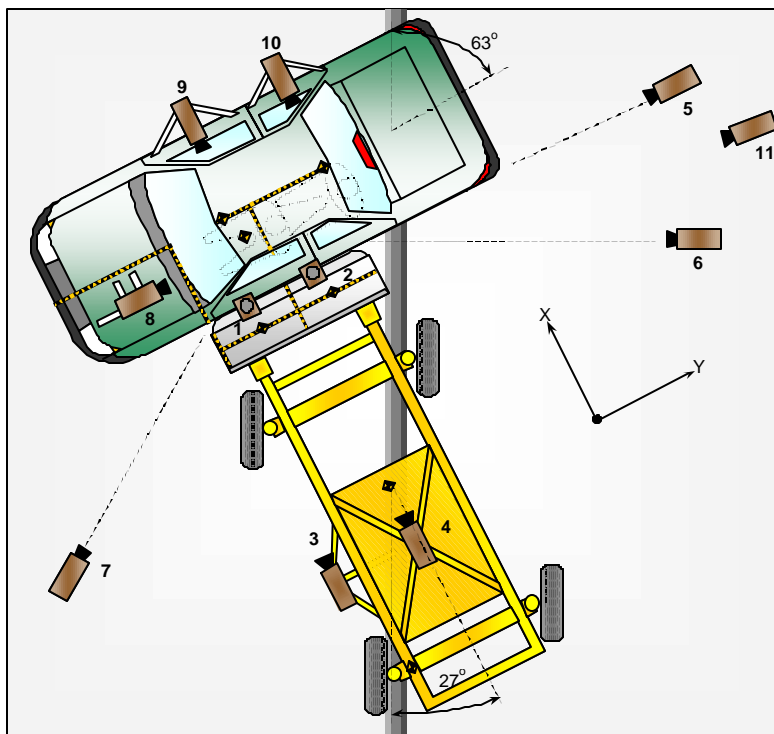

No.	Camera View	Location (mm)			Angle (deg.)	Lens (mm)	Film Speed (fr./sec.)
		X	Y	Z			
1	Overhead Overall	2438	609	5486	90	19	DNR
2	Overhead Close-up	1676	-1066	5486	90	24	1000
3	MDB Onboard, Impact Point Close-Up	0	-2133	1143	7	13	650
4	MDB Onboard, Centerline of Impact	838	-3911	1371	11	13	820
5	Right Side, Ground Level, Overall	15544	228	1422	1	25	1020
6	Right Side, Ground Level, Close-up	16459	-7188	939	0	80	1000
7	Left Side, Ground Level, Close-up	-4775	-2667	1473	4	13	1000
8	Vehicle Onboard Front SID, Front	-5181	508	1422	11	19	920
9	Vehicle Onboard Front SID, Side	889	1778	1143	7	19	1030
10	Vehicle Onboard Rear SID, Side	1701	1778	1143	7	19	1000
11	Vehicle Ground	41148	64008	1574	0	100	500
12	Real Time Coverage	N/A	N/A	N/A	N/A	N/A	N/A

DNR = Did Not Run

DATA SHEET NO. 16

FMVSS 301 FUEL SYSTEM INTEGRITY POST IMPACT DATA

Test Vehicle: 2003 Subaru Forester 2.5X AWD Wagon

NHTSA No.: M35500

Test Program: 55/28 km/h 90° Side Impact NCAP

Test Date: 10/29/02

Test Time: 12:32 PM

Temperature at Time of Impact: 20.5 °C

Stoddard Solvent Spillage Measurements

- A. From impact until vehicle motion ceases: 0.0 oz.
(Maximum Allowable = 1 ounce)
- B. For the 5 minute period after motion ceases: 0.0 oz.
(Maximum Allowable = 5 ounces)
- C. For the following 25 minutes: 0.0 oz.
(Maximum Allowable = 1 oz./minute)
- D. Spillage Details: No leakage occurred

DATA SHEET NO. 17
FMVSS 301 STATIC ROLLOVER DATA SHEET

Test Vehicle: 2003 Subaru Forester 2.5X AWD Wagon
 Test Program: 55/28 km/h 90° Side Impact NCAP

NHTSA No.: M35500
 Test Date: 10/29/02

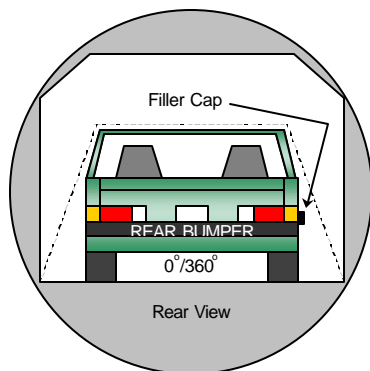

0° TO 90°

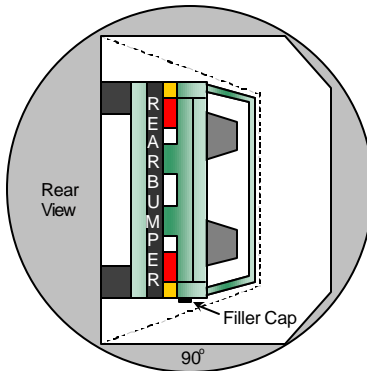

90° TO 180°

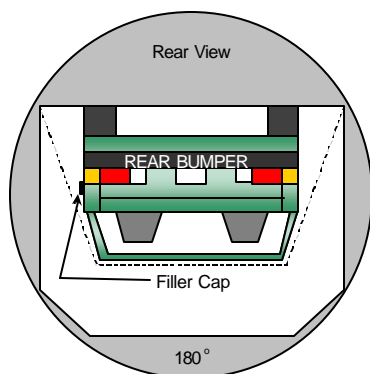
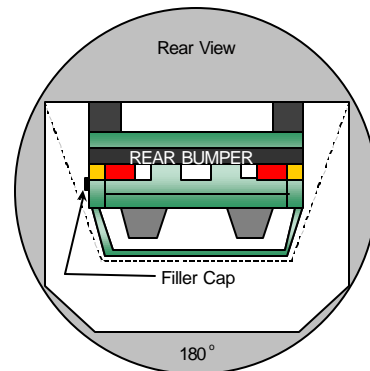

180° TO 270°

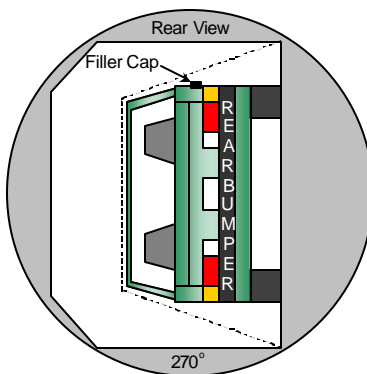

270° TO 360°

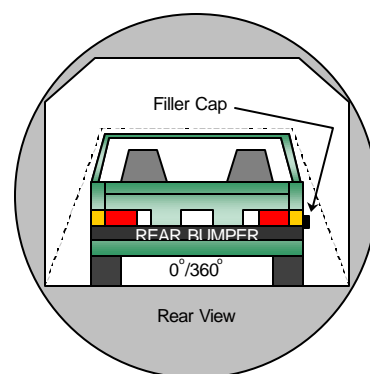

1. The specified fixture rollover rate for each 90° of rotation is 60 to 120 seconds.
2. The position hold time at each position is 300 seconds (minimum).
3. Details of Stoddard Solvent spillage locations.

No solvent leakage occurred during static rollover testing.

Rollover Test Phase	Rotation Time (sec.)	Hold Time (sec.)	Spillage (oz.)
0° TO 90°	82	300	0.0
90° TO 180°	80	300	0.0
180° TO 270°	79	300	0.0
270° TO 360°	80	0	0.0

APPENDIX A
PHOTOGRAPHS

LIST OF PHOTOGRAPHS

Figure		Page
A-1	Left Front as Received	A-1
A-2	Right Rear as Received	A-2
A-3	Vehicle Certification Label	A-3
A-4	Vehicle Tire Label	A-4
A-5	Front View, Pre-test	A-5
A-6	Front View, Post-Test	A-6
A-7	Left Front $\frac{3}{4}$ View, PreTest	A-7
A-8	Left Front $\frac{3}{4}$ View, PostTest	A-8
A-9	Left (Impacted) Side View, Pre-Test	A-9
A-10	Left (Impacted) Side View, Post-Test	A-10
A-11	Left Rear $\frac{3}{4}$ View, PreTest	A-11
A-12	Left Rear $\frac{3}{4}$ View, Post Test	A-12
A-13	Rear View, Pre-Test	A-13
A-14	Rear View, Post-Test	A-14
A-15	Overhead Overall View, Pre-Test	A-15
A-16	Overhead Overall View, Post-Test	A-16
A-17	Overhead Close-up View, Pre-Test	A-17
A-18	Overhead Close-up View, Post-Test	A-18
A-19	Impact Point Target Set-up, Pre-Test	A-19
A-20	Impact Point Target Set-up, Post-Test	A-20
A-21	Front $\frac{3}{4}$ View of Left Side Doors, PreTest	A-21
A-22	Front $\frac{3}{4}$ View of Left Side Doors, PostTest	A-22
A-23	Rear $\frac{3}{4}$ View of Left Side Doors, PreTest	A-23
A-24	Rear $\frac{3}{4}$ View of Left Side Doors, PostTest	A-24
A-25	Left Front Door Closed, Pre-Test	A-25
A-26	Left Front Door Closed, Post-Test	A-26
A-27	Left Rear Door Closed, Pre-Test	A-27
A-28	Left Rear Door Closed, Post-Test	A-28
A-29	Driver Dummy Left Side with Door Open, Pre-Test	A-29
A-30	Driver Dummy Left Side, Pre-Test	A-30
A-31	Driver Dummy Left Side, Post-Test	A-31
A-32	Driver Dummy Clearance, Pre-Test	A-32
A-33	Driver Dummy Clearance, Post-Test	A-33

LIST OF PHOTOGRAPHS, ...(Continued)

<u>Figure</u>		<u>Page</u>
A-34	Driver Dummy Inside View, Pre-Test	A-34
A-35	Driver Dummy Inside View, Post-Test	A-35
A-36	Driver Door Inside View, Pre-Test	A-36
A-37	Driver Dummy Contact Points Inside View, Post-Test (Vehicle Moved)	A-37
A-38	Passenger Dummy Left Side with Door Open, Pre-Test	A-38
A-39	Passenger Dummy Left Side, Pre-Test	A-39
A-40	Passenger Dummy Left Side, Post-Test	A-40
A-41	Passenger Dummy Clearance, Pre-Test	A-41
A-42	Passenger Dummy Clearance, Post-Test	A-42
A-43	Passenger Dummy Inside View, Pre-Test	A-43
A-44	Passenger Dummy Inside View, Post-Test	A-44
A-45	Passenger Door Inside View, Pre-Test	A-45
A-46	Passenger Dummy Contact Points Inside View, Post-Test(Vehicle Moved)	A-46
A-47	Front View of Deformable Barrier, Pre-Test	A-47
A-48	Front View of Deformable Barrier, Post-Test	A-48
A-49	Top View of Deformable Barrier, Pre-Test	A-49
A-50	Top View of Deformable Barrier, Post-Test	A-50
A-51	Right Side View of Deformable Barrier, Pre-Test	A-51
A-52	Right Side View of Deformable Barrier, Post-Test	A-52
A-53	Left Side View of Deformable Barrier, Pre-Test	A-53
A-54	Left Side View of Deformable Barrier, Post-Test	A-54
A-55	Vehicle On Rollover Device, Top View	A-55
A-56	Vehicle During Impact	A-56



Figure A-1: Left Front, as Received



Figure A-2: Right Rear, as Received

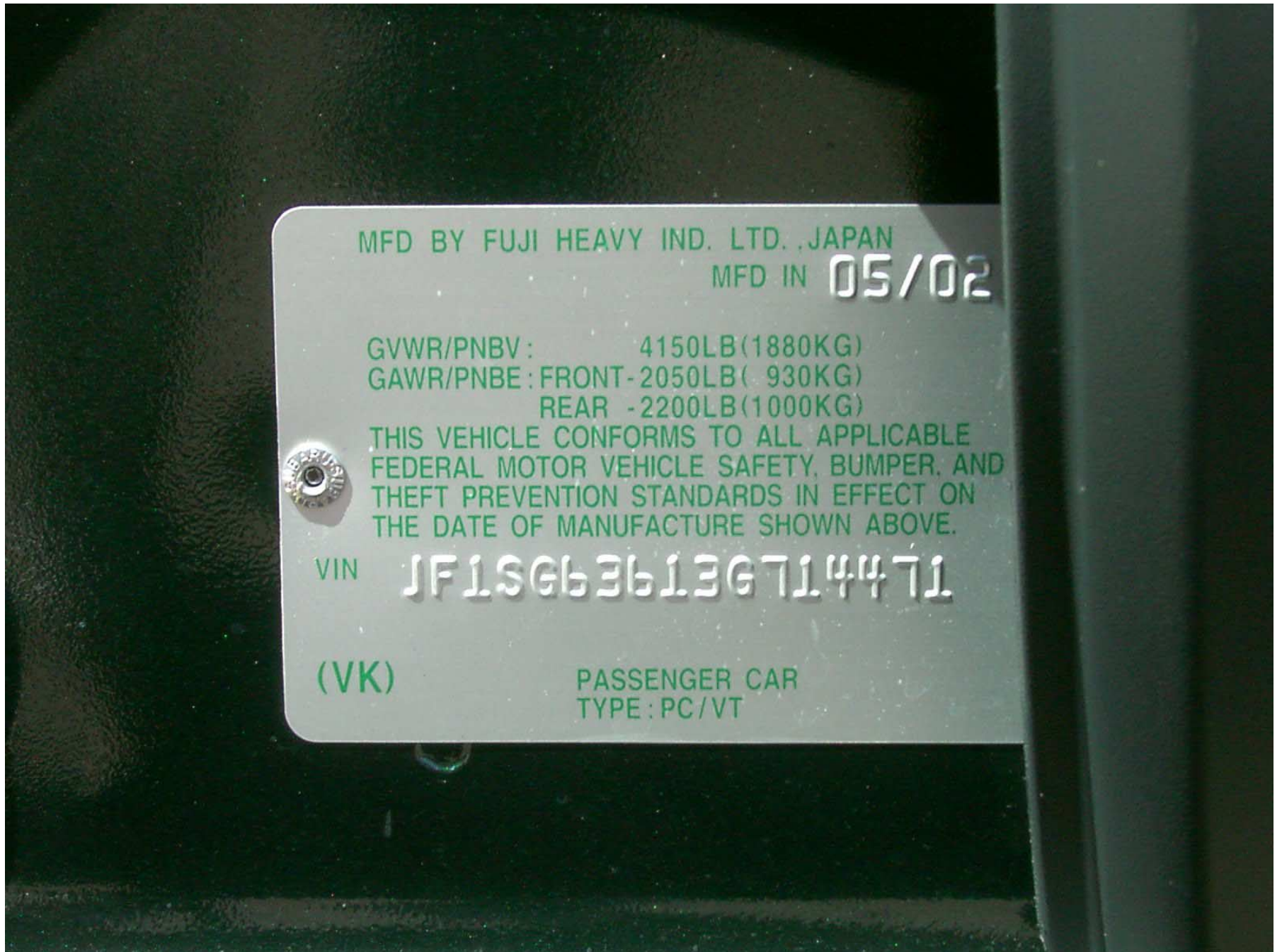

Figure A-3: Vehicle Certification Label



VEHICLE CAPACITY WEIGHT:
900LB(410KG)
NUMBER OF OCCUPANTS:
TOTAL 5 (FRONT 2/REAR 3)
RECOMMENDED TIRE INFLATION
PRESSURE kPa(psi)

TIRE SIZE		FRONT	REAR
P215/60R16 94H	LIGHT LOAD	200(29)	190(28)
	FULL LOAD	200(29)	250(36)

At trailer towing, rear inflation pressure is 280kPa(41psi).

SUBARU DW

SRS SIDE AIRBAG
! WARNING
TO AVOID SERIOUS

Figure A-4: Vehicle Tire Label



Figure A-5: Front View, Pre-Test

**Photograph Not
Available**

Figure A-6: Front View, Post-Test



A-7

TR-P23003-01-NC

Figure A-7: Left Front $\frac{3}{4}$ View, Pre-Test



Figure A-8: Left Front ¾ View, Post-Test



Figure A-9: Left (Impacted) Side View, Pre-Test



Figure A-10: Left (Impacted) Side View, Post-Test



Figure A-11: Left Rear $\frac{3}{4}$ View, Pre-Test



Figure A-12: Left Rear $\frac{3}{4}$ View, Post-Test



Figure A-13: Rear View, Pre-Test



Figure A-14: Rear View, Post-Test



Figure A-15: Overhead Overall View, Pre-Test



Figure A-16: Overhead Overall View, Post-Test



Figure A-17: Overhead Close-up View, Pre-Test



Figure A-18: Overhead Close-up View, Post-Test



Figure A-19: Impact Point Target Set-up, Pre-Test



Figure A-20: Impact Point Target, Post-Test



Figure A-21: Front $\frac{3}{4}$ View of Left Side Doors, Pre-Test



Figure A-22: Front $\frac{3}{4}$ View of Left Side Doors, Post-Test



Figure A-23: Rear ¾ View of Left Side Doors, Pre-Test



Figure A-24: Rear ¾ View of Left Side Doors, Post-Test

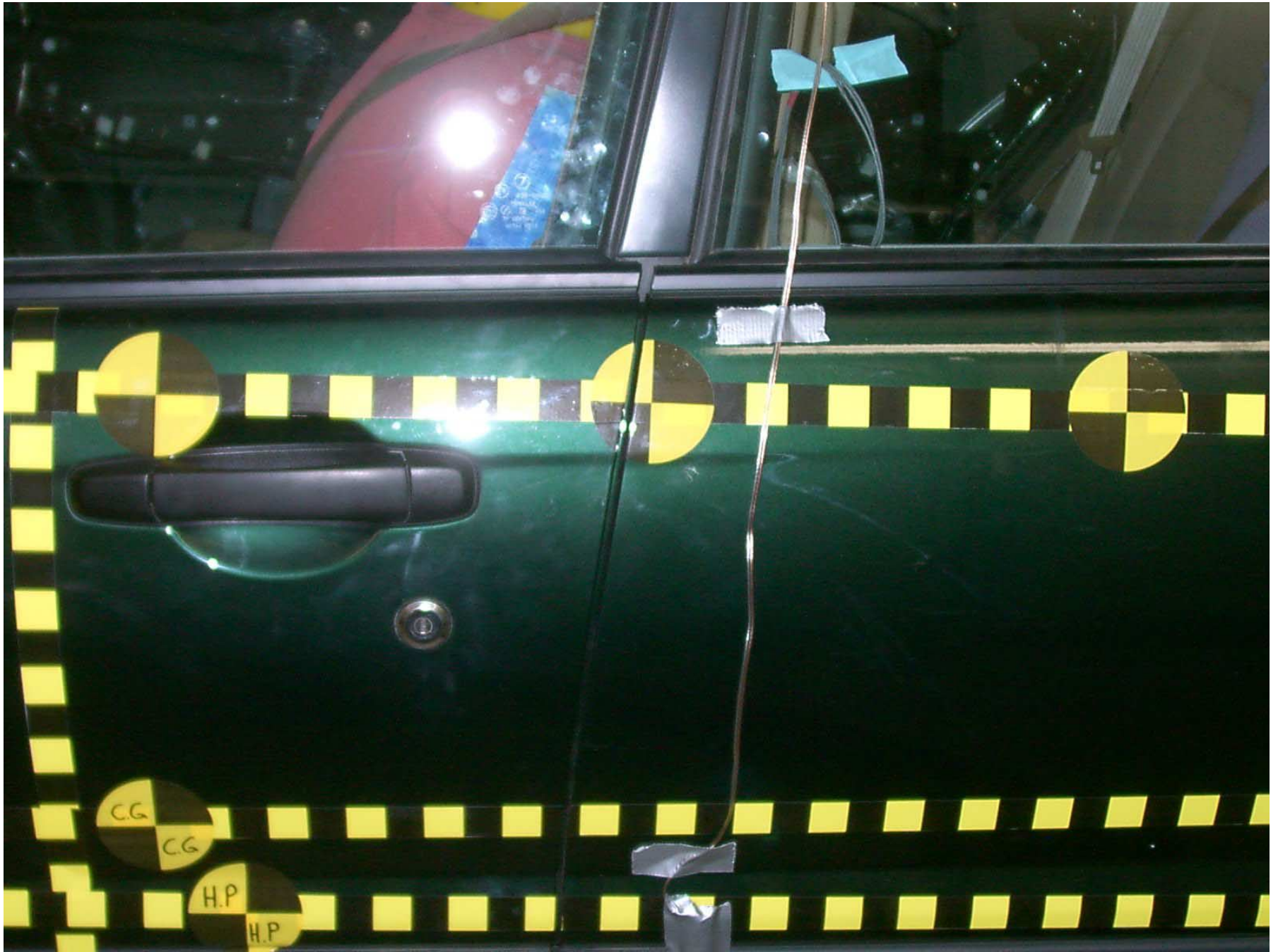

Figure A-25: Left Front Door Closed, Pre-Test



Figure A-26: Left Front Door Closed, Post-Test



Figure A-27: Left Rear Door Closed, Pre-Test



Figure A-28: Left Rear Door Closed, Post-Test



Figure A-29: Driver Dummy Left Side with Door Open, Pre-Test



Figure A-30: Driver Dummy Left Side, Pre-test



Figure A-31: Driver Dummy Left Side, Post-Test



Figure A-32: Driver Dummy Clearance, Pre-Test



Figure A-33: Driver Dummy Clearance, Post-Test



Figure A-34: Driver Dummy Inside View, Pre-Test



Figure A-35: Driver Dummy Inside View, Post-Test



Figure A-36: Driver Door Inside View, Pre-Test



Figure A-37: Driver Dummy Contact Points Inside View, Post-Test (Vehicle Moved)



Figure A-38: Passenger Dummy Left Side with Door Open, Pre-Test



Figure A-39: Passenger Dummy Left Side, Pre-Test



Figure A-40: Passenger Dummy Left Side, Post-Test



Figure A-41: Passenger Dummy Clearance, Pre-Test



Figure A-42: Passenger Dummy Clearance, Post-Test



Figure A-43: Passenger Dummy Inside View, Pre-Test



Figure A-44: Passenger Dummy Inside View, Post-Test



A-45

TR-P23003-01-NC

Figure A-45: Passenger Door Inside View, Pre-Test



Figure A-46: Passenger Dummy Contact Points Inside View, Post-Test (Vehicle Moved)



Figure A-47: Front View of Deformable Barrier, Pre-Test



Figure A-48: Front View of Deformable Barrier, Post-Test

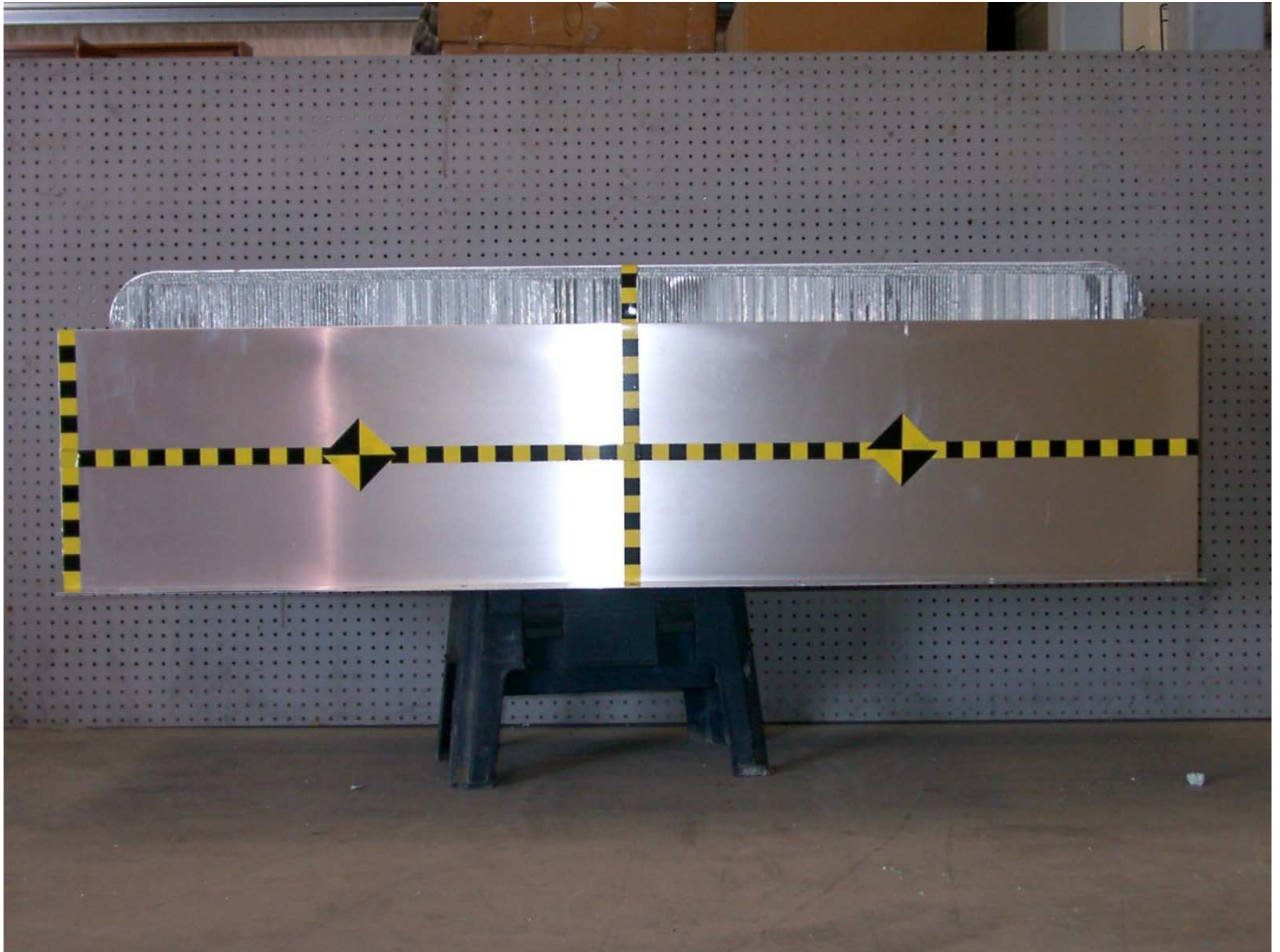

Figure A-49: Top View of Deformable Barrier, Pre-Test



Figure A-50: Top View of Deformable Barrier, Post-Test



Figure A-51: Right Side View of Deformable Barrier, Pre-Test



Figure A-52: Right Side View of Deformable Barrier, Post-Test



Figure A-53: Left Side View of Deformable Barrier, Pre-Test



Figure A-54: Left Side View of Deformable Barrier, Post-Test



Figure A-55: Vehicle on Rollover Device, Top View



Figure A-56: Vehicle During Impact

APPENDIX B
SID, VEHICLE, AND MDB RESPONSE DATA

LIST OF DATA PLOTS, DRIVER SID

Data Plot		Page
B-1	Driver Head X	B-1
B-2	Driver Head X Velocity	B-2
B-3	Driver Head Y	B-3
B-4	Driver Head Y Velocity	B-4
B-5	Driver Head Z	B-5
B-6	Driver Head Z Velocity	B-6
B-7	Driver Head Resultant	B-7
B-8	Driver Head X Redundant	B-8
B-9	Driver Head X Redundant Velocity	B-9
B-10	Driver Head Y Redundant	B-10
B-11	Driver Head Y Redundant Velocity	B-11
B-12	Driver Head Z Redundant	B-12
B-13	Driver Head Z Redundant Velocity	B-13
B-14	Driver Head Redundant Resultant	B-14
B-15	Driver Neck Force X	B-15
B-16	Driver Neck Force Y	B-16
B-17	Driver Neck Force Z	B-17
B-18	Driver Neck Force Resultant	B-18
B-19	Driver Neck Moment X	B-19
B-20	Driver Neck Moment Y	B-20
B-21	Driver Neck Moment Z	B-21
B-22	Driver Neck Moment Resultant	B-22
B-23	Driver Upper Rib Primary Y	B-23
B-24	Driver Upper Rib Primary Y Velocity	B-24
B-25	Driver Lower Rib Primary Y	B-25
B-26	Driver Lower Rib Primary Y Velocity	B-26
B-27	Driver Lower Spine Primary Y	B-27
B-28	Driver Lower Spine Primary Y Velocity	B-28
B-29	Driver Pelvis Primary Y	B-29
B-30	Driver Pelvis Primary Y Velocity	B-30
B-31	Driver Upper Rib Redundant Y	B-31
B-32	Driver Upper Rib Redundant Y Velocity	B-32
B-33	Driver Lower Rib Redundant Y	B-33
B-34	Driver Lower Rib Redundant Y Velocity	B-34
B-35	Driver Lower Spine Redundant Y	B-35

LIST OF DATA PLOTS, DRIVER SID

<u>Data Plot</u>		<u>Page</u>
B-36	Driver Lower Spine Redundant Y Velocity	B-36
B-37	Driver Pelvis Redundant Y	B-37
B-38	Driver Pelvis Redundant Y Velocity	B-38
B-39	Driver Thorax Contact	B-39
B-40	Driver Pelvis Contact	B-40

LIST OF DATA PLOTS, PASSENGER SID

Data Plot	Page	
B-41	Passenger Head X	B-41
B-42	Passenger Head X Velocity	B-42
B-43	Passenger Head Y	B-43
B-44	Passenger Head Y Velocity	B-44
B-45	Passenger Head Z	B-45
B-46	Passenger Head Z Velocity	B-46
B-47	Passenger Head Resultant	B-47
B-48	Passenger Head X Redundant	B-48
B-49	Passenger Head X Redundant Velocity	B-49
B-50	Passenger Head Y Redundant	B-50
B-51	Passenger Head Y Redundant Velocity	B-51
B-52	Passenger Head Z Redundant	B-52
B-53	Passenger Head Z Redundant Velocity	B-53
B-54	Passenger Head Redundant Resultant	B-54
B-55	Passenger Neck Force X	B-55
B-56	Passenger Neck Force Y	B-56
B-57	Passenger Neck Force Z	B-57
B-58	Passenger Neck Force Resultant	B-58
B-59	Passenger Neck Moment X	B-59
B-60	Passenger Neck Moment Y	B-60
B-61	Passenger Neck Moment Z	B-61
B-62	Passenger Neck Moment Resultant	B-62
B-63	Passenger Upper Rib Primary Y	B-63
B-64	Passenger Upper Rib Primary Y Velocity	B-64
B-65	Passenger Lower Rib primary Y	B-65
B-66	Passenger Lower Rib Primary Y Velocity	B-66
B-67	Passenger Lower Spine Primary Y	B-67
B-68	Passenger Lower Spine Primary Y Velocity	B-68
B-69	Passenger pelvis primary Y	B-69
B-70	Passenger pelvis Primary Y Velocity	B-70
B-71	Passenger Upper Rib Redundant Y	B-71
B-72	Passenger Upper Rib Redundant Y Velocity	B-72
B-73	Passenger Lower Rib Redundant Y	B-73
B-74	Passenger Lower Rib Redundant Y Velocity	B-74
B-75	Passenger Lower Spine Redundant Y	B-75

LIST OF DATA PLOTS, PASSENGER SID

<u>Data Plot</u>		<u>Page</u>
B-76	Passenger Lower Spine Redundant y Velocity	B-76
B-77	Passenger Pelvis Redundant Y	B-77
B-78	Passenger Pelvis Redundant Y Velocity	B-78
B-79	Passenger Thorax Contact	B-79
B-80	Passenger Pelvis Contact	B-80

LIST OF DATA PLOTS, VEHICLE

Data Plot	Page
B-81 Right Sill at Front Seat X	B-81
B-82 Right Sill at Front Seat X Velocity	B-82
B-83 Right Sill at Front Seat Y	B-83
B-84 Right Sill at Front Seat Y Velocity	B-84
B-85 Right Sill at Front Seat Z	B-85
B-86 Right Sill at Front Seat Z Velocity	B-86
B-87 Right Sill at Front Seat Resultant	B-87
B-88 Right Sill at Rear Seat X	B-88
B-89 Right Sill at Rear Seat X Velocity	B-89
B-90 Right Sill at Rear Seat Y	B-90
B-91 Right Sill at Rear Seat Y Velocity	B-91
B-92 Right Sill at Rear Seat Z	B-92
B-93 Right Sill at Rear Seat Z Velocity	B-93
B-94 Right Sill at Rear Seat Resultant	B-94
B-95 Rear Floor Pan Above Axle X	B-95
B-96 Rear Floor Pan Above Axle X Velocity	B-96
B-97 Rear Floor Pan Above Axle Y	B-97
B-98 Rear Floor Pan Above Axle Y Velocity	B-98
B-99 Rear Floor Above Axle Z	B-99
B-100 Rear Floor Pan Above Axle Z Velocity	B-100
B-101 Rear Floor Above Axle Resultant	B-101
B-102 Left Sill at Rear Door Y	B-102
B-103 Left Sill at Rear Door Y Velocity	B-103
B-104 Left Sill at Front Door Y	B-104
B-105 Left Sill at Front Door Y Velocity	B-105
B-106 Left Front Door Centerline Y	B-106
B-107 Left Front Door Centerline Y Velocity	B-107
B-108 Right Rear Occupant Compartment Y	B-108
B-109 Right Rear Occupant Compartment Y Velocity	B-109
B-110 Left Front Door Mid Rear Y	B-110
B-111 Left Front Door Mid Rear Y Velocity	B-111
B-112 Left Front Door Upper Centerline Y	B-112
B-113 Left Front Door Upper Centerline Y Velocity	B-113
B-114 Left Rear Door Mid Rear Y	B-114
B-115 Left Rear Door Mid Rear Y Velocity	B-115
B-116 Left Rear Door Upper Centerline Y	B-116

LIST OF DATA PLOTS, VEHICLE

<u>Data Plot</u>	<u>Page</u>	
B-117	Left Rear Door Upper Centerline Y Velocity	B-117
B-118	Left B-Post Lower Y	B-118
B-119	Left B-Post Lower Y Velocity	B-119
B-120	Left B-Post Middle Y	B-120
B-121	Left B-Post Middle Y Velocity	B-121
B-122	Left A-Post Lower Y	B-122
B-123	Left A-Post Lower Y Velocity	B-123
B-124	Left A-Post Middle Y	B-124
B-125	Left A-Post Middle Y Velocity	B-125
B-126	Left Front Seat Track Y	B-126
B-127	Left Front Seat Track Y Velocity	B-127
B-128	Left Rear Seat Structure Y	B-128
B-129	Left Rear Seat Structure Y Velocity	B-129
B-130	Vehicle CG X	B-130
B-131	Vehicle CG X Velocity	B-131
B-132	Vehicle CG Y	B-132
B-133	Vehicle CG Y Velocity	B-133
B-134	Vehicle CG Z	B-134
B-135	Vehicle CG Z Velocity	B-135
B-136	Vehicle CG Resultant	B-136

LIST OF DATA PLOTS, MDB

<u>Data Plot</u>		<u>Page</u>
B-137	Moving Deformable Barrier CG X	B-137
B-138	Moving Deformable Barrier CG X Velocity	B-138
B-139	Moving Deformable Barrier CG Y	B-139
B-140	Moving Deformable Barrier CG Y Velocity	B-140
B-141	Moving Deformable Barrier CG Z	B-141
B-142	Moving Deformable Barrier CG Z Velocity	B-142
B-143	Moving Deformable Barrier CG Resultant	B-143
B-144	Moving Deformable Barrier Rear X	B-144
B-145	Moving Deformable Barrier Rear X Velocity	B-145
B-146	Moving Deformable Barrier Rear Y	B-146
B-147	Moving Deformable Barrier Rear Y Velocity	B-147
B-148	Moving Deformable Barrier Right Bumper Contact Time	B-148

LIST OF DATA PLOTS, FIR FILTER DATA

<u>Data Plot</u>		<u>Page</u>
B-149	Driver Upper Rib Primary Y	B-149
B-150	Driver Lower Rib Primary Y	B-150
B-151	Driver Lower Spine Primary Y	B-151
B-152	Driver Pelvis Primary Y	B-152
B-153	Driver Upper Rib Redundant Y	B-153
B-154	Driver Lower Rib Redundant Y	B-154
B-155	Driver Lower Spine Redundant Y	B-155
B-156	Driver Pelvis Redundant Y	B-156
B-157	Passenger Upper Rib Primary Y	B-157
B-158	Passenger Lower Rib Primary Y	B-158
B-159	Passenger Lower Spine Primary Y	B-159
B-160	Passenger Pelvis Primary Y	B-160
B-161	Passenger Upper Rib Redundant Y	B-161
B-162	Passenger Lower Rib Redundant Y	B-162
B-163	Passenger Lower Spine Redundant Y	B-163
B-164	Passenger Pelvis Redundant Y	B-164

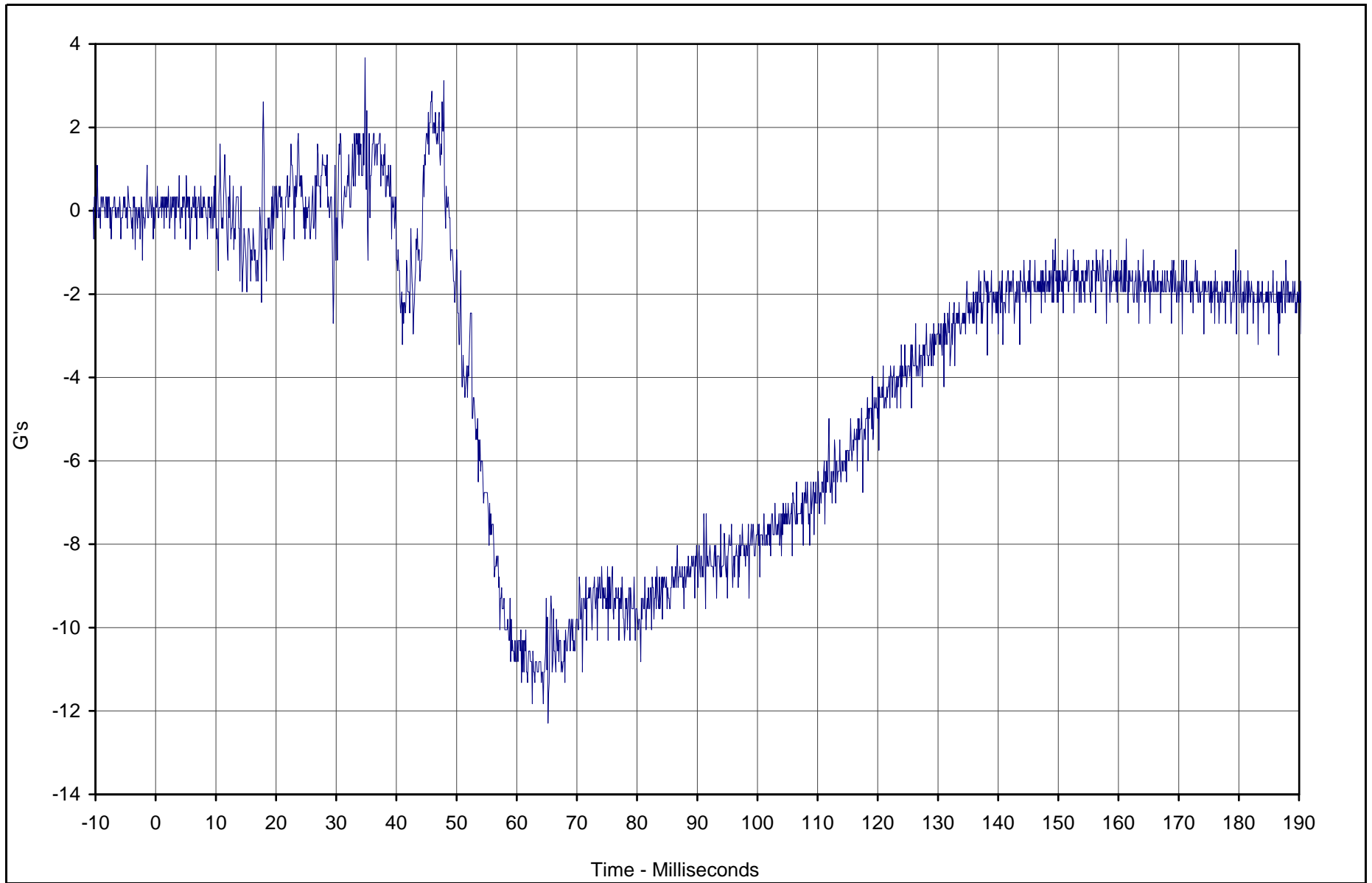

Curve Description	CURNO	Type	Units	Max	Time	Min	Time	SAE Class
Driver Head X	001	FIL	G's	3.7	34.8	-12.3	65.2	1000



Test Vehicle: 2003 Subaru Forester 2.5X AWD Wagon

Test Date: 10/29/02

Test Program: 55/28 km/h Side Impact NCAP

NHTSA No.: M35500

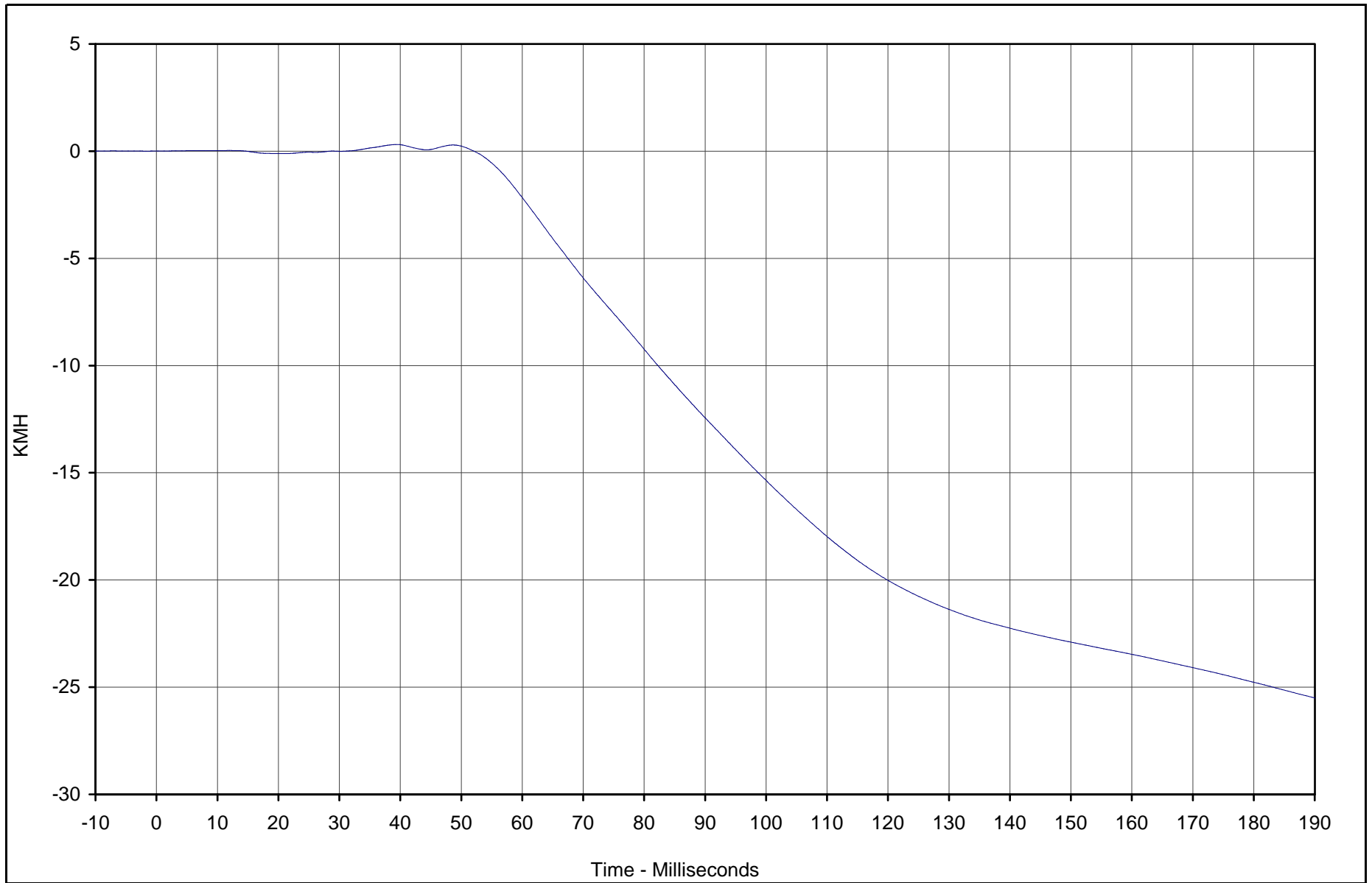

Curve Description	CURNO	Type	Units	Max	Time	Min	Time	SAE Class
Driver Head X Velocity	001	IN1	KMH	0.3	39.4	-25.5	189.9	180



Test Vehicle: 2003 Subaru Forester 2.5X AWD Wagon

Test Date: 10/29/02

Test Program: 55/28 km/h Side Impact NCAP

NHTSA No.: M35500

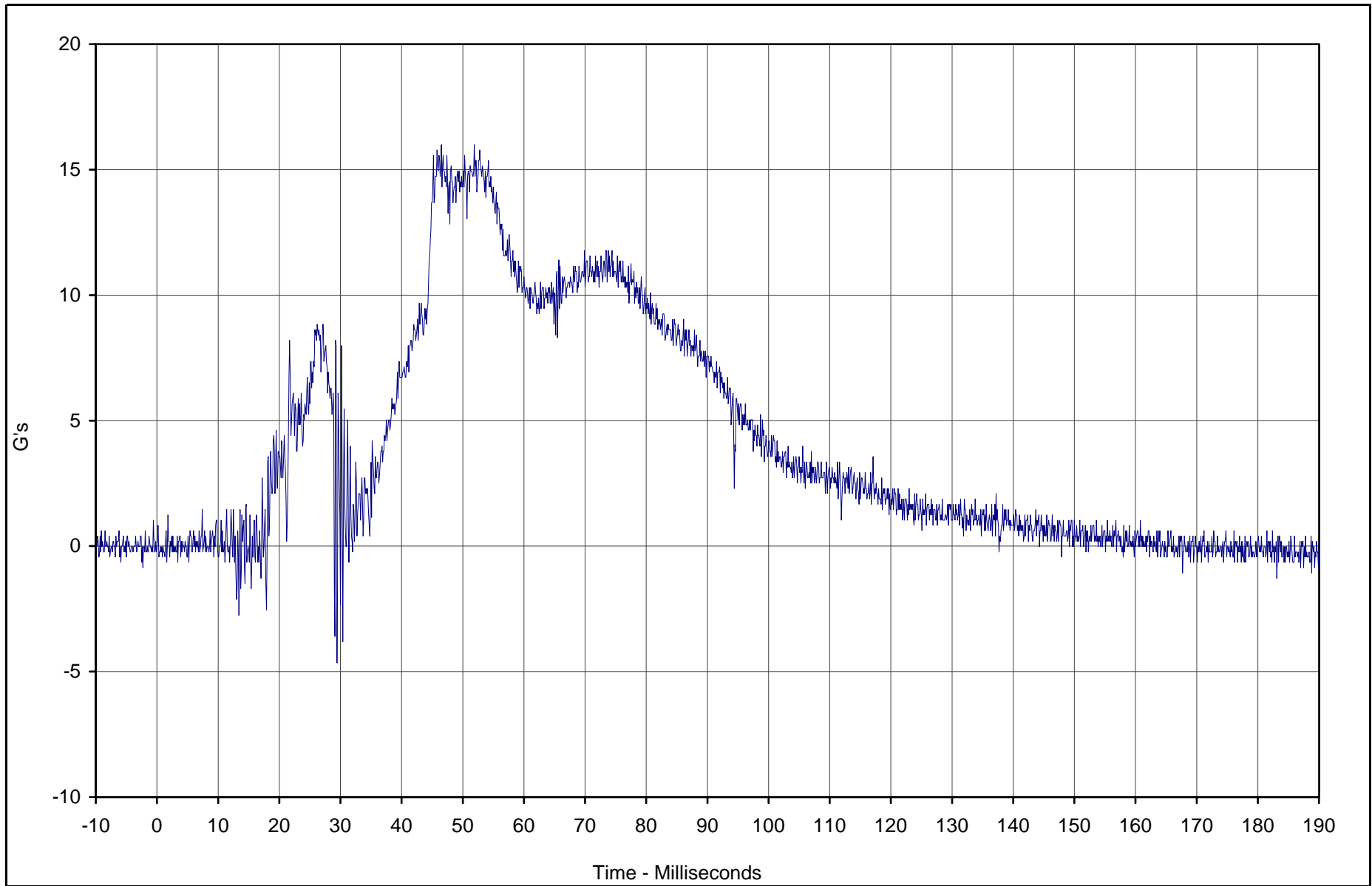

Curve Description	CURNO	Type	Units	Max	Time	Min	Time	SAE Class
Driver Head Y	002	FIL	G's	16.0	46.5	-4.7	29.4	1000



Test Vehicle: 2003 Subaru Forester 2.5X AWD Wagon

Test Date: 10/29/02

Test Program: 55/28 km/h Side Impact NCAP

NHTSA No.: M35500

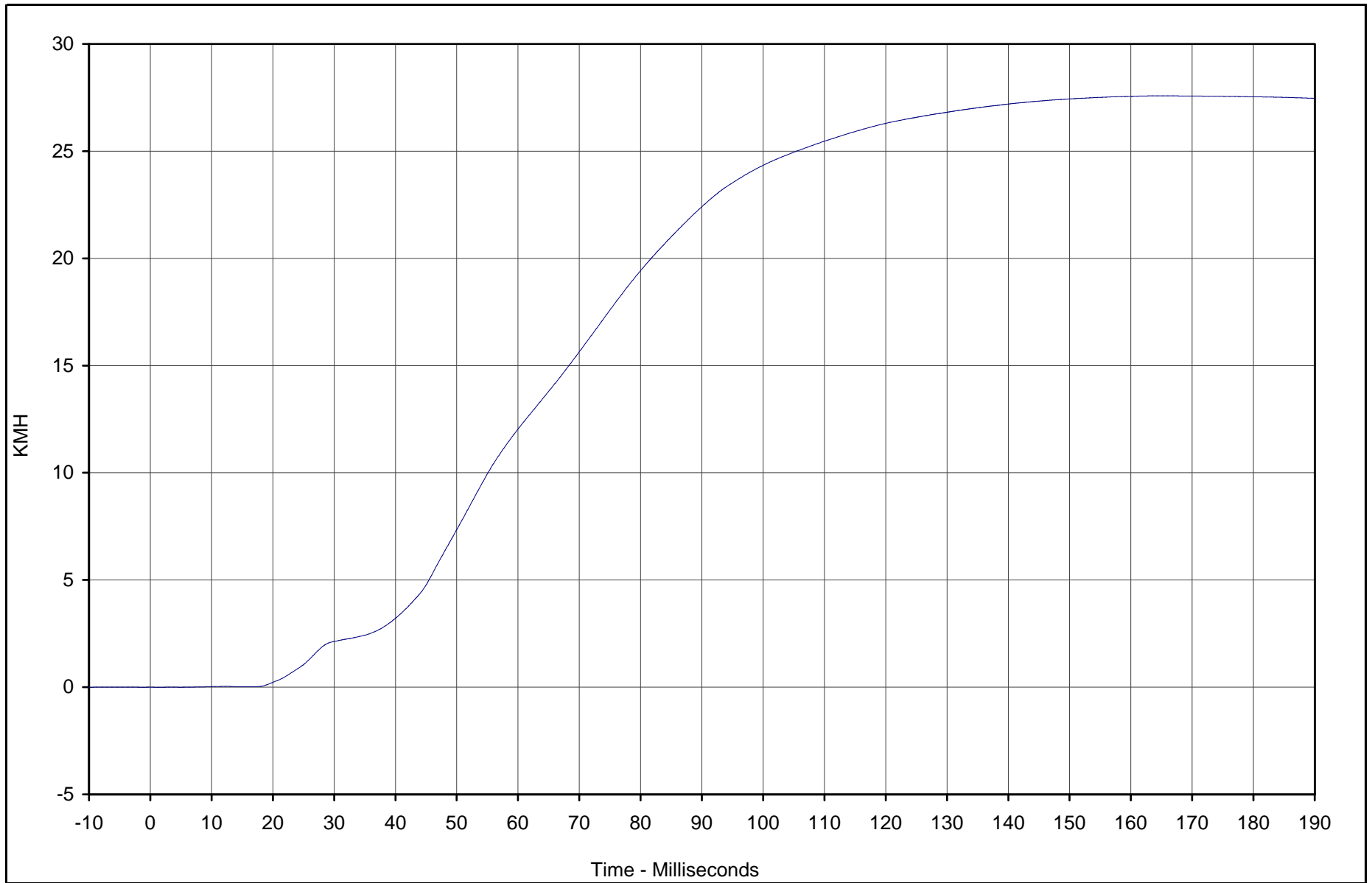

Curve Description	CURNO	Type	Units	Max	Time	Min	Time	SAE Class
Driver Head Y Velocity	002	IN1	KMH	27.6	164.3	0.0	1.4	180



Test Vehicle: 2003 Subaru Forester 2.5X AWD Wagon

Test Date: 10/29/02

Test Program: 55/28 km/h Side Impact NCAP

NHTSA No.: M35500

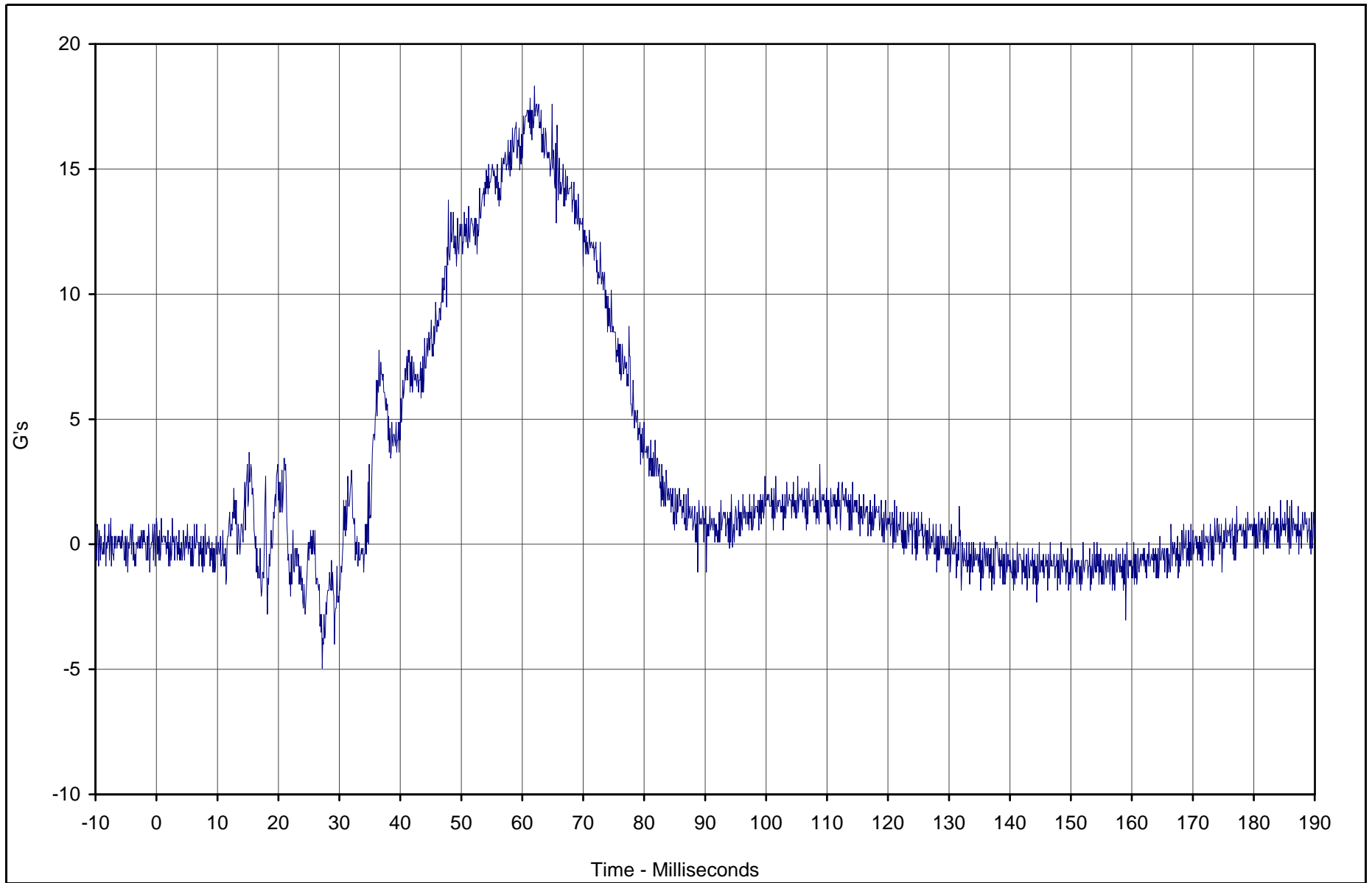

Curve Description	CURNO	Type	Units	Max	Time	Min	Time	SAE Class
Driver Head Z	003	FIL	G's	18.3	62.0	-5.0	27.2	1000



Test Vehicle: 2003 Subaru Forester 2.5X AWD Wagon

Test Date: 10/29/02

Test Program: 55/28 km/h Side Impact NCAP

NHTSA No.: M35500

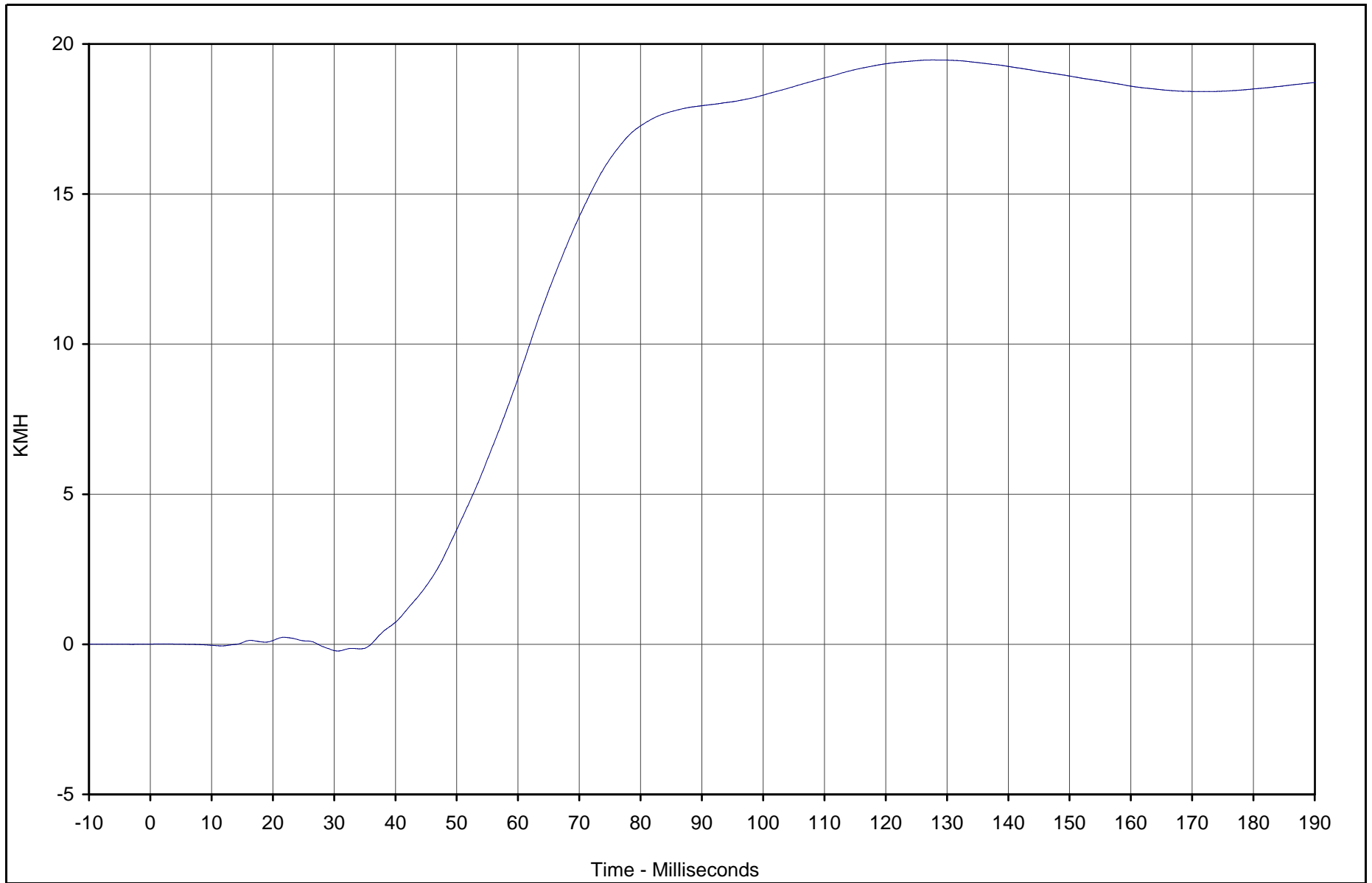

Curve Description	CURNO	Type	Units	Max	Time	Min	Time	SAE Class
Driver Head Z Velocity	003	IN1	KMH	19.5	127.7	-0.2	30.6	180



Test Vehicle: 2003 Subaru Forester 2.5X AWD Wagon

Test Date: 10/29/02

Test Program: 55/28 km/h Side Impact NCAP

NHTSA No.: M35500

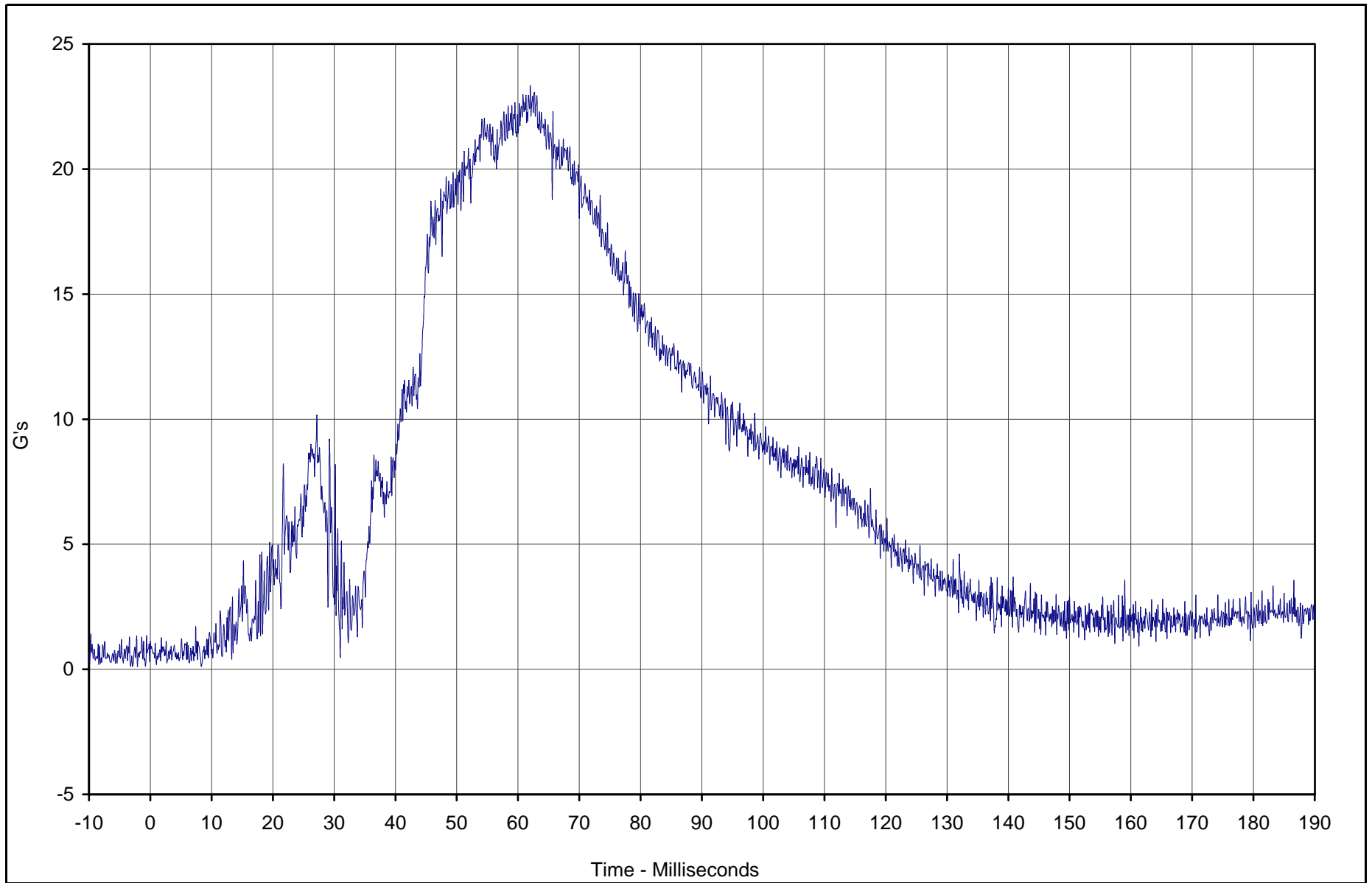

Curve Description	CURNO	Type	Units	Max	Time	Min	Time	SAE Class
Driver Head Resultant	001	RES	G's	23.3	62.0	0.1	8.3	1000



Test Vehicle: 2003 Subaru Forester 2.5X AWD Wagon

Test Date: 10/29/02

Test Program: 55/28 km/h Side Impact NCAP

NHTSA No.: M35500

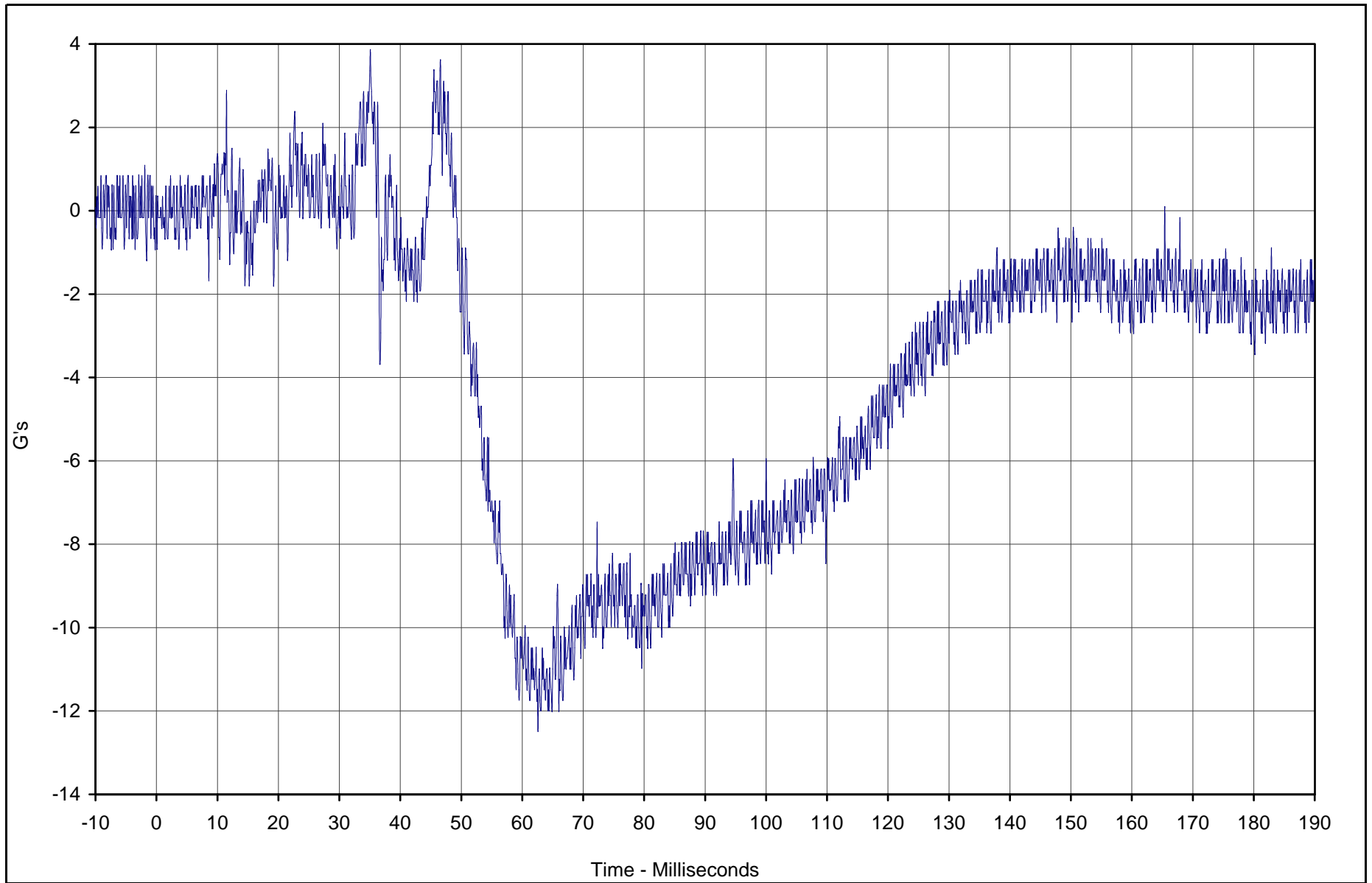

Curve Description	CURNO	Type	Units	Max	Time	Min	Time	SAE Class
Driver Head X Redundant	004	FIL	G's	3.9	35.1	-12.5	62.6	1000



Test Vehicle: 2003 Subaru Forester 2.5X AWD Wagon

Test Date: 10/29/02

Test Program: 55/28 km/h Side Impact NCAP

NHTSA No.: M35500

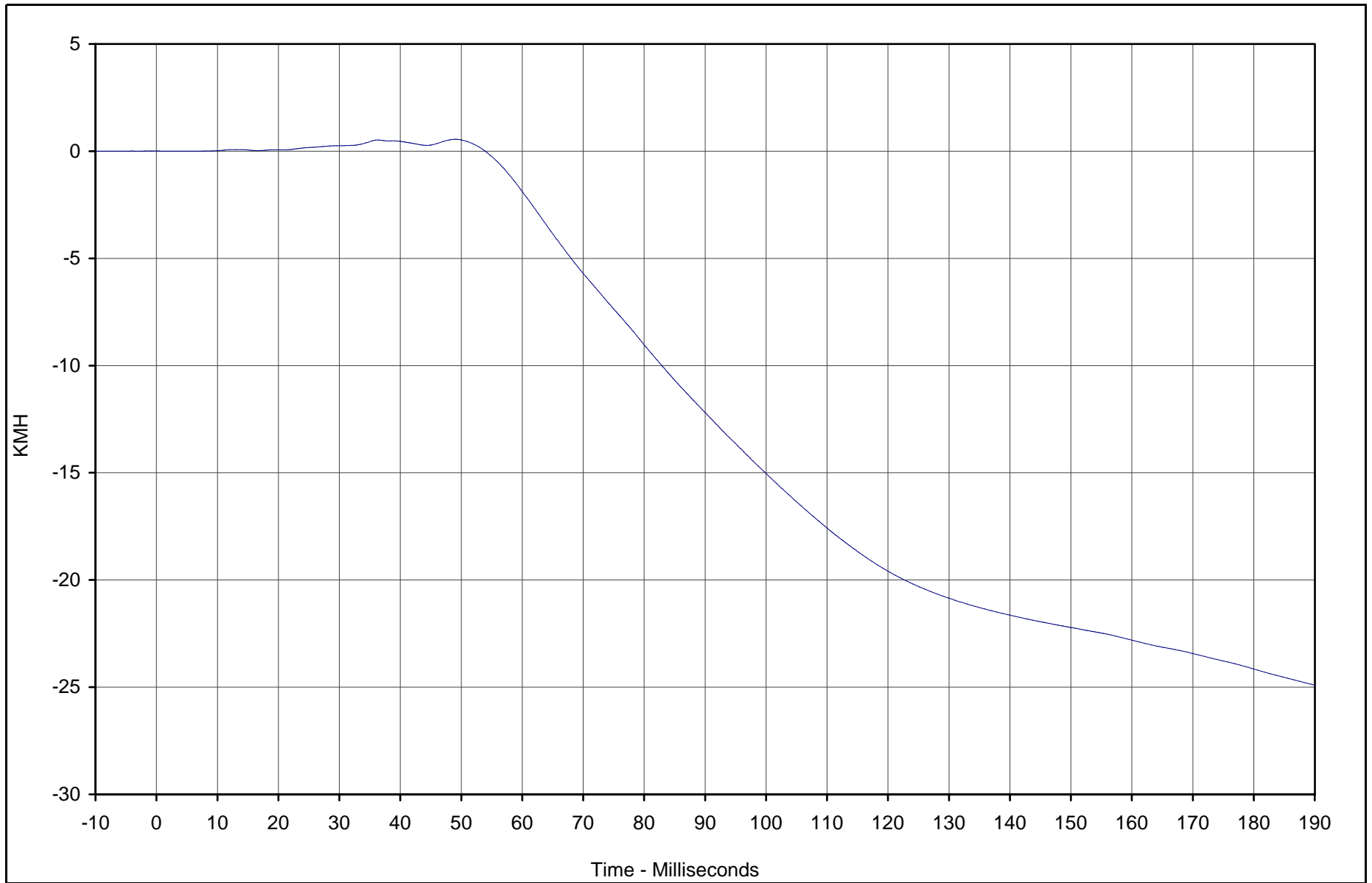

Curve Description	CURNO	Type	Units	Max	Time	Min	Time	SAE Class
Driver Head X Redundant Velocity	004	IN1	KMH	0.6	49.0	-24.9	189.9	180



Test Vehicle: 2003 Subaru Forester 2.5X AWD Wagon

Test Date: 10/29/02

Test Program: 55/28 km/h Side Impact NCAP

NHTSA No.: M35500

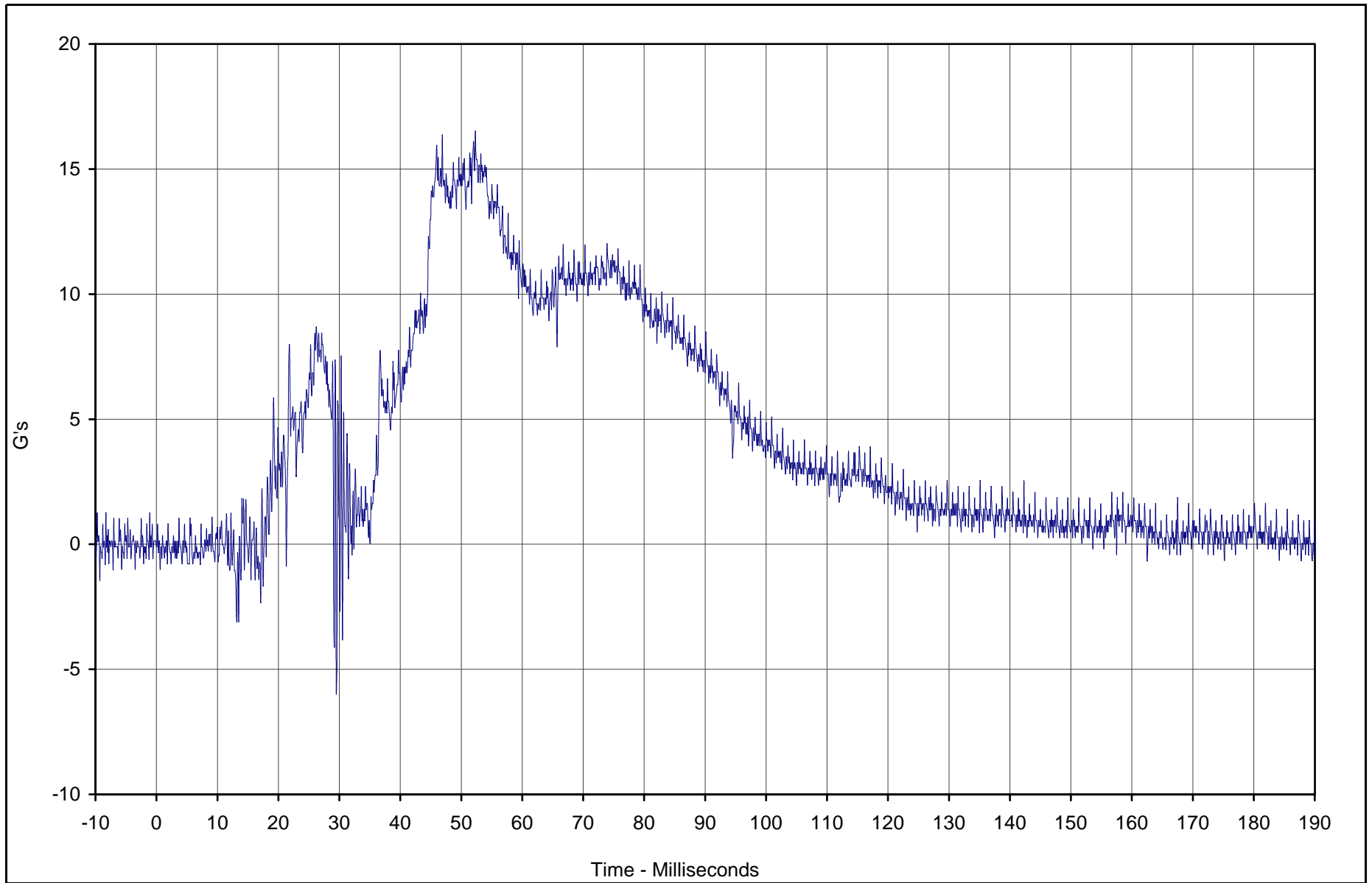

Curve Description	CURNO	Type	Units	Max	Time	Min	Time	SAE Class
Driver Head Y Redundant	005	FIL	G's	16.5	52.3	-5.9	29.5	1000



Test Vehicle: 2003 Subaru Forester 2.5X AWD Wagon

Test Date: 10/29/02

Test Program: 55/28 km/h Side Impact NCAP

NHTSA No.: M35500

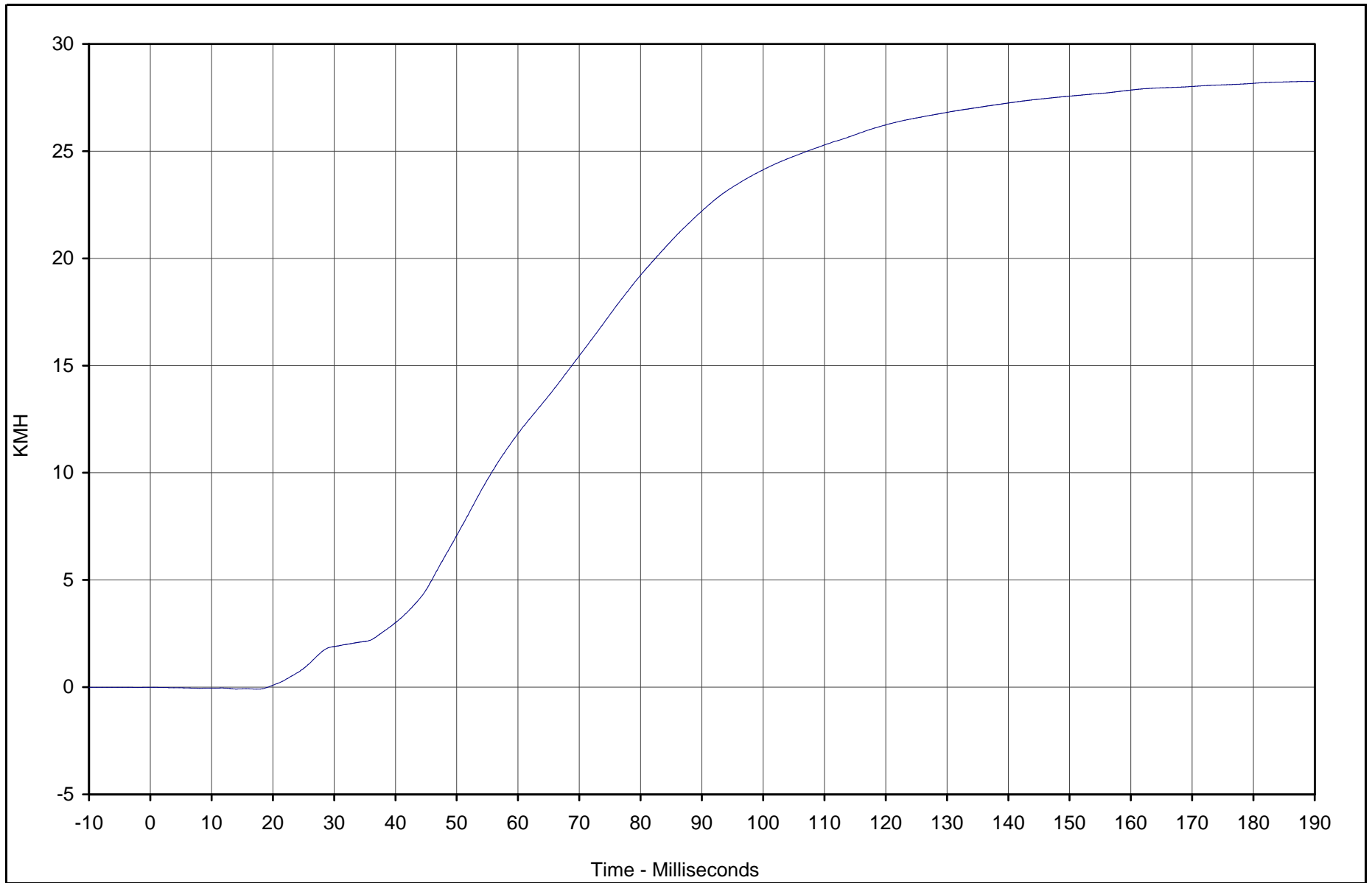

Curve Description	CURNO	Type	Units	Max	Time	Min	Time	SAE Class
Driver Head Y Redundant Velocity	005	IN1	KMH	28.3	189.3	-0.1	17.4	180



Test Vehicle: 2003 Subaru Forester 2.5X AWD Wagon

Test Date: 10/29/02

Test Program: 55/28 km/h Side Impact NCAP

NHTSA No.: M35500

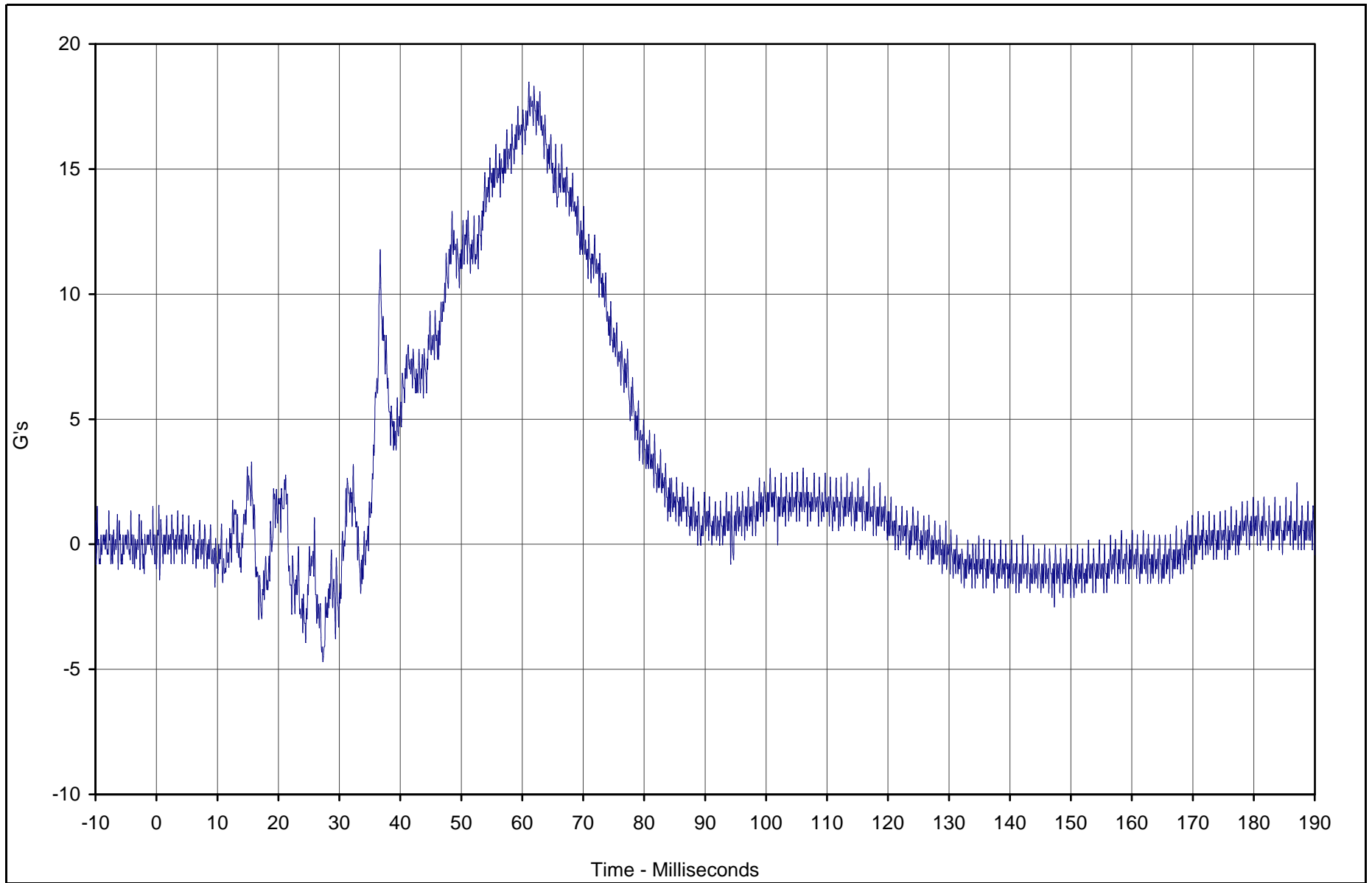

Curve Description	CURNO	Type	Units	Max	Time	Min	Time	SAE Class
Driver Head Z Redundant	006	FIL	G's	18.5	61.1	-4.7	27.3	1000



Test Vehicle: 2003 Subaru Forester 2.5X AWD Wagon

Test Date: 10/29/02

Test Program: 55/28 km/h Side Impact NCAP

NHTSA No.: M35500

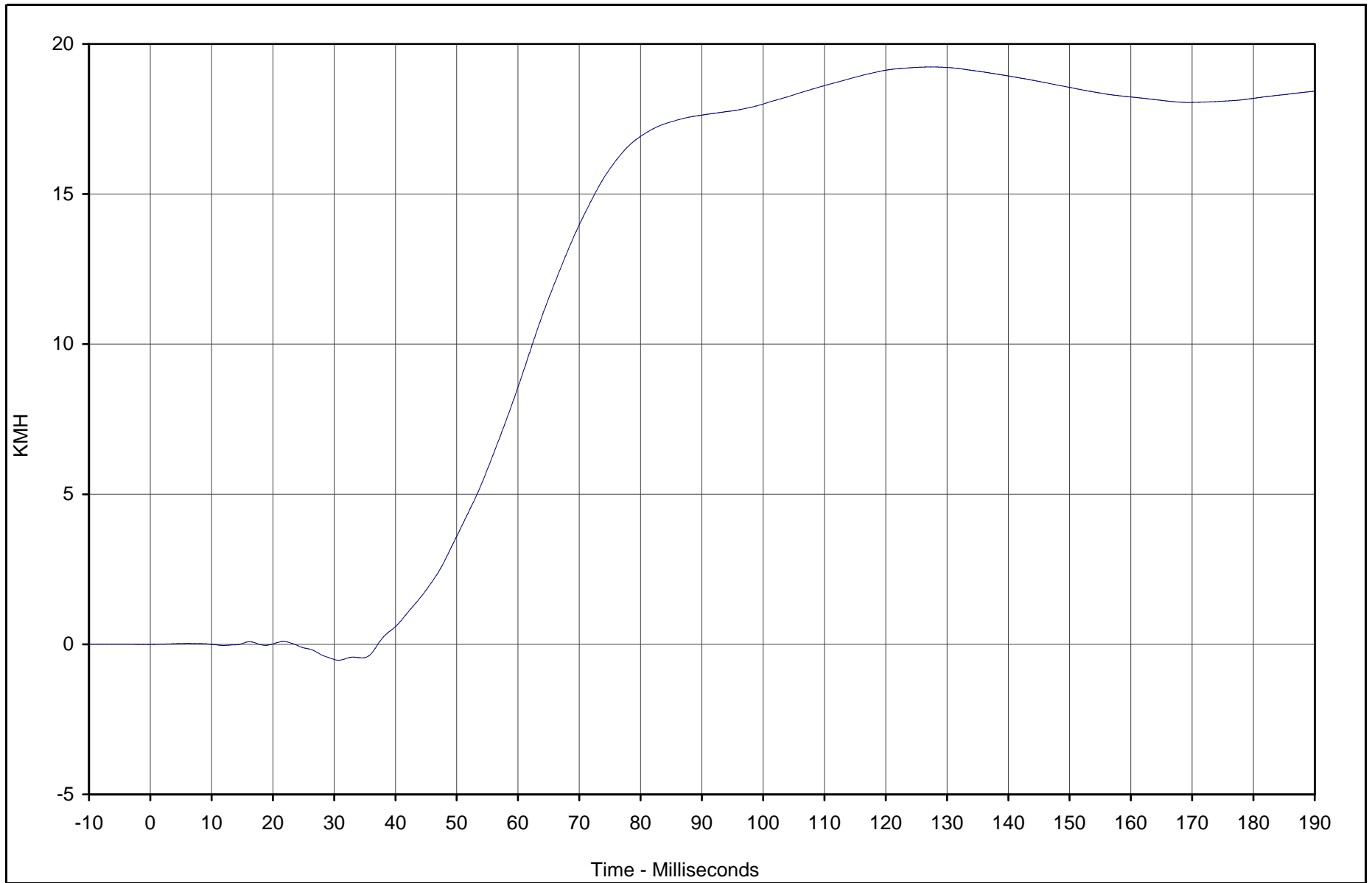

Curve Description	CURNO	Type	Units	Max	Time	Min	Time	SAE Class
Driver Head Z Redundant Velocity	006	IN1	KMH	19.2	127.4	-0.5	30.7	180



Test Vehicle: 2003 Subaru Forester 2.5X AWD Wagon

Test Date: 10/29/02

Test Program: 55/28 km/h Side Impact NCAP

NHTSA No.: M35500

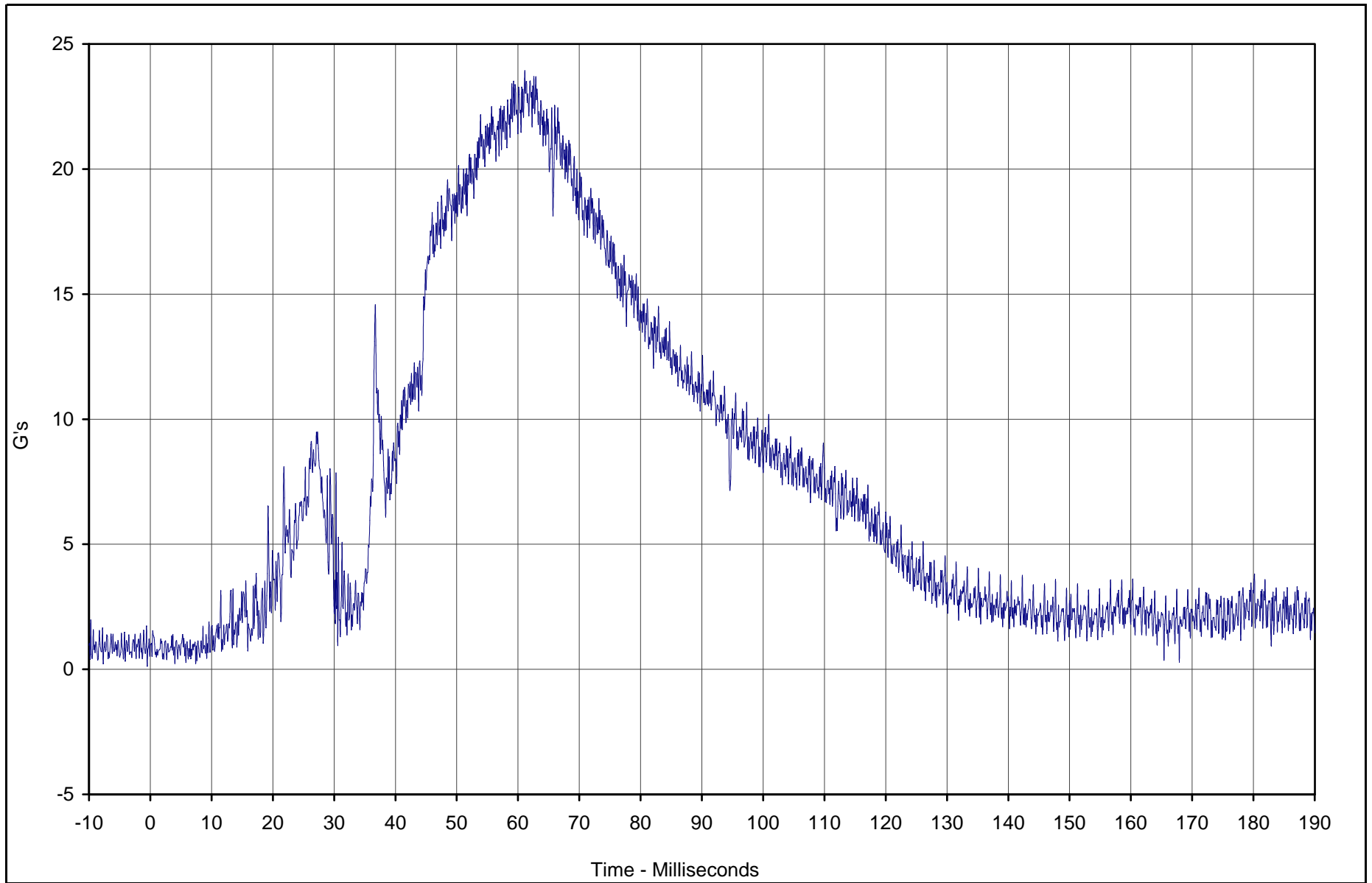

Curve Description	CURNO	Type	Units	Max	Time	Min	Time	SAE Class
Driver Head Redundant Resultant	004	RES	G's	23.9	61.1	0.2	4.0	1000



Test Vehicle: 2003 Subaru Forester 2.5X AWD Wagon

Test Date: 10/29/02

Test Program: 55/28 km/h Side Impact NCAP

NHTSA No.: M35500

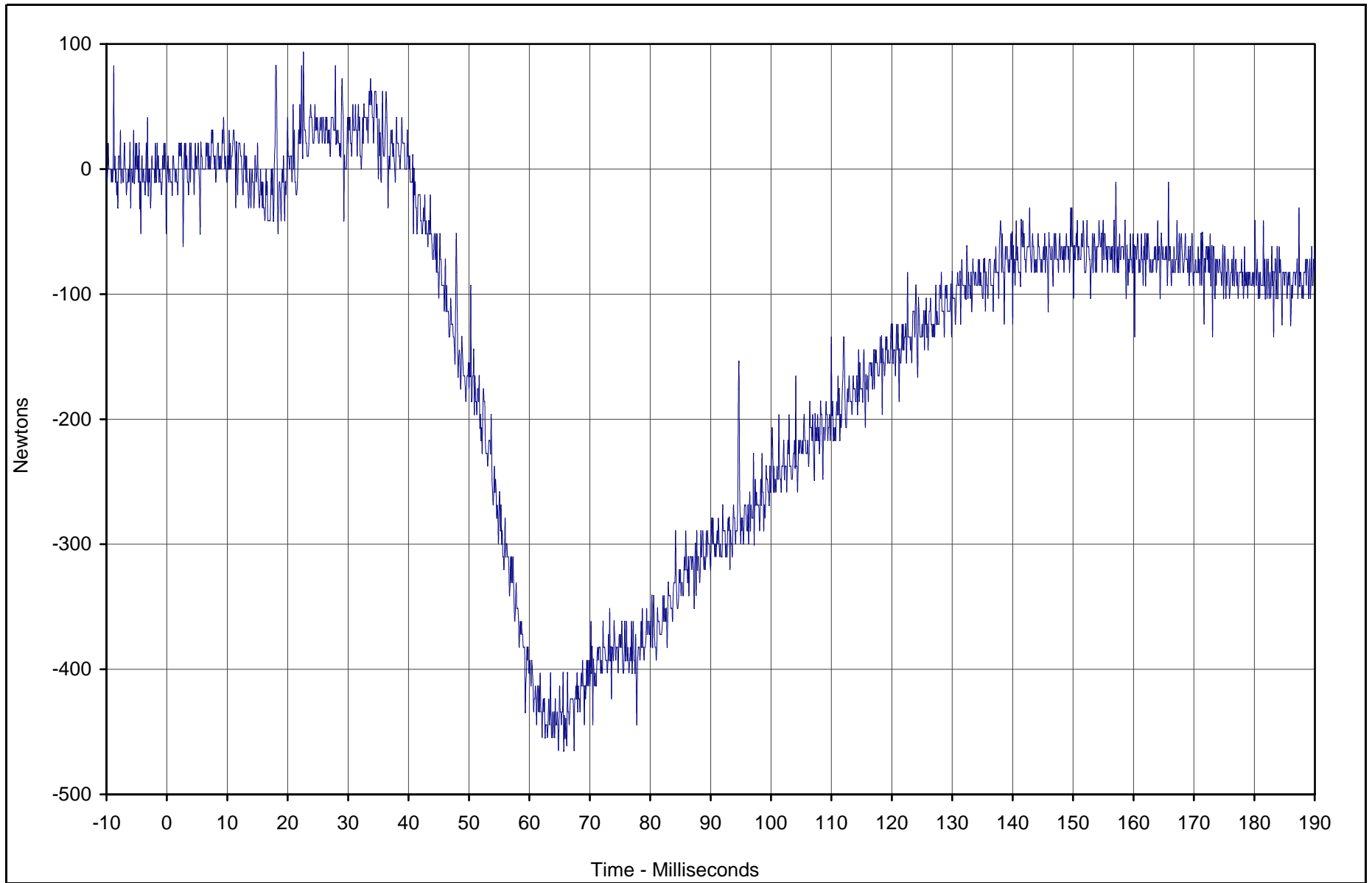

Curve Description	CURNO	Type	Units	Max	Time	Min	Time	SAE Class
Driver Neck Force X	007	FIL	Newtons	93.0	22.6	-465.0	64.8	1000



Test Vehicle: 2003 Subaru Forester 2.5X AWD Wagon

Test Date: 10/29/02

Test Program: 55/28 km/h Side Impact NCAP

NHTSA No.: M35500

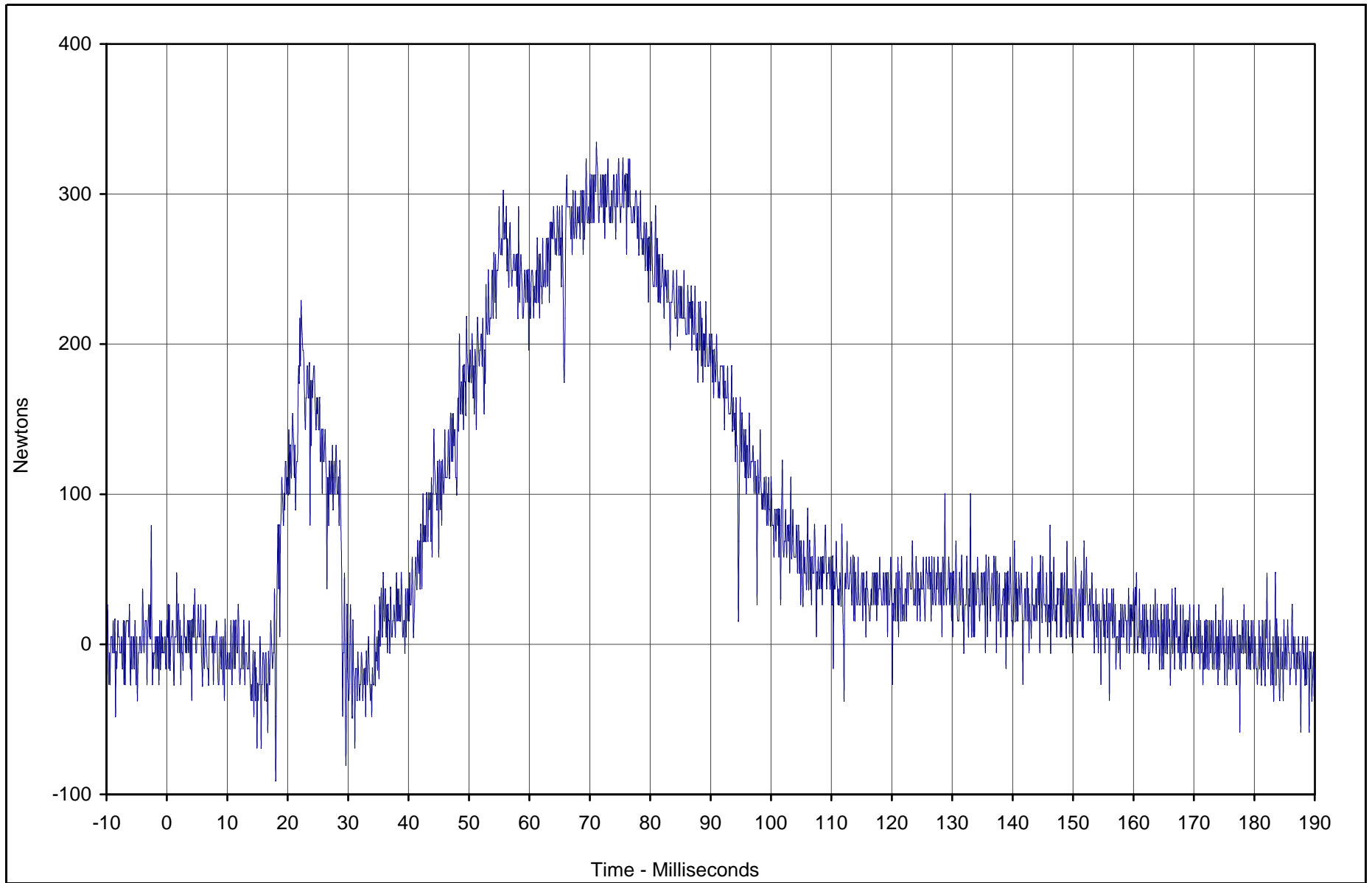

Curve Description	CURNO	Type	Units	Max	Time	Min	Time	SAE Class
Driver Neck Force Y	008	FIL	Newtons	334.0	71.1	-90.5	18.0	1000



Test Vehicle: 2003 Subaru Forester 2.5X AWD Wagon

Test Date: 10/29/02

Test Program: 55/28 km/h Side Impact NCAP

NHTSA No.: M35500

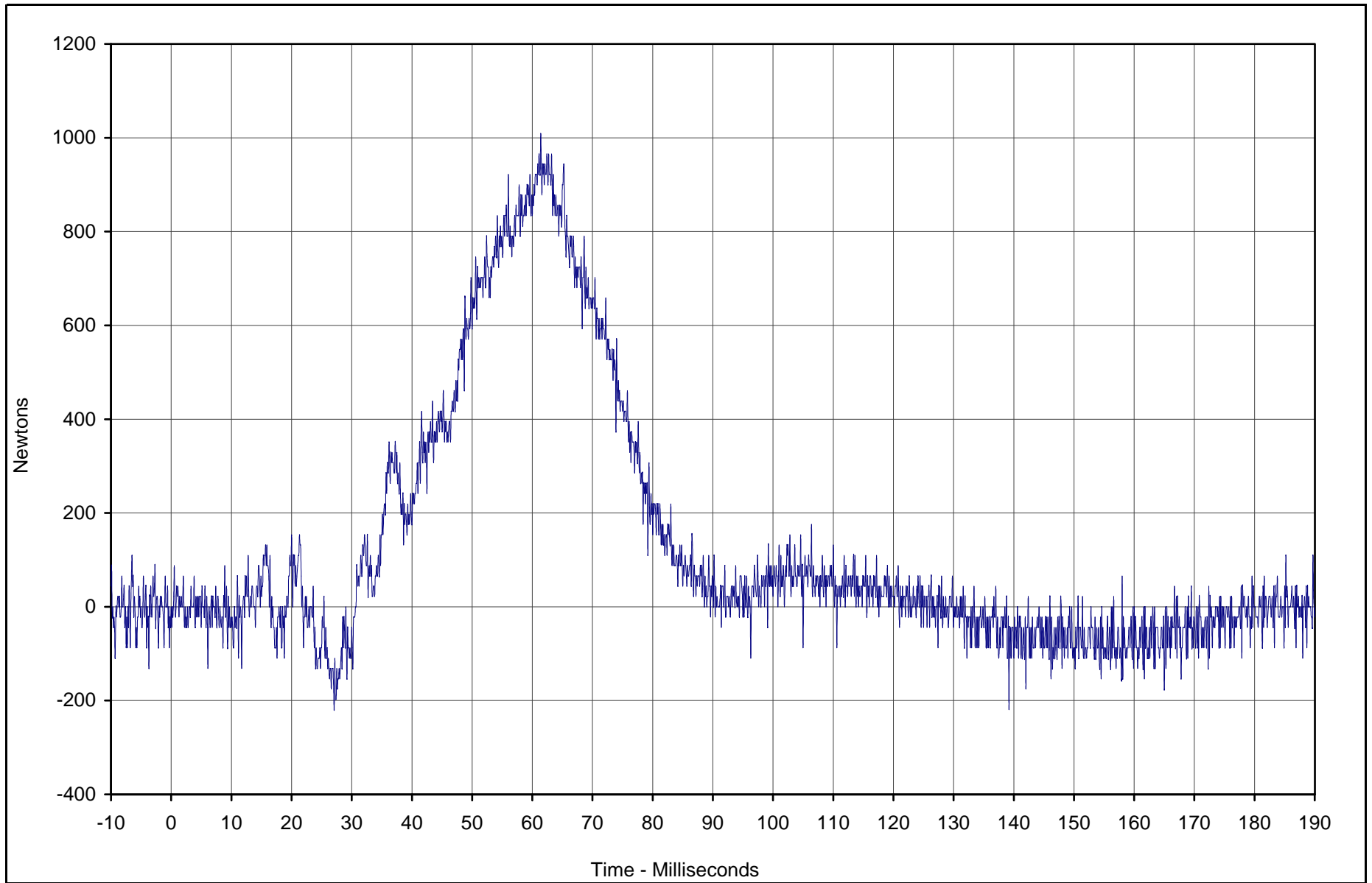

Curve Description	CURNO	Type	Units	Max	Time	Min	Time	SAE Class
Driver Neck Force Z	009	FIL	Newtons	1009.5	61.4	-219.5	27.1	1000



Test Vehicle: 2003 Subaru Forester 2.5X AWD Wagon

Test Date: 10/29/02

Test Program: 55/28 km/h Side Impact NCAP

NHTSA No.: M35500

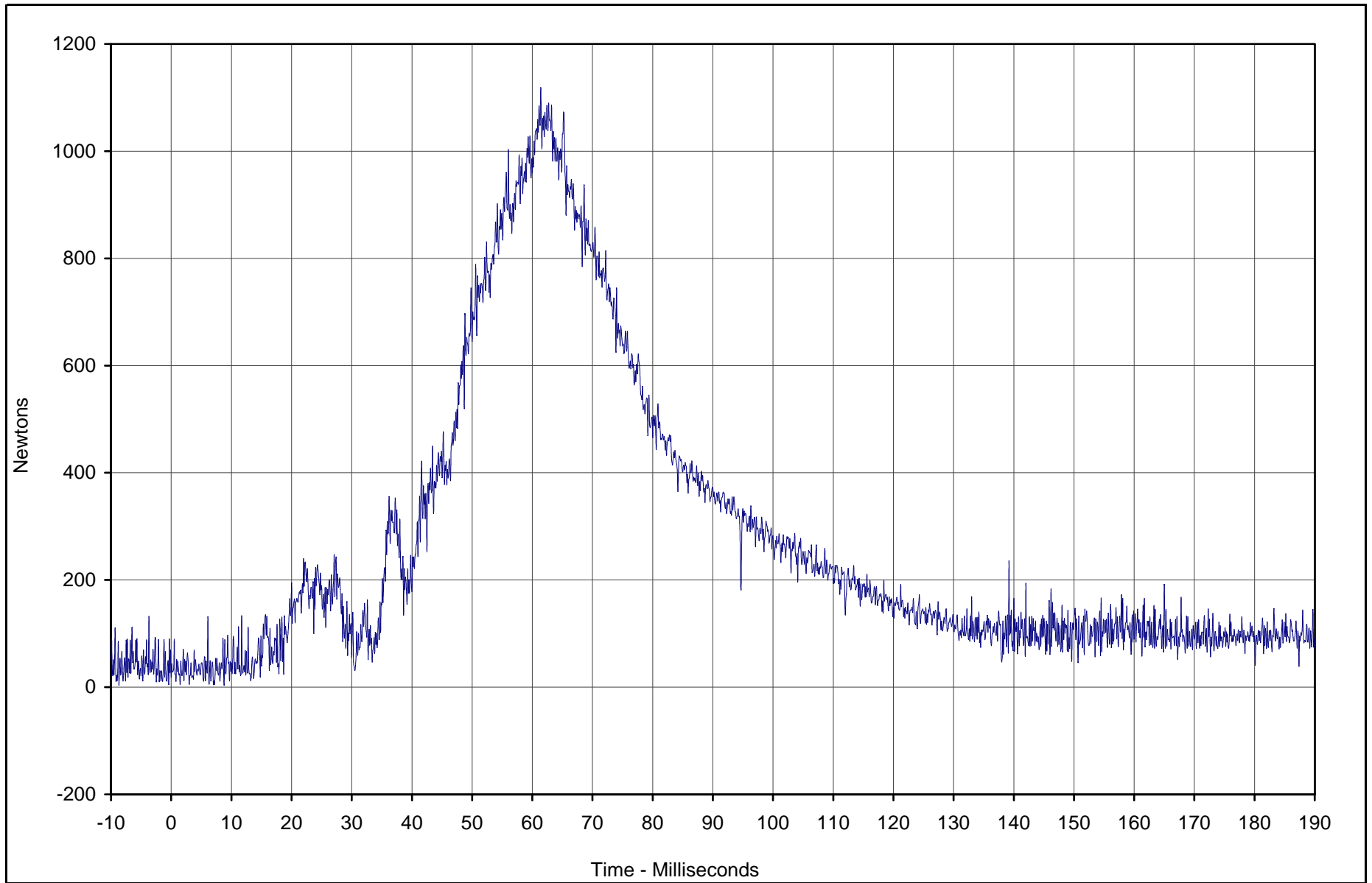

Curve Description	CURNO	Type	Units	Max	Time	Min	Time	SAE Class
Driver Neck Force Resultant	007	RES	Newtons	1119.0	61.4	5.0	1.5	1000



Test Vehicle: 2003 Subaru Forester 2.5X AWD Wagon

Test Date: 10/29/02

Test Program: 55/28 km/h Side Impact NCAP

NHTSA No.: M35500

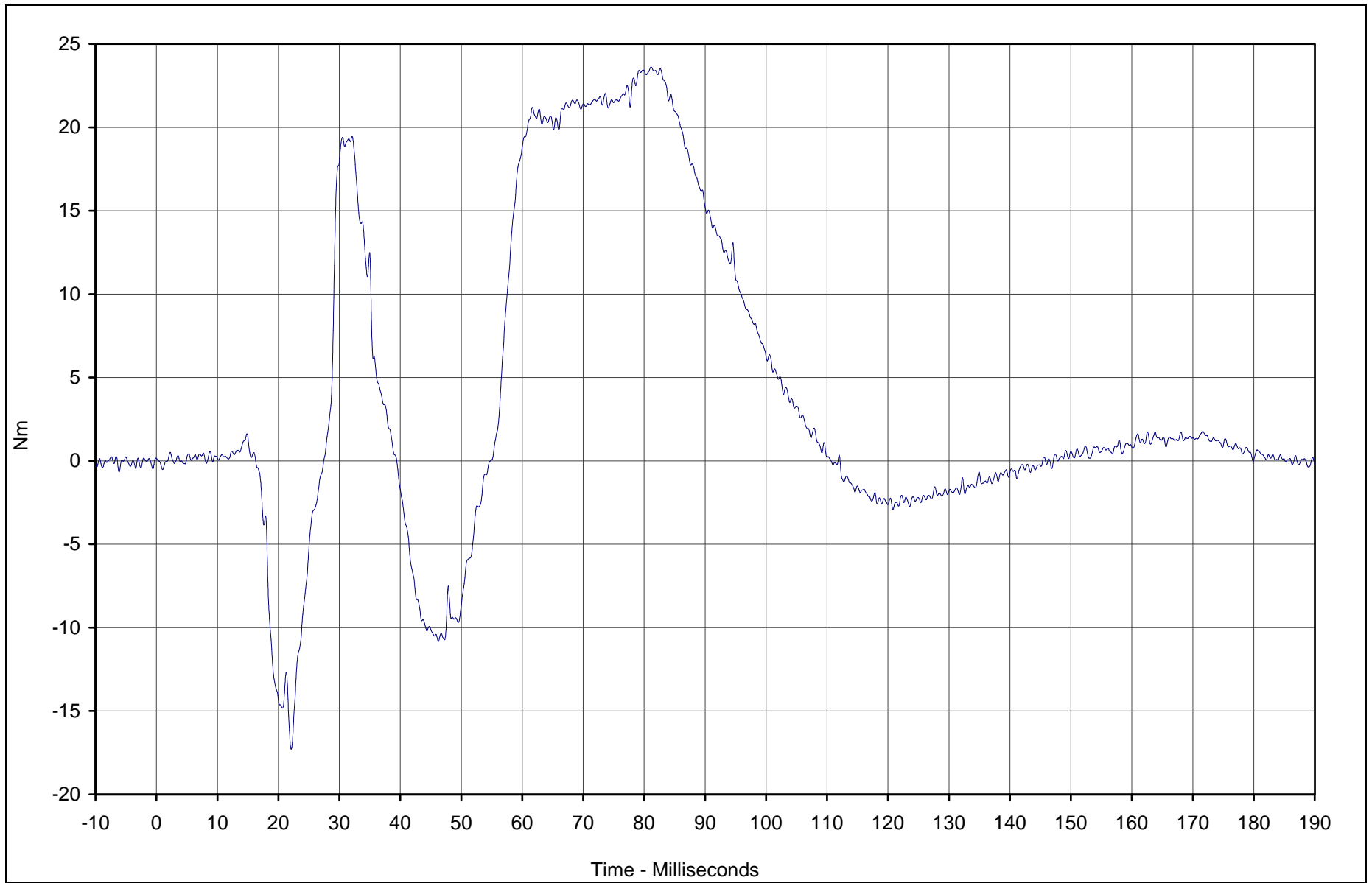

Curve Description	CURNO	Type	Units	Max	Time	Min	Time	SAE Class
Driver Neck Moment X	010	FIL	Nm	23.6	81.1	-17.3	22.1	600



Test Vehicle: 2003 Subaru Forester 2.5X AWD Wagon

Test Date: 10/29/02

Test Program: 55/28 km/h Side Impact NCAP

NHTSA No.: M35500

B-20

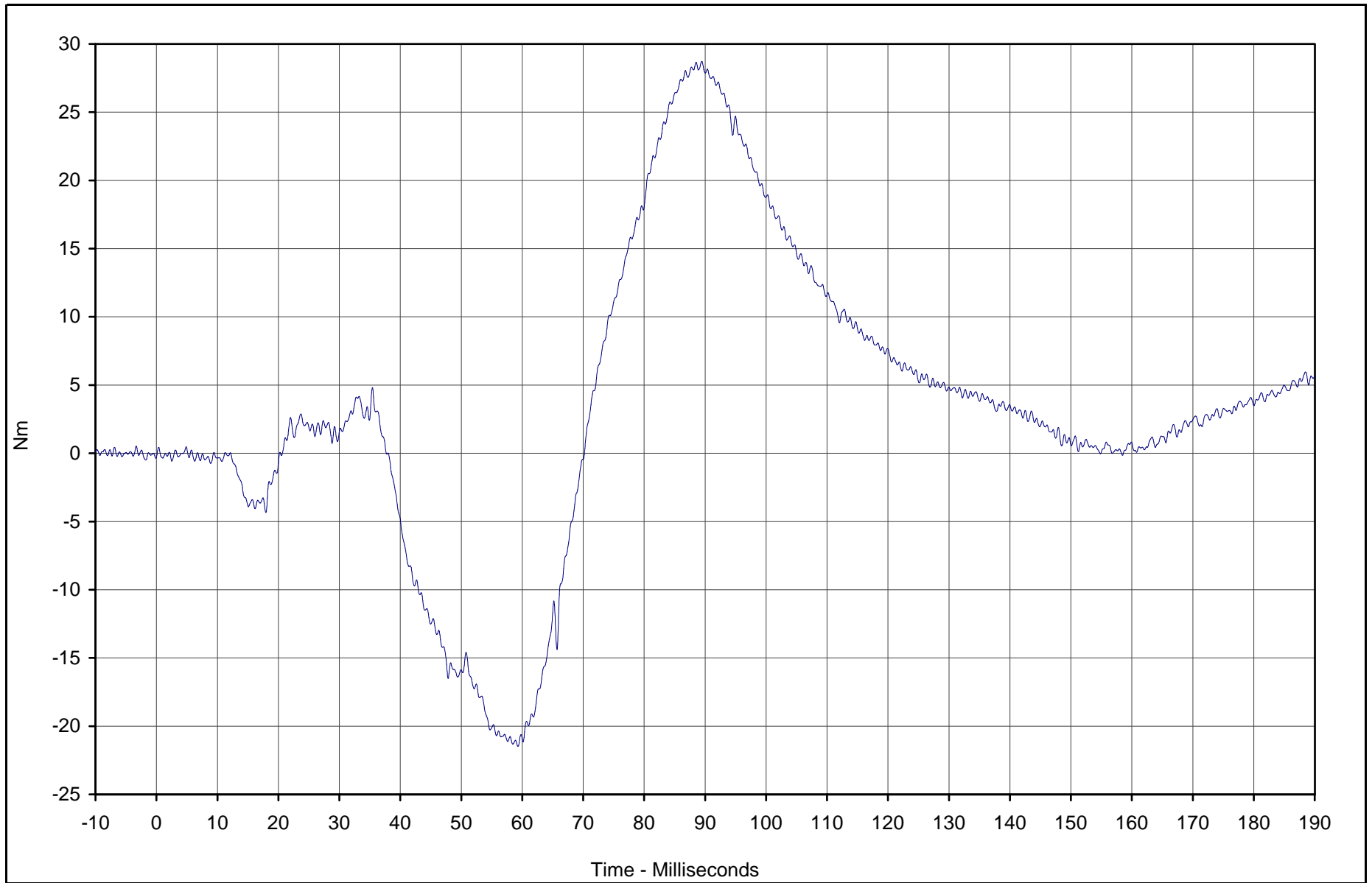

Curve Description	CURNO	Type	Units	Max	Time	Min	Time	SAE Class
Driver Neck Moment Y	011	FIL	Nm	28.7	89.5	-21.5	59.3	600



Test Vehicle: 2003 Subaru Forester 2.5X AWD Wagon

Test Date: 10/29/02

Test Program: 55/28 km/h Side Impact NCAP

NHTSA No.: M35500

TR-P23003-01-NC

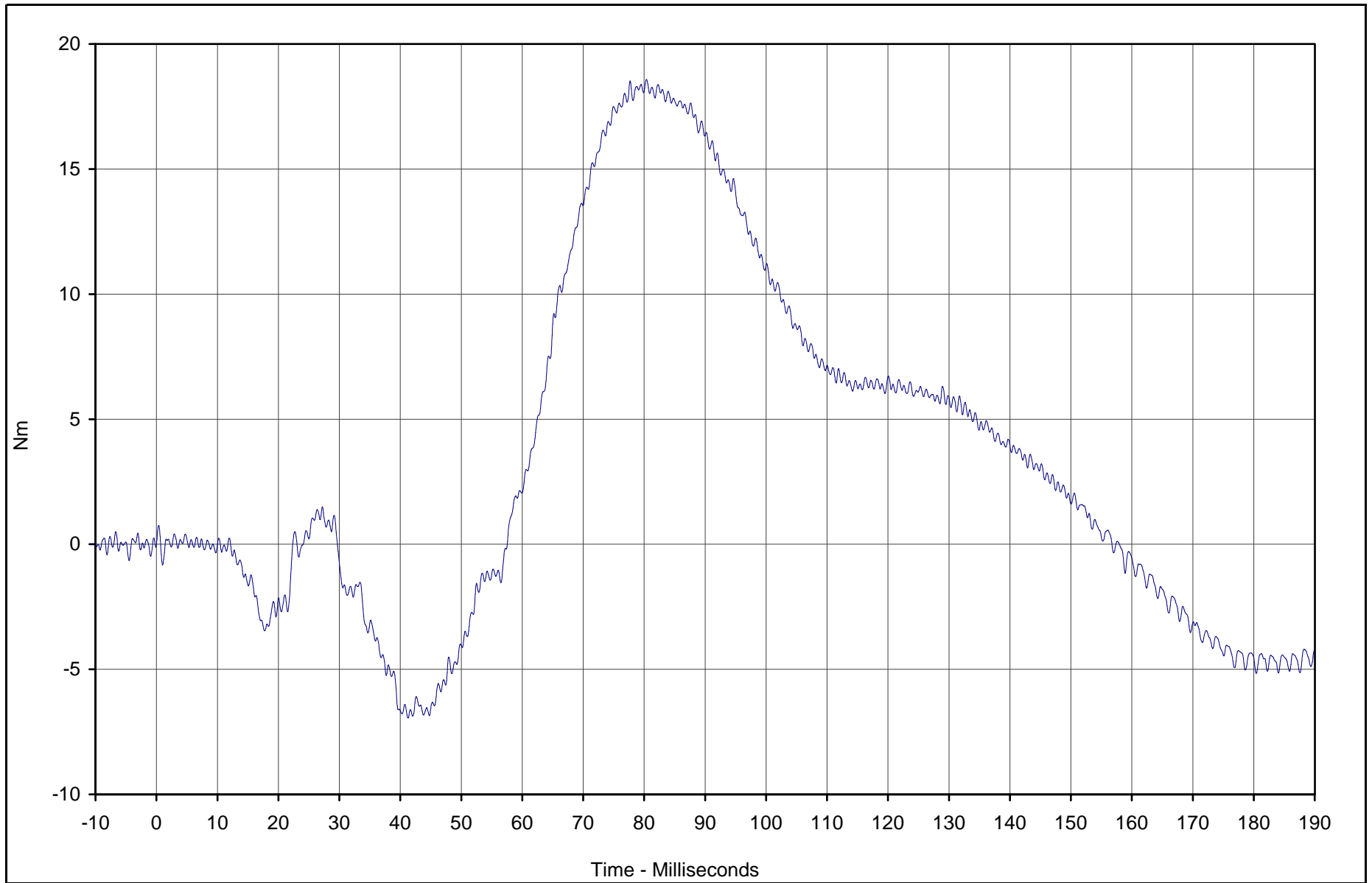

Curve Description	CURNO	Type	Units	Max	Time	Min	Time	SAE Class
Driver Neck Moment Z	012	FIL	Nm	18.6	80.4	-6.9	41.3	600



Test Vehicle: 2003 Subaru Forester 2.5X AWD Wagon

Test Date: 10/29/02

Test Program: 55/28 km/h Side Impact NCAP

NHTSA No.: M35500

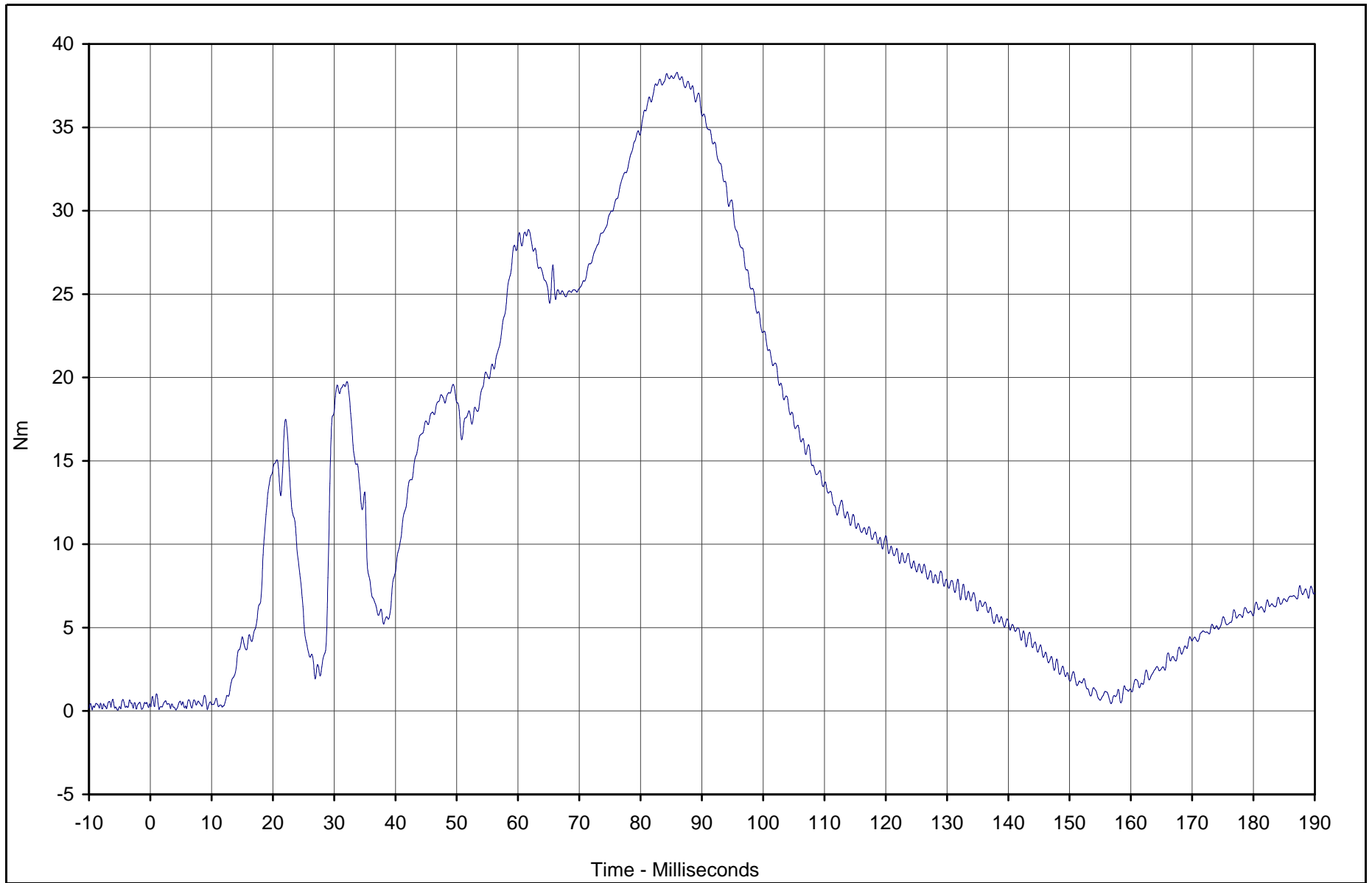

Curve Description	CURNO	Type	Units	Max	Time	Min	Time	SAE Class
Driver Neck Moment Resultant	010	RES	Nm	38.3	85.9	0.1	4.2	600



Test Vehicle: 2003 Subaru Forester 2.5X AWD Wagon

Test Date: 10/29/02

Test Program: 55/28 km/h Side Impact NCAP

NHTSA No.: M35500

B-23

TR-P23003-01-NC

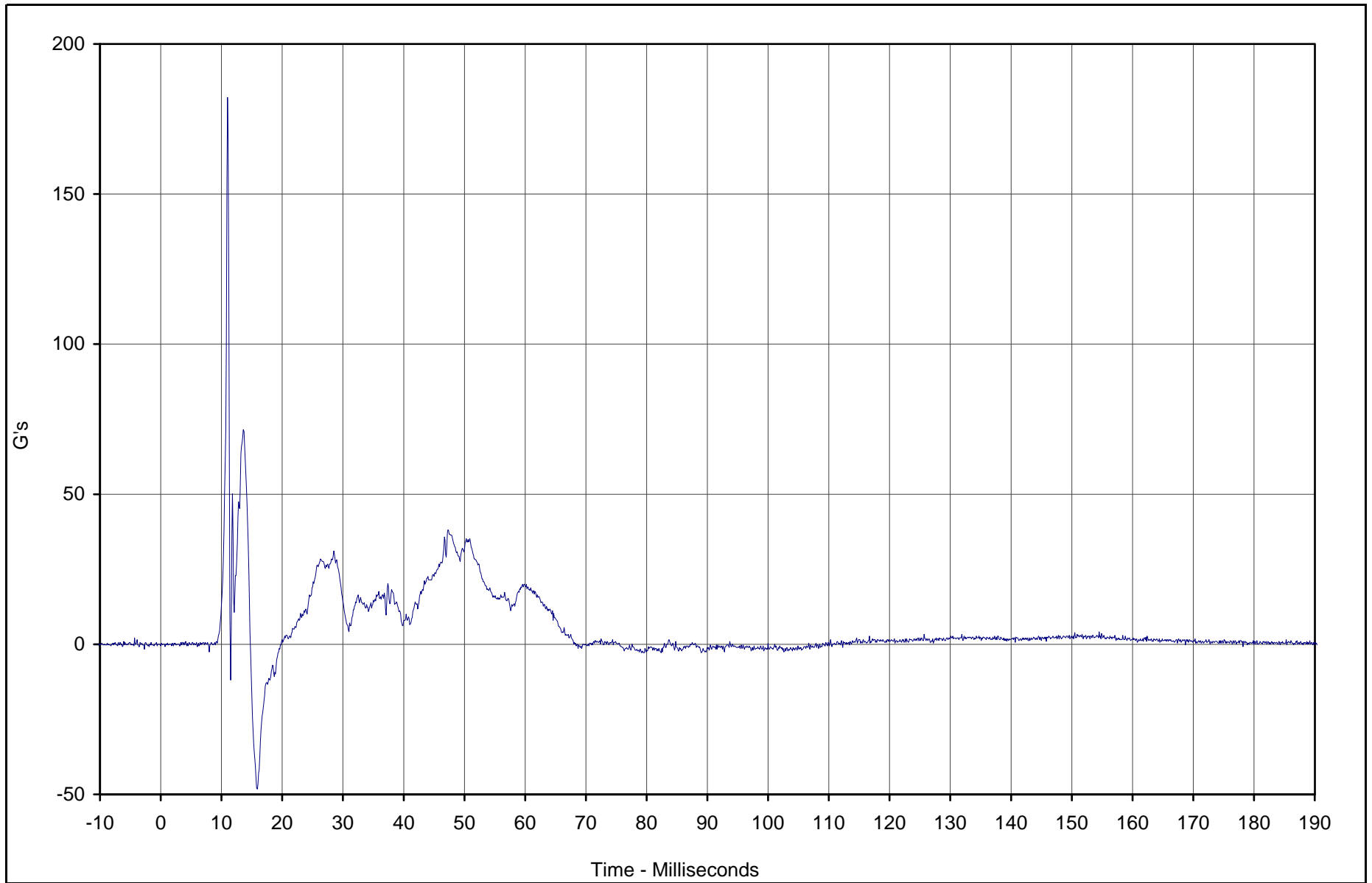

Curve Description	CURNO	Type	Units	Max	Time	Min	Time	SAE Class
Driver Upper Rib Primary Y	013	FIL	G's	182.2	11.0	-48.2	15.9	1000



Test Vehicle: 2003 Subaru Forester 2.5X AWD Wagon

Test Date: 10/29/02

Test Program: 55/28 km/h Side Impact NCAP

NHTSA No.: M35500

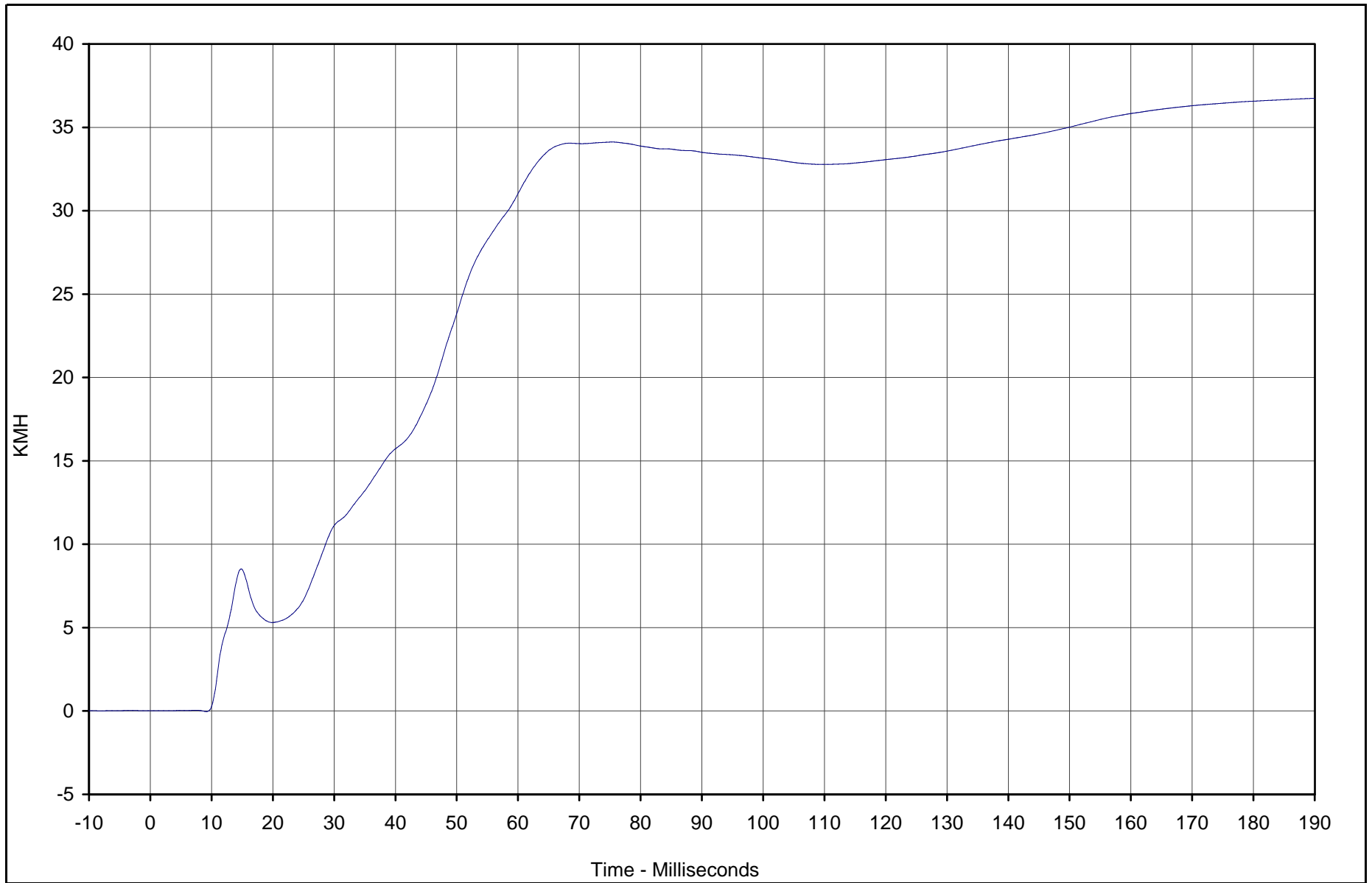

Curve Description	CURNO	Type	Units	Max	Time	Min	Time	SAE Class
Driver Upper Rib Primary Y Vel.	013	IN1	KMH	36.7	189.9	0.0	9.2	180



Test Vehicle: 2003 Subaru Forester 2.5X AWD Wagon

Test Date: 10/29/02

Test Program: 55/28 km/h Side Impact NCAP

NHTSA No.: M35500

B-25

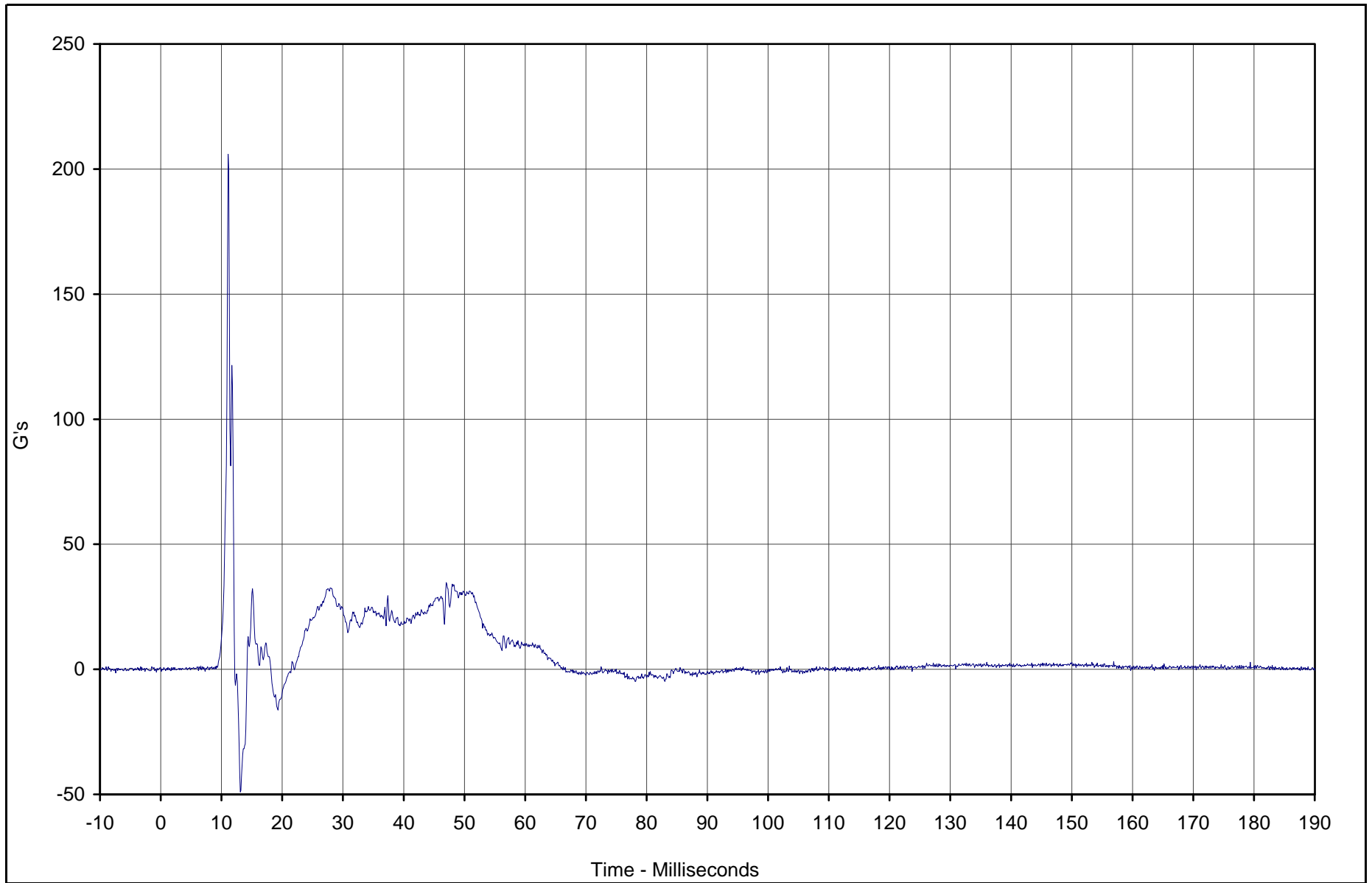

Curve Description	CURNO	Type	Units	Max	Time	Min	Time	SAE Class
Driver Lower Rib Primary Y	014	FIL	G's	206.0	11.1	-49.1	13.1	1000



Test Vehicle: 2003 Subaru Forester 2.5X AWD Wagon

Test Date: 10/29/02

Test Program: 55/28 km/h Side Impact NCAP

NHTSA No.: M35500

TR-P23003-01-NC

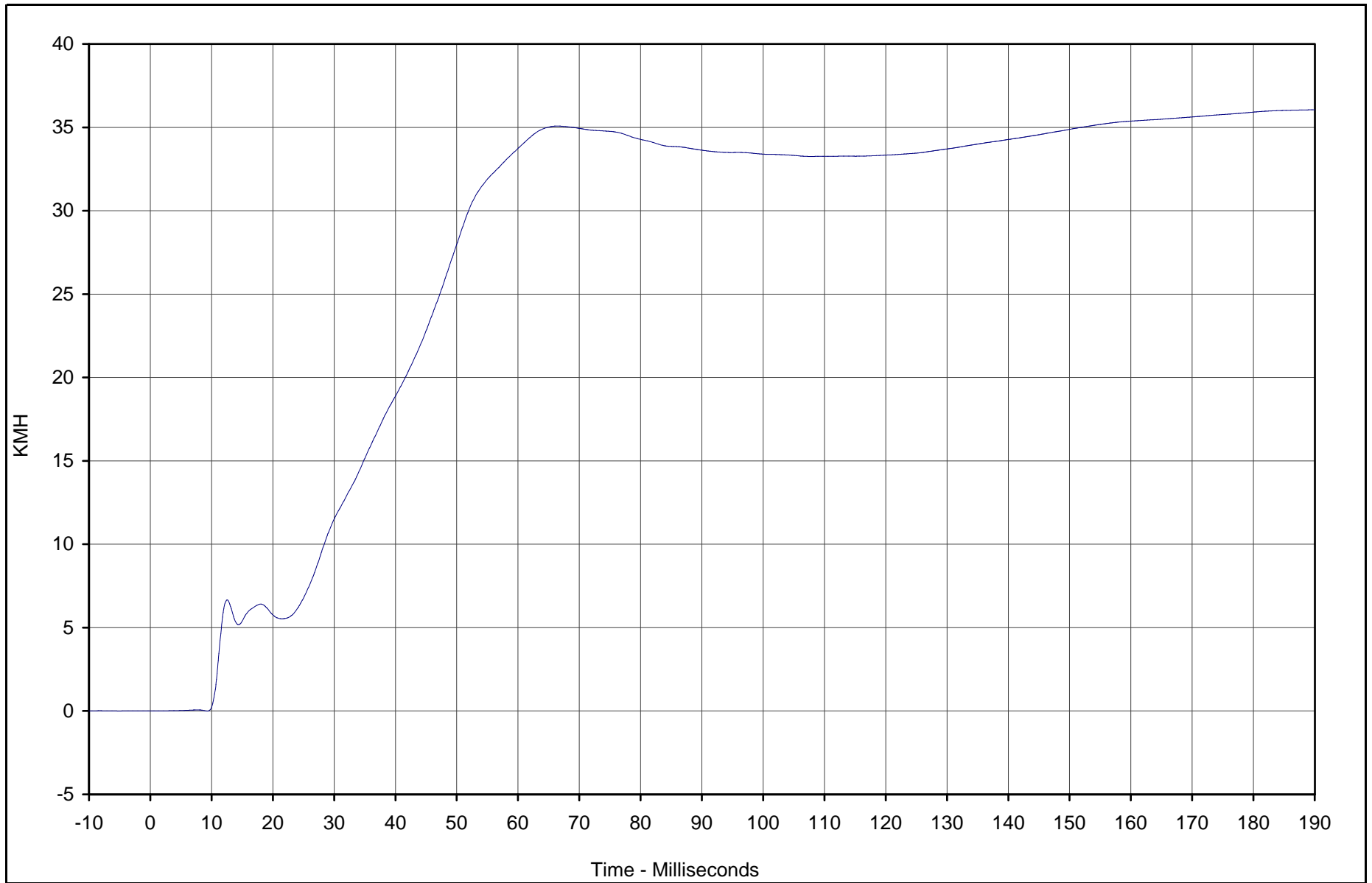

Curve Description	CURNO	Type	Units	Max	Time	Min	Time	SAE Class
Driver Lower Rib Primary Y Vel.	014	IN1	KMH	36.1	189.9	0.0	9.3	180



Test Vehicle: 2003 Subaru Forester 2.5X AWD Wagon

Test Date: 10/29/02

Test Program: 55/28 km/h Side Impact NCAP

NHTSA No.: M35500

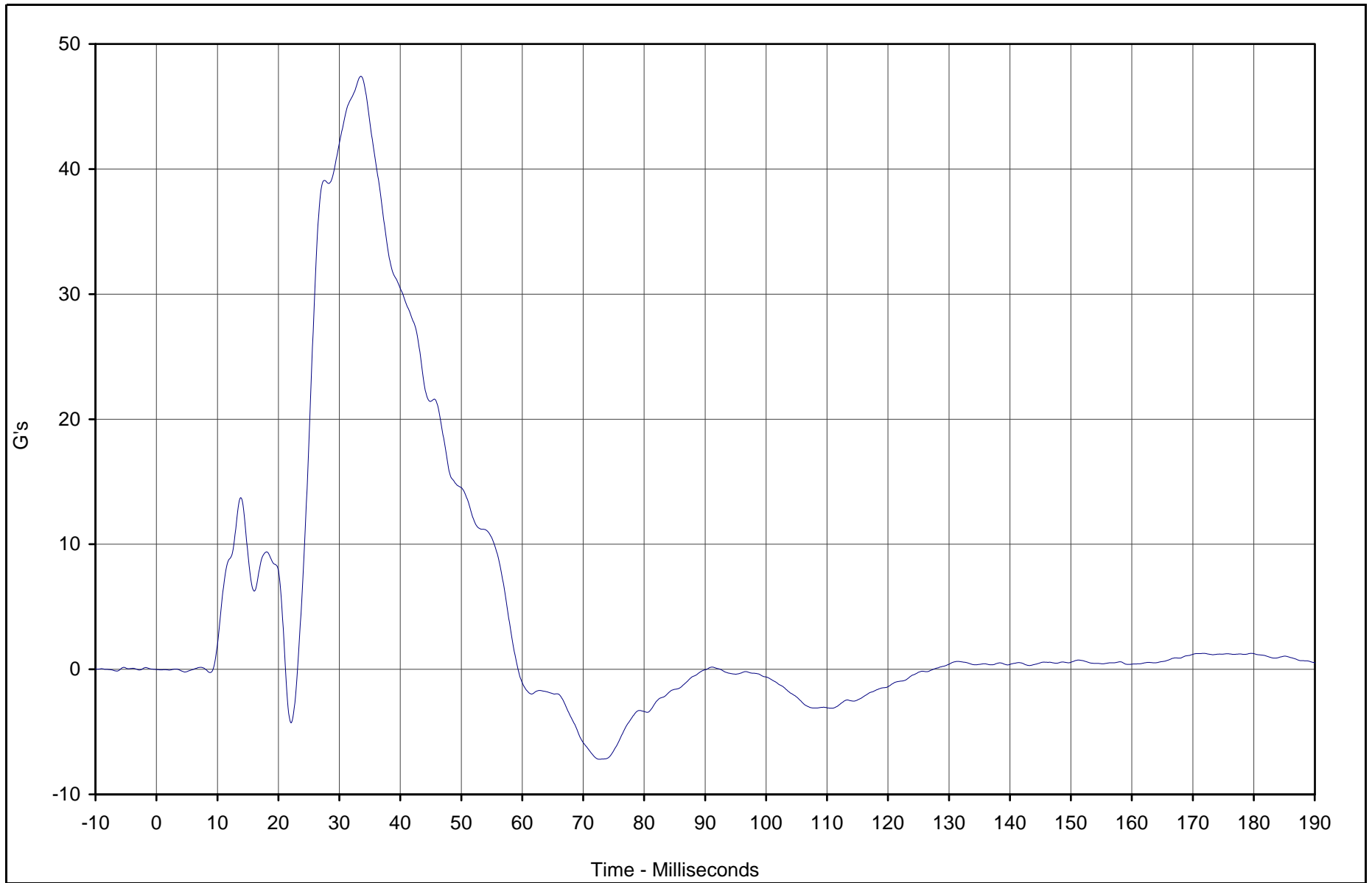

Curve Description	CURNO	Type	Units	Max	Time	Min	Time	SAE Class
Driver Lower Spine Primary Y	015	FIL	G's	47.4	33.5	-7.2	72.6	180



Test Vehicle: 2003 Subaru Forester 2.5X AWD Wagon

Test Date: 10/29/02

Test Program: 55/28 km/h Side Impact NCAP

NHTSA No.: M35500

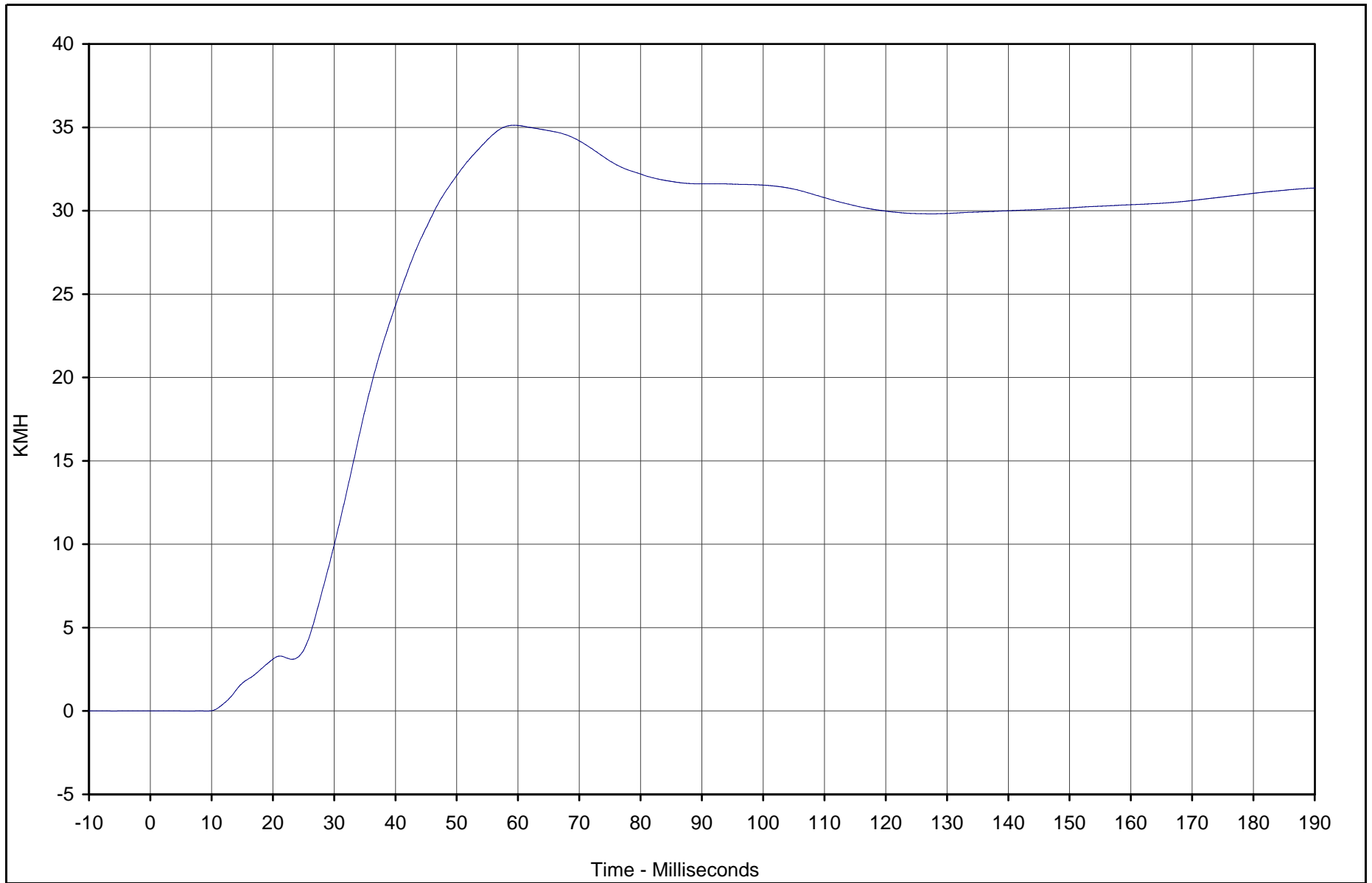

Curve Description	CURNO	Type	Units	Max	Time	Min	Time	SAE Class
Driver Lower Spine Primary Y Vel.	015	IN1	KMH	35.1	59.3	0.0	6.1	180



Test Vehicle: 2003 Subaru Forester 2.5X AWD Wagon

Test Date: 10/29/02

Test Program: 55/28 km/h Side Impact NCAP

NHTSA No.: M35500

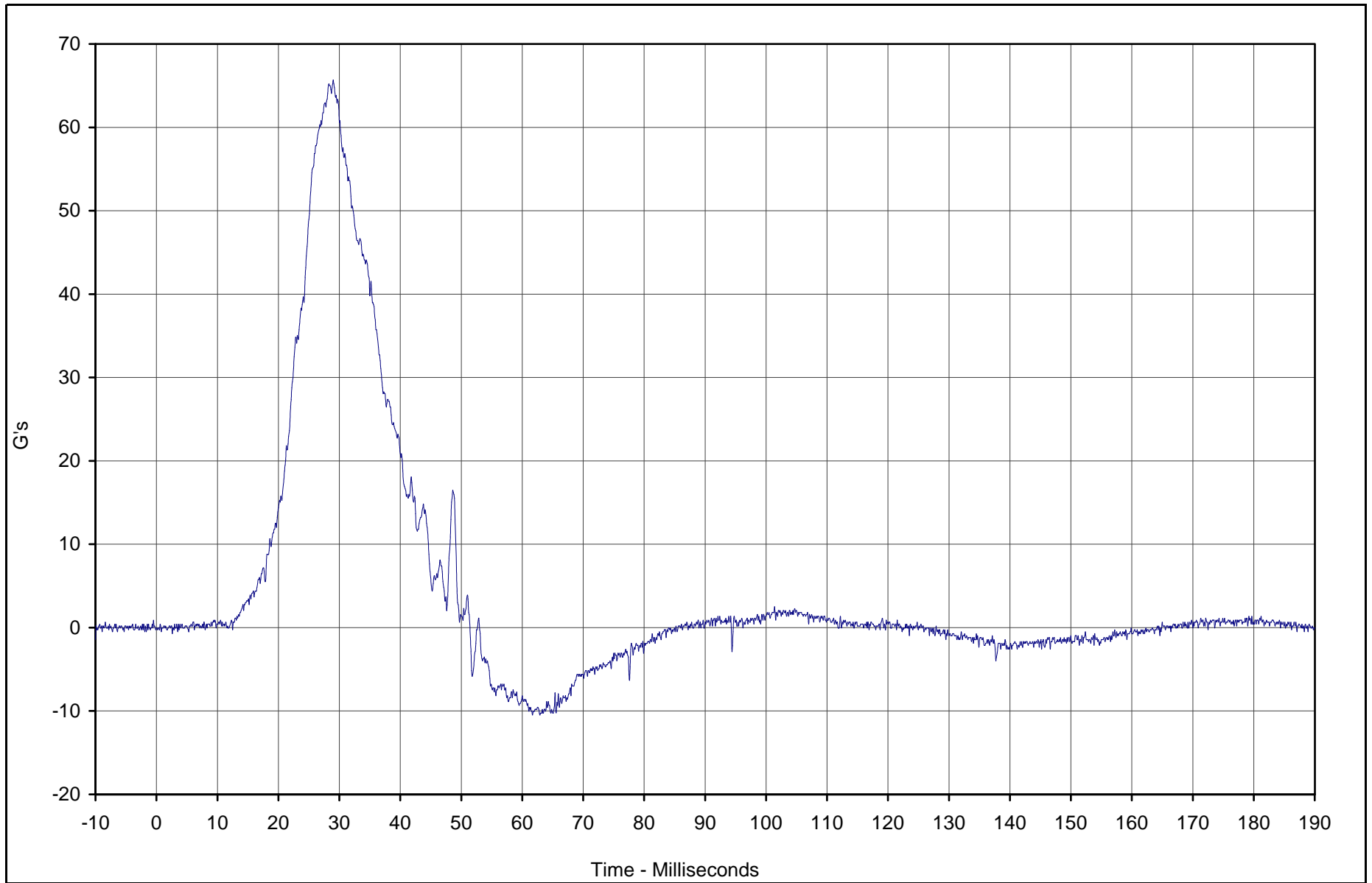

Curve Description	CURNO	Type	Units	Max	Time	Min	Time	SAE Class
Driver Pelvis Primary Y	016	FIL	G's	65.7	29.0	-10.5	61.7	1000



Test Vehicle: 2003 Subaru Forester 2.5X AWD Wagon

Test Date: 10/29/02

Test Program: 55/28 km/h Side Impact NCAP

NHTSA No.: M35500

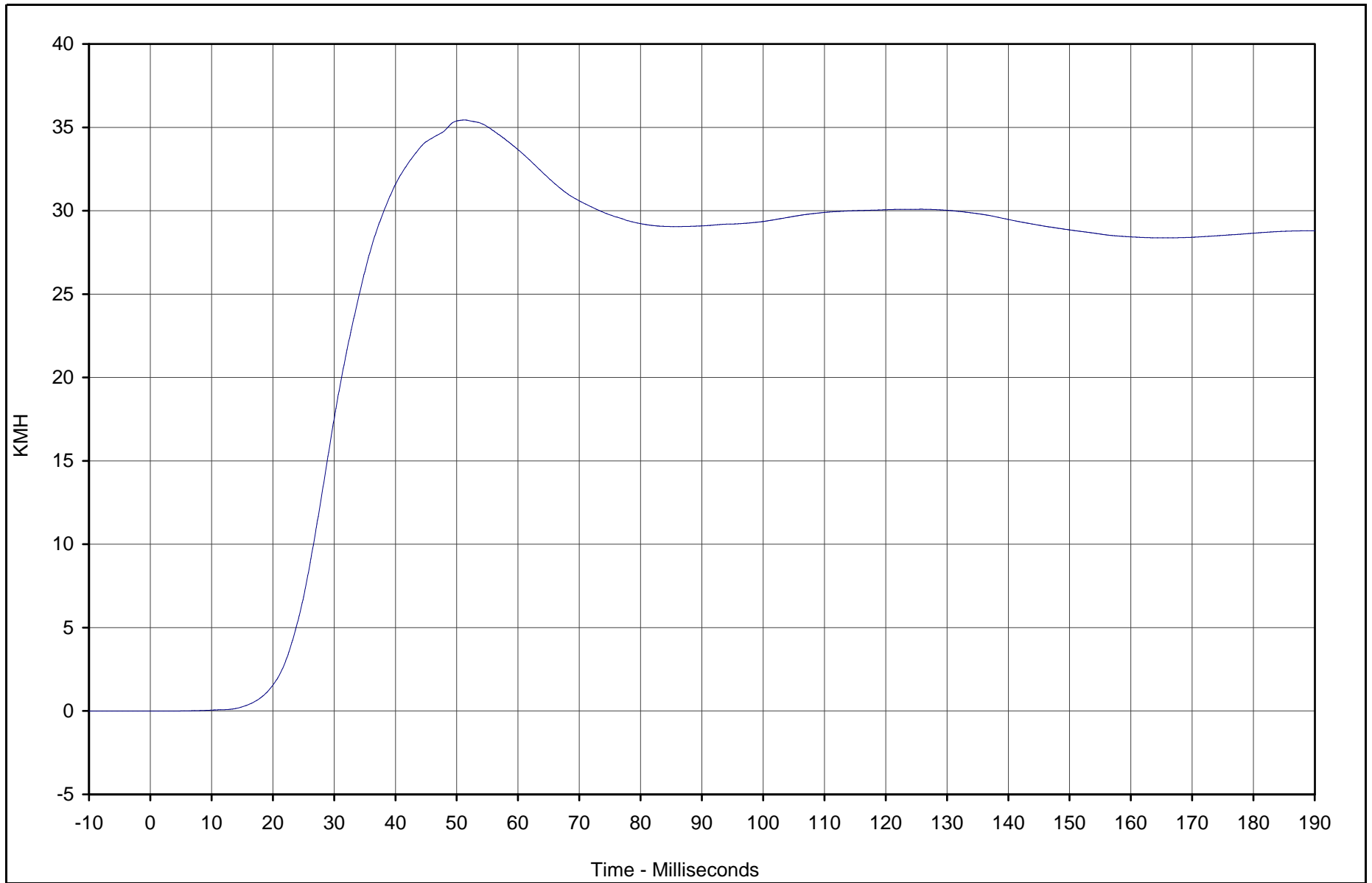

Curve Description	CURNO	Type	Units	Max	Time	Min	Time	SAE Class
Driver Pelvis Primary Y Vel.	016	IN1	KMH	35.4	51.2	0.0	3.0	180



Test Vehicle: 2003 Subaru Forester 2.5X AWD Wagon

Test Date: 10/29/02

Test Program: 55/28 km/h Side Impact NCAP

NHTSA No.: M35500

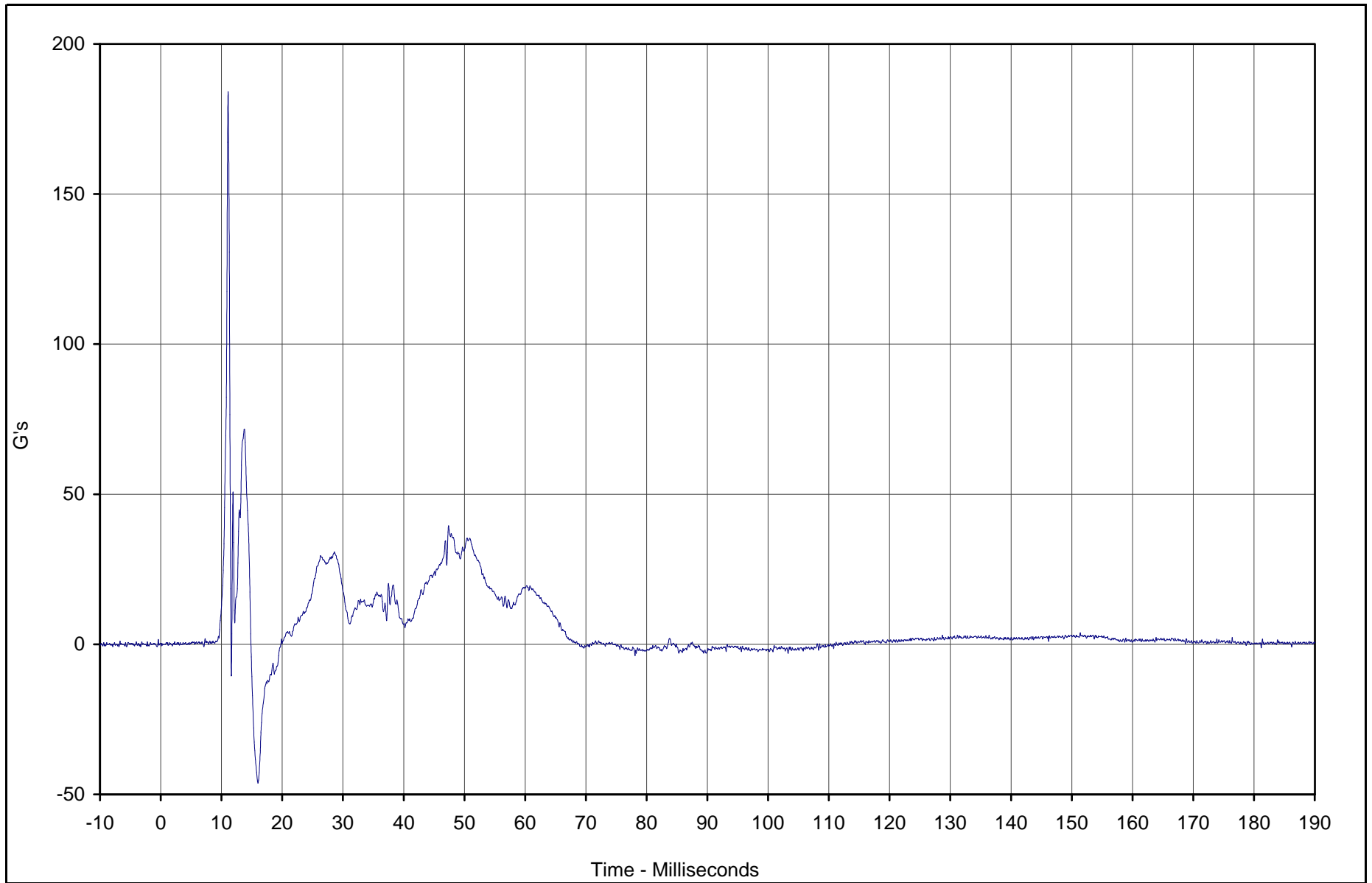

Curve Description	CURNO	Type	Units	Max	Time	Min	Time	SAE Class
Driver Upper Rib Redundant Y	017	FIL	G's	184.1	11.1	-46.3	16.0	1000



Test Vehicle: 2003 Subaru Forester 2.5X AWD Wagon

Test Date: 10/29/02

Test Program: 55/28 km/h Side Impact NCAP

NHTSA No.: M35500

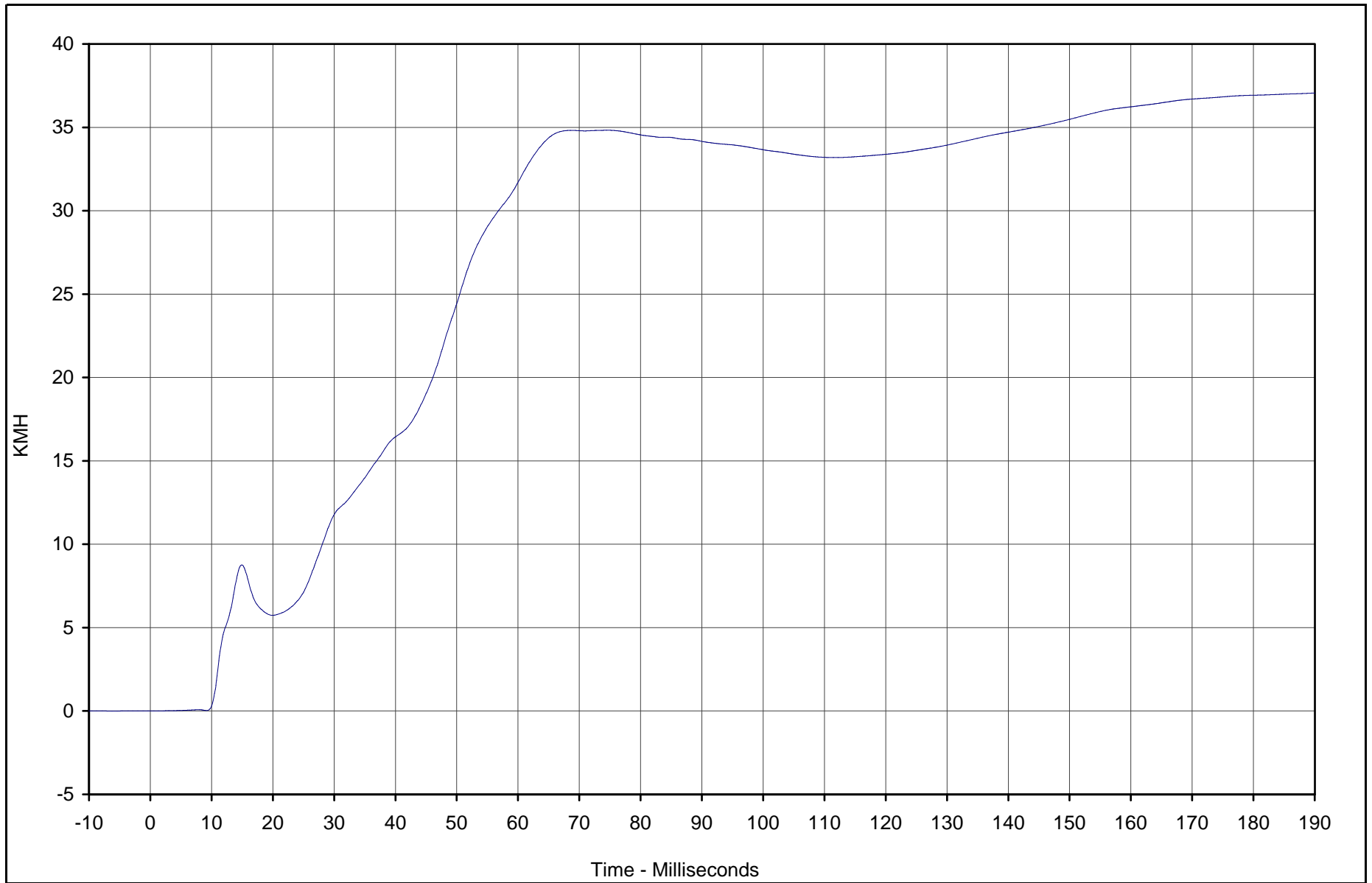

Curve Description	CURNO	Type	Units	Max	Time	Min	Time	SAE Class
Driver Upper Rib Redundant Y Vel.	017	IN1	KMH	37.1	189.9	0.0	0.0	180



Test Vehicle: 2003 Subaru Forester 2.5X AWD Wagon

Test Date: 10/29/02

Test Program: 55/28 km/h Side Impact NCAP

NHTSA No.: M35500

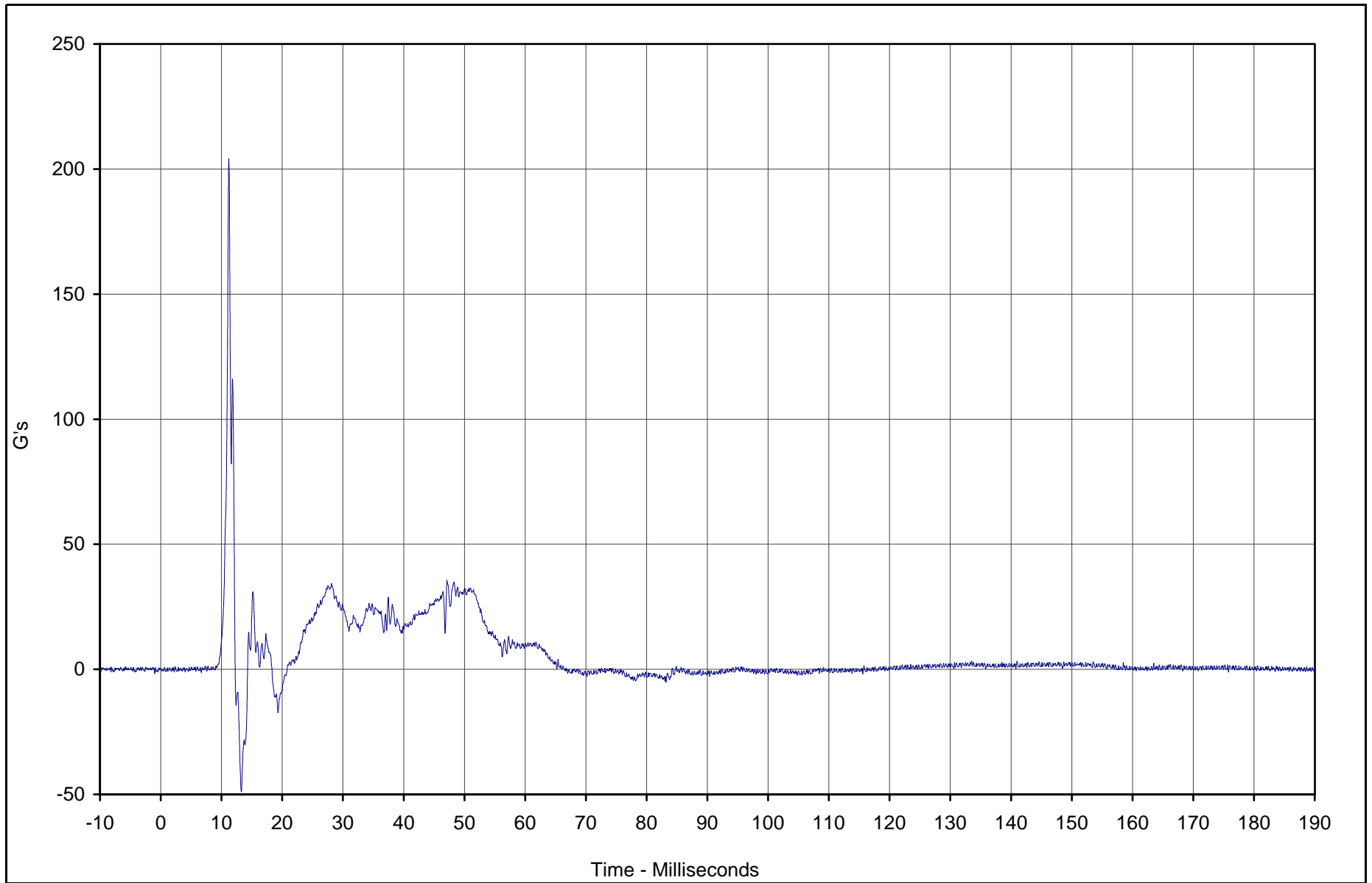

Curve Description	CURNO	Type	Units	Max	Time	Min	Time	SAE Class
Driver Lower Rib Redundant Y	018	FIL	G's	203.7	11.2	-48.9	13.3	1000



Test Vehicle: 2003 Subaru Forester 2.5X AWD Wagon

Test Date: 10/29/02

Test Program: 55/28 km/h Side Impact NCAP

NHTSA No.: M35500

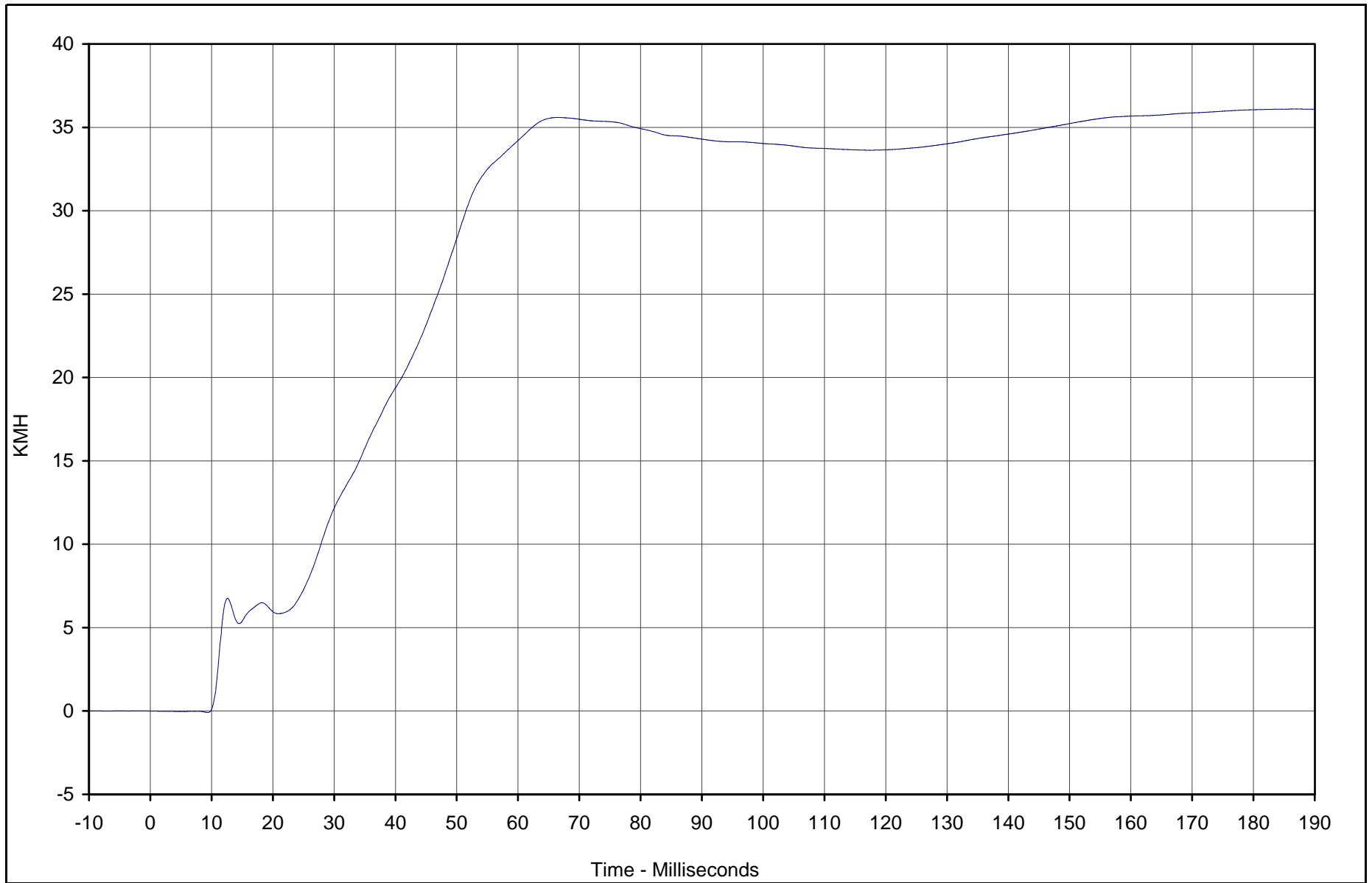

Curve Description	CURNO	Type	Units	Max	Time	Min	Time	SAE Class
Driver Lower Rib Redundant Y Vel.	018	IN1	KMH	36.1	187.0	-0.1	9.4	180



Test Vehicle: 2003 Subaru Forester 2.5X AWD Wagon

Test Date: 10/29/02

Test Program: 55/28 km/h Side Impact NCAP

NHTSA No.: M35500

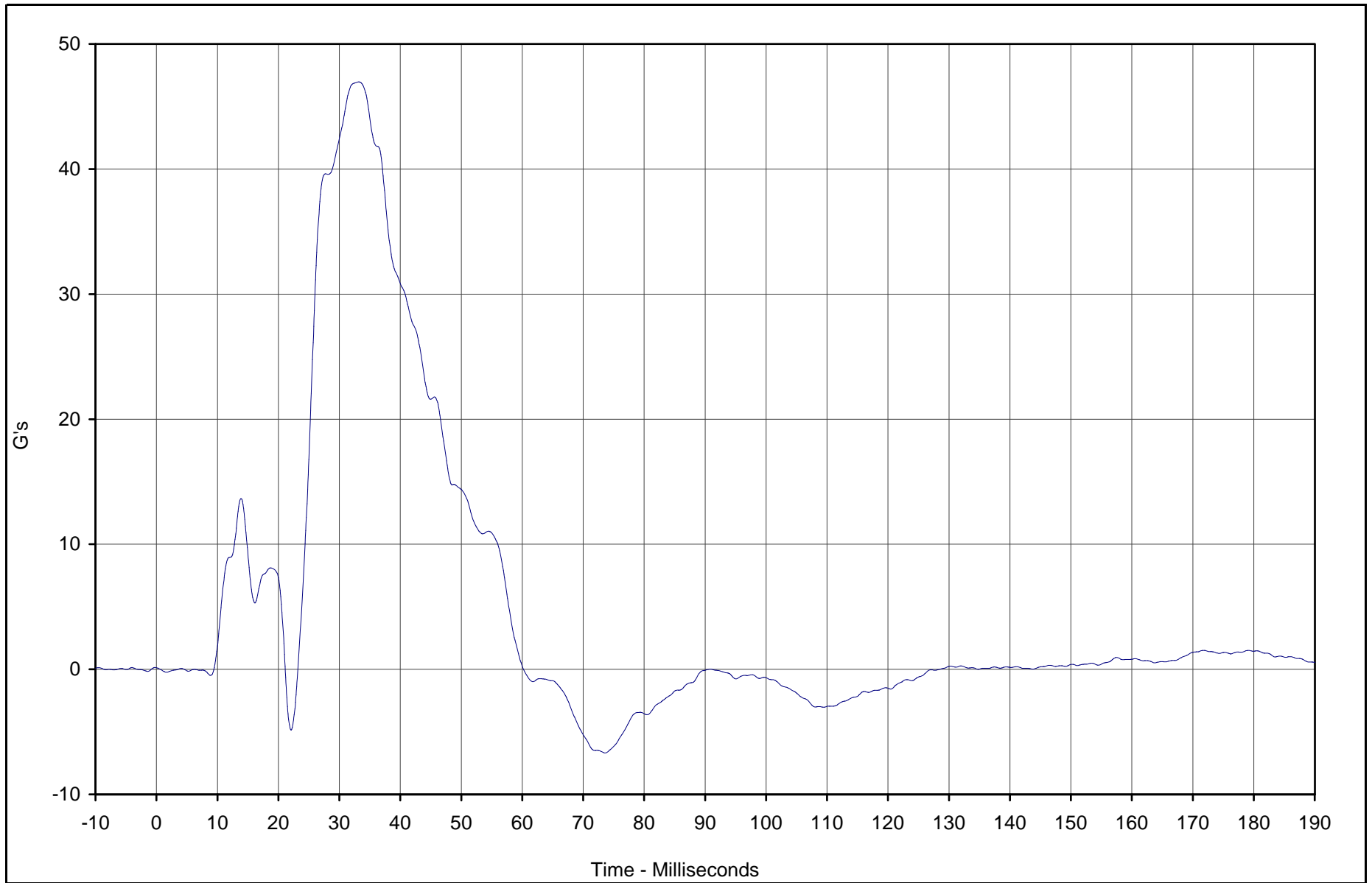

Curve Description	CURNO	Type	Units	Max	Time	Min	Time	SAE Class
Driver Lower Spine Redundant Y	019	FIL	G's	47.0	33.2	-6.7	73.6	180



Test Vehicle: 2003 Subaru Forester 2.5X AWD Wagon

Test Date: 10/29/02

Test Program: 55/28 km/h Side Impact NCAP

NHTSA No.: M35500

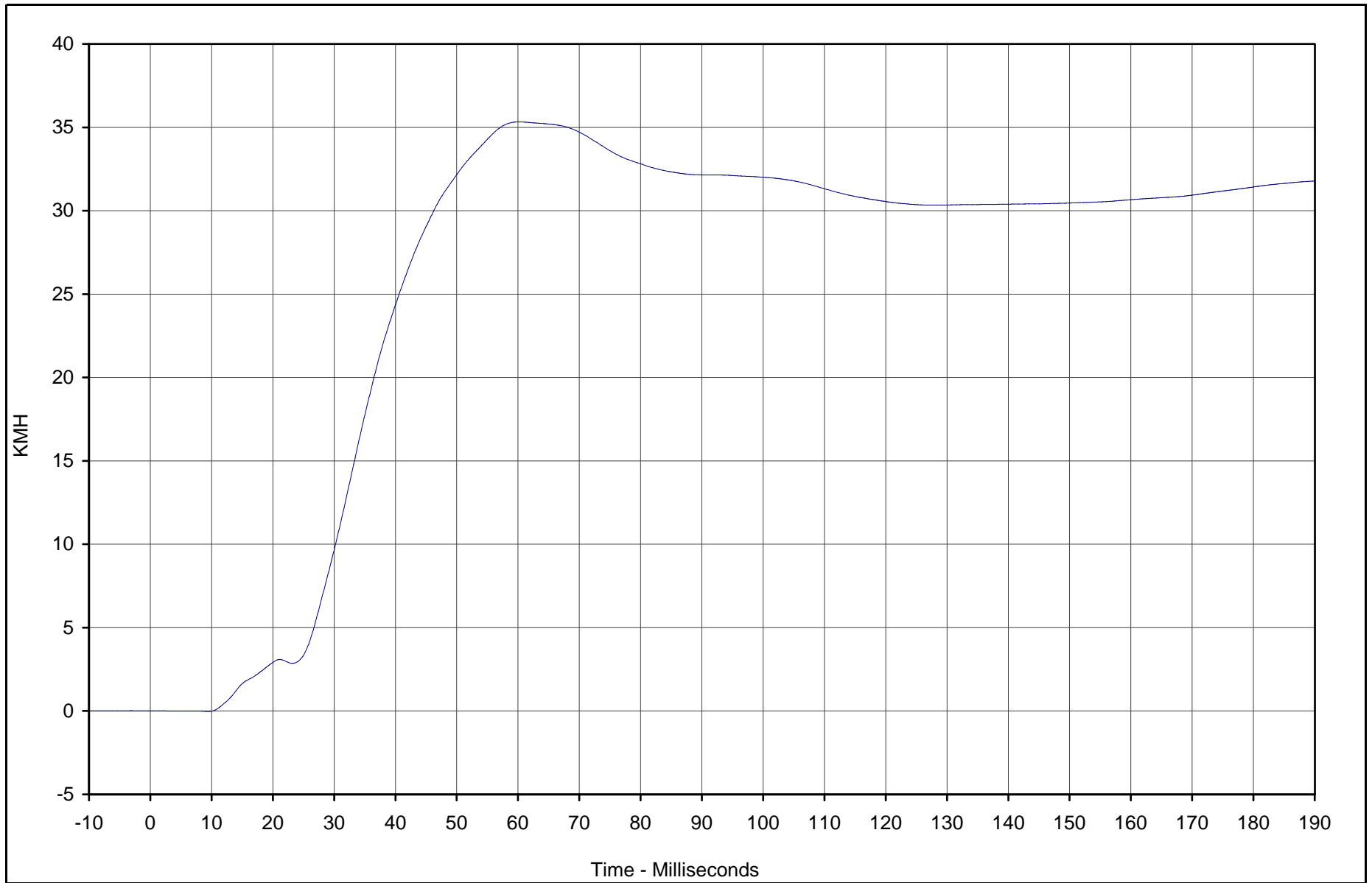

Curve Description	CURNO	Type	Units	Max	Time	Min	Time	SAE Class
Driver Lower Spine Redundant Y Vel.	019	IN1	KMH	35.3	60.2	0.0	9.4	180



Test Vehicle: 2003 Subaru Forester 2.5X AWD Wagon

Test Date: 10/29/02

Test Program: 55/28 km/h Side Impact NCAP

NHTSA No.: M35500

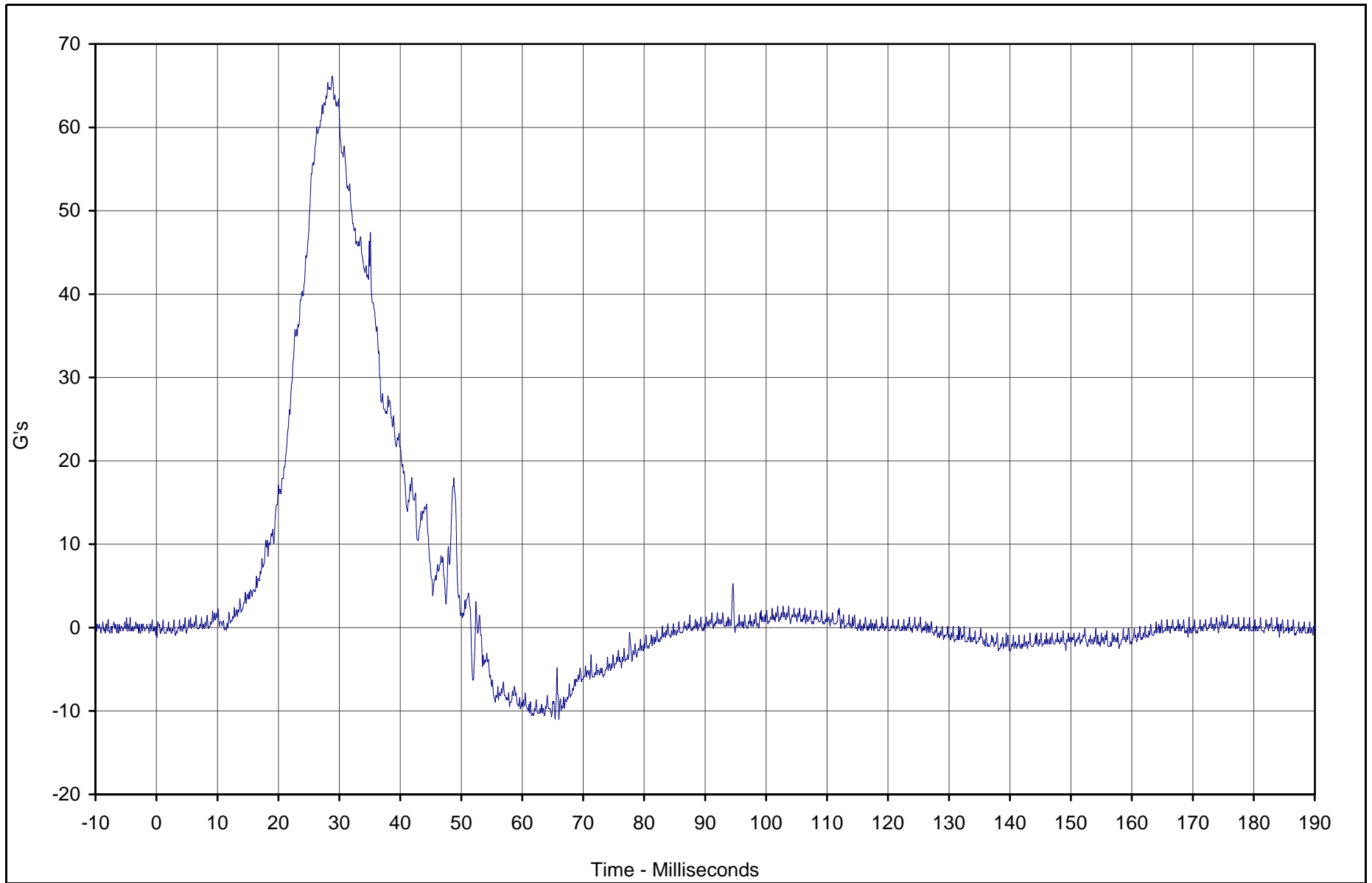

Curve Description	CURNO	Type	Units	Max	Time	Min	Time	SAE Class
Driver Pelvis Redundant Y	020	FIL	G's	66.1	28.8	-11.0	65.4	1000



Test Vehicle: 2003 Subaru Forester 2.5X AWD Wagon

Test Date: 10/29/02

Test Program: 55/28 km/h Side Impact NCAP

NHTSA No.: M35500

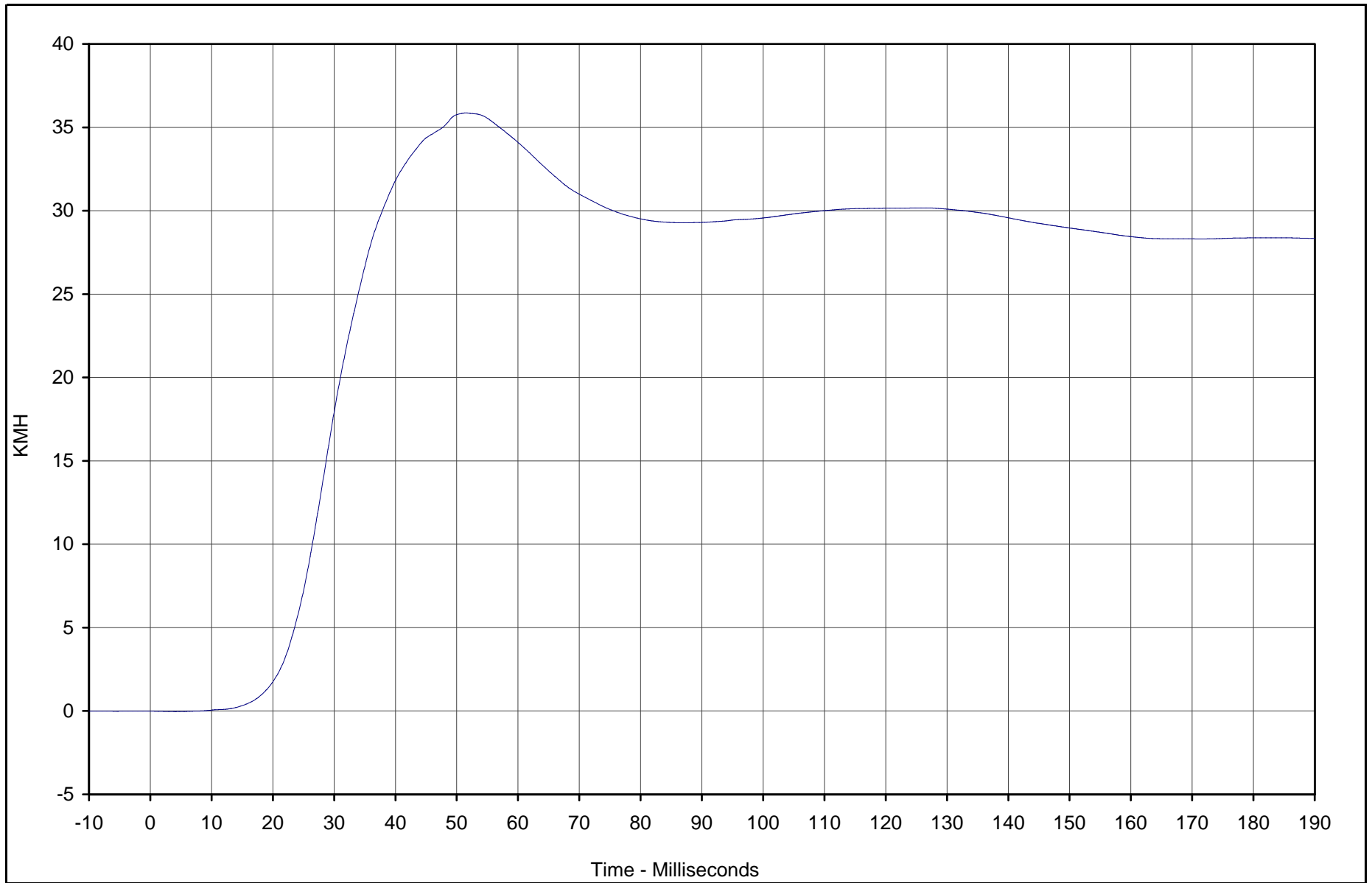

Curve Description	CURNO	Type	Units	Max	Time	Min	Time	SAE Class
Driver Pelvis Redundant Y Vel.	020	IN1	KMH	35.9	51.5	0.0	4.1	180



Test Vehicle: 2003 Subaru Forester 2.5X AWD Wagon

Test Date: 10/29/02

Test Program: 55/28 km/h Side Impact NCAP

NHTSA No.: M35500

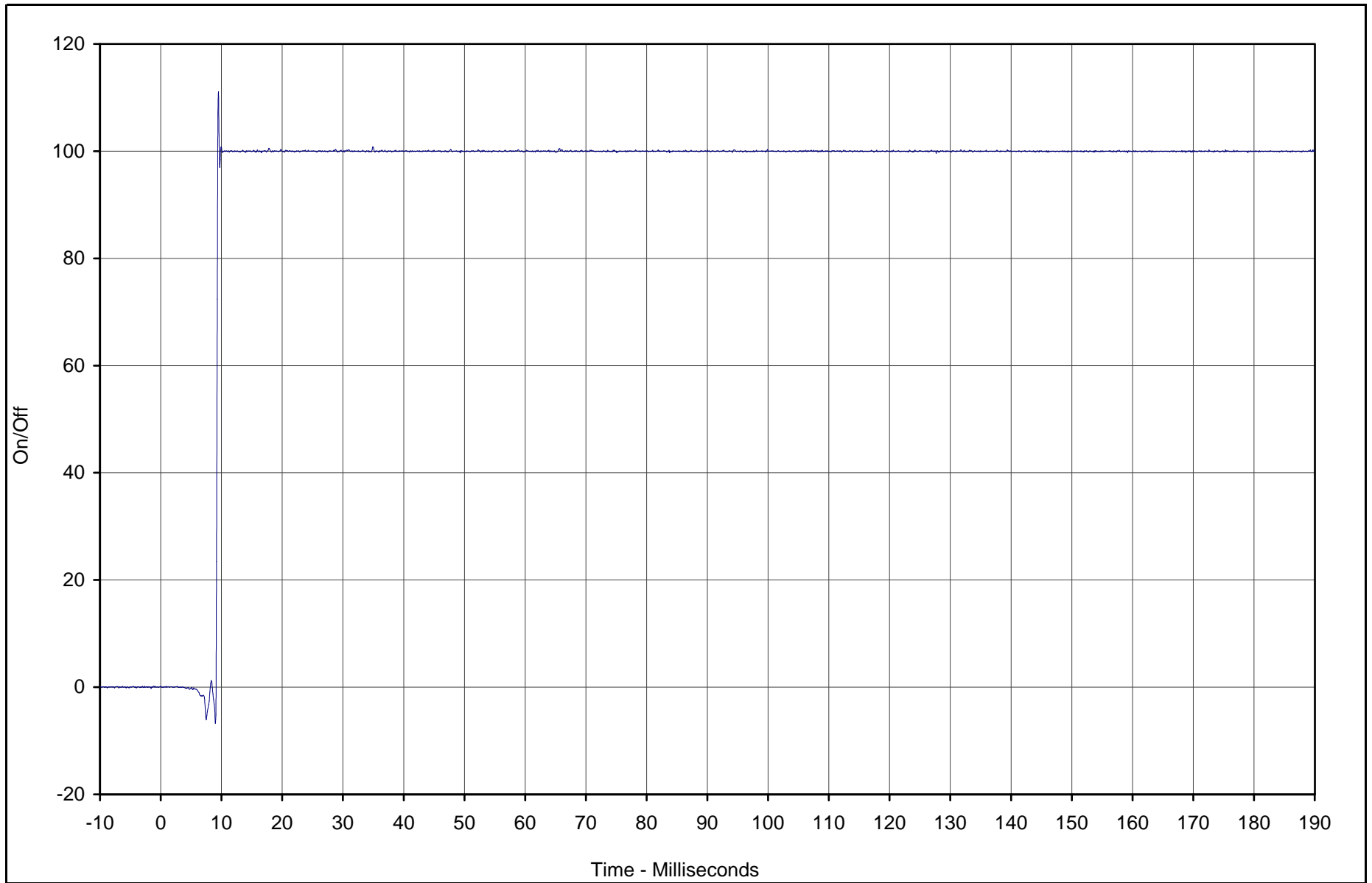

Curve Description	CURNO	Type	Units	Max	Time	Cross %	Time	SAE Class
Driver Thorax Contact	021	FIL	On/Off	111.0	9.5	50.0	9.3	1000



Test Vehicle: 2003 Subaru Forester 2.5X AWD Wagon

Test Date: 10/29/02

Test Program: 55/28 km/h Side Impact NCAP

NHTSA No.: M35500

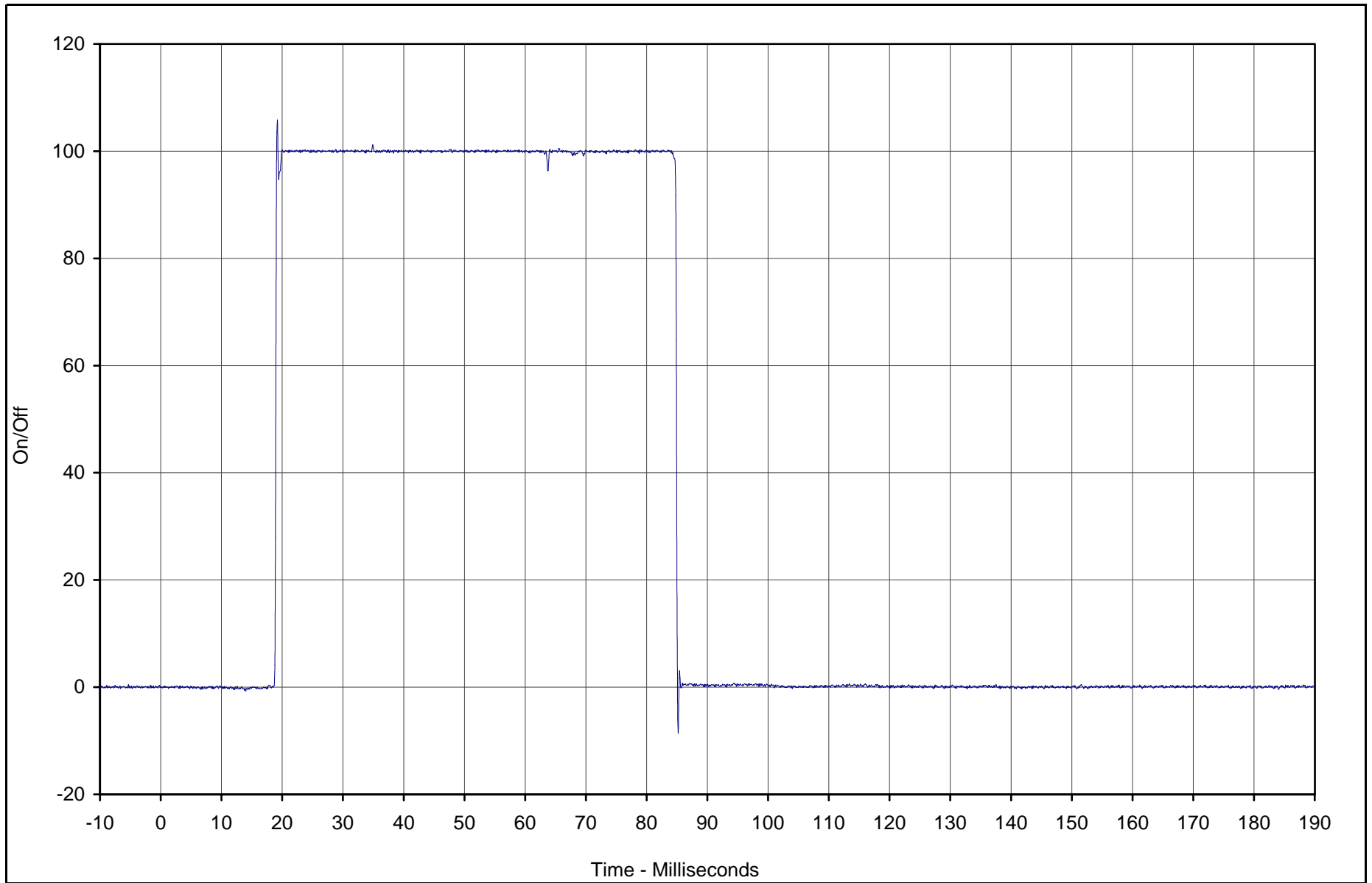

Curve Description	CURNO	Type	Units	Max	Time	Cross %	Time	SAE Class
Driver Pelvis Contact	022	FIL	On/Off	105.8	19.2	50.0	19.0	1000



Test Vehicle: 2003 Subaru Forester 2.5X AWD Wagon

Test Date: 10/29/02

Test Program: 55/28 km/h Side Impact NCAP

NHTSA No.: M35500

B-41

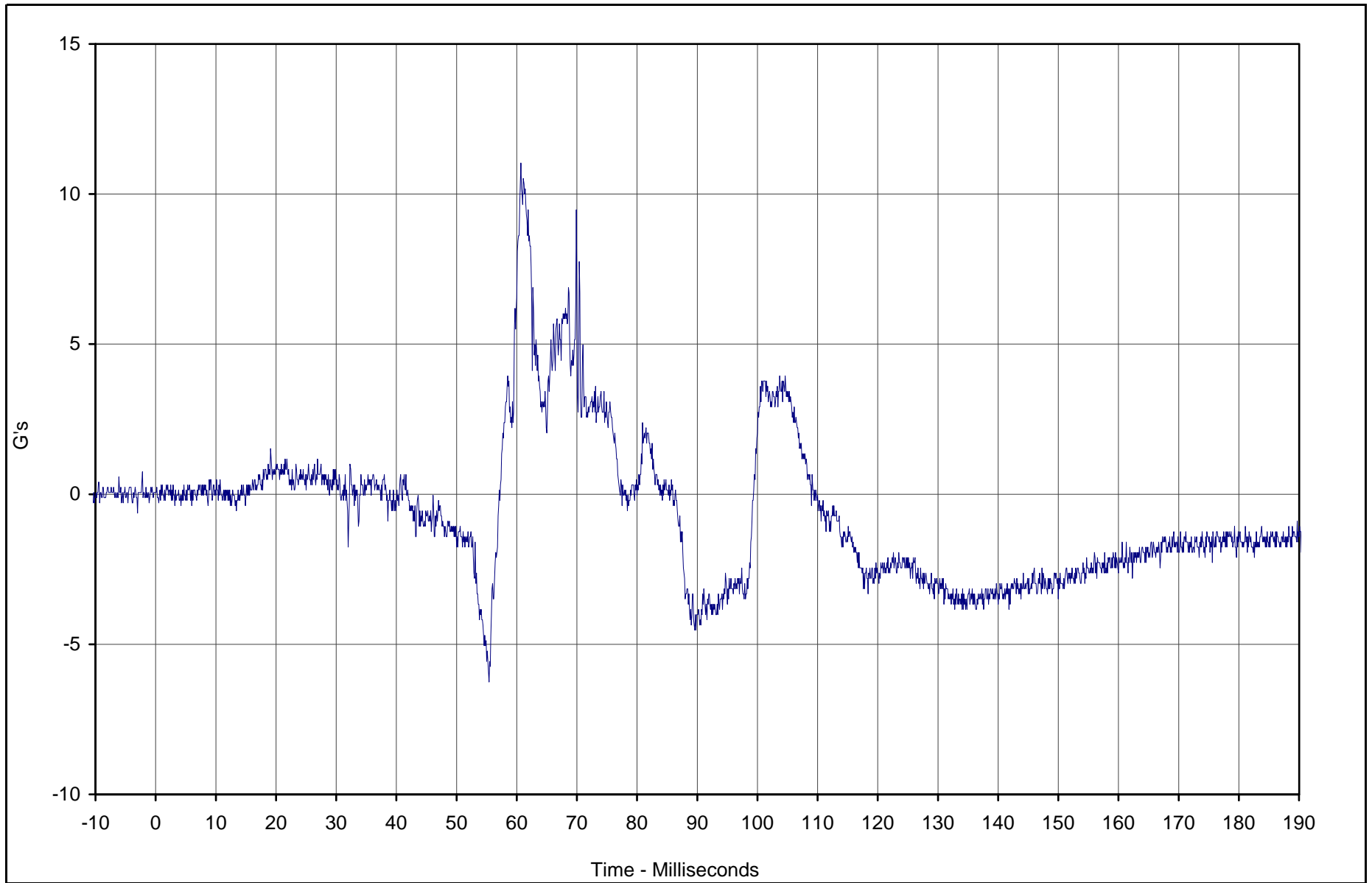

Curve Description	CURNO	Type	Units	Max	Time	Min	Time	SAE Class
Pass. Head X	023	FIL	G's	11.0	60.7	-6.3	55.4	1000



Test Vehicle: 2003 Subaru Forester 2.5X AWD Wagon

Test Date: 10/29/02

Test Program: 55/28 km/h Side Impact NCAP

NHTSA No.: M35500

TR-P23003-01-NC

B-42

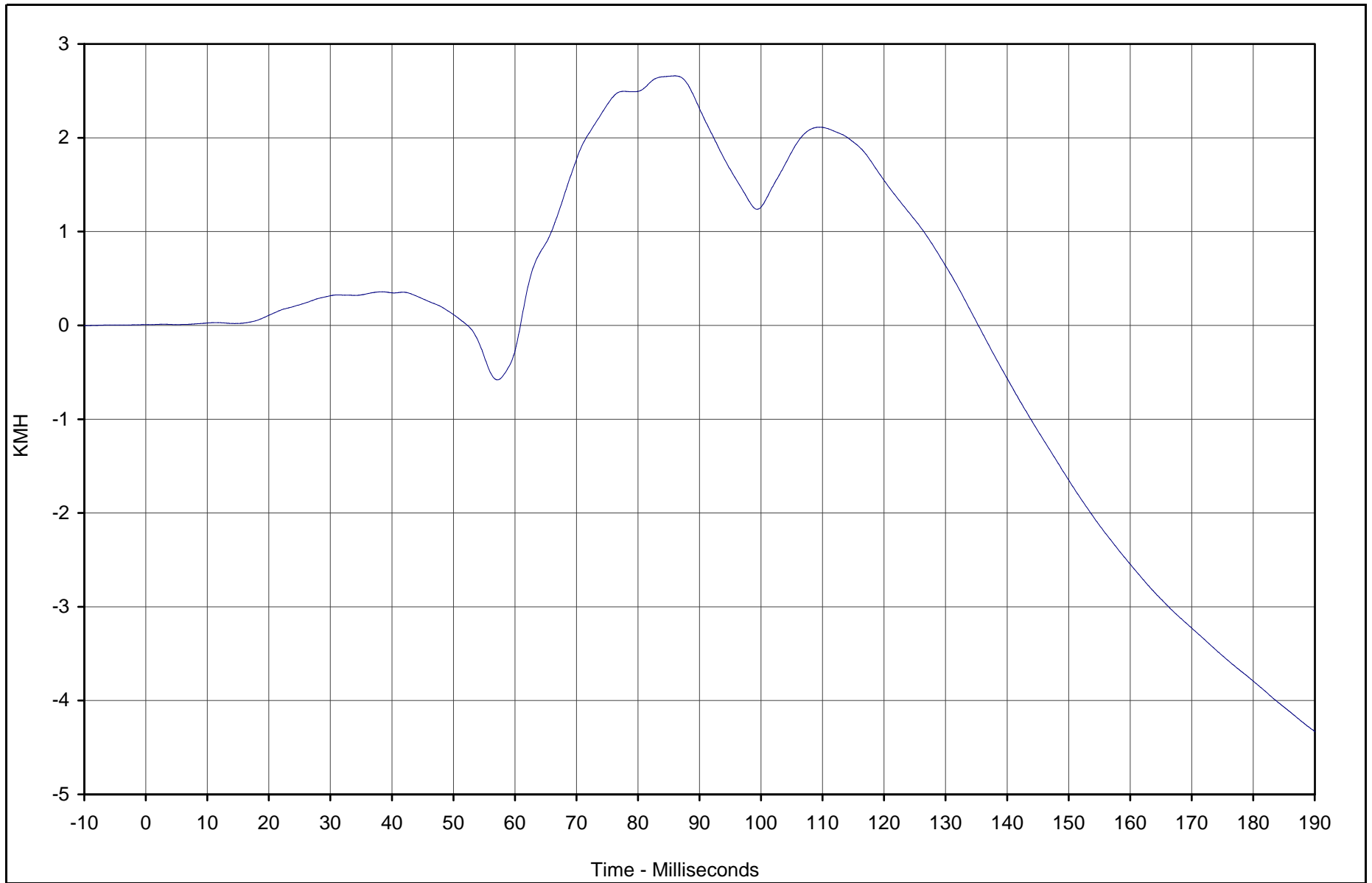

Curve Description	CURNO	Type	Units	Max	Time	Min	Time	SAE Class
Pass. Head X Velocity	023	IN1	KMH	2.7	86.0	-4.3	189.9	180



Test Vehicle: 2003 Subaru Forester 2.5X AWD Wagon

Test Date: 10/29/02

Test Program: 55/28 km/h Side Impact NCAP

NHTSA No.: M35500

TR-P23003-01-NC

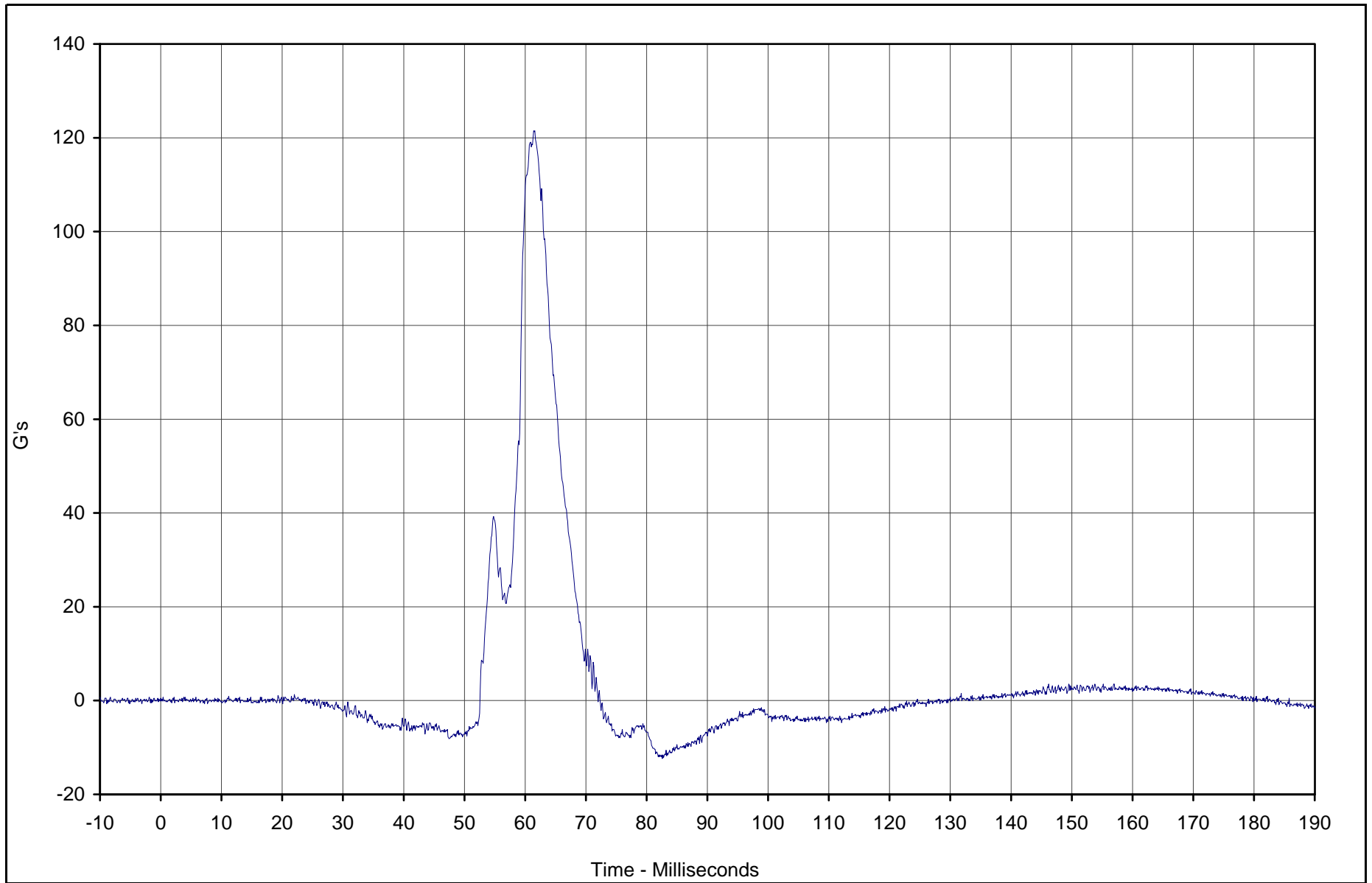

Curve Description	CURNO	Type	Units	Max	Time	Min	Time	SAE Class
Pass. Head Y	024	FIL	G's	121.5	61.4	-12.4	82.6	1000



Test Vehicle: 2003 Subaru Forester 2.5X AWD Wagon

Test Date: 10/29/02

Test Program: 55/28 km/h Side Impact NCAP

NHTSA No.: M35500

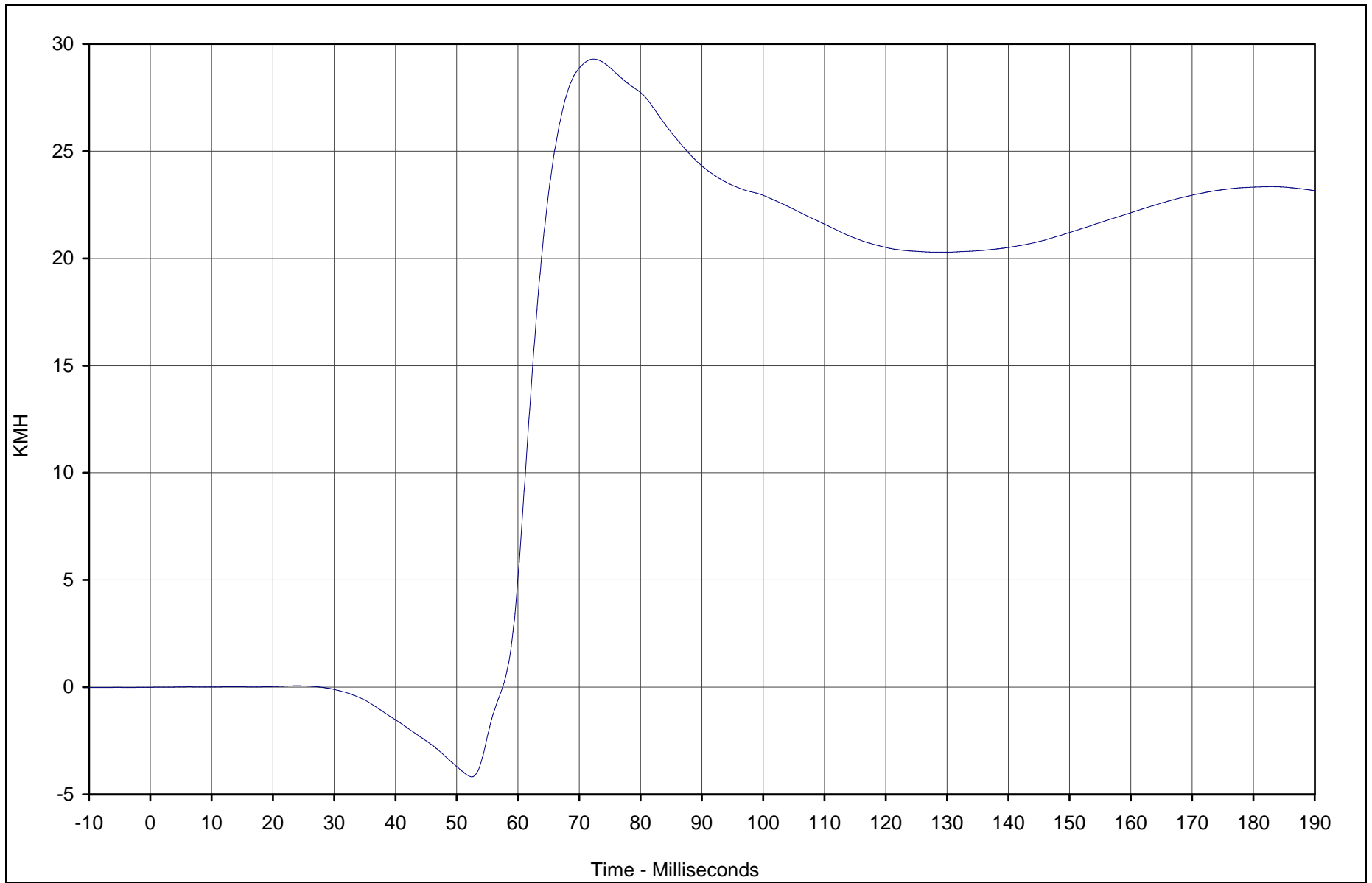

Curve Description	CURNO	Type	Units	Max	Time	Min	Time	SAE Class
Pass. Head Y Velocity	024	IN1	KMH	29.3	72.3	-4.2	52.4	180



Test Vehicle: 2003 Subaru Forester 2.5X AWD Wagon

Test Date: 10/29/02

Test Program: 55/28 km/h Side Impact NCAP

NHTSA No.: M35500

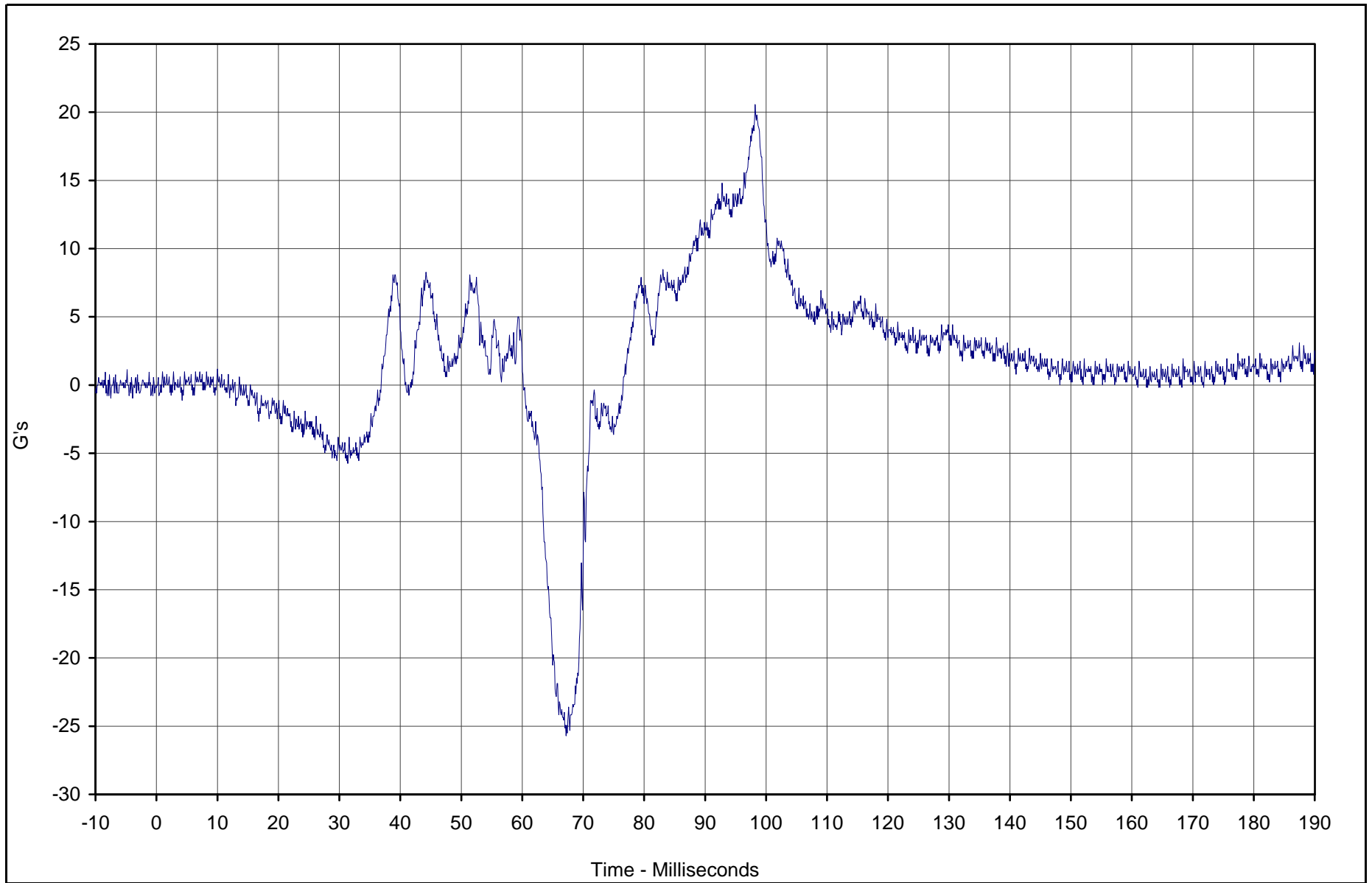

Curve Description	CURNO	Type	Units	Max	Time	Min	Time	SAE Class
Pass. Head Z	025	FIL	G's	20.6	98.2	-25.7	67.2	1000



Test Vehicle: 2003 Subaru Forester 2.5X AWD Wagon

Test Date: 10/29/02

Test Program: 55/28 km/h Side Impact NCAP

NHTSA No.: M35500

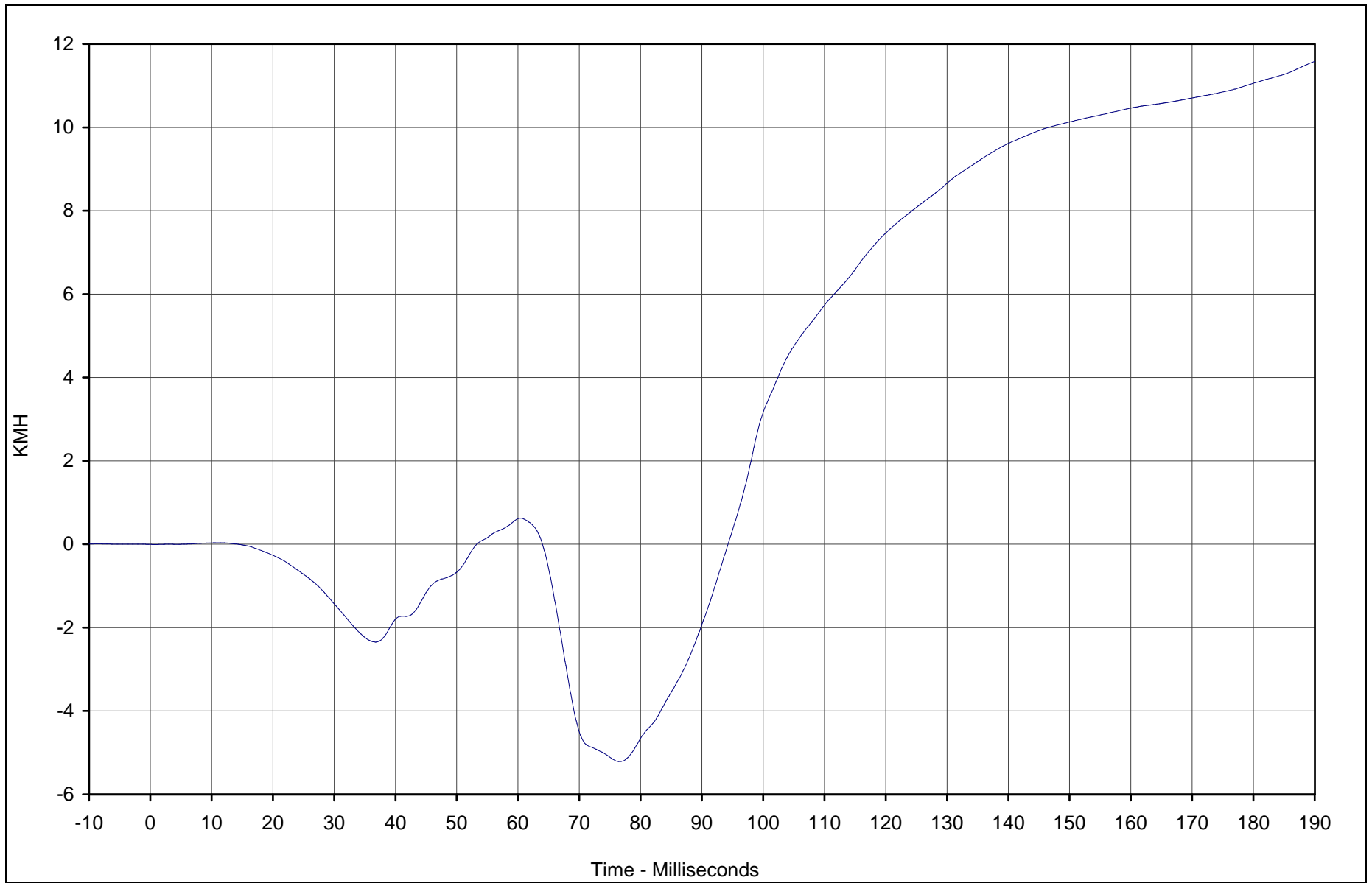

Curve Description	CURNO	Type	Units	Max	Time	Min	Time	SAE Class
Pass. Head Z Velocity	025	IN1	KMH	11.6	189.9	-5.2	76.6	180



Test Vehicle: 2003 Subaru Forester 2.5X AWD Wagon

Test Date: 10/29/02

Test Program: 55/28 km/h Side Impact NCAP

NHTSA No.: M35500

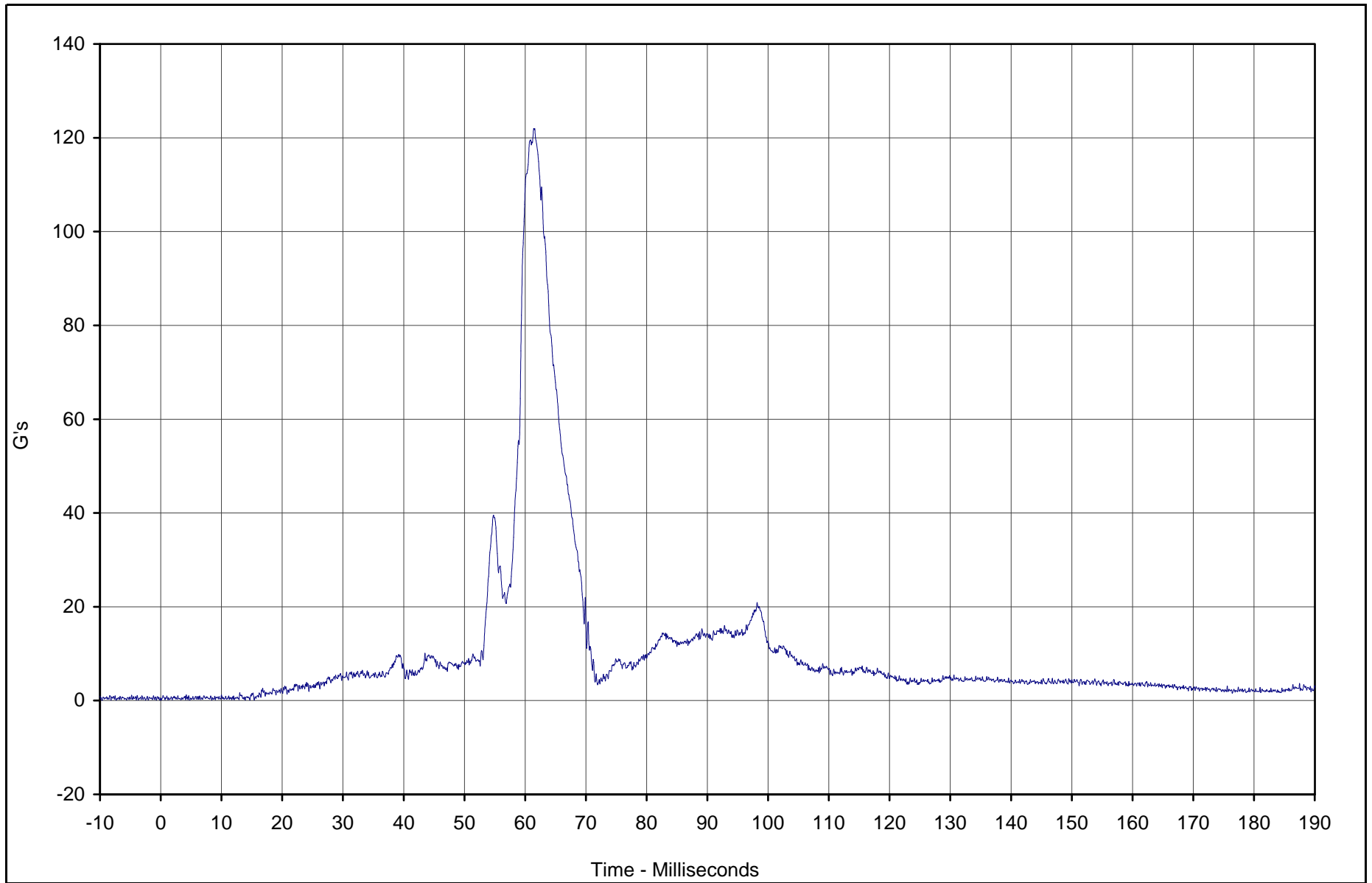

Curve Description	CURNO	Type	Units	Max	Time	Min	Time	SAE Class
Pass. Head Resultant	023	RES	G's	121.9	61.4	0.1	4.8	1000



Test Vehicle: 2003 Subaru Forester 2.5X AWD Wagon

Test Date: 10/29/02

Test Program: 55/28 km/h Side Impact NCAP

NHTSA No.: M35500

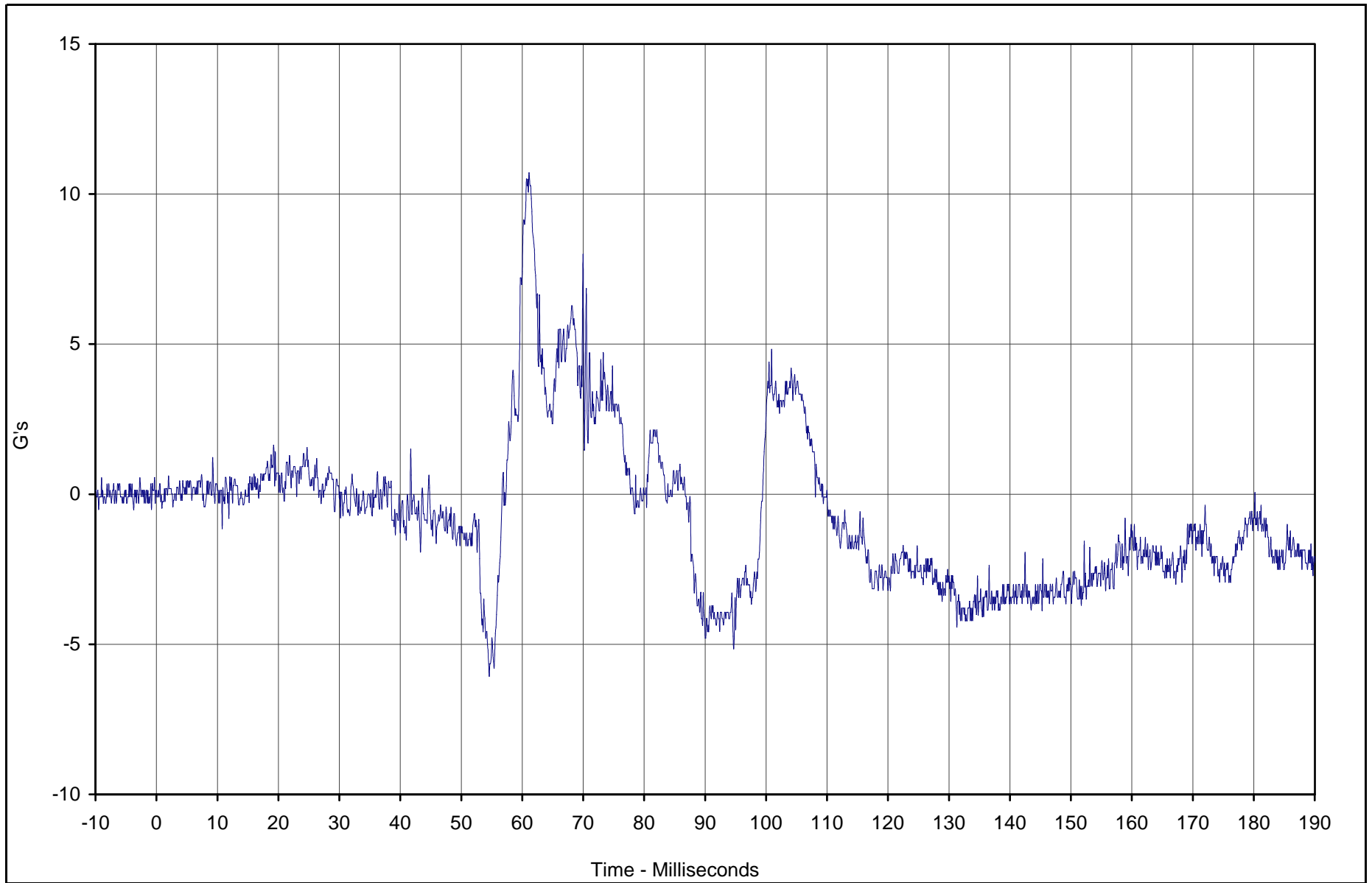

Curve Description	CURNO	Type	Units	Max	Time	Min	Time	SAE Class
Pass. Head X Redundant	026	FIL	G's	10.7	61.1	-6.1	54.6	1000



Test Vehicle: 2003 Subaru Forester 2.5X AWD Wagon

Test Date: 10/29/02

Test Program: 55/28 km/h Side Impact NCAP

NHTSA No.: M35500

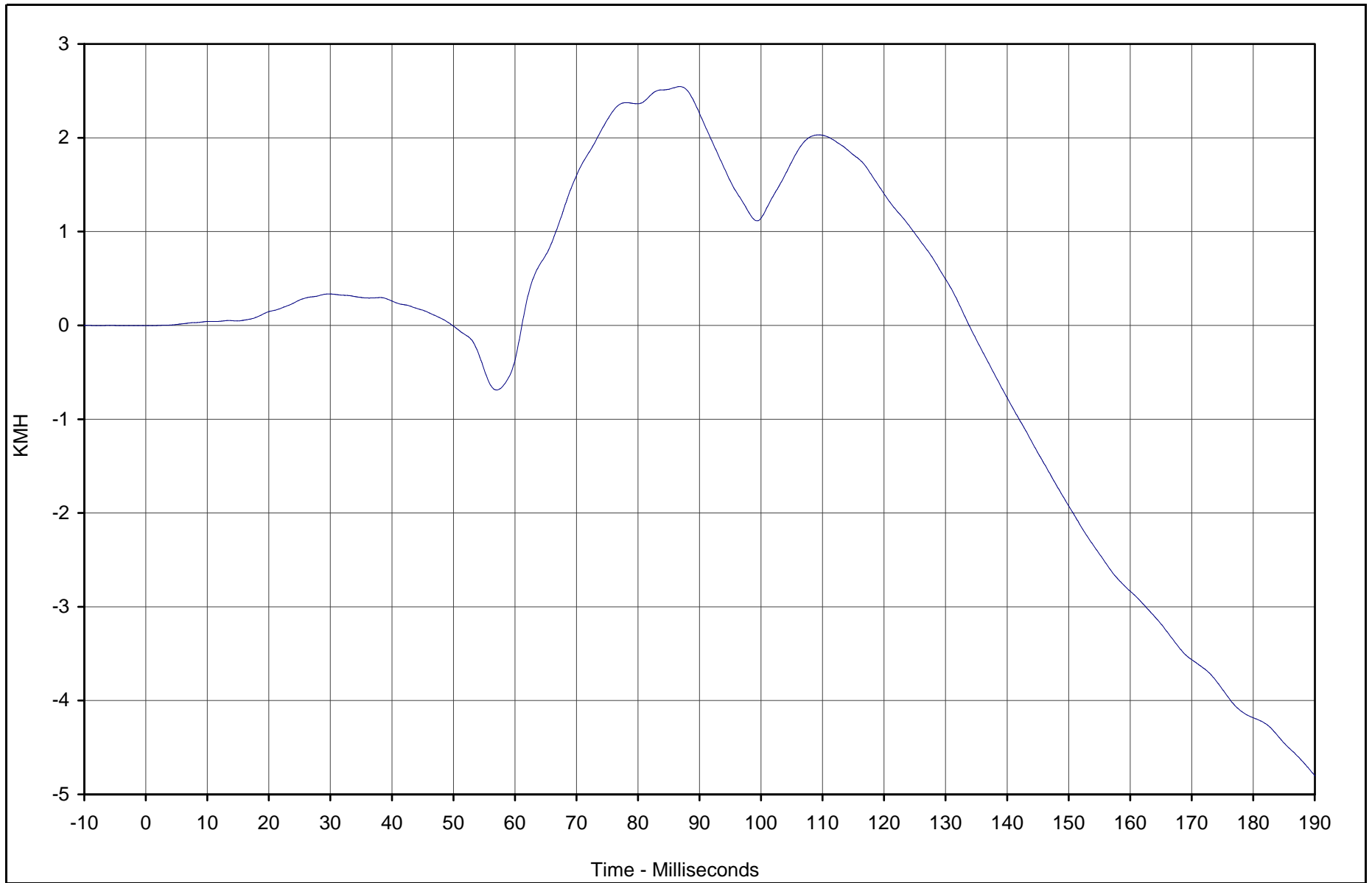

Curve Description	CURNO	Type	Units	Max	Time	Min	Time	SAE Class
Pass. Head X Redundant Velocity	026	IN1	KMH	2.5	86.8	-4.8	189.9	180



Test Vehicle: 2003 Subaru Forester 2.5X AWD Wagon

Test Date: 10/29/02

Test Program: 55/28 km/h Side Impact NCAP

NHTSA No.: M35500

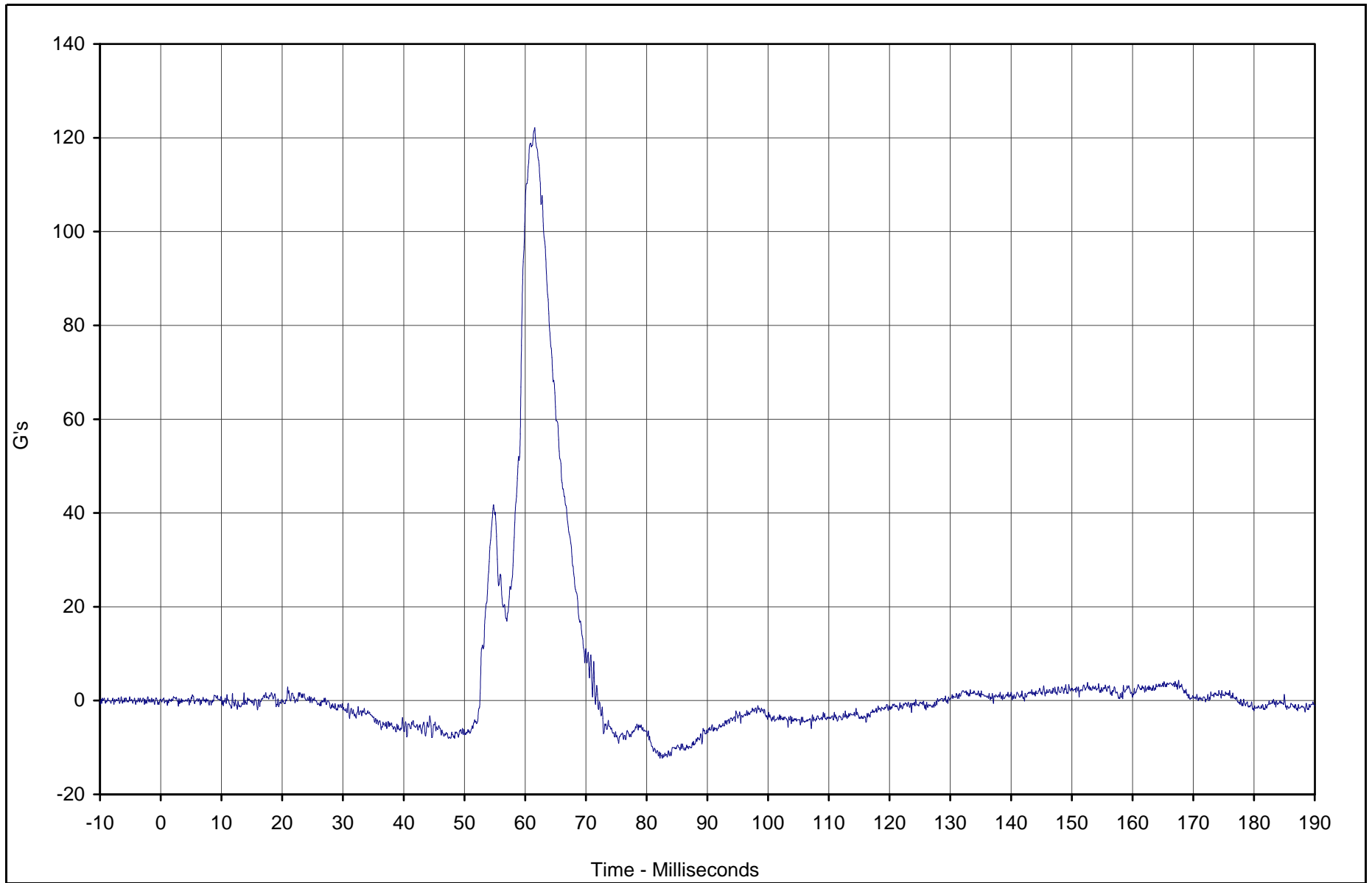

Curve Description	CURNO	Type	Units	Max	Time	Min	Time	SAE Class
Pass. Head Y Redundant	027	FIL	G's	122.1	61.6	-12.3	82.2	1000



Test Vehicle: 2003 Subaru Forester 2.5X AWD Wagon

Test Date: 10/29/02

Test Program: 55/28 km/h Side Impact NCAP

NHTSA No.: M35500

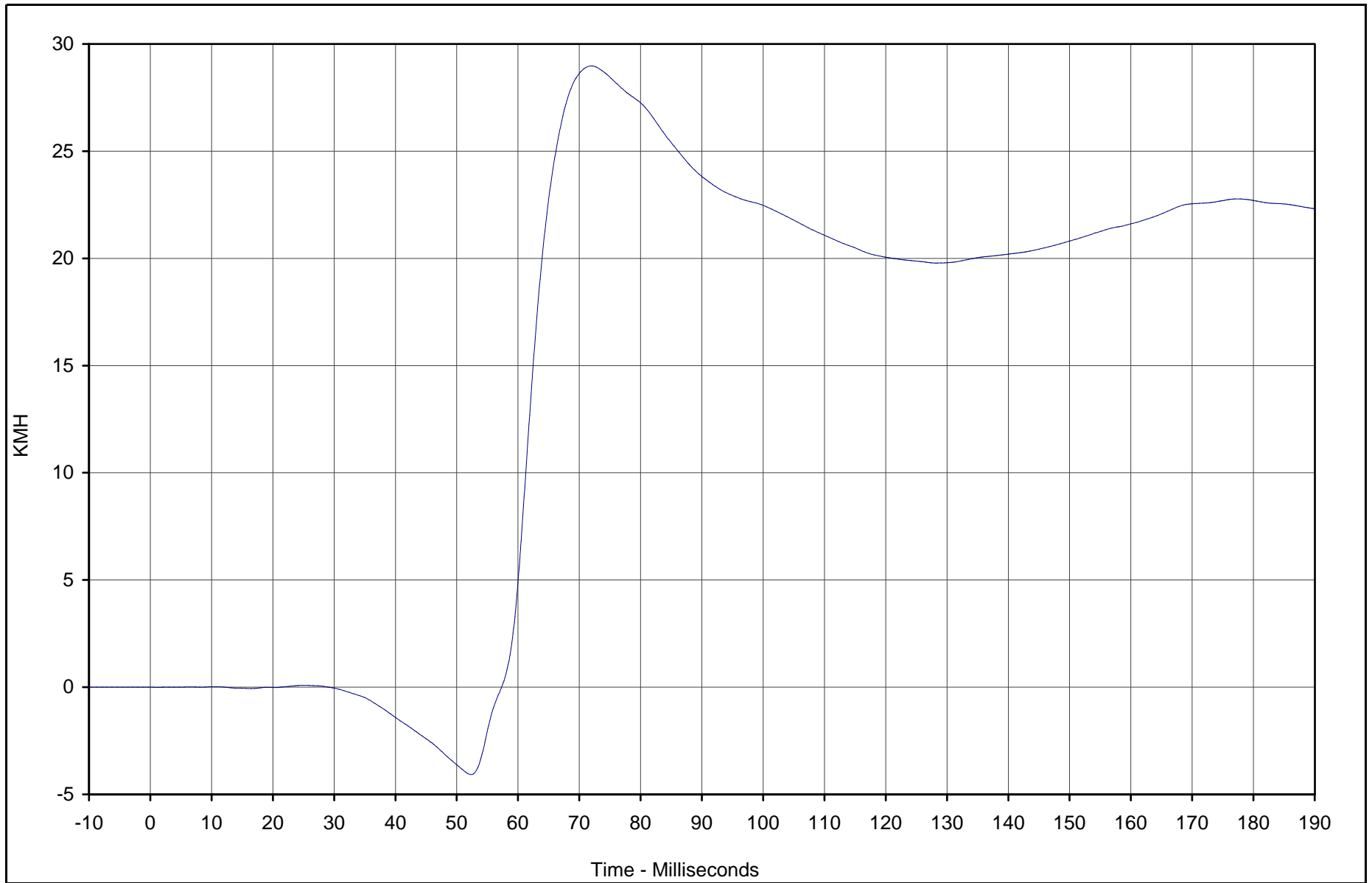

Curve Description	CURNO	Type	Units	Max	Time	Min	Time	SAE Class
Pass. Head Y Redundant Velocity	027	IN1	KMH	29.0	72.0	-4.1	52.4	180



Test Vehicle: 2003 Subaru Forester 2.5X AWD Wagon

Test Date: 10/29/02

Test Program: 55/28 km/h Side Impact NCAP

NHTSA No.: M35500

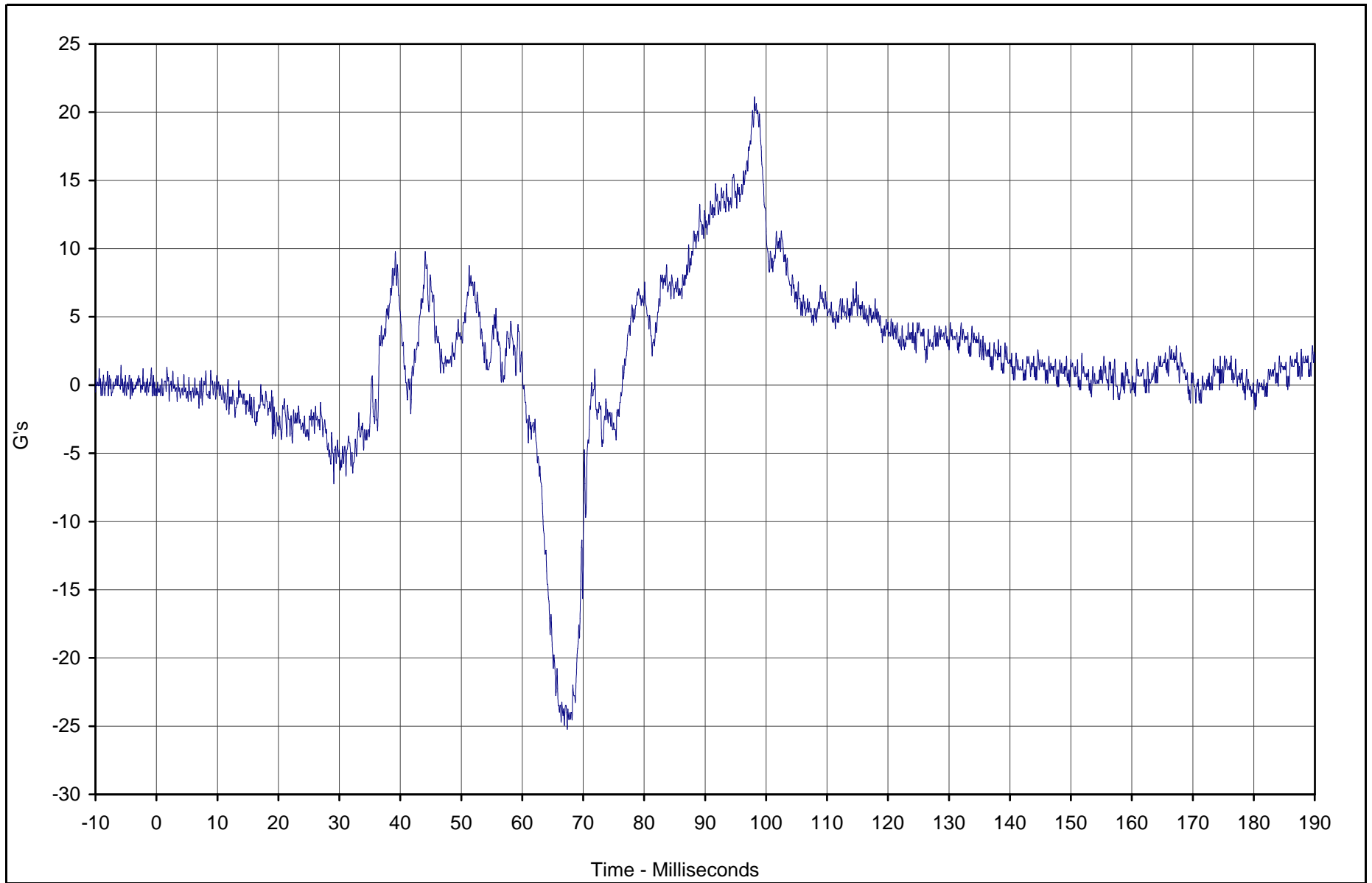

Curve Description	CURNO	Type	Units	Max	Time	Min	Time	SAE Class
Pass. Head Z Redundant	028	FIL	G's	21.1	98.1	-25.2	67.4	1000



Test Vehicle: 2003 Subaru Forester 2.5X AWD Wagon

Test Date: 10/29/02

Test Program: 55/28 km/h Side Impact NCAP

NHTSA No.: M35500

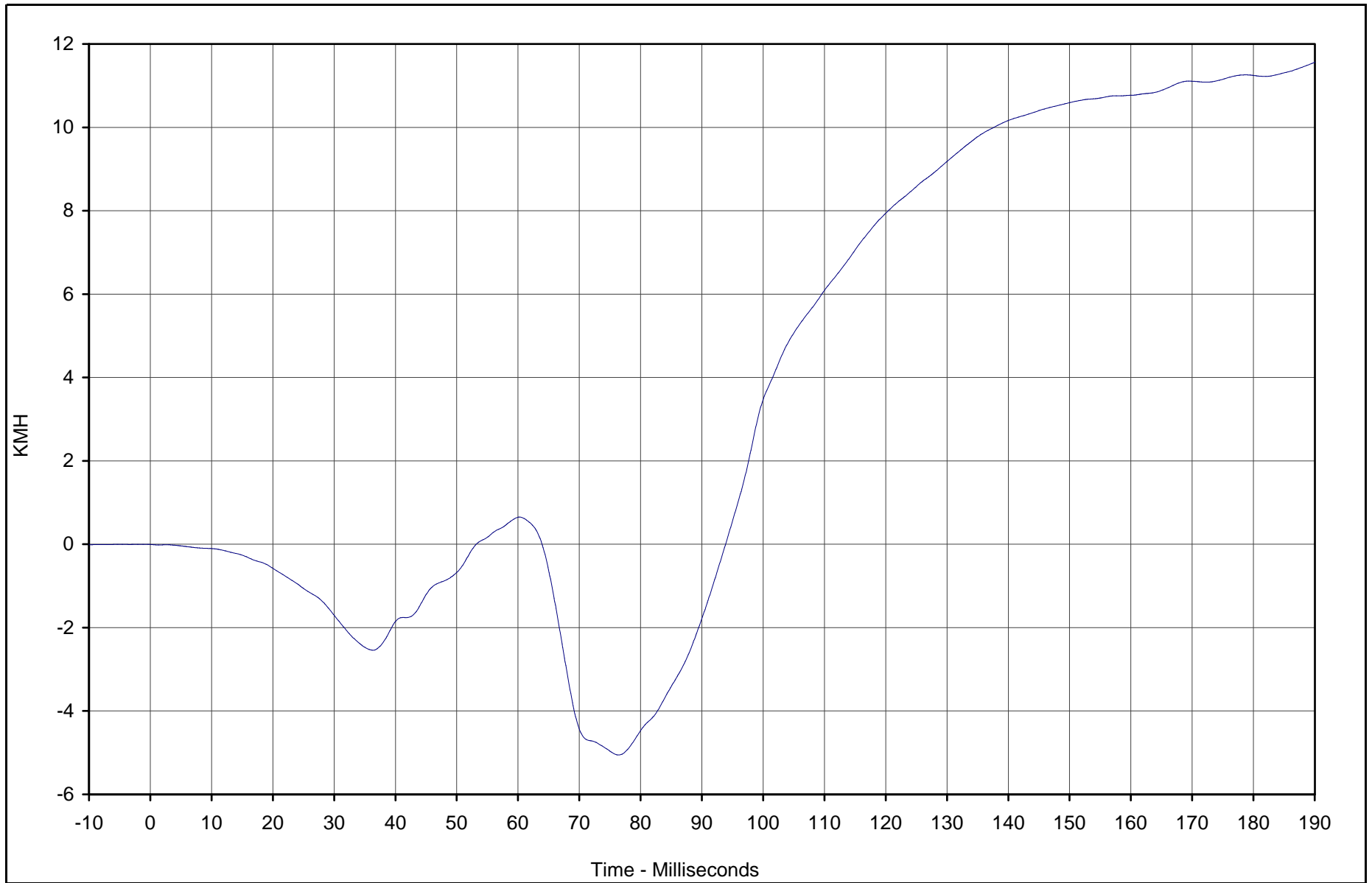

Curve Description	CURNO	Type	Units	Max	Time	Min	Time	SAE Class
Pass. Head Z Redundant Velocity	028	IN1	KMH	11.6	189.9	-5.1	76.4	180



Test Vehicle: 2003 Subaru Forester 2.5X AWD Wagon

Test Date: 10/29/02

Test Program: 55/28 km/h Side Impact NCAP

NHTSA No.: M35500

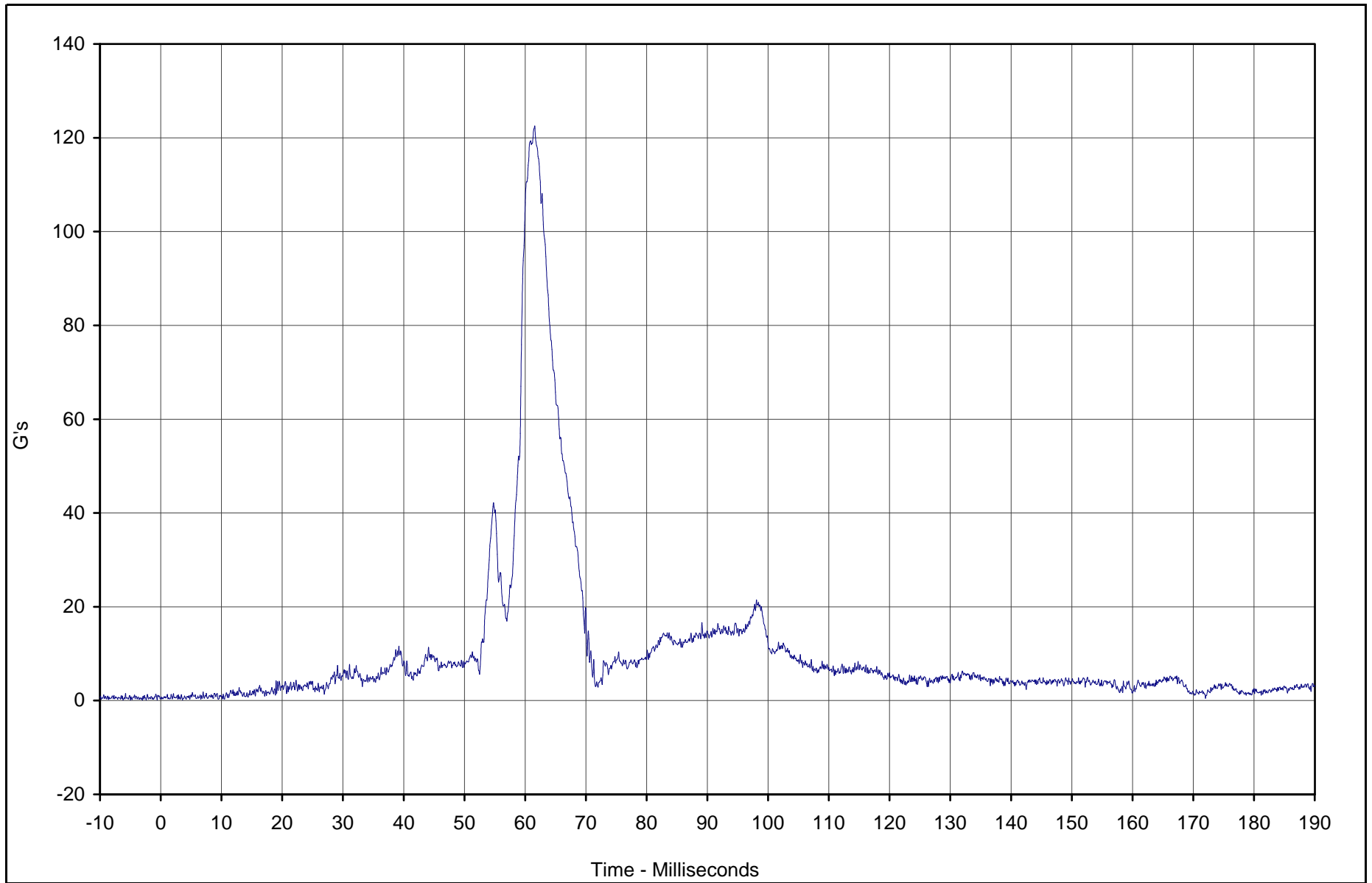

Curve Description	CURNO	Type	Units	Max	Time	Min	Time	SAE Class
Pass. Head Redundant Resultant	026	RES	G's	122.5	61.6	0.1	3.6	1000



Test Vehicle: 2003 Subaru Forester 2.5X AWD Wagon

Test Date: 10/29/02

Test Program: 55/28 km/h Side Impact NCAP

NHTSA No.: M35500

B-55

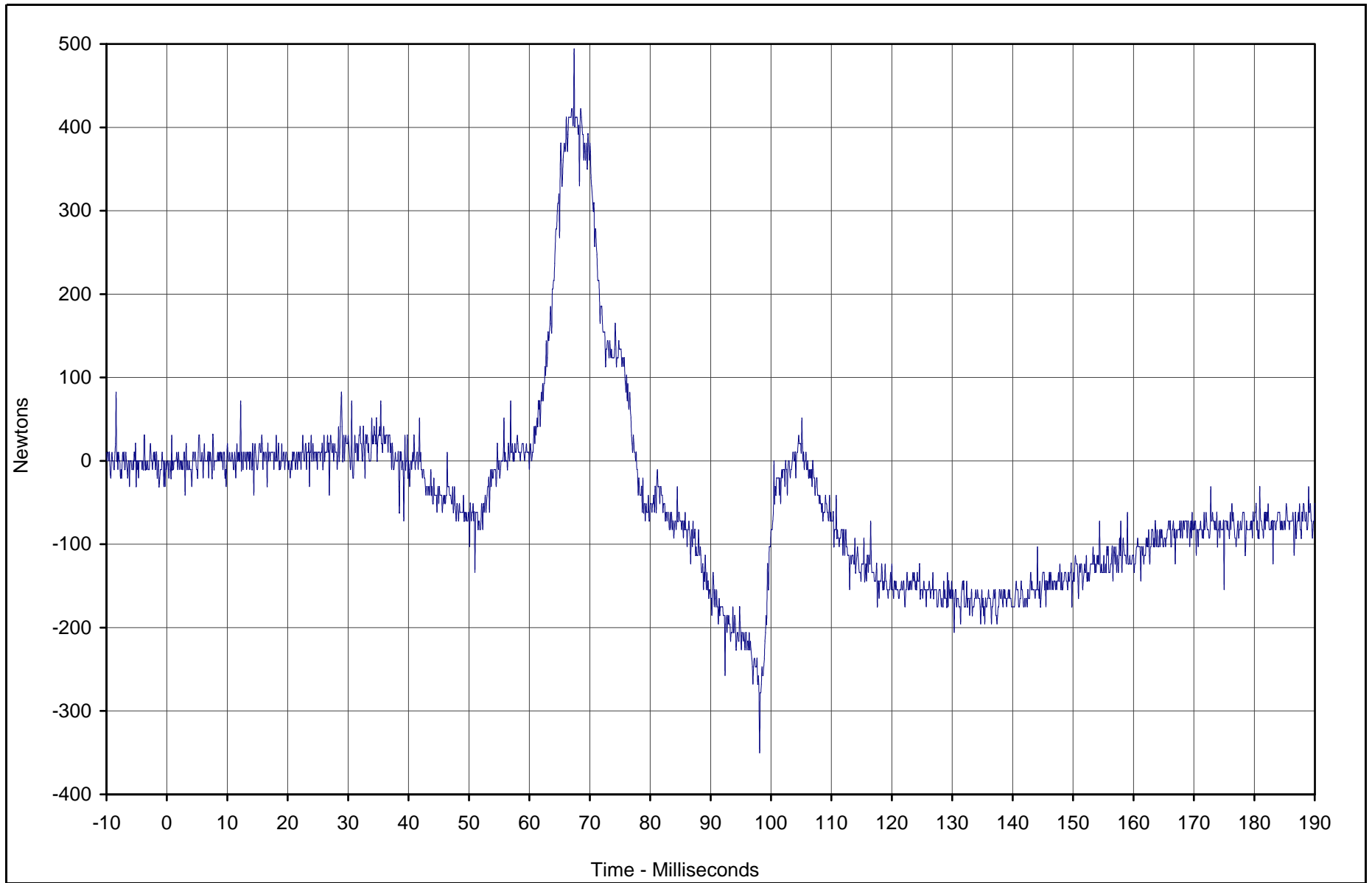

Curve Description	CURNO	Type	Units	Max	Time	Min	Time	SAE Class
Pass. Neck Force X	029	FIL	Newtons	494.5	67.4	-350.2	98.1	1000



Test Vehicle: 2003 Subaru Forester 2.5X AWD Wagon

Test Date: 10/29/02

Test Program: 55/28 km/h Side Impact NCAP

NHTSA No.: M35500

TR-P23003-01-NC

B-56

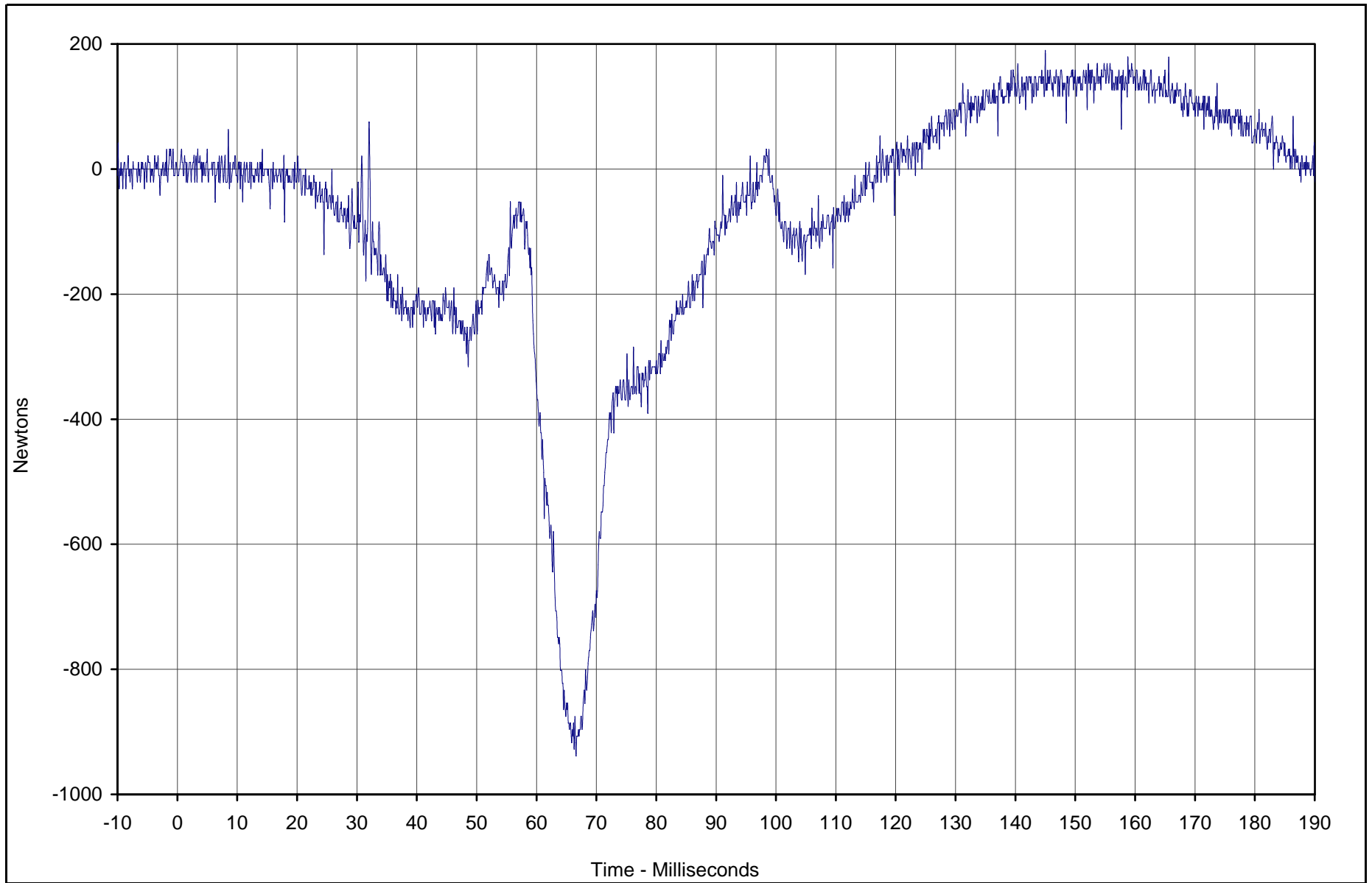

Curve Description	CURNO	Type	Units	Max	Time	Min	Time	SAE Class
Pass. Neck Force Y	030	FIL	Newtons	189.8	145.0	-938.6	66.6	1000



Test Vehicle: 2003 Subaru Forester 2.5X AWD Wagon

Test Date: 10/29/02

Test Program: 55/28 km/h Side Impact NCAP

NHTSA No.: M35500

TR-P23003-01-NC

B-57

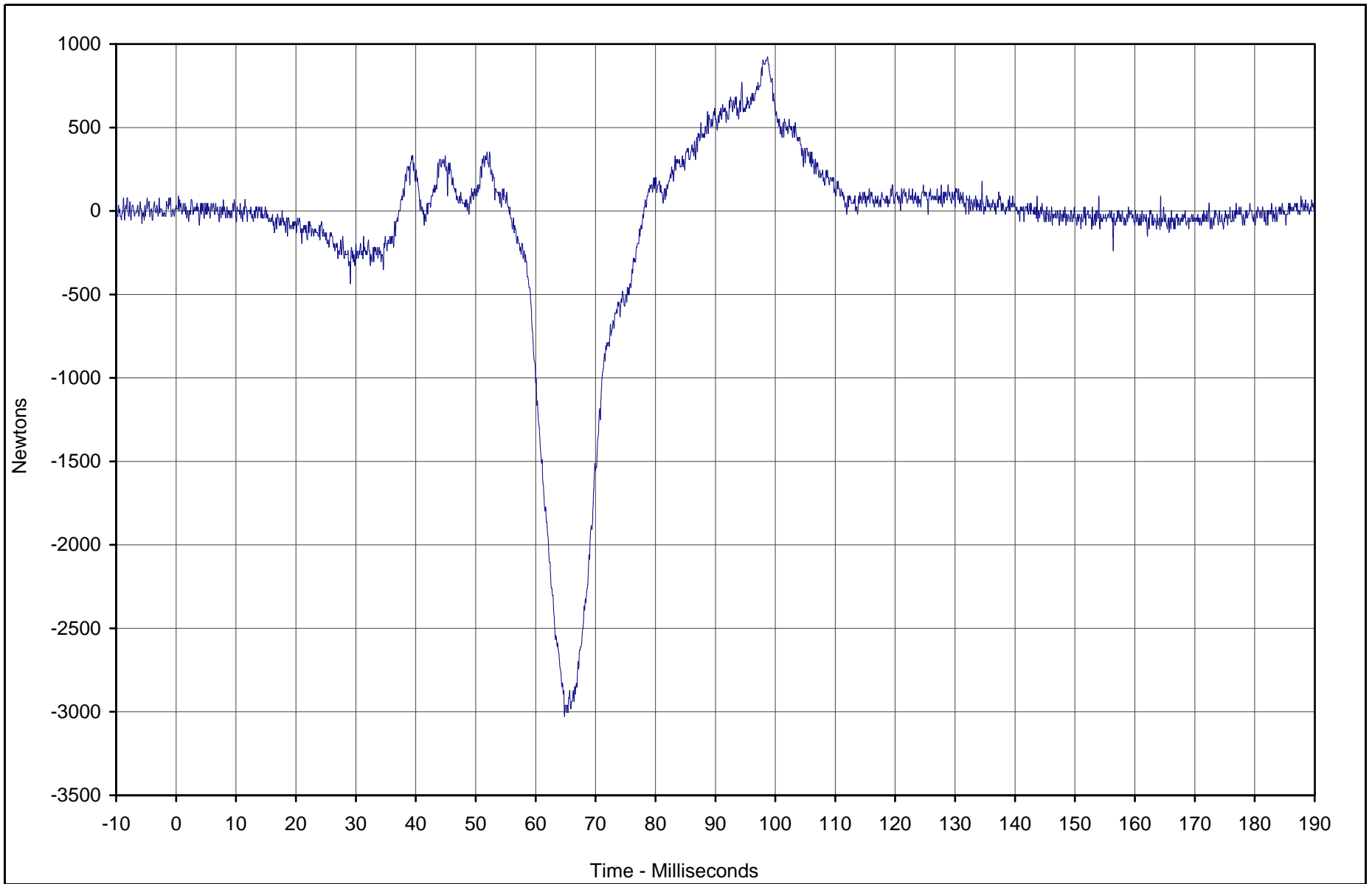

Curve Description	CURNO	Type	Units	Max	Time	Min	Time	SAE Class
Pass. Neck Force Z	031	FIL	Newtons	923.7	98.7	-3026.7	64.8	1000



Test Vehicle: 2003 Subaru Forester 2.5X AWD Wagon

Test Date: 10/29/02

Test Program: 55/28 km/h Side Impact NCAP

NHTSA No.: M35500

TR-P23003-01-NC

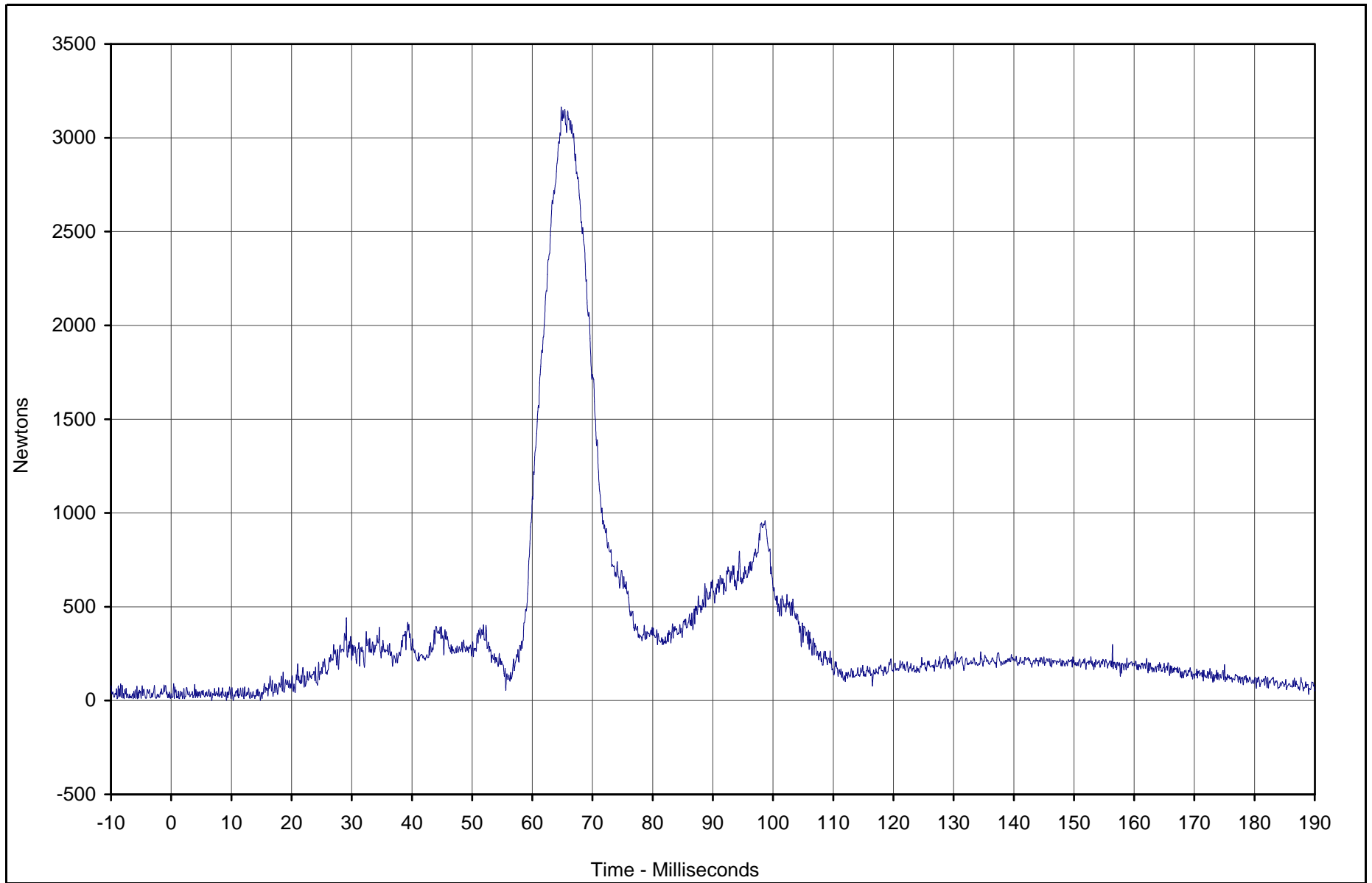

Curve Description	CURNO	Type	Units	Max	Time	Min	Time	SAE Class
Pass. Neck Force Resultant	029	RES	Newtons	3162.9	64.8	1.9	6.7	1000



Test Vehicle: 2003 Subaru Forester 2.5X AWD Wagon

Test Date: 10/29/02

Test Program: 55/28 km/h Side Impact NCAP

NHTSA No.: M35500

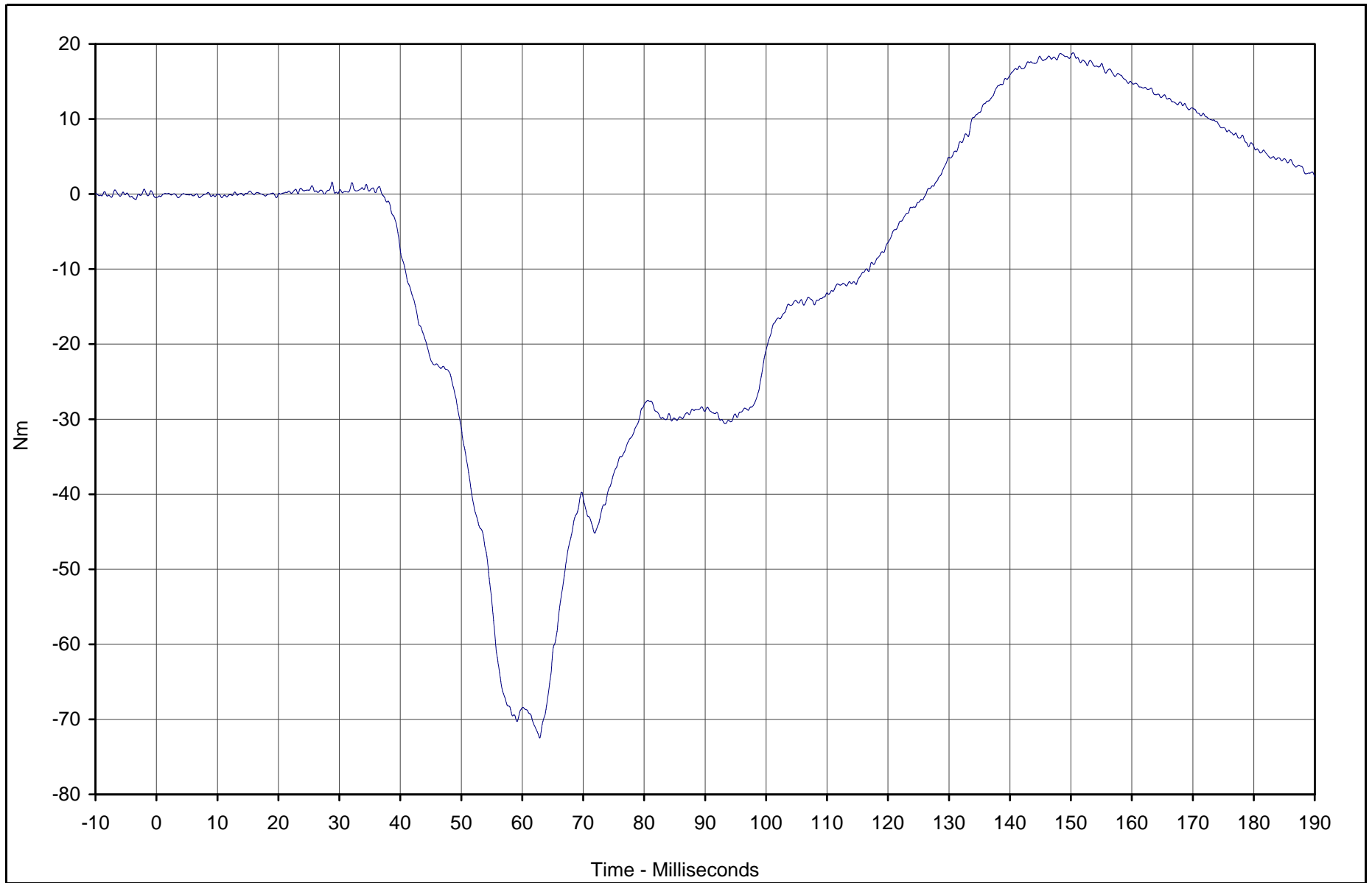

Curve Description	CURNO	Type	Units	Max	Time	Min	Time	SAE Class
Pass. Neck Moment X	032	FIL	Nm	18.8	150.4	-72.5	62.9	600



Test Vehicle: 2003 Subaru Forester 2.5X AWD Wagon

Test Date: 10/29/02

Test Program: 55/28 km/h Side Impact NCAP

NHTSA No.: M35500

B-60

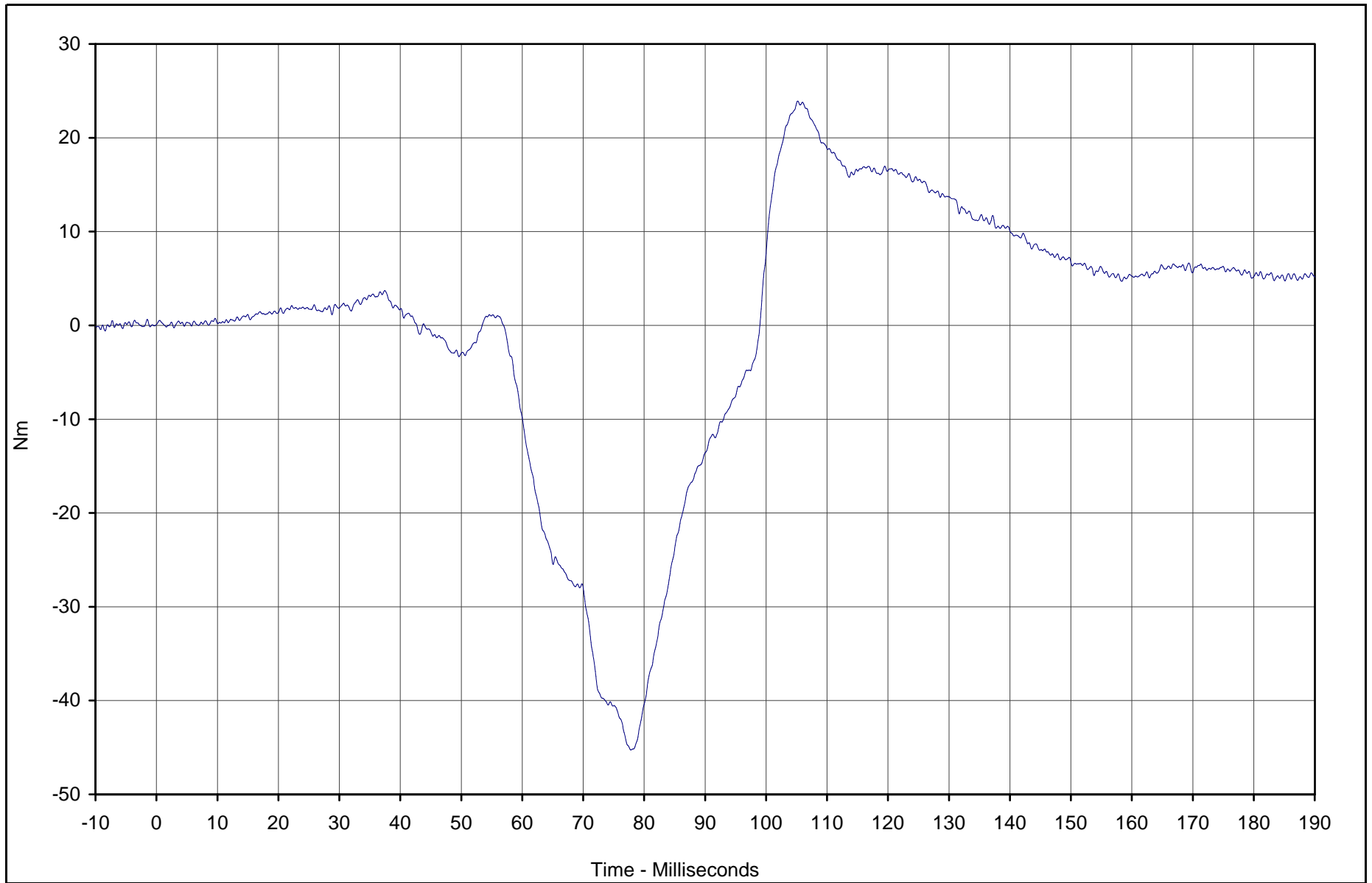

Curve Description	CURNO	Type	Units	Max	Time	Min	Time	SAE Class
Pass. Neck Moment Y	033	FIL	Nm	23.9	105.2	-45.3	77.8	600



Test Vehicle: 2003 Subaru Forester 2.5X AWD Wagon

Test Date: 10/29/02

Test Program: 55/28 km/h Side Impact NCAP

NHTSA No.: M35500

TR-P23003-01-NC

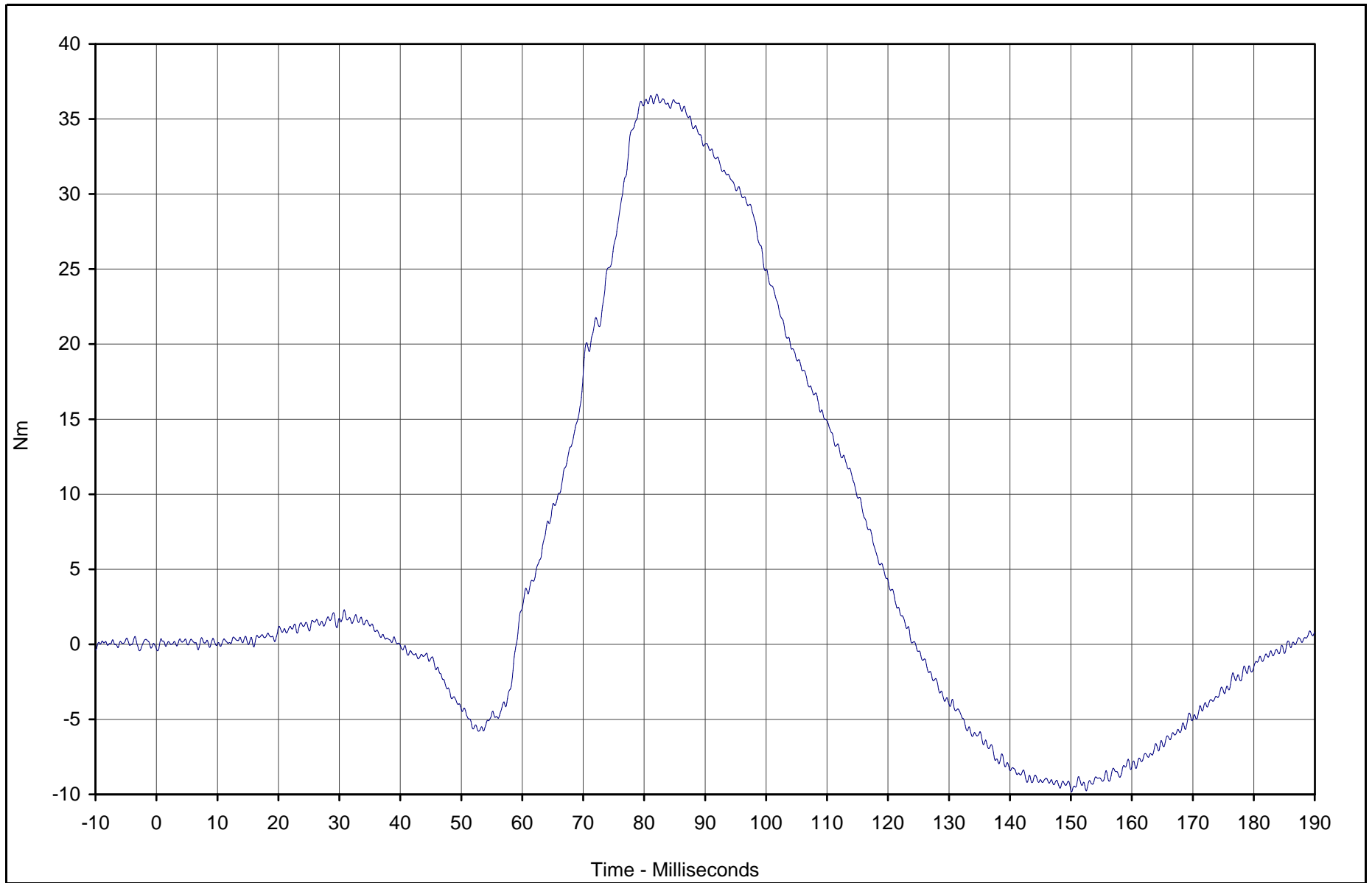

Curve Description	CURNO	Type	Units	Max	Time	Min	Time	SAE Class
Pass. Neck Moment Z	034	FIL	Nm	36.6	82.1	-9.8	150.1	600



Test Vehicle: 2003 Subaru Forester 2.5X AWD Wagon

Test Date: 10/29/02

Test Program: 55/28 km/h Side Impact NCAP

NHTSA No.: M35500

B-62

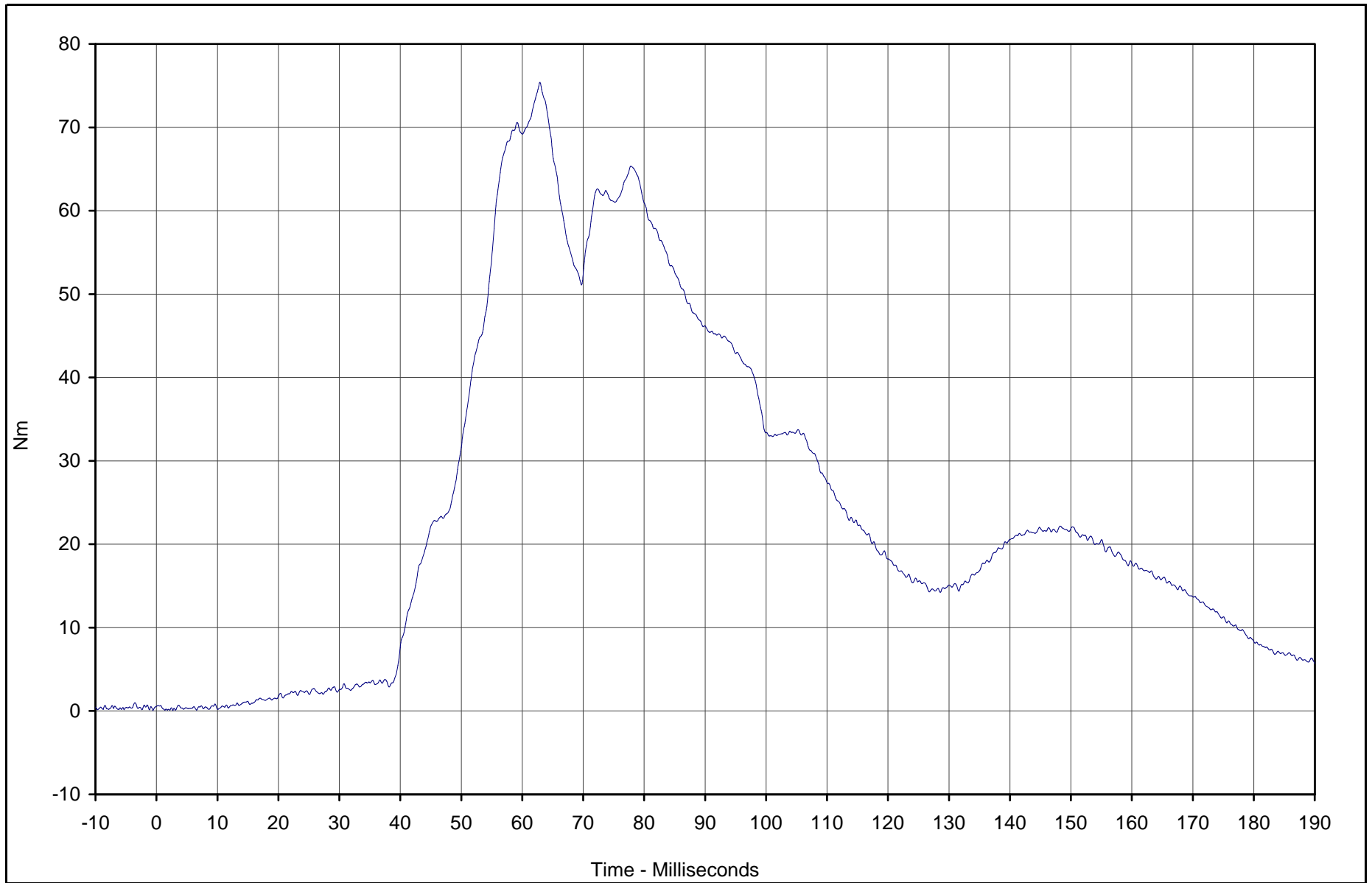

Curve Description	CURNO	Type	Units	Max	Time	Min	Time	SAE Class
Pass. Neck Moment Resultant	032	RES	Nm	75.4	62.9	0.1	2.7	600



Test Vehicle: 2003 Subaru Forester 2.5X AWD Wagon

Test Date: 10/29/02

Test Program: 55/28 km/h Side Impact NCAP

NHTSA No.: M35500

TR-P23003-01-NC

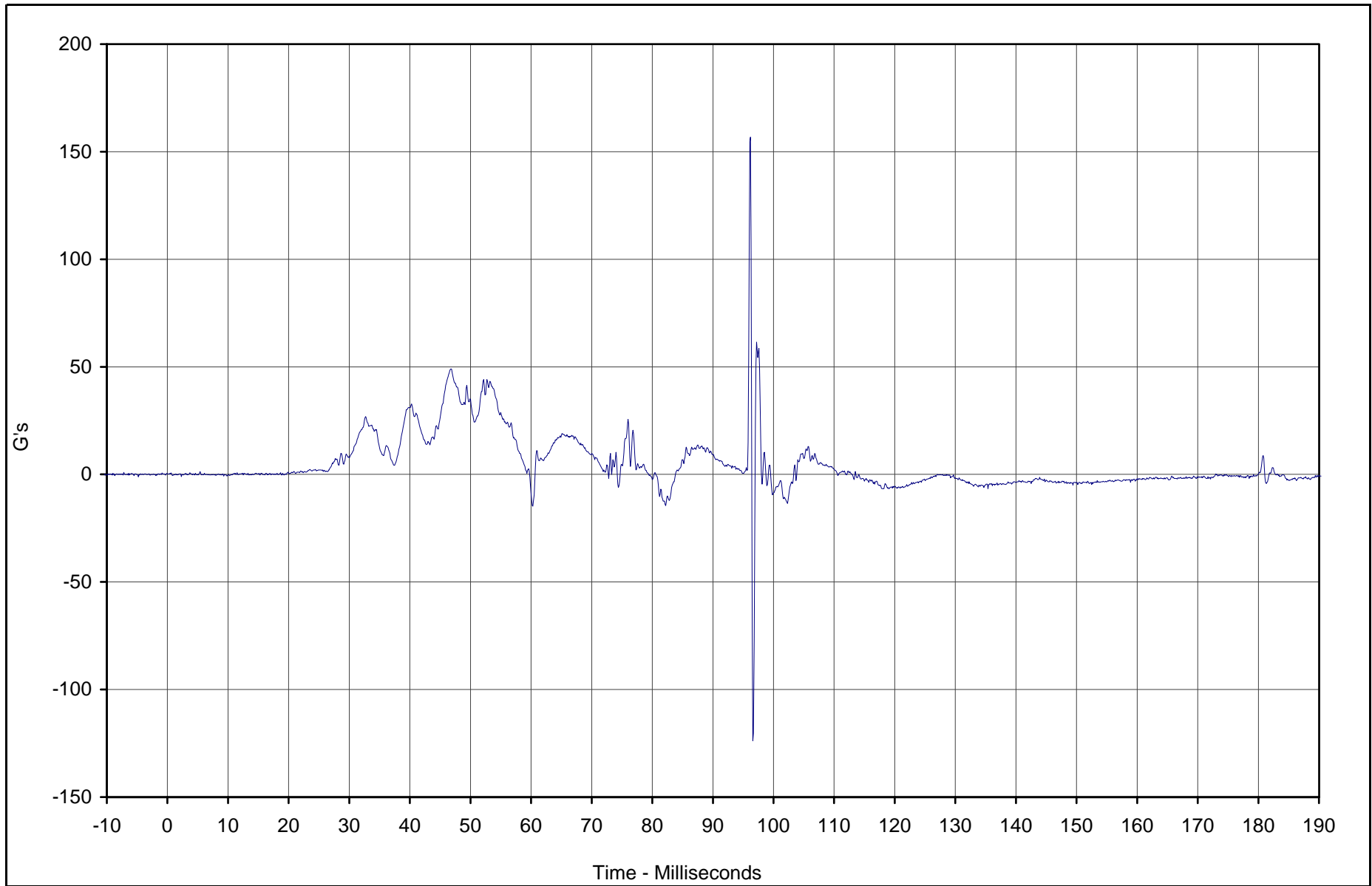

Curve Description	CURNO	Type	Units	Max	Time	Min	Time	SAE Class
Pass. Upper Rib Primary Y	035	FIL	G's	156.8	96.2	-123.8	96.6	1000



Test Vehicle: 2003 Subaru Forester 2.5X AWD Wagon

Test Date: 10/29/02

Test Program: 55/28 km/h Side Impact NCAP

NHTSA No.: M35500

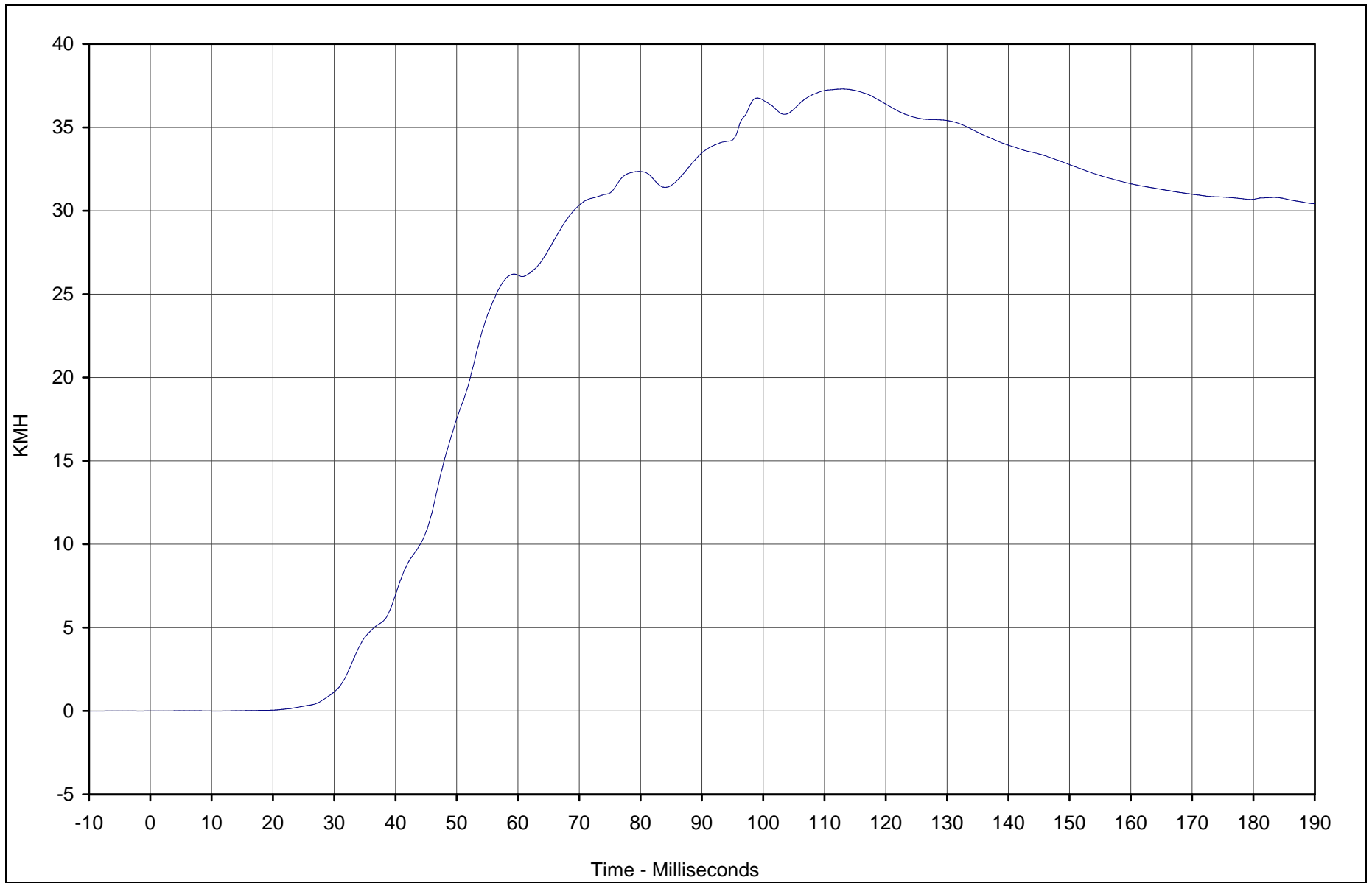

Curve Description	CURNO	Type	Units	Max	Time	Min	Time	SAE Class
Pass. Upper Rib Primary Y Vel.	035	IN1	KMH	37.3	112.9	0.0	10.8	180



Test Vehicle: 2003 Subaru Forester 2.5X AWD Wagon

Test Date: 10/29/02

Test Program: 55/28 km/h Side Impact NCAP

NHTSA No.: M35500

B-65

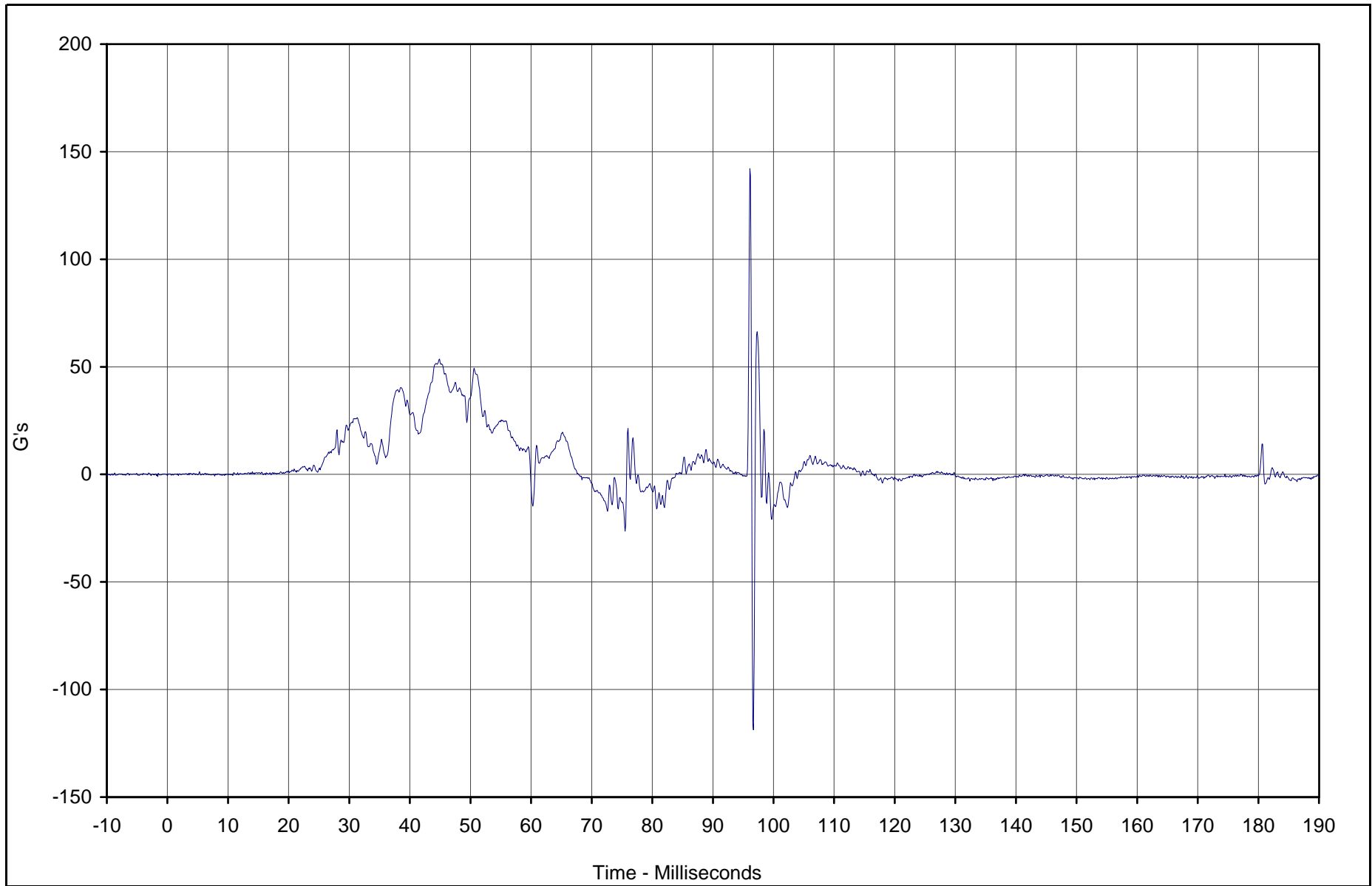

Curve Description	CURNO	Type	Units	Max	Time	Min	Time	SAE Class
Pass. Lower Rib Primary Y	036	FIL	G's	142.2	96.1	-118.7	96.7	1000



Test Vehicle: 2003 Subaru Forester 2.5X AWD Wagon

Test Date: 10/29/02

Test Program: 55/28 km/h Side Impact NCAP

NHTSA No.: M35500

TR-P23003-01-NC

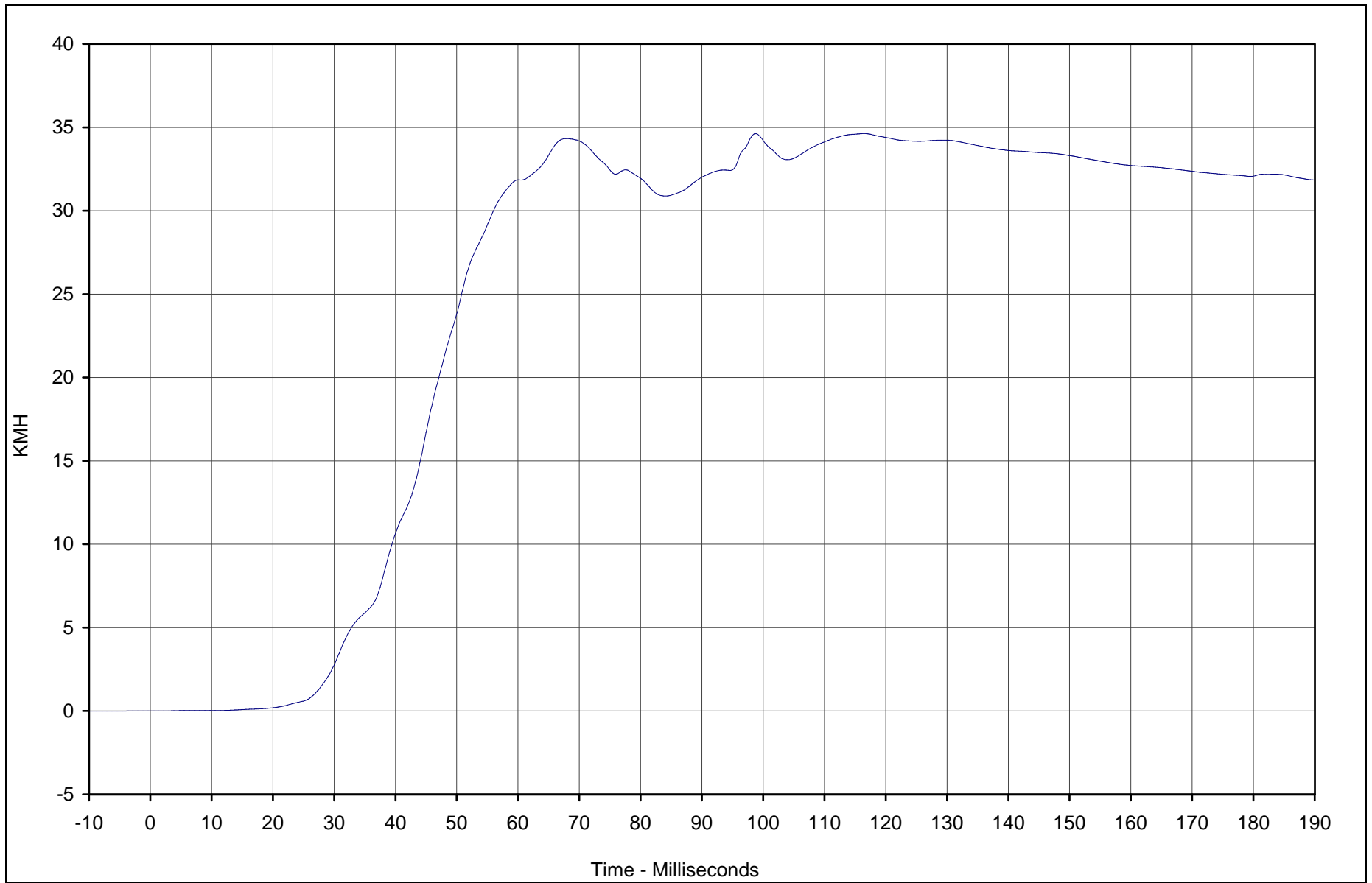

Curve Description	CURNO	Type	Units	Max	Time	Min	Time	SAE Class
Pass. Lower Rib Primary Y Vel.	036	IN1	KMH	34.6	116.5	0.0	0.0	180



Test Vehicle: 2003 Subaru Forester 2.5X AWD Wagon

Test Date: 10/29/02

Test Program: 55/28 km/h Side Impact NCAP

NHTSA No.: M35500

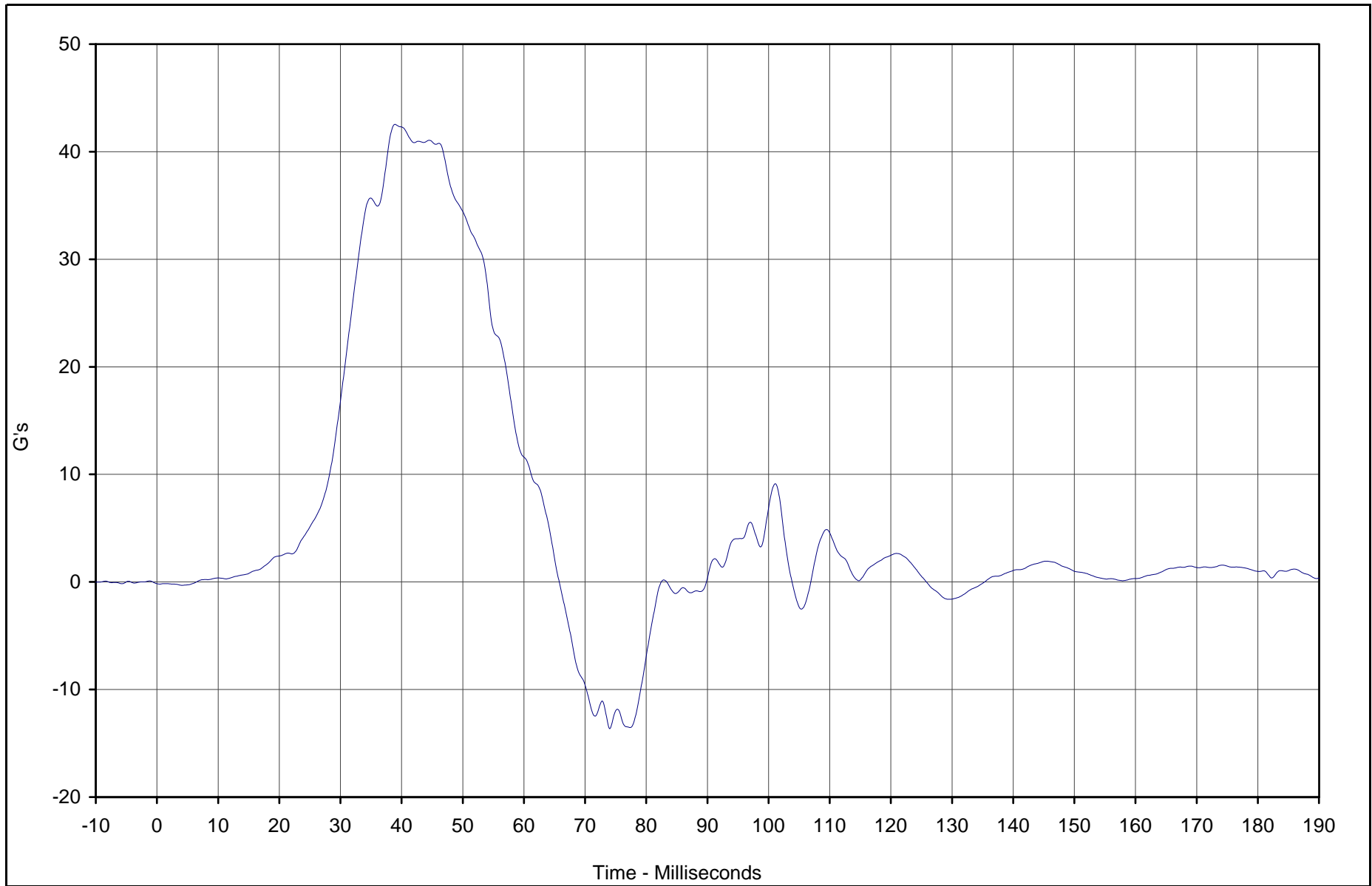

Curve Description	CURNO	Type	Units	Max	Time	Min	Time	SAE Class
Pass. Lower Spine Primary Y	037	FIL	G's	42.5	38.9	-13.6	74.0	180



Test Vehicle: 2003 Subaru Forester 2.5X AWD Wagon

Test Date: 10/29/02

Test Program: 55/28 km/h Side Impact NCAP

NHTSA No.: M35500

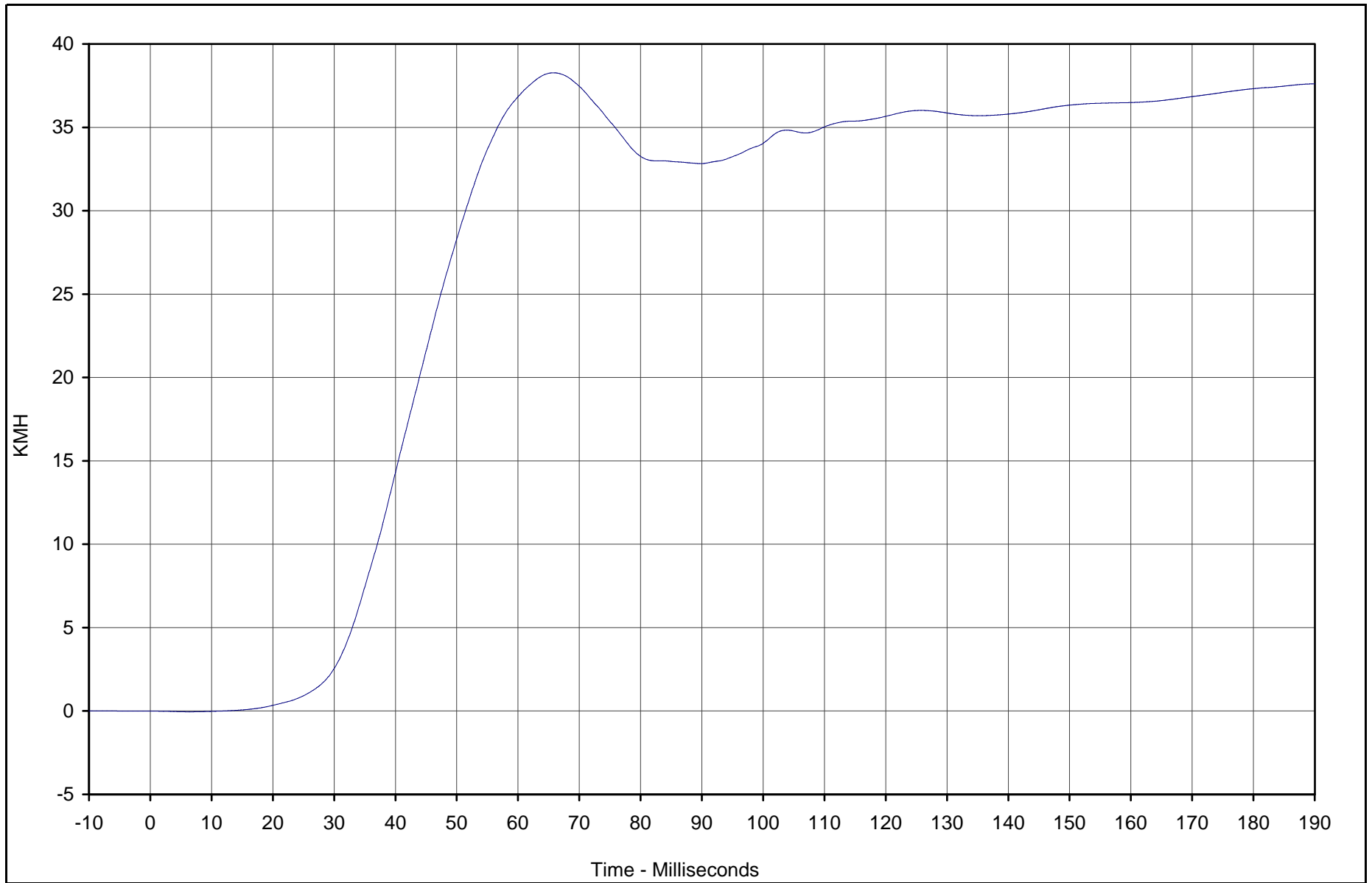

Curve Description	CURNO	Type	Units	Max	Time	Min	Time	SAE Class
Pass. Lower Spine Primary Y Vel.	037	IN1	KMH	38.3	65.8	-0.1	6.5	180



Test Vehicle: 2003 Subaru Forester 2.5X AWD Wagon

Test Date: 10/29/02

Test Program: 55/28 km/h Side Impact NCAP

NHTSA No.: M35500

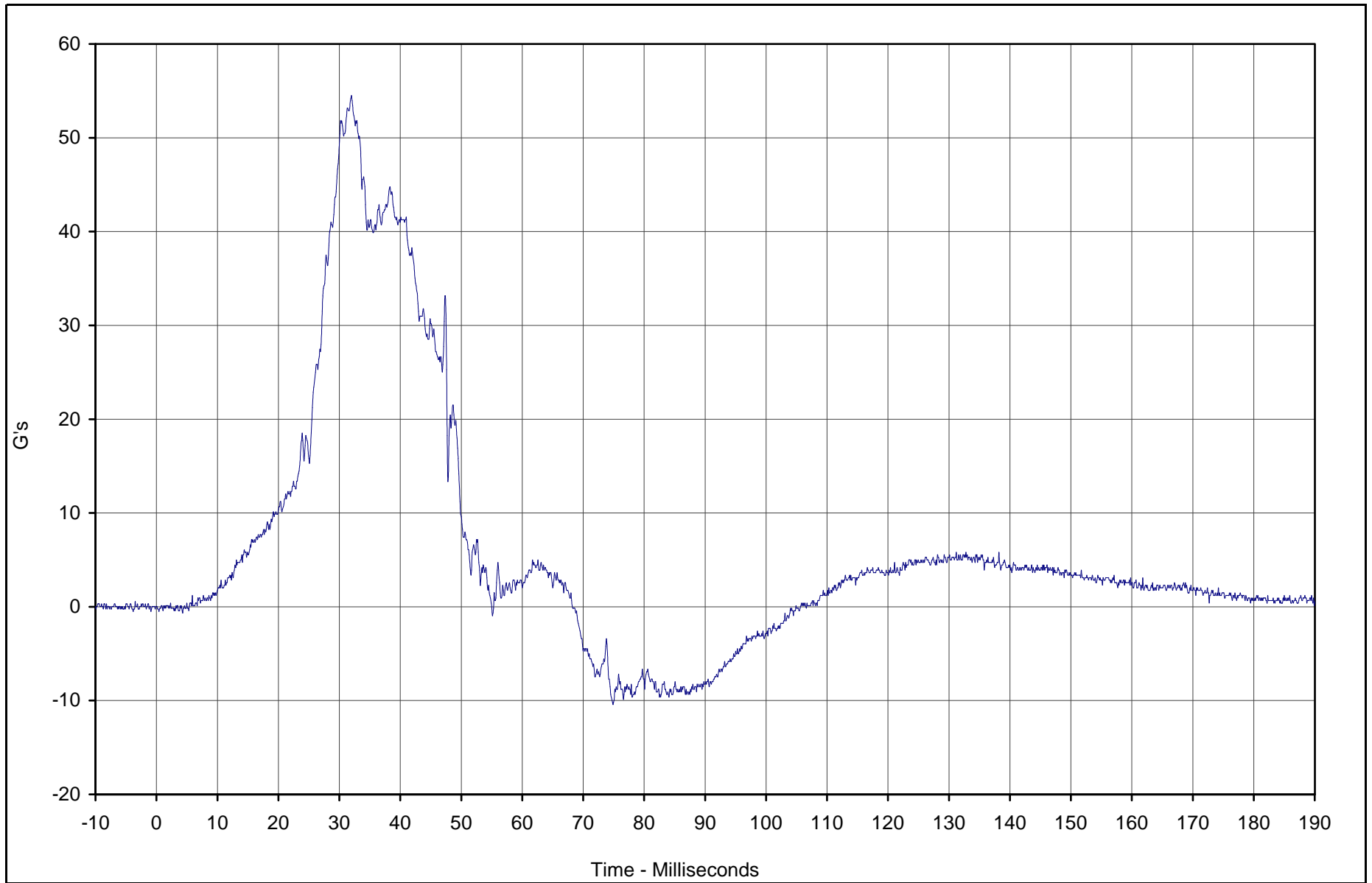

Curve Description	CURNO	Type	Units	Max	Time	Min	Time	SAE Class
Pass. Pelvis Primary Y	038	FIL	G's	54.5	32.0	-10.4	74.9	1000



Test Vehicle: 2003 Subaru Forester 2.5X AWD Wagon

Test Date: 10/29/02

Test Program: 55/28 km/h Side Impact NCAP

NHTSA No.: M35500

B-70

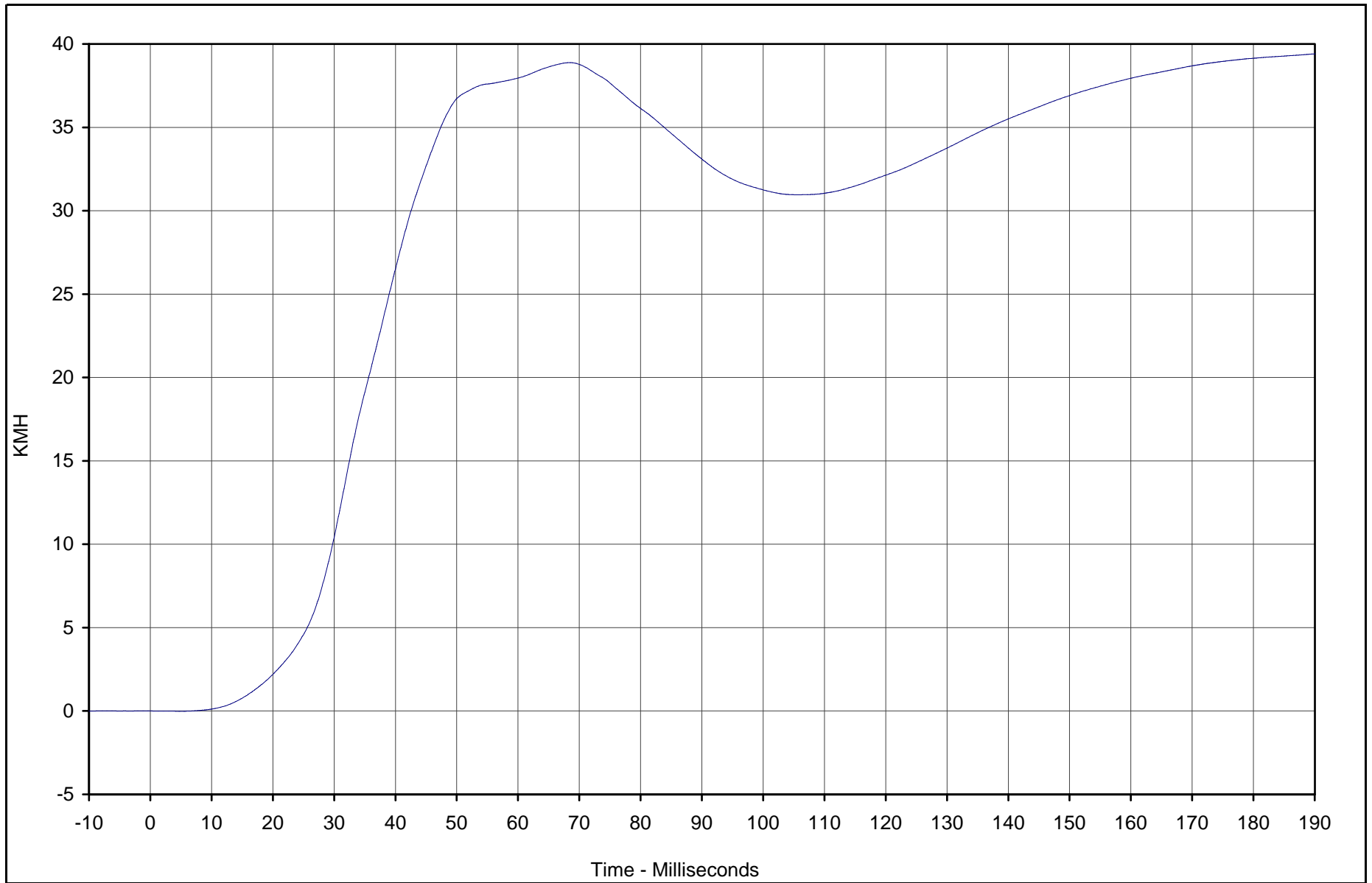

Curve Description	CURNO	Type	Units	Max	Time	Min	Time	SAE Class
Pass. Pelvis Primary Y Vel.	038	IN1	KMH	39.4	189.9	0.0	5.1	180



Test Vehicle: 2003 Subaru Forester 2.5X AWD Wagon

Test Date: 10/29/02

Test Program: 55/28 km/h Side Impact NCAP

NHTSA No.: M35500

TR-P23003-01-NC

B-71

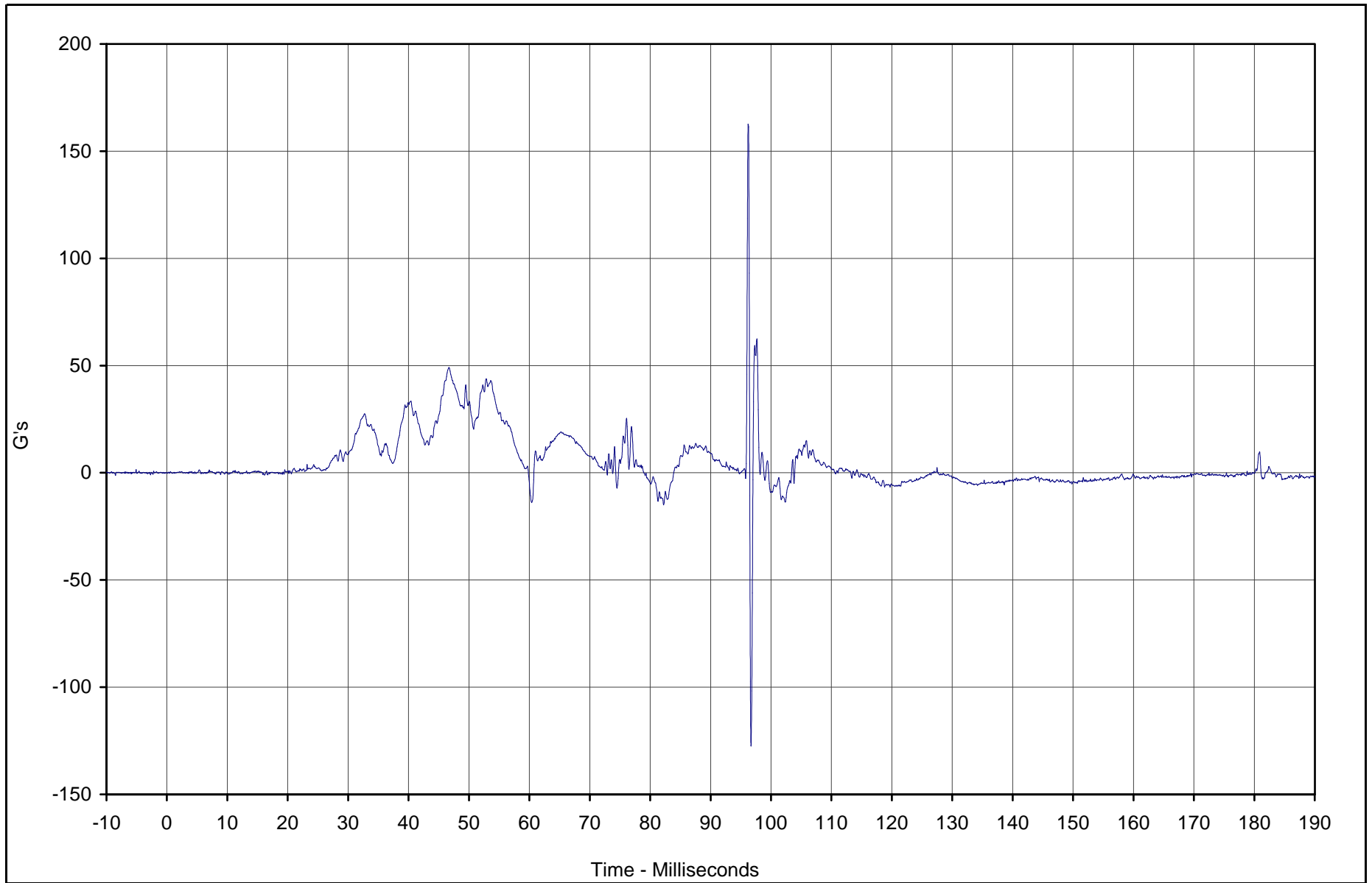

TR-P23003-01-NC

Curve Description	CURNO	Type	Units	Max	Time	Min	Time	SAE Class
Pass. Upper Rib Redundant Y	039	FIL	G's	162.5	96.2	-127.4	96.7	1000



Test Vehicle: 2003 Subaru Forester 2.5X AWD Wagon

Test Date: 10/29/02

Test Program: 55/28 km/h Side Impact NCAP

NHTSA No.: M35500

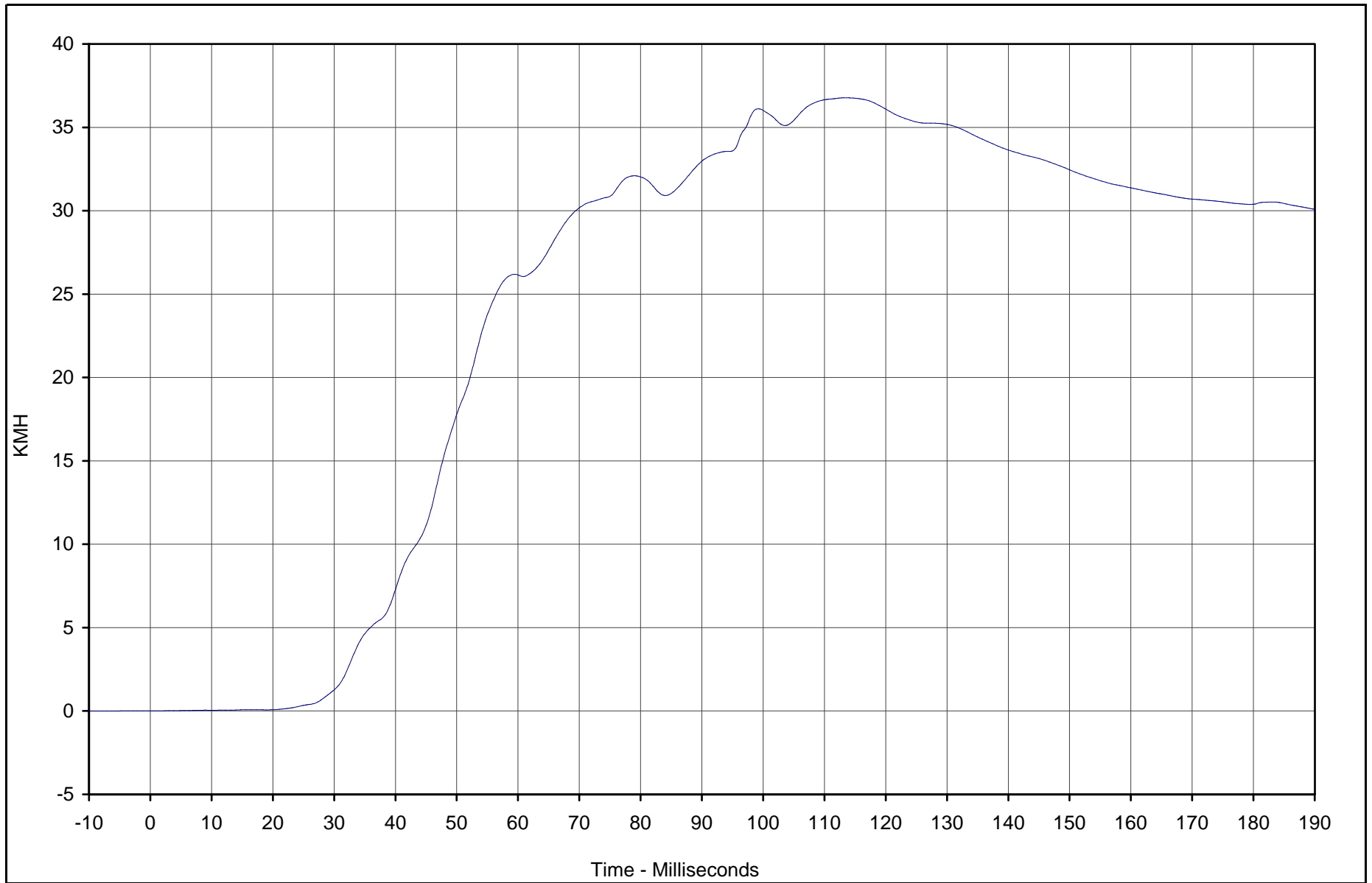

Curve Description	CURNO	Type	Units	Max	Time	Min	Time	SAE Class
Pass. Upper Rib Redundant Y Vel.	039	IN1	KMH	36.8	113.3	0.0	0.0	180



Test Vehicle: 2003 Subaru Forester 2.5X AWD Wagon

Test Date: 10/29/02

Test Program: 55/28 km/h Side Impact NCAP

NHTSA No.: M35500

B-73

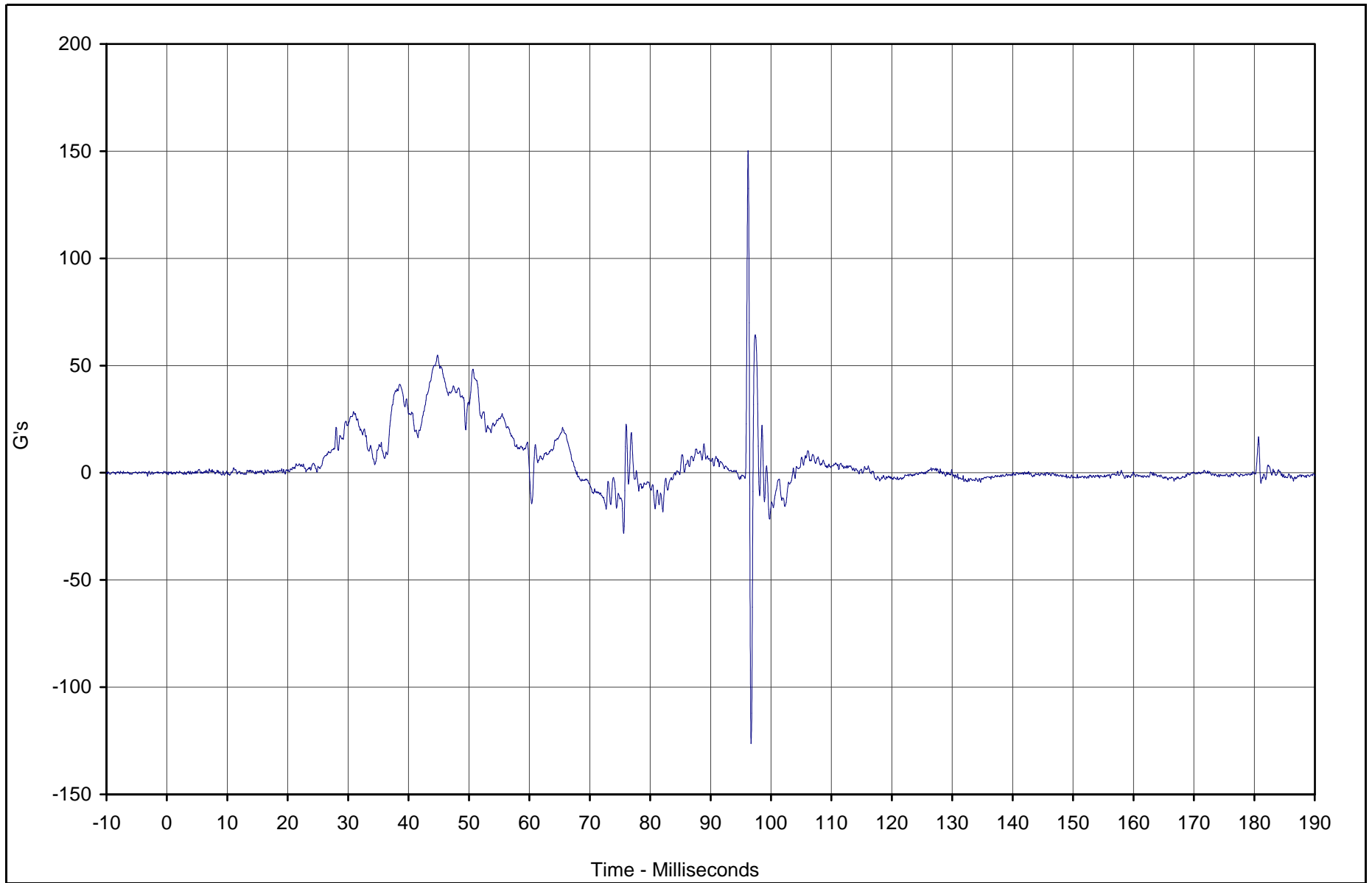

Curve Description	CURNO	Type	Units	Max	Time	Min	Time	SAE Class
Pass. Lower Rib Redundant Y	040	FIL	G's	150.0	96.2	-126.1	96.7	1000



Test Vehicle: 2003 Subaru Forester 2.5X AWD Wagon

Test Date: 10/29/02

Test Program: 55/28 km/h Side Impact NCAP

NHTSA No.: M35500

TR-P23003-01-NC

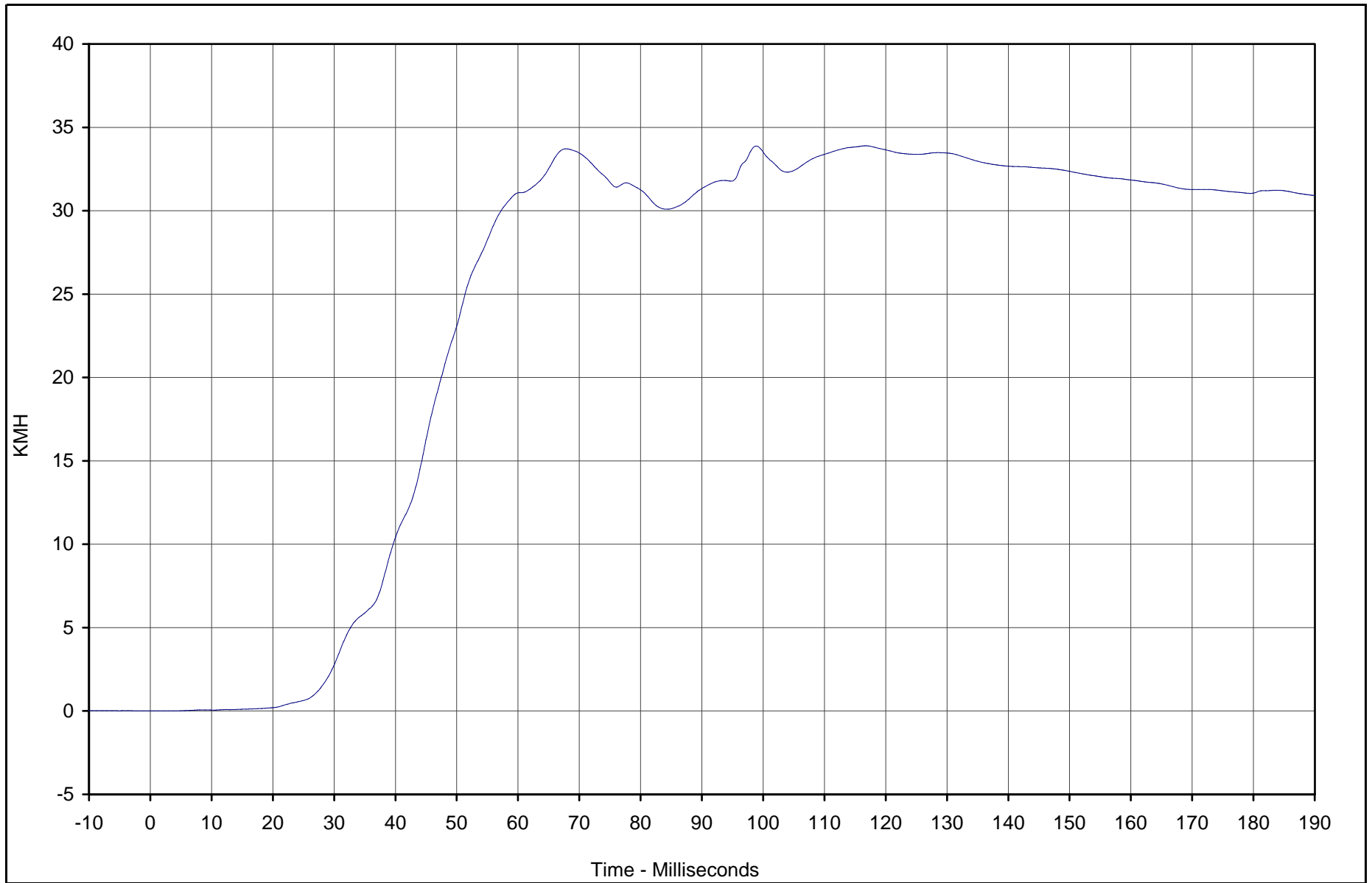

Curve Description	CURNO	Type	Units	Max	Time	Min	Time	SAE Class
Pass. Lower Rib Redundant Y Vel.	040	IN1	KMH	33.9	116.7	0.0	4.0	180



Test Vehicle: 2003 Subaru Forester 2.5X AWD Wagon

Test Date: 10/29/02

Test Program: 55/28 km/h Side Impact NCAP

NHTSA No.: M35500

B-75

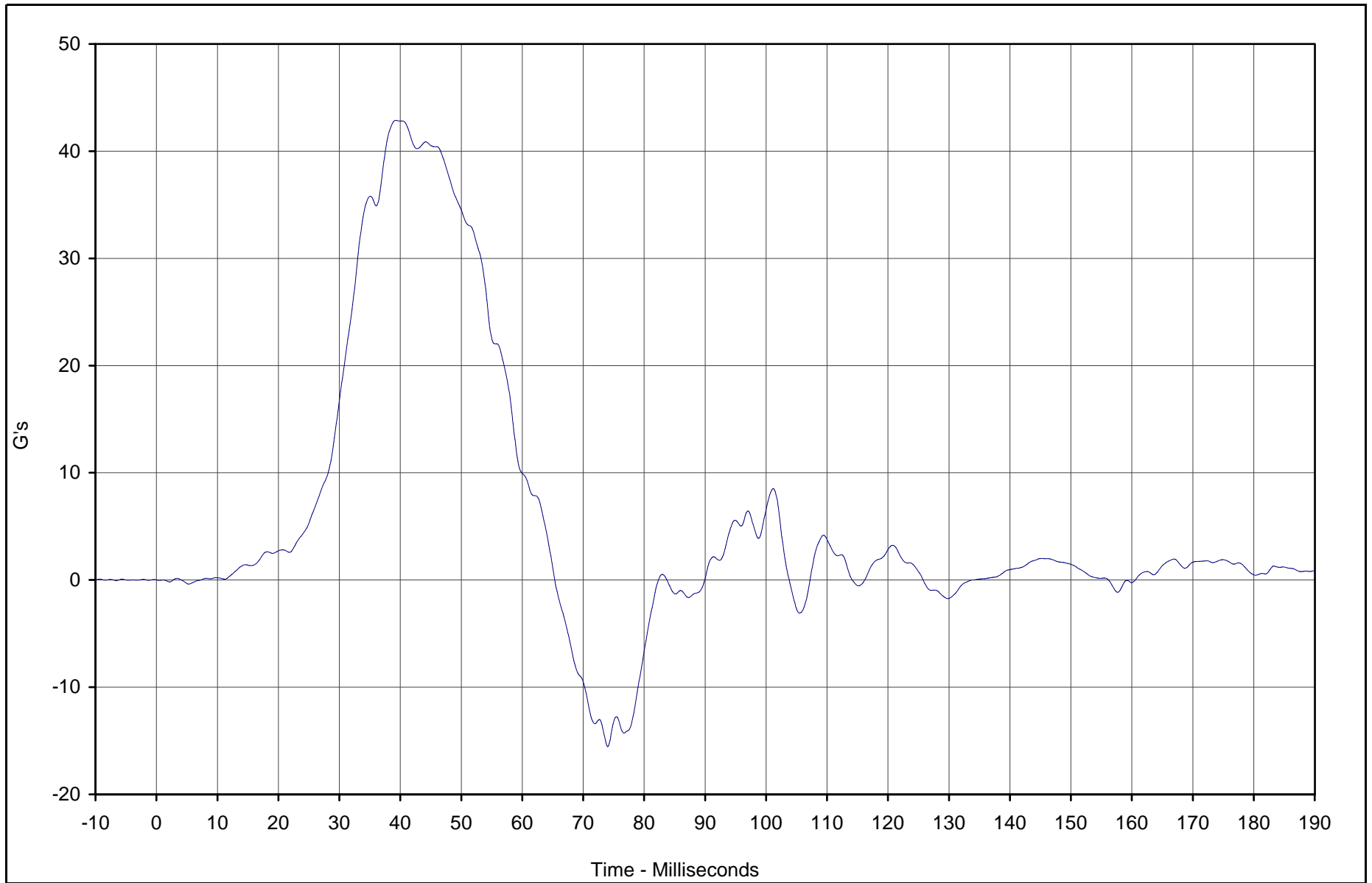

Curve Description	CURNO	Type	Units	Max	Time	Min	Time	SAE Class
Pass. Lower Spine Redundant Y	041	FIL	G's	42.9	39.3	-15.5	74.0	180



Test Vehicle: 2003 Subaru Forester 2.5X AWD Wagon

Test Date: 10/29/02

Test Program: 55/28 km/h Side Impact NCAP

NHTSA No.: M35500

TR-P23003-01-NC

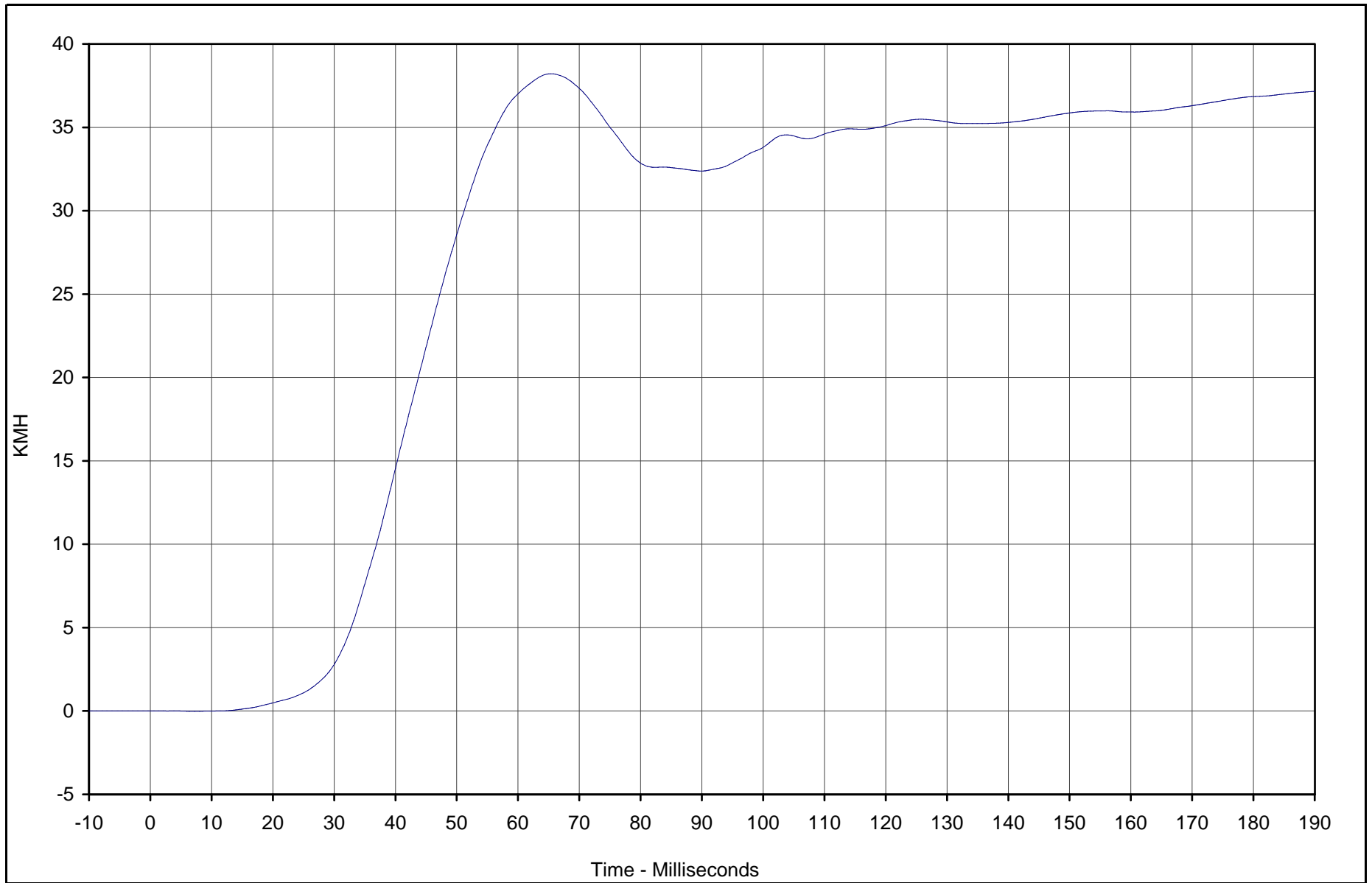

Curve Description	CURNO	Type	Units	Max	Time	Min	Time	SAE Class
Pass. Lower Spine Redundant Y Vel.	041	IN1	KMH	38.2	65.3	0.0	7.3	180



Test Vehicle: 2003 Subaru Forester 2.5X AWD Wagon

Test Date: 10/29/02

Test Program: 55/28 km/h Side Impact NCAP

NHTSA No.: M35500

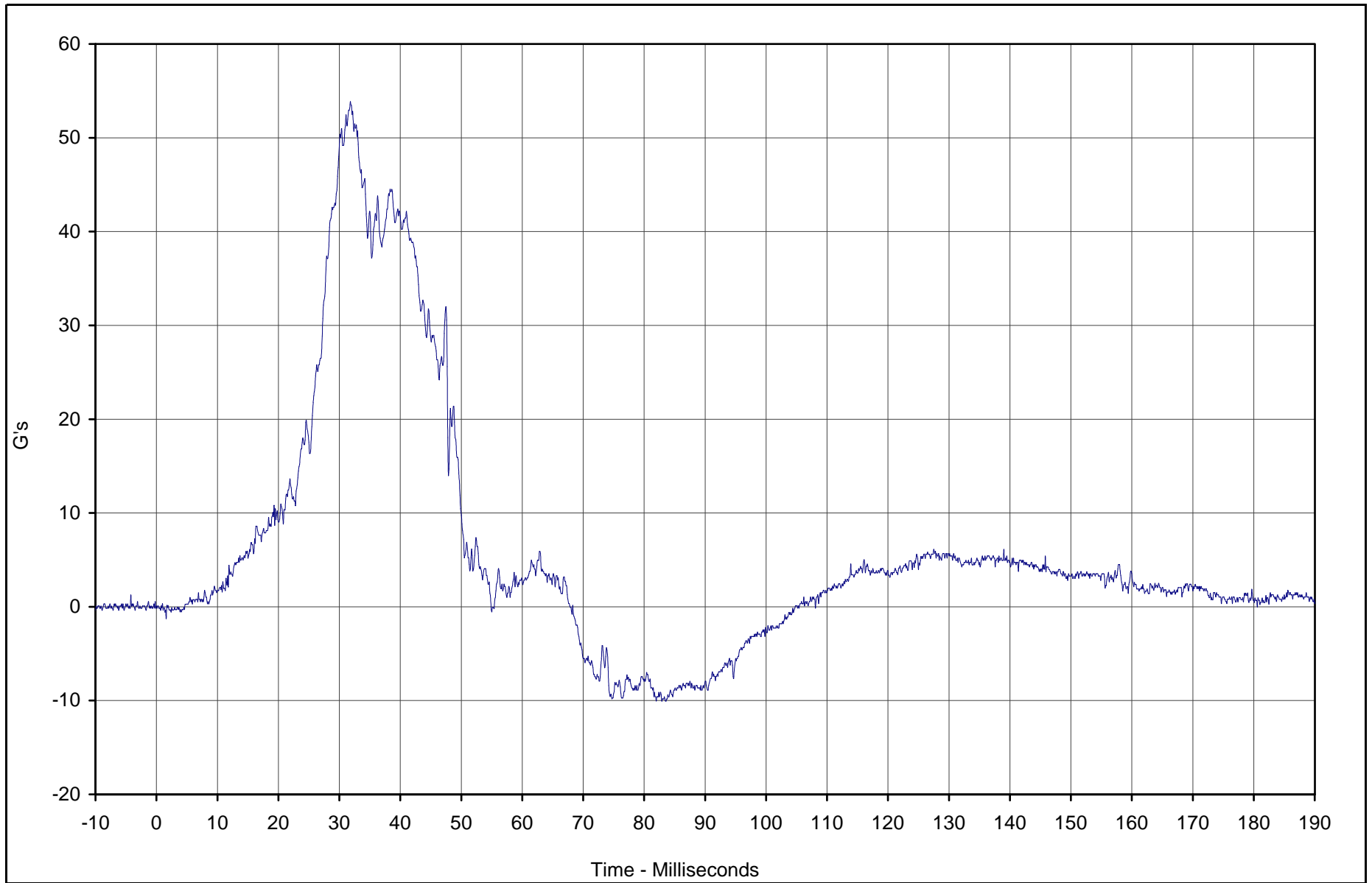

Curve Description	CURNO	Type	Units	Max	Time	Min	Time	SAE Class
Pass. Pelvis Redundant Y	042	FIL	G's	53.9	31.8	-10.1	82.0	1000



Test Vehicle: 2003 Subaru Forester 2.5X AWD Wagon

Test Date: 10/29/02

Test Program: 55/28 km/h Side Impact NCAP

NHTSA No.: M35500

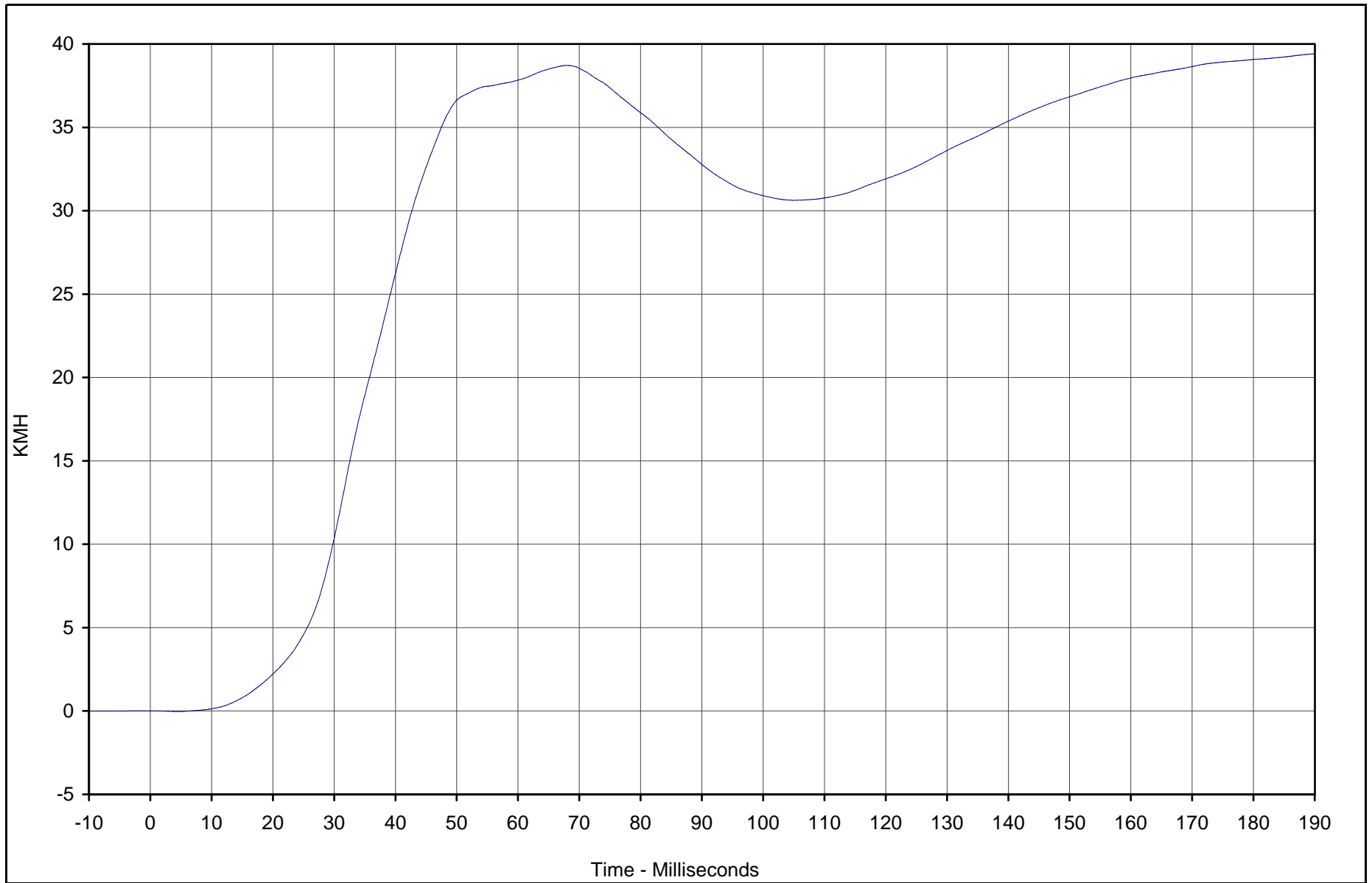

Curve Description	CURNO	Type	Units	Max	Time	Min	Time	SAE Class
Pass. Pelvis Redundant Y Vel.	042	IN1	KMH	39.4	189.9	0.0	4.6	180



Test Vehicle: 2003 Subaru Forester 2.5X AWD Wagon

Test Date: 10/29/02

Test Program: 55/28 km/h Side Impact NCAP

NHTSA No.: M35500

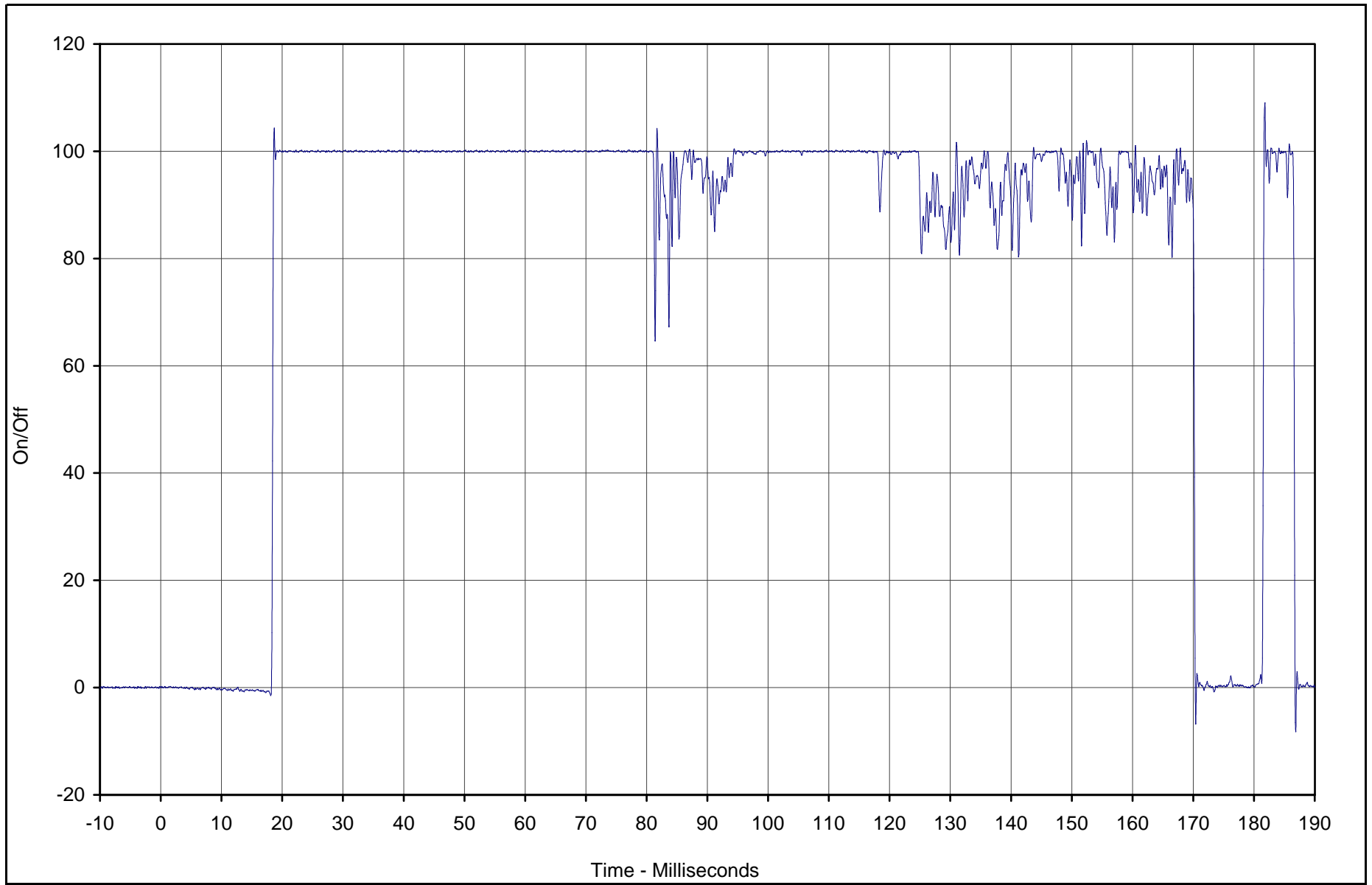

Curve Description	CURNO	Type	Units	Max	Time	Cross %	Time	SAE Class
Pass. Thorax Contact	043	FIL	On/Off	109.0	181.8	50.0	18.5	1000



Test Vehicle: 2003 Subaru Forester 2.5X AWD Wagon

Test Date: 10/29/02

Test Program: 55/28 km/h Side Impact NCAP

NHTSA No.: M35500

B-80

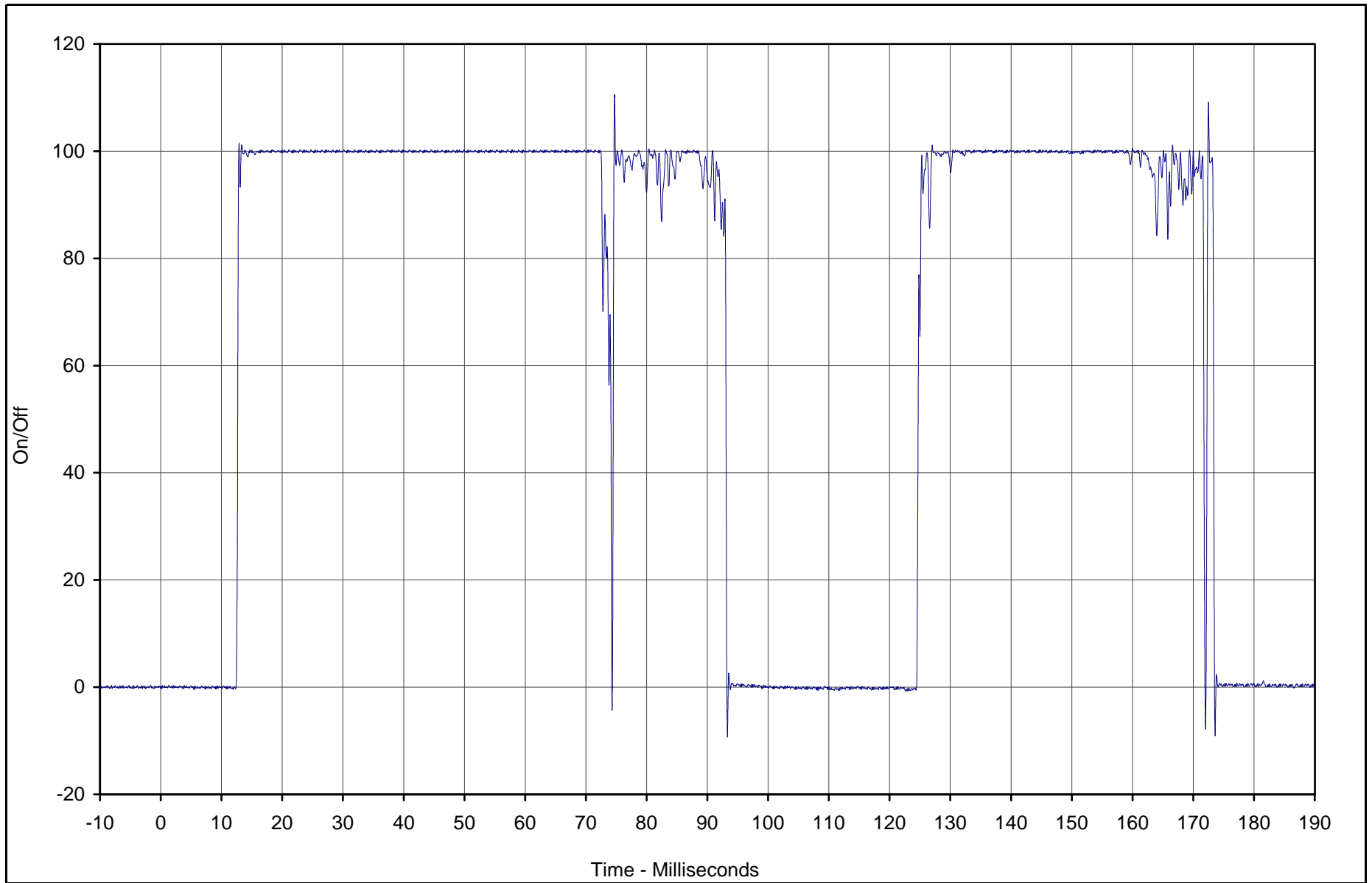

TR-P23003-01-NC

Curve Description	CURNO	Type	Units	Max	Time	Cross %	Time	SAE Class
Pass. Pelvis Contact	044	FIL	On/Off	110.1	74.7	50.0	12.7	1000



Test Vehicle: 2003 Subaru Forester 2.5X AWD Wagon

Test Date: 10/29/02

Test Program: 55/28 km/h Side Impact NCAP

NHTSA No.: M35500

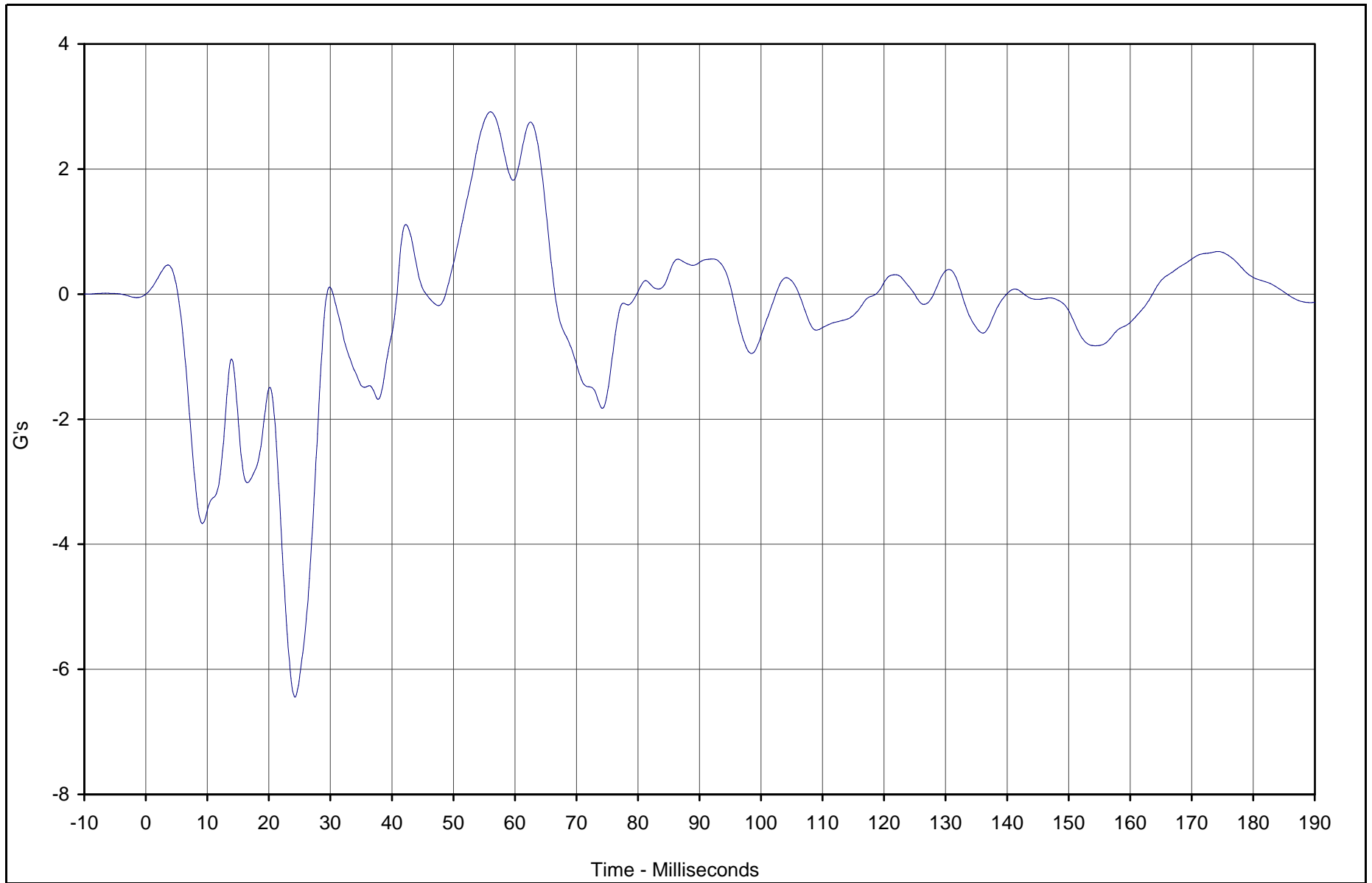

Curve Description	CURNO	Type	Units	Max	Time	Min	Time	SAE Class
Right Sill Front Seat X	045	FIL	G's	2.9	56.0	-6.4	24.3	60



Test Vehicle: 2003 Subaru Forester 2.5X AWD Wagon

Test Date: 10/29/02

Test Program: 55/28 km/h Side Impact NCAP

NHTSA No.: M35500

B-82

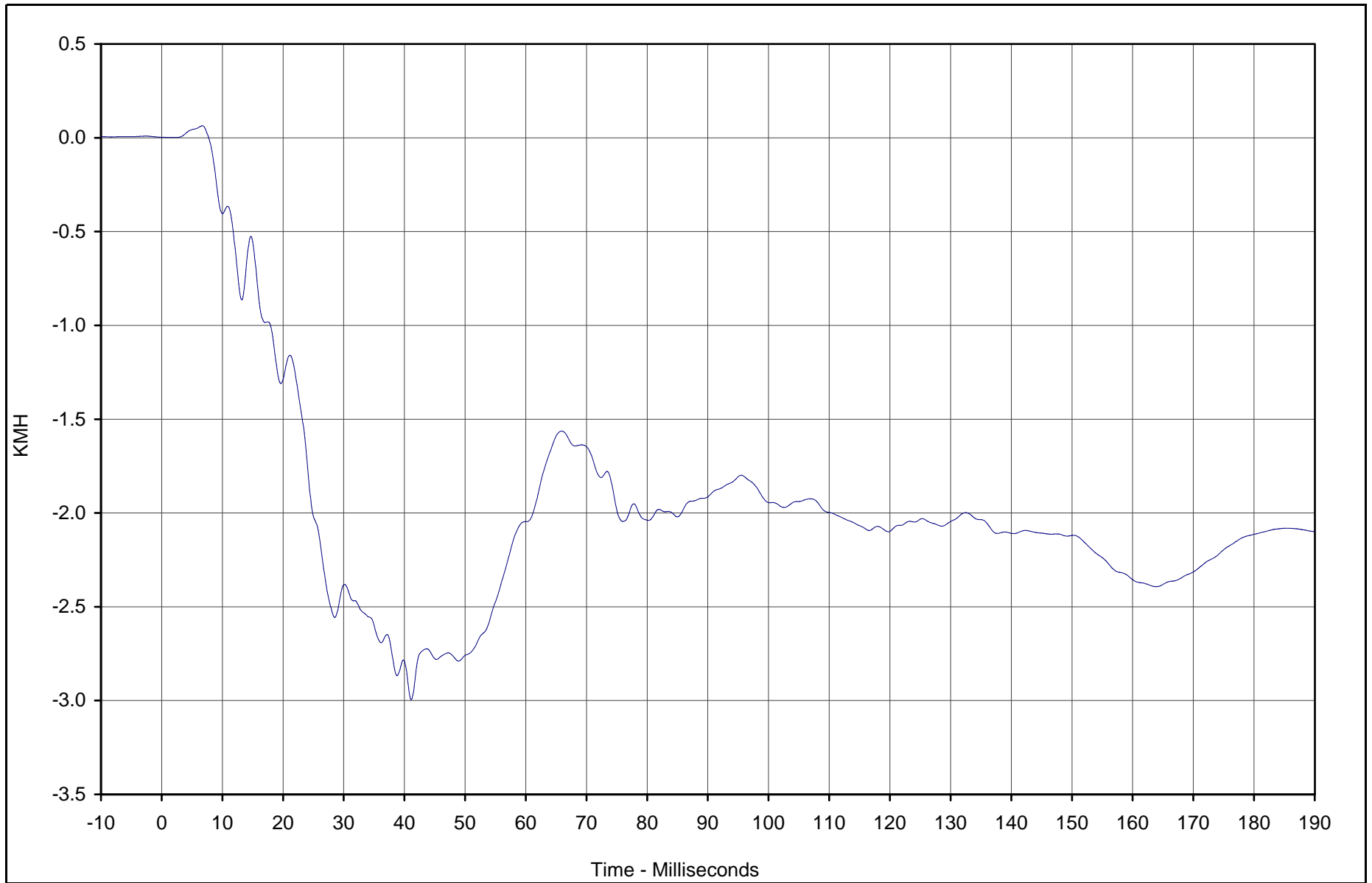

Curve Description	CURNO	Type	Units	Max	Time	Min	Time	SAE Class
Right Sill Front Seat X Velocity	045	IN1	KMH	0.1	6.7	-3.0	41.1	180



Test Vehicle: 2003 Subaru Forester 2.5X AWD Wagon

Test Date: 10/29/02

Test Program: 55/28 km/h Side Impact NCAP

NHTSA No.: M35500

TR-P23003-01-NC

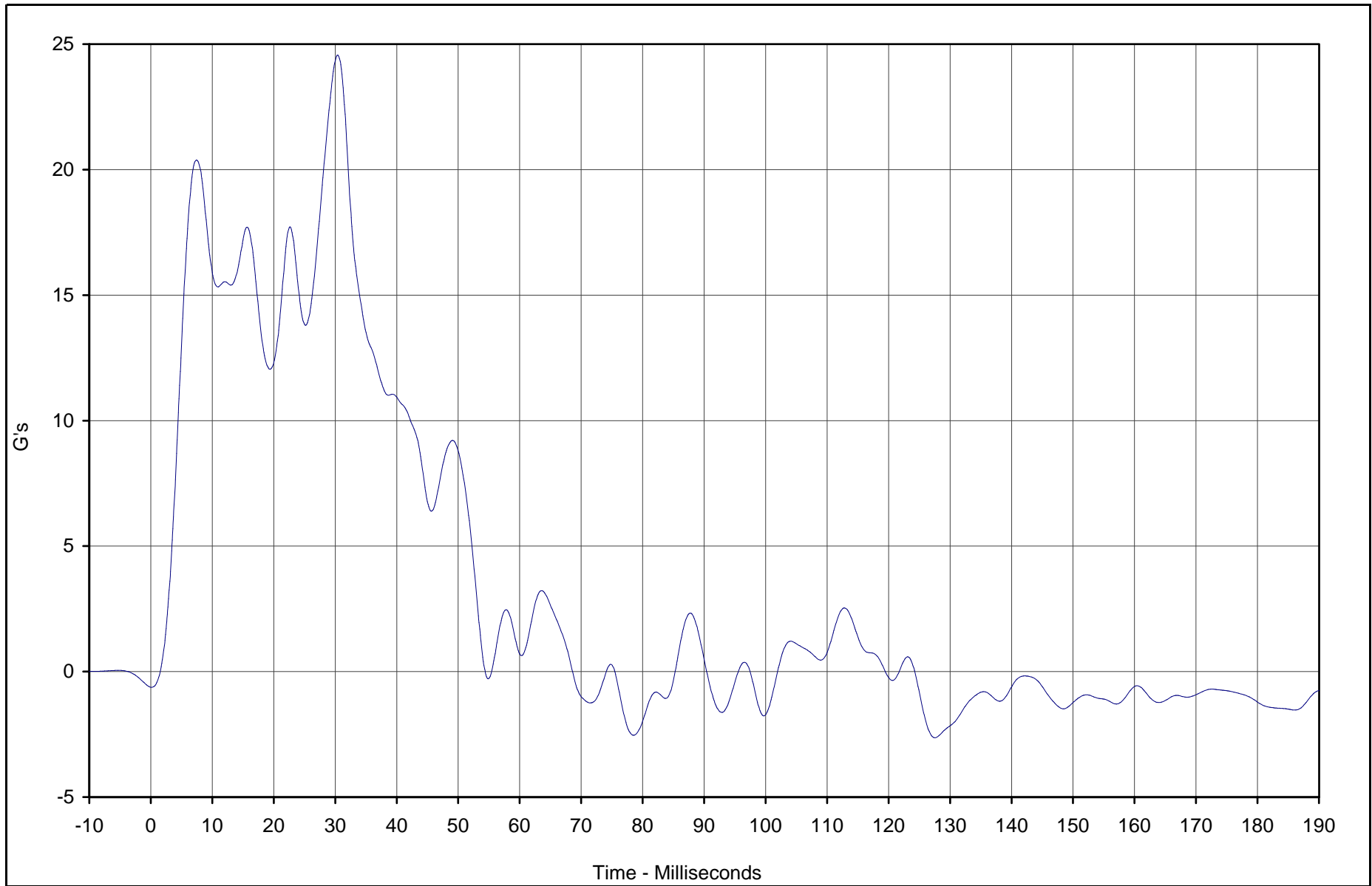

Curve Description	CURNO	Type	Units	Max	Time	Min	Time	SAE Class
Right Sill Front Seat Y	046	FIL	G's	24.6	30.4	-2.6	127.5	60



Test Vehicle: 2003 Subaru Forester 2.5X AWD Wagon

Test Date: 10/29/02

Test Program: 55/28 km/h Side Impact NCAP

NHTSA No.: M35500

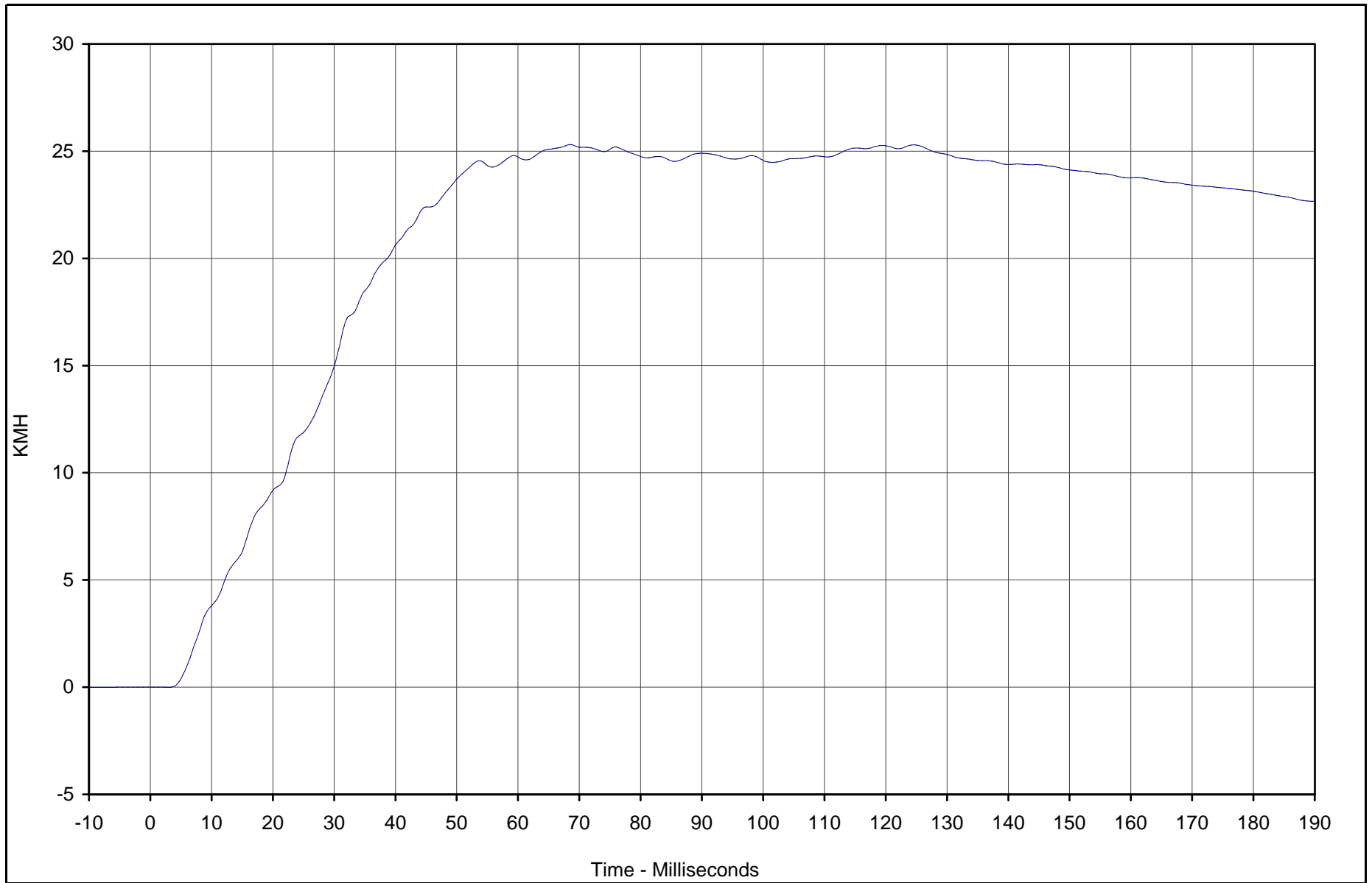

Curve Description	CURNO	Type	Units	Max	Time	Min	Time	SAE Class
Right Sill Front Seat Y Velocity	046	IN1	KMH	25.3	68.5	0.0	3.0	180



Test Vehicle: 2003 Subaru Forester 2.5X AWD Wagon

Test Date: 10/29/02

Test Program: 55/28 km/h Side Impact NCAP

NHTSA No.: M35500

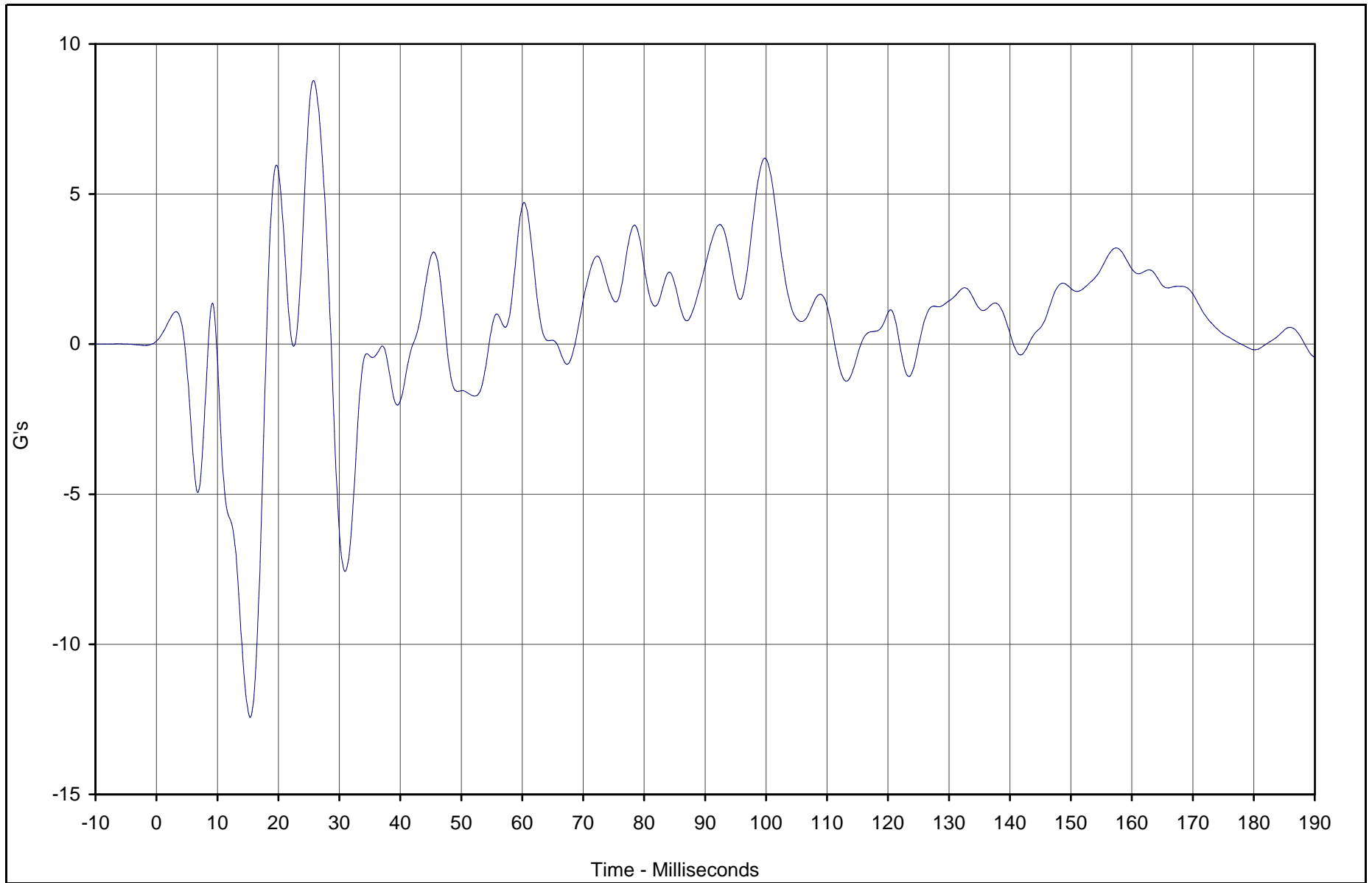

Curve Description	CURNO	Type	Units	Max	Time	Min	Time	SAE Class
Right Sill Front Seat Z	047	FIL	G's	8.8	25.8	-12.4	15.4	60



Test Vehicle: 2003 Subaru Forester 2.5X AWD Wagon

Test Date: 10/29/02

Test Program: 55/28 km/h Side Impact NCAP

NHTSA No.: M35500

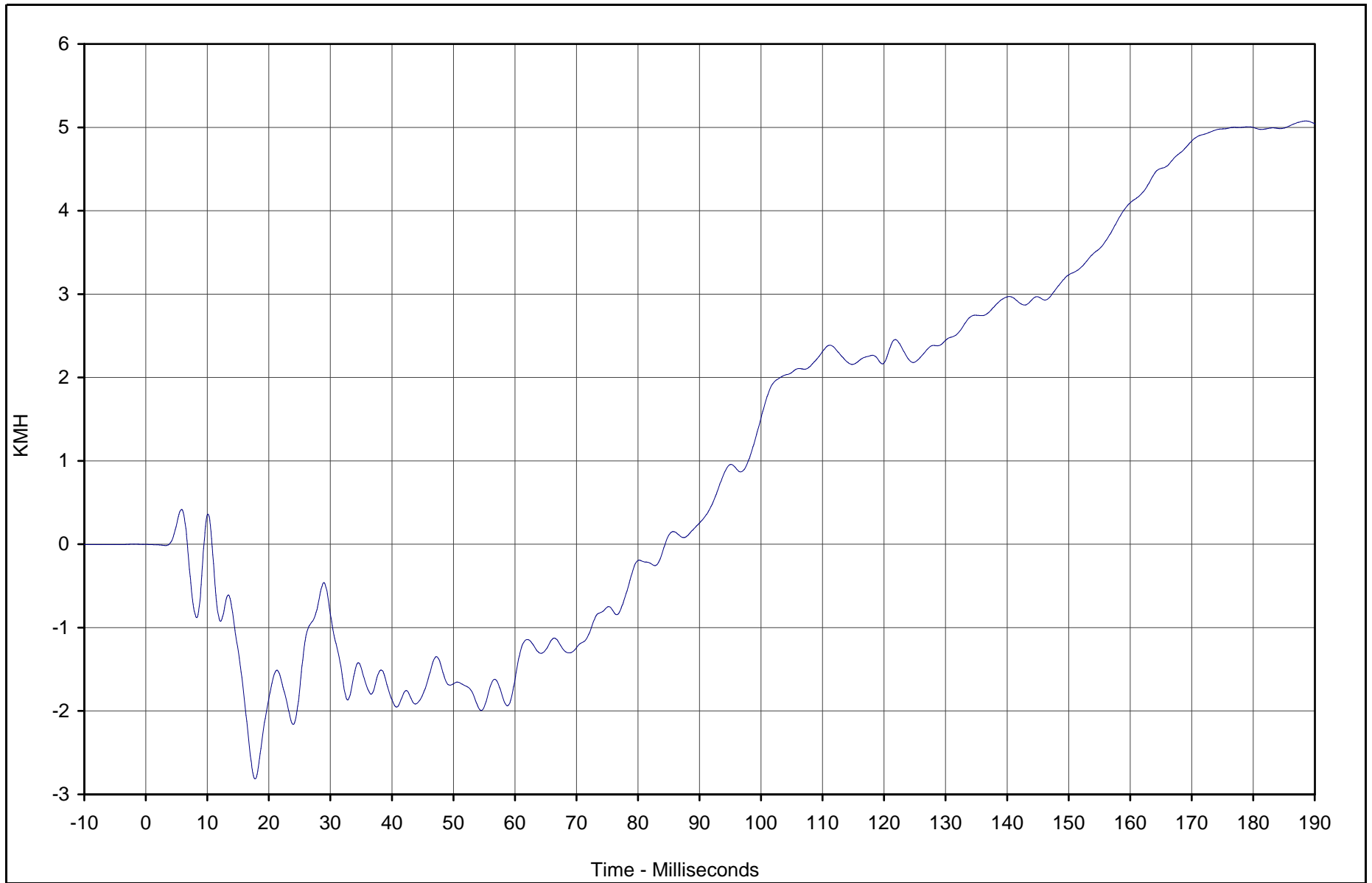

Curve Description	CURNO	Type	Units	Max	Time	Min	Time	SAE Class
Right Sill Front Seat Z Velocity	047	IN1	KMH	5.1	188.6	-2.8	17.8	180



Test Vehicle: 2003 Subaru Forester 2.5X AWD Wagon

Test Date: 10/29/02

Test Program: 55/28 km/h Side Impact NCAP

NHTSA No.: M35500

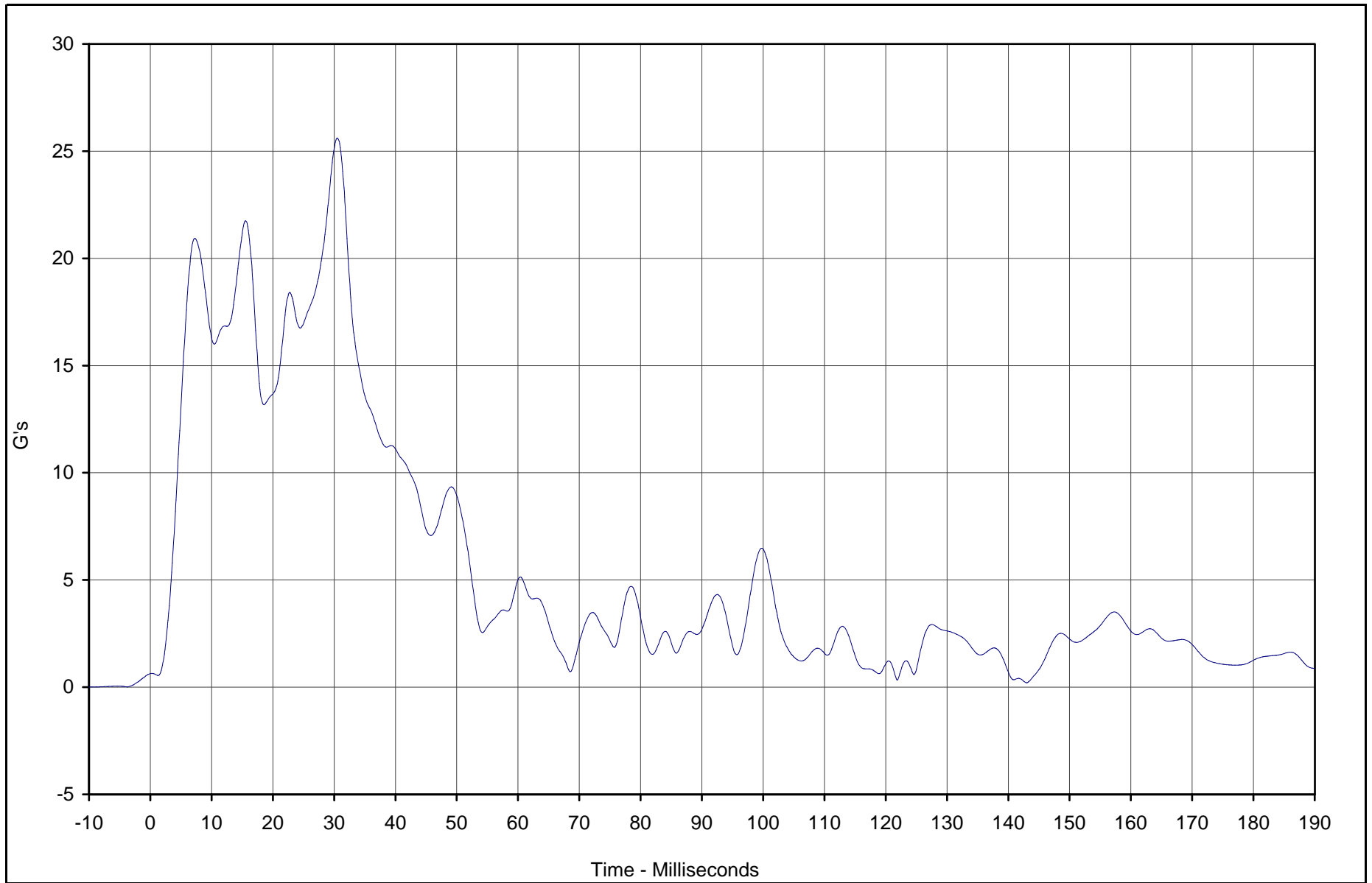

Curve Description	CURNO	Type	Units	Max	Time	Min	Time	SAE Class
Right Sill Front Seat Resultant	045	RES	G's	25.6	30.5	0.2	143.0	60



Test Vehicle: 2003 Subaru Forester 2.5X AWD Wagon

Test Date: 10/29/02

Test Program: 55/28 km/h Side Impact NCAP

NHTSA No.: M35500

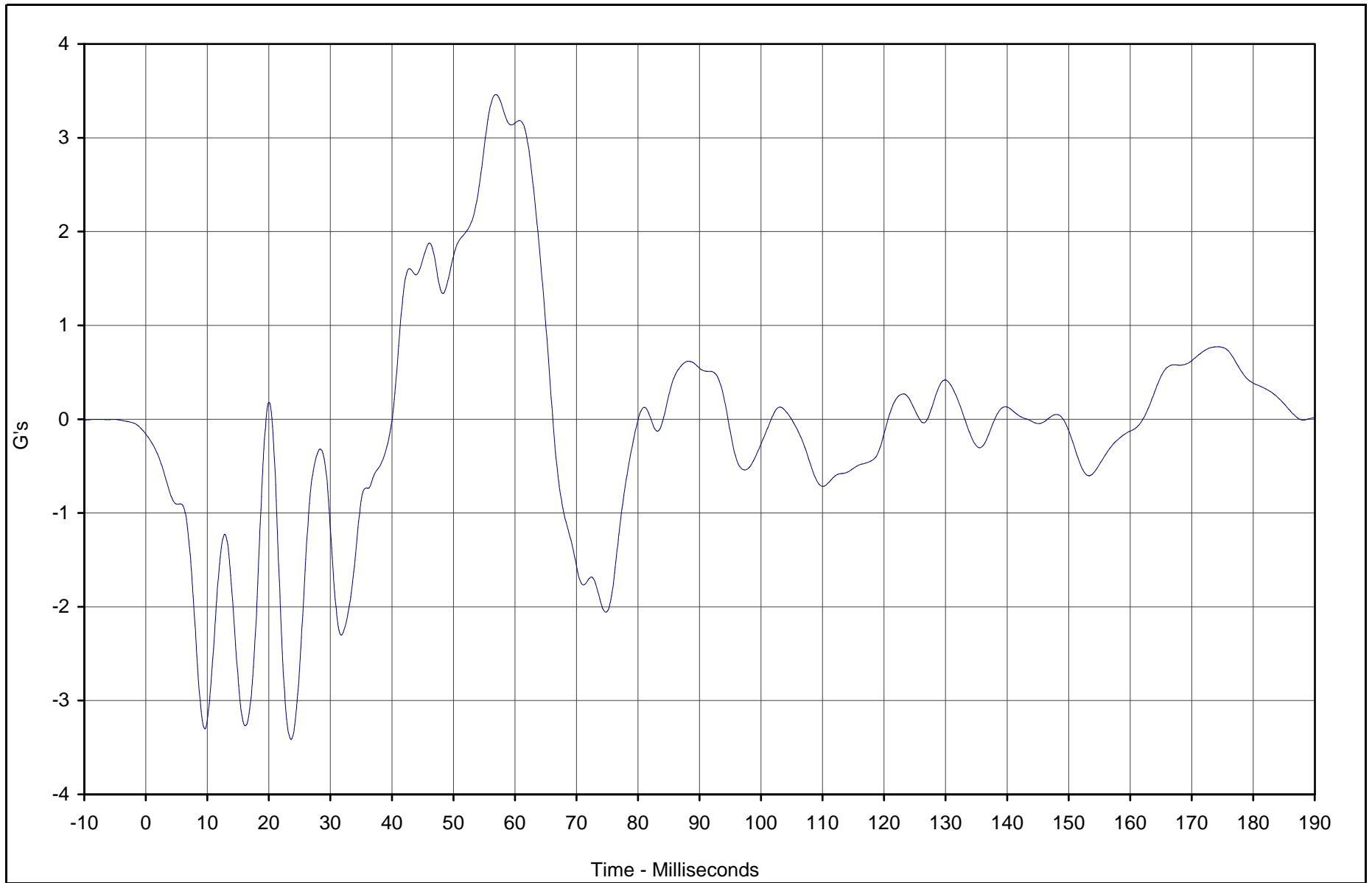

Curve Description	CURNO	Type	Units	Max	Time	Min	Time	SAE Class
Right Sill Rear Seat X	048	FIL	G's	3.5	56.9	-3.4	23.6	60



Test Vehicle: 2003 Subaru Forester 2.5X AWD Wagon

Test Date: 10/29/02

Test Program: 55/28 km/h Side Impact NCAP

NHTSA No.: M35500

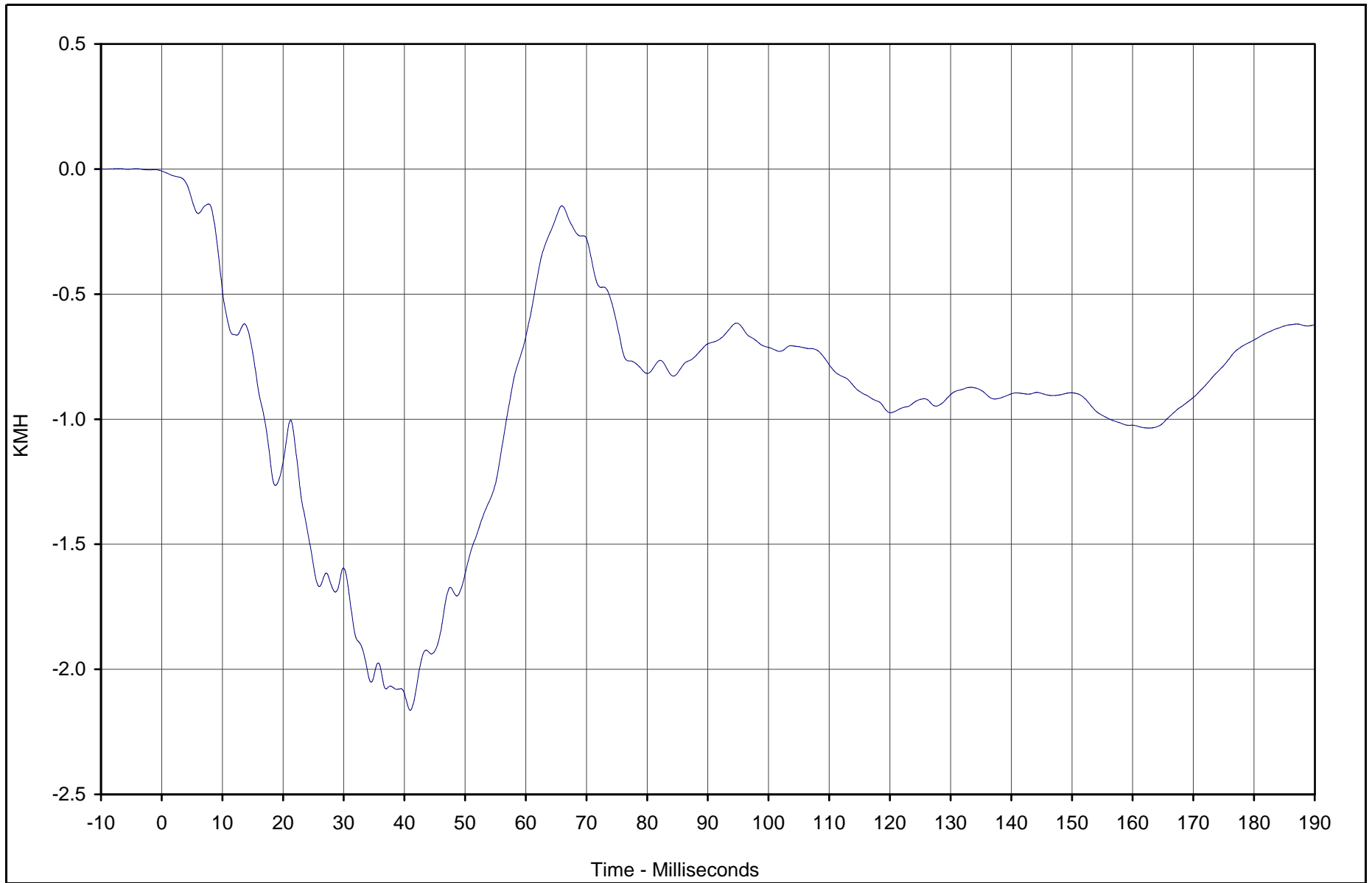

Curve Description	CURNO	Type	Units	Max	Time	Min	Time	SAE Class
Right Sill Rear Seat X Velocity	048	IN1	KMH	0.0	0.0	-2.2	41.0	180



Test Vehicle: 2003 Subaru Forester 2.5X AWD Wagon

Test Date: 10/29/02

Test Program: 55/28 km/h Side Impact NCAP

NHTSA No.: M35500

B-90

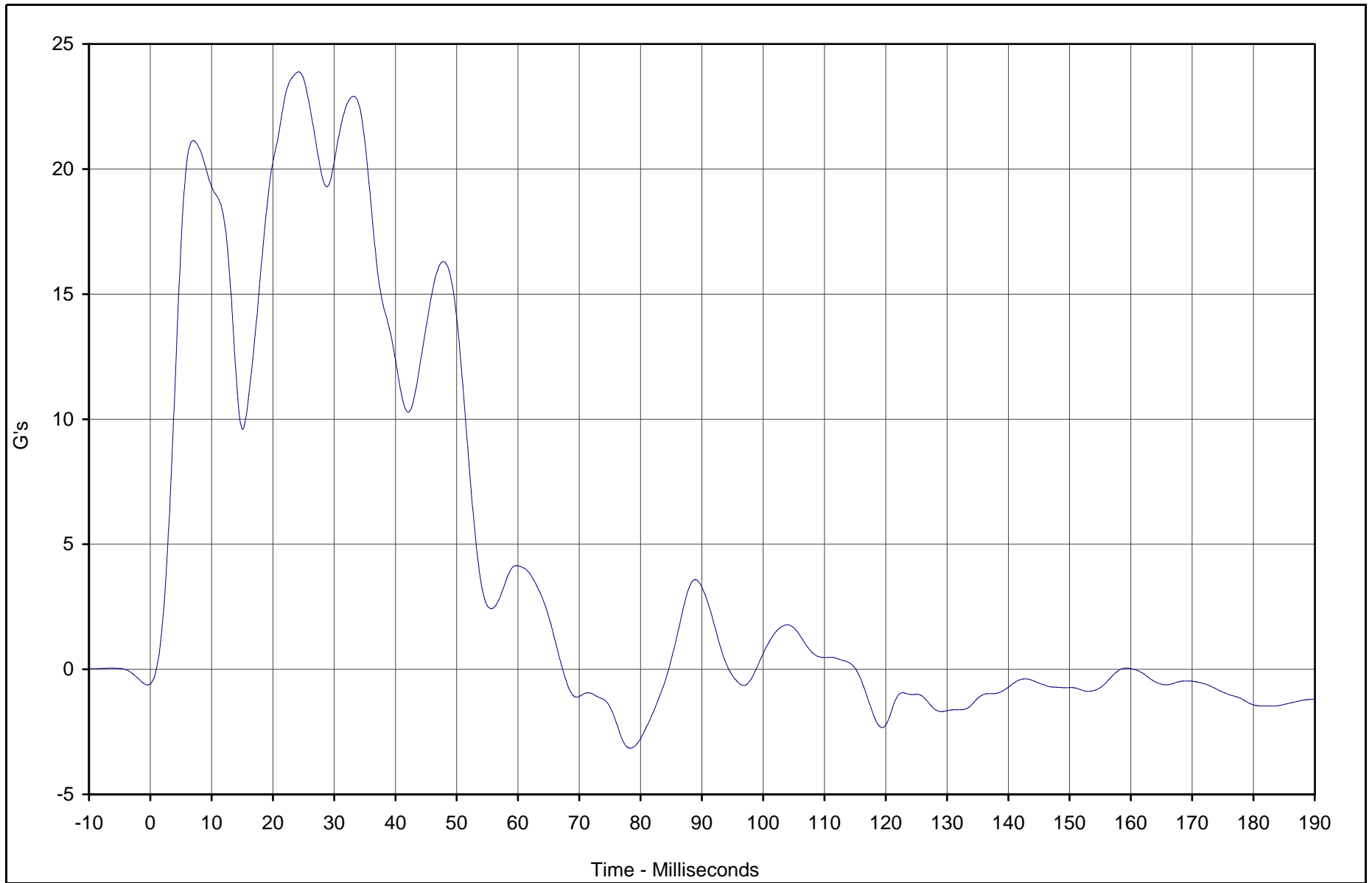

Curve Description	CURNO	Type	Units	Max	Time	Min	Time	SAE Class
Right Sill Rear Seat Y	049	FIL	G's	23.9	24.2	-3.2	78.3	60



Test Vehicle: 2003 Subaru Forester 2.5X AWD Wagon

Test Date: 10/29/02

Test Program: 55/28 km/h Side Impact NCAP

NHTSA No.: M35500

TR-P23003-01-NC

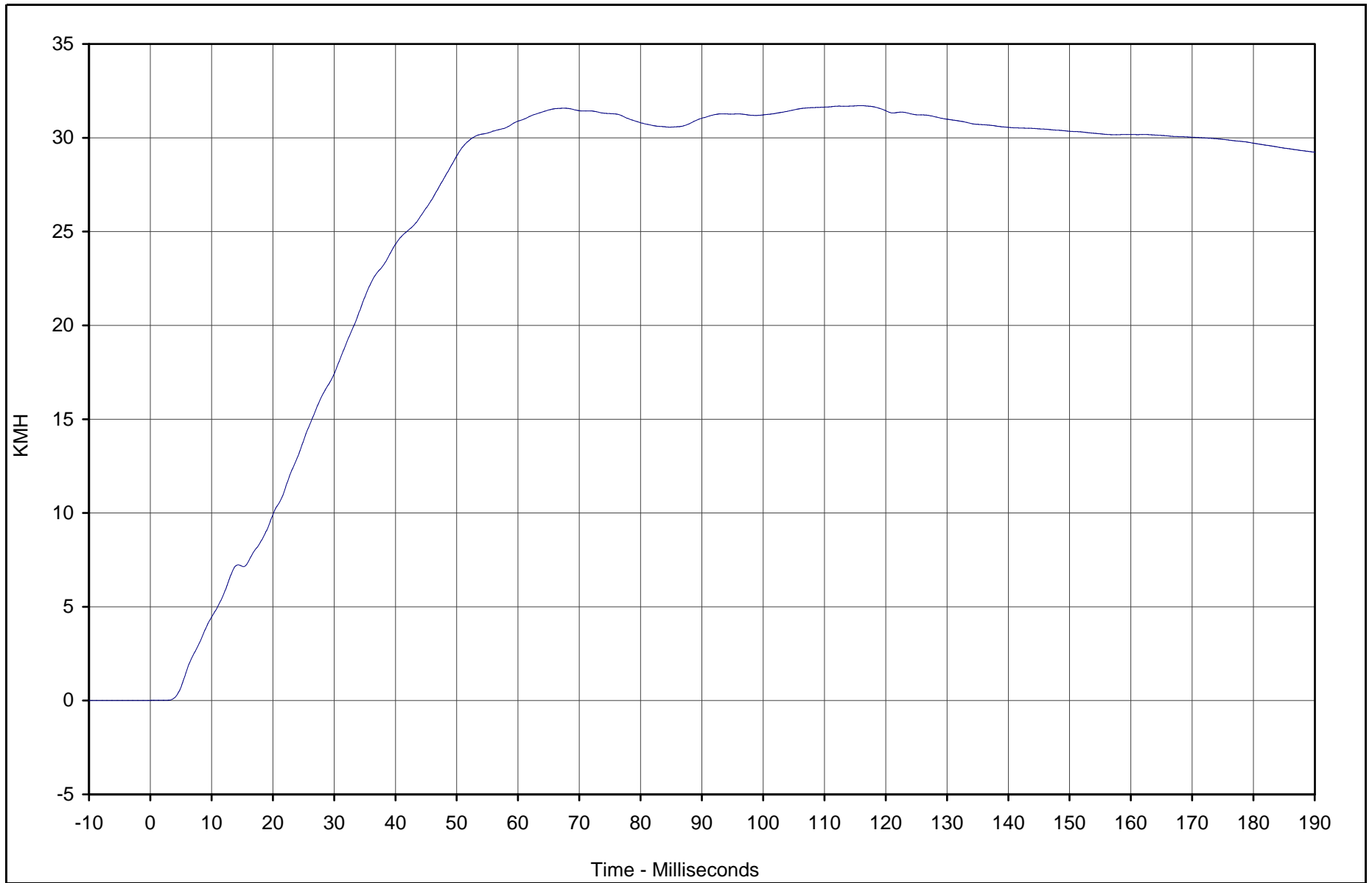

Curve Description	CURNO	Type	Units	Max	Time	Min	Time	SAE Class
Right Sill Rear Seat Y Velocity	049	IN1	KMH	31.7	115.9	0.0	0.0	180



Test Vehicle: 2003 Subaru Forester 2.5X AWD Wagon

Test Date: 10/29/02

Test Program: 55/28 km/h Side Impact NCAP

NHTSA No.: M35500

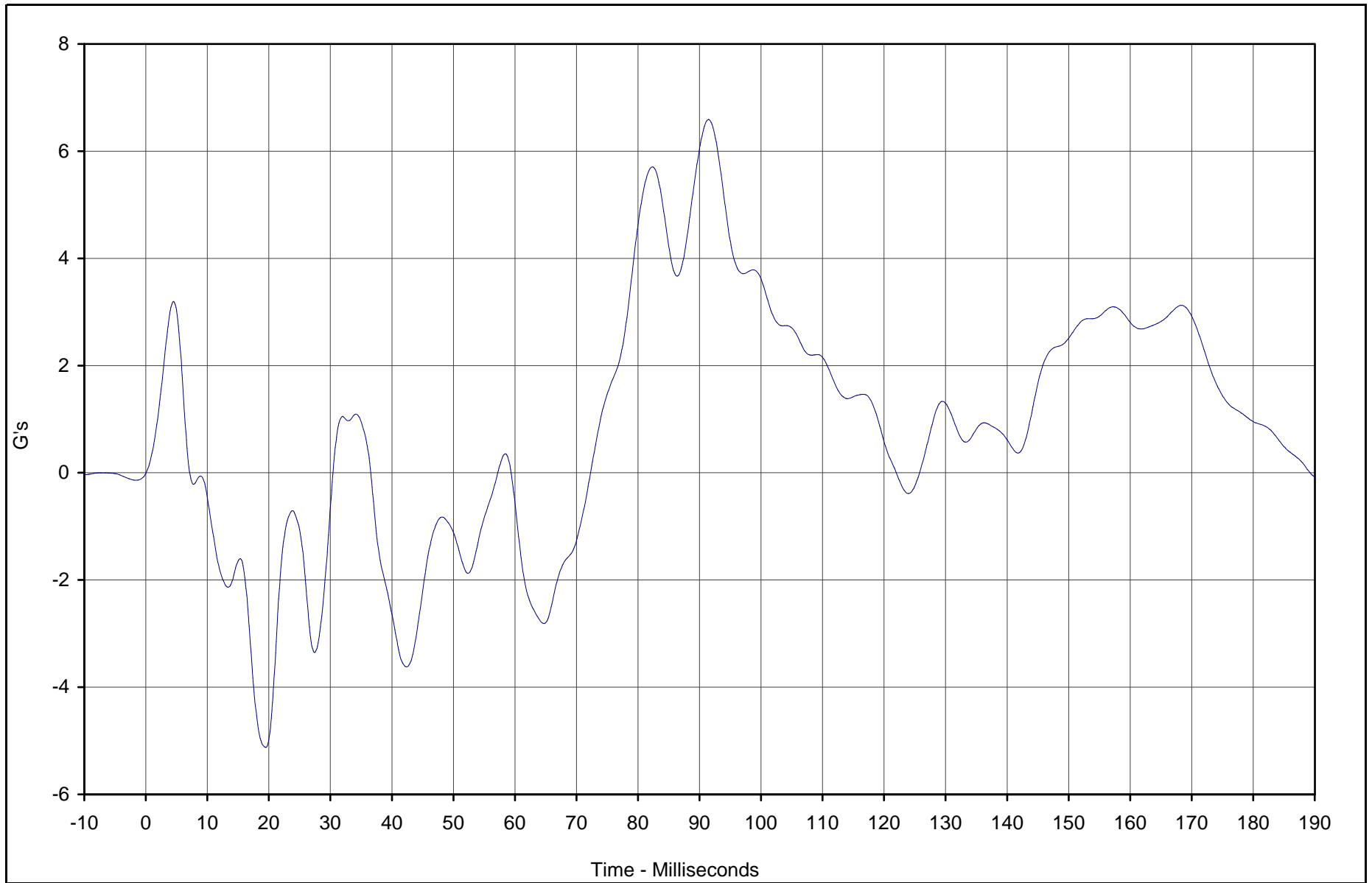

Curve Description	CURNO	Type	Units	Max	Time	Min	Time	SAE Class
Right Sill Rear Seat Z	050	FIL	G's	6.6	91.5	-5.1	19.5	60



Test Vehicle: 2003 Subaru Forester 2.5X AWD Wagon

Test Date: 10/29/02

Test Program: 55/28 km/h Side Impact NCAP

NHTSA No.: M35500

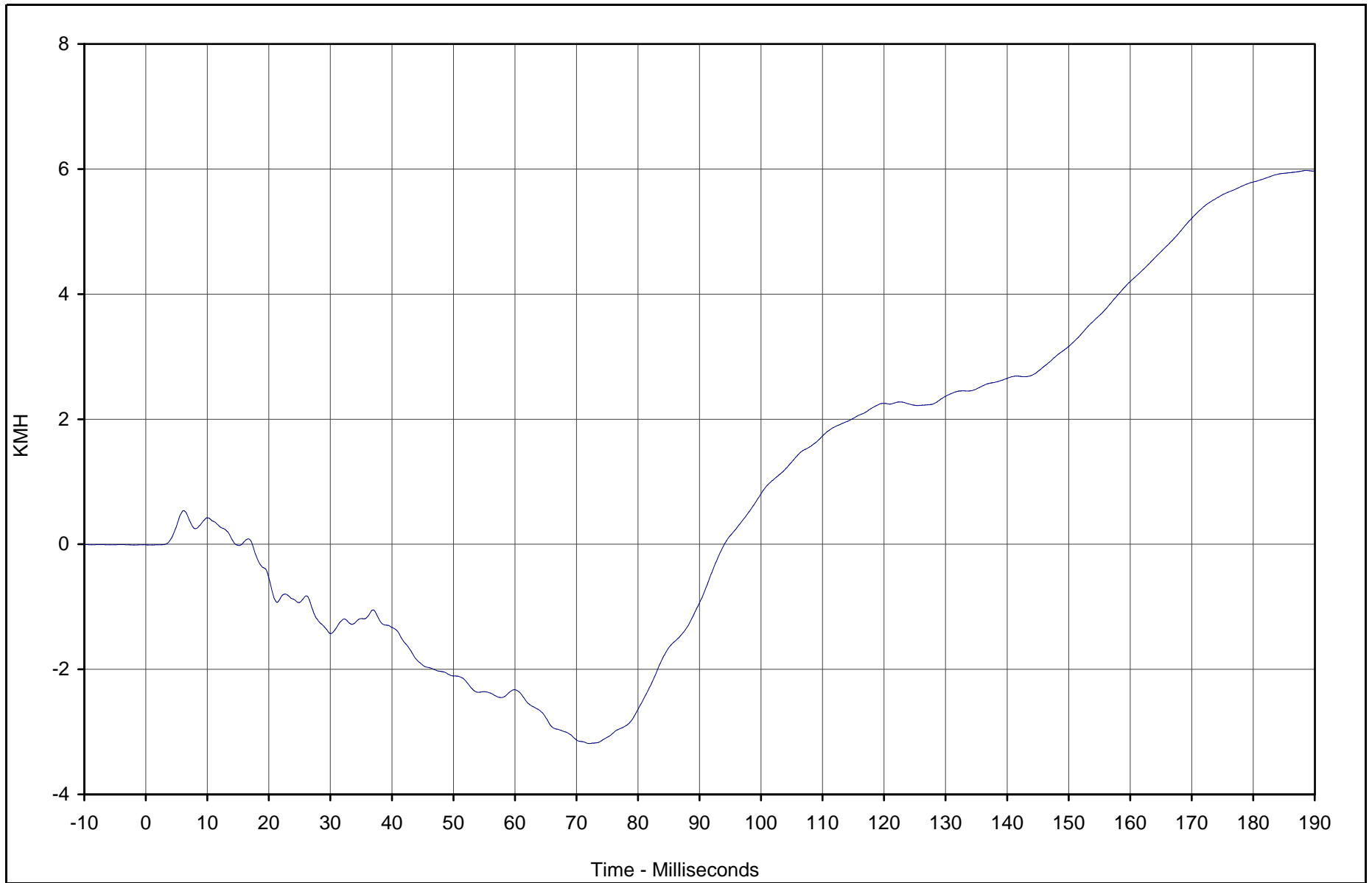

Curve Description	CURNO	Type	Units	Max	Time	Min	Time	SAE Class
Right Sill Rear Seat Z Velocity	050	IN1	KMH	6.0	188.6	-3.2	72.1	180



Test Vehicle: 2003 Subaru Forester 2.5X AWD Wagon

Test Date: 10/29/02

Test Program: 55/28 km/h Side Impact NCAP

NHTSA No.: M35500

B-94

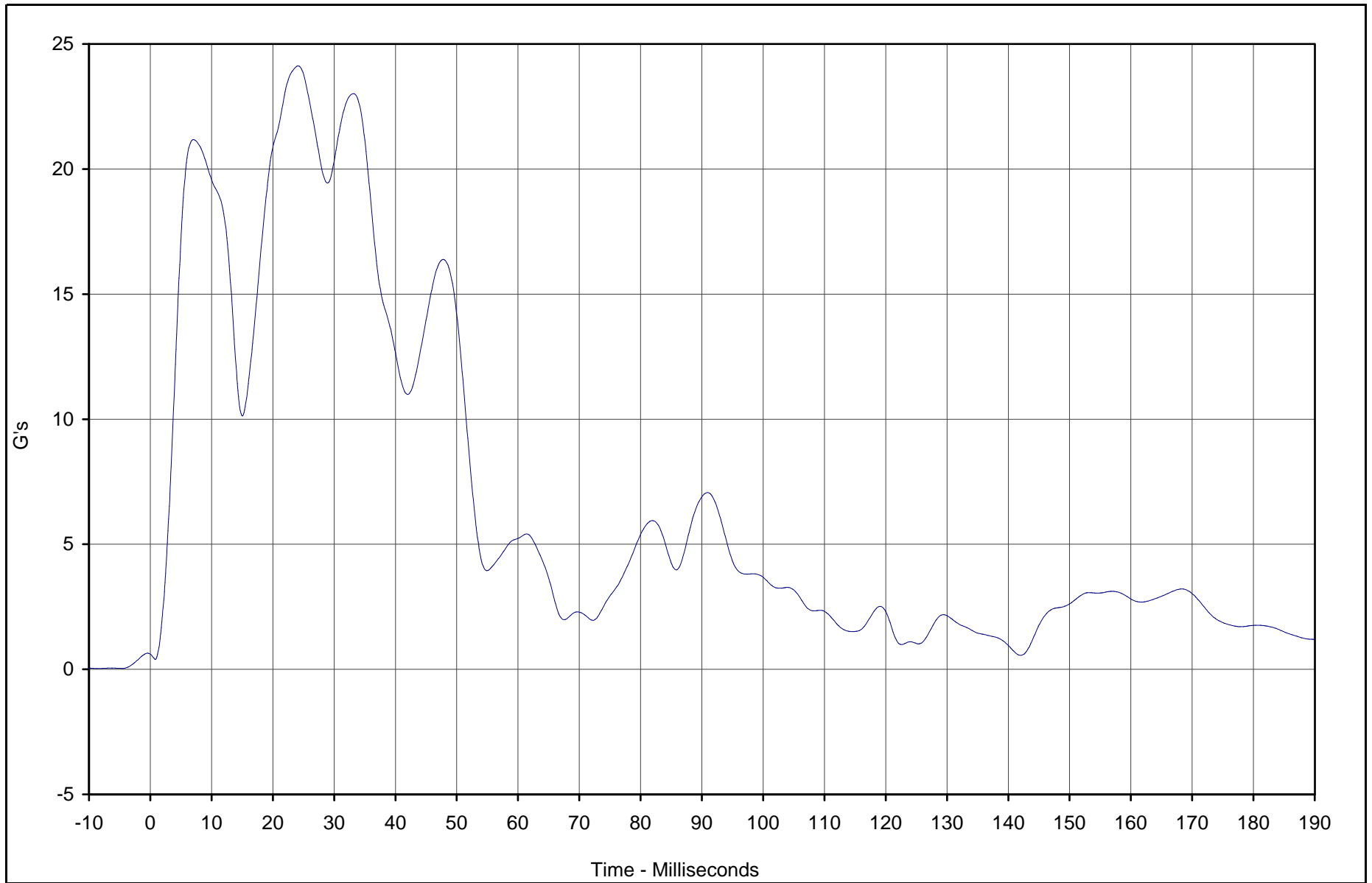

Curve Description	CURNO	Type	Units	Max	Time	Min	Time	SAE Class
Right Sill Rear Seat Resultant	048	RES	G's	24.1	24.1	0.4	0.8	60



Test Vehicle: 2003 Subaru Forester 2.5X AWD Wagon

Test Date: 10/29/02

Test Program: 55/28 km/h Side Impact NCAP

NHTSA No.: M35500

TR-P23003-01-NC

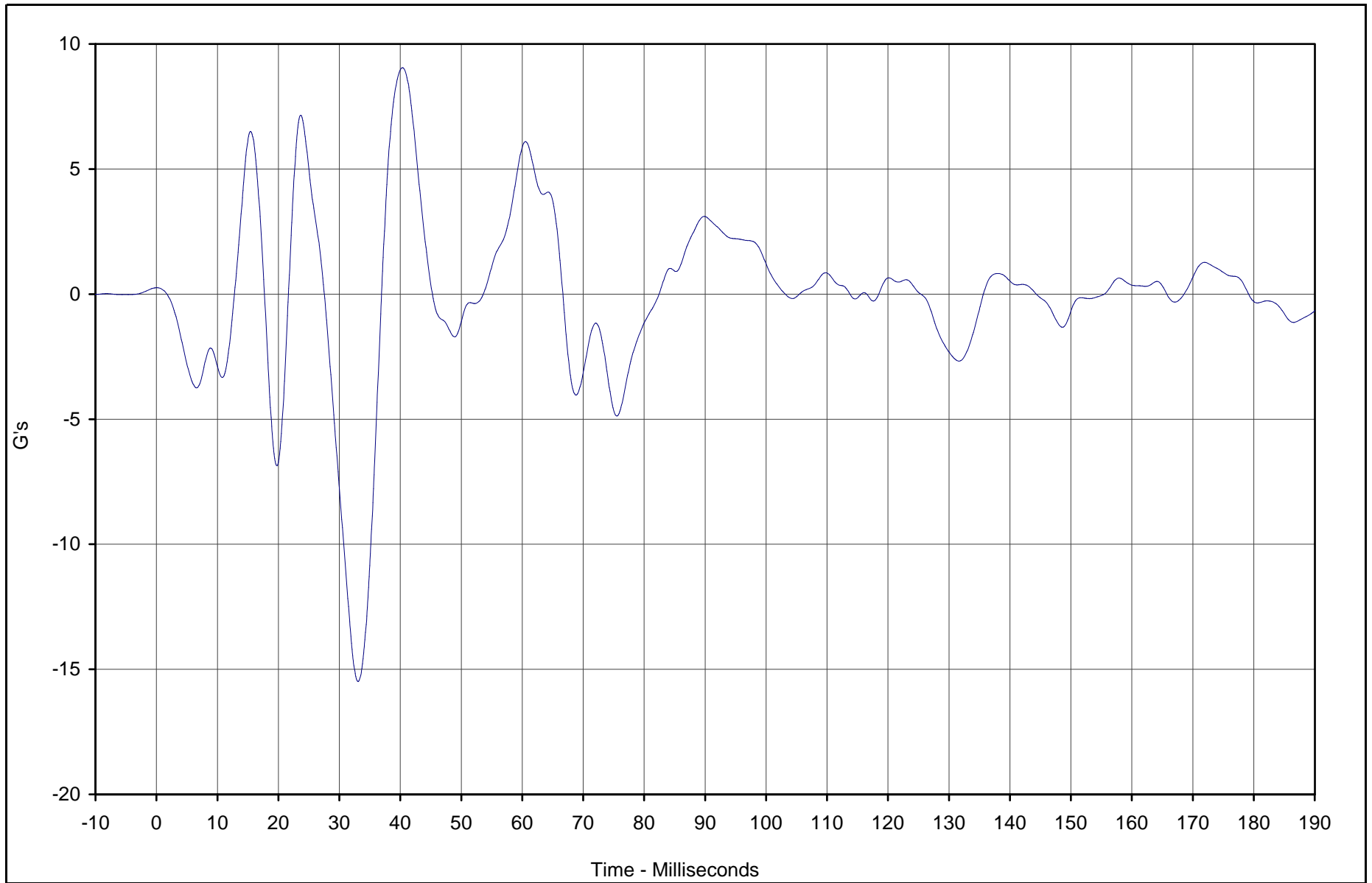

Curve Description	CURNO	Type	Units	Max	Time	Min	Time	SAE Class
Rear Floor Above Axle X	051	FIL	G's	9.1	40.4	-15.5	33.1	60



Test Vehicle: 2003 Subaru Forester 2.5X AWD Wagon

Test Date: 10/29/02

Test Program: 55/28 km/h Side Impact NCAP

NHTSA No.: M35500

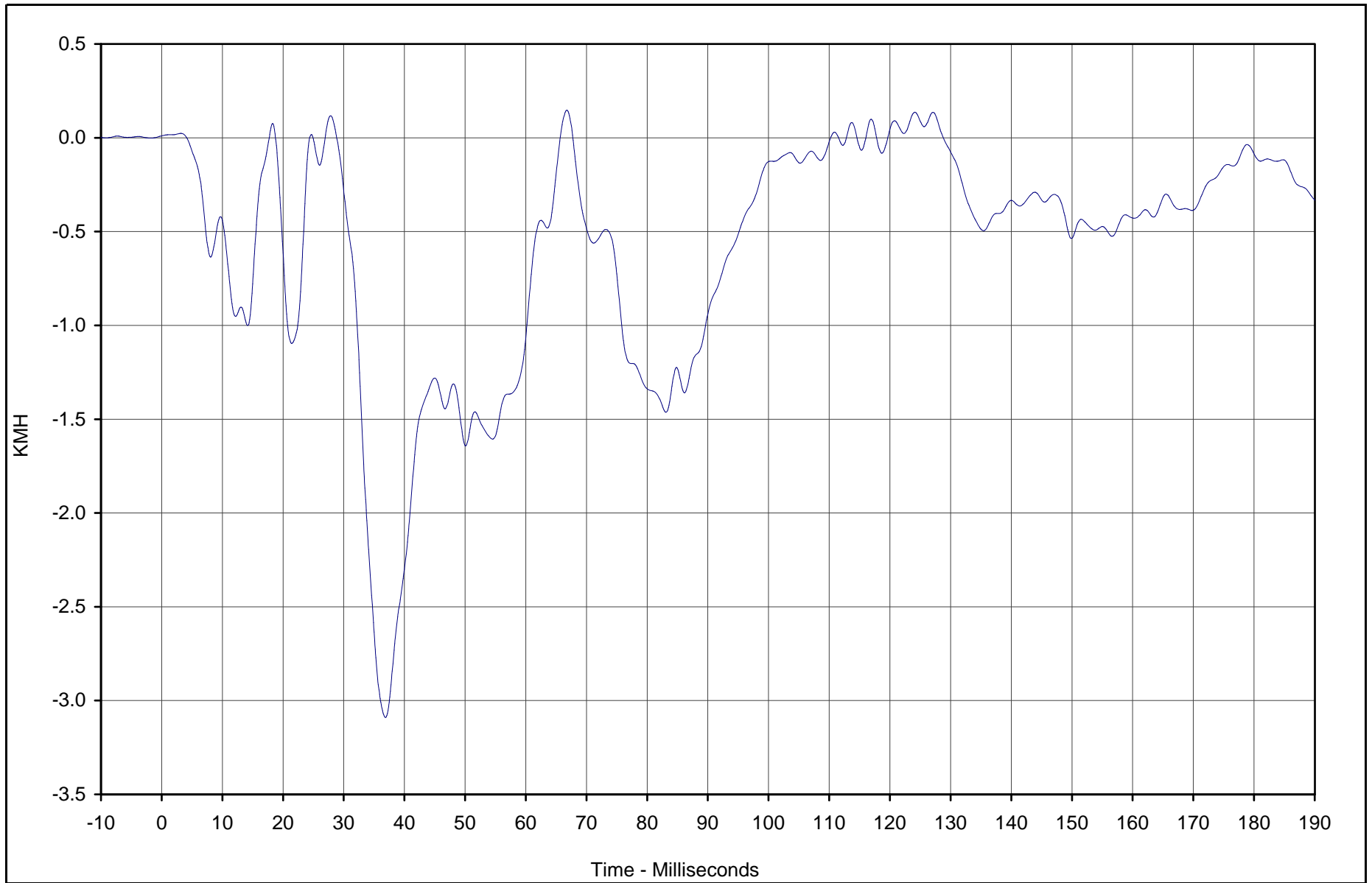

Curve Description	CURNO	Type	Units	Max	Time	Min	Time	SAE Class
Rear Floor Above Axle X Velocity	051	IN1	KMH	0.1	66.8	-3.1	36.9	180



Test Vehicle: 2003 Subaru Forester 2.5X AWD Wagon

Test Date: 10/29/02

Test Program: 55/28 km/h Side Impact NCAP

NHTSA No.: M35500

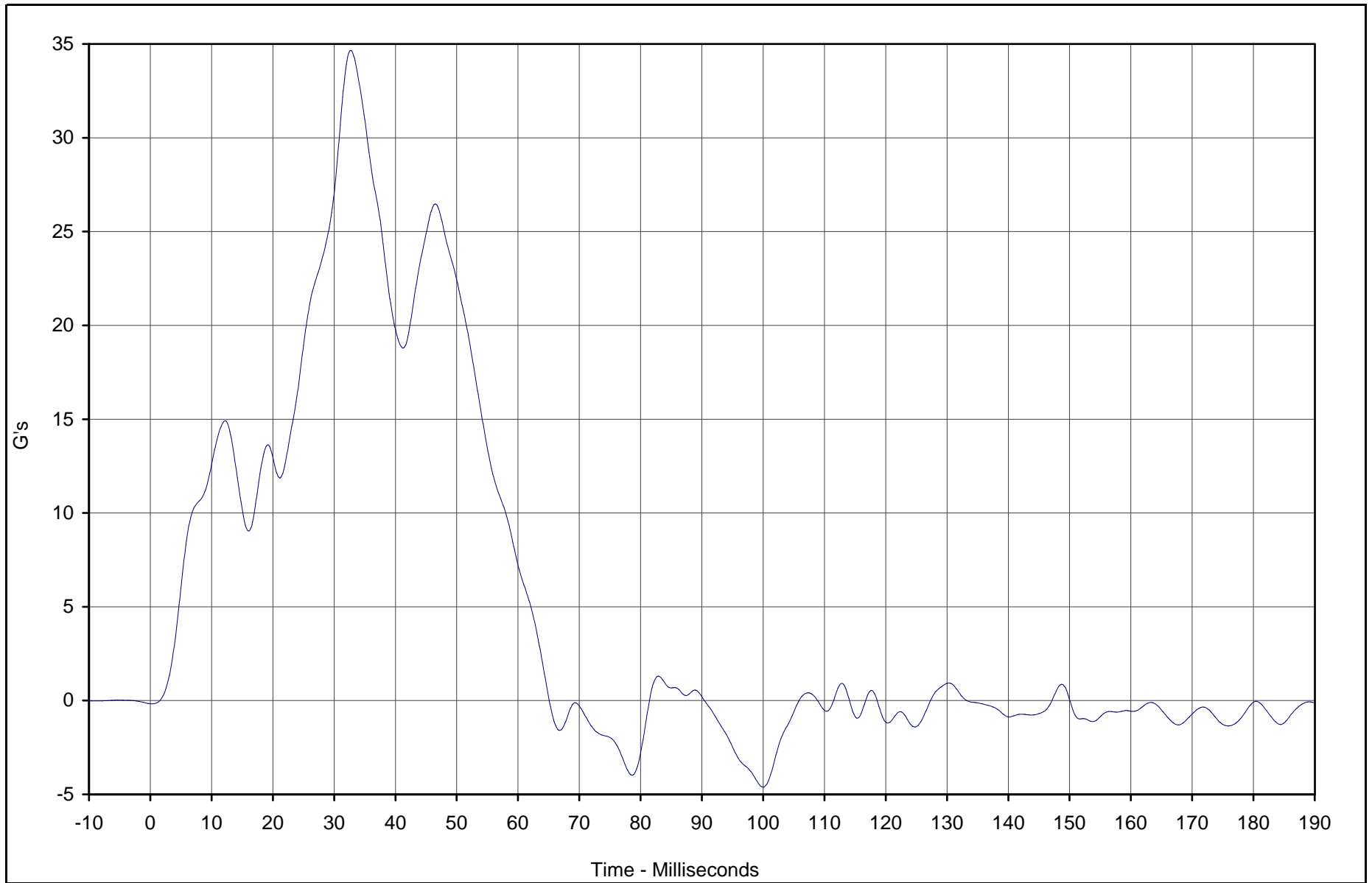

Curve Description	CURNO	Type	Units	Max	Time	Min	Time	SAE Class
Rear Floor Above Axle Y	052	FIL	G's	34.7	32.7	-4.6	100.0	60



Test Vehicle: 2003 Subaru Forester 2.5X AWD Wagon

Test Date: 10/29/02

Test Program: 55/28 km/h Side Impact NCAP

NHTSA No.: M35500

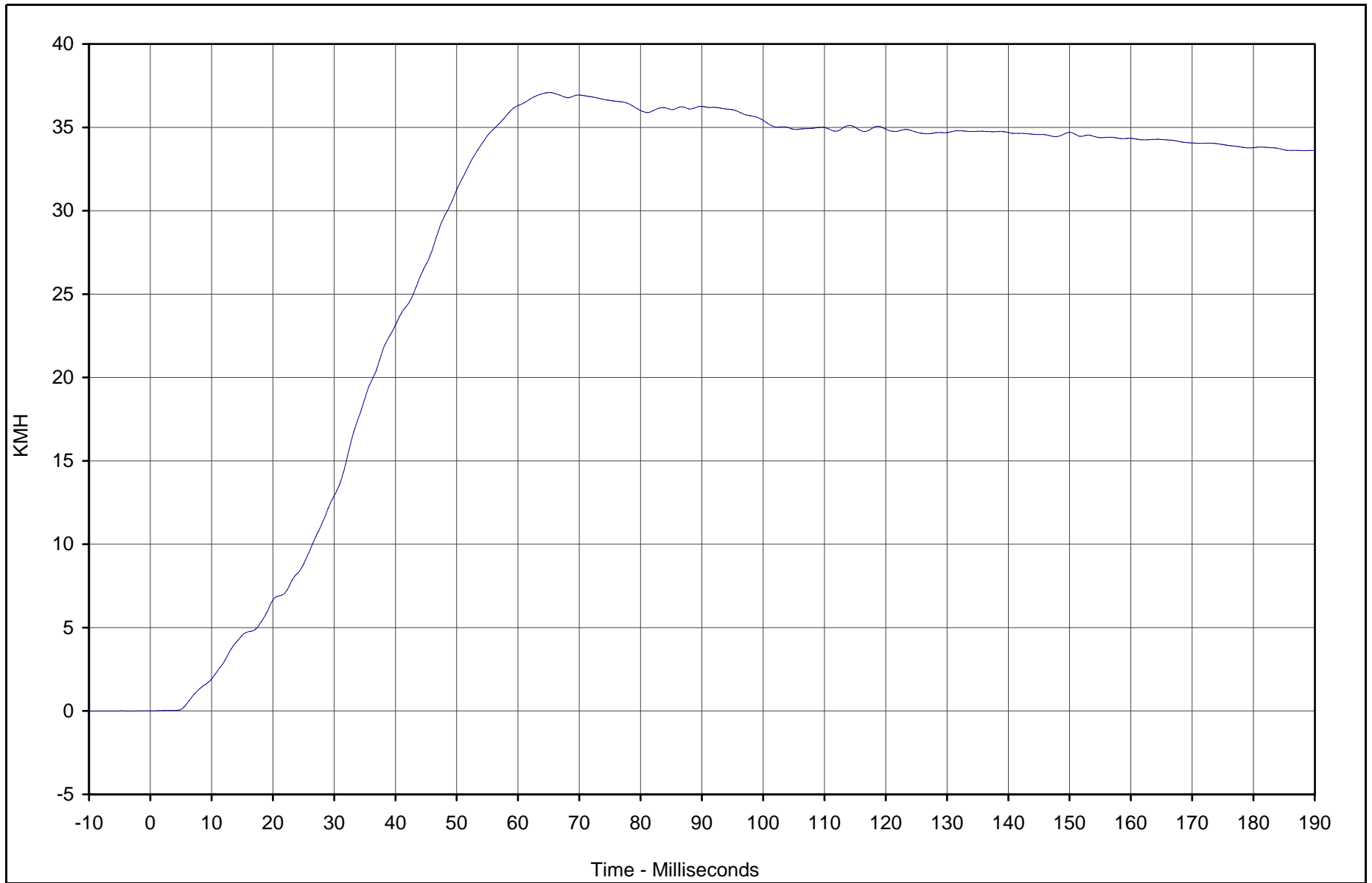

Curve Description	CURNO	Type	Units	Max	Time	Min	Time	SAE Class
Rear Floor Above Axle Y Velocity	052	IN1	KMH	37.1	65.1	0.0	0.0	180



Test Vehicle: 2003 Subaru Forester 2.5X AWD Wagon

Test Date: 10/29/02

Test Program: 55/28 km/h Side Impact NCAP

NHTSA No.: M35500

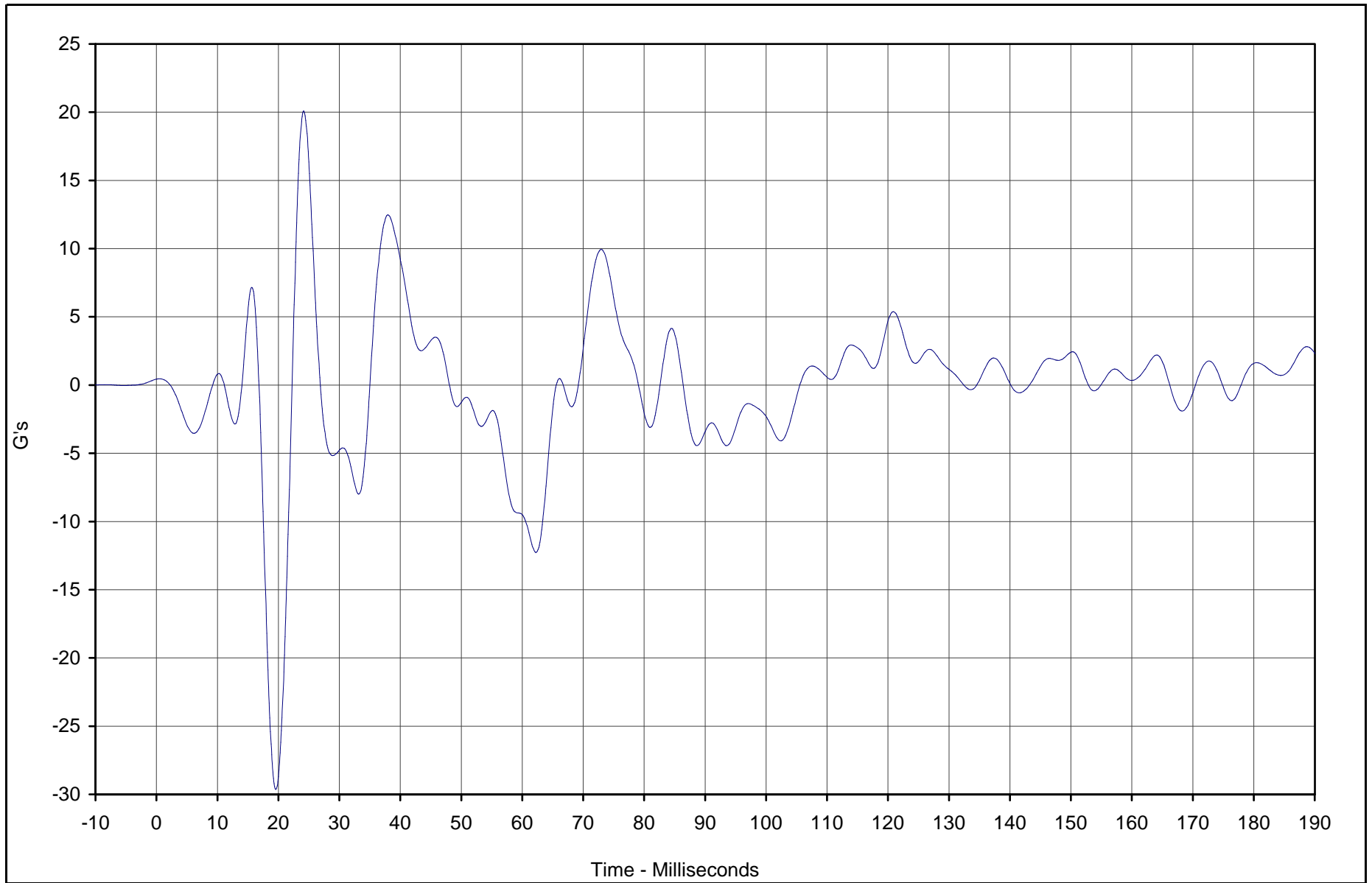

Curve Description	CURNO	Type	Units	Max	Time	Min	Time	SAE Class
Rear Floor Above Axle Z	053	FIL	G's	20.1	24.2	-29.6	19.6	60



Test Vehicle: 2003 Subaru Forester 2.5X AWD Wagon

Test Date: 10/29/02

Test Program: 55/28 km/h Side Impact NCAP

NHTSA No.: M35500

B-100

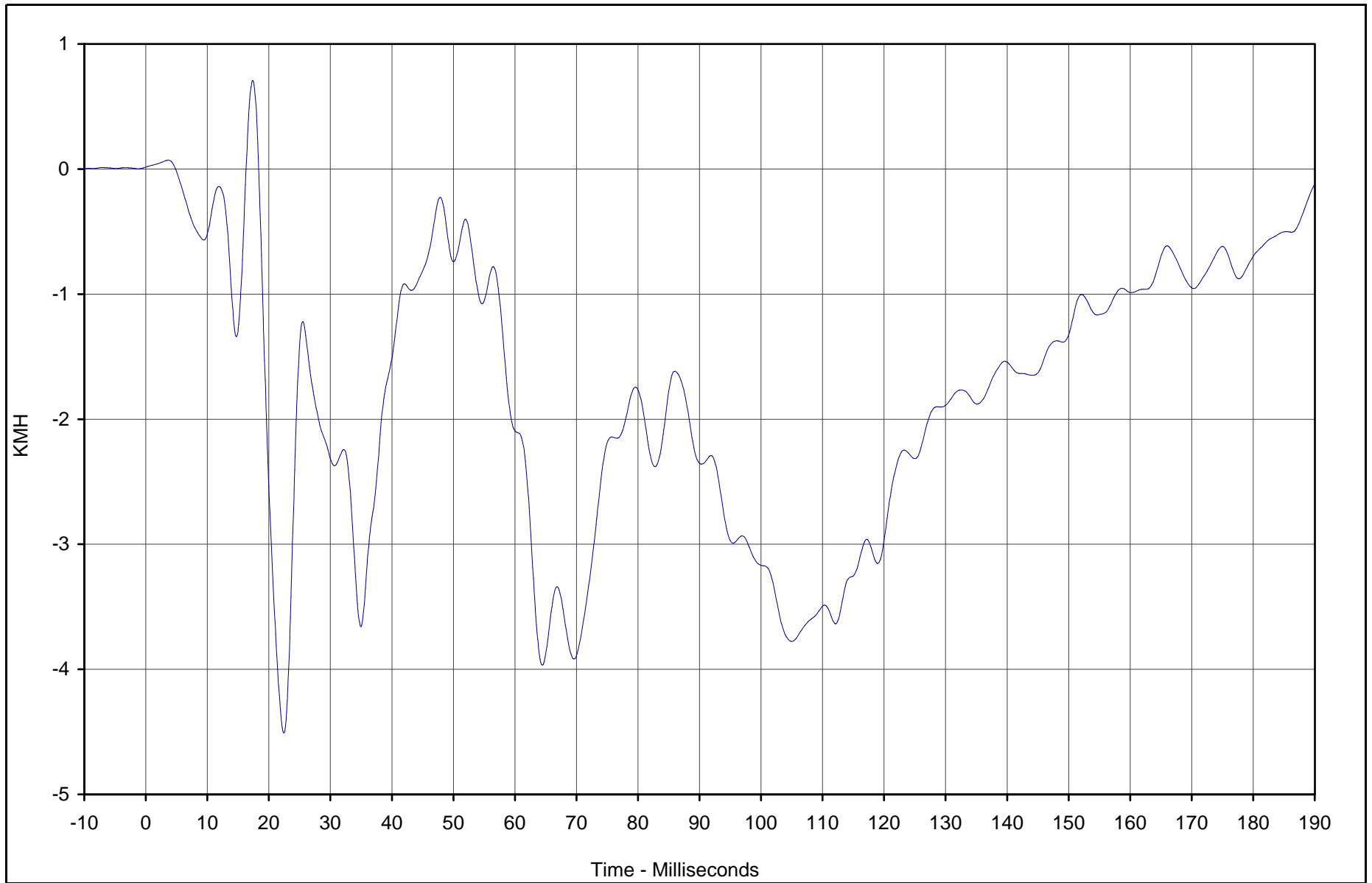

Curve Description	CURNO	Type	Units	Max	Time	Min	Time	SAE Class
Rear Floor Above Axle Z Velocity	053	IN1	KMH	0.7	17.4	-4.5	22.4	180



Test Vehicle: 2003 Subaru Forester 2.5X AWD Wagon

Test Date: 10/29/02

Test Program: 55/28 km/h Side Impact NCAP

NHTSA No.: M35500

TR-P23003-01-NC

B-101

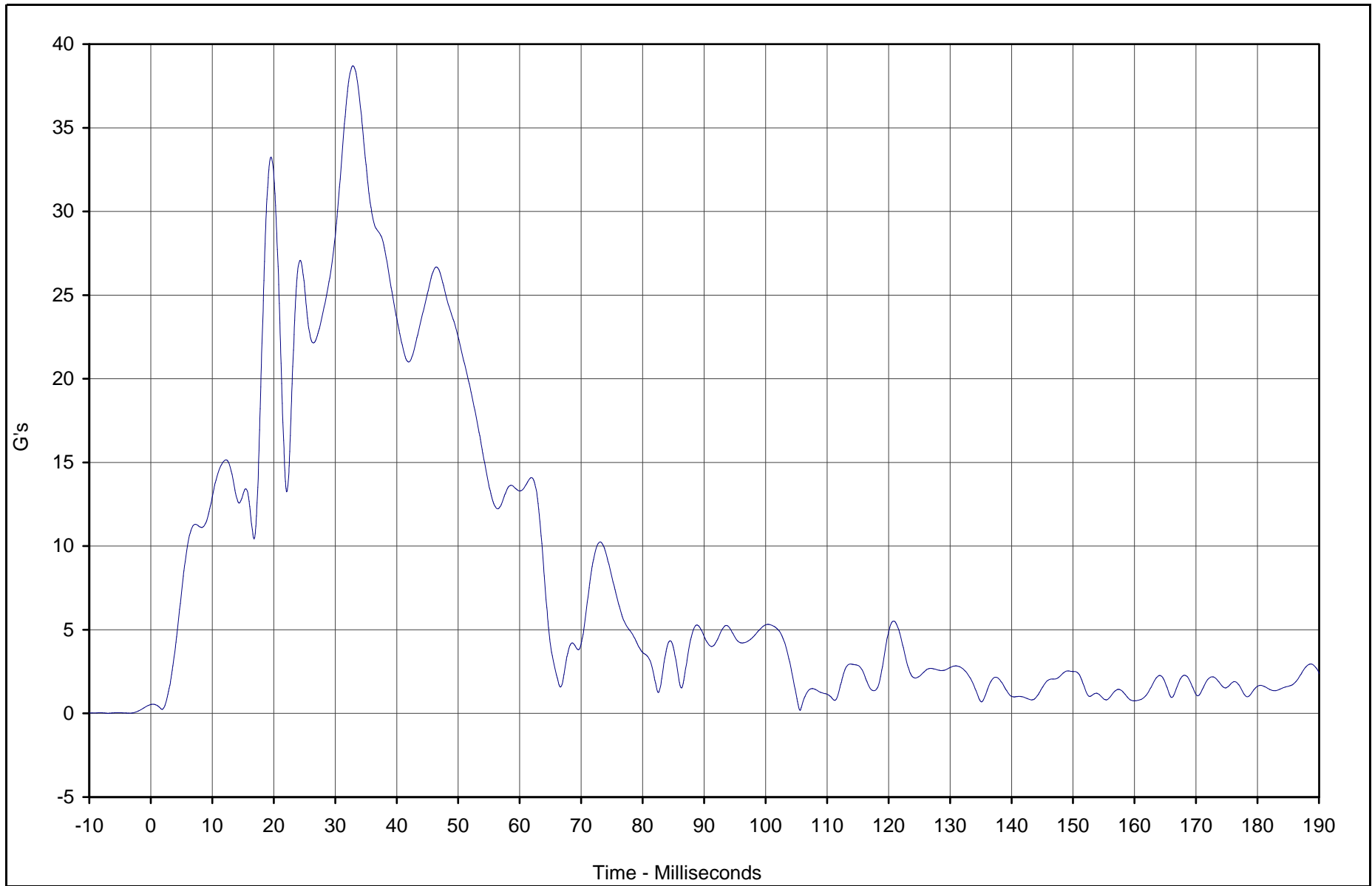

Curve Description	CURNO	Type	Units	Max	Time	Min	Time	SAE Class
Rear Floor Above Axle Resultant	051	RES	G's	38.7	32.9	0.2	105.6	60



Test Vehicle: 2003 Subaru Forester 2.5X AWD Wagon

Test Date: 10/29/02

Test Program: 55/28 km/h Side Impact NCAP

NHTSA No.: M35500

TR-P23003-01-NC

B-102

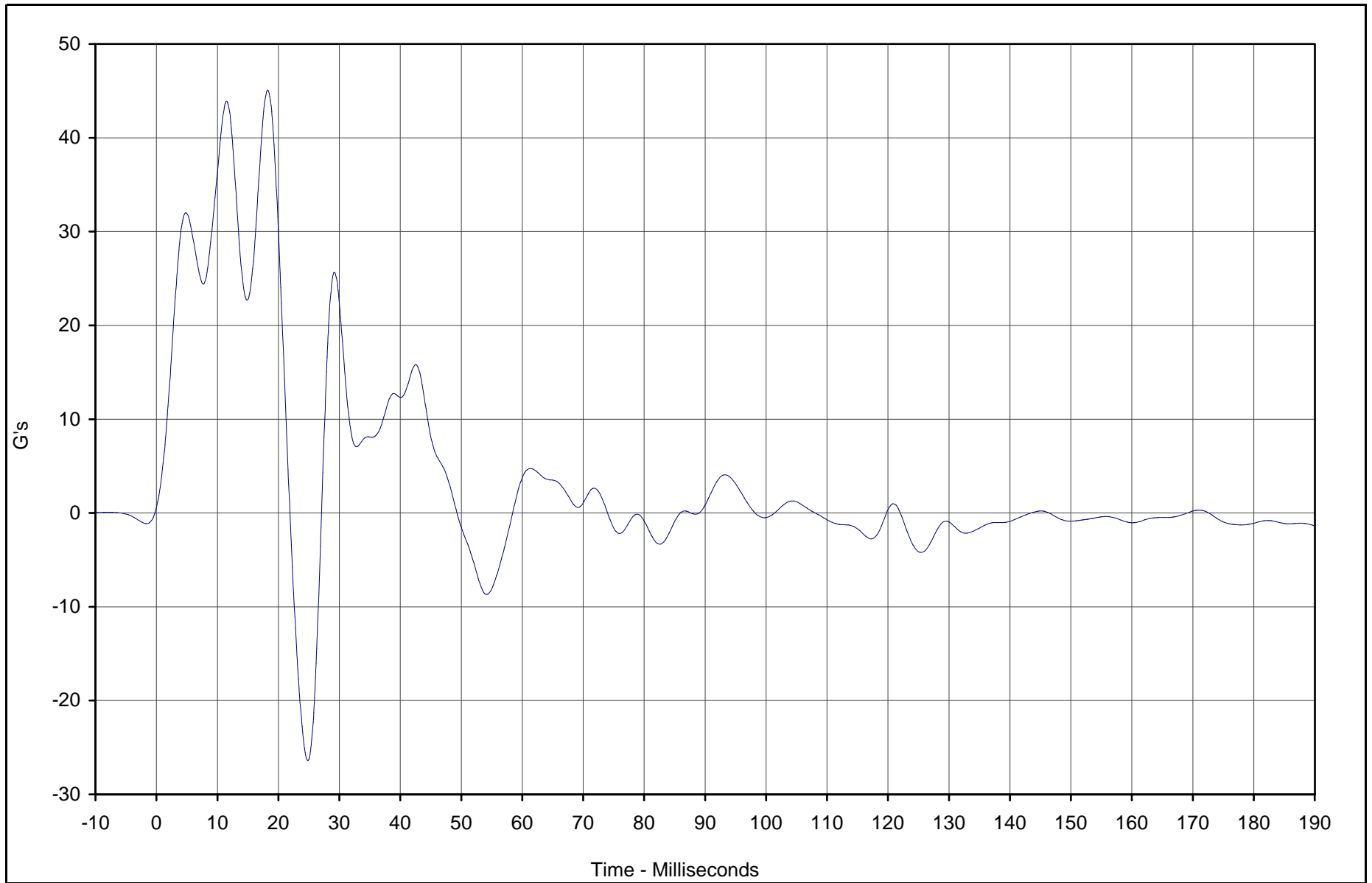

Curve Description	CURNO	Type	Units	Max	Time	Min	Time	SAE Class
Left Sill Rear Door Y	054	FIL	G's	45.1	18.3	-26.4	24.8	60



Test Vehicle: 2003 Subaru Forester 2.5X AWD Wagon

Test Date: 10/29/02

Test Program: 55/28 km/h Side Impact NCAP

NHTSA No.: M35500

TR-P23003-01-NC

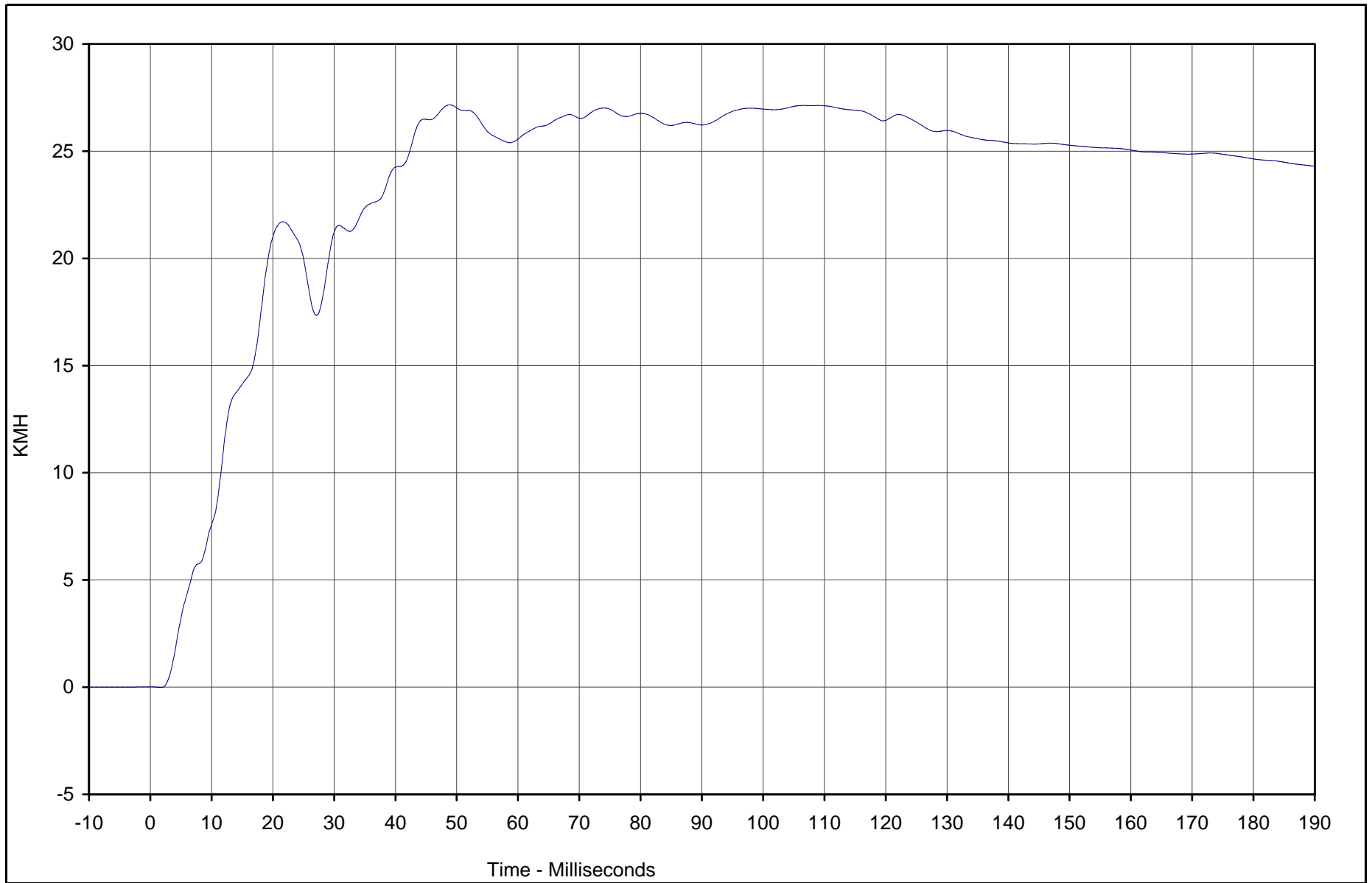

Curve Description	CURNO	Type	Units	Max	Time	Min	Time	SAE Class
Left Sill Rear Door Y Velocity	054	IN1	KMH	27.2	48.9	0.0	1.7	180



Test Vehicle: 2003 Subaru Forester 2.5X AWD Wagon

Test Date: 10/29/02

Test Program: 55/28 km/h Side Impact NCAP

NHTSA No.: M35500

B-104

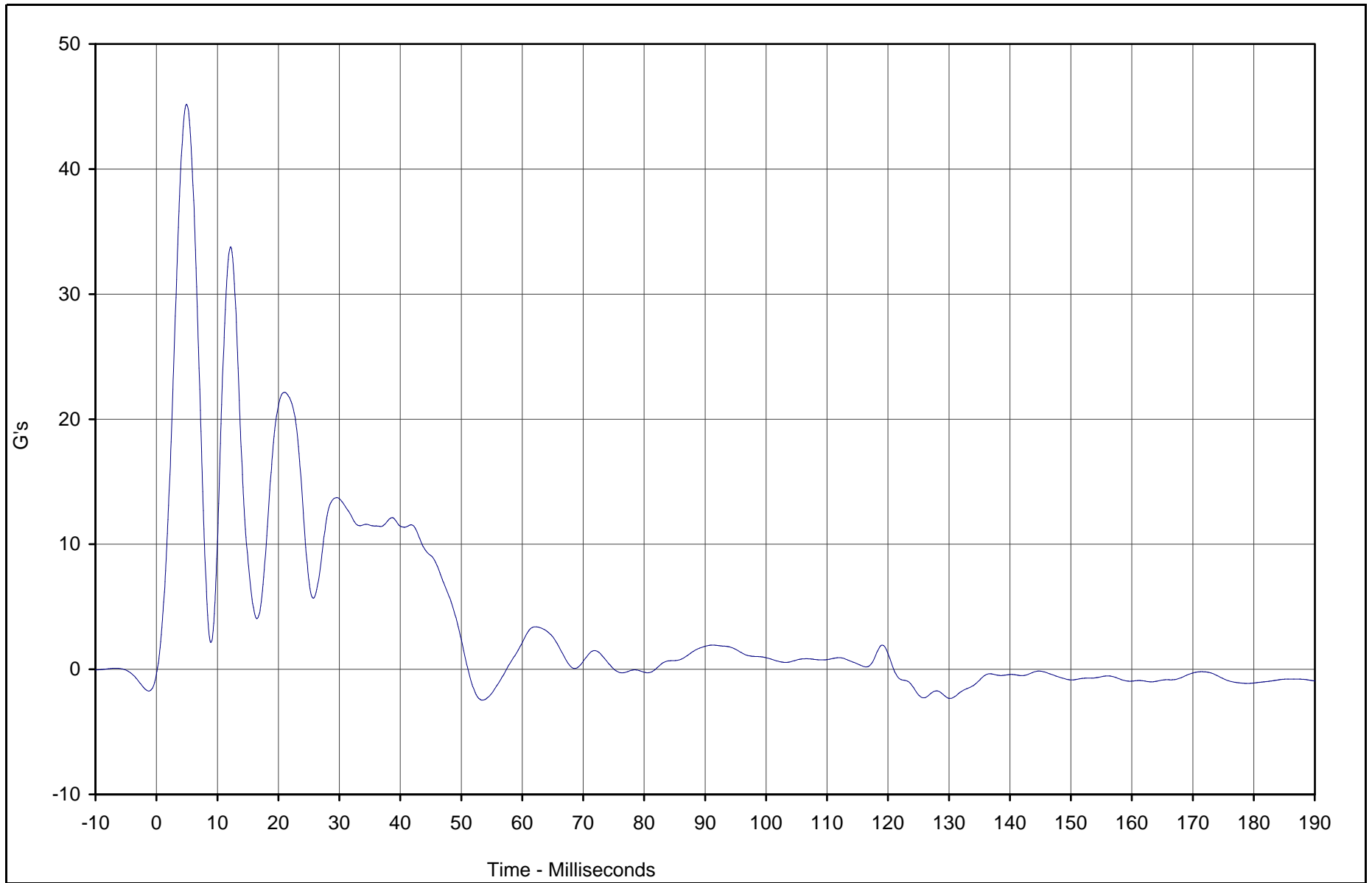

Curve Description	CURNO	Type	Units	Max	Time	Min	Time	SAE Class
Left Sill Front Door Y	055	FIL	G's	45.2	4.9	-2.5	53.5	60



Test Vehicle: 2003 Subaru Forester 2.5X AWD Wagon

Test Date: 10/29/02

Test Program: 55/28 km/h Side Impact NCAP

NHTSA No.: M35500

TR-P23003-01-NC

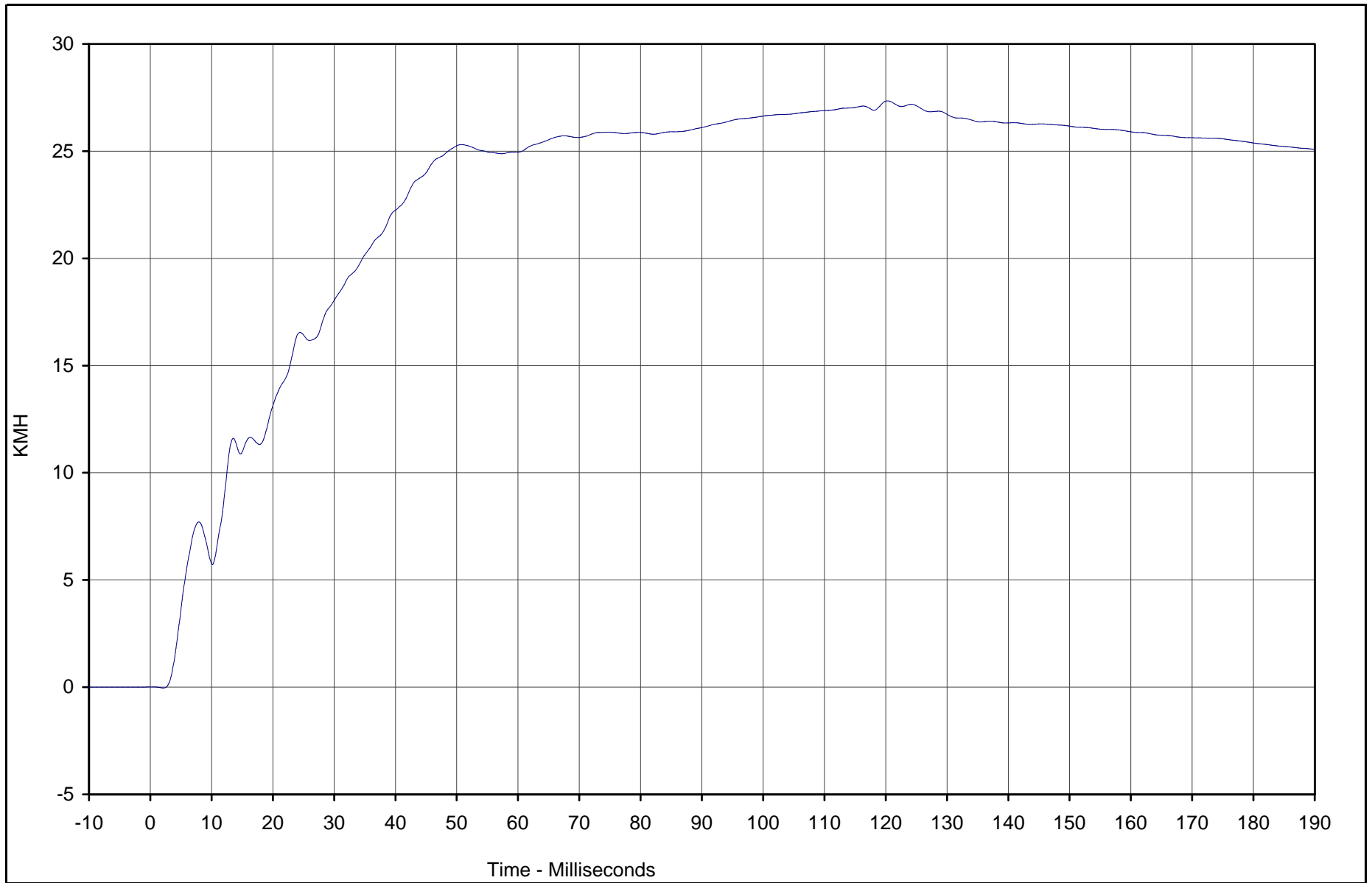

Curve Description	CURNO	Type	Units	Max	Time	Min	Time	SAE Class
Left Sill Front Door Y Velocity	055	IN1	KMH	27.3	120.3	0.0	2.2	180



Test Vehicle: 2003 Subaru Forester 2.5X AWD Wagon

Test Date: 10/29/02

Test Program: 55/28 km/h Side Impact NCAP

NHTSA No.: M35500

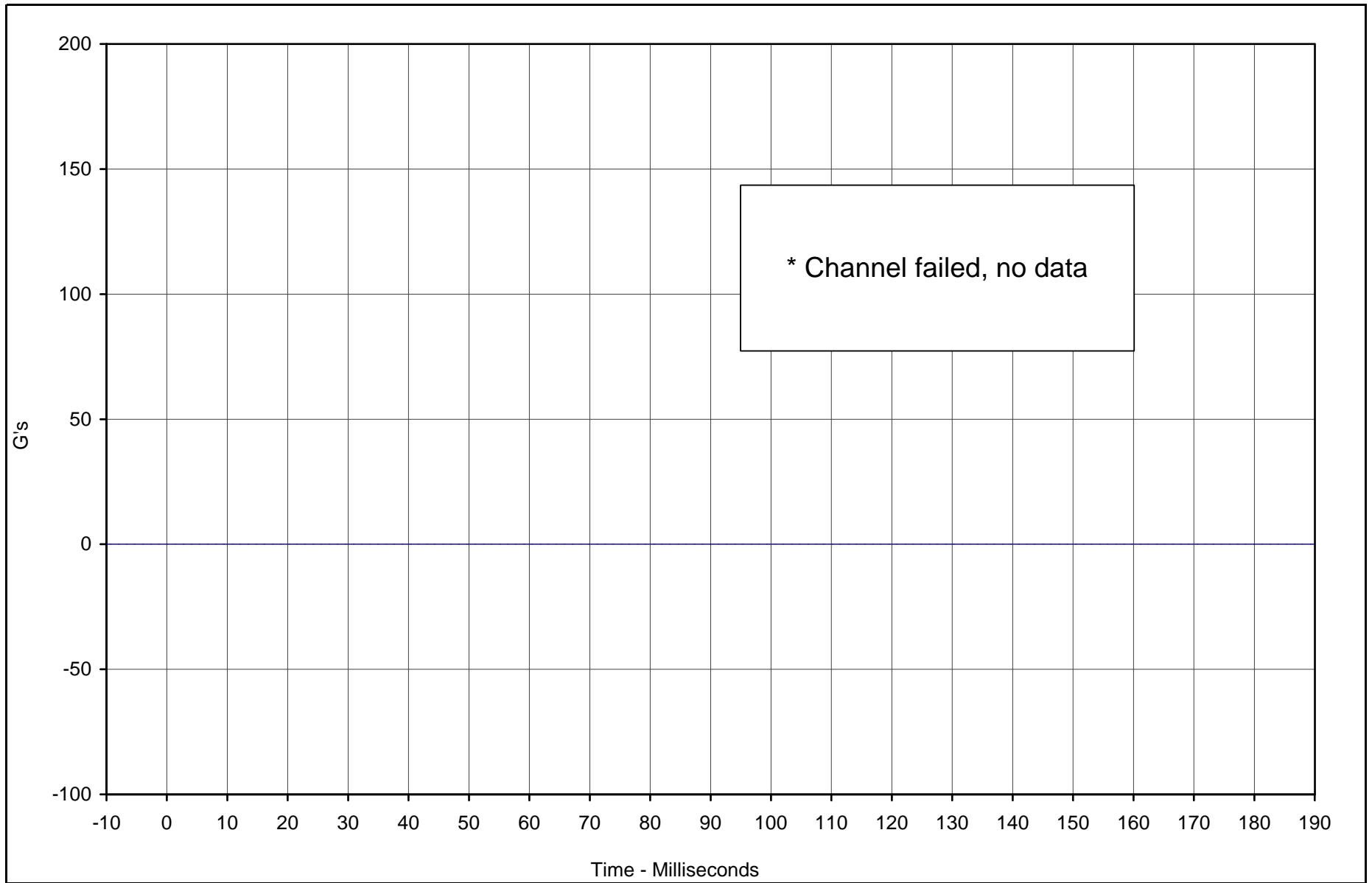

* Channel failed, no data

Curve Description	CURNO	Type	Units	Max	Time	Min	Time	SAE Class
Left Front Door CL Y	056	FIL	G's	0.0	0.0	0.0	0.0	60



Test Vehicle: 2003 Subaru Forester 2.5X AWD Wagon

Test Date: 10/29/02

Test Program: 55/28 km/h Side Impact NCAP

NHTSA No.: M35500

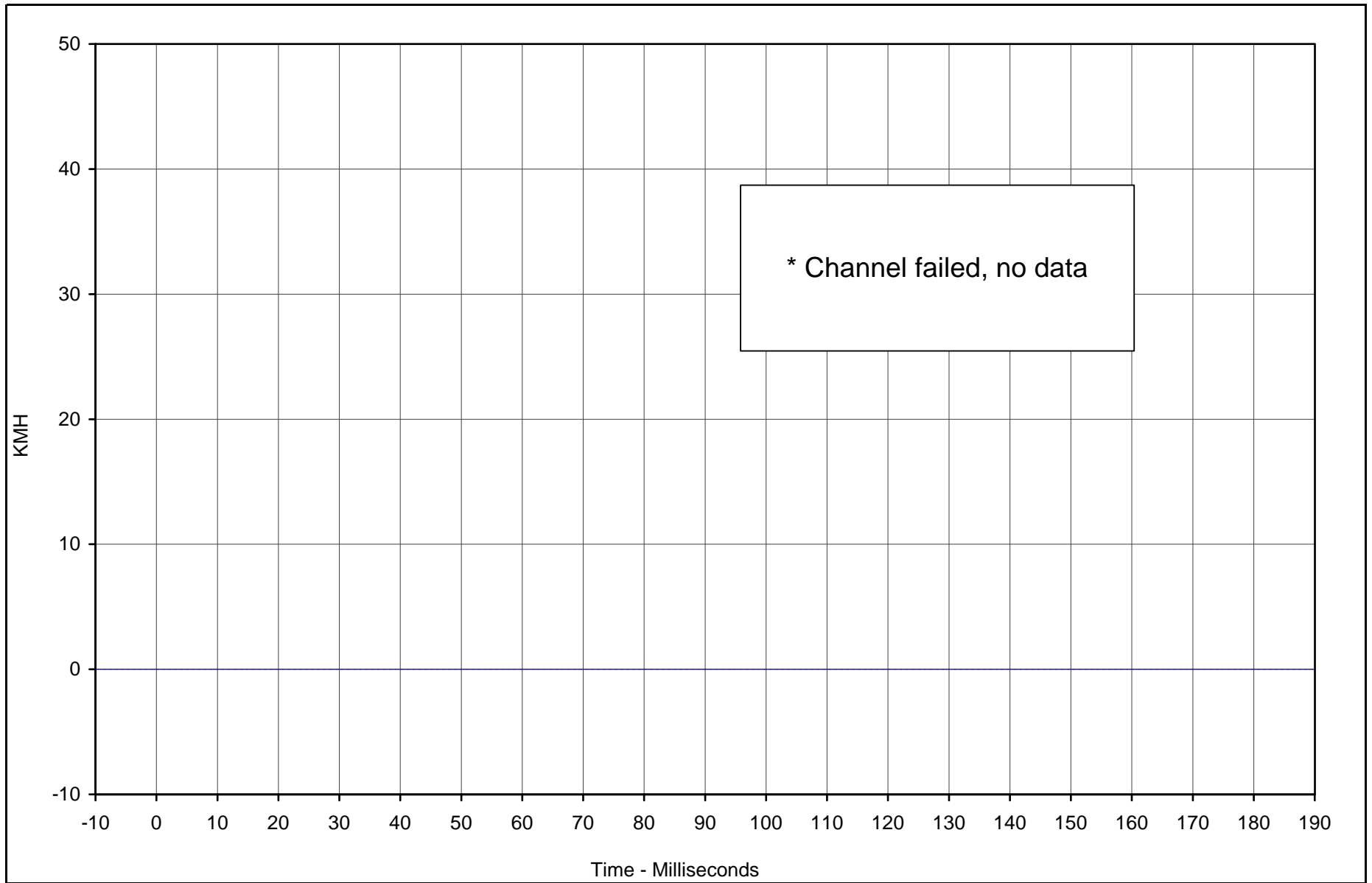

* Channel failed, no data

Curve Description	CURNO	Type	Units	Max	Time	Min	Time	SAE Class
Left Front Door CL Y Velocity	056	IN1	KMH	0.0	0.0	0.0	0.0	180



Test Vehicle: 2003 Subaru Forester 2.5X AWD Wagon

Test Date: 10/29/02

Test Program: 55/28 km/h Side Impact NCAP

NHTSA No.: M35500

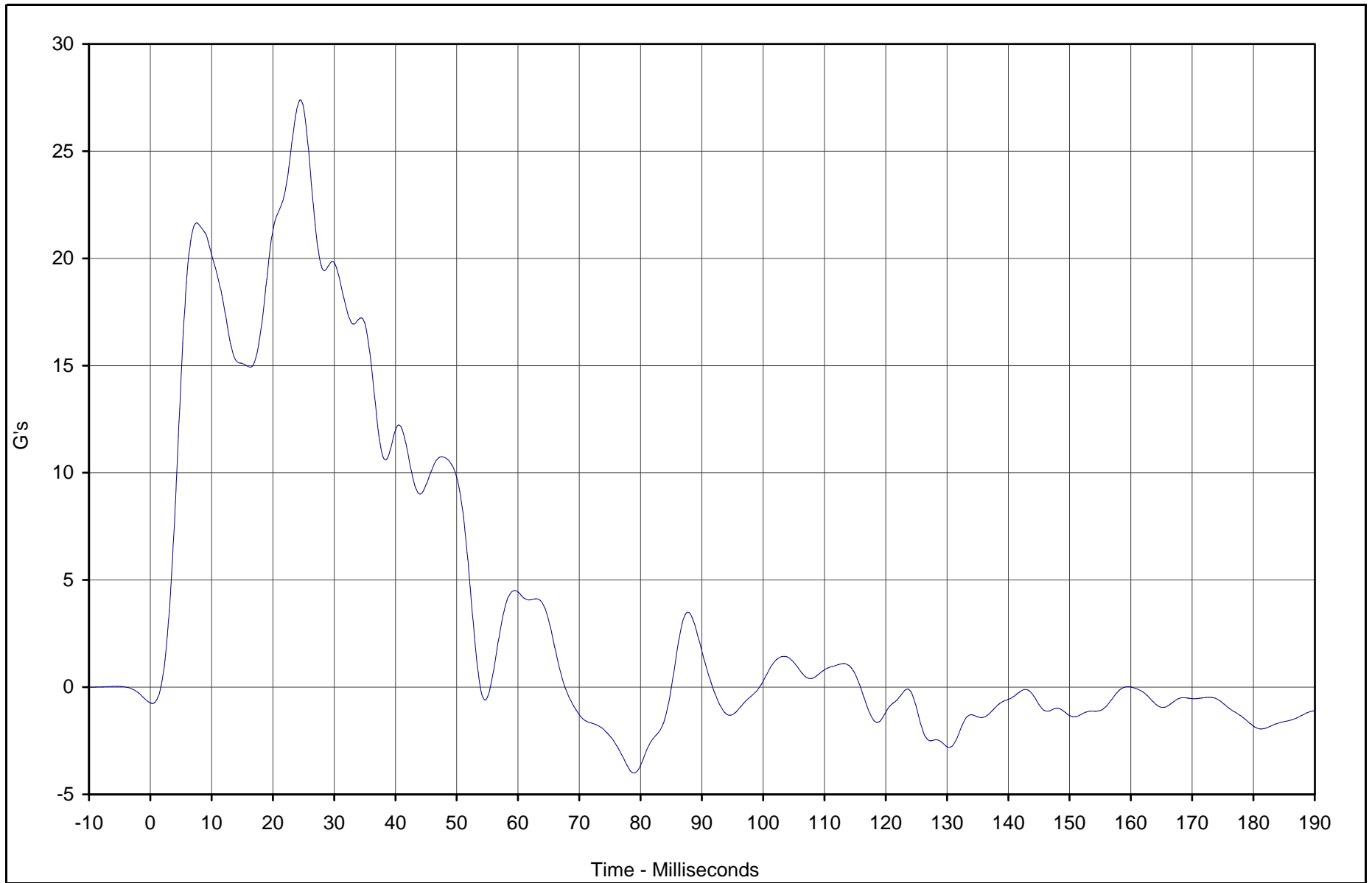

Curve Description	CURNO	Type	Units	Max	Time	Min	Time	SAE Class
Right Rear Occ. Comp. Y	057	FIL	G's	27.4	24.5	-4.0	78.9	60



Test Vehicle: 2003 Subaru Forester 2.5X AWD Wagon

Test Date: 10/29/02

Test Program: 55/28 km/h Side Impact NCAP

NHTSA No.: M35500

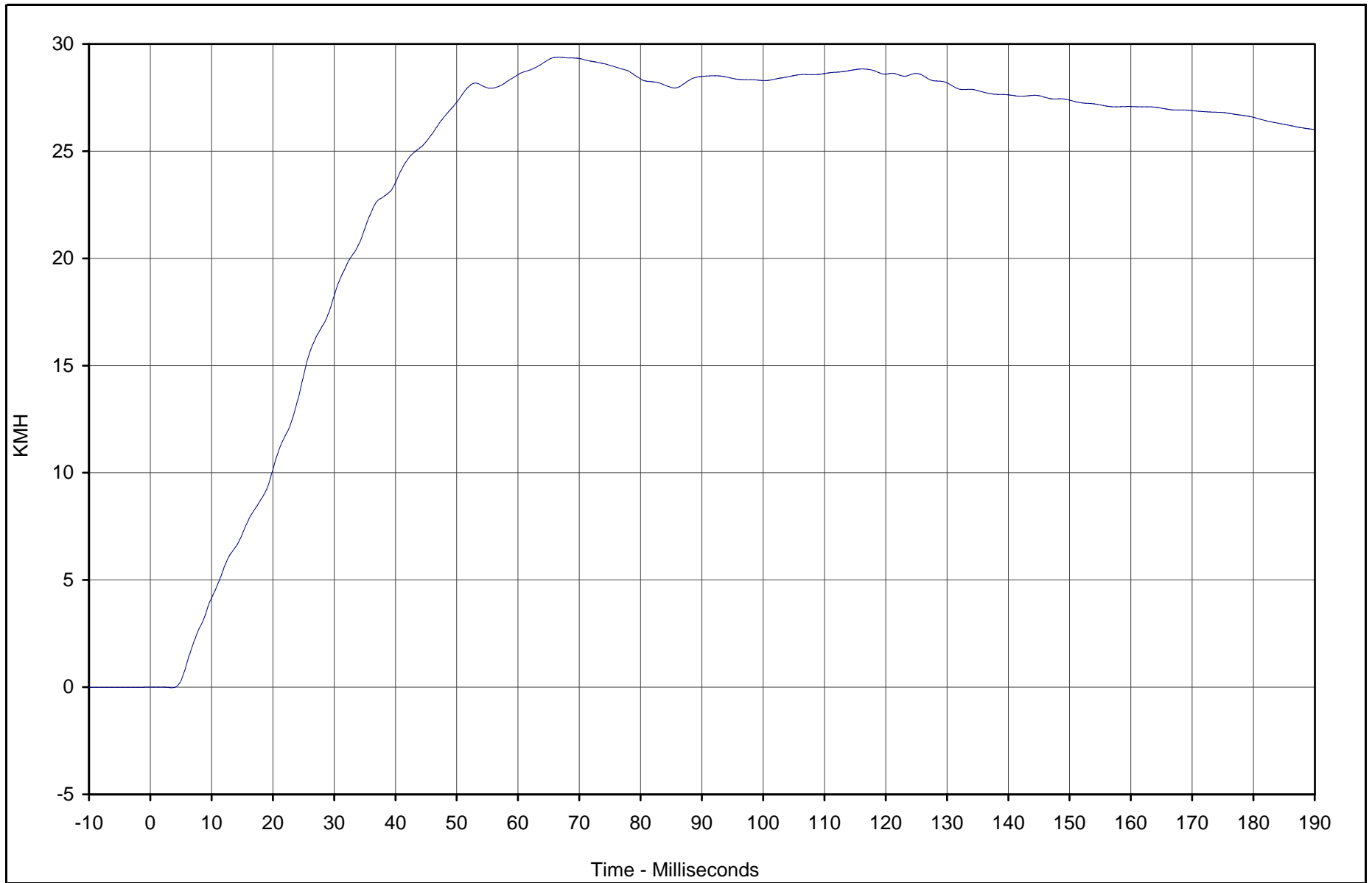

Curve Description	CURNO	Type	Units	Max	Time	Min	Time	SAE Class
Right Rear Occ. Comp. Y Velocity	057	IN1	KMH	29.4	66.6	0.0	3.6	180



Test Vehicle: 2003 Subaru Forester 2.5X AWD Wagon

Test Date: 10/29/02

Test Program: 55/28 km/h Side Impact NCAP

NHTSA No.: M35500

B-110

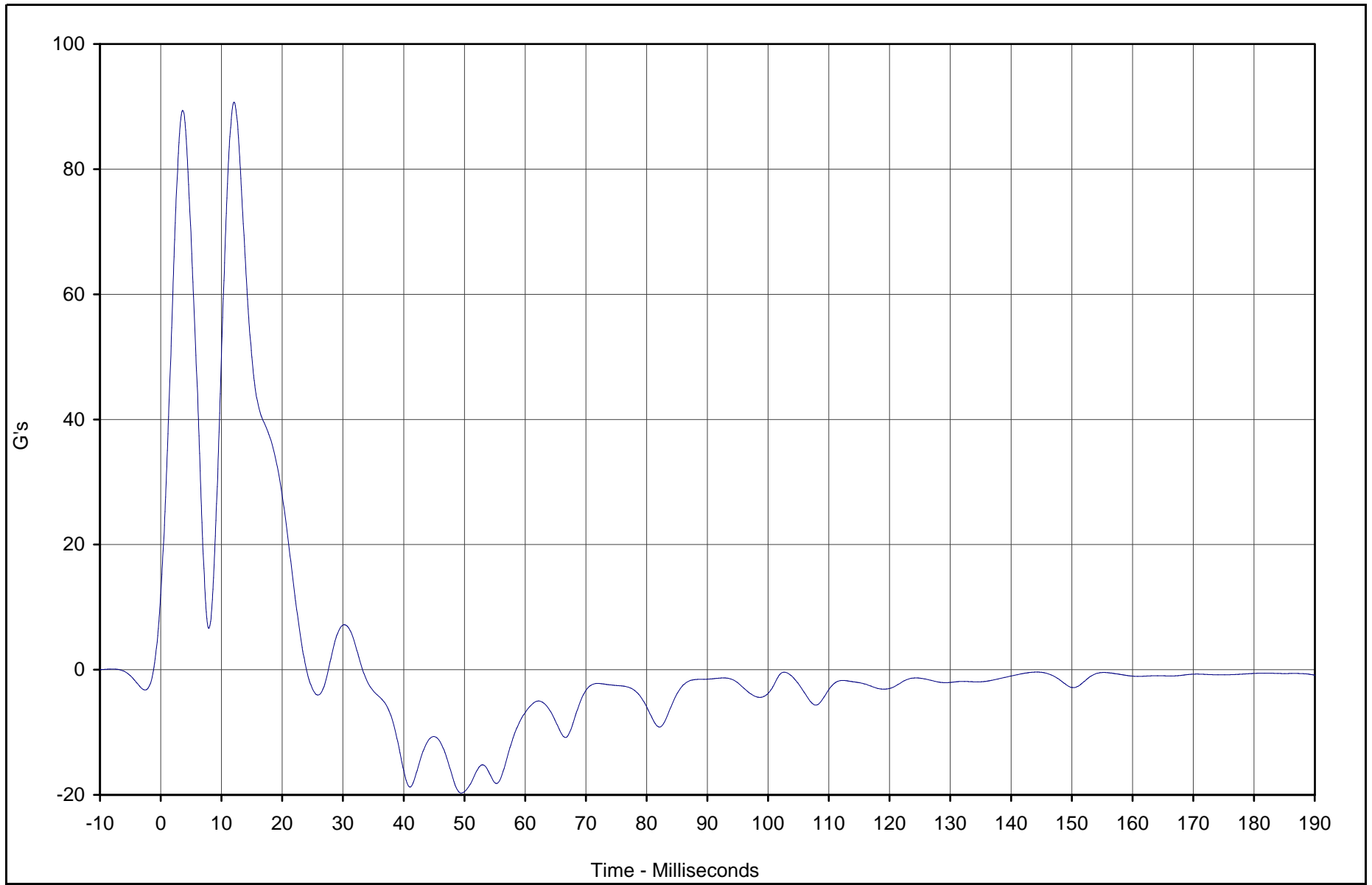

Curve Description	CURNO	Type	Units	Max	Time	Min	Time	SAE Class
Left Front Door Mid-Rear Y	058	FIL	G's	90.7	12.1	-19.7	49.5	60



Test Vehicle: 2003 Subaru Forester 2.5X AWD Wagon

Test Date: 10/29/02

Test Program: 55/28 km/h Side Impact NCAP

NHTSA No.: M35500

TR-P23003-01-NC

B-111

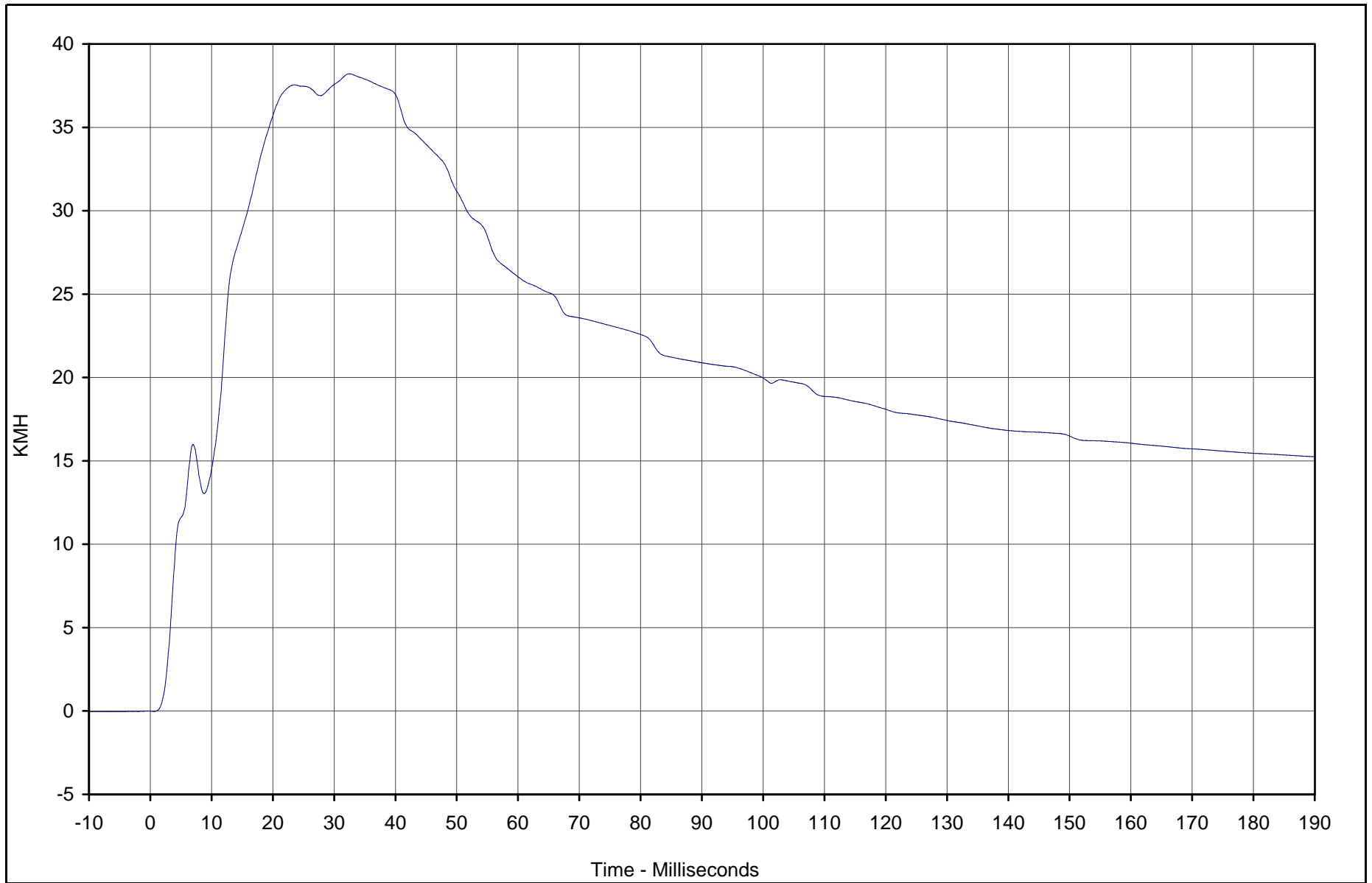

TR-P23003-01-NC

Curve Description	CURNO	Type	Units	Max	Time	Min	Time	SAE Class
Left Front Door Mid-Rear Y Velocity	058	IN1	KMH	38.2	32.5	0.0	0.6	180



Test Vehicle: 2003 Subaru Forester 2.5X AWD Wagon

Test Date: 10/29/02

Test Program: 55/28 km/h Side Impact NCAP

NHTSA No.: M35500

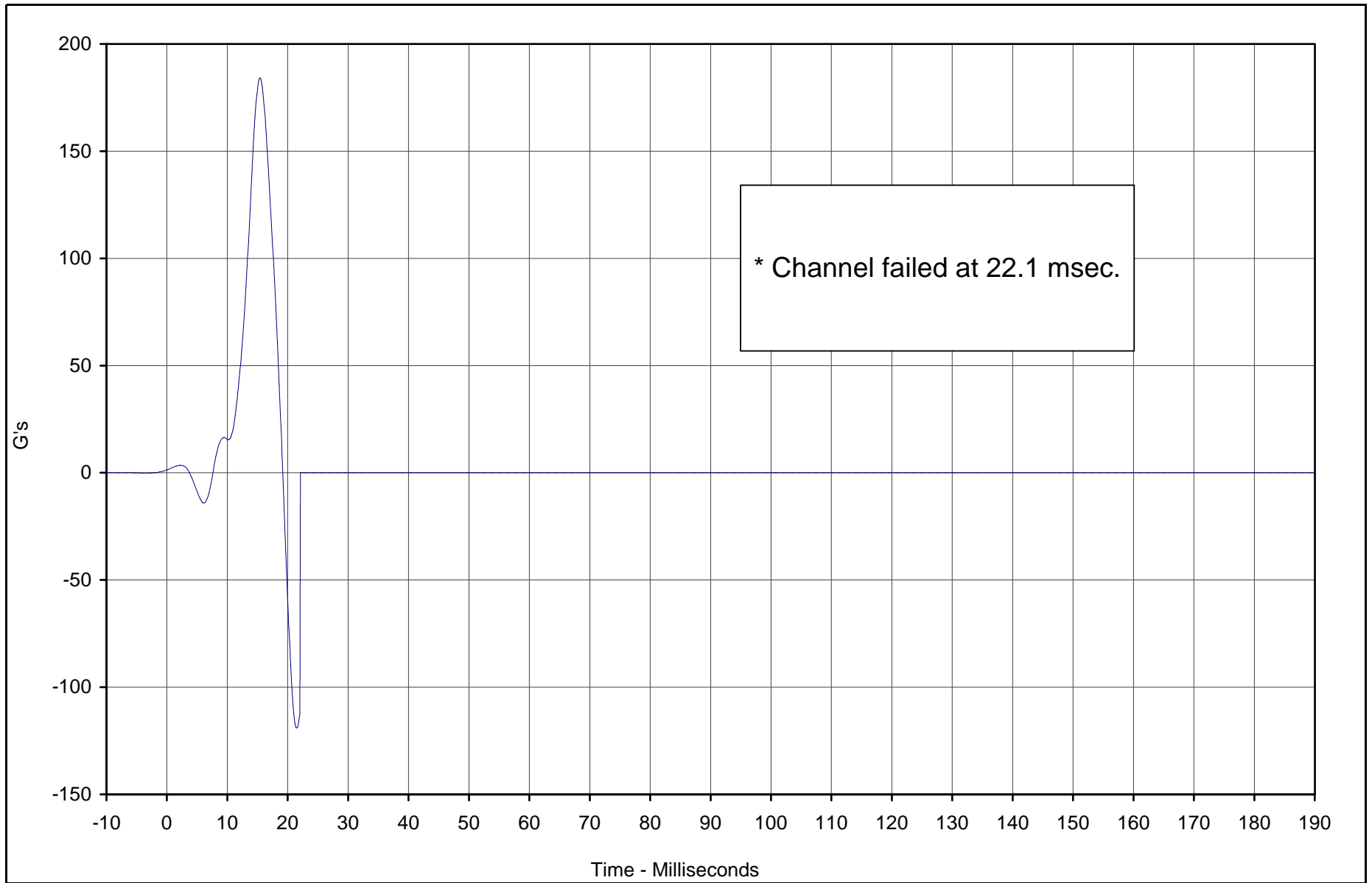

* Channel failed at 22.1 msec.

Curve Description	CURNO	Type	Units	Max	Time	Min	Time	SAE Class
Left Front Door Upper CL Y	059	FIL	G's	184.2	15.4	-119.1	21.5	60



Test Vehicle: 2003 Subaru Forester 2.5X AWD Wagon

Test Date: 10/29/02

Test Program: 55/28 km/h Side Impact NCAP

NHTSA No.: M35500

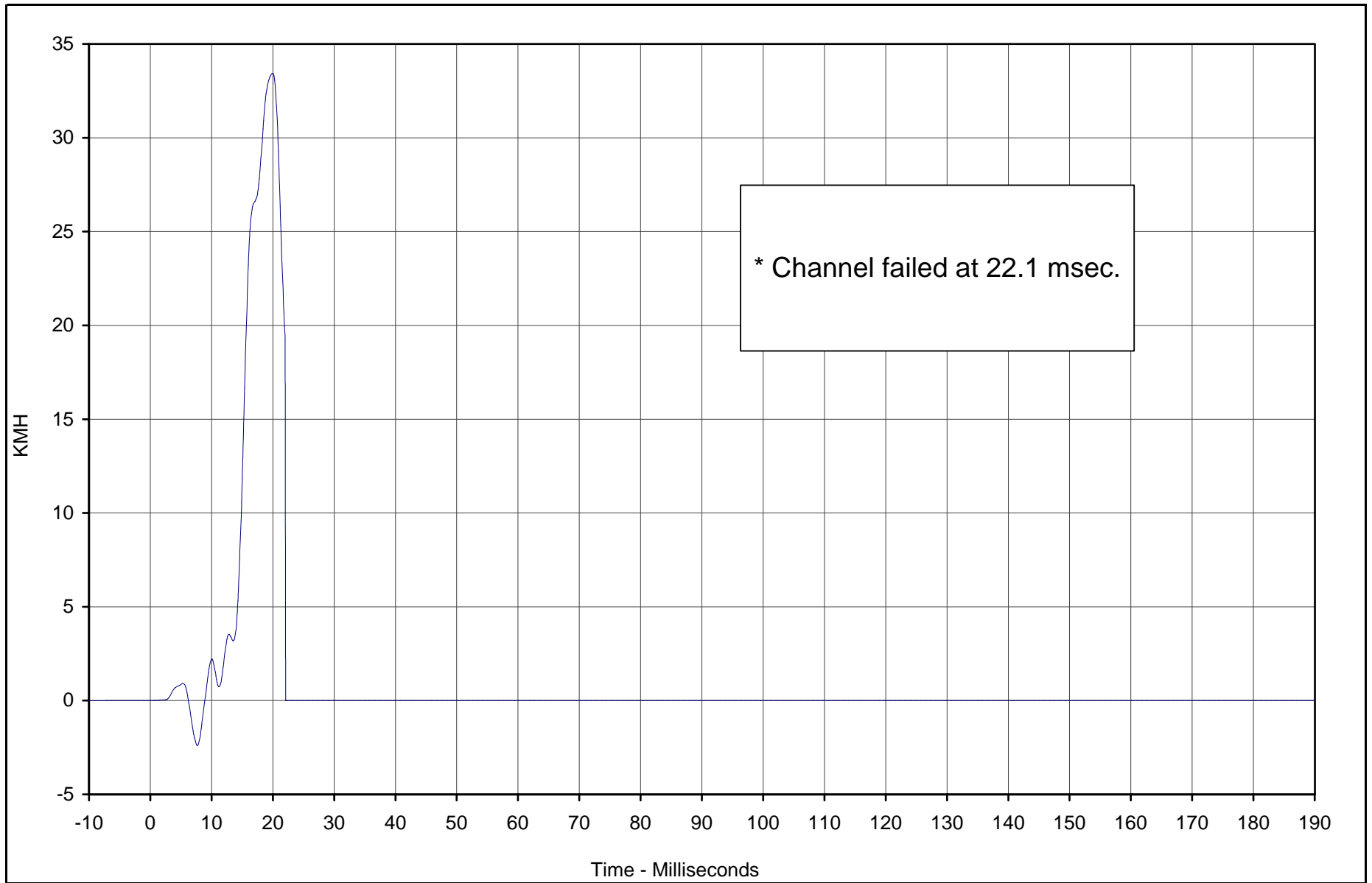

* Channel failed at 22.1 msec.

Curve Description	CURNO	Type	Units	Max	Time	Min	Time	SAE Class
Left Front Door Upper CL Y Velocity	059	IN1	KMH	33.4	20.0	-2.4	7.7	180



Test Vehicle: 2003 Subaru Forester 2.5X AWD Wagon

Test Date: 10/29/02

Test Program: 55/28 km/h Side Impact NCAP

NHTSA No.: M35500

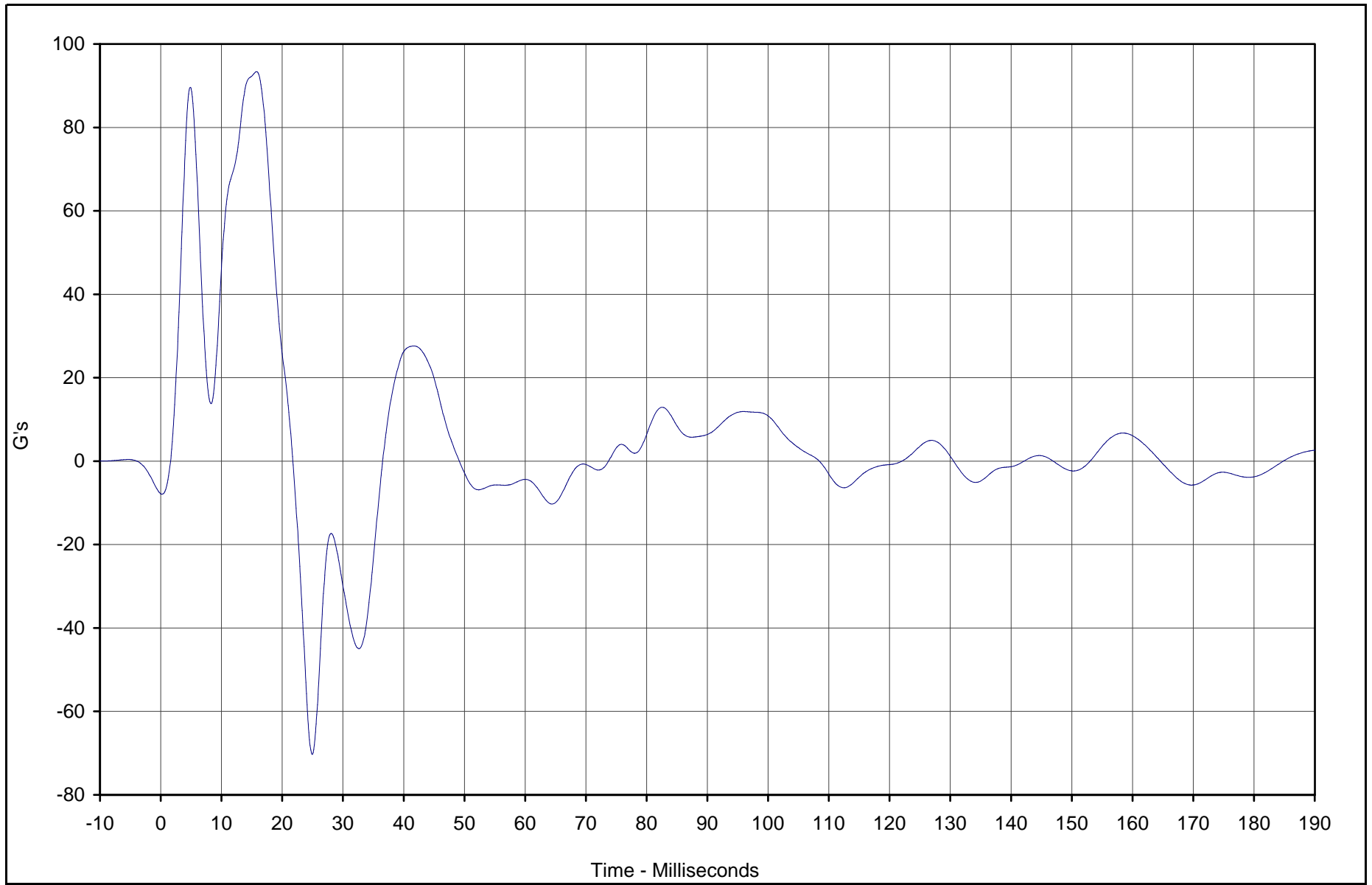

Curve Description	CURNO	Type	Units	Max	Time	Min	Time	SAE Class
Left Rear Door Mid-Rear Y	060	FIL	G's	93.4	15.8	-70.3	24.9	60



Test Vehicle: 2003 Subaru Forester 2.5X AWD Wagon

Test Date: 10/29/02

Test Program: 55/28 km/h Side Impact NCAP

NHTSA No.: M35500

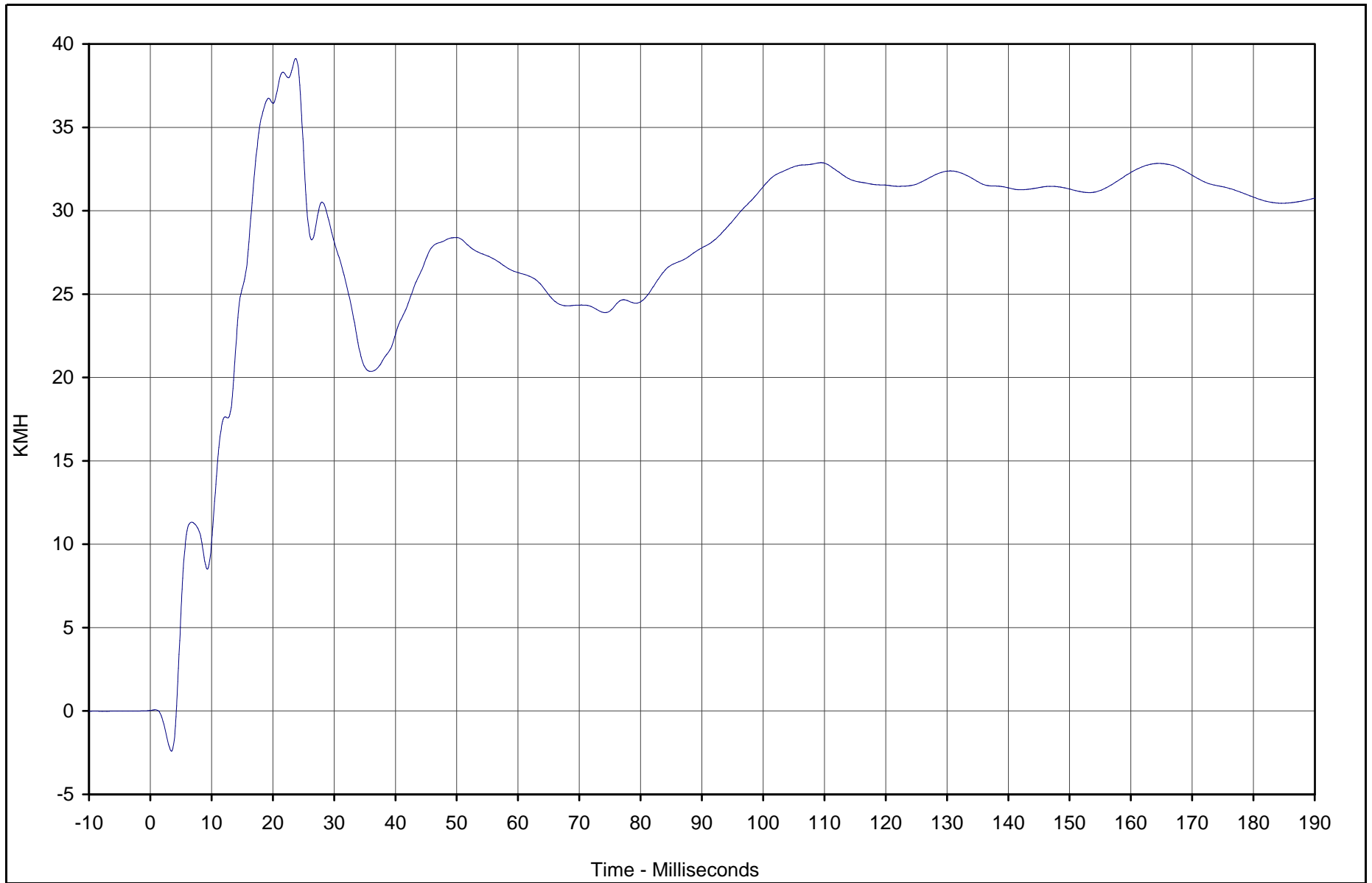

Curve Description	CURNO	Type	Units	Max	Time	Min	Time	SAE Class
Left Rear Door Mid-Rear Y Velocity	060	IN1	KMH	39.1	23.7	-2.4	3.5	180



Test Vehicle: 2003 Subaru Forester 2.5X AWD Wagon

Test Date: 10/29/02

Test Program: 55/28 km/h Side Impact NCAP

NHTSA No.: M35500

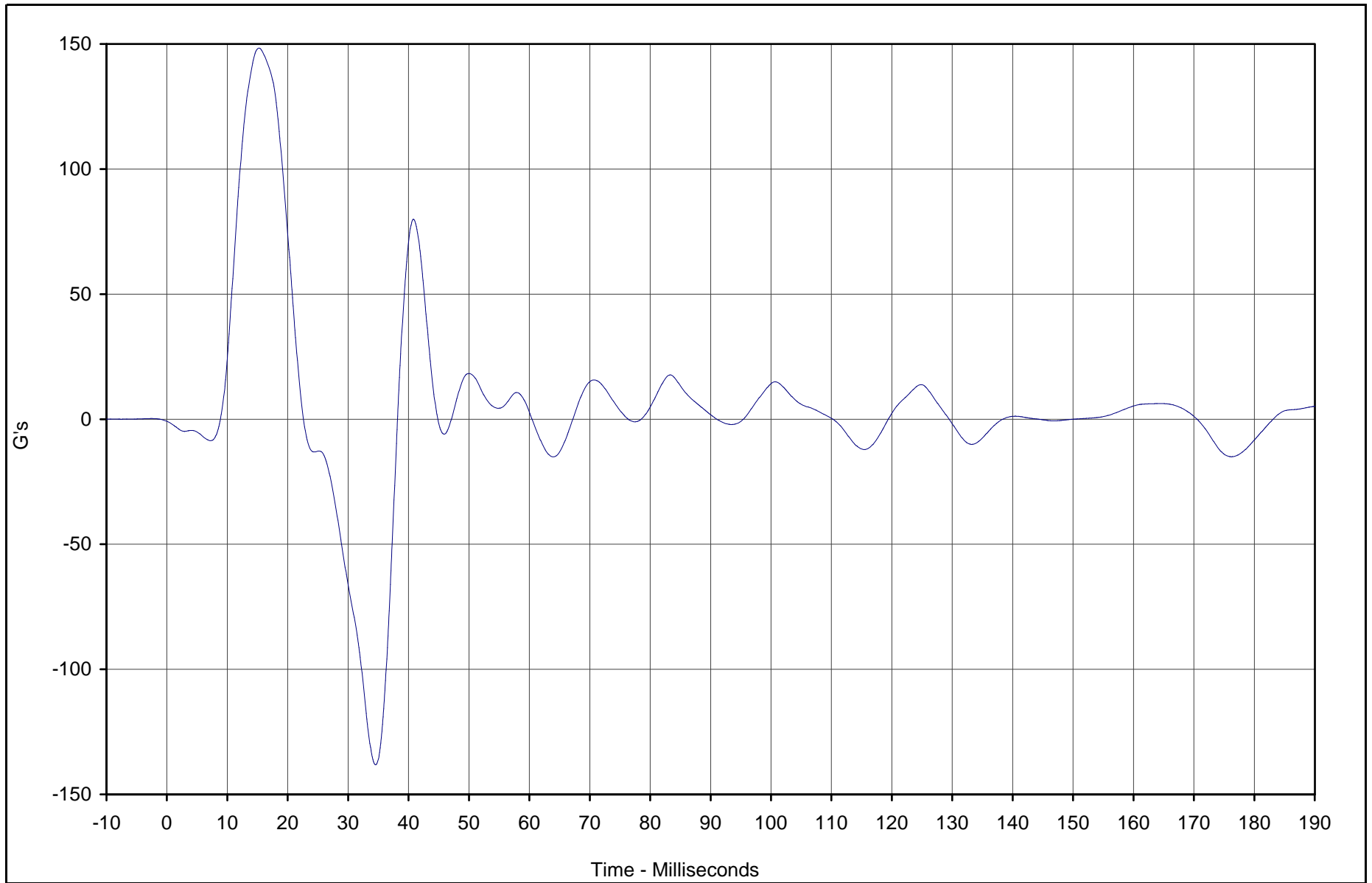

Curve Description	CURNO	Type	Units	Max	Time	Min	Time	SAE Class
Left Rear Door Upper CL Y	061	FIL	G's	148.4	15.2	-138.2	34.6	60



Test Vehicle: 2003 Subaru Forester 2.5X AWD Wagon

Test Date: 10/29/02

Test Program: 55/28 km/h Side Impact NCAP

NHTSA No.: M35500

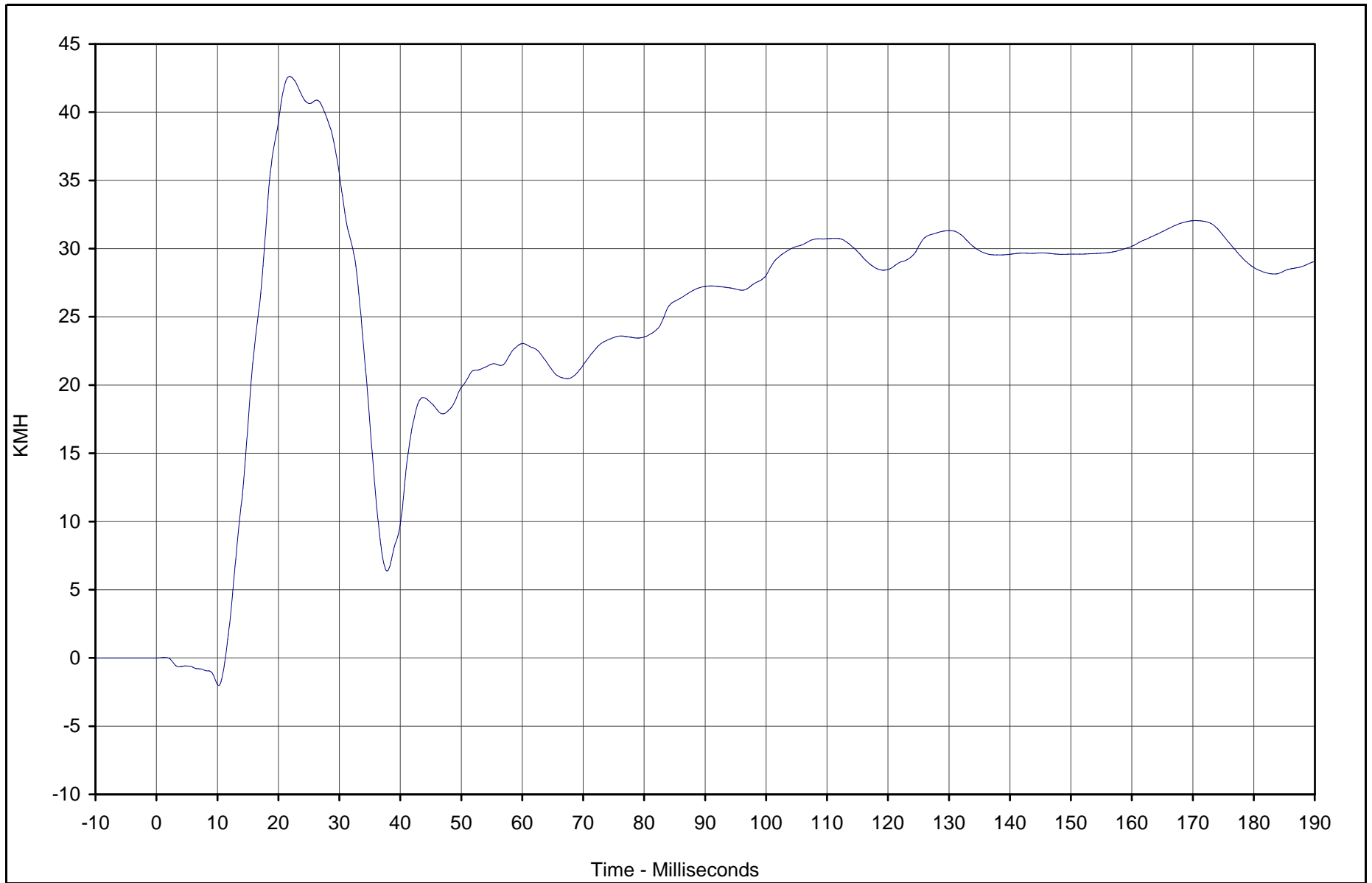

Curve Description	CURNO	Type	Units	Max	Time	Min	Time	SAE Class
Left Rear Door Upper CL Y Velocity	061	IN1	KMH	42.6	21.9	-2.0	10.2	180



Test Vehicle: 2003 Subaru Forester 2.5X AWD Wagon

Test Date: 10/29/02

Test Program: 55/28 km/h Side Impact NCAP

NHTSA No.: M35500

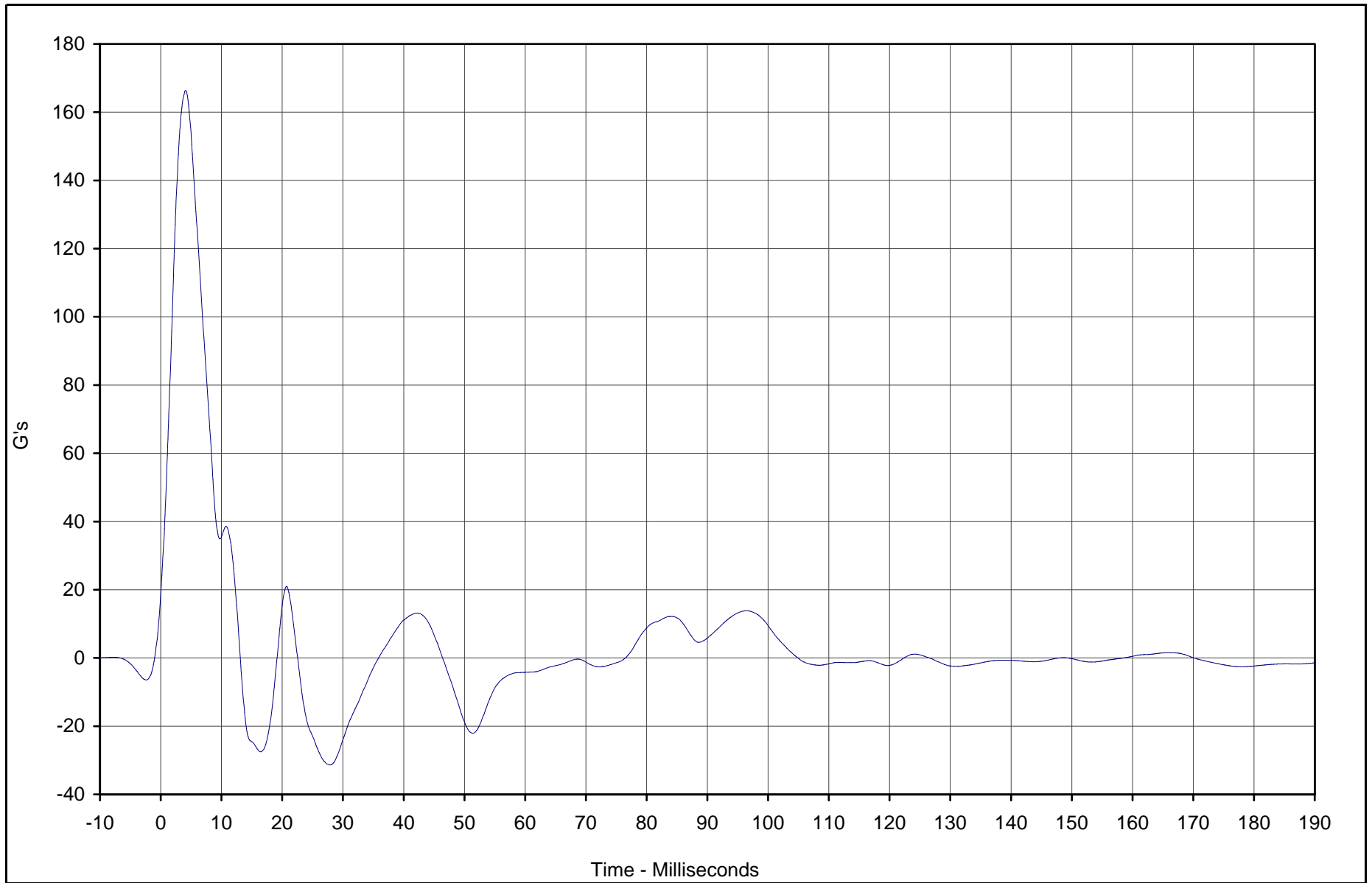

Curve Description	CURNO	Type	Units	Max	Time	Min	Time	SAE Class
B-Post Lower Y	062	FIL	G's	166.4	4.1	-31.3	27.8	60



Test Vehicle: 2003 Subaru Forester 2.5X AWD Wagon

Test Date: 10/29/02

Test Program: 55/28 km/h Side Impact NCAP

NHTSA No.: M35500

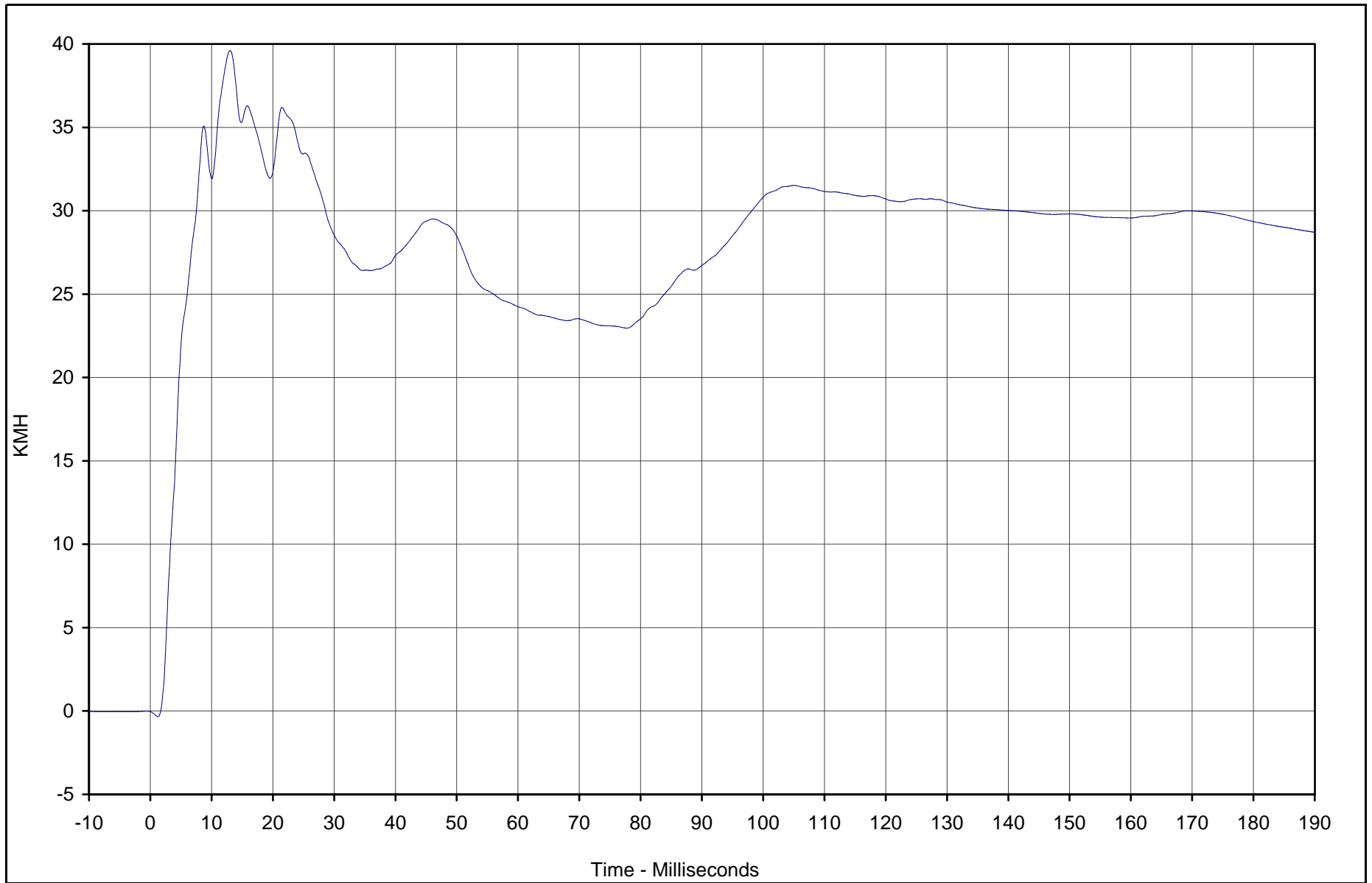

Curve Description	CURNO	Type	Units	Max	Time	Min	Time	SAE Class
B-Post Lower Y Velocity	062	IN1	KMH	39.6	13.0	-0.3	1.2	180



Test Vehicle: 2003 Subaru Forester 2.5X AWD Wagon

Test Date: 10/29/02

Test Program: 55/28 km/h Side Impact NCAP

NHTSA No.: M35500

B-120

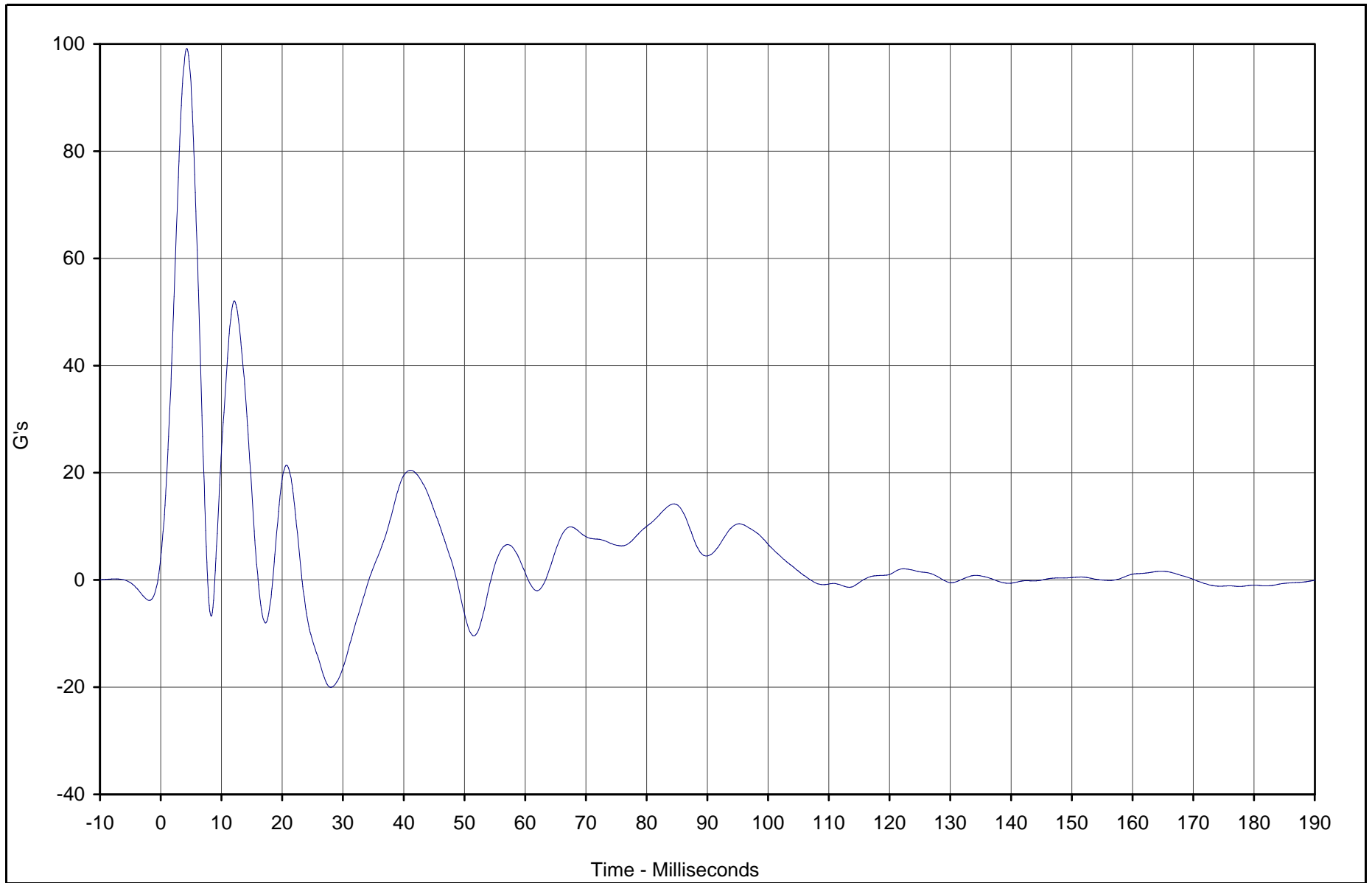

TR-P23003-01-NC

Curve Description	CURNO	Type	Units	Max	Time	Min	Time	SAE Class
B-Post Middle Y	063	FIL	G's	99.2	4.3	-20.0	28.0	60



Test Vehicle: 2003 Subaru Forester 2.5X AWD Wagon

Test Date: 10/29/02

Test Program: 55/28 km/h Side Impact NCAP

NHTSA No.: M35500

B-121

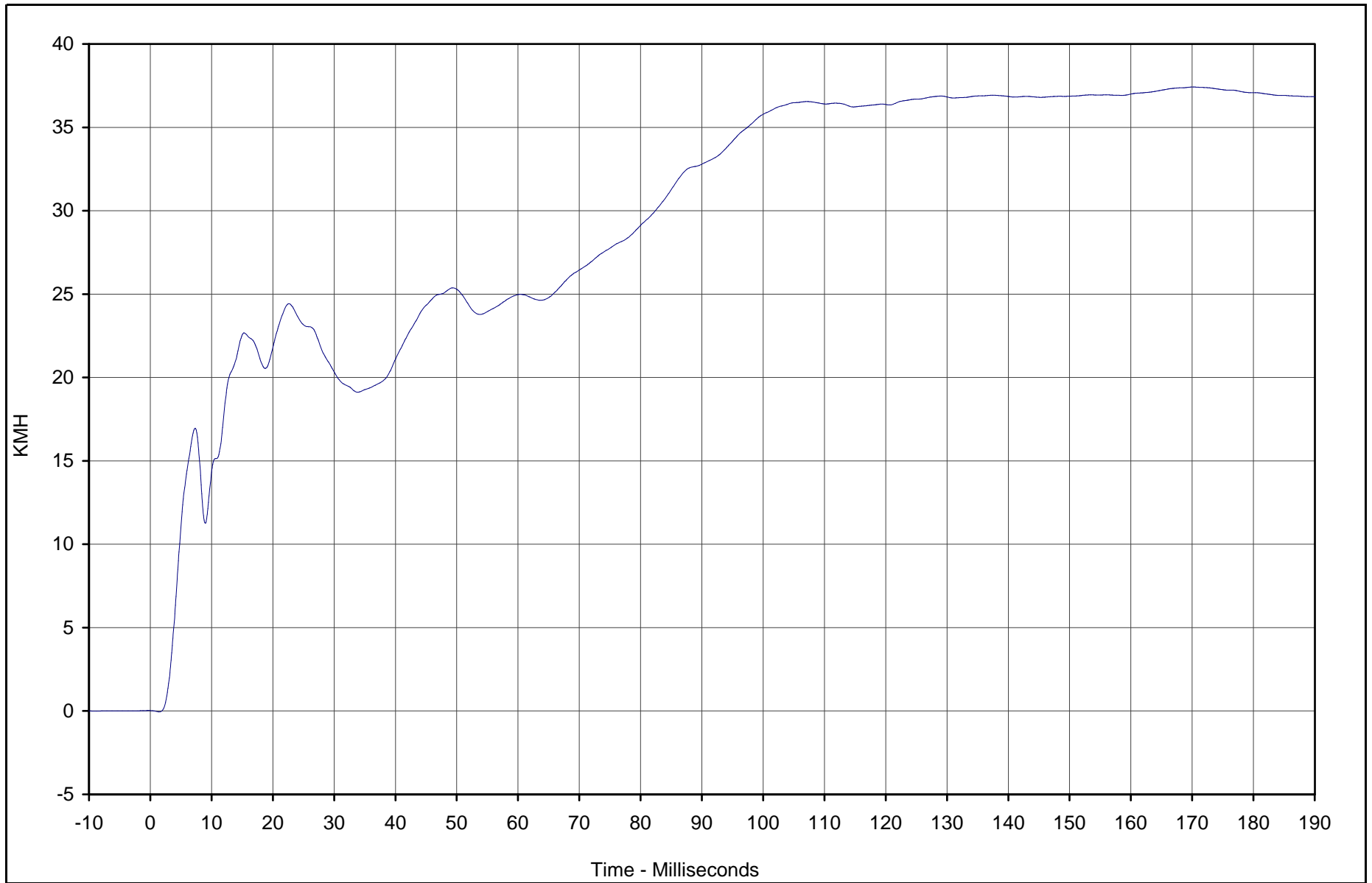

TR-P23003-01-NC

Curve Description	CURNO	Type	Units	Max	Time	Min	Time	SAE Class
B-Post Middle Y Velocity	063	IN1	KMH	37.4	170.1	-0.1	1.5	180



Test Vehicle: 2003 Subaru Forester 2.5X AWD Wagon

Test Date: 10/29/02

Test Program: 55/28 km/h Side Impact NCAP

NHTSA No.: M35500

B-122

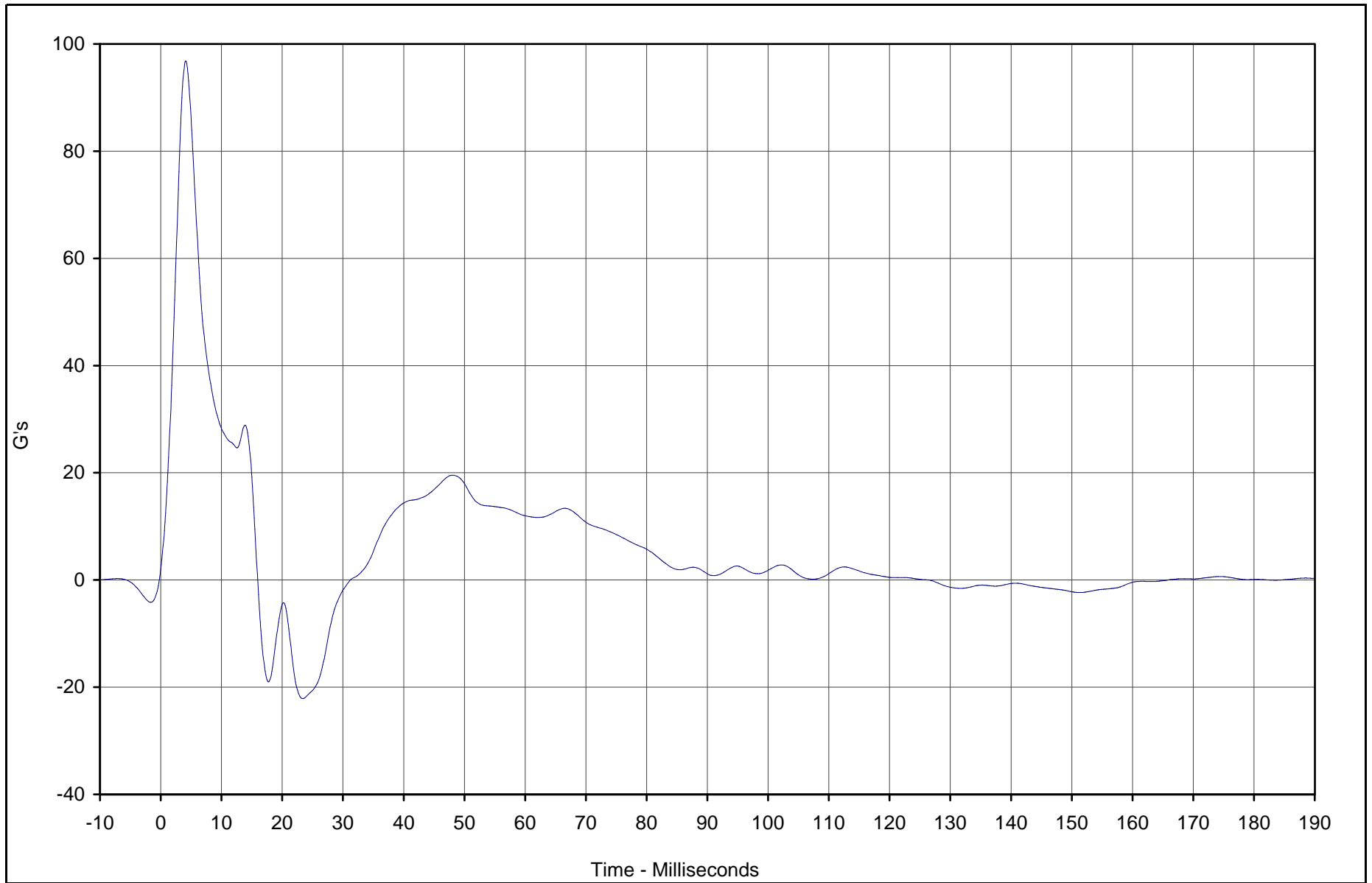

TR-P23003-01-NC

Curve Description	CURNO	Type	Units	Max	Time	Min	Time	SAE Class
A-Post Lower Y	064	FIL	G's	96.9	4.1	-22.1	23.4	60



Test Vehicle: 2003 Subaru Forester 2.5X AWD Wagon

Test Date: 10/29/02

Test Program: 55/28 km/h Side Impact NCAP

NHTSA No.: M35500

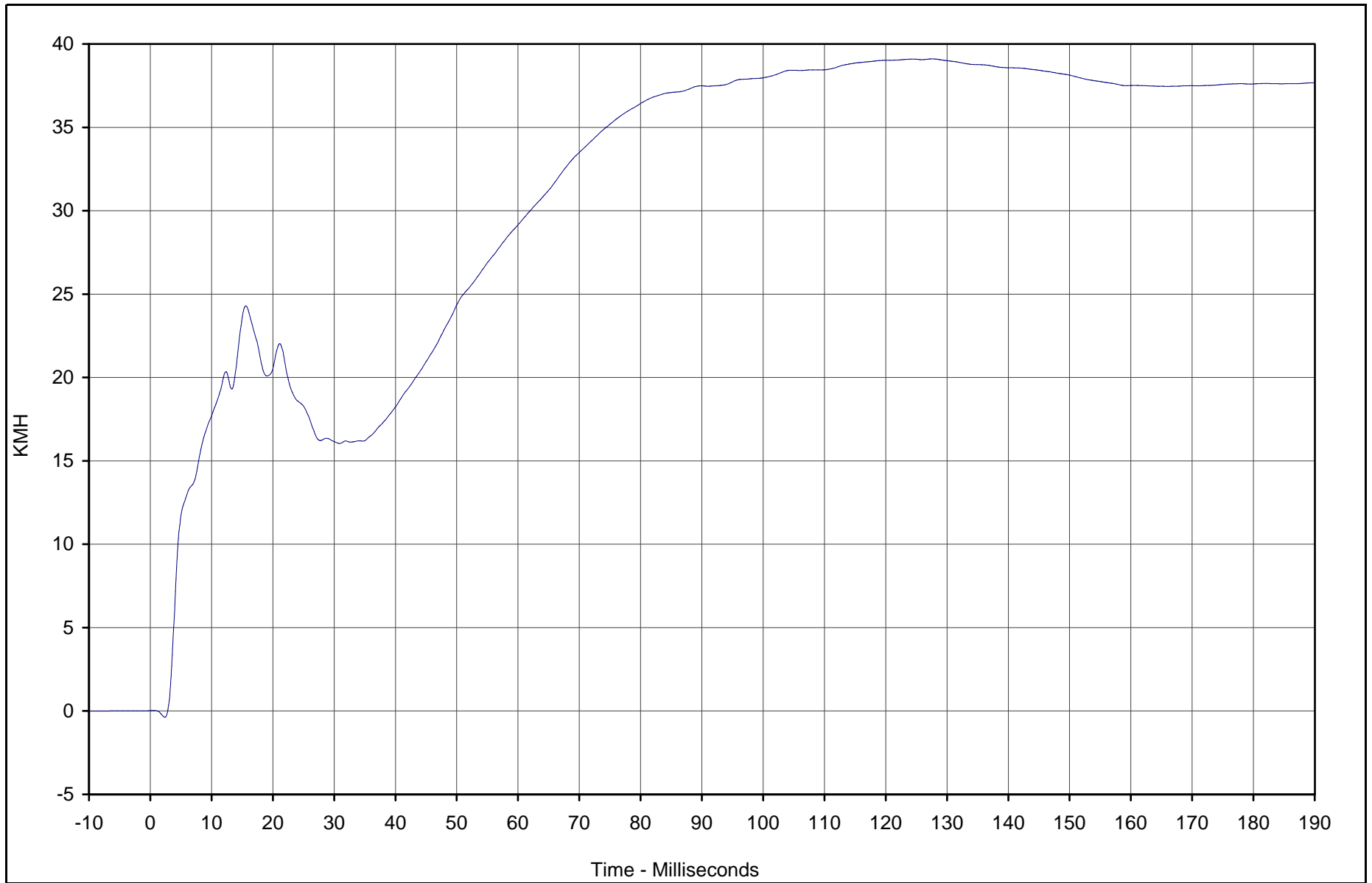

Curve Description	CURNO	Type	Units	Max	Time	Min	Time	SAE Class
A-Post Lower Y Velocity	064	IN1	KMH	39.1	127.6	-0.4	2.4	180



Test Vehicle: 2003 Subaru Forester 2.5X AWD Wagon

Test Date: 10/29/02

Test Program: 55/28 km/h Side Impact NCAP

NHTSA No.: M35500

B-124

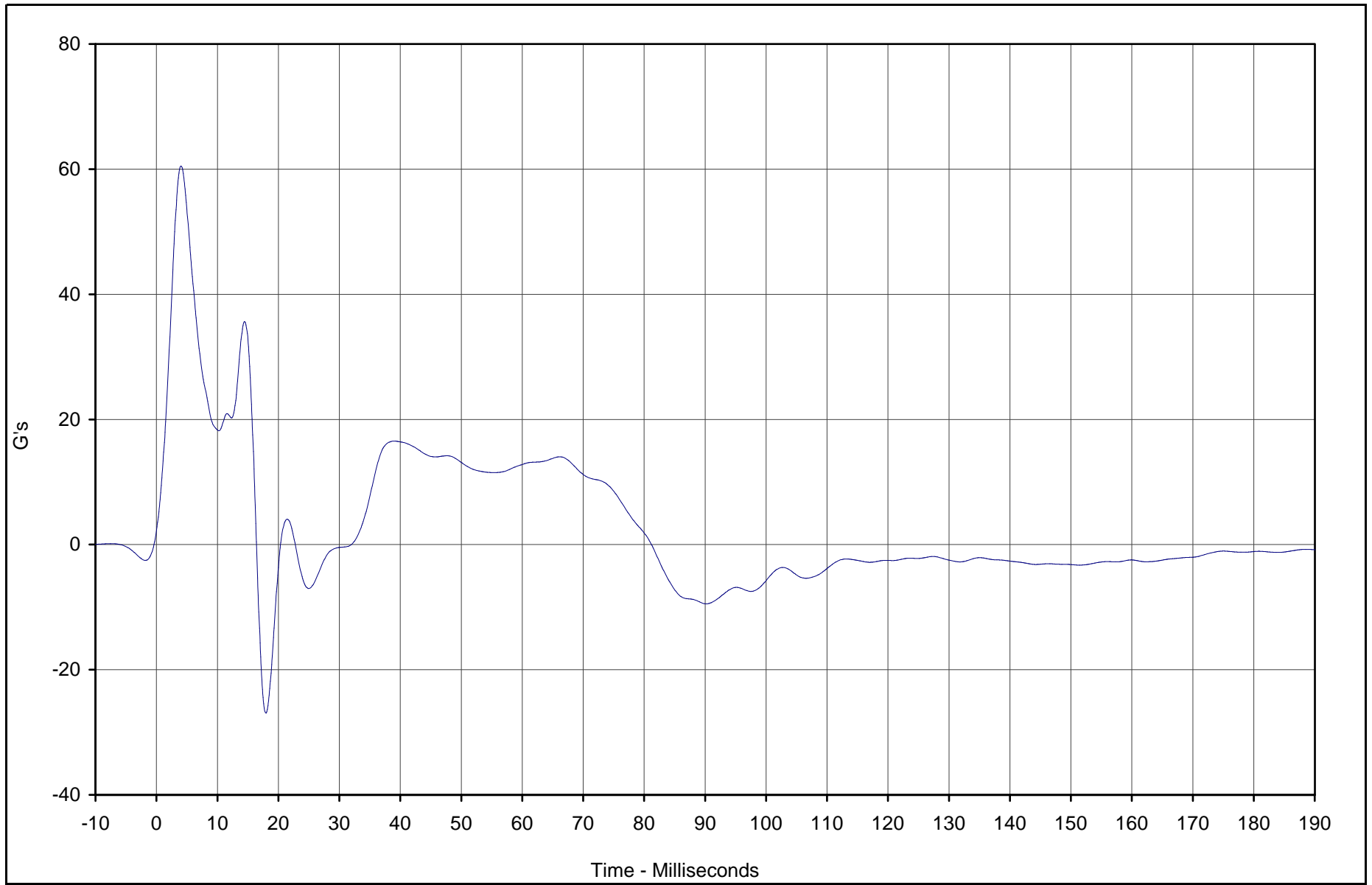

Curve Description	CURNO	Type	Units	Max	Time	Min	Time	SAE Class
A-Post Middle Y	065	FIL	G's	60.5	4.0	-26.9	18.0	60



Test Vehicle: 2003 Subaru Forester 2.5X AWD Wagon

Test Date: 10/29/02

Test Program: 55/28 km/h Side Impact NCAP

NHTSA No.: M35500

TR-P23003-01-NC

B-125

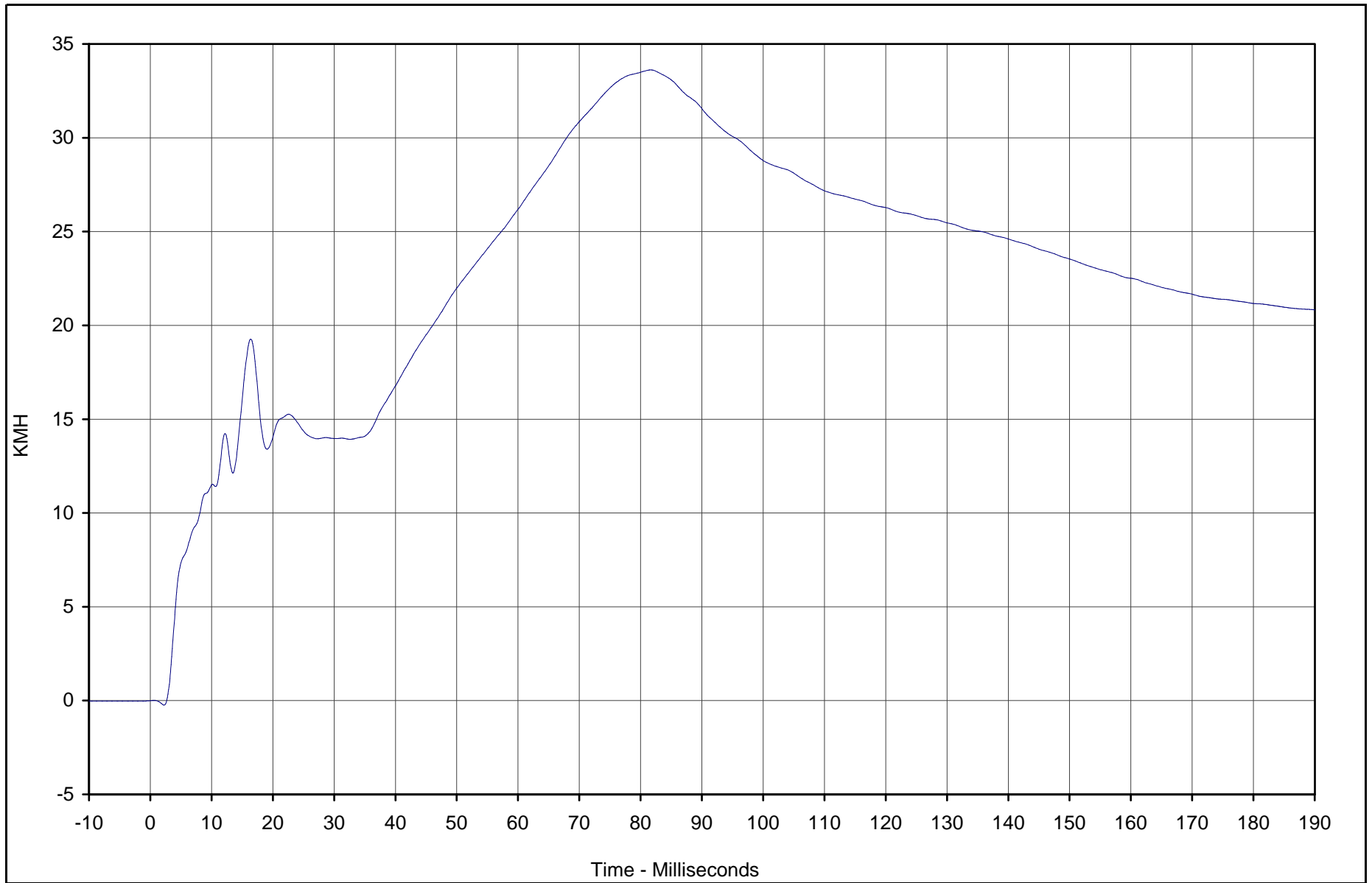

Curve Description	CURNO	Type	Units	Max	Time	Min	Time	SAE Class
A-Post Middle Y Velocity	065	IN1	KMH	33.6	81.6	-0.2	2.2	180



Test Vehicle: 2003 Subaru Forester 2.5X AWD Wagon

Test Date: 10/29/02

Test Program: 55/28 km/h Side Impact NCAP

NHTSA No.: M35500

TR-P23003-01-NC

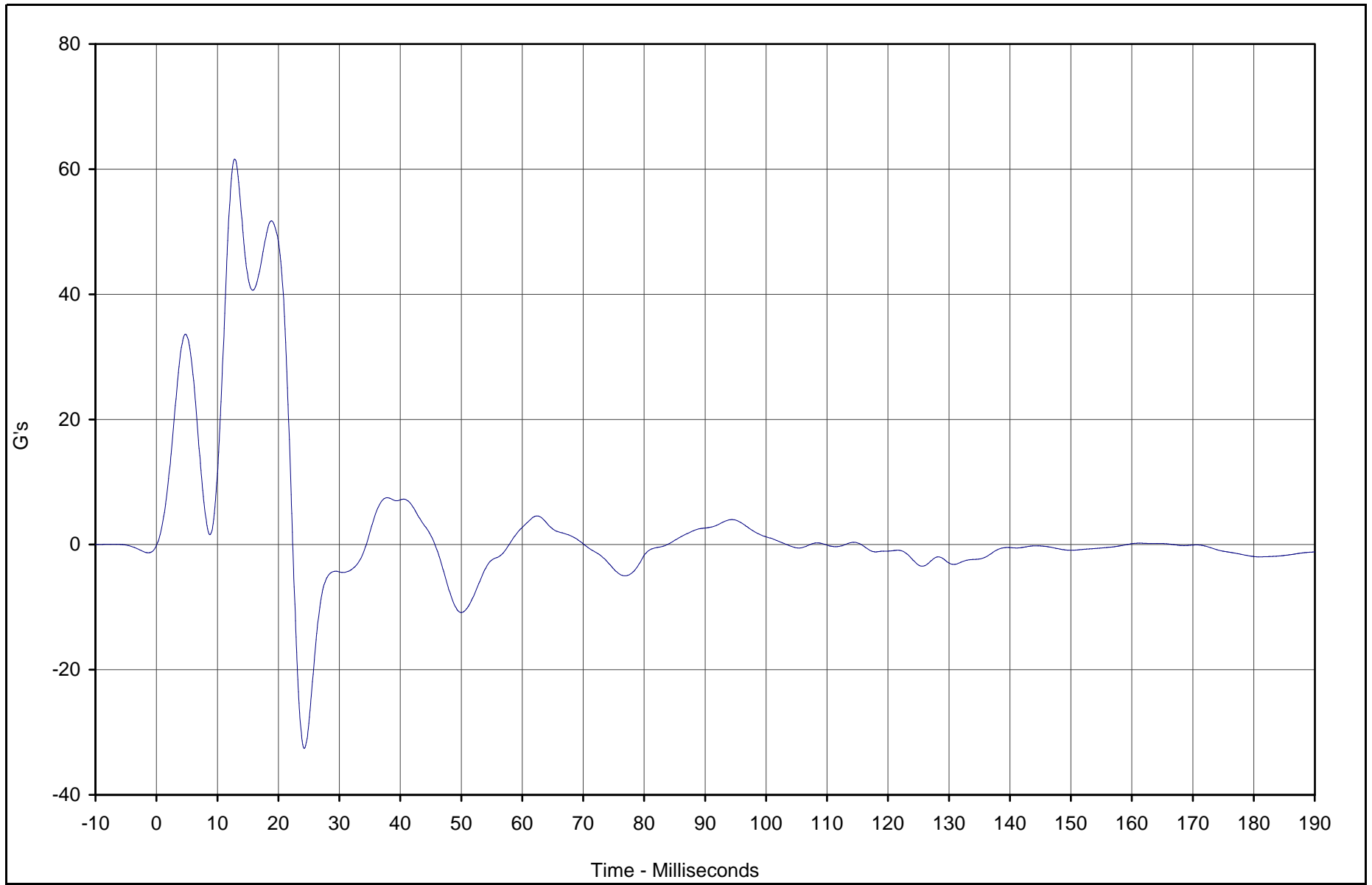

Curve Description	CURNO	Type	Units	Max	Time	Min	Time	SAE Class
Left Front Seat Track Y	066	FIL	G's	61.6	12.8	-32.6	24.3	60



Test Vehicle: 2003 Subaru Forester 2.5X AWD Wagon

Test Date: 10/29/02

Test Program: 55/28 km/h Side Impact NCAP

NHTSA No.: M35500

B-127

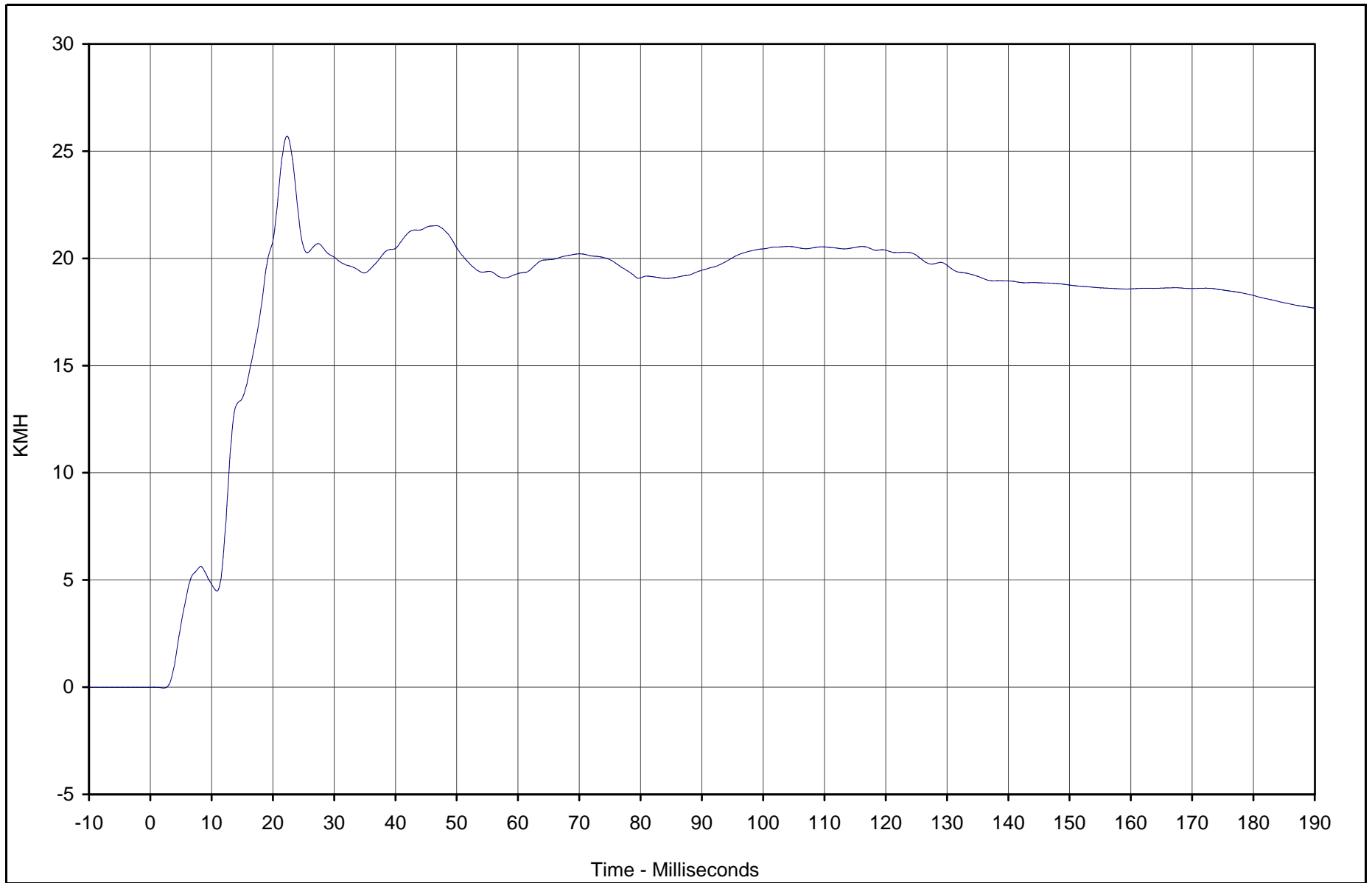

TR-P23003-01-NC

Curve Description	CURNO	Type	Units	Max	Time	Min	Time	SAE Class
Left Front Seat Track Y Velocity	066	IN1	KMH	25.7	22.3	0.0	2.2	180



Test Vehicle: 2003 Subaru Forester 2.5X AWD Wagon

Test Date: 10/29/02

Test Program: 55/28 km/h Side Impact NCAP

NHTSA No.: M35500

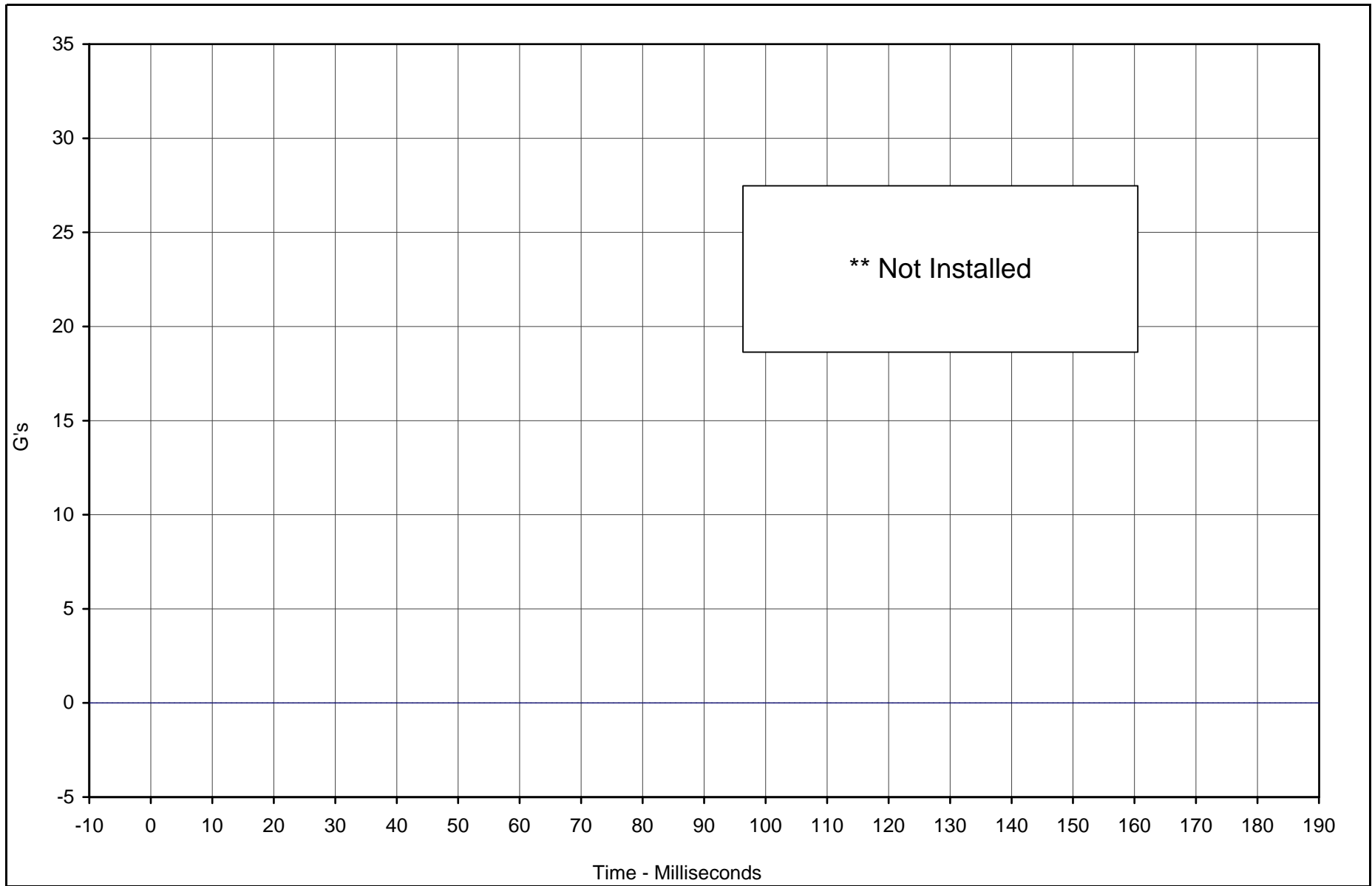

** Not installed

Curve Description	CURNO	Type	Units	Max	Time	Min	Time	SAE Class
Rear Seat Structure Y	067	FIL	G's	0.0	0.0	0.0	0.0	60



Test Vehicle: 2003 Subaru Forester 2.5X AWD Wagon

Test Date: 10/29/02

Test Program: 55/28 km/h Side Impact NCAP

NHTSA No.: M35500

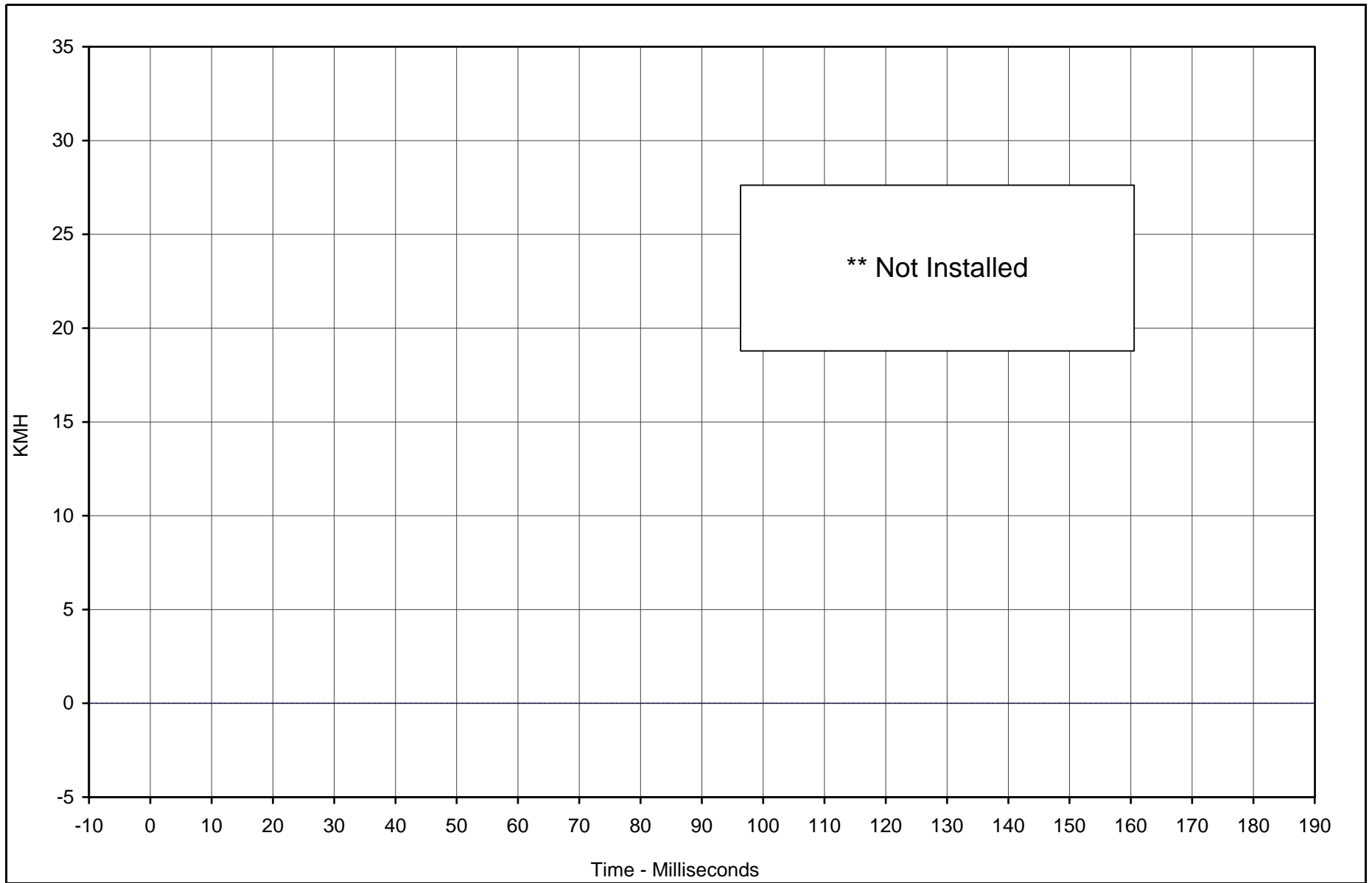

** Not installed

Curve Description	CURNO	Type	Units	Max	Time	Min	Time	SAE Class
Rear Seat Structure Y Velocity	067	IN1	KMH	0.0	0.0	0.0	0.0	180



Test Vehicle: 2003 Subaru Forester 2.5X AWD Wagon

Test Date: 10/29/02

Test Program: 55/28 km/h Side Impact NCAP

NHTSA No.: M35500

B-130

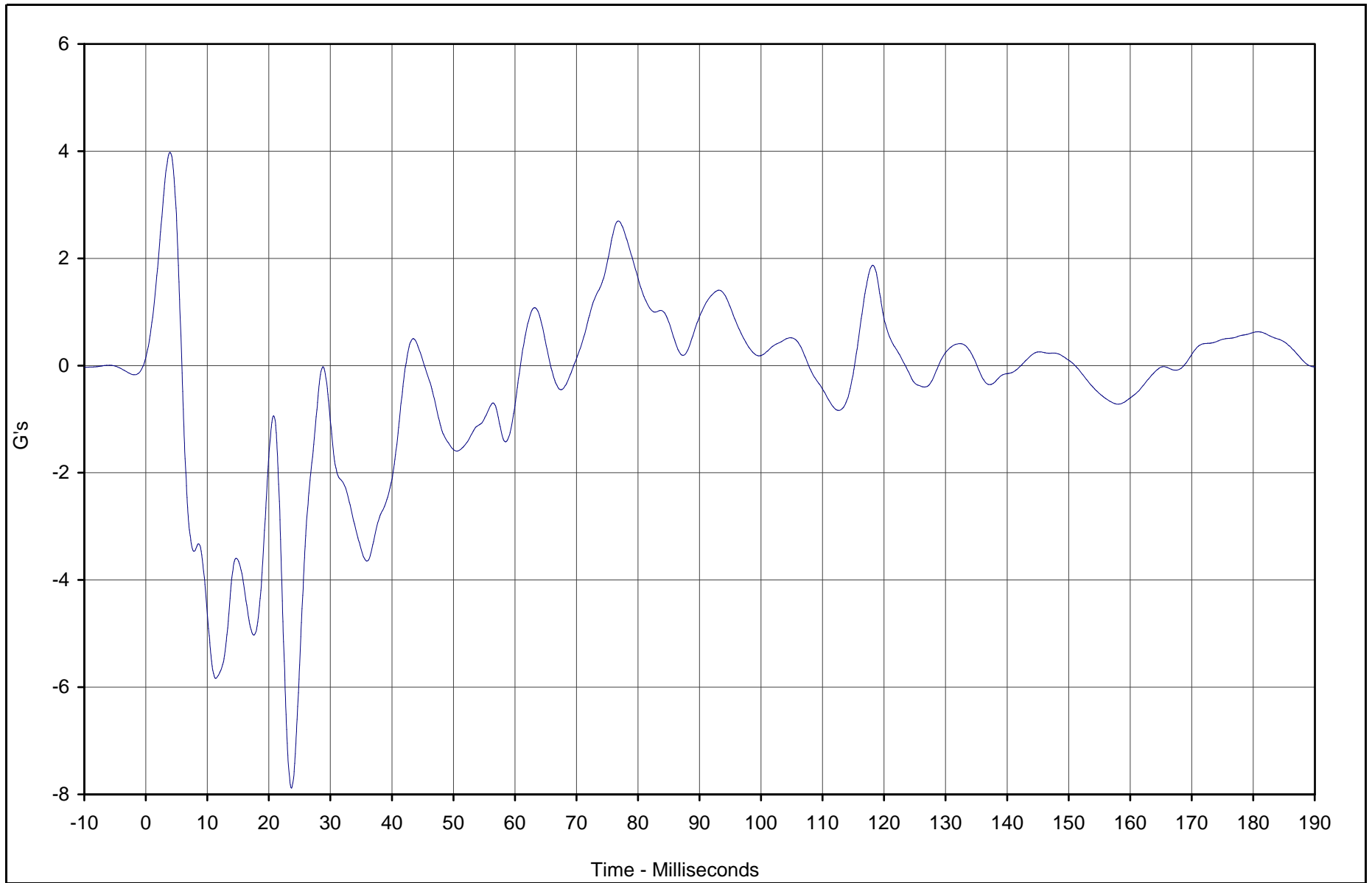

TR-P23003-01-NC

Curve Description	CURNO	Type	Units	Max	Time	Min	Time	SAE Class
Vehicle CG X	068	FIL	G's	4.0	3.9	-7.9	23.7	60



Test Vehicle: 2003 Subaru Forester 2.5X AWD Wagon

Test Date: 10/29/02

Test Program: 55/28 km/h Side Impact NCAP

NHTSA No.: M35500

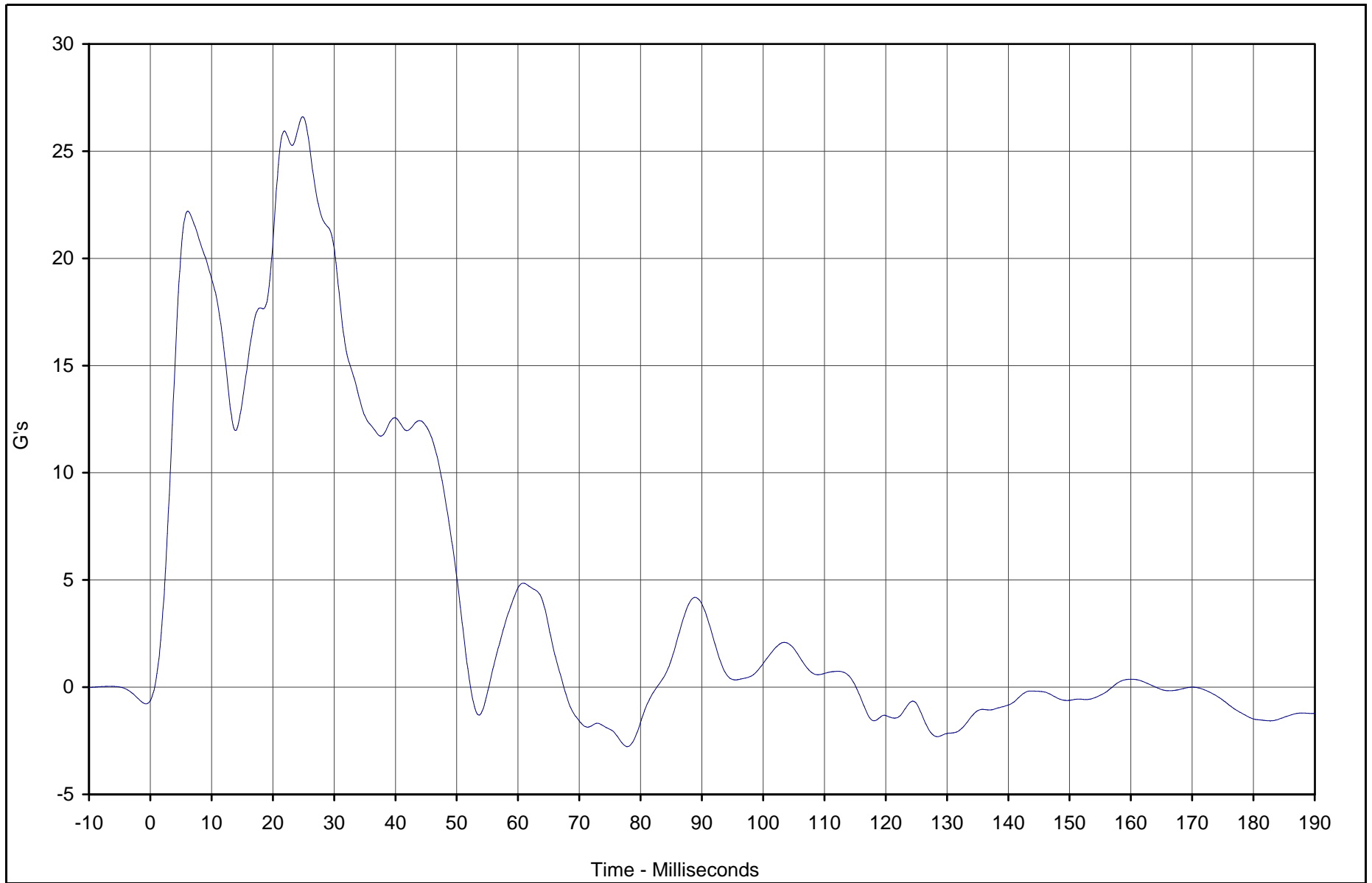

Curve Description	CURNO	Type	Units	Max	Time	Min	Time	SAE Class
Vehicle CG Y	069	FIL	G's	26.6	24.9	-2.8	77.8	60



Test Vehicle: 2003 Subaru Forester 2.5X AWD Wagon

Test Date: 10/29/02

Test Program: 55/28 km/h Side Impact NCAP

NHTSA No.: M35500

B-133

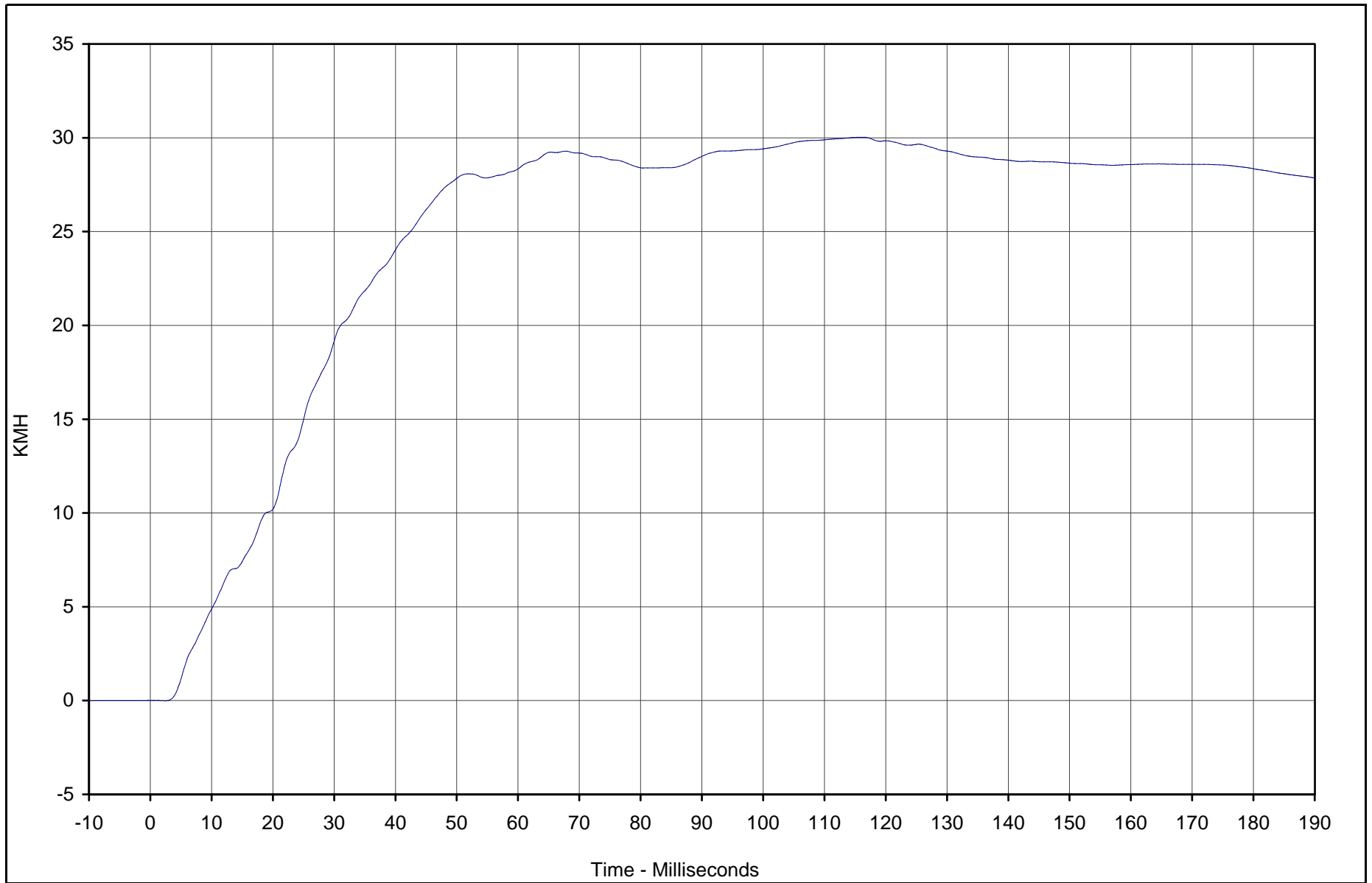

TR-P23003-01-NC

Curve Description	CURNO	Type	Units	Max	Time	Min	Time	SAE Class
Vehicle CG Y Velocity	069	IN1	KMH	30.0	116.2	0.0	2.4	180



Test Vehicle: 2003 Subaru Forester 2.5X AWD Wagon

Test Date: 10/29/02

Test Program: 55/28 km/h Side Impact NCAP

NHTSA No.: M35500

B-134

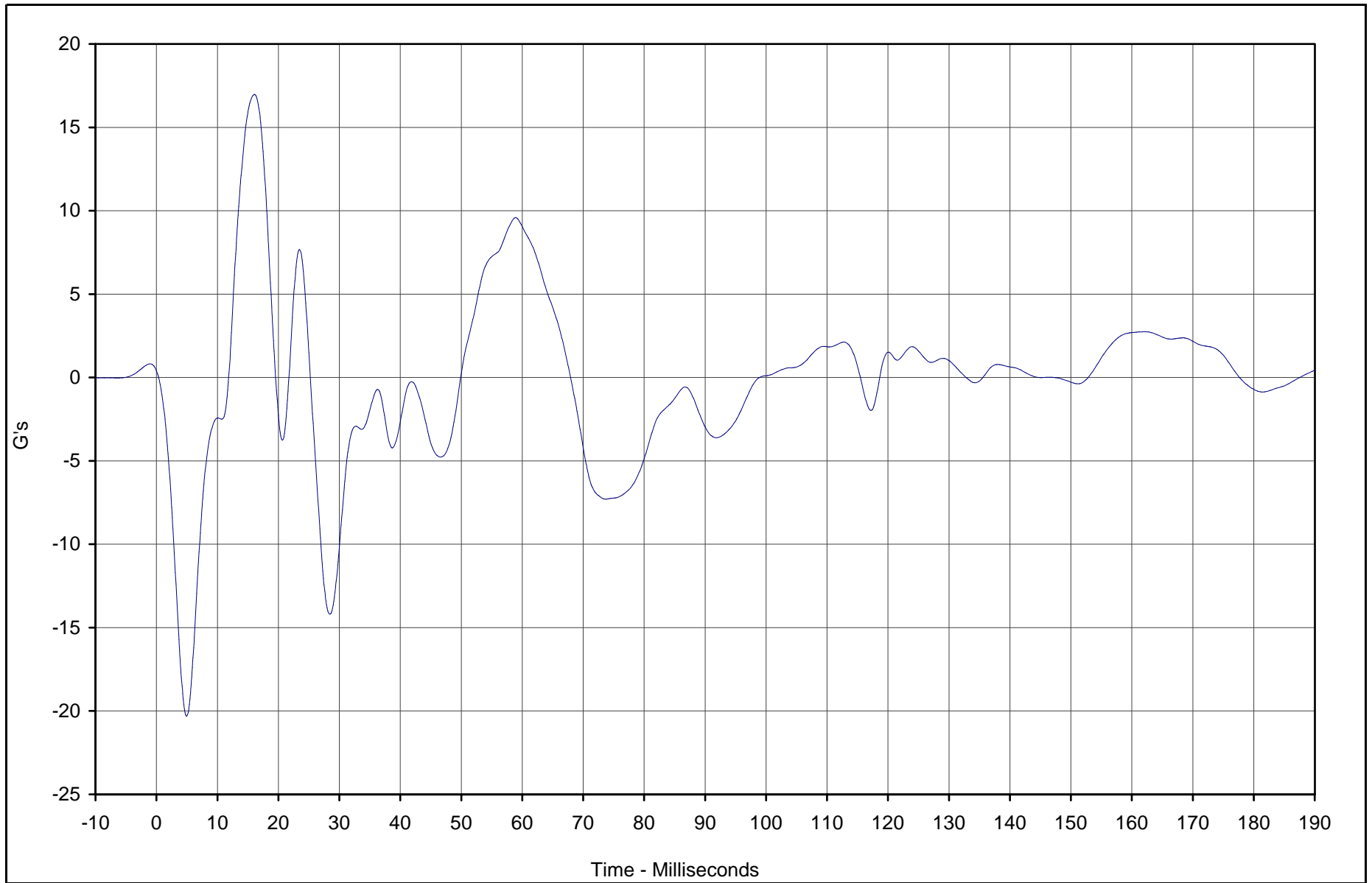

Curve Description	CURNO	Type	Units	Max	Time	Min	Time	SAE Class
Vehicle CG Z	070	FIL	G's	17.0	16.1	-20.3	4.9	60



Test Vehicle: 2003 Subaru Forester 2.5X AWD Wagon

Test Date: 10/29/02

Test Program: 55/28 km/h Side Impact NCAP

NHTSA No.: M35500

TR-P23003-01-NC

B-135

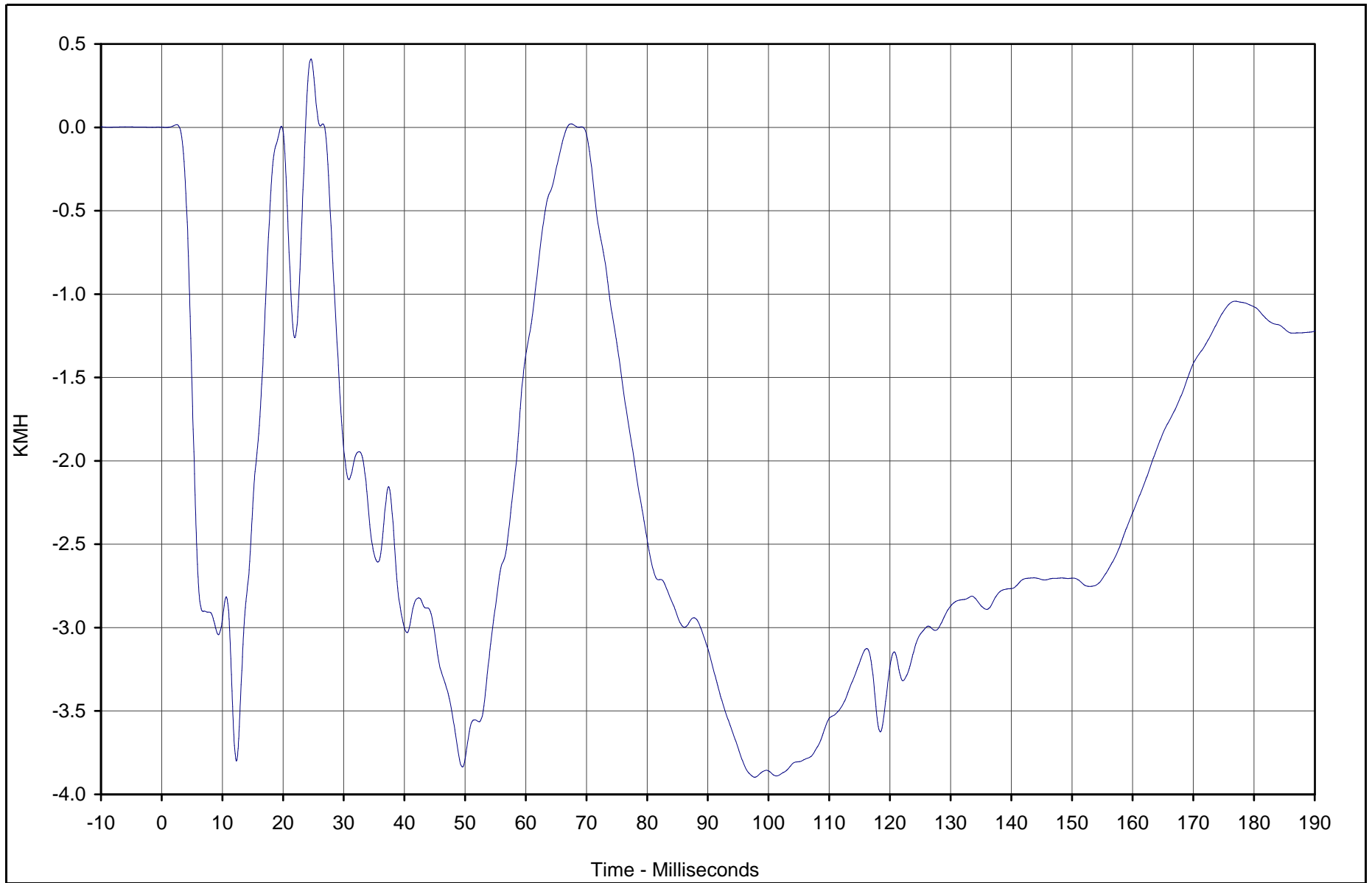

Curve Description	CURNO	Type	Units	Max	Time	Min	Time	SAE Class
Vehicle CG Z Velocity	070	IN1	KMH	0.4	24.6	-3.9	97.7	180



Test Vehicle: 2003 Subaru Forester 2.5X AWD Wagon

Test Date: 10/29/02

Test Program: 55/28 km/h Side Impact NCAP

NHTSA No.: M35500

TR-P23003-01-NC

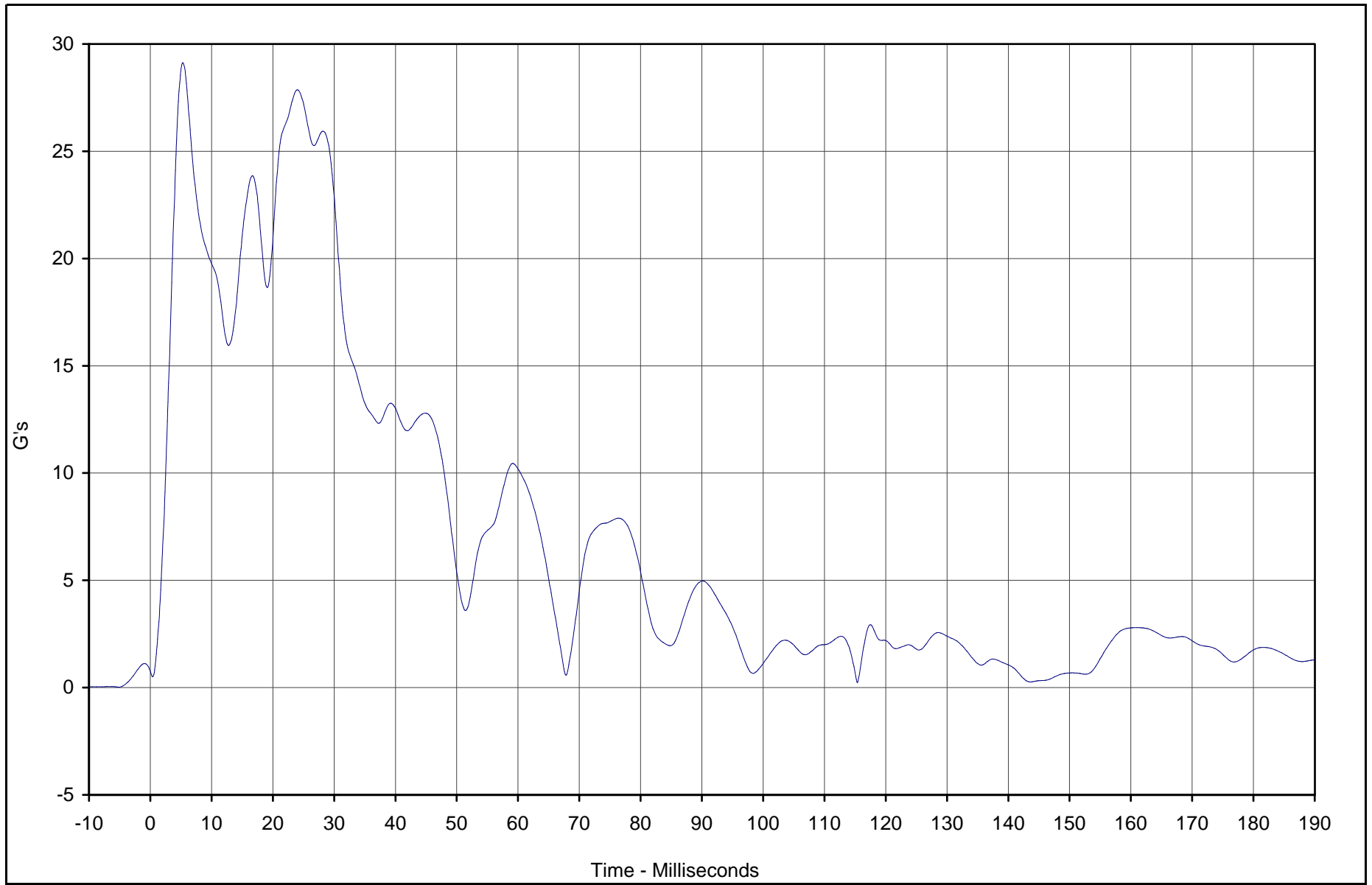

Curve Description	CURNO	Type	Units	Max	Time	Min	Time	SAE Class
Vehicle CG Resultant	068	RES	G's	29.1	5.3	0.2	115.4	60



Test Vehicle: 2003 Subaru Forester 2.5X AWD Wagon

Test Date: 10/29/02

Test Program: 55/28 km/h Side Impact NCAP

NHTSA No.: M35500

B-137

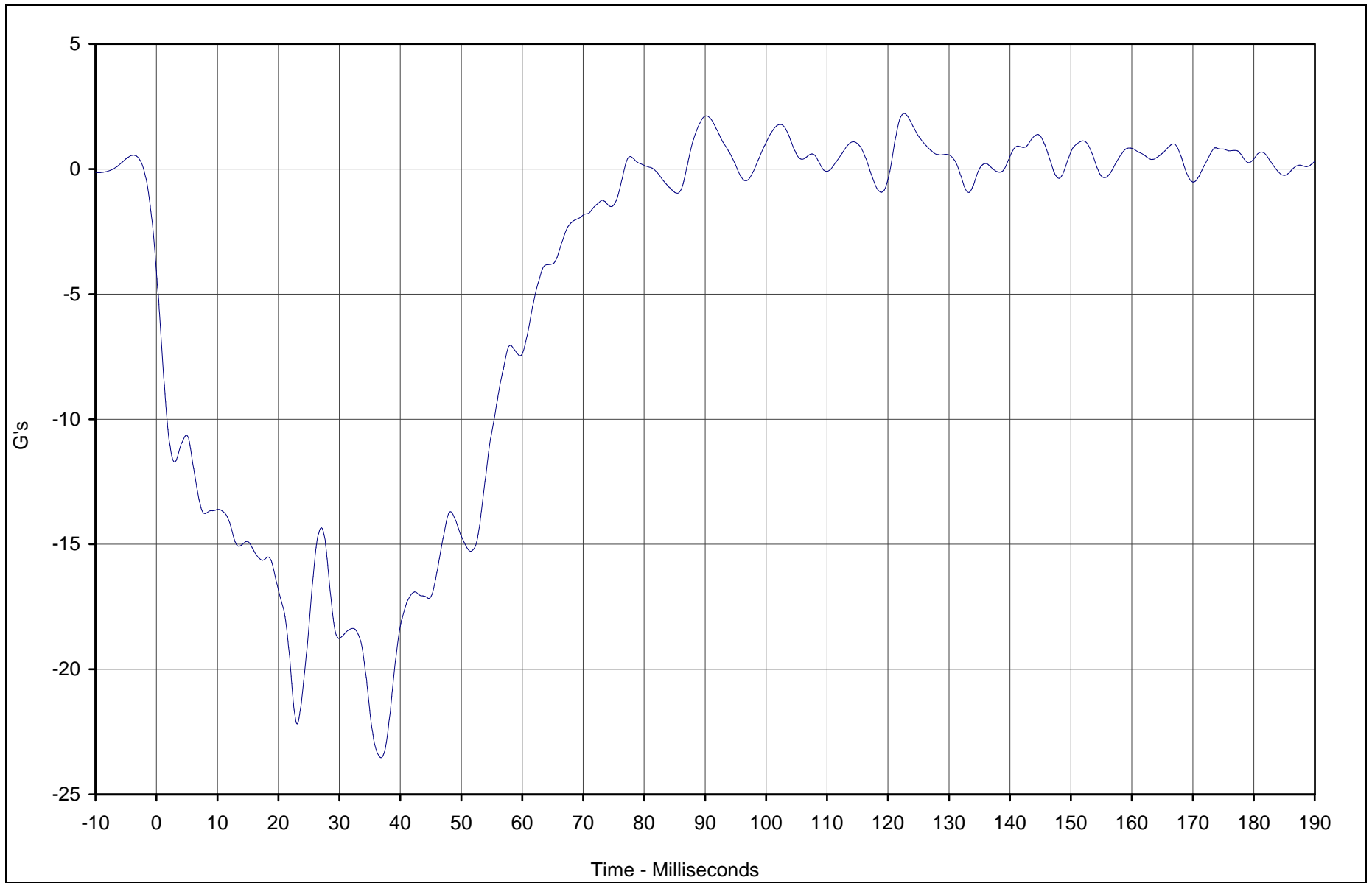

Curve Description	CURNO	Type	Units	Max	Time	Min	Time	SAE Class
MDB CG X	071	FIL	G's	2.2	122.6	-23.5	36.8	60



Test Vehicle: 2003 Subaru Forester 2.5X AWD Wagon

Test Date: 10/29/02

Test Program: 55/28 km/h Side Impact NCAP

NHTSA No.: M35500

TR-P23003-01-NC

B-138

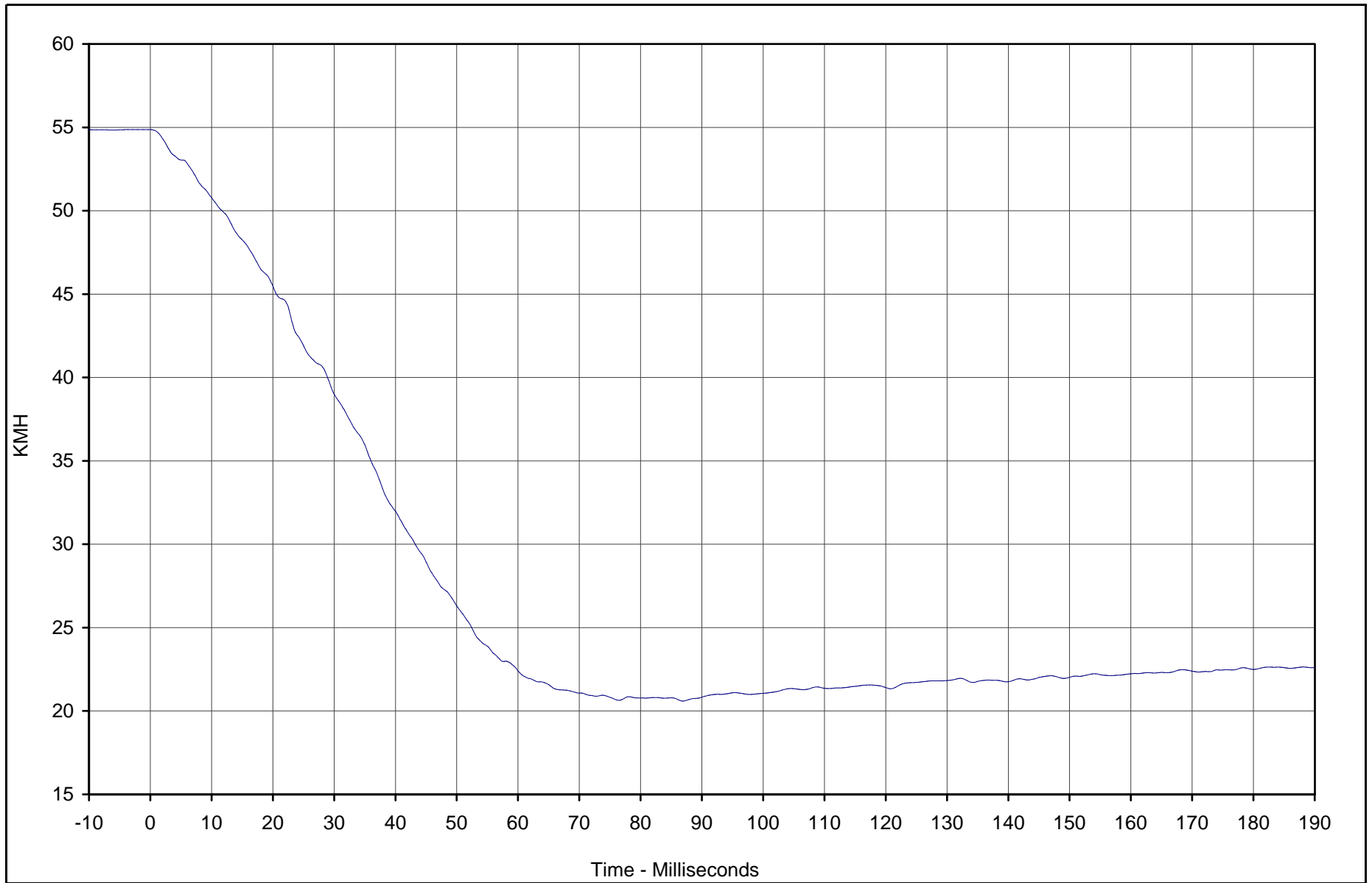

TR-P23003-01-NC

Curve Description	CURNO	Type	Units	Max	Time	Min	Time	SAE Class
MDB CG X Velocity	071	IN1	KMH	54.9	0.0	20.6	86.9	180



Test Vehicle: 2003 Subaru Forester 2.5X AWD Wagon

Test Date: 10/29/02

Test Program: 55/28 km/h Side Impact NCAP

NHTSA No.: M35500

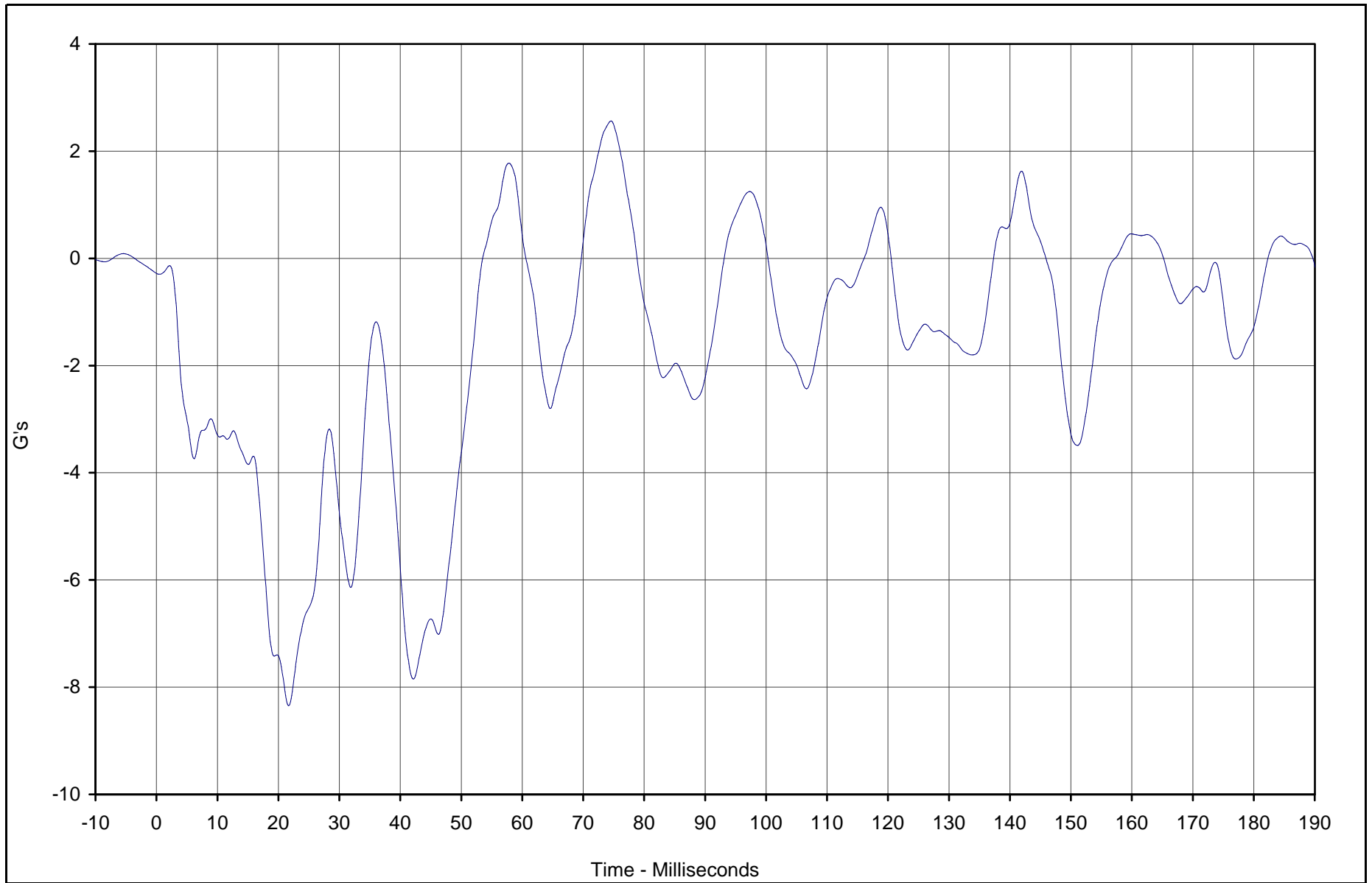

Curve Description	CURNO	Type	Units	Max	Time	Min	Time	SAE Class
MDB CG Y	072	FIL	G's	2.6	74.6	-8.3	21.7	60



Test Vehicle: 2003 Subaru Forester 2.5X AWD Wagon

Test Date: 10/29/02

Test Program: 55/28 km/h Side Impact NCAP

NHTSA No.: M35500

B-140

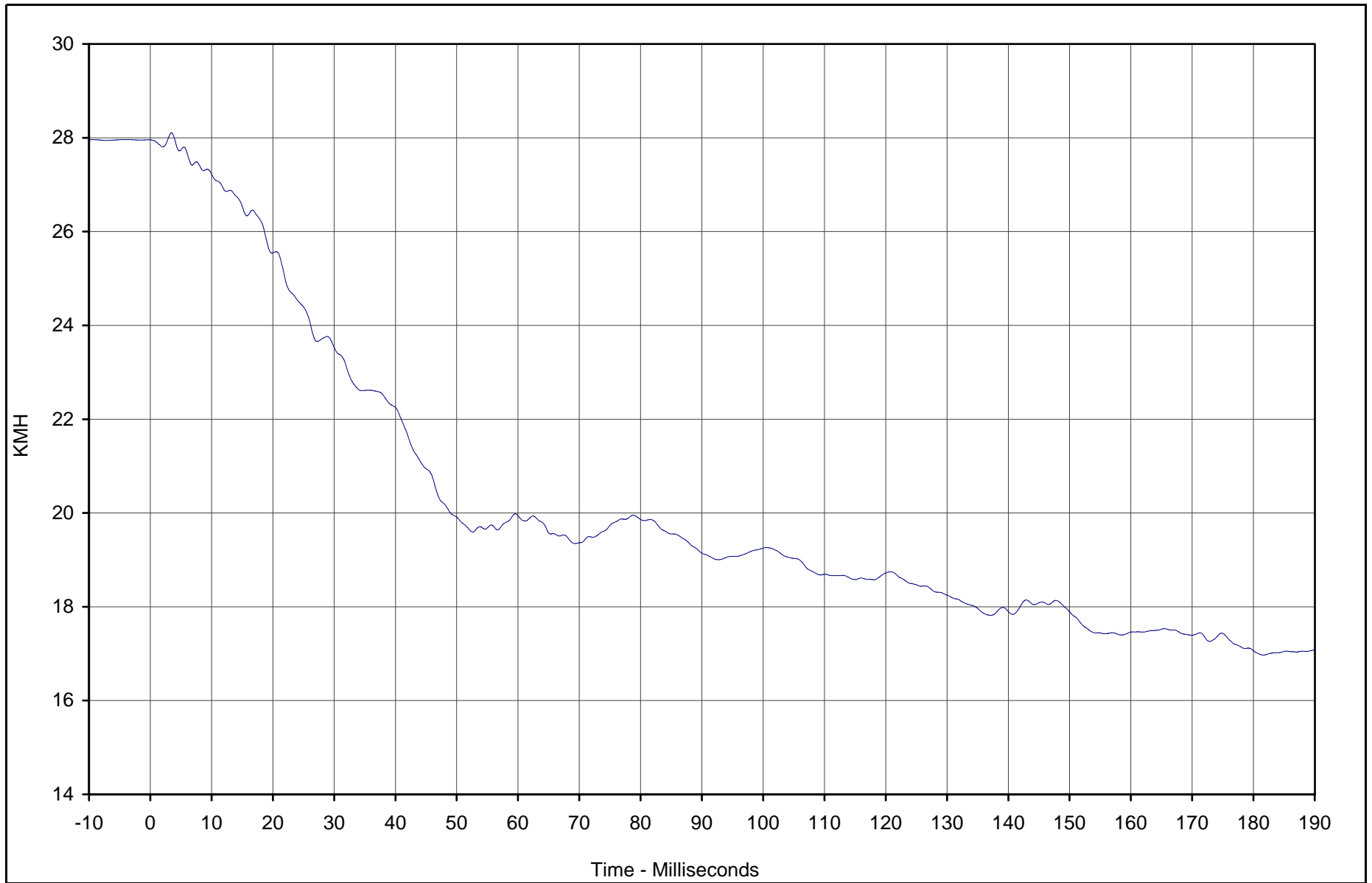

Curve Description	CURNO	Type	Units	Max	Time	Min	Time	SAE Class
MDB CG Y Velocity	072	IN1	KMH	28.1	3.5	17.0	181.6	180



Test Vehicle: 2003 Subaru Forester 2.5X AWD Wagon

Test Date: 10/29/02

Test Program: 55/28 km/h Side Impact NCAP

NHTSA No.: M35500

TR-P23003-01-NC

B-141

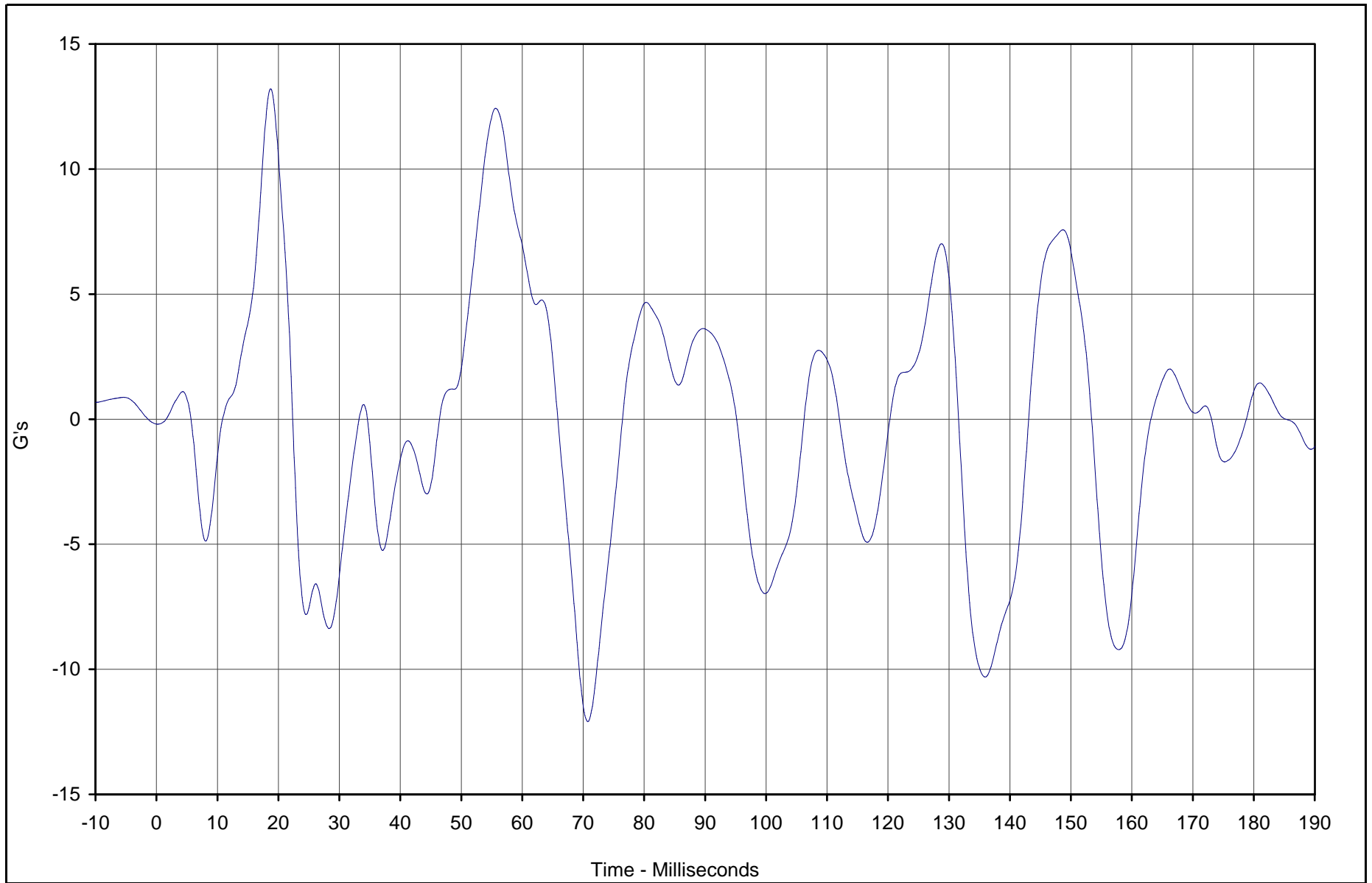

Curve Description	CURNO	Type	Units	Max	Time	Min	Time	SAE Class
MDB CG Z	073	FIL	G's	13.2	18.7	-12.1	70.8	60



Test Vehicle: 2003 Subaru Forester 2.5X AWD Wagon

Test Date: 10/29/02

Test Program: 55/28 km/h Side Impact NCAP

NHTSA No.: M35500

TR-P23003-01-NC

B-142

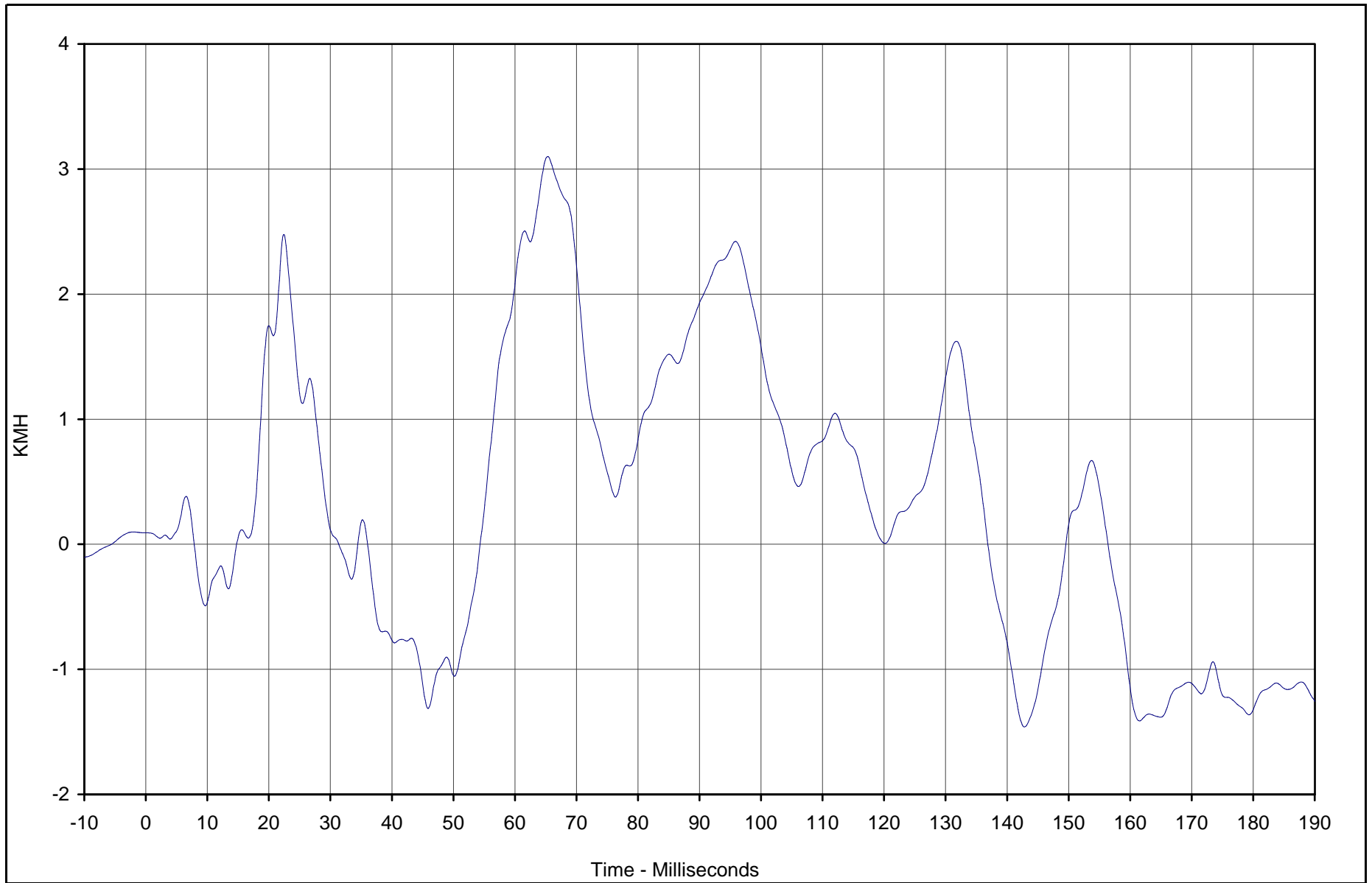

Curve Description	CURNO	Type	Units	Max	Time	Min	Time	SAE Class
MDB CG Z Velocity	073	IN1	KMH	3.1	65.3	-1.5	142.8	180



Test Vehicle: 2003 Subaru Forester 2.5X AWD Wagon

Test Date: 10/29/02

Test Program: 55/28 km/h Side Impact NCAP

NHTSA No.: M35500

TR-P23003-01-NC

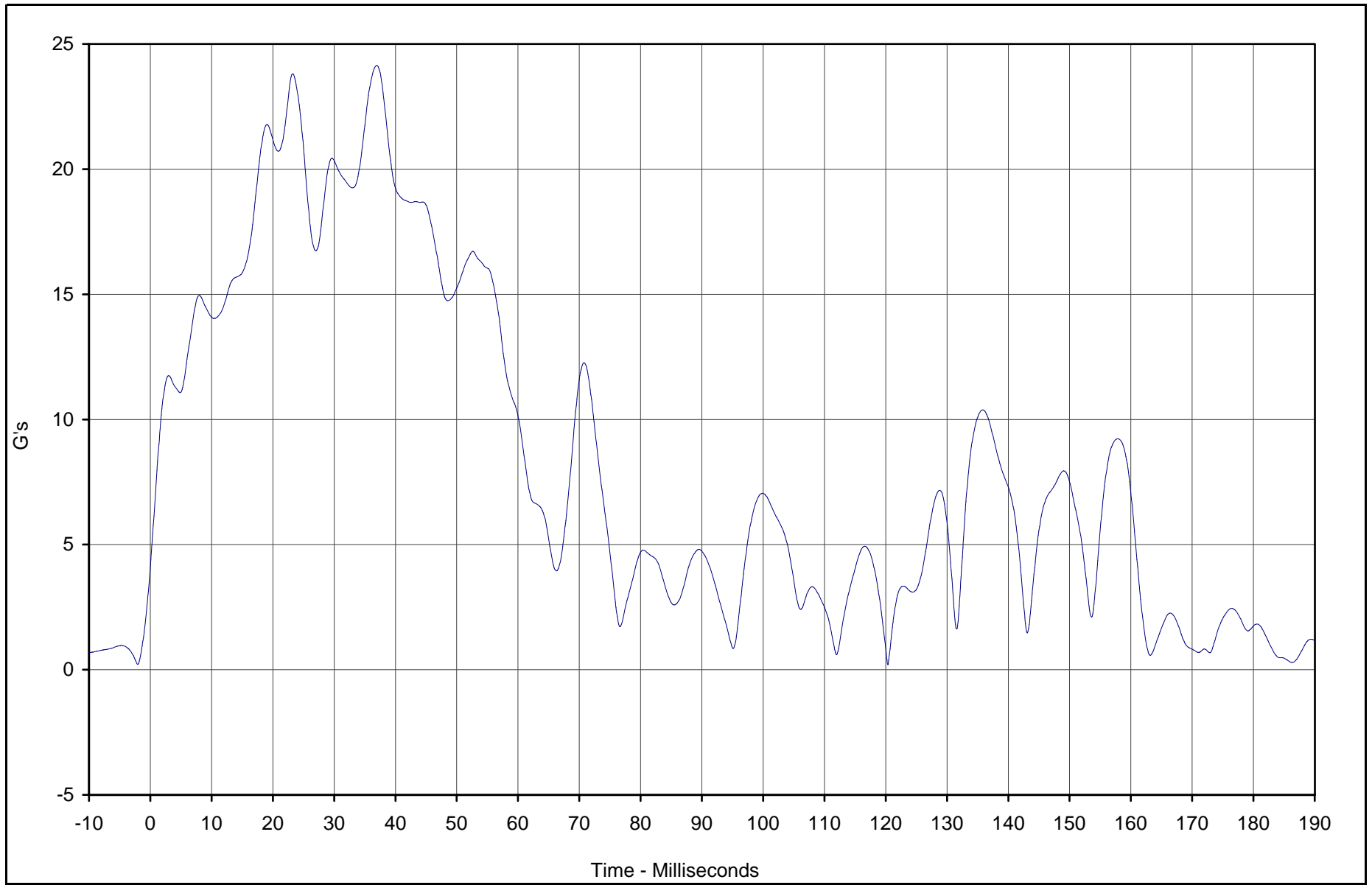

Curve Description	CURNO	Type	Units	Max	Time	Min	Time	SAE Class
MDB CG Resultant	071	RES	G's	24.1	36.9	0.2	120.4	60



Test Vehicle: 2003 Subaru Forester 2.5X AWD Wagon

Test Date: 10/29/02

Test Program: 55/28 km/h Side Impact NCAP

NHTSA No.: M35500

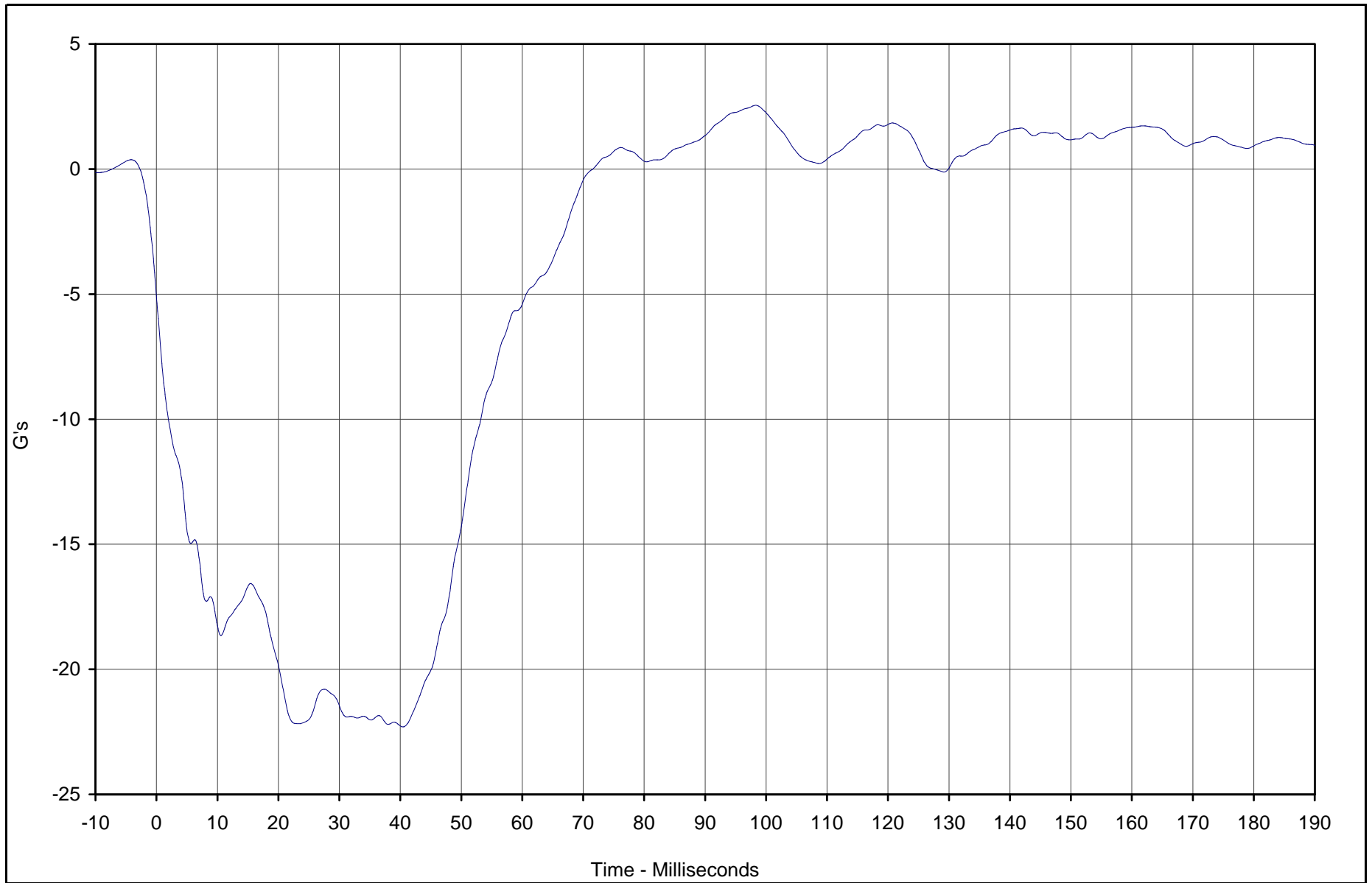

Curve Description	CURNO	Type	Units	Max	Time	Min	Time	SAE Class
MDB Rear X	074	FIL	G's	2.5	98.3	-22.3	40.4	60



Test Vehicle: 2003 Subaru Forester 2.5X AWD Wagon

Test Date: 10/29/02

Test Program: 55/28 km/h Side Impact NCAP

NHTSA No.: M35500

B-145

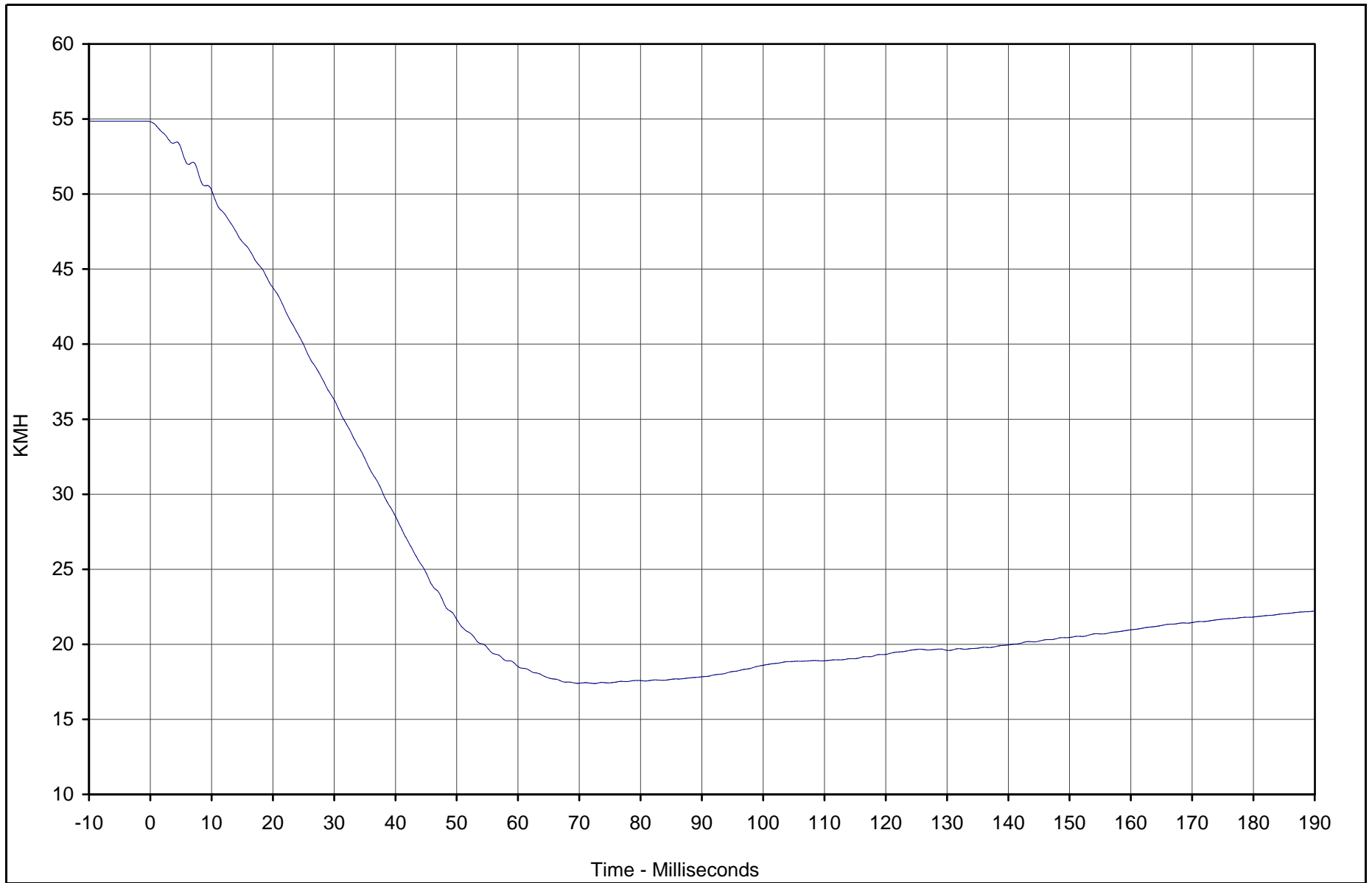

TR-P23003-01-NC

Curve Description	CURNO	Type	Units	Max	Time	Min	Time	SAE Class
MDB Rear X Velocity	074	IN1	KMH	54.8	0.0	17.4	72.4	180



Test Vehicle: 2003 Subaru Forester 2.5X AWD Wagon

Test Date: 10/29/02

Test Program: 55/28 km/h Side Impact NCAP

NHTSA No.: M35500

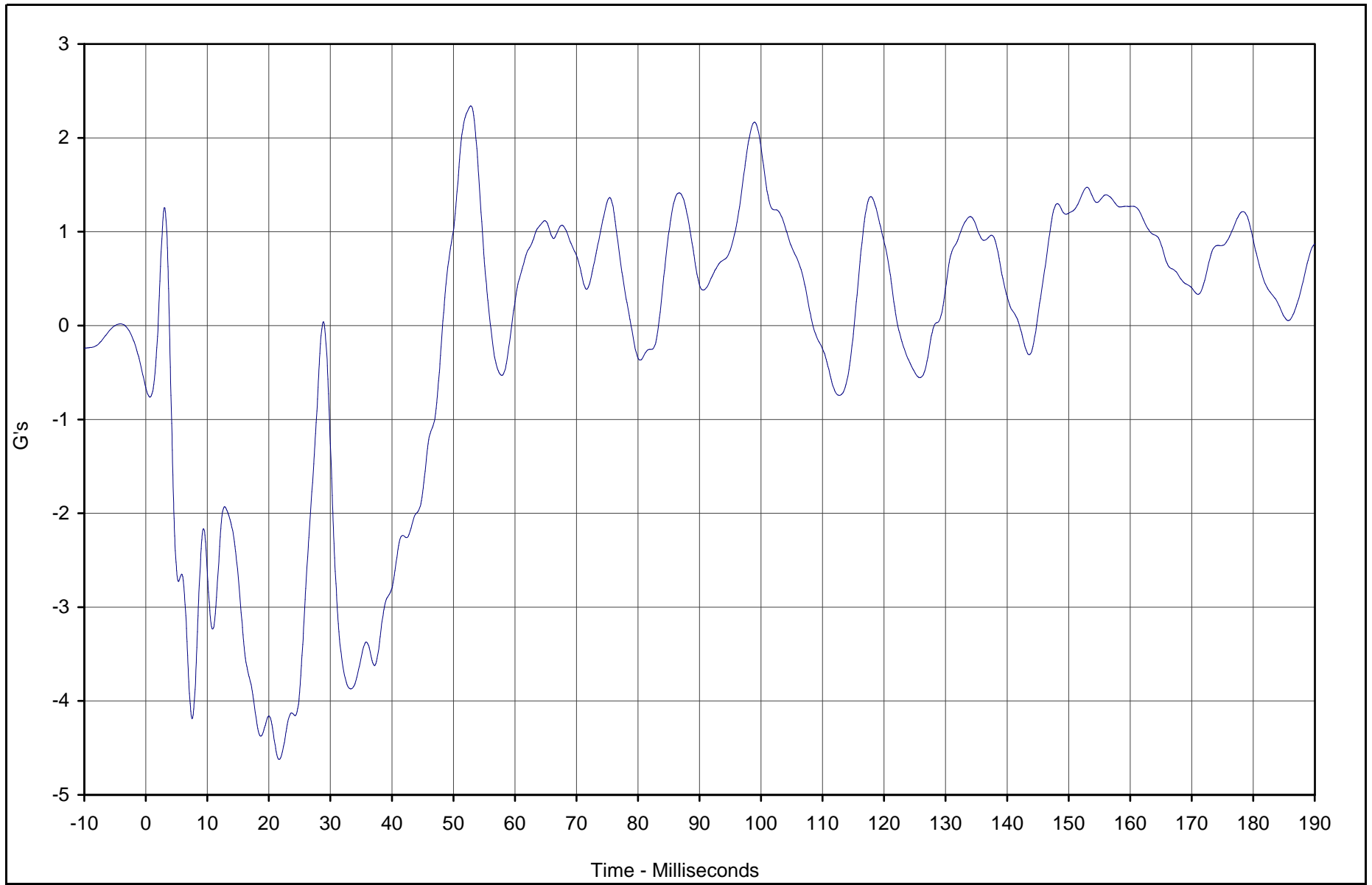

Curve Description	CURNO	Type	Units	Max	Time	Min	Time	SAE Class
MDB Rear Y	075	FIL	G's	2.3	52.8	-4.6	21.7	60



Test Vehicle: 2003 Subaru Forester 2.5X AWD Wagon

Test Date: 10/29/02

Test Program: 55/28 km/h Side Impact NCAP

NHTSA No.: M35500

B-147

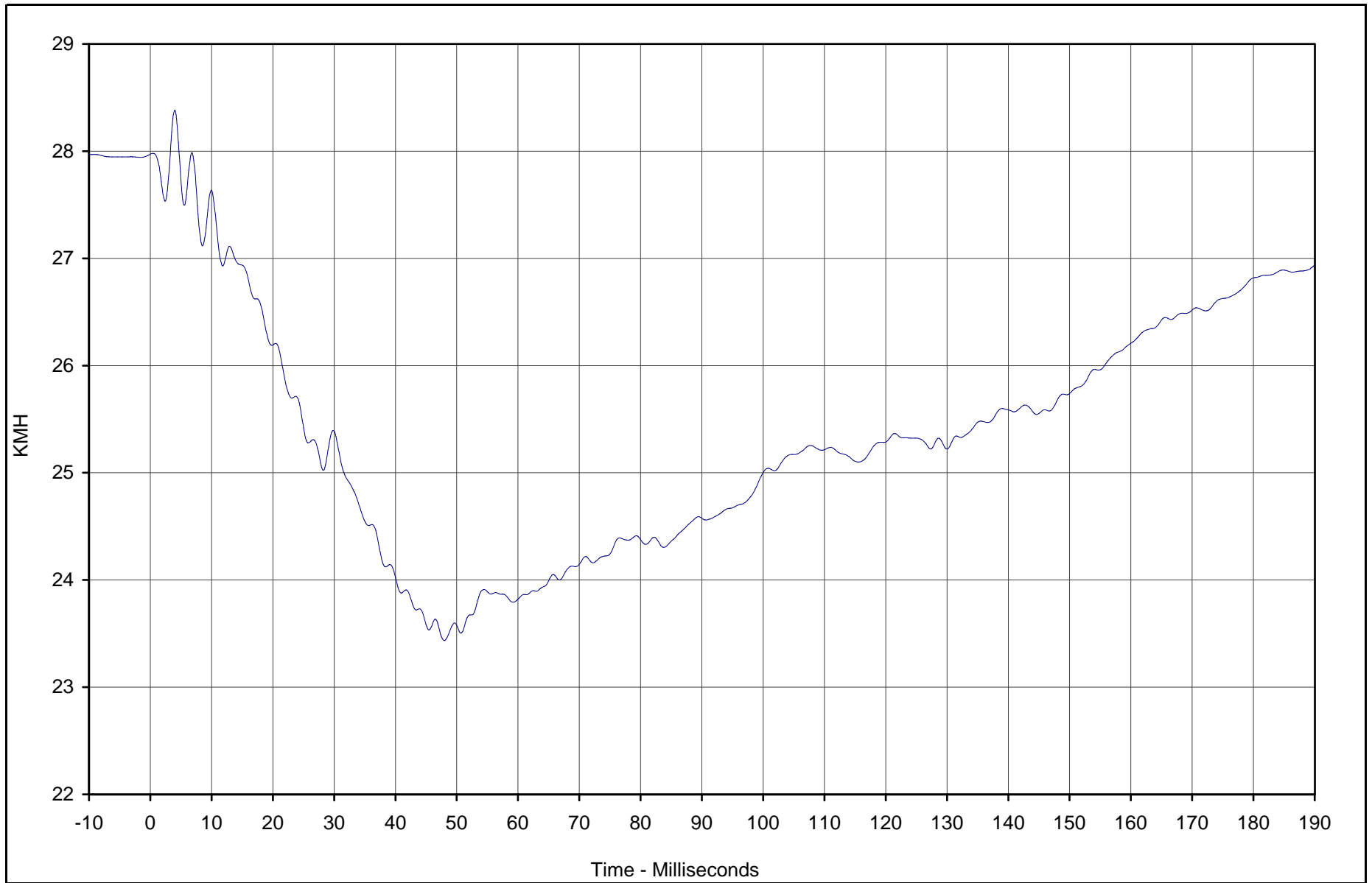

TR-P23003-01-NC

Curve Description	CURNO	Type	Units	Max	Time	Min	Time	SAE Class
MDB Rear Y Velocity	075	IN1	KMH	28.4	4.0	23.4	48.0	180



Test Vehicle: 2003 Subaru Forester 2.5X AWD Wagon

Test Date: 10/29/02

Test Program: 55/28 km/h Side Impact NCAP

NHTSA No.: M35500

B-148

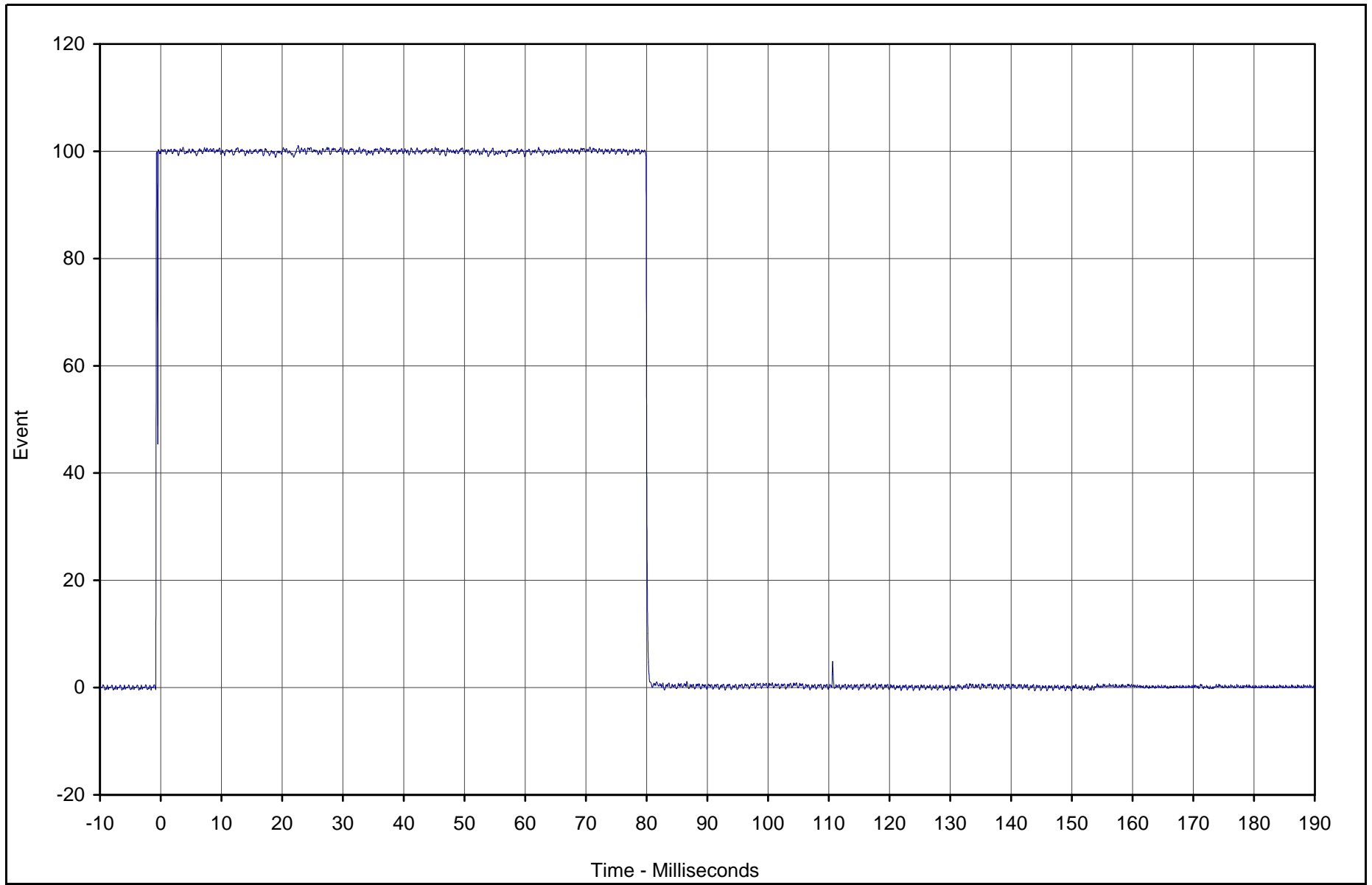

TR-P23003-01-NC

Curve Description	CURNO	Type	Units	Max	Time	Cross %	Time	SAE Class
MDB Right Bumper Contact	076	FIL	Event	101.1	22.6	50.0	-0.7	1000



Test Vehicle: 2003 Subaru Forester 2.5X AWD Wagon

Test Date: 10/29/02

Test Program: 55/28 km/h Side Impact NCAP

NHTSA No.: M35500

B-149

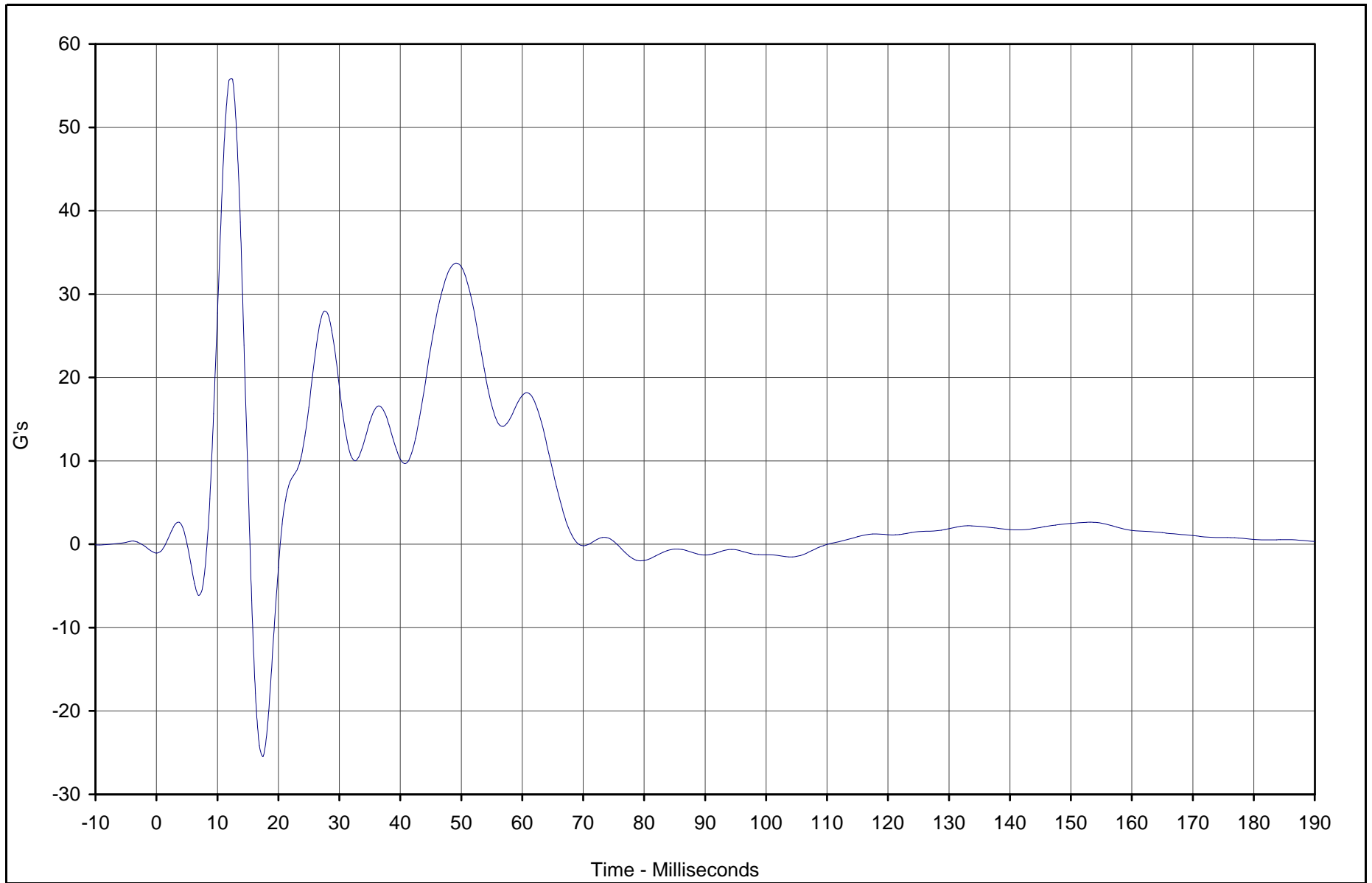

TR-P23003-01-NC

Curve Description	CURNO	Type	Units	Max	Time	Min	Time	SAE Class
Driver Upper Rib Primary Y	013	FIR	G's	55.7	12.5	-25.4	17.5	FIR100



Test Vehicle: 2003 Subaru Forester 2.5X AWD Wagon

Test Date: 10/29/02

Test Program: 55/28 km/h Side Impact NCAP

NHTSA No.: M35500

B-150

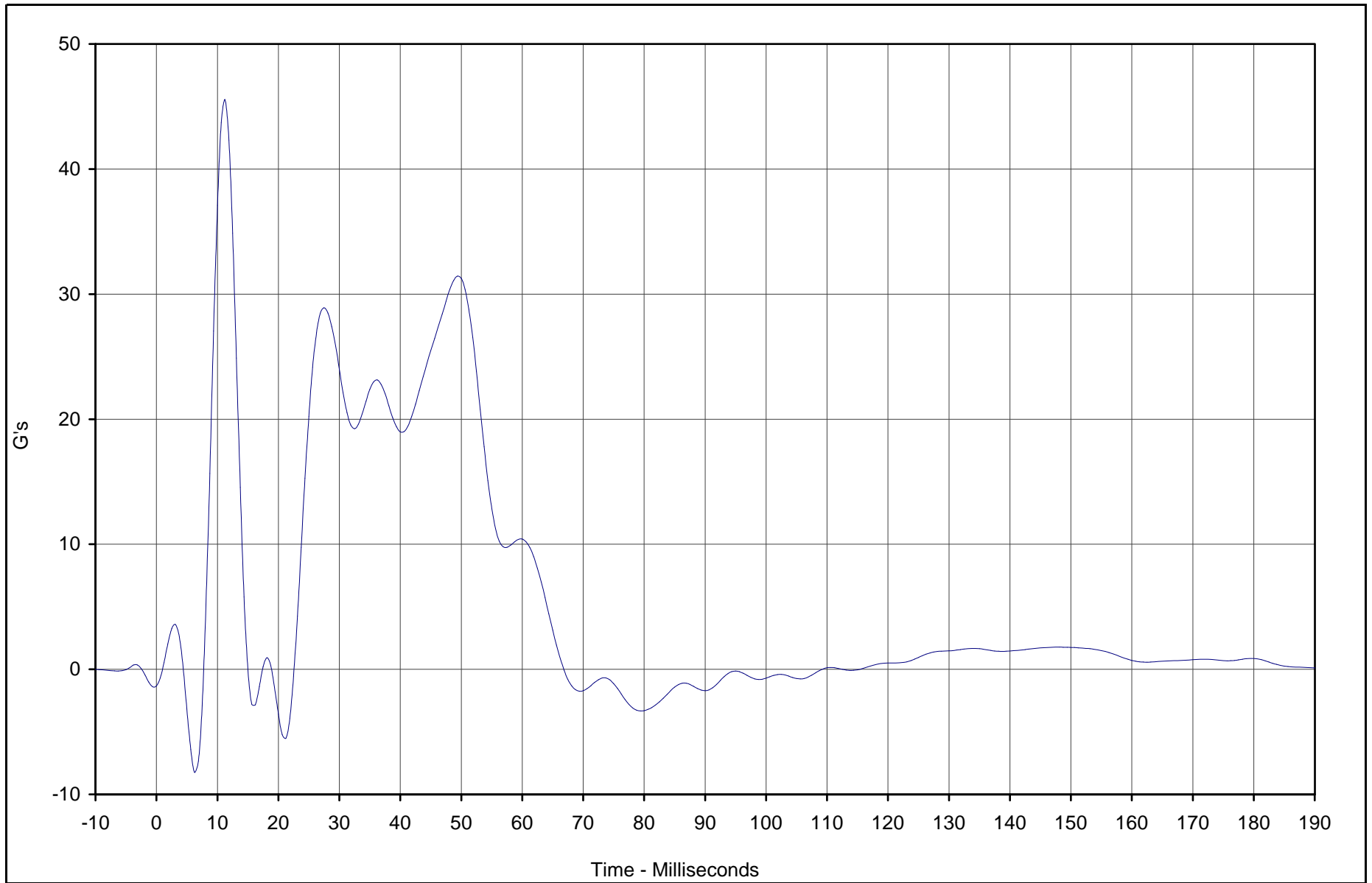

Curve Description	CURNO	Type	Units	Max	Time	Min	Time	SAE Class
Driver Lower Rib Primary Y	014	FIR	G's	45.5	11.3	-8.2	6.3	FIR100



Test Vehicle: 2003 Subaru Forester 2.5X AWD Wagon

Test Date: 10/29/02

Test Program: 55/28 km/h Side Impact NCAP

NHTSA No.: M35500

TR-P23003-01-NC

B-151

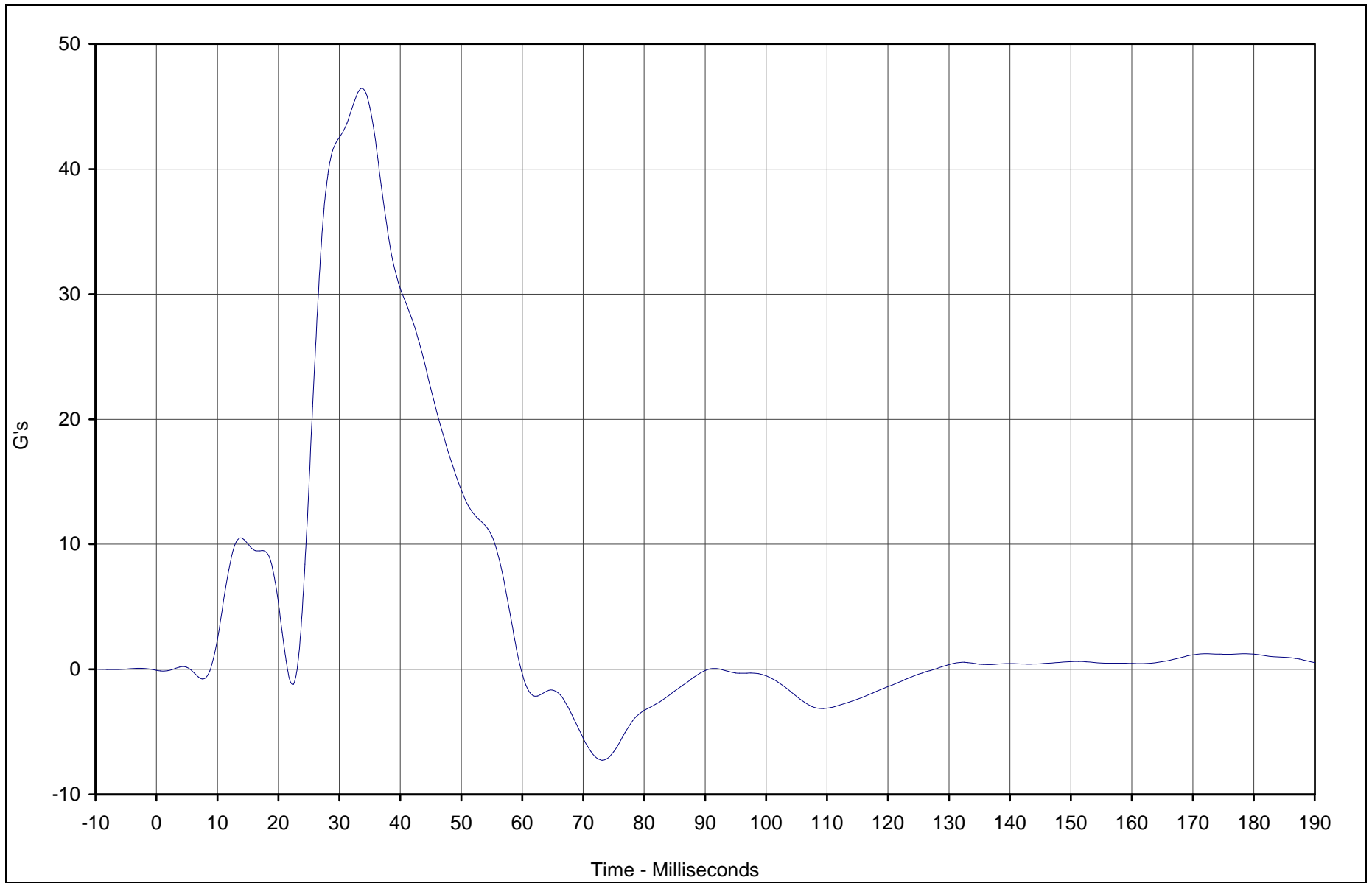

TR-P23003-01-NC

Curve Description	CURNO	Type	Units	Max	Time	Min	Time	SAE Class
Driver Lower Spine Primary Y	015	FIR	G's	46.4	33.8	-7.3	73.1	FIR100



Test Vehicle: 2003 Subaru Forester 2.5X AWD Wagon

Test Date: 10/29/02

Test Program: 55/28 km/h Side Impact NCAP

NHTSA No.: M35500

B-152

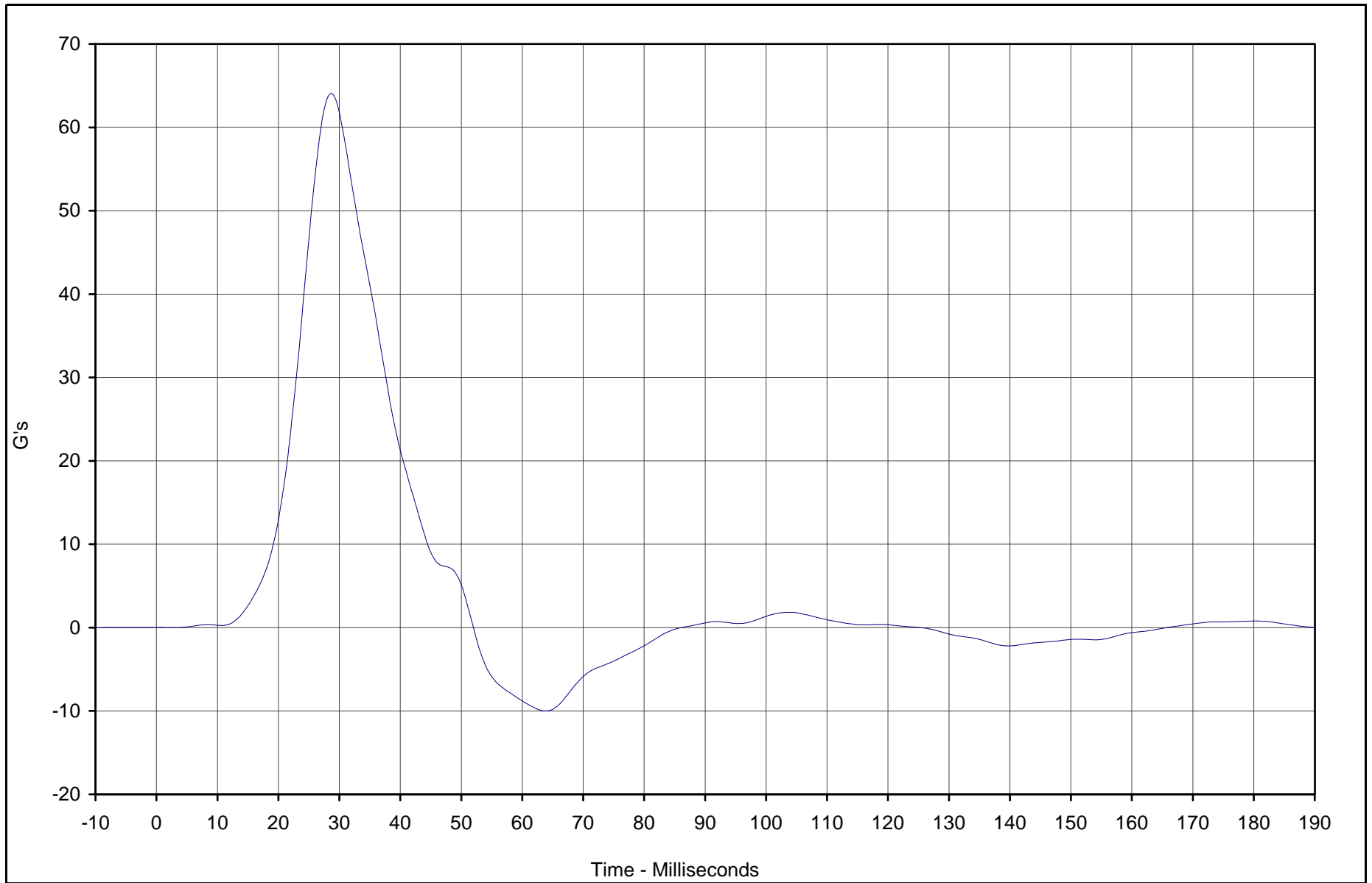

TR-P23003-01-NC

Curve Description	CURNO	Type	Units	Max	Time	Min	Time	SAE Class
Driver Pelvis Primary Y	016	FIR	G's	64.1	28.8	-10.0	63.8	FIR100



Test Vehicle: 2003 Subaru Forester 2.5X AWD Wagon

Test Date: 10/29/02

Test Program: 55/28 km/h Side Impact NCAP

NHTSA No.: M35500

B-153

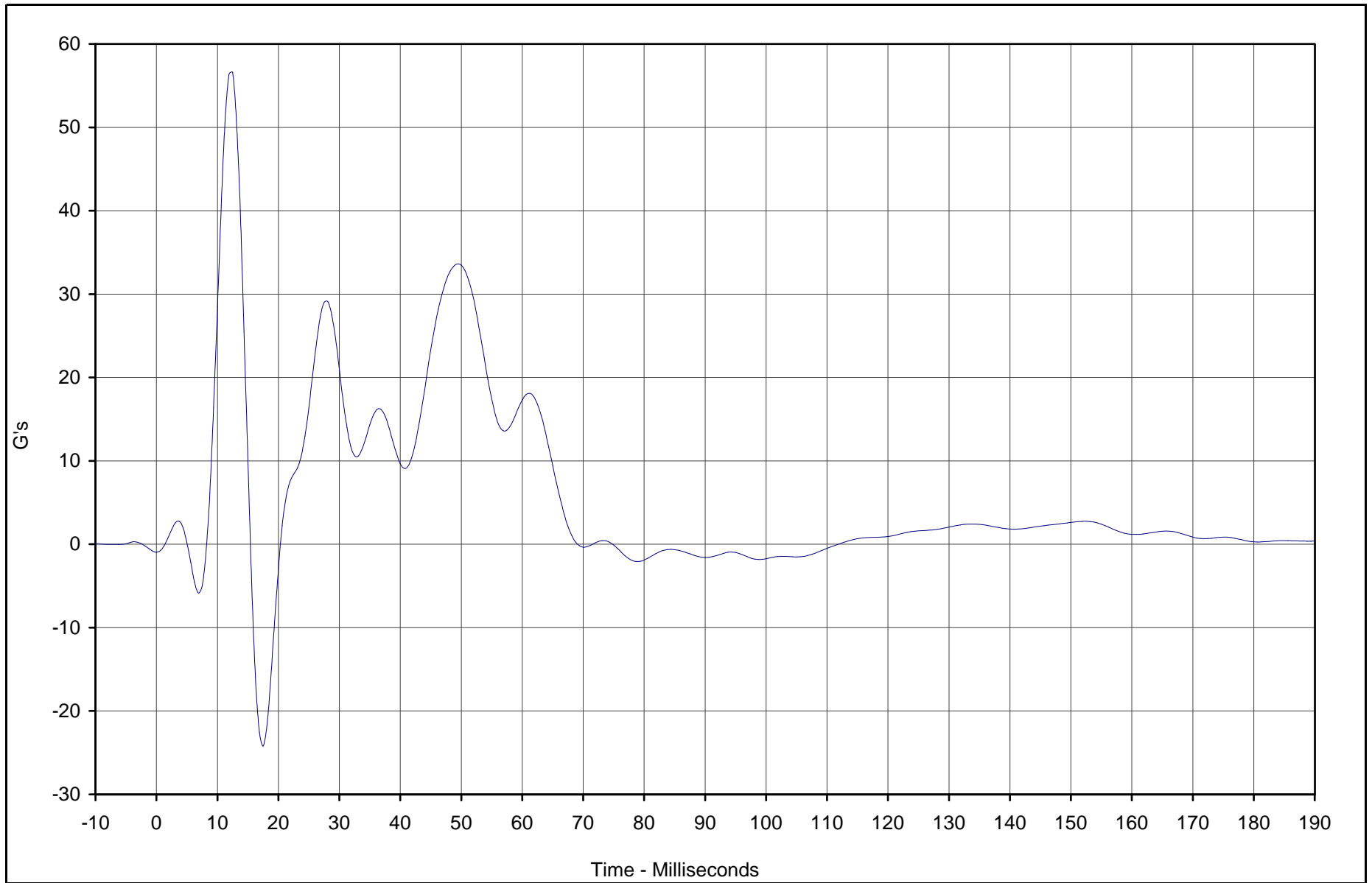

TR-P23003-01-NC

Curve Description	CURNO	Type	Units	Max	Time	Min	Time	SAE Class
Driver Upper Rib Redundant Y	017	FIR	G's	56.6	12.5	-24.2	17.5	FIR100



Test Vehicle: 2003 Subaru Forester 2.5X AWD Wagon

Test Date: 10/29/02

Test Program: 55/28 km/h Side Impact NCAP

NHTSA No.: M35500

B-154

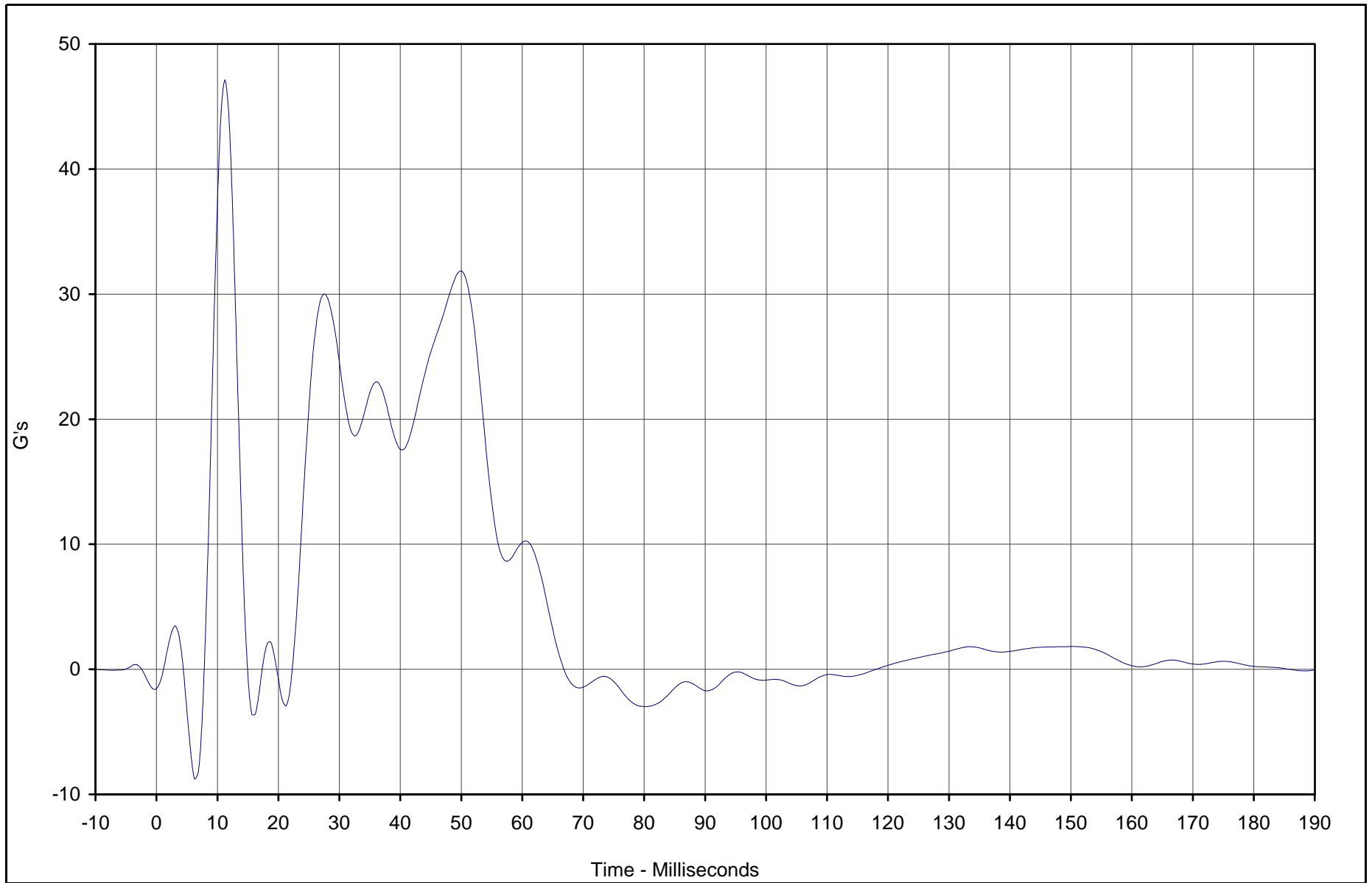

Curve Description	CURNO	Type	Units	Max	Time	Min	Time	SAE Class
Driver Lower Rib Redundant Y	018	FIR	G's	47.1	11.3	-8.8	6.3	FIR100



Test Vehicle: 2003 Subaru Forester 2.5X AWD Wagon

Test Date: 10/29/02

Test Program: 55/28 km/h Side Impact NCAP

NHTSA No.: M35500

TR-P23003-01-NC

B-155

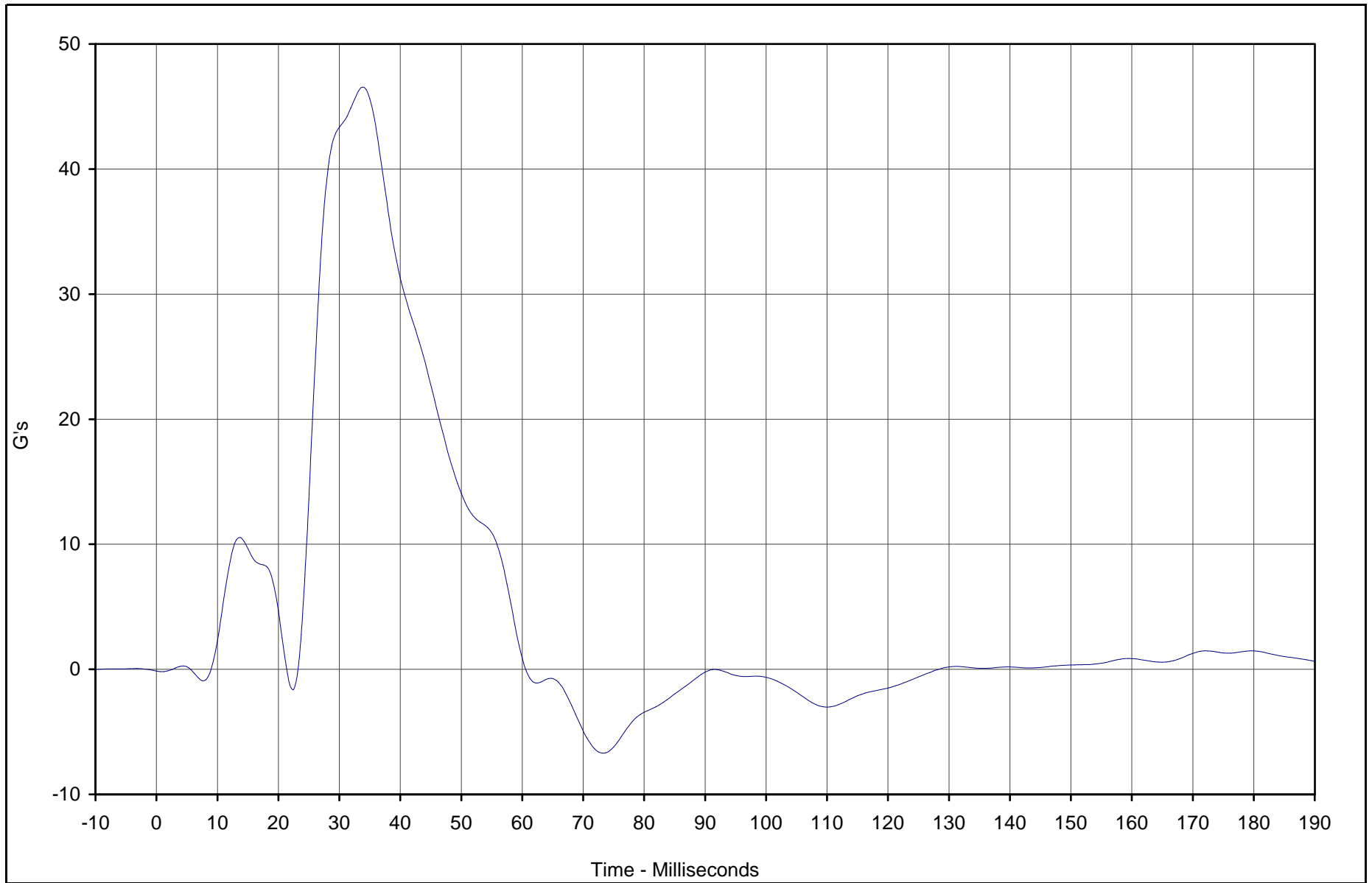

TR-P23003-01-NC

Curve Description	CURNO	Type	Units	Max	Time	Min	Time	SAE Class
Driver Lower Spine Redundant Y	019	FIR	G's	46.5	33.8	-6.7	73.1	FIR100



Test Vehicle: 2003 Subaru Forester 2.5X AWD Wagon

Test Date: 10/29/02

Test Program: 55/28 km/h Side Impact NCAP

NHTSA No.: M35500

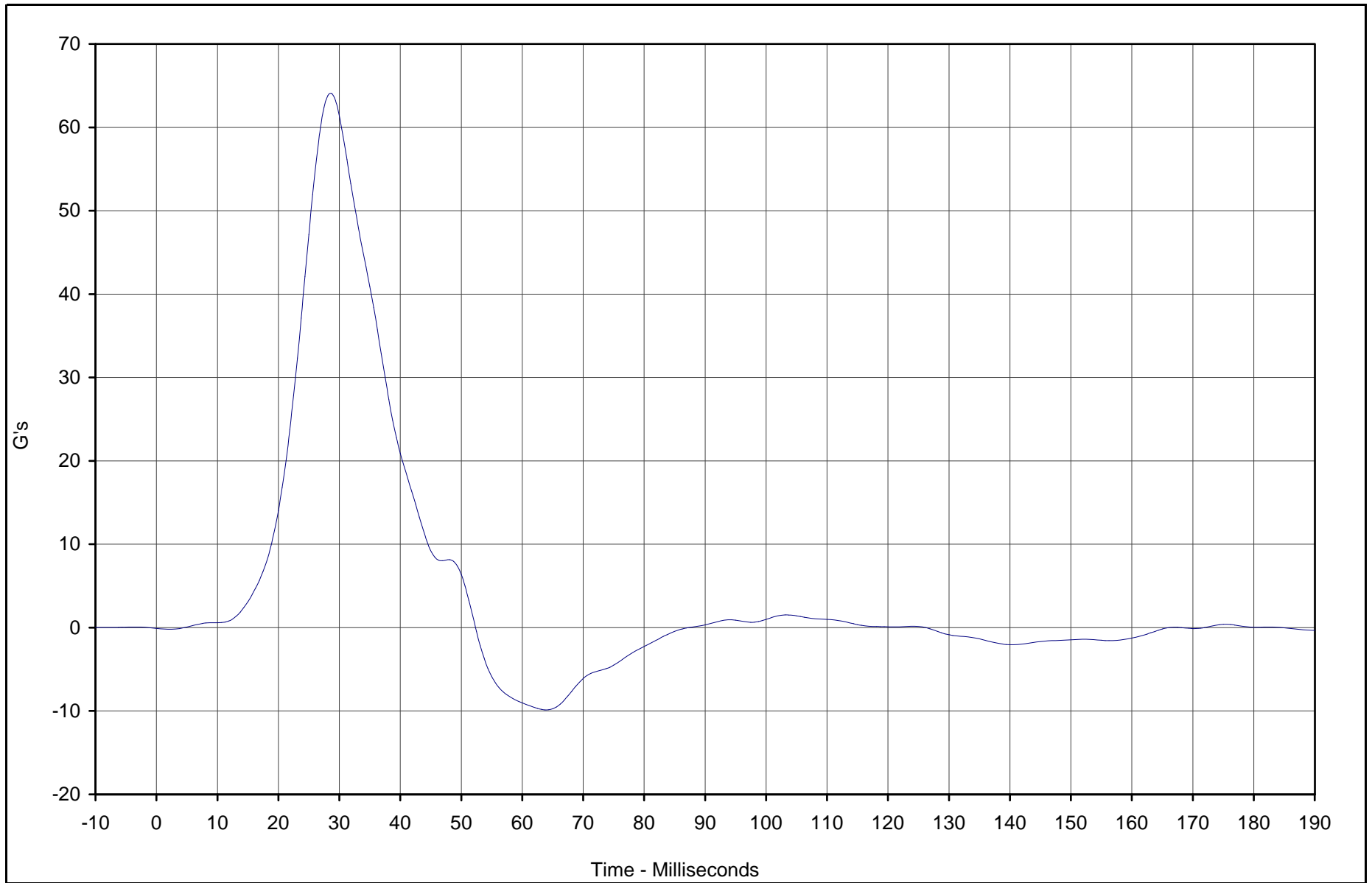

Curve Description	CURNO	Type	Units	Max	Time	Min	Time	SAE Class
Driver Pelvis Redundant Y	020	FIR	G's	64.1	28.8	-9.9	63.8	FIR100



Test Vehicle: 2003 Subaru Forester 2.5X AWD Wagon

Test Date: 10/29/02

Test Program: 55/28 km/h Side Impact NCAP

NHTSA No.: M35500

B-157

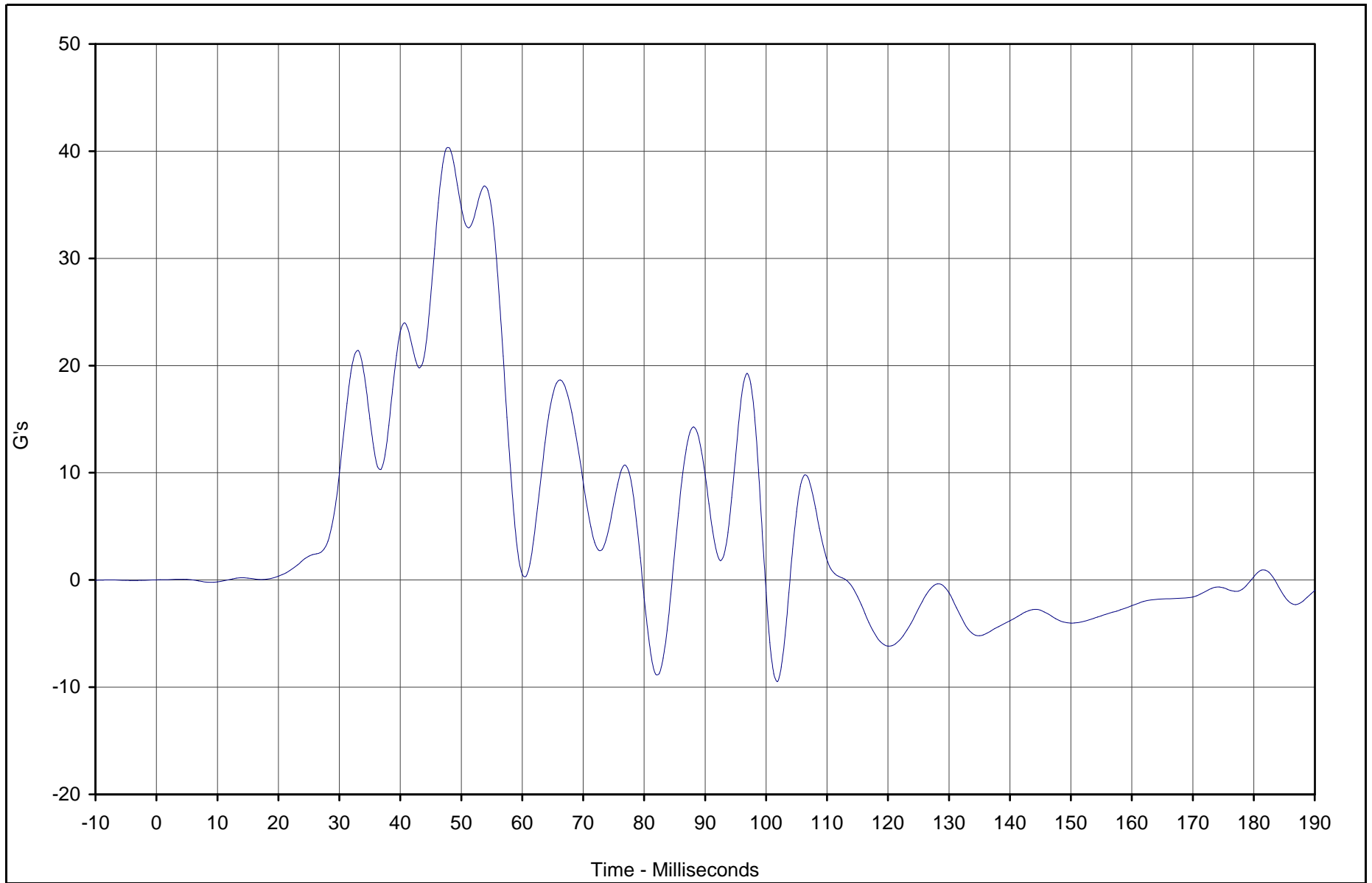

Curve Description	CURNO	Type	Units	Max	Time	Min	Time	SAE Class
Pass. Upper Rib Primary Y	035	FIR	G's	40.3	48.1	-9.5	101.9	FIR100



Test Vehicle: 2003 Subaru Forester 2.5X AWD Wagon

Test Date: 10/29/02

Test Program: 55/28 km/h Side Impact NCAP

NHTSA No.: M35500

TR-P23003-01-NC

B-158

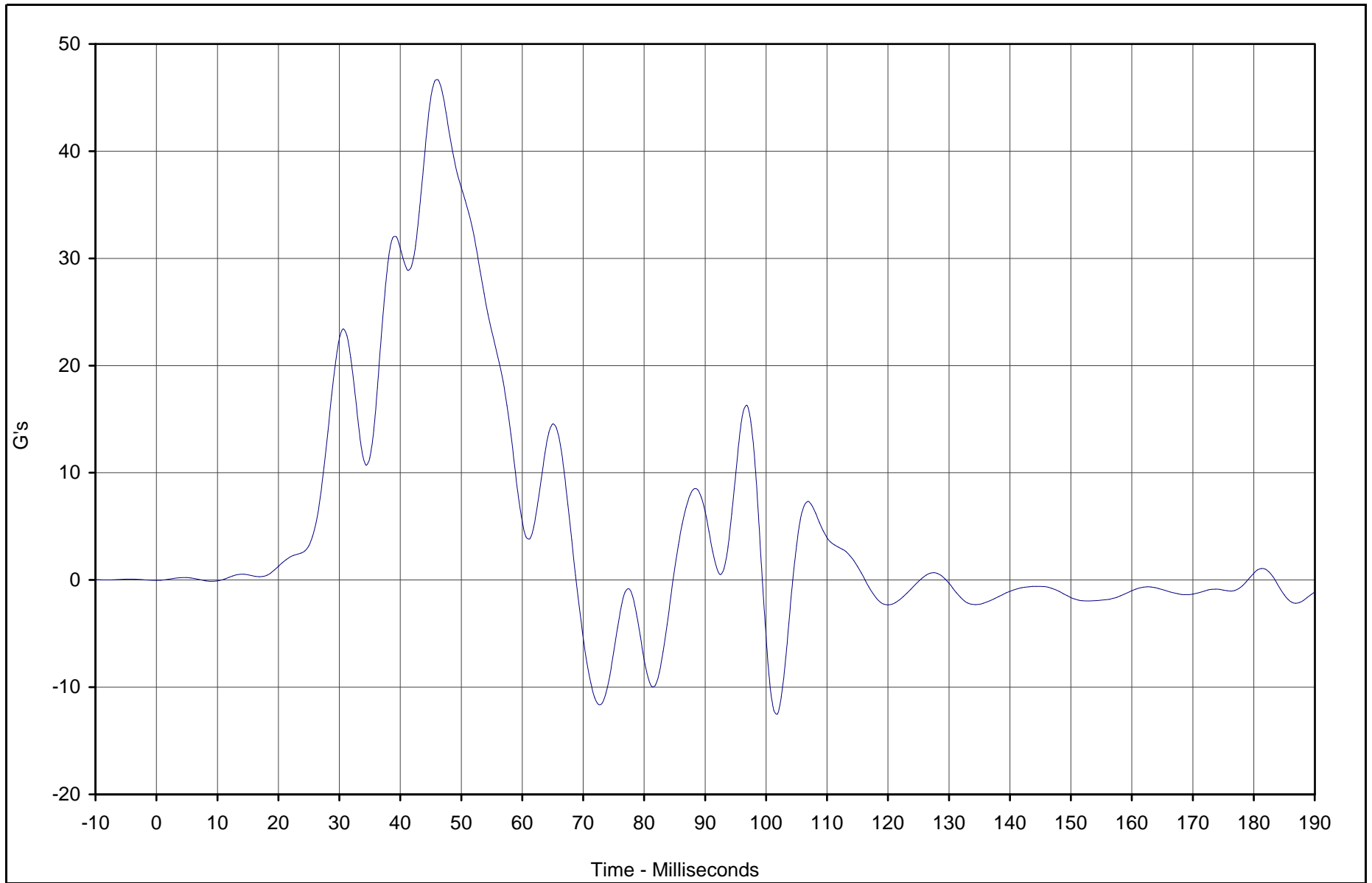

TR-P23003-01-NC

Curve Description	CURNO	Type	Units	Max	Time	Min	Time	SAE Class
Pass. Lower Rib Primary Y	036	FIR	G's	46.6	46.3	-12.5	101.9	FIR100



Test Vehicle: 2003 Subaru Forester 2.5X AWD Wagon

Test Date: 10/29/02

Test Program: 55/28 km/h Side Impact NCAP

NHTSA No.: M35500

B-159

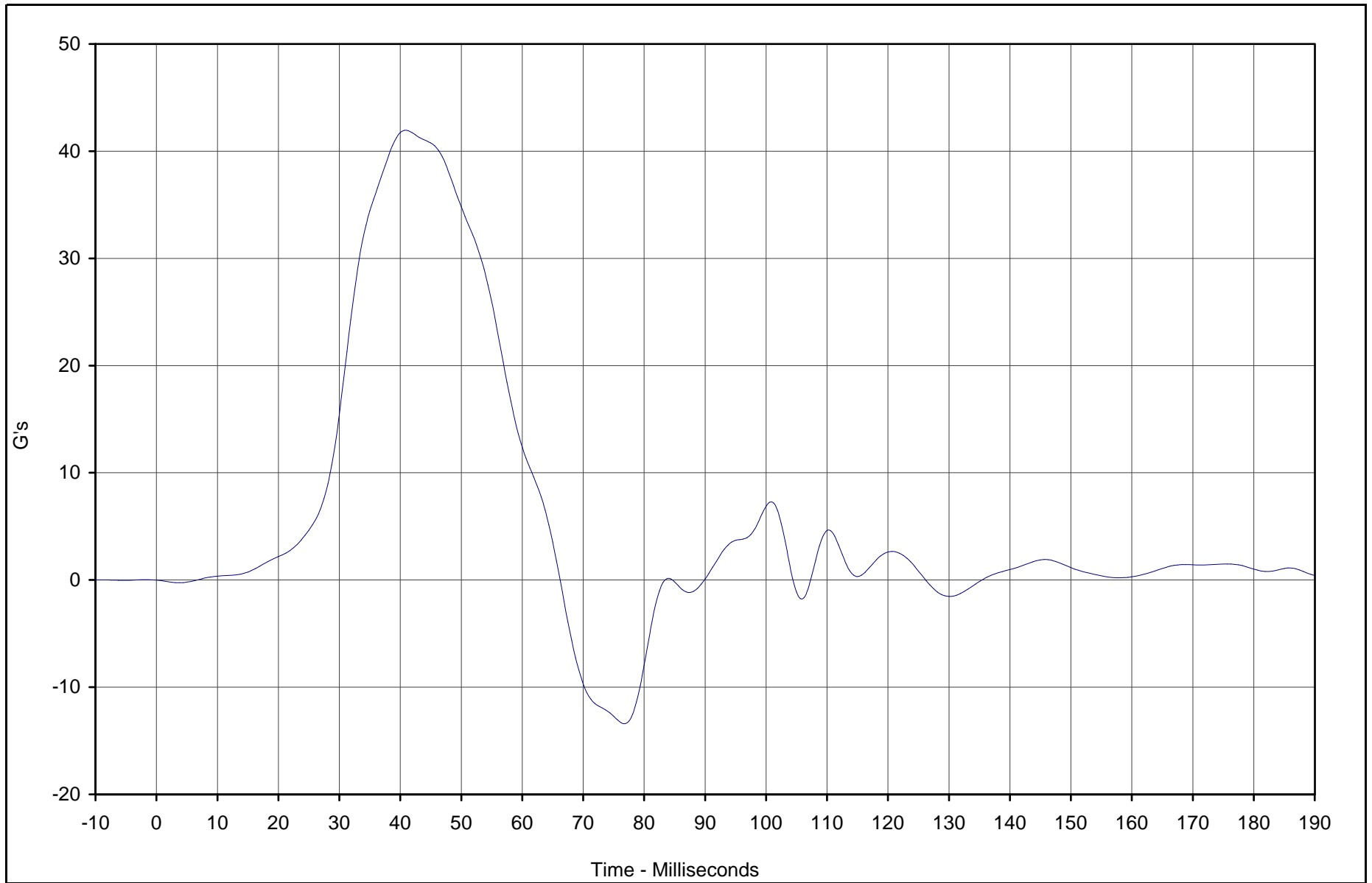

TR-P23003-01-NC

Curve Description	CURNO	Type	Units	Max	Time	Min	Time	SAE Class
Pass. Lower Spine Primary Y	037	FIR	G's	41.9	40.6	-13.4	76.9	FIR100



Test Vehicle: 2003 Subaru Forester 2.5X AWD Wagon

Test Date: 10/29/02

Test Program: 55/28 km/h Side Impact NCAP

NHTSA No.: M35500

B-160

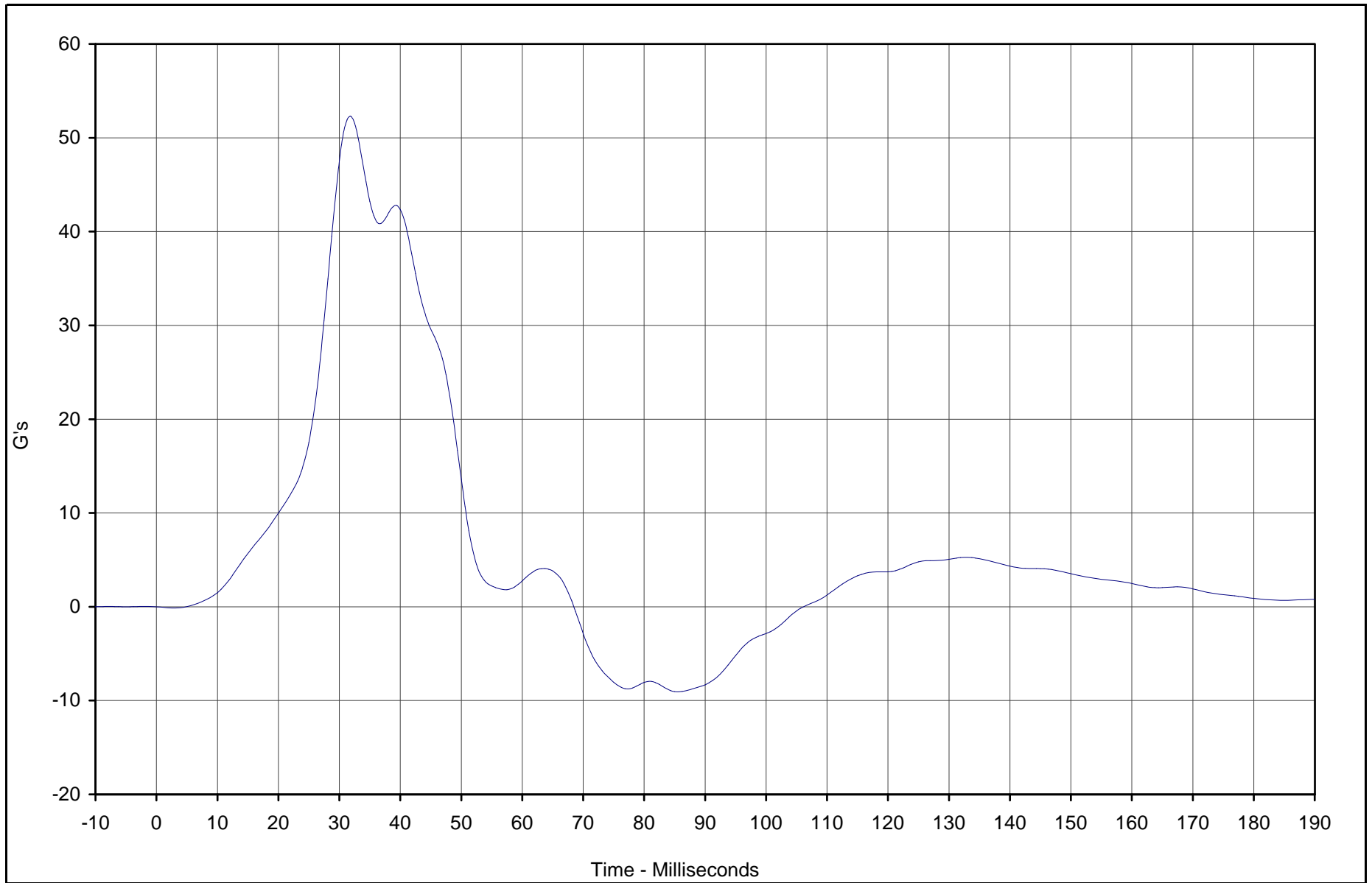

Curve Description	CURNO	Type	Units	Max	Time	Min	Time	SAE Class
Pass. Pelvis Primary Y	038	FIR	G's	52.3	31.9	-9.1	85.6	FIR100



Test Vehicle: 2003 Subaru Forester 2.5X AWD Wagon

Test Date: 10/29/02

Test Program: 55/28 km/h Side Impact NCAP

NHTSA No.: M35500

TR-P23003-01-NC

B-161

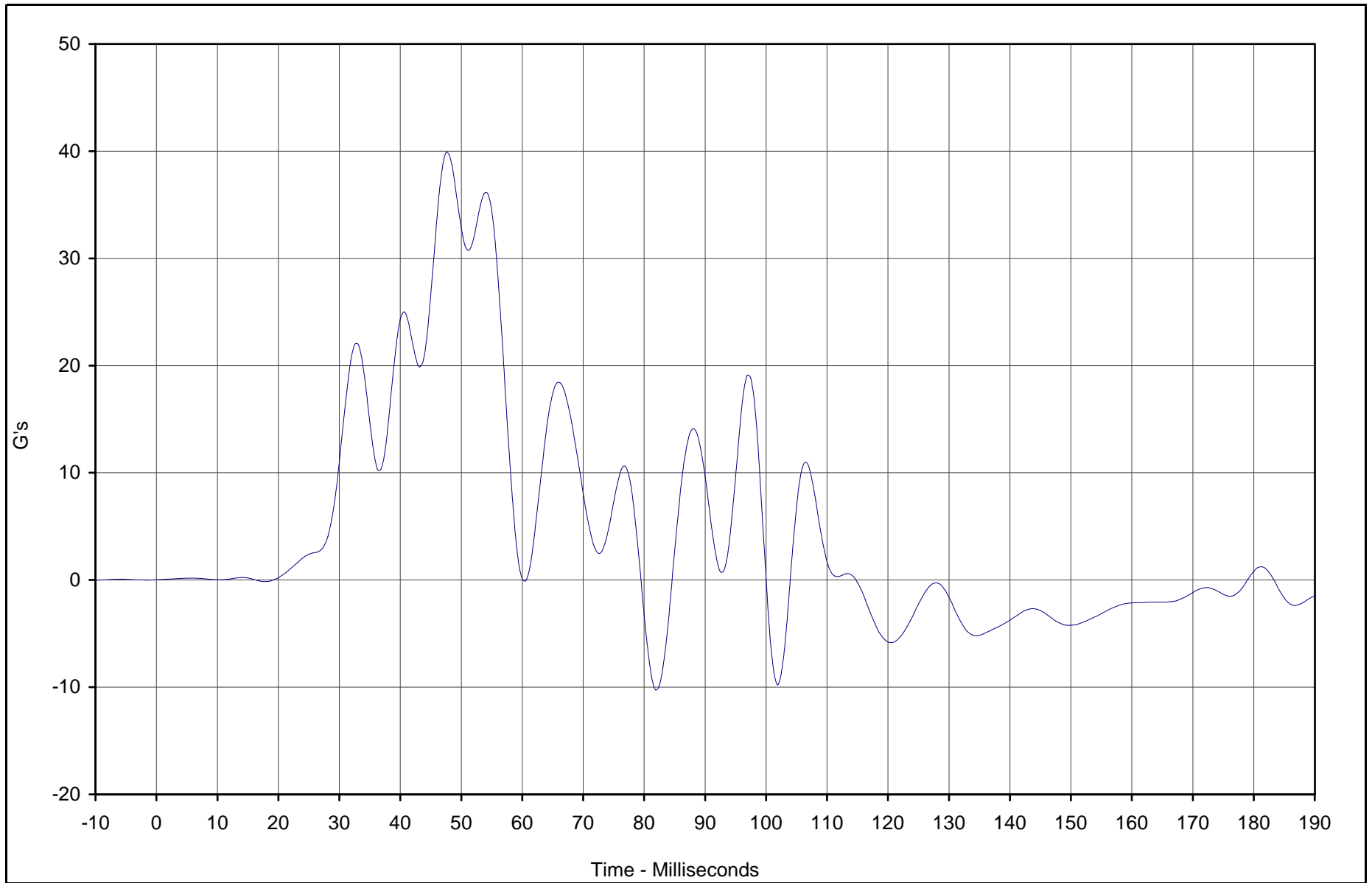

TR-P23003-01-NC

Curve Description	CURNO	Type	Units	Max	Time	Min	Time	SAE Class
Pass. Upper Rib Redundant Y	039	FIR	G's	39.9	47.5	-10.2	81.9	FIR100



Test Vehicle: 2003 Subaru Forester 2.5X AWD Wagon

Test Date: 10/29/02

Test Program: 55/28 km/h Side Impact NCAP

NHTSA No.: M35500

B-162

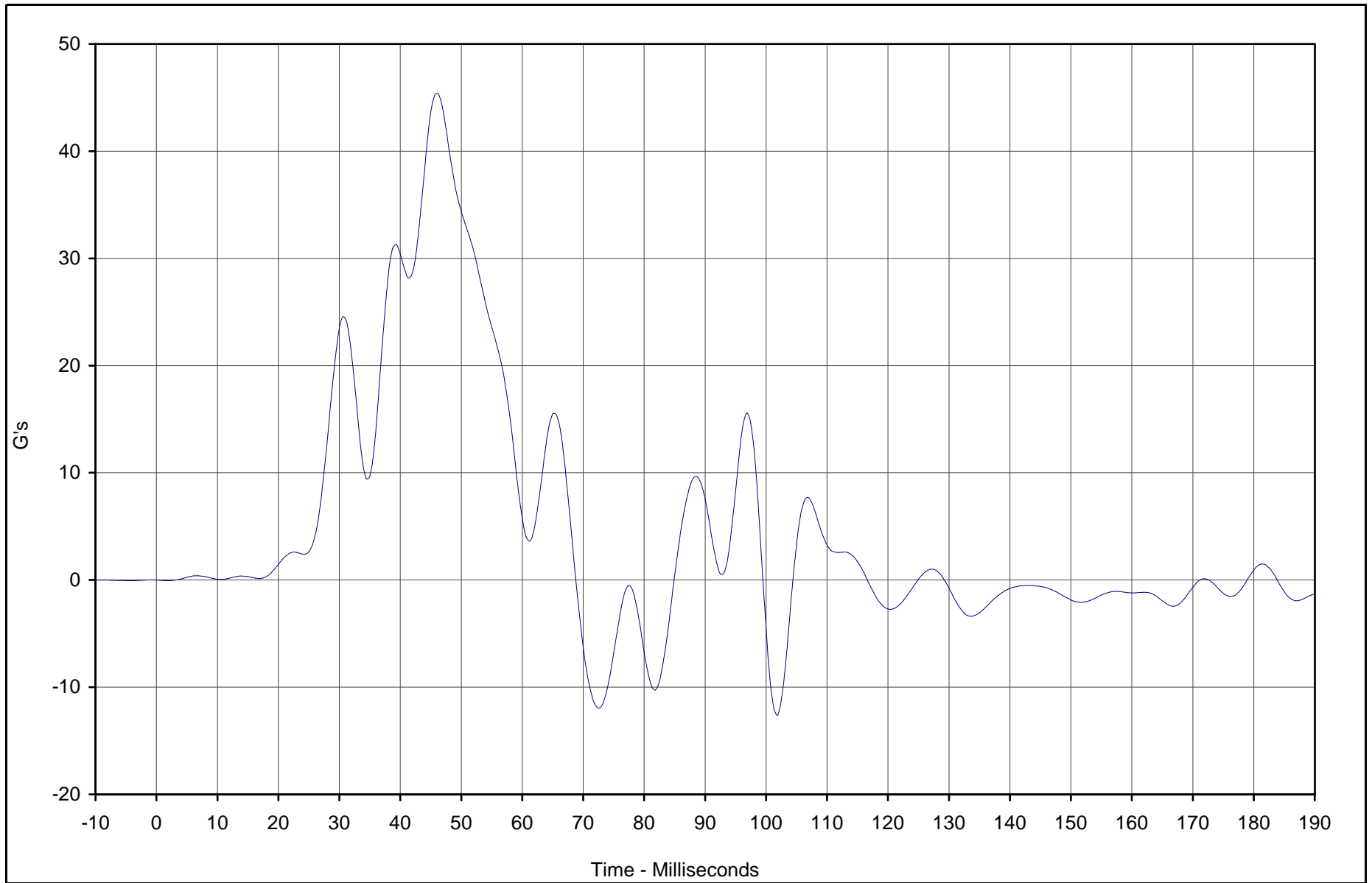

Curve Description	CURNO	Type	Units	Max	Time	Min	Time	SAE Class
Pass. Lower Rib Redundant Y	040	FIR	G's	45.3	46.3	-12.6	101.9	FIR100



Test Vehicle: 2003 Subaru Forester 2.5X AWD Wagon

Test Date: 10/29/02

Test Program: 55/28 km/h Side Impact NCAP

NHTSA No.: M35500

TR-P23003-01-NC

B-163

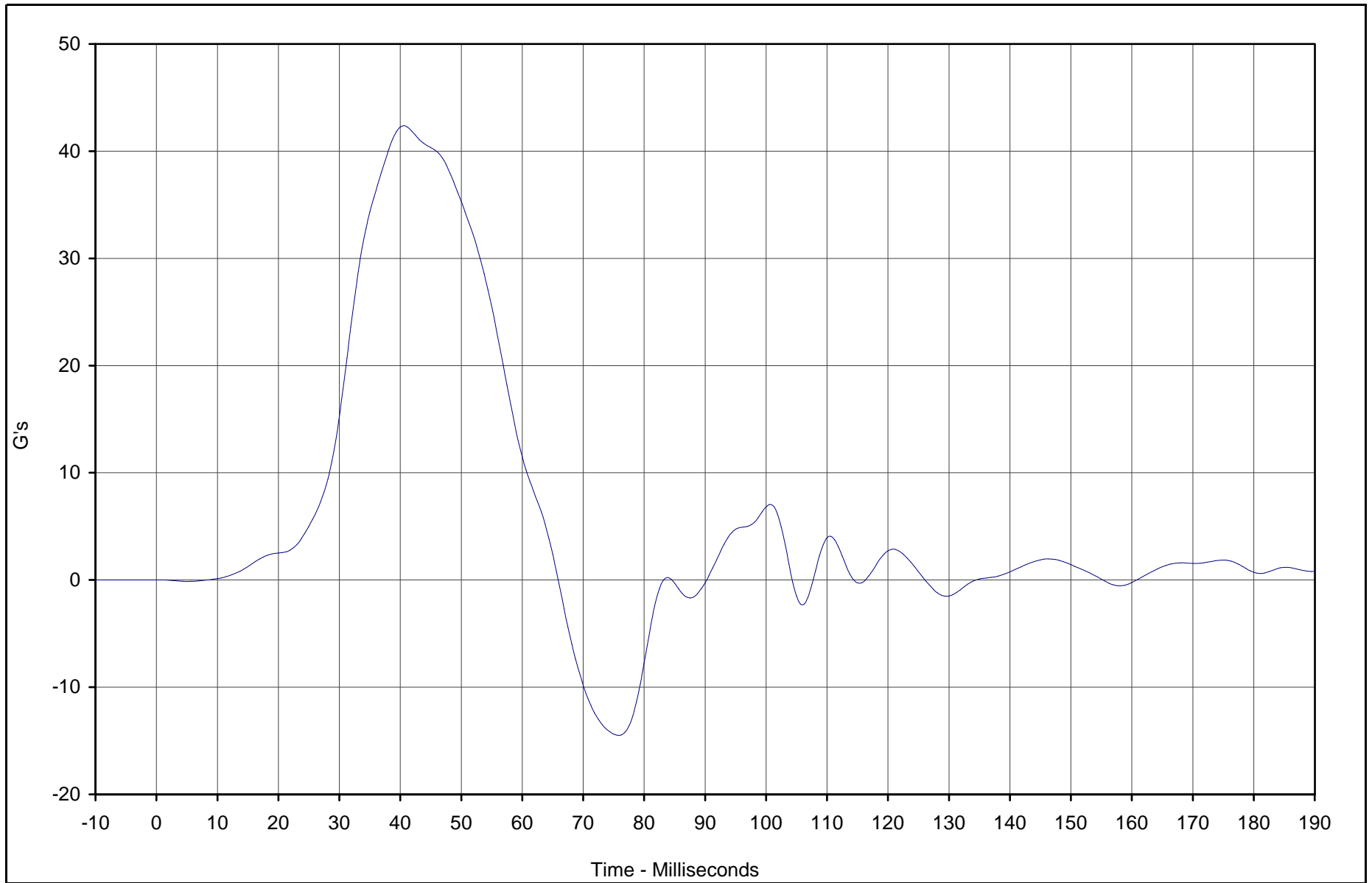

Curve Description	CURNO	Type	Units	Max	Time	Min	Time	SAE Class
Pass. Lower Spine Redundant Y	041	FIR	G's	42.4	40.6	-14.5	75.6	FIR100



Test Vehicle: 2003 Subaru Forester 2.5X AWD Wagon

Test Date: 10/29/02

Test Program: 55/28 km/h Side Impact NCAP

NHTSA No.: M35500

TR-P23003-01-NC

B-164

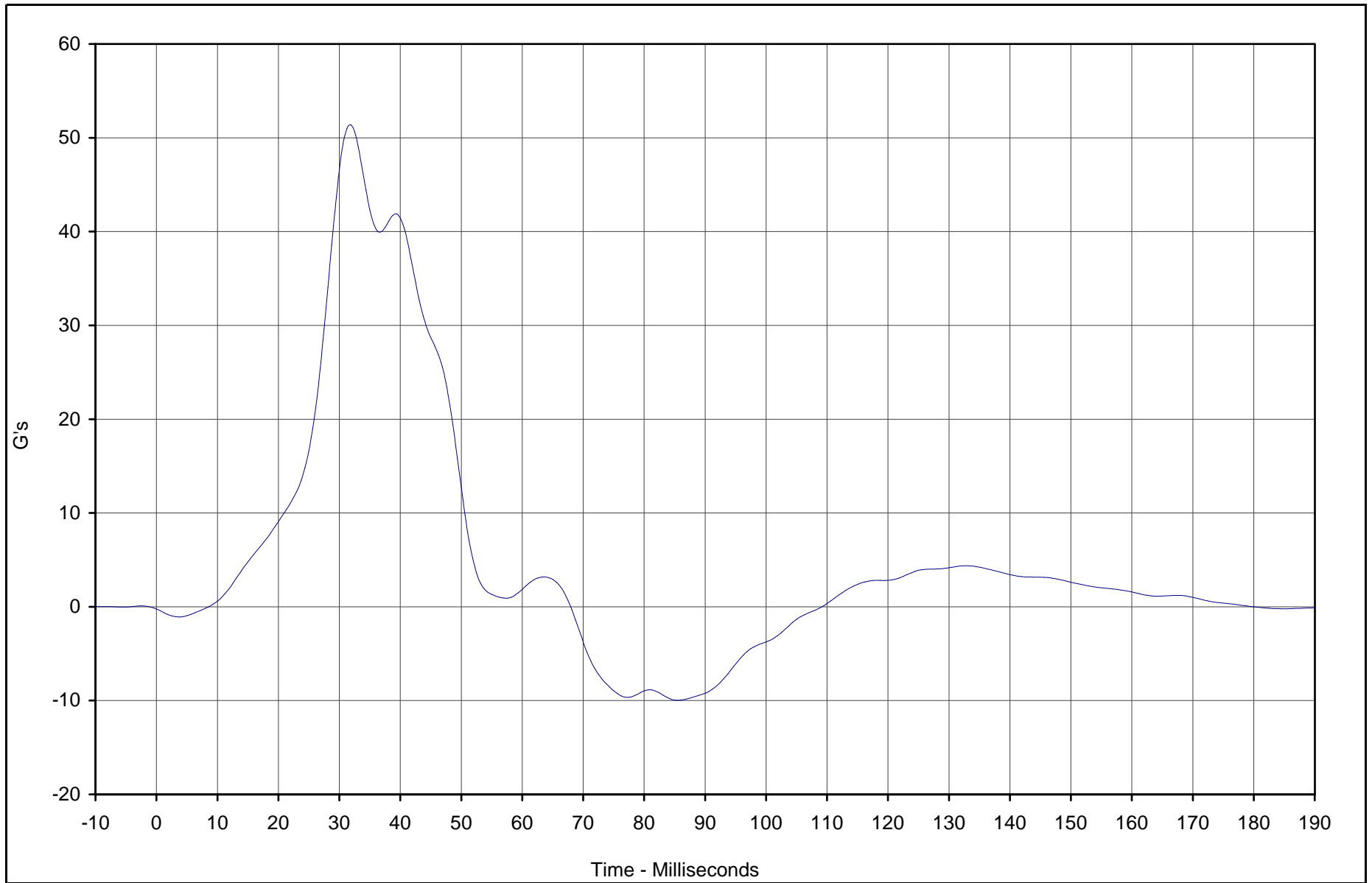

Curve Description	CURNO	Type	Units	Max	Time	Min	Time	SAE Class
Pass. Pelvis Redundant Y	042	FIR	G's	51.4	31.9	-10.0	85.6	FIR100



Test Vehicle: 2003 Subaru Forester 2.5X AWD Wagon

Test Date: 10/29/02

Test Program: 55/28 km/h Side Impact NCAP

NHTSA No.: M35500

TR-P23003-01-NC

APPENDIX C
SID CONFIGURATION AND PERFORMANCE VERIFICATION DATA

APPENDIX C
PRE-TEST SID / HIII CONFIGURATION AND PERFORMANCE VERIFICATION DATA



Calibration Data Sheet Side Impact Hybrid Dummy (SID/HIII) External Measurements

ATD Serial No.: 274

Tested Parameter	Units	Specification	Result	Pass/Fail
Laboratory Temperature	°C	18.9 to 25.6	21.1	Pass
Laboratory Relative Humidity	%	10 to 70	30	Pass
SH- Seated Height	mm	889 to 909	900	Pass
HP- Hip Point Height	mm	99 (reference)	99	Pass
RH- Rib Height	mm	502 to 520	515	Pass
KH- Knee Pivot From Back Line	mm	511 to 526	525	Pass
KV- Knee Pivot From Floor	mm	490 to 505	495	Pass
HW- Hip Width	mm	356 to 391	365	Pass
Overall Test Results				Pass

C-1

TR-P23003-01-NC

Laboratory Technician

October 25, 2002

Test Date



Calibration Data Sheet Side Impact Hybrid Dummy (SID/HIII) Thorax Lateral Impact

ATD Serial No.: 274

Test I.D.: TI10A

Tested Parameter	Units	Specification	Result	Pass/Fail
Laboratory Temperature	°C	18.9 to 25.6	21.1	Pass
Laboratory Relative Humidity	%	10 to 70	30	Pass
Probe Velocity	m/s	4.21 to 4.33	4.24	Pass
Upper Rib Acceleration	G's	37.0 to 46.0	38.6	Pass
Lower Rib Acceleration	G's	37.0 to 46.0	39.7	Pass
Thoracic Spine Acceleration	G's	15.0 to 22.0	17.8	Pass
Overall Test Results				Pass

C-2

TR-P23003-01-NC

Laboratory Technician

October 23, 2002

Test Date

C-3

TR-P23003-01-NC

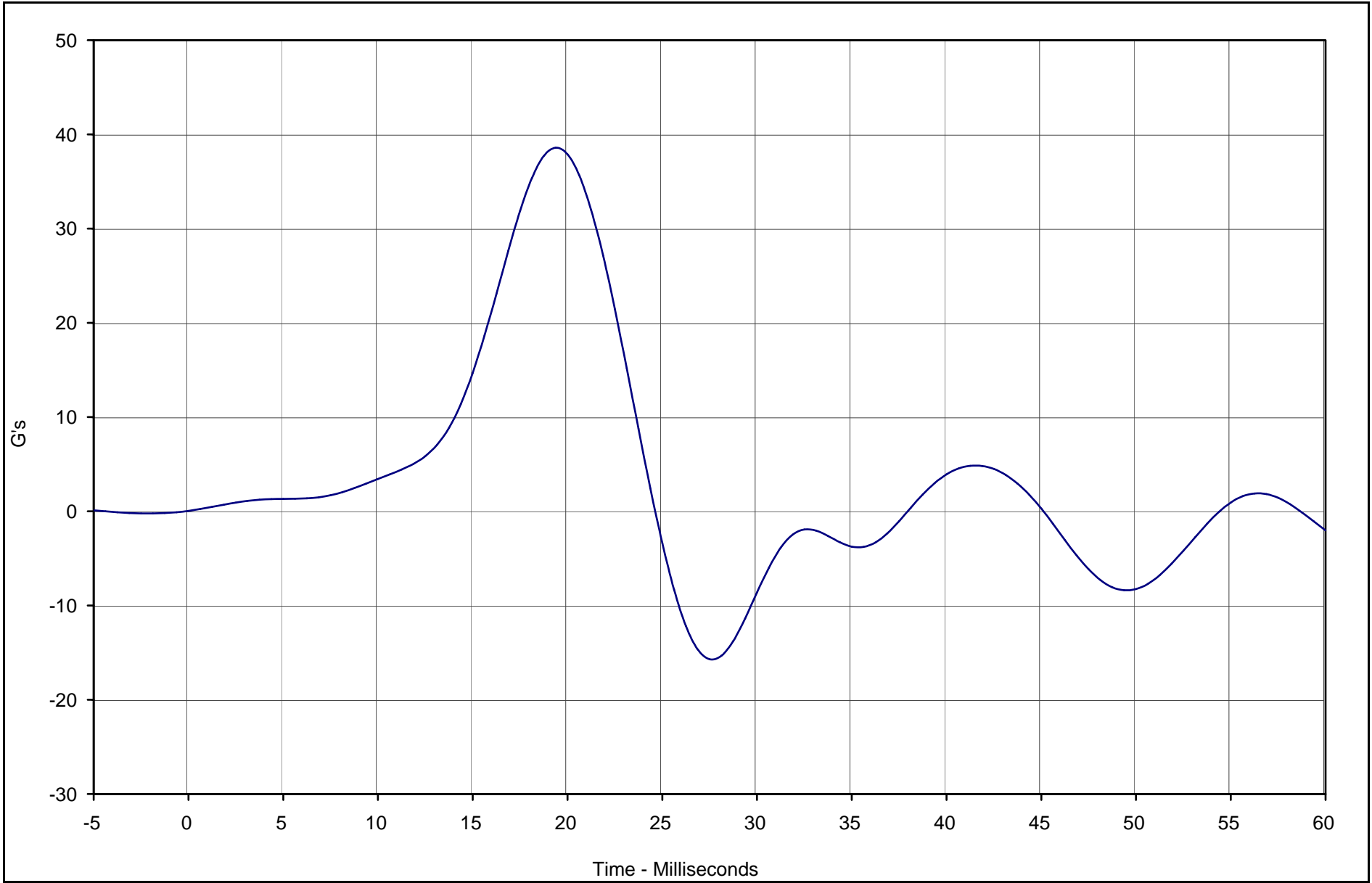

Curve Description	CURNO	Type	Units	Max	Time	Min	Time	SAE Class
Upper Rib Y Acceleration	001	FIL	G's	38.6	19.4	-15.7	27.5	FIR100



Test Vehicle: SID / HIII Thorax Lateral Impact

SID Serial No.: 274

Test Date: 10/23/02

Test I.D.: T110A

C-4

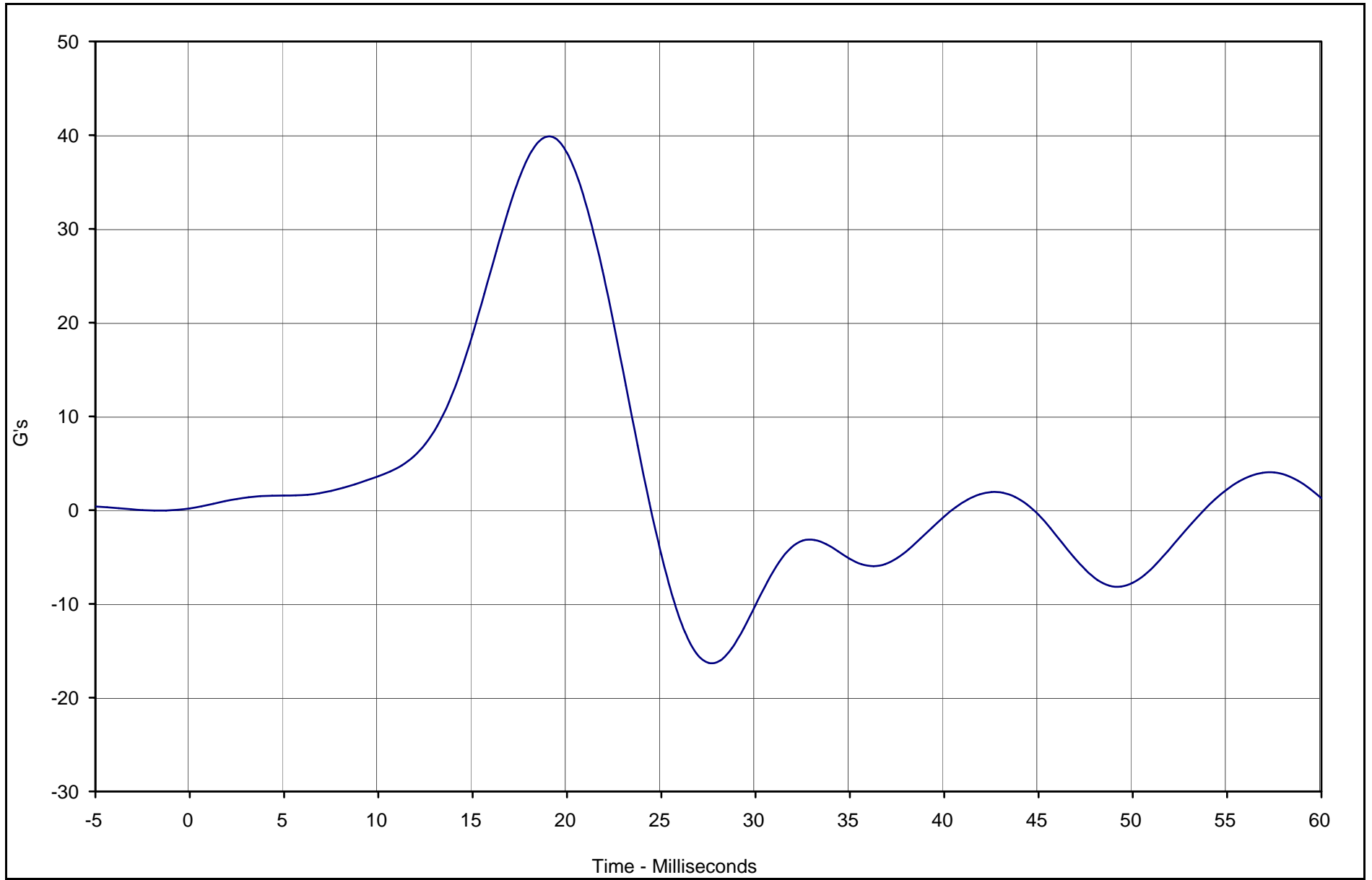

TR-P23003-01-NC

Curve Description	CURNO	Type	Units	Max	Time	Min	Time	SAE Class
Lower Rib Y Acceleration	002	FIL	G's	39.7	18.8	-16.3	27.5	FIR100



Test Vehicle: SID / HIII Thorax Lateral Impact

SID Serial No.: 274

Test Date: 10/23/02

Test I.D.: T110A

C-5

TR-P23003-01-NC

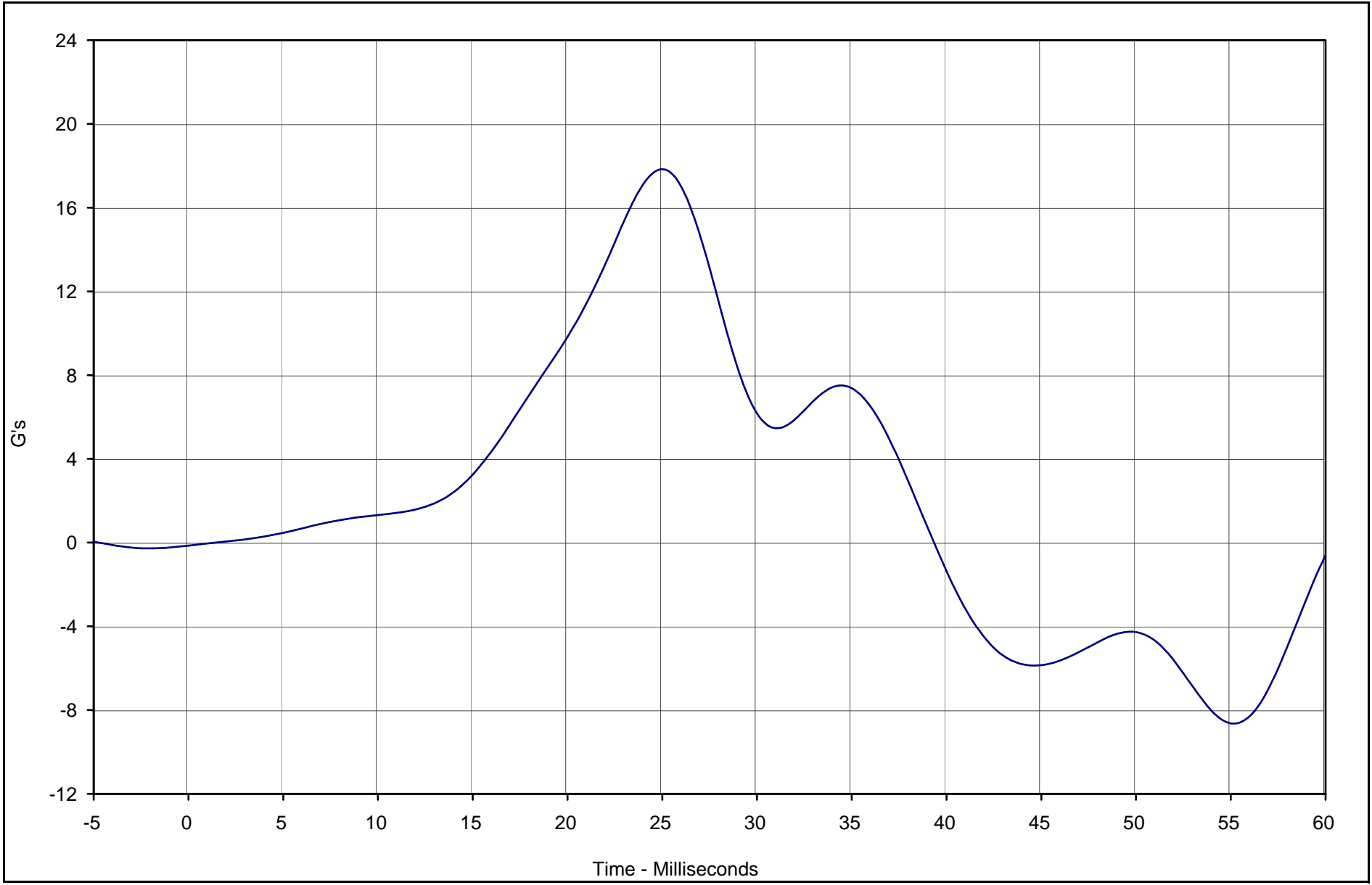

Curve Description	CURNO	Type	Units	Max	Time	Min	Time	SAE Class
Lower Spine Y Acceleration	003	FIL	G's	17.8	25.0	-8.6	55.0	FIR100



Test Vehicle: SID / HIII Thorax Lateral Impact

SID Serial No.: 274

Test Date: 10/23/02

Test I.D.: T110A



Calibration Data Sheet Side Impact Hybrid Dummy (SID/HIII) Pelvis Lateral Impact

ATD Serial No.: 274

Test I.D.: PI10A

Tested Parameter	Units	Specification	Result	Pass/Fail
Laboratory Temperature	°C	18.9 to 25.6	21.1	Pass
Laboratory Relative Humidity	%	10 to 70	30	Pass
Probe Velocity	m/s	4.21 to 4.33	4.28	Pass
Peak Pelvis Acceleration	G's	40.0 to 60.0	46.1	Pass
Acceleration Time Above 20 G's	Msec.	3.0 to 7.0	6.3	Pass
Overall Test Results				Pass

C-6

TR-P23003-01-NC

Laboratory Technician

October 23, 2002

Test Date

C-7

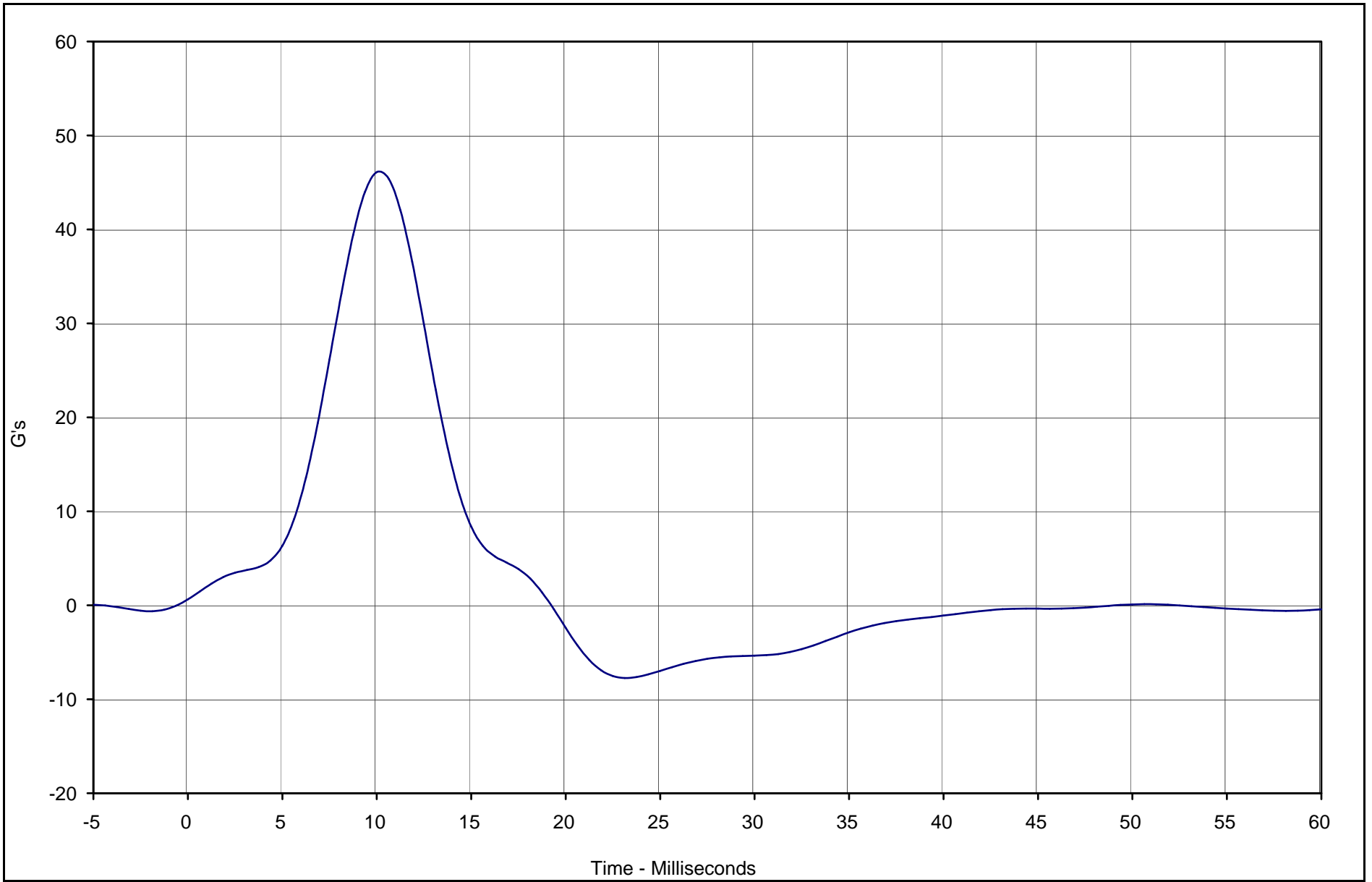

TR-P23003-01-NC

Curve Description	CURNO	Type	Units	Max	Time	Min	Time	SAE Class
Pelvis Y Acceleration	001	FIL	G's	46.1	10.0	-7.7	23.1	FIR100



Test Vehicle: Side Impact Dummy (SID) Pelvis Lateral Impact

SID Serial No.: 274

Test Date: 10/23/02

Test I.D.: PI10A



Calibration Data Sheet Side Impact Hybrid Dummy (SID/HIII) Head Drop Lateral Impact Test

ATD Serial No.: 274

Test I.D.: HD06A

Tested Parameter	Units	Specification	Result	Pass/Fail
Laboratory Temperature	°C	18.9 to 25.6	21.1	Pass
Laboratory Relative Humidity	%	10 to 70	30	Pass
Peak Resultant Acceleration	G's	120.0 to 150.0	130.1	Pass
Peak Longitudinal Acceleration	G's	≤15.0	13.3	Pass
Is Acceleration Unimodal?	Yes/No	Yes	Yes	Pass
Overall Test Results				Pass

C-8

TR-P23003-01-NC

Laboratory Technician

October 24, 2002

Test Date

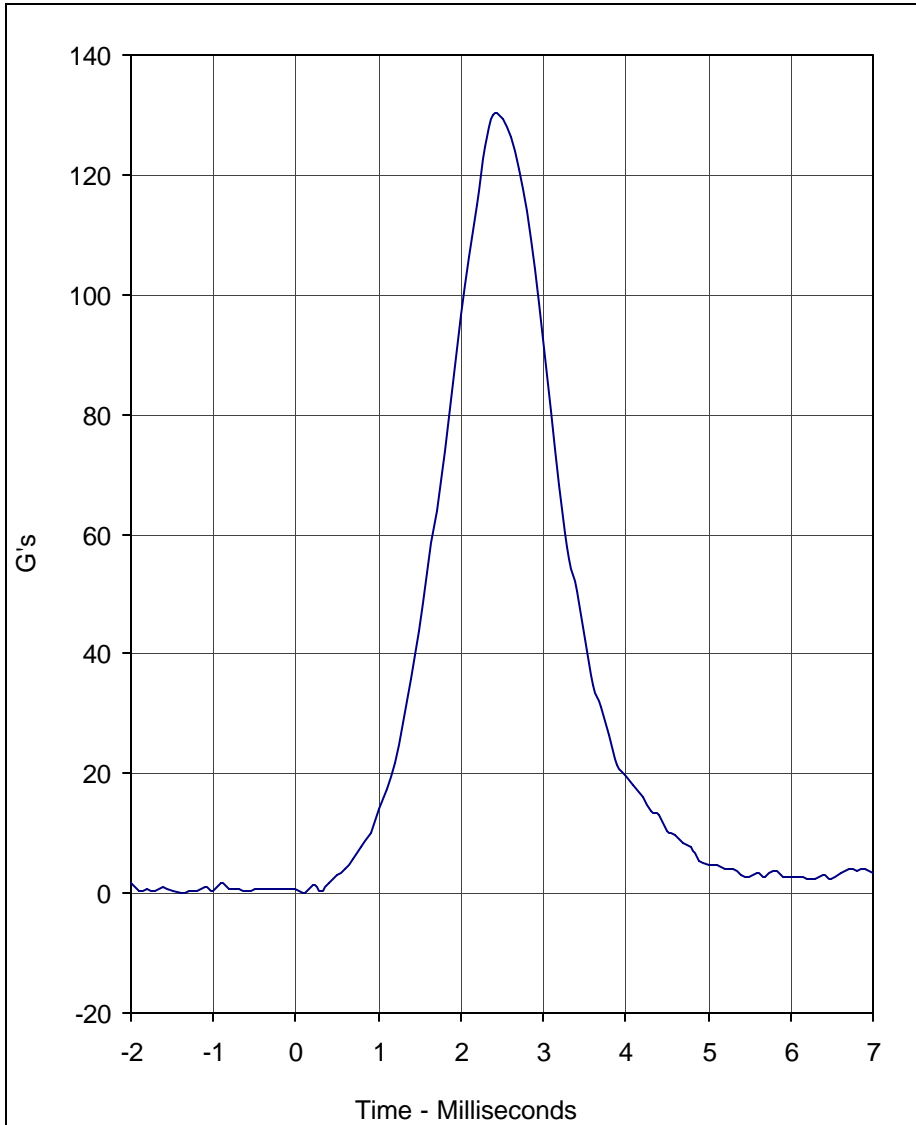

Curve Description	CURNO	Type
Head Resultant	001	RES

Units	Max	Time	Min	Time	SAE Class
G's	130.1	2.4	0.0	0.1	1000

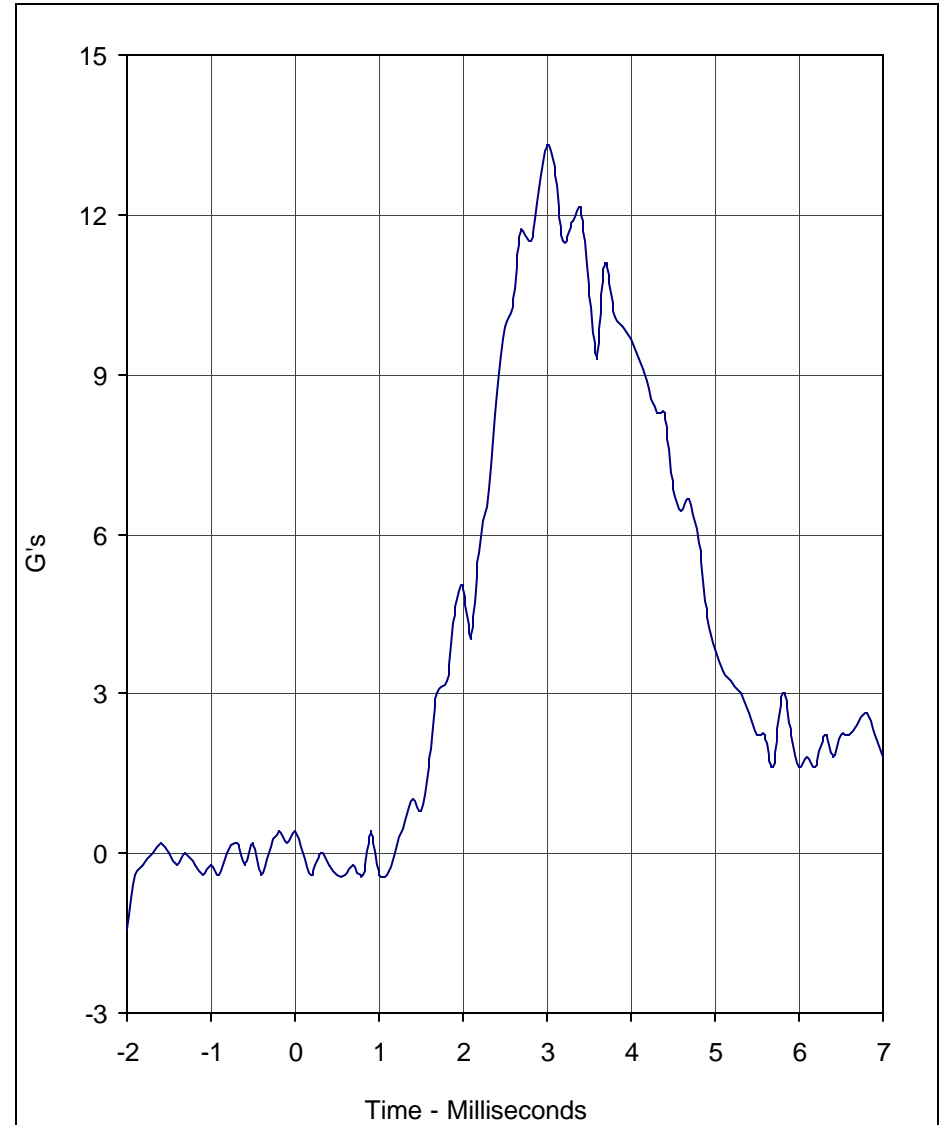

Curve Description	CURNO	Type
Head X	002	FIL

Units	Max	Time	Min	Time	SAE Class
G's	13.3	3.0	-1.4	-2.0	1000

Test Program: SID / HIII Head Drop Lateral Impact Test
 Test Date: 10/24/02

A.T.D. Serial No.: 274
 Test I.D.: HD06A





Calibration Data Sheet Side Impact Hybrid Dummy (SID/HIII) Neck Pendulum Lateral Test

ATD Serial No.: 274

Test I.D.: NB10B

Tested Parameter	Units	Specification	Result	Pass/Fail	
Laboratory Temperature	°C	20.6 to 22.2	21.1	Pass	
Laboratory Relative Humidity	%	10 to 70	30	Pass	
Pendulum Velocity	m/s	6.89 to 7.13	6.98	Pass	
Pendulum Deceleration	10	Msec.	1.96 to 2.55	1.97	Pass
	20	Msec.	4.12 to 5.10	4.31	Pass
	30	Msec.	5.73 to 7.01	6.45	Pass
	40 to 70	Msec.	6.27 to 7.64	7.13	Pass
Maximum "D" Plane Rotation	Degrees	66.0 to 82.0	81.0	Pass	
Maximum "D" Plane Rotation Time After Peak Moment	Msec.	2.0 to 15.0	13.8	Pass	
"D" Plane Rotation Decay Time From Peak Angle to Zero Angle	Msec.	58.0 to 67.0	66.4	Pass	
Calculated Moment About Occipital Condyle	N•m	73.0 to 88.0	77.1	Pass	
Moment About Occipital Condyle Decay, Time From Positive Peak Value To 0 N•m	Msec.	49.0 to 64.0	49.1	Pass	
			Overall Test Results	Pass	

C-10

TR-P23003-01-NC

Laboratory Technician

October 25, 2002

Test Date

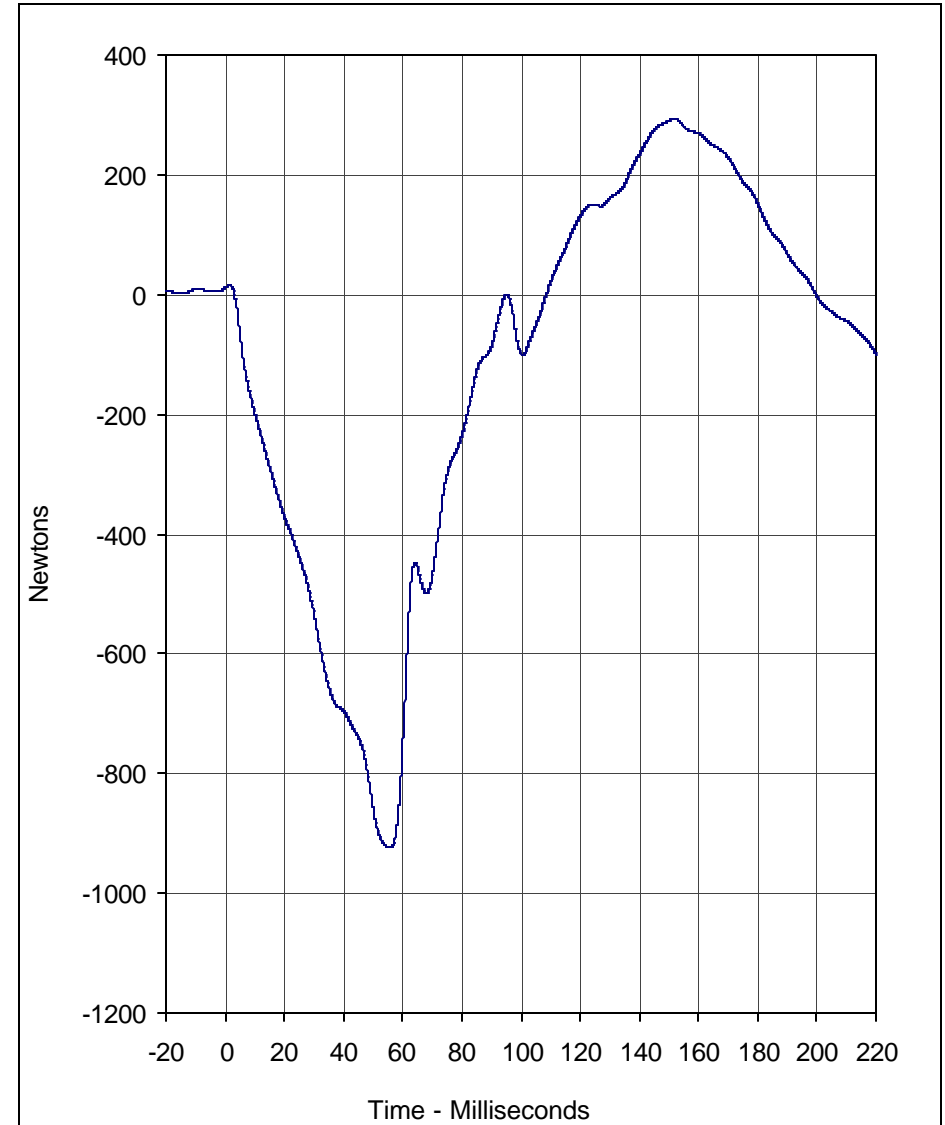
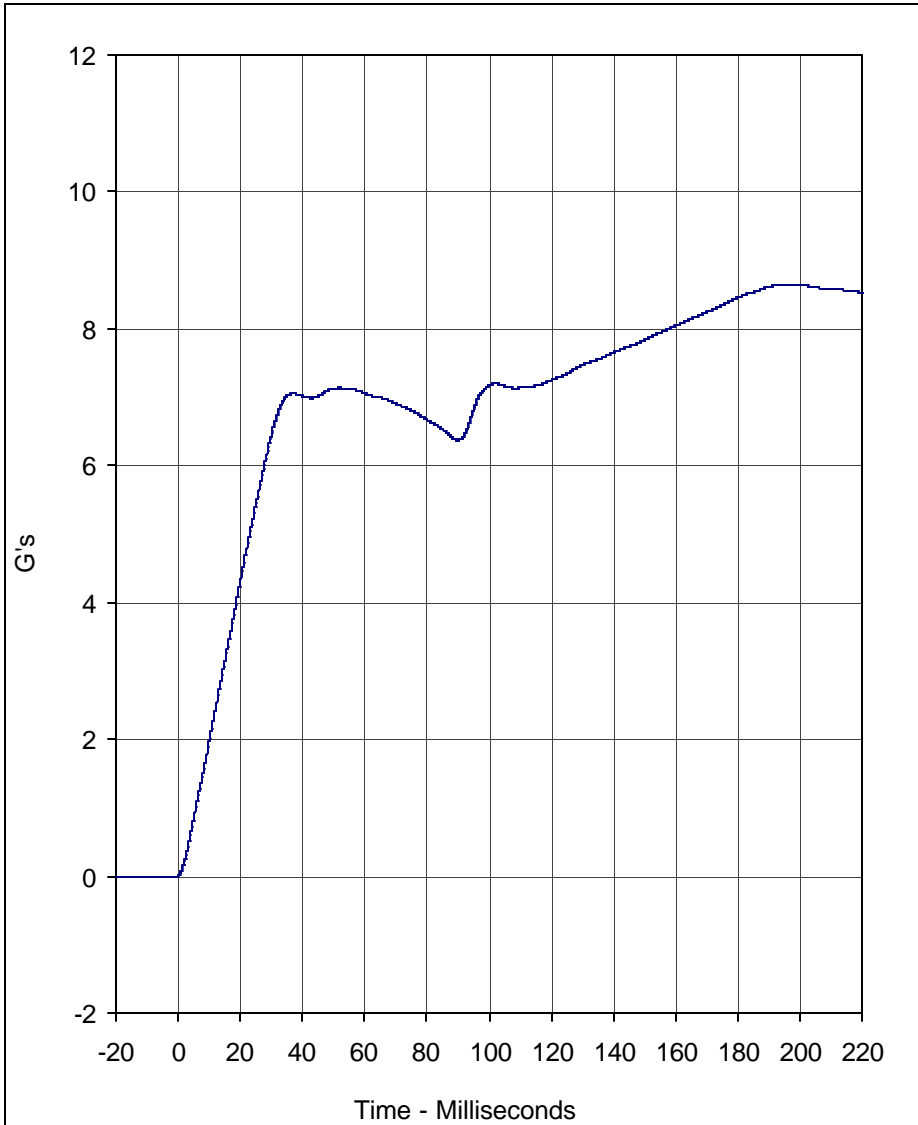

Curve Description	CURNO	Type
Pendulum Velocity	001	FIL

Curve Description	CURNO	Type
Neck Force Y	002	FIL

Units	Max	Time	Min	Time	SAE Class
G's	8.6	198.4	0.0	-1.6	60

Units	Max	Time	Min	Time	SAE Class
Newtons	294.0	151.6	-924.4	55.6	60

Test Program: SID / HIII Neck Pendulum Lateral Test
 Test Date: 10/25/02

A.T.D. Serial No.: 274
 Test I.D.: NB10B



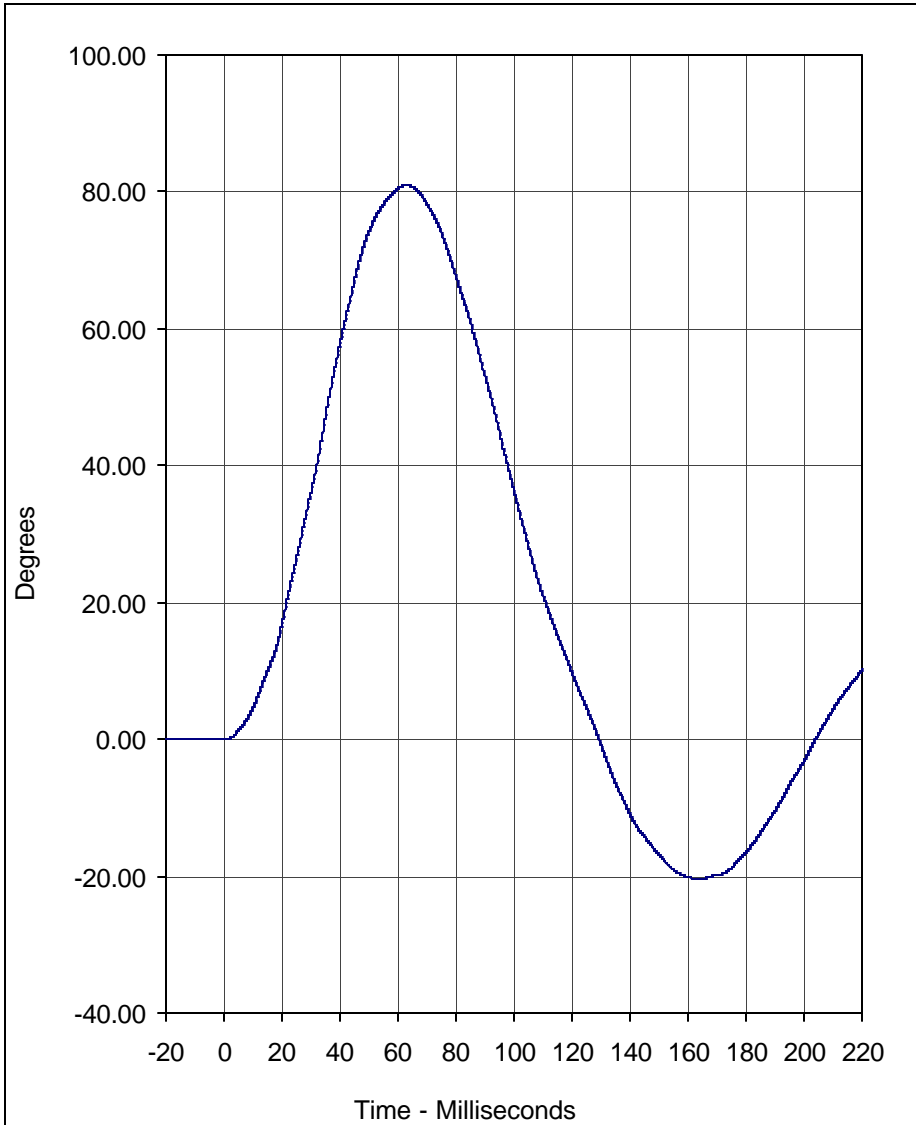

Curve Description	CURNO	Type
"D" Plane Rotation	003	FIL

Units	Max	Time	Min	Time	SAE Class
Degrees	81.0	62.9	-20.5	163.7	60

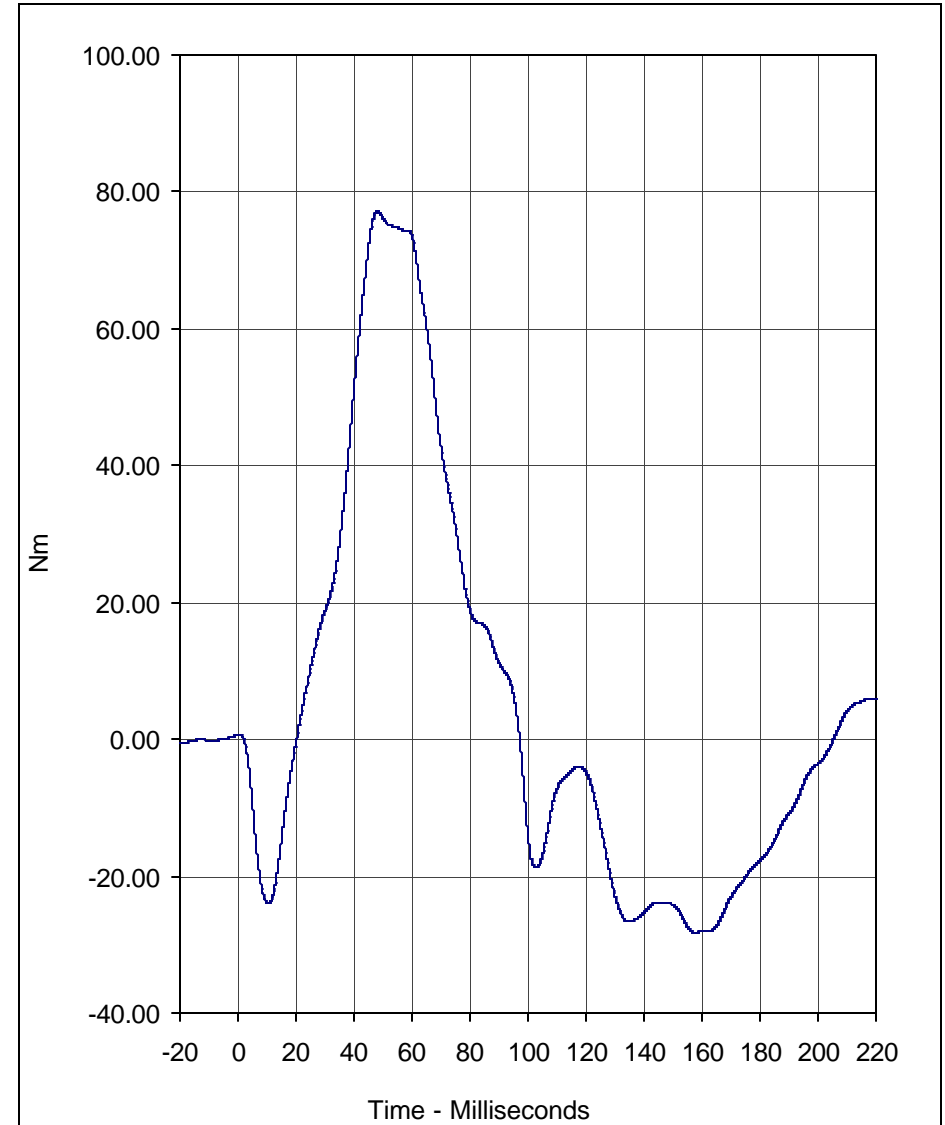

Curve Description	CURNO	Type
Moment About Occipital Condyle	004	FIL

Units	Max	Time	Min	Time	SAE Class
Nm	77.1	48.1	-28.3	157.5	60

Test Program: SID / HIII Neck Pendulum Lateral Test
 Test Date: 10/25/02

A.T.D. Serial No.: 274
 Test I.D.: NB10B





Calibration Data Sheet Side Impact Hybrid Dummy (SID/HIII) External Measurements

ATD Serial No.: 275

Tested Parameter	Units	Specification	Result	Pass/Fail
Laboratory Temperature	°C	18.9 to 25.6	21.1	Pass
Laboratory Relative Humidity	%	10 to 70	30	Pass
SH- Seated Height	mm	889 to 909	905	Pass
HP- Hip Point Height	mm	99 (reference)	99	Pass
RH- Rib Height	mm	502 to 520	515	Pass
KH- Knee Pivot From Back Line	mm	511 to 526	515	Pass
KV- Knee Pivot From Floor	mm	490 to 505	495	Pass
HW- Hip Width	mm	356 to 391	385	Pass
Overall Test Results				Pass

C-13

TR-P23003-01-NC

Laboratory Technician

October 25, 2002

Test Date



Calibration Data Sheet Side Impact Hybrid Dummy (SID/HIII) Thorax Lateral Impact

ATD Serial No.: 275

Test I.D.: TI10B

Tested Parameter	Units	Specification	Result	Pass/Fail
Laboratory Temperature	°C	18.9 to 25.6	21.1	Pass
Laboratory Relative Humidity	%	10 to 70	30	Pass
Probe Velocity	m/s	4.21 to 4.33	4.24	Pass
Upper Rib Acceleration	G's	37.0 to 46.0	41.5	Pass
Lower Rib Acceleration	G's	37.0 to 46.0	40.9	Pass
Thoracic Spine Acceleration	G's	15.0 to 22.0	16.8	Pass
Overall Test Results				Pass

C-14

TR-P23003-01-NC

Laboratory Technician

October 23, 2002

Test Date

C-15

TR-P23003-01-NC

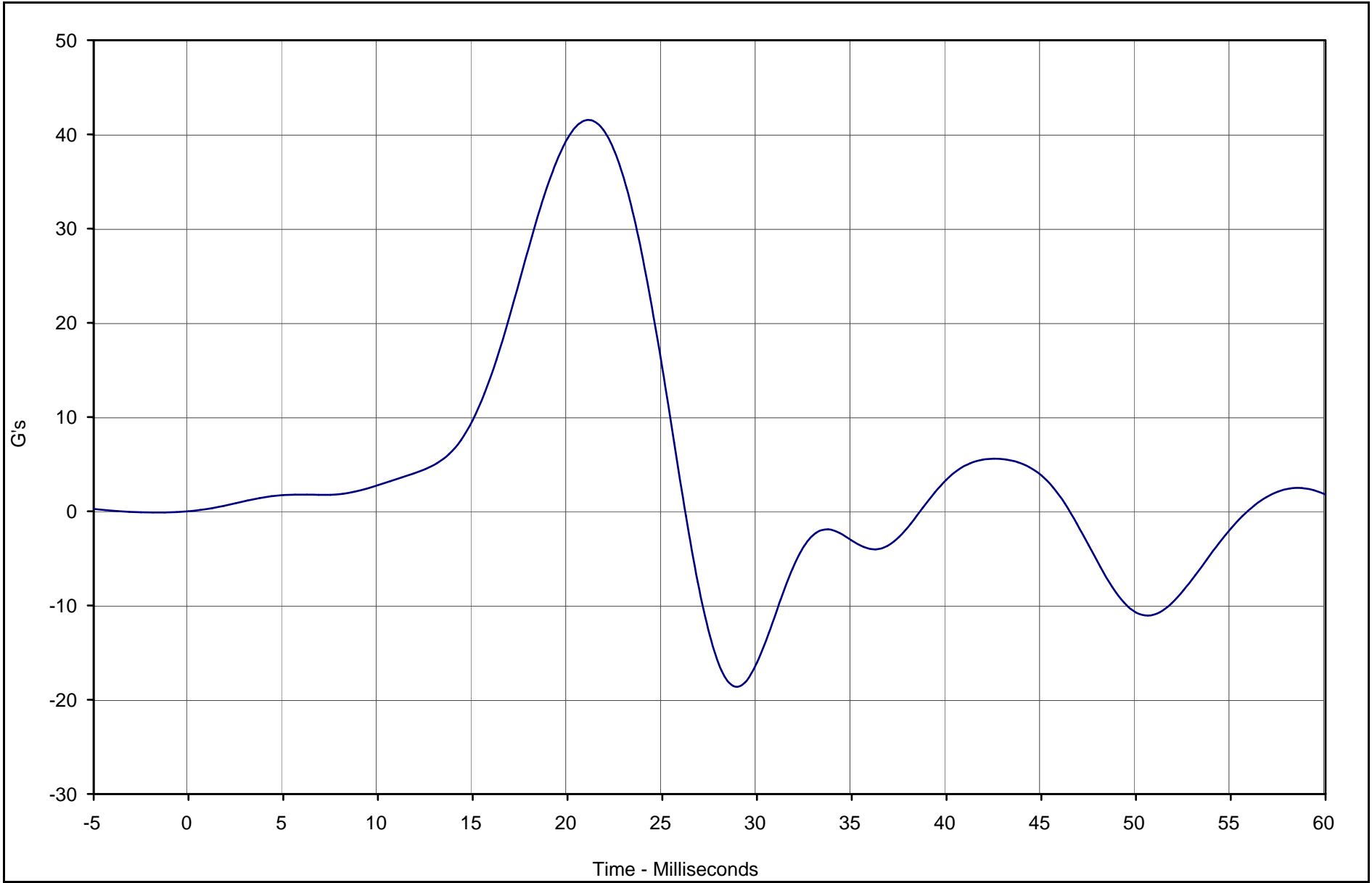

Curve Description	CURNO	Type	Units	Max	Time	Min	Time	SAE Class
Upper Rib Y Acceleration	001	FIL	G's	41.5	21.3	-18.5	28.8	FIR100



Test Vehicle: SID / HIII Thorax Lateral Impact

SID Serial No.: 275

Test Date: 10/23/02

Test I.D.: T110B

C-16

TR-P23003-01-NC

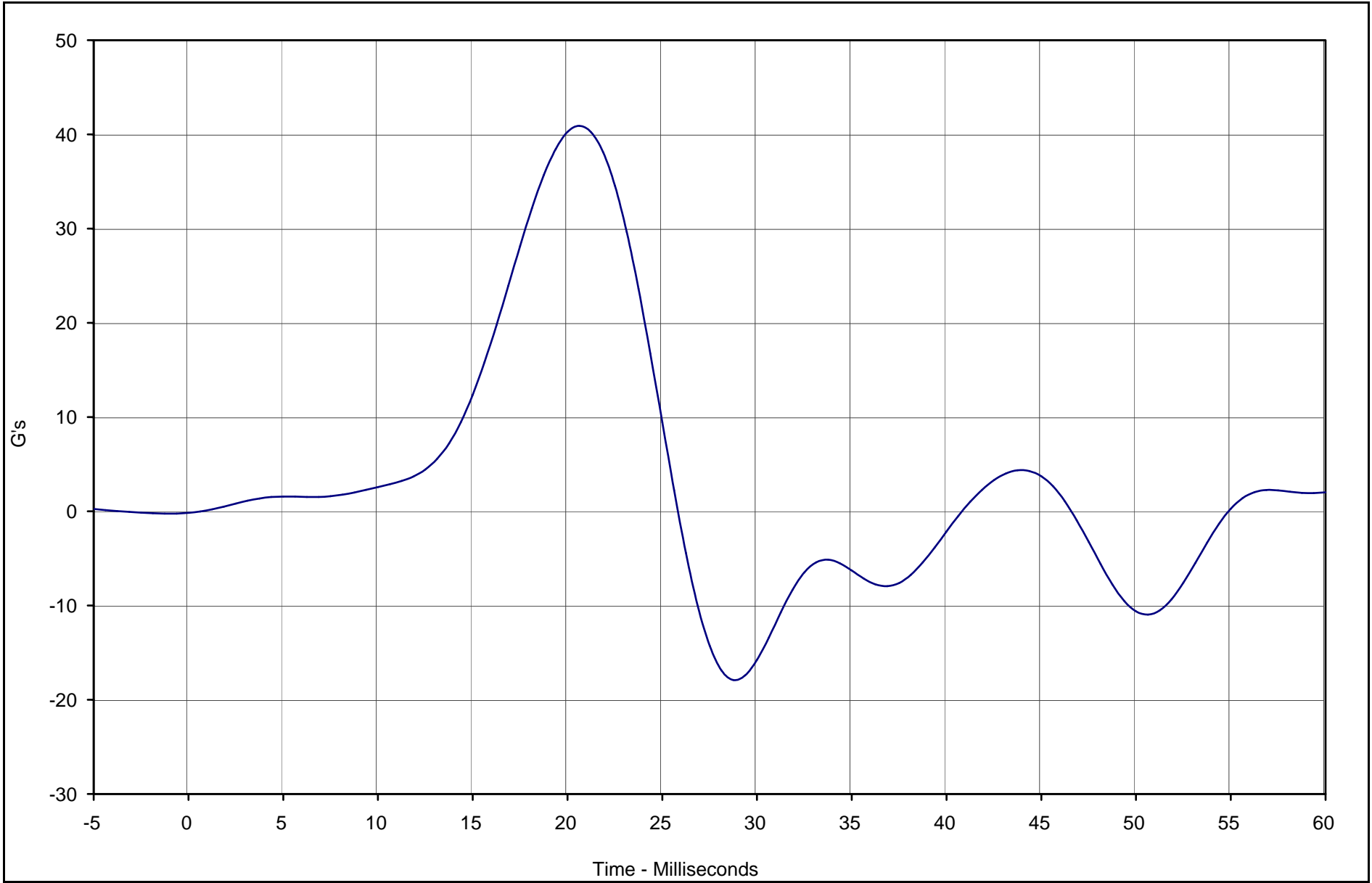

Curve Description	CURNO	Type	Units	Max	Time	Min	Time	SAE Class
Lower Rib Y Acceleration	002	FIL	G's	40.9	20.6	-17.9	28.8	FIR100



Test Vehicle: SID / HIII Thorax Lateral Impact

SID Serial No.: 275

Test Date: 10/23/02

Test I.D.: T110B

C-17

TR-P23003-01-NC

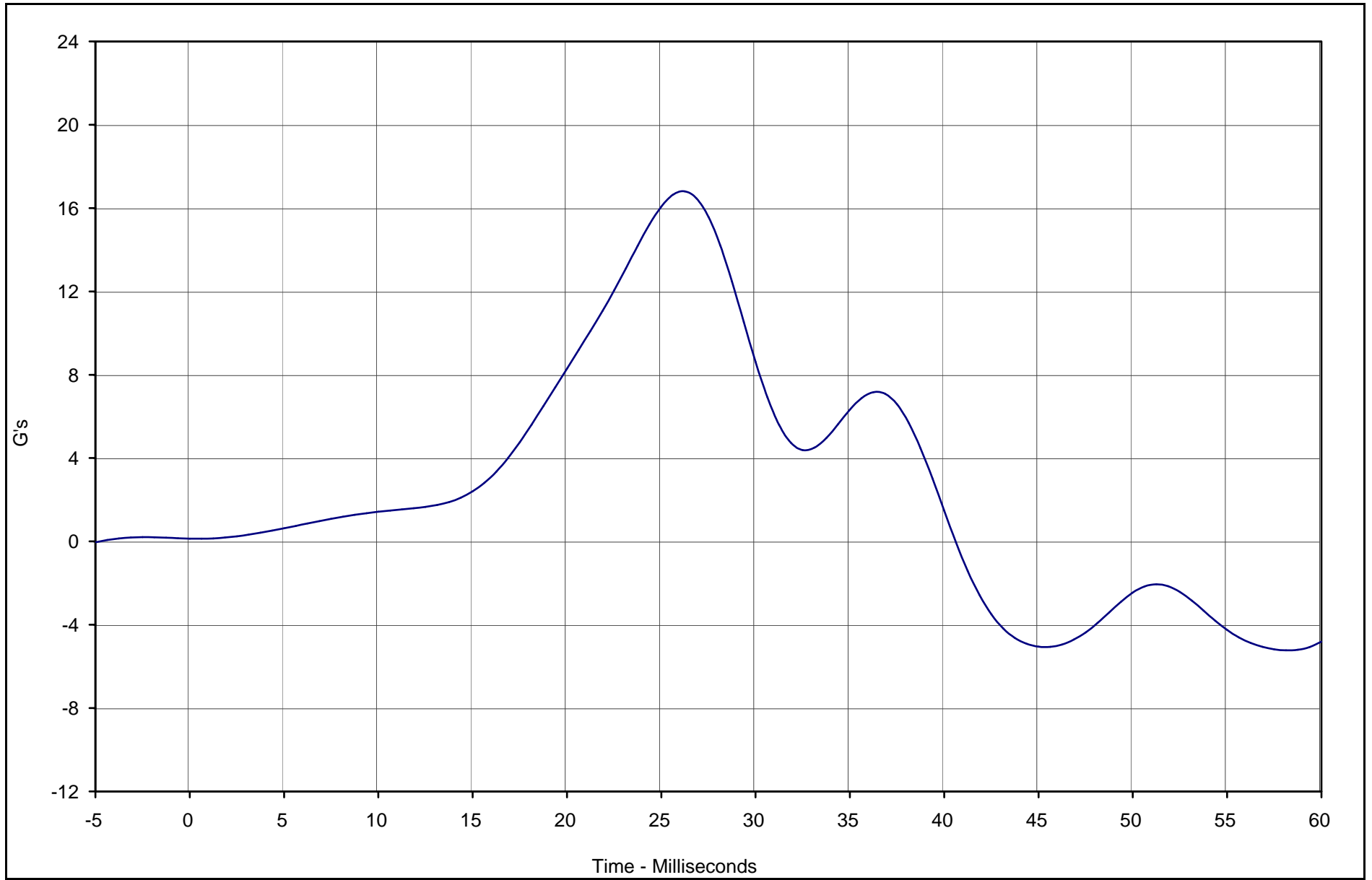

Curve Description	CURNO	Type	Units	Max	Time	Min	Time	SAE Class
Lower Spine Y Acceleration	003	FIL	G's	16.8	26.3	-5.2	58.1	FIR100



Test Vehicle: SID / HIII Thorax Lateral Impact

SID Serial No.: 275

Test Date: 10/23/02

Test I.D.: T110B



Calibration Data Sheet

Side Impact Hybrid Dummy (SID/HIII)

Pelvis Lateral Impact

ATD Serial No.: 275

Test I.D.: PI10B

Tested Parameter	Units	Specification	Result	Pass/Fail
Laboratory Temperature	°C	18.9 to 25.6	21.1	Pass
Laboratory Relative Humidity	%	10 to 70	30	Pass
Probe Velocity	m/s	4.21 to 4.33	4.28	Pass
Peak Pelvis Acceleration	G's	40.0 to 60.0	47.5	Pass
Acceleration Time Above 20 G's	Msec.	3.0 to 7.0	6.9	Pass
Overall Test Results				Pass

C-18

TR-P23003-01-NC

Laboratory Technician

October 23, 2002
Test Date

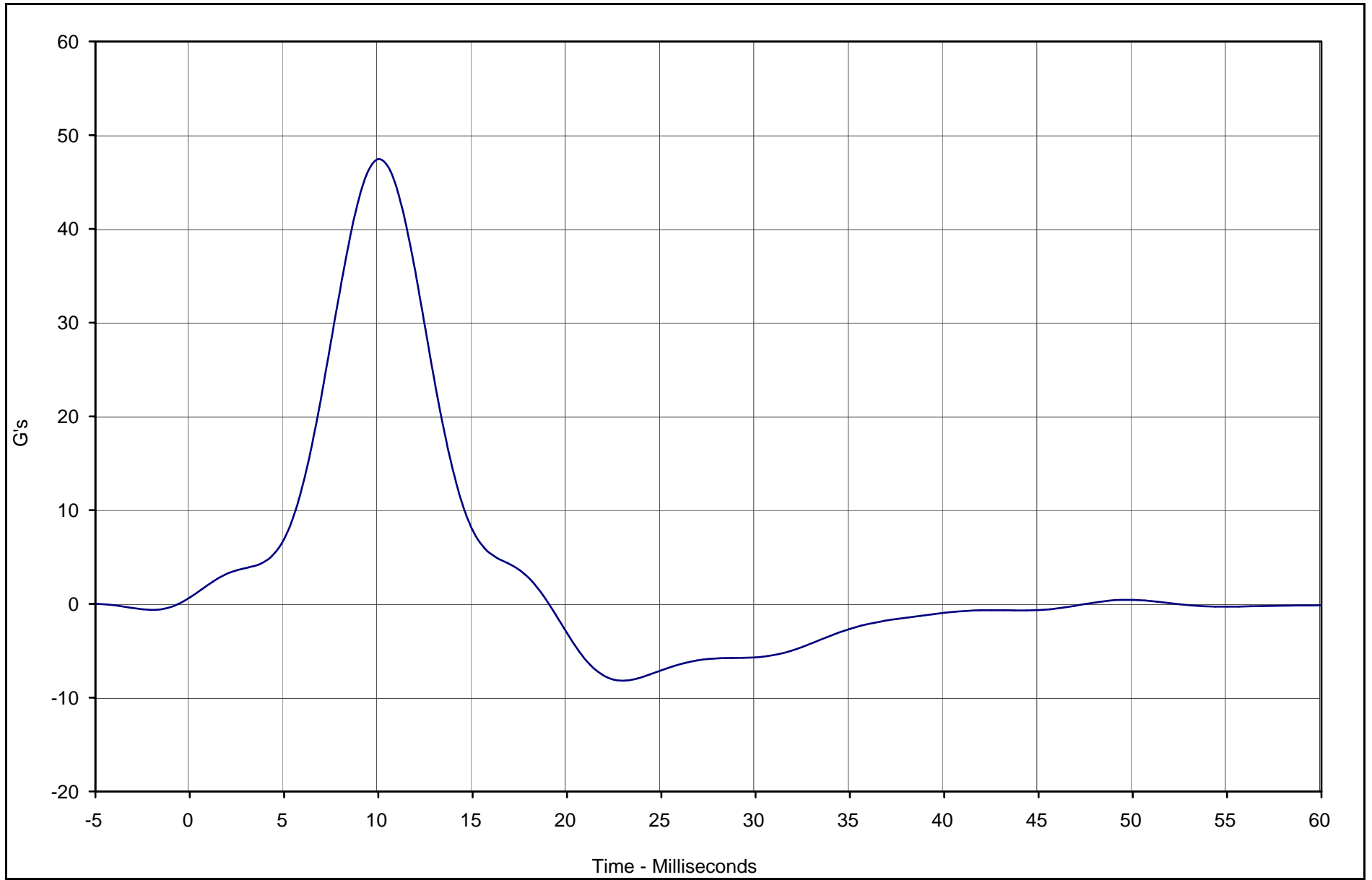

Curve Description	CURNO	Type	Units	Max	Time	Min	Time	SAE Class
Pelvis Y Acceleration	001	FIL	G's	47.5	10.0	-8.2	23.1	FIR100



Test Vehicle: Side Impact Dummy (SID) Pelvis Lateral Impact

SID Serial No.: 275

Test Date: 10/23/02

Test I.D.: PI10B



Calibration Data Sheet Side Impact Hybrid Dummy (SID/HIII) Head Drop Lateral Impact Test

ATD Serial No.: 275

Test I.D.: HD06A

Tested Parameter	Units	Specification	Result	Pass/Fail
Laboratory Temperature	°C	18.9 to 25.6	21.1	Pass
Laboratory Relative Humidity	%	10 to 70	30	Pass
Peak Resultant Acceleration	G's	120.0 to 150.0	133.7	Pass
Peak Longitudinal Acceleration	G's	≤15.0	11.6	Pass
Is Acceleration Unimodal?	Yes/No	Yes	Yes	Pass
Overall Test Results				Pass

C-20

TR-P23003-01-NC

Laboratory Technician

October 24, 2002

Test Date

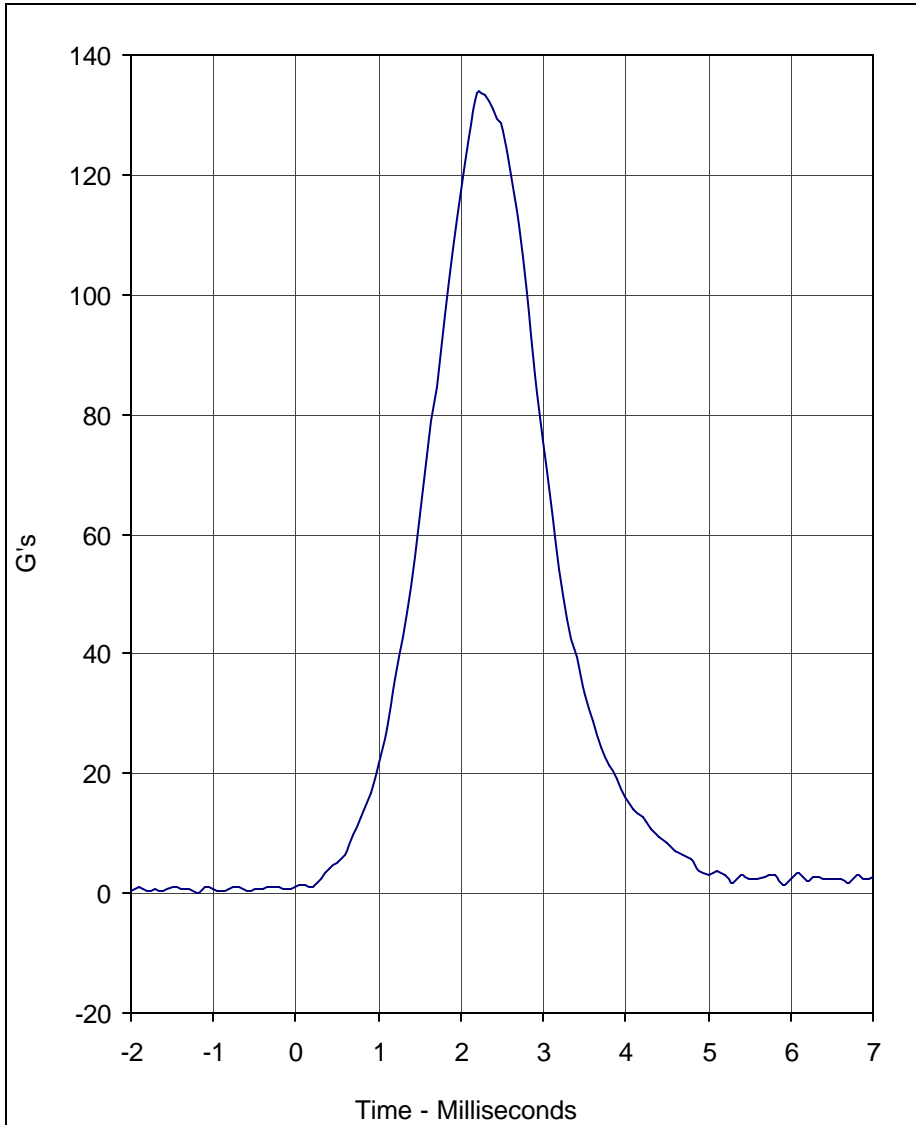

Curve Description	CURNO	Type
Head Resultant	001	RES

Units	Max	Time	Min	Time	SAE Class
G's	133.7	2.2	0.2	-1.2	1000

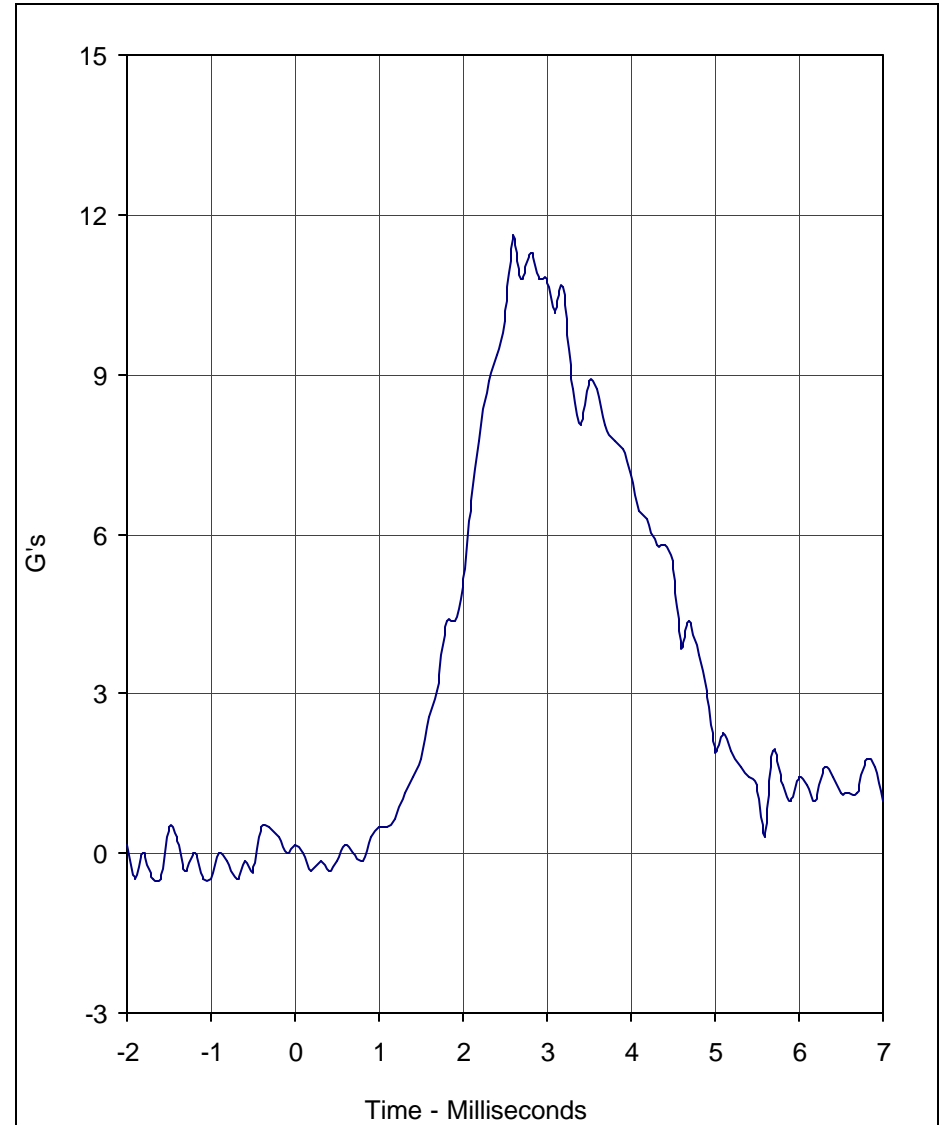

Curve Description	CURNO	Type
Head X	002	FIL

Units	Max	Time	Min	Time	SAE Class
G's	11.6	2.6	-0.5	-1.9	1000

Test Program: SID / HIII Head Drop Lateral Impact Test
 Test Date: 10/24/02

A.T.D. Serial No.: 275
 Test I.D.: HD06A





Calibration Data Sheet Side Impact Hybrid Dummy (SID/HIII) Neck Pendulum Lateral Test

ATD Serial No.: 275

Test I.D.: NB10C

Tested Parameter	Units	Specification	Result	Pass/Fail	
Laboratory Temperature	°C	20.6 to 22.2	21.1	Pass	
Laboratory Relative Humidity	%	10 to 70	30	Pass	
Pendulum Velocity	m/s	6.89 to 7.13	7.01	Pass	
Pendulum Deceleration	10	Msec.	1.96 to 2.55	2.30	Pass
	20	Msec.	4.12 to 5.10	4.78	Pass
	30	Msec.	5.73 to 7.01	6.86	Pass
	40 to 70	Msec.	6.27 to 7.64	7.13	Pass
Maximum "D" Plane Rotation	Degrees	66.0 to 82.0	78.4	Pass	
Maximum "D" Plane Rotation Time After Peak Moment	Msec.	2.0 to 15.0	9.7	Pass	
"D" Plane Rotation Decay Time From Peak Angle to Zero Angle	Msec.	58.0 to 67.0	62.8	Pass	
Calculated Moment About Occipital Condyle	N•m	73.0 to 88.0	86.7	Pass	
Moment About Occipital Condyle Decay, Time From Positive Peak Value To 0 N•m	Msec.	49.0 to 64.0	51.1	Pass	
			Overall Test Results	Pass	

C-22

TR-P23003-01-NC

Laboratory Technician

October 25, 2002

Test Date

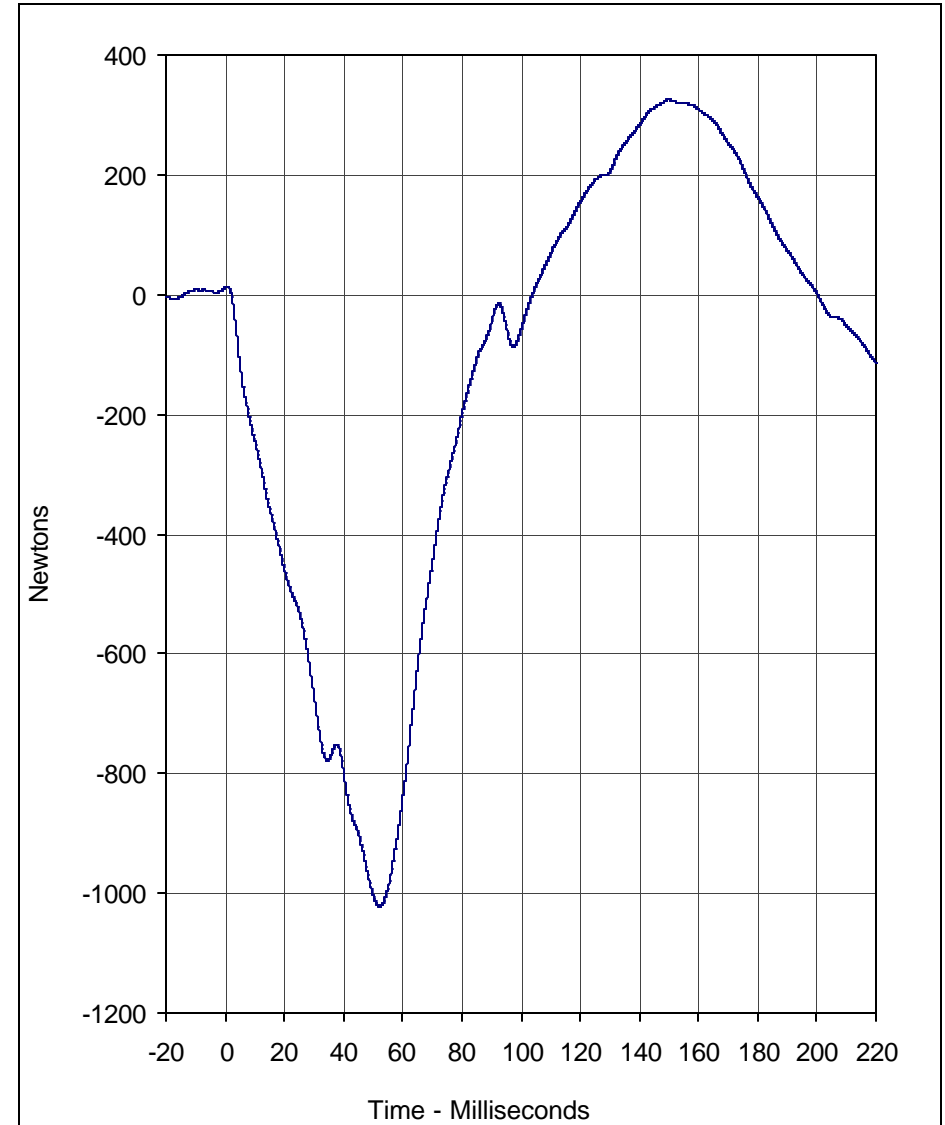
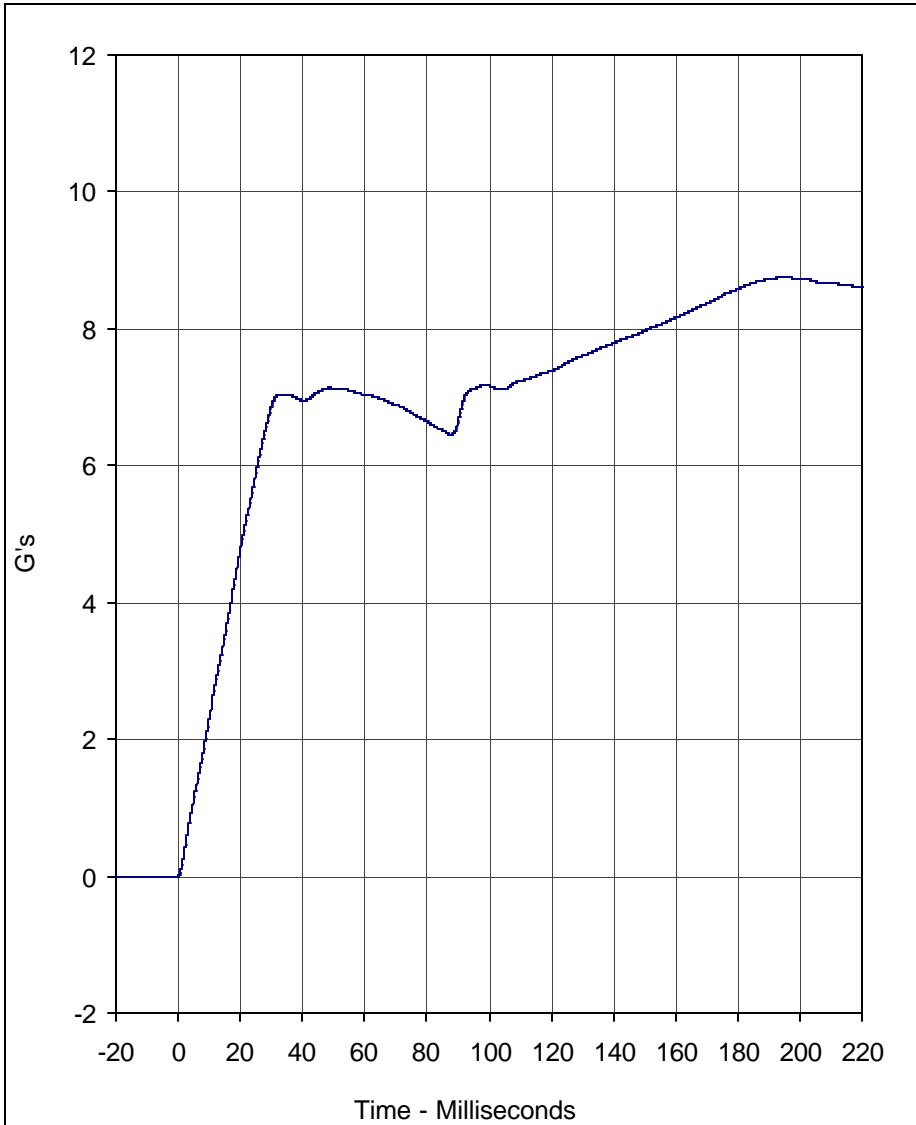

Curve Description	CURNO	Type
Pendulum Velocity	001	FIL

Curve Description	CURNO	Type
Neck Force Y	002	FIL

Units	Max	Time	Min	Time	SAE Class
G's	8.7	195.0	0.0	-0.5	180

Units	Max	Time	Min	Time	SAE Class
Newtons	325.3	149.9	-1021.7	52.2	60

Test Program: SID / HIII Neck Pendulum Lateral Test
 Test Date: 10/25/02

A.T.D. Serial No.: 275
 Test I.D.: NB10C



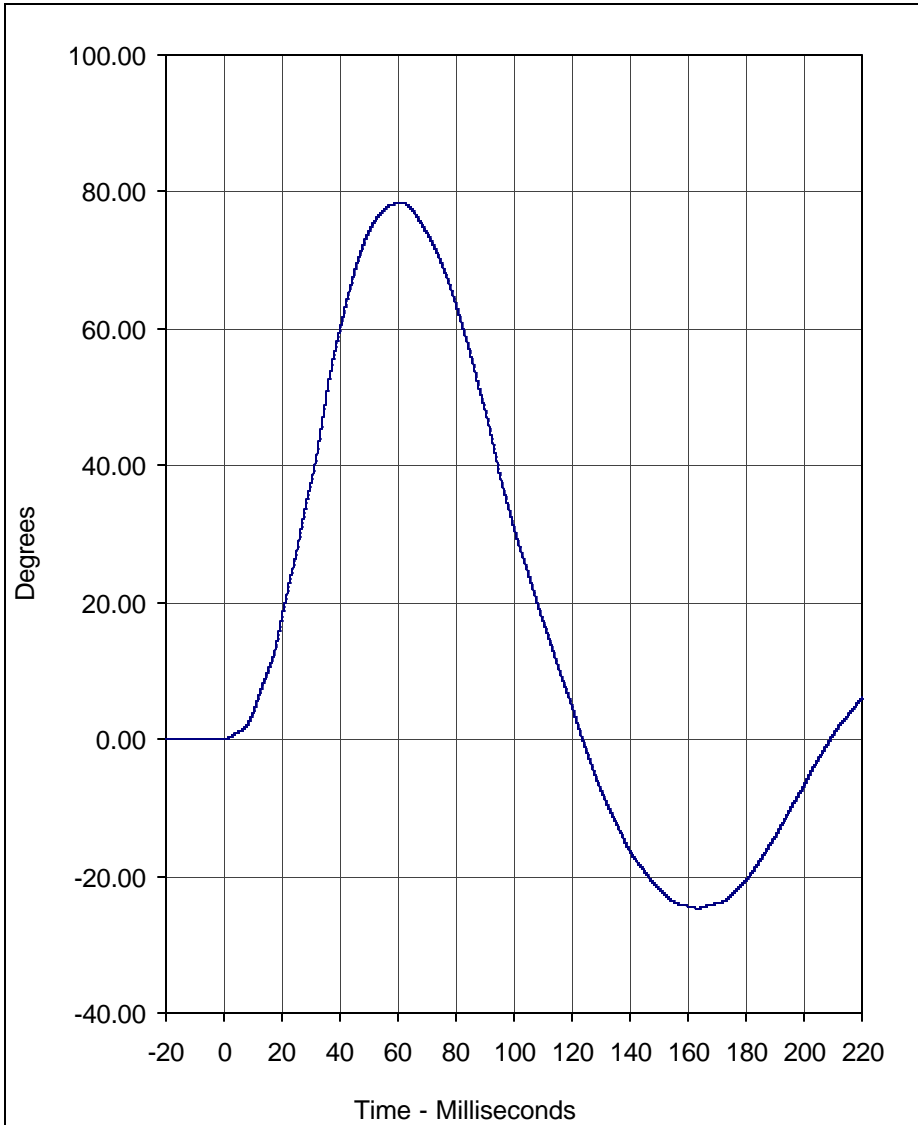

Curve Description	CURNO	Type
"D" Plane Rotation	003	FIL

Units	Max	Time	Min	Time	SAE Class
Degrees	78.4	60.8	-24.7	163.2	60

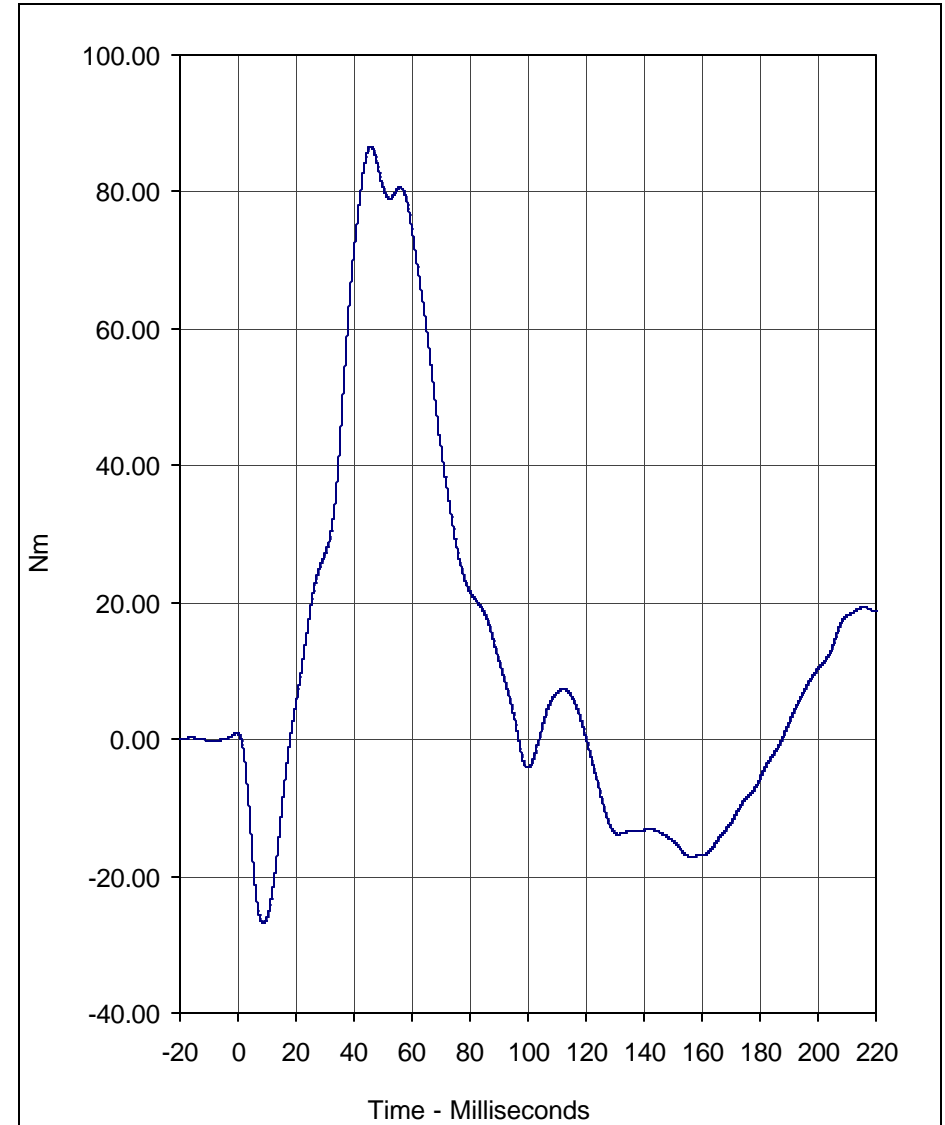

Curve Description	CURNO	Type
Moment About Occipital Condyle	004	FIL

Units	Max	Time	Min	Time	SAE Class
Nm	86.7	45.7	-27.0	8.7	60

Test Program: SID / HIII Neck Pendulum Lateral Test
 Test Date: 10/25/02

A.T.D. Serial No.: 275
 Test I.D.: NB10C



APPENDIX C
POST-TEST SID / HIII CONFIGURATION AND PERFORMANCE VERIFICATION DATA



Calibration Data Sheet Side Impact Hybrid Dummy (SID/HIII) External Measurements

ATD Serial No.: 274

Tested Parameter	Units	Specification	Result	Pass/Fail
Laboratory Temperature	°C	18.9 to 25.6	21.1	Pass
Laboratory Relative Humidity	%	10 to 70	30	Pass
SH- Seated Height	mm	889 to 909	900	Pass
HP- Hip Point Height	mm	99 (reference)	99	Pass
RH- Rib Height	mm	502 to 520	510	Pass
KH- Knee Pivot From Back Line	mm	511 to 526	520	Pass
KV- Knee Pivot From Floor	mm	490 to 505	500	Pass
HW- Hip Width	mm	356 to 391	390	Pass
Overall Test Results				Pass

C-25

TR-P23003-01-NC

Laboratory Technician

October 30, 2002

Test Date



Calibration Data Sheet Side Impact Hybrid Dummy (SID/HIII) Thorax Lateral Impact

ATD Serial No.: 274

Test I.D.: TI10C

Tested Parameter	Units	Specification	Result	Pass/Fail
Laboratory Temperature	°C	18.9 to 25.6	21.1	Pass
Laboratory Relative Humidity	%	10 to 70	30	Pass
Probe Velocity	m/s	4.21 to 4.33	4.22	Pass
Upper Rib Acceleration	G's	37.0 to 46.0	43.1	Pass
Lower Rib Acceleration	G's	37.0 to 46.0	42.8	Pass
Thoracic Spine Acceleration	G's	15.0 to 22.0	16.1	Pass
Overall Test Results				Pass

C-26

TR-P23003-01-NC

Laboratory Technician

October 30, 2002

Test Date

C-27

TR-P23003-01-NC

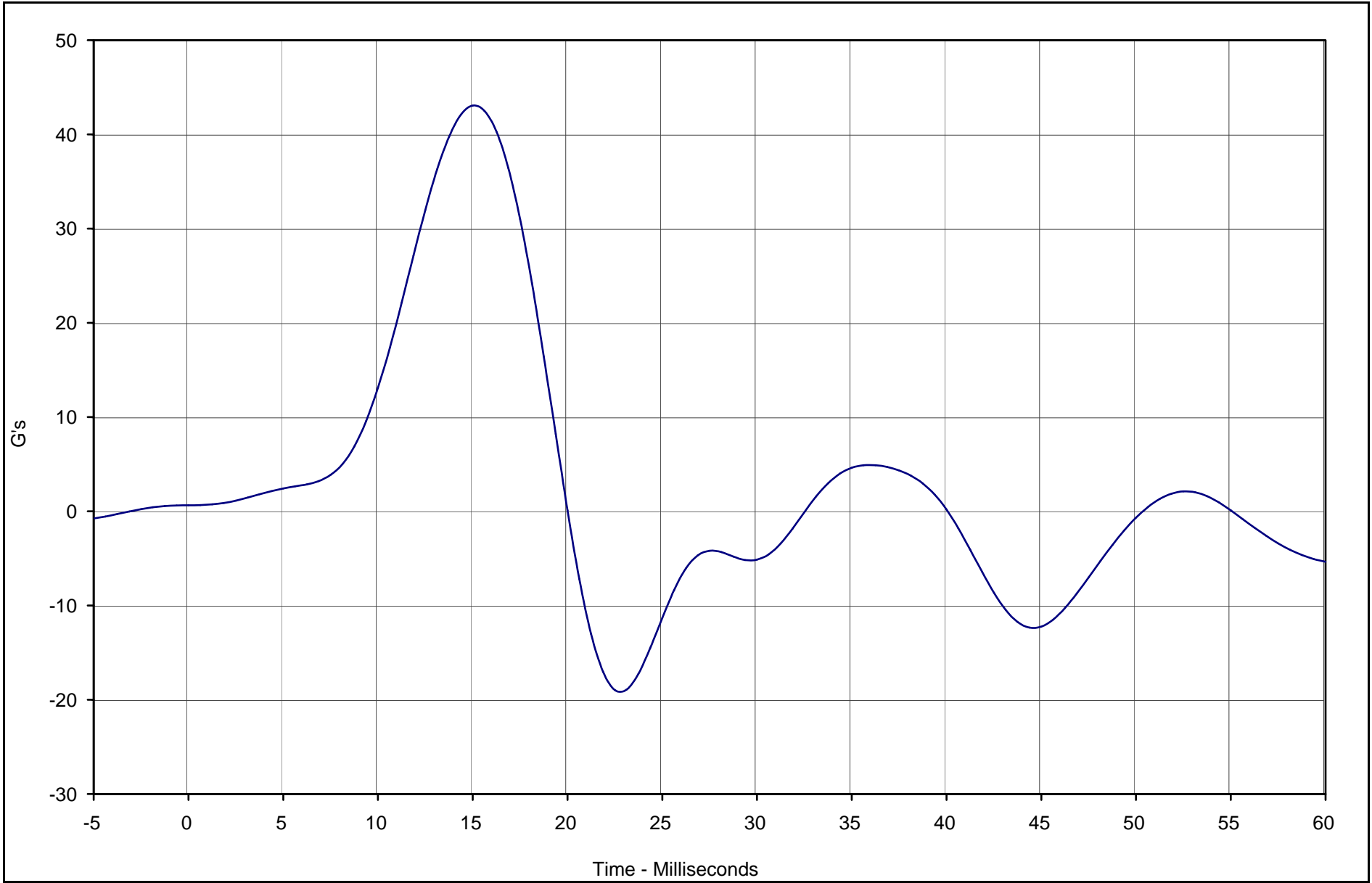

Curve Description	CURNO	Type	Units	Max	Time	Min	Time	SAE Class
Upper Rib Y Acceleration	001	FIL	G's	43.1	15.0	-19.0	22.5	FIR100



Test Vehicle: SID / HIII Thorax Lateral Impact

SID Serial No.: 274

Test Date: 10/30/02

Test I.D.: T110C

C-28

TR-P23003-01-NC

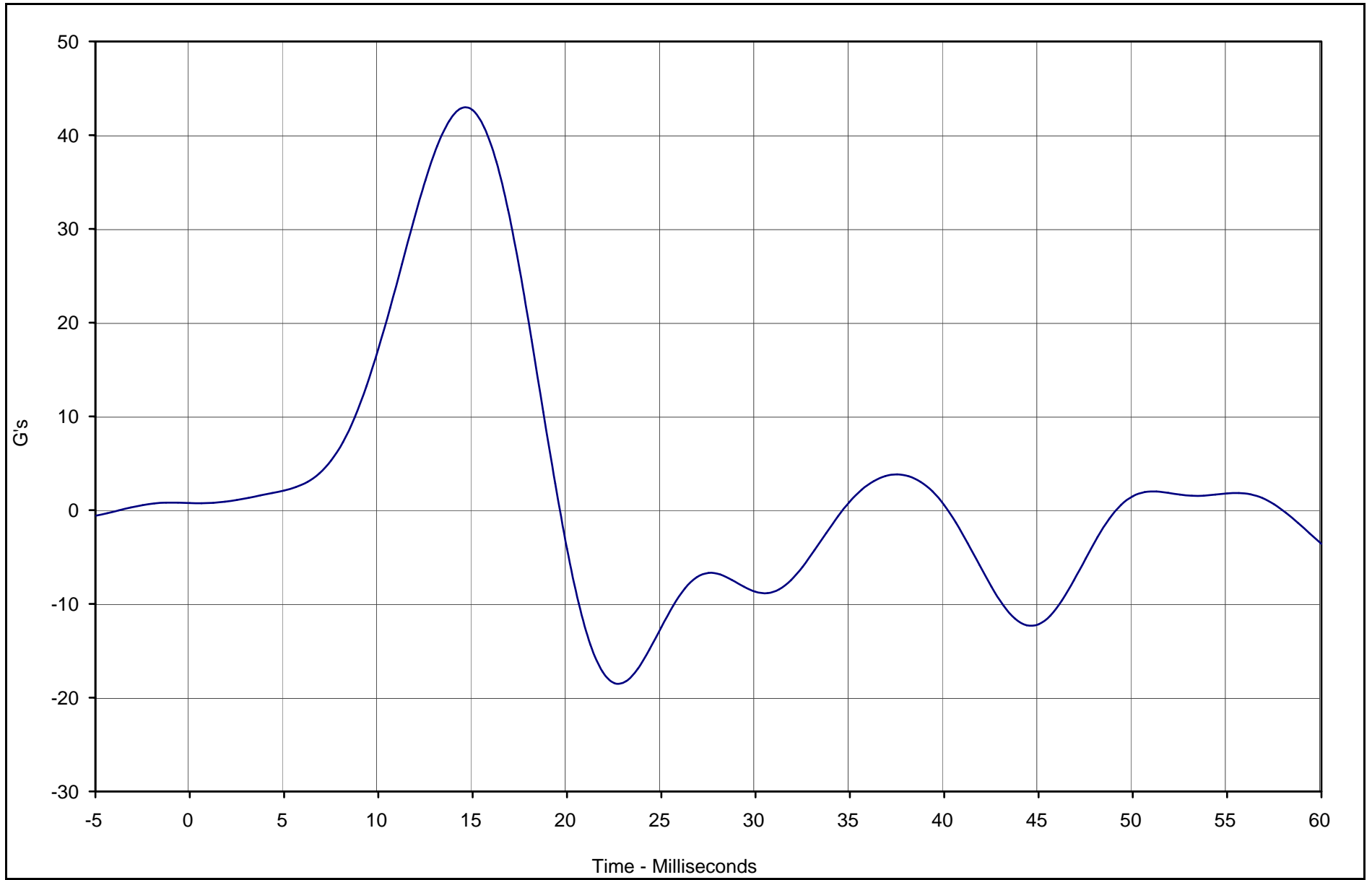

Curve Description	CURNO	Type	Units	Max	Time	Min	Time	SAE Class
Lower Rib Y Acceleration	002	FIL	G's	42.8	14.4	-18.4	22.5	FIR100



Test Vehicle: SID / HIII Thorax Lateral Impact

SID Serial No.: 274

Test Date: 10/30/02

Test I.D.: T110C

C-29

TR-P23003-01-NC

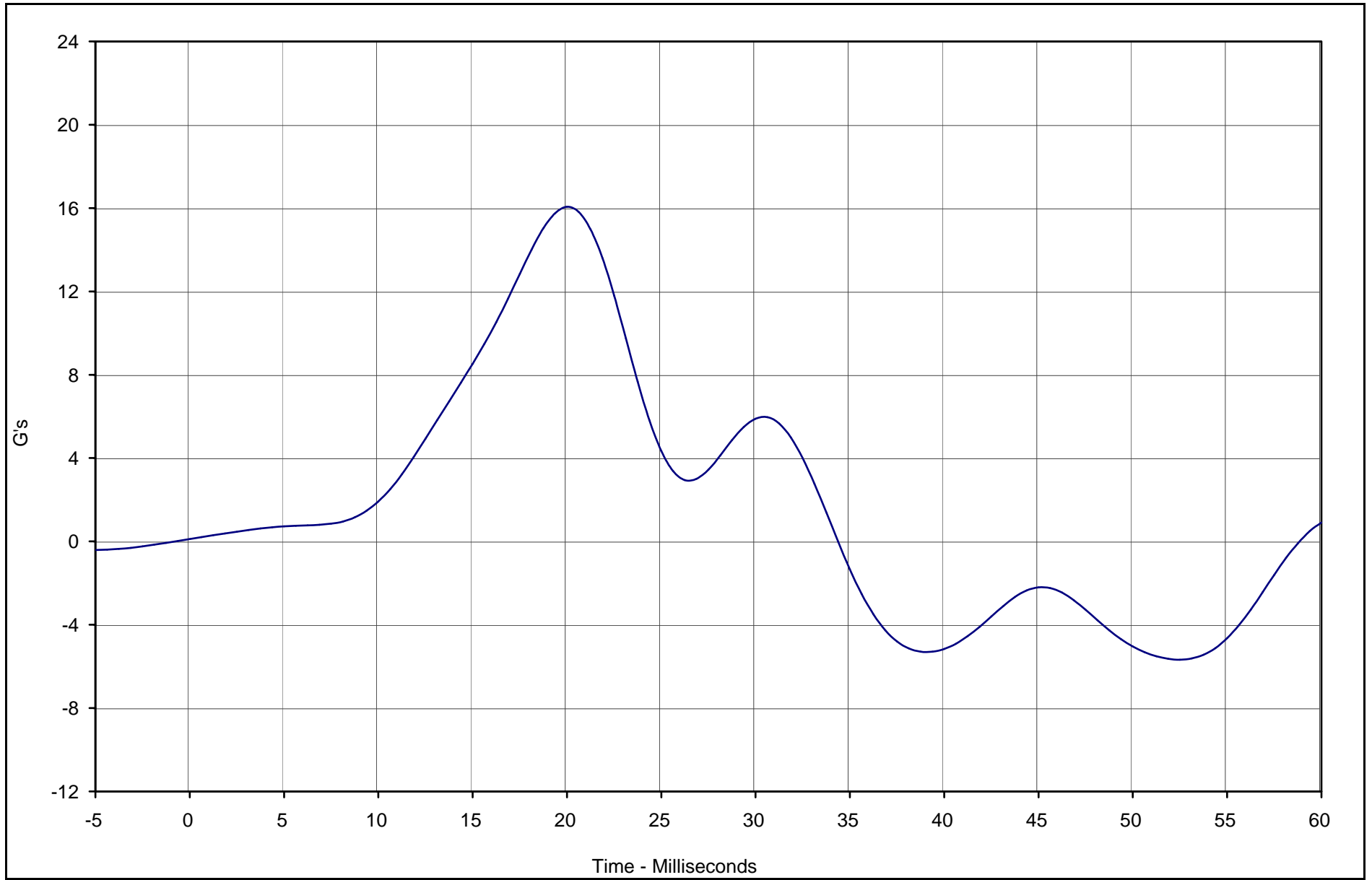

Curve Description	CURNO	Type	Units	Max	Time	Min	Time	SAE Class
Lower Spine Y Acceleration	003	FIL	G's	16.1	20.0	-5.7	52.5	FIR100



Test Vehicle: SID / HIII Thorax Lateral Impact

SID Serial No.: 274

Test Date: 10/30/02

Test I.D.: T110C



Calibration Data Sheet

Side Impact Hybrid Dummy (SID/HIII)

Pelvis Lateral Impact

ATD Serial No.: 274

Test I.D.: PI10C

Tested Parameter	Units	Specification	Result	Pass/Fail
Laboratory Temperature	°C	18.9 to 25.6	21.1	Pass
Laboratory Relative Humidity	%	10 to 70	30	Pass
Probe Velocity	m/s	4.21 to 4.33	4.30	Pass
Peak Pelvis Acceleration	G's	40.0 to 60.0	41.9	Pass
Acceleration Time Above 20 G's	Msec.	3.0 to 7.0	6.3	Pass
Overall Test Results				Pass

C-30

TR-P23003-01-NC

Laboratory Technician

October 30, 2002

Test Date

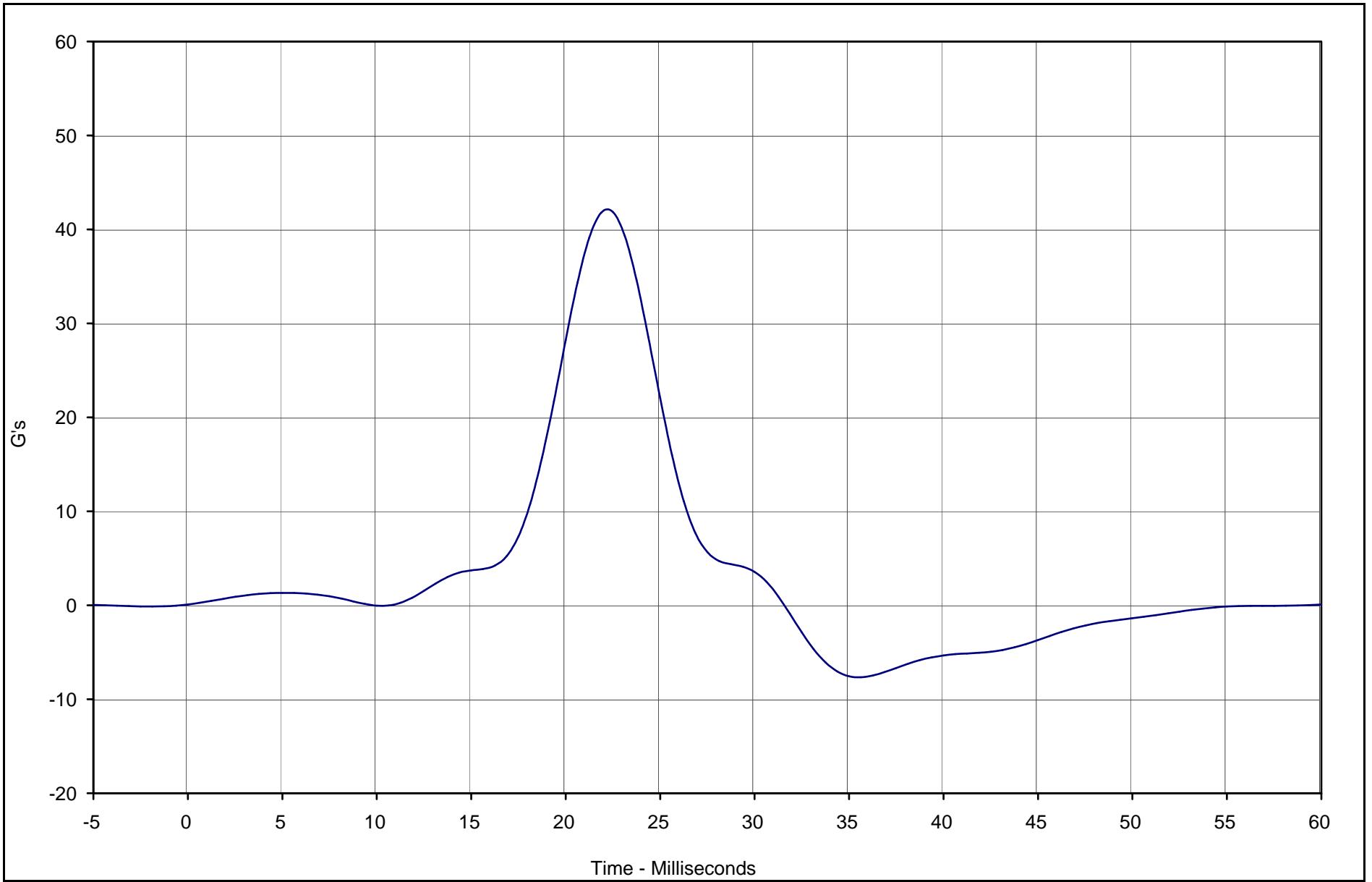

Curve Description	CURNO	Type	Units	Max	Time	Min	Time	SAE Class
Pelvis Y Acceleration	001	FIL	G's	41.9	22.5	-7.7	35.6	FIR100



Test Vehicle: Side Impact Dummy (SID) Pelvis Lateral Impact

SID Serial No.: 274

Test Date: 10/30/02

Test I.D.: PI10C



Calibration Data Sheet Side Impact Hybrid Dummy (SID/HIII) Head Drop Lateral Impact Test

ATD Serial No.: 274

Test I.D.: HD06A

Tested Parameter	Units	Specification	Result	Pass/Fail
Laboratory Temperature	°C	18.9 to 25.6	21.1	Pass
Laboratory Relative Humidity	%	10 to 70	30	Pass
Peak Resultant Acceleration	G's	120.0 to 150.0	128.5	Pass
Peak Longitudinal Acceleration	G's	≤15.0	11.9	Pass
Is Acceleration Unimodal?	Yes/No	Yes	Yes	Pass
Overall Test Results				Pass

C-32

TR-P23003-01-NC

Laboratory Technician

October 30, 2002

Test Date

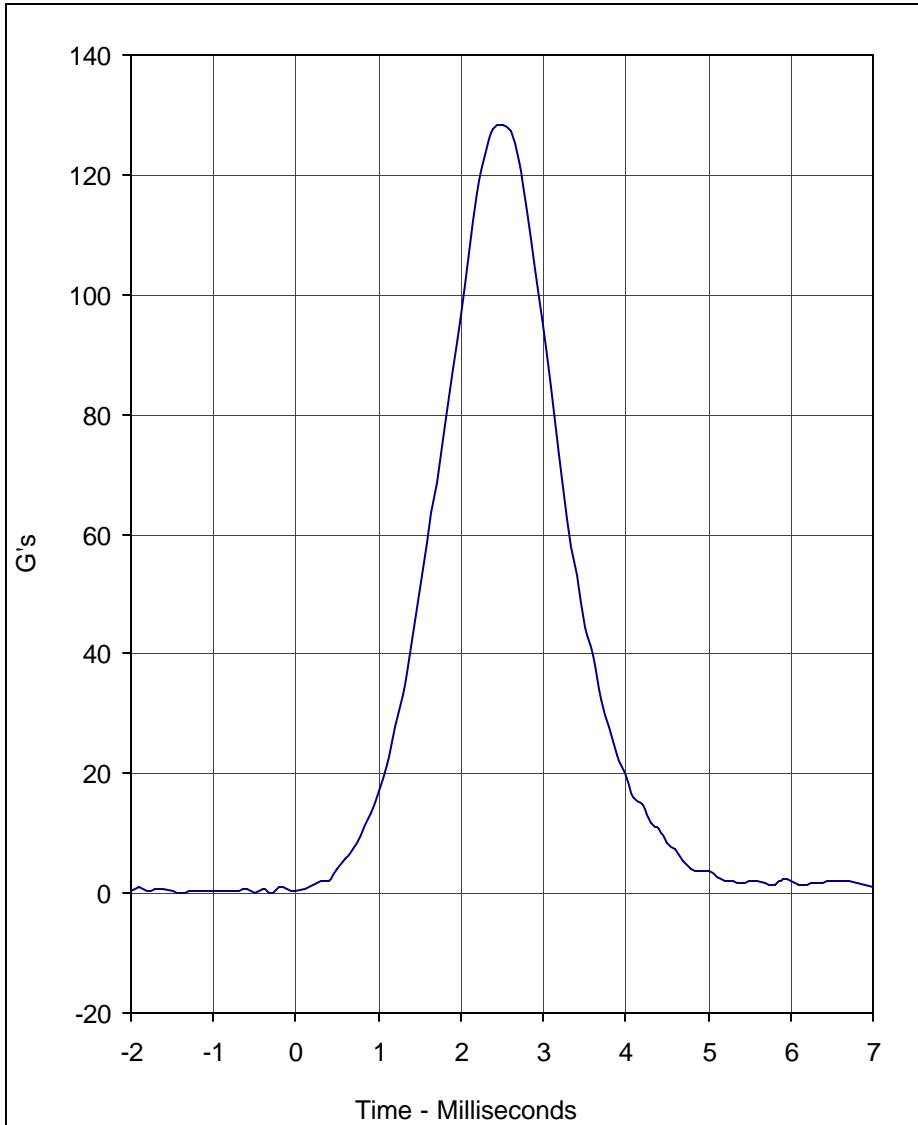

Curve Description	CURNO	Type
Head Resultant	001	RES

Units	Max	Time	Min	Time	SAE Class
G's	128.5	2.5	0.0	-1.4	1000

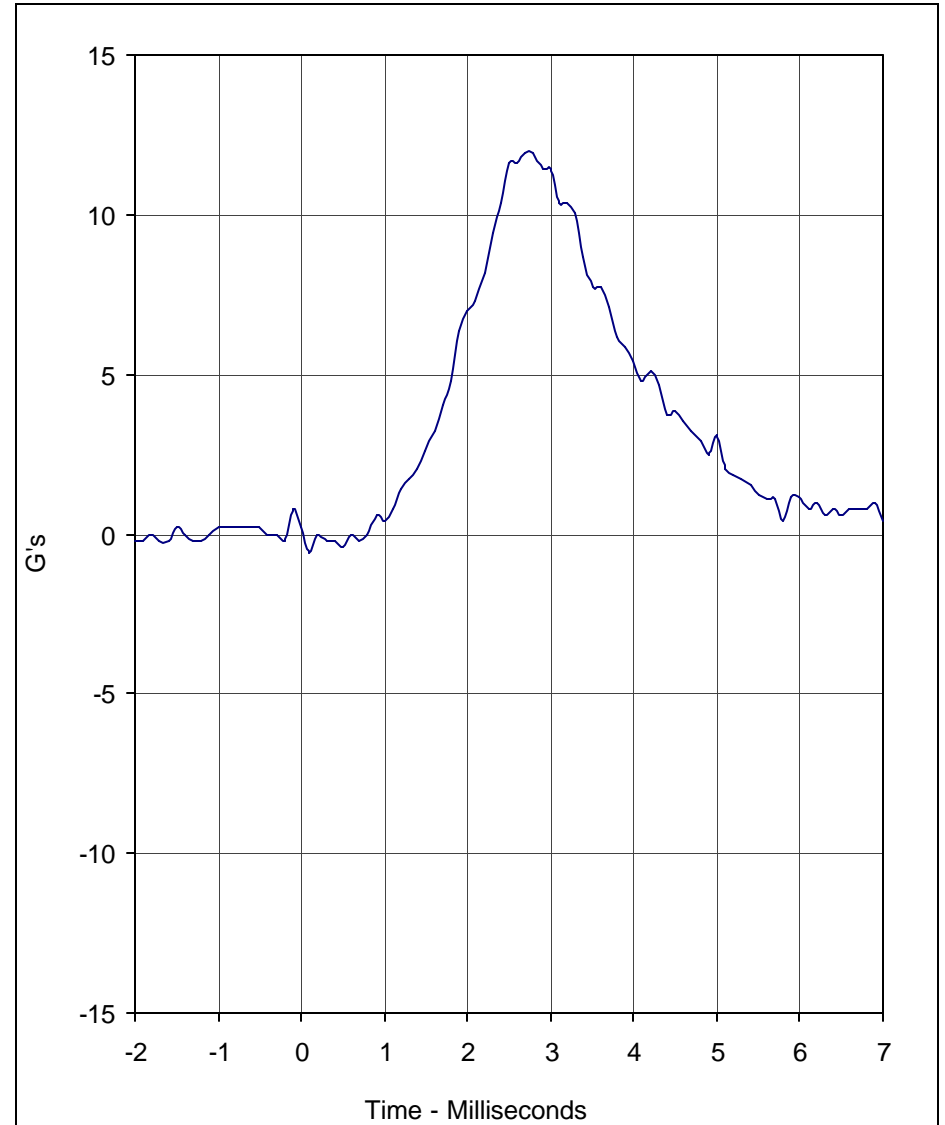

Curve Description	CURNO	Type
Head X	002	FIL

Units	Max	Time	Min	Time	SAE Class
G's	11.9	2.7	-0.6	0.1	1000

Test Program: SID / HIII Head Drop Lateral Impact Test
 Test Date: 10/30/02

A.T.D. Serial No.: 274
 Test I.D.: HD06A





Calibration Data Sheet Side Impact Hybrid Dummy (SID/HIII) Neck Pendulum Lateral Test

ATD Serial No.: 274

Test I.D.: NB11G

Tested Parameter	Units	Specification	Result	Pass/Fail	
Laboratory Temperature	°C	20.6 to 22.2	21.1	Pass	
Laboratory Relative Humidity	%	10 to 70	30	Pass	
Pendulum Velocity	m/s	6.89 to 7.13	6.98	Pass	
Pendulum Deceleration	10	Msec.	1.96 to 2.55	2.28	Pass
	20	Msec.	4.12 to 5.10	4.68	Pass
	30	Msec.	5.73 to 7.01	6.67	Pass
	40 to 70	Msec.	6.27 to 7.64	7.02	Pass
Maximum "D" Plane Rotation	Degrees	66.0 to 82.0	79.6	Pass	
Maximum "D" Plane Rotation Time After Peak Moment	Msec.	2.0 to 15.0	13.0	Pass	
"D" Plane Rotation Decay Time From Peak Angle to Zero Angle	Msec.	58.0 to 67.0	64.1	Pass	
Calculated Moment About Occipital Condyle	N•m	73.0 to 88.0	80.2	Pass	
Moment About Occipital Condyle Decay, Time From Positive Peak Value To 0 N•m	Msec.	49.0 to 64.0	51.6	Pass	
			Overall Test Results	Pass	

C-34

TR-P23003-01-NC

Laboratory Technician

October 30, 2002

Test Date

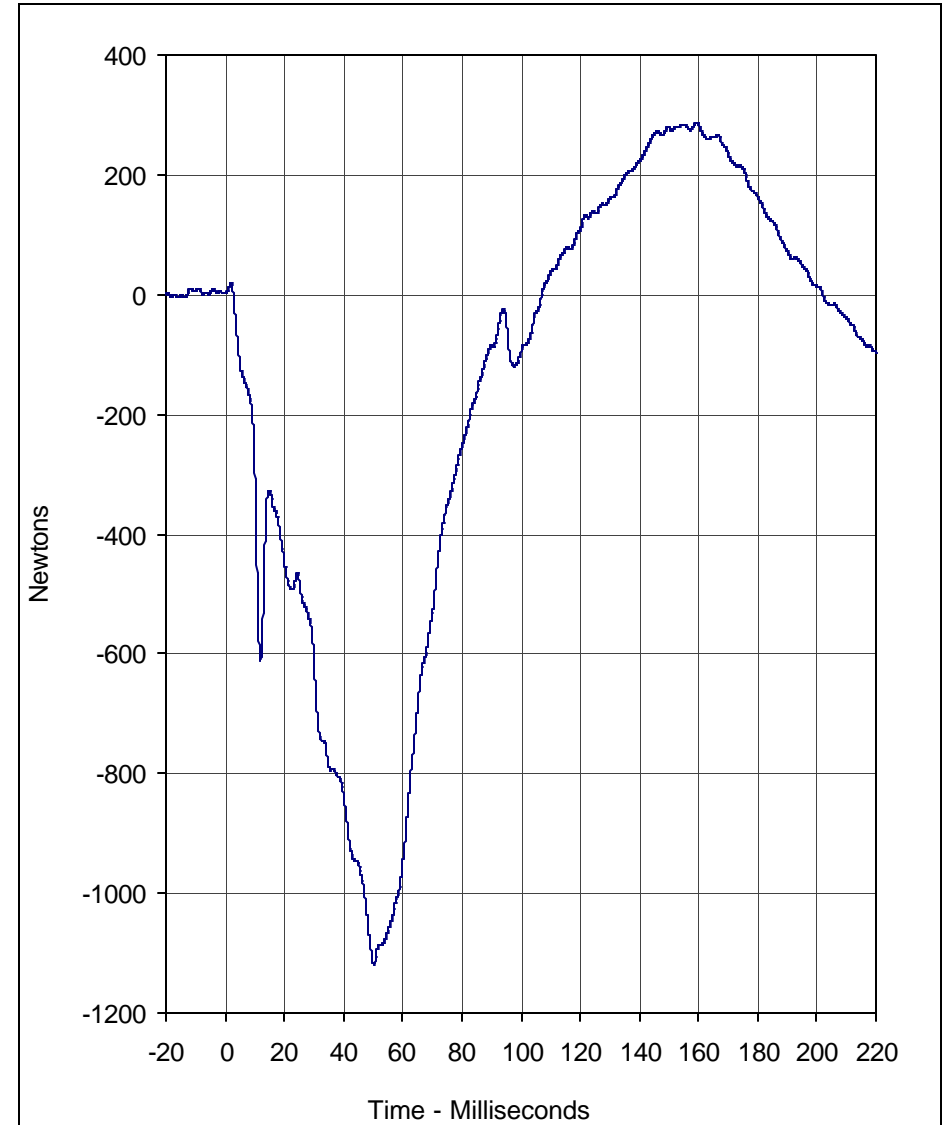
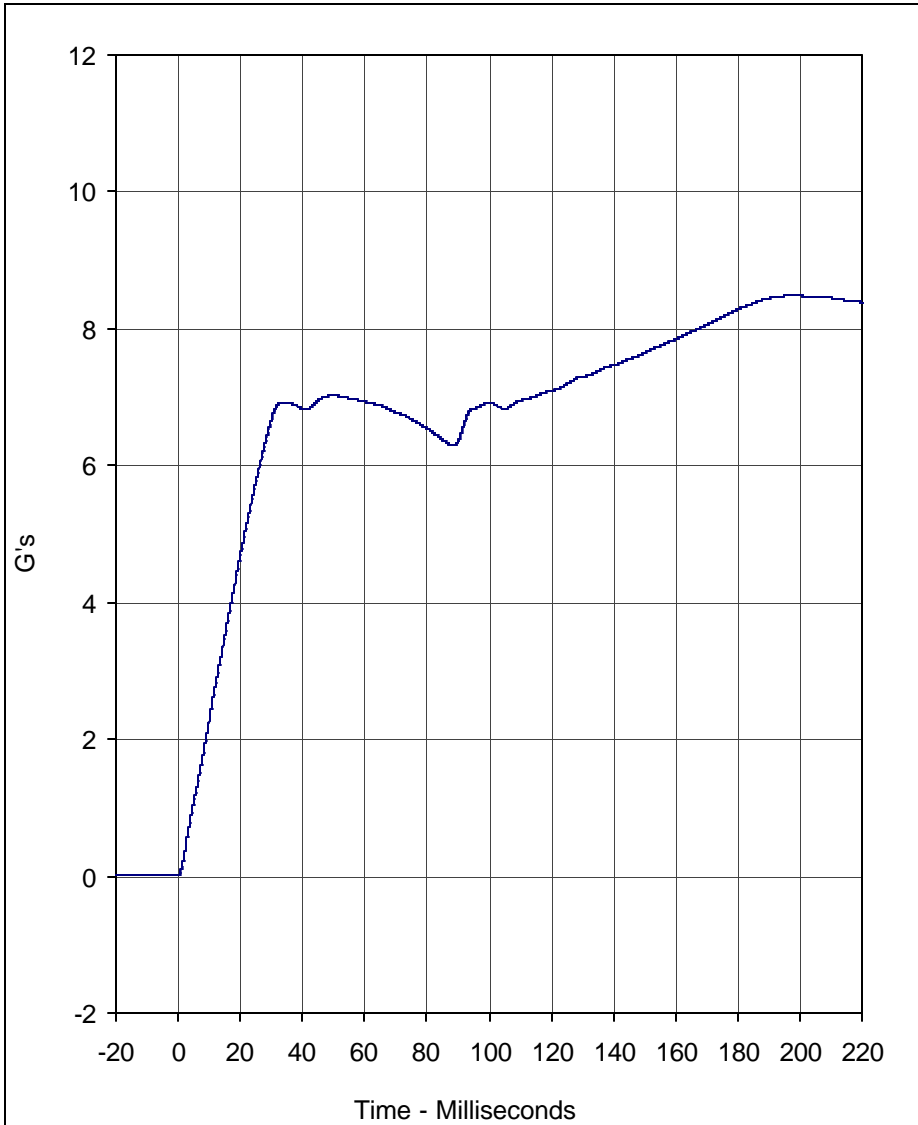

Curve Description	CURNO	Type
Pendulum Velocity	001	FIL

Curve Description	CURNO	Type
Neck Force Y	002	FIL

Units	Max	Time	Min	Time	SAE Class
G's	8.5	197.7	0.0	-14.8	180

Units	Max	Time	Min	Time	SAE Class
Newtons	287.2	159.4	-1118.5	50.2	180

Test Program: SID / HIII Neck Pendulum Lateral Test
 Test Date: 10/30/02

A.T.D. Serial No.: 274
 Test I.D.: NB11G



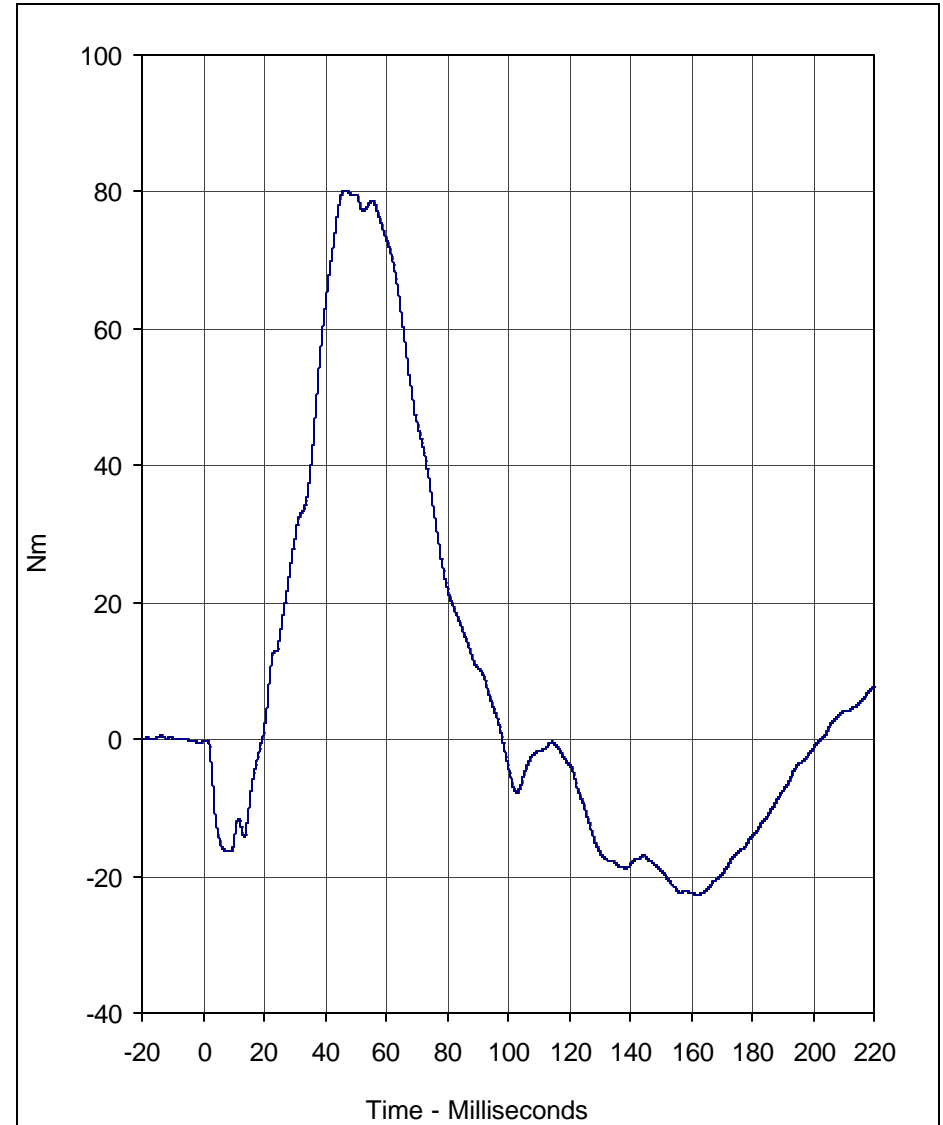
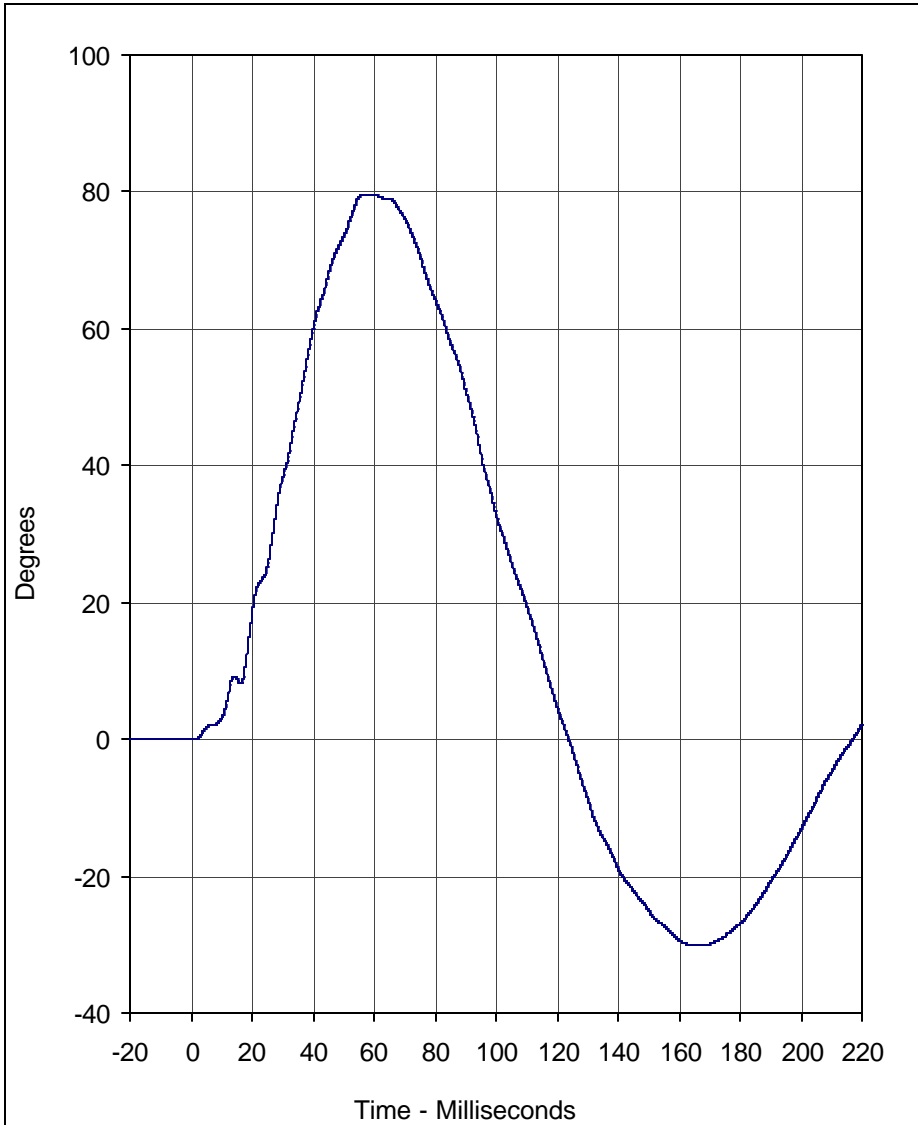

Curve Description				CURNO	Type
"D" Plane Rotation				003	FIL

Curve Description				CURNO	Type
Moment About Occipital Condyle				004	FIL

Units	Max	Time	Min	Time	SAE Class
Degrees	79.6	59.7	-30.2	167.2	180

Units	Max	Time	Min	Time	SAE Class
Nm	80.2	46.7	-22.8	162.1	180

Test Program: SID / HIII Neck Pendulum Lateral Test
 Test Date: 10/30/02

A.T.D. Serial No.: 274
 Test I.D.: NB11G





Calibration Data Sheet Side Impact Hybrid Dummy (SID/HIII) External Measurements

ATD Serial No.: 275

Tested Parameter	Units	Specification	Result	Pass/Fail
Laboratory Temperature	°C	18.9 to 25.6	21.1	Pass
Laboratory Relative Humidity	%	10 to 70	30	Pass
SH- Seated Height	mm	889 to 909	905	Pass
HP- Hip Point Height	mm	99 (reference)	99	Pass
RH- Rib Height	mm	502 to 520	515	Pass
KH- Knee Pivot From Back Line	mm	511 to 526	515	Pass
KV- Knee Pivot From Floor	mm	490 to 505	495	Pass
HW- Hip Width	mm	356 to 391	375	Pass
Overall Test Results				Pass

C-37

TR-P23003-01-NC

Laboratory Technician

October 30, 2002

Test Date



Calibration Data Sheet Side Impact Hybrid Dummy (SID/HIII) Thorax Lateral Impact

ATD Serial No.: 275

Test I.D.: TI10D

Tested Parameter	Units	Specification	Result	Pass/Fail
Laboratory Temperature	°C	18.9 to 25.6	21.1	Pass
Laboratory Relative Humidity	%	10 to 70	30	Pass
Probe Velocity	m/s	4.21 to 4.33	4.30	Pass
Upper Rib Acceleration	G's	37.0 to 46.0	40.4	Pass
Lower Rib Acceleration	G's	37.0 to 46.0	38.7	Pass
Thoracic Spine Acceleration	G's	15.0 to 22.0	18.9	Pass
Overall Test Results				Pass

C-38

TR-P23003-01-NC

Laboratory Technician

October 30, 2002

Test Date

C-39

TR-P23003-01-NC

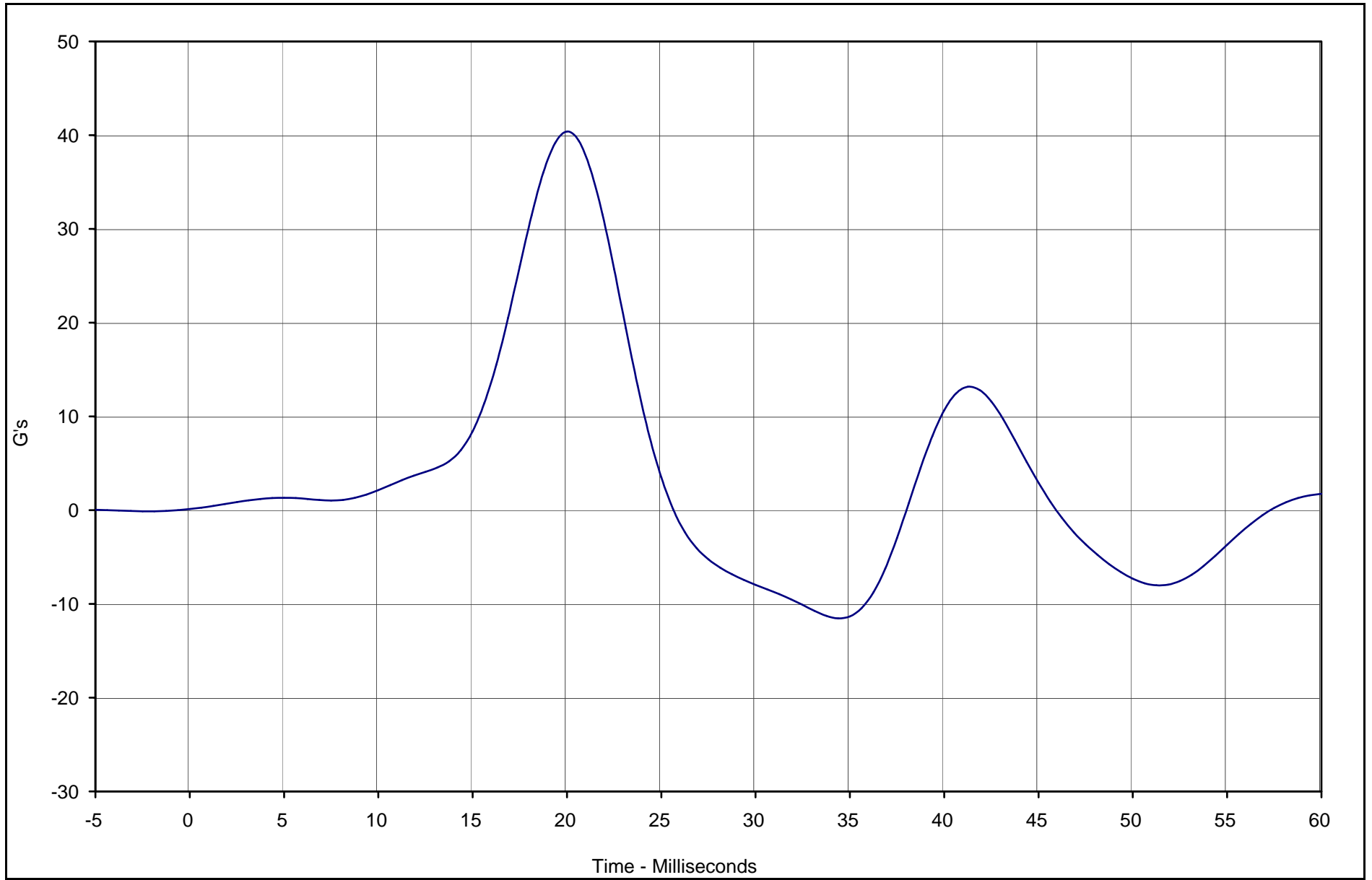

Curve Description	CURNO	Type	Units	Max	Time	Min	Time	SAE Class
Upper Rib Y Acceleration	001	FIL	G's	40.4	20.0	-11.6	34.4	FIR100



Test Vehicle: SID / HIII Thorax Lateral Impact

SID Serial No.: 275

Test Date: 10/30/02

Test I.D.: T110D

C-40

TR-P23003-01-NC

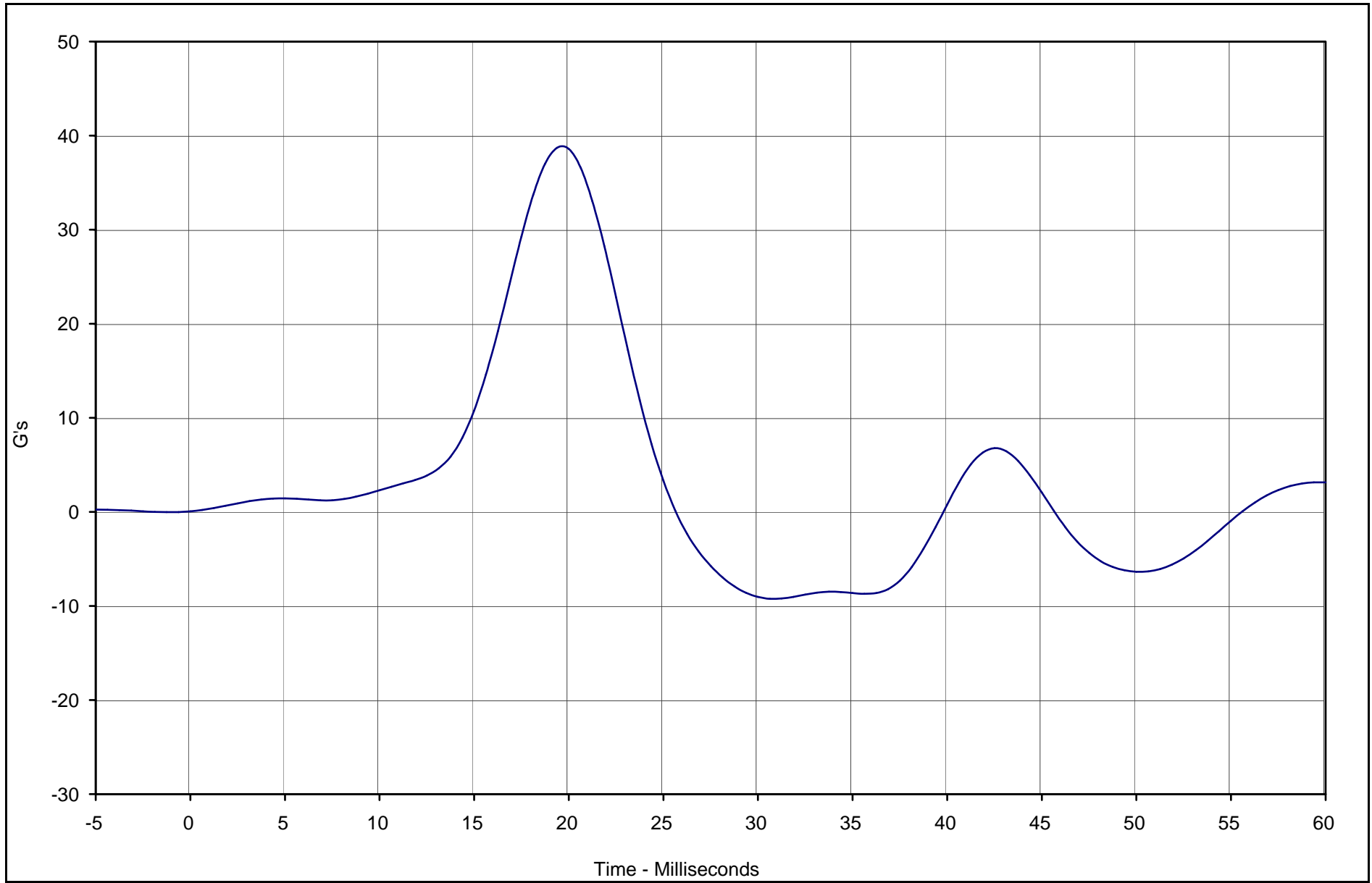

Curve Description	CURNO	Type	Units	Max	Time	Min	Time	SAE Class
Lower Rib Y Acceleration	002	FIL	G's	38.7	19.4	-9.2	30.6	FIR100



Test Vehicle: SID / HIII Thorax Lateral Impact

SID Serial No.: 275

Test Date: 10/30/02

Test I.D.: T110D

C-41

TR-P23003-01-NC

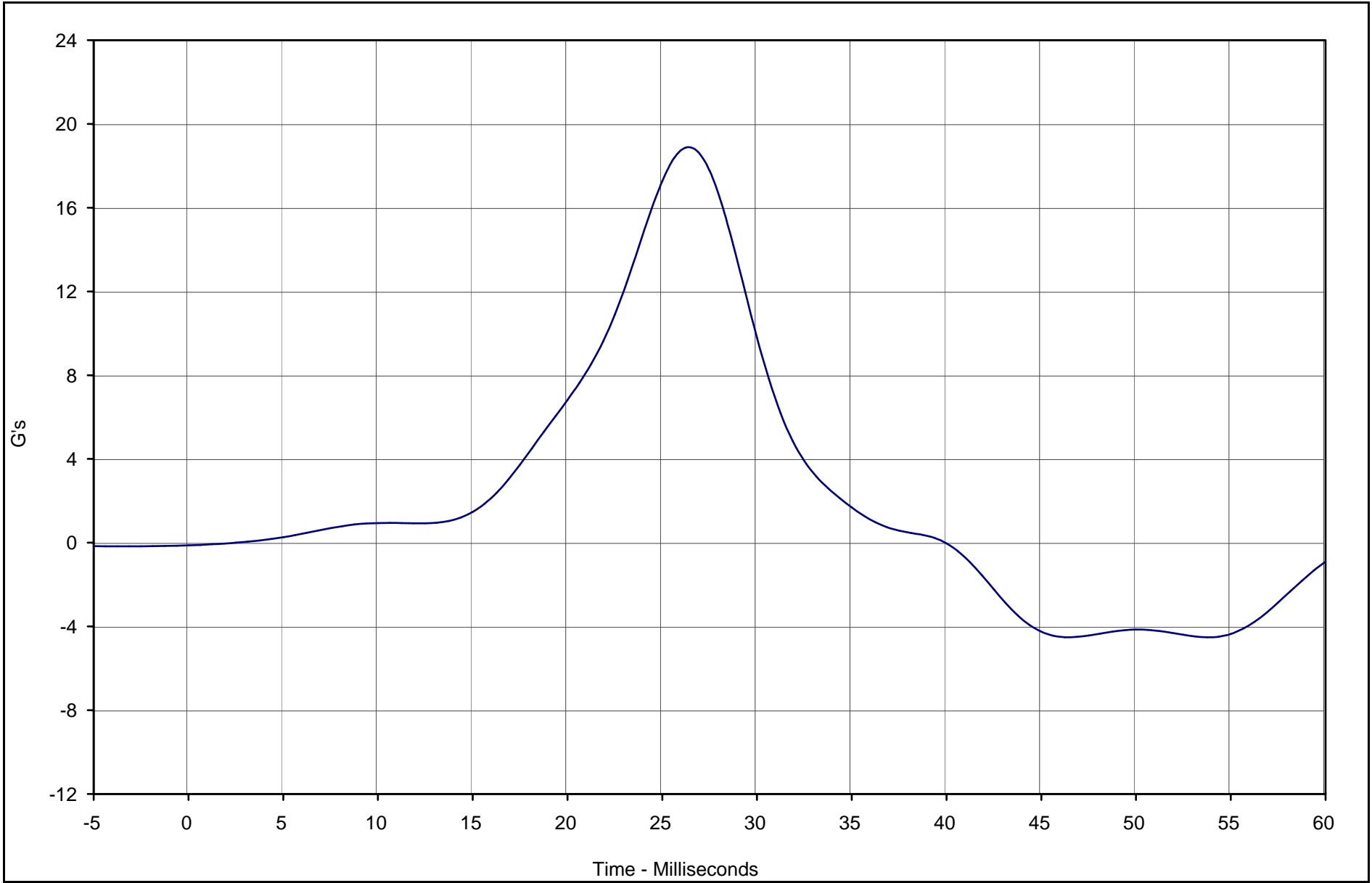

Curve Description	CURNO	Type	Units	Max	Time	Min	Time	SAE Class
Lower Spine Y Acceleration	003	FIL	G's	18.9	26.3	-4.5	53.8	FIR100



Test Vehicle: SID / HIII Thorax Lateral Impact

SID Serial No.: 275

Test Date: 10/30/02

Test I.D.: T110D



Calibration Data Sheet

Side Impact Hybrid Dummy (SID/HIII)

Pelvis Lateral Impact

ATD Serial No.: 275

Test I.D.: PI10D

Tested Parameter	Units	Specification	Result	Pass/Fail
Laboratory Temperature	°C	18.9 to 25.6	21.1	Pass
Laboratory Relative Humidity	%	10 to 70	30	Pass
Probe Velocity	m/s	4.21 to 4.33	4.25	Pass
Peak Pelvis Acceleration	G's	40.0 to 60.0	46.0	Pass
Acceleration Time Above 20 G's	Msec.	3.0 to 7.0	6.3	Pass
Overall Test Results				Pass

C-42

TR-P23003-01-NC

Laboratory Technician

October 30, 2002

Test Date

C-43

TR-P23003-01-NC

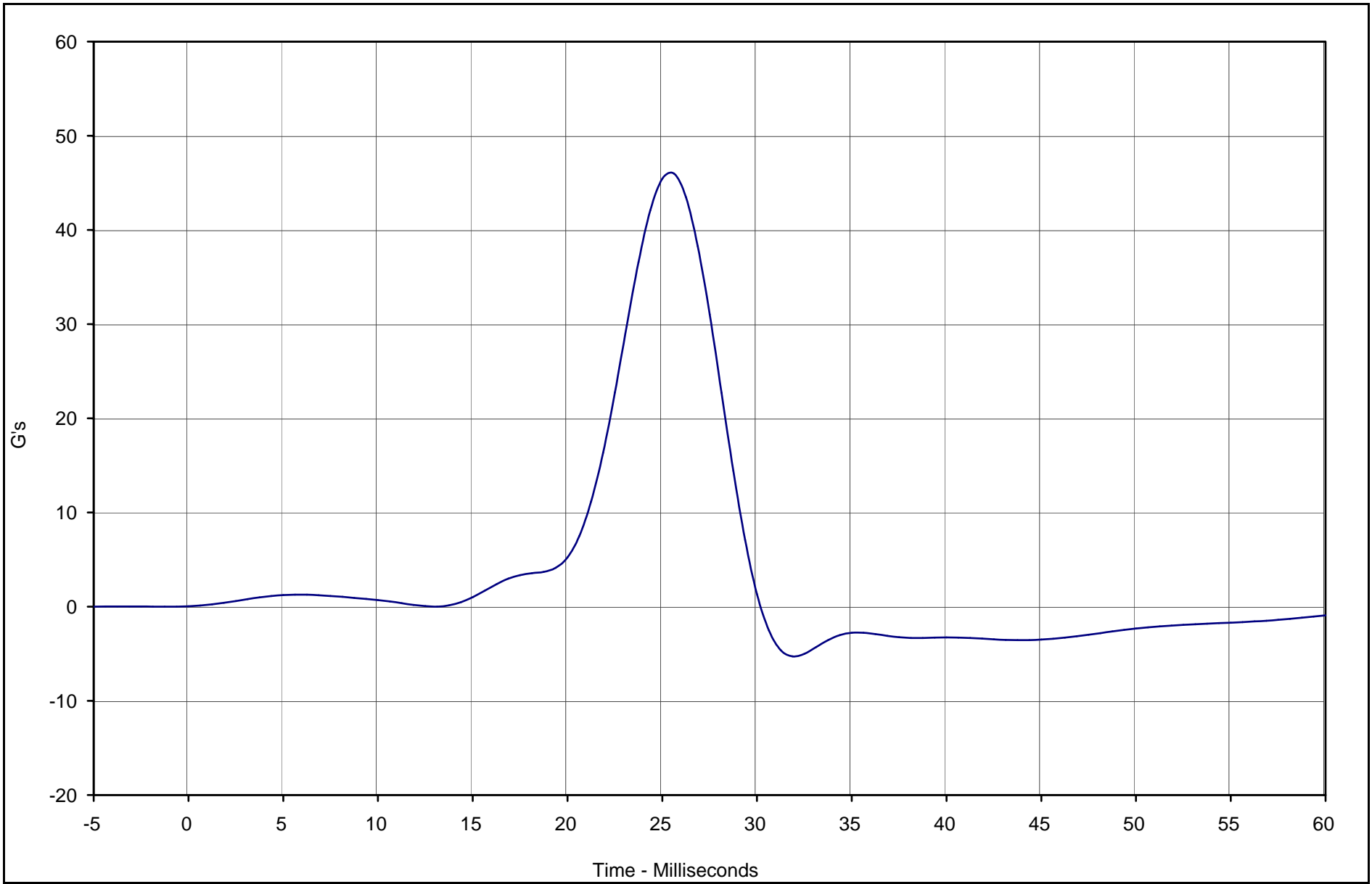

Curve Description	CURNO	Type	Units	Max	Time	Min	Time	SAE Class
Pelvis Y Acceleration	001	FIL	G's	46.0	25.6	-7.2	0.0	FIR100



Test Vehicle: Side Impact Dummy (SID) Pelvis Lateral Impact

SID Serial No.: 275

Test Date: 10/30/02

Test I.D.: PI10D



Calibration Data Sheet

Side Impact Hybrid Dummy (SID/HIII)

Head Drop Lateral Impact Test

ATD Serial No.: 275

Test I.D.: HD06A

Tested Parameter	Units	Specification	Result	Pass/Fail
Laboratory Temperature	°C	18.9 to 25.6	21.1	Pass
Laboratory Relative Humidity	%	10 to 70	30	Pass
Peak Resultant Acceleration	G's	120.0 to 150.0	131.1	Pass
Peak Longitudinal Acceleration	G's	≤15.0	10.2	Pass
Is Acceleration Unimodal?	Yes/No	Yes	Yes	Pass
Overall Test Results				Pass

C-44

TR-P23003-01-NC

Laboratory Technician

October 30, 2002

Test Date

C-45

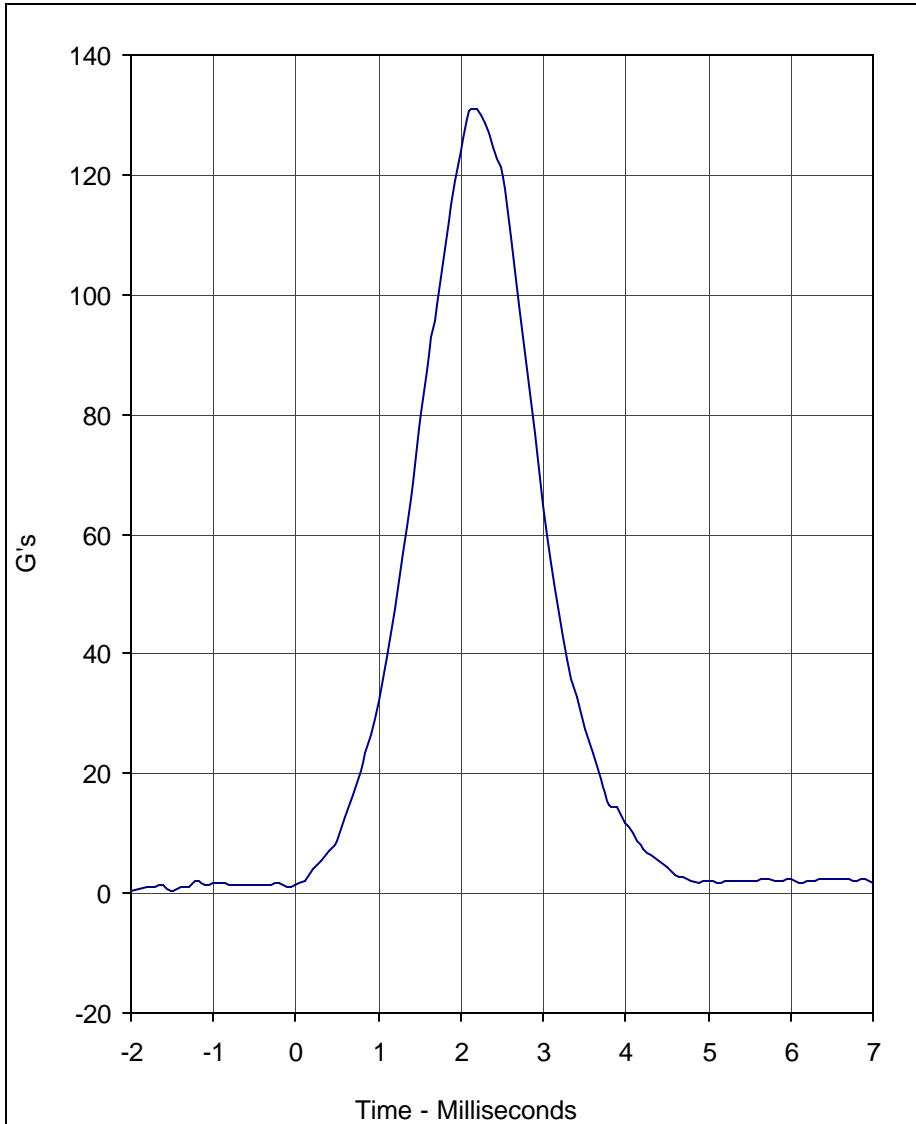

Curve Description	CURNO	Type
Head Resultant	001	RES

Units	Max	Time	Min	Time	SAE Class
G's	131.1	2.2	0.5	-1.5	1000

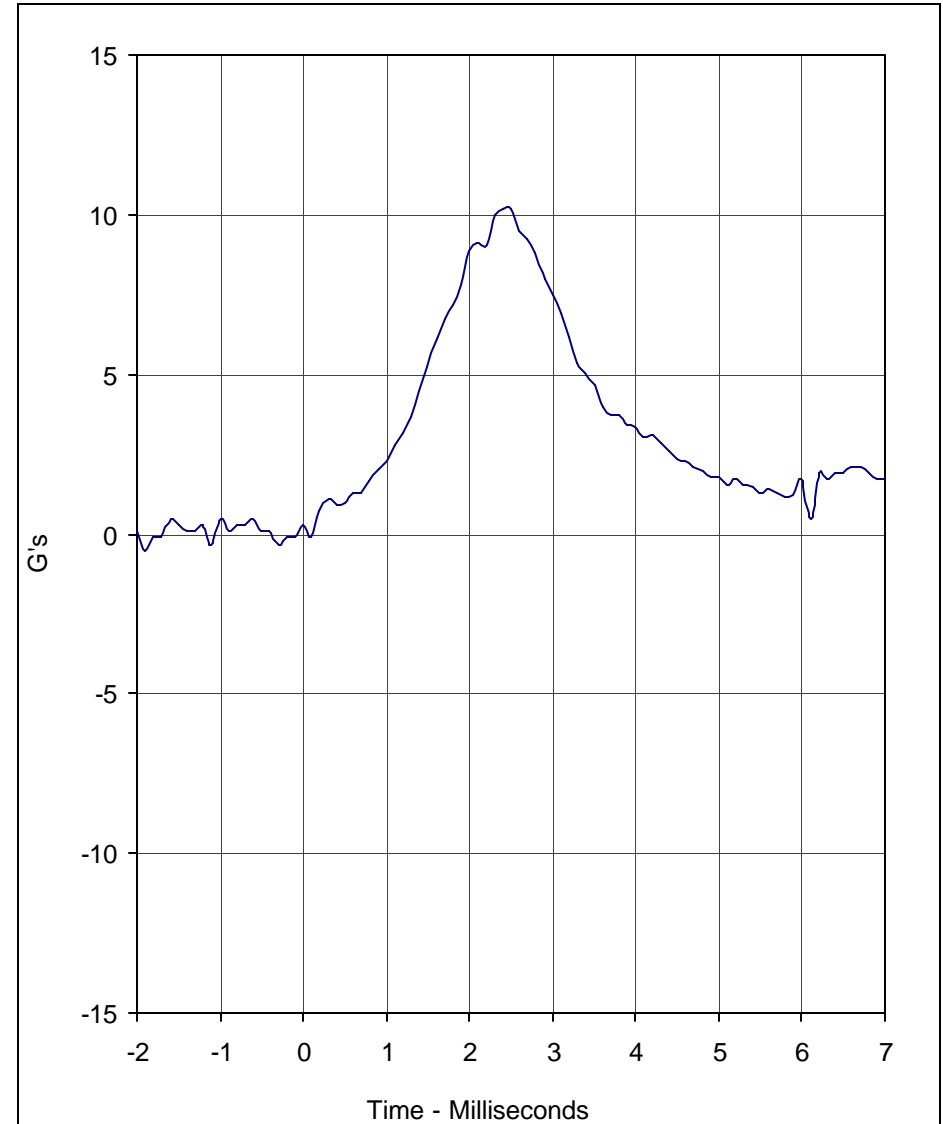

Curve Description	CURNO	Type
Head X	002	FIL

Units	Max	Time	Min	Time	SAE Class
G's	10.2	2.4	-0.5	-1.9	1000

Test Program: SID / HIII Head Drop Lateral Impact Test
 Test Date: 10/30/02

A.T.D. Serial No.: 275
 Test I.D.: HD06A



TR-P23003-01-NC



Calibration Data Sheet Side Impact Hybrid Dummy (SID/HIII) Neck Pendulum Lateral Test

ATD Serial No.: 275

Test I.D.: NB11H

Tested Parameter	Units	Specification	Result	Pass/Fail	
Laboratory Temperature	°C	20.6 to 22.2	21.1	Pass	
Laboratory Relative Humidity	%	10 to 70	30	Pass	
Pendulum Velocity	m/s	6.89 to 7.13	7.10	Pass	
Pendulum Deceleration	10	Msec.	1.96 to 2.55	2.31	Pass
	20	Msec.	4.12 to 5.10	4.61	Pass
	30	Msec.	5.73 to 7.01	6.57	Pass
	40 to 70	Msec.	6.27 to 7.64	6.98	Pass
Maximum "D" Plane Rotation	Degrees	66.0 to 82.0	76.4	Pass	
Maximum "D" Plane Rotation Time After Peak Moment	Msec.	2.0 to 15.0	14.3	Pass	
"D" Plane Rotation Decay Time From Peak Angle to Zero Angle	Msec.	58.0 to 67.0	63.2	Pass	
Calculated Moment About Occipital Condyle	N•m	73.0 to 88.0	82.1	Pass	
Moment About Occipital Condyle Decay, Time From Positive Peak Value To 0 N•m	Msec.	49.0 to 64.0	51.6	Pass	
			Overall Test Results	Pass	

C-46

TR-P23003-01-NC

Laboratory Technician

October 30, 2002

Test Date

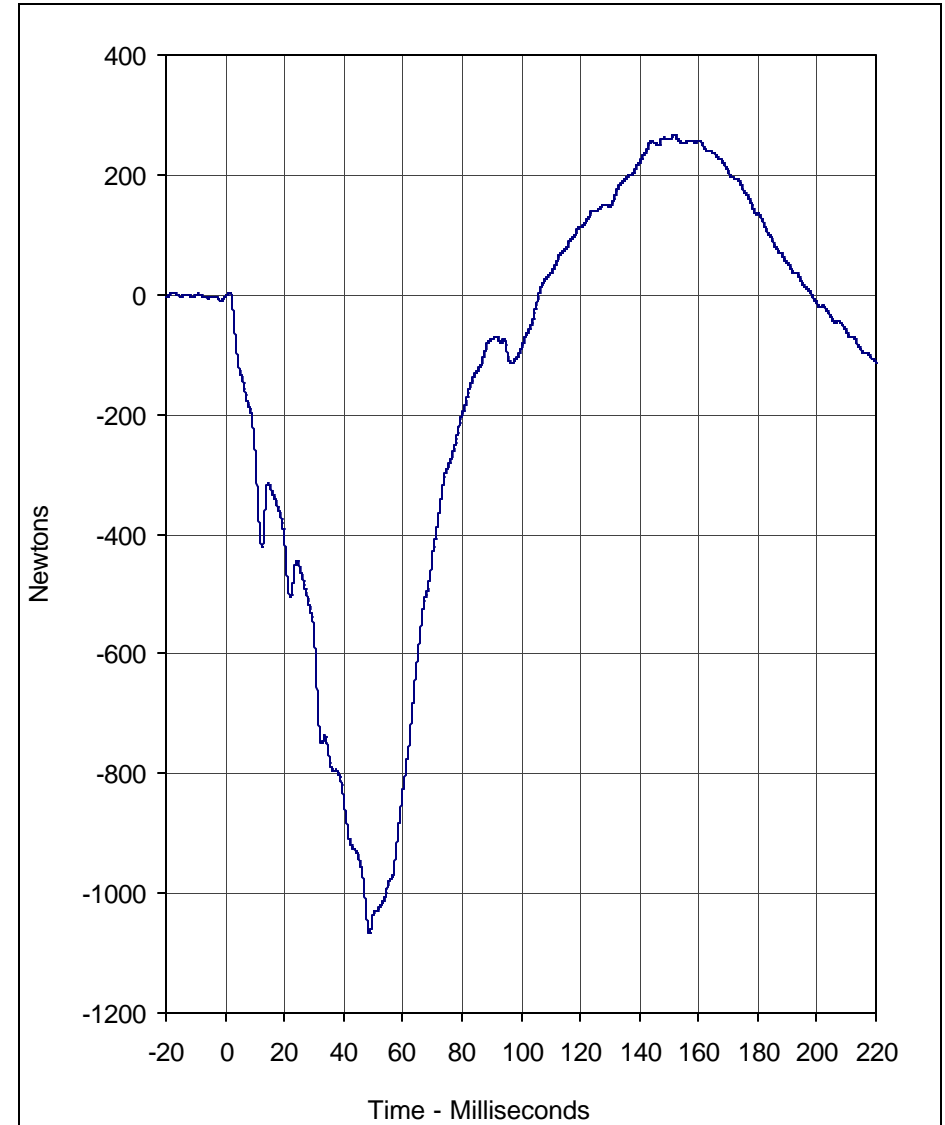
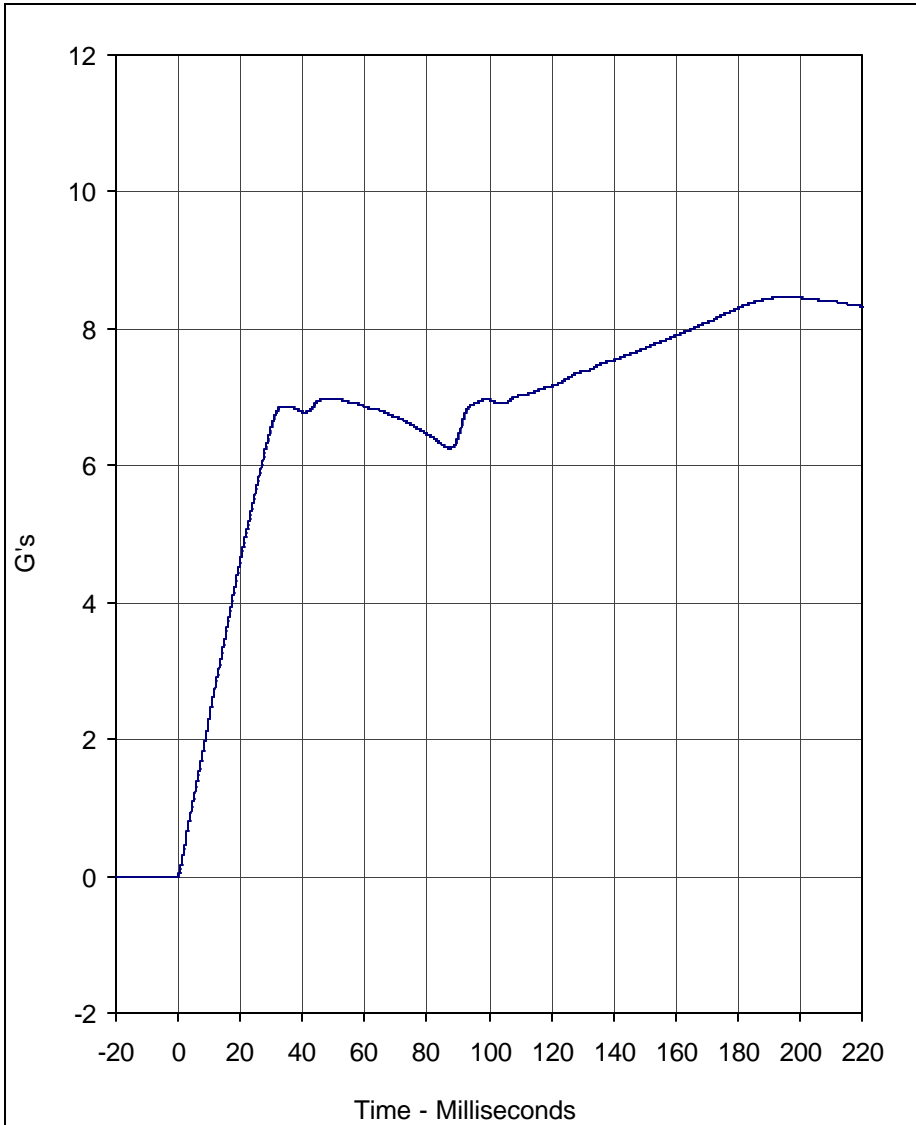

Curve Description	CURNO	Type
Pendulum Velocity	001	FIL

Units	Max	Time	Min	Time	SAE Class
G's	8.5	197.1	0.0	-0.8	180

Curve Description	CURNO	Type
Neck Force Y	002	FIL

Units	Max	Time	Min	Time	SAE Class
Newtons	268.0	151.8	-1066.2	48.8	180

Test Program: SID / HIII Neck Pendulum Lateral Test
 Test Date: 10/30/02

A.T.D. Serial No.: 275
 Test I.D.: NB11H



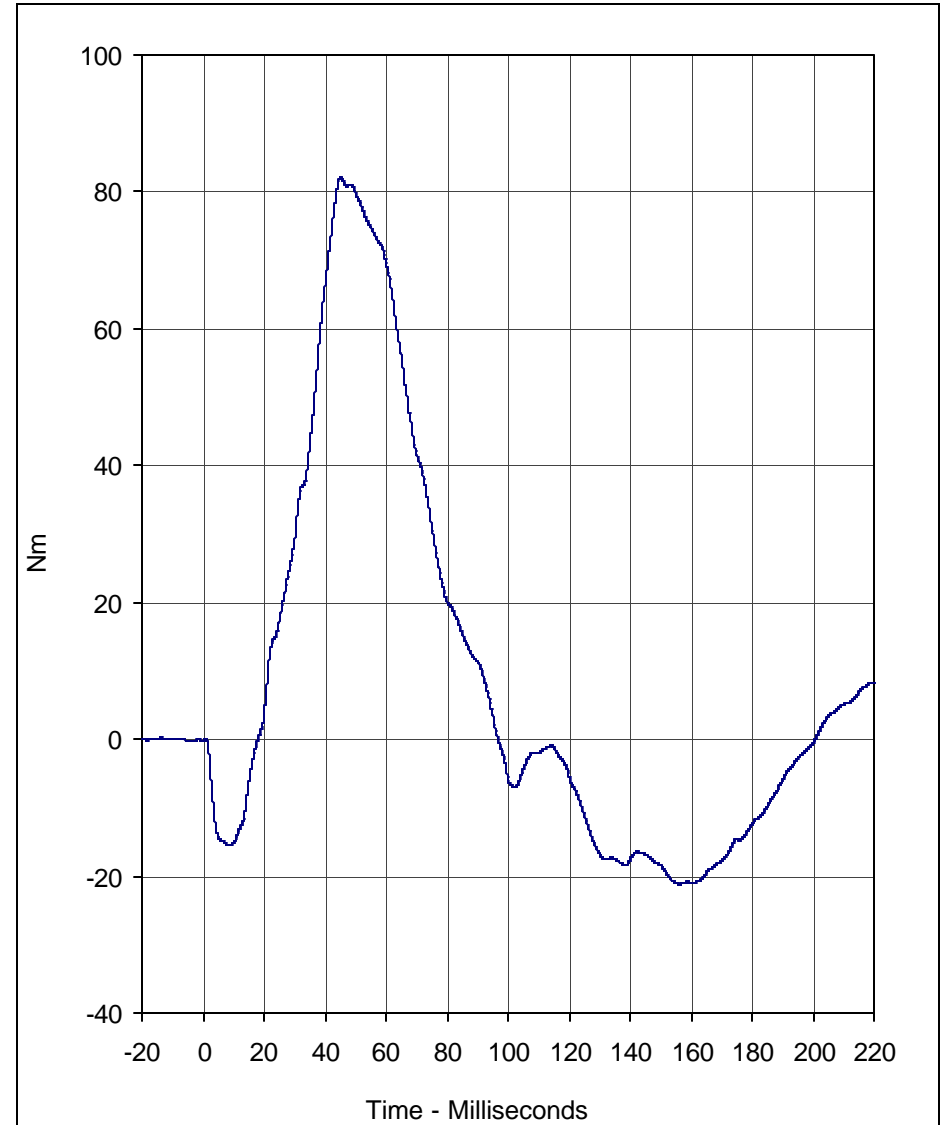
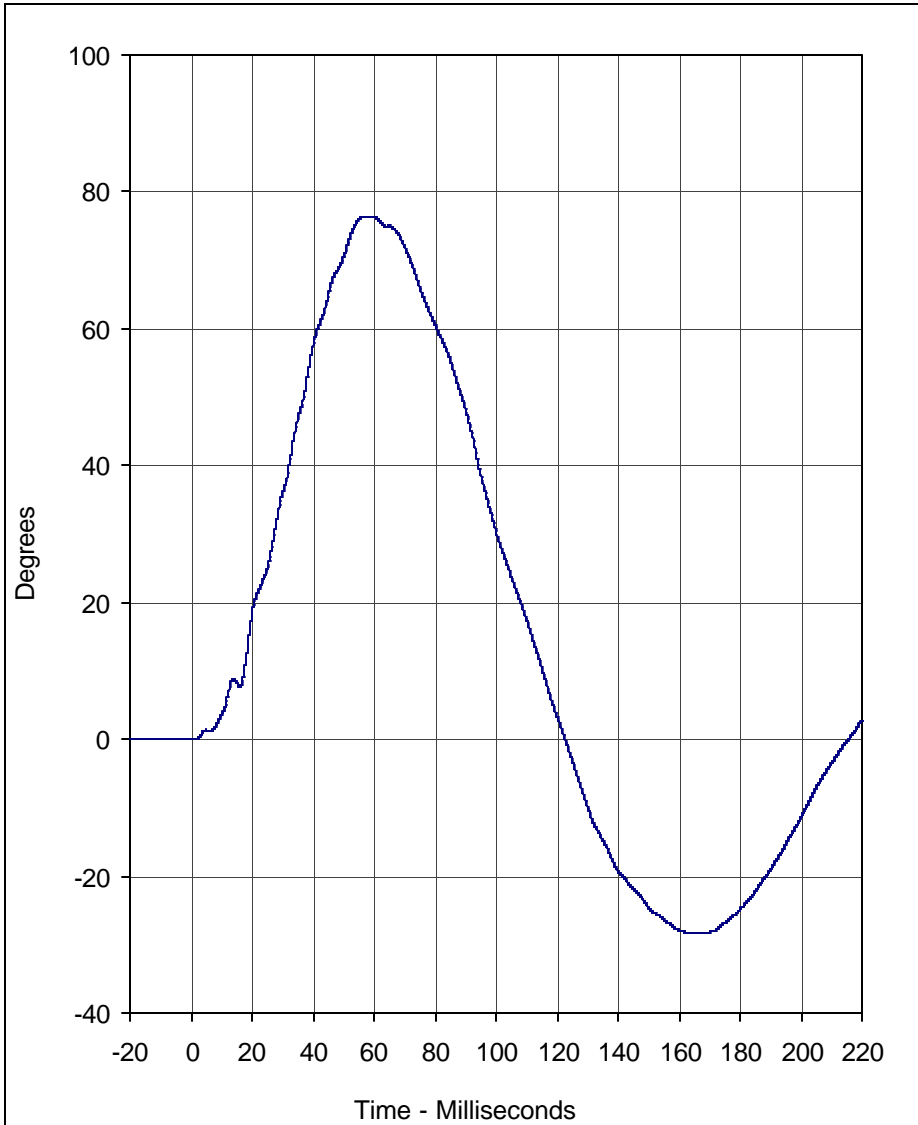

Curve Description				CURNO	Type
"D" Plane Rotation				003	FIL

Curve Description				CURNO	Type
Moment About Occipital Condyle				004	FIL

Units	Max	Time	Min	Time	SAE Class
Degrees	76.4	59.4	-28.4	166.0	180

Units	Max	Time	Min	Time	SAE Class
Nm	82.1	45.1	-21.2	156.3	180

Test Program: SID / HIII Neck Pendulum Lateral Test
 Test Date: 10/30/02

A.T.D. Serial No.: 275
 Test I.D.: NB11H



APPENDIX D
TEST EQUIPMENT LIST AND CALIBRATION INFORMATION

**55/28 km/h Side Impact NCAP
Instrumentation Data Channel Assignments
Driver HIII/SID Serial Number 274
10/29/02
2003 Subaru Forester 2.5X AWD Wagon**

CH.	LOCATION	AXIS	IDENT. NO.	DESCRIPTION	MFR	MODEL	UNITS
1	Head CG	X	KEAC086	Accel.,1/2 bridge	Endevco	7264-2000X	G
2	Head CG	Y	KEAC087	Accel.,1/2 bridge	Endevco	7264-2000Y	G
3	Head CG	Z	KEAC088	Accel.,1/2 bridge	Endevco	7264-2000Z	G
4	Head CG, Redundant	X	KEAC060	Accel.,1/2 bridge	Endevco	7264-2000	G
5	Head CG, Redundant	Y	KEAC061	Accel.,1/2 bridge	Endevco	7264-2000	G
6	Head CG, Redundant	Z	KEAC062	Accel.,1/2 bridge	Endevco	7264-2000	G
7	Neck Force	X	GPUN01FX	Load cell, six axis neck	R. A. Denton	1716A	N
8	Neck Force	Y	GPUN01FY	Load cell, six axis neck	R. A. Denton	1716A	N
9	Neck Force	Z	GPUN01FZ	Load cell, six axis neck	R. A. Denton	1716A	N
10	Neck Moment	X	GPUN01MX	Load cell, six axis neck	R. A. Denton	1716A	Nm
11	Neck Moment	Y	GPUN01MY	Load cell, six axis neck	R. A. Denton	1716A	Nm
12	Neck Moment	Z	GPUN01MZ	Load cell, six axis neck	R. A. Denton	1716A	Nm
13	Upper Rib Primary	Y	KEAC070	Accel.,1/2 bridge	Endevco	7264-2000X	G
14	Lower Rib, Primary	Y	KEAC071	Accel.,1/2 bridge	Endevco	7264-2000Y	G
15	Lower Spine, Primary	Y	KEAC072	Accel.,1/2 bridge	Endevco	7264-2000Z	G
16	Pelvis, Primary	Y	KEAC090	Accel.,Full bridge	Endevco	7264-2000X	G
17	Upper Rib Redundant	Y	KEAC076	Accel.,1/2 bridge	Endevco	7264-2000X	G
18	Lower Rib, Redundant	Y	KEAC077	Accel.,1/2 bridge	Endevco	7264-2000Y	G
19	Lower Spine, Redundant	Y	KEAC078	Accel.,1/2 bridge	Endevco	7264-2000Z	G
20	Pelvis, Redundant	Y	KEAC089	Accel.,1/2 bridge	Endevco	7264-2000X	G
21	Thorax Contact	N/A	T0	Contact Switch	Tapeswitch	8 oz. Yellow	%
22	Pelvis Contact	N/A	T0	Contact Switch	Tapeswitch	8 oz. Yellow	%

**55/28 km/h Side Impact NCAP
Instrumentation Data Channel Assignments
Passenger HIII/SID Serial Number 275
10/29/02
2003 Subaru Forester 2.5X AWD Wagon**

CH.	LOCATION	AXIS	IDENT. NO.	DESCRIPTION	MFR	MODEL	UNITS
23	Head CG	X	KEAC069	Accel.,1/2 bridge	Endevco	7264-2000X	G
24	Head CG	Y	KEAC080	Accel.,1/2 bridge	Endevco	7264-2000Y	G
25	Head CG	Z	KEAC082	Accel.,1/2 bridge	Endevco	7264-2000Z	G
26	Head CG, Redundant	X	KEAC083	Accel.,1/2 bridge	Endevco	7264-2000X	G
27	Head CG, Redundant	Y	KEAC084	Accel.,1/2 bridge	Endevco	7264-2000Y	G
28	Head CG, Redundant	Z	KEAC085	Accel.,1/2 bridge	Endevco	7264-2000Z	G
29	Neck Force	X	GPUN01FX	Load cell, six axis neck	R. A. Denton	1716A	N
30	Neck Force	Y	GPUN01FY	Load cell, six axis neck	R. A. Denton	1716A	N
31	Neck Force	Z	GPUN01FZ	Load cell, six axis neck	R. A. Denton	1716A	N
32	Neck Moment	X	GPUN01MX	Load cell, six axis neck	R. A. Denton	1716A	Nm
33	Neck Moment	Y	GPUN01MY	Load cell, six axis neck	R. A. Denton	1716A	Nm
34	Neck Moment	Z	GPUN01MZ	Load cell, six axis neck	R. A. Denton	1716A	Nm
35	Upper Rib Primary	Y	KEAC066	Accel.,1/2 bridge	Endevco	7264-2000X	G
36	Lower Rib, Primary	Y	KEAC067	Accel.,1/2 bridge	Endevco	7264-2000Y	G
37	Lower Spine, Primary	Y	KEAC068	Accel.,1/2 bridge	Endevco	7264-2000Z	G
38	Pelvis, Primary	Y	KEAC079	Accel.,1/2 bridge	Endevco	7264-2000X	G
39	Upper Rib Redundant	Y	KEAC073	Accel.,1/2 bridge	Endevco	7264-2000X	G
40	Lower Rib, Redundant	Y	KEAC074	Accel.,1/2 bridge	Endevco	7264-2000Y	G
41	Lower Spine, Redundant	Y	KEAC075	Accel.,1/2 bridge	Endevco	7264-2000Z	G
42	Pelvis, Redundant	Y	KEAC081	Accel.,1/2 bridge	Endevco	7264-2000X	G
43	Thorax Contact	Y	T0	Contact Switch	Tapeswitch	8 oz. Yellow	%
44	Pelvis Contact	Y	T0	Contact Switch	Tapeswitch	8 oz. Yellow	%

**55/28 km/h Side Impact NCAP
Instrumentation Data Channel Assignments
Vehicle Accelerometers
10/29/02
2003 Subaru Forester 2.5X AWD Wagon**

CH.	LOCATION	AXIS	IDENT. NO.	DESCRIPTION	MFR	MODEL	UNITS
45	Right at Sill Front Seat	X	KETX2A	Accel., Triax	I.C. Sensor	3031-200	G
46	Right at Sill Front Seat	Y	KETX2B	Accel., Triax	I.C. Sensor	3031-200	G
47	Right at Sill Front Seat	Z	KETX2C	Accel., Triax	I.C. Sensor	3031-200	G
48	Right at Sill Rear Seat	X	KETX3A	Accel., Triax	I.C. Sensor	3031-500	G
49	Right at Sill Rear Seat	Y	KETX3B	Accel., Triax	I.C. Sensor	3031-500	G
50	Right at Sill Rear Seat	Z	KETX3C	Accel., Triax	I.C. Sensor	3031-500	G
51	Rear Floorpan Above Axle	X	KETX4A	Accel., Triax	I.C. Sensor	3031-500	G
52	Rear Floorpan Above Axle	Y	KETX4B	Accel., Triax	I.C. Sensor	3031-500	G
53	Rear Floorpan Above Axle	Z	KETX4C	Accel., Triax	I.C. Sensor	3031-500	G
54	Left Sill at Rear Door	Y	KEVA012	Accel., Vehicle block	I.C. Sensor	3031-500	G
55	Left Sill at Front Door	Y	KEVA001	Accel., Vehicle block	I.C. Sensor	3031-500	G
56	Left Front Door Centerline	Y	ICST004X	Accel., Triax	I.C. Sensor	3031-500	G
57	Rear Occupant Compartment	Y	KEVA006	Accel., Vehicle block	I.C. Sensor	3031-200	G
58	Left Front Door Mid-Rear	Y	ICST004Y	Accel., Triax	I.C. Sensor	3031-500	G
59	Left Front Door Upper Centerline	Y	ICST004Z	Accel., Triax	I.C. Sensor	3031-500	G
60	Rear Door Mid-Rear	Y	ICST005X	Accel., Triax	I.C. Sensor	3031-500	G
61	Rear Door Upper Centerline	Y	ICST005Y	Accel., Triax	I.C. Sensor	3031-500	G
62	B-Post Lower	Y	KEBX2A	Accel., Biax	I.C. Sensor	3031-500	G
63	B-Post Middle	Y	KEBX2B	Accel., Biax	I.C. Sensor	3031-500	G
64	A-Post Lower	Y	KEBX1A	Accel., Biax	I.C. Sensor	3031-200	G
65	A-Post Middle	Y	KEBX1B	Accel., Biax	I.C. Sensor	3031-500	G
66	Front Seat Track	Y	KEIC008Y	Single	I.C. Sensor	3031-500	G
67	Rear Seat Structure	Y	N/A	N/A	N/A	N/A	N/A
68	Vehicle CG	X	KETX2A	Accel., Triax	I.C. Sensor	3031-200	G
69	Vehicle CG	Y	KETX2B	Accel., Triax	I.C. Sensor	3031-200	G
70	Vehicle CG	Z	KETX2C	Accel., Triax	I.C. Sensor	3031-200	G

**55/28 km/h Side Impact NCAP
Instrumentation Data Channel Assignments
Moving Deformable Barrier
10/29/02
2003 Subaru Forester 2.5X AWD Wagon**

CH.	LOCATION	AXIS	IDENT. NO.	DESCRIPTION	MFR	MODEL	UNITS
71	MDB CG	X	ICST001X	Accel., Triax	I.C. Sensor	3031-500	G
72	MDB CG	Y	ICST001Y	Accel., Triax	I.C. Sensor	3031-500	G
73	MDB CG	Z	ICST001Z	Accel., Triax	I.C. Sensor	3031-500	G
74	MDB Rear Centerline	X	ICST002X	Accel., Triax	I.C. Sensor	3031-50	G
75	MDB Rear Centerline	Y	ICST002Y	Accel., Triax	I.C. Sensor	3031-50	G
76	Right Bumper Contact	N/A	T0	Contact Switch	Tapeswitch	40 oz. Grey	%