

REPORT NUMBER: SLED-VER-2002-08

**CHILD RESTRAINT SYSTEM IN
DYNAMIC SLED TEST
SAFETY FIRST FORERUNNER, FORWARD-FACING UPRIGHT, CONVERTIBLE
CENTURY 1000 STE, FORWARD-FACING UPRIGHT, CONVERTIBLE**

TEST NUMBER: 22291

**PREPARED BY:
VERIDIAN ENGINEERING
4455 GENESEE STREET
BUFFALO, NEW YORK 14225**



March 25, 2002

FINAL REPORT

**PREPARED FOR:
U.S. DEPARTMENT OF TRANSPORTATION
NATIONAL HIGHWAY TRAFFIC SAFETY ADMINISTRATION
OFFICE OF CRASHWORTHINESS STANDARDS
400 SEVENTH STREET, SW, ROOM 5311
WASHINGTON, D.C. 20590**

This final test report was prepared for the U.S. Department of Transportation, National Highway Traffic Safety Administration, in response to Contract Number DTNH22-01-D-32005

This publication is distributed by the U.S. Department of Transportation, National Highway Traffic Safety Administration, in the interest of information exchange. The opinions, findings and conclusions expressed in this publication are those of the author(s) and not necessarily those of the Department of Transportation or the National Highway Traffic Safety Administration. The United States Government assumes no liability for its contents or use thereof. If trade or manufacturers' names or products are mentioned it is only because they are considered essential to the object of the publication and should not be construed as an endorsement. The United States Government does not endorse products or manufacturers.

Prepared by: _____ Date: _____
David P. Roberts, Project Engineer

Reviewed by: _____ Date: _____
David P. Roberts, Head of Occupant
Protection and Safety Research

FINAL REPORT ACCEPTED BY:

Manager, New Car Assessment Program

Date of Acceptance

COTR, NCAP Frontal Impact Program

Date of Acceptance

TABLE OF CONTENTS

<u>Section</u>		<u>Page No.</u>
1	Purpose and Test Procedure	1
2	P3 Child Restraint Information	2
3	P3 Post-Test Observations	3
4	P3 Hybrid III 3 Year Old ATD Injury Criteria and Sensor Data	4
5	P4 Child Restraint Information	6
6	P4 Post-Test Observations	7
7	P4 Hybrid III 3 Year Old ATD Injury Criteria and Sensor Data	8
8	Sled Test Set-Up	10
9	Camera Location	11
10	Photographs	12
11	Data Plots	21
12	Compression – Deflection Resistance Test	59
13	Child Dummy Calibration Data Traces and Tables	69
14	Test Equipment and Instrumentation Calibration	163
15	AVI Files	166

SECTION 1

PURPOSE AND TEST PROCEDURE

1.1 PURPOSE

This dynamic sled testing is part of the FY' 02 New Car Assessment Program (NCAP) sponsored by the National Highway Traffic Safety Administration (NHTSA) under Contract Number DTNH22-01-D-32005. The purpose of this test is to obtain child seat research data for frontal dynamic testing.

1.2 TEST PROCEDURE

This frontal dynamic sled test was conducted in accordance with the child restraint test procedure provided by the Office of Crashworthiness Standards (OCS), New Car Assessment Program (NCAP).

The test was conducted at Veridian Engineering on March 25, 2002 at a speed of 47.1 kph (29.2 mph). The FMVSS No. 213 sled pulse was used as a crash pulse. The requirements specified in the FMVSS No. 213 were also followed.

The bench seat contained two anthropomorphic test devices (ATD's). Two (2) Hybrid III 3 year old size ATD's, Serial Number 40 (P3) and 142 (P4), were instrumented with head, chest, and pelvic tri-axial accelerometers, and upper and lower neck load cells. The child ATD's were positioned according to the child seat manufacturer's instructions. The data was digitally sampled at 20,000 samples per second and processed per Section IP11 of the Laboratory Test Procedure.

1.3 POST-TEST COMMENTS

None

SECTION 2

CHILD RESTRAINT INFORMATION

Test No.: 22291S

Test Date: March 25, 2002

P3 Seating Position

Child Restraint Type (forward-facing, rearward facing, booster)	Forward facing, Upright, Convertible
LATCH or NON-LATCH	Non-Latch with tether*
Child Restraint Manufacturer	Safety First
Child Restraint Model	Forerunner
Model Number	02925BRD
Date of Manufacture	01/09/2002
Child Restraint Height Limits (mm)	482.6 – 1016.0
Child Restraint Weight Limits (kg)	2.3 – 18.0
Weight of Child Restraint (kg)	4.35
Tether Location	Lower

*Tether bar was lowered to 355.6mm above sled floor.

SECTION 3

POST-TEST OBSERVATIONS

Test No.: 22291S

Test Date: March 25, 2002

P3 Seating Position

Child Seat	Safety First Forerunner
Belt Fraying	None
Stress Marks	None
Cracks	None
Buckle Stress	None
Latch Hooks	None
Max. Head Excursion (mm)	726.4
Max. Knee Excursion (mm)	731.5
Velocity	29.2 mph, 47.1 kph
Acceleration (G's)	23.6

SECTION 4

HYBRID III 3 YEAR OLD ATD INJURY CRITERIA AND SENSOR DATA

Test No.: 22291S

Test Date: March 25, 2002

P3 Seating Position

HEAD PRIMARY PEAK ACCELERATIONS

Location	Axis	Units	P3 (South) Rear Passenger			
			Max	Time	Min	Time
Head CG	X	G's	33.3	224.6	-62.7	96.3
Head CG	Y	G's	3.9	98.9	-7.7	95.8
Head CG	Z	G's	47.5	81.0	-0.2	19.1
Head CG Resultant	N/A	G's	68.9	96.1		

CHEST PRIMARY PEAK ACCELERATIONS

Location	Axis	Units	P3 (South) Rear Passenger			
			Max	Time	Min	Time
Chest CG	X	G's	6.5	238.2	-31.3	58.1
Chest CG	Y	G's	4.1	67.5	-1.6	185.3
Chest CG	Z	G's	7.7	229.2	-15.4	59.2
Chest CG Resultant	N/A	G's	34.9	58.4		

SEAT BELT SENSOR PEAK VALUES

Location	Axis	Units	P3 (South) Rear Passenger			
			Max	Time	Min	Time
Tether Belt	N/A	Newtons	----	----		

HEAD INJURY CRITERIA (HIC)

Location	P3 (South) Rear Passenger			
	HIC	Avg. G's	T ¹	T ²
Head CG Primary (36 msec)	501	45.4	67.6	103.5
Head CG Primary (15 msec)	242	48.2	72.9	87.9

CHEST CLIP (3 MSEC)

Location	P3 (South) Rear Passenger		
	Clip	T ¹	T ²
Chest CG Primary	34.6	56.7	59.7

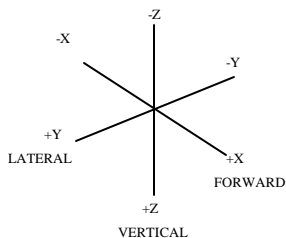

HYBRID III 3 YEAR OLD ATD INJURY CRITERIA AND SENSOR DATA...(continued)

Test No.: 22291S

Test Date: March 25, 2002

P3 Seating Position

PELVIC PEAK ACCELERATIONS

Location	Axis	Units	P3 (South) Rear Passenger			
			Max	Time	Min	Time
Pelvis	X	G's	22.6	121.8	-37.7	60.3
Pelvis	Y	G's	2.7	157.0	-1.9	71.5
Pelvis	Z	G's	13.4	122.2	-28.8	62.3

UPPER NECK PEAK FORCES AND MOMENTS

Location	Axis	Units	P3 (South) Rear Passenger			
			Max	Time	Min	Time
Neck Force	X	Newtons	0.4	44.3	-845.4	98.9
Neck Force	Y	Newtons	37.4	63.3	-35.8	98.9
Neck Force	Z	Newtons	1261.2	94.3	-52.3	246.0
Neck Moment	X	Nm	2.7	55.8	-2.3	154.6
Neck Moment	Y	Nm	5.7	155.8	-12.3	235.6
Neck Moment	Z	Nm	1.6	250.0	-1.0	86.9

LOWER NECK PEAK FORCES AND MOMENTS

Location	Axis	Units	P3 (South) Rear Passenger			
			Max	Time	Min	Time
Neck Force	X	Newtons	193.9	223.9	-1163.5	97.5
Neck Force	Y	Newtons	42.3	45.8	-110.1	97.8
Neck Force	Z	Newtons	936.7	77.0	-86.9	101.5
Neck Moment	X	Nm	6.9	61.0	-4.3	132.4
Neck Moment	Y	Nm	119.1	97.4	-13.5	223.6
Neck Moment	Z	Nm	3.4	63.3	-2.3	161.2

CHEST PEAK DISPLACEMENTS

Location	Axis	Units	P3 (South) Rear Passenger			
			Max	Time	Min	Time
Chest CG	X	mm			-26.6	108.2

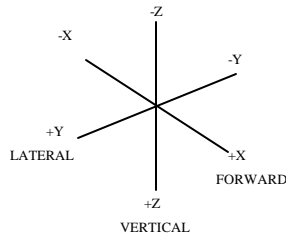

SECTION 5

CHILD RESTRAINT INFORMATION

Test No.: 22291N

Test Date: March 25, 2002

P4 Seating Position

Child Restraint Type (forward-facing, rearward facing, booster)	Forward facing, Upright, Convertible
LATCH or NON-LATCH	Non-Latch with tether*
Child Restraint Manufacturer	Century
Child Restraint Model	1000 STE
Model Number	44161
Date of Manufacture	01/14/2002
Child Restraint Height Limits (mm)	Up to 1016
Child Restraint Weight Limits (kg)	Rearward-facing Birth – 10 Forward-facing 9 - 18
Weight of Child Restraint (kg)	4.8
Tether Location	Lower

*Tether bar was lowered to 355.6mm above sled floor.

SECTION 6

POST-TEST OBSERVATIONS

Test No.: 22291N

Test Date: March 25, 2002

P4 Seating Position

Child Seat	Century 1000STE
Belt Fraying	None
Stress Marks	None
Cracks	None
Buckle Stress	None
Latch Hooks	None
Max. Head Excursion (mm)	716.3
Max. Knee Excursion (mm)	787.4
Velocity	29.2 mph, 47.1 kph
Acceleration (G's)	23.6

HYBRID III 3 YEAR OLD ATD INJURY CRITERIA AND SENSOR DATA...(continued)

Test No.: 22291N

Test Date: March 25, 2002

P4 Seating Position

PELVIC PEAK ACCELERATIONS

Location	Axis	Units	P4 (North) Rear Passenger			
			Max	Time	Min	Time
Pelvis	X	G's	5.4	155.0	-22.2	52.5
Pelvis	Y	G's	3.9	177.9	-10.1	85.3
Pelvis	Z	G's	9.6	192.6	-35.8	77.1

UPPER NECK PEAK FORCES AND MOMENTS

Location	Axis	Units	P4 (North) Rear Passenger			
			Max	Time	Min	Time
Neck Force	X	Newtons	38.6	229.4	-1099.3	95.7
Neck Force	Y	Newtons	128.5	92.7	-30.1	232.1
Neck Force	Z	Newtons	1888.5	94.7	-59.3	210.0
Neck Moment	X	Nm	4.2	86.9	-1.7	98.1
Neck Moment	Y	Nm	16.5	89.8	-8.3	49.4
Neck Moment	Z	Nm	3.5	194.4	-2.0	94.4

LOWER NECK PEAK FORCES AND MOMENTS

Location	Axis	Units	P4 (North) Rear Passenger			
			Max	Time	Min	Time
Neck Force	X	Newtons	392.4	179.6	-1924.5	94.7
Neck Force	Y	Newtons	161.7	81.6	-62.4	168.7
Neck Force	Z	Newtons	797.2	178.7	-305.5	95.9
Neck Moment	X	Nm	17.4	89.4	-4.0	232.5
Neck Moment	Y	Nm	169.3	93.4	-20.7	180.4
Neck Moment	Z	Nm	8.5	85.9	-1.3	156.8

CHEST PEAK DISPLACEMENTS

Location	Axis	Units	P4 (North) Rear Passenger			
			Max	Time	Min	Time
Chest CG	X	mm			-21.4	99.7

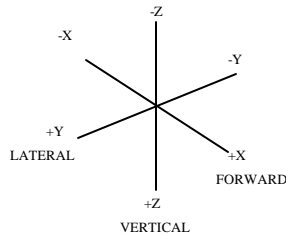

SECTION 8
SLED TEST SET-UP

Test No.: 22291

Test Date: March 25, 2002

An FMVSS 213 test bench was fixtured on the sled in order to simulate a frontal impact. Two child seats were placed on the bench and fastened in a manner suggested in the owner's manual of the child seat. Stadia poles were set up to measure dummy head and knee excursions.

Pre-test Infant and Car Seat Positions

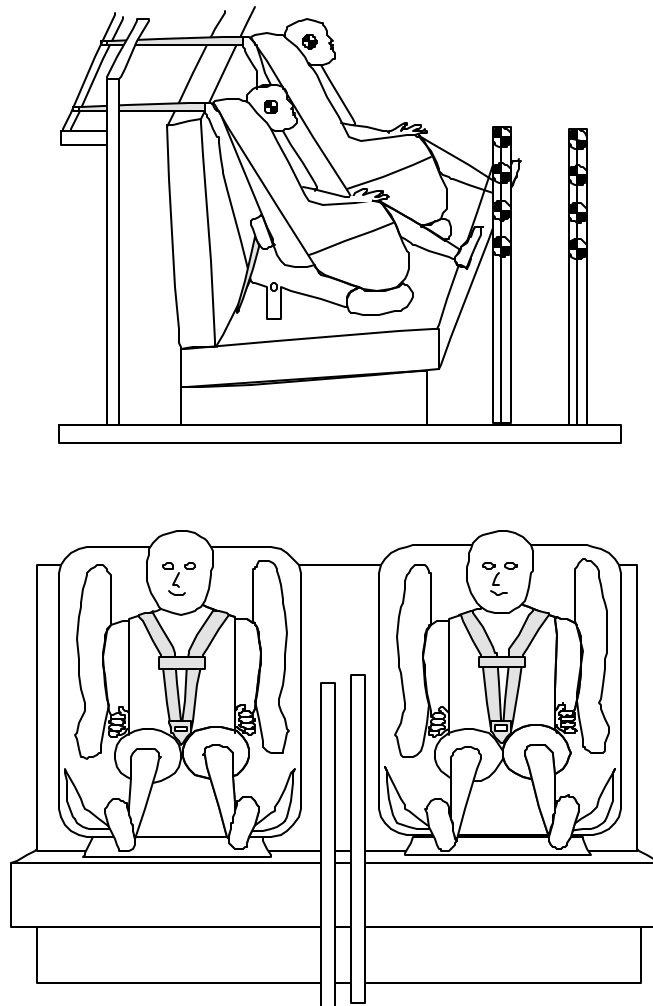

SECTION 9
CAMERA LOCATION

Test No.: 22291

Test Date: March 25, 2002

There were two cameras mounted onto the sled carriage for views of the left and right side of each child seat. All measurements are in millimeters.

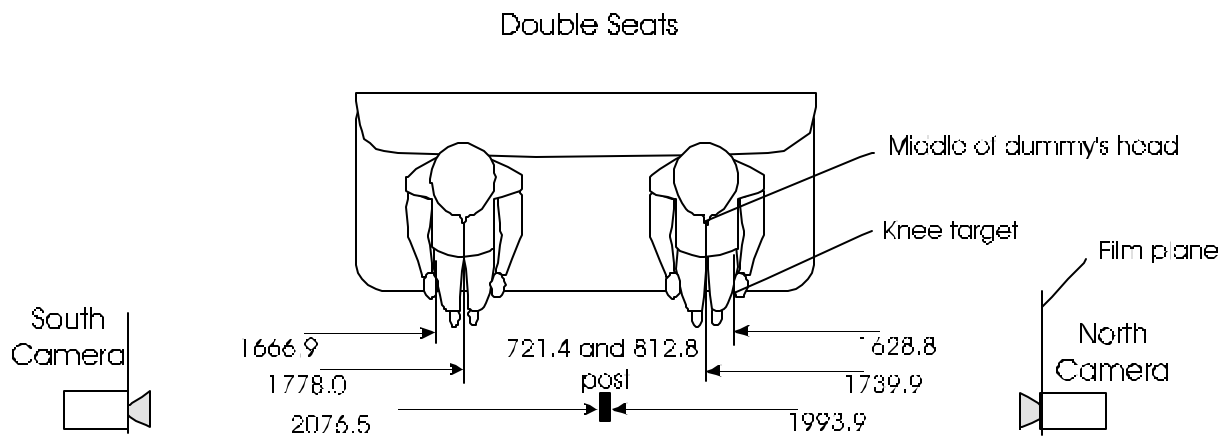

SECTION 10
PHOTOGRAPHS

TABLE OF PHOTOGRAPHS

<u>Photographs</u>	<u>Page No.</u>
Photo 1 – Pre-Test Right $\frac{3}{4}$ View	13
Photo 2 – Post-Test Right $\frac{3}{4}$ View	14
Photo 3 – Pre-Test Right Side View	15
Photo 4 – Post-Test Right Side View	16
Photo 5 – Pre-Test Left $\frac{3}{4}$ View	17
Photo 6 – Post-Test Left $\frac{3}{4}$ View	18
Photo 7 – Pre-Test Left Side View	19
Photo 8 – Post-Test Left Side View	20



Run #22291 Photo 1 - Pre-Test Right 3/4 View



Run #22291 Photo 2 - Post-Test Right 3/4 View



Run #22291 Photo 3 - Pre-Test Right Side View



Run #22291 Photo 4 - Post-Test Right Side View



Run #22291 Photo 5 - Pre-Test Left 3/4 View
17

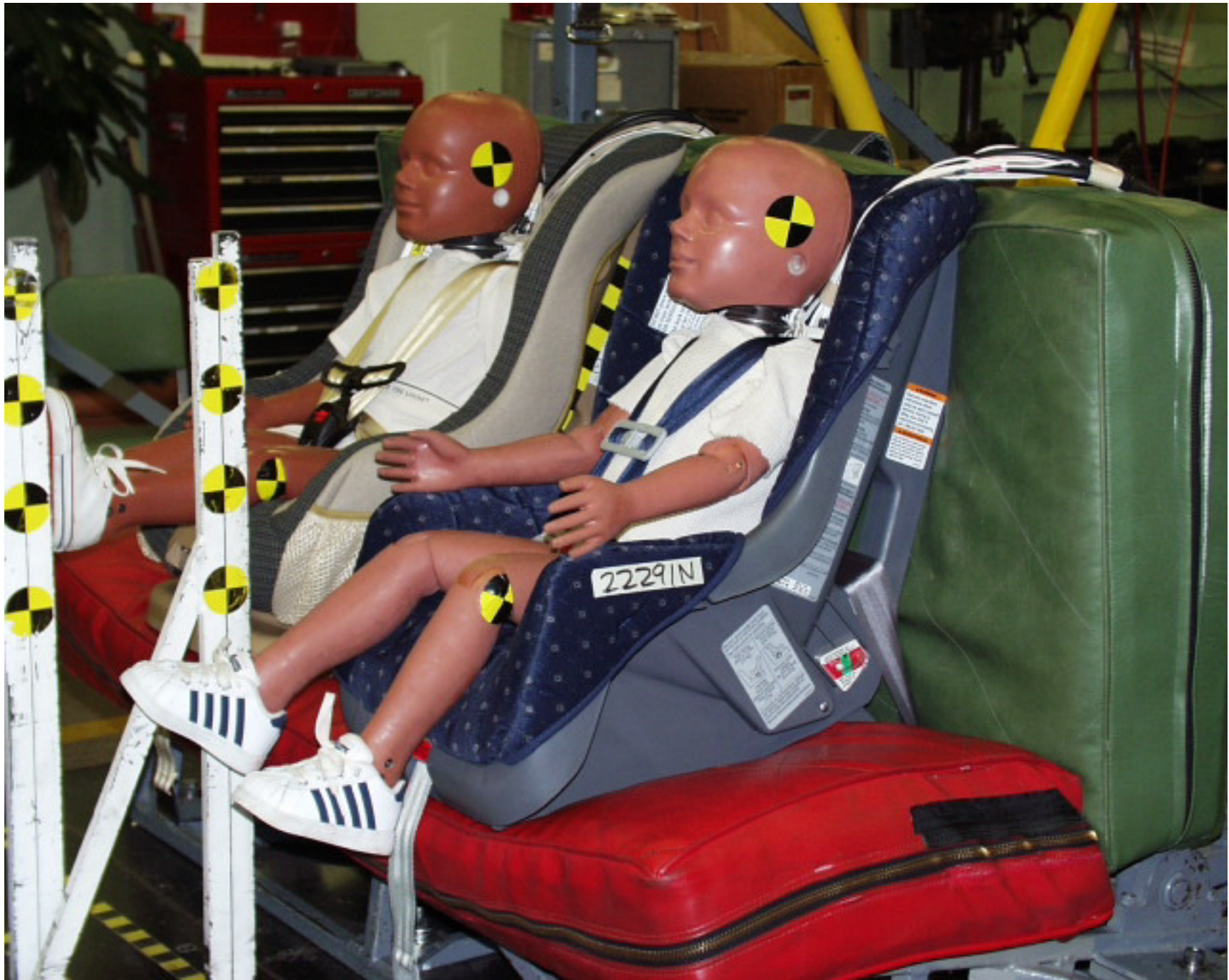

Run #22291 Photo 6 - Post-Test Left 3/4 View



Run #22291 Photo 7 - Pre-Test Left Side View



Run #22291 Photo 8 - Post-Test Left Side View

SECTION 11
DATA PLOTS

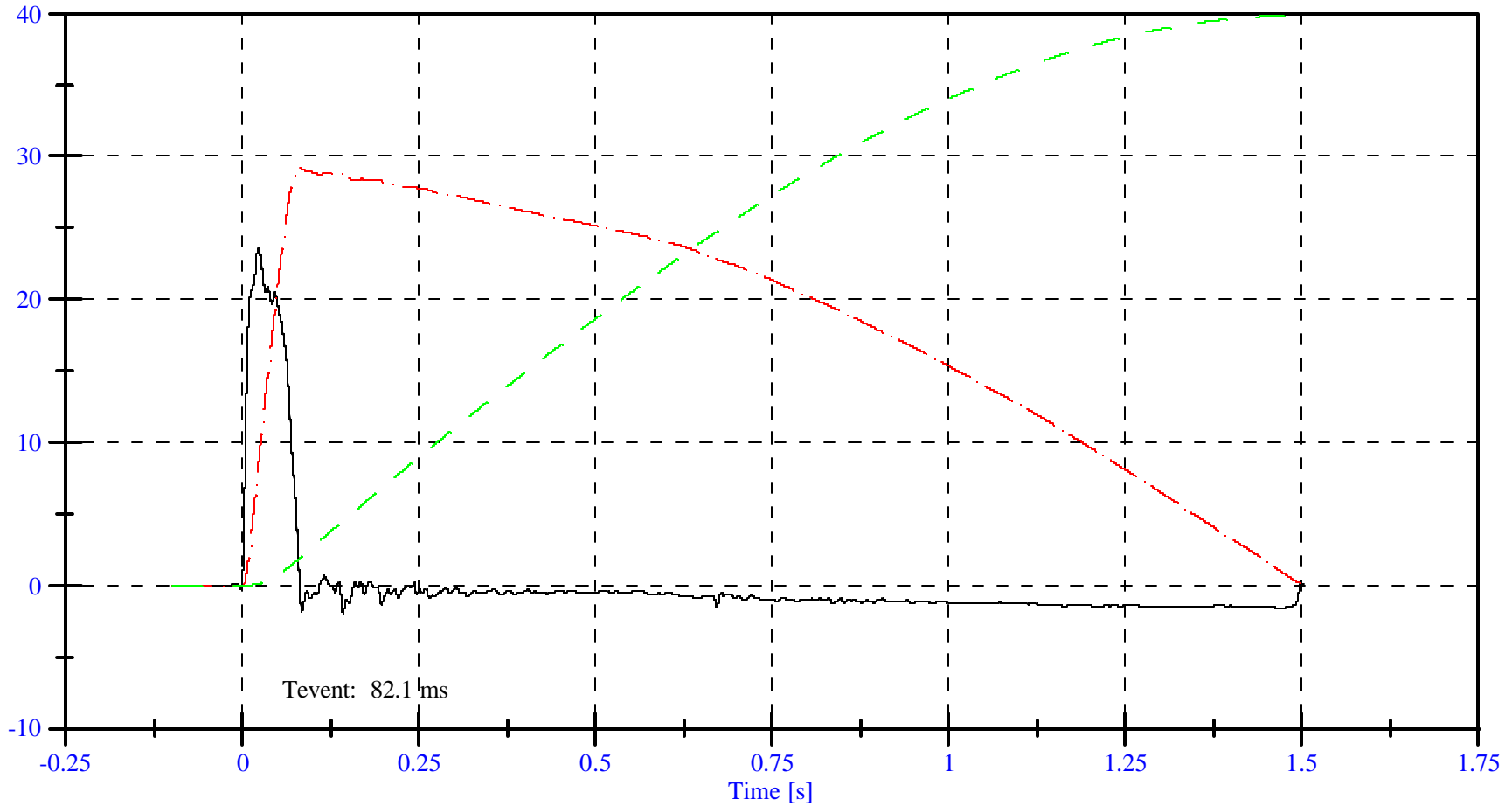

		Maximum	Time (ms)	Minimum	Time (ms)	Filter Class
Sled Ax	(g)	23.6	23.6	-2.0	143.4	CFC_60
Sled Vx	(mph)	29.3	82.1	-0.0	-18.5	CFC_180
Sled Dx	(ft)	39.9	1501.2	-0.0	-9.9	CFC_180

LEGEND	
—	Sled Ax
- . -	Sled Vx
- - -	Sled Dx

Sled Test Run 22291

Sled Pulse Corridor

Max: 23.6 [g] at 0.0236 [s]

Min: -2.0 [g] at 0.1434 [s]

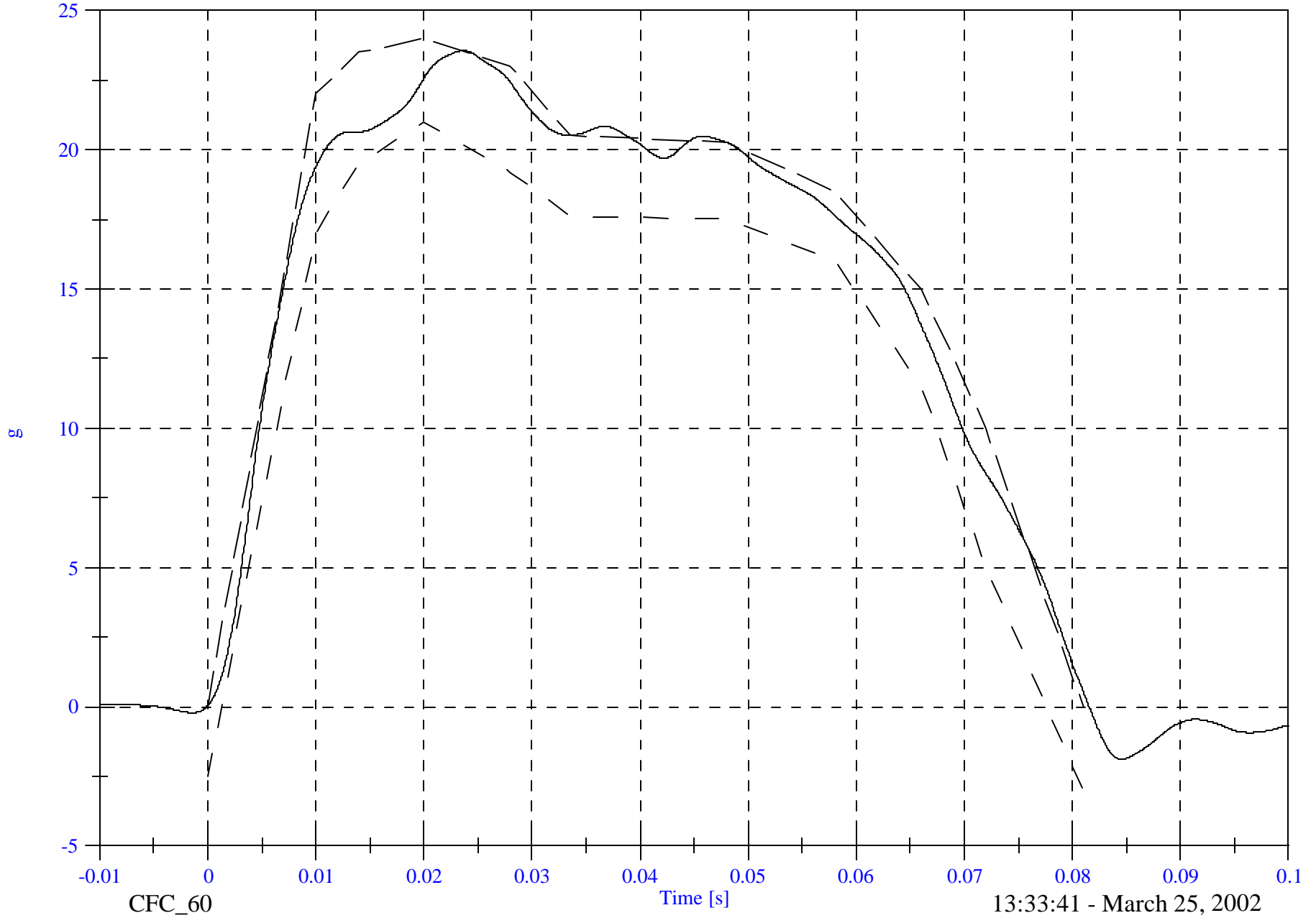

FACILITY: HYGE SLED

DATE: March 25, 2002

TEST#: 22291

TITLE: Sled Test Run 22291 Version 3.10 / 32 dev

CHN NAME	Unit	Max	msec	Min	msec	Filt	Comment
49 Sled Acceleration	g	23.6	23.6	-2.0	143.4	CFC_60	
50 Sled Acceleration Velocity	kph	47.1	82.1	-0.0	-18.5	CFC_180	
51 Sled Acceleration Displacement	mm	2719.8	250.0	-0.0	-9.9	CFC_180	
52 P3 Head x	g	33.3	224.6	-62.7	96.3	CFC_1000	
53 P3 Head y	g	3.9	98.9	-7.7	95.8	CFC_1000	
54 P3 Head z	g	47.5	81.0	-0.2	19.1	CFC_1000	
55 P3 Head Resultant	g	68.9	96.1	0.0	-28.5	CFC_1000	
56 P3 Upper Neck Fx	N	0.4	-44.3	-845.4	98.9	CFC_1000	
57 P3 Upper Neck Fy	N	37.4	63.3	-35.8	98.9	CFC_1000	
58 P3 Upper Neck Fz	N	1261.2	94.3	-52.3	246.0	CFC_1000	
59 P3 Upper Neck F Resultant	N	1451.3	94.7	0.0	-11.0	CFC_1000	
60 P3 Upper Neck Mx	N-m	2.7	55.8	-2.3	154.6	CFC_600	
61 P3 Upper Neck My	N-m	5.7	155.8	-12.3	235.6	CFC_600	
62 P3 Upper Neck Mz	N-m	1.6	250.0	-1.0	86.9	CFC_600	
63 P3 Upper Neck M Resultant	N-m	12.4	235.6	0.0	-40.1	CFC_600	
64 P3 Lower Neck Fx	N	193.9	223.9	-1163.5	97.5	CFC_1000	
65 P3 Lower Neck Fy	N	42.3	45.8	-110.1	97.8	CFC_1000	
66 P3 Lower Neck Fz	N	936.7	77.0	-86.9	101.5	CFC_1000	
67 P3 Lower Neck F Resultant	N	1245.2	81.0	0.0	-11.5	CFC_1000	
68 P3 Lower Neck Mx	N-m	6.9	61.0	-4.3	132.4	CFC_600	
69 P3 Lower Neck My	N-m	119.1	97.4	-13.5	223.6	CFC_600	
70 P3 Lower Neck Mz	N-m	3.4	63.3	-2.3	161.2	CFC_600	
71 P3 Lower Neck M Resultant	N-m	119.2	97.4	0.0	-15.4	CFC_600	
72 P3 Chest x	g	6.5	238.2	-31.3	58.1	CFC_180	
73 P3 Chest y	g	4.1	67.5	-1.6	185.3	CFC_180	
74 P3 Chest z	g	7.7	229.2	-15.4	59.2	CFC_180	
75 P3 Chest Resultant	g	34.9	58.4	0.0	-45.8	CFC_180	
76 P3 Pelvic x	g	22.6	121.8	-37.7	60.3	CFC_1000	
77 P3 Pelvic y	g	2.7	157.0	-1.9	71.5	CFC_1000	
78 P3 Pelvic z	g	13.4	122.2	-28.8	62.3	CFC_1000	
79 P3 Pelvic Resultant	g	46.6	60.6	0.0	-45.5	CFC_1000	
80 P3 Head Red z	g	71.9	95.9	-15.3	222.6	CFC_1000	
81 P3 Chest Compression	mm	0.0	20.0	-26.6	108.2	CFC_600	
82 P3 Upper Neck Mocy	N-m	5.7	155.8	-12.3	235.6	CFC_600	

FACILITY: HYGE SLED

DATE: March 25, 2002

TEST#: 22291

TITLE: Sled Test Run 22291 Version 3.10 / 32 dev

CHN	NAME	Unit	Max	msec	Min	msec	Filt	Comment
84	P3 Head x	g	32.9	224.7	-51.2	96.8	CFC_60	
85	P3 Head x Velocity	kph	0.0	-16.5	-64.2	210.3	CFC_180	
86	P3 Head y	g	2.3	235.6	-3.6	95.8	CFC_60	
87	P3 Head y Velocity	kph	2.4	92.1	-0.2	225.3	CFC_180	
88	P3 Head z	g	47.0	80.4	-0.0	-50.0	CFC_60	
89	P3 Head z Velocity	kph	114.1	250.0	-0.0	-43.2	CFC_180	
90	P3 Head Red z	g	61.8	96.0	-12.7	222.6	CFC_60	
91	P3 Head Red z Velocity	kph	113.4	249.1	-0.0	16.7	CFC_180	
92	P3 Chest x	g	6.5	238.8	-31.2	57.8	CFC_60	
93	P3 Chest x Velocity	kph	0.0	-19.7	-59.4	134.3	CFC_180	
94	P3 Chest y	g	3.9	67.2	-1.4	171.4	CFC_60	
95	P3 Chest y Velocity	kph	4.4	102.7	-0.0	-25.5	CFC_180	
96	P3 Chest z	g	7.4	229.3	-15.2	58.5	CFC_60	
97	P3 Chest z Velocity	kph	0.7	40.7	-16.7	193.4	CFC_180	
98	P3 Pelvic x	g	21.3	122.1	-37.4	59.2	CFC_60	
99	P3 Pelvic x Velocity	kph	0.0	-50.0	-47.7	115.3	CFC_180	
100	P3 Pelvic y	g	2.2	60.6	-1.3	72.1	CFC_60	
101	P3 Pelvic y Velocity	kph	2.9	226.1	-0.1	39.9	CFC_180	
102	P3 Pelvic z	g	12.7	122.5	-28.4	63.1	CFC_60	
103	P3 Pelvic z Velocity	kph	0.0	33.4	-40.9	116.1	CFC_180	
104	P4 Head x	g	35.1	187.9	-62.6	96.0	CFC_1000	
105	P4 Head y	g	14.0	95.7	-6.8	99.1	CFC_1000	
106	P4 Head z	g	48.7	85.5	-0.1	-43.0	CFC_1000	
107	P4 Head Resultant	g	72.8	95.8	0.0	-38.3	CFC_1000	
108	P4 Upper Neck Fx	N	38.6	229.4	-1099.3	95.7	CFC_1000	
109	P4 Upper Neck Fy	N	128.5	92.7	-30.1	232.1	CFC_1000	
110	P4 Upper Neck Fz	N	1888.5	94.7	-59.3	210.0	CFC_1000	
111	P4 Upper Neck F Resultant	N	2170.7	94.9	0.0	-9.7	CFC_1000	
112	P4 Upper Neck Mx	N-m	4.2	86.9	-1.7	98.1	CFC_600	
113	P4 Upper Neck My	N-m	16.5	89.8	-8.3	49.4	CFC_600	
114	P4 Upper Neck Mz	N-m	3.5	194.4	-2.0	94.4	CFC_600	
115	P4 Upper Neck M Resultant	N-m	16.8	89.8	0.0	-45.9	CFC_600	
116	P4 Lower Neck Fx	N	392.4	179.6	-1924.5	94.7	CFC_1000	
117	P4 Lower Neck Fy	N	161.7	81.6	-62.4	168.7	CFC_1000	

FACILITY: HYGE SLED

DATE: March 25, 2002

TEST#: 22291

TITLE: Sled Test Run 22291 Version 3.10 / 32 dev

CHN NAME	Unit	Max	msec	Min	msec	Filt	Comment
118 P4 Lower Neck Fz	N	797.2	178.7	-305.5	95.9	CFC_1000	
119 P4 Lower Neck F Resultant	N	1937.6	95.1	0.0	-39.0	CFC_1000	
120 P4 Lower Neck Mx	N-m	17.4	89.4	-4.0	232.5	CFC_600	
121 P4 Lower Neck My	N-m	169.3	93.4	-20.7	180.4	CFC_600	
122 P4 Lower Neck Mz	N-m	8.5	85.9	-1.3	156.8	CFC_600	
123 P4 Lower Neck M Resultant	N-m	170.2	93.3	0.0	-11.8	CFC_600	
124 P4 Chest x	g	20.6	93.3	-35.5	91.4	CFC_180	
125 P4 Chest y	g	5.6	76.3	-7.7	92.0	CFC_180	
126 P4 Chest z	g	11.0	95.4	-27.8	77.7	CFC_180	
127 P4 Chest Resultant	g	38.0	77.8	0.0	-38.5	CFC_180	
128 P4 Pelvic x	g	5.4	155.0	-22.2	52.5	CFC_1000	
129 P4 Pelvic y	g	3.9	177.9	-10.1	85.3	CFC_1000	
130 P4 Pelvic z	g	9.6	192.6	-35.8	77.1	CFC_1000	
131 P4 Pelvic Resultant	g	36.6	60.6	0.0	-41.6	CFC_1000	
132 P4 Head Red z	g	81.0	96.2	-9.6	187.6	CFC_1000	
133 P4 Chest Compression	mm	0.0	-16.3	-21.4	99.7	CFC_600	
134 P4 Upper Neck Mocyc	N-m	16.5	89.8	-8.3	49.4	CFC_600	
136 P4 Head x	g	34.3	188.5	-56.3	96.4	CFC_60	
137 P4 Head x Velocity	kph	0.0	-50.0	-69.1	169.8	CFC_180	
138 P4 Head y	g	6.8	95.2	-4.7	100.3	CFC_60	
139 P4 Head y Velocity	kph	3.4	97.4	-0.0	10.5	CFC_180	
140 P4 Head z	g	47.9	85.5	-0.0	-43.0	CFC_60	
141 P4 Head z Velocity	kph	114.2	250.0	-0.0	-31.9	CFC_180	
142 P4 Head Red z	g	77.5	95.9	-9.3	186.5	CFC_60	
143 P4 Head Red z Velocity	kph	115.5	243.6	-0.9	55.3	CFC_180	
144 P4 Chest x	g	10.0	176.7	-32.3	56.0	CFC_60	
145 P4 Chest x Velocity	kph	0.0	-10.6	-60.0	122.9	CFC_180	
146 P4 Chest y	g	5.5	76.1	-3.0	211.9	CFC_60	
147 P4 Chest y Velocity	kph	5.4	105.8	-0.0	18.5	CFC_180	
148 P4 Chest z	g	9.8	95.6	-27.5	77.1	CFC_60	
149 P4 Chest z Velocity	kph	0.7	41.7	-26.5	132.6	CFC_180	
150 P4 Pelvic x	g	5.2	155.1	-21.6	53.1	CFC_60	
151 P4 Pelvic x Velocity	kph	0.0	-41.8	-23.8	102.0	CFC_180	
152 P4 Pelvic y	g	3.8	177.3	-8.4	85.5	CFC_60	

FACILITY: HYGE SLED

DATE: March 25, 2002

TEST#: 22291

TITLE: Sled Test Run 22291 Version 3.10 / 32 dev

CHN NAME	Unit	Max	msec	Min	msec	Filt	Comment
153 P4 Pelvic y Velocity	kph	1.2	71.2	-1.9	118.7	CFC_180	
154 P4 Pelvic z	g	9.4	192.3	-34.9	76.5	CFC_60	
155 P4 Pelvic z Velocity	kph	0.0	-47.2	-41.0	120.8	CFC_180	

FACILITY: HYGE SLED

DATE: March 25, 2002

TEST#: 22291

TITLE: Sled Test Run 22291 Version 3.10 / 32 dev

=====

P3 HIC(FULL): 526.7

t1: 61.1 msec

t2: 111.2 msec

Duration: 50.1 msec

Average Acceleration: 40.6 g

Input channels: P3 Head x (2) CFC_1000

P3 Head y (3) CFC_1000

P3 Head z (4) CFC_1000

P3 UP NECK Fx: Max: 0.4 N -44.3 msec

Min: -845.4 N 98.9 msec

Input channel: P3 Upper Neck Fx (6) CFC_1000

P3 UP NECK Fz: Max: 1261.2 N 94.3 msec

Min: -52.3 N 246.0 msec

Input channel: P3 Upper Neck Fz (8) CFC_1000

P3 UP NECK Mocy (3YO Child OOP)

Max: 5.7 N-m 155.8 msec

Min: -12.3 N-m 235.6 msec

Input channels: P3 Upper Neck Fx (6) CFC_600

P3 Upper Neck My (10) CFC_600

Docy: 0

P3 UP NECK Nij (3YO Child OOP)

Ntf: 0.60 Nij 93.0 msec CVt: 2120 CVf: 68

Nte: 0.74 Nij 103.5 msec CVt: 2120 CVe: 27

Ncf: 0.00 Nij -46.7 msec CVc: 2120 CVf: 68

Nce: 0.40 Nij 239.7 msec CVc: 2120 CVe: 27

Input channels: P3 Upper Neck Fz (8) CFC_600

P3 Upper Neck Mocy [N-m, CFC_600] (159)

FACILITY: HYGE SLED

DATE: March 25, 2002

TEST#: 22291

TITLE: Sled Test Run 22291 Version 3.10 / 32 dev

P3 CLIP(3 ms): 34.6 g

t1: 56.7 msec

t2: 59.7 msec

Duration: 3.0 msec

P3 CSI: 224.7

Input channels: P3 Chest x (18) CFC_180

P3 Chest y (19) CFC_180

P3 Chest z (20) CFC_180

P3 CHEST DISP: Max: 0.0 mm 20.0 msec

Min: -26.6 mm 108.2 msec

Input channel: P3 Chest Compression (21) CFC_600

=====

P3 HIC(36 ms): 501.0

t1: 67.6 msec

t2: 103.5 msec

Duration: 36.0 msec

Average Acceleration: 45.4 g

Input channels: P3 Head x (2) CFC_1000

P3 Head y (3) CFC_1000

P3 Head z (4) CFC_1000

=====

P3 HIC(15 ms): 241.9

t1: 72.9 msec

t2: 87.9 msec

Duration: 15.0 msec

Average Acceleration: 48.2 g

Input channels: P3 Head x (2) CFC_1000

P3 Head y (3) CFC_1000

P3 Head z (4) CFC_1000

=====

FACILITY: HYG E SLED

DATE: March 25, 2002

TEST#: 22291

TITLE: Sled Test Run 22291 Version 3.10 / 32 dev

P4 HIC(FULL): 654.5

t1: 66.2 msec

t2: 106.0 msec

Duration: 39.8 msec

Average Acceleration: 48.6 g

Input channels: P4 Head x (25) CFC_1000

P4 Head y (26) CFC_1000

P4 Head z (27) CFC_1000

P4 UP NECK Fx: Max: 38.6 N 229.4 msec

Min: -1099.3 N 95.7 msec

Input channel: P4 Upper Neck Fx (29) CFC_1000

P4 UP NECK Fz: Max: 1888.5 N 94.7 msec

Min: -59.3 N 210.0 msec

Input channel: P4 Upper Neck Fz (31) CFC_1000

P4 UP NECK Mocy (3YO Child OOP)

Max: 16.5 N-m 89.8 msec

Min: -8.3 N-m 49.4 msec

Input channels: P4 Upper Neck Fx (29) CFC_600

P4 Upper Neck My (33) CFC_600

Docy: 0

P4 UP NECK Nij (3YO Child OOP)

Ntf: 1.05 Nij 94.0 msec CVt: 2120 CVf: 68

Nte: 0.74 Nij 79.0 msec CVt: 2120 CVe: 27

Ncf: 0.00 Nij -45.5 msec CVc: 2120 CVf: 68

Nce: 0.18 Nij 210.0 msec CVc: 2120 CVe: 27

Input channels: P4 Upper Neck Fz (31) CFC_600

P4 Upper Neck Mocy [N-m, CFC_600] (165)

FACILITY: HYGE SLED

DATE: March 25, 2002

TEST#: 22291

TITLE: Sled Test Run 22291 Version 3.10 / 32 dev

P4 CLIP(3 ms): 37.4 g

t1: 75.5 msec

t2: 78.5 msec

Duration: 3.0 msec

P4 CSI: 324.1

Input channels: P4 Chest x (41) CFC_180

P4 Chest y (42) CFC_180

P4 Chest z (43) CFC_180

P4 CHEST DISP: Max: 0.0 mm -16.3 msec

Min: -21.4 mm 99.7 msec

Input channel: P4 Chest Compression (44) CFC_600

=====

P4 HIC(36 ms): 650.2

t1: 68.5 msec

t2: 104.5 msec

Duration: 36.0 msec

Average Acceleration: 50.4 g

Input channels: P4 Head x (25) CFC_1000

P4 Head y (26) CFC_1000

P4 Head z (27) CFC_1000

=====

P4 HIC(15 ms): 369.3

t1: 84.5 msec

t2: 99.5 msec

Duration: 15.0 msec

Average Acceleration: 57.1 g

Input channels: P4 Head x (25) CFC_1000

P4 Head y (26) CFC_1000

P4 Head z (27) CFC_1000

=====

Sled Test Run 22291

Sled Acceleration

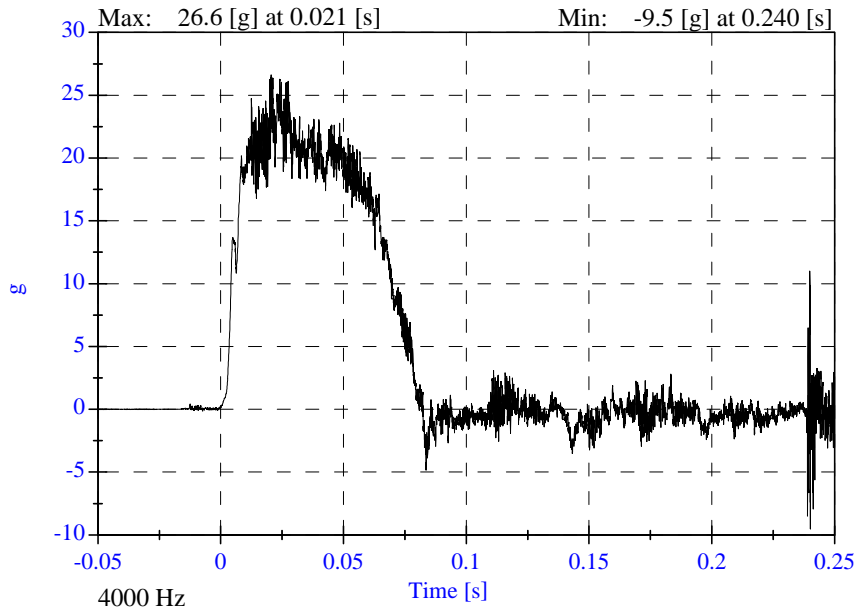

Version 3.10 / 32 dev - March 25, 2002

Sled Acceleration

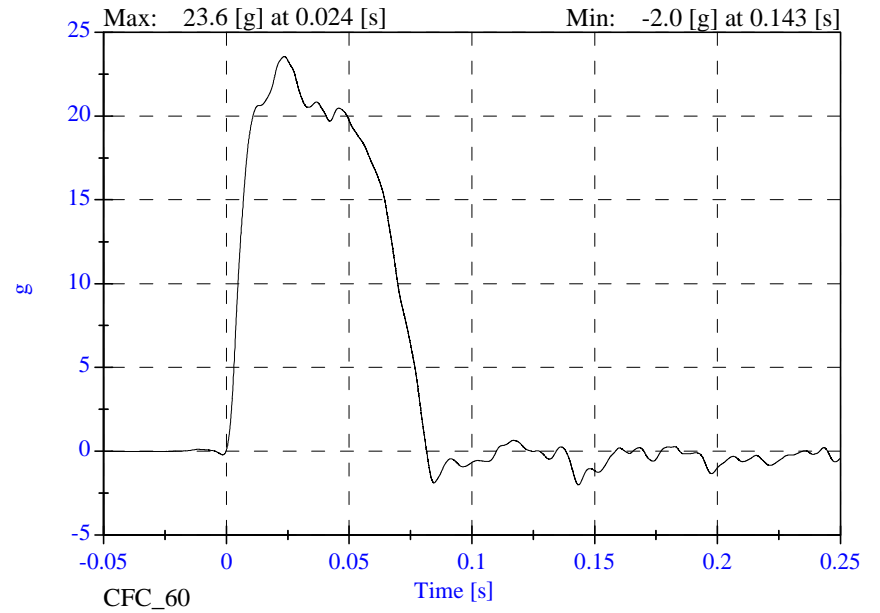

Sled Acceleration Velocity

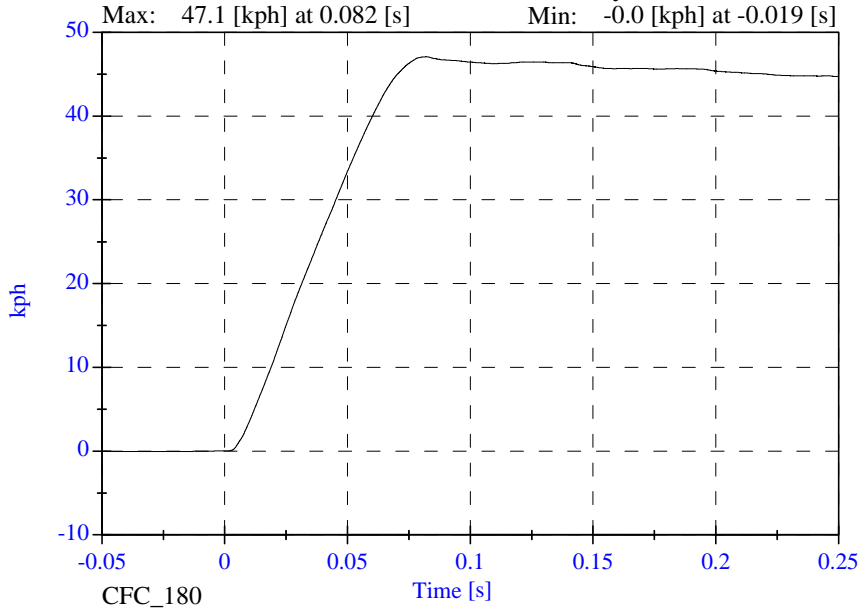

Sled Acceleration Displacement

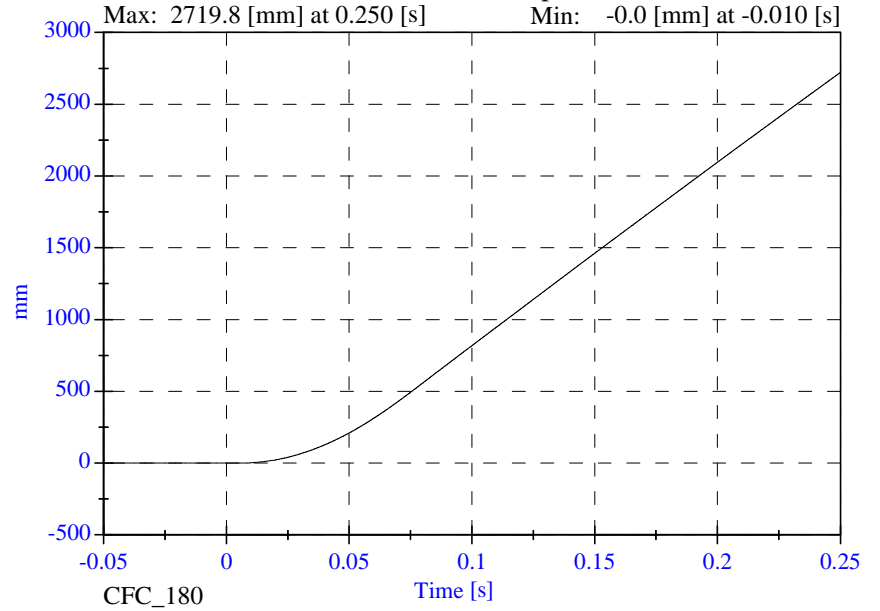

Sled Test Run 22291

Version 3.10 / 32 dev - March 25, 2002

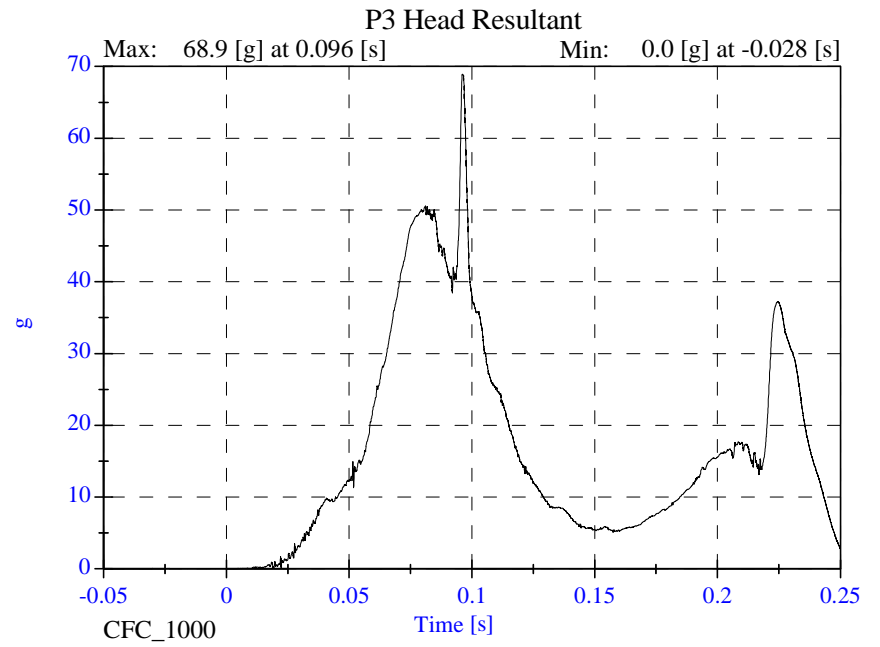
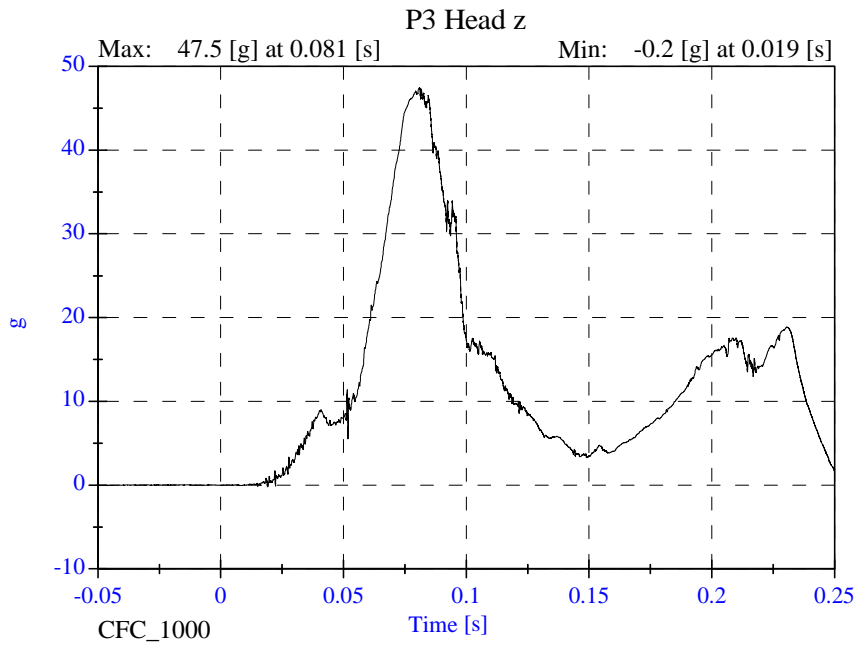
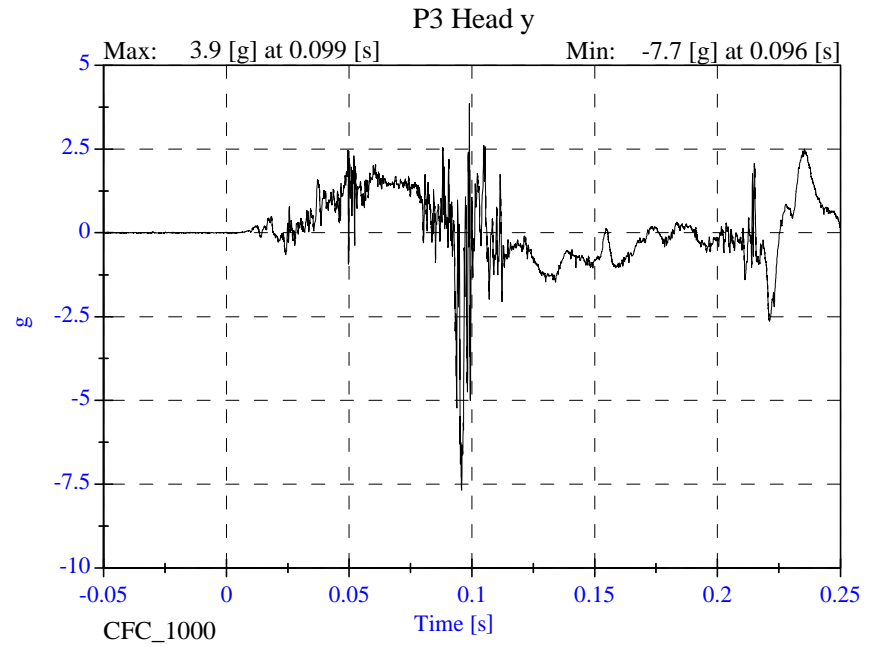
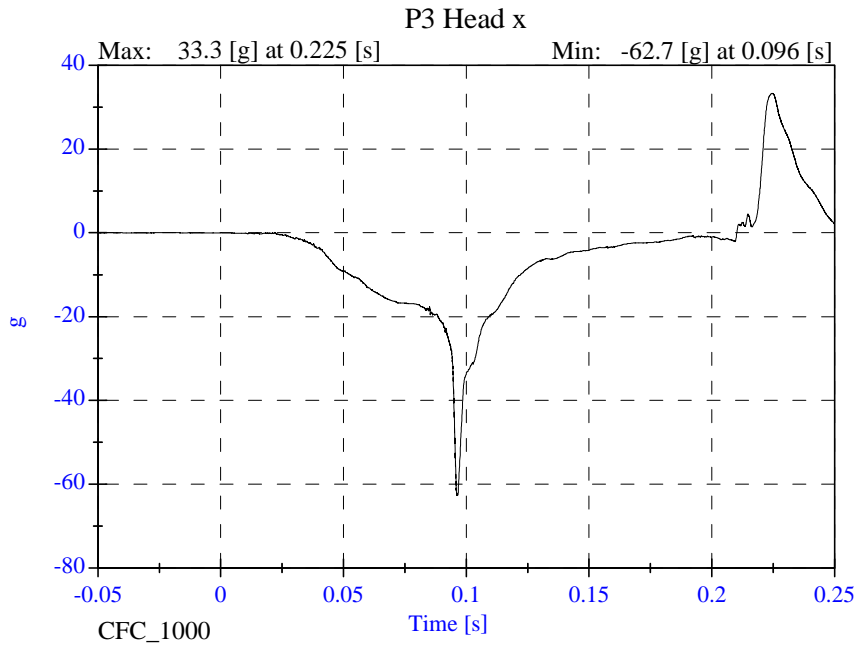

Sled Test Run 22291

P3 Upper Neck Fx

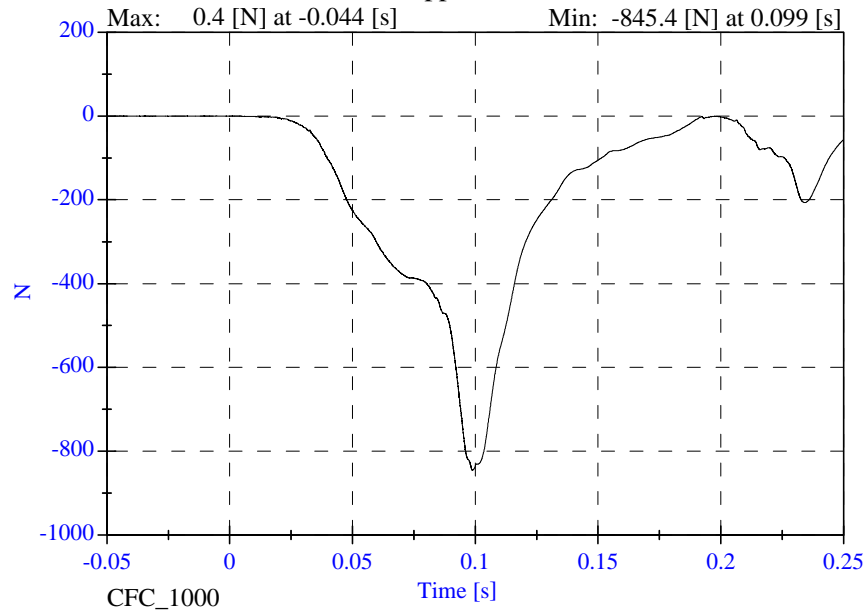

Version 3.10 / 32 dev - March 25, 2002

P3 Upper Neck Fy

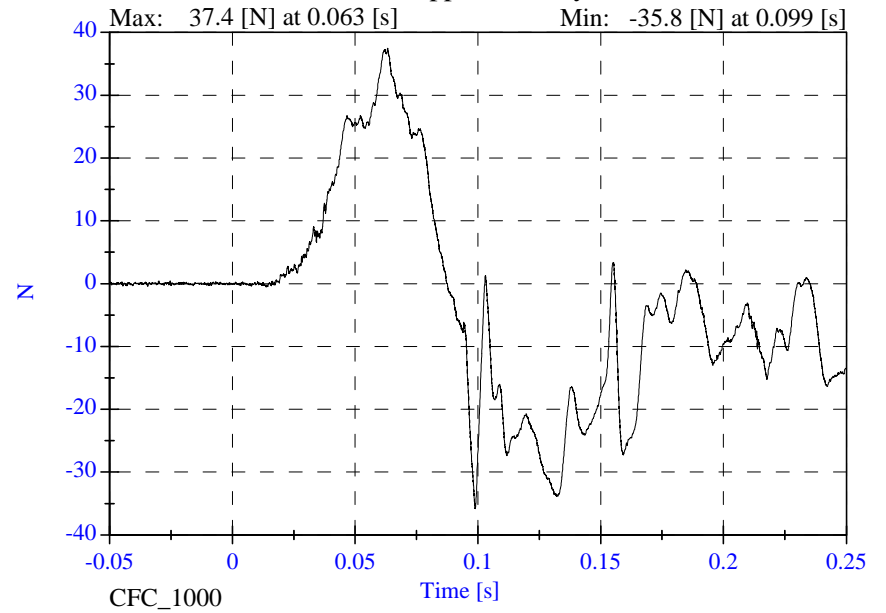

P3 Upper Neck Fz

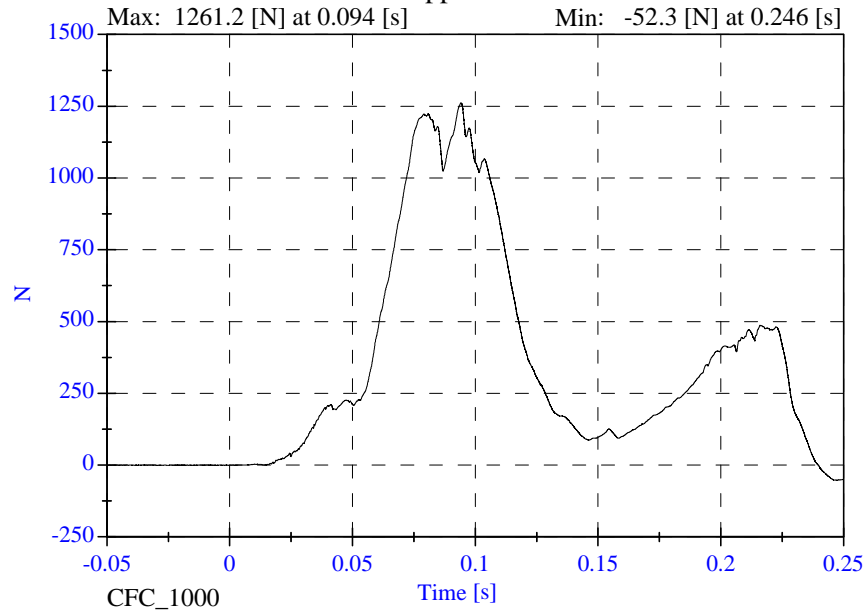

P3 Upper Neck F Resultant

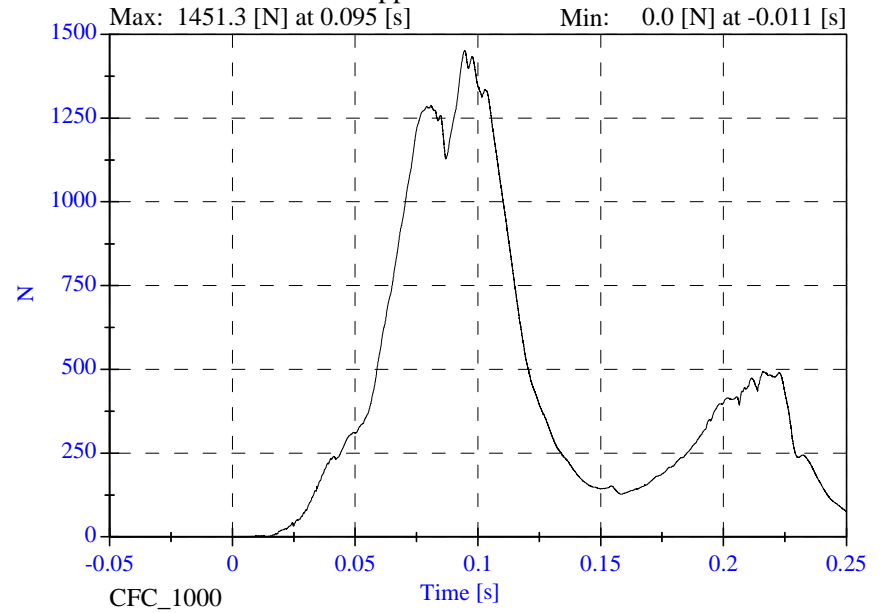

Sled Test Run 22291

Version 3.10 / 32 dev - March 25, 2002

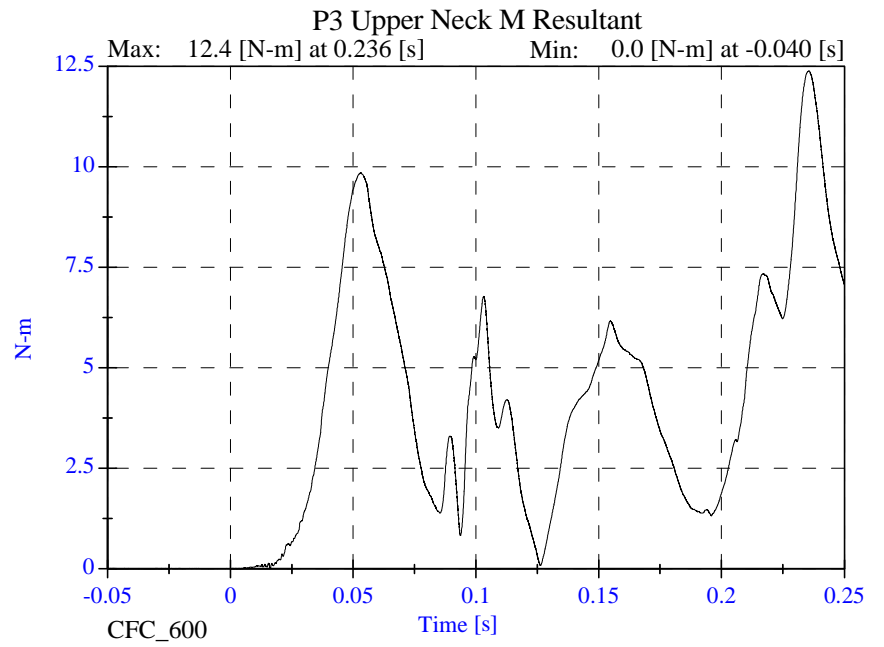
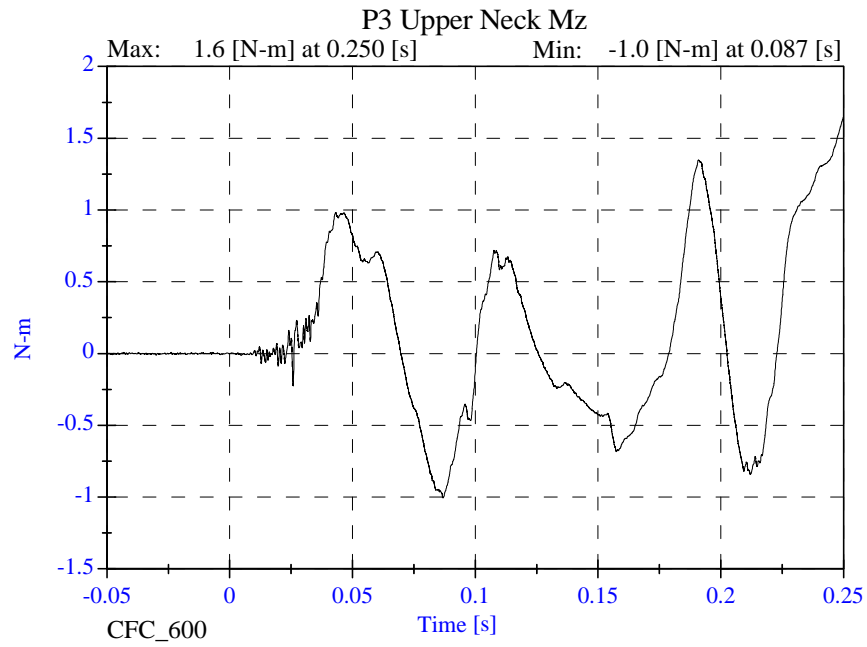
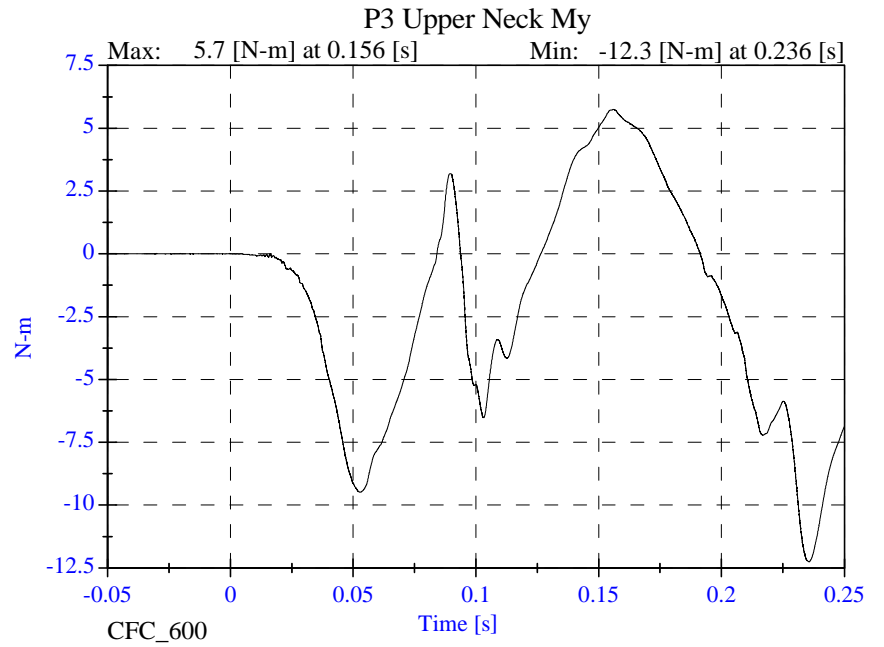
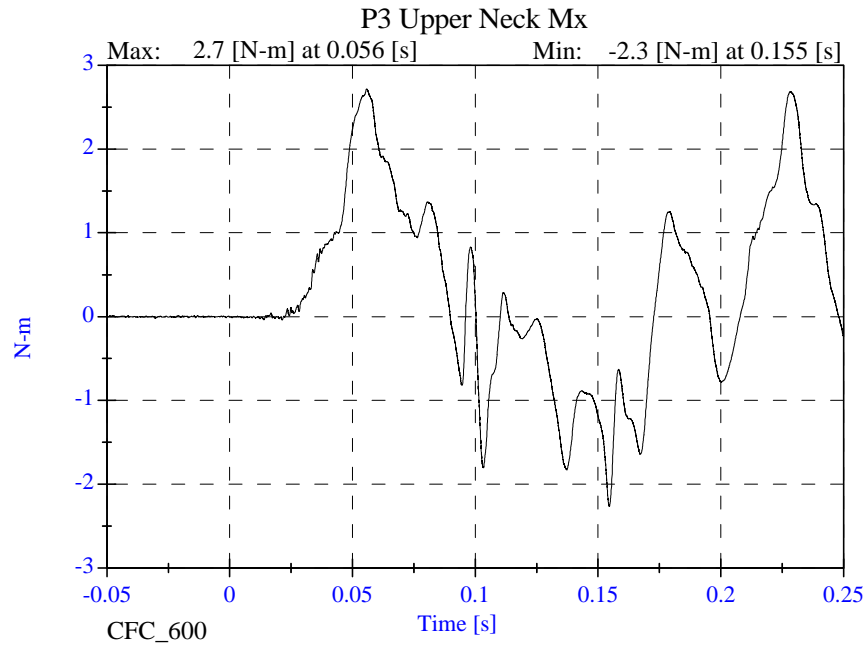

Sled Test Run 22291

P3 Lower Neck Fx

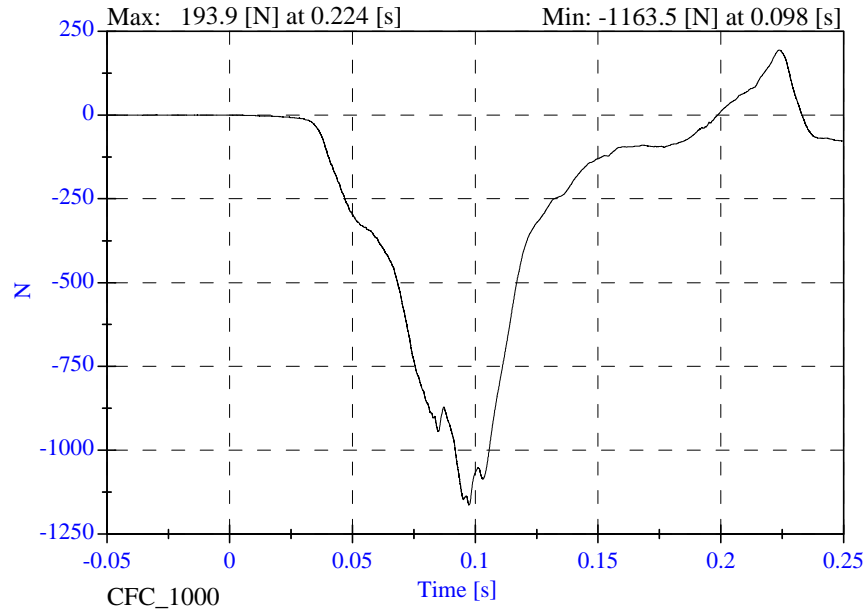

Version 3.10 / 32 dev - March 25, 2002

P3 Lower Neck Fy

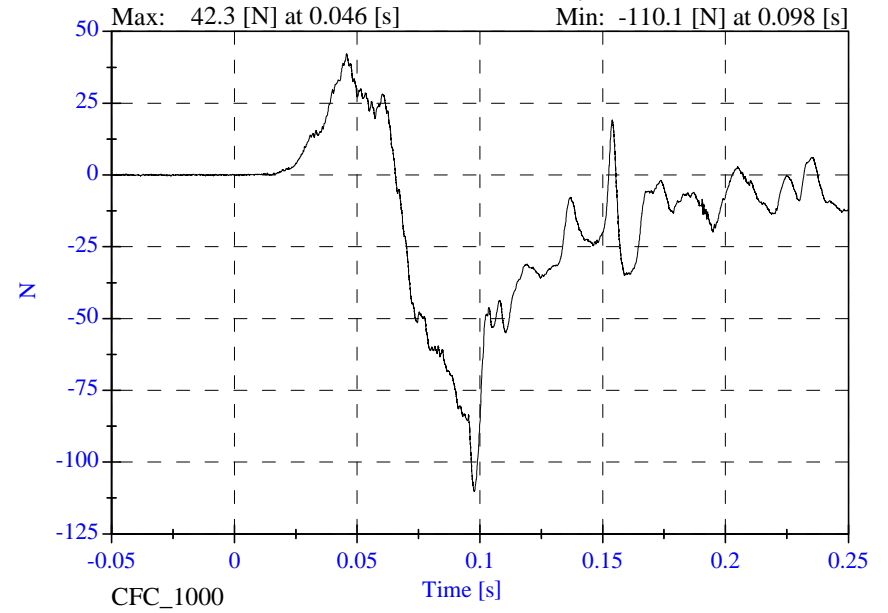

P3 Lower Neck Fz

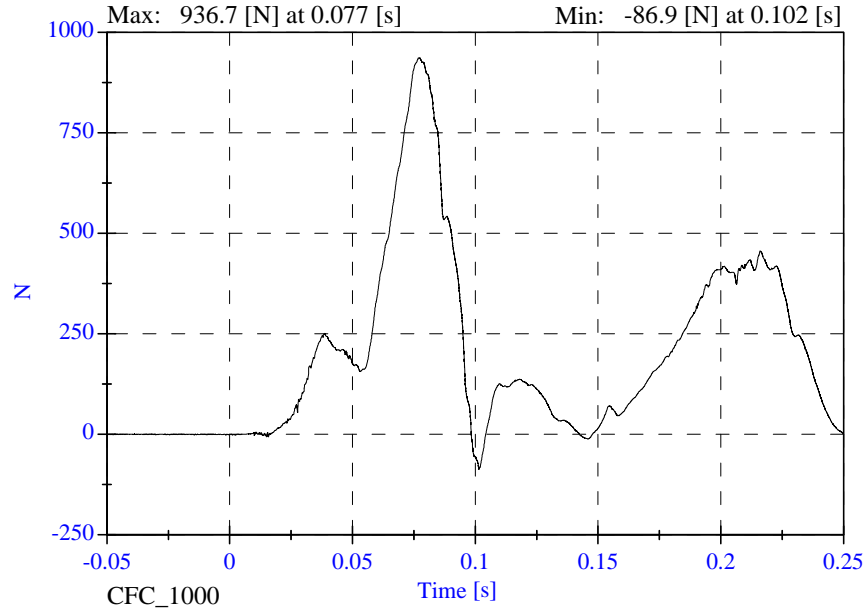

P3 Lower Neck F Resultant

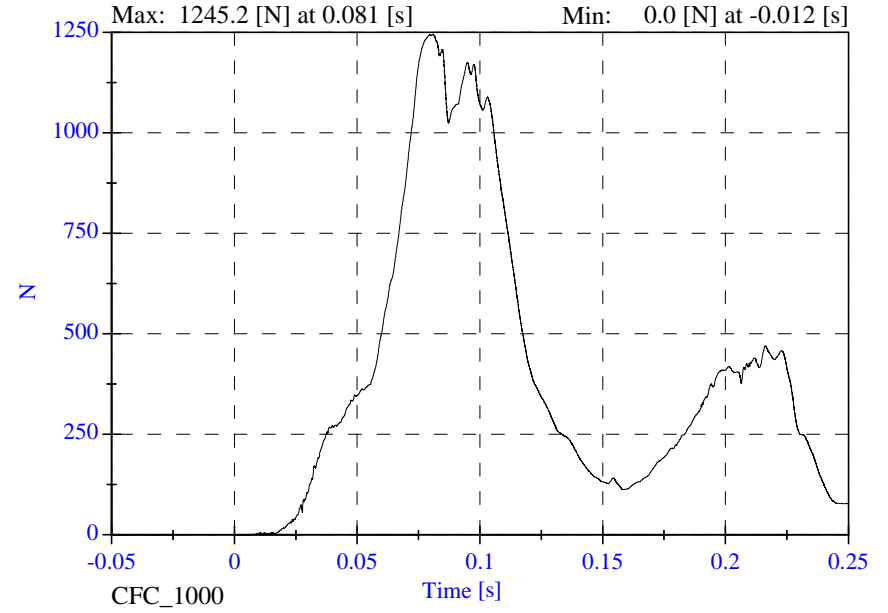

Sled Test Run 22291

Version 3.10 / 32 dev - March 25, 2002

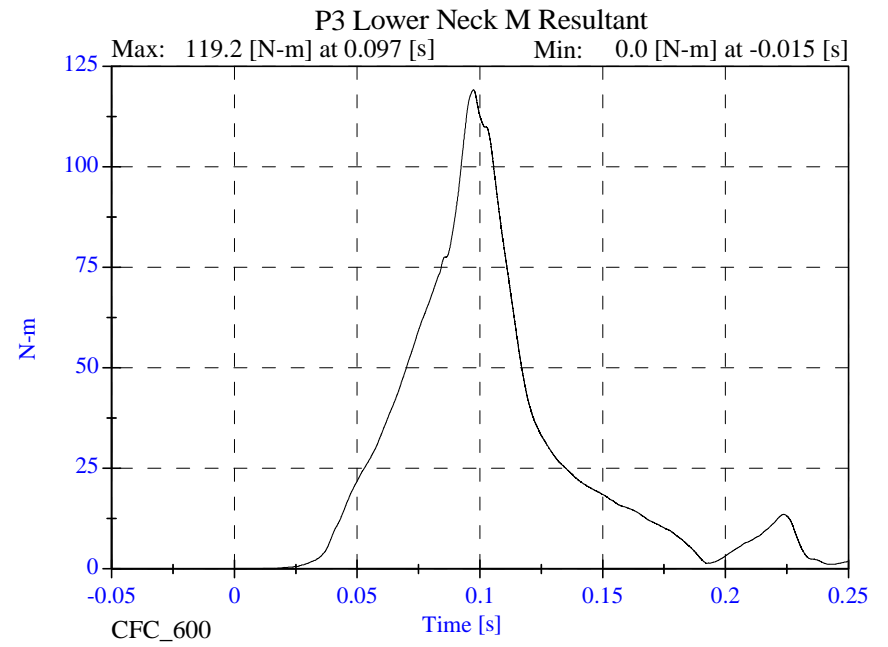
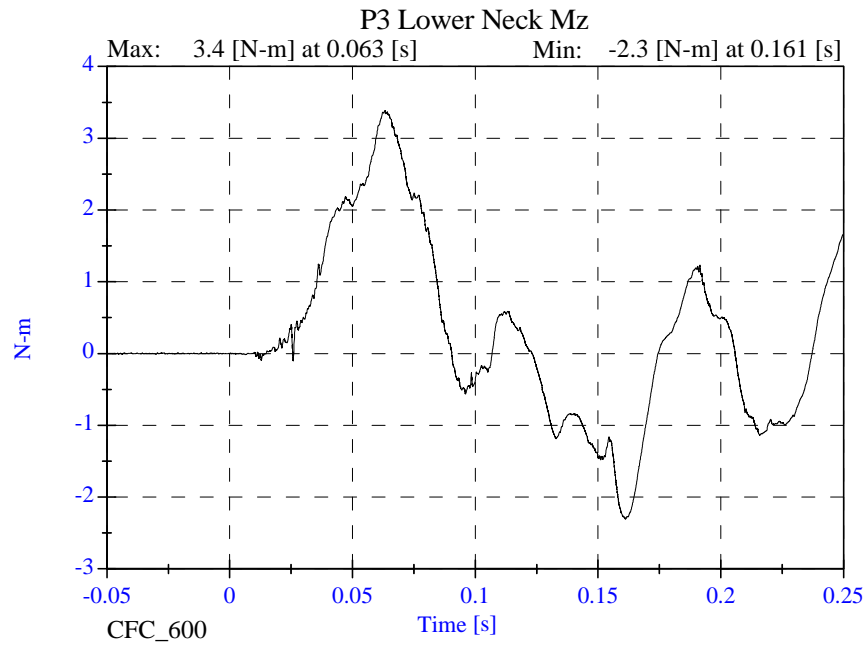
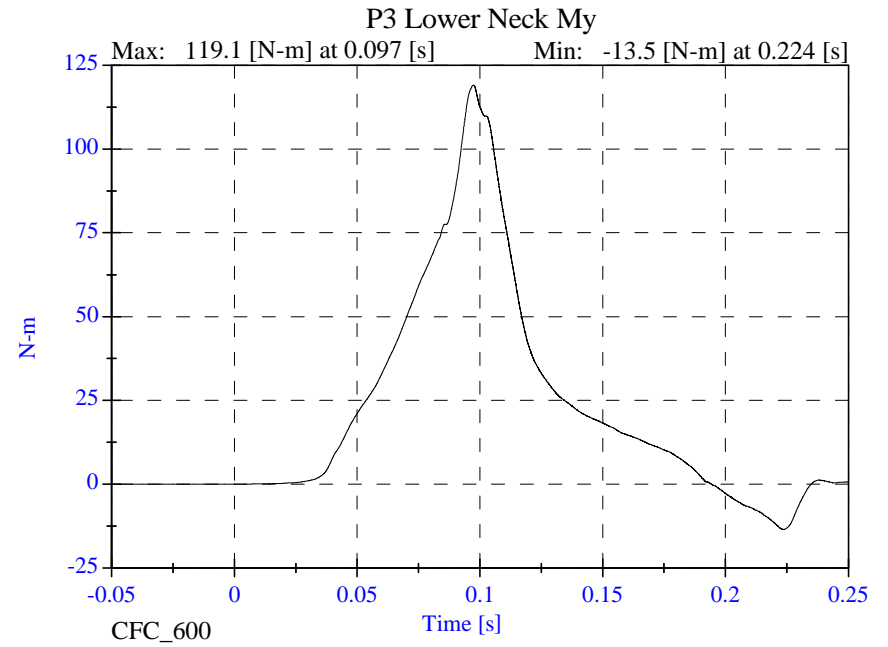
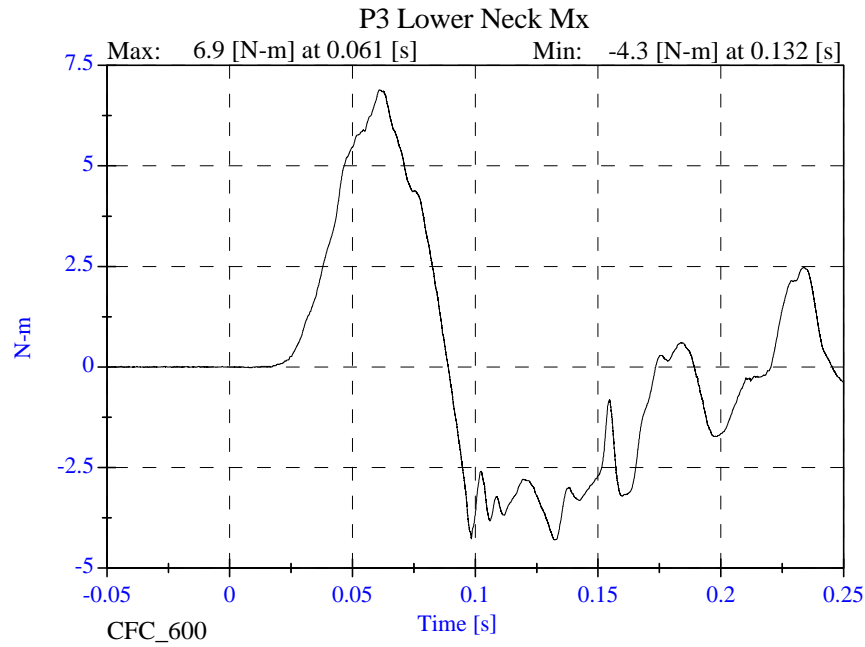

Sled Test Run 22291

Version 3.10 / 32 dev - March 25, 2002

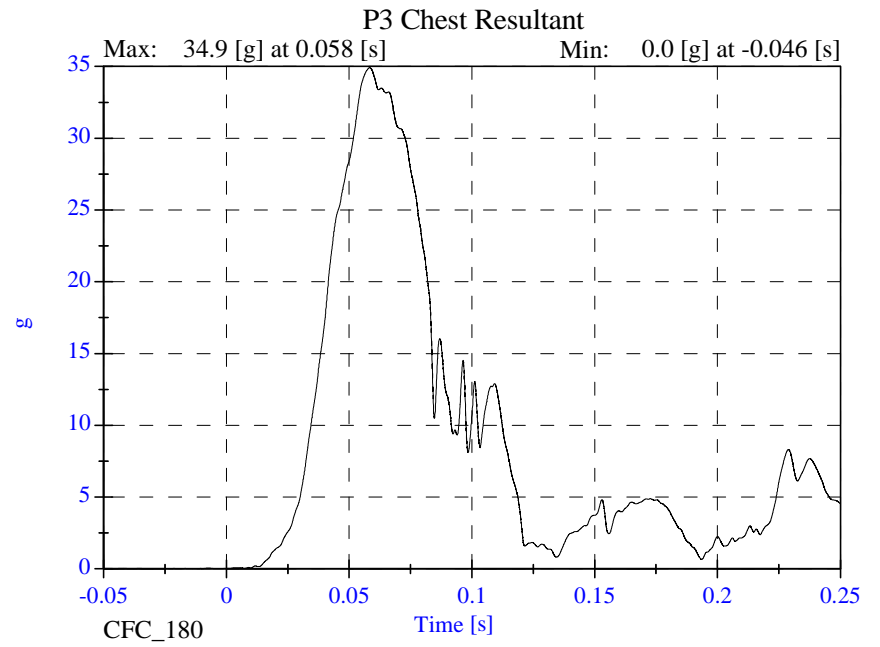
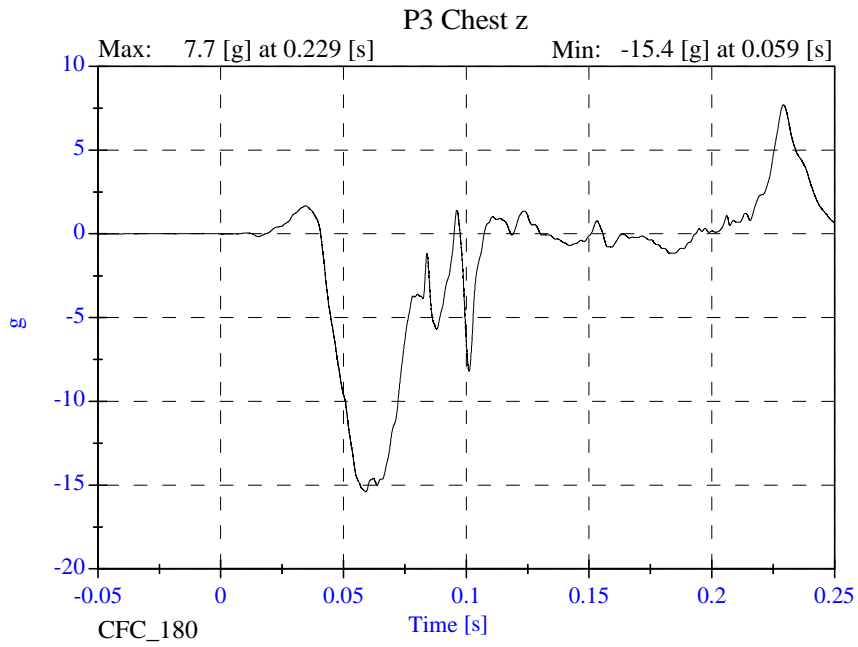
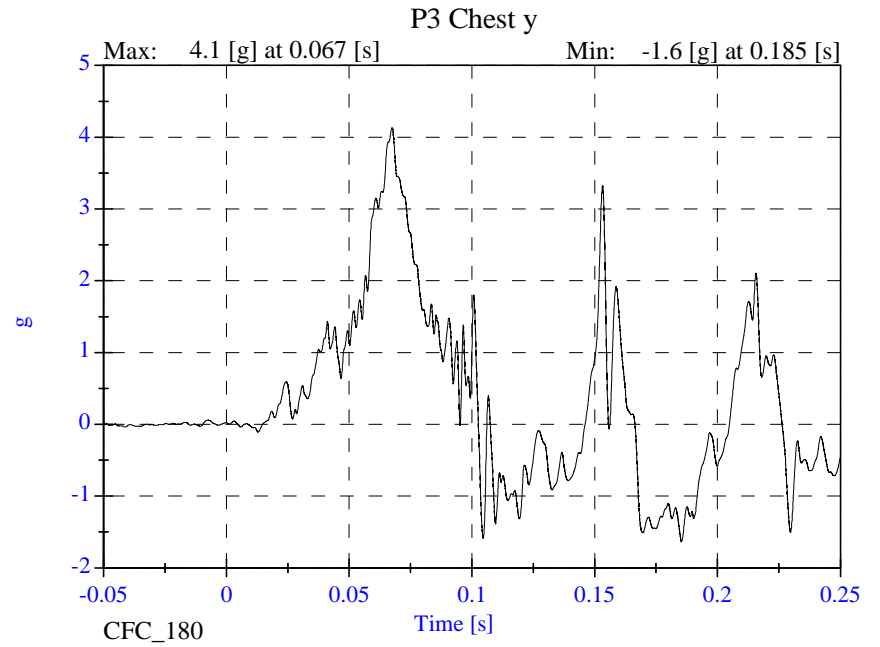
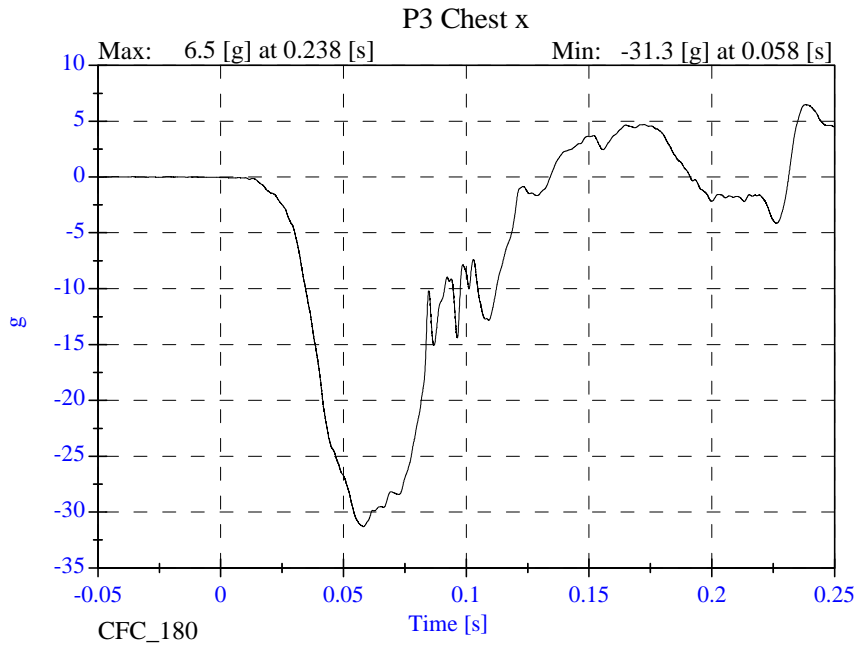

Sled Test Run 22291

Version 3.10 / 32 dev - March 25, 2002

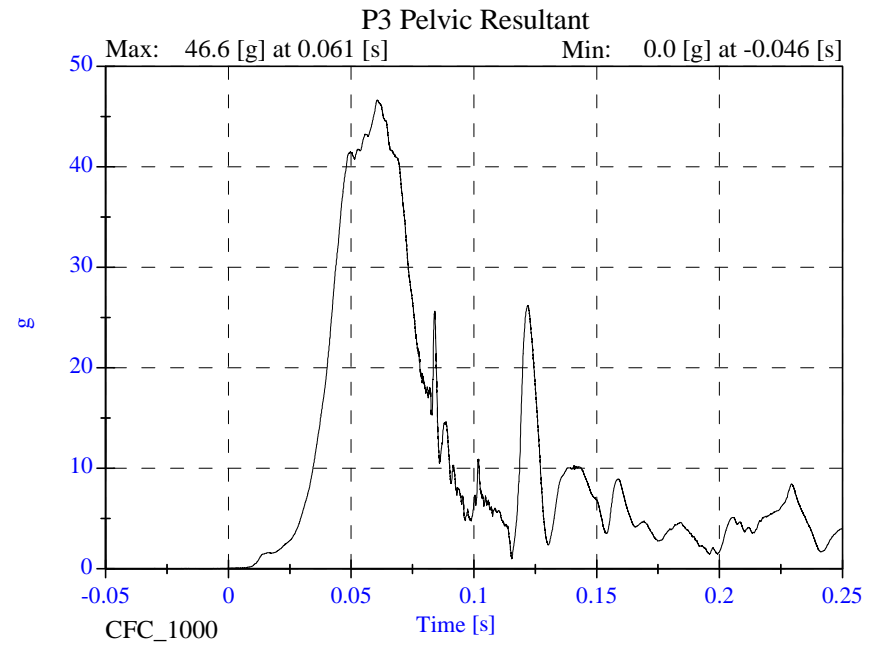
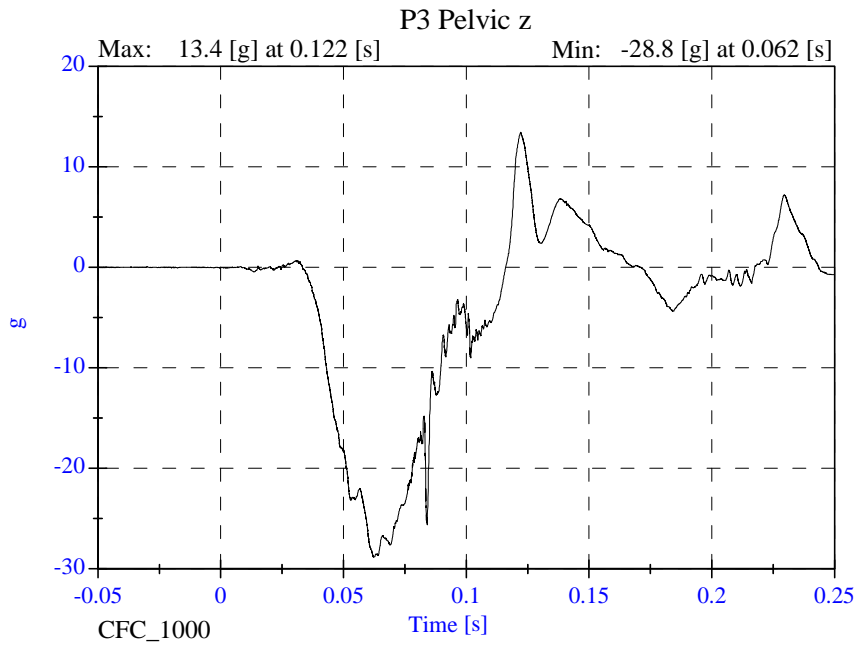
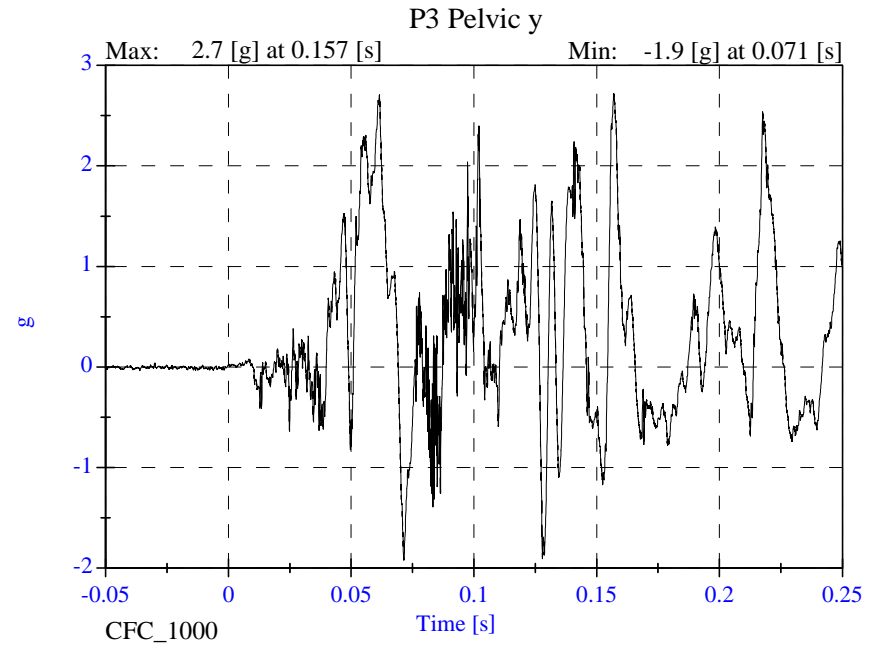
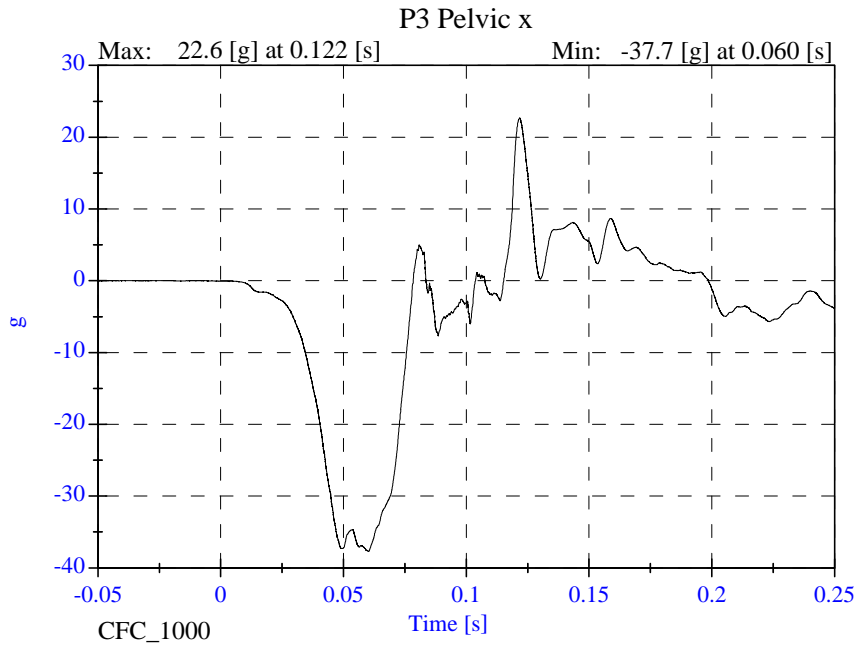

Sled Test Run 22291

Version 3.10 / 32 dev - March 25, 2002

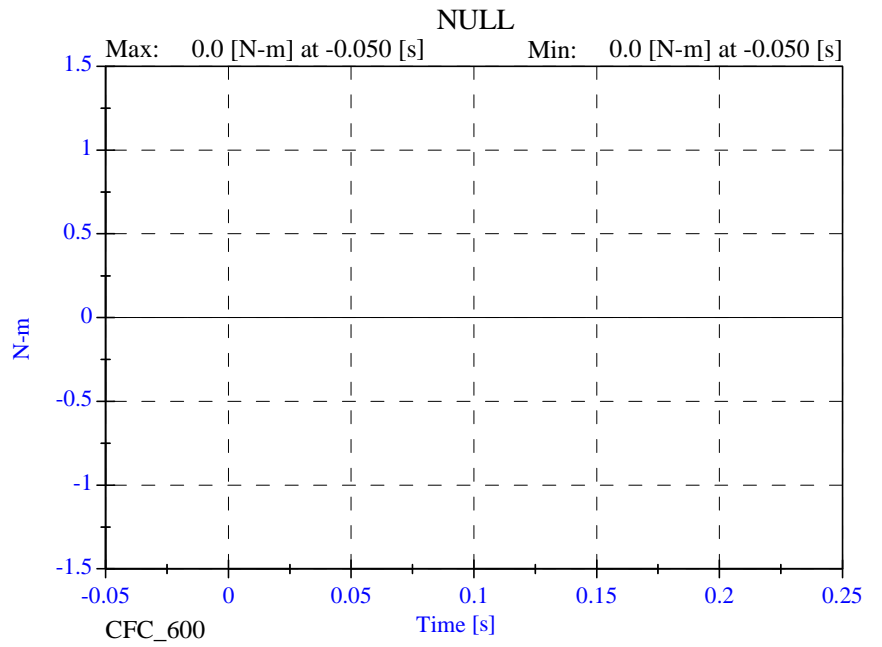
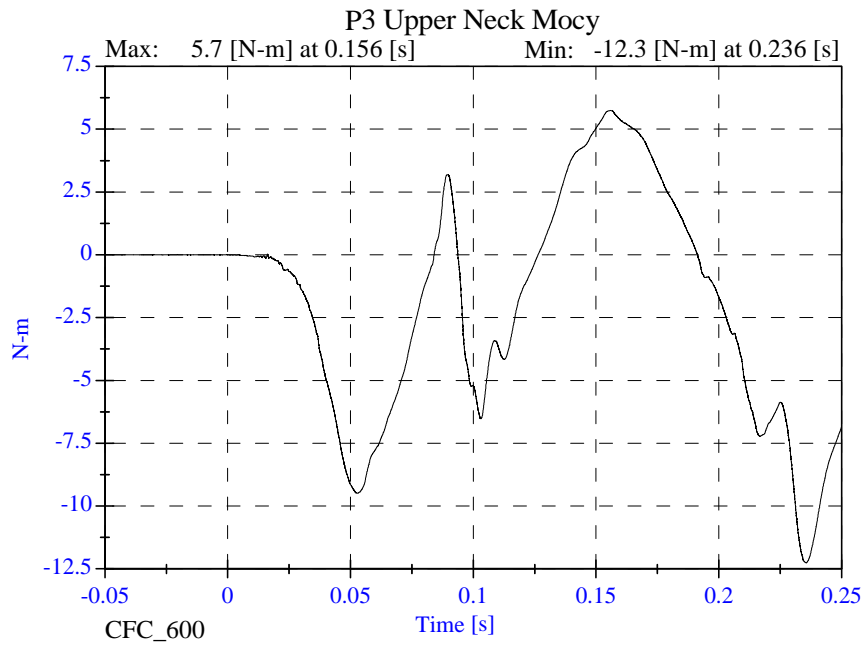
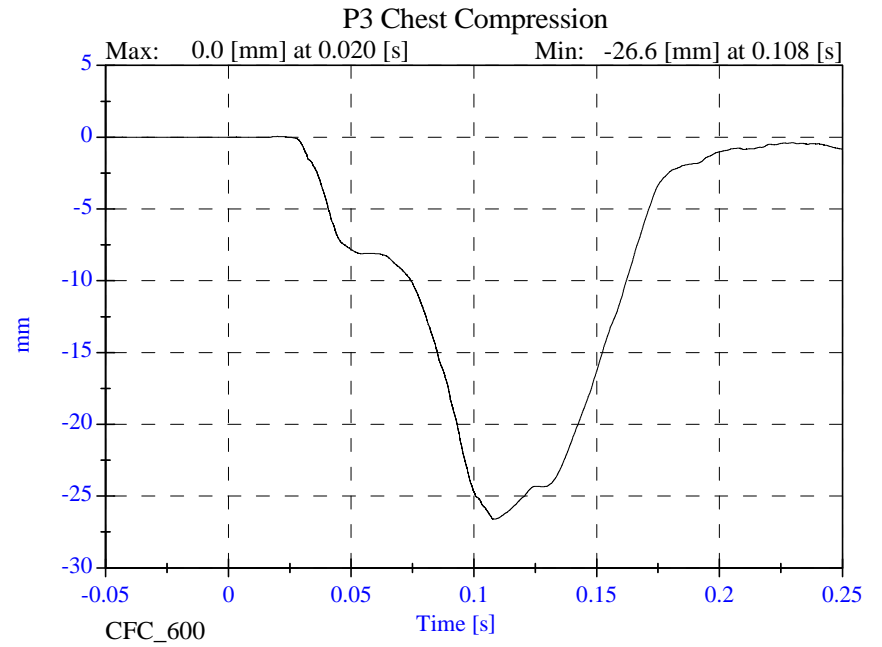
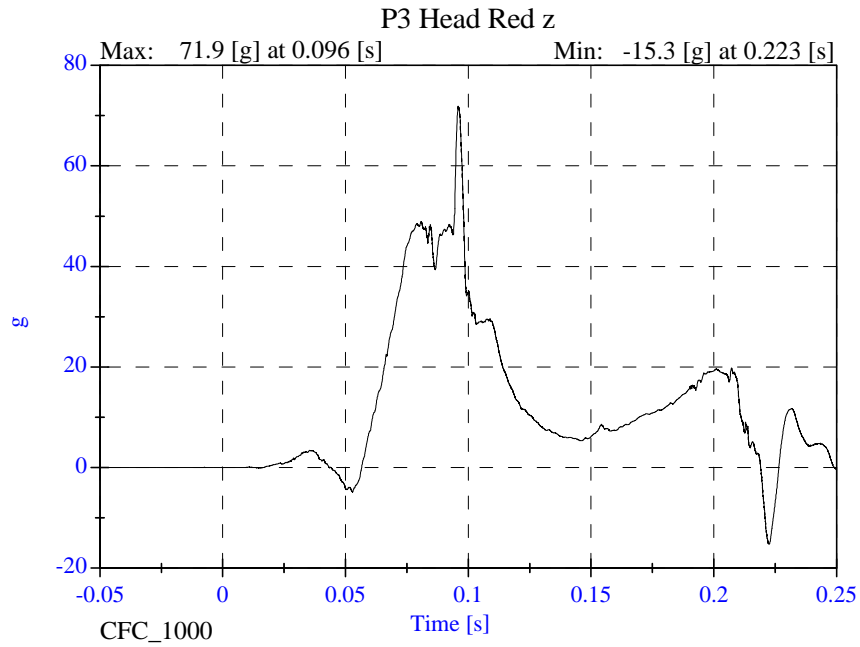

Sled Test Run 22291

Version 3.10 / 32 dev - March 25, 2002

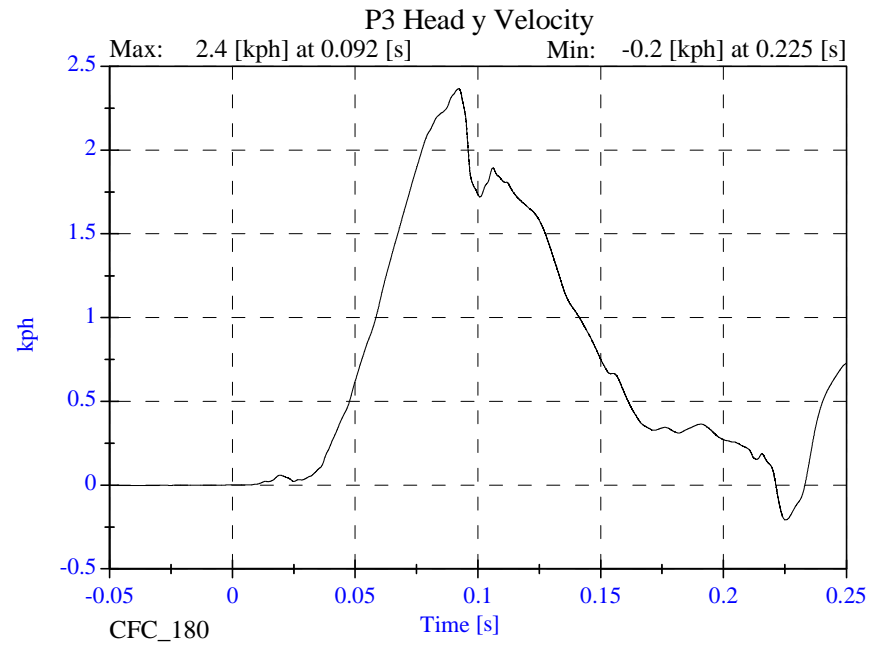
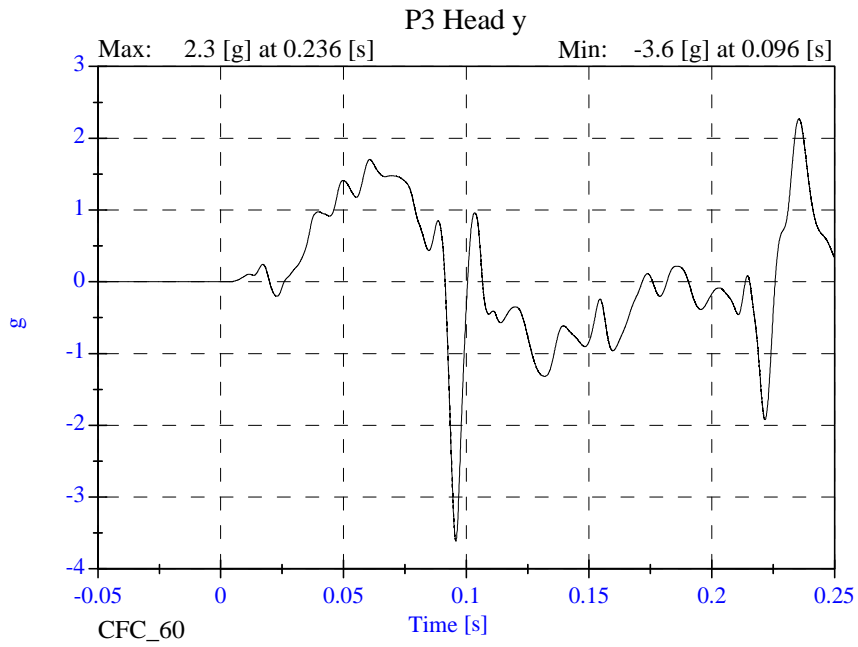
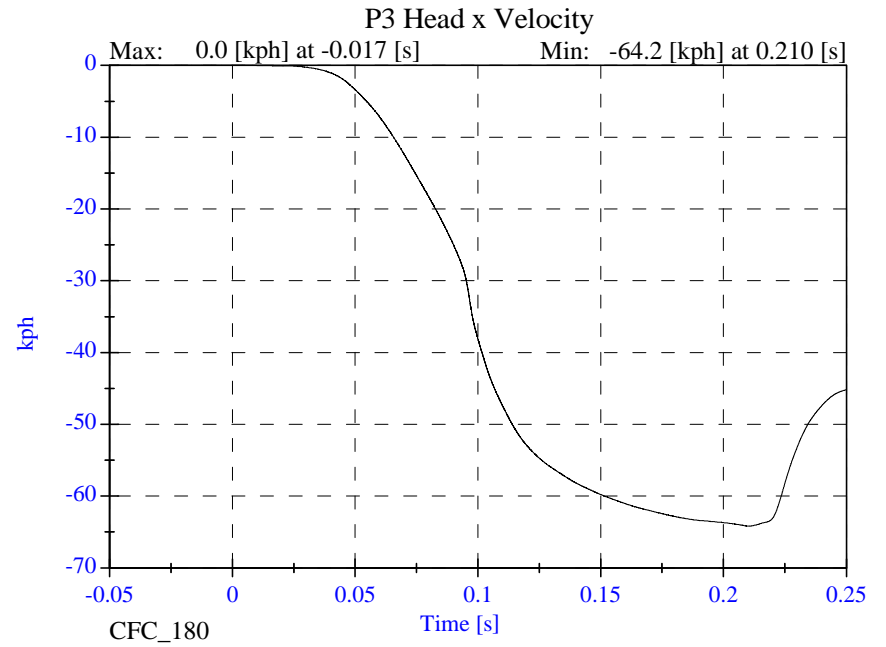
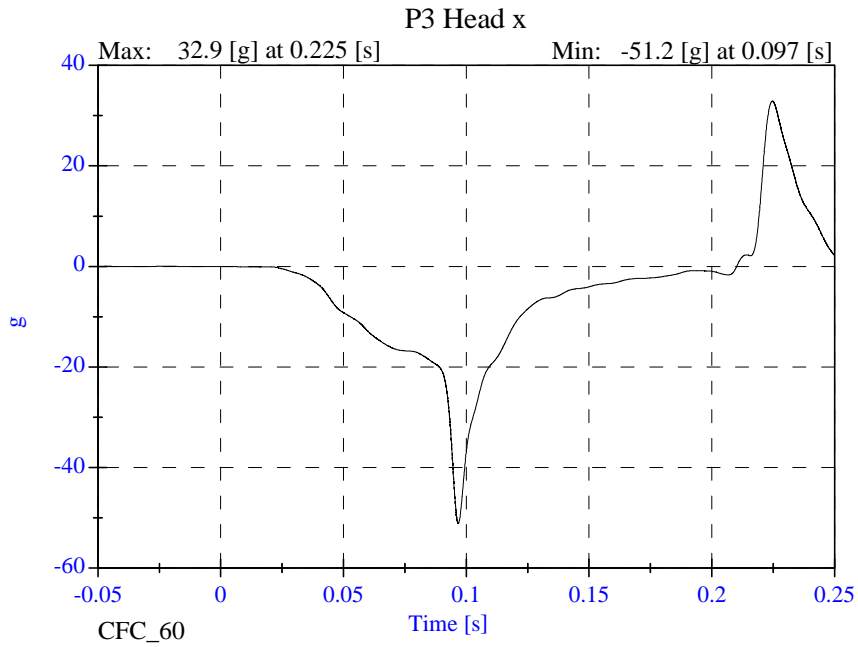

Sled Test Run 22291

Version 3.10 / 32 dev - March 25, 2002

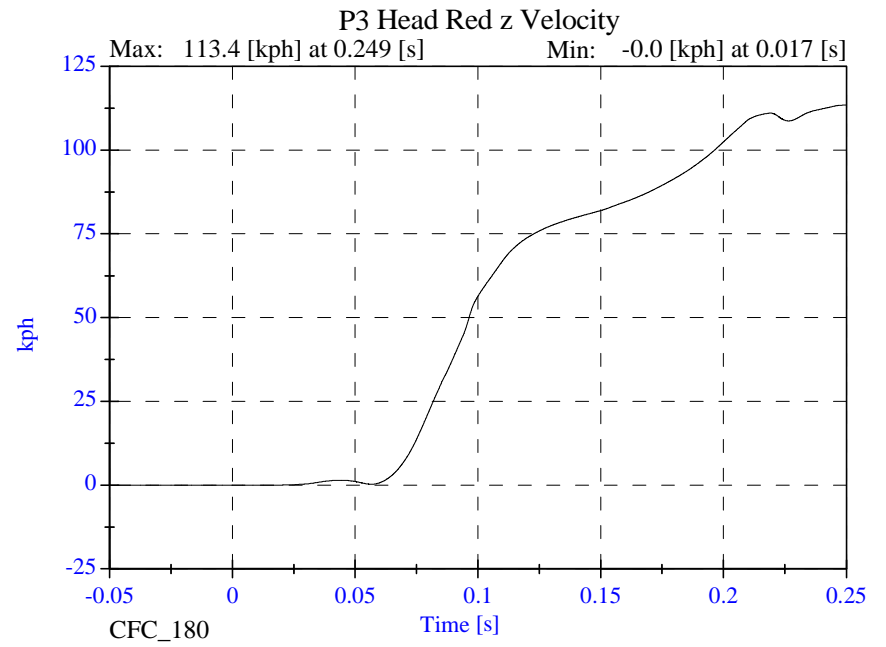
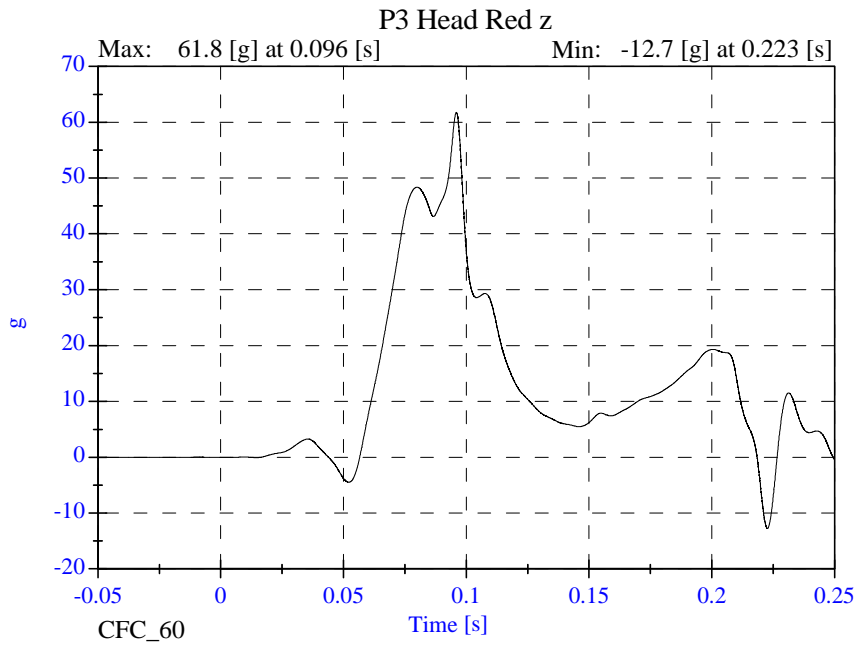
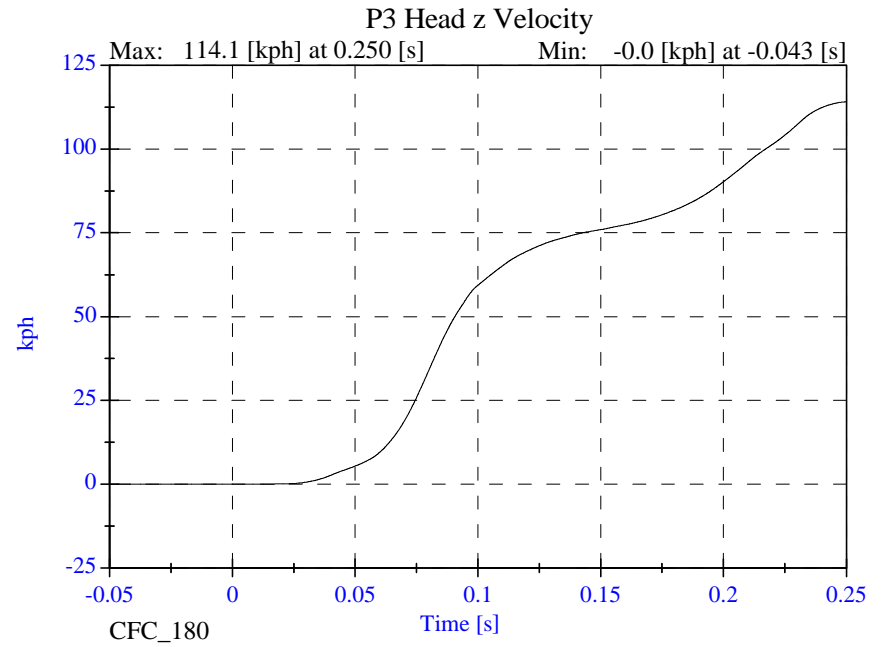
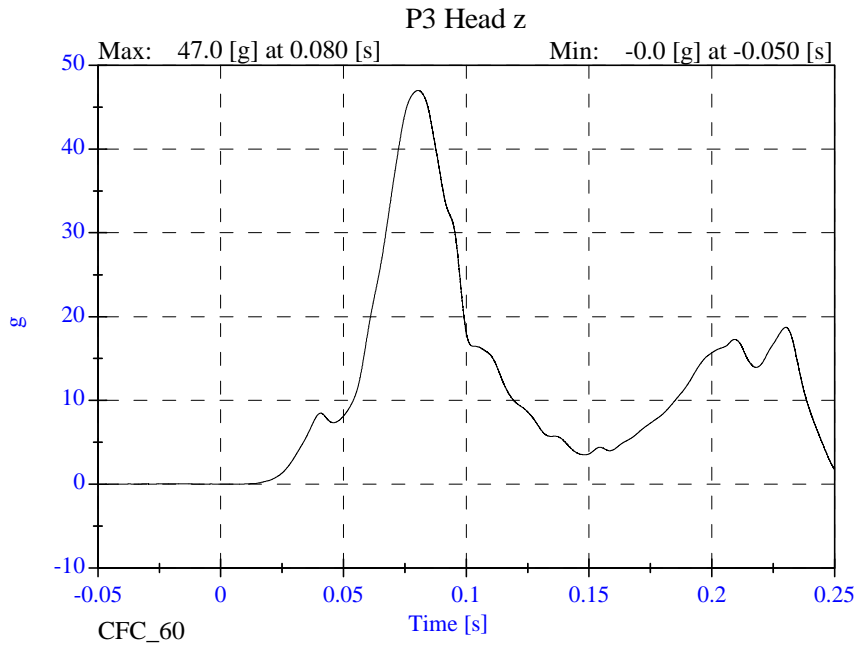

Sled Test Run 22291

Version 3.10 / 32 dev - March 25, 2002

P3 Chest x

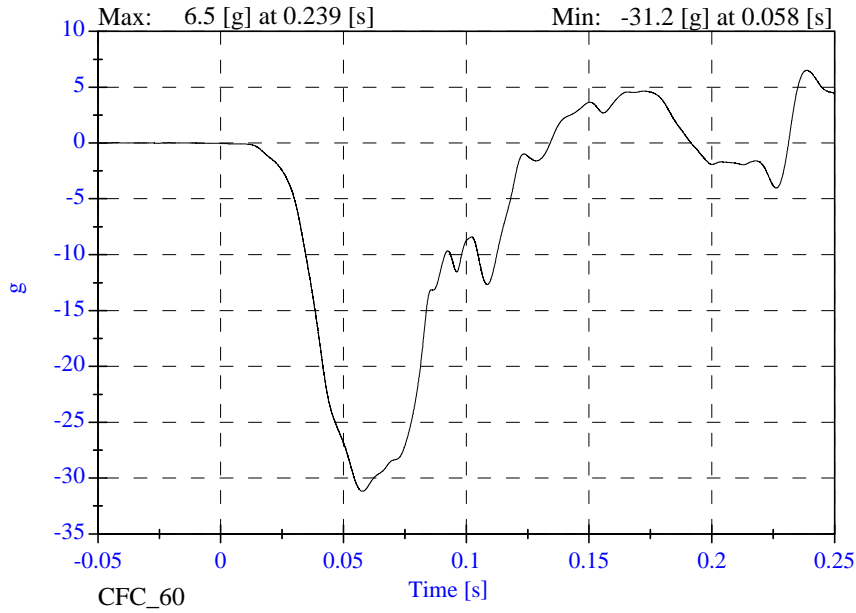

P3 Chest x Velocity

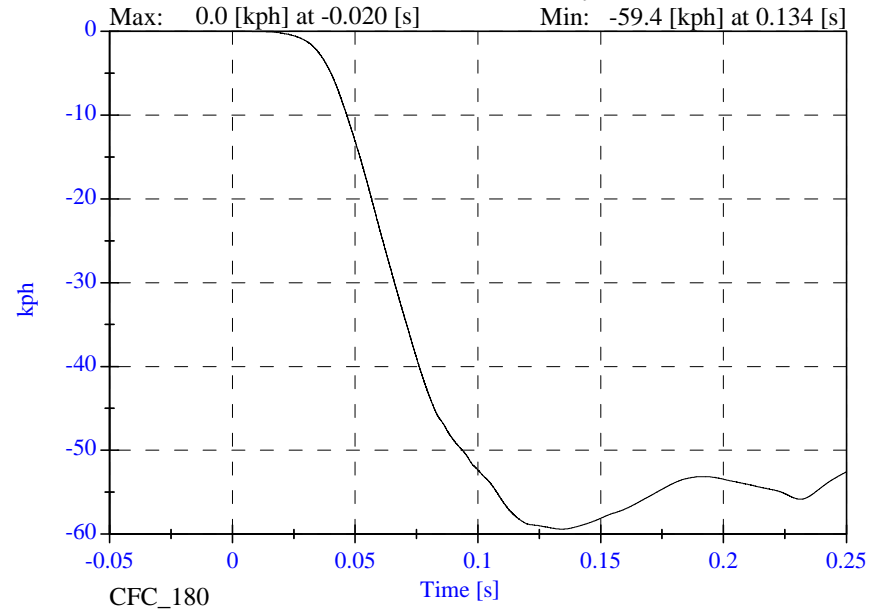

P3 Chest y

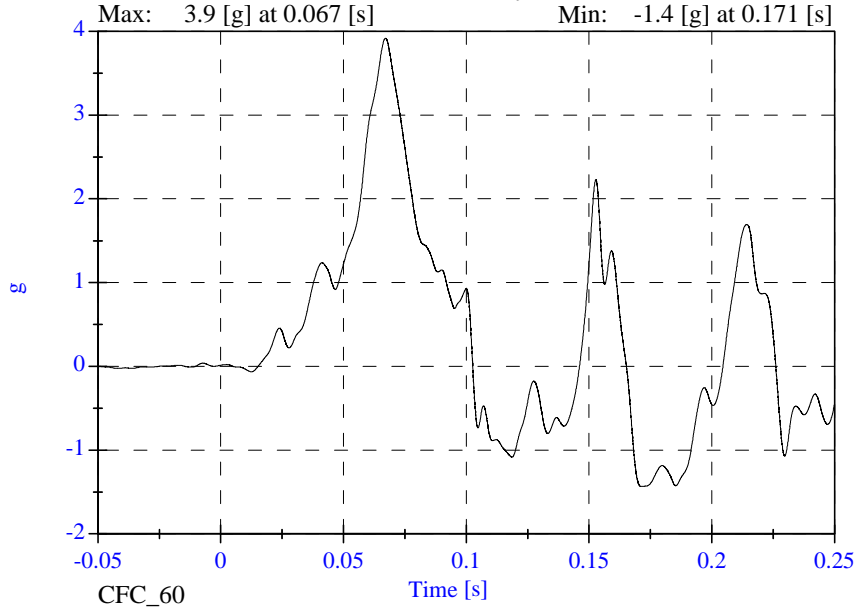

P3 Chest y Velocity

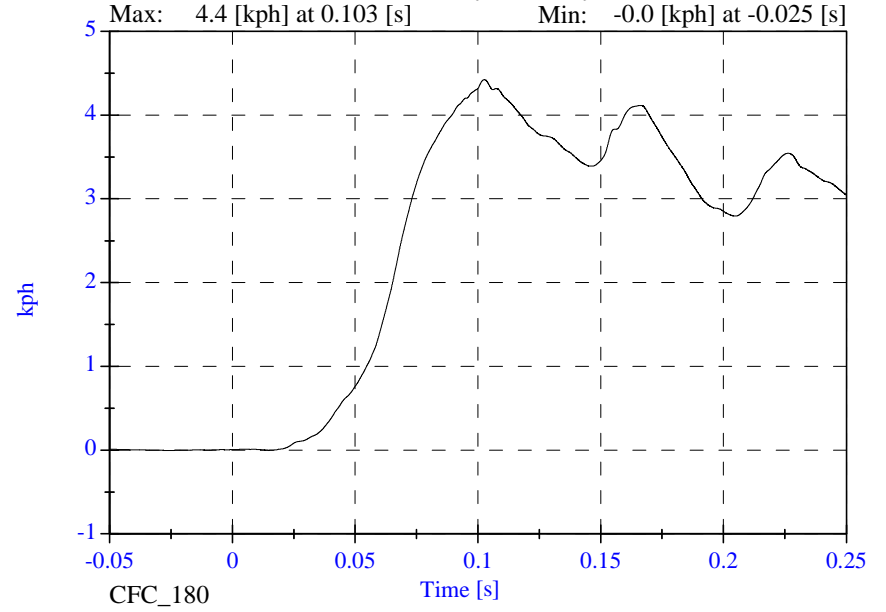

Sled Test Run 22291

Version 3.10 / 32 dev - March 25, 2002

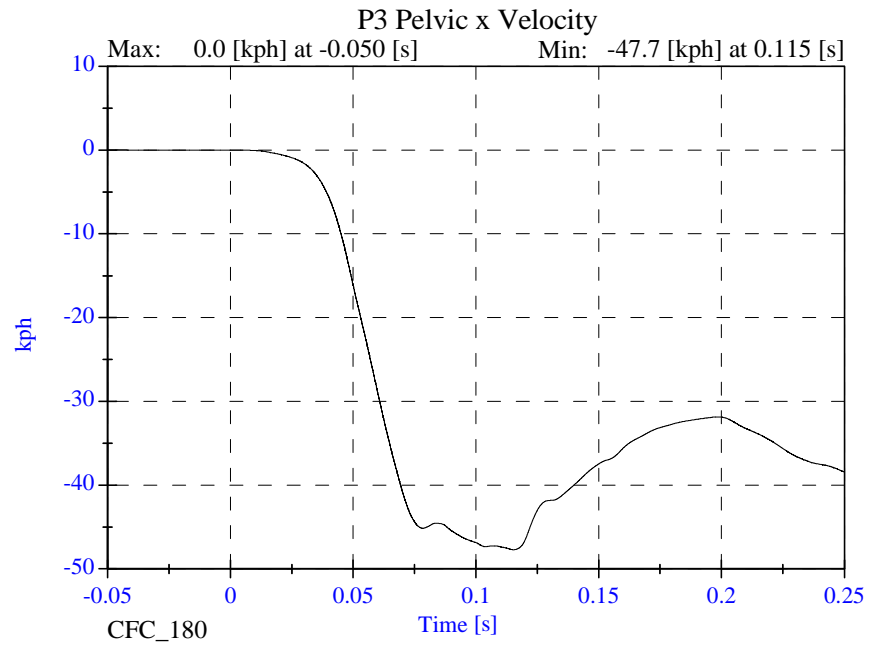
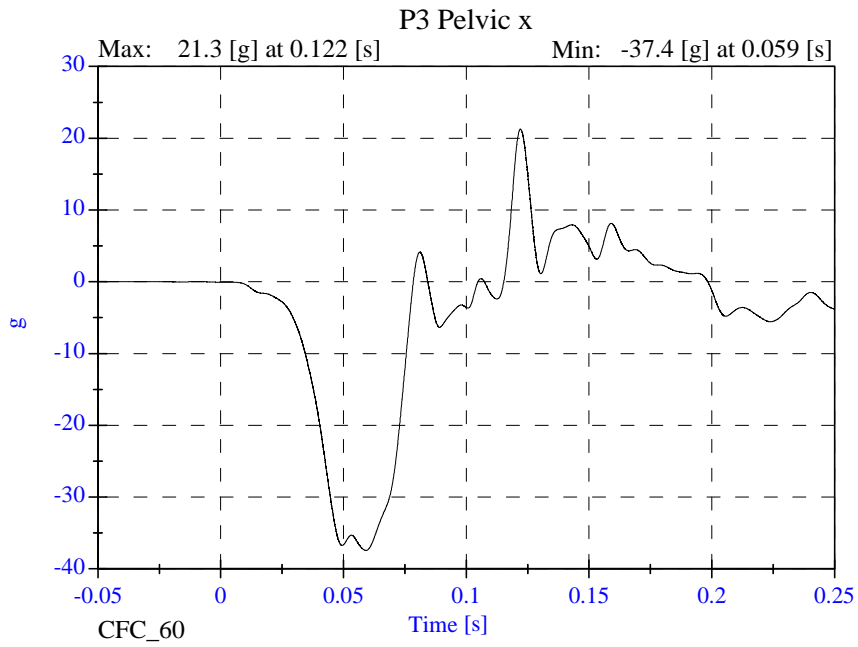
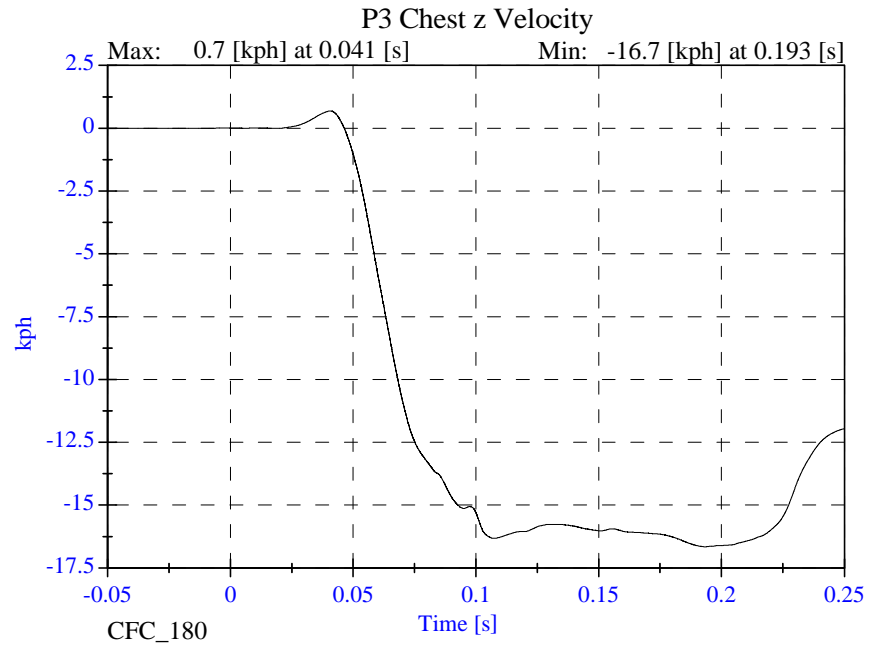
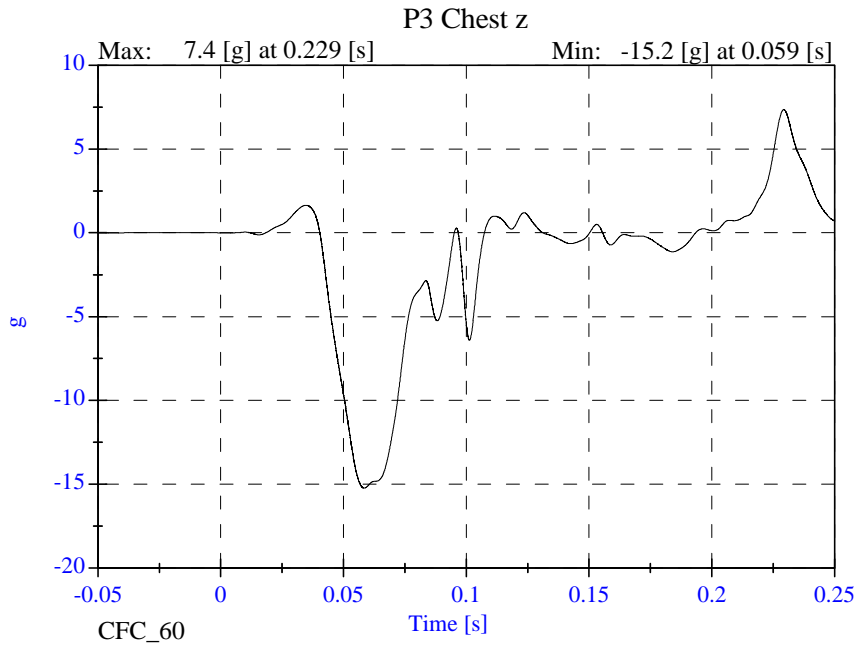

Sled Test Run 22291

Version 3.10 / 32 dev - March 25, 2002

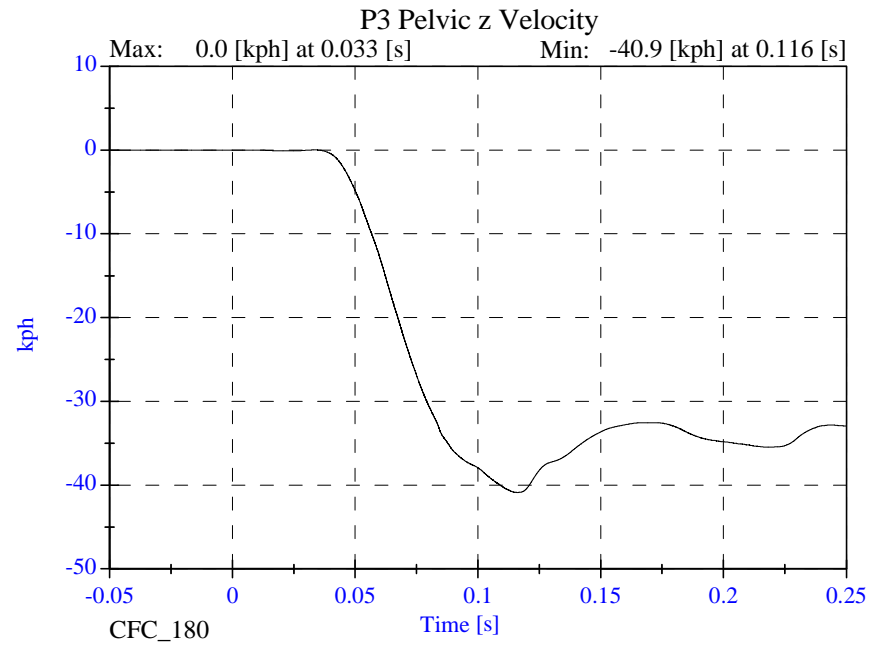
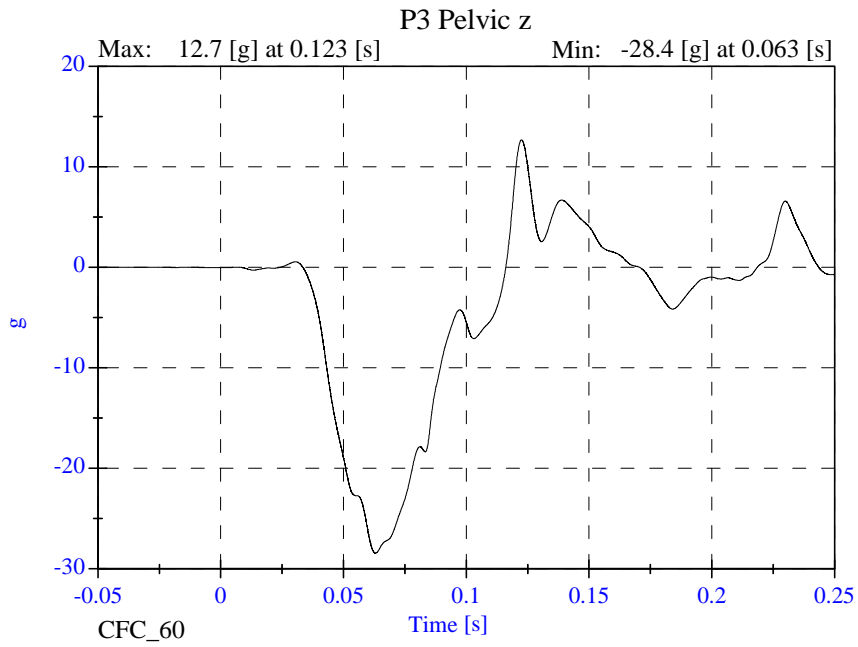
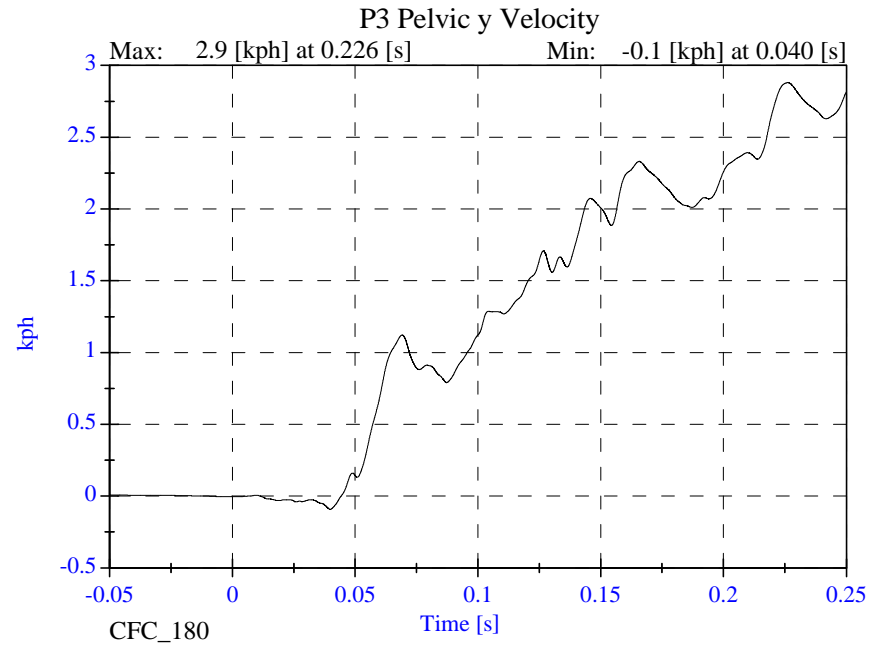
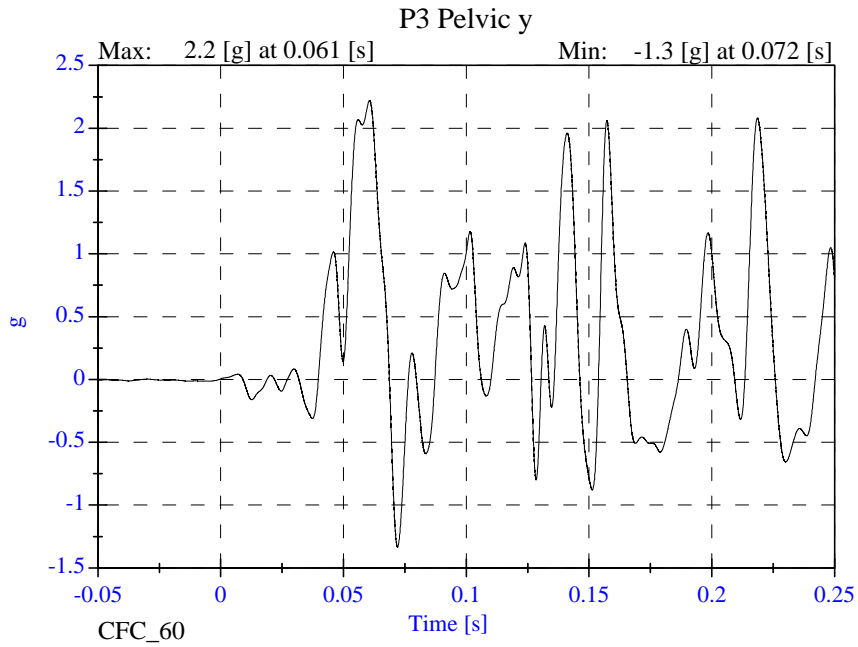

Sled Test Run 22291

P4 Head x

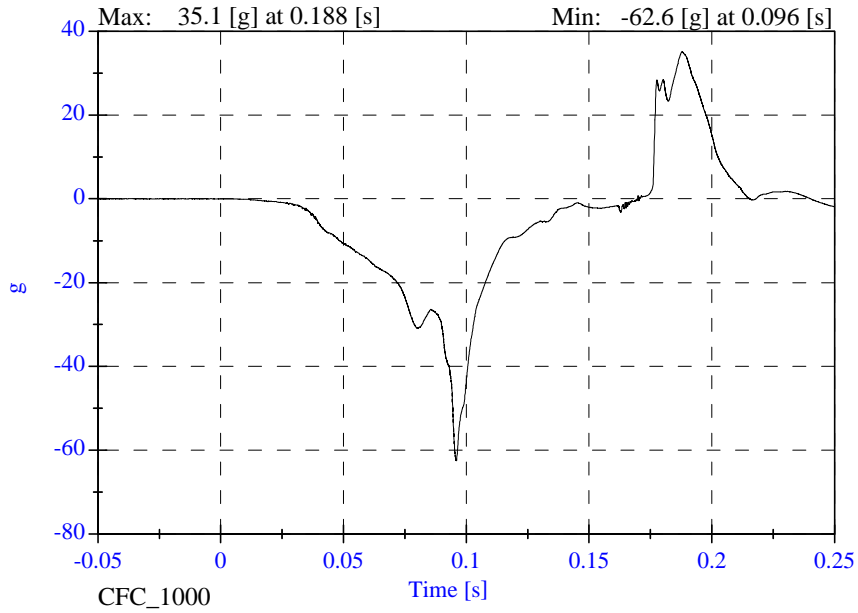

Version 3.10 / 32 dev - March 25, 2002

P4 Head y

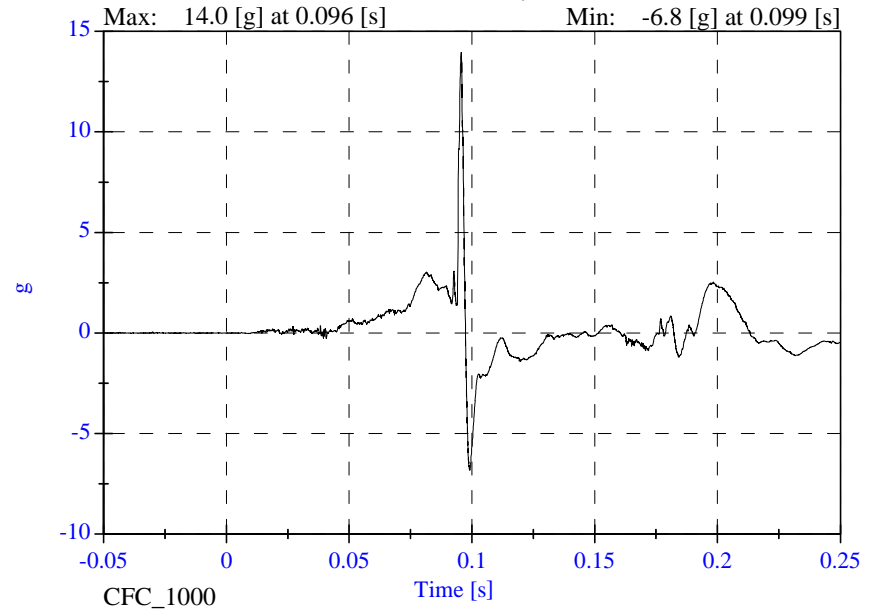

P4 Head z

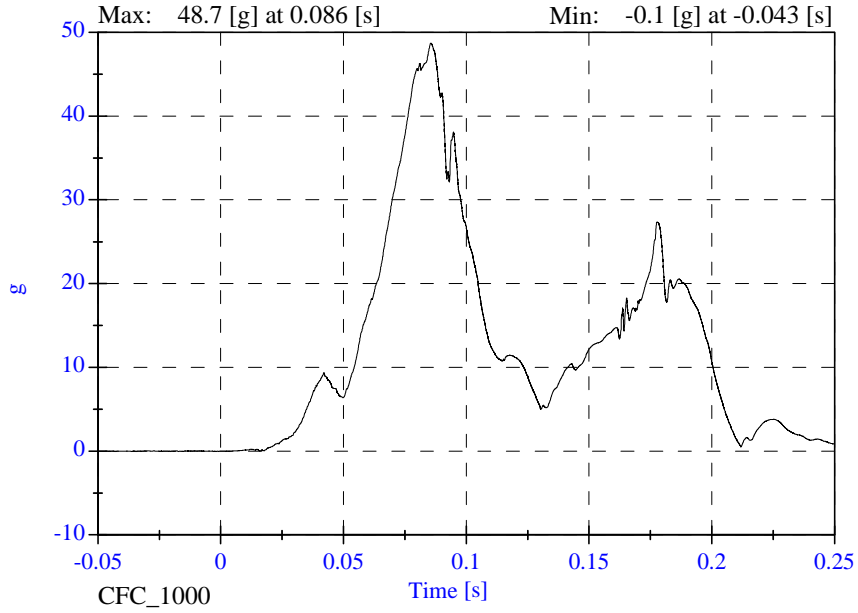

P4 Head Resultant

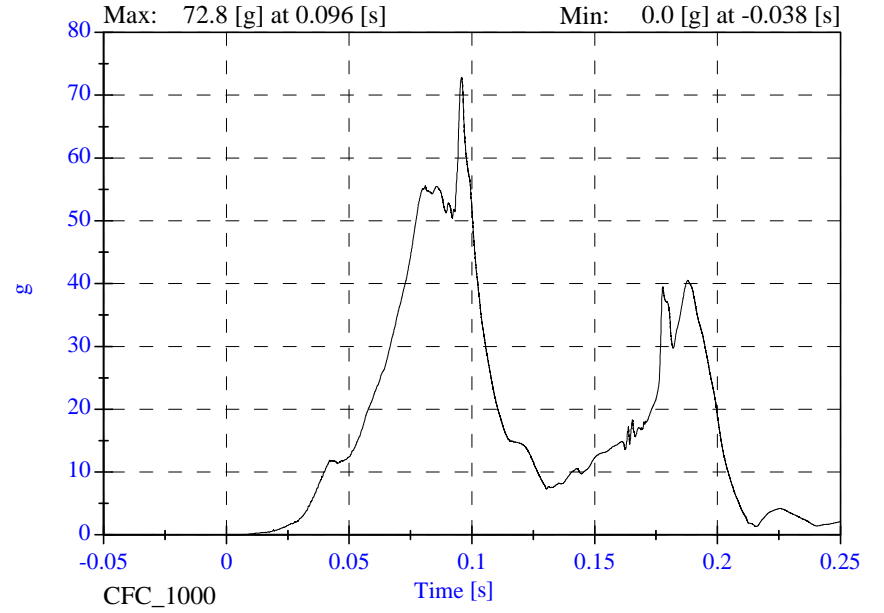

Sled Test Run 22291

Version 3.10 / 32 dev - March 25, 2002

P4 Upper Neck Fx

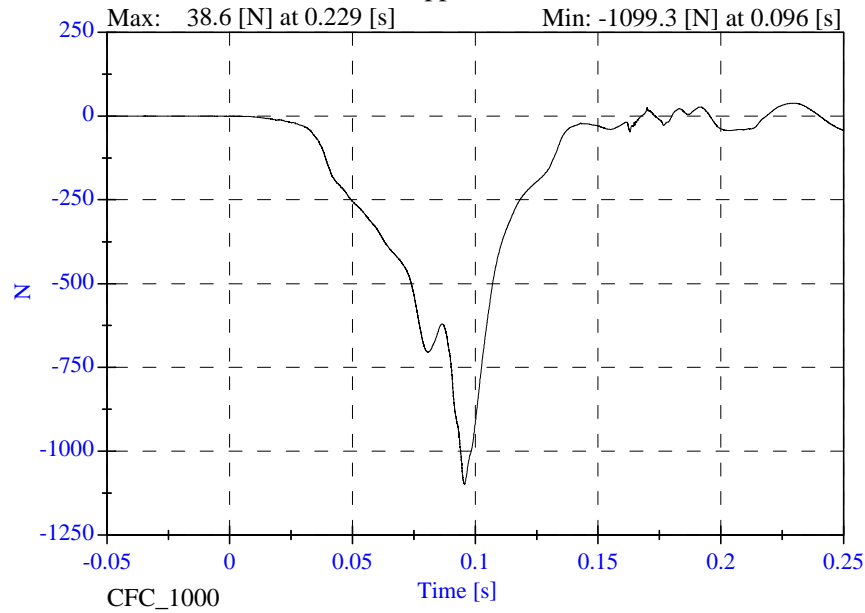

P4 Upper Neck Fy

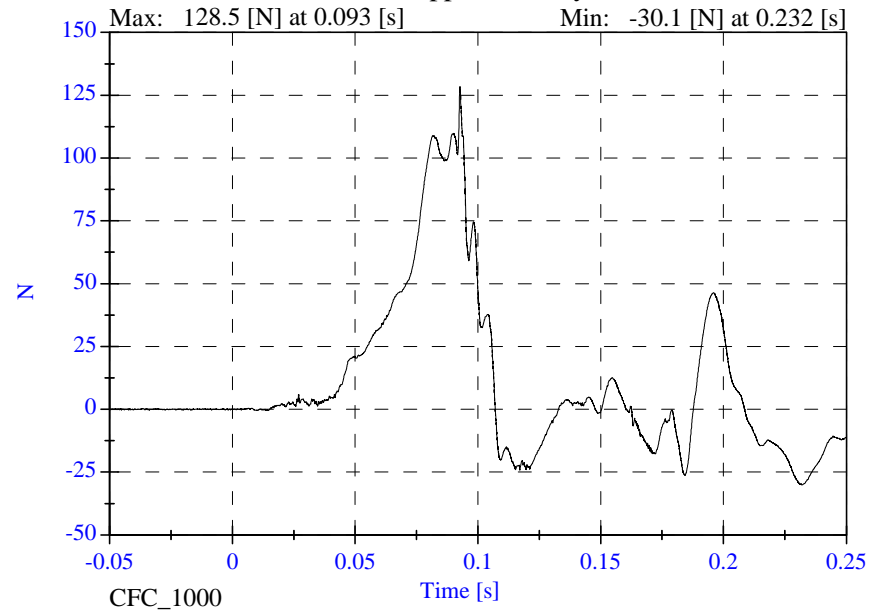

P4 Upper Neck Fz

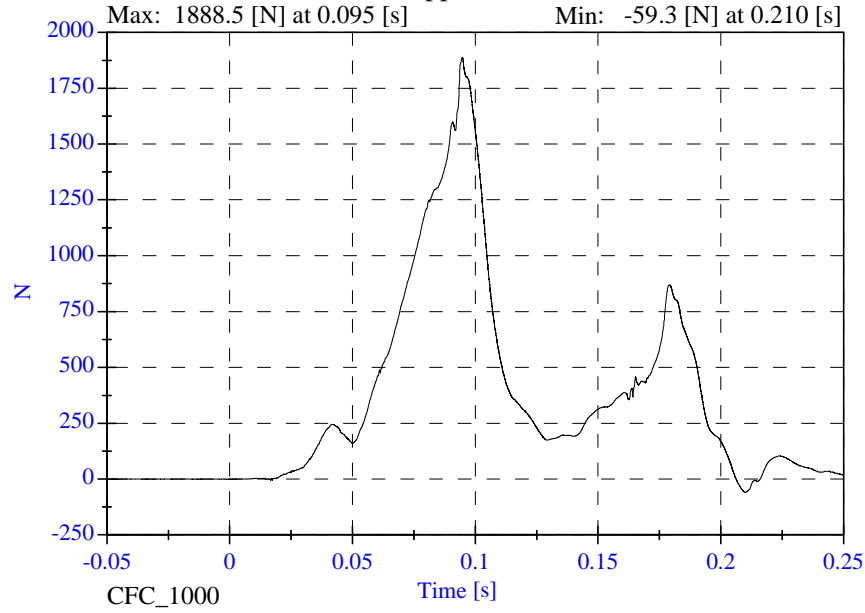

P4 Upper Neck F Resultant

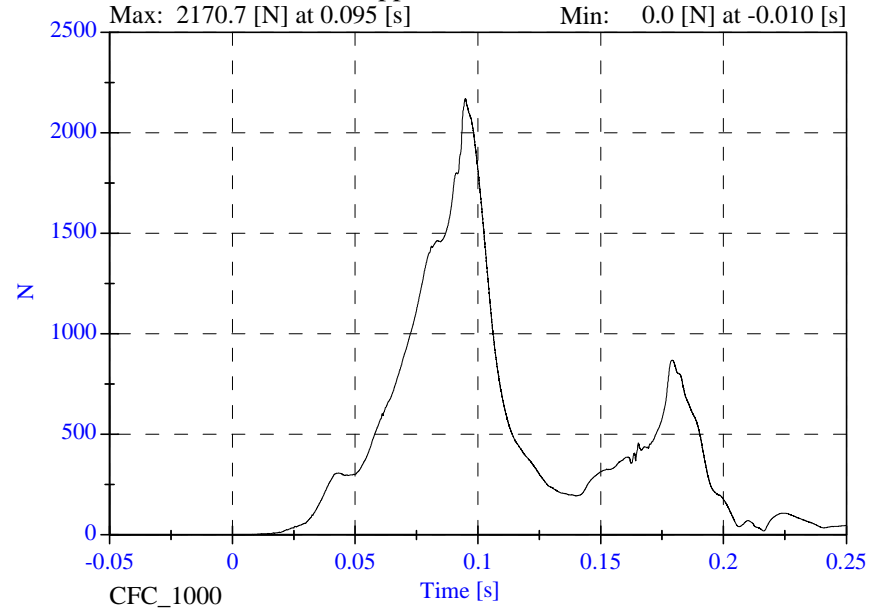

Sled Test Run 22291

Version 3.10 / 32 dev - March 25, 2002

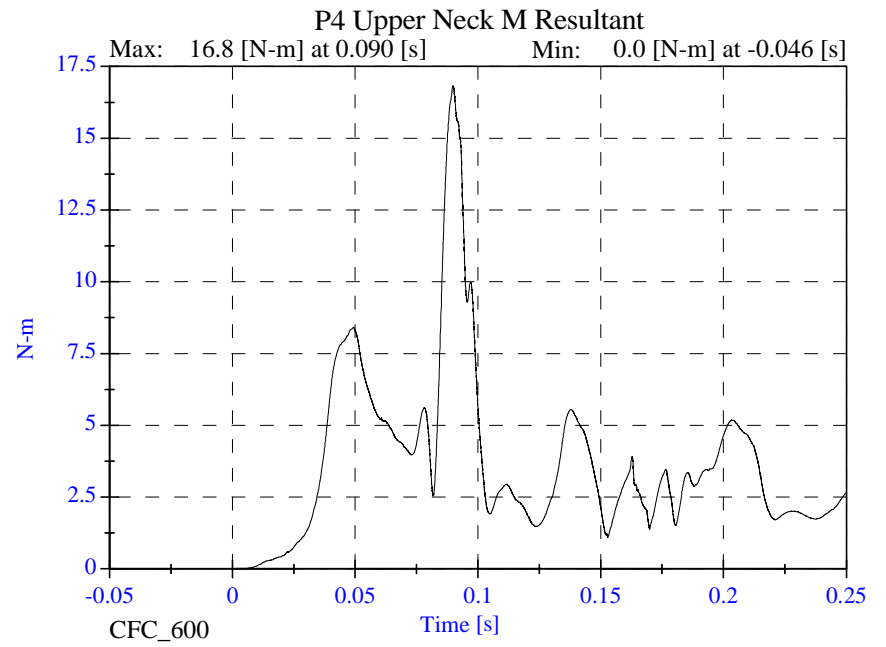
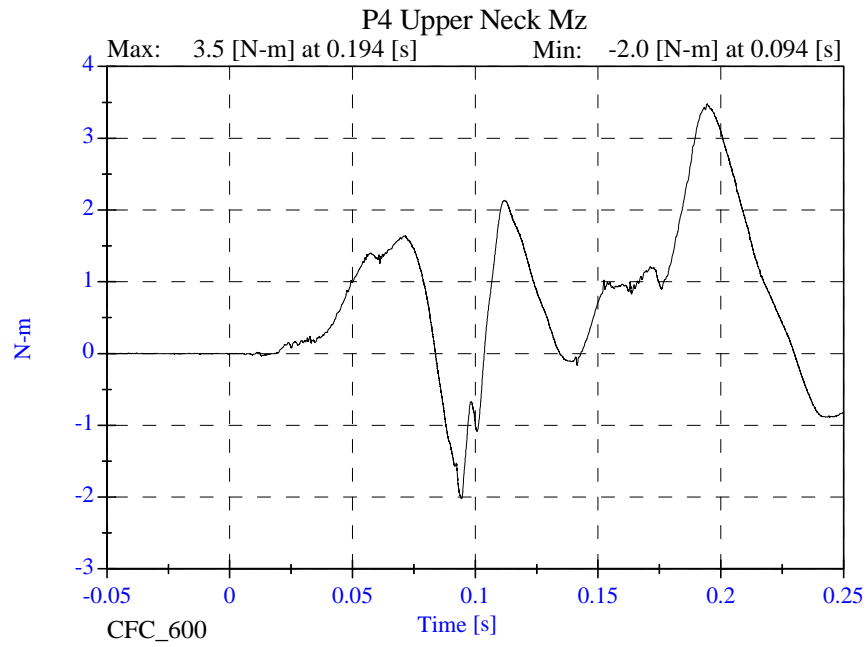
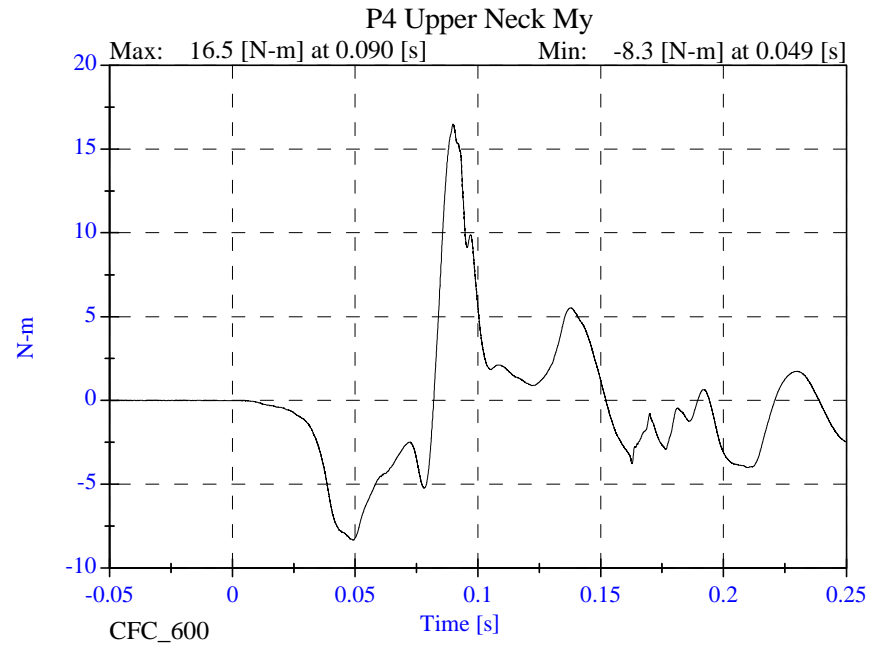
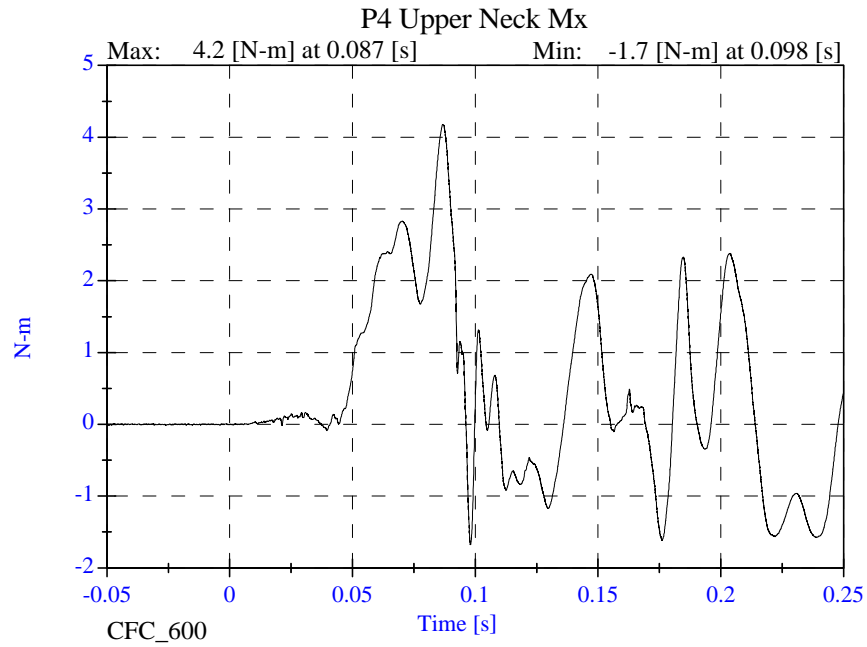

Sled Test Run 22291

Version 3.10 / 32 dev - March 25, 2002

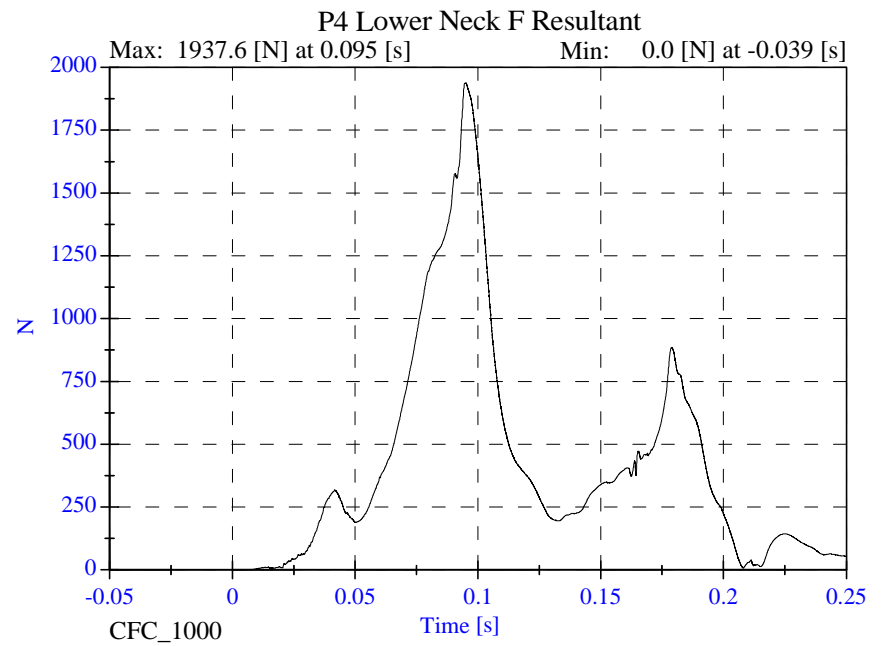
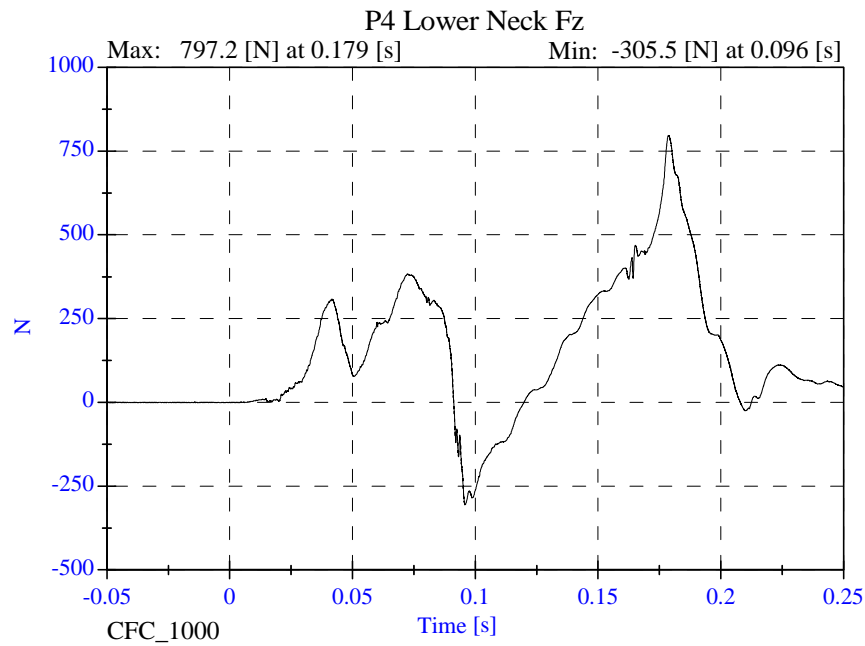
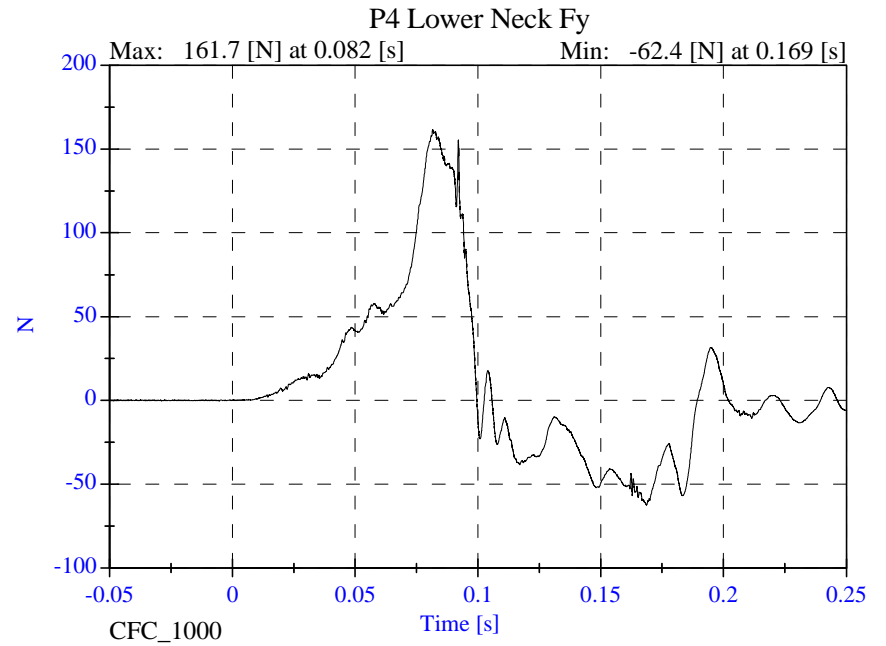
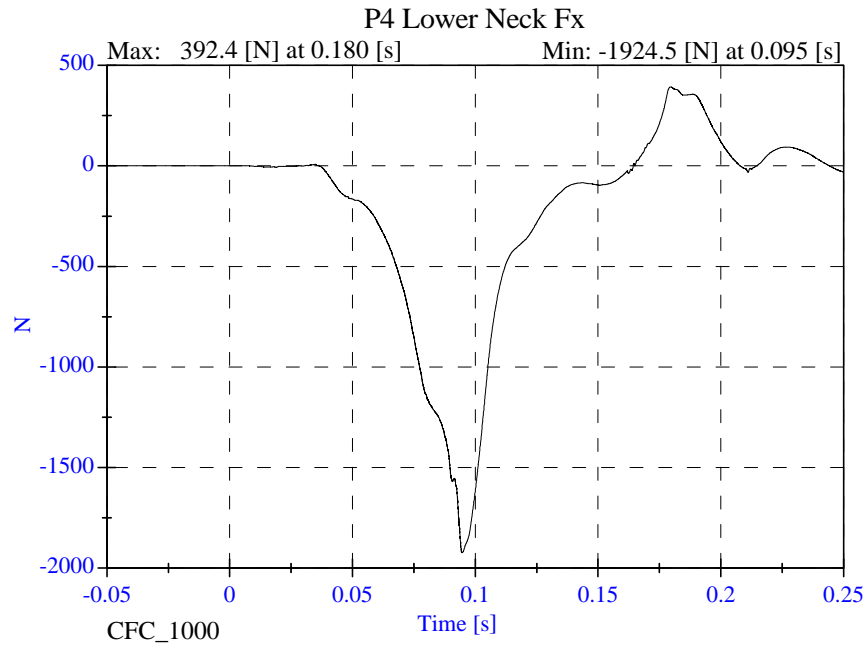

Sled Test Run 22291

Version 3.10 / 32 dev - March 25, 2002

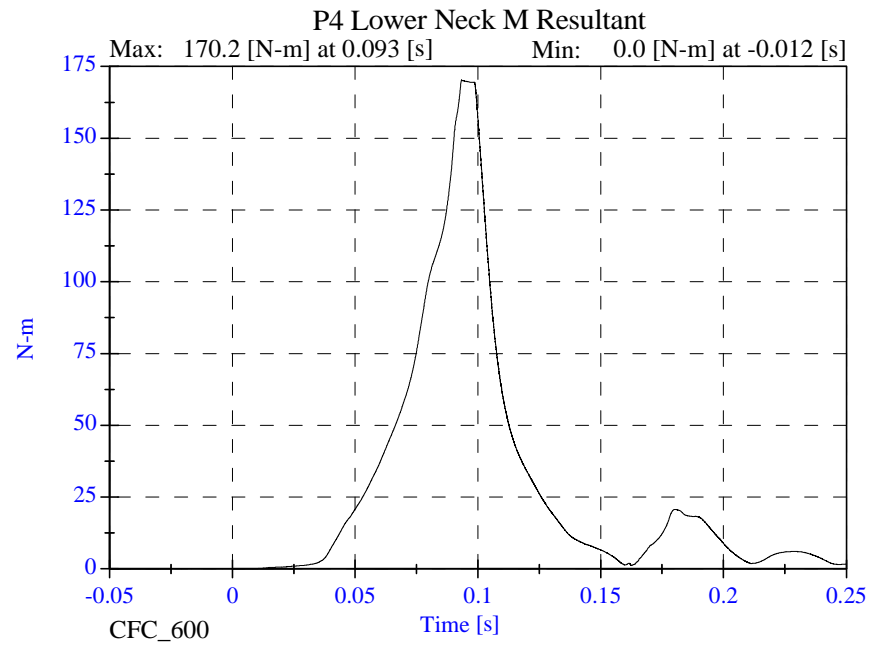
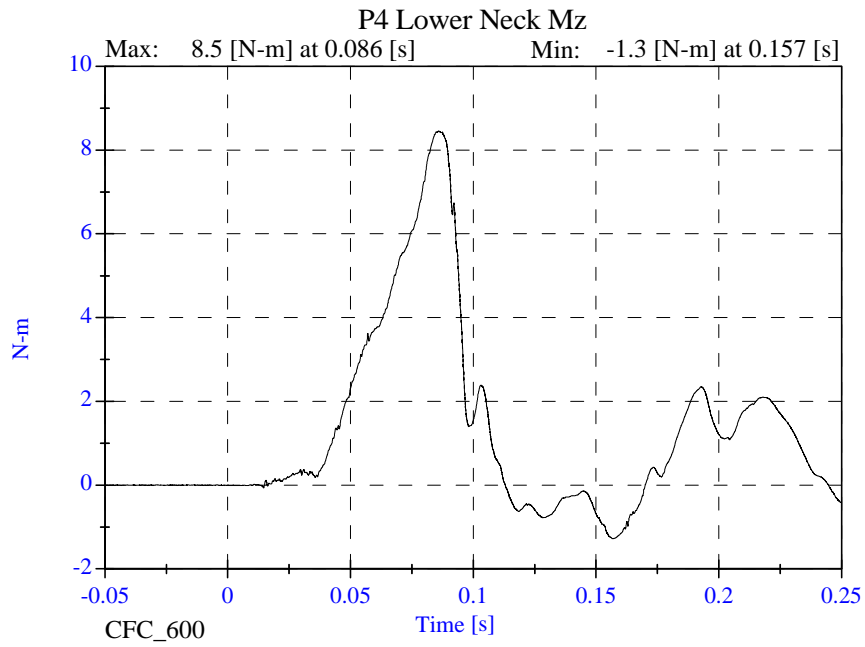
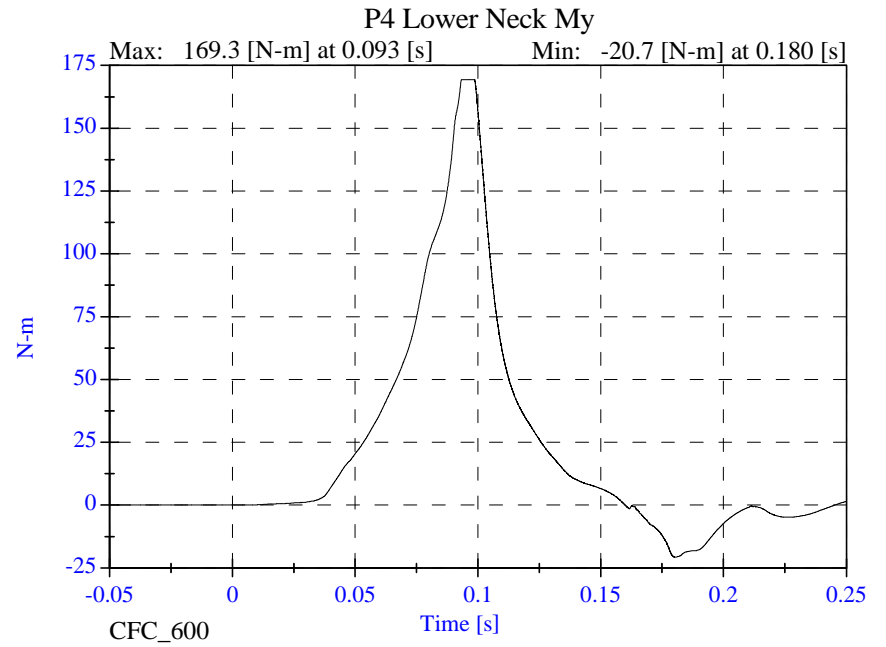
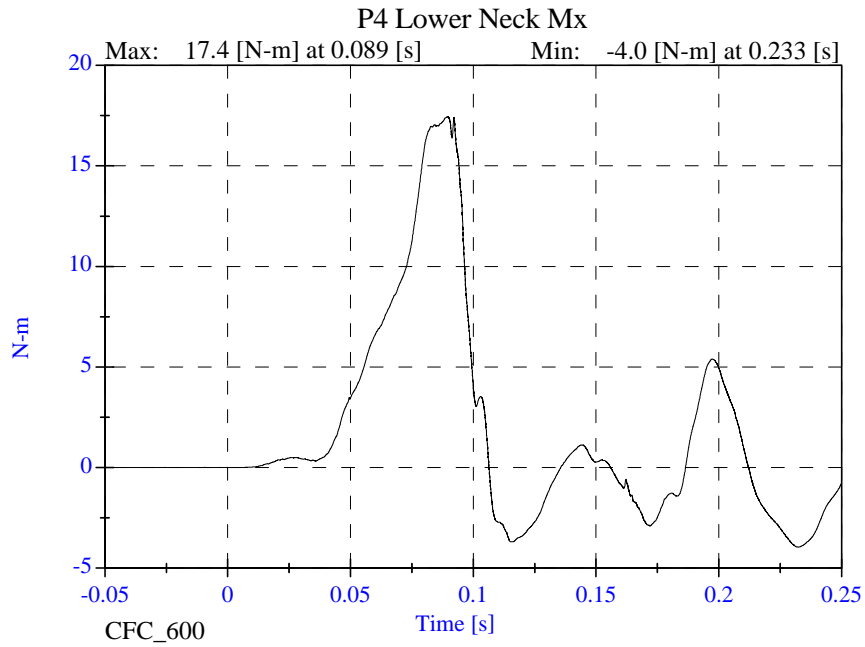

Sled Test Run 22291

Version 3.10 / 32 dev - March 25, 2002

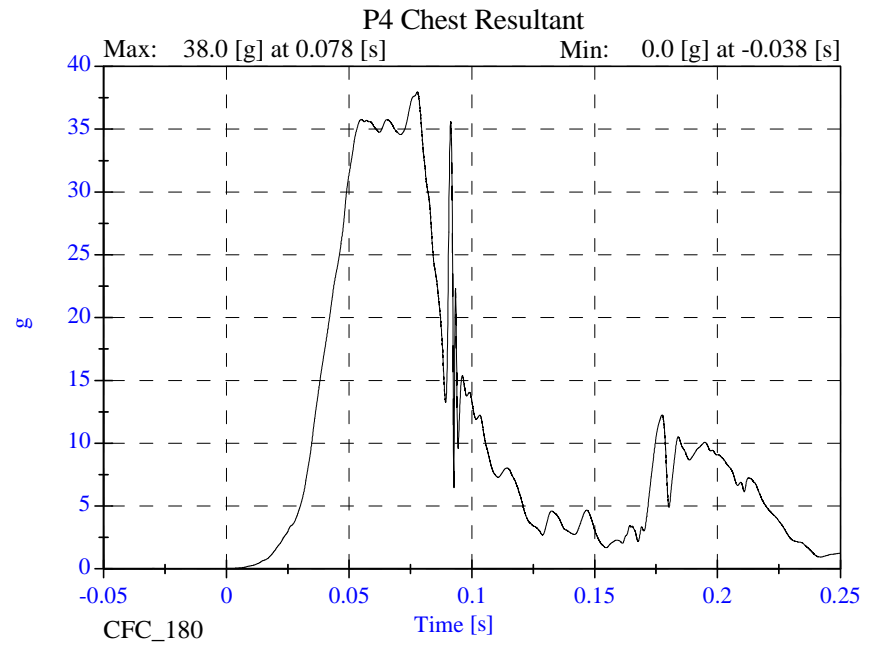
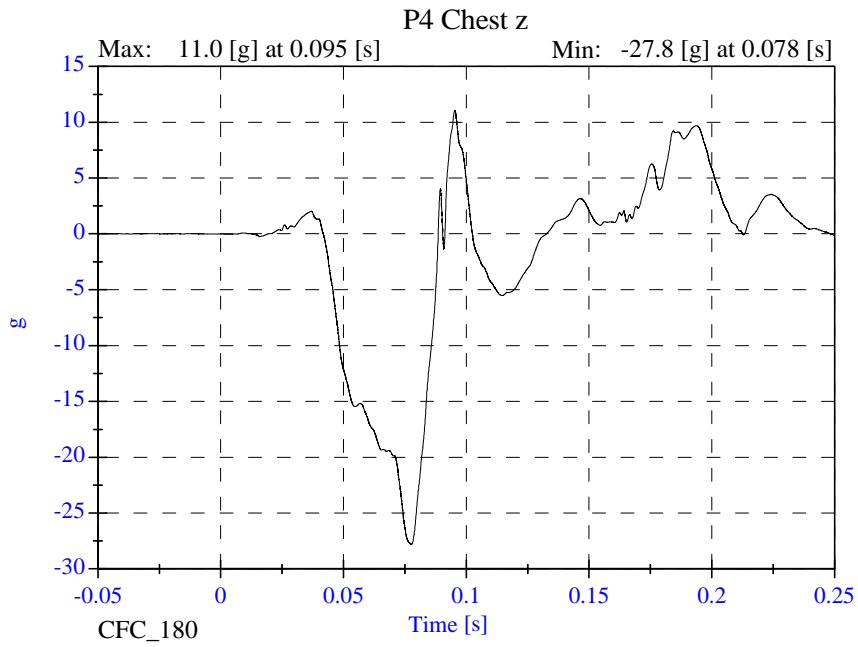
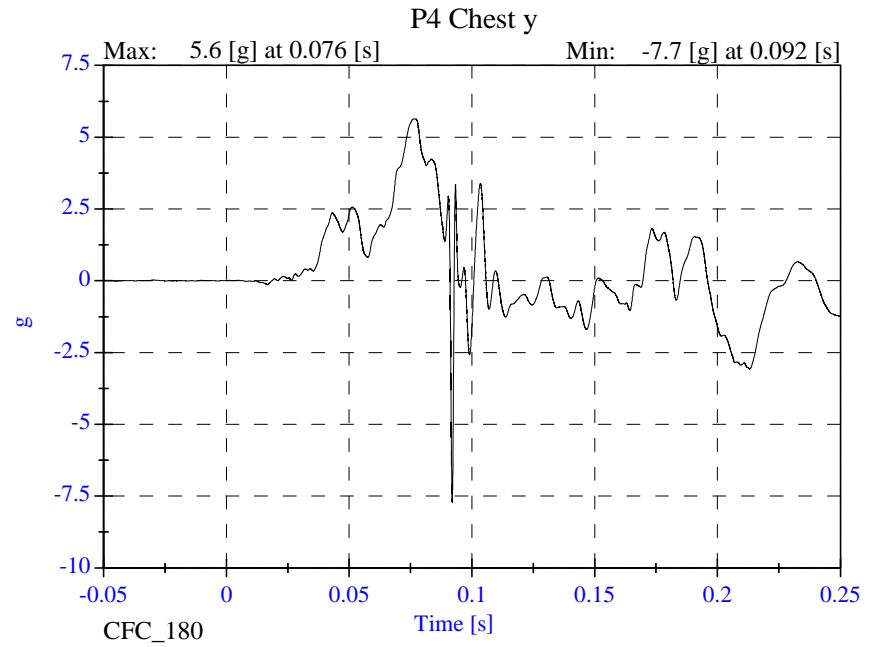
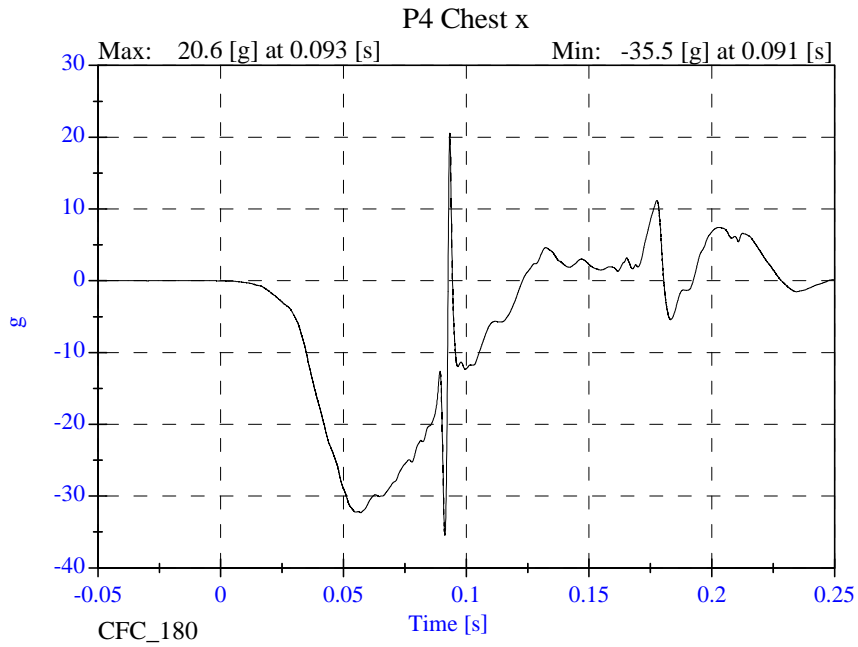

Sled Test Run 22291

Version 3.10 / 32 dev - March 25, 2002

P4 Pelvic x

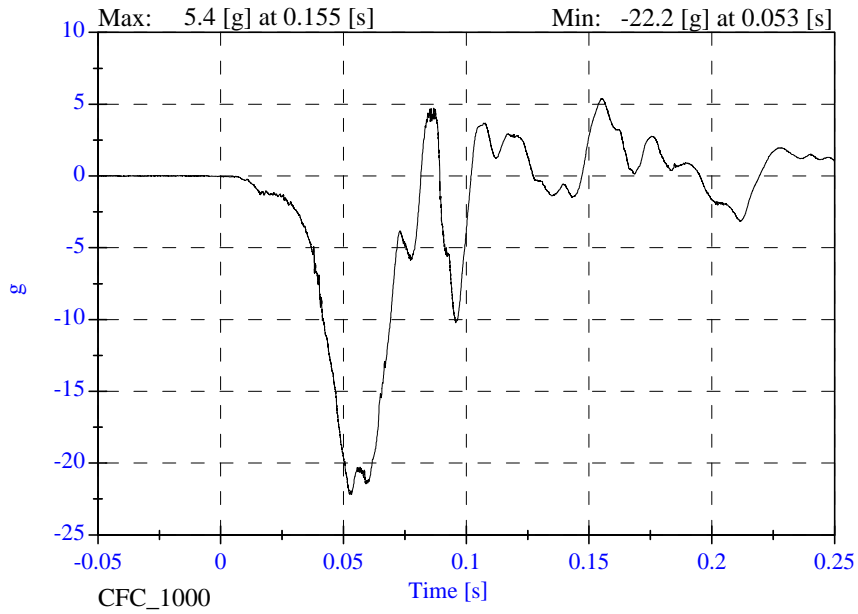

P4 Pelvic y

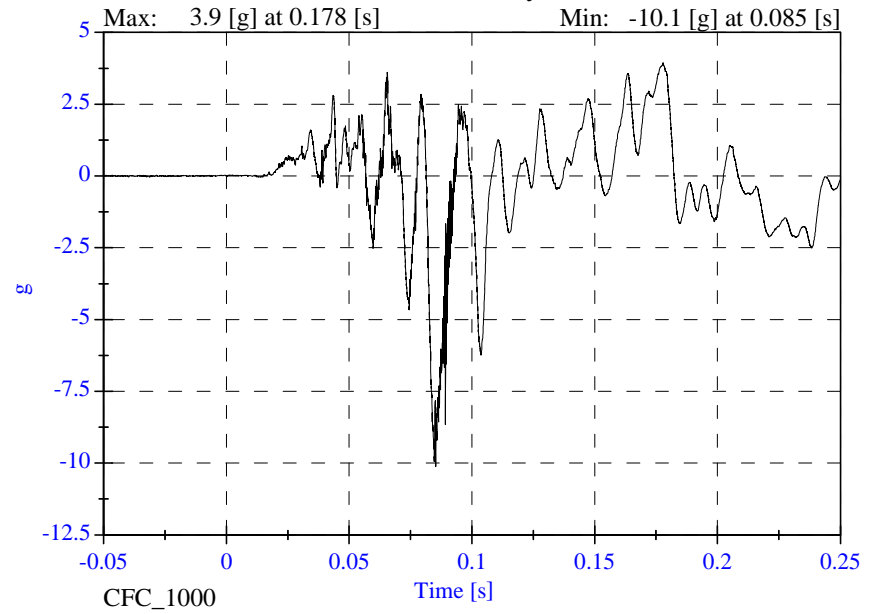

P4 Pelvic z

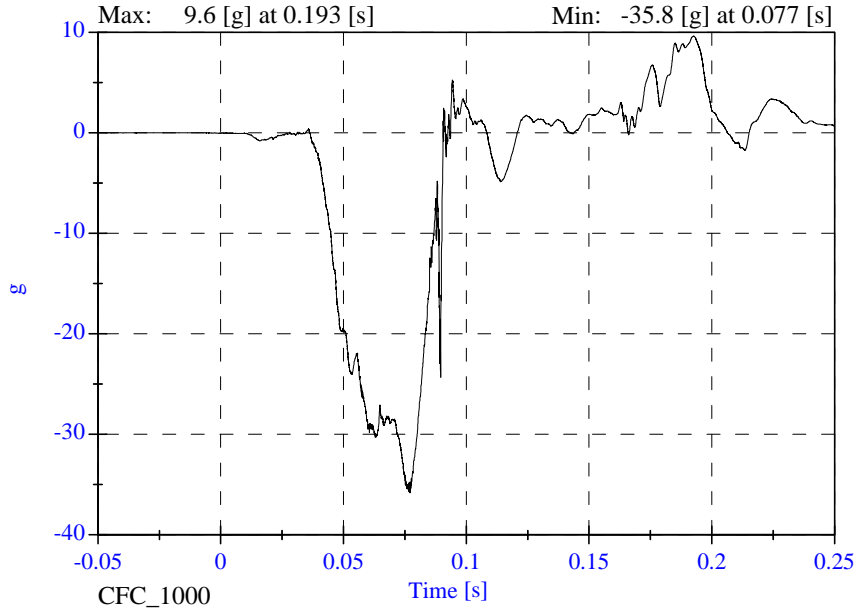

P4 Pelvic Resultant

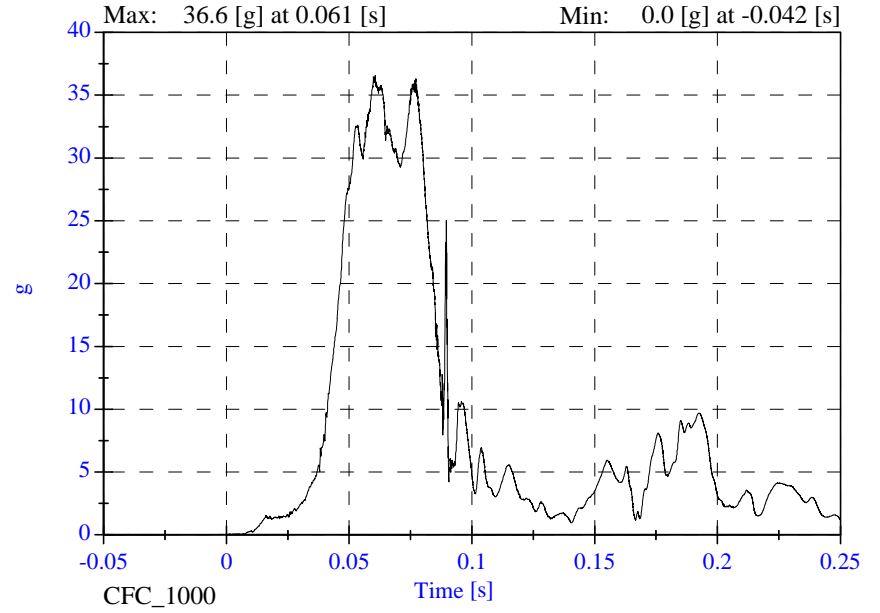

Sled Test Run 22291

Version 3.10 / 32 dev - March 25, 2002

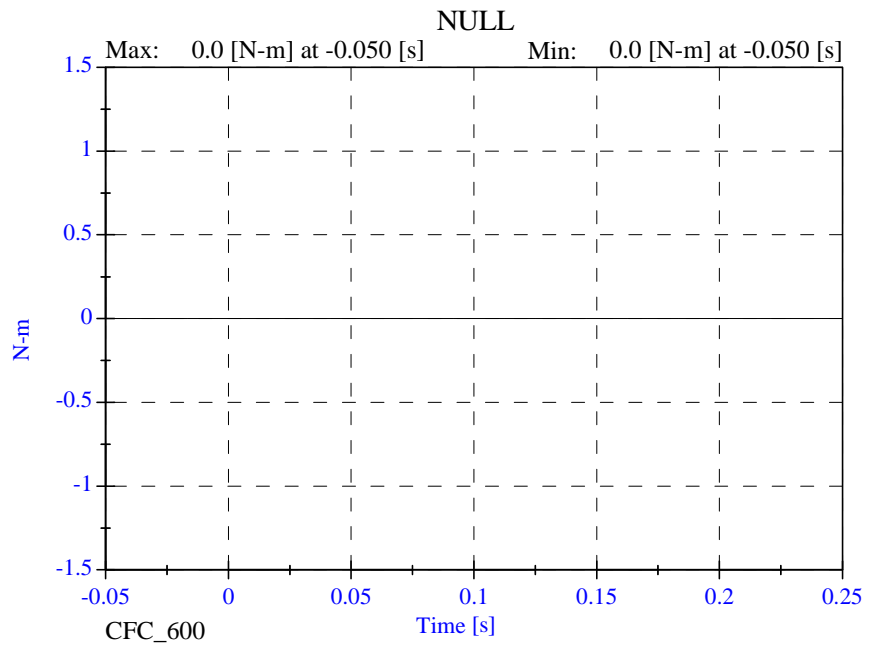
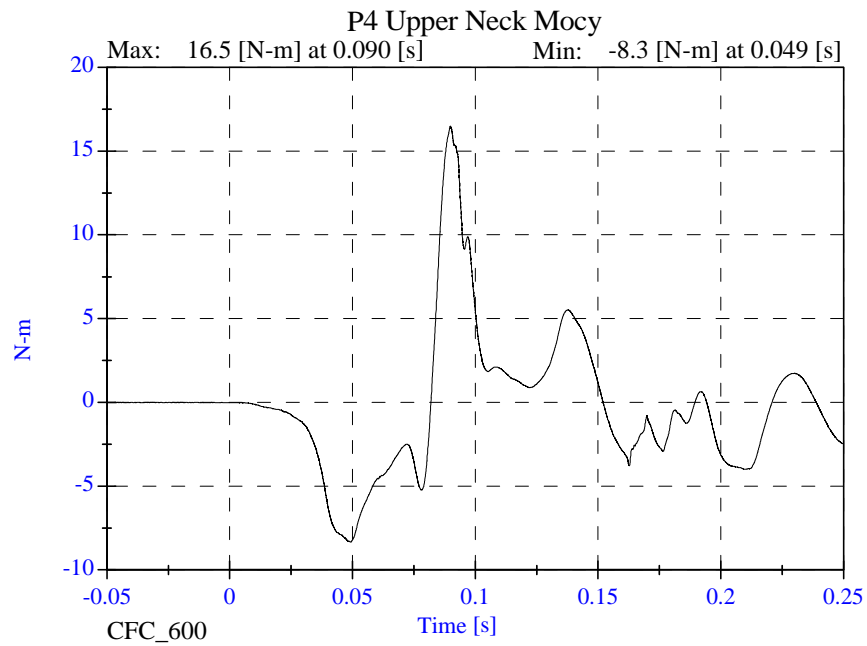
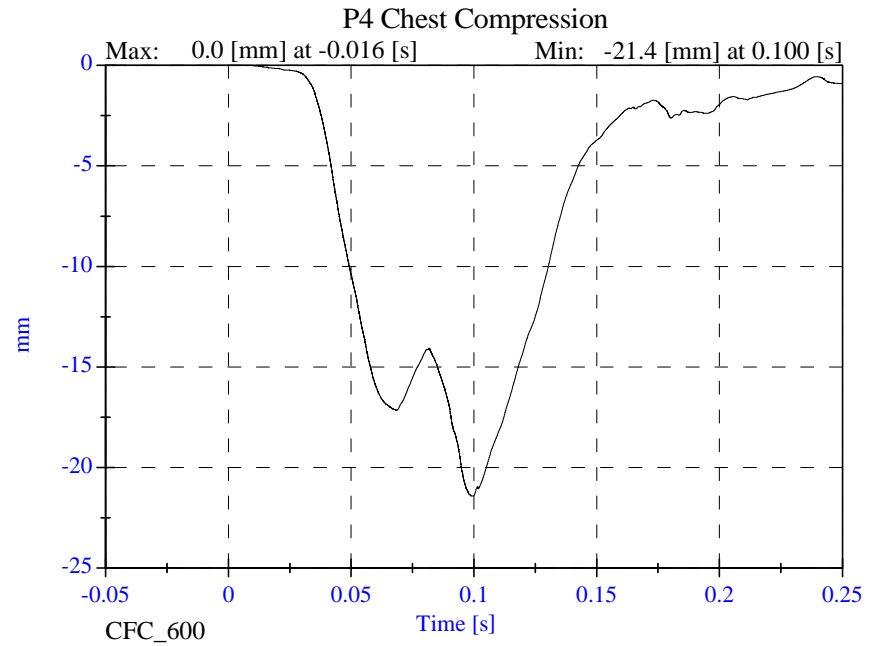
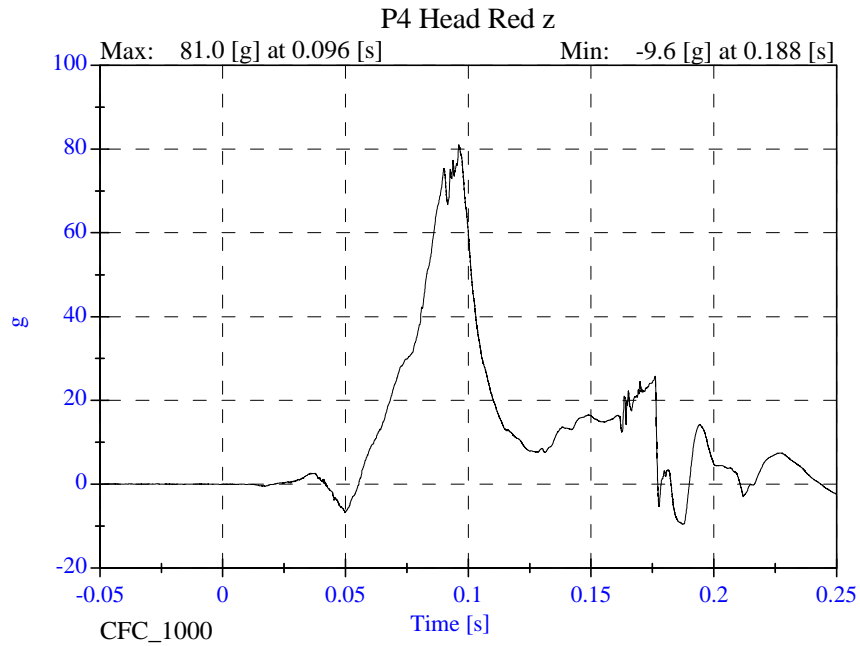

Sled Test Run 22291

Version 3.10 / 32 dev - March 25, 2002

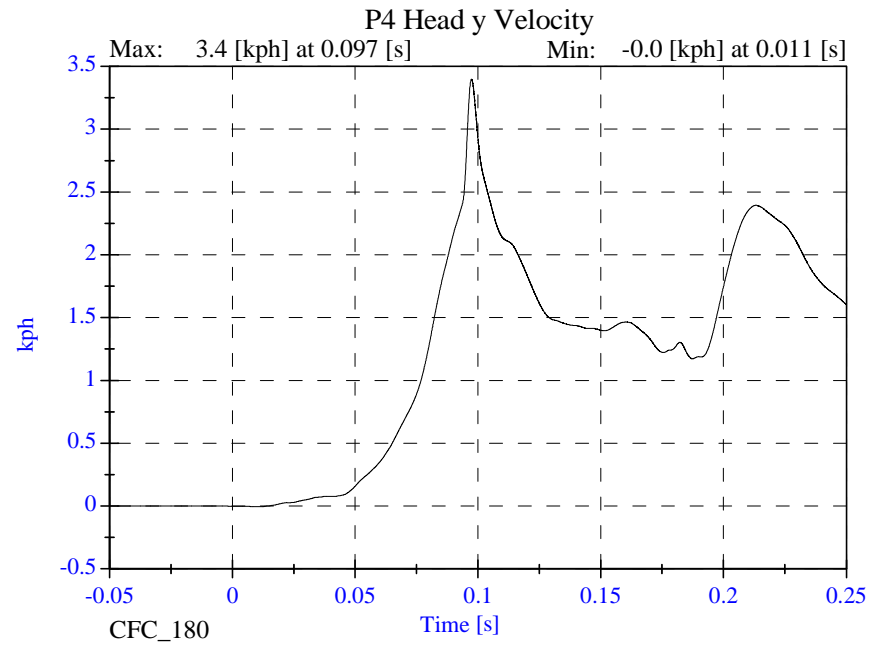
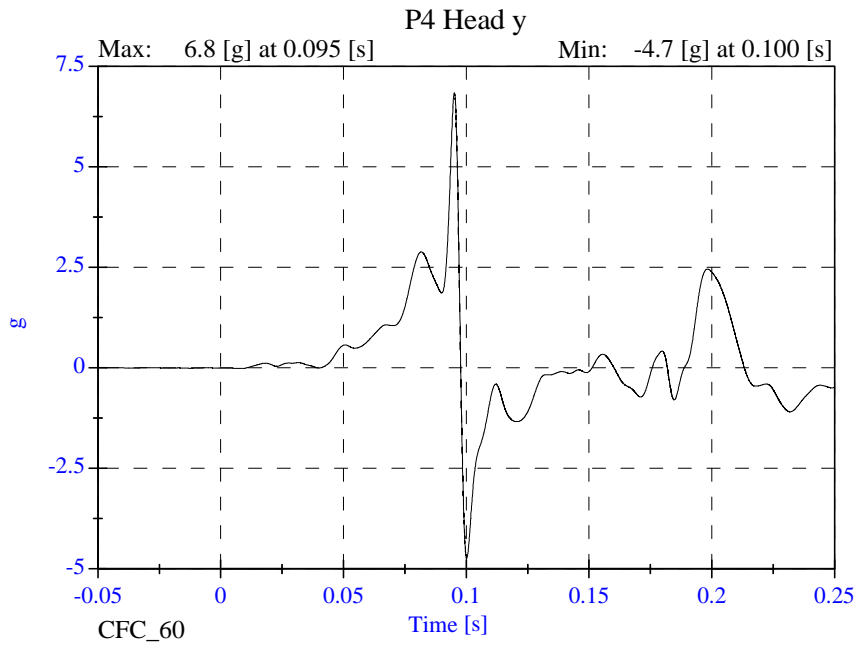
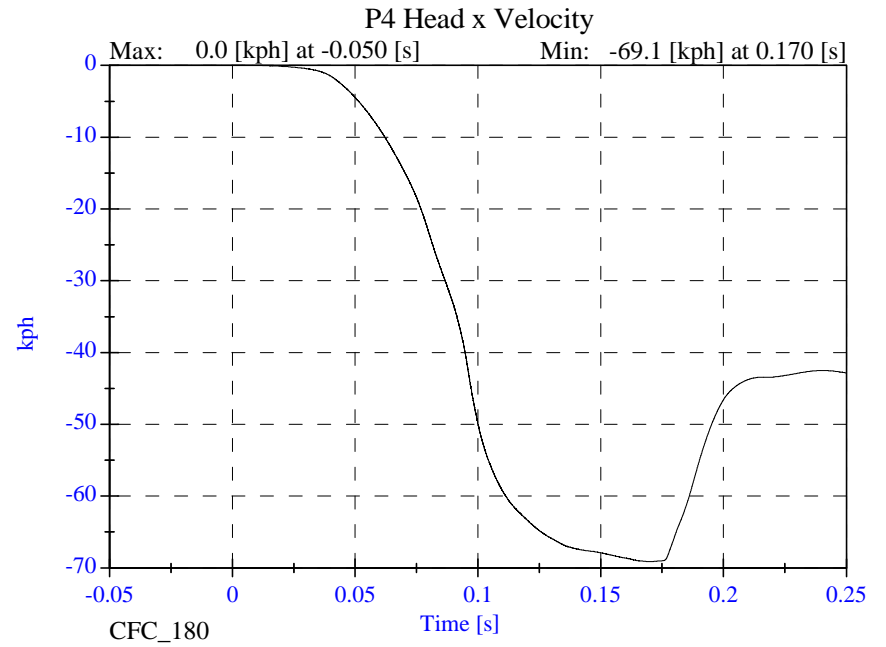
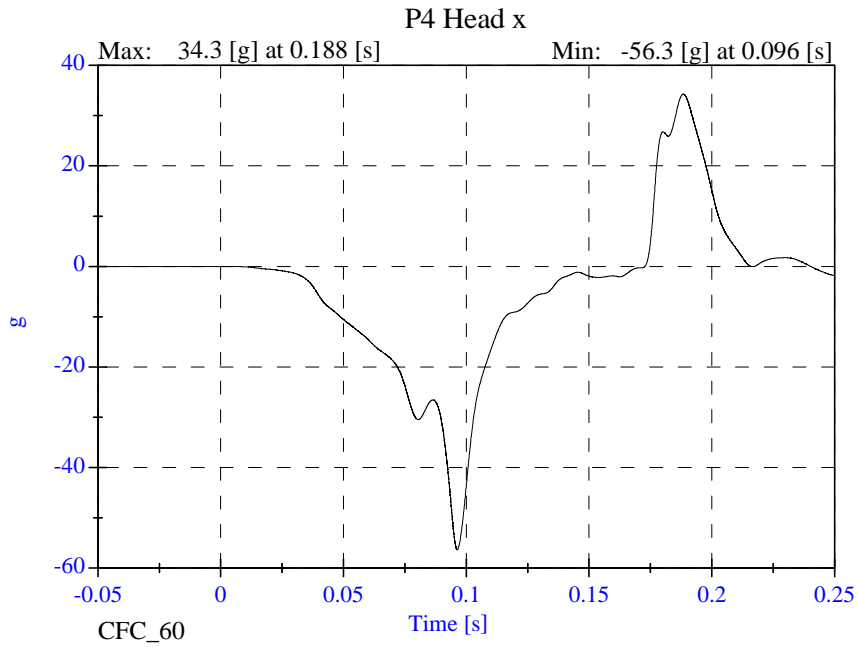

Sled Test Run 22291

Version 3.10 / 32 dev - March 25, 2002

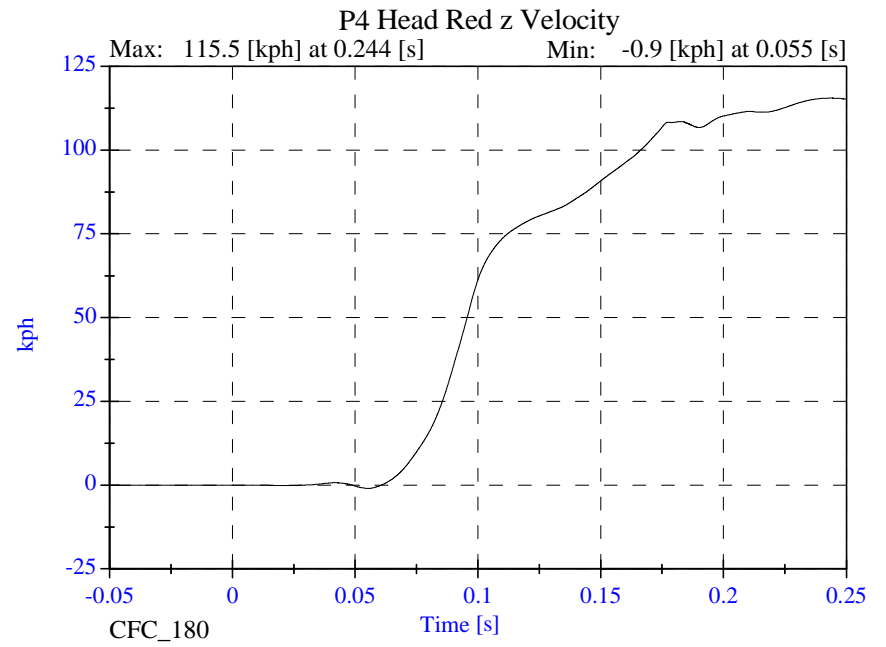
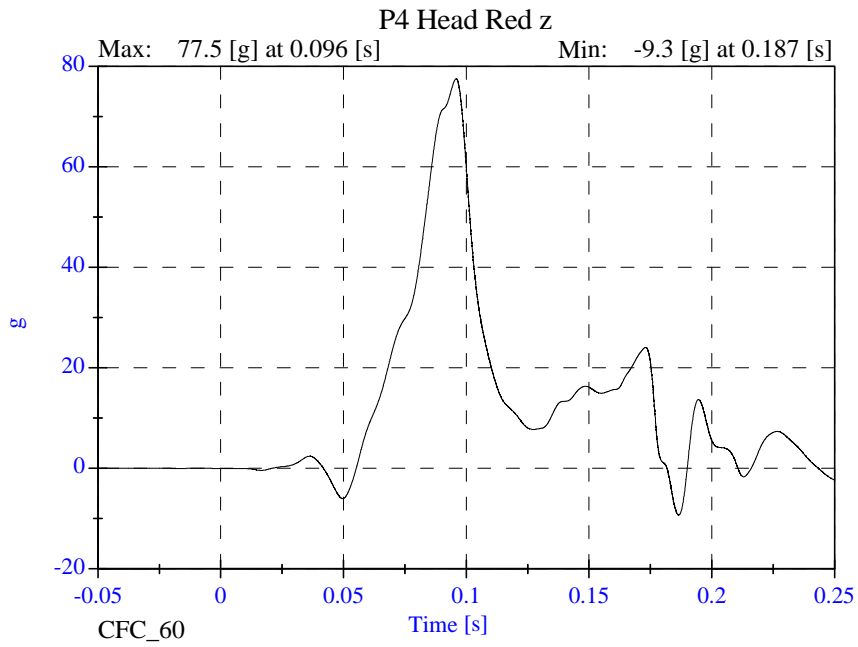
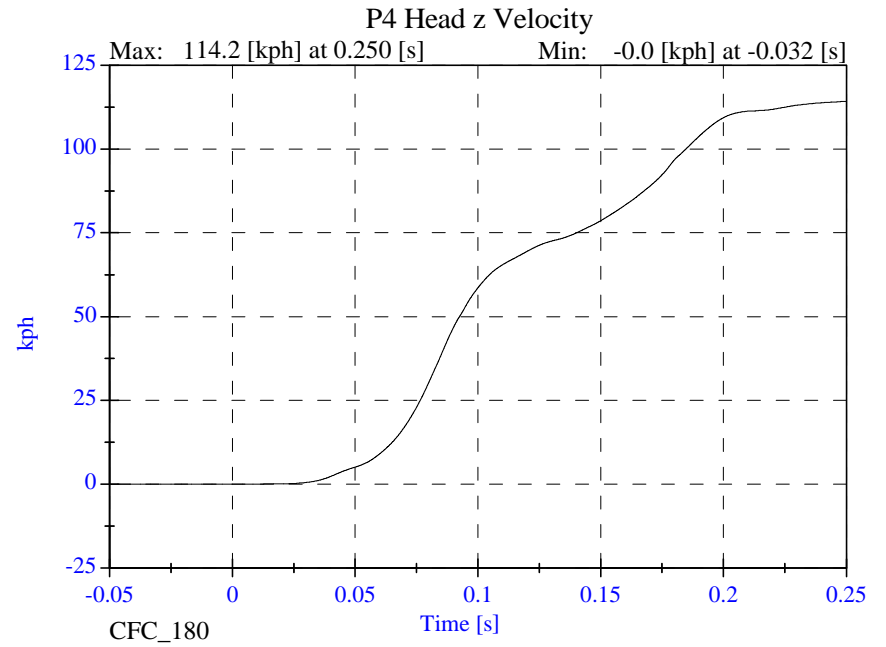
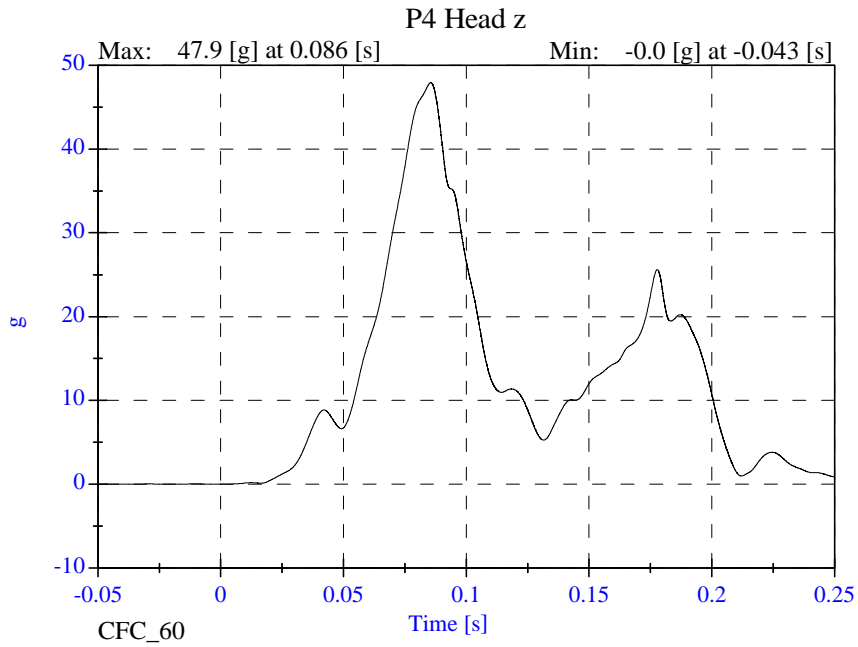

Sled Test Run 22291

Version 3.10 / 32 dev - March 25, 2002

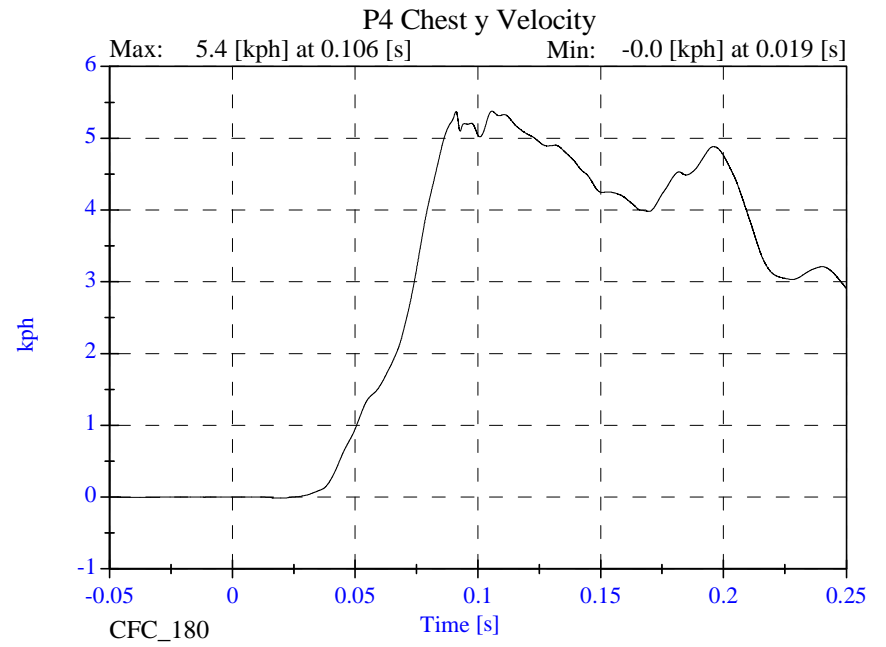
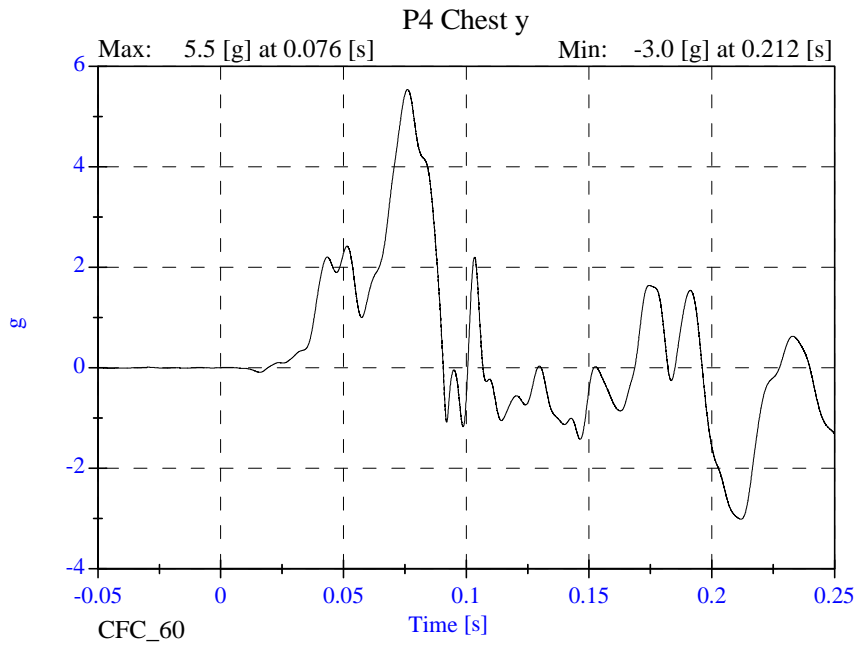
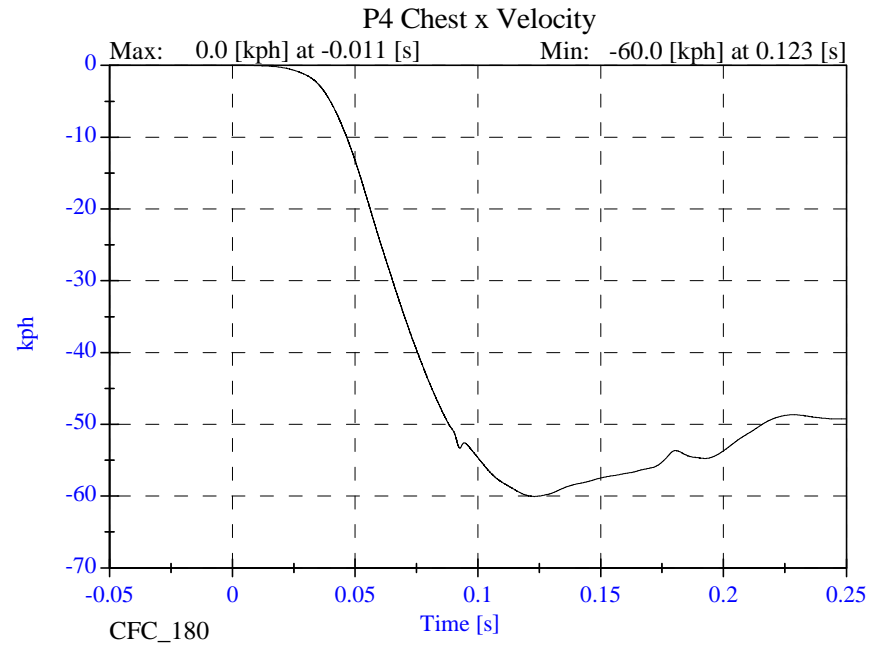
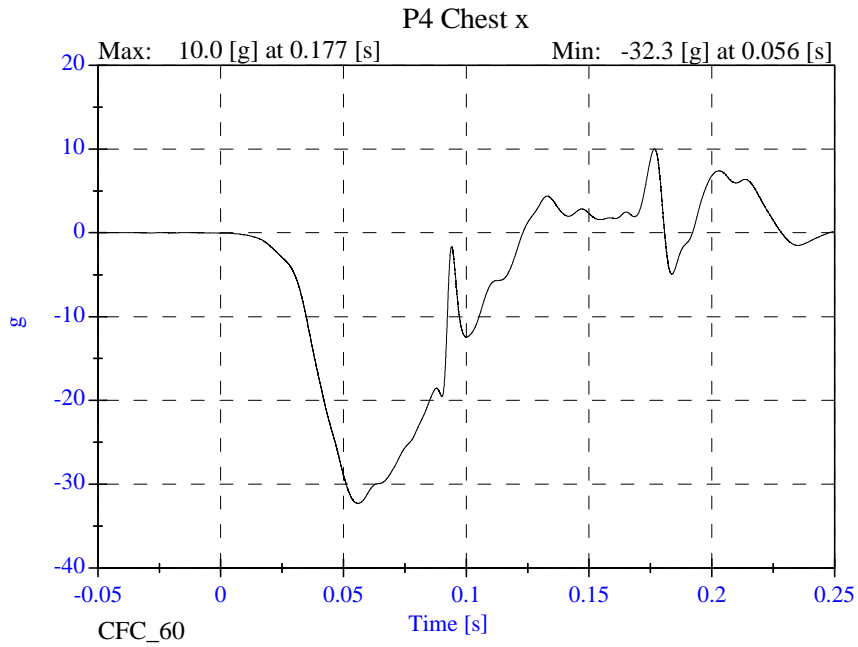

Sled Test Run 22291

Version 3.10 / 32 dev - March 25, 2002

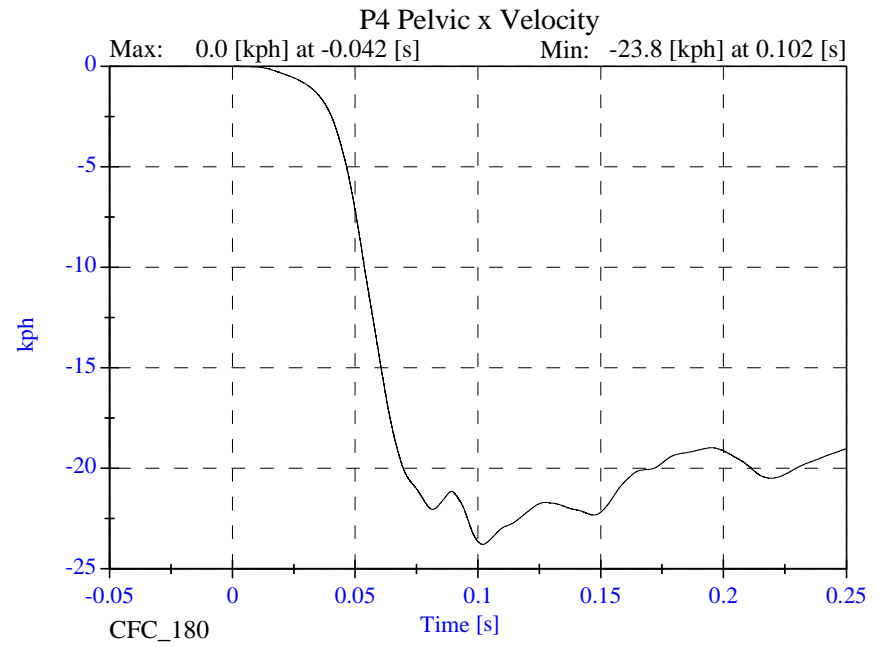
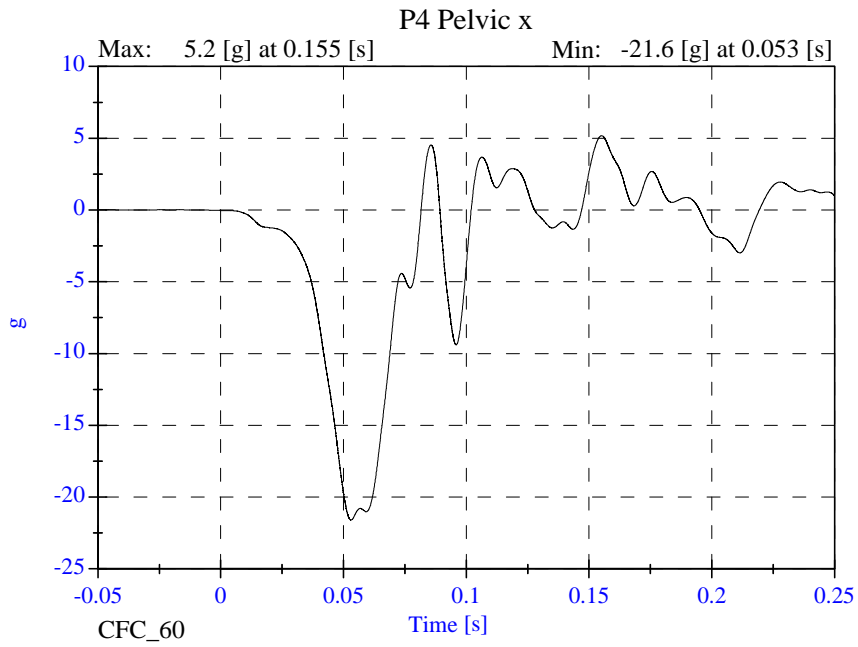
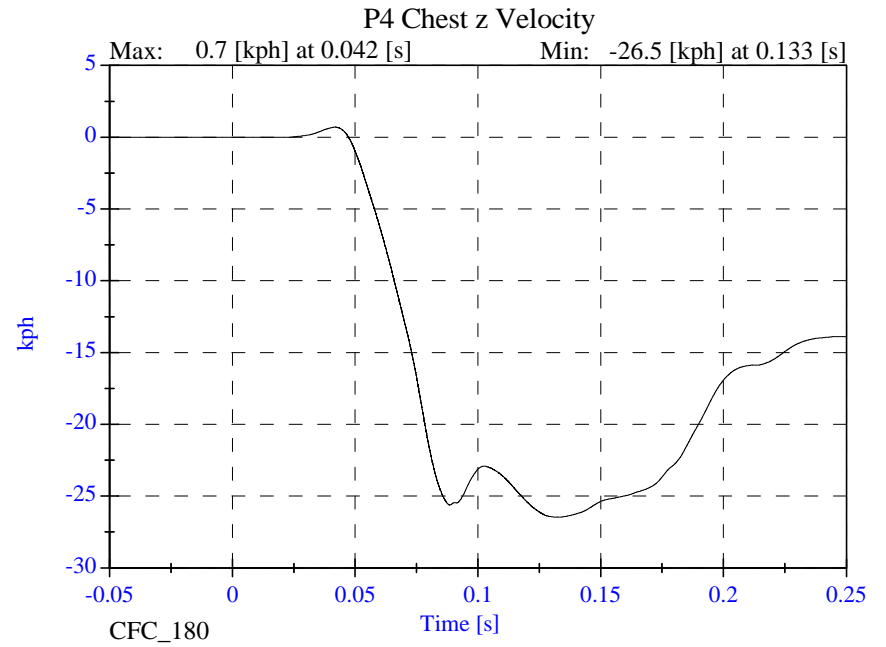
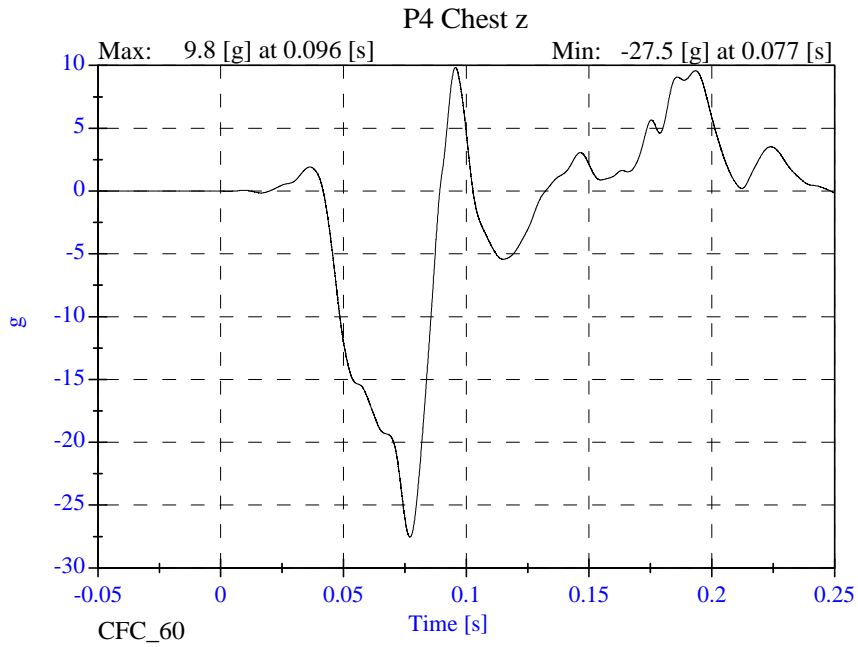

Sled Test Run 22291

Version 3.10 / 32 dev - March 25, 2002

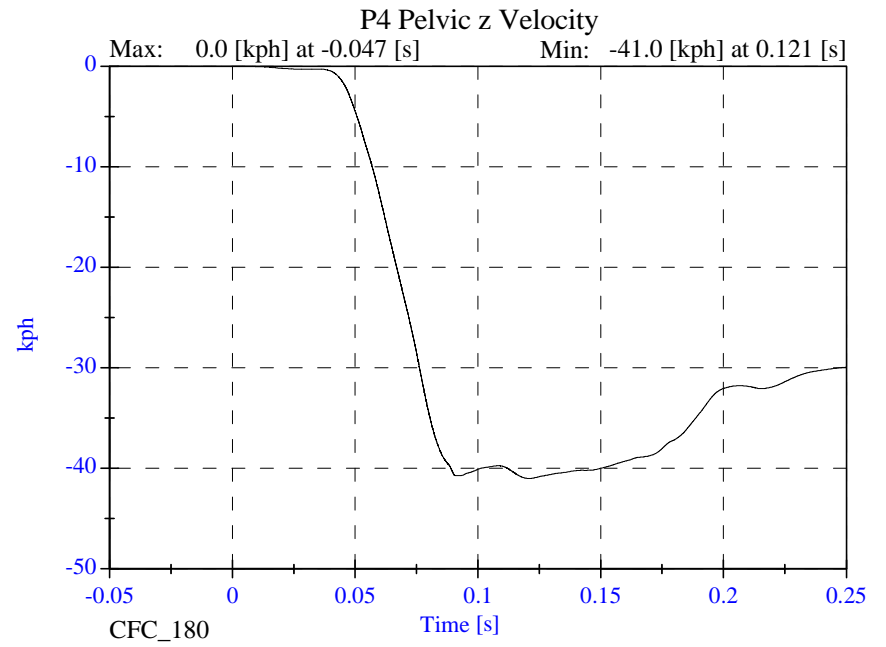
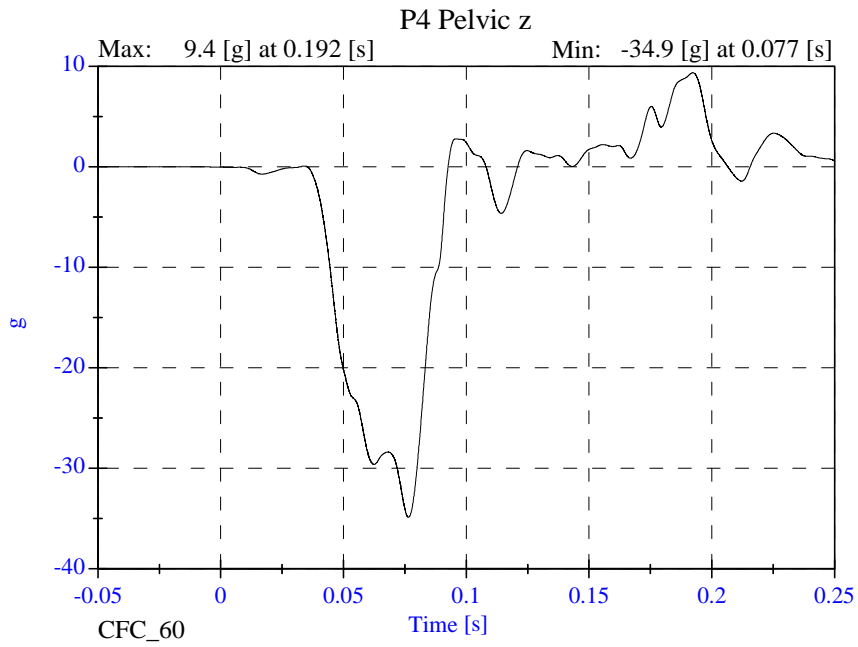
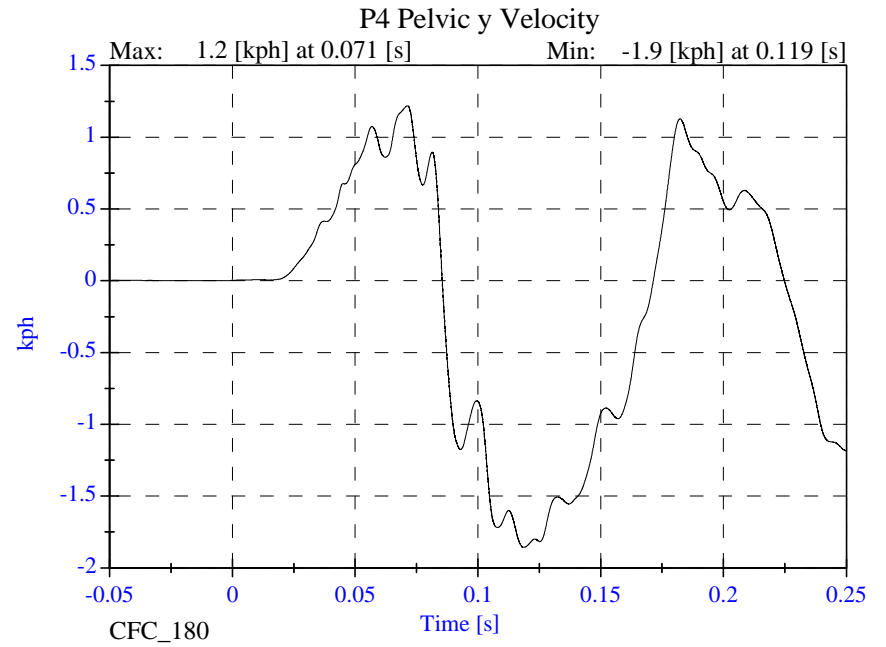
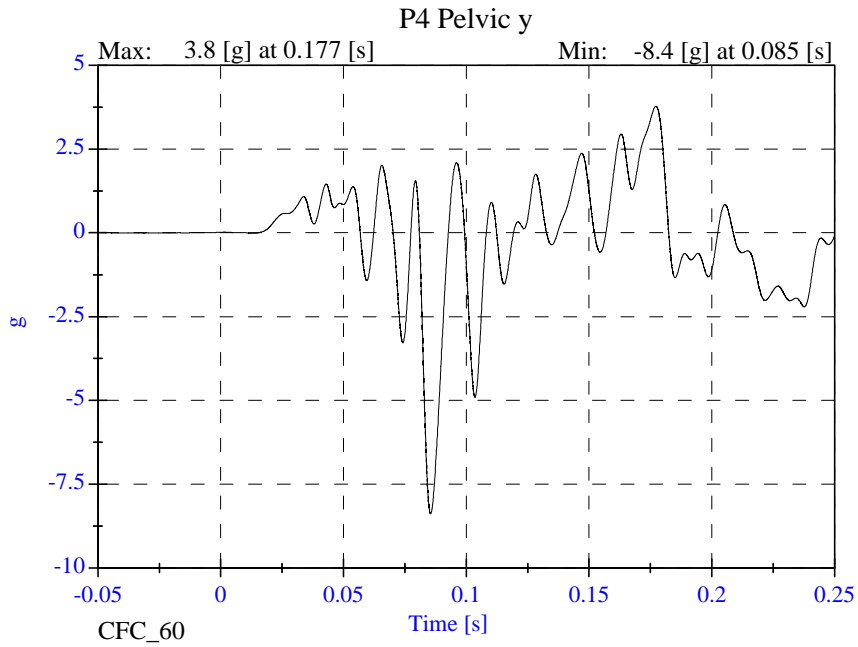

SECTION 12

COMPRESSION – DEFLECTION RESISTANCE TEST

Date 3/25/02
Performed By SD
Temp. 70°
Humidity 50%

Foam No. 2'x20" 2'x24" H9

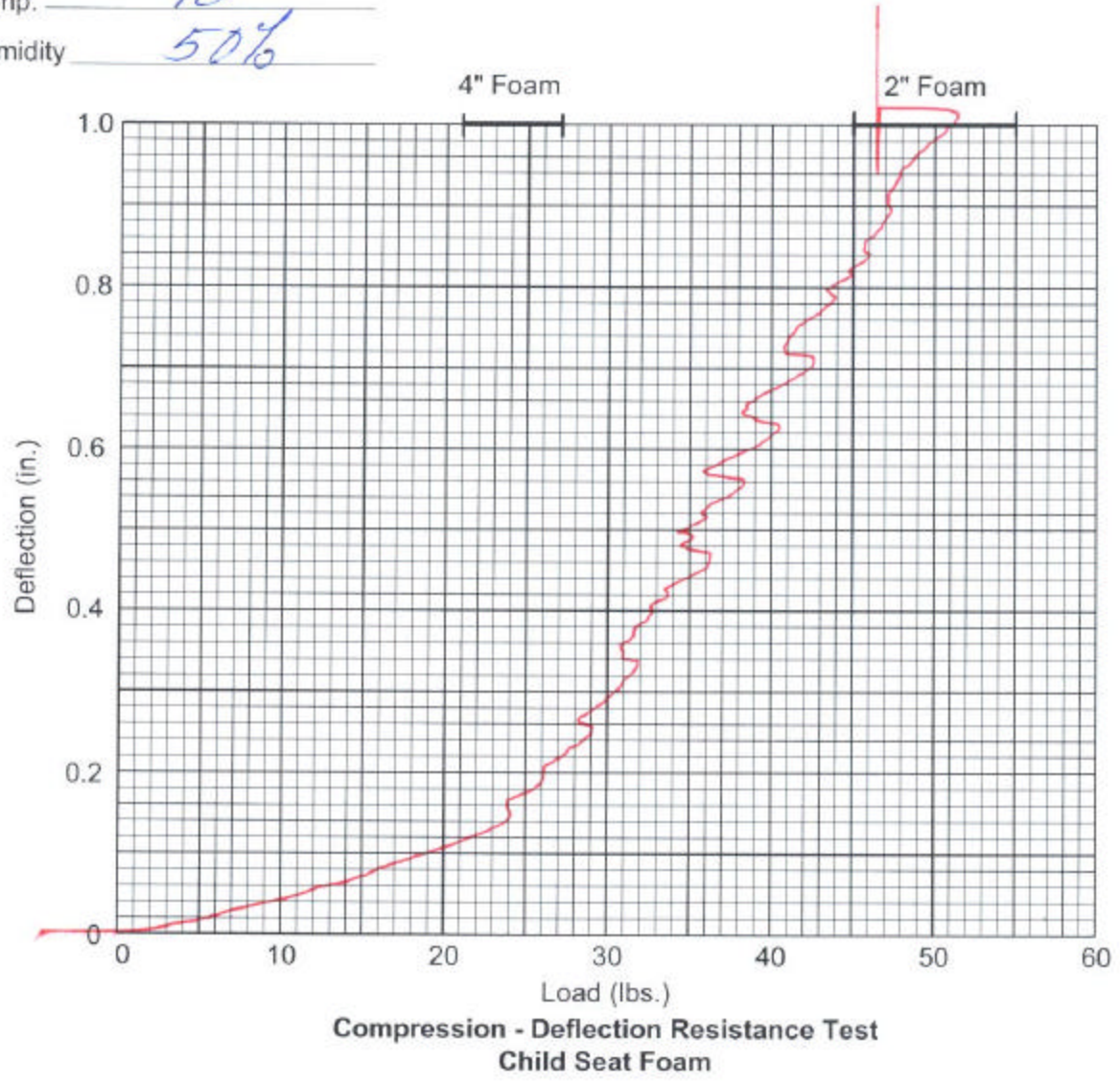

Date 3/25/02
Temp 70°
Humidity 50%
Foam No. 2" x 20" 2" x 24" H9

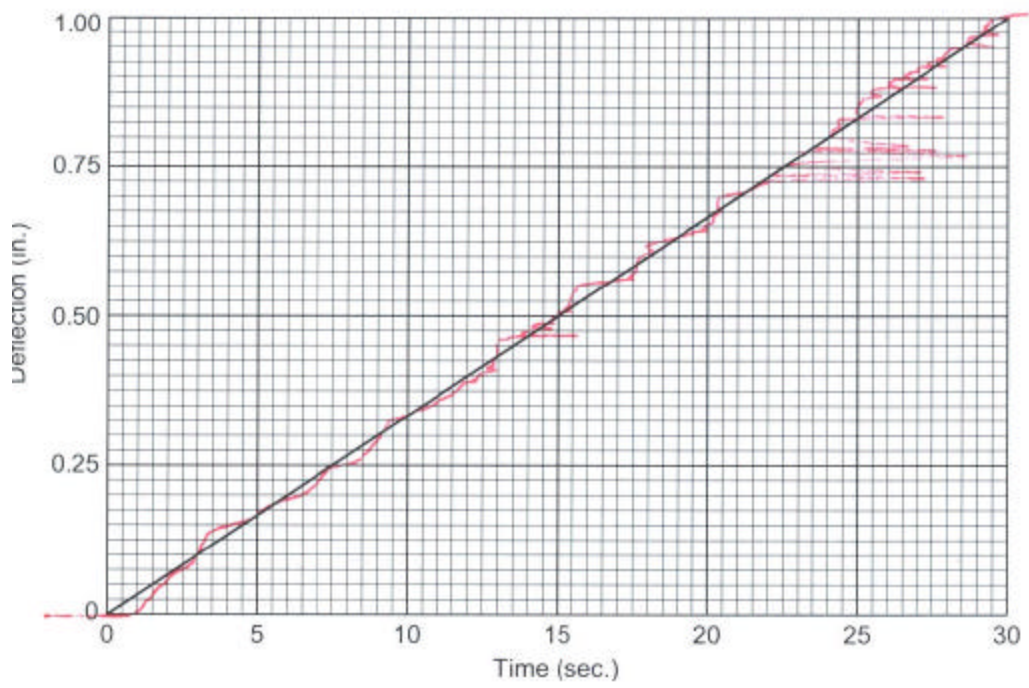

Compression - Deflection Resistance Test Child Seat Foam

SEAT FOAM USAGE LOG

Foam I.D. Number 2" x 20" 2" x 24" H9

Date	Peak Load	Pass/Fail
3/25/02	46.5 LBS	 PSS

Date 3/25/02
Performed By SD
Temp. 70°
Humidity 50%

Foam No. 4" x 20' H9

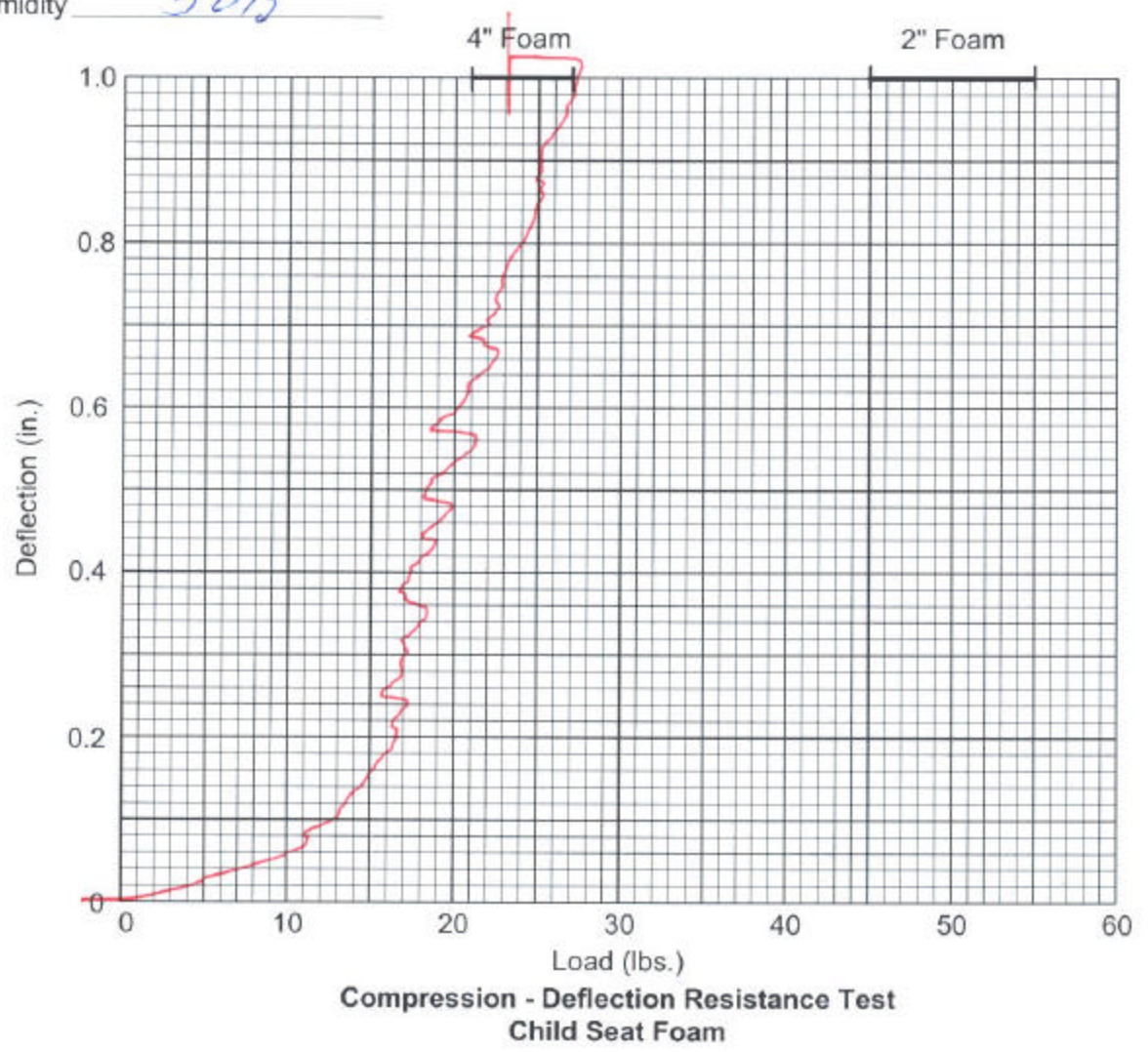

Date 3/25/02
Temp 70°
Humidity 50%
Foam No. A" X 20' H9

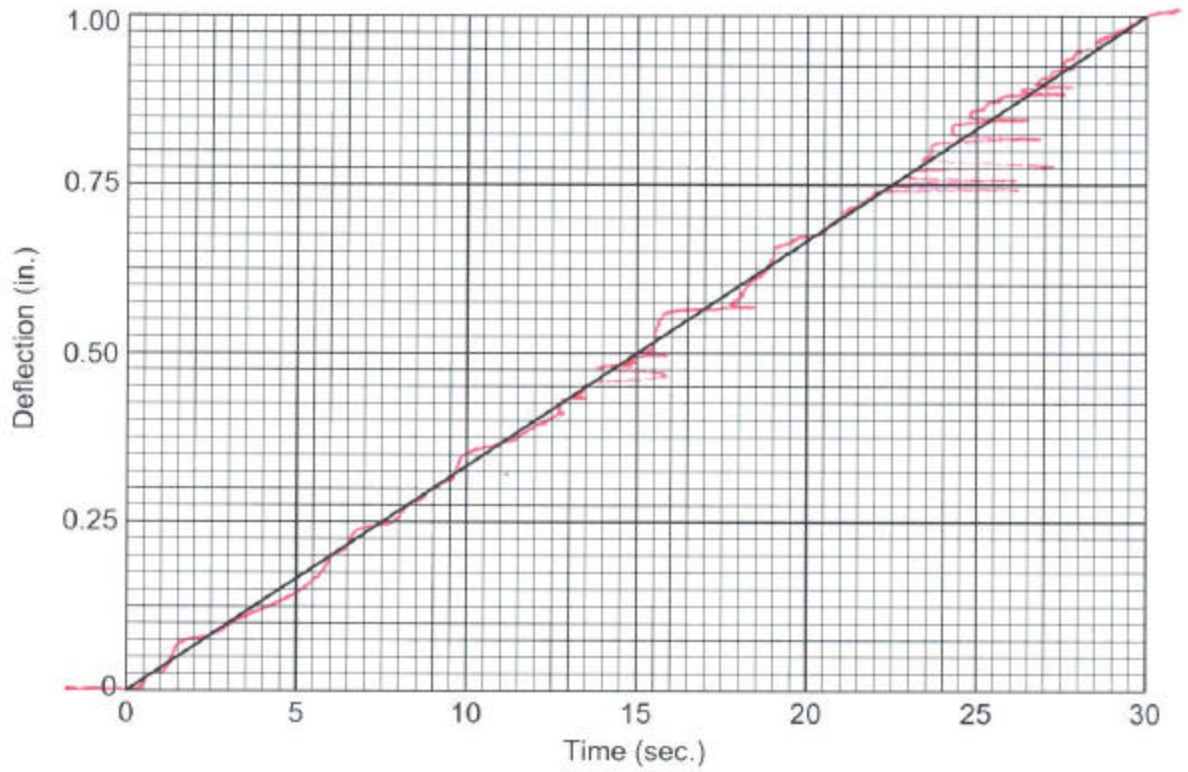

Compression - Deflection Resistance Test Child Seat Foam

T-201-001

SEAT FOAM USAGE LOG

Foam I.D. Number 4" x 20" H9

Date	Peak Load	Pass/Fail
3/25/02	23 LBS	Pass

Date 3/25/02
Performed By SD
Temp. 70°
Humidity 50%

Foam No. 9 x 24" H9

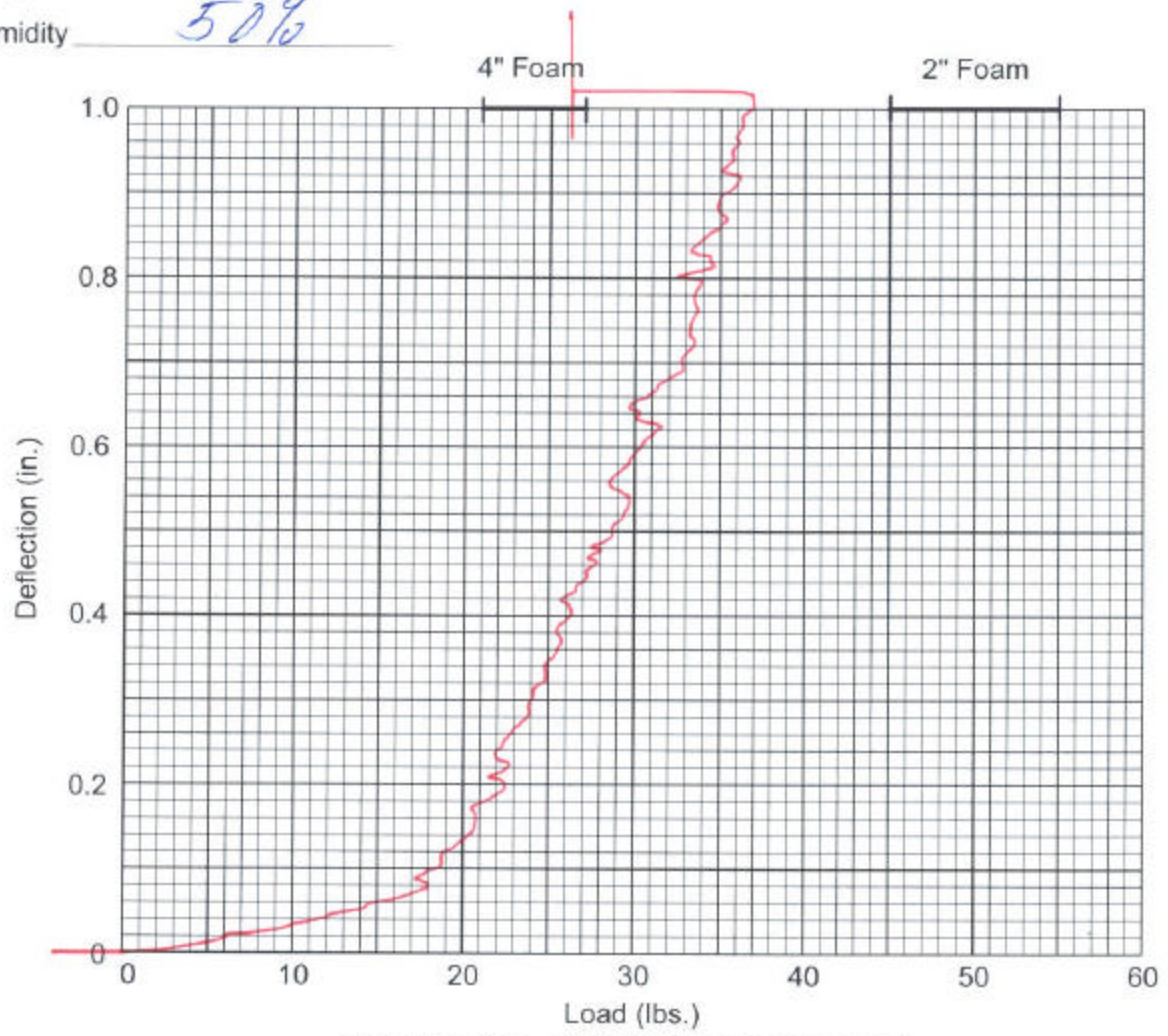

Compression - Deflection Resistance Test
Child Seat Foam

Date 3/25/02
Temp 70°
Humidity 50%
Foam No. 4" X 24" H9

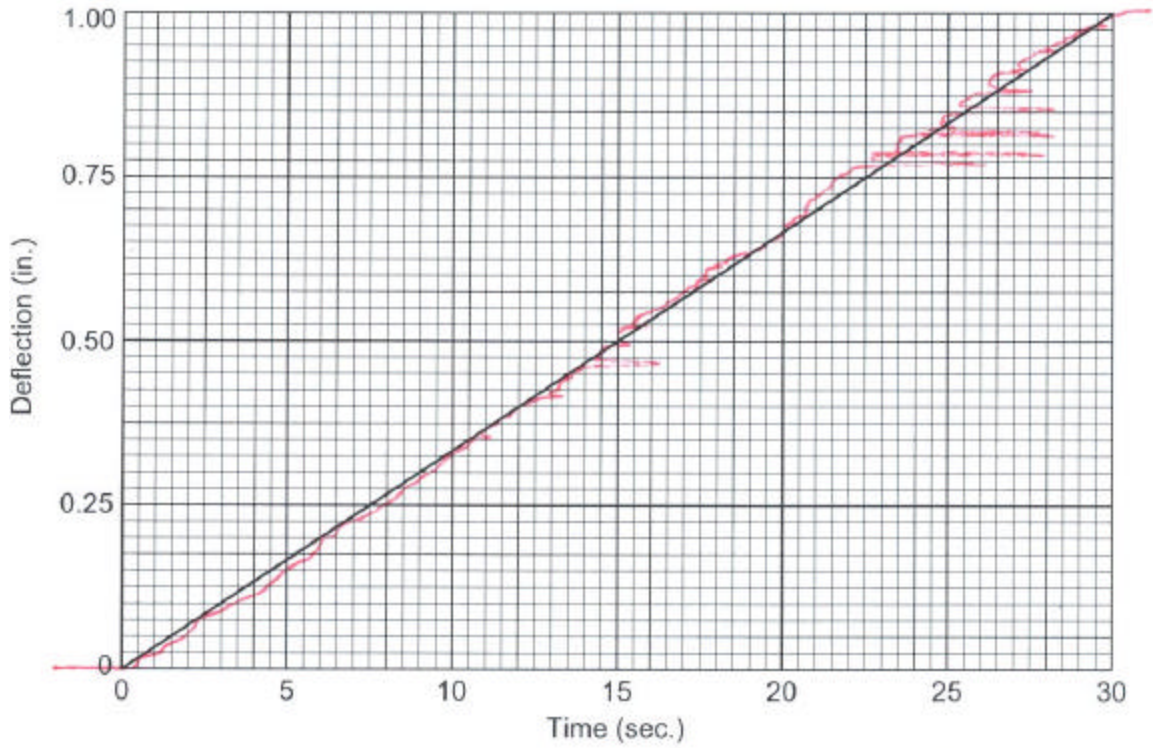

Compression - Deflection Resistance Test Child Seat Foam

SEAT FOAM USAGE LOG

Foam I.D. Number AX24H9

Date	Peak Load	Pass/Fail
3/25/02	26.25 LBS	Pass

SECTION 13

CHILD DUMMY CALIBRATION DATA TRACES AND TABLES

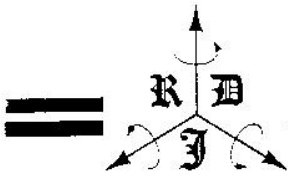

ROBERT A. DENTON, INC.

2967 Waterview Dr., Rochester Hills, MI 48309-4600

Tel (248) 852-5100 • Fax (248) 852-6060 • email: info@radenton.com • www.radenton.com

LOWER 01... 1-14-02

040

~~REPORT~~

Calibration Report Uni-Directional Calibration

Automated Load Cell Calibration System
Copyright (c) 1987-2000 Robert A. Denton, Inc.

Calibration No.	C2624017	Date	Jan 7, 2002	Due	Jan 7, 2003
Model No.	3303	Serial No.			210
Technician	J. Kovalchuk	Temp (C) / Hum. (%)		22.2 /	25.9
Customer	VRTC	Last Calibrated			Nov 28, 2000
Description	Child Neck	Customer Tag Number			N/A

Voltage Calibration

Bridge	Capacity	Zero Offset	Nonlinearity	Hysteresis	Output @ Capacity	% Change
FX	1000.0 lbf	0.0053 mV/V	0.03 % FS	0.04 % FS	2.3341 mV/V	0.10 % FS
FY	1000.0 lbf	-0.0028 mV/V	0.06 % FS	0.06 % FS	2.3262 mV/V	0.12 % FS
FZ	1500.0 lbf	0.0197 mV/V	0.01 % FS	0.07 % FS	-1.3346 mV/V	0.21 % FS
MX	1500.0 in-lbf	0.0108 mV/V	0.15 % FS	0.25 % FS	1.7200 mV/V	1.06 % FS
MY	1500.0 in-lbf	-0.0094 mV/V	0.07 % FS	0.17 % FS	1.7061 mV/V	0.27 % FS
MZ	1000.0 in-lbf	-0.0093 mV/V	0.08 % FS	0.57 % FS	1.7930 mV/V	-0.47 % FS

Shunt

Bridge	Shunt Value	Equivalent Load	Bridge Resistance (nom)
FX	60.0 K Ohms	630.9 lbf	350.0 Ohms
FY	60.0 K Ohms	634.7 lbf	350.0 Ohms
FZ	200.0 K Ohms	-986.5 lbf	700.0 Ohms
MX	120.0 K Ohms	645.3 in-lbf	350.0 Ohms
MY	120.0 K Ohms	651.2 in-lbf	350.0 Ohms
MZ	120.0 K Ohms	815.4 in-lbf	700.0 Ohms

NOTE: Positive shunt is between +Exc_+Sig Negative shunt is between -Exc_+Sig

Wire Color Codes

FX-MX	FY-MY	FZ-MZ
Brown + Exc.	Red Stripe + Exc.	Green + Exc.
Red + Sig.	Black + Sig.	Blue + Sig.
Orange - Exc.	White - Exc.	Violet - Exc.
Yellow - Sig.	Black Stripe - Sig.	Grey - Sig.

Reference Load Cell

Manufacturer	Model No.	Serial No.	Calibration Due Date
Interface	SSM-AF-2000	102751	Oct 4, 2002

Calibrated by

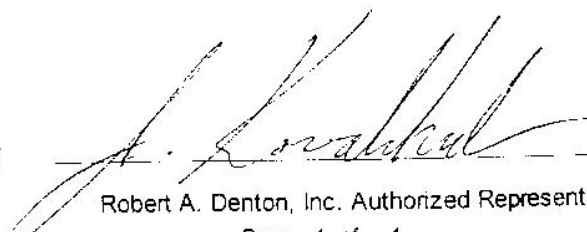

Robert A. Denton, Inc. Authorized Representative

GS

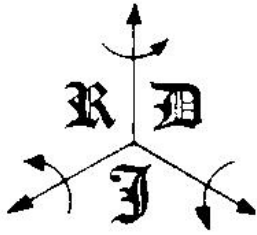

CALIBRATION REPORT

Uni-Directional Calibration Loading Sequence Summary

Automated Load Cell Calibration System
Copyright (c)1987-2000 Robert A. Denton, Inc.

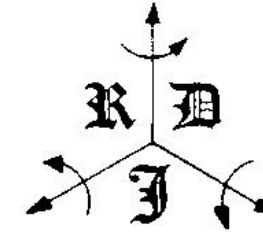

Calibration Number	C2624017	This Calibration	15:46:41	Jan 7, 2002
Model Number	3303	Calibration Due		Jan 7, 2003
Serial Number	210	Last Calibrated		Nov 28, 2000
Description	Child Neck	Temp (C) / Hum. (%)		22.2 / 25.9
Customer	VRTC	Customer Tag Number		N/A

Loading Sequence

Axis	FS Load EU	FS Output mV/V	Sensitivity mV/V/EU	Nonlinearity % FS	Hysteresis % FS	Moment Arm EU
FX	1000.0 lbf	2.3341	0.0023341	0.03	0.04	0.00
FY	1000.0 lbf	2.3262	0.0023262	0.06	0.06	0.00
FZ	1500.0 lbf	-1.3346	-0.0008897	0.01	0.07	0.00
MX	1500.0 in-lbf	1.7200	0.0011466	0.15	0.25	2.00
MY	1500.0 in-lbf	1.7061	0.0011374	0.07	0.17	2.00
MZ	1000.0 in-lbf	1.7930	0.0017930	0.08	0.57	2.00

Bridge Unbalance

FX Axis 0.0053 mV/V
 FY Axis -0.0028 mV/V
 FZ Axis 0.0197 mV/V
 MX Axis 0.0108 mV/V
 MY Axis -0.0094 mV/V
 MZ Axis -0.0093 mV/V

Linearization

Force (FX)	=	0.1	+	428.4	* Output (mV/V)
Force (FY)	=	0.2	+	429.9	* Output (mV/V)
Force (FZ)	=	0.0	+	-1124.0	* Output (mV/V)
Force (MX)	=	-1.0	+	872.1	* Output (mV/V)
Force (MY)	=	-0.4	+	879.1	* Output (mV/V)
Force (MZ)	=	0.2	+	557.9	* Output (mV/V)

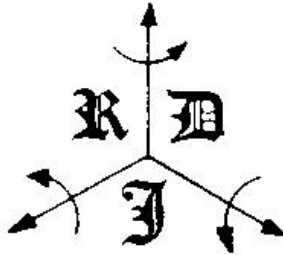

CALIBRATION REPORT

Uni-Directional Calibration Crosstalk Summary

Automated Load Cell Calibration System
Copyright (c)1987-2000 Robert A. Denton, Inc.

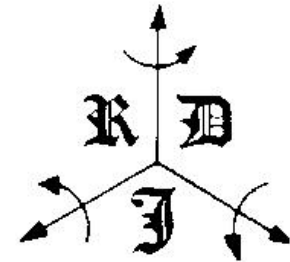

Calibration Number	C2624017	This Calibration	15:46:41	Jan 7, 2002
Model Number	3303	Calibration Due		Jan 7, 2003
Serial Number	210	Last Calibrated		Nov 28, 2000
Description	Child Neck	Temp (C) / Hum. (%)		22.2 / 25.9
Customer	VRTC	Customer Tag Number		N/A

Raw Crosstalk Data (mV/V)

<u>Bridge</u>		FX	FY	FZ	MX	MY	MZ
	<u>Applied Load</u>	1000.0	1000.0	1500.0	1500.0	1500.0	1000.0
		lbf	lbf	lbf	in-lbf	in-lbf	in-lbf
FX	1000.0 lbf	2.3341	-0.0036	-0.0073	0.0147	-0.0141	-0.0125
FY	1000.0 lbf	0.0006	2.3262	0.0094	0.0120	-0.0076	-0.0232
FZ	1500.0 lbf	-0.0022	0.0049	-1.3346	0.0226	0.0059	0.0002
MX	1500.0 in-lbf	0.0043	-0.0002	-0.6678	1.7200	-0.0073	-0.0084
MY	1500.0 in-lbf	0.0014	0.0073	-0.6669	0.0062	1.7061	0.0011
MZ	1000.0 in-lbf	1.1643	-0.0013	-0.0074	0.0021	-0.0078	1.7930

% FS Crosstalk *

<u>Bridge</u>		FX	FY	FZ	MX	MY	MZ
	<u>Applied Load</u>	1000.0	1000.0	1500.0	1500.0	1500.0	1000.0
		lbf	lbf	lbf	in-lbf	in-lbf	in-lbf
FX	1000.0 lbf	0.00%	-0.16%	0.54%	0.85%	-0.83%	-0.70%
FY	1000.0 lbf	0.03%	0.00%	-0.71%	0.70%	-0.45%	-1.29%
FZ	1500.0 lbf	-0.09%	0.21%	0.00%	1.31%	0.35%	0.01%
MX	1500.0 in-lbf	0.18%	-0.01%	0.04%	0.00%	-0.43%	-0.47%
MY	1500.0 in-lbf	0.06%	0.31%	0.03%	0.36%	0.00%	0.06%
MZ	1000.0 in-lbf	0.12%	-0.05%	0.55%	0.12%	-0.46%	0.00%

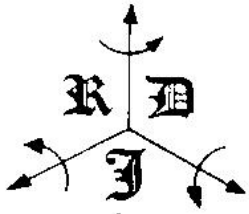

Measurement Report

Load Cell Bridge Impedance

Measurement Summary

Automated Load Cell Impedance Measurement System
Copyright © 1998 Robert A. Denton, Inc.

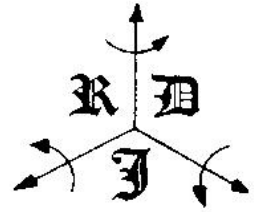

Calibration Number	C2624017	This Calibration	15:46:41	Jan 07, 2002
Model Number	3303	Calibration Due		Jan 07, 2003
Serial Number	210	Last Calibrated		Nov 28, 2000
Description	Child Neck	Temp (°C) / Hum (%)		22.6 / 20.8
Customer	VRTC	Customer Tag		N/A

Bridge Impedance Measurements *

<u>Axis</u>	<u>Input Impedance</u>	<u>Output Impedance</u>	
Channel 1 FX	355.70	355.63	Ohms
Channel 2 FY	355.72	355.52	Ohms
Channel 3 FZ	703.28	703.33	Ohms
Channel 4 MX	356.16	355.92	Ohms
Channel 5 MY	356.21	356.14	Ohms
Channel 6 MZ	705.00	704.94	Ohms

Bridge High Short Measurement **

<u>Axis</u>	<u>Bridge to Transducer Body</u>	
Channel 1 FX	>= 5.00	G Ohms (10 ⁹ Ohms)
Channel 2 FY	>= 5.00	G Ohms (10 ⁹ Ohms)
Channel 3 FZ	>= 5.00	G Ohms (10 ⁹ Ohms)
Channel 4 MX	>= 5.00	G Ohms (10 ⁹ Ohms)
Channel 5 MY	>= 5.00	G Ohms (10 ⁹ Ohms)
Channel 6 MZ	>= 5.00	G Ohms (10 ⁹ Ohms)

Measurement Equipment

Serial Number

Measurement Accuracy

Keithley Model 7001 Switch System	0698562	N/A
Keithley Model 2000 Multimeter	0643818	±0.045 Ohms/Year @ 23°C ±5°C
Keithley Model 6517A Electrometer/High Resistance Meter	0695446	±(11.25 x 10 ⁶) + 10 ⁵ Ohms/Year @ 18°C-28°C

* NOTE: Input impedance measurements taken between ±excitation, output impedance measurements taken between ±signal

** NOTE: High short measurements are taken between +excitation and the transducer body. Measurements are made at +50.0 VDC.

Robert A. Denton, Inc. certifies that all equipment used to perform measurements expressed in this report are traceable to the National Institute of Standards and Technology and are in accordance with ANSI/NCSL Z540-1-1994 (MIL-STD 45662A).

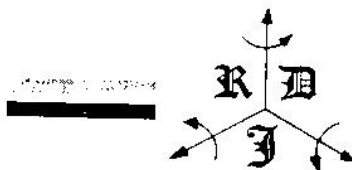

ROBERT A. DENTON, INC.

2967 Waterview Dr., Rochester Hills, MI 48309-4600

Tel: (248) 852-5100 Fax: (248) 852-6060 email: info@radenton.com www.radenton.com

Calibration Report Summary

Page 1 of 1

Calibration No. C2624017
 Customer Name Vehicle Research & Test Center/ USDOT
 Address 10820 St. Rte. 347 Logan County Bldg 60
East Liberty, OH 43319

Report Issue Date* 1/8/02

* Note: "Report Issue Date" indicates confirmation of calibration data and should be used to increment calibration interval

Manufacturer Denton
 Serial Number 210

Model Number 3303

As Received Condition

In Tolerance
 Out of Tolerance
 Operational
 Not Operational
 Damaged
 N/A

As Shipped Condition

In Tolerance
 Out of Tolerance
 Operational
 Not Operational
 Damaged
 N/A

Action Taken

Repair
 Full Calibration
 Special Calibration
 Returned As Is

Received Notes

FZ offset out of spec. (0.175 mV/V)

As Shipped Notes

Action Notes

Calibration Standards Used³

Standard ID Report No Due Date

2K03 SN102751:1002179034 10/04/02

Laboratory Scope:²

Robert A. Denton, Inc. offers A2LA commercial laboratory calibration services to the following criteria: (Mechanical)



Parameter/Equipment	Range	Best Uncertainty ¹ (±)	Comments
Force Dead Weights Load Cells	4 oz – 400 lbf	0.067%	Class F Weights
	50 – 500 lbf	0.065%	Axial Load
	100 – 1000 lbf	0.087%	
	200 – 2000 lbf	0.076%	
	500 – 5000 lbf	0.082%	
	1000 – 10000 lbf	0.080%	
	2500 – 25000 lbf	0.082%	
	5000 – 50000 lbf	0.084%	
8000 – 80000 lbf	0.110%		
Moment Load Cells	50 – 500 in – lbf	0.15%	Moment Load
	100 – 1000 in – lbf	0.11%	
	200 – 2000 in – lbf	0.10%	
	500 – 5000 in – lbf	0.16%	

21F014

Revision 2/12/01

¹ The uncertainties stated are expressed at approximately 95% confidence level using a coverage factor of k = 2.

² Robert A. Denton's calibration program is accredited to ISO/IEC Guide 25:1990 & ANSI/NCSL Z-540-1-1994 - Certificate # 1644.01, Valid to: December 31, 2002

³ Standards used in the calibration of this transducer are traceable to National Institute of Standards and Technology (NIST) values

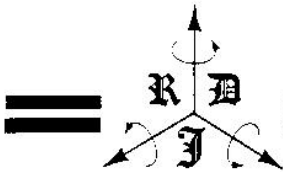

ROBERT A. DENTON, INC.
2967 Waterview Dr., Rochester Hills, MI 48309-4600

Tel (248) 852-5100 • Fax (248) 852-6060 • email: info@radenton.com • www.radenton.com

040 UPPER 600 1-14-02
Lower

Calibration Report
Uni-Directional Calibration

Automated Load Cell Calibration System
Copyright (c) 1987-2000 Robert A. Denton, Inc.

Calibration No.	C2624016	Date	Jan 7, 2002	Due	Jan 7, 2003
Model No.	3303	Serial No.	86		
Technician	J. Kovalchuk	Temp (C) / Hum. (%)	22.2 / 26.1		
Customer	VRTC	Last Calibrated	Nov 25, 1998		
Description	Child Neck	Customer Tag Number	N/A		

Voltage Calibration

Bridge	Capacity	Zero Offset	Nonlinearity	Hysteresis	Output @ Capacity	% Change
FX	1000.0 lbf	0.0118 mV/V	0.02 % FS	0.04 % FS	2.3333 mV/V	-0.16 % FS
FY	1000.0 lbf	-0.0014 mV/V	0.05 % FS	0.05 % FS	2.3230 mV/V	-0.07 % FS
FZ	1500.0 lbf	-0.0125 mV/V	0.02 % FS	0.05 % FS	-1.3368 mV/V	0.06 % FS
MX	1500.0 in-lbf	0.0108 mV/V	0.05 % FS	0.32 % FS	1.7256 mV/V	0.20 % FS
MY	1500.0 in-lbf	-0.0189 mV/V	0.08 % FS	0.20 % FS	1.7150 mV/V	-1.45 % FS
MZ	1000.0 in-lbf	-0.0046 mV/V	0.26 % FS	0.60 % FS	1.8205 mV/V	0.04 % FS

Shunt

Bridge	Shunt Value	Equivalent Load	Bridge Resistance (nom)
FX	60.0 K Ohms	633.0 lbf	350.0 Ohms
FY	60.0 K Ohms	636.7 lbf	350.0 Ohms
FZ	200.0 K Ohms	-983.7 lbf	700.0 Ohms
MX	120.0 K Ohms	642.8 in-lbf	350.0 Ohms
MY	120.0 K Ohms	647.4 in-lbf	350.0 Ohms
MZ	120.0 K Ohms	803.7 in-lbf	700.0 Ohms

NOTE: Positive shunt is between +Exc_+Sig Negative shunt is between -Exc_+Sig

Wire Color Codes

FX-MX		FY-MY		FZ-MZ	
Brown	+ Exc.	Red Stripe	+ Exc.	Green	+ Exc.
Red	+ Sig.	Black	+ Sig.	Blue	+ Sig.
Orange	- Exc.	White	- Exc.	Violet	- Exc.
Yellow	- Sig.	Black Stripe	- Sig.	Grey	- Sig.

Reference Load Cell

<u>Manufacturer</u>	<u>Model No.</u>	<u>Serial No.</u>	<u>Calibration Due Date</u>
Interface	SSM-AF-2000	102751	Oct 4, 2002

Calibrated by

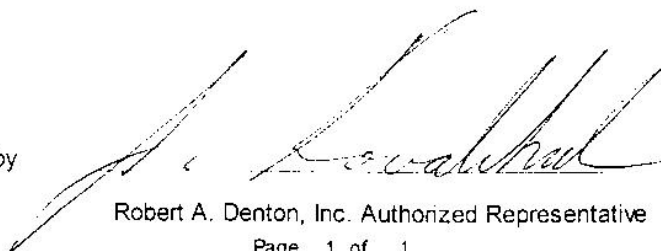

Robert A. Denton, Inc. Authorized Representative

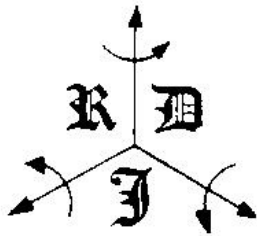

CALIBRATION REPORT

Uni-Directional Calibration Loading Sequence Summary

Automated Load Cell Calibration System
Copyright (c)1987-2000 Robert A. Denton, Inc.

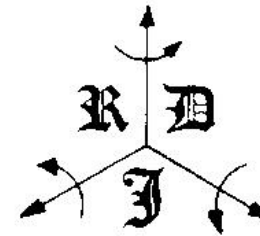

Calibration Number	C2624016	This Calibration	15:21:49	Jan 7, 2002
Model Number	3303	Calibration Due		Jan 7, 2003
Serial Number	86	Last Calibrated		Nov 25, 1998
Description	Child Neck	Temp (C) / Hum. (%)		22.2 / 26.1
Customer	VRTC	Customer Tag Number		N/A

Loading Sequence

Axis	FS Load EU	FS Output mV/V	Sensitivity mV/V/EU	Nonlinearity % FS	Hysteresis % FS	Moment Arm EU
FX	1000.0 lbf	2.3333	0.0023333	0.02	0.04	0.00
FY	1000.0 lbf	2.3230	0.0023230	0.05	0.05	0.00
FZ	1500.0 lbf	-1.3368	-0.0008912	0.02	0.05	0.00
MX	1500.0 in-lbf	1.7256	0.0011504	0.05	0.32	2.00
MY	1500.0 in-lbf	1.7150	0.0011433	0.08	0.20	2.00
MZ	1000.0 in-lbf	1.8205	0.0018205	0.26	0.60	2.00

Bridge Unbalance

FX Axis 0.0118 mV/V
 FY Axis -0.0014 mV/V
 FZ Axis -0.0125 mV/V
 MX Axis 0.0108 mV/V
 MY Axis -0.0169 mV/V
 MZ Axis -0.0046 mV/V

Linearization

Force (FX)	=	0.1	+	428.6	* Output (mV/V)
Force (FY)	=	0.2	+	430.5	* Output (mV/V)
Force (FZ)	=	-0.1	+	-1122.0	* Output (mV/V)
Force (MX)	=	0.3	+	869.0	* Output (mV/V)
Force (MY)	=	-0.4	+	874.5	* Output (mV/V)
Force (MZ)	=	0.9	+	549.6	* Output (mV/V)

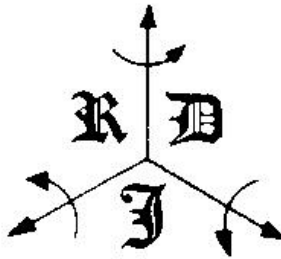

CALIBRATION REPORT

Uni-Directional Calibration Crosstalk Summary

Automated Load Cell Calibration System
Copyright (c)1987-2000 Robert A. Denton, Inc.

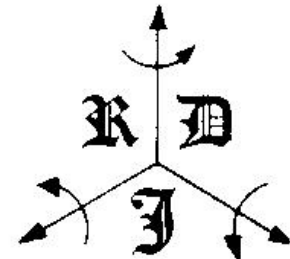

Calibration Number	C2624016	This Calibration	15:21:49	Jan 7, 2002
Model Number	3303	Calibration Due		Jan 7, 2003
Serial Number	86	Last Calibrated		Nov 25, 1998
Description	Child Neck	Temp (C) / Hum. (%)		22.2 / 26.1
Customer	VRTC	Customer Tag Number		N/A

Raw Crosstalk Data (mV/V)

<u>Bridge</u>		FX	FY	FZ	MX	MY	MZ
	<u>Applied Load</u>	1000.0	1000.0	1500.0	1500.0	1500.0	1000.0
		lbf	lbf	lbf	in-lbf	in-lbf	in-lbf
FX	1000.0 lbf	2.3333	-0.0066	0.0196	-0.0081	-0.0324	-0.0046
FY	1000.0 lbf	0.0103	2.3230	-0.0105	0.0421	-0.0277	-0.0221
FZ	1500.0 lbf	0.0046	0.0002	-1.3368	0.0285	0.0107	0.0044
MX	1500.0 in-lbf	-0.0058	-0.0100	-0.6780	1.7256	-0.0022	0.0047
MY	1500.0 in-lbf	0.0104	-0.0117	-0.6539	0.0088	1.7150	0.0063
MZ	1000.0 in-lbf	1.1691	0.0013	0.0214	-0.0150	-0.0216	1.8205

% FS Crosstalk *

<u>Bridge</u>		FX	FY	FZ	MX	MY	MZ
	<u>Applied Load</u>	1000.0	1000.0	1500.0	1500.0	1500.0	1000.0
		lbf	lbf	lbf	in-lbf	in-lbf	in-lbf
FX	1000.0 lbf	0.00%	-0.29%	-1.46%	-0.47%	-1.89%	-0.25%
FY	1000.0 lbf	0.44%	0.00%	0.79%	2.44%	-1.62%	-1.21%
FZ	1500.0 lbf	0.20%	0.01%	0.00%	1.65%	0.62%	0.24%
MX	1500.0 in-lbf	-0.25%	-0.43%	0.72%	0.00%	-0.13%	0.26%
MY	1500.0 in-lbf	0.45%	-0.50%	1.09%	0.51%	0.00%	0.35%
MZ	1000.0 in-lbf	0.10%	0.05%	-1.60%	-0.87%	-1.26%	0.00%

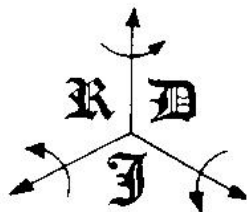

Measurement Report

Load Cell Bridge Impedance

Measurement Summary

Automated Load Cell Impedance Measurement System
Copyright © 1998 Robert A. Denton, Inc.

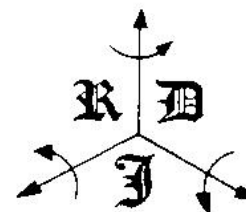

Calibration Number	C2624016	This Calibration	15:21:49	Jan 07, 2002
Model Number	3303	Calibration Due		Jan 07, 2003
Serial Number	86	Last Calibrated		Nov 25, 1998
Description	Child Neck	Temp (°C) / Hum (%)		22.4 / 18.3
Customer	VRTC	Customer Tag		N/A

Bridge Impedance Measurements*

<u>Axis</u>	<u>Input Impedance</u>	<u>Output Impedance</u>	
Channel 1 FX	356.16	356.11	Ohms
Channel 2 FY	356.26	356.08	Ohms
Channel 3 FZ	702.76	702.80	Ohms
Channel 4 MX	356.36	356.14	Ohms
Channel 5 MY	356.34	356.27	Ohms
Channel 6 MZ	705.25	705.22	Ohms

Bridge High Short Measurement**

<u>Axis</u>	<u>Bridge to Transducer Body</u>	
Channel 1 FX	>= 5.00	G Ohms (10 ⁹ Ohms)
Channel 2 FY	>= 5.00	G Ohms (10 ⁹ Ohms)
Channel 3 FZ	>= 5.00	G Ohms (10 ⁹ Ohms)
Channel 4 MX	>= 5.00	G Ohms (10 ⁹ Ohms)
Channel 5 MY	>= 5.00	G Ohms (10 ⁹ Ohms)
Channel 6 MZ	>= 5.00	G Ohms (10 ⁹ Ohms)

Measurement Equipment

Serial Number

Measurement Accuracy

Keithley Model 7001 Switch System	0698562	N/A
Keithley Model 2000 Multimeter	0643818	±0.045 Ohms/Year @ 23°C ±5°C
Keithley Model 6517A Electrometer/High Resistance Meter	0695446	±(11.25 × 10 ⁶) + 10 ⁵ Ohms/Year @ 18°C-28°C

* NOTE: Input impedance measurements taken between ±excitation, output impedance measurements taken between ±signal

NOTE: High short measurements are taken between +excitation and the transducer body. Measurements are made at +50.0 VDC.

** Robert A. Denton, Inc. certifies that all equipment used to perform measurements expressed in this report are traceable to the National Institute of Standards and Technology and are in accordance with ANSI/NCSL Z540-1-1994 (MIL-STD 45662A).

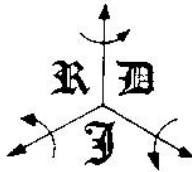

ROBERT A. DENTON, INC.

2967 Waterview Dr., Rochester Hills, MI 48309-4600

Tel (248) 852-5100 · Fax (248) 852-6060 · email: info@radenton.com www.radenton.com

Calibration Report Summary

Page 1 of 1

Calibration No. C2624016
 Customer Name Vehicle Research & Test Center/ USDOT
 Address 10820 St. Rte. 347 Logan County Bldg 60
East Liberty, OH 43319

Report Issue
 Date* 1/8/02

* Note: "Report Issue Date" indicates confirmation of calibration data and should be used to increment calibration interval

Manufacturer Denton
 Serial Number 86

Model Number 3303

As Received Condition

In Tolerance
 Out of Tolerance
 Operational
 Not Operational
 Damaged
 N/A

As Shipped Condition

In Tolerance
 Out of Tolerance
 Operational
 Not Operational
 Damaged
 N/A

Action Taken

Repair
 Full Calibration
 Special Calibration
 Returned As Is

Received Notes

FZ offset out of spec. (0.124 mV/V)

As Shipped Notes

Action Notes

Calibration Standards Used³

Standard ID Report No Due Date

2K03 SN102751:1002179034 10/04/02

Laboratory Scope:²

Robert A. Denton, Inc. offers A2LA commercial laboratory calibration services to the following criteria: (Mechanical)



Parameter:Equipment	Range	Best Uncertainty ¹ (±)	Comments
Force Dead Weights Load Cells	4 oz – 400 lbf	0.067%	Class F Weights
	50 – 500 lbf	0.065%	
	100 – 1000 lbf	0.087%	Axial Load
	200 – 2000 lbf	0.076%	
	500 – 5000 lbf	0.082%	
	1000 – 10000 lbf	0.080%	
	2500 – 25000 lbf	0.082%	
	5000 – 50000 lbf	0.084%	
8000 – 80000 lbf	0.110%		
Moment Load Cells	50 – 500 in – lbf	0.15%	Moment Load
	100 – 1000 in – lbf	0.11%	
	200 – 2000 in – lbf	0.10%	
	500 – 5000 in – lbf	0.16%	

¹ The uncertainties stated are expressed at approximately 95% confidence level using a coverage factor of k = 2.

² Robert A. Denton's calibration program is accredited to ISO/IEC Guide 25 1990 & ANSI/NCSL Z-540-1-1994 - Certificate # 1644.01. Valid to December 31, 2002

³ Standards used in the calibration of this transducer are traceable to National Institute of Standards and Technology (NIST) values

*****CALIBRATION CERTIFICATE*****

Vehicle Research & Test Center - PO Box 37 - E. Liberty, Ohio 43319

	Type	Manufacturer	Model	Serial No.
Transducer:	Chest pot	Servo	N/A	cst040
Cal. Equip:	Power Supply DMM	Elect. Development Kiethley	Cce-10d 197a	4876 us-894d0

Label	Pin	Color	Excitation	
+ Excit.	(3)	RED	10 Volts	INPUT RESISTANCE: _____ ohms
- Excit.	(7)	BLACK		
+ Signal	(2)	GREEN		SIGNAL RESISTANCE: _____ ohms
- Signal	(8)	WHITE		
Shield	(5)			COMPUTED OFFSET: 1.778195 [Volts]

CAL. ROOM TEMP: 70 Deg F MAX NON-LINEARITY: _____ %

CAL ROOM HUMIDITY: _____ % FULL SCALE: 40 mm

CAL. ROOM BAROMETER: _____ inches SENSITIVITY: -2.43529 mV/Volt/mm

TECHNICIAN: _____ Date: 1/4/2002
Dustin Walborn

ENGINEER UNITS	Y-axis READING [Volts]	NON-LINEARITY [%]	%FULL SCALE ERROR	
mm				
0	1.788	ERR	1.01%	Regression Output: 1.778195 0.005857 0.99973 9 7 -0.02435 0.000151
5	1.6569	0.41%	0.05% Constant	
10	1.5299	-1.93%	-0.49% Std Err of Y Est	
15	1.40818	-1.27%	-0.48% R Squared	
20	1.2871	-0.80%	-0.41% No. of Observations	
25	1.1667	-0.41%	-0.27% Degrees of Freedom	
30	1.044	-0.47%	-0.37%	
35	0.9277	0.24%	0.19% X Coefficient(s)	
40	0.81175	0.81%	0.79% Std Err of Coef.	

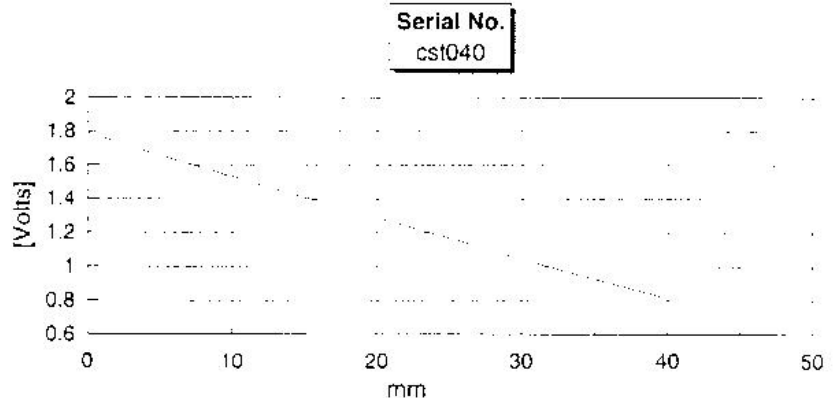

Servo
N/A

040 HILL 340
lead X Fwd

Calibration Certificate

Customer: VRTC
19950311-0130

Document number: 5891

Description: VRTC - Accelerometer
Manufacturer: ENDEVCO
Model Number: 7264-2KM5T
Serial Number: AC9F9

Input Resistance (ohms): 2825.5
ZMO (mV): -32.34
Resonance Frequency (Hz): 20180

0.2956 mV/g @ 100 Hz, 10g pk

Last Sens: 2.945E-1, Change: 0.38

Next cal date: 12/27/2002

Notes:

Excitation: 10.0 V

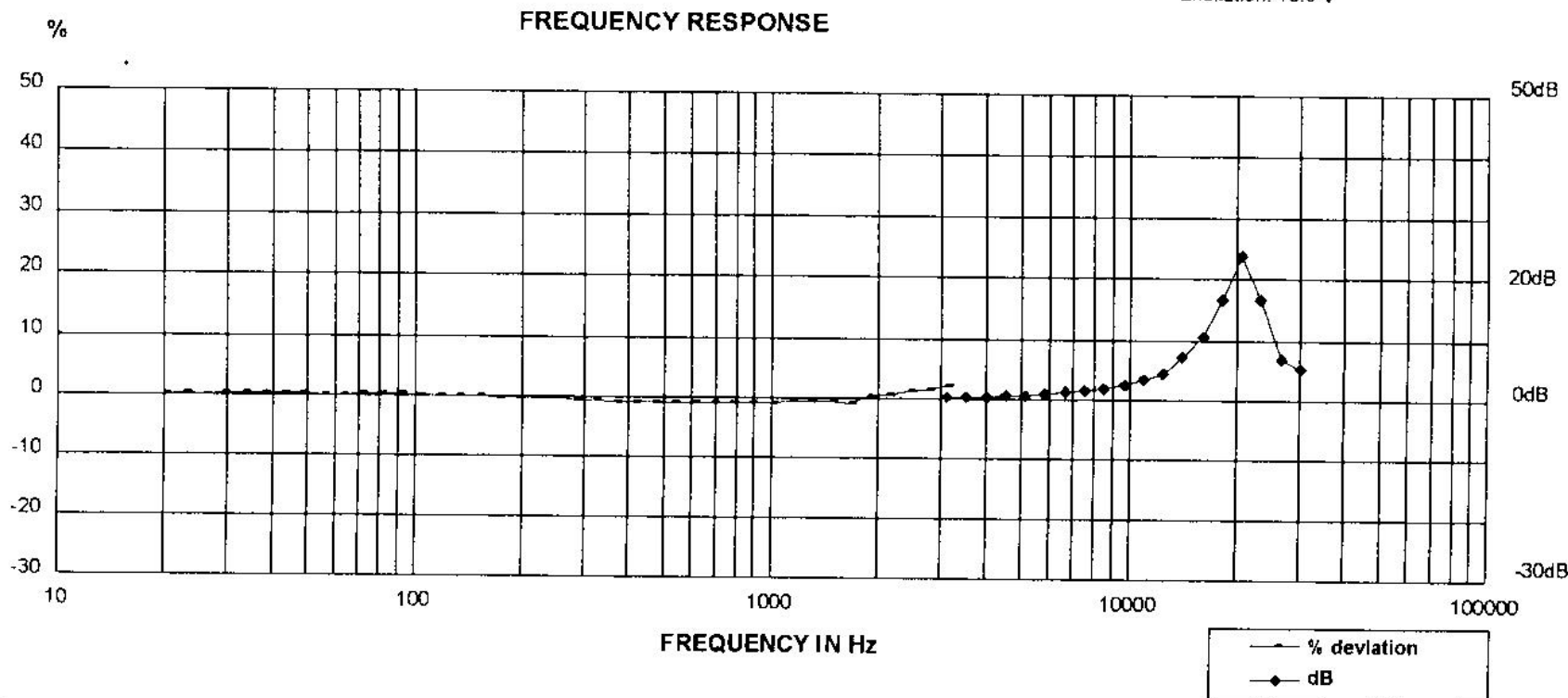

Endevco, a division of Meggitt, located at 30700 Rancho Viejo Road, San Juan Capistrano, CA, certifies that the above instrument was tested using comparison calibrations per ANSI S2.2 using Endevco IM68357. This calibration is traceable to the National Institute of Standards and Technology and is in accordance with ANSI/NCSS 2540-1-1994 (MIL-STD 45662A).

Uncertainty estimate (95% confidence, k=2)

Console serial number: AC27
NIST traceability #: 822/262802-00
Equipment used: 2901
Test definition: FINAL

+/- 1.1 %	100.0 Hz Sensitivity
+/- 5.0 %	10.0 to 20.0 Hz
+/- 1.5 %	20.0 to 2000.0 Hz
+/- 2.5 %	2000.0 to 10000.0 Hz
+/- 4.0 %	10000.0 to 20000.0 Hz

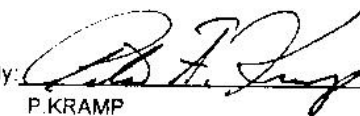
By: 
P. KRAMP

Date: 12/27/2001

Endevco
Transportation Research Center

040 HIII 340
Head Y-Left

Calibration Certificate

Customer: VRTC
19950311-0130

Document number: 5895

Description: VRTC - Accelerometer
Manufacturer: ENDEVCO
Model Number: 7264-2KM5T
Serial Number: AAMD5

Input Resistance (ohms): 2505.2
ZMO (mV): -27.92
Resonance Frequency (Hz): 18651

0.2577 mV/g @ 100 Hz, 10g pk

Last Sens: 2.649E-1, Change: -2.7

Next cal date: 12/27/2002

Notes:

Excitation: 10.0 V

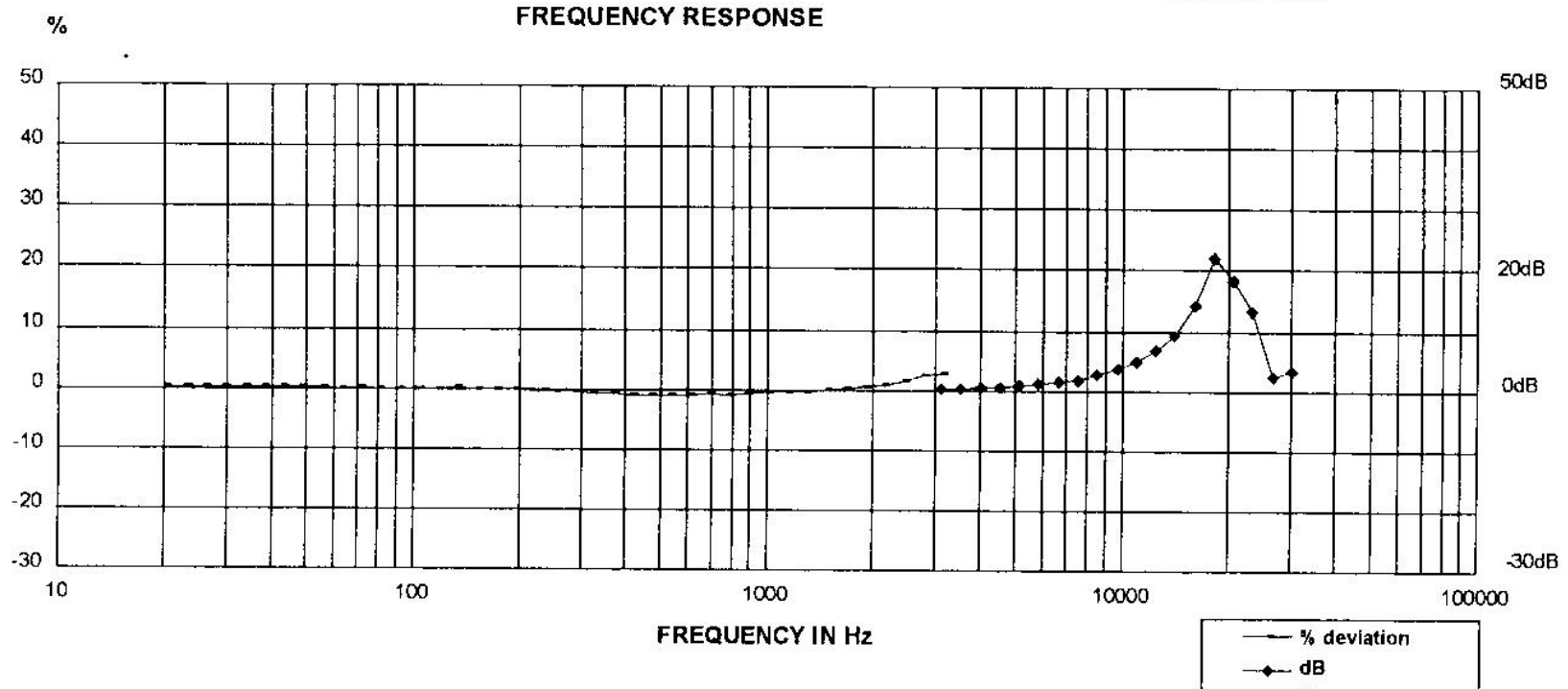

Endevco, a division of Meggitt, located at 30700 Rancho Viejo Road, San Juan Capistrano, CA, certifies that the above instrument was tested using comparison calibrations per ANSI S2.2 using Endevco IM68357. This calibration is traceable to the National Institute of Standards and Technology and is in accordance with ANSI/NCSL Z540-1-1994 (MIL-STD 45662A).

Uncertainty estimate (95% confidence, k=2)

Inssole serial number:	AC27	+/- 1.1 %	100.0 Hz Sensitivity
NIST traceability #:	822/262802-00	+/- 5.0 %	10.0 to 20.0 Hz
Equipment used:	2901	+/- 1.5 %	20.0 to 2000.0 Hz
Test definition:	FINAL	+/- 2.5 %	2000.0 to 10000.0 Hz
		+/- 4.0 %	10000.0 to 20000.0 Hz

By: *[Signature]*
P. KRAMP
Date: 12/27/2001

Endevco
Transportation Research Center

2 Hill 340
Head Z - nP

Calibration Certificate

Customer: VRTC
19950311-0130

Document number: 5901

Description: VRTC - Accelerometer
Manufacturer: ENDEVCO
Model Number: 7264-2000LC
Serial Number: AAKC3

Input Resistance (ohms): 2541.6

ZMO (mV): -0.939

Resonance Frequency (Hz): 23141

0.2796 mV/g @ 100 Hz, 10g pk

Last Sens: 2.793E-1, Change: 0.11

Next cal date: 12/27/2002

Notes:

Excitation: 10.0 V

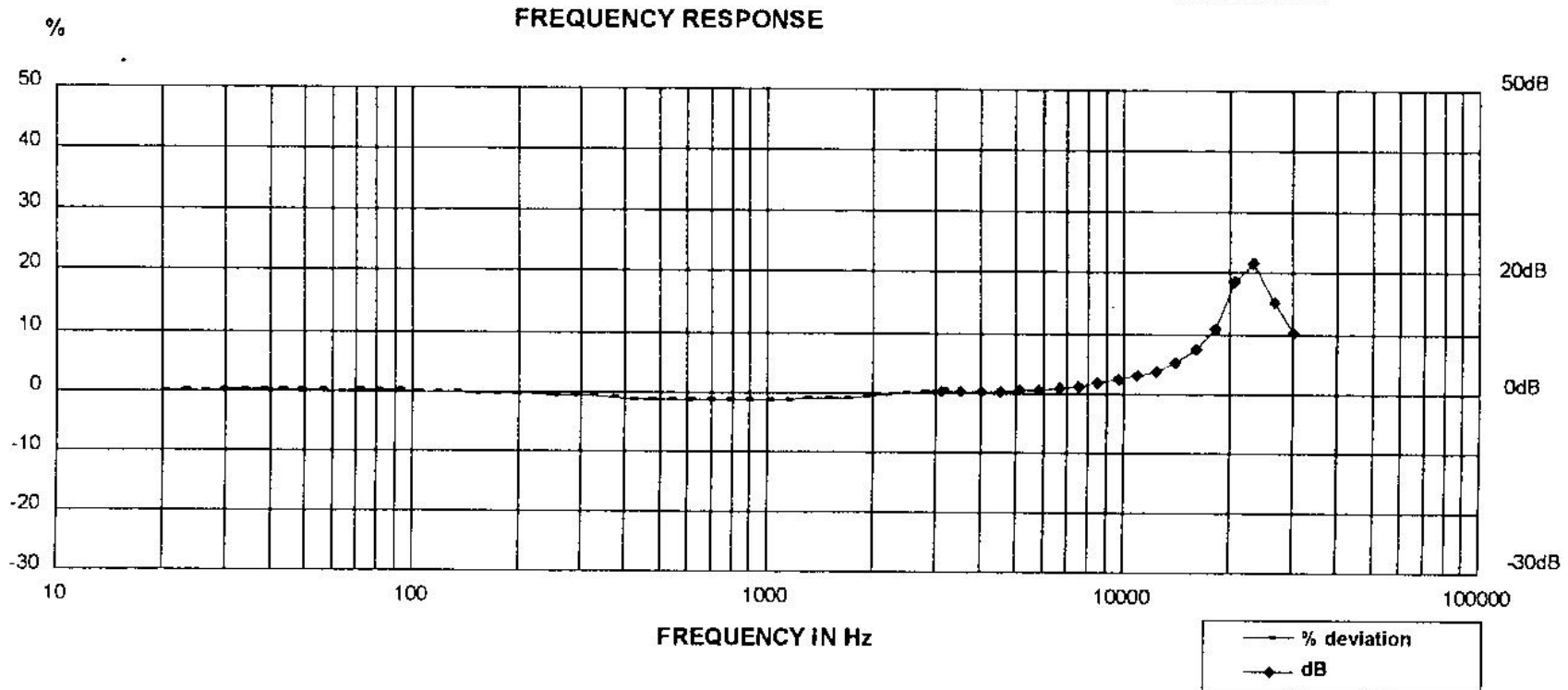

Endevco, a division of Meggitt, located at 30700 Rancho Viejo Road, San Juan Capistrano, CA, certifies that the above instrument was tested using comparison calibrations per ANSI S2.2 using Endevco IM68357. This calibration is traceable to the National Institute of Standards and Technology and is in accordance with ANSI/NCSL Z540-1-1994 (MIL-STD 45662A).

console serial number: AC27	+/- 1.1 %	100.0 Hz Sensitivity
NIST traceability #: 822/262802-00	+/- 5.0 %	10.0 to 20.0 Hz
Equipment used: 2901	+/- 1.5 %	20.0 to 2000.0 Hz
Test definition: FINAL	+/- 2.5 %	2000.0 to 10000.0 Hz
	+/- 4.0 %	10000.0 to 20000.0 Hz

By: *P. Kramp*
P. KRAMP

Date: 12/27/2001

Endevco
Transportation Research Center

040 H III 340

Head Red Z UP

Calibration Certificate

Customer: VRTC
19950311-0130

Document number: 5885

Description: VRTC - Accelerometer
Manufacturer: ENDEVCO
Model Number: 7264-2KM5T
Serial Number: J20014

Input Resistance (ohms): 2746.4
ZMO (mV): 6.1260
Resonance Frequency (Hz): 23221

0.2339 mV/g @ 100 Hz, 10g pk

Last Sens: 2.337E-1, Change: 0.12

Next cal date: 12/27/2002

Notes:

Excitation: 10.0 V

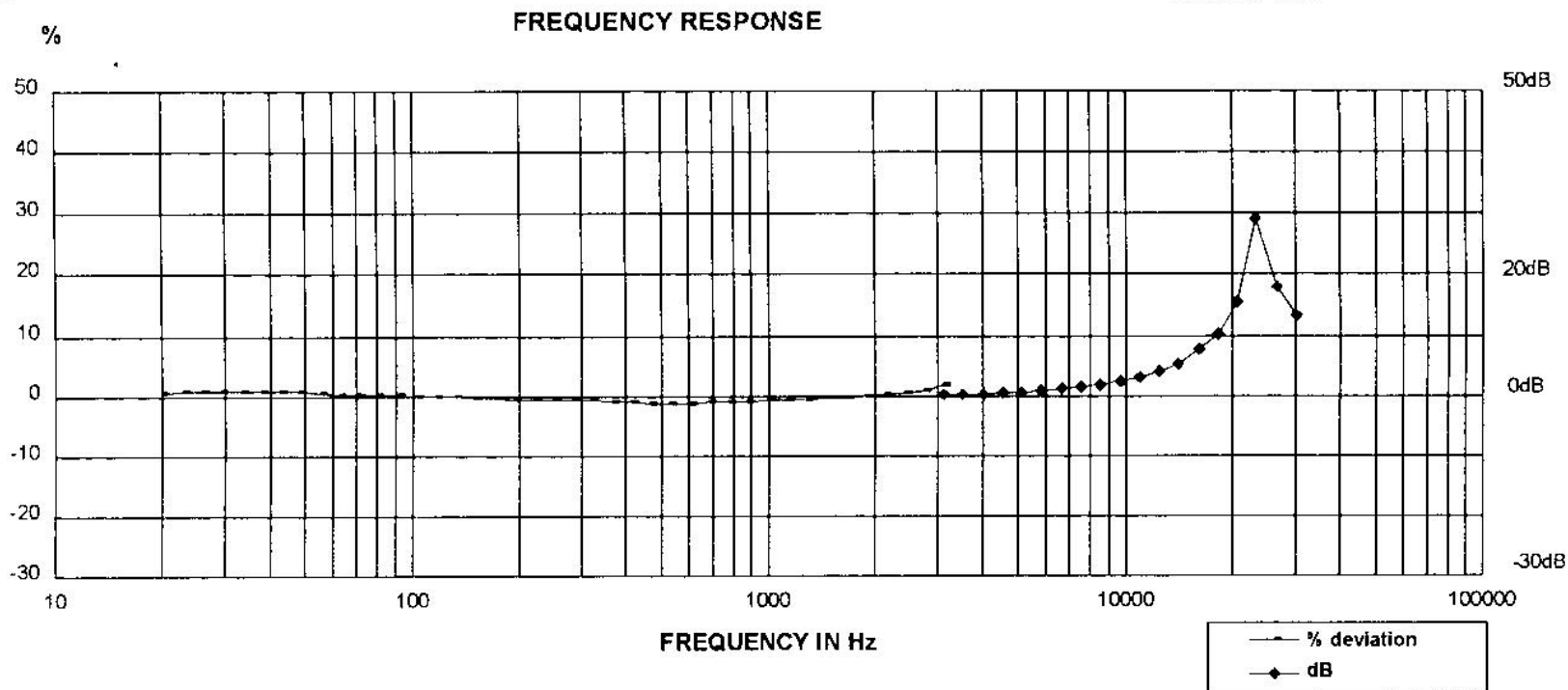

Endevco, a division of Meggitt, located at 30700 Rancho Viejo Road, San Juan Capistrano, CA, certifies that the above instrument was tested using comparison calibrations per ANSI S2.2 using Endevco IM68357. This calibration is traceable to the National Institute of Standards and Technology and is in accordance with ANSI/NCSL Z540-1-1994 (MIL-STD 45662A).

Uncertainty estimate (95% confidence, k=2)

Console serial number: AC27
NIST traceability #: 822/262802-00
Equipment used: 2901
Test definition: FINAL

+/- 1.1 %	100.0 Hz Sensitivity
+/- 5.0 %	10.0 to 20.0 Hz
+/- 1.5 %	20.0 to 2000.0 Hz
+/- 2.5 %	2000.0 to 10000.0 Hz
+/- 4.0 %	10000.0 to 20000.0 Hz

By: *[Signature]*
P. KRAMP

Date: 12/27/2001

Endevco
Transportation Research Center

#040 H11340
Chest X Fwd

Calibration Certificate

Customer: VRTC
19950311-0130

Document number: 5881

Description: VRTC - Accelerometer
Manufacturer: ENDEVCO
Model Number: 7264-2KM5T
Serial Number: AJ7R1

Input Resistance (ohms): 2259.7

ZMO (mV): 242.14
Resonance Frequency (Hz): 21554

0.2308 mV/g @ 100 Hz, 10g pk

Last Sens: 2.228E-1, Change: 3.61

Next cal date: 12/27/2002

Notes:

Excitation: 10.0 V

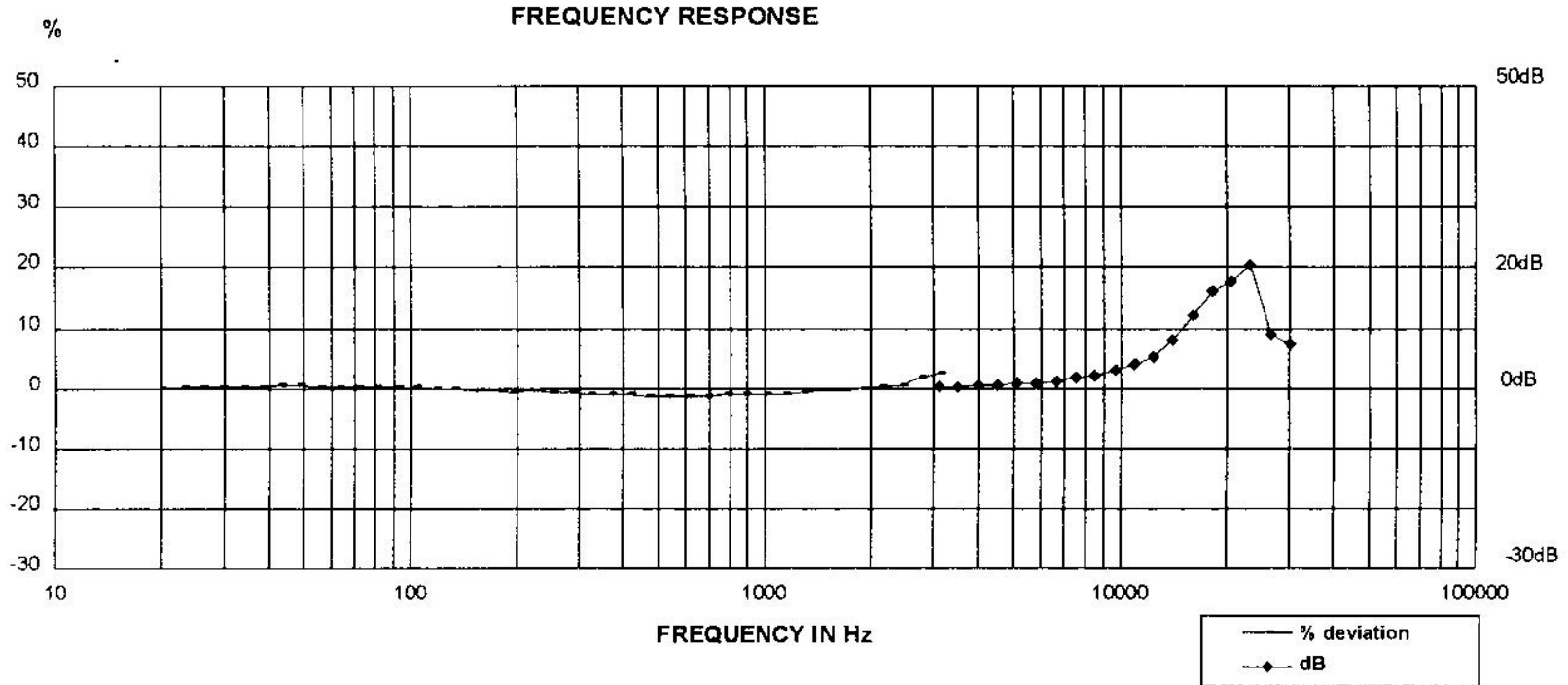

Endevco, a division of Meggitt, located at 30700 Rancho Viejo Road, San Juan Capistrano, CA, certifies that the above instrument was tested using comparison calibrations per ANSI S2.2 using Endevco IM68357. This calibration is traceable to the National Institute of Standards and Technology and is in accordance with ANSI/NCSS Z540-1-1994 (MIL-STD 45662A).

Console serial number: AC27
NIST traceability #: 822/262802-00
Equipment used: 2901
Test definition: FINAL

Uncertainty estimate (96% confidence, k=2)

+/- 1.1 %	100.0 Hz Sensitivity
+/- 5.0 %	10.0 to 20.0 Hz
+/- 1.5 %	20.0 to 2000.0 Hz
+/- 2.5 %	2000.0 to 10000.0 Hz
+/- 4.0 %	10000.0 to 20000.0 Hz

By:

P. KRAMP

Date: 12/27/2001

Endevco

Transportation Research Center

240 Hill 340
best 4-Left

Calibration Certificate

Customer: VRTC
19950311-0130

Document number: 5898

Description: VRTC - Accelerometer
Manufacturer: ENDEVCO
Model Number: 7264-2KM5T
Serial Number: J23996

Input Resistance (ohms): 2501.5
ZMO (mV): 10.798
Resonance Frequency (Hz): 28100

0.213 mV/g @ 100 Hz, 10g pk

Last Sens: 2.130E-1, Change: -0.02
Next cal date: 12/27/2002

Notes:

Excitation: 10.0 V

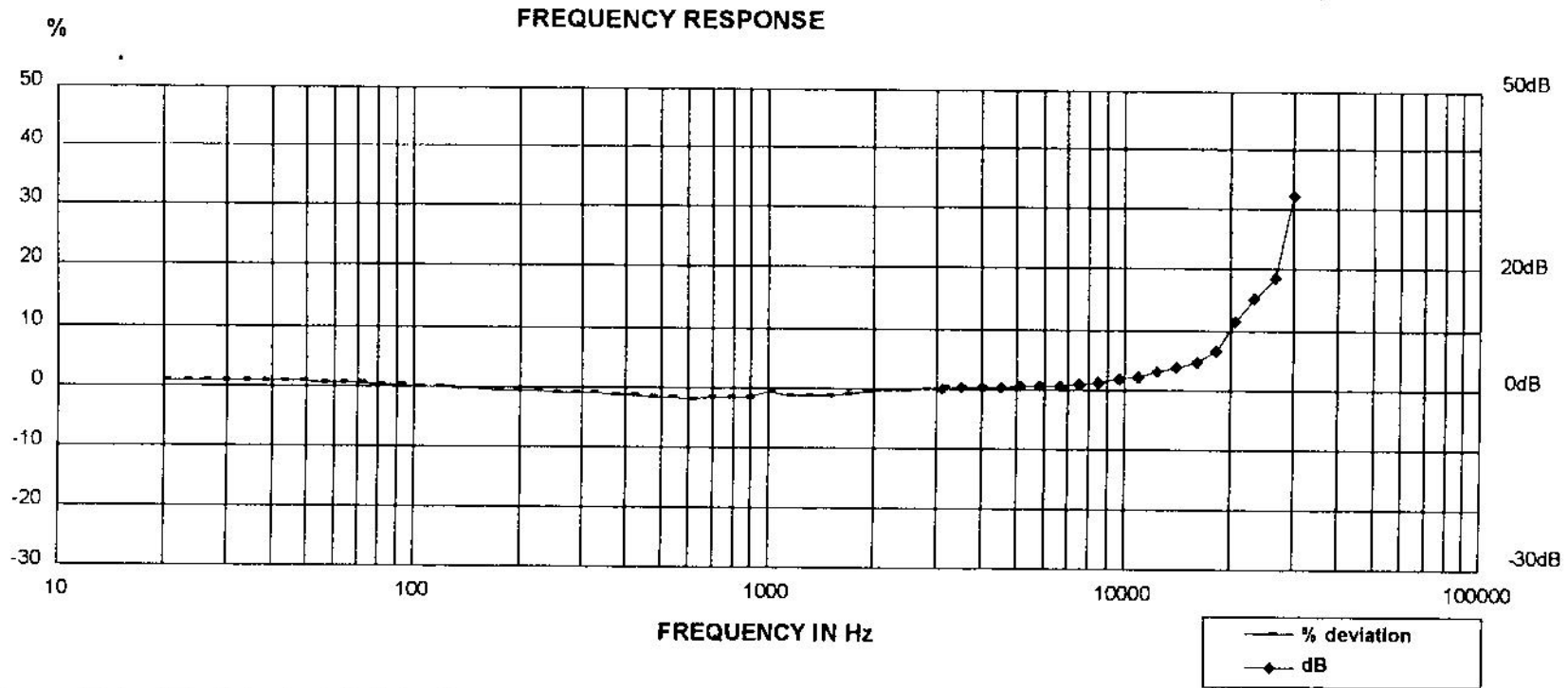

Endevco, a division of Meggitt, located at 30700 Rancho Viejo Road, San Juan Capistrano, CA, certifies that the above instrument was tested using comparison calibrations per ANSI S2.2 using Endevco IM68357. This calibration is traceable to the National Institute of Standards and Technology and is in accordance with ANSI/NCSL Z540-1-1994 (MIL-STD 45662A).

Uncertainty estimate (95% confidence, k=2)		
onsole serial number: AC27	+/- 1.1 %	100.0 Hz Sensitivity
NIST traceability #: 822/262802-00	+/- 5.0 %	10.0 to 20.0 Hz
Equipment used: 2901	+/- 1.5 %	20.0 to 2000.0 Hz
Test definition: FINAL	+/- 2.5 %	2000.0 to 10000.0 Hz
	+/- 4.0 %	10000.0 to 20000.0 Hz

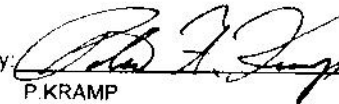
By: 
P. KRAMP
Date: 12/27/2001

Endevco
Transportation Research Center

040 HILL 340

Chest 2 WP

Calibration Certificate

Customer: VRTC
19950311-0130

Document number: 5877

Description: VRTC - Accelerometer
Manufacturer: ENTRAN
Model Number: EGE-738QE0-2000BF
Serial Number: 99H12-F08

Input Resistance (ohms): 967.13

ZMO (mV): 3.6412
Resonance Frequency (Hz): 23642

0.1765 mV/g @ 100 Hz, 10g pk

Last Sens: 1.776E-1, Change: -0.6

Next cal date: 12/27/2002

Notes:

Excitation: 10.0 V

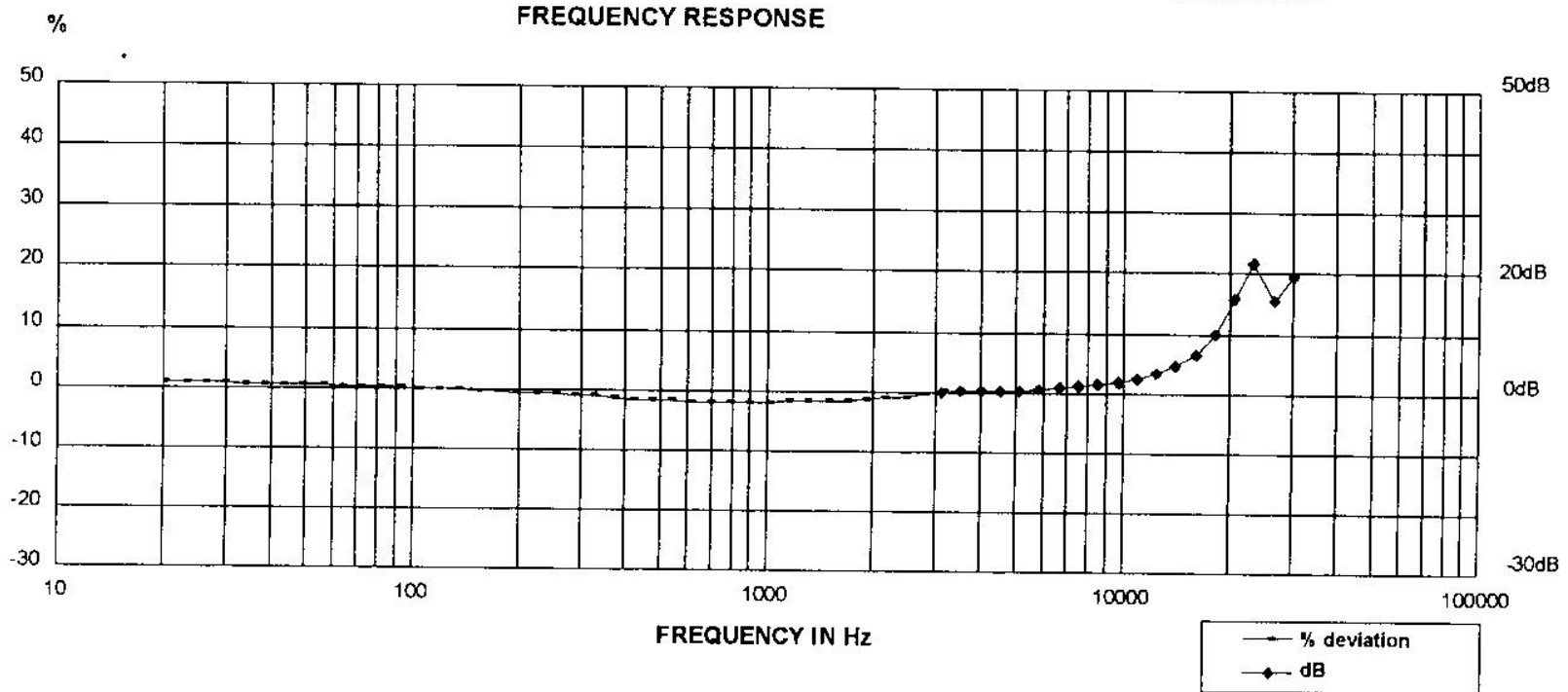

Endevco, a division of Meggitt, located at 30700 Rancho Viejo Road, San Juan Capistrano, CA, certifies that the above instrument was tested using comparison calibrations per ANSI S2.2 using Endevco IM68357. This calibration is traceable to the National Institute of Standards and Technology and is in accordance with ANSI/NCSL Z540-1-1994 (MIL-STD 45662A).

Uncertainty estimate (95% confidence, k=2)

Console serial number: AC27	+/- 1.1 %	100.0 Hz Sensitivity
NIST traceability #: 822/262802-00	+/- 5.0 %	10.0 to 20.0 Hz
Equipment used: 2901	+/- 1.5 %	20.0 to 2000.0 Hz
Test definition: FINAL	+/- 2.5 %	2000.0 to 10000.0 Hz
	+/- 4.0 %	10000.0 to 20000.0 Hz

By: *P. Kramp*
P. KRAMP

Date: 12/27/2001

Endevco
Transportation Research Center

10 HIII 3V0

Pelvis X Rear

Calibration Certificate

Customer: VRTC
19950311-0130

Document number: 5888

Description: VRTC - Accelerometer
Manufacturer: ENDEVCO
Model Number: 7264-2KM5T
Serial Number: BG37J

Input Resistance (ohms): 2387.0

ZMO (mV): 25.223

Resonance Frequency (Hz): 17441

0.3455 mV/g @ 100 Hz, 10g pk

Last Sens: 3.416E-1, Change: 1.16

Next cal date: 12/27/2002

Notes:

Excitation: 10.0 V

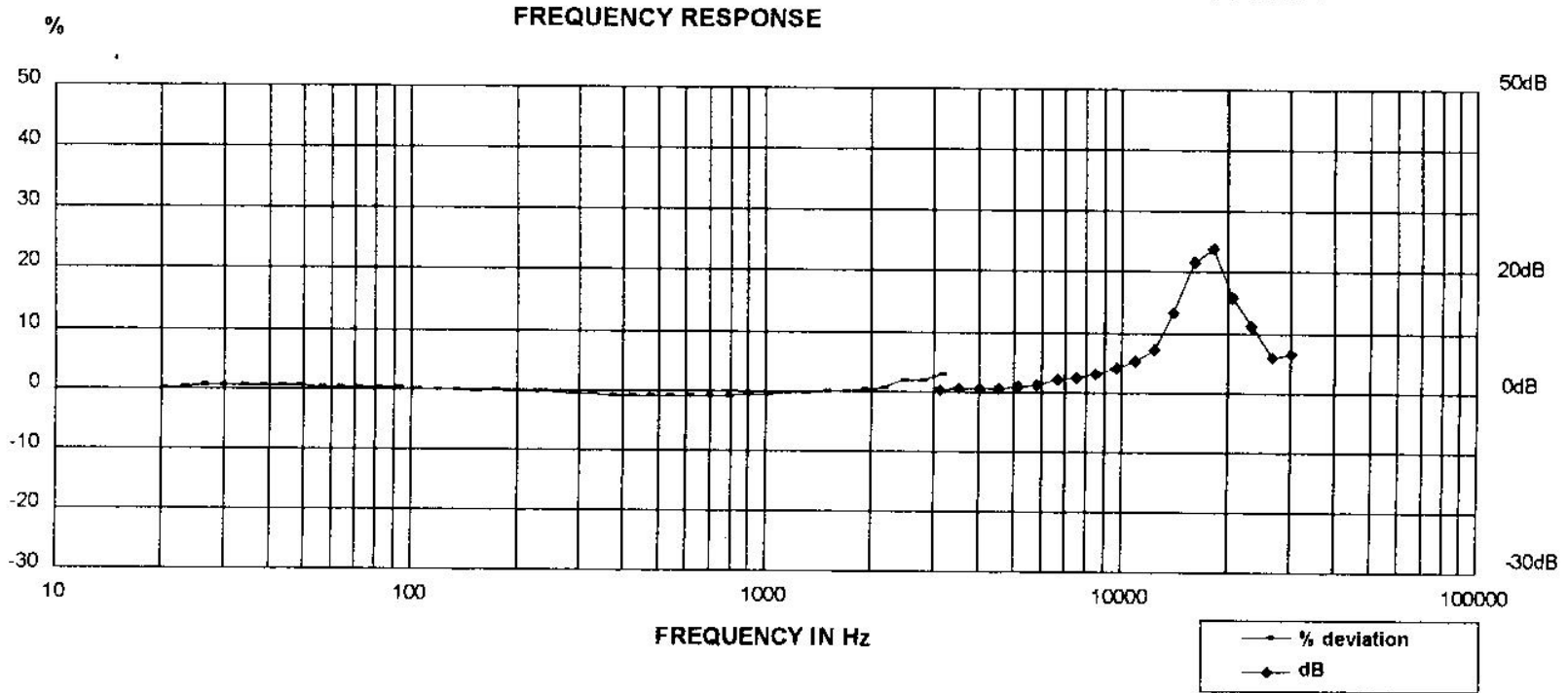

Endevco, a division of Meggitt, located at 30700 Rancho Viejo Road, San Juan Capistrano, CA, certifies that the above instrument was tested using comparison calibrations per ANSI S2.2 using Endevco IM68357. This calibration is traceable to the National Institute of Standards and Technology and is in accordance with ANSI/NCSL Z540-1-1994 (MIL-STD 45662A).

Uncertainty estimate (95% confidence, k=2)

Console serial number: AC27	+/- 1.1 %	100.0 Hz Sensitivity
NIST traceability #: 822/262802-00	+/- 5.0 %	10.0 to 20.0 Hz
Equipment used: 2901	+/- 1.5 %	20.0 to 2000.0 Hz
Test definition: FINAL	+/- 2.5 %	2000.0 to 10000.0 Hz
	+/- 4.0 %	10000.0 to 20000.0 Hz

By: *[Signature]*
P. KRAMP

Date: 12/27/2001

Endevco
Transportation Research Center

040 H111 540
Pelvis Y Left

Calibration Certificate

Customer: VRTC
19950311-0130

Document number: 5897

Description: VRTC - Accelerometer
Manufacturer: ENDEVCO
Model Number: 7264-2KM5T
Serial Number: J35560

Input Resistance (ohms): 2344.9

ZMO (mV): 2.3662

Resonance Frequency (Hz): 24873

0.2445 mV/g @ 100 Hz, 10g pk

Last Sens: 2.427E-1, Change: 0.71

Next cal date: 12/27/2002

Notes:

Excitation: 10.0 V

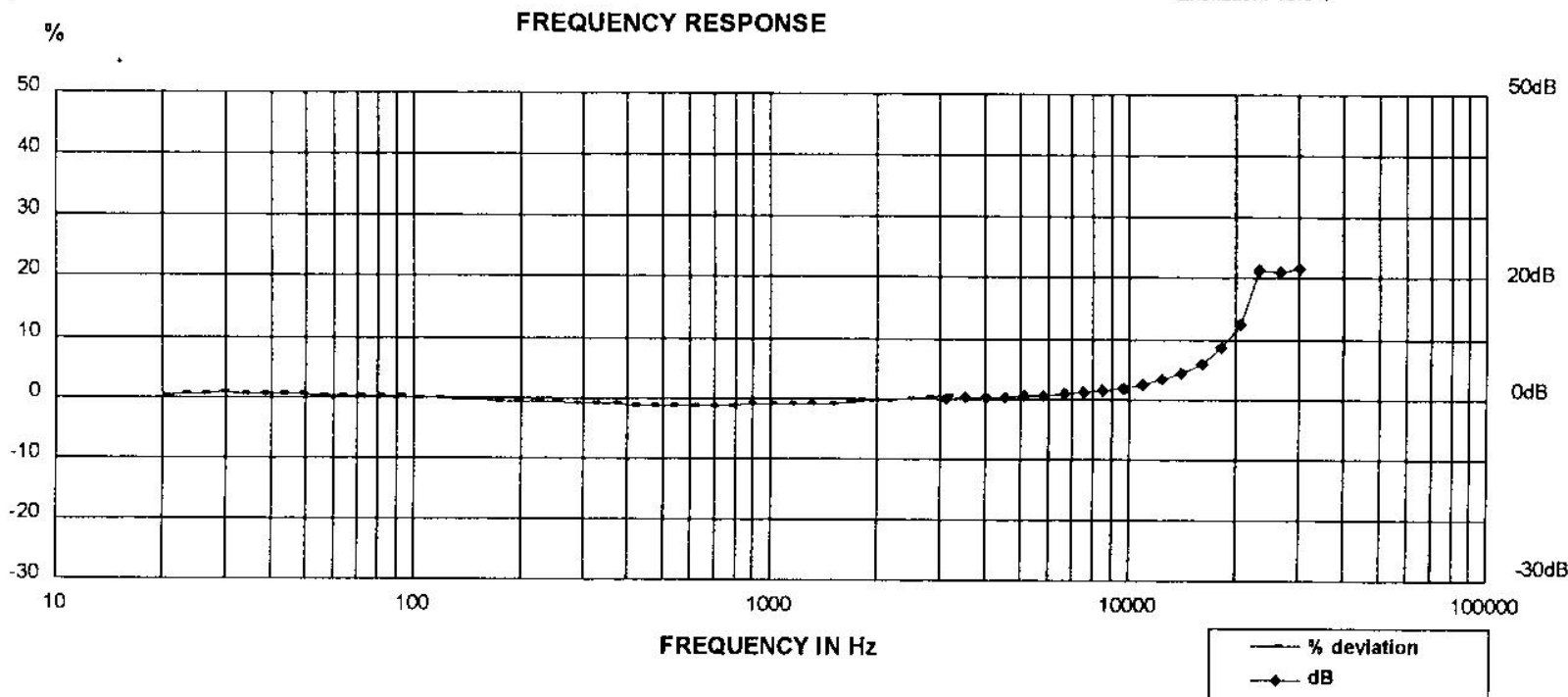

Endevco, a division of Meggitt, located at 30700 Rancho Viejo Road, San Juan Capistrano, CA, certifies that the above instrument was tested using comparison calibrations per ANSI S2.2 using Endevco IM68357. This calibration is traceable to the National Institute of Standards and Technology and is in accordance with ANSI/NCSL Z540-1-1994 (MIL-STD 45662A).

Console serial number: AC27
NIST traceability #: 822/262802-00
Equipment used: 2901
Test definition: FINAL

Uncertainty estimate (95% confidence, k=2)

+/- 1.1 %	100.0 Hz Sensitivity
+/- 5.0 %	10.0 to 20.0 Hz
+/- 1.5 %	20.0 to 2000.0 Hz
+/- 2.5 %	2000.0 to 10000.0 Hz
+/- 4.0 %	10000.0 to 20000.0 Hz

By:

P. Kramp
P. KRAMP

Date: 12/27/2001

Endevco

Transportation Research Center

Delois E WP

Calibration Certificate

Customer: VTRC
19950311-0130

Document number: 5900

Description: VRTC - Accelerometer
Manufacturer: ENDEVCO
Model Number: 7264-2KM5T
Serial Number: DE15J

Input Resistance (ohms): 2495.9
ZMO (mV): 4.9151
Resonance Frequency (Hz): 24914

0.2266 mV/g @ 100 Hz, 10g pk

Last Sens: 2.268E-1, Change: -0.06

Next cal date: 12/27/2002

Notes:

Excitation: 10.0 V

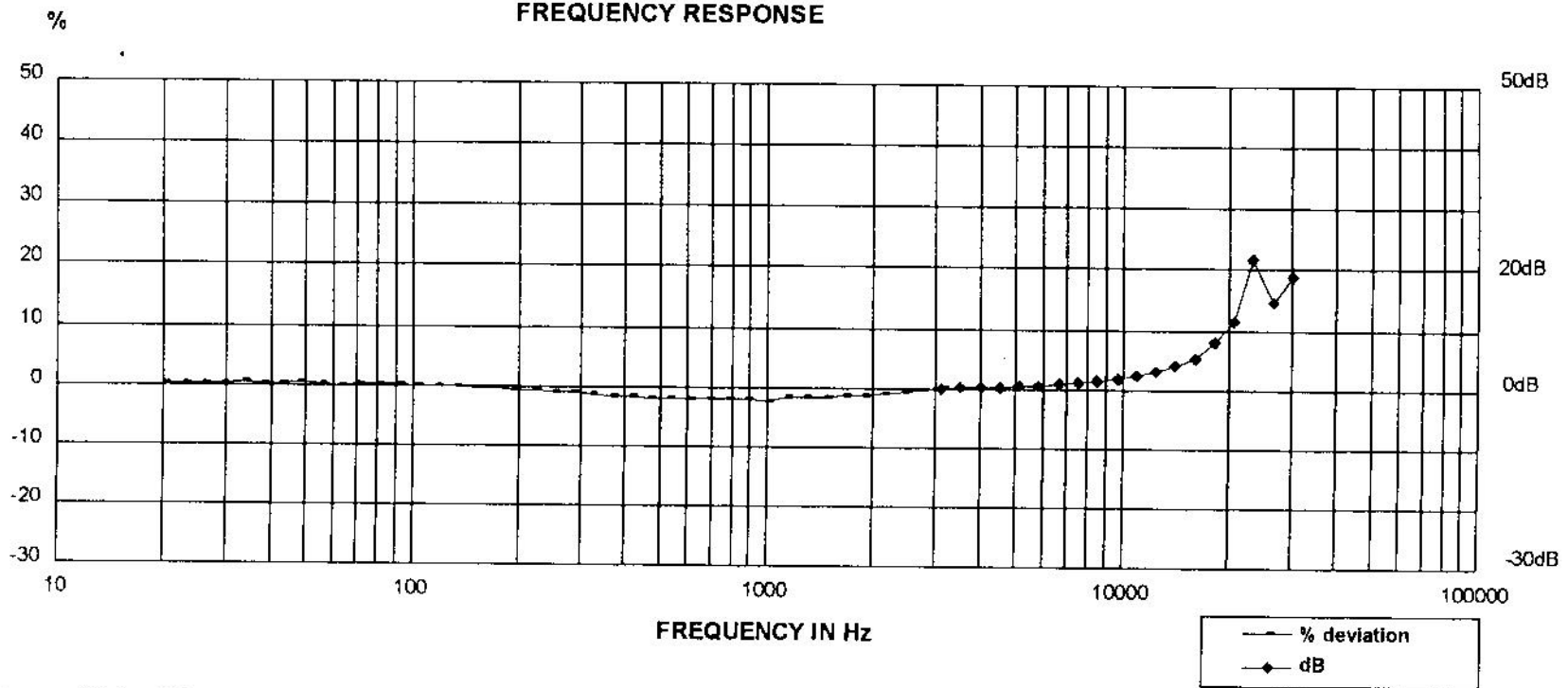

Endevco, a division of Meggitt, located at 30700 Rancho Viejo Road, San Juan Capistrano, CA, certifies that the above instrument was tested using comparison calibrations per ANSI S2.2 using Endevco IM68357. This calibration is traceable to the National Institute of Standards and Technology and is in accordance with ANSI/NCSL Z540-1-1994 (MIL-STD 45662A).

Uncertainty estimate (95% confidence, k=2)

onsole serial number: AC27	+/- 1.1 %	100.0 Hz Sensitivity
NIST traceability #: 822/262802-00	+/- 5.0 %	10.0 to 20.0 Hz
Equipment used: 2901	+/- 1.5 %	20.0 to 2000.0 Hz
Test definition: FINAL	+/- 2.5 %	2000.0 to 10000.0 Hz
	+/- 4.0 %	10000.0 to 20000.0 Hz

By: *P. Kramp*
P. KRAMP

Date: 12/27/2001

Endevco
Transportation Research Center

**TRANSPORTATION RESEARCH CENTER INC.
HYBRID III THREE-YEAR-OLD EXTERNAL DIMENSIONS**

SN: 040 MFG: Denton

DATE: 15-Jan-02

TRC INC. TEST NO: 040C01ED

572P SN040EXT. DIMENSION CAL 01

TEST PARAMETER	DIMEN.	SPECIFICATION	TEST RESULTS
Total Sitting Height	A	538.5 - 553.7 MM	548.6 MM
Shoulder Pivot Height	B	307.4 - 322.6 MM	312.4 MM
Hip Pivot Height	C	33 - 43.2 MM	38.1 MM
Hip Pivot from Backline	D	56.9 - 67.1 MM	61.0 MM
Shoulder Pivot from Backline	E	58.4 - 68.6 MM	66.0 MM
Thigh Clearance	F	81 - 91.2 MM	83.8 MM
Back of Elbow to Wrist Pivot	G	247.4 - 262.6 MM	248.9 MM
Head Back from Backline	H	48.2 - 58.4 MM	53.3 MM
Shoulder to Elbow Length	I	185.4 - 200.6 MM	193.0 MM
Elbow Rest Height	J	133.6 - 148.8 MM	137.2 MM
Buttock to Knee Length	K	287.3 - 302.5 MM	299.7 MM
Popliteal Height	L	221 - 236.2 MM	231.1 MM
Knee to Floor Height	M	241.6 - 256.8 MM	254.0 MM
Buttock Popliteal Length	N	218 - 233.2 MM	226.1 MM
Chest Depth	O	134.6 - 149.8 MM	142.2 MM
Foot Length	P	137.6 - 147.8 MM	139.7 MM
Stature	Q	932.2 - 957.6 MM	942.3 MM
Buttock to Knee Pivot Length	R	251.4 - 261.6 MM	256.5 MM
Head Breadth	S	128.3 - 143.5 MM	139.7 MM
Head Depth	T	167.4 - 182.6 MM	177.8 MM
Hip Breadth	U	200.7 - 215.9 MM	205.7 MM
Shoulder Breadth	V	236.5 - 251.7 MM	238.8 MM
Foot Breadth	W	53.6 - 63.8 MM	57.2 MM
Head Circumference	X	500.4 - 515.6 MM	502.9 MM
Chest Circumference with Jacket	Y	527.1 - 552.5 MM	530.9 MM
Waist Circumference	Z	527.1 - 552.5 MM	541.0 MM
Reference Location for Chest Circumference	AA	248.9 - 259.1 MM	254.0 MM
Reference Location for Waist Circumference	BB	160 - 170.2 MM	165.1 MM

DUMMY MEETS SPECIFICATION

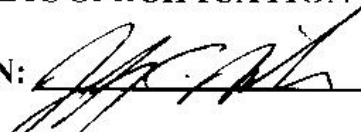
TECHNICIAN:  _____

TRANSPORTATION RESEARCH CENTER INC.

HEAD DROP TEST

HYBRID III THREE YEAR OLD

14-JAN-02

TRC INC.

TEST NO: 040C01HD1

572P 3YO SNO40 HEAD DROP CAL01

TEST PARAMETER	SPECIFICATION	TEST RESULTS
TEMPERATURE	18.9-25.6 DEG. C	20.6 DEG. C
RELATIVE HUMIDITY	10 - 70 %	25.0 %
PEAK RESULTANT ACCELERATION	250 - 280 G	252.61 G
PEAK LATERAL ACCELERATION	15 G MAX	12.80 G
IS ACCELERATION CURVE UNIMODAL?	YES	YES

TEST MEETS SPECIFICATIONS

TECHNICIAN

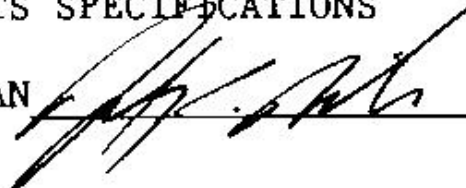

RUN NUMBER: 011402.1417;1

HYBRID III THREE YEAR OLD CHILD DUMMY HEAD CALIBRATION

HEAD ACCELERATION X AXIS

TRC TEST NUMBER 040C01HD1 572P 3YD SN040 HEAD DROP CAL01 RUN NUMBER: 011402 1420;1

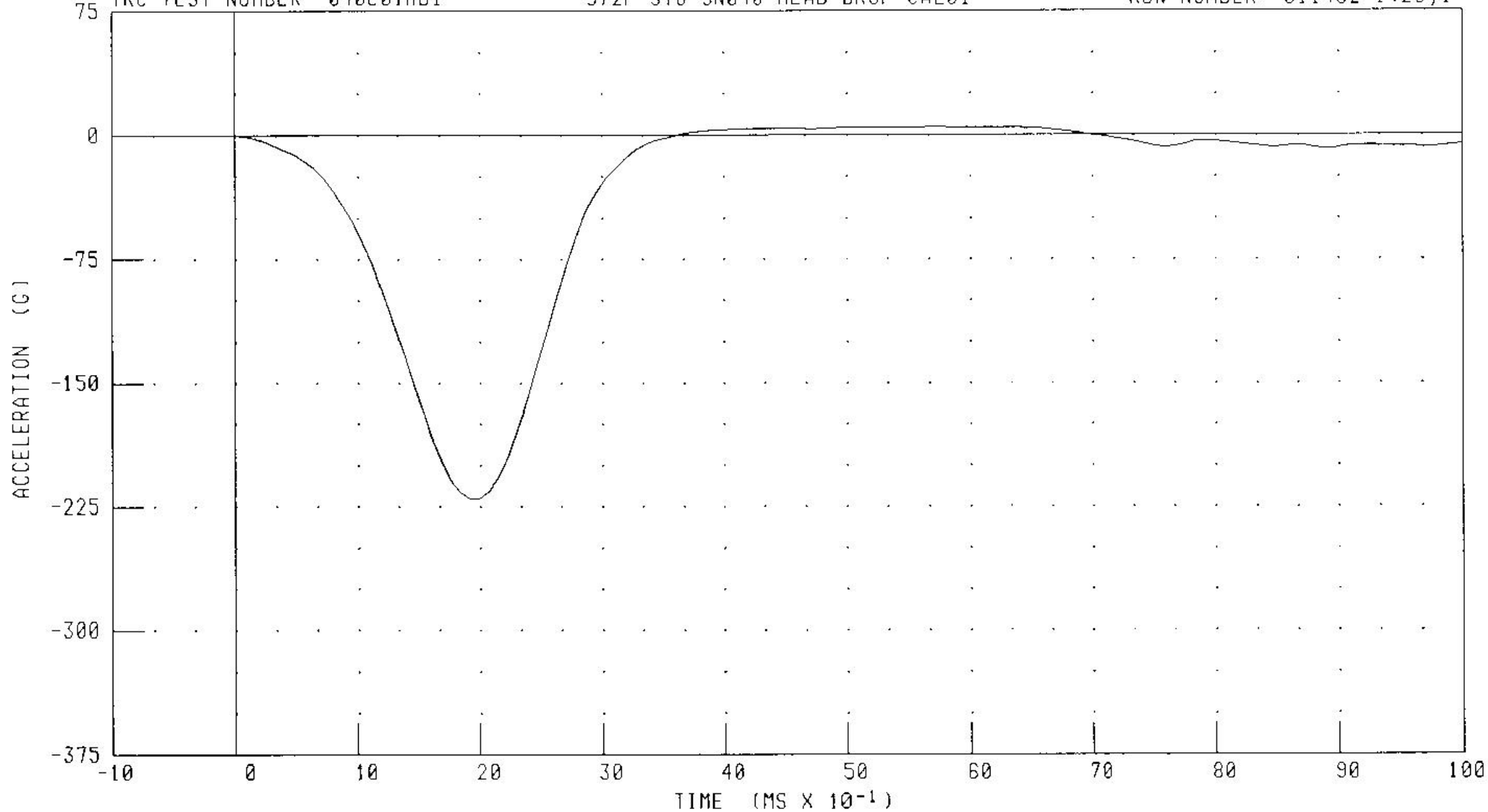

CHANNEL: HEDXC FILTER: CH CLASS 1000

PEAK DATA: 5.00 G @ 5.76 MS; -220.43 G @ 1.92 MS

HYBRID III THREE YEAR OLD CHILD DUMMY HEAD CALIBRATION

HEAD ACCELERATION Y AXIS

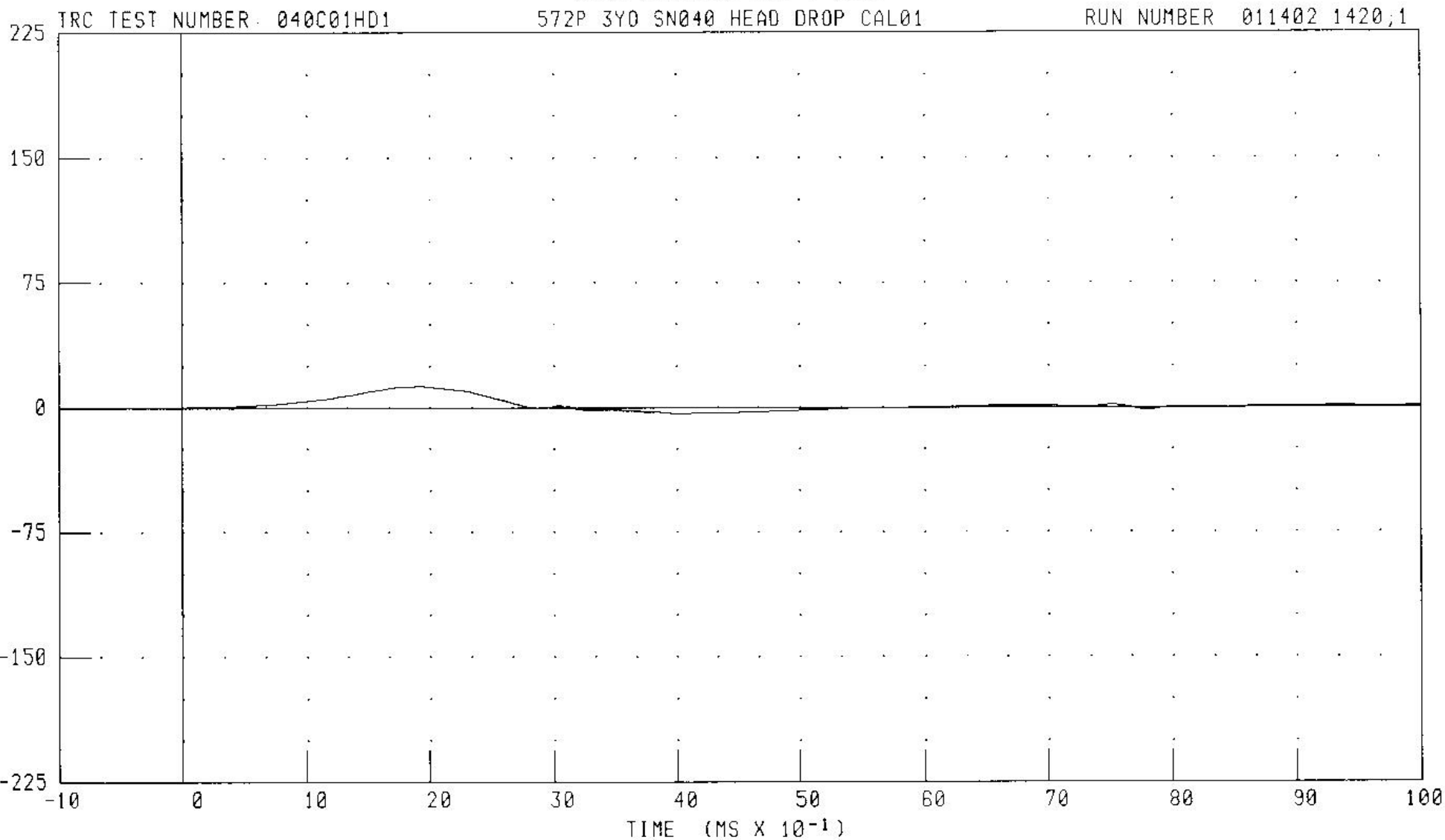

CHANNEL: HEDYG

FILTER: CH. CLASS 1000

PEAK DATA 12.81 G @ 1.92 MS, -3.94 G @ 4.00 MS

HYBRID III THREE YEAR OLD CHILD DUMMY HEAD CALIBRATION

HEAD ACCELERATION Z AXIS

TRC TEST NUMBER: 040C01HD1 572P 3YO SN040 HEAD DROP CAL01 RUN NUMBER: 011402.1420,1

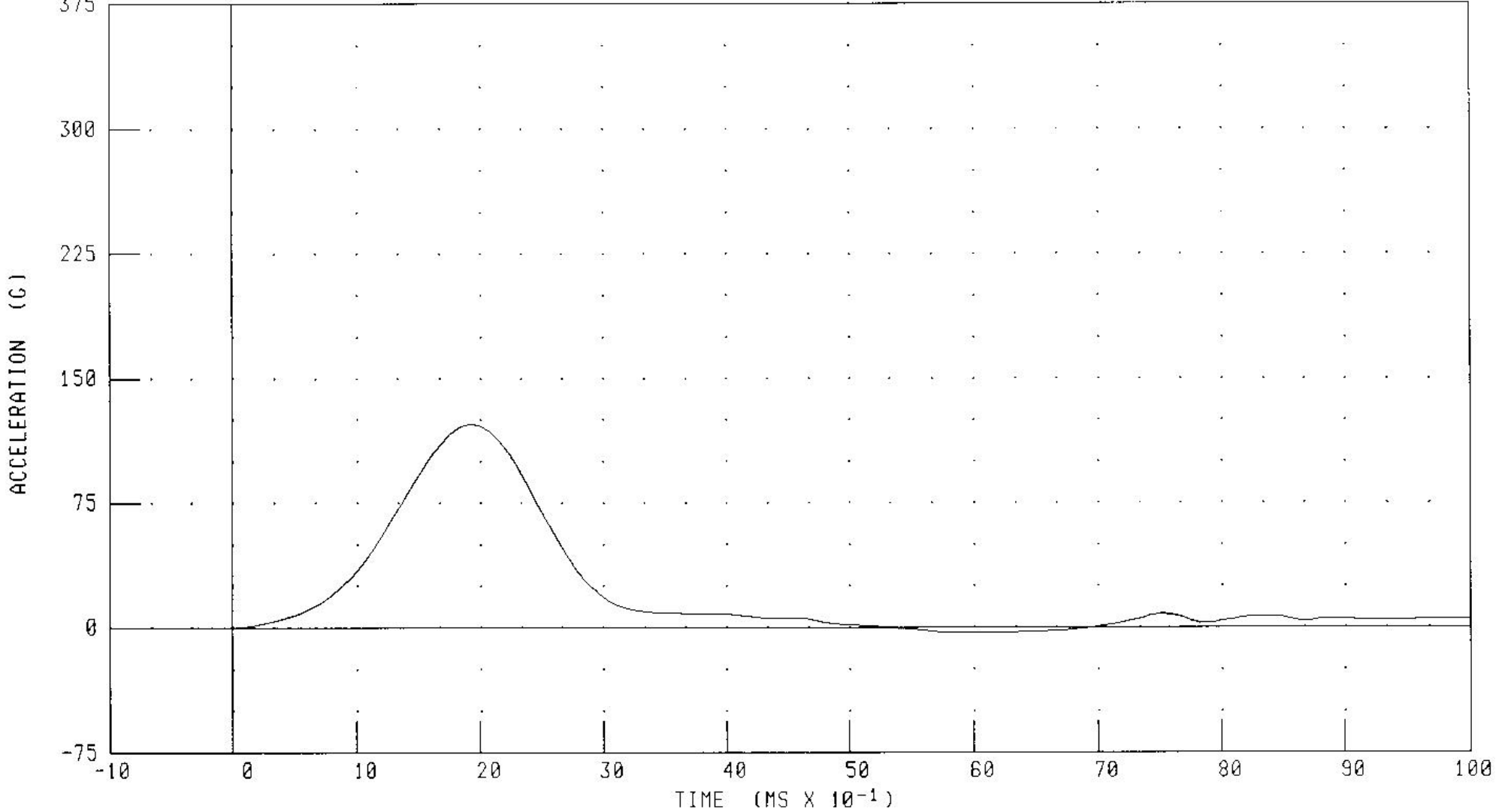

CHANNEL: HEDZG

FILTER: CH. CLASS 1000

PEAK DATA: 122.72 G @ 1.92 MS, -3.48 G @ 5.84 MS

HYBRID III THREE YEAR OLD CHILD DUMMY HEAD CALIBRATION

HEAD RESULTANT ACCELERATION

TRC TEST NUMBER: 040C01HD1

572P 3YO SN040 HEAD DROP CAL01

RUN NUMBER: 011402.1420,1

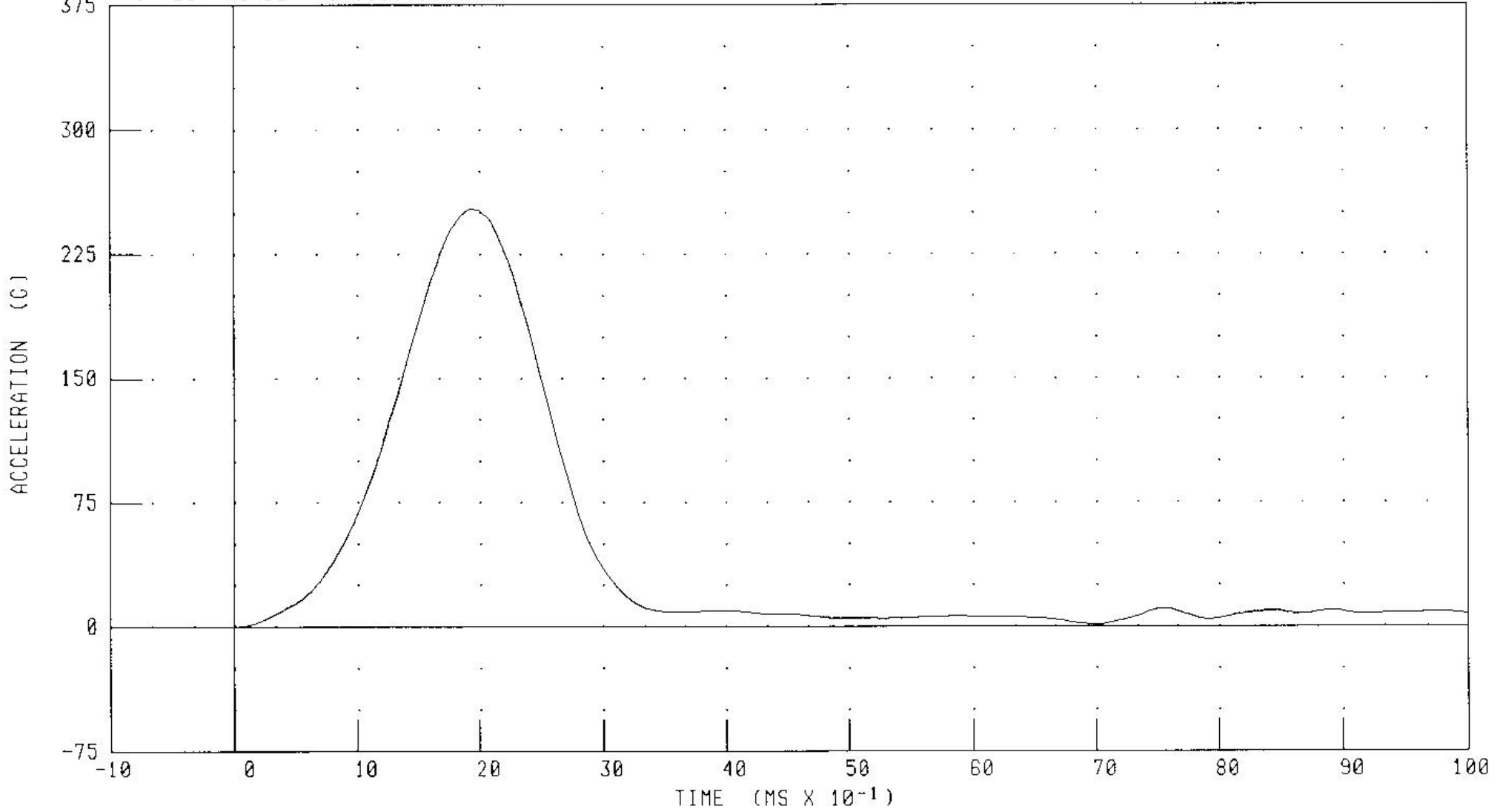

CHANNEL: HEDRG

FILTER: CH. CLASS 1000

PEAK DATA 252.61 G @ 1.92 MS, 0.00 G @ -0.80 MS

TRANSPORTATION RESEARCH CENTER INC.

HYBRID III THREE YEAR OLD

17-JAN-02

NECK FLEXION TEST

TRC INC. TEST NO: 040C01NF3 572P 3YO SN040 NECK FLEX CAL01

TEST PARAMETER	SPECIFICATION	TEST RESULTS
TEMPERATURE	20.6-22.2 DEG. C	21.1 DEG. C
RELATIVE HUMIDITY	10 - 70 %	18.0 %
IMPACT VELOCITY	5.40 - 5.60 M/S	5.60 M/S
INTEGRATED PENDULUM VELOCITY	10 MS 2.0 - 2.7 M/S	2.48 M/S
	15 MS 3.0 - 4.0 M/S	3.67 M/S
	20 MS 4.0 - 5.1 M/S	5.02 M/S
PEAK D-PLANE ROTATION	70 - 82 DEG.	70.70 DEG.
PEAK MOMENT DURING ROTATION INTERVAL	42 - 53 NM	45.48 NM
POSITIVE MOMENT DECAY TIME TO 10 NM LEVEL	60 - 80 MS	64.64 MS

TEST MEETS SPECIFICATIONS

TECHNICIAN

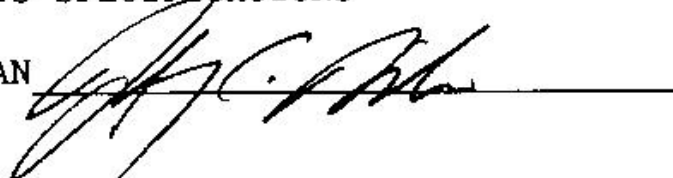

RUN NUMBER: 011702.0817;1

HYBRID III THREE YEAR OLD CHILD DUMMY NECK FLEXION CALIBRATION

PENDULUM DECELERATION

TRC TEST NUMBER: 040C01NF3

572P 3YO SN040 NECK FLEX CAL01

RUN NUMBER: 011702 0819,1

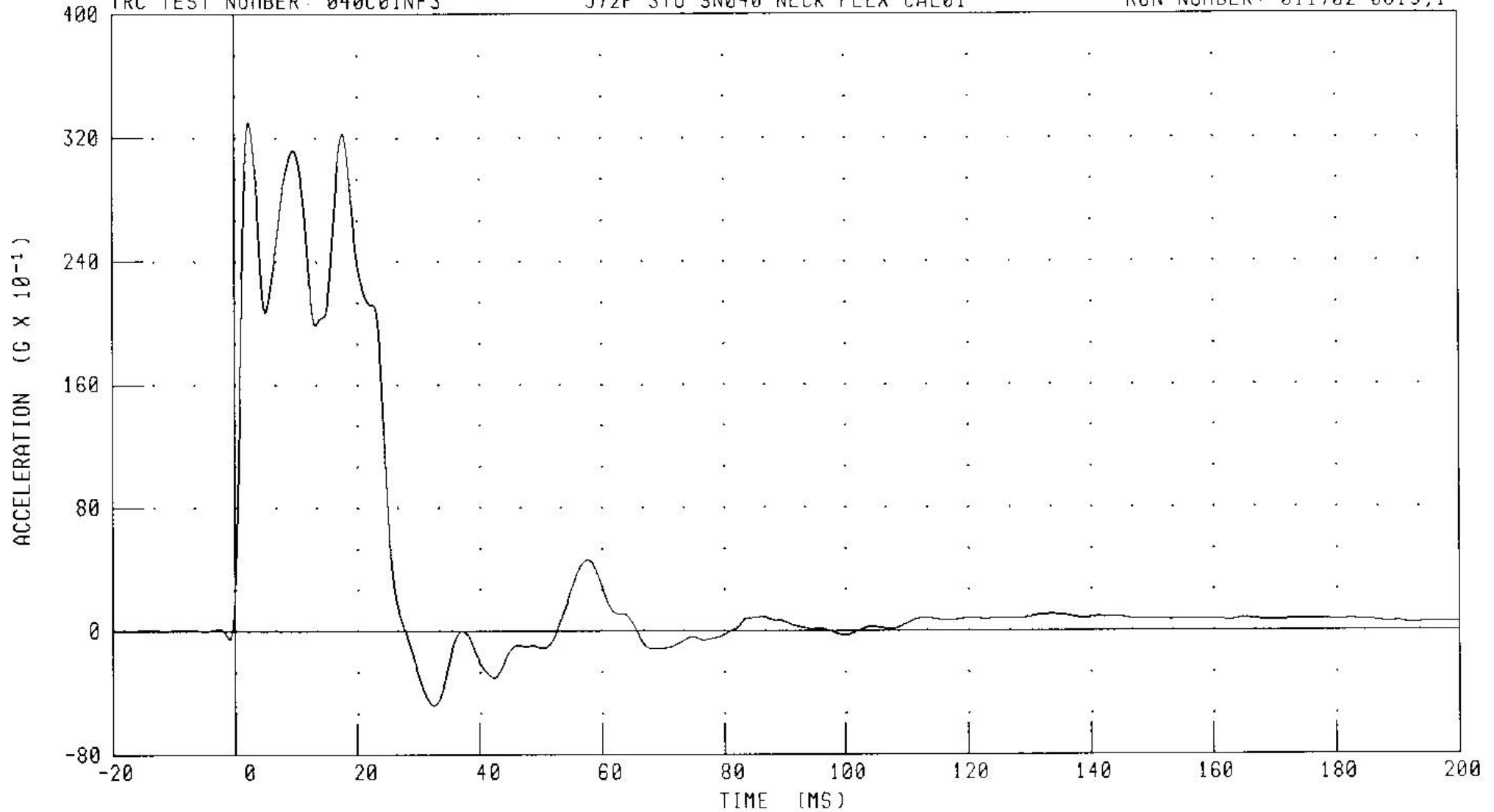

CHANNEL: PENXC

FILTER: CH. CLASS 100

PEAK DATA: 33.04 G @ 2.32 MS; -4.82 G @ 32.48 MS

HYBRID III THREE YEAR OLD CHILD DUMMY NECK FLEXION CALIBRATION
ROTATION ABOUT BASE OF NECK

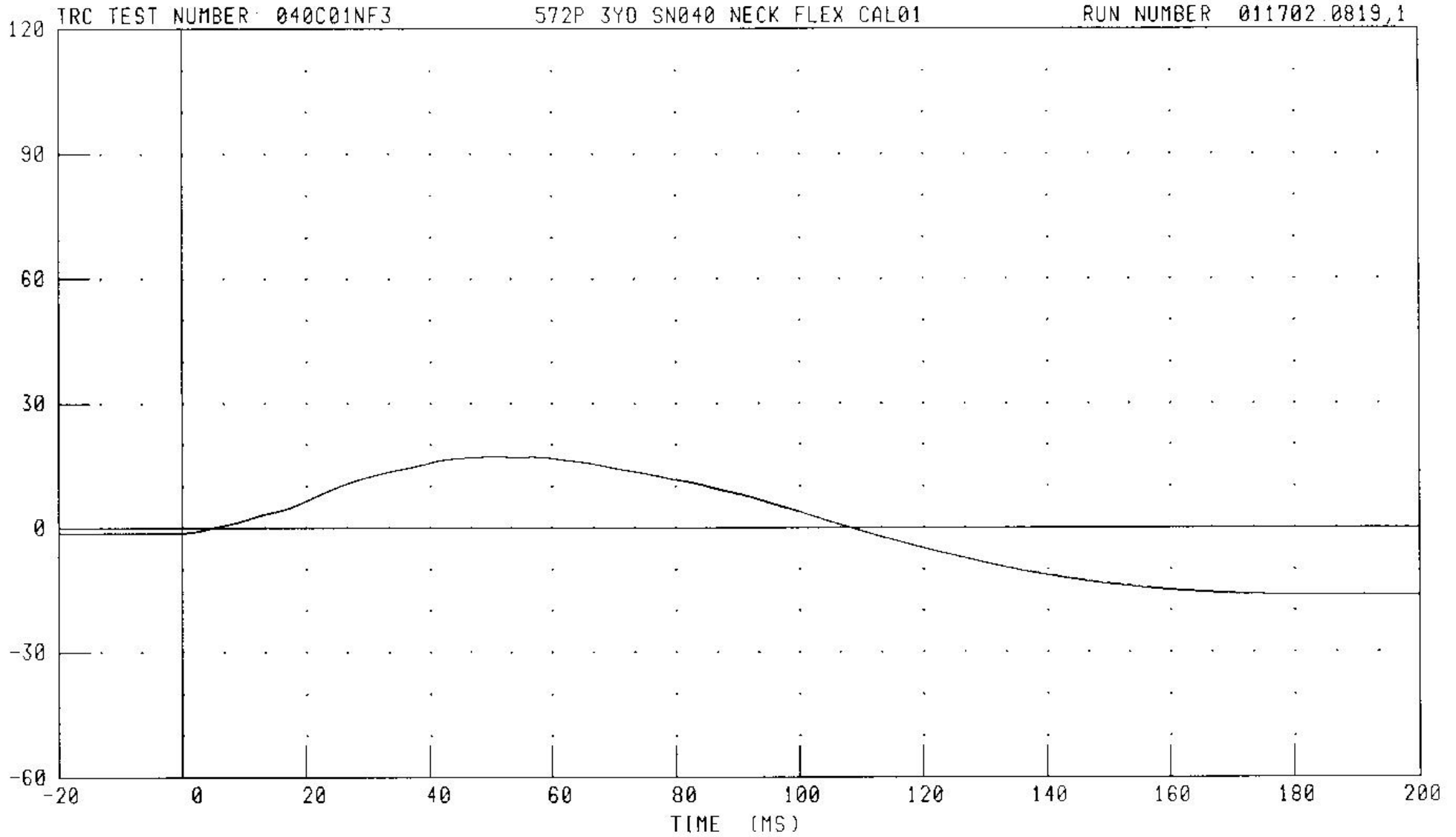

CHANNEL: BETA

FILTER: CH. CLASS 60

PEAK DATA: 17.12 ° @ 50.48 MS, -16.45 ° @ 190.16 MS

HYBRID III THREE YEAR OLD CHILD DUMMY NECK FLEXION CALIBRATION

ROTATION ABOUT OCCIPITAL CONDYLE

TRC TEST NUMBER: 040C01NF3

572P 3YO SN040 NECK FLEX CAL01

RUN NUMBER: 011702.0819,1

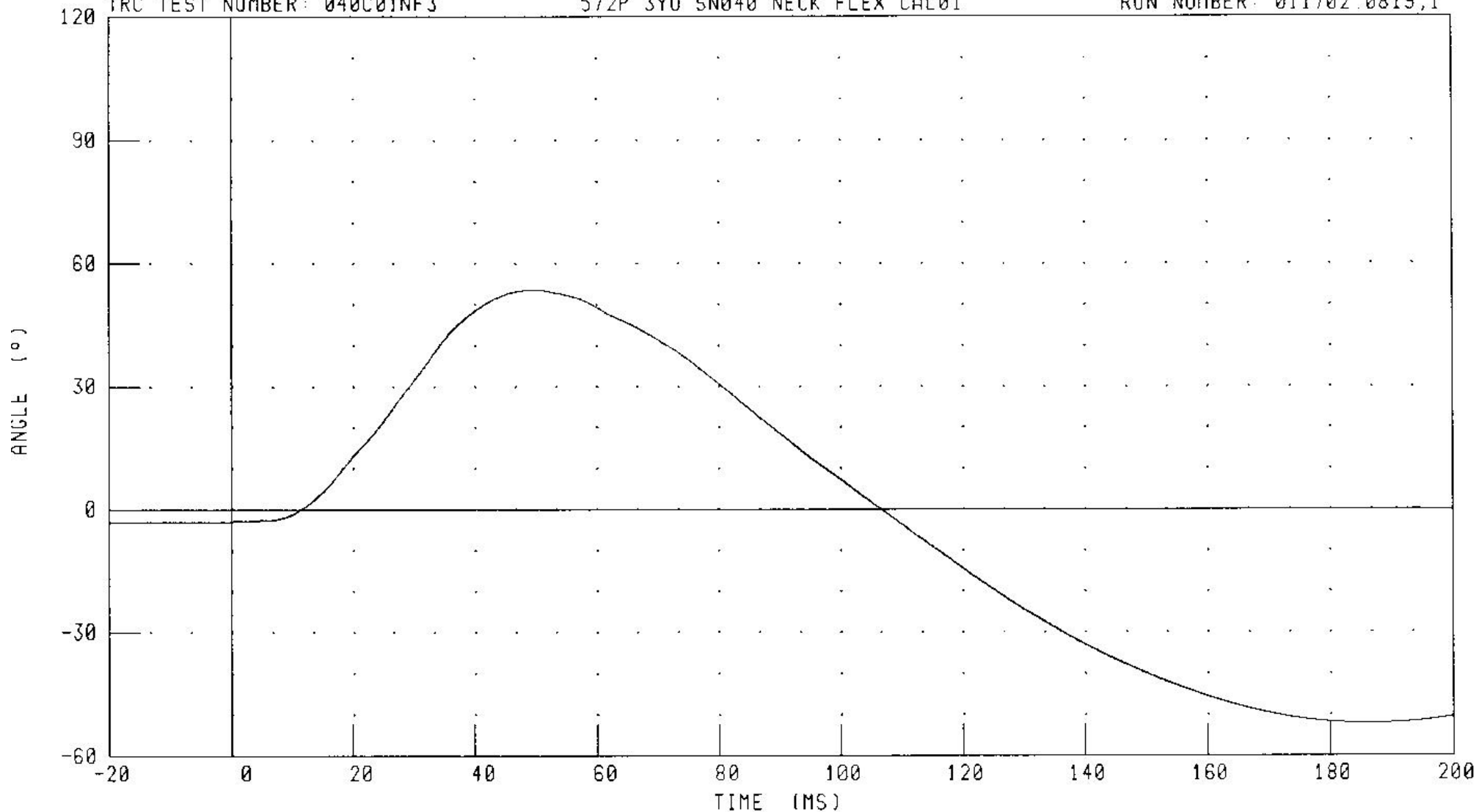

CHANNEL: THETA

FILTER: CH. CLASS 60

PEAK DATA: 53.59 ° @ 49.68 MS, -52.19 ° @ 186.16 MS

HYBRID III THREE YEAR OLD CHILD DUMMY NECK FLEXION CALIBRATION

TOTAL ROTATION

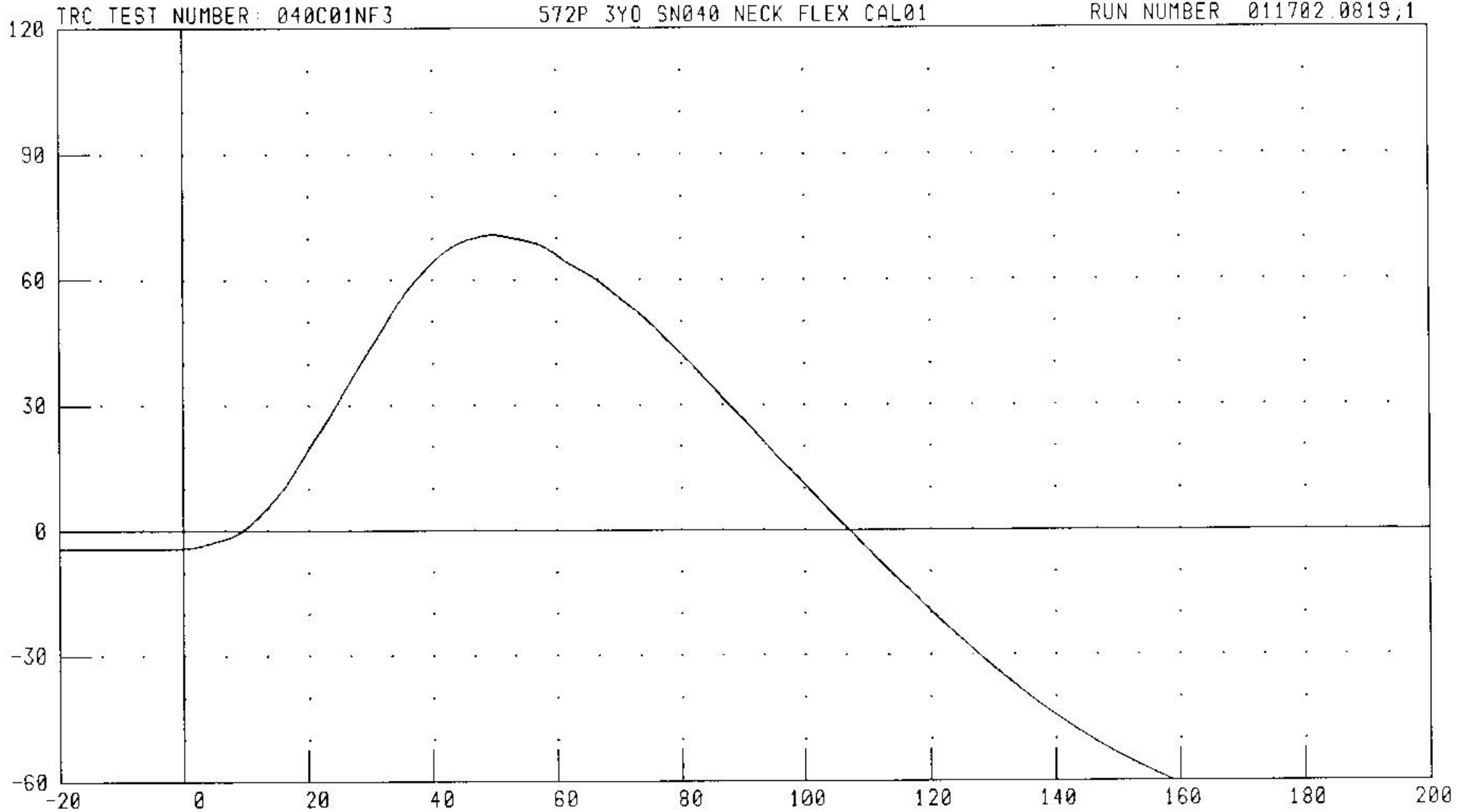

CHANNEL: TOTAN

FILTER: CH. CLASS 60

PEAK DATA: 70.70 ° @ 49.84 MS, -68.63 ° @ 186.24 MS

HYBRID III THREE YEAR OLD CHILD DUMMY NECK FLEXION CALIBRATION
MOMENT ABOUT OCCIPITAL CONDYLE

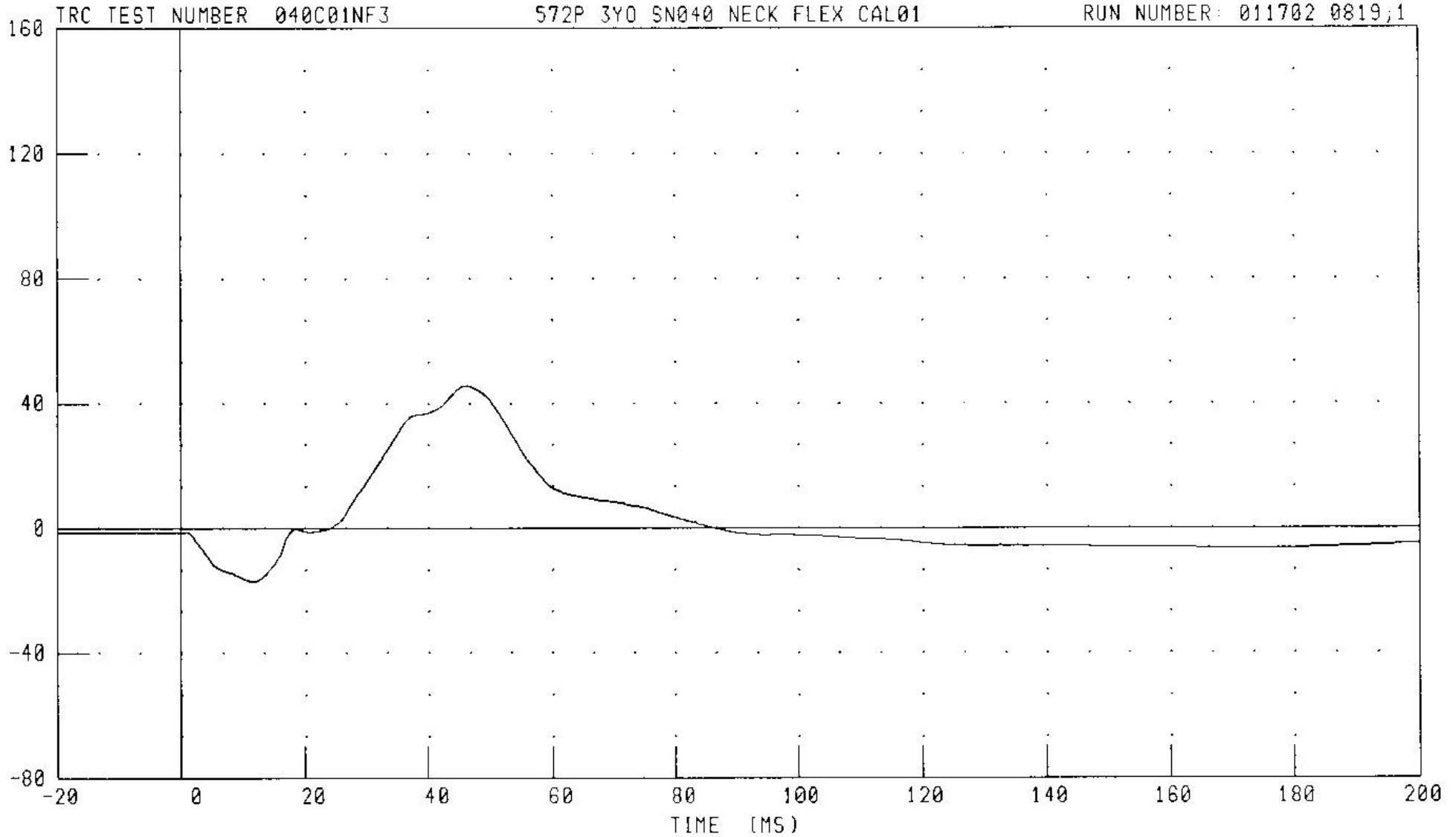

CHANNEL: NEKYM

FILTER: CH. CLASS 600

PEAK DATA: 45.75 N·M @ 46.00 MS, -17.17 N·M @ 11.60 MS

HYBRID III THREE YEAR OLD CHILD DUMMY NECK FLEXION CALIBRATION

TOTAL ROTATION VS OCCIPITAL CONDYLAR MOMENT

TRC TEST NUMBER: 040C01NF3

572P 3Y0 SN040 NECK FLEX CAL01

RUN NUMBER: 011702 0819;1

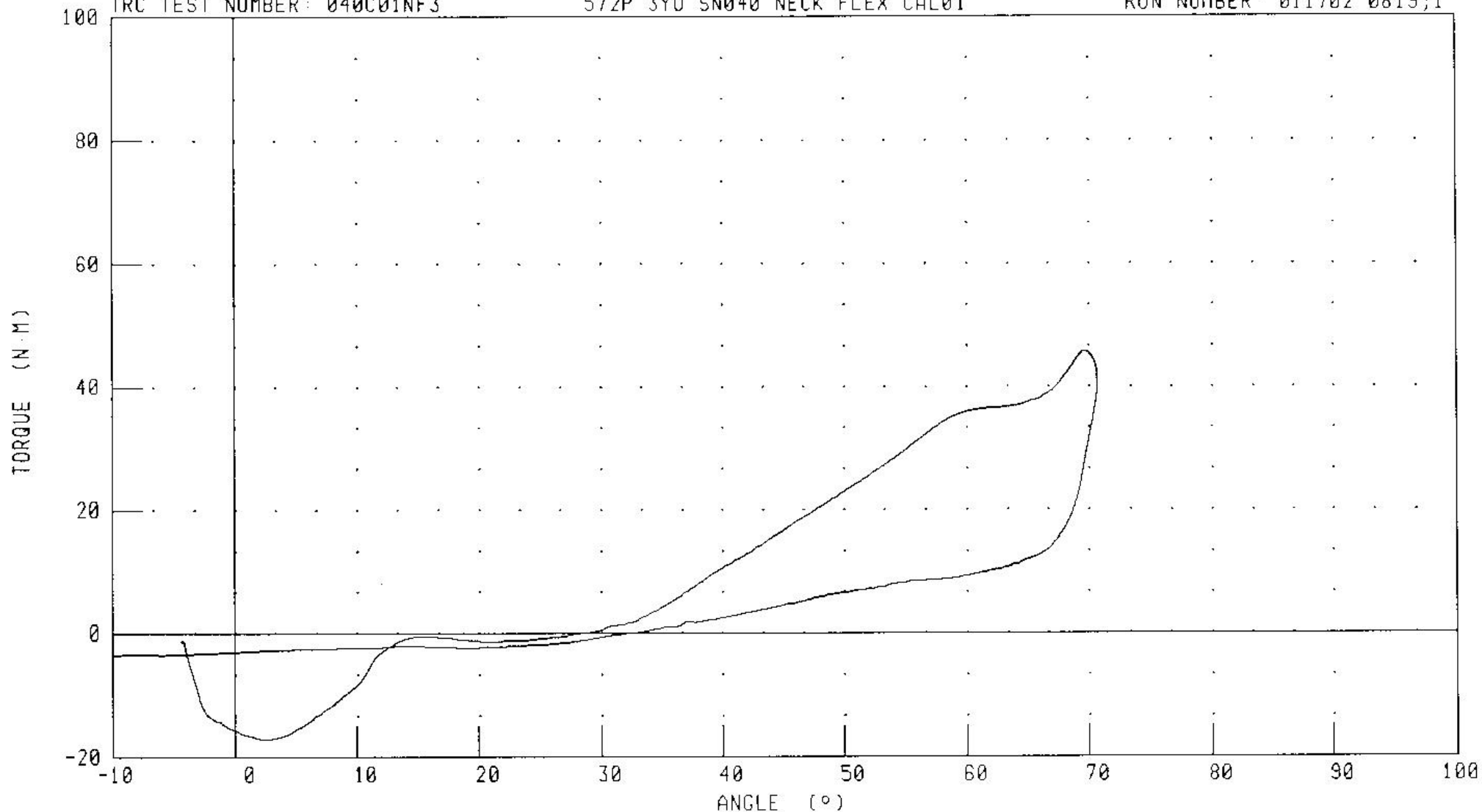

CHANNEL: TOTAN
NEKYM

FILTER: CH. CLASS 60
CH. CLASS 600

PEAK DATA: 70.70 ° @ 49.84 MS; -68.63 ° @ 186.24 MS
45.75 N M @ 46.00 MS; -17.17 N M @ 11.60 MS

TRANSPORTATION RESEARCH CENTER INC.

HYBRID III THREE YEAR OLD

15-JAN-02

NECK EXTENSION TEST

TRC INC. TEST NO: 040C01NE1 572P 3YO SN040 NECK EXT CAL01

TEST PARAMETER	SPECIFICATION	TEST RESULTS
TEMPERATURE	20.6 - 22.2 DEG. C	21.7 DEG. C
RELATIVE HUMIDITY	10 - 70 %	22.0 %
IMPACT VELOCITY	3.55 - 3.75 M/S	3.70 M/S
INTEGRATED PENDULUM VELOCITY	6 MS 1.0 - 1.4 M/S	1.26 M/S
	10 MS 1.9 - 2.5 M/S	2.32 M/S
	30 MS 2.8 - 3.5 M/S	3.37 M/S
PEAK D-PLANE ROTATION	83 - 93 DEG.	87.48 DEG.
PEAK MOMENT DURING ROTATION INTERVAL	-43.7 / -53.3 NM	-46.94 NM
NEGATIVE MOMENT DECAY TIME TO -10 NM LEVEL	60 - 80 MS	82.64 MS

TEST MEETS SPECIFICATIONS

TECHNICIAN 

RUN NUMBER: 011502.0758;1

HYBRID III THREE YEAR OLD CHILD DUMMY NECK EXTENSION CALIBRATION
PENDULUM DECELERATION

TRC TEST NUMBER: 040C01NE1

572P 3Y0 SN040 NECK EXT CAL01

RUN NUMBER 011502.0802,1

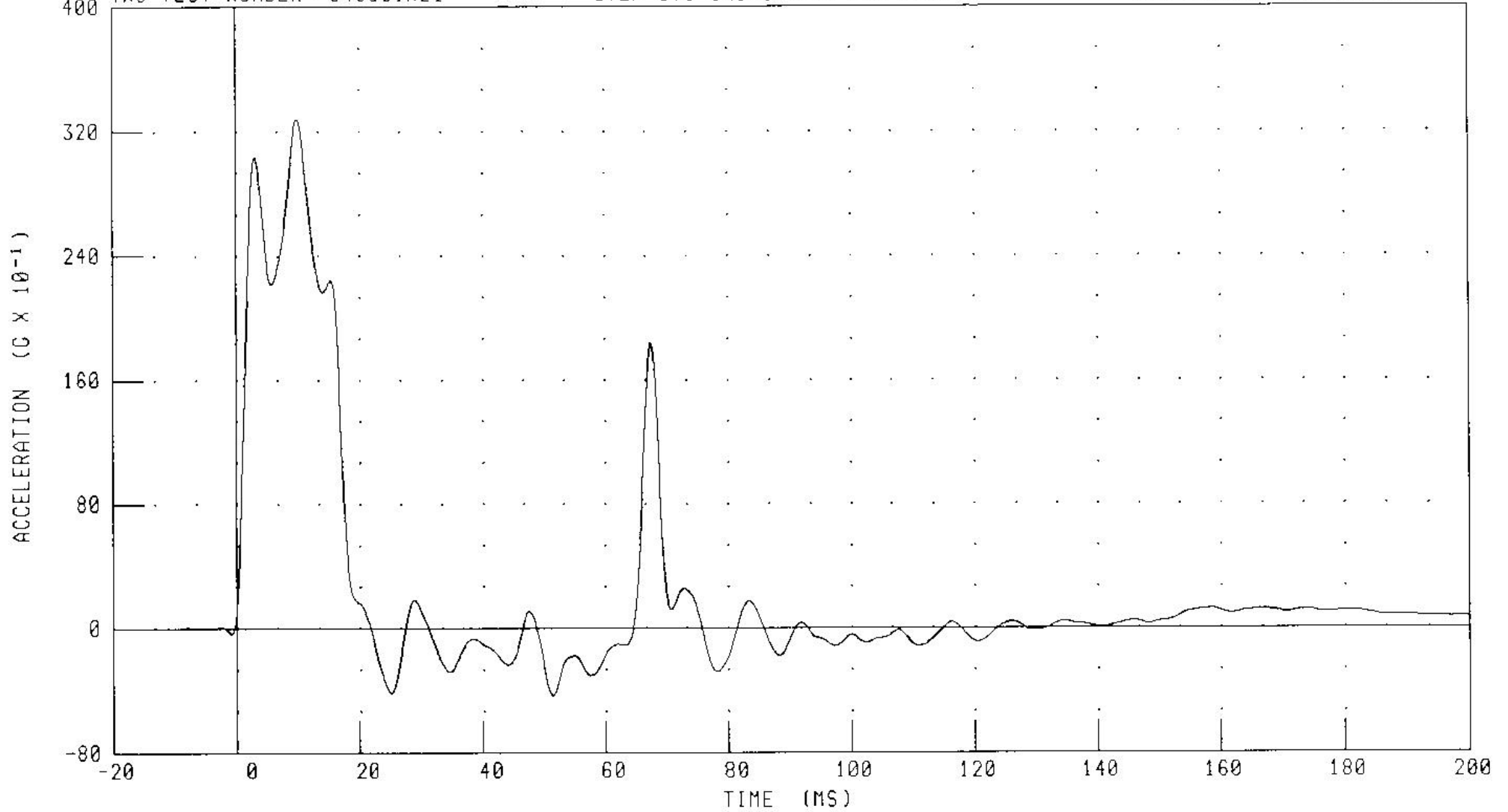

CHANNEL: PENXC

FILTER: CH CLASS 180

PEAK DATA: 32.80 G @ 10.00 MS; -4.34 G @ 51.52 MS

HYBRID III THREE YEAR OLD CHILD DUMMY NECK EXTENSION CALIBRATION

INTEGRATED PENDULUM VELOCITY

TRC TEST NUMBER: 040C01NE1

572P 3Y0 SN040 NECK EXT CAL01

RUN NUMBER: 011502 0802;1

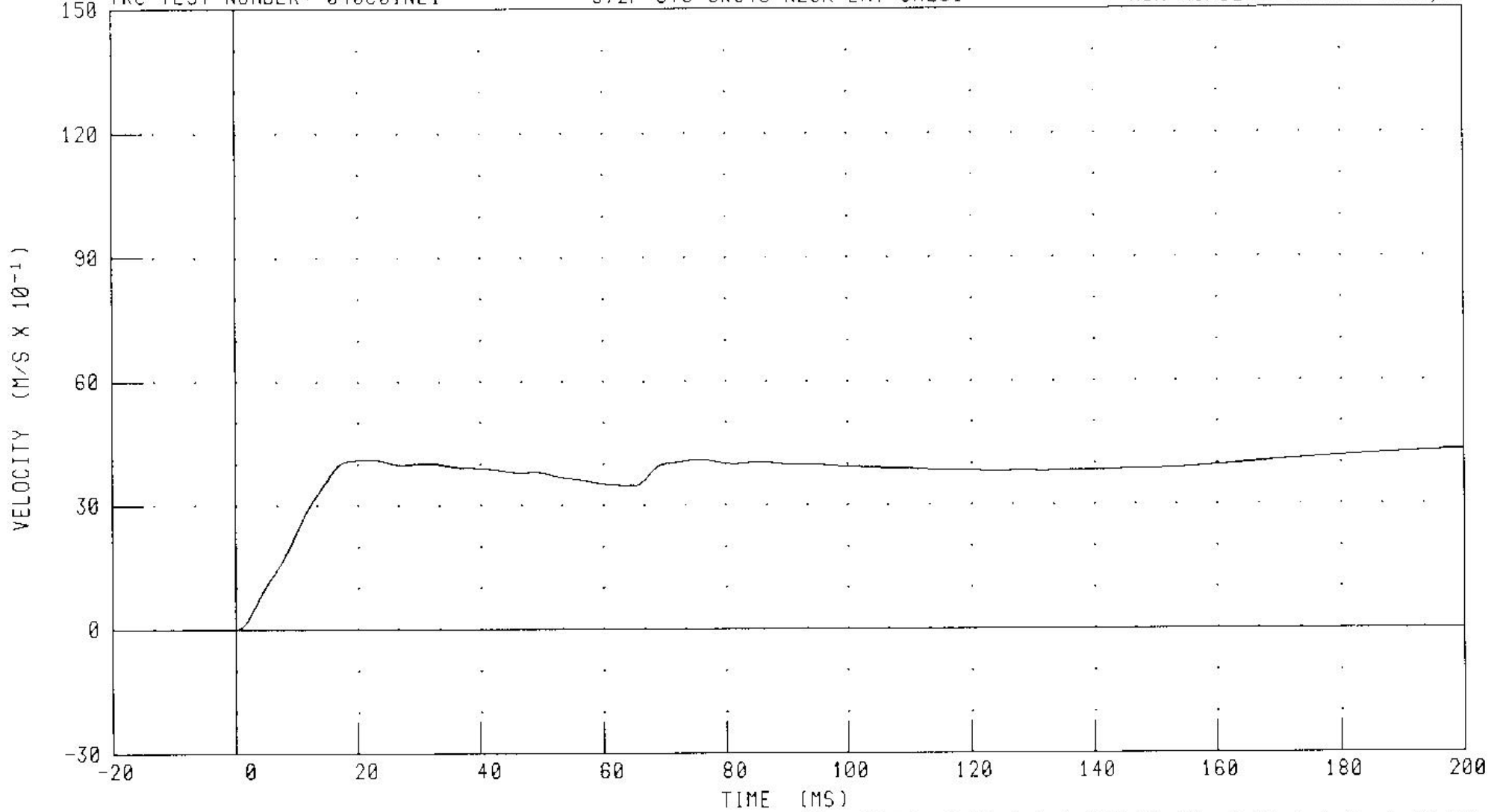

CHANNEL: PENXVI

FILTER CH. CLASS 180

PEAK DATA: 4.32 M/S @ 200.00 MS, 0.00 M/S @ -0.40 MS

HYBRID III THREE YEAR OLD CHILD DUMMY NECK EXTENSION CALIBRATION

ROTATION ABOUT BASE OF NECK

TRC TEST NUMBER: 040C01NE1

572P 3YO SN040 NECK EXT CAL01

RUN NUMBER: 011502.0802,1

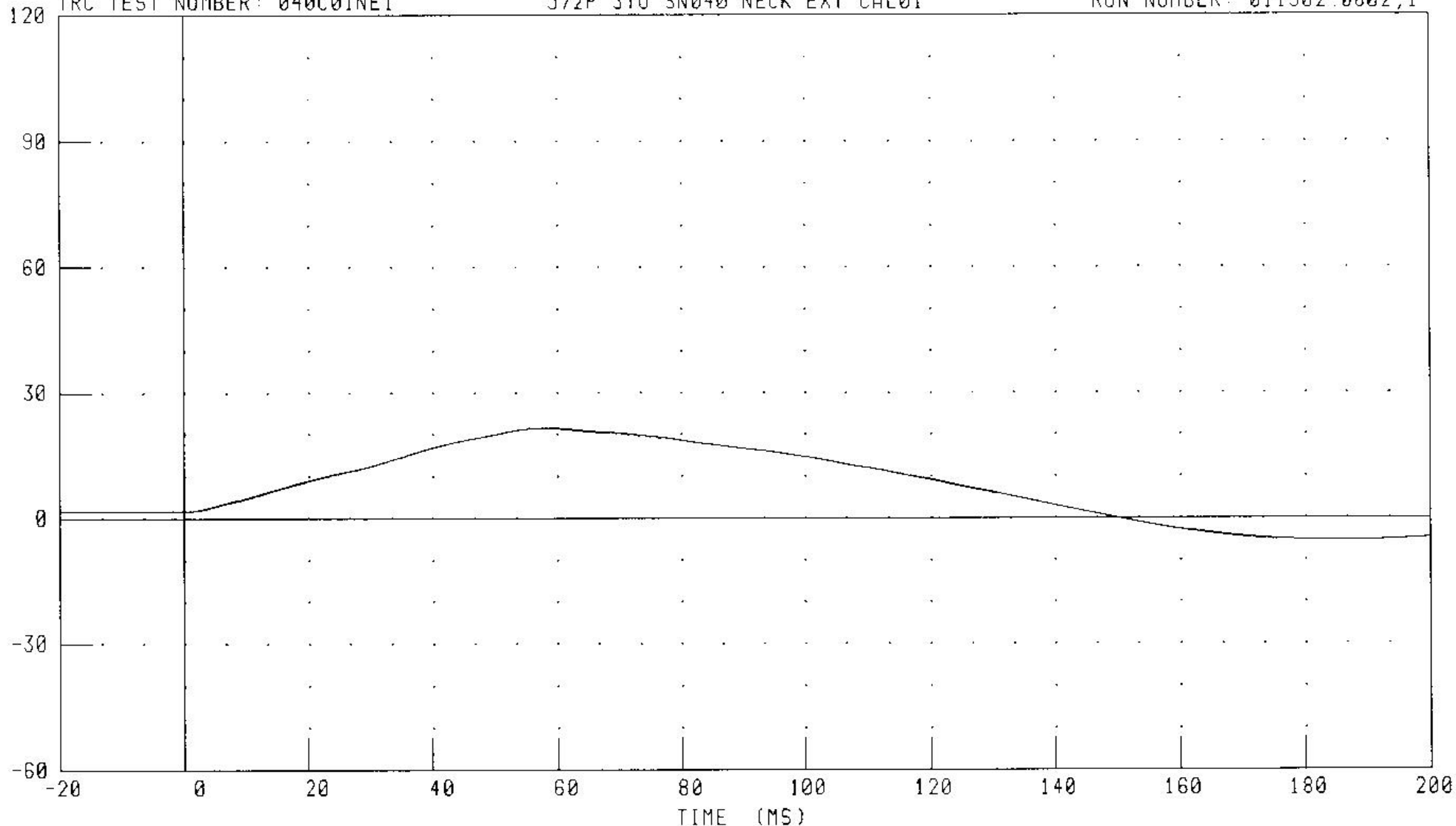

CHANNEL BETA

FILTER: CH. CLASS 60

PEAK DATA: 21.56 ° @ 57.68 MS, -5.43 ° @ 185.52 MS

HYBRID III THREE YEAR OLD CHILD DUMMY NECK EXTENSION CALIBRATION

ROTATION ABOUT OCCIPITAL CONDYLE

TRC TEST NUMBER: 040C01NE1

572P 3Y0 SN040 NECK EXT CAL01

RUN NUMBER: 011502 0802;1

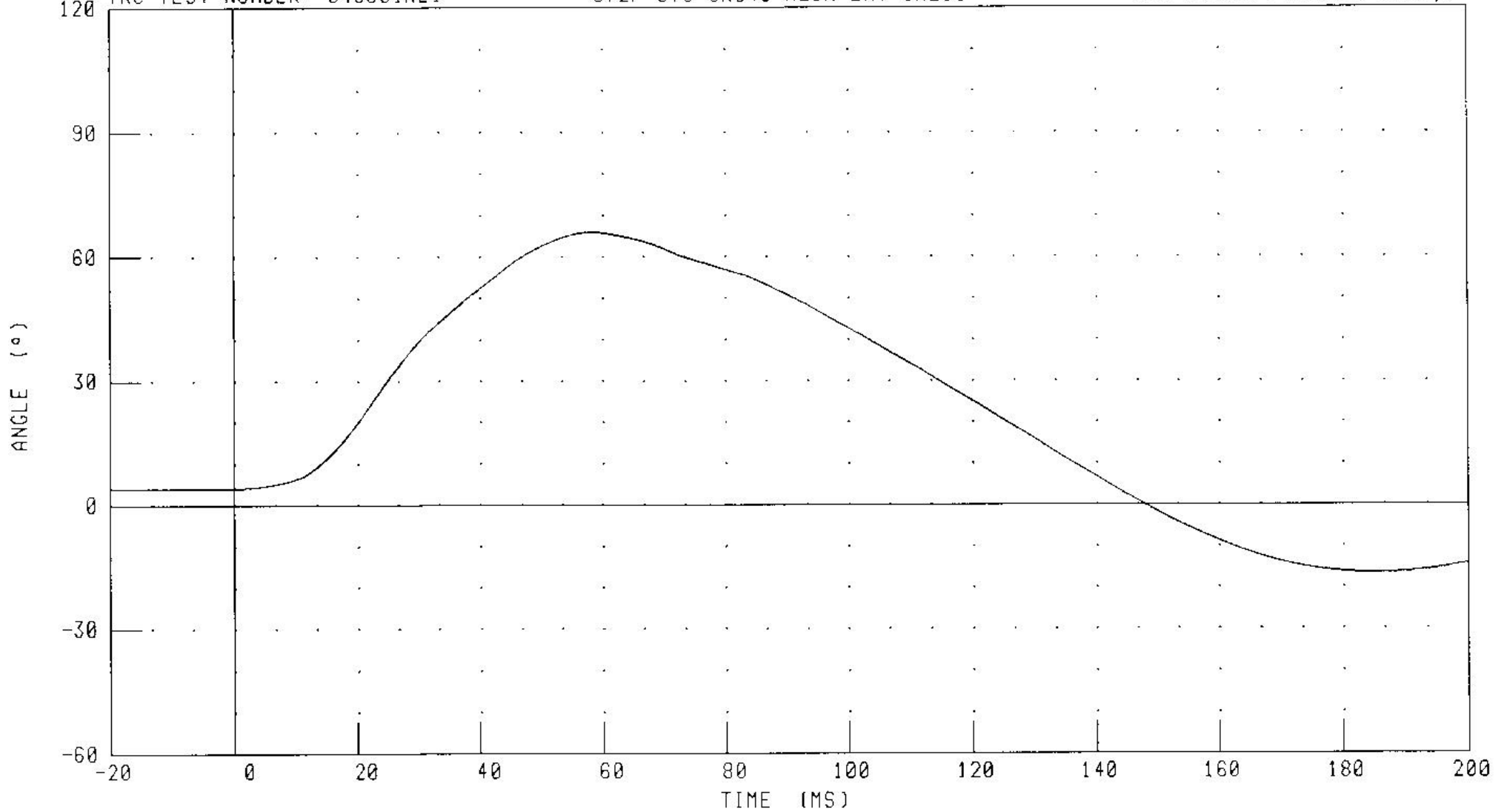

CHANNEL: THETA

FILTER: CH CLASS 60

PEAK DATA 65.93 ° @ 58.32 MS, -16.55 ° @ 185.28 MS

HYBRID III THREE YEAR OLD CHILD DUMMY NECK EXTENSION CALIBRATION
TOTAL ROTATION

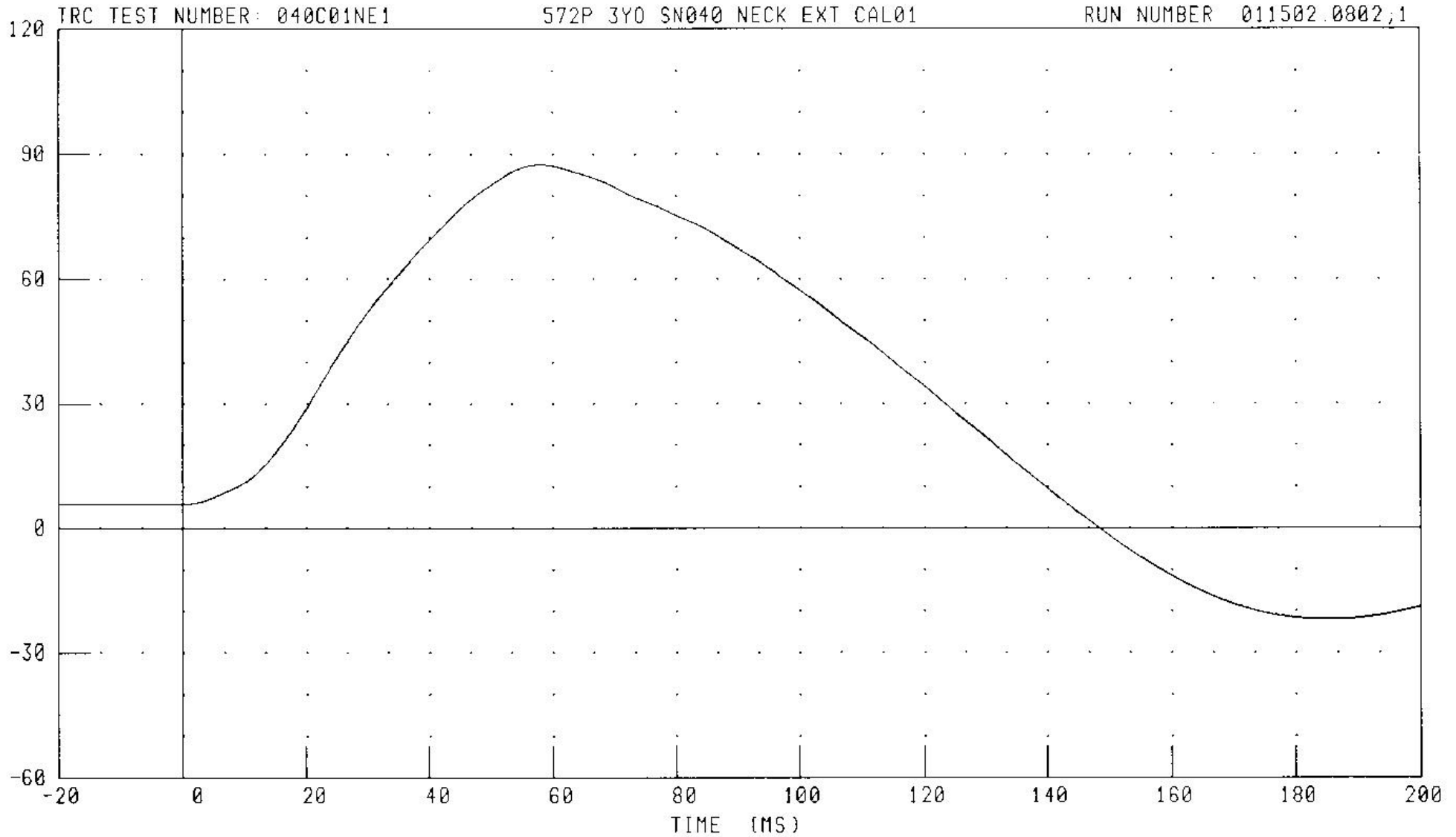

CHANNEL: TOTAN

FILTER CH. CLASS 60

PEAK DATA: 87.48 ° @ 58.08 MS, -21.98 ° @ 185.28 MS

HYBRID III THREE YEAR OLD CHILD DUMMY NECK EXTENSION CALIBRATION
MOMENT ABOUT OCCIPITAL CONDYLE

TRC TEST NUMBER: 040C01NE1 572P 3Y0 SN040 NECK EXT CAL01 RUN NUMBER 011502.0802,1

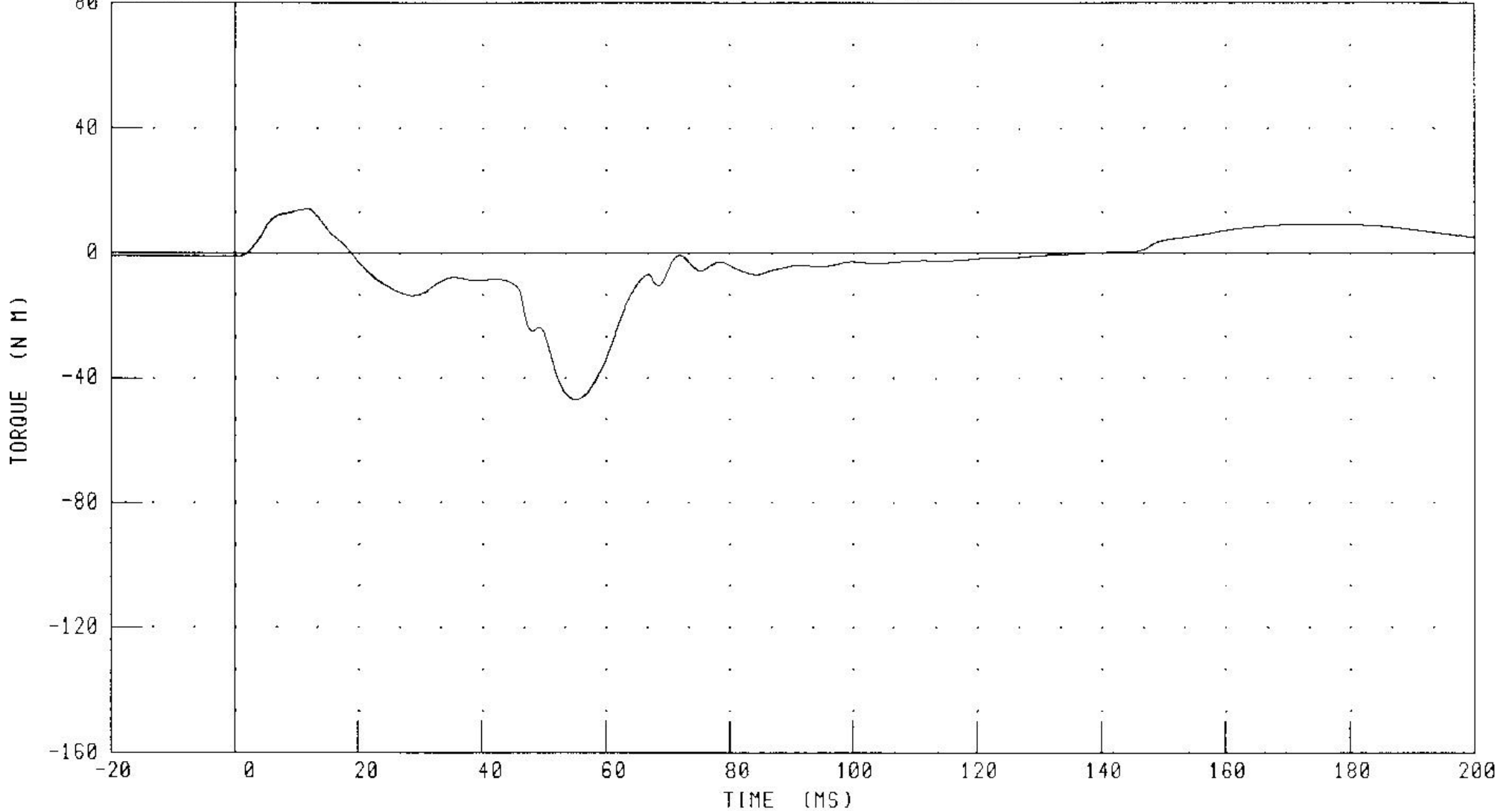

CHANNEL NEKYM FILTER: CH. CLASS 600

PEAK DATA 14.27 N·M @ 11.68 MS, -46.94 N·M @ 55.04 MS

HYBRID III THREE YEAR OLD CHILD DUMMY NECK EXTENSION CALIBRATION
TOTAL ROTATION VS OCCIPITAL CONDYLAR MOMENT

TRC TEST NUMBER: 040C01NE1 572P 3YO SN040 NECK EXT CAL01 RUN NUMBER: 011502 0802,1

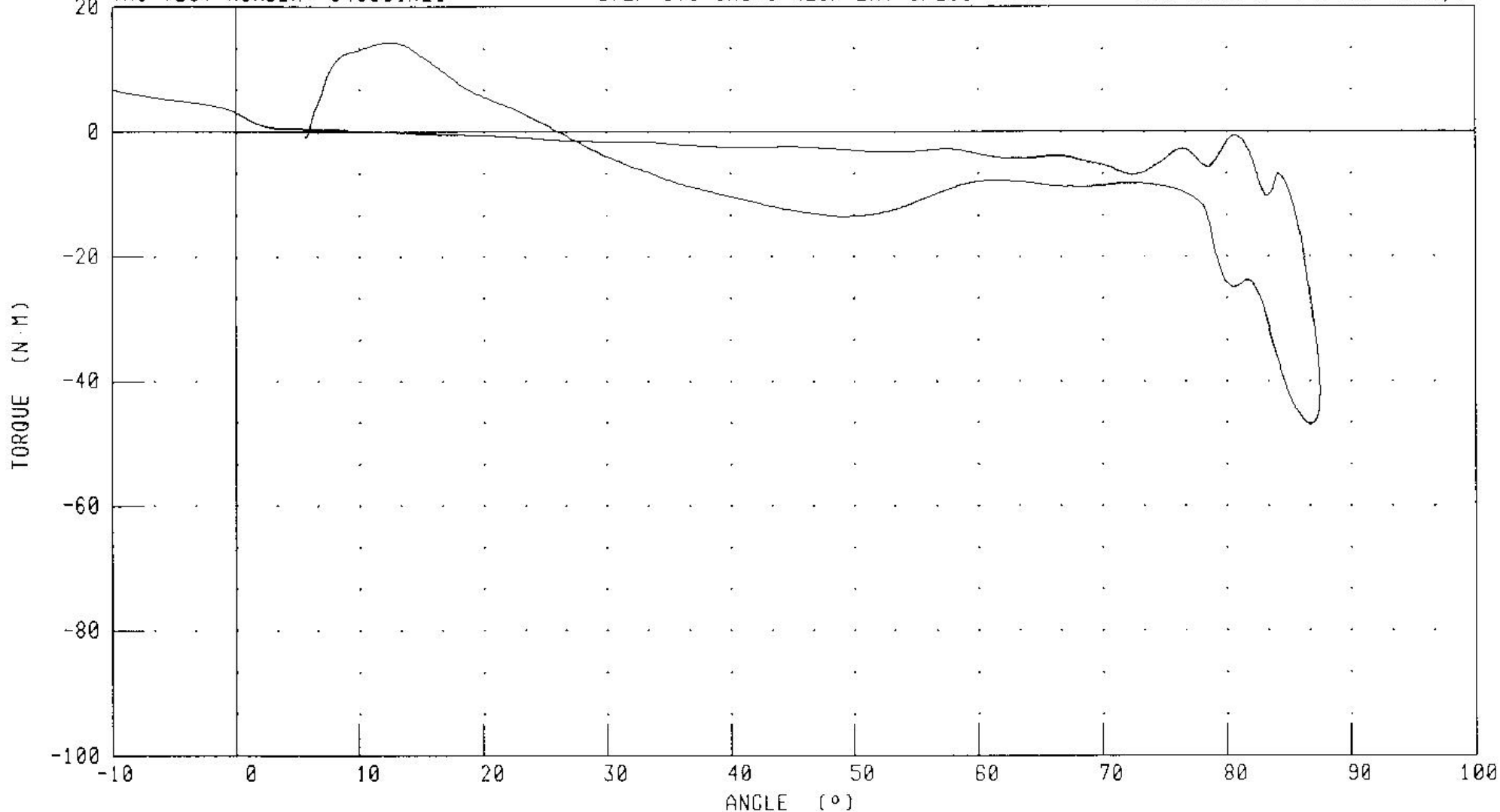

CHANNEL: TOTAN
NEKYM

FILTER: CH. CLASS 60
CH. CLASS 600

ANGLE (°)

PEAK DATA: 87.48 ° @ 58.08 MS; -21.98 ° @ 185.28 MS
14.27 N·M @ 11.68 MS; -46.94 N·M @ 55.04 MS

TRANSPORTATION RESEARCH CENTER INC.

THORAX IMPACT TEST

HYBRID III THREE YEAR OLD

15-JAN-02

TRC INC.

TEST NO: 040C01TH1

572P 3YO SN040 THORAX CAL 01

TEST PARAMETER	HIGH SPEED TEST SPECIFICATION	TEST RESULTS
TEMPERATURE	20.6-22.2 DEG. C	21.7 DEG. C
RELATIVE HUMIDITY	10 - 70 %	21.0 %
PENDULUM VELOCITY	5.90 - 6.10 M/S	5.97 M/S
MAXIMUM DEFLECTION	32 - 38 MM	33.7 MM
MAXIMUM FORCE DURING DEFLECTION INTERVAL	680 - 810 N	720. N
INTERNAL HYSTERESIS	65% - 85%	72.2%
MAXIMUM FORCE BETWEEN 12.5 & 32 MM OF DEFLECTION	<= 910 N	744. N

TEST MEETS SPECIFICATIONS

TECHNICIAN

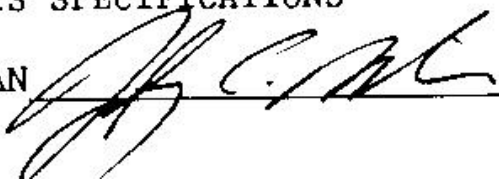

RUN NUMBER: 011502.1022;1

HYBRID III THREE YEAR OLD CHILD DUMMY THORAX CALIBRATION
PENDULUM DECELERATION

TRC TEST NUMBER: 040C01TH1

572P 3YO SN040 THORAX CAL 01

RUN NUMBER: 011502 1029,1

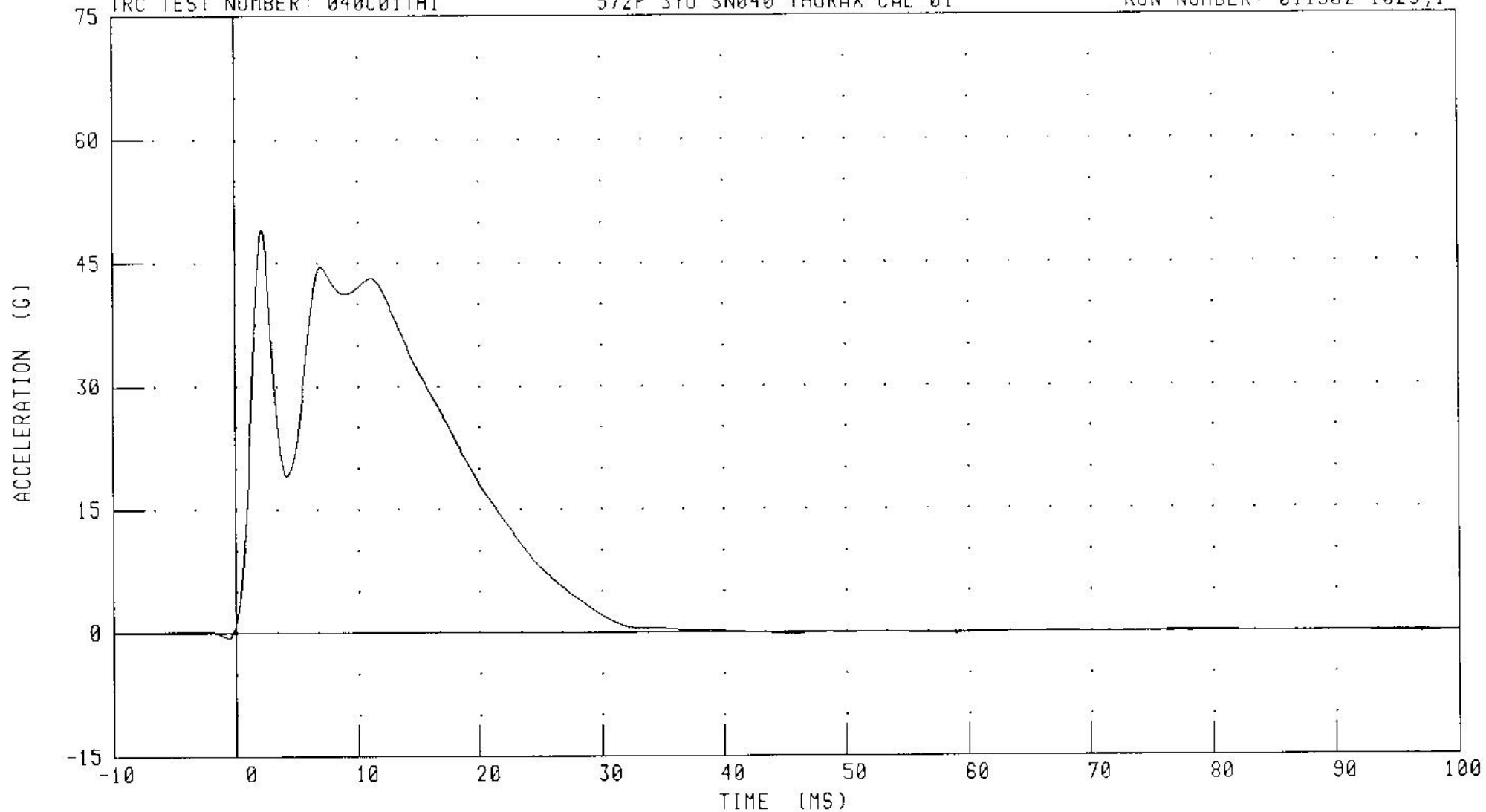

CHANNEL: PENXG

FILTER: CH. CLASS 180

PEAK DATA: 49.14 G @ 2.16 MS, -0.64 G @ -0.64 MS

HYBRID III THREE YEAR OLD CHILD DUMMY THORAX CALIBRATION
PENDULUM FORCE

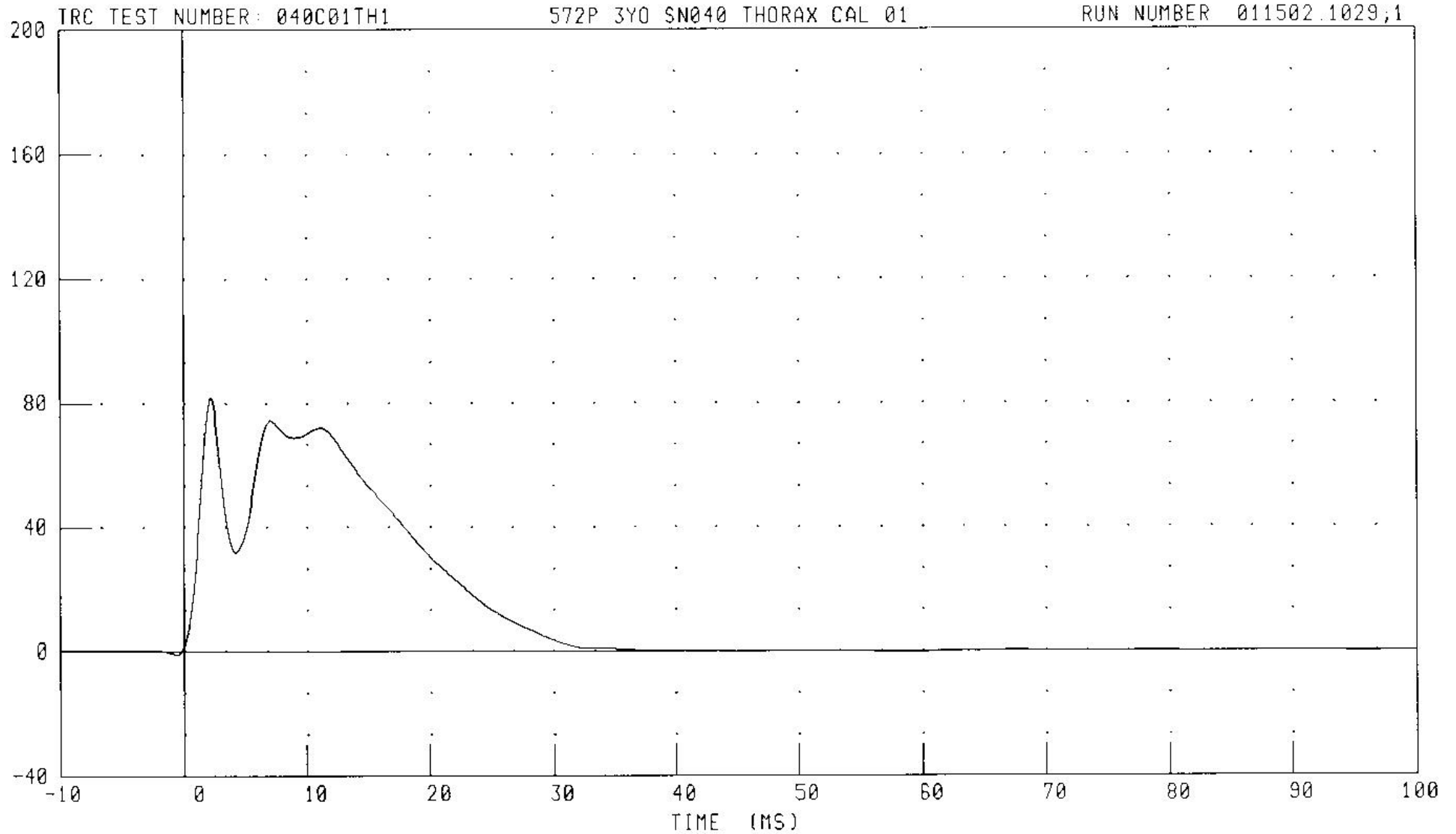

CHANNEL: PENXF

FILTER: CH. CLASS 100

PEAK DATA: 819.63 N @ 2.16 MS; -10.70 N @ -0.64 MS

HYBRID III THREE YEAR OLD CHILD DUMMY THORAX CALIBRATION

STERNUM DISPLACEMENT

TRC TEST NUMBER: 040C01TH1

572P 3Y0 SN040 THORAX CAL 01

RUN NUMBER: 011502.1029;1

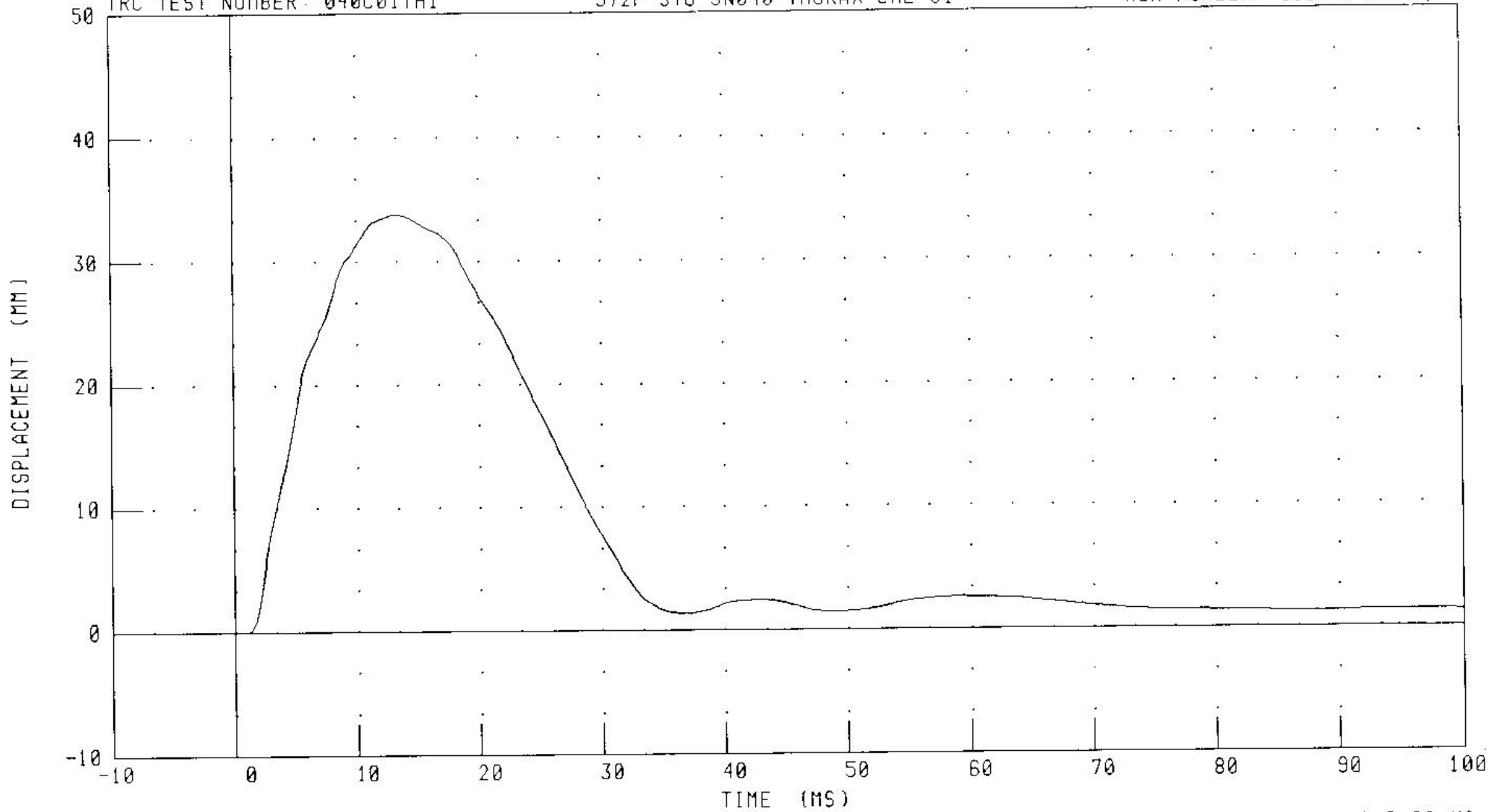

CHANNEL: CSTXD

FILTER CH. CLASS 600

PEAK DATA: 33.78 MM @ 13.36 MS; 0.00 MM @ 0.00 MS

HYBRID III THREE YEAR OLD CHILD DUMMY THORAX CALIBRATION
CHEST DISPLACEMENT VS PENDULUM FORCE

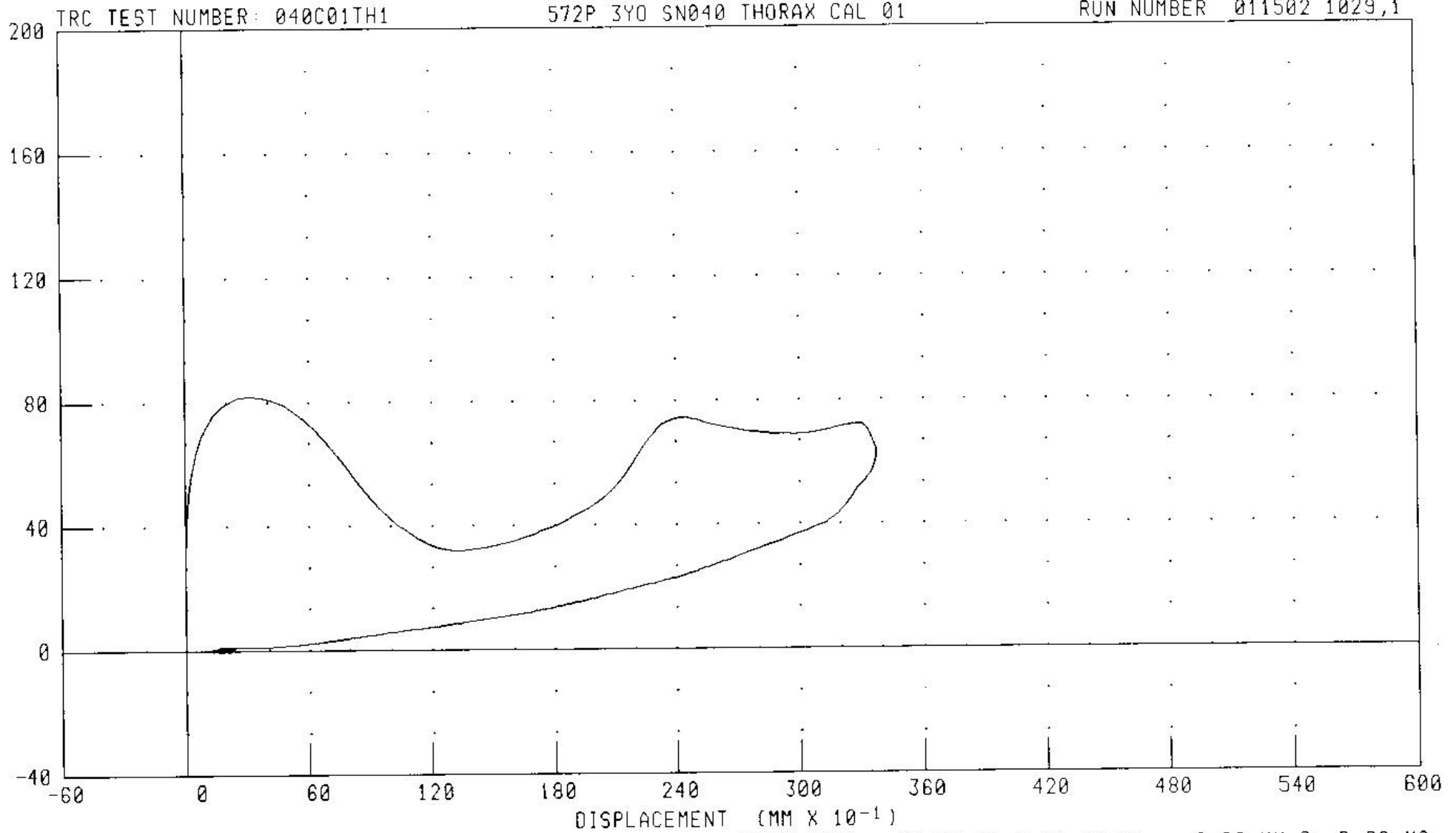

CHANNEL: CSTXD
PENXF

FILTER: CH. CLASS 600
CH. CLASS 180

PEAK DATA 33.78 MM @ 13.36 MS, 0.00 MM @ 0.80 MS
819.63 N @ 2.16 MS, -10.70 N @ -0.64 MS

TRANSPORTATION RESEARCH CENTER INC.

TORSO FLEXION TEST

HYBRID III THREE-YEAR-OLD

CAL DATE: 15-Jan-02

TRC, INC.

TEST NO: 040C01TF1

572 P SN040 TORSO FLEX CAL 01

TEST PARAMETER	SPECIFICATION	TEST RESULTS
TEMPERATURE	20.6 – 22.2 DEG. C	21.7 DEG. C
RELATIVE HUMIDITY	10 – 70 %	24 %
INITIAL ANGLE OF UNSUPPORTED DUMMY	<= 15 DEG. REFERENCED TO VERTICAL	2 DEG.
MAXIMUM FORCE AT 45 DEG. DURING 10 SECOND PERIOD	130 – 180 N	169 N
RETURN ANGLE	+/- 10 DEG OF INITIAL ANGLE	4 DEG.

TEST MEETS SPECIFICATIONS

TECHNICIAN

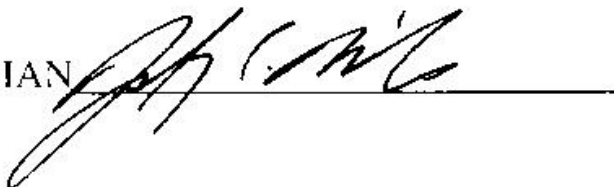

1612

upper

Certificate Of Calibration

Calibration ID	10890	Date of Calibration	08-Nov-00
Model	IF-234	Calibration Due Date	09-May-01
Model Description	CHILD NECK	Customer	VRTC US DOT NHTSA
Serial Number	121	Customer ID	D02910
Temp(F)/Humidity	72.0 / 37.0	Customer Order Number	16659
Technician	DENNIS	Units	IMPERIAL

Voltage Calibration Summary

	Direction	Capacity lb/in-lb	Offset mV/V	NonLinearity %Full Scale	Hysteresis %Full Scale	Output@Capacity mV/V	Change %
FX	Positive	1000	0.0145	0.08	0.19	2.6463	0.0
FY	Positive	1000	0.0143	0.15	0.31	2.6745	0.0
FZ	Negative	-1500	-0.0339	0.13	0.13	-1.4467	0.0
MX	Positive	1500	-0.0005	0.13	0.30	2.1227	0.0
MY	Positive	1500	0.0206	0.08	0.29	2.1323	0.0
MZ	Positive	1000	0.0016	0.45	0.79	2.3597	0.0

Wire Color Codes

FX and MX		FY and MY		FZ and MZ	
Brown	+Excitation	Red-Stripe	+Excitation	Green	+Excitation
Red	+Signal	Black	+Signal	Blue	+Signal
Orange	-Excitation	White	-Excitation	Violet	-Excitation
Yellow	-Signal	Black-Stripe	-Signal	Gray	-Signal

Reference Load Cell

Manufacturer	Interface - GOLDEN	Calibration Date	07-Sep-00
Model	1610ARC-2K	Calibration Due Date	07-Sep-01
Serial Number	113739		

Reference loadcell calibrated by Interface Inc.
Tracable to the National Institute of Standards and Technology (NIST)

Measurement Accuracy within 0.05% full scale output.

Calibration Certified by

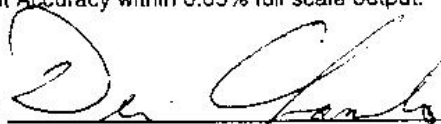

FTSS Authorized Representative

Calibration Procedure: FTSS Load Cell Calibration Procedure



Certificate Of Calibration

Calibration ID	10890	Date of Calibration	08-Nov-00
Model	IF-234	Calibration Due Date	09-May-01
Model Description	CHILD NECK	Customer	VRTC US DOT NHTSA
Serial Number	121	Customer ID	D02910
Temp(F)/Humidity	72.0 / 37.0	Customer Order Number	16659
Technician	DENNIS	Units	IMPERIAL

% Full Scale Crosstalk

	Direction	Load lb/in-lb	FX %Full Scale	FY %Full Scale	FZ %Full Scale	MX %Full Scale	MY %Full Scale	MZ %Full Scale
FX	Positive	1000	0.00	-1.25	1.27	0.38	1.97	0.30
FY	Positive	1000	1.23	0.00	0.63	-2.49	-0.19	-0.58
FZ	Negative	-1500	0.09	-0.34	0.00	-0.46	-0.24	-0.01
MX	Positive	1500	-0.23	0.60	-2.05	0.00	-1.14	-0.30
MY	Positive	1500	-0.42	-0.03	-1.68	1.19	0.00	-0.39
MZ	Positive	1000	0.42	0.53	-2.05	0.13	0.39	0.00

Shunt Calibration

	Loading	Shunt (Ohms)	+Ex to +Sig	+Ex to -Sig	-Ex to +Sig	-Ex to -Sig	Units	Bridge (Ohms)
FX	Positive	60000	555.6	-555.9	-554.9	555.6	LBF	350
	Positive	80000	417.4	-417.7	-416.6	417.0	LBF	350
	Positive	100000	334.0	-334.4	-333.4	333.9	LBF	350
FY	Positive	60000	549.8	-549.9	-549.5	549.4	LBF	350
	Positive	80000	412.9	-412.8	-412.5	412.4	LBF	350
	Positive	100000	330.5	-330.6	-330.2	330.0	LBF	350
FZ	Negative	120000	1509.4	-1513.3	-1506.4	1509.7	LBF	700
	Negative	150000	1209.4	-1211.6	-1206.0	1208.6	LBF	700
	Negative	300000	605.7	-606.3	-603.4	604.9	LBF	700
MX	Positive	60000	1036.8	-1038.8	-1038.0	1039.4	IN-LBF	350
	Positive	80000	778.8	-779.4	-779.1	780.0	IN-LBF	350
	Positive	100000	623.3	-624.0	-623.5	624.5	IN-LBF	350
MY	Positive	60000	1032.5	-1032.2	-1033.1	1033.5	IN-LBF	350
	Positive	80000	775.6	-775.6	-775.5	775.7	IN-LBF	350
	Positive	100000	620.9	-620.9	-621.0	620.9	IN-LBF	350
MZ	Positive	80000	925.9	-924.9	-926.4	926.3	IN-LBF	700
	Positive	100000	742.0	-741.3	-742.1	741.8	IN-LBF	700
	Positive	120000	618.6	-618.1	-618.7	618.5	IN-LBF	700

All shunt resistors are of 0.01% accuracy.

When the equivalent loads are calculated, the sensitivities of a channel for both positive and negative loading directions are assumed to be the same.

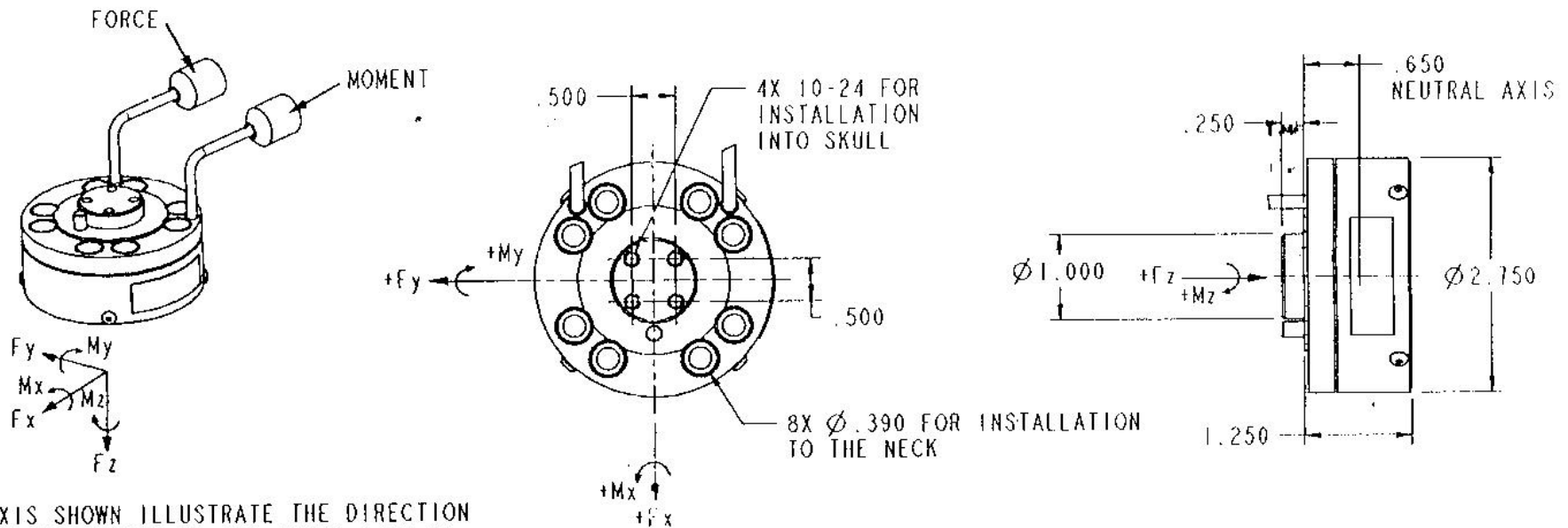

THE AXIS SHOWN ILLUSTRATE THE DIRECTION OF APPLIED FORCES TO THE LOWER PART OF LOADCELL FOR POSITIVE LOADCELL OUTPUT WHEN THIS LOADCELL IS USED AS AN UPPER NECK LOADCELL.

HOWEVER, WHEN THIS LOADCELL IS USED AS A LOWER NECK LOADCELL, THE POLARITY OF THE DATA FOR F_x AND M_x MUST BE CHANGED TO CONFORM TO S.A.E. J-211 SIGN CONVENTION.

	F_x	F_y	F_z	M_x	M_y	M_z
CAPACITY (LBF/IN-LBF)	1,000	1,000	1,500	1,500	1,500	1,000
OUTPUT (mV/V)	2.8	2.8	1.5	2.2	2.2	2.4
BRIDGE RES. (Ω)	350	350	700	350	350	700

WIRING CODE

F_x - M_x		F_y - M_y		F_z - M_z	
COLOR	FUNCTION	COLOR	FUNCTION	COLOR	FUNCTION
BROWN	+EXC.	RED STRIPE	+EXC.	GREEN	+EXC.
RED	+SIG.	BLACK	+SIG.	BLUE	+SIG.
ORANGE	-EXC.	WHITE	-EXC.	VIOLET	-EXC.
YELLOW	-SIG.	BLACK STRIPE	-SIG.	GREY	-SIG.

SPECIFICATIONS

CAPACITY (LBF/IN-LBF)	CHARTED
OVERLOAD CAPACITY (% F.S.)	150
OUTPUT @ F.S. (mV/V) NOMINAL	CHARTED
EXCITATION (VDC) MAX.	15
BRIDGE RESISTANCE (Ω) NOMINAL	CHARTED
NON-LINEARITY (% F.S.)	1.0
HYSTERESIS (% F.S.)	1.0
OPERATING TEMP. RANGE ($^{\circ}$ F)	-65 TO +250
CROSSTALK (% F.S.)	<5%
WEIGHT (LBS)	0.52

1 FIRST TECHNOLOGY
SAFETY SYSTEMS

CHILD SIX CHANNEL NECK LOADCELL

UNLESS OTHERWISE SPECIFIED
DIMENSIONS ARE IN INCHES

DWG. NO. 1F-234

REV
A

142

lower

Certificate Of Calibration

Calibration ID	10839	Date of Calibration	06-Nov-00
Model	IF-234	Calibration Due Date	06-May-01
Model Description	CHILD NECK	Customer	VRTC US DOT NHTSA
Serial Number	120	Customer ID	D02910
Temp(C)/Humidity	22.2 / 27.0	Customer Order Number	16659
Technician	DENNIS	Units	METRIC

Voltage Calibration Summary

	Direction	Capacity N/N-M	Offset mV/V	NonLinearity %Full Scale	Hysteresis %Full Scale	Output@Capacity mV/V	Change %
FX	Positive	4450	-0.0099	0.14	0.29	2.7148	0.0
FY	Positive	4450	0.0001	0.17	0.34	2.7001	0.0
FZ	Negative	-6670	0.0131	0.12	0.11	-1.4629	0.0
MX	Positive	170	-0.0148	0.10	0.29	2.1545	0.0
MY	Positive	170	-0.0065	0.09	0.33	2.1515	0.0
MZ	Positive	110	0.0220	0.47	0.85	2.3500	0.0

Wire Color Codes

FX and MX		FY and MY		FZ and MZ	
Brown	+Excitation	Red-Stripe	+Excitation	Green	+Excitation
Red	+Signal	Black	+Signal	Blue	+Signal
Orange	-Excitation	White	-Excitation	Violet	-Excitation
Yellow	-Signal	Black-Stripe	-Signal	Gray	-Signal

Reference Load Cell

Manufacturer	Interface - GOLDEN	Calibration Date	07-Sep-00
Model	1610ARC-2K	Calibration Due Date	07-Sep-01
Serial Number	113739		

Reference loadcell calibrated by Interface Inc.

Tracable to the National Institute of Standards and Technology (NIST)

Measurement Accuracy within 0.05% full scale output.

Calibration Certified by

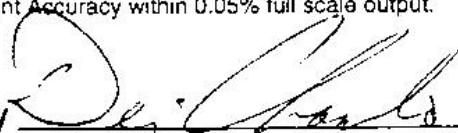

FTSS Authorized Representative

Calibration in conformance with FTSS Loadcell Calibration Procedure.



Certificate Of Calibration

Calibration ID	10839	Date of Calibration	06-Nov-00
Model	IF-234	Calibration Due Date	06-May-01
Model Description	CHILD NECK	Customer	VRTC US DOT NHTSA
Serial Number	120	Customer ID	D02910
Temp(C)/Humidity	22.2 / 27.0	Customer Order Number	16659
Technician	DENNIS	Units	METRIC

% Full Scale Crosstalk

	Direction	Load N/N-M	FX %Full Scale	FY %Full Scale	FZ %Full Scale	MX %Full Scale	MY %Full Scale	MZ %Full Scale
FX	Positive	4450	0.00	0.12	1.09	0.63	2.46	3.00
FY	Positive	4450	-0.35	0.00	-1.45	-2.99	-1.34	2.24
FZ	Negative	-6670	0.12	0.13	0.00	0.12	-0.42	0.14
MX	Positive	170	-0.05	0.20	-0.80	0.00	1.14	-0.52
MY	Positive	170	-0.36	-0.23	-1.14	0.07	0.00	0.38
MZ	Positive	110	0.19	-0.24	-0.55	-0.21	-0.15	0.00

Shunt Calibration

	Loading	Shunt (Ohms)	+Ex to +Sig	+Ex to -Sig	-Ex to +Sig	-Ex to -Sig	Units	Bridge (Ohms)
FX	Positive	60000	2407.4	-2406.9	-2406.5	2405.2	N	350
	Positive	80000	1808.2	-1808.2	-1804.6	1806.4	N	350
	Positive	100000	1447.0	-1447.5	-1444.8	1446.1	N	350
FY	Positive	60000	2424.3	-2419.8	-2420.7	2418.9	N	350
	Positive	80000	1820.7	-1817.5	-1818.0	1817.5	N	350
	Positive	100000	1457.2	-1454.6	-1455.0	1455.0	N	350
FZ	Negative	120000	6649.2	-6645.2	-6650.1	6642.5	N	700
	Negative	150000	5321.0	-5324.5	-5322.7	5320.5	N	700
	Negative	300000	2664.5	-2666.3	-2665.4	2664.0	N	700
MX	Positive	60000	115.6	-115.8	-115.5	115.8	N-M	350
	Positive	80000	87.0	-87.0	-86.9	86.9	N-M	350
	Positive	100000	69.6	-69.6	-69.5	69.6	N-M	350
MY	Positive	60000	115.8	-115.4	-116.0	115.8	N-M	350
	Positive	80000	87.0	-86.8	-87.1	86.8	N-M	350
	Positive	100000	69.6	-69.5	-69.7	69.5	N-M	350
MZ	Positive	80000	102.3	-102.1	-102.3	102.2	N-M	700
	Positive	100000	82.0	-81.8	-81.9	81.8	N-M	700
	Positive	120000	68.3	-68.2	-68.3	68.2	N-M	700

All shunt resistors are of 0.01% accuracy.

When the equivalent loads are calculated, the sensitivities of a channel for both positive and negative loading directions are assumed to be the same.

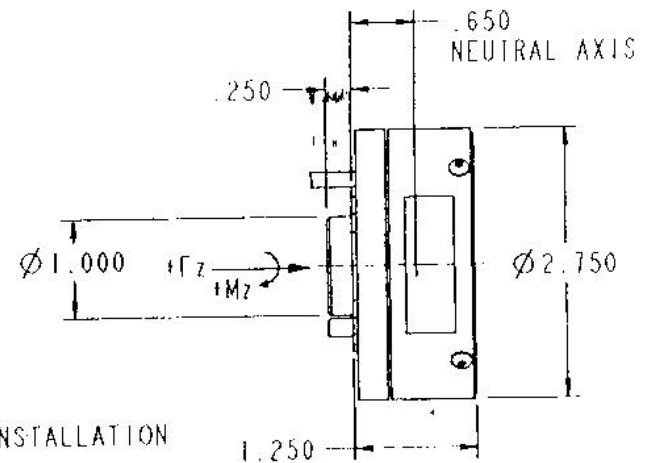
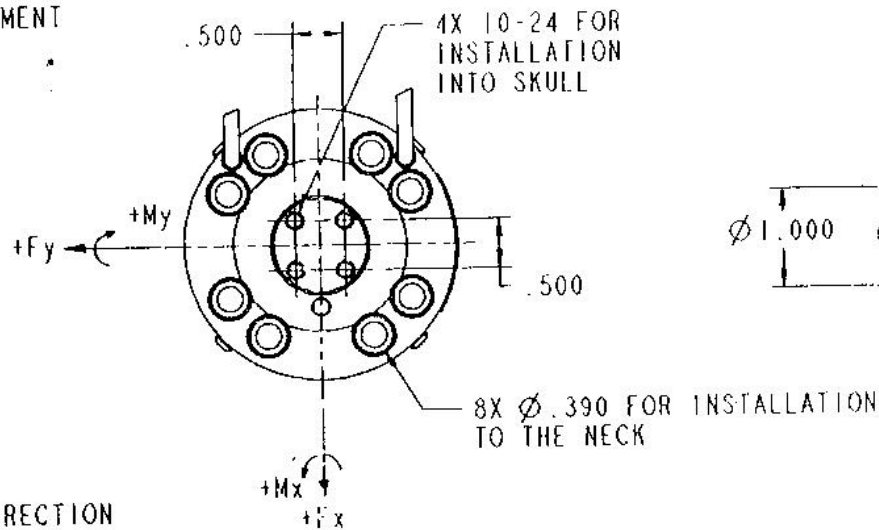
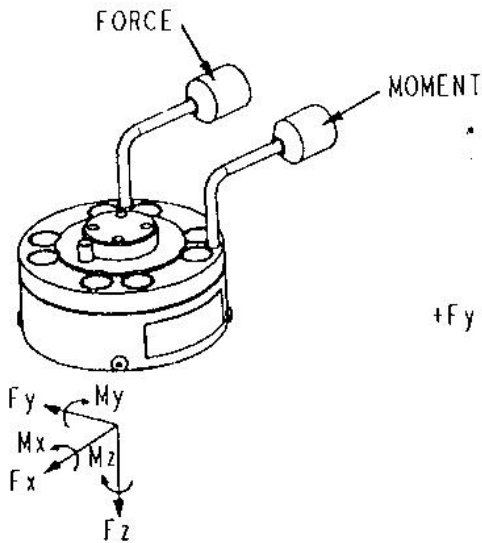

THE AXIS SHOWN ILLUSTRATE THE DIRECTION OF APPLIED FORCES TO THE LOWER PART OF LOADCELL FOR POSITIVE LOADCELL OUTPUT WHEN THIS LOADCELL IS USED AS AN UPPER NECK LOADCELL.

HOWEVER, WHEN THIS LOADCELL IS USED AS A LOWER NECK LOADCELL, THE POLARITY OF THE DATA FOR F_x AND M_x MUST BE CHANGED TO CONFORM TO S.A.E. J-211 SIGN CONVENTION.

SPECIFICATIONS

CAPACITY (LBF/IN-LBF)	CHARTED
OVERLOAD CAPACITY (% F.S.)	150
OUTPUT @ F.S. (mV/V) NOMINAL	CHARTED
EXCITATION (VDC) MAX.	15
BRIDGE RESISTANCE (Ω) NOMINAL	CHARTED
NON-LINEARITY (% F.S.)	1.0
HYSTERESIS (% F.S.)	1.0
OPERATING TEMP. RANGE ($^{\circ}$ F)	-65 TO +250
CROSSTALK (% F.S.)	<5%
WEIGHT (LBS)	0.52

	F_x	F_y	F_z	M_x	M_y	M_z
CAPACITY (LBF/IN-LBF)	1,000	1,000	1,500	1,500	1,500	1,000
OUTPUT (mV/V)	2.8	2.8	1.5	2.2	2.2	2.4
BRIDGE RES. (Ω)	350	350	700	350	350	700

WIRING CODE

F_x - M_x		F_y - M_y		F_z - M_z	
COLOR	FUNCTION	COLOR	FUNCTION	COLOR	FUNCTION
BROWN	+EXC.	RED STRIPE	+EXC.	GREEN	+EXC.
RED	+SIG.	BLACK	+SIG.	BLUE	+SIG.
ORANGE	-EXC.	WHITE	-EXC.	VIOLET	-EXC.
YELLOW	-SIG.	BLACK STRIPE	-SIG.	GREY	-SIG.

**FIRST TECHNOLOGY
SAFETY SYSTEMS**

CHILD SIX CHANNEL NECK LOADCELL

UNLESS OTHERWISE SPECIFIED
DIMENSIONS ARE IN INCHES

DWG. NO.

1F-234

REV.

A

*****CALIBRATION CERTIFICATE*****

Vehicle Research & Test Center - PO Box 37 - E. Liberty, Ohio 43319

	Type	Manufacturer	Model	Serial No.
Transducer:	Chest pot	Servo	N/A	142
Cal. Equip:	Power Supply DMM	Elect. Developement Kiethley	Cce-10d 197a	4876 us-894d0

Label	Pin	Color	Excitation	
+ Excit.	(3)	RED	10 Volts	INPUT RESISTANCE: _____ ohms
- Excit.	(7)	BLACK		
+ Signal	(2)	GREEN		SIGNAL RESISTANCE: _____ ohms
- Signal	(8)	WHITE		
Shield	(5)			COMPUTED OFFSET: 5.241133 [Volts]
CAL. ROOM TEMP:		70 Deg F	MAX NON-LINEARITY: _____ %	
CAL ROOM HUMIDITY: _____ %		FULL SCALE:		45 mm
CAL. ROOM BAROMETER: _____ inches		SENSITIVITY:		2.421 mV/Volt/mm

TECHNICIAN: _____ Date: 1/14/2002
Joshua Smith

ENGINEER UNITS mm	Y-axis READING [Volts]	NON-LINEARITY [%]	%FULL SCALE ERROR		
0	5.231	ERR	0.93%	Regression Output:	
5	5.357	4.37%	0.48%	Constant	5.241133
10	5.486	-1.05%	-0.25%	Std Err of Y Est	0.010967
15	5.609	-1.20%	-0.43%	R Squared	0.999043
20	5.734	-1.69%	-0.80%	No. of Observations	9
25	5.854	-1.16%	-0.70%	Degrees of Freedom	7
30	5.974	-0.81%	-0.60%		
35	6.095	-0.67%	-0.60%	X Coefficient(s)	0.02421
40	6.188	2.32%	1.98%	Std Err of Coef.	0.000283

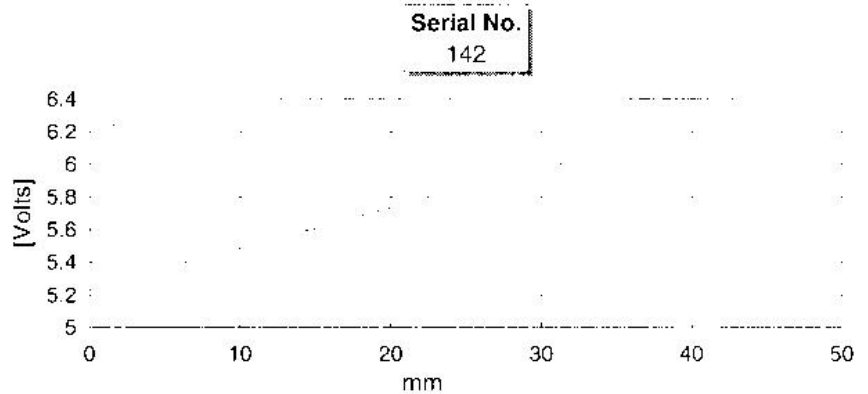

Servo
N/A

#142 HIII 340
Head X Fnd

Calibration Certificate

Customer: VRTC
20010620-0270

Document number: 5932

Description: VRTC - Accelerometer
Manufacturer: ENTRAN
Model Number: EGE-73BE0Q-2000BF
Serial Number: 99108-F29

Input Resistance (ohms): 944.51
ZMO (mV): 16.825
Resonance Frequency (Hz): 25146

0.1987 mV/g @ 100 Hz, 10g pk

Last Sens: 1.987E-1, Change: -0.02
Next cal date: 7/9/2002

Notes:

Excitation: 10.0 V

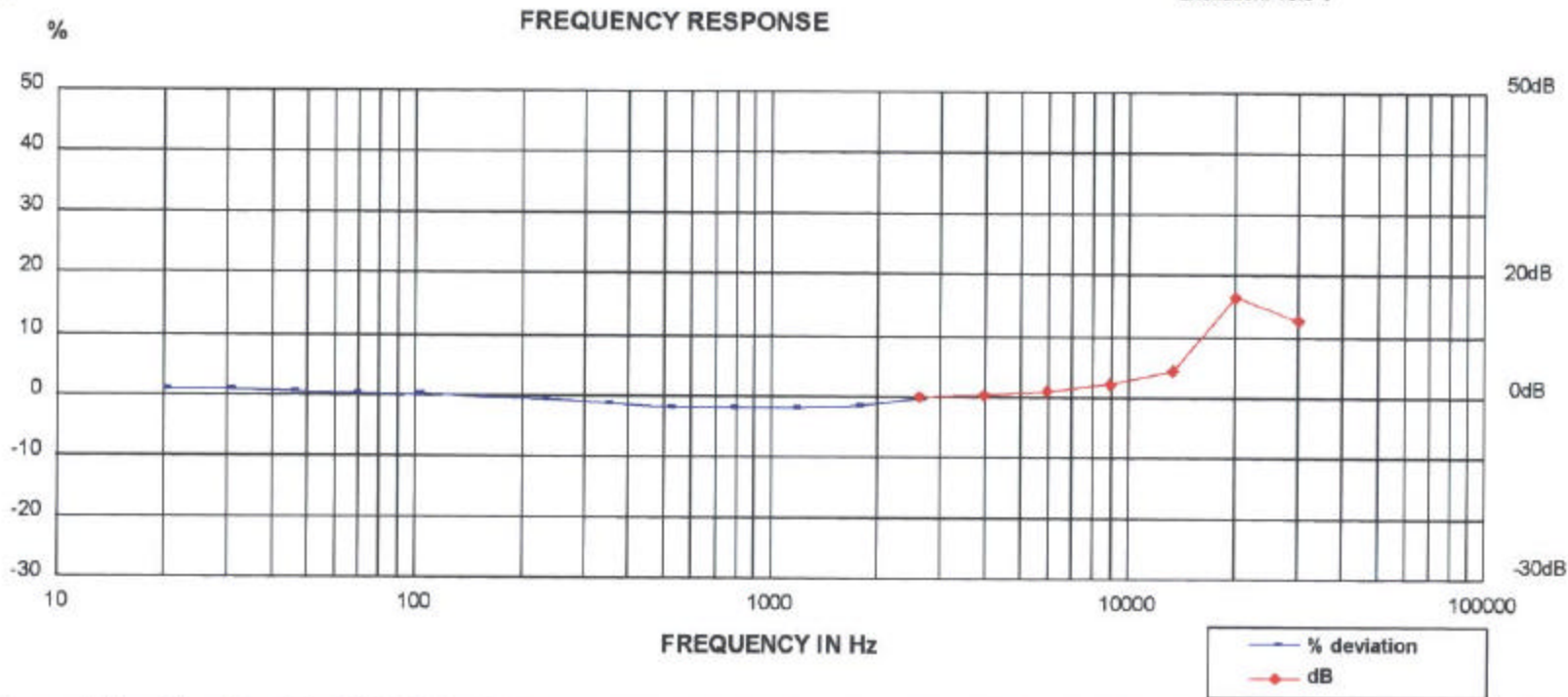

Endevco, a division of Meggitt, located at 30700 Rancho Viejo Road, San Juan Capistrano, CA, certifies that the above instrument was tested using comparison calibrations per ANSI S2.2 using Endevco IM68357. This calibration is traceable to the National Institute of Standards and Technology and is in accordance with ANSI/NC SL Z540-1-1994 (MIL-STD 45662A).

Uncertainty estimate (95% confidence, k=2)

Console serial number: AC27	+/- 1.1 %	100.0 Hz Sensitivity
NIST traceability #: 822/262802-00	+/- 5.0 %	10.0 to 20.0 Hz
Equipment used: 2901	+/- 1.5 %	20.0 to 2000.0 Hz
Test definition: FINAL	+/- 2.5 %	2000.0 to 10000.0 Hz
	+/- 4.0 %	10000.0 to 20000.0 Hz

By: _____
P. KRAMP
Date: 1/9/2002

Endevco
Transportation Research Center

F142 HIII 3Y0
Head Y - LEFT

Calibration Certificate

Customer: VRTC
20010620-0270

Document number: 5929

Description: VRTC - Accelerometer
Manufacturer: ENTRAN
Model Number: EGE-73BE0Q-2000BF
Serial Number: 99102-F12

Input Resistance (ohms): 997.42

ZMO (mV): -11.12

Resonance Frequency (Hz): 27776

0.1839 mV/g @ 100 Hz, 10g pk

Last Sens: 1.836E-1, Change: 0.19

Next cal date: 7/9/2002

Notes:

Excitation: 10.0 V

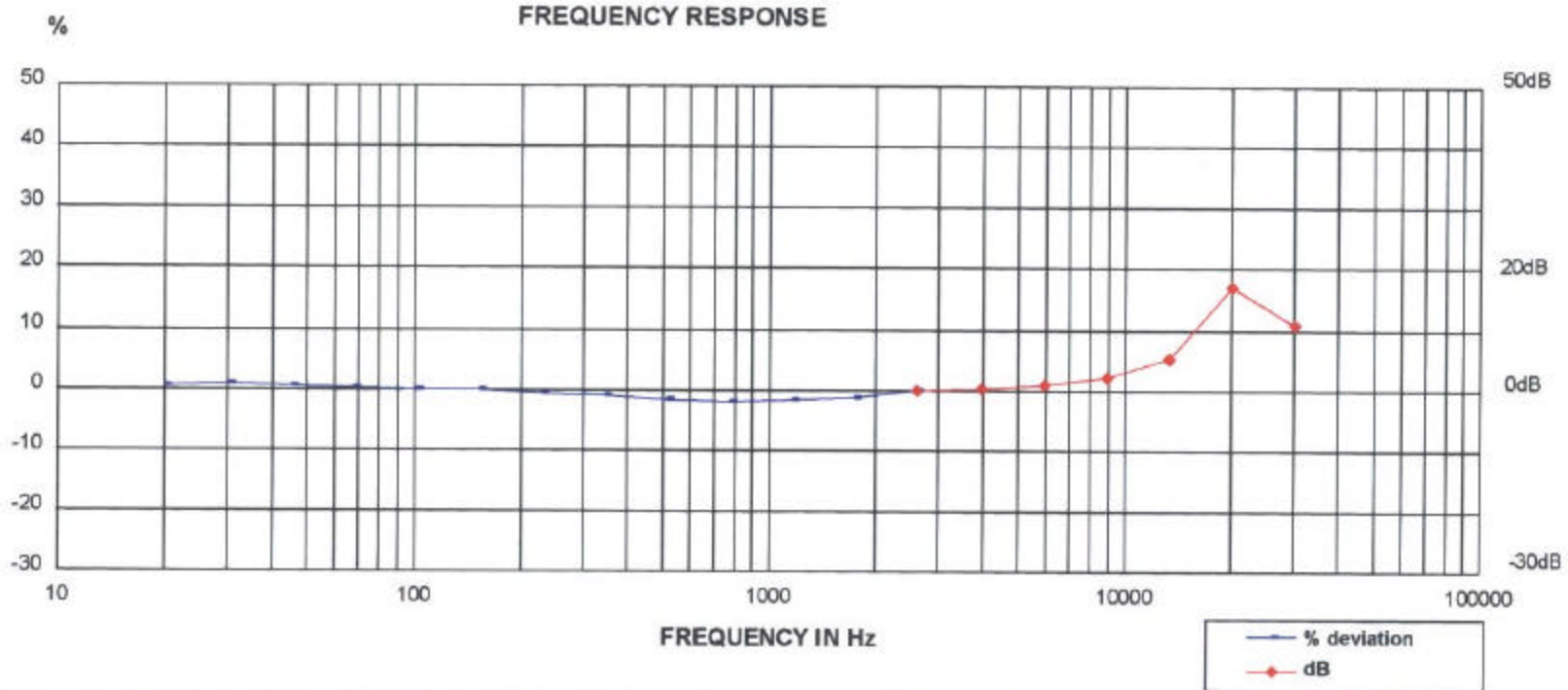

Endevco, a division of Meggitt, located at 30700 Rancho Viejo Road, San Juan Capistrano, CA, certifies that the above instrument was tested using comparison calibrations per ANSI S2.2 using Endevco IM68357. This calibration is traceable to the National Institute of Standards and Technology and is in accordance with ANSI/NCSL Z540-1-1994 (MIL-STD 45662A).

Uncertainty estimate (95% confidence, k=2)

Console serial number: AC27
NIST traceability #: 822/262802-00
Equipment used: 2901
Test definition: FINAL

+/- 1.1 %	100.0 Hz Sensitivity
+/- 5.0 %	10.0 to 20.0 Hz
+/- 1.5 %	20.0 to 2000.0 Hz
+/- 2.5 %	2000.0 to 10000.0 Hz
+/- 4.0 %	10000.0 to 20000.0 Hz

By: _____
P. KRAMP
Date: 1/9/2002

Endevco
Transportation Research Center

142 H III 340

Head \approx WP

Calibration Certificate

Customer: VRTC
20010620-0270

Document number: 5934

Description: VRTC - Full Bridge Accelerometer
Manufacturer: ENTRAN
Model Number: EGE-73BQ-2000BF
Serial Number: 00L13-F03

Input Resistance (ohms): 455.2
Output Resistance (ohms): 458.82
ZMO (mV): -7.172
Resonance Frequency (Hz): 18429

0.2506 mV/g @ 100 Hz, 10g pk

Last Sens: 2.486E-1, Change: 0.79

Next cal date: 1/9/2003

Notes:

Excitation: 10.0 V

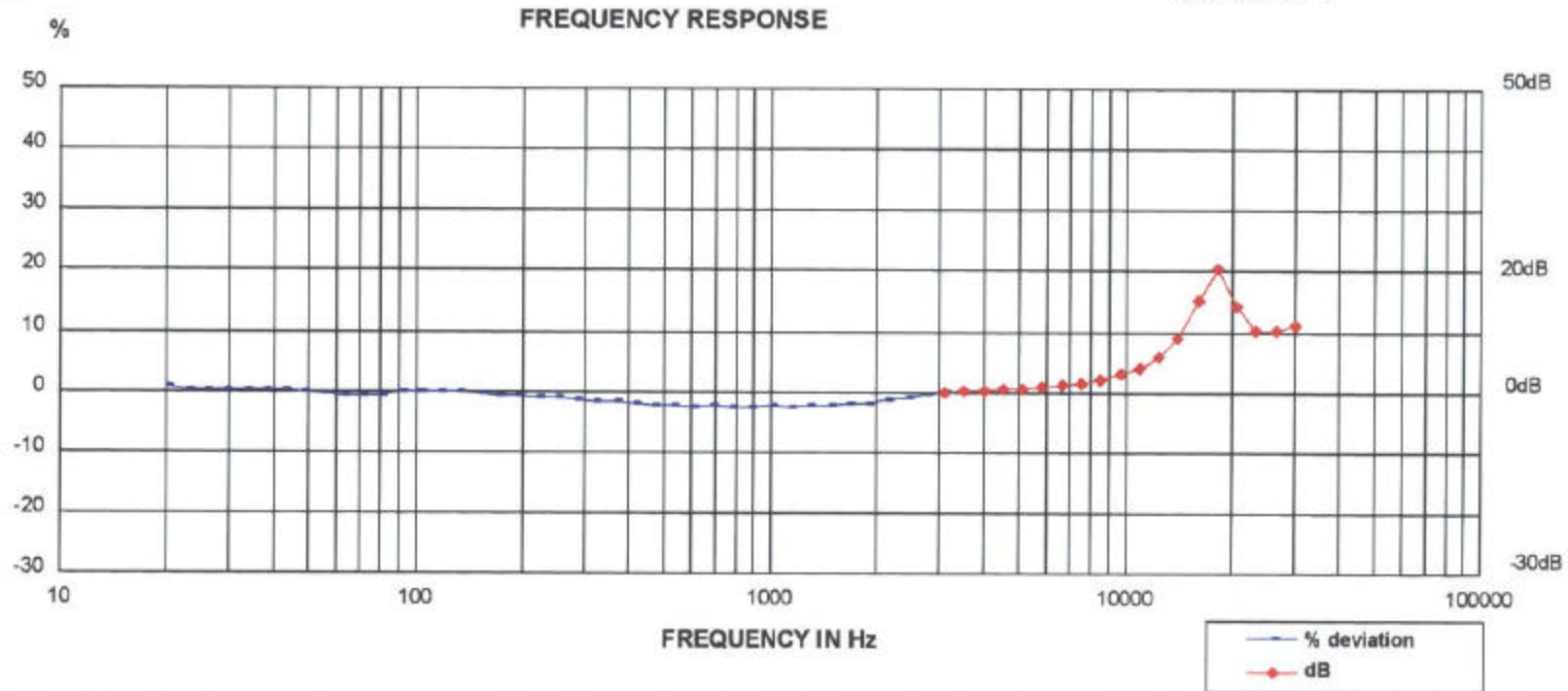

Endevco, a division of Meggitt, located at 30700 Rancho Viejo Road, San Juan Capistrano, CA, certifies that the above instrument was tested using comparison calibrations per ANSI S2.2 using Endevco IM68357. This calibration is traceable to the National Institute of Standards and Technology and is in accordance with ANSI/NCSL Z540-1-1994 (MIL-STD 45662A).

console serial number: AC27
NIST traceability #: 822/262802-00
Equipment used: 2901
Test definition: FINAL

Uncertainty estimate (95% confidence, k=2)

+/- 1.1 %	100.0 Hz Sensitivity
+/- 5.0 %	10.0 to 20.0 Hz
+/- 1.5 %	20.0 to 2000.0 Hz
+/- 2.5 %	2000.0 to 10000.0 Hz
+/- 4.0 %	10000.0 to 20000.0 Hz

By: _____

P. KRAMP

Date: 1/9/2002

Endevco

Transportation Research Center

142 HTII 340

Head Red \approx uP

Calibration Certificate

Customer: VRTC
20010620-0270

Document number: 5933

Description: VRTC - Full Bridge Accelerometer
Manufacturer: ENTRAN
Model Number: EGE-73BQ-2000BF
Serial Number: 98G18-F18

Input Resistance (ohms): 501.49
Output Resistance (ohms): 500.5
ZMO (mV): 14.539
Resonance Frequency (Hz): 19536

0.1861 mV/g @ 100 Hz, 10g pk

Last Sens: 1.852E-1, Change: 0.46

Next cal date: 1/9/2003

Notes:

Excitation: 10.0 V

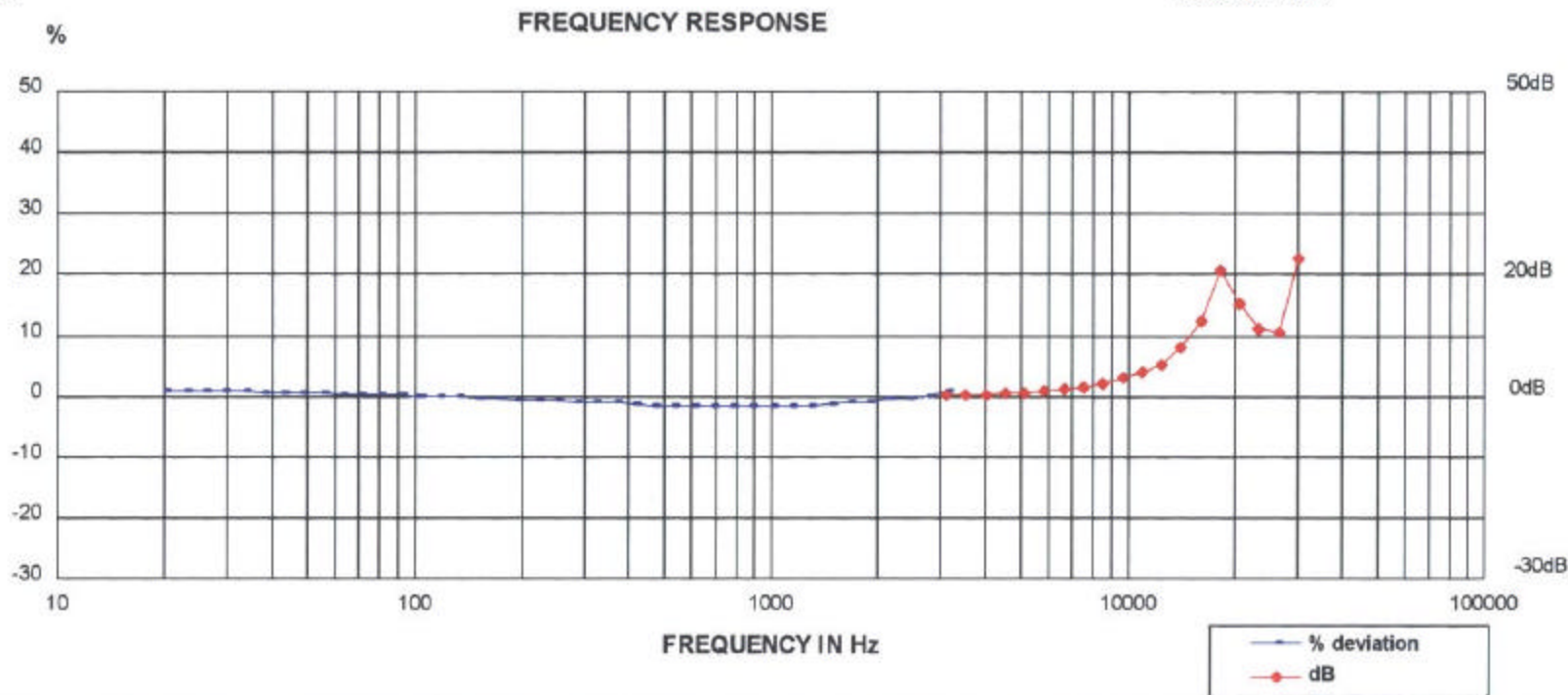

Endevco, a division of Meggitt, located at 30700 Rancho Viejo Road, San Juan Capistrano, CA, certifies that the above instrument was tested using comparison calibrations per ANSI S2.2 using Endevco IM68357. This calibration is traceable to the National Institute of Standards and Technology and is in accordance with ANSI/NC SL Z540-1-1994 (MIL-STD 45662A).

Console serial number: AC27
NIST traceability #: 822/262802-00
Equipment used: 2901
Test definition: FINAL

Uncertainty estimate (95% confidence, k=2)

+/- 1.1 %	100.0 Hz Sensitivity
+/- 5.0 %	10.0 to 20.0 Hz
+/- 1.5 %	20.0 to 2000.0 Hz
+/- 2.5 %	2000.0 to 10000.0 Hz
+/- 4.0 %	10000.0 to 20000.0 Hz

By: _____
P.KRAMP
Date: 1/9/2002

Endevco
Transportation Research Center

12HIII 3V0

Chest X Fwd

Calibration Certificate

Customer: VRTC
20010620-0270

Document number: 5920

Description: VRTC - Accelerometer
Manufacturer: ENTRAN
Model Number: EGE-73BE0Q-2000BF
Serial Number: 99H30-Z04

Input Resistance (ohms): 986.93
ZMO (mV): 0.6887
Resonance Frequency (Hz): 18207

0.2054 mV/g @ 100 Hz, 10g pk

Last Sens: 2.042E-1, Change: 0.59

Next cal date: 7/9/2002

Notes:

Excitation: 10.0 V

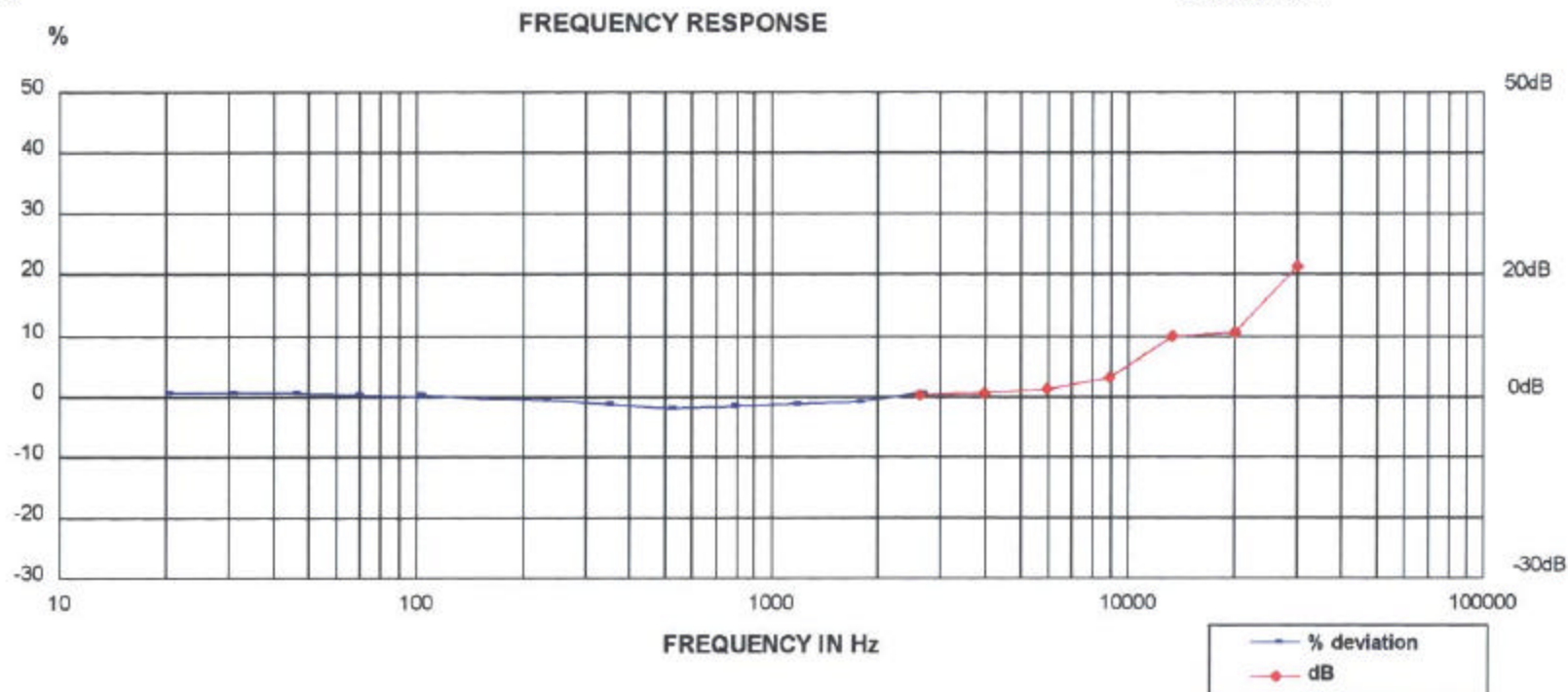

Endevco, a division of Meggitt, located at 30700 Rancho Viejo Road, San Juan Capistrano, CA, certifies that the above instrument was tested using comparison calibrations per ANSI S2.2 using Endevco IM68357. This calibration is traceable to the National Institute of Standards and Technology and is in accordance with ANSI/NCSL Z540-1-1994 (MIL-STD 45662A).

Console serial number: AC27
NIST traceability #: 822/262802-00
Equipment used: 2901
Test definition: FINAL

Uncertainty estimate (95% confidence, k=2)

+/- 1.1 %	100.0 Hz Sensitivity
+/- 5.0 %	10.0 to 20.0 Hz
+/- 1.5 %	20.0 to 2000.0 Hz
+/- 2.5 %	2000.0 to 10000.0 Hz
+/- 4.0 %	10000.0 to 20000.0 Hz

By: _____

P. KRAMP

Date: 1/9/2002

Endevco

Transportation Research Center

#142 HTIII 340

Chest 4 Left

Customer: VRTC
20010620-0270

Calibration Certificate

Document number: 5927

Description: VRTC - Accelerometer
Manufacturer: ENTRAN
Model Number: EGE-73BE0Q-2000BF
Serial Number: 99108-F28

Input Resistance (ohms): 1007.1
ZMO (mV): 1.4745
Resonance Frequency (Hz): 17533

0.2226 mV/g @ 100 Hz, 10g pk

Last Sens: 2.220E-1, Change: 0.27

Next cal date: 7/9/2002

Notes:

Excitation: 10.0 V

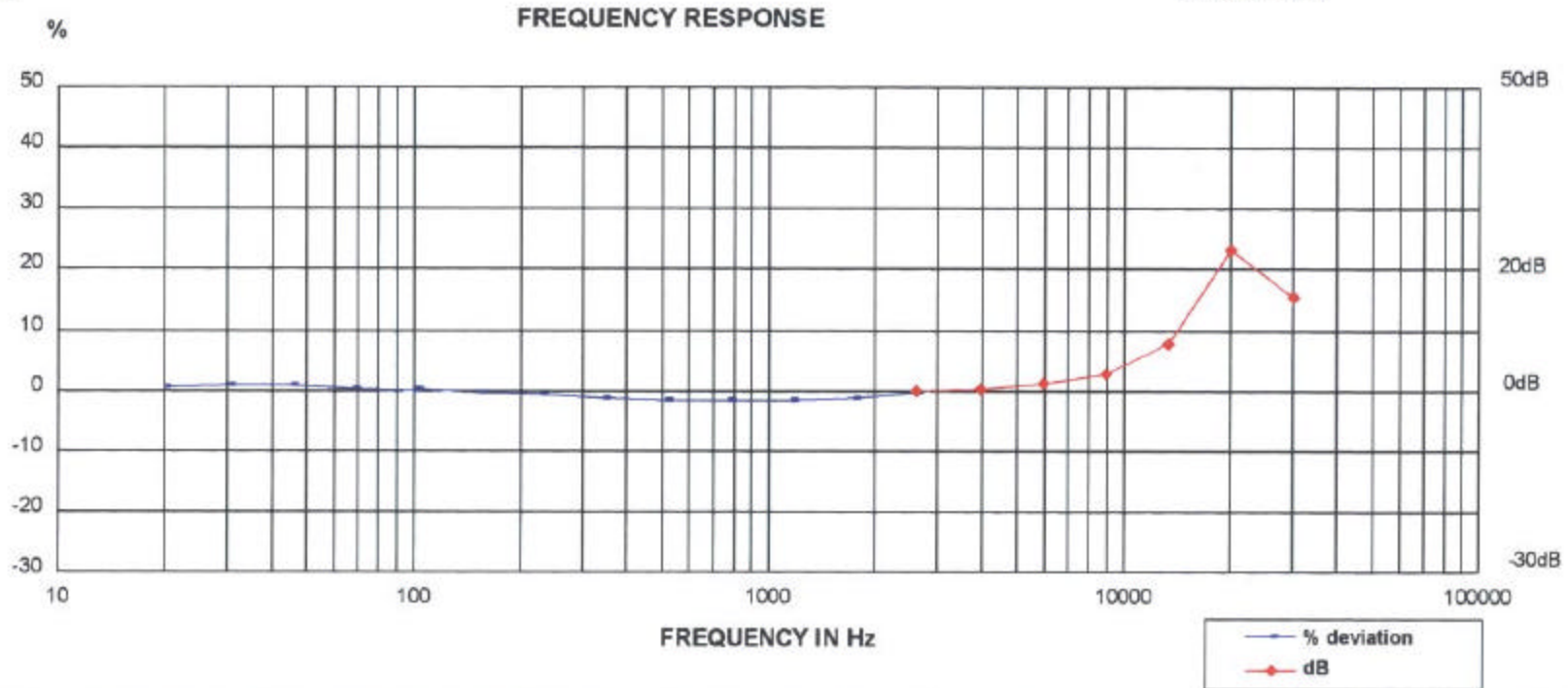

Endevco, a division of Meggitt, located at 30700 Rancho Viejo Road, San Juan Capistrano, CA, certifies that the above instrument was tested using comparison calibrations per ANSI S2.2 using Endevco IM68357. This calibration is traceable to the National Institute of Standards and Technology and is in accordance with ANSI/NC SL Z540-1-1994 (MIL-STD 45662A).

Console serial number: AC27
NIST traceability #: 822/262802-00
Equipment used: 2901
Test definition: FINAL

Uncertainty estimate (95% confidence, k=2)

+/- 1.1 %	100.0 Hz Sensitivity
+/- 5.0 %	10.0 to 20.0 Hz
+/- 1.5 %	20.0 to 2000.0 Hz
+/- 2.5 %	2000.0 to 10000.0 Hz
+/- 4.0 %	10000.0 to 20000.0 Hz

By: _____
P. KRAMP
Date: 1/9/2002

Endevco
Transportation Research Center

#142 HIII 3V0

Chest z wA

Calibration Certificate

Customer: VRTC
20010620-0270

Document number: 5924

Description: VRTC - Accelerometer
Manufacturer: ENTRAN
Model Number: EGE-73BE0Q-2000BF
Serial Number: 99108-F30

Input Resistance (ohms): 1039.0

ZMO (mV): -12.98

Resonance Frequency (Hz): 17523

0.2347 mV/g @ 100 Hz, 10g pk

Last Sens: 2.343E-1, Change: 0.16

Next cal date: 7/9/2002

Notes:

Excitation: 10.0 V

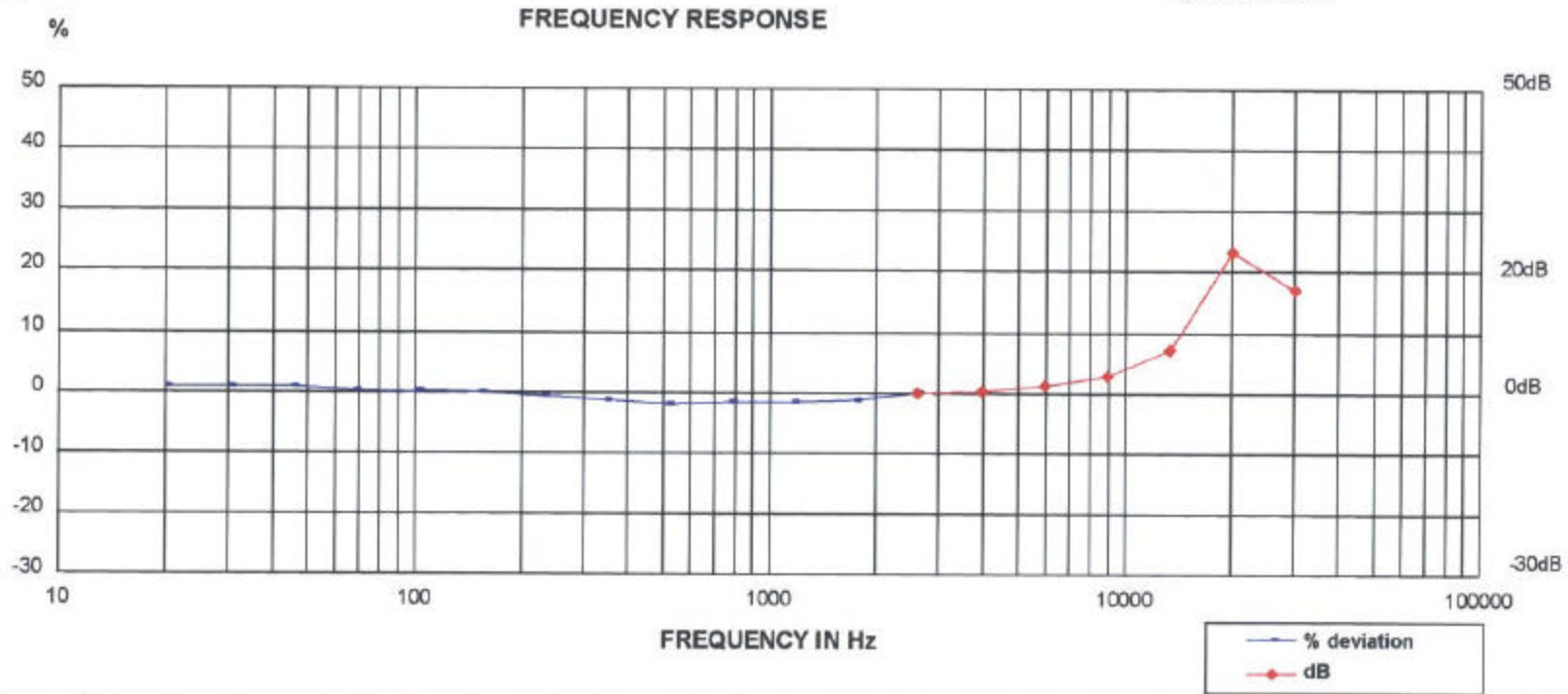

Endevco, a division of Meggitt, located at 30700 Rancho Viejo Road, San Juan Capistrano, CA, certifies that the above instrument was tested using comparison calibrations per ANSI S2.2 using Endevco IM68357. This calibration is traceable to the National Institute of Standards and Technology and is in accordance with ANSI/NCSL Z540-1-1994 (MIL-STD 45662A).

Uncertainty estimate (96% confidence, k=2)

Console serial number: AC27
NIST traceability #: 822/262802-00
Equipment used: 2901
Test definition: FINAL

+/- 1.1 %	100.0 Hz Sensitivity
+/- 5.0 %	10.0 to 20.0 Hz
+/- 1.5 %	20.0 to 2000.0 Hz
+/- 2.5 %	2000.0 to 10000.0 Hz
+/- 4.0 %	10000.0 to 20000.0 Hz

By: _____
P. KRAMP
Date: 1/9/2002

Endevco
Transportation Research Center

142 H III 340
Pelvis Rear

Calibration Certificate

Customer: VRTC
20010620-0270

Document number: 5923

Description: VRTC - Accelerometer
Manufacturer: ENTRAN
Model Number: EGE-73BE0Q-2000BF
Serial Number: 99102-F06

Input Resistance (ohms): 935.54

ZMO (mV): -8.56
Resonance Frequency (Hz): 28185

0.1859 mV/g @ 100 Hz, 10g pk

Last Sens: 1.860E-1, Change: -0.01

Next cal date: 7/9/2002

Notes:

Excitation: 10.0 V

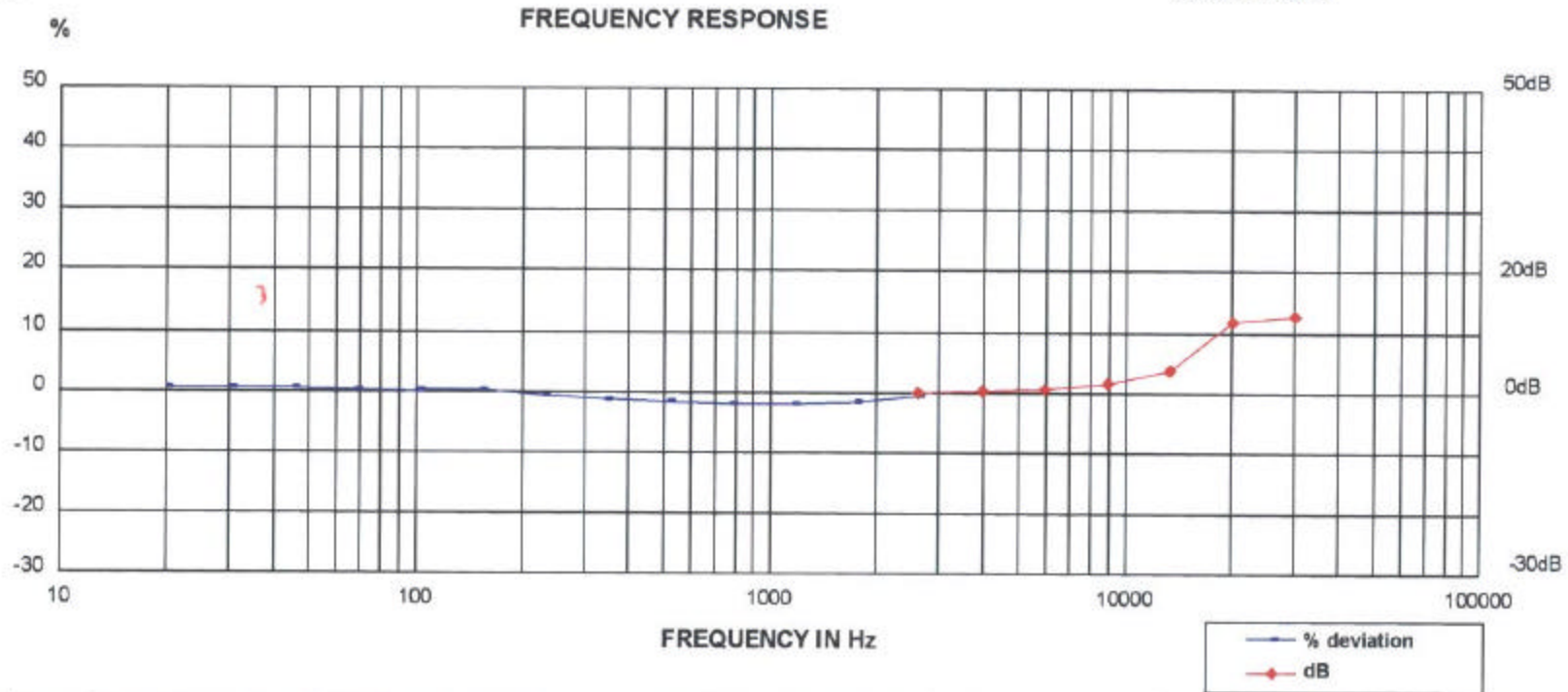

Endevco, a division of Meggitt, located at 30700 Rancho Viejo Road, San Juan Capistrano, CA, certifies that the above instrument was tested using comparison calibrations per ANSI S2.2 using Endevco IM68357. This calibration is traceable to the National Institute of Standards and Technology and is in accordance with ANSI/NCSL Z540-1-1994 (MIL-STD 45662A).

Console serial number: AC27
NIST traceability #: 822/262802-00
Equipment used: 2901
Test definition: FINAL

Uncertainty estimate (95% confidence, k=2)

+/- 1.1 %	100.0 Hz Sensitivity
+/- 5.0 %	10.0 to 20.0 Hz
+/- 1.5 %	20.0 to 2000.0 Hz
+/- 2.5 %	2000.0 to 10000.0 Hz
+/- 4.0 %	10000.0 to 20000.0 Hz

By: _____

P. KRAMP

Date: 1/9/2002

Endevco

Transportation Research Center

#142 + III 340
Pelvis y Left

Calibration Certificate

Customer: VRTC
20010620-0270

Document number: 5922

Description: VRTC - Accelerometer
Manufacturer: ENTRAN
Model Number: EGE-73BE0Q-2000BF
Serial Number: 99102-F15

Input Resistance (ohms): 958.27

ZMO (mV): -6.154
Resonance Frequency (Hz): 25281

0.1854 mV/g @ 100 Hz, 10g pk

Last Sens: 1.852E-1, Change: 0.14

Next cal date: 7/9/2002

Notes:

Excitation: 10.0 V

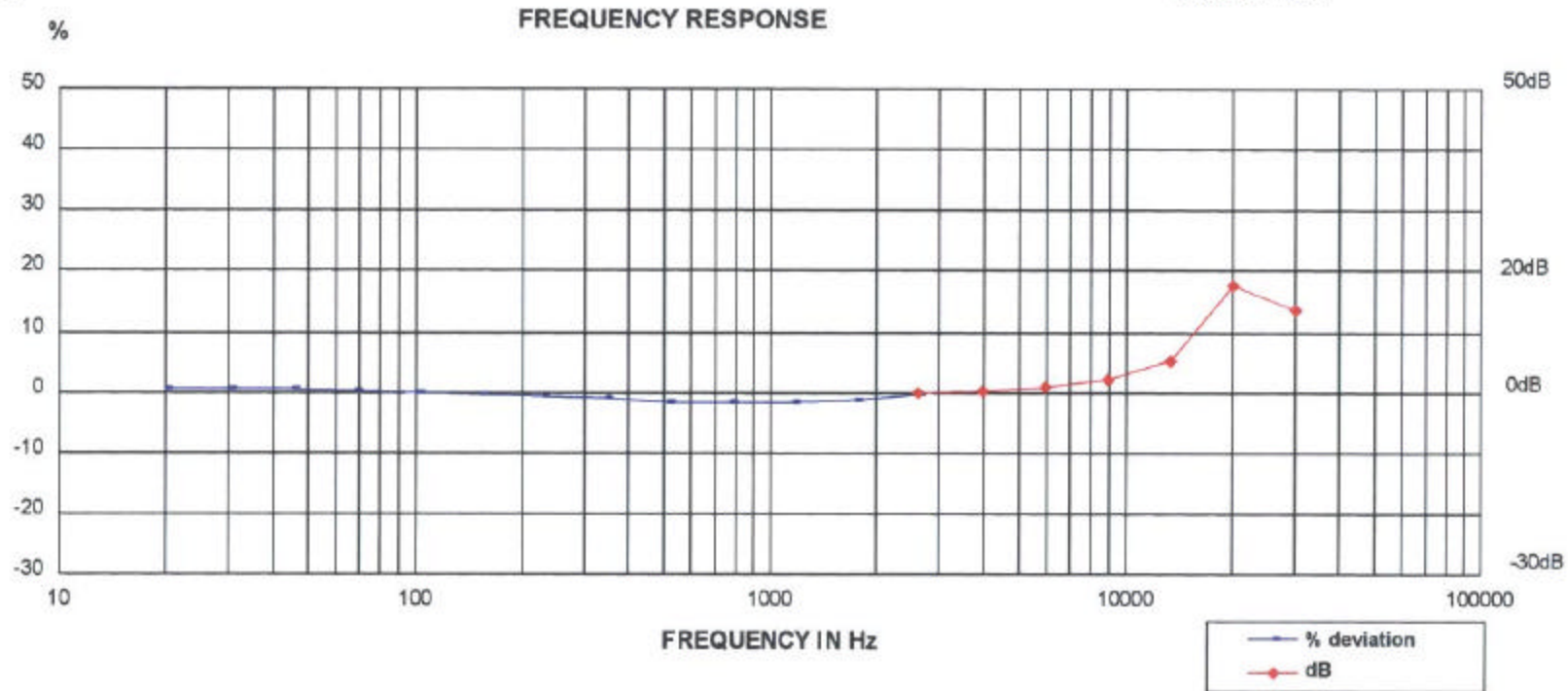

Endevco, a division of Meggitt, located at 30700 Rancho Viejo Road, San Juan Capistrano, CA, certifies that the above instrument was tested using comparison calibrations per ANSI S2.2 using Endevco IM68357. This calibration is traceable to the National Institute of Standards and Technology and is in accordance with ANSI/NC SL Z540-1-1994 (MIL-STD 45662A).

Uncertainty estimate (95% confidence, k=2)

Console serial number: AC27
NIST traceability #: 822/262802-00
Equipment used: 2901
Test definition: FINAL

+/- 1.1 %	100.0 Hz Sensitivity
+/- 5.0 %	10.0 to 20.0 Hz
+/- 1.5 %	20.0 to 2000.0 Hz
+/- 2.5 %	2000.0 to 10000.0 Hz
+/- 4.0 %	10000.0 to 20000.0 Hz

By: _____
P. KRAMP

Date: 1/9/2002

Endevco
Transportation Research Center

#142 H11 340

Delvis ZWA

Calibration Certificate

Customer: VRTC
20010620-0270

Document number: 5921

Description: VRTC - Accelerometer
Manufacturer: ENTRAN
Model Number: EGE-73BE0Q-2000BF
Serial Number: 99G29-Q13

Input Resistance (ohms): 632.69

ZMO (mV): -25.21
Resonance Frequency (Hz): 18488

0.2320 mV/g @ 100 Hz, 10g pk

Last Sens: 2.278E-1, Change: 1.83

Next cal date: 7/9/2002

Notes:

Excitation: 10.0 V

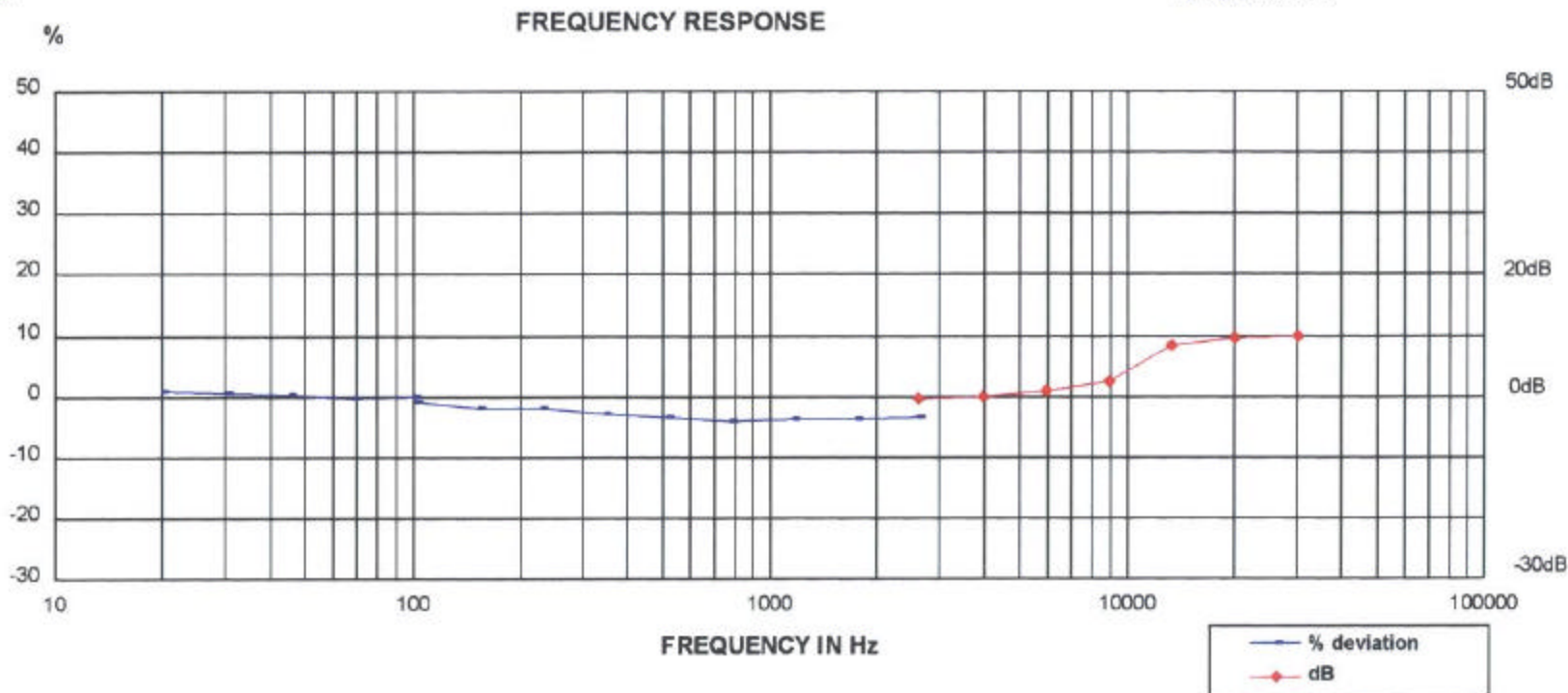

Endevco, a division of Meggitt, located at 30700 Rancho Viejo Road, San Juan Capistrano, CA, certifies that the above instrument was tested using comparison calibrations per ANSI S2.2 using Endevco IM68357. This calibration is traceable to the National Institute of Standards and Technology and is in accordance with ANSI/NCSL Z540-1-1994 (MIL-STD 45662A).

Uncertainty estimate (95% confidence, k=2)

Console serial number:	AC27	+/- 1.1 %	100.0 Hz	Sensitivity
NIST traceability #:	822/262802-00	+/- 5.0 %	10.0 to 20.0 Hz	
Equipment used:	2901	+/- 1.5 %	20.0 to 2000.0 Hz	
Test definition:	FINAL	+/- 2.5 %	2000.0 to 10000.0 Hz	
		+/- 4.0 %	10000.0 to 20000.0 Hz	

By: _____
P. KRAMP
Date: 1/9/2002

Endevco
Transportation Research Center

**TRANSPORTATION RESEARCH CENTER INC.
HYBRID III THREE-YEAR-OLD EXTERNAL DIMENSIONS**

SN: 142 MFG: FTSS

DATE: 17-Jan-02

TRC INC. TEST NO: 142C01ED

572P SN142EXT. DIMENSION CAL 01

TEST PARAMETER	DIMEN.	SPECIFICATION	TEST RESULTS
Total Sitting Height	A	538.5 - 553.7 MM	548.6 MM
Shoulder Pivot Height	B	307.4 - 322.6 MM	317.5 MM
Hip Pivot Height	C	33 - 43.2 MM	33.0 MM
Hip Pivot from Backline	D	56.9 - 67.1 MM	63.5 MM
Shoulder Pivot from Backline	E	58.4 - 68.6 MM	66.0 MM
Thigh Clearance	F	81 - 91.2 MM	86.4 MM
Back of Elbow to Wrist Pivot	G	247.4 - 262.6 MM	256.5 MM
Head Back from Backline	H	48.2 - 58.4 MM	53.3 MM
Shoulder to Elbow Length	I	185.4 - 200.6 MM	190.5 MM
Elbow Rest Height	J	133.6 - 148.8 MM	139.7 MM
Buttock to Knee Length	K	287.3 - 302.5 MM	292.1 MM
Popliteal Height	L	221 - 236.2 MM	226.1 MM
Knee to Floor Height	M	241.6 - 256.8 MM	254.0 MM
Buttock Popliteal Length	N	218 - 233.2 MM	223.5 MM
Chest Depth	O	134.6 - 149.8 MM	144.8 MM
Foot Length	P	137.6 - 147.8 MM	139.7 MM
Stature	Q	932.2 - 957.6 MM	942.3 MM
Buttock to Knee Pivot Length	R	251.4 - 261.6 MM	251.5 MM
Head Breadth	S	128.3 - 143.5 MM	137.2 MM
Head Depth	T	167.4 - 182.6 MM	172.7 MM
Hip Breadth	U	200.7 - 215.9 MM	205.7 MM
Shoulder Breadth	V	236.5 - 251.7 MM	241.3 MM
Foot Breadth	W	53.6 - 63.8 MM	57.2 MM
Head Circumference	X	500.4 - 515.6 MM	510.5 MM
Chest Circumference with Jacket	Y	527.1 - 552.5 MM	535.9 MM
Waist Circumference	Z	527.1 - 552.5 MM	541.0 MM
Reference Location for Chest Circumference	AA	248.9 - 259.1 MM	254.0 MM
Reference Location for Waist Circumference	BB	160 - 170.2 MM	165.1 MM

DUMMY MEETS SPECIFICATION

TECHNICIAN: 

TRANSPORTATION RESEARCH CENTER INC.

HEAD DROP TEST

HYBRID III THREE YEAR OLD

17-JAN-02

TRC INC.

TEST NO: 142C01HD2

572P 3YO SN142 HEAD DROP CAL01

TEST PARAMETER	SPECIFICATION	TEST RESULTS
TEMPERATURE	18.9-25.6 DEG. C	21.7 DEG. C
RELATIVE HUMIDITY	10 - 70 %	16.0 %
PEAK RESULTANT ACCELERATION	250 - 280 G	271.87 G
PEAK LATERAL ACCELERATION	15 G MAX	-1.87 G
IS ACCELERATION CURVE UNIMODAL?	YES	YES

TEST MEETS SPECIFICATIONS

TECHNICIAN

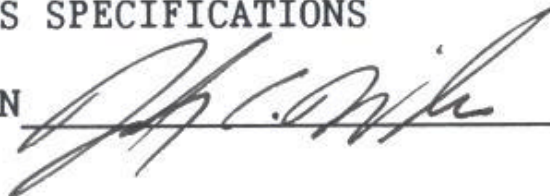

RUN NUMBER: 011702.0645;1

HYBRID III THREE YEAR OLD CHILD DUMMY HEAD CALIBRATION

HEAD ACCELERATION X AXIS

TRC TEST NUMBER: 142C01HD2

572P 3YO SN142 HEAD DROP CAL01

RUN NUMBER: 011702.0647;1

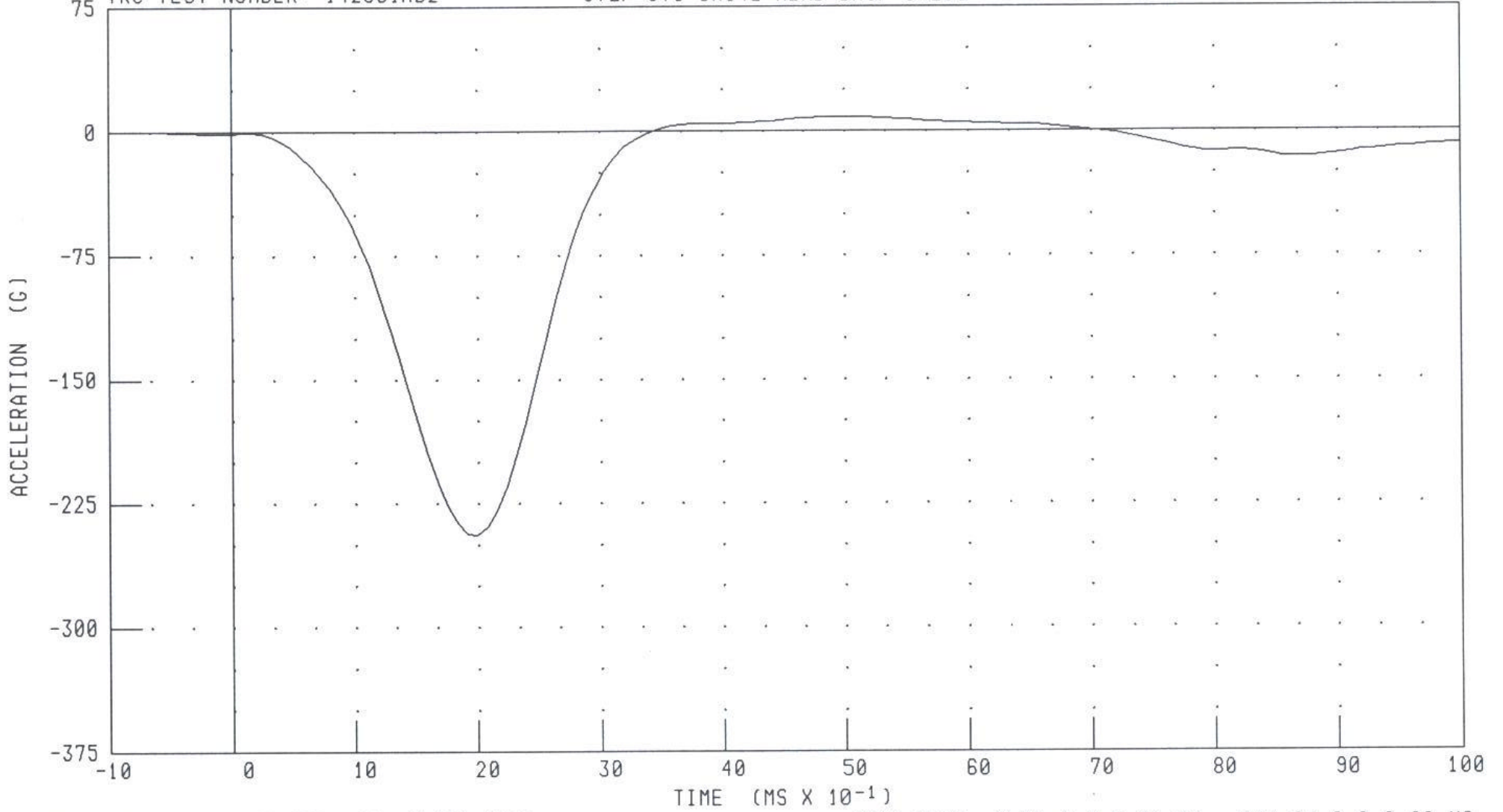

CHANNEL: HEDXC

FILTER: CH. CLASS 1000

PEAK DATA: 8.62 G @ 5.04 MS; -244.24 G @ 2.00 MS

HYBRID III THREE YEAR OLD CHILD DUMMY HEAD CALIBRATION
HEAD ACCELERATION Y AXIS

TRC TEST NUMBER: 142C01HD2

572P 3YD SN142 HEAD DROP CAL01

RUN NUMBER: 011702.0647,1

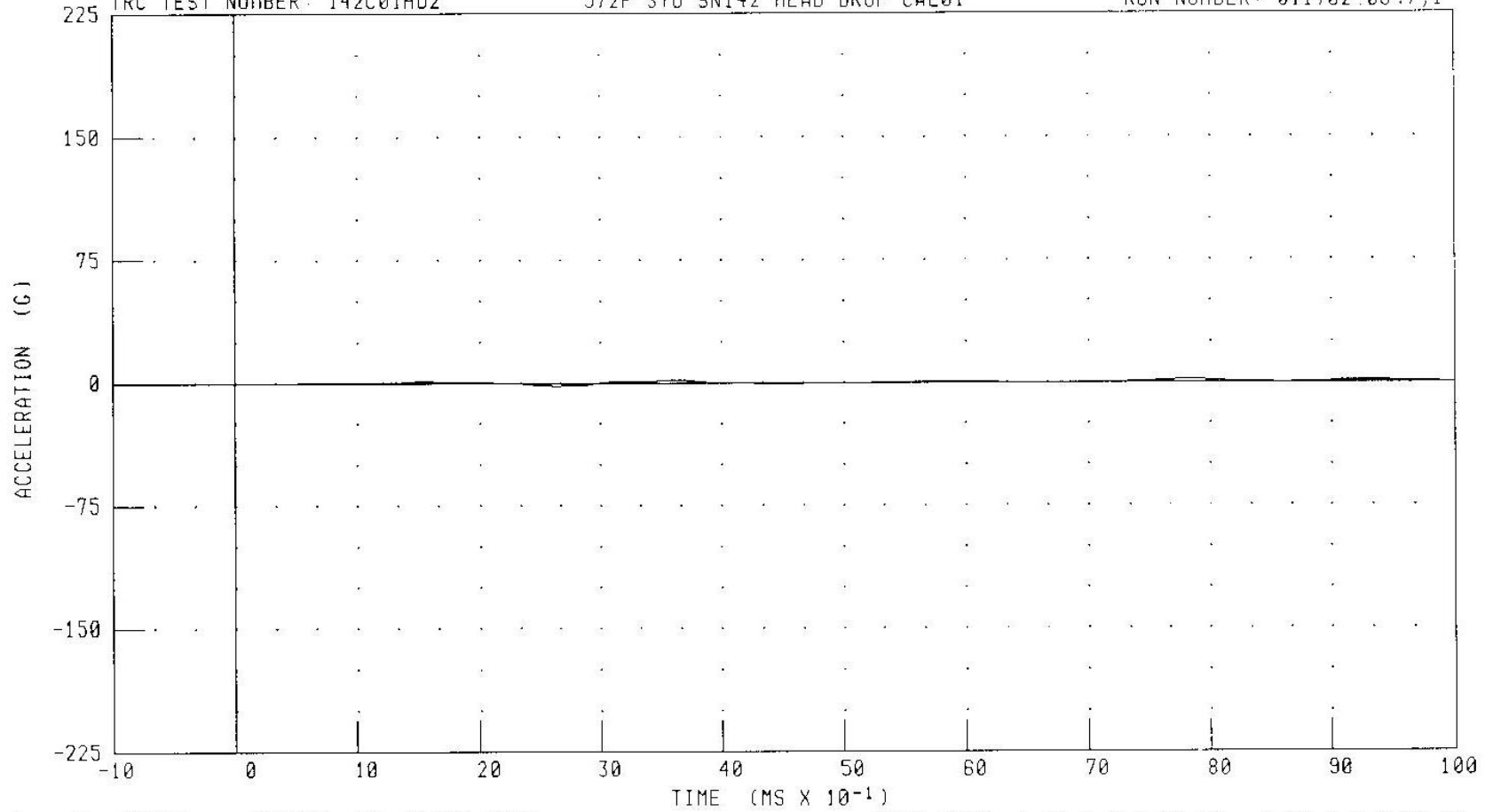

HYBRID III THREE YEAR OLD CHILD DUMMY HEAD CALIBRATION

HEAD ACCELERATION Z AXIS

TRC TEST NUMBER: 142C01HD2

572P 3Y0 SN142 HEAD DROP CAL01

RUN NUMBER 011702.0647,1

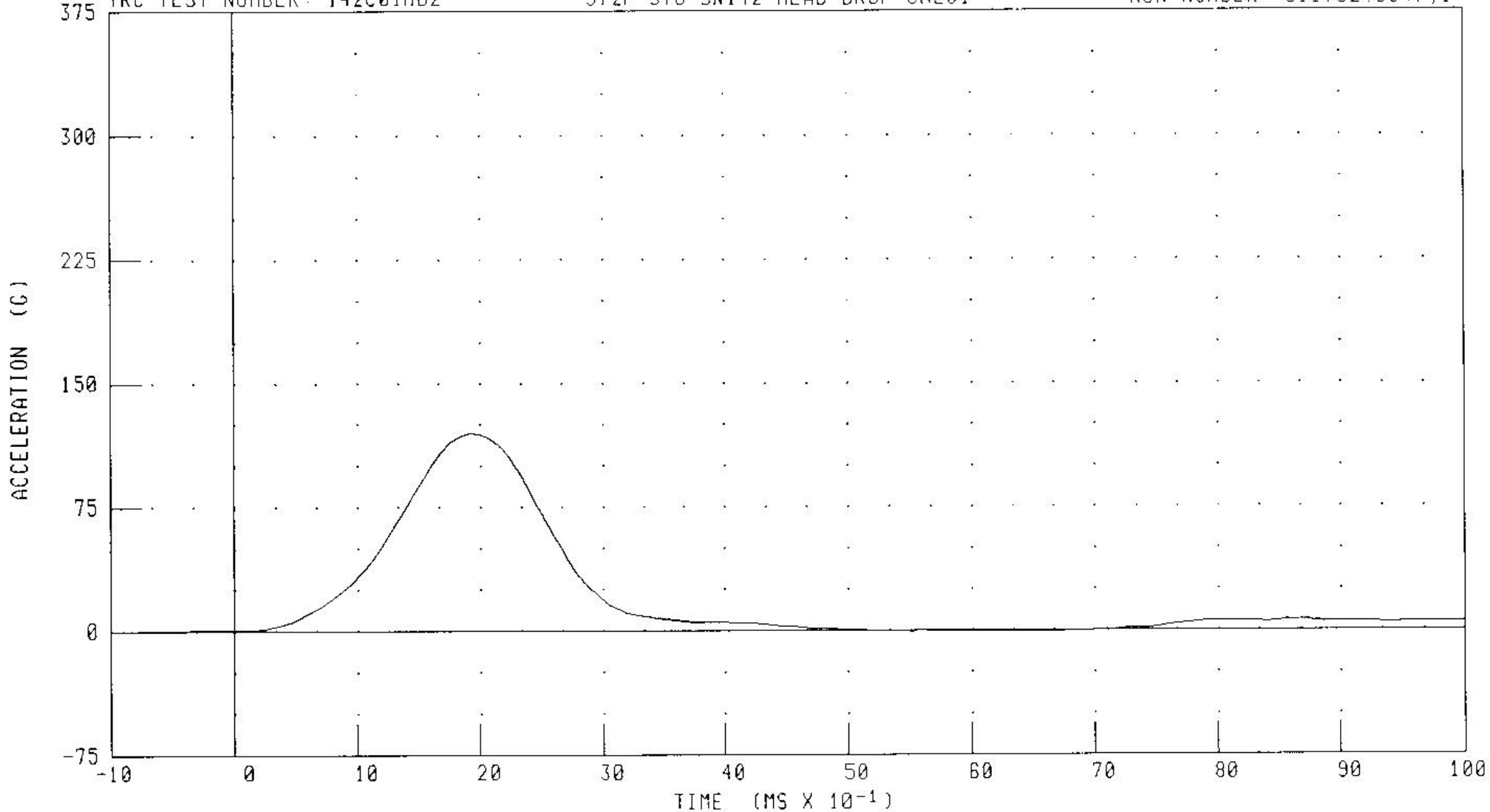

CHANNEL: HEDZG

FILTER: CH. CLASS 1000

PEAK DATA: 119.68 G @ 1.92 MS, -0.97 G @ 600 MS

HYBRID III THREE YEAR OLD CHILD DUMMY HEAD CALIBRATION
HEAD RESULTANT ACCELERATION

TRC TEST NUMBER: 142C01HD2

572P 3YD SN142 HEAD DROP CAL01

RUN NUMBER 011702.0647;1

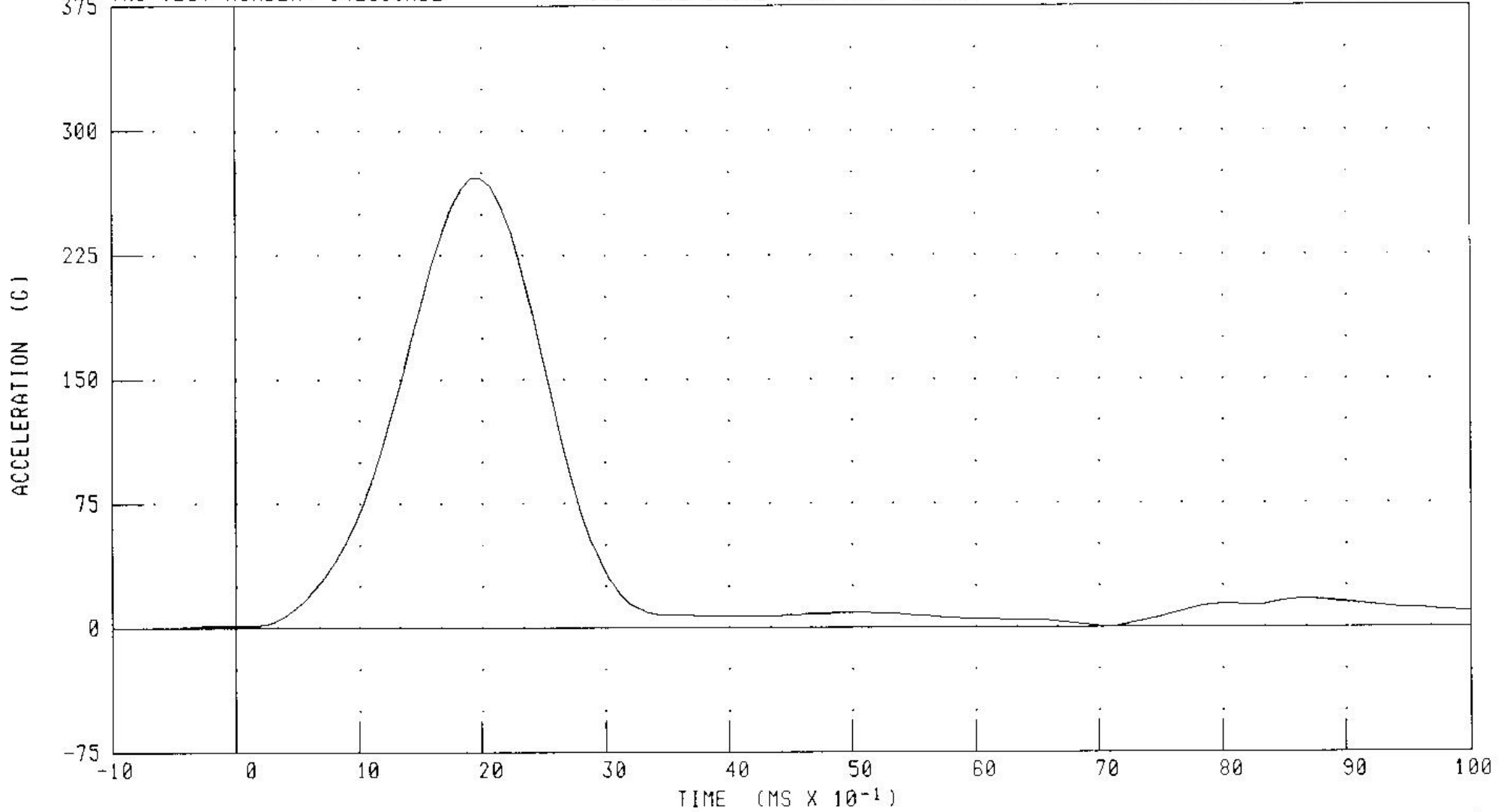

CHANNEL: HEDRG

FILTER CH CLASS 1000

PEAK DATA 271 88 G @ 2.00 MS, 0 01 G @ -0 88 MS

TRANSPORTATION RESEARCH CENTER INC.

HYBRID III THREE YEAR OLD

16-JAN-02

NECK FLEXION TEST

TRC INC. TEST NO: 142C01NF3 572P 3YO SN142 NECK FLEX CAL01

TEST PARAMETER	SPECIFICATION	TEST RESULTS
TEMPERATURE	20.6-22.2 DEG. C	21.7 DEG. C
RELATIVE HUMIDITY	10 - 70 %	16.0 %
IMPACT VELOCITY	5.40 - 5.60 M/S	5.56 M/S
INTEGRATED PENDULUM VELOCITY	10 MS 2.0 - 2.7 M/S	2.51 M/S
	15 MS 3.0 - 4.0 M/S	3.76 M/S
	20 MS 4.0 - 5.1 M/S	5.10 M/S
PEAK D-PLANE ROTATION	70 - 82 DEG.	73.26 DEG.
PEAK MOMENT DURING ROTATION INTERVAL	42 - 53 NM	45.58 NM
POSITIVE MOMENT DECAY TIME TO 10 NM LEVEL	60 - 80 MS	68.72 MS

TEST MEETS SPECIFICATIONS

TECHNICIAN

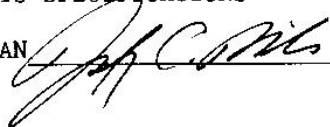

RUN NUMBER: 011602.1112;2

HYBRID III THREE YEAR OLD CHILD DUMMY NECK FLEXION CALIBRATION
PENDULUM DECELERATION

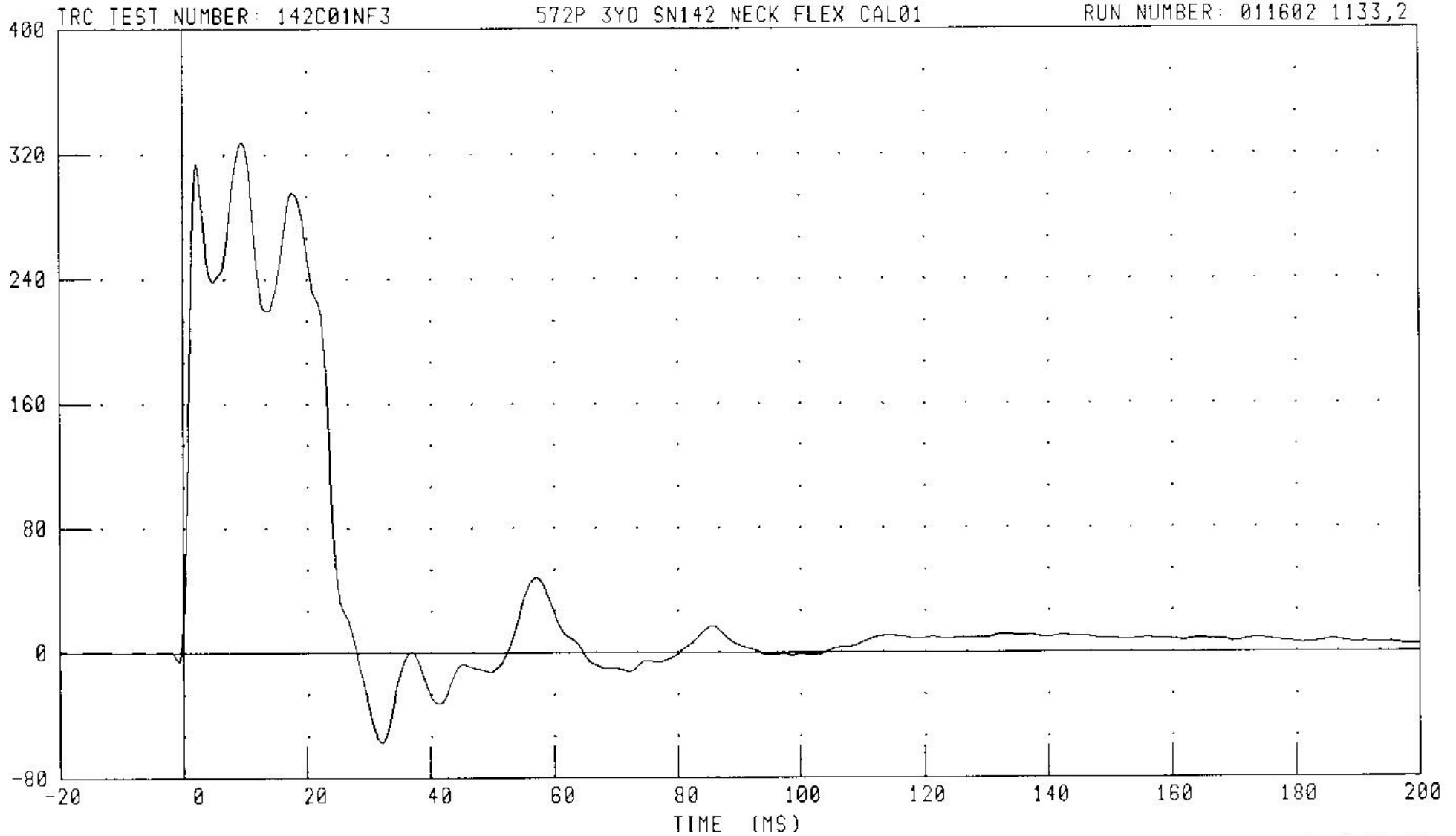

CHANNEL: PENXG

FILTER: CH. CLASS 180

PEAK DATA: 32.76 G @ 9.60 MS; -5.75 G @ 32.08 MS

HYBRID III THREE YEAR OLD CHILD DUMMY NECK FLEXION CALIBRATION

PENDULUM INTEGRATED VELOCITY

TRC TEST NUMBER: 142C01NF3

572P 3YO SN142 NECK FLEX CAL01

RUN NUMBER 011602 1133;2

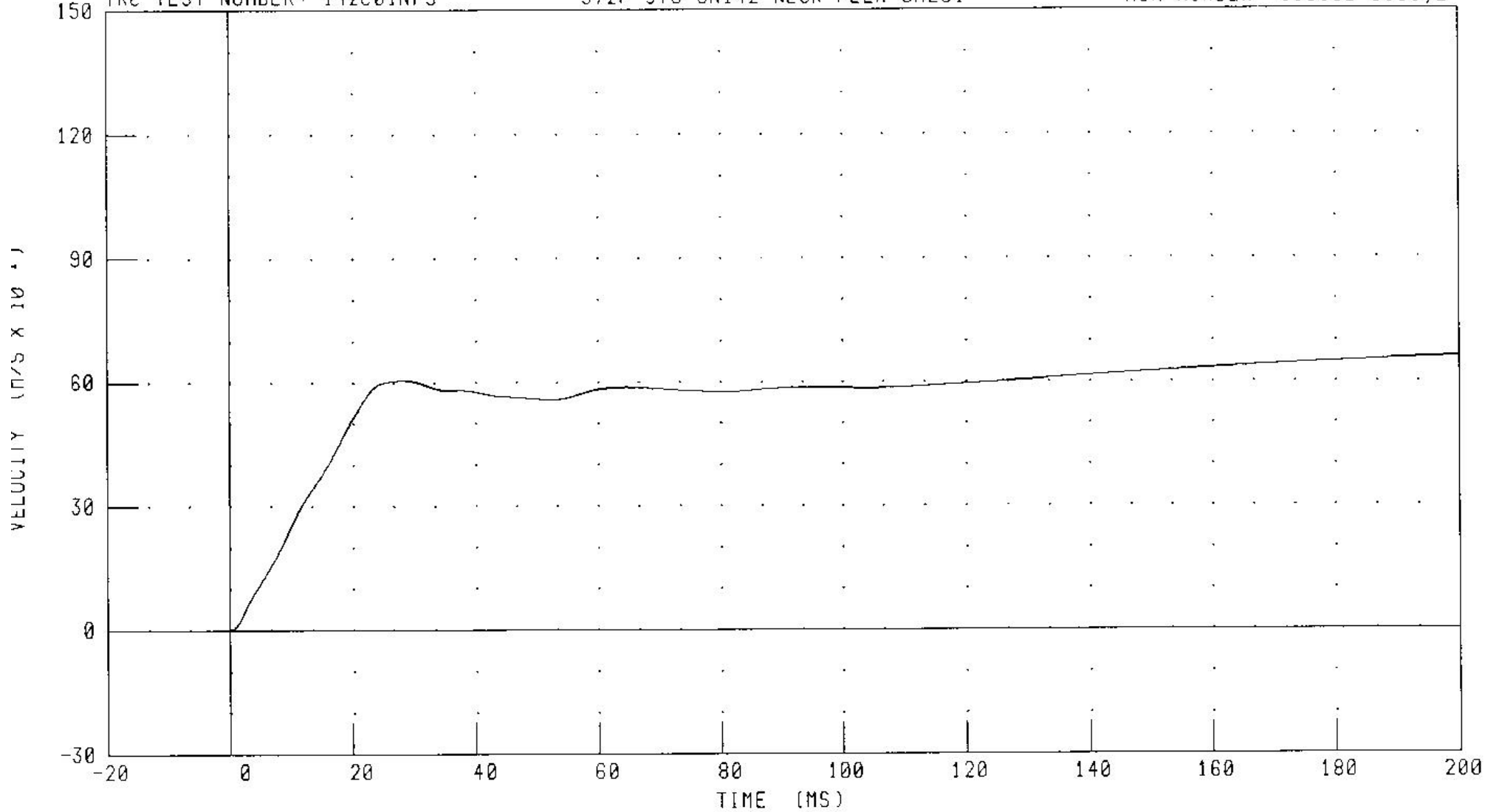

CHANNEL PENXVI FILTER: CH CLASS 180

PEAK DATA: 6.60 M/S @ 200.00 MS, -0.01 M/S @ -0.40 MS

HYBRID III THREE YEAR OLD CHILD DUMMY NECK FLEXION CALIBRATION
ROTATION ABOUT BASE OF NECK

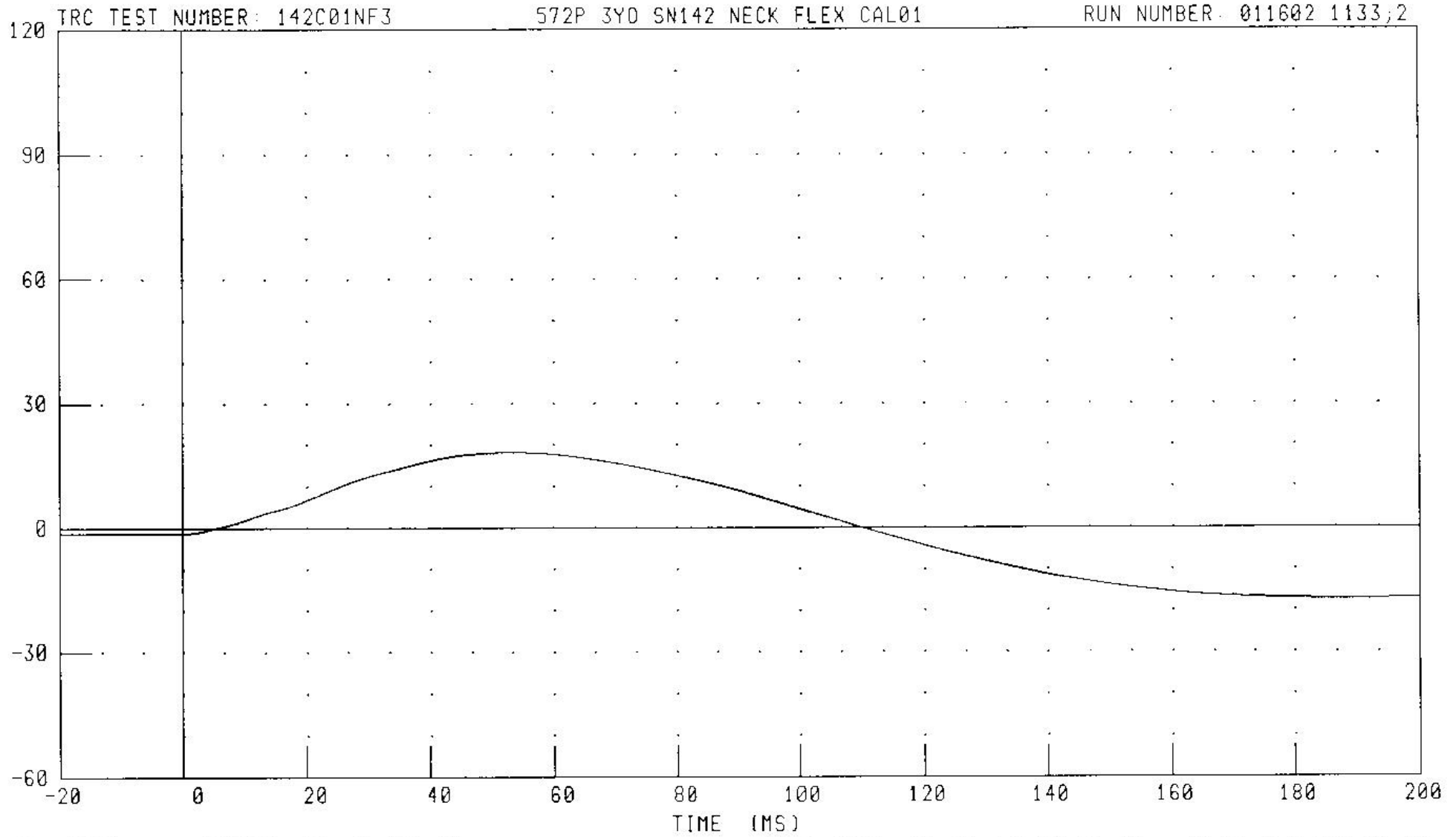

CHANNEL: BETA

FILTER: CH. CLASS 60

PEAK DATA 18.16 ° @ 52.96 MS, -17.31 ° @ 189.36 MS

HYBRID II) THREE YEAR OLD CHILD DUMMY NECK FLEXION CALIBRATION
ROTATION ABOUT OCCIPITAL CONDYLE

TRC TEST NUMBER: 142C01NF3

572P 3Y0 SN142 NECK FLEX CAL01

RUN NUMBER: 011602.1133,2

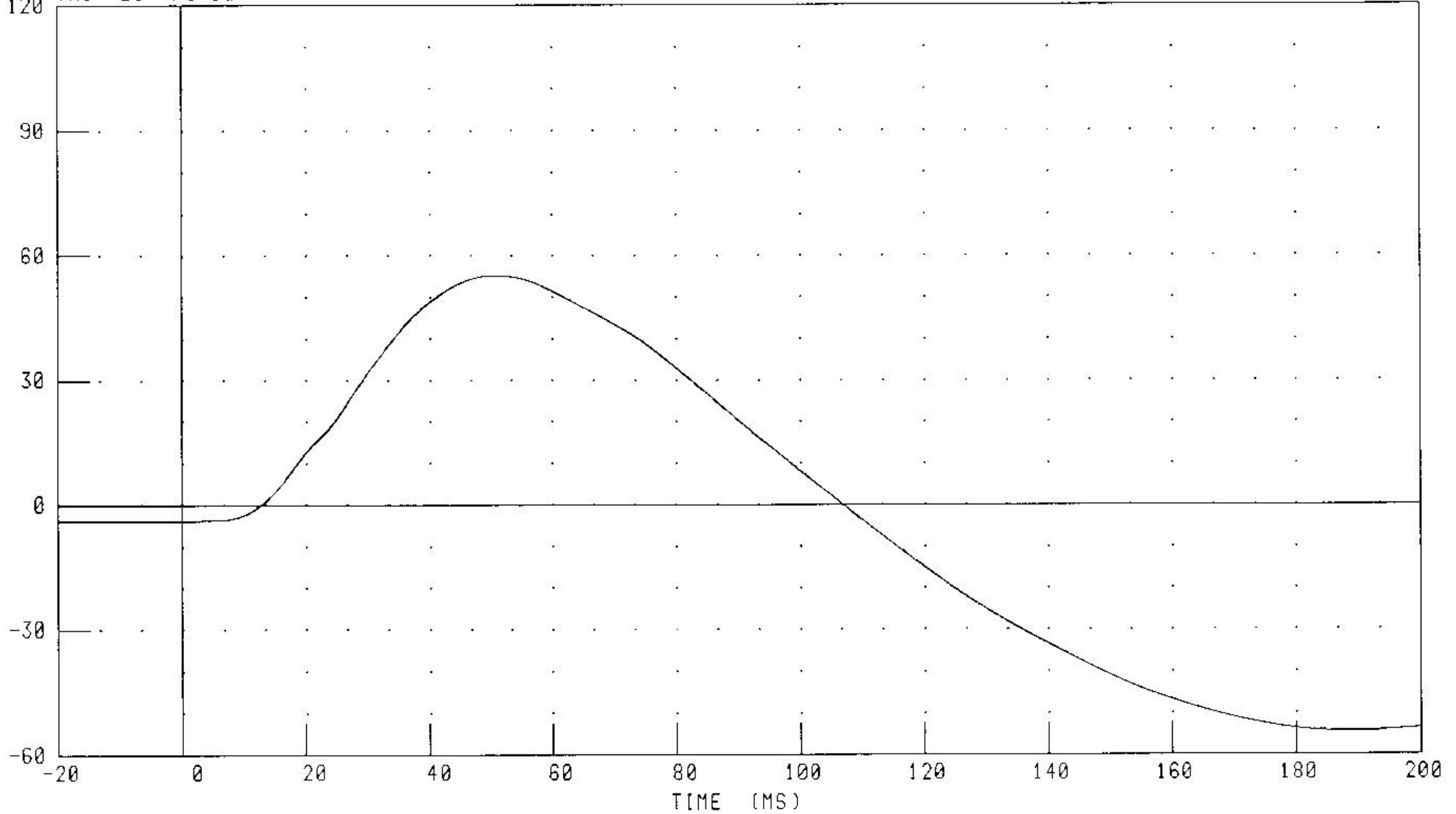

CHANNEL: THETA

FILTER CH. CLASS 60

PEAK DATA: 55.16 ° @ 50.72 MS, -54.43 ° @ 188.48 MS

HYBRID III THREE YEAR OLD CHILD DUMMY NECK FLEXION CALIBRATION
TOTAL ROTATION

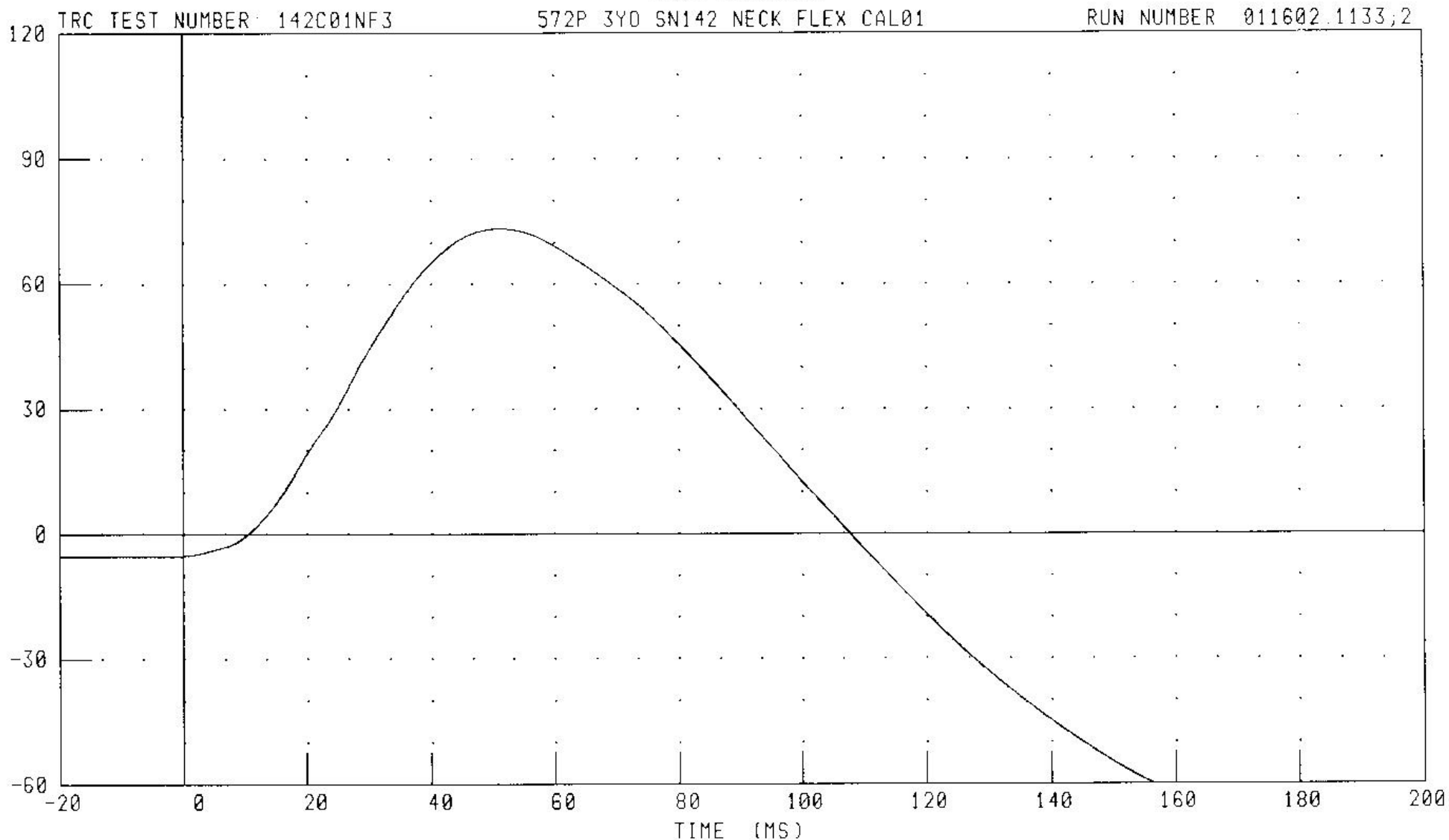

CHANNEL: TOTAN

FILTER: CH. CLASS 60

PEAK DATA: 73.27 ° @ 51.36 MS; -71.73 ° @ 188.56 MS

HYBRID III THREE YEAR OLD CHILD DUMMY NECK FLEXION CALIBRATION
MOMENT ABOUT OCCIPITAL CONDYLE

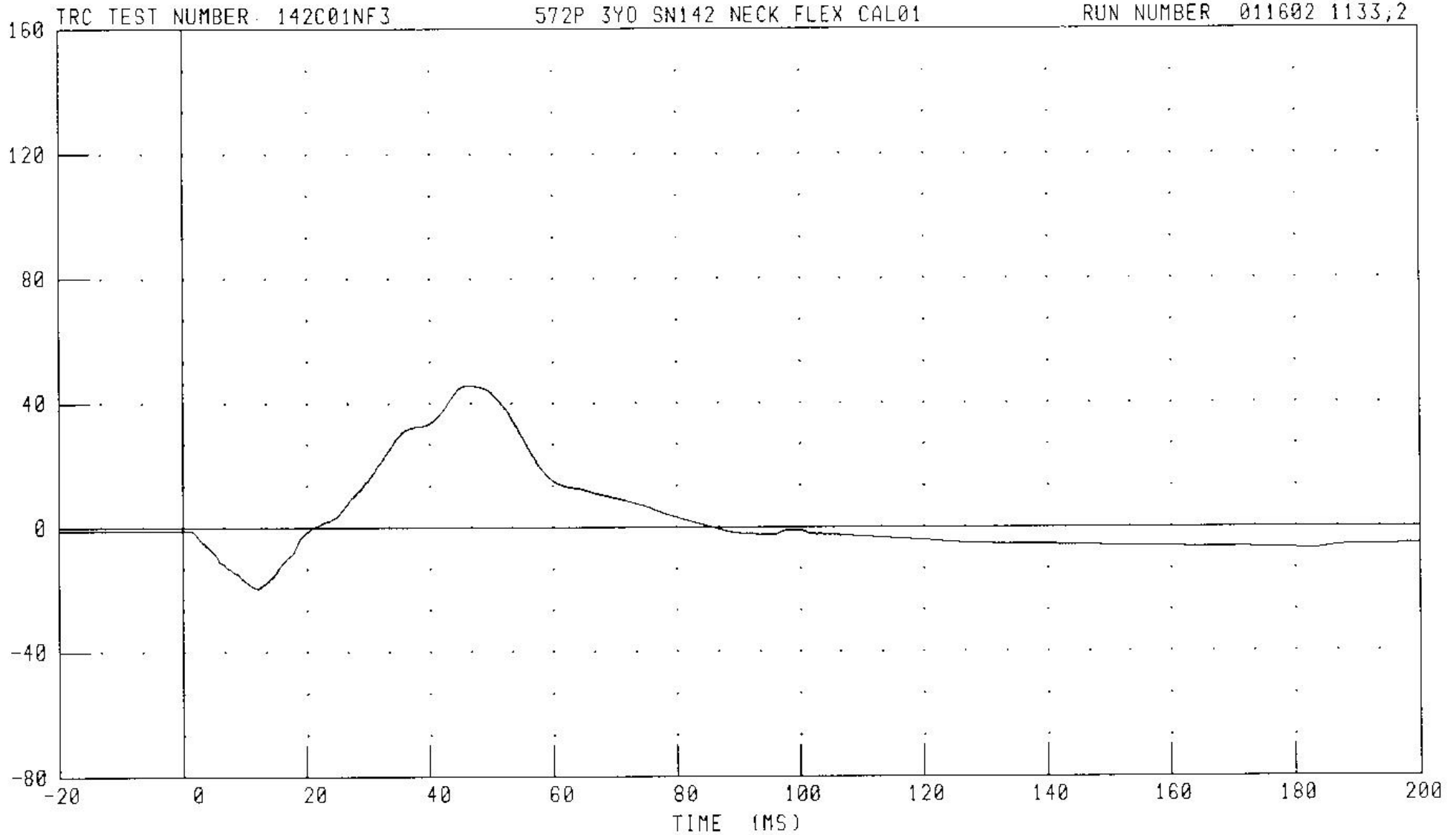

CHANNEL NEKYM

FILTER: CH. CLASS 600

PEAK DATA: 45.58 N·M @ 46.72 MS, -19.59 N·M @ 12.00 MS

HYBRID III THREE YEAR OLD CHILD DUMMY NECK FLEXION CALIBRATION

TOTAL ROTATION VS OCCIPITAL CONDYLAR MOMENT

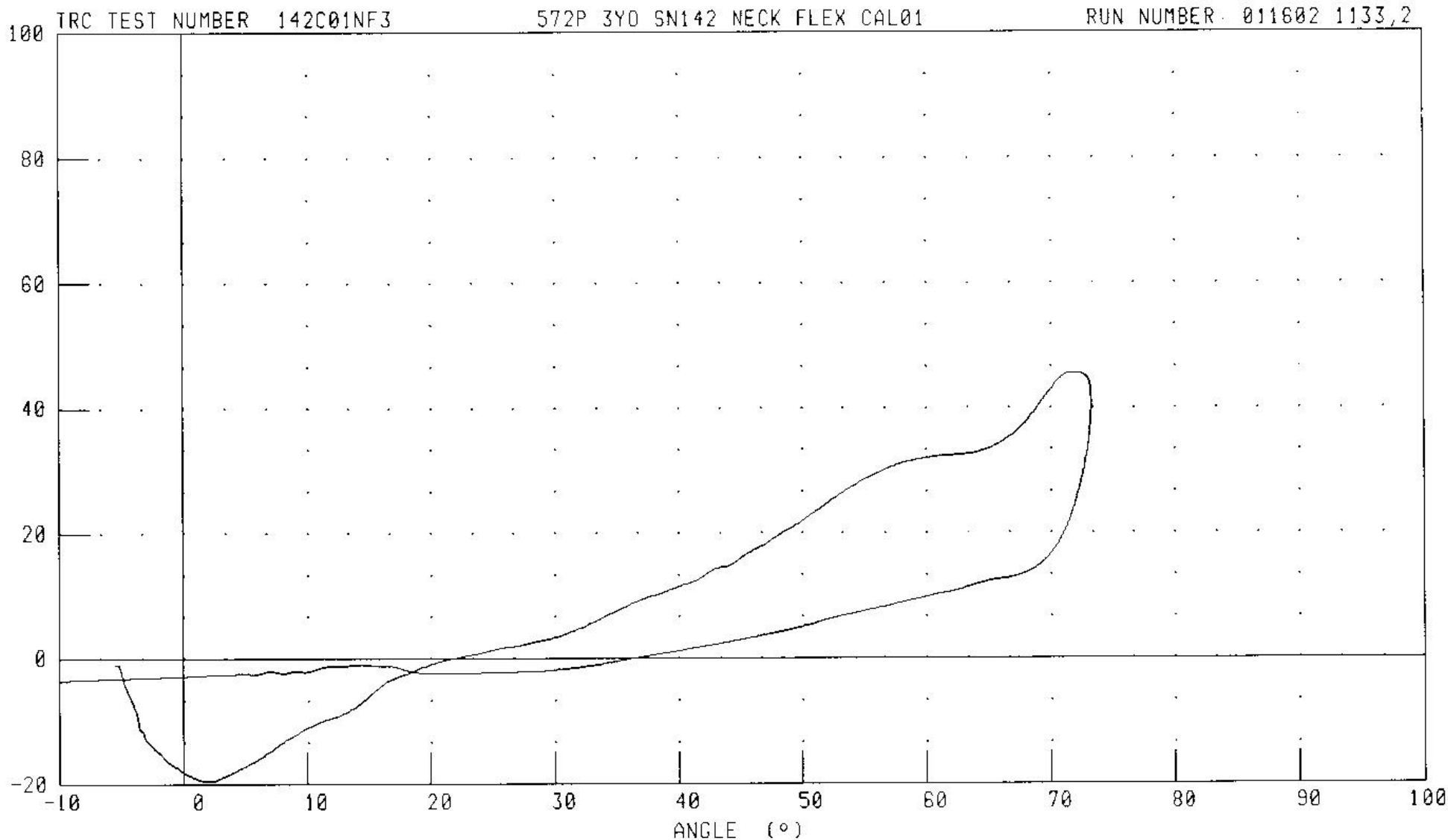

CHANNEL: TOTAN
NEKYM

FILTER: CH. CLASS 60
CH. CLASS 600

PEAK DATA: 73.27 ° @ 51.36 MS, -71.73 ° @ 100.56 MS
45.58 N.M @ 46.72 MS, -19.59 N.M @ 12.00 MS

TRANSPORTATION RESEARCH CENTER INC.

HYBRID III THREE YEAR OLD

17-JAN-02

NECK EXTENSION TEST

TRC INC. TEST NO: 142C01NE2 572P 3YO SN142 NECK EXT CAL01

TEST PARAMETER	SPECIFICATION	TEST RESULTS
TEMPERATURE	20.6 - 22.2 DEG. C	21.7 DEG. C
RELATIVE HUMIDITY	10 - 70 %	15.0 %
IMPACT VELOCITY	3.55 - 3.75 M/S	3.68 M/S
INTEGRATED PENDULUM VELOCITY	6 MS 1.0 - 1.4 M/S	1.12 M/S
	10 MS 1.9 - 2.5 M/S	2.06 M/S
	14 MS 2.8 - 3.5 M/S	2.98 M/S
PEAK D-PLANE ROTATION	83 - 93 DEG.	89.11 DEG.
PEAK MOMENT DURING ROTATION INTERVAL	-43.7 / -53.3 NM	-49.45 NM
NEGATIVE MOMENT DECAY TIME TO -10 NM LEVEL	60 - 80 MS	66.72 MS

TEST MEETS SPECIFICATIONS

TECHNICIAN 

RUN NUMBER: 011702.1251;1

HYBRID III THREE YEAR OLD CHILD DUMMY NECK EXTENSION CALIBRATION
PENDULUM DECELERATION

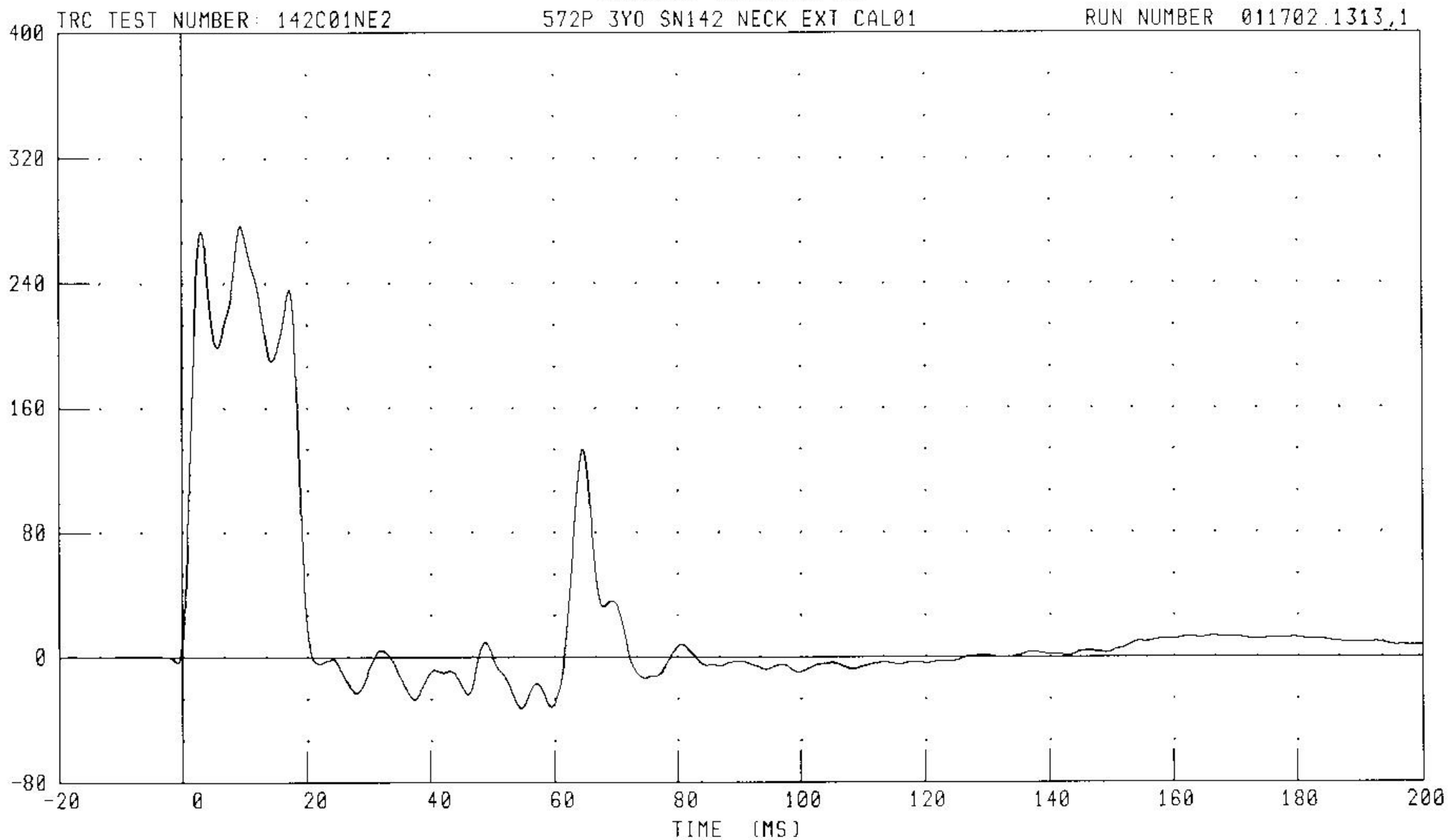

CHANNEL: PENXC

FILTER: CH. CLASS 180

PEAK DATA: 276.9 G @ 9.44 MS; -32.4 G @ 54.72 MS

HYBRID III THREE YEAR OLD CHILD DUMMY NECK EXTENSION CALIBRATION
INTEGRATED PENDULUM VELOCITY

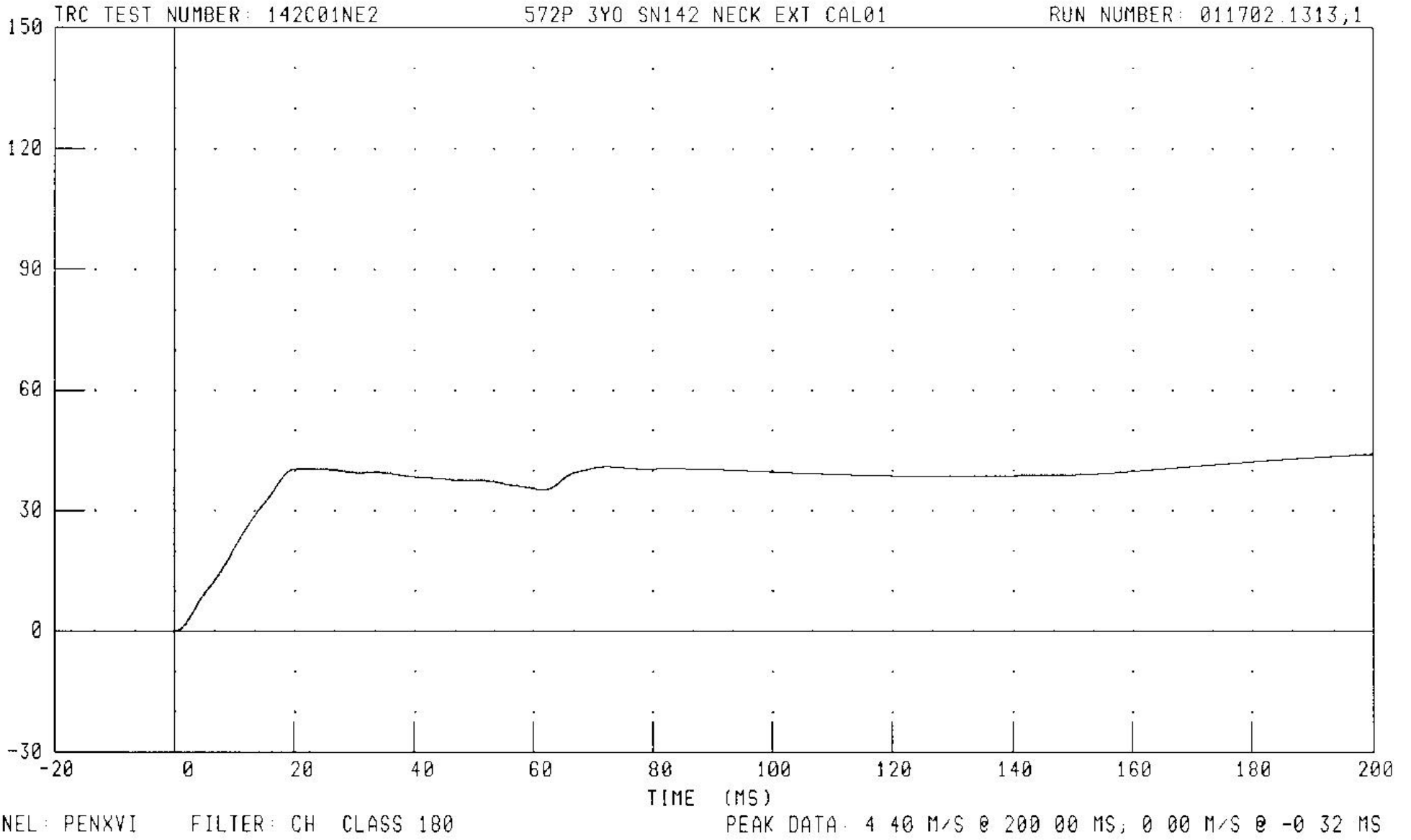

HYBRID III THREE YEAR OLD CHILD DUMMY NECK EXTENSION CALIBRATION

ROTATION ABOUT BASE OF NECK

TRC TEST NUMBER 142C01NE2

572P 3YO SN142 NECK EXT CAL01

RUN NUMBER 011702.1313;1

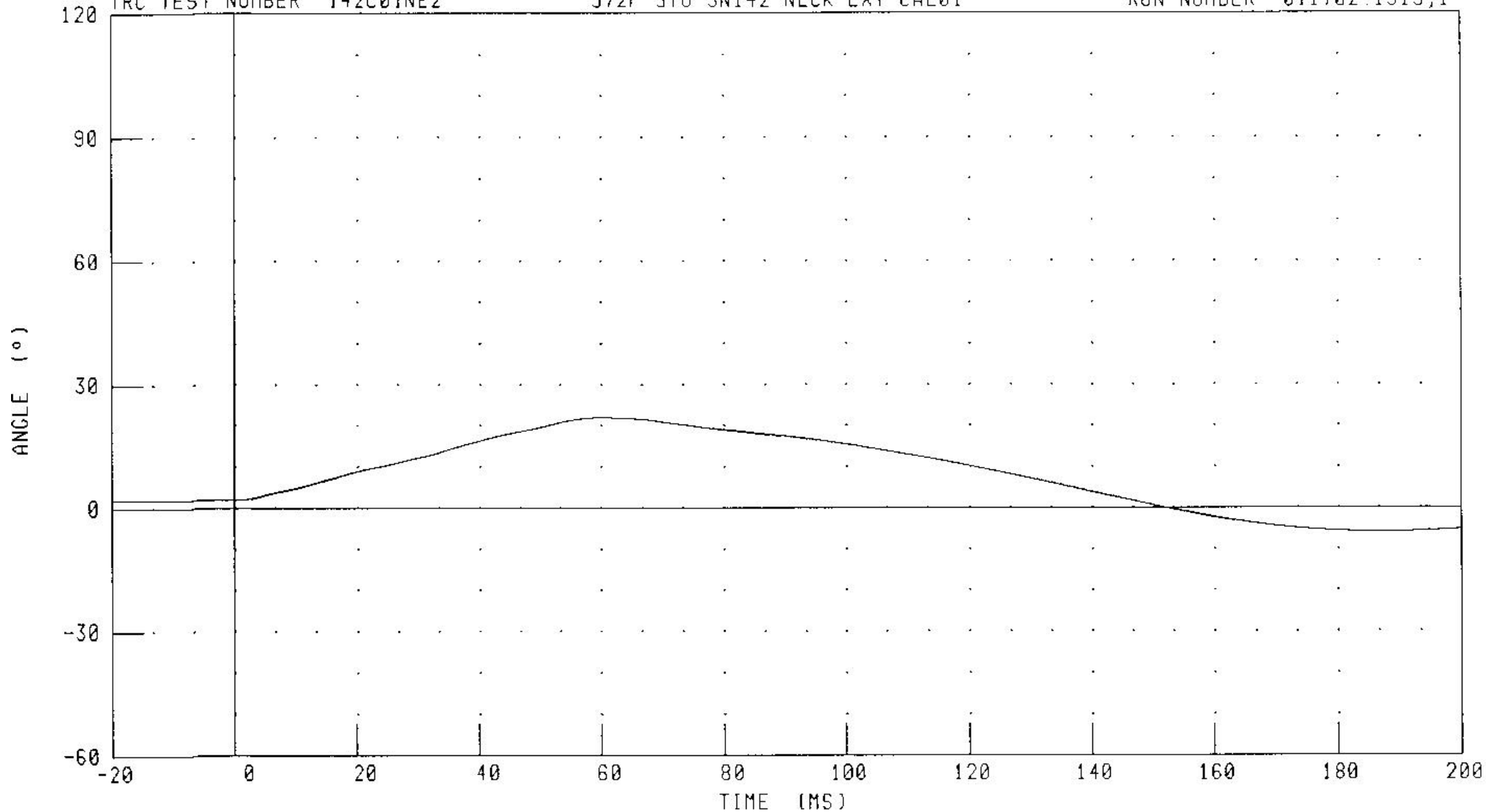

CHANNEL: BETA

FILTER: CH. CLASS 60

PEAK DATA 21.96 ° @ 60.16 MS; -5.89 ° @ 186.24 MS

HYBRID III THREE YEAR OLD CHILD DUMMY NECK EXTENSION CALIBRATION
ROTATION ABOUT OCCIPITAL CONDYLE

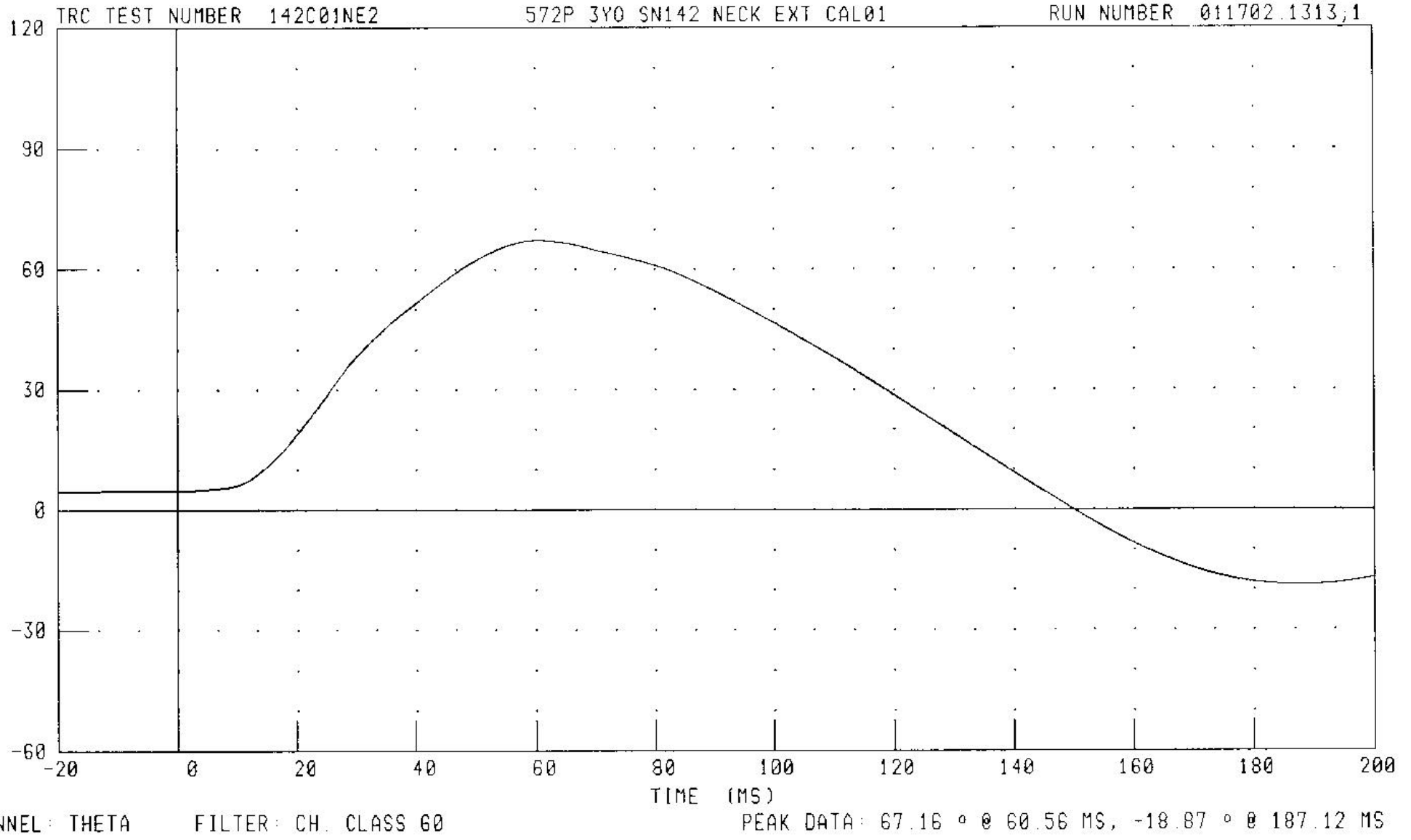

HYBRID III THREE YEAR OLD CHILD DUMMY NECK EXTENSION CALIBRATION
TOTAL ROTATION

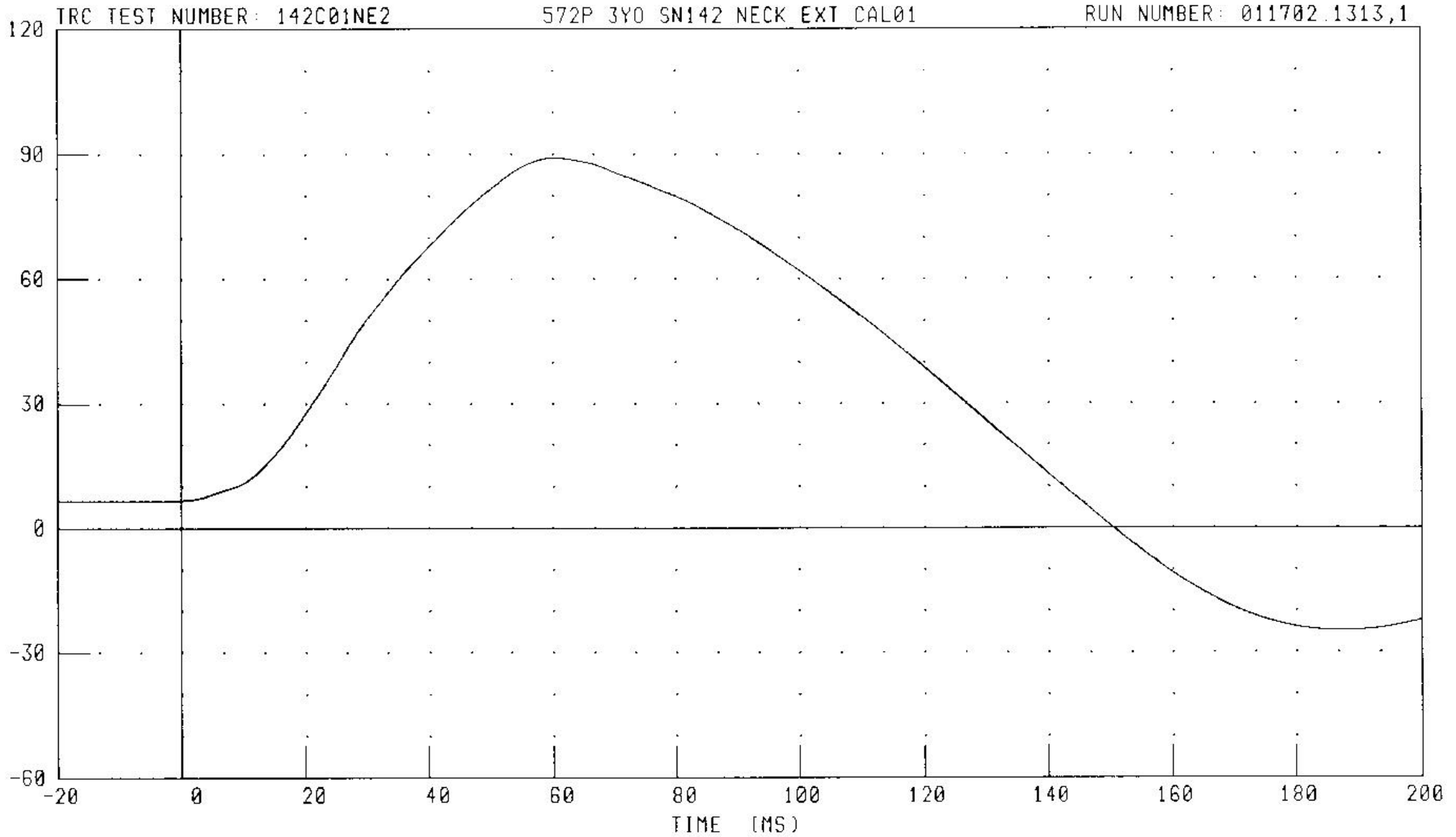

CHANNEL: TOTAN

FILTER: CH. CLASS 60

PEAK DATA: 89.11 ° @ 60.40 MS, -24.76 ° @ 186.96 MS

HYBRID III THREE YEAR OLD CHILD DUMMY NECK EXTENSION CALIBRATION
MOMENT ABOUT OCCIPITAL CONDYLE

TRC TEST NUMBER: 142C01NE2

572P 3YO SN142 NECK EXT CAL01

RUN NUMBER: 011702.1313;1

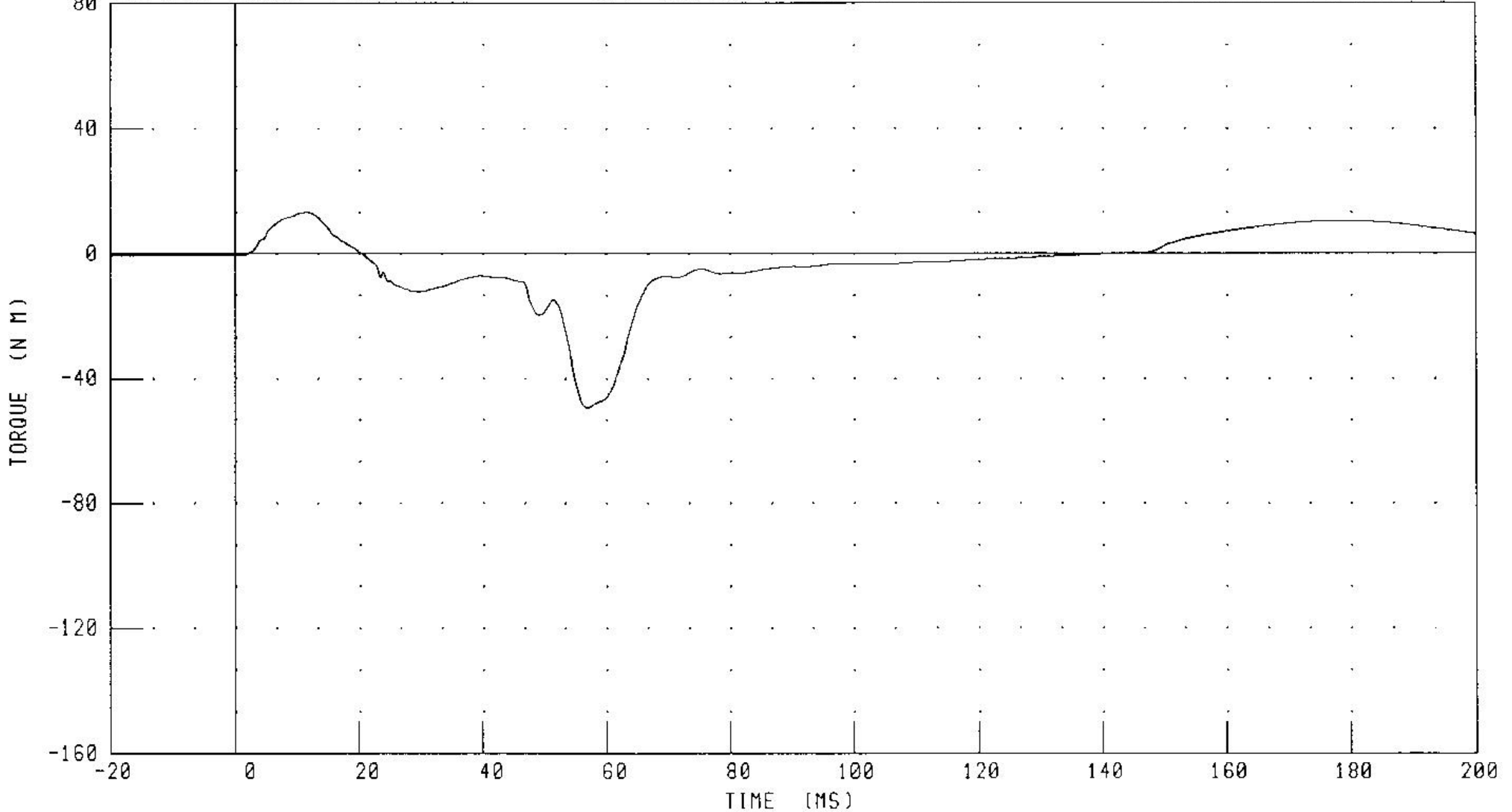

CHANNEL: NEKYM

FILTER: CH. CLASS 600

PEAK DATA: 13.26 N M @ 11.52 MS, -49.45 N M @ 57.04 MS

HYBRID III THREE YEAR OLD CHILD DUMMY NECK EXTENSION CALIBRATION
 TOTAL ROTATION VS OCCIPITAL CONDYLAR MOMENT

TRC TEST NUMBER 142C01NE2

572P 3Y0 SN142 NECK EXT CAL01

RUN NUMBER 011702.1313;1

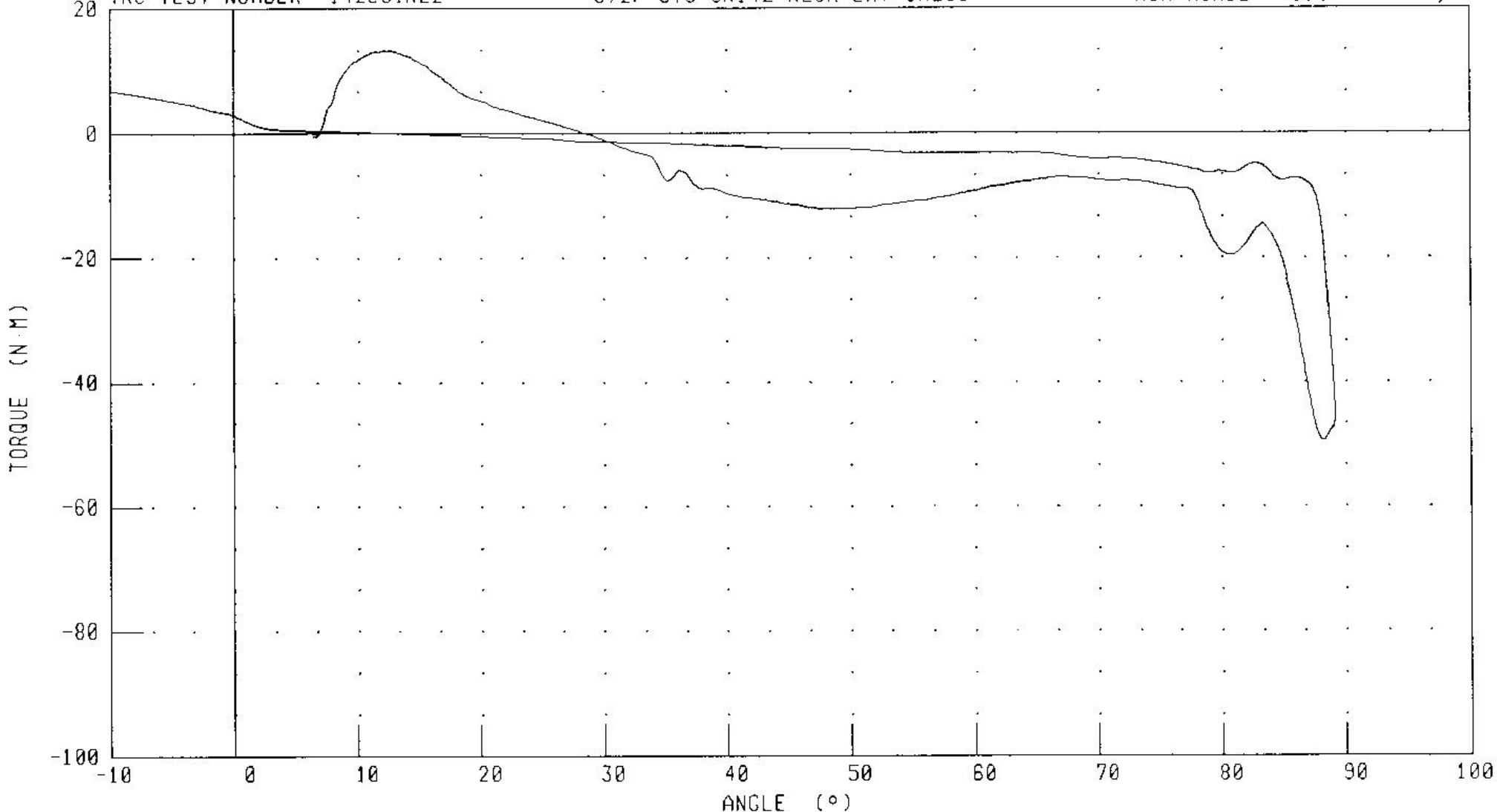

CHANNEL TOTAN FILTER CH CLASS 60
 NEKYM CH CLASS 600

ANGLE (°)

PEAK DATA 89.11 ° @ 60.40 MS; -24.76 ° @ 186.96 MS
 13.26 N.M @ 11.52 MS; -49.45 N.M @ 57.04 MS

TRANSPORTATION RESEARCH CENTER INC.

THORAX IMPACT TEST

HYBRID III THREE YEAR OLD

17-JAN-02

TRC INC.

TEST NO: 142C01TH1

572P 3YO SN142 THORAX CAL 01

TEST PARAMETER	HIGH SPEED TEST SPECIFICATION	TEST RESULTS
TEMPERATURE	20.6-22.2 DEG. C	21.7 DEG. C
RELATIVE HUMIDITY	10 - 70 %	14.0 %
PENDULUM VELOCITY	5.90 - 6.10 M/S	5.99 M/S
MAXIMUM DEFLECTION	32 - 38 MM	33.2 MM
MAXIMUM FORCE DURING DEFLECTION INTERVAL	680 - 910 N	735. N
INTERNAL HYSTERESIS	65% - 85%	72.3%
MAXIMUM FORCE BEWTWEEN 12.5 & 32 MM OF DEFLECTION	<= 910. N	799. N

TEST MEETS SPECIFICATIONS

TECHNICIAN

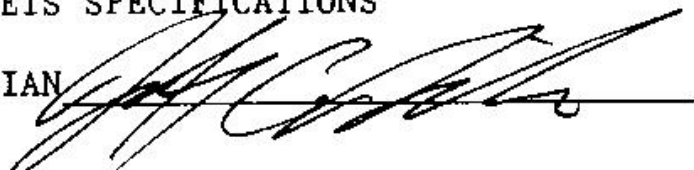

RUN NUMBER: 011702.1504;1

HYBRID III THREE YEAR OLD CHILD DUMMY THORAX CALIBRATION
PENDULUM DECELERATION

TRC TEST NUMBER: 142C01TH1

572P 3Y0 SN142 THORAX CAL 01

RUN NUMBER: 011702 1507,1

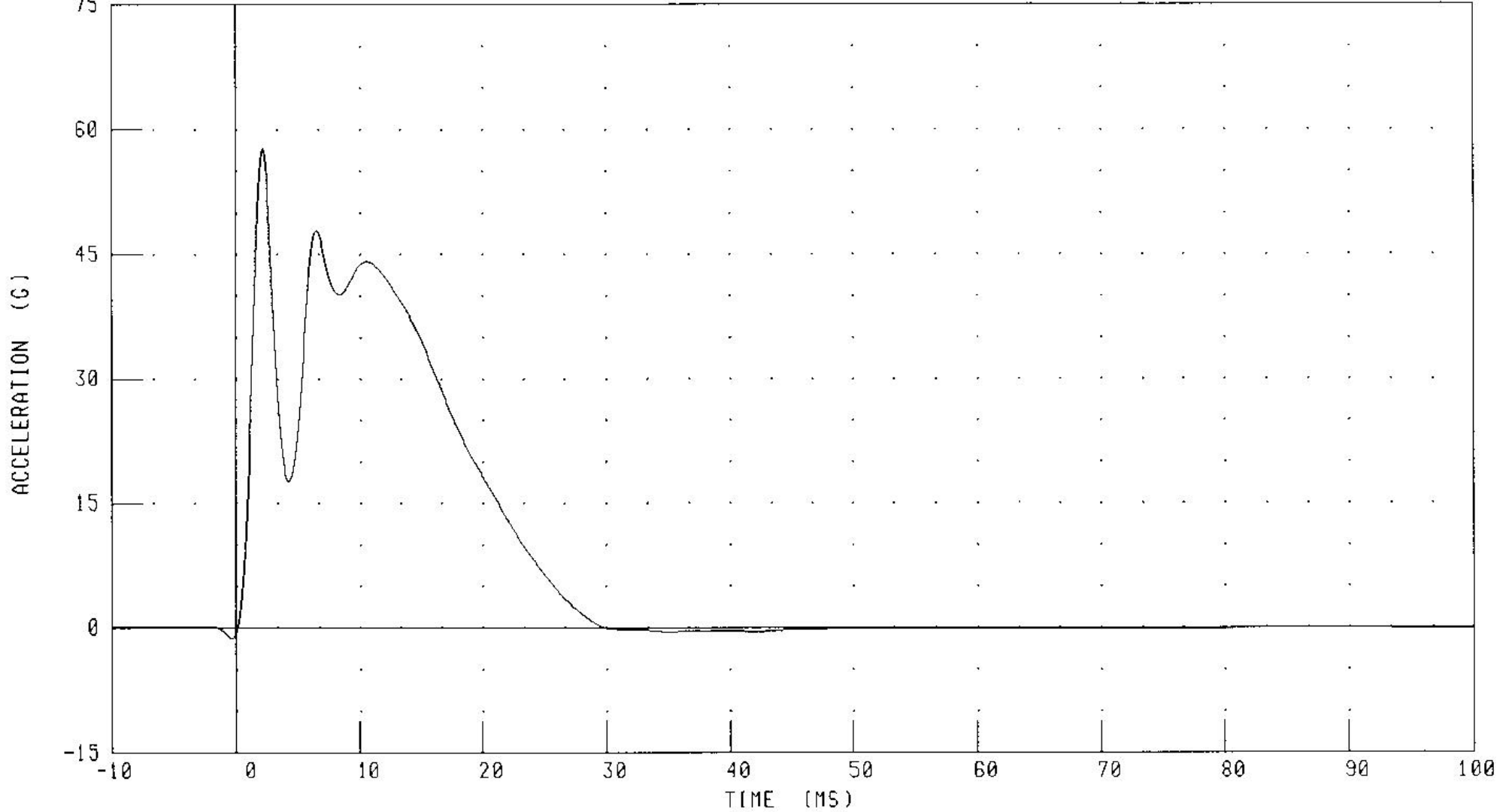

CHANNEL: PENXC

FILTER: CH. CLASS 180

PEAK DATA 57.71 G @ 2.16 MS, -1.34 G @ -0.32 MS

HYBRID III THREE YEAR OLD CHILD DUMMY THORAX CALIBRATION
PENDULUM FORCE

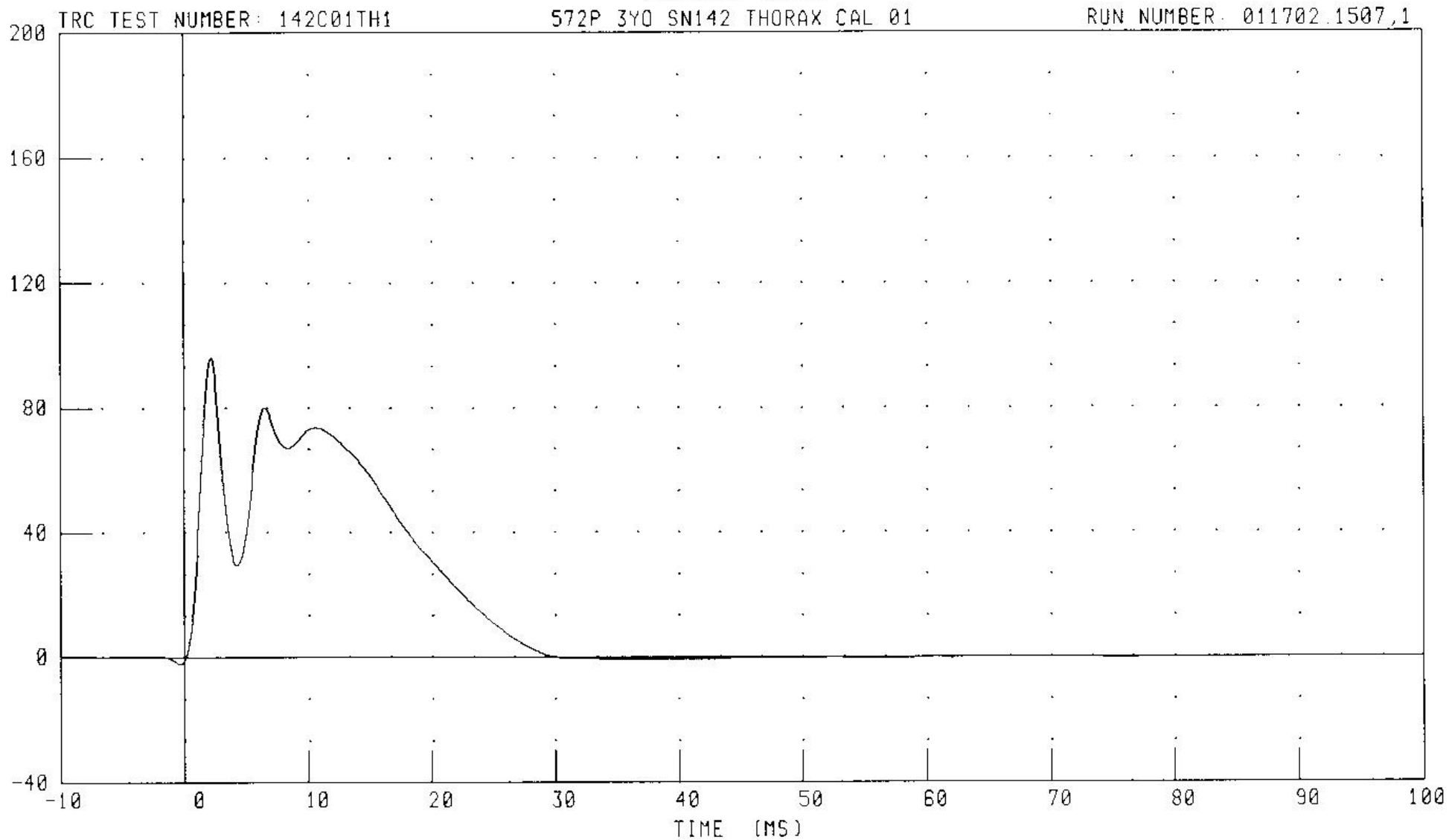

CHANNEL: PENXF

FILTER: CH. CLASS 100

PEAK DATA: 962 61 N @ 2 16 MS; -22.42 N @ -0 32 MS

HYBRID III THREE YEAR OLD CHILD DUMMY THORAX CALIBRATION

STERNUM DISPLACEMENT

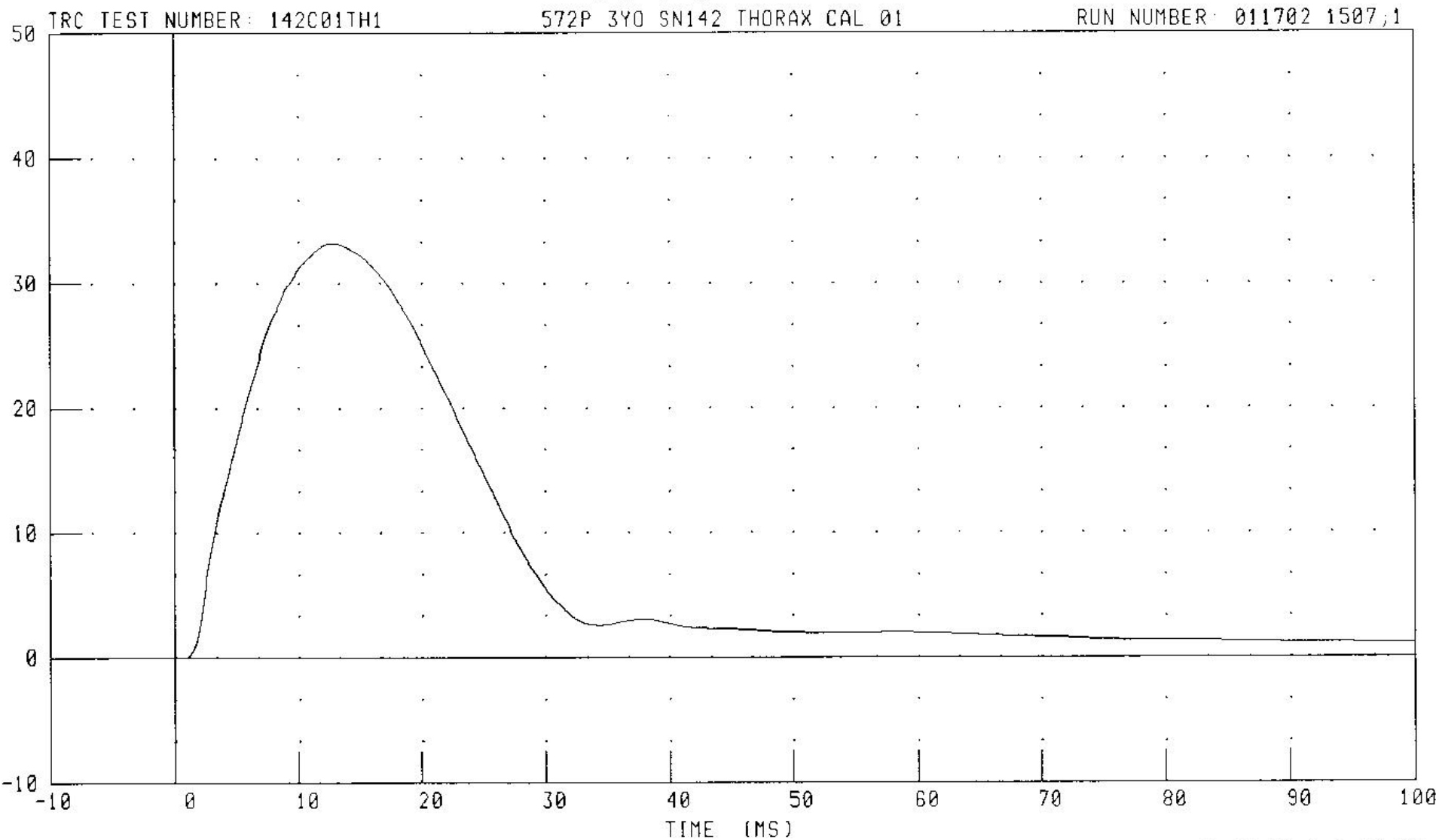

CHANNEL: CSTXD

FILTER CH. CLASS 600

PEAK DATA: 33.21 MM @ 12.80 MS; -0.02 MM @ 0.88 MS

HYBRID III THREE YEAR OLD CHILD DUMMY THORAX CALIBRATION
CHEST DISPLACEMENT VS PENDULUM FORCE

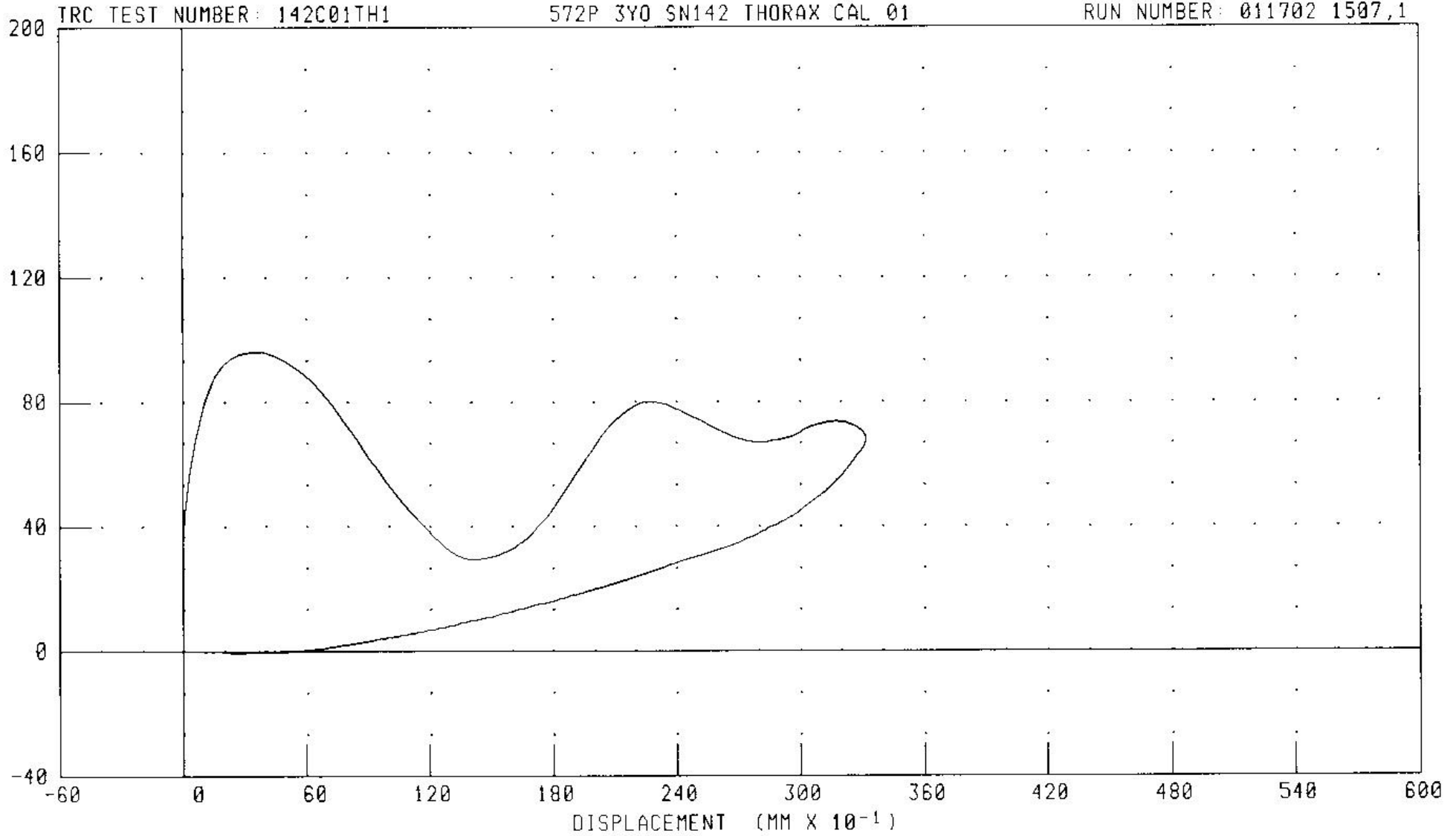

CHANNEL: CSTXD
PENXF

FILTER: CH. CLASS 600
CH. CLASS 180

PEAK DATA: 33.21 MM @ 12.80 MS; -0.02 MM @ 0.88 MS
962.61 N @ 2.16 MS; -22.42 N @ -0.32 MS

TRANSPORTATION RESEARCH CENTER INC.

TORSO FLEXION TEST

HYBRID III THREE-YEAR-OLD

CAL DATE: 15-Jan-02

TRC, INC.

TEST NO: 142C01TF1

572 P SN142 TORSO FLEX CAL 01

TEST PARAMETER	SPECIFICATION	TEST RESULTS
TEMPERATURE	20.6 – 22.2 DEG. C	21.7 DEG. C
RELATIVE HUMIDITY	10 – 70 %	23 %
INITIAL ANGLE OF UNSUPPORTTED DUMMY	<= 15 DEG. REFERENCED TO VERTICAL	1 DEG.
MAXIMUM FORCE AT 45 DEG. DURING 10 SECOND PERIOD	130 – 180 N	169 N
RETURN ANGLE	+/- 10 DEG OF INITIAL ANGLE	3 DEG.

TEST MEETS SPECIFICATIONS

TECHNICIAN



SECTION 14

TEST EQUIPMENT AND INSTRUMENTATION CALIBRATION

CERTIFICATION INSTRUMENTATION

Instrument	Certification Test	Calibration Date	Due Date
Slide Potentiometer Oceanside Mfg. Co. Model LCP 20-50 2.0 inches travel, 10,000 ohms	Neck Pendulum	3/02	9/02
C.G. Head Potentiometer Oceanside Mfg. Co. Model SP 221 Serial HNR2 10K, linearity = 1.5%	Neck Pendulum	3/02	9/02
C.G. Pendulum Potentiometer Oceanside Mfg. Co. Model SP 221 Serial HNR1 10K, linearity = 1.5%	Neck Pendulum	3/02	9/02
Bourns Potentiometer Model 3520S--1-502 5K +/-, linearity = 0.3%	Lumbar Spine Flexion	5/02	11/02
Transducer Inc. Load Cell S/N 20051, 50#	Lumbar Spine Flexion	2/02	6/02
Lebow Load Cell Model 3397-100 S/N 11564	Lumbar Spine Flexion	6/02	12/02
Endevco Accelerometers S/N AC-A183 +/- .075% Accuracy	Neck Pendulum (ATD)	12/01 6/02	6/02 12/02

CERTIFICATION INSTRUMENTATION (cont'd)

Instrument	Certification Test	Calibration Date	Due Date
Chatillon 20 Pound Gauge +/- 8 oz. Accuracy		2/02	8/02
Chatillon 40 Pound Gauge +/- 1% Accuracy		2/02	8/02
Belt Tension Gauge, +/- 1 lb.		2/02	8/02
Force Gauge, Chatillon Model DPTH 250		2/02	8/02
Weather Measure Cord Temp. & Humidity Recorder S/N 1545 +/- 3% Accuracy		6/01	7/02
Pot. #6 CIC Linear Potentiometer (Foam Certification)		2/02	8/02
Load Cell for Foam S/N 72952 +/- .10% Accuracy		2/02	8/02
Load Cell, Lap Belt North Sensotec S/N 283076 +/- 1.32 lbs. Accuracy		5/02	11/02
Load Cell, Lap Belt South Sensotec S/N 288386 +/- 1.32 lbs. Accuracy		5/02	11/02
Dillon Force Gauge Model E Serial # 4346 50#		3/02	9/02

SECTION 15

AVI FILES

AVI FILES (continued)