

Report Number: NCAP-TRC-02-004

New Car Assessment Program
“Side Impact Testing”

Bayerische Motoren Werke AG
2002 MINI Cooper

NHTSA Number: M20501

Transportation Research Center Inc.
10820 State Route 347
P. O. Box B-67
East Liberty, OH 43319



July 2, 2002

Final Report

U. S. Department Of Transportation
National Highway Traffic Safety Administration
Safety Performance Standards
Office of Crashworthiness Standards
400 Seventh Street, S. W.
Room No. 5313 (NPS-10)
Washington, DC 20590

This Final Test Report was prepared for the U.S. Department of Transportation, National Highway Traffic Safety Administration, under Contract No. DTNH22-98-D-12001. This publication is distributed by the U. S. Department of Transportation, National Highway Traffic Safety Administration, in the interest of information exchange. The opinions, findings, and conclusions expressed in this publication are those of the author(s) and not necessarily those of the Department of Transportation or the National Highway Traffic Safety Administration. The United States Government assumes no liability for its contents or use thereof. If trade or manufacturers' names or products are mentioned, it is only because they are considered essential to the object of the publication and should not be construed as an endorsement. The United States Government does not endorse products or manufacturers.

Test Performed By: Michael S. Postle, Engineering Technician

Report Approved By: _____

Virginia L. Watters, Project Manager
Transportation Research Center Inc.

Approval Date: _____

FINAL REPORT ACCEPTANCE BY OCS:

Accepted By: _____

Acceptance Date: _____

1. Report No. NCAP-TRC-02-004	2. Government Accession No.	3. Recipient's Catalog No.																									
4. Title and Subtitle Final Report of New Car Assessment Program Side Impact Testing of a 2002 MINI Cooper NHTSA No.: M20501		5. Report Date July 2, 2002																									
		6. Performing Organization Code TRC Inc.																									
7. Author(s) Virginia L. Watters, Project Manager Transportation Research Center Inc.		8. Performing Organization Report No. NCAP-TRC-02-004																									
9. Performing Organization Name and Address Transportation Research Center Inc. 10820 State Route 347 East Liberty, OH 43319		10. Work Unit No. (TRAIS)																									
		11. Contract or Grant No. DTNH22-98-D-12001																									
12. Sponsoring Agency Name and Address U.S. Department of Transportation National Highway Traffic Safety Administration Office of Crashworthiness Standards (NPS-10) 400 Seventh Street, S.W., Room 5313 Washington, DC 20590		13. Type of Report and Period Covered Final Report June - July 2002																									
		14. Sponsoring Agency Code NPS-10																									
15. Supplemental Notes																											
16. Abstract <p>This 58/28 km/h 270° Moving Deformable Barrier NCAP Side Impact Test was conducted on the subject vehicle, a 2002 MINI Cooper, in accordance with the specifications of the Office of Crashworthiness Standards Test Procedure for the generation of consumer information on vehicle side crash protection. This test was conducted by Transportation Research Center Inc. in East Liberty, Ohio, on June 19, 2002.</p> <p>The impact velocity of the Moving Deformable Barrier (MDB) was 62.1 km/h, and the ambient temperature at the struck (Drivers Side) side of the target vehicle at the time of impact was 21° C. The target vehicle's post-test maximum crush was 201 mm at Level 2. The test vehicle's performance follows:</p> <table border="0" style="width: 100%; border-collapse: collapse;"> <thead> <tr> <th style="width: 60%;"></th> <th style="text-align: center; border-bottom: 1px solid black;">Front SID</th> <th style="width: 10%;"></th> <th style="text-align: center; border-bottom: 1px solid black;">Rear SID</th> </tr> </thead> <tbody> <tr> <td>Left Upper Rib (LUR) Acceleration, g:</td> <td style="text-align: center; border-bottom: 1px solid black;">58.4</td> <td style="text-align: center;">g's</td> <td style="text-align: center; border-bottom: 1px solid black;">N/A</td> </tr> <tr> <td>Left Lower Rib (LLR) Acceleration, g:</td> <td style="text-align: center; border-bottom: 1px solid black;">50.9</td> <td style="text-align: center;">g's</td> <td style="text-align: center; border-bottom: 1px solid black;">N/A</td> </tr> <tr> <td>Lower Spine (T₁₂) Acceleration, g:</td> <td style="text-align: center; border-bottom: 1px solid black;">69.8</td> <td style="text-align: center;">g's</td> <td style="text-align: center; border-bottom: 1px solid black;">N/A</td> </tr> <tr> <td>Thoracic Trauma Index, (TTI):</td> <td style="text-align: center; border-bottom: 1px solid black;">64.1</td> <td style="text-align: center;">g's</td> <td style="text-align: center; border-bottom: 1px solid black;">N/A</td> </tr> <tr> <td>Pelvis (PEV) Acceleration, g:</td> <td style="text-align: center; border-bottom: 1px solid black;">74.8</td> <td style="text-align: center;">g's</td> <td style="text-align: center; border-bottom: 1px solid black;">N/A</td> </tr> </tbody> </table> <p>The two doors on the struck side of the vehicle did not separate from the body at the hinges or latches and the opposite doors did not open during side impact event. The rear seat was exempt from performance criteria because a rear dummy could not be seated according to the requirements of S7 of FMVSS No. 214D. The left rear (Pos. #4) SID was included for ballast only and the legs were removed due to space constraints.</p>					Front SID		Rear SID	Left Upper Rib (LUR) Acceleration, g:	58.4	g's	N/A	Left Lower Rib (LLR) Acceleration, g:	50.9	g's	N/A	Lower Spine (T ₁₂) Acceleration, g:	69.8	g's	N/A	Thoracic Trauma Index, (TTI):	64.1	g's	N/A	Pelvis (PEV) Acceleration, g:	74.8	g's	N/A
	Front SID		Rear SID																								
Left Upper Rib (LUR) Acceleration, g:	58.4	g's	N/A																								
Left Lower Rib (LLR) Acceleration, g:	50.9	g's	N/A																								
Lower Spine (T ₁₂) Acceleration, g:	69.8	g's	N/A																								
Thoracic Trauma Index, (TTI):	64.1	g's	N/A																								
Pelvis (PEV) Acceleration, g:	74.8	g's	N/A																								
17. Key Words New Car Assessment Program (NCAP) Side Impact MDB Side Impact Dummy (SID)		18. Distribution Statement <u>Copies of this report are available from:</u> NHTSA Technical Reference Division Room 5108 (NAD-52), 400 Seventh Street, S.W. Washington, DC 20590 Telephone No. (202) 366-4946 Attn: Robert Hornicle																									
19. Security Classification (of this report) Unclassified	20. Security Classification (of this page) Unclassified	21. Number of Pages 291	22. Price																								

METRIC CONVERSION FACTORS

Approximate Conversions to Metric Measures

Symbol	When You Know	Multiply by	To Find	Symbol
LENGTH				
in	inches	*2.5	centimeters	cm
ft	feet	30	centimeters	cm
yd	yards	0.9	meters	m
mi	miles	1.6	kilometers	km
AREA				
in ²	square inches	6.5	square centimeters	cm ²
ft ²	square feet	0.09	square meters	m ²
yd ²	square yards	0.8	square meters	m ²
mi ²	square miles	2.6	square kilometers	km ²
	acres	0.4	hectares	ha
MASS (weight)				
oz	ounces	28	grams	g
lb	pounds	0.45	kilograms	kg
	short tons (2000 lb)	0.9	tonnes	t
VOLUME				
tsp	teaspoons	5	milliliters	ml
Tbsp	tablespoons	15	milliliters	ml
fl oz	fluid ounces	30	milliliters	ml
c	cups	0.24	liters	l
pt	pints	0.47	liters	l
qt	quarts	0.95	liters	l
gal	gallons	3.8	liters	l
ft ³	cubic feet	0.03	cubic meters	m ³
yd ³	cubic yards	0.76	cubic meters	m ³
TEMPERATURE (exact)				
°F	Fahrenheit temperature	5/9 (after subtracting 32)	Celsius temperature	°C

*1 in = 2.54 (exactly). For other exact conversions and more detailed tables, see NBS Misc. Publ. 286, Units of Weights and Measures, Price \$2.25, SD Catalog No. C13.10:286.

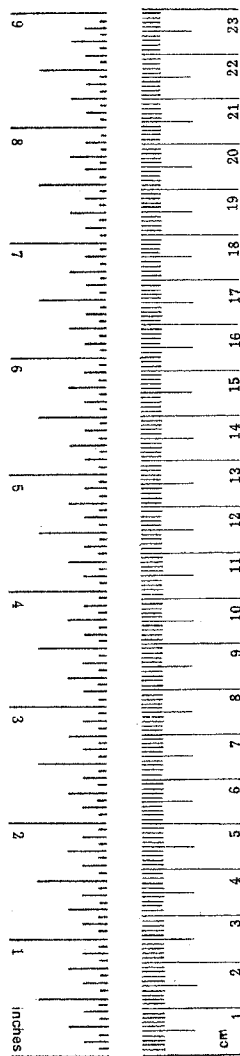

Approximate Conversions from Metric Measures

Symbol	When You Know	Multiply by	To Find	Symbol
LENGTH				
mm	millimeters	0.04	inches	in
cm	centimeters	0.4	inches	in
m	meters	3.3	feet	ft
m	meters	1.1	yards	yd
km	kilometers	0.6	miles	mi
AREA				
cm ²	square centimeters	0.16	square inches	in ²
m ²	square meters	1.2	square yards	yd ²
km ²	square kilometers	0.4	square miles	mi ²
ha	hectares (10,000 m ²)	2.5	acres	
MASS (weight)				
g	grams	0.035	ounces	oz
kg	kilograms	2.2	pounds	lb
t	tonnes (1000 kg)	1.1	short tons	
VOLUME				
ml	milliliters	0.03	fluid ounces	fl oz
l	liters	2.1	pints	pt
l	liters	1.06	quarts	qt
l	liters	0.26	gallons	gal
m ³	cubic meters	35	cubic feet	ft ³
m ³	cubic meters	1.3	cubic yards	yd ³

TEMPERATURE (exact)

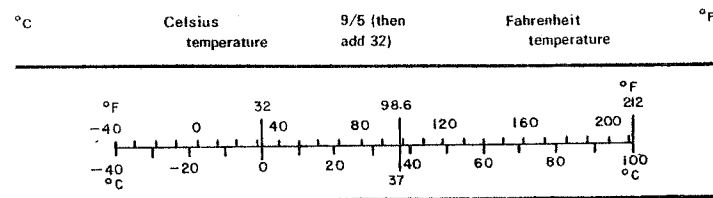

Table of Contents

<u>Section</u>	<u>Description</u>	<u>Page No.</u>
1	Purpose and Test Procedure	1-1
2	Summary of Side Impact Test	2-1
3	Vehicle Test Data	3-1
	Data Sheet 1 - General Vehicle Test Parameter Data	3-2
	Data Sheet 2 - Test Vehicle Summary of Results	3-7
	Data Sheet 3 - Moving Deformable Barrier (MDB) Summary	3-8
	Data Sheet 4 - Post-Test Observations	3-9
4	Occupant and Vehicle Information	4-1
	Data Sheet 5 - SID Instrumentation Data	4-2
	Data Sheet 6 - Vehicle Pre-Test And Post-Test Measurements	4-3
	Data Sheet 7 - SID Longitudinal Clearance Dimensions	4-4
	Data Sheet 8 - SID Lateral Clearance Dimensions	4-5
	Data Sheet 9 - Vehicle Side Measurements	4-6
	Data Sheet 10 - Vehicle Exterior Crush Profiles - All Levels	4-7
	Data Sheet 11 - Vehicle Damage Profile Distances	4-14
	Data Sheet 12 - Exterior Static Crush For Impactor Face	4-15
	Data Sheet 13 - Test Vehicle Accelerometer Locations and Data Summary	4-24
	Data Sheet 14 - MDB Accelerometer Locations and Data Summary	4-28
	Data Sheet 15 - High-Speed Camera Locations and Data Summary	4-29
5	Vehicle Fuel System Integrity	5-1
	Data Sheet 16 - FMVSS 301 Fuel System Integrity Data	5-2
	Data Sheet 17 - FMVSS 301 Rollover Data	5-3
Appendix A	Photographs	A-1
Appendix B	Data Plots	B-1
Appendix C	SID Configuration and Performance Verification Data	C-1
Appendix D	Test Equipment List and Calibration Information	D-1

Section 1

Purpose and Test Procedure

This side impact test is part of the FY2002 New Car Assessment Program Side Impact Test Program sponsored by the National Highway Traffic Safety Administration (NHTSA) under Contract No. DTNH22-98-D-12001. The purpose of this test was to generate comparative side impact performance data in a 2002 MINI Cooper. The test was conducted in accordance with the Office of Crashworthiness Standards' Laboratory Test Procedure dated May 1999.

Section 2

Summary of Side Impact Test

A 2002 MINI Cooper was impacted on the driver's side by a Moving Deformable Barrier (MDB) which was moving forward in a 27° crabbed position to the tow road guidance system at a velocity of 62.1 km/h (38.6 mph). The target vehicle was stationary and was positioned at an angle of 63° to the line of forward motion. The side impact test was conducted by Transportation Research Center Inc. in East Liberty, Ohio on June 19, 2002. Pre-test and post-test photographs of the test vehicle, the moving deformable barrier (MDB), and the driver side impact dummy (SID) are included in Appendix A.

One restrained Side Impact Dummy (SID) was placed in the driver (Pos. #1) designated seating position according to the instructions specified in the OCS Side Impact Laboratory Test Procedure dated May 1999. The rear seat was exempt from performance criteria because a rear dummy could not be seated according to the requirements of S7 of FMVSS No. 214D. The left rear (Pos. #4) SID was included for ballast only and the legs were removed due to space constraints. The driver SID was certified prior to this test. The side impact test was documented by one real-time camera and 8 high-speed cameras. Camera locations and other pertinent camera information are included in this report.

The driver SID was instrumented with the following accelerometers:

1. Left Upper Rib (LUR) uniaxial accelerometers (Y-axis primary and redundant)
2. Left Lower Rib (LLR) uniaxial accelerometers (Y-direction primary and redundant)
3. Lower Thoracic Spine (T₁₂) uniaxial accelerometers (Y-direction primary and redundant)
4. Pelvic (PEV) section uniaxial accelerometers (Y-direction primary and redundant)
5. Head (HED) triaxial accelerometers (X-Y-Z-directions)

A total of 50 channels of data were recorded. Appendix B contains the data plots. Appendix C contains a summary of the side impact dummy (SID) configuration and verification test data.

The following table summarizes the results of the test.

Injury Criteria	Front SID	Rear SID
Thoracic Trauma Index, TTI (g)	64.1	N/A
Pelvis Acceleration (g)	74.8	N/A

Head Injury Criteria

Injury Criteria	HIC	t ₁ (ms)	t ₂ (ms)	Avg. Accel. t ₁ -t ₂ (g)
Front SID	135	29.280	65.280	26.88
Rear SID	N/A	N/A	N/A	N/A

HIC is as defined in FMVSS 208. The maximum time interval from t₁ to t₂ is 36 ms.

Neck Injury Criteria¹

Maximum Values	Front SID	Rear SID
Neck X-axis Force (N)	-363.0	N/A
Neck Y-axis Force (N)	493.8	N/A
Neck Z-axis Force (N)	-1817.0	N/A
Neck Moment About X Axis (Nm) ²	-100.0	N/A
Neck Moment About Y Axis (Nm)	-31.5	N/A
Neck Moment About Z Axis (Nm)	-16.2	N/A

¹ Sign convention per SAE J211, March 1995.

² Calculated about the occipital condyle with the following formula: $M_{occ} = M_x + 0.01778 F_y$.

Data Acquisition Explanations

The vehicle's left front door mid-rear Y-axis acceleration data channel, LFMYG1, recorded a data spike that exceeded its full-scale value at approximately 23 milliseconds and recorded no valid data after that. This also affected the integrated velocity data channel.

The vehicle's left middle A-post accelerometer data channel, LMAYG1, exceeded its full-scale value at approximately 14 milliseconds and recorded no valid data after that. This also affected the integrated velocity data channel.

Pre-test measurements of the MDB face Row C (points 18-34) were not recorded. These measurements were approximated for comparison to post-test measurements by using the pre-test measurements of Row D (points 1-17) above and subtracting 127 mm from all Z-axis measurements.

Section 3

Vehicle Test Data

Data Sheet 1
General Test Vehicle Parameter Data

Vehicle: 2002 MINI Cooper

NHTSA No: M20501

Test Vehicle Information:

Year/Make/Model: 2002 MINI Cooper
Body Style/Color: 2-door hatchback/Pure Silver Metallic
VIN: WMWRC33492TE10277
NHTSA No.: M20501 Build Date: 03/02
Engine Data: 4 Cylinders; CID; 1.6 Liters; cc
Engine Placement: X Longitudinal; Lateral
Transmission: 6 Speed; - Manual; X Automatic; - Overdrive
Final Drive: - RWD; X FWD; - Four Wheel Drive
Odometer Reading: 20 miles
Options: X A/C; X Power steering; X Power brakes;
X Tilt wheel; X Power windows; X Power locks

Data From Vehicle's Tire Placard:

Tire Pressure (at capacity)¹ 303 kPa Front; 303 kPa Rear
Recommended Tire Size: 175/65R15
Tires on Test Vehicle: 175/65R15 Manufacturer: Continental

Vehicle Capacity Data:

Number of Occupants: 2 Front; 2 Rear; N/A 3rd seat; 4 Total
Type of Front Seats: X Bucket; - Bench; - Split bench
Type of Front Seat Back: - Fixed; X Adjustable with X Lever or - Knob
Vehicle Max. Capacity Loading = 357.0 kg (A)
No. of Occupants x 68.04 kg. = 272.2 kg (B)
Vehicle Cargo Capacity (A-B) = 84.8 kg

¹ Tire pressure used in test.

Data Sheet 1 (Continued)
General Test Vehicle Parameter Data

Vehicle: 2002 MINI Cooper

NHTSA No: M20501

Restraint Information

Driver:

3-point safety belt
Frontal airbag (did not deploy)
Side airbag in seat
Head airbag

Rear Passenger:

3-point safety belt
Head airbag

Test Vehicle Delivered Weight With Maximum Fluids:

Right Front	=	<u>359.2</u> kg	Right Rear	=	<u>226.3</u> kg
Left Front	=	<u>362.9</u> kg	Left Rear	=	<u>226.3</u> kg
Total Front	=	<u>722.1</u> kg	Total Rear	=	<u>452.6</u> kg
Front % of Total Weight	=	<u>61.5</u> %	Rear % of Total Weight	=	<u>38.5</u> %
Total Weight	=	<u>1174.7</u> kg			

Calculation Of Vehicle's Target Test Weight:

Total Test Vehicle Delivered Weight with Max. Fluids	=	<u>1174.7</u> kg (A)
Maximum Cargo Carrying Capacity of Test Vehicle	=	<u>98.0</u> kg (B)
Weight of Instrumented Side Impact Dummies (1 or 2 X <u>77.5</u> kg)	=	<u>155.0</u> kg (C)
Test Vehicle Target Weight:	=	<u>1427.7</u> kg (A+B+C)

Data Sheet 1 (Continued)
General Test Vehicle Parameter Data

Vehicle: 2002 MINI Cooper

NHTSA No: M20501

Fully Loaded Test Vehicle (UDW + 1 or 2 SID(s) + Cargo):

Right Front	=	<u>363.5</u> kg	Right Rear	=	<u>325.5</u> kg
Left Front	=	<u>410.0</u> kg	Left Rear	=	<u>345.0</u> kg
Total Front	=	<u>773.5</u> kg	Total Rear	=	<u>670.5</u> kg
Front % of Total Weight	=	<u>53.6</u> %	Rear % of Total Weight	=	<u>46.4</u> %
Total Weight	=	<u>1444.0</u> kg			

As Tested Weight of Test Vehicle (1 or 2 SID(s) + Cargo + Equipment & Instrumentation):

Right Front	=	<u>408.8</u> kg	Right Rear	=	<u>294.6</u> kg
Left Front	=	<u>420.8</u> kg	Left Rear	=	<u>298.4</u> kg
Total Front	=	<u>829.6</u> kg	Total Rear	=	<u>593.0</u> kg
Front % of Total Weight	=	<u>58.3</u> %	Rear % of Total Weight	=	<u>41.7</u> %
Total Weight	=	<u>1422.6</u> kg			

Test Vehicle Attitude:

As Delivered	Fully Loaded	Ready For Test
Right Front <u>665</u> mm	Right Front <u>650</u> mm	Right Front <u>650</u> mm
Left Front <u>660</u> mm	Left Front <u>645</u> mm	Left Front <u>645</u> mm
Right Rear <u>654</u> mm	Right Rear <u>604</u> mm	Right Rear <u>620</u> mm
Left Rear <u>657</u> mm	Left Rear <u>600</u> mm	Left Rear <u>630</u> mm

Test Vehicle Wheelbase: 2468 mm

C.G. = 1029 mm rearward of front wheel centerline

Total Vehicle Length:

Right Side = 3385 mm

Left Side = 3385 mm

Centerline = 3640 mm

Data Sheet 1 (Continued)
General Test Vehicle Parameter Data

Vehicle: 2002 MINI Cooper

NHTSA No: M20501

Nominal Design Riding Position for adjustable driver and passenger seat backs. Please describe how to position the inclinometer to measure the seat back angle. Include description of the location of the adjustment latch detent, if applicable.

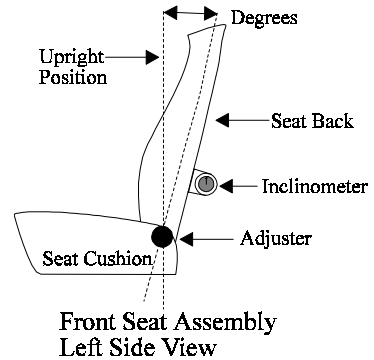

Front Seat Cushion Placement: In the first locking catch behind the geometrical center position: the 16th latch, counting the 1st locking latch as number one.

Total Length of Fore/Aft Adjustment Travel: 240 mm

Total Number of Adjustment Positions or Detents: 30

Front Seat Back Adjustment Position: The front seat back angle was verified with 16° on the rear surface of extended head restraint bar. Use of the 3-dimensional H-point machine according to SAE J826 to achieve 25° torso angle results in 16° on the head restraint bar.

Back Torso Angle: 25 degrees

Second Position Seat Placement: N/A

Total Length Of Fore/Aft Adjustment Travel: N/A mm

Seat Back Adjustment Position: N/A

Adjustable Steering Column Position: 66.6 degrees measured from the steering wheel hub at the geometric center of its height adjustment range of 64.8 to 68.4.

Window Positions:

Right Front: Open

Right Rear: Fixed

Left Front: Closed

Left Rear: Fixed

Note: Windows will be in closed position on struck side of test vehicle and in open position on opposite side.

Data Sheet 1 (Continued)
General Test Vehicle Parameter Data

Vehicle: 2002 MINI Cooper

NHTSA No: M20501

Amount of Stoddard Solvent In Fuel Tank:

50.0 liters (fuel tank usable capacity)

46.4 liters used in test (92% - 94% of fuel tank usable capacity)

Location of Impact Point On Test Vehicle Side To Be Impacted:

Wheelbase = 2468 mm

Intended Impact Point: 294 mm rearward of front axle centerline

(which is 940 mm forward of the wheelbase midpoint)

Actual Impact Point: 306 mm rearward of front axle centerline

Data Sheet 2
Test Vehicle Summary of Results

Vehicle Identification:

Vehicle Year/Make/Model: 2002/MINI/Cooper

Body Style: 2 door hatchback

VIN: WMWRC33492TE10277

NHTSA No.: M20501

Build Date: 03/02

Test Date: 06/19/02

Vehicle Overall Length = 3640 mm

Overall Width = 1675 mm

Vehicle Test Weight (Pre-Test):

Left Front = 420.8 kg Left Rear = 298.4 kg

Right Front = 408.8 kg Right Rear = 294.6 kg

Total Front = 829.6 kg Total Rear = 593 kg

Total Weight = 1422.6 kg

Wheelbase = 2468 mm

Longitudinal C.G. From Center Of Front Axle = 1029 mm

Impact Angle With Respect To Impactor = 90 degrees

Impact Point:

Actual Impact Point is 12 mm right of nominal impact ref. line (Lateral)

Actual Impact Point is 2 mm up from nominal impact point (Vertical)

Maximum Exterior Static Crush:

1. Level 1 (318 mm above ground) = 51 mm

2. Level 2 (454 mm above ground) = 201 mm

3. Level 3 (610 mm above ground) = 198 mm

4. Level 4 (870 mm above ground) = 147 mm

5. Level 5 (1371 mm above ground) = 15 mm

Maximum Post-Test Intrusion = 201 mm

Occupants:

Front Passenger

Rear Passenger

Dummy Identification 270

N/A

Restraints Used/Deployed Seat Belt, Head Airbag, Side Airbag

N/A

Instrumentation:

Number of Vehicle Data Channels: = 26

Number of Cameras: Onboard Veh./MDB = 4 Offboard = 5 Total = 9

Data Sheet 3
Moving Deformable Barrier(MDB) Summary

MDB Face Manufacturer And Serial Number:

Plascore, Block #033A0801, Sample ID# IN323473

Position Of Impactor (MDB) On Monorail:

Crabbed 27° to the right.

MDB Specifications:

Overall Width of Framework Carriage = 1251 mm

Overall Length of MDB (Incl. honeycomb impact face) = 4014 mm

Wheelbase of Framework Carriage = 2591 mm

Track Width of Framework Carriage (Front & Rear) = 1881 mm

C.G. Location (Rearward of Front Axle) = 1113 mm

MDB Weight:

Left Front = 407.6 kg Left Rear = 263.8 kg

Right Front = 368.8 kg Right Rear = 321.0 kg

Total Front = 776.4 kg Total Rear = 584.8 kg

Total MDB Weight = 1361.2 kg

Impact Angle (MDB C/L to Target Vehicle C/L) = 90 degrees

Impact Speed = 62.1 km/h

Maximum Static Crush of Honeycomb Impact Face:

1. Row A at Center of Bumper Level¹ = N/A mm

2. Row B at Top of Bumper Level = 102.5 mm

3. Row C at Mid Level = 50.7 mm

4. Row D at Top of Stack Level = 165.7 mm

Instrumentation:

Number of MDB Data Channels = 7

¹ Bumper portion of deformable barrier face fell off post-test.

Data Sheet 4
Post-Test Observations

Vehicle: 2002 MINI Cooper

NHTSA No.: M20501

Visible Dummy Contact Points:

	<u>Left Front SID</u>	<u>Left Rear SID</u>
Head:	<u>Airbag, Head restraint</u>	<u>N/A</u>
Upper Torso:	<u>Airbag</u>	<u>N/A</u>
Lower Torso:	<u>Airbag</u>	<u>N/A</u>
Left Knee:	<u>Door Panel</u>	<u>N/A</u>
Right Knee:	<u>None</u>	<u>N/A</u>

Door Opening:

	<u>Left Side</u>	<u>Right Side</u>
Front:	<u>Remained latch/Jammed shut</u>	<u>Remained shut and operational</u>
Rear:	<u>No door</u>	<u>No door</u>

MDB Distance From Target Impact Point:

Vertical: 2 mm up from target
Horizontal: 12 mm right from target

Arm Rest Locations:

Front: None
Rear: None

Seat Movement:

Front: None
Rear: None

Glazing Damage:

Windshield: Left side at A-Pillar
Window: Left side driver's window shattered.
Pillar Separation: No
Sill Separation: No

Data Sheet 4 (Continued)
Post-Test Observations

Vehicle: 2002 MINI Cooper

NHTSA No.: M20501

Airbag Deployment Status:

	<u>Driver</u>	<u>Front Passenger</u>	<u>Rear Passenger</u>
Front:	<u>Did not deploy</u>	<u>Did not deploy</u>	<u>N/A</u>
Side:	<u>Deployed</u>	<u>Did not deploy</u>	<u>N/A</u>
Head:	<u>Deployed</u>	<u>Did not deploy</u>	<u>left side deployed</u>

Other Notable Impact Effects: None

Section 4

Occupant and Vehicle Information

Data Sheet 5
SID Instrumentation Data

Vehicle: 2002 MINI Cooper

NHTSA No.: M20501

TEST NUMBER: 020619

DRIVER DUMMY SERIAL NUMBER: 270

POSITIVE
DIRECTION

NEGATIVE
DIRECTION

HEAD ACCELERATION

LONGITUDINAL	4.6 g	@ 183.4 ms	17.6 g	@ 56.7 ms
LATERAL	41.7 g	@ 41.4 ms	5.8 g	@ 222.2 ms
VERTICAL	19.4 g	@ 63.4 ms	2.3 g	@ 94.3 ms
RESULTANT	43.6 g	@ 41.4 ms		
HIC	135 from 29.3 to 65.3 ms			

NECK FORCE

X-AXIS SHEAR	121.5 N	@ 43.4 ms	363.0 N	@ 106.6 ms
Y-AXIS SHEAR	493.8 N	@ 76.4 ms	269.7 N	@ 29.0 ms
Z-AXIS AXIAL	420.3 N	@ 63.3 ms	1817.0 N	@ 44.1 ms

NECK MOMENT

ABOUT X AXIS	27.8 N-m	@ 89.8 ms	106.9 N-m	@ 42.2 ms
ABOUT Y AXIS	31.0 N-m	@ 101.5 ms	31.5 N-m	@ 44.8 ms
ABOUT Z AXIS	15.3 N-m	@ 97.0 ms	16.2 N-m	@ 43.8 ms
OCCIP. CONDYLE	36.1 N-m	@ 89.8 ms	100.0 N-m	@ 42.1 ms

LEFT UPPER RIB ACCELERATION

LATERAL (P)	58.4 g	@ 32.5 ms	13.7 g	@ 68.8 ms
LATERAL (R)	59.7 g	@ 32.5 ms	14.0 g	@ 69.4 ms

LEFT LOWER RIB ACCELERATION

LATERAL (P)	50.9 g	@ 16.9 ms	8.7 g	@ 85.6 ms
LATERAL (R)	51.7 g	@ 16.9 ms	9.0 g	@ 85.6 ms
TTI d (P)	64.1			
TTI d (R)	65.6			

LOWER SPINE ACCELERATION

LATERAL (P)	69.8 g	@ 34.4 ms	14.8 g	@ 63.8 ms
LATERAL (R)	71.6 g	@ 34.4 ms	14.3 g	@ 63.8 ms

PELVIS ACCELERATION

LATERAL (P)	74.7 g	@ 30.0 ms	7.9 g	@ 75.0 ms
LATERAL (R)	74.2 g	@ 30.0 ms	8.0 g	@ 75.0 ms

Data Sheet 6
Vehicle Pre-Test And Post-Test Measurements

Vehicle: 2002 MINI Cooper

NHTSA No.: M20501

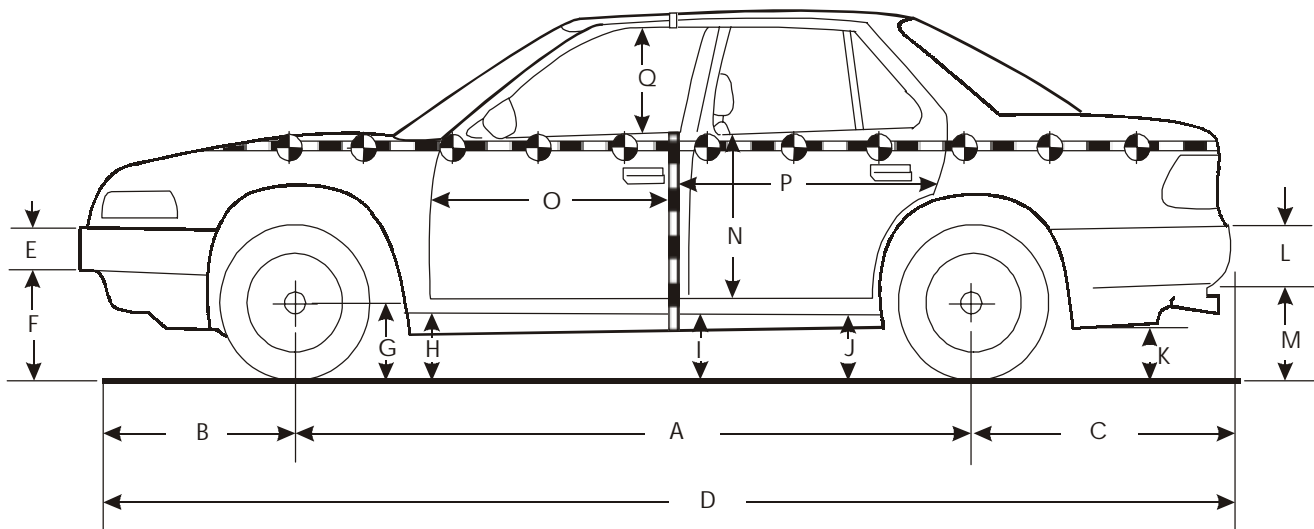

Left Side View

Note: All measurements are in millimeters with tolerance of ± 3 mm

	Pre-Test (as delivered)	Pre-Test (as tested)	Post-Test (as tested)	Change
A	2468	2468	2461	7
B	635	635	630	5
C	537	537	540	-3
D	3640	3640	3640	0
E	130	130	132	-2
F	362	349	358	-9
G	284	284	285	-1
H	174	155	205	-50
I	177	160	204	-44
J1	155	140	155	-15
J2	185	170	205	-35
K	280	280	288	-8
L	140	140	144	-4
M	364	360	370	-10
N	N/A	N/A	N/A	N/A
O	606	606	620	-14
P	N/A	N/A	N/A	N/A
Q	375	375	361	14
R	3385	3385	3385	0
S	3385	3385	3385	0
T	1205	1205	1105	100

D = Length at centerline
T = Width at B-pillar

E&L = Bumper Thickness
J1 = To Pinch Weld

R = Right Side Length
J2 = To Sill

S = Left Side Length

Data Sheet 7
SID Longitudinal Clearance Dimensions

Vehicle: 2002 MINI Cooper

NHTSA No.: M20501

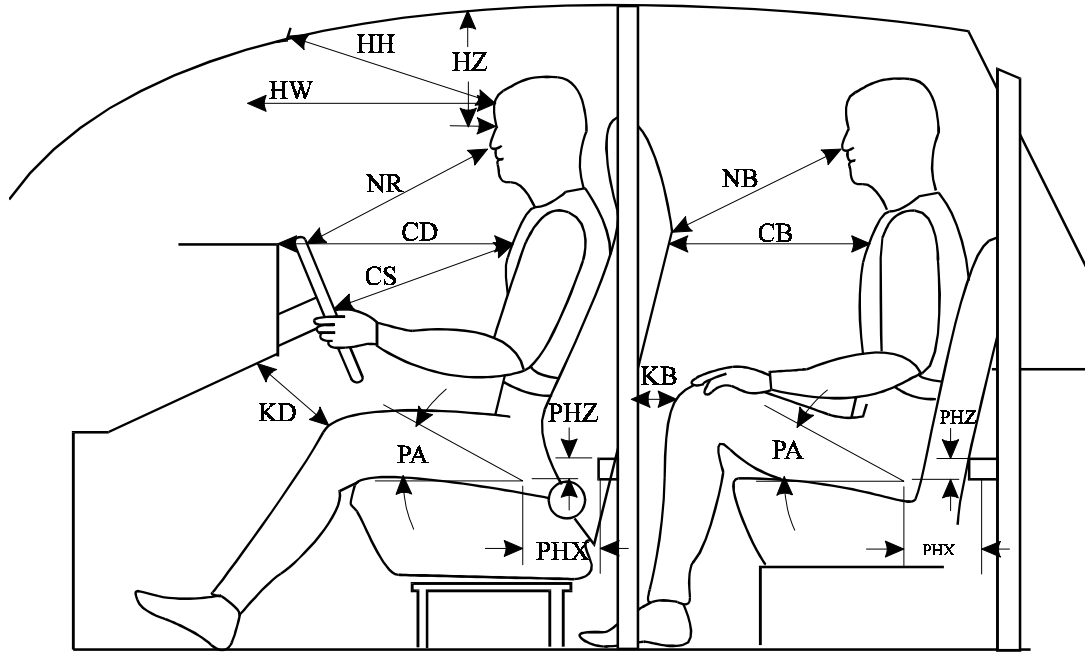

Left Side View

Note: All measurements are in millimeters with tolerance of ± 3 mm

Measurement	Driver SID # 270	Left Rear Passenger SID #
HH	713	N/A
HW	814	N/A
HZ	170	N/A
NR/NB	512	N/A
CD/CB ¹	578	N/A
CS	389	N/A
KDL(KDA°)/KBL(KBA°)	149/61.6°	N/A
KDR(KDA°)/KBR(KBA°)	142/67.2°	N/A
PA°	24.4°	N/A
PHX	345	N/A
PHZ	218	N/A

Note: 2-door vehicle shown. Rear dummy PHX and PHZ measurements for 4-door vehicle use the C-post striker as a reference point.

¹ Measured from chest to the center of the tachometer.

Data Sheet 8
SID Lateral Clearance Dimensions

Vehicle: 2002 MINI Cooper

NHTSA No.: M20501

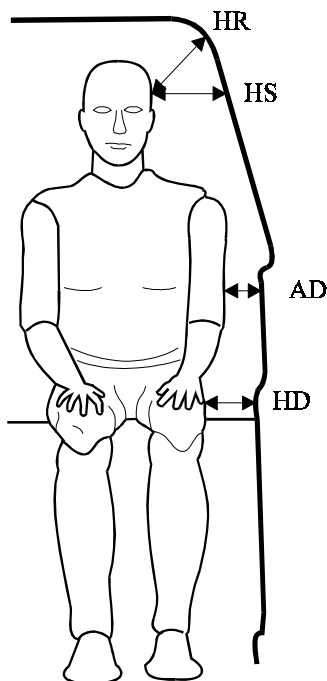

Note: All measurements are in millimeters with tolerance of ± 3 mm

Measurement	Driver SID # 270	Left Rear Passenger SID #
HR	210	N/A
HS	210	N/A
AD*	Lower: 78 Upper: 65	Lower: N/A Upper: N/A
HD	90	N/A

* Lower measurement is taken laterally at center of the lower rib accelerometer height from the SID arm segment to the closest part of the vehicle side.

Upper measurement is taken laterally at center of the upper rib accelerometer height from the SID arm segment to the closest part of the vehicle side.

Data Sheet 9
Vehicle Side Measurements

Vehicle: 2002 MINI Cooper

NHTSA No.: M20501

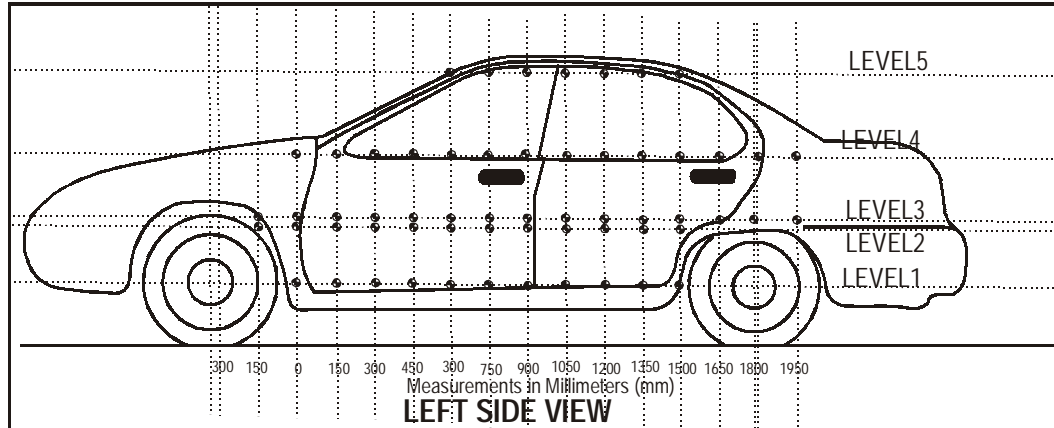

- Level 5 - Window Top
- Level 4 - Window Sill
- Level 3 - Mid-Door
- Level 2 - Occupant H-Point
- Level 1 - Axle Centerline Height or Sill Top Height

Measurements Are Taken When The Vehicle Is In The “As Tested” Configuration.

Measurements along the vertical 750 mm line shown above:

Level 5 @ Window Top	=	<u>1371</u>	mm
Level 4 @ Window Sill	=	<u>870</u>	mm
Level 3 @ Mid Door	=	<u>610</u>	mm
Level 2 @ Occupant H-Point	=	<u>454</u>	mm
Level 1 @ Axle Centerline Height (or Sill Top Height)	=	<u>318</u>	mm

Data Sheet 10

Vehicle Exterior Crush Profiles - All Levels

Vehicle: 2002 MINI Cooper

NHTSA No.: M20501

Location	Height		(mm) From Impact Point															
			-1200	-1050	-900	-750	-600	-450	-300	-150	0	150	300	450	600	750		
Level 1 Side Sill	318	Pre	N/A	N/A	N/A	N/A	N/A	N/A	N/A	N/A	N/A	N/A	721	729	726	722	725	
		Post	N/A	N/A	N/A	N/A	N/A	N/A	N/A	N/A	N/A	N/A	N/A	747	777	777	772	772
		Crush	N/A	N/A	N/A	N/A	N/A	N/A	N/A	N/A	N/A	N/A	N/A	26	48	51	50	47
Level 2 H-Point	454	Pre	N/A	N/A	N/A	N/A	N/A	N/A	N/A	N/A	N/A	N/A	700	703	703	702	703	
		Post	N/A	N/A	N/A	N/A	N/A	N/A	N/A	N/A	N/A	N/A	N/A	839	846	885	898	902
		Crush	N/A	N/A	N/A	N/A	N/A	N/A	N/A	N/A	N/A	N/A	N/A	139	143	182	196	199
Level 3 Mid-Door	610	Pre	N/A	N/A	N/A	N/A	N/A	N/A	N/A	N/A	669	690	696	695	693	694	693	
		Post	N/A	N/A	N/A	N/A	N/A	N/A	N/A	N/A	N/A	735	805	825	846	864	875	
		Crush	N/A	N/A	N/A	N/A	N/A	N/A	N/A	N/A	N/A	45	109	130	153	170	182	
Level 4 Window Sill	870	Pre	N/A	N/A	N/A	N/A	N/A	N/A	N/A	810	796	784	780	772	766	758	752	
		Post	N/A	N/A	N/A	N/A	N/A	N/A	N/A	N/A	810	800	791	791	806	824	835	834
		Crush	N/A	N/A	N/A	N/A	N/A	N/A	N/A	N/A	0	4	7	11	34	58	77	82
Level 5 Window Top	1371	Pre	N/A	N/A	N/A	N/A	N/A	N/A	N/A	N/A	N/A	N/A	N/A	N/A	N/A	990	978	
		Post	N/A	N/A	N/A	N/A	N/A	N/A	N/A	N/A	N/A	N/A	N/A	N/A	N/A	N/A	991	987
		Crush	N/A	N/A	N/A	N/A	N/A	N/A	N/A	N/A	N/A	N/A	N/A	N/A	N/A	N/A	1	9

4-7

020619

Data Sheet 10 (Continued)

Vehicle Exterior Crush Profiles - All Levels

Vehicle: 2002 MINI Cooper

NHTSA No.: M20501

Location	Height		(mm) From Impact Point												
			900	1050	1200	1350	1500	1650	1800	1950	2100	2250	2400	2550	2700
Level 1 Side Sill	318	Pre	726	727	730	733	735	737	710	N/A	N/A	N/A	N/A	N/A	N/A
		Post	770	770	770	765	750	730	685	N/A	N/A	N/A	N/A	N/A	N/A
		Crush	44	43	40	32	15	-7	-25	N/A	N/A	N/A	N/A	N/A	N/A
Level 2 H-Point	454	Pre	705	707	710	712	715	720	700	N/A	N/A	N/A	N/A	N/A	N/A
		Post	906	900	881	855	828	790	N/A	N/A	N/A	N/A	N/A	N/A	N/A
		Crush	201	193	171	143	113	70	N/A	N/A	N/A	N/A	N/A	N/A	N/A
Level 3 Mid-Door	610	Pre	694	696	698	702	705	710	709	681	N/A	N/A	N/A	N/A	N/A
		Post	888	894	892	854	847	860	830	N/A	N/A	N/A	N/A	N/A	N/A
		Crush	194	198	194	152	142	150	121	N/A	N/A	N/A	N/A	N/A	N/A
Level 4 Window Sill	870	Pre	747	744	742	741	745	745	746	750	752	759	781	N/A	N/A
		Post	845	847	851	864	892	830	833	N/A	772	772	N/A	N/A	N/A
		Crush	98	103	109	123	147	85	87	N/A	20	13	N/A	N/A	N/A
Level 5 Window Top	1371	Pre	980	980	981	987	983	990	994	992	1008	N/A	N/A	N/A	N/A
		Post	995	992	991	1000	987	990	995	1000	1010	N/A	N/A	N/A	N/A
		Crush	15	12	10	13	4	0	1	8	2	N/A	N/A	N/A	N/A

Data Sheet 10 (Continued)

Vehicle Exterior Crush Profiles - All Levels

Vehicle: 2002 MINI Cooper

NHTSA No.: M20501

Side Profile Level 1 318 mm Above Ground

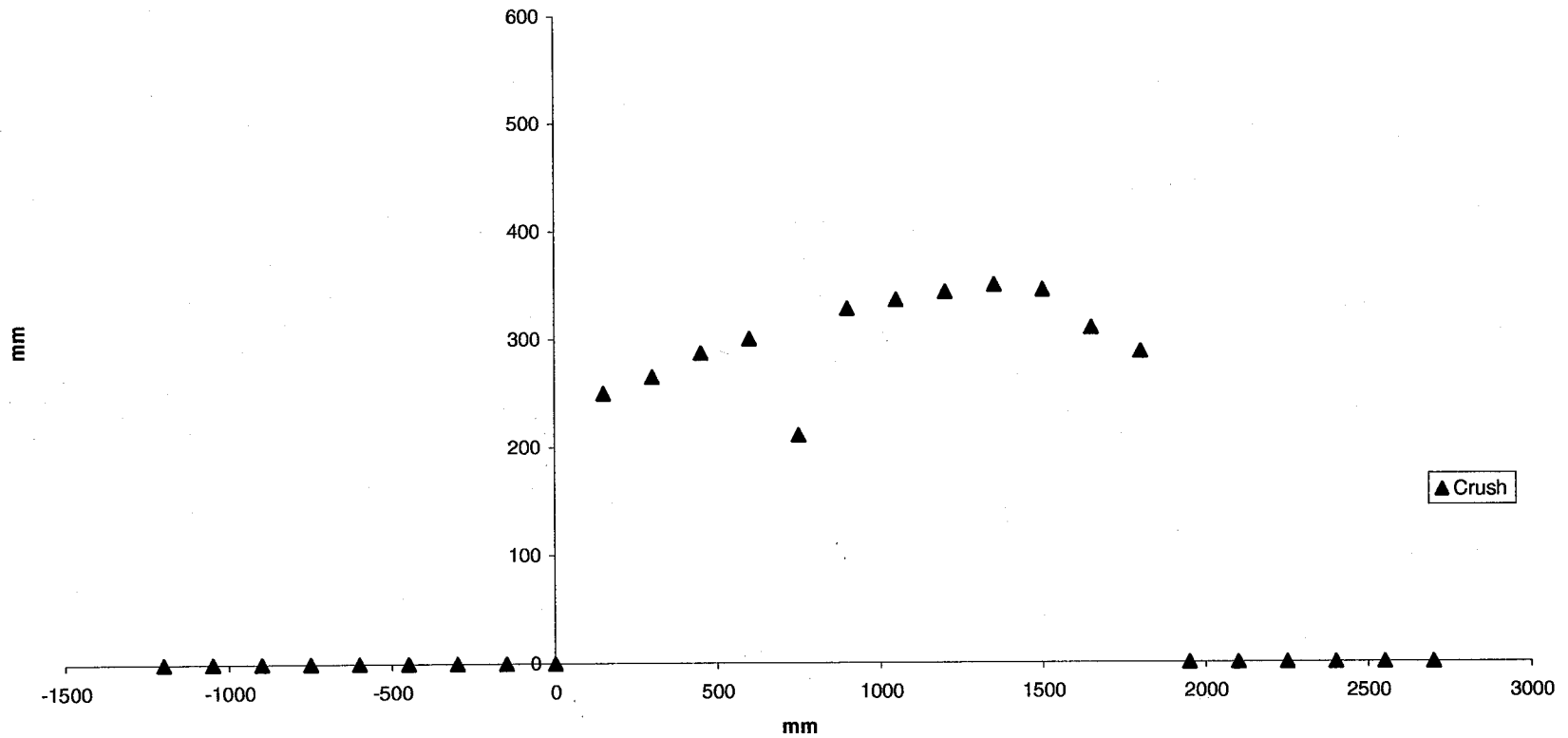

Data Sheet 10 (Continued)

Vehicle Exterior Crush Profiles - All Levels

Vehicle: 2002 MINI Cooper

NHTSA No.: M20501

Side Profile Level 2 454 mm Above Ground

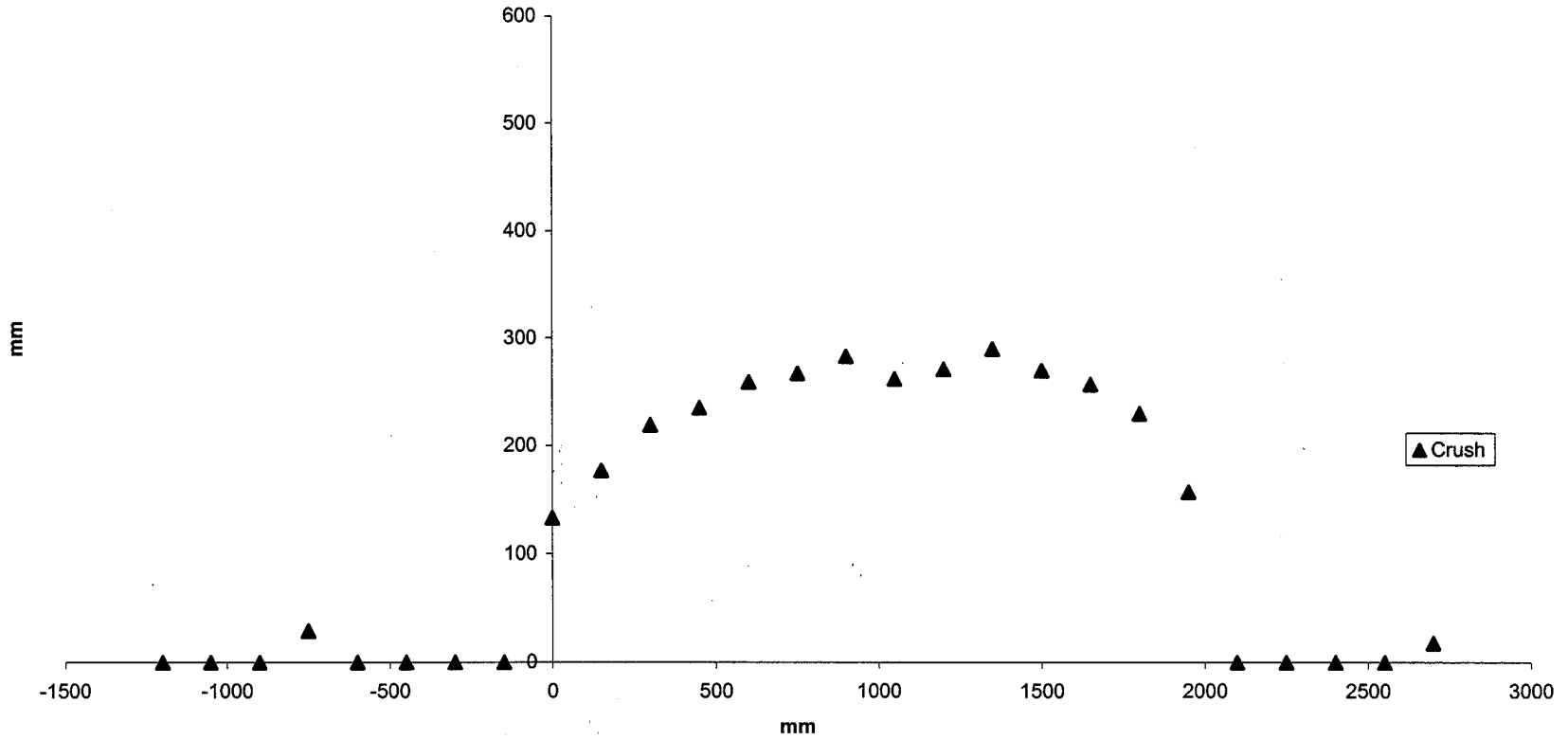

4-10

020619

Data Sheet 10 (Continued)

Vehicle Exterior Crush Profiles - All Levels

Vehicle: 2002 MINI Cooper

NHTSA No.: M20501

Side Profile Level 3 610 mm Above Ground

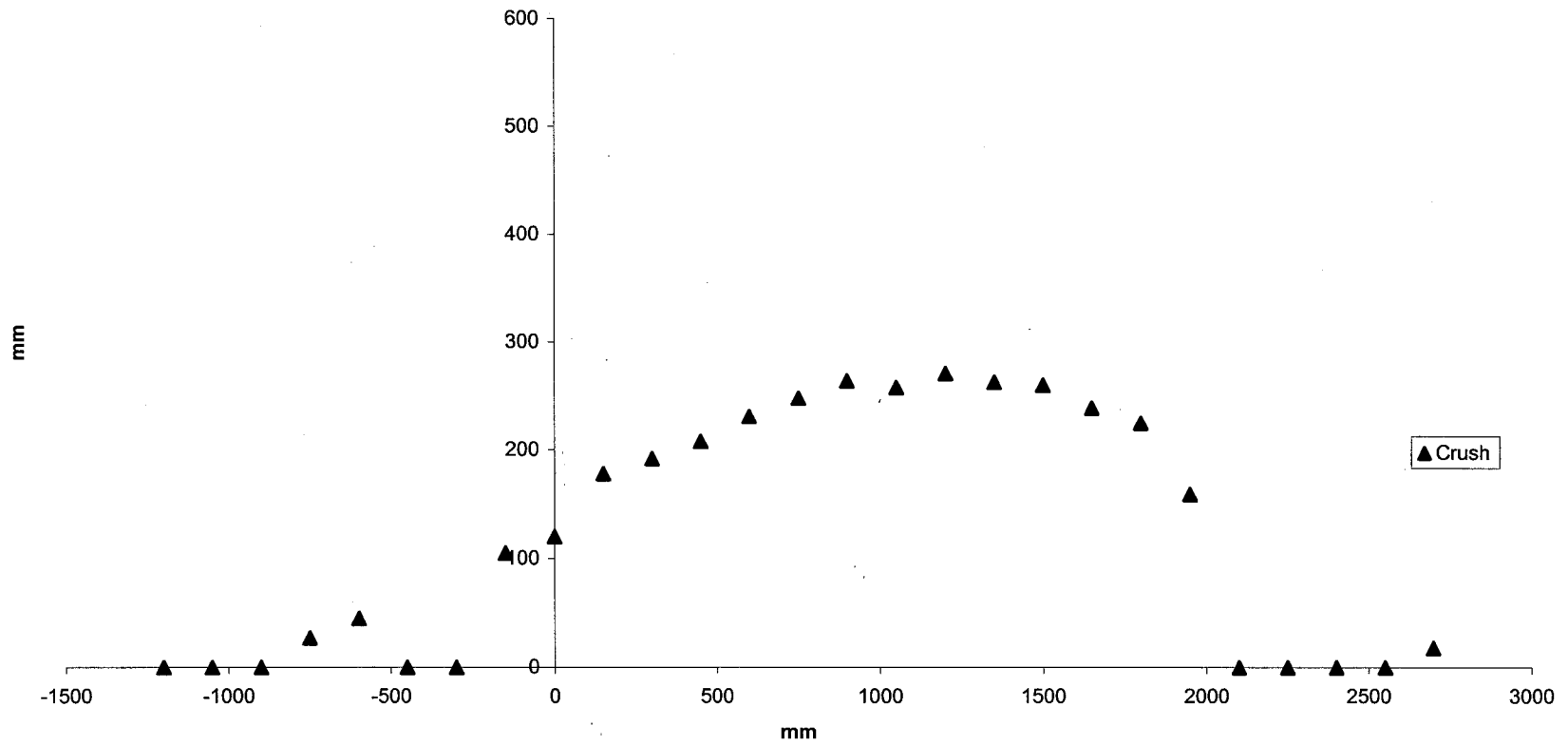

4-11

020619

Data Sheet 10 (Continued)

Vehicle Exterior Crush Profiles - All Levels

Vehicle: 2002 MINI Cooper

NHTSA No.: M20501

Side Profile Level 4 870 mm Above Ground

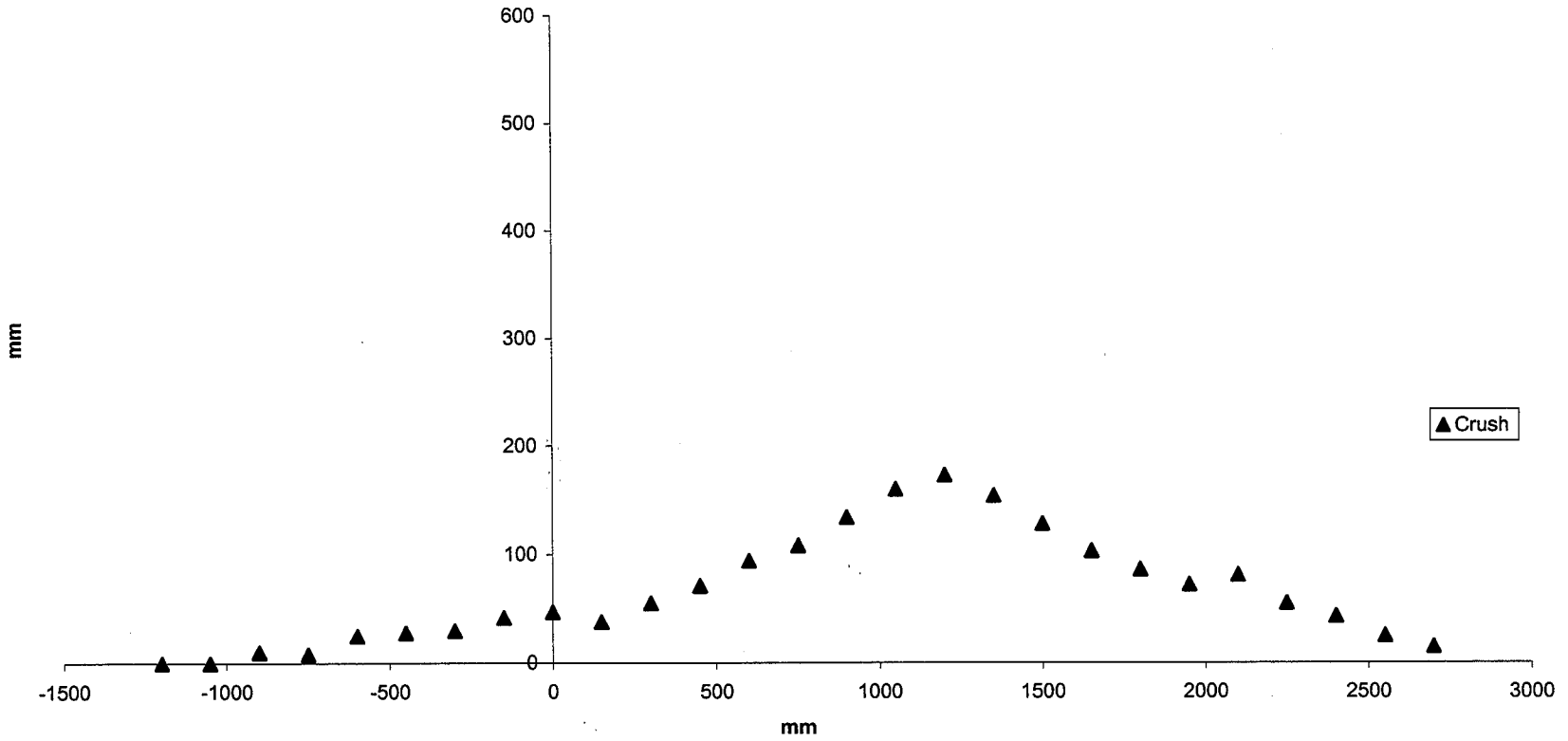

4-12

020619

Data Sheet 10 (Continued)

Vehicle Exterior Crush Profiles - All Levels

Vehicle: 2002 MINI Cooper

NHTSA No.: M20501

Side Profile Level 5 1371 mm Above Ground

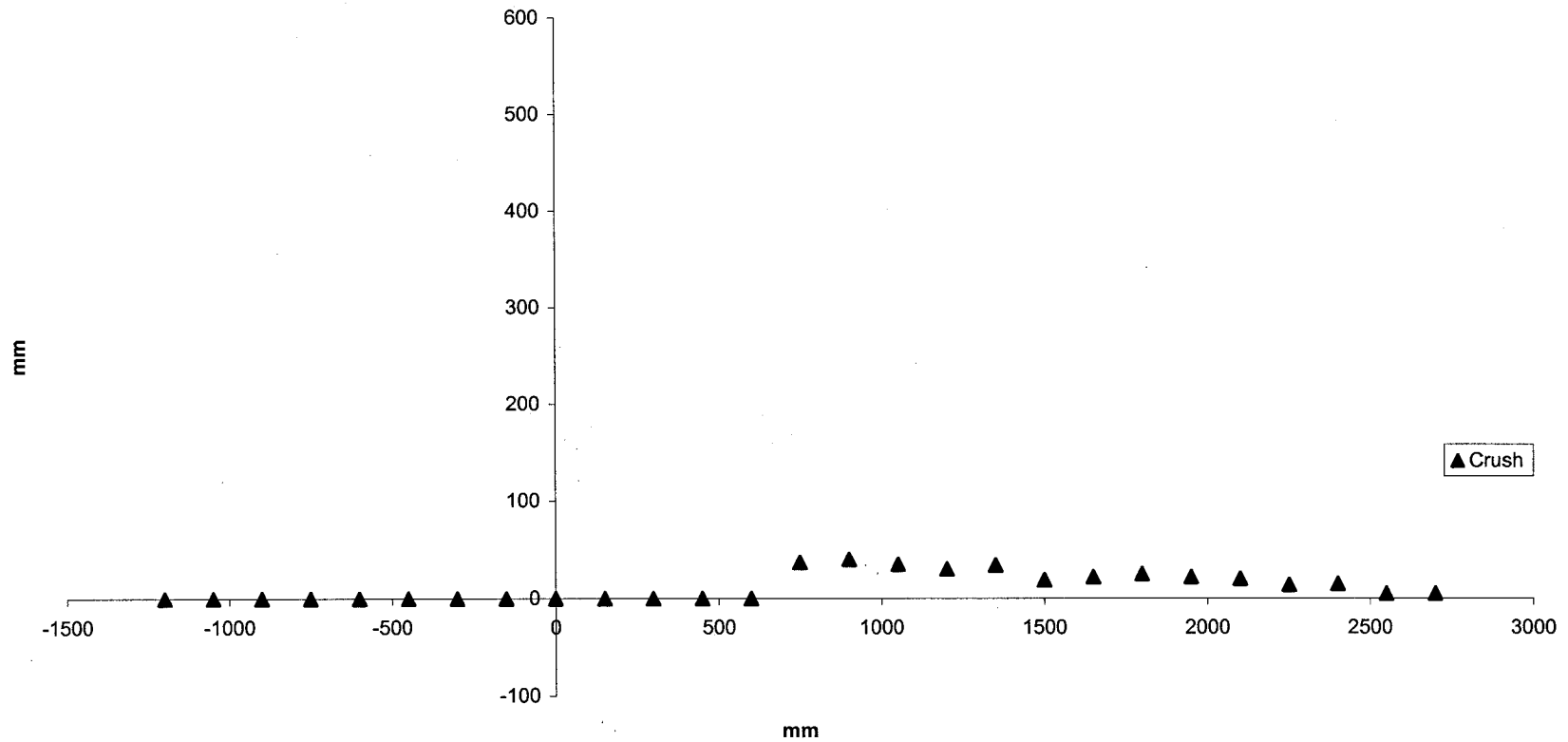

4-13

020619

Data Sheet 11

Vehicle Damage Profile Distances

Vehicle: 2002 MINI Cooper

NHTSA No.: M20501

NOTE: All measurements are in millimeters (mm) and should be accurate to plus or minus 3mm.

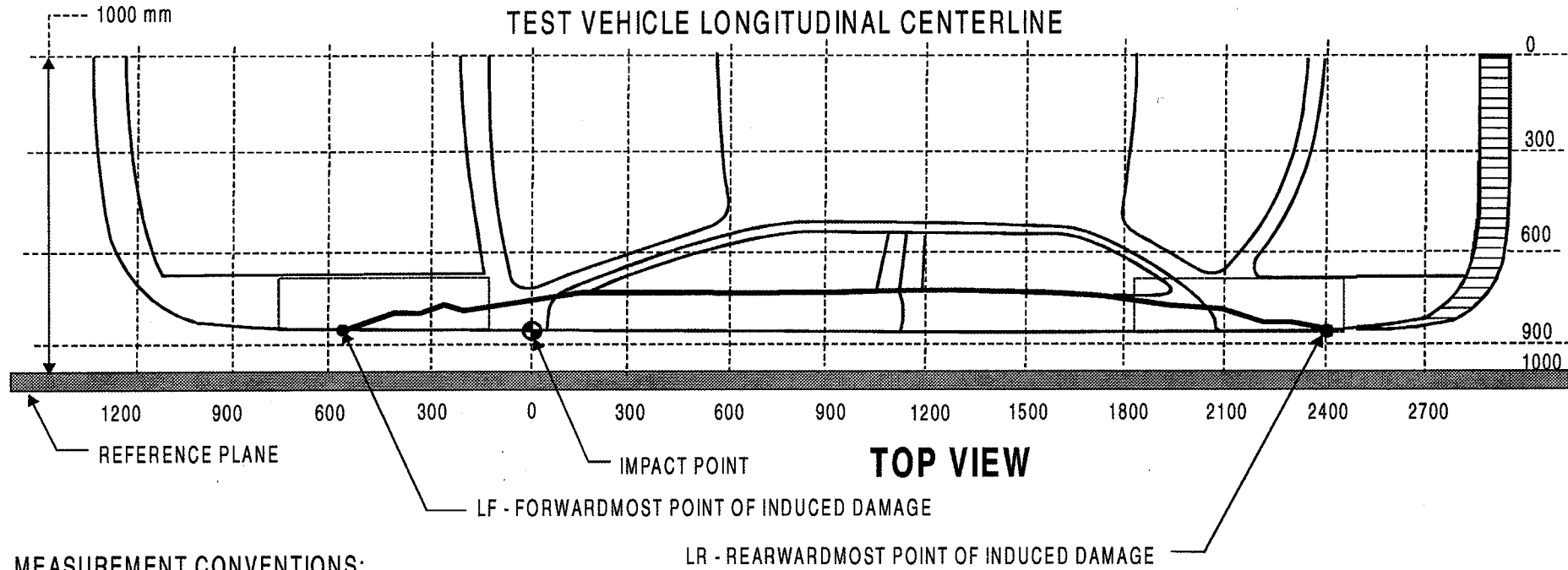

MEASUREMENT CONVENTIONS:

Forward of the impact point (towards front of vehicle) is considered negative (-)

Rearward of the impact point (towards rear end of vehicle) is considered positive (+)

DPD Measurements	Post-Test (mm)	Pre-Test (mm)	Static Crush (mm)
6: LF = -300 mm (Level 4)	810	810	0
5: 300 mm (Level 2)	846	703	143
4: 750 mm (Level 2)	902	703	199
3: 1200 mm (Level 3)	892	698	194
2: 1650 mm (Level 3)	860	710	150
1: LR = 2250 mm (Level 4)	772	759	13

4-14

020619

Data Sheet 12

Exterior Static Crush For Impactor Face

(Grid as looking at MDB from front)

Vehicle: 2002 MINI Cooper

NHTSA No.: M20501

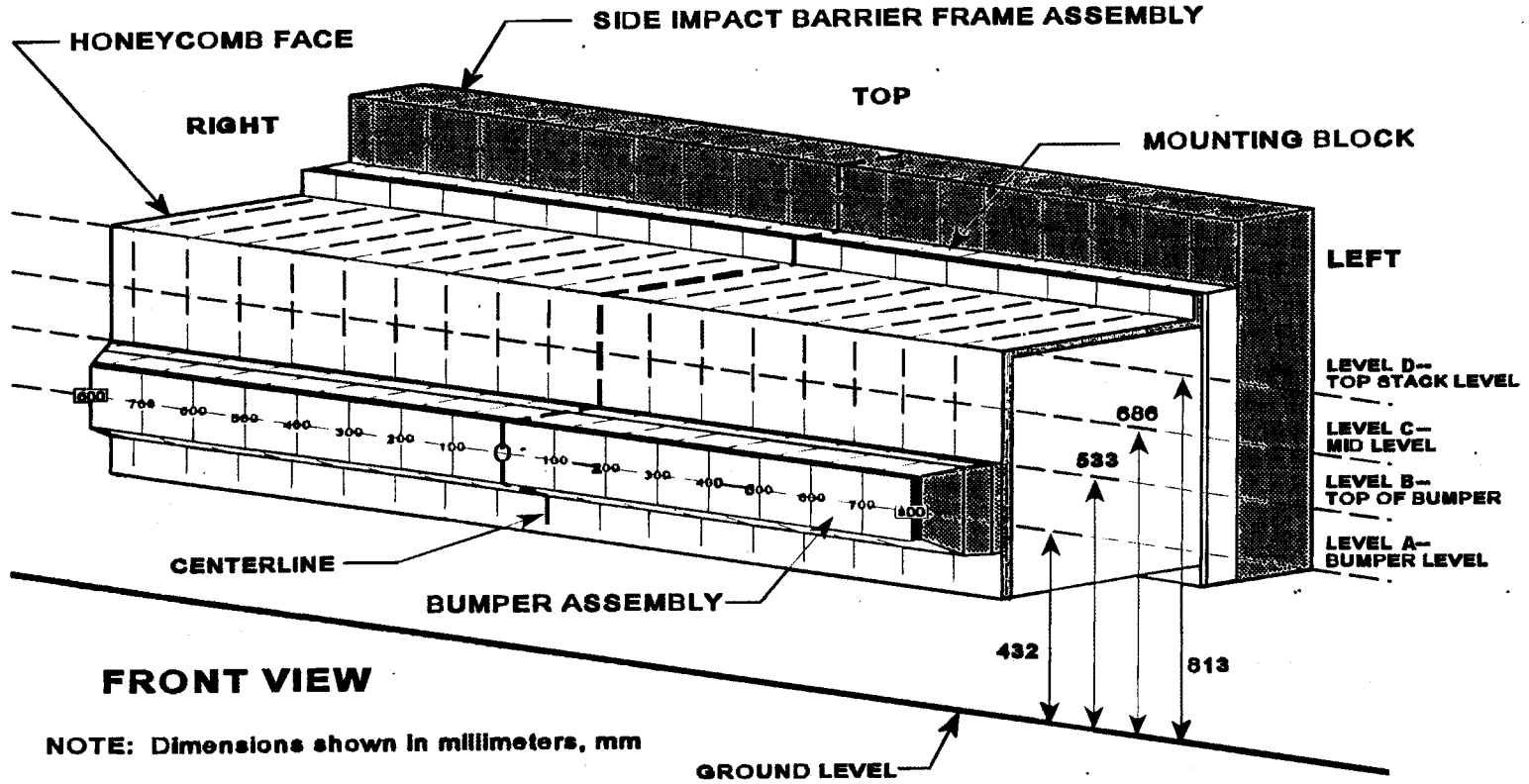

NOTE: Dimensions shown in millimeters, mm

4-15

020619

Data Sheet 12 (Continued)

Exterior Static Crush For Impactor Face

Vehicle: 2002 MINI Cooper

NHTSA No.: M20501

Location	Height At CL	Distance Right of Center (mm)									Distance Left of Center (mm)							
		800	700	600	500	400	300	200	100	0	100	200	300	400	500	600	700	800
Top Stack Level Level D	814	-68.3	-16.6	-10.5	-34.4	-34.4	-25.8	-17.5	-21.7	-28.1	-36.6	-43.1	-57.1	-82.4	-93.9	-123.7	-143.0	-165.7
Mid Level Level C ¹	687	-49.4	-24.1	-26.5	-50.7	-32.6	-17.1	-14.4	-11.8	-11.9	-14.6	-16.4	-22.9	-36.8	-70.4	-112.9	-146.3	-148.6
Top Bumper Level - Level B	559	-102.5	-100.3	-96.6	-87.4	-65.6	-46.0	-32.9	-28.8	-33.1	-34.0	-39.5	-45.1	-53.0	-70.0	-87.8	-107.8	-114.3
Mid Bumper Level - Level A ²	432	N/A	N/A	N/A	N/A	N/A	N/A	N/A	N/A	N/A	N/A	N/A	N/A	N/A	N/A	N/A	N/A	N/A

All measurements are in millimeters and have a tolerance of ± 3 mm.

¹Pre-test Row C data were not available. The data was approximated using Row D and adjusting the height (Z-axis) measurement.

²Bumper fell off post-test.

4-16

020619

Data Sheet 12 (Continued)

Exterior Static Crush For Impactor Face

Vehicle: 2002 MINI Cooper

NHTSA No.: M20501

Deformable Barrier Face Profile

Pre-Test¹

Index	Xmm	Ymm	Zmm
1	-406.6	791.8	-74.8
2	-406.3	692.0	-74.8
3	-406.3	591.8	-75.6
4	-406.4	491.4	-76.3
5	-406.4	392.4	-77.1
6	-406.3	291.7	-77.1
7	-406.3	191.0	-77.8
8	-406.6	91.2	-78.2
9	-405.9	-8.7	-79.3
10	-406.3	-108.7	-78.8
11	-406.1	-208.7	-79.8
12	-405.6	-307.9	-80.0
13	-405.3	-408.0	-81.5
14	-405.2	-508.8	-81.7
15	-404.8	-607.5	-82.2
16	-404.2	-708.7	-81.7
17	-403.8	-807.7	-82.5
18	-406.6	791.8	-201.8
19	-406.3	692.0	-201.8
20	-406.3	591.8	-202.6
21	-406.4	491.4	-203.3
22	-406.4	392.4	-204.1

Post-Test

Index	Xmm	Ymm	Zmm
1	-338.3	731.4	-142.9
2	-389.7	646.5	-138.5
3	-395.8	548.3	-135.6
4	-372.0	453.4	-129.0
5	-372.0	354.7	-128.5
6	-380.5	254.3	-123.3
7	-388.9	154.5	-119.0
8	-385.0	56.1	-119.6
9	-377.9	-43.5	-121.8
10	-369.7	-143.4	-125.6
11	-363.0	-241.0	-126.3
12	-348.6	-338.4	-117.2
13	-322.9	-437.6	-121.1
14	-311.3	-537.6	-113.3
15	-281.2	-629.6	-111.9
16	-261.2	-726.8	-111.2
17	-238.1	-822.6	-107.2
18	-357.2	736.1	-266.6
19	-382.2	636.0	-267.0
20	-379.8	543.5	-263.7
21	-355.8	449.1	-256.9
22	-373.8	352.5	-254.4

Difference¹

Index	Xmm	Ymm	Zmm
1	-68.3	60.4	68.1
2	-16.6	45.6	63.8
3	-10.5	43.6	60.0
4	-34.4	38.0	52.7
5	-34.4	37.7	51.4
6	-25.8	37.5	46.2
7	-17.5	36.5	41.2
8	-21.7	35.1	41.4
9	-28.1	34.8	42.5
10	-36.6	34.7	46.8
11	-43.1	32.3	46.5
12	-57.1	30.5	37.2
13	-82.4	29.6	39.6
14	-93.9	28.8	31.6
15	-123.7	22.1	29.7
16	-143.0	18.1	29.5
17	-165.7	14.9	24.8
18	-49.4	55.8	64.8
19	-24.1	56.0	65.3
20	-26.5	48.3	61.1
21	-50.7	42.4	53.6
22	-32.6	39.9	50.3

¹ Pre-test Row C data (points 18-34) were not available. The data was approximated using Row D and adjusting the height (Z-axis) measurement.

Data Sheet 12 (Continued)

Exterior Static Crush For Impactor Face

Vehicle: 2002 MINI Cooper

NHTSA No.: M20501

Deformable Barrier Face Profile Cont'd.

Pre-Test

Index	Xmm	Ymm	Zmm
23	-406.3	291.7	-204.1
24	-406.3	191.0	-204.8
25	-406.6	91.2	-205.2
26	-405.9	-8.7	-206.3
27	-406.3	-108.7	-205.8
28	-406.1	-208.7	-206.8
29	-405.6	-307.9	-207.0
30	-405.3	-408.0	-208.5
31	-405.2	-508.8	-208.7
32	-404.8	-607.5	-209.2
33	-404.2	-708.7	-208.7
34	-403.8	-807.7	-209.5
35	-406.0	794.2	-328.9
36	-405.9	694.2	-329.7
37	-406.1	593.0	-330.6
38	-406.4	493.6	-331.3
39	-406.5	392.8	-331.9
40	-406.7	293.2	-332.5
41	-406.4	192.3	-332.5
42	-406.7	92.2	-332.9
43	-405.9	-6.5	-334.3
44	-405.5	-108.0	-335.2

Post-Test

Index	Xmm	Ymm	Zmm
23	-389.2	252.0	-249.7
24	-392.0	153.1	-245.2
25	-394.9	51.5	-245.1
26	-394.0	-51.3	-242.3
27	-391.7	-150.2	-235.3
28	-389.7	-247.8	-237.2
29	-382.7	-350.4	-232.9
30	-368.5	-450.6	-228.0
31	-334.8	-545.9	-233.8
32	-291.9	-638.1	-237.6
33	-257.9	-730.6	-239.4
34	-255.2	-832.6	-226.5
35	-303.5	743.1	-336.6
36	-305.7	643.1	-337.0
37	-309.6	541.5	-341.0
38	-319.0	442.8	-339.8
39	-341.0	346.0	-356.9
40	-360.8	248.2	-365.9
41	-373.5	148.7	-368.2
42	-377.9	47.4	-364.7
43	-372.8	-53.0	-356.3
44	-371.5	-153.9	-360.7

Difference

Index	Xmm	Ymm	Zmm
23	-17.1	39.8	45.7
24	-14.4	37.9	40.4
25	-11.8	39.8	39.9
26	-11.9	42.7	36.0
27	-14.6	41.5	29.5
28	-16.4	39.1	30.4
29	-22.9	42.5	25.9
30	-36.8	42.6	19.5
31	-70.4	37.1	25.1
32	-112.9	30.6	28.5
33	-146.3	21.8	30.7
34	-148.6	24.8	17.1
35	-102.5	51.1	7.8
36	-100.3	51.1	7.3
37	-96.6	51.5	10.4
38	-87.4	50.8	8.5
39	-65.6	46.8	25.0
40	-46.0	45.1	33.4
41	-32.9	43.6	35.7
42	-28.8	44.8	31.8
43	-33.1	46.5	22.0
44	-34.0	45.9	25.5

Data Sheet 12 (Continued)

Exterior Static Crush For Impactor Face

Vehicle: 2002 MINI Cooper

NHTSA No.: M20501

Deformable Barrier Face Profile Cont'd.

Pre-Test

Index	Xmm	Ymm	Zmm
45	-405.0	-206.8	-335.6
46	-404.9	-305.1	-336.0
47	-404.4	-404.9	-337.0
48	-403.8	-506.4	-337.3
49	-404.3	-605.6	-338.3
50	-403.9	-706.7	-339.3
51	-403.3	-807.4	-338.9
52	-499.3	789.7	-457.2
53	-509.3	692.7	-457.8
54	-509.6	593.5	-458.9
55	-509.6	491.7	-458.3
56	-509.1	391.9	-459.5
57	-509.2	291.8	-459.9
58	-509.2	191.1	-460.9
59	-509.5	93.8	-460.6
60	-509.0	-6.4	-461.4
61	-508.6	-106.0	-461.8
62	-508.4	-207.1	-462.3
63	-508.5	-306.3	-463.0
64	-508.3	-406.8	-463.4
65	-508.0	-507.1	-464.7
66	-507.7	-607.4	-464.7
67	-507.9	-708.0	-465.2
68	-495.9	-804.9	-466.1

Post-Test

Index	Xmm	Ymm	Zmm
45	-365.5	-253.2	-356.6
46	-359.8	-352.1	-354.4
47	-351.4	-450.2	-353.0
48	-333.8	-551.1	-343.8
49	-316.5	-648.5	-340.6
50	-296.1	-747.2	-346.0
51	-289.0	-846.5	-344.3
52	N/A	N/A	N/A
53	N/A	N/A	N/A
54	N/A	N/A	N/A
55	N/A	N/A	N/A
56	N/A	N/A	N/A
57	N/A	N/A	N/A
58	N/A	N/A	N/A
59	N/A	N/A	N/A
60	N/A	N/A	N/A
61	N/A	N/A	N/A
62	N/A	N/A	N/A
63	N/A	N/A	N/A
64	N/A	N/A	N/A
65	N/A	N/A	N/A
66	N/A	N/A	N/A
67	N/A	N/A	N/A
68	N/A	N/A	N/A

Difference

Index	Xmm	Ymm	Zmm
45	-39.5	46.4	21.1
46	-45.1	47.0	18.4
47	-53.0	45.3	16.1
48	-70.0	44.8	6.5
49	-87.8	42.9	2.3
50	-107.8	40.6	6.7
51	-114.3	39.1	5.4
52	N/A	N/A	N/A
53	N/A	N/A	N/A
54	N/A	N/A	N/A
55	N/A	N/A	N/A
56	N/A	N/A	N/A
57	N/A	N/A	N/A
58	N/A	N/A	N/A
59	N/A	N/A	N/A
60	N/A	N/A	N/A
61	N/A	N/A	N/A
62	N/A	N/A	N/A
63	N/A	N/A	N/A
64	N/A	N/A	N/A
65	N/A	N/A	N/A
66	N/A	N/A	N/A
67	N/A	N/A	N/A
68	N/A	N/A	N/A

Data Sheet 12 (Continued)

Exterior Static Crush For Impactor Face

Vehicle: 2002 MINI Cooper

NHTSA No.: M20501

Row D - Deformable Barrier Face Profile 1-17

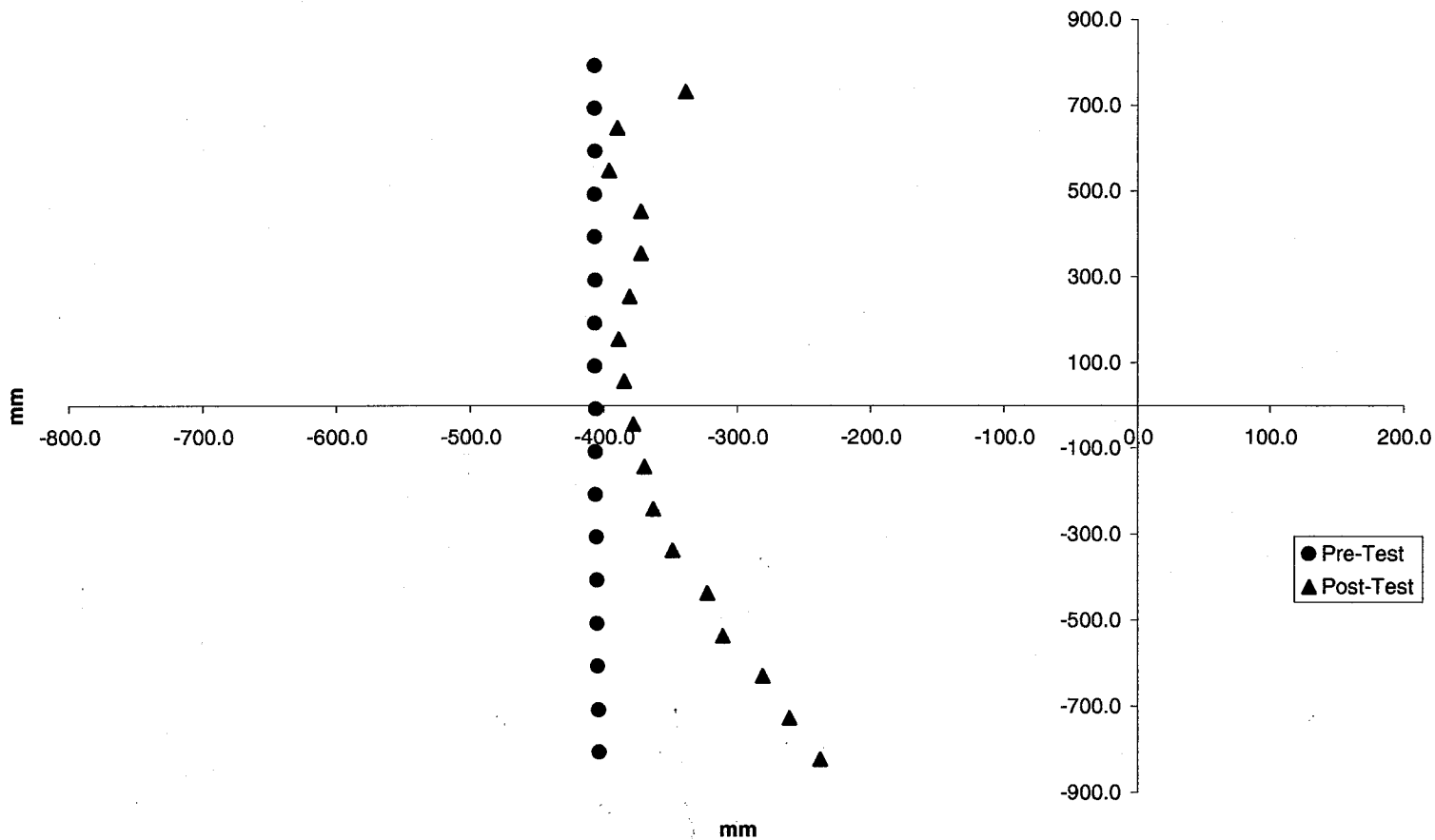

4-20

020619

Positive Y-axis values are to the left of barrier face centerline.

Data Sheet 12 (Continued)

Exterior Static Crush For Impactor Face

Vehicle: 2002 MINI Cooper

NHTSA No.: M20501

Row C - Deformable Barrier Face Profile 18-34¹

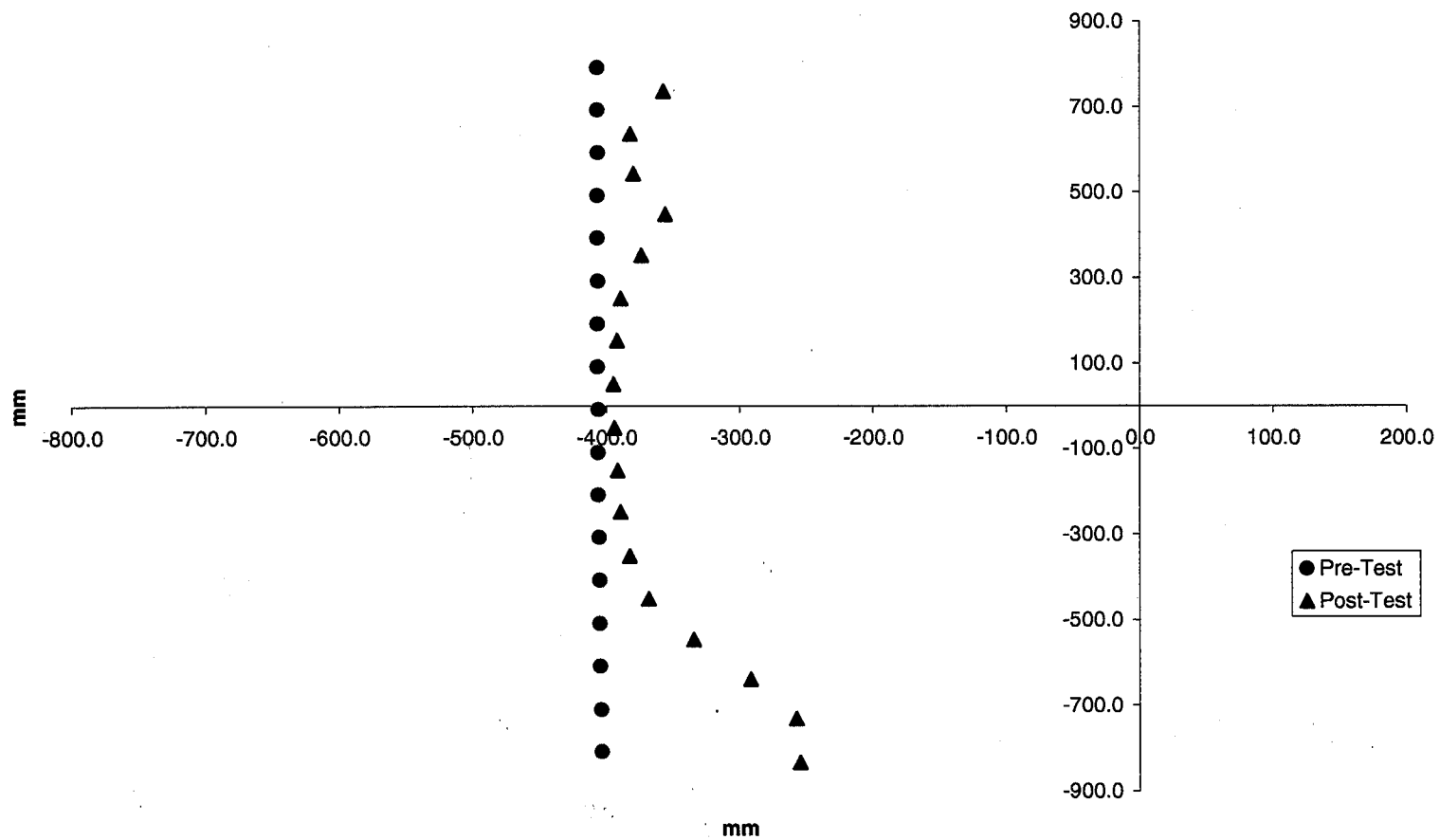

4-21

020619

¹Pre-test Row C data were not available. This data was approximated using Row D data and adjusting the height (Z-axis) measurement. Positive Y-axis values are to the left of barrier face centerline.

Data Sheet 12 (Continued)

Exterior Static Crush For Impactor Face

Vehicle: 2002 MINI Cooper

NHTSA No.: M20501

Row B - Deformable Barrier Face Profile 35-51

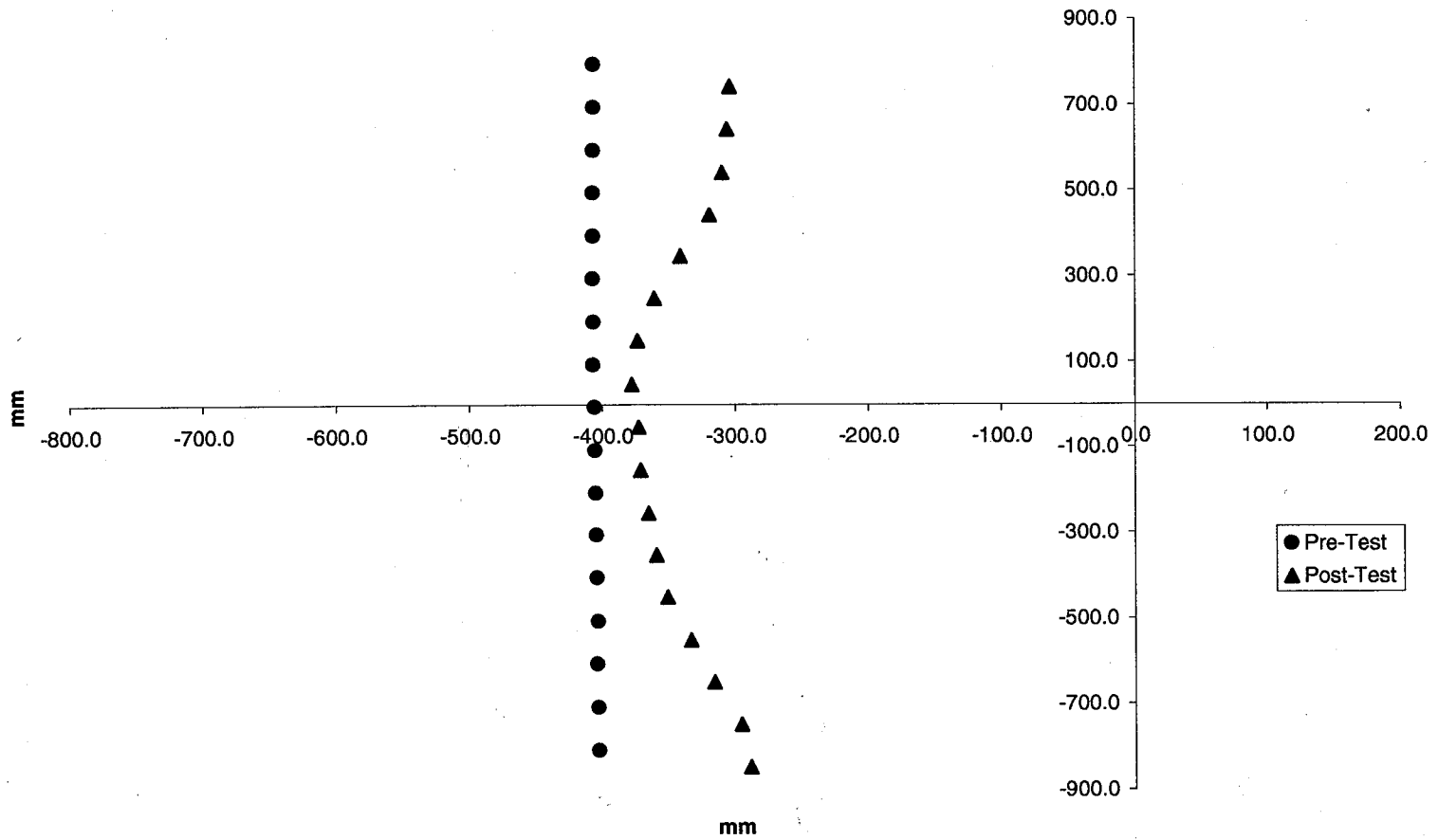

4-22

020619

Positive Y-axis values are to the left of barrier face centerline.

Data Sheet 12 (Continued)

Exterior Static Crush For Impactor Face

Vehicle: 2002 MINI Cooper

NHTSA No.: M20501

Row A - Deformable Barrier Face Profile 52-68

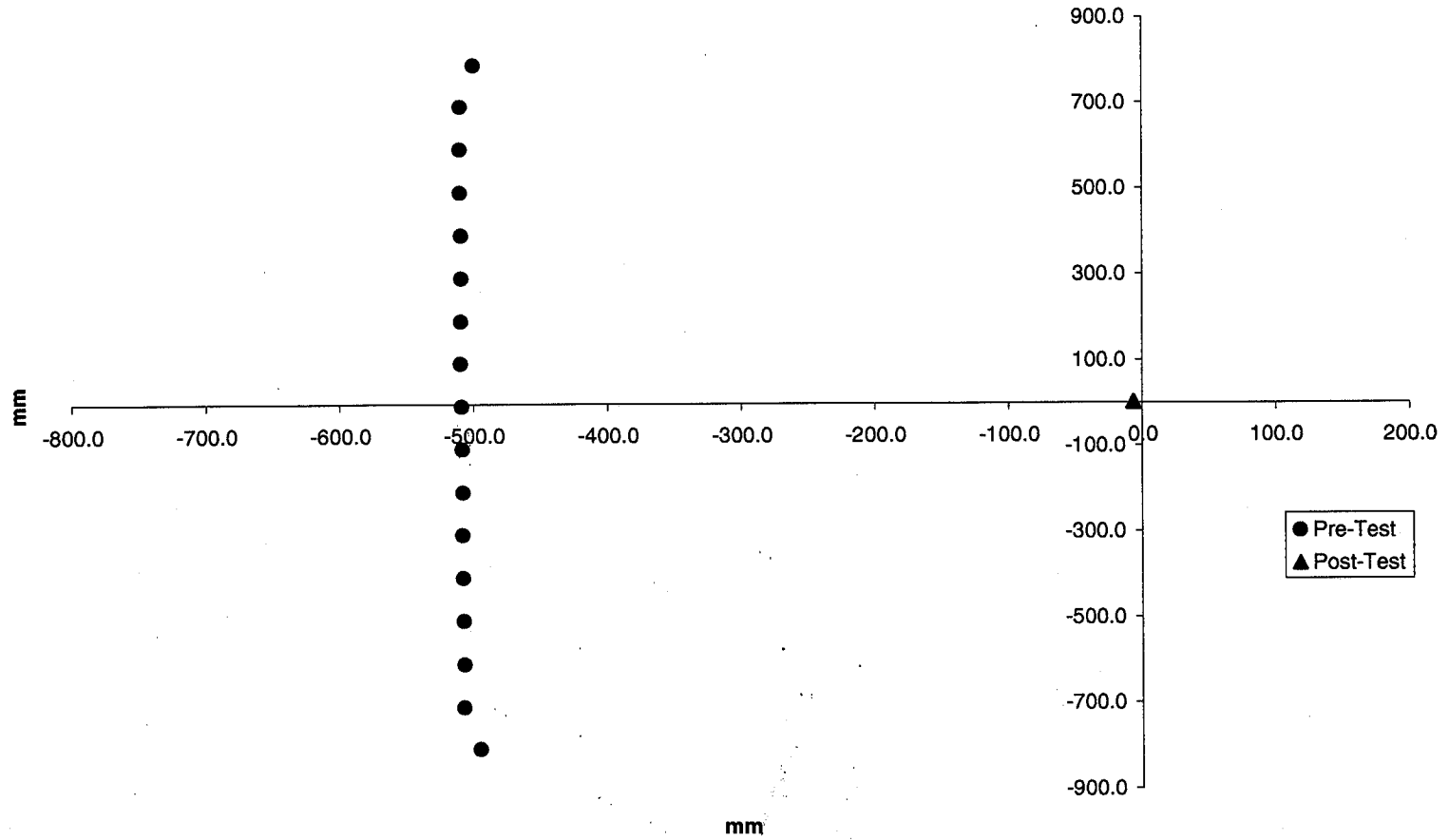

4-23

020619

Positive Y-axis values are to the left of barrier face centerline.

Data Sheet 13
Test Vehicle Accelerometer Locations and Data Summary

Vehicle: 2002 MINI Cooper

NHTSA No.: M20501

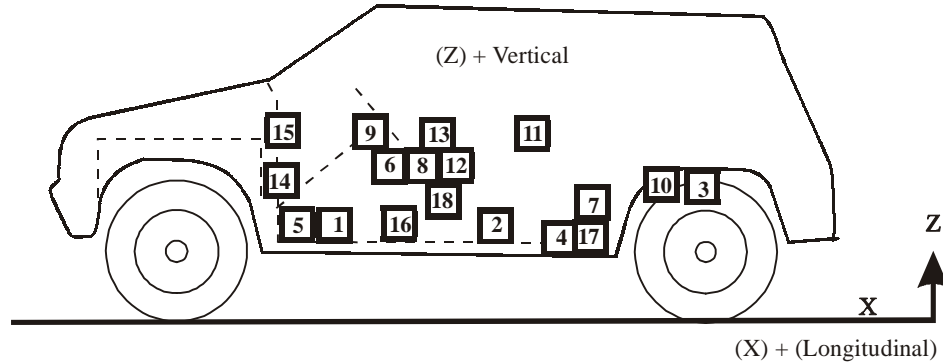

Side View

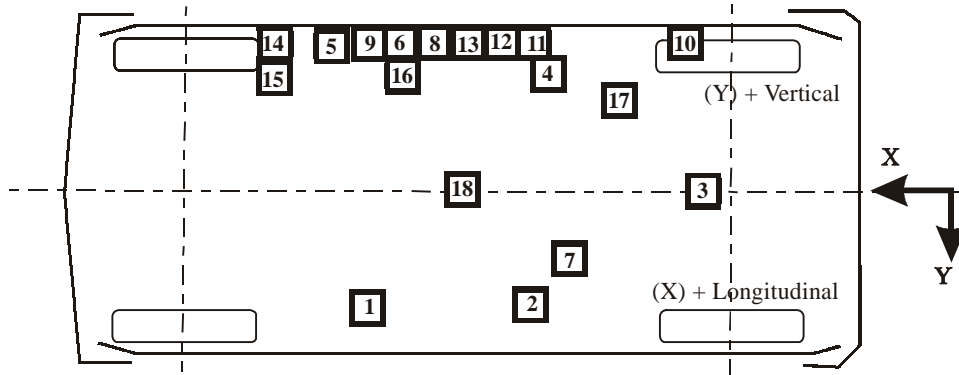

Bottom View

- | | |
|------------------------------------|--|
| 1-Right Side Sill at Front Seat | 10-Left Rear Side Panel Mid Rear |
| 2-Right Side Sill at Rear Seat | 11-Left Rear Side Panel Upper Centerline |
| 3-Rear Floorpan Above Axle | 12-Left Lower B-pillar |
| 4-Left Side Sill at Rear Seat | 13-Left Middle B-pillar |
| 5-Left Side Sill at Front Seat | 14-Left Lower A-pillar |
| 6-Left Front Door on Centerline | 15-Left Middle A-pillar |
| 7-Right Rear Occupant Compartment | 16-Left Front Seat Track at H-point |
| 8-Left Front Door Mid Rear | 17-Left Rear Seat Track at H-point |
| 9-Left Front Door Upper Centerline | 18-Vehicle Center of Gravity |

Data Sheet 13 (Continued)

Test Vehicle Accelerometer Locations and Data Summary

Vehicle: 2002 MINI Cooper

NHTSA No.: M20501

TEST NUMBER: 020619					POSITIVE			NEGATIVE
No.	LOCATION	X	Y	Z	DIRECTION			DIRECTION
1	RIGHT SIDE SILL	PRE	2394 mm	620 mm	280 mm			
	AT FRONT SEAT	POST	2394 mm	620 mm	265 mm			
	LONGITUDINAL					6.8 g	@ 28.4 ms	7.3 g @ 15.4 ms
	LATERAL					31.1 g	@ 9.0 ms	2.9 g @ 29.2 ms
	VERTICAL					3.8 g	@ 16.6 ms	9.9 g @ 9.8 ms
	RESULTANT					32.5 g	@ 9.0 ms	
2	RIGHT SIDE SILL	PRE	1201 mm	565 mm	480 mm			
	AT REAR SEAT	POST	1201 mm	565 mm	503 mm			
	LONGITUDINAL					7.1 g	@ 29.4 ms	7.9 g @ 13.7 ms
	LATERAL					38.9 g	@ 6.9 ms	1.9 g @ 110.0 ms
	VERTICAL					7.2 g	@ 29.9 ms	11.9 g @ 12.1 ms
	RESULTANT					39.2 g	@ 6.9 ms	
3	REAR FLOORPAN	PRE	612 mm	-49 mm	440 mm			
	ABOVE AXLE	POST	612 mm	-49 mm	395 mm			
	LONGITUDINAL					3.8 g	@ 57.1 ms	10.4 g @ 13.6 ms
	LATERAL					31.2 g	@ 21.2 ms	3.2 g @ 65.9 ms
	VERTICAL					6.2 g	@ 10.7 ms	3.4 g @ 48.4 ms
	RESULTANT					31.5 g	@ 21.2 ms	
4	LEFT SIDE SILL	PRE	1201 mm	-565 mm	480 mm			
	AT REAR SEAT	POST	1185 mm	-550 mm	514 mm			
	LATERAL					37.8 g	@ 6.2 ms	-1.4 g @ 0.0 ms
5	LEFT SIDE SILL	PRE	2394 mm	-620 mm	270 mm			
	AT FRONT SEAT	POST	2414 mm	-565 mm	300 mm			
	LATERAL					60.8 g	@ 5.9 ms	14.4 g @ 12.6 ms

4-25

020619

Data Sheet 13 (Continued)

Test Vehicle Accelerometer Locations and Data Summary

Vehicle: 2002 MINI Cooper

NHTSA No.: M20501

TEST NUMBER: 020619									
No. LOCATION		X	Y	Z	POSITIVE DIRECTION		NEGATIVE DIRECTION		
6 LEFT FRONT DOOR ON CENTERLINE LATERAL	PRE	1864 mm	-690 mm	410 mm					
	POST	1817 mm	-590 mm	422 mm	120.2 g	@ 6.2 ms	70.5 g	@ 10.7 ms	
7 RIGHT REAR OCCUPANT COMPARTMENT LATERAL	PRE	1294 mm	265 mm	320 mm					
	POST	1266 mm	280 mm	325 mm	38.4 g	@ 6.8 ms	1.7 g	@ 109.9 ms	
8 LEFT FRONT DOOR MIDREAR LATERAL ¹	PRE	1374 mm	-690 mm	660 mm					
	POST	1399 mm	-560 mm	690 mm	---	---	---	---	
9 LEFT FRONT DOOR UPPER CENTERLINE LATERAL	PRE	1864 mm	-690 mm	815 mm					
	POST	1817 mm	-590 mm	844 mm	200.5 g	@ 16.2 ms	77.8 g	@ 22.6 ms	
10 LEFT REAR SIDE PANEL MIDREAR LATERAL	PRE	789 mm	-635 mm	865 mm					
	POST	774 mm	-600 mm	856 mm	56.9 g	@ 22.3 ms	7.9 g	@ 28.4 ms	
11 LEFT REAR SIDE PANEL UPPER CENTERLINE LATERAL	PRE	1003 mm	-635 mm	865 mm					
	POST	979 mm	-610 mm	856 mm	65.8 g	@ 21.8 ms	13.3 g	@ 27.7 ms	
12 LEFT LOWER B-POST LATERAL	PRE	1285 mm	-620 mm	640 mm					
	POST	1266 mm	-531 mm	660 mm	86.6 g	@ 5.9 ms	12.6 g	@ 9.4 ms	
13 LEFT MIDDLE B-POST LATERAL	PRE	1285 mm	-620 mm	800 mm					
	POST	1266 mm	-531 mm	820 mm	111.9 g	@ 14.6 ms	16.0 g	@ 46.6 ms	

4-26

020619

Data Sheet 13 (Continued)

Test Vehicle Accelerometer Locations and Data Summary

Vehicle: 2002 MINI Cooper

NHTSA No.: M20501

TEST NUMBER: 020619									
No. LOCATION		X	Y	Z	POSITIVE DIRECTION			NEGATIVE DIRECTION	
14 LEFT LOWER A-POST	PRE	2438 mm	-677 mm	480 mm					
	POST	2418 mm	-630 mm	500 mm					
LATERAL					92.9 g	@	4.4 ms	39.7 g	@ 11.9 ms
15 LEFT MIDDLE A-POST	PRE	2438 mm	-677 mm	620 mm					
	POST	2418 mm	-630 mm	640 mm					
LATERAL ¹					---		---	---	---
16 LEFT FRONT SEAT TRACK	PRE	1927 mm	-560 mm	240 mm					
	POST	1927 mm	-500 mm	277 mm					
LATERAL					33.0 g	@	6.7 ms	1.7 g	@ 111.4 ms
17 LEFT REAR SEAT TRACK	PRE	757 mm	-510 mm	490 mm					
	POST	757 mm	-500 mm	510 mm					
LATERAL					31.6 g	@	6.2 ms	2.7 g	@ 66.0 ms
18 VEHICLE CENTER OF GRAVITY	PRE	1474 mm	0 mm	377 mm					
	POST	1474 mm	0 mm	380 mm					
LONGITUDINAL					4.7 g	@	35.9 ms	13.3 g	@ 16.5 ms
LATERAL					37.9 g	@	7.1 ms	1.7 g	@ 125.8 ms
VERTICAL					17.3 g	@	12.7 ms	10.6 g	@ 23.7 ms
RESULTANT					38.7 g	@	7.1 ms		

REFERENCE: X: + FORWARD FROM REAR BUMPER
 Y: + RIGHTWARD FROM VEHICLE CENTERLINE
 Z: + UPWARD FROM GROUND LEVEL

For acceleration data sign convention, see Report Sign Convention in Appendix D.

¹ See DATA ACQUISITION EXPLANATIONS

4-27

020619

Data Sheet 14
 MDB Accelerometer Locations and Data Summary

Vehicle: 2002 MINI Cooper

NHTSA No.: M20501

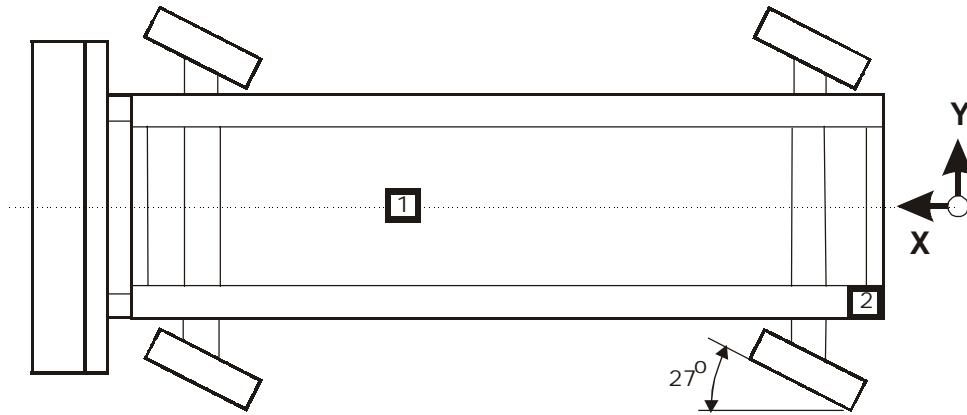

TOP VIEW

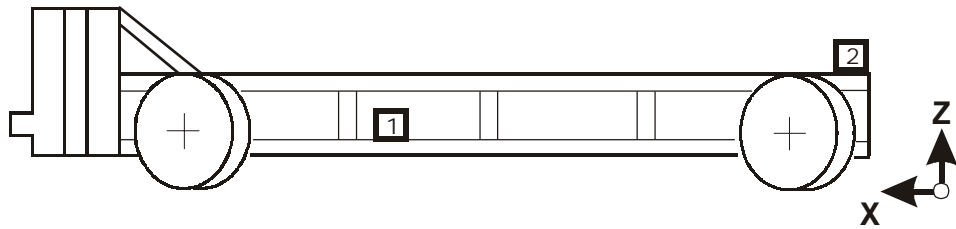

SIDE VIEW

Accel. No.	Location	Coordinates (millimeters)			Positive Direction		Negative Direction	
		X*	Y*	Z*	Max. (g)	Time (ms)	Max. (g)	Time (ms)
1	MDB Center of Gravity	1757	0	250				
	Longitudinal X				2.9	115.4	23.8	30.9
	Lateral Y				4.2	59.2	8.5	23.8
	Vertical Z				7.2	29.0	8.3	93.9
	Resultant R				24.8	16.6		
2	Rear Frame Member	410	-657	625				
	Longitudinal X				2.7	114.2	24.2	31.1
	Lateral Y				3.5	20.2	3.4	92.8

*Reference: X = Rear Bumper (+ Forward)
 Y = Vehicle Centerline (+ To Right)
 Z = Ground Level (+ Up)

All measurements accurate to within ±3 mm.

Data Sheet 15
High-Speed Camera Locations and Data Summary

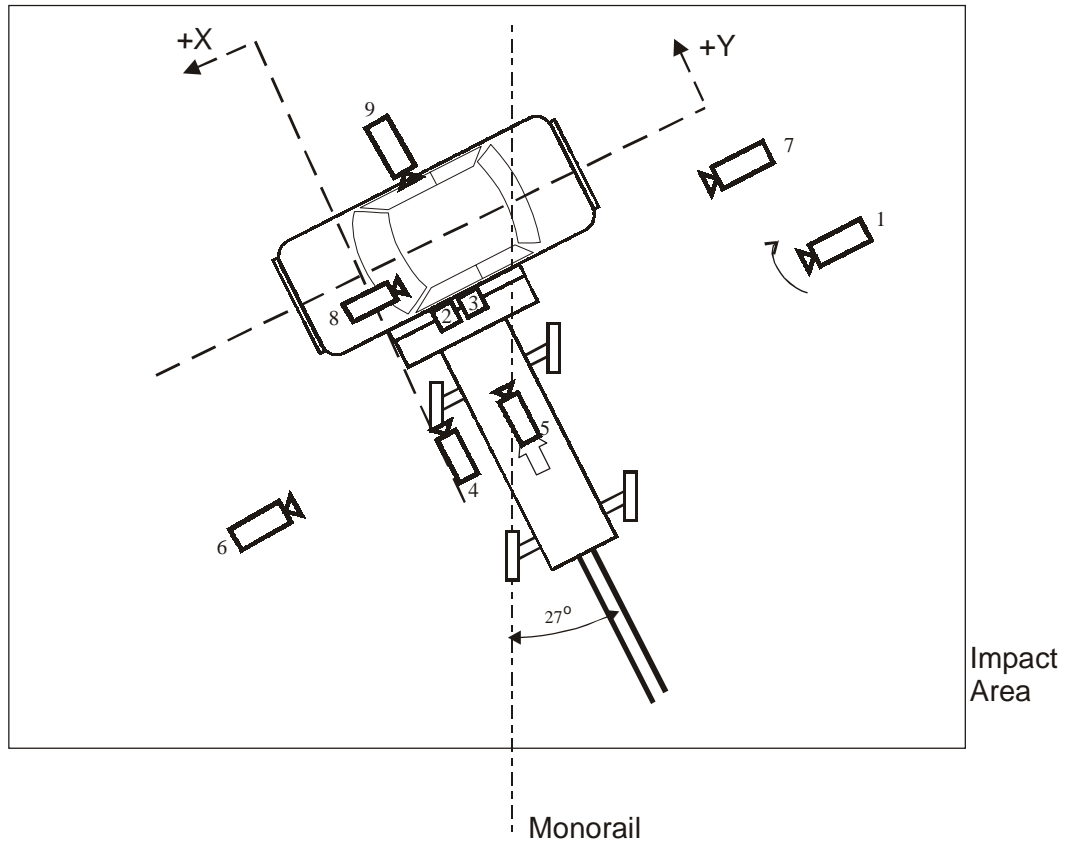

Camera Number	Location	Location, mm			Lens (mm)	Speed (fps)
		X	Y	Z		
1	Real-time Panning	N/A	N/A	N/A	---	24
2	Overhead wide	N/A	N/A	N/A	13	970
3	Overhead tight	N/A	N/A	N/A	25	1005
4	Onboard MDB left side	40	-2573	790	17	1000
5	Onboard MDB center	-860	-3310	1393	13	1000
6	Front Wide	-6074	-5070	986	13	1010
7	Rear Wide	5725	-285	1135	13	1000
8	Onboard vehicle front	270	-295	1150	8	1005
9	Onboard side front door	-940	870	955	8	997

+X: Forward from impact point

+Y: Toward right from vehicle centerline

+Z: Upward from ground level

All measurements are accurate to ± 6 mm

Section 5

Vehicle Fuel System Integrity

Data Sheet 16
FMVSS 301 Fuel System Integrity Data

NHTSA No.: M20501

Test Date: June 19, 2002

Vehicle Year/Make/Model/Body Style: 2002 MINI Cooper

Test Vehicle Impact Type : Frontal (48.28 km/h)
 Oblique (48.28 km/h) with ° barrier
 face first contacting the (driver/passenger) side
 Rear Moving Barrier (48.28 km/h)
 Lateral Moving Barrier (32.19 km/h)
 X Side Impact Moving Deformable Barrier
 (38.5) contacting the Drivers Side side

Fuel Spillage Measurement:

1. From impact until vehicle motion ceases
2. For five-minute period after vehicle motion ceases
3. For next 25 minutes.

Actual	Maximum Allowed
0 g	28 g
0 g	142 g
0 g	28 g/1 minute

Solvent Spillage Details :

None

Data Sheet 17
 FMVSS 301 Rollover Data

Vehicle: 2002 MINI Cooper

NHTSA No.: M20501

0 - 90 Degrees

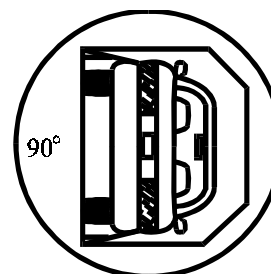
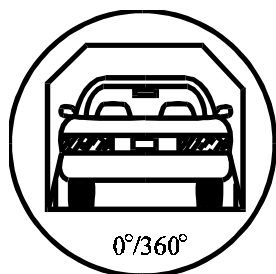

1. Determination of Solvent Collection Time Period:

Rollover Fixture 90° Rotation Time	1	minutes	2	seconds
(Spec. Range = 1 to 3 minutes)				
FMVSS 301 Position Hold Time +	5	minutes	0	seconds
Total	6	minutes	2	seconds
Next whole minute interval	7	minutes		

2. FMVSS 301 Requirements:

(1) Time Period

First 5 minutes from onset of rotation	6th min.	7th min.	8th min. (if required)
--	----------	----------	------------------------

(2) Maximum Allowable Solvent Spillage

142 g	28 g	28 g	28 g
-------	------	------	------

3. Actual Test Vehicle Solvent Spillage:

0 g	0 g	0 g	N/A
-----	-----	-----	-----

Note: Record spillage for whole minute intervals only as determined above.

4. Solvent Spillage Location(s):

None

Data Sheet 17 (Continued)
FMVSS 301 Rollover Data

Vehicle: 2002 MINI Cooper

NHTSA No.: M20501

90 - 180 Degrees

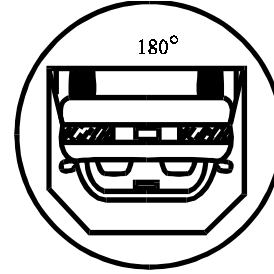
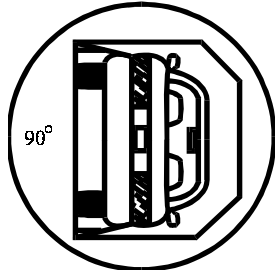

1. Determination of Solvent Collection Time Period:

Rollover Fixture 90° Rotation Time	1	minutes	2	seconds
(Spec. Range = 1 to 3 minutes)				
FMVSS 301 Position Hold Time +	5	minutes	0	seconds
Total	6	minutes	2	seconds
Next whole minute interval	7	minutes		

2. FMVSS 301 Requirements:

(1) Time Period

First 5 minutes from onset of rotation	6th min.	7th min.	8th min. (if required)
--	----------	----------	------------------------

(2) Maximum Allowable Solvent Spillage

142 g	28 g	28 g	28 g
-------	------	------	------

3. Actual Test Vehicle Solvent Spillage:

0 g	0 g	0 g	N/A
-----	-----	-----	-----

Note: Record spillage for whole minute intervals only as determined above.

4. Solvent Spillage Location(s):

None

Data Sheet 17 (Continued)
FMVSS 301 Rollover Data

Vehicle: 2002 MINI Cooper

NHTSA No.: M20501

180 - 270 Degrees

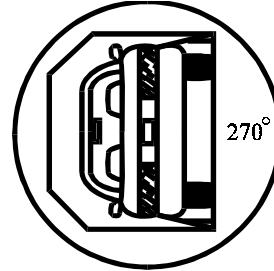
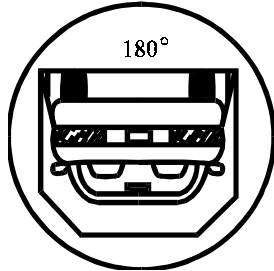

1. Determination of Solvent Collection Time Period:

Rollover Fixture 90° Rotation Time	<u> 1 </u> minutes	<u> 2 </u> seconds
(Spec. Range = 1 to 3 minutes)		
FMVSS 301 Position Hold Time +	<u> 5 </u> minutes	<u> 0 </u> seconds
Total	<u> 6 </u> minutes	<u> 2 </u> seconds
Next whole minute interval	<u> 7 </u> minutes	

2. FMVSS 301 Requirements:

(1) Time Period

First 5 minutes from onset of rotation	6th min.	7th min.	8th min. (if required)
--	----------	----------	------------------------

(2) Maximum Allowable Solvent Spillage

142 g	28 g	28 g	28 g
-------	------	------	------

3. Actual Test Vehicle Solvent Spillage:

0 g	0 g	0 g	N/A
-----	-----	-----	-----

Note: Record spillage for whole minute intervals only as determined above.

4. Solvent Spillage Location(s):

None

Data Sheet 17 (Continued)
FMVSS 301 Rollover Data

Vehicle: 2002 MINI Cooper

NHTSA No.: M20501

270 - 360 Degrees

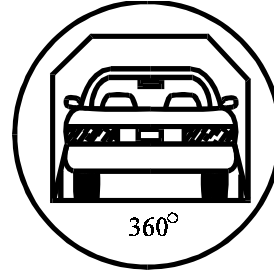
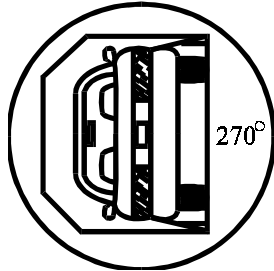

1. Determination Of Solvent Collection Time Period:

Rollover Fixture 90° Rotation Time	1	minutes	2	seconds
(Spec. Range = 1 to 3 minutes)				
FMVSS 301 Position Hold Time +	5	minutes	0	seconds
Total	6	minutes	2	seconds
Next whole minute interval	7	minutes		

2. FMVSS 301 Requirements:

(1) Time Period

First 5 minutes from onset of rotation	6th min.	7th min.	8th min. (if required)
--	----------	----------	------------------------

(2) Maximum Allowable Solvent Spillage

142 g	28 g	28 g	28 g
-------	------	------	------

3. Actual Test Vehicle Solvent Spillage:

0 g	0 g	0 g	N/A
-----	-----	-----	-----

Note: Record spillage for whole minute intervals only as determined above.

4. Solvent Spillage Location(s):

None

Appendix A

Photographs

List of Photographs

<u>Figure</u>	<u>Description</u>	<u>Page</u>
Figure A-1	Pre-Test Front View of Test Vehicle	A-4
Figure A-2	Post-Test Front View of Test Vehicle	A-5
Figure A-3	Pre-Test Impacted Side View of Test Vehicle	A-6
Figure A-4	Post-Test Impacted Side View of Test Vehicle	A-7
Figure A-5	Pre-Test Rear View of Test Vehicle	A-8
Figure A-6	Post-Test Rear View of Test Vehicle	A-9
Figure A-7	Pre-Test Frontal View of Impactor Face	A-10
Figure A-8	Post-Test Frontal View of Impactor Face	A-11
Figure A-9	Pre-Test Left Side View of Impactor Face	A-12
Figure A-10	Post-Test Left Side View of Impactor Face	A-13
Figure A-11	Pre-Test Right Side View of Impactor Face	A-14
Figure A-12	Post-Test Right Side View of Impactor Face	A-15
Figure A-13	Pre-Test Top View of Impactor Face	A-16
Figure A-14	Post-Test Top View of Impactor Face	A-17
Figure A-15	Pre-Test Overhead View of MDB and Vehicle Alignment	A-18
Figure A-16	Pre-Test Left Side View of MDB and Vehicle Alignment	A-19
Figure A-17	Pre-Test Primary Impact Point View	A-20
Figure A-18	Post-Test Primary Impact Point View	A-21
Figure A-19	Pre-Test Secondary Impact Point View	A-22
Figure A-20	Post-Test Secondary Impact Point View	A-23
Figure A-21	Pre-Test Occupant Compartment Right View of Front SID	A-24
Figure A-22	Post-Test Occupant Compartment Right View of Front SID	A-25
Figure A-23	Pre-Test Occupant Compartment Left View of Front SID - View 1	A-26
Figure A-24	Post-Test Occupant Compartment Left View of Front SID - View 1	A-27
Figure A-25	Pre-Test Occupant Compartment Left View of Front SID - View 2	A-28
Figure A-26	Pre-Test Occupant Compartment Left View of Front SID - View 3	A-29
Figure A-27	Pre-Test Door Clearance View of Front SID View	A-30
Figure A-28	Post-Test Door Clearance View of Front SID View	A-31

List of Photographs, Cont'd.

<u>Figure</u>	<u>Description</u>	<u>Page</u>
Figure A-29	Post-Test Interior Showing Front SID Impact Locations - View 1	A-32
Figure A-30	Post-Test Interior Showing Front SID Impact Locations - View 2	A-33
Figure A-31	Post-Test Interior Showing Front SID Impact Locations - View 3	A-34
Figure A-32	Post-Test Front SID Contact View	A-35
Figure A-33	Pre-Test Vehicle Certification Label View	A-36
Figure A-34	Pre-Test Vehicle Recommended Tire Pressure Label View	A-37
Figure A-35	Pre-Test Fuel Cap View	A-38
Figure A-36	Post-Test Fuel Cap View	A-39
Figure A-37	FMVSS 301 Rollover View at 90°	A-40
Figure A-38	FMVSS 301 Rollover View at 180°	A-41
Figure A-39	FMVSS 301 Rollover View at 270°	A-42
Figure A-40	FMVSS 301 Rollover View at 360°	A-43
Figure A-41	Impact Event	A-44

Appendix B

Data Plots

Table Of Data Plots

Driver Instrumentation Plots

Head and Rib Acceleration Data - Filter Class 1000; Lower Spine Filter Class 180
Integration Data Filter Class 180; Contact Data - Filter Class 1000

<u>Plot No.</u>	<u>Data Plot Title</u>	<u>Page</u>
1	Driver Head X-Axis Acceleration	B-7
2	Driver Head X-Axis Velocity	B-8
3	Driver Head Y-Axis Acceleration	B-9
4	Driver Head Y-Axis Velocity	B-10
5	Driver Head Z-Axis Acceleration	B-11
6	Driver Head Z-Axis Velocity	B-12
7	Driver Head Resultant Acceleration	B-13
10	Driver Neck X-Axis Shear Force	B-14
11	Driver Neck Y-Axis Shear Force	B-15
12	Driver Neck Z-Axis Axial Force	B-16
13	Driver Neck Moment about X-Axis	B-17
14	Driver Neck Moment about Y-Axis	B-18
15	Driver Neck Moment about Z-Axis	B-19
16	Driver Neck Occipital Condyle Moment about X-Axis	B-20
17	Driver Upper Rib Y-Axis Acceleration	B-21
18	Driver Upper Rib Y-Axis Velocity	B-22
19	Driver Lower Rib Y-Axis Acceleration	B-23
20	Driver Lower Rib Y-Axis Velocity	B-24
21	Driver Lower Spine Y-Axis Acceleration	B-25
22	Driver Lower Spine Y-Axis Velocity	B-26
23	Driver Pelvis Y-Axis Acceleration	B-27
24	Driver Pelvis Y-Axis Velocity	B-28
25	Driver Upper Rib Y-Axis Redundant Acceleration	B-29

Table Of Data Plots Cont'd.

<u>Plot No.</u>	<u>Data Plot Title</u>	<u>Page</u>
26	Driver Upper Rib Y-Axis Redundant Velocity	B-30
27	Driver Lower Rib Y-Axis Redundant Acceleration	B-31
28	Driver Lower Rib Y-Axis Redundant Velocity	B-32
29	Driver Lower Spine Y-Axis Redundant Acceleration	B-33
30	Driver Lower Spine Y-Axis Redundant Velocity	B-34
31	Driver Pelvis Y-Axis Redundant Acceleration	B-35
32	Driver Pelvis Y-Axis Redundant Velocity	B-36

Test Vehicle Instrumentation Plots

Acceleration Data - Filter Class 60

Integration Data - Filter Class 180

<u>Plot No.</u>	<u>Data Plot Title</u>	<u>Page</u>
33	Right Side Sill at Front Seat X-Axis Acceleration	B-37
34	Right Side Sill at Front Seat X-Axis Velocity	B-38
35	Right Side Sill at Front Seat Y-Axis Acceleration	B-39
36	Right Side Sill at Front Seat Y-Axis Velocity	B-40
37	Right Side Sill at Front Seat Z-Axis Acceleration	B-41
38	Right Side Sill at Front Seat Z-Axis Velocity	B-42
39	Right Side Sill at Front Seat Resultant Acceleration	B-43
40	Right Side Sill at Rear Seat X-Axis Acceleration	B-44
41	Right Side Sill at Rear Seat X-Axis Velocity	B-45
42	Right Side Sill at Rear Seat Y-Axis Acceleration	B-46
43	Right Side Sill at Rear Seat Y-Axis Velocity	B-47
44	Right Side Sill at Rear Seat Z-Axis Acceleration	B-48
45	Right Side Sill at Rear Seat Z-Axis Velocity	B-49
46	Right Side Sill at Rear Seat Resultant Acceleration	B-50
47	Rear Floorpan above Axle X-Axis Acceleration	B-51

Table Of Data Plots Cont'd.

<u>Plot No.</u>	<u>Data Plot Title</u>	<u>Page</u>
48	Rear Floorpan above Axle X-Axis Velocity	B-52
49	Rear Floorpan above Axle Y-Axis Acceleration	B-53
50	Rear Floorpan above Axle Y-Axis Velocity	B-54
51	Rear Floorpan above Axle Z-Axis Acceleration	B-55
52	Rear Floorpan above Axle Z-Axis Velocity	B-56
53	Rear Floorpan above Axle Resultant Acceleration	B-57
54	Left Side Sill at Rear Seat Y-Axis Acceleration	B-58
55	Left Side Sill at Rear Seat Y-Axis Velocity	B-59
56	Left Side Sill at Front Seat Y-Axis Acceleration	B-60
57	Left Side Sill at Front Seat Y-Axis Velocity	B-61
58	Left Front Door on Centerline Y-Axis Acceleration	B-62
59	Left Front Door on Centerline Y-Axis Velocity	B-63
60	Right Rear Occupant Compartment Y-Axis Acceleration	B-64
61	Right Rear Occupant Compartment Y-Axis Velocity	B-65
62	Left Front Door Mid-Rear Y-Axis Acceleration	B-66
63	Left Front Door Mid-Rear Y-Axis Velocity	B-67
64	Left Front Door Upper Centerline Y-Axis Acceleration	B-68
65	Left Front Door Upper Centerline Y-Axis Velocity	B-69
66	Left Rear Side Panel Mid-Rear Y-Axis Acceleration	B-70
67	Left Rear Side Panel Mid-Rear Y-Axis Velocity	B-71
68	Left Rear Side Panel Upper Centerline Y-Axis Acceleration	B-72
69	Left Rear Side Panel Upper Centerline Y-Axis Velocity	B-73
70	Left Lower B-Post Y-Axis Acceleration	B-74

Table Of Data Plots Cont'd.

<u>Plot No.</u>	<u>Data Plot Title</u>	<u>Page</u>
71	Left Lower B-Post Y-Axis Velocity	B-75
72	Left Middle B-Post Y-Axis Acceleration	B-76
73	Left Middle B-Post Y-Axis Velocity	B-77
74	Left Lower A-Post Y-Axis Acceleration	B-78
75	Left Lower A-Post Y-Axis Velocity	B-79
76	Left Middle A-Post Y-Axis Acceleration	B-80
77	Left Middle A-Post Y-Axis Velocity	B-81
78	Left Front Seat Track Y-Axis Acceleration	B-82
79	Left Front Seat Track Y-Axis Velocity	B-83
80	Left Rear Seat Track Y-Axis Acceleration	B-84
81	Left Rear Seat Track Y-Axis Velocity	B-85
82	Vehicle Center of Gravity X-Axis Acceleration	B-86
83	Vehicle Center of Gravity X-Axis Velocity	B-87
84	Vehicle Center of Gravity Y-Axis Acceleration	B-88
85	Vehicle Center of Gravity Y-Axis Velocity	B-89
86	Vehicle Center of Gravity Z-Axis Acceleration	B-90
87	Vehicle Center of Gravity Z-Axis Velocity	B-91
88	Vehicle Center of Gravity Resultant Acceleration	B-92

Moving Deformable Barrier Instrumentation Plots

Acceleration Data - Filter Class 60

Integration Data - Filter Class 180

Contact Data - Filter Class 1000

<u>Plot No.</u>	<u>Data Plot Title</u>	<u>Page</u>
89	MDB Center of Gravity X-Axis Acceleration	B-93
90	MDB Center of Gravity X-Axis Velocity	B-94
91	MDB Center of Gravity Y-Axis Acceleration	B-95
92	MDB Center of Gravity Y-Axis Velocity	B-96
93	MDB Center of Gravity Z-Axis Acceleration	B-97
94	MDB Center of Gravity Z-Axis Velocity	B-98
95	MDB Center of Gravity Resultant Acceleration	B-99
96	MDB Left Rear X-Axis Acceleration	B-100

Table Of Data Plots Cont'd.

<u>Plot No.</u>	<u>Data Plot Title</u>	<u>Page</u>
97	MDB Left Rear X-Axis Velocity	B-101
98	MDB Left Rear Y-Axis Acceleration	B-102
99	MDB Left Rear Y-Axis Velocity	B-103
100	MDB Right Side Contact Switch	B-104
101	MDB Left Side Contact Switch	B-105

Driver Dummy Instrumentation Plots

Acceleration Data - FIR100 Filtered

<u>Plot No.</u>	<u>Data Plot Title</u>	<u>Page</u>
120	Driver Upper Rib Y-Axis Acceleration - Primary	B-106
121	Driver Lower Rib Y-Axis Acceleration - Primary	B-107
122	Driver Lower Spine Y-Axis Acceleration - Primary	B-108
123	Driver Pelvis Y-Axis Acceleration - Primary	B-109
124	Driver Upper Rib Y-Axis Acceleration - Redundant	B-110
125	Driver Lower Rib Y-Axis Acceleration - Redundant	B-111
126	Driver Lower Spine Y-Axis Acceleration - Redundant	B-112
127	Driver Pelvis Y-Axis Acceleration - Redundant	B-113

Appendix C

SID Configuration And Performance Verification Data

Summary
SID H3 Pre-Test And Post-Test Calibration

Configured For Left Side Impact

Calibration Dates: Pre: June 17-18, 2002 (Damper: November 23, 2001)
Post: June 27-July 1, 2002
Laboratory Technician: Jack Willeke
TRC Inc. Calibration Numbers: SN 270 CAL04 and CAL05

Test Parameter	Specification	SID 270		SID	
		Pre-Test	Post-Test	Pre-Test	Post-Test
SH - seated height (mm)	889-909	899.2	902.0	N/A	N/A
RH - Rib Height (mm)	502-520	510.5	510.0	N/A	N/A
HP - Hip Pivot Height (mm)	99 ref	99.1	99.0	N/A	N/A
RD - Rib from Back Line (mm)	229-241	236.2	236.0	N/A	N/A
KV - Knee Pivot from Back Line (mm)	511-526	520.7	520.0	N/A	N/A
SW - Knee Pivot to Floor (mm)	490-505	497.8	497.0	N/A	N/A
HW - Hip Width (mm)	356-391	373.4	373.0	N/A	N/A
Thorax Impacts					
Temperature (°C)	18.9-25.5	21.1	21.7	N/A	N/A
Relative Humidity (%)	10-70	58	56	N/A	N/A
Probe Speed (m/s)	4.27-4.33	4.31	4.27	N/A	N/A
Upper Rib (g's)	37-46	43.4	45.5	N/A	N/A
Lower Rib (g's)	37-46	42.2	44.8	N/A	N/A
Lower Spine (g's)	15-22	19.0	21.5	N/A	N/A
Pelvis Impacts					
Temperature (°C)	18.9-25.5	21.1	21.7	N/A	N/A
Relative Humidity (%)	10-70	55	56	N/A	N/A
Probe Speed (m/s)	4.27-4.33	4.25	4.32	N/A	N/A
Pelvis (g's)	40-60	45.2	51.7	N/A	N/A

Summary
 SID H3 Pre-Test And Post-Test Calibration, Cont'd.

Test Parameter	Specification	SID 270		SID	
		Pre-Test	Post-Test	Pre-Test	Post-Test
Head Drop Tests					
Temperature (°C)	18.9-25.5	21.7	21.7	N/A	N/A
Relative Humidity (%)	10-70	46.0	56.0	N/A	N/A
Peak Resultant Acceleration (g)	120-150	135.8	146.8	N/A	N/A
Pelvis (g's) Peak Longitudinal Acceleration (g)	15 Max.	-12.4	-7.4	N/A	N/A
Is Acceleration Curve Unimodal?	Yes	Yes	Yes	N/A	N/A
Lateral Neck Pendulum Tests					
Temperature (°C)	20.6-22.2	21.7	21.7	N/A	N/A
Relative Humidity (%)	10.70	51.0	57.0	N/A	N/A
Impact Velocity (m/s)	6.89-7.13	7.12	7.12	N/A	N/A
Integrated Velocity at 10 ms (m/s)	1.96-2.55	2.43	2.27	N/A	N/A
Integrated Velocity at 20 ms (m/s)	4.12-5.10	4.93	4.50	N/A	N/A
Integrated Velocity at 30 ms (m/s)	5.73-7.01	7.00	6.34	N/A	N/A
Integrated Velocity at 40-70 ms (m/s)	6.27-7.64	7.3-7.4	7.2-7.4	N/A	N/A
Maximum Midsagittal Plane Rotation (degree)	66-82	69.6	76.4	N/A	N/A
Rotation Angle Decay Time from Peak to Zero (ms)	58-67	58.7	60.3	N/A	N/A
Maximum Moment about Occipital Condyle (Nm)	73-88	82.5	83.1	N/A	N/A
Positive Moment Decay Time from Peak to Zero (ms)	49-64	55.4	50.0	N/A	N/A
Time of Maximum Rotation after Maximum Moment	2-16	14.3	9.8	N/A	N/A

Calibration Test Results

Pre-Test

SID H3: 270

Configured for Left Side Impact

External Dimensions:	The dummy passed all external dimension requirements.
Head Drop Test:	The head met all left side head drop test requirements.
Lateral Neck Test:	The neck passed all lateral pendulum test requirements.
Lateral Thorax Impact Test:	The lateral thorax passed all impact test requirements.
Pelvis Impact Test:	The lateral pelvis passed all impact test requirements.
Thoracic Shock Absorber:	The thorax passed all shock absorber requirements (tested on November 23, 2001, for a previous calibration series).
Abdominal Compression Test:	The abdomen met the Part 572B compression test requirements.
Lumbar Flexion Test:	The dummy met the Part 572B lumbar flexion test requirements.

Calibration Test Results

Post-Test

SID H3: 270

Configured for Left Side Impact

External Dimensions:	The dummy passed all external dimension requirements.
Head Drop Test:	The head met all left side head drop test requirements.
Lateral Neck Test:	The neck passed all lateral pendulum test requirements.
Lateral Thorax Impact Test:	The lateral thorax passed all impact test requirements.
Pelvis Impact Test:	The lateral pelvis passed all impact test requirements.
Thoracic Shock Absorber:	The thorax passed all impact test requirements.
Abdominal Compression Test:	The abdomen met the Part 572B compression test requirements.
Lumbar Flexion Test:	The dummy met the Part 572B lumbar flexion test requirements.

Type: SID S/N: 270
 Proj./Seg. No.: 19970454-3400

Mfr: First Tech Test Date: 06/19/02
 Test Eng.: Ginny Watters

Item	Pre-Use	
Head: HYBIII Head		
Head Ballast Condition		
Accelerometer Mount Bolts and Cables		
Skull Cap Bolts	X	
Head Skin Condition	X	
Accelerometer Cable Exit (left or right)	(Left)	(Right)
Neck:		
* Rubber Condition and Separation From End Caps	X	
Thorax:		
Stacked Shoulder Foams and Bolts	X	
* Rib Cage Spring and Support Assembly	X	
* Rib Cage Bolts	X	
* Damper Rear Attachment Ring, Pivot Pins, and Bracket (No Damper Pot) Left	X	
* Location and Adjustment of Chest Pot Bracket and Collars	X	
* Chest Pot Rod End Nuts and Eyebolt	X	
Arm Foam Orientation	X	
Thorax/Lumbar Spine Bolts	X	
Pelvis:		
Tightness and Alignment of H-Point Tool Insert	X	
* Hips Range of Motion and 1-2g Adjustment (before calibration only)	X	
Upper Femur Bolt Adjustment and Position	X	
Check Spine Kits (Yellow tape = Kits/No Tape = No kits)	(With) X	(Without)
Legs and Feet:		
Femur Load Cell Bolts (40 ft/lbs.)	X	
Breakaway Femur Bolts (5-6 ft/lbs)	X	
Knee Joint Function and Range of Motion	X	
Leg Skin Condition and Position	X	
Ankle Range of Motion	X	
Foot Condition	X	
Other:		
Cleanliness	X	
Target Position mid-calf pants	X	
Clothes	X	
Shoes	X	
Knee and Ankle One G Joint Adjustments	X	

Inspection Completed By: J. Clarridge

Date: 06/18/02

Type: SID S/N: 270
 Proj./Seg. No.: 19970454-3400

Mfr: First Tech Test Date: 06/19/02
 Test Eng.: Ginny Watters

Item	Post-Use
Head: HYBIII Head	
Head Skin Condition	
Head Ballast Condition	
Neck:	
Rubber Condition and Separation from End Caps	X
Thorax:	
Jacket Condition	X
Arm Foam Condition	X
Damper and Movement and Condition	X
Rib Cage Spring and Support Assembly Condition	X
Rib Wrap Condition	X
Abdomen Condition	X
Thorax/Lumbar Spine Bolts	X
Lumbar Spine Condition and Separation from End Caps	X
Pelvis:	
Iliac Crest Bone	X
Flesh Condition	X
Hip Range of Motion	X
Legs and Feet:	
Knee Skins and Castings Condition	X
Leg Skin Condition	X
Foot Condition	X
Knee Joint Range of Motion	X
Ankle Range of Motion	X

Notes: No damage to report.

Inspection Completed By: J. Clarridge Date: 06/21/02

Appendix D

Test Equipment List and Calibration Information

Report Sign Convention
SAE J211 MAR95

<u>Accelerometers:</u>	+X: Forward
	+Y: Rightward
	+Z: Downward
<u>Potentiometers:</u>	+Chest longitudinal deflection: Outward
	+Chest lateral deflection: Leftward
	+Seat belt displacement: Outward
	+Seat belt extension: Elongation
	+Knee slider displacement: Distance between femur and tibia increased (in relation to a seated dummy)
<u>Rotation potentiometers:</u>	
	+About the X-axis: Left foot-eversion Right foot-inversion
	+About the Y-axis: Left/right foot-dorsiflexion
	+About the Z-axis: Left foot-internal Right foot-external
<u>Load cells:</u>	+Femur force: Tension
	+Seat belt force: Tension
	+Barrier force: Tension
<u>Neck load cells:</u>	+X force: Head pushed rearward
	+Y force: Head pushed leftward
	+Z force: Head pulled upward (tension on neck)
	+X moment: Left ear rotating toward left shoulder
	+Y moment: Chin rotating toward chest
	+Z moment: Chin rotating toward left shoulder
<u>Tibia load cells:</u>	+X force: Ankle forward, knee rearward
	+Y force: Ankle rightward, knee leftward
	+Z force: Tension
	+X moment: Bottom of tibia moving leftward
	+Y moment: Bottom of tibia moving rearward

¹ The chest deflection and knee slider displacement presented in the dummy certification in Appendix C are opposite of J211 polarity.

Frequency Response Classes
SAE J211 MAR95

<u>Typical Test Measurements</u>	<u>Channel Class</u>
Vehicle Structural Accelerations for use in:	
Total vehicle comparison	60
Collision simulation input	60
Component analysis	600
Integration for velocity or displacement	180
Barrier Face Forces	60
Belt Restraint System Loads	60
Anthropomorphic Test Device	
Head accelerations (linear and angular)	1000
Neck	
Forces	1000
Moments	600
Thorax	
Spine accelerations	180
Rib accelerations	1000
Sternum accelerations	1000
Deflections	180
Lumbar	
Forces	1000
Moments	1000
Pelvis	
Accelerations	1000
Forces	1000
Moments	1000
Femur/Knee/Tibia/Ankle	
Forces	600
Moments	600
Displacements	180
Sled Accelerations	60
Steering Column Loads	600
Head form Accelerations	1000

The direction column on the following sheets describes the transducer output as mounted and wired in the test location. The polarity column indicates whether a polarity change occurred during data acquisition to conform to J211 MAR95. See Report Sign Convention sheet for description of data output as presented in the report: occasionally channels have been adjusted in post-acquisition processing to conform to J211 MAR95.

Channel Report

6/19/2002 8:07:47 AM

Name of Test 020619

System MINIDAU

Name of DAU DAU6

Chan.#	Sensor #	Mnemonic	Description	Dir.	Range	Pol.	Cal.	Group	Mfg.	Model
6001	EVENT0	SYNC6	SYNC6		5.12	V	+ 4/15/2002	OK -1	TRC	Event
6002	J40456	BCGXG1	MDB CG X-AXIS	FWD	597.32835	g	+ 3/20/2002	OK -1	Endevco	7264-2000TZ
6003	J40529	BCGYG1	MDB CG Y-AXIS	LT	593.91239	g	- 3/20/2002	OK -1	Endevco	7264-2000TZ
6004	J40726	BCGZG1	MDB CG Z-AXIS	UP	599.25093	g	- 3/20/2002	OK -1	Endevco	7264-2000TZ
6005	J38609	LRRXG1	MDB LT RR X-AXIS	RR	596.56972	g	- 5/10/2002	OK -1	Endevco	7264-2000TZ
6006	J38149	LRRYG1	MDB LT RR Y-AXIS	RT	601.02361	g	+ 5/10/2002	OK -1	Endevco	7264-2000TZ

D-5

020619

Channel Report

6/19/2002 8:07:47 AM

Name of Test 020619

System MINIDAU

Name of DAU DAU7

Chan.#	Sensor #	Mnemonic	Description	Dir.	Range	Pol.	Cal.	Group	Mfg.	Model
7001	EVENT	EVENT	EVENT		5.12	V	+ 4/15/2002	OK -1	TRC	Event
7002	J26885	HEDXG1	Head Accel X	Rwd	806.93459	g	- 11/21/2001	--- 270n	Endevco	7264-2000TZ
7003	J26864	HEDYG1	Head Accel Y	Lft	794.42660	g	- 11/21/2001	--- 270n	Endevco	7264-2000TZ
7004	J27950	HEDZG1	Head Accel Z	Up	795.33980	g	- 11/21/2001	--- 270n	Endevco	7264-2000TZ
7005	1716A-858-FX	NEKXF1	Neck Force X	Hd	8899.0017	N	- 8/16/2001	--- 270n	Denton	1716A
7006	1716A-858-FY	NEKYF1	Neck Force Y	Hd	8893.9293	N	+ 8/16/2001	--- 270n	Denton	1716A
7007	1716A-858-FZ	NEKZF1	Neck Force Z	Hd	13346.730	N	+ 8/16/2001	--- 270n	Denton	1716A
7008	1716A-858-MX	NEKXM1	Neck Moment X	Rt Ear	282.48320	N·m	- 8/16/2001	--- 270n	Denton	1716A
7009	1716A-858-MY	NEKYM1	Neck Moment Y	Chn	282.26711	N·m	+ 8/16/2001	--- 270n	Denton	1716A
7010	1716A-858-MZ	NEKZM1	Neck Moment Z	Chn	282.21777	N·m	+ 8/16/2001	--- 270n	Denton	1716A
7011	J34404	LURYG1	Left Upper Rib Y	Rgt	802.26891	g	+ 11/21/2001	--- 270n	Endevco	7264-2000TZ
7012	J34078	LURYR1	Left Upper Rib Red Y	Rgt	811.34616	g	+ 11/21/2001	--- 270n	Endevco	7264-2000TZ
7013	J34630	LLRYG1	Left Lower Rib Y	Rgt	809.92153	g	+ 11/21/2001	--- 270n	Endevco	7264-2000TZ
7014	J34438	LLRYR1	Left Lower Rib Red Y	Rgt	811.17906	g	+ 11/21/2001	--- 270n	Endevco	7264-2000TZ
7015	J34352	T12YG1	Lower Spine Y	Lft	399.39778	g	- 11/23/2001	--- 270n	Endevco	7264-2000TZ
7016	J22046	T12YR1	Lower Spine Red Y	Lft	399.50062	g	- 11/23/2001	--- 270n	Endevco	7264-2000TZ
7017	J20561	PEVYG1	Pelvis Accel Y	Lft	398.53041	g	- 11/23/2001	--- 270n	Endevco	7264-2000TZ
7018	J27111	PEVYR1	Pelvis Accel Red Y	Rgt	398.54903	g	+ 11/23/2001	--- 270n	Endevco	7264-2000TZ
7019	J29684	RFSXG1	RGT SIDE SILL FRNT ST X	FWD	402.04161	g	+ 6/3/2002	OK -1	Endevco	7264-2000TZ
7020	J32161	RFSYG1	RGT SIDE SILL FRNT ST Y	LT	1008.7278	g	- 6/3/2002	OK -1	Endevco	7264-2000TZ
7021	J37958	RFSZG1	RGT SIDE SILL FRNT ST Z	DN	402.07950	g	+ 6/3/2002	OK -1	Endevco	7264-2000TZ
7022	J14144	RRSXG1	RGT SIDE SILL RR ST X	RR	394.72669	g	- 5/23/2002	OK -1	Endevco	7264-2000TZ
7023	J14404	RRSYG1	RGT SIDE SILL RR ST Y	RT	1010.4598	g	+ 5/23/2002	OK -1	Endevco	7264-2000TZ
7024	AJ460	RRSZG1	RGT SIDE SILL RR ST Z	UP	395.74879	g	- 5/23/2002	OK -1	Endevco	7264-2000TZ
7025	J41115	RDKXG1	RR FLRPAN ABV AXLE X	FWD	1019.6968	g	+ 5/23/2002	OK -1	Endevco	7264-2000TZ
7026	J35676	RDKYG1	RR FLRPAN ABV AXLE Y	LT	1012.6582	g	- 4/17/2002	OK -1	Endevco	7264-2000TZ
7027	J41119	RDKZG1	RR FLRPAN ABV AXLE Z	UP	979.34200	g	- 5/23/2002	OK -1	Endevco	7264-2000TZ
7028	J34531	LFSYG1	LFT SIDE SILL FRNT ST Y	RT	998.05068	g	+ 1/18/2002	OK -1	Endevco	7264-2000TZ
7029	J40742	LRSYG1	LFT SIDE SILL RR ST Y	RT	985.75279	g	+ 6/3/2002	OK -1	Endevco	7264-2000TZ
7030	J39580	LFCYG1	LFT FRNT DOOR CTRLN Y	RT	1452.7707	g	+ 6/5/2002	OK -1	Endevco	7264-2000TZ

Page

020619

Channel Report

6/19/2002 8:07:47 AM

7031	J39915	RRTYG1	RGT RR OCP COMP Y	LT	1452.7295	g	-	6/5/2002	OK	-1	Endevco	7264-2000TZ
7032	J41622	LFMYG1	LFT FRNT DOOR MIDRR Y	LT	1503.8212	g	-	6/5/2002	OK	-1	Endevco	7264-2000TZ

D-7

020619

Channel Report

6/19/2002 8:07:47 AM

Name of Test 020619

System MINIDAU

Name of DAU DAU8

Chan.#	Sensor #	Mnemonic	Description	Dir.	Range	Pol.	Cal.	Group	Mfg.	Model
8001	J39918	LFUYG1	LFT FRNT DOOR UPPER C/L	RT	1475.3342	g	+ 6/5/2002	OK -1	Endevco	7264-2000TZ
8002	J36709	LRMYG1	LFT RR DORR MIDREAR Y	RT	1496.2447	g	+ 5/2/2002	OK -1	Endevco	7264-2000TZ
8003	J39407	LRUYG1	LT RR DR UPPER CL Y	RT	1480.9244	g	+ 6/5/2002	OK -1	Endevco	7264-2000TZ
8004	J40541	LLAYG1	LFT LOWER A-POST Y	LT	1486.6434	g	- 4/8/2002	OK -1	Endevco	7264-2000TZ
8005	J40559	LUAYG1	LFT MID A-POST Y	LT	1470.6304	g	- 3/20/2002	OK -1	Endevco	7264-2000TZ
8006	J40929	LLBYG1	LFT LOWER B-POST Y	RT	1488.4586	g	+ 6/6/2002	OK -1	Endevco	7264-2000TZ
8007	J22047	LUBYG1	LFT MID B-POST Y	RT	1478.8284	g	+ 2/14/2002	OK -1	Endevco	7264-2000TZ
8008	J39676	LFTYG1	LFT FRNT ST TRK Y	LT	1474.3571	g	- 6/5/2002	OK -1	Endevco	7264-2000TZ
8009	J30467	LRTYG1	LFT RR ST TR Y	RT	1474.8242	g	+ 2/19/2002	OK -1	Endevco	7264-2000TZ
8010	J40534	VCGXG1	VEH C/G X	FWD	983.55617	g	+ 3/20/2002	OK -1	Endevco	7264-2000TZ
8011	J40538	VCGYG1	VEH C/G Y	RT	992.30575	g	+ 3/20/2002	OK -1	Endevco	7264-2000TZ
8012	J22197	VCGZG1	VEH C/G Z	UP	1007.3782	g	- 6/6/2002	OK -1	Endevco	7264-2000TZ

D-8

020619

Digital and System Channel Report

2002-06-19 08:07:34

Name of Test 020619

System MINIDAU

Name of DAU DAU6

descriptio

enable Channel
Yes 6501

Short Name

Type
dig0

Data File
DAT66501

Module Type
KM3710 Controller

bit position	bit	short	long	descriptio
MSB = bit 15	1	CAMERA	CAMERA START	
bit 14	1	MDBR1	MDB RIGHT SIDE CONTACT SWITCH	H
bit 13	1	MDBL1	MDB LEFT SIDE CONTACT SWITCH	G
bit 12	0			
bit 11	0			
bit 10	0			
bit 09	0			
bit 08	0			
bit 07	0			
bit 06	0			
bit 05	0			
bit 04	0			
bit 03	0			
bit 02	0			
bit 01	0			
LSB = bit 00	0			

D-9

020619

Dummy 270n Type SID Description NHTSA - 270n SID-LEFT IMP. CONFIG. CAL DUE 5-17-02(DKS 11)

Chsname	Location	Model	Name	Manufacturer	Sens./mV/V/U	Fullscale	Caldate	TRC Dir
HEDXG	Head Accel X	7264-2000TZ	J26885	Endevco	0.0235 g	2000	11/21/2001	Rwd
HEDYG	Head Accel Y	7264-2000TZ	J26864	Endevco	0.02387 g	2000	11/21/2001	Lft
HEDZG	Head Accel Z	7264-2000TZ	J27950	Endevco	0.02575 g	2000	11/21/2001	Up
NEKXF	Neck Force X	1716A	1716A-858-FX	Denton	0.000193719 N	8896.4	08/16/2001	Hd Fd,Cst Rr
NEKYF	Neck Force Y	1716A	1716A-858-FY	Denton	0.000186907 N	8896.4	08/16/2001	Hd Lt,Cst Rt
NEKZF	Neck Force Z	1716A	1716A-858-FZ	Denton	0.000096144 N	13344.6	08/16/2001	Hd Up,Cst Dn
NEKXM	Neck Moment X	1716A	1716A-858-MX	Denton	0.005827965 N·m	282.5	08/16/2001	Rt Ear to Rt Shld
NEKYM	Neck Moment Y	1716A	1716A-858-MY	Denton	0.005966726 N·m	282.5	08/16/2001	Chn to Strnm
NEKZM	Neck Moment Z	1716A	1716A-858-MZ	Denton	0.008246372 N·m	282.5	08/16/2001	Chn to Lt Shld
LURYG	Left Upper Rib Y	7264-2000TZ	J34404	Endevco	0.03039 g	2000	11/21/2001	Rgt
LURYR	Left Upper Rib Red Y	7264-2000TZ	J34078	Endevco	0.03005 g	2000	11/21/2001	Rgt
LLRYG	Left Lower Rib Y	7264-2000TZ	J34630	Endevco	0.02634 g	2000	11/21/2001	Rgt
LLRYR	Left Lower Rib Red Y	7264-2000TZ	J34438	Endevco	0.03322 g	2000	11/21/2001	Rgt
T12YG	Lower Spine Y	7264-2000TZ	J34352	Endevco	0.02249 g	2000	11/23/2001	Lft
T12YR	Lower Spine Red Y	7264-2000TZ	J22046	Endevco	0.0267 g	2000	11/23/2001	Lft
PEVYG	Pelvis Accel Y	7264-2000TZ	J20561	Endevco	0.02424 g	2000	11/23/2001	Lft
PEVYR	Pelvis Accel Red Y	7264-2000TZ	J27111	Endevco	0.02106 g	2000	11/23/2001	Rgt

D-10

020619



PLASCORE

SIDE IMPACTOR BARRIER CERTIFICATION

Date: September 12, 2001

To: Transportation Research
Ship & Rec Bldg 50
10820 St. Route 347
East Liberty, OH 43319-0367

PURCHASE ORDER INFORMATION

Customer P.O. Number: 14572
Work Order Number: 10512
Quantity: 05 pieces

CORE INFORMATION

Core Type: PCGA-1/4-5.2-P-3003-T
Measured Cell Size: 0.250 inches
Measured Density: 5.2 pcf

Unit Numbers: 033A0801 - 05 pcs.

This is to certify that the aluminum honeycomb core supplied, under the unit numbers provided, meets the crush requirements of 232 – 250 psi as per DWG# DSL-1285.

Quality Control Representative
Karl D. Zwaanstra





Crush Data
232 - 250 psi per DWG # DSL-1285

Block Number: 033A0801

<u>Specimen Number</u>	<u>Zone 1</u>	<u>Zone 2</u>	<u>Zone 3</u>
1	232.12	233.03	236.22
2	239.79	244.02	245.85
3	233.62	235.47	234.04
4	243.59	243.72	244.91
5	234.15	234.82	235.01
6	234.74	236.21	238.29
7	233.99	233.53	236.16

BLOCK # 033A0801 Sample ID: IN323473

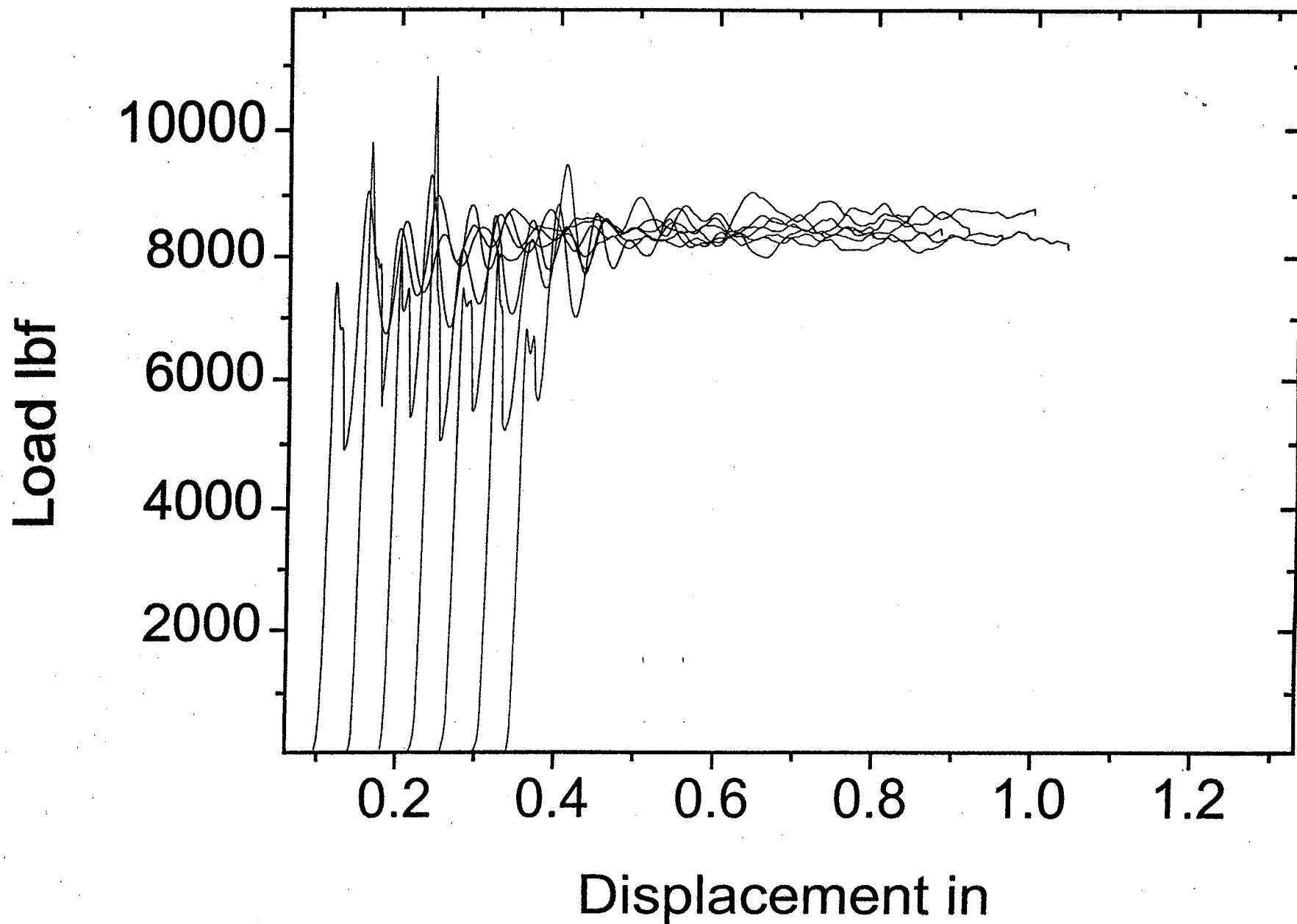

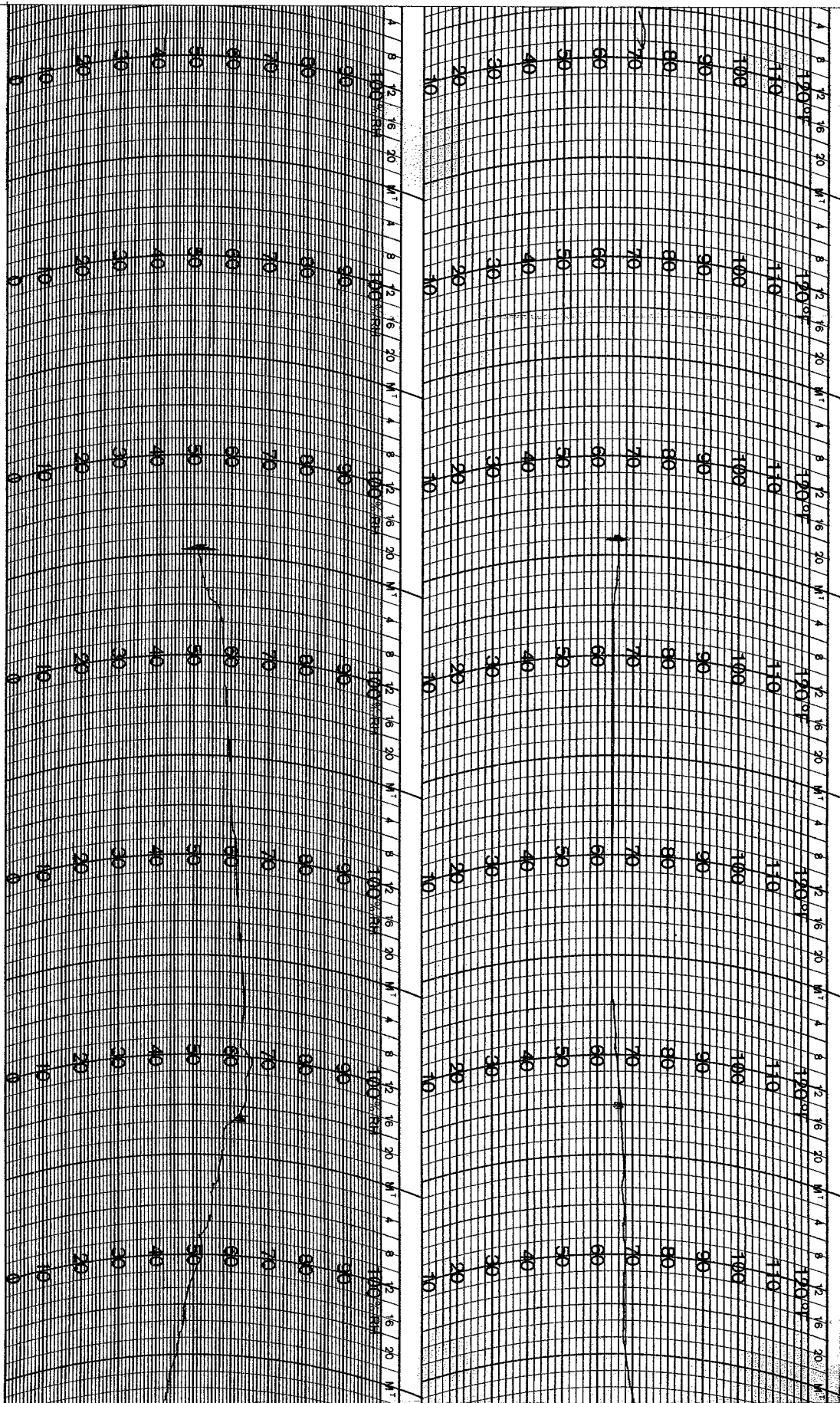

19970454-3400

GRAPHIC CONTROLS CORPORATION
BUFFALO, NEW YORK

HYGROTHERMOGRAPH

No. C311WHF PRINTED IN U.S.A.

STATION CTF.

DATE ON 6-18-02 DATE OFF _____