

REPORT NUMBER: SLED-VER-2002-12

**CHILD RESTRAINT SYSTEM IN
DYNAMIC SLED TEST
CENTURY 1000 STE, REARWARD-FACING RECLINED, CONVERTIBLE
CENTURY 1000 STE, FORWARD-FACING UPRIGHT, CONVERTIBLE**

TEST NUMBER: 22467

**PREPARED BY:
VERIDIAN ENGINEERING
4455 GENESEE STREET
BUFFALO, NEW YORK 14225**



April 29, 2002

FINAL REPORT

**PREPARED FOR:
U.S. DEPARTMENT OF TRANSPORTATION
NATIONAL HIGHWAY TRAFFIC SAFETY ADMINISTRATION
OFFICE OF CRASHWORTHINESS STANDARDS
400 SEVENTH STREET, SW, ROOM 5311
WASHINGTON, D.C. 20590**

This final test report was prepared for the U.S. Department of Transportation, National Highway Traffic Safety Administration, in response to Contract Number DTNH22-01-D-32005

This publication is distributed by the U.S. Department of Transportation, National Highway Traffic Safety Administration, in the interest of information exchange. The opinions, findings and conclusions expressed in this publication are those of the author(s) and not necessarily those of the Department of Transportation or the National Highway Traffic Safety Administration. The United States Government assumes no liability for its contents or use thereof. If trade or manufacturers' names or products are mentioned it is only because they are considered essential to the object of the publication and should not be construed as an endorsement. The United States Government does not endorse products or manufacturers.

Prepared by: _____ Date: _____
David P. Roberts, Project Engineer

Reviewed by: _____ Date: _____
David P. Roberts, Head of Occupant
Protection and Safety Research

FINAL REPORT ACCEPTED BY:

Manager, New Car Assessment Program

Date of Acceptance

COTR, NCAP Frontal Impact Program

Date of Acceptance

TABLE OF CONTENTS

<u>Section</u>		<u>Page No.</u>
1	Purpose and Test Procedure	1
2	P3 Child Restraint Information	2
3	P3 Post-Test Observations	3
4	P3 CRABI 12 Month Old ATD Injury Criteria and Sensor Data	4
5	P4 Child Restraint Information	6
6	P4 Post-Test Observations	7
7	P4 CRABI 12 Month Old ATD Injury Criteria and Sensor Data	8
8	Sled Test Set-Up	10
9	Camera Location	11
10	Photographs	12
11	Data Plots	31
12	Compression – Deflection Resistance Test	73
13	Child Dummy Calibration Data Traces and Tables	83
14	Test Equipment and Instrumentation Calibration	200
15	AVI Files	203

SECTION 1

PURPOSE AND TEST PROCEDURE

1.1 PURPOSE

This dynamic sled testing is part of the FY' 02 New Car Assessment Program (NCAP) sponsored by the National Highway Traffic Safety Administration (NHTSA) under Contract Number DTNH22-01-D-32005. The purpose of this test is to obtain child seat research data for frontal dynamic testing.

1.2 TEST PROCEDURE

This frontal dynamic sled test was conducted in accordance with the child restraint test procedure provided by the Office of Crashworthiness Standards (OCS), New Car Assessment Program (NCAP).

The test was conducted at Veridian Engineering on April 29, 2002 at a speed of 48.2 kph (29.9 mph). The FMVSS No. 213 sled pulse was used as a crash pulse. The requirements specified in the FMVSS No. 213 were also followed.

The bench seat contained two anthropomorphic test devices (ATD's). Two (2) CRABI 12 month old size ATD's, Serial Number 22 (P3) and 17 (P4), were instrumented with head, chest, and pelvic tri-axial accelerometers, and upper and lower neck load cells. The child ATD's were positioned according to the child seat manufacturer's instructions. The data was digitally sampled at 20,000 samples per second and processed per Section IP11 of the Laboratory Test Procedure.

1.3 POST-TEST COMMENTS

On the South (P3) seat the left lower lateral support rib cracked ~3/8".

SECTION 2

CHILD RESTRAINT INFORMATION

Test No.: 22467S

Test Date: April 29, 2002

P3 Seating Position

Child Restraint Type (forward-facing, rearward facing, booster)	Rearward facing, Reclined, Convertible
LATCH or NON-LATCH	Non-latch
Child Restraint Manufacturer	Century
Child Restraint Model	1000 STE
Model Number	44161 BLC
Date of Manufacture	1/31/2002
Child Restraint Height Limits (mm)	Up to 1016
Child Restraint Weight Limits (kg)	Rearward-facing Birth – 10 Forward-facing 9 - 18
Weight of Child Restraint (kg)	4.98
Tether Location	Upper

SECTION 3

POST-TEST OBSERVATIONS

Test No.: 22467S

Test Date: April 29, 2002

P3 Seating Position

Child Seat	Century 1000 STE
Belt Fraying	None
Stress Marks	None
Cracks	Left lower lateral support rib crack ~3/8"
Buckle Stress	None
Latch Hooks	None
Seat Back Rotation Angle	53°
Velocity	29.9 mph, 48.2 kph
Acceleration (G's)	24.3

SECTION 4

CRABI 12 MONTH OLD ATD INJURY CRITERIA AND SENSOR DATA

Test No.: 22467S

Test Date: April 29, 2002

P3 Seating Position

HEAD PRIMARY PEAK ACCELERATIONS

Location	Axis	Units	P3 (South) Rear Passenger			
			Max	Time	Min	Time
Head CG	X	G's	36.6	93.8	-1.1	181.2
Head CG	Y	G's	7.5	98.2	-1.7	150.2
Head CG	Z	G's	31.4	57.8	-15.8	102.1
Head CG Resultant	N/A	G's	38.9	93.8		

CHEST PRIMARY PEAK ACCELERATIONS

Location	Axis	Units	P3 (South) Rear Passenger			
			Max	Time	Min	Time
Chest CG	X	G's	29.2	64.5	-0.9	151.3
Chest CG	Y	G's	5.4	75.2	-2.1	118.5
Chest CG	Z	G's	26.1	59.0	-17.7	94.0
Chest CG Resultant	N/A	G's	37.4	63.5		

SEAT BELT SENSOR PEAK VALUES

Location	Axis	Units	P3 (South) Rear Passenger			
			Max	Time	Min	Time
Tether Belt	N/A	Newtons	----	----		

HEAD INJURY CRITERIA (HIC)

Location	P3 (South) Rear Passenger			
	HIC	Avg. G's	T ¹	T ²
Head CG Primary (36 msec)	187	30.6	72.2	108.2
Head CG Primary (15 msec)	112	35.4	88.8	103.8

CHEST CLIP (3 MSEC)

Location	P3 (South) Rear Passenger		
	Clip	T ¹	T ²
Chest CG Primary	37.3	61.8	64.8

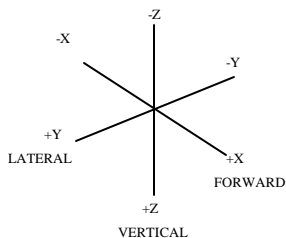

CRABI 12 MONTH OLD ATD INJURY CRITERIA AND SENSOR DATA...(continued)

Test No.: 22467S

Test Date: April 29, 2002

P3 Seating Position

PELVIC PEAK ACCELERATIONS

Location	Axis	Units	P3 (South) Rear Passenger			
			Max	Time	Min	Time
Pelvis	X	G's	28.2	56.4	-1.0	249.9
Pelvis	Y	G's	7.3	76.5	-2.0	122.0
Pelvis	Z	G's	34.5	58.3	-15.1	94.6

UPPER NECK PEAK FORCES AND MOMENTS

Location	Axis	Units	P3 (South) Rear Passenger			
			Max	Time	Min	Time
Neck Force	X	Newtons	197.1	98.5	-249.8	60.0
Neck Force	Y	Newtons	108.7	100.8	-34.3	147.7
Neck Force	Z	Newtons	756.2	56.4	-183.5	105.0
Neck Moment	X	Nm	0.8	126.0	-3.3	97.2
Neck Moment	Y	Nm	12.5	101.4	-8.4	60.5
Neck Moment	Z	Nm	1.7	103.3	-0.6	169.5

LOWER NECK PEAK FORCES AND MOMENTS

Location	Axis	Units	P3 (South) Rear Passenger			
			Max	Time	Min	Time
Neck Force	X	Newtons	225.1	97.3	-25.8	179.7
Neck Force	Y	Newtons	87.6	94.9	-28.7	148.2
Neck Force	Z	Newtons	867.6	57.0	-208.1	105.8
Neck Moment	X	Nm	5.6	98.9	-2.7	148.8
Neck Moment	Y	Nm	1.9	195.0	-9.6	95.6
Neck Moment	Z	Nm	0.6	78.8	-0.3	170.5

LUMBAR PEAK FORCES AND MOMENTS

Location	Axis	Units	P3 (South) Rear Passenger			
			Max	Time	Min	Time
Lumbar Force	X	Newtons	54.4	89.0	-68.4	46.8
Lumbar Force	Y	Newtons	6.3	86.4	-19.1	121.6
Lumbar Force	Z	Newtons	215.2	46.0	-0.4	49.6
Lumbar Moment	X	Nm	1.0	48.9	-0.9	174.1
Lumbar Moment	Y	Nm	3.7	114.6	-2.9	100.3
Lumbar Moment	Z	Nm	0.2	249.7	-0.9	56.8

CHEST PEAK DISPLACEMENTS

Location	Axis	Units	P3 (South) Rear Passenger			
			Max	Time	Min	Time
Chest CG	X	mm			----	----

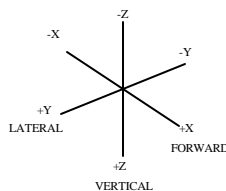

SECTION 5

CHILD RESTRAINT INFORMATION

Test No.: 22467N

Test Date: April 29, 2002

P4 Seating Position

Child Restraint Type (forward-facing, rearward facing, booster)	Forward facing, Upright, Convertible
LATCH or NON-LATCH	Non-latch with tether
Child Restraint Manufacturer	Century
Child Restraint Model	1000 STE
Model Number	44161
Date of Manufacture	1/31/2002
Child Restraint Height Limits (mm)	Up to 1016
Child Restraint Weight Limits (kg)	Rearward-facing Birth – 10 Forward-facing 9 - 18
Weight of Child Restraint (kg)	4.98
Tether Location	Upper

SECTION 6

POST-TEST OBSERVATIONS

Test No.: 22467N

Test Date: April 29, 2002

P4 Seating Position

Child Seat	Century 1000 STE
Belt Fraying	None
Stress Marks	None
Cracks	None
Buckle Stress	None
Latch Hooks	None
Max. Head Excursion (mm)	589.3
Max. Knee Excursion (mm)	~538.5
Velocity	29.9 mph, 48.2 kph
Acceleration (G's)	24.3

SECTION 7

CRABI 12 MONTH OLD ATD INJURY CRITERIA AND SENSOR DATA

Test No.: 22467N

Test Date: April 29, 2002

P4 Seating Position

HEAD PRIMARY PEAK ACCELERATIONS

Location	Axis	Units	P4 (North) Rear Passenger			
			Max	Time	Min	Time
Head CG	X	G's	24.3	227.7	-36.7	104.8
Head CG	Y	G's	2.6	148.6	-4.0	127.2
Head CG	Z	G's	61.2	70.6	0.0	2.8
Head CG Resultant	N/A	G's	61.9	70.5		

CHEST PRIMARY PEAK ACCELERATIONS

Location	Axis	Units	P4 (North) Rear Passenger			
			Max	Time	Min	Time
Chest CG	X	G's	9.5	241.5	-41.7	48.6
Chest CG	Y	G's	5.1	51.5	-4.1	63.1
Chest CG	Z	G's	29.2	74.3	-28.7	53.1
Chest CG Resultant	N/A	G's	49.6	52.0		

SEAT BELT SENSOR PEAK VALUES

Location	Axis	Units	P4 (North) Rear Passenger			
			Max	Time	Min	Time
Tether Belt	N/A	Newtons	3358.2	37.1		

HEAD INJURY CRITERIA (HIC)

Location	P4 (North) Rear Passenger			
	HIC	Avg. G's	T ¹	T ²
Head CG Primary (36 msec)	449	48.1	55.5	83.5
Head CG Primary (15 msec)	350	55.8	61.9	76.9

CHEST CLIP (3 MSEC)

Location	P4 (North) Rear Passenger		
	Clip	T ¹	T ²
Chest CG Primary	48.9	50.3	53.3

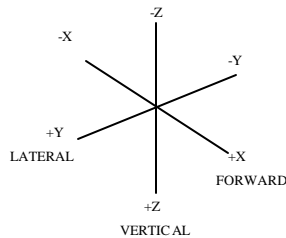

CRABI 12 MONTH OLD ATD INJURY CRITERIA AND SENSOR DATA...(continued)

Test No.: 22467N

Test Date: April 29, 2002

P4 Seating Position

PELVIC PEAK ACCELERATIONS

Location	Axis	Units	P4 (North) Rear Passenger			
			Max	Time	Min	Time
Pelvis	X	G's	25.1	98.4	-53.8	53.9
Pelvis	Y	G's	7.3	43.1	-6.1	68.4
Pelvis	Z	G's	18.0	98.7	-33.3	50.6

UPPER NECK PEAK FORCES AND MOMENTS

Location	Axis	Units	P4 (North) Rear Passenger			
			Max	Time	Min	Time
Neck Force	X	Newtons	2.0	222.2	-673.4	102.8
Neck Force	Y	Newtons	151.7	104.6	-39.7	71.3
Neck Force	Z	Newtons	1692.0	70.8	-94.8	249.9
Neck Moment	X	Nm	4.4	71.0	-2.0	97.8
Neck Moment	Y	Nm	9.1	105.6	-11.8	50.2
Neck Moment	Z	Nm	1.7	131.6	-3.6	109.0

LOWER NECK PEAK FORCES AND MOMENTS

Location	Axis	Units	P4 (North) Rear Passenger			
			Max	Time	Min	Time
Neck Force	X	Newtons	63.8	224.2	-890.8	65.9
Neck Force	Y	Newtons	17.2	61.2	-117.3	102.3
Neck Force	Z	Newtons	1290.0	70.6	-806.3	103.2
Neck Moment	X	Nm	6.3	104.7	-2.7	126.4
Neck Moment	Y	Nm	56.5	107.3	-5.5	222.3
Neck Moment	Z	Nm	3.3	63.0	-1.2	91.9

LUMBAR PEAK FORCES AND MOMENTS

Location	Axis	Units	P4 (North) Rear Passenger			
			Max	Time	Min	Time
Lumbar Force	X	Newtons	602.3	101.0	-31.8	168.0
Lumbar Force	Y	Newtons	62.4	50.7	-45.0	104.3
Lumbar Force	Z	Newtons	131.9	211.1	-1434.4	53.5
Lumbar Moment	X	Nm	3.0	54.3	-3.0	109.0
Lumbar Moment	Y	Nm	24.1	99.1	-15.0	52.0
Lumbar Moment	Z	Nm	0.9	233.1	-3.6	108.4

CHEST PEAK DISPLACEMENTS

Location	Axis	Units	P4 (North) Rear Passenger			
			Max	Time	Min	Time
Chest CG	X	mm			----	----

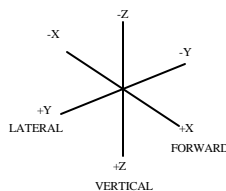

SECTION 8
SLED TEST SET-UP

Test No.: 22467

Test Date: April 29, 2002

An FMVSS 213 test bench was fixtured on the sled in order to simulate a frontal impact. Two child seats were placed on the bench and fastened in a manner suggested in the owner's manual of the child seat. Stadia poles were set up to measure dummy head and knee excursions.

Pre-test Infant and Car Seat Positions

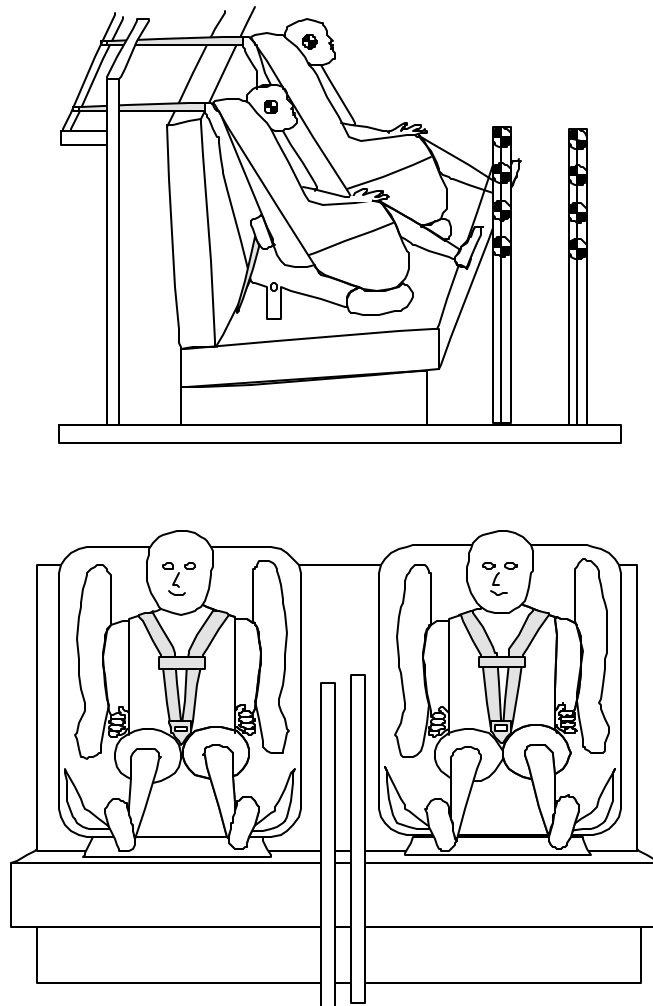

SECTION 9
CAMERA LOCATION

Test No.: 22467

Test Date: April 29, 2002

There were two cameras mounted onto the sled carriage for views of the left and right side of each child seat. All measurements are in millimeters.

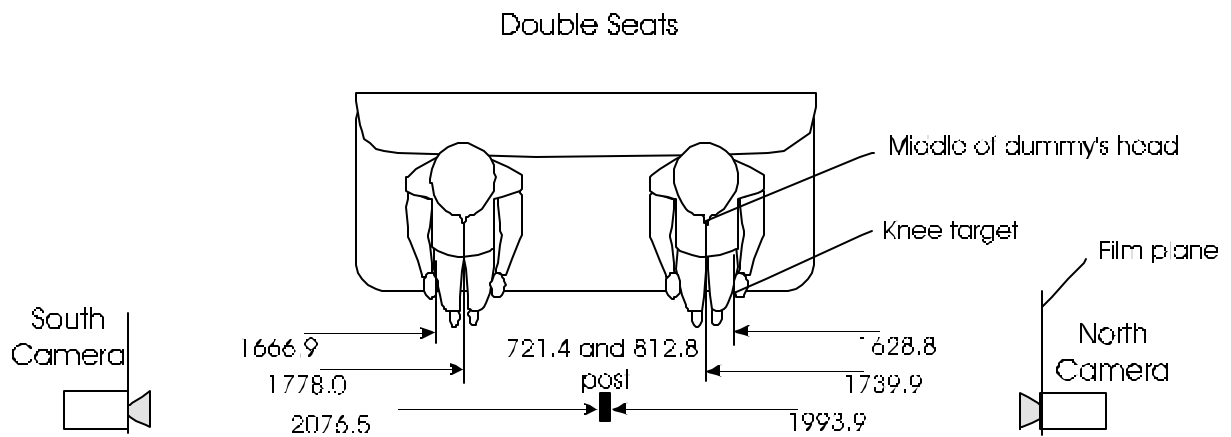

SECTION 10
PHOTOGRAPHS

TABLE OF PHOTOGRAPHS

<u>Photographs</u>	<u>Page No.</u>
Photo 1 – Pre-Test Front View	13
Photo 2 – Post-Test Front View	14
Photo 3 – Pre-Test Rear View	15
Photo 4 – Post-Test Rear View	16
Photo 5 – Pre-Test Left Side View	17
Photo 6 – Post-Test Left Side View	18
Photo 7 – Pre-Test Right Side View	19
Photo 8 – Post-Test Right Side View	20
Photo 9 – Pre-Test Fixture	21
Photo 10 – Post-Test Fixture	22
Photo 11 – Post-Test Front View of P3 Child Seat	23
Photo 12 – Post-Test Rear View of P3 Child Seat	24
Photo 13 – Post-Test Left View of P3 Child Seat	25
Photo 14 – Post-Test Right View of P3 Child Seat	26
Photo 15 – Post-Test Front View of P4 Child Seat	27
Photo 16 – Post-Test Rear View of P4 Child Seat	28
Photo 17 – Post-Test Left View of P4 Child Seat	29
Photo 18 – Post-Test Right View of P4 Child Seat	30



Run #22467 Photo 1 - Pre-Test Front View



Run #22467 Photo 2 - Post-Test Front View

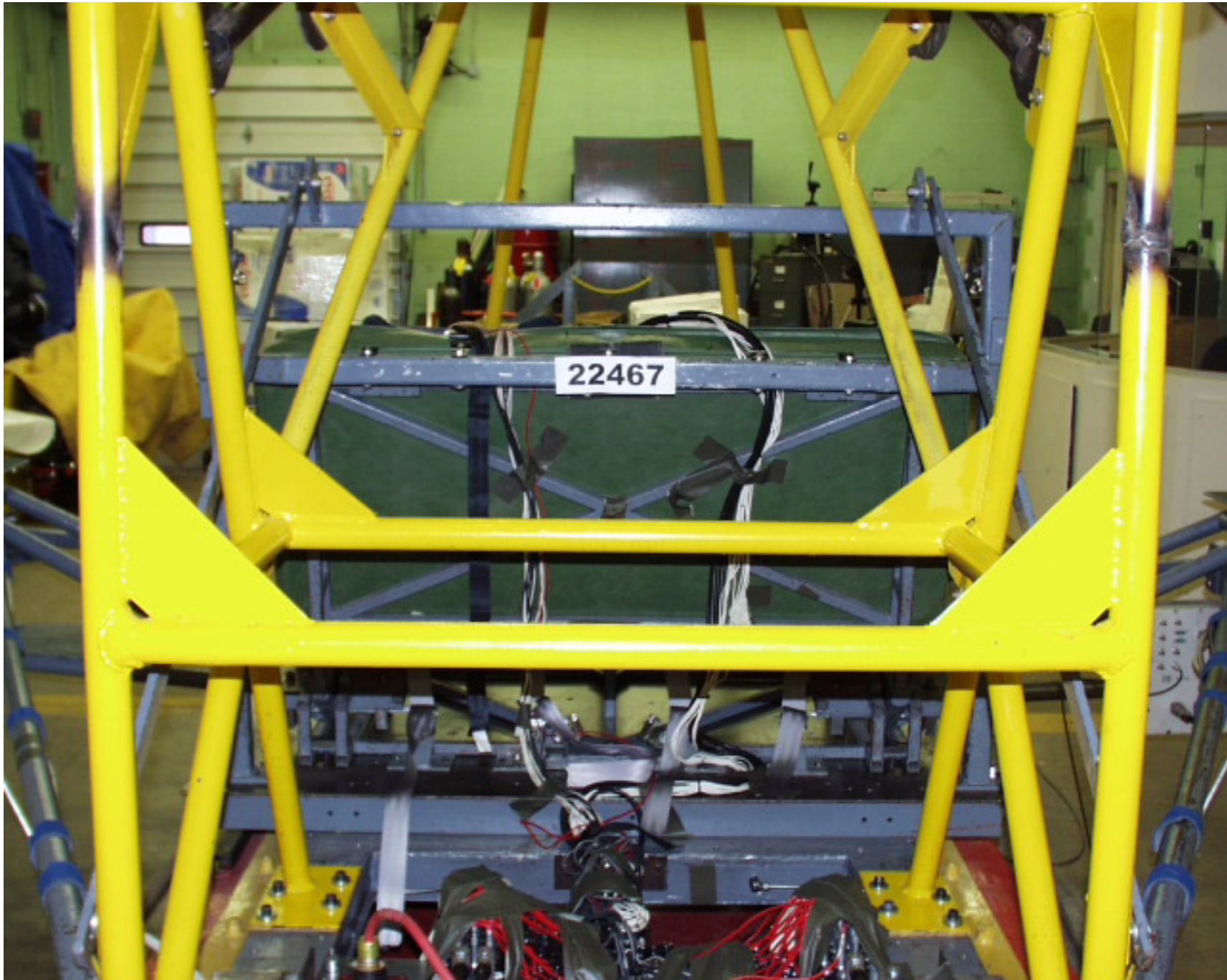

Run #22467 Photo 3 - Pre-Test Rear View



Run #22467 Photo 4 - Post-Test Rear View



Run #22467 Photo 5 - Pre-Test Left Side View



Run #22467 Photo 6 - Post-Test Left Side View



Run #22467 Photo 7 - Pre-Test Right Side View



Run #22467 Photo 8 - Post-Test Right Side View



Run #22467 Photo 9 - Pre-Test Fixture



Run #22467 Photo 10 - Post-Test Fixture



Run #22467 Photo 11 - Post-Test Front View of Child Seat - P3



Run #22467 Photo 12 - Post-Test Rear View of Child Seat - P3



Run #22467 Photo 13 - Post-Test Left View of Child Seat - P3



Run #22467 Photo 14 - Post-Test Right View of Child Seat - P3



Run #22467 Photo 15 - Post-Test Front View of Child Seat - P4



Run #22467 Photo 16 - Post-Test Rear View of Child Seat - P4



Run #22467 Photo 17 - Post-Test Left View of Child Seat - P4



Run #22467 Photo 18 - Post-Test Right View of Child Seat - P4

SECTION 11
DATA PLOTS

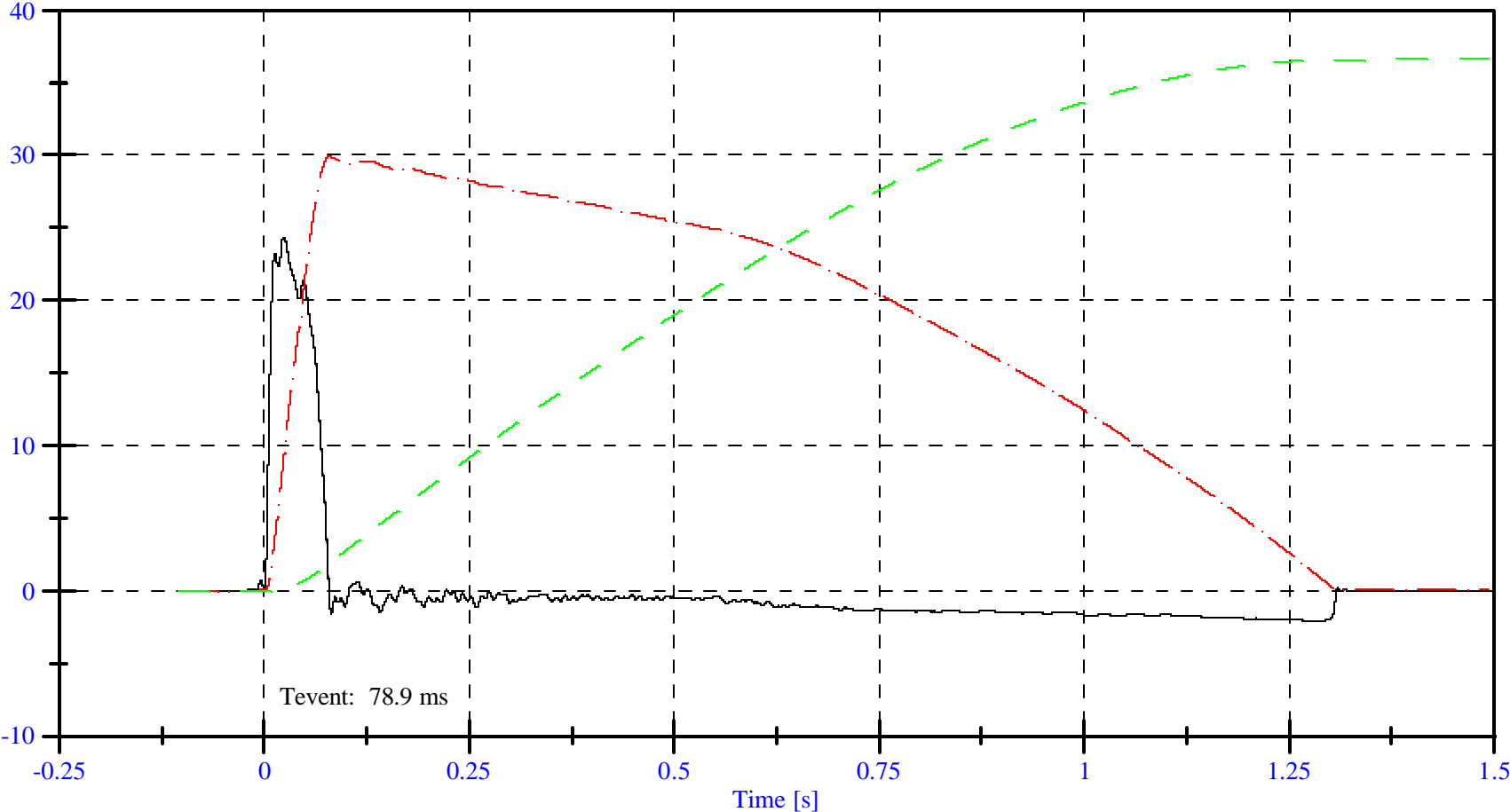

		Maximum	Time (ms)	Minimum	Time (ms)	Filter Class
Sled Ax	(g)	24.3	24.2	-2.1	1286.0	CFC_60
Sled Vx	(mph)	29.9	78.9	-0.0	-25.2	CFC_180
Sled Dx	(ft)	36.6	1494.7	-0.0	-10.8	CFC_180

LEGEND	
—	Sled Ax
- . -	Sled Vx
- - -	Sled Dx

Sled Test Run 22467

Sled Pulse Corridor

Max: 24.3 [g] at 0.0244 [s]

Min: -1.7 [g] at 0.0817 [s]

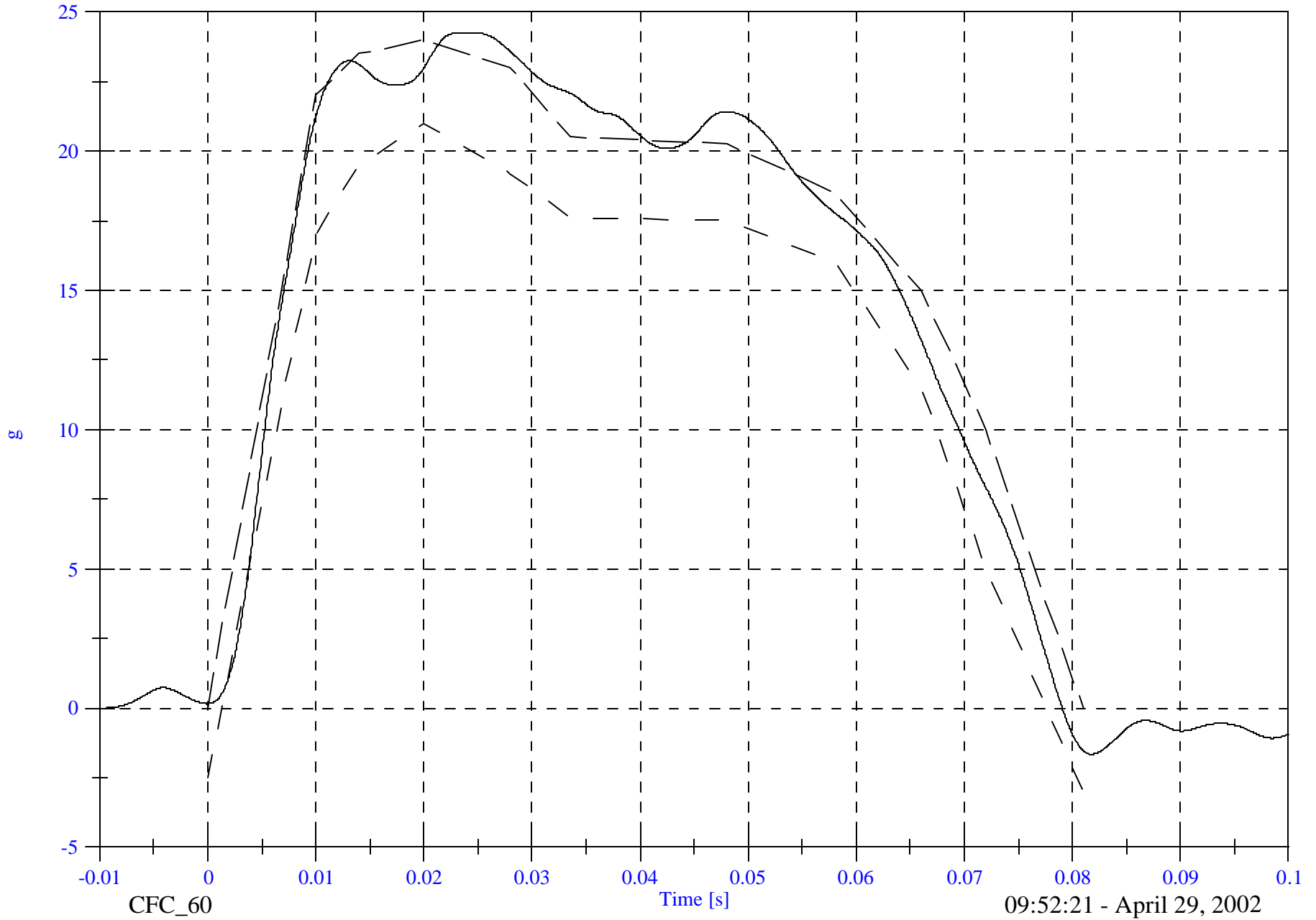

FACILITY: HYGE SLED

DATE: April 29, 2002

TEST#: 22467

TITLE: Sled Test Run 22467

CHN NAME	Unit	Max	msec	Min	msec	Filt	Comment
62 Sled Acceleration	g	24.3	24.4	-1.7	81.7	CFC_60	
63 Sled Acceleration Velocity	kph	48.1	79.1	-0.0	-19.6	CFC_180	
64 Sled Acceleration Displacement	mm	2781.5	250.1	-0.1	-4.9	CFC_180	
65 P3 Head x	g	36.6	93.8	-1.1	181.2	CFC_1000	
66 P3 Head y	g	7.5	98.2	-1.7	150.2	CFC_1000	
67 P3 Head z	g	31.4	57.8	-15.8	102.1	CFC_1000	
68 P3 Head Resultant	g	38.9	93.8	0.0	-28.9	CFC_1000	
69 P3 Upper Neck Fx	N	197.1	98.6	-249.8	60.0	CFC_1000	
70 P3 Upper Neck Fy	N	108.7	100.8	-34.3	147.8	CFC_1000	
71 P3 Upper Neck Fz	N	756.2	56.4	-183.5	105.0	CFC_1000	
72 P3 Upper Neck F Resultant	N	789.3	56.8	0.0	-47.7	CFC_1000	
73 P3 Upper Neck Mx	N-m	0.8	126.0	-3.3	97.2	CFC_600	
74 P3 Upper Neck My	N-m	12.5	101.4	-8.4	60.5	CFC_600	
75 P3 Upper Neck Mz	N-m	1.7	103.3	-0.6	169.6	CFC_600	
76 P3 Upper Neck M Resultant	N-m	13.0	101.4	0.0	-17.2	CFC_600	
77 P3 Lower Neck Fx	N	225.1	97.3	-25.8	179.8	CFC_1000	
78 P3 Lower Neck Fy	N	87.6	94.9	-28.7	148.2	CFC_1000	
79 P3 Lower Neck Fz	N	867.6	57.0	-208.1	105.8	CFC_1000	
80 P3 Lower Neck F Resultant	N	869.3	57.0	0.0	-31.1	CFC_1000	
81 P3 Lower Neck Mx	N-m	5.6	98.9	-2.7	148.8	CFC_600	
82 P3 Lower Neck My	N-m	1.9	195.0	-9.6	95.6	CFC_600	
83 P3 Lower Neck Mz	N-m	0.6	78.9	-0.3	170.6	CFC_600	
84 P3 Lower Neck M Resultant	N-m	10.9	95.9	0.0	-17.0	CFC_600	
85 P3 Chest x	g	29.2	64.5	-0.9	151.3	CFC_180	
86 P3 Chest y	g	5.4	75.2	-2.1	118.5	CFC_180	
87 P3 Chest z	g	26.1	59.0	-17.7	94.0	CFC_180	
88 P3 Chest Resultant	g	37.4	63.5	0.0	-39.2	CFC_180	
89 P3 Pelvic x	g	28.2	56.4	-1.0	250.1	CFC_1000	
90 P3 Pelvic y	g	7.3	76.5	-2.0	122.0	CFC_1000	
91 P3 Pelvic z	g	34.5	58.3	-15.1	94.6	CFC_1000	
92 P3 Pelvic Resultant	g	44.5	57.5	0.0	-18.1	CFC_1000	
93 P3 Head Red z	g	30.4	57.8	-18.7	92.7	CFC_1000	
94 P3 Upper Neck Mocy	N-m	11.4	101.5	-7.0	60.6	CFC_600	
97 P4 Head x	g	24.3	227.7	-36.7	104.8	CFC_1000	

FACILITY: HYGE SLED

DATE: April 29, 2002

TEST#: 22467

TITLE: Sled Test Run 22467

98	P4	Head y	g	2.6	148.6	-4.0	127.2	CFC_1000
99	P4	Head z	g	61.2	70.6	-0.0	-2.8	CFC_1000
100	P4	Head Resultant	g	61.9	70.5	0.0	-36.6	CFC_1000
101	P4	Upper Neck Fx	N	2.0	222.3	-673.4	102.8	CFC_1000
102	P4	Upper Neck Fy	N	151.7	104.6	-39.7	71.3	CFC_1000
103	P4	Upper Neck Fz	N	1692.0	70.8	-97.5	250.1	CFC_1000
104	P4	Upper Neck F Resultant	N	1704.1	70.8	0.0	-16.7	CFC_1000
105	P4	Upper Neck Mx	N-m	4.4	71.0	-2.0	97.9	CFC_600
106	P4	Upper Neck My	N-m	9.1	105.6	-11.8	50.2	CFC_600
107	P4	Upper Neck Mz	N-m	1.7	131.6	-3.6	109.0	CFC_600
108	P4	Upper Neck M Resultant	N-m	11.9	50.2	0.0	-38.2	CFC_600
109	P4	Lower Neck Fx	N	63.8	224.2	-890.8	65.9	CFC_1000
110	P4	Lower Neck Fy	N	17.2	61.2	-117.3	102.3	CFC_1000
111	P4	Lower Neck Fz	N	1289.9	70.6	-806.3	103.2	CFC_1000
112	P4	Lower Neck F Resultant	N	1567.4	70.6	0.0	-24.4	CFC_1000
113	P4	Lower Neck Mx	N-m	6.3	104.7	-2.7	126.4	CFC_600
114	P4	Lower Neck My	N-m	56.5	107.3	-5.5	222.3	CFC_600
115	P4	Lower Neck Mz	N-m	3.3	63.0	-1.2	91.9	CFC_600
116	P4	Lower Neck M Resultant	N-m	56.9	104.7	0.0	-36.7	CFC_600
117	P4	Chest x	g	9.5	241.5	-41.7	48.7	CFC_180
118	P4	Chest y	g	5.1	51.5	-4.1	63.1	CFC_180
119	P4	Chest z	g	29.2	74.3	-28.7	53.1	CFC_180
120	P4	Chest Resultant	g	49.6	52.0	0.0	-37.7	CFC_180
121	P4	Pelvic x	g	25.1	98.4	-53.8	53.9	CFC_1000
122	P4	Pelvic y	g	7.3	43.1	-6.1	68.4	CFC_1000
123	P4	Pelvic z	g	18.0	98.7	-33.3	50.6	CFC_1000
124	P4	Pelvic Resultant	g	63.0	53.8	0.0	-41.3	CFC_1000
125	P3	Lumbar Fx	N	54.4	89.1	-68.4	46.8	CFC_1000
126	P3	Lumbar Fy	N	6.3	86.4	-19.1	121.6	CFC_1000
127	P3	Lumbar Fz	N	215.2	46.0	-0.4	-49.6	CFC_1000
128	P3	Lumbar F Resultant	N	225.8	46.0	0.0	-36.1	CFC_1000
129	P3	Lumbar Mx	N-m	1.0	48.9	-0.9	174.1	CFC_1000
130	P3	Lumbar My	N-m	3.7	114.6	-2.9	100.3	CFC_1000
131	P3	Lumbar Mz	N-m	0.2	250.1	-0.9	56.8	CFC_1000
132	P3	Lumbar M Resultant	N-m	3.8	114.6	0.0	-40.8	CFC_1000

FACILITY: HYGE SLED

DATE: April 29, 2002

TEST#: 22467

TITLE: Sled Test Run 22467

133	P4	Lumbar Fx	N	602.3	101.0	-31.8	168.0	CFC_1000
134	P4	Lumbar Fy	N	62.4	50.7	-45.0	104.3	CFC_1000
135	P4	Lumbar Fz	N	131.9	211.1	-1434.4	53.6	CFC_1000
136	P4	Lumbar F Resultant	N	1437.3	53.6	0.0	-24.5	CFC_1000
137	P4	Lumbar Mx	N-m	3.0	54.3	-3.0	109.0	CFC_1000
138	P4	Lumbar My	N-m	24.1	99.1	-15.0	52.0	CFC_1000
139	P4	Lumbar Mz	N-m	0.9	233.1	-3.6	108.4	CFC_1000
140	P4	Lumbar M Resultant	N-m	24.1	99.1	0.0	-30.8	CFC_1000
141	P4	Head Red z	g	69.6	70.5	-11.9	47.8	CFC_1000
142	P4	Upper Neck Mocy	N-m	12.7	105.3	-9.4	49.7	CFC_600
143	P4	Tether Belt Load	N	3358.2	37.1	-1.3	-49.8	CFC_60
145	P3	Head x	g	36.2	94.1	-1.1	181.2	CFC_60
146	P3	Head x Velocity	kph	56.2	165.7	-0.0	-25.5	CFC_180
147	P3	Head y	g	7.4	98.2	-1.5	57.1	CFC_60
148	P3	Head y Velocity	kph	6.1	126.3	-1.2	73.1	CFC_180
149	P3	Head z	g	31.0	57.6	-15.7	102.3	CFC_60
150	P3	Head z Velocity	kph	41.8	87.5	-0.0	-18.2	CFC_180
151	P3	Head Red z	g	29.6	57.9	-18.0	92.4	CFC_60
152	P3	Head Red z Velocity	kph	42.1	84.2	-0.0	-15.6	CFC_180
153	P3	Chest x	g	29.0	63.8	-0.9	152.0	CFC_60
154	P3	Chest x Velocity	kph	61.6	208.4	-0.0	-16.0	CFC_180
155	P3	Chest y	g	5.0	75.7	-1.8	118.0	CFC_60
156	P3	Chest y Velocity	kph	6.0	103.5	-0.0	-26.2	CFC_180
157	P3	Chest z	g	25.8	58.6	-17.4	93.8	CFC_60
158	P3	Chest z Velocity	kph	34.5	83.6	-0.0	-11.4	CFC_180
159	P3	Pelvic x	g	27.9	57.2	-1.0	250.1	CFC_60
160	P3	Pelvic x Velocity	kph	47.3	156.1	-0.0	-12.8	CFC_180
161	P3	Pelvic y	g	7.2	76.1	-1.6	122.2	CFC_60
162	P3	Pelvic y Velocity	kph	9.6	250.1	-0.0	-38.5	CFC_180
163	P3	Pelvic z	g	34.3	58.0	-14.3	94.0	CFC_60
164	P3	Pelvic z Velocity	kph	45.8	84.9	-0.0	-13.5	CFC_180
165	P4	Head x	g	23.9	227.8	-35.1	104.5	CFC_60
166	P4	Head x Velocity	kph	0.0	-8.6	-64.3	213.0	CFC_180
167	P4	Head y	g	1.7	148.5	-3.5	127.4	CFC_60
168	P4	Head y Velocity	kph	0.0	55.0	-5.4	250.1	CFC_180

FACILITY: HYGE SLED

DATE: April 29, 2002

TEST#: 22467

TITLE: Sled Test Run 22467

169	P4 Head z	g	60.3	70.7	-0.0	-49.8	CFC_60
170	P4 Head z Velocity	kph	95.3	250.1	-0.0	-26.5	CFC_180
171	P4 Head Red z	g	67.6	70.3	-11.4	48.4	CFC_60
172	P4 Head Red z Velocity	kph	91.3	250.1	-0.7	53.8	CFC_180
173	P4 Chest x	g	9.4	241.7	-41.2	49.4	CFC_60
174	P4 Chest x Velocity	kph	0.0	-14.9	-60.1	228.2	CFC_180
175	P4 Chest y	g	4.8	51.1	-3.6	63.0	CFC_60
176	P4 Chest y Velocity	kph	2.1	58.0	-3.5	241.3	CFC_180
177	P4 Chest z	g	29.0	74.3	-28.6	53.0	CFC_60
178	P4 Chest z Velocity	kph	2.5	87.2	-11.1	62.8	CFC_180
179	P4 Pelvic x	g	20.2	97.9	-53.0	53.8	CFC_60
180	P4 Pelvic x Velocity	kph	0.0	-12.0	-54.2	85.3	CFC_180
181	P4 Pelvic y	g	5.5	42.0	-4.6	67.1	CFC_60
182	P4 Pelvic y Velocity	kph	2.4	50.0	-3.2	250.1	CFC_180
183	P4 Pelvic z	g	12.7	99.2	-33.0	51.8	CFC_60
184	P4 Pelvic z Velocity	kph	0.0	-11.7	-29.4	72.2	CFC_180

FACILITY: HYGE SLED
TEST#: 22467
TITLE: Sled Test Run 22467
Version 5.00

DATE: April 29, 2002

=====
P3 HIC(FULL): 320.6
 t1: 37.8 msec
 t2: 110.1 msec
 Duration: 72.2 msec
 Average Acceleration: 28.8 g
 Input channels: P3 Head x (2) CFC_1000
 P3 Head y (3) CFC_1000
 P3 Head z (4) CFC_1000

P3 UP NECK Fx: Max: 197.1 N 98.4 msec
 Min: -249.8 N 59.8 msec
 Input channel: P3 Upper Neck Fx (6) CFC_1000

P3 UP NECK Fz: Max: 756.2 N 56.2 msec
 Min: -183.5 N 104.8 msec
 Input channel: P3 Upper Neck Fz (8) CFC_1000

P3 UP NECK Mocy (1YO Infant OOP)
 Max: 11.4 N-m 101.3 msec
 Min: -7.0 N-m 60.4 msec
 Input channels: P3 Upper Neck Fx (6) CFC_600
 P3 Upper Neck My (10) CFC_600
 Docy: 0.0058

P3 UP NECK Nij (1YO Infant OOP)
 Ntf: 0.21 Nij 94.9 msec CVt: 1460 CVf: 43
 Nte: 0.90 Nij 57.6 msec CVt: 1460 CVe: 17
 Ncf: 0.38 Nij 103.5 msec CVc: 1460 CVf: 43
 Nce: 0.01 Nij 124.3 msec CVc: 1460 CVe: 17
 Input channels: P3 Upper Neck Fz (8) CFC_600
 P3 Upper Neck Mocy [N-m, CFC_600] (182)

FACILITY: HYGE SLED
TEST#: 22467
TITLE: Sled Test Run 22467

DATE: April 29, 2002

P3 CLIP(3 ms): 37.3 g
t1: 61.6 msec
t2: 64.6 msec
Duration: 3.0 msec

P3 CSI: 291.6
Input channels: P3 Chest x (18) CFC_180
P3 Chest y (19) CFC_180
P3 Chest z (20) CFC_180

=====

P3 HIC(36 ms): 186.7
t1: 72.0 msec
t2: 108.0 msec
Duration: 36.0 msec
Average Acceleration: 30.6 g
Input channels: P3 Head x (2) CFC_1000
P3 Head y (3) CFC_1000
P3 Head z (4) CFC_1000

=====

P3 HIC(15 ms): 112.0
t1: 88.6 msec
t2: 103.6 msec
Duration: 15.0 msec
Average Acceleration: 35.4 g
Input channels: P3 Head x (2) CFC_1000
P3 Head y (3) CFC_1000
P3 Head z (4) CFC_1000

=====

FACILITY: HYGE SLED
TEST#: 22467
TITLE: Sled Test Run 22467

DATE: April 29, 2002

P4 HIC(FULL): 495.0

t1: 52.6 msec

t2: 110.7 msec

Duration: 58.1 msec

Average Acceleration: 37.3 g

Input channels: P4 Head x (24) CFC_1000

P4 Head y (25) CFC_1000

P4 Head z (26) CFC_1000

P4 UP NECK Fx: Max: 2.0 N 222.1 msec

Min: -673.4 N 102.6 msec

Input channel: P4 Upper Neck Fx (28) CFC_1000

P4 UP NECK Fz: Max: 1692.0 N 70.6 msec

Min: -97.1 N 249.9 msec

Input channel: P4 Upper Neck Fz (30) CFC_1000

P4 UP NECK Mocy (1YO Infant OOP)

Max: 12.7 N-m 105.1 msec

Min: -9.4 N-m 49.5 msec

Input channels: P4 Upper Neck Fx (28) CFC_600

P4 Upper Neck My (32) CFC_600

Docy: 0.0058

P4 UP NECK Nij (1YO Infant OOP)

Ntf: 1.20 Nij 70.6 msec CVt: 1460 CVf: 43

Nte: 0.92 Nij 64.2 msec CVt: 1460 CVe: 17

Ncf: 0.00 Nij -30.5 msec CVc: 1460 CVf: 43

Nce: 0.50 Nij 241.9 msec CVc: 1460 CVe: 17

Input channels: P4 Upper Neck Fz (30) CFC_600

P4 Upper Neck Mocy [N-m, CFC_600] (188)

FACILITY: HYGE SLED
TEST#: 22467
TITLE: Sled Test Run 22467

DATE: April 29, 2002

P4 CLIP(3 ms): 48.9 g
t1: 50.1 msec
t2: 53.1 msec
Duration: 3.0 msec

P4 CSI: 397.6
Input channels: P4 Chest x (40) CFC_180
P4 Chest y (41) CFC_180
P4 Chest z (42) CFC_180

=====

P4 HIC(36 ms): 448.9
t1: 55.3 msec
t2: 83.3 msec
Duration: 28.0 msec
Average Acceleration: 48.1 g
Input channels: P4 Head x (24) CFC_1000
P4 Head y (25) CFC_1000
P4 Head z (26) CFC_1000

=====

P4 HIC(15 ms): 349.6
t1: 61.7 msec
t2: 76.7 msec
Duration: 15.0 msec
Average Acceleration: 55.8 g
Input channels: P4 Head x (24) CFC_1000
P4 Head y (25) CFC_1000
P4 Head z (26) CFC_1000

=====

Sled Test Run 22467

- April 29, 2002

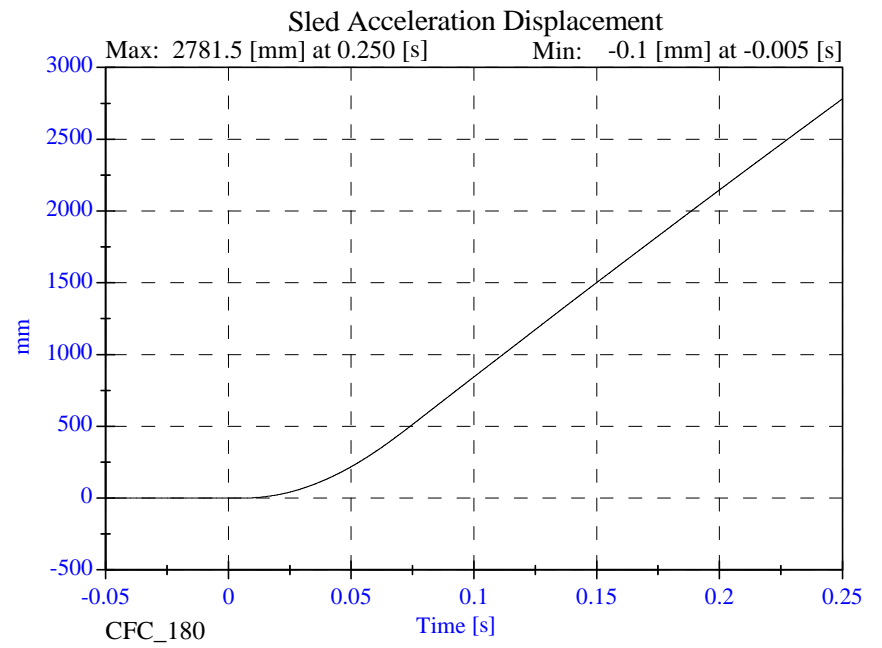
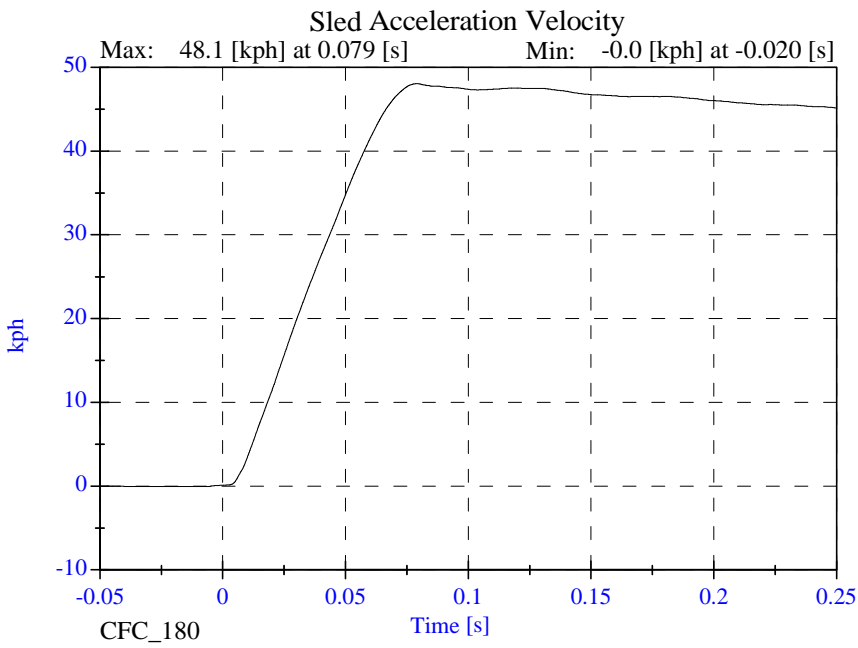
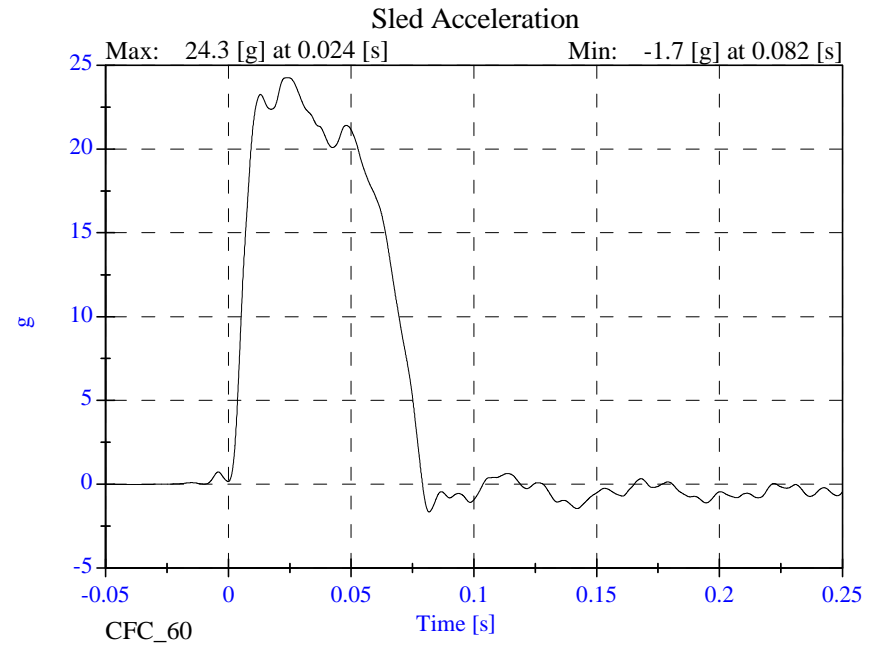
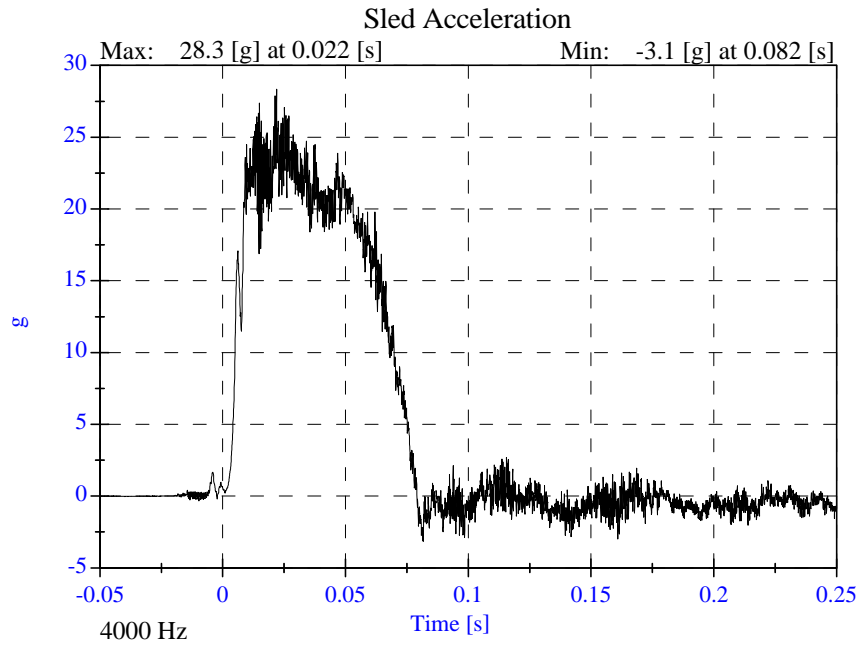

Sled Test Run 22467

- April 29, 2002

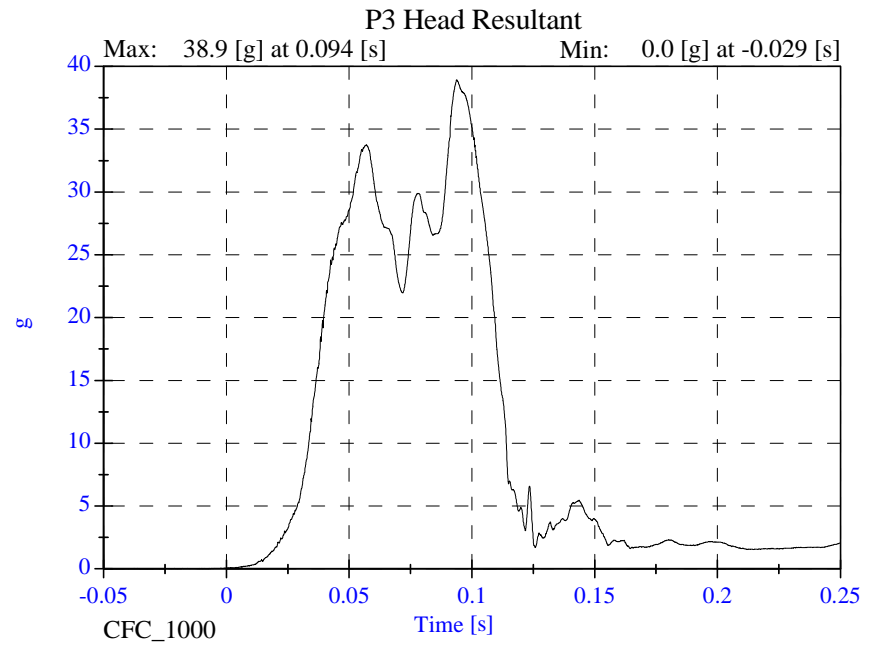
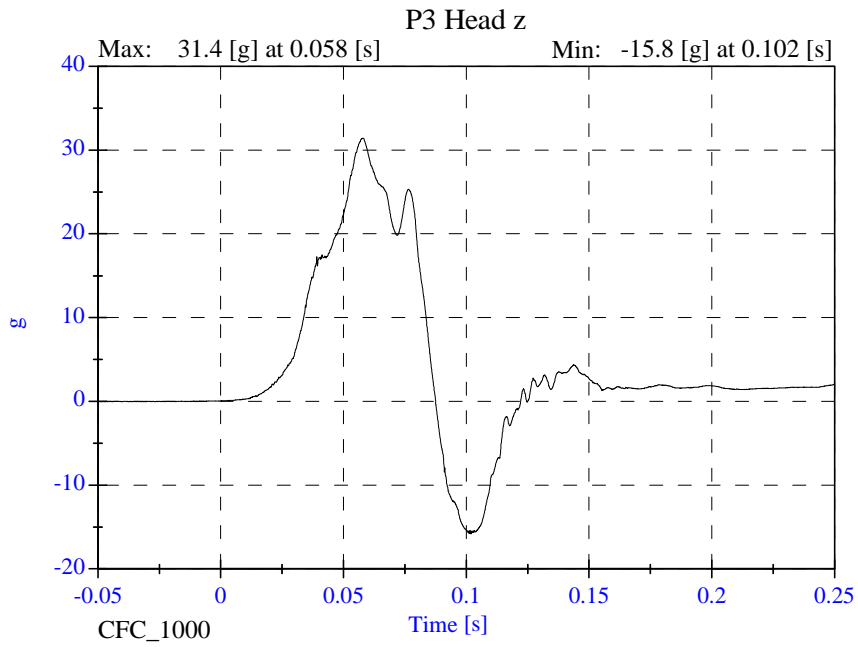
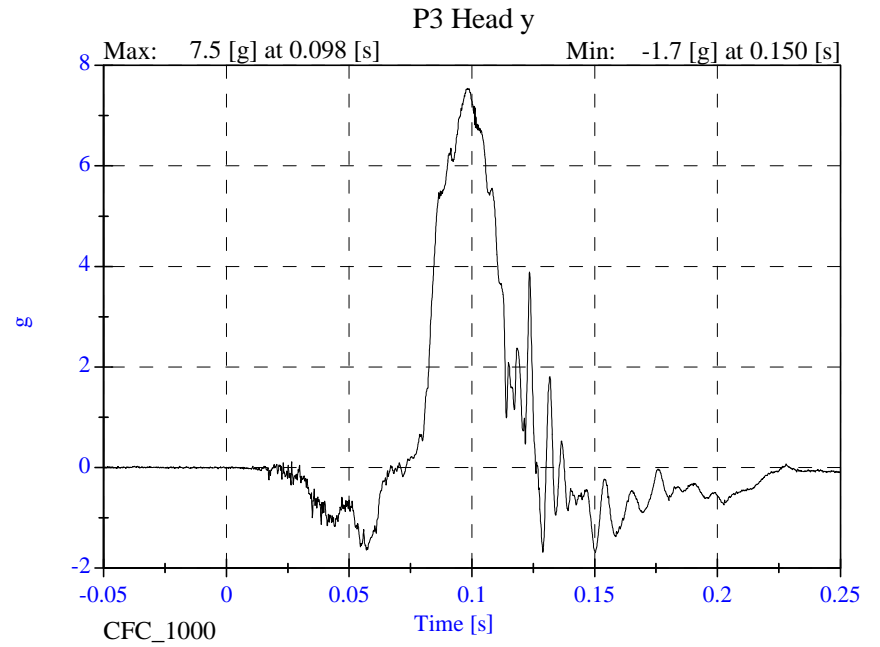
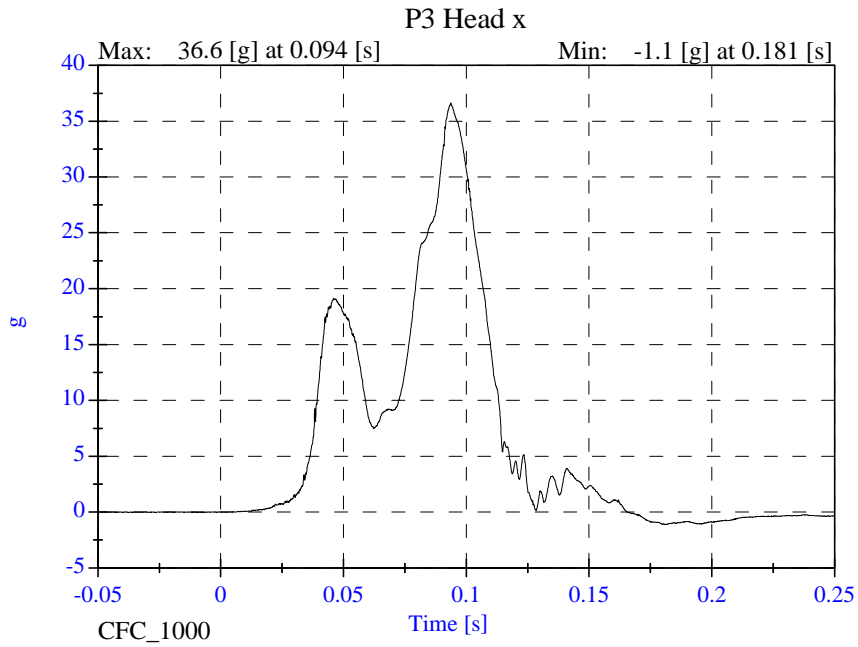

Sled Test Run 22467

- April 29, 2002

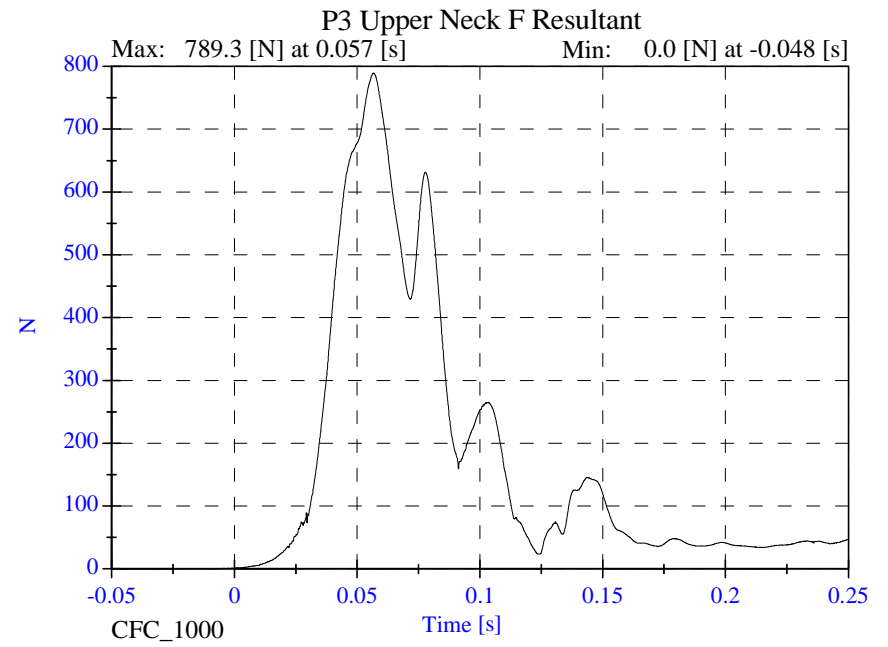
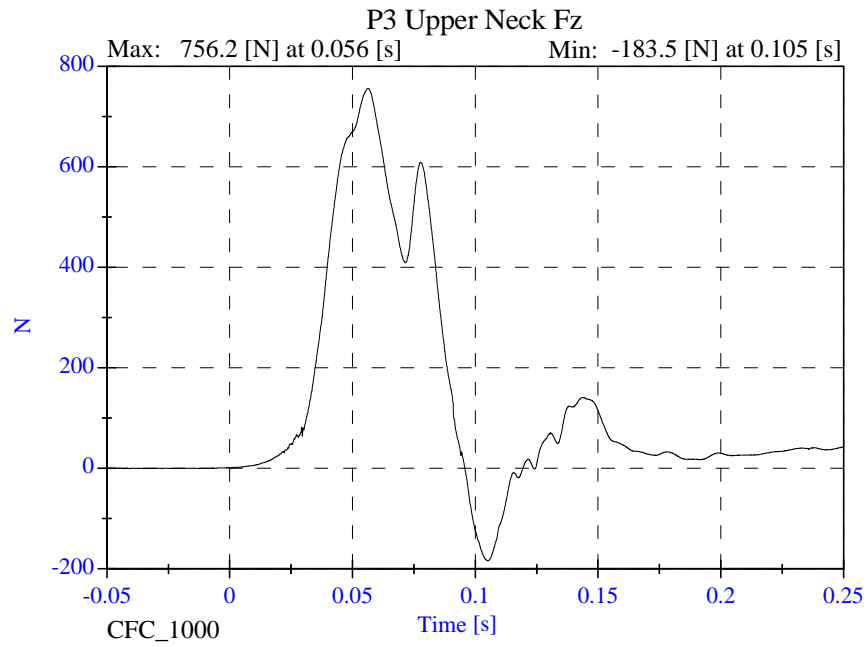
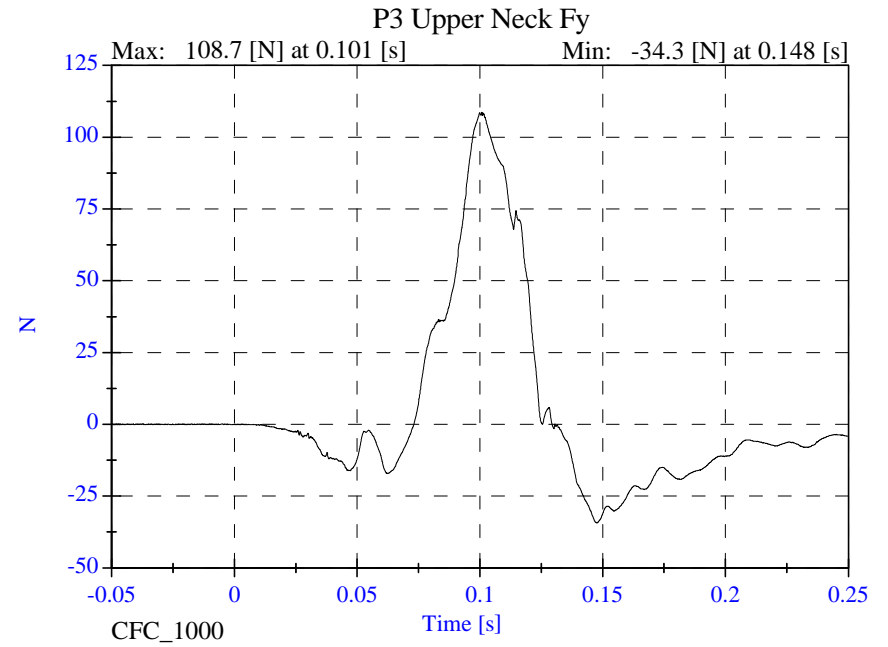
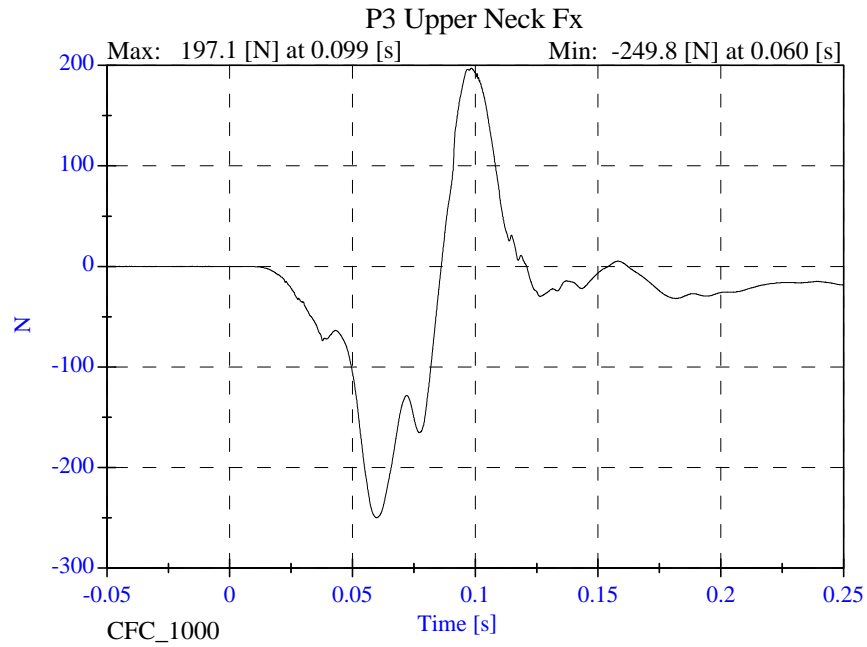

Sled Test Run 22467

- April 29, 2002

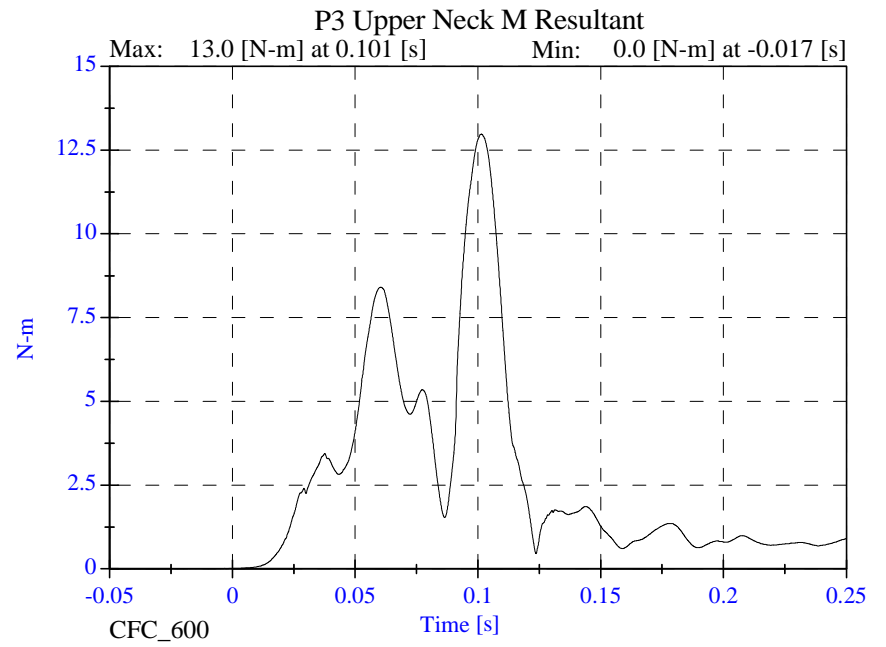
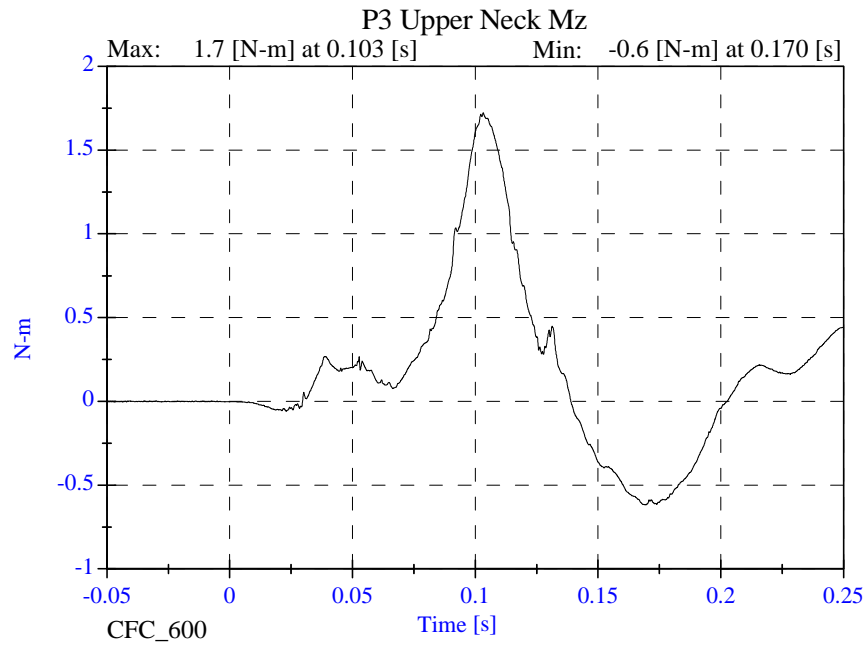
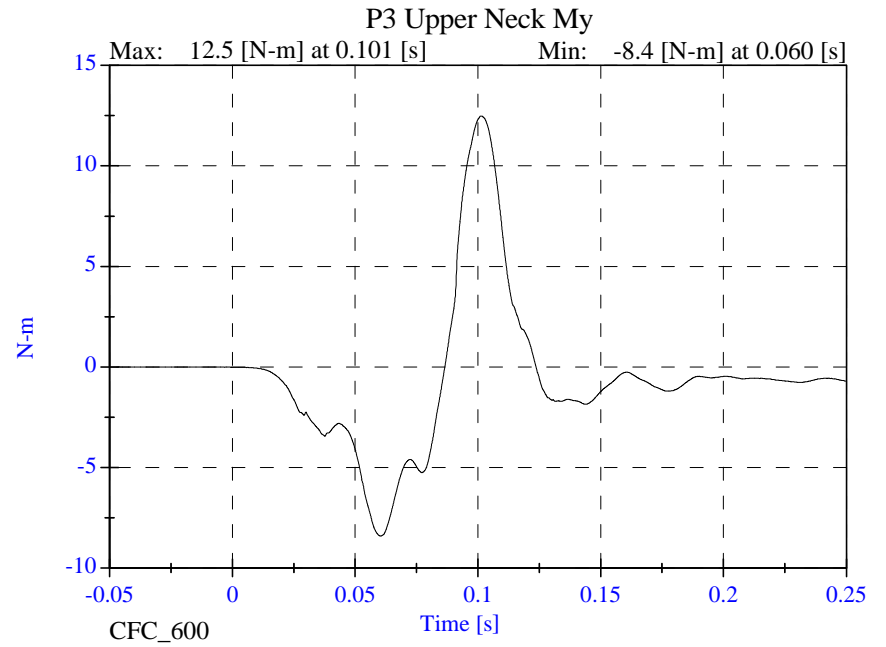
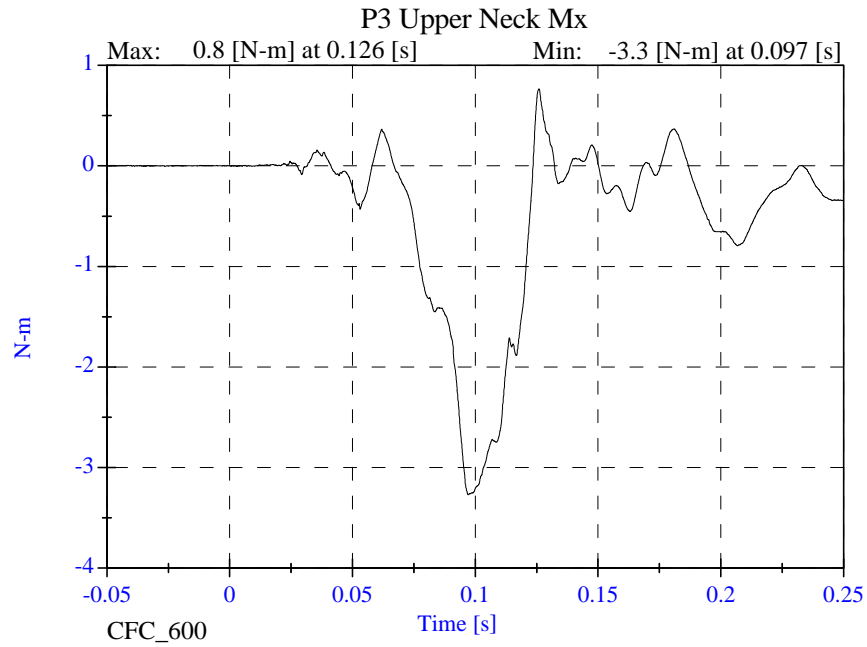

Sled Test Run 22467

- April 29, 2002

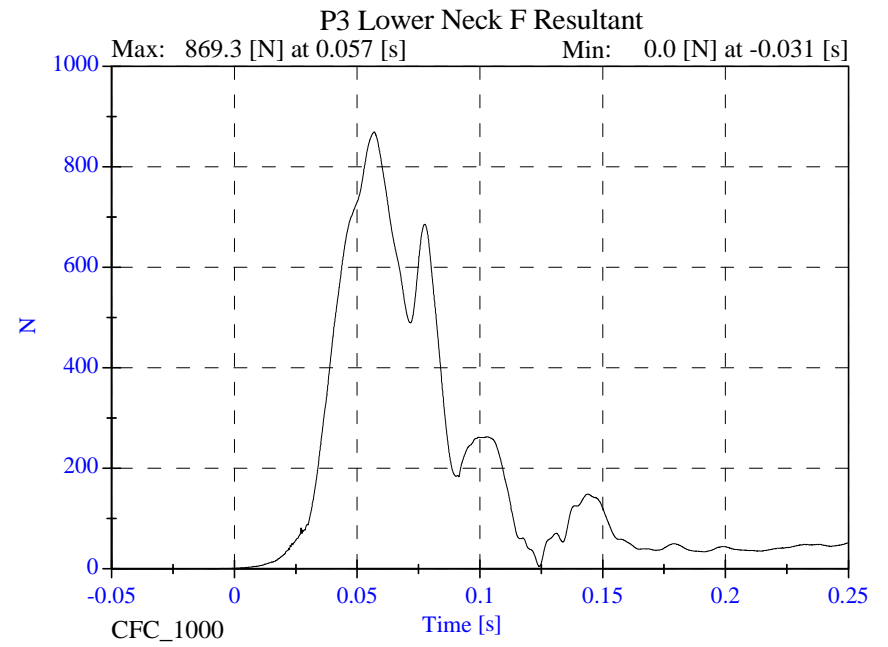
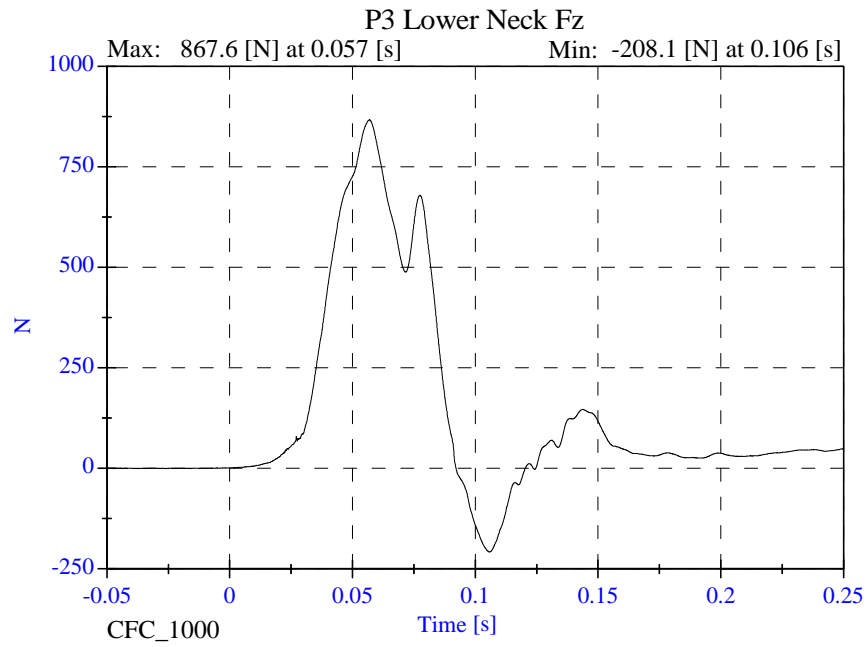
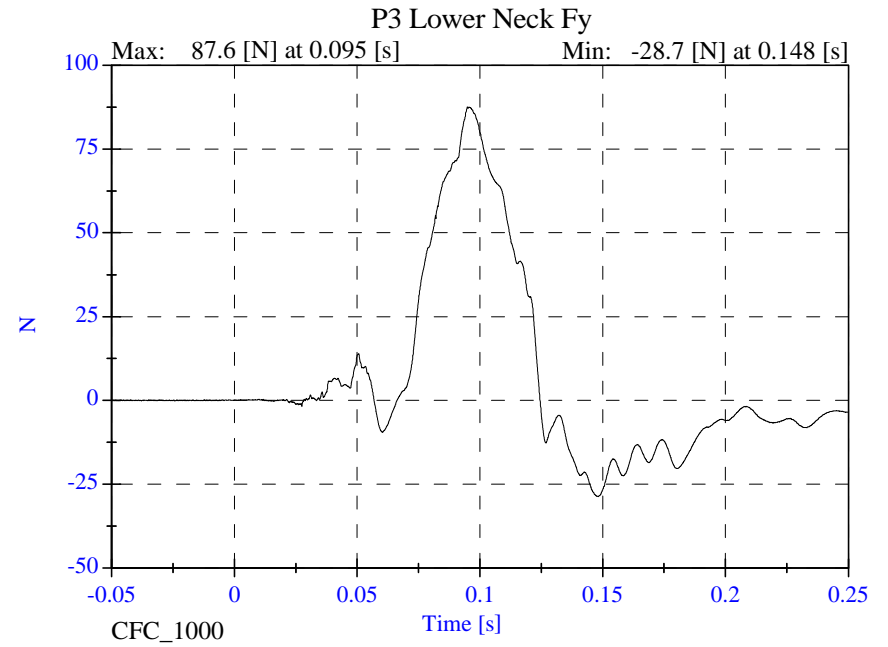
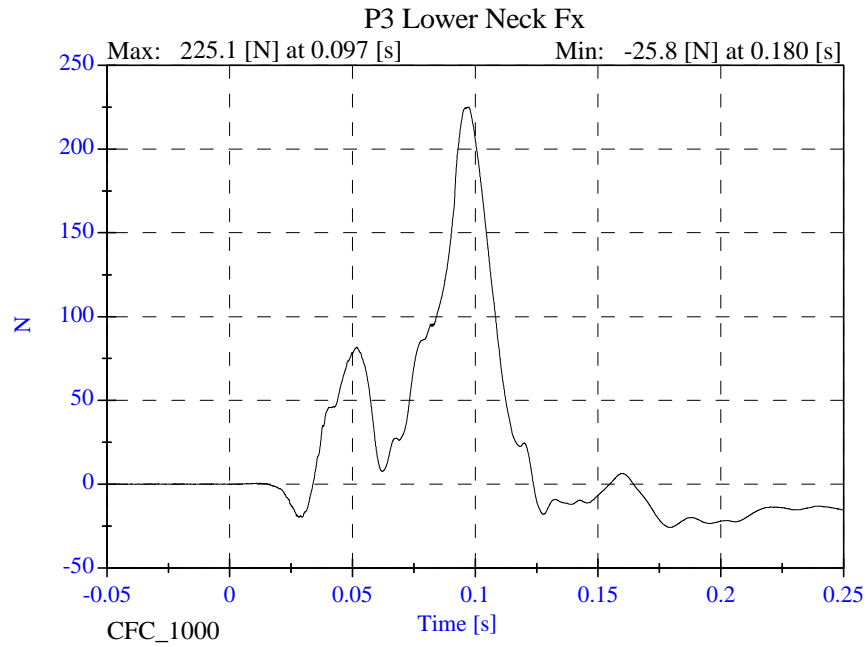

Sled Test Run 22467

- April 29, 2002

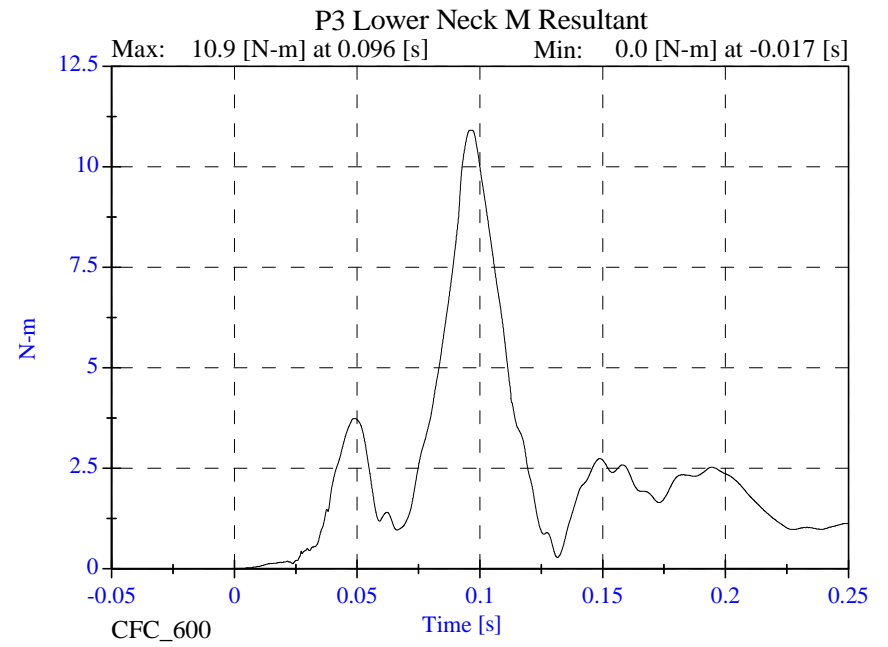
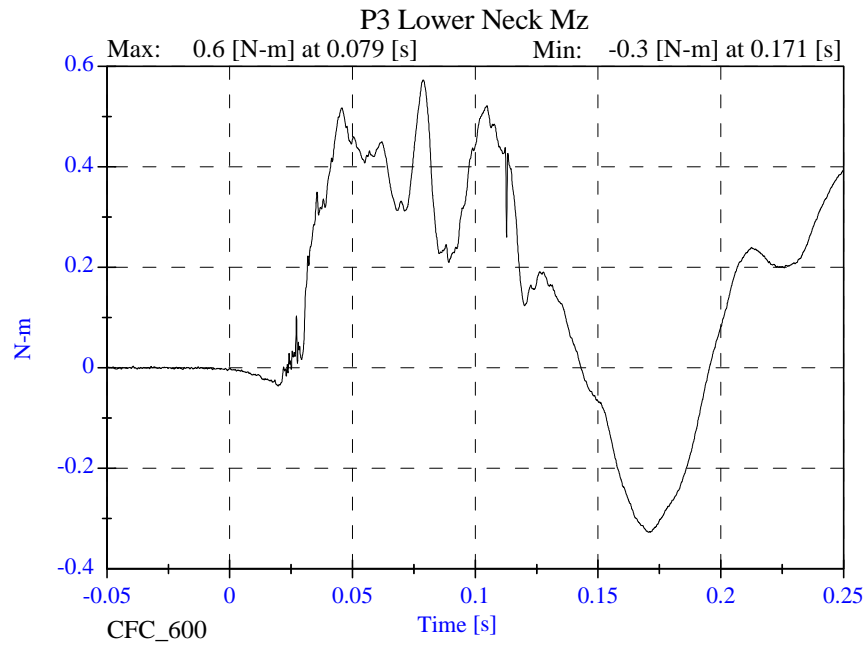
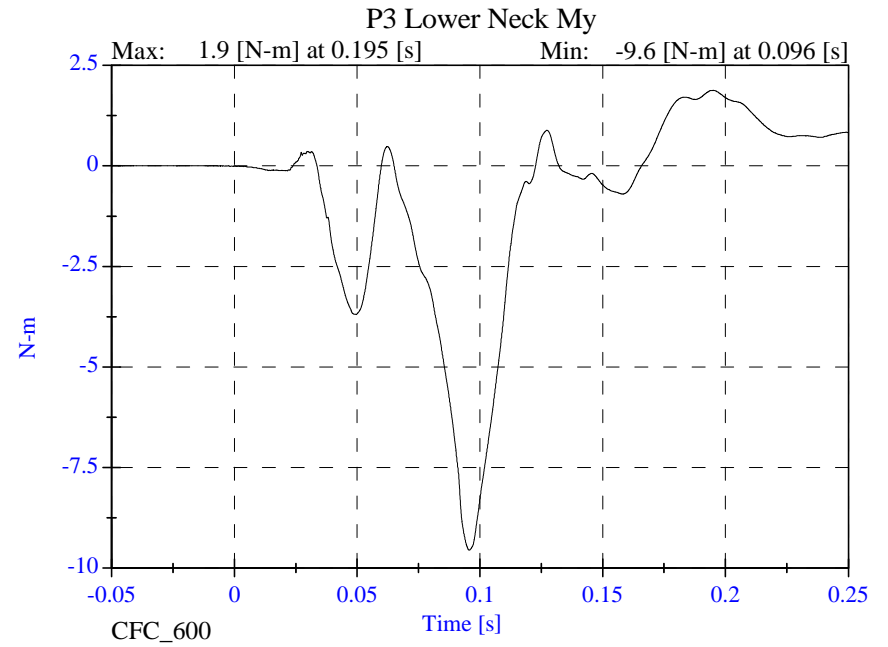
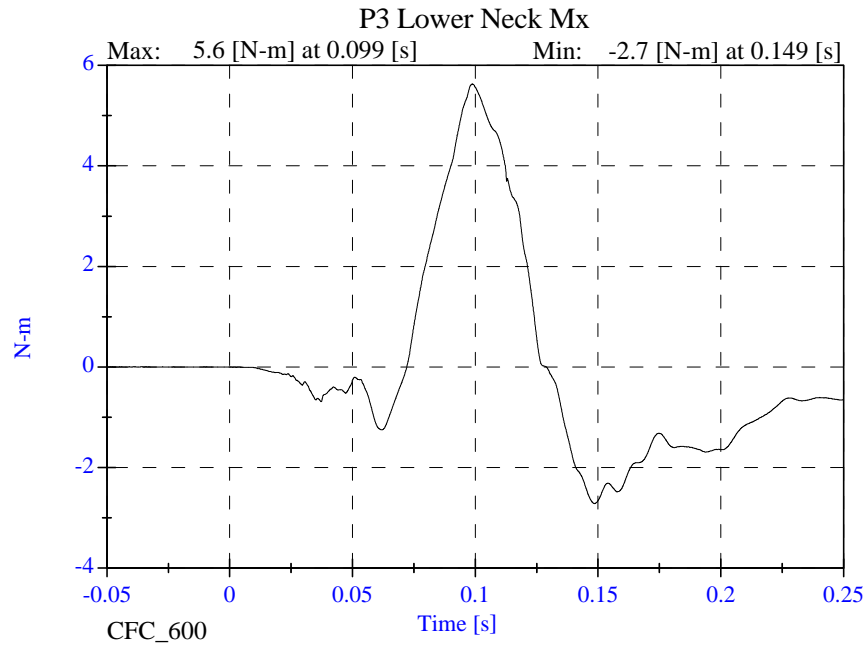

Sled Test Run 22467

- April 29, 2002

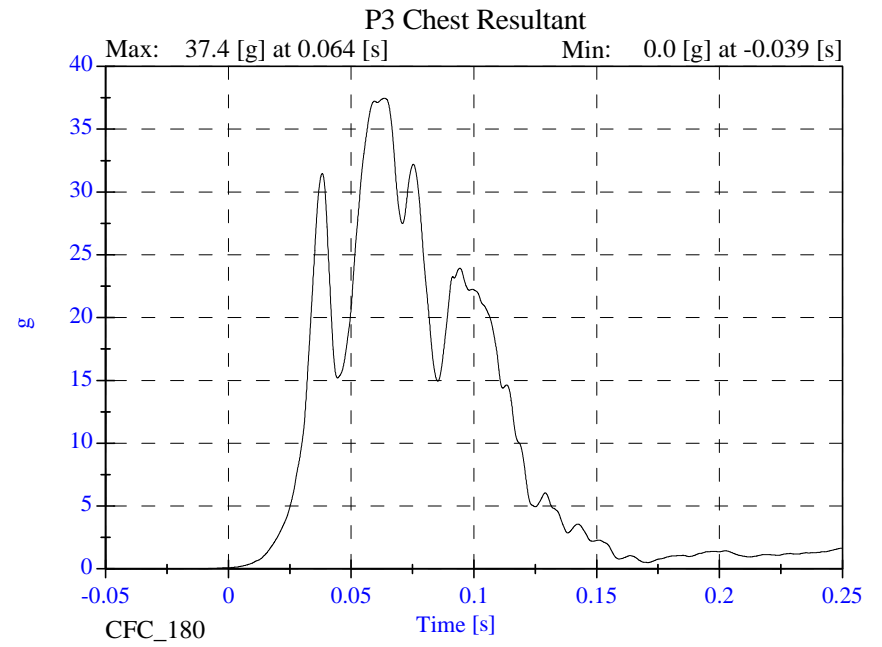
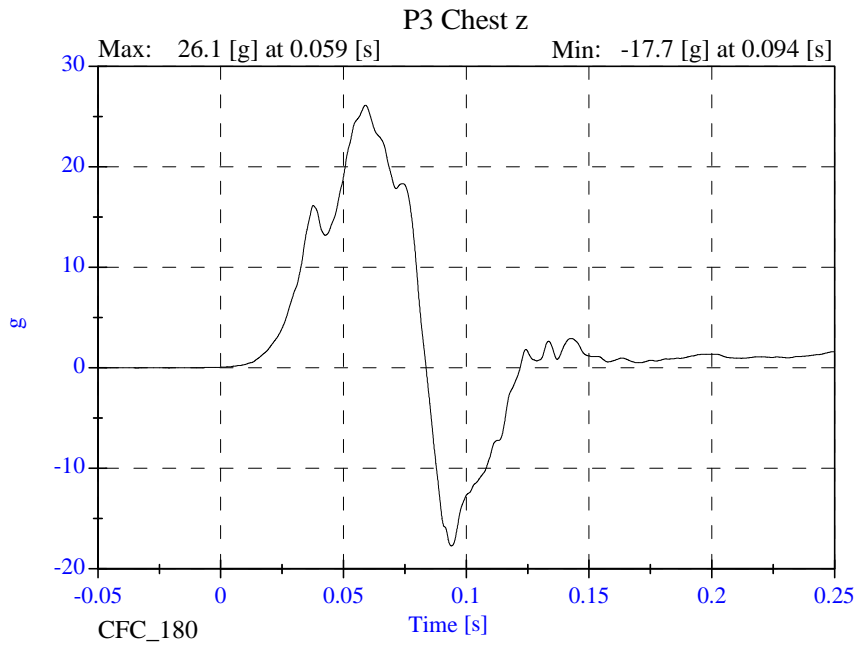
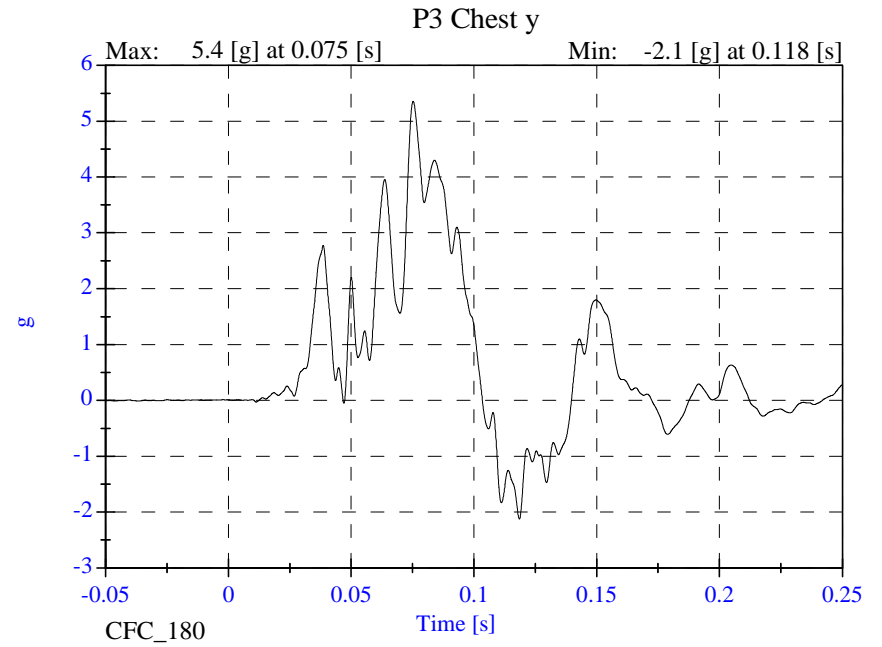
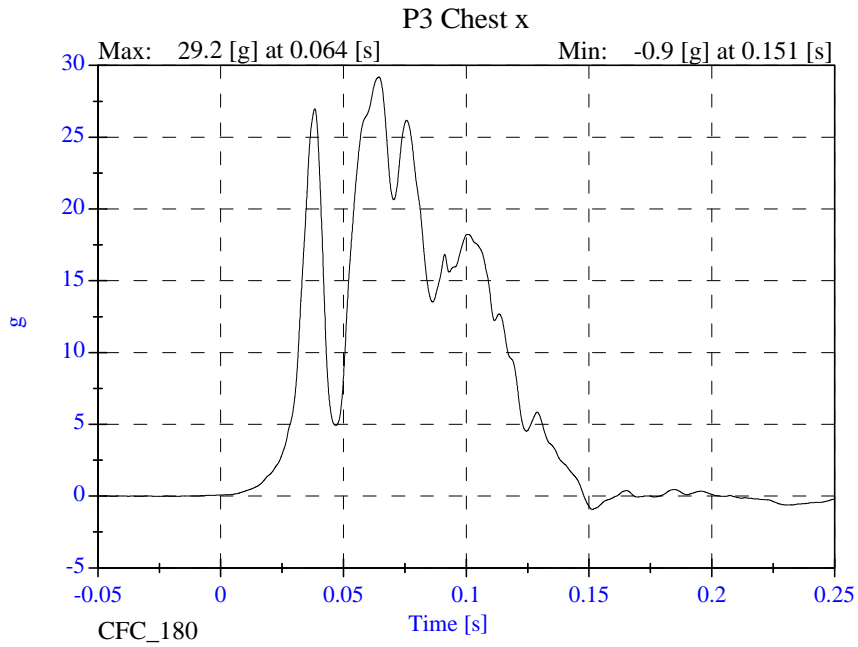

Sled Test Run 22467

- April 29, 2002

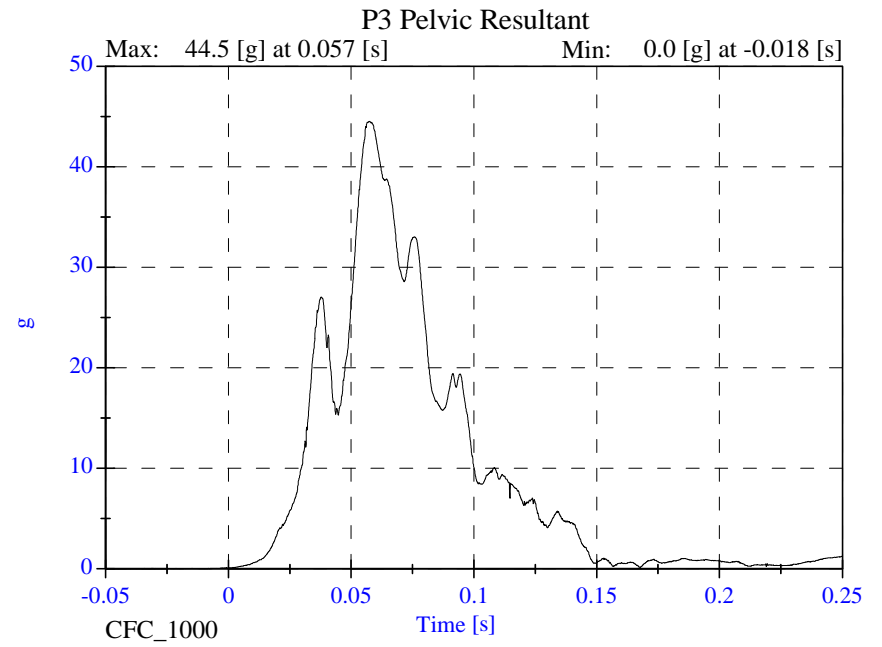
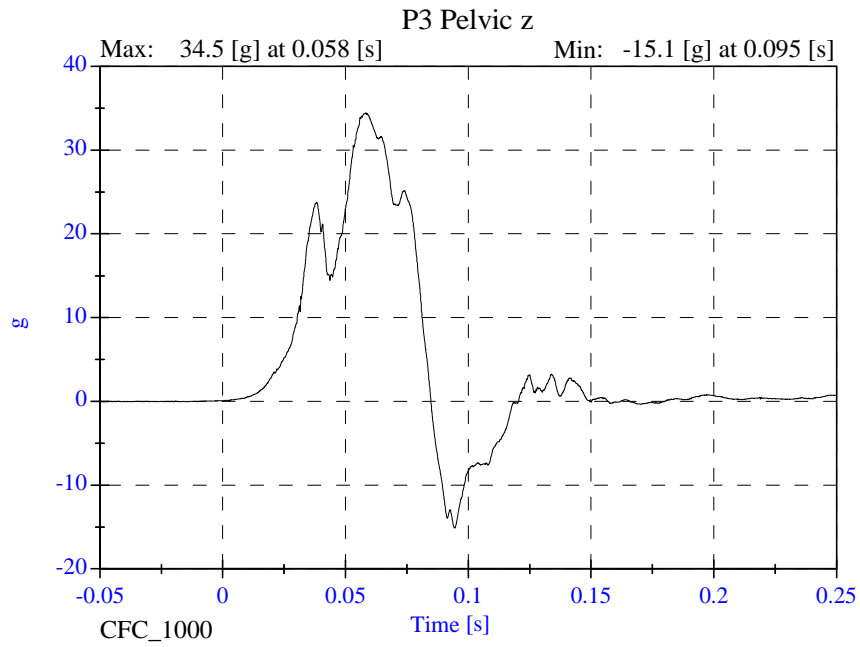
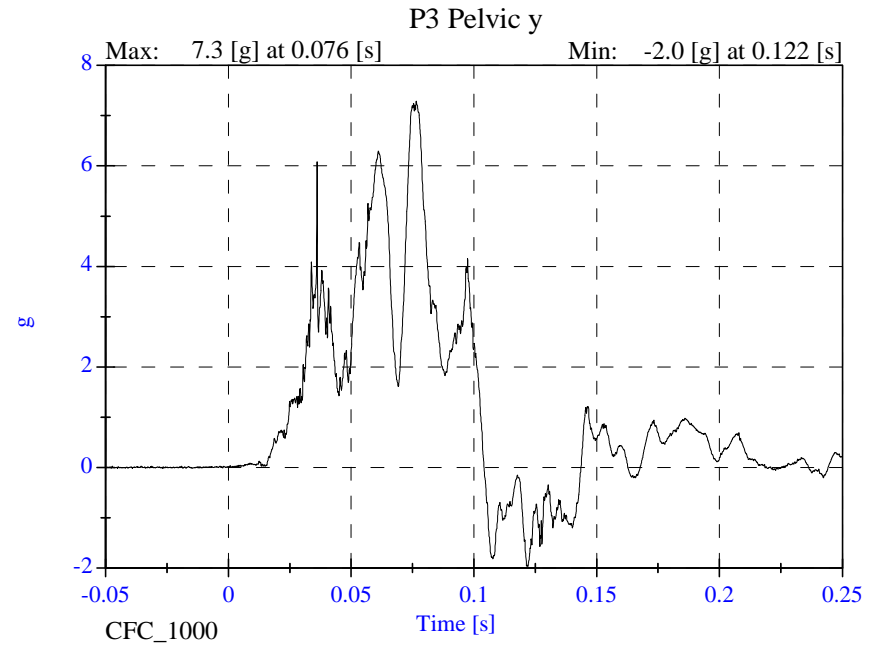
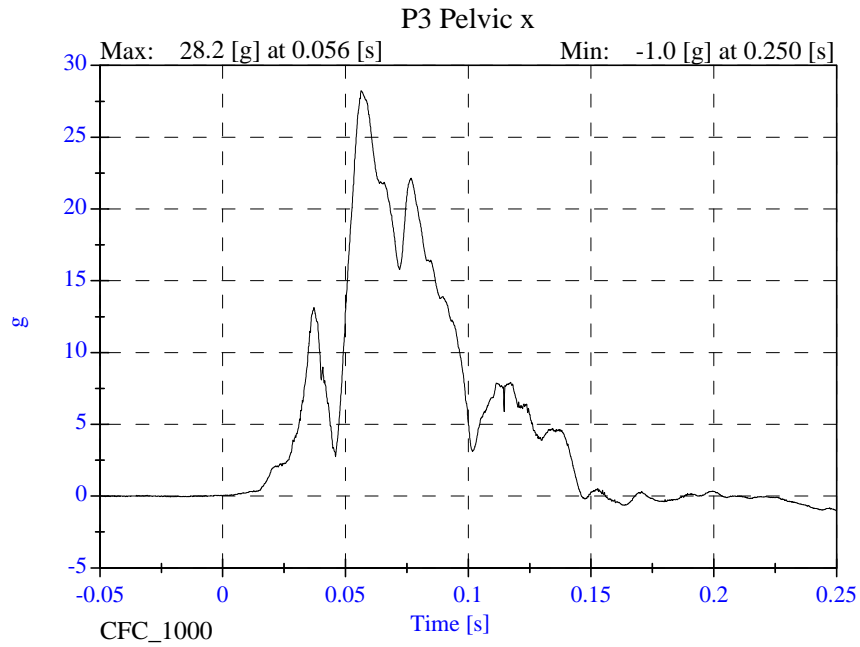

Sled Test Run 22467

- April 29, 2002

P3 Head Red z

P3 Upper Neck Mocy

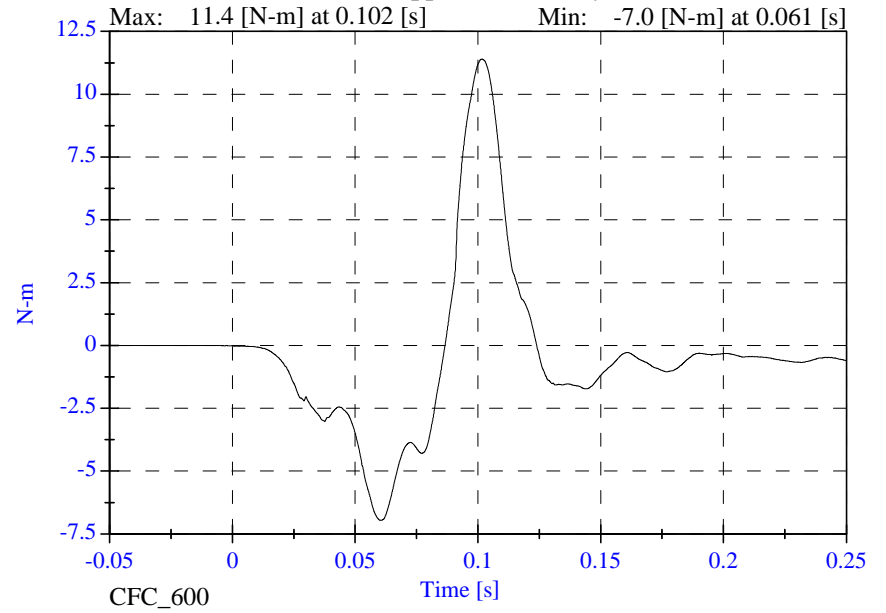
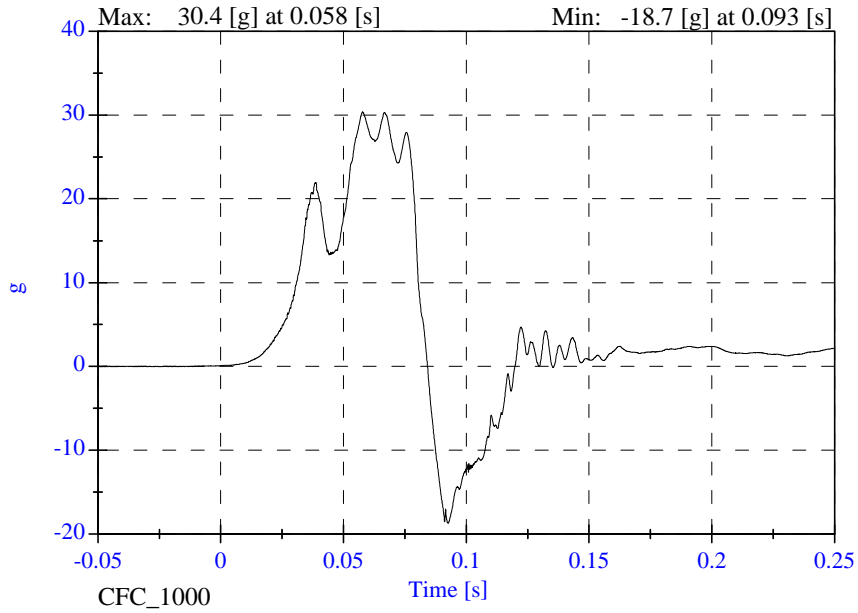

NULL

NULL

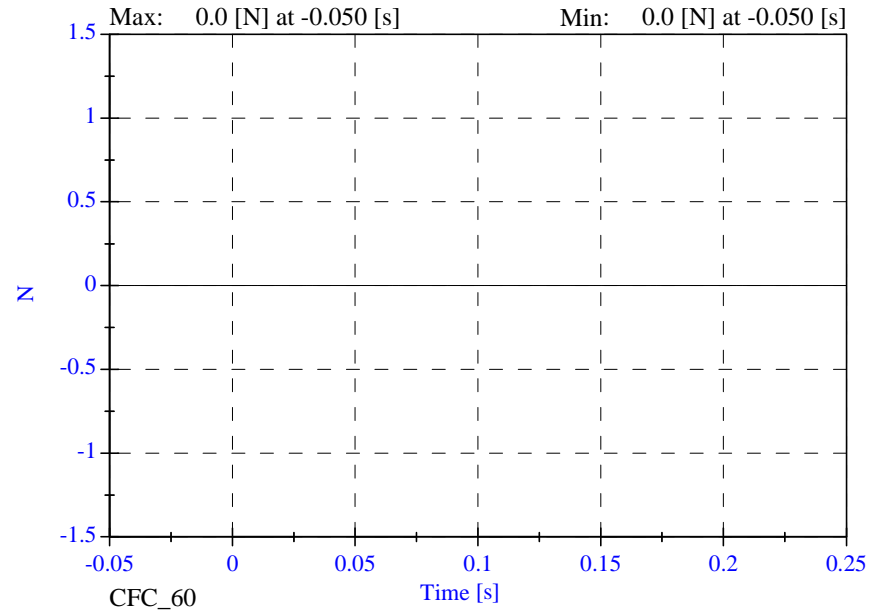
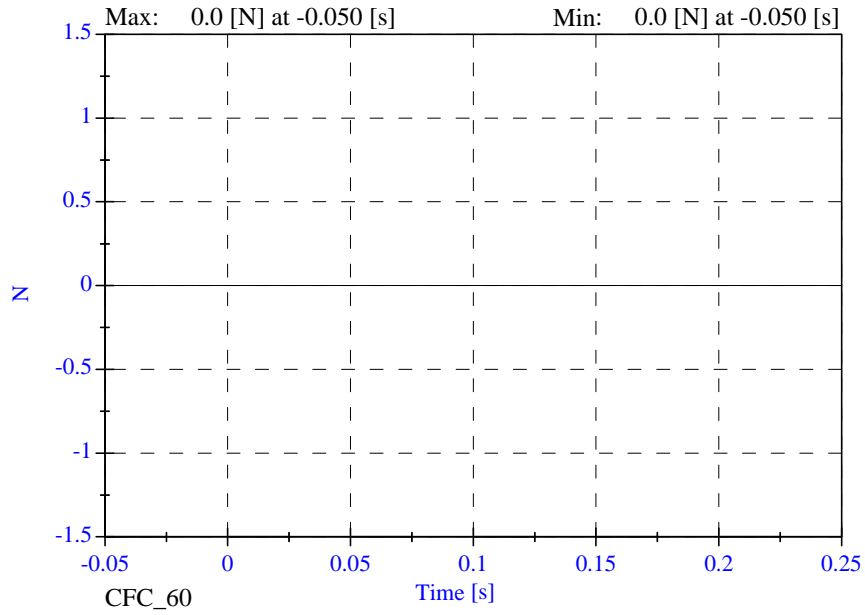

Sled Test Run 22467

- April 29, 2002

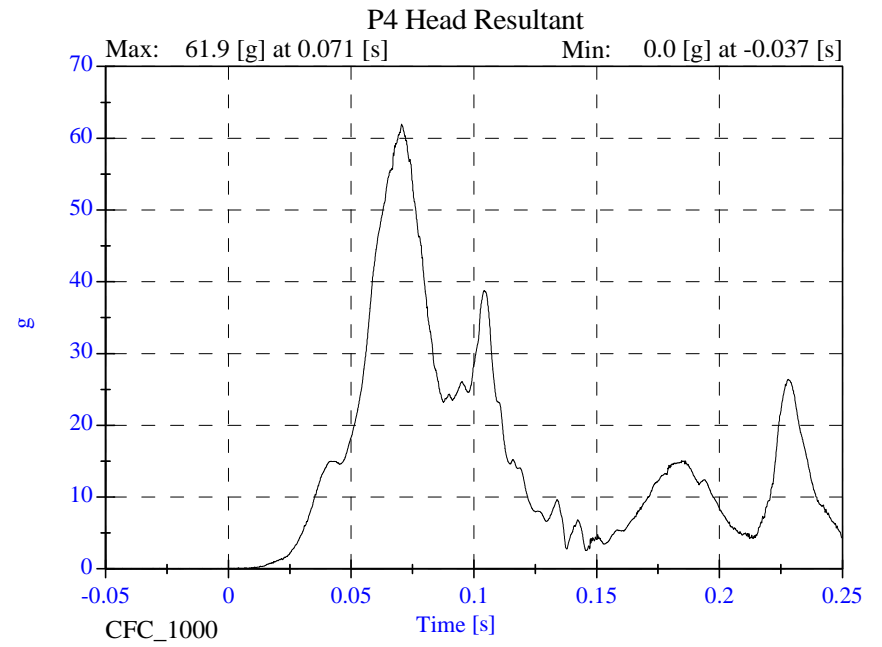
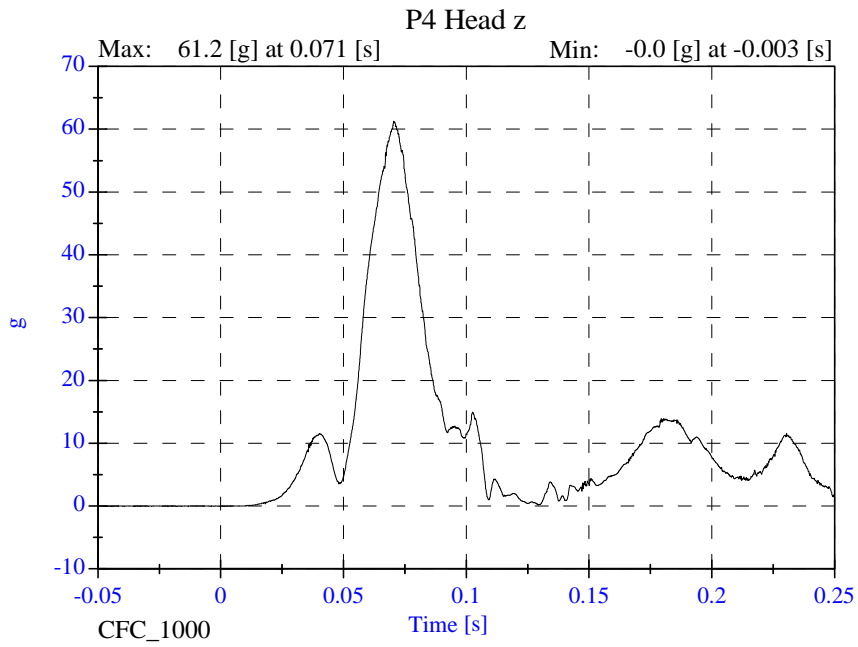
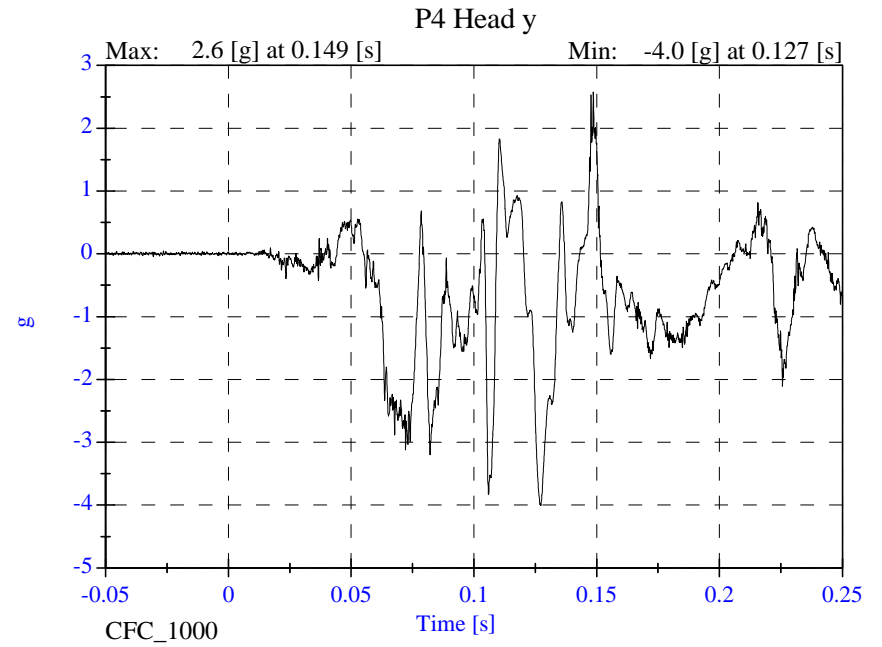
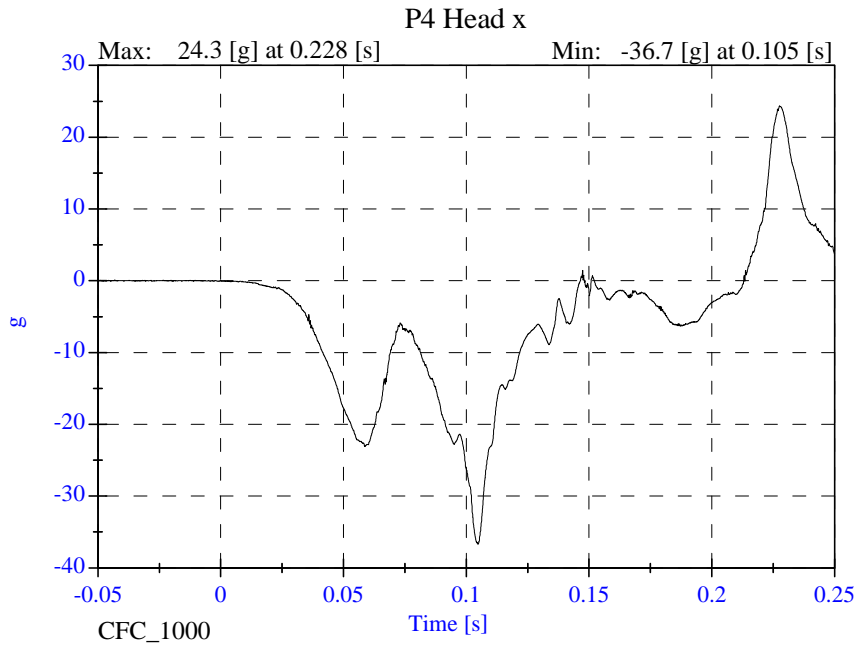

Sled Test Run 22467

- April 29, 2002

P4 Upper Neck Fx

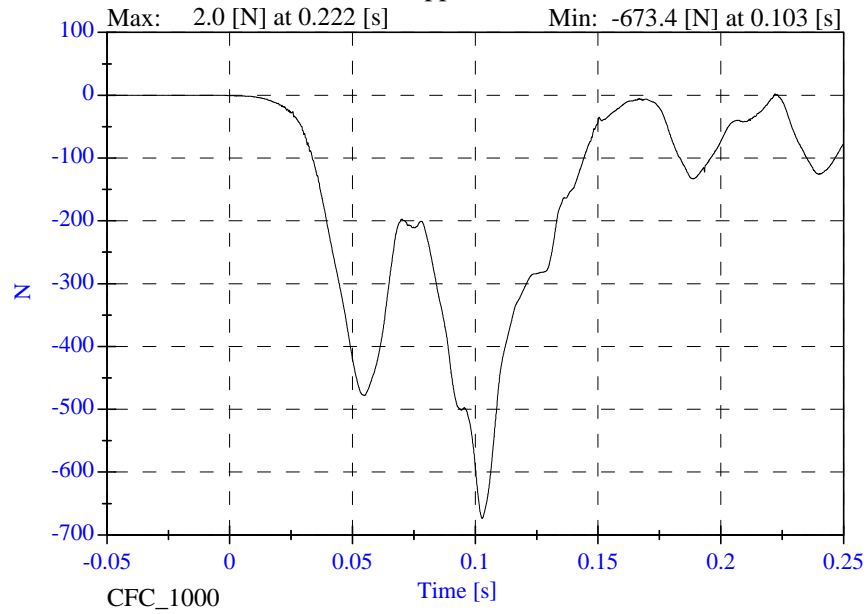

P4 Upper Neck Fy

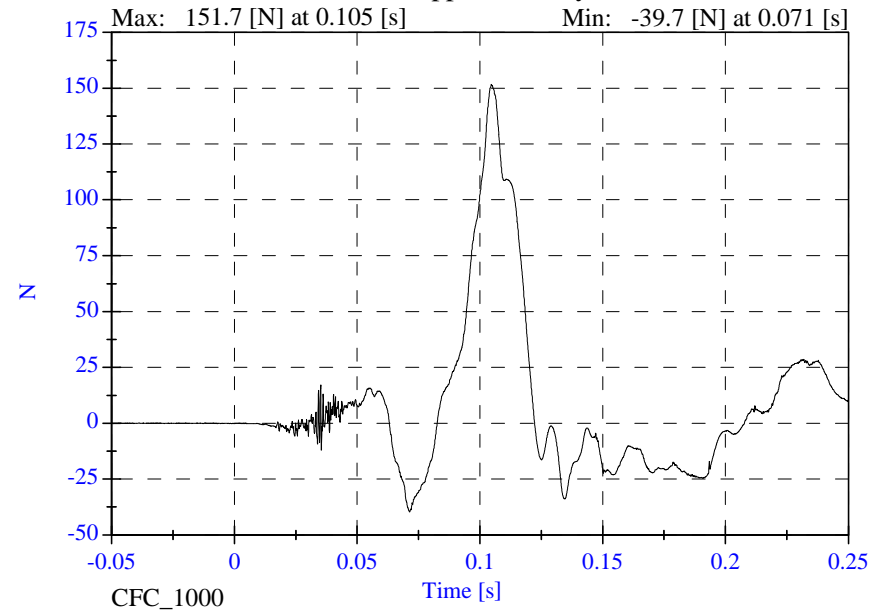

P4 Upper Neck Fz

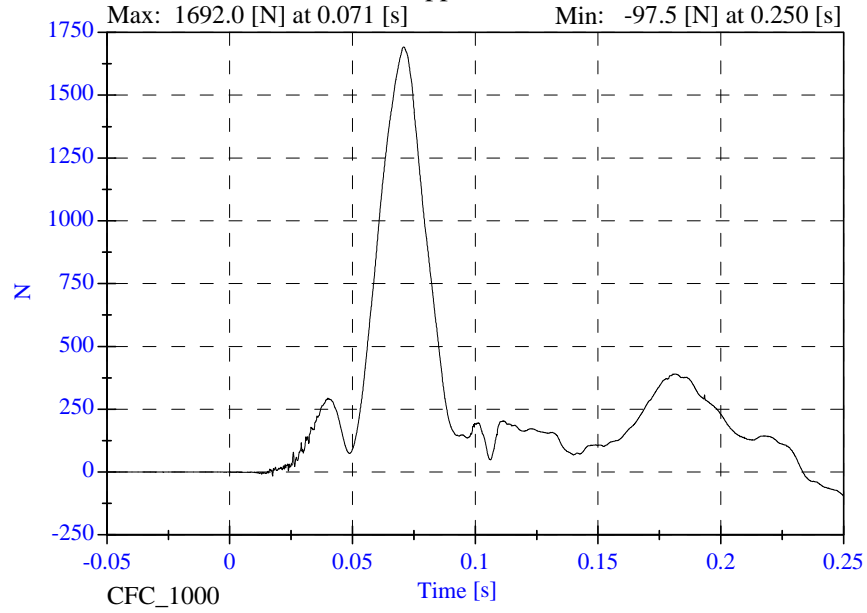

P4 Upper Neck F Resultant

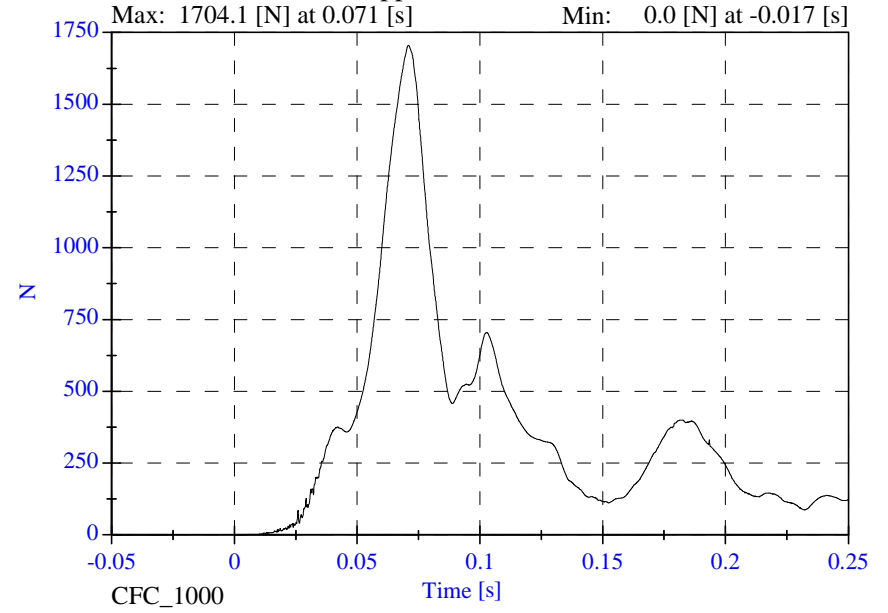

Sled Test Run 22467

- April 29, 2002

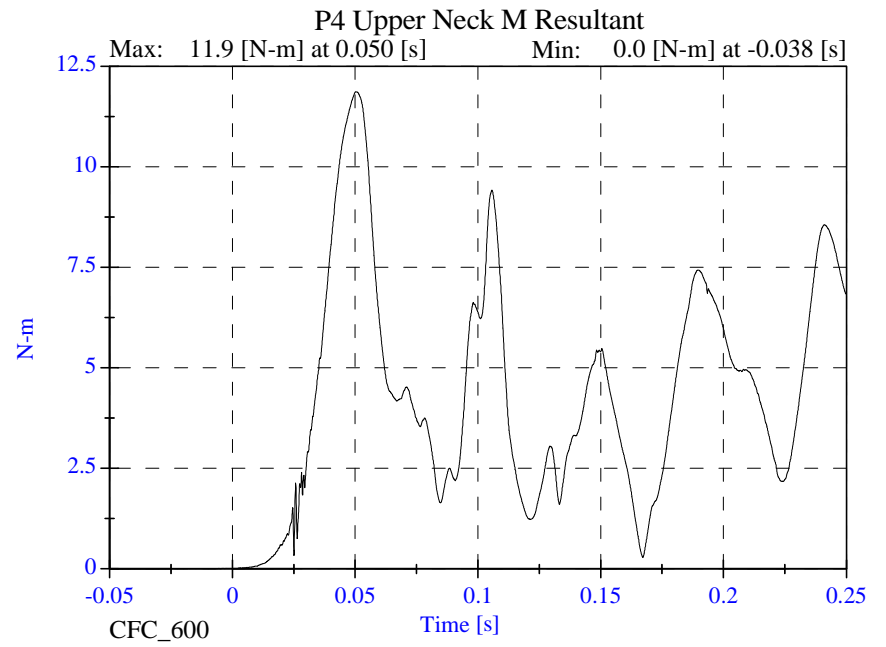
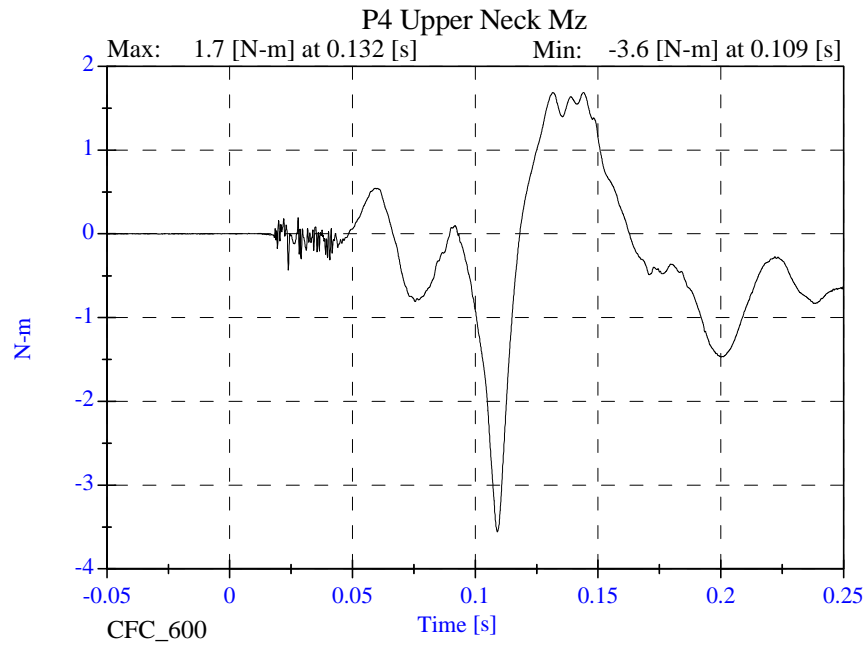
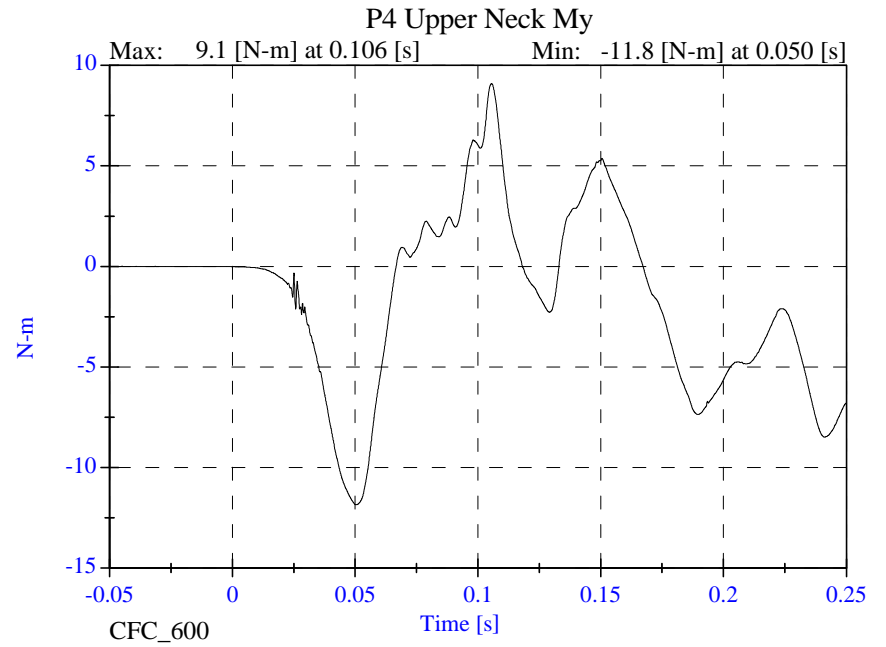
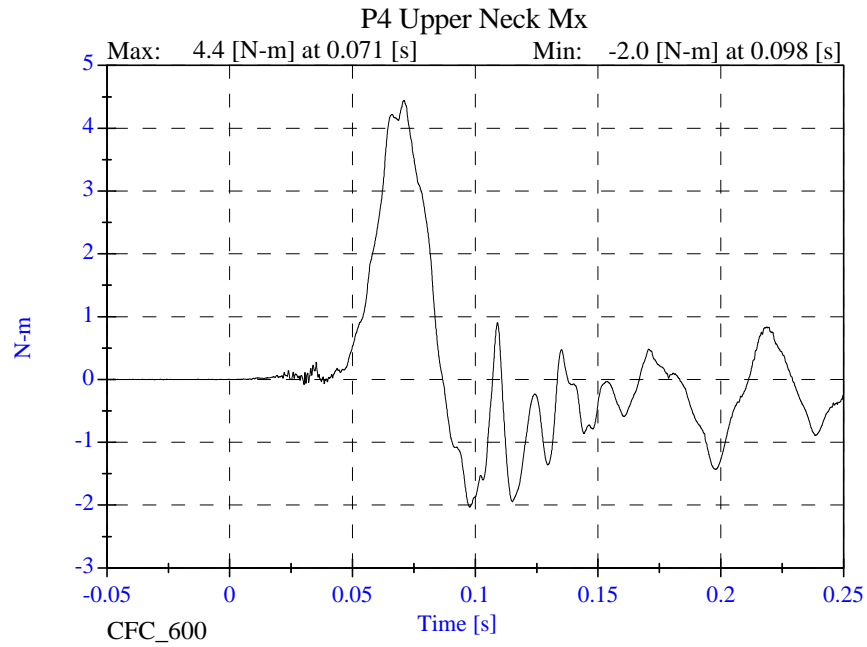

Sled Test Run 22467

- April 29, 2002

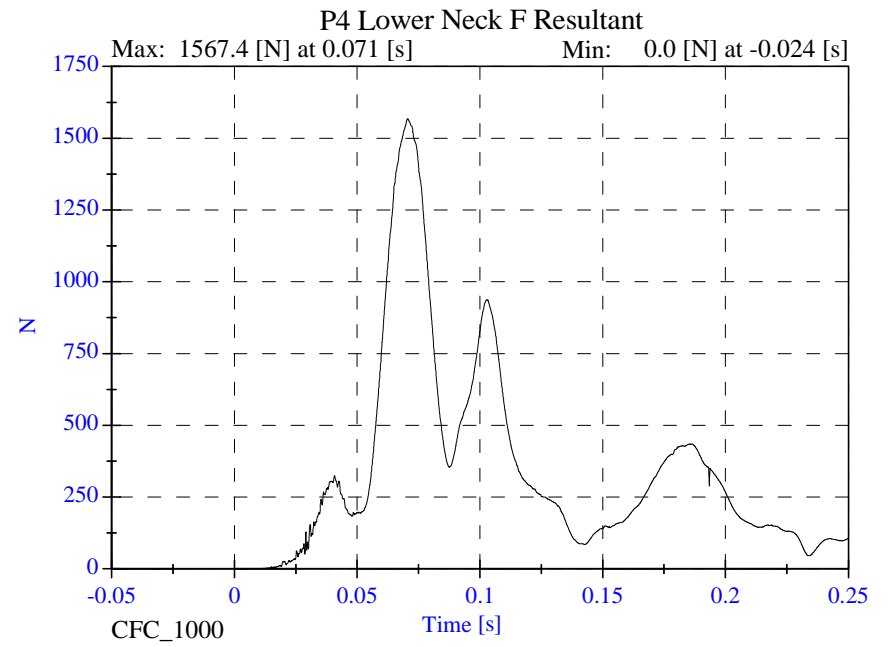
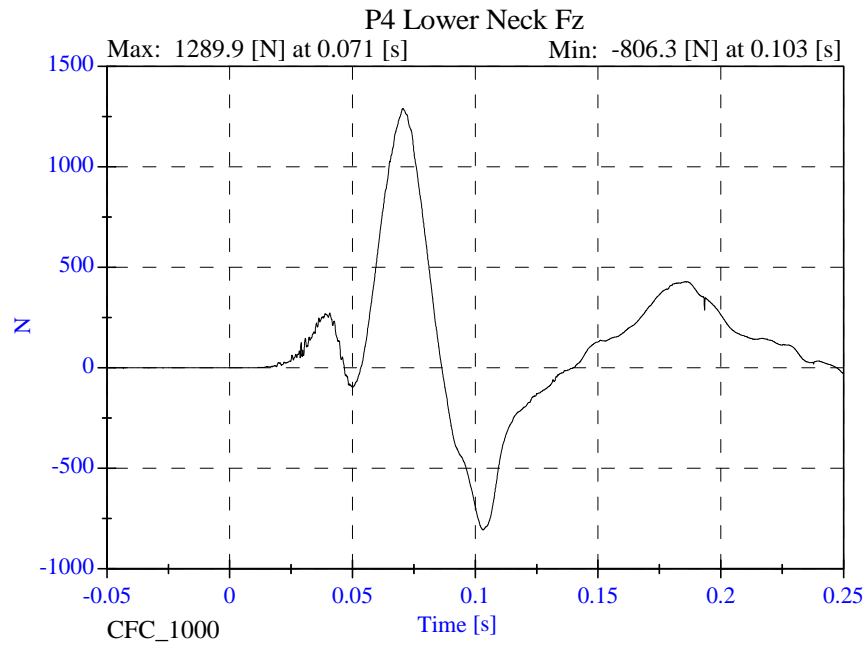
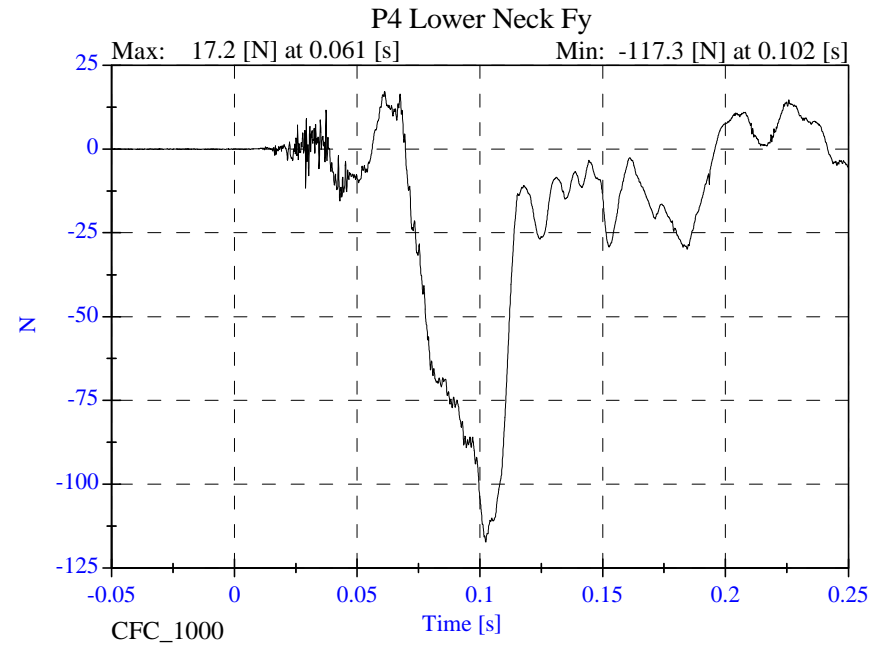
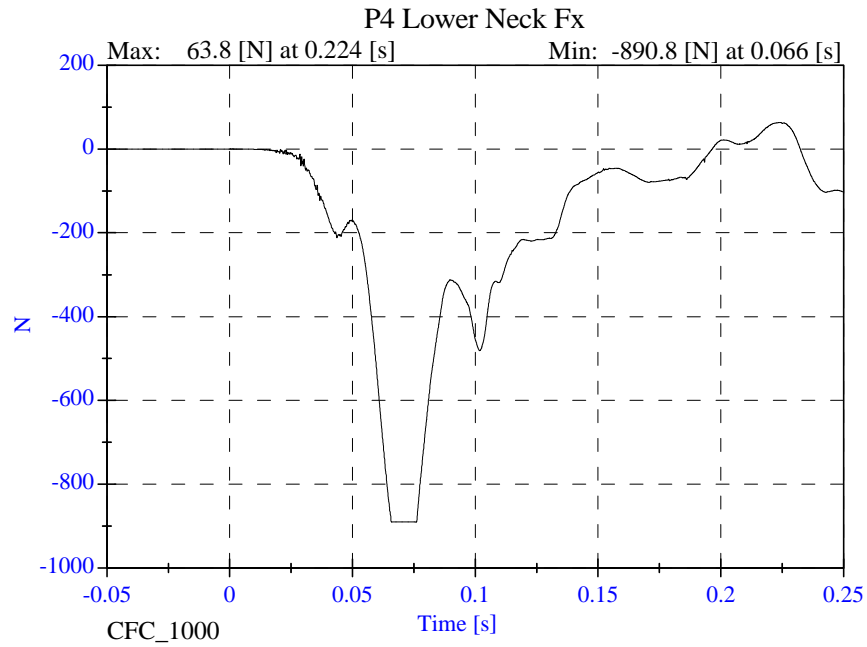

Sled Test Run 22467

- April 29, 2002

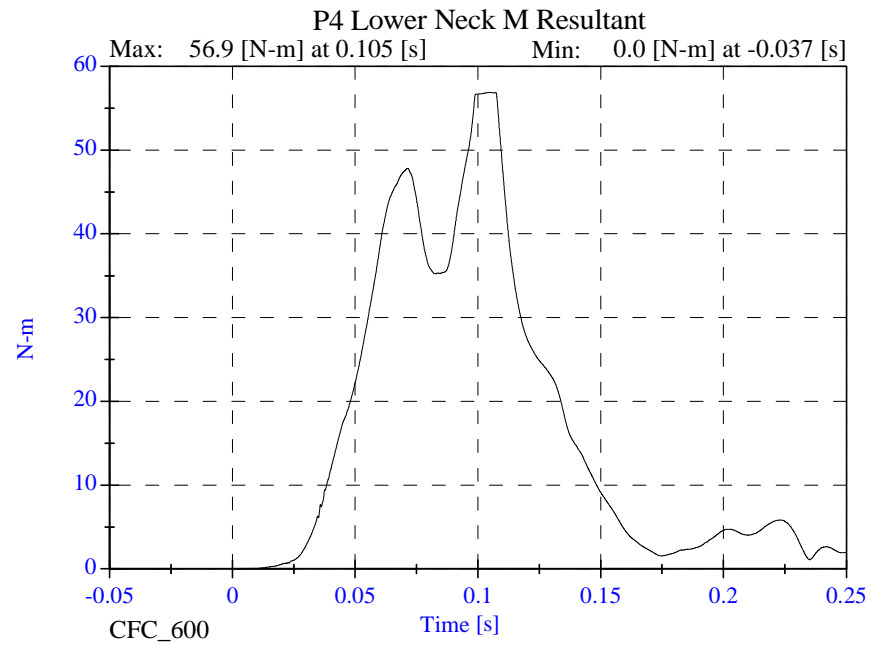
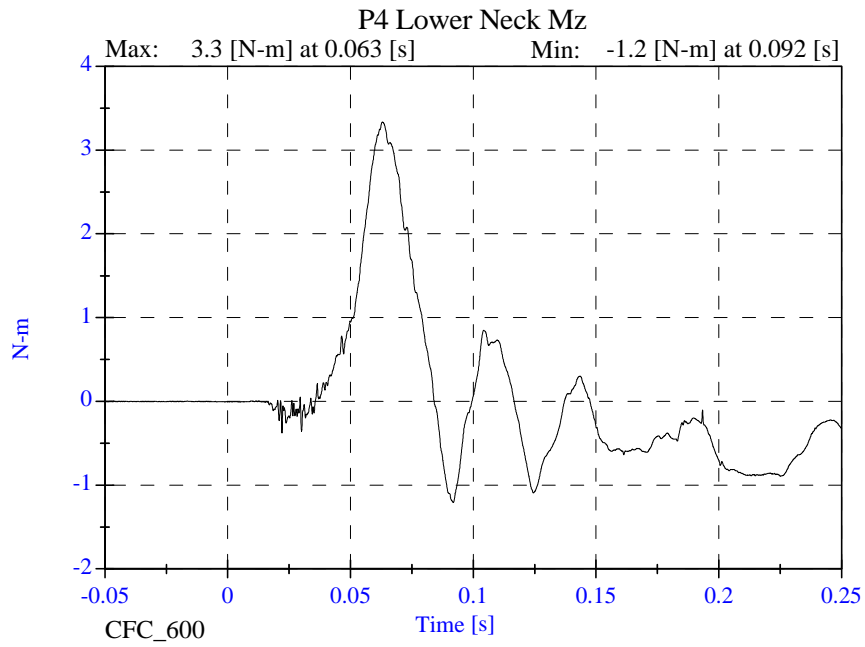
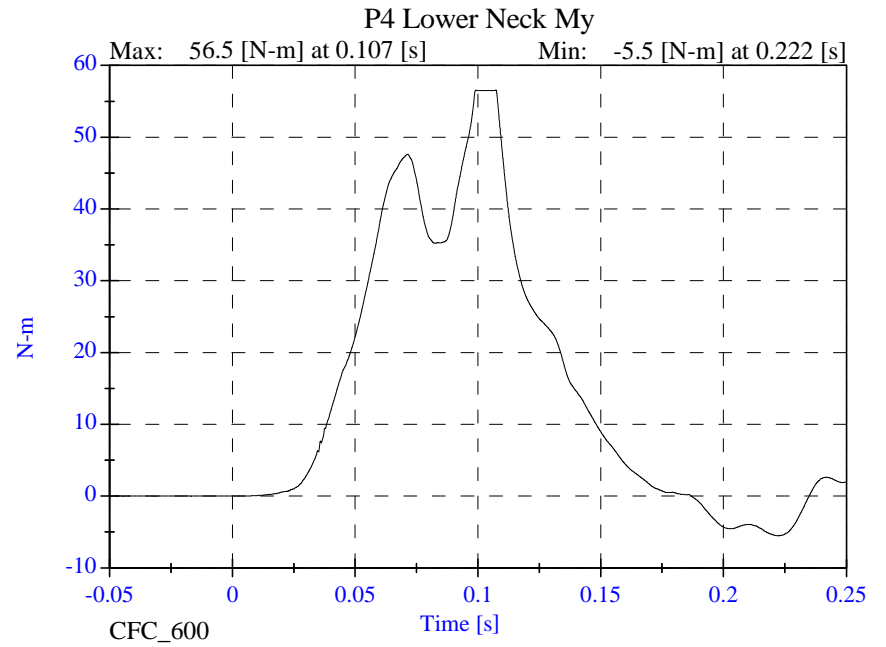
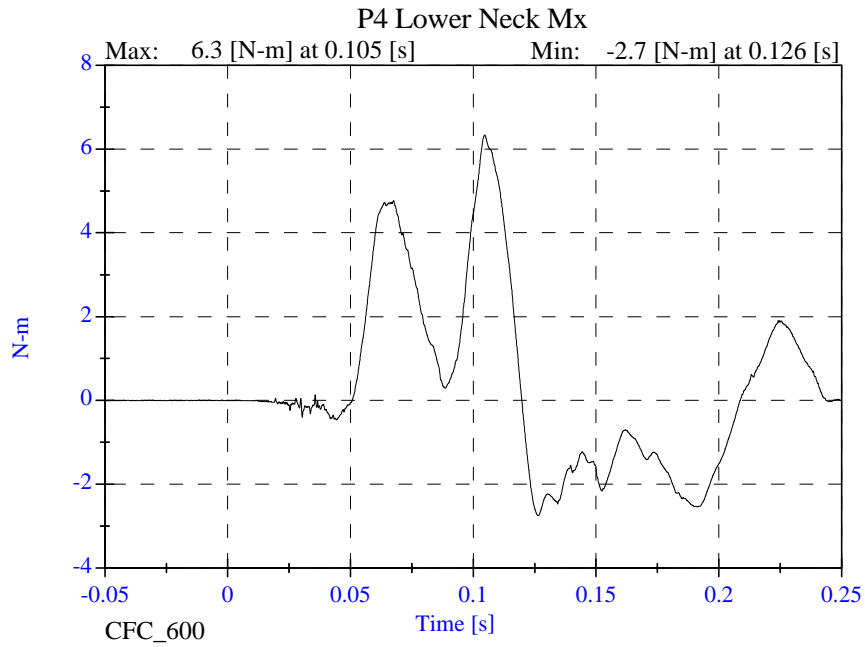

Sled Test Run 22467

- April 29, 2002

P4 Chest x

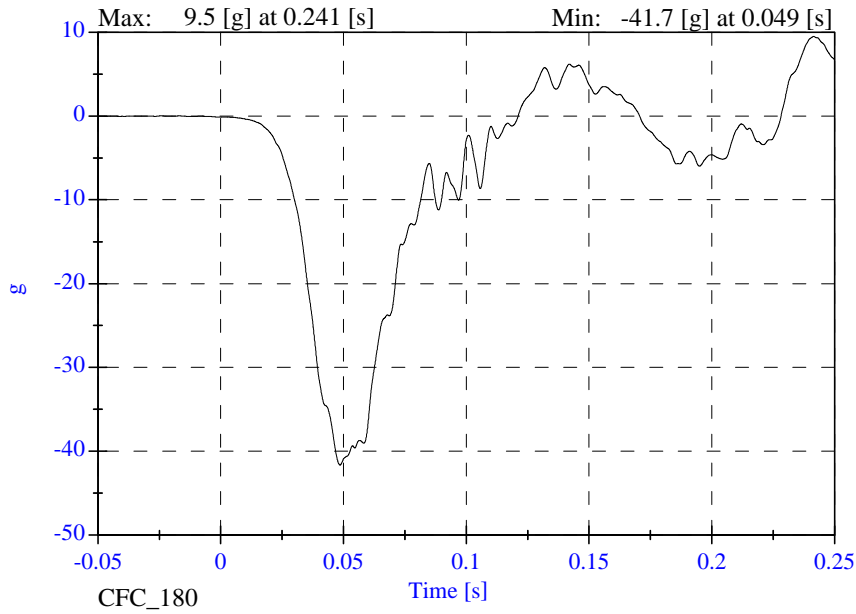

P4 Chest y

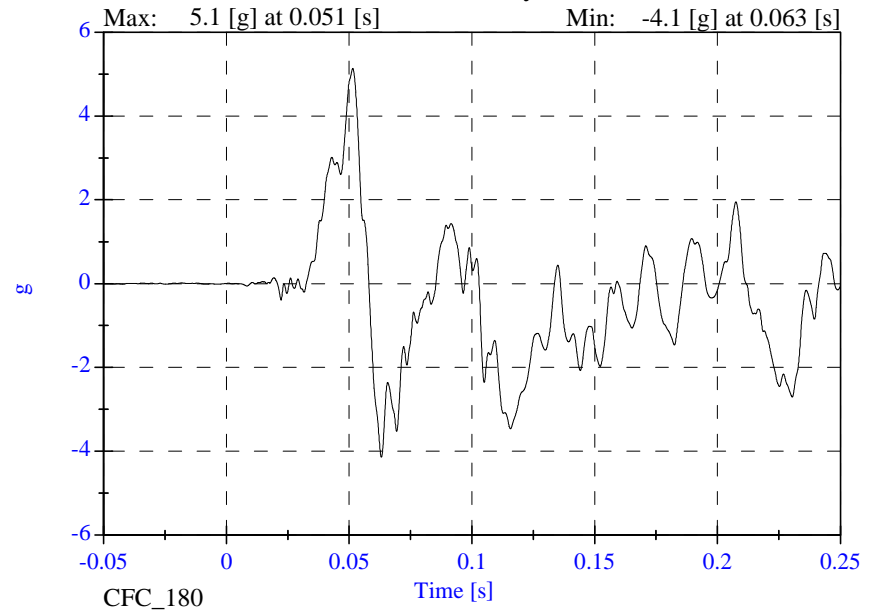

P4 Chest z

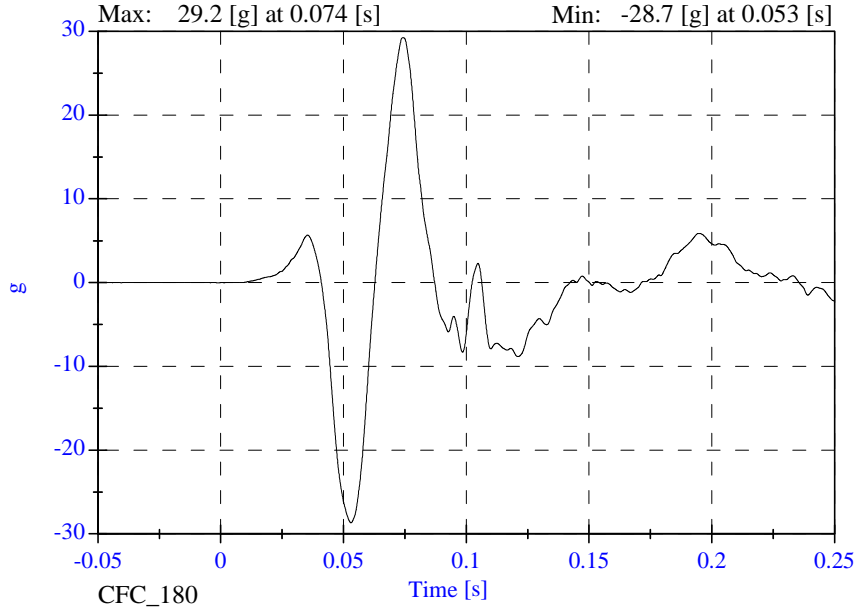

P4 Chest Resultant

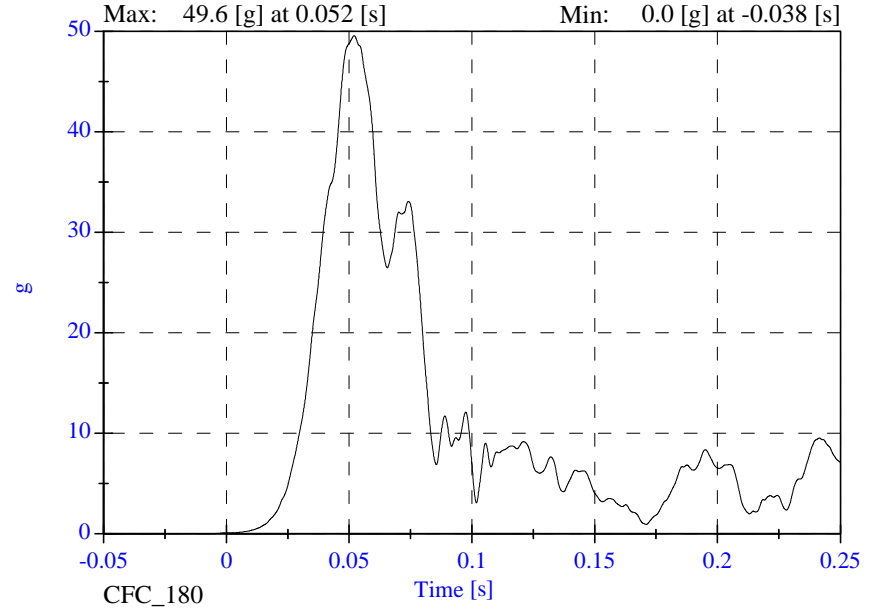

Sled Test Run 22467

- April 29, 2002

P4 Pelvic x

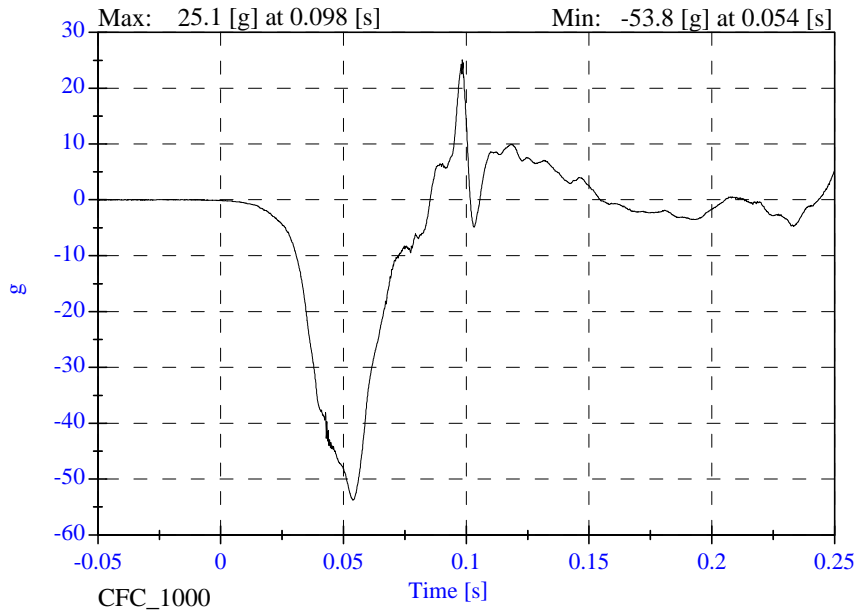

P4 Pelvic y

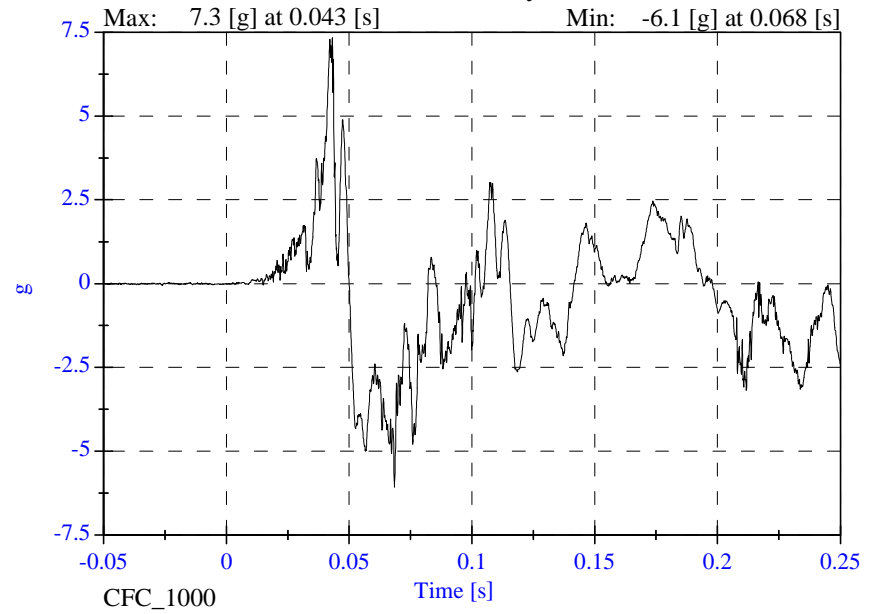

P4 Pelvic z

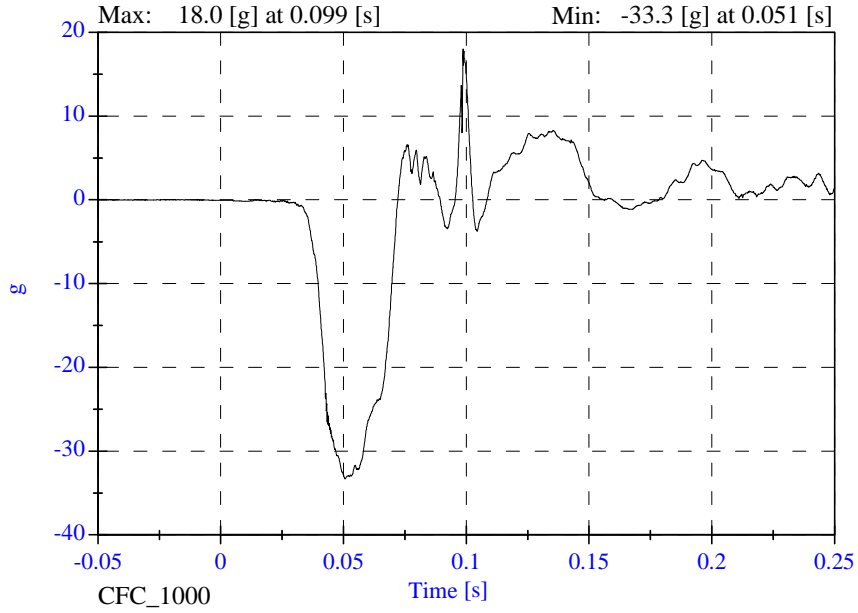

P4 Pelvic Resultant

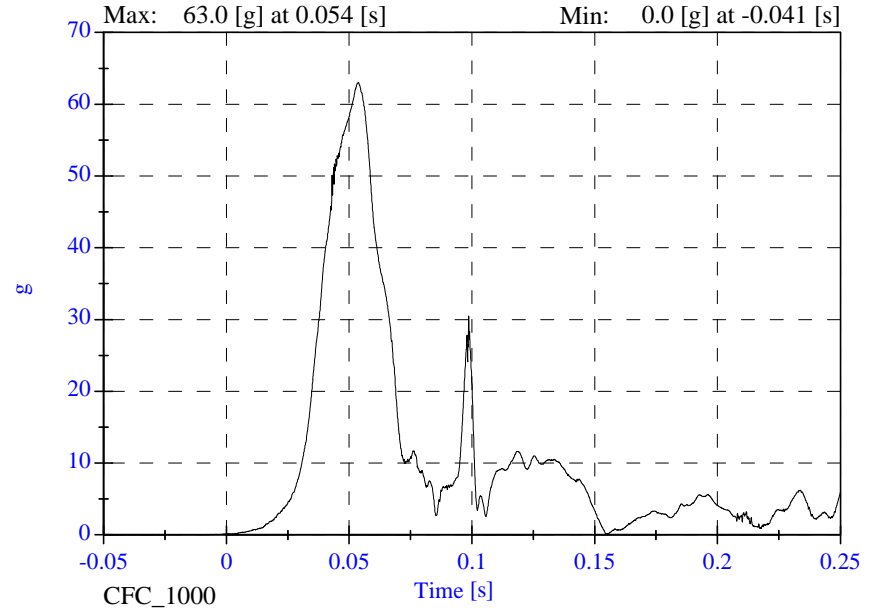

Sled Test Run 22467

- April 29, 2002

P3 Lumbar Fx

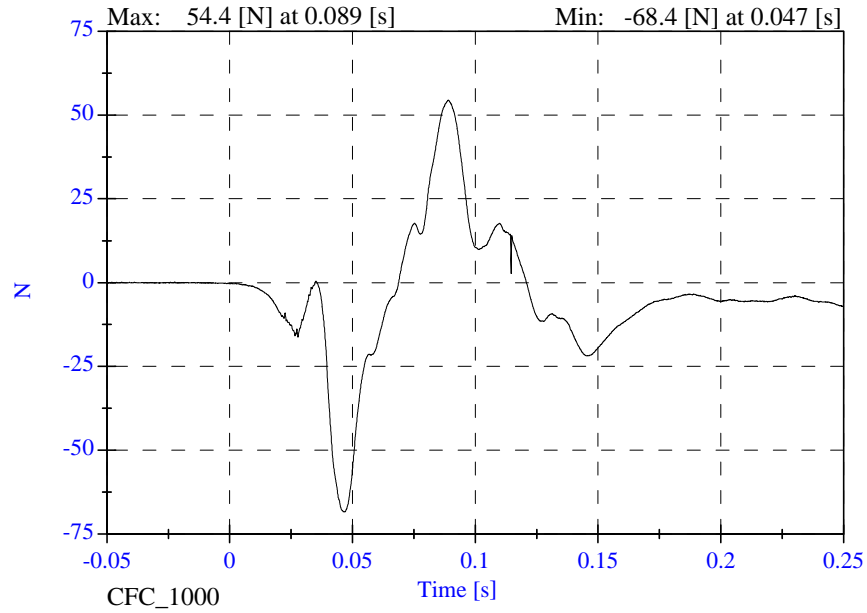

P3 Lumbar Fy

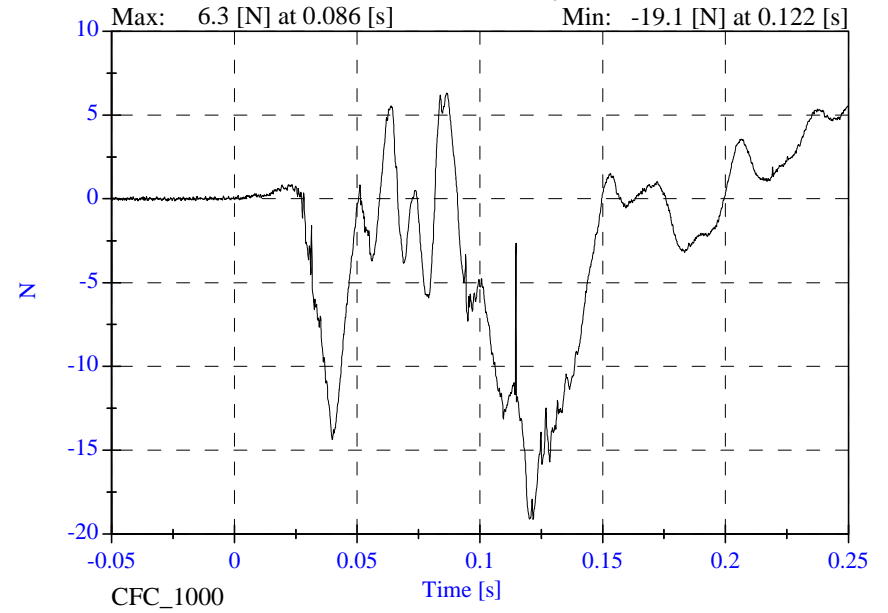

P3 Lumbar Fz

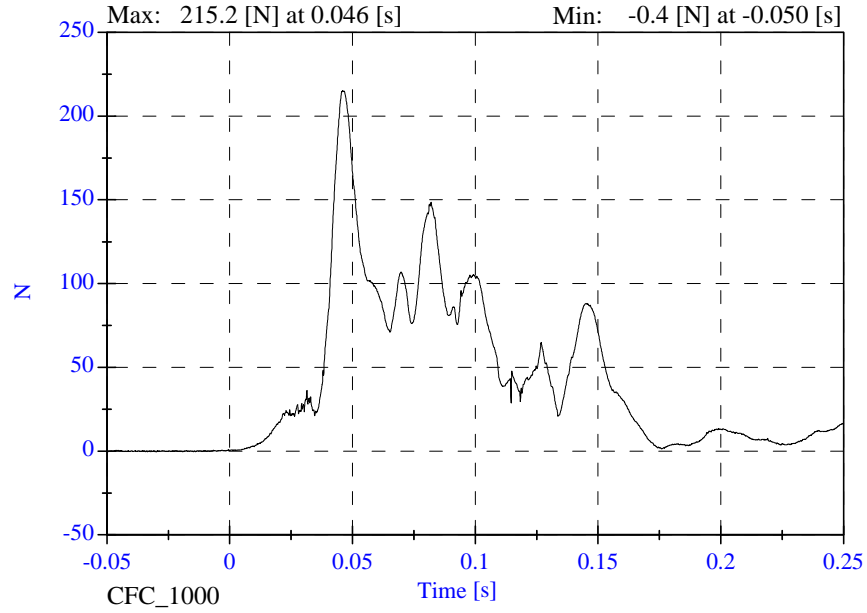

P3 Lumbar F Resultant

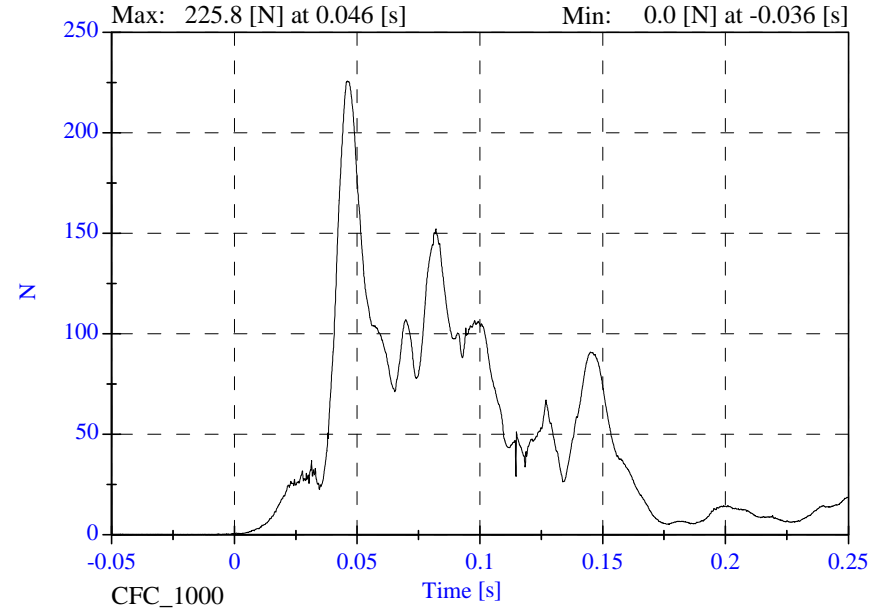

Sled Test Run 22467

- April 29, 2002

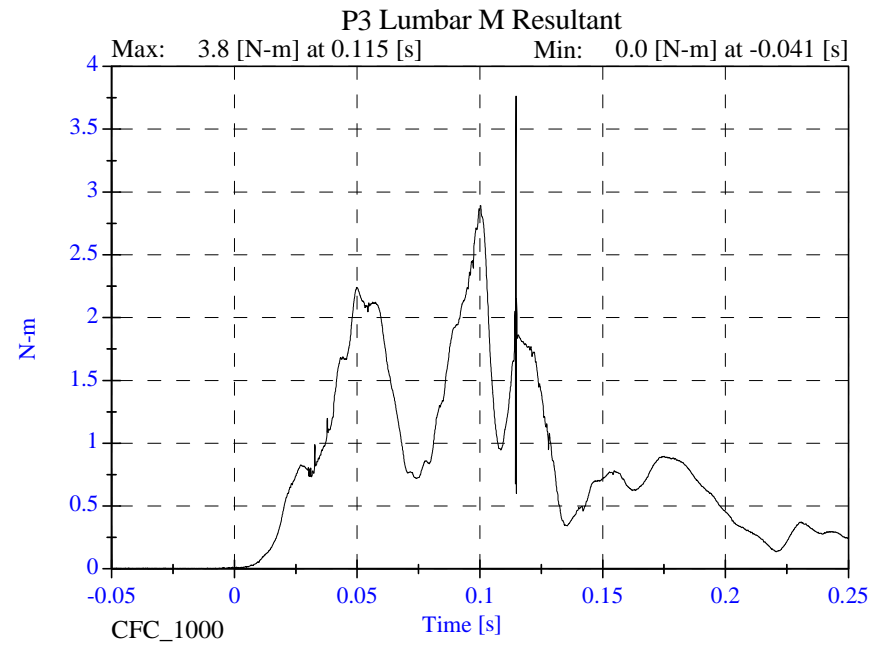
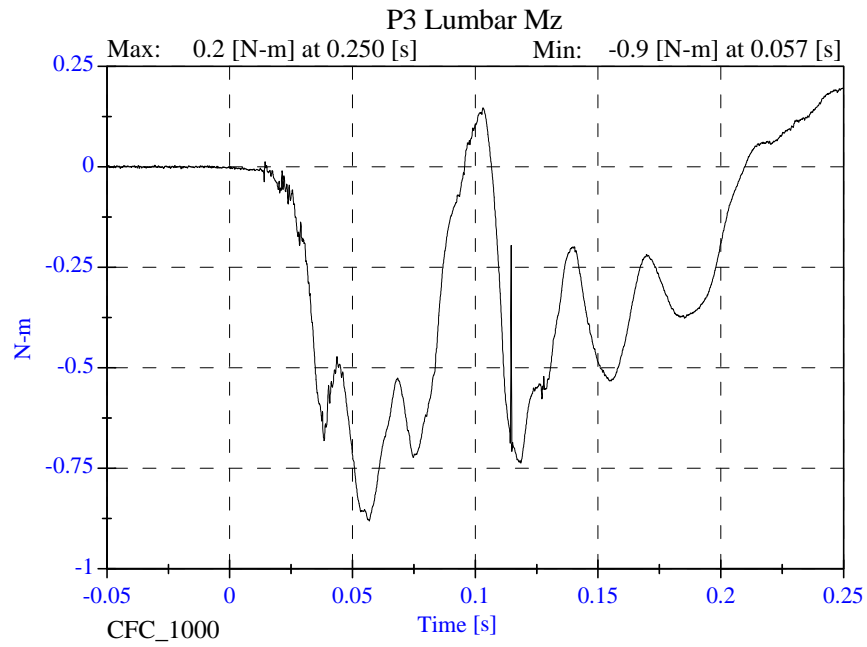
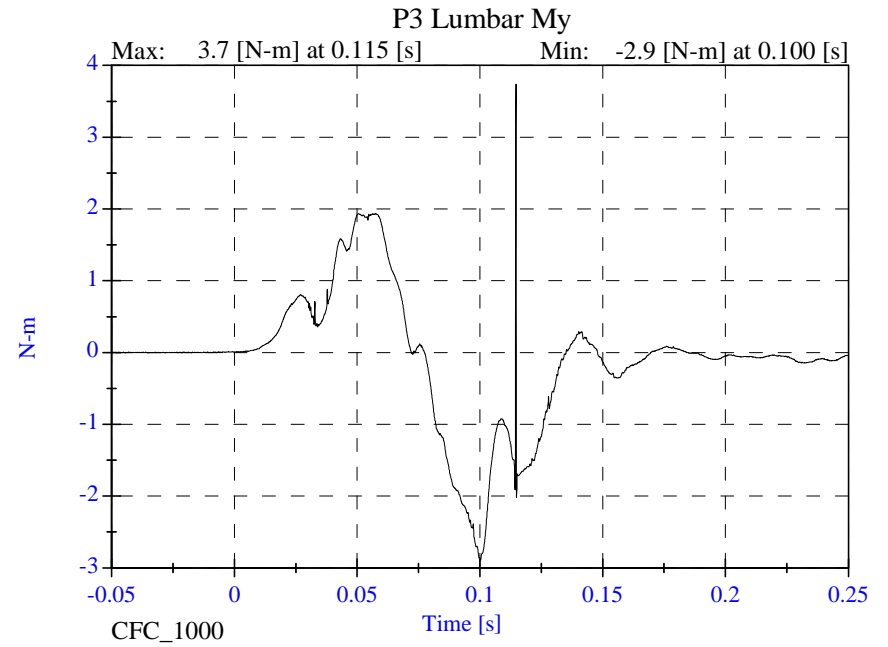
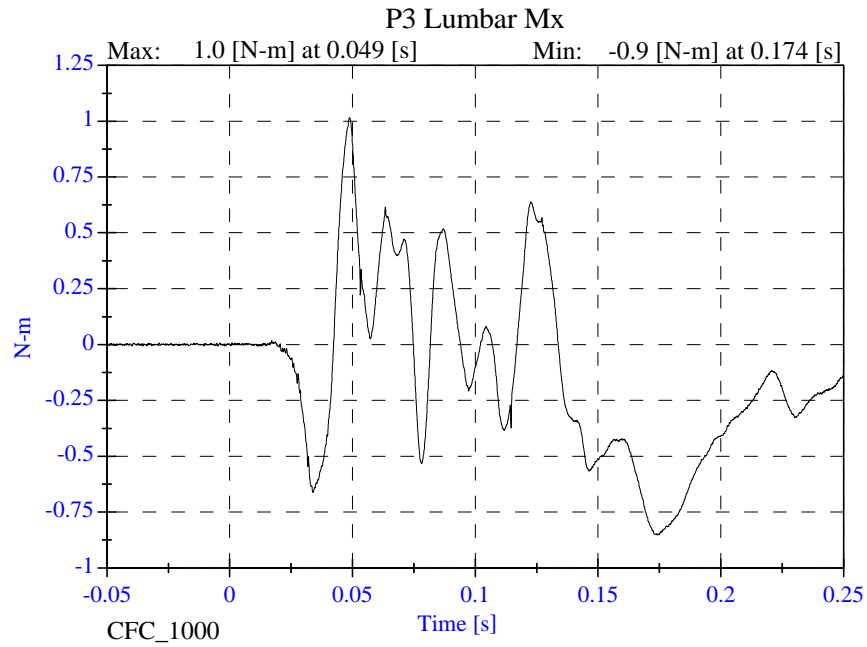

Sled Test Run 22467

- April 29, 2002

P4 Lumbar Fx

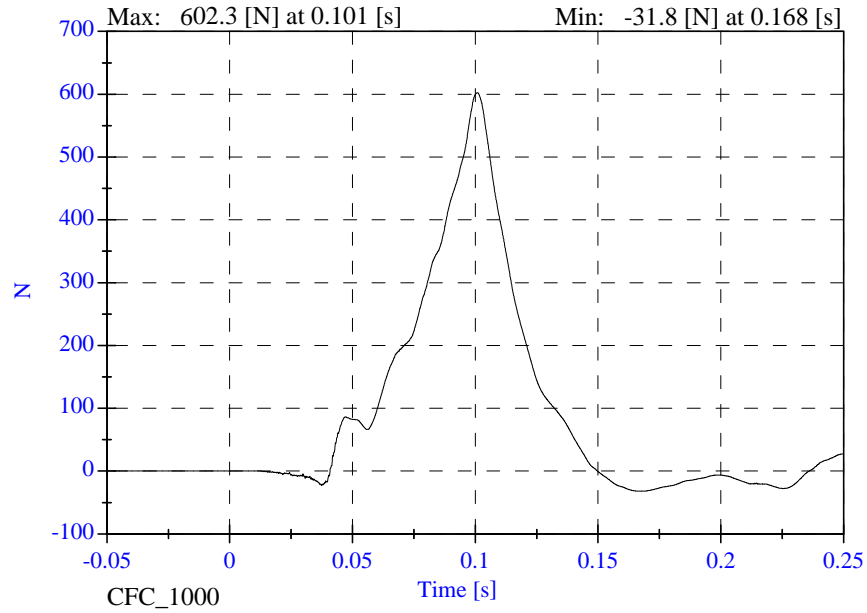

P4 Lumbar Fy

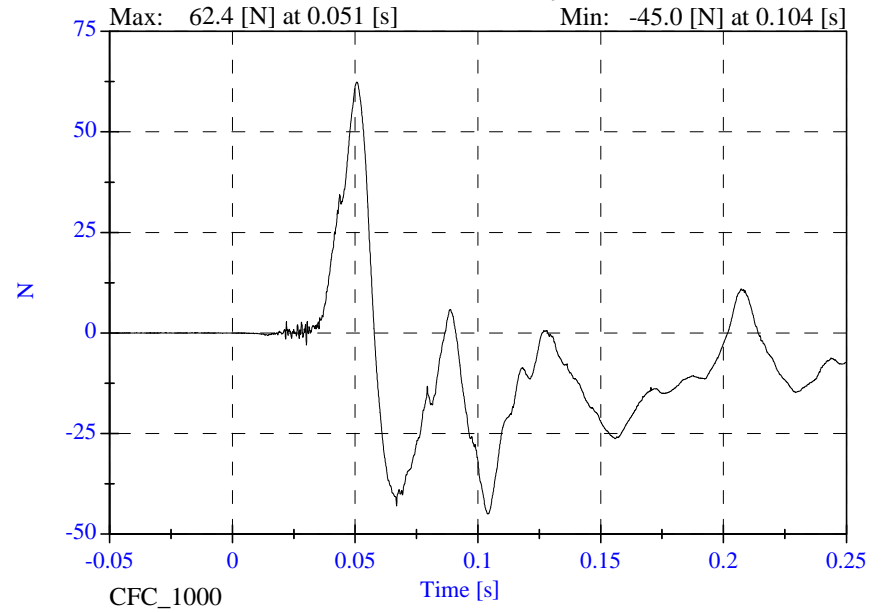

P4 Lumbar Fz

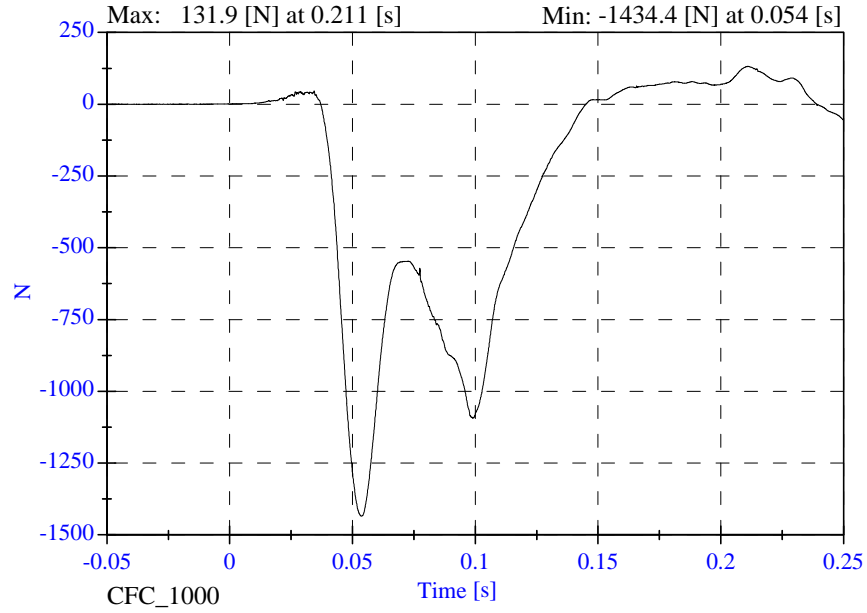

P4 Lumbar F Resultant

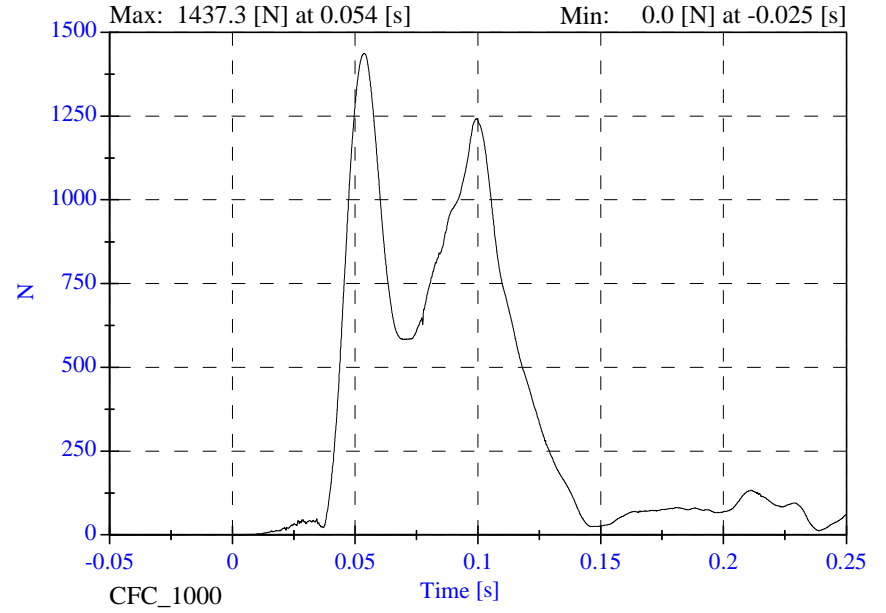

Sled Test Run 22467

- April 29, 2002

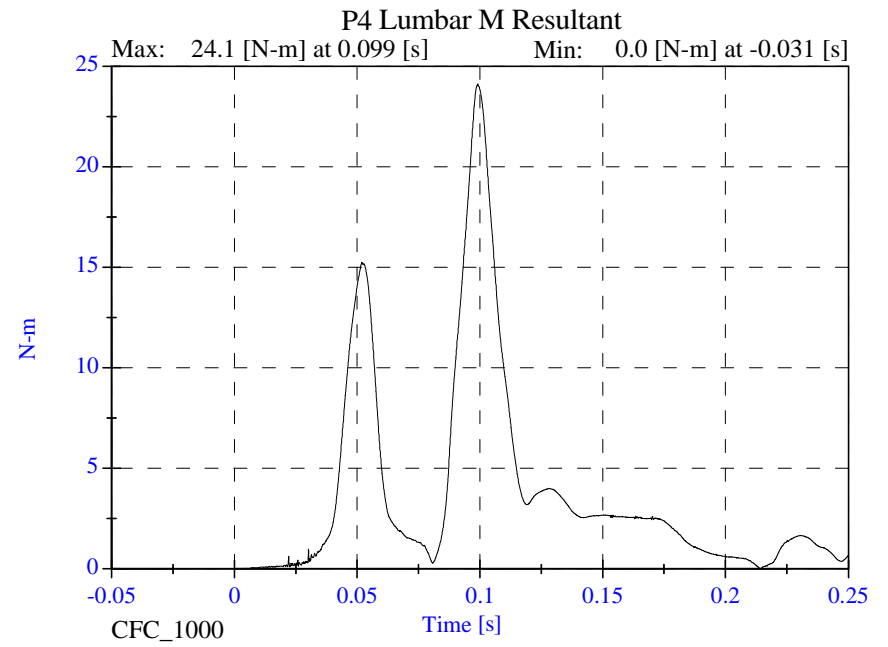
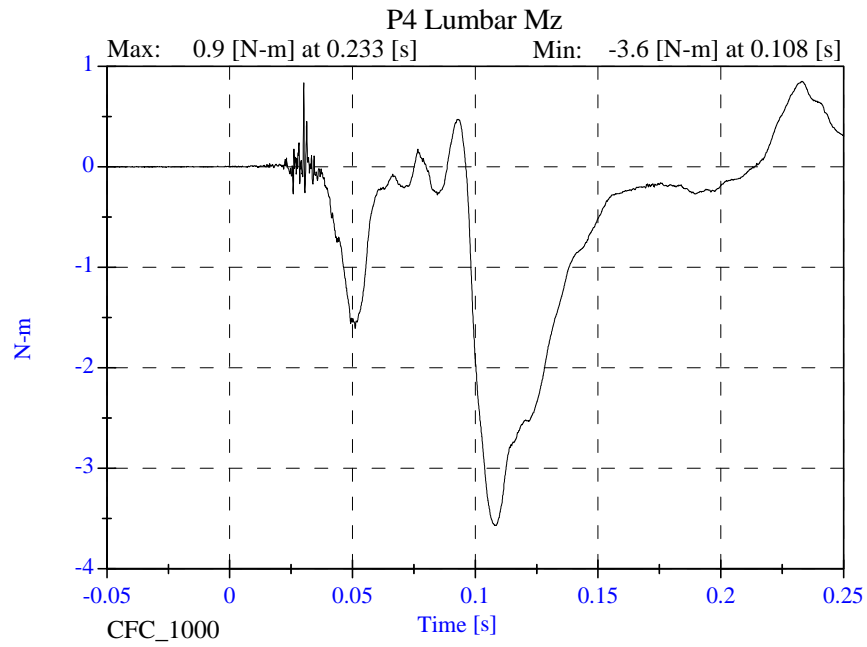
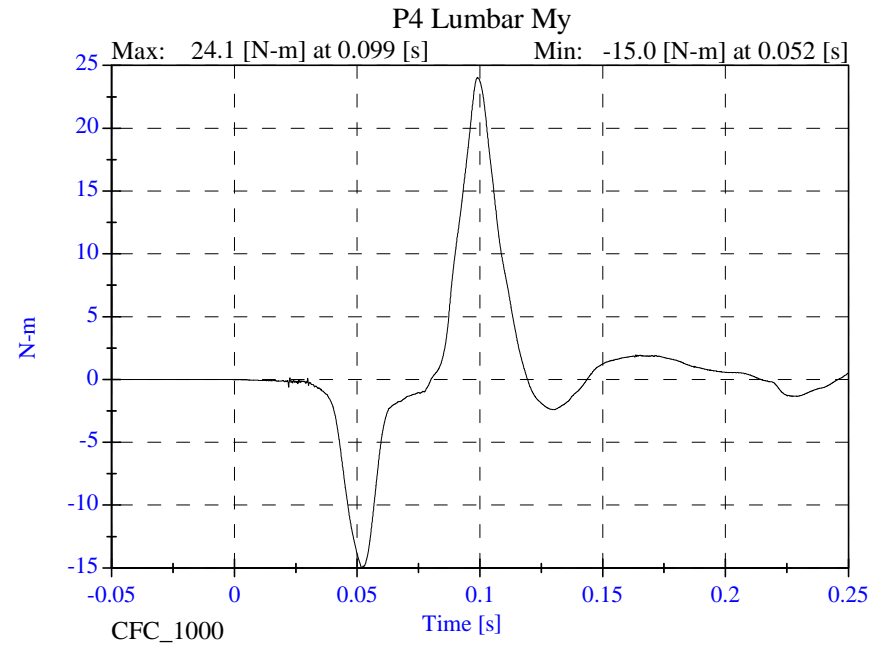
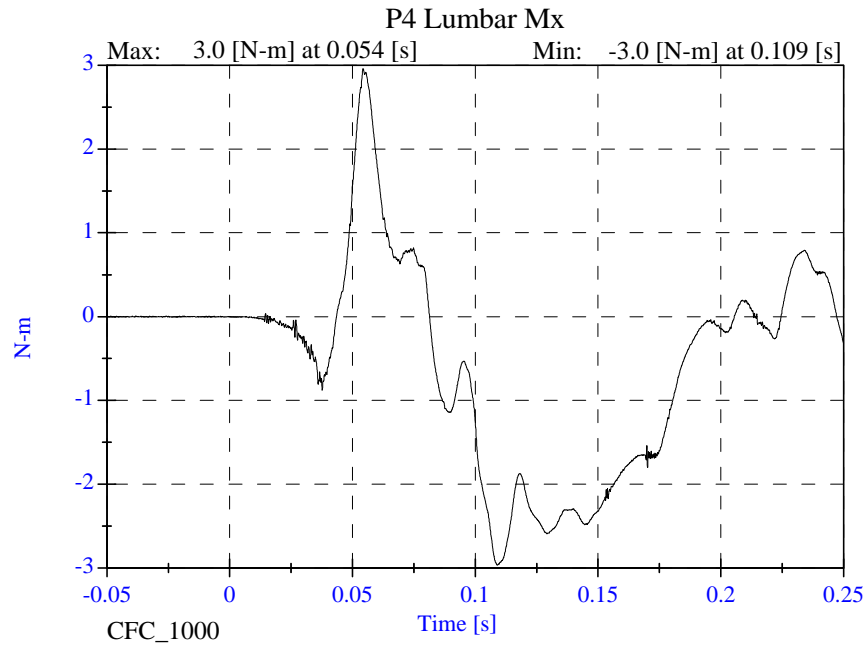

Sled Test Run 22467

- April 29, 2002

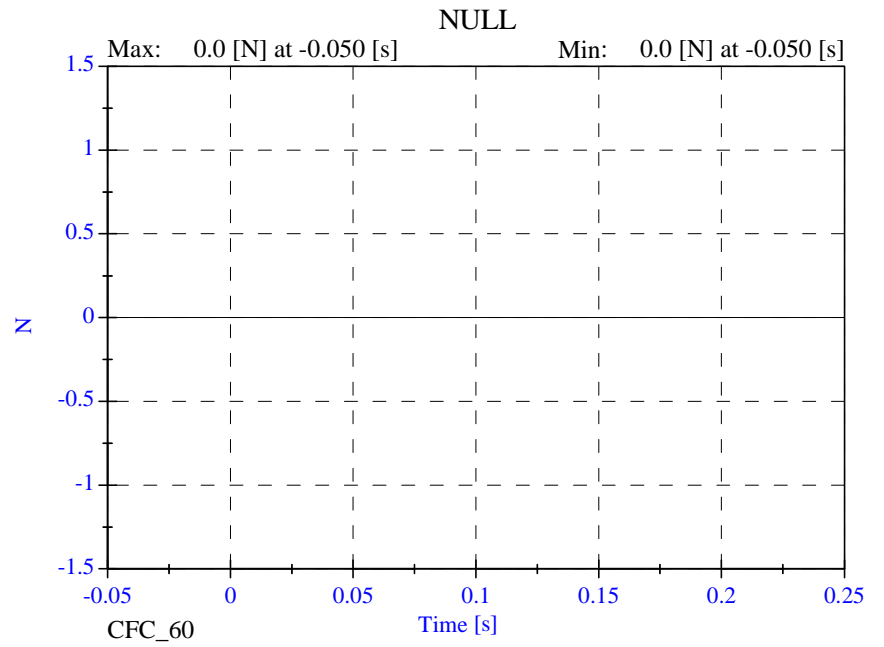
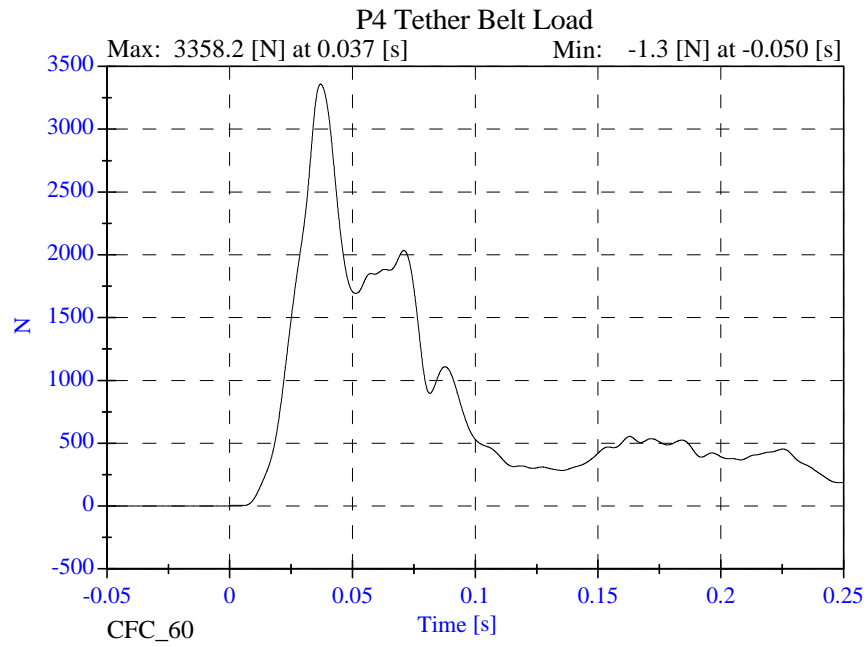
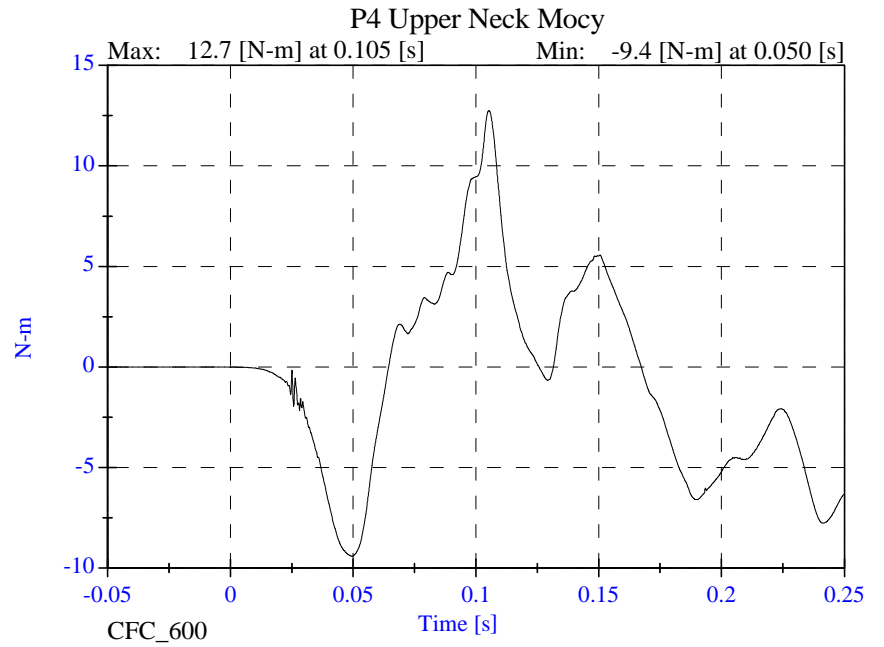
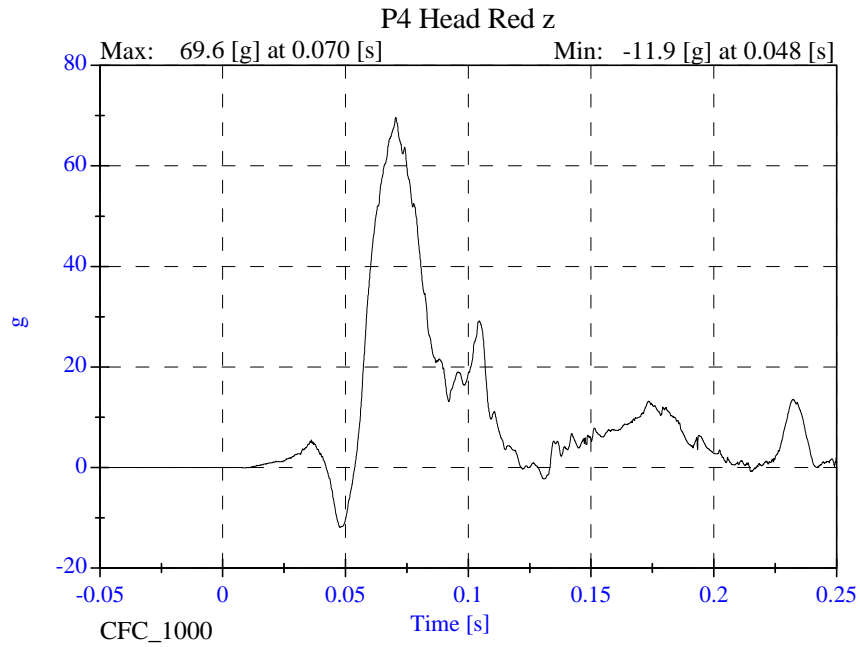

Sled Test Run 22467

- April 29, 2002

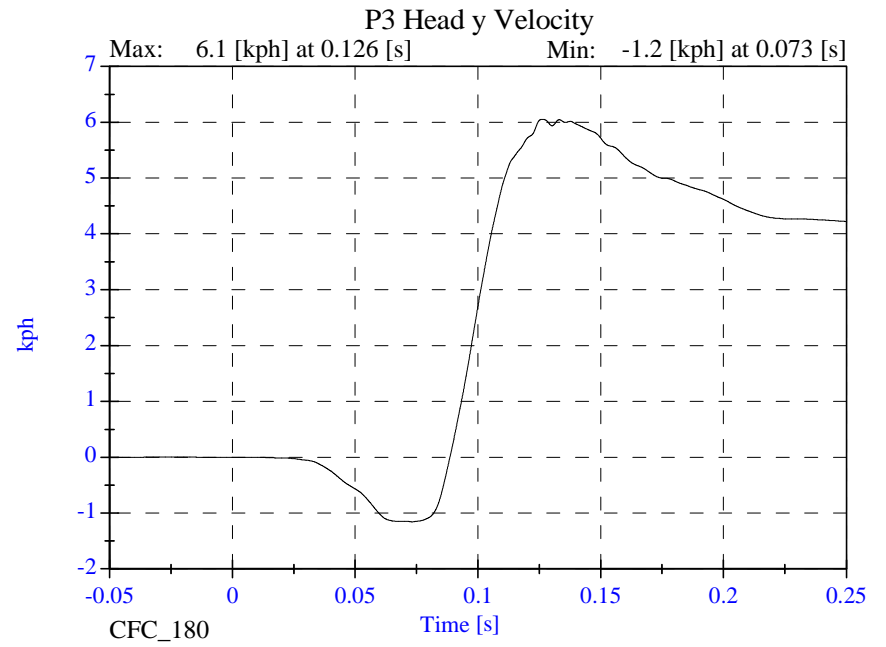
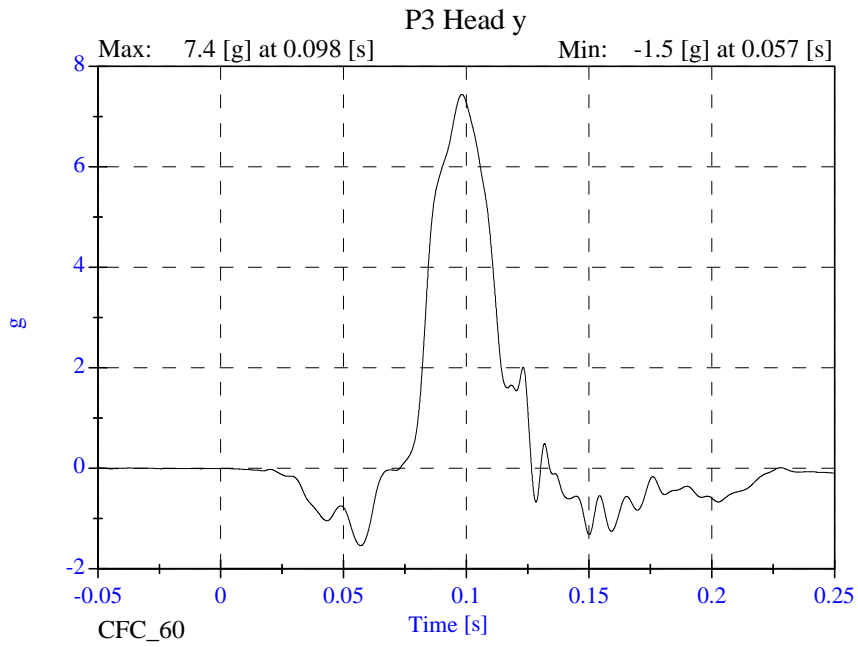
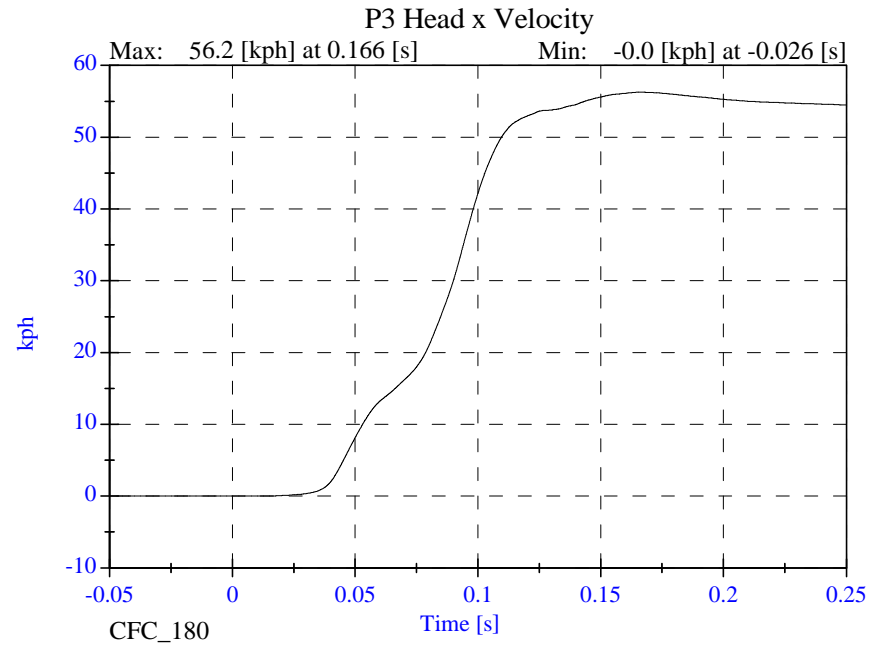
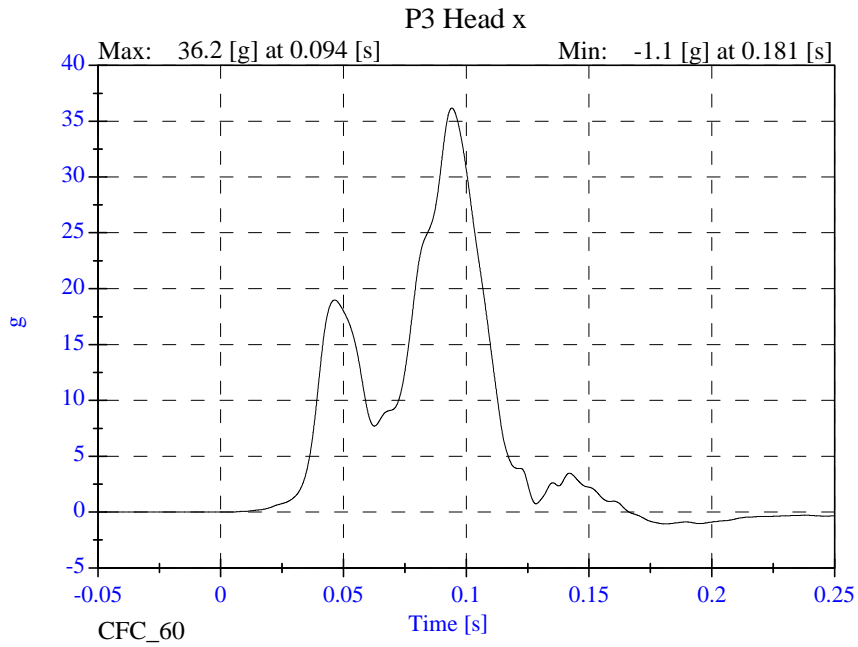

Sled Test Run 22467

- April 29, 2002

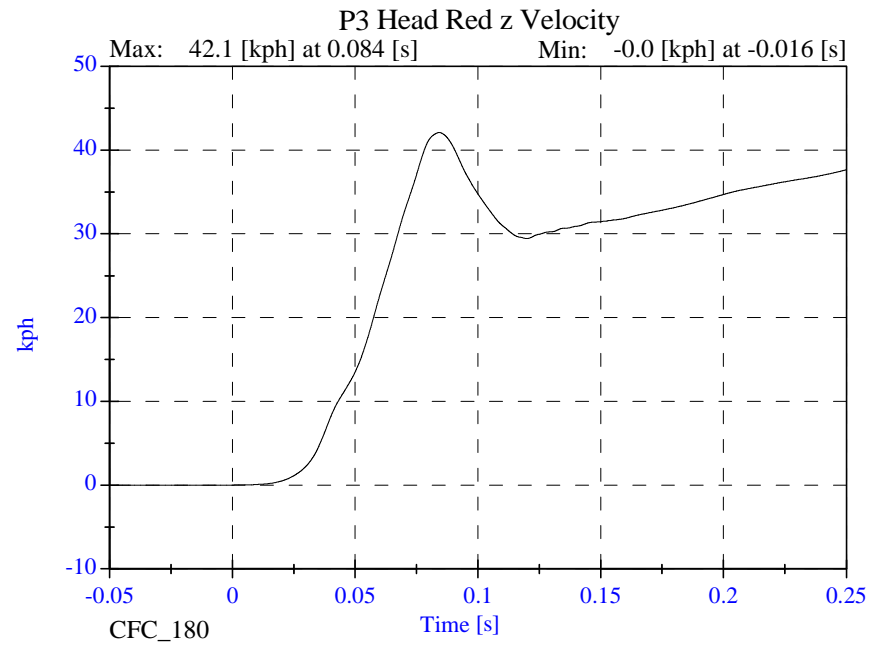
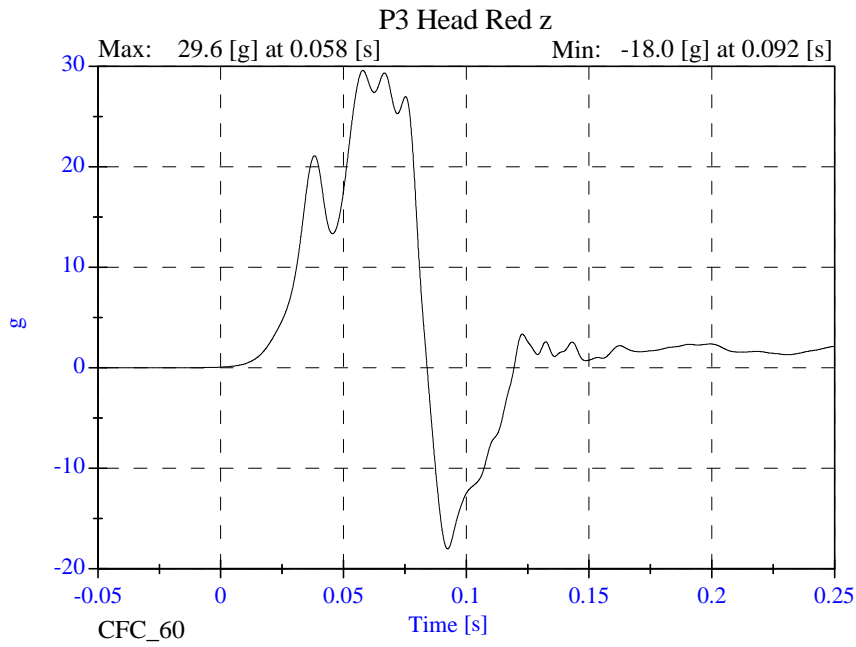
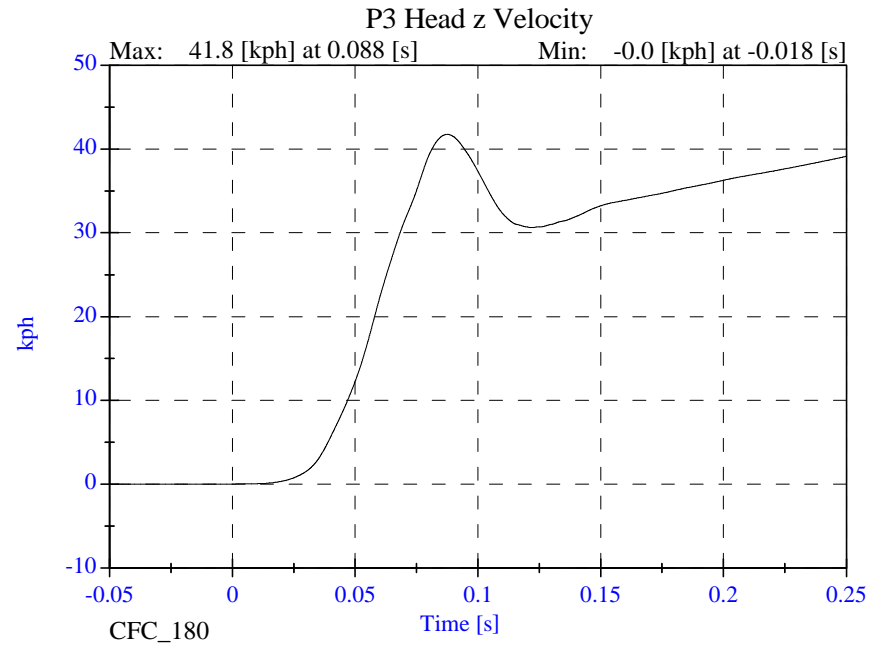
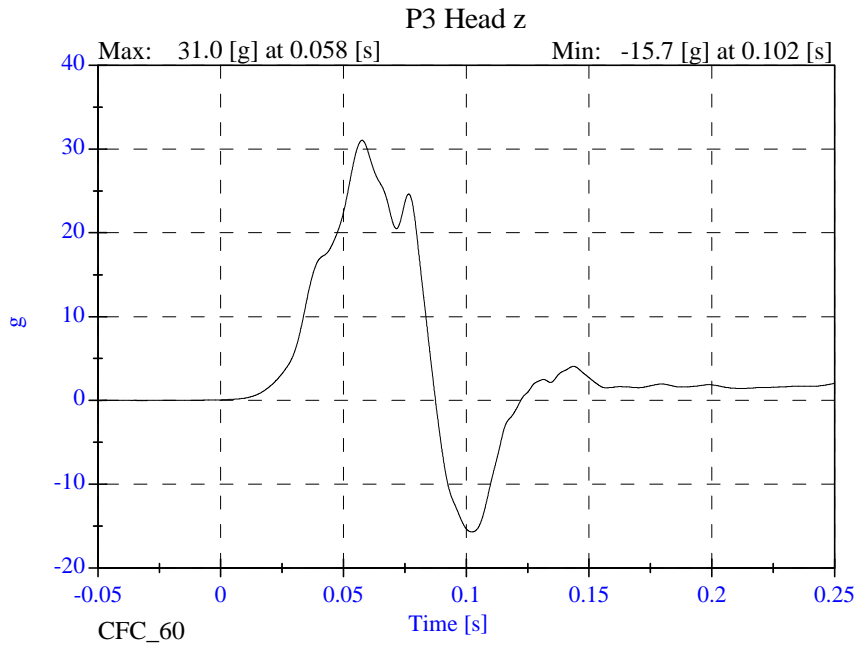

Sled Test Run 22467

- April 29, 2002

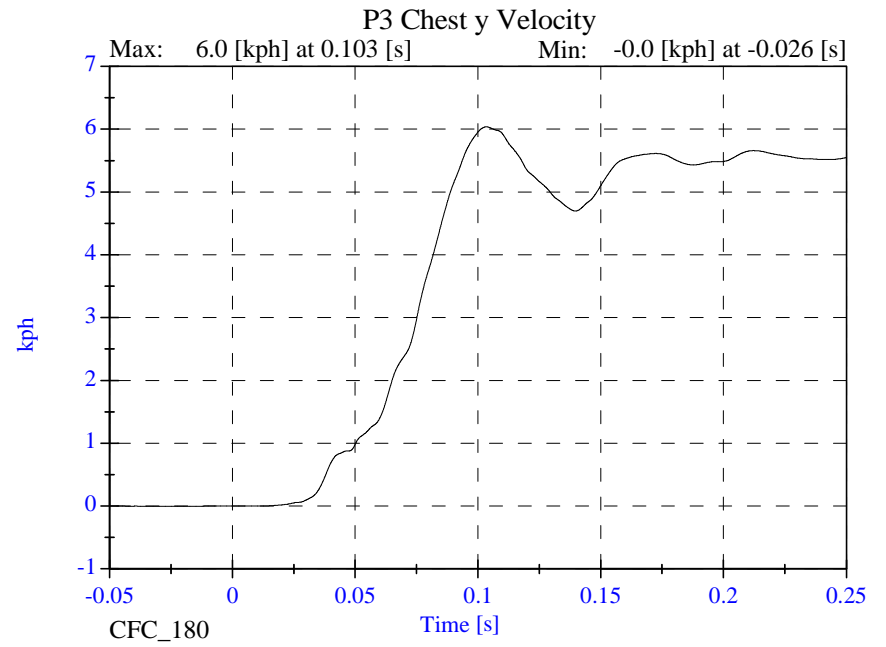
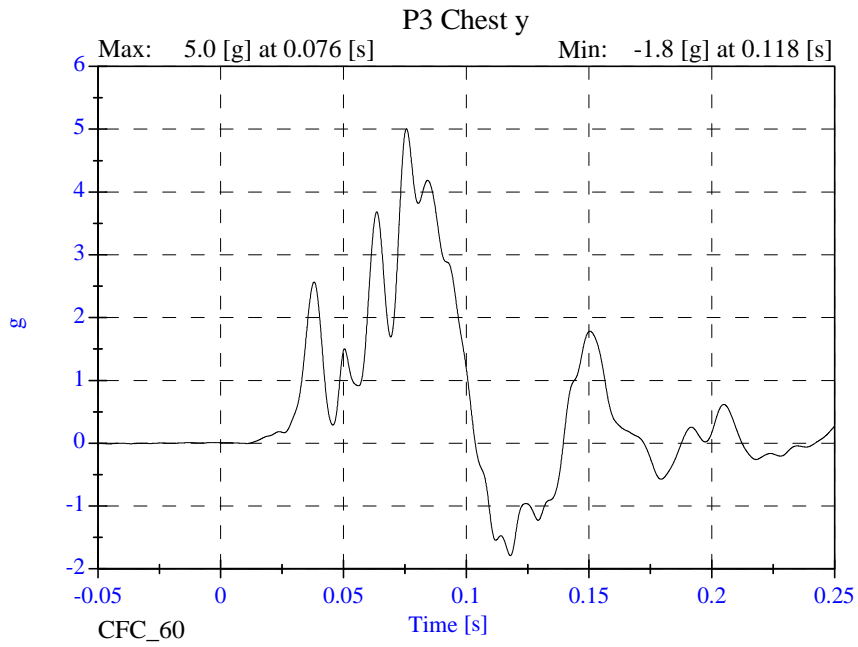
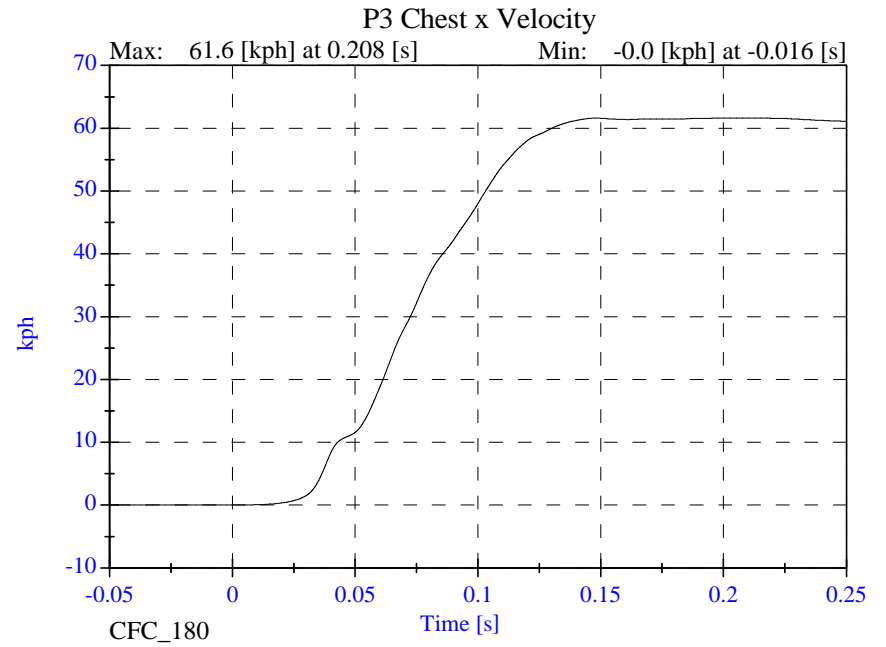
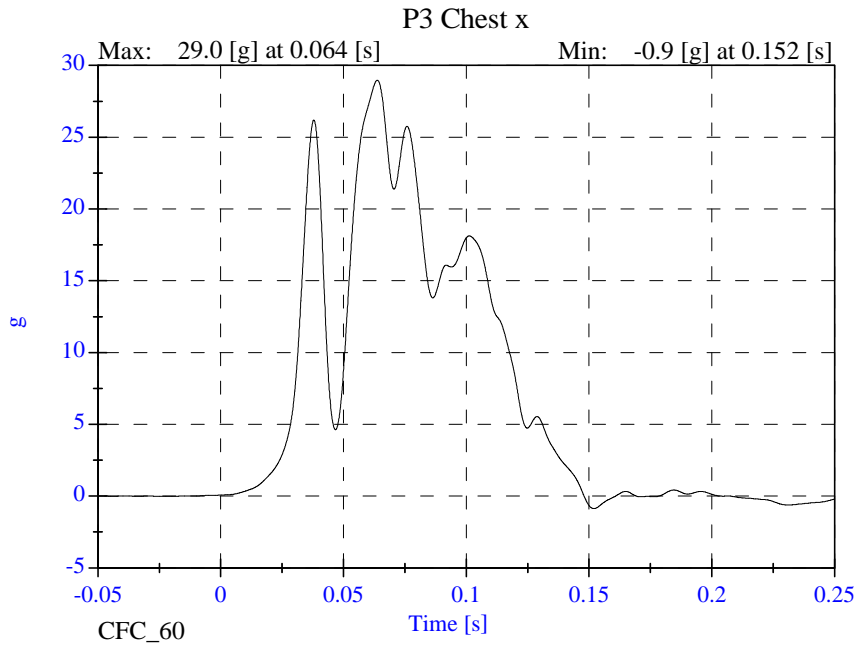

Sled Test Run 22467

- April 29, 2002

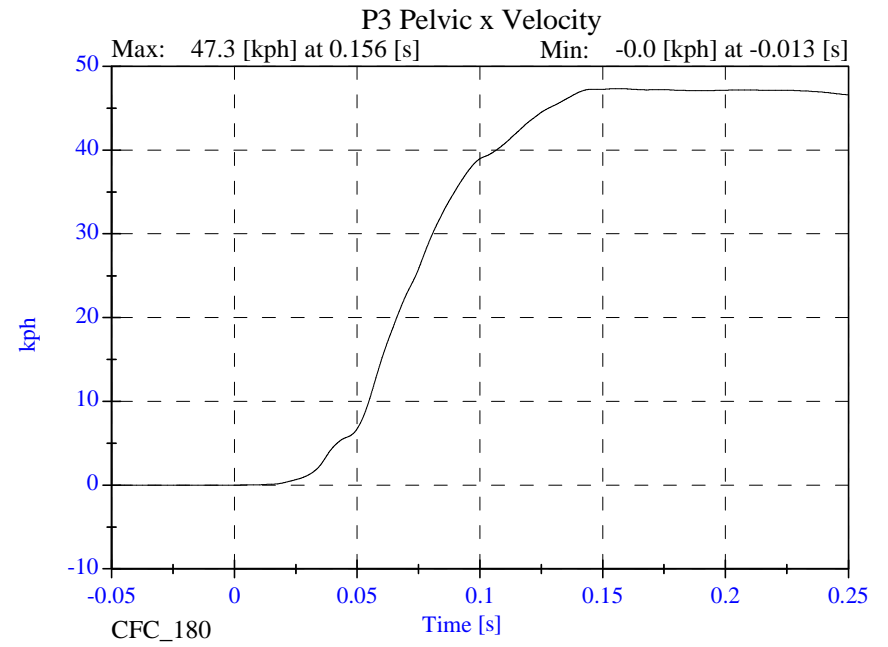
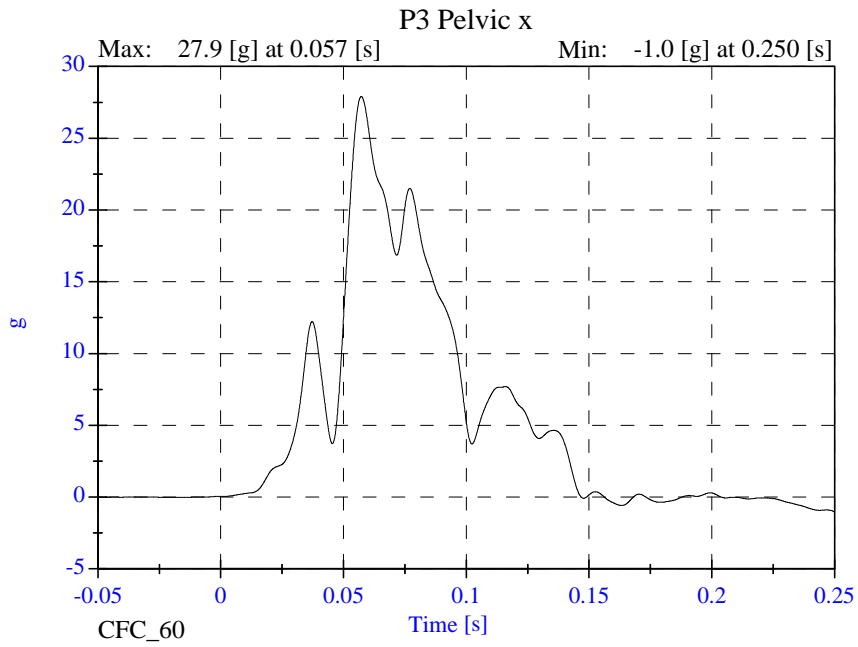
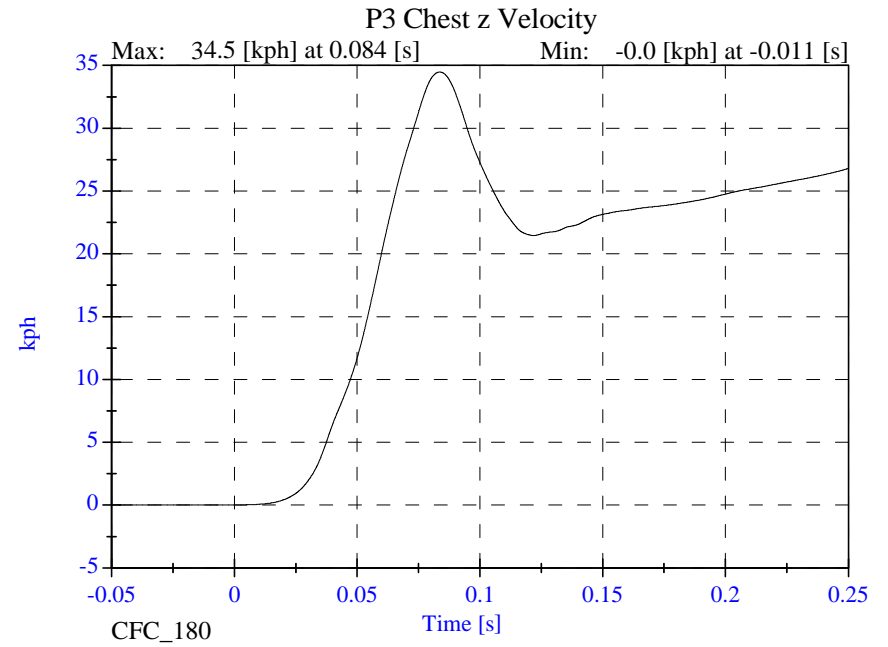
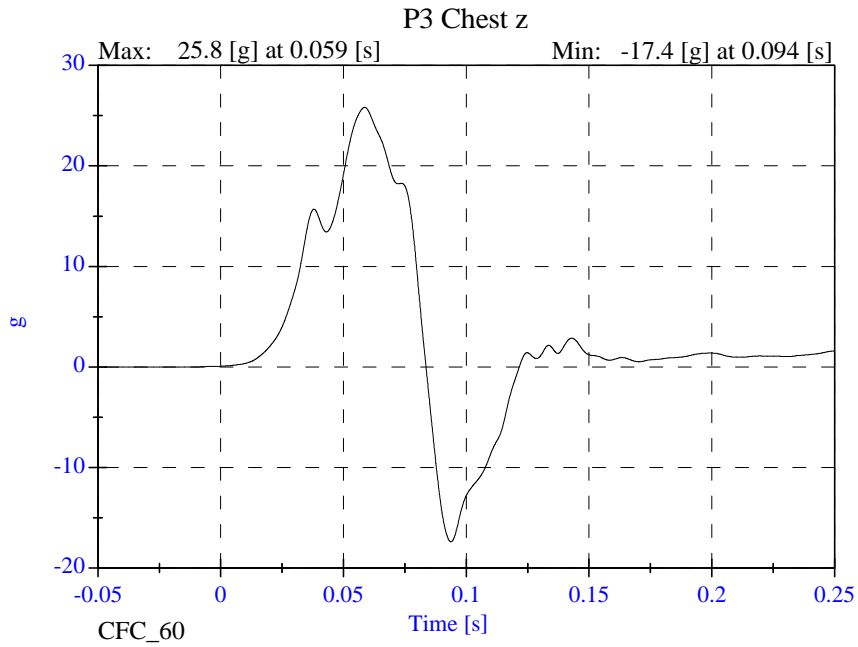

Sled Test Run 22467

- April 29, 2002

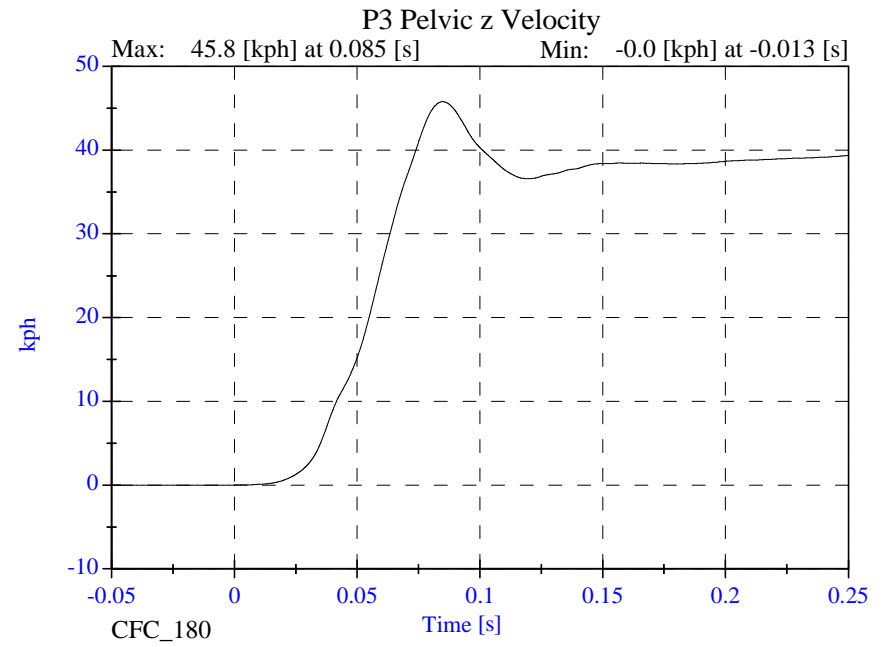
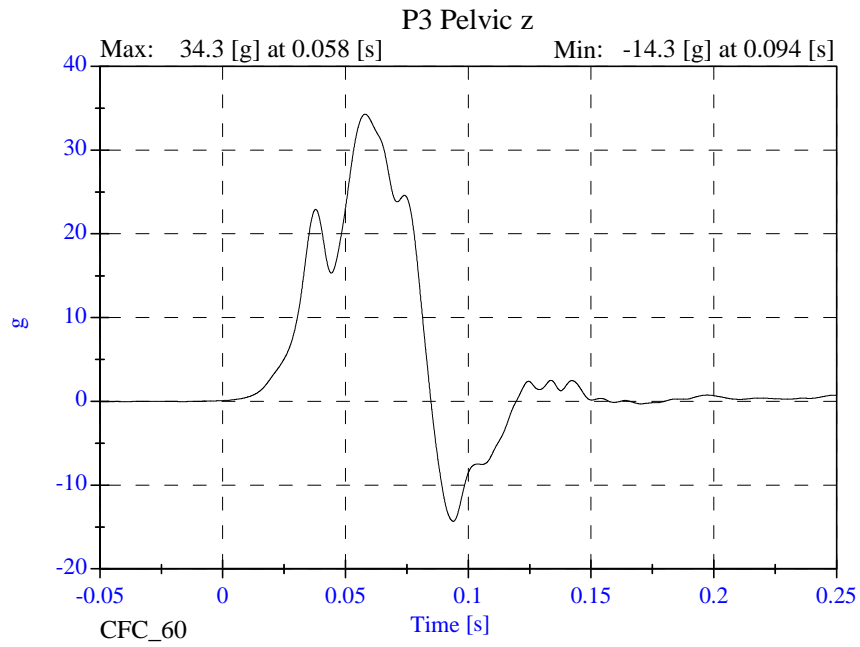
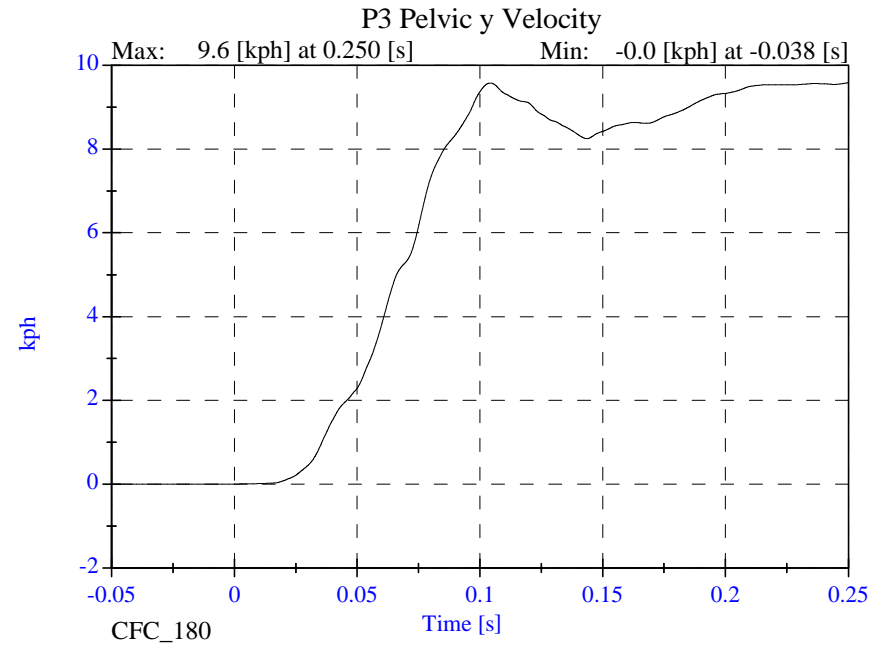
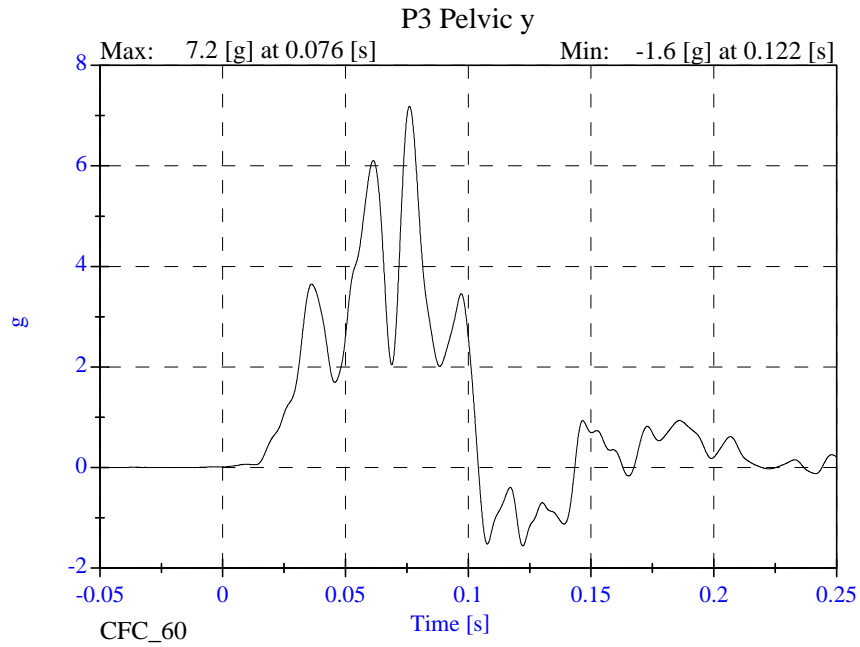

Sled Test Run 22467

- April 29, 2002

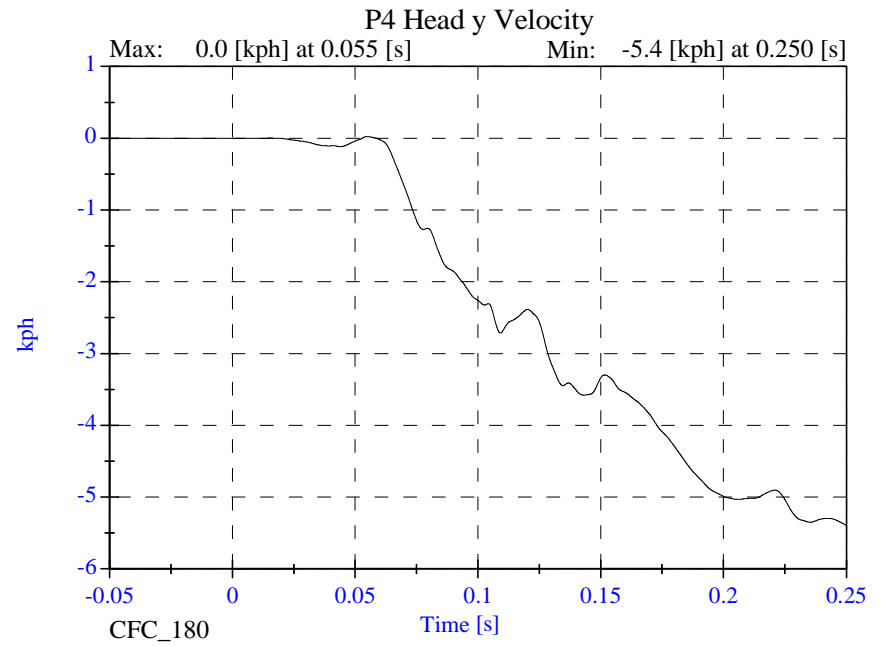
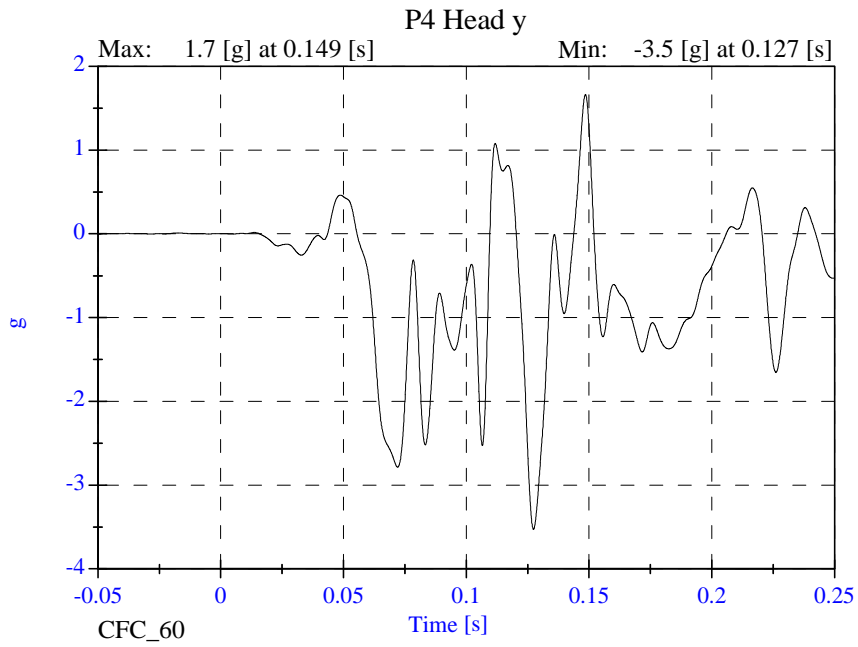
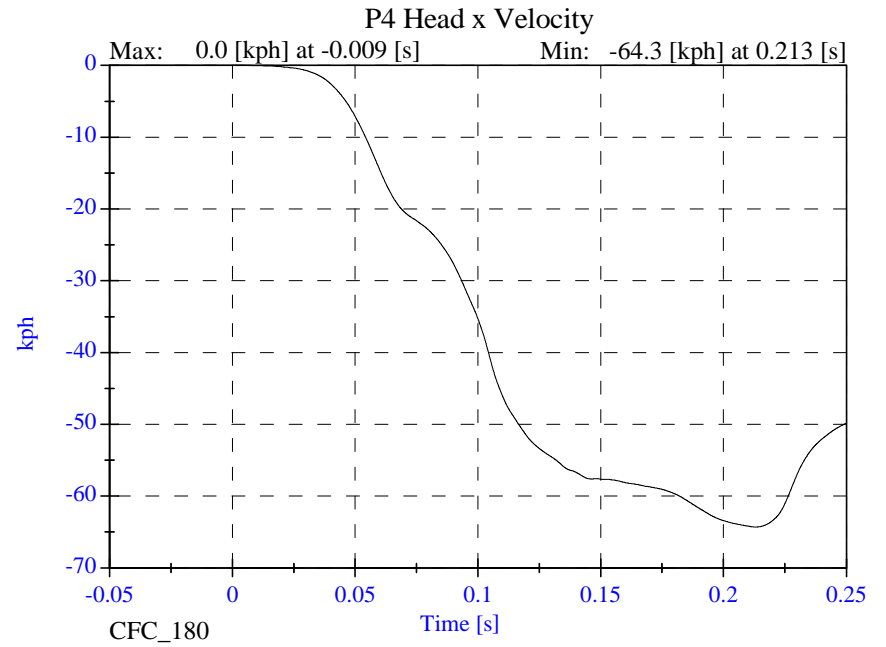
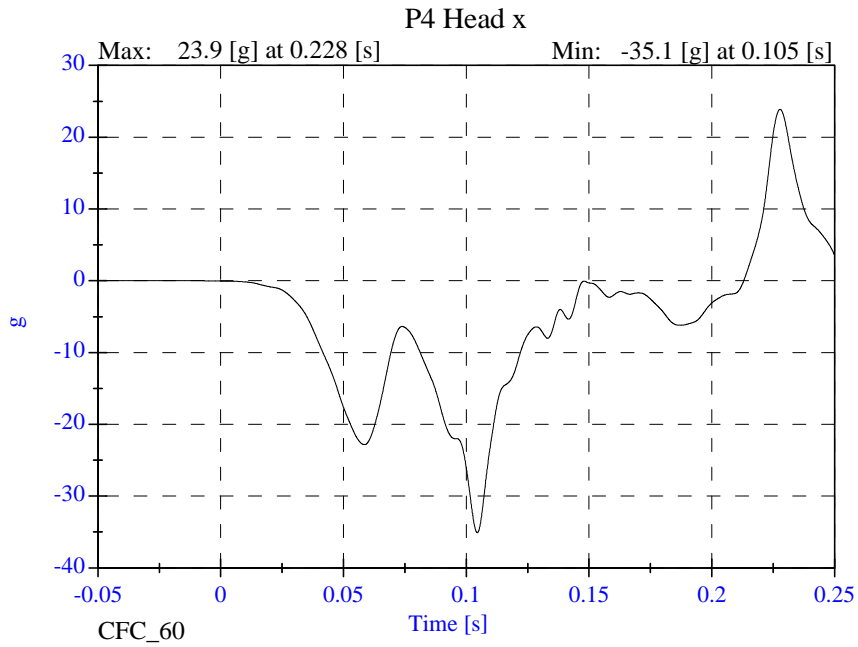

Sled Test Run 22467

- April 29, 2002

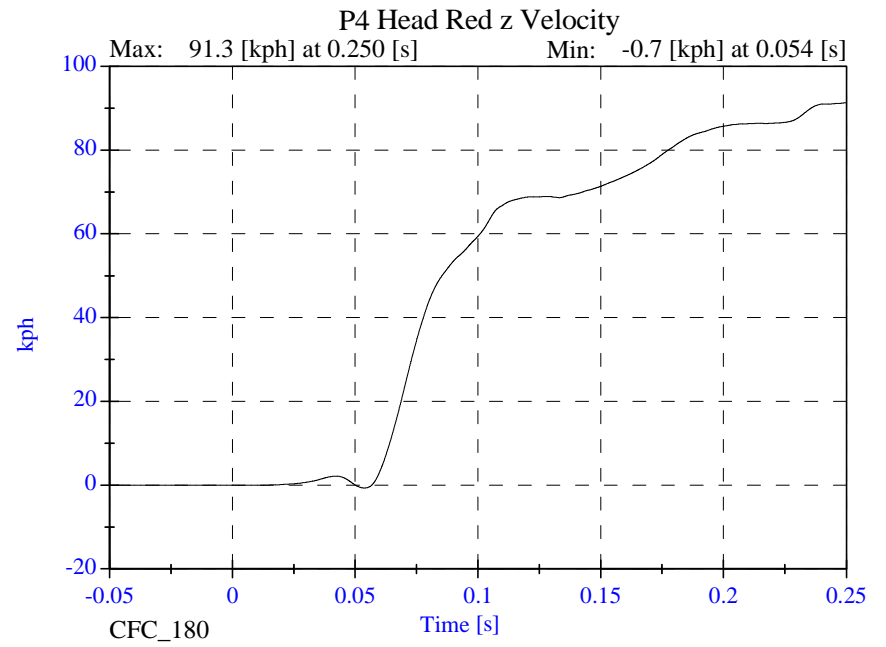
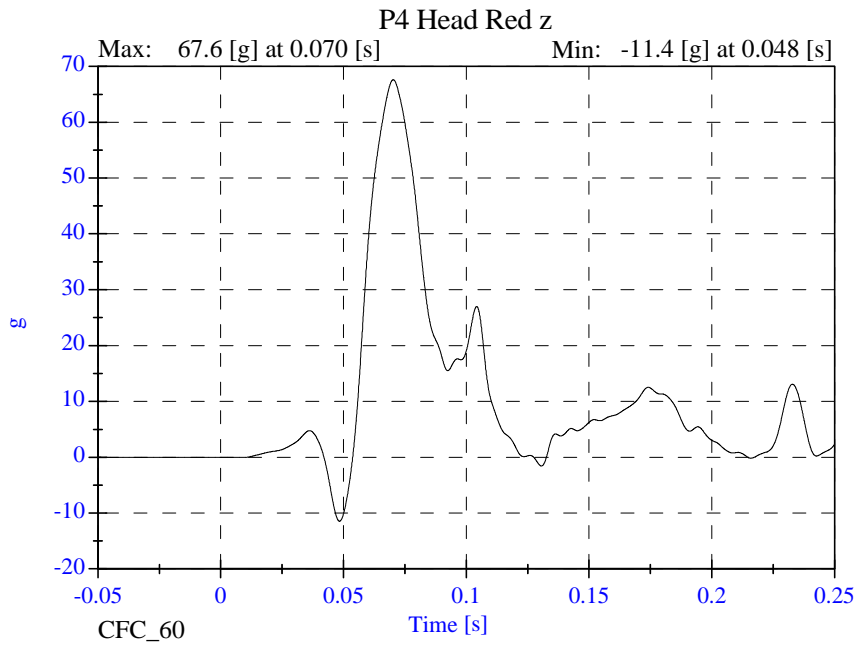
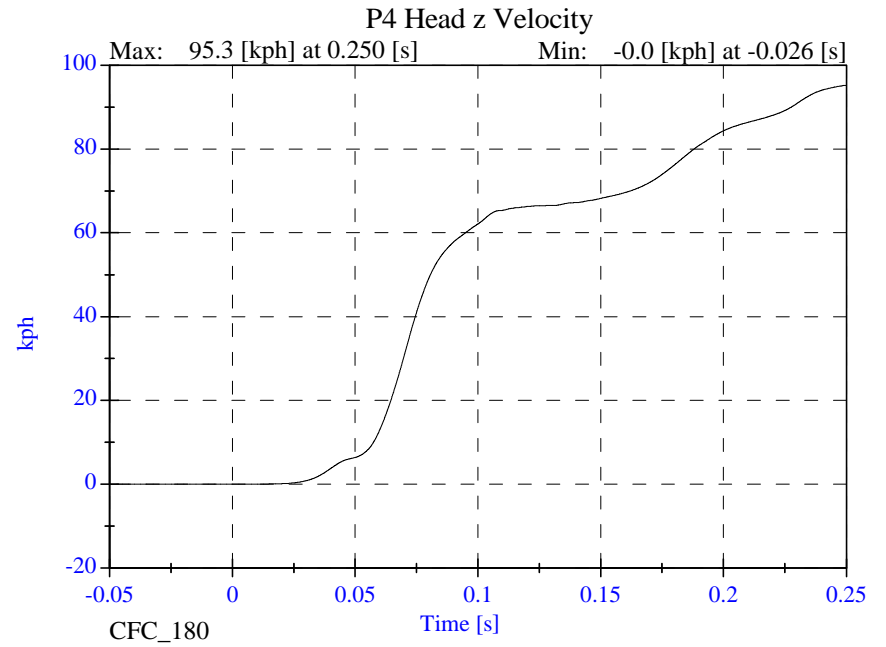
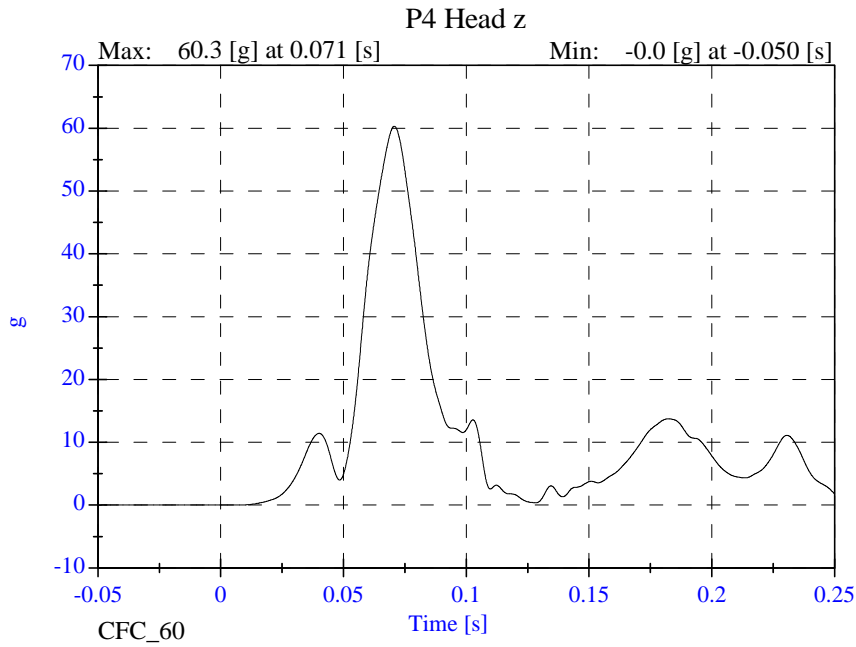

Sled Test Run 22467

- April 29, 2002

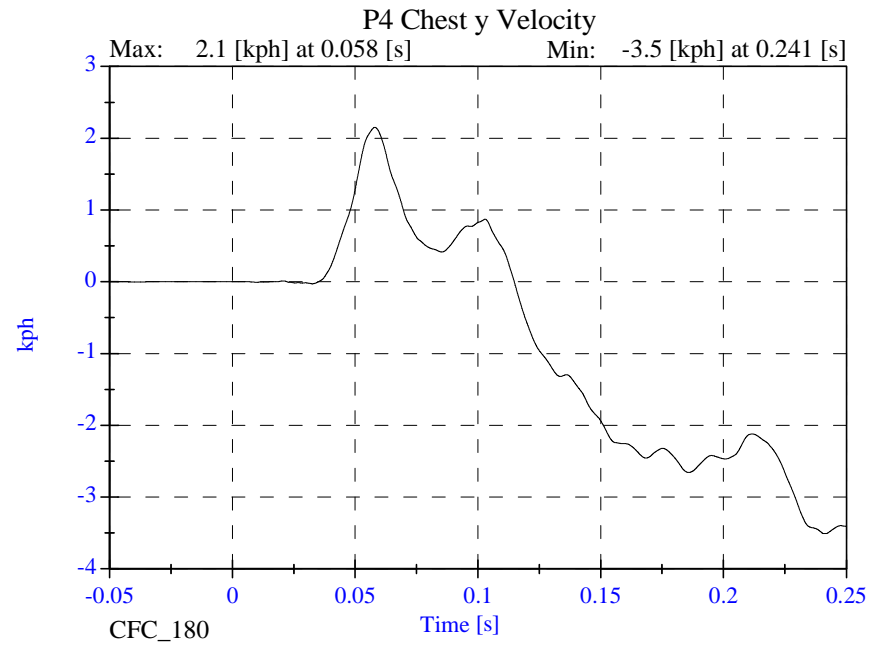
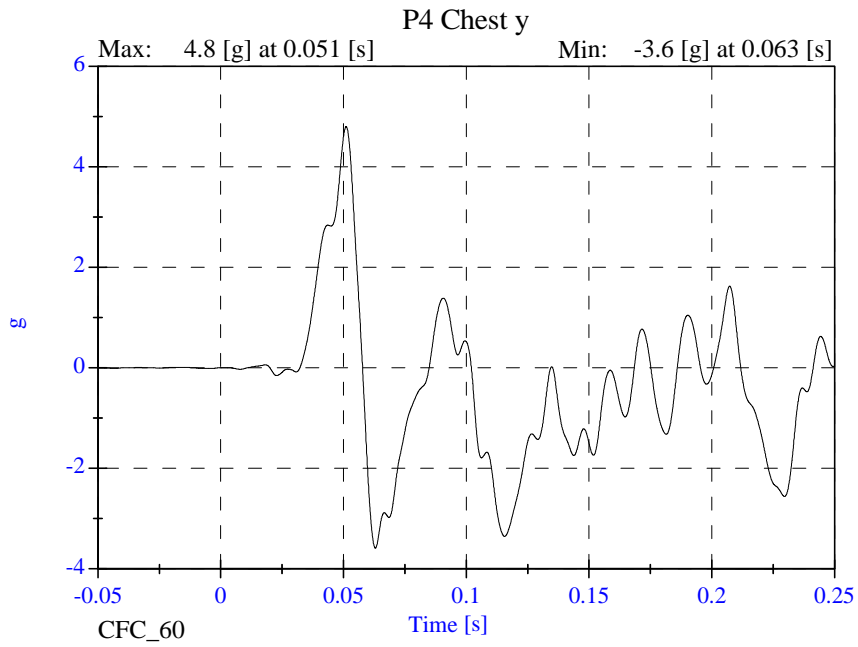
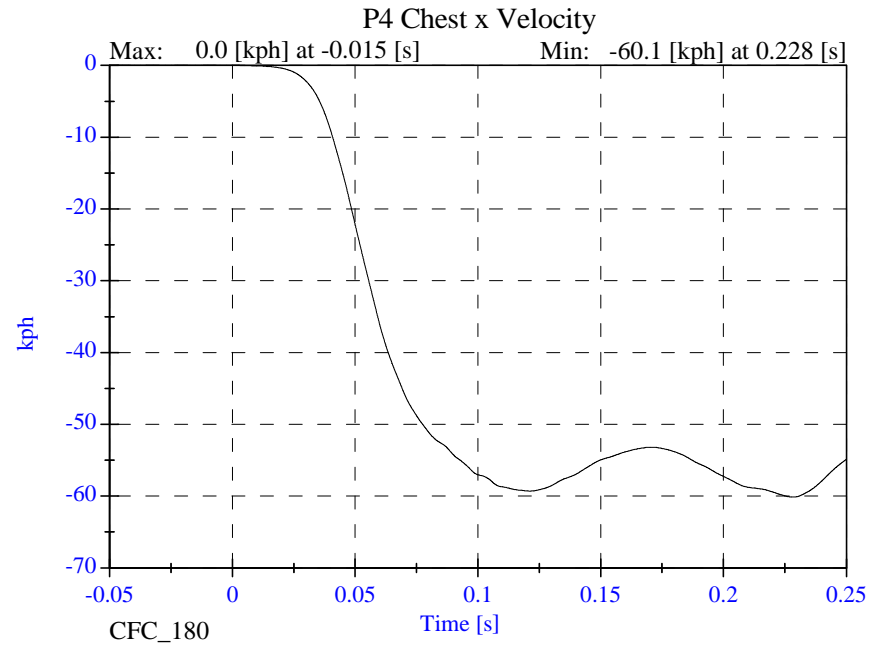
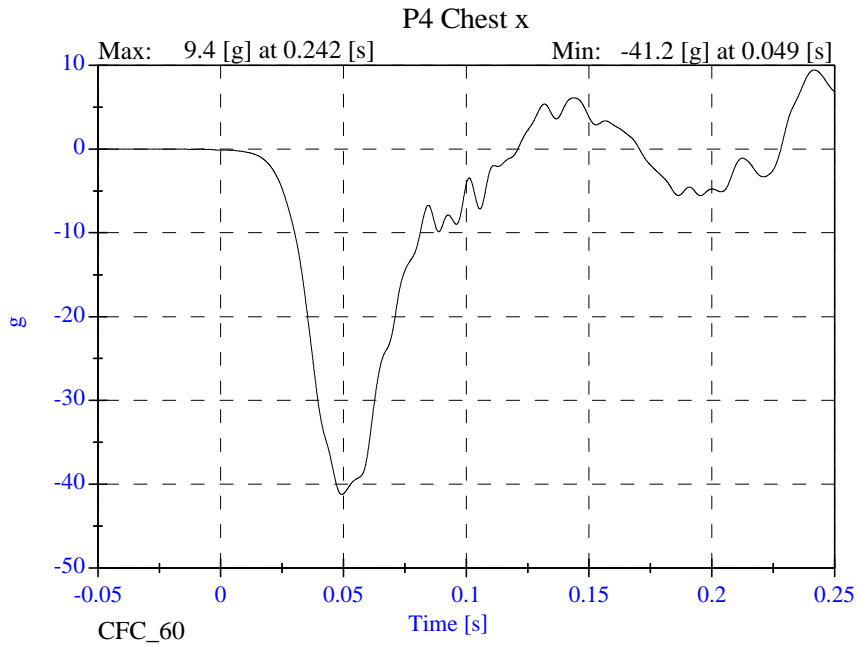

Sled Test Run 22467

- April 29, 2002

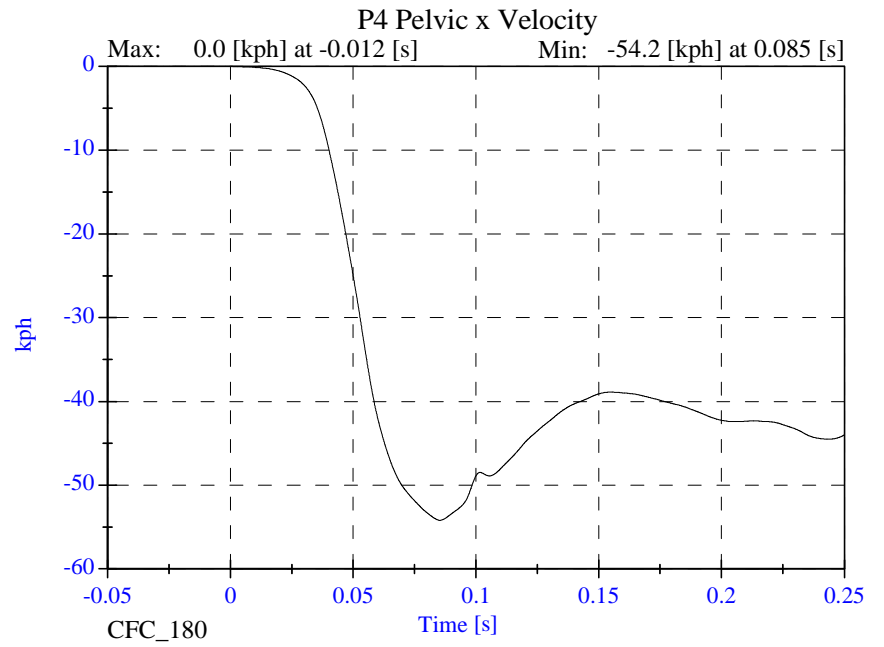
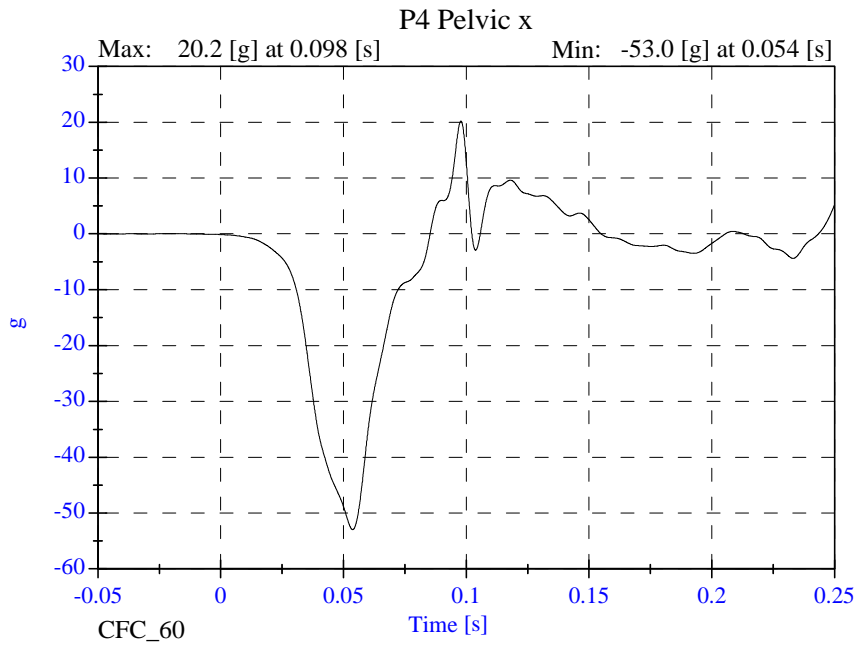
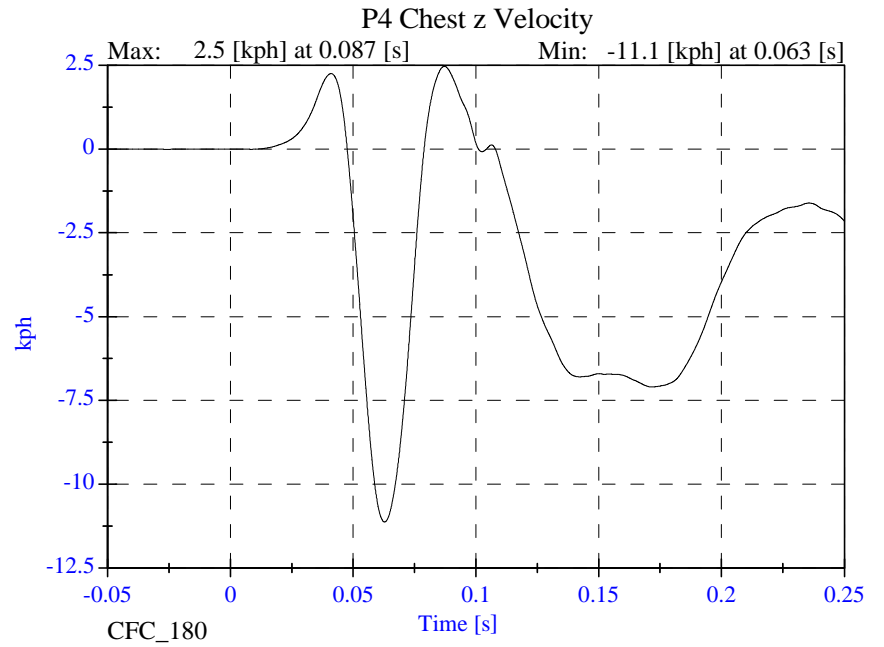
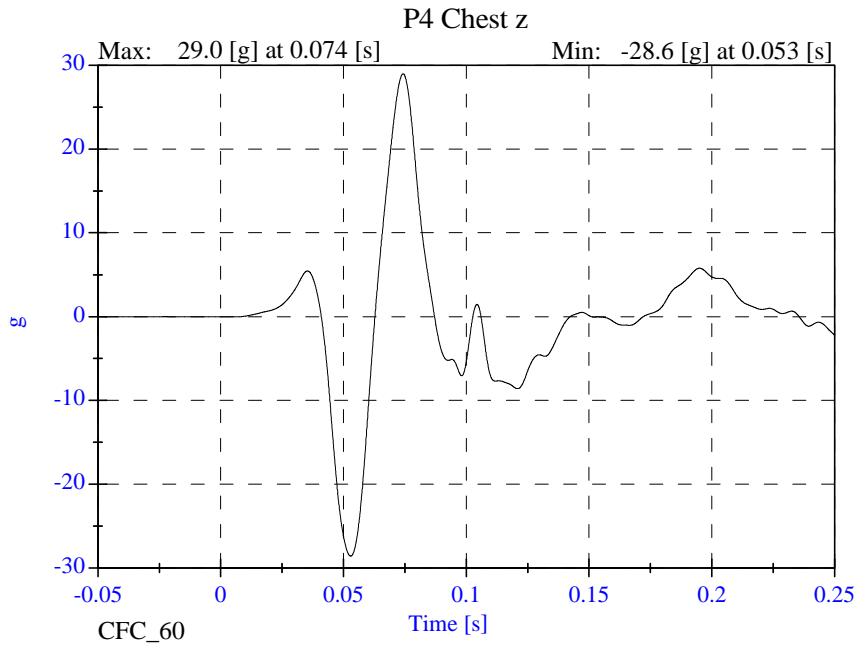

Sled Test Run 22467

- April 29, 2002

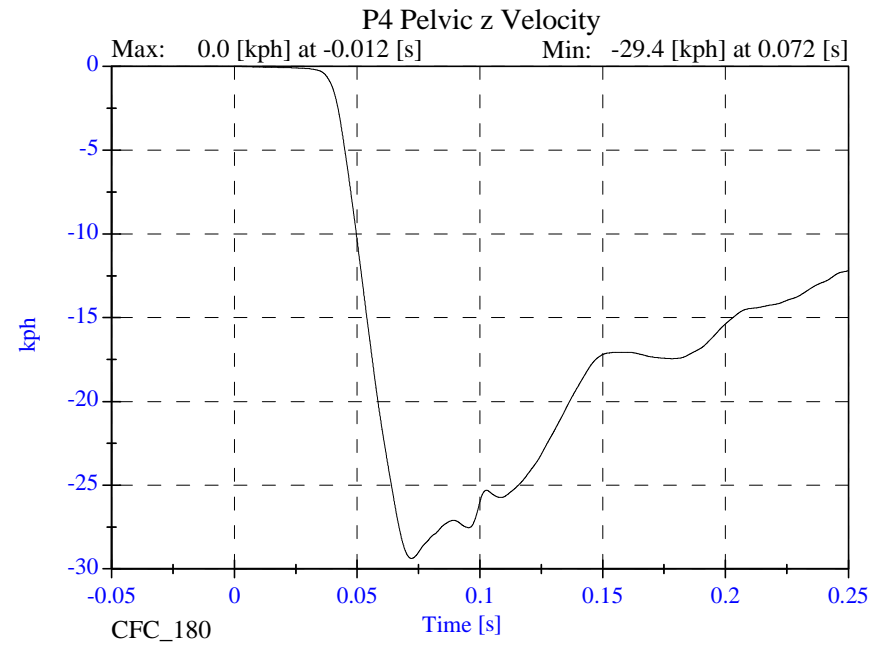
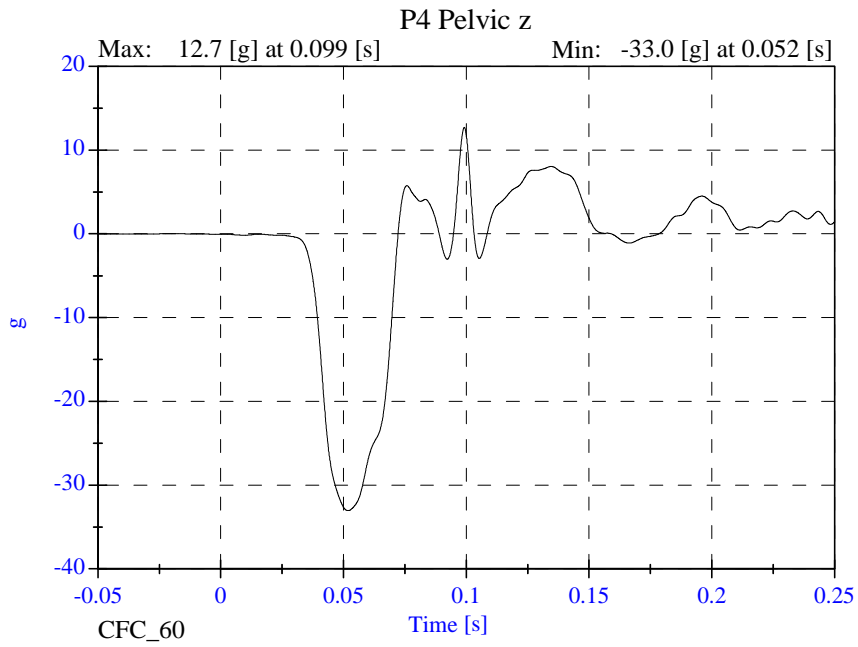
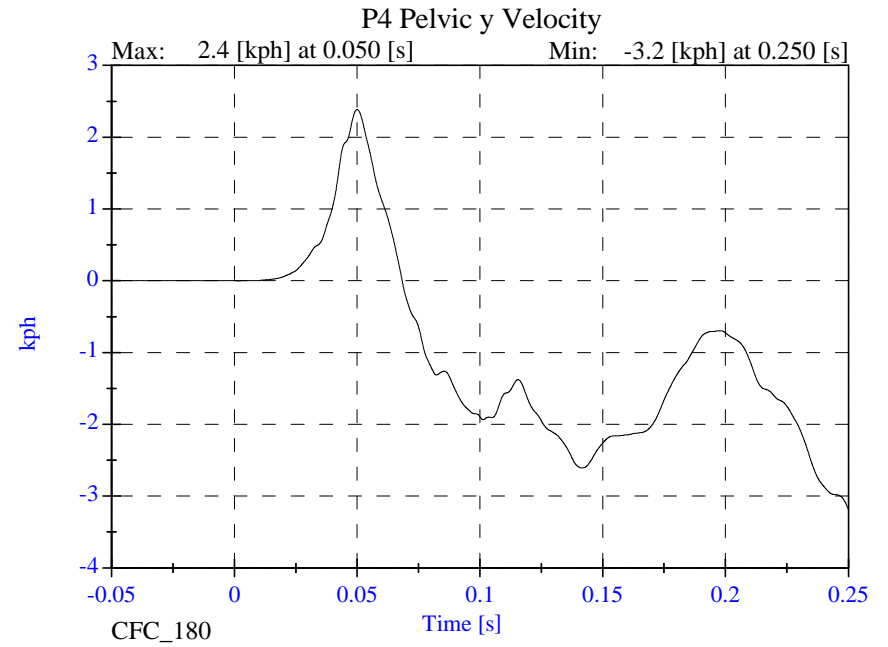
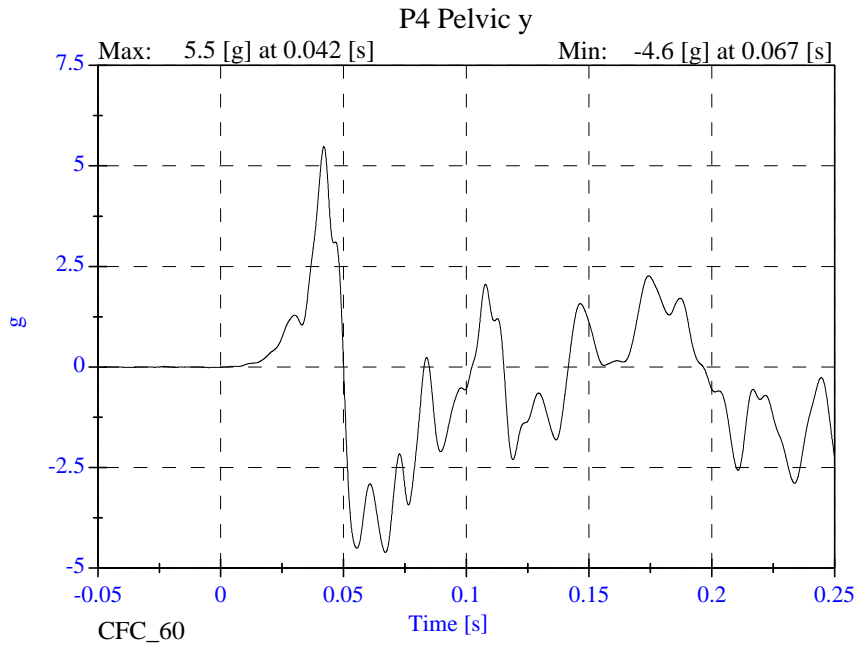

SECTION 12

COMPRESSION – DEFLECTION RESISTANCE TEST

Date 4/29/02
Performed By SD
Temp. 70°
Humidity 50%

Foam No. 2 x 20" x 29" HB

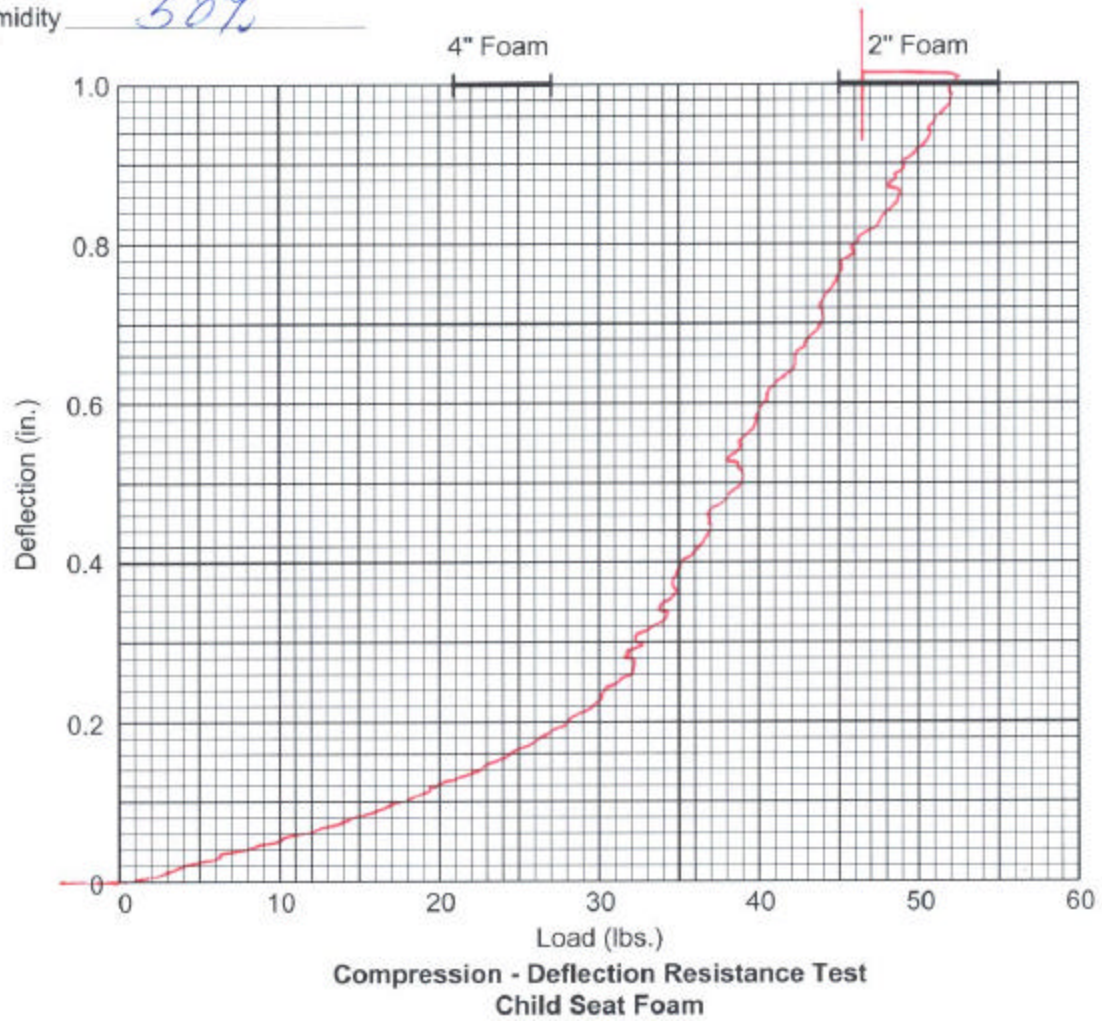

Date 4/29/02
Temp 70°
Humidity 50%
Foam No. 2" X 20" 2" X 29" #13

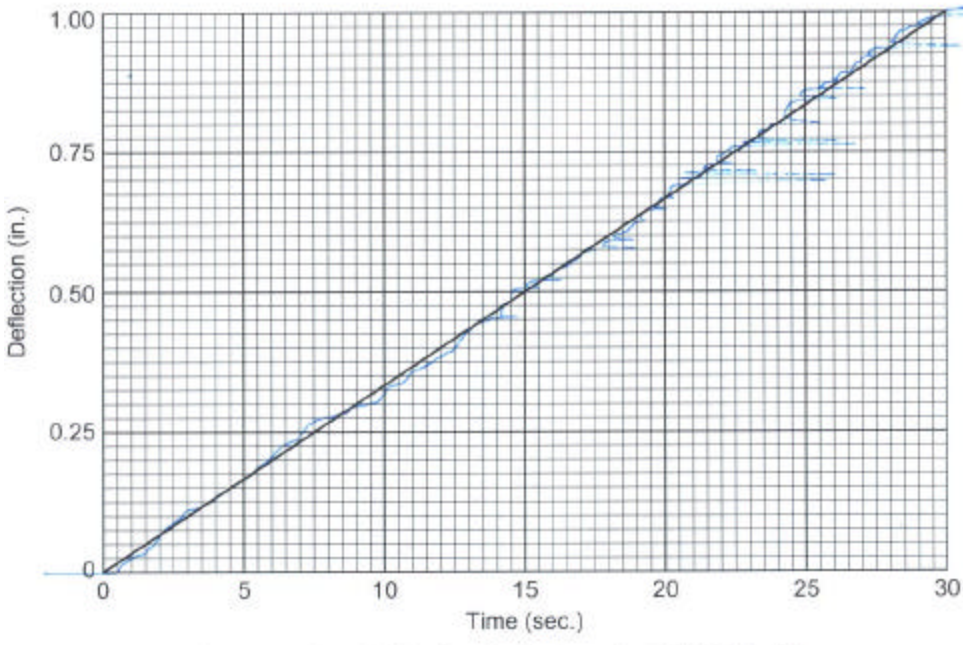

Compression - Deflection Resistance Test Child Seat Foam

SEAT FOAM USAGE LOG

Foam I.D. Number 2" x 20" 2' x 24" H3

Date	Peak Load	Pass/Fail
4/29/02	46.5 LBS	

Date 1/29/02
Performed By SD
Temp. 70°
Humidity 50%

Foam No. 4" x 20" #13

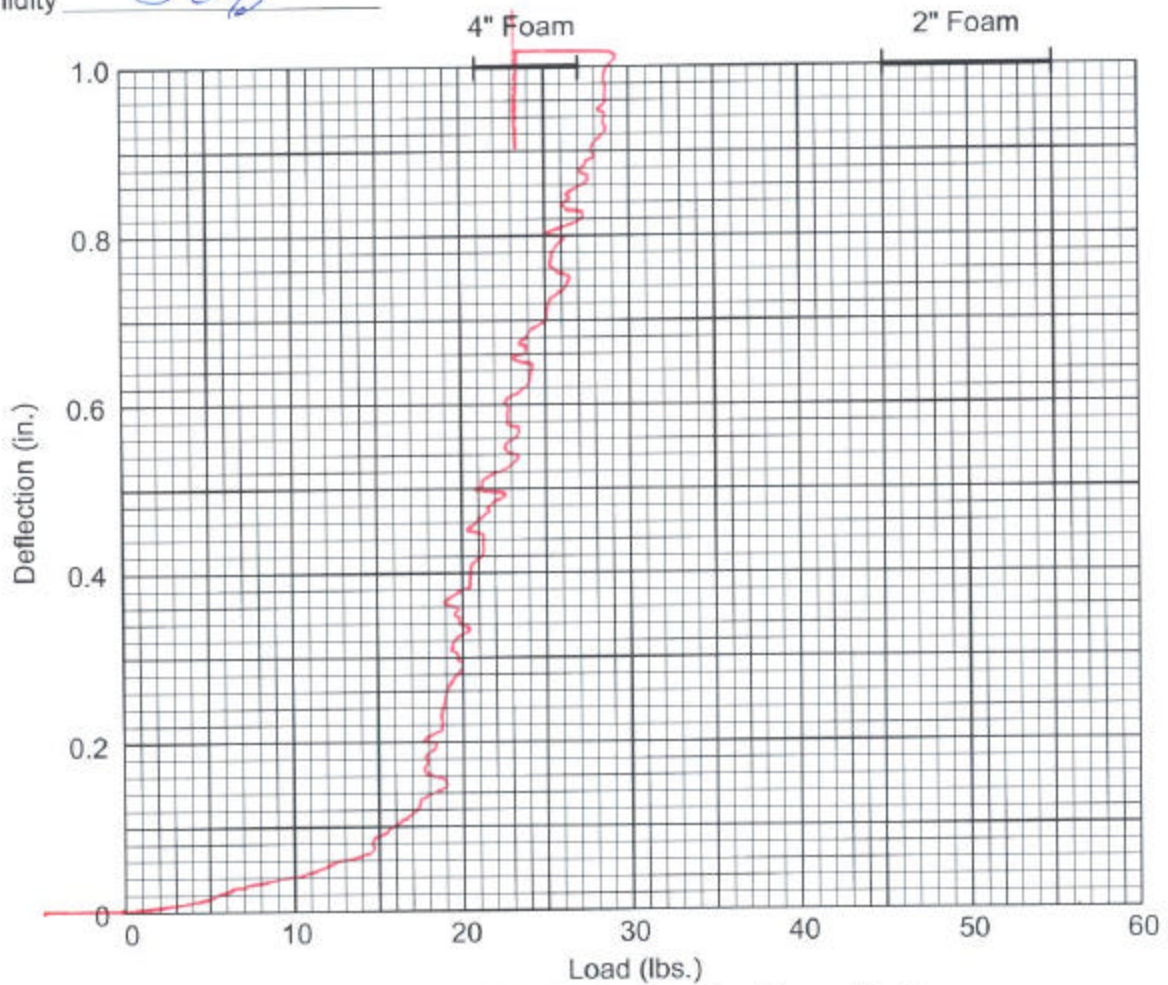

Compression - Deflection Resistance Test
Child Seat Foam

Date 4/29/02
Temp 70°
Humidity 50%
Foam No. 4" X 20" H3

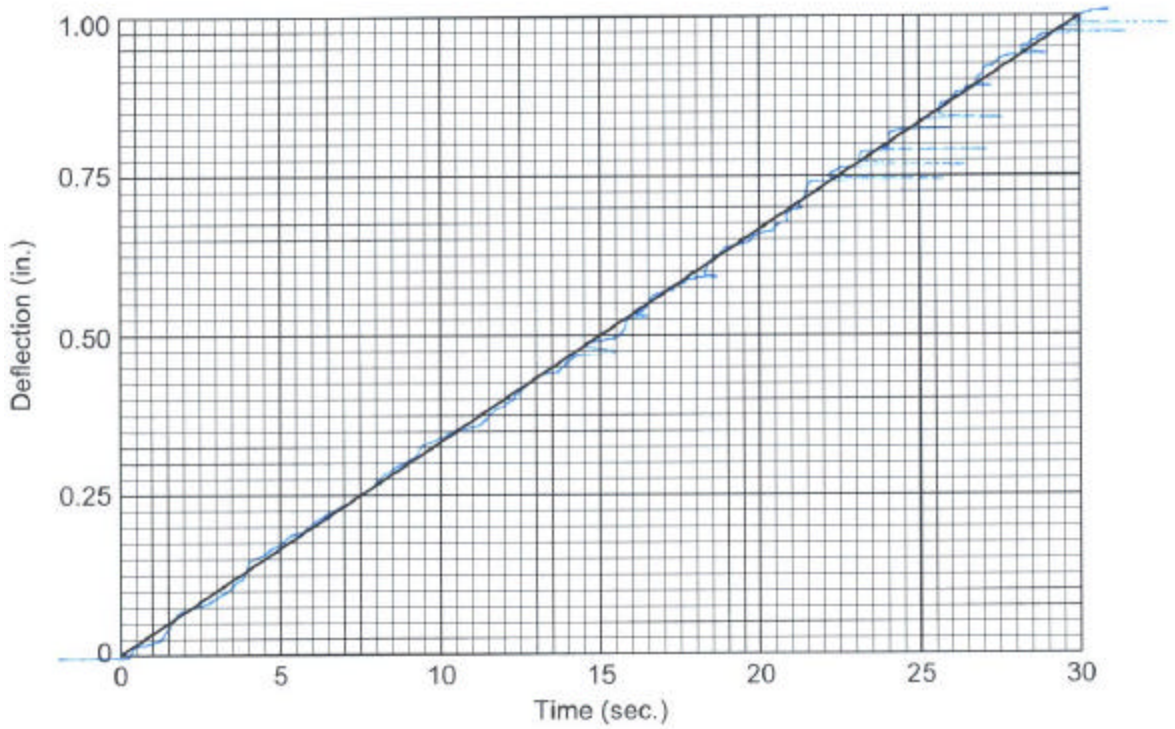

Compression - Deflection Resistance Test Child Seat Foam

T-001-R01

SEAT FOAM USAGE LOG

Foam I.D. Number 1" x 20" H3

Date	Peak Load	Pass/Fail
9/29/02	23.25 LBS	 PASS

Date 4/29/02
Performed By SO
Temp. 70°
Humidity 50%

Foam No. 4" X 24" H3

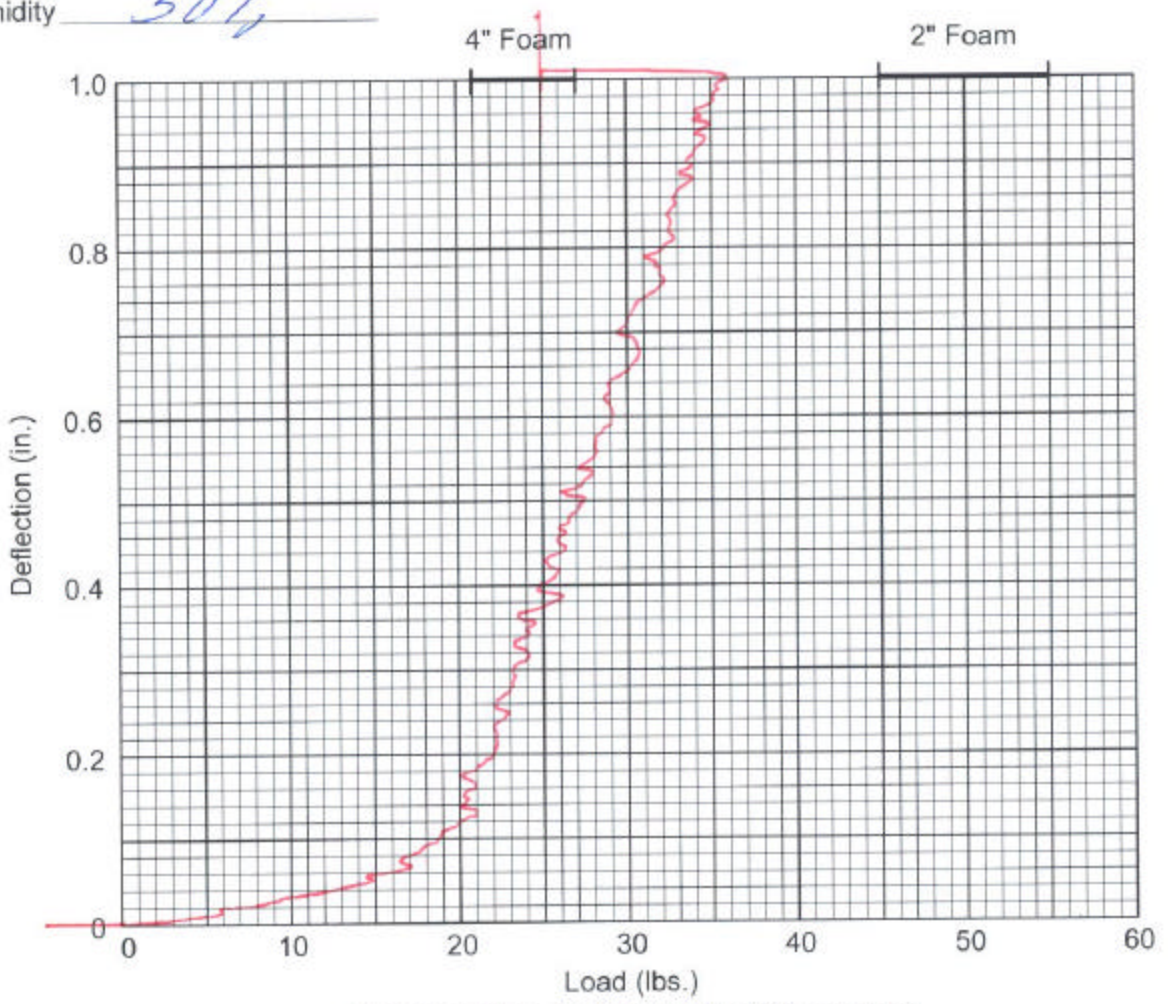

**Compression - Deflection Resistance Test
Child Seat Foam**

Date 4/23/02
Temp 70'
Humidity 50%
Foam No. 4" X 24" H3

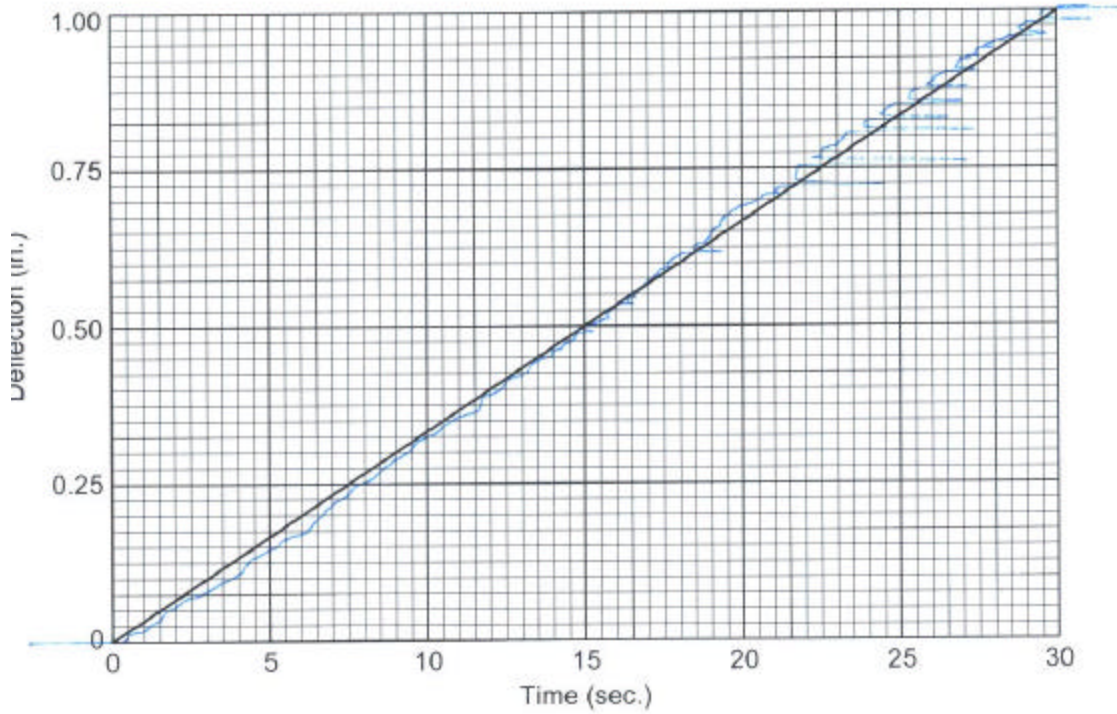

Compression - Deflection Resistance Test Child Seat Foam

001-R01

SEAT FOAM USAGE LOG

Foam ID, Number 4" X 24" H3

Date	Peak Load	Pass/Fail
4/29/02	25 LBS	

SECTION 13

CHILD DUMMY CALIBRATION DATA TRACES AND TABLES

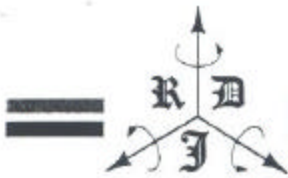

ROBERT A. DENTON, INC.
 2967 Waterview Dr., Rochester Hills, MI 48309-4600

Tel (248) 852-5100 • Fax (248) 852-6060 • email: info@radenton.com • www.radenton.com

Crab: #022

Upper Neck

Calibration Report
Uni-Directional Calibration

Automated Load Cell Calibration System
 Copyright (c) 1987-2000 Robert A. Denton, Inc.

Calibration No.	C2624000	Date	Jan 7, 2002	Due	Jan 7, 2003
Model No.	IF-954	Serial No.	128		
Technician	J. Kovalchuk	Temp (C) / Hum. (%)	21.5 / 23.5		
Customer	VRTC	Last Calibrated	Jan 7, 2002		
Description	Infant Neck	Customer Tag Number	N/A		

Voltage Calibration

Bridge	Capacity	Zero Offset	Nonlinearity	Hysteresis	Output @ Capacity	% Change
FX	200.0 lbf	0.0027 mV/V	0.08 % FS	0.14 % FS	-0.9660 mV/V	0.00 % FS
FY	200.0 lbf	0.0002 mV/V	0.06 % FS	0.13 % FS	0.9619 mV/V	0.00 % FS
FZ	500.0 lbf	-0.0384 mV/V	0.02 % FS	0.03 % FS	-0.7631 mV/V	0.00 % FS
MX	500.0 in-lbf	0.0306 mV/V	0.09 % FS	0.63 % FS	-1.3446 mV/V	0.00 % FS
MY	500.0 in-lbf	-0.0214 mV/V	0.17 % FS	0.78 % FS	1.3175 mV/V	0.00 % FS
MZ	300.0 in-lbf	-0.0182 mV/V	0.18 % FS	0.26 % FS	1.4495 mV/V	0.00 % FS

Shunt

Bridge	Shunt Value	Equivalent Load	Bridge Resistance (nom)
FX	120.0 K Ohms	-153.2 lbf	350.0 Ohms
FY	120.0 K Ohms	154.1 lbf	350.0 Ohms
FZ	300.0 K Ohms	-383.4 lbf	700.0 Ohms
MX	80.0 K Ohms	-412.3 in-lbf	350.0 Ohms
MY	80.0 K Ohms	420.9 in-lbf	350.0 Ohms
MZ	160.0 K Ohms	227.2 in-lbf	700.0 Ohms

NOTE: Positive shunt is between +Exc_+Sig Negative shunt is between -Exc_+Sig

Wire Color Codes

FX-MX		FY-MY		FZ-MZ	
Brown	+ Exc.	Red Stripe	+ Exc.	Green	+ Exc.
Red	+ Sig.	Black	+ Sig.	Blue	+ Sig.
Orange	- Exc.	White	- Exc.	Violet	- Exc.
Yellow	- Sig.	Black Stripe	- Sig.	Grey	- Sig.

Reference Load Cell

Manufacturer	Model No.	Serial No.	Calibration Due Date
Revere	363-B10-500-20P1	H607172L	Jul 24, 2002

Calibrated by

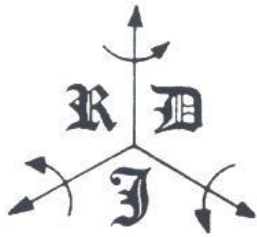

 Robert A. Denton, Inc. Authorized Representative



CALIBRATION REPORT

Uni-Directional Calibration Loading Sequence Summary

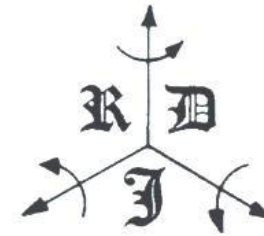
Automated Load Cell Calibration System
Copyright (c)1987-2000 Robert A. Denton, Inc.



Calibration Number	C2624000	This Calibration	08:36:53	Jan 7, 2002
Model Number	IF-954	Calibration Due		Jan 7, 2003
Serial Number	128	Last Calibrated		Jan 7, 2002
Description	Infant Neck	Temp (C) / Hum. (%)		21.5 / 23.5
Customer	VRTC	Customer Tag Number		N/A

Loading Sequence

Axis	FS Load EU	FS Output mV/V	Sensitivity mV/V/EU	Nonlinearity % FS	Hysteresis % FS	Moment Arm EU
FX	200.0 lbf	-0.9660	-0.0048300	0.08	0.14	0.00
FY	200.0 lbf	0.9619	0.0048093	0.06	0.13	0.00
FZ	500.0 lbf	-0.7631	-0.0015262	0.02	0.03	0.00
MX	500.0 in-lbf	-1.3446	-0.0026893	0.09	0.63	1.00
MY	500.0 in-lbf	1.3175	0.0026350	0.17	0.78	1.00
MZ	300.0 in-lbf	1.4495	0.0048318	0.18	0.26	1.50

Bridge Unbalance

FX Axis	0.0027 mV/V
FY Axis	0.0002 mV/V
FZ Axis	-0.0384 mV/V
MX Axis	0.0306 mV/V
MY Axis	-0.0214 mV/V
MZ Axis	-0.0182 mV/V

Linearization

Force (FX)	=	0.1	+	-207.0	* Output (mV/V)
Force (FY)	=	0.1	+	207.8	* Output (mV/V)
Force (FZ)	=	0.1	+	-655.1	* Output (mV/V)
Force (MX)	=	0.2	+	-371.8	* Output (mV/V)
Force (MY)	=	0.3	+	379.7	* Output (mV/V)
Force (MZ)	=	0.3	+	206.8	* Output (mV/V)

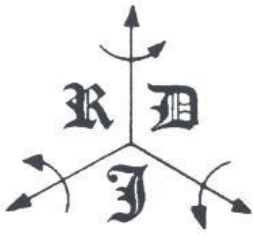

CALIBRATION REPORT

Uni-Directional Calibration Crosstalk Summary

Automated Load Cell Calibration System
Copyright (c)1987-2000 Robert A. Denton, Inc.

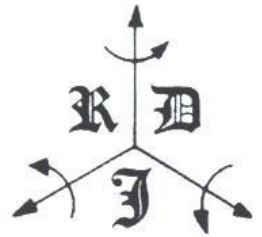

Calibration Number	C2624000	This Calibration	08:36:53	Jan 7, 2002
Model Number	IF-954	Calibration Due		Jan 7, 2003
Serial Number	128	Last Calibrated		Jan 7, 2002
Description	Infant Neck	Temp (C) / Hum. (%)		21.5 / 23.5
Customer	VRTC	Customer Tag Number		N/A

Raw Crosstalk Data (mV/V)

Bridge		FX	FY	FZ	MX	MY	MZ
	<u>Applied Load</u>	200.0	200.0	500.0	500.0	500.0	300.0
		<u>lbf</u>	<u>lbf</u>	<u>lbf</u>	<u>in-lbf</u>	<u>in-lbf</u>	<u>in-lbf</u>
FX	200.0 lbf	-0.9660	0.0046	0.0050	0.0040	-0.0090	-0.0107
FY	200.0 lbf	0.0055	0.9619	0.0025	-0.0167	0.0011	-0.0131
FZ	500.0 lbf	0.0003	0.0011	-0.7631	0.0094	-0.0057	0.0046
MX	500.0 in-lbf	0.0047	0.0087	-0.7561	-1.3446	0.0033	0.0158
MY	500.0 in-lbf	0.0081	0.0008	-0.7649	0.0141	1.3175	0.0125
MZ	300.0 in-lbf	0.0155	0.9678	0.0205	-0.0080	-0.0039	1.4495

% FS Crosstalk *

Bridge		FX	FY	FZ	MX	MY	MZ
	<u>Applied Load</u>	200.0	200.0	500.0	500.0	500.0	300.0
		<u>lbf</u>	<u>lbf</u>	<u>lbf</u>	<u>in-lbf</u>	<u>in-lbf</u>	<u>in-lbf</u>
FX	200.0 lbf	0.00%	0.48%	-0.66%	-0.30%	-0.68%	-0.74%
FY	200.0 lbf	-0.57%	0.00%	-0.33%	1.24%	0.08%	-0.90%
FZ	500.0 lbf	-0.03%	0.11%	0.00%	-0.70%	-0.43%	0.32%
MX	500.0 in-lbf	-0.49%	0.90%	0.91%	0.00%	0.25%	1.09%
MY	500.0 in-lbf	-0.83%	0.08%	0.24%	-1.05%	0.00%	0.86%
MZ	300.0 in-lbf	-1.60%	0.62%	-2.69%	0.59%	-0.30%	0.00%

* Percentage crosstalk for force channels applying moments are corrected for the applied force.



Measurement Report

Load Cell Bridge Impedance Measurement Summary

Automated Load Cell Impedance Measurement System
Copyright © 1998 Robert A. Denton, Inc.



Calibration Number	C2624000	This Calibration	08:36:53	Jan 07, 2002
Model Number	IF-954	Calibration Due		Jan 07, 2003
Serial Number	128	Last Calibrated		Jan 07, 2002
Description	Infant Neck	Temp (°C) / Hum (%)		22.3 / 16.4
Customer	VRTC	Customer Tag		N/A

Bridge Impedance Measurements*

Axis	Input Impedance	Output Impedance	
Channel 1 FX	355.95	355.83	Ohms
Channel 2 FY	356.19	356.20	Ohms
Channel 3 FZ	704.22	704.28	Ohms
Channel 4 MX	355.81	355.68	Ohms
Channel 5 MY	356.06	356.04	Ohms
Channel 6 MZ	705.02	705.21	Ohms

Bridge High Short Measurement**

Axis	Bridge to Transducer Body	
Channel 1 FX	>= 5.00	G Ohms (10 ⁹ Ohms)
Channel 2 FY	>= 5.00	G Ohms (10 ⁹ Ohms)
Channel 3 FZ	>= 5.00	G Ohms (10 ⁹ Ohms)
Channel 4 MX	>= 5.00	G Ohms (10 ⁹ Ohms)
Channel 5 MY	>= 5.00	G Ohms (10 ⁹ Ohms)
Channel 6 MZ	>= 5.00	G Ohms (10 ⁹ Ohms)

Measurement Equipment	Serial Number	Measurement Accuracy
Keithley Model 7001 Switch System	0698562	N/A
Keithley Model 2000 Multimeter	0643818	±0.045 Ohms/Year @ 23°C ±5°C
Keithley Model 6517A Electrometer/High Resistance Meter	0695446	±(11.25 x 10 ⁶) + 10 ⁵ Ohms/Year @ 18°C-28°C

* NOTE: Input impedance measurements taken between ±excitation, output impedance measurements taken between ±signal

* NOTE: High short measurements are taken between +excitation and the transducer body. Measurements are made at +50.0 VDC.

** Robert A. Denton, Inc. certifies that all equipment used to perform measurements expressed in this report are traceable to the National Institute of Standards and Technology and are in accordance with ANSI/NCSS Z540-1-1994 (MIL-STD 45662A).



ROBERT A. DENTON, INC.

2967 Waterview Dr., Rochester Hills, MI 48309-4600

Tel (248) 852-5100 · Fax (248) 852-6060 email: info@radenton.com · www.radenton.com

Calibration Report Summary

Page 1 of 1

Calibration No. C2624000
 Customer Name Vehicle Research & Test Center/ USDOT
 Address 10820 St. Rte. 347 Logan County Bldg 60
East Liberty, OH 43319

Report Issue
 Date* 1/8/02

* Note: "Report Issue Date" indicates confirmation of calibration data and should be used to increment calibration interval

Manufacturer FTSS
 Serial Number 128

Model Number IF-954

As Received Condition

In Tolerance
 Out of Tolerance
 Operational
 Not Operational
 Damaged
 N/A

Received Notes

As Shipped Condition

In Tolerance
 Out of Tolerance
 Operational
 Not Operational
 Damaged
 N/A

As Shipped Notes

Action Taken

Repair
 Full Calibration
 Special Calibration
 Returned As Is

Action Notes

Calibration Standards Used³

Standard ID Report No Due Date

500-02 SNH607172L:99600599 7/24/02

Laboratory Scope:²

Robert A. Denton, Inc. offers A2LA commercial laboratory calibration services to the following criteria: (Mechanical)



Parameter/Equipment	Range	Best Uncertainty ¹ (±)	Comments
Force Dead Weights Load Cells	4 oz – 400 lbf	0.067%	Class F Weights
	50 – 500 lbf	0.065%	
	100 – 1000 lbf	0.087%	Axial Load
	200 – 2000 lbf	0.076%	
	500 – 5000 lbf	0.082%	
	1000 – 10000 lbf	0.080%	
	2500 – 25000 lbf	0.082%	
	5000 – 50000 lbf	0.084%	
8000 – 80000 lbf	0.110%		
Moment Load Cells	50 – 500 in – lbf	0.15%	Moment Load
	100 – 1000 in – lbf	0.11%	
	200 – 2000 in – lbf	0.10%	
	500 – 5000 in – lbf	0.16%	

CLF014

Revision 2/12/01

¹ The uncertainties stated are expressed at approximately 95% confidence level using a coverage factor of k = 2.

² Robert A. Denton's calibration program is accredited to ISO/IEC Guide 25 1990 & ANSI/NCSL Z-540-1-1994 - Certificate # 1644.01, Valid to: December 31, 2002

³ Standards used in the calibration of this transducer are traceable to National Institute of Standards and Technology (NIST) values

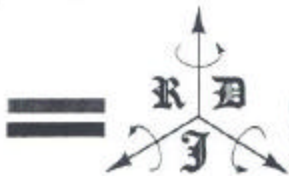

ROBERT A. DENTON, INC.

2967 Waterview Dr., Rochester Hills, MI 48309-4600

Tel (248) 852-5100 • Fax (248) 852-6060 • email: info@radenton.com • www.radenton.com

Crab: #022

Lower Neck

Calibration Report Uni-Directional Calibration

Automated Load Cell Calibration System
Copyright (c) 1987-2000 Robert A. Denton, Inc.

Calibration No.	C2622006	Date	Jan 5, 2002	Due	Jan 5, 2003
Model No.	IF-954	Serial No.	130		
Technician	J. Kovalchuk	Temp (C) / Hum. (%)	22.4 / 22.9		
Customer	VRTC	Last Calibrated	Jan 5, 2002		
Description	Infant Neck	Customer Tag Number	N/A		

Voltage Calibration

Bridge	Capacity	Zero Offset	Nonlinearity	Hysteresis	Output @ Capacity	% Change
FX	200.0 lbf	0.0038 mV/V	0.06 % FS	0.11 % FS	-1.0123 mV/V	0.00 % FS
FY	200.0 lbf	0.0093 mV/V	0.05 % FS	0.15 % FS	1.0204 mV/V	0.00 % FS
FZ	500.0 lbf	-0.0258 mV/V	0.02 % FS	0.05 % FS	-0.7734 mV/V	0.00 % FS
MX	500.0 in-lbf	0.0166 mV/V	0.11 % FS	0.55 % FS	-1.3524 mV/V	0.00 % FS
MY	500.0 in-lbf	-0.0204 mV/V	0.11 % FS	0.41 % FS	1.3478 mV/V	0.00 % FS
MZ	300.0 in-lbf	0.0175 mV/V	0.17 % FS	0.20 % FS	1.4719 mV/V	0.00 % FS

Shunt

Bridge	Shunt Value	Equivalent Load	Bridge Resistance (nom)
FX	120.0 K Ohms	-146.0 lbf	350.0 Ohms
FY	120.0 K Ohms	145.1 lbf	350.0 Ohms
FZ	300.0 K Ohms	-377.5 lbf	700.0 Ohms
MX	80.0 K Ohms	-408.9 in-lbf	350.0 Ohms
MY	80.0 K Ohms	410.7 in-lbf	350.0 Ohms
MZ	160.0 K Ohms	223.6 in-lbf	700.0 Ohms

NOTE: Positive shunt is between +Exc_+Sig Negative shunt is between -Exc_+Sig

Wire Color Codes

FX-MX		FY-MY		FZ-MZ	
Brown	+ Exc.	Red Stripe	+ Exc.	Green	+ Exc.
Red	+ Sig.	Black	+ Sig.	Blue	+ Sig.
Orange	- Exc.	White	- Exc.	Violet	- Exc.
Yellow	- Sig.	Black Stripe	- Sig.	Grey	- Sig.

Reference Load Cell

Manufacturer	Model No.	Serial No.	Calibration Due Date
Revere	363-B10-500-20P1	H607172L	Jul 24, 2002

Calibrated by



Robert A. Denton, Inc. Authorized Representative

File: UGALRPT.FPC

01/05/02 13:14:32

Page 1 of 1

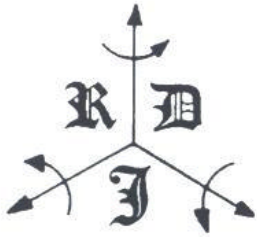
Creating the Standard in Safety Measurement Since 1974



CALIBRATION REPORT

Uni-Directional Calibration Loading Sequence Summary

Automated Load Cell Calibration System
Copyright (c)1987-2000 Robert A. Denton, Inc.

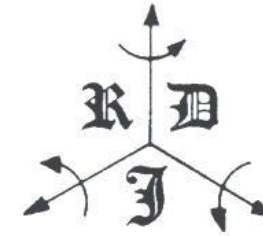

Calibration Number	C2622006	This Calibration	13:01:35	Jan 5, 2002
Model Number	IF-954	Calibration Due		Jan 5, 2003
Serial Number	130	Last Calibrated		Jan 5, 2002
Description	Infant Neck	Temp (C) / Hum. (%)		22.4 / 22.9
Customer	VRTC	Customer Tag Number		N/A.

Loading Sequence

Axis	FS Load EU	FS Output mV/V	Sensitivity mV/V/EU	Nonlinearity % FS	Hysteresis % FS	Moment Arm EU
FX	200.0 lbf	-1.0123	-0.0050613	0.06	0.11	0.00
FY	200.0 lbf	1.0204	0.0051022	0.05	0.15	0.00
FZ	500.0 lbf	-0.7734	-0.0015469	0.02	0.05	0.00
MX	500.0 in-lbf	-1.3524	-0.0027048	0.11	0.55	1.00
MY	500.0 in-lbf	1.3478	0.0026956	0.11	0.41	1.00
MZ	300.0 in-lbf	1.4719	0.0049063	0.17	0.20	1.50

Bridge Unbalance

FX Axis 0.0038 mV/V
 FY Axis 0.0093 mV/V
 FZ Axis -0.0258 mV/V
 MX Axis 0.0166 mV/V
 MY Axis -0.0204 mV/V
 MZ Axis 0.0175 mV/V

Linearization

Force (FX)	=	0.1	+	-197.5	*	Output (mV/V)
Force (FY)	=	0.1	+	196.0	*	Output (mV/V)
Force (FZ)	=	0.0	+	-646.4	*	Output (mV/V)
Force (MX)	=	0.3	+	-369.6	*	Output (mV/V)
Force (MY)	=	0.3	+	370.9	*	Output (mV/V)
Force (MZ)	=	0.2	+	203.6	*	Output (mV/V)

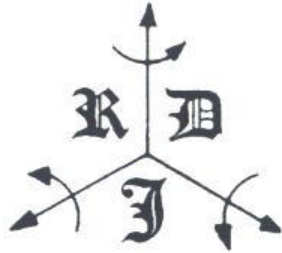

CALIBRATION REPORT

Uni-Directional Calibration Crosstalk Summary

Automated Load Cell Calibration System
Copyright (c)1987-2000 Robert A. Denton, Inc.

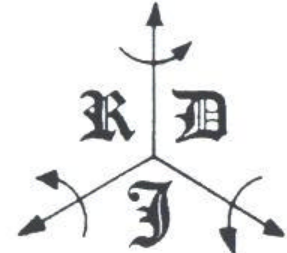

Calibration Number	C2622006	This Calibration	13:01:35	Jan 5, 2002
Model Number	IF-954	Calibration Due		Jan 5, 2003
Serial Number	130	Last Calibrated		Jan 5, 2002
Description	Infant Neck	Temp (C) / Hum. (%)		22.4 / 22.9
Customer	VRTC	Customer Tag Number		N/A

Raw Crosstalk Data (mV/V)

<u>Bridge</u>		FX	FY	FZ	MX	MY	MZ
	<u>Applied Load</u>	200.0	200.0	500.0	500.0	500.0	300.0
		<u>lbf</u>	<u>lbf</u>	<u>lbf</u>	<u>in-lbf</u>	<u>in-lbf</u>	<u>in-lbf</u>
FX	200.0 lbf	-1.0123	0.0052	0.0017	-0.0045	-0.0036	-0.0148
FY	200.0 lbf	0.0063	1.0204	0.0013	-0.0056	0.0003	-0.0066
FZ	500.0 lbf	0.0005	0.0002	-0.7734	0.0173	-0.0083	-0.0103
MX	500.0 in-lbf	0.0019	0.0084	-0.7668	-1.3524	-0.0069	-0.0204
MY	500.0 in-lbf	0.0087	0.0052	-0.7656	0.0064	1.3478	0.0062
MZ	300.0 in-lbf	0.0180	1.0321	0.0112	-0.0046	-0.0101	1.4719

% FS Crosstalk *

<u>Bridge</u>		FX	FY	FZ	MX	MY	MZ
	<u>Applied Load</u>	200.0	200.0	500.0	500.0	500.0	300.0
		<u>lbf</u>	<u>lbf</u>	<u>lbf</u>	<u>in-lbf</u>	<u>in-lbf</u>	<u>in-lbf</u>
FX	200.0 lbf	0.00%	0.51%	-0.22%	0.34%	-0.27%	-1.01%
FY	200.0 lbf	-0.62%	0.00%	-0.16%	0.41%	0.02%	-0.45%
FZ	500.0 lbf	-0.05%	0.02%	0.00%	-1.28%	-0.61%	-0.70%
MX	500.0 in-lbf	-0.19%	0.82%	0.86%	0.00%	-0.52%	-1.38%
MY	500.0 in-lbf	-0.86%	0.51%	1.01%	-0.47%	0.00%	0.42%
MZ	300.0 in-lbf	-1.78%	1.15%	-1.45%	0.34%	-0.75%	0.00%



Measurement Report

Load Cell Bridge Impedance

Measurement Summary

Automated Load Cell Impedance Measurement System
Copyright © 1998 Robert A. Denton, Inc.



Calibration Number	C2622006	This Calibration	13:01:35	Jan 05, 2002
Model Number	IF-954	Calibration Due		Jan 05, 2003
Serial Number	130	Last Calibrated		Jan 05, 2002
Description	Infant Neck	Temp (°C) / Hum (%)		23.1 / 16.9
Customer	VRTC	Customer Tag		N/A

Bridge Impedance Measurements*

Axis	Input Impedance	Output Impedance	
Channel 1 FX	355.69	355.54	Ohms
Channel 2 FY	355.86	355.83	Ohms
Channel 3 FZ	703.89	703.95	Ohms
Channel 4 MX	355.64	355.63	Ohms
Channel 5 MY	355.79	355.65	Ohms
Channel 6 MZ	704.91	705.08	Ohms

Bridge High Short Measurement**

Axis	Bridge to Transducer Body	
Channel 1 FX	>= 5.00	G Ohms (10 ⁹ Ohms)
Channel 2 FY	>= 5.00	G Ohms (10 ⁹ Ohms)
Channel 3 FZ	>= 5.00	G Ohms (10 ⁹ Ohms)
Channel 4 MX	>= 5.00	G Ohms (10 ⁹ Ohms)
Channel 5 MY	>= 5.00	G Ohms (10 ⁹ Ohms)
Channel 6 MZ	>= 5.00	G Ohms (10 ⁹ Ohms)

Measurement Equipment

Serial Number

Measurement Accuracy

Keithley Model 7001 Switch System	0698562	N/A
Keithley Model 2000 Multimeter	0643818	±0.045 Ohms/Year @ 23°C ±5°C
Keithley Model 6517A Electrometer/High Resistance Meter	0695446	±(11.25 x 10 ⁶) + 10 ⁵ Ohms/Year @ 18°C-28°C

* NOTE: Input impedance measurements taken between ±excitation, output impedance measurements taken between ±signal

** NOTE: High short measurements are taken between +excitation and the transducer body. Measurements are made at +50.0 VDC.

** Robert A. Denton, Inc. certifies that all equipment used to perform measurements expressed in this report are traceable to the National Institute of Standards and Technology and are in accordance with ANSI/NCSL Z540-1-1994 (MIL-STD 45662A).



ROBERT A. DENTON, INC.

2967 Waterview Dr., Rochester Hills, MI 48309-4600

Tel (248) 852-5100 - Fax (248) 852-6080 - email: info@radenton.com - www.radenton.com

Calibration Report Summary

Page 1 of 1

Calibration No. C2622006
 Customer Name Vehicle Research & Test Center/ USDOT
 Address 10820 St. Rte. 347 Logan County Bldg 60
East Liberty, OH 43319

Report Issue Date* 1/8/02

* Note: "Report Issue Date" indicates confirmation of calibration data and should be used to increment calibration interval

Manufacturer FTSS
 Serial Number 130

Model Number IF-954

As Received Condition

In Tolerance
 Out of Tolerance
 Operational
 Not Operational
 Damaged
 N/A

Received Notes

As Shipped Condition

In Tolerance
 Out of Tolerance
 Operational
 Not Operational
 Damaged
 N/A

As Shipped Notes

Action Taken

Repair
 Full Calibration
 Special Calibration
 Returned As Is

Action Notes

Calibration Standards Used³

Standard ID Report No Due Date

500-02 SNH607172L:99600599 7/24/02

Laboratory Scope:²

Robert A. Denton, Inc. offers A2LA commercial laboratory calibration services to the following criteria: (Mechanical)



Parameter/Equipment	Range	Best Uncertainty ¹ (±)	Comments
Force Dead Weights Load Cells	4 oz – 400 lbf	0.067%	Class F Weights
	50 – 500 lbf	0.065%	
	100 – 1000 lbf	0.087%	Axial Load
	200 – 2000 lbf	0.076%	
	500 – 5000 lbf	0.082%	
	1000 – 10000 lbf	0.080%	
	2500 – 25000 lbf	0.082%	
	5000 – 50000 lbf	0.084%	
8000 – 80000 lbf	0.110%		
Moment Load Cells	50 – 500 in – lbf	0.15%	Moment Load
	100 – 1000 in – lbf	0.11%	
	200 – 2000 in – lbf	0.10%	
	500 – 5000 in – lbf	0.16%	

CLF014

Revision 2/12/01

¹ The uncertainties stated are expressed at approximately 95% confidence level using a coverage factor of k = 2.

² Robert A. Denton's calibration program is accredited to ISO/IEC Guide 25 1990 & ANSI/NCCL Z-540-1-1994 - Certificate # 1644.01, Valid to: December 31, 2002

³ Standards used in the calibration of this transducer are traceable to National Institute of Standards and Technology (NIST) values

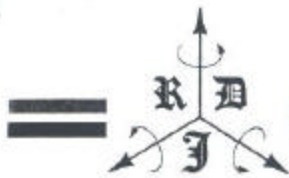

ROBERT A. DENTON, INC.

2967 Waterview Dr., Rochester Hills, MI 48309-4600

Tel (248) 852-5100 • Fax (248) 852-6060 • email: info@radenton.com • www.radenton.com

Crabi #022
Lumbar

Calibration Report Uni-Directional Calibration

Automated Load Cell Calibration System
Copyright (c) 1987-2000 Robert A. Denton, Inc.

Calibration No.	C2622007	Date	Jan 5, 2002	Due	Jan 5, 2003
Model No.	IF-954	Serial No.	140		
Technician	J. Kovalchuk	Temp (C) / Hum. (%)	22.5 / 23.6		
Customer	VRTC	Last Calibrated	Jan 5, 2002		
Description	Infant Neck	Customer Tag Number	N/A		

Voltage Calibration

Bridge	Capacity	Zero Offset	Nonlinearity	Hysteresis	Output @ Capacity	% Change
FX	200.0 lbf	-0.0142 mV/V	0.04 % FS	0.11 % FS	-0.9791 mV/V	0.00 % FS
FY	200.0 lbf	-0.0071 mV/V	0.05 % FS	0.12 % FS	0.9768 mV/V	0.00 % FS
FZ	500.0 lbf	-0.0289 mV/V	0.05 % FS	0.02 % FS	-0.7693 mV/V	0.00 % FS
MX	500.0 in-lbf	0.0096 mV/V	0.07 % FS	0.66 % FS	-1.3571 mV/V	0.00 % FS
MY	500.0 in-lbf	-0.0092 mV/V	0.06 % FS	0.53 % FS	1.3462 mV/V	0.00 % FS
MZ	300.0 in-lbf	0.0077 mV/V	0.15 % FS	0.21 % FS	1.4779 mV/V	0.00 % FS

Shunt

Bridge	Shunt Value	Equivalent Load	Bridge Resistance (nom)
FX	120.0 K Ohms	-151.1 lbf	350.0 Ohms
FY	120.0 K Ohms	151.7 lbf	350.0 Ohms
FZ	300.0 K Ohms	-380.2 lbf	700.0 Ohms
MX	80.0 K Ohms	-408.5 in-lbf	350.0 Ohms
MY	80.0 K Ohms	411.7 in-lbf	350.0 Ohms
MZ	160.0 K Ohms	223.0 in-lbf	700.0 Ohms

NOTE: Positive shunt is between +Exc_+Sig Negative shunt is between -Exc_+Sig

Wire Color Codes

FX-MX	FY-MY	FZ-MZ
Brown + Exc.	Red Stripe + Exc.	Green + Exc.
Red + Sig.	Black + Sig.	Blue + Sig.
Orange - Exc.	White - Exc.	Violet - Exc.
Yellow - Sig.	Black Stripe - Sig.	Grey - Sig.

Reference Load Cell

<u>Manufacturer</u>	<u>Model No.</u>	<u>Serial No.</u>	<u>Calibration Due Date</u>
Revere	363-B10-500-20P1	H607172L	Jul 24, 2002

Calibrated by

Robert A. Denton, Inc. Authorized Representative

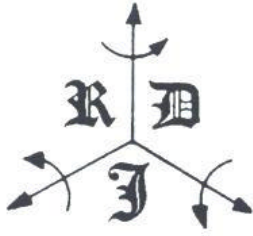

CALIBRATION REPORT

Uni-Directional Calibration Loading Sequence Summary

Automated Load Cell Calibration System
Copyright (c)1987-2000 Robert A. Denton, Inc.

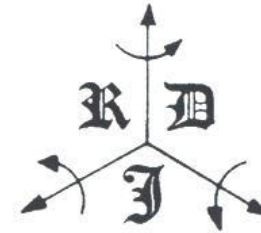

Calibration Number	C2622007	This Calibration	13:23:28	Jan 5, 2002
Model Number	IF-954	Calibration Due		Jan 5, 2003
Serial Number	140	Last Calibrated		Jan 5, 2002
Description	Infant Neck	Temp (C) / Hum. (%)		22.5 / 23.6
Customer	VRTC	Customer Tag Number		N/A

Loading Sequence

Axis	FS Load EU	FS Output mV/V	Sensitivity mV/V/EU	Nonlinearity % FS	Hysteresis % FS	Moment Arm EU
FX	200.0 lbf	-0.9791	-0.0048954	0.04	0.11	0.00
FY	200.0 lbf	0.9768	0.0048840	0.05	0.12	0.00
FZ	500.0 lbf	-0.7693	-0.0015387	0.05	0.02	0.00
MX	500.0 in-lbf	-1.3571	-0.0027143	0.07	0.66	1.00
MY	500.0 in-lbf	1.3462	0.0026924	0.06	0.53	1.00
MZ	300.0 in-lbf	1.4779	0.0049262	0.15	0.21	1.50

Bridge Unbalance

FX Axis	-0.0142 mV/V
FY Axis	-0.0071 mV/V
FZ Axis	-0.0289 mV/V
MX Axis	0.0096 mV/V
MY Axis	-0.0092 mV/V
MZ Axis	0.0077 mV/V

Linearization

Force (FX)	=	0.0	+	-204.3	* Output (mV/V)
Force (FY)	=	0.0	+	204.7	* Output (mV/V)
Force (FZ)	=	0.1	+	-649.7	* Output (mV/V)
Force (MX)	=	-0.2	+	-368.5	* Output (mV/V)
Force (MY)	=	0.0	+	371.3	* Output (mV/V)
Force (MZ)	=	0.2	+	202.9	* Output (mV/V)

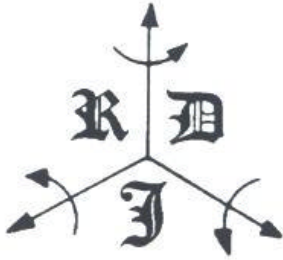

CALIBRATION REPORT

Uni-Directional Calibration Crosstalk Summary

Automated Load Cell Calibration System
Copyright (c)1987-2000 Robert A. Denton, Inc.

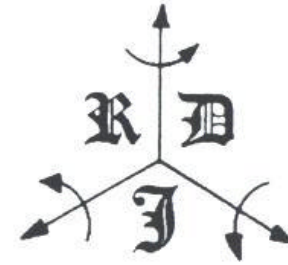

Calibration Number	C2622007	This Calibration	13:23:28	Jan 5, 2002
Model Number	IF-954	Calibration Due		Jan 5, 2003
Serial Number	140	Last Calibrated		Jan 5, 2002
Description	Infant Neck	Temp (C) / Hum. (%)		22.5 / 23.6
Customer	VRTC	Customer Tag Number		N/A

Raw Crosstalk Data (mV/V)

<u>Bridge</u>	<u>Applied Load</u>	FX	FY	FZ	MX	MY	MZ
		200.0	200.0	500.0	500.0	500.0	300.0
		<u>lbf</u>	<u>lbf</u>	<u>lbf</u>	<u>in-lbf</u>	<u>in-lbf</u>	<u>in-lbf</u>
FX	200.0 lbf	-0.9791	0.0038	-0.0014	0.0064	0.0073	-0.0068
FY	200.0 lbf	0.0011	0.9768	0.0011	0.0024	0.0001	-0.0058
FZ	500.0 lbf	0.0035	-0.0033	-0.7693	0.0086	0.0019	0.0016
MX	500.0 in-lbf	0.0030	-0.0057	-0.7682	-1.3571	0.0054	0.0079
MY	500.0 in-lbf	0.0019	0.0003	-0.7660	0.0162	1.3462	0.0047
MZ	300.0 in-lbf	-0.0036	0.9923	-0.0011	0.0064	0.0069	1.4779

% FS Crosstalk *

<u>Bridge</u>	<u>Applied Load</u>	FX	FY	FZ	MX	MY	MZ
		200.0	200.0	500.0	500.0	500.0	300.0
		<u>lbf</u>	<u>lbf</u>	<u>lbf</u>	<u>in-lbf</u>	<u>in-lbf</u>	<u>in-lbf</u>
FX	200.0 lbf	0.00%	0.39%	0.18%	-0.47%	0.54%	-0.46%
FY	200.0 lbf	-0.11%	0.00%	-0.14%	-0.18%	0.01%	-0.39%
FZ	500.0 lbf	-0.35%	-0.34%	0.00%	-0.64%	0.14%	0.11%
MX	500.0 in-lbf	-0.31%	-0.58%	0.15%	0.00%	0.40%	0.53%
MY	500.0 in-lbf	-0.19%	0.03%	0.43%	-1.19%	0.00%	0.32%
MZ	300.0 in-lbf	0.37%	1.59%	0.14%	-0.47%	0.51%	0.00%

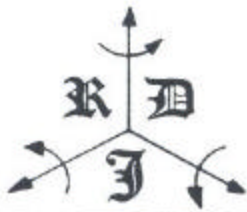

Measurement Report

Load Cell Bridge Impedance

Measurement Summary

Automated Load Cell Impedance Measurement System
Copyright © 1998 Robert A. Denton, Inc.

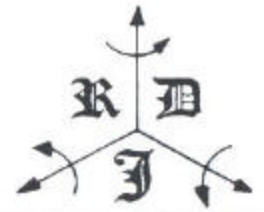

Calibration Number	C2622007	This Calibration	13:23:28	Jan 05, 2002
Model Number	IF-954	Calibration Due		Jan 05, 2003
Serial Number	140	Last Calibrated		Jan 05, 2002
Description	Infant Neck	Temp (°C) / Hum (%)		21.6 / 19
Customer	VRTC	Customer Tag		N/A

Bridge Impedance Measurements*

Axis	Input Impedance	Output Impedance	
Channel 1 FX	356.27	356.35	Ohms
Channel 2 FY	356.31	356.27	Ohms
Channel 3 FZ	703.89	704.07	Ohms
Channel 4 MX	356.08	355.88	Ohms
Channel 5 MY	356.12	356.07	Ohms
Channel 6 MZ	705.59	705.68	Ohms

Bridge High Short Measurement**

Axis	Bridge to Transducer Body	
Channel 1 FX	>= 5.00	G Ohms (10 ⁹ Ohms)
Channel 2 FY	>= 5.00	G Ohms (10 ⁹ Ohms)
Channel 3 FZ	>= 5.00	G Ohms (10 ⁹ Ohms)
Channel 4 MX	>= 5.00	G Ohms (10 ⁹ Ohms)
Channel 5 MY	>= 5.00	G Ohms (10 ⁹ Ohms)
Channel 6 MZ	>= 5.00	G Ohms (10 ⁹ Ohms)

Measurement Equipment

Serial Number

Measurement Accuracy

Keithley Model 7001 Switch System	0698562	N/A
Keithley Model 2000 Multimeter	0643818	±0.045 Ohms/Year @ 23°C ±5°C
Keithley Model 6517A Electrometer/High Resistance Meter	0695446	±(11.25 x 10 ⁶) + 10 ⁵ Ohms/Year @ 18°C-28°C

* NOTE: Input impedance measurements taken between ±excitation, output impedance measurements taken between ±signal

** NOTE: High short measurements are taken between +excitation and the transducer body. Measurements are made at +50.0 VDC.

** Robert A. Denton, Inc. certifies that all equipment used to perform measurements expressed in this report are traceable to the National Institute of Standards and Technology and are in accordance with ANSI/NCSL Z540-1-1994 (MIL-STD 45662A).



ROBERT A. DENTON, INC.

2967 Waterview Dr., Rochester Hills, MI 48309-4600

Tel (248) 852-5100 · Fax (248) 852-6060 · email: info@radenton.com · www.radenton.com

Calibration Report Summary

Page 1 of 1

Calibration No. C2622007
 Customer Name Vehicle Research & Test Center/ USDOT
 Address 10820 St. Rte. 347 Logan County Bldg 60
East Liberty, OH 43319

Report Issue Date* 1/8/02

* Note: "Report Issue Date" indicates confirmation of calibration data and should be used to increment calibration interval

Manufacturer FTSS
 Serial Number 140

Model Number IF-954

As Received Condition

In Tolerance
 Out of Tolerance
 Operational
 Not Operational
 Damaged
 N/A

Received Notes

As Shipped Condition

In Tolerance
 Out of Tolerance
 Operational
 Not Operational
 Damaged
 N/A

As Shipped Notes

Action Taken

Repair
 Full Calibration
 Special Calibration
 Returned As Is

Action Notes

Calibration Standards Used³

Standard ID Report No Due Date

500-02 SNH607172L:99600599 7/24/02

Laboratory Scope:²

Robert A. Denton, Inc. offers A2LA commercial laboratory calibration services to the following criteria: (Mechanical)



Parameter/Equipment	Range	Best Uncertainty ¹ (±)	Comments
Force			
Dead Weights	4 oz – 400 lbf	0.067%	Class F Weights
Load Cells	50 – 500 lbf	0.065%	Axial Load
	100 – 1000 lbf	0.087%	
	200 – 2000 lbf	0.076%	
	500 – 5000 lbf	0.082%	
	1000 – 10000 lbf	0.080%	
	2500 – 25000 lbf	0.082%	
	5000 – 50000 lbf	0.084%	
8000 – 80000 lbf	0.110%		
Moment			
Load Cells	50 – 500 in – lbf	0.15%	Moment Load
	100 – 1000 in – lbf	0.11%	
	200 – 2000 in – lbf	0.10%	
	500 – 5000 in – lbf	0.16%	

CLF014

Revision 2/12/01

¹ The uncertainties stated are expressed at approximately 95% confidence level using a coverage factor of k = 2.

² Robert A. Denton's calibration program is accredited to ISO/IEC Guide 25 1990 & ANSI/NCSL Z-540-1-1994 - Certificate # 1644.01, Valid to: December 31, 2002

³ Standards used in the calibration of this transducer are traceable to National Institute of Standards and Technology (NIST) values

This report applies only to the item identified herein. This report shall not be reproduced except in full, without the written approval of Robert A. Denton, Inc.

Crab: #022
lead X - Fwd

Calibration Certificate

Customer: VRTC
20010620-0250

Document number: 5945

Description: VRTC - Accelerometer
Manufacturer: ENDEVCO
Model Number: 7264C-2KLC-2-240
Serial Number: P16336

Input Resistance (ohms): 560
Output Resistance (ohms): 564.56
ZMO (mV): 12.466
Resonance Frequency (Hz): 27538

0.1396 mV/g @ 100 Hz, 10g pk

Last Sens: 1.374E-1, Change: 1.61

Next cal date: 1/14/2003

Notes:

Excitation: 10.0 V

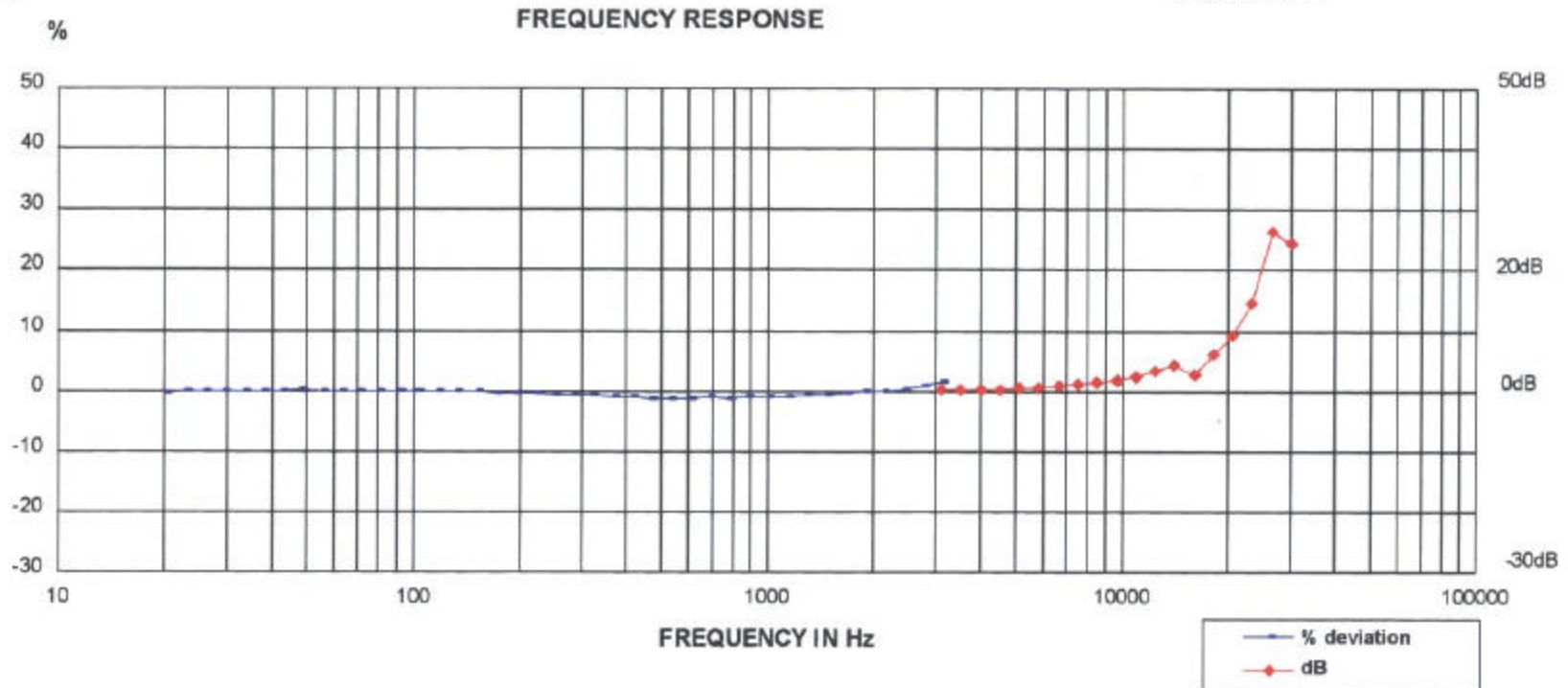

Endevco, a division of Meggitt, located at 30700 Rancho Viejo Road, San Juan Capistrano, CA, certifies that the above instrument was tested using comparison calibrations per ANSI S2.2 using Endevco IM68357. This calibration is traceable to the National Institute of Standards and Technology and is in accordance with ANSI/NCSL Z540-1-1994 (MIL-STD 45662A).

Console serial number: AC27
NIST traceability #: 822/262802-00
Equipment used: 2901
Test definition: FINAL

Uncertainty estimate (95% confidence, k=2)

+/- 1.1 %	100.0 Hz Sensitivity
+/- 5.0 %	10.0 to 20.0 Hz
+/- 1.5 %	20.0 to 2000.0 Hz
+/- 2.5 %	2000.0 to 10000.0 Hz
+/- 4.0 %	10000.0 to 20000.0 Hz

By: 
P. KRAMP
Date: 1/14/2002

Endevco
Transportation Research Center

Crab: #022

Head Y - Left

Calibration Certificate

Customer: VRTC
20010620-0250

Document number: 5954

Description: VRTC - Accelerometer
Manufacturer: ENDEVCO
Model Number: 7264C-2KLC-2-240
Serial Number: P14936

Input Resistance (ohms): 549.34
Output Resistance (ohms): 543.73
ZMO (mV): -15.66
Resonance Frequency (Hz): 24859

0.1424 mV/g @ 100 Hz, 10g pk

Last Sens: 1.403E-1, Change: 1.55
Next cal date: 1/14/2003

Notes:

Excitation: 10.0 V

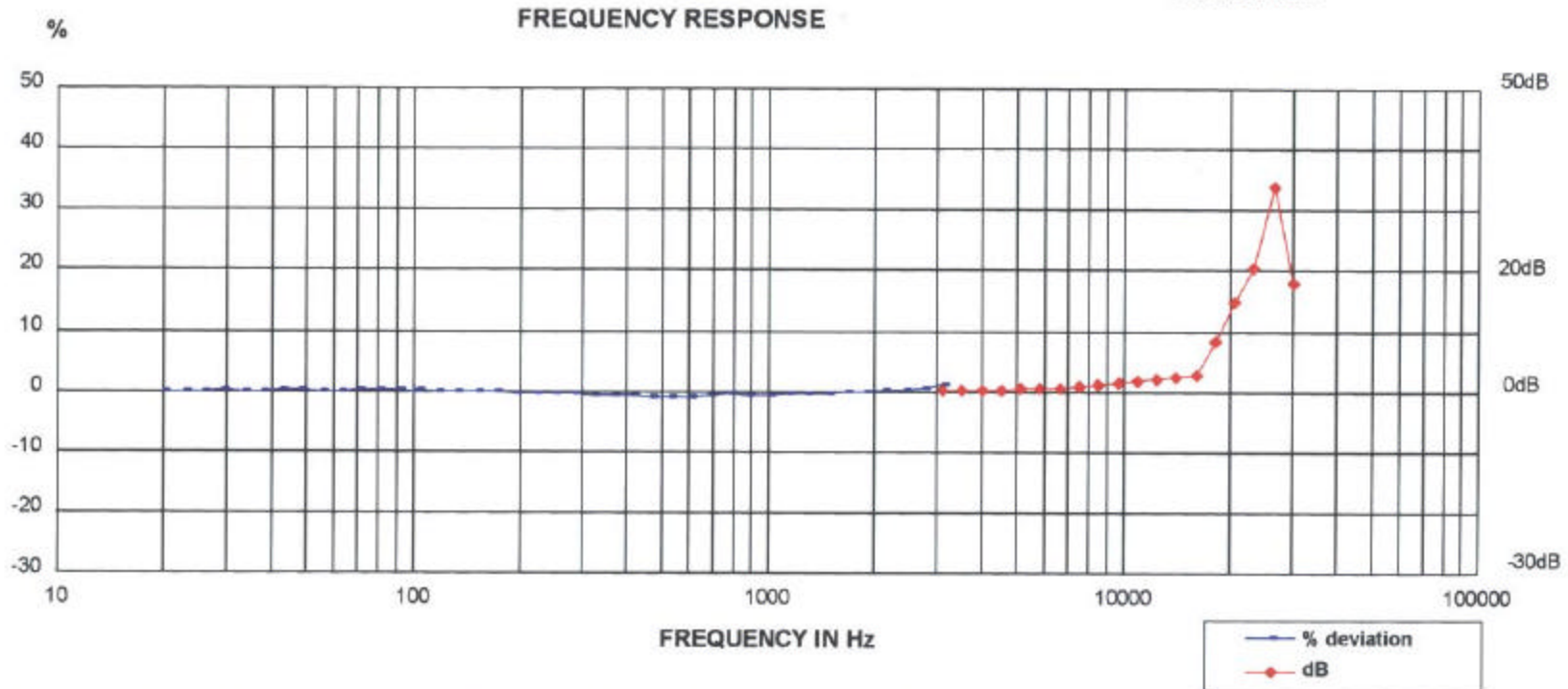

Endevco, a division of Meggitt, located at 30700 Rancho Viejo Road, San Juan Capistrano, CA, certifies that the above instrument was tested using comparison calibrations per ANSI S2.2 using Endevco IM68357. This calibration is traceable to the National Institute of Standards and Technology and is in accordance with ANSI/NCSL Z540-1-1994 (MIL-STD 45662A).

Console serial number: AC27
NIST traceability #: 822/262802-00
Equipment used: 2901
Test definition: FINAL

Uncertainty estimate (95% confidence, k=2)

+/- 1.1 %	100.0 Hz Sensitivity
+/- 5.0 %	10.0 to 20.0 Hz
+/- 1.5 %	20.0 to 2000.0 Hz
+/- 2.5 %	2000.0 to 10000.0 Hz
+/- 4.0 %	10000.0 to 20000.0 Hz

By: *[Signature]*
P. KRAMP
Date: 1/14/2002

Endevco
Transportation Research Center

Crabi #022
Head z - Down

Calibration Certificate

Customer: VRTC
20010620-0250

Document number: 5944

Description: VRTC - Accelerometer
Manufacturer: ENDEVCO
Model Number: 7264C-2KLC-2-240
Serial Number: P17837

Input Resistance (ohms): 495.69
Output Resistance (ohms): 495.52
ZMO (mV): -2.451
Resonance Frequency (Hz): 25288

0.1405 mV/g @ 100 Hz, 10g pk

Last Sens: 1.382E-1, Change: 1.66

Next cal date: 1/14/2003

Notes:

Excitation: 10.0 V

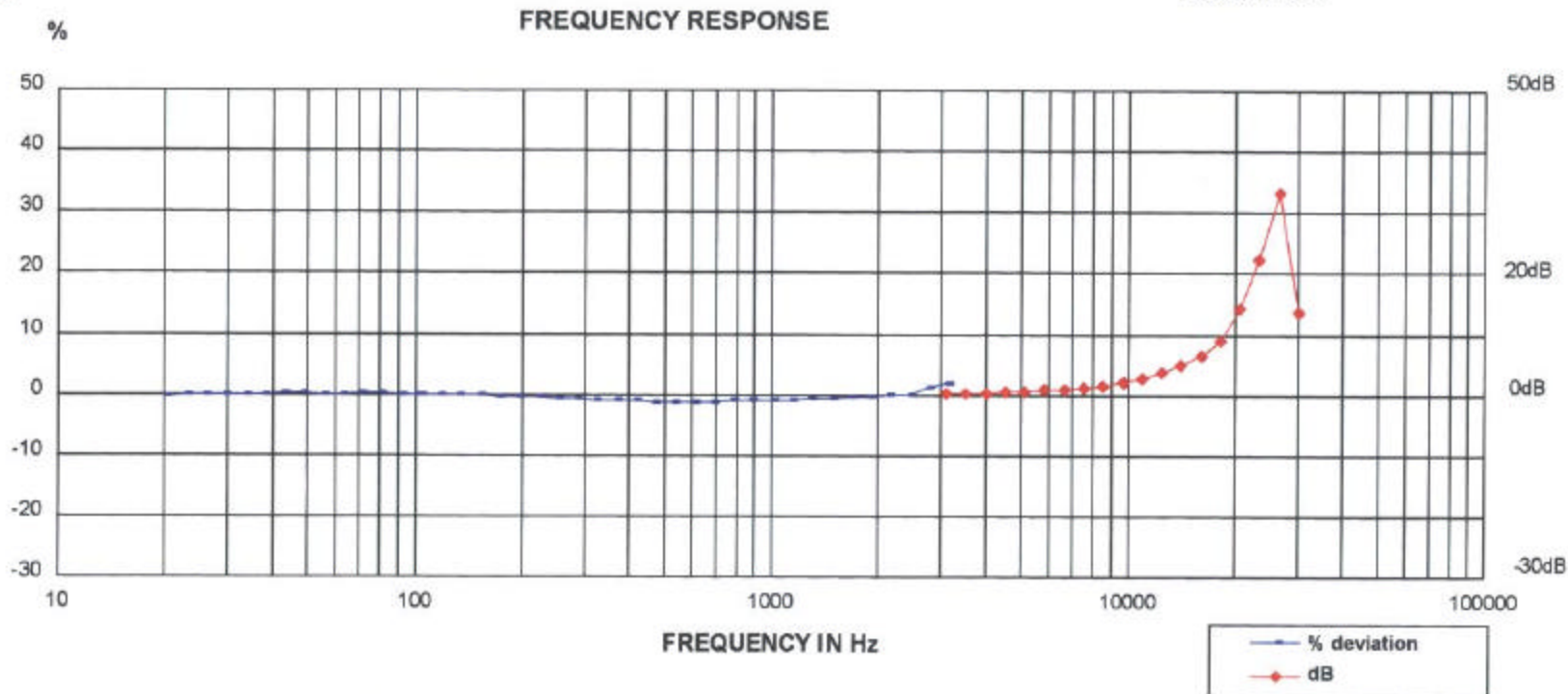

Endevco, a division of Meggitt, located at 30700 Rancho Viejo Road, San Juan Capistrano, CA, certifies that the above instrument was tested using comparison calibrations per ANSI S2.2 using Endevco IM68357. This calibration is traceable to the National Institute of Standards and Technology and is in accordance with ANSI/NCSL Z540-1-1994 (MIL-STD 45662A).

Console serial number: AC27
NIST traceability #: 822/262802-00
Equipment used: 2901
Test definition: FINAL

Uncertainty estimate (95% confidence, k=2)

+/- 1.1 %	100.0 Hz	Sensitivity
+/- 5.0 %	10.0 to 20.0 Hz	
+/- 1.5 %	20.0 to 2000.0 Hz	
+/- 2.5 %	2000.0 to 10000.0 Hz	
+/- 4.0 %	10000.0 to 20000.0 Hz	

By

P. KRAMP

Date: 1/14/2002

Endevco

Transportation Research Center

Crab: #022
 Head Reel 2-ND

Calibration Certificate

Customer: VRTC
 20010620-0250

Document number: 5956

Description: VRTC - Accelerometer
 Manufacturer: ENDEVCO
 Model Number: 7264C-2KLC-2-240
 Serial Number: P14914

Input Resistance (ohms): 647.93
 Output Resistance (ohms): 704.58
 ZMO (mV): -21.79
 Resonance Frequency (Hz): 28129

0.2565 mV/g @ 100 Hz, 10g pk

Last Sens: 2.530E-1, Change: 1.40

Next cal date: 1/14/2003

Notes:

Excitation: 10.0 V

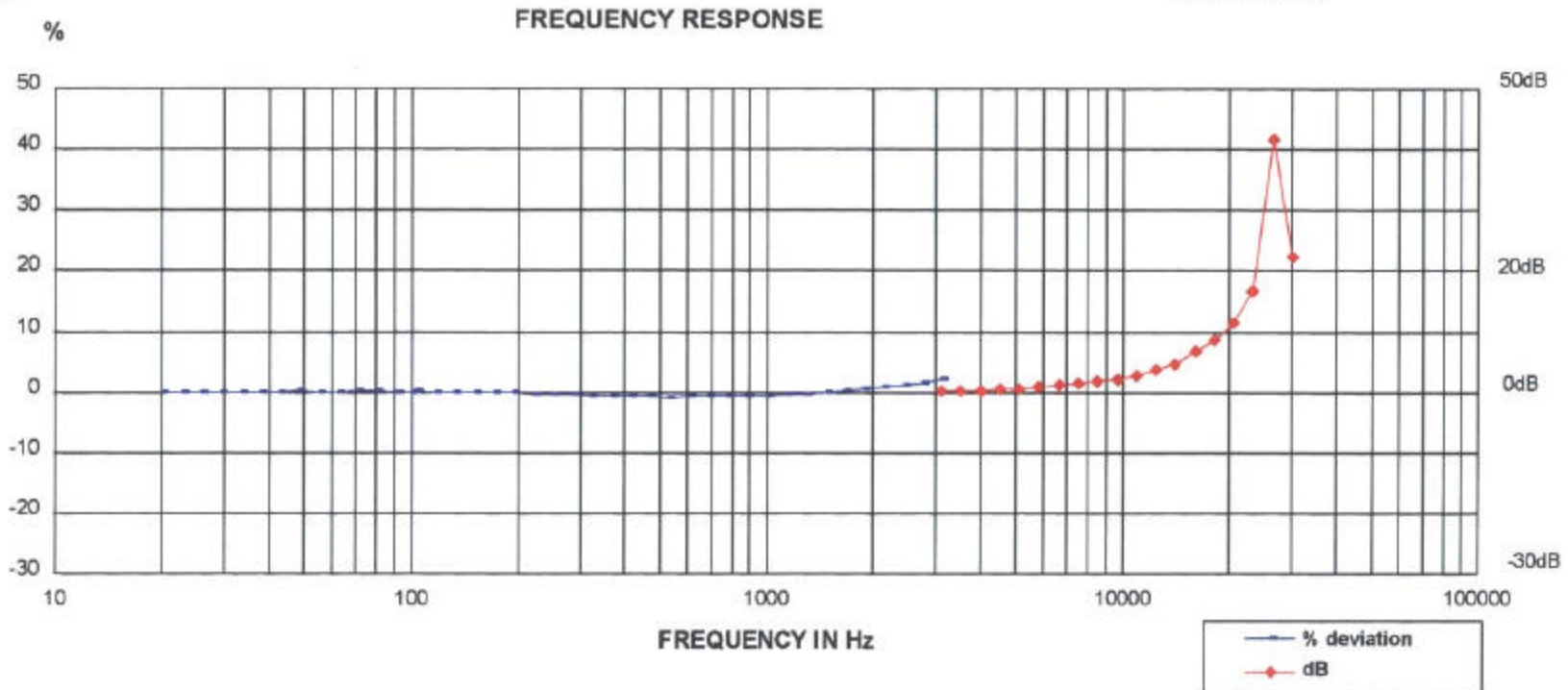

Endevco, a division of Meggitt, located at 30700 Rancho Viejo Road, San Juan Capistrano, CA, certifies that the above instrument was tested using comparison calibrations per ANSI S2.2 using Endevco IM68357. This calibration is traceable to the National Institute of Standards and Technology and is in accordance with ANSI/NCSL Z540-1-1994 (MIL-STD 45662A).

Uncertainty estimate (95% confidence, k=2)

Console serial number: AC27	+/- 1.1 %	100.0 Hz Sensitivity
NIST traceability #: 822/262802-00	+/- 5.0 %	10.0 to 20.0 Hz
Equipment used: 2901	+/- 1.5 %	20.0 to 2000.0 Hz
Test definition: FINAL	+/- 2.5 %	2000.0 to 10000.0 Hz
	+/- 4.0 %	10000.0 to 20000.0 Hz

By: *P. Kramp*
 P. KRAMP
 Date: 1/14/2002

Endevco
 Transportation Research Center

Crabi #022
 Chest X - Fwd

Calibration Certificate

Customer: VRTC
 20010620-0250

Document number: 5963

Description: VRTC - Accelerometer
 Manufacturer: ENTRAN
 Model Number: EGE-73BQE0-2000BF
 Serial Number: 99108-F26

Input Resistance (ohms): 1058
 ZMO (mV): 6.5106
 Resonance Frequency (Hz): 21987

0.2386 mV/g @ 100 Hz, 10g pk

Last Sens: 2.365E-1, Change: 0.92
 Next cal date: 1/14/2003

Notes:

Excitation: 10.0 V

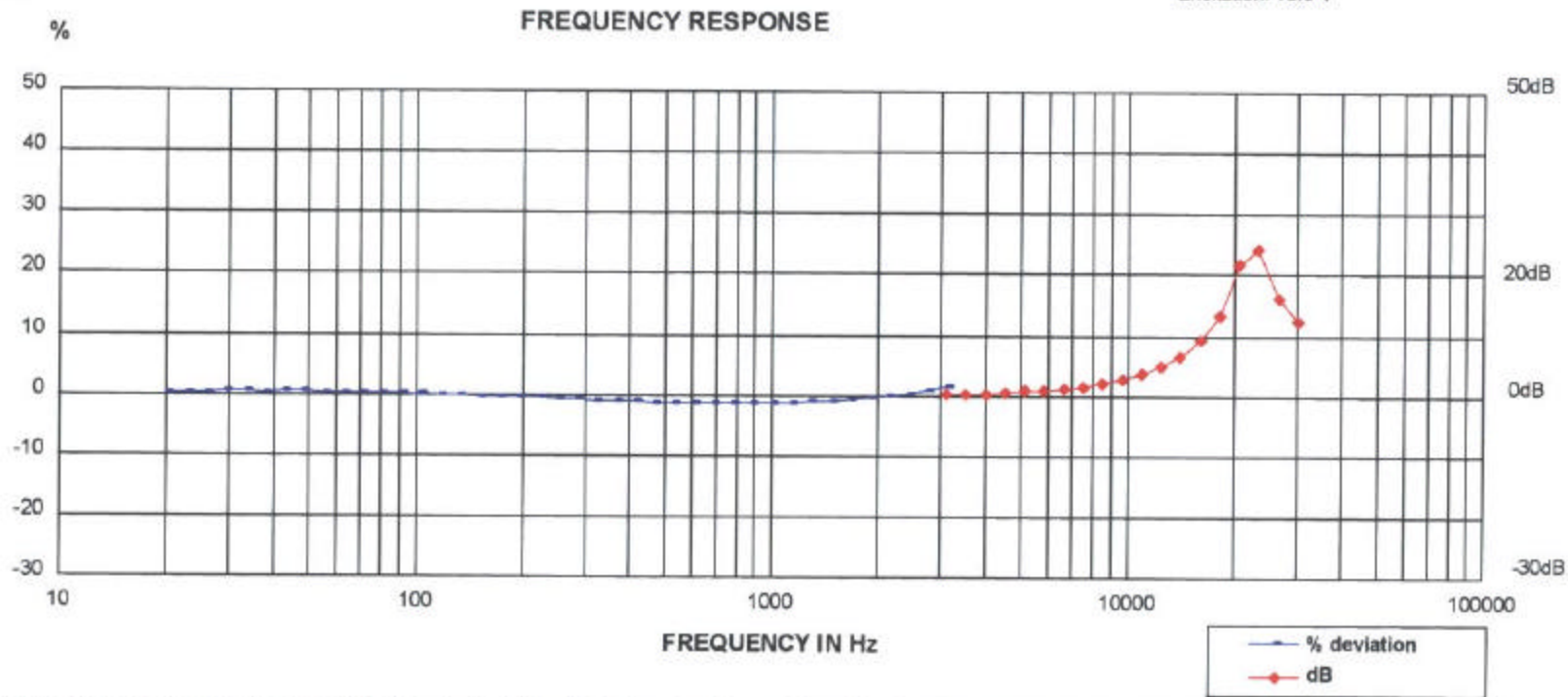

Endevco, a division of Meggitt, located at 30700 Rancho Viejo Road, San Juan Capistrano, CA, certifies that the above instrument was tested using comparison calibrations per ANSI S2.2 using Endevco IM68357. This calibration is traceable to the National Institute of Standards and Technology and is in accordance with ANSI/NC SL Z540-1-1994 (MIL-STD 45662A).

Console serial number: AC27
 NIST traceability #: 822/262802-00
 Equipment used: 2901
 Test definition: FINAL

Uncertainty estimate (95% confidence, k=2)

+/- 1.1 %	100.0 Hz Sensitivity
+/- 5.0 %	10.0 to 20.0 Hz
+/- 1.5 %	20.0 to 2000.0 Hz
+/- 2.5 %	2000.0 to 10000.0 Hz
+/- 4.0 %	10000.0 to 20000.0 Hz

By: *P. Kramp*
 P. KRAMP
 Date: 1/14/2002

Endevco
 Transportation Research Center

rab: #022

~~544~~ Chest Y - Right

Calibration Certificate

Customer: VRTC
20010620-0270

Document number: 5926

Description: VRTC - Accelerometer
Manufacturer: ENTRAN
Model Number: EGE-73BE0Q-2000BF
Serial Number: 99102-F09

Input Resistance (ohms): 955.72

ZMO (mV): -6.362

Resonance Frequency (Hz): 22338

0.1998 mV/g @ 100 Hz, 10g pk

Last Sens: 1.994E-1, Change: 0.17

Next cal date: 7/9/2002

Notes:

Excitation: 10.0 V

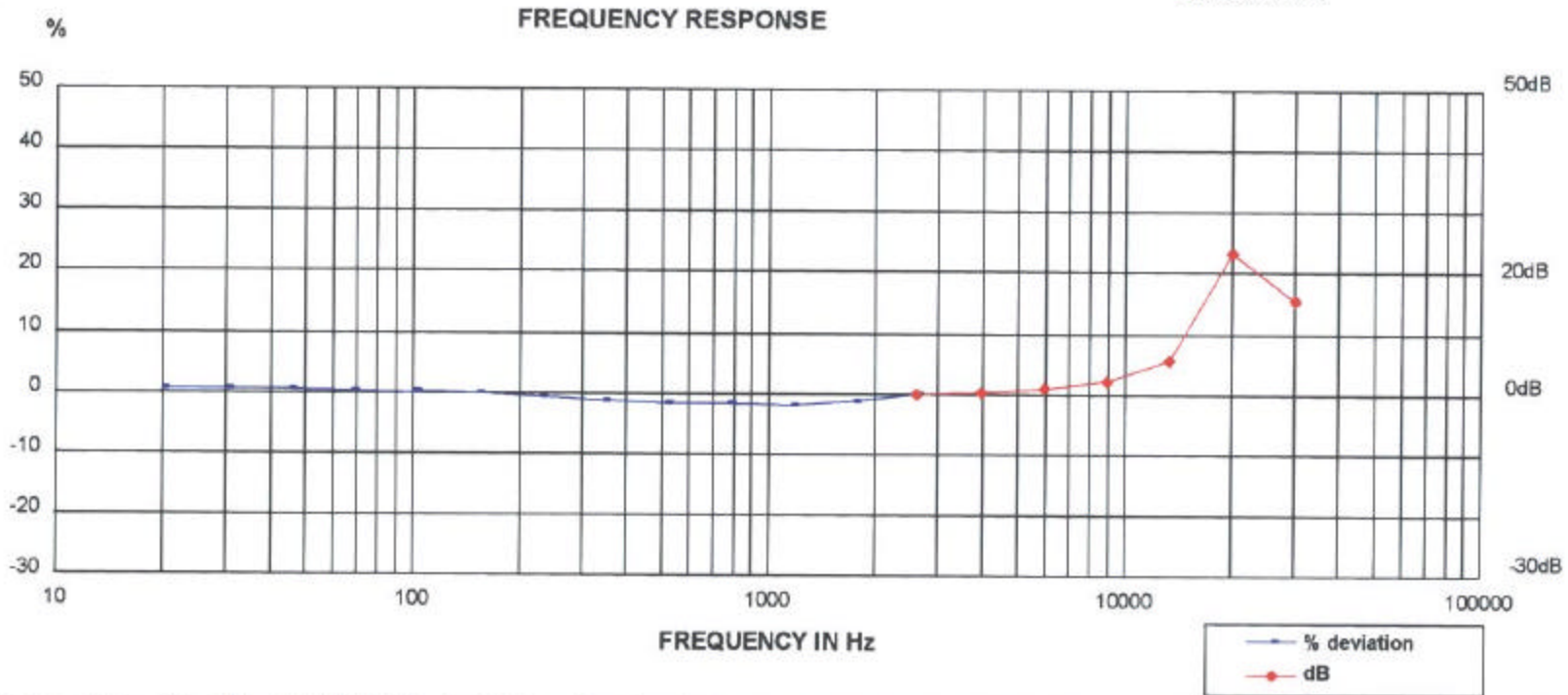

Endevco, a division of Meggitt, located at 30700 Rancho Viejo Road, San Juan Capistrano, CA, certifies that the above instrument was tested using comparison calibrations per ANSI S2.2 using Endevco IM68357. This calibration is traceable to the National Institute of Standards and Technology and is in accordance with ANSI/NCSL Z540-1-1994 (MIL-STD 45662A).

Uncertainty estimate (96% confidence, k=2)

Console serial number: AC27	+/- 1.1 %	100.0 Hz Sensitivity
NIST traceability #: 822/262802-00	+/- 5.0 %	10.0 to 20.0 Hz
Equipment used: 2901	+/- 1.5 %	20.0 to 2000.0 Hz
Test definition: FINAL	+/- 2.5 %	2000.0 to 10000.0 Hz
	+/- 4.0 %	10000.0 to 20000.0 Hz

By: _____

P. KRAMP

Date: 1/9/2002

Endevco

Transportation Research Center

Lab: #022
 Chest Z-NA

Calibration Certificate

Customer: VRTC
 20010620-0270

Document number: 5925

Description: VRTC - Accelerometer
 Manufacturer: ENTRAN
 Model Number: EGE-73BE0Q-2000BF
 Serial Number: 99H30-Z08

Input Resistance (ohms): 936.16
 ZMO (mV): -15.25
 Resonance Frequency (Hz): 17348

0.1876 mV/g @ 100 Hz, 10g pk

Last Sens: 1.867E-1, Change: 0.50
 Next cal date: 7/9/2002

Notes:

Excitation: 10.0 V

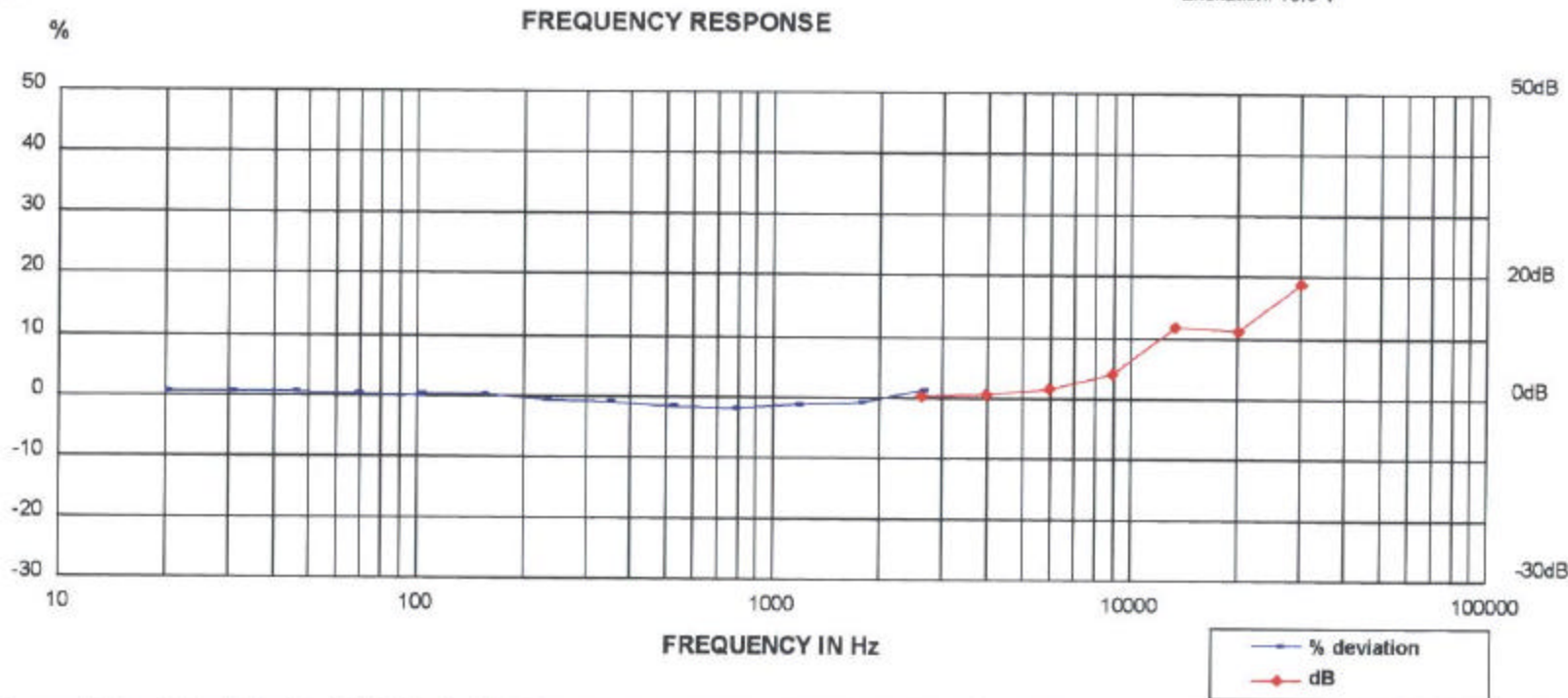

Endevco, a division of Meggitt, located at 30700 Rancho Viejo Road, San Juan Capistrano, CA, certifies that the above instrument was tested using comparison calibrations per ANSI S2.2 using Endevco IM68357. This calibration is traceable to the National Institute of Standards and Technology and is in accordance with ANSI/NC SL Z540-1-1994 (MIL-STD 45662A).

Uncertainty estimate (95% confidence, k=2)

Console serial number: AC27
 NIST traceability #: 822/262802-00
 Equipment used: 2901
 Test definition: FINAL

+/- 1.1 %	100.0 Hz Sensitivity
+/- 5.0 %	10.0 to 20.0 Hz
+/- 1.5 %	20.0 to 2000.0 Hz
+/- 2.5 %	2000.0 to 10000.0 Hz
+/- 4.0 %	10000.0 to 20000.0 Hz

By: _____
 P. KRAMP
 Date: 1/9/2002

Endevco
 Transportation Research Center

Crabi #022

Pelvis X - Rear

Calibration Certificate

Customer: VRTC
20010620-0270

Document number: 5935

Description: VRTC - Full Bridge Accelerometer
Manufacturer: ENTRAN
Model Number: EGE-73BQ-2000BF
Serial Number: 01G19-F01

Input Resistance (ohms): 482.42
Output Resistance (ohms): 483.2
ZMO (mV): 5.6894
Resonance Frequency (Hz): 28240

0.1995 mV/g @ 100 Hz, 10g pk

Last Sens: 1.993E-1, Change: 0.1

Next cal date: 1/9/2003

Notes:

Excitation: 10.0 V

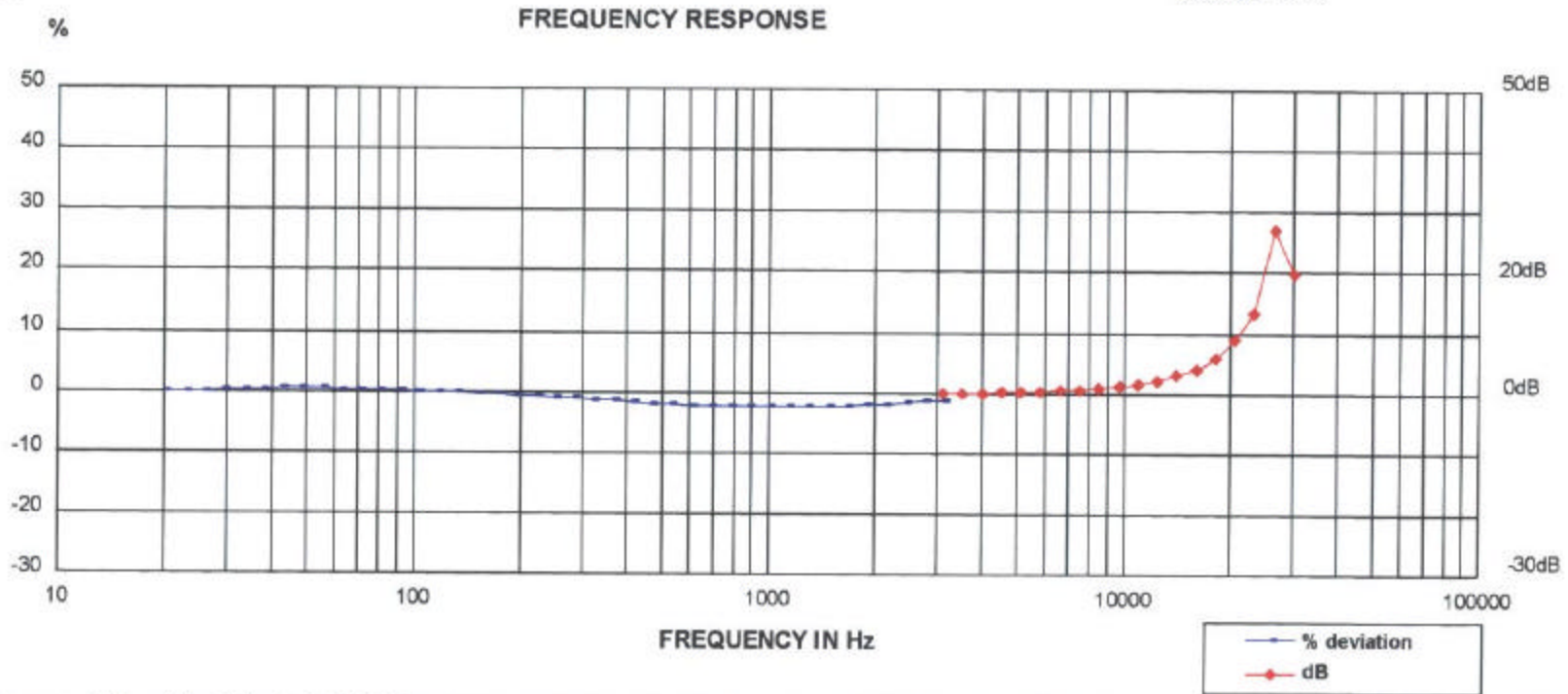

Endevco, a division of Meggitt, located at 30700 Rancho Viejo Road, San Juan Capistrano, CA, certifies that the above instrument was tested using comparison calibrations per ANSI S2.2 using Endevco IM68357. This calibration is traceable to the National Institute of Standards and Technology and is in accordance with ANSI/NC SL Z540-1-1994 (MIL-STD 45662A).

Uncertainty estimate (95% confidence, k=2)

Console serial number: AC27	+/- 1.1 %	100.0 Hz Sensitivity
NIST traceability #: 822/262802-00	+/- 5.0 %	10.0 to 20.0 Hz
Equipment used: 2901	+/- 1.5 %	20.0 to 2000.0 Hz
Test definition: FINAL	+/- 2.5 %	2000.0 to 10000.0 Hz
	+/- 4.0 %	10000.0 to 20000.0 Hz

By: _____

P. KRAMP

Date: 1/9/2002

Endevco

Transportation Research Center

Crabi #022

Pelvisy - 2A+

Calibration Certificate

Customer: VRTC
20010620-0270

Document number: 5926

Description: VRTC - Accelerometer
Manufacturer: ENTRAN
Model Number: EGE-73BE0Q-2000BF
Serial Number: 99H30-Z05

Input Resistance (ohms): 963.7

ZMO (mV): 2.5145
Resonance Frequency (Hz): 25087

0.1916 mV/g @ 100 Hz, 10g pk

Last Sens: 1.914E-1, Change: 0.09

Next cal date: 7/9/2002

Notes:

Excitation: 10.0 V

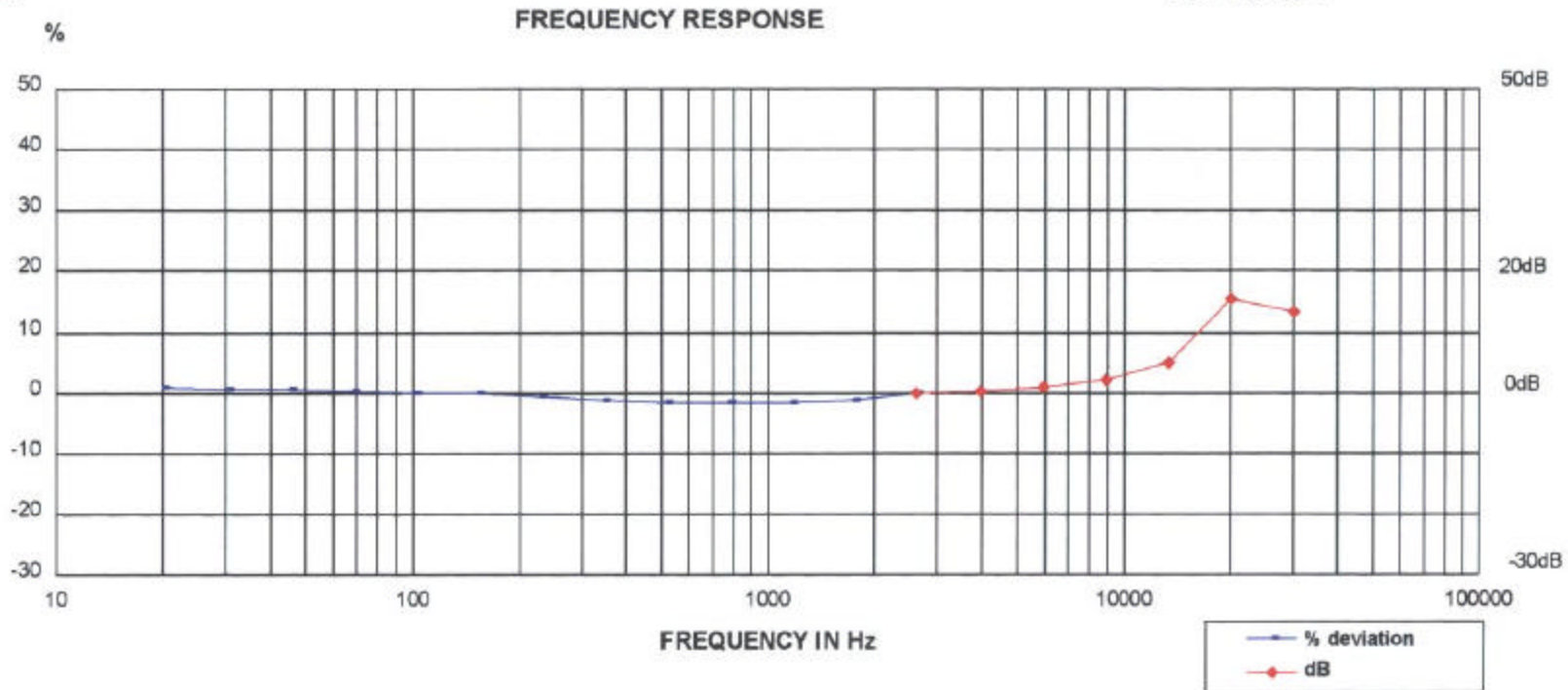

Endevco, a division of Meggitt, located at 30700 Rancho Viejo Road, San Juan Capistrano, CA, certifies that the above instrument was tested using comparison calibrations per ANSI S2.2 using Endevco IM68357. This calibration is traceable to the National Institute of Standards and Technology and is in accordance with ANSI/NCSL Z540-1-1994 (MIL-STD 45662A).

Uncertainty estimate (95% confidence, k=2)

Console serial number: AC27
NIST traceability #: 822/262802-00
Equipment used: 2901
Test definition: FINAL

+/- 1.1 %	100.0 Hz Sensitivity
+/- 5.0 %	10.0 to 20.0 Hz
+/- 1.5 %	20.0 to 2000.0 Hz
+/- 2.5 %	2000.0 to 10000.0 Hz
+/- 4.0 %	10000.0 to 20000.0 Hz

By: _____
P. KRAMP

Date: 1/9/2002

Endevco
Transportation Research Center

Crabi #022

Delois E-4A

Calibration Certificate

Customer: VRTC
20010620-0270

Document number: 5931

Description: VRTC - Accelerometer
Manufacturer: ENTRAN
Model Number: EGE-73BE0Q-2000BF
Serial Number: 99H30-Z03

Input Resistance (ohms): 983.01

ZMO (mV): -12.97
Resonance Frequency (Hz): 25550

0.1974 mV/g @ 100 Hz, 10g pk

Last Sens: 1.972E-1, Change: 0.09

Next cal date: 7/9/2002

Notes:

Excitation: 10.0 V

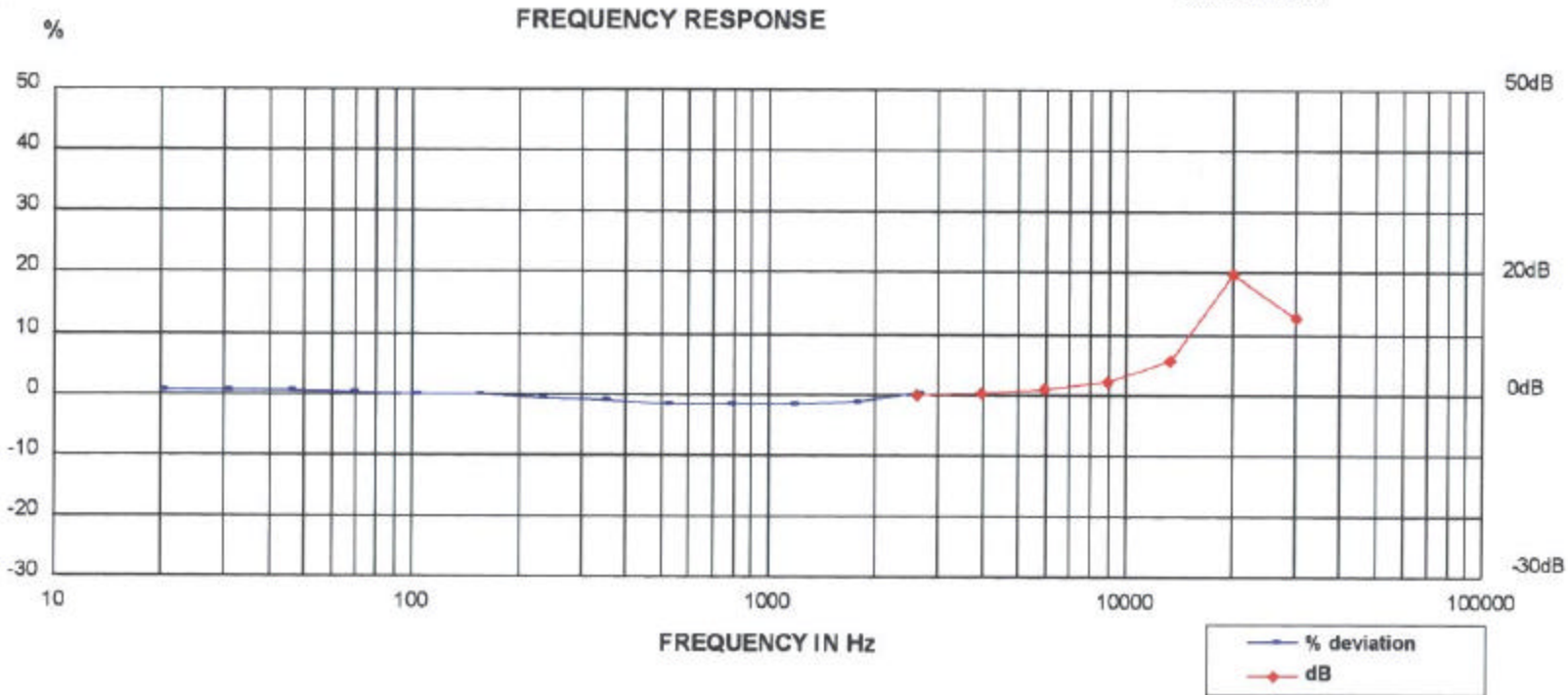

Endevco, a division of Meggitt, located at 30700 Rancho Viejo Road, San Juan Capistrano, CA, certifies that the above instrument was tested using comparison calibrations per ANSI S2.2 using Endevco IM68357. This calibration is traceable to the National Institute of Standards and Technology and is in accordance with ANSI/NCSS Z540-1-1994 (MIL-STD 45662A).

Uncertainty estimate (95% confidence, k=2)		
Console serial number: AC27	+/- 1.1 %	100.0 Hz Sensitivity
NIST traceability #: 822/262802-00	+/- 5.0 %	10.0 to 20.0 Hz
Equipment used: 2901	+/- 1.5 %	20.0 to 2000.0 Hz
Test definition: FINAL	+/- 2.5 %	2000.0 to 10000.0 Hz
	+/- 4.0 %	10000.0 to 20000.0 Hz

By: _____
P. KRAMP
Date: 1/9/2002

Endevco
Transportation Research Center

TRANSPORTATION RESEARCH CENTER INC.

FRONTAL HEAD DROP TEST

CRABI 12-MONTH

24-JAN-02

TRC INC.

TEST NO: 022C01HF1

572R SN022 HEAD DROP CAL 01

TEST PARAMETER	SPECIFICATION	TEST RESULTS
TEMPERATURE	18.9-25.6 DEG. C	21.7 DEG. C
RELATIVE HUMIDITY	10 - 70 %	45.0 %
PEAK RESULTANT ACCELERATION	100 - 120 G	117.62 G
PEAK LATERAL ACCELERATION	15 G MAX	5.78 G
IS ACCELERATION CURVE UNIMODAL? (<= 17%)	YES	YES (10.6%)

TEST MEETS SPECIFICATIONS

TECHNICIAN



RUN NUMBER: 012402.1243;2

PART 572R CRABI FRONTAL HEAD DROP CALIBRATION

HEAD ACCELERATION X AXIS

TRC TEST NUMBER: 022C01HF1

572R SN022 HEAD DROP CAL 01

RUN NUMBER: 012402.1244;2

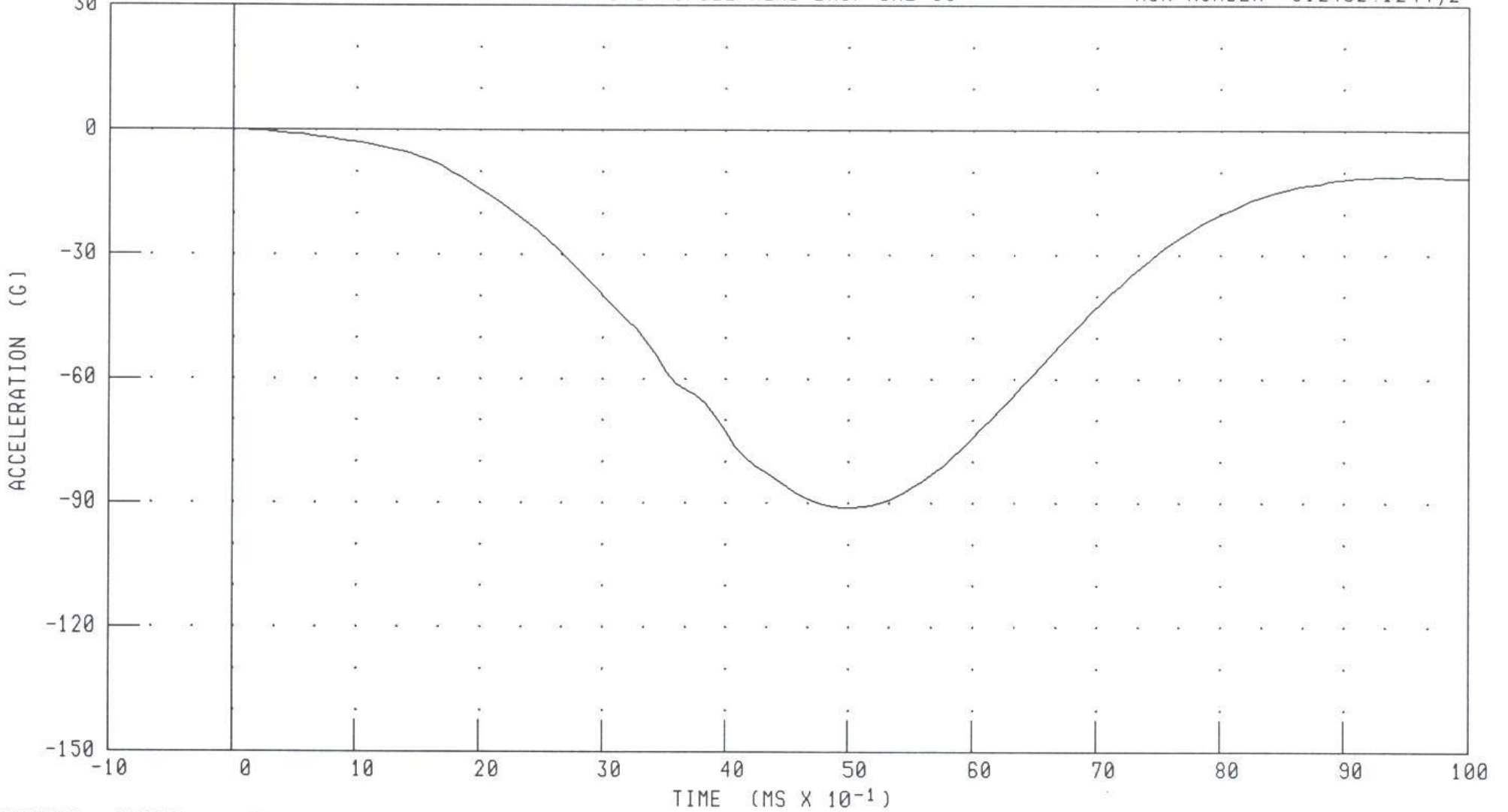

CHANNEL: HEDXC

FILTER: CH. CLASS 1000

PEAK DATA: 0.09 G @ -0.96 MS; -91.07 G @ 4.96 MS

PART 572R CRABI FRONTAL HEAD DROP CALIBRATION

HEAD ACCELERATION Y AXIS

TRC TEST NUMBER: 022C01HF1

572R SN022 HEAD DROP CAL 01

RUN NUMBER: 012402.1244,2

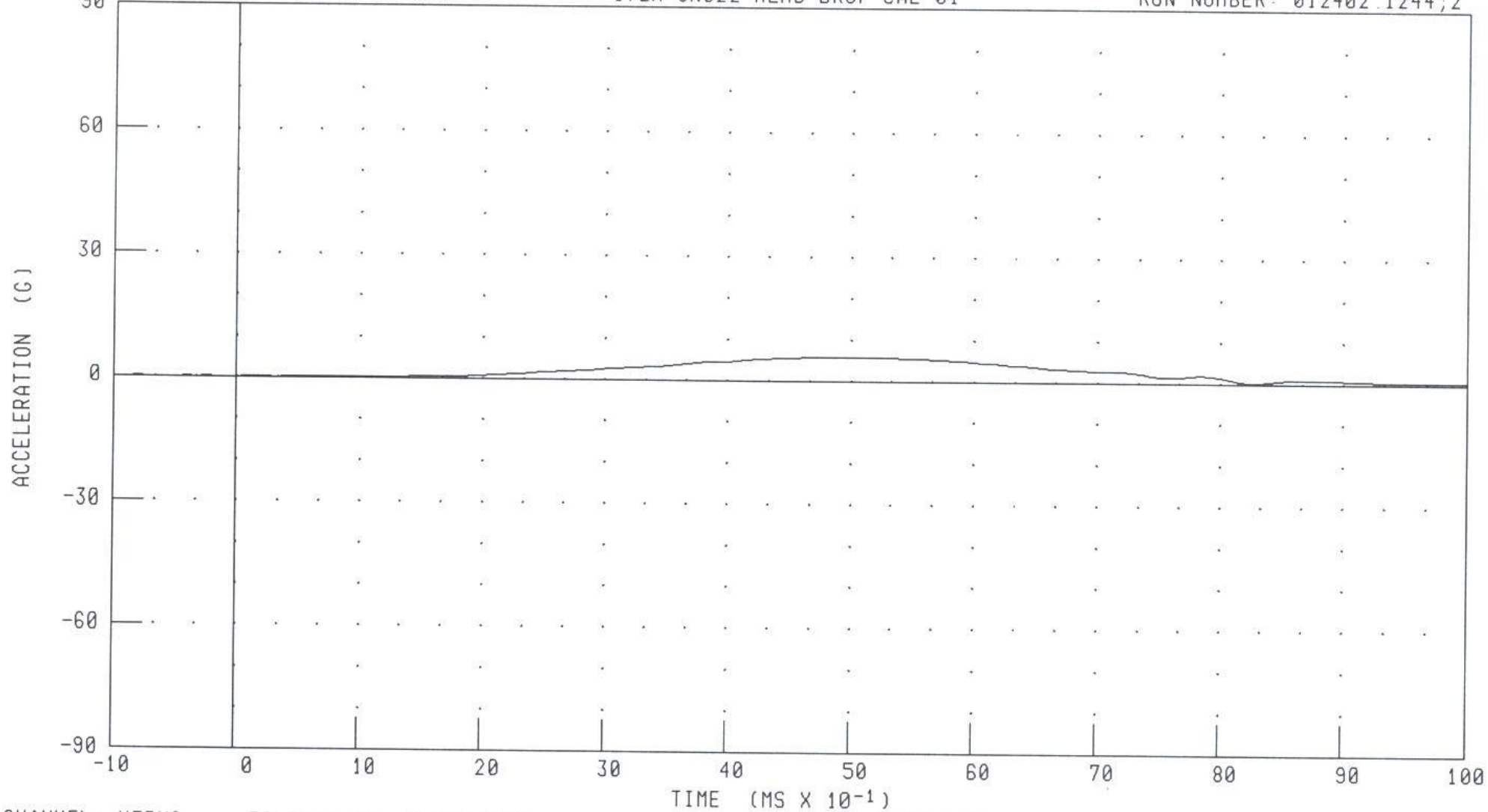

CHANNEL: HEDYG

FILTER: CH. CLASS 1000

PEAK DATA: 5.79 G @ 4.88 MS; -0.01 G @ 0.00 MS

PART 572R CRABI FRONTAL HEAD DROP CALIBRATION

HEAD ACCELERATION Z AXIS

TRC TEST NUMBER: 022C01HF1

572R SN022 HEAD DROP CAL 01

RUN NUMBER: 012402.1244;2

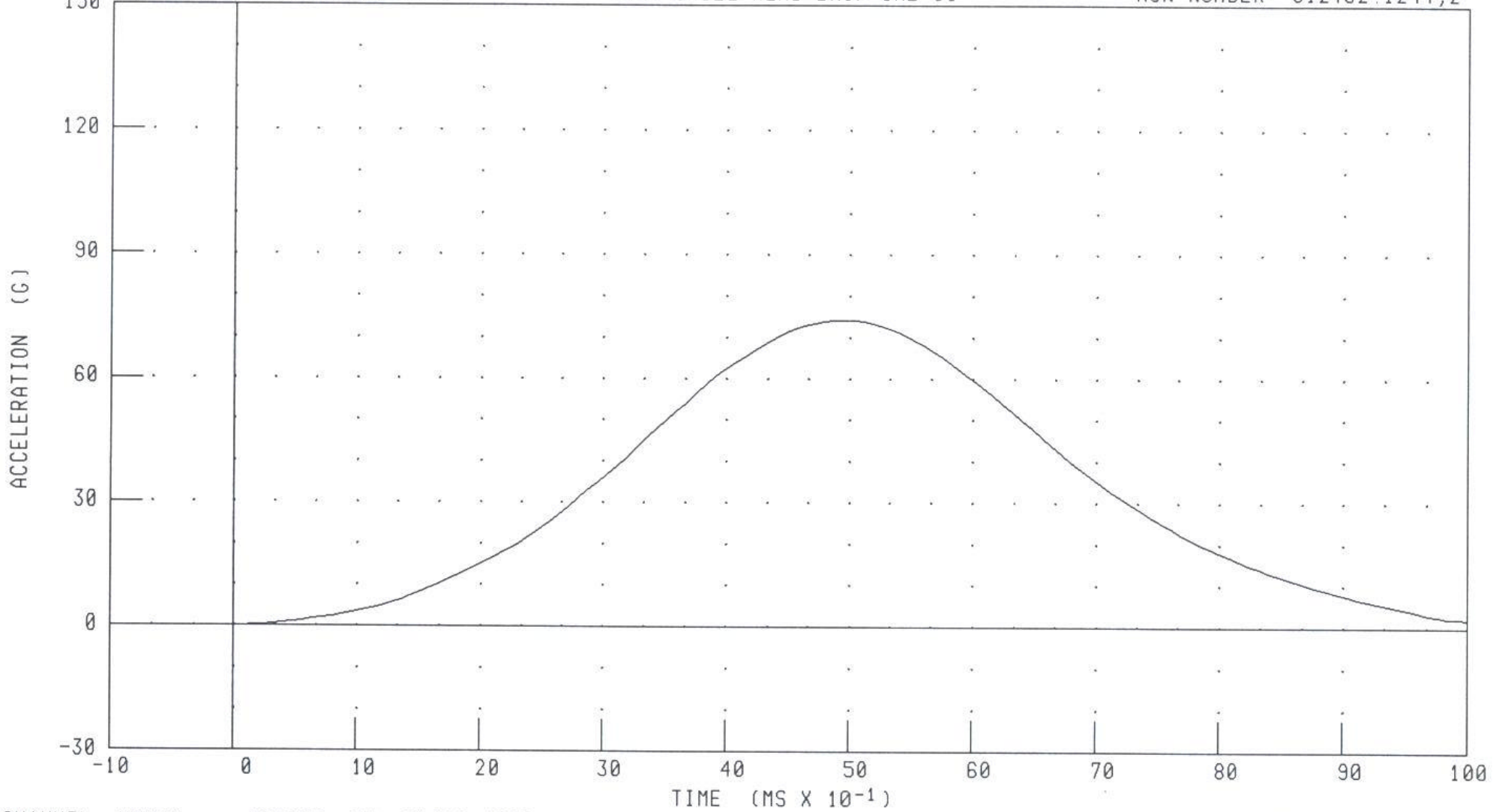

CHANNEL: HEDZG

FILTER: CH. CLASS 1000

PEAK DATA: 74.23 G @ 4.96 MS; -0.02 G @ -0.80 MS

PART 572R CRABI FRONTAL HEAD DROP CALIBRATION

HEAD RESULTANT ACCELERATION

572R SN022 HEAD DROP CAL 01

TRC TEST NUMBER: 022C01HF1

RUN NUMBER: 012402 1244;2

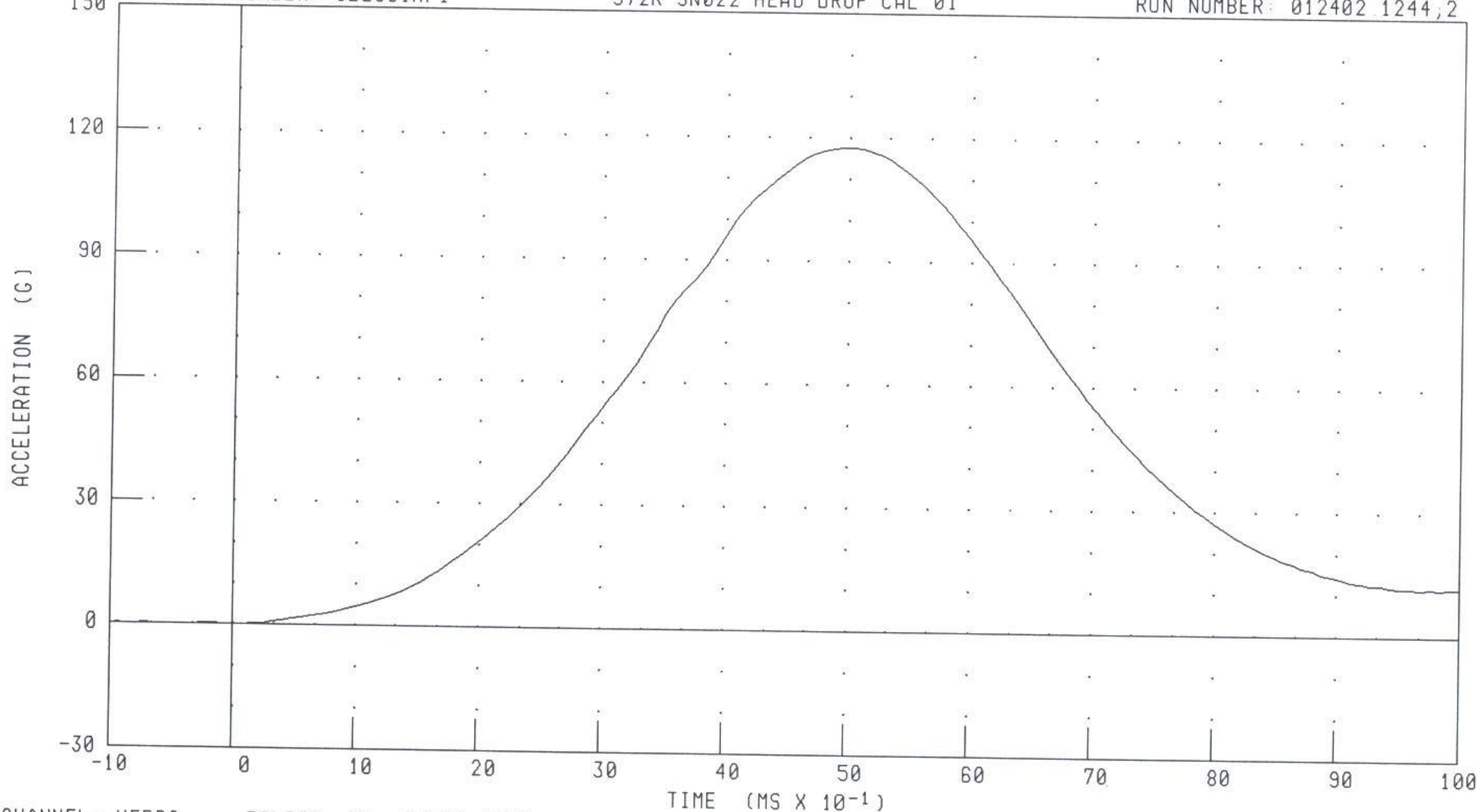

CHANNEL: HEDRG

FILTER: CH. CLASS 1000

PEAK DATA: 117.63 G @ 4.96 MS; 0.03 G @ -0.88 MS

TRANSPORTATION RESEARCH CENTER INC.

REAR HEAD DROP TEST

CRABI 12-MONTH

24-JAN-02

TRC INC.

TEST NO: 022C01HR1

572R SN022 HEAD DROP CAL 01

TEST PARAMETER	SPECIFICATION	TEST RESULTS
TEMPERATURE	18.9-25.6 DEG. C	21.7 DEG. C
RELATIVE HUMIDITY	10 - 70 %	33.0 %
PEAK RESULTANT ACCELERATION	55 - 71 G	62.36 G
PEAK LATERAL ACCELERATION	15 G MAX	2.07 G
IS ACCELERATION CURVE UNIMODAL? (<=17%)	YES	YES (9.7%)

TEST MEETS SPECIFICATIONS

TECHNICIAN

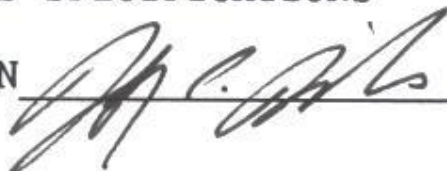

RUN NUMBER: 012402.1449;5

PART 572R CRABI REAR HEAD DROP CALIBRATION

HEAD ACCELERATION X AXIS

TRC TEST NUMBER: 022C01HR1

572R SN022 HEAD DROP CAL 01

RUN NUMBER: 012802.1014,5

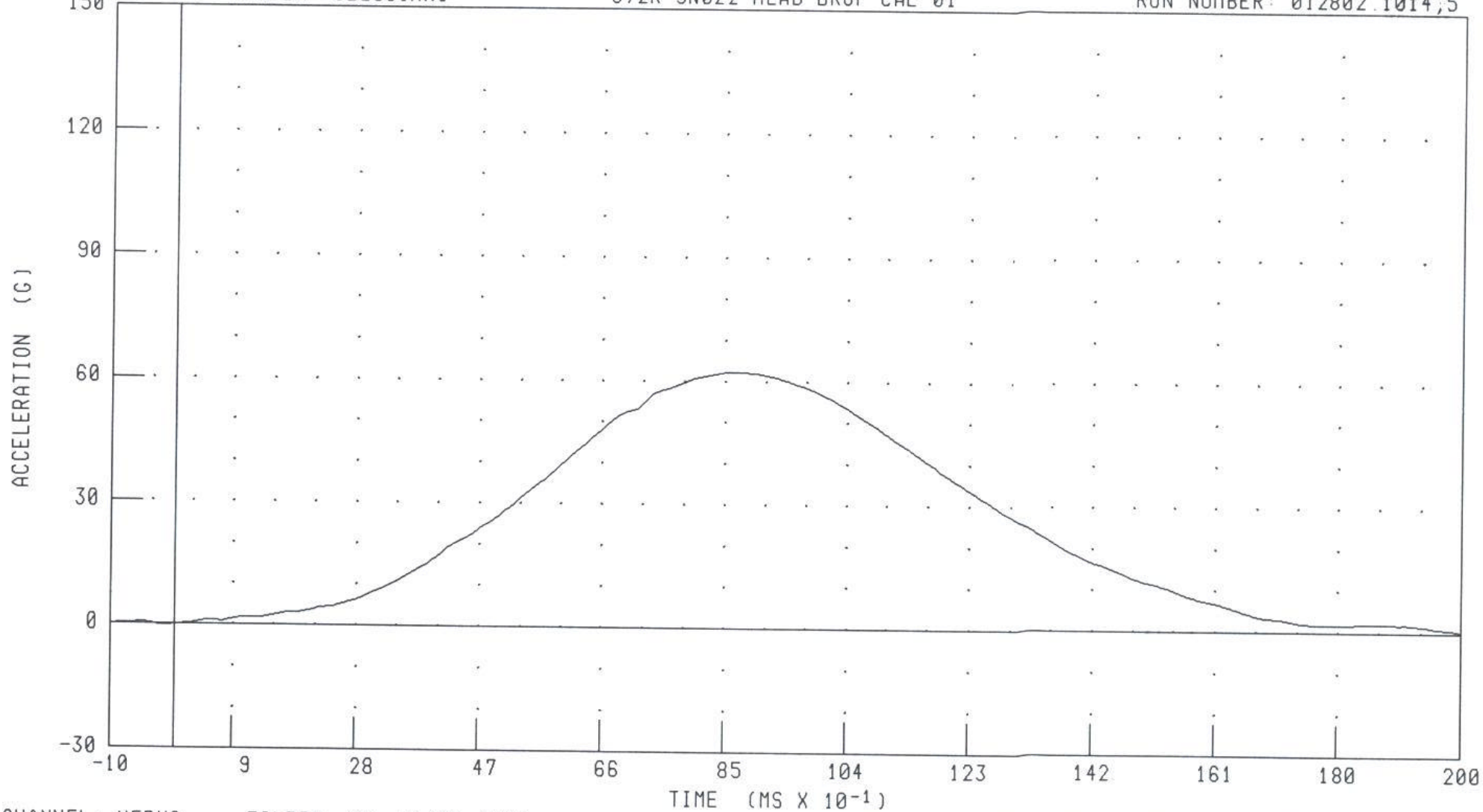

CHANNEL: HEDXC

FILTER: CH. CLASS 1000

PEAK DATA: 62.20 G @ 8.88 MS; -0.32 G @ -0.16 MS

PART 572R CRABI REAR HEAD DROP CALIBRATION

HEAD ACCELERATION Y AXIS

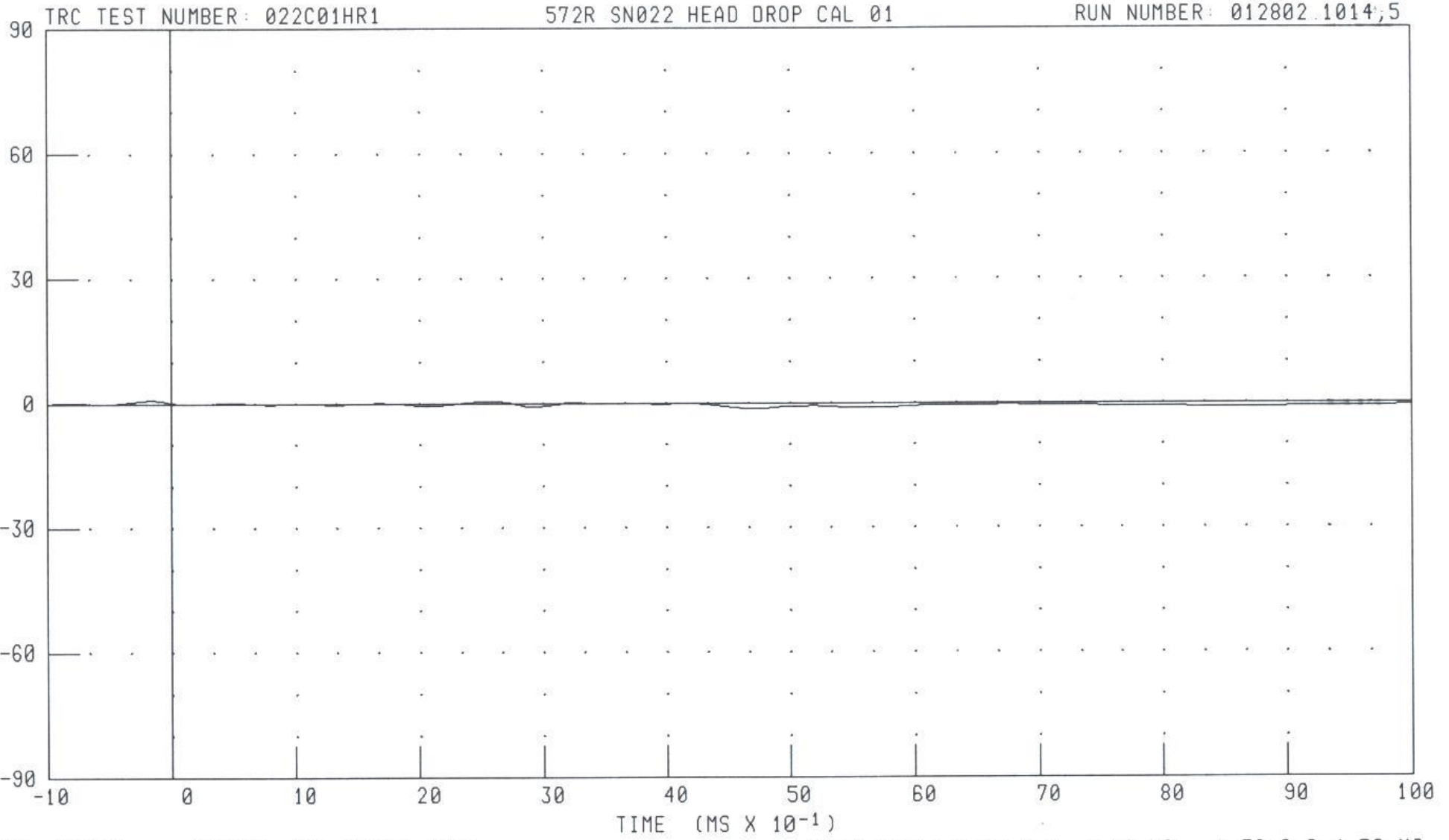

PART 572R CRABI REAR HEAD DROP CALIBRATION

HEAD ACCELERATION Z AXIS

TRC TEST NUMBER: 022C01HR1

572R SN022 HEAD DROP CAL 01

RUN NUMBER: 012802.1014,5

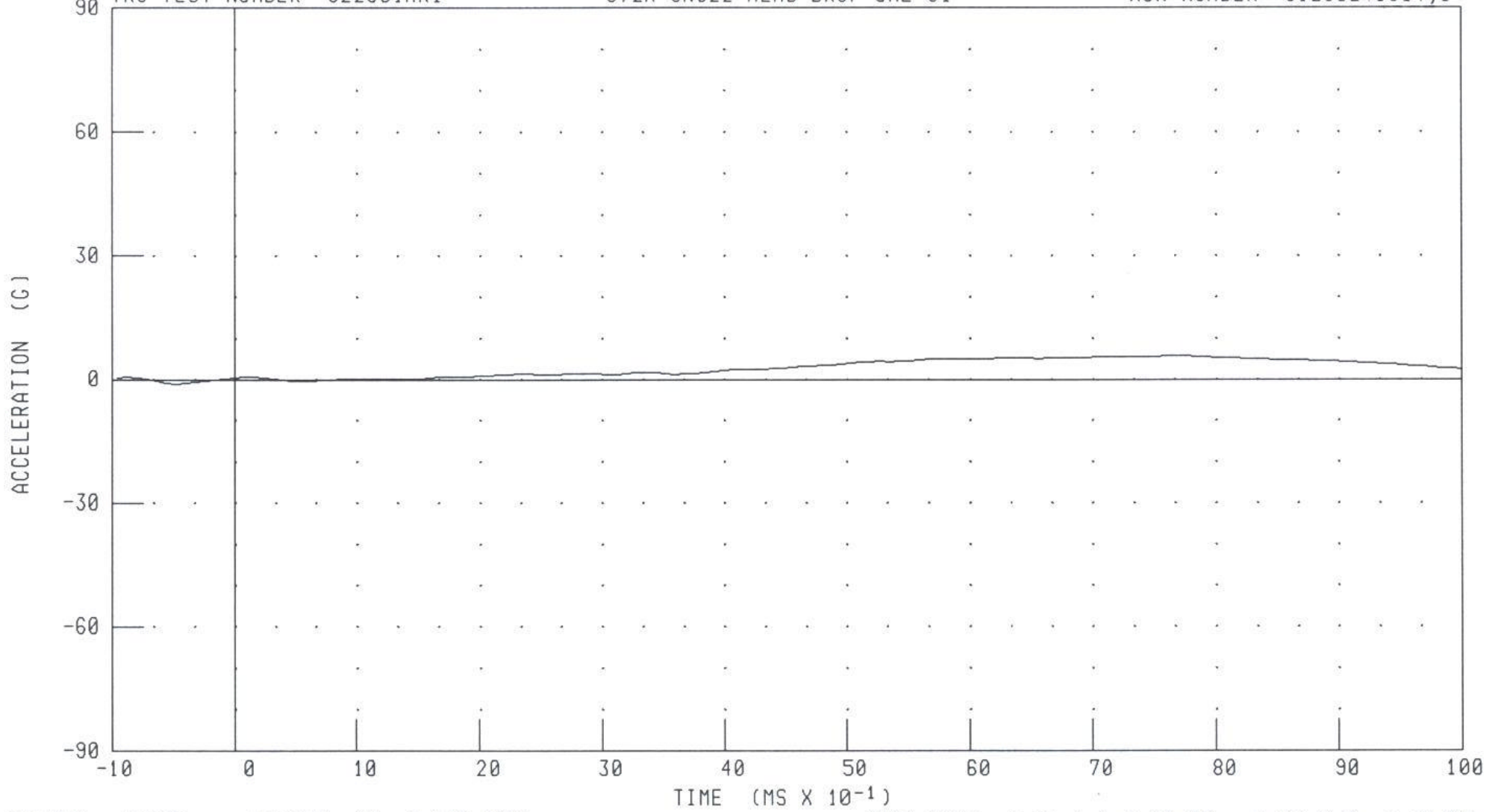

CHANNEL: HEDZG

FILTER: CH. CLASS 1000

PEAK DATA: 5.67 G @ 7.68 MS; -1.07 G @ -0.48 MS

PART 572R CRABI REAR HEAD DROP CALIBRATION

HEAD RESULTANT ACCELERATION

TRC TEST NUMBER: 022C01HR1

572R SN022 HEAD DROP CAL 01

RUN NUMBER: 012802.1014;5

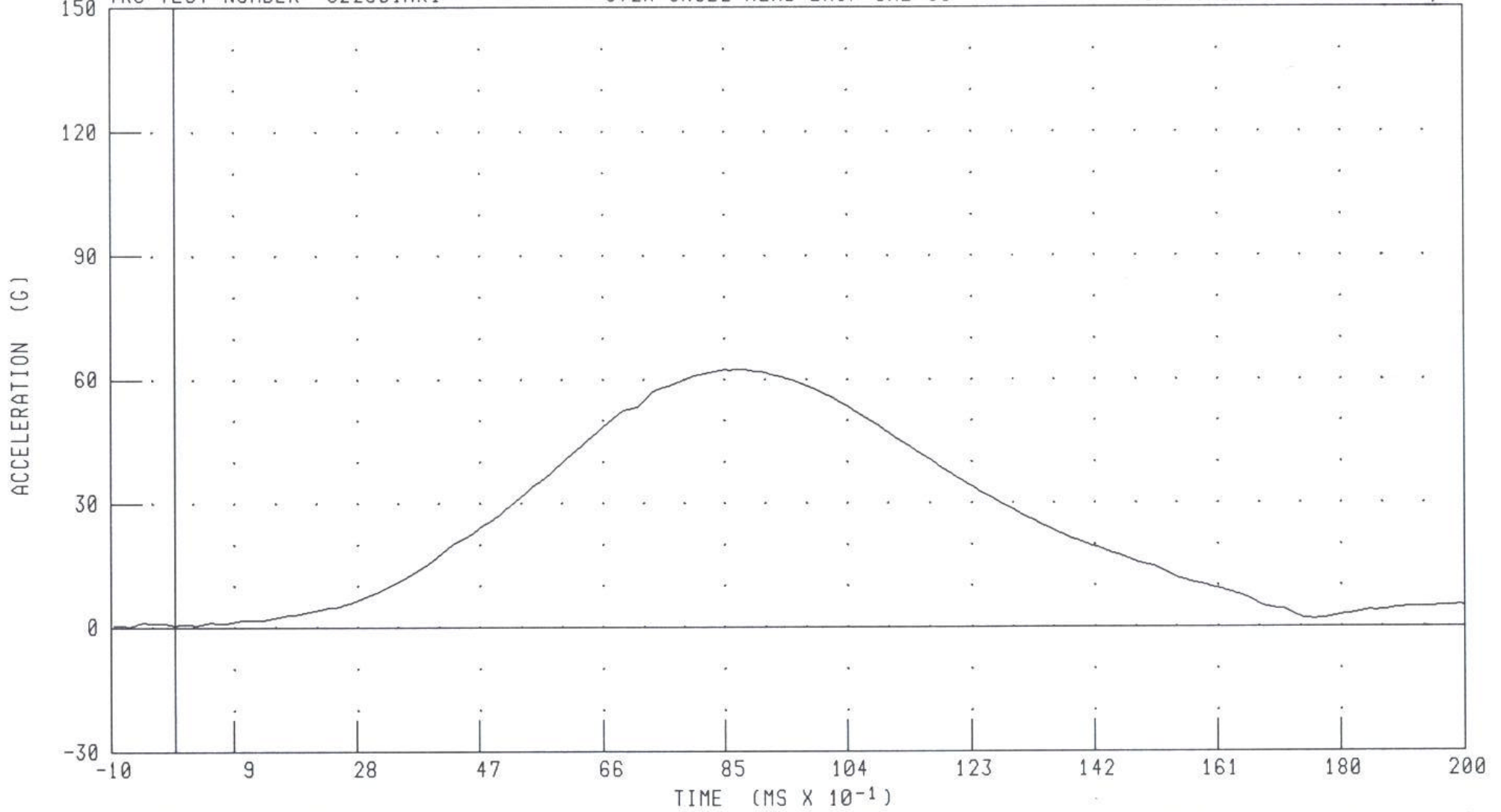

CHANNEL: HEDRG

FILTER: CH. CLASS 1000

PEAK DATA: 62.37 G @ 8.88 MS; 0.24 G @ -0.72 MS

TRANSPORTATION RESEARCH CENTER INC.

NECK FLEXION TEST

CRABI 12-MONTH

25-JAN-02

TRC INC. TEST NO: 022C01NF2 572R SN022 NECK FLEX CAL01

TEST PARAMETER	SPECIFICATION	TEST RESULTS
TEMPERATURE	20.6-22.2 DEG. C	21.1 DEG. C
RELATIVE HUMIDITY	10 - 70 %	24.0 %
IMPACT VELOCITY	5.1 - 5.3 M/S	5.25 M/S
INTEGRATED PENDULUM VELOCITY	10 MS 1.6 - 2.3 G	2.03 M/S
	20 MS 3.4 - 4.2 M/S	4.18 M/S
	25 MS 4.3 - 5.2 M/S	5.10 M/S
PEAK D-PLANE ROTATION	75 - 86 DEG.	76.94 DEG.
PEAK MOMENT DURING ROTATION INTERVAL	39 - 45 NM	40.64 NM
POSITIVE MOMENT DECAY TIME TO 5 NM LEVEL	60 - 80 MS	69.92 MS

TEST MEETS SPECIFICATIONS

TECHNICIAN

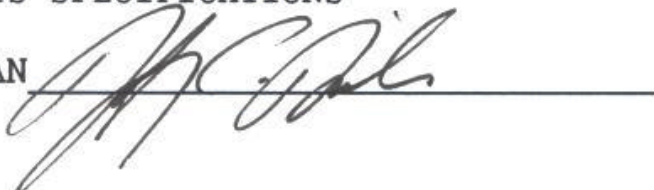

RUN NUMBER: 012502.0928;1

PART 572R CRABI NECK FLEXION CALIBRATION
PENDULUM DECELERATION

TRC TEST NUMBER: 022C01NF2

572R SN022 NECK FLEX CAL01

RUN NUMBER: 012502.1332;2

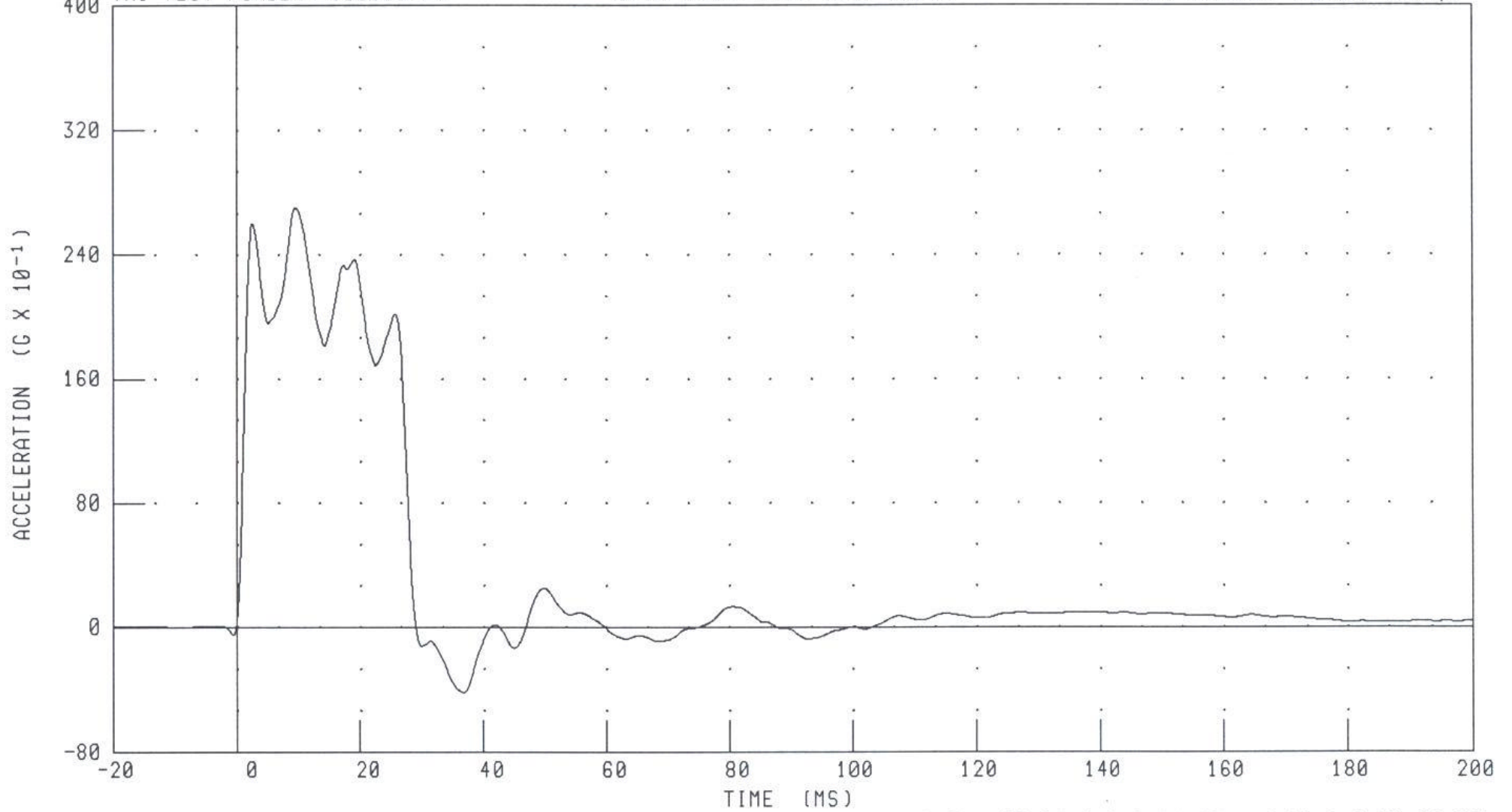

CHANNEL: PENXC

FILTER: CH. CLASS 180

PEAK DATA: 27.04 G @ 9.44 MS; -4.19 G @ 36.80 MS

PART 572R CRABI NECK FLEXION CALIBRATION

PENDULUM INTEGRATED VELOCITY

TRC TEST NUMBER: 022C01NF2

572R SN022 NECK FLEX CAL01

RUN NUMBER: 012502.1332;2

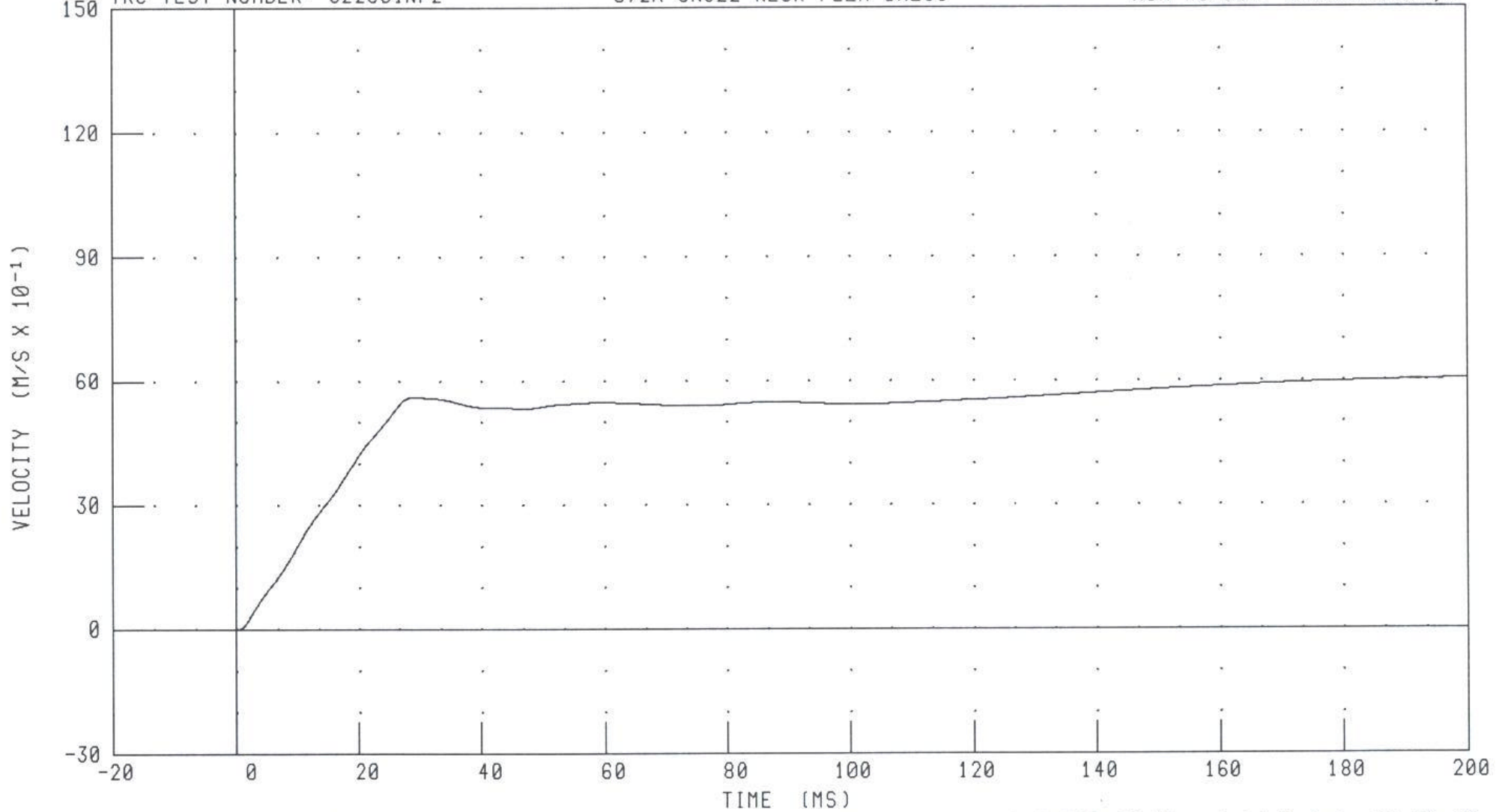

CHANNEL: PENXVI

FILTER: CH. CLASS 180

PEAK DATA: 6.04 M/S @ 200.00 MS; -0.01 M/S @ -20.00 MS

PART 572R CRABI NECK FLEXION CALIBRATION
ROTATION ABOUT BASE OF NECK

TRC TEST NUMBER: 022C01NF2

572R SN022 NECK FLEX CAL01

RUN NUMBER: 012502.1332;2

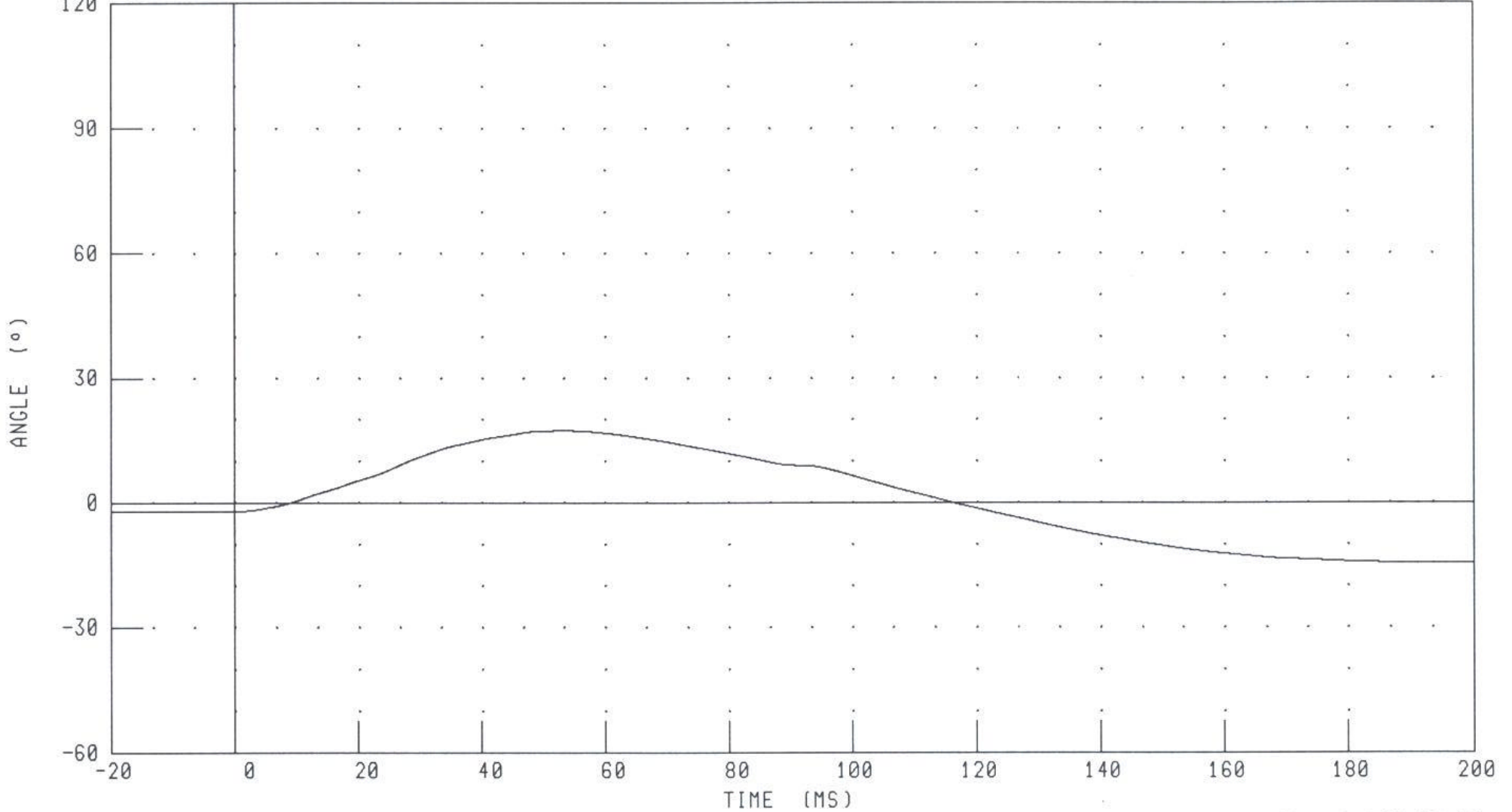

CHANNEL: BETA

FILTER: CH. CLASS 60

PEAK DATA: 17.34 ° @ 53.28 MS; -14.62 ° @ 193.20 MS

PART 572R CRABI NECK FLEXION CALIBRATION
ROTATION ABOUT OCCIPITAL CONDYLE

TRC TEST NUMBER: 022C01NF2

572R SN022 NECK FLEX CAL01

RUN NUMBER: 012502.1332;2

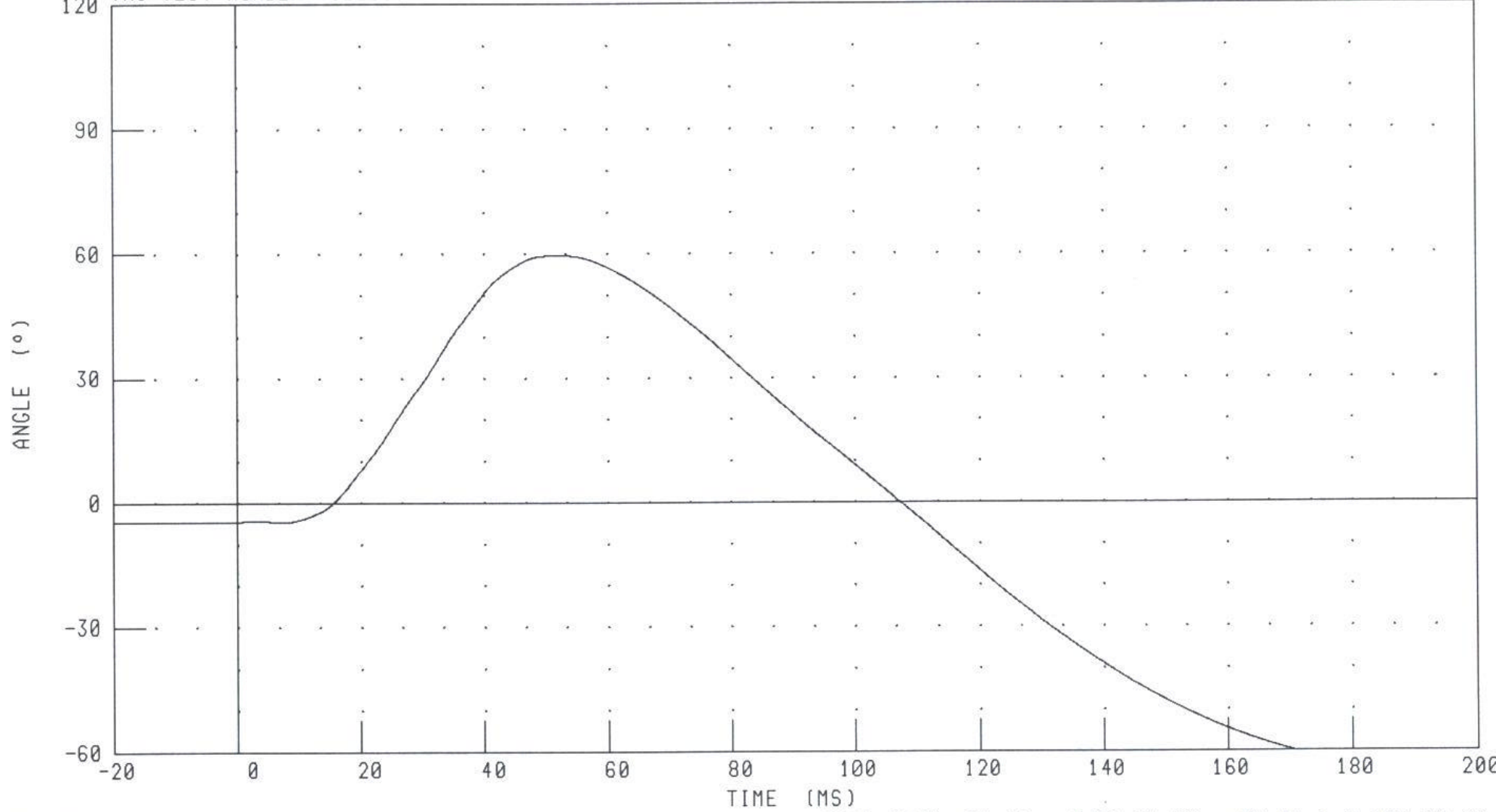

CHANNEL: THETA

FILTER: CH. CLASS 60

PEAK DATA: 59.61 ° @ 52.24 MS; -62.43 ° @ 185.36 MS

PART 572R CRABI NECK FLEXION CALIBRATION

TOTAL ROTATION

TRC TEST NUMBER: 022C01NF2

572R SN022 NECK FLEX CAL01

RUN NUMBER: 012502.1332;2

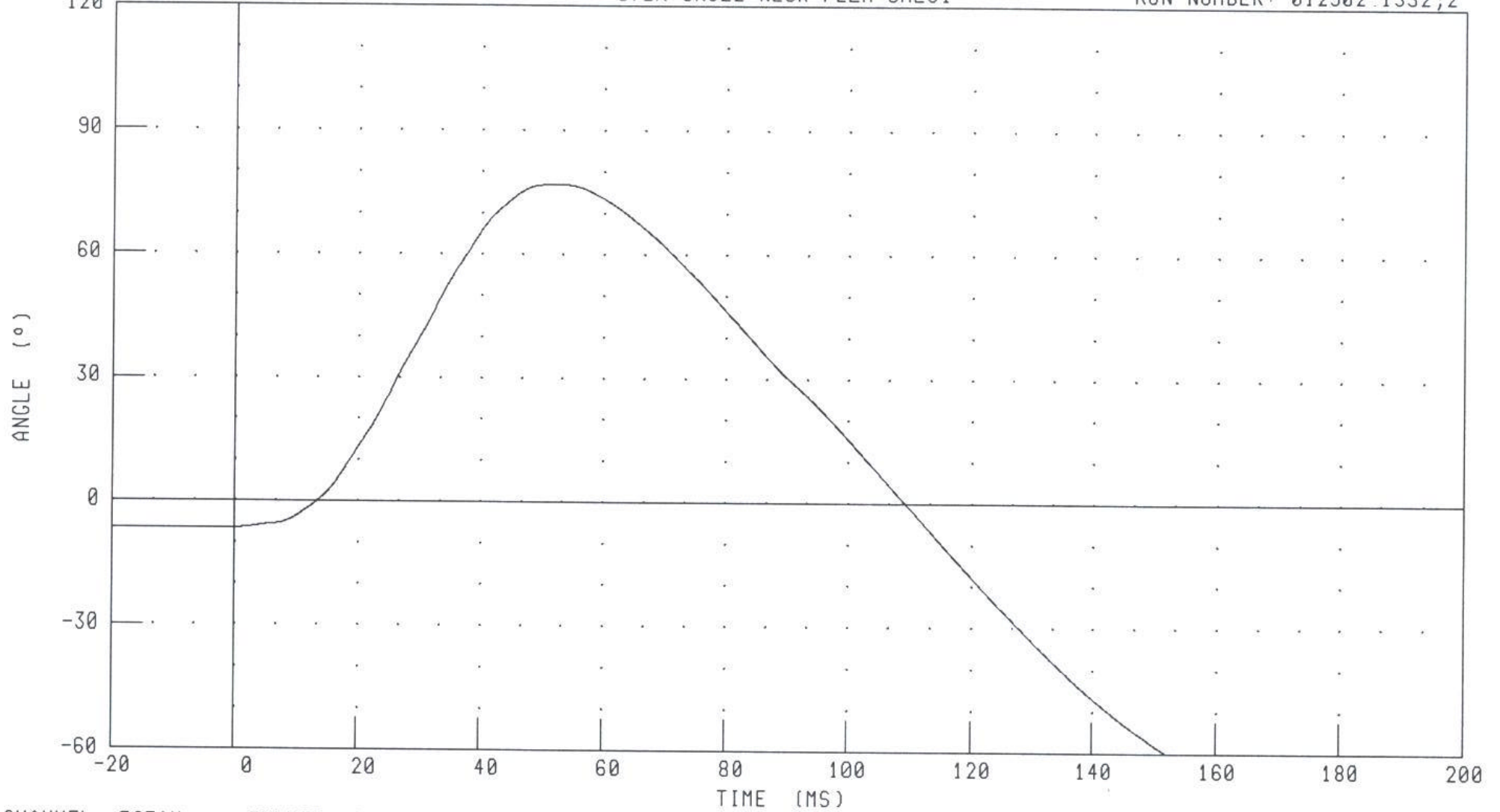

CHANNEL: TOTAN

FILTER: CH. CLASS 60

PEAK DATA: 76.94 ° @ 52.48 MS; -76.97 ° @ 189.60 MS

PART 572R CRABI NECK FLEXION CALIBRATION

NECK FORCE X AXIS

TRC TEST NUMBER: 022C01NF2

572R SN022 NECK FLEX CAL01

RUN NUMBER: 012502.1332;2

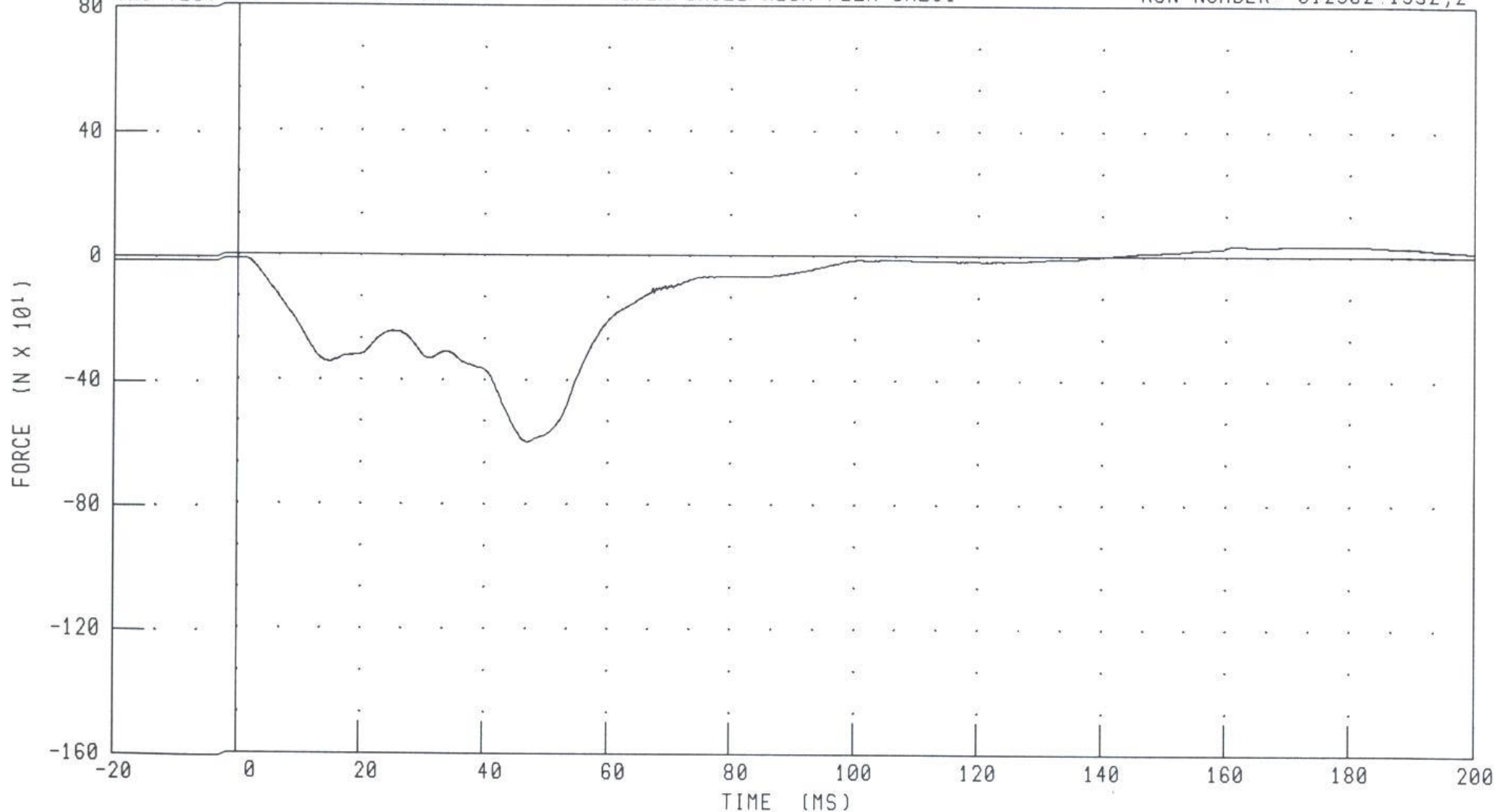

CHANNEL: NEKXF

FILTER: CH, CLASS 1000

PEAK DATA: 37.02 N @ 172.32 MS; -601.30 N @ 46.88 MS

PART 572R CRABI NECK FLEXION CALIBRATION

NECK MOMENT Y AXIS

TRC TEST NUMBER: 022C01NF2

572R SN022 NECK FLEX CAL01

RUN NUMBER: 012502.1332;2

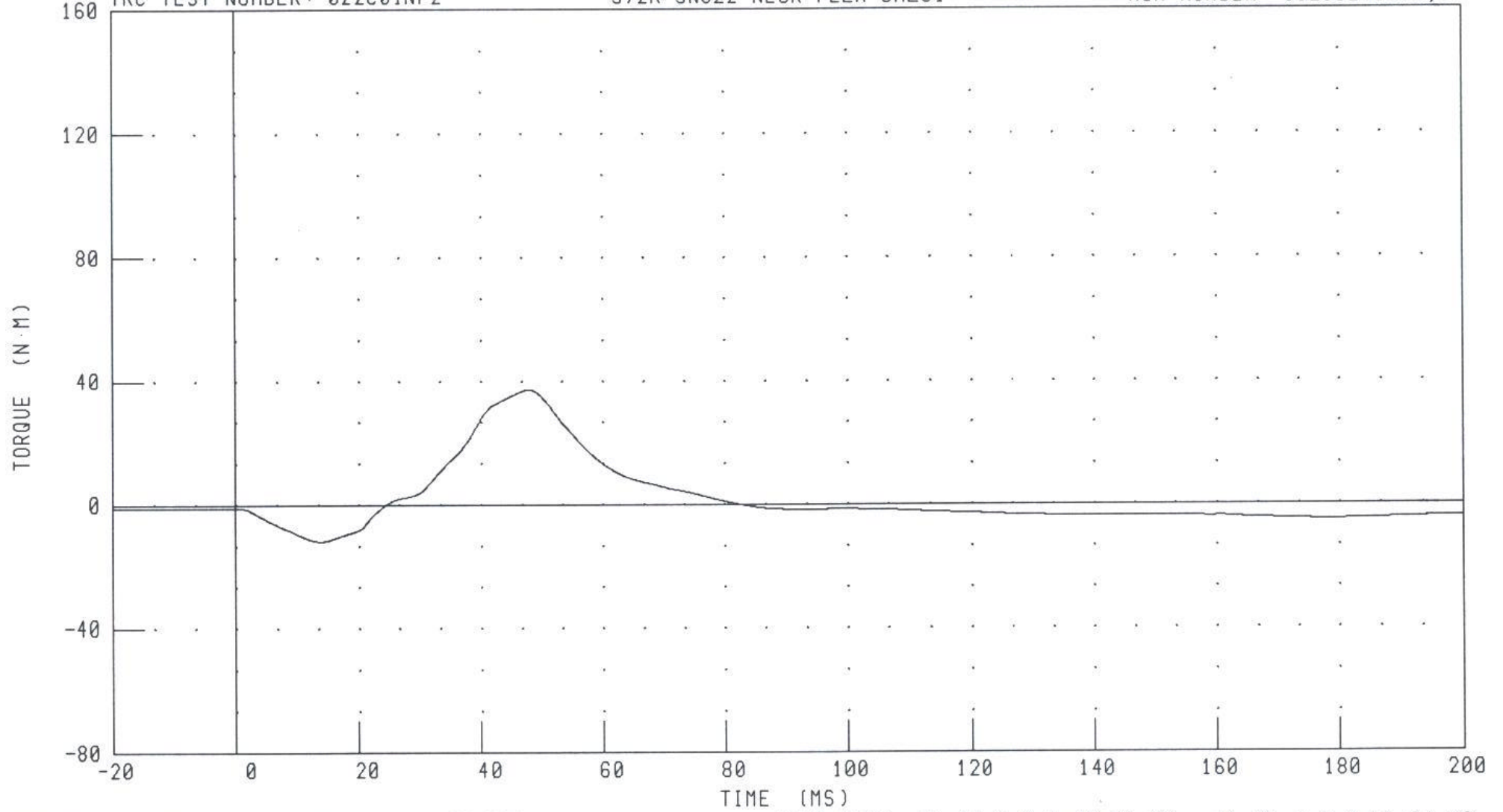

CHANNEL: NEKYM

FILTER: CH. CLASS 600

PEAK DATA: 37.17 N·M @ 48.08 MS; -11.85 N·M @ 13.84 MS

PART 572R CRABI NECK FLEXION CALIBRATION
MOMENT ABOUT OCCIPITAL CONDYLE

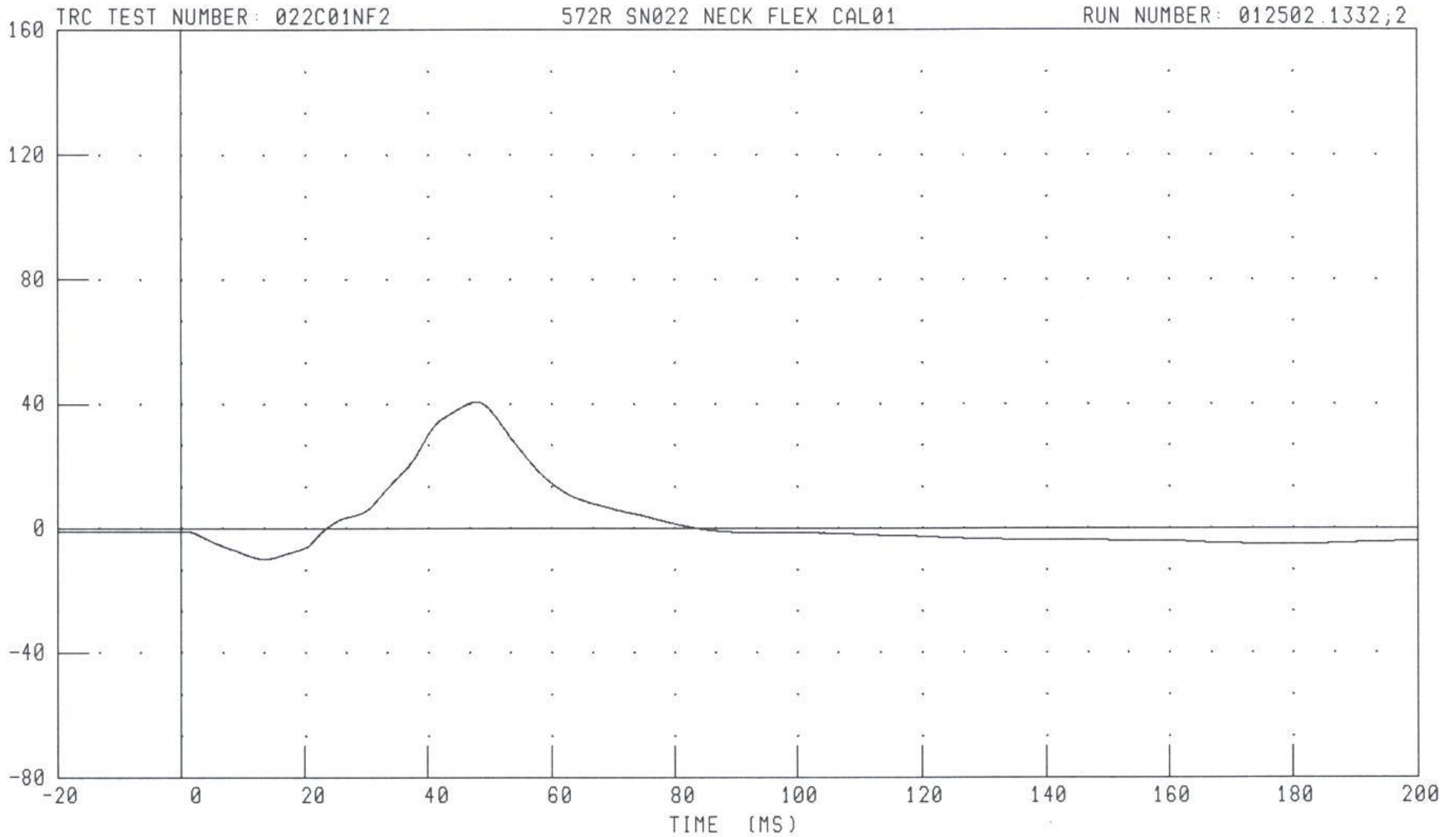

CHANNEL: NEKOM

FILTER: CH. CLASS 600

PEAK DATA: 40.64 N·M @ 47.84 MS; -9.89 N·M @ 13.68 MS

PART 572R CRABI NECK FLEXION CALIBRATION
TOTAL ROTATION VS OCCIPITAL CONDYLAR MOMENT

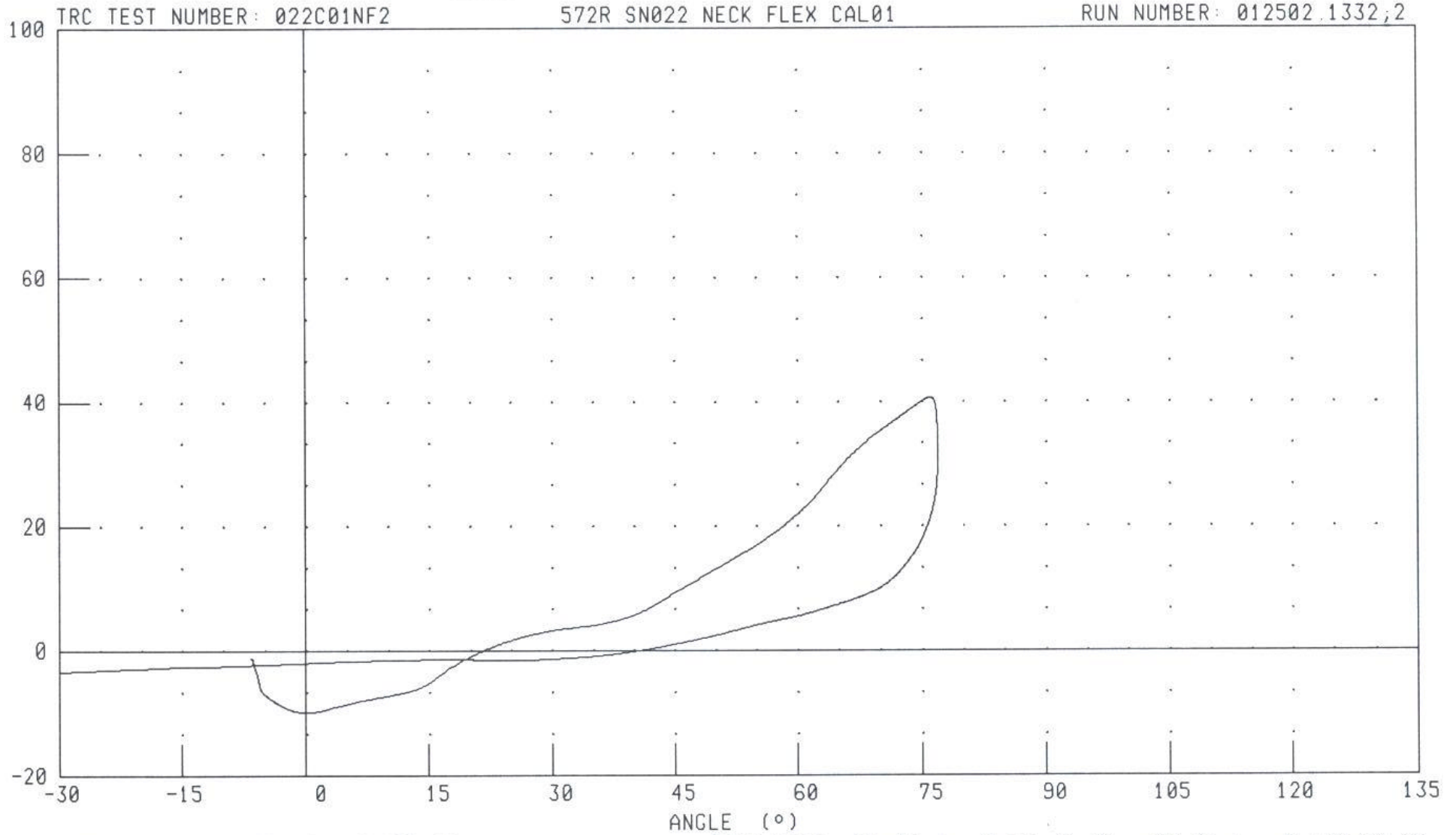

CHANNEL: TOTAN
NEKOM

FILTER: CH. CLASS 60
CH. CLASS 600

ANGLE (°)
PEAK DATA: 76.94 ° @ 52.48 MS; -76.97 ° @ 189.60 MS
40.64 N·M @ 47.84 MS; -9.89 N·M @ 13.68 MS

TRANSPORTATION RESEARCH CENTER INC.

NECK EXTENSION TEST

CRABI 12-MONTH

25-JAN-02

TRC INC. TEST NO: 022C01NE1 572R SN022 NECK EXT. CAL01

TEST PARAMETER	SPECIFICATION	TEST RESULTS
TEMPERATURE	20.6-22.2 DEG. C	21.1 DEG. C
RELATIVE HUMIDITY	10 - 70 %	32.0 %
IMPACT VELOCITY	2.4 - 2.6 M/S	2.59 M/S
INTEGRATED PENDULUM VELOCITY	6 MS	0.8 - 1.2 M/S
	10 MS	1.5 - 2.1 M/S
	20 MS	2.2 - 2.9 M/S
PEAK D-PLANE ROTATION	80 - 92 DEG.	84.93 DEG.
PEAK MOMENT DURING ROTATION INTERVAL	-12 / -23 NM	-18.06 NM
POSITIVE MOMENT DECAY TIME TO -5 NM LEVEL	76 - 90 MS	82.24 MS

TEST MEETS SPECIFICATIONS

TECHNICIAN



RUN NUMBER: 012502.1359;2

PART 572R CRABI NECK EXTENSION CALIBRATION
PENDULUM DECELERATION

TRC TEST NUMBER: 022C01NE1

572R SN022 NECK EXT. CAL01

RUN NUMBER: 012502.1402;2

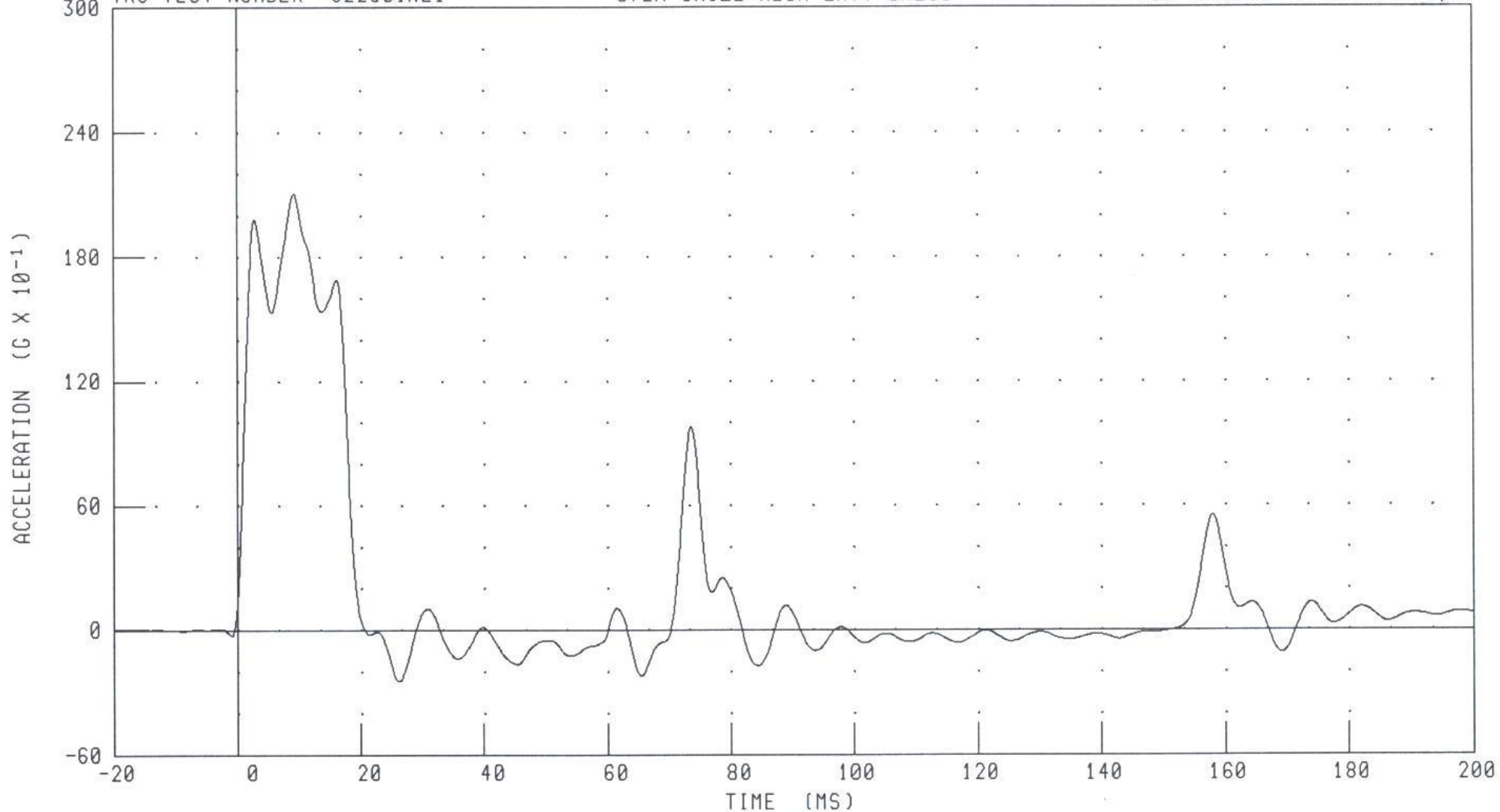

CHANNEL: PENXC

FILTER: CH. CLASS 180

PEAK DATA: 21.06 G @ 9.20 MS; -2.47 G @ 26.24 MS

PART 572R CRABI NECK EXTENSION CALIBRATION

INTEGRATED PENDULUM VELOCITY

TRC TEST NUMBER: 022C01NE1

572R SN022 NECK EXT. CAL01

RUN NUMBER: 012502.1402;2

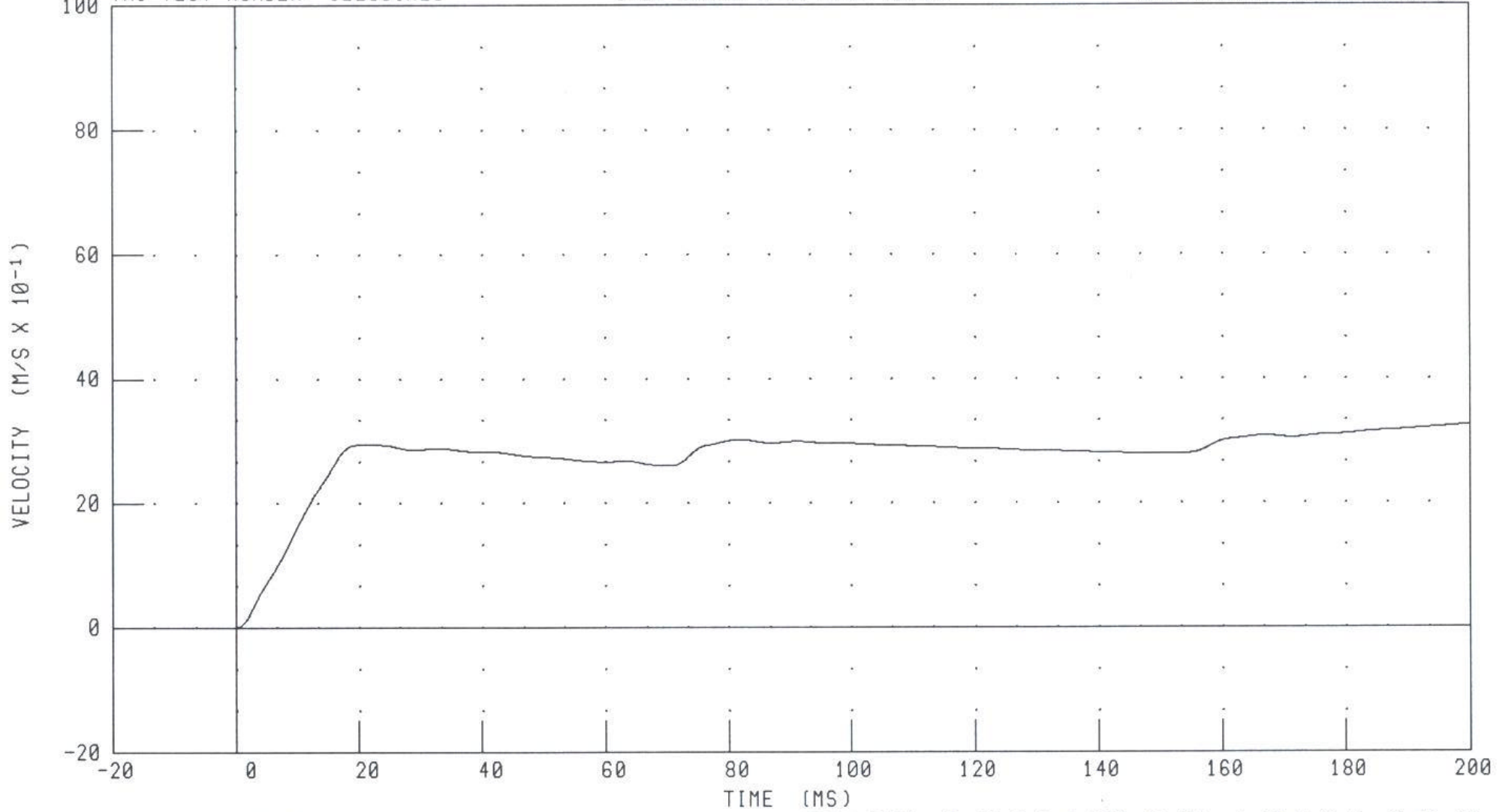

CHANNEL: PENXVI

FILTER: CH. CLASS 180

PEAK DATA: 3.25 M/S @ 200.00 MS; 0.00 M/S @ -0.48 MS

PART 572R CRABI NECK EXTENSION CALIBRATION
ROTATION ABOUT BASE OF NECK

TRC TEST NUMBER: 022C01NE1

572R SN022 NECK EXT. CAL01

RUN NUMBER: 012502.1402;2

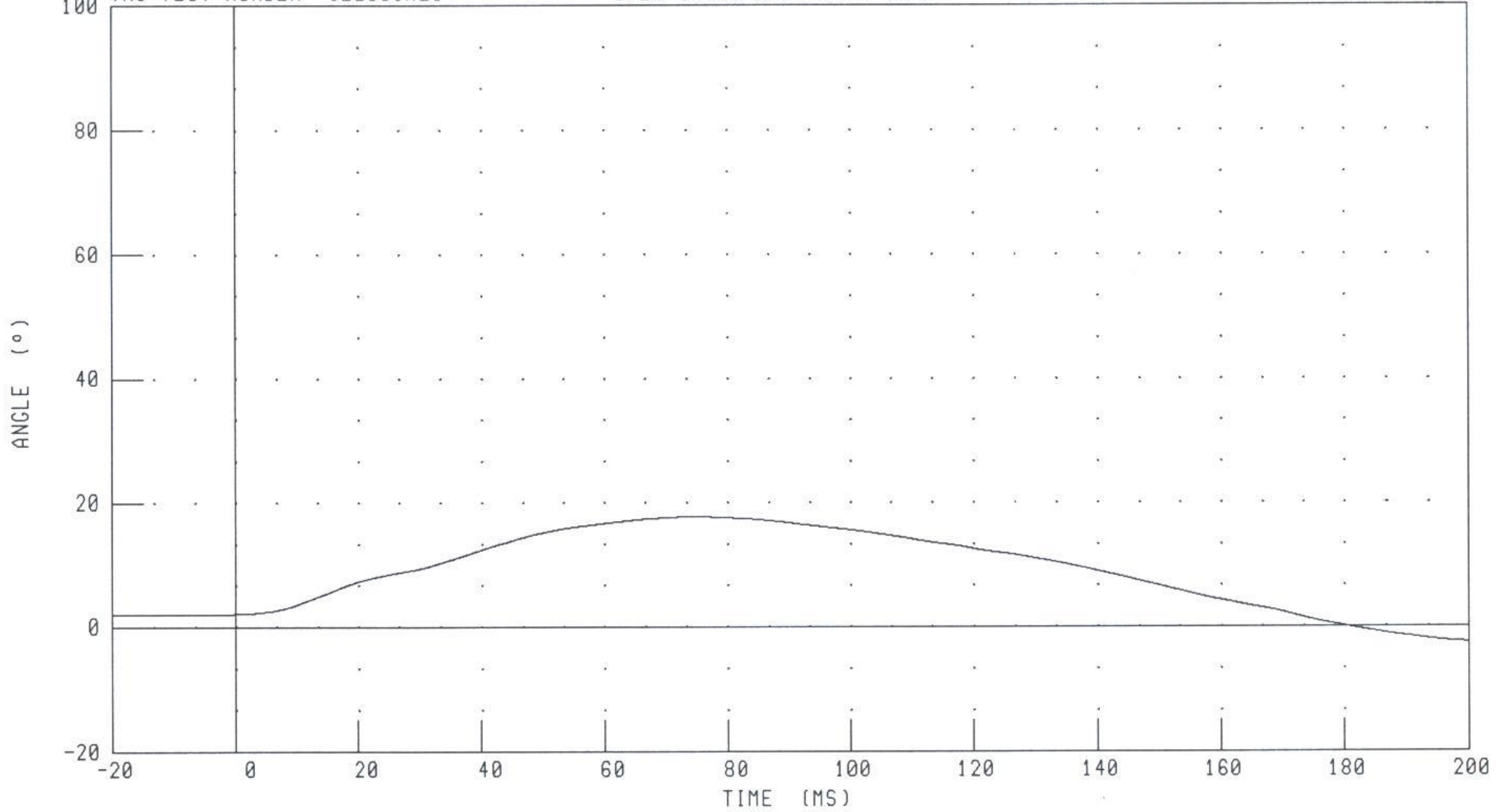

CHANNEL: BETA

FILTER: CH. CLASS 60

PEAK DATA: 17.72 ° @ 74.80 MS; -2.54 ° @ 200.00 MS

PART 572R CRABI NECK EXTENSION CALIBRATION
ROTATION ABOUT OCCIPITAL CONDYLE

TRC TEST NUMBER: 022C01NE1

572R SN022 NECK EXT. CAL01

RUN NUMBER: 012502.1402;2

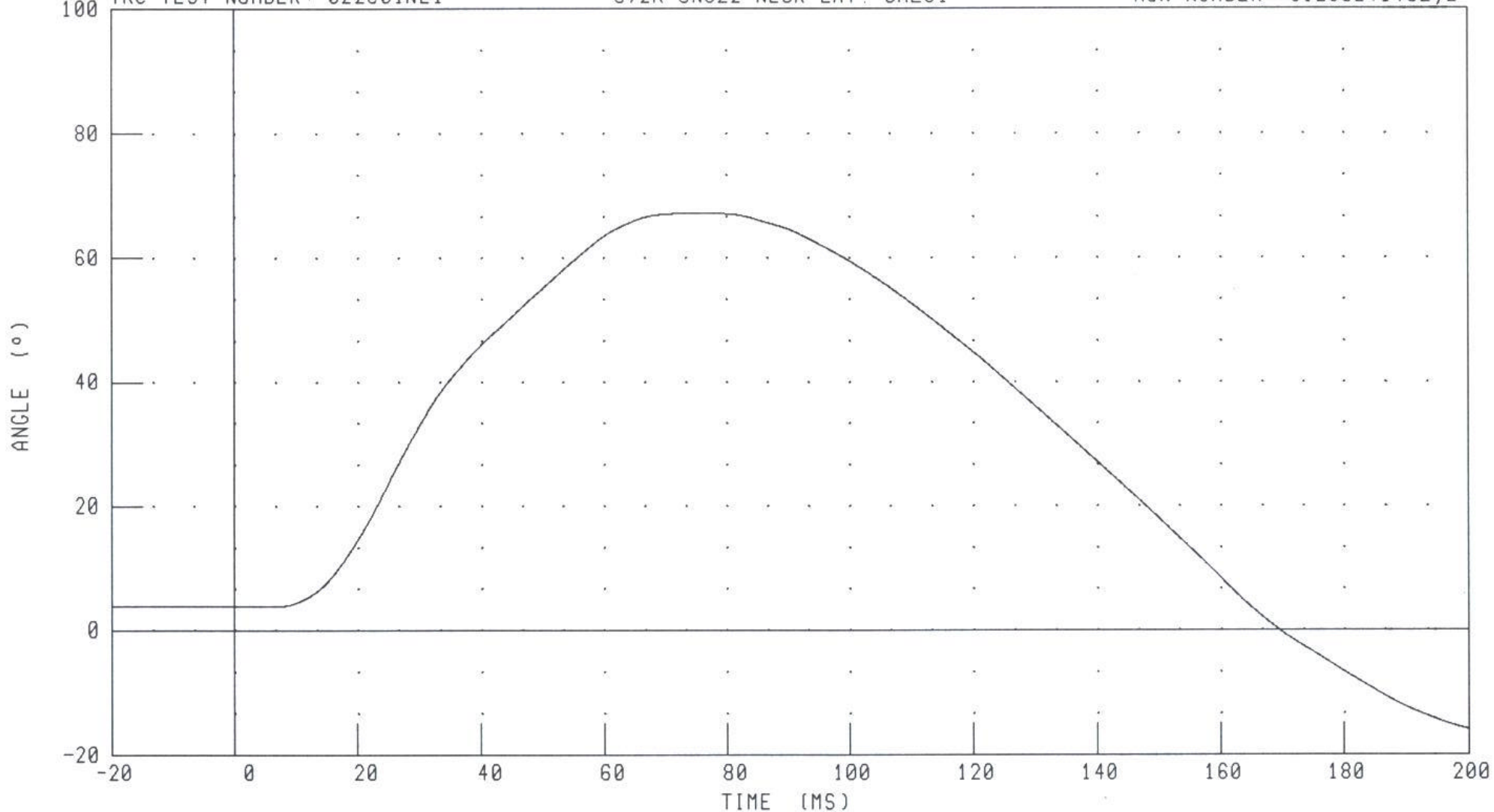

CHANNEL: THETA

FILTER: CH. CLASS 60

PEAK DATA: 67.21 ° @ 74.72 MS; -15.98 ° @ 200.00 MS

PART 572R CRABI NECK EXTENSION CALIBRATION

TOTAL ROTATION

TRC TEST NUMBER: 022C01NE1

572R SN022 NECK EXT. CAL01

RUN NUMBER: 012502.1402;2

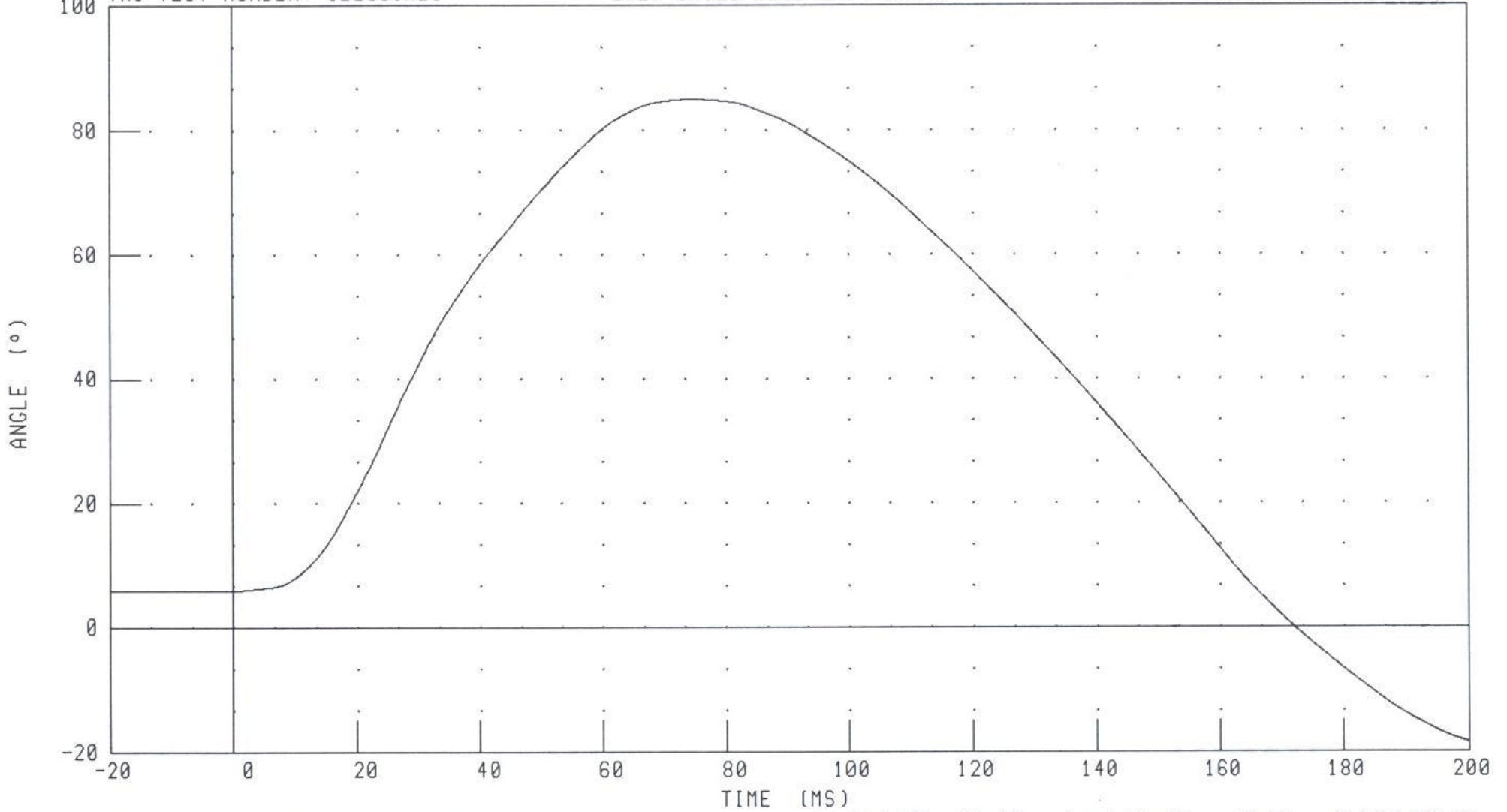

CHANNEL: TOTAN

FILTER: CH. CLASS 60

PEAK DATA: 84.93 ° @ 74.80 MS, -18.52 ° @ 200.00 MS

PART 572R CRABI NECK EXTENSION CALIBRATION

NECK FORCE X AXIS

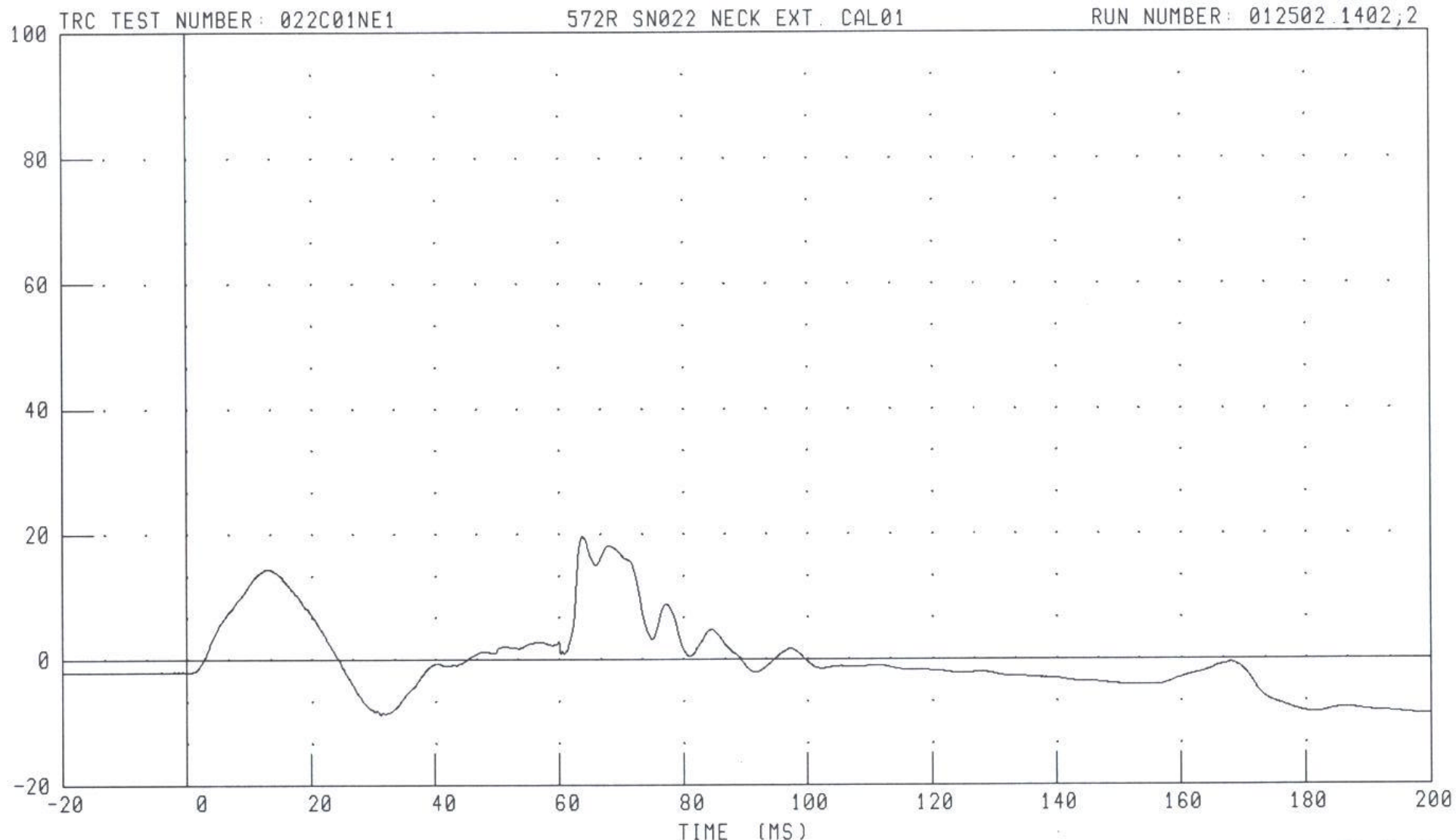

CHANNEL: NEKXF

FILTER: CH. CLASS 1000

PEAK DATA: 195.65 N @ 63.92 MS; -88.80 N @ 199.60 MS

PART 572R CRABI NECK EXTENSION CALIBRATION

NECK MOMENT Y AXIS

TRC TEST NUMBER: 022C01NE1

572R SN022 NECK EXT. CAL01

RUN NUMBER: 012502.1402;2

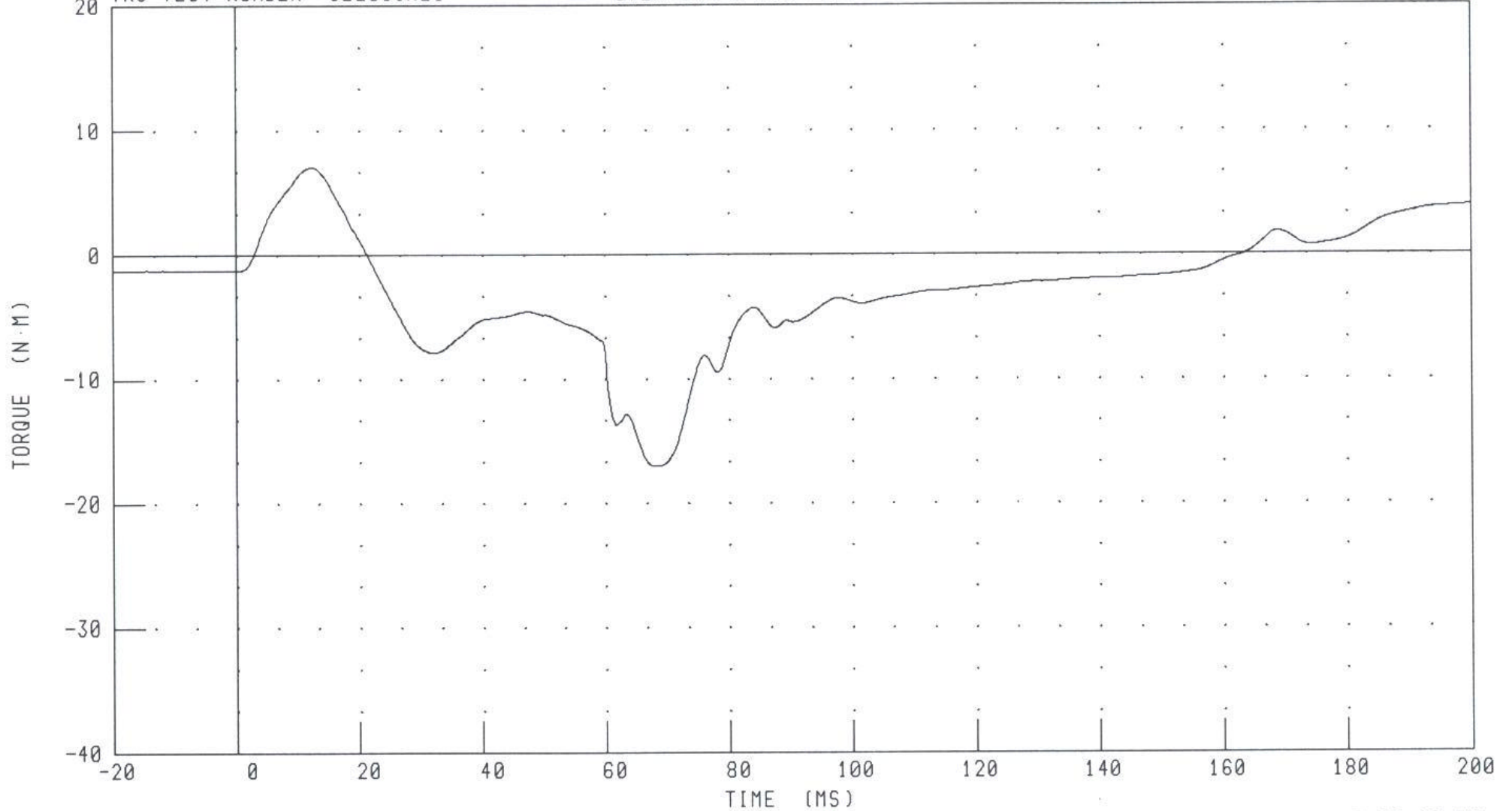

CHANNEL: NEKYM

FILTER: CH. CLASS 600

PEAK DATA: 7.09 N·M @ 12.48 MS; -17.01 N·M @ 68.56 MS

PART 572R CRABI NECK EXTENSION CALIBRATION
MOMENT ABOUT OCCIPITAL CONDYLE

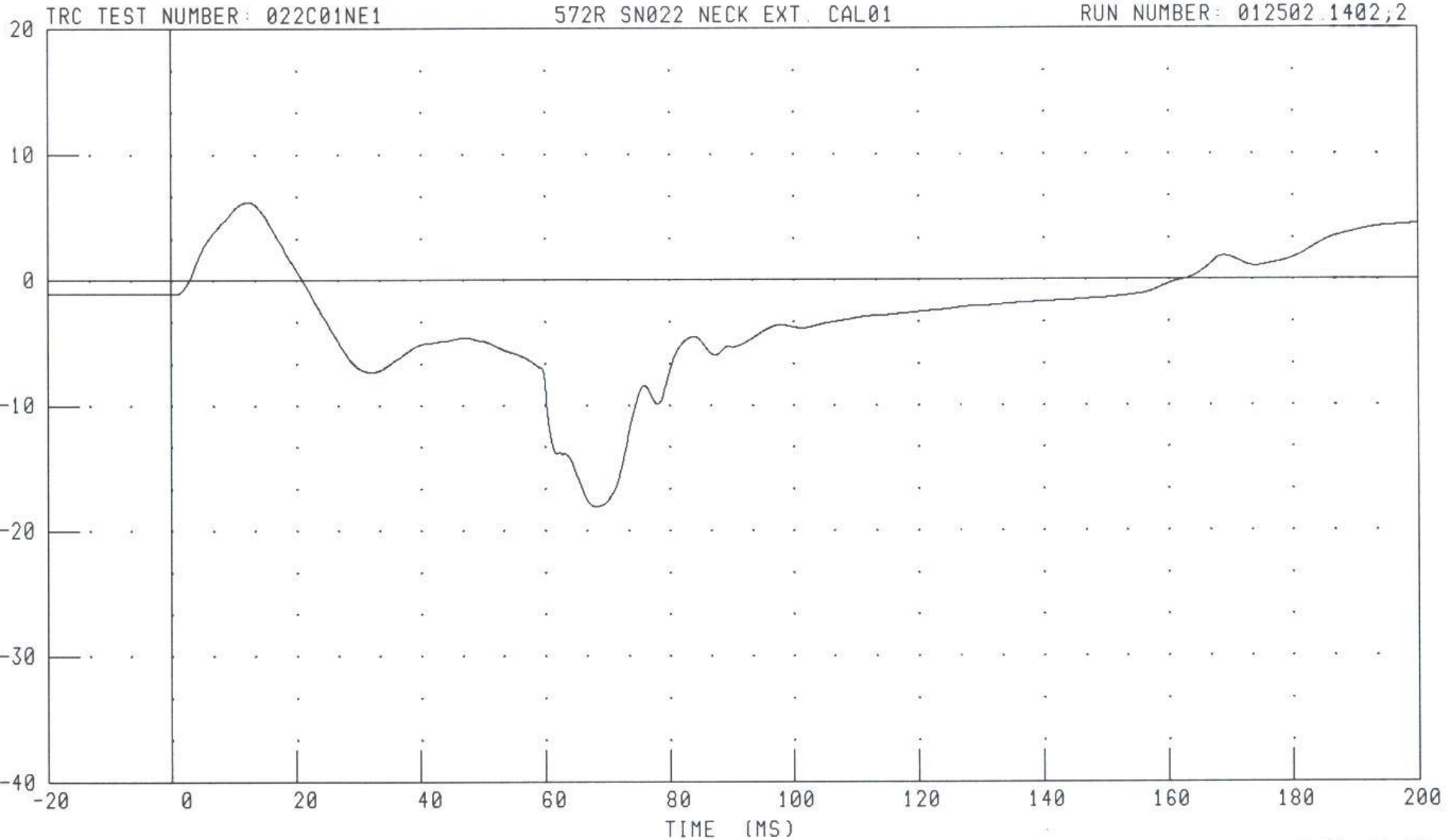

CHANNEL: NEKOM

FILTER: CH CLASS 600

PEAK DATA: 6.26 N·M @ 12.48 MS; -18.06 N·M @ 68.48 MS

PART 572R CRABI NECK EXTENSION CALIBRATION
TOTAL ROTATION VS OCCIPITAL CONDYLAR MOMENT

TRC TEST NUMBER: 022C01NE1

572R SN022 NECK EXT. CAL01

RUN NUMBER: 012502.1402;2

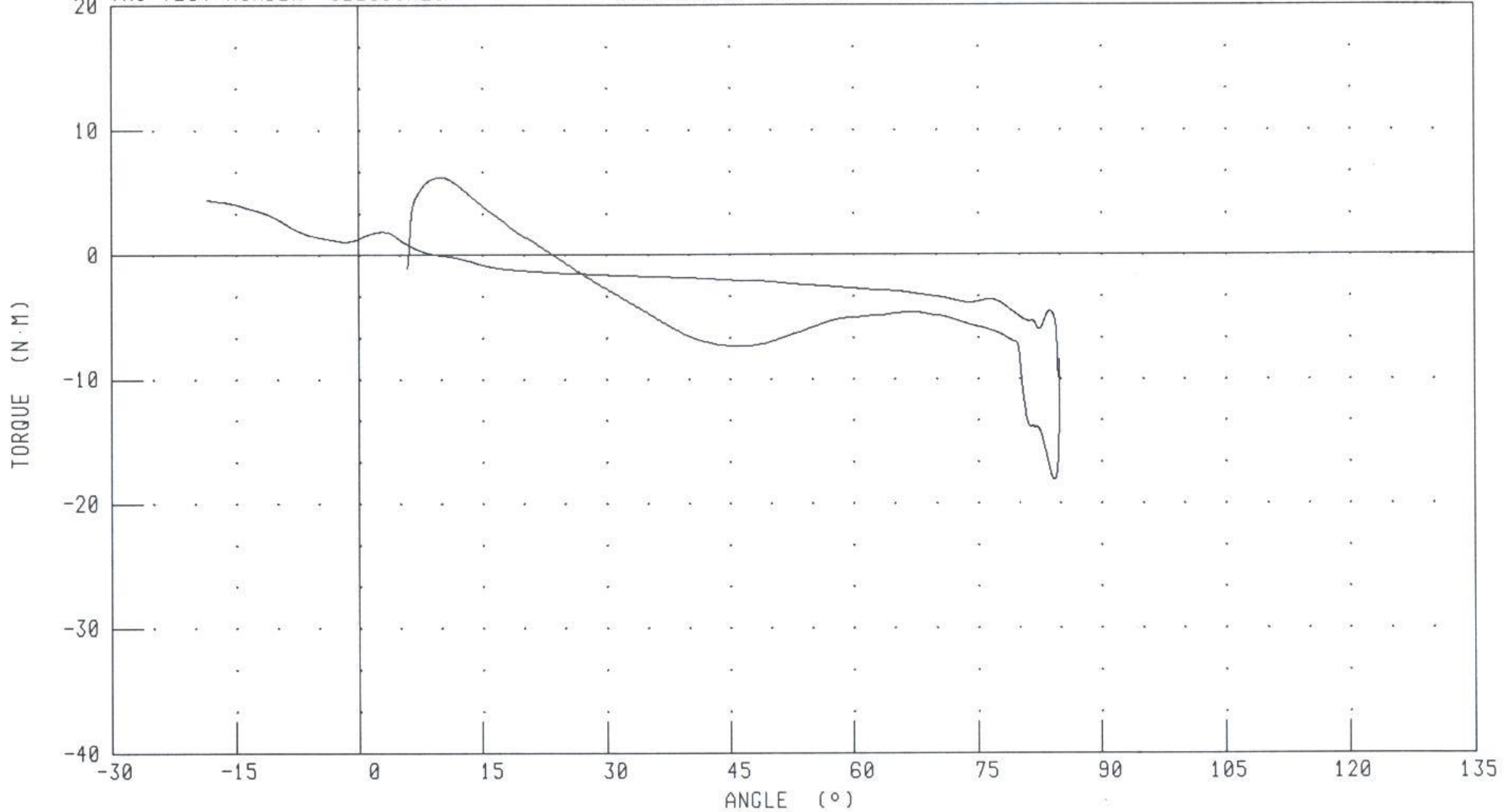

CHANNEL: TOTAN
NEKOM

FILTER: CH CLASS 60
CH CLASS 600

ANGLE (°)

PEAK DATA: 84.93 ° @ 74.80 MS; -18.52 ° @ 200.00 MS
6.26 N·M @ 12.48 MS; -18.06 N·M @ 68.48 MS

TRANSPORTATION RESEARCH CENTER INC.

THORAX IMPACT TEST

CRABI 12-MONTH

28-JAN-02

TRC INC.

TEST NO: 022C01TH3

572R SN022 THORAX CAL 01

TEST PARAMETER	HIGH SPEED TEST ----- SPECIFICATION	TEST RESULTS
TEMPERATURE	20.6-22.2 DEG. C	21.1 DEG. C
RELATIVE HUMIDITY	10 - 70 %	41.0 %
PENDULUM VELOCITY	4.90 - 5.10 M/S	4.93 M/S
MAXIMUM RESISTIVE FORCE	1514 - 1796 N	1554. N

TEST MEETS SPECIFICATIONS

TECHNICIAN *Rich A. Waldeck*

RUN NUMBER: 012802.1001;1

PART 572R CRABI THORAX IMPACT TEST
PENDULUM DECELERATION

TRC TEST NUMBER: 022C01TH3

572R SN022 THORAX CAL 01

RUN NUMBER: 012802.1002;1

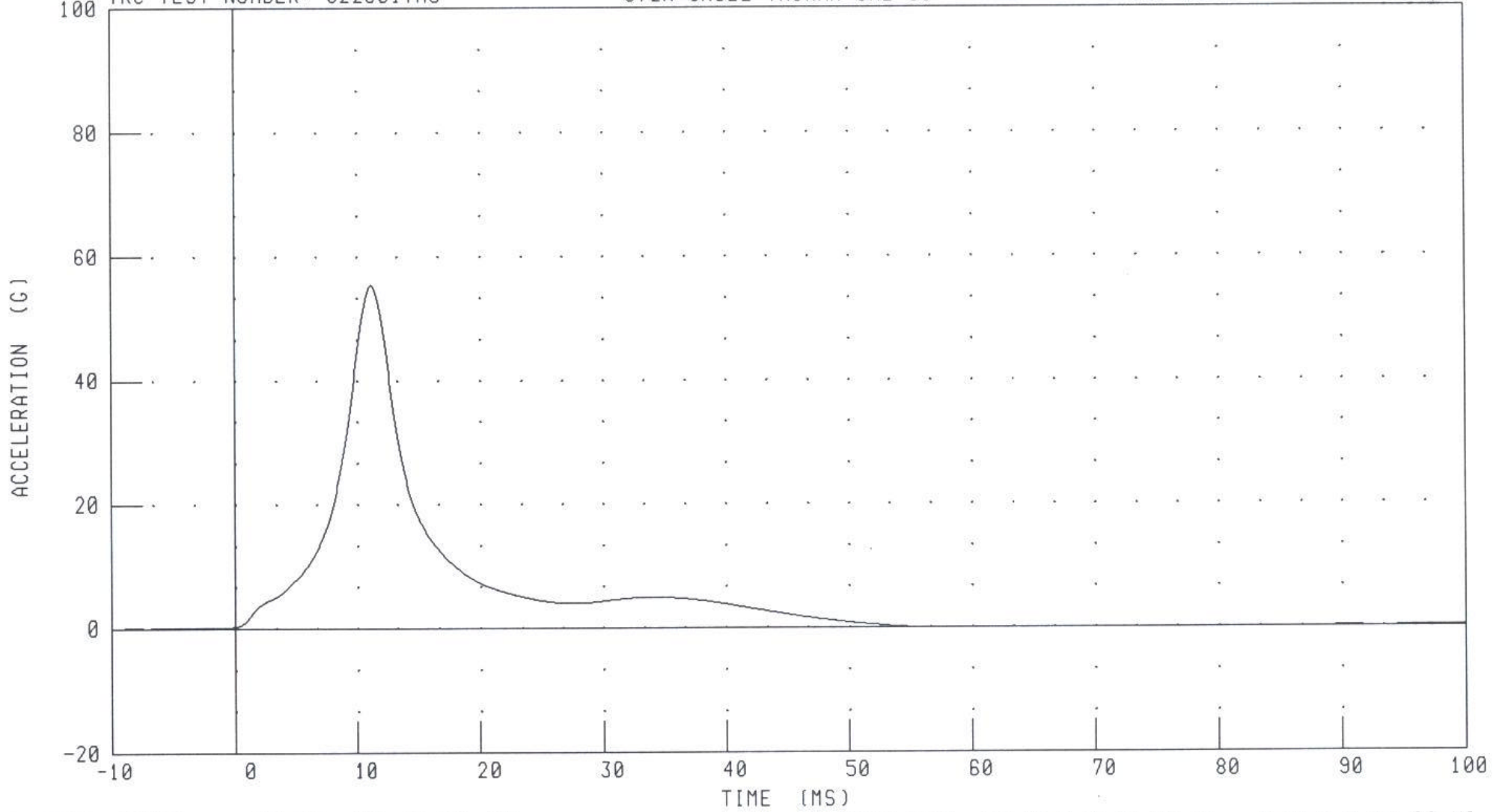

CHANNEL: PENXC

FILTER: CH. CLASS 180

PEAK DATA: 55.49 G @ 11.20 MS; -0.12 G @ 64.96 MS

PART 572R CRABI THORAX IMPACT TEST
PENDULUM FORCE

TRC TEST NUMBER: 022C01TH3

572R SN022 THORAX CAL 01

RUN NUMBER: 012802.1002;1

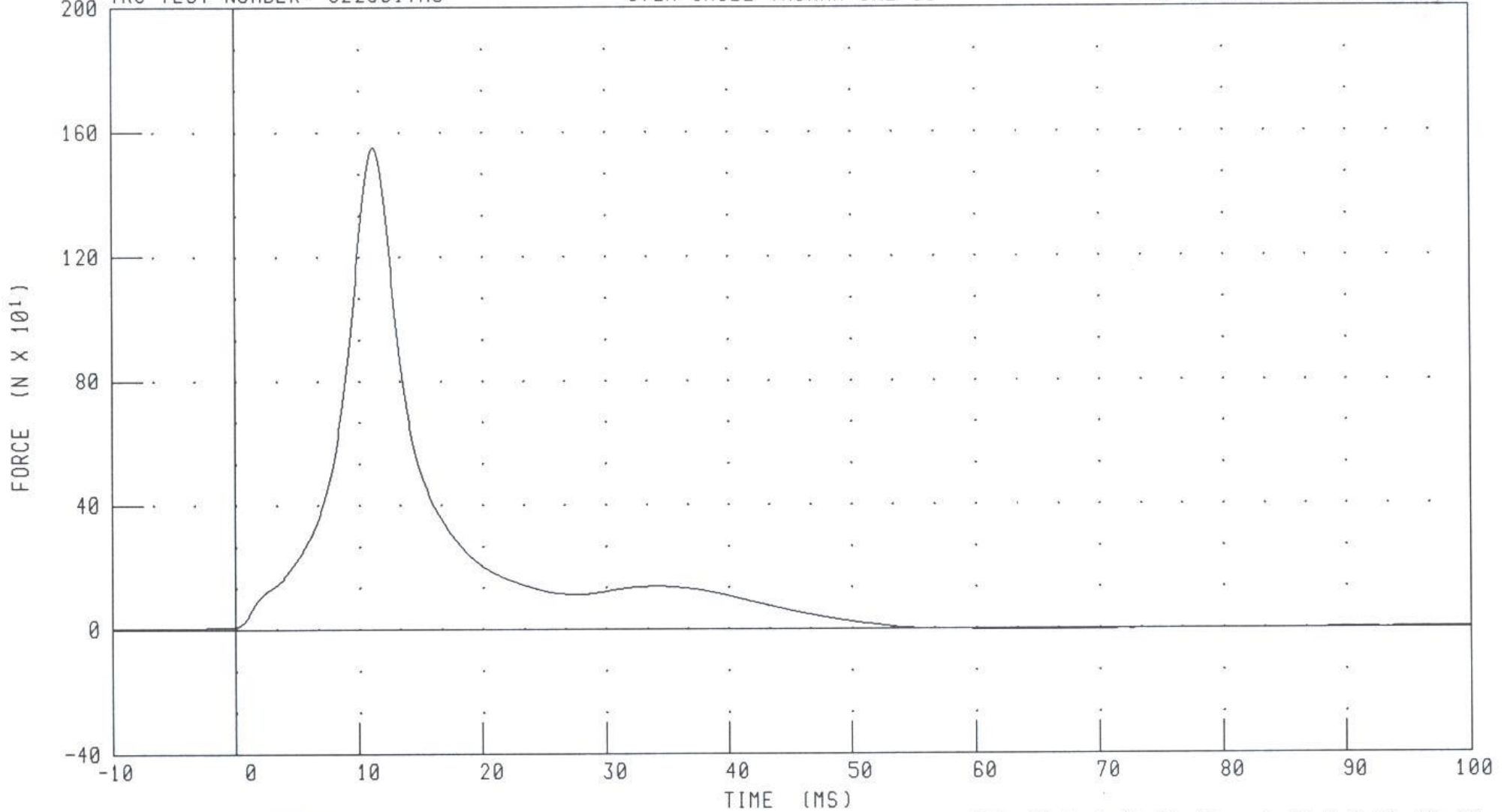

CHANNEL: PENXF

FILTER: CH. CLASS 180

PEAK DATA: 1554.99 N @ 11.20 MS; -3.35 N @ 64.96 MS



ROBERT A. DENTON, INC.
2967 Waterview Dr., Rochester Hills, MI 48309-4600

Tel (248) 852-5100 • Fax (248) 852-6060 • email: info@radenton.com • www.radenton.com

Crabi #017
Lower Neck

Calibration Report
Uni-Directional Calibration

Automated Load Cell Calibration System
Copyright (c) 1987-2000 Robert A. Denton, Inc.

Calibration No.	C2632002	Date	Jan 15, 2002	Due	Jan 15, 2003
Model No.	2554A	Serial No.	280		
Technician	J. Kovalchuk	Temp (C) / Hum. (%)	21.6 / 33.5		
Customer	VRTC	Last Calibrated	Jan 15, 2002		
Description	Infant Neck	Customer Tag Number	N/A		

Voltage Calibration

Bridge	Capacity	Zero Offset	Nonlinearity	Hysteresis	Output @ Capacity	% Change
FX	200.0 lbf	0.0028 mV/V	0.02 % FS	0.07 % FS	1.9757 mV/V	0.00 % FS
FY	200.0 lbf	-0.0019 mV/V	0.04 % FS	0.05 % FS	1.9803 mV/V	0.00 % FS
FZ	500.0 lbf	-0.0132 mV/V	0.04 % FS	0.04 % FS	-0.8590 mV/V	0.00 % FS
MX	500.0 in-lbf	-0.0079 mV/V	0.16 % FS	0.38 % FS	1.2889 mV/V	0.00 % FS
MY	500.0 in-lbf	-0.0228 mV/V	0.29 % FS	0.25 % FS	1.3061 mV/V	0.00 % FS
MZ	300.0 in-lbf	-0.0091 mV/V	0.06 % FS	0.65 % FS	1.4120 mV/V	0.00 % FS

Shunt

Bridge	Shunt Value	Equivalent Load	Bridge Resistance (nom)
FX	120.0 K Ohms	147.2 lbf	700.0 Ohms
FY	120.0 K Ohms	147.1 lbf	700.0 Ohms
FZ	300.0 K Ohms	-340.6 lbf	700.0 Ohms
MX	80.0 K Ohms	429.1 in-lbf	350.0 Ohms
MY	80.0 K Ohms	424.6 in-lbf	350.0 Ohms
MZ	160.0 K Ohms	231.1 in-lbf	700.0 Ohms

NOTE: Positive shunt is between +Exc_+Sig Negative shunt is between -Exc_+Sig

Wire Color Codes

FX-MX		FY-MY		FZ-MZ	
Brown	+ Exc.	Red Stripe	+ Exc.	Green	+ Exc.
Red	+ Sig.	Black	+ Sig.	Blue	+ Sig.
Orange	- Exc.	White	- Exc.	Violet	- Exc.
Yellow	- Sig.	Black Stripe	- Sig.	Grey	- Sig.

Reference Load Cell

Manufacturer	Model No.	Serial No.	Calibration Due Date
Revere	363-B10-500-20P1	H607172L	Jul 24, 2002

Calibrated by _____

J. Kovalchuk
Robert A. Denton, Inc. Authorized Representative

CS

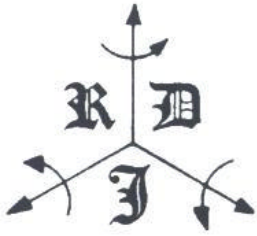

CALIBRATION REPORT

Uni-Directional Calibration Loading Sequence Summary

Automated Load Cell Calibration System
Copyright (c)1987-2000 Robert A. Denton, Inc.

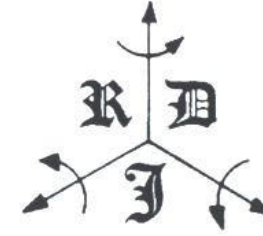

Calibration Number	C2632002	This Calibration	10:27:27	Jan 15, 2002
Model Number	2554A	Calibration Due		Jan 15, 2003
Serial Number	280	Last Calibrated		Jan 15, 2002
Description	Infant Neck	Temp (C) / Hum. (%)		21.6 / 33.5
Customer	VRTC	Customer Tag Number		N/A

Loading Sequence

Axis	FS Load EU	FS Output mV/V	Sensitivity mV/V/EU	Nonlinearity % FS	Hysteresis % FS	Moment Arm EU
FX	200.0 lbf	1.9757	0.0098785	0.02	0.07	0.00
FY	200.0 lbf	1.9803	0.0099016	0.04	0.05	0.00
FZ	500.0 lbf	-0.8590	-0.0017181	0.04	0.04	0.00
MX	500.0 in-lbf	1.2889	0.0025778	0.16	0.38	1.00
MY	500.0 in-lbf	1.3061	0.0026123	0.29	0.25	1.00
MZ	300.0 in-lbf	1.4120	0.0047068	0.06	0.65	1.50

Bridge Unbalance

FX Axis	0.0028 mV/V
FY Axis	-0.0019 mV/V
FZ Axis	-0.0132 mV/V
MX Axis	-0.0079 mV/V
MY Axis	-0.0228 mV/V
MZ Axis	-0.0091 mV/V

Linearization

Force (FX)	=	0.0	+	101.2	*	Output (mV/V)
Force (FY)	=	0.0	+	101.0	*	Output (mV/V)
Force (FZ)	=	0.1	+	-582.0	*	Output (mV/V)
Force (MX)	=	-0.4	+	387.9	*	Output (mV/V)
Force (MY)	=	-0.4	+	382.5	*	Output (mV/V)
Force (MZ)	=	0.1	+	212.4	*	Output (mV/V)

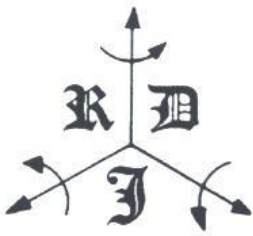

CALIBRATION REPORT

Uni-Directional Calibration Crosstalk Summary

Automated Load Cell Calibration System
Copyright (c)1987-2000 Robert A. Denton, Inc.

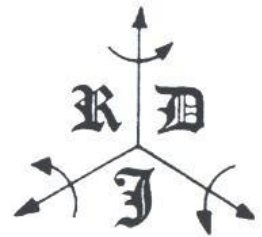

Calibration Number	C2632002	This Calibration	10:27:27	Jan 15, 2002
Model Number	2554A	Calibration Due		Jan 15, 2003
Serial Number	280	Last Calibrated		Jan 15, 2002
Description	Infant Neck	Temp (C) / Hum. (%)		21.6 / 33.5
Customer	VRTC	Customer Tag Number		N/A

Raw Crosstalk Data (mV/V)

<u>Bridge</u>	<u>Applied Load</u>	FX	FY	FZ	MX	MY	MZ
		200.0 <u>lbf</u>	200.0 <u>lbf</u>	500.0 <u>lbf</u>	500.0 <u>in-lbf</u>	500.0 <u>in-lbf</u>	300.0 <u>in-lbf</u>
FX	200.0 lbf	1.9757	-0.0109	-0.0027	0.0012	-0.0102	-0.0019
FY	200.0 lbf	0.0168	1.9803	-0.0092	0.0073	-0.0017	-0.0111
FZ	500.0 lbf	0.0049	-0.0005	-0.8590	-0.0065	0.0035	0.0130
MX	500.0 in-lbf	0.0039	0.0098	-0.8568	1.2889	0.0067	0.0276
MY	500.0 in-lbf	0.0077	0.0141	-0.8521	-0.0064	1.3061	-0.0139
MZ	300.0 in-lbf	0.0169	1.9700	-0.0103	0.0040	-0.0083	1.4120

% FS Crosstalk *

<u>Bridge</u>	<u>Applied Load</u>	FX	FY	FZ	MX	MY	MZ
		200.0 <u>lbf</u>	200.0 <u>lbf</u>	500.0 <u>lbf</u>	500.0 <u>in-lbf</u>	500.0 <u>in-lbf</u>	300.0 <u>in-lbf</u>
FX	200.0 lbf	0.00%	-0.55%	0.31%	0.09%	-0.78%	-0.13%
FY	200.0 lbf	0.85%	0.00%	1.07%	0.56%	-0.13%	-0.78%
FZ	500.0 lbf	0.25%	-0.02%	0.00%	-0.51%	0.27%	0.92%
MX	500.0 in-lbf	0.20%	0.49%	0.26%	0.00%	0.51%	1.96%
MY	500.0 in-lbf	0.39%	0.71%	0.81%	-0.50%	0.00%	-0.98%
MZ	300.0 in-lbf	0.86%	0.52%	1.20%	0.31%	-0.64%	0.00%

* Percentage crosstalk for force channels applying moments are corrected for the applied force.



Measurement Report

Load Cell Bridge Impedance

Measurement Summary

Automated Load Cell Impedance Measurement System
Copyright © 1998 Robert A. Denton, Inc.

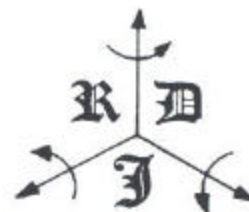

Calibration Number	C2632002	This Calibration	10:27:27	Jan 15, 2002
Model Number	2554A	Calibration Due		Jan 15, 2003
Serial Number	280	Last Calibrated		Jan 15, 2002
Description	Infant Neck	Temp (°C) / Hum (%)		22.2 / 25.3
Customer	VRTC	Customer Tag		N/A

Bridge Impedance Measurements*

Axis	Input Impedance	Output Impedance	
Channel 1 FX	701.48	701.44	Ohms
Channel 2 FY	701.01	701.02	Ohms
Channel 3 FZ	702.73	702.60	Ohms
Channel 4 MX	355.54	355.49	Ohms
Channel 5 MY	355.69	355.77	Ohms
Channel 6 MZ	700.60	700.49	Ohms

Bridge High Short Measurement**

Axis	Bridge to Transducer Body	
Channel 1 FX	>= 5.00	G Ohms (10 ⁹ Ohms)
Channel 2 FY	>= 5.00	G Ohms (10 ⁹ Ohms)
Channel 3 FZ	>= 5.00	G Ohms (10 ⁹ Ohms)
Channel 4 MX	>= 5.00	G Ohms (10 ⁹ Ohms)
Channel 5 MY	>= 5.00	G Ohms (10 ⁹ Ohms)
Channel 6 MZ	>= 5.00	G Ohms (10 ⁹ Ohms)

Measurement Equipment

Serial Number

Measurement Accuracy

Keithley Model 7001 Switch System	0698562	N/A
Keithley Model 2000 Multimeter	0643818	±0.045 Ohms/Year @ 23°C ±5°C
Keithley Model 6517A Electrometer/High Resistance Meter	0695446	±(11.25 x 10 ⁶) + 10 ⁵ Ohms/Year @ 18°C-28°C

* NOTE: Input impedance measurements taken between ±excitation, output impedance measurements taken between ±signal

NOTE: High short measurements are taken between +excitation and the transducer body. Measurements are made at +50.0 VDC.

** Robert A. Denton, Inc. certifies that all equipment used to perform measurements expressed in this report are traceable to the National Institute of Standards and Technology and are in accordance with ANSI/NCSL Z540-1-1994 (MIL-STD 45662A).

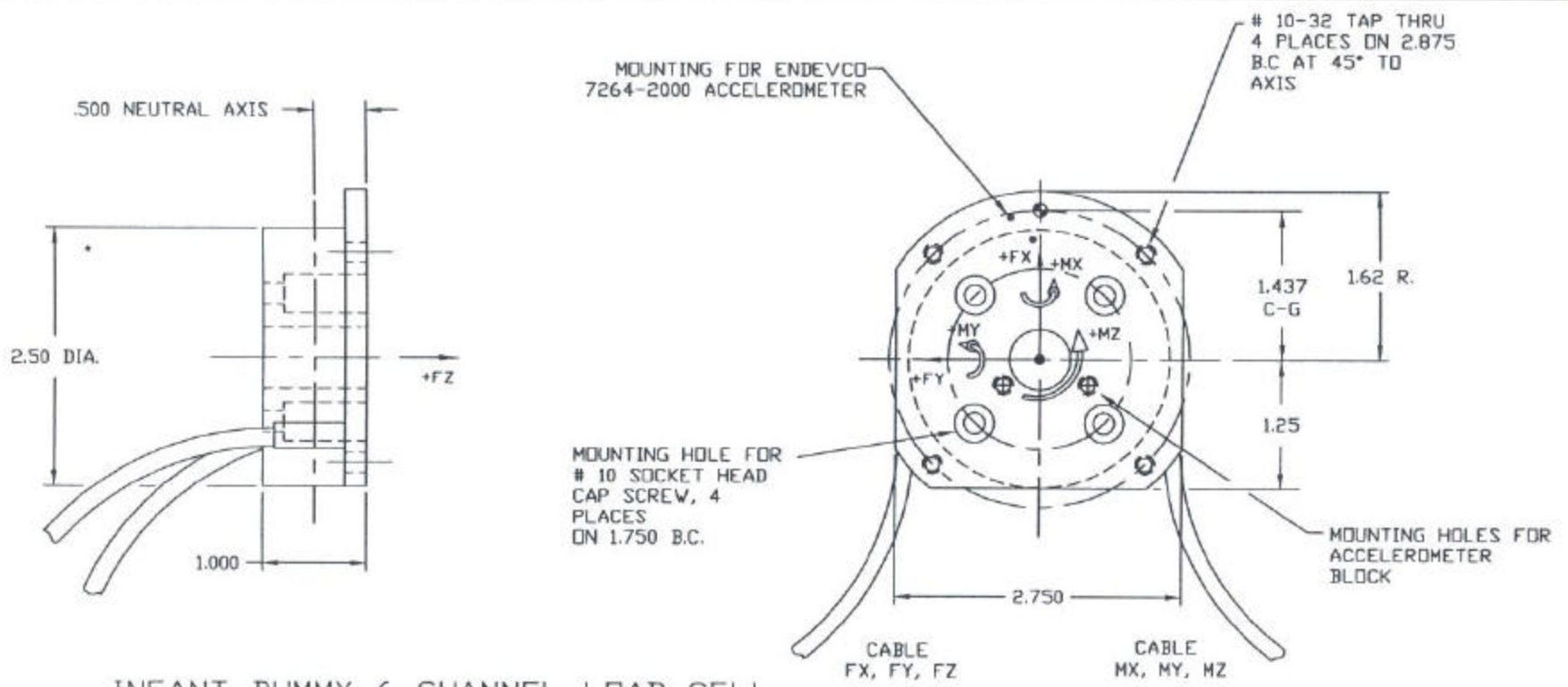

INFANT DUMMY 6-CHANNEL LOAD CELL

AXIS	CAPACITY	OUTPUT @ CAPACITY	MODEL 2554 BRIDGE RESISTANCE	MODEL 2554A BRIDGE RESISTANCE
FX	200 LBS.	1.8 mV/V NOMINAL	700 OHMS	700 OHMS
FY	200 LBS.	1.8 mV/V NOMINAL	700 OHMS	700 OHMS
FZ	500 LBS.	.8 mV/V NOMINAL	480 OHMS	700 OHMS
MX	500 LB.-IN.	1.3 mV/V NOMINAL	350 OHMS	350 OHMS
MY	500 LB.-IN.	1.3 mV/V NOMINAL	350 OHMS	350 OHMS
MZ	300 LB.-IN.	1.3 mV/V NOMINAL	700 OHMS	700 OHMS

NONLINEARITY < 1% OF FULL SCALE
 CROSSTALK < 5% OF FULL SCALE
 WEIGHT - 0.30 LBS. NOMINAL (C)

NOTE:
 THIS LOAD CELL IS UTILIZED
 IN THE UPPER NECK, LOWER NECK
 AND LUMBAR SPINE OF THE
 INFANT DUMMY. FX AND MX
 POLARITY WILL CHANGE BASED
 ON MOUNTING LOCATION.

C	WAS .40 LBS.	4/99
B	WAS DRG. B-2554	4/99
A	ADD WEIGHT SPEC	12/98
SYM	REVISION	DATE

INFANT DUMMY LOAD CELL		
SCALE: FULL	DATE: 10/18/91	DRAWN BY: C.E. MORGAN
MODEL: 2554		UNLESS OTHERWISE SPECIFIED
TWO PLACE DECIMALS ± .010		SURFACE FINISH 125
THREE PLACE DECIMALS ± .005		REMOVE ALL BURRS & SHARP EDGES
ANGLES ± 0° 30'		DIMENSION LIMITS HELD AFTER PLATING
ROBERT A. DENTON, INC. ROCHESTER HILLS, MICHIGAN		DRAWING NUMBER: B-2554-D



ROBERT A. DENTON, INC.

2967 Waterview Dr., Rochester Hills, MI 48309-4600

Tel (248) 852-5100 • Fax (248) 852-6060 • email: info@radenton.com • www.radenton.com

Crabi: #017

283

Calibration Report Uni-Directional Calibration

Automated Load Cell Calibration System
Copyright (c) 1987-2000 Robert A. Denton, Inc.

Calibration No.	C2633005	Date	Jan 16, 2002	Due	Jan 16, 2003
Model No.	2554A	Serial No.	283		
Technician	J. Kovalchuk	Temp (C) / Hum. (%)	22.6 / 26.9		
Customer	VRTC	Last Calibrated	Jan 16, 2002		
Description	Infant Neck	Customer Tag Number	N/A		

Voltage Calibration

Bridge	Capacity	Zero Offset	Nonlinearity	Hysteresis	Output @ Capacity	% Change
FX	200.0 lbf	0.0003 mV/V	0.04 % FS	0.04 % FS	1.9630 mV/V	0.00 % FS
FY	200.0 lbf	0.0028 mV/V	0.05 % FS	0.06 % FS	1.9697 mV/V	0.00 % FS
FZ	500.0 lbf	-0.0159 mV/V	0.02 % FS	0.05 % FS	-0.8627 mV/V	0.00 % FS
MX	500.0 in-lbf	0.0008 mV/V	0.11 % FS	0.20 % FS	1.3043 mV/V	0.00 % FS
MY	500.0 in-lbf	0.0074 mV/V	0.18 % FS	0.41 % FS	1.2928 mV/V	0.00 % FS
MZ	300.0 in-lbf	0.0109 mV/V	0.14 % FS	0.19 % FS	1.3871 mV/V	0.00 % FS

Shunt

Bridge	Shunt Value	Equivalent Load	Bridge Resistance (nom)
FX	120.0 K Ohms	149.0 lbf	700.0 Ohms
FY	120.0 K Ohms	148.4 lbf	700.0 Ohms
FZ	300.0 K Ohms	-339.1 lbf	700.0 Ohms
MX	80.0 K Ohms	425.8 in-lbf	350.0 Ohms
MY	80.0 K Ohms	429.1 in-lbf	350.0 Ohms
MZ	160.0 K Ohms	237.5 in-lbf	700.0 Ohms

NOTE: Positive shunt is between +Exc_+Sig Negative shunt is between -Exc_+Sig

Wire Color Codes

FX-MX		FY-MY		FZ-MZ	
Brown	+ Exc.	Red Stripe	+ Exc.	Green	+ Exc.
Red	+ Sig.	Black	+ Sig.	Blue	+ Sig.
Orange	- Exc.	White	- Exc.	Violet	- Exc.
Yellow	- Sig.	Black Stripe	- Sig.	Grey	- Sig.

Reference Load Cell

Manufacturer	Model No.	Serial No.	Calibration Due Date
Revere	363-B10-500-20P1	H607172L	Jul 24, 2002

Calibrated by

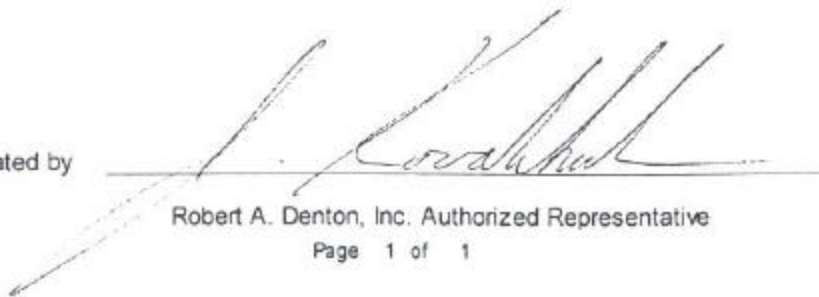

Robert A. Denton, Inc. Authorized Representative

File: UCAURPT.FPC

01/16/02 13:32:50

Page 1 of 1

Creating the Standard in Safety Measurement Since 1974

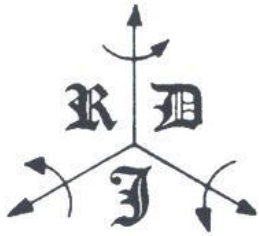

CALIBRATION REPORT

Uni-Directional Calibration Loading Sequence Summary

Automated Load Cell Calibration System
Copyright (c)1987-2000 Robert A. Denton, Inc.

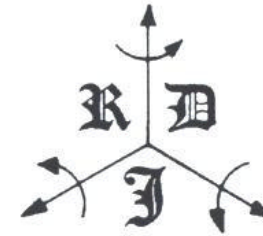

Calibration Number	C2633005	This Calibration	13:20:36	Jan 16, 2002
Model Number	2554A	Calibration Due		Jan 16, 2003
Serial Number	283	Last Calibrated		Jan 16, 2002
Description	Infant Neck	Temp (C) / Hum. (%)		22.6 / 26.9
Customer	VRTC	Customer Tag Number		N/A

Loading Sequence

Axis	FS Load EU	FS Output mV/V	Sensitivity mV/V/EU	Nonlinearity % FS	Hysteresis % FS	Moment Arm EU
FX	200.0 lbf	1.9630	0.0098149	0.04	0.04	0.00
FY	200.0 lbf	1.9697	0.0098486	0.05	0.06	0.00
FZ	500.0 lbf	-0.8627	-0.0017255	0.02	0.05	0.00
MX	500.0 in-lbf	1.3043	0.0026086	0.11	0.20	1.00
MY	500.0 in-lbf	1.2928	0.0025857	0.18	0.41	1.00
MZ	300.0 in-lbf	1.3871	0.0046236	0.14	0.19	1.50

Bridge Unbalance

FX Axis	0.0003 mV/V
FY Axis	0.0028 mV/V
FZ Axis	-0.0159 mV/V
MX Axis	0.0008 mV/V
MY Axis	0.0074 mV/V
MZ Axis	0.0109 mV/V

Linearization

Force (FX)	=	0.0	+	101.9	* Output (mV/V)
Force (FY)	=	0.0	+	101.5	* Output (mV/V)
Force (FZ)	=	0.0	+	-579.5	* Output (mV/V)
Force (MX)	=	0.3	+	383.2	* Output (mV/V)
Force (MY)	=	-0.6	+	386.9	* Output (mV/V)
Force (MZ)	=	-0.0	+	216.2	* Output (mV/V)

CALIBRATION REPORT

Uni-Directional Calibration Crosstalk Summary

Automated Load Cell Calibration System
Copyright (c)1987-2000 Robert A. Denton, Inc.

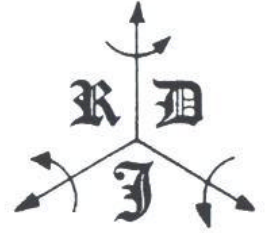
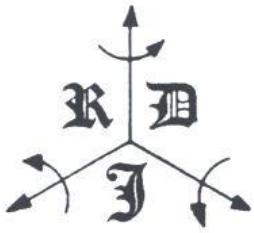

Calibration Number	C2633005	This Calibration	13:20:36	Jan 16, 2002
Model Number	2554A	Calibration Due		Jan 16, 2003
Serial Number	283	Last Calibrated		Jan 16, 2002
Description	Infant Neck	Temp (C) / Hum. (%)		22.6 / 26.9
Customer	VRTC	Customer Tag Number		N/A

Raw Crosstalk Data (mV/V)

Bridge		FX	FY	FZ	MX	MY	MZ
	<u>Applied Load</u>	200.0	200.0	500.0	500.0	500.0	300.0
		<u>lbf</u>	<u>lbf</u>	<u>lbf</u>	<u>in-lbf</u>	<u>in-lbf</u>	<u>in-lbf</u>
FX	200.0 lbf	1.9630	-0.0050	0.0000	-0.0009	-0.0014	0.0047
FY	200.0 lbf	-0.0003	1.9697	-0.0032	0.0114	-0.0019	0.0030
FZ	500.0 lbf	-0.0068	0.0024	-0.8627	0.0212	-0.0025	0.0096
MX	500.0 in-lbf	-0.0111	-0.0008	-0.8541	1.3043	-0.0011	0.0153
MY	500.0 in-lbf	-0.0050	0.0079	-0.8641	0.0137	1.2928	-0.0066
MZ	300.0 in-lbf	0.0095	1.9624	-0.0117	0.0077	-0.0097	1.3871

% FS Crosstalk *

Bridge		FX	FY	FZ	MX	MY	MZ
	<u>Applied Load</u>	200.0	200.0	500.0	500.0	500.0	300.0
		<u>lbf</u>	<u>lbf</u>	<u>lbf</u>	<u>in-lbf</u>	<u>in-lbf</u>	<u>in-lbf</u>
FX	200.0 lbf	0.00%	-0.26%	0.00%	-0.07%	-0.11%	0.34%
FY	200.0 lbf	-0.02%	0.00%	0.37%	0.88%	-0.15%	0.22%
FZ	500.0 lbf	-0.35%	0.12%	0.00%	1.62%	-0.20%	0.70%
MX	500.0 in-lbf	-0.56%	-0.04%	1.00%	0.00%	-0.09%	1.10%
MY	500.0 in-lbf	-0.26%	0.40%	0.16%	1.05%	0.00%	-0.48%
MZ	300.0 in-lbf	0.48%	0.37%	1.35%	0.59%	-0.75%	0.00%

* Percentage crosstalk for force channels applying moments are corrected for the applied force.



Measurement Report

Load Cell Bridge Impedance

Measurement Summary

Automated Load Cell Impedance Measurement System
Copyright © 1998 Robert A. Denton, Inc.



Calibration Number	C2633005	This Calibration	13:20:36	Jan 16, 2002
Model Number	2554A	Calibration Due		Jan 16, 2003
Serial Number	283	Last Calibrated		Jan 16, 2002
Description	Infant Neck	Temp (°C) / Hum (%)		22.3 / 21.2
Customer	VRTC	Customer Tag		N/A

Bridge Impedance Measurements *

Axis	Input Impedance	Output Impedance	
Channel 1 FX	704.05	704.06	Ohms
Channel 2 FY	703.54	703.42	Ohms
Channel 3 FZ	703.44	703.21	Ohms
Channel 4 MX	356.11	356.22	Ohms
Channel 5 MY	356.34	356.38	Ohms
Channel 6 MZ	705.28	705.23	Ohms

Bridge High Short Measurement **

Axis	Bridge to Transducer Body	
Channel 1 FX	>= 5.00	G Ohms (10 ⁹ Ohms)
Channel 2 FY	>= 5.00	G Ohms (10 ⁹ Ohms)
Channel 3 FZ	>= 5.00	G Ohms (10 ⁹ Ohms)
Channel 4 MX	>= 5.00	G Ohms (10 ⁹ Ohms)
Channel 5 MY	>= 5.00	G Ohms (10 ⁹ Ohms)
Channel 6 MZ	>= 5.00	G Ohms (10 ⁹ Ohms)

Measurement Equipment

Serial Number

Measurement Accuracy

Keithley Model 7001 Switch System	0698562	N/A
Keithley Model 2000 Multimeter	0643818	±0.045 Ohms/Year @ 23°C ±5°C
Keithley Model 6517A Electrometer/High Resistance Meter	0695446	±(11.25 x 10 ⁻⁶) + 10 ⁻⁵ Ohms/Year @ 18°C-28°C

NOTE: Input impedance measurements taken between ±excitation, output impedance measurements taken between ±signal

* NOTE: High short measurements are taken between +excitation and the transducer body. Measurements are made at +50.0 VDC.

** Robert A. Denton, Inc. certifies that all equipment used to perform measurements expressed in this report are traceable to the National Institute of Standards and Technology and are in accordance with ANSI/NCSS Z540-1-1994 (MIL-STD 45662A).

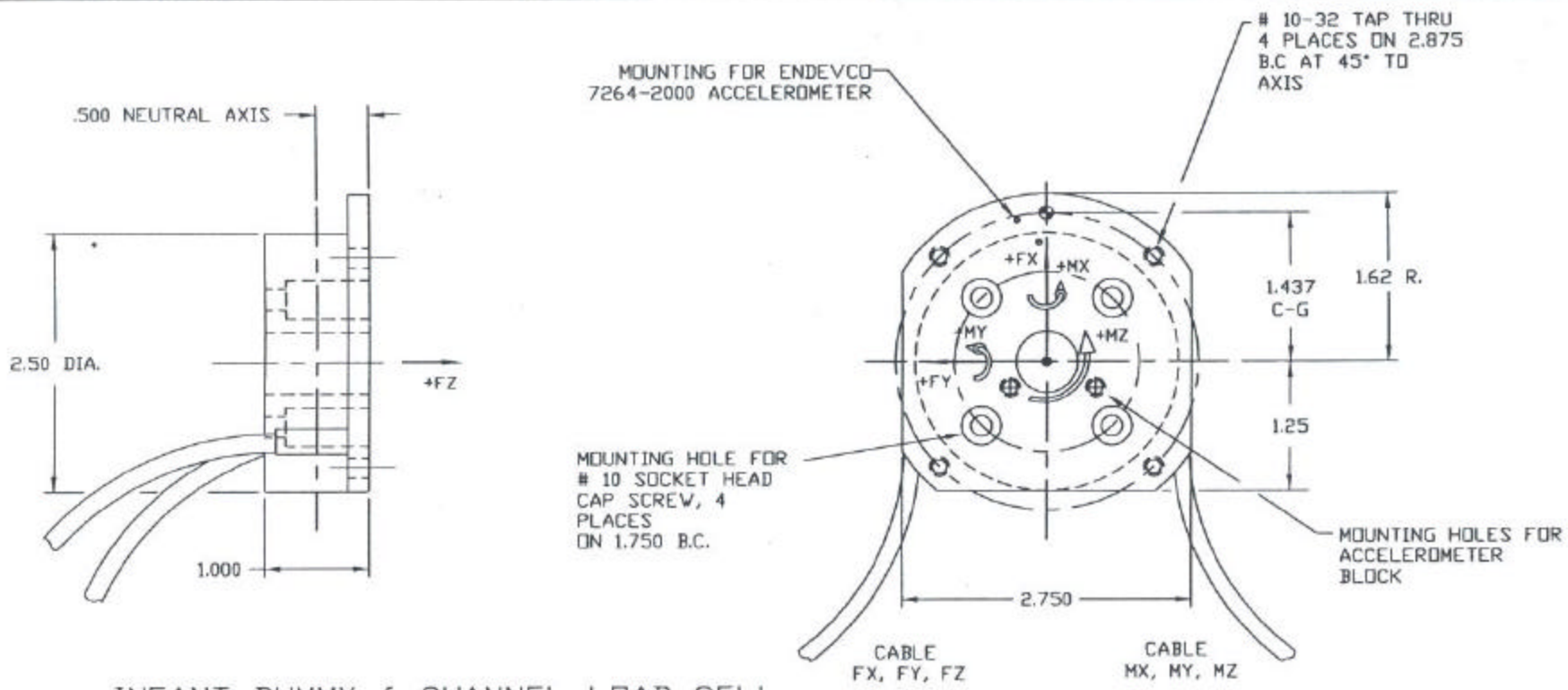

INFANT DUMMY 6-CHANNEL LOAD CELL

AXIS	CAPACITY	OUTPUT @ CAPACITY	MODEL 2554 BRIDGE RESISTANCE	MODEL 2554A BRIDGE RESISTANCE
FX	200 LBS.	1.8 mV/V NOMINAL	700 OHMS	700 OHMS
FY	200 LBS.	1.8 mV/V NOMINAL	700 OHMS	700 OHMS
FZ	500 LBS.	.8 mV/V NOMINAL	480 OHMS	700 OHMS
MX	500 LB.-IN.	1.3 mV/V NOMINAL	350 OHMS	350 OHMS
MY	500 LB.-IN.	1.3 mV/V NOMINAL	350 OHMS	350 OHMS
MZ	300 LB.-IN.	1.3 mV/V NOMINAL	700 OHMS	700 OHMS

NONLINEARITY < 1% OF FULL SCALE
 CROSSTALK < 5% OF FULL SCALE
 WEIGHT - 0.30 LBS. NOMINAL (C)

NOTE:
 THIS LOAD CELL IS UTILIZED
 IN THE UPPER NECK, LOWER NECK
 AND LUMBAR SPINE OF THE
 INFANT DUMMY. FX AND MX
 POLARITY WILL CHANGE BASED
 ON MOUNTING LOCATION.

C	WAS .40 LBS.	4/99
B	WAS DRG. B-2554	4/99
A	ADD WEIGHT SPEC	12/98
SYM	REVISION	DATE

INFANT DUMMY LOAD CELL		
SCALE: FULL		DRAWN BY: C.R. MORGAN
DATE: 10/18/91		MODEL: 2554
TWO PLACE DECIMALS ± .010		SURFACE FINISH 125 ✓
THREE PLACE DECIMALS ± .005		REMOVE ALL BURRS & SHARP EDGES
ANGLES ± 0' 30"		DIMENSION LOKITS HELD AFTER PLATING
ROBERT A. DENTON, INC. ROCHESTER HILLS, MICHIGAN		DRAWING NUMBER: B-2554-D



ROBERT A. DENTON, INC.

2967 Waterview Dr., Rochester Hills, MI 48309-4600

Tel (248) 852-5100 • Fax (248) 852-6060 • email: info@radenton.com • www.radenton.com

Crab: #017

UPPER Neck

Calibration Report Uni-Directional Calibration

Automated Load Cell Calibration System
Copyright (c) 1987-2000 Robert A. Denton, Inc.

Calibration No.	A2631002	Date	Jan 14, 2002	Due	Jan 14, 2003
Model No.	2554A	Serial No.	277		
Technician	B. Biermacher	Temp (C) / Hum. (%)	21.9 / 28.1		
Customer	VRTC	Last Calibrated	Jan 14, 2002		
Description	Infant Neck	Customer Tag Number	N/A		

Voltage Calibration

Bridge	Capacity	Zero Offset	Nonlinearity	Hysteresis	Output @ Capacity	% Change
FX	200.0 lbf	0.0096 mV/V	0.14 % FS	0.06 % FS	1.9565 mV/V	0.00 % FS
FY	200.0 lbf	-0.0035 mV/V	0.08 % FS	0.11 % FS	1.9620 mV/V	0.00 % FS
FZ	500.0 lbf	-0.0230 mV/V	0.20 % FS	0.06 % FS	-0.8538 mV/V	0.00 % FS
MX	500.0 in-lbf	0.0022 mV/V	0.33 % FS	0.55 % FS	1.3113 mV/V	0.00 % FS
MY	500.0 in-lbf	0.0112 mV/V	0.08 % FS	0.92 % FS	1.2882 mV/V	0.00 % FS
MZ	300.0 in-lbf	0.0879 mV/V	0.22 % FS	0.91 % FS	1.3871 mV/V	0.00 % FS

Shunt

Bridge	Shunt Value	Equivalent Load	Bridge Resistance (nom)
FX	120.0 K Ohms	148.8 lbf	700.0 Ohms
FY	120.0 K Ohms	148.3 lbf	700.0 Ohms
FZ	300.0 K Ohms	-342.6 lbf	700.0 Ohms
MX	80.0 K Ohms	422.6 in-lbf	350.0 Ohms
MY	80.0 K Ohms	429.7 in-lbf	350.0 Ohms
MZ	160.0 K Ohms	236.4 in-lbf	700.0 Ohms

NOTE: Positive shunt is between +Exc_+Sig Negative shunt is between -Exc_+Sig

Wire Color Codes

FX-MX	FY-MY	FZ-MZ
Brown + Exc.	Red Stripe + Exc.	Green + Exc.
Red + Sig.	Black + Sig.	Blue + Sig.
Orange - Exc.	White - Exc.	Violet - Exc.
Yellow - Sig.	Black Stripe - Sig.	Grey - Sig.

Reference Load Cell

<u>Manufacturer</u> Revere	<u>Model No.</u> 363-B10-500-20P1	<u>Serial No.</u> H607172L	<u>Calibration Due Date</u> Jul 24, 2002
-------------------------------	--------------------------------------	-------------------------------	---

Calibrated by

GS

Robert A. Denton, Inc. Authorized Representative

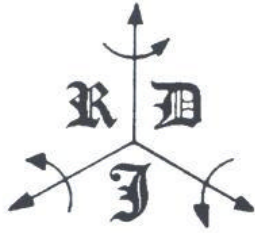

CALIBRATION REPORT

Uni-Directional Calibration Loading Sequence Summary

Automated Load Cell Calibration System
Copyright (c)1987-2000 Robert A. Denton, Inc.

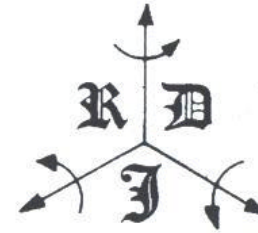

Calibration Number	A2631002	This Calibration	09:35:00	Jan 14, 2002
Model Number	2554A	Calibration Due		Jan 14, 2003
Serial Number	277	Last Calibrated		Jan 14, 2002
Description	Infant Neck	Temp (C) / Hum. (%)		21.9 / 28.1
Customer	VRTC	Customer Tag Number		N/A

Loading Sequence

Axis	FS Load EU	FS Output mV/V	Sensitivity mV/V/EU	Nonlinearity % FS	Hysteresis % FS	Moment Arm EU
FX	200.0 lbf	1.9565	0.0097824	0.14	0.06	0.00
FY	200.0 lbf	1.9620	0.0098102	0.08	0.11	0.00
FZ	500.0 lbf	-0.8538	-0.0017076	0.20	0.06	0.00
MX	500.0 in-lbf	1.3113	0.0026226	0.33	0.55	1.00
MY	500.0 in-lbf	1.2882	0.0025763	0.08	0.92	1.00
MZ	300.0 in-lbf	1.3871	0.0046238	0.22	0.91	1.50

Bridge Unbalance

FX Axis	0.0096 mV/V
FY Axis	-0.0035 mV/V
FZ Axis	-0.0230 mV/V
MX Axis	0.0022 mV/V
MY Axis	0.0112 mV/V
MZ Axis	0.0879 mV/V

Linearization

Force (FX)	=	0.2	+	102.2	*	Output (mV/V)
Force (FY)	=	0.1	+	101.9	*	Output (mV/V)
Force (FZ)	=	-0.2	+	-585.2	*	Output (mV/V)
Force (MX)	=	0.8	+	381.1	*	Output (mV/V)
Force (MY)	=	0.2	+	387.8	*	Output (mV/V)
Force (MZ)	=	0.4	+	216.1	*	Output (mV/V)

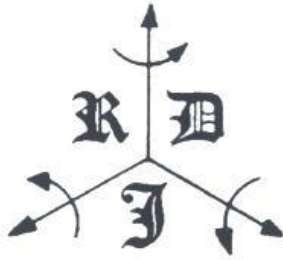

CALIBRATION REPORT

Uni-Directional Calibration Crosstalk Summary

Automated Load Cell Calibration System
Copyright (c)1987-2000 Robert A. Denton, Inc.

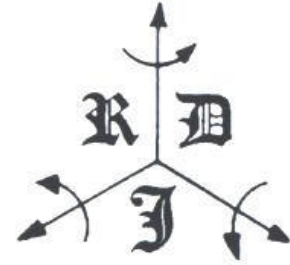

Calibration Number	A2631002	This Calibration	09:35:00	Jan 14, 2002
Model Number	2554A	Calibration Due		Jan 14, 2003
Serial Number	277	Last Calibrated		Jan 14, 2002
Description	Infant Neck	Temp (C) / Hum. (%)		21.9 / 28.1
Customer	VRTC	Customer Tag Number		N/A

Raw Crosstalk Data (mV/V)

<u>Bridge</u>		FX	FY	FZ	MX	MY	MZ
	<u>Applied Load</u>	200.0	200.0	500.0	500.0	500.0	300.0
		<u>lbf</u>	<u>lbf</u>	<u>lbf</u>	<u>in-lbf</u>	<u>in-lbf</u>	<u>in-lbf</u>
FX	200.0 lbf	1.9565	-0.0100	0.0041	-0.0062	-0.0079	0.0006
FY	200.0 lbf	-0.0124	1.9620	0.0006	0.0080	0.0029	0.0154
FZ	500.0 lbf	0.0019	-0.0033	-0.8538	0.0201	-0.0120	0.0175
MX	500.0 in-lbf	0.0014	0.0057	-0.8450	1.3113	-0.0070	0.0041
MY	500.0 in-lbf	-0.0068	0.0019	-0.8513	0.0088	1.2882	-0.0150
MZ	300.0 in-lbf	-0.0084	1.9641	0.0099	-0.0046	0.0067	1.3871

% FS Crosstalk *

<u>Bridge</u>		FX	FY	FZ	MX	MY	MZ
	<u>Applied Load</u>	200.0	200.0	500.0	500.0	500.0	300.0
		<u>lbf</u>	<u>lbf</u>	<u>lbf</u>	<u>in-lbf</u>	<u>in-lbf</u>	<u>in-lbf</u>
FX	200.0 lbf	0.00%	-0.51%	-0.48%	-0.47%	-0.61%	0.05%
FY	200.0 lbf	-0.63%	0.00%	-0.07%	0.61%	0.22%	1.11%
FZ	500.0 lbf	0.10%	-0.17%	0.00%	1.53%	-0.93%	1.26%
MX	500.0 in-lbf	0.07%	0.29%	1.02%	0.00%	-0.54%	0.30%
MY	500.0 in-lbf	-0.35%	0.10%	0.29%	0.67%	0.00%	-1.08%
MZ	300.0 in-lbf	-0.43%	0.10%	-1.16%	-0.35%	0.52%	0.00%

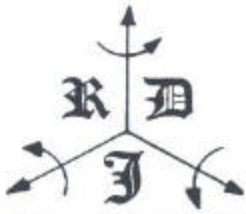

Measurement Report

Load Cell Bridge Impedance Measurement Summary

Automated Load Cell Impedance Measurement System
Copyright © 1998 Robert A. Denton, Inc.



Calibration Number	A2631002	This Calibration	09:35:00	Jan 14, 2002
Model Number	2554A	Calibration Due		Jan 14, 2003
Serial Number	277	Last Calibrated		Jan 14, 2002
Description	Infant Neck	Temp (°C) / Hum (%)		22.5 / 21.4
Customer	VRTC	Customer Tag		N/A

Bridge Impedance Measurements*

Axis	Input Impedance	Output Impedance	
Channel 1 FX	701.06	701.02	Ohms
Channel 2 FY	700.81	700.81	Ohms
Channel 3 FZ	702.23	702.09	Ohms
Channel 4 MX	356.01	355.96	Ohms
Channel 5 MY	355.46	355.49	Ohms
Channel 6 MZ	701.17	701.08	Ohms

Bridge High Short Measurement**

Axis	Bridge to Transducer Body	
Channel 1 FX	>= 5.00	G Ohms (10 ⁹ Ohms)
Channel 2 FY	>= 5.00	G Ohms (10 ⁹ Ohms)
Channel 3 FZ	>= 5.00	G Ohms (10 ⁹ Ohms)
Channel 4 MX	>= 5.00	G Ohms (10 ⁹ Ohms)
Channel 5 MY	>= 5.00	G Ohms (10 ⁹ Ohms)
Channel 6 MZ	>= 5.00	G Ohms (10 ⁹ Ohms)

Measurement Equipment

Serial Number

Measurement Accuracy

Keithley Model 7001 Switch System	0698562	N/A
Keithley Model 2000 Multimeter	0643818	±0.045 Ohms/Year @ 23°C ±5°C
Keithley Model 6517A Electrometer/High Resistance Meter	0695446	±(11.25 x 10 ⁶) + 10 ⁵ Ohms/Year @ 18°C-28°C

* NOTE: Input impedance measurements taken between ±excitation, output impedance measurements taken between ±signal

** NOTE: High short measurements are taken between +excitation and the transducer body. Measurements are made at +50.0 VDC.

Robert A. Denton, Inc. certifies that all equipment used to perform measurements expressed in this report are traceable to the National Institute of Standards and Technology and are in accordance with ANSI/NCSS Z540-1-1994 (MIL-STD 45662A).

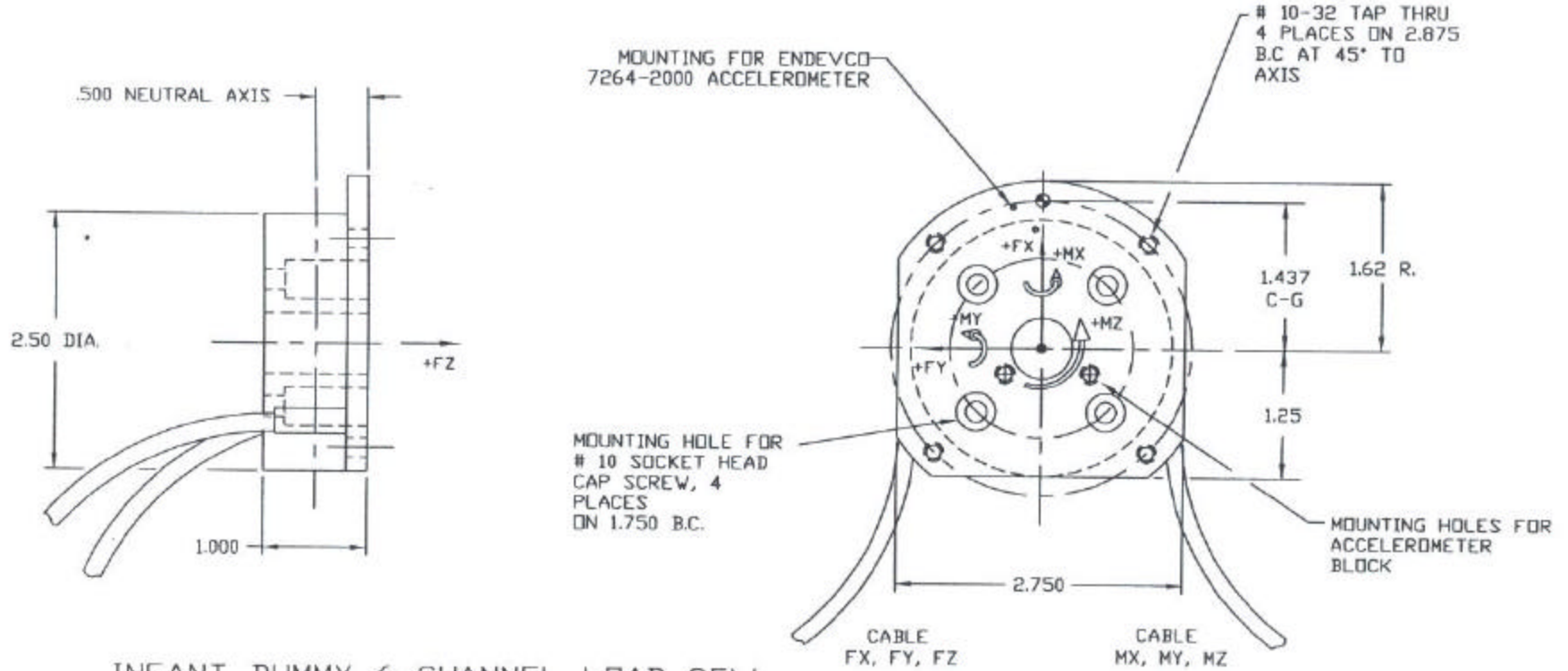

INFANT DUMMY 6-CHANNEL LOAD CELL

AXIS	CAPACITY	OUTPUT @ CAPACITY	MODEL 2554 BRIDGE RESISTANCE	MODEL 2554A BRIDGE RESISTANCE
FX	200 LBS.	1.8 mV/V NOMINAL	700 OHMS	700 OHMS
FY	200 LBS.	1.8 mV/V NOMINAL	700 OHMS	700 OHMS
FZ	500 LBS.	.8 mV/V NOMINAL	480 OHMS	700 OHMS
MX	500 LB.-IN.	1.3 mV/V NOMINAL	350 OHMS	350 OHMS
MY	500 LB.-IN.	1.3 mV/V NOMINAL	350 OHMS	350 OHMS
MZ	300 LB.-IN.	1.3 mV/V NOMINAL	700 OHMS	700 OHMS

NONLINEARITY < 1% OF FULL SCALE
 CROSSTALK < 5% OF FULL SCALE
 WEIGHT - 0.30 LBS. NOMINAL (C)

NOTE:
 THIS LOAD CELL IS UTILIZED
 IN THE UPPER NECK, LOWER NECK
 AND LUMBAR SPINE OF THE
 INFANT DUMMY. FX AND MX
 POLARITY WILL CHANGE BASED
 ON MOUNTING LOCATION.

C	WAS .40 LBS.	4/99
B	WAS DRG. B-2554	4/99
A	ADD WEIGHT SPEC	12/98
SYN	REVISION	DATE

INFANT DUMMY LOAD CELL		
SCALE: FULL	DATE: 10/18/91	DRAWN BY: C.R. MORGAN
		MODEL: 2554
TWO PLACE DECIMALS THREE PLACE DECIMALS	UNLESS OTHERWISE SPECIFIED ± .010 ± .005	SURFACE FINISH: USA REMOVE ALL BURRS & SHARP EDGES DIMENSION LIMITS HELD AFTER PLATING
ROBERT A. DENTON, INC. ROCHESTER HILLS, MICHIGAN		DRAWING NUMBER: B-2554-D

rab: #017
Head X - Forward

Calibration Certificate

Customer: VRTC
20010620-0250

Document number: 5955

Description: VRTC - Accelerometer
Manufacturer: ENDEVCO
Model Number: 7264C-2KLC-2-240
Serial Number: P16194

Input Resistance (ohms): 522.73
Output Resistance (ohms): 522.69
ZMO (mV): 7.8787
Resonance Frequency (Hz): 27825

0.1395 mV/g @ 100 Hz, 10g pk

Last Sens: 1.371E-1, Change: 1.75

Next cal date: 1/14/2003

Notes:

Excitation: 10.0 V

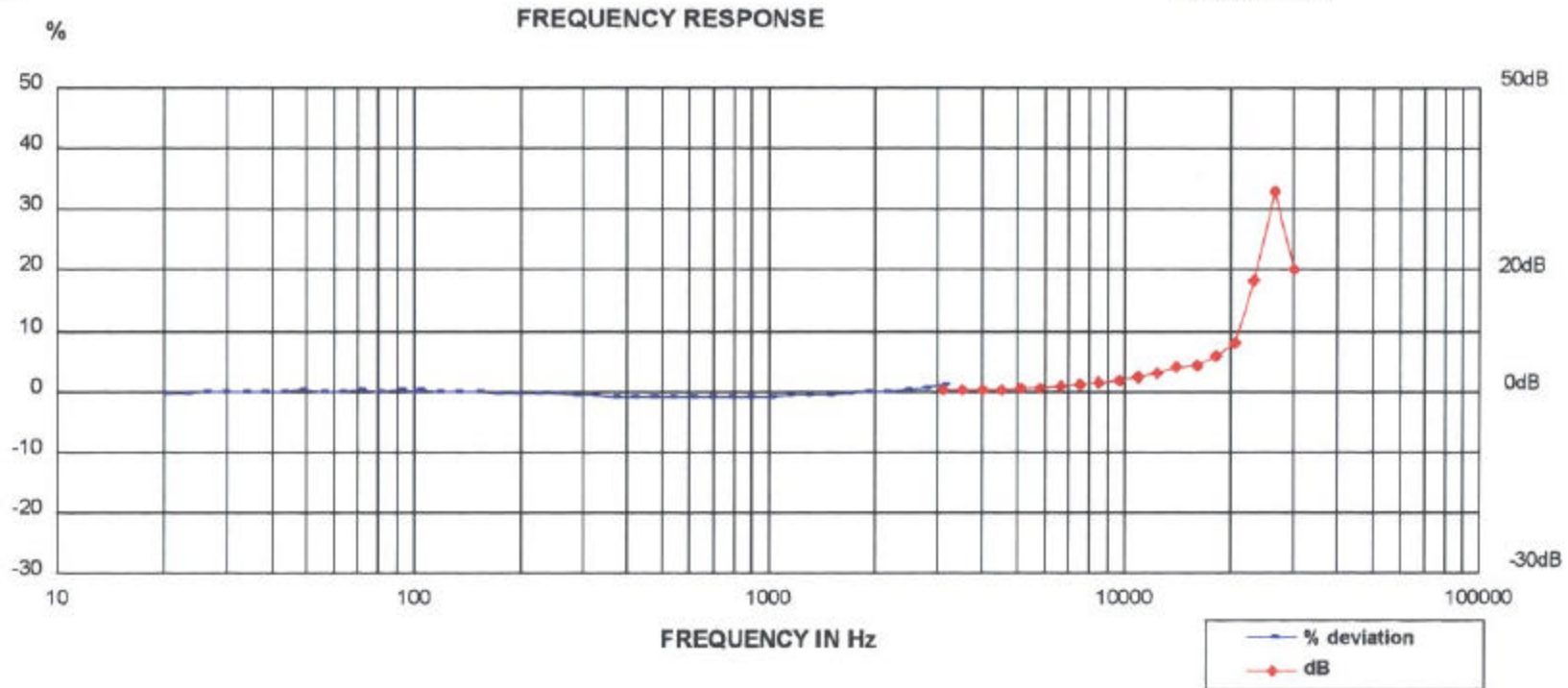

Endevco, a division of Meggitt, located at 30700 Rancho Viejo Road, San Juan Capistrano, CA, certifies that the above instrument was tested using comparison calibrations per ANSI S2.2 using Endevco IM68357. This calibration is traceable to the National Institute of Standards and Technology and is in accordance with ANSI/NC SL Z540-1-1994 (MIL-STD 45662A).

Uncertainty estimate (95% confidence, k=2)

Console serial number:	AC27	+/- 1.1 %	100.0 Hz Sensitivity
NIST traceability #:	822/262802-00	+/- 5.0 %	10.0 to 20.0 Hz
Equipment used:	2901	+/- 1.5 %	20.0 to 2000.0 Hz
Test definition:	FINAL	+/- 2.5 %	2000.0 to 10000.0 Hz
		+/- 4.0 %	10000.0 to 20000.0 Hz

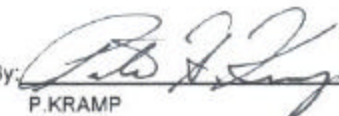
By: 
P. KRAMP
Date: 1/14/2002

Endevco
Transportation Research Center

Crabi #017

Head Y - Left

Calibration Certificate

Customer: VRTC
20010620-0250

Document number: 5938

Description: VRTC - Accelerometer
Manufacturer: ENDEVCO
Model Number: 7264C-2KLC-2-240
Serial Number: P16428

Input Resistance (ohms): 485.21
Output Resistance (ohms): 485.33
ZMO (mV): -5.984
Resonance Frequency (Hz): 28084

0.1483 mV/g @ 100 Hz, 10g pk

Last Sens: 1.459E-1, Change: 1.64
Next cal date: 1/14/2003

Notes:

Excitation: 10.0 V

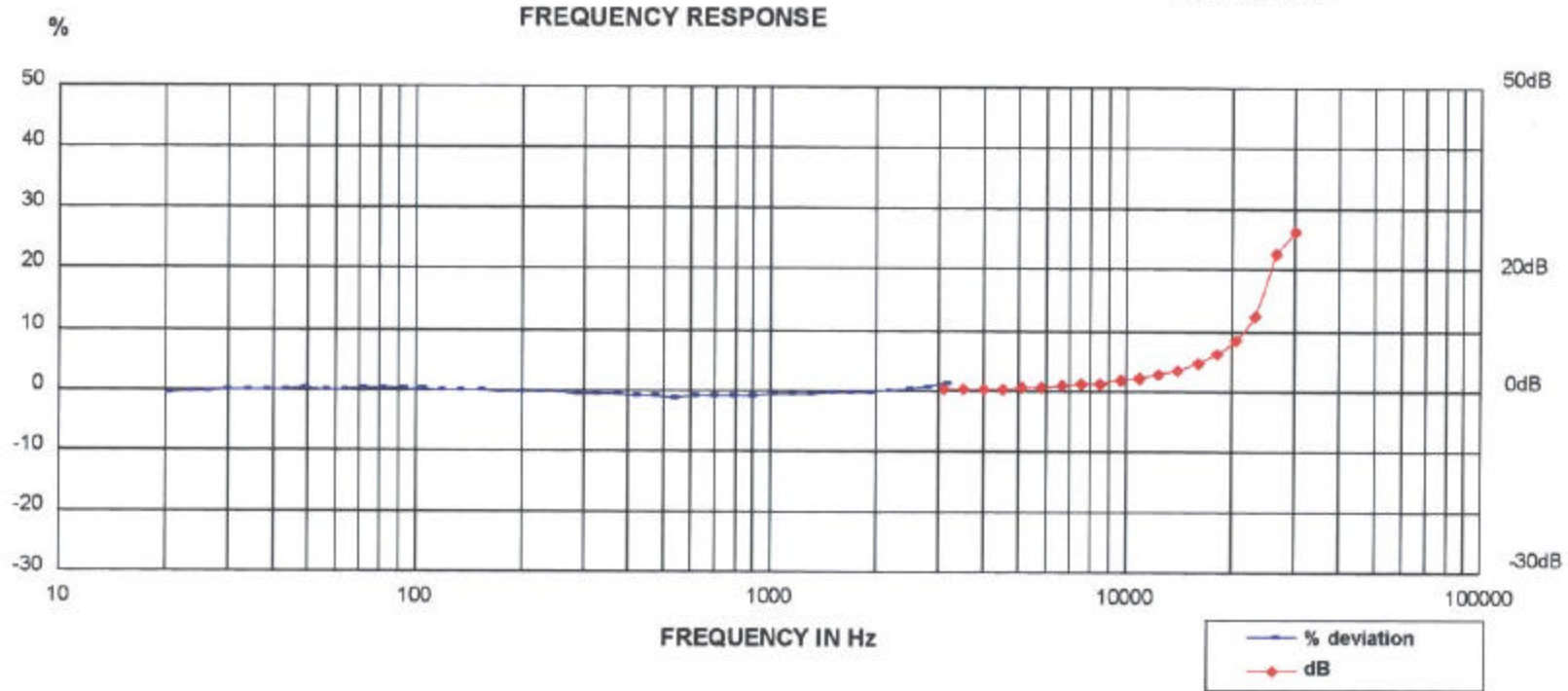

Endevco, a division of Meggitt, located at 30700 Rancho Viejo Road, San Juan Capistrano, CA, certifies that the above instrument was tested using comparison calibrations per ANSI S2.2 using Endevco IM68357. This calibration is traceable to the National Institute of Standards and Technology and is in accordance with ANSI/NCSS Z540-1-1994 (MIL-STD 45662A).

Console serial number: AC27	Uncertainty estimate (95% confidence, k=2)	
NIST traceability #: 822/262802-00	+/- 1.1 %	100.0 Hz Sensitivity
Equipment used: 2901	+/- 5.0 %	10.0 to 20.0 Hz
Test definition: FINAL	+/- 1.5 %	20.0 to 2000.0 Hz
	+/- 2.5 %	2000.0 to 10000.0 Hz
	+/- 4.0 %	10000.0 to 20000.0 Hz

By:
P. KRAMP
Date: 1/14/2002

Endevco
Transportation Research Center



rabi #017
Head Z - Down

Calibration Certificate

Customer: VRTC
20010620-0250

Document number: 5946

Description: VRTC - Accelerometer
Manufacturer: ENDEVCO
Model Number: 7264C-2KLC-2-240
Serial Number: P16517

Input Resistance (ohms): 537.25
Output Resistance (ohms): 539.22
ZMO (mV): -9.835
Resonance Frequency (Hz): 28314

0.1496 mV/g @ 100 Hz, 10g pk

Last Sens: 1.473E-1, Change: 1.6

Next cal date: 1/14/2003

Notes:

Excitation: 10.0 V

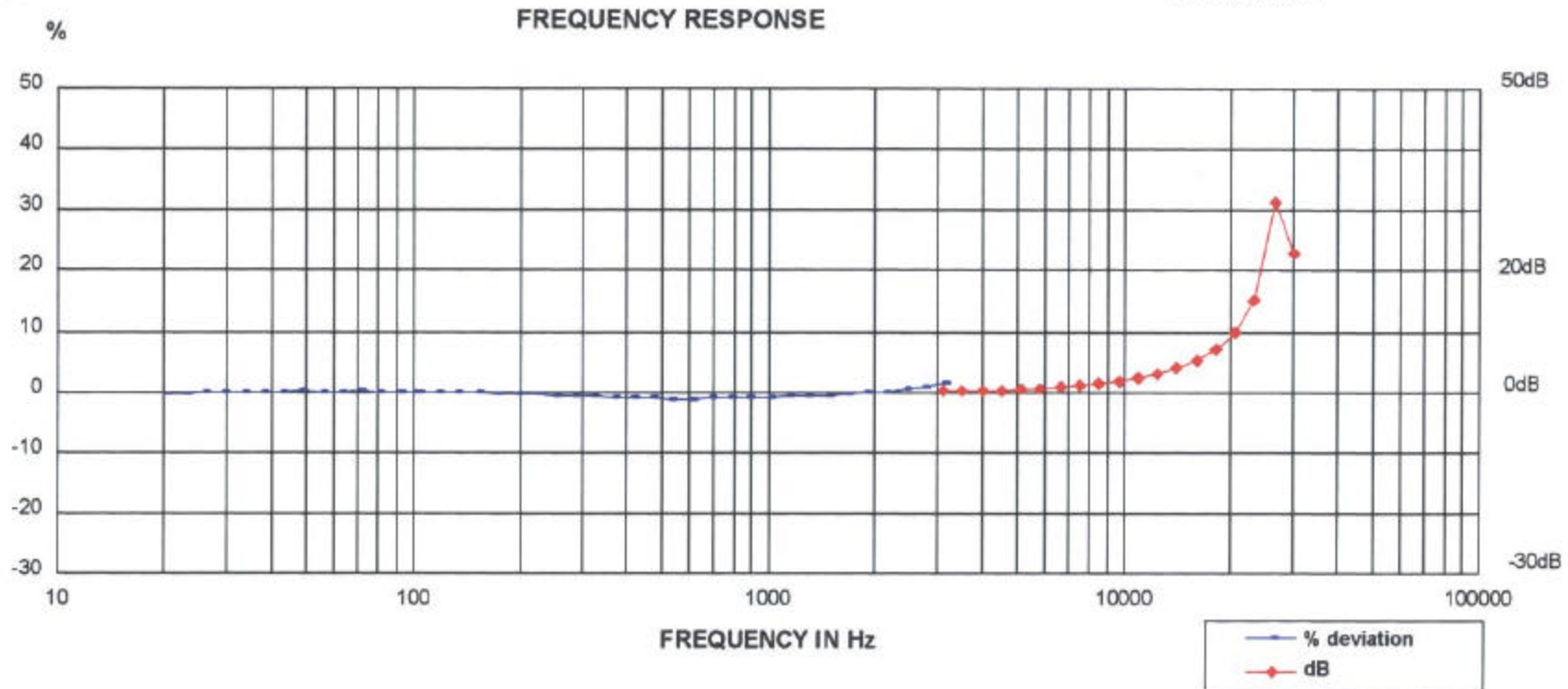

Endevco, a division of Meggitt, located at 30700 Rancho Viejo Road, San Juan Capistrano, CA, certifies that the above instrument was tested using comparison calibrations per ANSI S2.2 using Endevco IM68357. This calibration is traceable to the National Institute of Standards and Technology and is in accordance with ANSI/NCSS Z540-1-1994 (MIL-STD 45662A).

onsole serial number: AC27
NIST traceability #: 822/262802-00
Equipment used: 2901
Test definition: FINAL

Uncertainty estimate (95% confidence, k=2)

+/- 1.1 %	100.0 Hz Sensitivity
+/- 5.0 %	10.0 to 20.0 Hz
+/- 1.5 %	20.0 to 2000.0 Hz
+/- 2.5 %	2000.0 to 10000.0 Hz
+/- 4.0 %	10000.0 to 20000.0 Hz

By 
P. KRAMP

Date: 1/14/2002

Endevco
Transportation Research Center

Crabi #017
Chest X - Fwd

Calibration Certificate

Customer: VRTC
20010620-0250

Document number: 5959

Description: VRTC - Accelerometer
Manufacturer: ENDEVCO
Model Number: 7264-2KM5T
Serial Number: J27467

Input Resistance (ohms): 2364.8

ZMO (mV): -12.94
Resonance Frequency (Hz): 27885

0.2241 mV/g @ 100 Hz, 10g pk

Last Sens: 2.237E-1, Change: 0.18

Next cal date: 1/14/2003

Notes:

Excitation: 10.0 V

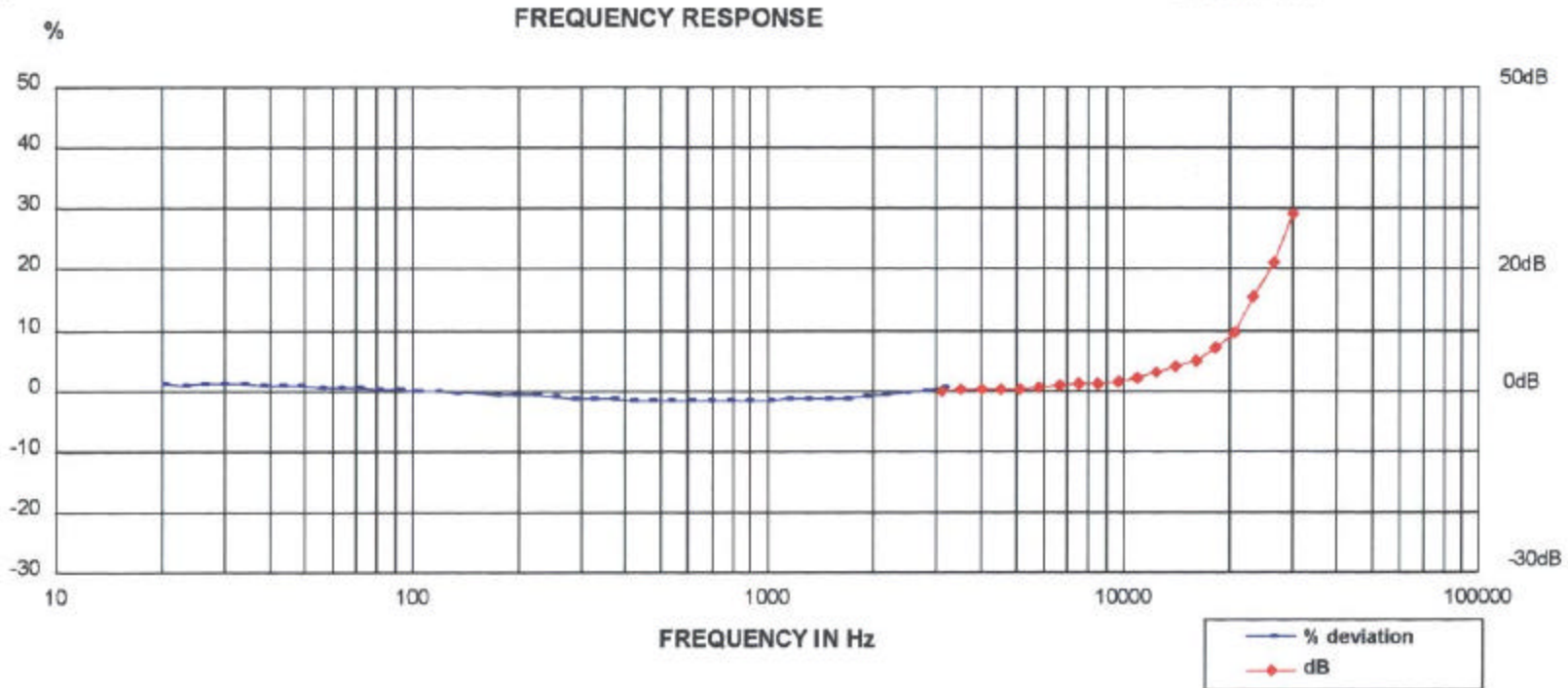

Endevco, a division of Meggitt, located at 30700 Rancho Viejo Road, San Juan Capistrano, CA, certifies that the above instrument was tested using comparison calibrations per ANSI S2.2 using Endevco IM68357. This calibration is traceable to the National Institute of Standards and Technology and is in accordance with ANSI/NCSS Z540-1-1994 (MIL-STD 45662A).

Console serial number: AC27
NIST traceability #: 822/262802-00
Equipment used: 2901
Test definition: FINAL

Uncertainty estimate (95% confidence, k=2)

+/- 1.1 %	100.0 Hz Sensitivity
+/- 5.0 %	10.0 to 20.0 Hz
+/- 1.5 %	20.0 to 2000.0 Hz
+/- 2.5 %	2000.0 to 10000.0 Hz
+/- 4.0 %	10000.0 to 20000.0 Hz

By: 
P. KRAMP

Date: 1/14/2002

Endevco
Transportation Research Center

Crab: #017
Chest Y - Right

Calibration Certificate

Customer: VRTC
20010620-0250

Document number: 5958

Description: VRTC - Accelerometer
Manufacturer: ENDEVCO
Model Number: 7264-2KM5T
Serial Number: AJ4Y5

Input Resistance (ohms): 2487.6

ZMO (mV): -8.321
Resonance Frequency (Hz): 23473

0.2655 mV/g @ 100 Hz, 10g pk

Last Sens: 2.645E-1, Change: 0.39

Next cal date: 1/14/2003

Notes:

Excitation: 10.0 V

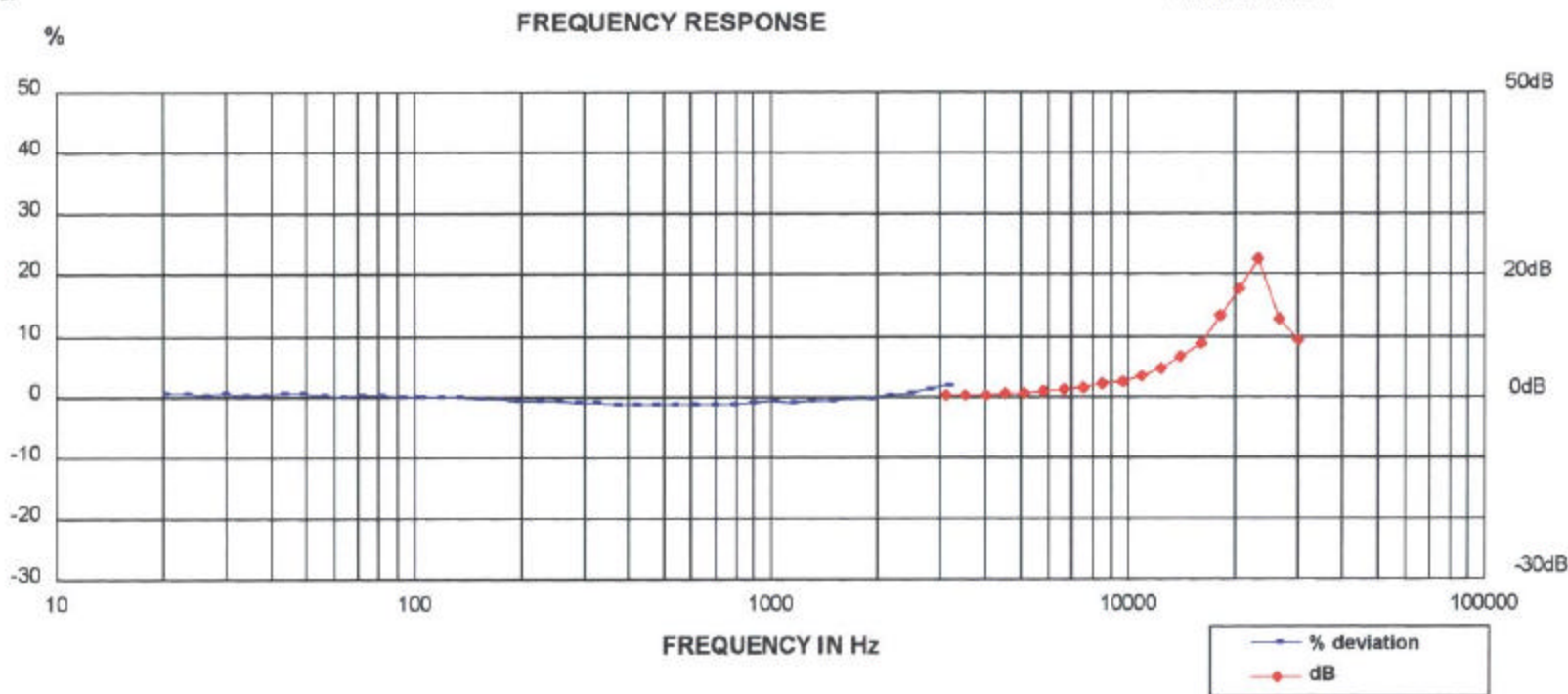

Endevco, a division of Meggitt, located at 30700 Rancho Viejo Road, San Juan Capistrano, CA, certifies that the above instrument was tested using comparison calibrations per ANSI S2.2 using Endevco IM68357. This calibration is traceable to the National Institute of Standards and Technology and is in accordance with ANSI/NC SL Z540-1-1994 (MIL-STD 45662A).

Console serial number: AC27
NIST traceability #: 822/262802-00
Equipment used: 2901
Test definition: FINAL

Uncertainty estimate (95% confidence, k=2)

+/- 1.1 %	100.0 Hz Sensitivity
+/- 5.0 %	10.0 to 20.0 Hz
+/- 1.5 %	20.0 to 2000.0 Hz
+/- 2.5 %	2000.0 to 10000.0 Hz
+/- 4.0 %	10000.0 to 20000.0 Hz

By: *P. Kramp*
P. KRAMP
Date: 1/14/2002

Endevco
Transportation Research Center

Crabi #017
Chest z-up

Calibration Certificate

Customer: VRTC
20010620-0250

Document number: 5941

Description: VRTC - Accelerometer
Manufacturer: ENDEVCO
Model Number: 7264C-2KLC-2-240
Serial Number: P17559

Input Resistance (ohms): 491.89
Output Resistance (ohms): 491.09
ZMO (mV): -3.179
Resonance Frequency (Hz): 27054

0.14 mV/g @ 100 Hz, 10g pk

Last Sens: 1.378E-1, Change: 1.62
Next cal date: 1/14/2003

Notes:

Excitation: 10.0 V

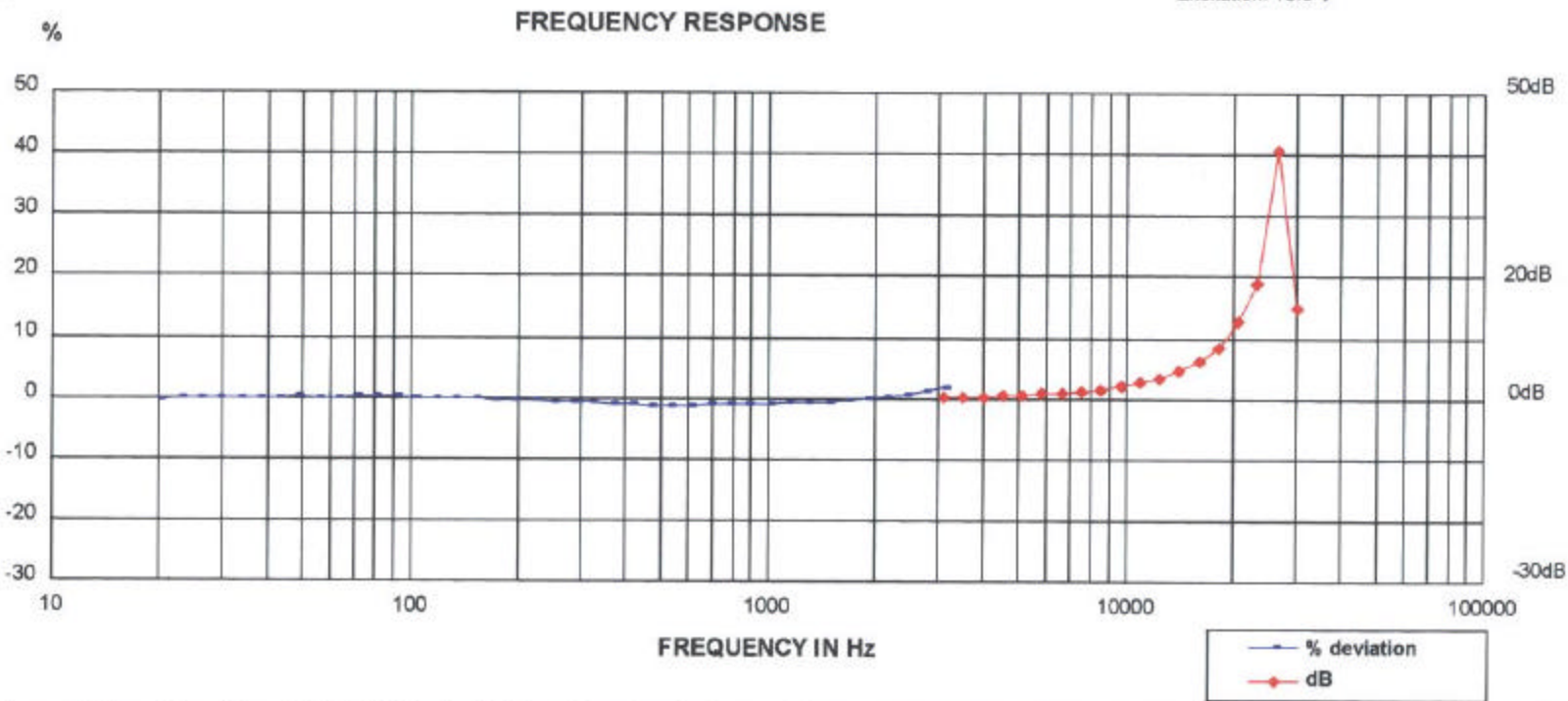

Endevco, a division of Meggitt, located at 30700 Rancho Viejo Road, San Juan Capistrano, CA, certifies that the above instrument was tested using comparison calibrations per ANSI S2.2 using Endevco IM68357. This calibration is traceable to the National Institute of Standards and Technology and is in accordance with ANSI/NCSL Z540-1-1994 (MIL-STD 45662A).

		Uncertainty estimate (95% confidence, k=2)	
Console serial number:	AC27	+/- 1.1 %	100.0 Hz Sensitivity
NIST traceability #:	822/262802-00	+/- 5.0 %	10.0 to 20.0 Hz
Equipment used:	2901	+/- 1.5 %	20.0 to 2000.0 Hz
Test definition:	FINAL	+/- 2.5 %	2000.0 to 10000.0 Hz
		+/- 4.0 %	10000.0 to 20000.0 Hz

By: *P. Kramp*
P. KRAMP

Date: 1/14/2002

Endevco
Transportation Research Center

Crabi #017
Pelvis X-Rear

Calibration Certificate

Customer: VRTC
20010620-0250

Document number: 5942

Description: VRTC - Accelerometer
Manufacturer: ENDEVCO
Model Number: 7264C-2KLC-2-240
Serial Number: P15856

Input Resistance (ohms): 543.75
Output Resistance (ohms): 546.30
ZMO (mV): 10.56
Resonance Frequency (Hz): 27530

0.1461 mV/g @ 100 Hz, 10g pk

Last Sens: 1.439E-1, Change: 1.56

Next cal date: 1/14/2003

Notes:

Excitation: 10.0 V

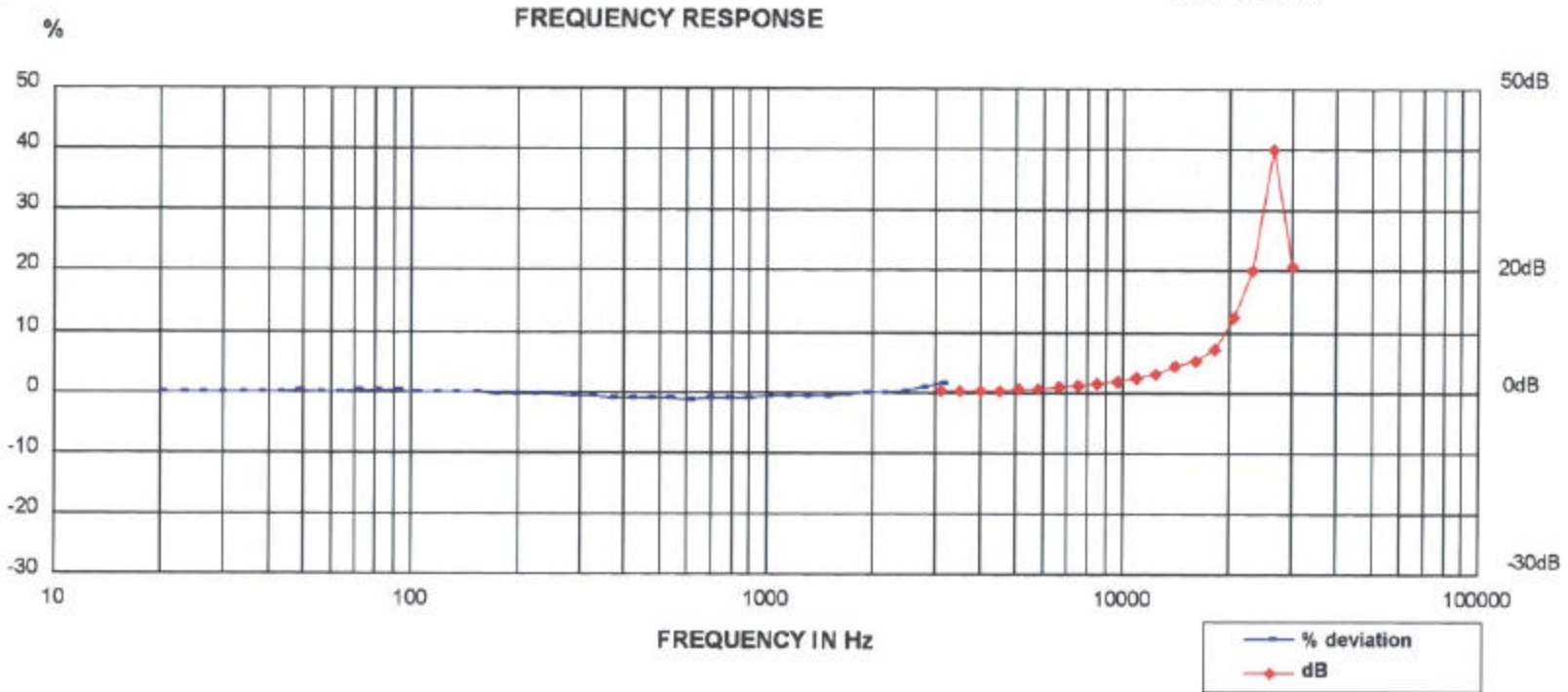

Endevco, a division of Meggitt, located at 30700 Rancho Viejo Road, San Juan Capistrano, CA, certifies that the above instrument was tested using comparison calibrations per ANSI S2.2 using Endevco IM68357. This calibration is traceable to the National Institute of Standards and Technology and is in accordance with ANSI/NC SL Z540-1-1994 (MIL-STD 45662A).

Console serial number: AC27
NIST traceability #: 822/262802-00
Equipment used: 2901
Test definition: FINAL

Uncertainty estimate (95% confidence, k=2)

+/- 1.1 %	100.0 Hz Sensitivity
+/- 5.0 %	10.0 to 20.0 Hz
+/- 1.5 %	20.0 to 2000.0 Hz
+/- 2.5 %	2000.0 to 10000.0 Hz
+/- 4.0 %	10000.0 to 20000.0 Hz

By: 
P. KRAMP

Date: 1/14/2002

Endevco
Transportation Research Center

Crab: #017
Pelvis Y-Left

Calibration Certificate

Customer: VRTC
20010620-0250

Document number: 5957

Description: VRTC - Accelerometer
Manufacturer: ENDEVCO
Model Number: 7264-2KM5T
Serial Number: J27496

Input Resistance (ohms): 2694.9

ZMO (mV): 7.2351
Resonance Frequency (Hz): 25622

0.2795 mV/g @ 100 Hz, 10g pk

Last Sens: 2.795E-1, Change: 0.007

Next cal date: 1/14/2003

Notes:

Excitation: 10.0 V

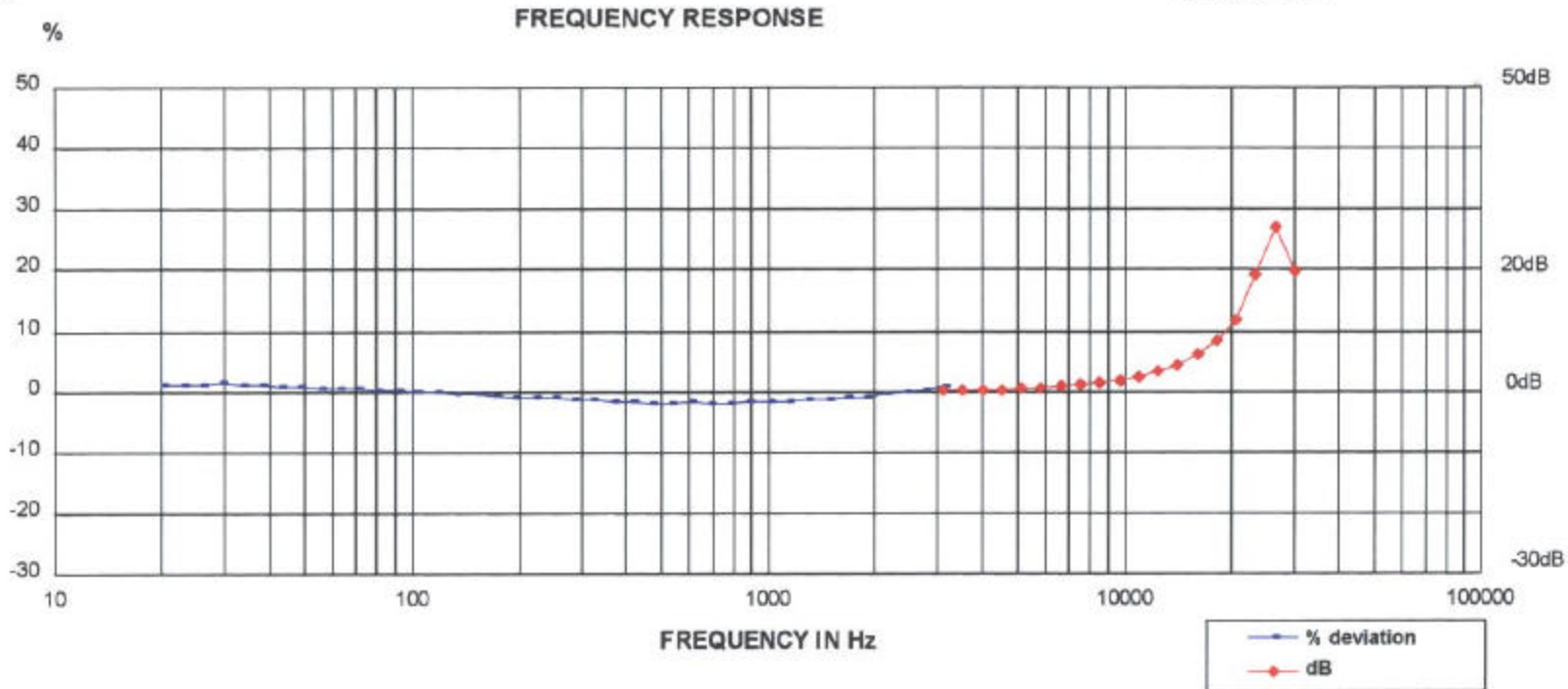

Endevco, a division of Meggitt, located at 30700 Rancho Viejo Road, San Juan Capistrano, CA, certifies that the above instrument was tested using comparison calibrations per ANSI S2.2 using Endevco IM68357. This calibration is traceable to the National Institute of Standards and Technology and is in accordance with ANSI/NCSL Z540-1-1994 (MIL-STD 45662A).

Uncertainty estimate (95% confidence, k=2)

Console serial number: AC27
NIST traceability #: 822/262802-00
Equipment used: 2901
Test definition: FINAL

+/- 1.1 %	100.0 Hz Sensitivity
+/- 5.0 %	10.0 to 20.0 Hz
+/- 1.5 %	20.0 to 2000.0 Hz
+/- 2.5 %	2000.0 to 10000.0 Hz
+/- 4.0 %	10000.0 to 20000.0 Hz

By: 
P. KRAMP

Date: 1/14/2002

Endevco
Transportation Research Center

Crab: #017
Pelvis E-WP

Calibration Certificate

Customer: VRTC
20010620-0250

Document number: 5952

Description: VRTC - Accelerometer
Manufacturer: ENDEVCO
Model Number: 7264C-2KLC-2-240
Serial Number: P15638

Input Resistance (ohms): 527.62
Output Resistance (ohms): 527.76
ZMO (mV): -0.423
Resonance Frequency (Hz): 28532

0.141 mV/g @ 100 Hz, 10g pk

Last Sens: 1.410E-1, Change: -0.04

Next cal date: 1/14/2003

Notes:

Excitation: 10.0 V

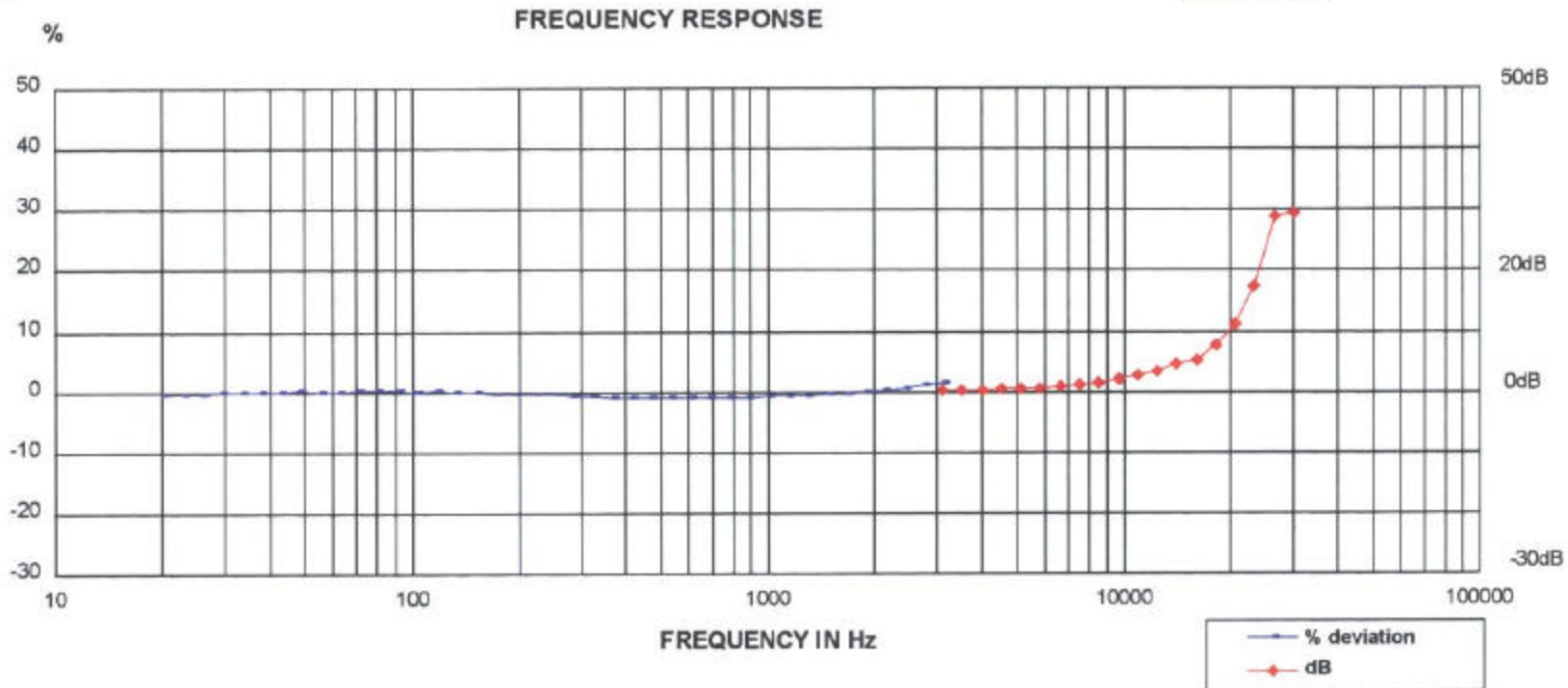

Endevco, a division of Meggitt, located at 30700 Rancho Viejo Road, San Juan Capistrano, CA, certifies that the above instrument was tested using comparison calibrations per ANSI S2.2 using Endevco IM68357. This calibration is traceable to the National Institute of Standards and Technology and is in accordance with ANSI/NC SL Z540-1-1994 (MIL-STD 45662A).

Console serial number: AC27
NIST traceability #: 822/262802-00
Equipment used: 2901
Test definition: FINAL

Uncertainty estimate (95% confidence, k=2)

+/- 1.1 %	100.0 Hz Sensitivity
+/- 5.0 %	10.0 to 20.0 Hz
+/- 1.5 %	20.0 to 2000.0 Hz
+/- 2.5 %	2000.0 to 10000.0 Hz
+/- 4.0 %	10000.0 to 20000.0 Hz

By: 
P. KRAMP

Date: 1/14/2002

Endevco
Transportation Research Center

26: #017
Head Red Z-up

Calibration Certificate

Customer: VRTC
20010620-0250

Document number: 5964

Description: VRTC - Accelerometer
Manufacturer: ENTRAN
Model Number: EGE-73BQE0-2000BF
Serial Number: 99H30-Z07

Input Resistance (ohms): 973.91
ZMO (mV): 15.817
Resonance Frequency (Hz): 19489

0.1994 mV/g @ 100 Hz, 10g pk

Last Sens: 1.959E-1, Change: 1.82
Next cal date: 1/14/2003

Notes:

Excitation: 10.0 V

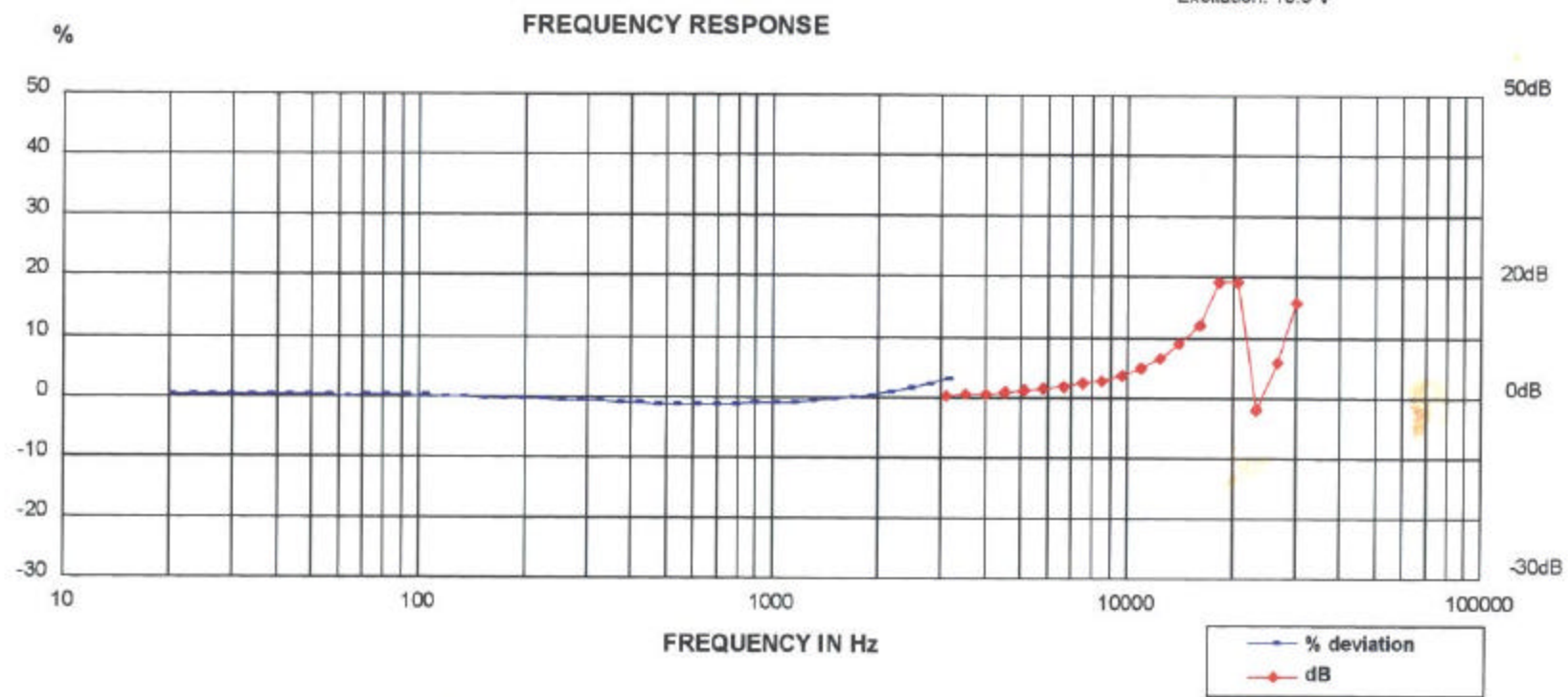

Endevco, a division of Meggitt, located at 30700 Rancho Viejo Road, San Juan Capistrano, CA, certifies that the above instrument was tested using comparison calibrations per ANSI S2.2 using Endevco IM68357. This calibration is traceable to the National Institute of Standards and Technology and is in accordance with ANSI/NCSL Z540-1-1994 (MIL-STD 45662A).

onsole serial number: AC27	+/- 1.1 %	100.0 Hz Sensitivity
NIST traceability #: 822/262802-00	+/- 5.0 %	10.0 to 20.0 Hz
Equipment used: 2901	+/- 1.5 %	20.0 to 2000.0 Hz
Test definition: FINAL	+/- 2.5 %	2000.0 to 10000.0 Hz
	+/- 4.0 %	10000.0 to 20000.0 Hz

By: *P. Kramp*
P. KRAMP
Date: 1/14/2002

Endevco
Transportation Research Center

TRANSPORTATION RESEARCH CENTER INC.

FRONTAL HEAD DROP TEST

CRABI 12-MONTH

30-JAN-02

TRC INC.

TEST NO: 017C01HF1

572R SN017 HEAD DROP CAL 01

TEST PARAMETER	SPECIFICATION	TEST RESULTS
TEMPERATURE	18.9-25.6 DEG. C	21.7 DEG. C
RELATIVE HUMIDITY	10 - 70 %	50.0 %
PEAK RESULTANT ACCELERATION	100 - 120 G	103.35 G
PEAK LATERAL ACCELERATION	15 G MAX	2.21 G
IS ACCELERATION CURVE UNIMODAL? (= < 17%)	YES	YES (9%)

TEST MEETS SPECIFICATIONS

TECHNICIAN

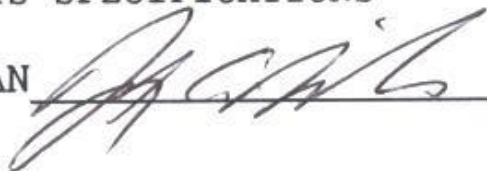

RUN NUMBER: 013002.0749;2

PART 572R CRABI FRONTAL HEAD DROP CALIBRATION
HEAD ACCELERATION X AXIS

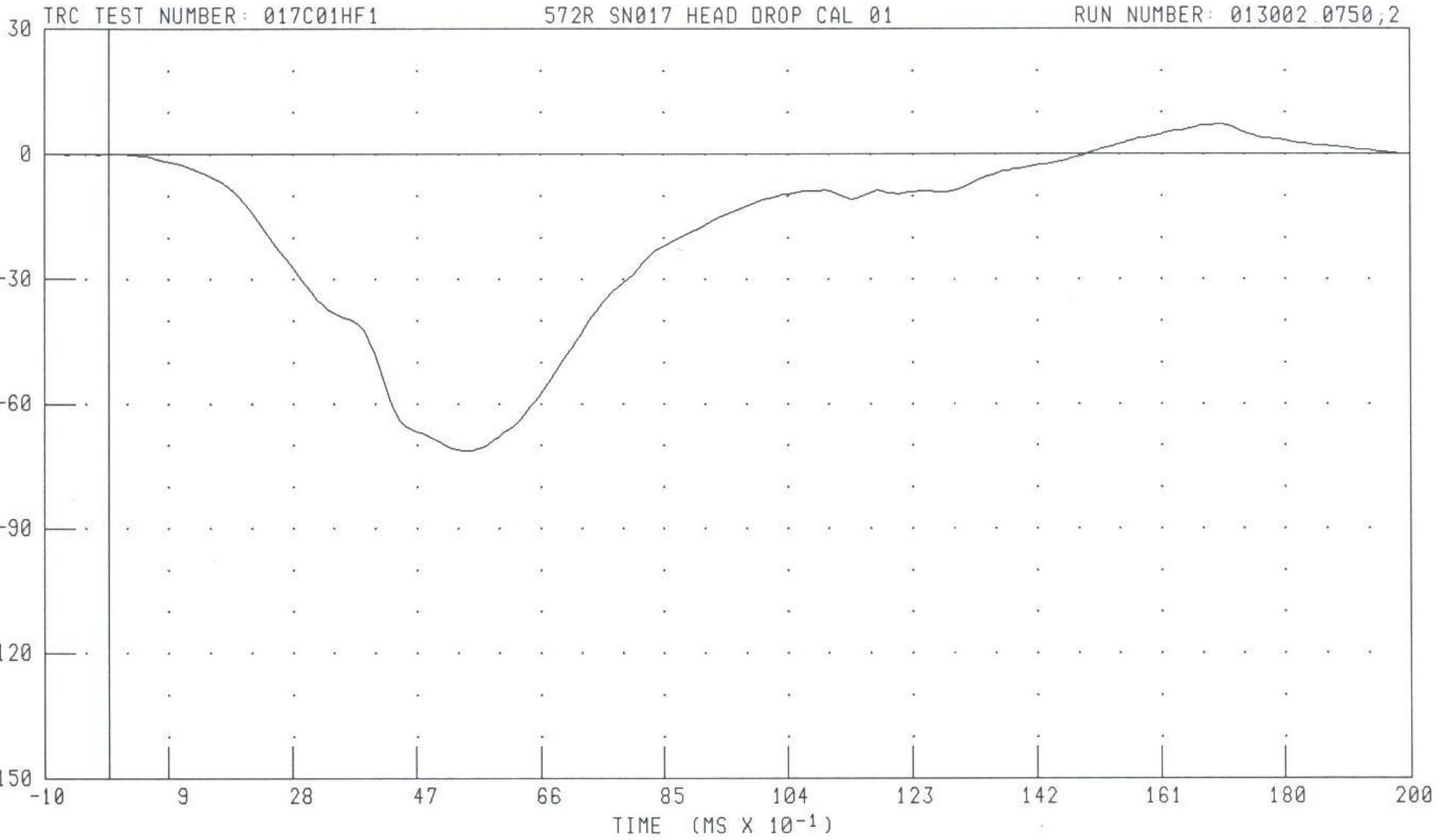

CHANNEL: HEDXC

FILTER: CH. CLASS 1000

PEAK DATA: 7.14 G @ 17.12 MS; -71.29 G @ 5.52 MS

PART 572R CRABI FRONTAL HEAD DROP CALIBRATION

HEAD ACCELERATION Y AXIS

TRC TEST NUMBER: 017C01HF1

572R SN017 HEAD DROP CAL 01

RUN NUMBER: 013002.0750;2

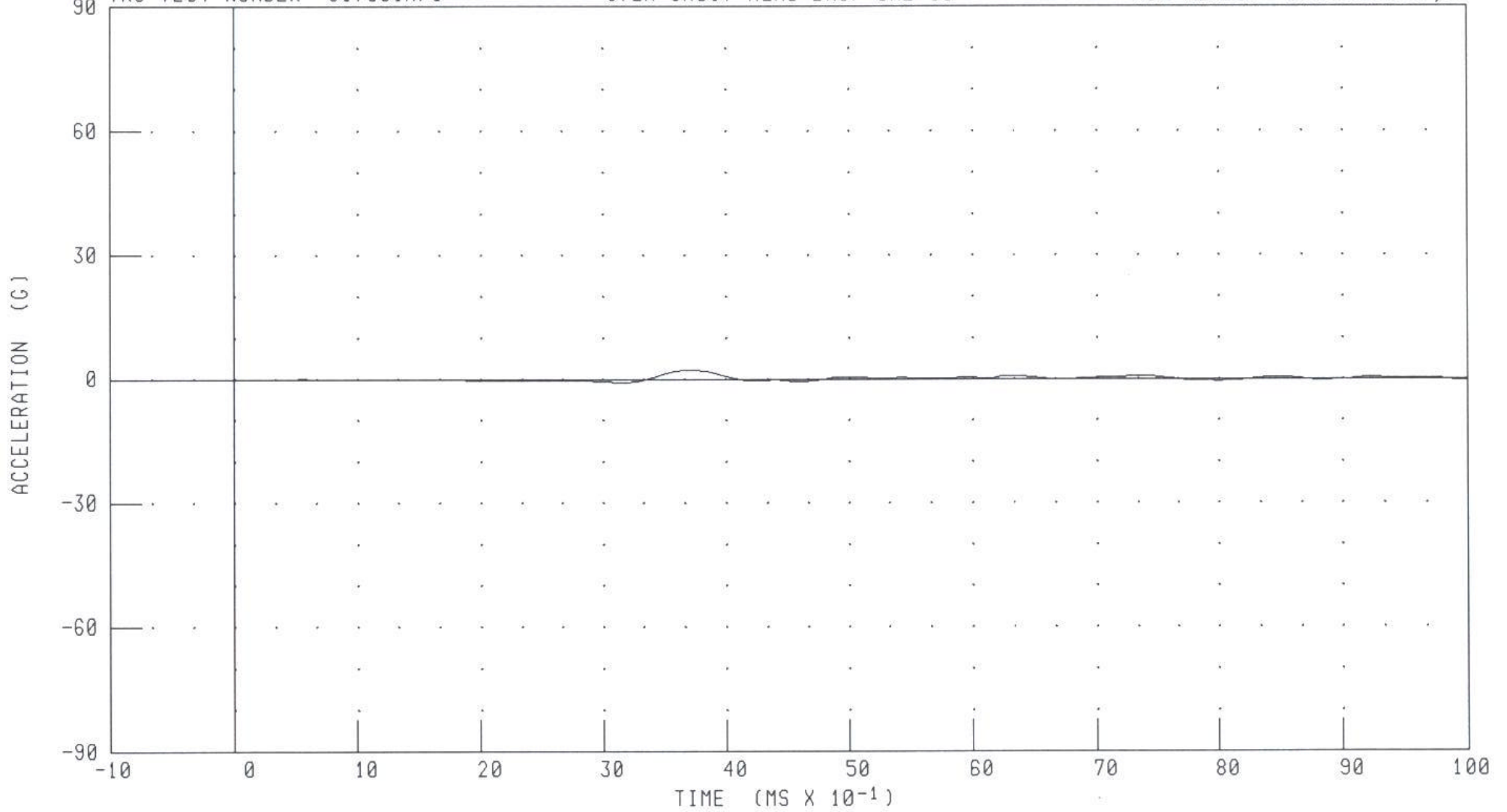

CHANNEL: HEDYG

FILTER: CH CLASS 1000

PEAK DATA: 2.21 G @ 3.68 MS; -0.79 G @ 3.20 MS

PART 572R CRABI FRONTAL HEAD DROP CALIBRATION
HEAD ACCELERATION Z AXIS

TRC TEST NUMBER: 017C01HF1

572R SN017 HEAD DROP CAL 01

RUN NUMBER: 013002.0750,2

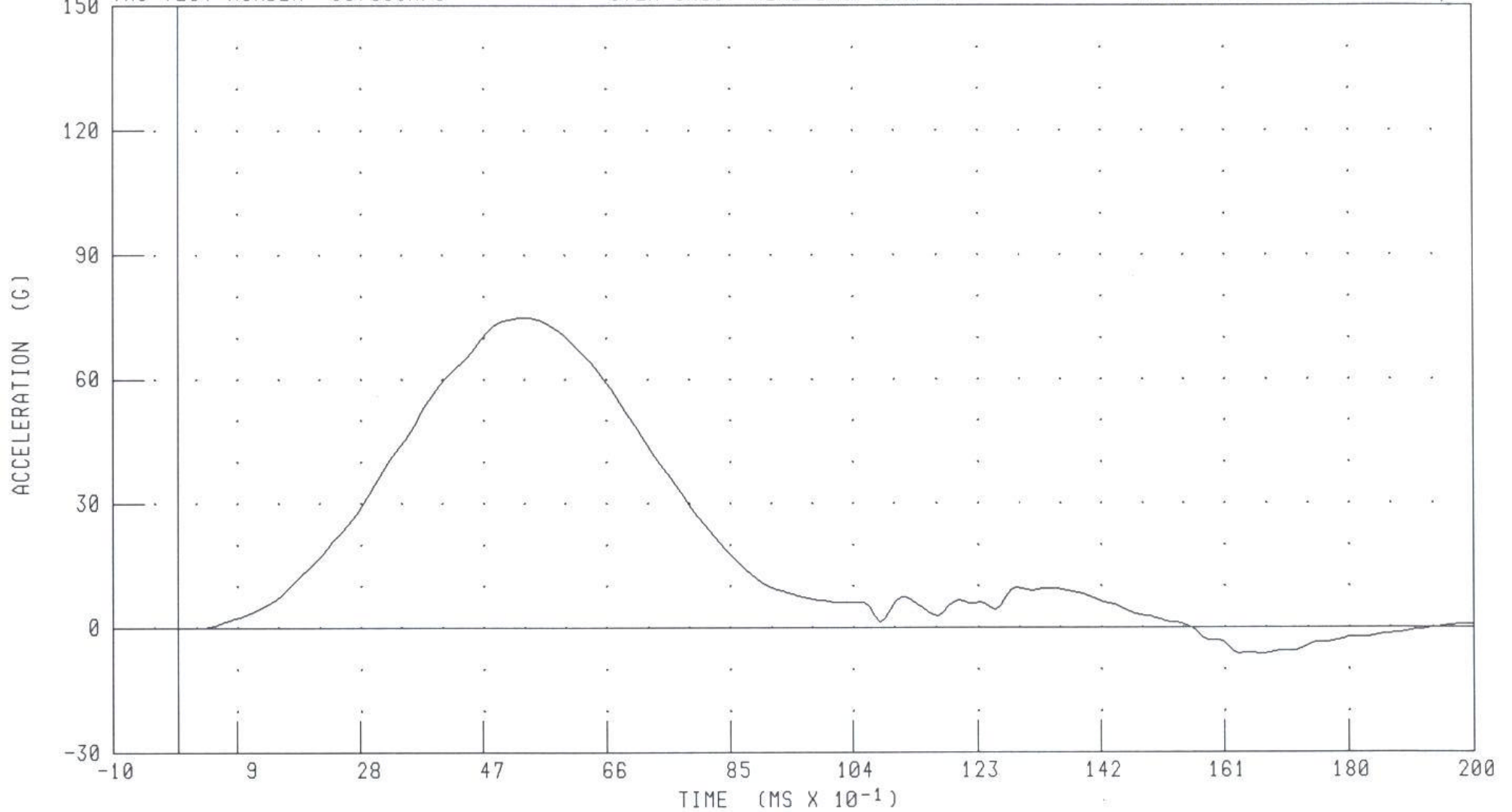

CHANNEL: HEDZG

FILTER: CH. CLASS 1000

PEAK DATA: 74.91 G @ 5.36 MS; -6.41 G @ 16.72 MS

PART 572R CRABI FRONTAL HEAD DROP CALIBRATION

HEAD RESULTANT ACCELERATION

TRC TEST NUMBER: 017C01HF1

572R SN017 HEAD DROP CAL 01

RUN NUMBER: 013002.0750;2

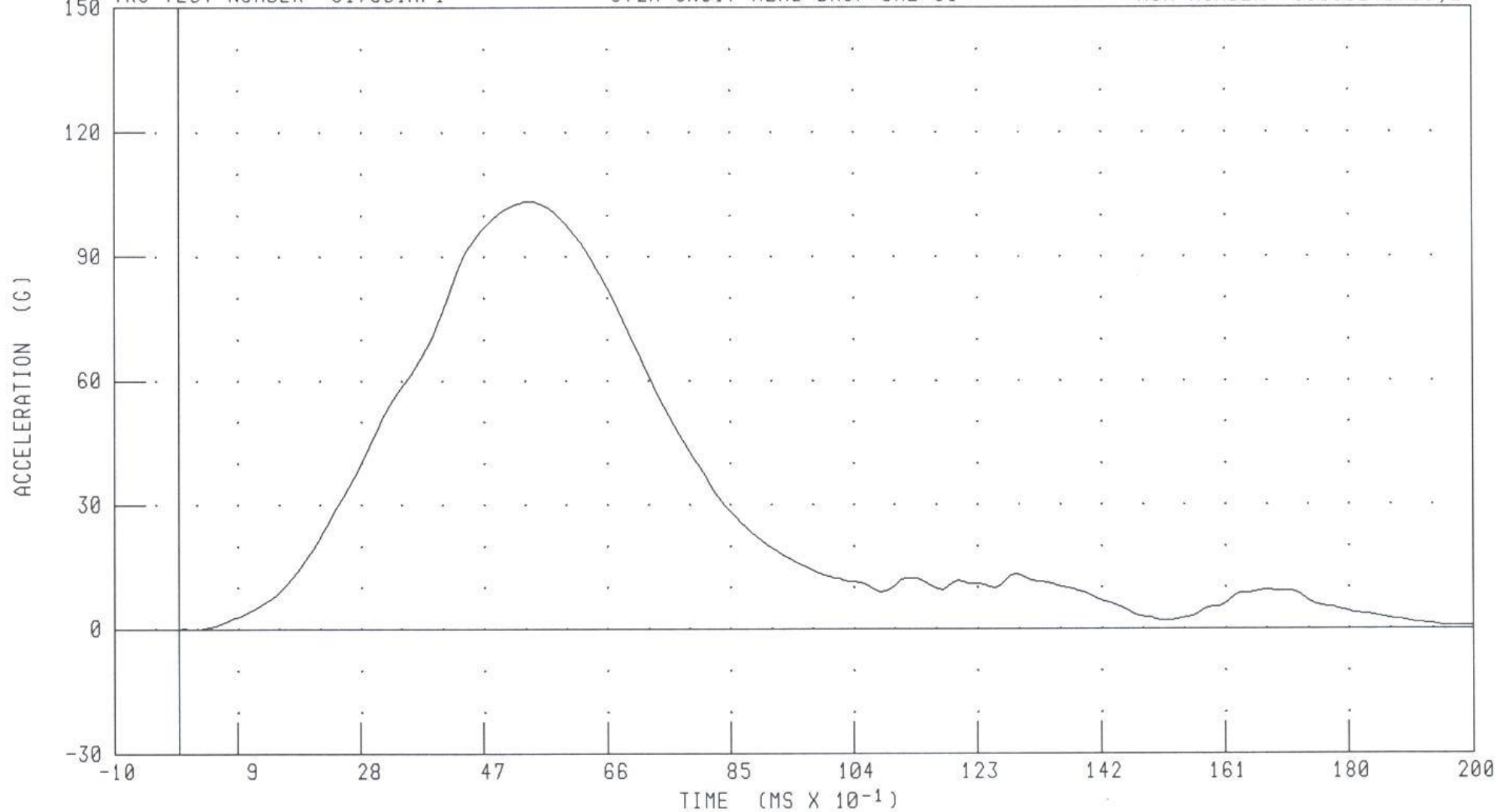

CHANNEL: HEDRG

FILTER: CH. CLASS 1000

PEAK DATA: 103.36 G @ 5.44 MS; 0.01 G @ -0.80 MS

TRANSPORTATION RESEARCH CENTER INC.

REAR HEAD DROP TEST

CRABI 12-MONTH

30-JAN-02

TRC INC.

TEST NO: 017C01HR1

572R SN017 HEAD DROP CAL 01

TEST PARAMETER	SPECIFICATION	TEST RESULTS
TEMPERATURE	18.9-25.6 DEG. C	21.7 DEG. C
RELATIVE HUMIDITY	10 - 70 %	51.0 %
PEAK RESULTANT ACCELERATION	55 - 71 G	70.01 G
PEAK LATERAL ACCELERATION	15 G MAX	-2.24 G
IS ACCELERATION CURVE UNIMODAL? (<= 17%)	YES	YES (12%)

TEST MEETS SPECIFICATIONS

TECHNICIAN



RUN NUMBER: 013002.0813;1

PART 572R CRABI REAR HEAD DROP CALIBRATION

HEAD ACCELERATION X AXIS

TRC TEST NUMBER: 017C01HR1

572R SN017 HEAD DROP CAL 01

RUN NUMBER: 013002.0819;1

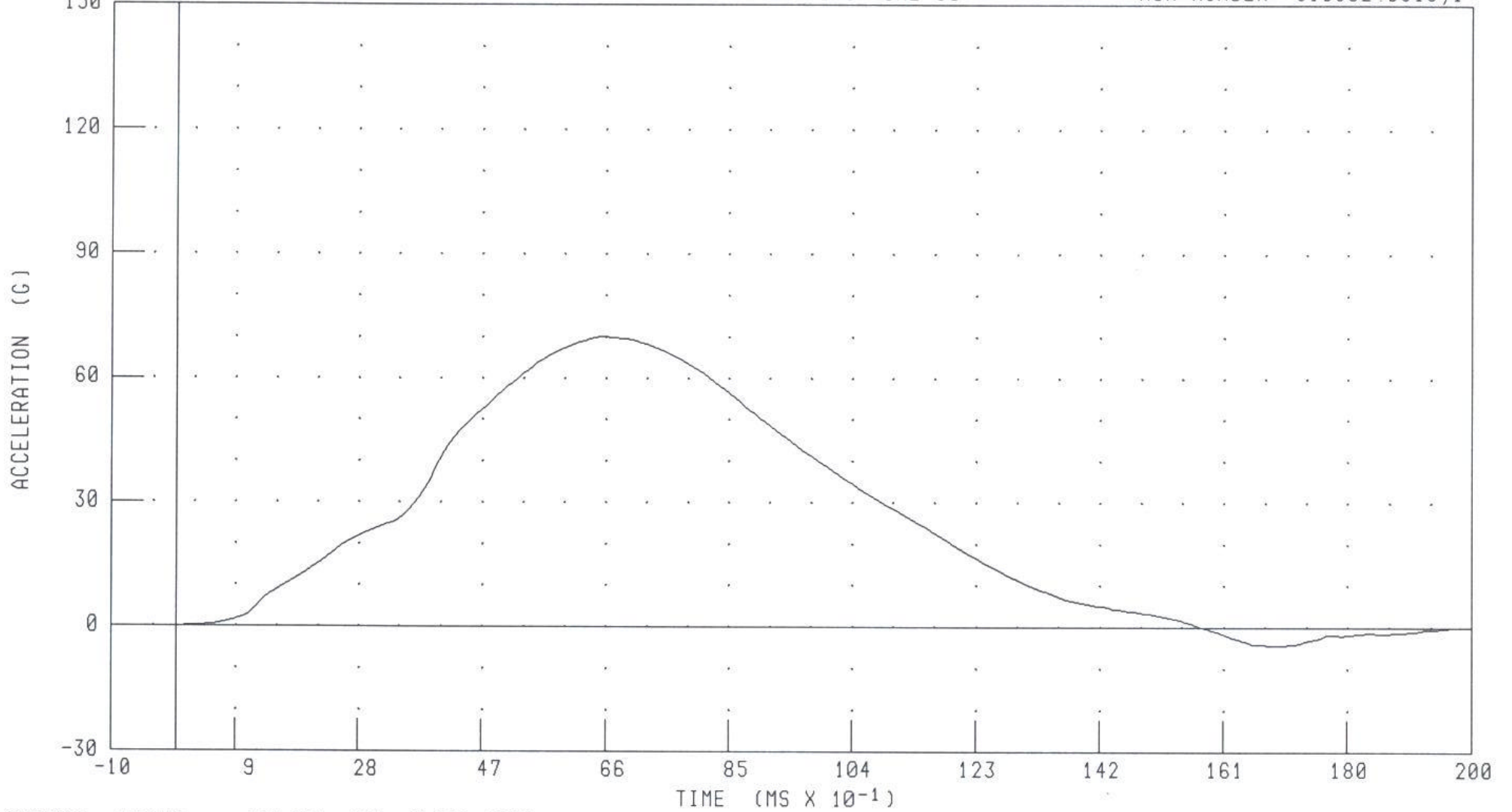

CHANNEL: HEDXC

FILTER: CH. CLASS 1000

PEAK DATA: 69.98 G @ 6.56 MS, -4.42 G @ 17.12 MS

PART 572R CRABI REAR HEAD DROP CALIBRATION

HEAD ACCELERATION Y AXIS

TRC TEST NUMBER: 017C01HR1

572R SN017 HEAD DROP CAL 01

RUN NUMBER: 013002.0819;1

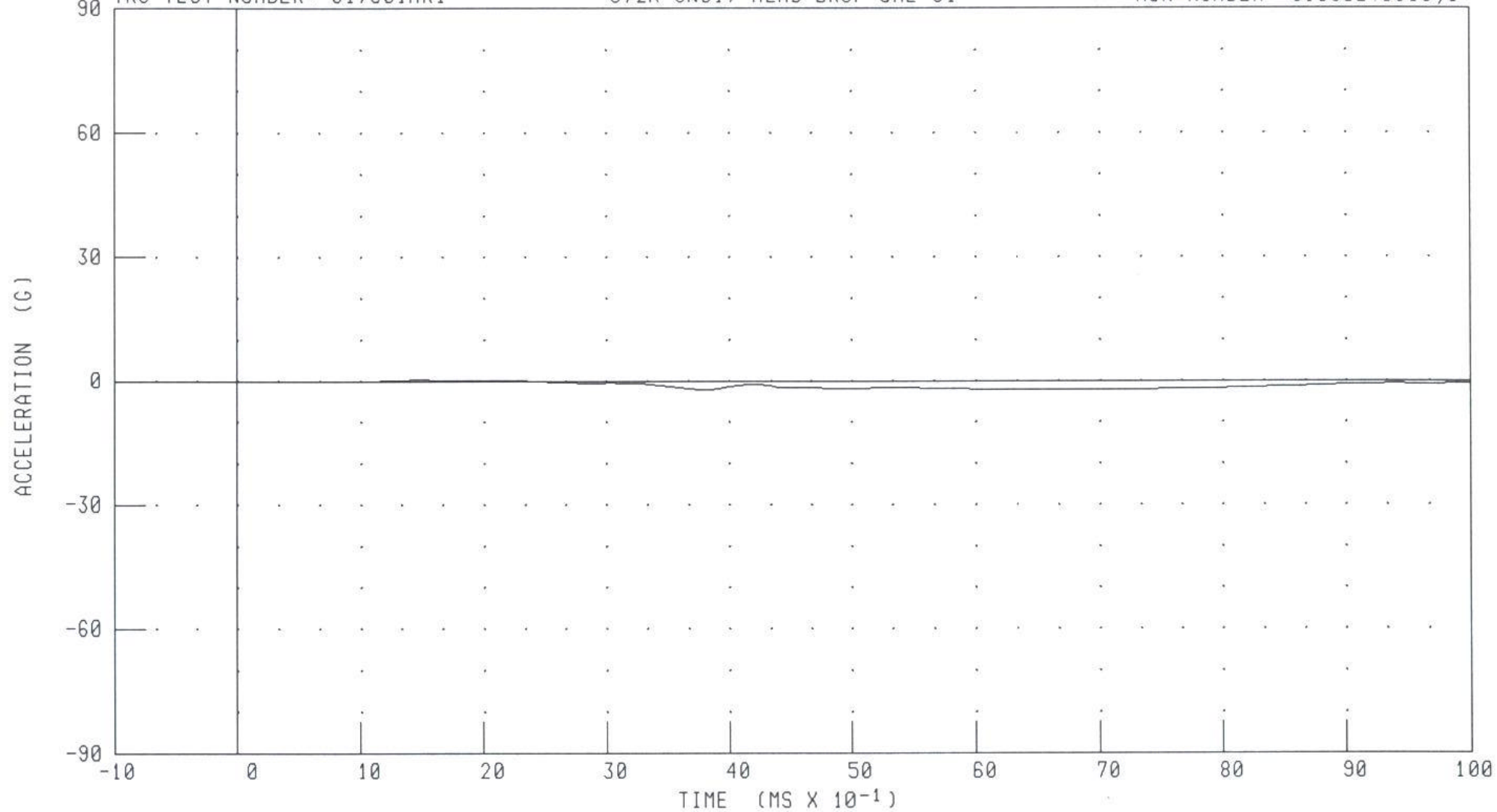

CHANNEL: HEDYC

FILTER: CH. CLASS 1000

PEAK DATA: 0.35 G @ 1.44 MS; -2.25 G @ 6.56 MS

PART 572R CRABI REAR HEAD DROP CALIBRATION

HEAD ACCELERATION Z AXIS

TRC TEST NUMBER: 017C01HR1

572R SN017 HEAD DROP CAL 01

RUN NUMBER: 013002.0819;1

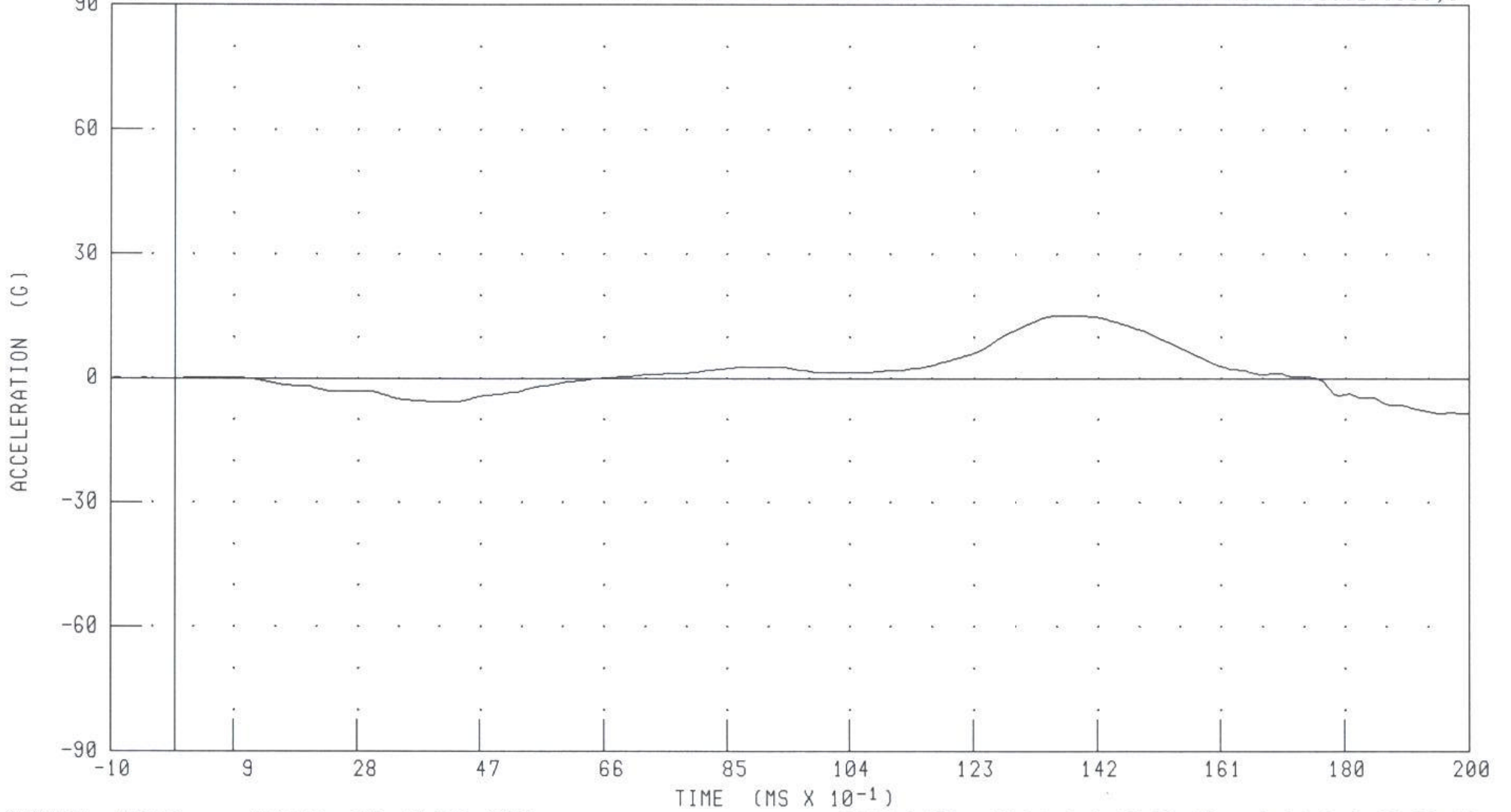

CHANNEL: HEDZG

FILTER: CH. CLASS 1000

PEAK DATA: 15.21 G @ 13.76 MS, -8.61 G @ 20.00 MS

PART 572R CRABI REAR HEAD DROP CALIBRATION

HEAD RESULTANT ACCELERATION

TRC TEST NUMBER: 017C01HR1

572R SN017 HEAD DROP CAL 01

RUN NUMBER: 013002.0819;1

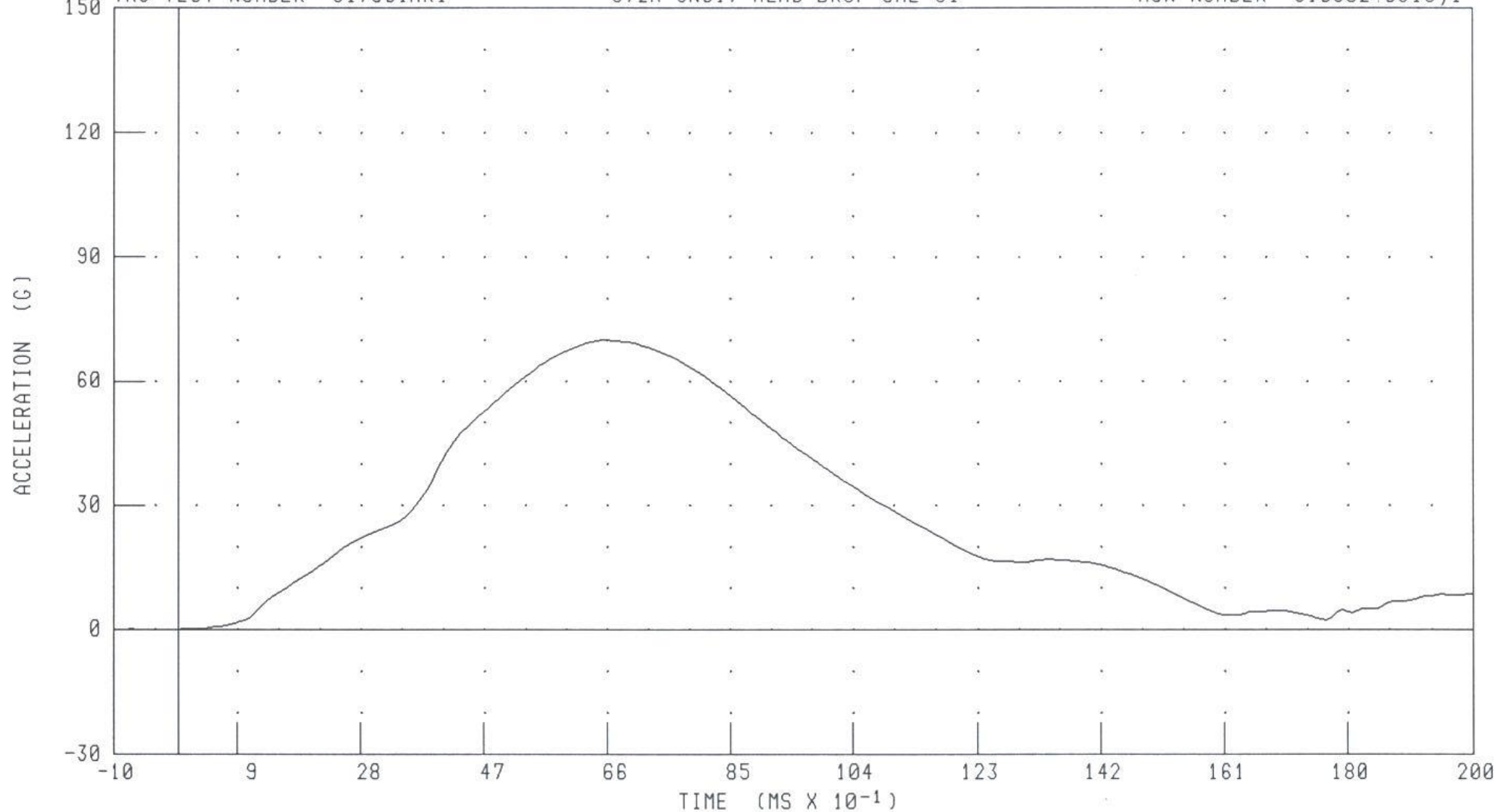

CHANNEL: HEDRG

FILTER: CH. CLASS 1000

PEAK DATA: 70.02 G @ 65.56 MS; 0.03 G @ -0.56 MS

TRANSPORTATION RESEARCH CENTER INC.

NECK FLEXION TEST

CRABI 12-MONTH

30-JAN-02

TRC INC. TEST NO: 017C01NF1 572R SN017 NECK FLEX CAL01

TEST PARAMETER	SPECIFICATION	TEST RESULTS
TEMPERATURE	20.6-22.2 DEG. C	21.1 DEG. C
RELATIVE HUMIDITY	10 - 70 %	30.0 %
IMPACT VELOCITY	5.1 - 5.3 M/S	5.25 M/S
INTEGRATED PENDULUM VELOCITY	10 MS 1.6 - 2.3 G	1.95 M/S
	20 MS 3.4 - 4.2 M/S	3.84 M/S
	25 MS 4.3 - 5.2 M/S	4.78 M/S
PEAK D-PLANE ROTATION	75 - 86 DEG.	79.59 DEG.
PEAK MOMENT DURING ROTATION INTERVAL	36 - 45 NM	38.57 NM
POSITIVE MOMENT DECAY TIME TO 5 NM LEVEL	60 - 80 MS	75.20 MS

TEST MEETS SPECIFICATIONS

TECHNICIAN 

RUN NUMBER: 013102.0644;4

PART 572R CRABI NECK FLEXION CALIBRATION

PENDULUM DECELERATION

TRC TEST NUMBER: 017C01NF1

572R SN017 NECK FLEX CAL01

RUN NUMBER: 013102.0646;4

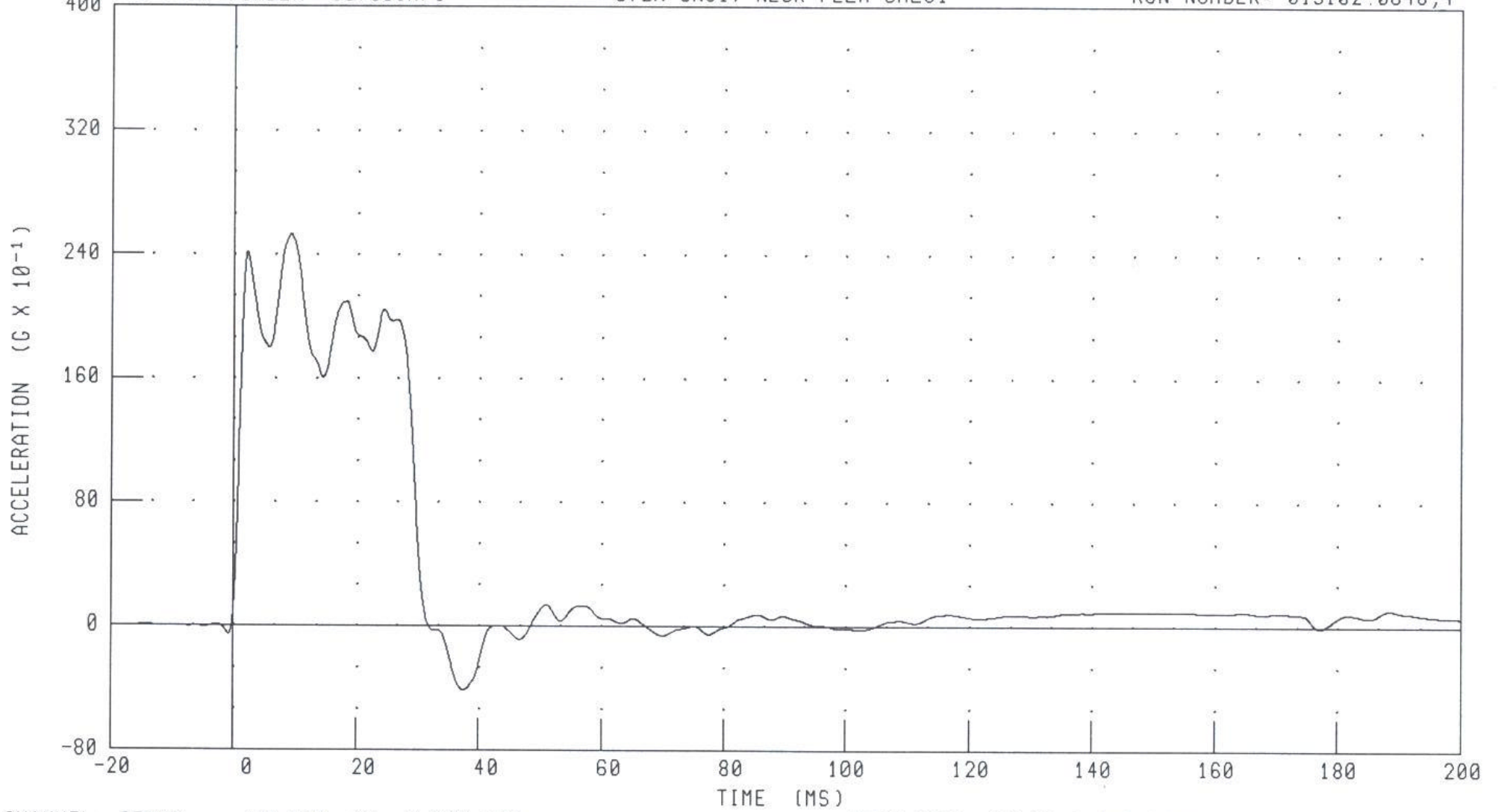

CHANNEL: PENXC

FILTER: CH. CLASS 180

PEAK DATA: 25.33 G @ 9.20 MS, -4.13 G @ 37.52 MS

PART 572R CRABI NECK FLEXION CALIBRATION
PENDULUM INTEGRATED VELOCITY

TRC TEST NUMBER: 017C01NF1

572R SN017 NECK FLEX CAL01

RUN NUMBER: 013102.0646;4

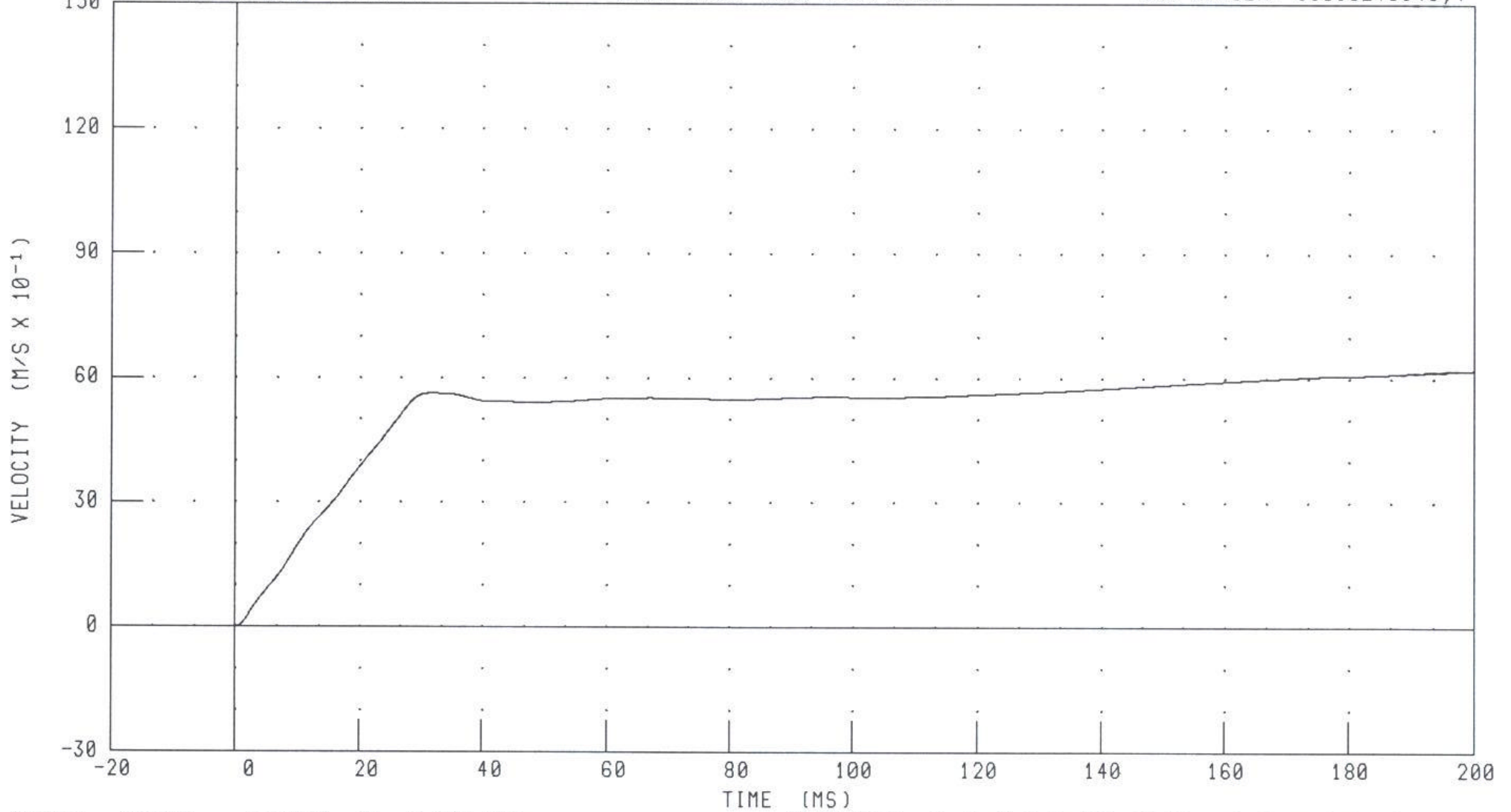

CHANNEL: PENXVI FILTER: CH. CLASS 180

PEAK DATA: 6.21 M/S @ 200.00 MS; -0.01 M/S @ -0.24 MS

PART 572R CRABI NECK FLEXION CALIBRATION

ROTATION ABOUT BASE OF NECK

TRC TEST NUMBER: 017C01NF1

572R SN017 NECK FLEX CAL01

RUN NUMBER: 013102.0646;4

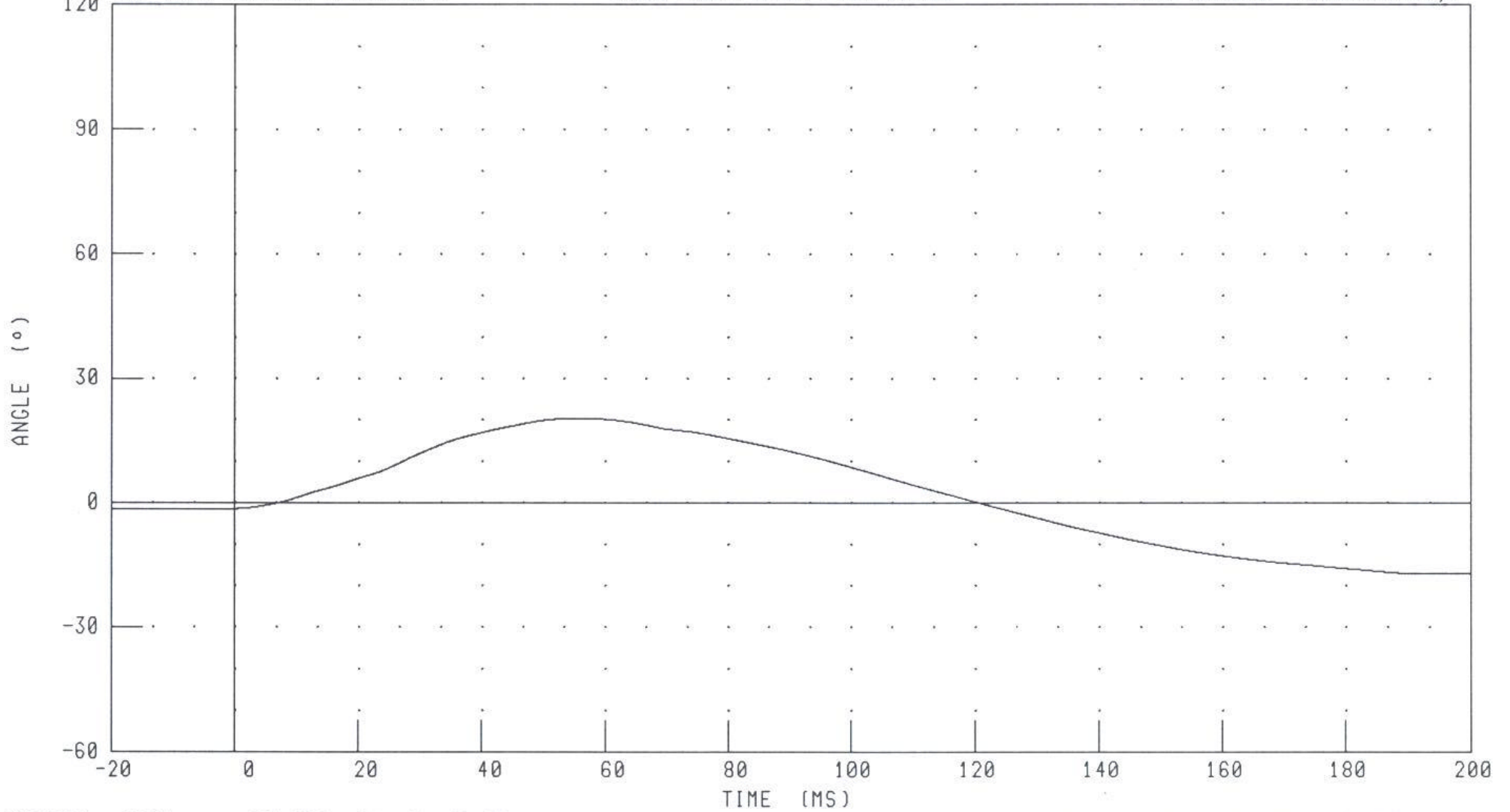

CHANNEL: BETA

FILTER: CH. CLASS 60

PEAK DATA: 20.32 ° @ 55.28 MS; -17.15 ° @ 193.68 MS

PART 572R CRABI NECK FLEXION CALIBRATION
ROTATION ABOUT OCCIPITAL CONDYLE

TRC TEST NUMBER: 017C01NF1

572R SN017 NECK FLEX CAL01

RUN NUMBER: 013102.0646;4

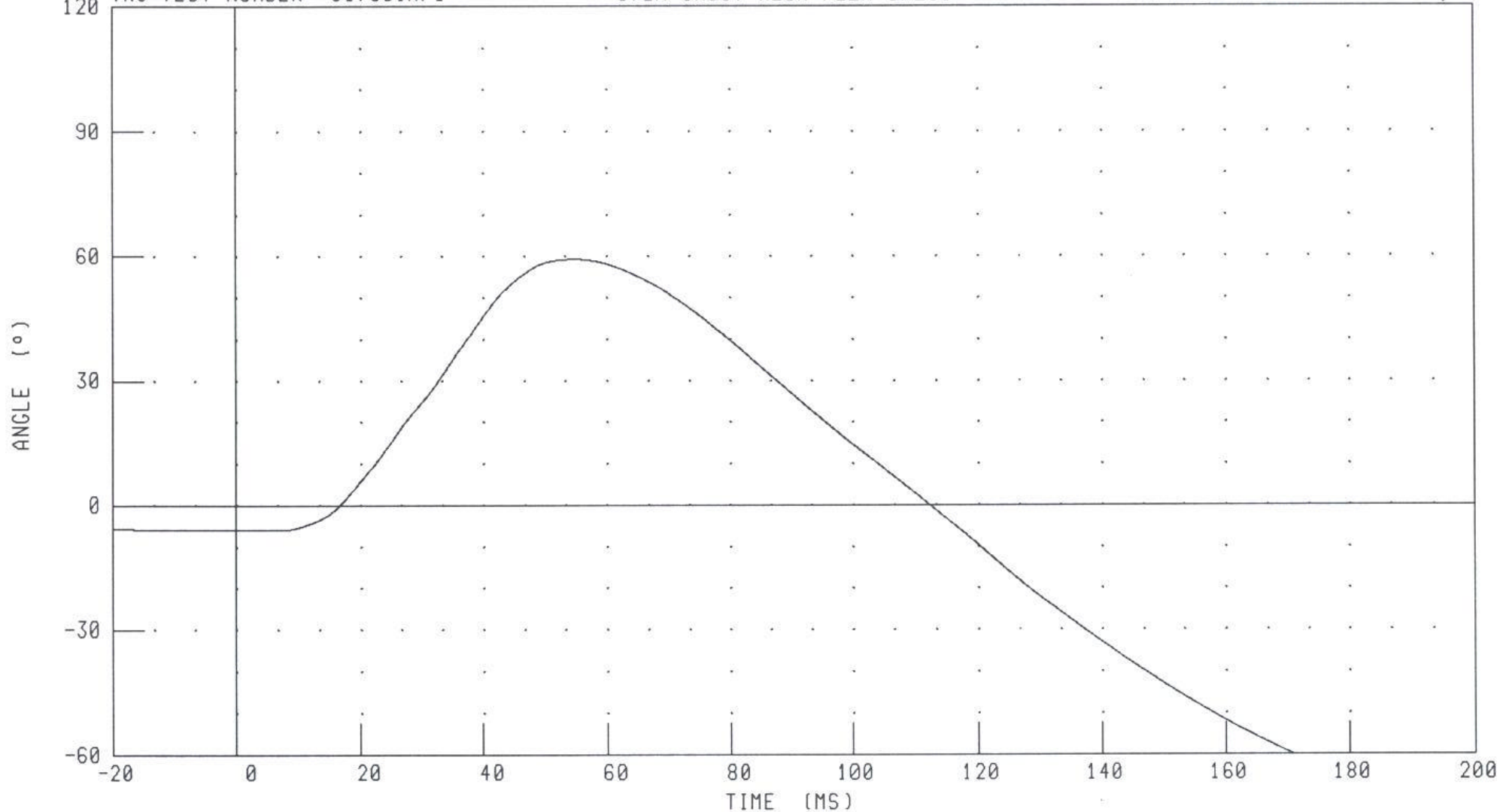

CHANNEL: THETA

FILTER: CH. CLASS 60

PEAK DATA: 59.27 ° @ 54.96 MS; -67.33 ° @ 194.72 MS

PART 572R CRABI NECK FLEXION CALIBRATION
TOTAL ROTATION

TRC TEST NUMBER: 017C01NF1

572R SN017 NECK FLEX CAL01

RUN NUMBER: 013102.0646;4

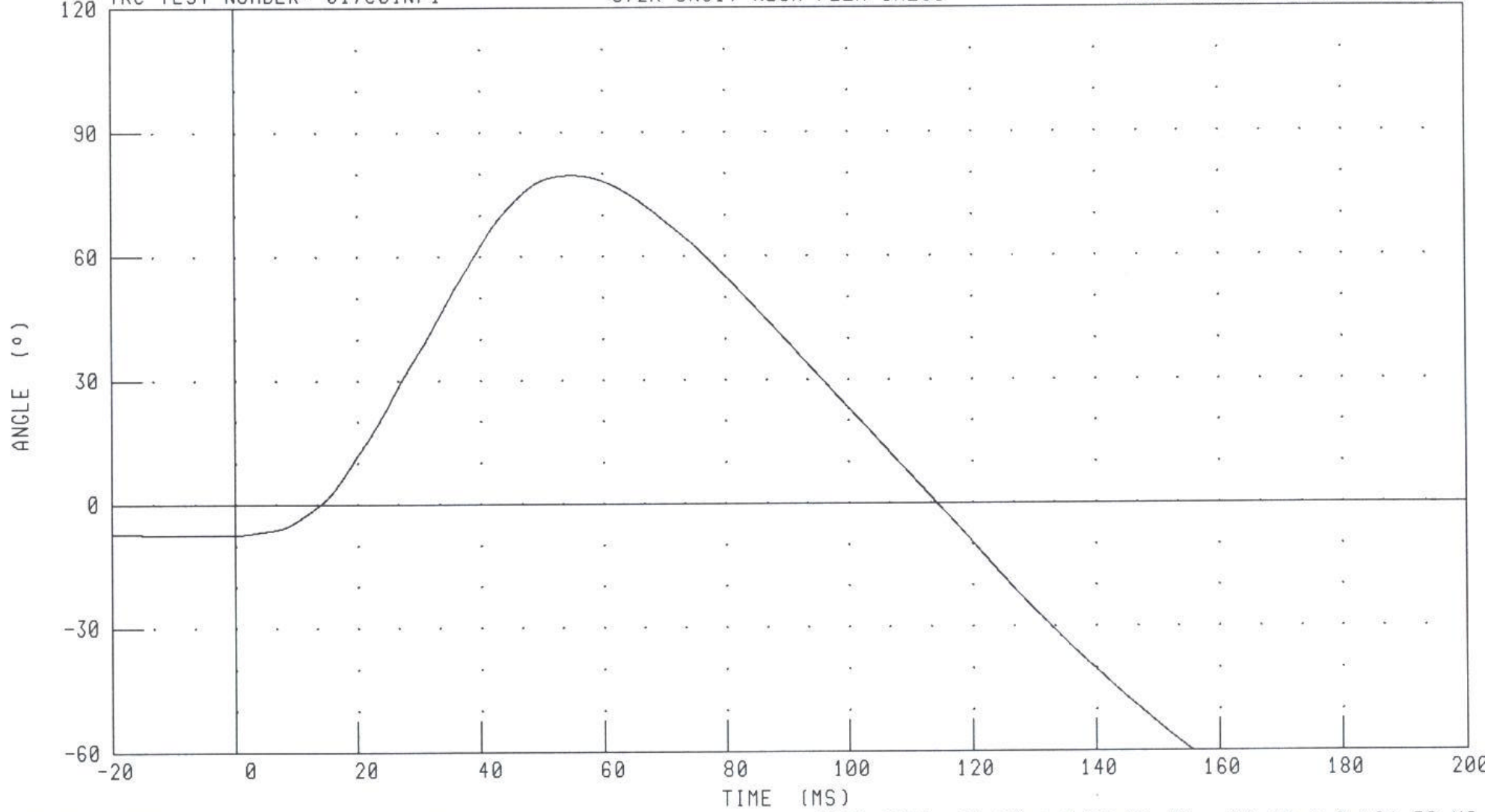

CHANNEL: TOTAN

FILTER: CH. CLASS 60

PEAK DATA: 79.59 ° @ 55.04 MS; -84.48 ° @ 194.56 MS

PART 572R CRABI NECK FLEXION CALIBRATION

NECK FORCE X AXIS

TRC TEST NUMBER: 017C01NF1 572R SN017 NECK FLEX CAL01 RUN NUMBER: 013102.0646,4

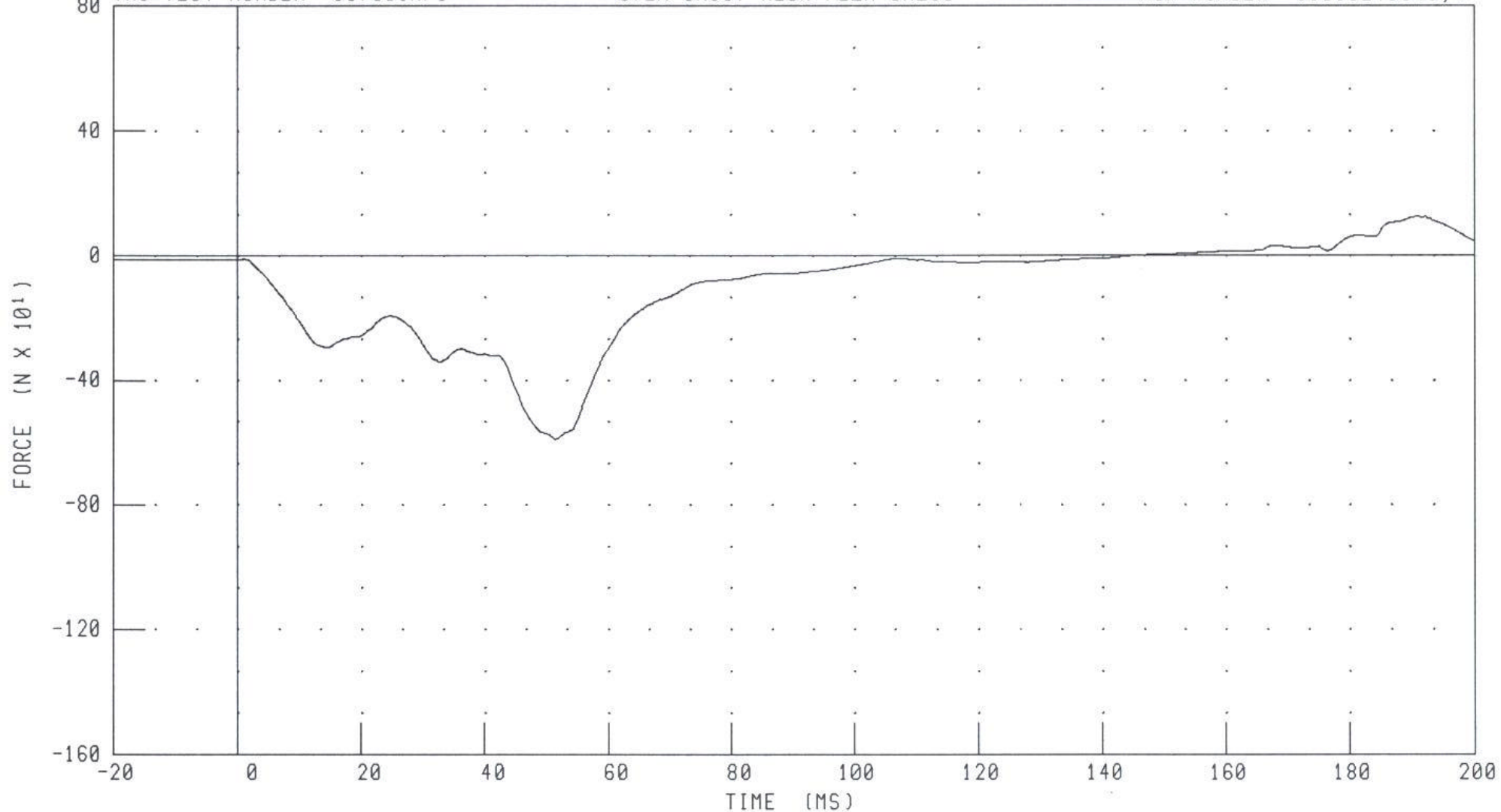

CHANNEL: NEKXF

FILTER: CH. CLASS 1000

PEAK DATA: 127.43 N @ 192.00 MS; -590.21 N @ 51.36 MS

PART 572R CRABI NECK FLEXION CALIBRATION

NECK MOMENT Y AXIS

TRC TEST NUMBER: 017C01NF1

572R SN017 NECK FLEX CAL01

RUN NUMBER: 013102.0646,4

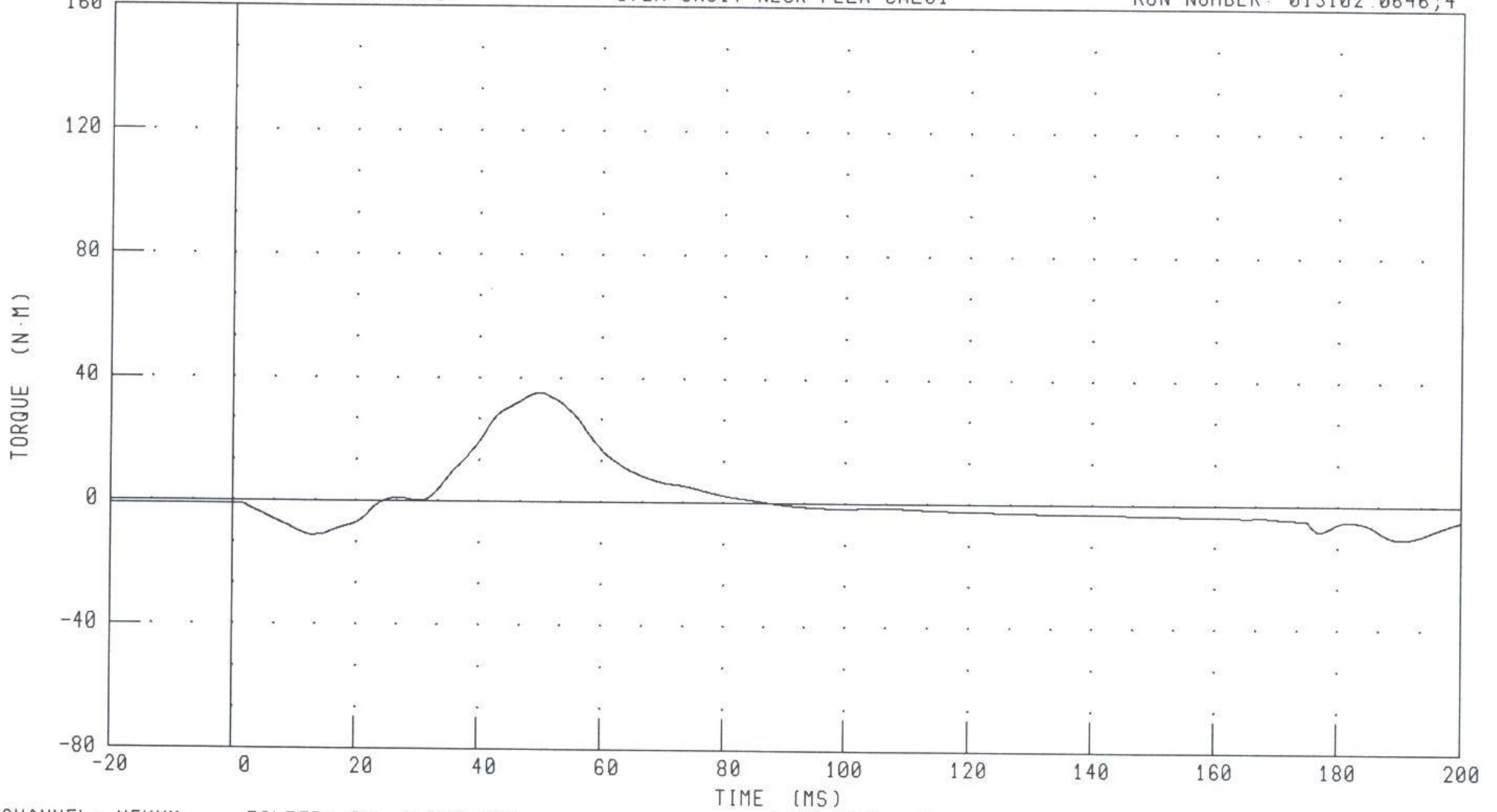

CHANNEL: NEKYM

FILTER: CH. CLASS 600

PEAK DATA: 35.23 N·M @ 50.16 MS, -11.19 N·M @ 12.88 MS

PART 572R CRABI NECK FLEXION CALIBRATION

MOMENT ABOUT OCCIPITAL CONDYLE

TRC TEST NUMBER: 017C01NF1

572R SN017 NECK FLEX CAL01

RUN NUMBER: 013102.0646,4

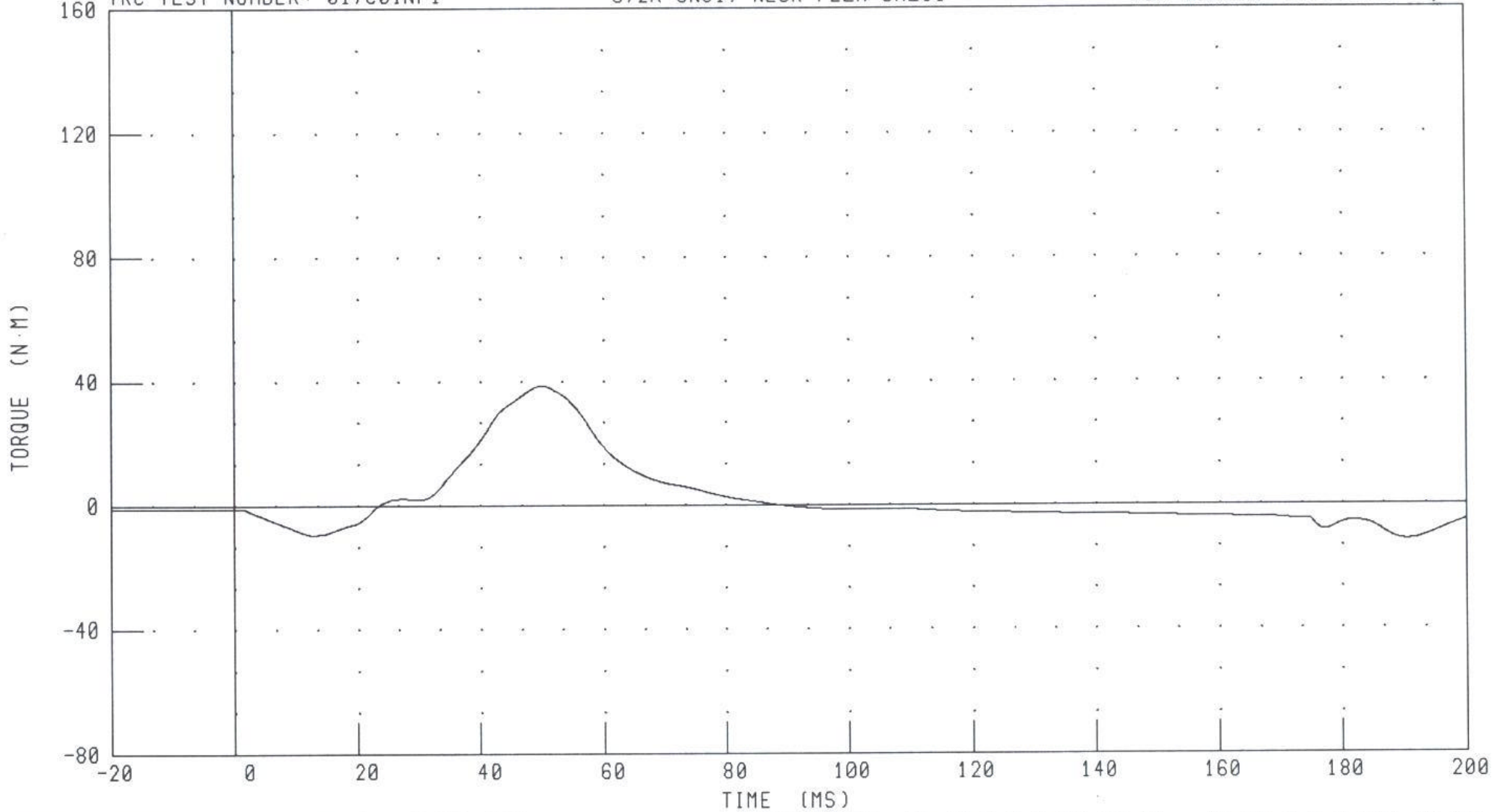

CHANNEL: NEKOM

FILTER: CH. CLASS 600

PEAK DATA: 38.57 N·M @ 50.16 MS; -11.50 N·M @ 190.40 MS

PART 572R CRABI NECK FLEXION CALIBRATION
TOTAL ROTATION VS OCCIPITAL CONDYLAR MOMENT

TRC TEST NUMBER: 017C01NF1

572R SN017 NECK FLEX CAL01

RUN NUMBER: 013102.0646;4

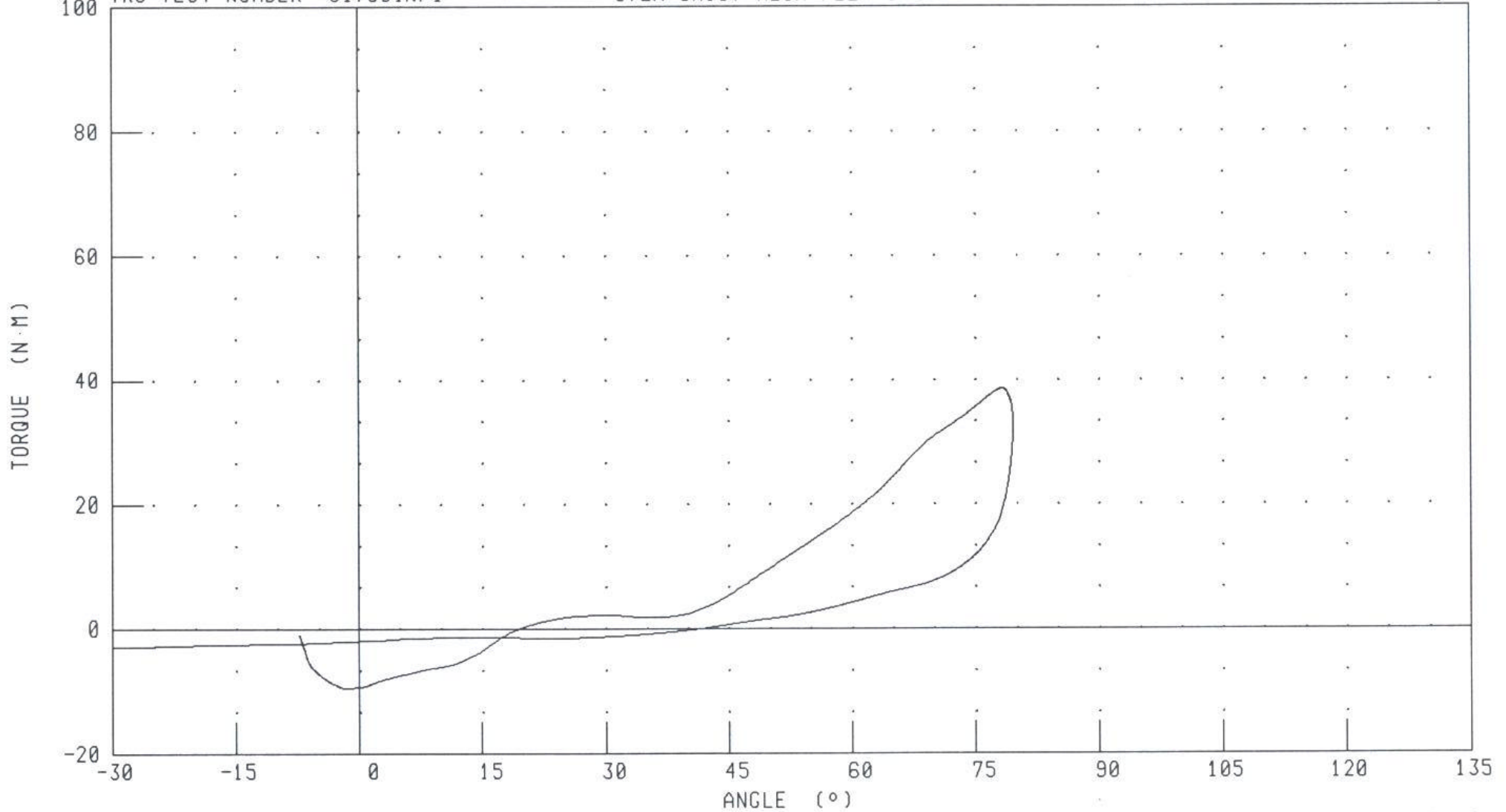

CHANNEL: TOTAN
NEKOM

FILTER: CH. CLASS 60
CH. CLASS 600

ANGLE (°)

PEAK DATA: 79.59 ° @ 55.04 MS; -84.48 ° @ 194.56 MS
38.57 N·M @ 50.16 MS; -11.50 N·M @ 190.40 MS

TRANSPORTATION RESEARCH CENTER INC.

NECK EXTENSION TEST

CRABI 12-MONTH

31-JAN-02

TRC INC.

TEST NO: 017C01NE1

572R SN017 NECK EXT. CAL01

TEST PARAMETER	SPECIFICATION	TEST RESULTS
TEMPERATURE	20.6-22.2 DEG. C	21.1 DEG. C
RELATIVE HUMIDITY	10 - 70 %	30.0 %
IMPACT VELOCITY	2.4 - 2.6 M/S	2.59 M/S
INTEGRATED PENDULUM VELOCITY	6 MS 0.8 - 1.2 G	0.82 M/S
	10 MS 1.5 - 2.1 M/S	1.53 M/S
	14 MS 2.2 - 2.9 M/S	2.25 M/S
PEAK D-PLANE ROTATION	80 - 92 DEG.	87.35 DEG.
PEAK MOMENT DURING ROTATION INTERVAL	-12 / -23 NM	-19.77 NM
POSITIVE MOMENT DECAY TIME TO -5 NM LEVEL	76 - 90 MS	82.40 MS

TEST MEETS SPECIFICATIONS

TECHNICIAN



RUN NUMBER: 013102.0714;1

PART 572R CRABI NECK EXTENSION CALIBRATION

PENDULUM DECELERATION

TRC TEST NUMBER: 017C01NE1

572R SN017 NECK EXT. CAL01

RUN NUMBER: 013102.0717;1

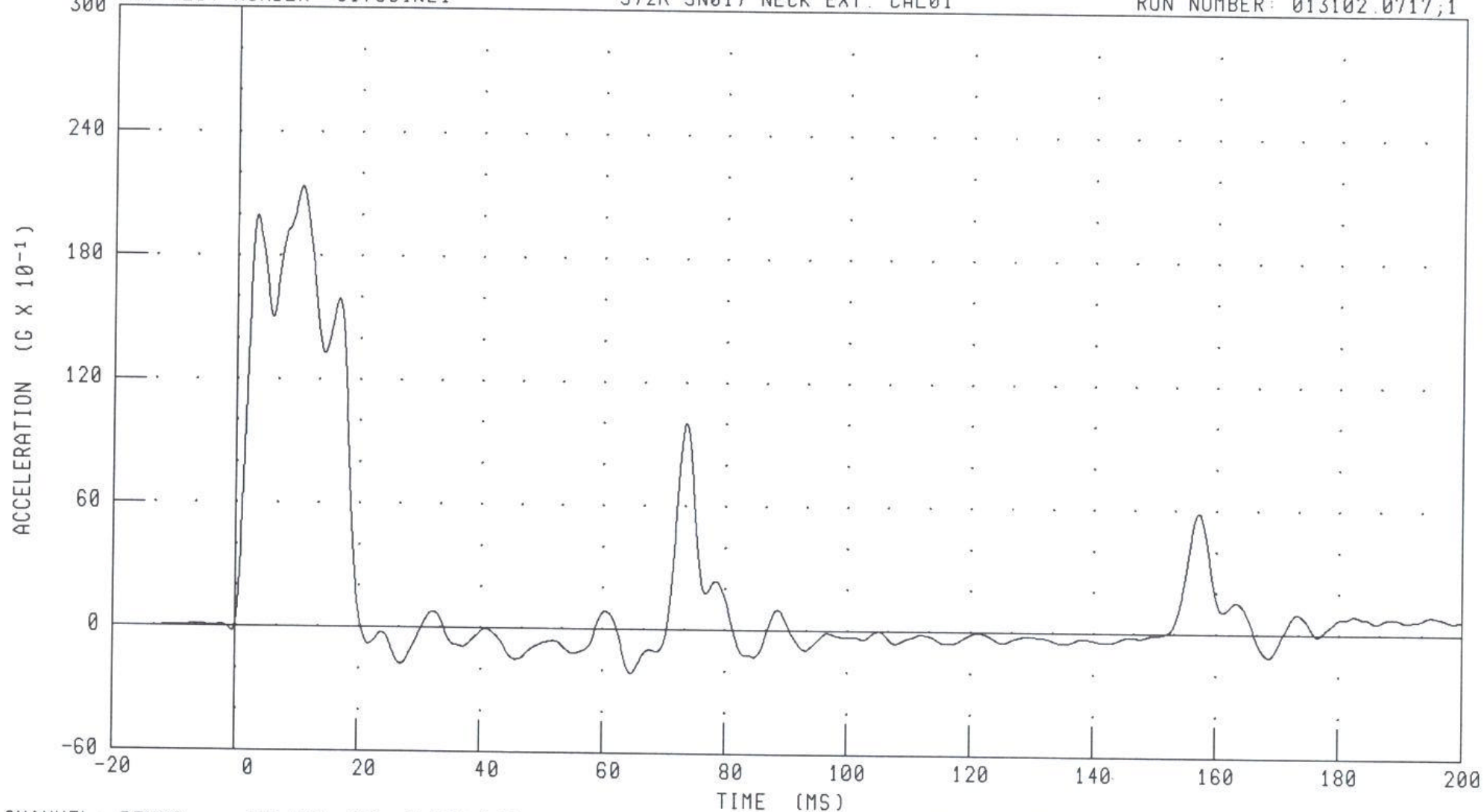

CHANNEL: PENXC

FILTER: CH. CLASS 180

PEAK DATA: 21.37 G @ 10.40 MS; -2.14 G @ 64.72 MS

PART 572R CRABI NECK EXTENSION CALIBRATION

INTEGRATED PENDULUM VELOCITY

572R SN017 NECK EXT. CAL01

RUN NUMBER: 013102.0717;1

TRC TEST NUMBER: 017C01NE1

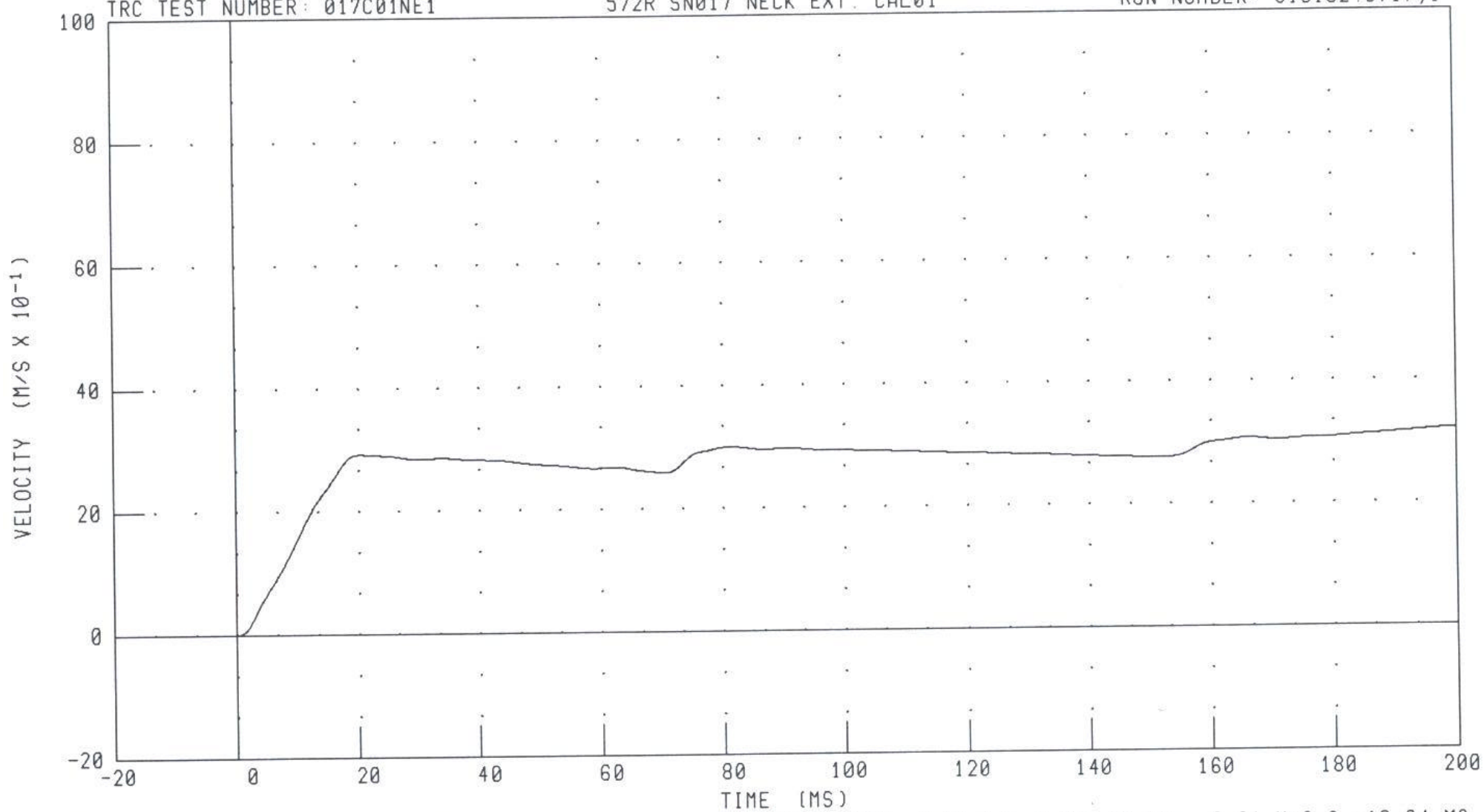

CHANNEL: PENXVI

FILTER: CH. CLASS 180

PEAK DATA: 3.21 M/S @ 200.00 MS; -0.01 M/S @ -12.24 MS

PART 572R CRABI NECK EXTENSION CALIBRATION

ROTATION ABOUT BASE OF NECK

TRC TEST NUMBER: 017C01NE1

572R SN017 NECK EXT. CAL01

RUN NUMBER: 013102.0717;1

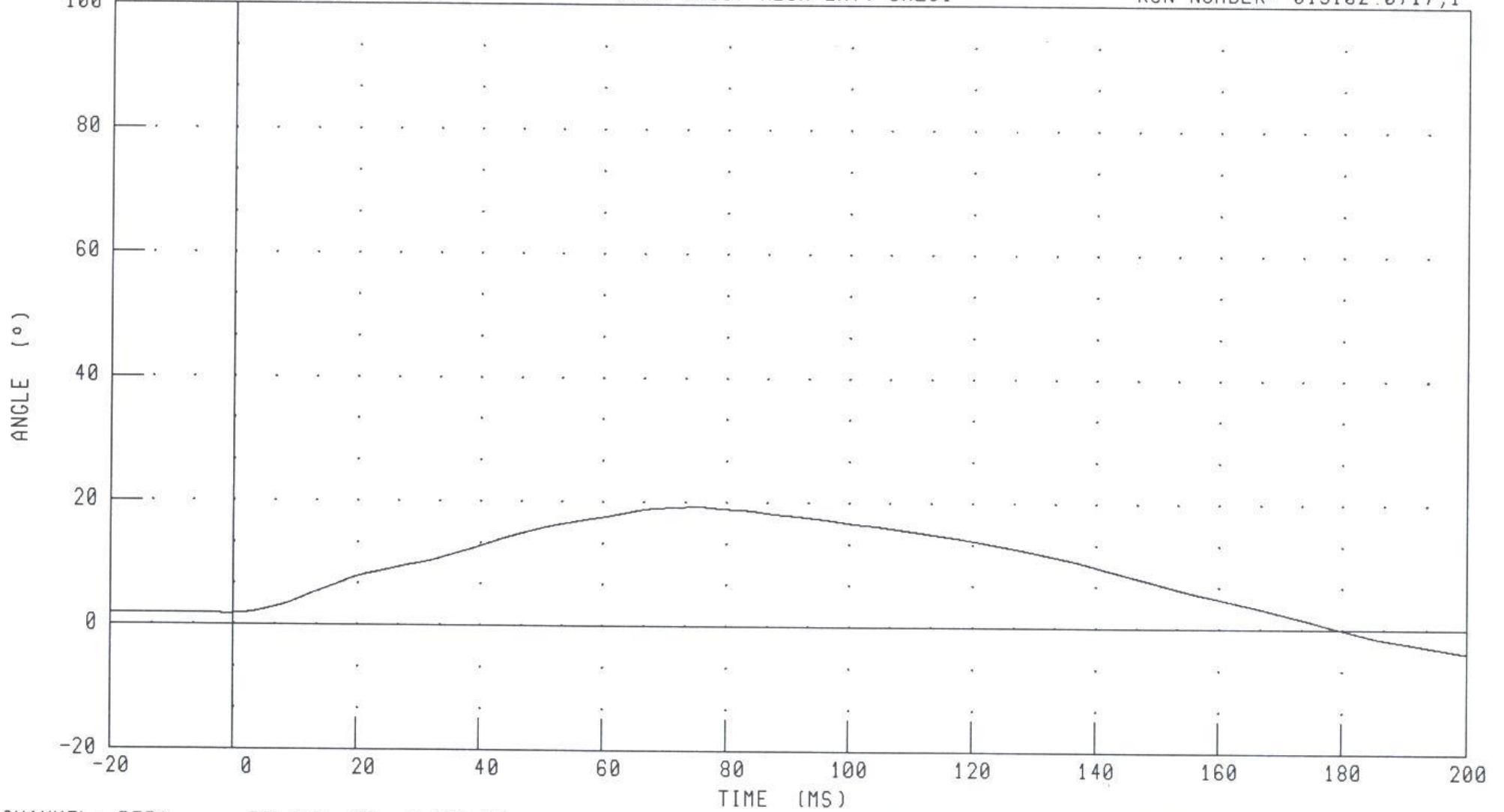

CHANNEL: BETA

FILTER: CH. CLASS 60

PEAK DATA: 19.25 ° @ 75.20 MS; -3.85 ° @ 200.00 MS

PART 572R CRABI NECK EXTENSION CALIBRATION
ROTATION ABOUT OCCIPITAL CONDYLE

TRC TEST NUMBER: 017C01NE1

572R SN017 NECK EXT. CAL01

RUN NUMBER: 013102.0717;1

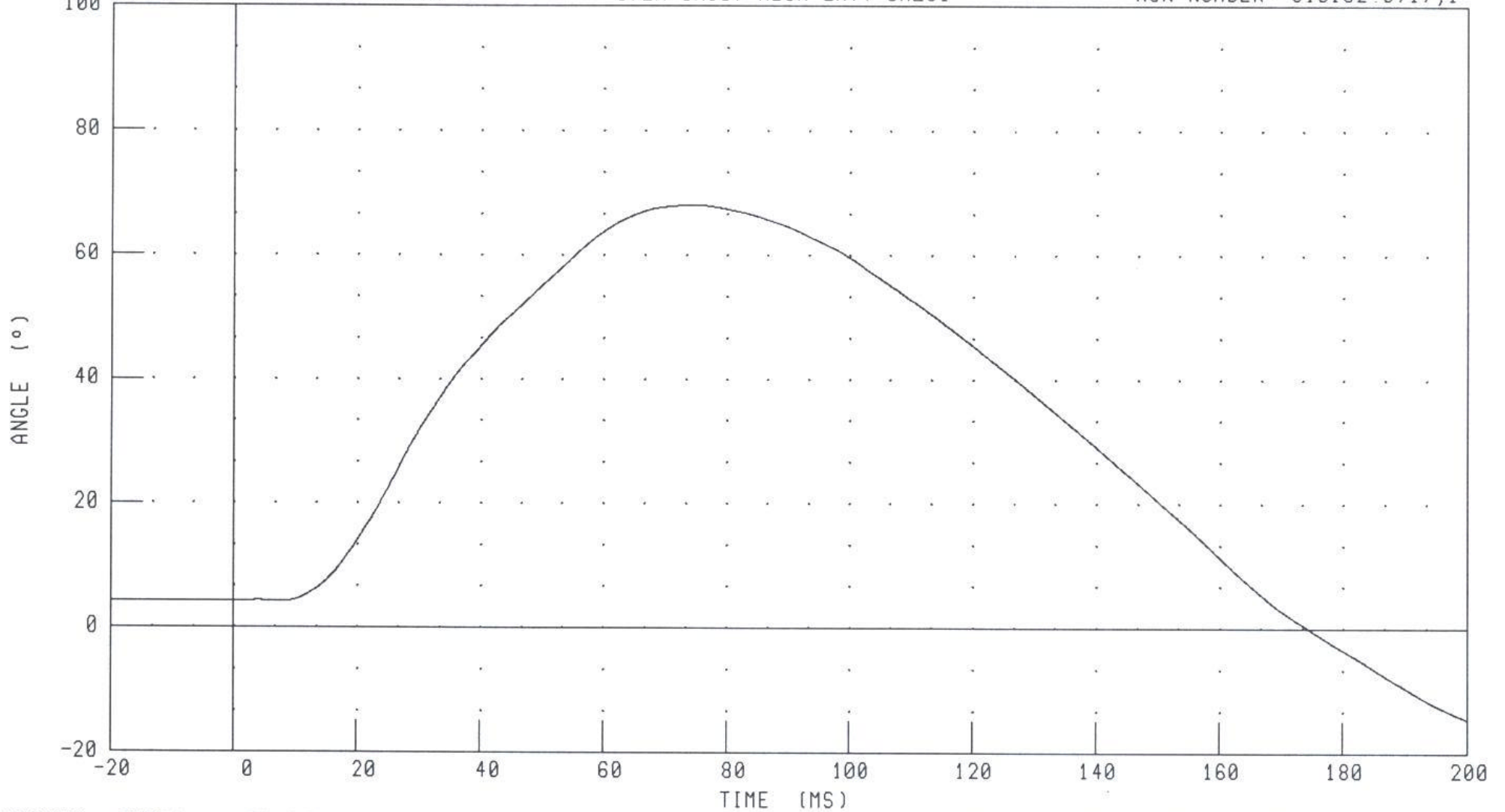

CHANNEL: THETA

FILTER: CH. CLASS 60

PEAK DATA: 68.11 ° @ 74.48 MS; -14.63 ° @ 200.00 MS

PART 572R CRABI NECK EXTENSION CALIBRATION

TOTAL ROTATION

TRC TEST NUMBER: 017C01NE1

572R SN017 NECK EXT. CAL01

RUN NUMBER: 013102.0717;1

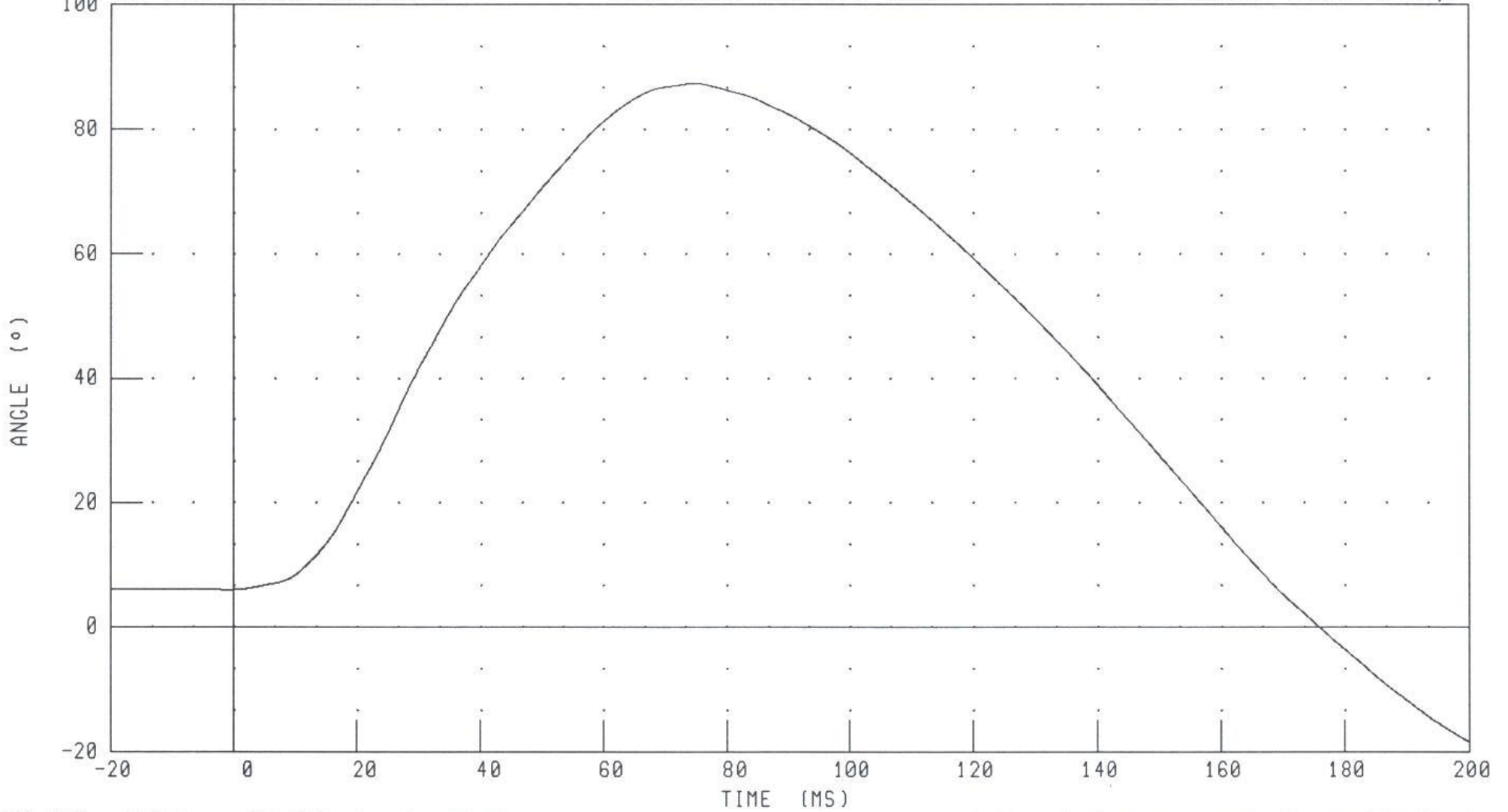

CHANNEL: TOTAN

FILTER: CH. CLASS 60

PEAK DATA: 87.36 ° @ 74.80 MS, -18.49 ° @ 200.00 MS

PART 572R CRABI NECK EXTENSION CALIBRATION

NECK FORCE X AXIS

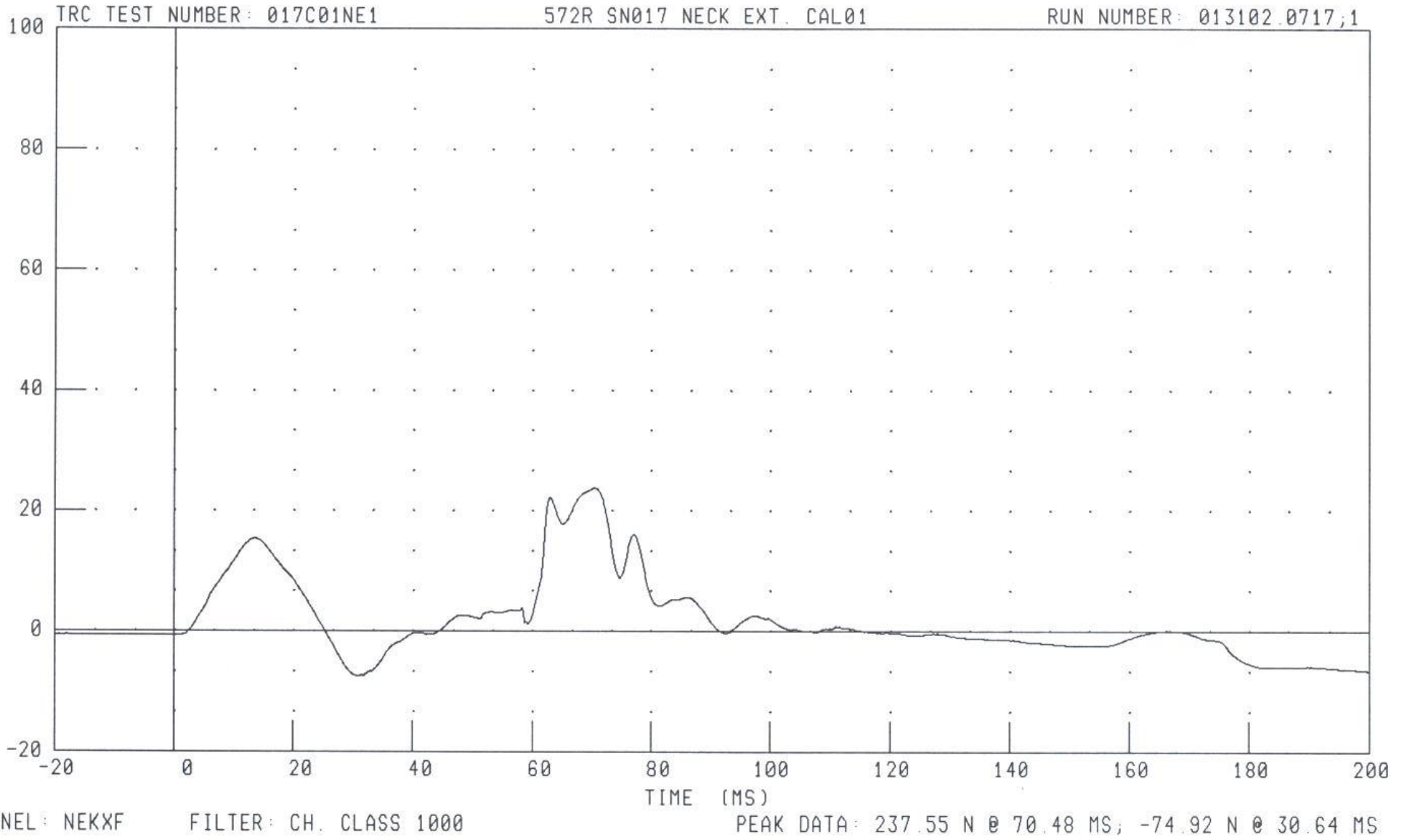

PART 572R CRABI NECK EXTENSION CALIBRATION

NECK MOMENT Y AXIS

TRC TEST NUMBER: 017C01NE1

572R SN017 NECK EXT. CAL01

RUN NUMBER: 013102.0717;1

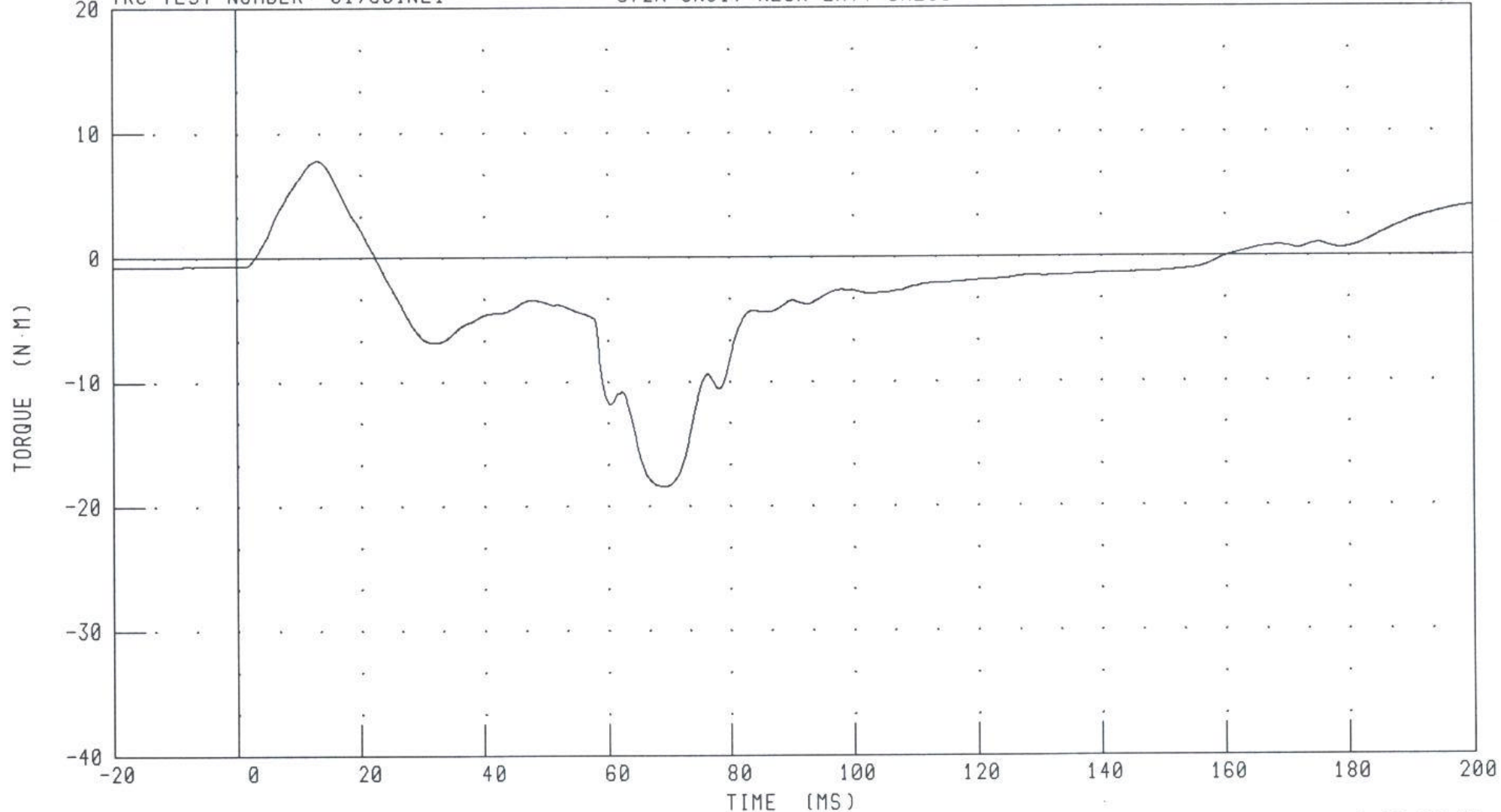

CHANNEL: NEKYM

FILTER: CH. CLASS 600

PEAK DATA: 7.81 N·M @ 13.04 MS; -18.43 N·M @ 68.96 MS

PART 572R CRABI NECK EXTENSION CALIBRATION
MOMENT ABOUT OCCIPITAL CONDYLE

TRC TEST NUMBER: 017C01NE1

572R SN017 NECK EXT. CAL01

RUN NUMBER: 013102.0717;1

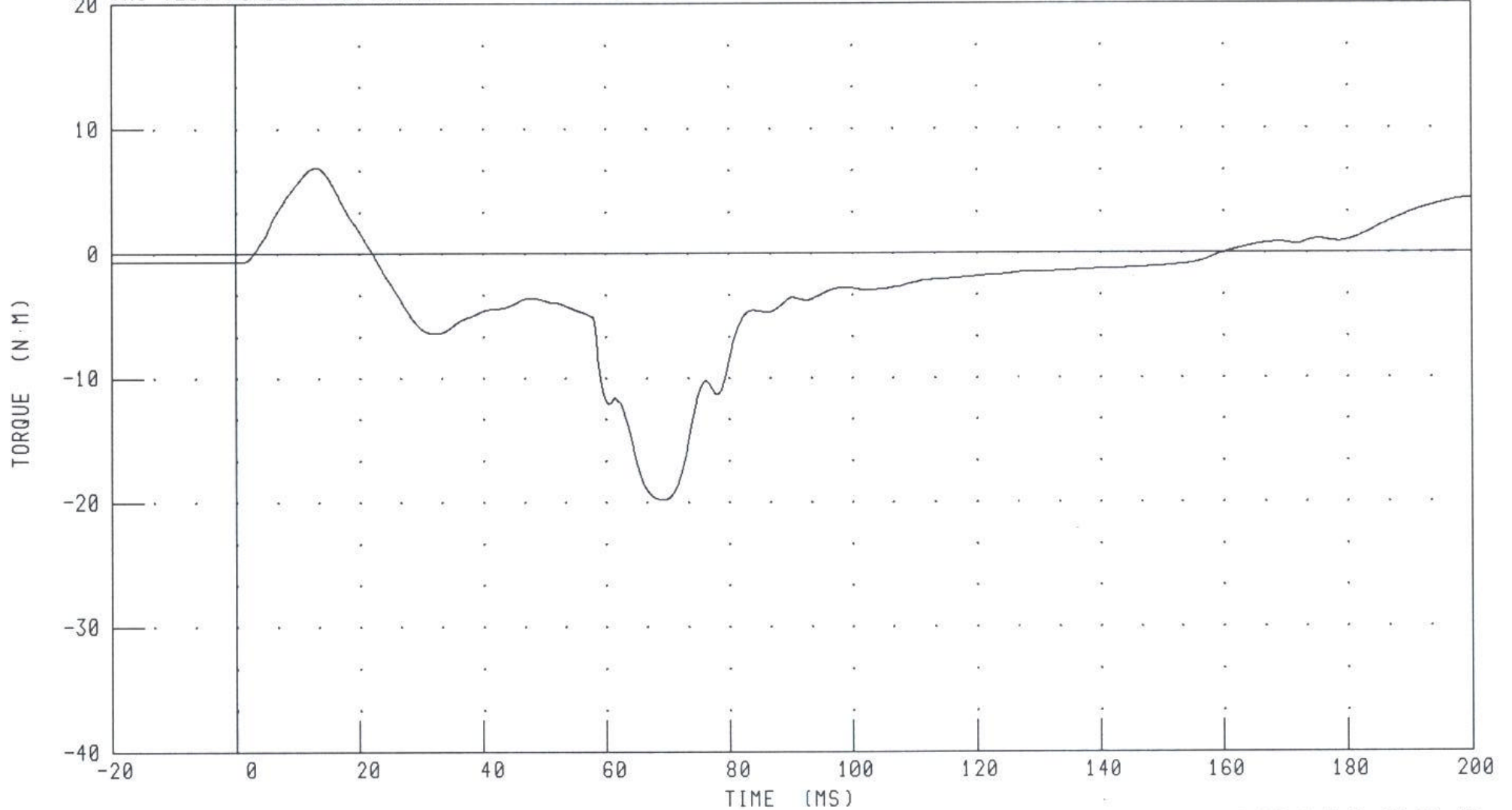

CHANNEL: NEKOM

FILTER: CH. CLASS 600

PEAK DATA: 6.92 N·M @ 13.04 MS; -19.77 N·M @ 69.04 MS

PART 572R CRABI NECK EXTENSION CALIBRATION
TOTAL ROTATION VS OCCIPITAL CONDYLAR MOMENT

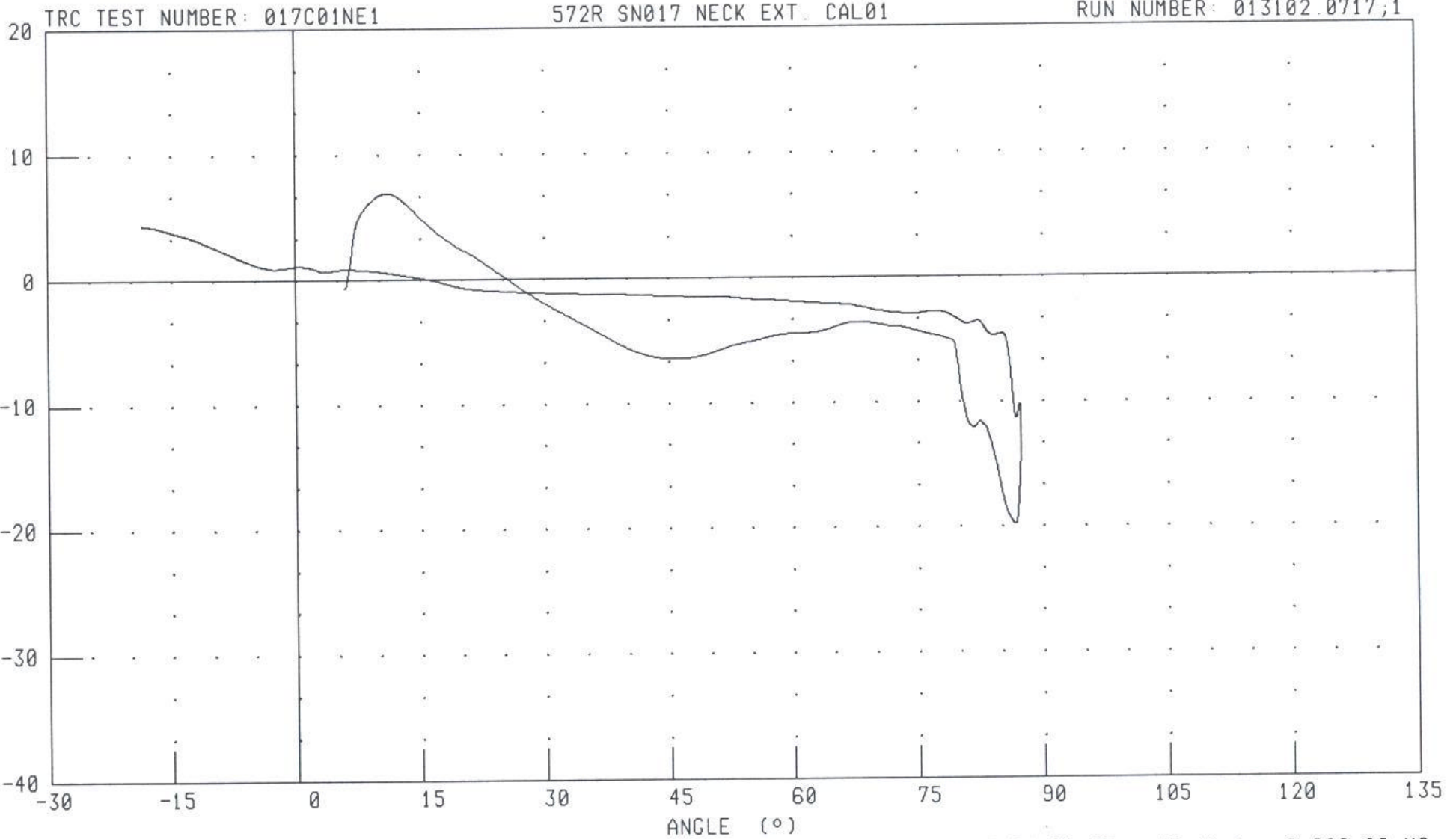

CHANNEL: TOTAN
NEKOM

FILTER: CH. CLASS 60
CH. CLASS 600

ANGLE (°)

PEAK DATA: 87.36 ° @ 74.80 MS; -18.49 ° @ 200.00 MS
6.92 N·M @ 13.04 MS; -19.77 N·M @ 69.04 MS

TRANSPORTATION RESEARCH CENTER INC.

THORAX IMPACT TEST

CRABI 12 -MONTH

31-JAN-02

TRC INC.

TEST NO: 017C01TH1

572R SN017 THORAX CAL 01

TEST PARAMETER	HIGH SPEED TEST ----- SPECIFICATION	TEST RESULTS
TEMPERATURE	20.6-22.2 DEG. C	21.1 DEG. C
RELATIVE HUMIDITY	10 - 70 %	33.0 %
PENDULUM VELOCITY	4.90 - 5.10 M/S	4.91 M/S
MAXIMUM RESISTIVE FORCE	1514 - 1796 N	1527. N

TEST MEETS SPECIFICATIONS

TECHNICIAN

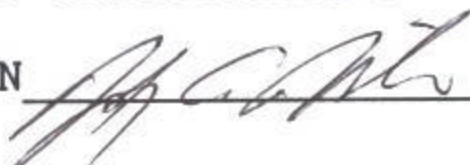

RUN NUMBER: 013102.0913;1

PART 572R CRABI THORAX IMPACT TEST
PENDULUM DECELERATION

TRC TEST NUMBER: 017C01TH1

572R SN017 THORAX CAL 01

RUN NUMBER: 013102.0915;1

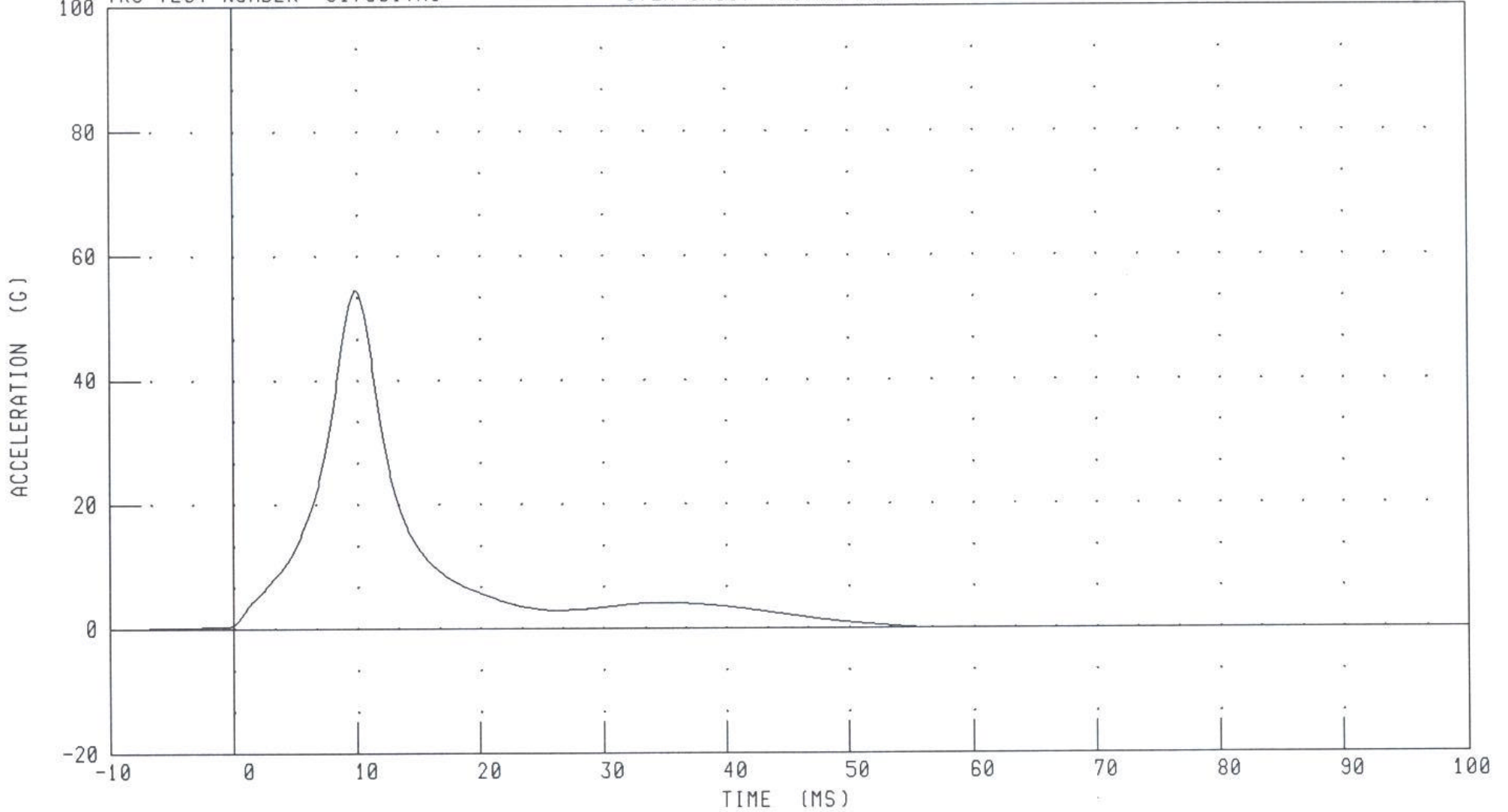

CHANNEL: PENXC

FILTER: CH. CLASS 180

PEAK DATA: 54.51 G @ 9.92 MS; -0.07 G @ 58.56 MS

PART 572R CRABI THORAX IMPACT TEST
PENDULUM FORCE

TRC TEST NUMBER: 017C01TH1

572R SN017 THORAX CAL 01

RUN NUMBER: 013102.0915;1

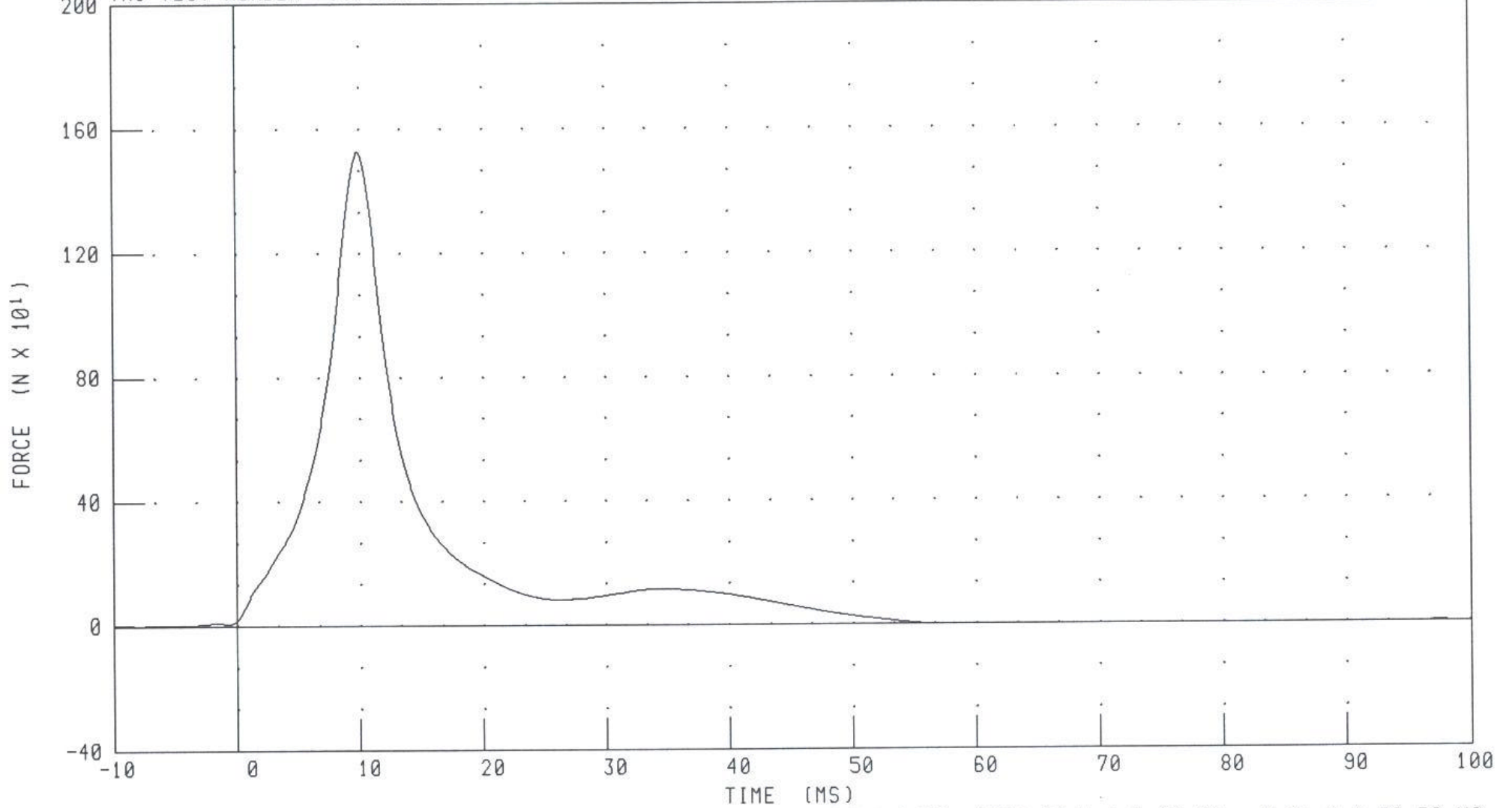

CHANNEL: PENXF

FILTER: CH. CLASS 180

PEAK DATA: 1527.60 N @ 9.92 MS; -2.05 N @ 58.56 MS

SECTION 14

TEST EQUIPMENT AND INSTRUMENTATION CALIBRATION

CERTIFICATION INSTRUMENTATION

Instrument	Certification Test	Calibration Date	Due Date
Slide Potentiometer Oceanside Mfg. Co. Model LCP 20-50 2.0 inches travel, 10,000 ohms	Neck Pendulum	3/02	9/02
C.G. Head Potentiometer Oceanside Mfg. Co. Model SP 221 Serial HNR2 10K, linearity = 1.5%	Neck Pendulum	3/02	9/02
C.G. Pendulum Potentiometer Oceanside Mfg. Co. Model SP 221 Serial HNR1 10K, linearity = 1.5%	Neck Pendulum	3/02	9/02
Bourns Potentiometer Model 3520S--1-502 5K +/-, linearity = 0.3%	Lumbar Spine Flexion	5/02	11/02
Transducer Inc. Load Cell S/N 20051, 50#	Lumbar Spine Flexion	2/02	6/02
Lebow Load Cell Model 3397-100 S/N 11564	Lumbar Spine Flexion	6/02	12/02
Endevco Accelerometers S/N AC-A183 +/- .075% Accuracy	Neck Pendulum (ATD)	12/01 6/02	6/02 12/02

CERTIFICATION INSTRUMENTATION (cont'd)

Instrument	Certification Test	Calibration Date	Due Date
Chatillon 20 Pound Gauge +/- 8 oz. Accuracy		2/02	8/02
Chatillon 40 Pound Gauge +/- 1% Accuracy		2/02	8/02
Belt Tension Gauge, +/- 1 lb.		2/02	8/02
Force Gauge, Chatillon Model DPTH 250		2/02	8/02
Weather Measure Cord Temp. & Humidity Recorder S/N 1545 +/- 3% Accuracy		6/01	7/02
Pot. #6 CIC Linear Potentiometer (Foam Certification)		2/02	8/02
Load Cell for Foam S/N 72952 +/- .10% Accuracy		2/02	8/02
Load Cell, Lap Belt North Sensotec S/N 283076 +/- 1.32 lbs. Accuracy		5/02	11/02
Load Cell, Lap Belt South Sensotec S/N 288386 +/- 1.32 lbs. Accuracy		5/02	11/02
Dillon Force Gauge Model E Serial # 4346 50#		3/02	9/02

SECTION 15

AVI FILES