

REPORT NUMBER: CAL-02-18

**NEW CAR ASSESSMENT PROGRAM (NCAP)
FRONTAL BARRIER IMPACT TEST**

GENERAL MOTORS CORP
2003 CADILLAC CTS
4-DOOR SEDAN

NHTSA NUMBER: M30101

VERIDIAN TEST NUMBER: 8642-NCAP-18

VERIDIAN ENGINEERING
TRANSPORTATION SCIENCES CENTER
P.O. BOX 400
BUFFALO, NEW YORK 14225

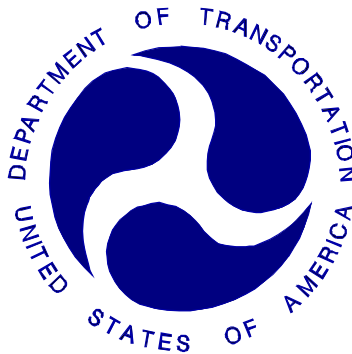

May 31, 2002

FINAL REPORT

PREPARED FOR:

U. S. DEPARTMENT OF TRANSPORTATION
National Highway Traffic Safety Administration
Safety Performance Standards
Office of Crashworthiness Standards
Mail Code: NPS-10
400 Seventh Street, SW, Room No. 5313
Washington, DC 20590

This publication is distributed by the U. S. Department of Transportation, National Highway Traffic Safety Administration, in the interest of information exchange. The opinions, findings and conclusions expressed in this publication are those of the author(s) and not necessarily those of the Department of Transportation or the National Highway Traffic Safety Administration. The United States Government assumes no liability for its contents or use thereof. If trade or manufacturers' names or products are mentioned, it is only because they are considered essential to the object of the publication and should not be construed as an endorsement. The United States Government does not endorse products or manufacturers.

Prepared by:

Patrick G. MacDiarmid, Jr., Project Engineer

Approved by:

David J. Travale, Program Manager
Transportation Science Center

Approval Date:

FINAL REPORT ACCEPTANCE BY OCS:

Manager, New Car Assessment Program (NCAP)
NHTSA, Office of Crashworthiness Standards

Date of Report Acceptance

COTR, New Car Assessment Program (NCAP)
NHTSA, Office of Crashworthiness Standards

Date of Report Acceptance

TECHNICAL REPORT STANDARD TITLE PAGE

1. <i>Report No.</i> CAL-02-18		2. <i>Government Accession No.</i>		3. <i>Recipient's Catalog No.</i>	
4. <i>Title and Subtitle</i> Final Report of NEW CAR ASSESSMENT PROGRAM (NCAP) Testing of a 2003 Cadillac CTS 4-Door Sedan NHTSA No. M30101				5. <i>Report Date</i> May 31, 2002	
				6. <i>Performing Organization Code</i> CAL	
7. <i>Author(s)</i> David J. Travale, Program Manager Patrick G. MacDiarmid, Jr., Project Engineer				8. <i>Performing Organization Report No.</i> 8642-NCAP-18	
9. <i>Performing Organization Name and Address</i> Veridian Engineering 4455 Genesee Street Buffalo, New York 14225				10. <i>Work Unit No.</i>	
				11. <i>Contract or Grant No.</i> DTNH22-01-D-32005	
12. <i>Sponsoring Agency Name and Address</i> U.S. Department of Transportation National Highway Traffic Safety Administration Office of Crashworthiness Standards Mail Code: NPS-10 400 Seventh, SW, Room 5313 Washington, D.C. 20590				13. <i>Type of Report and Period Covered</i> Final Report May – June 2002	
				14. <i>Sponsoring Agency Code</i> NPS-10	
15. <i>Supplementary Notes</i>					
16. <i>Abstract</i> A frontal load cell barrier test of a 2003 Cadillac CTS 4-Door Sedan was performed at Veridian Engineering crash test facility in Buffalo, New York, on May 31, 2002. The impact velocity was 56.65 kph and the temperature at the barrier face was 21°C. The maximum post-test vehicle crush was 579 mm. The test vehicle was equipped with seat integrated 3-point restraint systems with lap belt pretensioners and force limiters, knee bolsters, adjustable head restraints and airbags at both the driver and right outboard passenger seating positions. With respect to FMVSS 208 "Occupant Crash Protection - Injury Criteria" both the driver and passenger appeared to comply with head, chest, and femur requirements.					
ATD Position	HIC	Clip (g's)	Chest Disp (mm)	Left Femur (N)	Right Femur (N)
Driver (150)	521.8	46.3	33.1	3762.3	4906.7
Passenger (245)	661.3	54.8	25.1	2225.4	1777.4
17. <i>Key Words</i> 56 kph Frontal Barrier Impact test New Car Assessment Program (NCAP)				18. <i>Distribution Statement</i> <u>Copies of this report are available from:</u> NHTSA Technical Reference Division National Highway Traffic Safety Admin. 400 Seventh St., SW, Room 5108 Washington, DC 20590	
19. <i>Security Classif. (of this report)</i> UNCLASSIFIED		20. <i>Security Classif. (of this page)</i> UNCLASSIFIED		21. <i>No. of Pages</i> 289	22. <i>Price</i>

Form DOT F1700.7 (8-69)

TABLE OF CONTENTS

<u>Section</u>		<u>Page No.</u>
1	PURPOSE AND SUMMARY OF NCAP TEST	1-1
2	OCCUPANT AND VEHICLE INFORMATION	2-1
<u>Data Sheet</u>	<u>Description</u>	
1.	CRASH TEST SUMMARY	2-1
2.	GENERAL TEST AND VEHICLE PARAMETER DATA	2-2
3.	POST IMPACT DATA	2-4
4.	TEST VEHICLE INFORMATION	2-5
5.	DUMMY POSITIONING IN VEHICLE	2-7
6.	SEAT BELT POSITIONING DATA	2-9
7.	VEHICLE ACCELEROMETER LOCATION AND DATA SUMMARY	2-10
8.	DUMMY INJURY CRITERIA VALUES	2-12
9.	SEAT BELT PERFORMANCE DATA	2-16
10.	SUMMARY OF FMVSS 212 DATA	2-17
11.	WINDSHIELD ZONE INTRUSION FMVSS 219 DATA	2-18
12.	FMVSS 301 FUEL SYSTEM INTEGRITY DATA	2-19
13.	FMVSS 301 ROLLOVER DATA	2-20
14.	VEHICLE MEASUREMENTS	2-21
15.	CAMERA DATA	2-28
16.	REFERENCE PHOTO TARGETS	2-30
17.	LOAD CELL LOCATIONS ON FIXED BARRIER	2-31
18.	POST TEST AIR BAG DATA	2-32
19.	ACCIDENT INVESTIGATION DIVISION DATA	2-33
APPENDIX A	PHOTOGRAPHS	A-1
APPENDIX B	VEHICLE, LOAD CELL BARRIER AND DUMMY RESPONSE DATA	B-1
APPENDIX C	PART 572E DUMMY CONFIGURATION AND PERFORMANCE VERIFICATION TESTS	C-1
APPENDIX D	DUMMY, VEHICLE AND LABORATORY INSTRUMENT CALIBRATION	D-1

SECTION 1

PURPOSE AND SUMMARY OF TEST

1.1 PURPOSE

This 56.65 kph frontal barrier impact test is part of the Vehicle Barrier Impact Testing Program sponsored by the National Highway Traffic Safety Administration (NHTSA) under Contract No. DTNH22-01-D-32005. The purpose of this test was to obtain vehicle crashworthiness and occupant restraint system performance data for an impact speed in excess of the current 48.3 kph requirements.

The 56.65 kph frontal barrier impact test was conducted in accordance with the Office of Crashworthiness Standards Laboratory Indicant Test procedure.

1.2 TEST PROCEDURE

This 56.65 kph frontal barrier impact test was conducted in accordance with the Office of Crashworthiness Standards (OCS) New Car Assessment Program (NCAP) Laboratory Indicant Test Procedure, dated December 1999. Data was obtained indicant of FMVSS 208, "Occupant Crash Protection"; FMVSS 212, "Windshield Retention"; FMVSS 219, "Windshield Zone Intrusion (Partial)"; and FMVSS 301 "Fuel System Integrity" performance. Procedures for receiving, inspection testing and reporting of test results are described in the test procedures and are not repeated in this report.

One real-time camera and 16 high-speed cameras were used to document the frontal barrier impact event. Camera locations and other pertinent camera information can be found in this report.

Two Part 572E, 50th percentile male anthropomorphic test devices (ATDs), were placed in the driver and right-front passenger seating positions according to dummy placement instructions specified in the Laboratory Indicant Test Procedure.

Both ATDs were fully instrumented with nine accelerometer array head, chest and pelvis triaxial accelerometers, chest displacement potentiometers, upper neck transducers, right/left femur load cells, left and right knee sliders, and lower leg instrumentation. The driver (position 1) ATD (Serial No. 150) and the right-front passenger (position 2) ATD (Serial No.245) were used in two tests (M25502 and M20300) previous to this test where they did not exceed FMVSS 208 head, chest and femur injury criteria. Certification details, along with instrumentation calibration data, are found in Appendix C.

The vehicle, occupant, camera and measurement data are presented in Section 2. Appendix A contains the still photograph prints. The 139 channels of data were recorded on an on-board data acquisition system. Appendix B contains the vehicle, load cell barrier and dummy response data traces. Appendix C contains the dummy calibration data and Appendix D contains the transducer calibration dates.

1.3 SUMMARY OF FRONTAL BARRIER IMPACT TEST

A load cell barrier consisting of 36 load cells was impacted by a 2003 Cadillac CTS 4-Door Sedan at a velocity of 56.65 kph. The test was performed at Veridian Engineering on May 31, 2002. Pre- and post-test photographs of the vehicle and dummies can be found in Appendix A.

The occupant data is summarized below.

	HIC	Clip (g)	Chest Disp. (mm)	Left Femur (N)	Right Femur (N)	Belt Spool (mm)	Belt Stretch (mm/50 mm)
Driver ATD	521.8	46.3	33.1	3762.3	4906.7	-	-
Passenger ATD	661.3	54.8	25.1	2225.4	1777.4	-	-

There was 100 percent windshield retention and no intrusion into the protected zone of the windshield during the event. There was no Stoddard solvent leakage after the event or during any phase of the static rollover.

The maximum vehicle static crush was 579 mm and both the driver and passenger side doors remained closed and latched during the impact event and were operable without tools after the impact.

The driver's visible contact points were as follows: The face to the airbag, the back of the head to the headrest, the chest to the airbag and the knees to the knee bolster. The passenger's visible contact points were as follows: The face to the airbag, the back of the head to the headrest, the chest to the airbag and the knees to the knee bolster.

The 2003 Cadillac CTS 4-Door Sedan did not exceed the requirements of FMVSS 208, FMVSS 212, FMVSS 219, and FMVSS 301. Data pertaining to these standards are presented in the data sheets.

DATA SHEET NO. 2 GENERAL TEST AND VEHICLE PARAMETER DATA

TEST VEHICLE INFORMATION:

Year/Make/Model/Body Style: 2003 Cadillac CTS 4-Door Sedan

NHTSA No. : M30101 ; VIN: 1G6DM57N130114861 ; Color: Cashmere

Engine Data: 6 cylinders; - CID; 3.2 Liters; - cc

Placement: X Longitudinal or In-Line; - Transverse or Lateral

Transmission Data: 5 speeds; - Manual; X Automatic; X Overdrive

Final Drive: X Rear Wheel Drive; - Front Wheel Drive; - Four Wheel Drive

Safety Belt Features - Driver X Pretensioner (lap); X Load Limiter; - Adj. Anchorage

Safety Belt Features - Passenger X Pretensioner (lap); X Load Limiter; - Adj. Anchorage

Major Options: X A/C; X Pwr.Strg.; X Pwr. Brakes

X Pwr. Windows; X Pwr. Door Locks; X Tilt Wheel

Date Received: 5-24-02 ; Odometer Reading 74 km

Selling Dealer: Keyser Brothers Cadillac, Inc.

& Address: 4130 Sheridan Drive Williamsville, NY 14221

DATA FROM TIRE VEHICLE'S CERTIFICATION LABEL:

Vehicle Manufactured by: General Motors Corp

Date of Manufacture 05/02

GVWR: 2039 kg; GAWR: 973 kg FRONT; 1066 kg REAR

DATA FROM TIRE PLACARD:

Tire Pressure with Maximum Capacity Vehicle Load: 300 kpa FRONT

300 kpa REAR

Recommended Tire Size: P225/55R16

* Recommended Cold Tire Pressure: 210 kpa FRONT; 210 kpa REAR

Size of Tires on Test Vehicle: P225/55R16 ; Manufacturer: Goodyear

Vehicle Capacity Data:

Type of Front Seats: - Bench; X Bucket; - Split Bench

Number of Occupants: 2 Front; 3 Rear; 5 Total

Vehicle Capacity Weight (VCW) = 400 kg

No. of Occupants x 68.04 kg = 340.2 kg

Rated Cargo/Luggage Weight (RCLW) = 59.8 kg

*Tire pressure used for test

DATA SHEET NO. 2 GENERAL TEST AND VEHICLE PARAMETER DATA (cont.)

WEIGHT OF TEST VEHICLE AS RECEIVED FROM DEALER (with maximum fluids)= UDW:

Right Front =	<u>445.0</u>	kg	Right Rear =	<u>376.0</u>	kg
Left Front =	<u>445.0</u>	kg	Left Rear =	<u>379.0</u>	kg
TOTAL FRONT =	<u>890.0</u>	kg	TOTAL REAR =	<u>755.0</u>	kg
TOTAL DELIVERED WEIGHT =	<u>1645.0</u>	kg			
% of Total Front of Vehicle Weight =	<u>54.1%</u>		% of Total Rear Weight =	<u>45.9%</u>	%

CALCULATION OF VEHICLE'S TARGET TEST WEIGHT:

Total Delivered Weight (UDW) =	<u>1645.0</u>	kg
Rated Cargo/Luggage Weight (RCLW) =	<u>59.8</u>	kg
Weight of 2 p.572 Dummies @ 76 each =	<u>152</u>	kg
TARGET TEST WEIGHT =	<u>1856.8</u>	kg

WEIGHT OF TEST VEHICLE WITH TWO DUMMIES AND 54.0 KG OF CARGO WEIGHT:

Right Front =	<u>470.5</u>	kg	Right Rear =	<u>451.5</u>	kg
Left Front =	<u>478.0</u>	kg	Left Rear =	<u>451.0</u>	kg
TOTAL FRONT =	<u>948.5</u>	kg	TOTAL REAR =	<u>902.5</u>	kg
TOTAL TEST WEIGHT =	<u>1851.0</u>	kg			
% of Total Front Weight =	<u>51.2%</u>	%	% of Total Rear Weight =	<u>48.8%</u>	%
Weight of Ballast Secured in Vehicle Trunk Area =	<u>0</u>	kg			
Vehicle Components Removed for Weight Reduction:	<u>Side Mirrors, rear seat cushion, spare tire, trunk lights and license holder</u>				

VEHICLE ATTITUDE (all dimension in millimeters):

AS DELIVERED:	RF	<u>699</u>	LF	<u>695</u>	RR	<u>715</u>	LR	<u>713</u>
FULLY LOADED:	RF	<u>693</u>	LF	<u>690</u>	RR	<u>693</u>	LR	<u>690</u>
AS TESTED:	RF	<u>697</u>	LF	<u>693</u>	RR	<u>693</u>	LR	<u>693</u>
Vehicle's Wheel Base:	<u>3325</u> mm							
Location of Vehicle's C.G.:	<u>1621</u> mm rearward of front wheel center.							

FUEL SYSTEM DATA:

Fuel System Capacity From Owner's Manual =	<u>66.2</u>	liters		
Usable Capacity Figure Furnished by COTR =	<u>66.2</u>	liters		
Test Volume Range (92 to 94% of Usable Capacity) =	<u>60.9</u>	to	<u>62.23</u>	liters
ACTUAL TEST VOLUME=	<u>61.2</u>	liters (with entire fuel system filled)		
Test Fluid Type:	<u>Stoddard Solution</u>	; Spec. Grav. =	<u>0.764</u>	
Kinematic Viscosity =	<u>0.96</u>	centistokes;	Color = <u>Orange</u>	
Type of Fuel Pump: Electric-	<u>X</u>	; Mechanical-	<u>-</u>	
Does Electric Pump operate with ignition switch "ON" & engine "OFF"	Yes- <u>X</u>	No- <u>-</u>		
<u>Details of Fuel System: Tank – centered ahead of rear axle; lines – inside right frame stiffener; filler neck - right side behind rear axle.</u>				

DATA SHEET NO. 3 POST IMPACT DATA

TYPE OF TEST:

Type of Test: Frontal Barrier Impact Angle: 0°
Test Date: May 31, 2002 Time: 11:30 Temperature: 21 °C
Vehicle NHTSA No.: M30101
Required Impact Velocity Range: 55.5 to 57.1 kph

BARRIER IMPACT VELOCITY: (Speed traps within 5 feet of impact plane.)

Trap No. 1 = 56.65 kph; Trap No. 2 = 56.65 kph
Distance from vehicle to barrier: (1) entering trap = 813 mm
(2) exiting trap = 305 mm

VEHICLE STATIC CRUSH: (mm) (For frontal and rear impacts only.)

Vehicle Length:

Pre-Test	Left = <u>4749</u> ; C/L = <u>4818</u> ; Right = <u>4756</u>
Post-Test	Left = <u>4286</u> ; C/L = <u>4239</u> ; Right = <u>4358</u>
Crush	Left = <u>463</u> ; C/L = <u>579</u> ; Right = <u>398</u>
AVERAGE	= <u>480</u> mm

VEHICLE REBOUND: (From rigid barrier only.)

Distance from front of test vehicle to impact point:

	Left = <u>491</u> ; C/L = <u>559</u> ; Right = <u>433</u>
AVERAGE	= <u>494</u> mm

DATA SHEET NO. 4 TEST VEHICLE INFORMATION

VEHICLE IDENTIFICATION:

Model Year : 2003 Vehicle Model: Cadillac CTS Body Style : 4-Door Sedan

1. Nominal Design Riding Position for adjustable driver and passenger seat backs. Please describe how to position the inclinometer to measure the seat back angle. Include description of the location of the adjustment latch detent, if applicable.

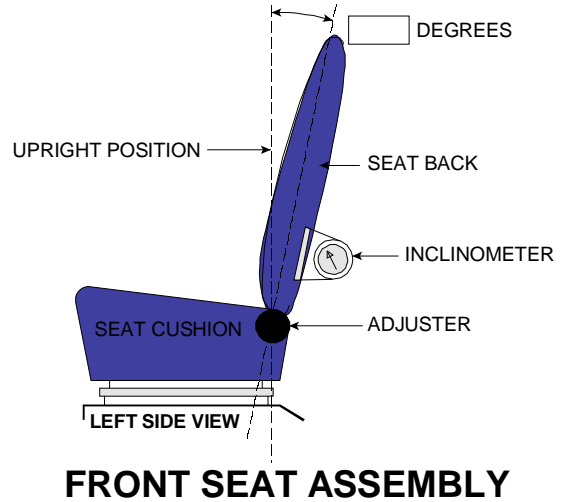

Seat back angle for driver's seat: 21

Measurement instructions: Measure angle on seatback frame below seatbelt tower.

Seat back angle for passenger's seat: 21

Measurement instructions: Same as the driver's seat

2. Seat Fore and Aft Positioning

Positioning of the driver's seat: Placed in mid-position

Positioning of the passenger's seat: The seat detents are labeled from 0 to 21; test position is detent 11.

3. Fuel Tank Capacity Data

3.1 A. "Usable Capacity" of the standard equipment fuel tank is 66.2 liters

B. "Usable Capacity" of the optional equipment fuel tank is - liters

C. "Usable Capacity" of the vehicle(s) used for certification testing to requirements of FMVSS 301 = 66.2 liters

3.2 Amount of Stoddard solvent added to vehicle(s) used for certification test(s) = 62.9 liters

3.3 Is vehicle equipped with electric fuel pump? Yes- X ; No- -

If YES, explain the vehicle operating conditions under which the fuel pump will pump fuel.

When the key is turned "ON" the fuel pump operates for 3 to 4 seconds or while the engine is running

DATA SHEET NO. 4 TEST VEHICLE INFORMATION (cont.)

4. STEERING COLUMN ADJUSTMENTS:

Steering wheel and column adjustments are made so that the steering wheel hub is at the geometric center of the locus it describes when it is moved through its full range of driving positions. If the tested vehicle has any of these adjustments, does your company use any specific procedures to determine the geometric center.

Operational Instructions: Placed in mid-position

5. SEAT BELT UPPER ANCHORAGE

Nominal design riding position: Not adjustable

DATA SHEET NO. 5 FRONT SEAT DUMMY POSITIONING MEASUREMENTS IN VEHICLE
DUMMY MEASUREMENT FOR FRONT SEAT PASSENGERS

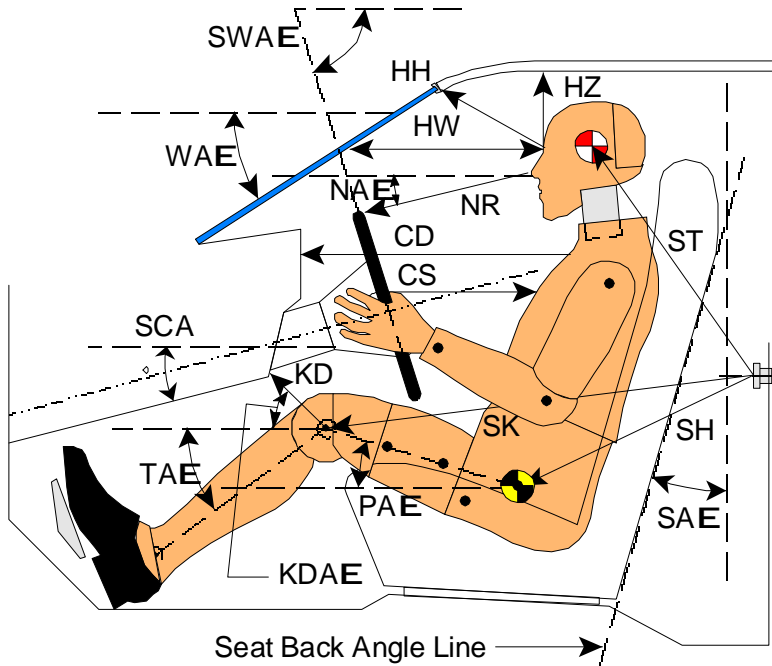

- AD - Arm to Door
- HD - H-Point to Door
- HR - Head to Side Header
- HS - Head to Side Window
- KK - Knee to Knee
- AA - Ankle to Ankle
- SHY- Striker to H-Point (Y Direction)

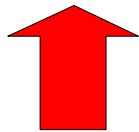

- CD - Chest to Dash
- CS - Steering Wheel to Chest
- HH - Head to Header
- HW - Head to Windshield
- HZ - Head to Roof
- KDA - Knee to Dash Angle
- KDL- Left Knee to Dash
- KDR - Right Knee to Dash
- NA - Nose to Rim Angle
- NR - Nose to Rim
- PA - Pelvic Angle
- RA - Rim to Abdomen
- SA - Seat Back Angle
- SCA - Steering Column Angle
- SH - Striker to H-Point
- SK - Striker to Knee
- ST - Striker to Head
- SWA- Steering Wheel Angle
- TA - Tibial Angle
- WA - Windshield Angle

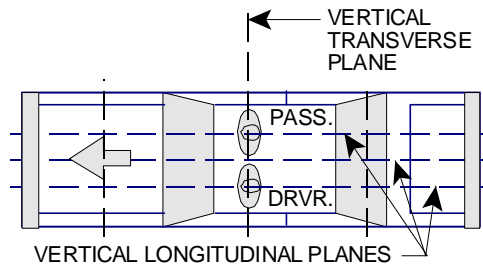
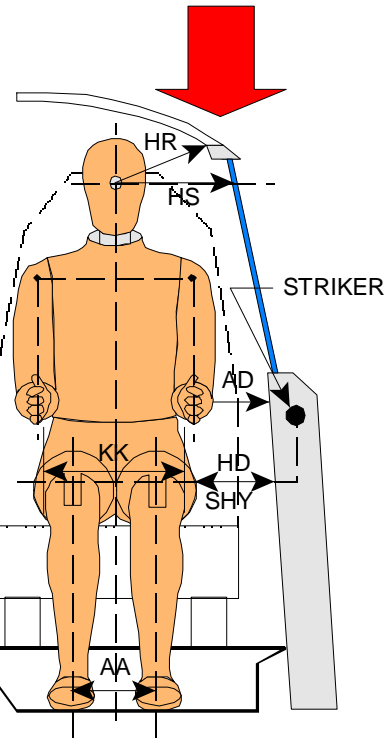

DATA SHEET NO. 5 FRONT SEAT DUMMY POSITIONING MEASUREMENTS IN VEHICLE (cont.)

	DRIVER (Serial #150)			PASS. (Serial #245)		
WA ^o	25.3 deg.			N/A		
SWA ^o	70 deg.			N/A		
SCA ^o	20 deg.			N/A		
SA ^o	21 deg.			21 deg.		
HZ	196			199		
HH	366			369		
HW	638			634		
HR	197			207		
NR	397	Angle	-8 deg.	N/A		
CD	514			496		
CS	317			N/A		
RA	207			N/A		
KDL	165	Angle (KDA)	40 deg.	120		
KDR	162			135	Angle (KDA)	30 deg.
PA ^o	22.5 deg.			23.8 deg.		
TA ^o	35.5 deg.			42.0 deg.		
KK	320			245		
AA	320			245		
ST	505	Angle	2 deg.	503	Angle	5 deg.
SK	540	Angle	88 deg.	535	Angle	88 deg.
SH	205	Angle	125 deg.	205	Angle	124 deg.
SHY	230			225		
HS	308			324		
HD	117			115		
AD	104			114		

Dimensions in millimeters

SEAT BELT POSITIONING DATA

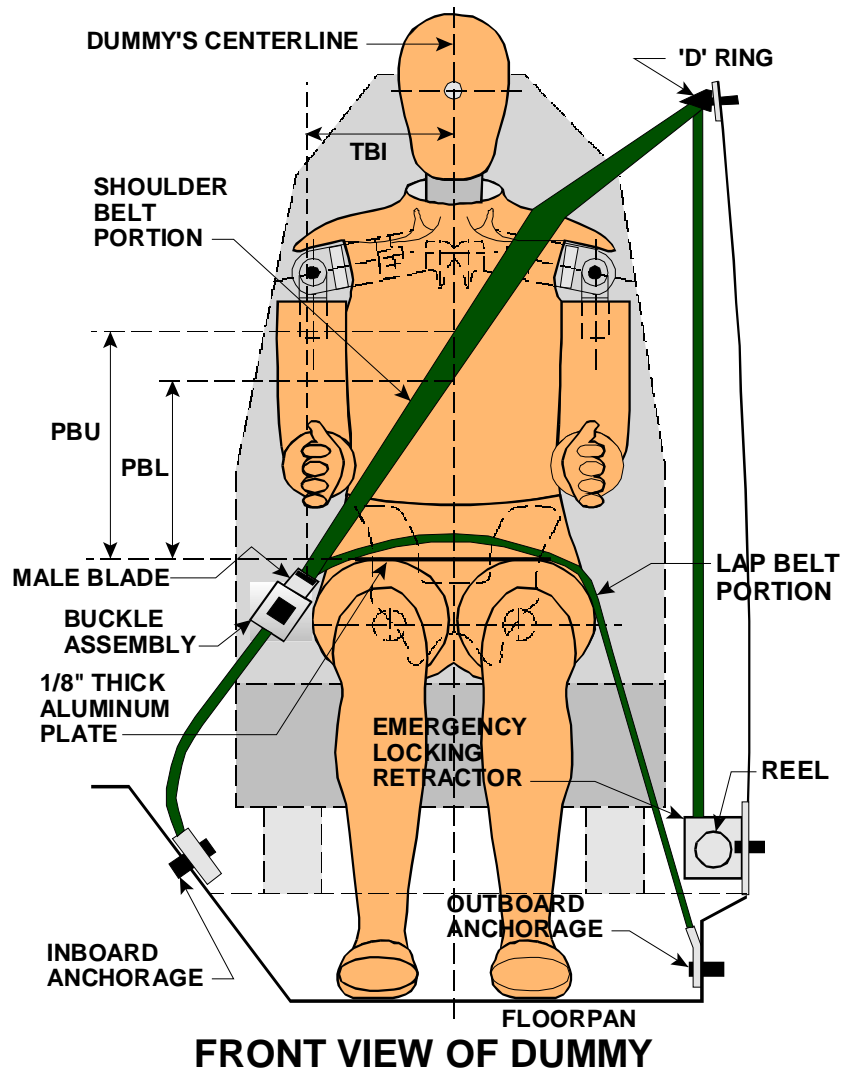

	DRIVER DUMMY (mm)	PASSENGER DUMMY (mm)
PBU -- Top surface of alum. plate to upper edge	370	370
PBL-- Top surface of alum. plate to belt lower edge	290	290
LAP BELT TENSION	10 N	10 N
SHOULDER BELT TENSION	Retractor	Retractor

VEHICLE ACCELEROMETER LOCATION AND DATA SUMMARY

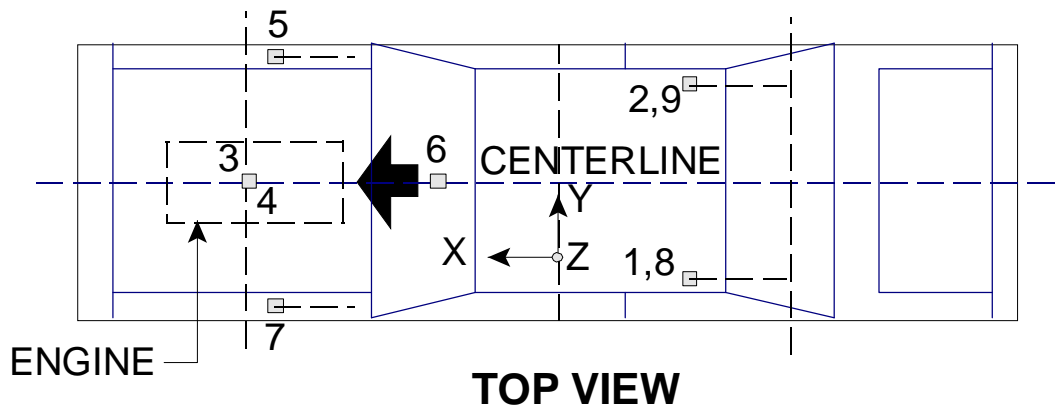

REAR SEAT CUSHION
ASSY. FRONT ATTACHMENT
BRACKET SUPPORT

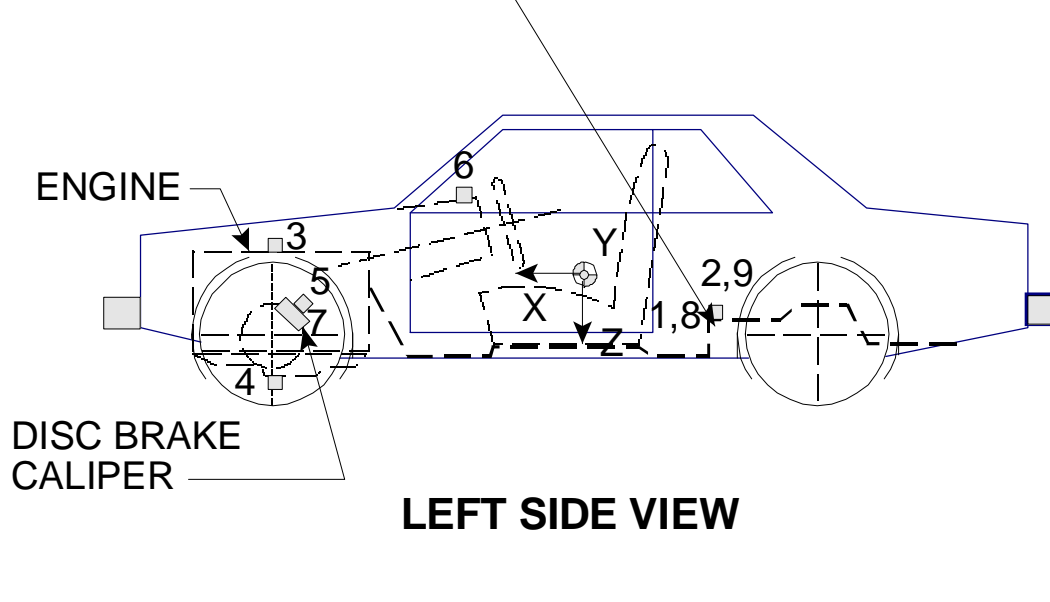

Note: Vehicle accelerometer location and data summary shown in DATA SHEET NO. 7

DATA SHEET NO. 7 VEHICLE ACCELEROMETER LOCATIONS AND DATA SUMMARY (cont.)

LOCATION		PRE-TEST LENGTH (mm)		
		X	Y	Z
1	Left Rear Seat Cross Member X	1982	-727	-364
2	Right Rear Seat Cross Member X	1979	725	-370
3	Top of Engine Block	4044	-190	-798
4	Bottom of Engine	3855	236	-241
5	Disc Brake Caliper @ Right Side	3869	830	-403
6	Instrument Panel	2947	6	-881
7	Disc Brake Caliper @Left Side	3867	-833	-405
8	Left Rear Seat Cross Member Z	1982	-727	-364
9	Right Rear Seat Cross Member Z	1979	725	-370

LOCATION NUMBER	DESCRIPTION	MAXIMUM VALUE (g's)			
		Pos.	msec.	Neg.	msec.
1	Left Rear Seat Cross Member X	4.1	16.8	-45.3	56.9
2	Right Rear Seat Cross Member X	*	*	*	*
3	Top of Engine Block	38.7	56.7	-124.8	40.5
4	Bottom of Engine	**	**	**	**
5	Disc Brake Caliper @ Right Side	83.3	57.6	-81.9	35.9
6	Instrument Panel	19.8	32.9	-95.1	55.7
7	Disc Brake Caliper @Left Side	38.5	56.8	-116.8	36.5
8	Left Rear Seat Cross Member Z	***	***	***	***
9	Right Rear Seat Cross Member Z	****	****	****	****

* Wire Cut at 72 ms; ** Wire Cut at 37 ms; *** Data Spikes; ****Sensor Opened

DATA SHEET NO. 8 DUMMY INJURY CRITERIA VALUES

Vehicle Year/Make/Model/Body Style: 2003 Cadillac CTS 4-Door Sedan

NHTSA Test No.: M30101 Test Date: May 31, 2002

DESCRIPTION	Unit	MAXIMUM VALUE							
		Driver				Passenger			
		Pos	msec	Neg	msec	Pos	msec	Neg	msec
Head 9 Array X Arm Y	g	5.0	144.4	-6.6	72.7	6.2	63.6	-21.9	54.0
Head 9 Array X Arm Z	g	25.1	46.5	-8.7	128.5	30.1	62.7	-7.5	154.7
Head 9 Array Y Arm X	g	8.9	260.7	-57.1	77.2	14.7	260.4	-60.9	82.0
Head 9 Array Y Arm Z	g	23.2	67.1	-6.7	91.2	24.9	75.5	-11.0	99.4
Head 9 Array Z Arm X	g	11.2	239.6	-65.0	77.6	26.4	254.7	-70.7	81.6
Head 9 Array Z Arm Y	g	9.0	127.4	-9.0	72.9	8.4	64.4	-23.8	84.2
Head X	g	8.8	293.0	-58.0	77.5	15.0	260.5	-61.1	81.9
Head Y	g	6.0	124.7	-6.8	72.3	4.4	59.4	-19.4	84.8
Head Z	g	21.3	67.0	-7.6	91.4	26.7	74.1	-8.1	99.3
Head Resultant	g	59.2	75.4	0.0	-8.6	65.4	81.4	0.0	-26.6
Redundant Head X	g	8.8	292.1	-58.5	77.9	15.1	259.4	-60.9	81.6
Redundant Head Y	g	5.9	124.1	-7.9	71.9	3.9	60.2	-18.7	88.1
Redundant Head Z	g	21.4	67.0	-7.3	90.8	26.4	75.2	-8.8	98.7
Redundant Head Resultant	g	59.7	76.2	0.0	-10.4	65.1	80.5	0.0	-26.3
Upper Neck Fx	N	1083.6	77.4	-542.7	138.0	645.6	75.0	-421.4	145.2
Upper Neck Fy	N	174.8	121.5	-75.9	86.5	256.0	72.0	-114.3	132.1
Upper Neck Fz	N	1266.8	66.5	-159.2	91.7	1184.5	74.0	-395.1	99.5
Upper Neck F Resultant	N	1589.6	66.5	1.2	-27.6	1359.9	74.1	1.8	-9.9
Upper Neck Mx	N-m	17.3	129.9	-10.7	98.9	7.9	103.9	-25.8	57.6
Upper Neck My	N-m	76.9	65.2	-18.9	107.8	38.8	153.5	-19.1	104.7
Upper Neck Mz	N-m	9.3	153.2	-11.9	115.4	9.8	94.6	-8.0	150.4
Upper Neck M Resultant	N-m	77.1	65.2	0.0	-19.7	39.9	153.4	0.0	-5.1
Chest X	g	3.0	137.2	-45.1	72.0	4.1	299.9	-51.9	70.5
Chest Y	g	9.3	70.7	-3.4	45.1	1.5	48.2	-11.1	70.9
Chest Z	g	10.9	66.9	-3.3	102.7	20.5	75.7	-5.4	114.0
Chest Resultant	g	46.7	71.9	0.0	-8.5	55.0	72.0	0.0	-7.8

DATA SHEET NO. 8 DUMMY INJURY CRITERIA VALUES (cont.)

Vehicle Year/Make/Model/Body Style: 2003 Cadillac CTS 4-Door Sedan

NHTSA Test No.: M30101 Test Date: May 31, 2002

DESCRIPTION	Unit	MAXIMUM VALUE							
		Driver				Passenger			
		Pos	msec	Neg	msec	Pos	msec	Neg	msec
Redundant Chest X	g	2.9	255.5	-45.6	72.3	3.9	299.9	-53.6	70.4
Redundant Chest Y	g	9.4	70.8	-3.6	45.4	1.9	47.8	-11.2	70.9
Redundant Chest Z	g	11.0	68.2	-3.5	102.6	20.7	75.7	-5.5	111.4
Redundant Chest Resultant	g	47.1	72.2	0.0	-25.7	56.3	70.7	0.0	-26.3
Chest Displacement	mm	0.0	2.6	-33.1	86.4	0.0	6.8	-25.1	72.9
Pelvic X	g	4.7	209.3	-59.8	48.8	4.3	113.1	-52.0	67.2
Pelvic Y	g	9.0	64.3	-6.3	47.8	4.2	36.8	-6.9	59.0
Pelvic Z	g	4.1	226.4	-25.4	68.3	3.2	228.9	-27.6	70.0
Pelvic Resultant	g	61.4	48.9	0.0	-48.4	57.0	67.9	0.0	-45.4
Left Femur	N	399.2	29.4	-3762.3	49.5	341.9	23.6	-2225.4	65.8
Right Femur	N	412.4	15.5	-4906.7	49.2	548.5	30.5	-1777.4	71.1
Left Upper Tibia Mx	N-m	19.8	123.7	-39.5	83.6	76.3	65.0	-11.1	165.3
Left Upper Tibia My	N-m	38.2	48.0	-62.7	40.2	41.3	37.1	-73.6	61.3
Left Lower Tibia Fz	N	151.5	119.8	-1853.9	42.9	260.3	32.1	-2099.2	75.2
Left Lower Tibia Mx	N-m	57.2	62.0	-20.2	46.9	19.3	77.3	-5.0	53.4
Left Lower Tibia My	N-m	35.6	50.9	-50.8	40.8	26.2	52.5	-30.4	46.6
Right Upper Tibia Mx	N-m	48.2	42.3	-12.6	121.3	17.1	151.6	-40.5	46.7
Right Upper Tibia My	N-m	41.5	106.8	-78.0	61.5	25.0	32.9	-82.4	72.3
Right Lower Tibia Fz	N	100.4	124.1	-3991.0	48.0	137.1	32.8	-2214.1	73.4
Right Lower Tibia Mx	N-m	13.9	41.6	-66.4	56.8	65.4	71.6	-21.1	46.2
Right Lower Tibia My	N-m	93.9	48.5	-33.2	37.2	13.0	86.3	-115.4	40.9
Left Foot Aft Ax	g	40.8	52.0	-96.5	41.9	22.2	50.8	-88.1	40.2
Left Foot Aft Az	g	13.5	50.9	-55.6	44.2	12.6	34.7	-45.3	51.2
Left Foot Fore Az	g	73.1	51.0	-142.2	42.0	63.8	34.6	-121.7	44.5
Right Foot Aft Ax	g	51.2	48.3	-77.3	34.1	9.2	85.5	-76.2	47.0
Right Foot Aft Az	g	10.9	240.9	-91.5	39.4	20.2	37.5	-41.4	50.6
Right Foot Fore Az	g	41.5	43.5	-168.4	36.8	74.2	34.4	-93.8	48.2

DATA SHEET NO. 8 DUMMY INJURY CRITERIA VALUES (cont.)

Vehicle Year/Make/Model/Body Style: 2003 Cadillac CTS 4-Door Sedan

NHTSA Test No.: M30101 Test Date: May 31, 2002

HEAD INJURY CRITERIA (HIC)				
	HIC**	t ₁ (msec)	t ₂ (msec)	Average Acceleration t ₁ to t ₂
Position #1 - Driver	521.8	56.3	91.5	46.6
Position #2 - Passenger	661.3	61.7	97.7	50.8

** HIC is as defined in FMVSS 208. The maximum time interval from t₁ to t₂ is 36 milliseconds.

CLIP SUMMARY*				
	CLIP (g's)	t ₁ (msec)	t ₂ (msec)	CSI
Position #1 - Driver	46.3	68.8	73.0	499.2
Position #2 - Passenger	54.8	70.8	73.8	522.2

* The maximum chest resultant acceleration is defined as the maximum acceleration which exceeds 0.003 seconds in duration.

DATA SHEET NO. 8 DUMMY INJURY CRITERIA VALUES (cont.)
REDUNDANT DATA

Vehicle Year/Make/Model/Body Style: 2003 Cadillac CTS 4-Door Sedan

NHTSA Test No.: M30101 Test Date: May 31, 2002

HEAD INJURY CRITERIA (HIC) REDUNDANT				
	HIC**	t ₁ (msec)	t ₂ (msec)	Average Acceleration t ₁ to t ₂
Position #1 - Driver	521.1	56.5	91.5	46.7
Position #2 - Passenger	639.7	62.1	98.1	50.1

** HIC is as defined in FMVSS 208. The maximum time interval from t₁ to t₂ is 36 milliseconds.

CLIP SUMMARY* REDUNDANT				
	CLIP (g's)	t ₁ (msec)	t ₂ (msec)	CSI
Position #1 - Driver	46.5	70.3	73.3	504.9
Position #2 - Passenger	55.9	70.1	73.3	543.8

* The maximum chest resultant acceleration is defined as the maximum acceleration which exceeds 0.003 seconds in duration.

DATA SHEET NO. 9 SEAT BELT PERFORMANCE ASSESSMENT TEST DATA

BELT LENGTH DATA:

Belt length from trim panel exit
to bolt hole anchor point for
continuous webbing systems.

Driver

Passenger

1390

1390

Shoulder belt length as measured
on Part 572 Dummy.

600

600

Lap belt length as measured
on Part 572 Dummy.

790

790

Dimensions in millimeters

DATA SHEET NO.10 SUMMARY OF FMVSS 212 DATA

FMVSS NO. 212 - "WINDSHIELD MOUNTING" DATA

DETAILS OF WINDSHIELD MOUNTING SUCH AS RETENTION METHOD, TRIM TYPE, ETC.:

Windshield is bonded in place and covered with a 25 mm molding.

FMVSS 212 REQUIREMENTS:

The Post-Test periphery retention amount must be at least 75% of the Pre-Test periphery measurement for vehicles NOT equipped with automatic restraints, and 50% for each side of the windshield for vehicles equipped with automatic restraint systems for front occupants,

FMVSS 212 TEST DATA

	WINDSHIELD PERIPHERY		% OF RETENTION
	PRE-TEST (mm)	POST-TEST (mm)	
RIGHT SIDE	2160	2160	100.0%
LEFT SIDE	2160	2160	100.0%
TOTAL	4320	4320	100.0%

AREA OF RETENTION FAILURE: None

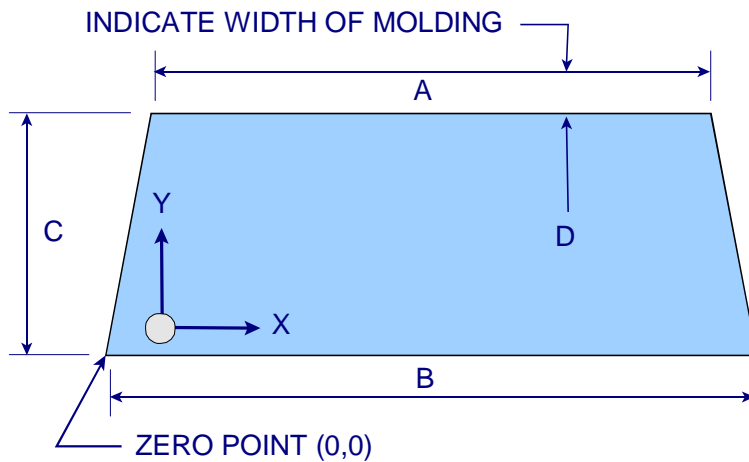

DIMENSIONS (mm)	
A	1160
B	1520
C	820
D	25

FRONT VIEW OF WINDSHIELD

FAILURE DETAILS: None

DATA SHEET NO. 11 FMVSS NO. 219 (PARTIAL) - "WINDSHIELD ZONE INTRUSION" DATA

PROTECTED ZONE LOWER EDGE REQUIREMENT:

The lower edge of the protected zone is determined by placing a 165 mm diameter rigid sphere weighing 6.8 kg in a position such that it simultaneously contacts the inner surface of the windshield and the top surface of the instrument panel including padding. The locus of points is drawn on the inner surface of the windshield contacted by the sphere across the width of the instrument panel. From the outermost contactable points extend the locus line horizontally to the edges of the windshield, then draw a line on the inner surface of the windshield below and 13 mm distant from the locus line. The LOWER EDGE OF THE PROTECTED ZONE is the longitudinal projection of this line onto the outer surface of the windshield.

FMVSS 219 TEST DATA:

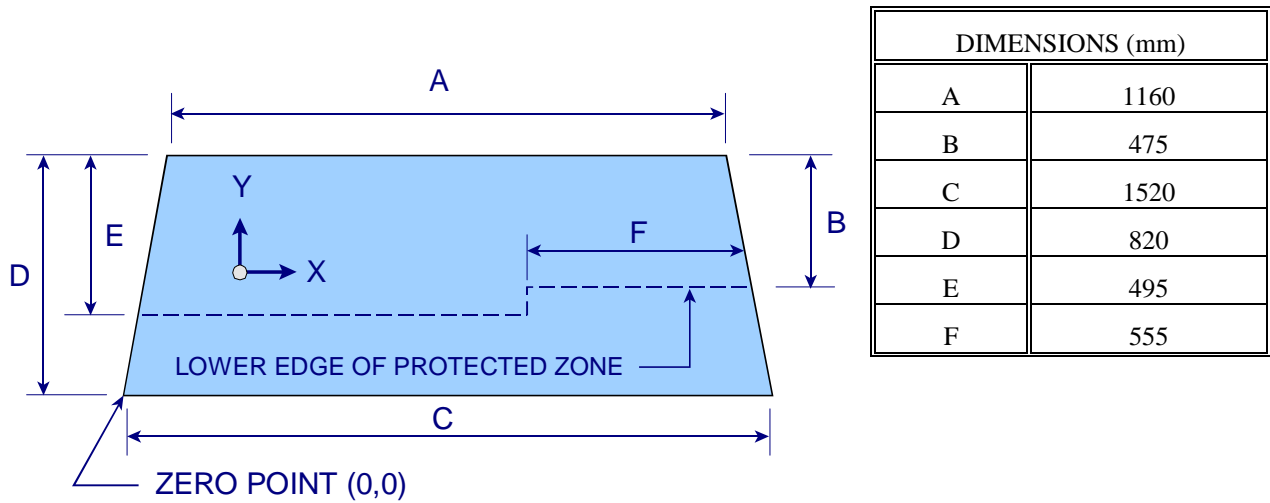

FRONT VIEW OF WINDSHIELD

DETAILS OF WINDSHIELD GLASS PENETRATION GREATER THAN 6 mm: None

(Show location of penetration on the above sketch)

	COORDINATES	
	X	Y
1.	-	-
2.	-	-
3.	-	-
4.	-	-

DATA SHEET NO. 12 FMVSS NO. 301-75 "FUEL SYSTEM INTEGRITY" POST IMPACT TEST DATA

NHTSA TEST No.: M30101 TEST DATE: May 31, 2002
VEHICLE MAKE/MODEL: 2003 Cadillac CTS 4-Door Sedan

The test vehicle was filled from 92% to 94% of the manufacturer's "usable" capacity. The electric fuel pump was operating if it will operate without engine operation. Two Part 572 anthropomorphic test devices were located at each of the front designated seating positions.

=====

TEST VEHICLE IMPACT TYPE: X Frontal (56 kph)
- Oblique (48 kph) with _____ deg. barrier face first contacting _____
- (driver/passenger) side
- Rear Moving Barrier (48 kph)
- Lateral Moving Barrier (32 kph)

FUEL SPILLAGE MEASUREMENT:

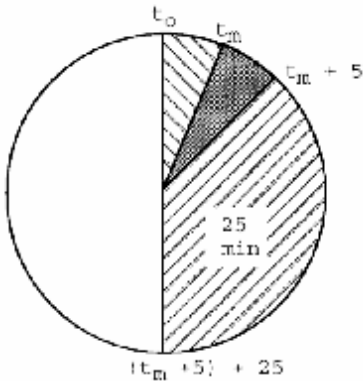

1. From impact until vehicle motion ceases
2. For 5 minute period after vehicle motion ceases
3. For next 25 minutes

ACTUAL	MAX ALLOWED
0	28 g
0	141 g
0	28 g/min.

SOLVENT SPILLAGE DETAILS: None

DATA SHEET NO. 13 - ROLLOVER DATA

Vehicle: 2003 Cadillac CTS 4-Door Sedan

NHTSA No.: M30101

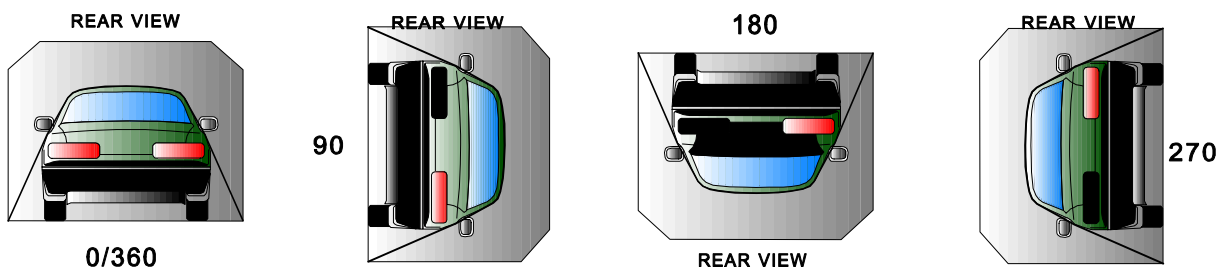

I. DETERMINATION OF SOLVENT COLLECTION TIME PERIOD:

Rollover Stage	Rotation Time (spec. 1 -3 min)				FMVSS 301 Hold Time		Total Time				Next Whole Minute Interval	
	minutes	seconds	minutes	seconds	minutes	seconds	minutes	seconds	minutes	seconds	minutes	seconds
0° - 90°	1	11	5	6	11	7	1	6	11	7	1	7
90° - 180°	1	07	5	6	7	7	1	6	7	7	1	7
180°-270°	1	01	5	6	1	7	1	6	1	7	1	7
270°-360°	1	13	5	6	13	7	1	6	13	7	1	7

II. FMVSS 301 REQUIREMENTS: (Maximum allowable solvent spillage):

First 5 minutes from onset of rotation	6th min.	7th min.	8th min. (if required)
142 g	28 g	28 g	28 g

III. ACTUAL TEST VEHICLE SOLVENT SPILLAGE:

Rollover Stage	First 5 minutes from onset of rotation (g)	6th min. (g)	7th min. (g)	8th min. (if required) (g)
0° - 90°	0	0	0	N/A
90° - 180°	0	0	0	N/A
180°-270°	0	0	0	N/A
270°-360°	0	0	0	N/A

Note: Record spillage for whole minute intervals only as determined above.

IV. SOLVENT SPILLAGE LOCATION(S):

Rollover Stage	Spillage Location
0° - 90°	None
90° - 180°	None
180°-270°	None
270°-360°	None

DATA SHEET NO. 14 TEST VEHICLE MEASUREMENTS

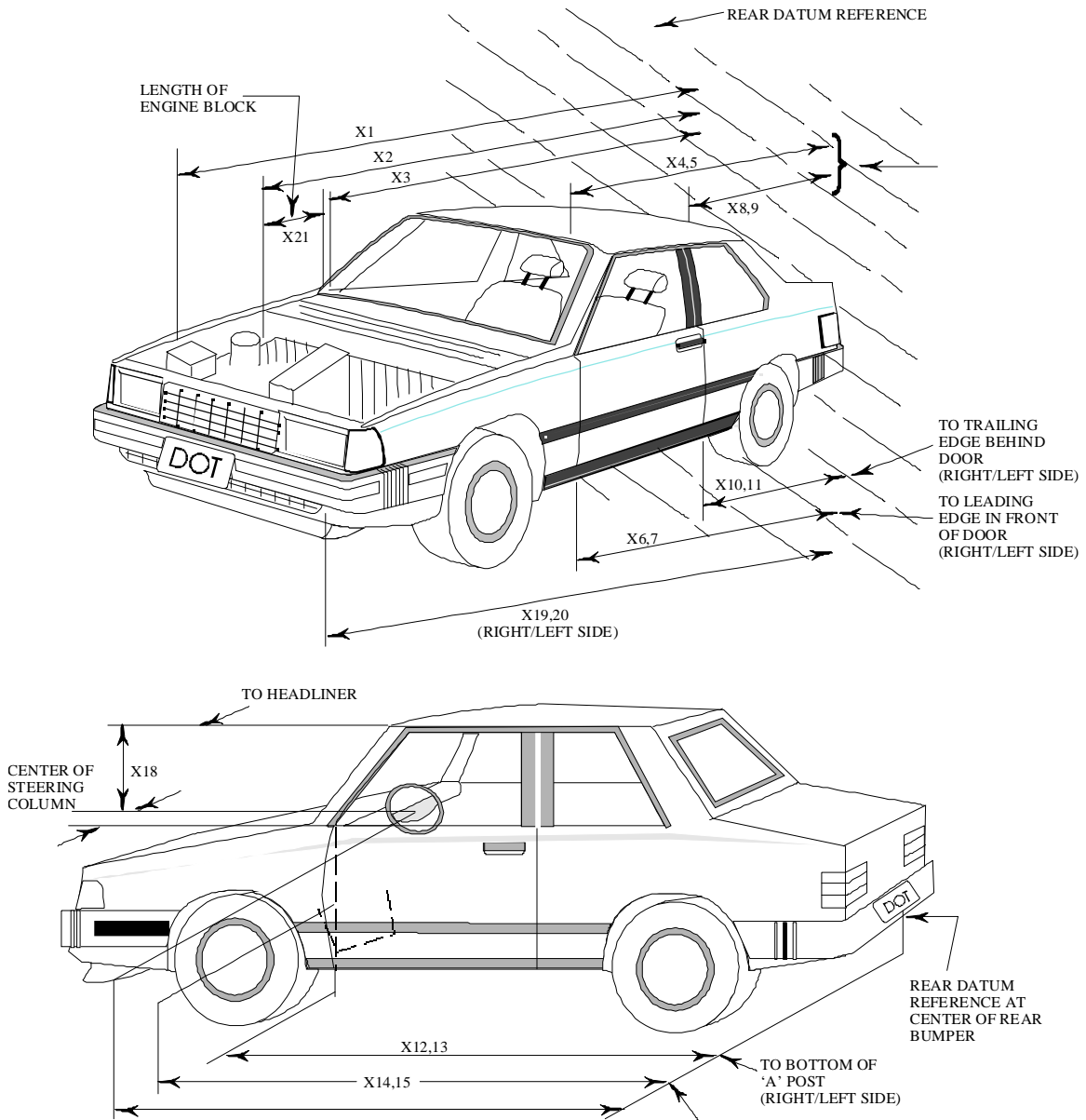

DATA SHEET NO.14 VEHICLE MEASUREMENTS (cont.)

No.		Pre-Test	Post-Test	Difference
X1	Total Length of Vehicle at Centerline	4818	4239	579
X2	Rear Surface of Vehicle to Front of Engine	4175	4091	84
X3	Rear Surface of Vehicle to Firewall	3715	3708	7
X4	Rear Surface of Vehicle to Upper Leading Edge of Right Door	3303	3299	4
X5	Rear Surface of Vehicle to Upper Leading Edge of Left Door	3301	3301	0
X6	Rear Surface of Vehicle to Lower Leading Edge of Right Door	3326	3323	3
X7	Rear Surface of Vehicle to Lower Leading Edge of Left Door	3324	3323	1
X8	Rear Surface of Vehicle to Upper Trailing Edge of Right Door	2223	2219	4
X9	Rear Surface of Vehicle to Upper Trailing Edge of Left Door	2224	2222	2
X10	Rear Surface of Vehicle to Lower Trailing Edge of Right Door	2271	2265	6
X11	Rear Surface of Vehicle to Lower Trailing Edge of Left Door	2268	2265	3
X12	Rear Surface of Vehicle to Bottom of "A" Post of Right Side	3313	3312	1
X13	Rear Surface of Vehicle to Bottom of "A" Post of Left Side	3318	3320	-2
X14	Rear Surface of Vehicle to Firewall, Right Side	3648	3624	24
X15	Rear Surface of Vehicle to Firewall, Left Side	3717	3707	10
X16	Rear Surface of Vehicle to Steering Column	2822	2809	13
X17	Center of Steering Column to "A" Post	284	286	-2
X18	Center of Steering Column to Headliner	410	428	-18
X19	Rear Surface of Vehicle to Right Side of Front Bumper	4756	4358	398
X20	Rear Surface of Vehicle to Left Side of Front Bumper	4749	4286	463
X21	Length of Engine Block	462	462	0
RD	Rear Surface of Vehicle to Right Side of Dash Panel	2980	2982	-2
CD	Rear Surface of Vehicle to Center of Dash Panel	2958	2946	12
LD	Rear Surface of Vehicle to Left Side of Dash Panel	2985	2985	0

All Dimensions in mm

DATA SHEET NO.14 VEHICLE MEASUREMENTS (cont.)
 VEHICLE INTRUSION MEASUREMENTS
 DOOR OPENING WIDTH

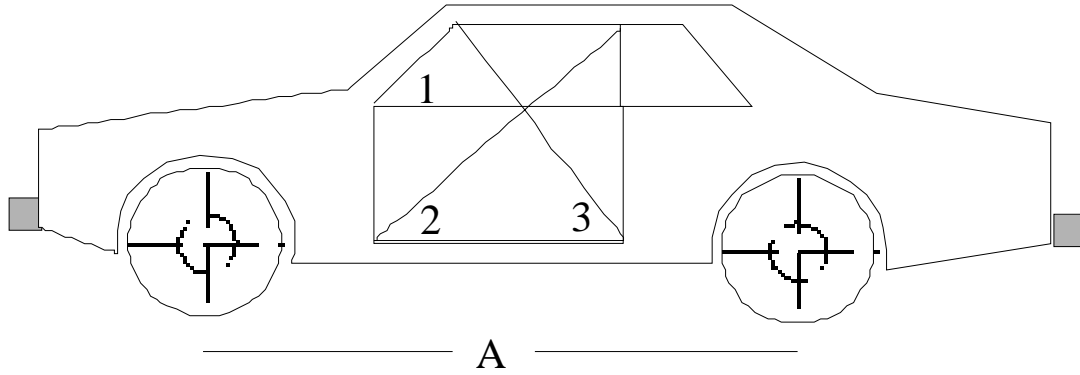

UNITS (mm)	LEFT			RIGHT		
MEASUREMENT	1	2	3	1	2	3
BEFORE TEST	1014	1443	907	1006	1445	936
AFTER TEST	1014	1443	913	1003	1443	930
DIFFERENCE	0	0	-6	3	2	6

UNITS (mm)	A = WHEELBASE LEFT	A = WHEELBASE RIGHT
BEFORE TEST	2885	2885
AFTER TEST	2789	2777
DIFFERENCE	96	108

DATA SHEET NO.14 VEHICLE MEASUREMENTS (cont.)
 VEHICLE INTRUSION MEASUREMENTS
 STATIC FOOTWELL DEFORMATION

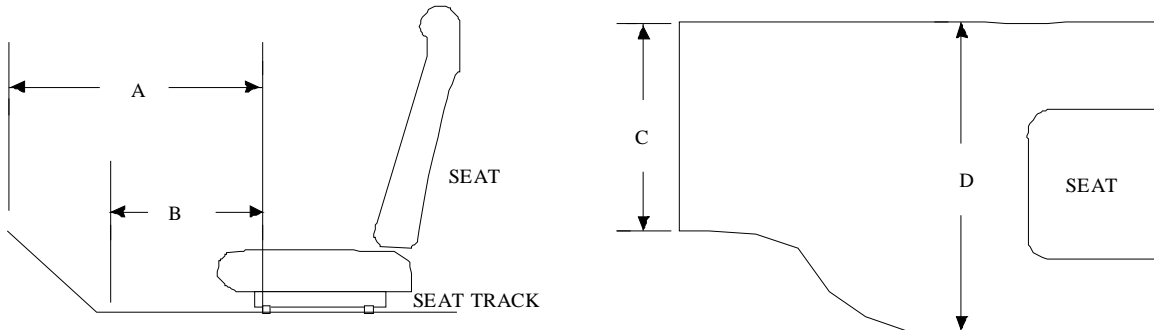

DRIVER

Measurement	Pre-Test	Post-Test	Difference
A	722	656	66
B	580	573	7
C	458	498	-40
D	505	501	4

PASSENGER

Measurement	Pre-Test	Post-Test	Difference
A	712	677	35
B	560	557	3
C	396	391	5
D	512	503	9

Units = mm

DATA SHEET NO.14 VEHICLE MEASUREMENTS (cont.)
VEHICLE INTRUSION MEASUREMENTS
STATIC PASSENGER COMPARTMENT INTRUSION

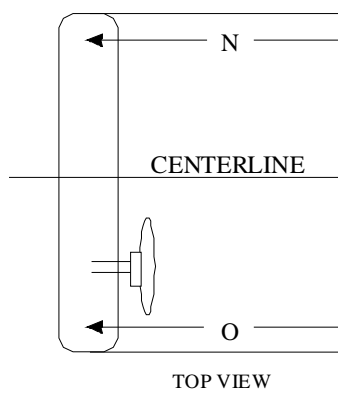
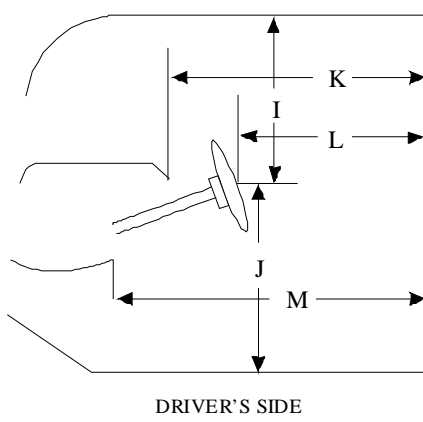

MEASUREMENTS
FROM C-PILLAR
BELT ANCHORAGE

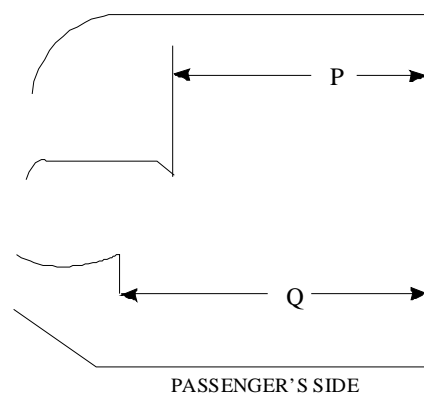

Measurement	Pre-Test	Post-Test	Difference
I	410	428	-18
J	606	601	5
K	1676	1666	10
L	1502	1480	22
M	1693	1681	12
N	1655	1649	6
O	1665	1656	9
P = K (PASS.)	1697	1677	20
Q = M (PASS.)	1675	1664	11

Units = mm

DATA SHEET NO.14 VEHICLE MEASUREMENTS (cont.)
FLOORBOARD DEFORMATION

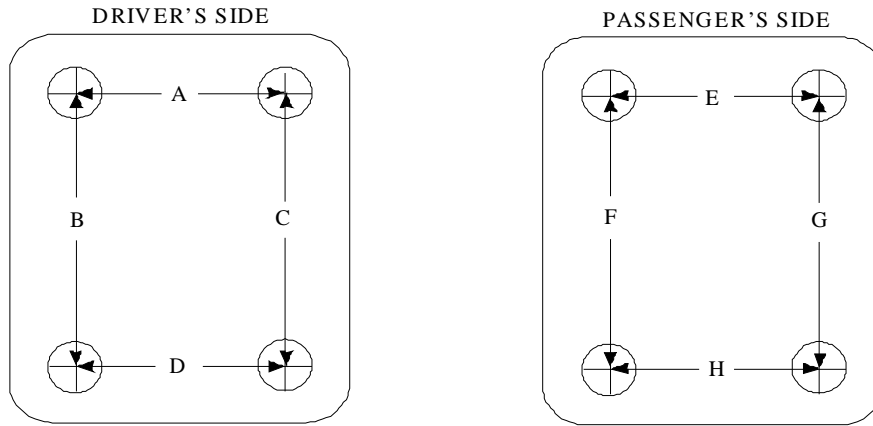

TOP VIEW THROUGH FLOOR PAN

Measurement	Pre-Test	Post-Test	Difference
A	458	498	-40
B	480	480	0
C	475	411	64
D	505	501	3
E	396	391	5
F	500	502	-2
G	468	449	18
H	512	503	10

Units = mm

DATA SHEET NO.14 VEHICLE MEASUREMENTS (cont.)
TOE-PAN INTRUSION

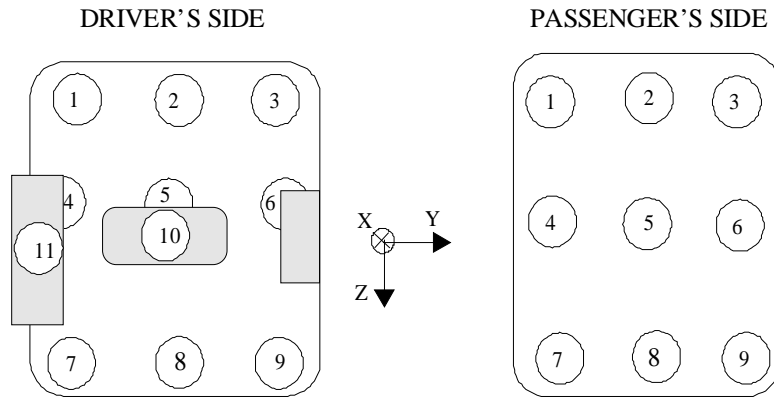

Driver Side Toe-pan Measurements

Toe-pan Location	X Deformation (mm)			Z Deformation (mm)		
	Pre-Test	Post-Test	Difference	Pre-Test	Post-Test	Difference
1	3490	3458	32	-464	-464	0
2	3510	3445	65	-447	-464	17
3	3497	3472	25	-451	-464	13
4	3435	3422	13	-385	-379	-6
5	3445	3417	28	-378	-391	13
6	3442	3419	23	-371	-369	-2
7	3364	3357	7	-317	-308	-9
8	3367	3362	5	-310	-299	-11
9	3301	3359	-58	-293	-297	4
10	3333	3326	7	-480	-472	-8
11	3402	3401	1	-436	-428	-8

Passenger Side Toe-pan Measurements

Toe-pan Location	X Deformation (mm)			Z Deformation (mm)		
	Pre-Test	Post-Test	Difference	Pre-Test	Post-Test	Difference
1	3488	3478	10	-434	-436	2
2	3496	3463	33	-431	-435	4
3	3490	3470	20	-462	-468	6
4	3334	3403	-69	-334	-362	28
5	3425	3408	17	-356	-365	9
6	3438	3433	5	-370	-365	-5
7	3334	3336	-2	-294	-286	-8
8	3345	3343	2	-298	-292	-6
9	3357	3358	-1	-308	-304	-4

Reference: SAE: X = Rear Bumper (Positive: forward); Z = Ground (Positive: down)

DATA SHEET NO.15 HIGH-SPEED CAMERA LOCATIONS

NOTE: Camera information shown in DATA SHEET NO. 15.

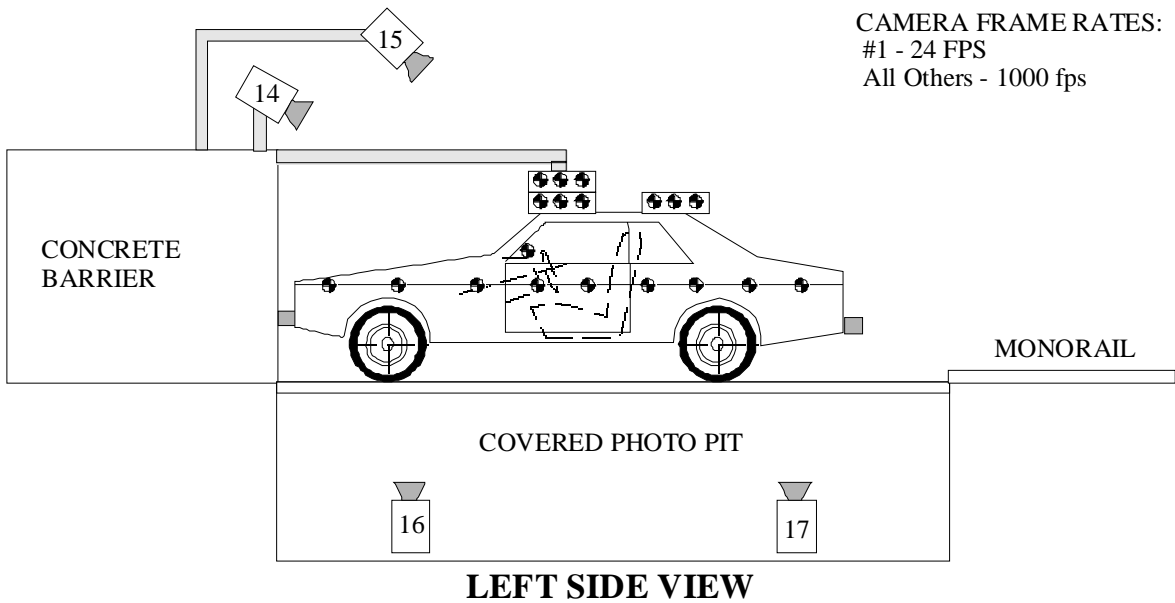
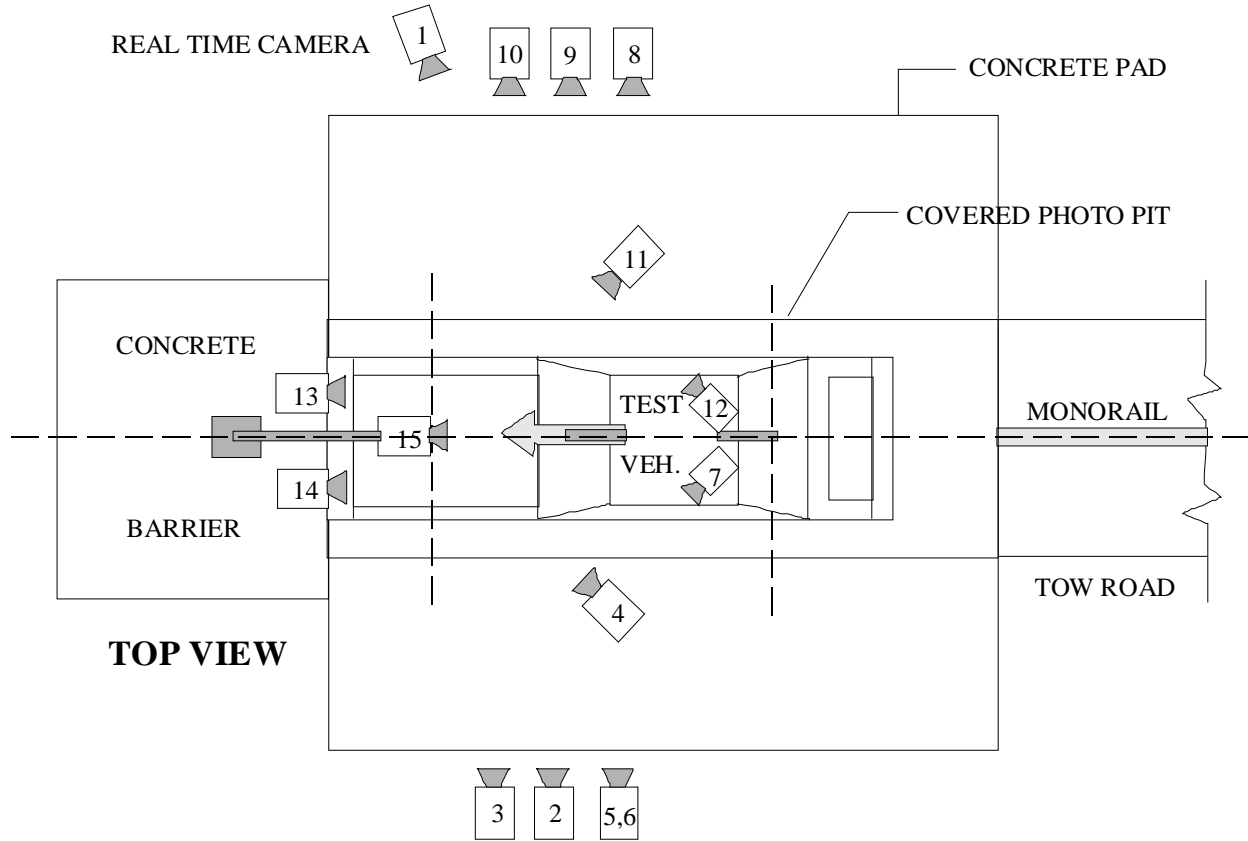

CAMERA FRAME RATES:
 #1 - 24 FPS
 All Others - 1000 fps

DATA SHEET NO.15 HIGH-SPEED CAMERA LOCATIONS (cont.)

NHTSA Test No.: M30101 Vehicle: 2003 Cadillac CTS 4-Door Sedan

CAMERA NO.	VIEW	CAMERA POSITIONS (mm)*			ANGLE (deg)**	FILM PLANE TO HEAD TARGET	LENS (mm)	SPEED (fps)
		X	Y	Z				
1	Real-Time Camera	-	-	-	-	-	-	24
2	Overall Left Side	6753	1677	1067	-2	6477	12.5	1005
3	Left Side View	7990	1099	1110	-2	7714	25	1000
4	Driver and Interior View	7620	2551	1995	-10	-	25	1055
5	Steering Column (Bottom)	7755	1881	1177	-4	7479	25	1010
6	Steering Column (Top)	7755	1881	1777	-4	7479	25	1010
7	Left Belt	-	-	-	-	-	-	-
8	Overall Right Side	7045	1964	1069	-2	7364	12.5	1005
9	Right Side View	8180	1509	1085	-2	8499	25	1015
10	Right Passenger View	7855	1774	1425	-4	8174	35	1000
11	Passenger and Interior View	7620	2630	1967	-9	-	25	1000
12	Right Belt	-	-	-	-	-	-	-
13	Passenger Front View	620	-92	1987	-42	-	13	1010
14	Driver Front View	620	-92	1987	-41	-	13	1000
15	Windshield View	0	-530	3374	-52	-	13	1000
16	Pit View of Engine	0	615	-3048	90	-	13	1050
17	Pit View of Fuel Tank	0	2800	-3048	90	-	13	1005

*X = film plane to monorail centerline ** = referenced to horizontal plane

Y = film plane to impact location N.T. indicates No Timing

Z = film plane to ground

DATA SHEET NO. 16 VEHICLE REFERENCE PHOTO TARGET LOCATIONS

(Dimensions in millimeters)

A	395
B	595
C	1222
D	2129
E	346
F	1504
G	988
H	989
I	132
J	1283
K	1121
L	1426
M	344
N	130
O	992
P	988
Q	1426
R	1122
S	1281

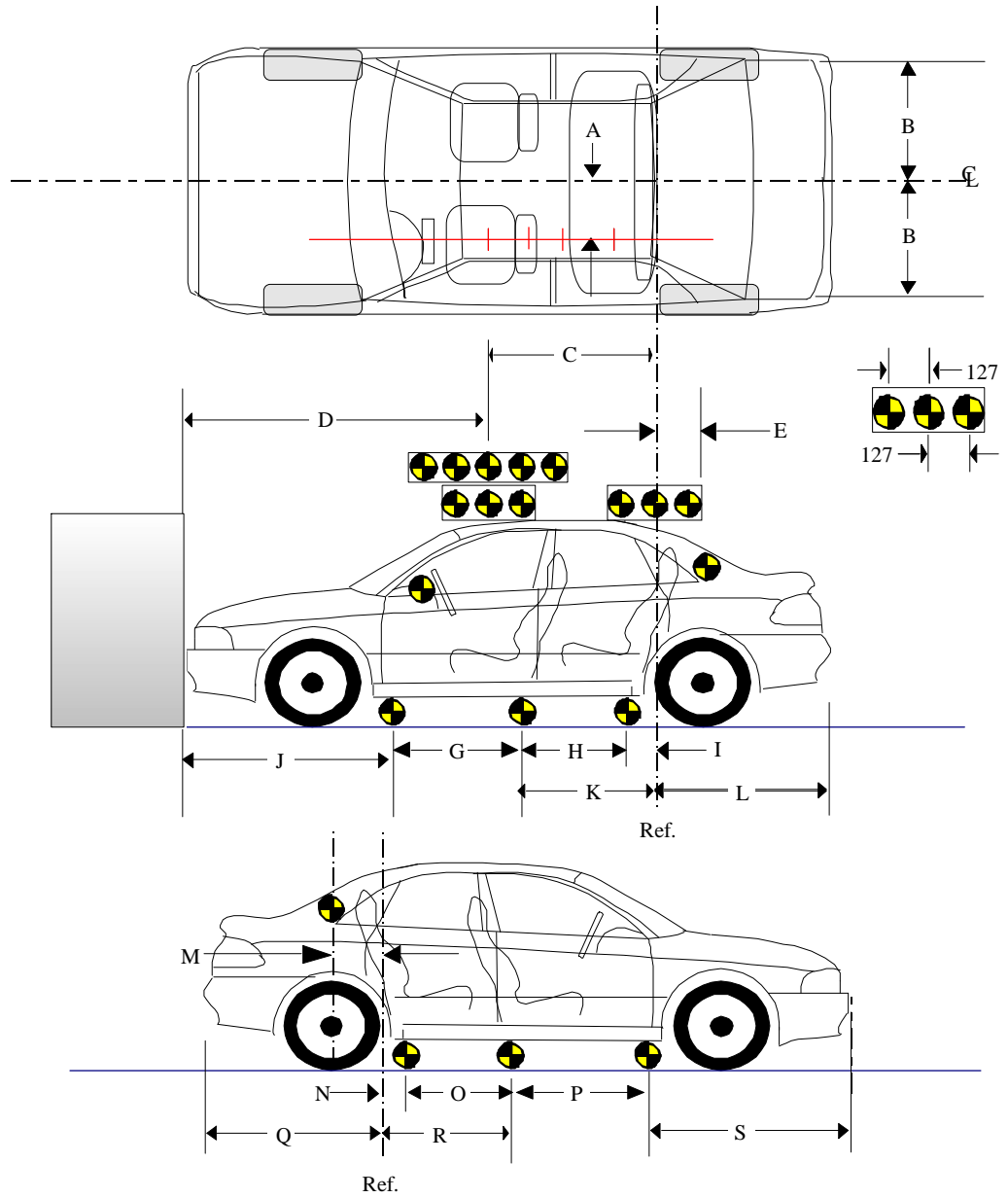

DATA SHEET NO. 17 LOAD CELL LOCATIONS ON FIXED BARRIER

- 36 Load Cells
- 4 Rows
- 9 Columns
- 6 Groupings (6 cells/group)

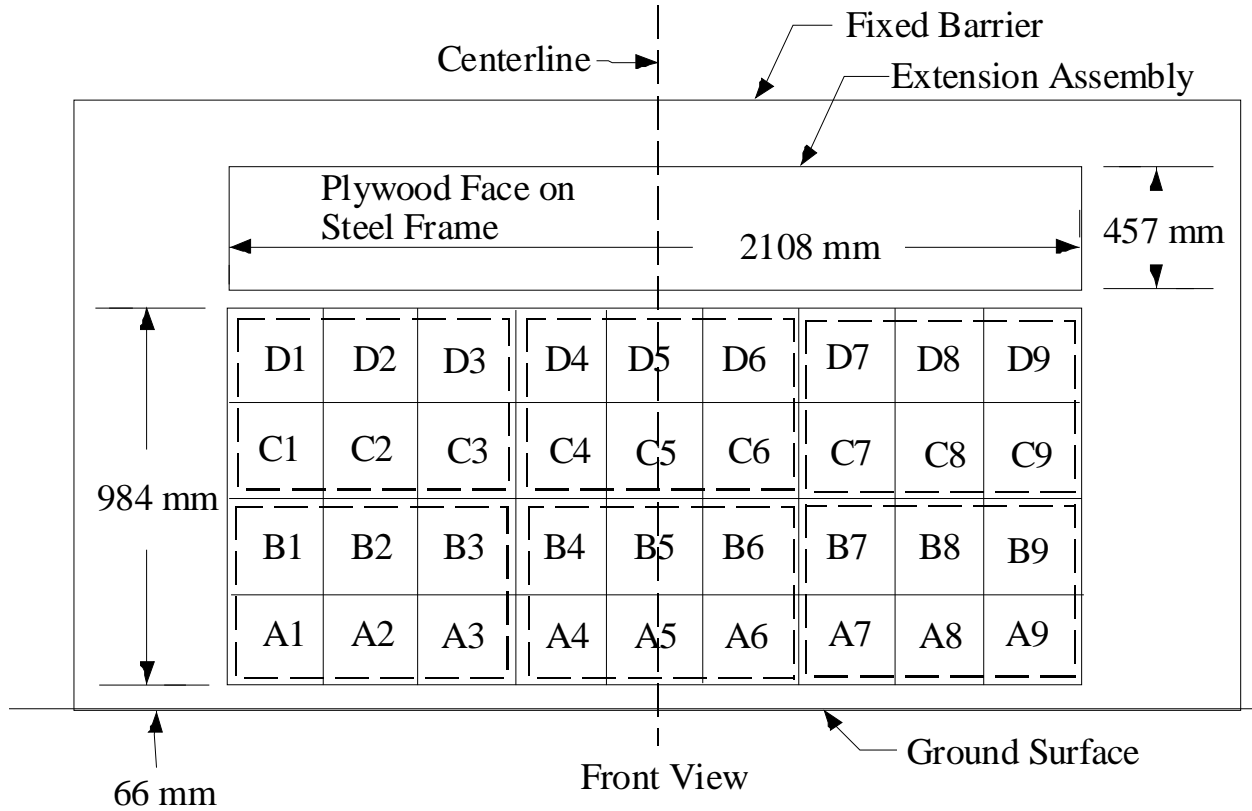

6 GROUPS OF 6 LOAD CELLS EACH

Group 4 C1 thru D3	Group 5 C4 thru D6	Group 6 C7 thru D9
Group 1 A1 thru B3	Group 2 A4 thru B6	Group 3 A7 thru B9

The following data is presented in Appendix B:

- (1) Data from 36 individual load cells
- (2) Total or Sum of 36 individual load cells
- (3) Data from 6 Groupings shown above (6 cells/group)

DATA SHEET NO. 18 POST TEST AIR BAG DATA

NHTSA No.: M30101; Test Date: May 31, 2002; Technician: Patrick MacDiarmid

Vehicle Model Year/Make/Model: 2003 Cadillac CTS 4-Door Sedan

A. No. of vent holes: 2 -Driver 2 -Passenger

B. Size of vent holes: (mm²) 491 -Driver 1257 -Passenger

C. Total vent area: (mm²) 982 -Driver 2514 -Passenger

D. Deflated air bag length and width dimensions or, if round, diameter. (mm)

Driver: 550 -Height; 460 -Width; 250 -Depth

Passenger: 680 -Height; 310 -Width; 650 -Depth

E. Is the air bag tethered?

Driver: X -Yes; - -No; If yes, record length of tether- 250

Passenger: X -Yes; - -No; If yes, record length of tether- 600

Sketch the air bag showing the location of the vent holes, how the bag is tethered, and where the bag is tethered. Also describe how the tethers are attached to the bag and the steering wheel.

(Note: Not to scale; V_n = Vent hole_n, T_n = Tether_n).

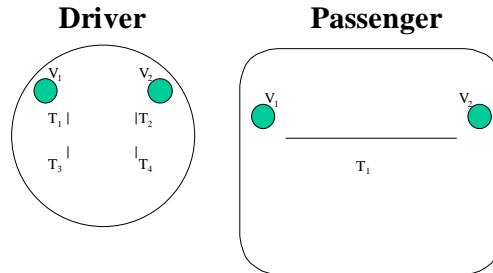

F. Record part numbers and manufacturer name of the air bag and gas generator.

Driver: Air bag: 312285 315d

 Generator: AB8185Q6W9LV0N

Passenger: Air bag: -

 Generator: AL8010M3112Y0123 GL2N4N4OACK

DATA SHEET NO. 19 ACCIDENT INVESTIGATION DIVISION DATA

FOR FRONTAL BARRIER IMPACT

Vehicle Make/Model/Body Style: Cadillac CTS 4-Door Sedan

NHTSA Test No.: M30101 VIN: 1G6DM57N130114861

Model Year: 2003 Build Date: 05/02 Test Date: May 31, 2002

Vehicle Size Category: Mid-Size Test Weight: 1851.0 kg

Vehicle Wheelbase: 3325 mm; Front Overhang: 833 mm; Overall Width: 1790 mm

Collision Deformation Classification (CDC) Code: 12FDEW3

Crush Depth Dimensions

	PRE (mm)	POST (mm)	DIFF (mm)
C1 =	4654	4338	316
C2 =	4754	4292	462
C3 =	4805	4258	547
C4 =	4808	4288	520
C5 =	4763	4354	409
C6 =	4661	4381	280

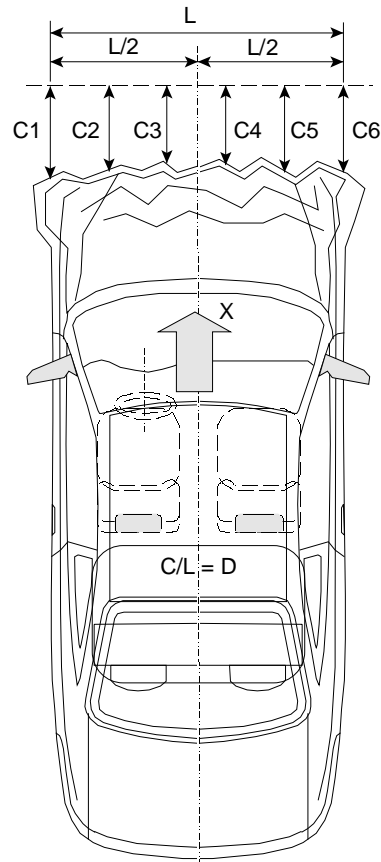

Midpoint of Damage: D = Vehicle Centerline (Longitudinal)

Length of Damaged Region: L1= 1522 mm

L2= 761.0 mm

L5= 304.4 mm

APPENDIX A
PHOTOGRAPHS

TABLE OF PHOTOGRAPHS

<u>Figure</u>	<u>Title</u>	<u>Page</u>
A-1	LOAD CELL LOCATIONS.	A-3
A-2	PRE-TEST FRONT VIEW	A-4
A-3	POST-TEST FRONT VIEW.	A-5
A-4	PRE-TEST LEFT SIDE VIEW	A-6
A-5	POST-TEST LEFT SIDE VIEW	A-7
A-6	PRE-TEST RIGHT SIDE VIEW	A-8
A-7	POST-TEST RIGHT SIDE VIEW	A-9
A-8	PRE-TEST RIGHT FRONT THREE-QUARTER VIEW	A-10
A-9	POST-TEST RIGHT FRONT THREE-QUARTER VIEW	A-11
A-10	PRE-TEST LEFT REAR THREE-QUARTER VIEW	A-12
A-11	POST-TEST LEFT REAR THREE-QUARTER VIEW	A-13
A-12	PRE-TEST WINDSHIELD VIEW	A-14
A-13	POST-TEST WINDSHIELD VIEW	A-15
A-14	PRE-TEST ENGINE COMPARTMENT VIEW	A-16
A-15	FUEL CAP VIEW	A-17
A-16	PRE-TEST FRONT UNDERBODY VIEW	A-18
A-17	POST-TEST FRONT UNDERBODY VIEW	A-19
A-18	PRE-TEST FRONT SIDE UNDERBODY VIEW	A-20
A-19	POST-TEST FRONT SIDE UNDERBODY VIEW	A-21
A-20	PRE-TEST REAR UNDERBODY VIEW	A-22
A-21	POST-TEST REAR UNDERBODY VIEW	A-23
A-22	PRE-TEST DRIVER POSITION VIEW	A-24
A-23	POST-TEST DRIVER POSITION VIEW	A-25
A-24	PRE-TEST PASSENGER POSITION VIEW	A-26
A-25	POST-TEST PASSENGER POSITION VIEW	A-27
A-26	PRE-TEST DRIVER AND INTERIOR VIEW	A-28
A-27	POST-TEST DRIVER AND INTERIOR VIEW	A-29
A-28	PRE-TEST PASSENGER AND INTERIOR VIEW	A-30
A-29	POST-TEST PASSENGER AND INTERIOR VIEW	A-31
A-30	PRE-TEST DRIVER HEAD LOCATION	A-32
A-31	POST-TEST DRIVER HEAD LOCATION	A-33
A-32	PRE-TEST PASSENGER HEAD LOCATION	A-34
A-33	POST-TEST PASSENGER HEAD LOCATION	A-35
A-34	PRE-TEST DRIVER FLOOR PAN VIEW	A-36
A-35	POST-TEST DRIVER FLOOR PAN VIEW	A-37
A-36	PRE-TEST PASSENGER FLOOR PAN VIEW	A-38
A-37	POST-TEST PASSENGER FLOOR PAN VIEW	A-39
A-38	ROLLOVER VIEW	A-40
A-39	IMPACT VIEW	A-41
A-40	VEHICLE PLACARD	A-42
A-41	TIRE PLACARD	A-43

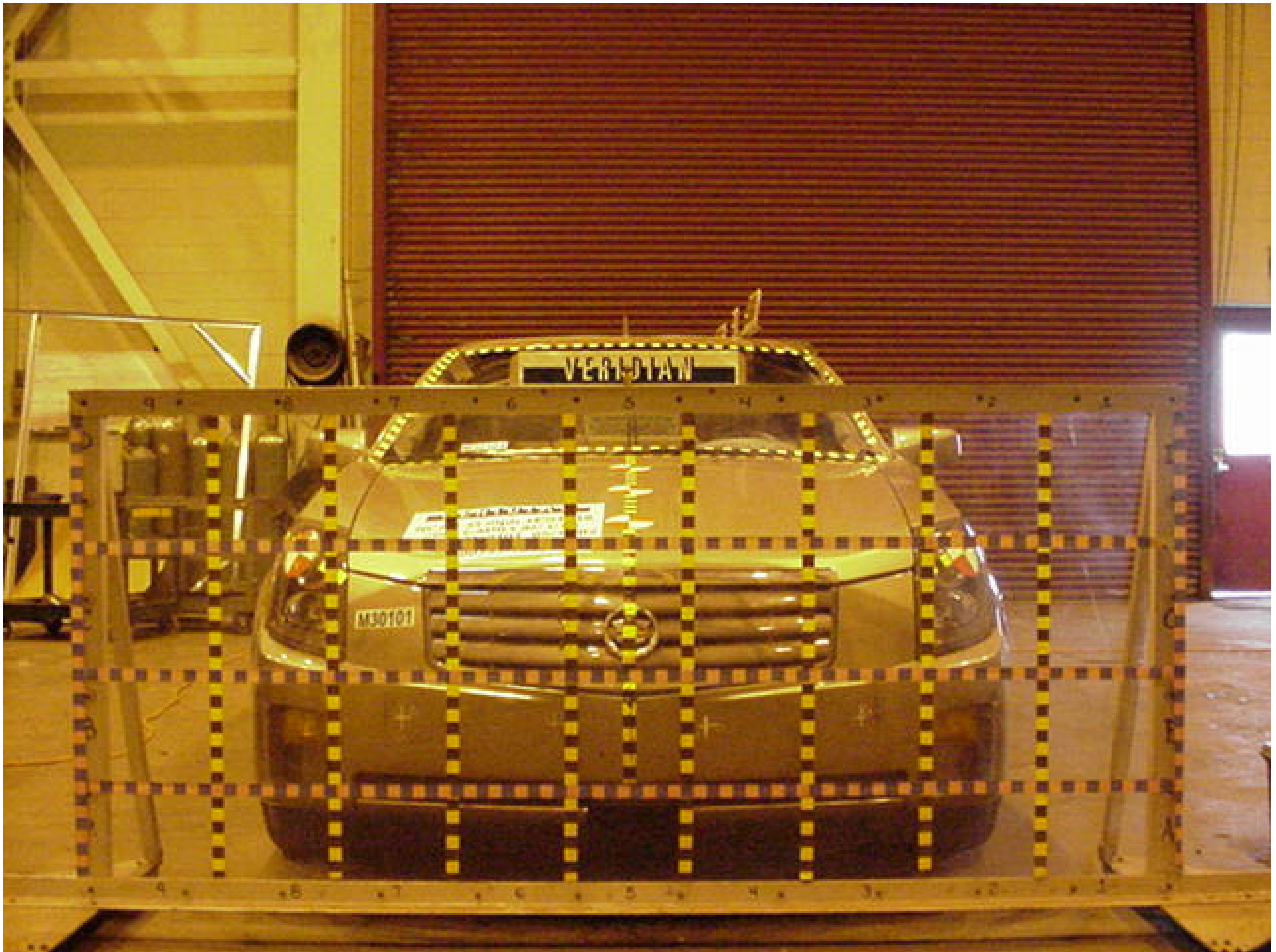

Figure A-1 LOAD CELL LOCATIONS



Figure A-2 PRE-TEST FRONT VIEW



Figure A-3 POST-TEST FRONT VIEW



Figure A-4 PRE-TEST LEFT SIDE VIEW



Figure A-5 POST-TEST LEFT SIDE VIEW



Figure A-6 PRE-TEST RIGHT SIDE VIEW



Figure A-7 POST-TEST RIGHT SIDE VIEW



Figure A-8 PRE-TEST RIGHT FRONT THREE-QUARTER VIEW



Figure A-9 POST-TEST RIGHT FRONT THREE-QUARTER VIEW



Figure A-10 PRE-TEST LEFT REAR THREE-QUARTER VIEW



Figure A-11 POST-TEST LEFT REAR THREE-QUARTER VIEW



Figure A-12 PRE-TEST WINDSHIELD VIEW

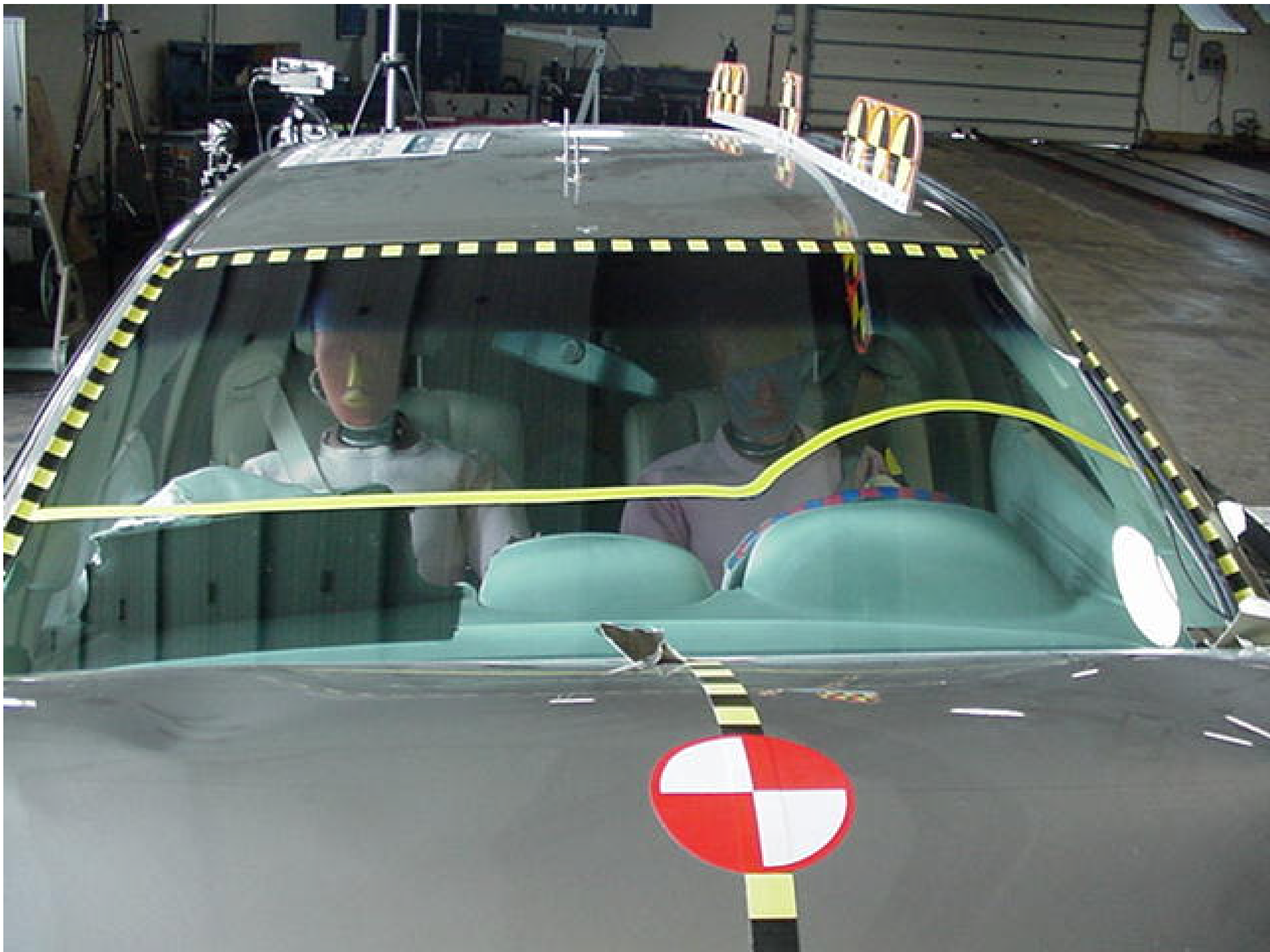

Figure A-13 POST-TEST WINDSHIELD VIEW



A-16

8642-NCAP-18

Figure A-14 PRE-TEST ENGINE COMPARTMENT VIEW



Figure A-15 FUEL CAP VIEW

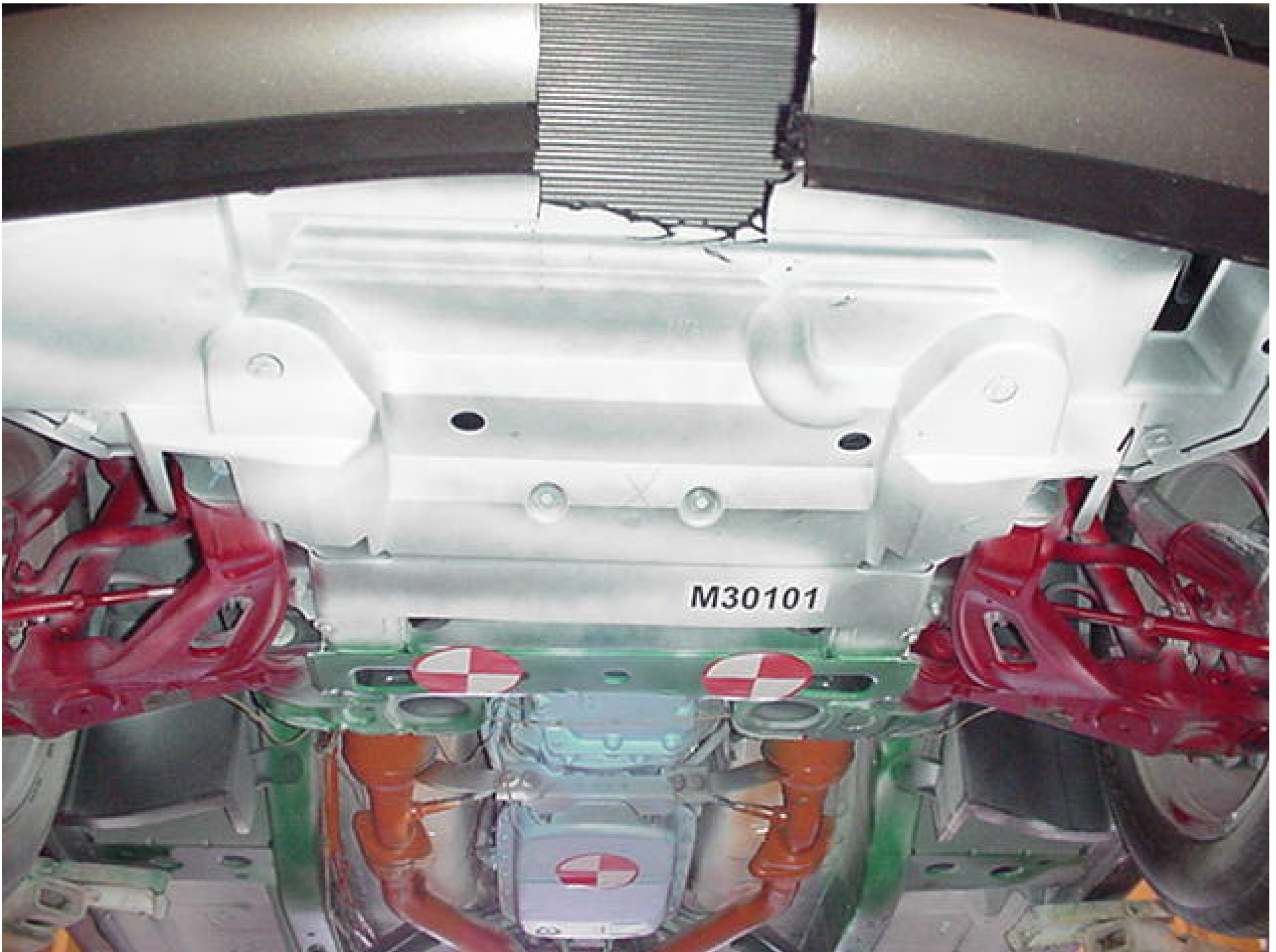

A-18

8642-NCAP-18

Figure A-16 PRE-TEST FRONT UNDERBODY VIEW

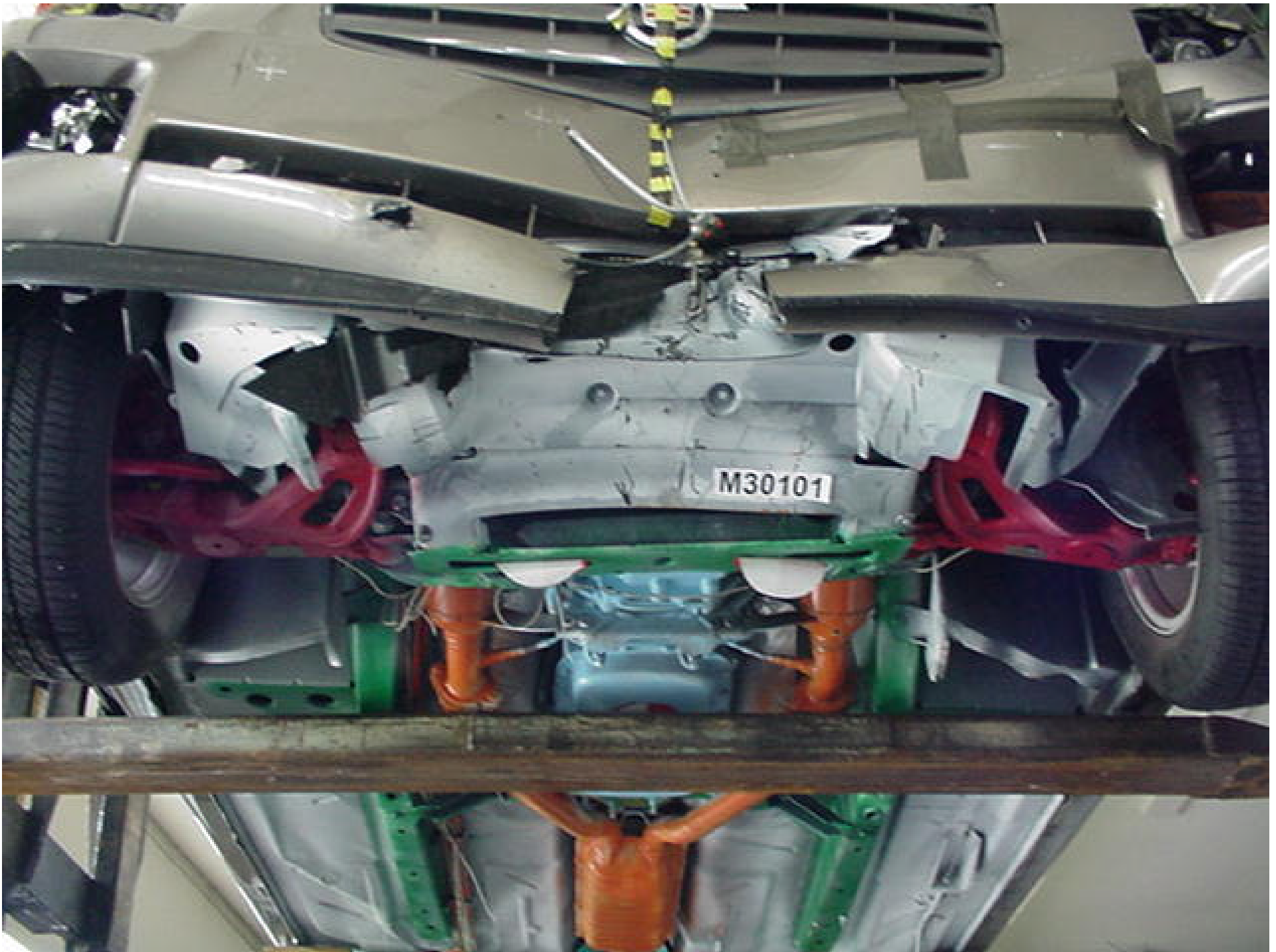

A-19

8642-NCAP-18

Figure A-17 POST-TEST FRONT UNDERBODY VIEW

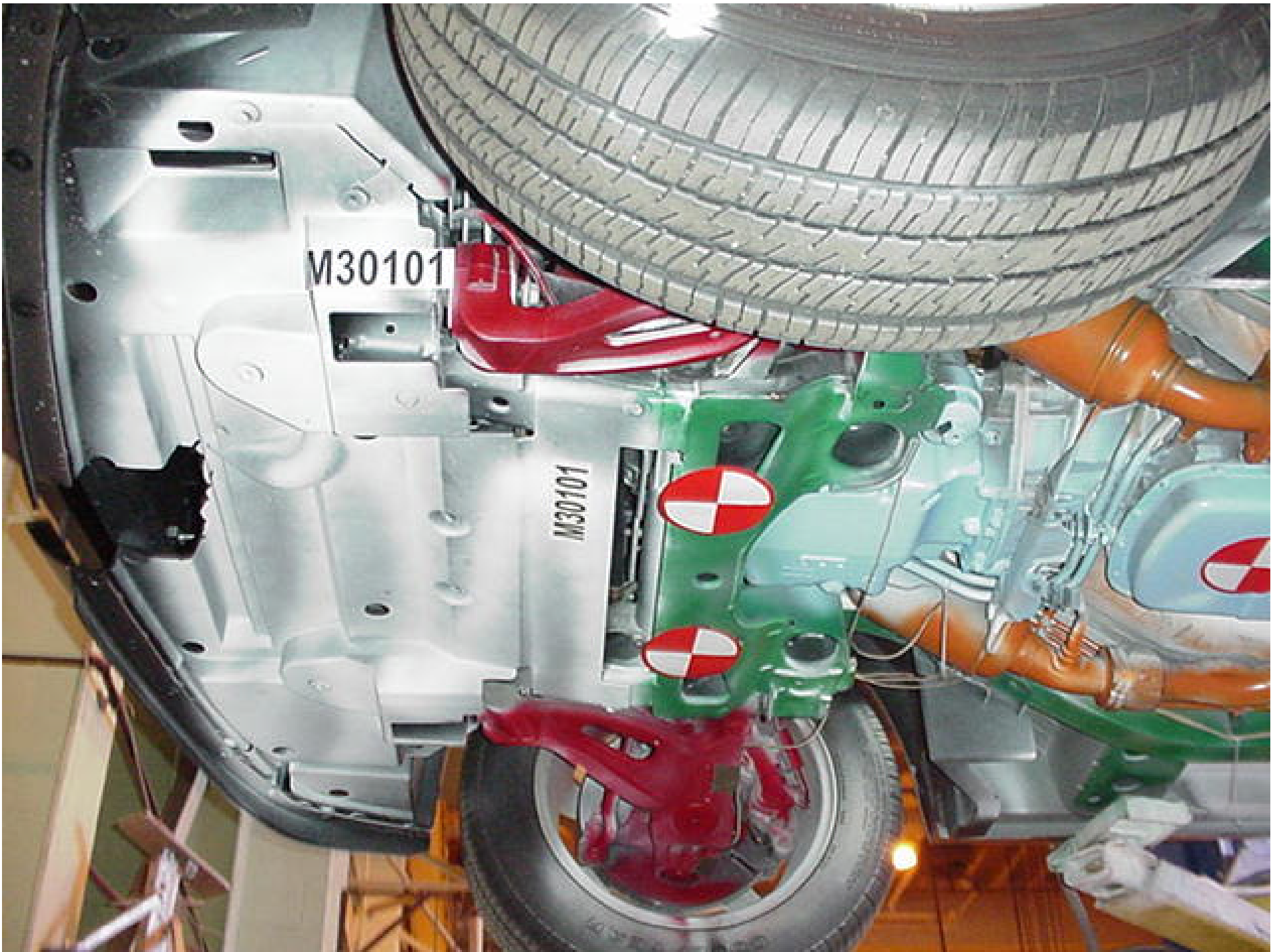

Figure A-18 PRE-TEST FRONT SIDE UNDERBODY VIEW

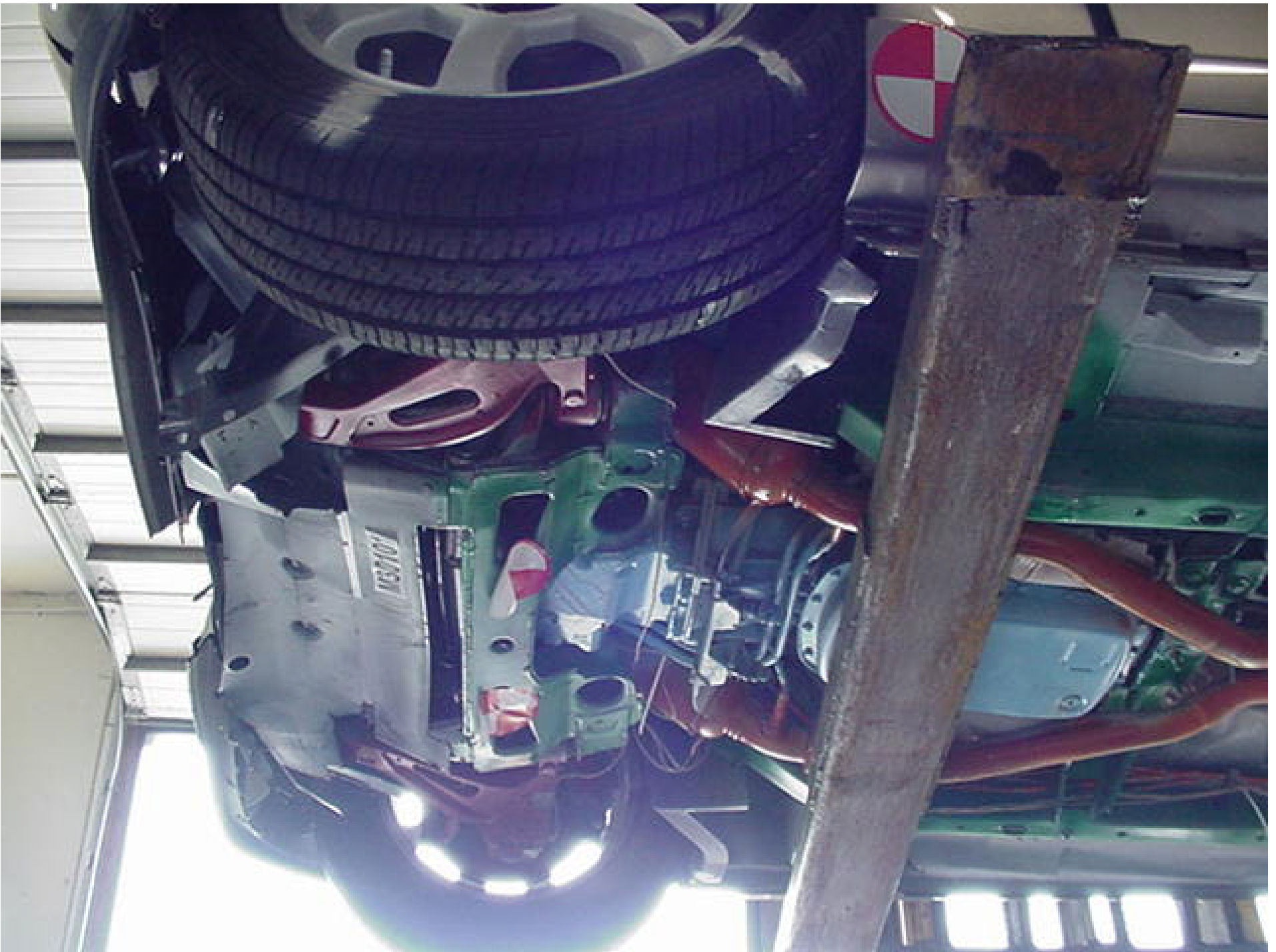

Figure A-19 POST-TEST FRONT SIDE UNDERBODY VIEW

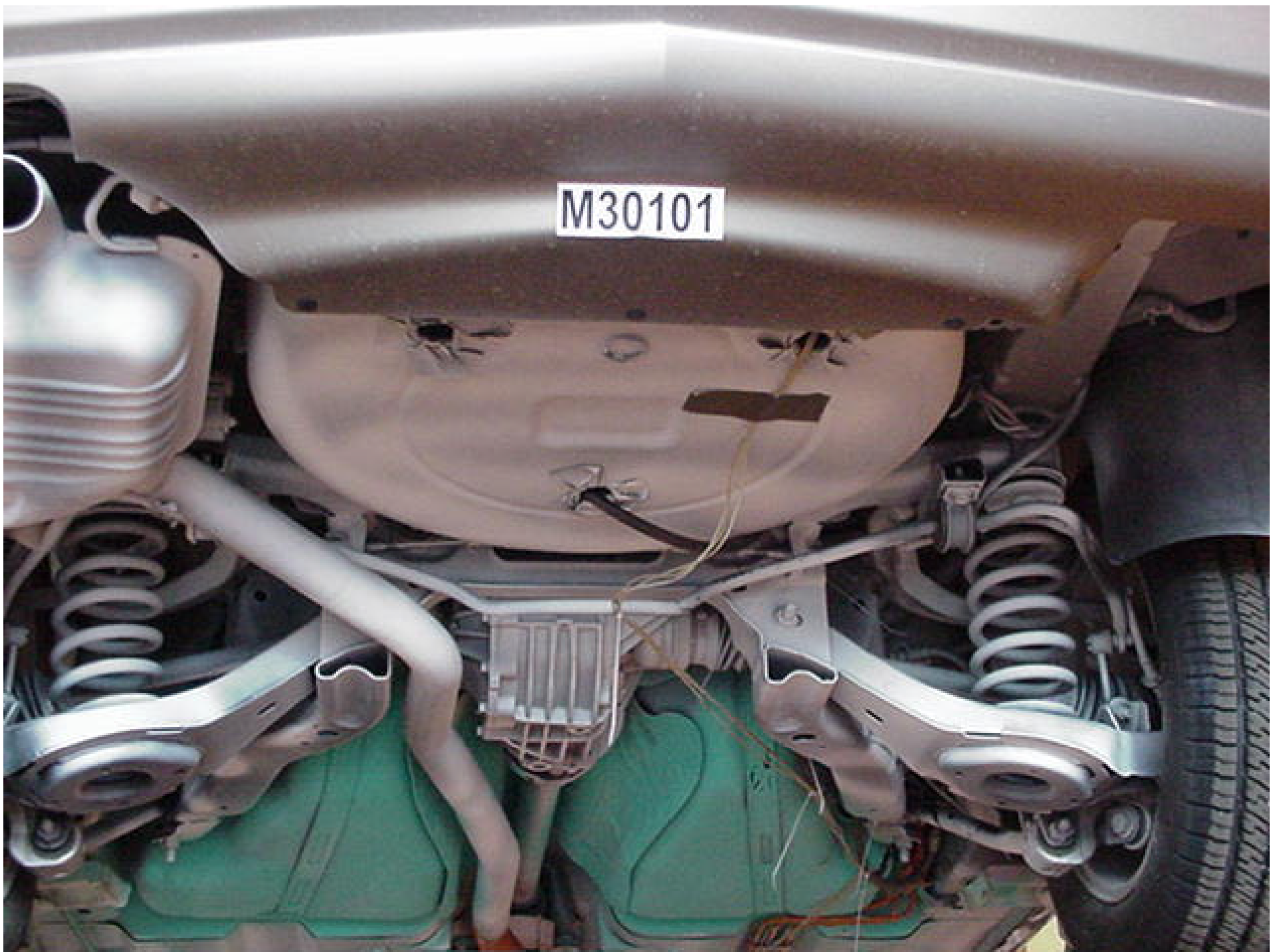

Figure A-20 PRE-TEST REAR UNDERBODY VIEW

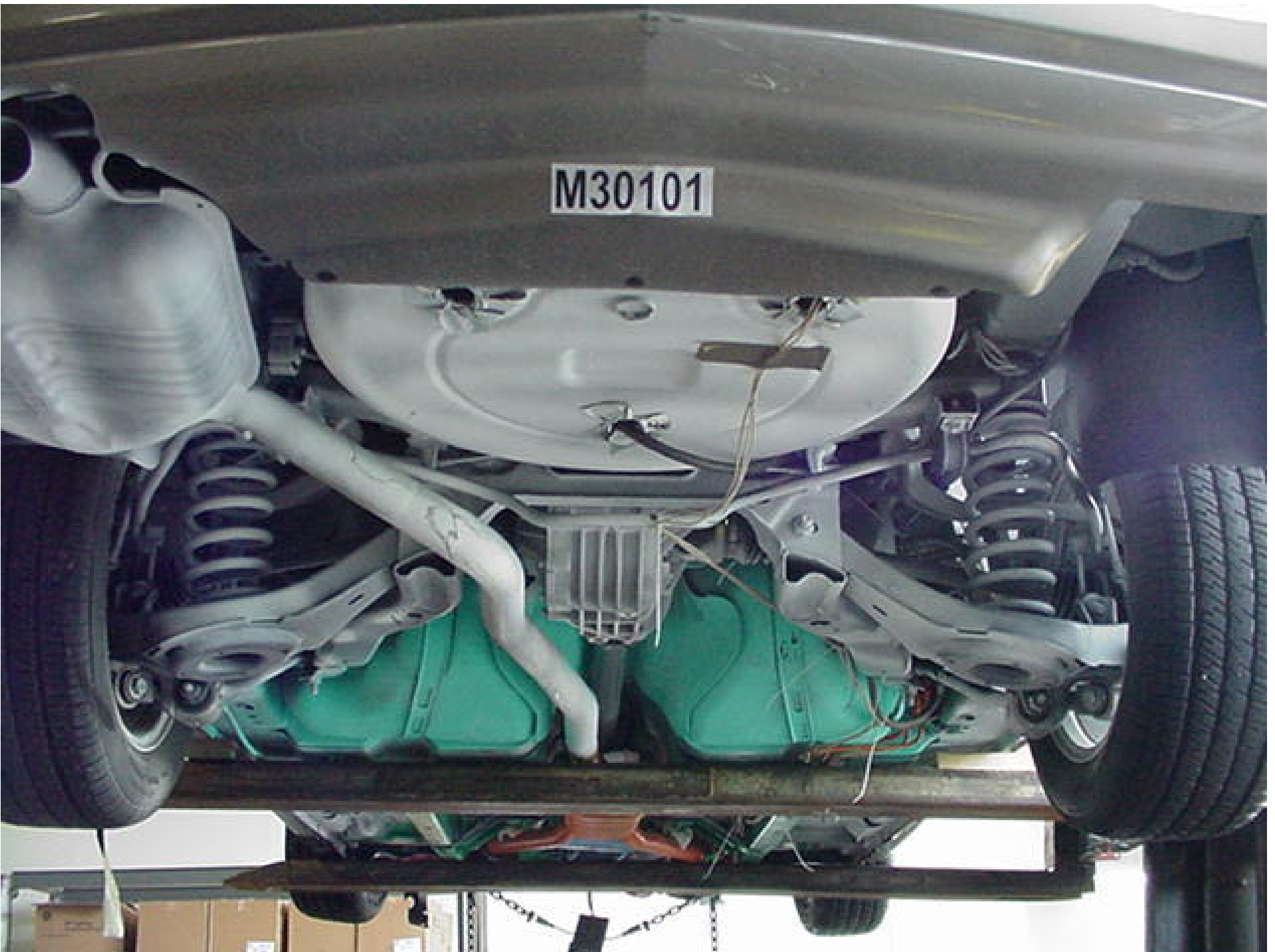

Figure A-21 POST-TEST REAR UNDERBODY VIEW



Figure A-22 PRE-TEST DRIVER POSITION VIEW



Figure A-23 POST-TEST DRIVER POSITION VIEW



Figure A-24 PRE-TEST PASSENGER POSITION VIEW



Figure A-25 POST-TEST PASSENGER POSITION VIEW



Figure A-26 PRE-TEST DRIVER AND INTERIOR VIEW



Figure A-27 POST-TEST DRIVER AND INTERIOR VIEW



Figure A-28 PRE-TEST PASSENGER AND INTERIOR VIEW



A-31

8642-NCAP-18

Figure A-29 POST-TEST PASSENGER AND INTERIOR VIEW



Figure A-30 PRE-TEST DRIVER HEAD LOCATION



Figure A-31 POST-TEST DRIVER HEAD LOCATION



Figure A-32 PRE-TEST PASSENGER HEAD LOCATION



Figure A-33 POST-TEST PASSENGER HEAD LOCATION



A-36

8642-NCAP-18

Figure A-34 PRE-TEST DRIVER FLOOR PAN VIEW



Figure A-35 POST-TEST DRIVER FLOOR PAN VIEW



A-38

8642-NCAP-18

Figure A-36 PRE-TEST PASSENGER FLOOR PAN VIEW



Figure A-37 POST-TEST PASSENGER FLOOR PAN VIEW



Figure A-38 ROLLOVER VIEW

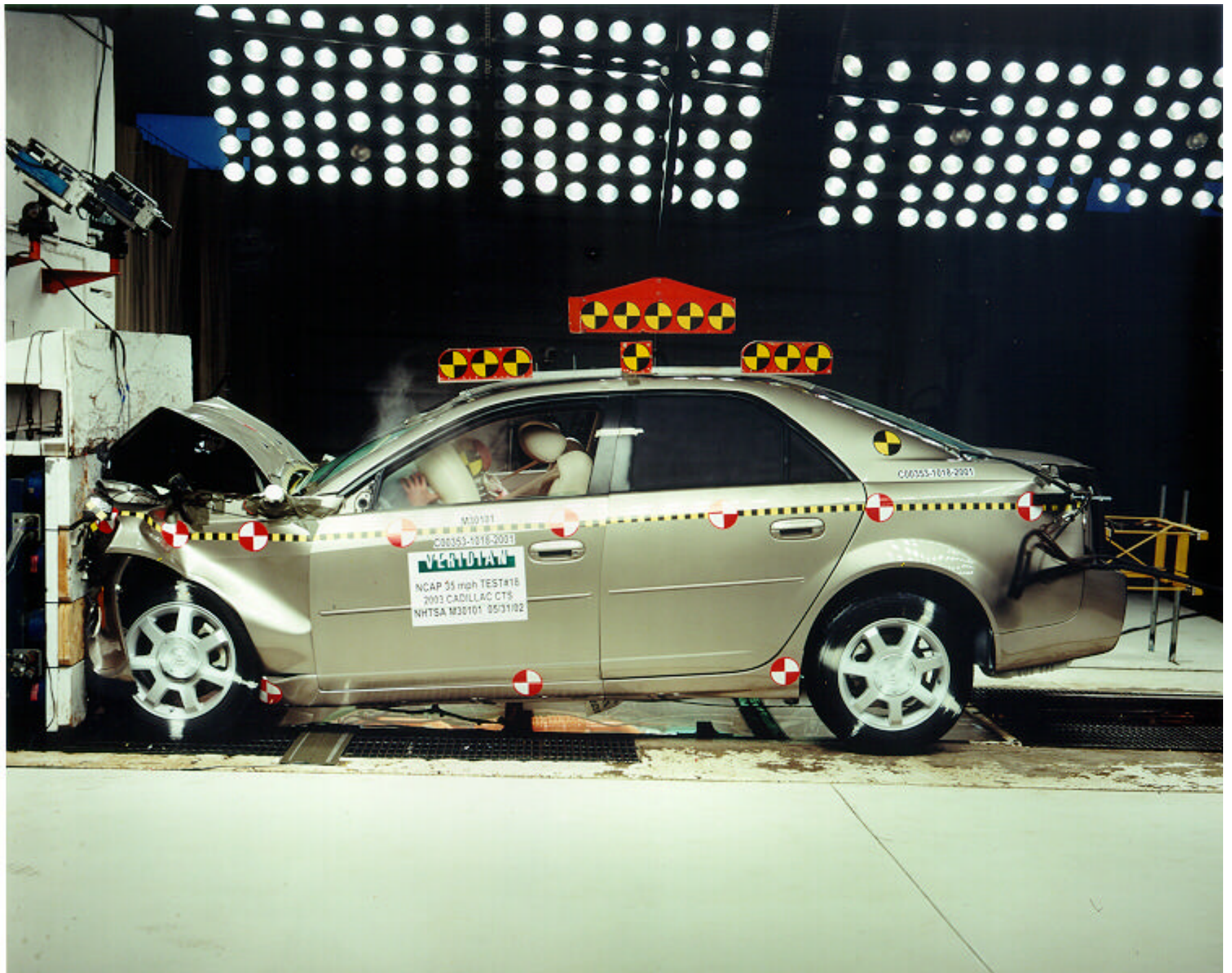

Figure A-39 IMPACT VIEW



Figure A-40 VEHICLE PLACARD



TIRE – LOADING INFORMATION

OCCUPANTS				VEHICLE CAP. WT.	
FRT.	CTR.	RR.	TOTAL	KG	LBS
2	0	3	5	400	882

MAX. LOADING @ GVWR SAME AS VEHICLE CAPACITY WEIGHT.

1G6DM57N130114861

MODEL: DM69 DAC

	TIRE SIZE	SPEED RTG	COLD TIRE PRESSURE
FRT	P225/55R16	H	210KPA(30PSI)
RR	P225/55R16	H	210KPA(30PSI)
SPA	T125/70R16	M	420KPA(60PSI)

IF TIRES ARE HOT, ADD 28KPA(4PSI).

SEE OWNER'S MANUAL  FOR MORE INFORMATION.

Figure A-41 TIRE PLACARD

APPENDIX B

DUMMY, VEHICLE AND LOAD CELL BARRIER RESPONSE DATA

**Hybrid III Dummy Sign Conventions
Load Cells and Special Transducers**

Transducer	SAE Sign Convention (positive unless noted)
Upper Neck Load Cell	Fx Head rearward Fy Head left Fz Neck in tension Mx Left ear to left shoulder My Chin to chest (flexion) Mz Chin to left shoulder (look left)
Chest Displacement Potentiometer	Compression is negative
Pelvic Load Cell (Lower Lumbar)	Fx Chest rearward Fy Chest left Fz Spine in tension
Femur Load Cell	Compression is negative
Upper Tibia Load Cell (right and left leg)	Mx Support tibia at ends, load left side center My Support tibia at ends, load front (shin) center
Lower Tibia Load Cell (right and left leg)	Fz Tibia in tension Mx Support tibia at ends, load left side center My Support tibia at ends, load front (shin) center

DATA CHANNEL FILTER CLASS SUMMARY

NHTSA TEST NO.

DATA TYPE	SAE FILTER CLASS (Hz)
Dummy Head Accelerations	1000
Dummy Chest Accelerations	180
Dummy Chest Displacements	600
Dummy Femur Forces	600
Dummy Belt Loads	60
Dummy Belt Displacements	180
Dummy Neck Forces	1000
Dummy Neck Moments	600
Vehicle Accelerations	60
Vehicle Velocity Integrations	180
Vehicle Displacement Integrations	180
Load Cell Barrier Forces	60

2002 NCAP Test 18 2003 Cadillac CTS

Max: 5.0 [g] at 0.144 [s]

Min: -6.6 [g] at 0.073 [s]

P1 Head 9 Array X Arm Ay

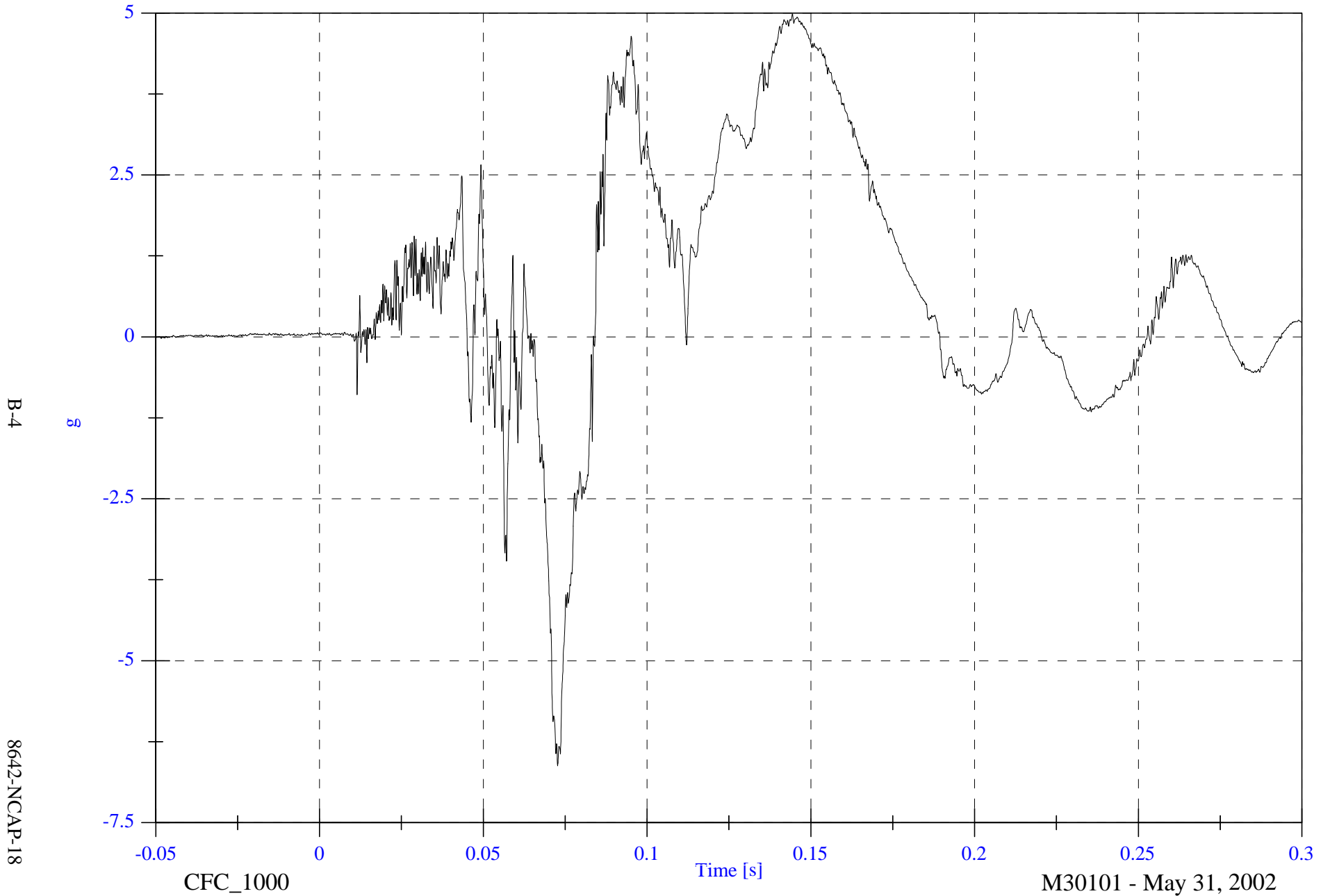

2002 NCAP Test 18 2003 Cadillac CTS

P1 Head 9 Array X Arm Az

Max: 25.1 [g] at 0.047 [s]

Min: -8.7 [g] at 0.129 [s]

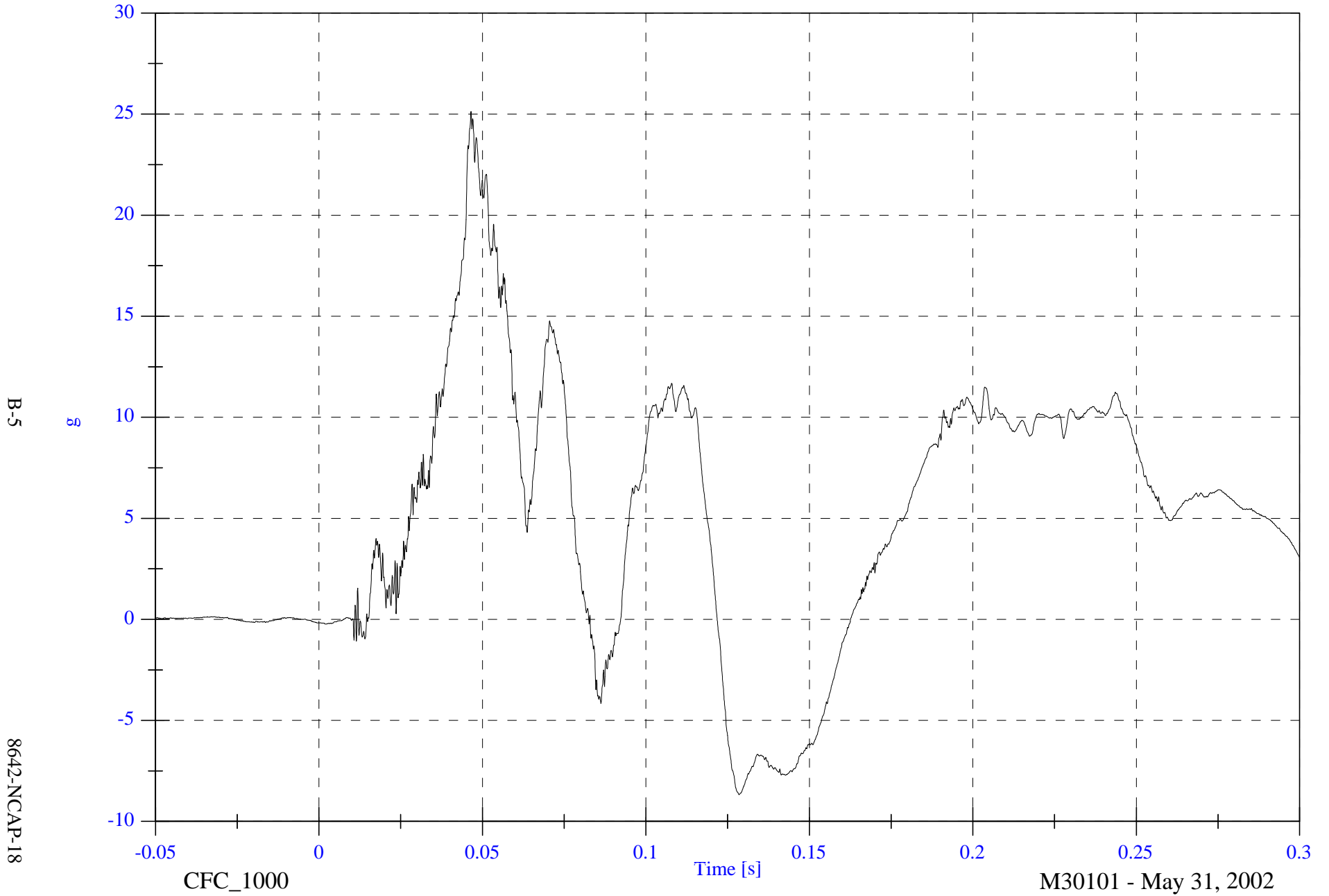

2002 NCAP Test 18 2003 Cadillac CTS

P1 Head 9 Array Y Arm Ax

Max: 8.9 [g] at 0.261 [s]

Min: -57.1 [g] at 0.077 [s]

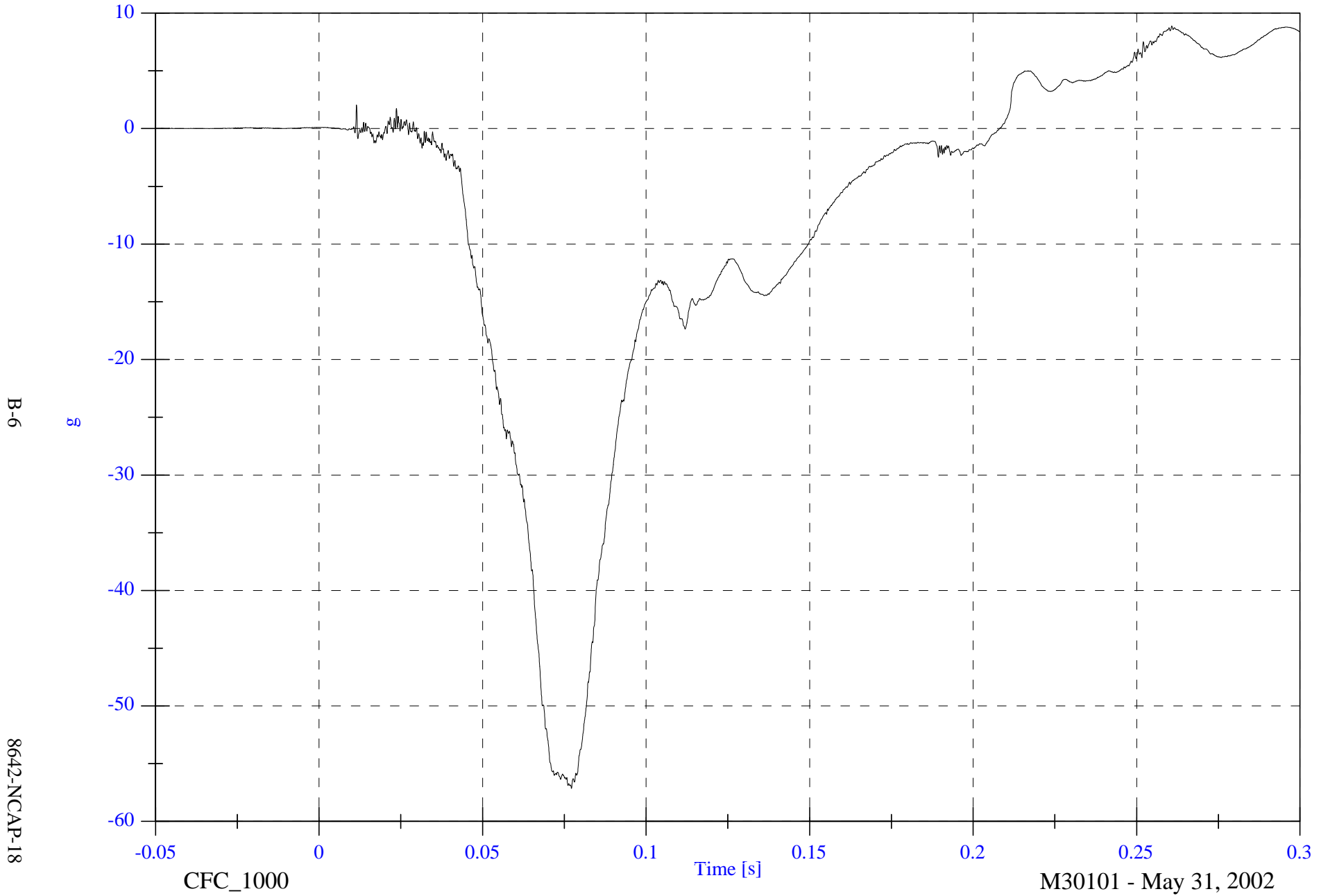

2002 NCAP Test 18 2003 Cadillac CTS

P1 Head 9 Array Y Arm Az

Max: 23.2 [g] at 0.067 [s]

Min: -6.7 [g] at 0.091 [s]

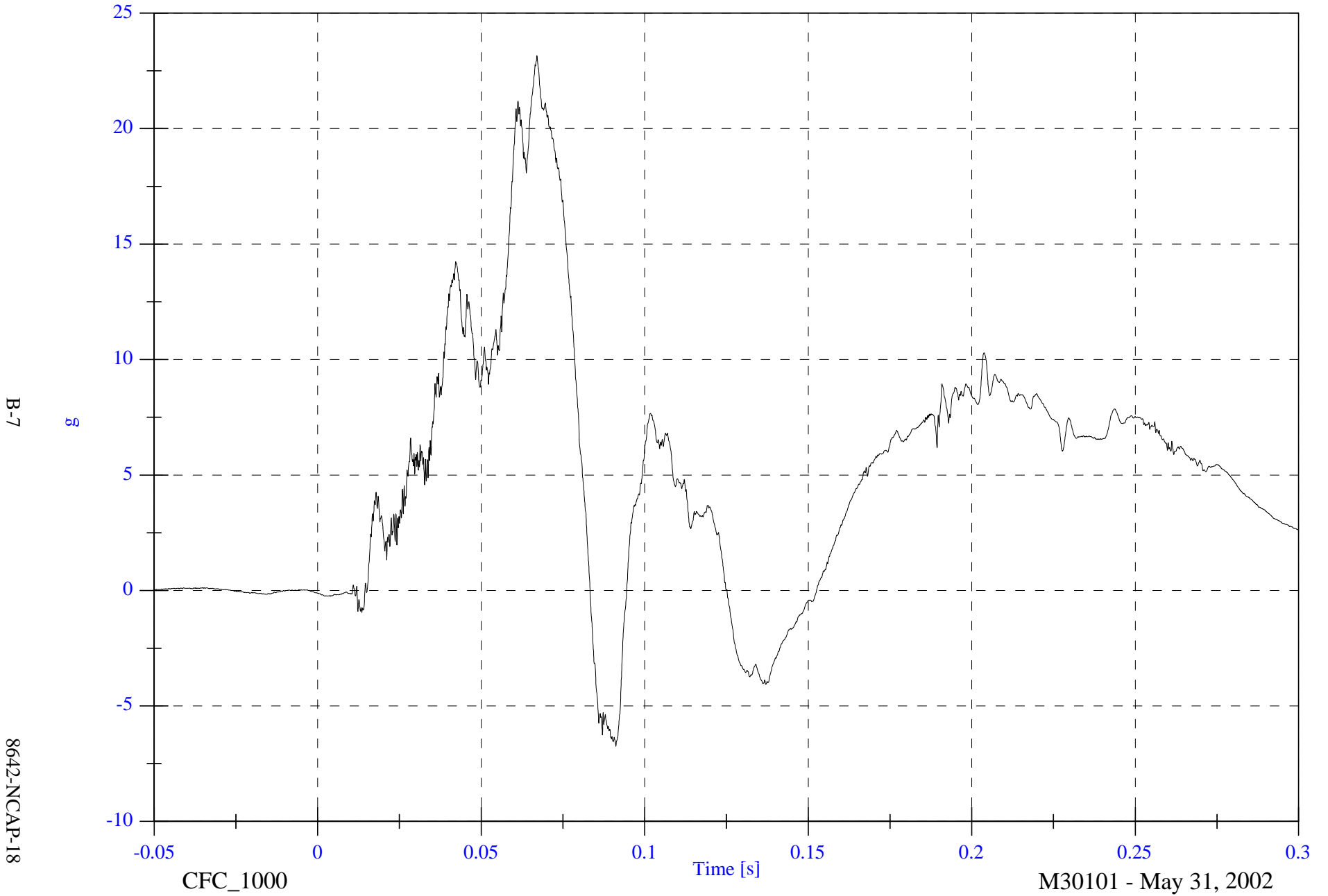

B-7

8642-NCAP-18

2002 NCAP Test 18 2003 Cadillac CTS

P1 Head 9 Array Z Arm Ax

Max: 11.2 [g] at 0.240 [s]

Min: -65.0 [g] at 0.078 [s]

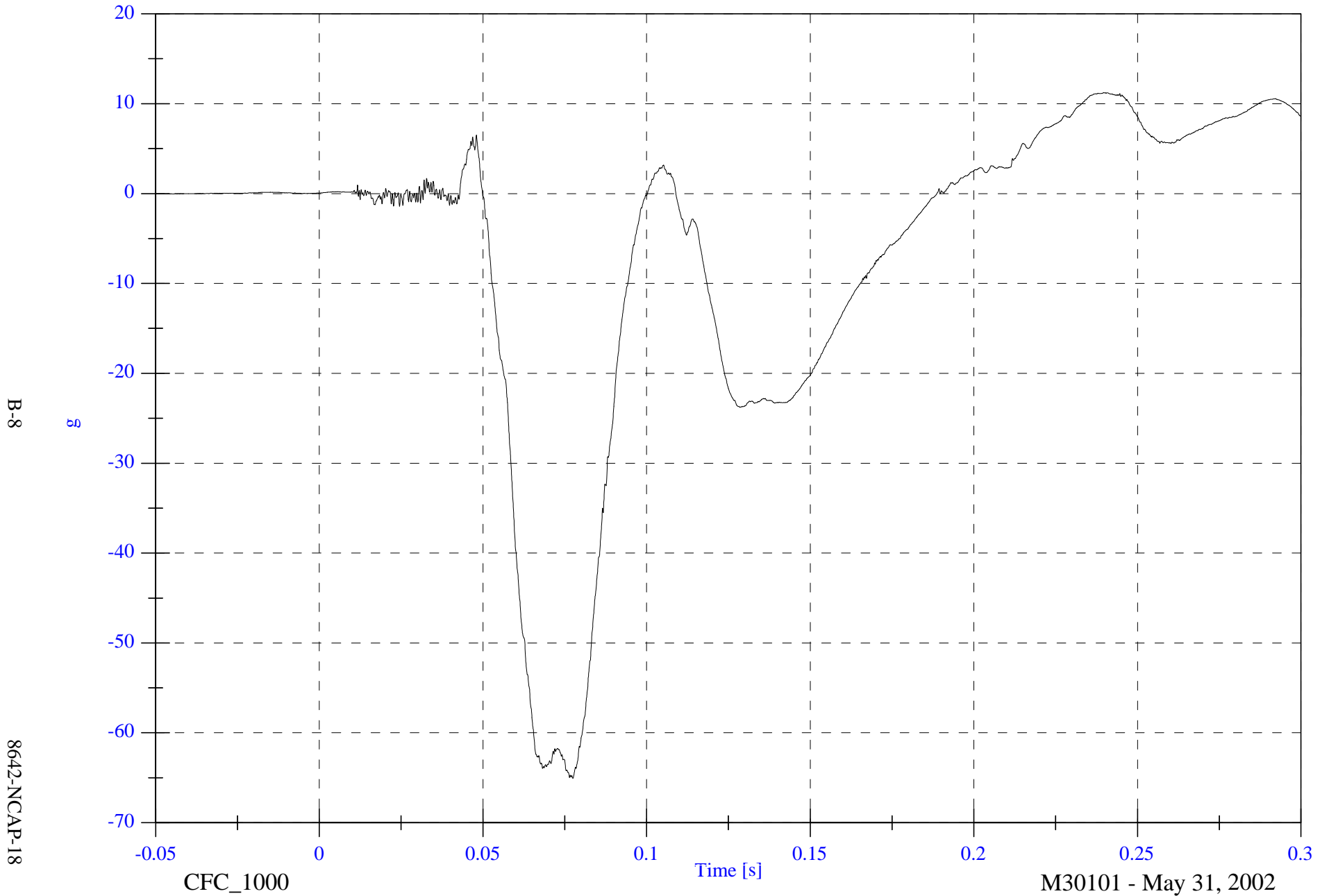

B-8

8642-NCAP-18

CFC_1000

Time [s]

M30101 - May 31, 2002

2002 NCAP Test 18 2003 Cadillac CTS

Max: 9.0 [g] at 0.127 [s]

Min: -9.0 [g] at 0.073 [s]

P1 Head 9 Array Z Arm Ay

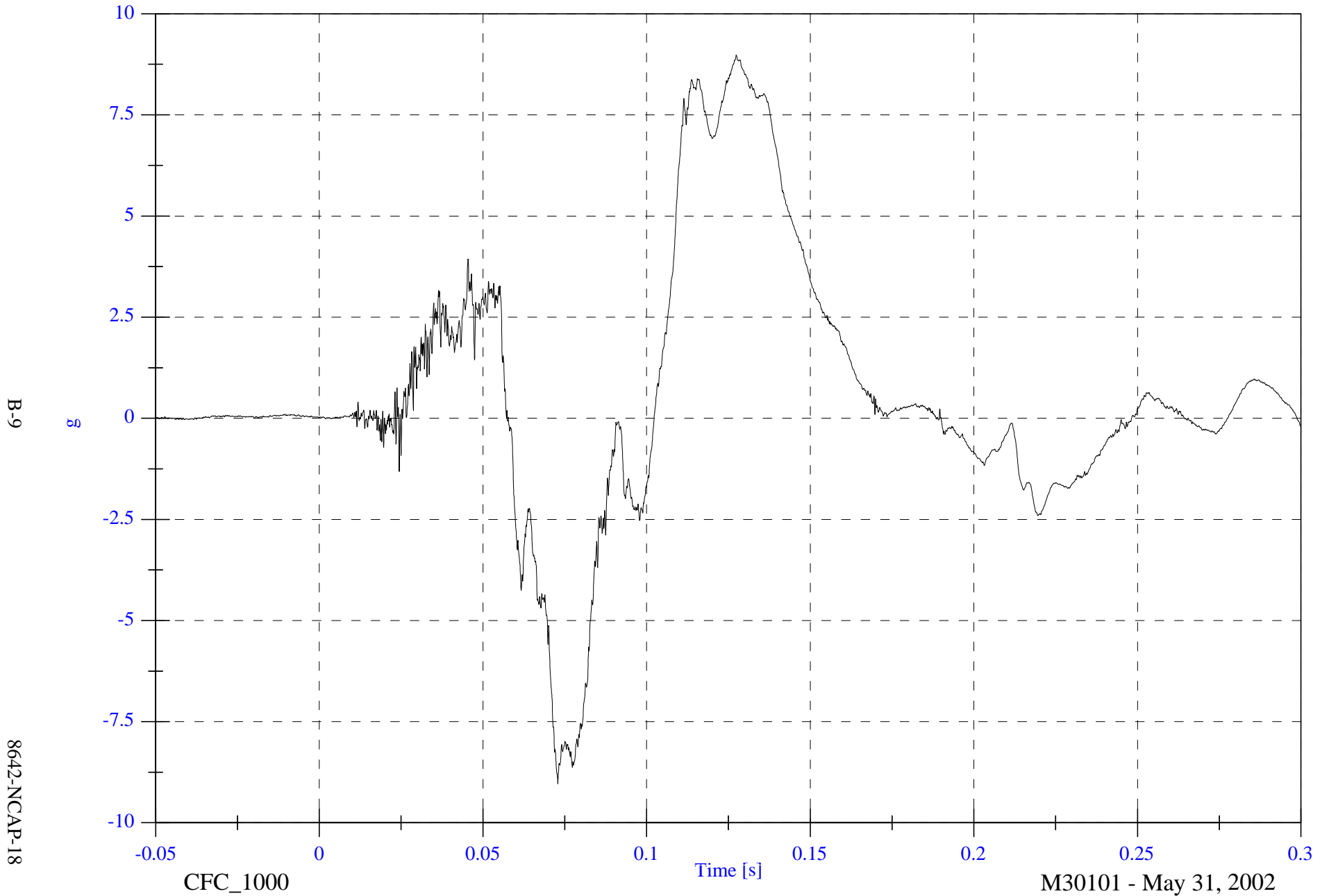

2002 NCAP Test 18 2003 Cadillac CTS

Max: 8.8 [g] at 0.293 [s]

Min: -58.0 [g] at 0.078 [s]

P1 Head CG x

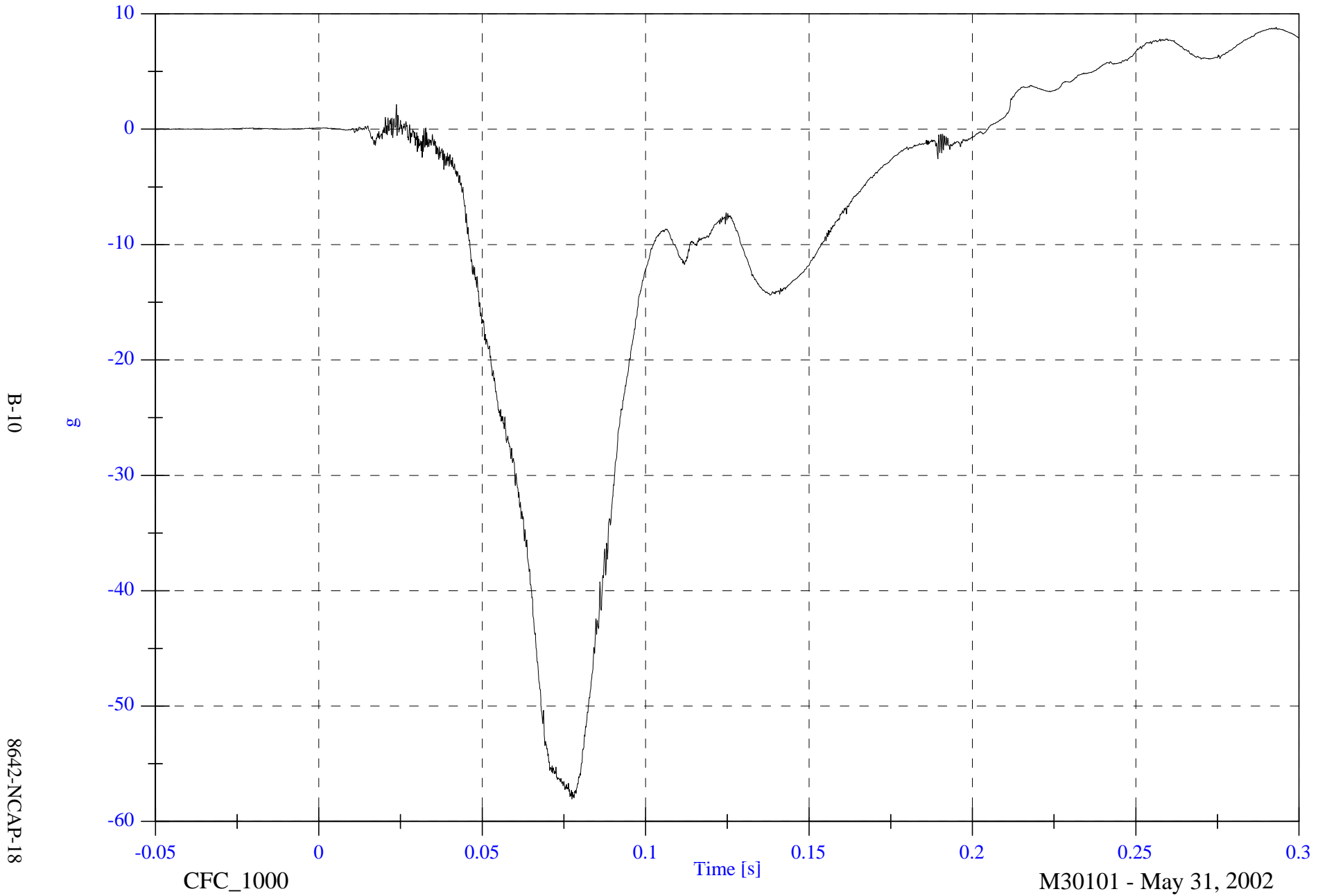

2002 NCAP Test 18 2003 Cadillac CTS

Max: 6.0 [g] at 0.125 [s]
Min: -6.8 [g] at 0.072 [s]

P1 Head CG y

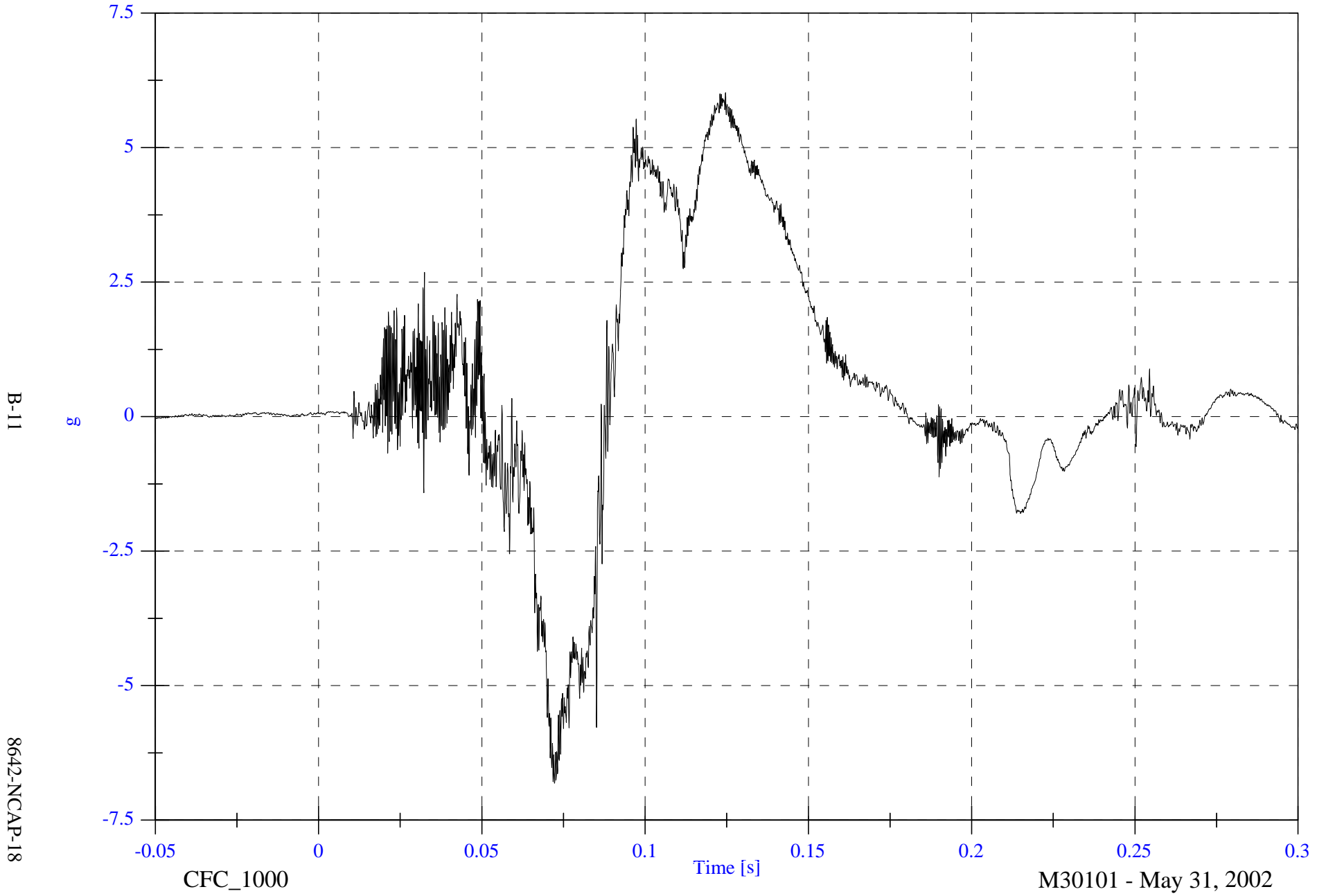

2002 NCAP Test 18 2003 Cadillac CTS

Max: 21.3 [g] at 0.067 [s]

Min: -7.6 [g] at 0.091 [s]

P1 Head CG z

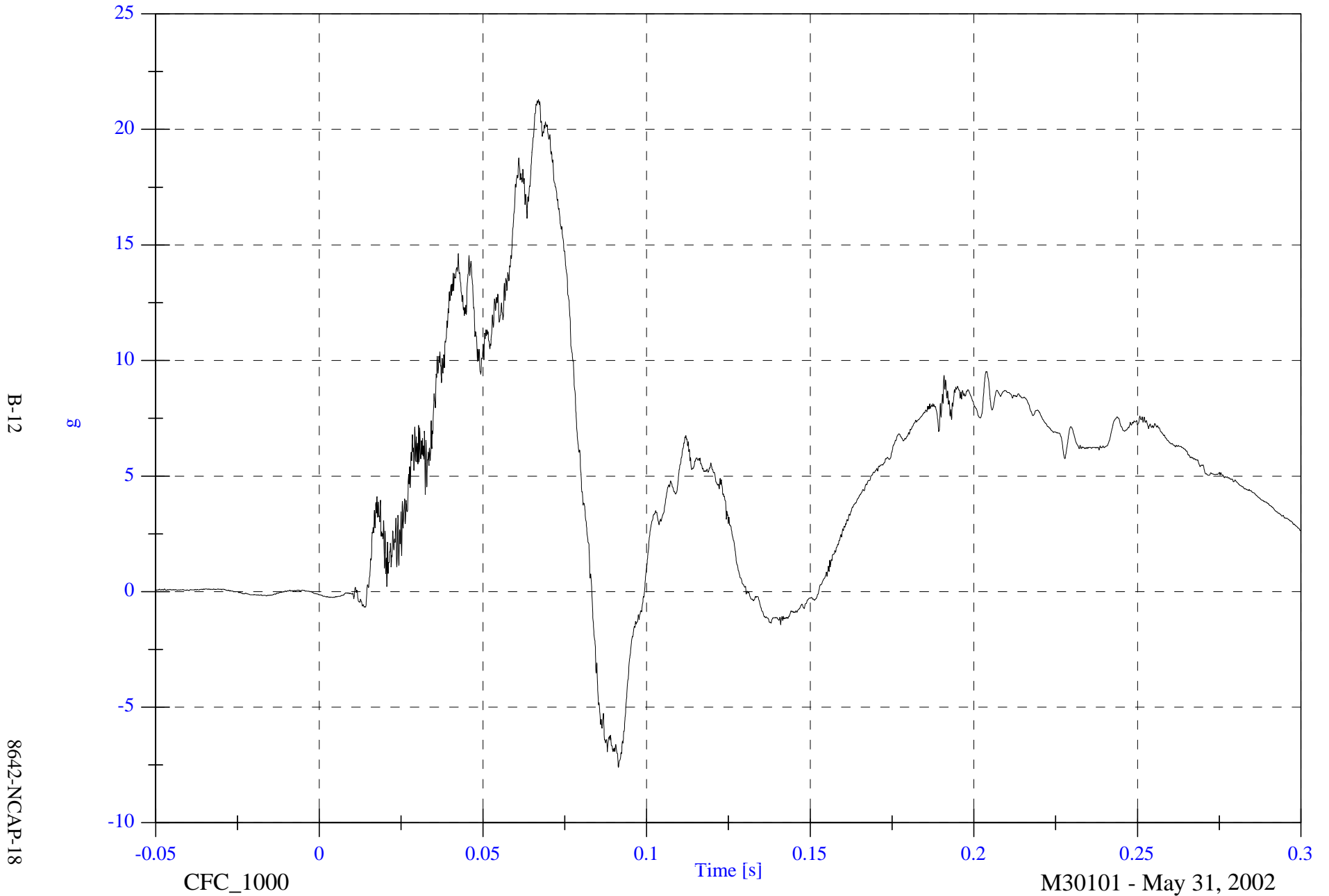

2002 NCAP Test 18 2003 Cadillac CTS

P1 Head CG Resultant

Max: 59.2 [g] at 0.075 [s]

Min: 0.0 [g] at -0.009 [s]

B-13

8642-NCAP-18

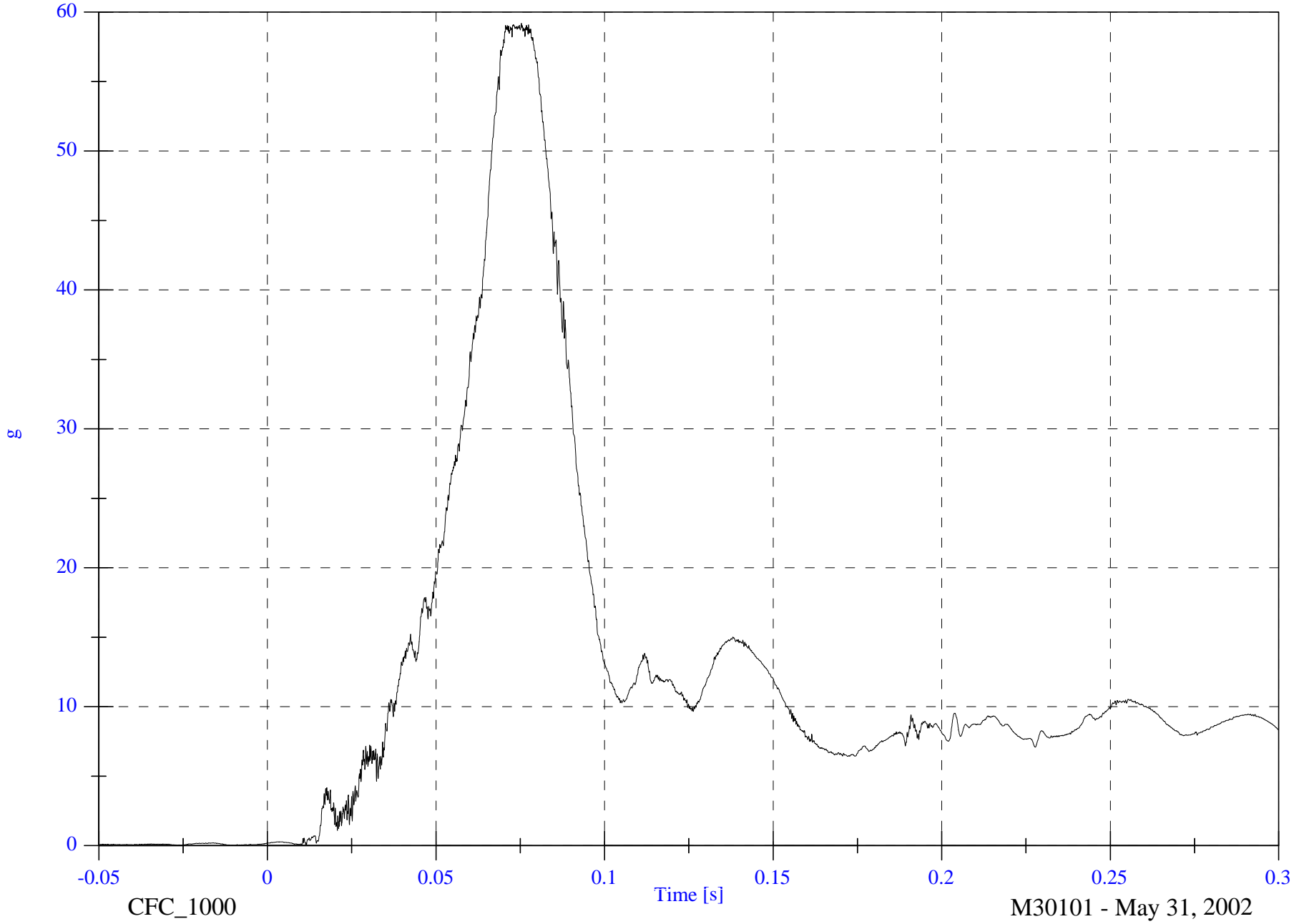

CFC_1000

Time [s]

M30101 - May 31, 2002

2002 NCAP Test 18 2003 Cadillac CTS

P1 Head CG Red x

Max: 8.8 [g] at 0.292 [s]

Min: -58.5 [g] at 0.078 [s]

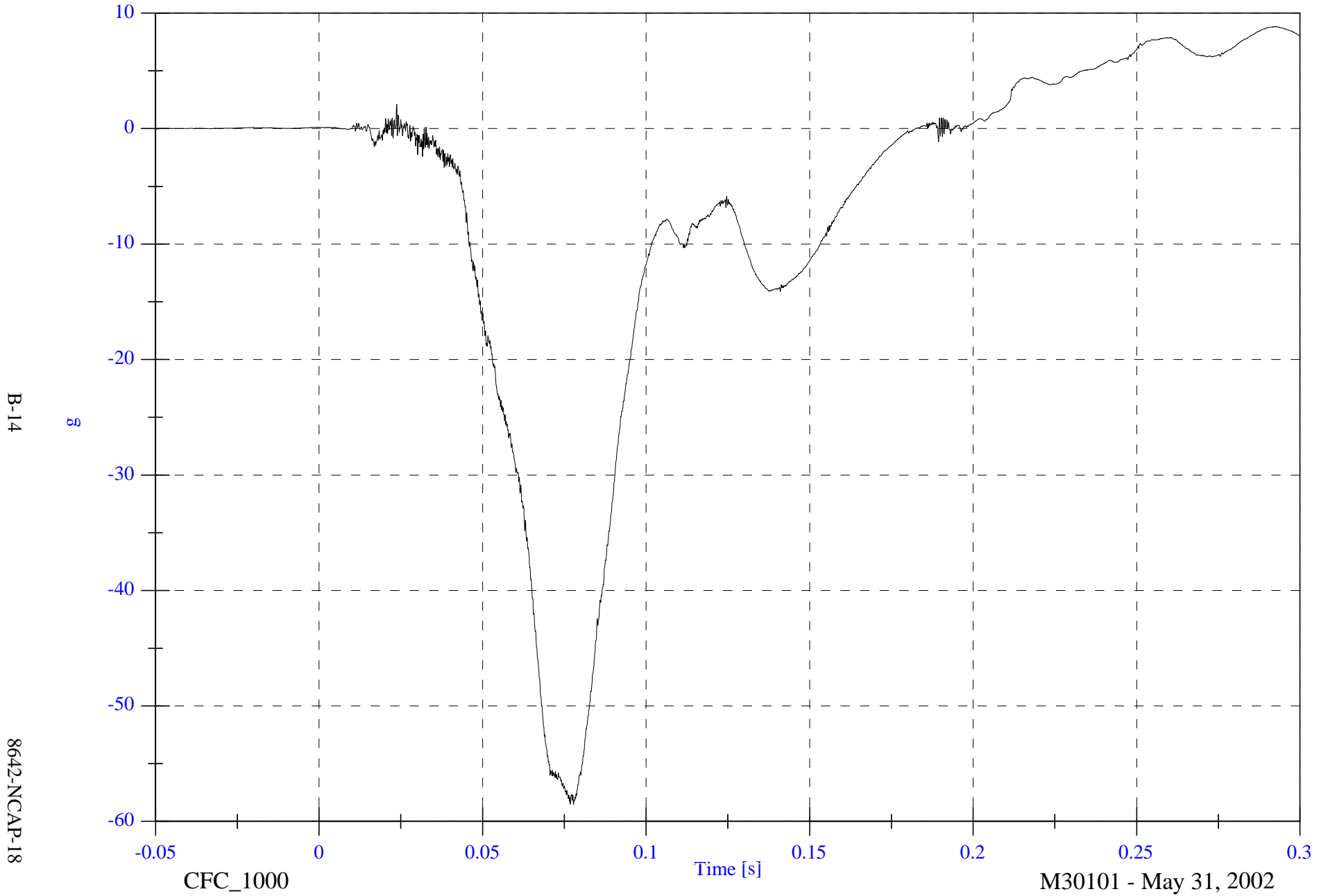

2002 NCAP Test 18 2003 Cadillac CTS

Max: 5.9 [g] at 0.124 [s]

Min: -7.9 [g] at 0.072 [s]

P1 Head CG Red y

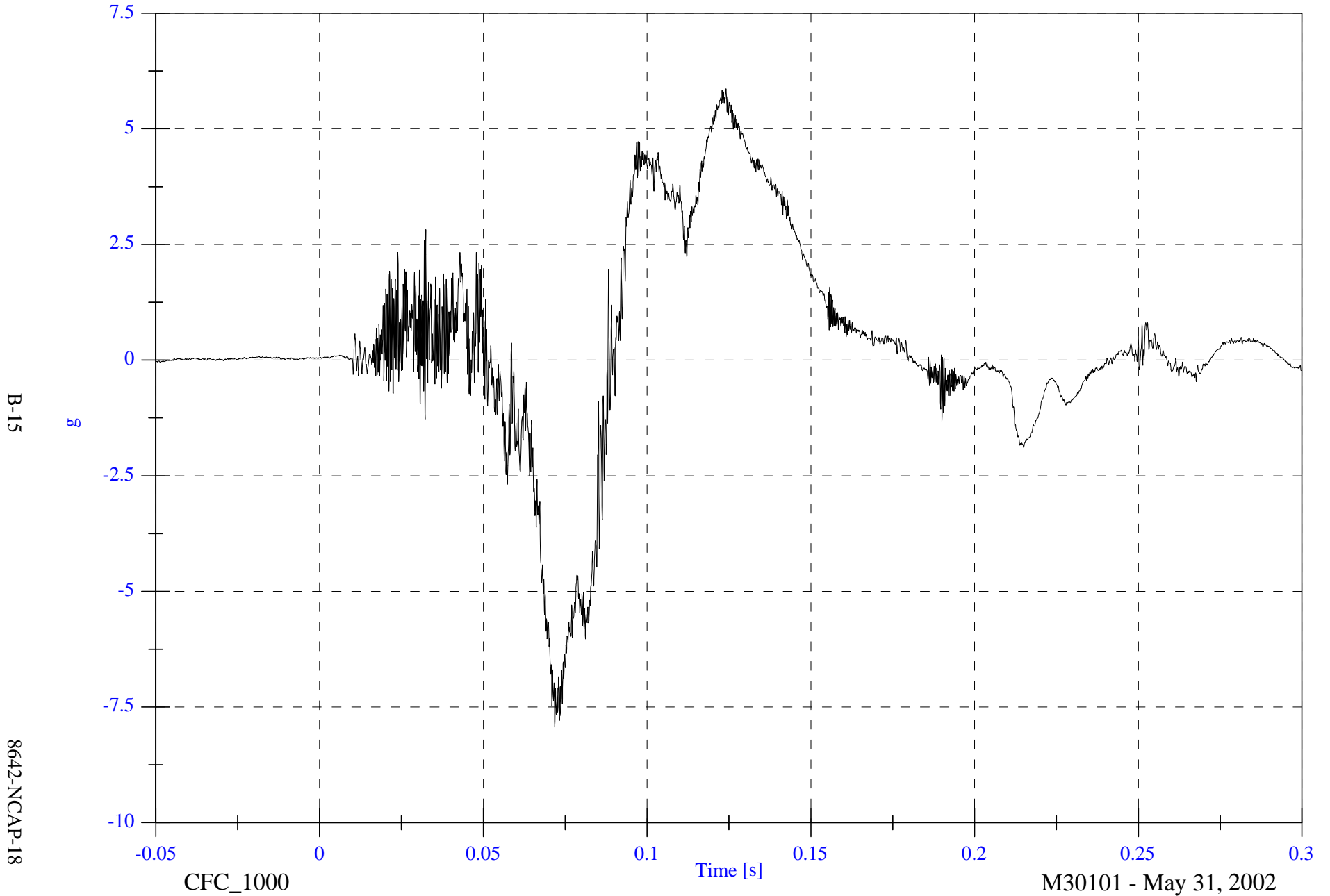

2002 NCAP Test 18 2003 Cadillac CTS

P1 Head CG Red z

Max: 21.4 [g] at 0.067 [s]

Min: -7.3 [g] at 0.091 [s]

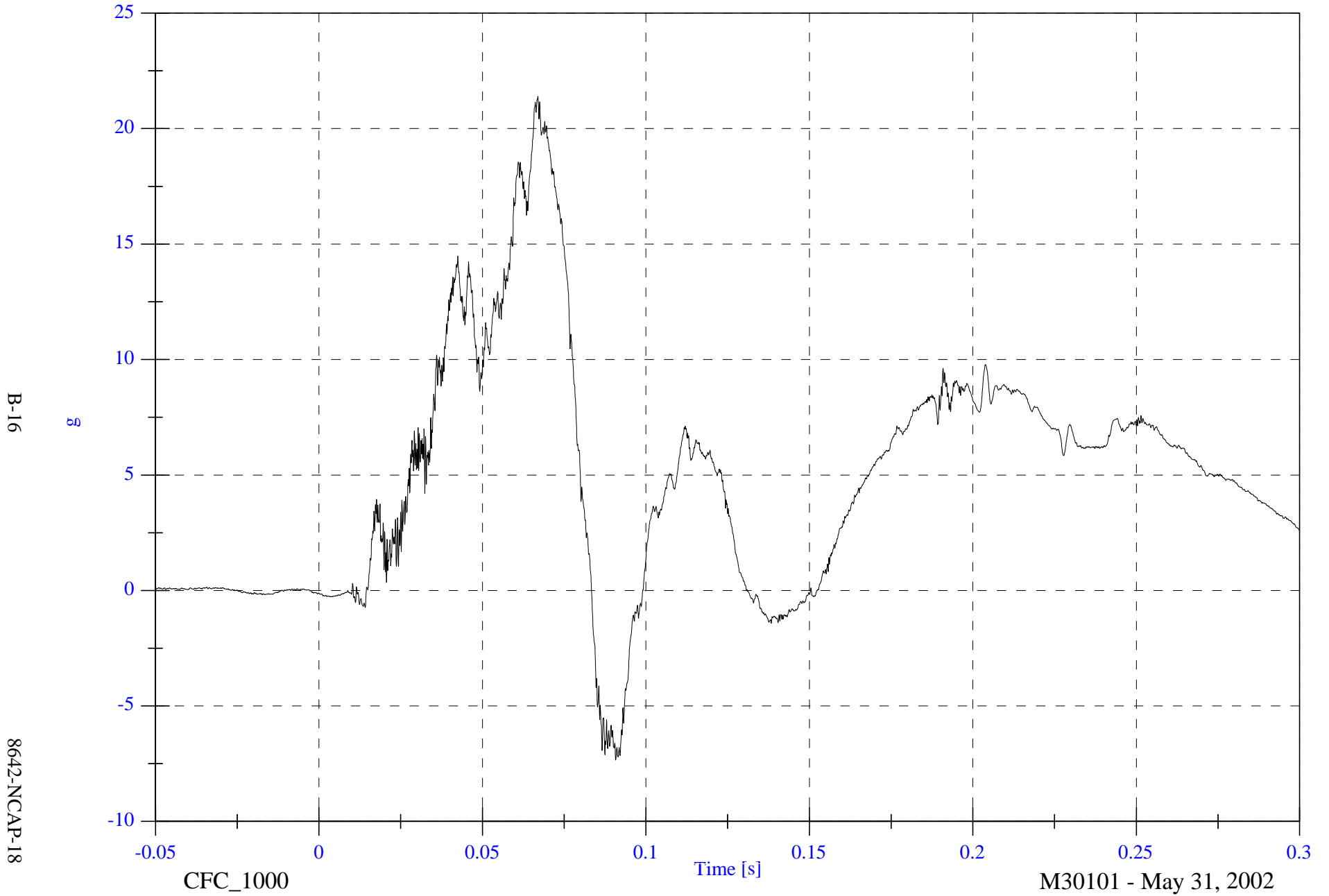

B-16

8642-NCAP-18

CFC_1000

Time [s]

M30101 - May 31, 2002

2002 NCAP Test 18 2003 Cadillac CTS

Max: 59.7 [g] at 0.076 [s]

P1 Head CG Red Resultant

Min: 0.0 [g] at -0.010 [s]

B-17

8642-NCAP-18

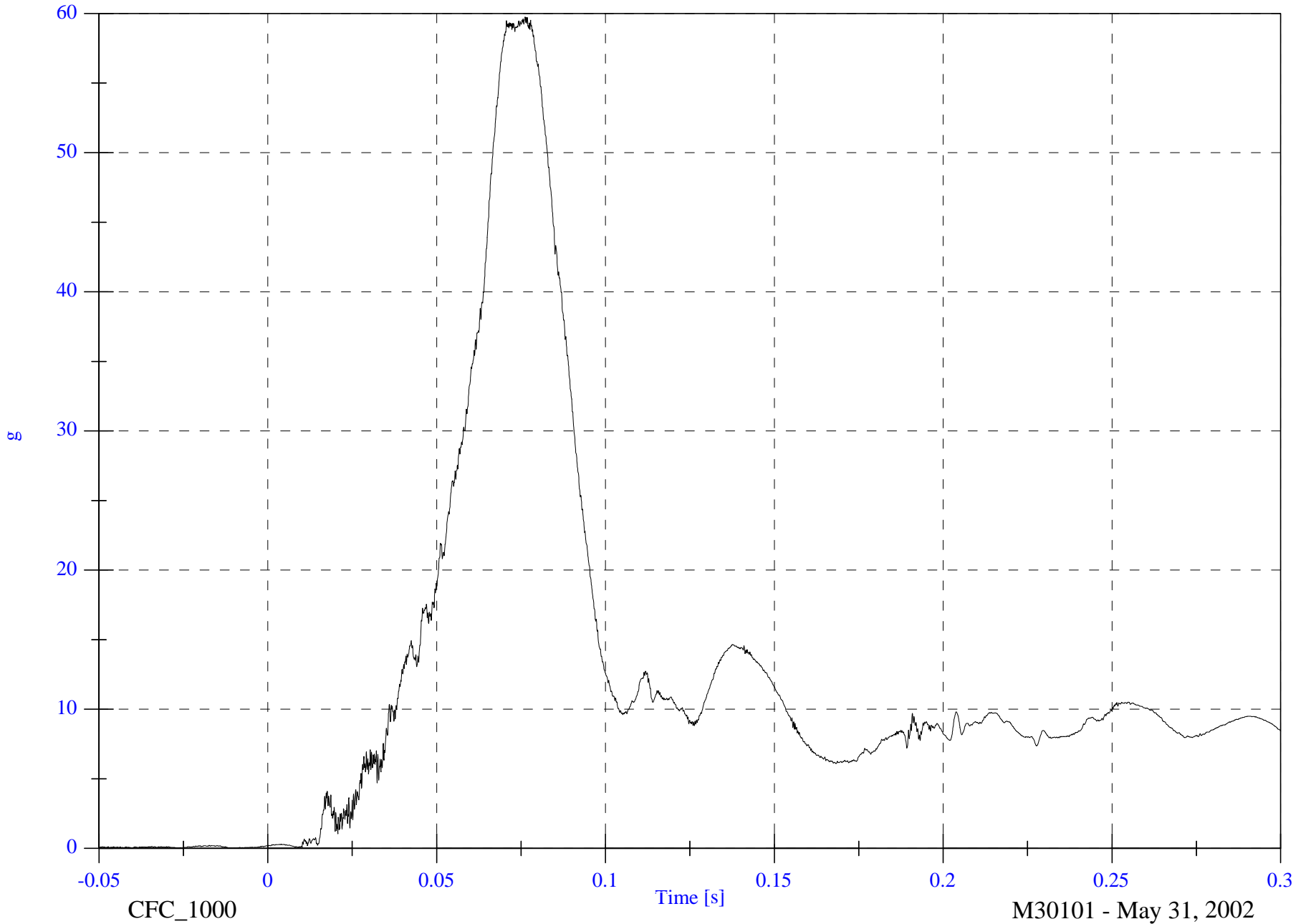

2002 NCAP Test 18 2003 Cadillac CTS

Max: 1083.6 [N] at 0.077 [s]

Min: -542.7 [N] at 0.138 [s]

P1 Upper Neck Fx

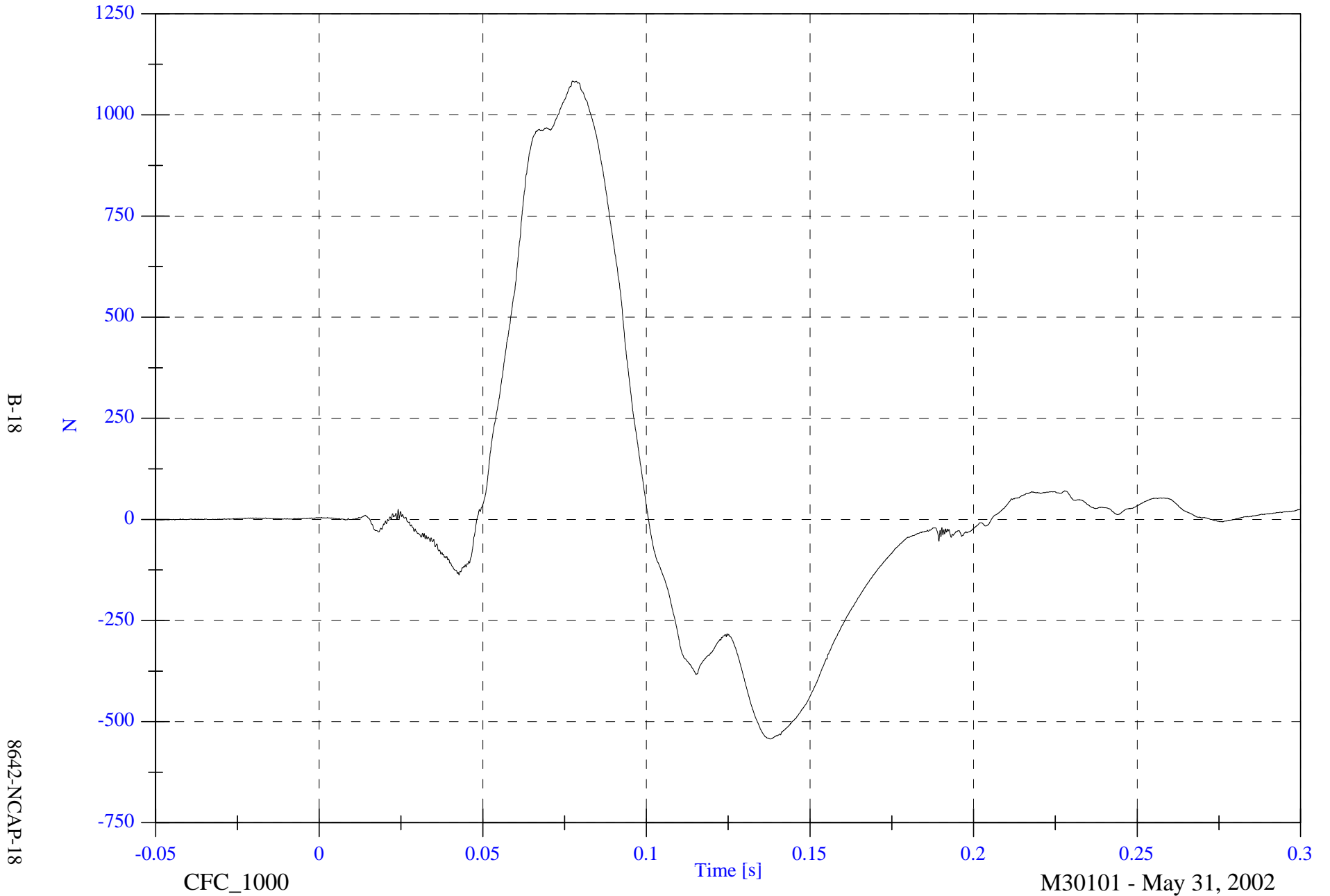

B-18

8642-NCAP-18

CFC_1000

M30101 - May 31, 2002

2002 NCAP Test 18 2003 Cadillac CTS

Max: 174.8 [N] at 0.121 [s]

Min: -75.9 [N] at 0.087 [s]

P1 Upper Neck Fy

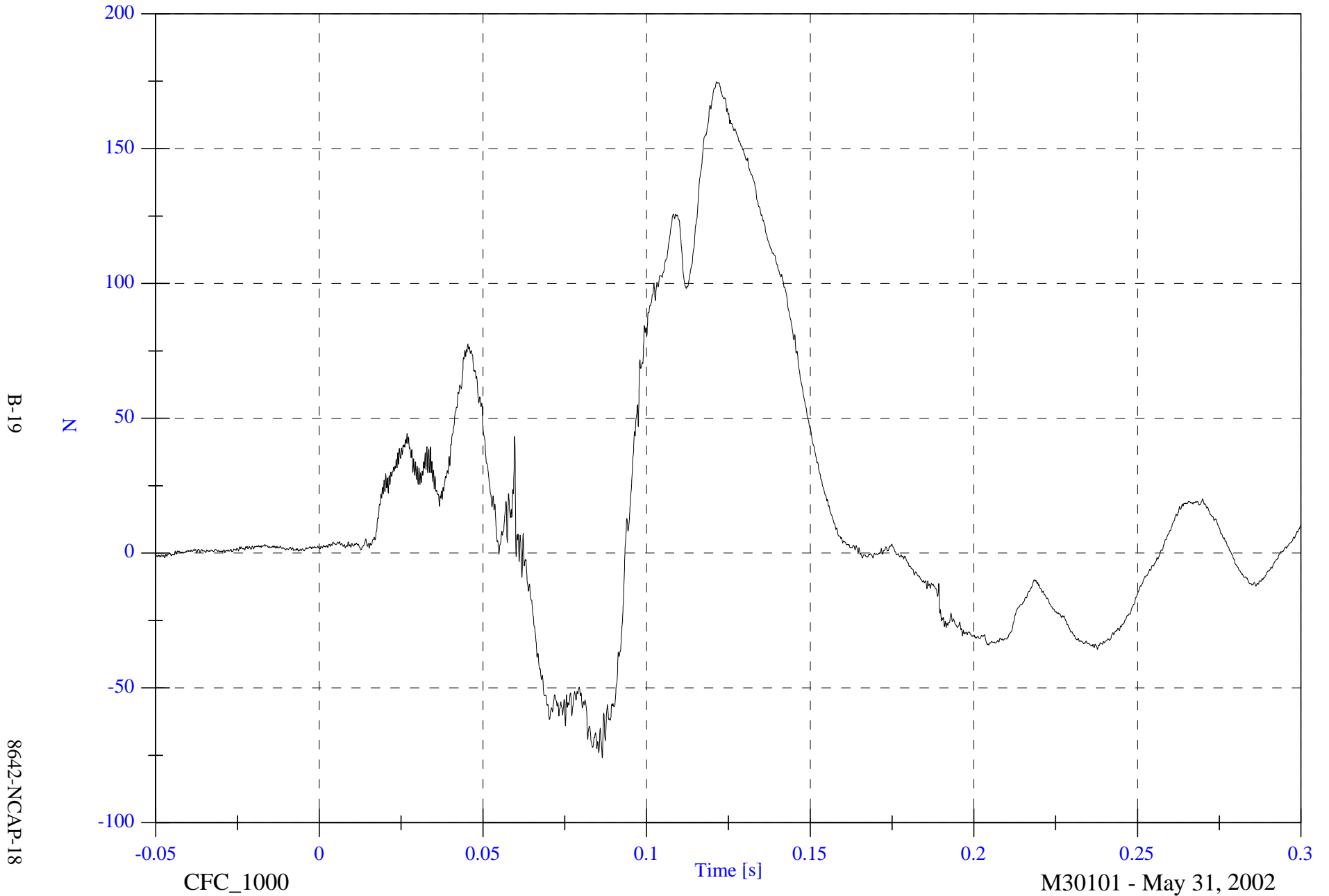

2002 NCAP Test 18 2003 Cadillac CTS

Max: 1266.8 [N] at 0.066 [s]

Min: -159.2 [N] at 0.092 [s]

P1 Upper Neck Fz

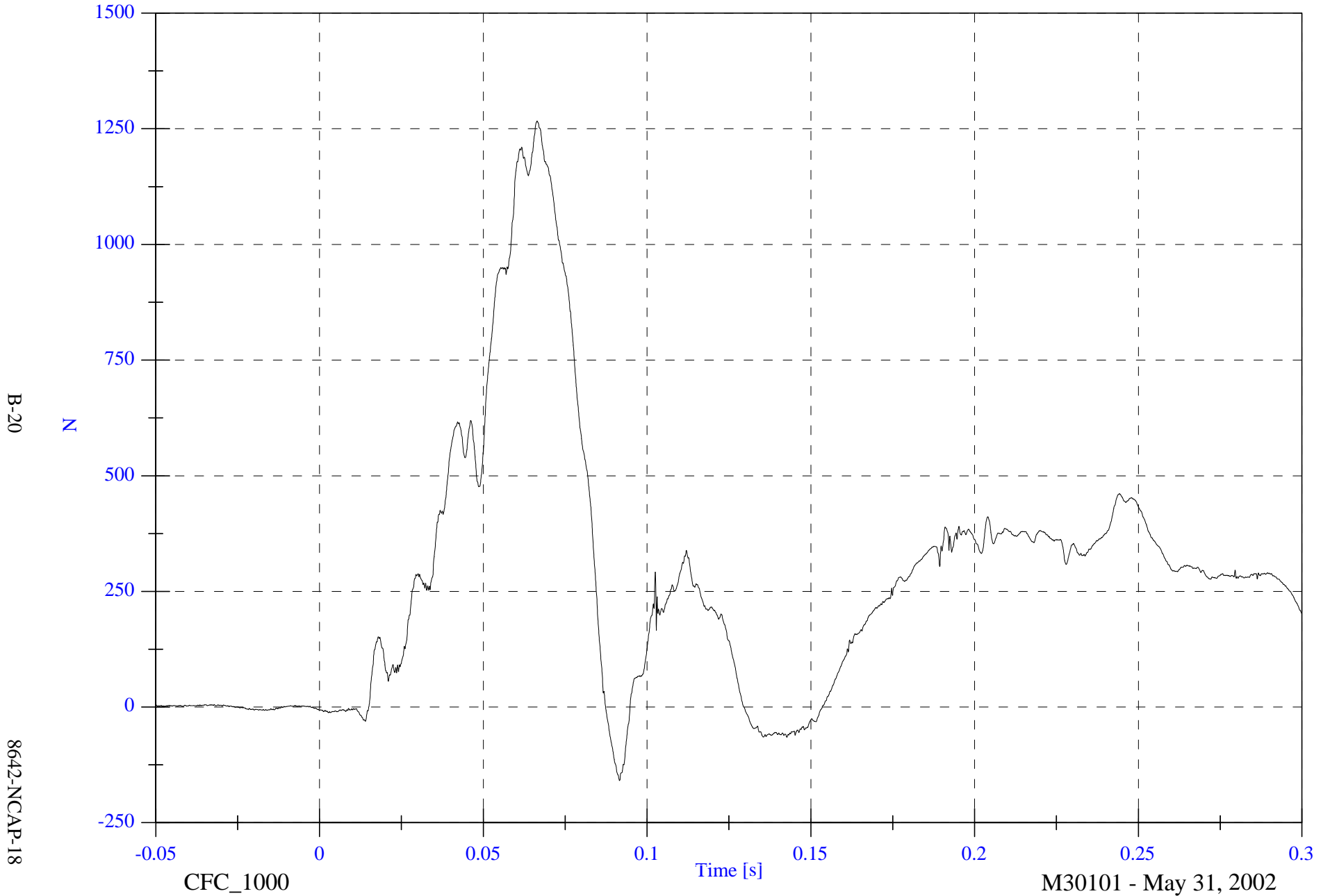

B-20

8642-NCAP-18

CFC_1000

Time [s]

M30101 - May 31, 2002

2002 NCAP Test 18 2003 Cadillac CTS

Max: 1589.6 [N] at 0.066 [s]

P1 Upper Neck F Resultant

Min: 1.2 [N] at -0.028 [s]

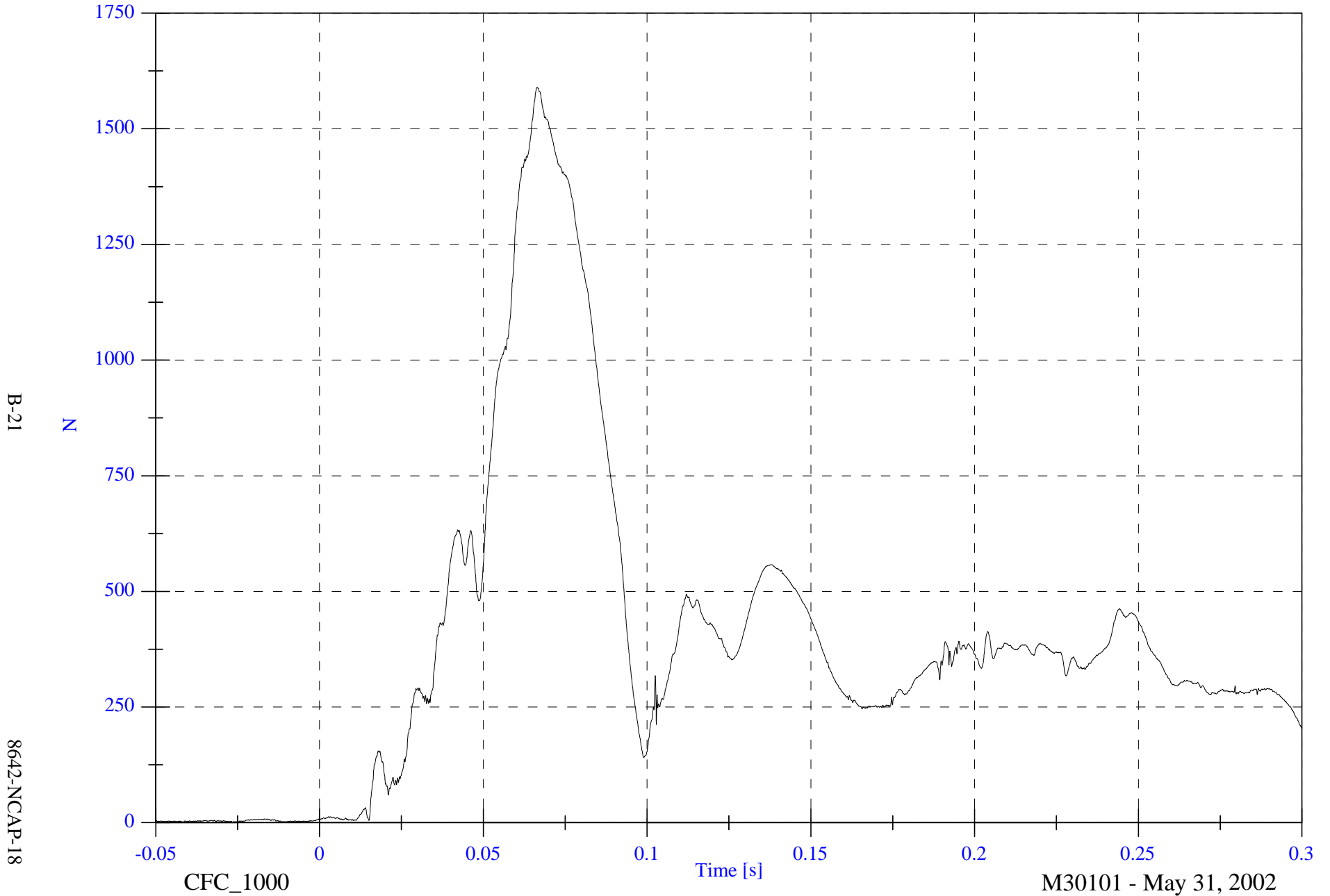

B-21

8642-NCAP-18

2002 NCAP Test 18 2003 Cadillac CTS

Max: 17.3 [N-m] at 0.130 [s]

Min: -10.7 [N-m] at 0.099 [s]

P1 Upper Neck Mx

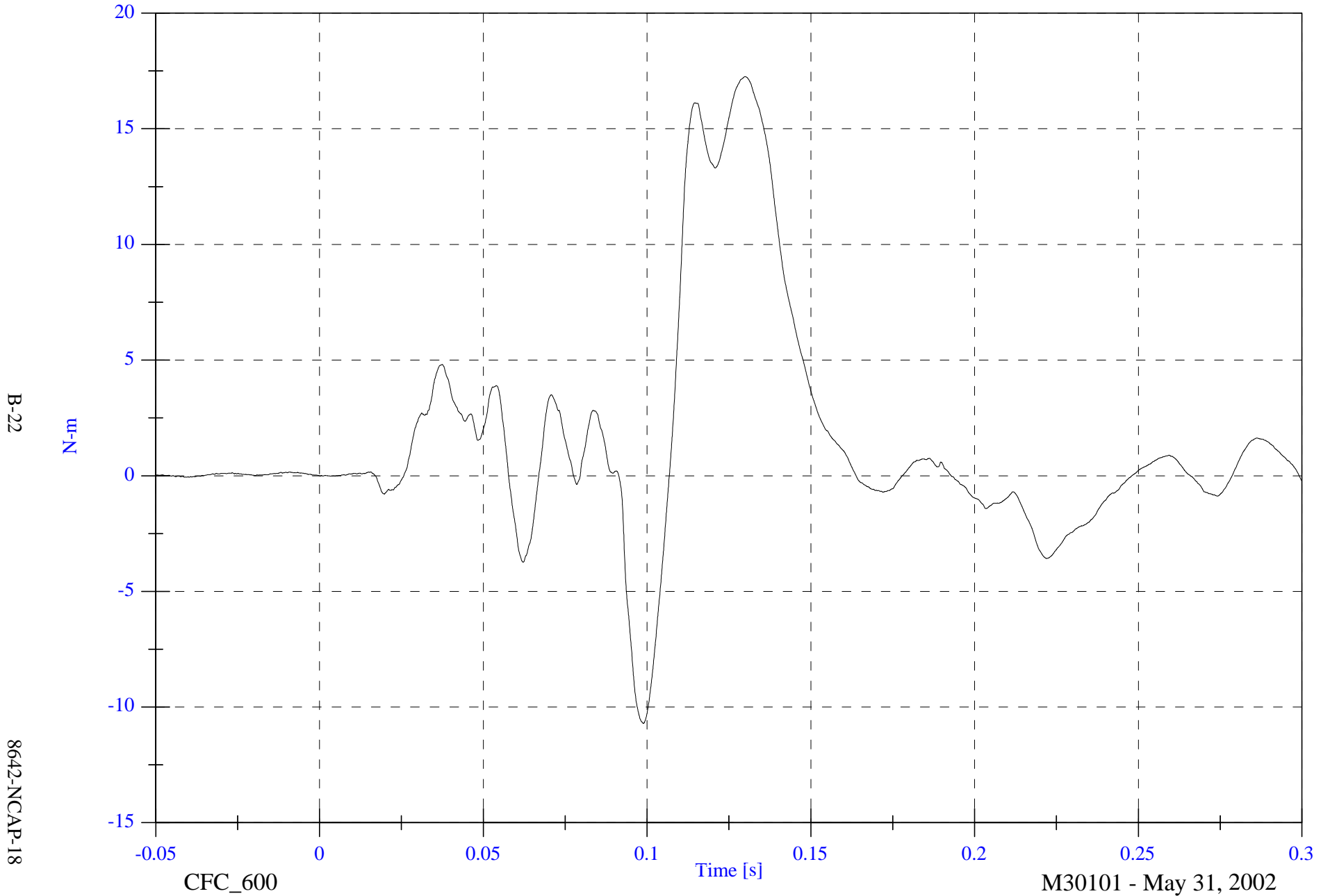

B-22

8642-NCAP-18

CFC_600

Time [s]

M30101 - May 31, 2002

2002 NCAP Test 18 2003 Cadillac CTS

Max: 76.9 [N-m] at 0.065 [s]

Min: -18.9 [N-m] at 0.108 [s]

P1 Upper Neck My

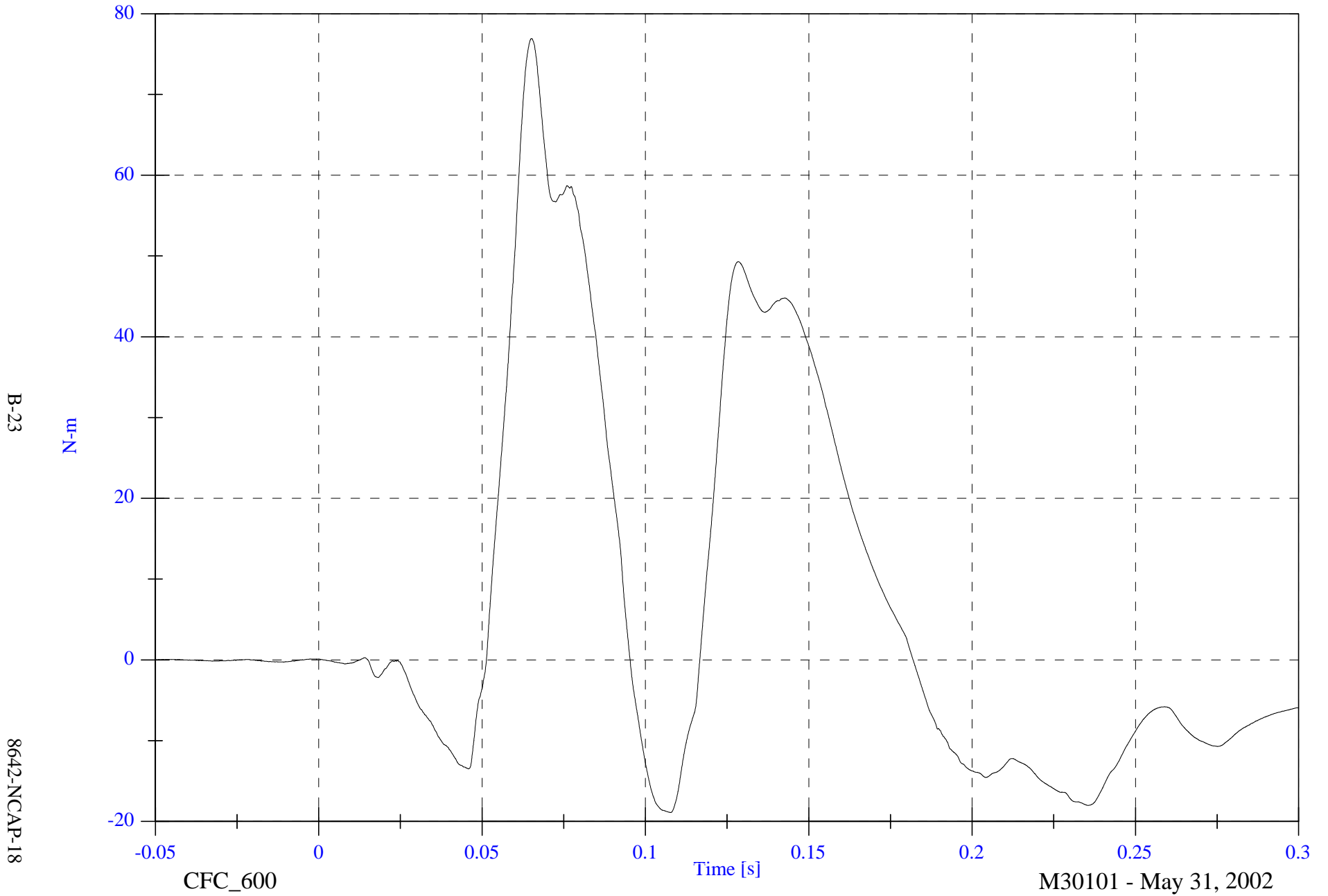

2002 NCAP Test 18 2003 Cadillac CTS

Max: 9.3 [N-m] at 0.153 [s]
Min: -11.9 [N-m] at 0.115 [s]

P1 Upper Neck Mz

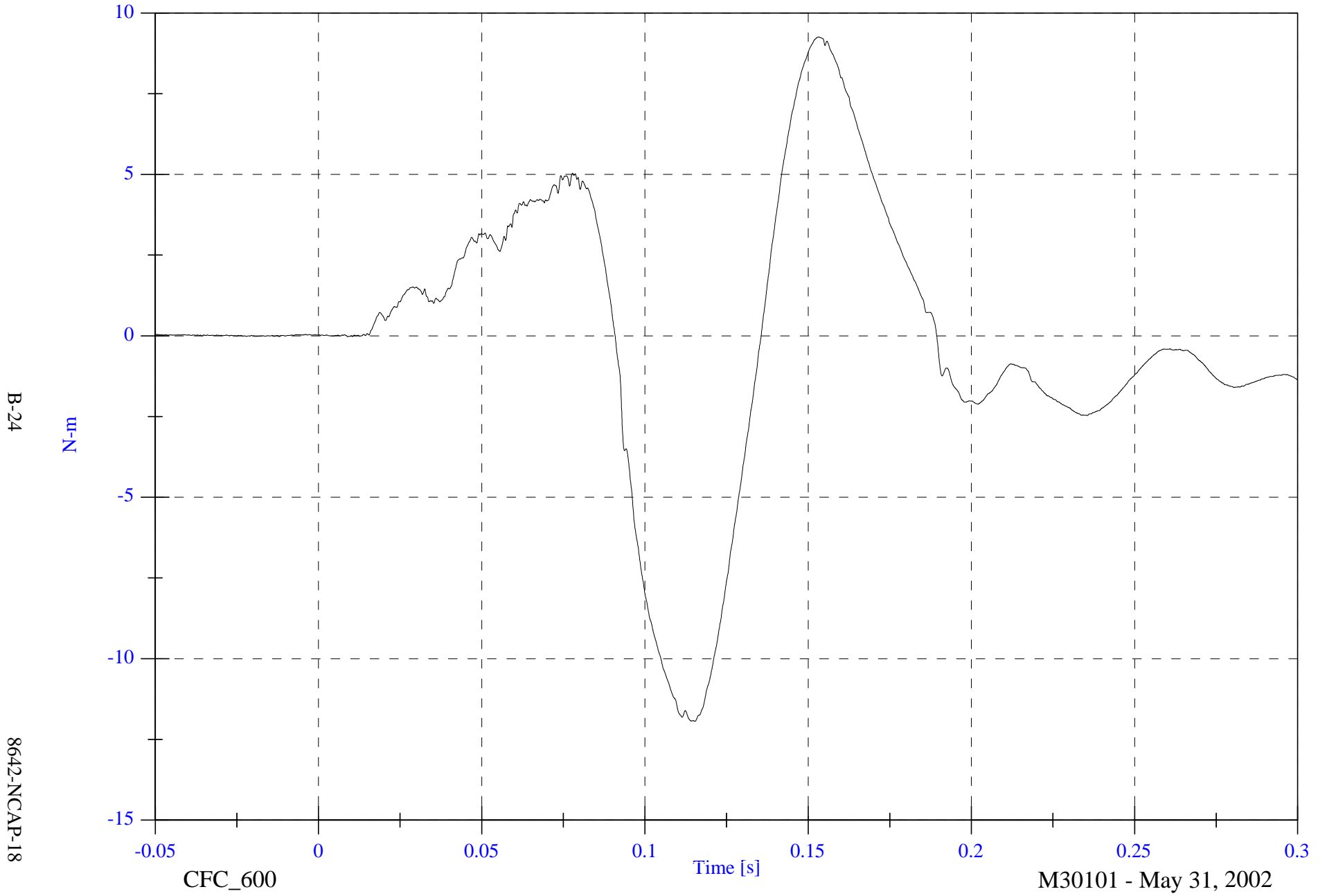

B-24

8642-NCAP-18

CFC_600

Time [s]

M30101 - May 31, 2002

2002 NCAP Test 18 2003 Cadillac CTS

Max: 77.1 [N-m] at 0.065 [s]

P1 Upper Neck M Resultant

Min: 0.0 [N-m] at -0.020 [s]

B-25

8642-NCAP-18

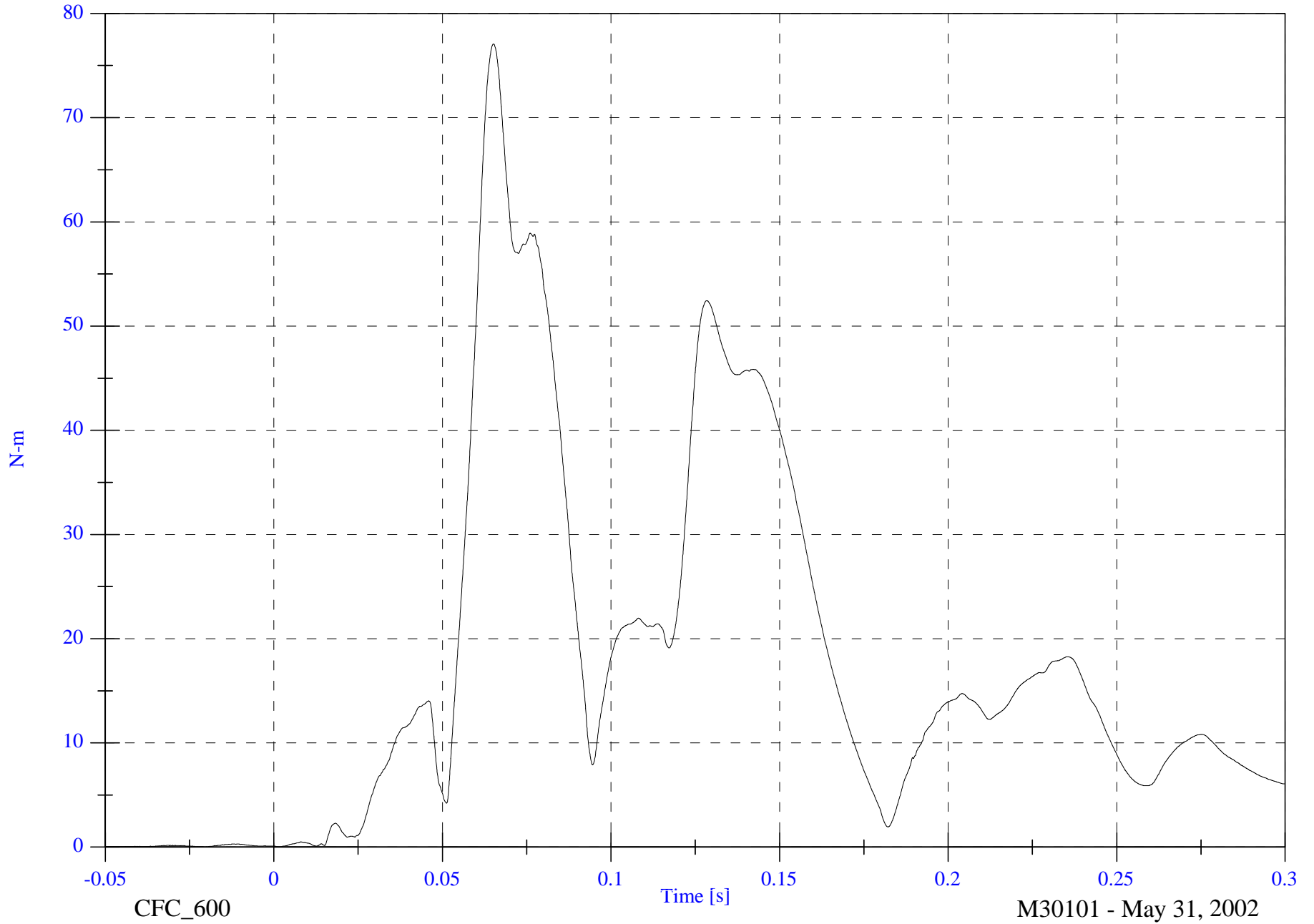

CFC_600

Time [s]

M30101 - May 31, 2002

2002 NCAP Test 18 2003 Cadillac CTS

Max: 3.0 [g] at 0.137 [s]

Min: -45.1 [g] at 0.072 [s]

P1 Chest x

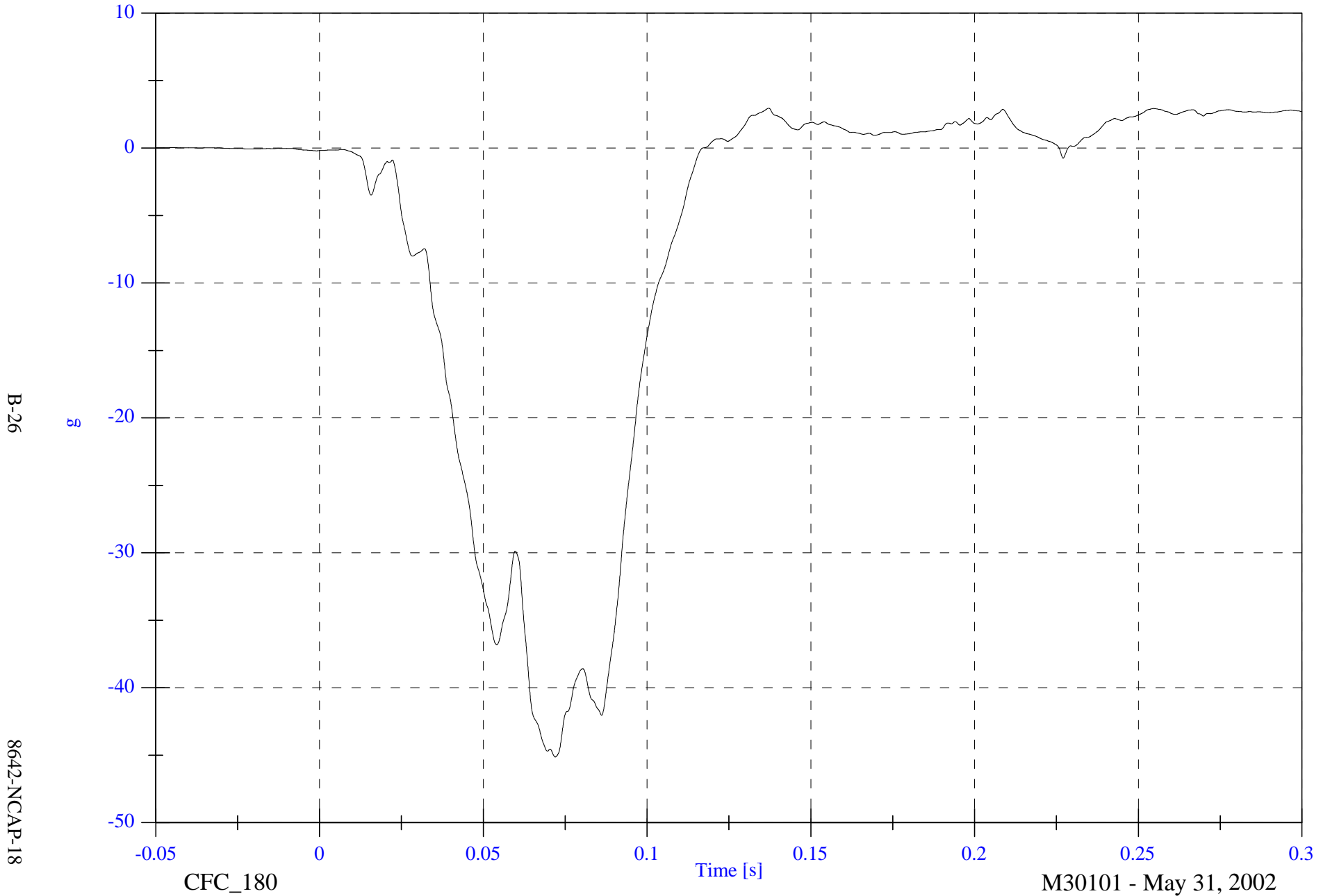

2002 NCAP Test 18 2003 Cadillac CTS

Max: 9.3 [g] at 0.071 [s]

Min: -3.4 [g] at 0.045 [s]

P1 Chest y

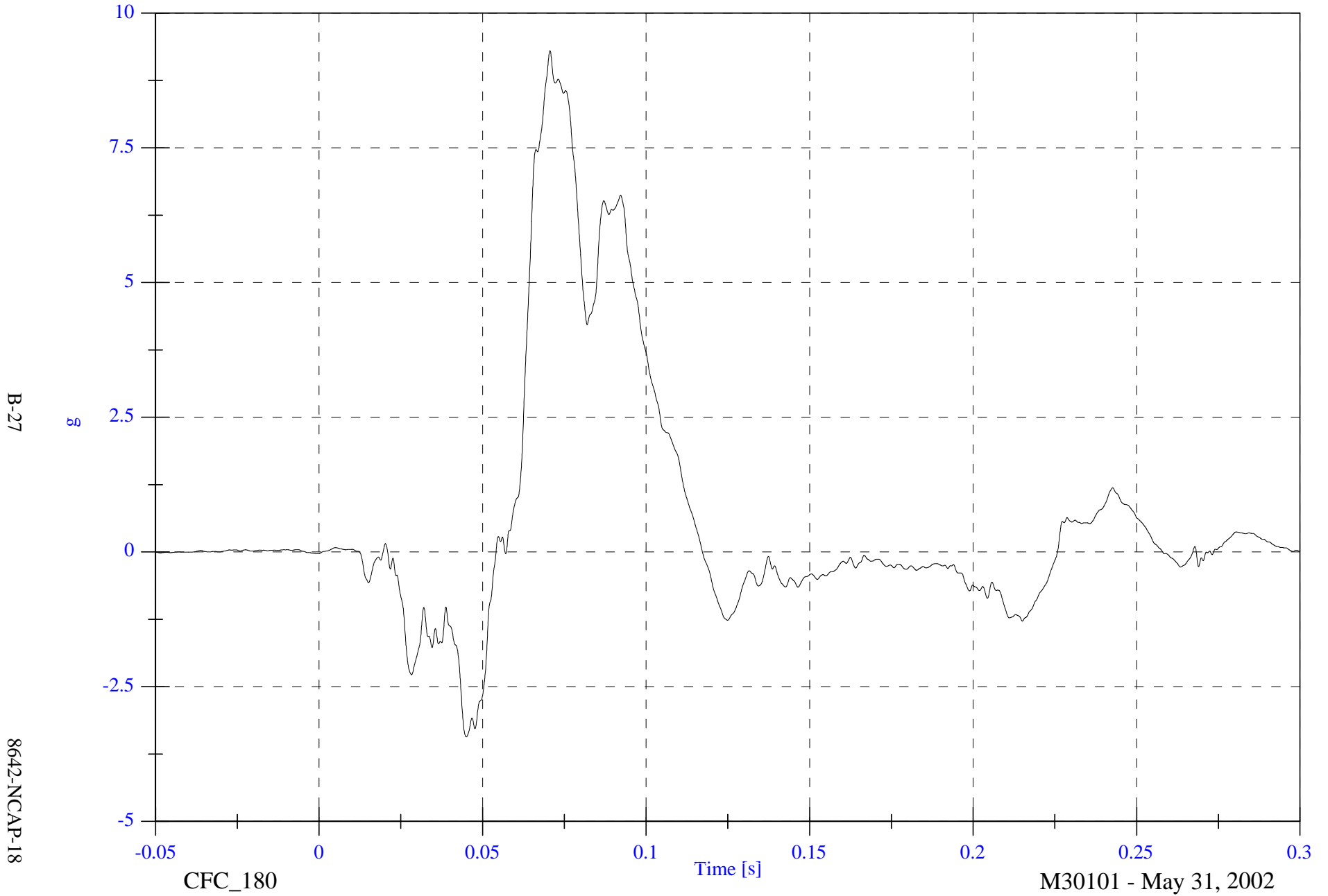

2002 NCAP Test 18 2003 Cadillac CTS

Max: 10.9 [g] at 0.067 [s]
Min: -3.3 [g] at 0.103 [s]

P1 Chest z

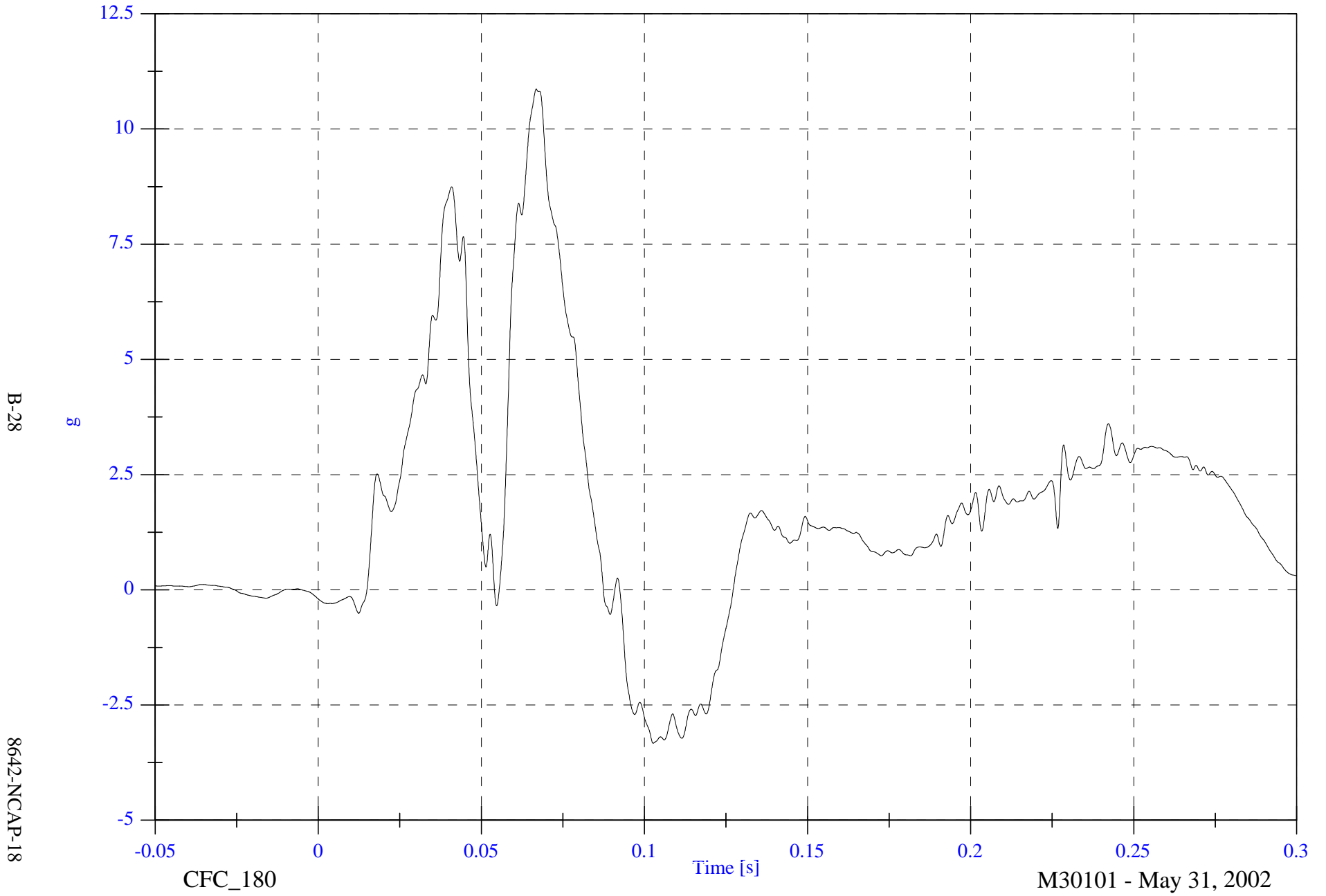

2002 NCAP Test 18 2003 Cadillac CTS

P1 Chest Resultant

Max: 46.7 [g] at 0.072 [s]

Min: 0.0 [g] at -0.008 [s]

B-29

8642-NCAP-18

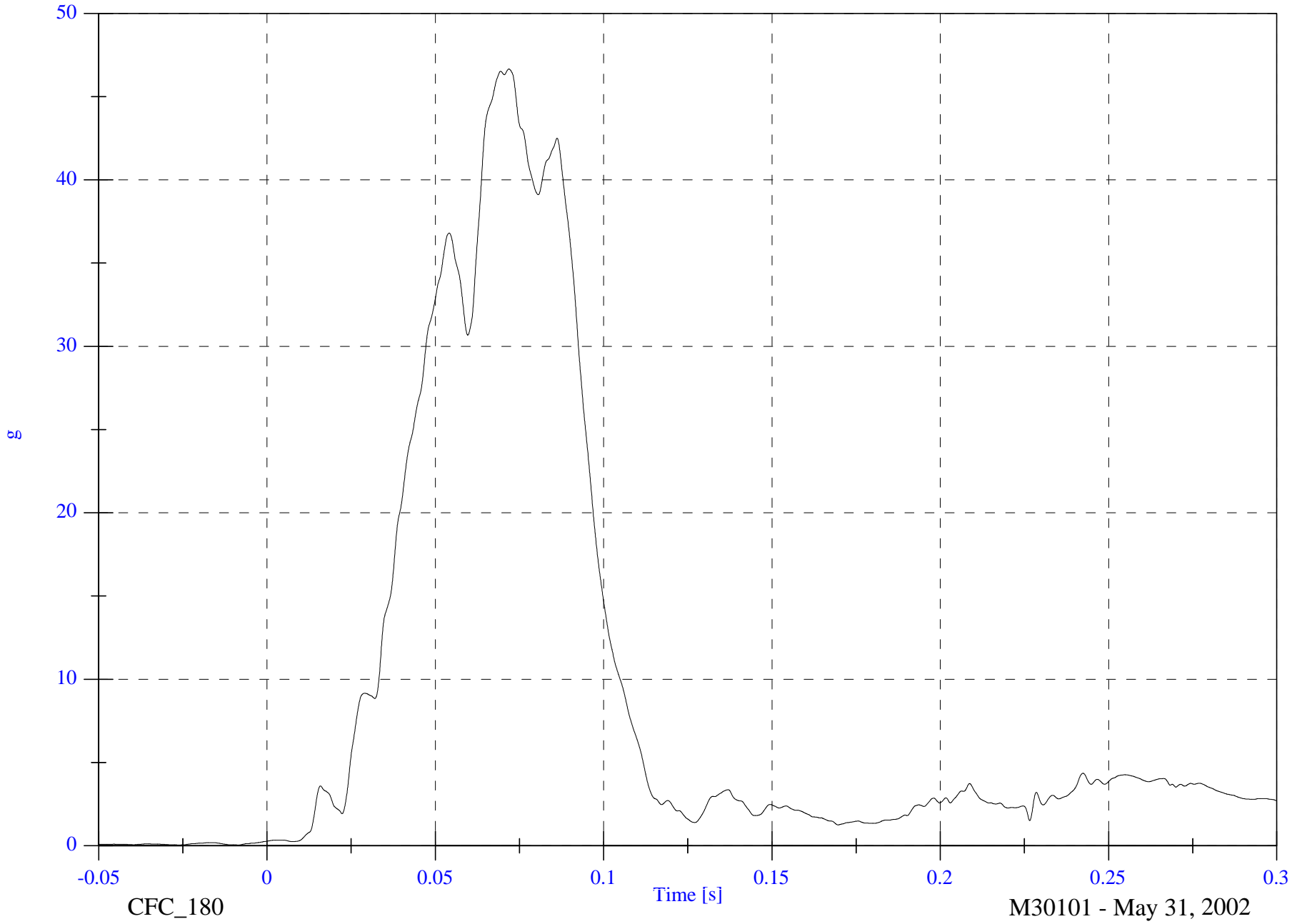

CFC_180

M30101 - May 31, 2002

2002 NCAP Test 18 2003 Cadillac CTS

Max: 2.9 [g] at 0.255 [s]

Min: -45.6 [g] at 0.072 [s]

P1 Chest Red x

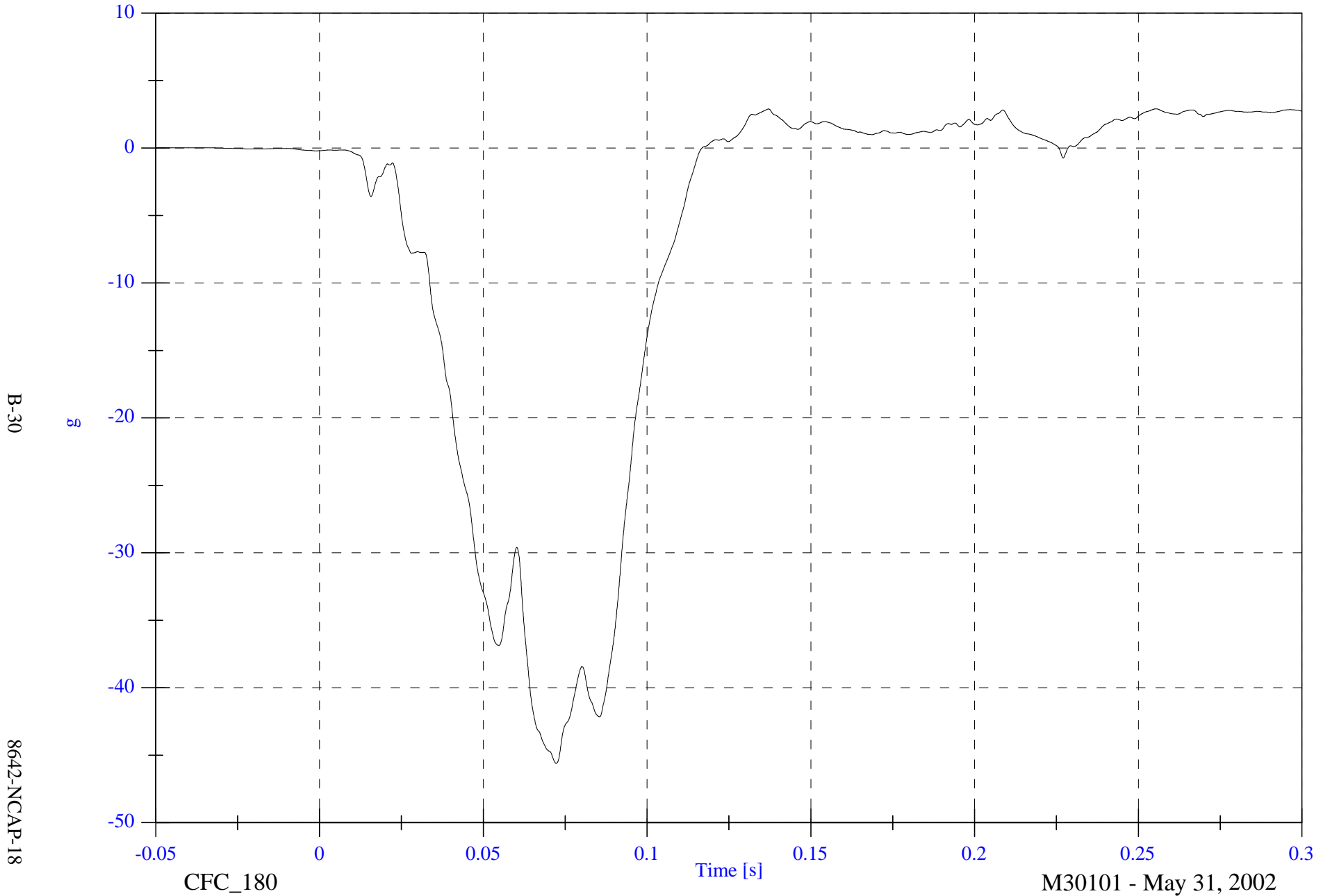

B-30

8642-NCAP-18

CFC_180

Time [s]

M30101 - May 31, 2002

2002 NCAP Test 18 2003 Cadillac CTS

Max: 9.4 [g] at 0.071 [s]

Min: -3.6 [g] at 0.045 [s]

P1 Chest Red y

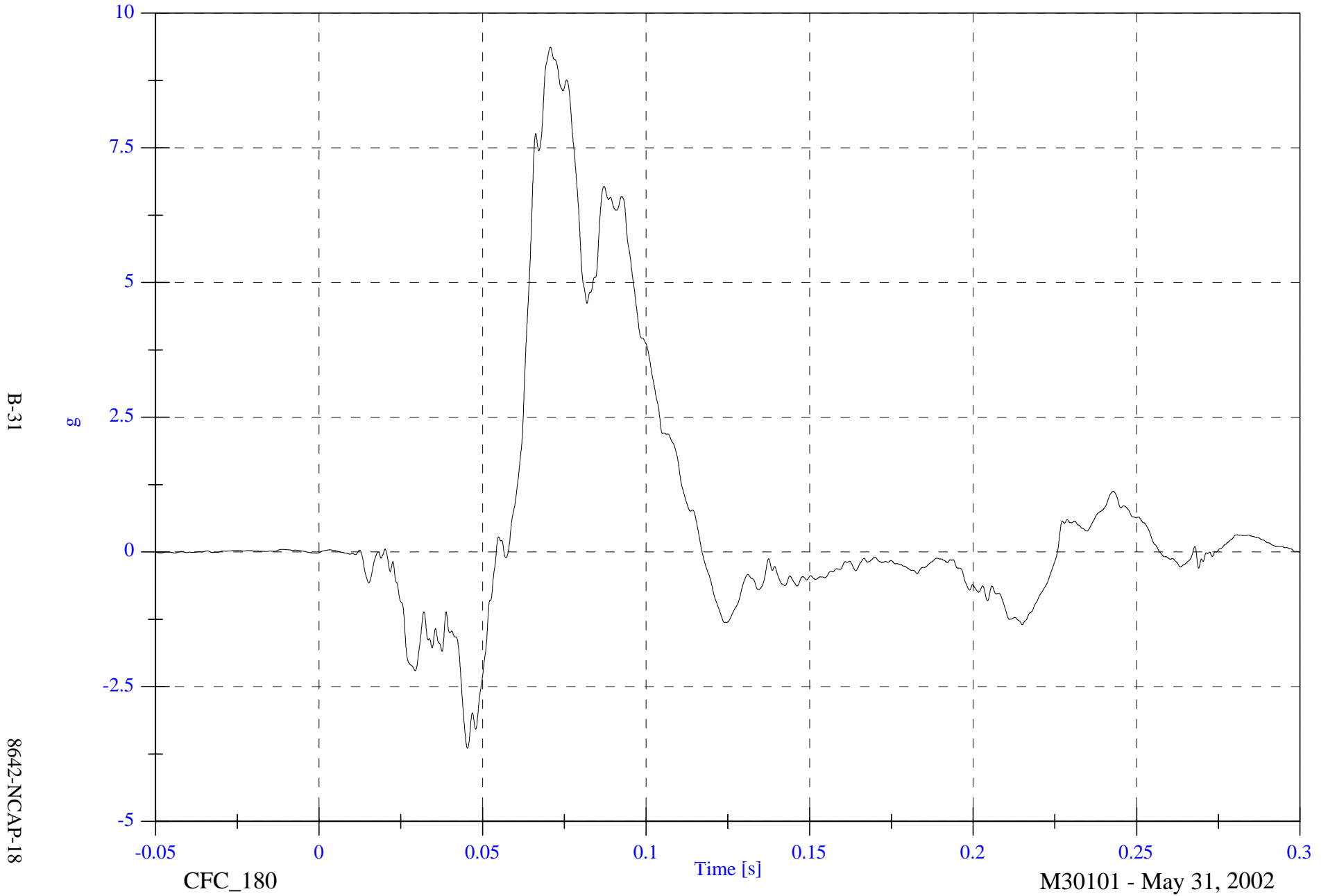

2002 NCAP Test 18 2003 Cadillac CTS

P1 Chest Red z

Max: 11.0 [g] at 0.068 [s]

Min: -3.5 [g] at 0.103 [s]

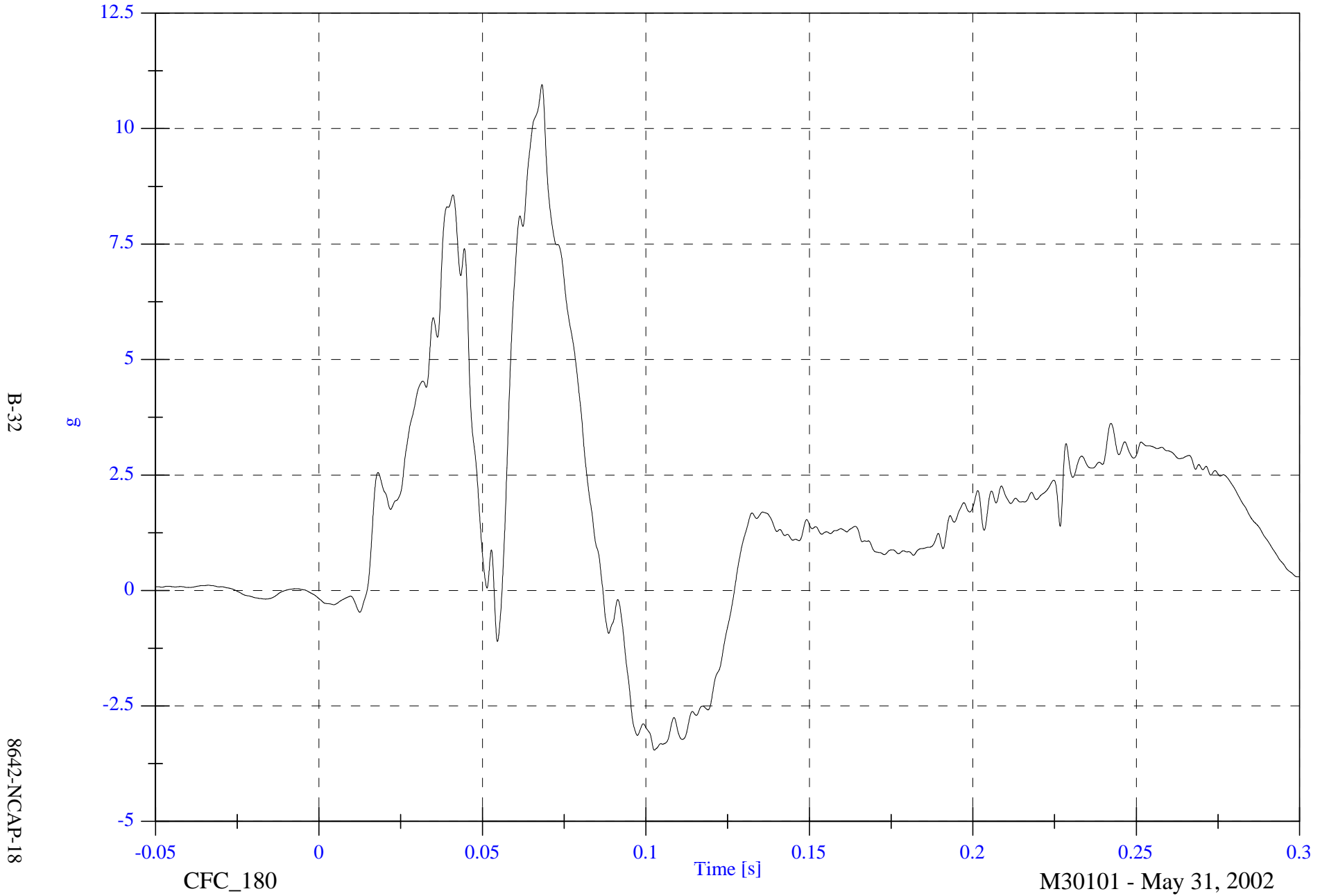

2002 NCAP Test 18 2003 Cadillac CTS

P1 Chest Red Resultant

Max: 47.1 [g] at 0.072 [s]

Min: 0.0 [g] at -0.026 [s]

B-33

8642-NCAP-18

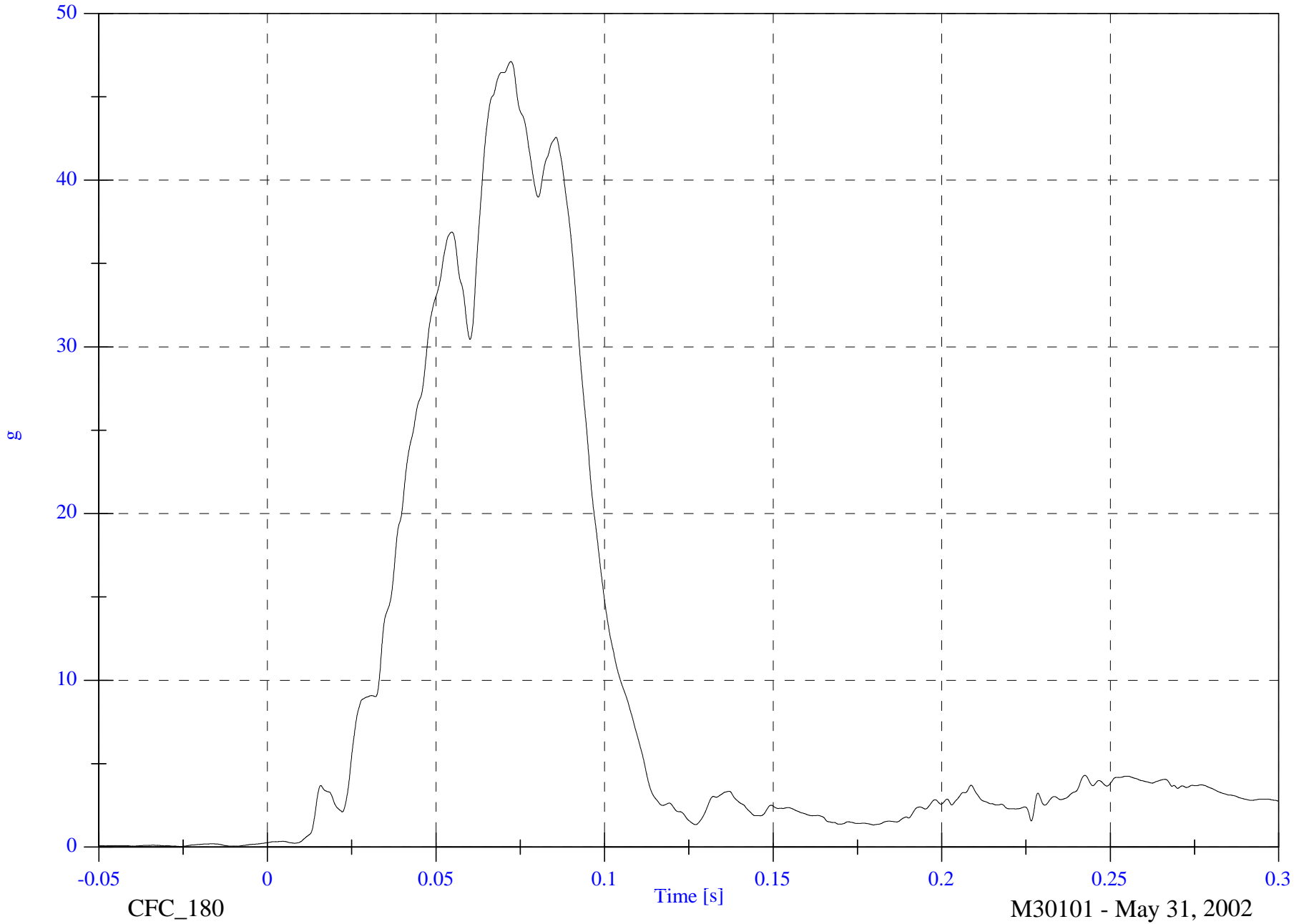

2002 NCAP Test 18 2003 Cadillac CTS

Max: 0.0 [mm] at 0.003 [s]

P1 Chest Compression

Min: -33.1 [mm] at 0.086 [s]

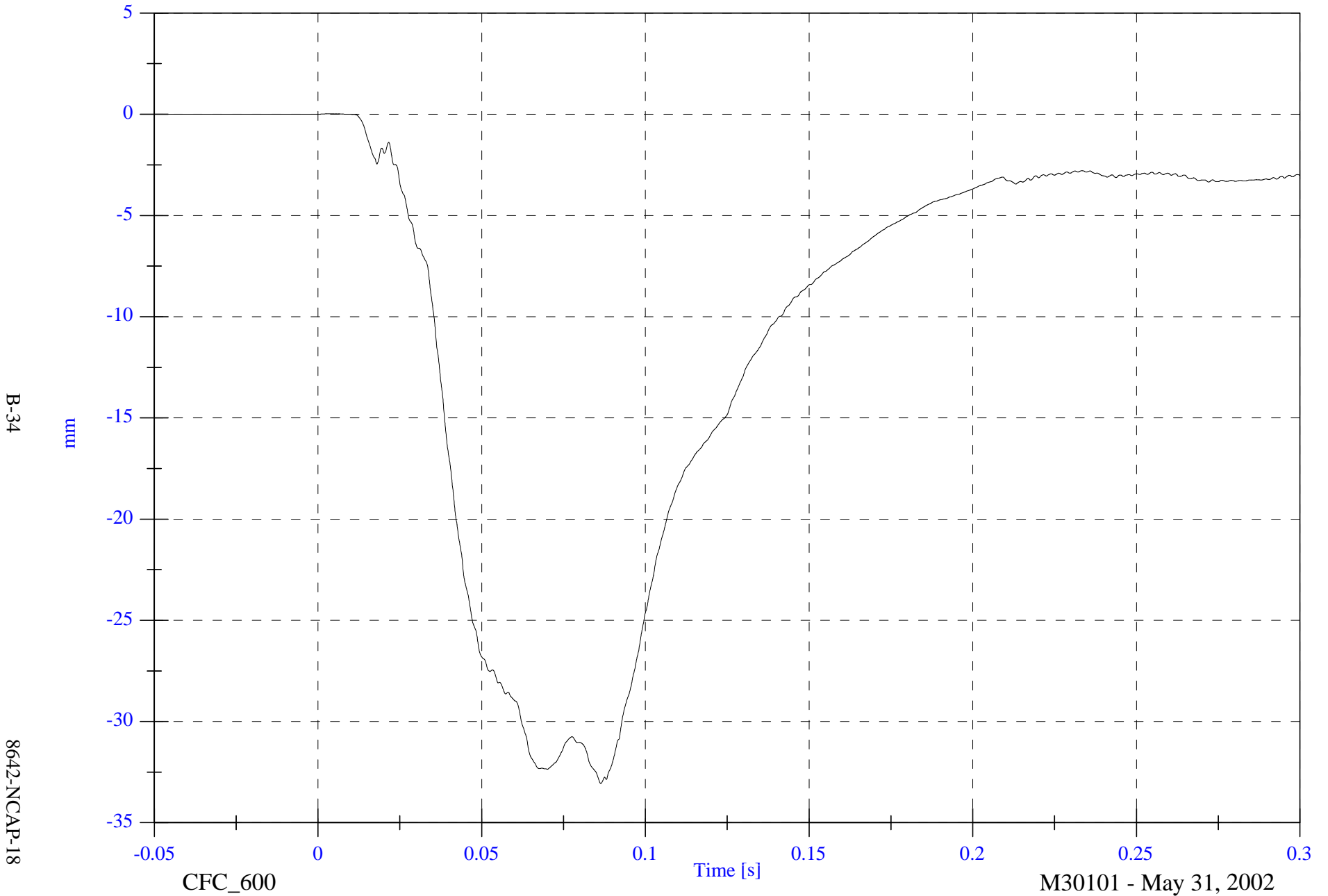

2002 NCAP Test 18 2003 Cadillac CTS

Max: 4.7 [g] at 0.209 [s]

Min: -59.8 [g] at 0.049 [s]

P1 Pelvic x

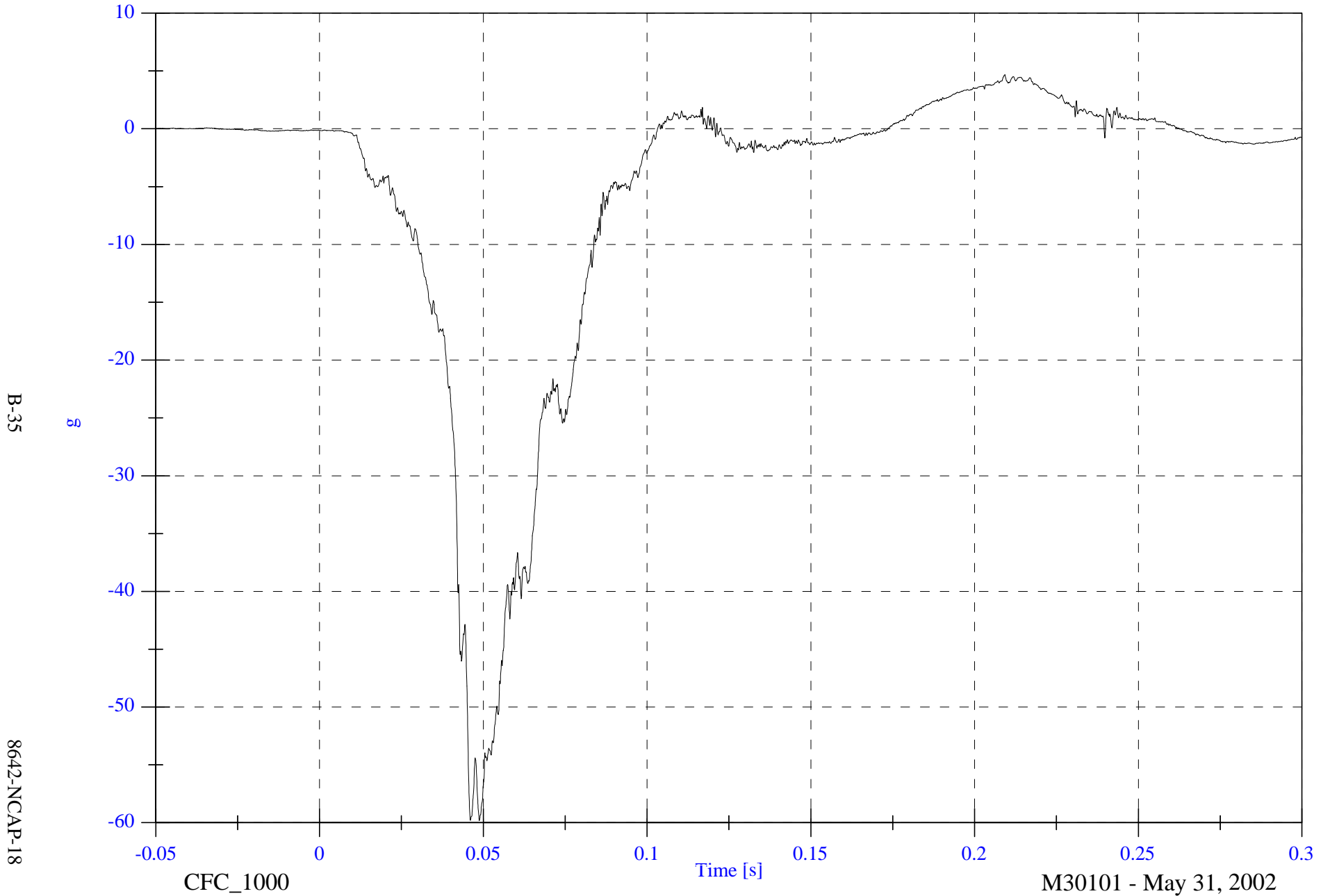

2002 NCAP Test 18 2003 Cadillac CTS

Max: 9.0 [g] at 0.064 [s]

Min: -6.3 [g] at 0.048 [s]

P1 Pelvic y

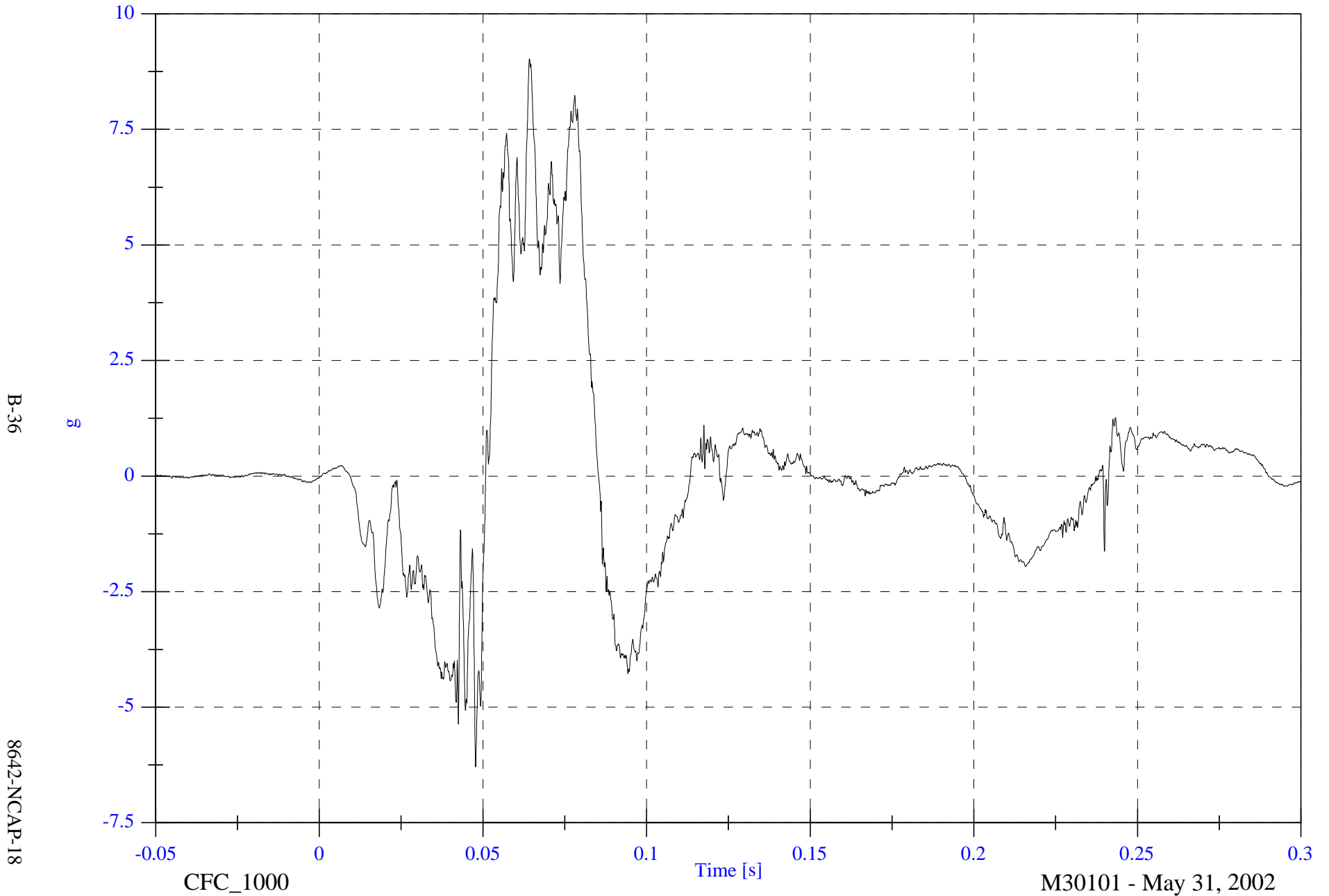

2002 NCAP Test 18 2003 Cadillac CTS

Max: 4.1 [g] at 0.226 [s]

Min: -25.4 [g] at 0.068 [s]

P1 Pelvic z

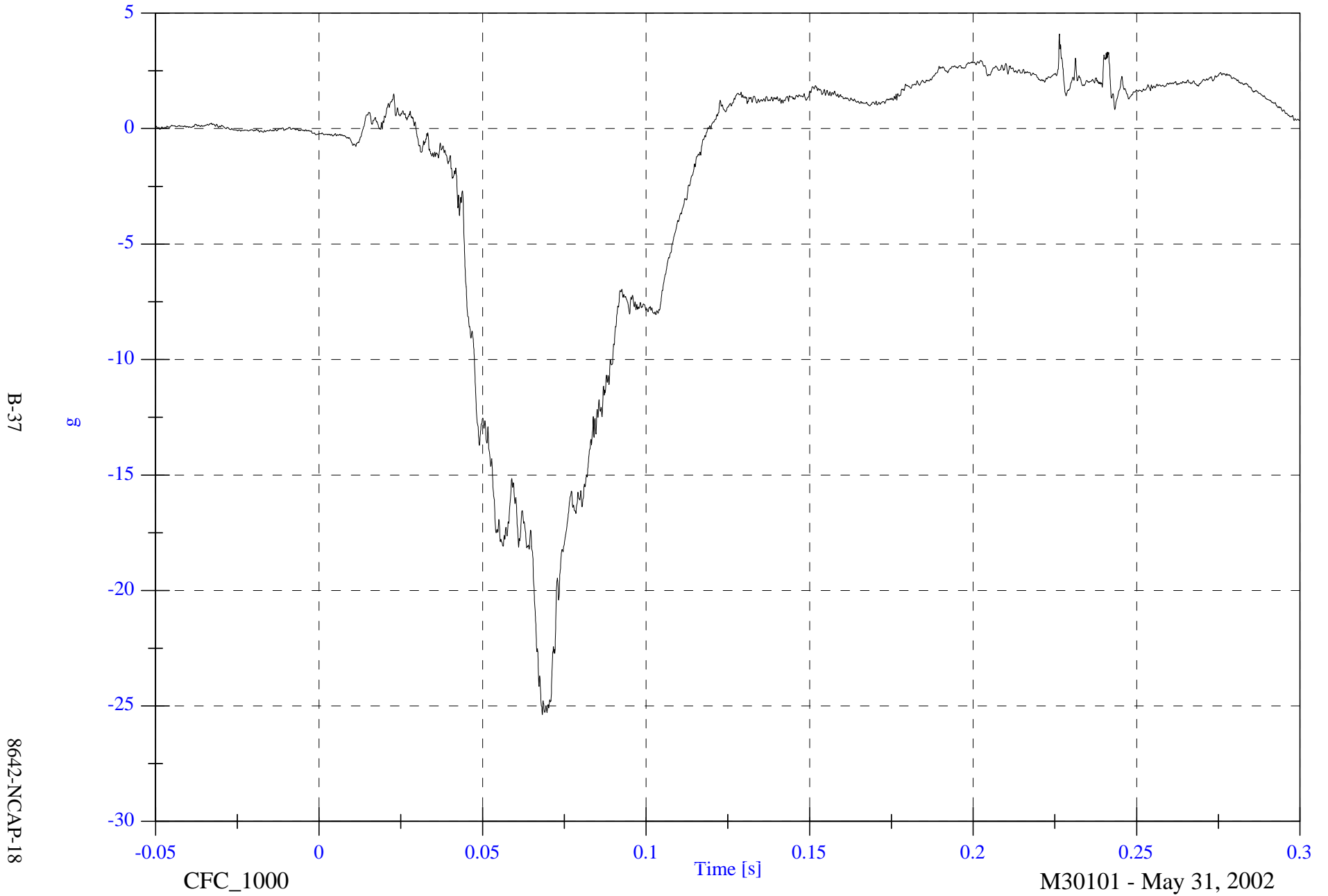

2002 NCAP Test 18 2003 Cadillac CTS

P1 Pelvic Resultant

Max: 61.4 [g] at 0.049 [s]

Min: 0.0 [g] at -0.048 [s]

B-38

8642-NCAP-18

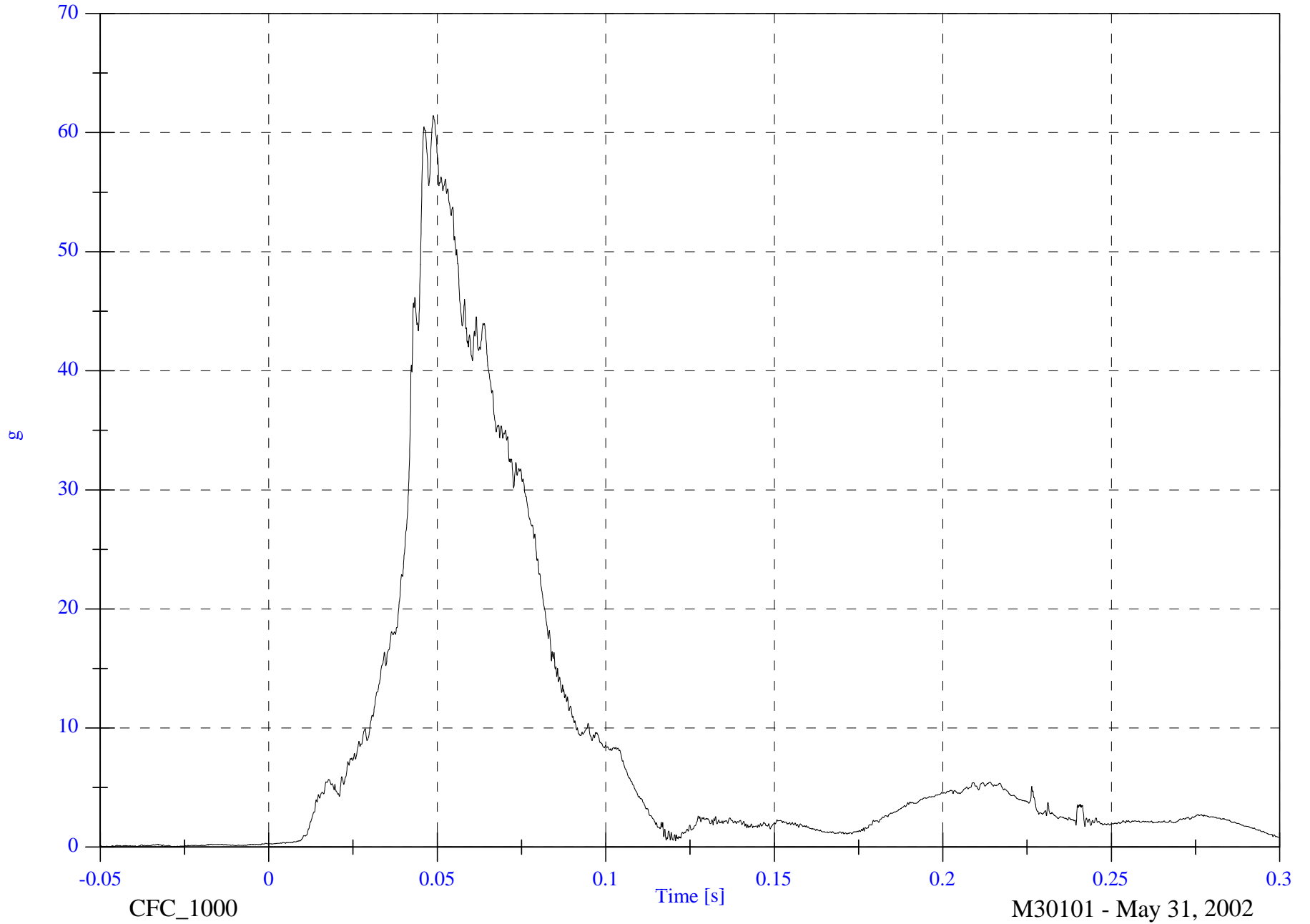

CFC_1000

Time [s]

M30101 - May 31, 2002

2002 NCAP Test 18 2003 Cadillac CTS

P1 Left Femur

Max: 399.2 [N] at 0.029 [s]
Min: -3762.3 [N] at 0.050 [s]

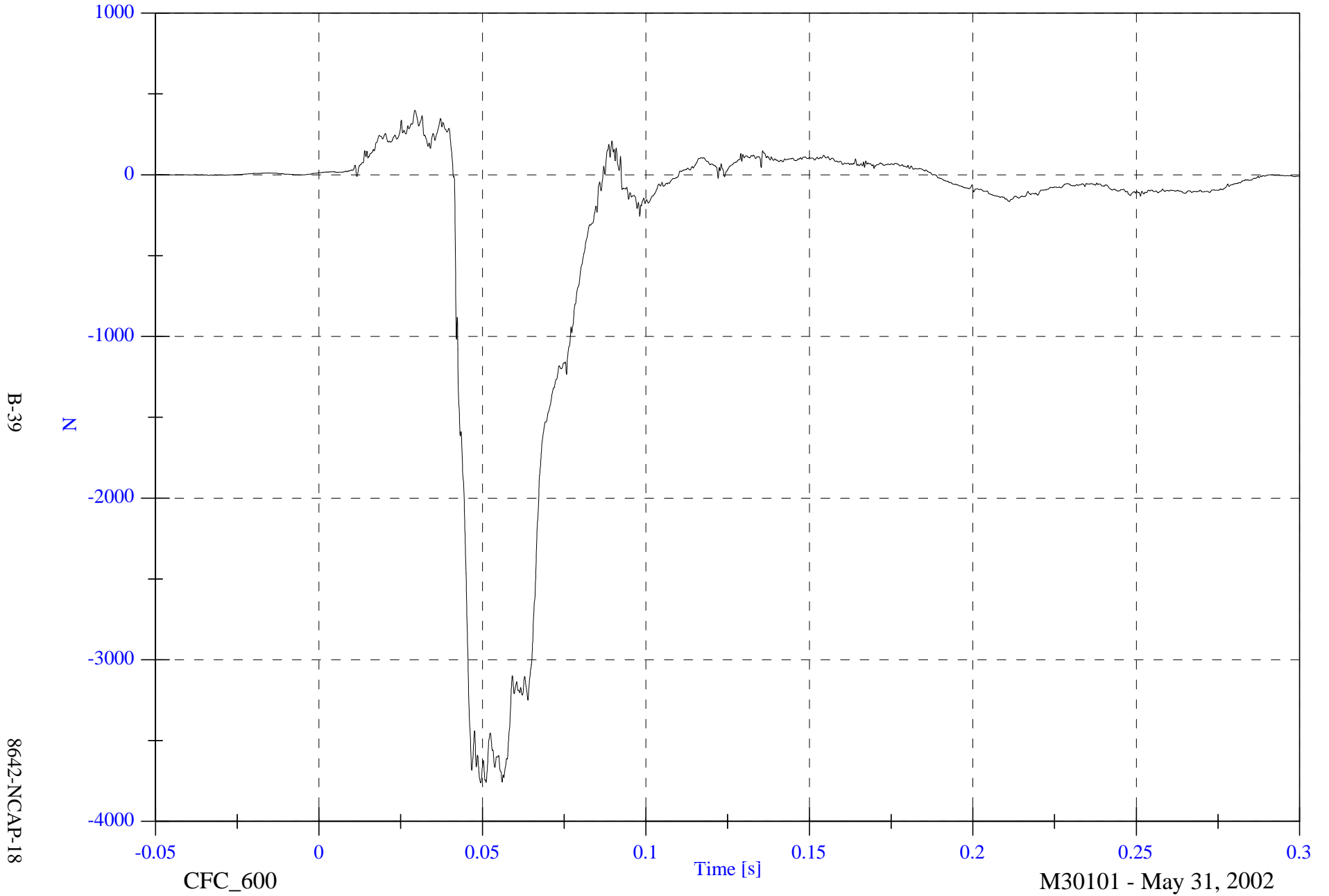

2002 NCAP Test 18 2003 Cadillac CTS

P1 Right Femur

Max: 412.4 [N] at 0.016 [s]

Min: -4906.7 [N] at 0.049 [s]

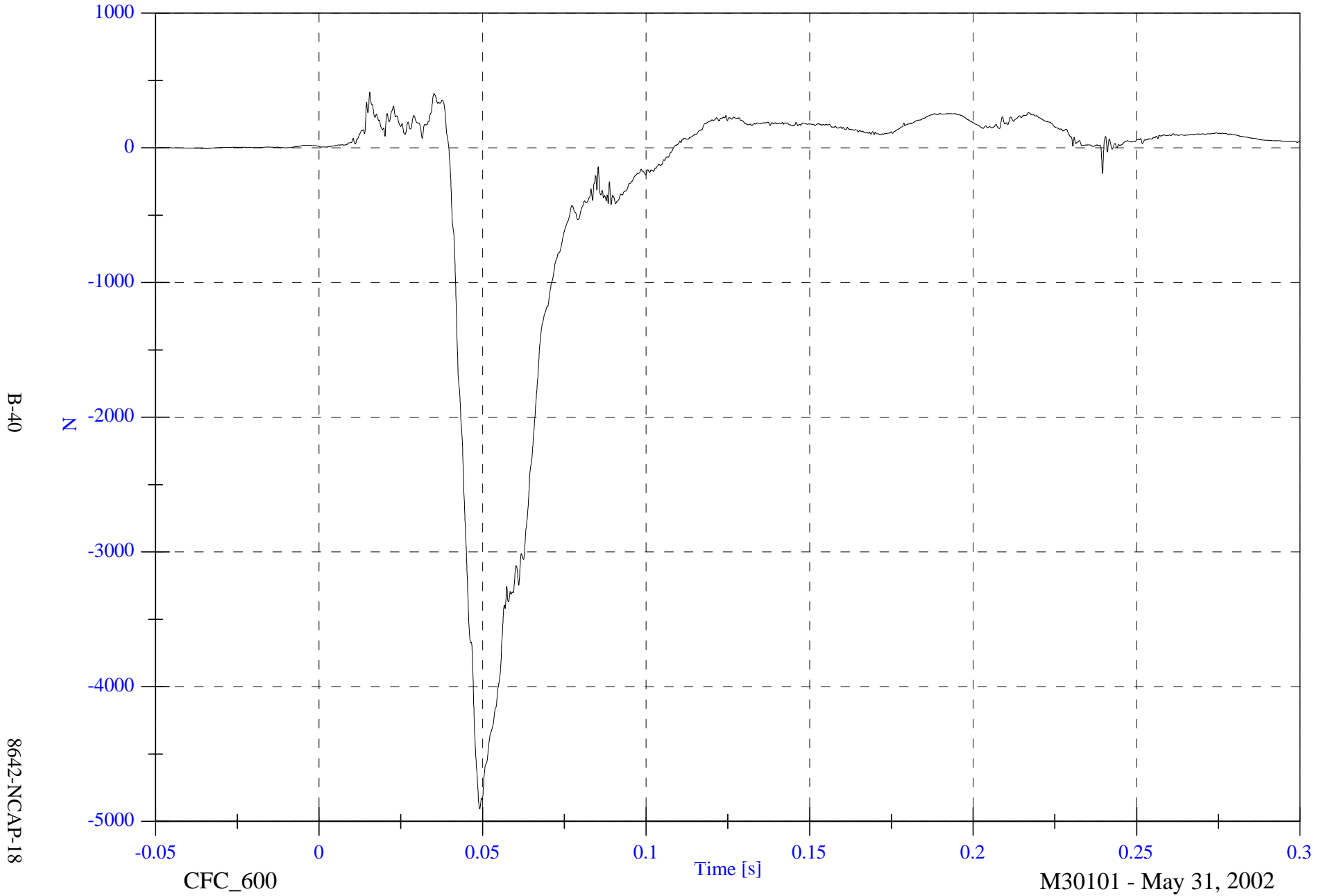

2002 NCAP Test 18 2003 Cadillac CTS

Max: 19.8 [N-m] at 0.124 [s]

Min: -39.5 [N-m] at 0.084 [s]

P1 Left Upper Tibia Mx

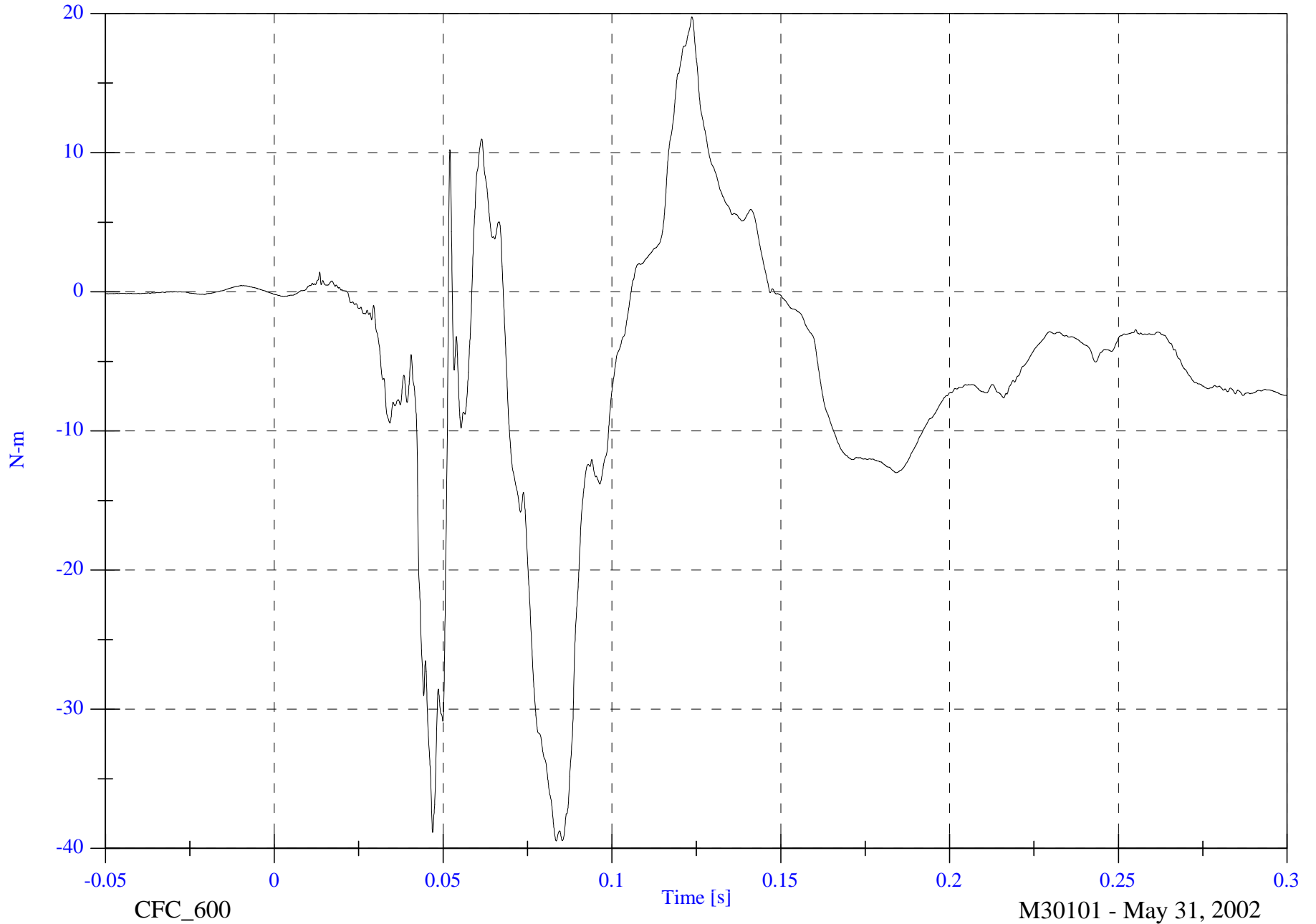

B-41

8642-NCAP-18

2002 NCAP Test 18 2003 Cadillac CTS

Max: 38.2 [N-m] at 0.048 [s]

Min: -62.7 [N-m] at 0.040 [s]

P1 Left upper Tibia My

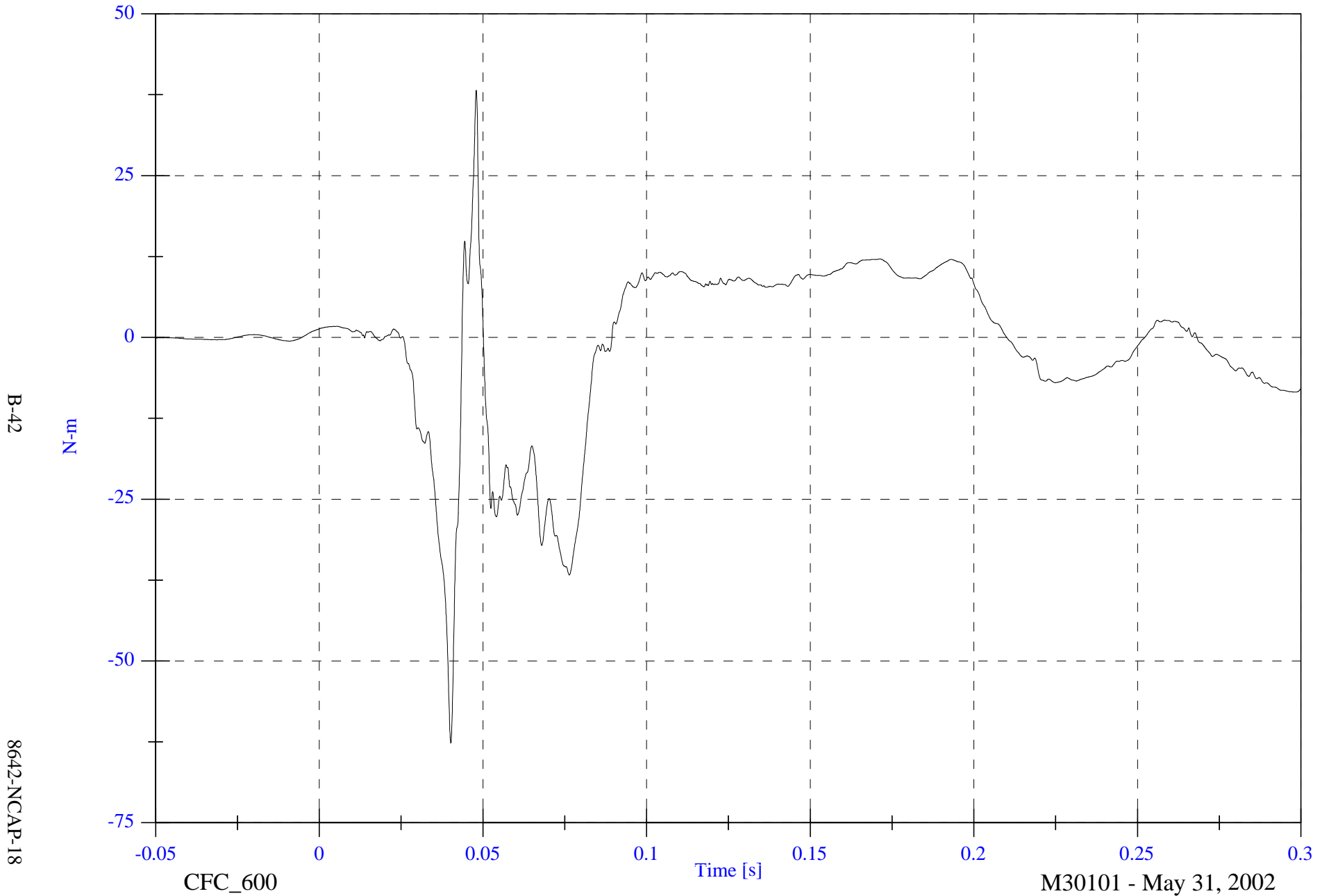

B-42

8642-NCAP-18

CFC_600

Time [s]

M30101 - May 31, 2002

2002 NCAP Test 18 2003 Cadillac CTS

Max: 151.5 [N] at 0.120 [s]

Min: -1853.9 [N] at 0.043 [s]

P1 Left Lower Tibia Fz

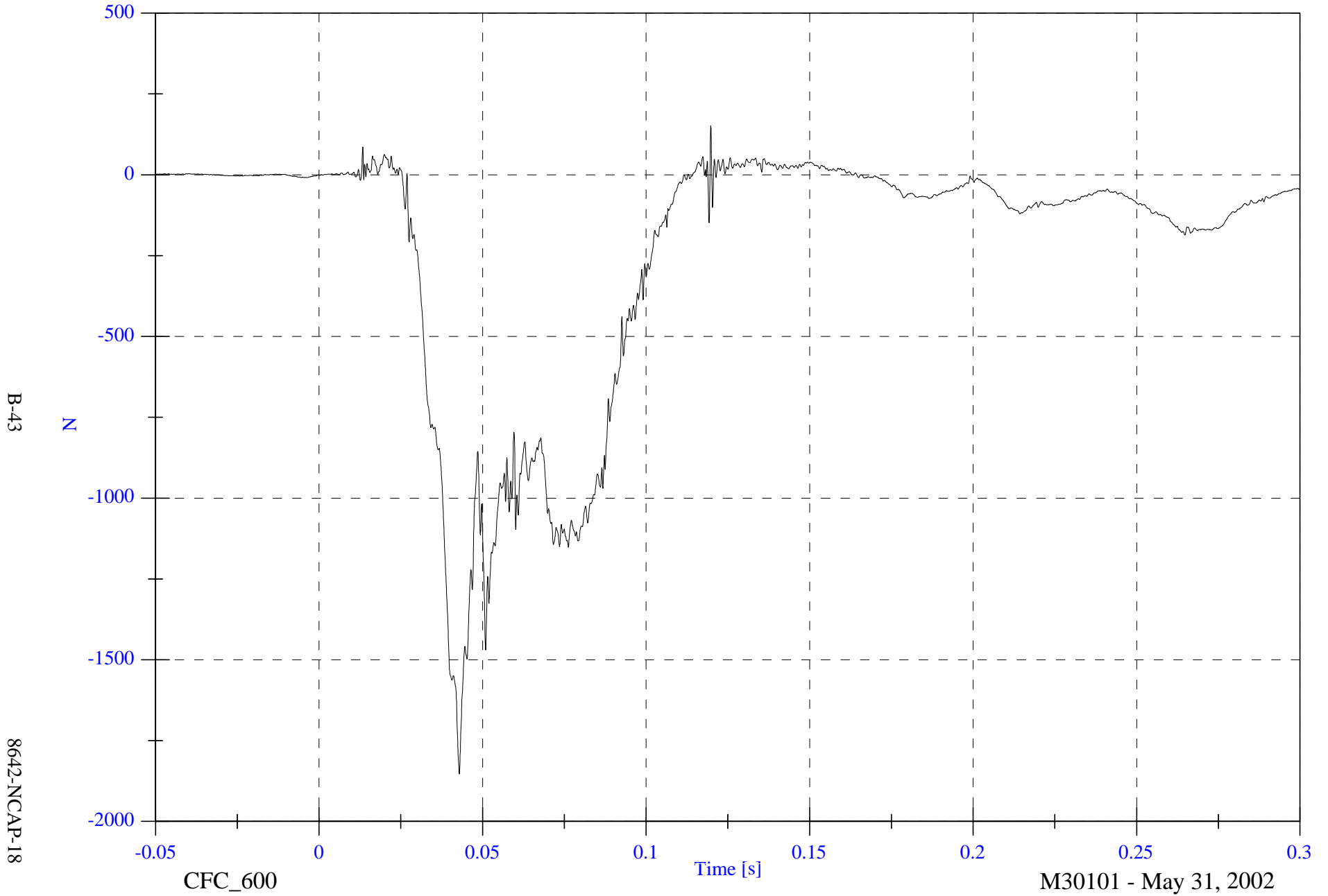

B-43

8642-NCAP-18

CFC_600

Time [s]

M30101 - May 31, 2002

2002 NCAP Test 18 2003 Cadillac CTS

Max: 57.2 [N-m] at 0.062 [s]

Min: -20.2 [N-m] at 0.047 [s]

P1 Left Lower Tibia Mx

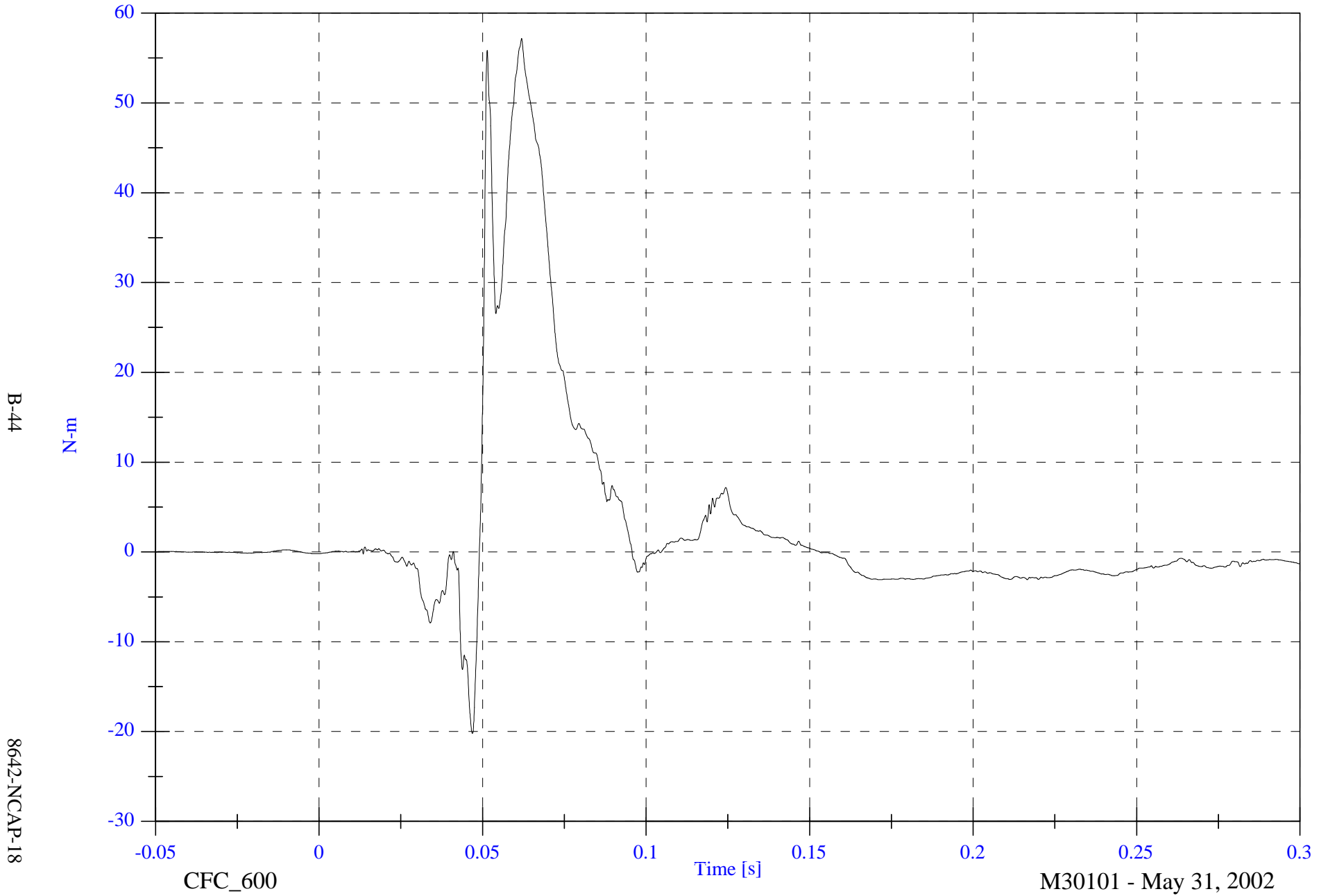

B-44

8642-NCAP-18

CFC_600

Time [s]

M30101 - May 31, 2002

2002 NCAP Test 18 2003 Cadillac CTS

Max: 35.6 [N-m] at 0.051 [s]

Min: -50.8 [N-m] at 0.041 [s]

P1 Left Lower tibia My

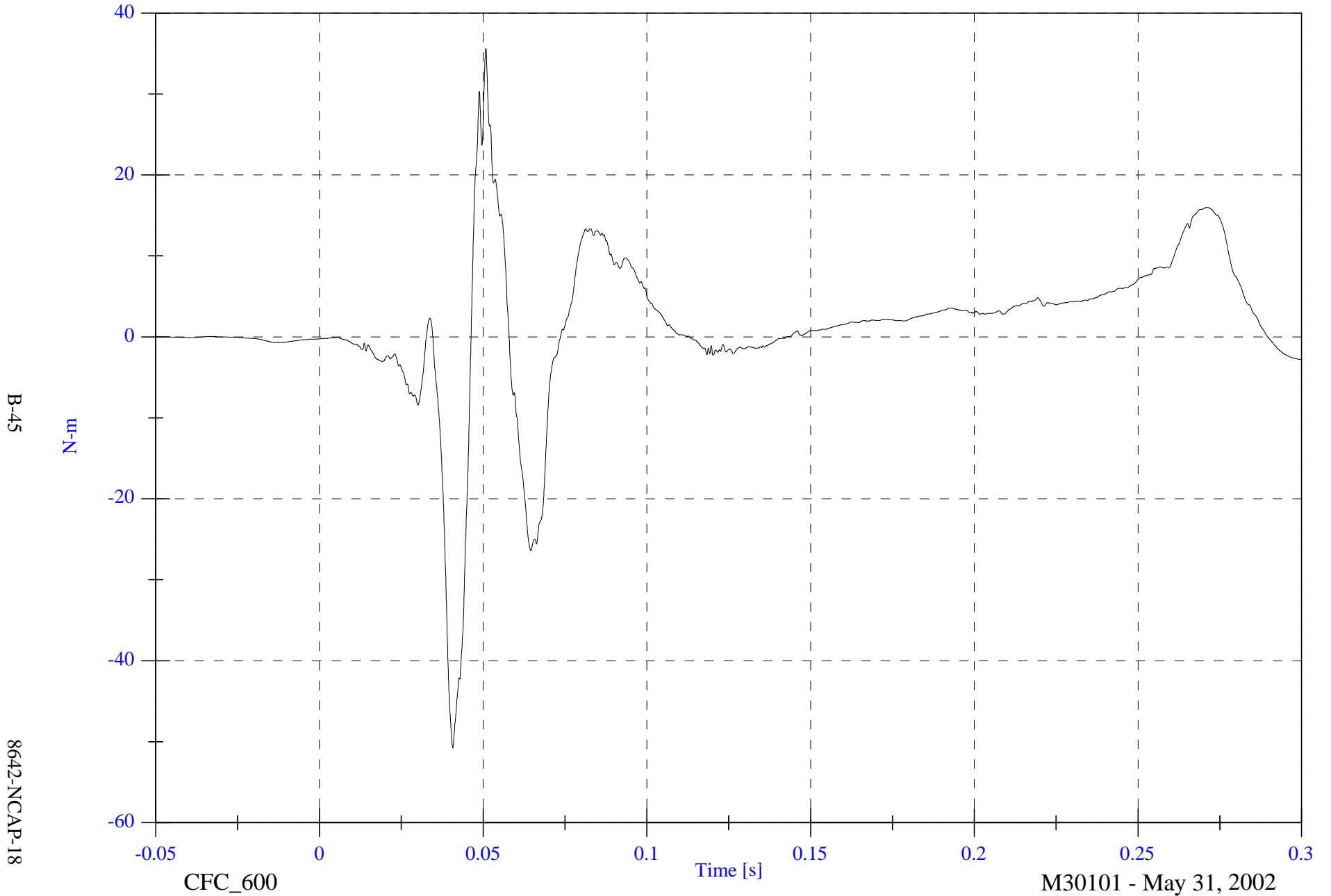

B-45

8642-NCAP-18

CFC_600

Time [s]

M30101 - May 31, 2002

2002 NCAP Test 18 2003 Cadillac CTS

Max: 48.2 [N-m] at 0.042 [s]

Min: -12.6 [N-m] at 0.121 [s]

P1 Right Upper Tibia Mx

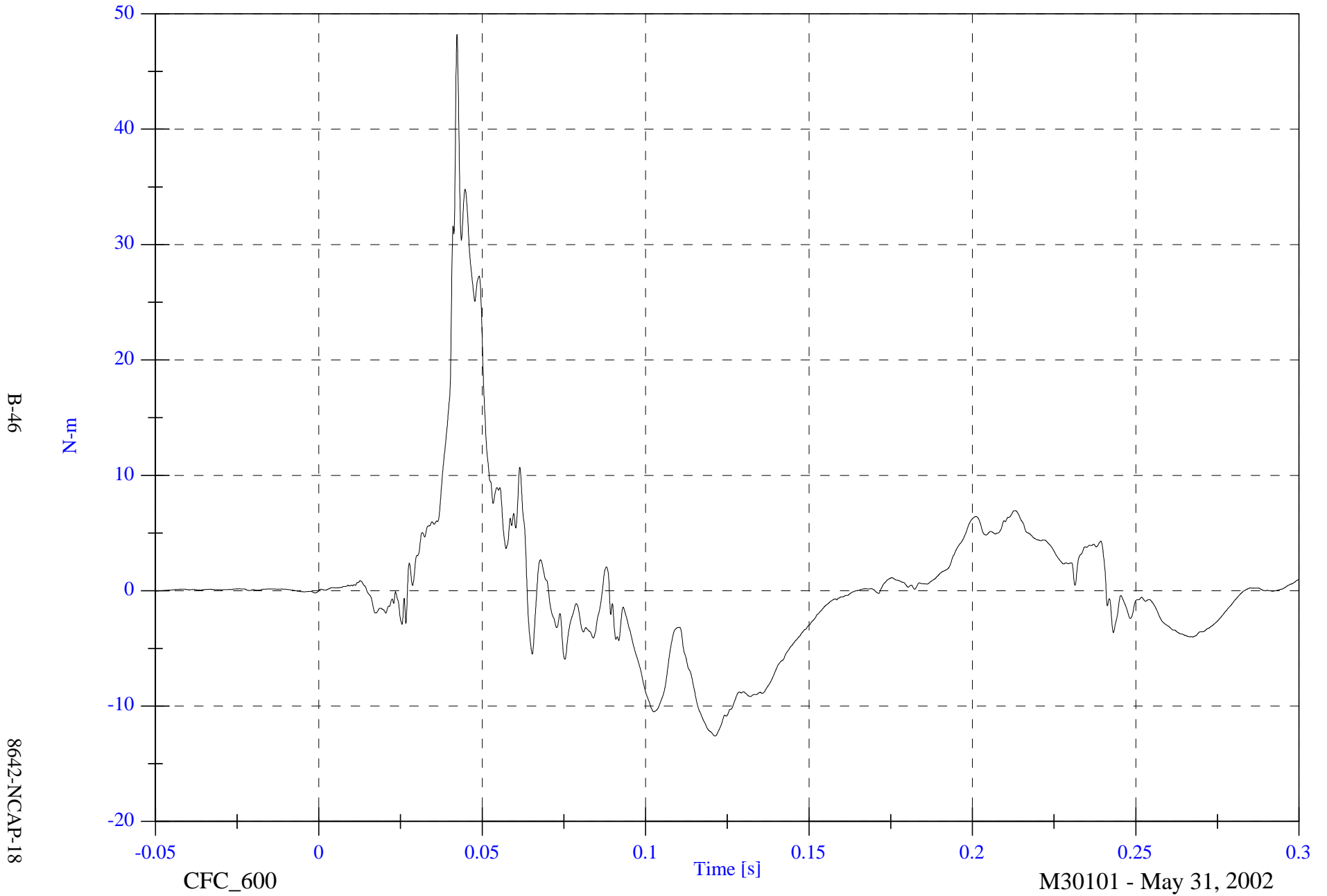

B-46

8642-NCAP-18

CFC_600

Time [s]

M30101 - May 31, 2002

2002 NCAP Test 18 2003 Cadillac CTS

Max: 41.5 [N-m] at 0.107 [s]

Min: -78.0 [N-m] at 0.061 [s]

P1 Right Upper Tibia My

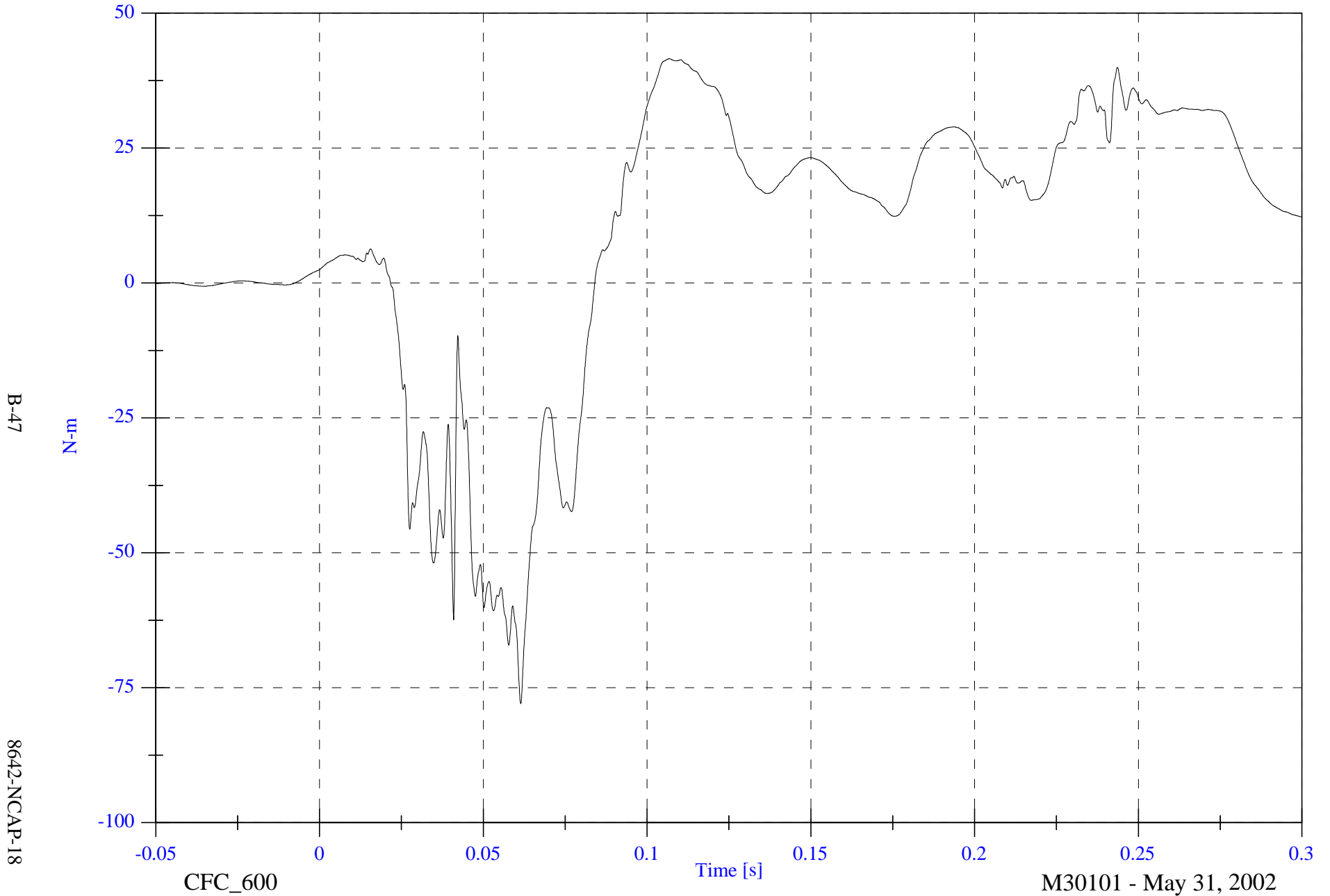

B-47

8642-NCAP-18

CFC_600

Time [s]

M30101 - May 31, 2002

2002 NCAP Test 18 2003 Cadillac CTS

Max: 100.4 [N] at 0.124 [s]

Min: -3991.0 [N] at 0.048 [s]

P1 Right Lower Tibia Fz

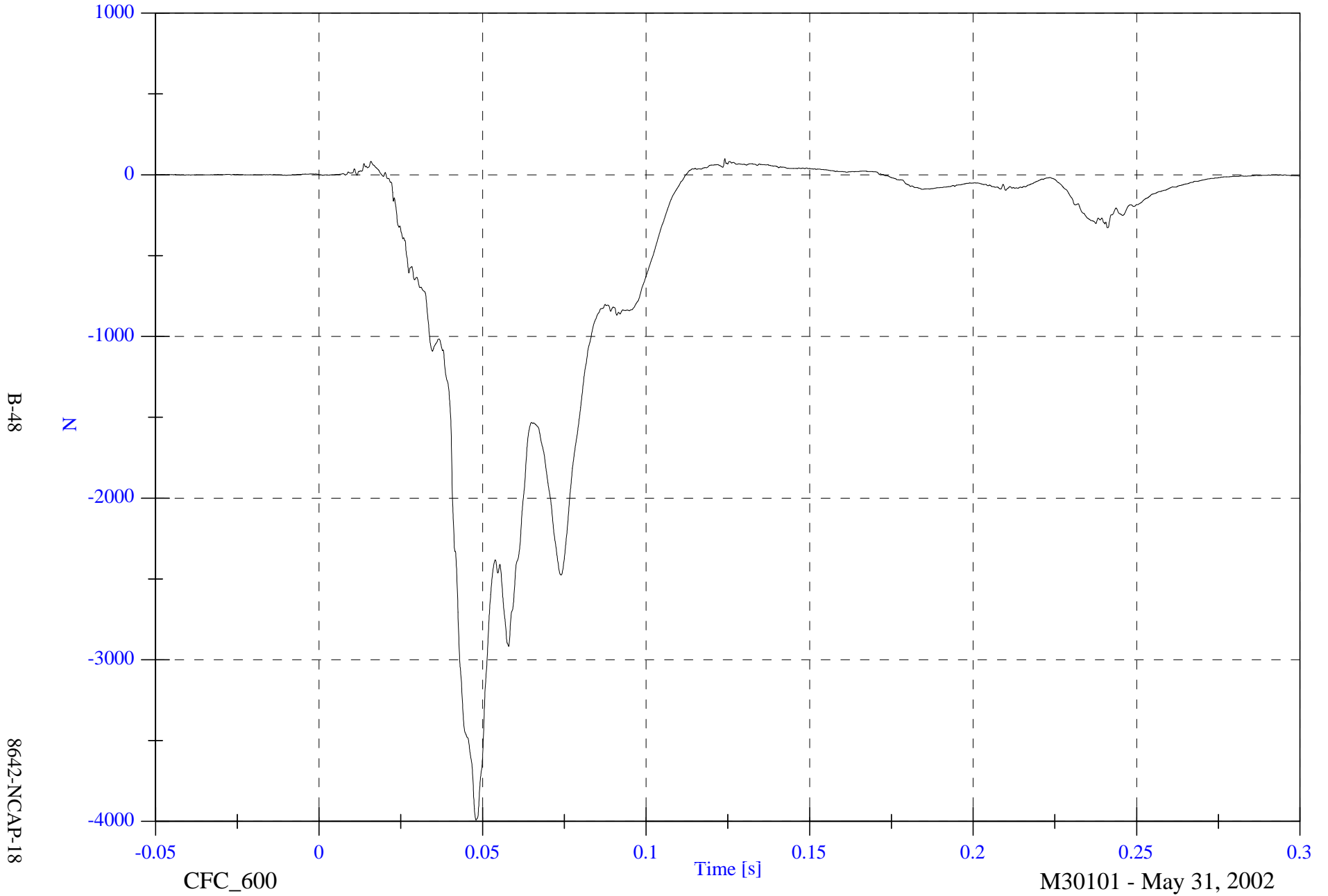

2002 NCAP Test 18 2003 Cadillac CTS

Max: 13.9 [N-m] at 0.042 [s]

Min: -66.4 [N-m] at 0.057 [s]

P1 Right Lower tibia Mx

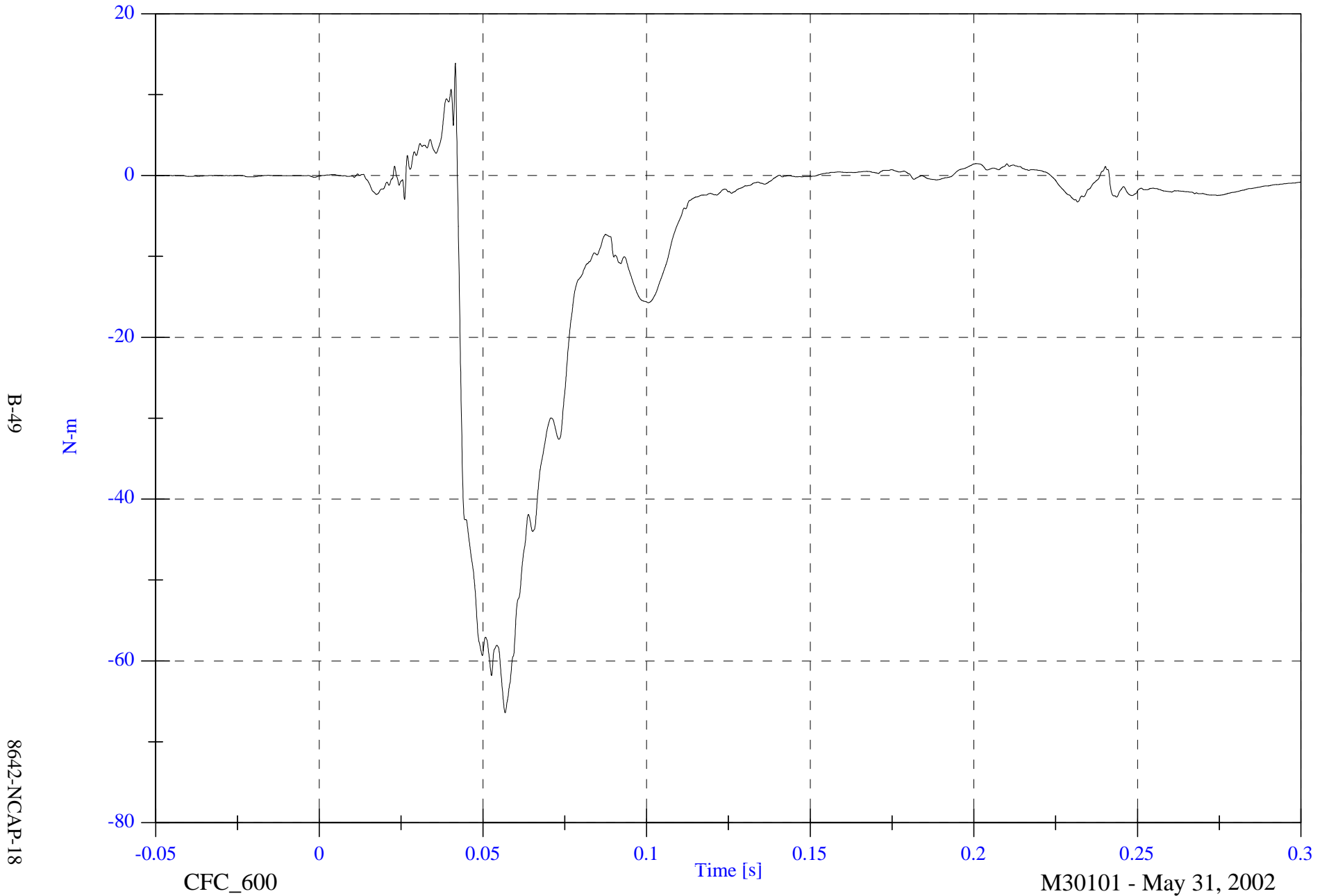

B-49

8642-NCAP-18

2002 NCAP Test 18 2003 Cadillac CTS

Max: 93.9 [N-m] at 0.049 [s]

Min: -33.2 [N-m] at 0.037 [s]

P1 Right Lower Tibia My

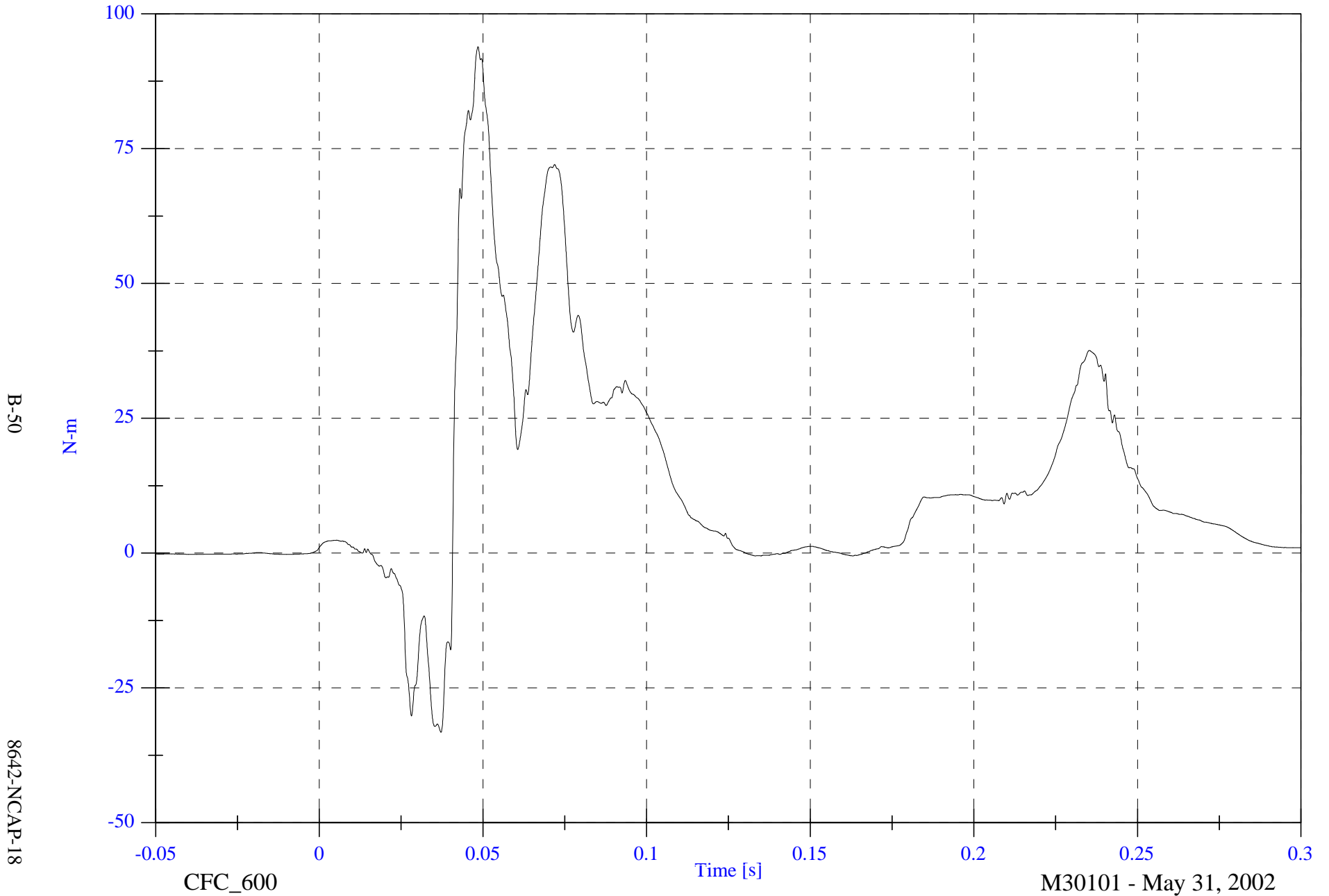

2002 NCAP Test 18 2003 Cadillac CTS

Max: 40.8 [g] at 0.052 [s]

Min: -96.5 [g] at 0.042 [s]

P1 Left Foot Aft Ax

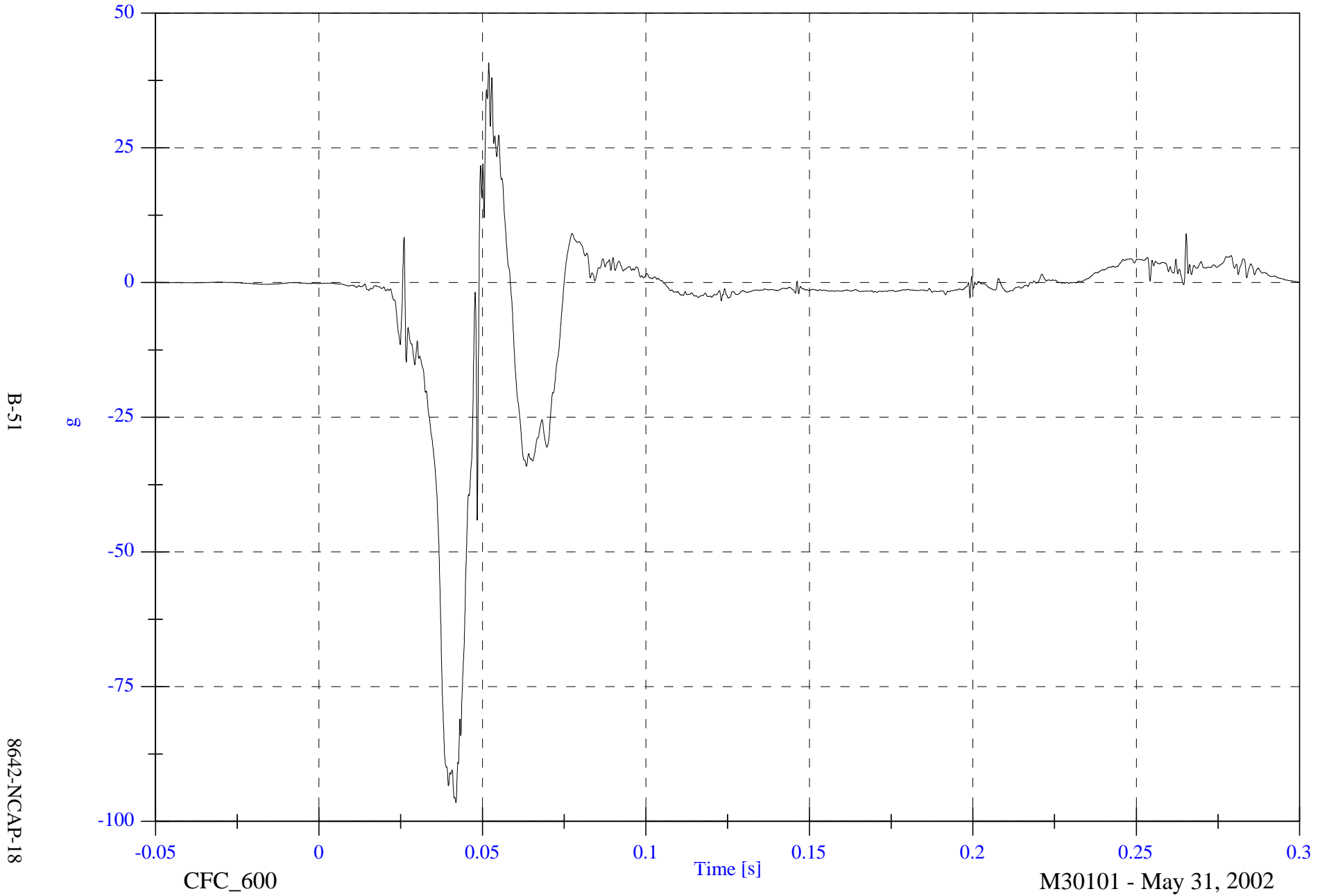

2002 NCAP Test 18 2003 Cadillac CTS

Max: 13.5 [g] at 0.051 [s]

Min: -55.6 [g] at 0.044 [s]

P1 Left Foot Aft Az

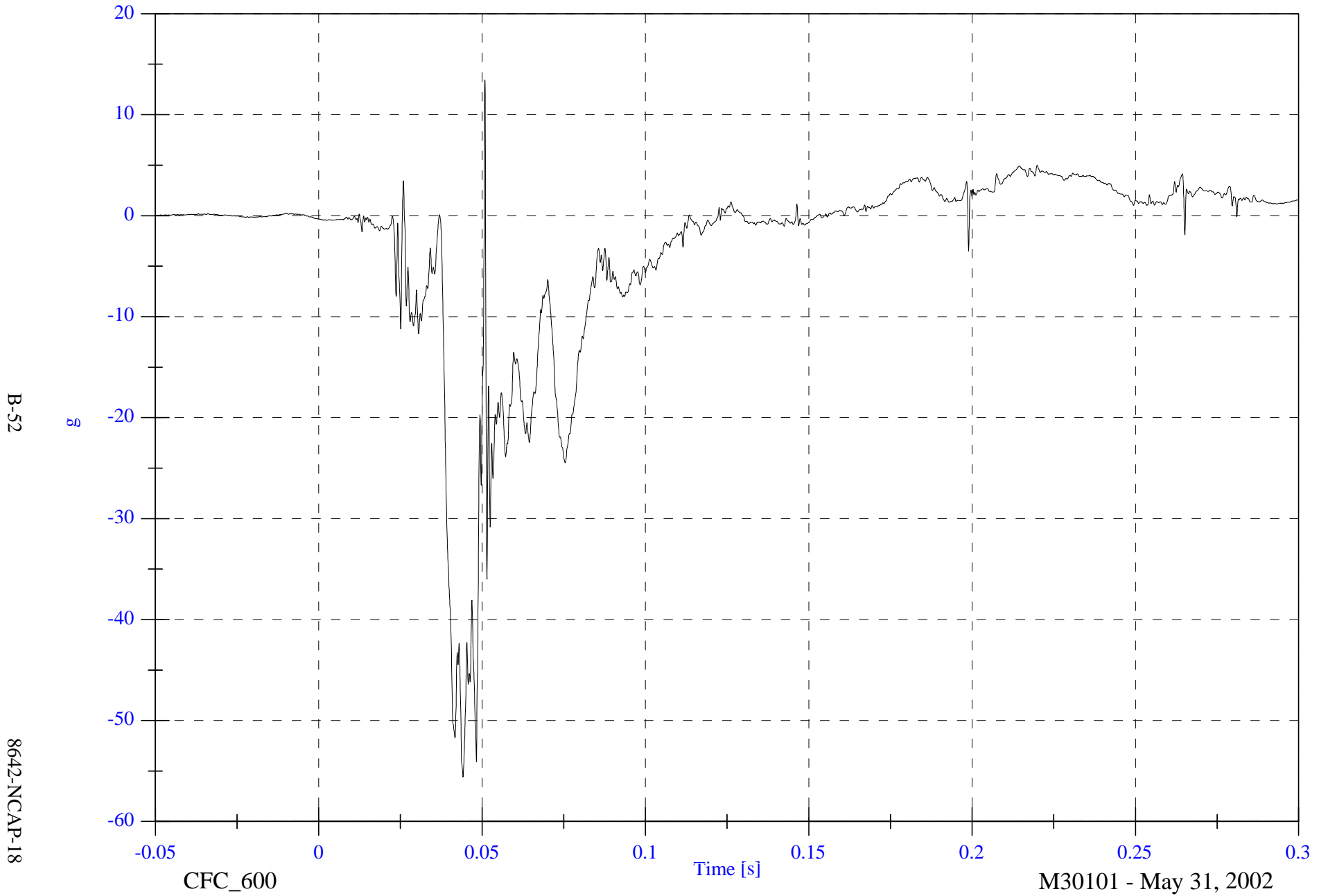

B-52

8642-NCAP-18

CFC_600

Time [s]

M30101 - May 31, 2002

2002 NCAP Test 18 2003 Cadillac CTS

Max: 73.1 [g] at 0.051 [s]

Min: -142.2 [g] at 0.042 [s]

P1 Left Foot Fore Az

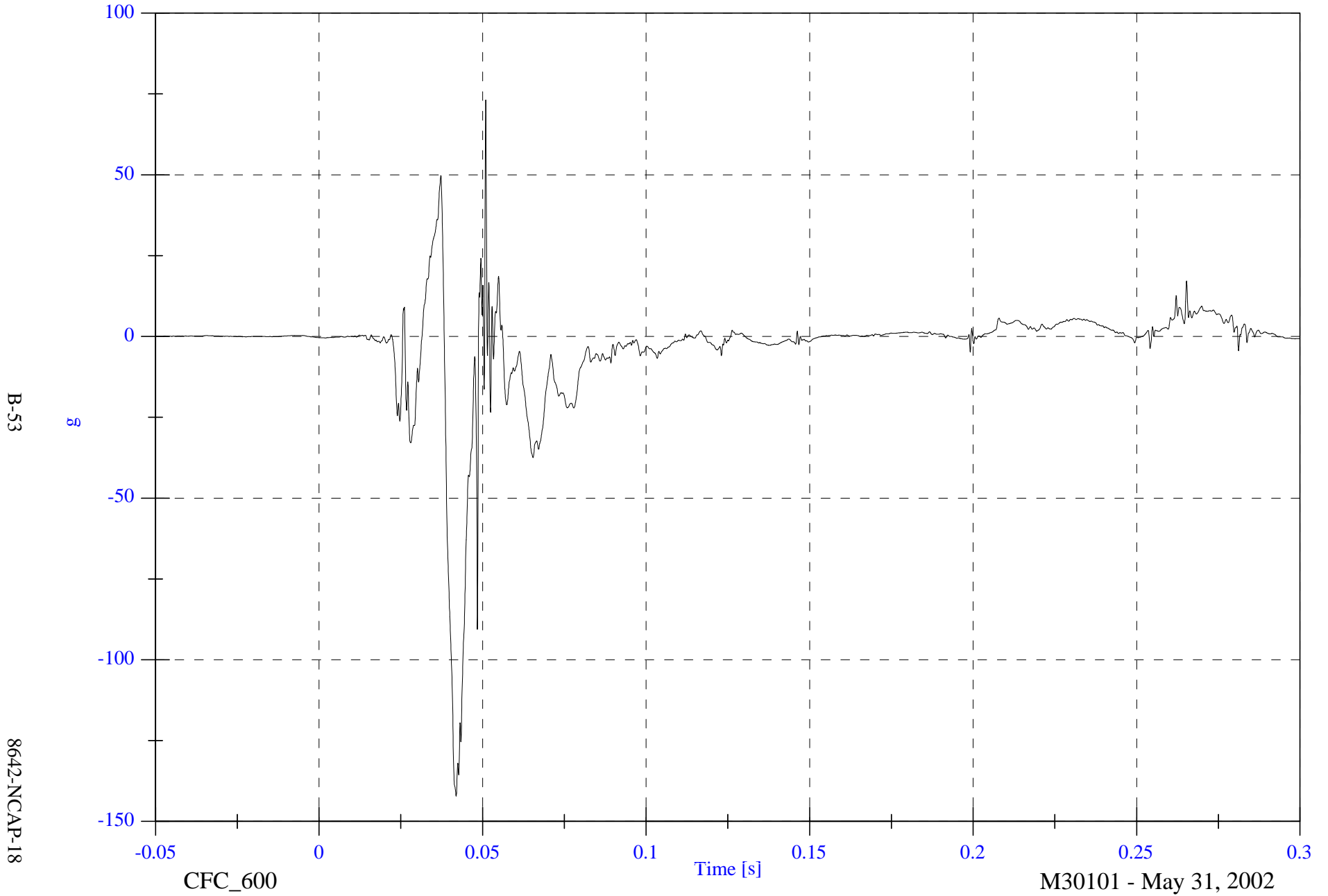

2002 NCAP Test 18 2003 Cadillac CTS

Max: 51.2 [g] at 0.048 [s]

Min: -77.3 [g] at 0.034 [s]

P1 Right Foot Aft x

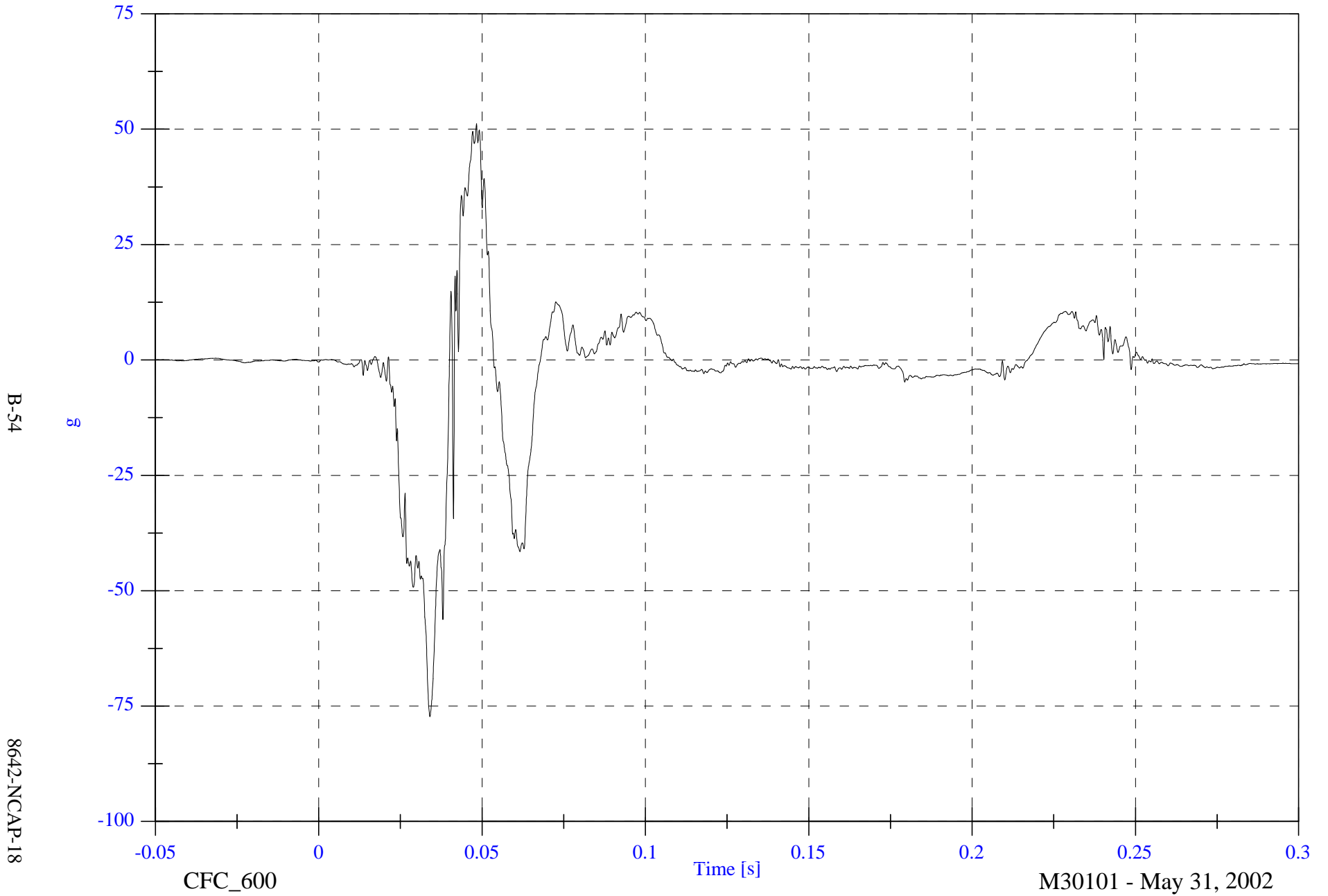

2002 NCAP Test 18 2003 Cadillac CTS

Max: 10.9 [g] at 0.241 [s]

Min: -91.5 [g] at 0.039 [s]

P1 Right Foot Aft z

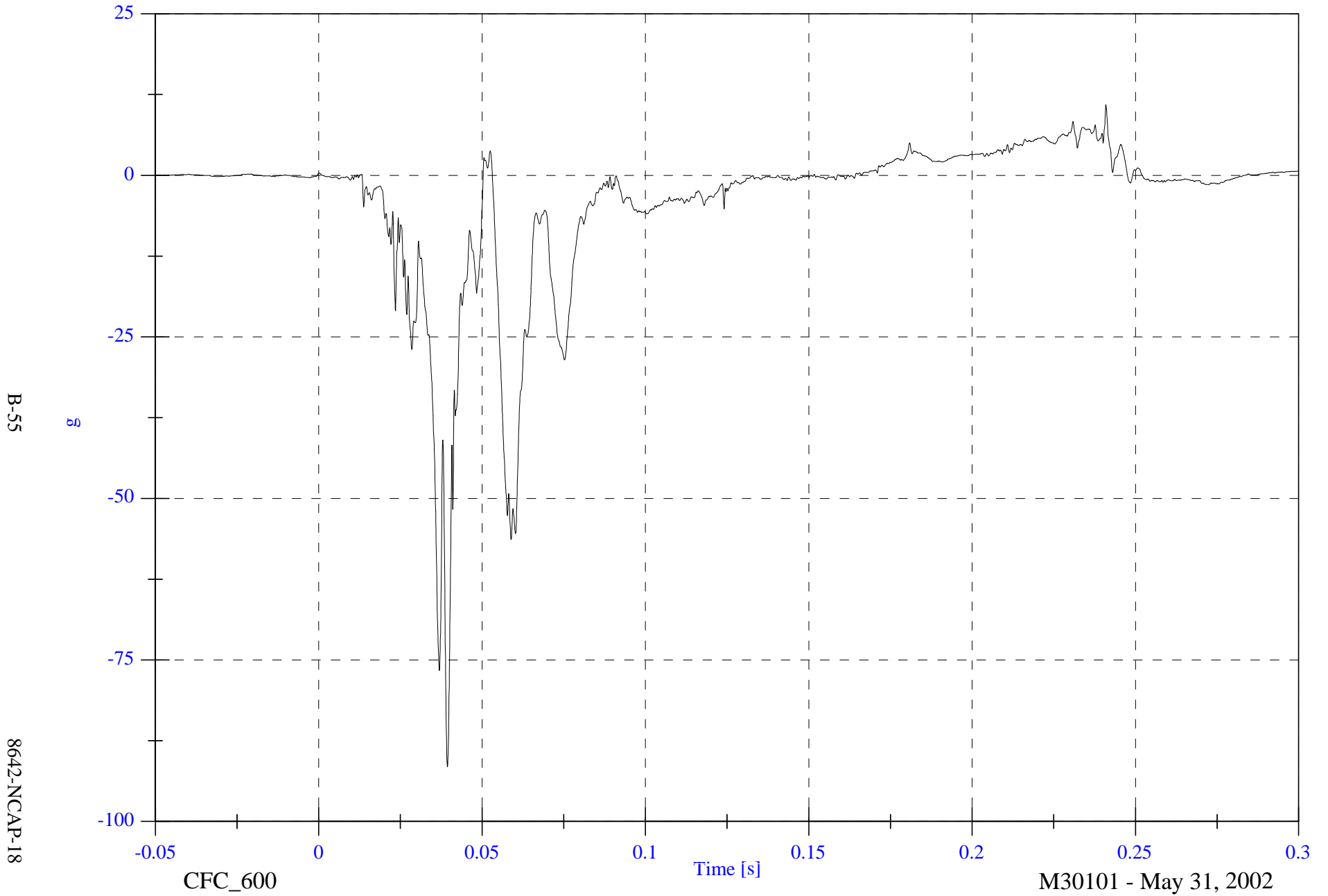

2002 NCAP Test 18 2003 Cadillac CTS

Max: 41.5 [g] at 0.043 [s]

Min: -168.4 [g] at 0.037 [s]

P1 Right Foot Fore z

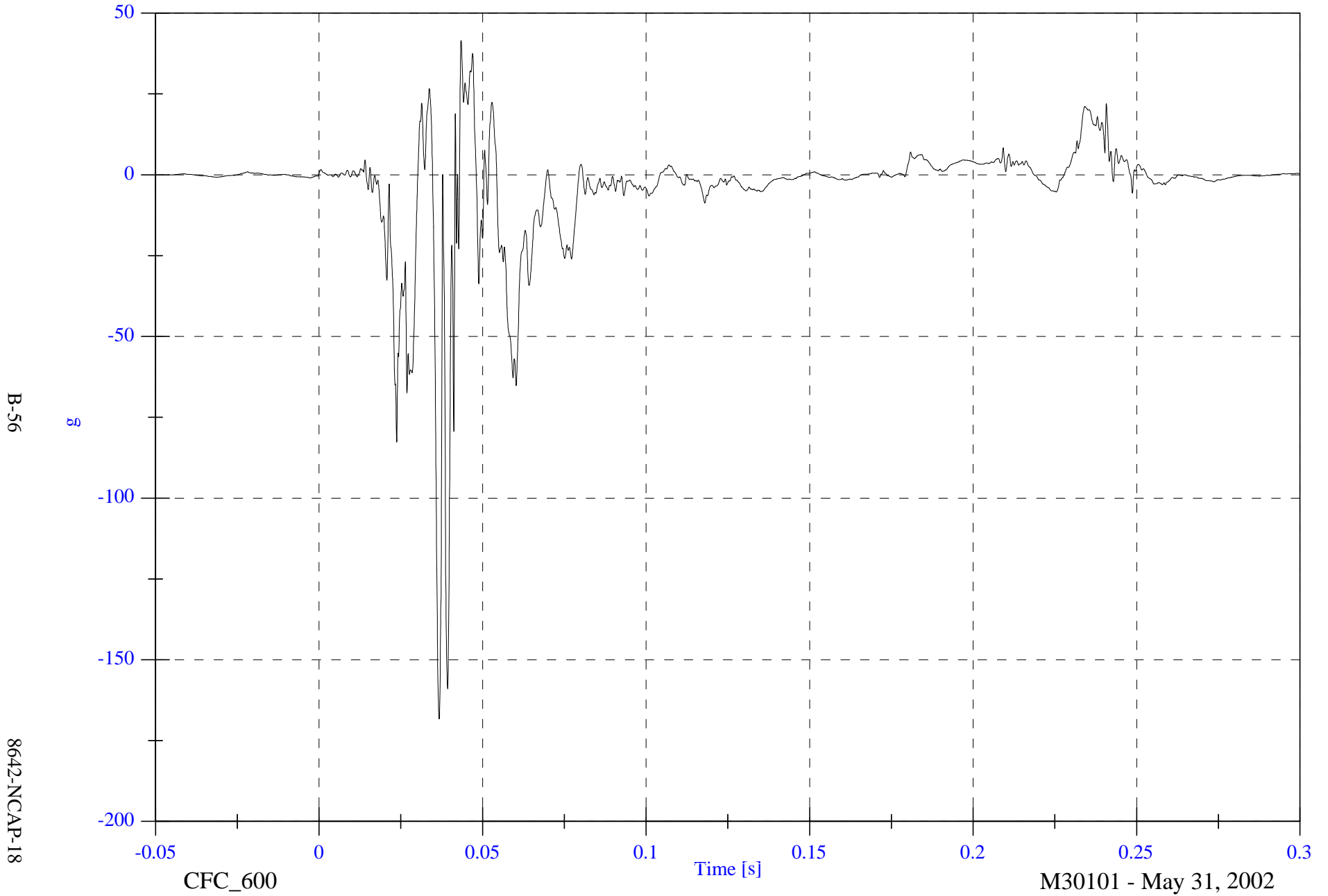

2002 NCAP Test 18 2003 Cadillac CTS

Max: 6.2 [g] at 0.064 [s]

Min: -21.9 [g] at 0.054 [s]

P2 Head 9 Array X Arm y

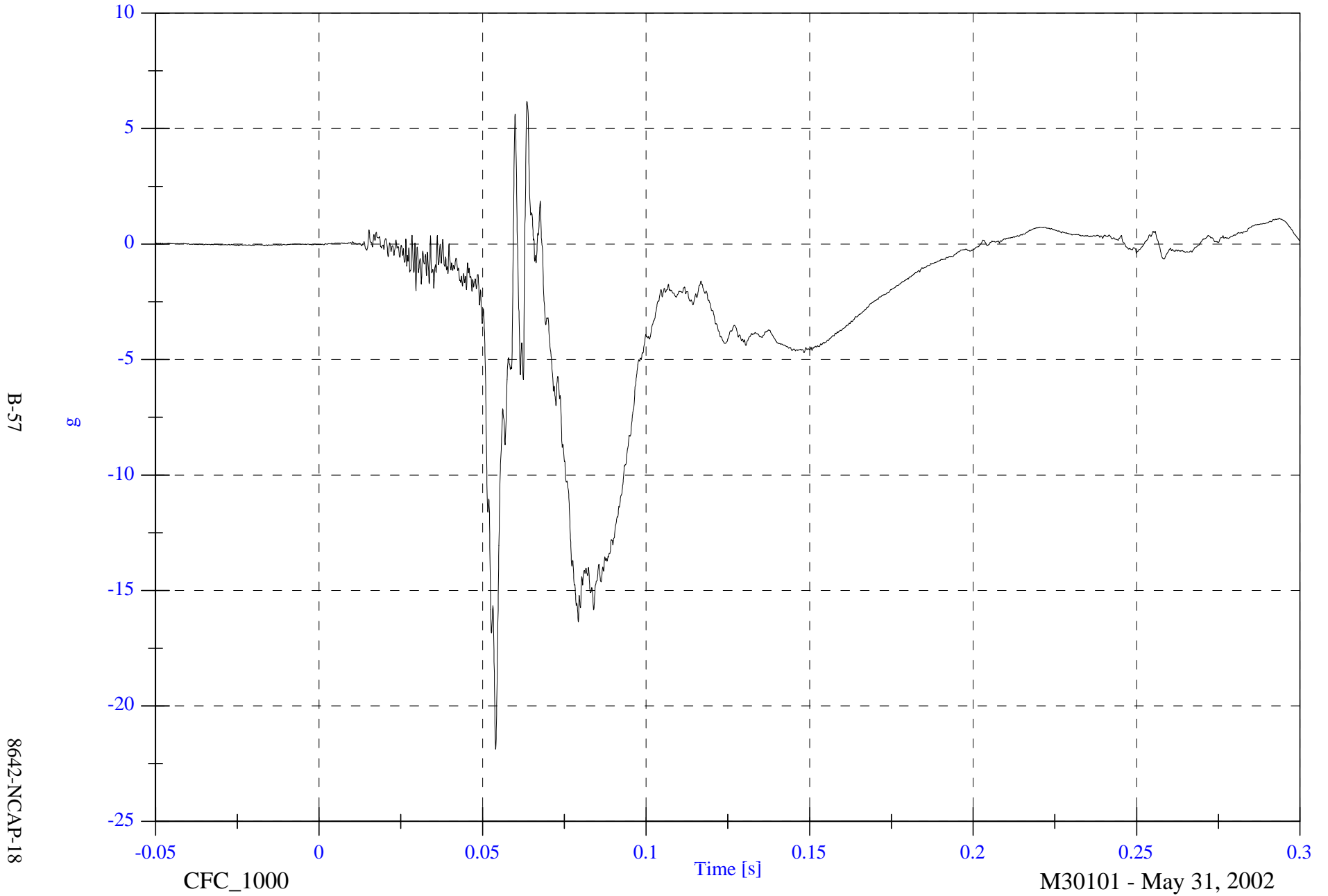

B-57

8642-NCAP-18

2002 NCAP Test 18 2003 Cadillac CTS

Max: 30.1 [g] at 0.063 [s]

Min: -7.5 [g] at 0.155 [s]

P2 Head 9 Array X Arm z

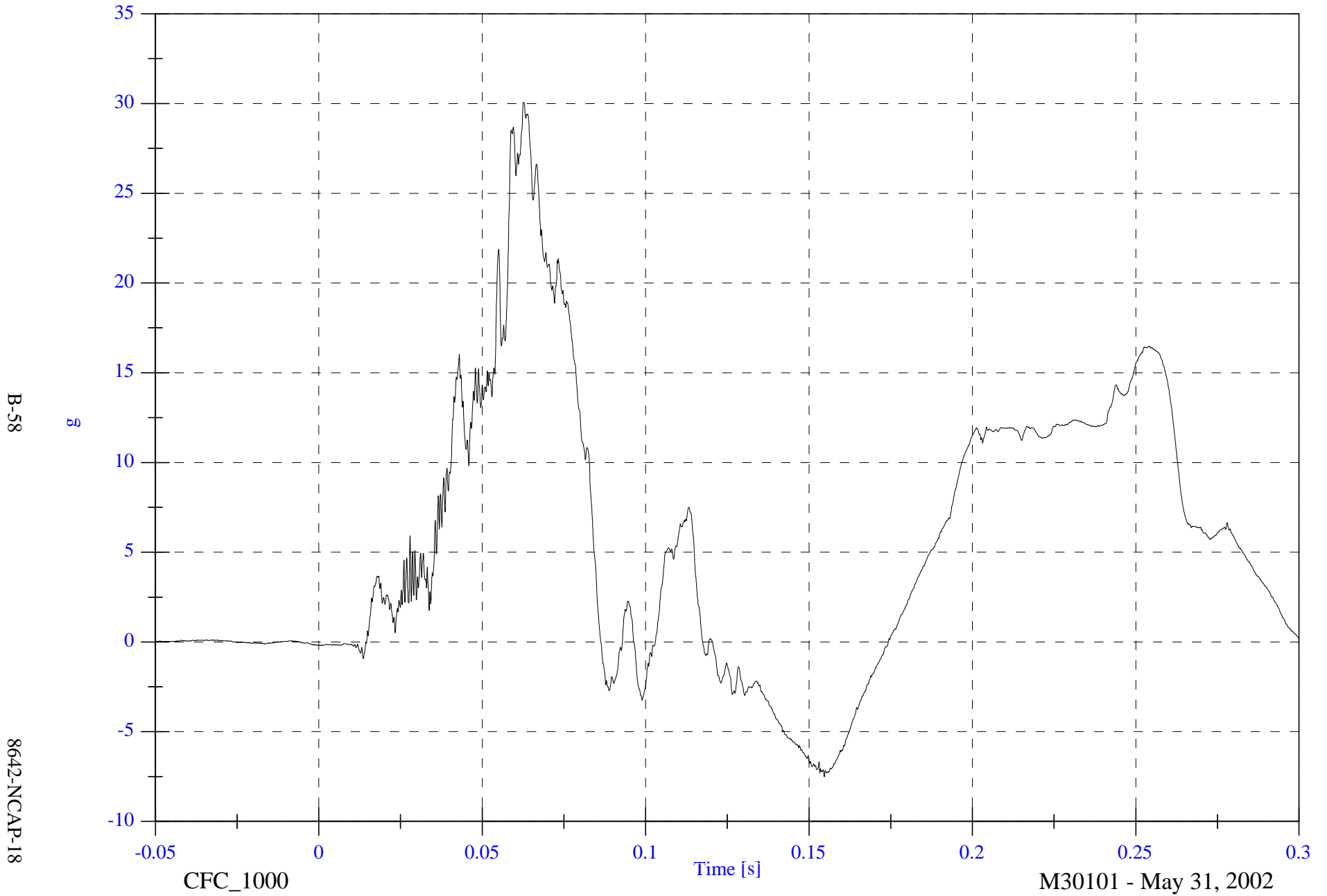

B-58

8642-NCAP-18

CFC_1000

Time [s]

M30101 - May 31, 2002

2002 NCAP Test 18 2003 Cadillac CTS

Max: 14.7 [g] at 0.260 [s]

Min: -60.9 [g] at 0.082 [s]

P2 Head 9 Array Y Arm x

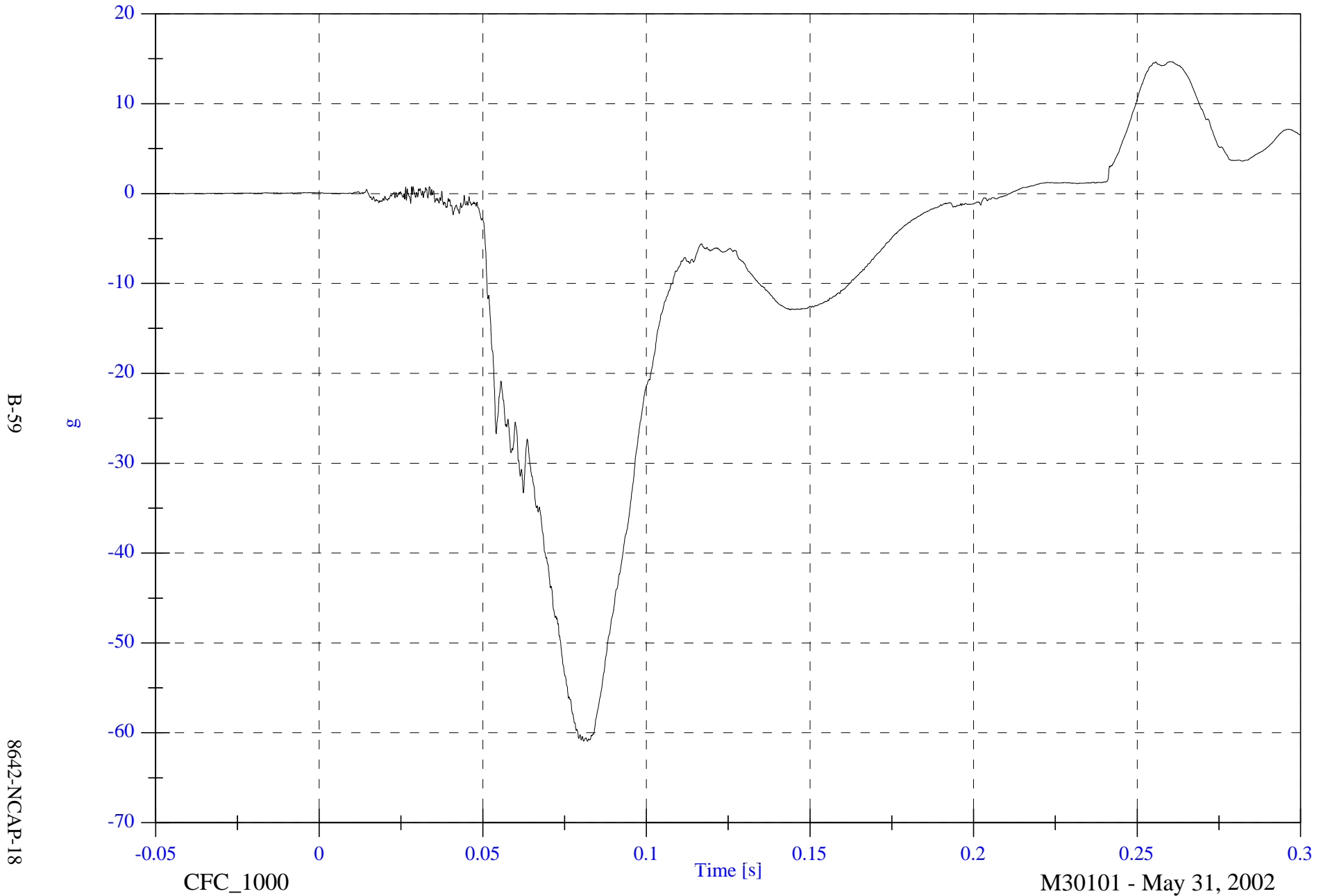

2002 NCAP Test 18 2003 Cadillac CTS

Max: 24.9 [g] at 0.076 [s]

Min: -11.0 [g] at 0.099 [s]

P2 Head 9 Array Y Arm z

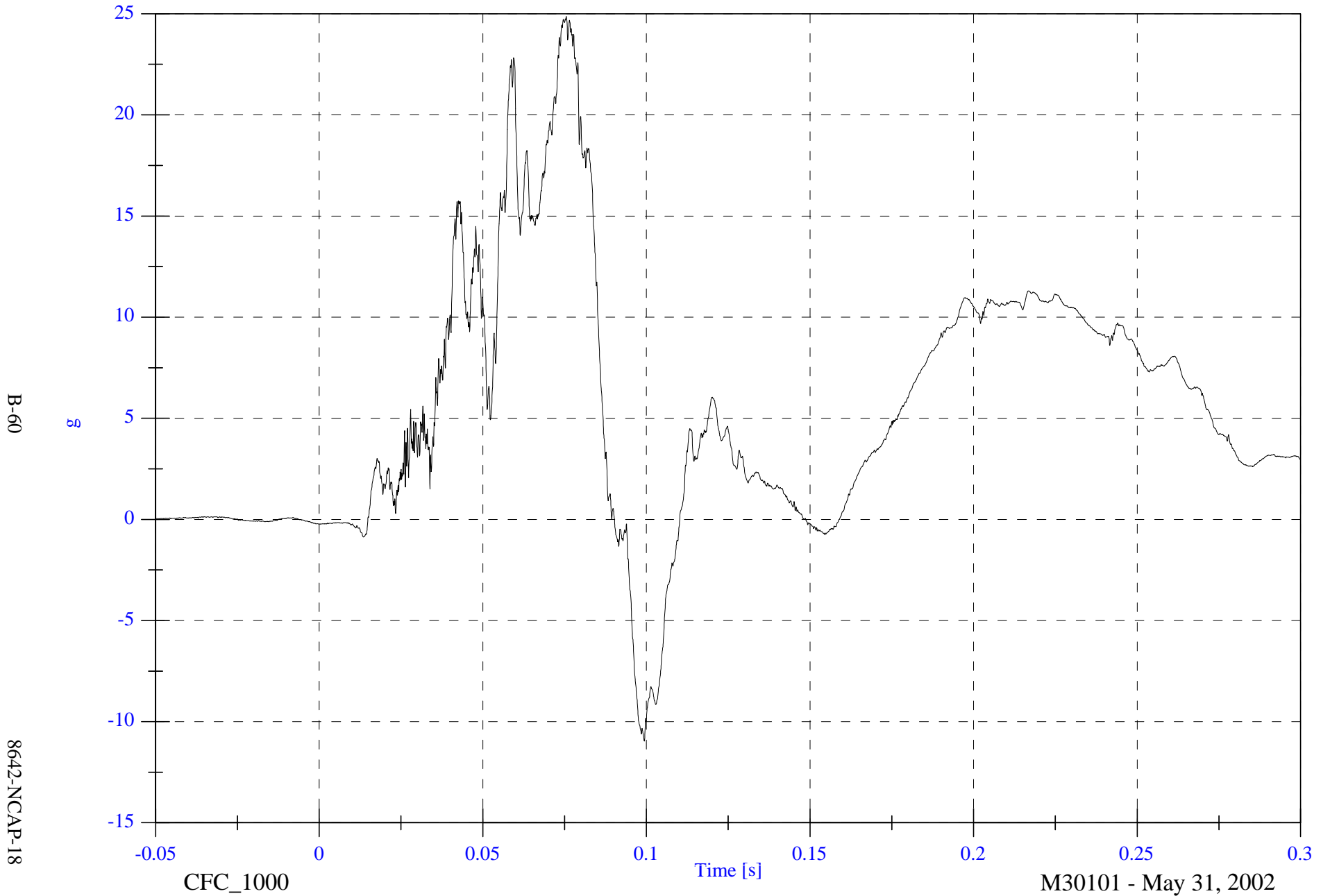

2002 NCAP Test 18 2003 Cadillac CTS

Max: 26.4 [g] at 0.255 [s]

Min: -70.7 [g] at 0.082 [s]

P2 Head 9 Array Z Arm x

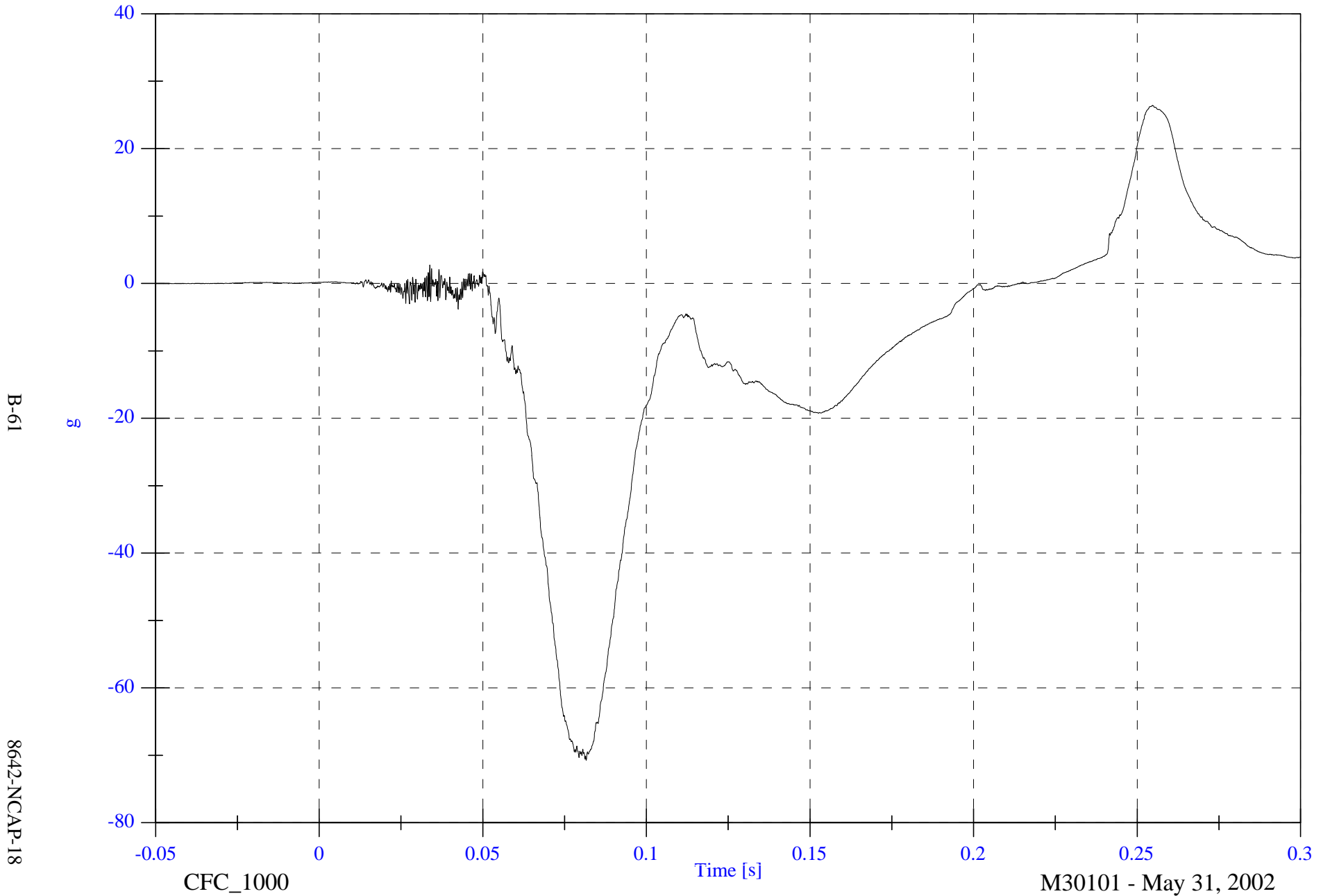

B-61

8642-NCAP-18

CFC_1000

Time [s]

M30101 - May 31, 2002

2002 NCAP Test 18 2003 Cadillac CTS

Max: 8.4 [g] at 0.064 [s]

Min: -23.8 [g] at 0.084 [s]

P2 Head 9 Array Z Arm y

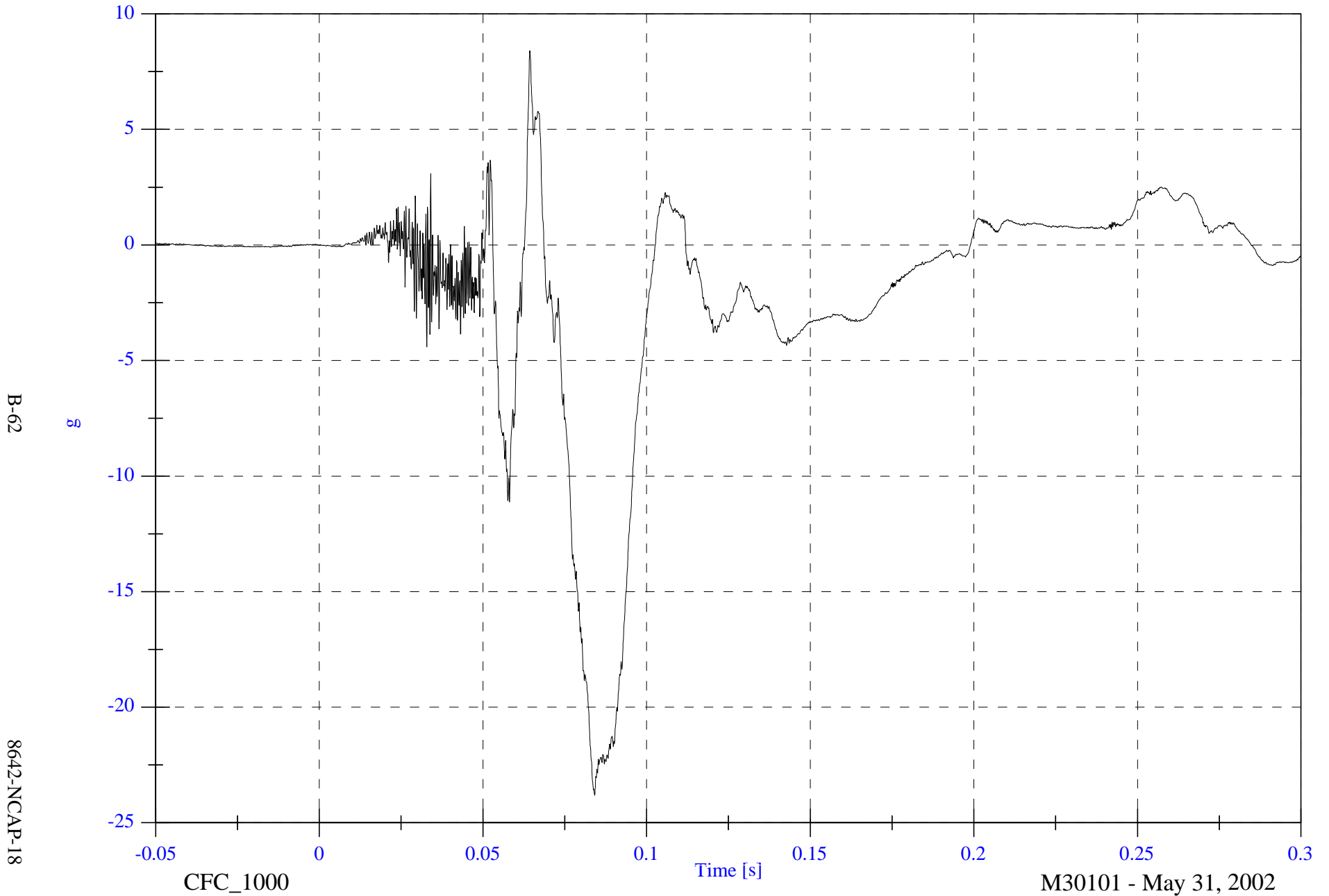

2002 NCAP Test 18 2003 Cadillac CTS

P2 Head CG x

Max: 15.0 [g] at 0.261 [s]

Min: -61.1 [g] at 0.082 [s]

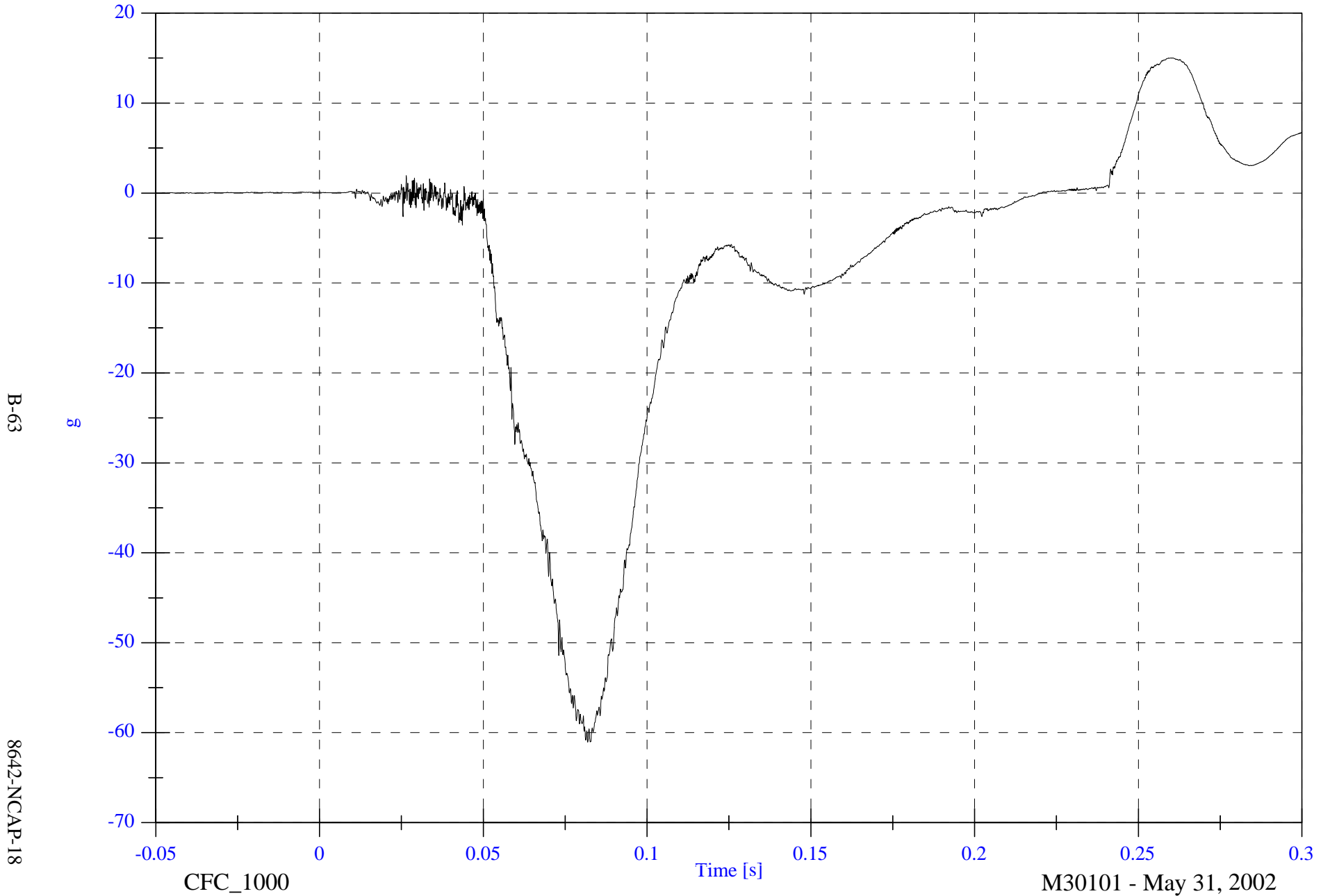

2002 NCAP Test 18 2003 Cadillac CTS

Max: 4.4 [g] at 0.059 [s]

Min: -19.4 [g] at 0.085 [s]

P2 Head CG y

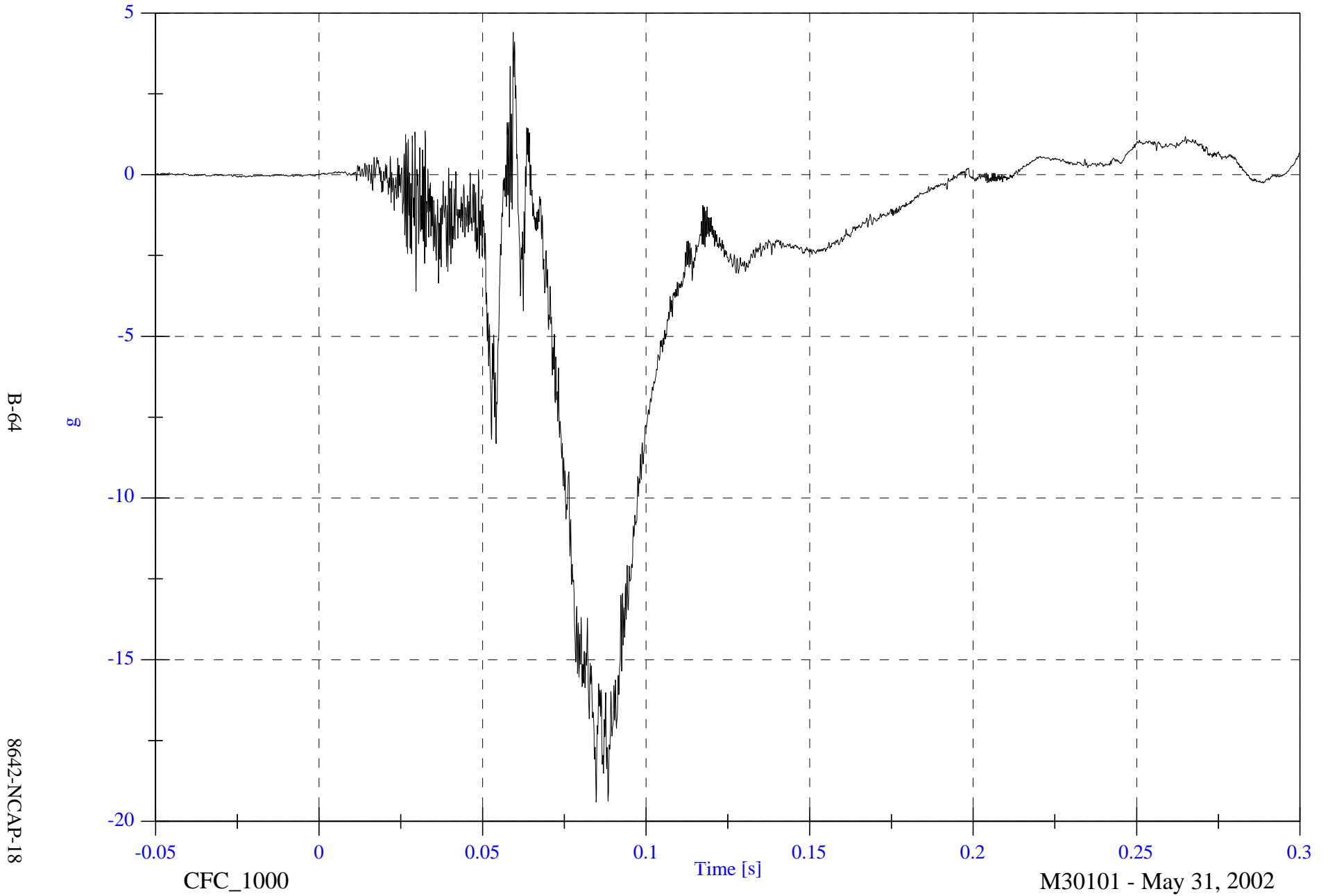

2002 NCAP Test 18 2003 Cadillac CTS

Max: 26.7 [g] at 0.074 [s]
Min: -8.1 [g] at 0.099 [s]

P2 Head CG z

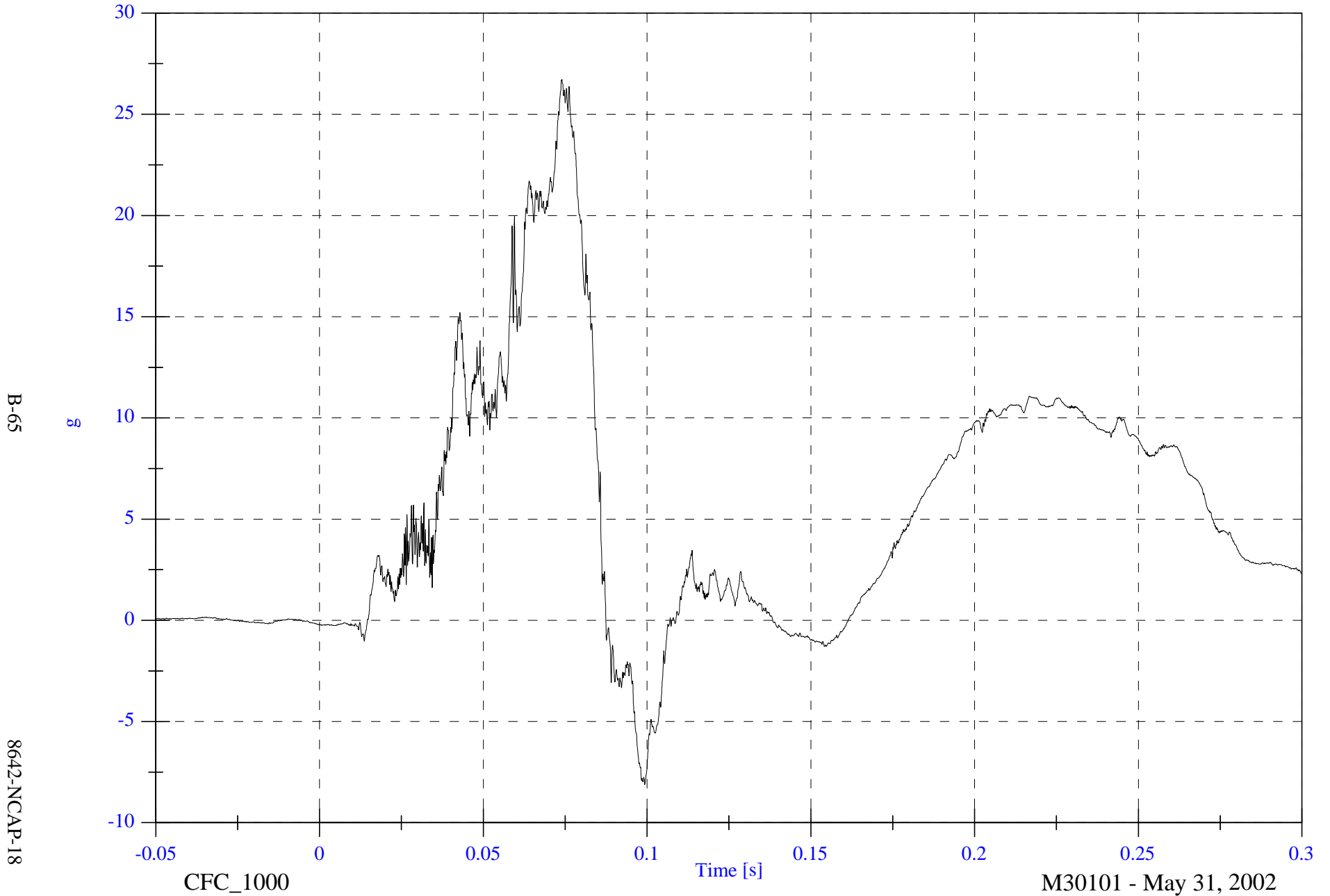

2002 NCAP Test 18 2003 Cadillac CTS

P2 Head CG Resultant

Max: 65.4 [g] at 0.081 [s]

Min: 0.0 [g] at -0.027 [s]

B-66

8642-NCAP-18

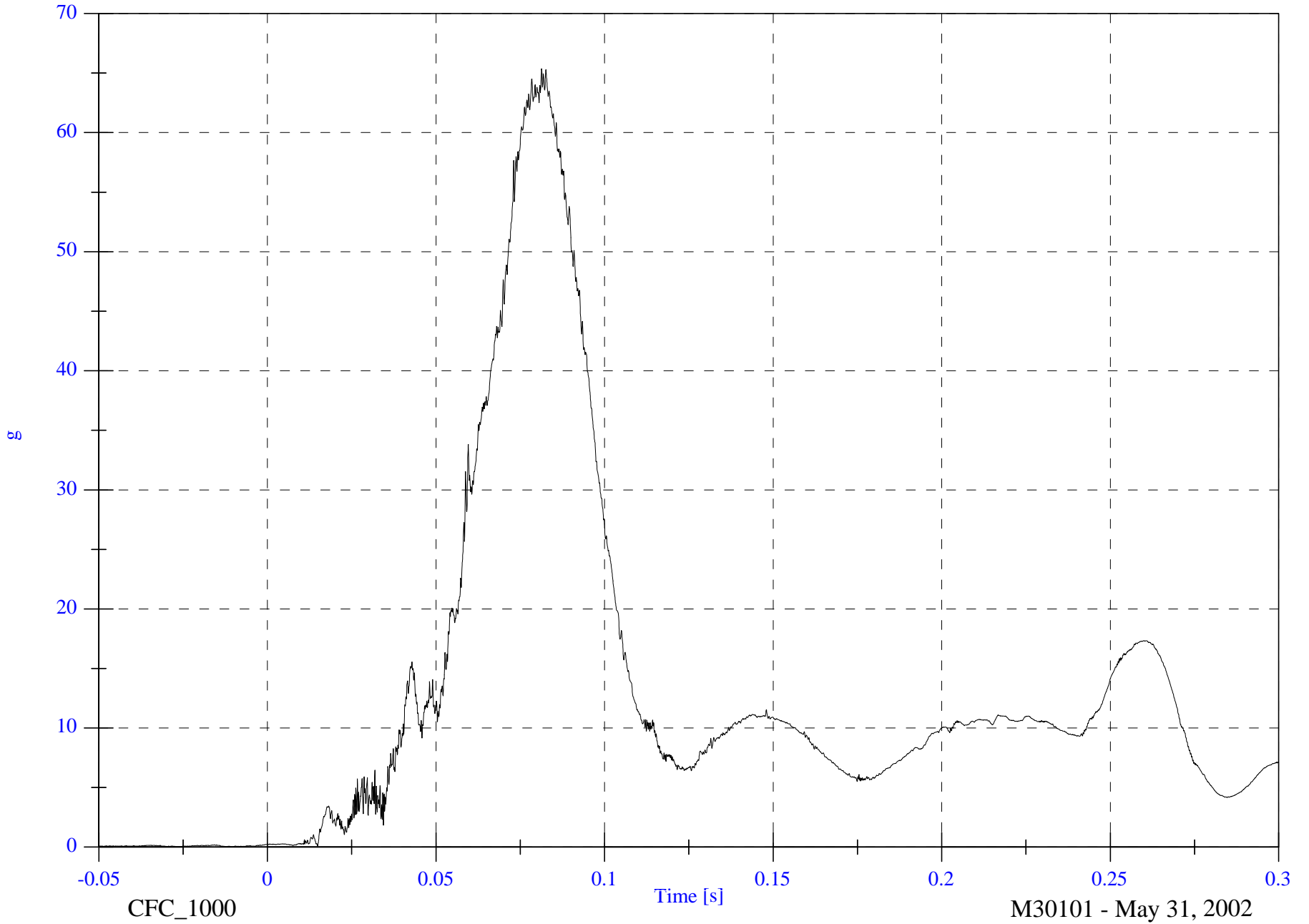

CFC_1000

M30101 - May 31, 2002

2002 NCAP Test 18 2003 Cadillac CTS

P2 Head CG Red x

Max: 15.1 [g] at 0.259 [s]

Min: -60.9 [g] at 0.082 [s]

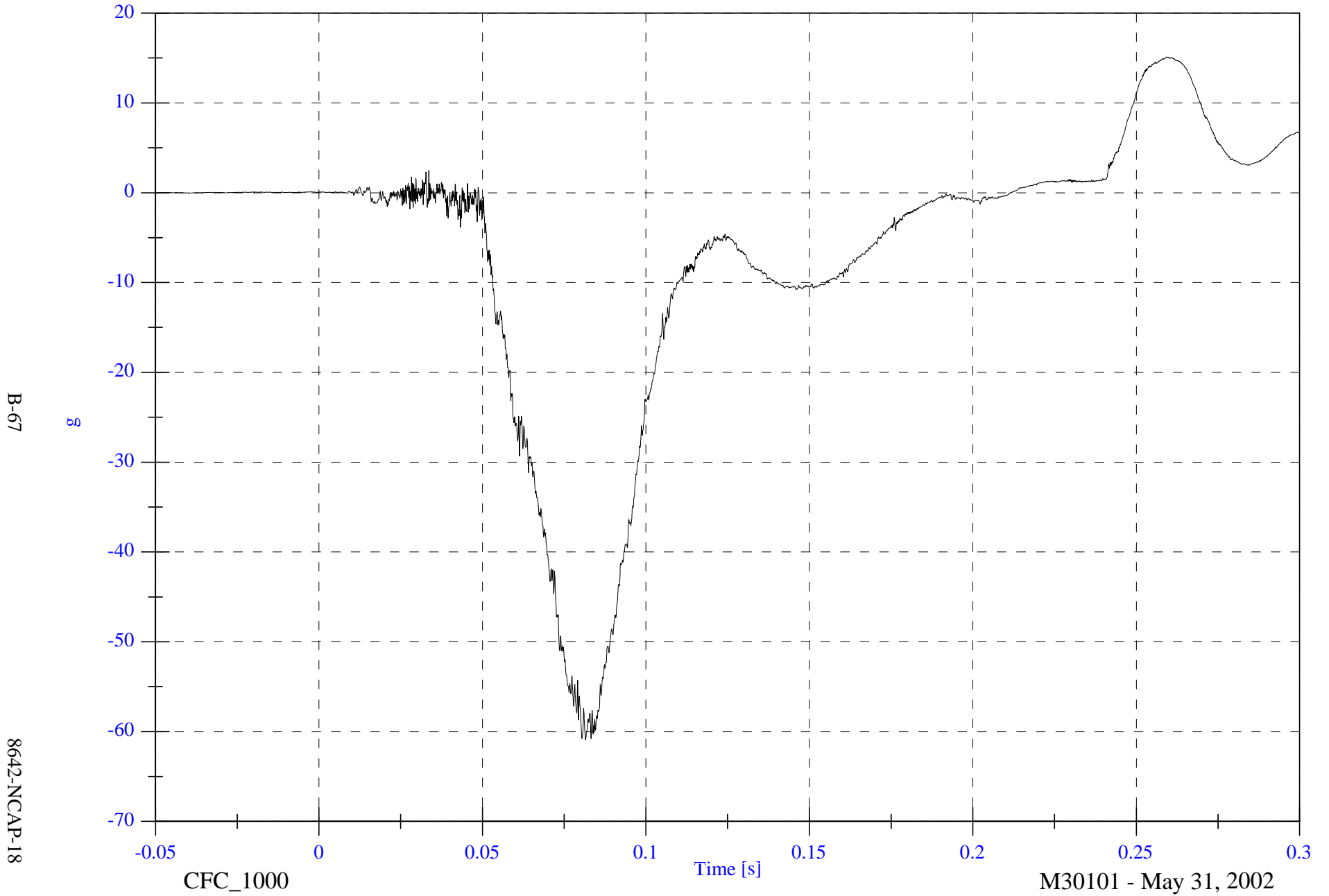

2002 NCAP Test 18 2003 Cadillac CTS

P2 Head CG Red y

Max: 3.9 [g] at 0.060 [s]

Min: -18.7 [g] at 0.088 [s]

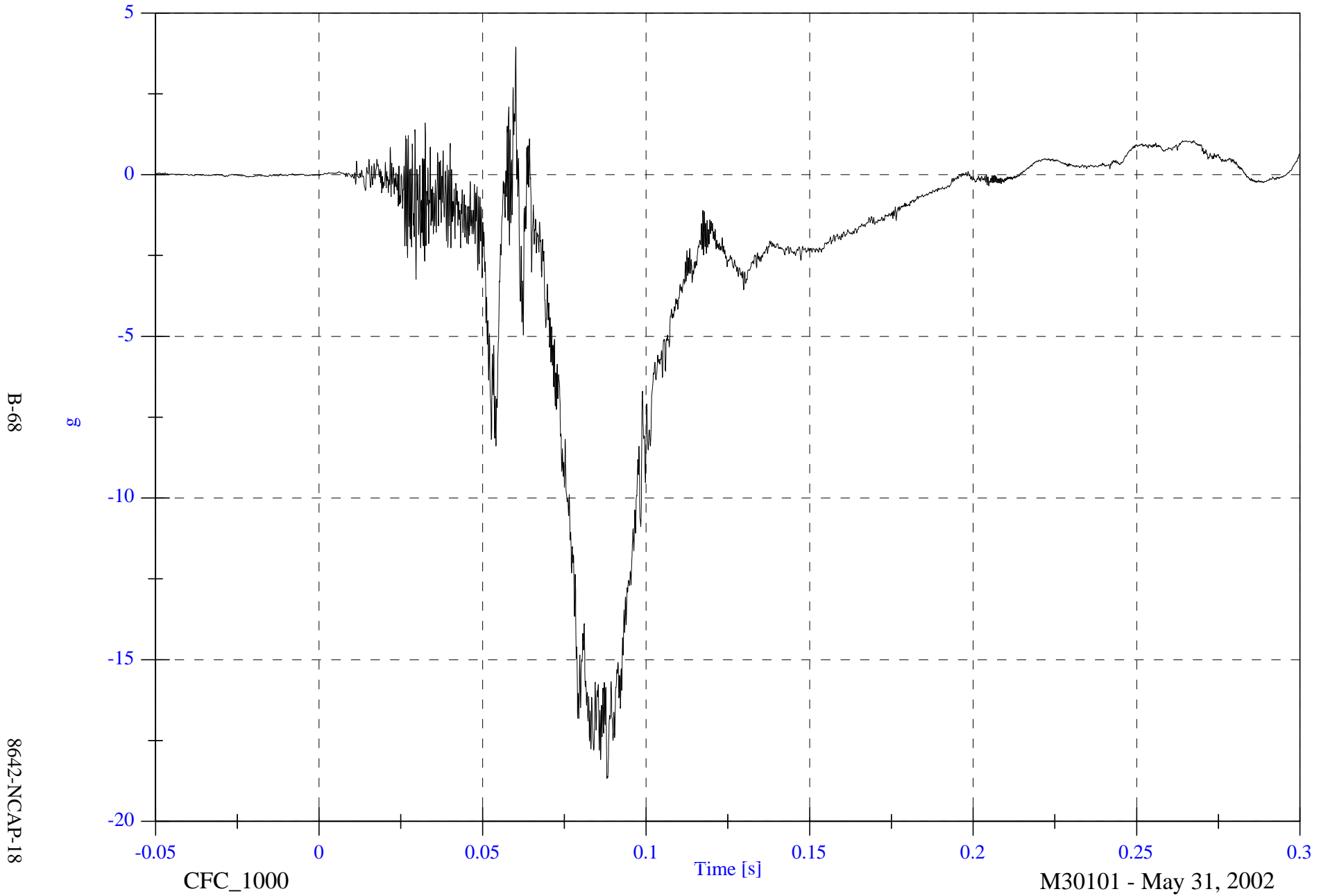

2002 NCAP Test 18 2003 Cadillac CTS

P2 Head CG Red z

Max: 26.4 [g] at 0.075 [s]

Min: -8.8 [g] at 0.099 [s]

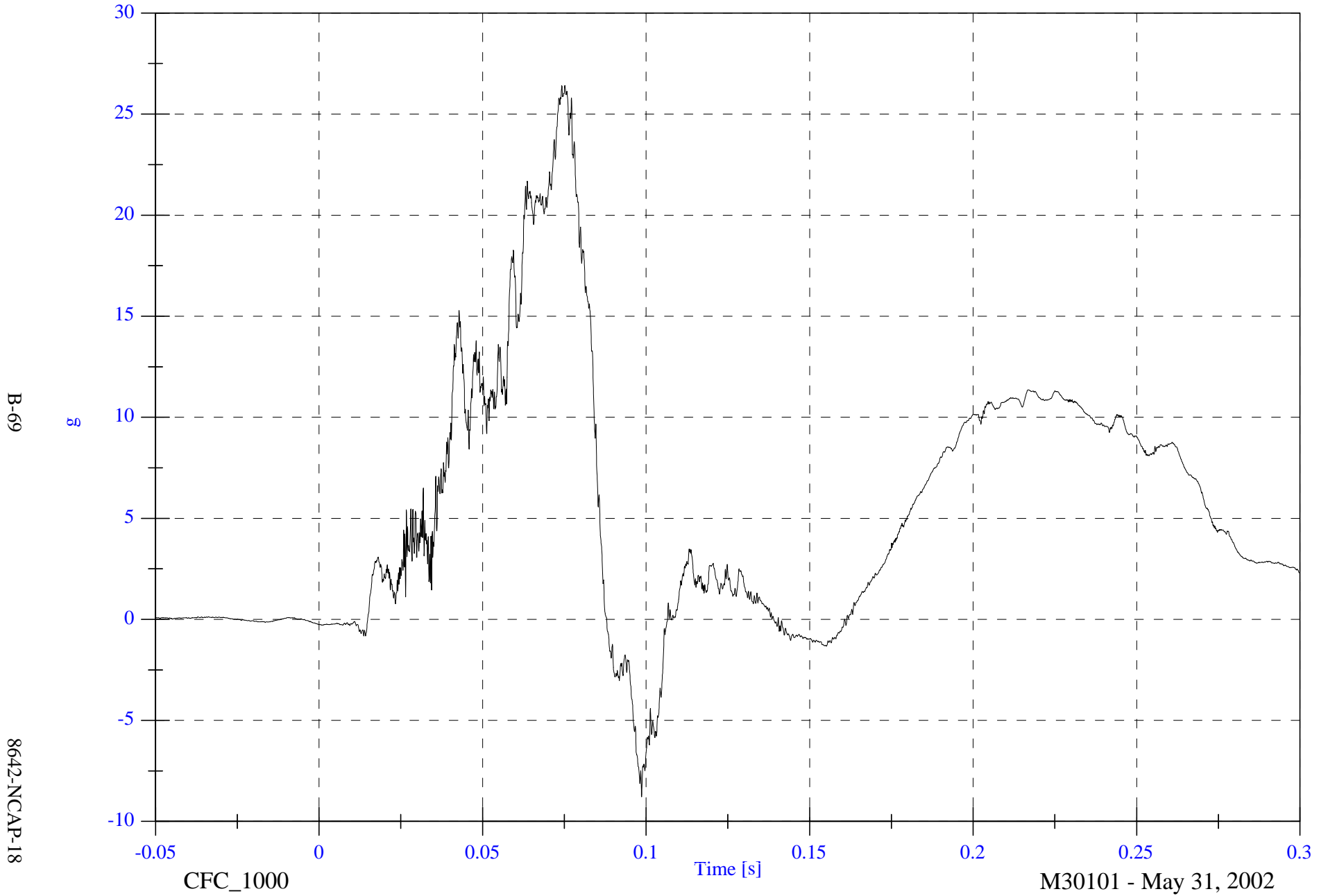

B-69

8642-NCAP-18

CFC_1000

Time [s]

M30101 - May 31, 2002

2002 NCAP Test 18 2003 Cadillac CTS

Max: 65.1 [g] at 0.080 [s]

Min: 0.0 [g] at -0.026 [s]

P2 Head CG Red Resultant

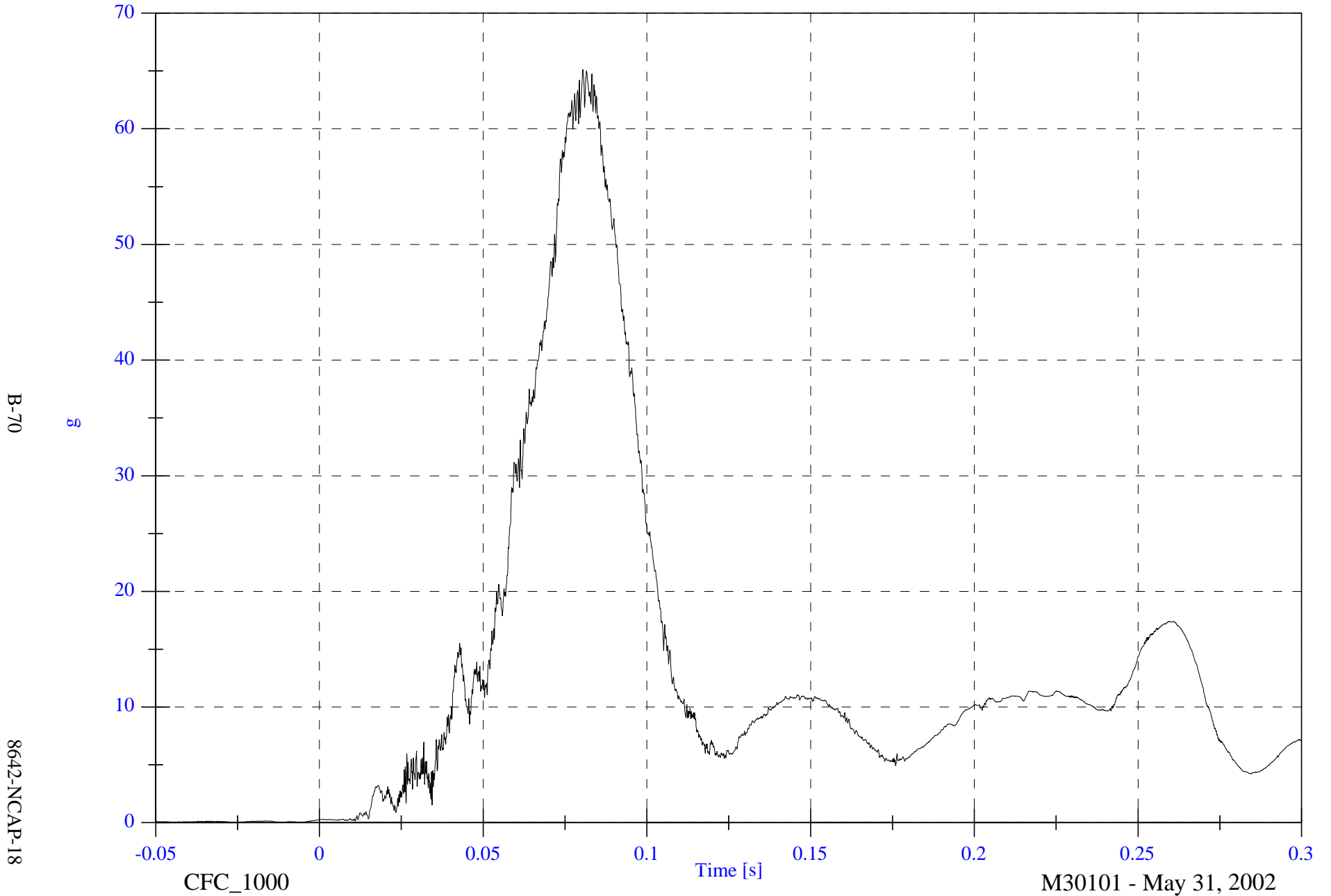

B-70

8642-NCAP-18

CFC_1000

Time [s]

M30101 - May 31, 2002

2002 NCAP Test 18 2003 Cadillac CTS

Max: 645.6 [N] at 0.075 [s]

Min: -421.4 [N] at 0.145 [s]

P2 Upper Neck Fx

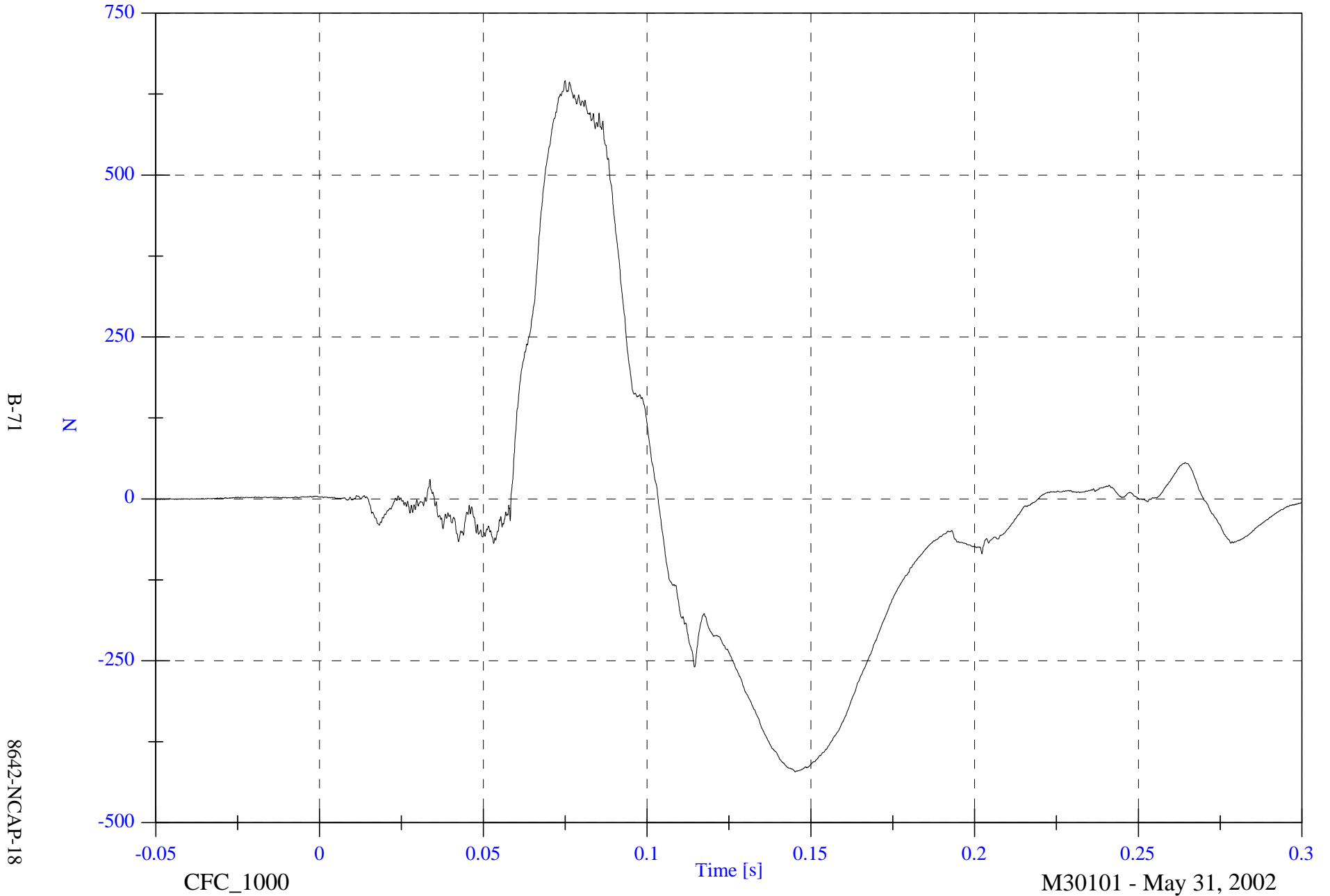

B-71

8642-NCAP-18

CFC_1000

Time [s]

M30101 - May 31, 2002

2002 NCAP Test 18 2003 Cadillac CTS

Max: 256.0 [N] at 0.072 [s]

Min: -114.3 [N] at 0.132 [s]

P2 Upper Neck Fy

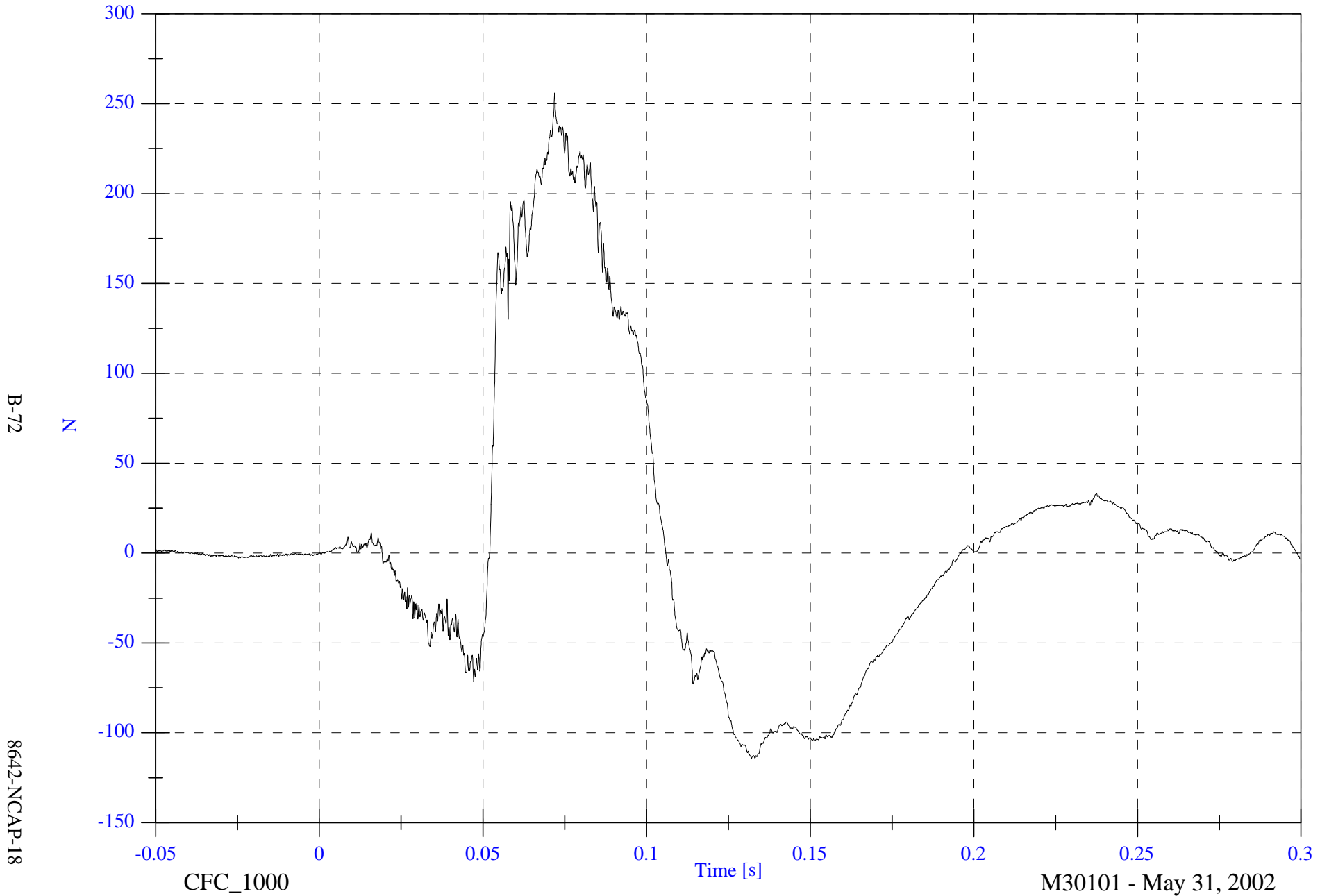

B-72

8642-NCAP-18

CFC_1000

M30101 - May 31, 2002

2002 NCAP Test 18 2003 Cadillac CTS

Max: 1184.5 [N] at 0.074 [s]

Min: -395.1 [N] at 0.099 [s]

P2 Upper Neck Fz

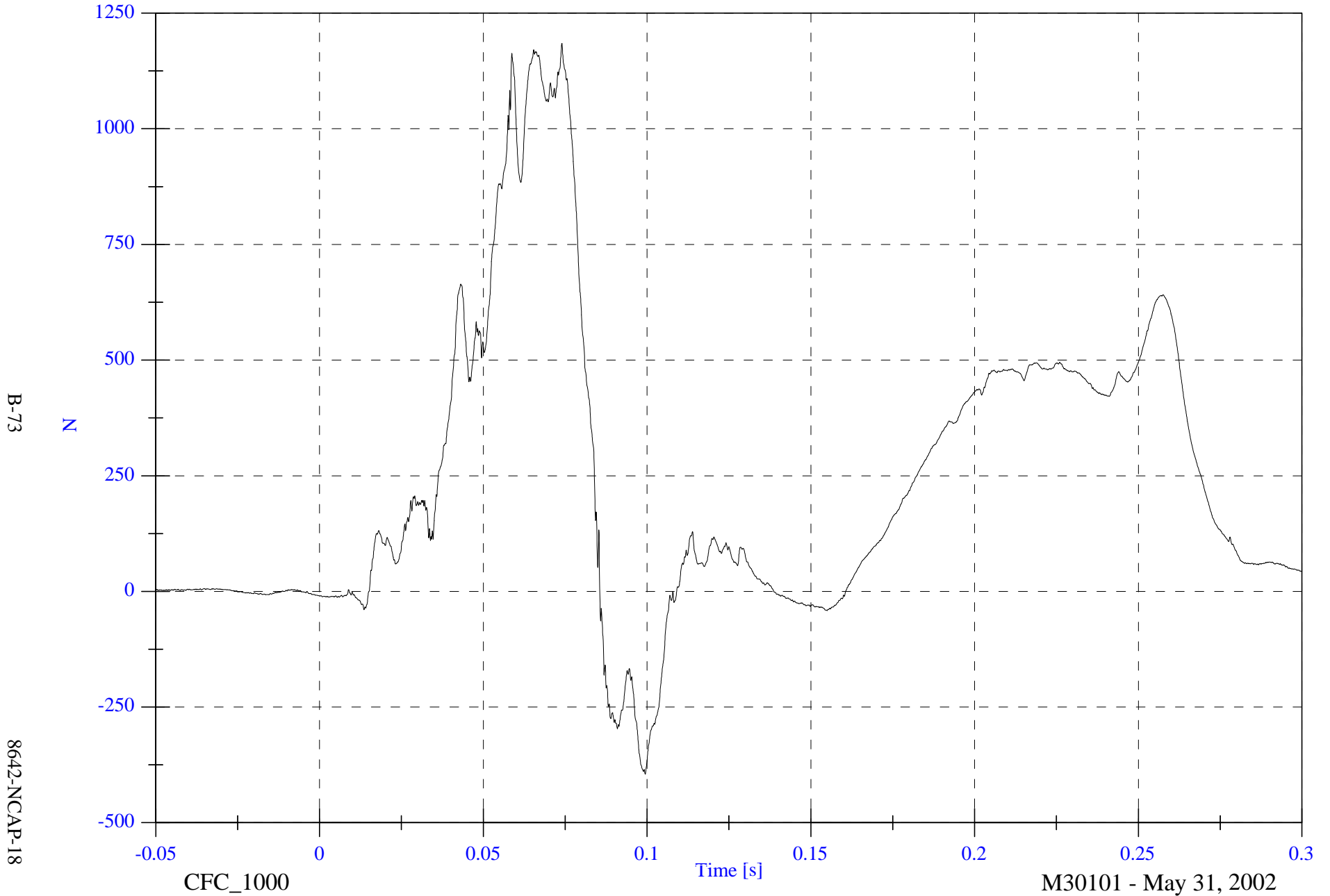

2002 NCAP Test 18 2003 Cadillac CTS

Max: 1359.9 [N] at 0.074 [s]

P2 Upper Neck F Resultant

Min: 1.8 [N] at -0.010 [s]

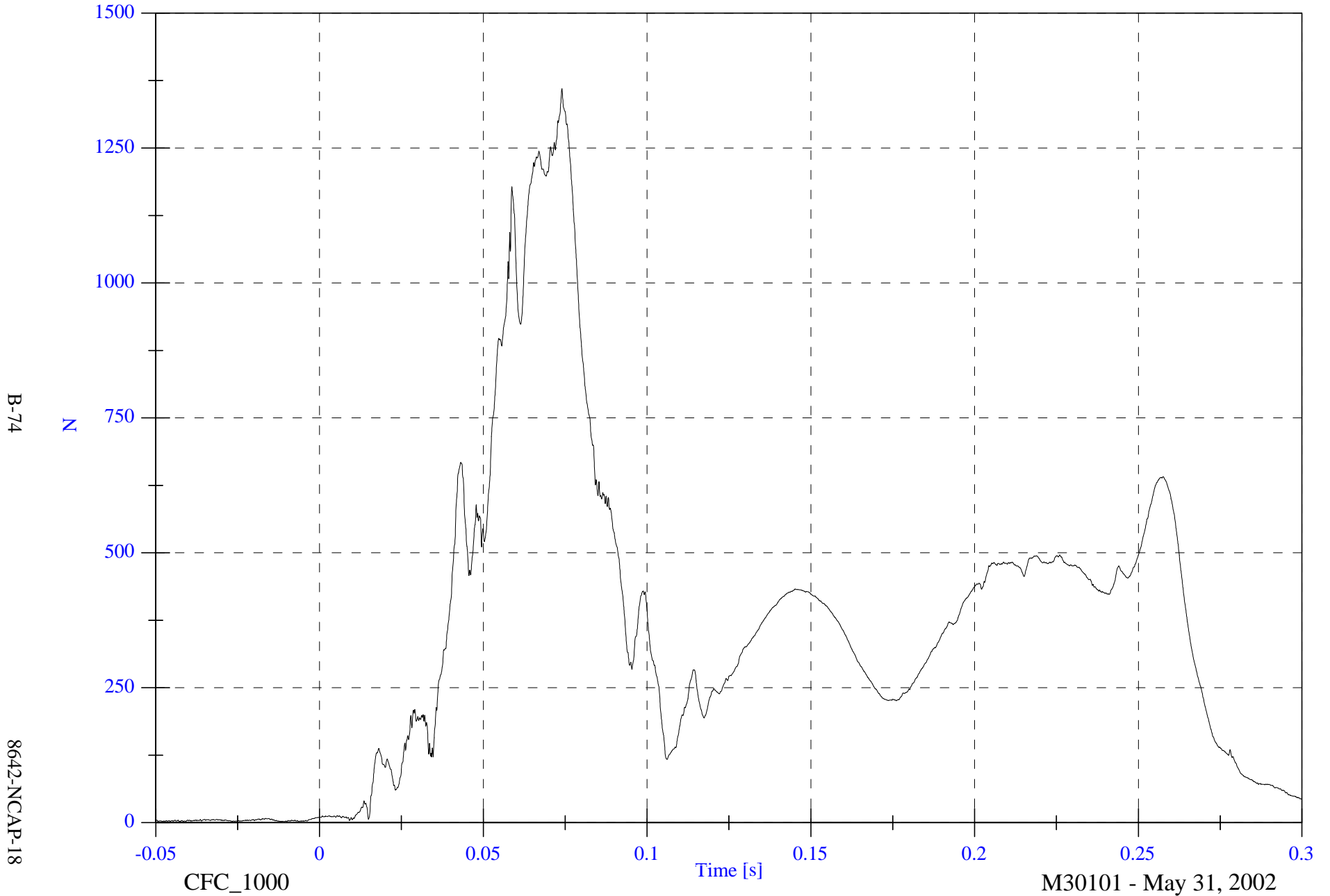

B-74

8642-NCAP-18

CFC_1000

Time [s]

M30101 - May 31, 2002

2002 NCAP Test 18 2003 Cadillac CTS

P2 Upper Neck Mx

Max: 7.9 [N-m] at 0.104 [s]
Min: -25.8 [N-m] at 0.058 [s]

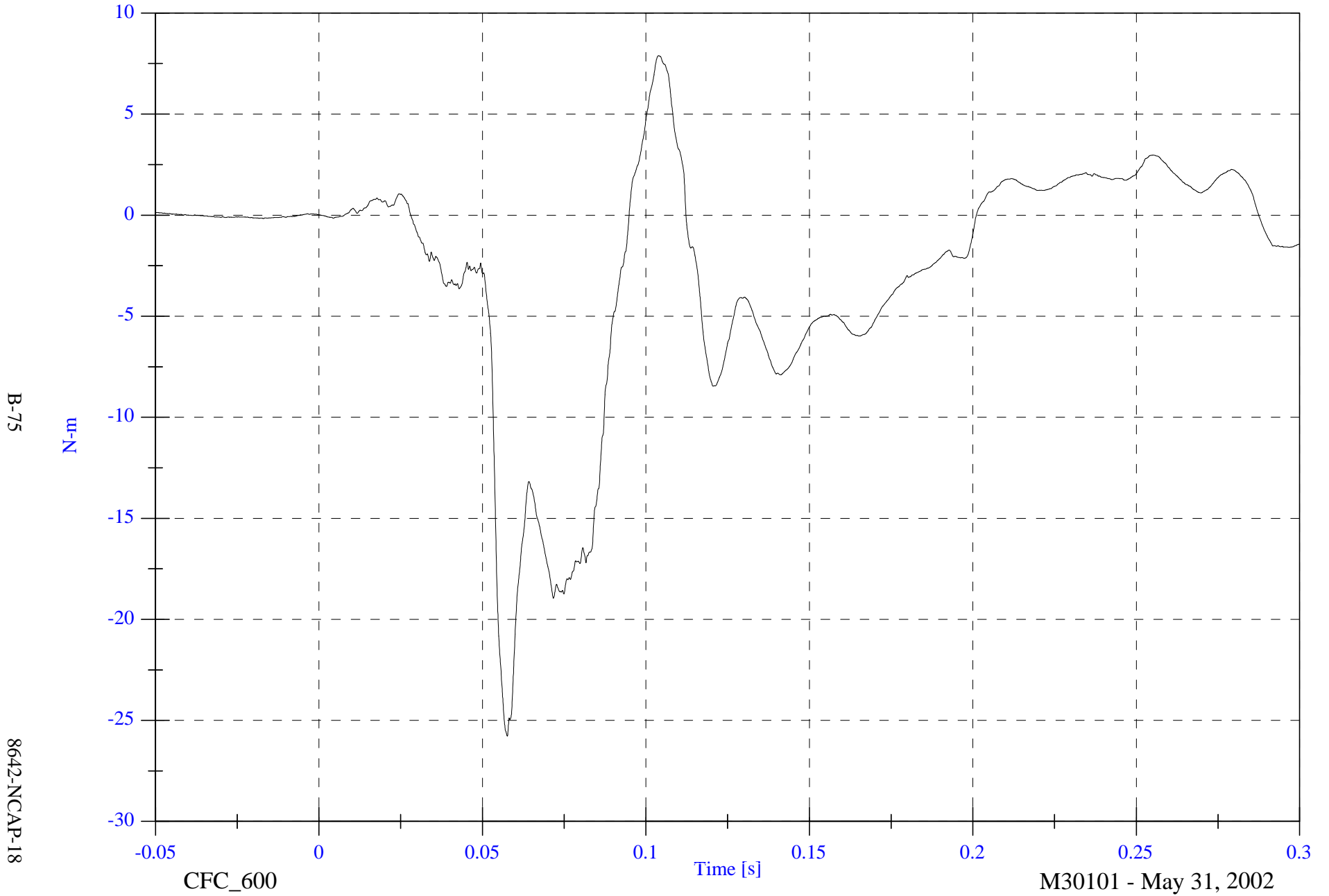

B-75

8642-NCAP-18

CFC_600

Time [s]

M30101 - May 31, 2002

2002 NCAP Test 18 2003 Cadillac CTS

Max: 38.8 [N-m] at 0.153 [s]

Min: -19.1 [N-m] at 0.105 [s]

P2 Upper Neck My

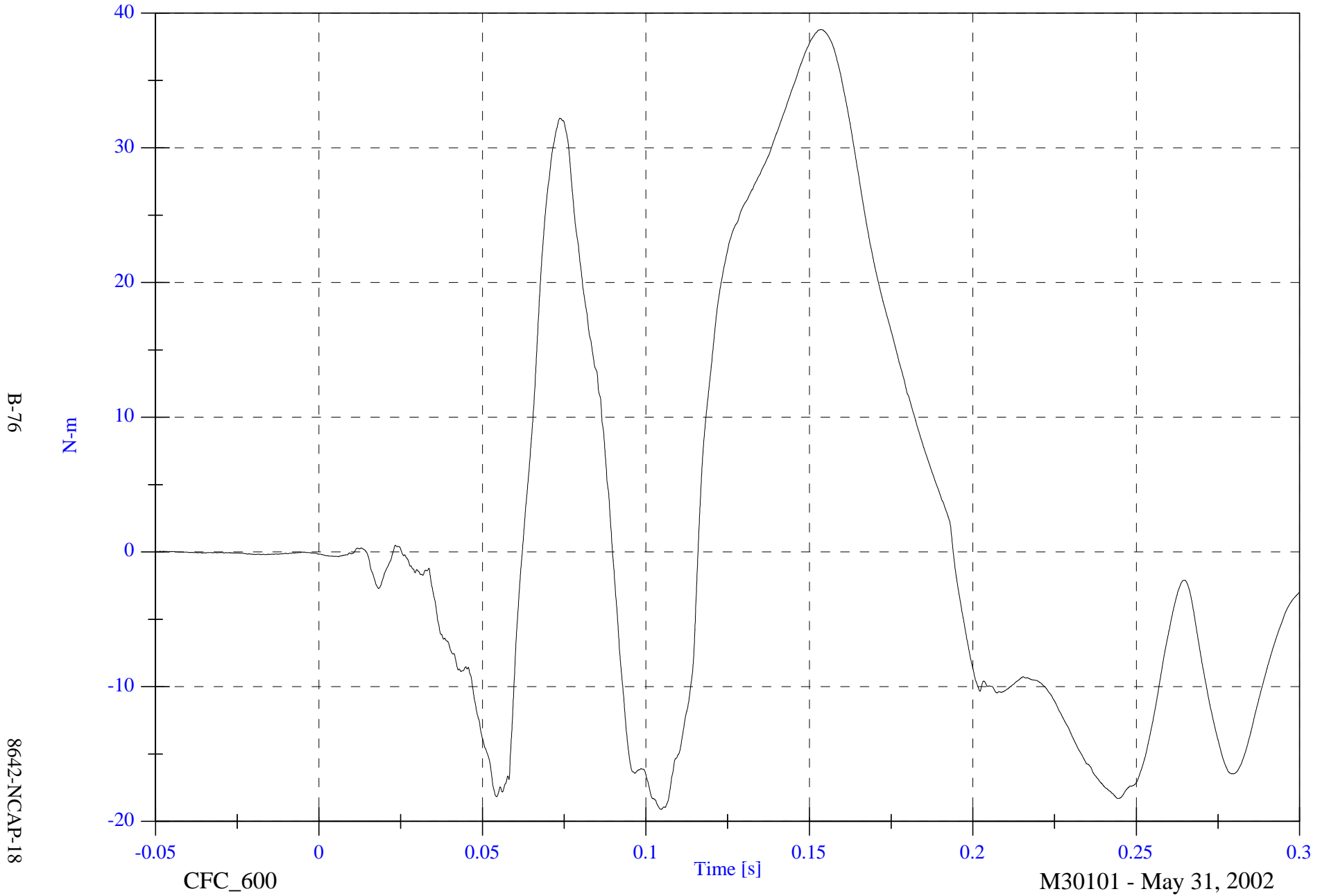

B-76

8642-NCAP-18

CFC_600

M30101 - May 31, 2002

2002 NCAP Test 18 2003 Cadillac CTS

Max: 9.8 [N-m] at 0.095 [s]

Min: -8.0 [N-m] at 0.150 [s]

P2 Upper Neck Mz

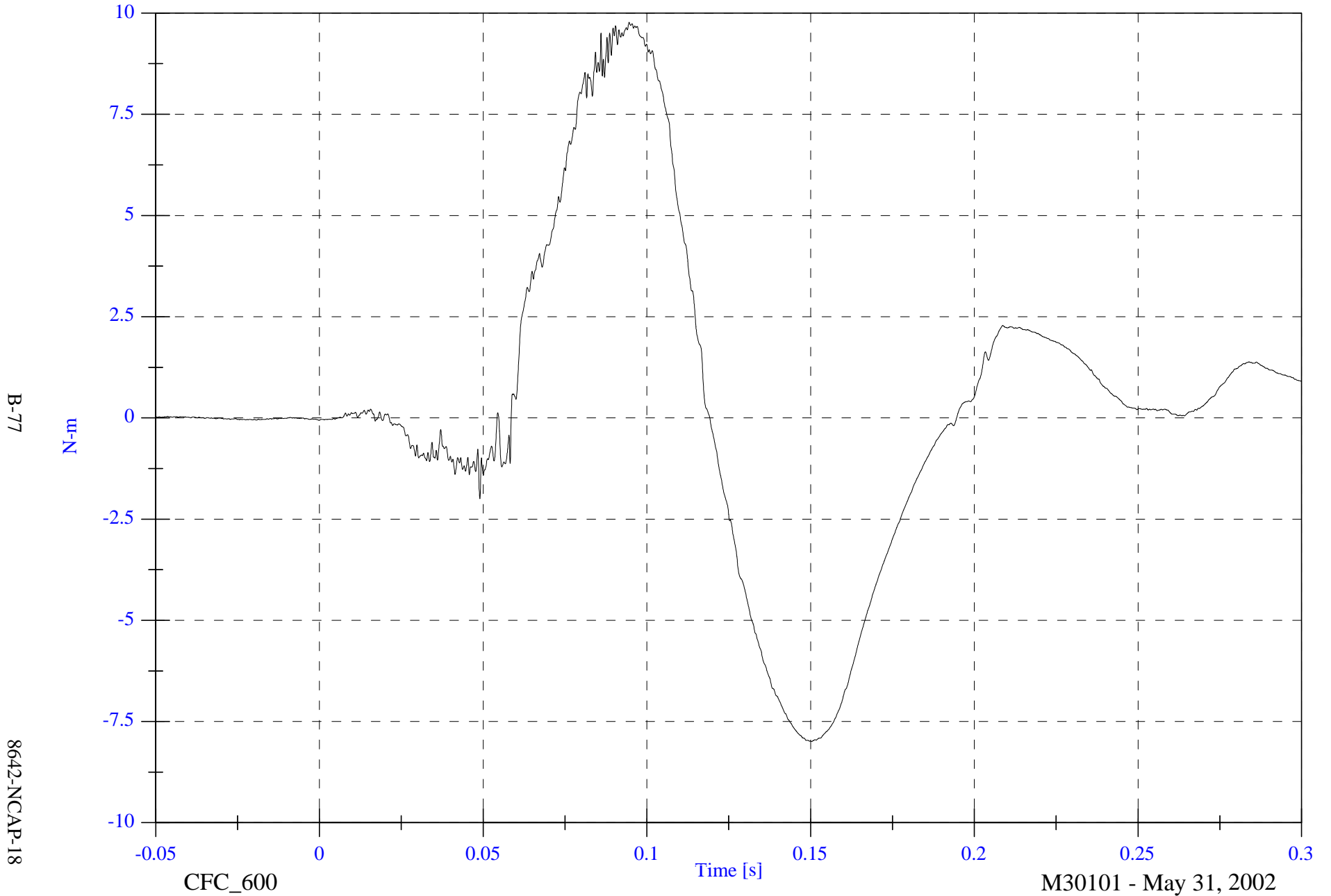

B-77

8642-NCAP-18

CFC_600

Time [s]

M30101 - May 31, 2002

2002 NCAP Test 18 2003 Cadillac CTS

Max: 39.9 [N-m] at 0.153 [s]

P2 Upper Neck M Resultant

Min: 0.0 [N-m] at -0.005 [s]

B-78

8642-NCAP-18

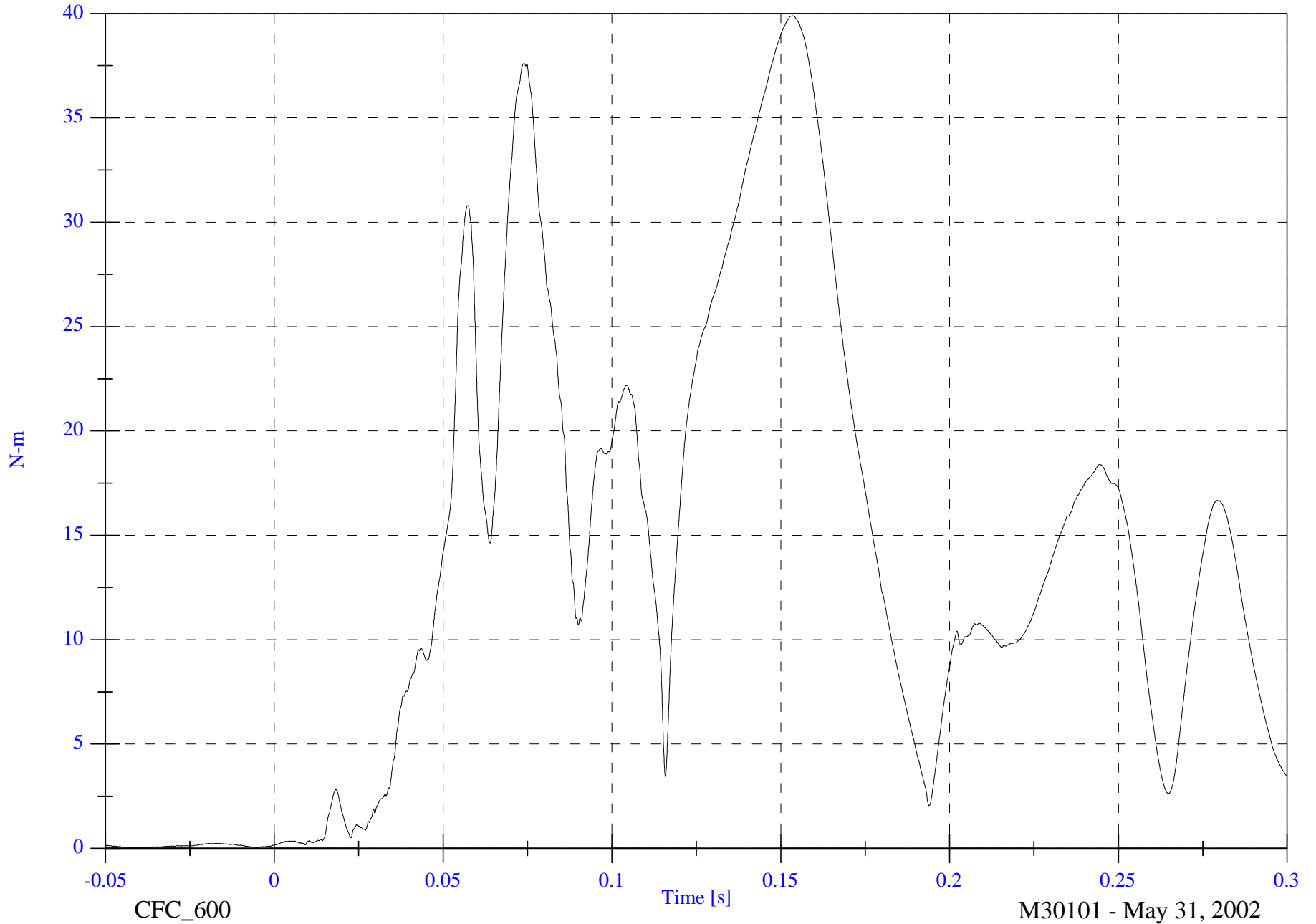

CFC_600

M30101 - May 31, 2002

2002 NCAP Test 18 2003 Cadillac CTS

Max: 4.1 [g] at 0.300 [s]

Min: -51.9 [g] at 0.070 [s]

P2 Chest x

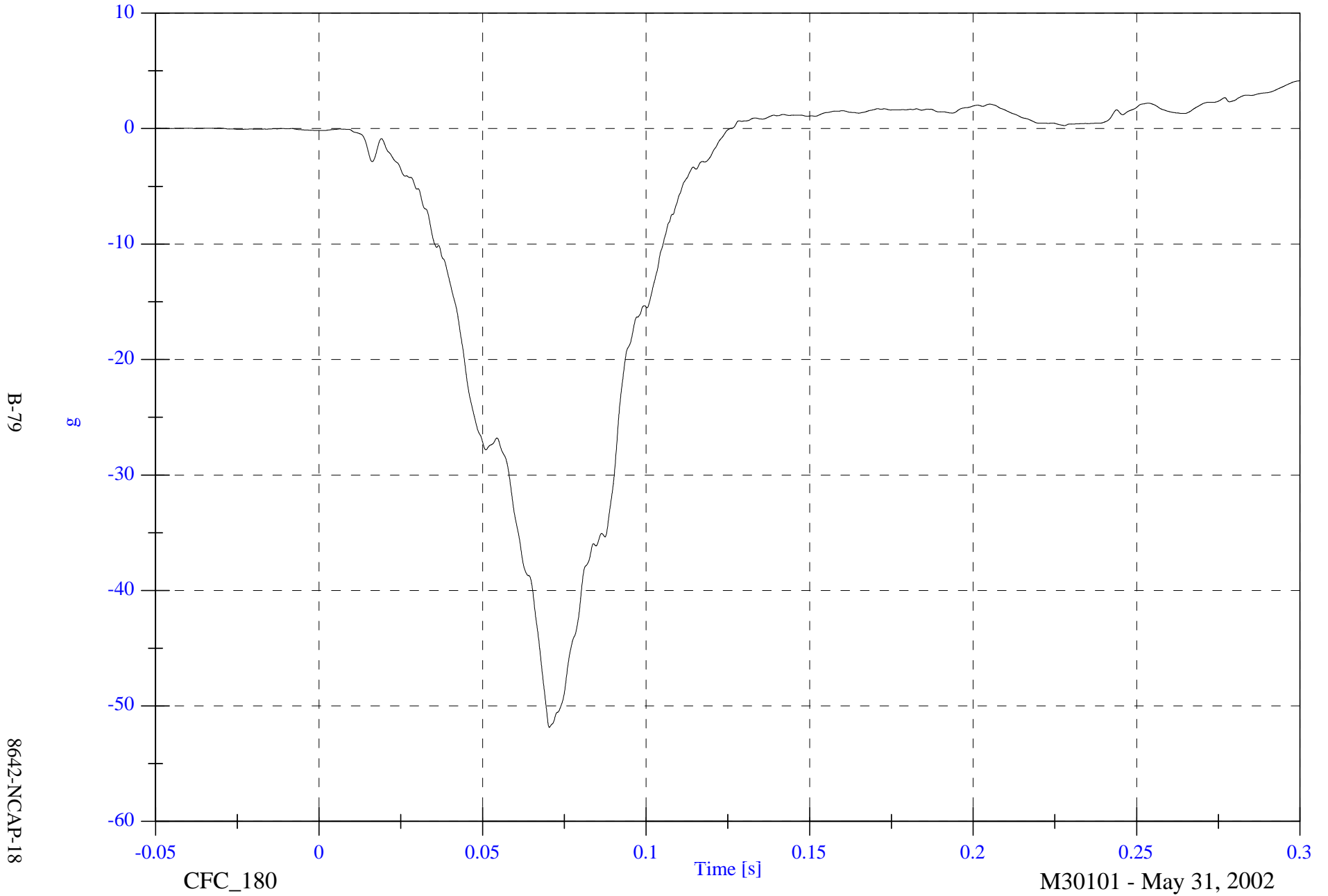

B-79

8642-NCAP-18

CFC_180

Time [s]

M30101 - May 31, 2002

2002 NCAP Test 18 2003 Cadillac CTS

Max: 1.5 [g] at 0.048 [s]

Min: -11.1 [g] at 0.071 [s]

P2 Chest y

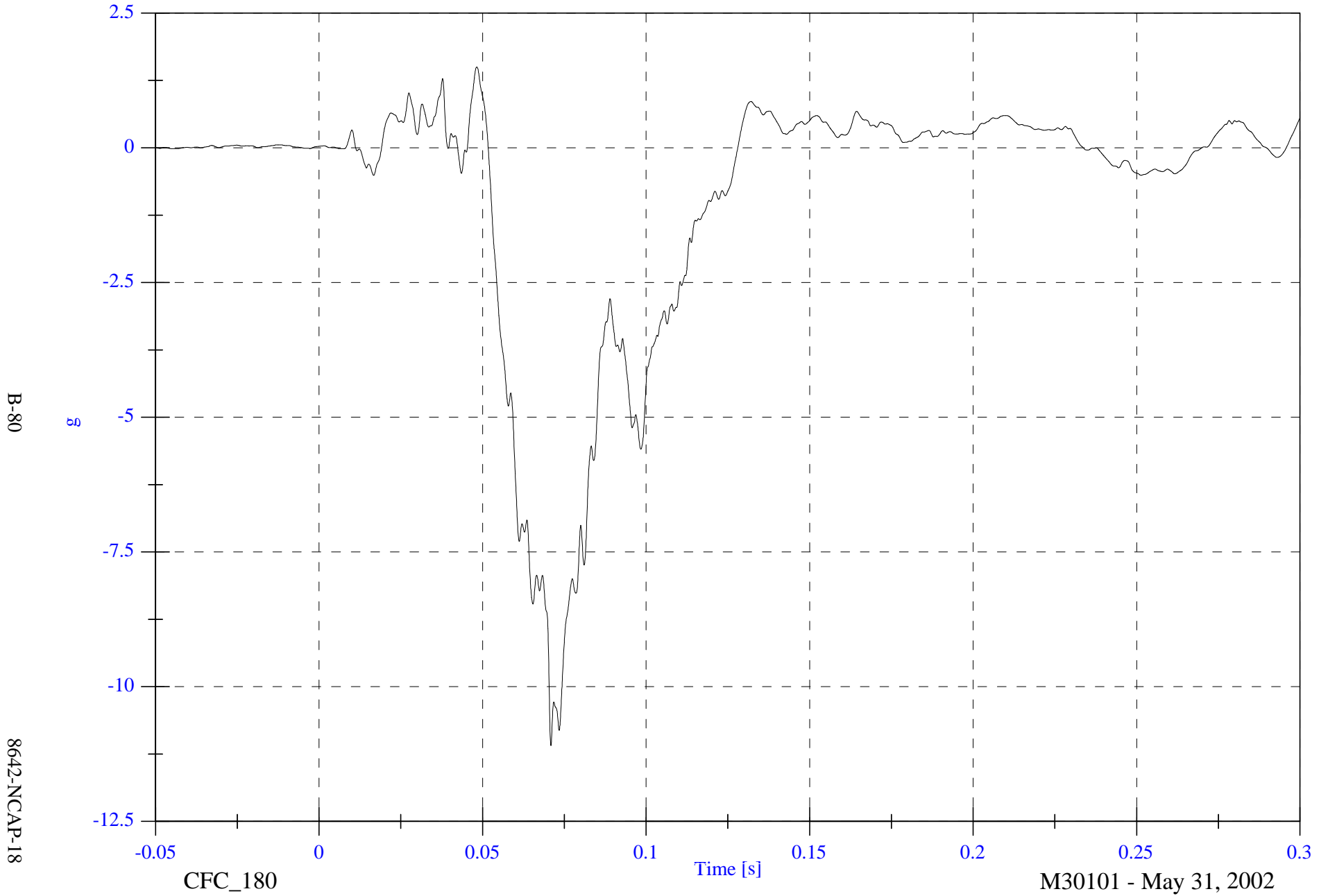

2002 NCAP Test 18 2003 Cadillac CTS

Max: 20.5 [g] at 0.076 [s]
Min: -5.4 [g] at 0.114 [s]

P2 Chest z

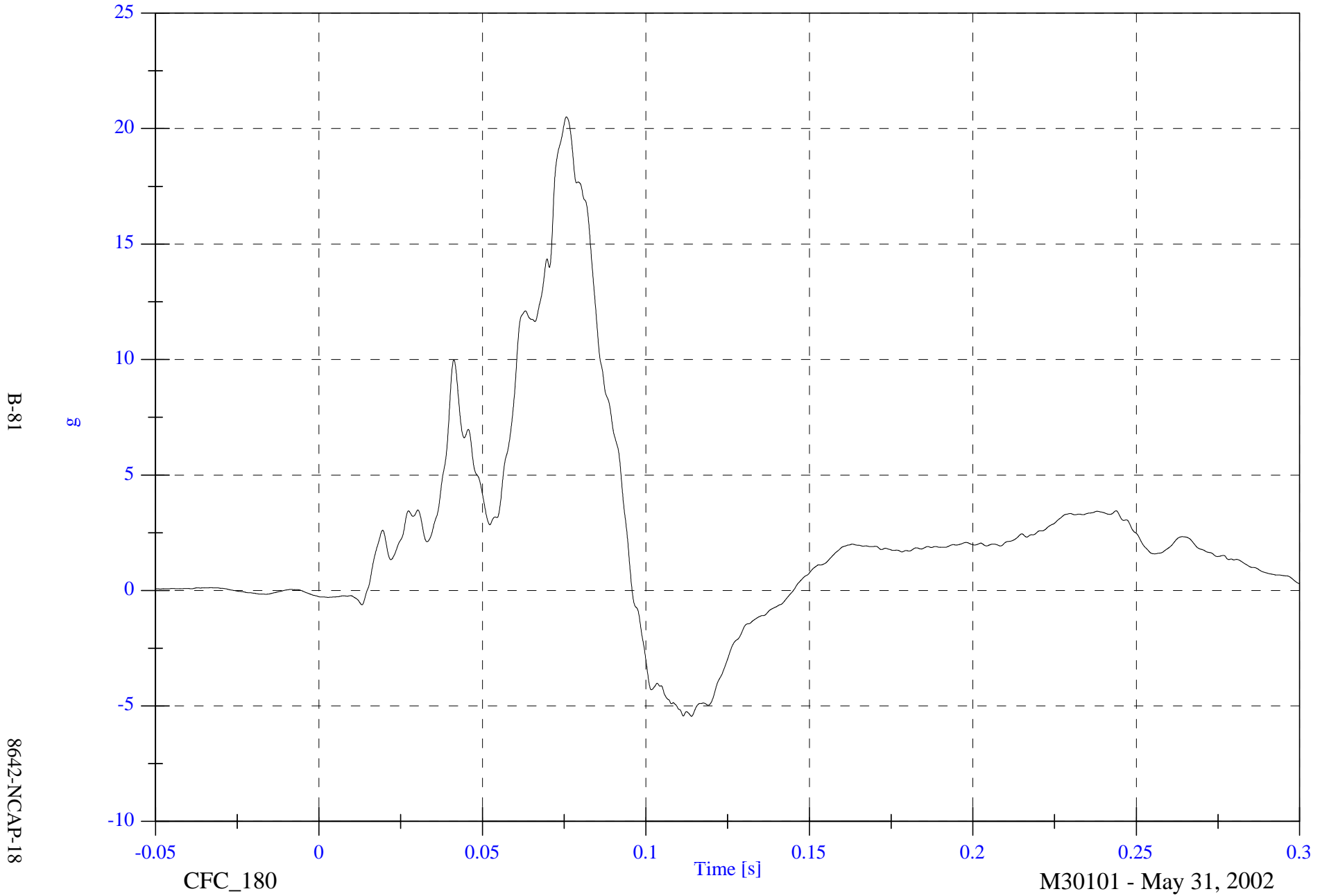

2002 NCAP Test 18 2003 Cadillac CTS

P2 Chest Resultant

Max: 55.0 [g] at 0.072 [s]

Min: 0.0 [g] at -0.008 [s]

B-82

8642-NCAP-18

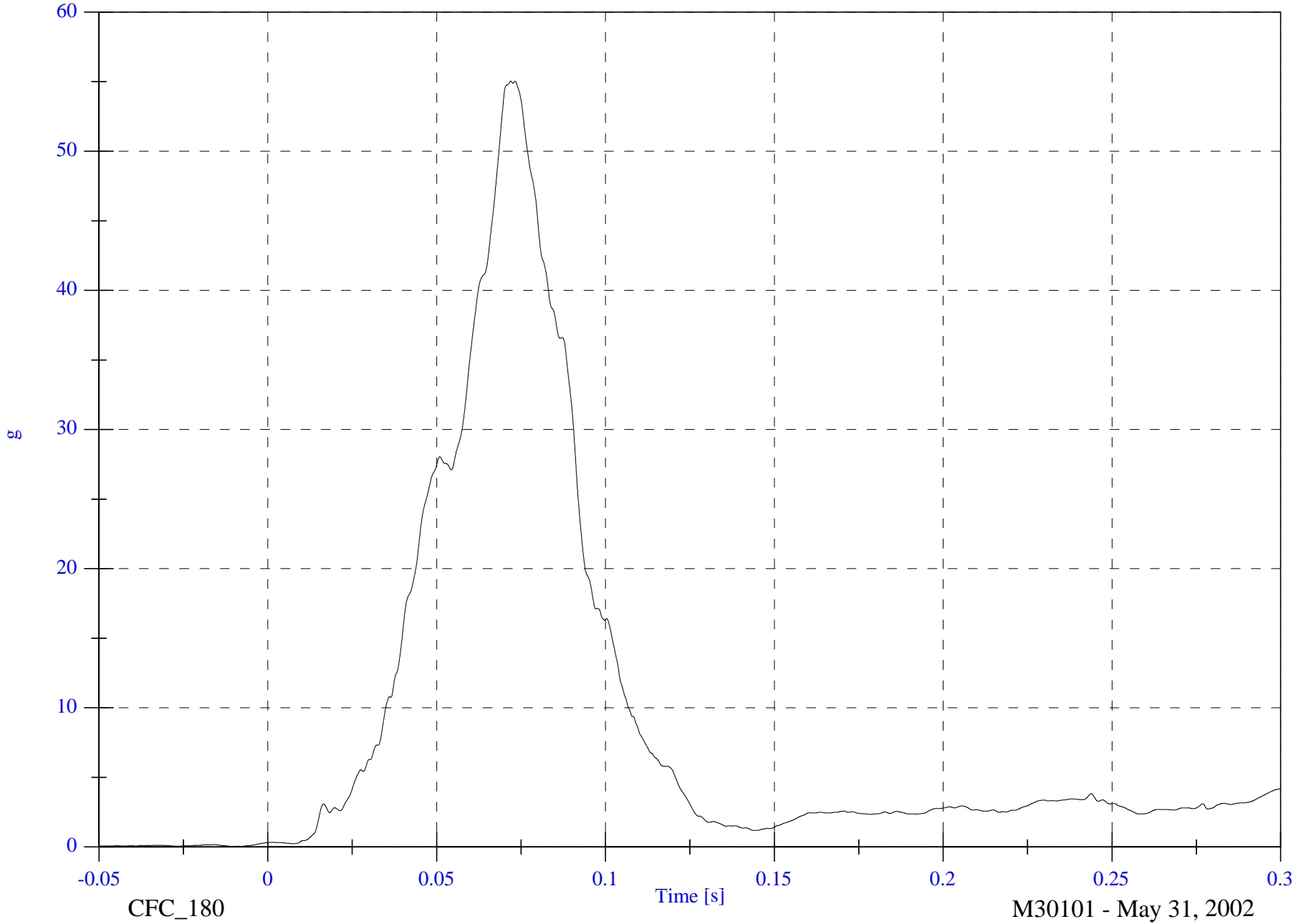

CFC_180

Time [s]

M30101 - May 31, 2002

2002 NCAP Test 18 2003 Cadillac CTS

Max: 3.9 [g] at 0.300 [s]

Min: -53.6 [g] at 0.070 [s]

P2 Chest Red x

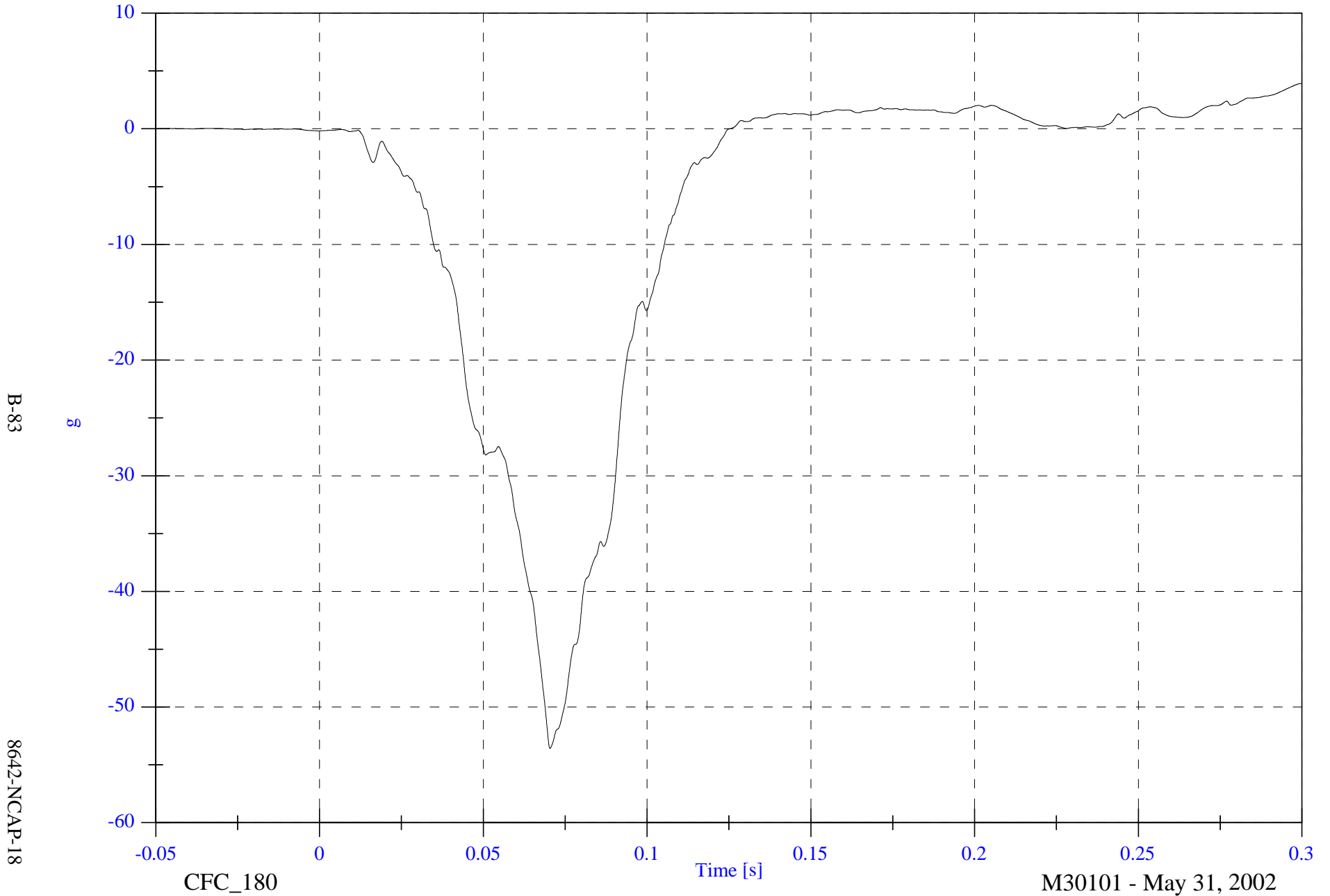

B-83

8642-NCAP-18

CFC_180

Time [s]

M30101 - May 31, 2002

2002 NCAP Test 18 2003 Cadillac CTS

Max: 1.9 [g] at 0.048 [s]

Min: -11.2 [g] at 0.071 [s]

P2 Chest Red y

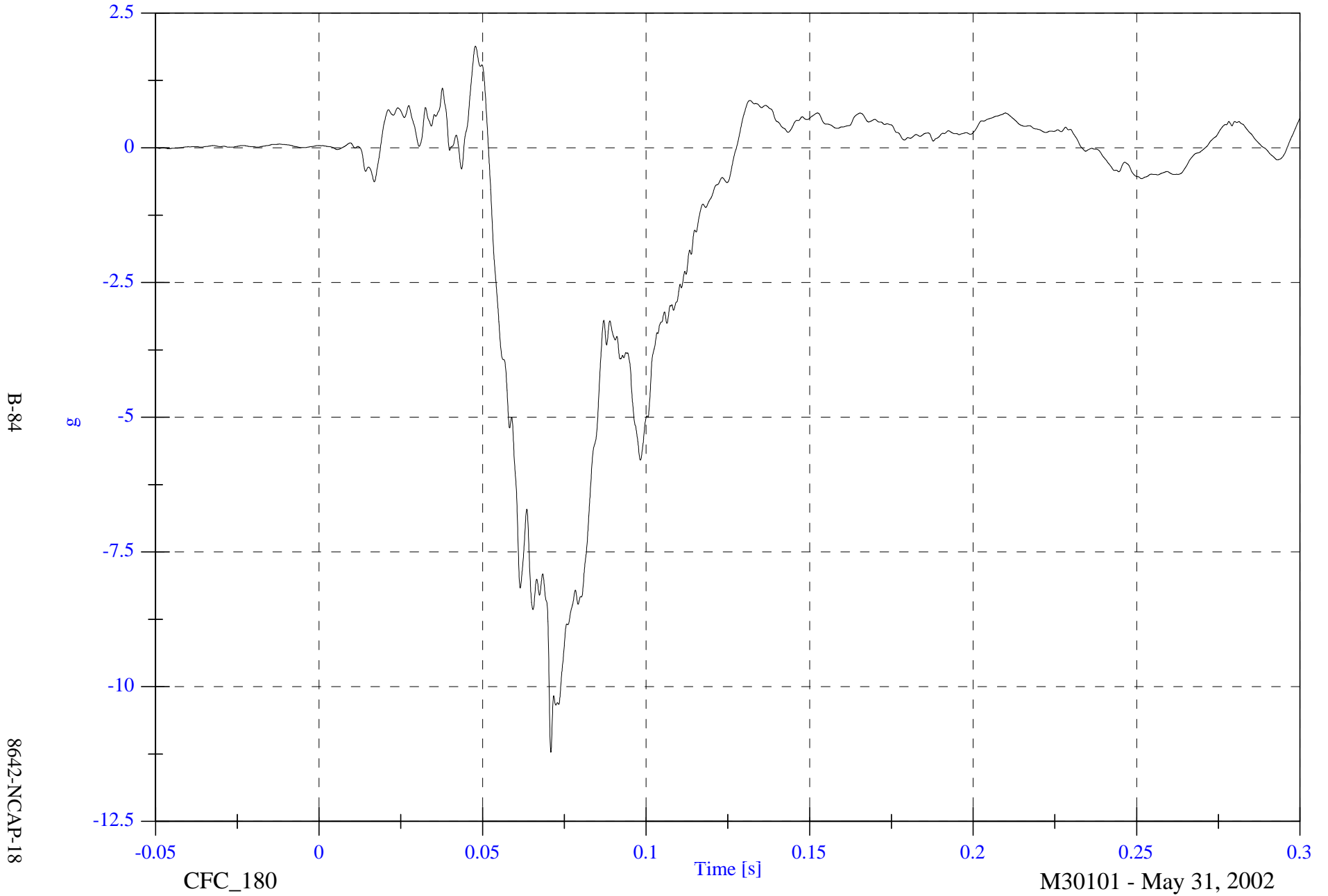

2002 NCAP Test 18 2003 Cadillac CTS

Max: 20.7 [g] at 0.076 [s]

Min: -5.5 [g] at 0.111 [s]

P2 Chest Red z

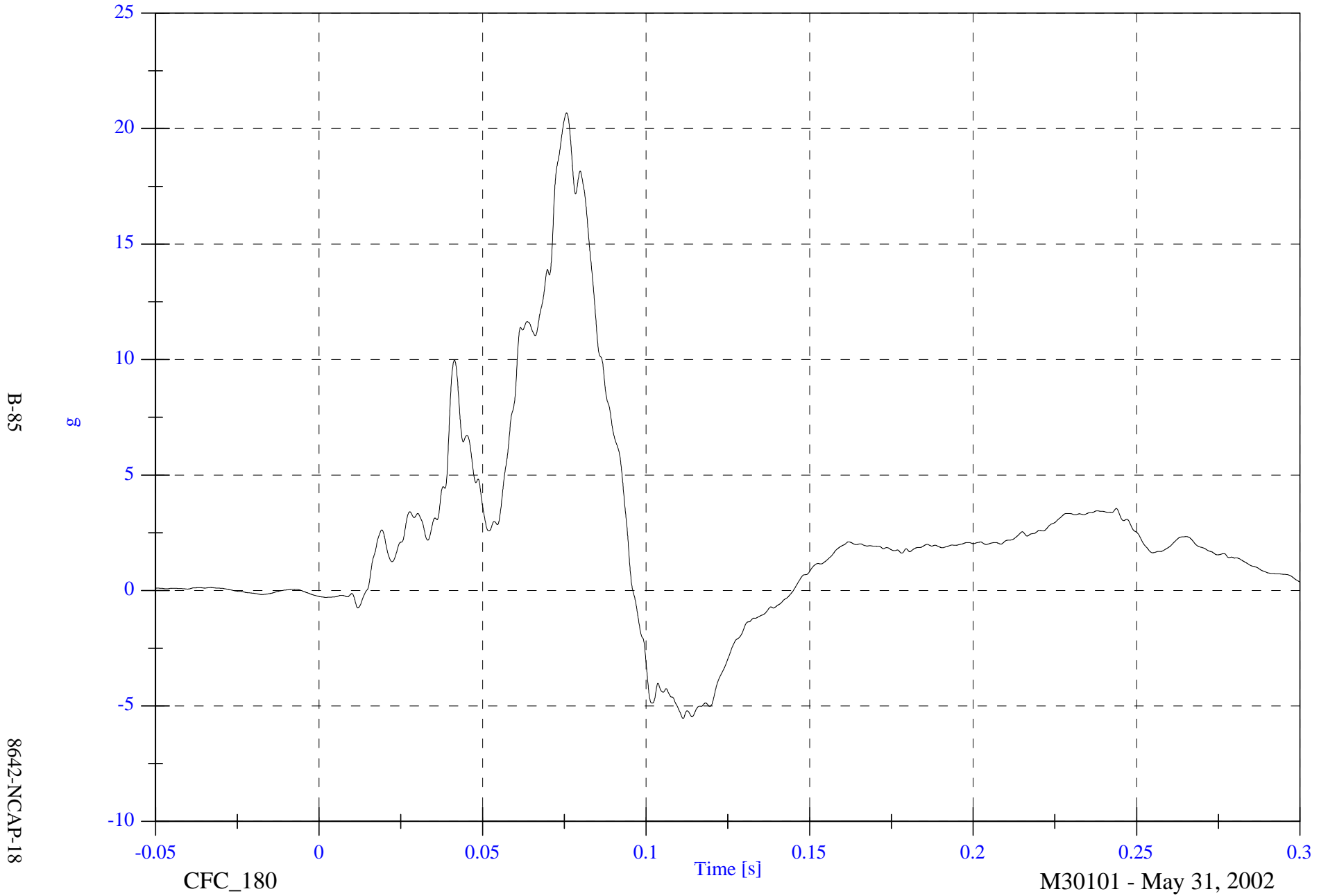

2002 NCAP Test 18 2003 Cadillac CTS

Max: 56.3 [g] at 0.071 [s]

Min: 0.0 [g] at -0.026 [s]

P2 Chest Red Resultant

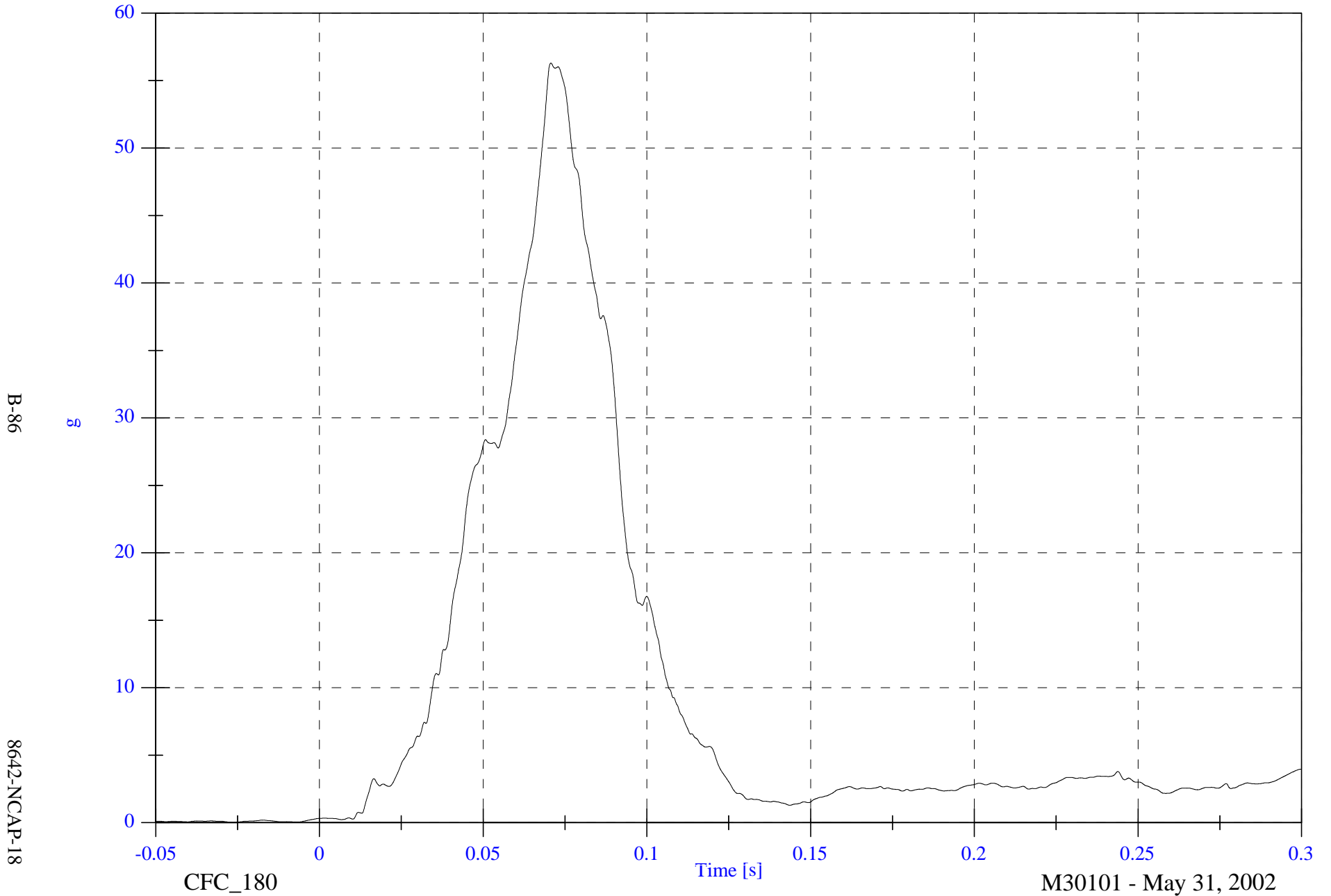

B-86

8642-NCAP-18

CFC_180

M30101 - May 31, 2002

2002 NCAP Test 18 2003 Cadillac CTS

Max: 0.0 [mm] at 0.007 [s]

Min: -25.1 [mm] at 0.073 [s]

P2 Chest Compression

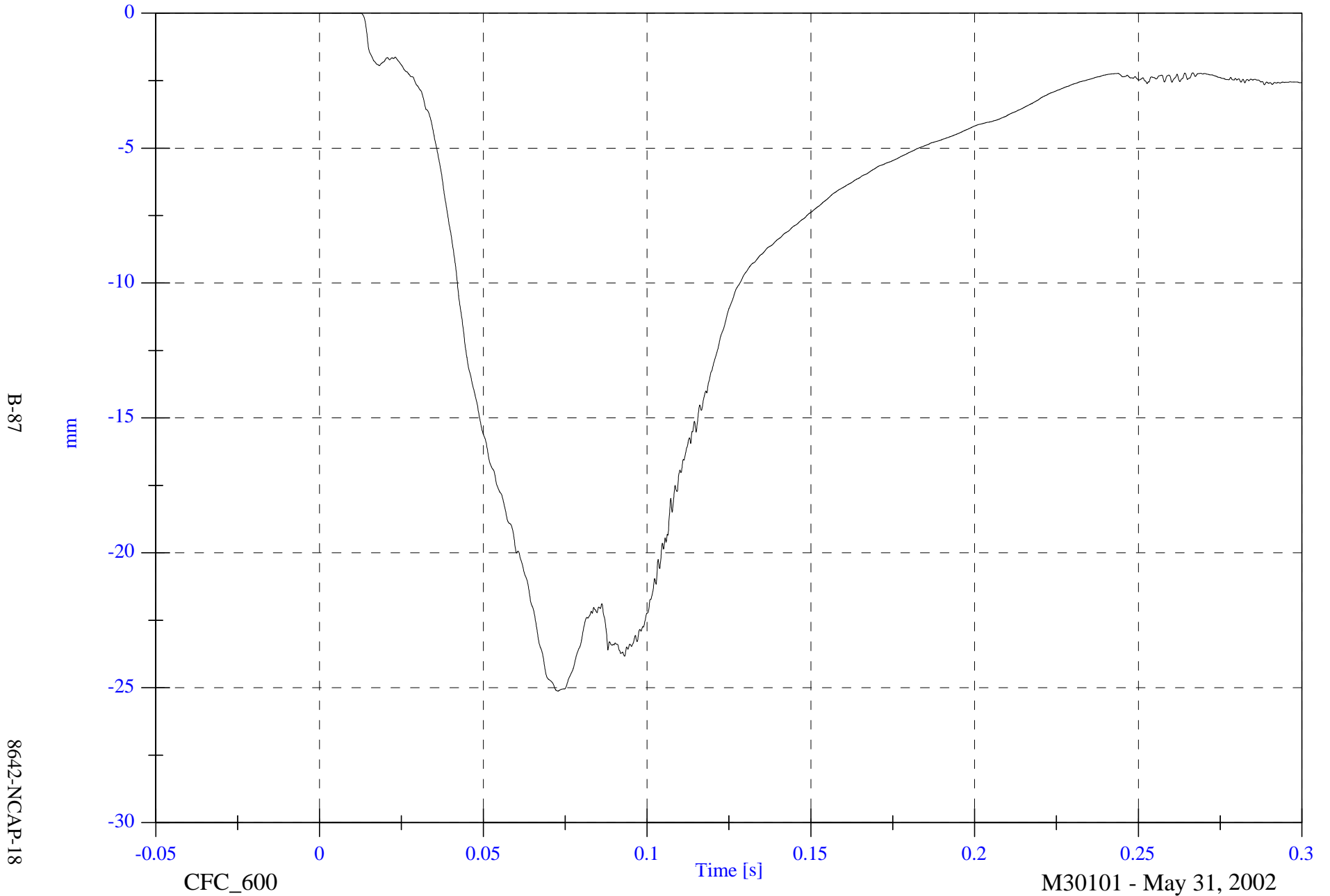

B-87

8642-NCAP-18

CFC_600

Time [s]

M30101 - May 31, 2002

2002 NCAP Test 18 2003 Cadillac CTS

Max: 4.3 [g] at 0.113 [s]

Min: -52.0 [g] at 0.067 [s]

P2 Pelvic x

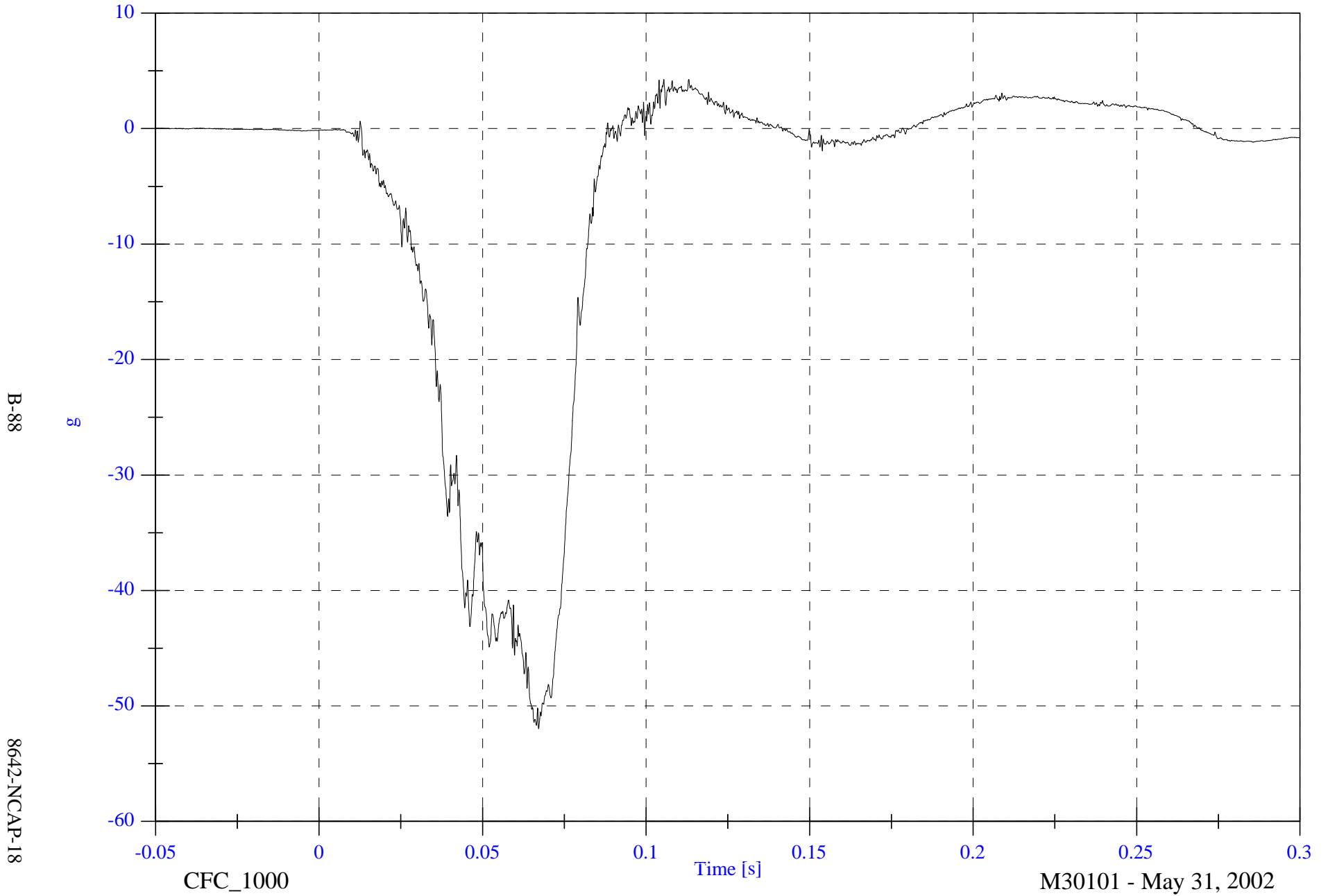

2002 NCAP Test 18 2003 Cadillac CTS

Max: 4.2 [g] at 0.037 [s]

Min: -6.9 [g] at 0.059 [s]

P2 Pelvic y

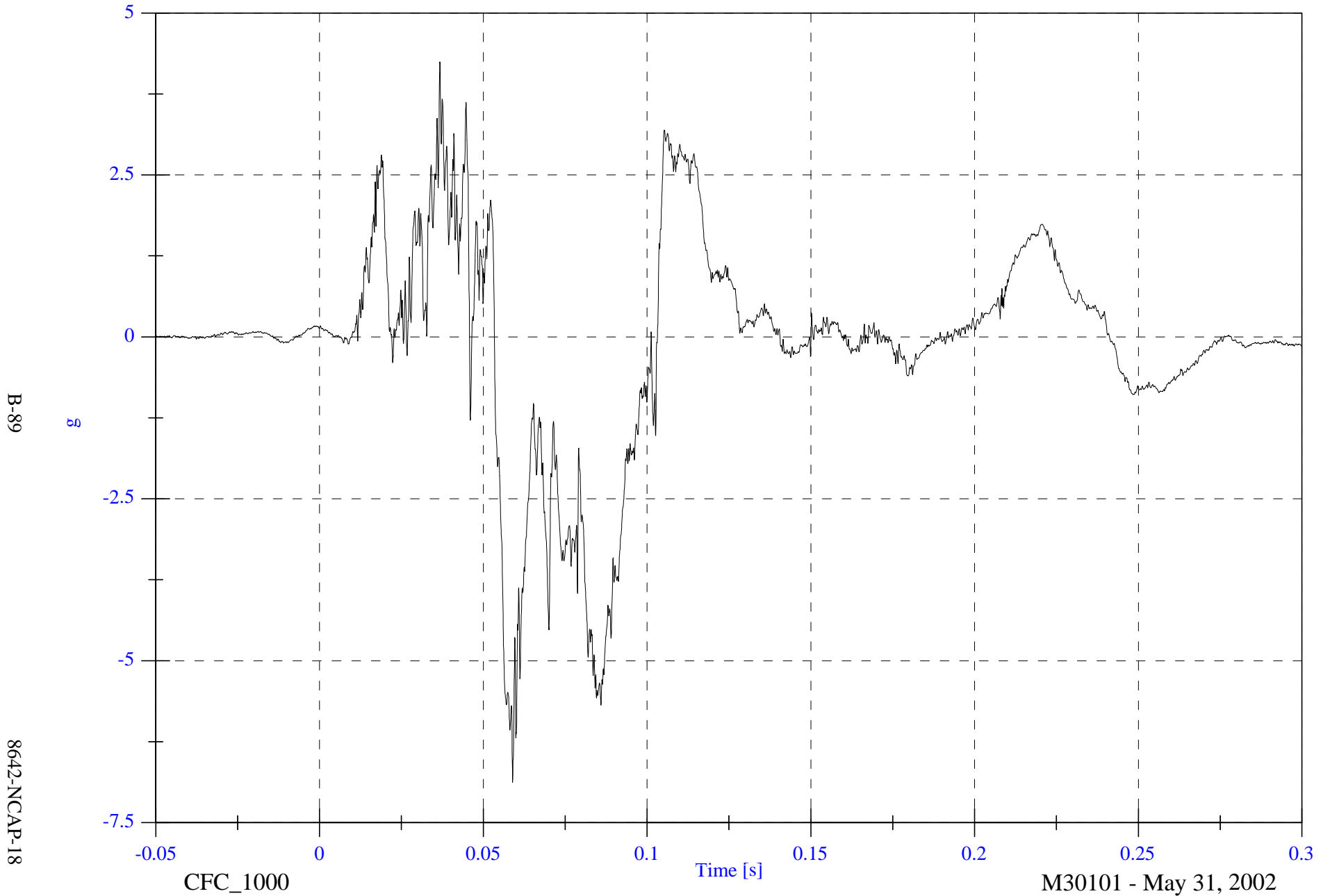

2002 NCAP Test 18 2003 Cadillac CTS

Max: 3.2 [g] at 0.229 [s]

Min: -27.6 [g] at 0.070 [s]

P2 Pelvic z

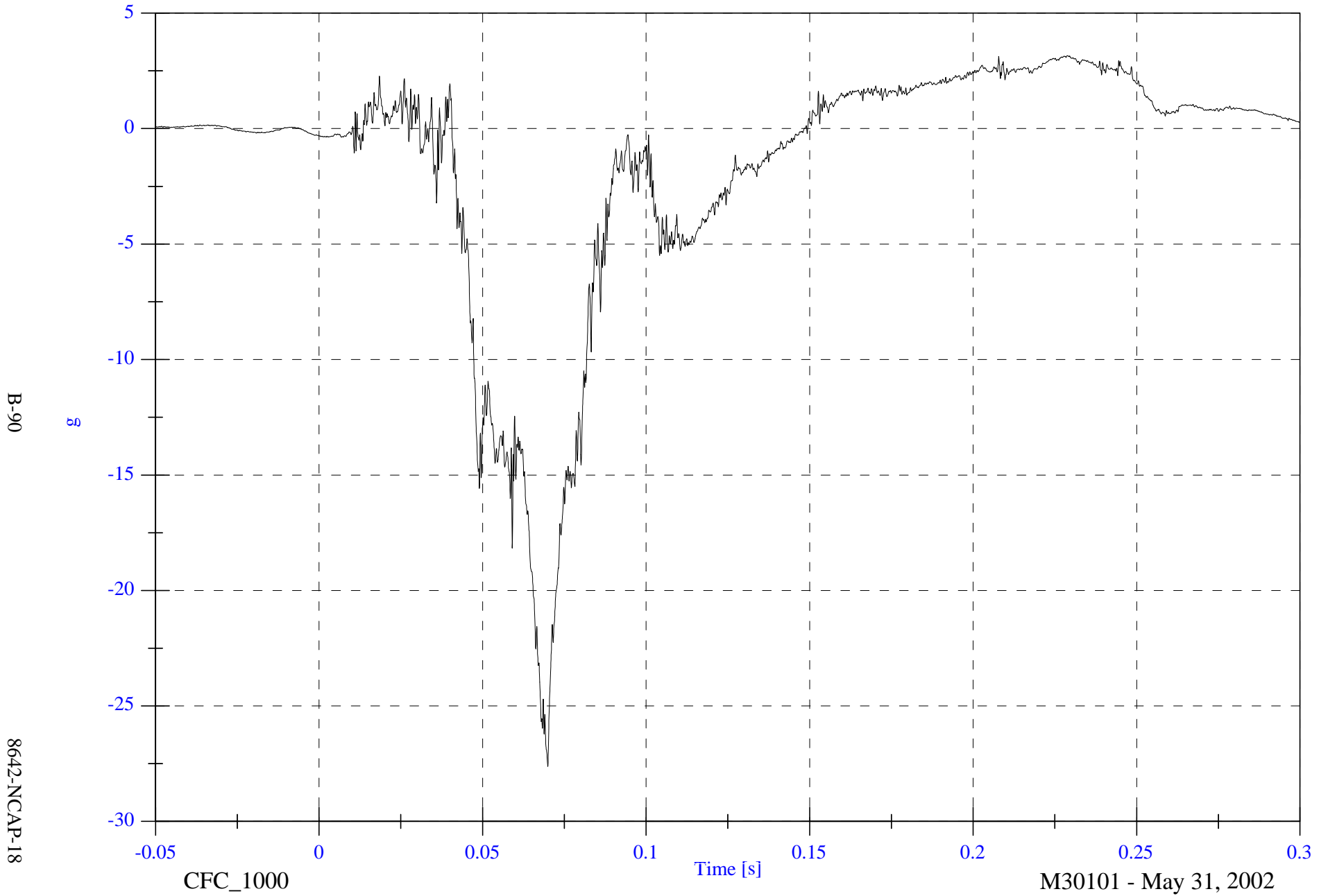

2002 NCAP Test 18 2003 Cadillac CTS

P2 Pelvic Resultant

Max: 57.0 [g] at 0.068 [s]

Min: 0.0 [g] at -0.045 [s]

B-91

8642-NCAP-18

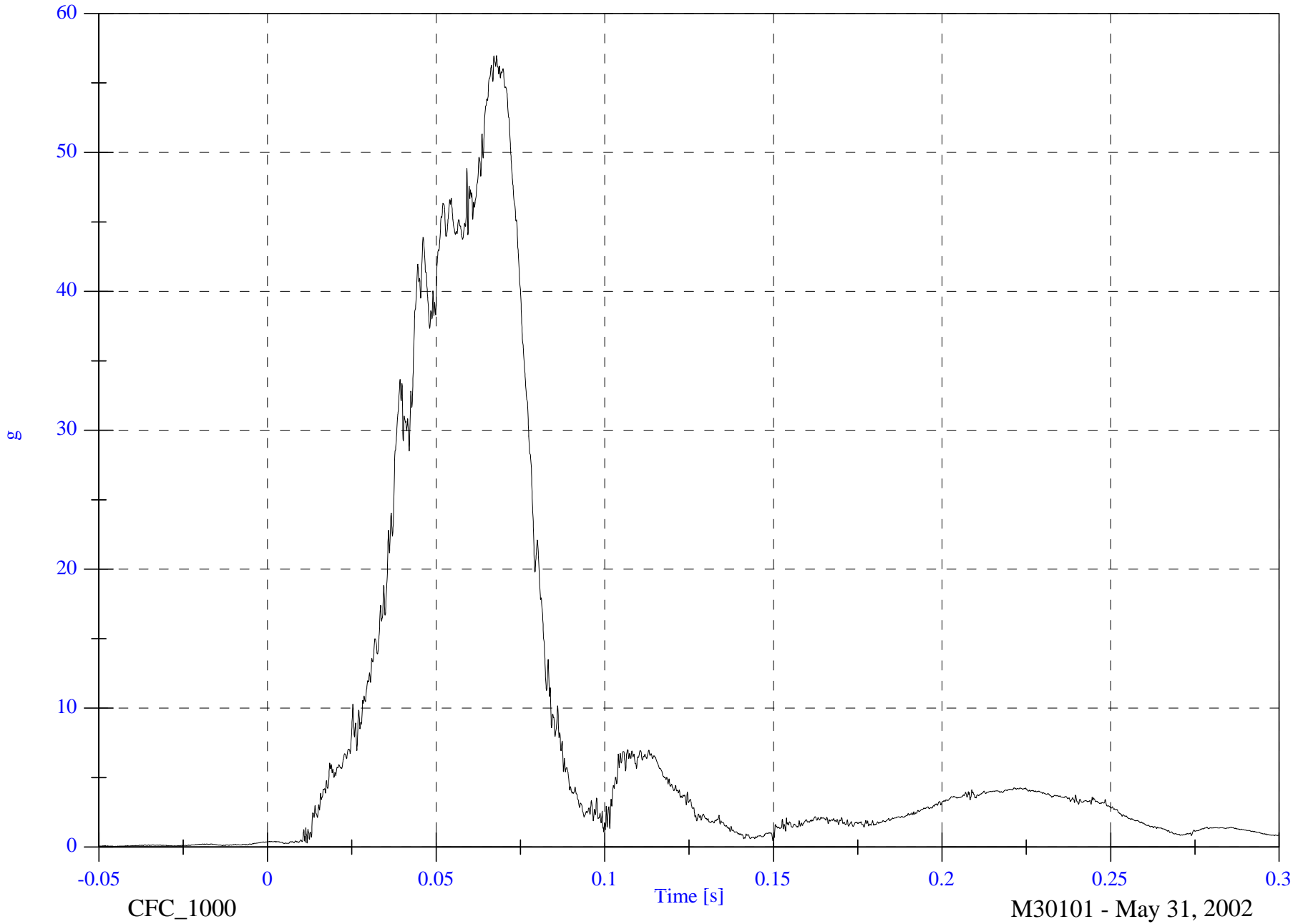

2002 NCAP Test 18 2003 Cadillac CTS

P2 Left Femur

Max: 341.9 [N] at 0.024 [s]

Min: -2225.4 [N] at 0.066 [s]

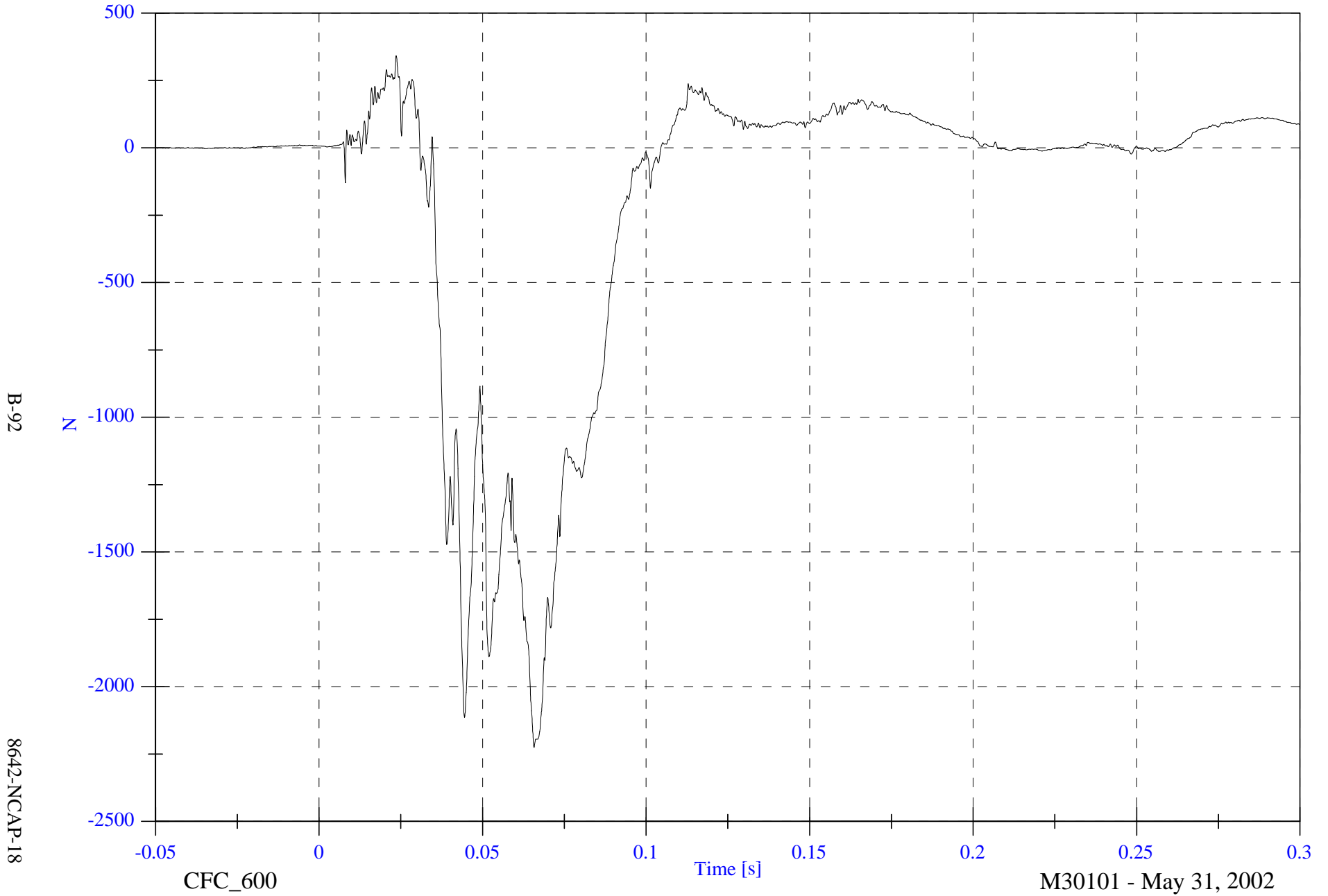

2002 NCAP Test 18 2003 Cadillac CTS

Max: 548.5 [N] at 0.030 [s]

Min: -1777.4 [N] at 0.071 [s]

P2 Right Femur

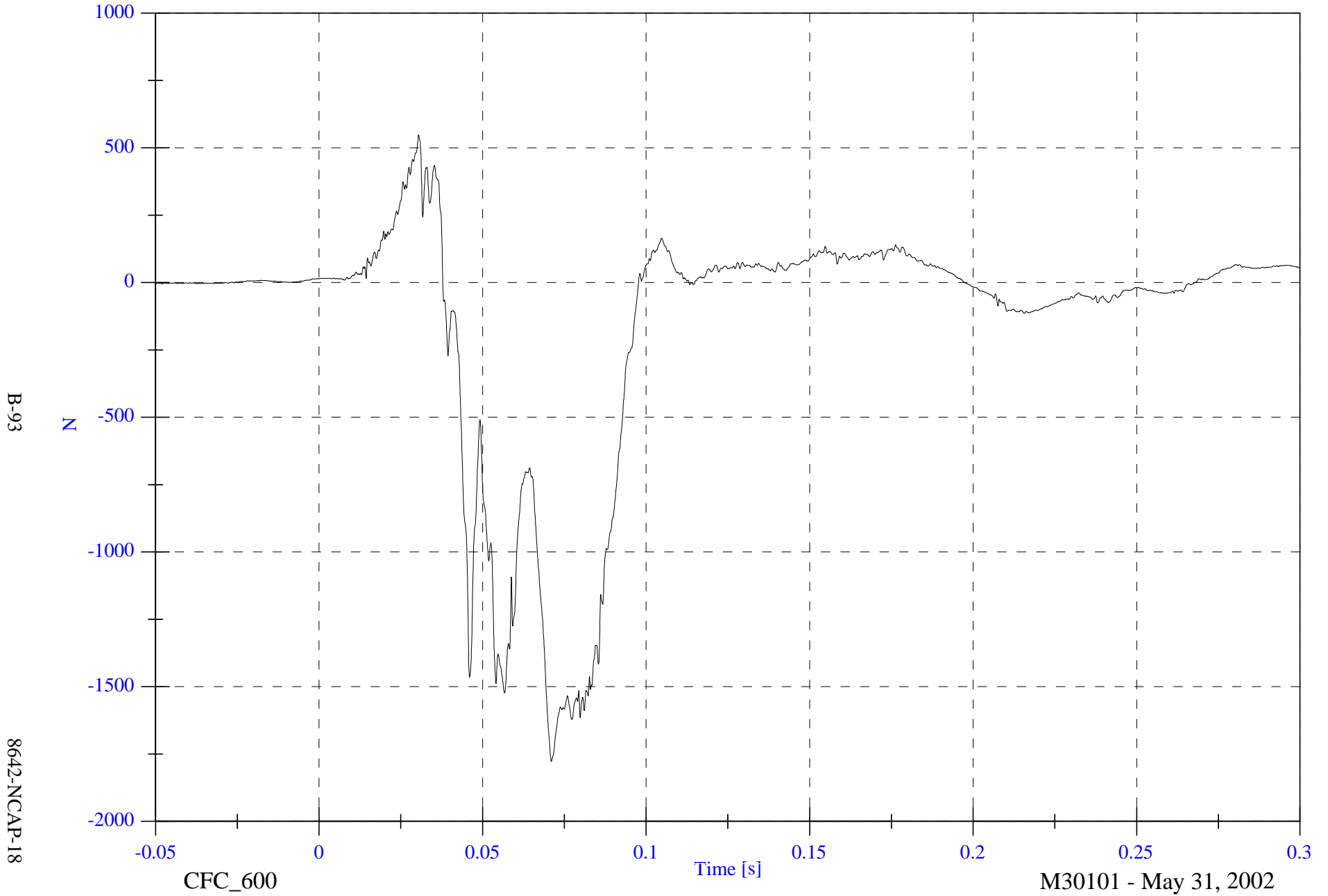

2002 NCAP Test 18 2003 Cadillac CTS

Max: 76.3 [N-m] at 0.065 [s]

Min: -11.1 [N-m] at 0.165 [s]

P2 Left Upper Tibia Mx

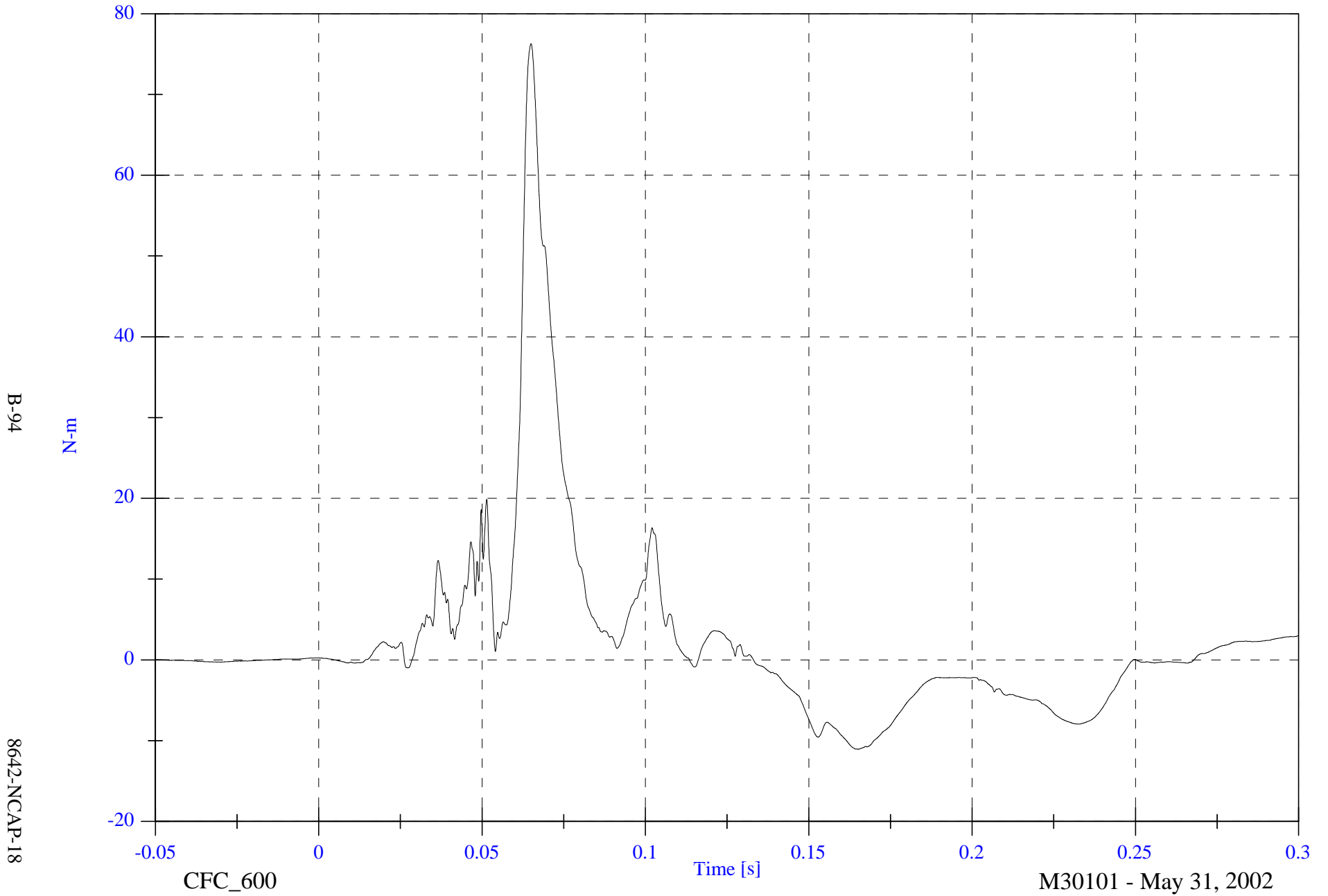

2002 NCAP Test 18 2003 Cadillac CTS

Max: 41.3 [N-m] at 0.037 [s]

Min: -73.6 [N-m] at 0.061 [s]

P2 Left Upper Tibia My

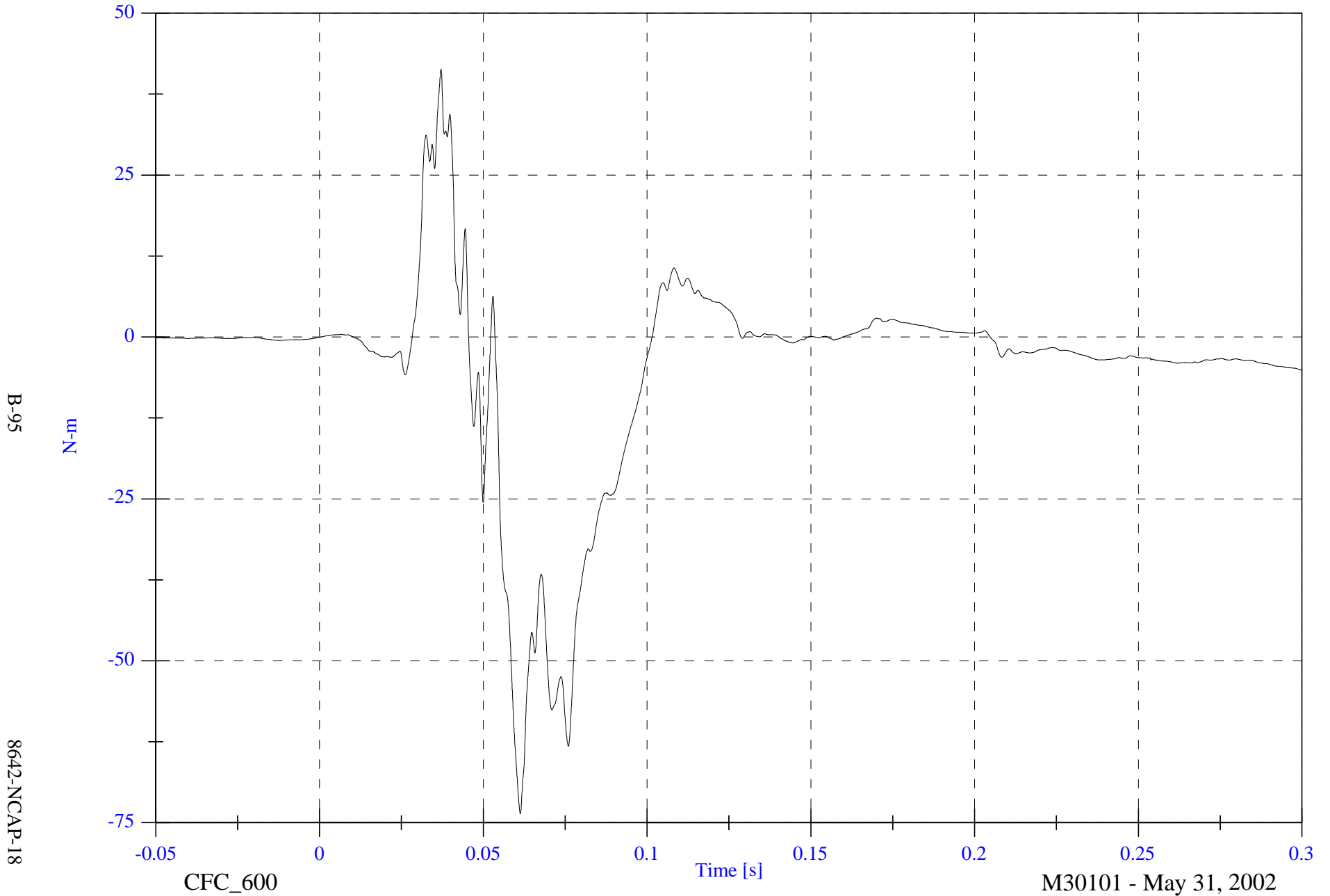

2002 NCAP Test 18 2003 Cadillac CTS

P2 Left Lower Tibia Fz

Max: 260.3 [N] at 0.032 [s]

Min: -2099.2 [N] at 0.075 [s]

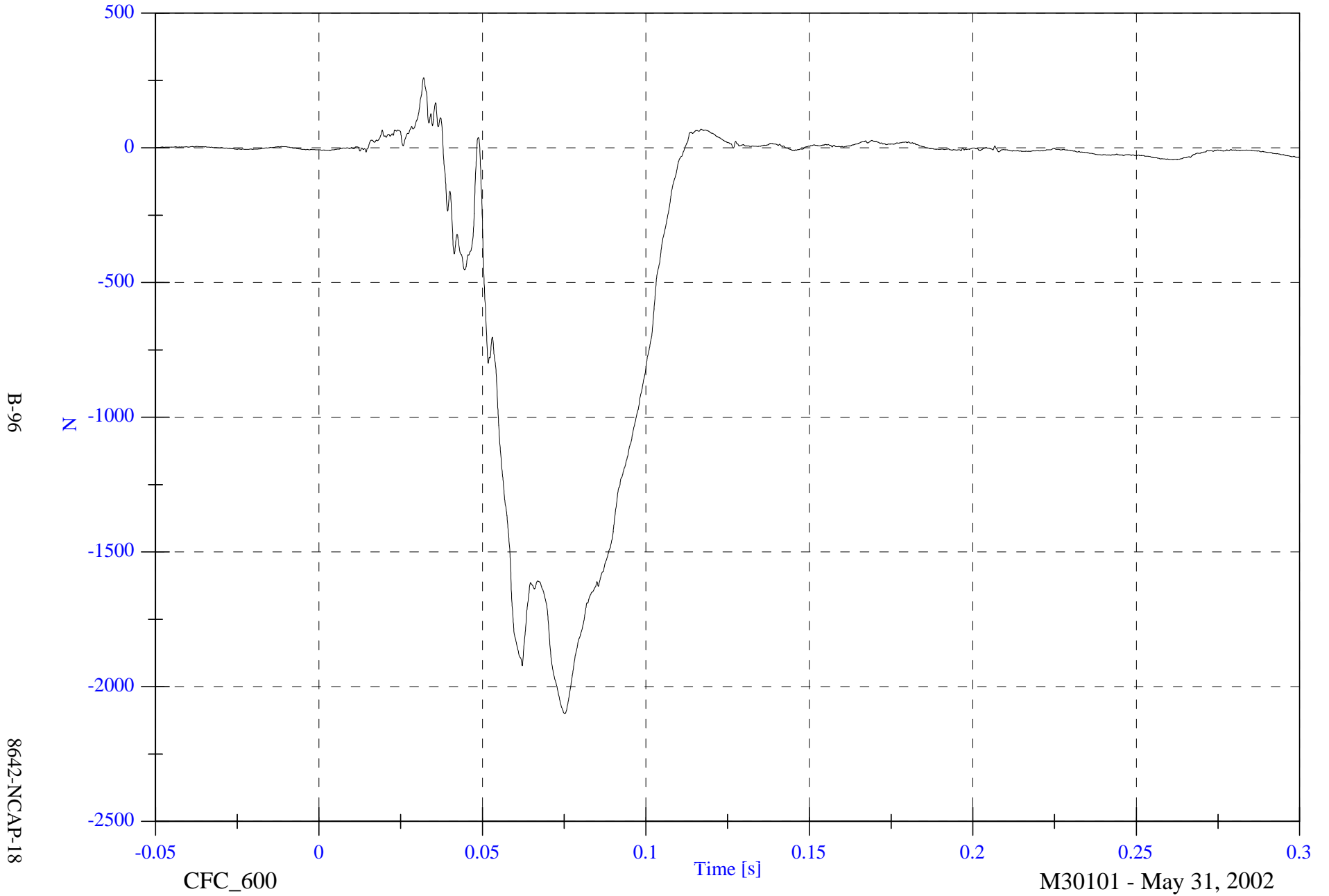

B-96

8642-NCAP-18

CFC_600

Time [s]

M30101 - May 31, 2002

2002 NCAP Test 18 2003 Cadillac CTS

Max: 19.3 [N-m] at 0.077 [s]

Min: -5.0 [N-m] at 0.053 [s]

P2 Left Lower Tibia Mx

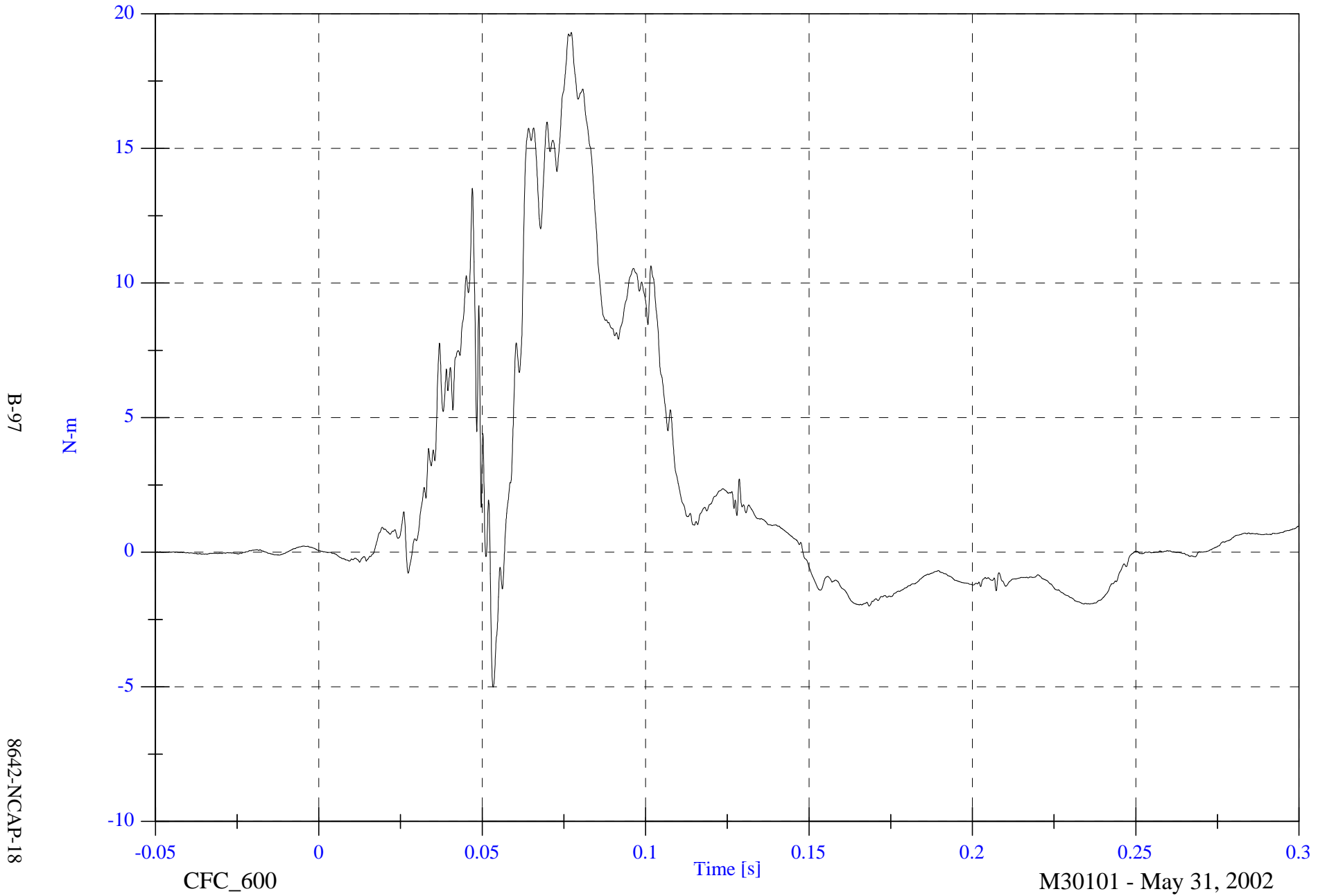

2002 NCAP Test 18 2003 Cadillac CTS

Max: 26.2 [N-m] at 0.052 [s]

Min: -30.4 [N-m] at 0.047 [s]

P2 Left Lower Tibia My

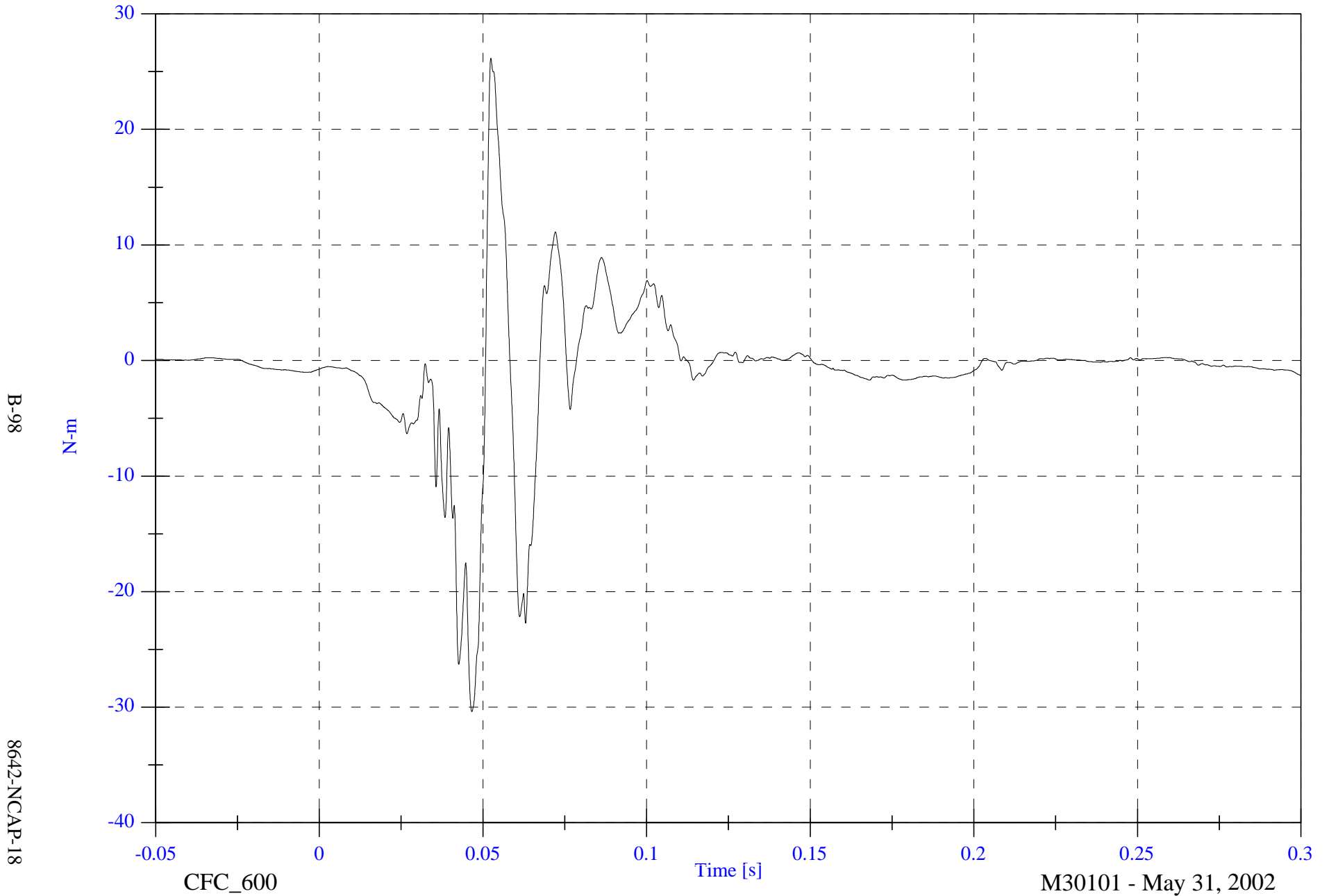

2002 NCAP Test 18 2003 Cadillac CTS

Max: 17.1 [N-m] at 0.152 [s]

Min: -40.5 [N-m] at 0.047 [s]

P2 Right Upper Tibia Mx

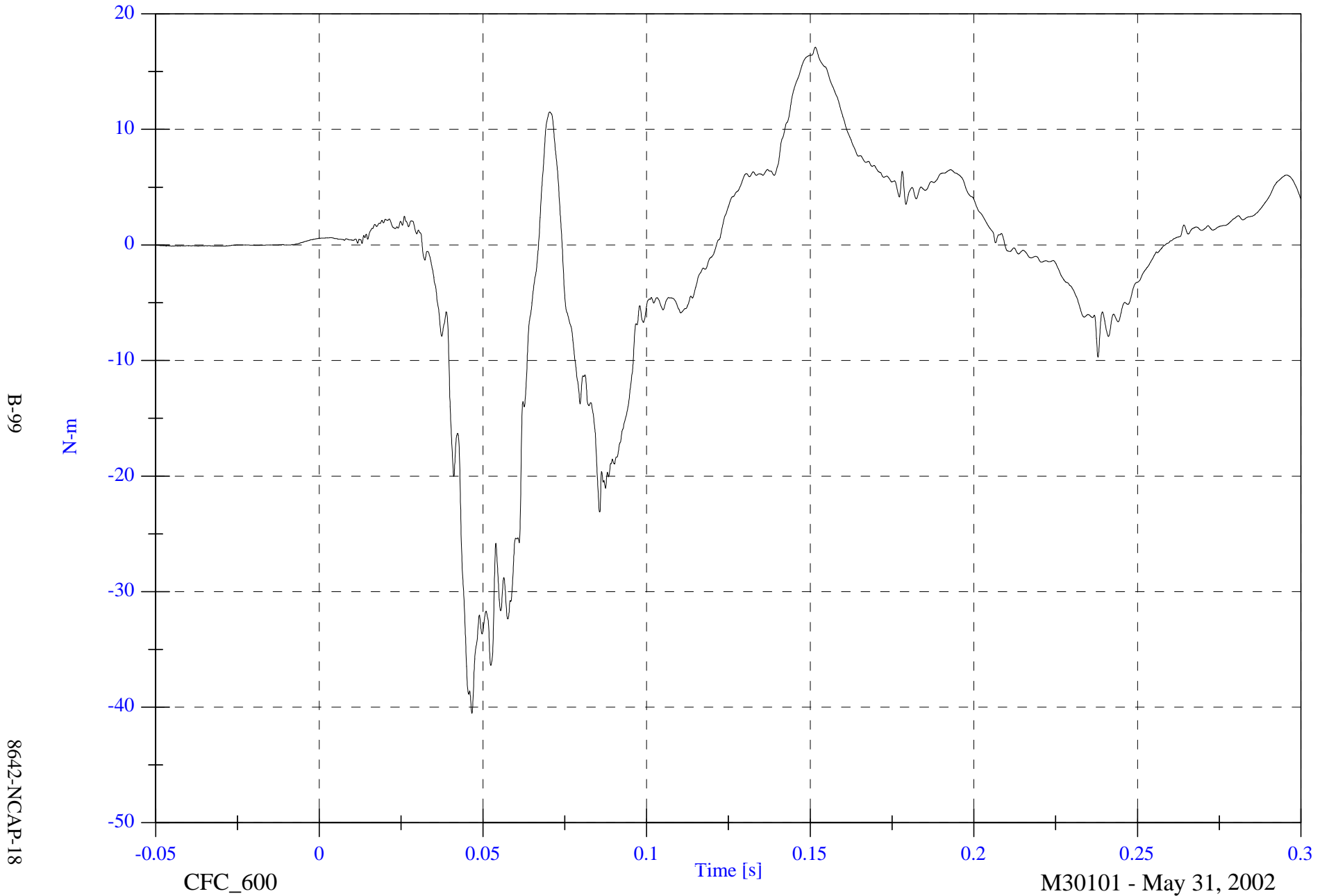

2002 NCAP Test 18 2003 Cadillac CTS

Max: 25.0 [N-m] at 0.033 [s]

Min: -82.4 [N-m] at 0.072 [s]

P2 Right Upper Tibia My

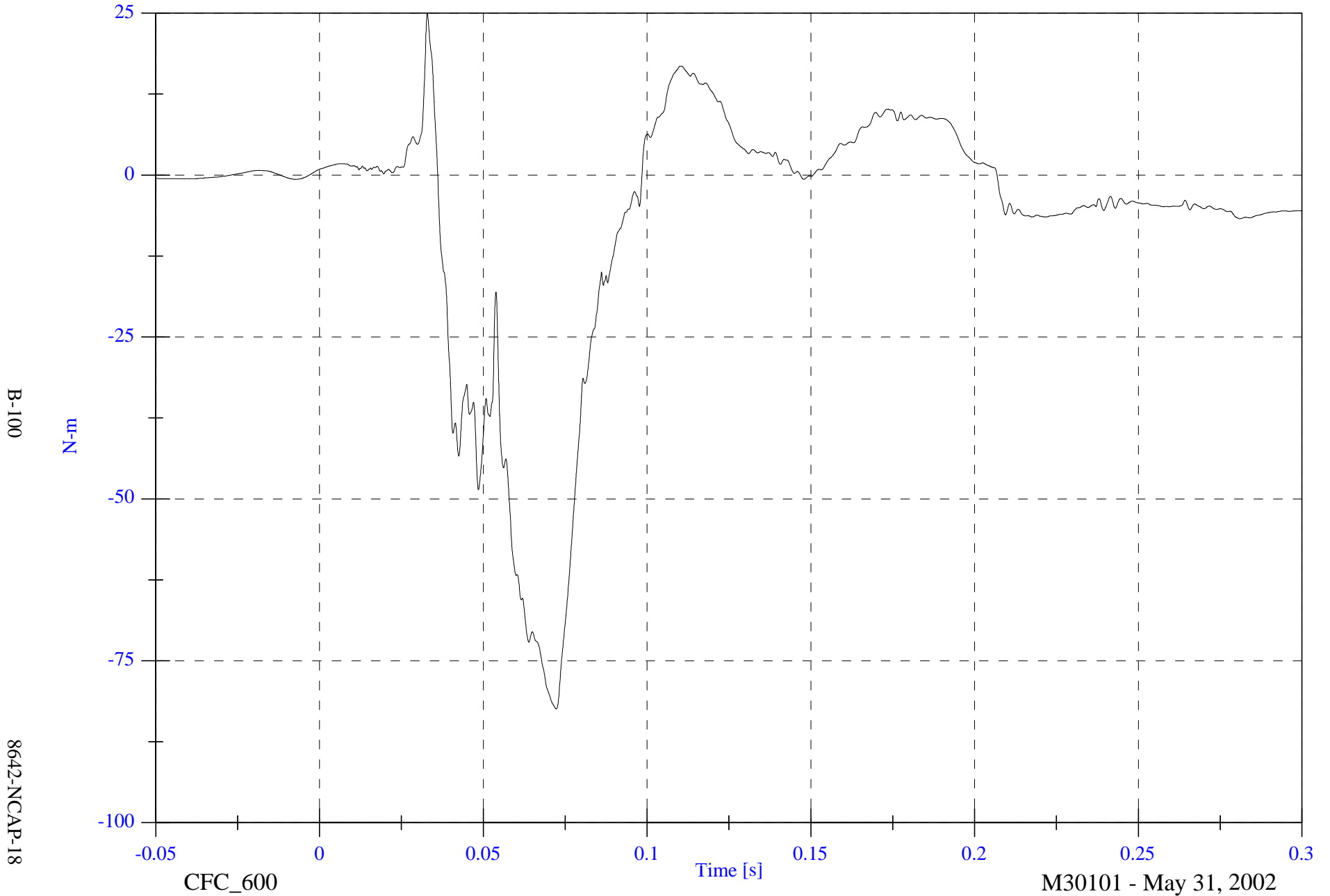

2002 NCAP Test 18 2003 Cadillac CTS

Max: 137.1 [N] at 0.033 [s]

Min: -2214.1 [N] at 0.073 [s]

P2 Right Lower Tibia Fz

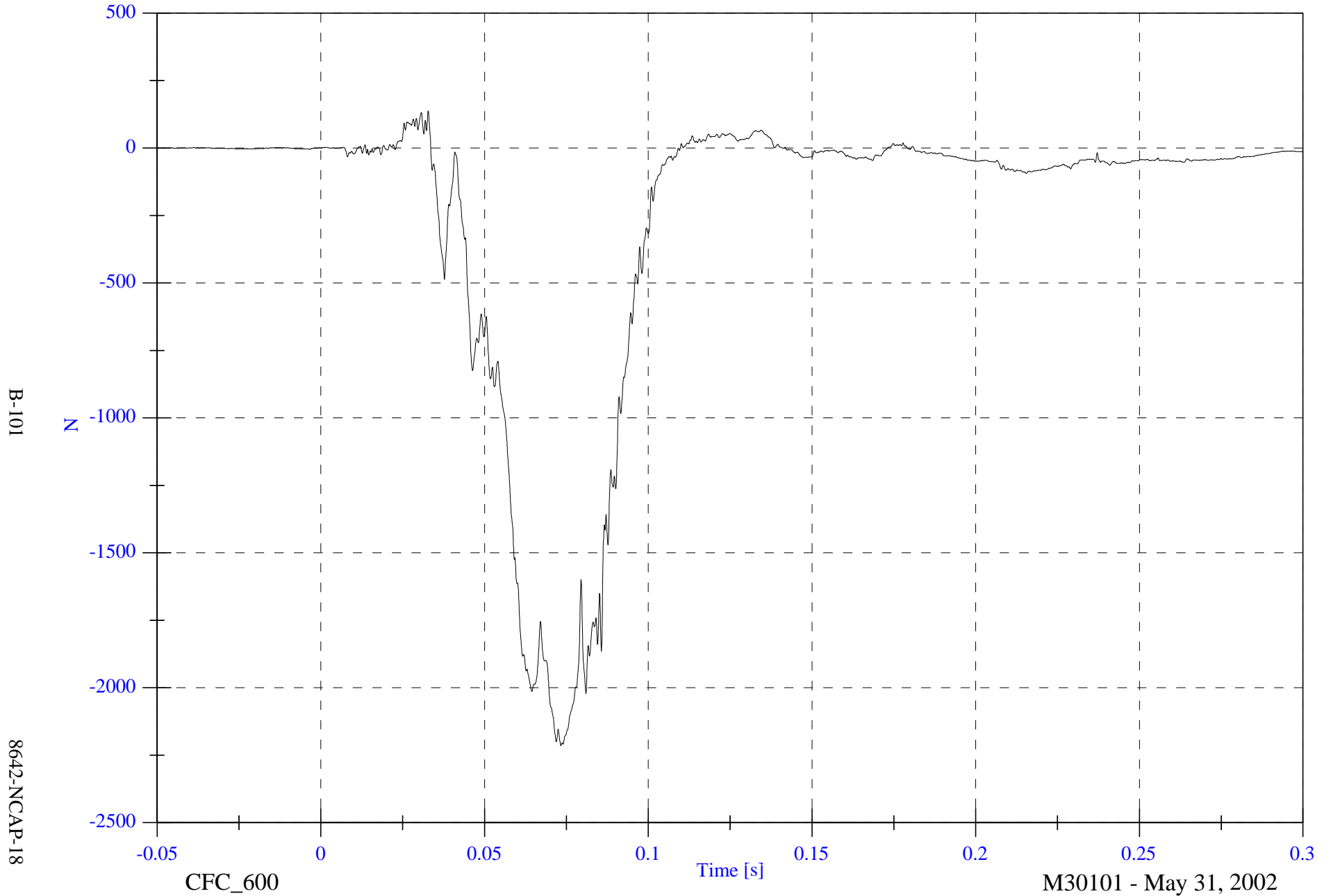

B-101

8642-NCAP-18

CFC_600

Time [s]

M30101 - May 31, 2002

2002 NCAP Test 18 2003 Cadillac CTS

Max: 65.4 [N-m] at 0.072 [s]

Min: -21.1 [N-m] at 0.046 [s]

P2 Right Lower Tibia Mx

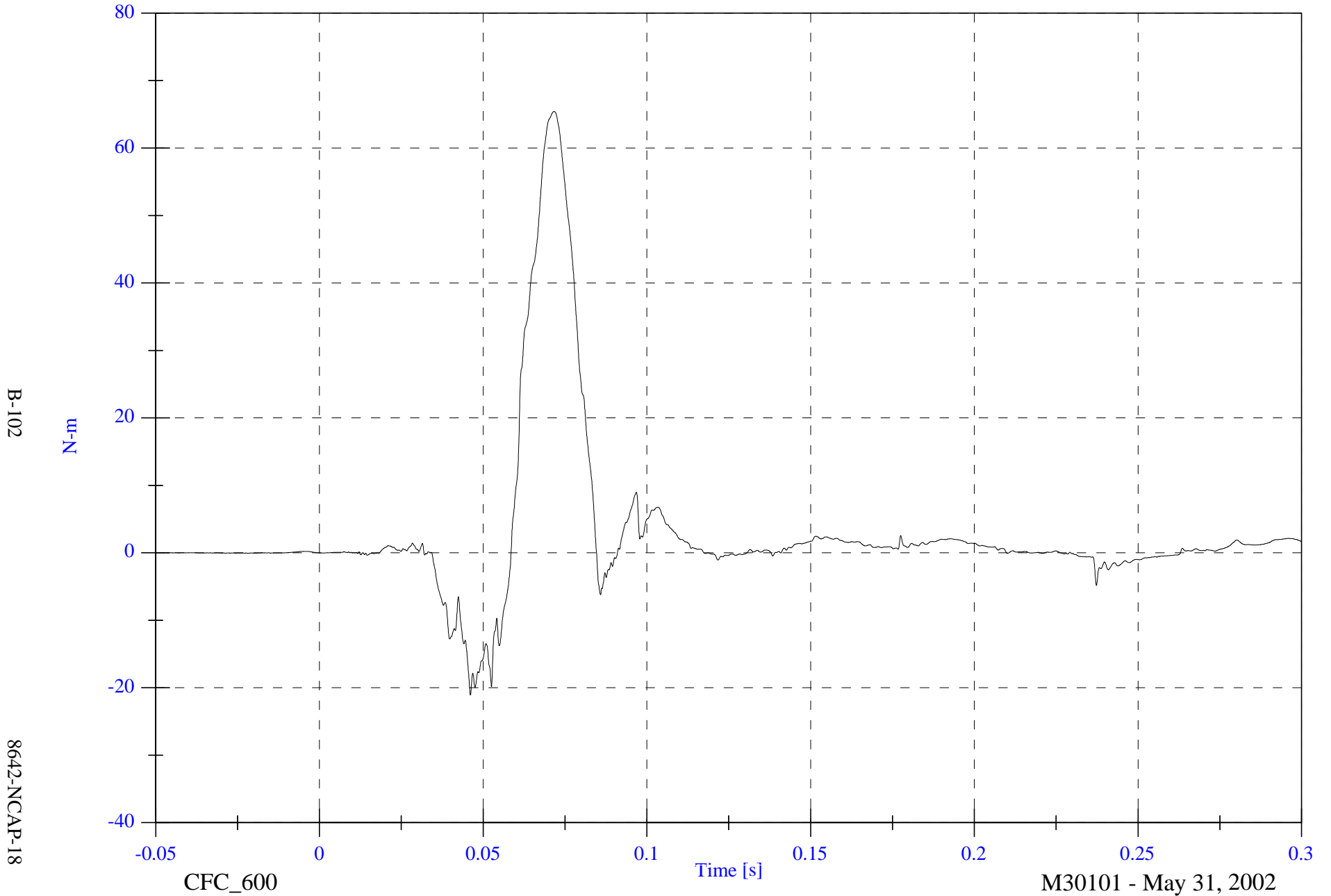

2002 NCAP Test 18 2003 Cadillac CTS

Max: 13.0 [N-m] at 0.086 [s]

Min: -115.4 [N-m] at 0.041 [s]

P2 Right Lower Tibia My

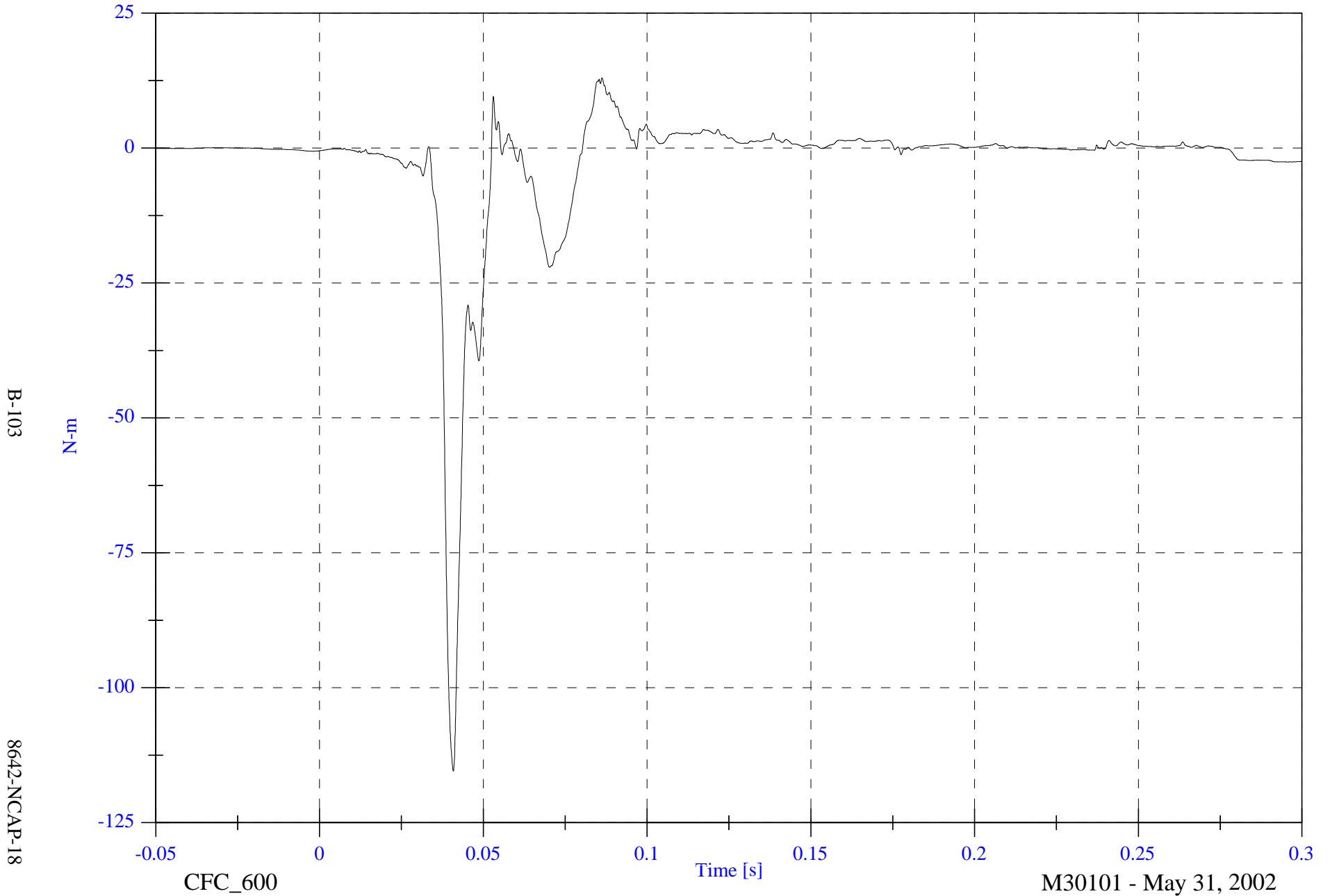

2002 NCAP Test 18 2003 Cadillac CTS

Max: 22.2 [g] at 0.051 [s]

Min: -88.1 [g] at 0.040 [s]

P2 Left foot Aft x

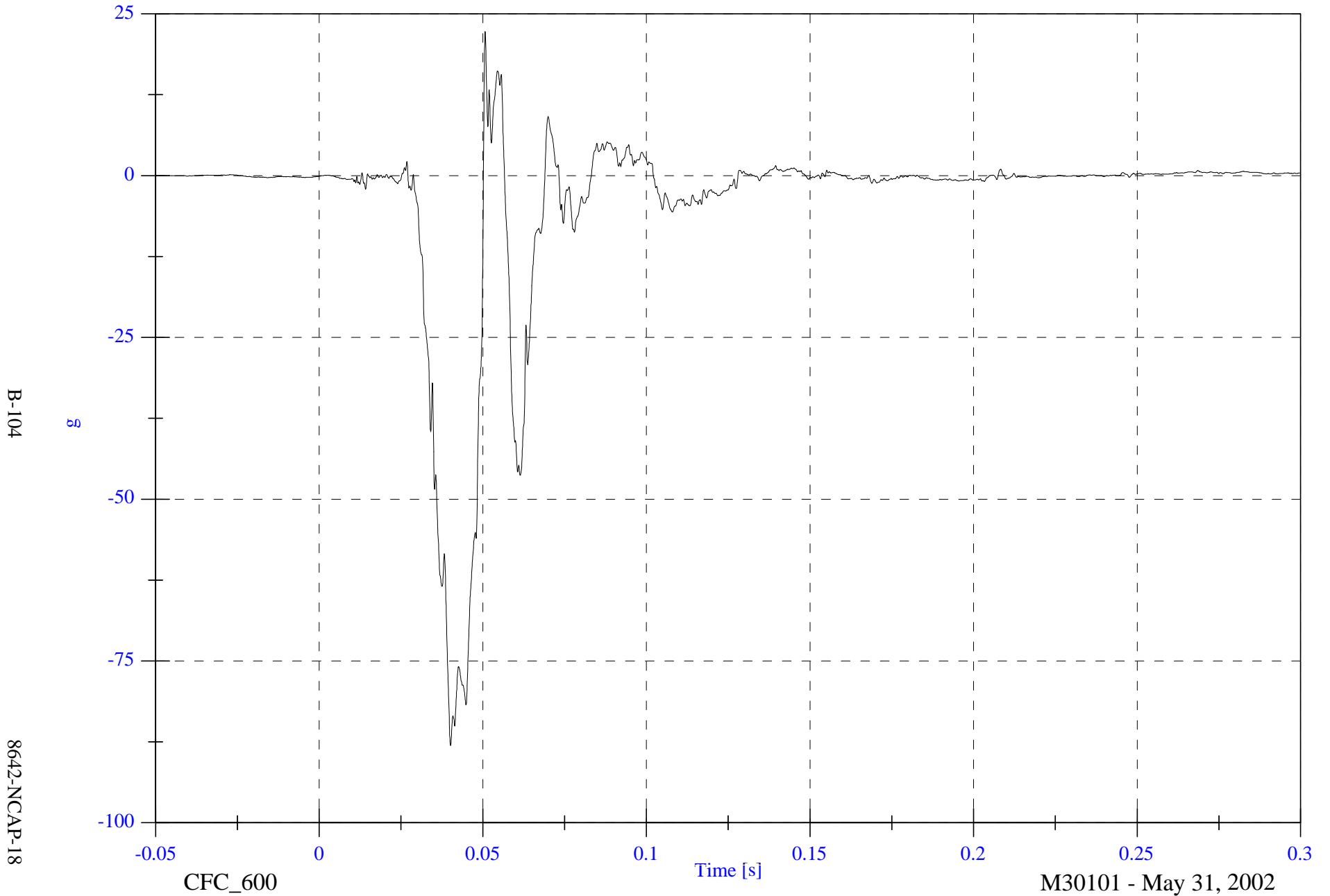

B-104

8642-NCAP-18

CFC_600

Time [s]

M30101 - May 31, 2002

2002 NCAP Test 18 2003 Cadillac CTS

Max: 12.6 [g] at 0.035 [s]

Min: -45.3 [g] at 0.051 [s]

P2 Left Foot Aft z

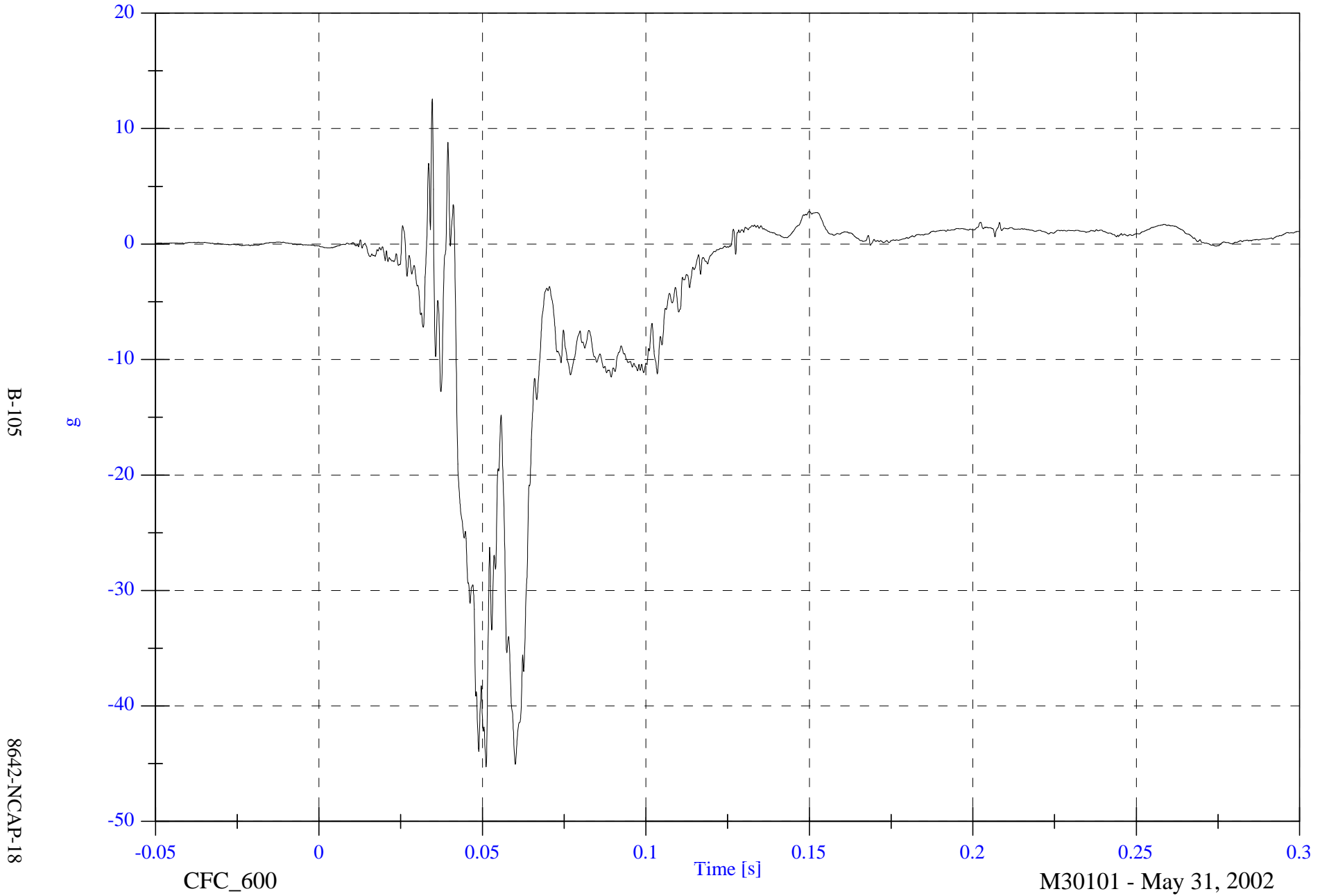

B-105

8642-NCAP-18

2002 NCAP Test 18 2003 Cadillac CTS

Max: 63.8 [g] at 0.035 [s]
Min: -121.7 [g] at 0.045 [s]

P2 Left Foot Fore z

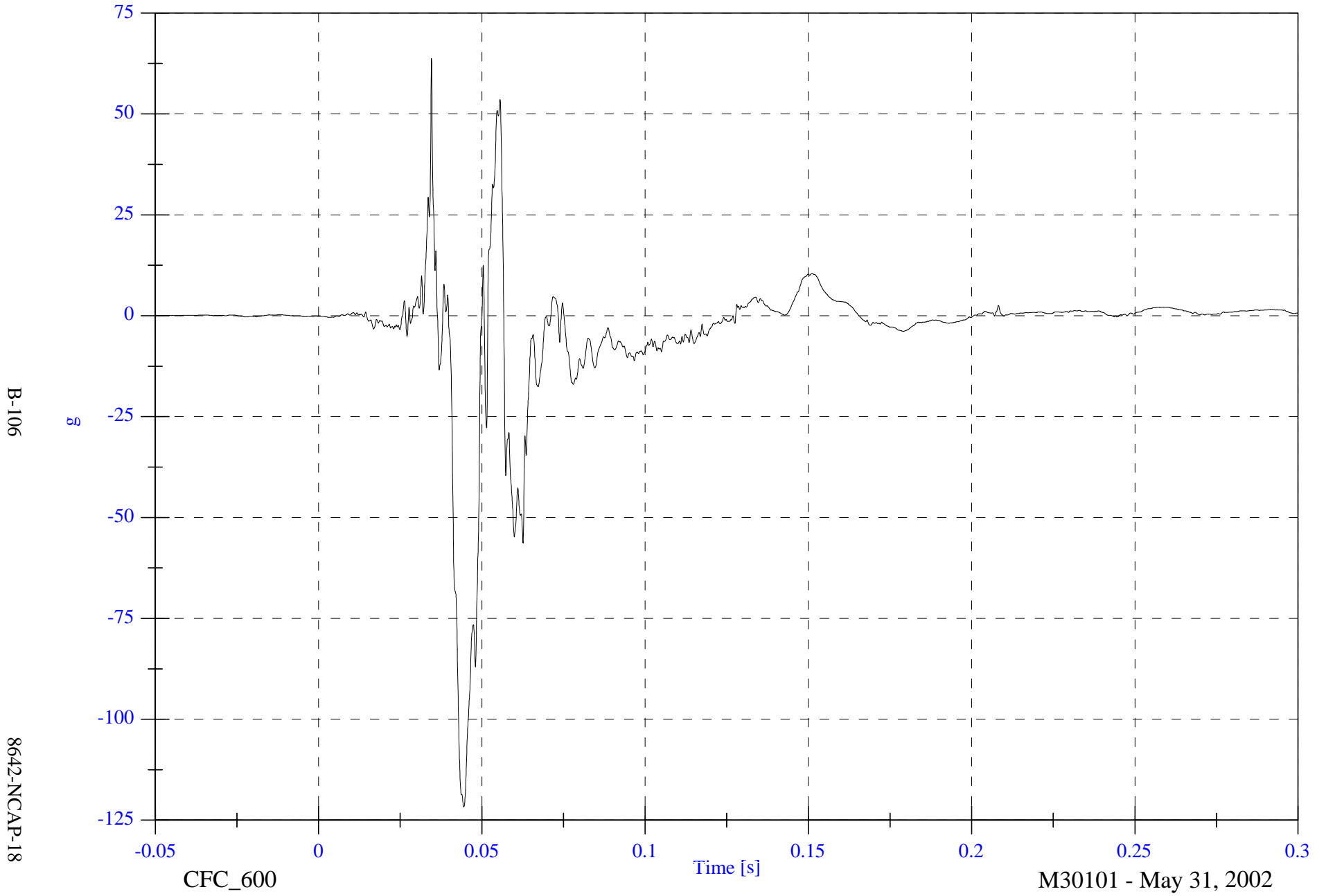

2002 NCAP Test 18 2003 Cadillac CTS

Max: 9.2 [g] at 0.086 [s]

Min: -76.2 [g] at 0.047 [s]

P2 Right Foot Aft x

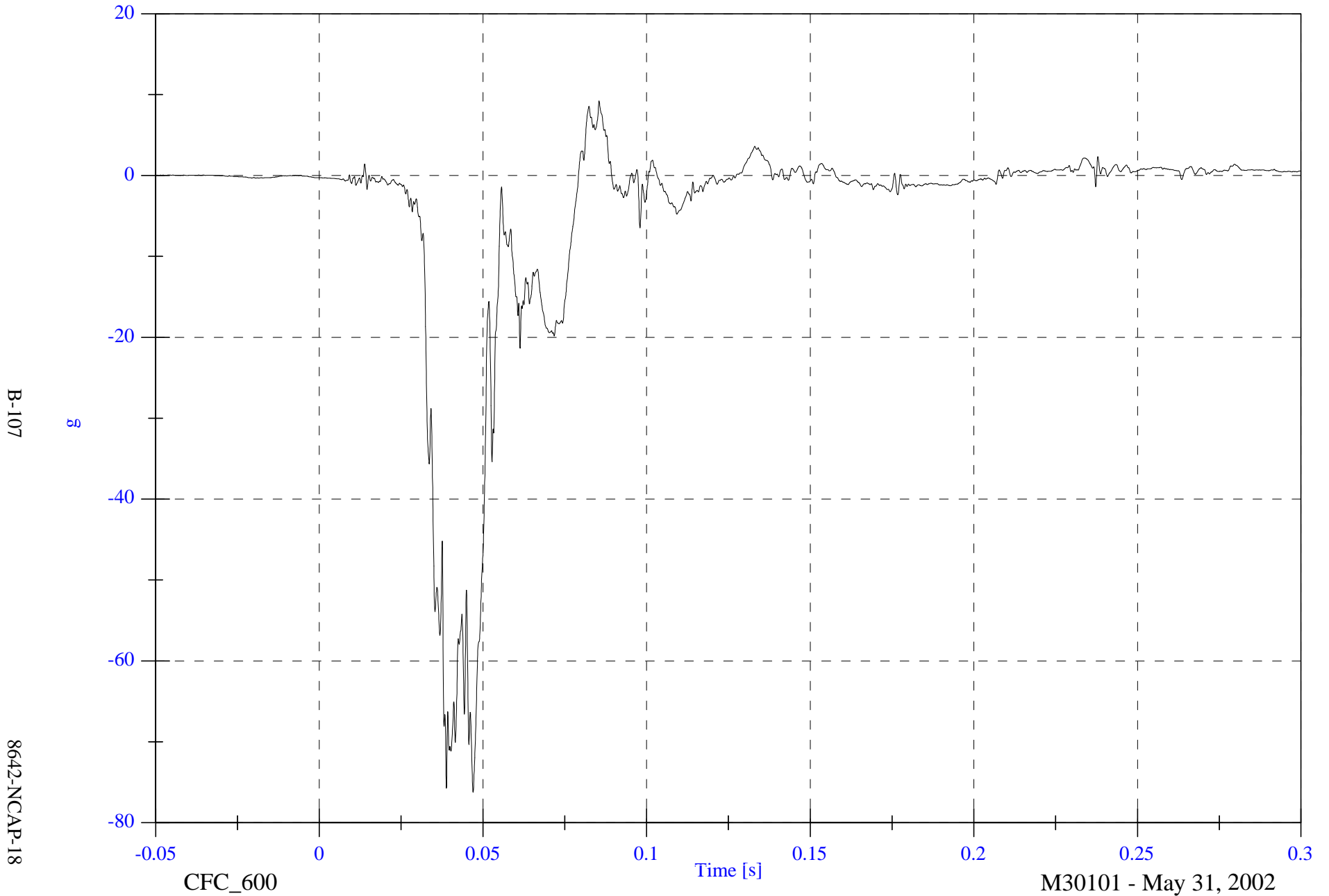

2002 NCAP Test 18 2003 Cadillac CTS

Max: 20.2 [g] at 0.038 [s]

Min: -41.4 [g] at 0.051 [s]

P2 Right Foot Aft z

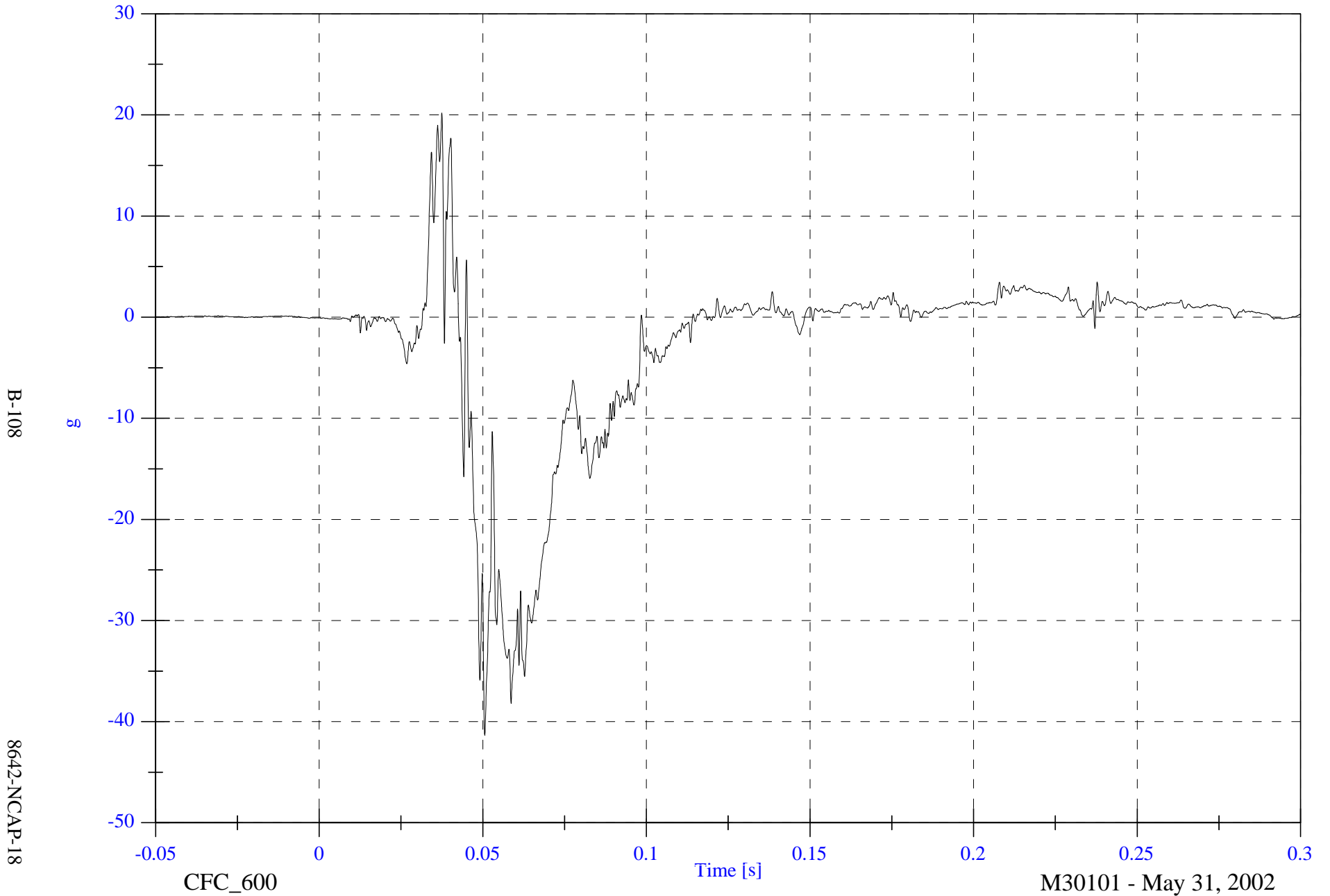

B-108

8642-NCAP-18

CFC_600

Time [s]

M30101 - May 31, 2002

2002 NCAP Test 18 2003 Cadillac CTS

Max: 74.2 [g] at 0.034 [s]

Min: -93.8 [g] at 0.048 [s]

P2 Right Foot Fore z

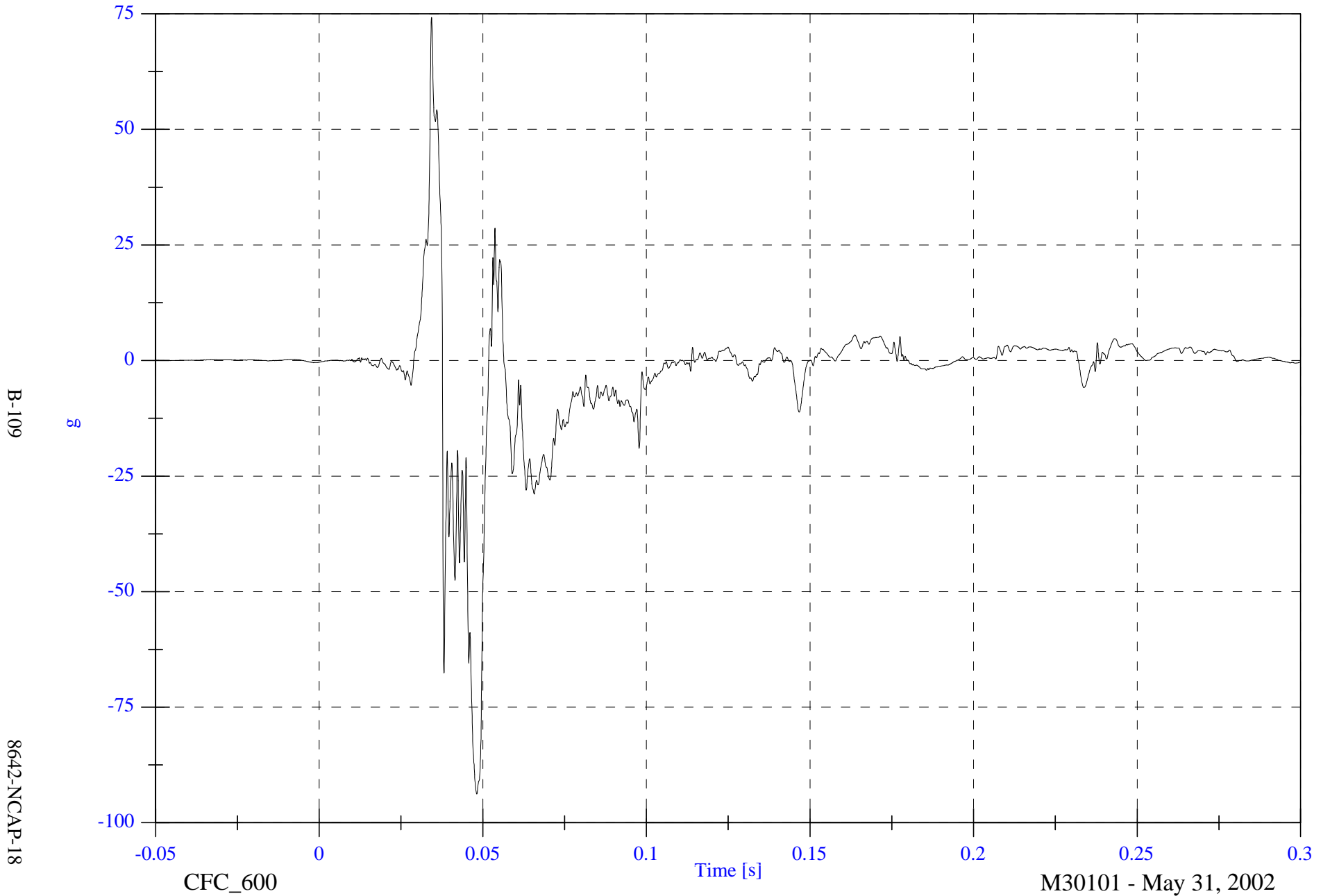

2002 NCAP Test 18 2003 Cadillac CTS

Max: 4.1 [g] at 0.017 [s]

Min: -45.3 [g] at 0.057 [s]

Left Rear #1x

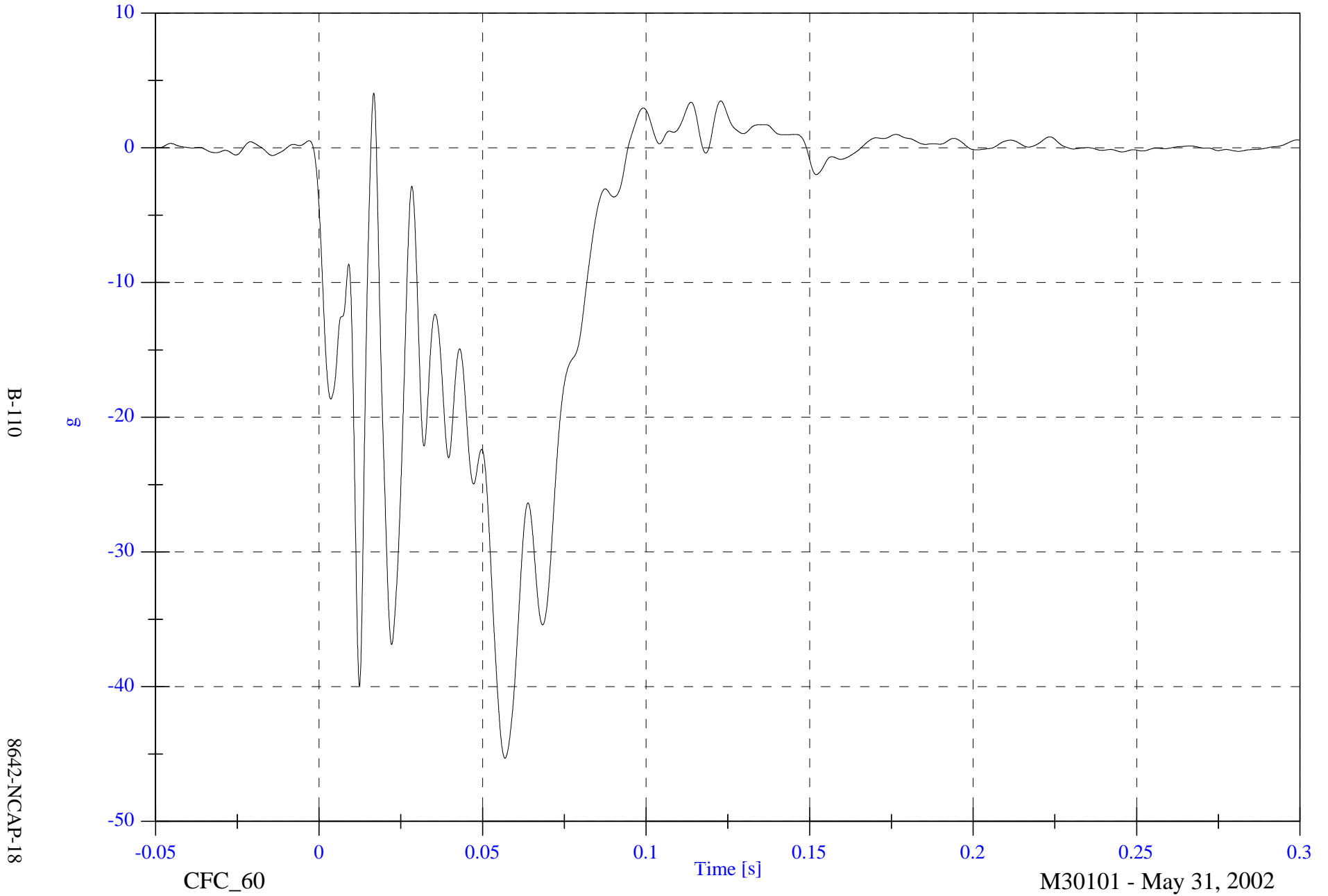

B-110

8642-NCAP-18

2002 NCAP Test 18 2003 Cadillac CTS

Max: 56.8 [kph] at -0.035 [s]

Min: -8.8 [kph] at 0.094 [s]

Left Rear #1x Velocity

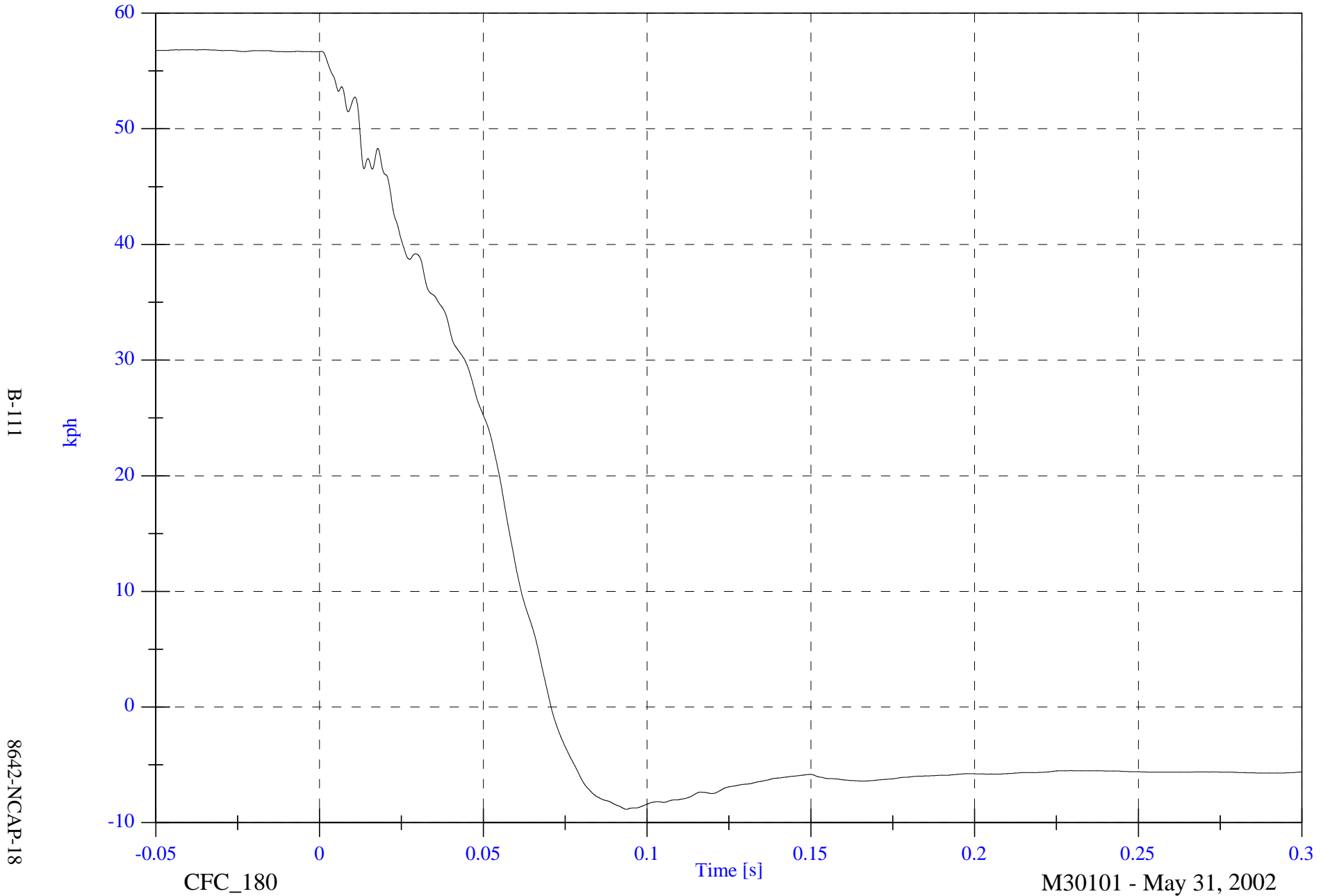

B-111

8642-NCAP-18

CFC_180

Time [s]

M30101 - May 31, 2002

2002 NCAP Test 18 2003 Cadillac CTS

Max: 651.7 [mm] at 0.071 [s]

Min: -788.2 [mm] at -0.050 [s]

Left Rear #1x Displacement

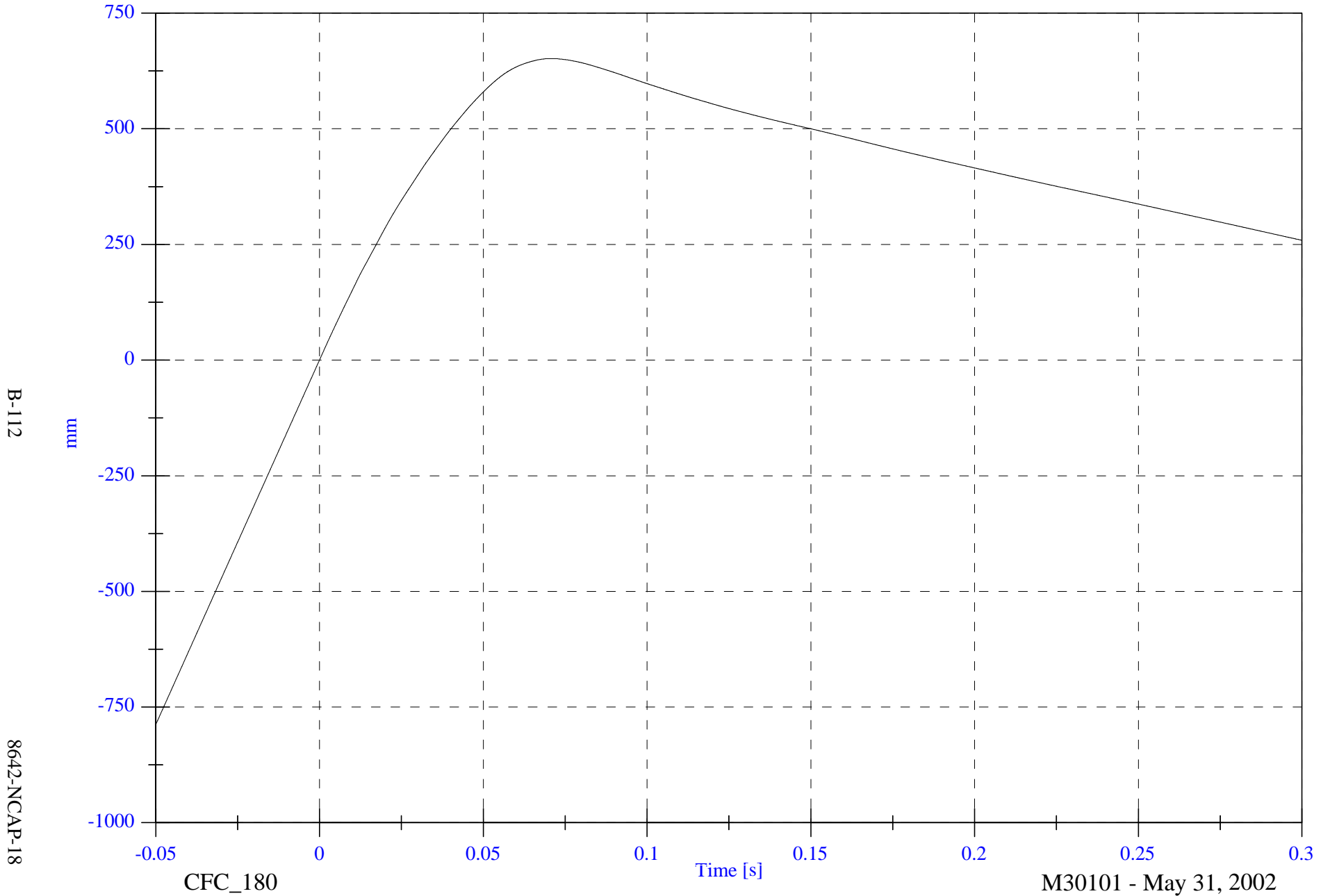

B-112

8642-NCAP-18

CFC_180

Time [s]

M30101 - May 31, 2002

2002 NCAP Test 18 2003 Cadillac CTS

Right Rear #2x

Max: 50.6 [g] at 0.081 [s]
Min: -516.4 [g] at 0.091 [s]

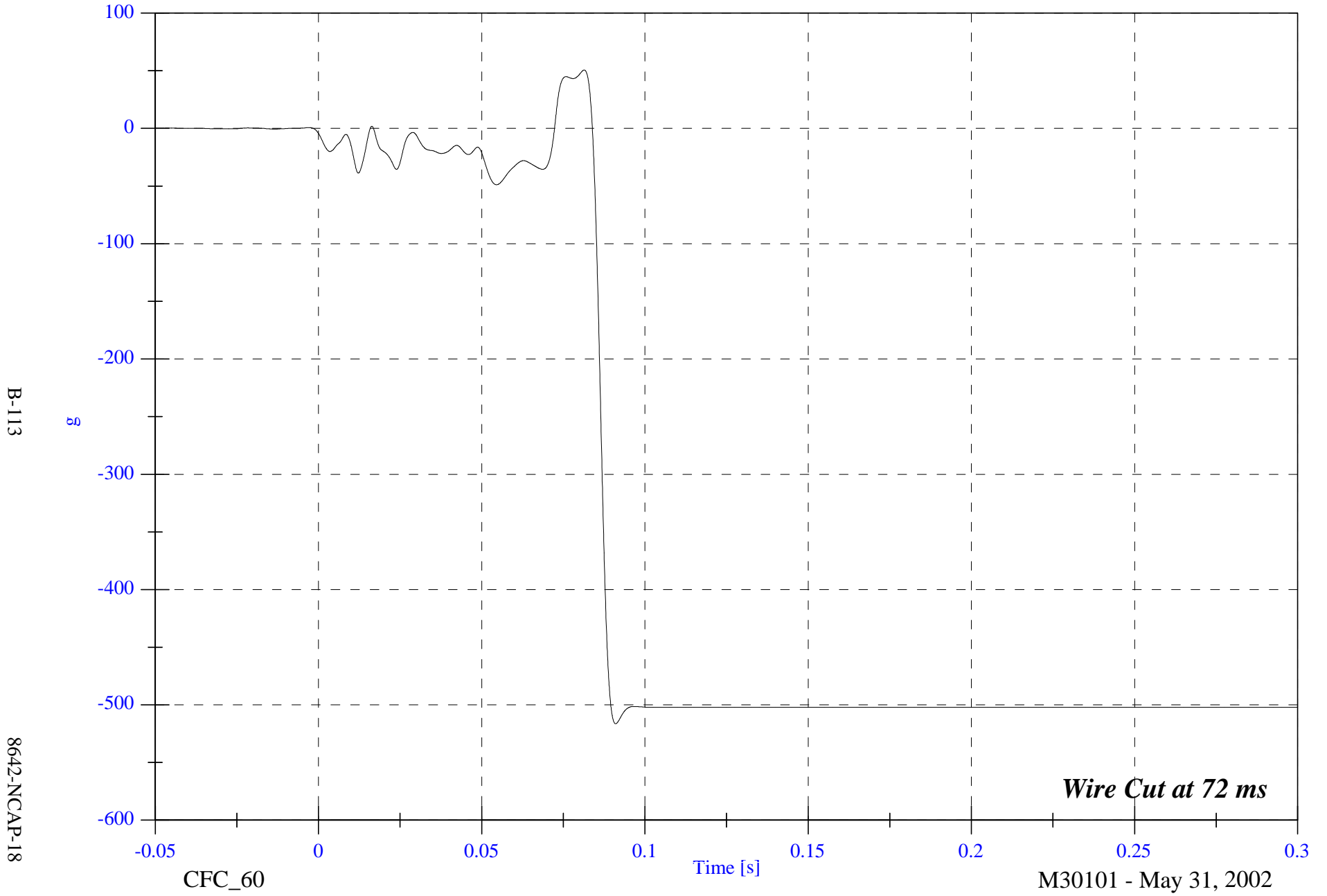

2002 NCAP Test 18 2003 Cadillac CTS

Max: 56.8 [kph] at -0.040 [s]

Min: -3768.9 [kph] at 0.300 [s]

Right Rear #2x Velocity

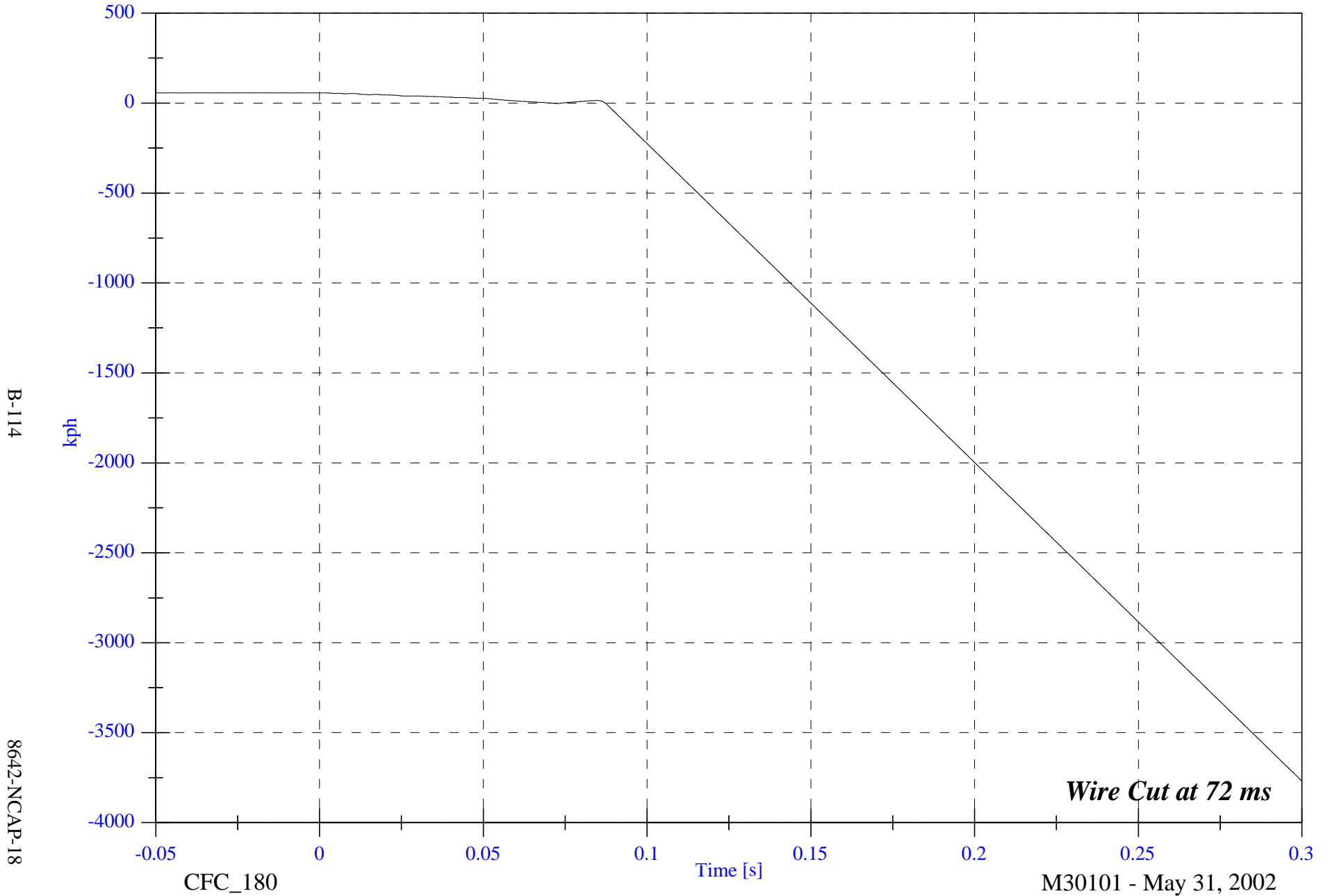

B-114

8642-NCAP-18

CFC_180

Time [s]

M30101 - May 31, 2002

Wire Cut at 72 ms

2002 NCAP Test 18 2003 Cadillac CTS

Right Rear #2x Displacement

Max: 680.0 [mm] at 0.087 [s]
Min: -110631.8 [mm] at 0.300 [s]

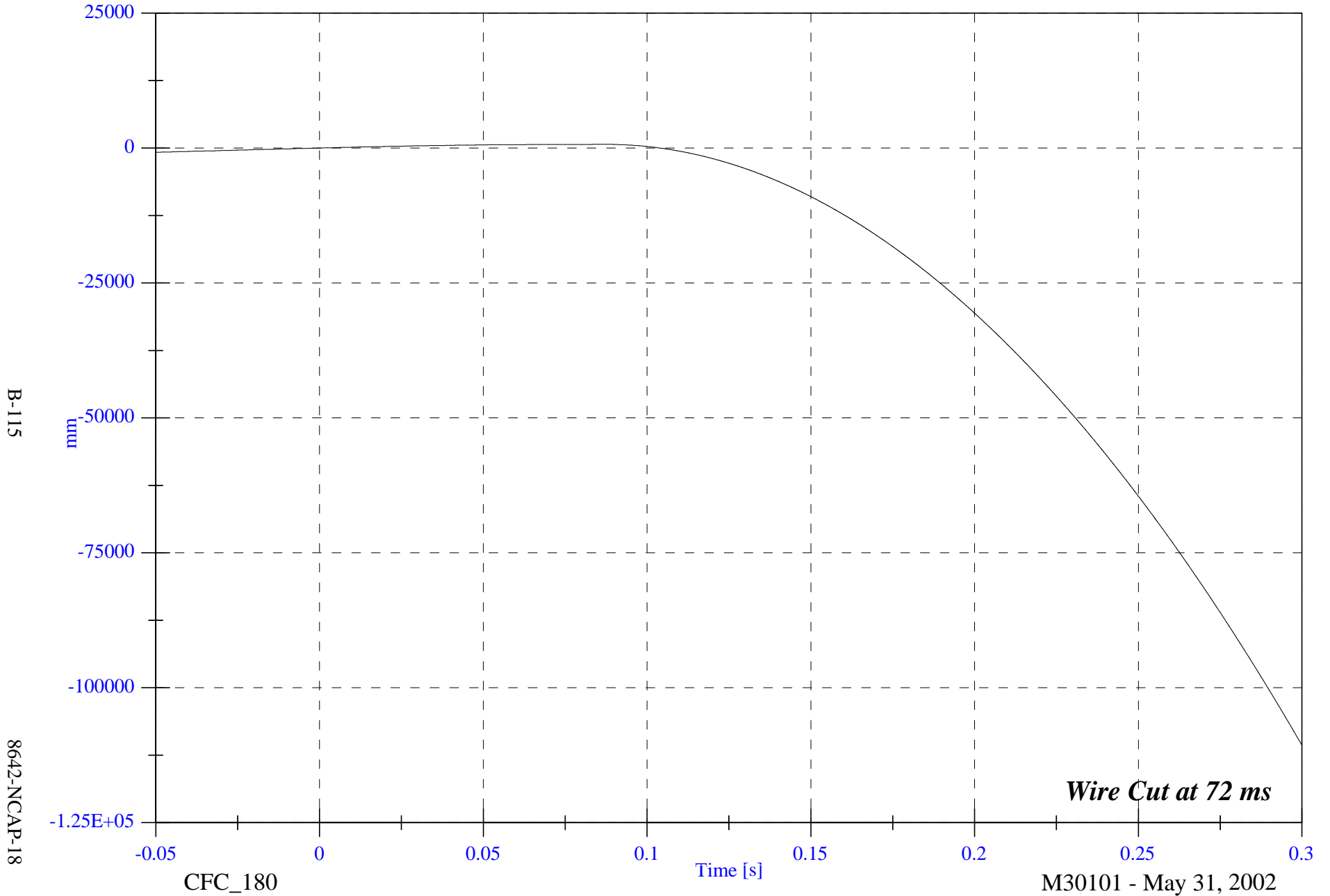

B-115

8642-NCAP-18

CFC_180

Time [s]

M30101 - May 31, 2002

Wire Cut at 72 ms

2002 NCAP Test 18 2003 Cadillac CTS

Max: 38.7 [g] at 0.057 [s]

Min: -124.8 [g] at 0.041 [s]

Engine Top #3x

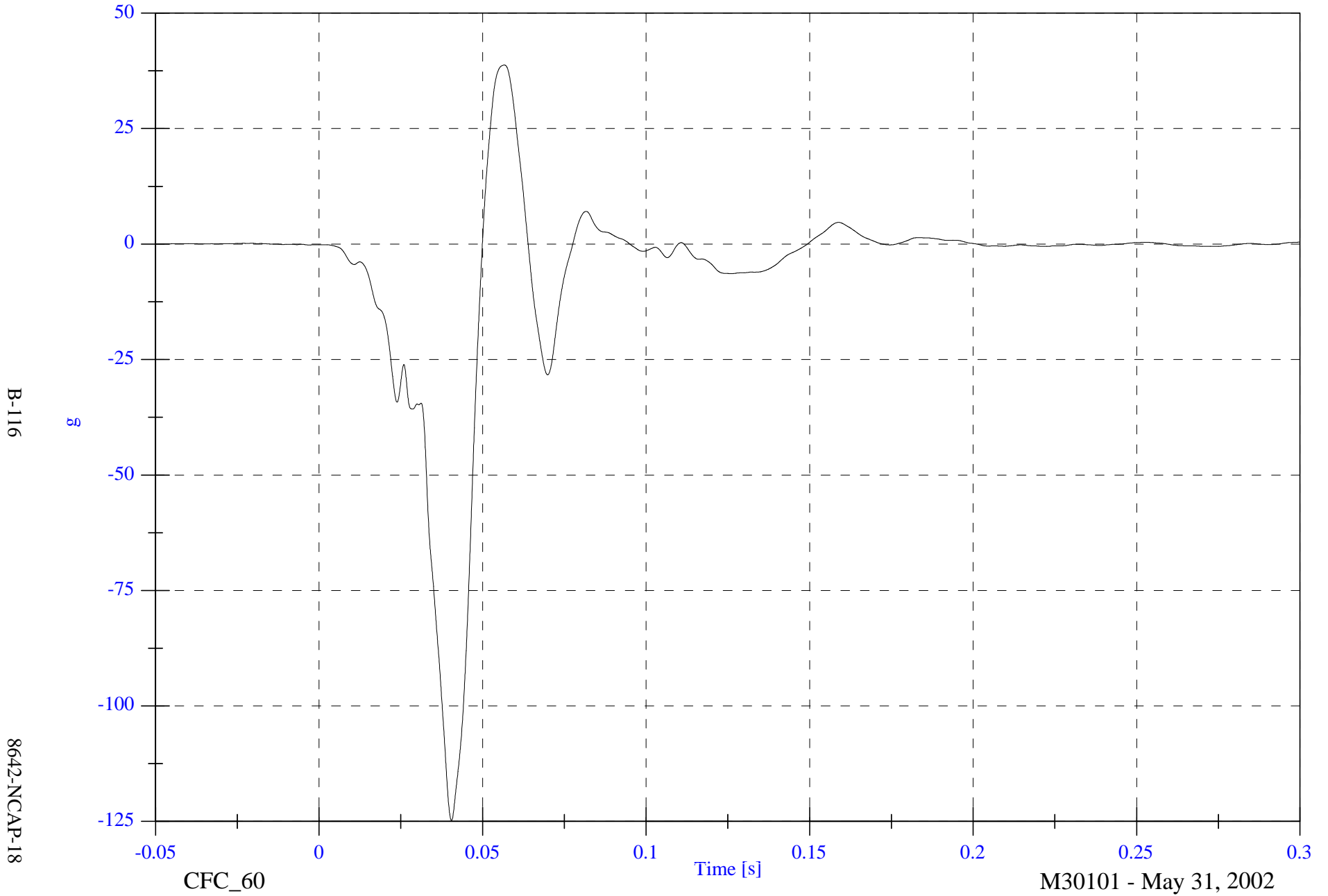

2002 NCAP Test 18 2003 Cadillac CTS

Max: 56.7 [kph] at -0.012 [s]

Min: -10.5 [kph] at 0.050 [s]

Engine Top #3x Velocity

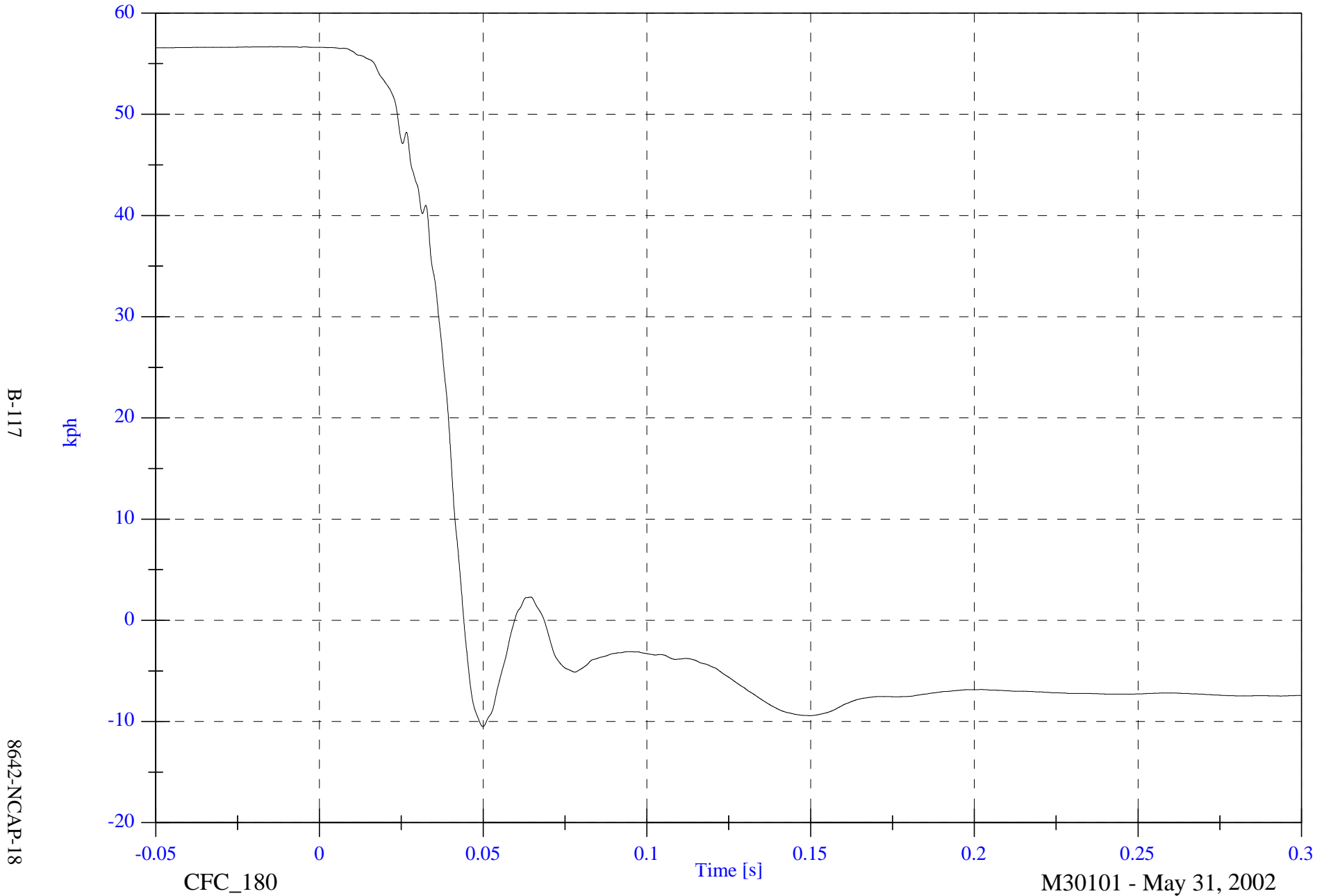

B-117

8642-NCAP-18

CFC_180

Time [s]

M30101 - May 31, 2002

2002 NCAP Test 18 2003 Cadillac CTS

Max: 545.4 [mm] at 0.044 [s]

Min: -786.5 [mm] at -0.050 [s]

Engine Top #3x Displacement

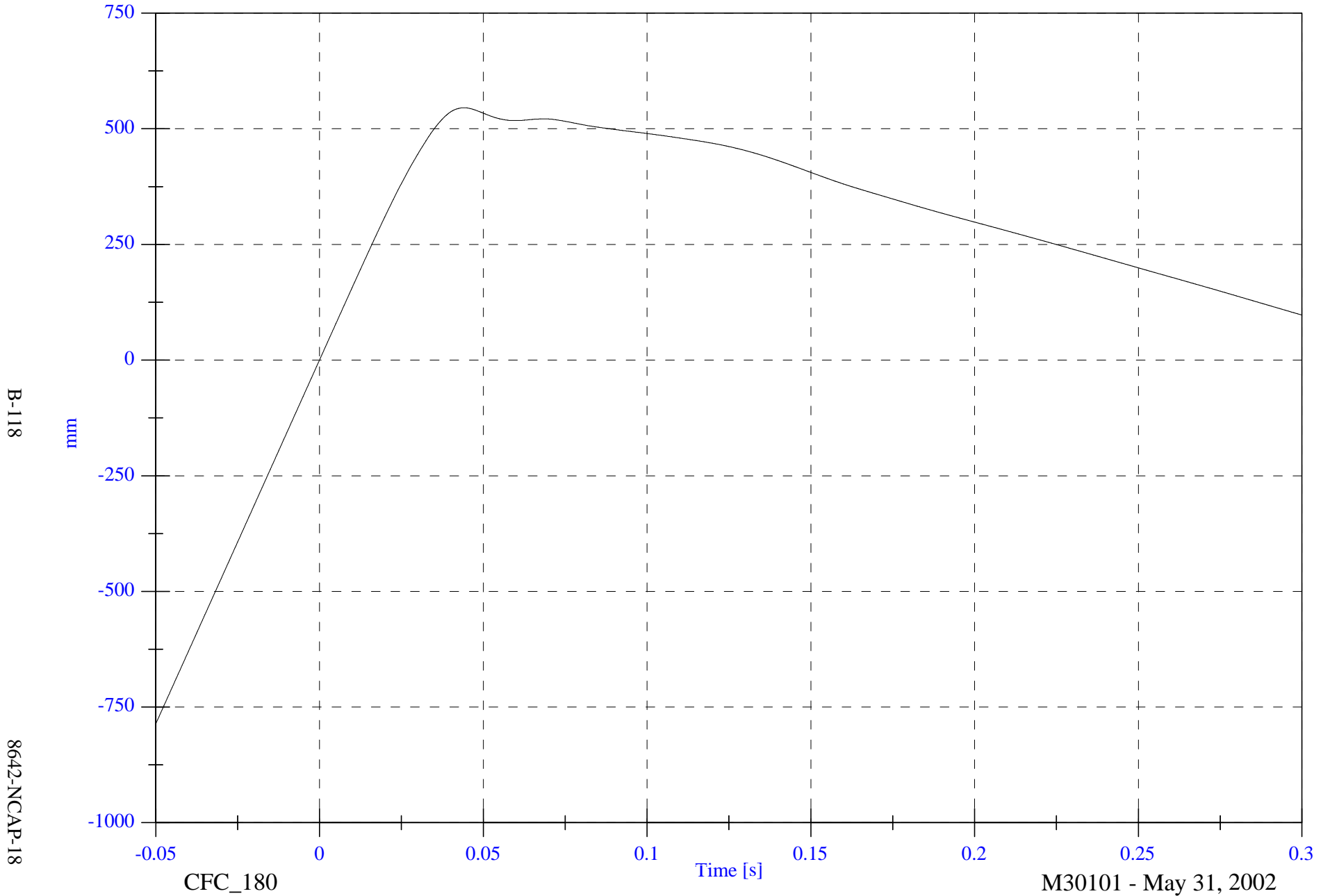

B-118

8642-NCAP-18

CFC_180

Time [s]

M30101 - May 31, 2002

2002 NCAP Test 18 2003 Cadillac CTS

Max: 1822.0 [g] at 0.042 [s]

Min: -97.3 [g] at 0.033 [s]

Engine Bottom #4x

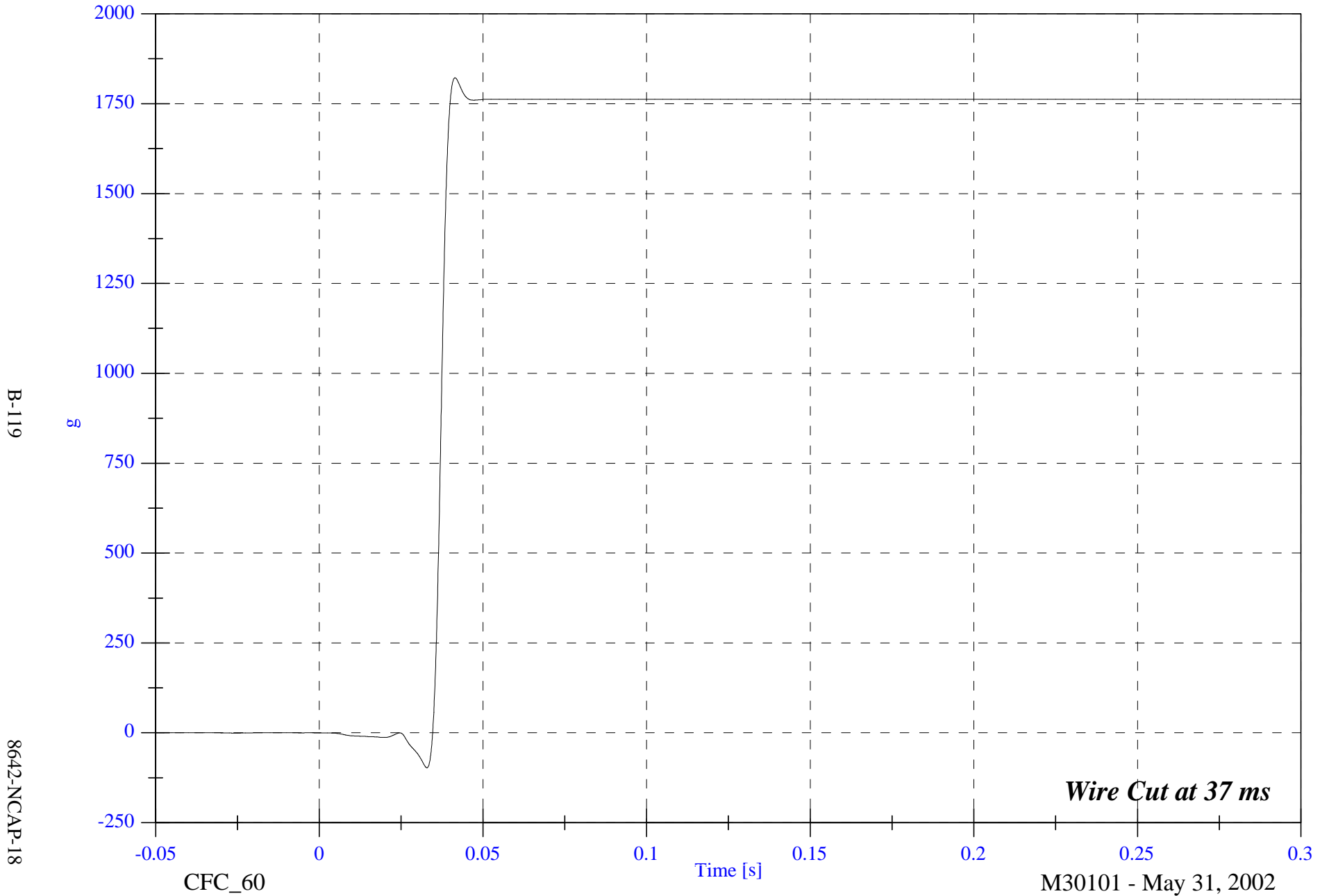

B-119

8642-NCAP-18

CFC_60

Time [s]

Wire Cut at 37 ms

M30101 - May 31, 2002

2002 NCAP Test 18 2003 Cadillac CTS

Max: 16382.4 [kph] at 0.300 [s]

Engine Bottom #4x Velocity

Min: 35.8 [kph] at 0.036 [s]

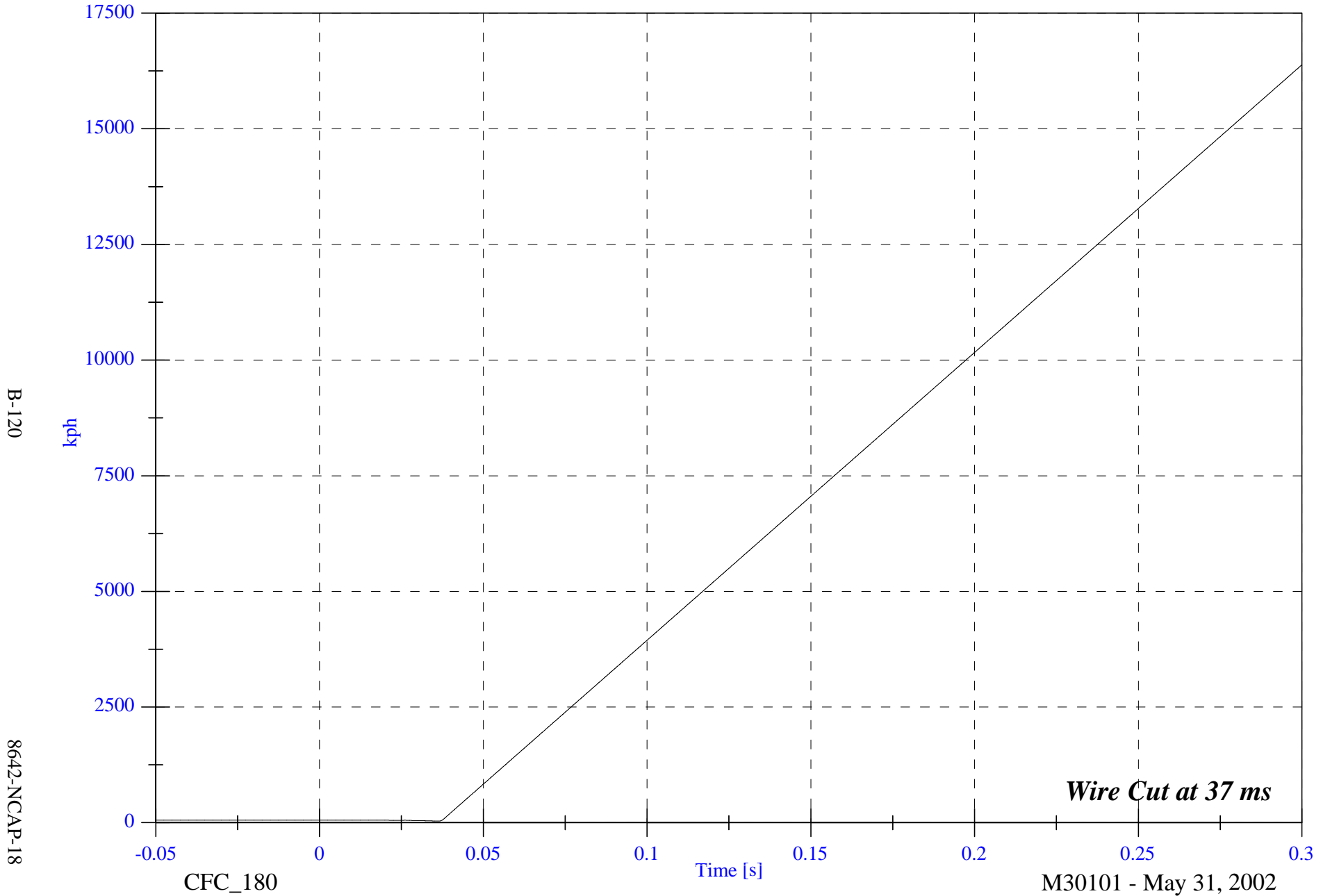

B-120

8642-NCAP-18

CFC_180

Time [s]

M30101 - May 31, 2002

Wire Cut at 37 ms

2002 NCAP Test 18 2003 Cadillac CTS

Max: 599656.9 [mm] at 0.300 [s]

Engine Bottom #4x Displacement

Min: -786.8 [mm] at -0.050 [s]

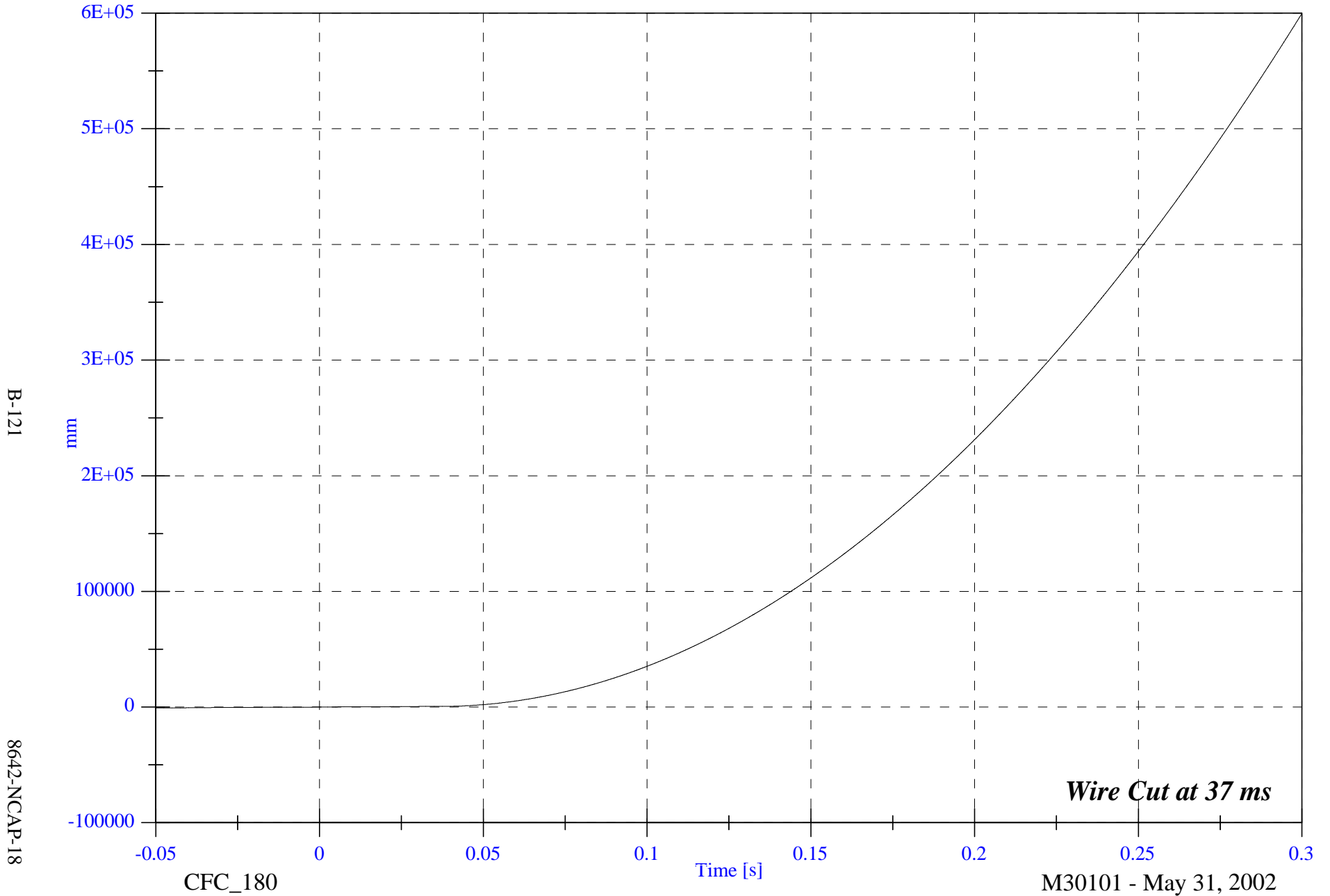

B-121

8642-NCAP-18

CFC_180

Time [s]

M30101 - May 31, 2002

2002 NCAP Test 18 2003 Cadillac CTS

Right Caliper #5x

Max: 83.3 [g] at 0.058 [s]

Min: -81.9 [g] at 0.036 [s]

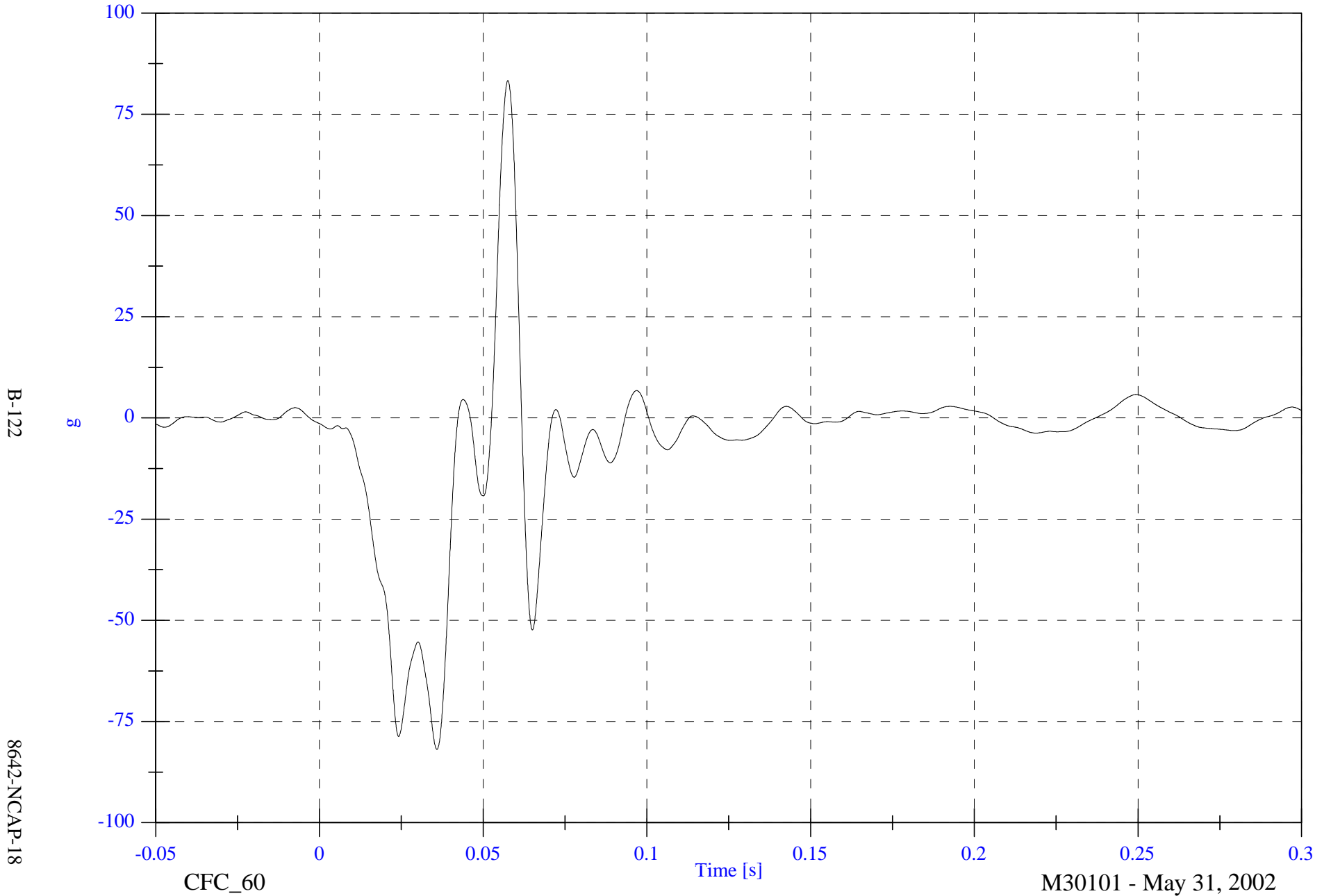

2002 NCAP Test 18 2003 Cadillac CTS

Max: 57.1 [kph] at -0.003 [s]

Min: -4.4 [kph] at 0.238 [s]

Right Caliper #5x Velocity

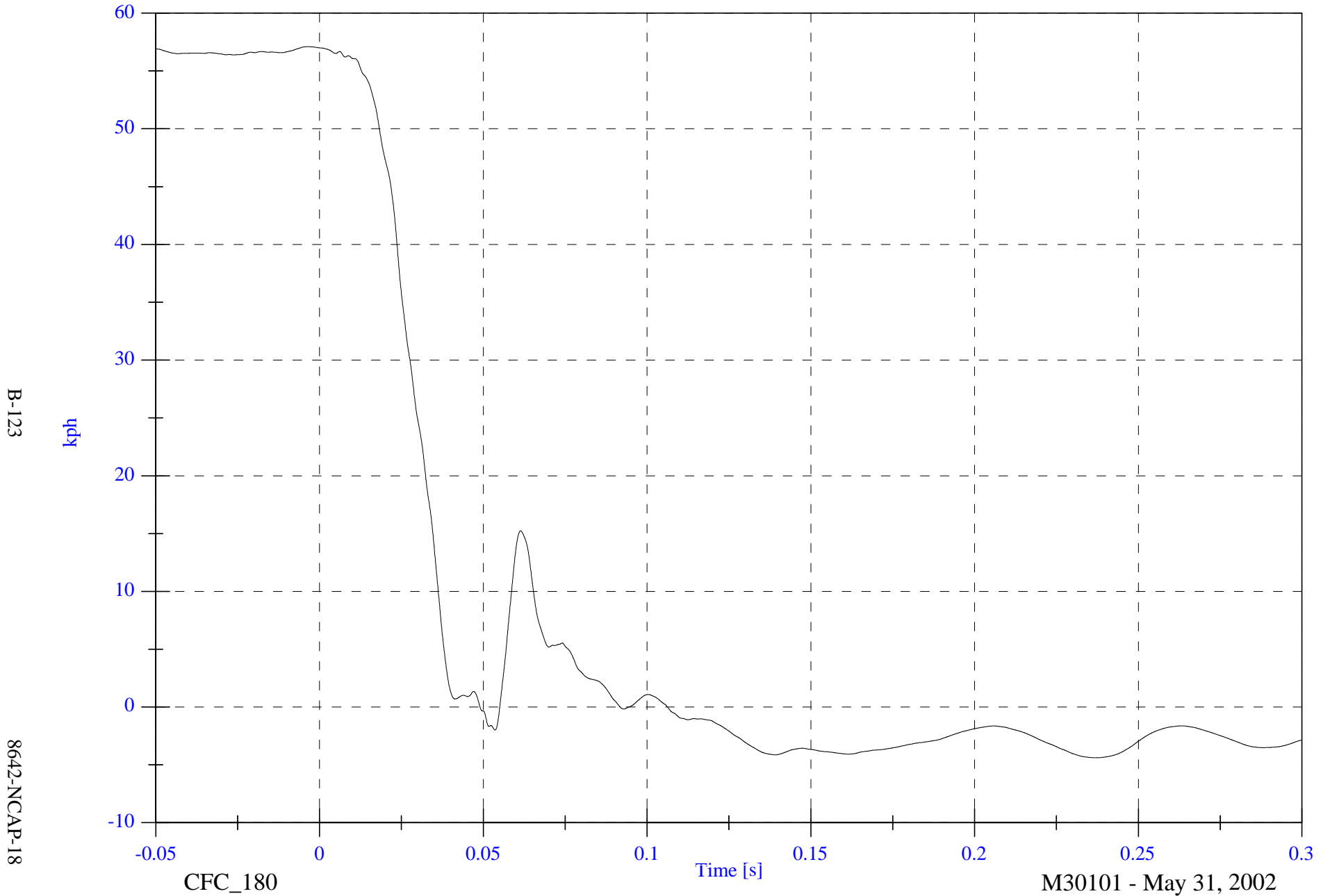

B-123

8642-NCAP-18

CFC_180

Time [s]

M30101 - May 31, 2002

2002 NCAP Test 18 2003 Cadillac CTS

Max: 502.9 [mm] at 0.106 [s]

Min: -786.7 [mm] at -0.050 [s]

Right Caliper #5x Displacement

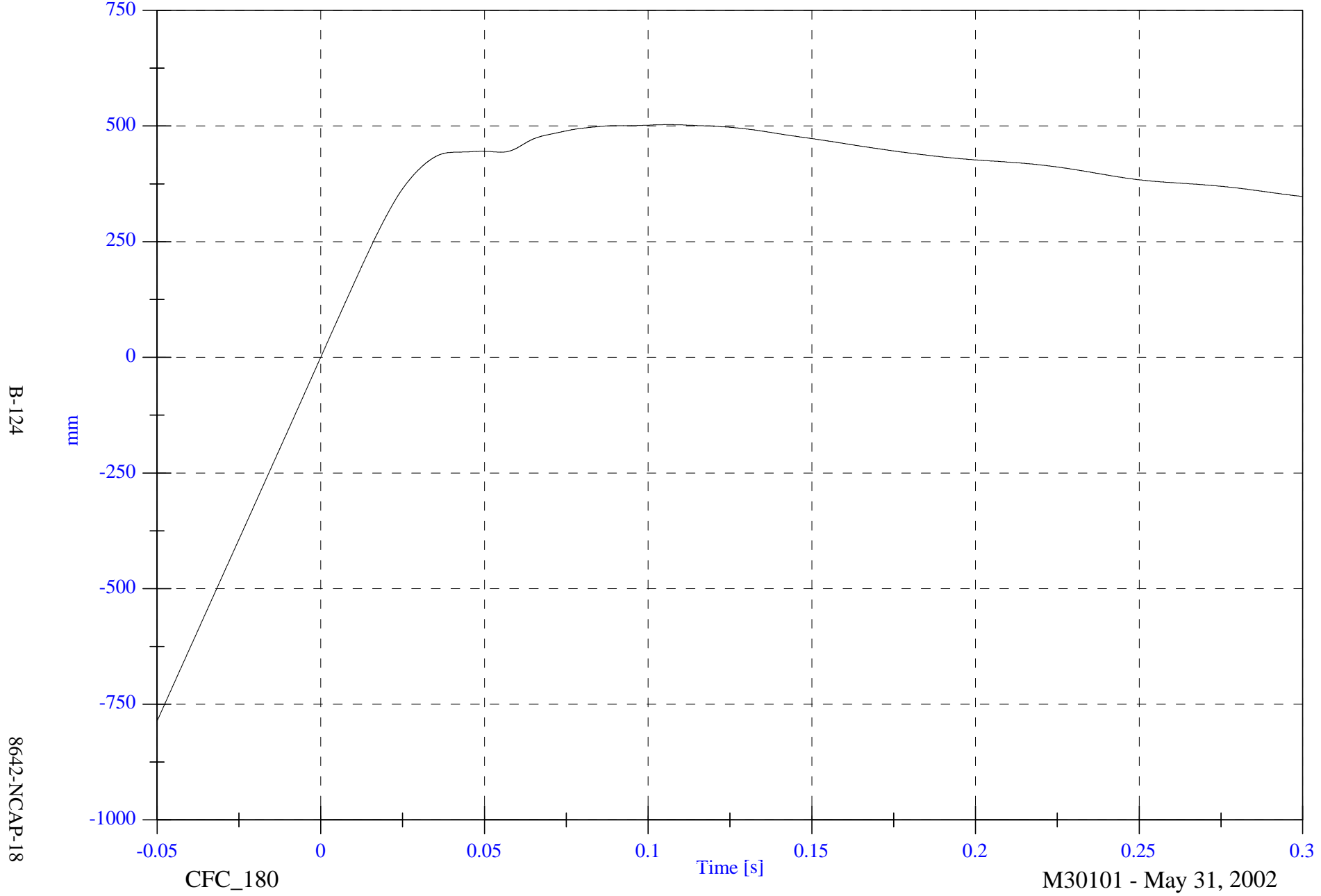

B-124

8642-NCAP-18

CFC_180

Time [s]

M30101 - May 31, 2002

2002 NCAP Test 18 2003 Cadillac CTS

Max: 19.8 [g] at 0.033 [s]

Min: -95.1 [g] at 0.056 [s]

Instrument Panel #6x

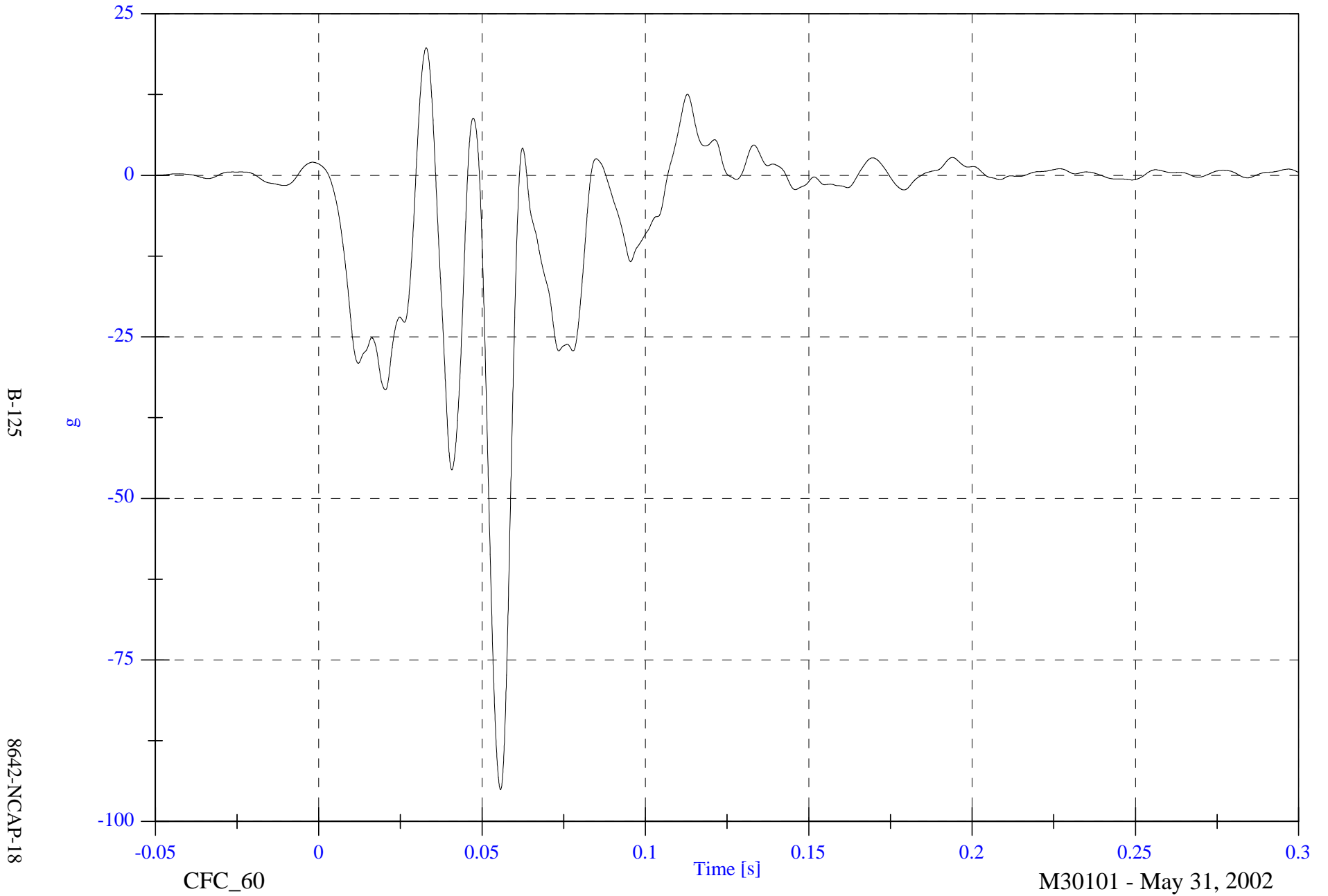

2002 NCAP Test 18 2003 Cadillac CTS

Max: 57.0 [kph] at -0.019 [s]

Instrument Panel #6x Velocity

Min: -8.2 [kph] at 0.106 [s]

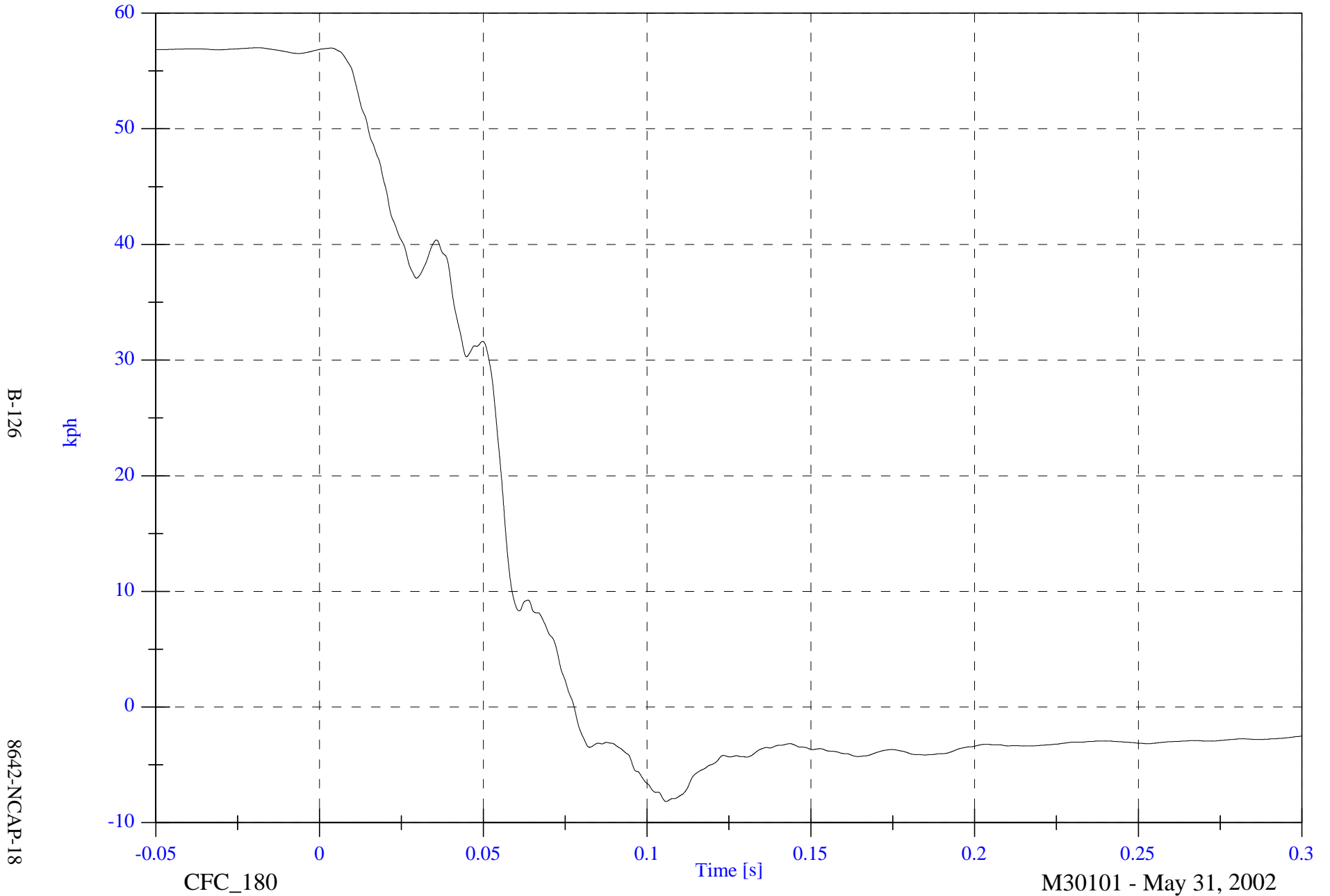

2002 NCAP Test 18 2003 Cadillac CTS

Max: 693.6 [mm] at 0.078 [s]

Min: -789.3 [mm] at -0.050 [s]

Instrument Panel #6x Displacement

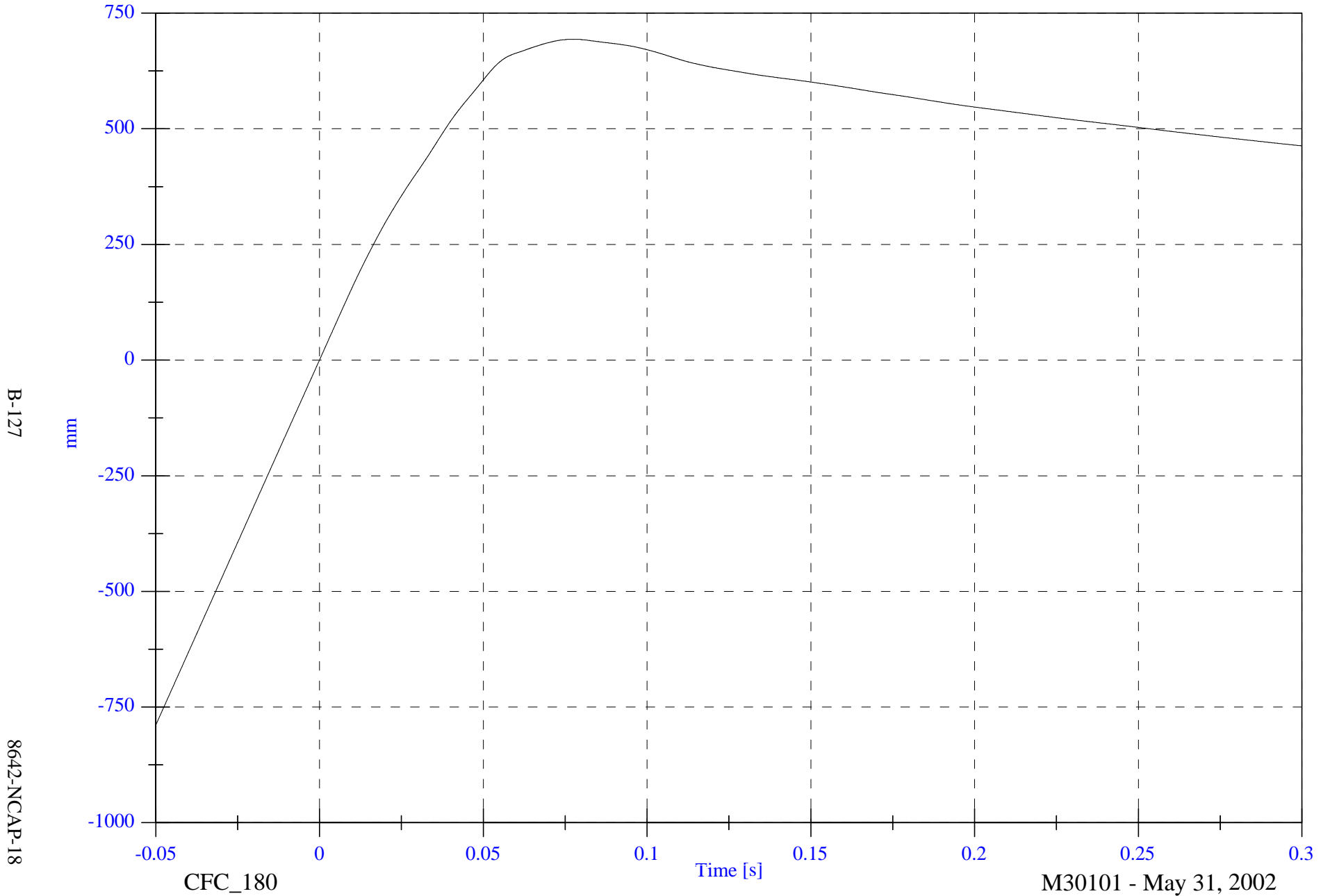

B-127

8642-NCAP-18

CFC_180

Time [s]

M30101 - May 31, 2002

2002 NCAP Test 18 2003 Cadillac CTS

Left Caliper #7x

Max: 38.5 [g] at 0.057 [s]

Min: -116.8 [g] at 0.037 [s]

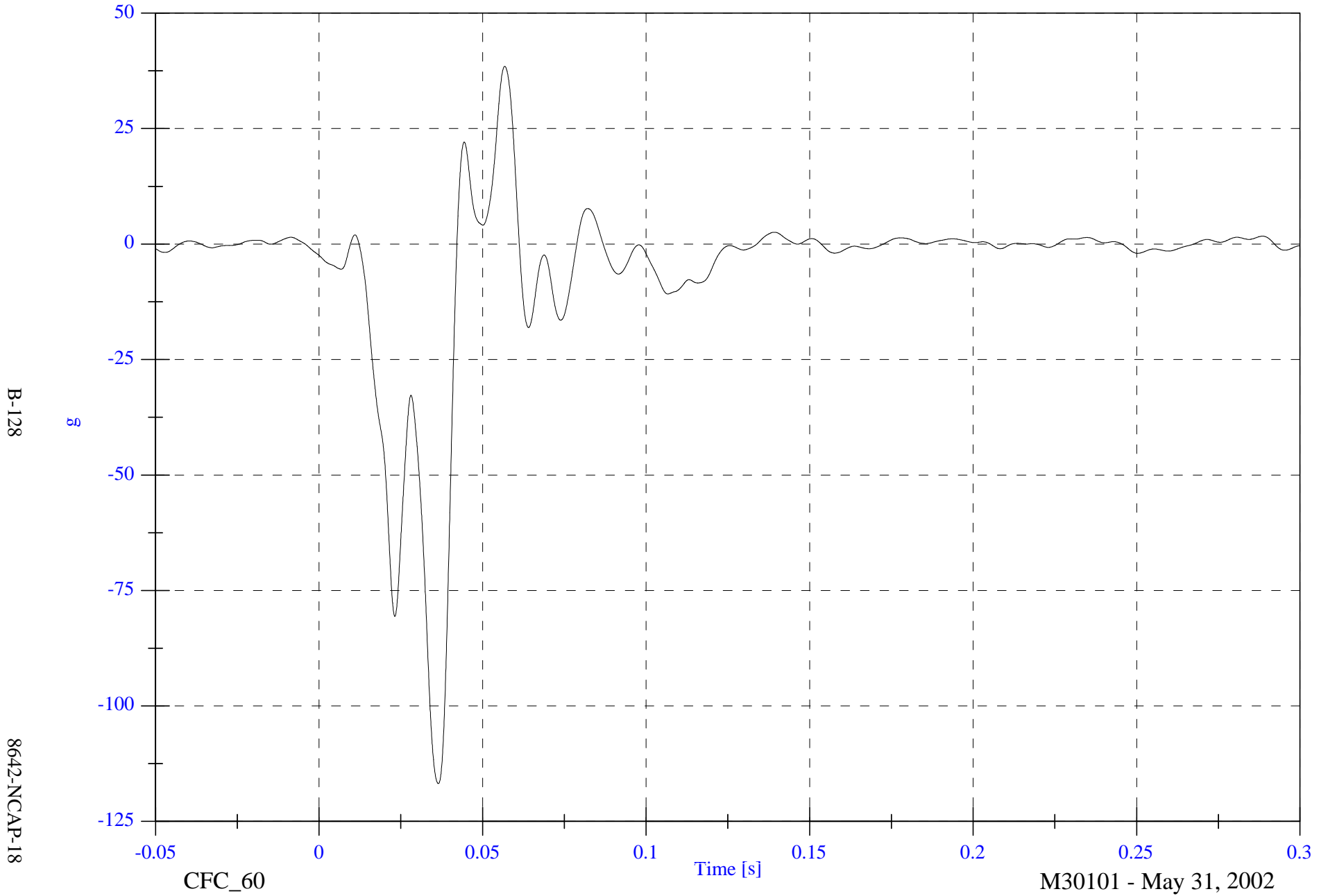

2002 NCAP Test 18 2003 Cadillac CTS

Max: 56.9 [kph] at -0.003 [s]

Min: -5.4 [kph] at 0.135 [s]

Left Caliper #7x Velocity

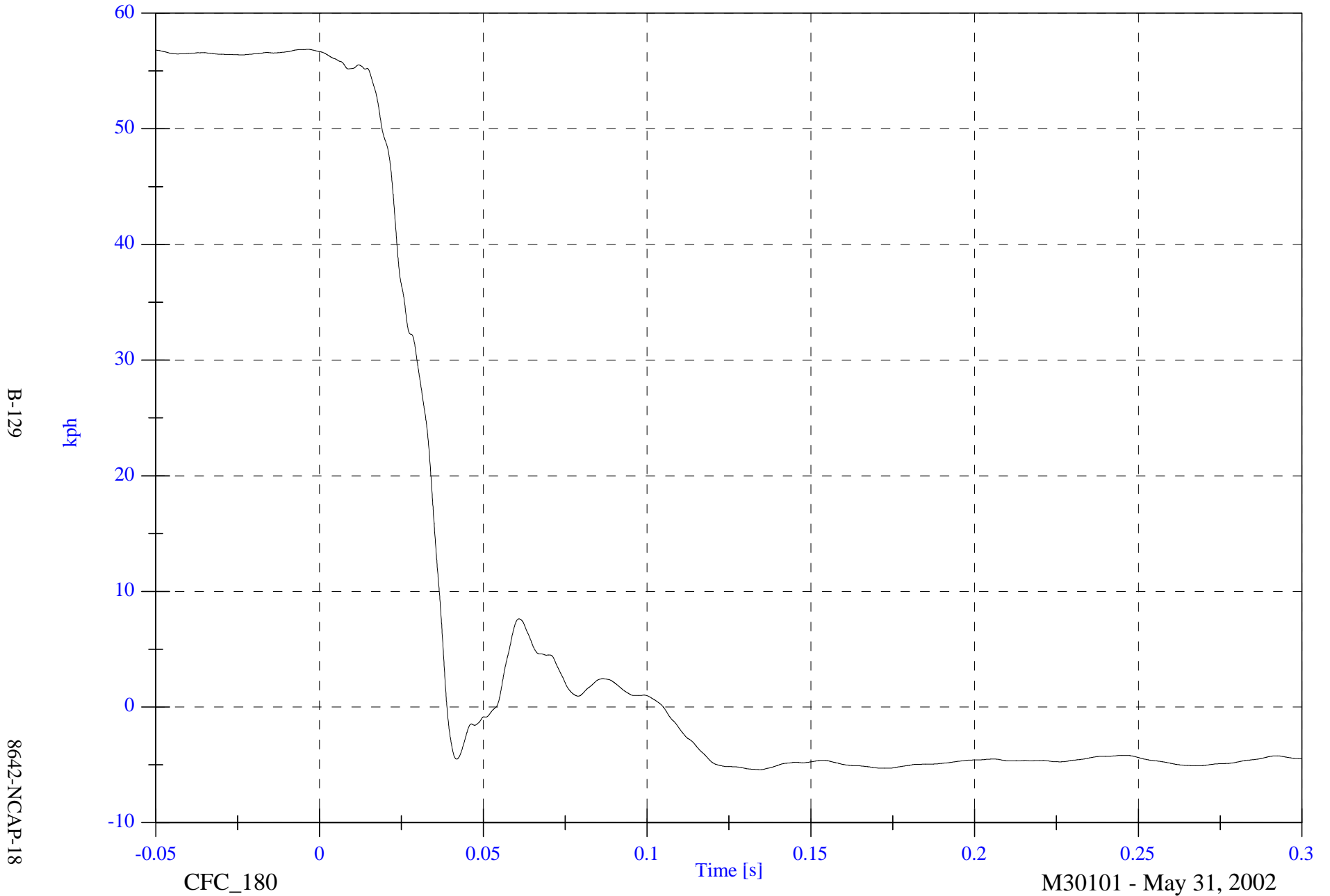

B-129

8642-NCAP-18

CFC_180

Time [s]

M30101 - May 31, 2002

2002 NCAP Test 18 2003 Cadillac CTS

Max: 484.1 [mm] at 0.105 [s]

Min: -785.8 [mm] at -0.050 [s]

Left Caliper #7x Displacement

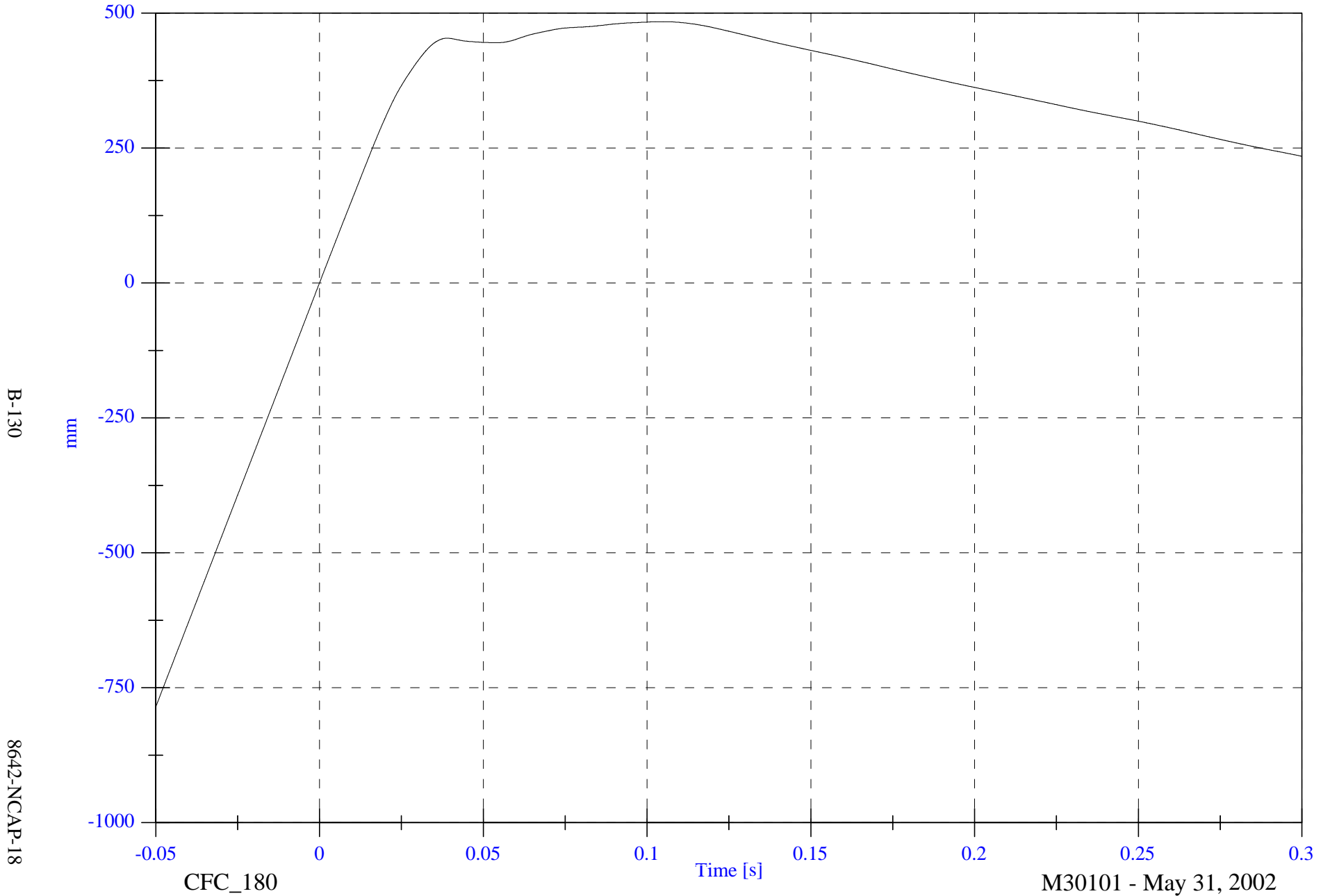

B-130

8642-NCAP-18

CFC_180

Time [s]

M30101 - May 31, 2002

2002 NCAP Test 18 2003 Cadillac CTS

Max: 55.1 [g] at 0.101 [s]
Min: -5.4 [g] at 0.074 [s]

Left Rear #8z

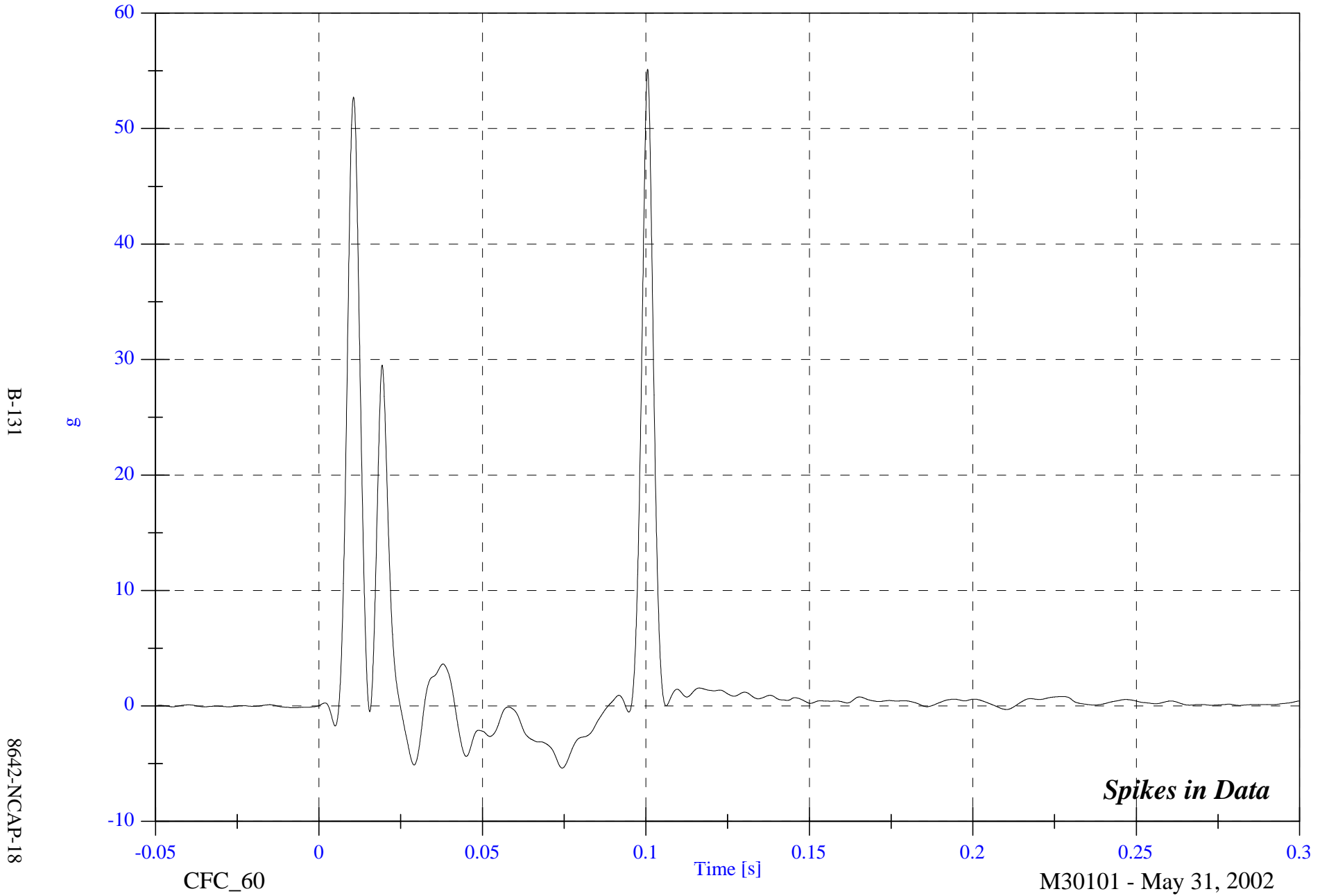

2002 NCAP Test 18 2003 Cadillac CTS

Max: 19.1 [kph] at 0.300 [s]

Left Rear #8z Velocity

Min: -0.2 [kph] at 0.008 [s]

B-132

8642-NCAP-18

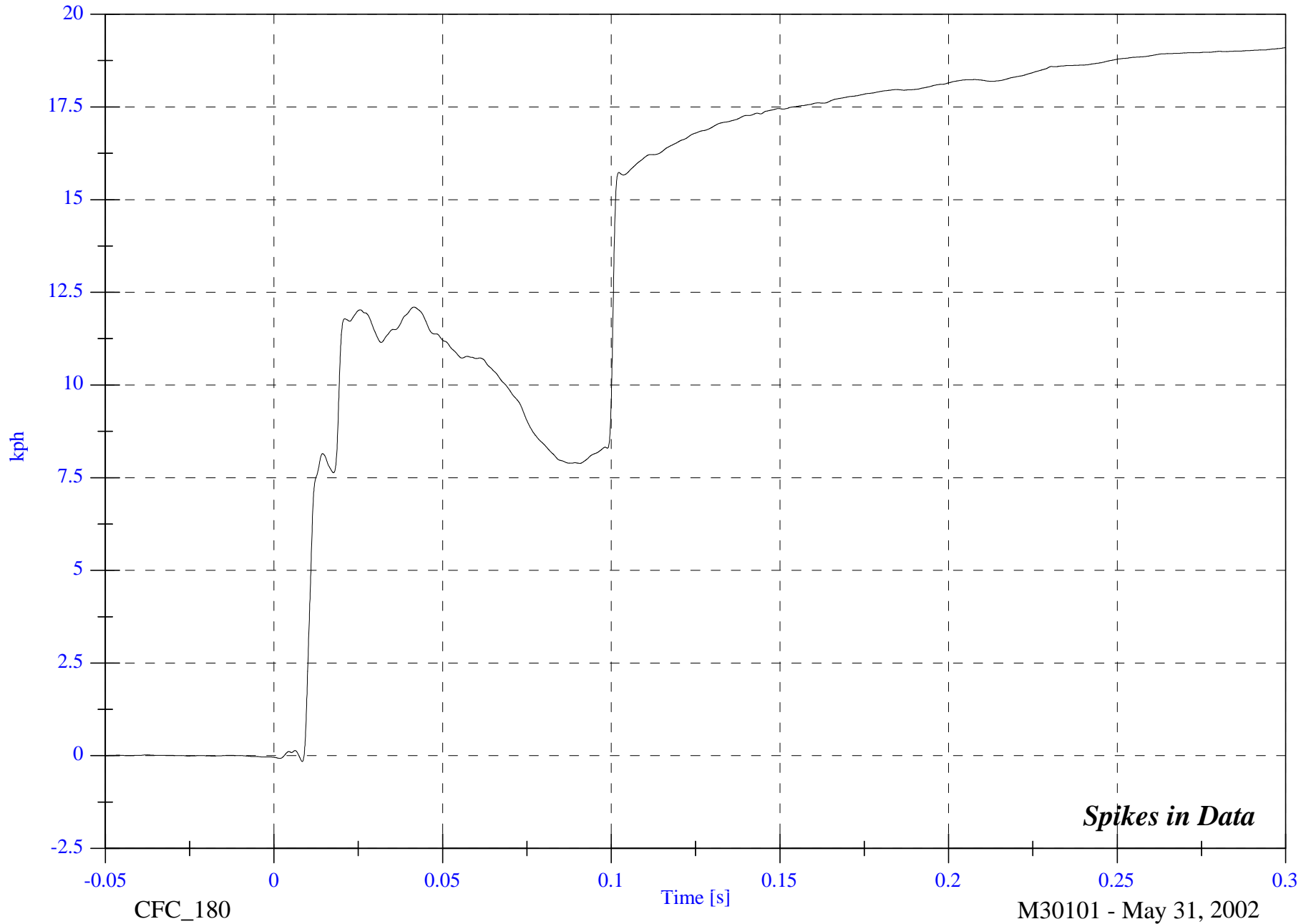

Spikes in Data

CFC_180

Time [s]

M30101 - May 31, 2002

2002 NCAP Test 18 2003 Cadillac CTS

Max: 1244.6 [mm] at 0.300 [s]

Min: -0.0 [mm] at 0.003 [s]

Left Rear #8z Displacement

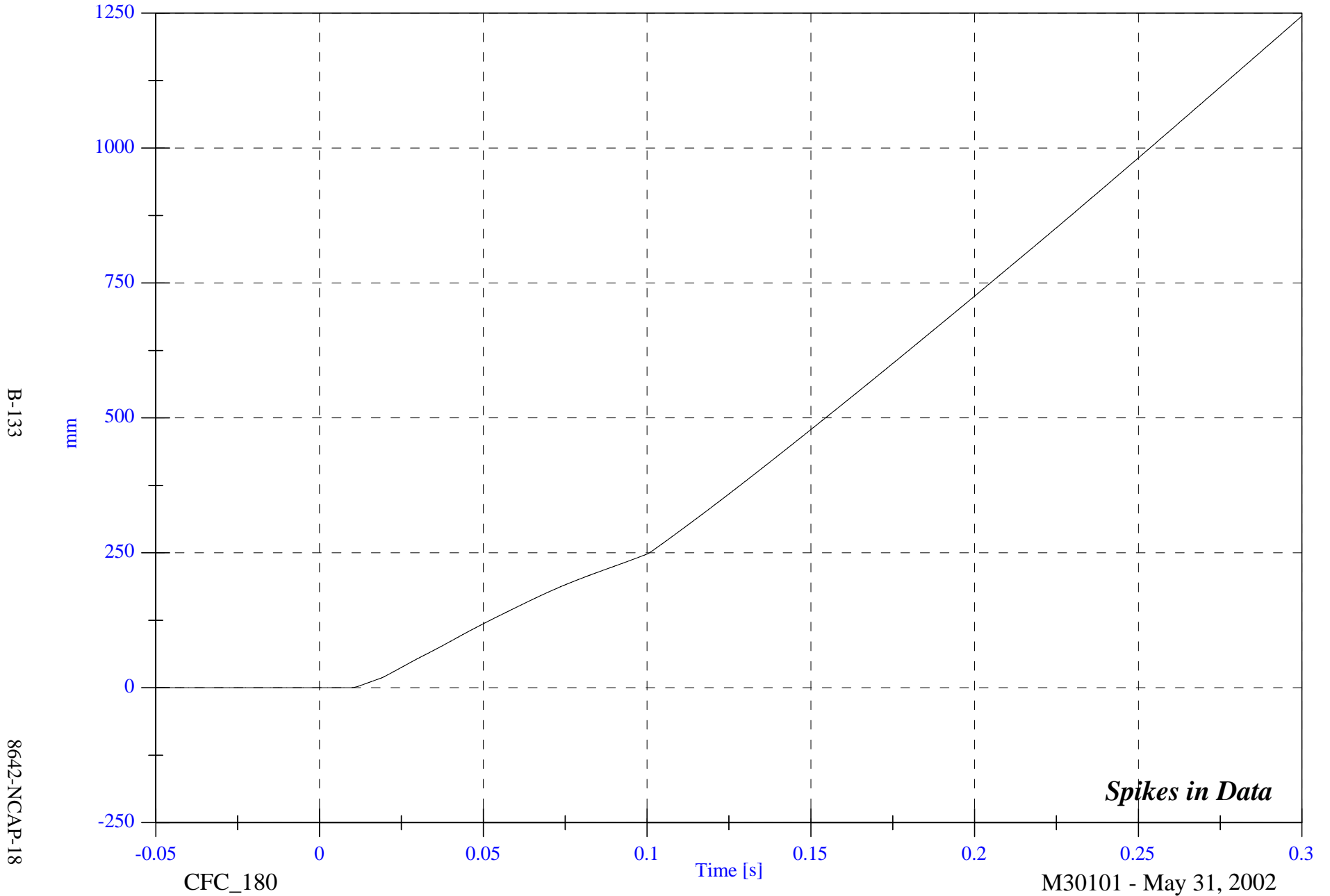

B-133

8642-NCAP-18

CFC_180

Time [s]

M30101 - May 31, 2002

Spikes in Data

2002 NCAP Test 18 2003 Cadillac CTS

Right Rear #9z

Max: 18.5 [g] at 0.126 [s]
Min: -520.4 [g] at 0.118 [s]

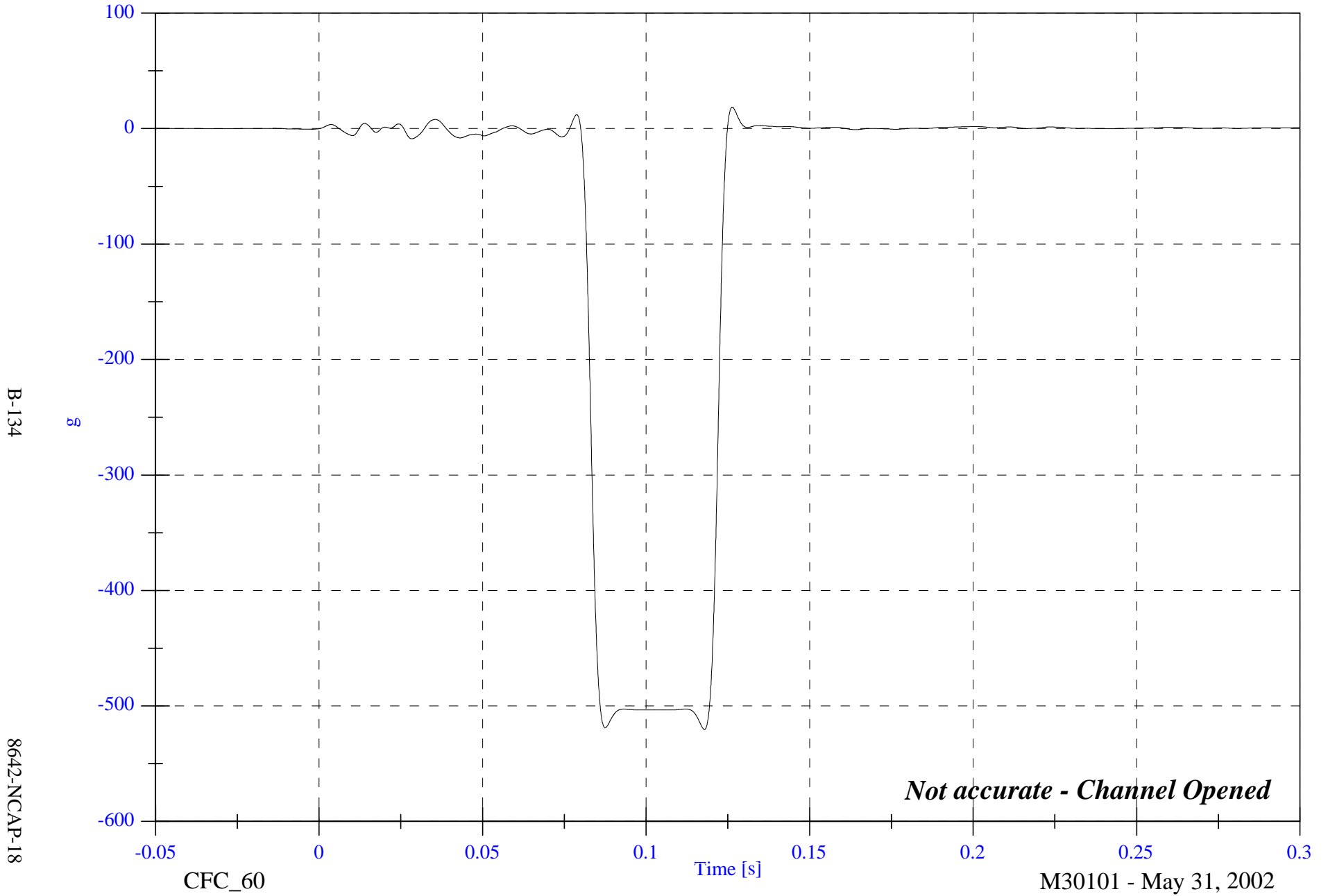

2002 NCAP Test 18 2003 Cadillac CTS

Max: 0.4 [kph] at 0.026 [s]

Min: -699.5 [kph] at 0.123 [s]

Right Rear #9z Velocity

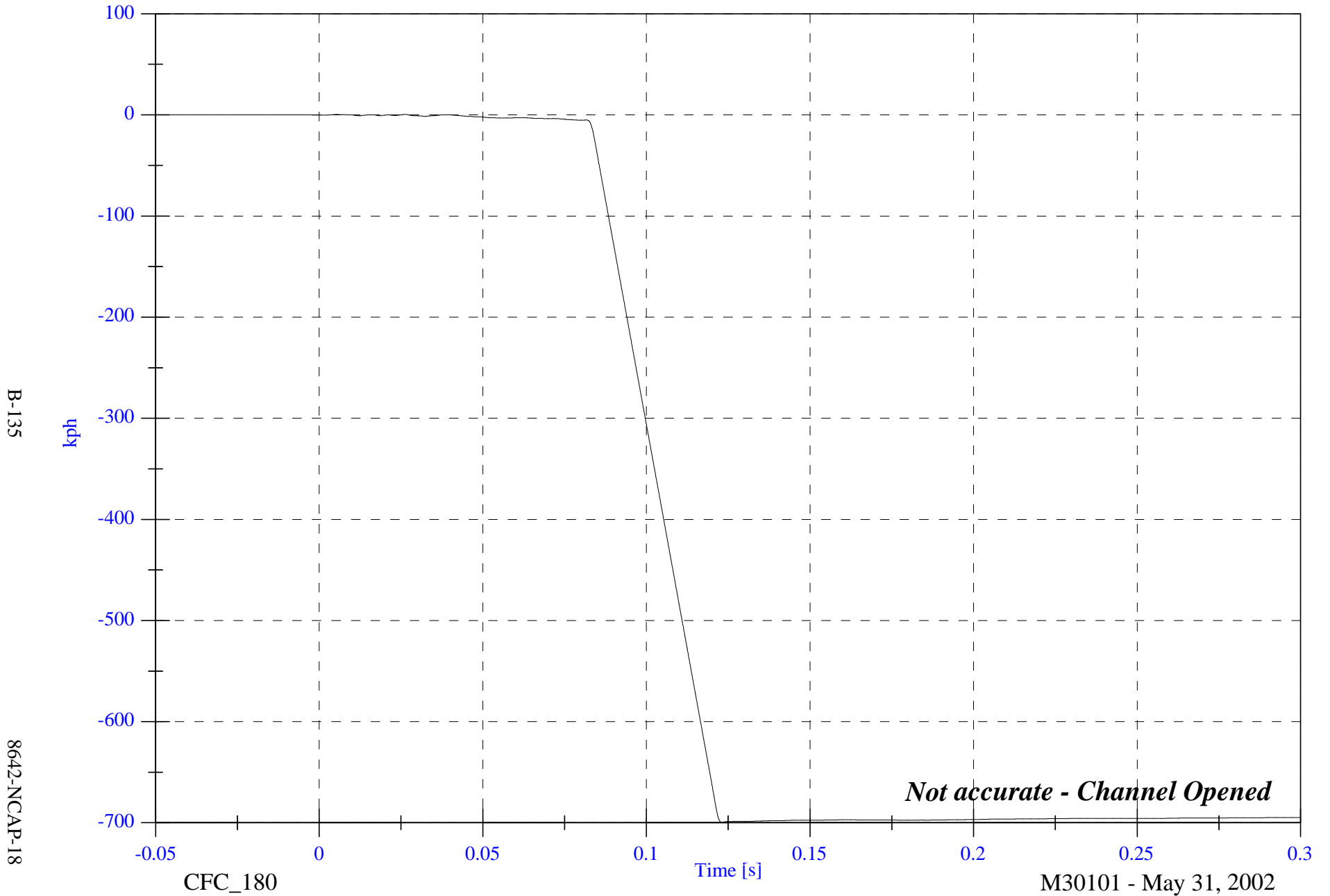

B-135

8642-NCAP-18

CFC_180

Time [s]

M30101 - May 31, 2002

Not accurate - Channel Opened

2002 NCAP Test 18 2003 Cadillac CTS

Max: 0.2 [mm] at -0.026 [s]
Min: -38263.7 [mm] at 0.300 [s]

Right Rear #9z Displacement

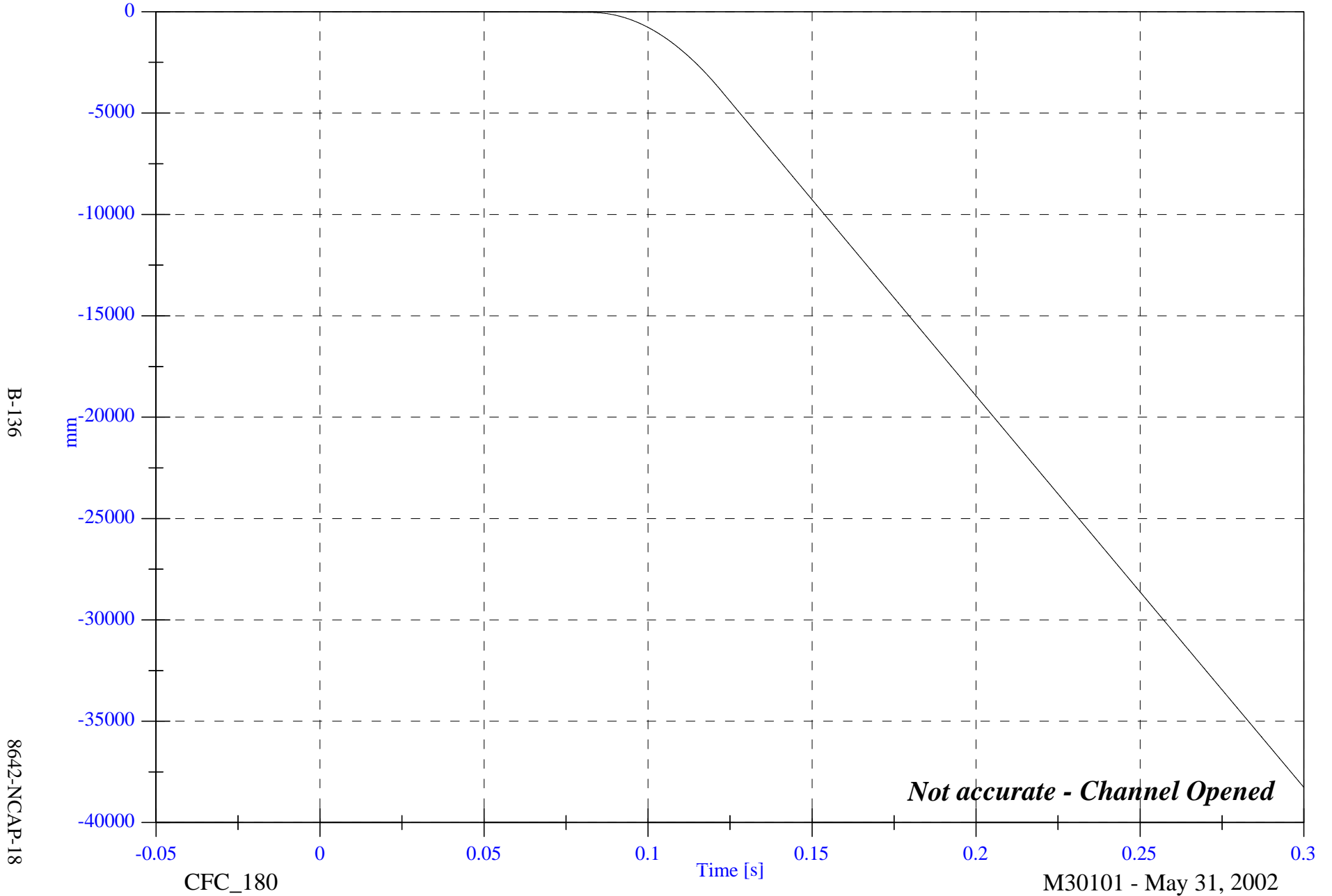

B-136

8642-NCAP-18

CFC_180

Time [s]

M30101 - May 31, 2002

NCAP Test 18- 2003 Cadillac CTS

Barrier Load Cell A1 Fx

Max: 2541.5 [N] at 0.031 [S]

Min: -715.1 [N] at 0.020 [S]

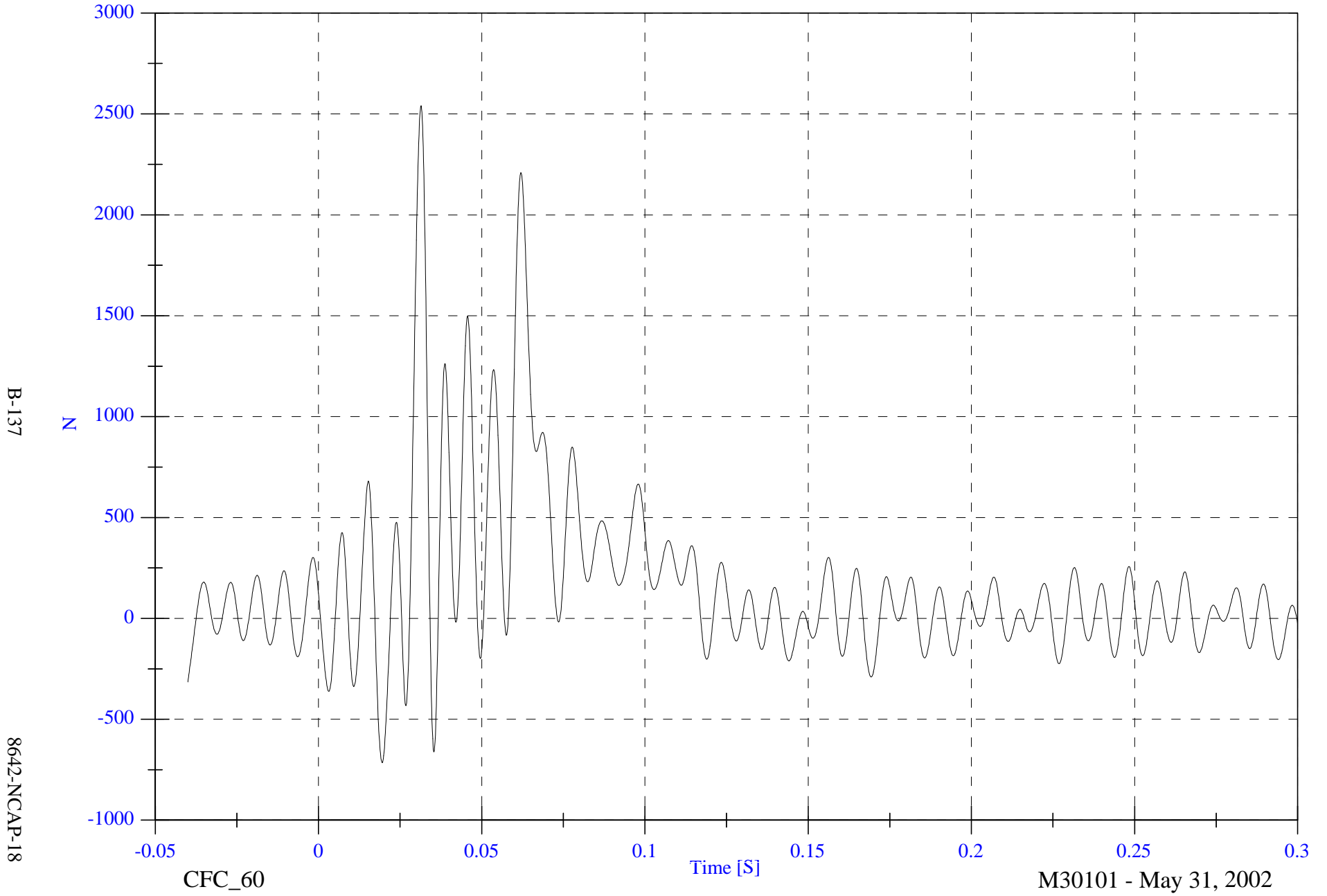

NCAP Test 18- 2003 Cadillac CTS

Barrier Load Cell A2 Fx

Max: 7365.8 [N] at 0.039 [S]

Min: -534.7 [N] at 0.002 [S]

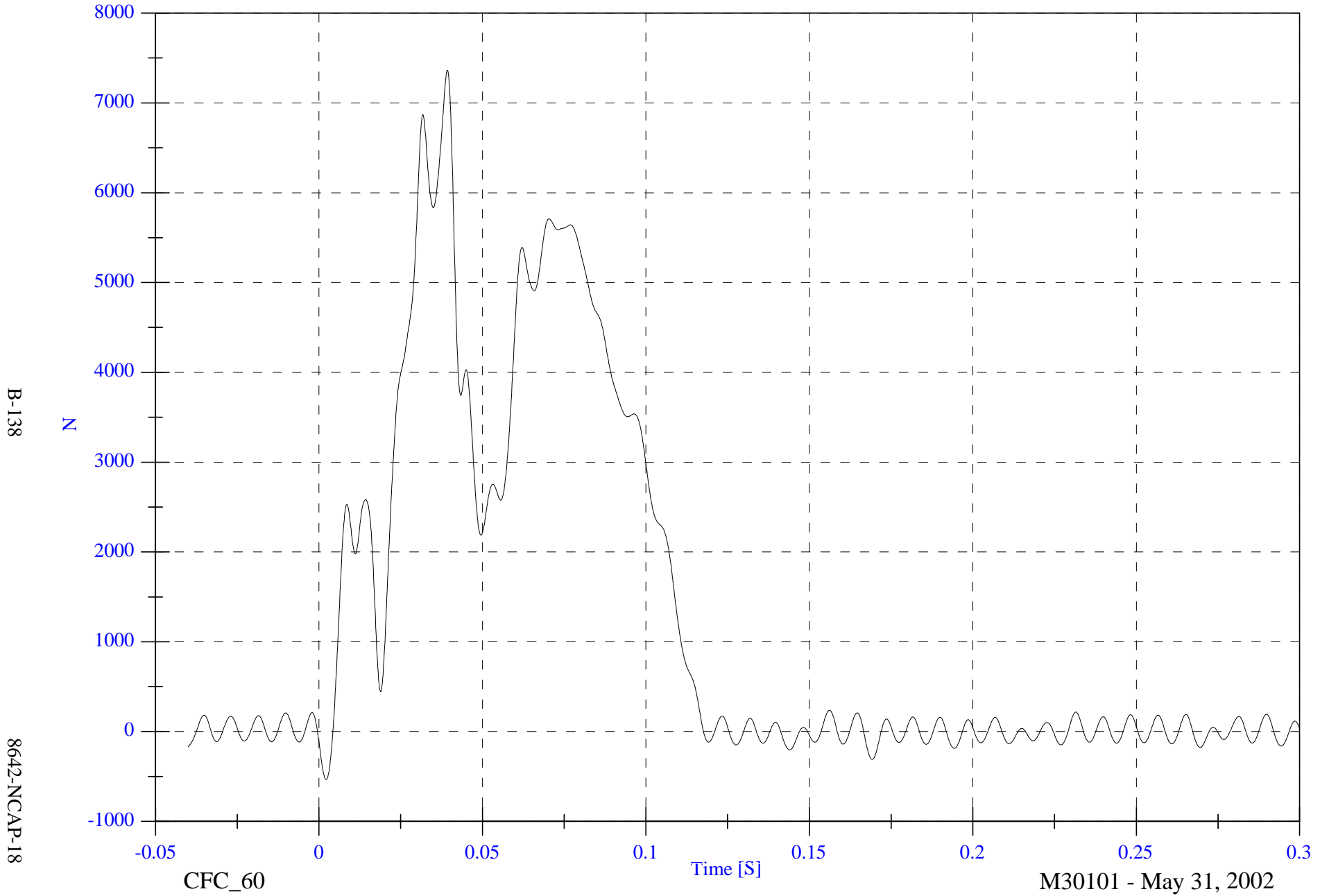

B-138

8642-NCAP-18

CFC_60

Time [S]

M30101 - May 31, 2002

NCAP Test 18- 2003 Cadillac CTS

Barrier Load Cell A3 Fx

Max: 10835.7 [N] at 0.039 [S]

Min: -1507.4 [N] at 0.019 [S]

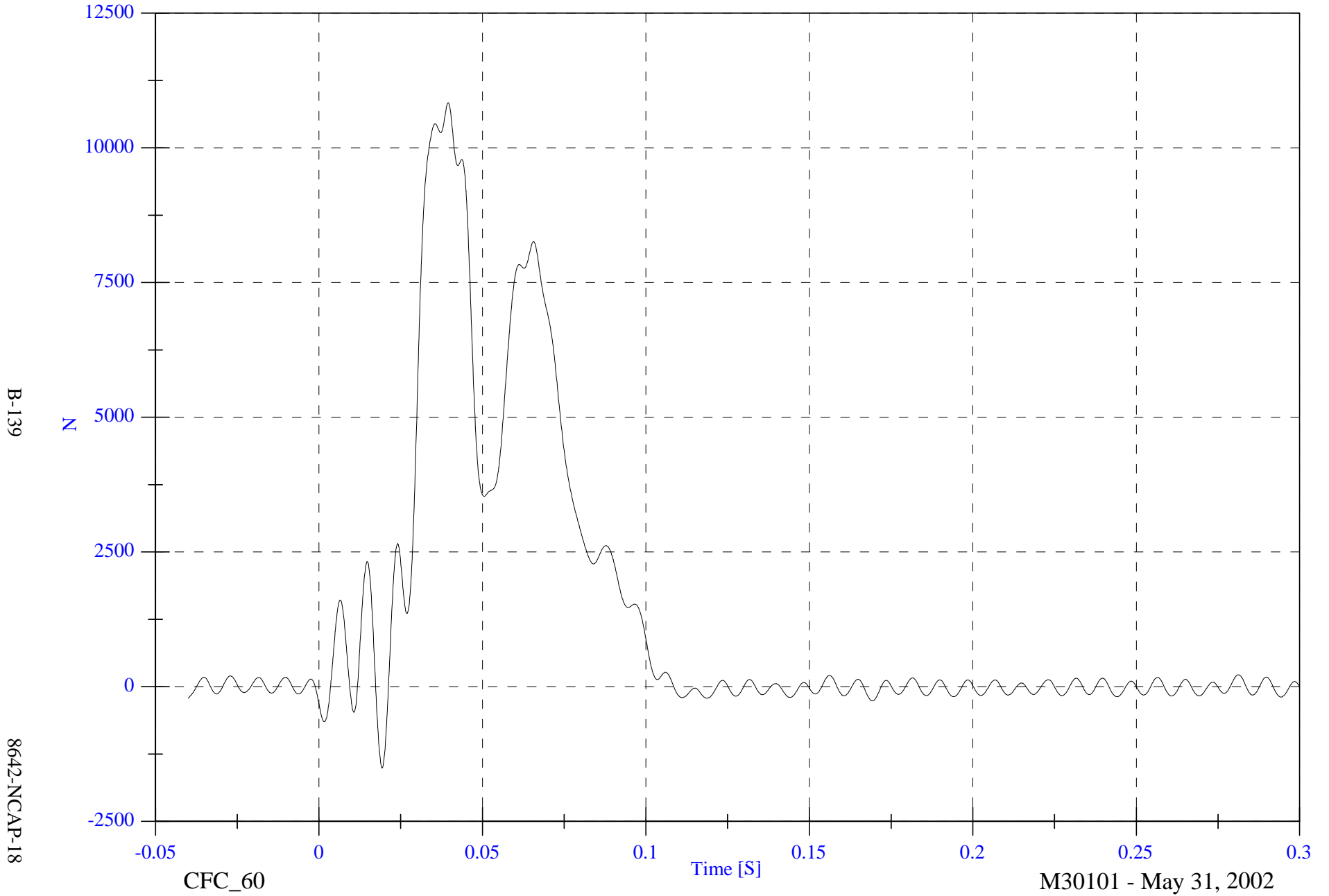

NCAP Test 18- 2003 Cadillac CTS

Barrier Load Cell A4 Fx

Max: 69463.3 [N] at 0.034 [S]

Min: -1529.3 [N] at 0.017 [S]

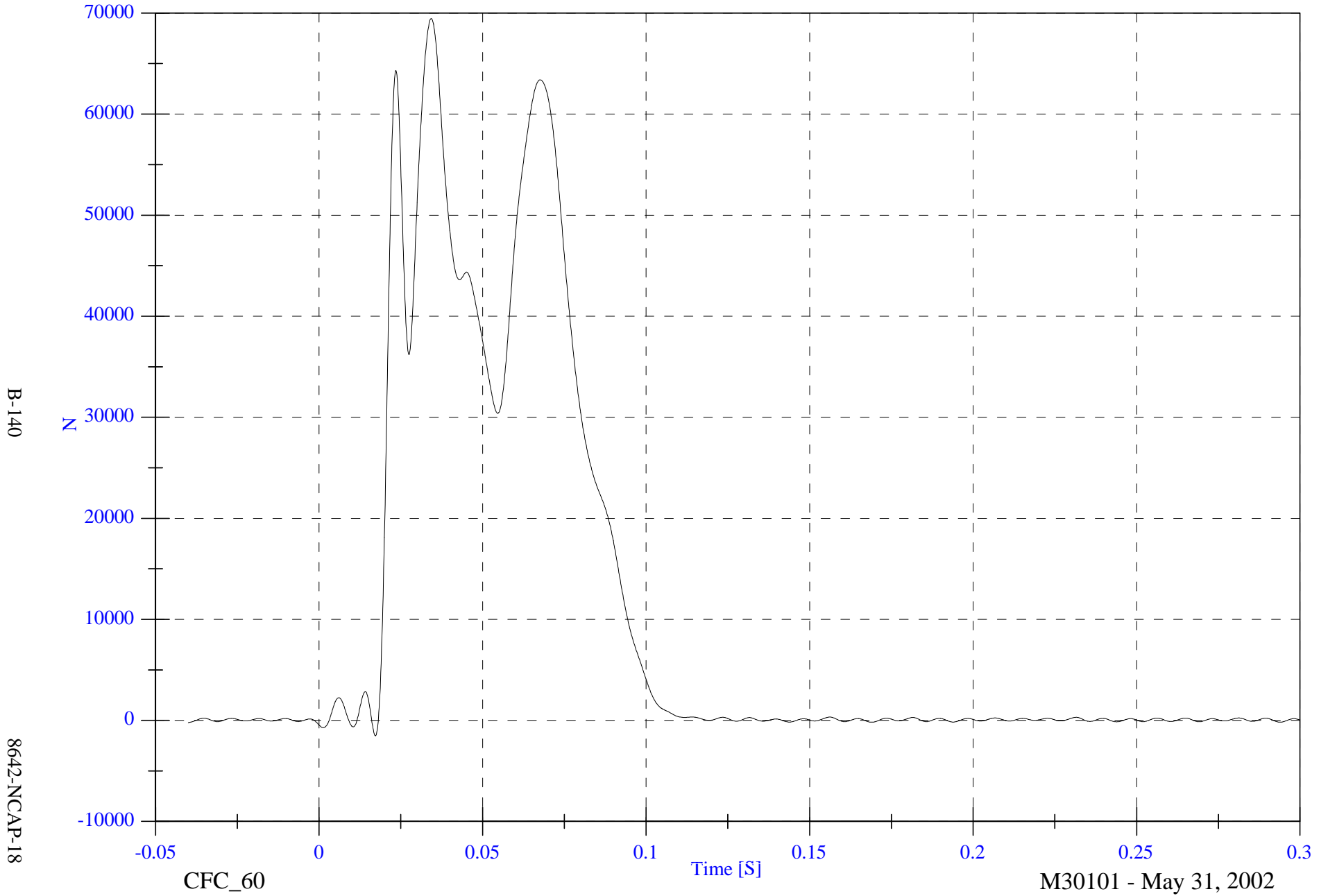

NCAP Test 18- 2003 Cadillac CTS

Barrier Load Cell A5 Fx

Max: 28866.4 [N] at 0.038 [S]

Min: -3209.2 [N] at 0.029 [S]

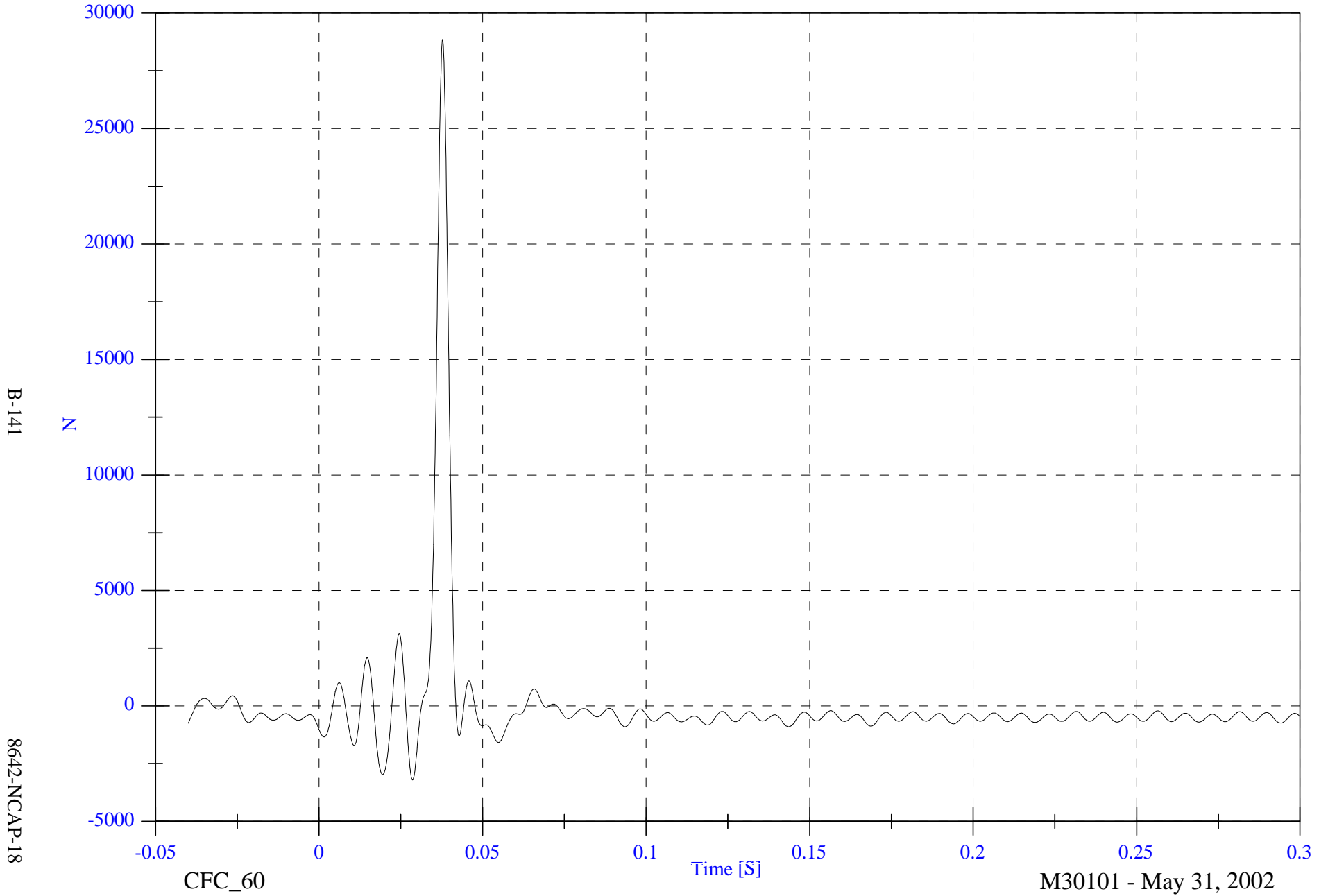

NCAP Test 18- 2003 Cadillac CTS

Barrier Load Cell A6 Fx

Max: 63079.4 [N] at 0.024 [S]

Min: -742.1 [N] at 0.001 [S]

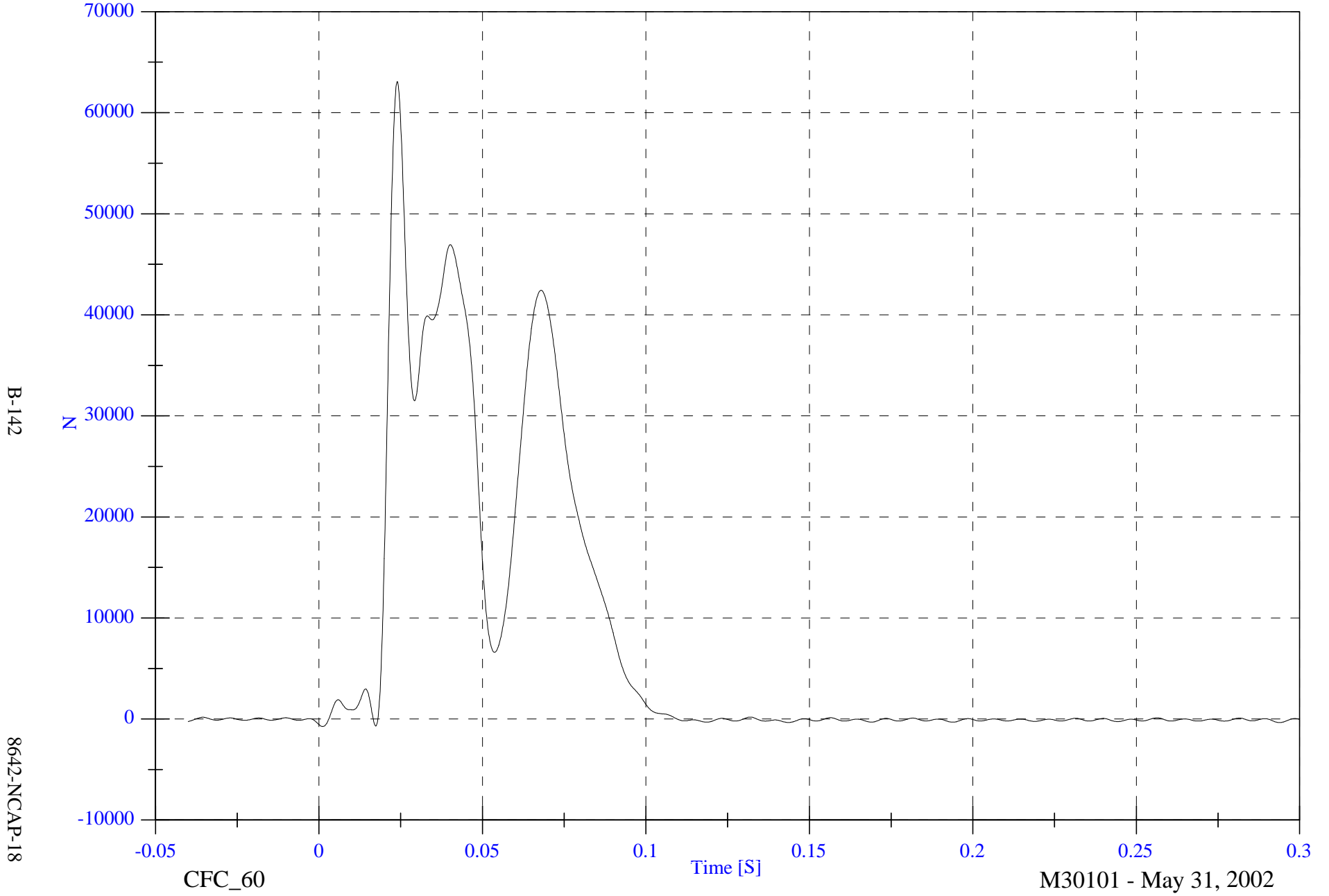

B-142

8642-NCAP-18

CFC_60

Time [S]

M30101 - May 31, 2002

NCAP Test 18- 2003 Cadillac CTS

Barrier Load Cell A7 Fx

Max: 3569.5 [N] at 0.032 [S]

Min: -1159.3 [N] at 0.019 [S]

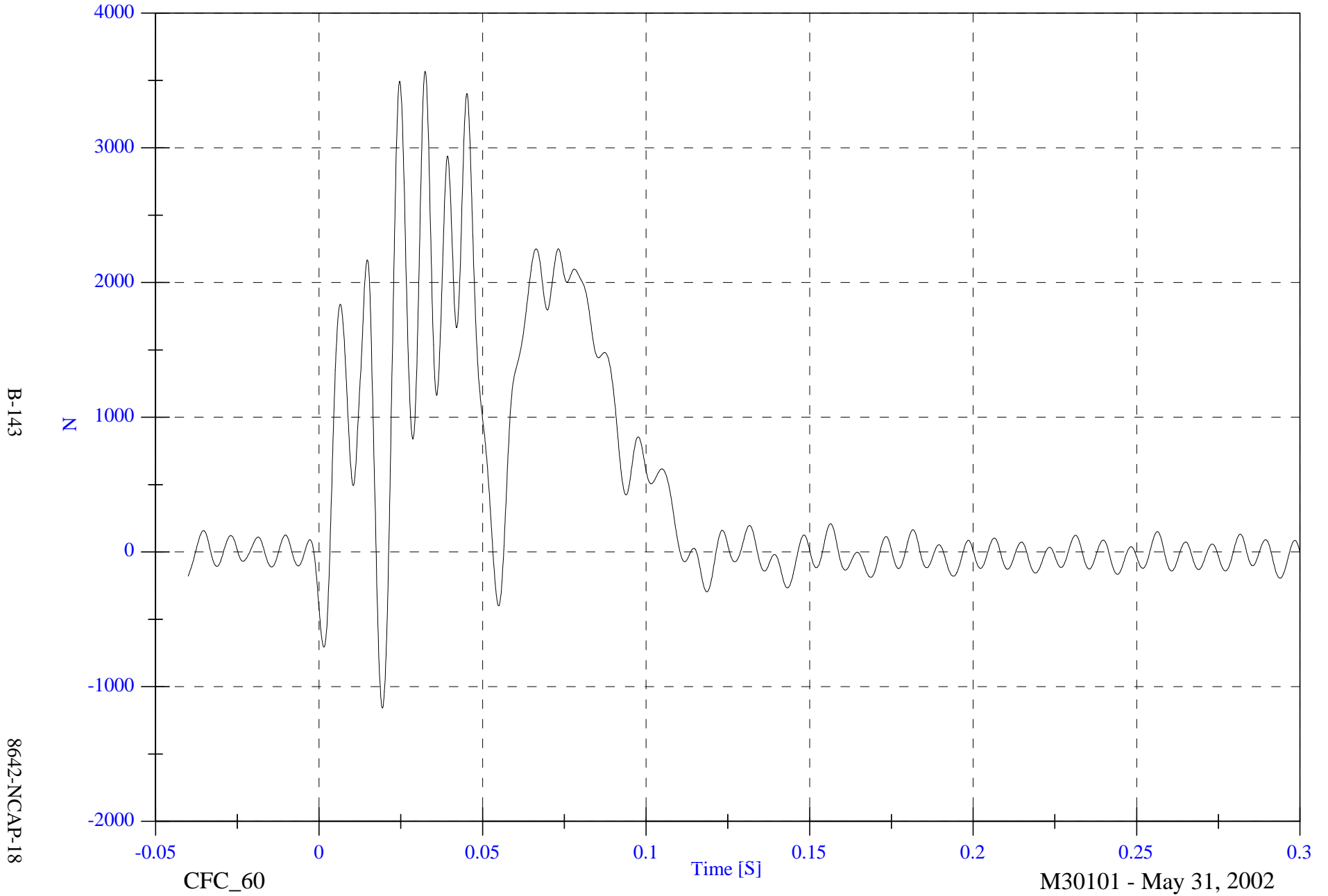

B-143

8642-NCAP-18

CFC_60

Time [S]

M30101 - May 31, 2002

NCAP Test 18- 2003 Cadillac CTS

Barrier Load Cell A8 Fx

Max: 12757.6 [N] at 0.063 [S]

Min: -643.3 [N] at 0.002 [S]

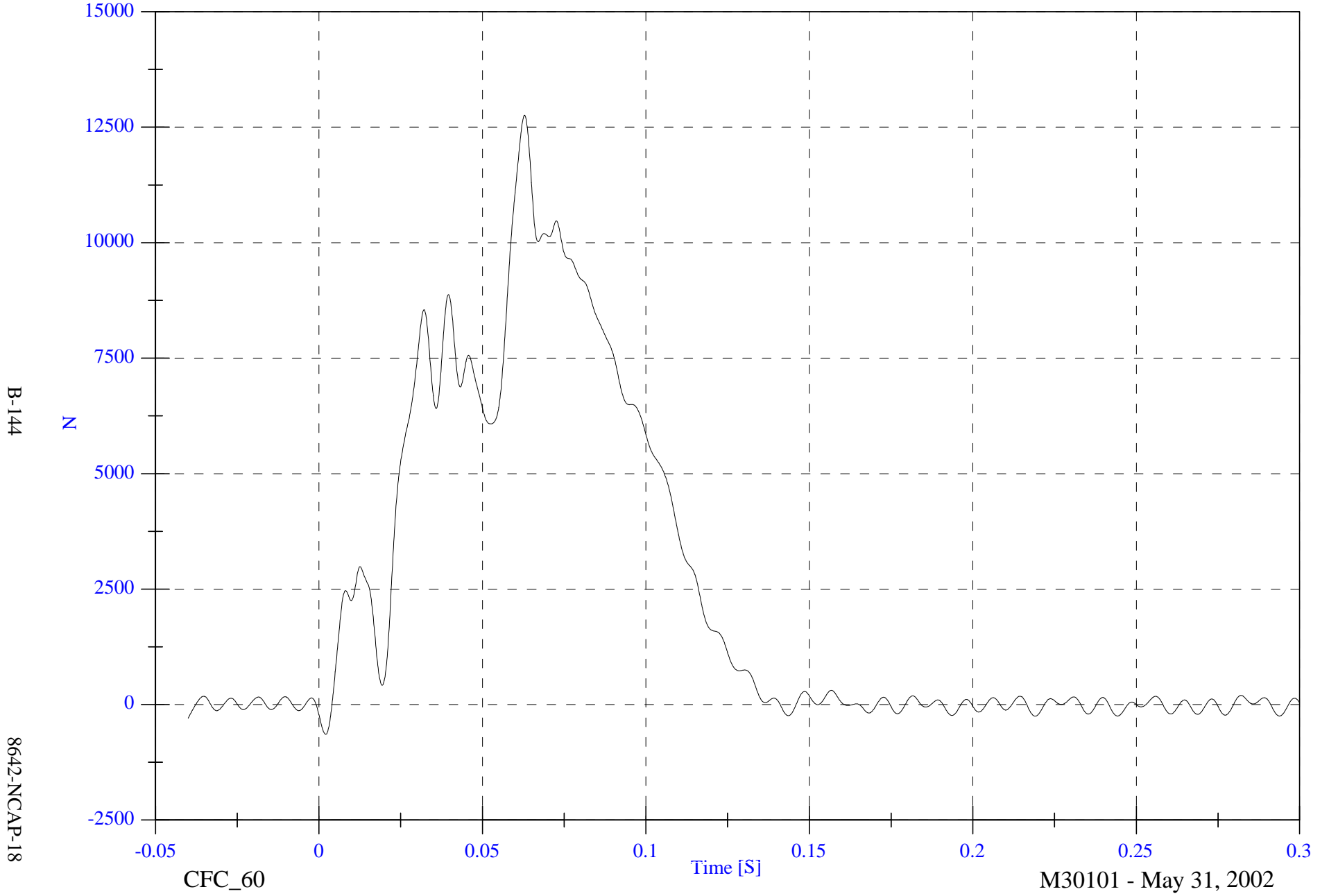

B-144

8642-NCAP-18

CFC_60

Time [S]

M30101 - May 31, 2002

NCAP Test 18- 2003 Cadillac CTS

Barrier Load Cell A9 Fx

Max: 1661.8 [N] at 0.031 [S]

Min: -2227.6 [N] at 0.036 [S]

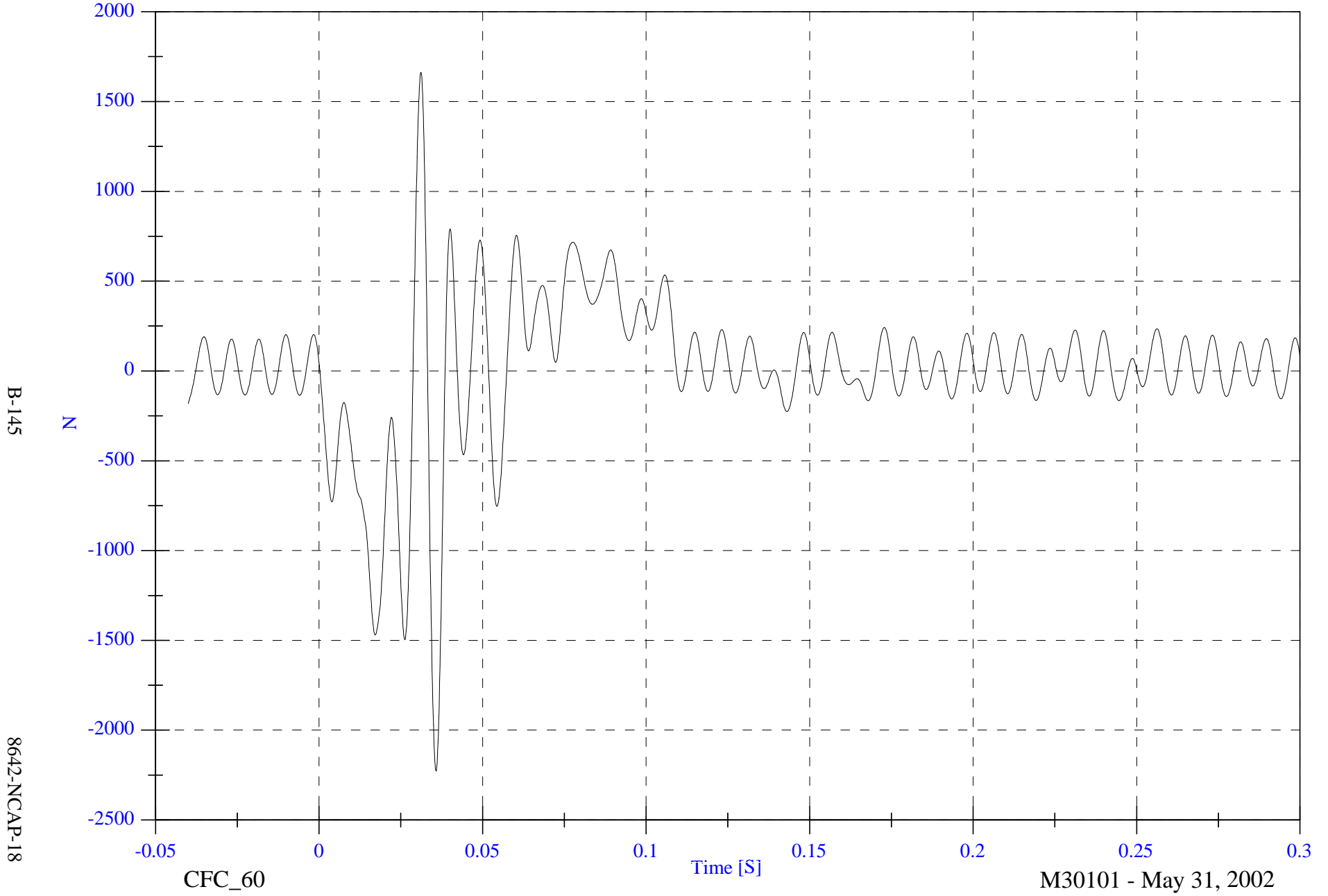

B-145

8642-NCAP-18

CFC_60

Time [S]

M30101 - May 31, 2002

NCAP Test 18- 2003 Cadillac CTS

Barrier Load Cell B1 Fx

Max: 1368.3 [N] at 0.062 [S]

Min: -786.1 [N] at 0.035 [S]

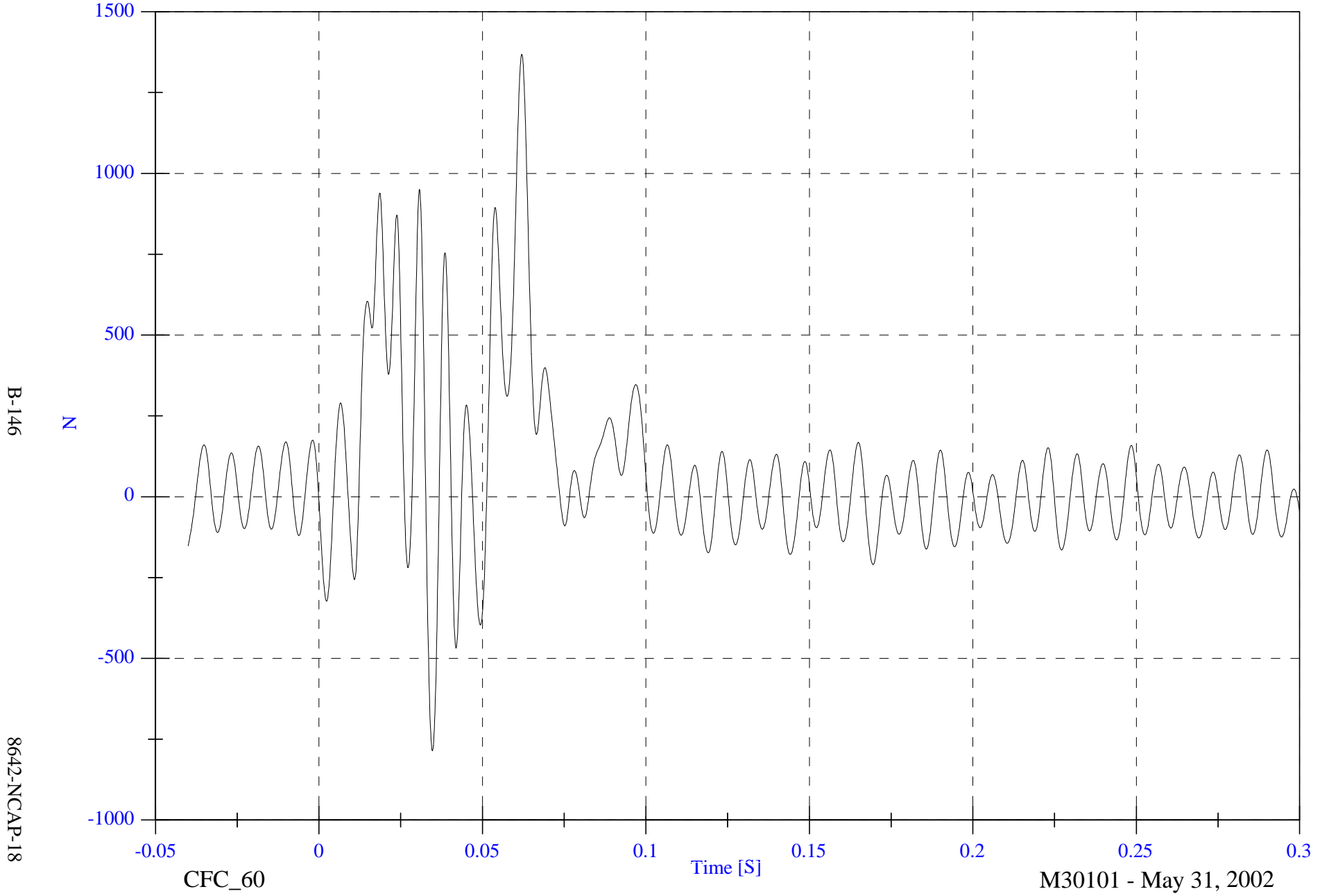

NCAP Test 18- 2003 Cadillac CTS

Barrier Load Cell B2 Fx

Max: 6720.2 [N] at 0.031 [S]

Min: -379.4 [N] at 0.002 [S]

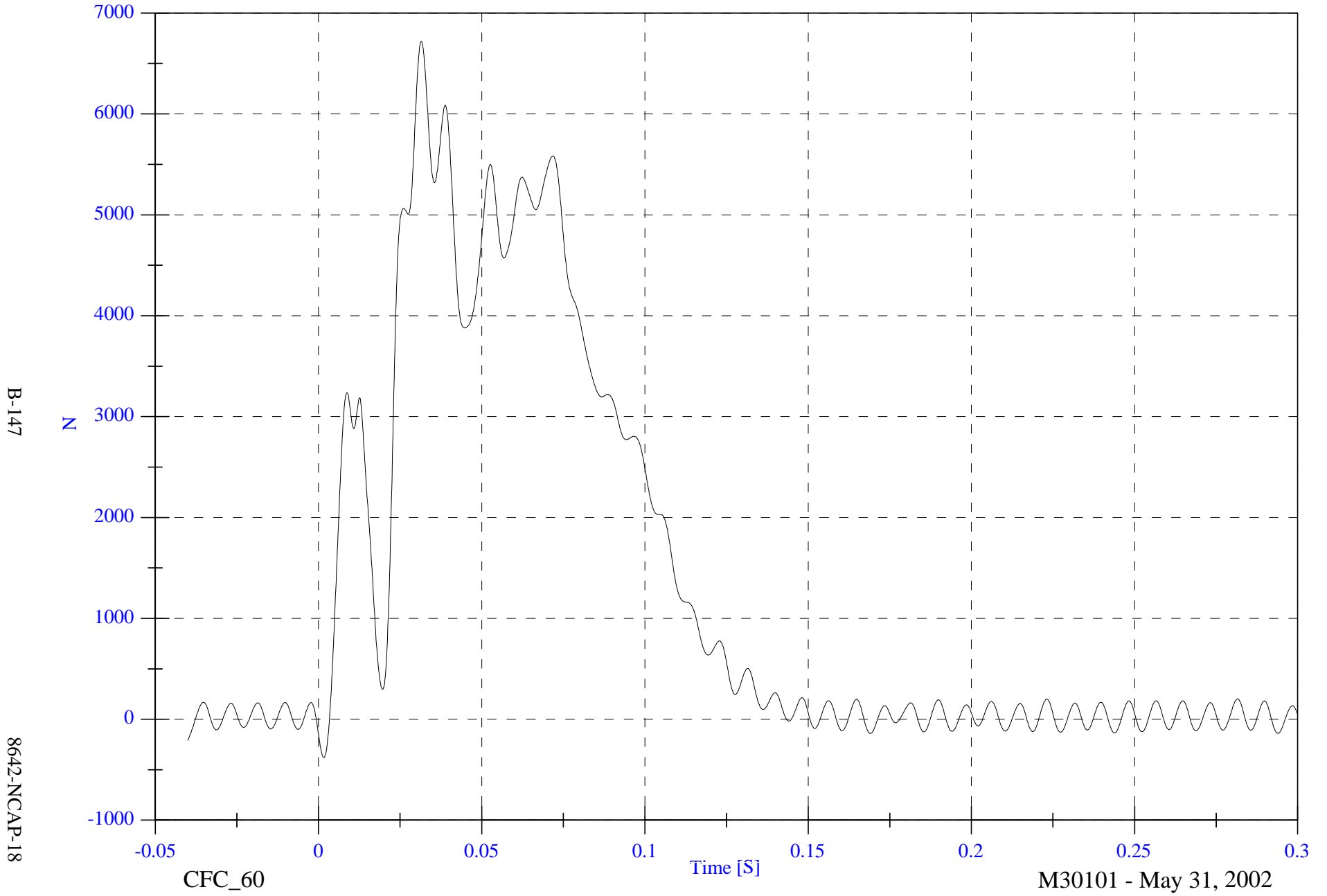

B-147

8642-NCAP-18

CFC_60

Time [S]

M30101 - May 31, 2002

NCAP Test 18- 2003 Cadillac CTS

Barrier Load Cell B3 Fx

Max: 103408.7 [N] at 0.024 [S]

Min: -1261.8 [N] at -0.001 [S]

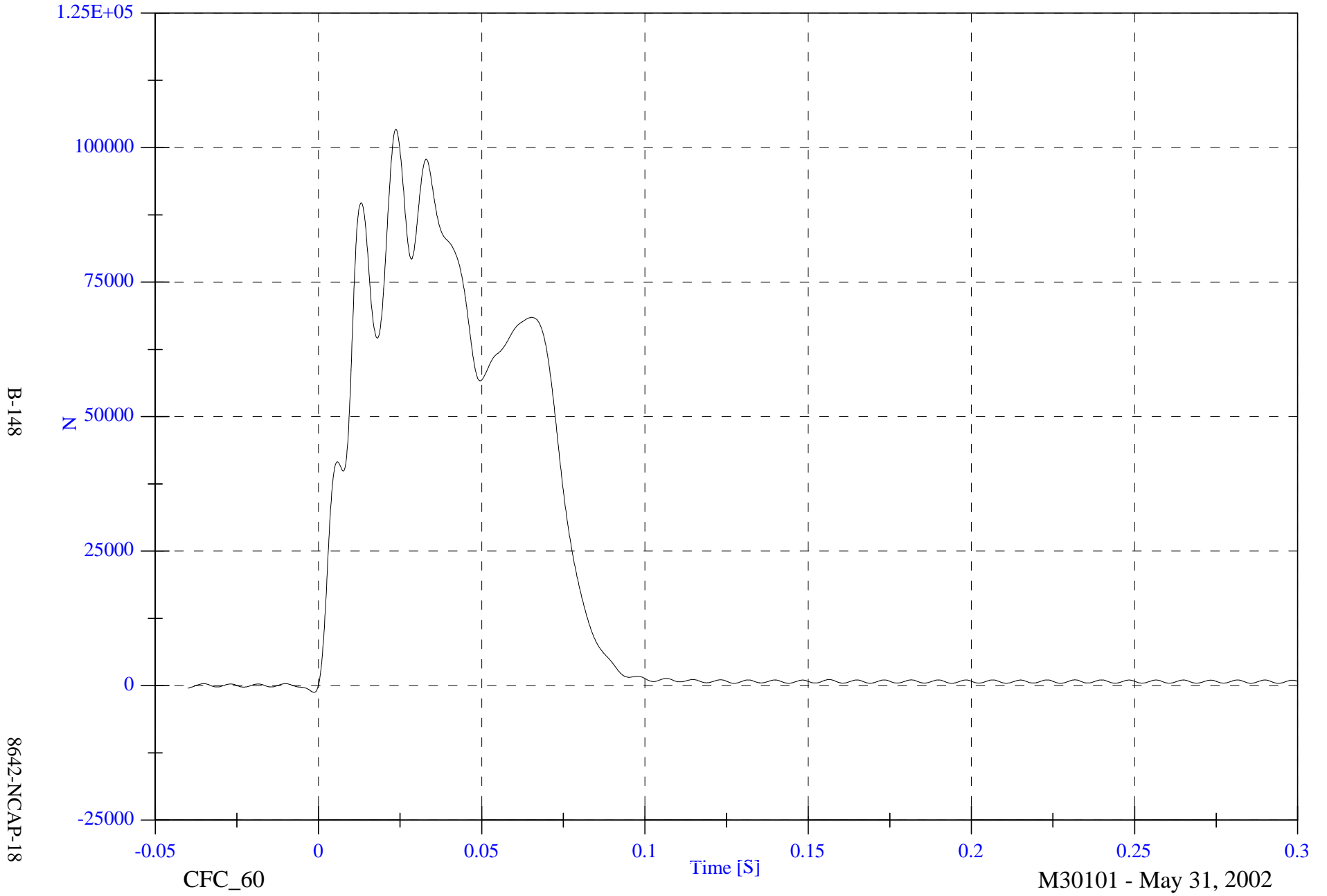

B-148

8642-NCAP-18

CFC_60

Time [S]

M30101 - May 31, 2002

NCAP Test 18- 2003 Cadillac CTS

Barrier Load Cell B4 Fx

Max: 99590.6 [N] at 0.039 [S]

Min: -1004.8 [N] at -0.003 [S]

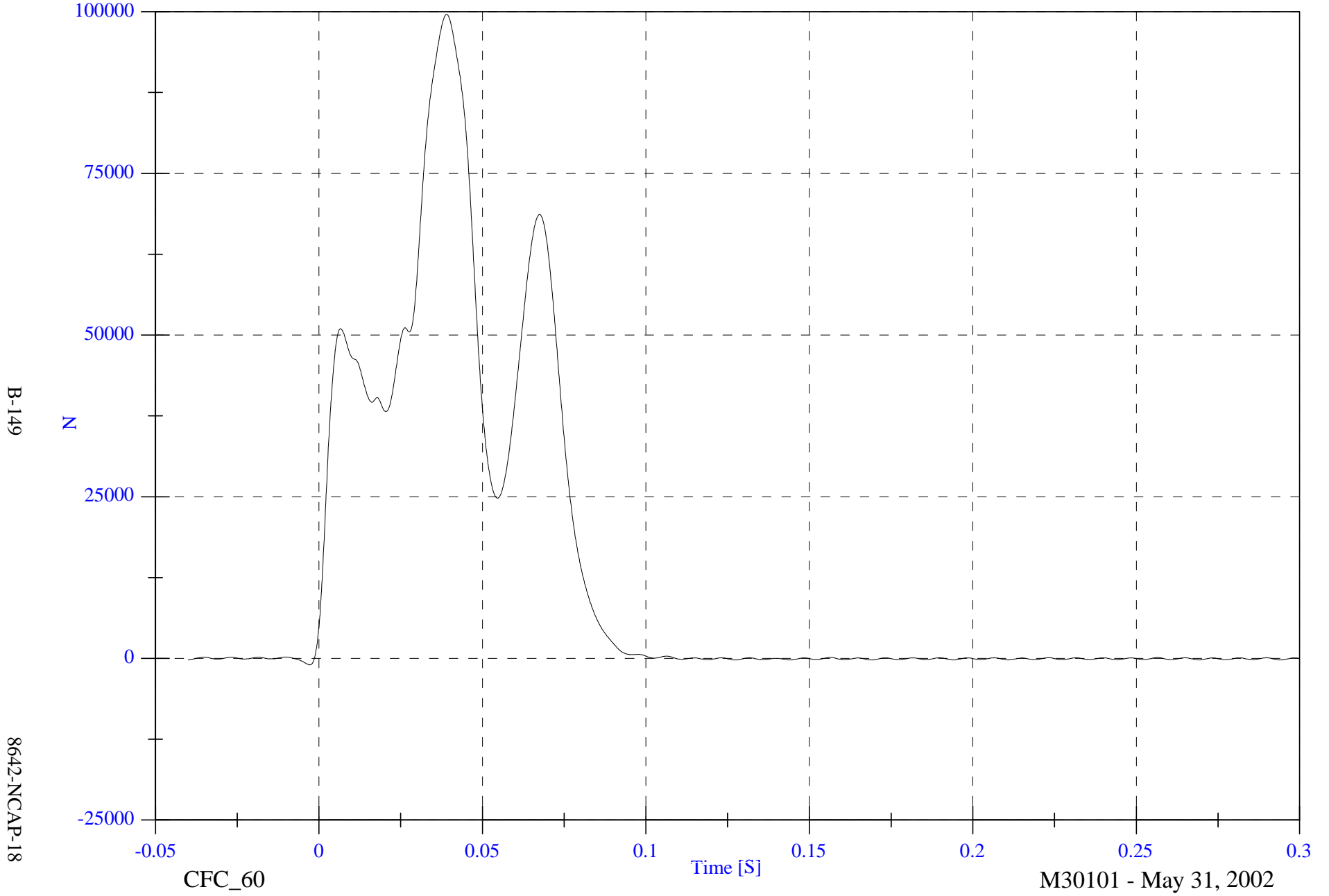

NCAP Test 18- 2003 Cadillac CTS

Barrier Load Cell B5 Fx

Max: 37070.7 [N] at 0.001 [S]

Min: -1471.7 [N] at -0.005 [S]

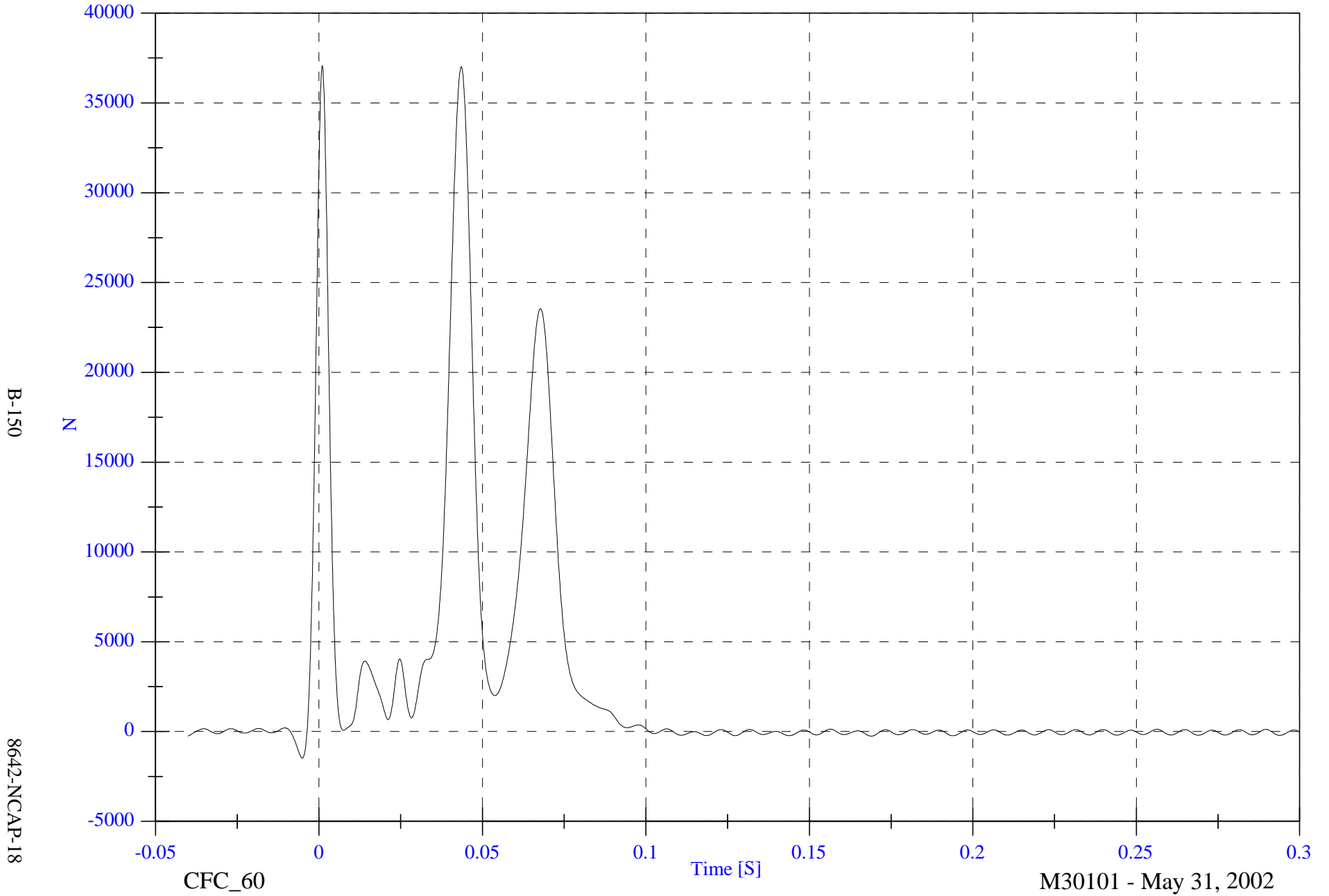

B-150

8642-NCAP-18

CFC_60

Time [S]

M30101 - May 31, 2002

NCAP Test 18- 2003 Cadillac CTS

Barrier Load Cell B6 Fx

Max: 112796.5 [N] at 0.043 [S]

Min: -1221.6 [N] at -0.003 [S]

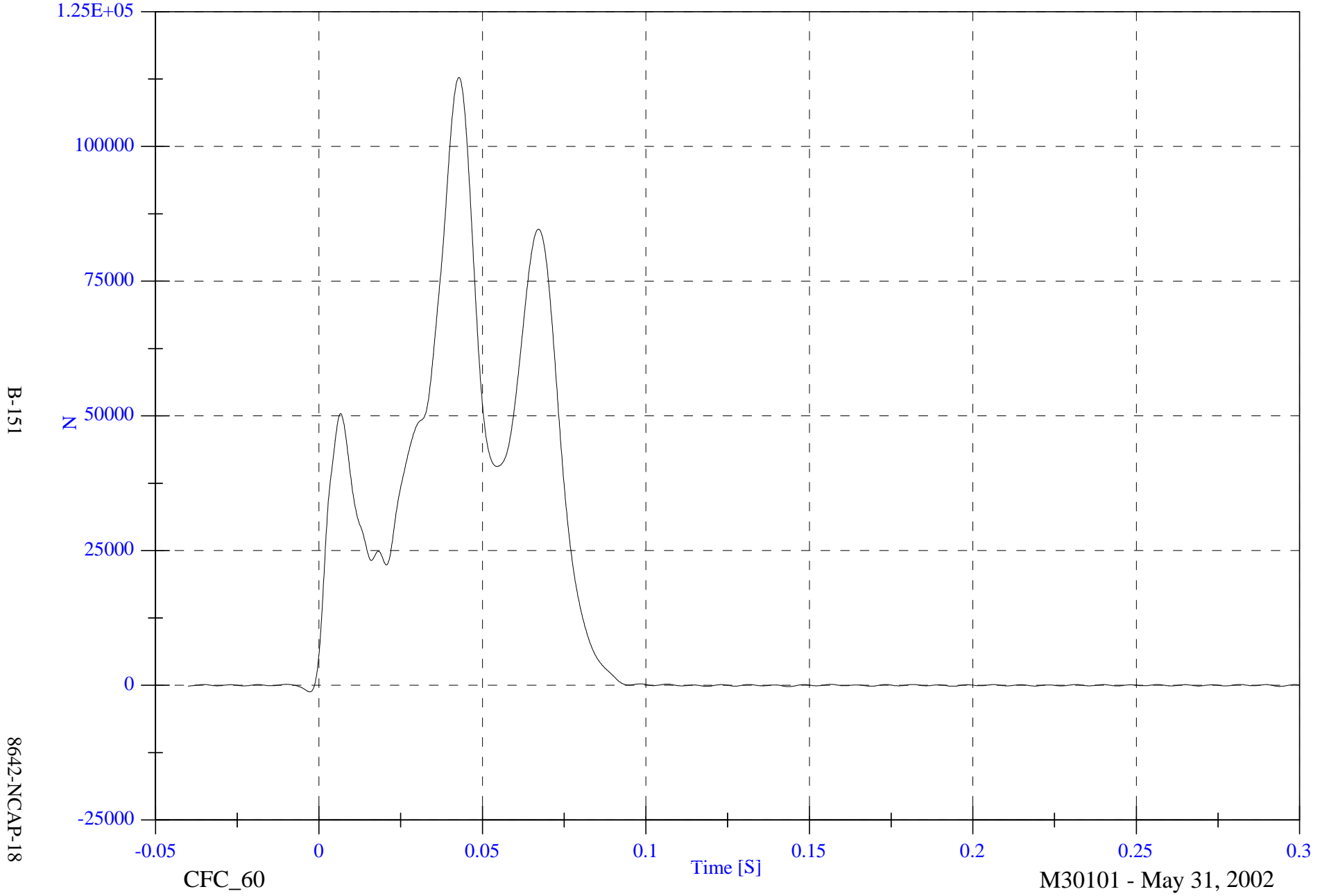

B-151

8642-NCAP-18

CFC_60

Time [S]

M30101 - May 31, 2002

NCAP Test 18- 2003 Cadillac CTS

Barrier Load Cell B7 Fx

Max: 113528.7 [N] at 0.023 [S]

Min: -1432.2 [N] at -0.002 [S]

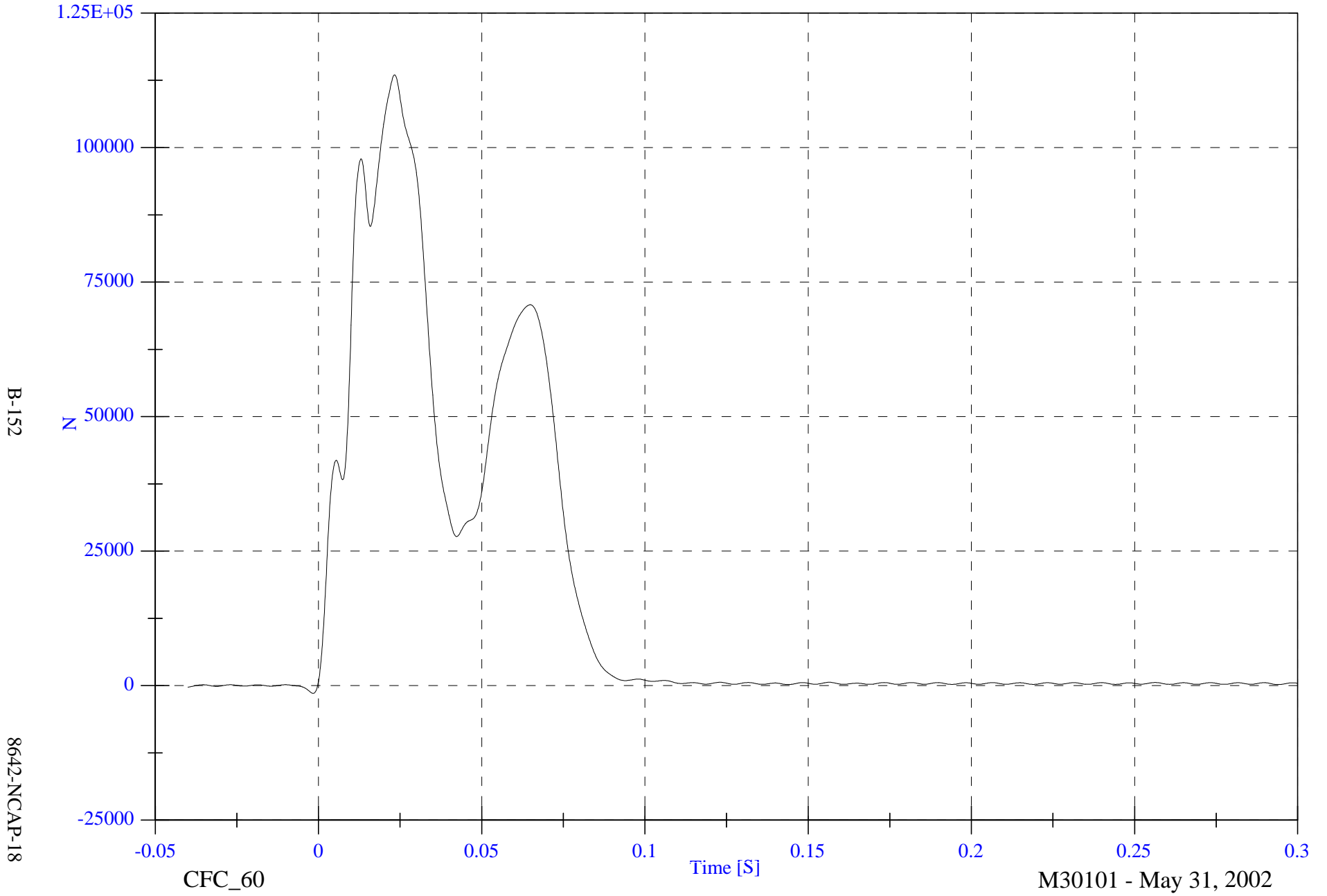

B-152

8642-NCAP-18

CFC_60

Time [S]

M30101 - May 31, 2002

NCAP Test 18- 2003 Cadillac CTS

Barrier Load Cell B8 Fx

Max: 7977.2 [N] at 0.059 [S]

Min: -592.4 [N] at 0.177 [S]

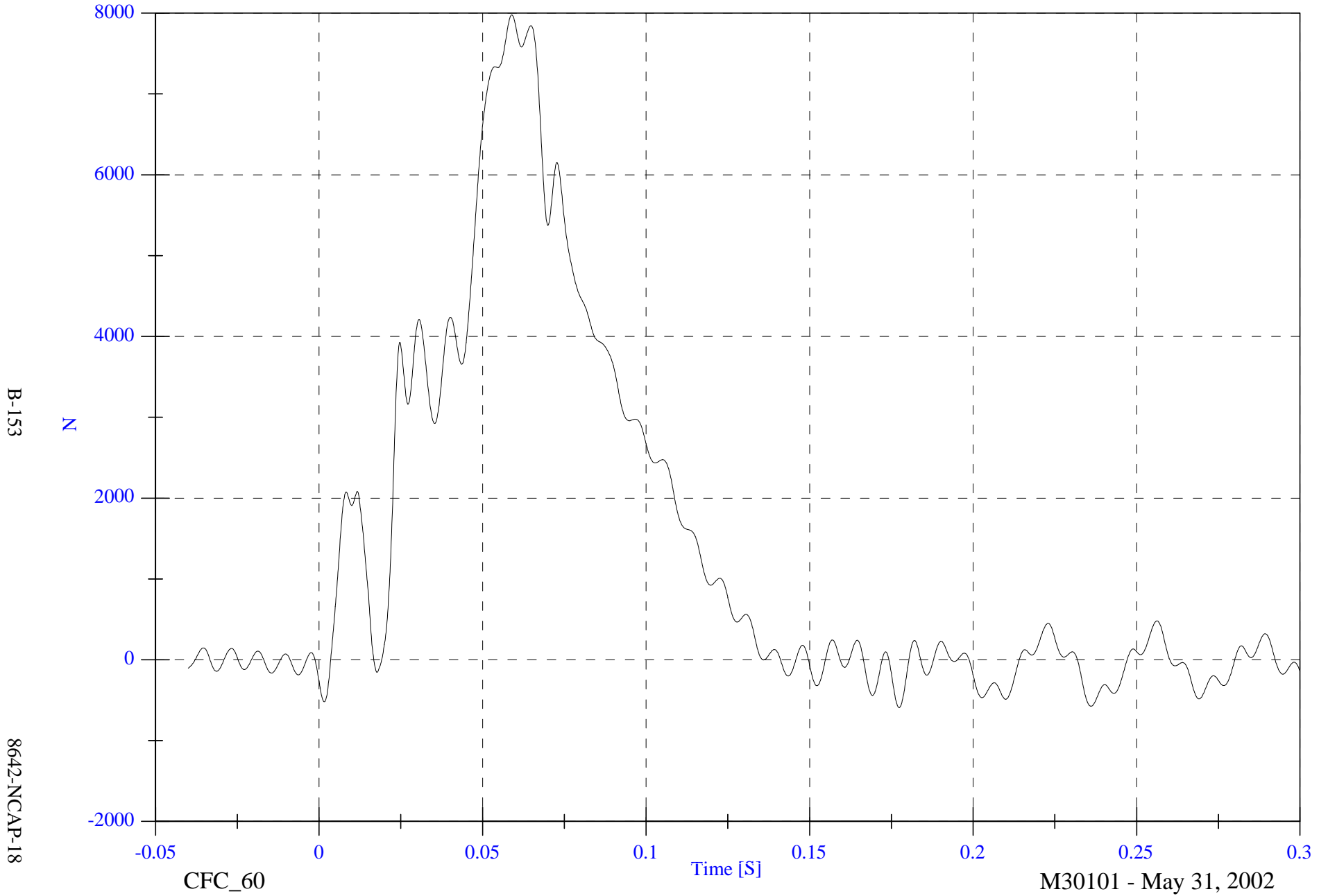

B-153

8642-NCAP-18

CFC_60

Time [S]

M30101 - May 31, 2002

NCAP Test 18- 2003 Cadillac CTS

Barrier Load Cell B9 Fx

Max: 1671.7 [N] at 0.031 [S]

Min: -1177.4 [N] at 0.035 [S]

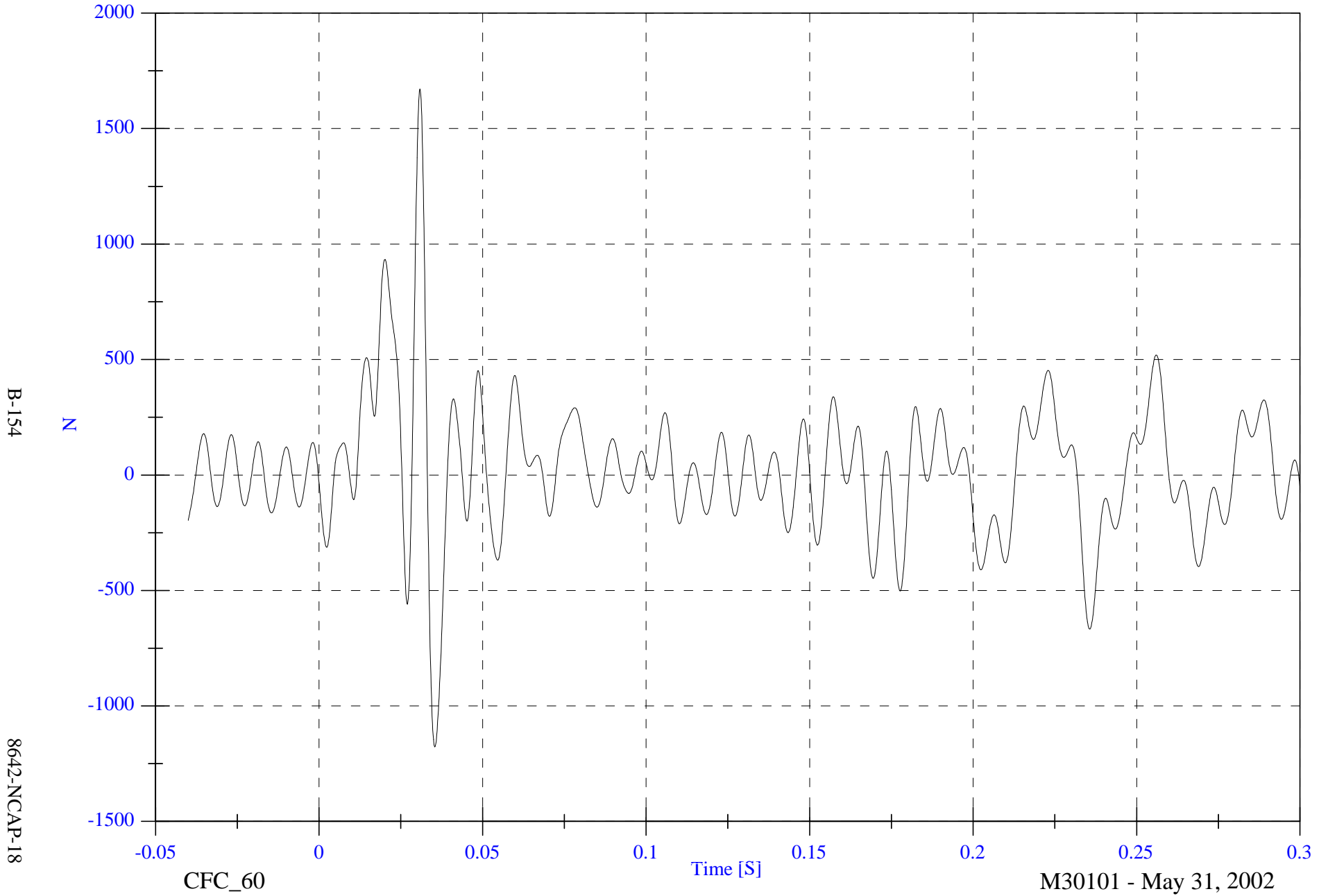

NCAP Test 18- 2003 Cadillac CTS

Barrier Load Cell C1 Fx

Max: 674.9 [N] at 0.053 [S]

Min: -662.6 [N] at 0.016 [S]

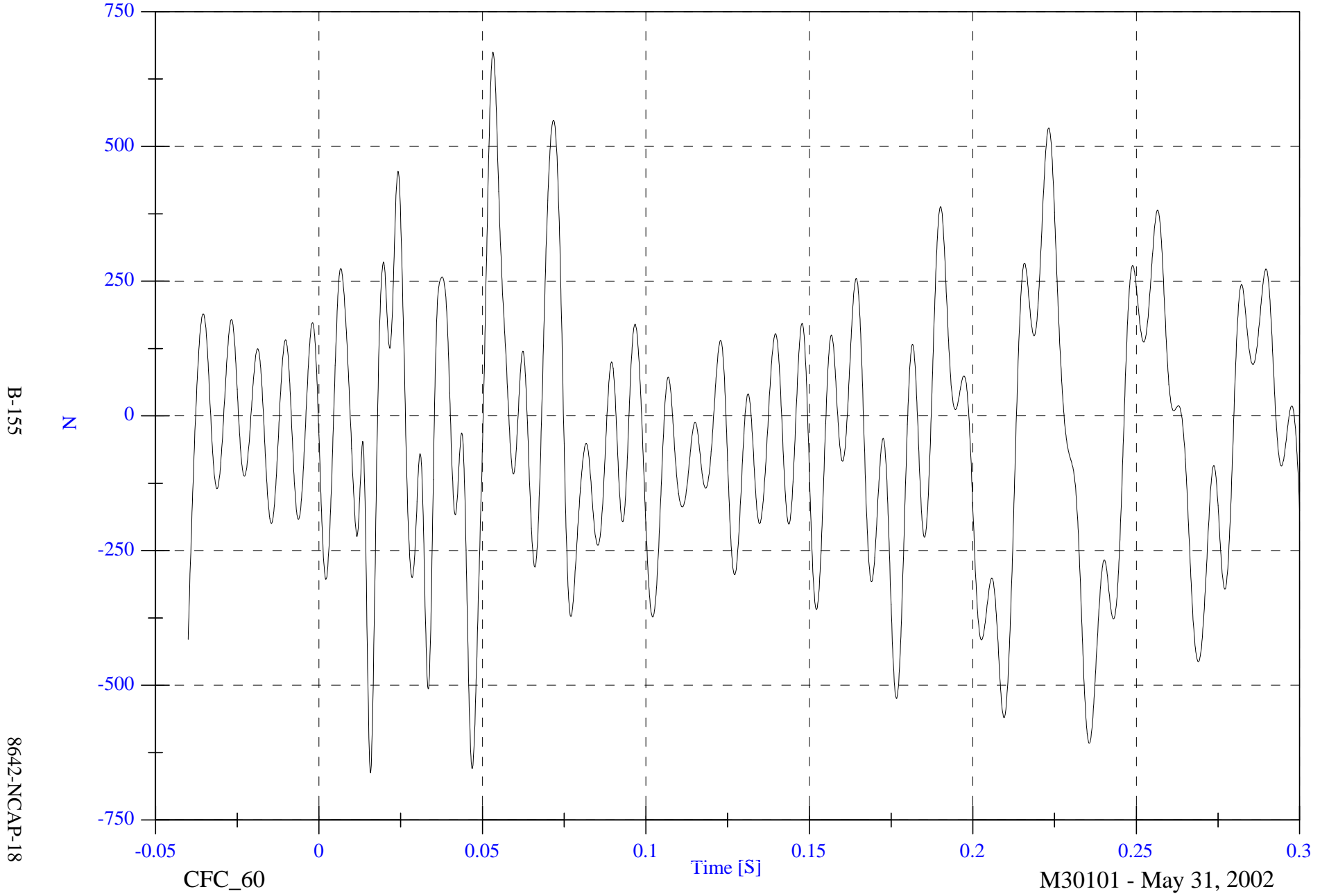

B-155

8642-NCAP-18

CFC_60

Time [S]

M30101 - May 31, 2002

NCAP Test 18- 2003 Cadillac CTS

Barrier Load Cell C2 Fx

Max: 19139.3 [N] at 0.032 [S]

Min: -735.3 [N] at 0.236 [S]

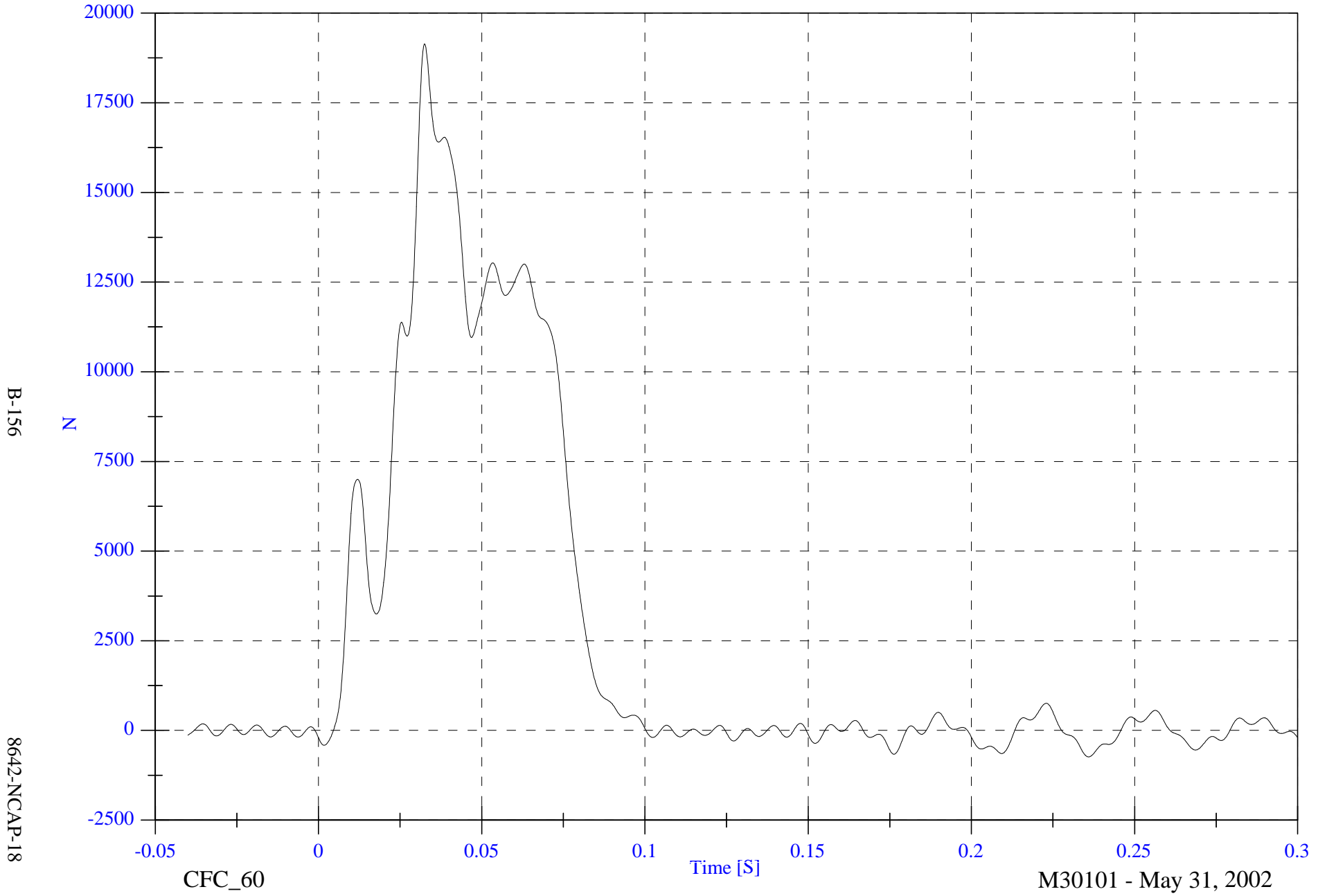

NCAP Test 18- 2003 Cadillac CTS

Barrier Load Cell C3 Fx

Max: 13201.8 [N] at 0.017 [S]

Min: -1062.2 [N] at 0.243 [S]

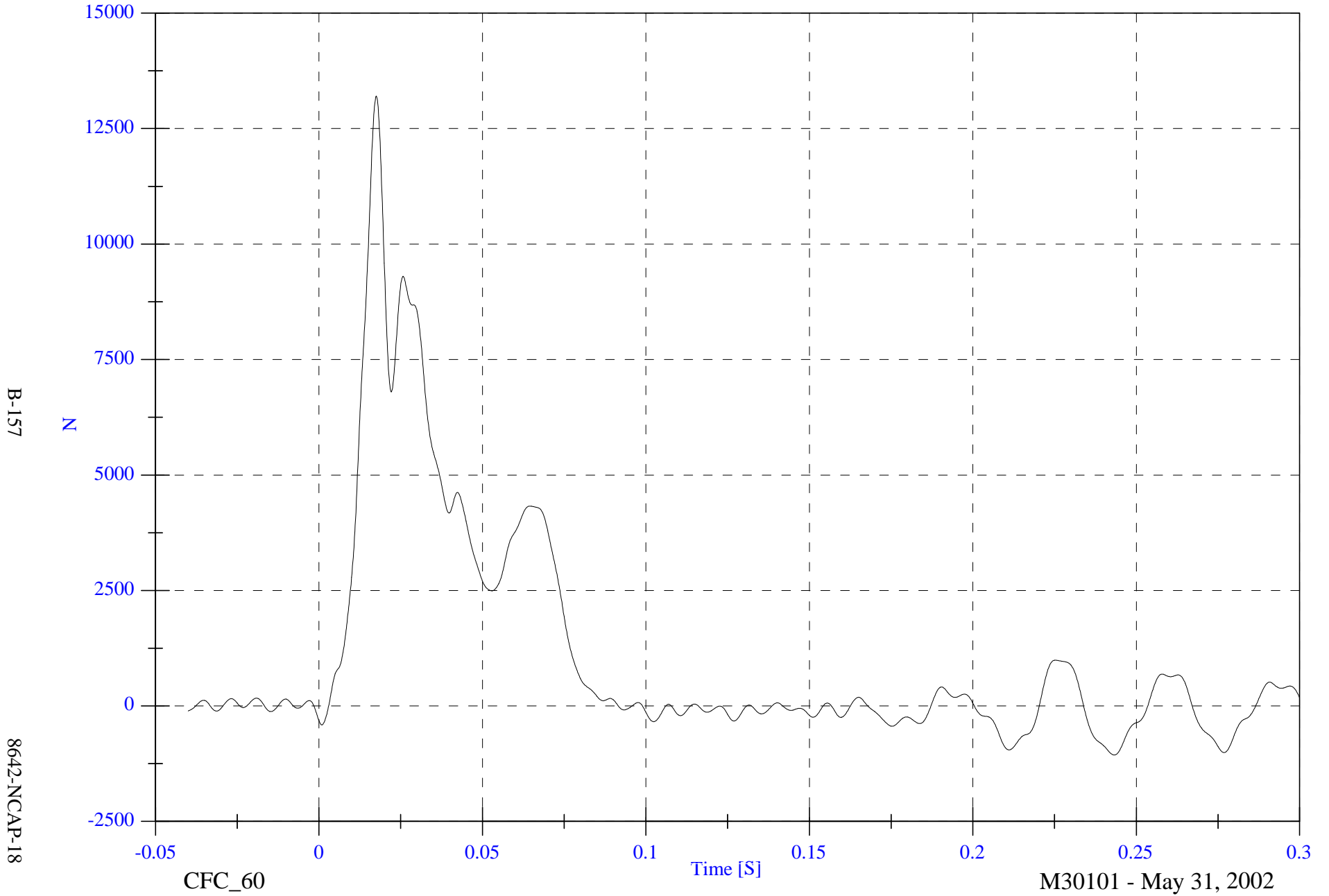

B-157

8642-NCAP-18

CFC_60

Time [S]

M30101 - May 31, 2002

NCAP Test 18- 2003 Cadillac CTS

Barrier Load Cell C4 Fx

Max: 11051.0 [N] at 0.041 [S]

Min: -1022.8 [N] at 0.243 [S]

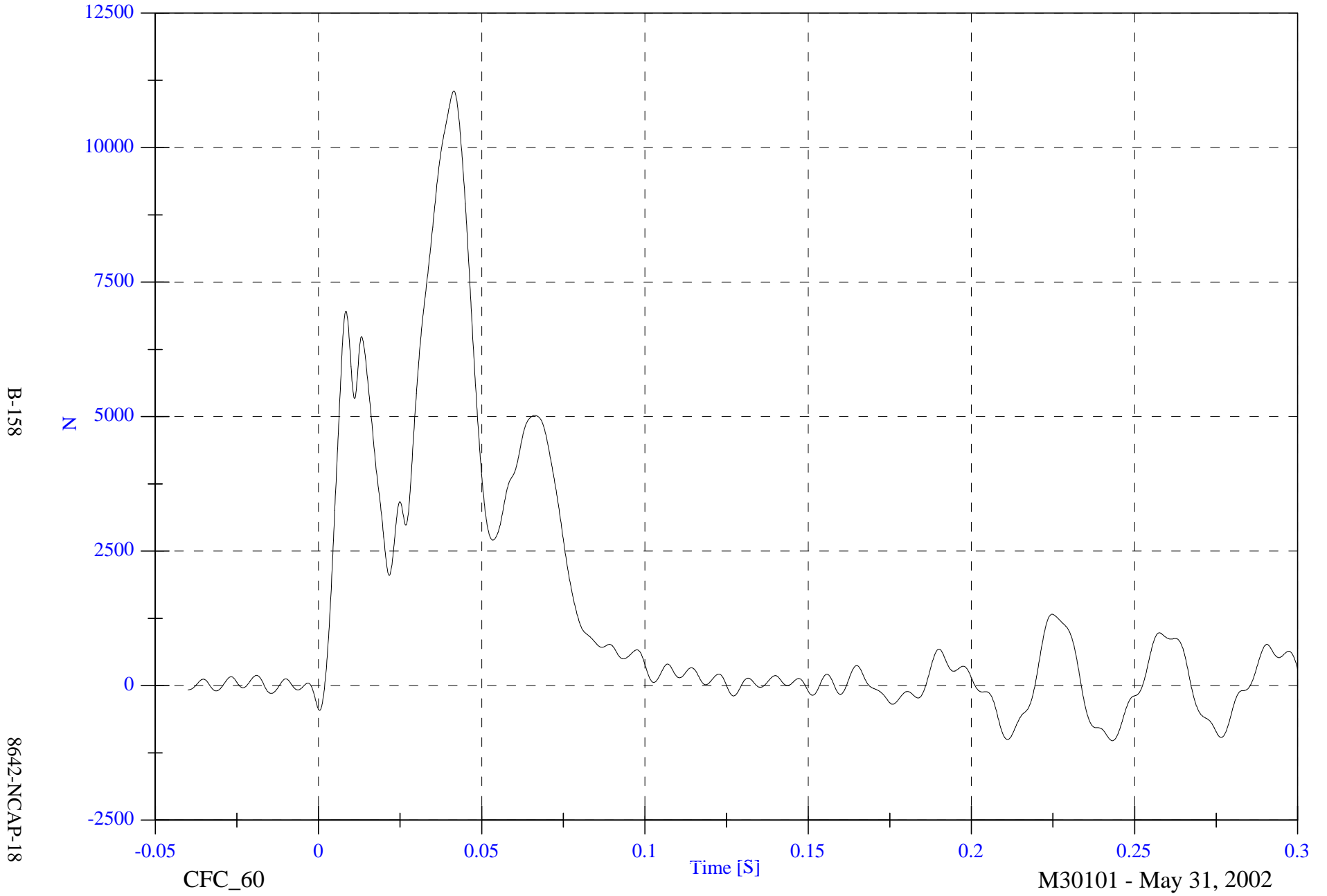

B-158

8642-NCAP-18

CFC_60

Time [S]

M30101 - May 31, 2002

NCAP Test 18- 2003 Cadillac CTS

Barrier Load Cell C5 Fx

Max: 47834.5 [N] at 0.042 [S]

Min: -1196.9 [N] at 0.243 [S]

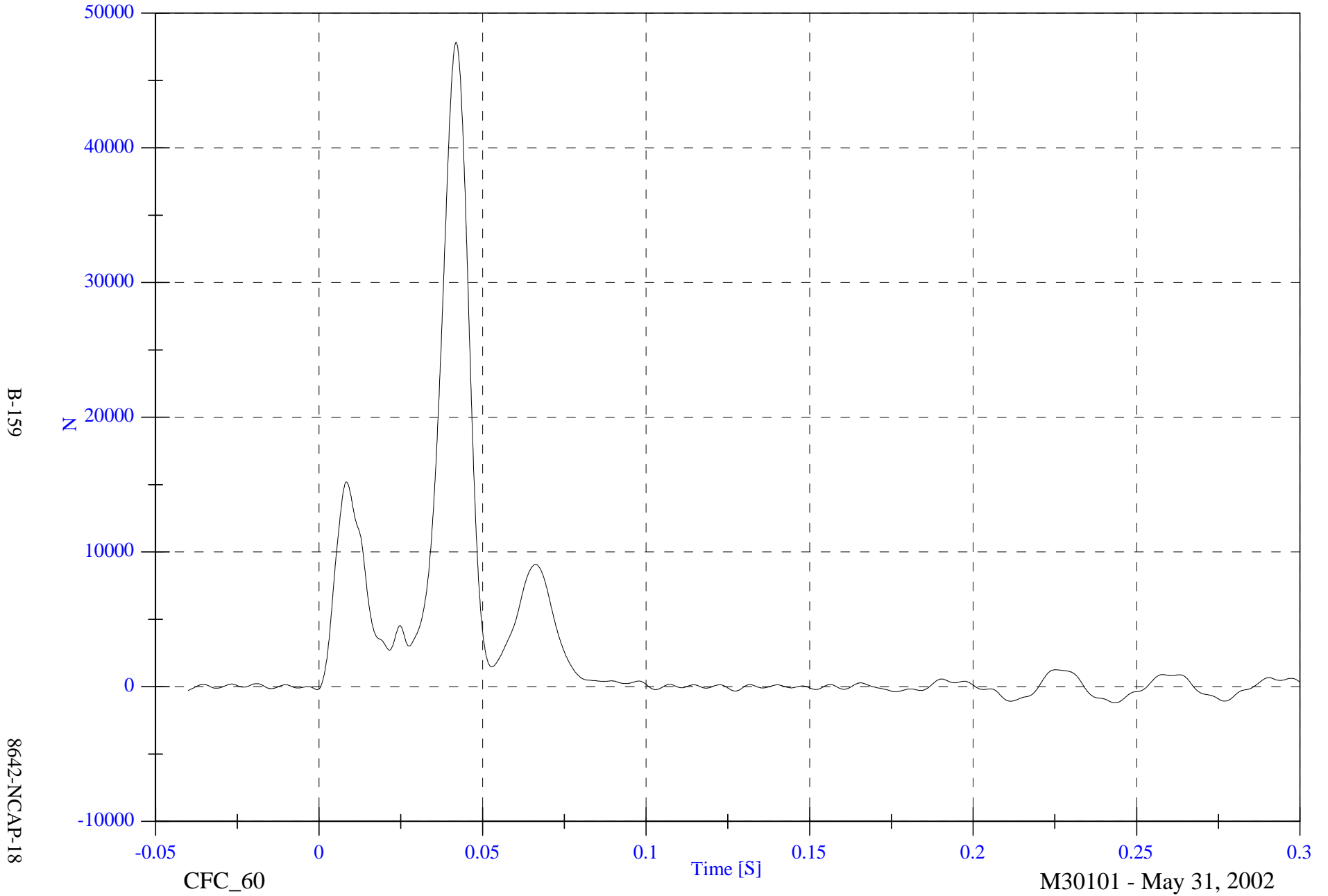

B-159

8642-NCAP-18

CFC_60

Time [S]

M30101 - May 31, 2002

NCAP Test 18- 2003 Cadillac CTS

Barrier Load Cell C6 Fx

Max: 10617.7 [N] at 0.042 [S]

Min: -1202.8 [N] at 0.243 [S]

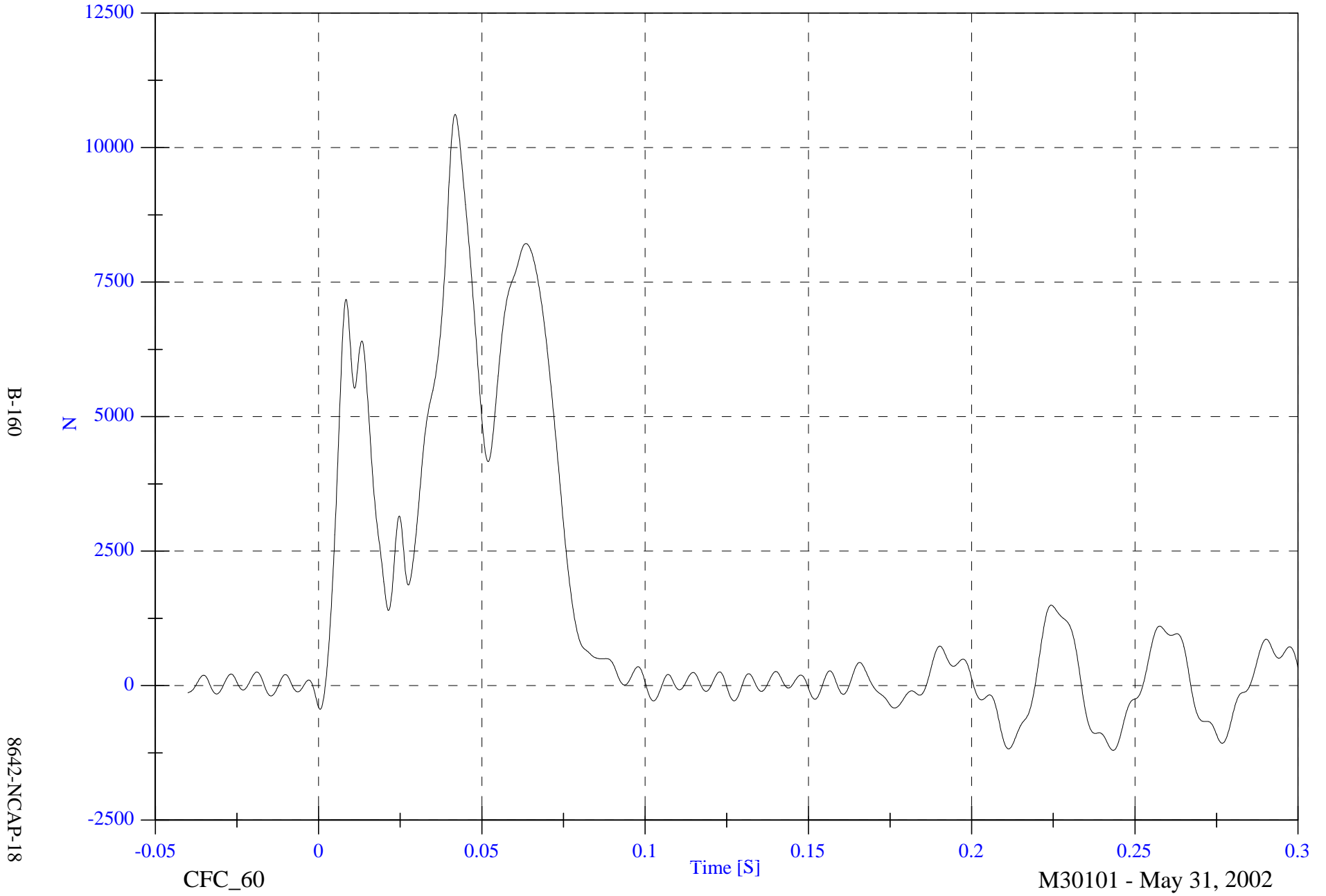

NCAP Test 18- 2003 Cadillac CTS

Barrier Load Cell C7 Fx

Max: 13416.5 [N] at 0.025 [S]

Min: -2001.9 [N] at 0.210 [S]

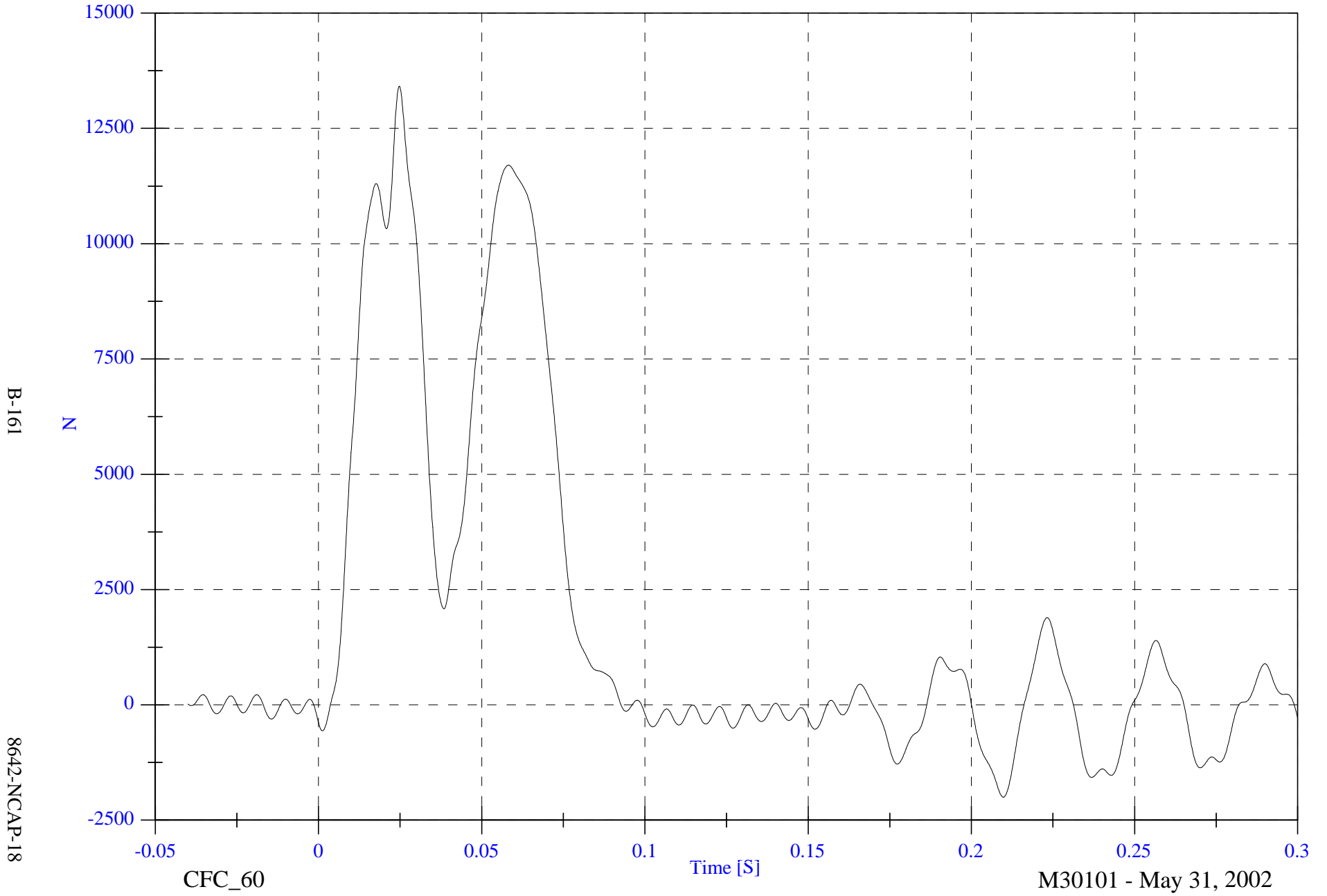

B-161

8642-NCAP-18

CFC_60

Time [S]

M30101 - May 31, 2002

NCAP Test 18- 2003 Cadillac CTS

Barrier Load Cell C8 Fx

Max: 14777.8 [N] at 0.053 [S]

Min: -1943.1 [N] at 0.209 [S]

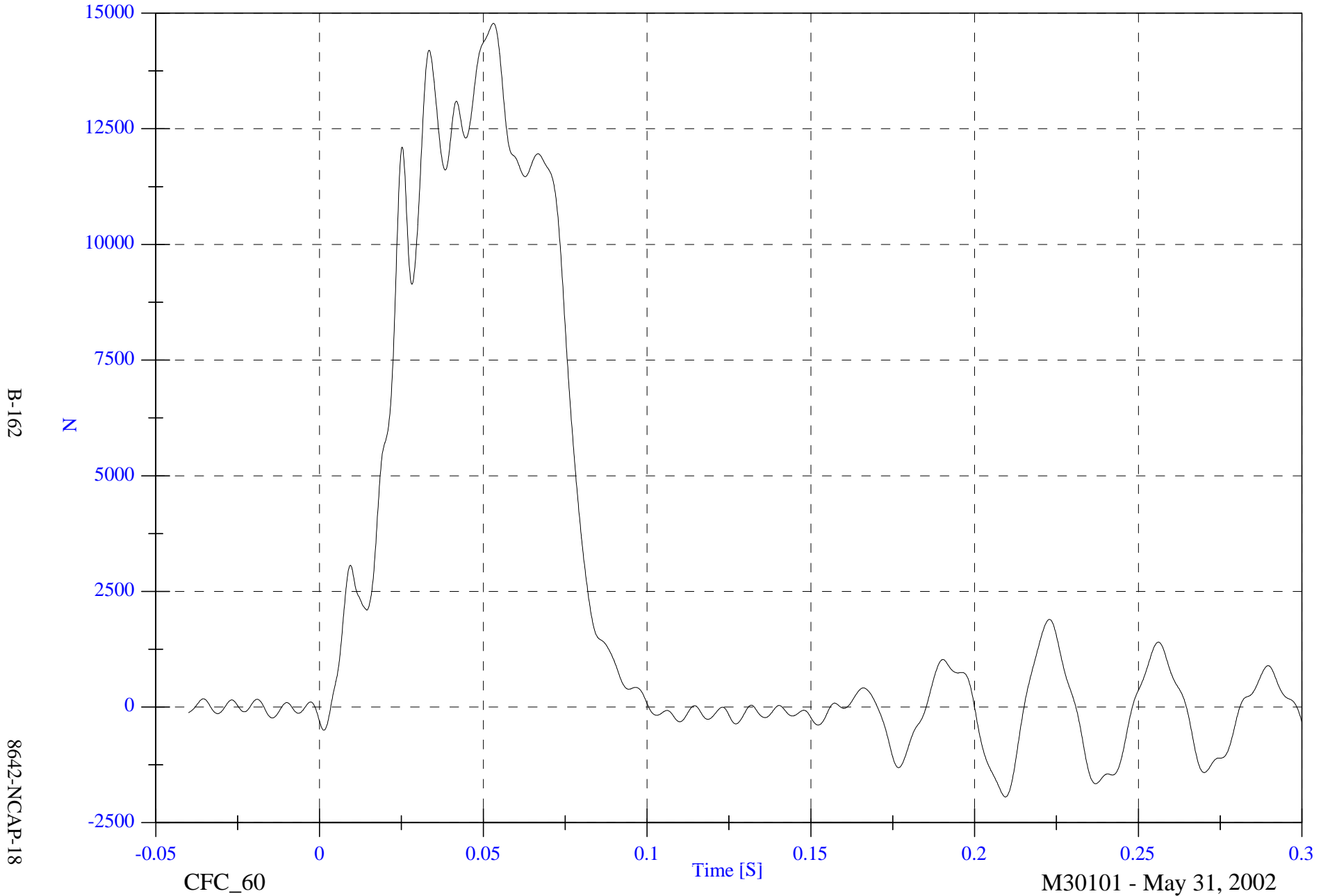

NCAP Test 18- 2003 Cadillac CTS

Barrier Load Cell C9 Fx

Max: 1848.8 [N] at 0.223 [S]

Min: -1853.4 [N] at 0.210 [S]

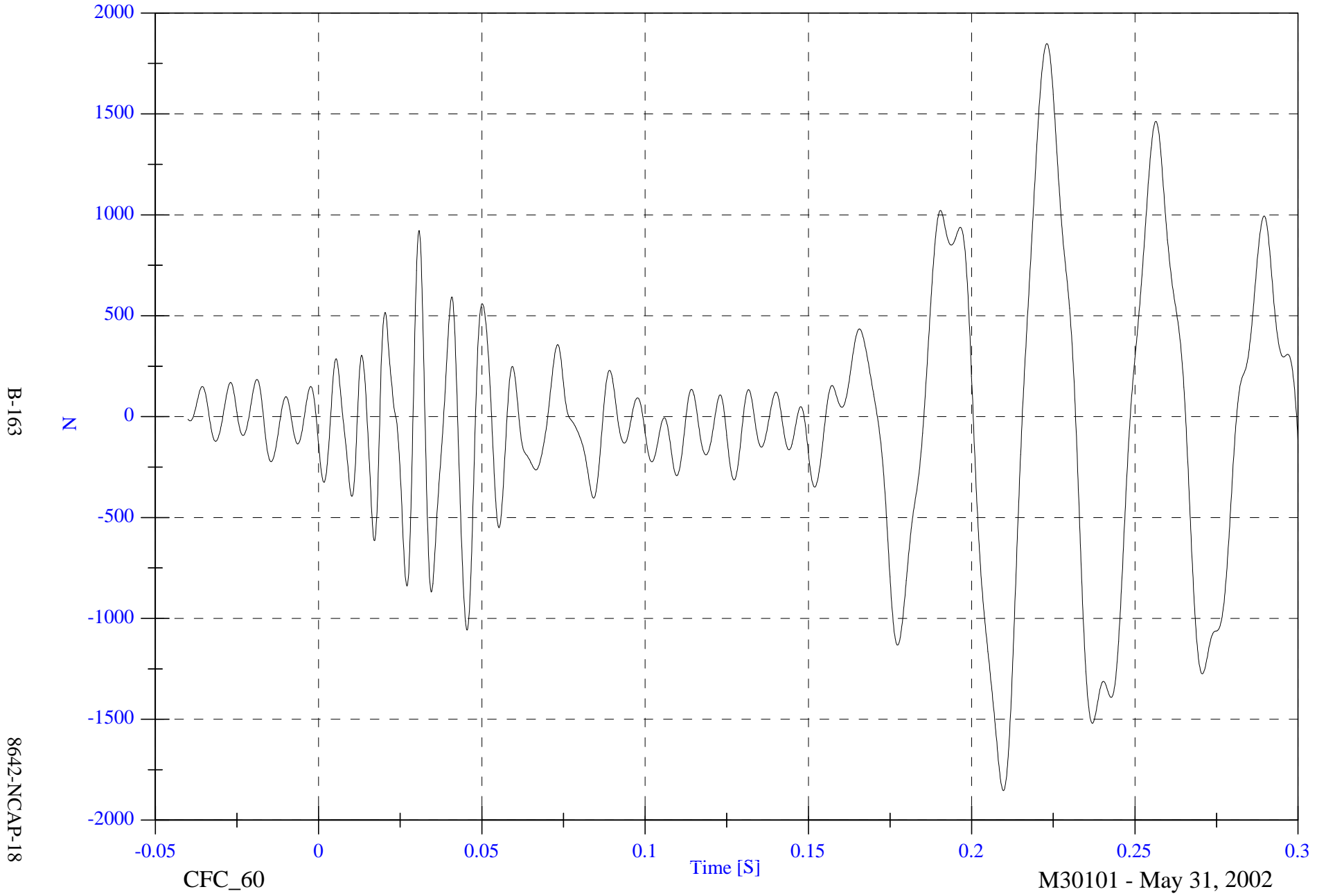

NCAP Test 18- 2003 Cadillac CTS

Barrier Load Cell D1 Fx

Max: 2338.9 [N] at 0.223 [S]

Min: -2242.9 [N] at 0.209 [S]

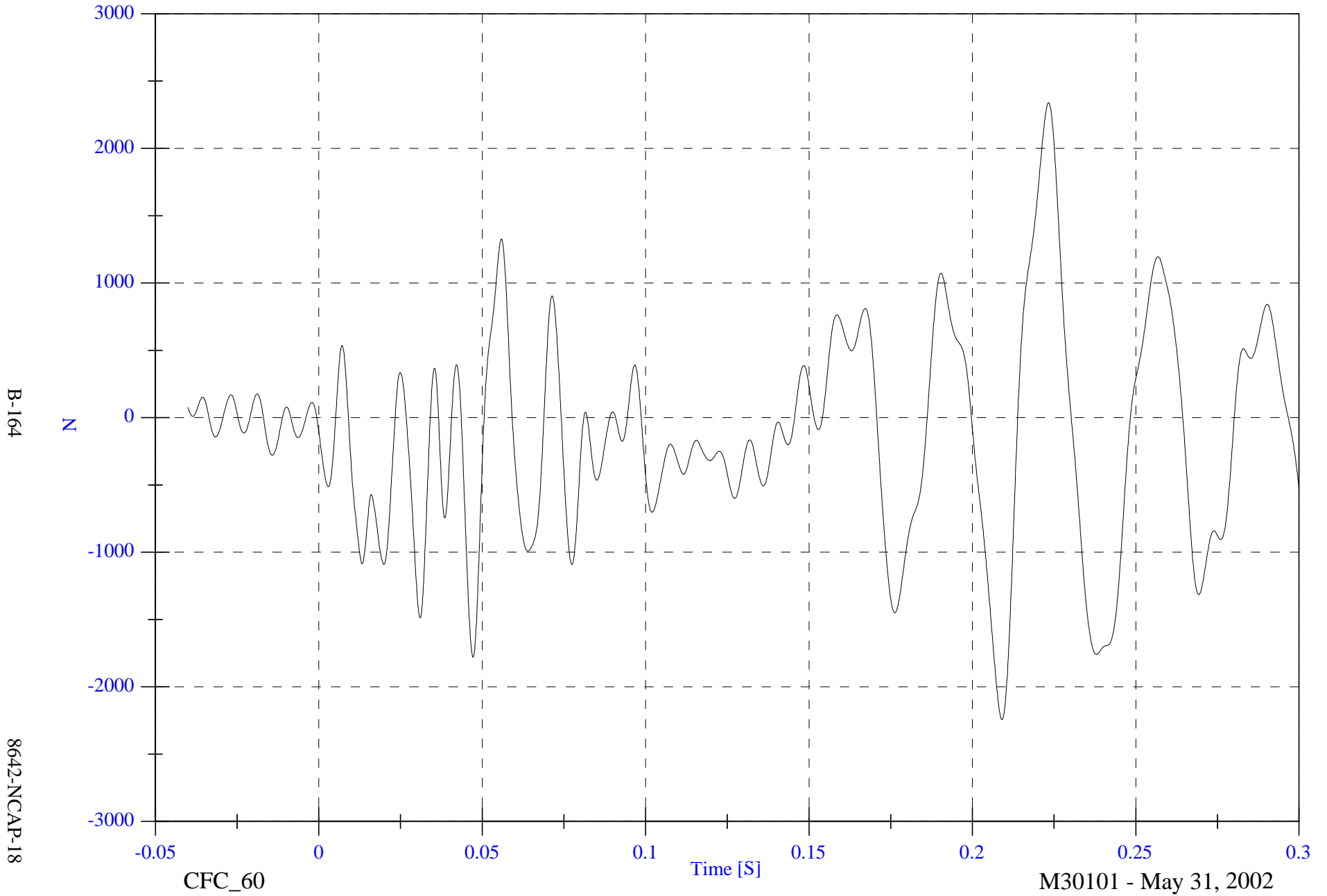

NCAP Test 18- 2003 Cadillac CTS

Barrier Load Cell D2 Fx

Max: 13507.3 [N] at 0.040 [S]

Min: -1570.7 [N] at 0.244 [S]

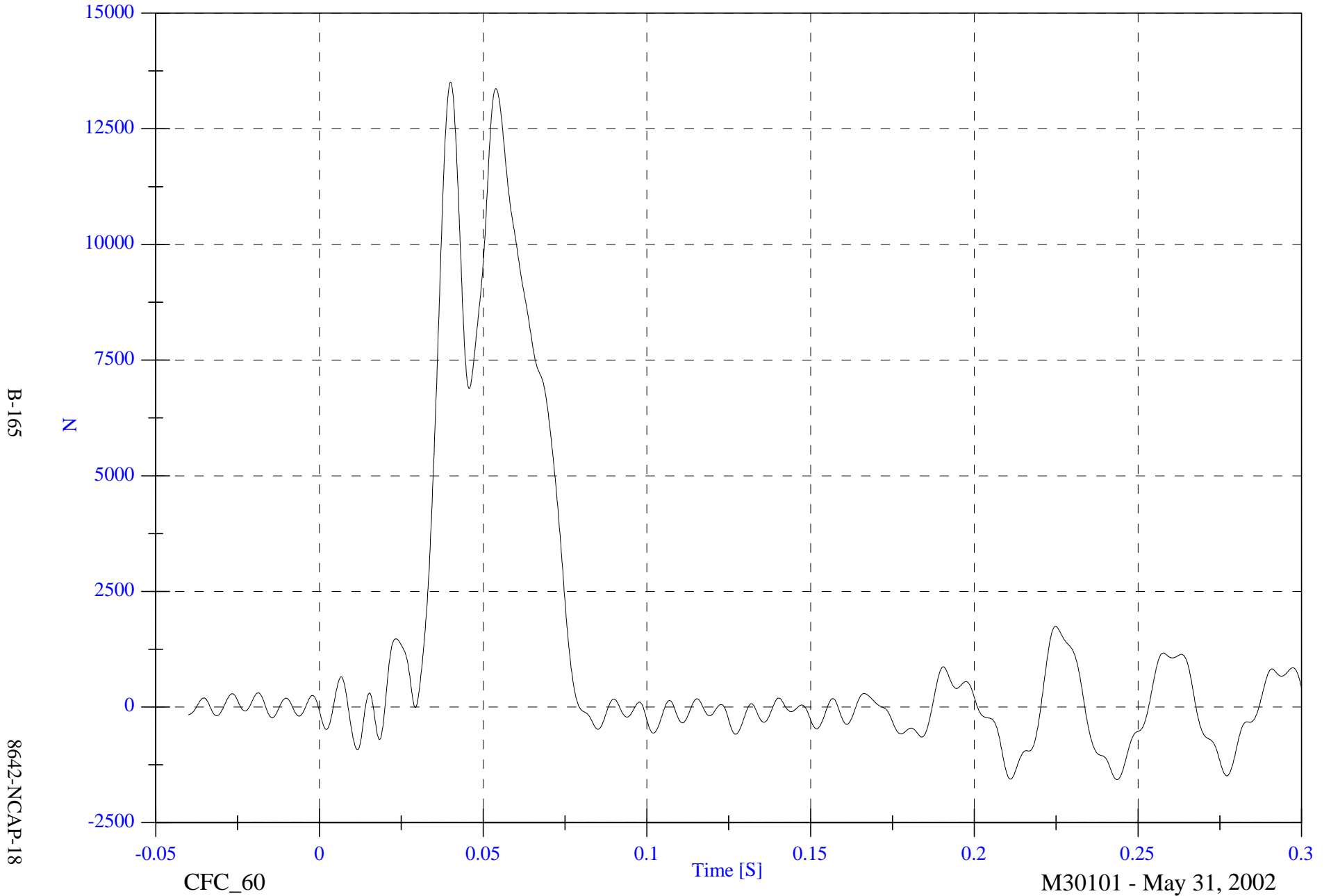

B-165

8642-NCAP-18

CFC_60

Time [S]

M30101 - May 31, 2002

NCAP Test 18- 2003 Cadillac CTS

Barrier Load Cell D3 Fx

Max: 5983.3 [N] at 0.033 [S]

Min: -1596.9 [N] at 0.211 [S]

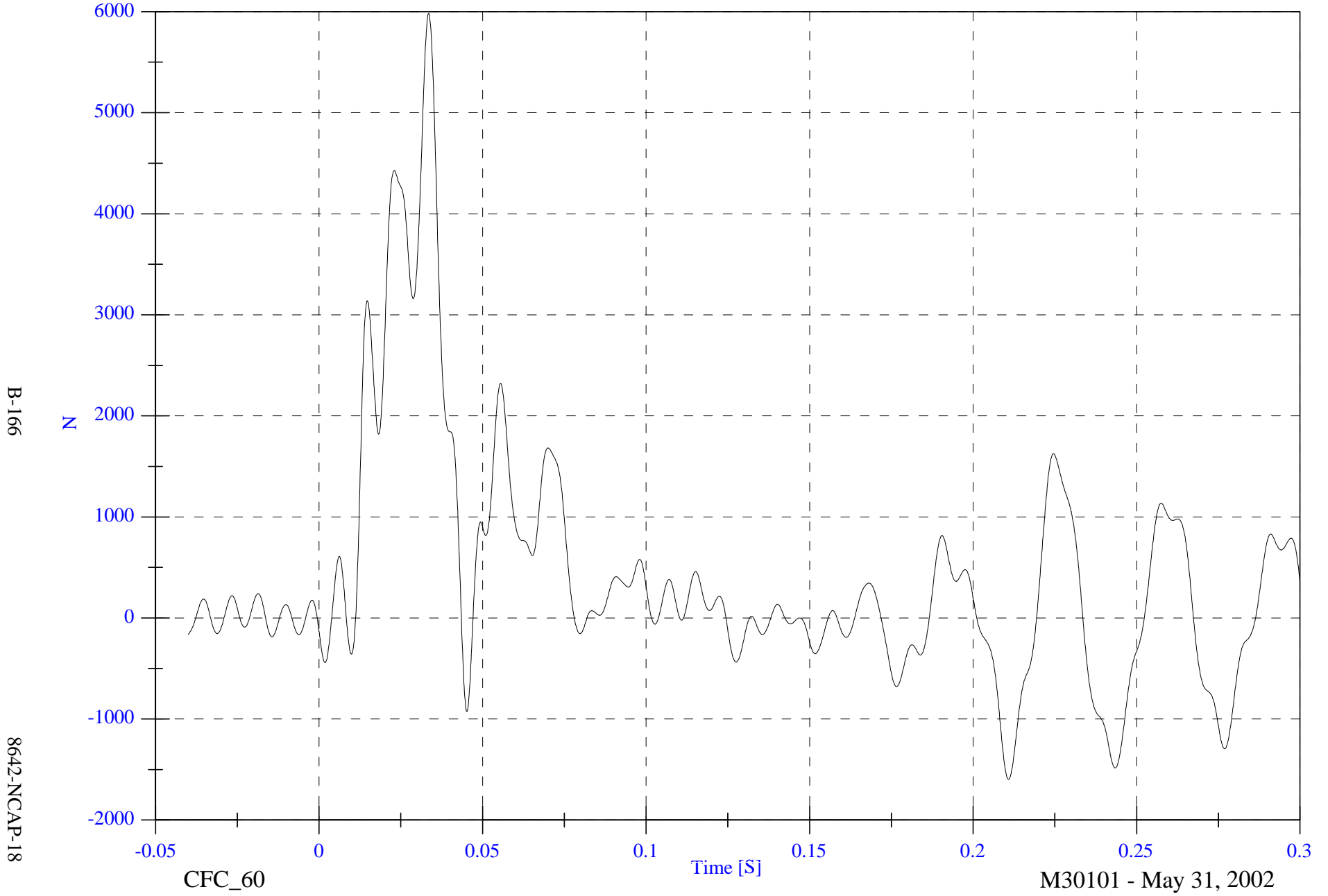

B-166

8642-NCAP-18

CFC_60

Time [S]

M30101 - May 31, 2002

NCAP Test 18- 2003 Cadillac CTS

Barrier Load Cell D4 Fx

Max: 2000.5 [N] at 0.023 [S]

Min: -1455.2 [N] at 0.211 [S]

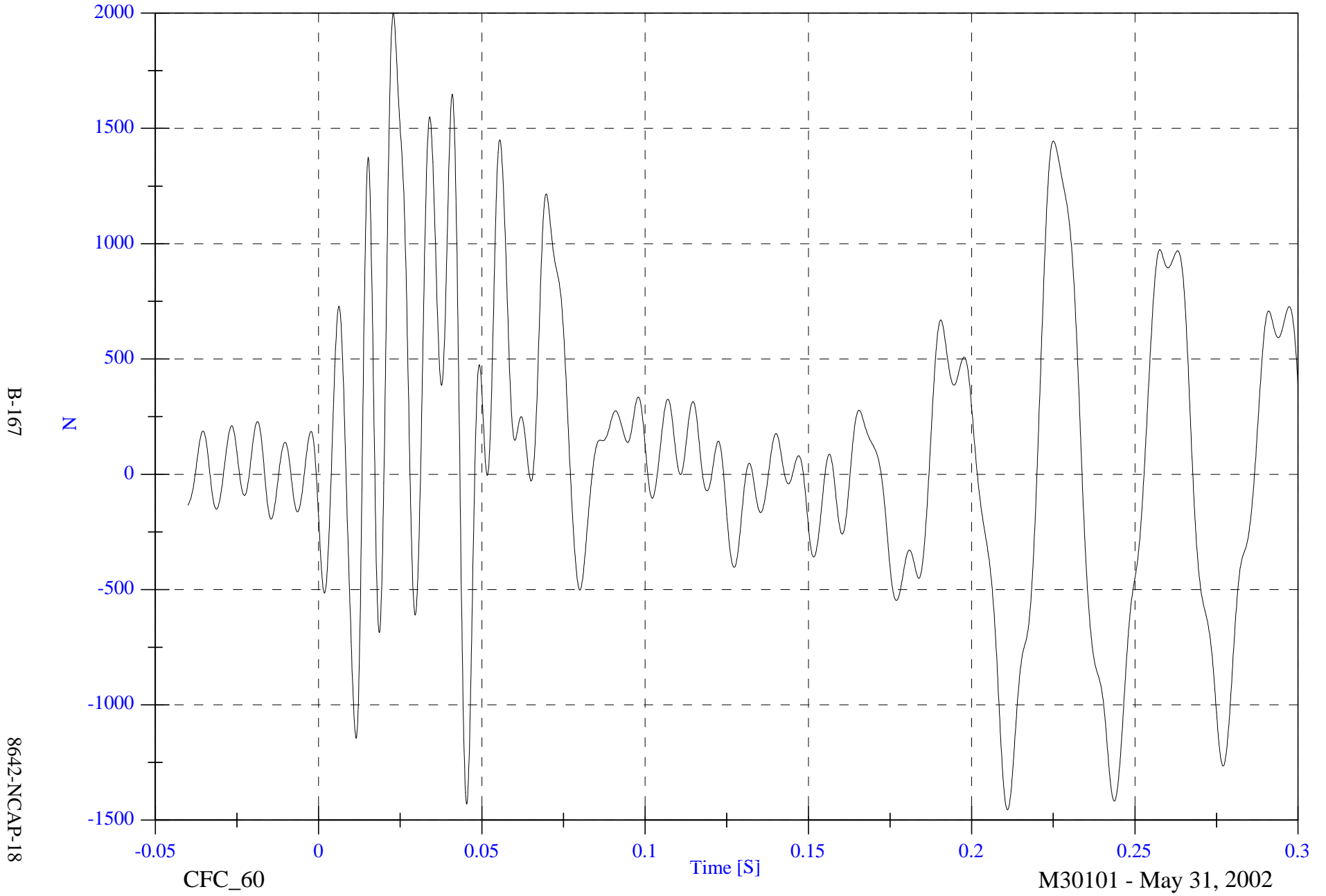

B-167

8642-NCAP-18

NCAP Test 18- 2003 Cadillac CTS

Barrier Load Cell D5 Fx

Max: 2273.5 [N] at 0.015 [S]

Min: -1473.2 [N] at 0.211 [S]

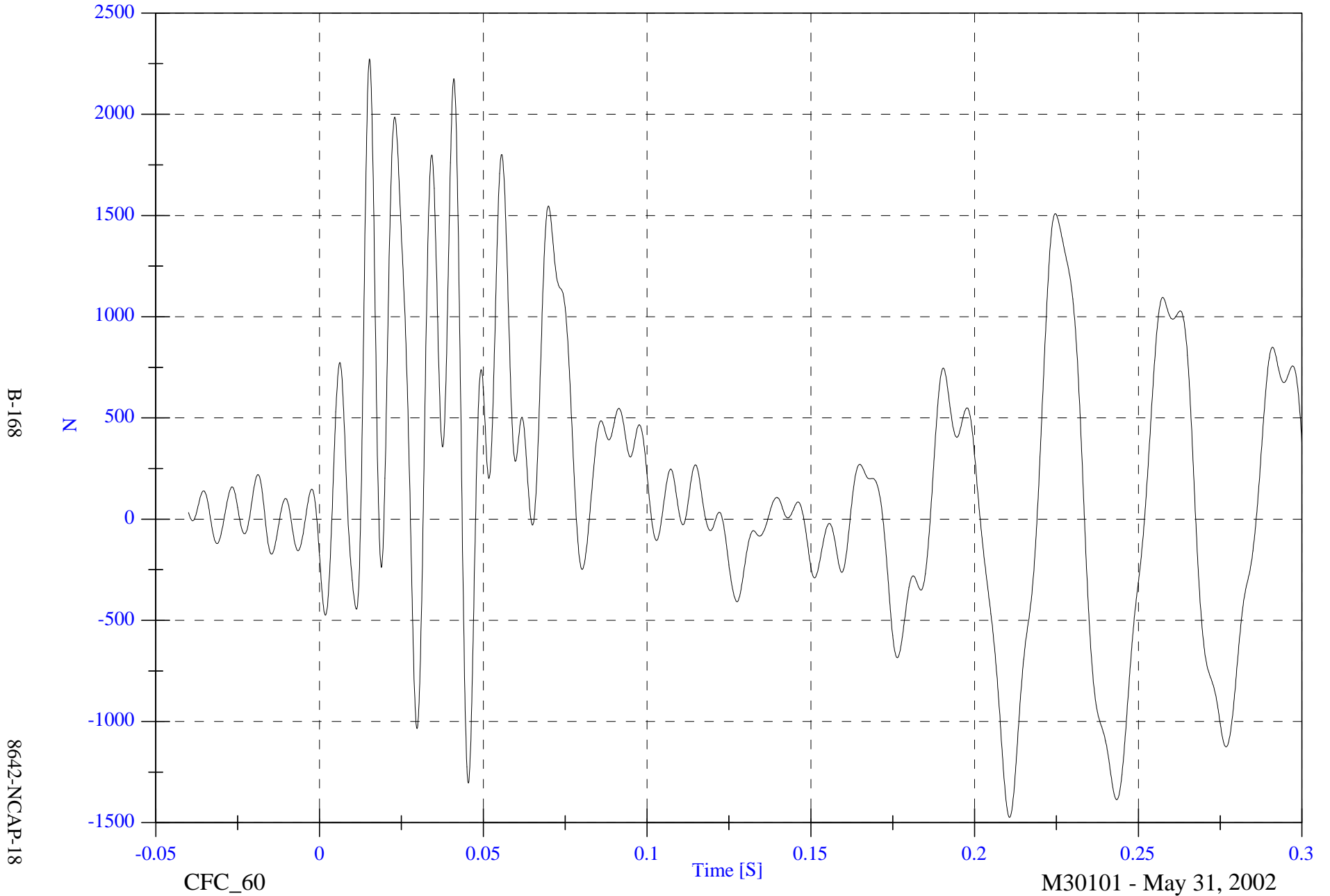

NCAP Test 18- 2003 Cadillac CTS

Barrier Load Cell D6 Fx

Max: 3971.8 [N] at 0.023 [S]

Min: -1160.6 [N] at 0.045 [S]

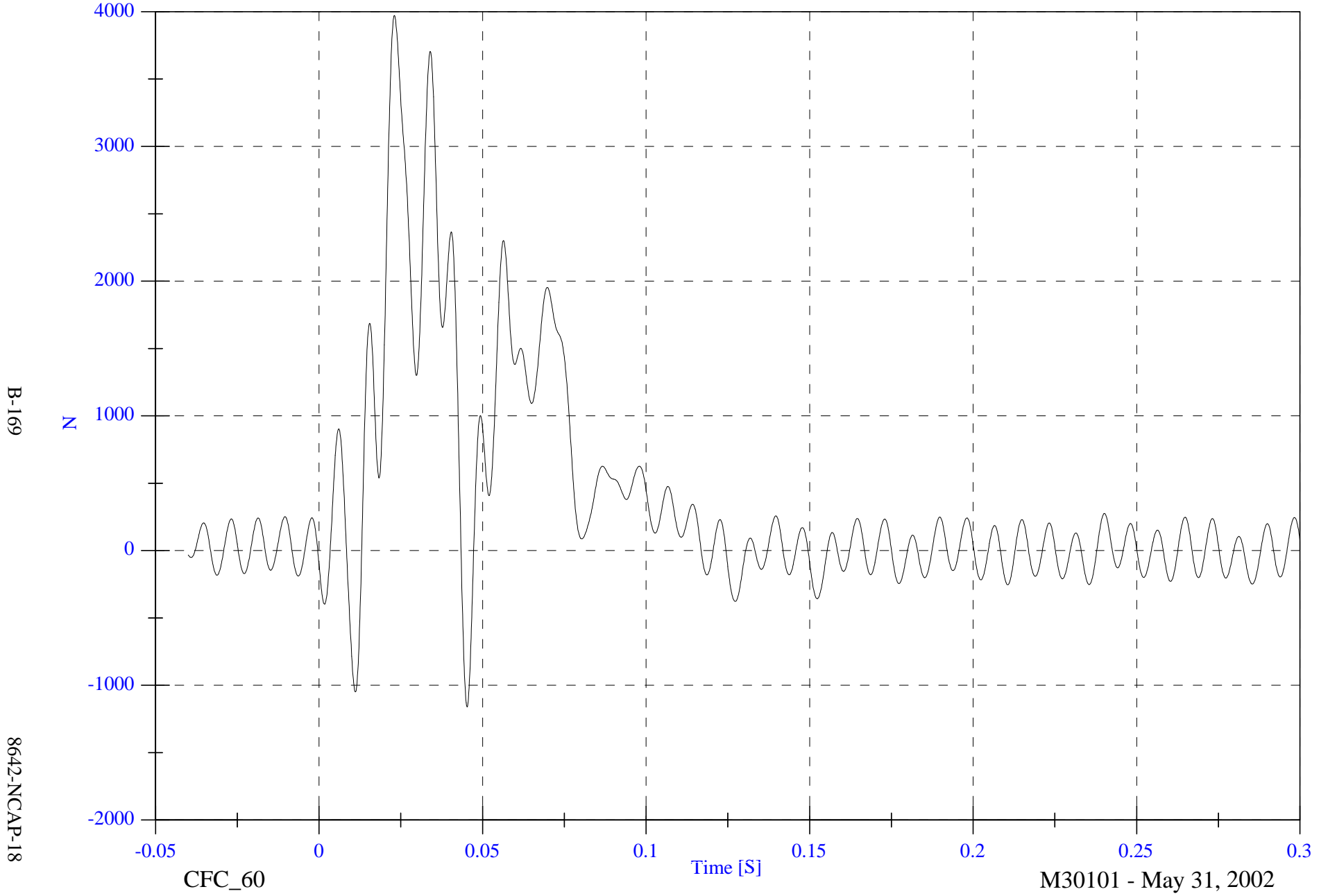

B-169

8642-NCAP-18

CFC_60

Time [S]

M30101 - May 31, 2002

NCAP Test 18- 2003 Cadillac CTS

Barrier Load Cell D7 Fx

Max: 6453.6 [N] at 0.034 [S]

Min: -1040.4 [N] at 0.045 [S]

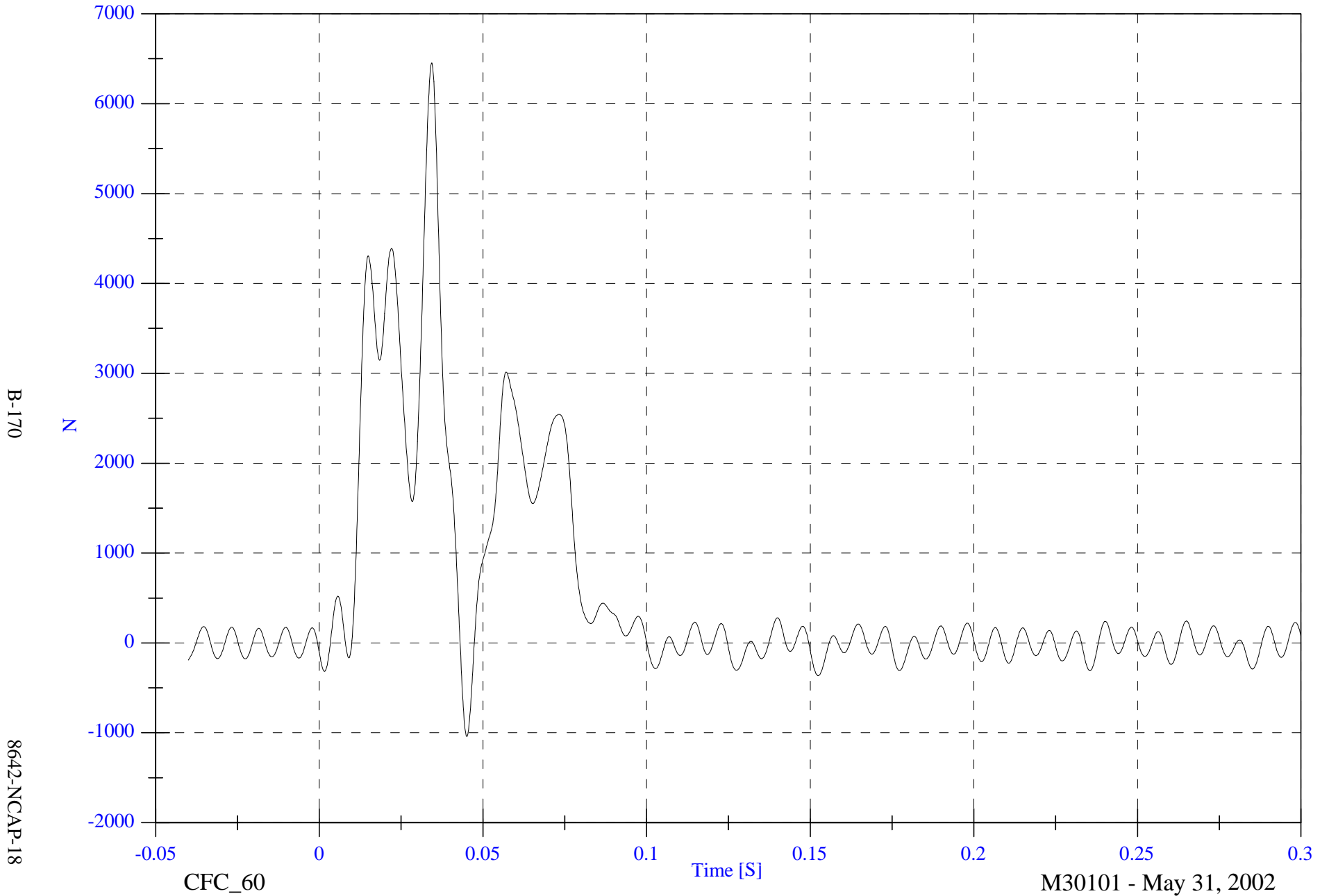

B-170

8642-NCAP-18

CFC_60

Time [S]

M30101 - May 31, 2002

NCAP Test 18- 2003 Cadillac CTS

Barrier Load Cell D8 Fx

Max: 12989.2 [N] at 0.040 [S]

Min: -769.9 [N] at 0.010 [S]

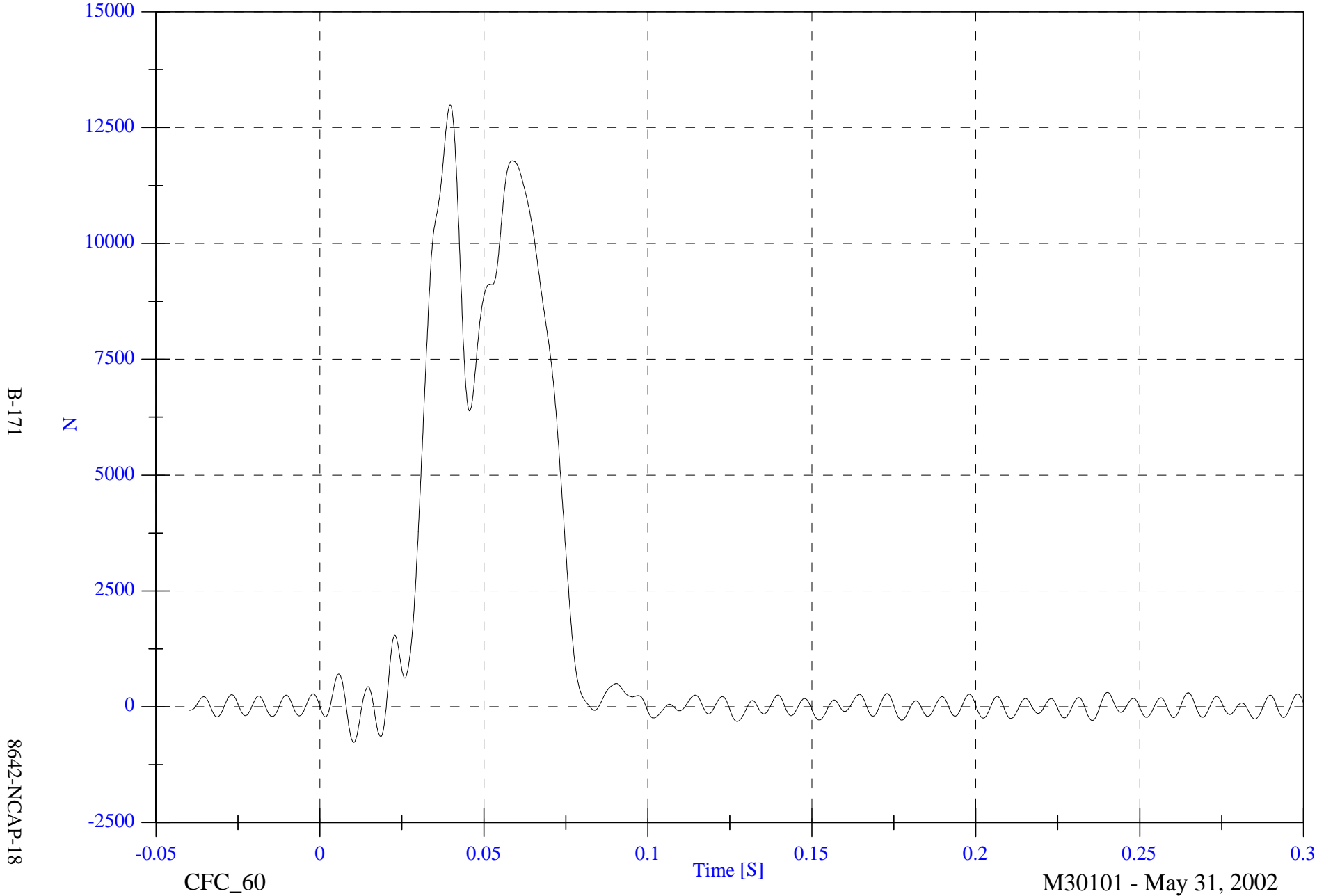

B-171

8642-NCAP-18

CFC_60

Time [S]

M30101 - May 31, 2002

NCAP Test 18- 2003 Cadillac CTS

Barrier Load Cell D9 Fx

Max: 1482.2 [N] at 0.022 [S]

Min: -1731.7 [N] at 0.046 [S]

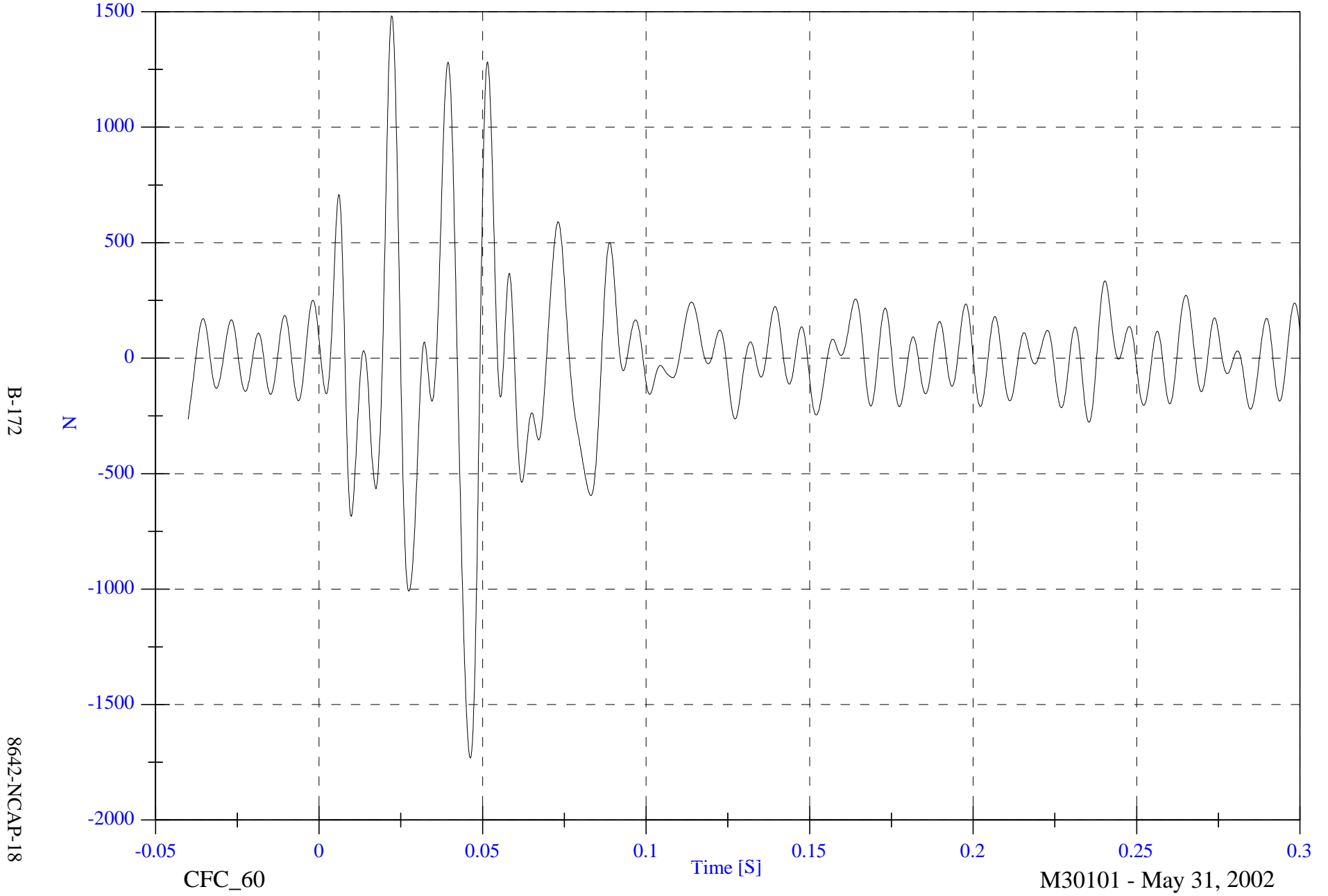

NCAP Test 18- 2003 Cadillac CTS

Group 1 Load Cell Sum (A1,A2,A3,B1,B2,B3)

Max: 122034.0 [N] at 0.032 [S]

Min: -1534.9 [N] at -0.040 [S]

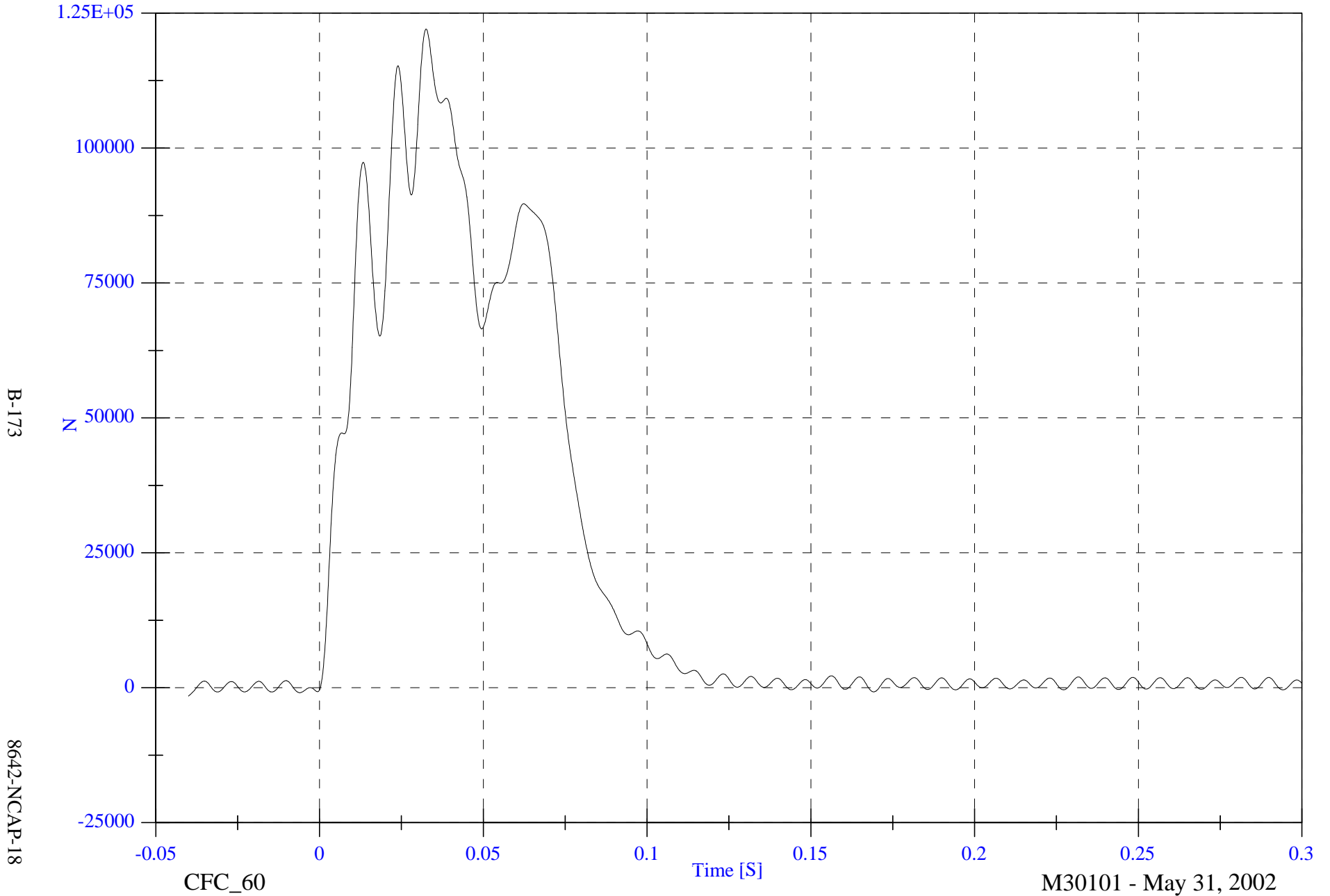

B-173

8642-NCAP-18

CFC_60

Time [S]

M30101 - May 31, 2002

NCAP Test 18- 2003 Cadillac CTS

Max: 327436.8 [N] at 0.042 [S]

Group 2 Load Cell Sum (A4,A5,A6,B4,B5,B6)

Min: -3188.3 [N] at -0.005 [S]

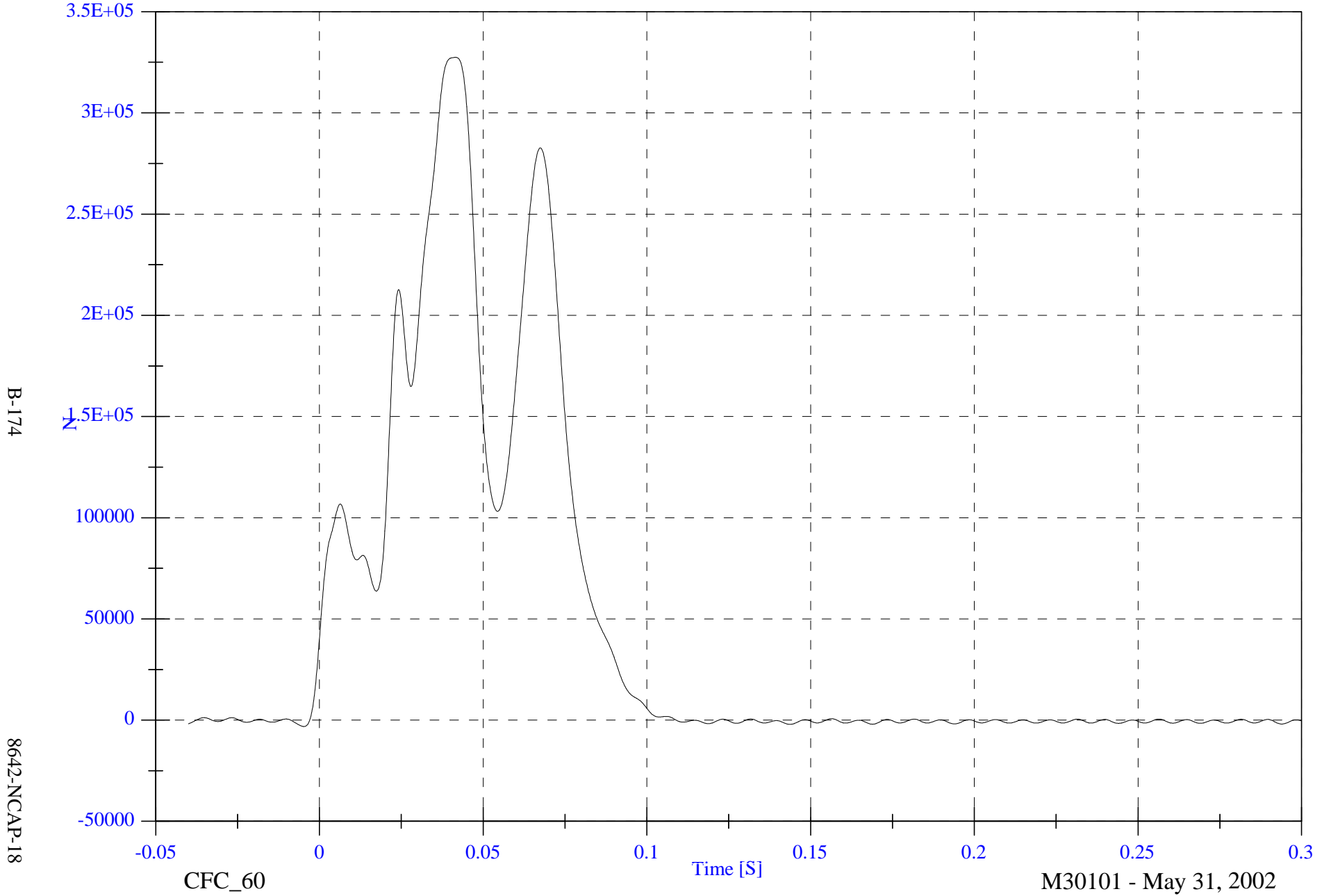

B-174

8642-NCAP-18

CFC_60

Time [S]

M30101 - May 31, 2002

NCAP Test 18- 2003 Cadillac CTS

Group 3 Load Cell Sum (A7,A8,A9,B7,B8,B9)

Max: 124078.4 [N] at 0.024 [S]

Min: -1453.3 [N] at 0.236 [S]

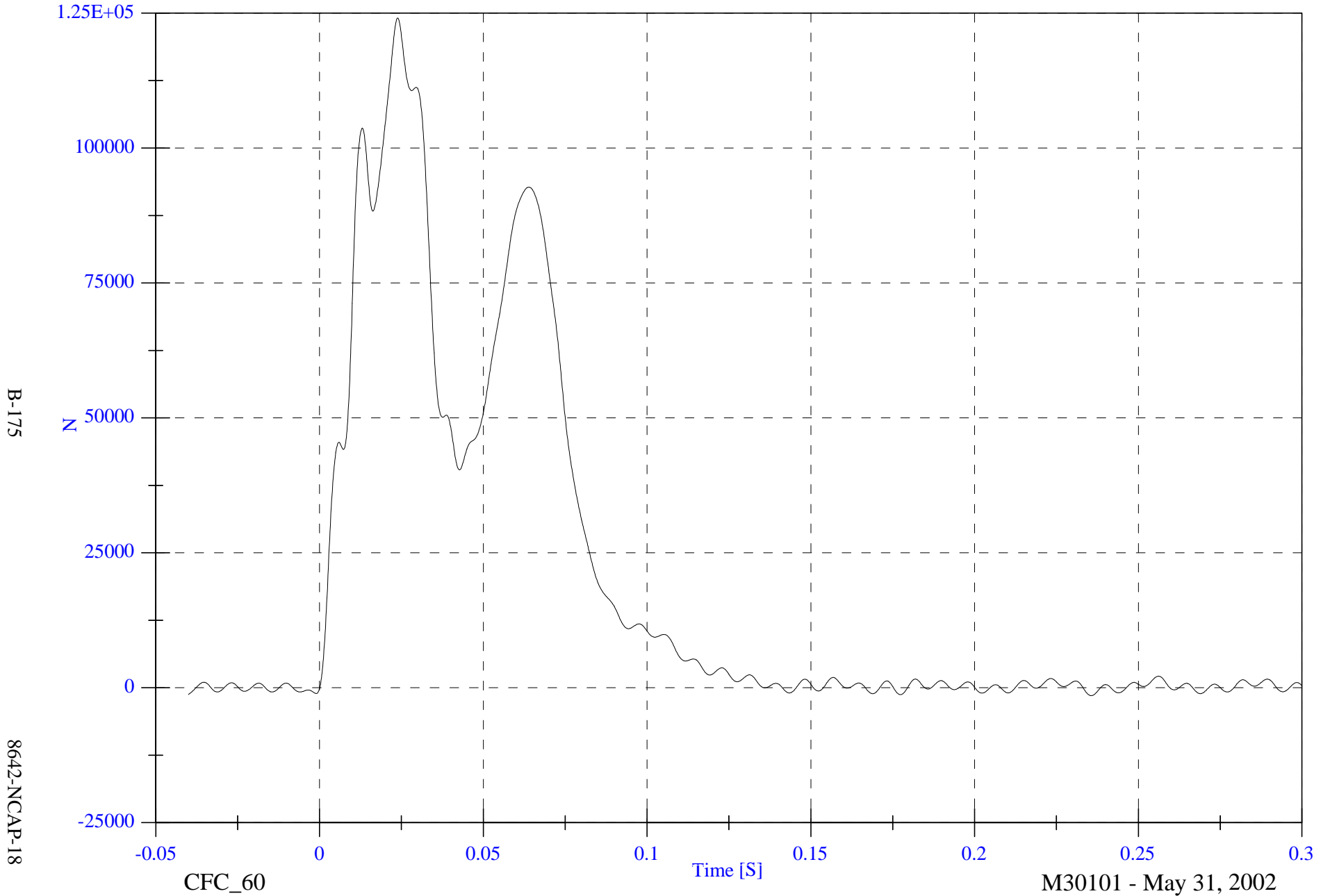

B-175

8642-NCAP-18

CFC_60

Time [S]

M30101 - May 31, 2002

NCAP Test 18- 2003 Cadillac CTS

Group 4 Load Cell Sum (C1,C2,C3,D1,D2,D3)

Max: 35536.9 [N] at 0.040 [S]

Min: -7189.5 [N] at 0.210 [S]

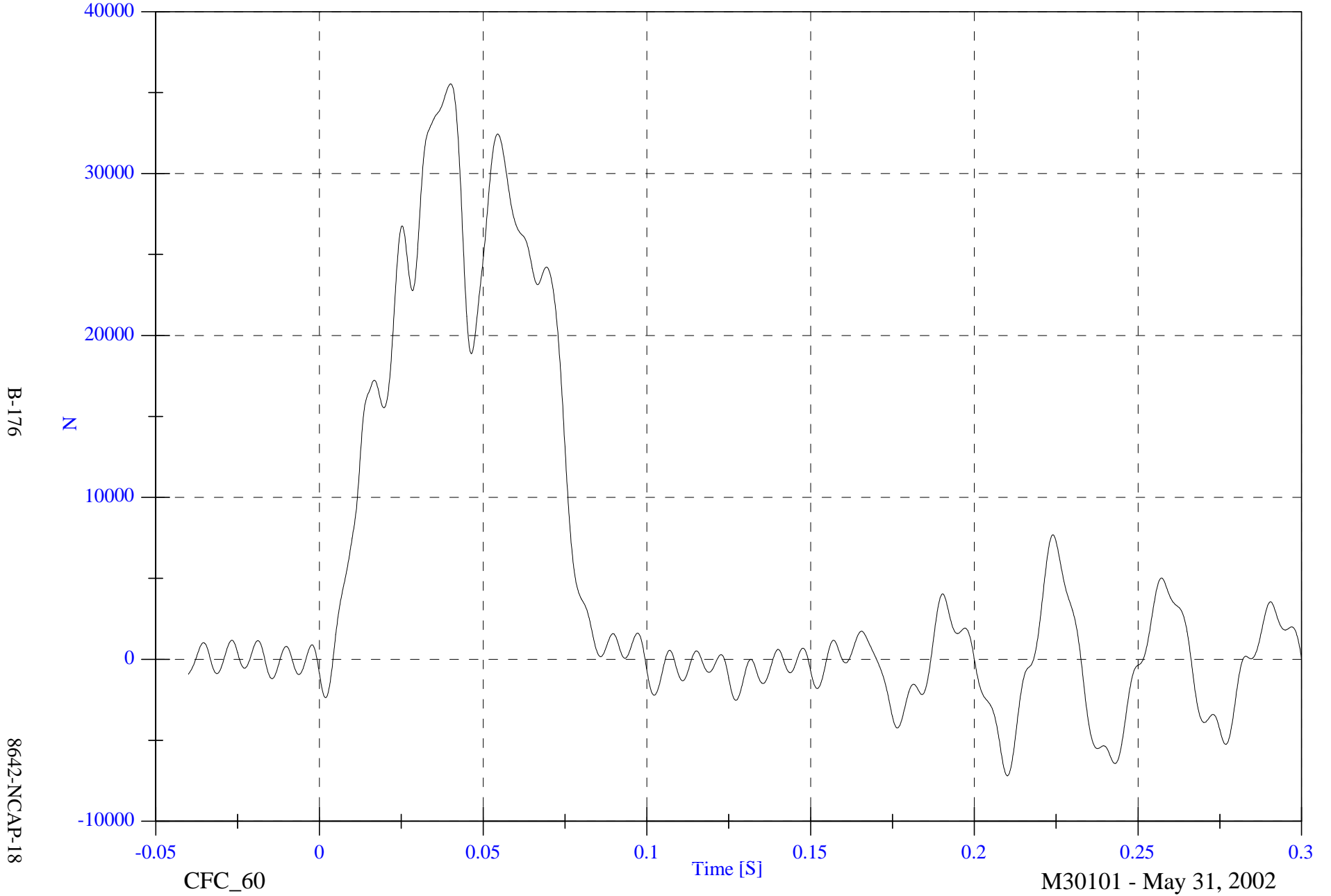

NCAP Test 18- 2003 Cadillac CTS

Group 5 Load Cell Sum (C4,C5,C6,D4,D5,D6)

Max: 74786.4 [N] at 0.041 [S]

Min: -6405.9 [N] at 0.211 [S]

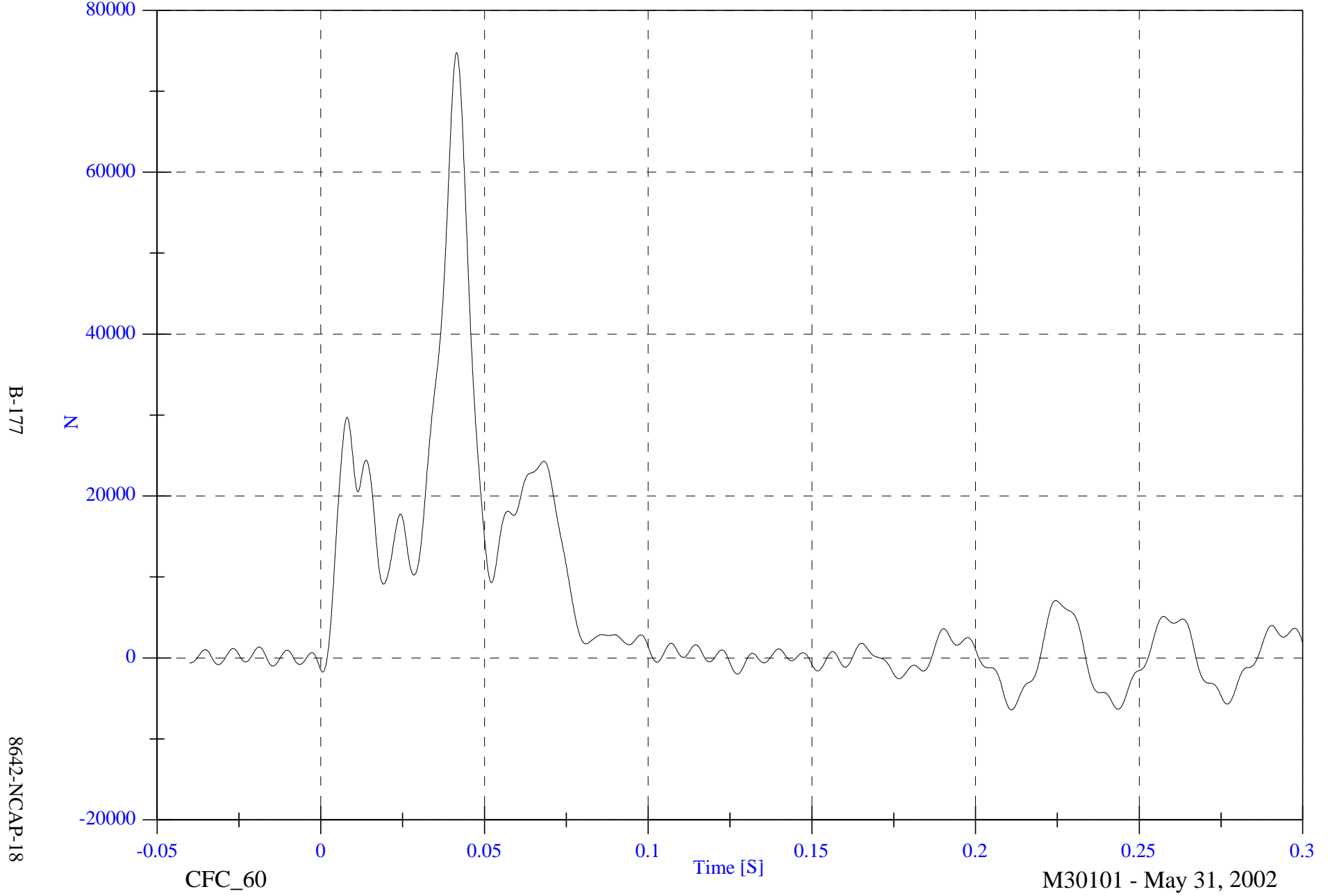

B-177

8642-NCAP-18

CFC_60

Time [S]

M30101 - May 31, 2002

NCAP Test 18- 2003 Cadillac CTS

Group 6 Load Cell Sum (C7,C8,C9,D7,D8,D9)

Max: 38889.3 [N] at 0.058 [S]

Min: -6317.9 [N] at 0.210 [S]

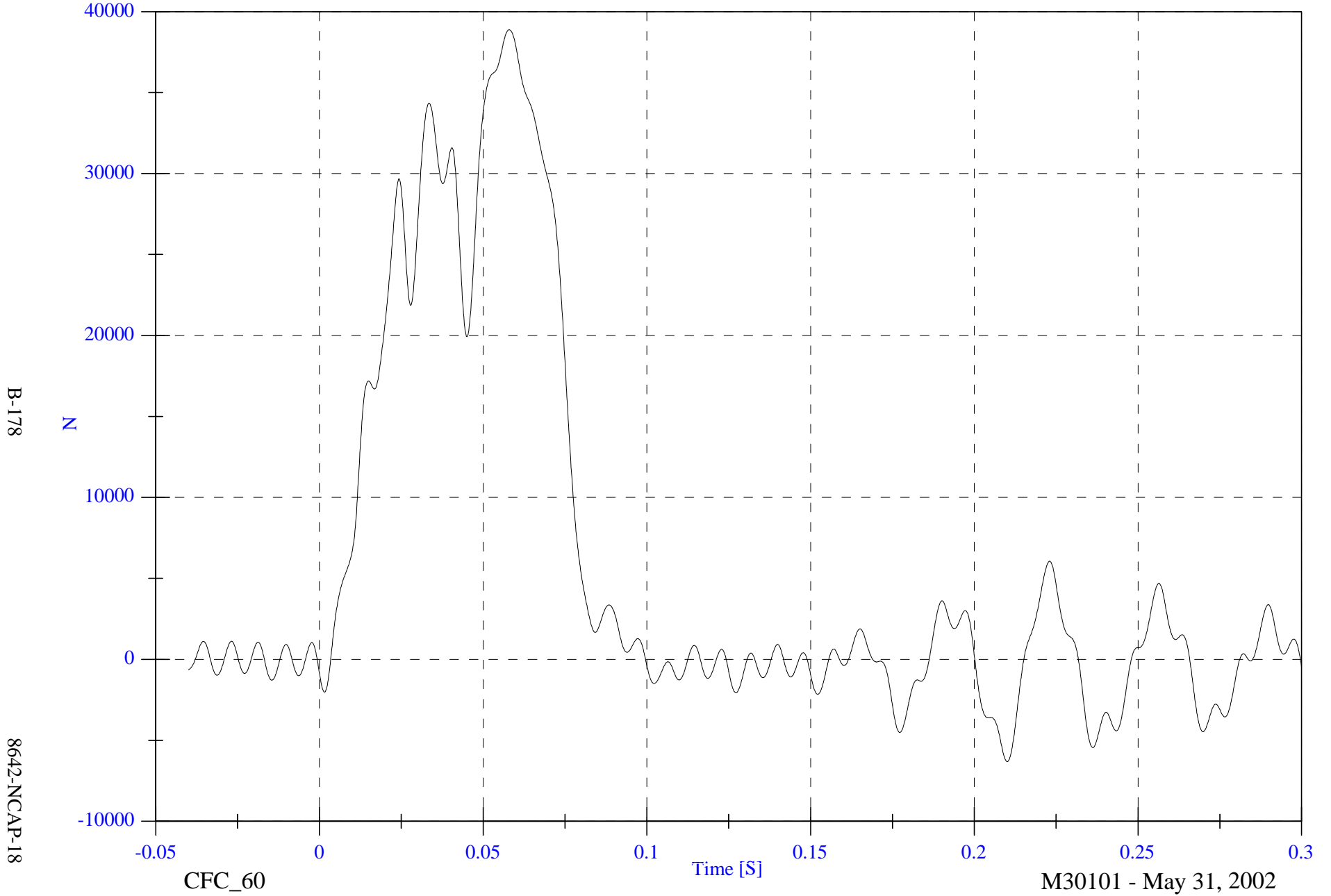

NCAP Test 18- 2003 Cadillac CTS

Max: 617932.4 [N] at 0.040 [S]

Total Load Cell Sum (All 6 Groups)

Min: -22261.1 [N] at 0.210 [S]

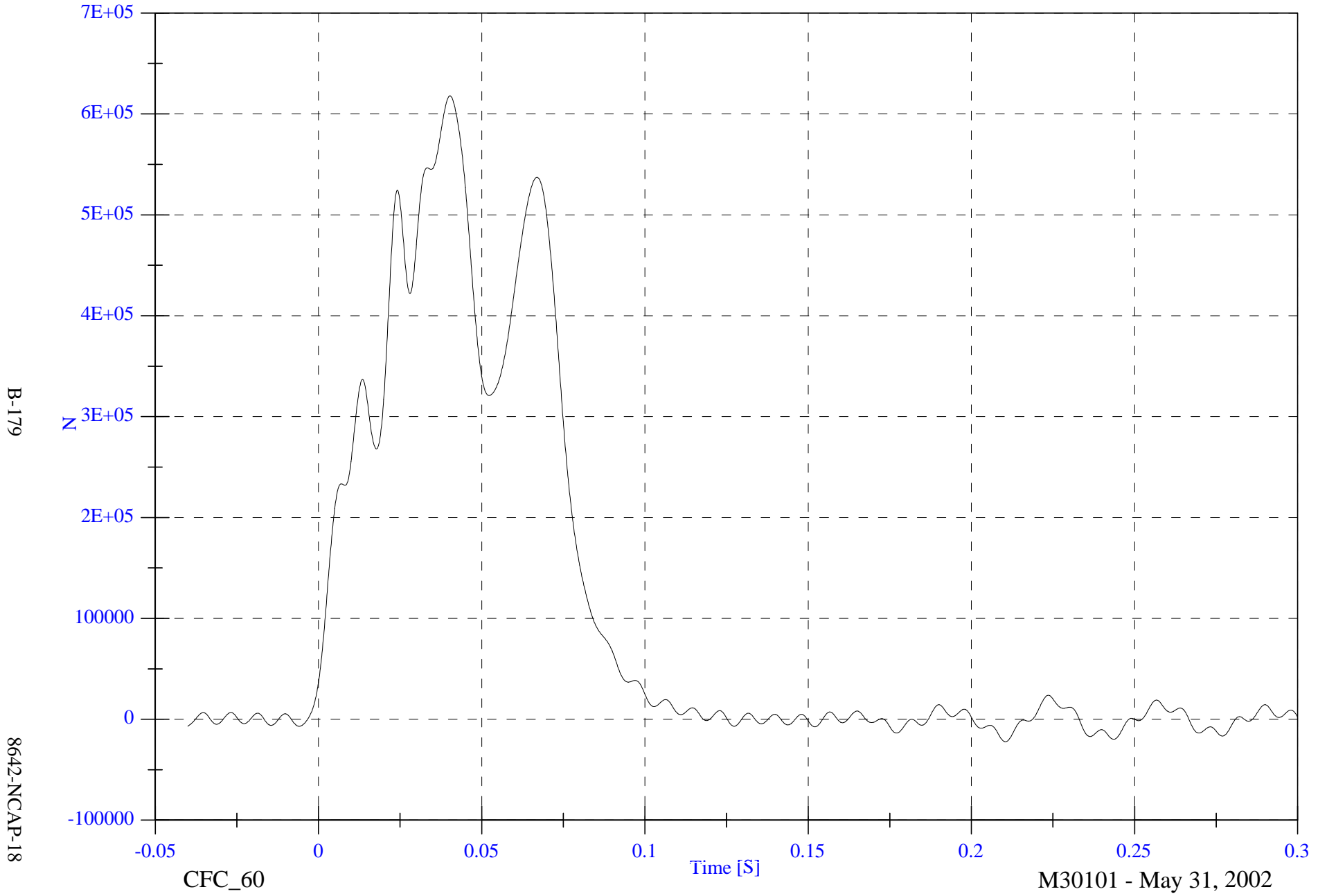

B-179

8642-NCAP-18

CFC_60

Time [S]

M30101 - May 31, 2002

APPENDIX C

**PART 572B/E DUMMY CONFIGURATION
AND PERFORMANCE VERIFICATION DATA SHEETS**

Appendix C contains the results from certification tests performed on the 50th percentile male anthropomorphic test devices utilized for this crash test. The results indicate that the dummies meet all of the performance requirements of the six standard tests as specified in 49 CFR Part 572, Federal Register, Volume 42, No. 25, dated February 7, 1977.

The tests were conducted at the Dummy Certification Test Facility of Veridian Engineering. A summary of the test results, and Part 572 specifications are included in this Appendix.

Dummy serial Appendix C contains the results from certification tests performed on the 50th percentile male anthropomorphic test devices utilized for this crash test. The results indicate that the dummies meet all of the performance requirements of the six standard tests as specified in 49 CFR Part 572, Federal Register, Volume 42, No. 25, dated February 7, 1977.

The tests were conducted at the Dummy Certification Test Facility of Veridian Engineering. A summary of the test results, and Part 572 specifications are included in this Appendix.

Dummy serial numbers and certification dates are:

<u>Position No./Location</u>	<u>Serial No.</u>	<u>Completion Date</u>
#1/Driver	150	May 16, 2002
#2/Right Front Passenger	245	May 16, 2002

Electronic Test Equipment

The complement of signal conditioning, recording and display equipment, in conjunction with dummy certification testing, can be found in New Car Assessment and Standards Indicant Testing Final Report No. 6525-V-1.

DUMMY CONFIGURATION DIMENSIONS

EXTERNAL DIMENSIONS
SPECIFICATIONS

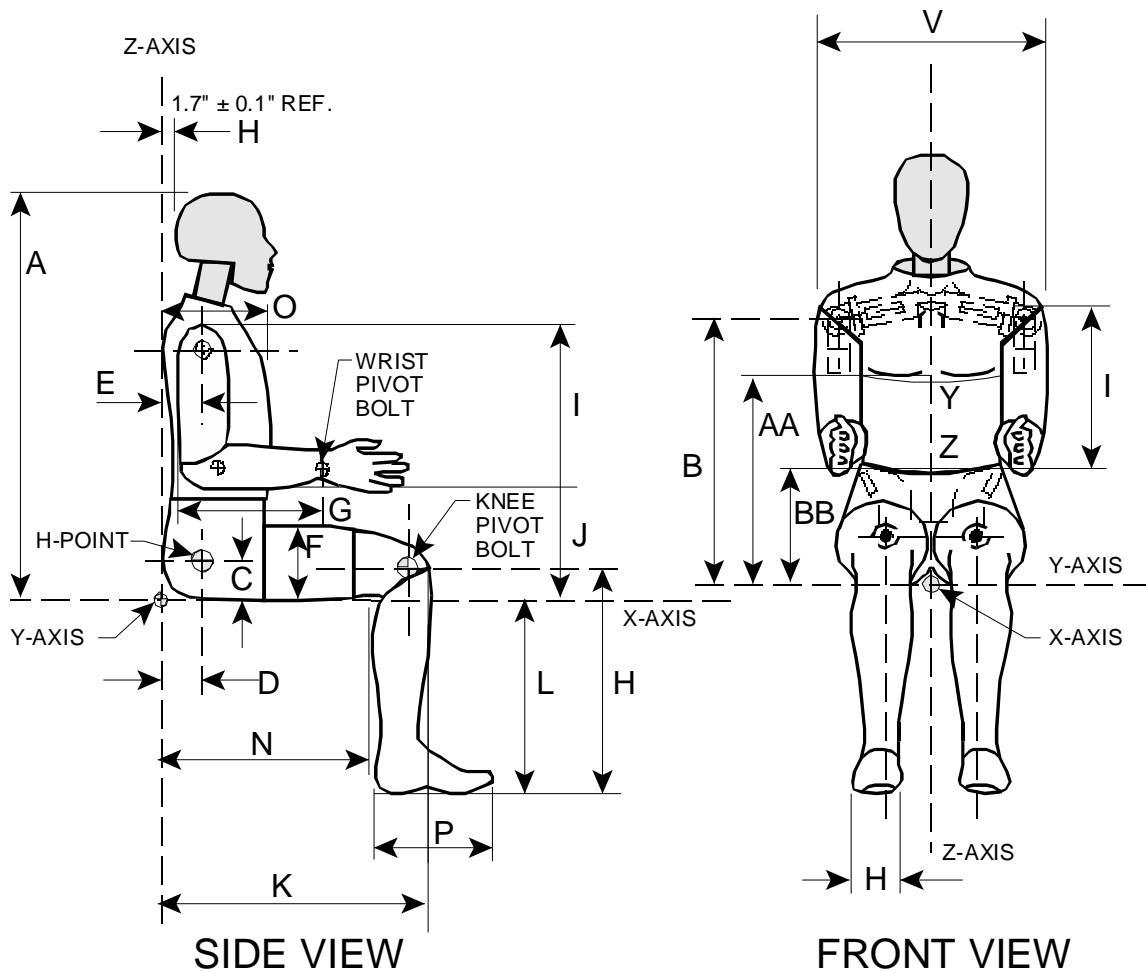

NOTE: Figure is referenced to the erect seated position. The curved lumbar does not allow the Hybrid III to be positioned in a perfect erect attitude. (REF: S572.31(A)(6))

PART 572E
HEAD DROP TEST

Dummy Serial Number 150
Sequential Test Number 1
Date May 9, 2002
Workfile 150H

TEST PARAMETER	SPECIFICATION	TEST RESULTS
Temperature	66-78 Deg F	70.0
Relative Humidity	10% - 70%	33.0
Peak Resultant Acceleration	225-275 G's	237.55
Peak Lateral Acceleration	15 G's Max	5.23
Is Acceleration Curve Unimodal?	YES	YES

Remarks:

Laboratory Technician:

B. Swiecicki

PART 572E
NECK EXTENSION TEST

Dummy Serial Number	150	
Sequential Test Number	1	
Date	May 14, 2002	6 Axis Neck Transducer
Workfile	150Ext	

TEST PARAMETER		SPECIFICATION	TEST RESULTS
Temperature		69-72 Deg F	70.0
Relative Humidity		10% - 70%	42.0
Impact Velocity		19.50 - 20.30 Ft/s	19.84
Pendulum Deceleration	10 ms	17.20 - 21.20 G's	19.02
	20 ms	14.00 - 19.00 G's	16.34
	30 ms	11.00 - 16.00 G's	13.32
Max Pendulum G's Above 30 ms		22 G's Max	14.20
Deceleration - Time Curve Decay Time to 5 G's		38 - 46 ms	40.10
D Plane Rotation	Max	81 - 106 Deg	96.09
	Time	72 - 82 ms	77.60
Moment About Occipital Condyle	Max	-59.0 - -39.0 Ft-Lbs	-44.80
	Time	65 - 79 ms	74.0
Rotation Angle - Time Curve Decay Time to Zero		147 - 174 ms	156.50
Positive Moment - Time Curve Decay Time to Zero		120 - 148 ms	145.70

Remarks:

Laboratory Technician:

B. Swiecicki

PART 572E
THORAX IMPACT TEST

Dummy Serial Number 150
Sequential Test Number 1
Date May 16, 2002
Workfile 150T

TEST PARAMETER	SPECIFICATION	TEST RESULTS
Temperature	69-72 Deg F	71.0
Relative Humidity	10% - 70%	36.0
Pendulum Velocity	21.6 - 22.4 Ft/s	22.01
Maximum Deflection	2.50 - 2.86 in	2.58
Maximum Resistive Force	1160 - 1325 Lbs	1297.31
Internal Hysteresis	69 - 85 %	72.32

Remarks:

Laboratory Technician:

_____ B. Swiecicki

PART 572E
KNEE IMPACT TEST

Dummy Serial Number 150
 Sequential Test Number 1
 Date May 16, 2002
 Workfile 150LF/150RF

TEST PARAMETER	SPECIFICATION	TEST RESULTS
LEFT KNEE		
Temperature	66 - 78 Deg F	71.0
Relative Humidity	10% - 70%	41.0
Probe Velocity	6.8 - 7.0 Ft/s	7.00
Peak Knee Impact Force	1060 - 1300 Lbs	1166.09
RIGHT KNEE		
Temperature	66 - 78 Deg F	71.0
Relative Humidity	10% - 70%	41.0
Probe Velocity	6.8 - 7.0 Ft/s	7.00
Peak Knee Impact Force	1060 - 1300 Lbs	1177.25

Remarks:

Laboratory Technician:

_____ B. Swiecicki

PART 572E
EXTERNAL DIMENSIONS

Dummy Serial Number 150
 Sequential Test Number 1
 Date May 16, 2002

TEST PARAMETER		SPECIFICATION	TEST RESULTS
Temperature			71
Relative Humidity			40
Location for Chest Circumference	AA	16.9 - 17.1 in	17.0
Location for Waist Circumference	BB	8.9 - 9.1 in	9.0
Chest Circumference (With Jacket)	Y	38.2 - 39.4 in	39.1
Waist Circumference	Z	32.9 - 34.1 in	34.0
Chest Depth	O	8.4 - 9.0 in	8.4
H-Point Height	C	3.3 - 3.5 in	3.4
H-Point from Backline	D	5.3 - 5.5 in	5.4
Skull Cap to Backline	H	1.6 - 1.8 in	1.7
Total Sitting Height	A	34.6 - 35.0 in	34.6
Thigh Clearance	F	5.5 - 6.1 in	5.8
Buttock Knee Length	K	22.8 - 23.8 in	23.4
Buttock Popliteal Length	N	17.8 - 18.8 in	18.5
Popliteal Height	L	16.9 - 17.9 in	17.8
Knee Pivot Height	M	19.1 - 19.7 in	19.6
Foot Length	P	9.9 - 10.5 in	10.1
Foot Breadth	W	3.6 - 4.2 in	3.8
Shoulder Pivot from Backline	E	3.3 - 3.7 in	3.7
Shoulder Breadth	V	16.6 - 17.2 in	16.8
Shoulder Pivot Height	B	19.9 - 20.5 in	20.2
Elbow Rest Height	J	7.5 - 8.3 in	8.1
Shoulder - Elbow Length	I	13.0 - 13.6 in	13.2
Back of Elbow to Wrist Pivot	G	11.4 - 12.0 in	11.5

Remarks:

Laboratory Technician:

B. Swiecicki

PART 572E
HEAD DROP TEST

Dummy Serial Number 245
Sequential Test Number 1
Date May 10, 2002
Workfile 245H

TEST PARAMETER	SPECIFICATION	TEST RESULTS
Temperature	66-78 Deg F	71.0
Relative Humidity	10% - 70%	40.0
Peak Resultant Acceleration	225-275 G's	264.25
Peak Lateral Acceleration	15 G's Max	13.14
Is Acceleration Curve Unimodal?	YES	YES

Remarks:

Laboratory Technician:

B. Swiecicki

PART 572E
NECK FLEXION TEST

Dummy Serial Number	245	
Sequential Test Number	1	
Date	May 10, 2002	6 Axis Neck Transducer
Workfile	245Flx	

TEST PARAMETER	SPECIFICATION	TEST RESULTS
Temperature	69-72 Deg F	70.0
Relative Humidity	10% - 70%	40.0
Impact Velocity	22.60 - 23.40 Ft/s	23.05
Pendulum Deceleration	10 ms	22.50 - 27.50 G's
	20 ms	17.60 - 22.60 G's
	30 ms	12.50 - 18.50 G's
Max Pendulum G's Above 30 ms	29 G's Max	16.65
Deceleration - Time Curve Decay Time to 5 G's	34 - 42 ms	35.90
D Plane Rotation	Max	64 - 78 Deg
	Time	57 - 64 ms
Moment About Occipital Condyle	Max	65 - 80 Ft-Lbs
	Time	47 - 58 ms
Rotation Angle - Time Curve Decay Time to Zero	113 - 128 ms	122.70
Positive Moment - Time Curve Decay Time to Zero	97 - 107 ms	103.00

Remarks:

Laboratory Technician:

B. Swiecicki

PART 572E
NECK EXTENSION TEST

Dummy Serial Number	245	
Sequential Test Number	1	
Date	May 14, 2002	6 Axis Neck Transducer
Workfile	245Ext	

TEST PARAMETER		SPECIFICATION	TEST RESULTS
Temperature		69-72 Deg F	69.0
Relative Humidity		10% - 70%	41.0
Impact Velocity		19.50 - 20.30 Ft/s	19.84
Pendulum Deceleration	10 ms	17.20 - 21.20 G's	19.02
	20 ms	14.00 - 19.00 G's	16.22
	30 ms	11.00 - 16.00 G's	13.25
Max Pendulum G's Above 30 ms		22 G's Max	13.52
Deceleration - Time Curve Decay Time to 5 G's		38 - 46 ms	39.80
D Plane Rotation	Max	81 - 106 Deg	100.89
	Time	72 - 82 ms	77.50
Moment About Occipital Condyle	Max	-59.0 - -39.0 Ft-Lbs	-41.99
	Time	65 - 79 ms	72.10
Rotation Angle - Time Curve Decay Time to Zero		147 - 174 ms	164.60
Positive Moment - Time Curve Decay Time to Zero		120 - 148 ms	144.20

Remarks:

Laboratory Technician:

B. Swiecicki

PART 572E
THORAX IMPACT TEST

Dummy Serial Number 245
Sequential Test Number 1
Date May 16, 2002
Workfile 245T

TEST PARAMETER	SPECIFICATION	TEST RESULTS
Temperature	69-72 Deg F	70.0
Relative Humidity	10% - 70%	35.0
Pendulum Velocity	21.6 - 22.4 Ft/s	22.12
Maximum Deflection	2.50 - 2.86 in	2.54
Maximum Resistive Force	1160 - 1325 Lbs	1266.06
Internal Hysteresis	69 - 85 %	73.50

Remarks:

Laboratory Technician:

_____ B. Swiecicki

PART 572E
KNEE IMPACT TEST

Dummy Serial Number 245
 Sequential Test Number 1
 Date May 16, 2002
 Workfile 245LF/245RF

TEST PARAMETER	SPECIFICATION	TEST RESULTS
LEFT KNEE		
Temperature	66 - 78 Deg F	71.0
Relative Humidity	10% - 70%	41.0
Probe Velocity	6.8 - 7.0 Ft/s	7.00
Peak Knee Impact Force	1060 - 1300 Lbs	1197.12
RIGHT KNEE		
Temperature	66 - 78 Deg F	71.0
Relative Humidity	10% - 70%	41.0
Probe Velocity	6.8 - 7.0 Ft/s	7.00
Peak Knee Impact Force	1060 - 1300 Lbs	1280.43

Remarks:

Laboratory Technician:

_____ B. Swiecicki

PART 572E
EXTERNAL DIMENSIONS

Dummy Serial Number 245
 Sequential Test Number 1
 Date May 16, 2002

TEST PARAMETER		SPECIFICATION	TEST RESULTS
Temperature			71
Relative Humidity			40
Location for Chest Circumference	AA	16.9 - 17.1 in	17.0
Location for Waist Circumference	BB	8.9 - 9.1 in	9.0
Chest Circumference (With Jacket)	Y	38.2 - 39.4 in	39.2
Waist Circumference	Z	32.9 - 34.1 in	33.8
Chest Depth	O	8.4 - 9.0 in	8.4
H-Point Height	C	3.3 - 3.5 in	3.4
H-Point from Backline	D	5.3 - 5.5 in	5.4
Skull Cap to Backline	H	1.6 - 1.8 in	1.7
Total Sitting Height	A	34.6 - 35.0 in	34.7
Thigh Clearance	F	5.5 - 6.1 in	6.0
Buttock Knee Length	K	22.8 - 23.8 in	23.4
Buttock Popliteal Length	N	17.8 - 18.8 in	18.5
Popliteal Height	L	16.9 - 17.9 in	17.5
Knee Pivot Height	M	19.1 - 19.7 in	19.2
Foot Length	P	9.9 - 10.5 in	10.2
Foot Breadth	W	3.6 - 4.2 in	3.8
Shoulder Pivot from Backline	E	3.3 - 3.7 in	3.6
Shoulder Breadth	V	16.6 - 17.2 in	16.8
Shoulder Pivot Height	B	19.9 - 20.5 in	20.2
Elbow Rest Height	J	7.5 - 8.3 in	8.0
Shoulder - Elbow Length	I	13.0 - 13.6 in	13.2
Back of Elbow to Wrist Pivot	G	11.4 - 12.0 in	11.6

Remarks:

Laboratory Technician:

B. Swiecicki

APPENDIX D

DUMMY, VEHICLE AND LABORATORY INSTRUMENT CALIBRATION

INSTRUMENT CALIBRATION FOR DRIVER DUMMY
(Six Month Calibration Minimum)

DRIVER DUMMY (S/N 150)	Manufacturer	Serial #	Calibration		
			Last	Next	
Head 9 Array	X Arm Y	ENDEVCO	AC-P17531	25-Mar-02	25-Sep-02
	X Arm Z	ENDEVCO	AC-P14965	25-Mar-02	25-Sep-02
	Y Arm X	ENDEVCO	AC-P17563	25-Mar-02	25-Sep-02
	Y Arm Z	ENDEVCO	AC-P18551	25-Mar-02	25-Sep-02
	Z Arm X	ENDEVCO	AC-P17539	25-Mar-02	25-Sep-02
	Z Arm Y	ENDEVCO	AC-P18718	25-Mar-02	25-Sep-02
Head	X	ENDEVCO	AC-P16832	26-Mar-02	26-Sep-02
	Y	ENDEVCO	AC-P16591	26-Mar-02	26-Sep-02
	Z	ENDEVCO	AC-P16286	26-Mar-02	26-Sep-02
Head	X (R)	ENDEVCO	AC-P17141	26-Mar-02	26-Sep-02
	Y (R)	ENDEVCO	AC-P17242	26-Mar-02	26-Sep-02
	Z (R)	ENDEVCO	AC-P17152	26-Mar-02	26-Sep-02
Neck Load Cell	X	DENTON	LC-269Fx	17-Jan-02	17-Jul-02
	Y	DENTON	LC-269Fy	17-Jan-02	17-Jul-02
	Z	DENTON	LC-269Fz	17-Jan-02	17-Jul-02
Neck Moment	X	DENTON	LC-269Mx	17-Jan-02	17-Jul-02
	Y	DENTON	LC-269My	17-Jan-02	17-Jul-02
	Z	DENTON	LC-269Mz	17-Jan-02	17-Jul-02
Chest	X	ENDEVCO	AC-P17235	04-Apr-02	04-Oct-02
	Y	ENDEVCO	AC-P14393	04-Apr-02	04-Oct-02
	Z	ENDEVCO	AC-P17285	04-Apr-02	04-Oct-02
Chest	X (R)	ENDEVCO	AC-P16863	04-Apr-02	04-Oct-02
	Y (R)	ENDEVCO	AC-P17248	04-Apr-02	04-Oct-02
	Z (R)	ENDEVCO	AC-P17283	04-Apr-02	04-Oct-02
Chest Deflection	X	SERVO	DS-150	22-Mar-02	22-Sep-02
Pelvic	X	ENDEVCO	AC-J30041	25-Mar-02	25-Sep-02
	Y	ENDEVCO	AC-P13355	25-Mar-02	25-Sep-02
	Z	ENDEVCO	AC-P13329	25-Mar-02	25-Sep-02

INSTRUMENT CALIBRATION FOR DRIVER DUMMY
(Six Month Calibration Minimum)

DRIVER DUMMY (S/N 150)	Manufacturer	Serial #	Calibration		
			Last	Next	
Left Femur Load Cell Fz	GSE	LC-418	24-Jan-02	24-Jul-02	
Right Femur Load Cell Fz	GSE	LC-419	24-Jan-02	24-Jul-02	
Left Upper Tibia	Mx	DENTON	LC-265Mx	16-May-02	16-Nov-02
	My	DENTON	LC-265My	16-May-02	16-Nov-02
Left Lower Tibia	Fz	DENTON	LC-178Fz	16-May-02	16-Nov-02
	Mx	DENTON	LC-178Mx	16-May-02	16-Nov-02
	My	DENTON	LC-178My	16-May-02	16-Nov-02
Right Upper Tibia	Mx	DENTON	LC-199Mx	16-May-02	16-Nov-02
	My	DENTON	LC-199My	16-May-02	16-Nov-02
Right Lower Tibia	Fz	DENTON	LC-128Fz	16-May-02	16-Nov-02
	Mx	DENTON	LC-128Mx	16-May-02	16-Nov-02
	My	DENTON	LC-128My	16-May-02	16-Nov-02
Left Foot Rear	X	ENDEVCO	AC-J19868	17-May-02	17-Nov-02
	Z	ENDEVCO	AC-AJ8C0	17-May-02	17-Nov-02
Left Foot Front	Z	ENDEVCO	AC-J34378	17-May-02	17-Nov-02
Right Foot Rear	X	ENDEVCO	AC-AJ7F6	17-May-02	17-Nov-02
	Z	ENDEVCO	AC-J27079	17-May-02	17-Nov-02
Right Foot Front	Z	ENDEVCO	AC-J23997	17-May-02	17-Nov-02

INSTRUMENT CALIBRATION FOR PASSENGER DUMMY
(Six Month Calibration Minimum)

PASSENGER DUMMY (S/N 245)	Manufacturer	Serial #	Calibration		
			Last	Next	
Head 9 Array	X Arm Y	ENDEVCO	AC-P18558	21-Mar-02	21-Sep-02
	X Arm Z	ENDEVCO	AC-P19212	21-Mar-02	21-Sep-02
	Y Arm X	ENDEVCO	AC-P19197	21-Mar-02	21-Sep-02
	Y Arm Z	ENDEVCO	AC-P18738	21-Mar-02	21-Sep-02
	Z Arm X	ENDEVCO	AC-P19217	21-Mar-02	21-Sep-02
	Z Arm Y	ENDEVCO	AC-P18739	21-Mar-02	21-Sep-02
Head	X	ENDEVCO	AC-J32184	22-Mar-02	22-Sep-02
	Y	ENDEVCO	AC-J32185	22-Mar-02	22-Sep-02
	Z	ENDEVCO	AC-J31011	22-Mar-02	22-Sep-02
Head	X (R)	ENDEVCO	AC-J31020	24-Mar-02	24-Mar-02
	Y (R)	ENDEVCO	AC-J31101	22-Mar-02	22-Sep-02
	Z (R)	ENDEVCO	AC-J31059	22-Mar-02	22-Sep-02
Neck Load Cell	X	DENTON	LC-076Fx	17-Jan-02	17-Jul-02
	Y	DENTON	LC-076Fy	17-Jan-02	17-Jul-02
	Z	DENTON	LC-076Fz	17-Jan-02	17-Jul-02
Neck Moment	X	DENTON	LC-076Mx	17-Jan-02	17-Jul-02
	Y	DENTON	LC-076My	17-Jan-02	17-Jul-02
	Z	DENTON	LC-076Mz	17-Jan-02	17-Jul-02
Chest	X	ENDEVCO	AC-J34019	21-Mar-02	21-Sep-02
	Y	ENDEVCO	AC-J33018	21-Mar-02	21-Sep-02
	Z	ENDEVCO	AC-J32783	21-Mar-02	21-Sep-02
Chest	X (R)	ENDEVCO	AC-J31066	21-Mar-02	21-Sep-02
	Y (R)	ENDEVCO	AC-P16979	21-Mar-02	21-Sep-02
	Z (R)	ENDEVCO	AC-J31022	21-Mar-02	21-Sep-02
Chest Deflection	X	SERVO	DS-245	22-Mar-02	22-Sep-02
Pelvic	X	ENDEVCO	AC-J31034	21-Mar-02	21-Sep-02
	Y	ENDEVCO	AC-P17258	21-Mar-02	21-Sep-02
	Z	ENDEVCO	AC-J31010	21-Mar-02	21-Sep-02

INSTRUMENT CALIBRATION FOR PASSENGER DUMMY
(Six Month Calibration Minimum)

PASSENGER DUMMY (S/N 245)	Manufacturer	Serial #	Calibration		
			Last	Next	
Left Femur Load Cell Fz	GSE	LC-551	24-Jan-02	24-Jul-02	
Right Femur Load Cell Fz	GSE	LC-951	24-Jan-02	24-Jul-02	
Left Upper Tibia	Mx	DENTON	LC-200Mx	16-May-02	16-Nov-02
	My	DENTON	LC-200My	16-May-02	16-Nov-02
Left Lower Tibia	Fz	DENTON	LC-129Fz	16-May-02	16-Nov-02
	Mx	DENTON	LC-129Mx	16-May-02	16-Nov-02
	My	DENTON	LC-129My	16-May-02	16-Nov-02
Right Upper Tibia	Mx	DENTON	LC-264Mx	16-May-02	16-Nov-02
	My	DENTON	LC-264My	16-May-02	16-Nov-02
Right Lower Tibia	Fz	DENTON	LC-177Fz	16-May-02	16-Nov-02
	Mx	DENTON	LC-177Mx	16-May-02	16-Nov-02
	My	DENTON	LC-177My	16-May-02	16-Nov-02
Left Foot Rear	X	ENDEVCO	AC-J18059	17-May-02	17-Nov-02
	Z	ENDEVCO	AC-J18662	17-May-02	17-Nov-02
Left Foot Front	Z	ENDEVCO	AC-J36176	17-May-02	17-Nov-02
Right Foot Rear	X	ENDEVCO	AC-J20084	17-May-02	17-Nov-02
	Z	ENDEVCO	AC-J28727	17-May-02	17-Nov-02
Right Foot Front	Z	ENDEVCO	AC-J18738	17-May-02	17-Nov-02

INSTRUMENT CALIBRATION FOR VEHICLE ACCELEROMETERS
(Six Month Calibration Minimum)

	Manufacturer	Serial #	Calibration	
			Last	Next
Left Seat Rear Crossmember X	ICS	AC-X83	15-Jan-02	15-Jul-02
Right Rear Seat Crossmember X	ICS	AC-X86	25-Apr-02	25-Oct-02
Top of Engine	ENDEVCO	AC-J22064	25-Apr-02	25-Oct-02
Bottom of Engine	ENDEVCO	AC-J32186	11-Feb-02	11-Aug-02
Right Disc Brake Caliper	ENDEVCO	AC-J32098	14-Feb-02	14-Aug-02
Instrument Panel	ENDEVCO	AC-P23288	25-Apr-02	25-Oct-02
Left Disc Brake Caliper	ENDEVCO	AC-J32383	14-Feb-02	14-Aug-02
Left Seat Rear Crossmember Z	ICS	AC-D82	04-Apr-02	04-Oct-02
Right Seat Rear Crossmember Z	ICS	AC-Y13	11-Feb-02	11-Aug-02