

**REPORT NUMBER KAR21061-01**

**NEW CAR ASSESSMENT PROGRAM  
FRONTAL BARRIER IMPACT TEST**

**HONDA MOTOR COMPANY  
2002 HONDA CR-V LX  
4WD SUV**

**NHTSA NUMBER: HO5300**

**PREPARED BY:  
KARCO ENGINEERING, LLC  
9270 HOLLY ROAD  
ADELANTO, CALIFORNIA 92301**



**FEBRUARY 15, 2002**

**FINAL REPORT**

**PREPARED FOR:  
U.S. DEPARTMENT OF TRANSPORTATION  
NATIONAL HIGHWAY TRAFFIC SAFETY ADMINISTRATION  
SAFETY PERFORMANCE STANDARDS  
OFFICE OF CRASHWORTHINESS STANDARDS  
MAIL CODE: NPS-10  
400 SEVENTH STREET, SW, ROOM 5313  
WASHINGTON, D.C. 20590**

This final test report was prepared for the U.S. Department of Transportation, National Highway Traffic Safety Administration, in response to Contract Number DTNH22-01-D-02005.

This publication is distributed by the U.S. Department of Transportation, National Highway Traffic Safety Administration, in the interest of information exchange. The opinions, findings and conclusions expressed in this publication are those of the author(s) and not necessarily those of the Department of Transportation or the National Highway Traffic Safety Administration. The United States Government assumes no liability for its contents or use thereof. If trade or manufacturers' names or products are mentioned, it is only because they are considered essential to the object of the publication and should not be construed as an endorsement. The United States Government does not endorse products or manufacturers.

Prepared by: \_\_\_\_\_  
Mr. James E. Gorth, Project Engineer  
KARCO Engineering, LLC

Date: February 15, 2002

Reviewed by: \_\_\_\_\_  
Mr. Jerry L. Kratzke, Director of Operations  
KARCO Engineering, LLC

Date: February 15, 2002

Approved by: \_\_\_\_\_  
Mr. Frank D. Richardson, Program Manager  
KARCO Engineering, LLC

Date: February 15, 2002

FINAL REPORT ACCEPTED BY:

\_\_\_\_\_  
Manager, New Car Assessment Program

\_\_\_\_\_  
Date of Acceptance

\_\_\_\_\_  
COTR, NCAP Frontal Impact Program

\_\_\_\_\_  
Date of Acceptance

### Technical Report Documentation Page

1. Report No.  KAR21061-01	2. Government Accession No.	3. Recipients Catalog No.	
4. Title and Subtitle  Final Report of New Car Assessment Program Testing of a 2002 Honda CR-V LX 4WD SUV NHTSA No. HO5300		5. Report Date  February 15, 2002	
7. Author(s)  Mr. James E Gorth, Project Engineer, Karco Mr. Frank Richardson, Project Manager, Karco		6. Performing Organization Code  KAR	
9. Performing Organization Name and Address  KARCO Engineering, LLC 9270 Holly Road Adelanto, CA 92301		8. Performing Organization Report No.  KAR21061-01	
12. Sponsoring Agency Name and Address  U.S. Department of Transportation National Highway Traffic Safety Administration Safety Performance Standards Office of Crashworthiness Standards Mail Code: NPS-10 400 Seventh Street, SW, Room 5313 Washington, D.C. 20590		10. Work Unit No.	
15. Supplementary Notes		11. Contract or Grant No.  DTNH22-01-D-02005	
16. Abstract  A 35 mph (56.3 km/h) frontal barrier impact was conducted on a 2002 honda CR-V LX 4WD SUV at KARCO Engineering, LLC on 1/29/02. This test was conducted to obtain data indicant of FMVSS 208, 212, 219 (partial), 301, and footwell intrusion performance. The impact velocity is 55.6 km/h. The ambient temperature at the barrier face at the time of impact is 3.3 degrees Celcius. The vehicle's maximum post test static crush is 543 mm located to the left of the vehicle centerline. The test vehicle is equipped with a 3-point continuous belt system and second generation supplemental airbags in both front outboard seating positions. With respect to FMVSS 208 "Occupant Crash Protection", the occupant injury criteria summary is as follows:		13. Type of Report and Period Covered  Final Test Report Option Year 1	
17. Key Words  56.3 km/h NCAP Frontal Barrier Impact Test New Car Assessment Program (NCAP) 2002 Honda CR-V LX 4WD SUV NHTSA No. HO5300		14. Sponsoring Agency Code  DOT/NHTSA/NRM/OCS	
19. Security Classification(this report)  Unclassified		18. Distribution Statement  Copies of this report available from: NHTSA Technical Reference Division National Highway Traffic Safety Admin. 400 Seventh St., SW, Room 5108 Washington, DC 20590	
20. Security Classification(this page)  Unclassified		21. No. of Pages  370	22. Price

TABLE OF CONTENTS

Section	Description	Page
1	Purpose, Test Procedures and Summary of Test HO5300	1
2	Occupant and Vehicle Information Data Sheets	3

Data Sheet	Description	Page
1	Crash Test Summary	4
2	General Test and Vehicle Parameter Data	5
3	Post Impact Data	7
4	Test Vehicle Information	8
5	Dummy Positioning in Vehicle	10
6	Seatbelt Positioning Data	12
7	Vehicle Accelerometer Location and Data Summary	13
8	Hybrid III ATD Injury Criteria and Sensor Data	14
9	Seatbelt Assessment Test Data	17
10	Summary of FMVSS 212 Data	18
11	Windshield Zone Intrusion FMVSS 219 Data (Partial)	19
12	FMVSS 301 Fuel System Integrity Post Impact Data	20
13	FMVSS 301 Static Rollover Data	21
14	Vehicle Measurements	22
15	Camera Locations	24
16	Photographic Reference Target Locations	25
17	Vehicle Intrusion Measurements	26
18	Load Cell Locations on Fixed Barrier	30
19	Accident Investigation Division Data	31
20	Dummy/Vehicle Temperature Stabilization	32

Appendix	Description	Appendix
A	Photographs	A
B	Dummy and Vehicle Response Data Traces	B
C	Load Cell Barrier Data Traces	C
D	Instrumentation and Data Channel Assignments	D
E	Dummy Calibration Data Traces and Tables	E
F	Owners Manual	F
G	Nine Accelerometer Head Array Data	G

**SECTION 1**  
**PURPOSE AND SUMMARY OF TEST HY5000**

**1.1 PURPOSE**

This 35 mph (56.3 km/h) frontal barrier impact test is part of the Vehicle Barrier Impact Testing Program sponsored by the National Highway Traffic Safety Administration (NHTSA) under Contract No. DTNH22-01-D-02005. The purpose of this test was to obtain vehicle crashworthiness and occupant restraint system performance data for an impact speed in excess of the current 30 mph (48.3 km/h) requirements.

The 35 mph (56.3 km/h) frontal barrier impact test was conducted in accordance with the Office of Crashworthiness Standards Laboratory Test procedure.

**1.2 SUMMARY**

A load cell barrier consisting of 24 load cells was impacted by a 2002 Honda CR-V LX 4WD SUV at a velocity of 55.62 km/h. The test was performed at Karco Engineering, LLC on January 29, 2002. Pre- and post-test photographs of the vehicle and dummies can be found in Appendix A.

One real-time and 16 high-speed cameras were used to document the frontal barrier impact event. Camera locations and other pertinent camera information can be found in this report.

Two Part 572E, 50<sup>th</sup> percentile male anthropomorphic test devices (ATDs), were placed in the driver and right-front passenger seating positions according to dummy placement instructions specified in the Laboratory Indicant Test Procedure.

Both ATDs were fully instrumented with nine accelerometer array head, chest and pelvis triaxial accelerometers, chest displacement potentiometers, upper neck transducers, right/left femur load cells, left and right knee sliders, and lower leg instrumentation. Seat belt load cells were also on the driver's and passenger's lap and shoulder belts to measure dummy torso and pelvic section loading. The driver (position 1) ATD (Serial No. 34) and the right-front passenger (position 2) ATD (Serial No. 35) were calibrated previous to this test.

The One Hundred and Thirteen (113) channels of data were recorded on an on-board data acquisition system. Appendix B contains the vehicle and dummy response data traces. Appendix C contains Load Cell Barrier information. Appendix D contains the Instrumentation Data Channel assignments. Appendix E contains the Dummy Calibration data and Appendix F contains the owner's manual instructions for the occupant and restraint systems.

There was 100 percent windshield retention and no intrusion into the protected zone of the windshield during the event. There was no Stoddard solvent leakage after the event or during any phase of the static rollover.

The maximum static crush of the vehicle was 543 mm and both the driver and the passenger side doors remained closed during the impact event and were opened by hand after the impact.

The driver’s visible contact points were as follows: The driver ATD head contacted the airbag and headrest, its chest and abdomen contacted the airbag and seat belt, and both knees contacted the knee bolster/steering column.

The passenger’s visible contact points were as follows: The passenger ATD head contacted the airbag and headrest. The chest and abdomen contacted the airbag and belt. Both knees contacted the glove box/dash.

Occupant injury data is contained in table below.

**OCCUPANT DATA SUMMARY**

ATD Position	HIC	Clip (g)	Chest Disp (mm)	Left Femur (N)	Right Femur (N)	Belt Spool (mm)
Driver	265.4	39.0	-28.7	-2253.6	-2149.4	N/A
Passenger	297.8	42.6	-22.2	-3893.3	-1897.8	N/A

**SECTION 2**  
**OCCUPANT AND VEHICLE INFORMATION/DATA SHEETS**

Test Vehicle: 2002 Honda CR-V LX 4WD SUV  
 Test Program: 2002 NHTSA 35mph NCAP

NHTSA No.: HO5300  
 Test Date: 1/29/02

**CONVERSION FACTORS USED IN THIS REPORT\***

Quantity	Typical Application	Std Units	Metric Unit	Multiply By
Mass	Vehicle Weight	lb	kg	0.4536
Linear Velocity	Impact Velocity	mile/h	km/h	1.609
Length or Distance	Measurements	in	mm	25.4
Volume	Fuel Systems	gal	liter	3.785
Volume	Small Fluids	oz	mL	29.573
Pressure	Tire Pressures	lbf/in <sup>2</sup>	kPa	7.0
Volume	Liquid	gal	liter	3.785
Temperature	General Use	°F	°C	$=(tf - 32)/1.8$
Force	Dynamic Forces	lbf	N	4.448
Moment	Torque	lbf/ft	Nm	1.355

\* Based on the Recommended Practice in SAE J916, May 85

**DATA SHEET NO. 1  
CRASH TEST SUMMARY**

Test Vehicle: 2002 Honda CR-V LX 4WD SUV  
 Test Program: 2002 NHTSA 35mph NCAP

NHTSA No.: HO5300  
 Test Date: 1/29/02

**PRIMARY IMPACT DATA**

Measured Parameter	Units	Value
Velocity at Impact	km/h	55.62
Test Weight	kg	1699
Impact Angle	degrees	0
Average Rebound	mm	562
Maximum Static Crush	mm	543

**DOOR OPENING AND SEAT TRACK INFORMATION**

Description	Driver	Passenger
Front Door Opening	Opened by Hand	Opened by Hand
Rear Door Opening	Opened by Hand	Opened by Hand
Seat Track Shift (mm)	None	None
Seat Back Failure	None	None

**TEST DUMMY INFORMATION**

Description	Driver	Passenger
Dummy Type / Serial No.	50% Male Hybrid III / No. 34	50% Male Hybrid III / No. 35
Head Contact	Airbag/Headrest	Airbag/Headrest
Chest Contact	Belt/ Airbag	Airbag
Abdomen Contact	Belt	Airbag
Left Knee Contact	Steering Column/Knee Bolster	Glove Box/Dash
Right Knee Contact	Steering Column/Knee Bolster	Glove Box/Dash

**16mm MOVIE COVERAGE**

High Speed	16
Real Time	1
Total	17

**DATA CHANNELS**

Driver ATD Sensors	48
Passenger ATD Sensors	48
Belt Assessment Sensors	8
Vehicle Structure Accelerometers	9
Rigid Barrier Load Cells	24
Total	137

**DATA SHEET NO. 2**  
**GENERAL TEST AND VEHICLE PARAMETER DATA**

Test Vehicle: 2002 Honda CR-V LX 4WD SUV  
 Test Program: 2002 NHTSA 35mph NCAP

NHTSA No.: HO5300  
 Test Date: 1/29/02

**TEST VEHICLE INFORMATION**

Make	Honda
Model	CR-V LX
Body Style	5-Door
NHTSA No.	HO5300
VIN	JHLRD78472C011609
Color	Satin Silver
Delivery Date	12/27/2001
Odometer Reading (mi.)	19
Dealer	Valley-Hi Toyota/Honda
Transmission	4-Speed Automatic
Final Drive	AWD
Type/No. Cylinders	4
Engine Displacement (L)	2.4
Engine Placement	Transverse
Front Seat Side Airbag	No

**TEST VEHICLE OPTIONS**

Driver Front Airbag	Yes
Pass. Front Airbag	Yes
Power Windows	Yes
Power Steering	Yes
Power Door Locks	Yes
Tilt Wheel	Yes
Air Conditioning	Yes
Power Brakes	Yes
Disc Brakes, Front	Yes
Disc Brakes, Rear	Yes
Anti-lock Brakes	No
Head Airbag	No
Anti-Theft System	No
Cruise Control	Yes
Bucket Seats	Yes

**DATA FROM CERTIFICATION LABEL**

Manufactured By	Honda Motor Company	GVWR (kg)	1960
Date of Manufacture	November-02	GAWR Front (kg)	980
		GAWR Rear (kg)	1021

**DATA FROM TIRE PLACARD**

Measured Parameter	Front	Rear
Max. Tire Pressure (kPa)	180	180
Cold Pressure (kPa)	180	180
Recommend Tire Size	P205/70R15	P205/70R15
Tire Size on Vehicle	P205/70R15	P205/70R15
Tire Manufacturer	Bridgestone	Bridgestone

**VEHICLE SEATING AND CAPACITY WEIGHT INFORMATION**

Measured Parameter	Front	Rear	Third	Total
Type of Seats	Bucket	Bench	None	
Number of Occupants	2	3		5
Capacity Wt. (VCW) (kg)				0
Cargo Weight (RCLW) (kg)				45

**DATA SHEET NO. 2...(CONTINUED)**  
**GENERAL TEST AND VEHICLE PARAMETER DATA**

Test Vehicle: 2002 Honda CR-V LX 4WD SUV  
 Test Program: 2002 NHTSA 35mph NCAP

NHTSA No.: HO5300  
 Test Date: 1/29/02

**TEST VEHICLE WEIGHTS**

	Units	As Delivered (UVW)			As Tested (ATW)		
		Front Axle	Rear Axle	Total	Front Axle	Rear Axle	Total
Left	kg	405	347		449	404	
Right	kg	423	335		455	391	
Ratio	%	54.8	45.2		53.2	46.8	
Totals	kg	827	682	1510	904	795	1699

**TARGET TEST WEIGHT CALCULATION**

Measured Parameter	Units	Value
Total Delivered Weight (UVW)	kg	1510
Weight of 2 P572 ATD's	kg	152
Rated Cargo/Luggage Weight (RCLW)	kg	45
Calculated Vehicle Target Weight (TVTW)	kg	1707

**TEST VEHICLE ATTITUDE AND CG**

	Units	LF	RF	LR	RR	CG (aft of front axle)
As Delivered	mm	809	807	815	812	1186
As Tested	mm	790	790	790	790	1228

Vehicle Wheel base (mm): 2623  
 Weight of Ballast secured in cargo area (kg): 13  
 Vehicle Components Removed: spare tire, rear seat, rear interior panels & tail lights

\* Ballast weight does not include cameras, instrumentation, and brake abort system.

**FUEL SYSTEM DATA**

Fuel System Capacity From Owner's Manual (L): 57.9  
 Usable Capacity Figure Furnished by COTR (L): 57.9  
 Actual Test Volume with entire fuel System Filled (L): 53.8  
 Test Fluid Type: Stoddard Solvent ; Specific Gravity: 0.764  
 Kinematic Viscosity: as per ASTM Standard D484-71 ; Color: Red  
 Is Vehicle Fuel Pump Electric or Mechanical?: Electric  
 If electric, does pump operate with ignition switch "ON" & engine "OFF"? Yes  
 Fuel System Particulars: Driver side filler door, tank mounted at rear.

**DATA SHEET NO. 3  
POST IMPACT DATA**

Test Vehicle: 2002 Honda CR-V LX 4WD SUV  
 Test Program: 2002 NHTSA 35mph NCAP

NHTSA No.: HO5300  
 Test Date: 1/29/02

Measured Parameter	Units	Requirement	Value
Trap No. 1 Velocity (Primary)	km/h	55.51 to 57.12	55.62
Trap No. 1 Entry Distance	mm	< 1524	1524
Trap No. 1 Exit Distance	mm	< 1524	305
Trap No. 2 Velocity (Redundant)	km/h	55.51 to 57.12	55.59
Trap No. 2 Entry Distance	mm	< 1524	1524
Trap No. 2 Exit Distance	mm	< 1524	305

**VEHICLE STATIC CRUSH**

Measured Parameter	Units	Pre-Test	Post-Test	Difference
Left Side	mm	4056	3900	-156
Center	mm	4346	3872	-474
Right Side	mm	4056	3947	-109

**VEHICLE REBOUND FROM BARRIER**

Measured Parameter	Units	Value
Left Side	mm	578
Center	mm	575
Right Side	mm	532
Average	mm	562

**DATA SHEET NO. 4**  
**TEST VEHICLE INFORMATION**

Test Vehicle: 2002 Honda CR-V LX 4WD SUV  
Test Program: 2002 NHTSA 35mph NCAP

NHTSA No.: HO5300  
Test Date: 1/29/02

**NOMINAL DESIGN RIDING POSITION**

The driver and passenger seat backs are positioned to the manufacturers designated angle. The procedure is as follows: A special application tool with pointed probes is inserted through the fabric to make contact with the rigid portion of the lower seat frame assembly, approximately 13 inches above the pivot point of the seat back. An inclinometer is placed against the flat surface of the tool and the seat back angle is measured directly from the dial face.

Driver seat back angle: 24° with a seated dummy  
Passenger seat back angle: 24° with a seated dummy

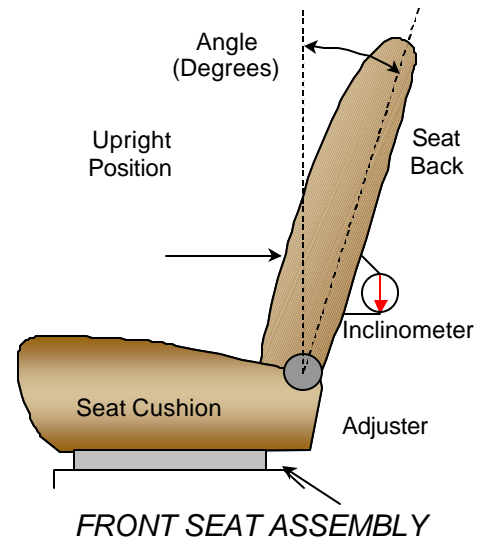

**SEAT FORE/AFT POSITIONS**

Driver seat has 24 positions or detents and passenger seat has 25 positions or detents. The first or forward most position is counted as number one (1). The fore/aft position is set aft of the middle position for both driver and passenger.

Driver seat fore/aft total travel: 24 seating positions or detents  
Driver seat fore/aft position: 13th detent from forward most  
Passenger seat fore/aft total travel: 25 seating positions or detents  
Passenger seat fore/aft position: 13th detent from forward most

**SEAT BELT UPPER ANCHORAGE**

The test vehicle is equipped with adjustable anchorages for both driver and passenger seat positions. There are 4 positions or detents. Both the driver and the passenger anchorages are placed in the 2nd position from the uppermost.

**DATA SHEET NO. 4...(CONTINUED)**  
**TEST VEHICLE INFORMATION**

Test Vehicle: 2002 Honda CR-V LX 4WD SUV  
 Test Program: 2002 NHTSA 35mph NCAP

NHTSA No.: HO5300  
 Test Date: 1/29/02

**FUEL TANK CAPACITY DATA**

The "Usable Capacity" of the standard equipment fuel tank is: 57.9 liters  
 The "Usable Capacity" of any optional equipment fuel tank is: 57.9 liters  
 "Usable Capacity" used for certification tests FMVSS 301 requirements: 53.3 to 54.4 liters  
 Actual amount of Stoddard solvent added to vehicle for certification test: 53.8 liters

The test vehicle is equipped with an electric fuel pump. The fuel pump operates for approximately two seconds after the ignition is placed in the "ON" position, after which the fuel pump automatically shuts off. The fuel filler door is located on the right rear fender. The standard fuel tank occupies the area under the rear seat. Fuel lines run inside the right frame rail to the engine compartment.

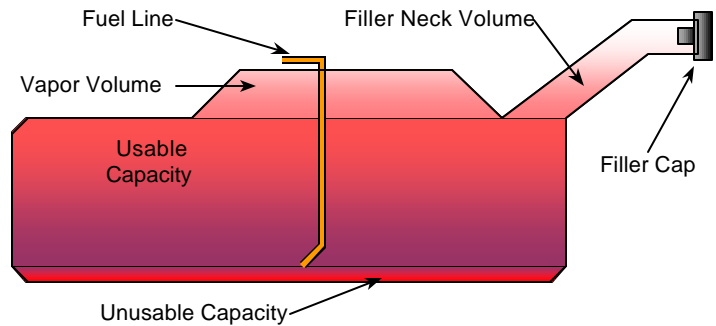

VEHICLE FUEL TANK ASSEMBLY

**STEERING COLUMN ADJUSTMENT**

Steering wheel and column adjustments are made so that the steering wheel hub is at the geometric center of the locus it describes when moved through its full range of motion. An aluminum plate is placed across the rim of the steering wheel, an inclinometer is placed on the plate and the angle is measured. The steering column has seven (7) positions or detents and is set in the fourth (4) detent as indicated by the diagram at right and the angle below.

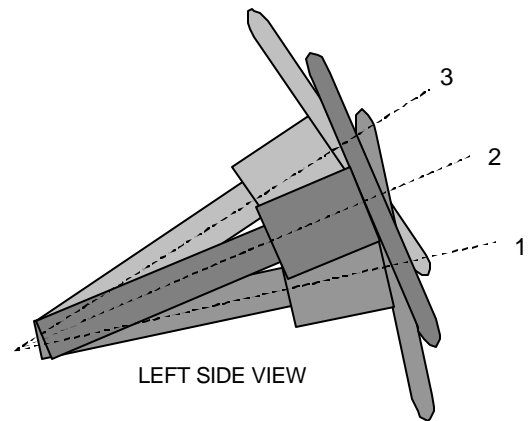

STEERING COLUMN ASSEMBLY

Lowermost; position 1: 67.5°  
 Geometric center; position 2: 63.0°  
 Uppermost position 3: 58.5°

**DATA SHEET NO. 5**  
**DUMMY POSITIONING IN VEHICLE**

Test Vehicle: 2002 Honda CR-V LX 4WD SUV  
Test Program: 2002 NHTSA 35mph NCAP

NHTSA No.: HO5300  
Test Date: 1/29/02

**TEST DUMMY POSITION MEASUREMENTS**

Code	Measurement Description	Driver		Passenger	
		Length (mm)	Angle (°)	Length (mm)	Angle (°)
WA	Windshield Angle		66		
SWA	Steering Wheel Angle		63		
SCA	Steering Column Angle		37		
SA	Seat Back Angle		24		24
HZ	Head to Roof (Z)	234	90	225	90
HH	Head to Header	392		378	
HW	Head to Windshield	610		605	
HR	Head to Side Header (Y)	293		275	
NR	Nose to Rim	422	13		
CD	Chest to Dash	562		535	
CS	Chest to Steering Hub	327			
RA	Rim to Abdomen	192			
KDL	Left Knee to Dash	115	21	100	
KDR	Right Knee to Dash	148		104	28
PA	Pelvic Angle		25		24
TA	Tibia Angle		34		50
KK	Knee to Knee (Y)	333		270	
ST	Striker to Head	599	2	615	4
SK	Striker to Knee	576	85	564	86
SH	Striker to H-Point	235		242	
SHY	Striker to H-Point (Y)	213		223	
HS	Head to Side Window	327		300	
HD	H-Point to Door (Y)	188		218	
AD	Arm to Door (Y)	100		120	
SHZ	Striker to H-Point (Z)	104		122	

**DATA SHEET NO. 5...(CONTINUED)**  
**DUMMY POSITIONING IN VEHICLE**

Test Vehicle: 2002 Honda CR-V LX 4WD SUV  
 Test Program: 2002 NHTSA 35mph NCAP

NHTSA No.: HO5300  
 Test Date: 1/29/02

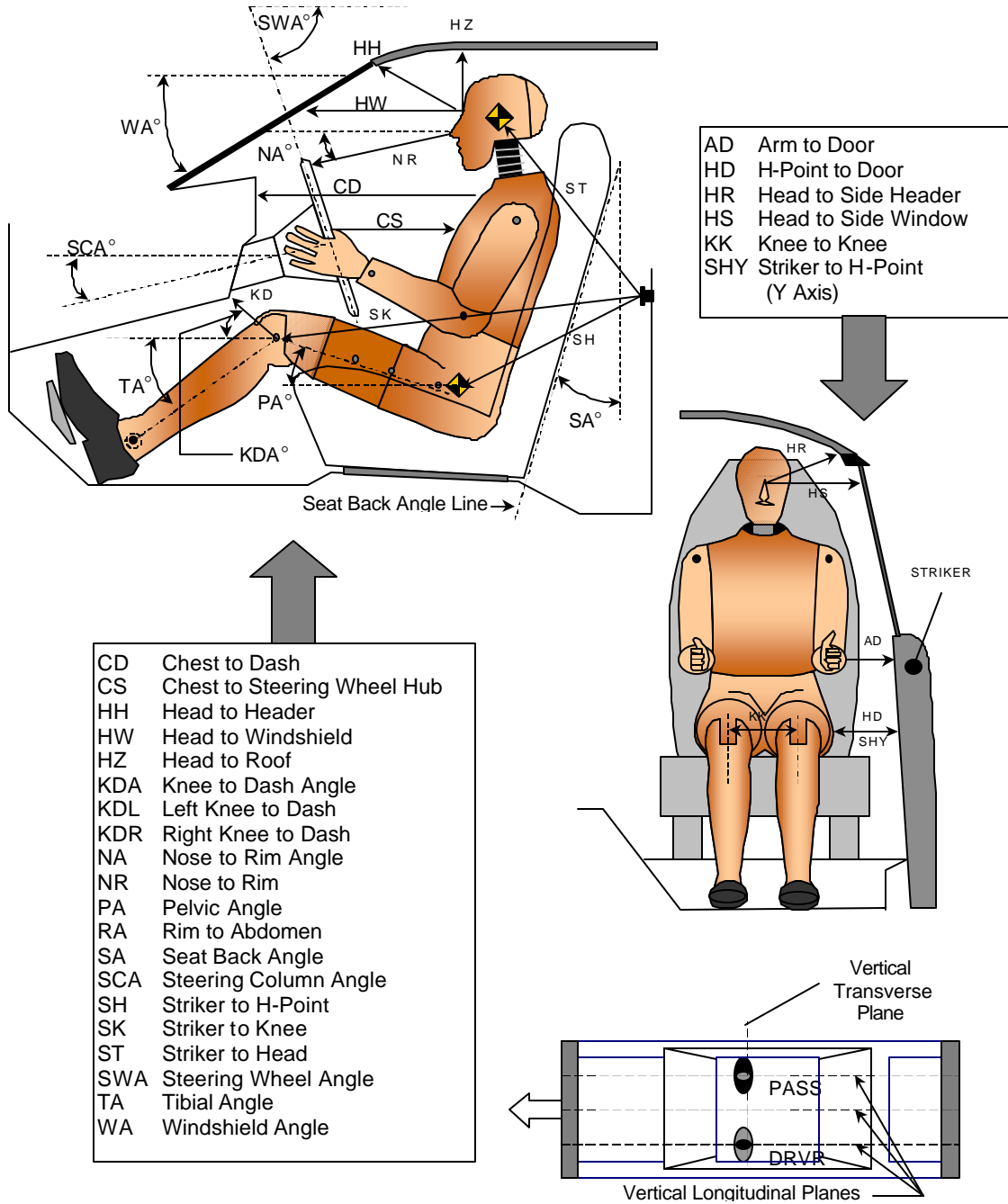

- CD Chest to Dash
- CS Chest to Steering Wheel Hub
- HH Head to Header
- HW Head to Windshield
- HZ Head to Roof
- KDA Knee to Dash Angle
- KDL Left Knee to Dash
- KDR Right Knee to Dash
- NA Nose to Rim Angle
- NR Nose to Rim
- PA Pelvic Angle
- RA Rim to Abdomen
- SA Seat Back Angle
- SCA Steering Column Angle
- SH Striker to H-Point
- SK Striker to Knee
- ST Striker to Head
- SWA Steering Wheel Angle
- TA Tibial Angle
- WA Windshield Angle

**DUMMY MEASUREMENTS FOR FRONT SEAT OCCUPANTS**

**DATA SHEET NO. 6  
SEATBELT POSITIONING DATA**

Test Vehicle: 2002 Honda CR-V LX 4WD SUV  
 Test Program: 2002 NHTSA 35mph NCAP

NHTSA No.: HO5300  
 Test Date: 1/29/02

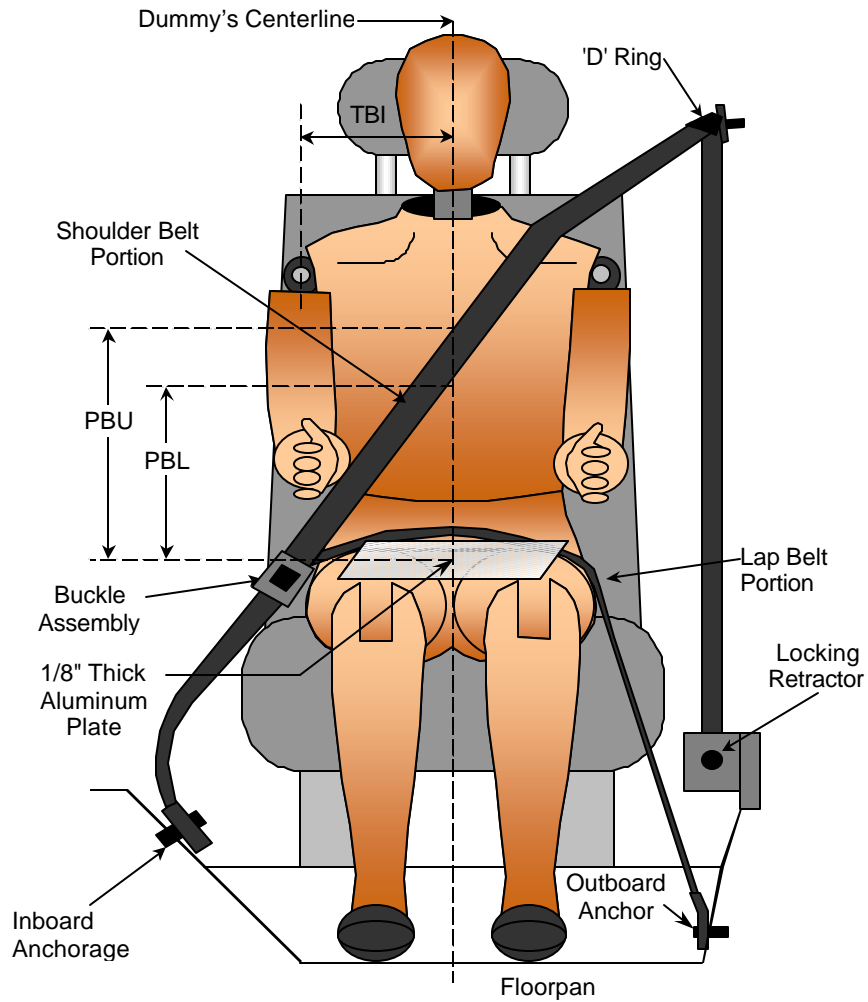

**SEAT BELT POSITIONING MEASUREMENTS**

Measurement Description	Units	Driver	Passenger
TBI - Dummy C/L to Lap/Shoulder Belt Intersect	mm	198	210
PBU - Top surface of reference to belt upper edge	mm	361	310
PBL - Top surface of reference to belt lower edge	mm	274	240
Lap Belt tension	Newton's	10	10
Shoulder Belt tension	N/A	Retractor	Retractor

## DATA SHEET NO. 7 - VEHICLE ACCELEROMETER LOCATION AND DATA SUMMARY

Test Vehicle: 2002 Honda CR-V LX 4WD SUV

NHTSA No.: HO5300

Test Program: 2002 NHTSA 35mph NCAP

Test Date: 1/29/02

### VEHICLE ACCELEROMETER PEAK DATA AND PRE-TEST LOCATIONS

No.	Accelerometer Location	Measurements (mm)			Peak Values				
		X	Y	Z	Units	Max	Time	Min	Time
1	Left Rear X-Member	1630	-620	485	G's	2.7	86.3	-40.0	32.1
2	Right Rear X-Member	1630	620	485	G's	2.2	90.0	-38.8	40.0
3	Engine Top	3665	70	890	G's	62.4	39.8	-183.2	24.8
4	Engine Bottom	3820	260	205	G's	36.2	35.4	-228.3	22.4
5	Left Brake Caliper	3430	-730	270	G's	52.3	41.3	-86.6	20.3
6	Right Brake Caliper	3430	730	270	G's	19.0	63.4	-88.9	26.3
7	Instrument Panel	2920	0	1030	G's	19.1	34.9	-72.3	47.7
8	Left Rear X-Member (Z-Axis)	1710	620	485	G's	15.0	19.7	-5.7	30.0
9	Right Rear X-Member (Z-Axis)	1710	620	485	G's	25.9	44.2	-9.1	48.5

Reference Points      X - From Rear Surface of Vehicle      Y - Vehicle Centerline      Z - Ground Plane

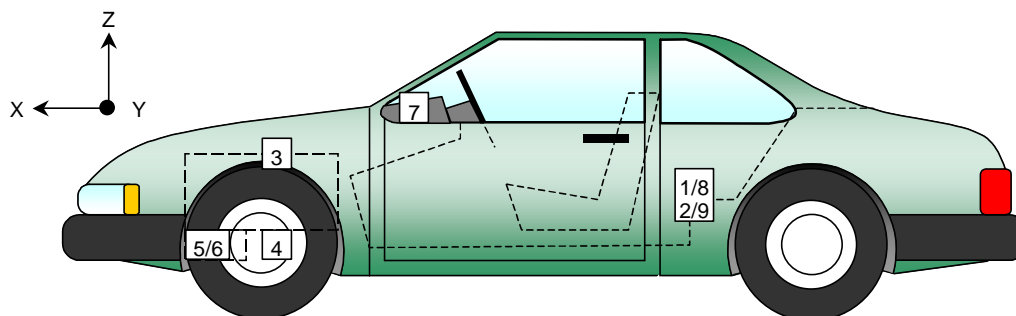
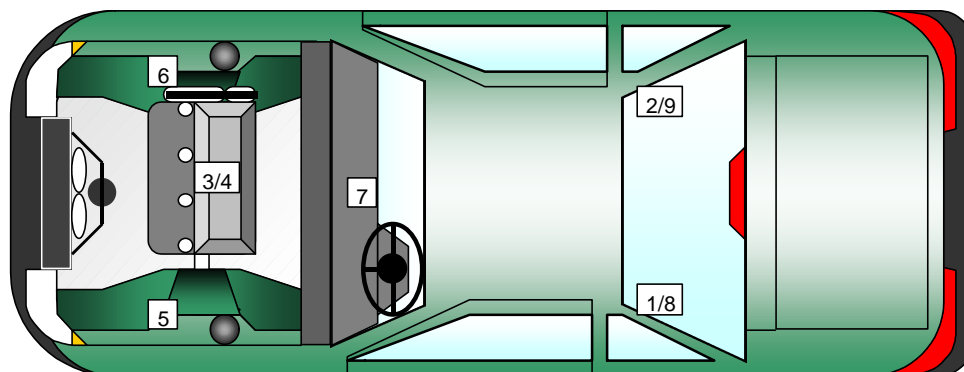

**DATA SHEET NO. 8 - HYBRID III ATD INJURY CRITERIA AND SENSOR DATA**

Test Vehicle: 2002 Honda CR-V LX 4WD SUV

NHTSA No.: HO5300

Test Program: 2002 NHTSA 35mph NCAP

Test Date: 1/29/02

**HEAD PRIMARY PEAK ACCELERATIONS**

Location	Axis	Units	Driver				Passenger			
			Max	Time	Min	Time	Max	Time	Min	Time
Head CG	X	G's	8.4	231.3	-48.4	70.7	10.3	262.4	-41.8	71.9
Head CG	Y	G's	4.8	156.8	-4.7	43.5	5.1	53.5	-11.6	84.3
Head CG	Z	G's	16.5	40.6	-14.7	88.2	20.4	69.1	-1.7	134.5
Head CG Resultant	N/A	G's	48.6	70.7			46.0	69.2		

**CHEST PRIMARY PEAK ACCELERATIONS**

Location	Axis	Units	Driver				Passenger			
			Max	Time	Min	Time	Max	Time	Min	Time
Chest CG	X	G's	3.5	126.8	-39.6	79.1	2.2	295.1	-43.7	64.7
Chest CG	Y	G's	3.3	57.8	-3.0	43.0	3.7	45.7	-10.0	79.1
Chest CG	Z	G's	7.5	39.0	-9.8	91.4	7.9	70.9	-4.3	94.7
Chest CG Resultant	N/A	G's	39.8	79.1			44.2	64.7		

**FEMUR PEAK FORCES AND KNEE DISPLACEMENTS**

Location	Axis	Units	Driver				Passenger			
			Max	Time	Min	Time	Max	Time	Min	Time
Left Femur	Z	Newtons	339.9	29.4	-2253.6	60.9	415.5	19.6	-3893.3	44.2
Right Femur	Z	Newtons	344.4	20.7	-2149.4	61.5	324.3	89.6	-1897.8	57.0
Left Knee Slider	Z	MM	0.38	60.3	-0.52	80.6	0.23	88.7	-8.60	60.1
Right Knee Slider	Z	MM	0.34	70.3	-0.11	239.4	0.92	90.7	-5.90	42.8

**SEAT BELT SENSOR PEAK VALUES**

Location	Axis	Units	Driver				Passenger			
			Max	Time	Min	Time	Max	Time	Min	Time
Lap Belt Force	N/A	Newtons	8794.4	53.4	-19.0	9.9	6471.6	53.8	2.6	0.0
Shoulder Belt Force	N/A	Newtons	5569.1	46.7	-55.0	156.8	4508.2	51.2	-17.7	9.6
Shoulder Belt Pullout	N/A	MM	0.0	0.0	0.0	0.0	0.0	0.0	0.0	0.0

\* Not installed by manufacturers request

**PRIMARY HEAD INJURY CRITERIA (HIC)**

Location	Driver				Passenger			
	HIC	Avg G	T <sup>1</sup>	T <sup>2</sup>	HIC	Avg G	T <sup>1</sup>	T <sup>2</sup>
Head CG Primary	265.4	35.3	52.2	88.1	297.8	36.9	56.9	92.8

**PRIMARY CHEST CLIP (3MSEC)**

Location	Driver			Passenger		
	CLIP	T <sup>1</sup>	T <sup>2</sup>	CLIP	T <sup>1</sup>	T <sup>2</sup>
Chest CG Primary	39.0	77.8	80.8	42.6	66.4	69.4

**DATA SHEET NO. 8...(continued)**

Test Vehicle: 2002 Honda CR-V LX 4WD SUV

NHTSA No.: HO5300

Test Program: 2002 NHTSA 35mph NCAP

Test Date: 1/29/02

**PELVIC PEAK ACCELERATIONS**

Location	Axis	Units	Driver				Passenger			
			Max	Time	Min	Time	Max	Time	Min	Time
Pelvis	X	G's	4.0	85.6	-56.4	54.9	5.8	107.7	-60.0	51.8
Pelvis	Y	G's	5.0	86.4	-9.3	53.7	8.0	38.4	-9.4	56.0
Pelvis	Z	G's	2.4	17.6	-30.5	66.8	3.2	16.8	-31.9	63.7

**UPPER NECK PEAK FORCES AND MOMENTS**

Location	Axis	Units	Driver				Passenger			
			Max	Time	Min	Time	Max	Time	Min	Time
Neck Force	X	Newtons	247.6	58.9	-515.9	130.9	329.6	76.6	-525.4	126.4
Neck Force	Y	Newtons	168.0	53.1	-94.5	137.0	148.6	63.6	-201.6	110.6
Neck Force	Z	Newtons	1470.4	65.3	-270.9	88.0	1354.3	57.9	-240.3	293.4
Neck Moment	X	N•m	3.6	75.5	-12.0	52.4	15.1	84.6	-7.6	53.6
Neck Moment	Y	N•m	42.9	118.3	-37.5	83.7	40.3	133.8	-35.2	90.1
Neck Moment	Z	N•m	5.7	58.8	-4.4	157.9	12.0	87.4	-5.5	148.9

**FOOT PEAK ACCELERATIONS**

Location	Axis	Units	Driver				Passenger			
			Max	Time	Min	Time	Max	Time	Min	Time
Left Foot Aft	X	G's	16.1	80.6	-52.7	43.6	10.6	63.1	-51.5	45.7
Left Foot Aft	Z	G's	12.5	63.6	-29.0	79.6	11.0	67.4	-62.5	51.9
Left Foot Fore	Z	G's	14.0	55.2	-30.5	59.4	34.6	67.9	-82.3	52.9
Right Foot Aft	X	G's	13.5	79.6	-116.0	45.3	38.1	78.4	-81.7	46.7
Right Foot Aft	Z	G's	6.2	61.7	-82.9	37.1	17.7	78.3	-63.3	50.7
Right Foot Fore	Z	G's	15.6	61.4	-135.6	41.5	40.9	79.3	-84.4	49.0

**UPPER AND LOWER TIBIA PEAK FORCES AND MOMENTS**

Location	Axis	Units	Driver				Passenger			
			Max	Time	Min	Time	Max	Time	Min	Time
Left Lower Moment	X	N•m	11.3	63.1	-10.9	77.4	5.1	24.1	-9.7	91.2
Left Lower Moment	Y	N•m	38.5	79.1	-32.6	56.7	67.7	53.3	-11.2	19.8
Left Lower Force	Z	Newtons	149.7	145.4	-1595.5	79.4	123.9	122.5	-2633.1	52.7
Left Upper Moment	X	N•m	32.6	57.1	-25.1	83.3	29.3	61.2	-26.2	39.4
Left Upper Moment	Y	N•m	17.3	109.5	-84.5	46.9	87.8	58.9	-18.7	20.7
Right Lower Moment	X	N•m	21.1	43.2	-64.8	72.9	2.2	25.1	-35.4	51.5
Right Lower Moment	Y	N•m	34.8	74.7	-58.5	44.8	84.2	55.1	-11.8	88.2
Right Lower Force	Z	Newtons	152.1	155.4	-4042.8	37.2	70.3	119.7	-3402.8	51.8
Right Upper Moment	X	N•m	55.5	45.5	-23.7	106.8	17.4	60.0	-57.6	79.2
Right Upper Moment	Y	N•m	12.7	90.1	-127.8	45.6	51.4	57.0	-24.2	68.8

**DATA SHEET NO. 8...(continued)**

Test Vehicle: 2002 Honda CR-V LX 4WD SUV

NHTSA No.: HO5300

Test Program: 2002 NHTSA 35mph NCAP

Test Date: 1/29/02

**CHEST PEAK DISPLACEMENTS**

Location	Axis	Units	Driver				Passenger			
			Max	Time	Min	Time	Max	Time	Min	Time
Chest CG	X	MM	0.1	3.9	-28.7	57.2	0.4	11.4	-22.2	81.4

**HEAD REDUNDANT PEAK ACCELERATIONS**

Location	Axis	Units	Driver				Passenger			
			Max	Time	Min	Time	Max	Time	Min	Time
Head CG	X	G's	9.4	231.1	-48.9	69.7	9.6	256.2	-41.8	72.4
Head CG	Y	G's	5.8	64.7	-4.0	44.5	4.4	31.0	-10.8	84.5
Head CG	Z	G's	16.9	40.0	-14.7	87.5	20.6	69.0	-1.2	2.8
Head CG Resultant	N/A	G's	49.1	71.4			46.6	68.9		

**CHEST REDUNDANT PEAK ACCELERATIONS**

Location	Axis	Units	Driver				Passenger			
			Max	Time	Min	Time	Max	Time	Min	Time
Chest CG	X	G's	3.1	273.0	-40.7	79.1	2.4	299.5	-43.4	64.7
Chest CG	Y	G's	3.9	78.2	-2.6	43.4	4.6	45.8	-8.5	79.1
Chest CG	Z	G's	7.6	39.1	-10.0	91.7	8.3	70.8	-3.9	94.6
Chest CG Resultant	N/A	G's	40.9	79.1			43.8	64.8		

**REDUNDANT HEAD INJURY CRITERIA (HIC)**

Location	Driver				Passenger			
	HIC	Avg G	T <sup>1</sup>	T <sup>2</sup>	HIC	Avg G	T <sup>1</sup>	T <sup>2</sup>
Head CG Redundant	274.6	35.7	51.9	87.8	303.7	37.2	56.8	92.7

**REDUNDANT CHEST CLIP (3MSEC)**

Location	Driver			Passenger		
	CLIP	T <sup>1</sup>	T <sup>2</sup>	CLIP	T <sup>1</sup>	T <sup>2</sup>
Chest CG Redundant	39.9	77.8	80.8	42.3	66.4	69.4

**DATA SHEET NO. 9**  
**SEATBELT ASSESSMENT TEST DATA**

Test Vehicle: 2002 Honda CR-V LX 4WD SUV  
Test Program: 2002 NHTSA 35mph NCAP

NHTSA No.: HO5300  
Test Date: 1/29/02

**SEAT BELT PLACEMENT MEASUREMENTS**

Measurement Description	Units	Driver	Passenger
TBI - Dummy C/L to Lap/Shoulder Belt Intersect	mm	198	210
PBU - Top surface of reference to belt upper edge	mm	361	310
PBL - Top surface of reference to belt lower edge	mm	274	240
Lap Belt tension	Newton's	10	10
Shoulder Belt tension	N/A	Retractor	Retractor

**BELT LENGTH DATA**

Measurement Description	Units	Driver	Passenger
Retractor reel to 'D' ring	mm	650	650
Shoulder belt length as measured on ATD	mm	895	900
Lap belt length as measured on ATD	mm	860	915
Remainder of belt on reel	mm	790	763
Total belt length for continuous webbing systems	mm	3195	3228

**SHOULDER BELT SPOOL-OFF DATA**

Measurement Description	Units	Driver	Passenger
As determined mechanically	mm	205.0	242.0
As determined electronically	mm	**	**

\*\*Not used by request of Manufacturer

**BELT STRETCH DATA**

Measurement Description	Units	Driver	Passenger
Electronically between shoulder belt load cell and "D" ring	mm/cm	*	*
Mechanically	mm/cm	None	None

\*Not used with shoulder belt pre-tensioner systems.

**DATA SHEET NO. 10  
SUMMARY OF FMVSS 212 DATA**

Test Vehicle: 2002 Honda CR-V LX 4WD SUV  
 Test Program: 2002 NHTSA 35mph NCAP

NHTSA No.: HO5300  
 Test Date: 1/29/02

Windshield Mounting Details: Windshield glass is secured to the vehicle frame with a rubber type adhesive. No molding covers the windshield periphery at any point.

The standard requires that the posttest retention measurement be a minimum of 75 percent of the pretest total periphery measurement for vehicles not equipped with occupant passive restraints and 50 percent for each side of the windshield for vehicles that are equipped with occupant passive restraints.

Temperature of windshield molding during test: 21.1 °C

**WINDSHIELD PERIPHERY MEASUREMENTS**

Measurement	Pre-Test(mm)	Post-Test (mm)	% of Retention
Left Side	2142	2142	100
Right Side	2142	2142	100
Total	4284	4284	100

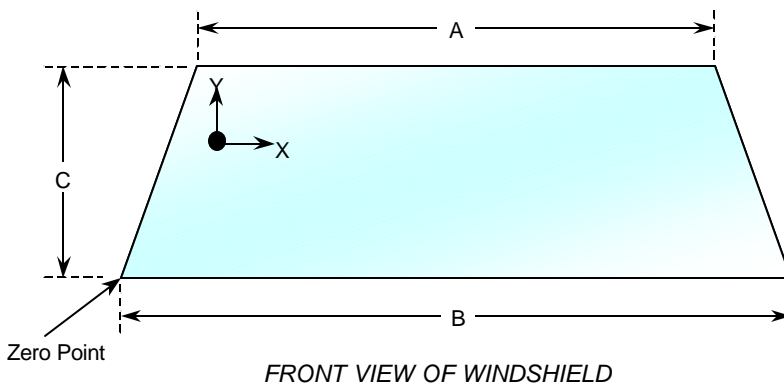

**WINDSHIELD DIMENSIONS**

Item	Units	Segment Length	Molding Width
A	mm	1230	13
B	mm	1540	N/A
C	mm	757	N/A

**DATA SHEET NO. 11**  
**WINDSHIELD ZONE INTRUSION FMVSS 219 DATA(PARTIAL)**

Test Vehicle: 2002 Honda CR-V LX 4WD SUV  
 Test Program: 2002 NHTSA 35mph NCAP

NHTSA No.: HO5300  
 Test Date: 1/29/02

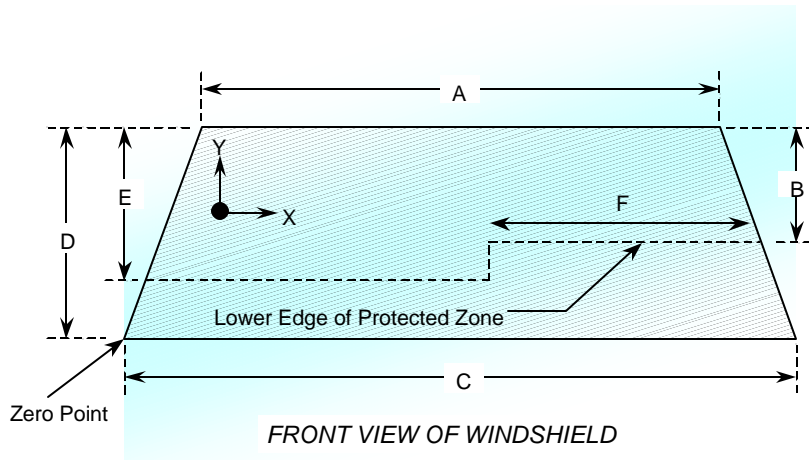

**WINDSHIELD AND  
 PROTECTED ZONE**

Item	Units	Value
A	mm	1230
B	mm	561
C	mm	1540
D	mm	757
E	mm	474
F	mm	510

**A OF PROTECTED ZONE FAILURES**

- A. Provide coordinates of the area that the protected zone was penetrated more than 0.25 in. by a vehicle component other than one that is normally in contact with the windshield.

X	Y
N/A	N/A
N/A	N/A
N/A	N/A
N/A	N/A

- B. Provide coordinates of the area beneath the protected zone that the inner surface of the windshield was penetrated by a vehicle component.

X	Y
N/A	N/A
N/A	N/A
N/A	N/A
N/A	N/A

**DATA SHEET NO. 12**  
**FMVSS 301 FUEL SYSTEM INTEGRITY POST IMPACT DATA**

Test Vehicle: 2002 Honda CR-V LX 4WD SUV  
Test Program: 2002 NHTSA 35mph NCAP

NHTSA No.: HO5300  
Test Date: 1/29/02

Test Time: 12:42 P.M.

Temperature at Time of Impact 3.3Deg. C

**STODDARD SOLVENT SPILLAGE MEASUREMENTS**

- A. From impact until vehicle motion ceases: 0.0 oz.  
(Maximum Allowable = 1 ounce)
- B. For the 5 minute period after motion ceases: 0.0 oz.  
(Maximum Allowable = 5 ounces)
- C. For the following 25 minutes: 0.0 oz.  
(Maximum Allowable = 1 oz./minute)
- D. Spillage Location Details: No leakage occurred

**DATA SHEET NO. 13**  
**FMVSS 301 STATIC ROLLOVER DATA SHEET**

Test Vehicle: 2002 Honda CR-V LX 4WD SUV  
 Test Program: 2002 NHTSA 35mph NCAP

NHTSA No.: HO5300  
 Test Date: 1/29/02

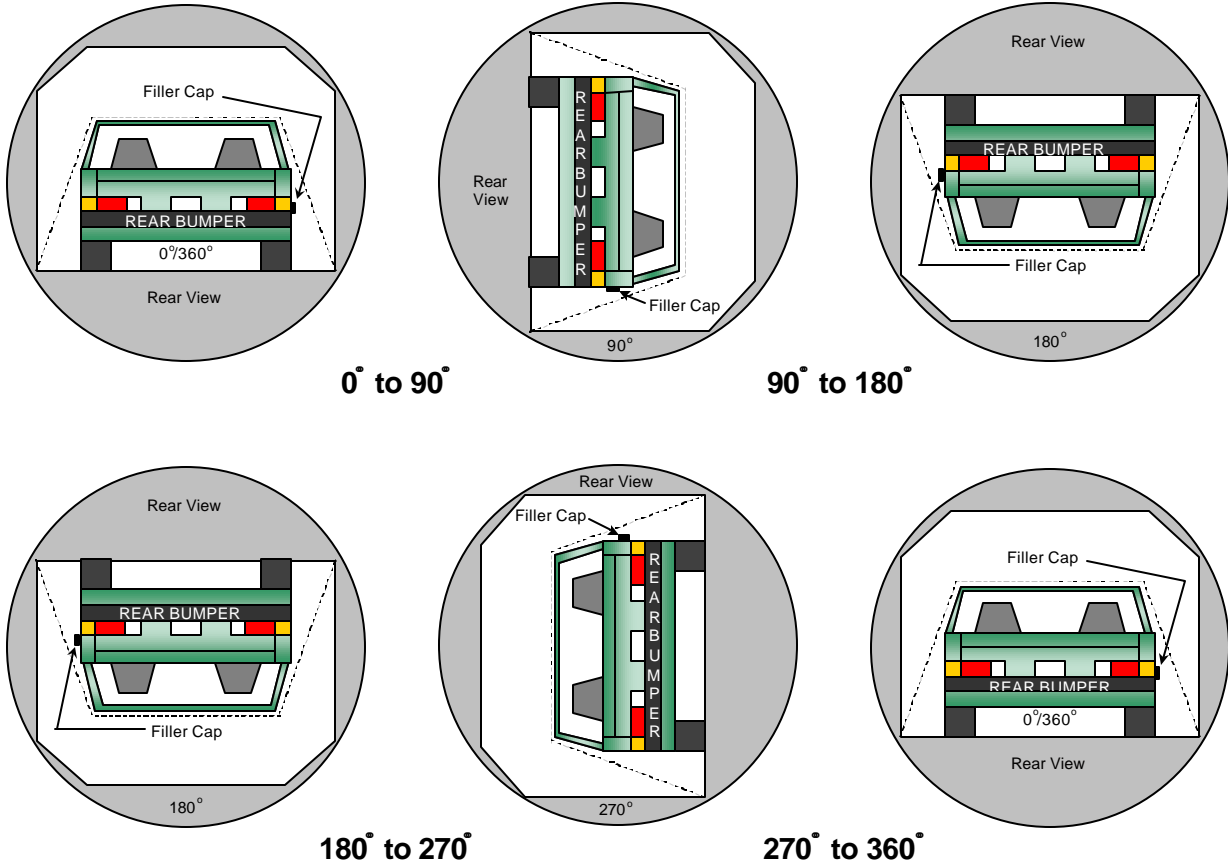

1. The specified fixture rollover rate for each 90° of rotation is 60 to 120 seconds.
2. The position hold time at each position is 300 seconds (minimum).
3. No solvent leakage occurred during rollover.

Test Phase	Rotation Time (sec.)	Hold Time (sec.)	Spillage (oz.)
0° to 90°	82	300	0.0
90° to 180°	82	300	0.0
180° to 270°	78	300	0.0
270° to 360°	82	300	0.0

**DATA SHEET NO. 14**  
**VEHICLE MEASUREMENTS**

Test Vehicle: 2002 Honda CR-V LX 4WD SUV  
Test Program: 2002 NHTSA 35mph NCAP

NHTSA No.: HO5300  
Test Date: 1/29/02

No.	Measurement Description	Units	Pre-Test	Post-Test	Difference
1	Total length of vehicle at centerline	mm	4346	3872	-474
2	RSOV to front of engine	mm	3752	3484	-268
3	RSOV to firewall centerline	mm	3380	3343	-37
4	RSOV to leading edge of right door	mm	3049	3071	22
5	RSOV to leading edge of left door	mm	3052	3063	11
6	RSOV to lower leading edge of right door	mm	3019	3031	12
7	RSOV to lower leading edge of left door	mm	3018	3024	6
8	RSOV to upper trailing edge of right door	mm	1977	1999	22
9	RSOV to upper trailing edge of left door	mm	1978	1992	14
10	RSOV to lower trailing edge of right door	mm	1977	1993	16
11	RSOV to lower trailing edge of left door	mm	1980	1988	8
12	RSOV to bottom of right 'A' pillar	mm	3045	3047	2
13	RSOV to bottom of left 'A' pillar	mm	3032	3039	7
14	RSOV to firewall on right side	mm	3364	3350	-14
15	RSOV to firewall of left side	mm	3354	3360	6
16	RSOV to steering column	mm	2622	2658	36
17	Center of steering column to left 'A' pillar	mm	385	355	-30
18	Center of steering column to headlining	mm	450	407	-43
19	RSOV to right side of front bumper	mm	4056	3947	-109
20	RSOV to left side of front bumper	mm	4056	3900	-156
21	Length of engine block	mm	500	500	0
RD	RSOV to right side of dash panel	mm	2838	2832	-6
CD	RSOV to center of dash panel	mm	2755	2745	-10
LD	RSOV to left side of dash panel	mm	2842	2829	-13

**DATA SHEET NO. 14...(CONTINUED)**  
**VEHICLE MEASUREMENTS**

Test Vehicle: 2002 Honda CR-V LX 4WD SUV  
 Test Program: 2002 NHTSA 35mph NCAP

NHTSA No.: HO5300  
 Test Date: 1/29/02

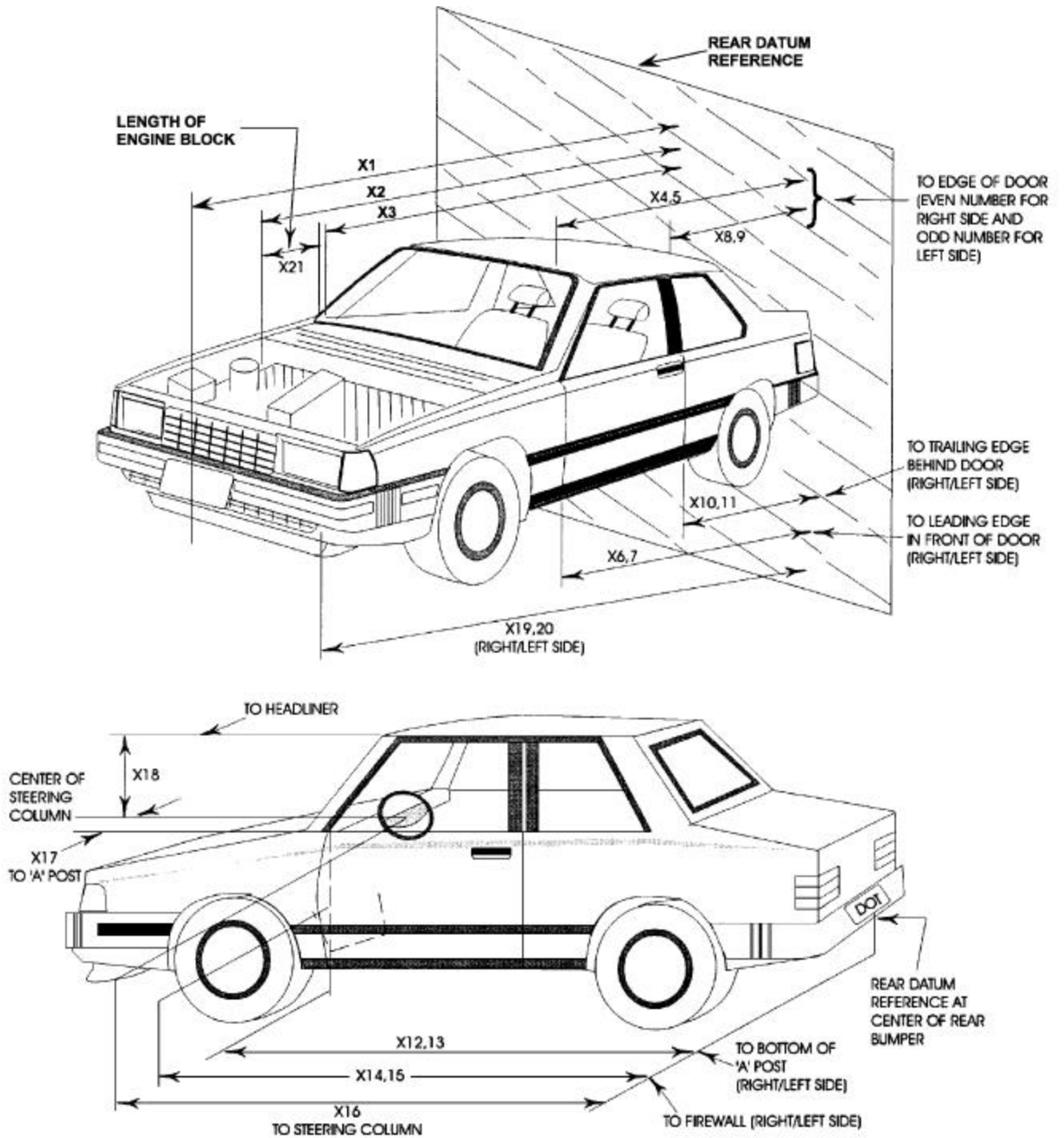

**DATA SHEET NO. 15**  
**CAMERA LOCATIONS**

Test Vehicle: 2002 Honda CR-V LX 4WD SUV  
Test Program: 2002 NHTSA 35mph NCAP

NHTSA No.: HO5300  
Test Date: 1/29/02

No.	Camera View	Location (mm)			Angle (Deg.)	Film Plane to Head	Lens (mm)	Speed (fps)
		X	Y	Z				
1	Right Side, Real Time	3454	10973	1245	0	1651	Zoom	24
2	Left Side, No. 1	1960	-8250	880	-1	7868	13	1020
3	Left Side, No. 2	1060	-6210	1440	0	5914	25	1010
4	Left Side, No. 3	6500	-10580	4640	-16	11537	65	1010
5	Left Side, No. 4	1460	-8250	3100	-16	8067	19	1010
6	Left Side, No. 5	1460	-8250	2700	-13	7991	19	990
7	Right Side, No. 1	2280	8150	1450	-1	7751	19	1030
8	Right Side, No. 2	960	8150	1450	-1	7753	35	1020
9	Right Side, No. 3	7860	8900	2800	-9	10332	80	880
10	Right Side, No. 4	2750	9600	1500	-2	9220	50	900
11	Overhead Overall	250	0	4460	-86	N/A	13	1140
12	Front View, Driver	2970	-380	1330	-43	N/A	12	N/A
13	Front View, Passenger	2970	380	1330	-55	N/A	13	1010
14	Pit Camera, Engine	580	0	-1360	-90	N/A	10	950
15	Pit Camera, Fuel Tank	3760	0	-1680	-55	N/A	10	N/A
16	Driver Belt	2970	-300	1330	-6	N/A	13	840
17	Passenger Belt	2970	300	1330	-3	N/A	13	860
18	Left Side Extra							

X - Barrier Face    Y - Monorail Centerline    Z - Ground

**DATA SHEET NO. 16**  
**PHOTOGRAPHIC REFERENCE TARGET LOCATIONS**

Test Vehicle: 2002 Honda CR-V LX 4WD SUV  
 Test Program: 2002 NHTSA 35mph NCAP

NHTSA No.: HO5300  
 Test Date: 1/29/02

in mm

Item	Value
A	400
B	891
C	1993
D	609
E	1686
F	155
G	1580
H	1074
I	1250
J	877
K	877
L	1346
M	1069
N	1342
O	874
P	874
Q	1259

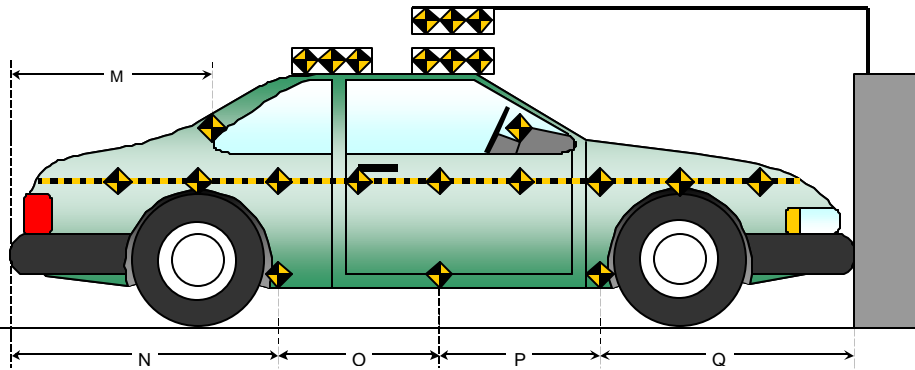
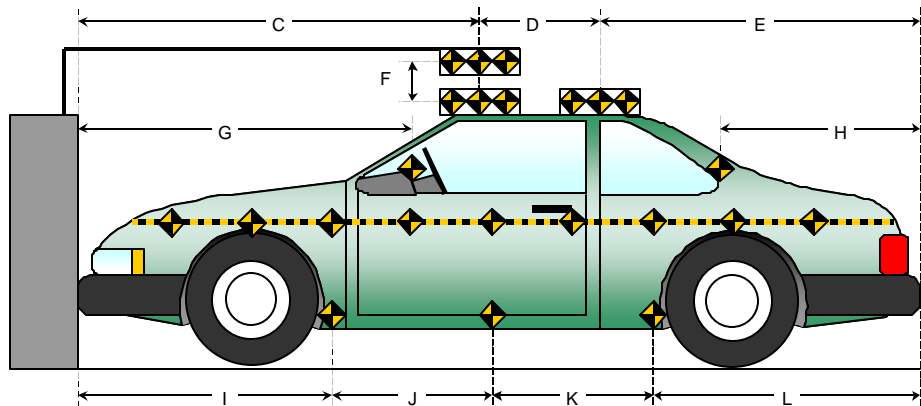
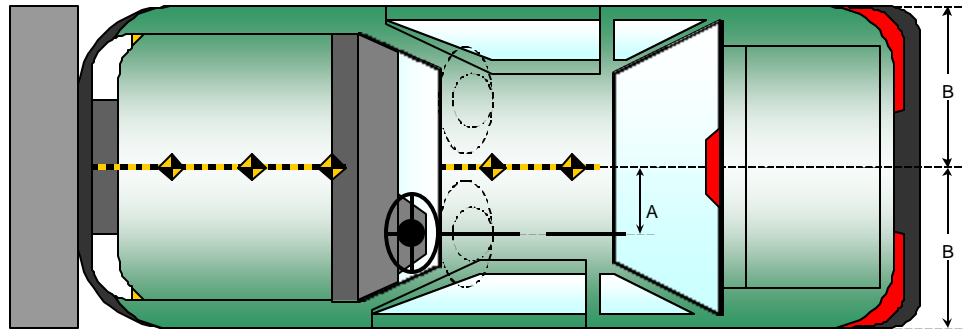

**DATA SHEET NO. 17**  
**VEHICLE INTRUSION MEASUREMENTS**

Test Vehicle: 2002 Honda CR-V LX 4WD SUV  
 Test Program: 2002 NHTSA 35mph NCAP

NHTSA No.: HO5300  
 Test Date: 1/29/02

**DOOR OPENING WIDTH**

Item	Description	Units	Pre-Test	Post-Test	Difference
A	Left Side Upper	mm	991	986	-5
B	Left Side Lower	mm	863	868	5
D	Right Side Upper	mm	994	991	-3
E	Right Side Lower	mm	872	876	4

**WHEELBASE MEASUREMENTS**

Item	Description	Units	Pre-Test	Post-Test	Difference
C	Left Side Wheel base	mm	2623	2517	-106
F	Right Side Wheel base	mm	2623	2527	-96

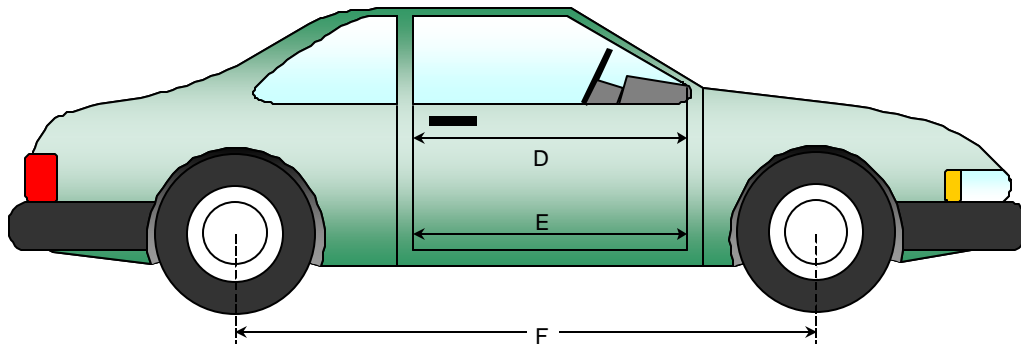
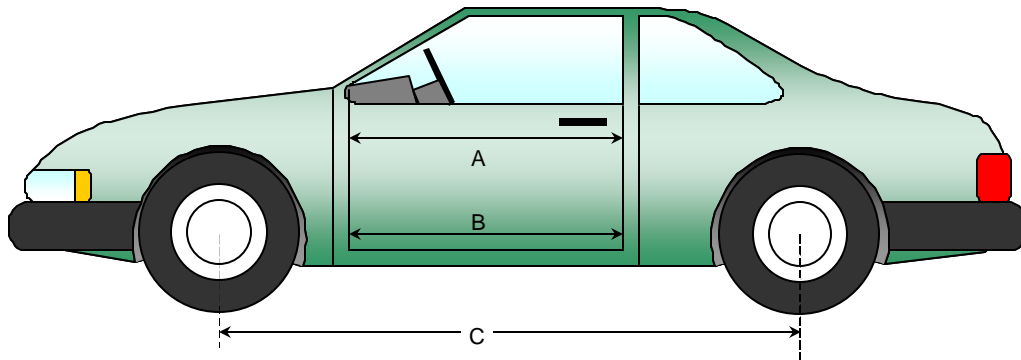

**DATA SHEET NO. 17...(CONTINUED)**  
**VEHICLE INTRUSION MEASUREMENTS**

Test Vehicle: 2002 Honda CR-V LX 4WD SUV  
 Test Program: 2002 NHTSA 35mph NCAP

NHTSA No.: HO5300  
 Test Date: 1/29/02

**DRIVER COMPARTMENT INTRUSION**

Item	Description	Units	Pre-Test	Post-Test	Difference
AB	Door Opening (Inside window jam)	mm	991	986	-5
CX	Left Knee Bolster to X	mm	311	341	30
DX	Right Knee Bolster to X	mm	309	339	30
EX	Brake Pedal to X	mm	638	601	-37
FX	Foot Rest to X	mm	732	681	-51
GX	Center of Steering Wheel Hub to X	mm	125	171	46

X = Left Front Seat Outboard Anchor Bolt Head

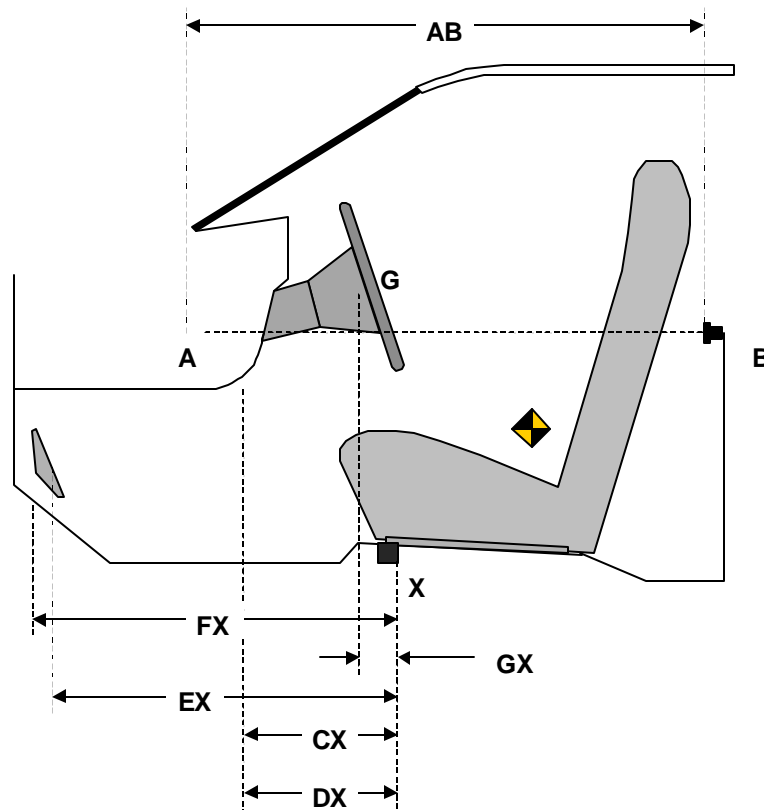

**DATA SHEET NO. 17...(CONTINUED)**  
**VEHICLE INTRUSION MEASUREMENTS**

Test Vehicle: 2002 Honda CR-V LX 4WD SUV  
 Test Program: 2002 NHTSA 35mph NCAP

NHTSA No.: HO5300  
 Test Date: 1/29/02

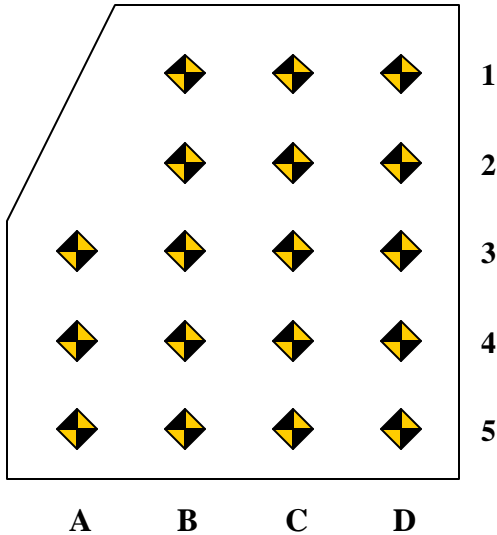

Measurement reference point for X and Z-axis is the forward outboard seat mounting bolt.

Columns A through D are evenly spaced.

Rows 1 and 2 are on the toe kick portion of the floor pan. Rows 3,4 and 5 are located on the most level portion of the floor pan.

Row 3 will be at the intersection of the toe kick and the level sections of the floor pan.

**DRIVER FLOOR PAN X-AXIS**

	Pre-Test				Post-Test				Difference			
	A	B	C	D	A	B	C	D	A	B	C	D
1		748	743	751		729	735	730		-19	-8	-21
2		648	645	654		630	630	626		-18	-15	-28
3	551	548	545	551	535	530	530	521	-16	-18	-15	-30
4	451	449	445	441	437	434	430	420	-14	-15	-15	-21
5	351	349	346	341	338	335	331	329	-13	-14	-15	-12

**DRIVER FLOOR PAN Z-AXIS**

	Pre-Test				Post-Test				Difference			
	A	B	C	D	A	B	C	D	A	B	C	D
1		-14	-6	-1		-4	4	2		10	10	3
2		-53	-47	-45		-43	-41	-35		10	6	10
3	-58	-62	-59	-58	-60	-63	-48	-60	-2	-1	11	-2
4	-55	-52	-53	-58	-40	-55	-60	-62	15	-3	-7	-4
5	-59	-62	-55	-50	-68	-62	-66	-75	-9	0	-11	-25

**DATA SHEET NO. 17...(CONTINUED)  
VEHICLE INTRUSION MEASUREMENTS**

Test Vehicle: 2002 Honda CR-V LX 4WD SUV  
 Test Program: 2002 NHTSA 35mph NCAP

NHTSA No.: HO5300  
 Test Date: 1/29/02

Measurement reference point for X and Z axis is the forward outboard seat mounting bolt.

Columns A through D are evenly spaced.

Rows 1 and 2 are on the toe kick portion of the floor pan. Rows 3,4, and 5 are located on the most level portion of the floor pan.

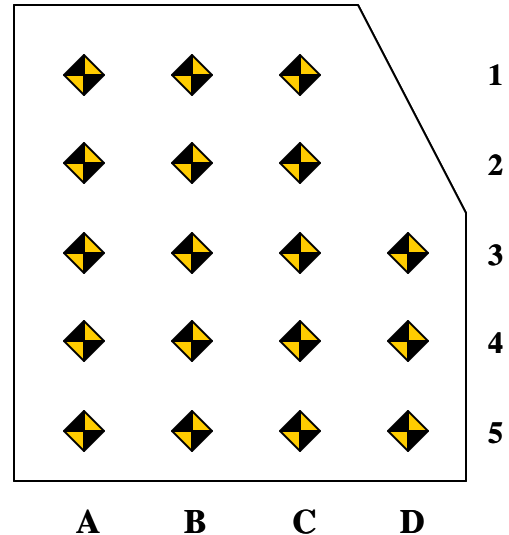

Row 3 will be at the intersection of the toe kick and the level sections of the floor pan.

**PASSENGER FLOOR PAN X-AXIS**

	Pre-Test				Post-Test				Difference			
	A	B	C	D	A	B	C	D	A	B	C	D
1	685	681	685		646	652	657		-39	-29	-28	
2	587	581	585		551	552	557		-36	-29	-28	
3	487	481	483	485	453	453	458	484	-34	-28	-25	-1
4	384	383	383	385	351	371	385	387	-33	-12	2	2
5	284	283	283	282	282	284	287	287	-2	1	4	5

**PASSENGER FLOOR PAN Z-AXIS**

	Pre-Test				Post-Test				Difference			
	A	B	C	D	A	B	C	D	A	B	C	D
1	-33	-33	-35		-22	-27	-27		11	6	8	
2	-38	-58	-60		-38	-55	-58		0	3	2	
3	-40	-60	-55	-52	-36	-64	-68	-42	4	-4	-13	10
4	-33	-60	-62	-60	-52	-45	-45	-58	-19	15	17	2
5	-60	-62	-60	-58	-80	-78	-64	-63	-20	-16	-4	-5

**DATA SHEET NO. 18**  
**LOAD CELL LOCATION ON FIXED BARRIER**

Test Vehicle: 2002 Honda CR-V LX 4WD SUV  
 Test Program: 2002 NHTSA 35mph NCAP

NHTSA No.: HO5300  
 Test Date: 1/29/02

**36 Load Cell Rigid Barrier (NHTSA Standard)**  
**Load Cell Locations on Fixed Barrier**

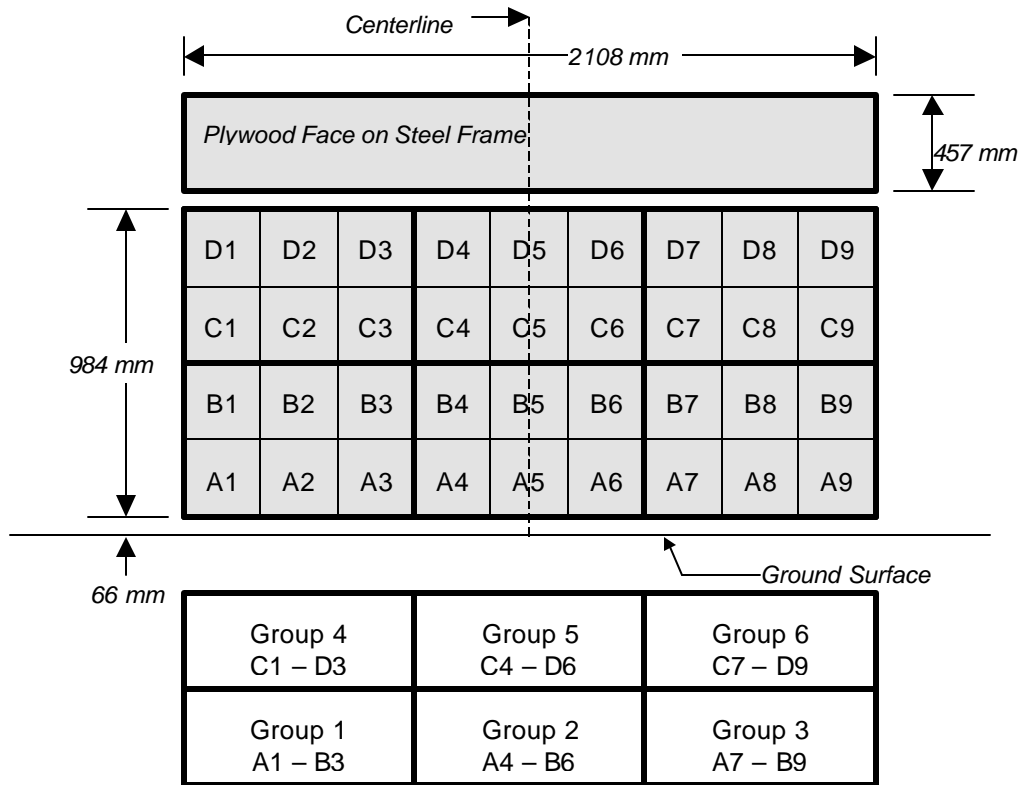

6 Groups of 6 Load Cells Each

The Data is presented in Appendix C with the following requirements:

- 1.) Data from 36 individual load cells
- 2.) Sum data from 6 groupings shown above (6 cells/group)
- 3.) Total or sum of all 36 individual load cells
- 4.) Sum of all 36 individual load cells vs. vehicle dynamic crush

**DATA SHEET NO. 19**  
**ACCIDENT INVESTIGATION DIVISION DATA**

Test Vehicle: 2002 Honda CR-V LX 4WD SUV  
 Test Program: 2002 NHTSA 35mph NCAP

NHTSA No.: HO5300  
 Test Date: 1/29/02

**VEHICLE INFORMATION**

VIN: JHLRD78472C011609  
 Vehicle Size Category: 4WD SUV

Wheel base (mm): 2623  
 Test Weight (kg): 1699

**ACCELEROMETER DATA**

Accelerometer Location: Left rear floor pan  
 Cal. Procedure/Interval: 6 months / drop test  
 Integration Algorithm: NHTSA Standard  
 Impact Velocity (km/h): 55.62  
 Velocity Change (km/h): 62.24

Linearity: Good

Time of Separation (msec): 82.4

**CRUSH PROFILE**

Collision Deformation Classification: 12FDEW6 Midpoint of Damage: Vehicle Centerline  
 Damage Region Length (mm): 1569 Impact Mode: Full Frontal

No.	Measurement Description	Units	Pre-Test	Post-Test	Difference
C1	Crush zone 1 at left side	mm	290	446	-156
C2	Crush zone 2 on left side	mm	49	478	-429
C3	Crush zone 3 on left side	mm	3	546	-543
C4	Crush zone 4 on right side	mm	3	471	-468
C5	Crush zone 5 on right side	mm	49	534	-485
C6	Crush zone 6 at right side	mm	290	399	-109

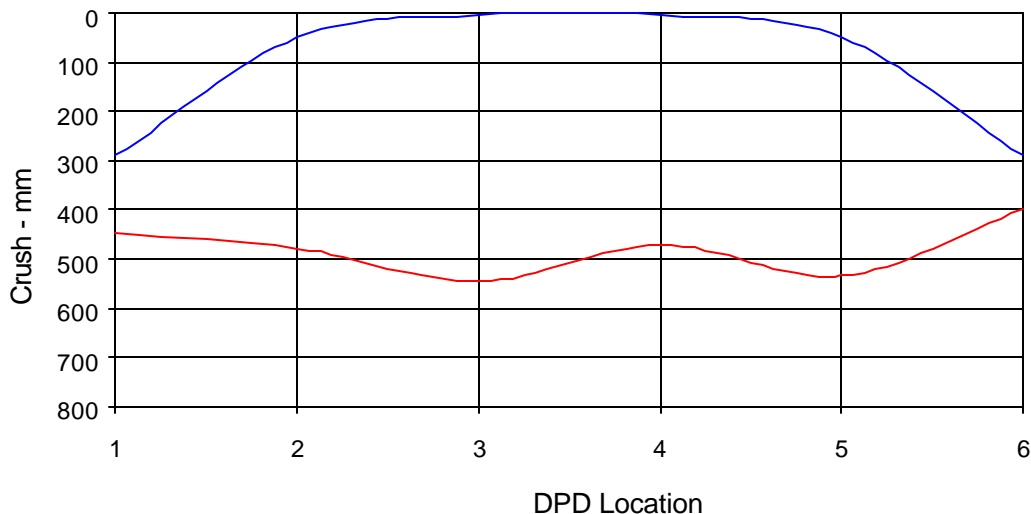

**DATA SHEET NO. 20**  
**DUMMY/VEHICLE TEMPERATURE STABILIZATION**

Test Vehicle: 2002 Honda CR-V LX 4WD SUV  
Test Program: 2002 NHTSA 35mph NCAP

NHTSA No.: HO5300  
Test Date: 1/29/02

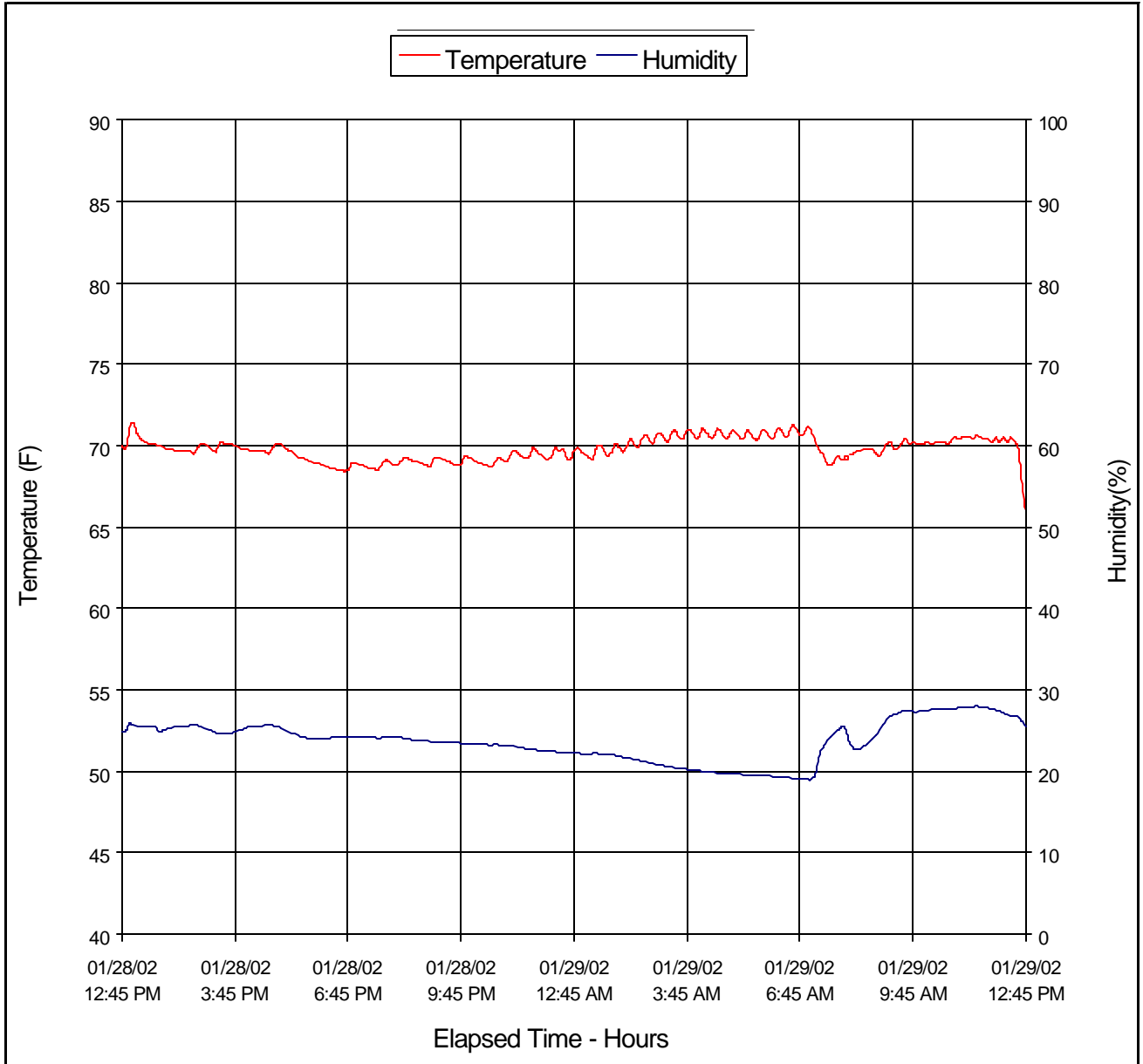

**APPENDIX A**

**PHOTOGRAPHS**

## LIST OF PHOTOGRAPHS

Figure		Page
A-1	Right Front, as Received	A-1
A-2	Left Rear, as Received	A-2
A-3	Vehicle Certification Label	A-3
A-4	Vehicle Tire Label	A-4
A-5	Front View, Pre-Test	A-5
A-6	Front View, Post-Test	A-6
A-7	Left Side View, Pre-Test	A-7
A-8	Left Side View, Post-Test	A-8
A-9	Right Side View, Pre-Test	A-9
A-10	Right Side View, Post-Test	A-10
A-11	Right Front View, Pre-Test	A-11
A-12	Right Front View, Post-Test	A-12
A-13	Left Rear View, Pre-Test	A-13
A-14	Left Rear View, Post-Test	A-14
A-15	Windshield, Pre-Test	A-15
A-16	Windshield, Post-Test	A-16
A-17	Engine Compartment, Pre-Test	A-17
A-18	Engine Compartment, Post-Test (Vehicle Moved)	A-18
A-19	Fuel Cap, Pre-Test	A-19
A-20	Fuel Cap, Post-Test	A-20
A-21	Front Underside, Pre-Test	A-21
A-22	Front Underside, Post-Test	A-22
A-23	Rear Underside, Pre-Test	A-23
A-24	Rear Underside, Post-Test	A-24
A-25	Driver Dummy Front View, Pre-Test	A-25
A-26	Driver Dummy Front View, Post-Test	A-26
A-27	Driver Dummy Through Window, Pre-Test	A-27
A-28	Driver Dummy Through Window, Post-Test	A-28
A-29	Driver Dummy Door Open, Pre-Test	A-29
A-30	Driver Dummy Door Open, Post-Test	A-30
A-31	Driver Dummy 90° To Vehicle, Pre-Test	A-31
A-32	Driver Dummy 90° to Vehicle, Post-Test	A-32

## LIST OF PHOTOGRAPHS...(Continued)

Figure		Page
A-33	Driver Dummy Feet, Pre-Test	A-33
A-34	Driver Dummy Feet and Knee Contact, Post-Test	A-34
A-35	Driver Side Knee Bolster, Pre-Test	A-35
A-36	Driver Side Knee Bolster, Post-Test	A-36
A-37	Driver Side Floor Pan, Pre-Test	A-37
A-38	Driver Side Floor Pan, Post-Test	A-38
A-39	Driver Dummy Head, Post-Test	A-39
A-40	Driver Dummy Contact, Post-Test	A-40
A-41	Passenger Dummy Front View, Pre-Test	A-41
A-42	Passenger Dummy Front View, Post-Test	A-42
A-43	Passenger Dummy Through Window, Pre-Test	A-43
A-44	Passenger Dummy Through Window, Post-Test	A-44
A-45	Passenger Dummy Door Open, Pre-Test	A-45
A-46	Passenger Dummy Door Open, Post-Test	A-46
A-47	Passenger Dummy 90° to Vehicle, Pre-Test	A-47
A-48	Passenger Dummy 90° to Vehicle, Post-Test	A-48
A-49	Passenger Dummy Feet, Pre-Test	A-49
A-50	Passenger Dummy Feet and Knee Contact, Post-Test	A-50
A-51	Passenger Side Floor Pan, Pre-Test	A-51
A-52	Passenger Side Floor Pan, Post-Test	A-52
A-53	Passenger Side Knee Bolster, Pre-Test	A-53
A-54	Passenger Side Knee Bolster, Post-Test	A-54
A-55	Passenger Head, Post-Test	A-55
A-56	Passenger Dummy Contact, Post-Test	A-56
A-57	$\frac{3}{4}$ Left Rear View of Doors Closed After Impact	A-57
A-58	$\frac{3}{4}$ Right Rear View of Doors Closed After Impact	A-58
A-59	Vehicle on Rollover Device	A-59
A-60	Vehicle During Impact	A-60



Figure A-1: Right Front, as Received



Figure A-2: Left Rear, as Received

MFD. IN JAPAN BY HONDA MOTOR CO., LTD; 11/'01  
GVWR 4320LBS GAWR F 2160LBS R 2250LBS  
THIS VEHICLE CONFORMS TO ALL APPLICABLE  
FEDERAL MOTOR VEHICLE SAFETY,  
AND THEFT PREVENTION STANDARDS IN EFFECT  
ON THE DATE OF MANUFACTURE SHOWN ABOVE:

V.I.N. **JHLRD78472C011609**



MPV

Figure A-3: Vehicle Certification Label



TIRE INFORMATION		S9AA-A0	
GVWR	4320LBS		
GAWR	FRONT	REAR	
	2160LBS	2250LBS	
TIRE SIZE	P205/70R15 95S		
RIM SIZE	15×6JJ		
COLD TIRE INFLATION PRESSURE	180kPa, 26 psi		
	UP TO GAWR		
● SEE OWNER'S MANUAL FOR ADDITIONAL INFORMATION.			

Figure A-4: Vehicle Tire Label



Figure A-5: Front View, Pre-Test



Figure A-6: Front View, Post-Test



Figure A-7: Left Side View, Pre-Test



Figure A-8: Left Side View, Post-Test



Figure A-9: Right Side View, Pre-Test



A-10

KAR21061-01

Figure A-10: Right Side View, Post-Test



Figure A-11: Right Front View, Pre-Test



Figure A-12: Right Front View, Post-Test



Figure A-13: Left Rear View, Pre-Test



Figure A-14: Left Rear View, Post-Test



Figure A-15: Windshield, Pre-Test



Figure A-16: Windshield, Post-Test



Figure A-17: Engine Compartment, Pre-Test



Figure A-18: Engine Compartment, Post-Test



Figure A-19: Fuel Cap, Pre-test



Figure A-20: Fuel Cap, Post-Test



Figure A-21: Front Underside, Pre-Test

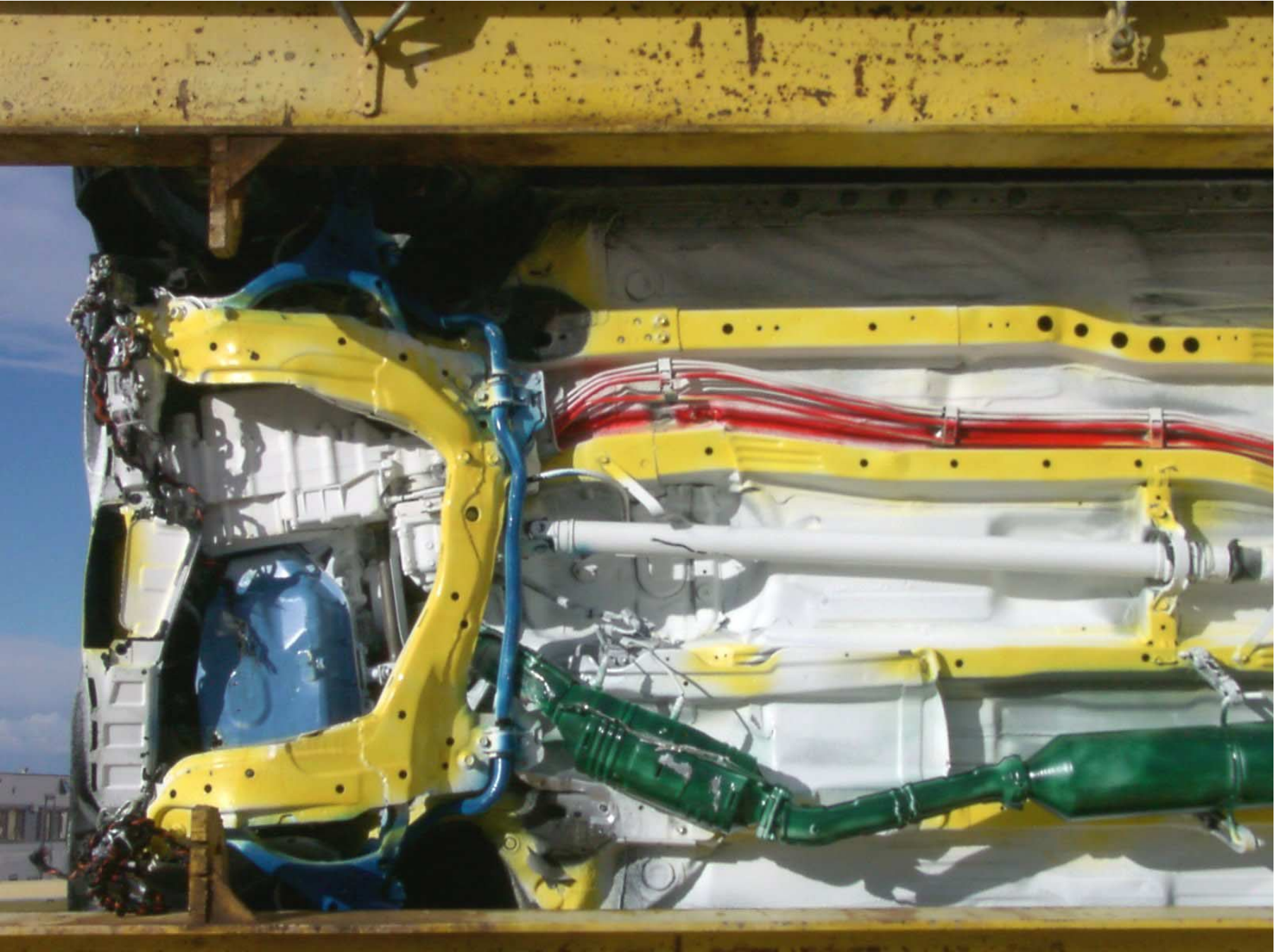

Figure A-22: Front Underside, Post-Test

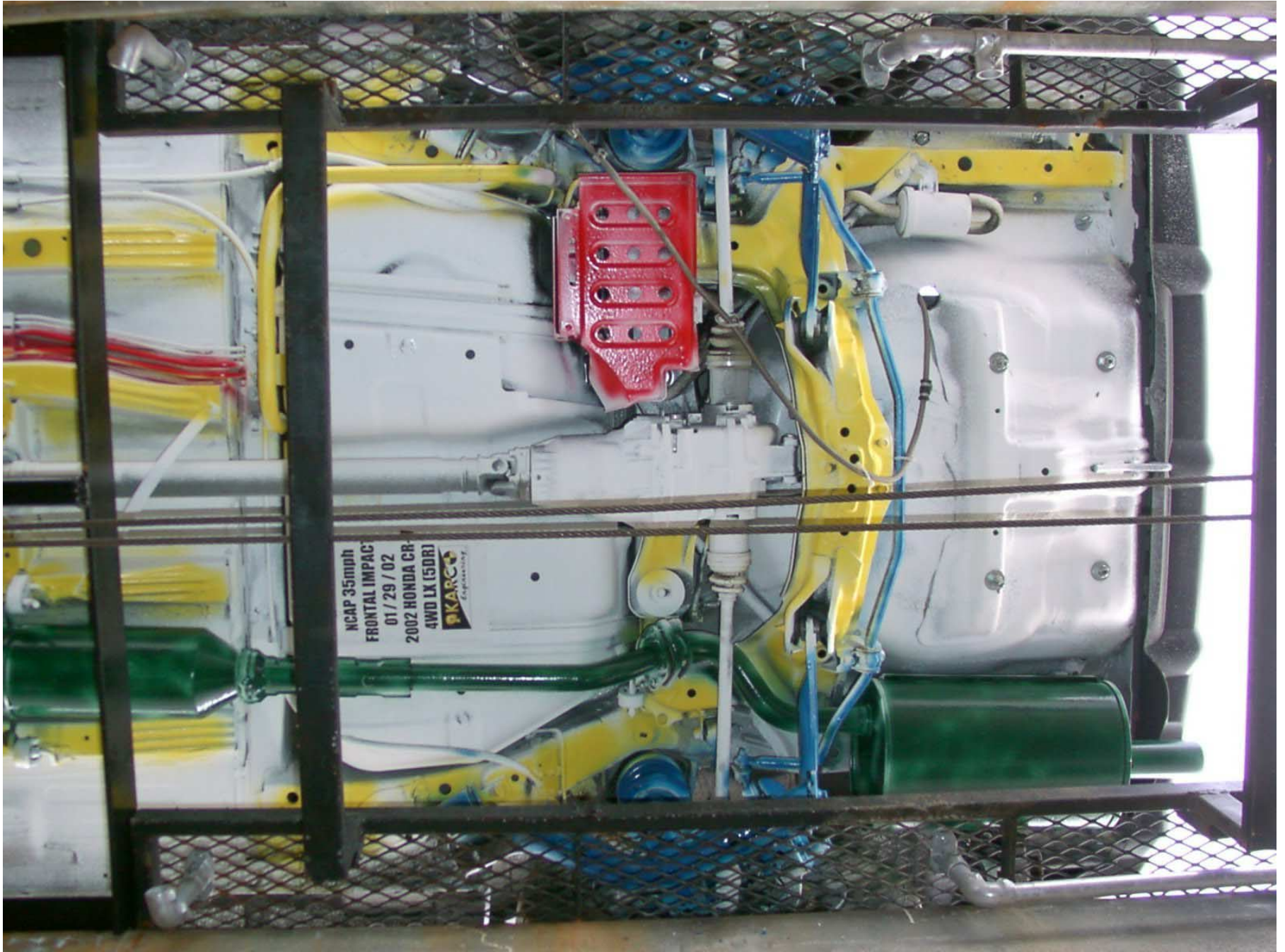

Figure A-23: Rear Underside, Pre-Test

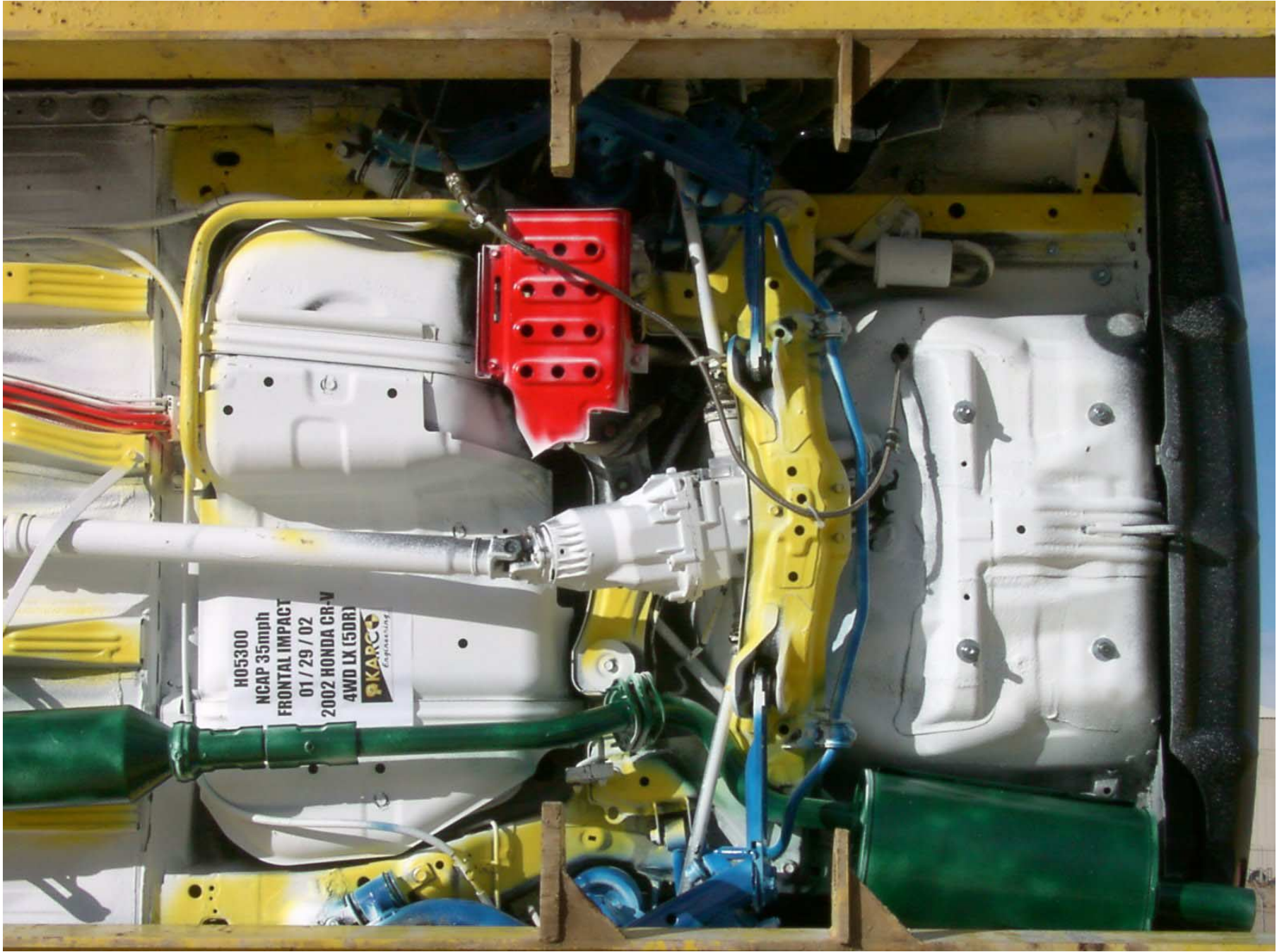

Figure A-24: Rear Underside, Post-Test



A-25

KAR21061-01

Figure A-25: Driver Dummy Front View, Pre-Test



Figure A-26: Driver Dummy Front View, Post-Test



Figure A-27: Driver Dummy Through Window, Pre-Test



Figure A-28: Driver Dummy Through Window, Post-Test



Figure A-29: Driver Dummy Door Open, Pre-Test



A-30

KAR21061-01

Figure A-30: Driver Dummy Door Open, Post-Test



Figure A-31: Driver Dummy 90° To Vehicle, Pre-Test



Figure A-32: Driver Dummy 90° To Vehicle, Post-Test



Figure A-33: Driver Dummy Feet, Pre-Test



A-34

KAR21061-01

Figure A-34: Driver Dummy Feet and Knee Contact, Post-Test



A-35

KAR21061-01

Figure A-35: Driver Side Knee Bolster, Pre-Test



Figure A-36: Driver Side Knee Bolster, Post-Test



Figure A-37: Driver Side Floor Pan, Pre-Test



Figure A-38: Driver Side Floor Pan, Post-Test



Figure A-39: Driver Dummy Head, Post-Test



Figure A-40: Driver Dummy Contact, Post-Test

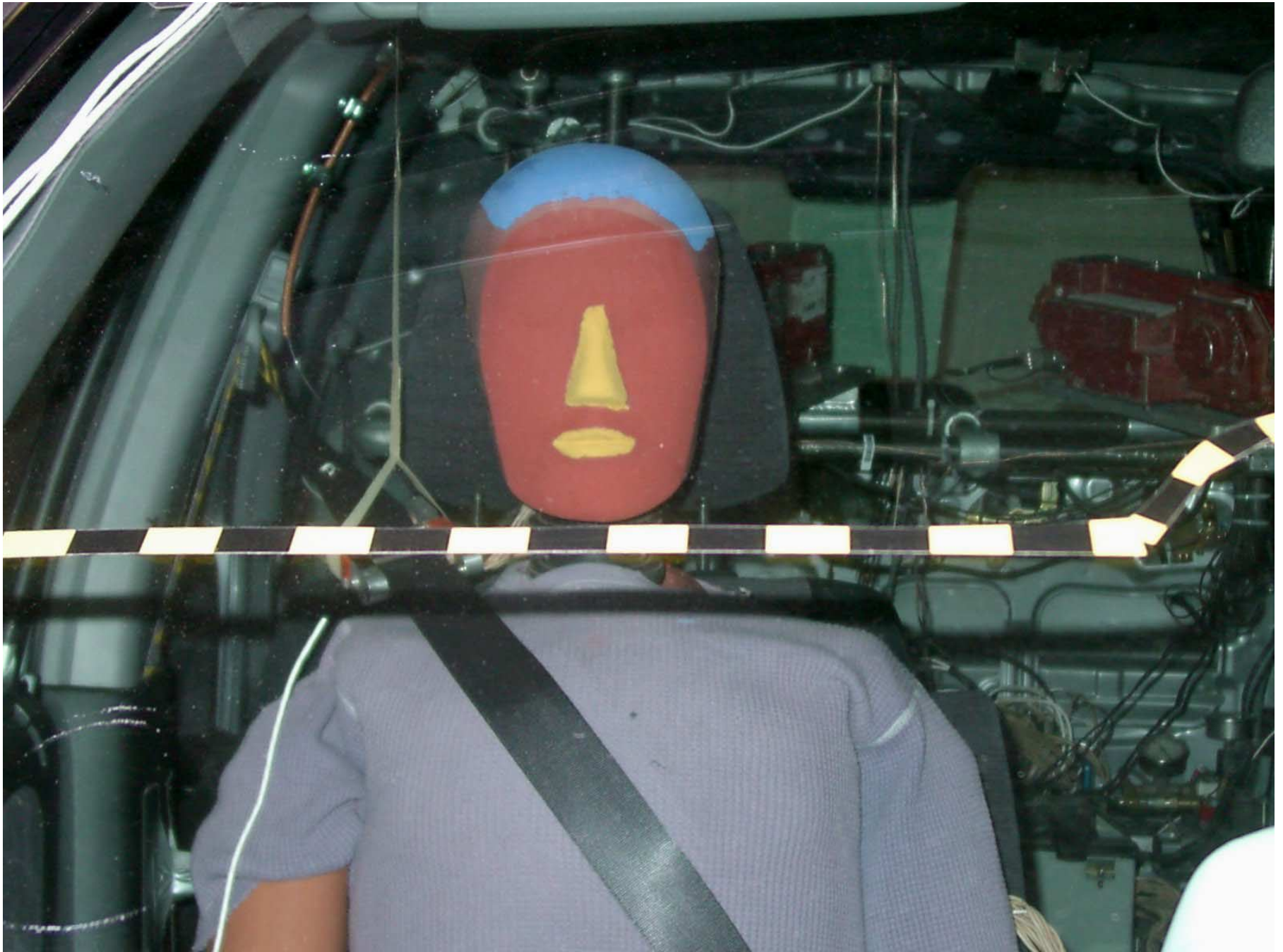

Figure A-41: Passenger Dummy Front View, Pre-Test



Figure A-42: Passenger Dummy Front View, Post-Test



Figure A-43: Passenger Dummy Through Window, Pre-Test



Figure A-44: Passenger Dummy Through Window, Post-Test



Figure A-45: Passenger Dummy Door Open, Pre-Test



Figure A-46: Passenger Dummy Door Open, Post-Test



Figure A-47: Passenger Dummy 90° To Vehicle, Pre-Test



Figure A-48: Passenger Dummy 90° To Vehicle, Post-Test



Figure A-49: Passenger Dummy Feet, Pre-Test



Figure A-50: Passenger Dummy Feet and Knee Contact, Post-Test

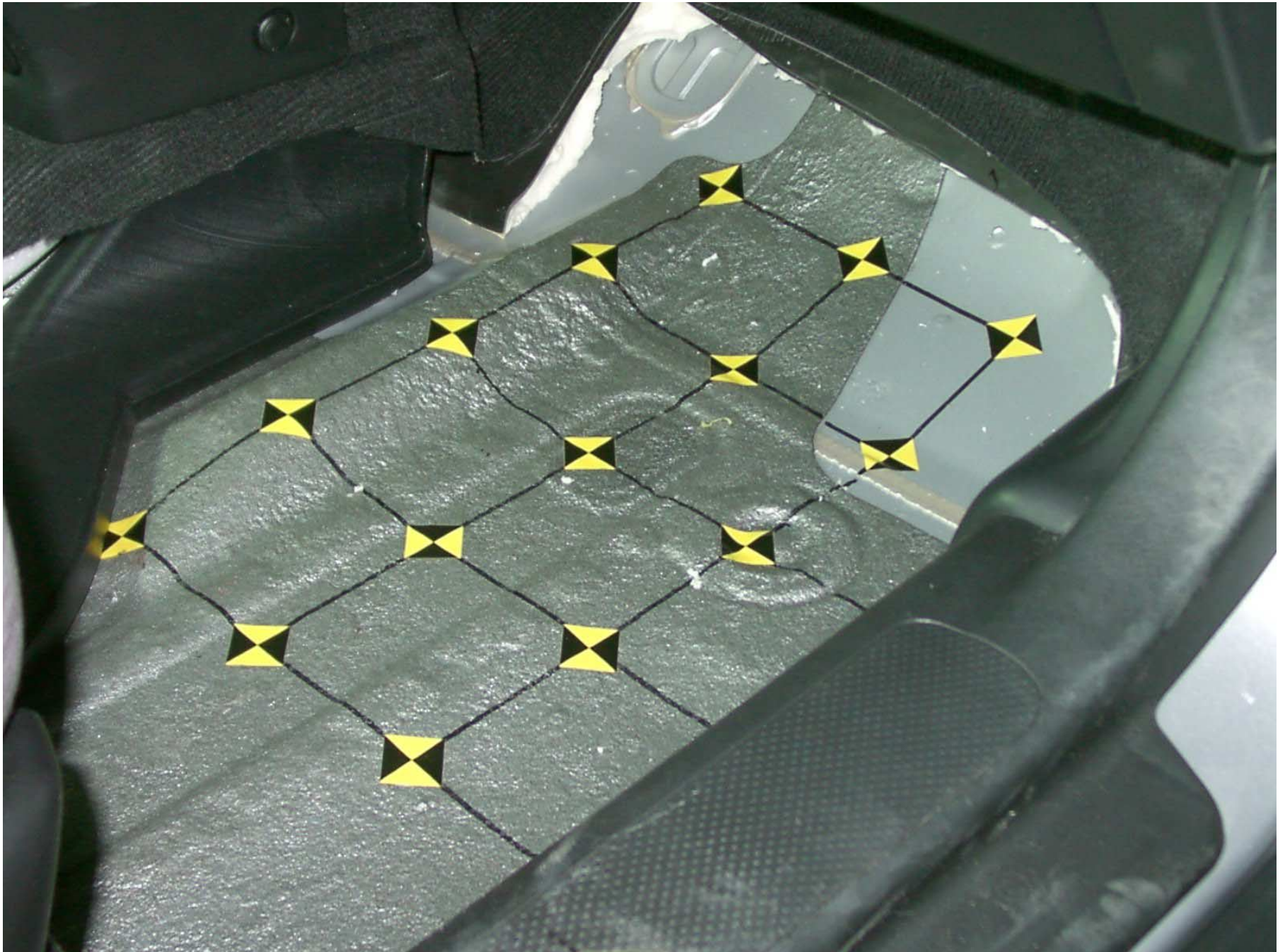

Figure A-51: Passenger Side Floor Pan, Pre-Test



Figure A-52: Passenger Side Floor Pan, Post-Test



Figure A-53: Passenger Side Knee Bolster, Pre-Test



Figure A-54: Passenger Side Knee Bolster, Post-Test



Figure A-55: Passenger Head, Post-Test



Figure A-56: Passenger Dummy Contact, Post-Test



A-57

KAR21061-01

Figure A-57: ¾ Left Rear View of Doors Closed After Impact



Figure A-58: 3/4 Right Rear View of Doors Closed After Impact



Figure A-59: Vehicle on Rollover Device



Figure A-60: Vehicle During Impact

## **APPENDIX B**

### **DATA PLOTS**

LIST OF DATA PLOTS

Data Plot	Page	
B-1	Driver Head Primary X	B-1
B-2	Driver Head Primary X Velocity	B-2
B-3	Driver Head Primary X Displacement	B-3
B-4	Driver Head Primary Y	B-4
B-5	Driver Head Primary Z	B-5
B-6	Driver Head Resultant Primary	B-6
B-7	Driver Head Redundant X	B-7
B-8	Driver Head Redundant X Velocity	B-8
B-9	Driver Head Redundant X Displacement	B-9
B-10	Driver Head Redundant Y	B-10
B-11	Driver Head Redundant Z	B-11
B-12	Driver Head Resultant Redundant	B-12
B-13	Driver Neck Force X	B-13
B-14	Driver Neck Force Y	B-14
B-15	Driver Neck Force Z	B-15
B-16	Driver Neck Force Resultant	B-16
B-17	Driver Neck Moment X	B-17
B-18	Driver Neck Moment Y	B-18
B-19	Driver Neck Moment Z	B-19
B-20	Driver Neck Moment Resultant	B-20
B-21	Driver Chest Primary X	B-21
B-22	Driver Chest Primary X Velocity	B-22
B-23	Driver Chest Primary X Displacement	B-23
B-24	Driver Chest Primary Y	B-24
B-25	Driver Chest Primary Z	B-25
B-26	Driver Chest Primary Resultant	B-26
B-27	Driver Chest Redundant X	B-27
B-28	Driver Chest Redundant X Velocity	B-28
B-29	Driver Chest Redundant X Displacement	B-29
B-30	Driver Chest Redundant Y	B-30
B-31	Driver Chest Redundant Z	B-31
B-32	Driver Chest Redundant Resultant	B-32
B-33	Driver Chest Displacement X	B-33

LIST OF DATA PLOTS...(Continued)

Data Plot	Page	Page
B-34	Driver Pelvis X	B-34
B-35	Driver Pelvis X Velocity	B-35
B-36	Driver Pelvis X Displacement	B-36
B-37	Driver Pelvis Y	B-37
B-38	Driver Pelvis Z	B-38
B-39	Driver Pelvis Resultant	B-39
B-40	Driver Left Femur Force	B-40
B-41	Driver Right Femur Force	B-41
B-42	Driver Left Knee Slider	B-42
B-43	Driver Right Knee Slider	B-43
B-44	Driver Left Upper Tibia Moment X	B-44
B-45	Driver Left Upper Tibia Moment Y	B-45
B-46	Driver Right Upper Tibia Moment X	B-46
B-47	Driver Right Upper Tibia Moment Y	B-47
B-48	Driver Left Lower Tibia Moment X	B-48
B-49	Driver Left Lower Tibia Moment Y	B-49
B-50	Driver Left Lower Tibia Force Z	B-50
B-51	Driver Right Lower Tibia Moment X	B-51
B-52	Driver Right Lower Tibia Moment Y	B-52
B-53	Driver Right Lower Tibia Force Z	B-53
B-54	Driver Left Foot Aft X	B-54
B-55	Driver Left Foot Aft Z	B-55
B-56	Driver Left Foot Fore Z	B-56
B-57	Driver Right Foot Aft X	B-57
B-58	Driver Right Foot Aft Z	B-58
B-59	Driver Right Foot Fore Z	B-59
B-60	Driver Lap Belt Force	B-60
B-61	Driver Shoulder Belt Force	B-61
B-62	Driver Shoulder Belt Pullout	B-62
B-63	Driver Shoulder Belt Elongation	B-63

LIST OF DATA PLOTS...(Continued)

Data Plot		Page
B-64	Passenger Head Primary X	B-64
B-65	Passenger Head Primary X Velocity	B-65
B-66	Passenger Head Primary X Displacement	B-66
B-67	Passenger Head Primary Y	B-67
B-68	Passenger Head Primary Z	B-68
B-69	Passenger Head Resultant Primary	B-69
B-70	Passenger Head Redundant X	B-70
B-71	Passenger Head Redundant X Velocity	B-71
B-72	Passenger Head Redundant X Displacement	B-72
B-73	Passenger Head Redundant Y	B-73
B-74	Passenger Head Redundant Z	B-74
B-75	Passenger Head Resultant Redundant	B-75
B-76	Passenger Neck Force X	B-76
B-77	Passenger Neck Force Y	B-77
B-78	Passenger Neck Force Z	B-78
B-79	Passenger Neck Force Resultant	B-79
B-80	Passenger Neck Moment X	B-80
B-81	Passenger Neck Moment Y	B-81
B-82	Passenger Neck Moment Z	B-82
B-83	Passenger Neck Moment Resultant	B-83
B-84	Passenger Chest Primary X	B-84
B-85	Passenger Chest Primary X Velocity	B-85
B-86	Passenger Chest Primary X Displacement	B-86
B-87	Passenger Chest Primary Y	B-87
B-88	Passenger Chest Primary Z	B-88
B-89	Passenger Chest Primary Resultant	B-89
B-90	Passenger Chest Redundant X	B-90
B-91	Passenger Chest Redundant X Velocity	B-91
B-92	Passenger Chest Redundant X Displacement	B-92
B-93	Passenger Chest Redundant Y	B-93
B-94	Passenger Chest Redundant Z	B-94
B-95	Passenger Chest Redundant Resultant	B-95
B-96	Passenger Chest Displacement X	B-96

LIST OF DATA PLOTS...(Continued)

Data Plot	Page	
B-97	Passenger Pelvis X	B-97
B-98	Passenger Pelvis X Velocity	B-98
B-99	Passenger Pelvis X Displacement	B-99
B-100	Passenger Pelvis Y	B-100
B-101	Passenger Pelvis Z	B-101
B-102	Passenger Pelvis Resultant	B-102
B-103	Passenger Left Femur Force	B-103
B-104	Passenger Right Femur Force	B-104
B-105	Passenger Left Knee Slider	B-105
B-106	Passenger Right Knee Slider	B-106
B-107	Passenger Left Upper Tibia Moment X	B-107
B-108	Passenger Left Upper Tibia Moment Y	B-108
B-109	Passenger Right Upper Tibia Moment X	B-109
B-110	Passenger Right Upper Tibia Moment Y	B-110
B-111	Passenger Left Lower Tibia Moment X	B-111
B-112	Passenger Left Lower Tibia Moment Y	B-112
B-113	Passenger Left Lower Tibia Force Z	B-113
B-114	Passenger Right Lower Tibia Moment X	B-114
B-115	Passenger Right Lower Tibia Moment Y	B-115
B-116	Passenger Right Lower Tibia Force Z	B-116
B-117	Passenger Left Foot Aft X	B-117
B-118	Passenger Left Foot Aft Z	B-118
B-119	Passenger Left Foot Fore Z	B-119
B-120	Passenger Right Foot Aft X	B-120
B-121	Passenger Right Foot Aft Z	B-121
B-122	Passenger Right Foot Fore Z	B-122
B-123	Passenger Lap Belt Force	B-123
B-124	Passenger Shoulder Belt Force	B-124
B-125	Passenger Shoulder Belt Pullout	B-125
B-126	Passenger Shoulder Belt Elongation	B-126

LIST OF DATA PLOTS...(Continued)

Data Plot		Page
B-127	Vehicle Left Rear X	B-127
B-128	Vehicle Left Rear X Velocity	B-128
B-129	Vehicle Left Rear X Displacement	B-129
B-130	Vehicle Right Rear X	B-130
B-131	Vehicle Right Rear X Velocity	B-131
B-132	Vehicle Right Rear X Displacement	B-132
B-133	Vehicle Engine Top	B-133
B-134	Vehicle Engine Top Velocity	B-134
B-135	Vehicle Engine Top Displacement	B-135
B-136	Vehicle Engine Bottom	B-136
B-137	Vehicle Engine Bottom Velocity	B-137
B-138	Vehicle Engine Bottom Displacement	B-138
B-139	Vehicle Left Brake Caliper	B-139
B-140	Vehicle Left Brake Caliper Velocity	B-140
B-141	Vehicle Left Brake Caliper Displacement	B-141
B-142	Vehicle Right Brake Caliper	B-142
B-143	Vehicle Right Brake Caliper Velocity	B-143
B-144	Vehicle Right Brake Caliper Displacement	B-144
B-145	Vehicle Instrument Panel	B-145
B-146	Vehicle Instrument Panel Velocity	B-146
B-147	Vehicle Instrument Panel Displacement	B-147
B-148	Vehicle Left Rear Z	B-148
B-149	Vehicle Left Rear Z Velocity	B-149
B-150	Vehicle Left Rear Z Displacement	B-150
B-151	Vehicle Right Rear Z	B-151
B-152	Vehicle Right Rear Z Velocity	B-152
B-153	Vehicle Right Rear Z Displacement	B-153

B-1

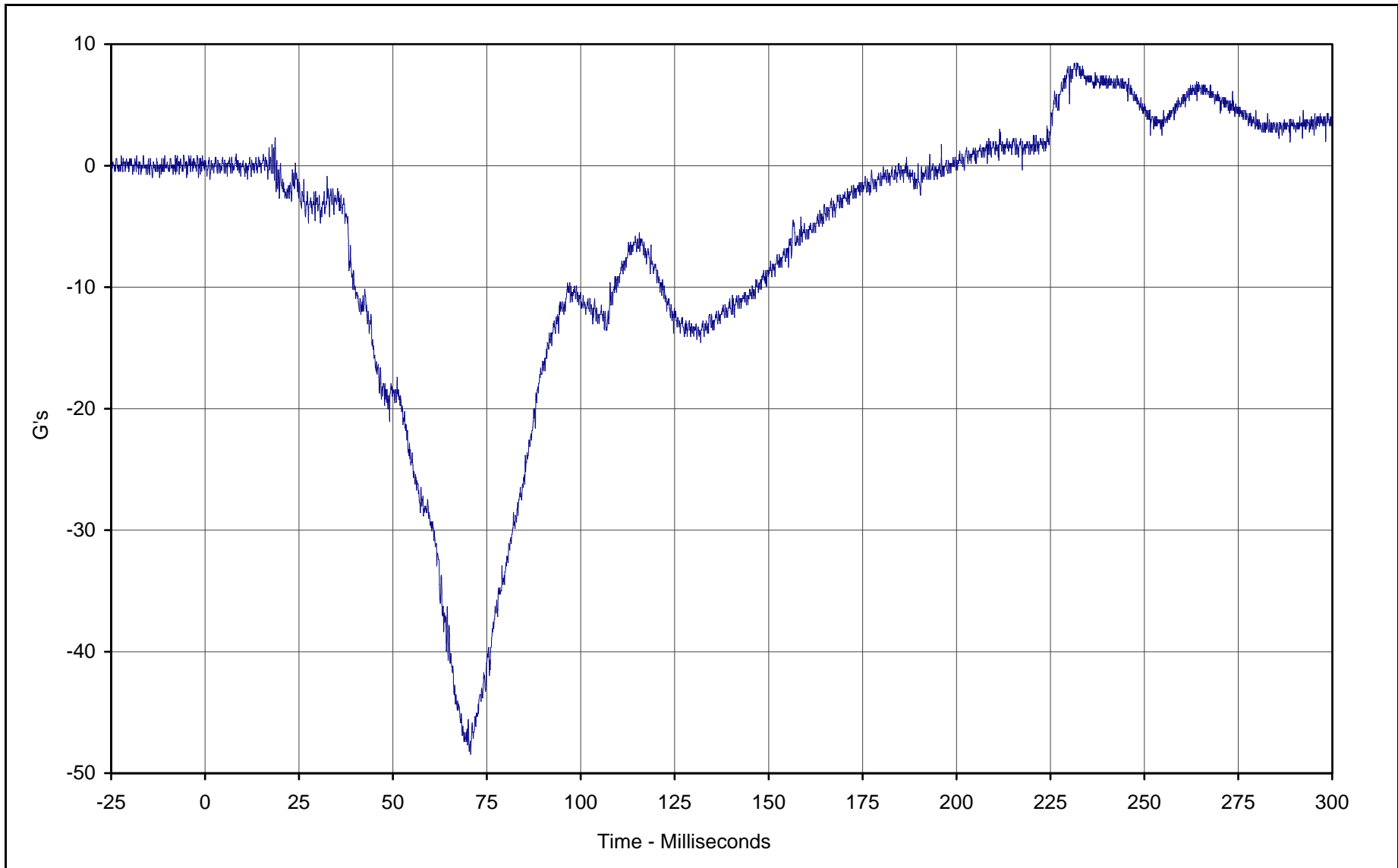

Curve Description: Driver Head Primary X  
Maximum Value: 8.4 at 231.3 Milliseconds  
Minimum Value: -48.4 at 70.7 Milliseconds  
SAE Filter Class: 1000  
Date of Test: 1/29/02  
Curve Number: FIL-001

Test Program: 2002 NHTSA 35mph NCAP No.: HO5300  
Test Vehicle: 2002 Honda CR-V LX 4WD SUV



KAR21061-01

B-2

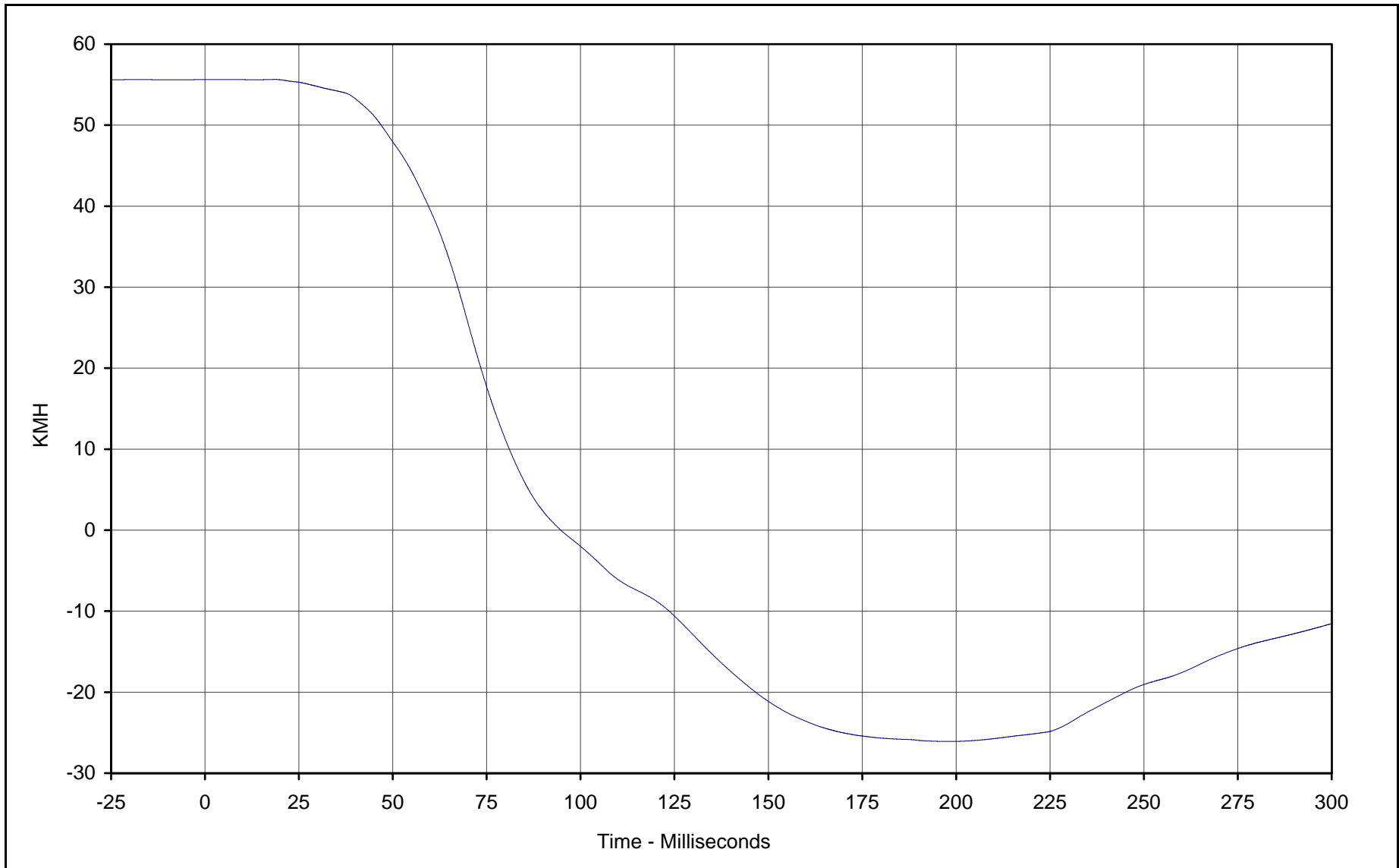

Curve Description: Driver Head Primary X Velocity  
Maximum Value: 55.6 at 18.6 Milliseconds  
Minimum Value: -26.1 at 198.5 Milliseconds  
SAE Filter Class: 180  
Date of Test: 1/29/02  
Curve Number: IN1-001

Test Program: 2002 NHTSA 35mph NCAP No.: HO5300  
Test Vehicle: 2002 Honda CR-V LX 4WD SUV

KAR21061-01



B-3

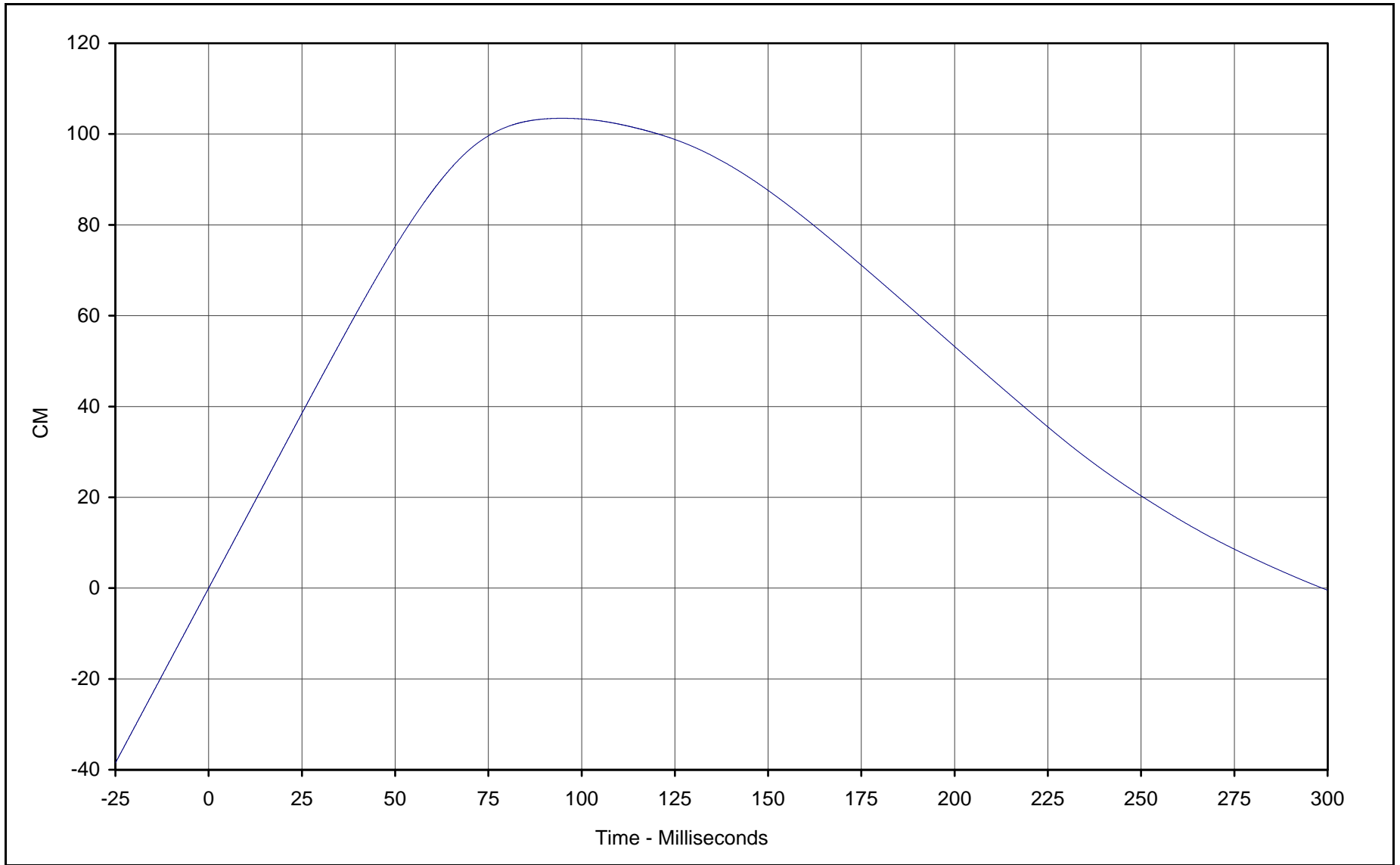

Curve Description: Driver Head Primary X Displ.  
Maximum Value: 103.5 at 94.7 Milliseconds  
Minimum Value: -0.4 at 299.9 Milliseconds  
SAE Filter Class: 180  
Date of Test: 1/29/02  
Curve Number: IN2-001

Test Program: 2002 NHTSA 35mph NCAP No.: HO5300  
Test Vehicle: 2002 Honda CR-V LX 4WD SUV



KAR21061-01

B-4

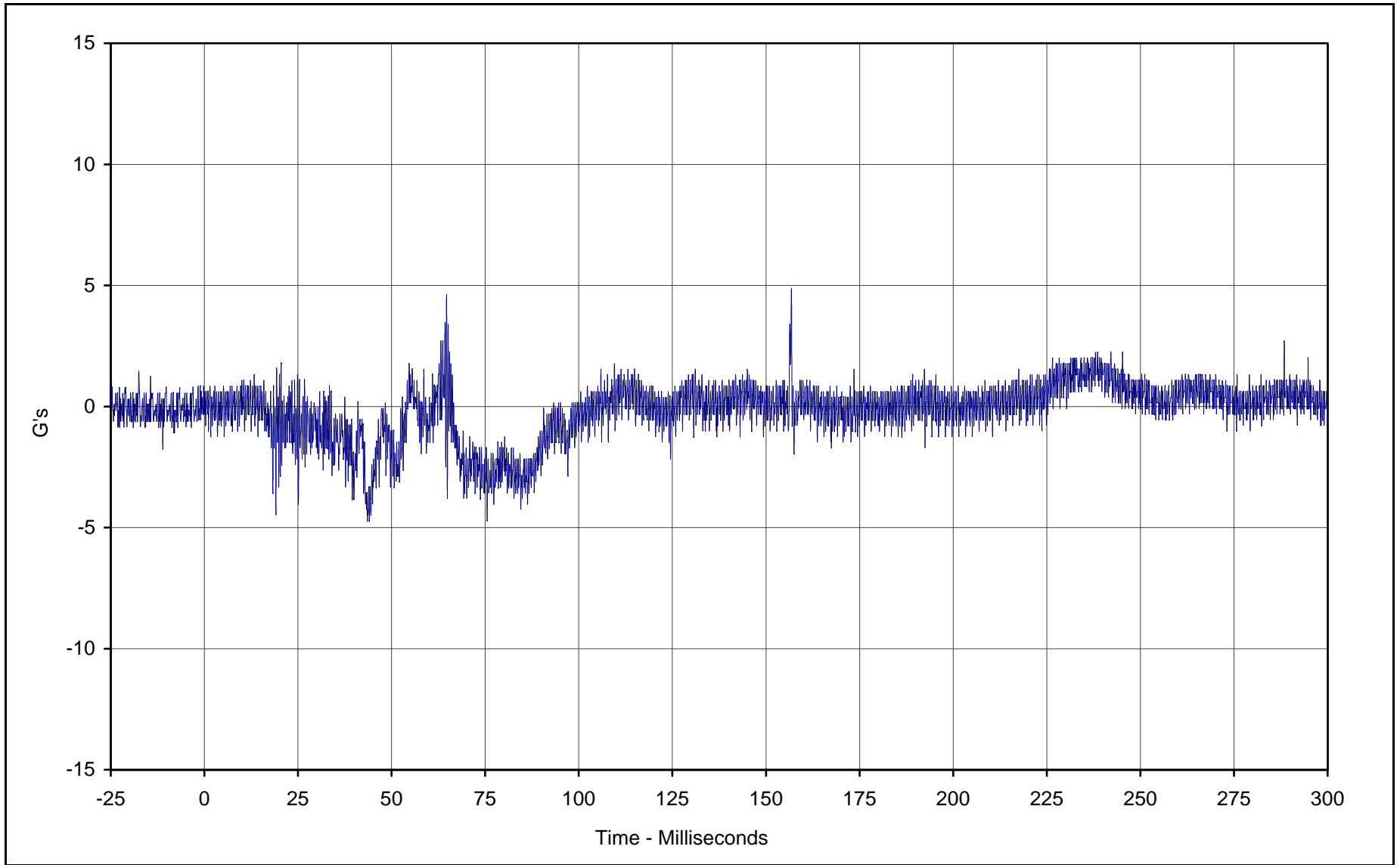

Curve Description: Driver Head Primary Y  
Maximum Value: 4.8 at 156.8 Milliseconds  
Minimum Value: -4.7 at 43.5 Milliseconds  
SAE Filter Class: 1000  
Date of Test: 1/29/02  
Curve Number: FIL-002

Test Program: 2002 NHTSA 35mph NCAP No.: HO5300  
Test Vehicle: 2002 Honda CR-V LX 4WD SUV



KAR21061-01

B-5

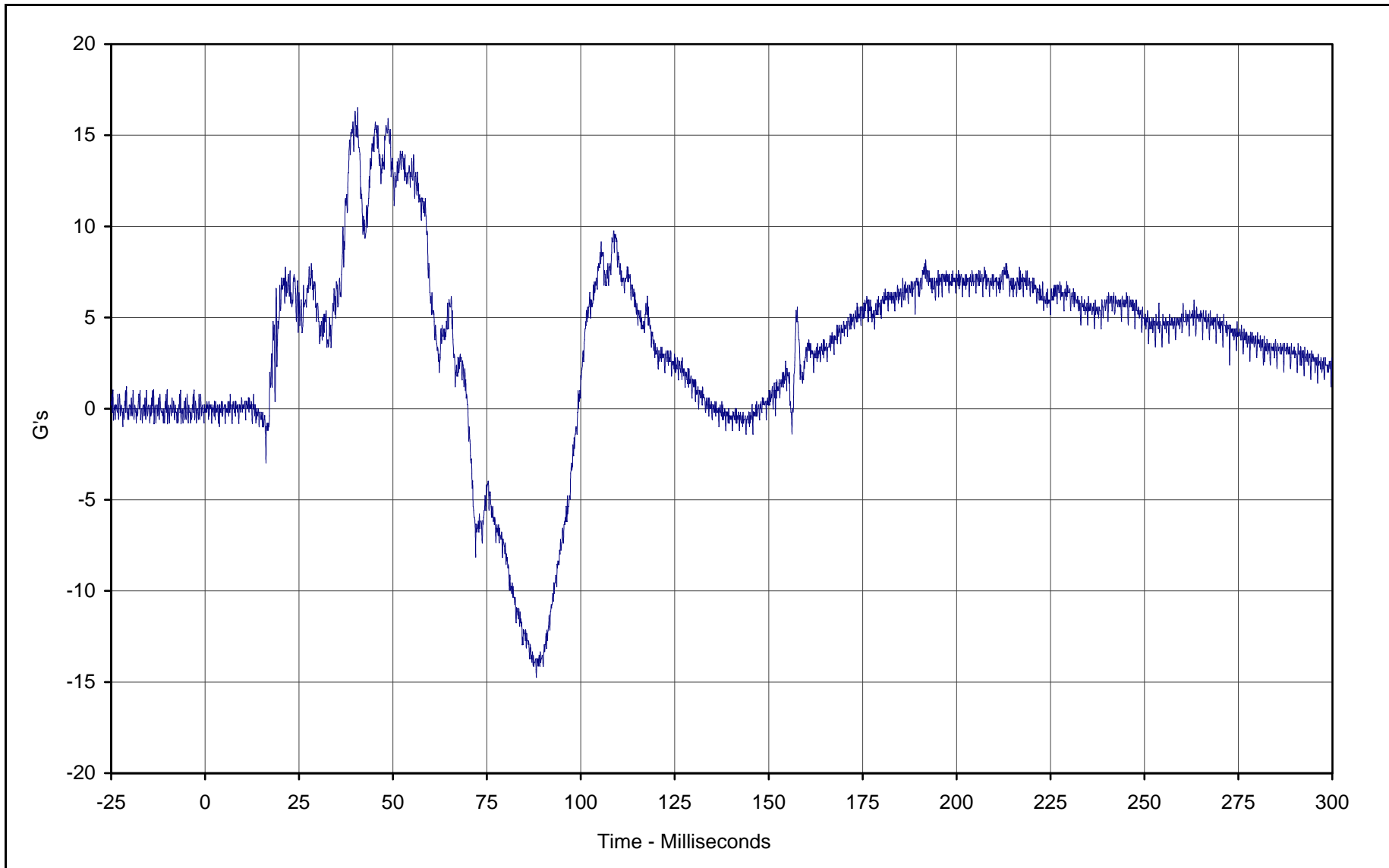

Curve Description: Driver Head Primary Z  
Maximum Value: 16.5 at 40.6 Milliseconds  
Minimum Value: -14.7 at 88.2 Milliseconds  
SAE Filter Class: 1000  
Date of Test: 1/29/02  
Curve Number: FIL-003

Test Program: 2002 NHTSA 35mph NCAP No.: HO5300  
Test Vehicle: 2002 Honda CR-V LX 4WD SUV



KAR21061-01

B-6

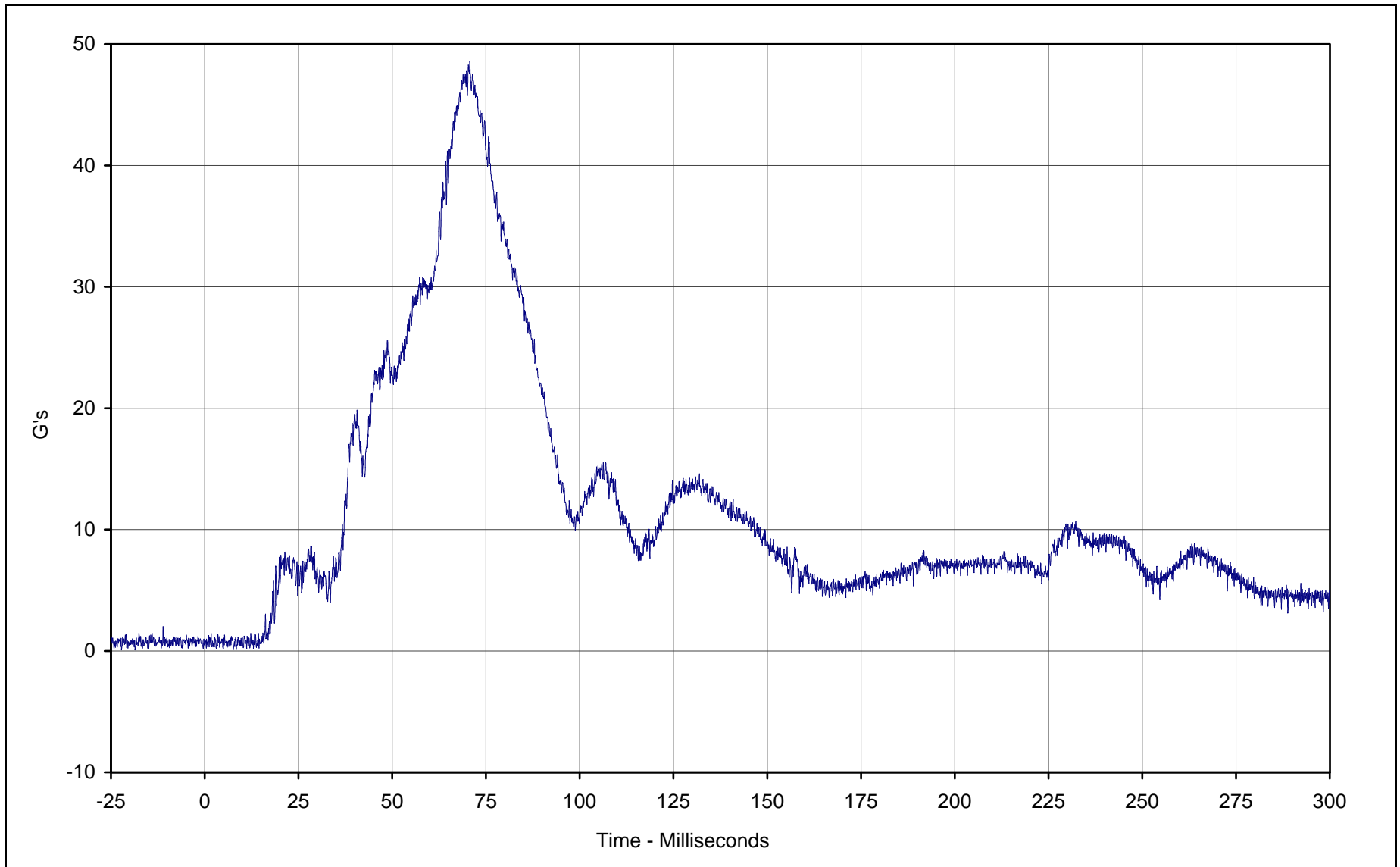

Curve Description: Driver Head Resultant Primary  
Maximum Value: 48.6 at 70.7 Milliseconds  
Minimum Value: 0.1 at 7.6 Milliseconds  
SAE Filter Class: 1000  
Date of Test: 1/29/02  
Curve Number: RES-001

Test Program: 2002 NHTSA 35mph NCAP No.: HO5300  
Test Vehicle: 2002 Honda CR-V LX 4WD SUV



KAR21061-01

B-7

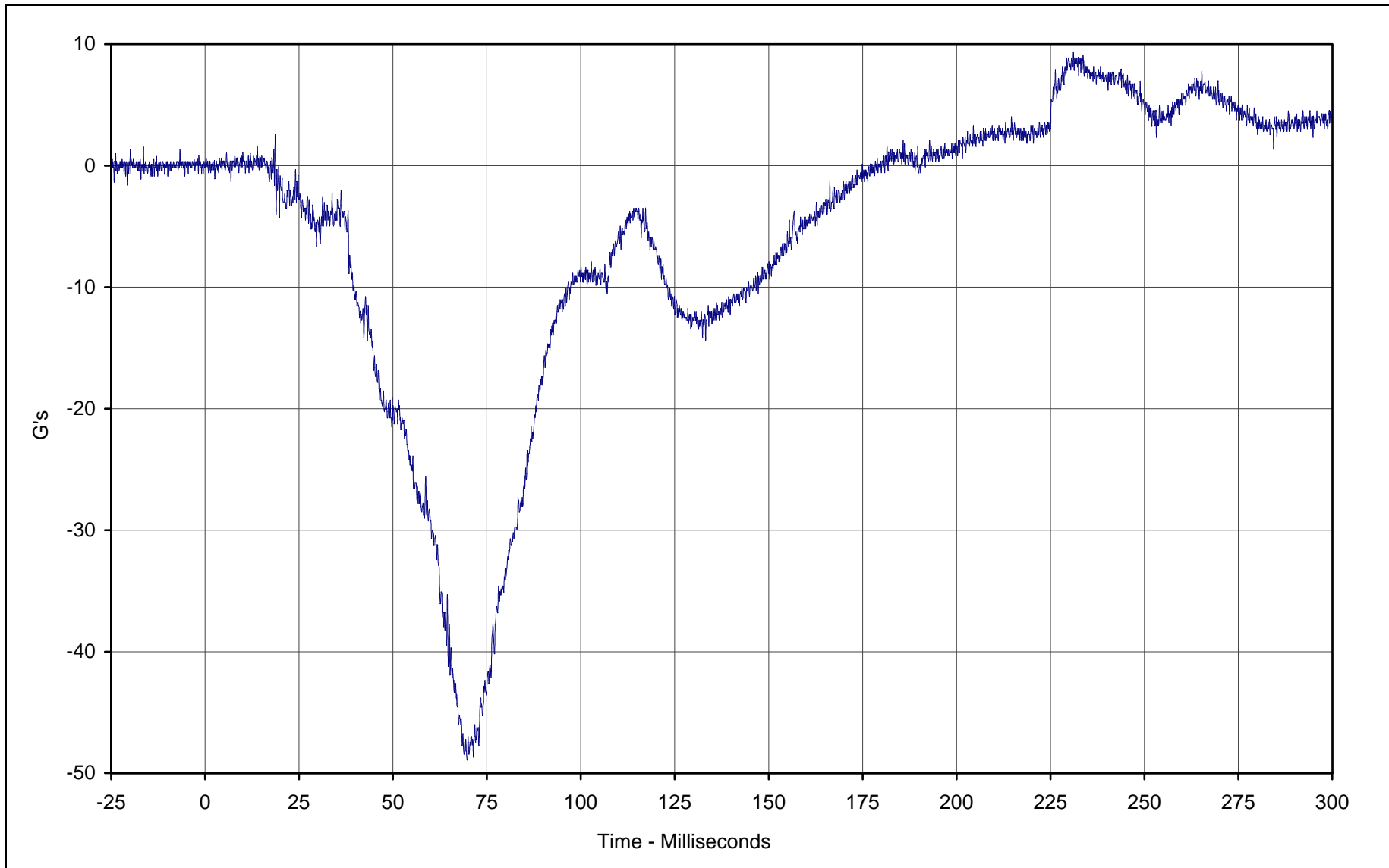

Curve Description: Driver Head Redundant X  
Maximum Value: 9.4 at 231.1 Milliseconds  
Minimum Value: -48.9 at 69.7 Milliseconds  
SAE Filter Class: 1000  
Date of Test: 1/29/02  
Curve Number: FIL-004

Test Program: 2002 NHTSA 35mph NCAP No.: HO5300  
Test Vehicle: 2002 Honda CR-V LX 4WD SUV



KAR21061-01

B-8

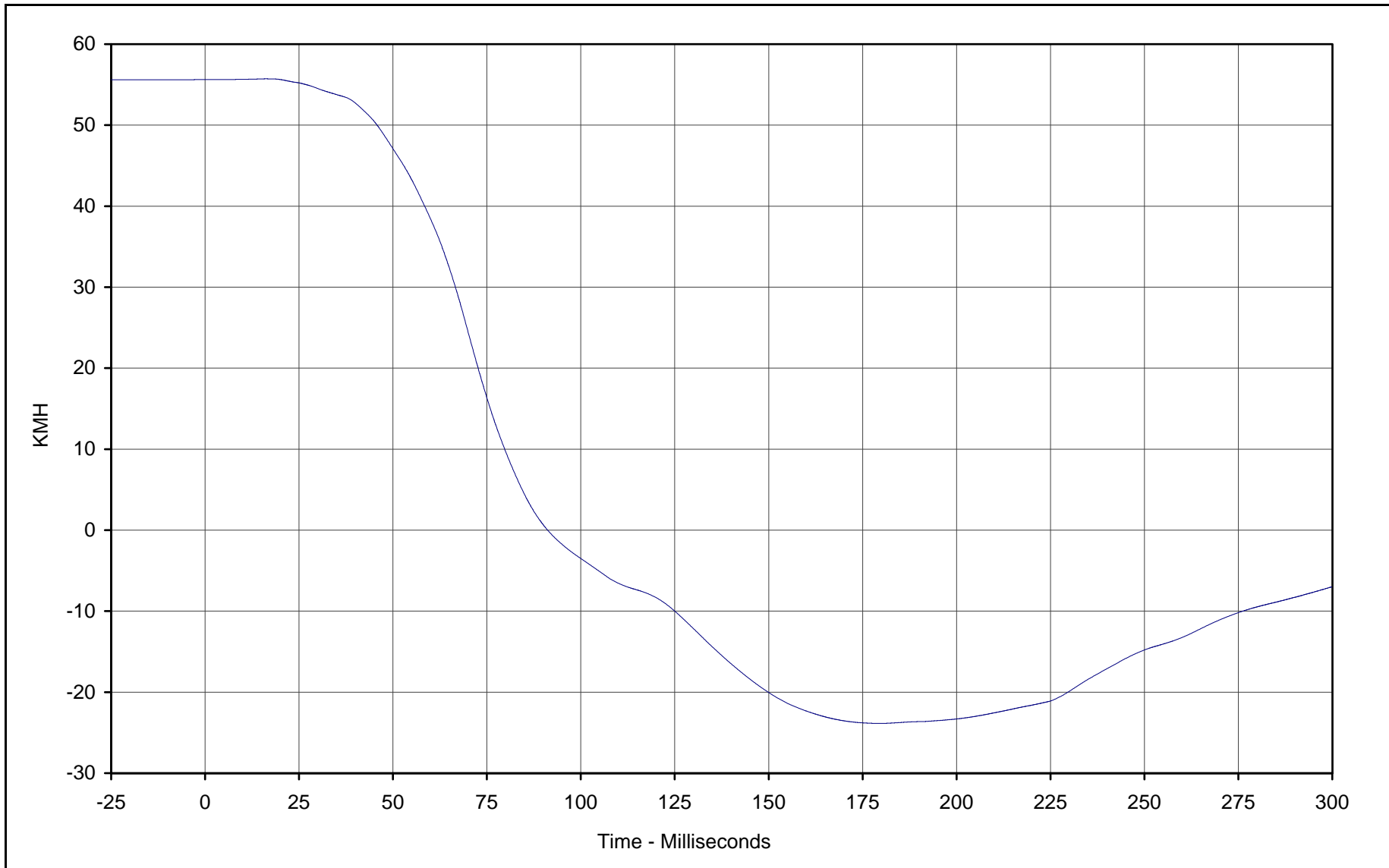

Curve Description: Driver Head Redundant X Velocity  
Maximum Value: 55.7 at 16.2 Milliseconds  
Minimum Value: -23.9 at 179.8 Milliseconds  
SAE Filter Class: 180  
Date of Test: 1/29/02  
Curve Number: IN1-004

Test Program: 2002 NHTSA 35mph NCAP No.: HO5300  
Test Vehicle: 2002 Honda CR-V LX 4WD SUV

KAR21061-01



B-9

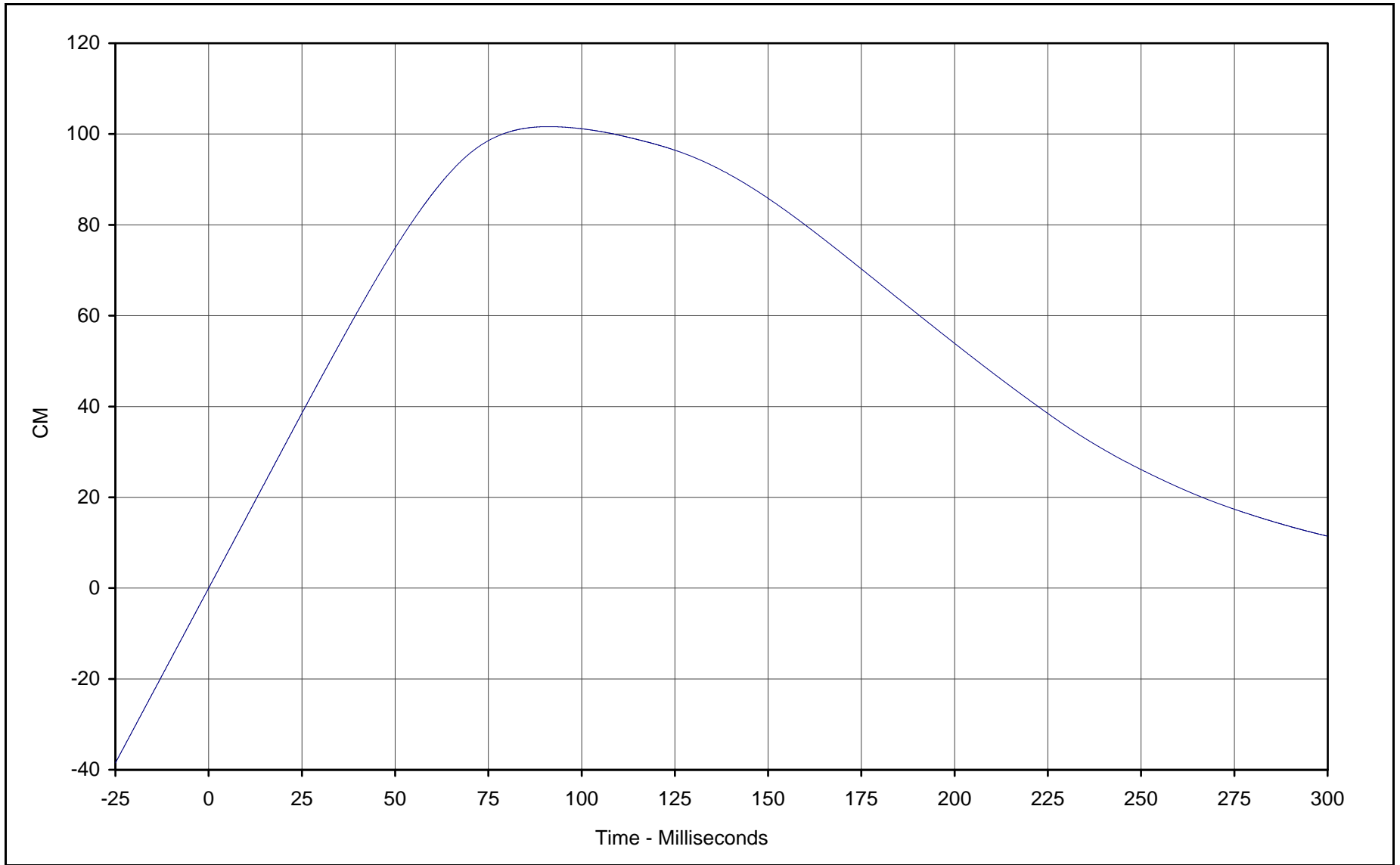

Curve Description: Driver Head Redundant X Displ.  
Maximum Value: 101.6 at 91.2 Milliseconds  
Minimum Value: 0.0 at 0.0 Milliseconds  
SAE Filter Class: 180  
Date of Test: 1/29/02  
Curve Number: IN2-004

Test Program: 2002 NHTSA 35mph NCAP No.: HO5300  
Test Vehicle: 2002 Honda CR-V LX 4WD SUV



KAR21061-01

B-10

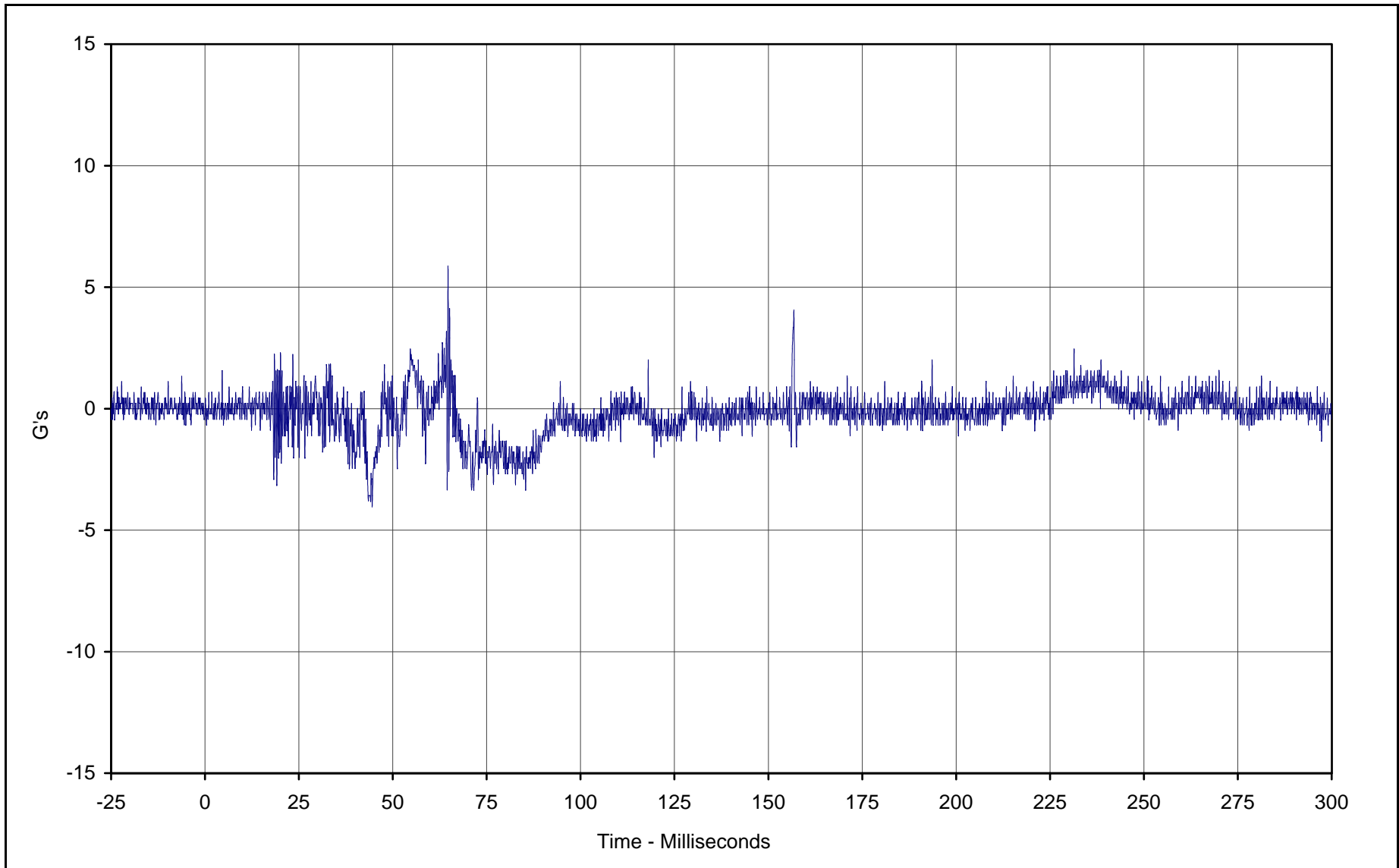

Curve Description: Driver Head Redundant Y  
Maximum Value: 5.8 at 64.7 Milliseconds  
Minimum Value: -4.0 at 44.5 Milliseconds  
SAE Filter Class: 1000  
Date of Test: 1/29/02  
Curve Number: FIL-005

Test Program: 2002 NHTSA 35mph NCAP No.: HO5300  
Test Vehicle: 2002 Honda CR-V LX 4WD SUV



KAR21061-01

B-11

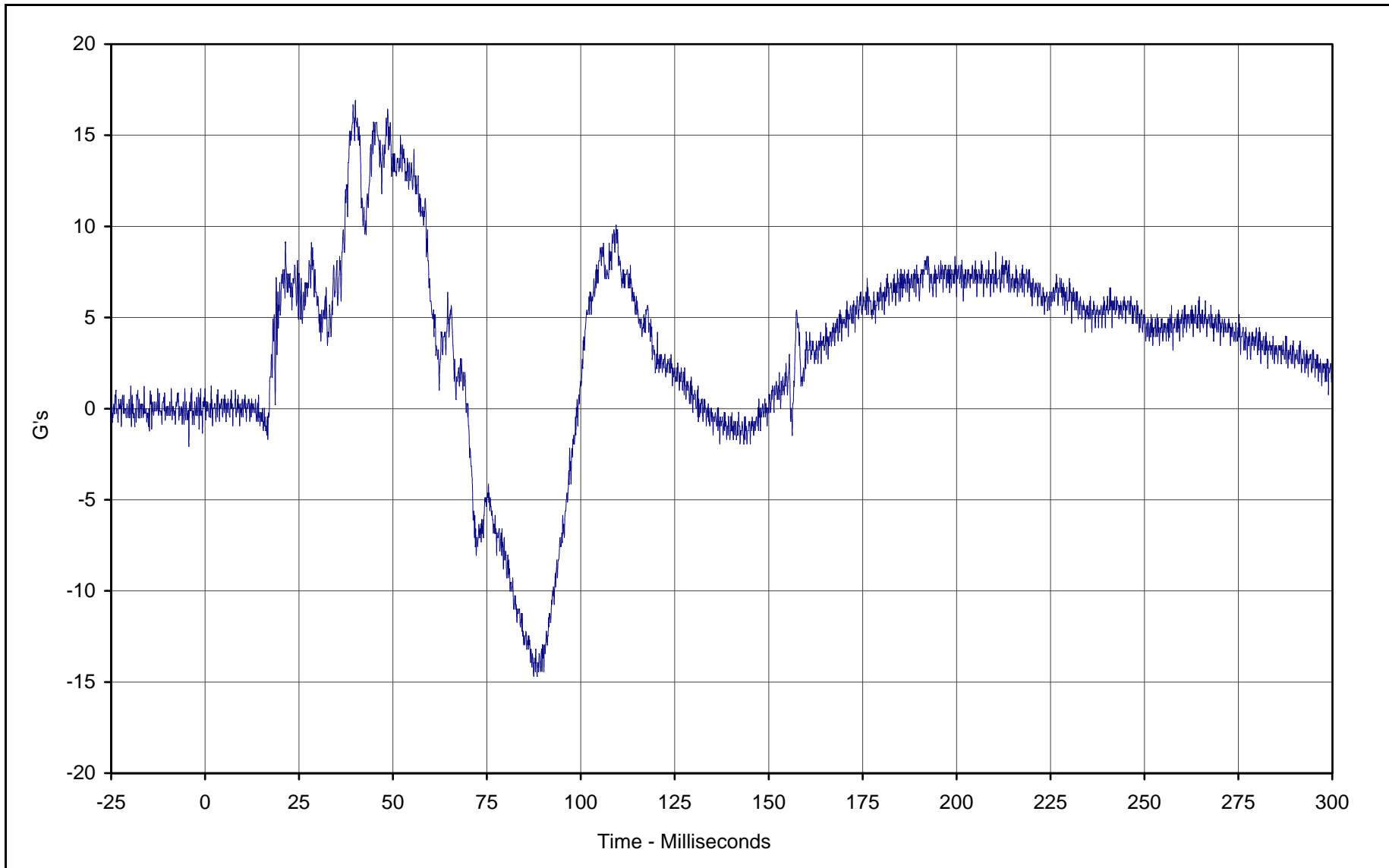

Curve Description: Driver Head Redundant Z  
Maximum Value: 16.9 at 40.0 Milliseconds  
Minimum Value: -14.7 at 87.5 Milliseconds  
SAE Filter Class: 1000  
Date of Test: 1/29/02  
Curve Number: FIL-006

Test Program: 2002 NHTSA 35mph NCAP No.: HO5300  
Test Vehicle: 2002 Honda CR-V LX 4WD SUV



KAR21061-01

B-12

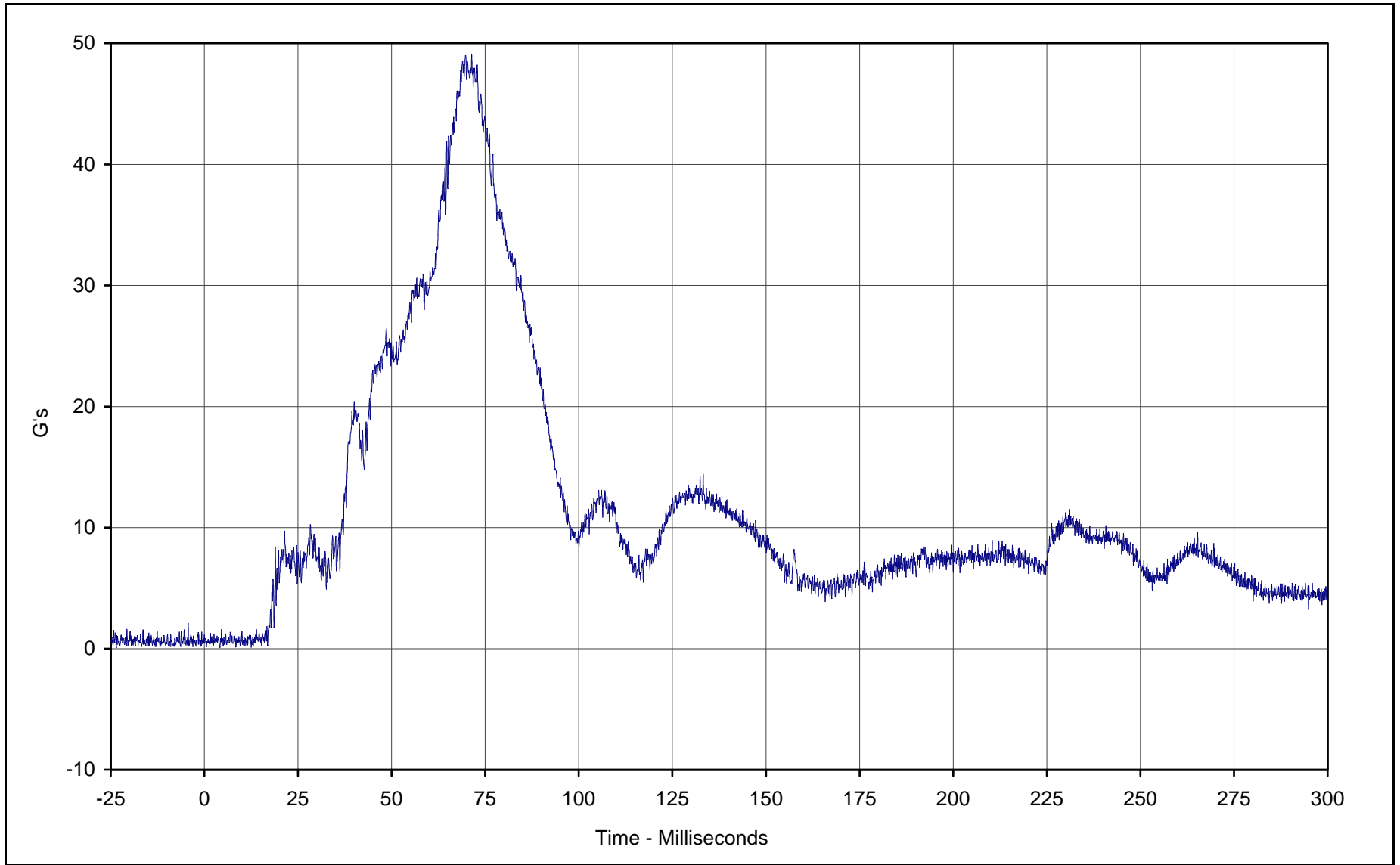

Curve Description: Driver Head Resultant Redundant  
Maximum Value: 49.1 at 71.4 Milliseconds  
Minimum Value: 0.1 at 4.1 Milliseconds  
SAE Filter Class: 1000  
Date of Test: 1/29/02  
Curve Number: RES-004

Test Program: 2002 NHTSA 35mph NCAP No.: HO5300  
Test Vehicle: 2002 Honda CR-V LX 4WD SUV



KAR21061-01

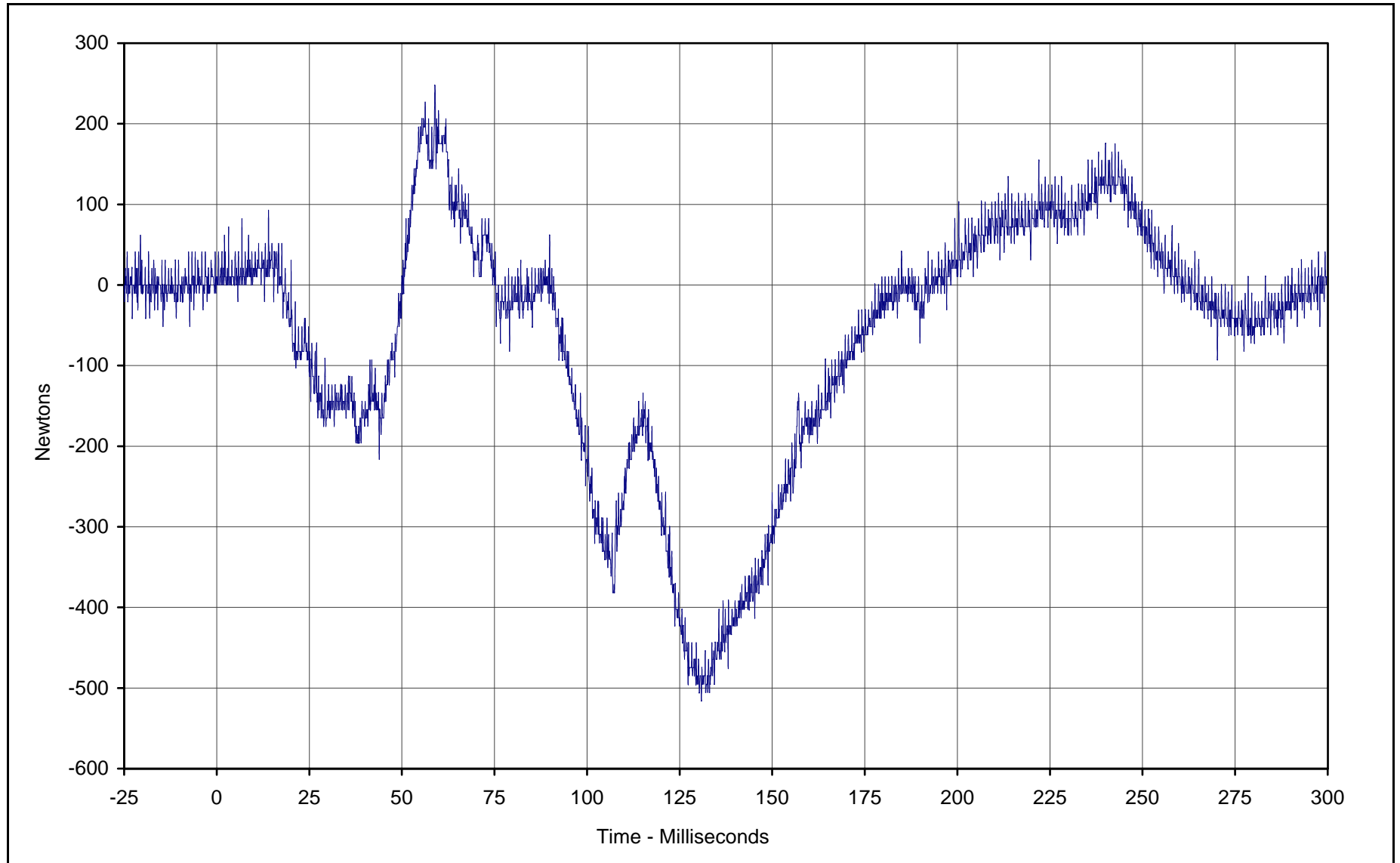

Curve Description: Driver Neck Force X  
 Maximum Value: 247.6 at 58.9 Milliseconds  
 Minimum Value: -515.9 at 130.9 Milliseconds  
 SAE Filter Class: 1000  
 Date of Test: 1/29/02  
 Curve Number: FIL-007

Test Program: 2002 NHTSA 35mph NCAP No.: HO5300  
 Test Vehicle: 2002 Honda CR-V LX 4WD SUV



B-14

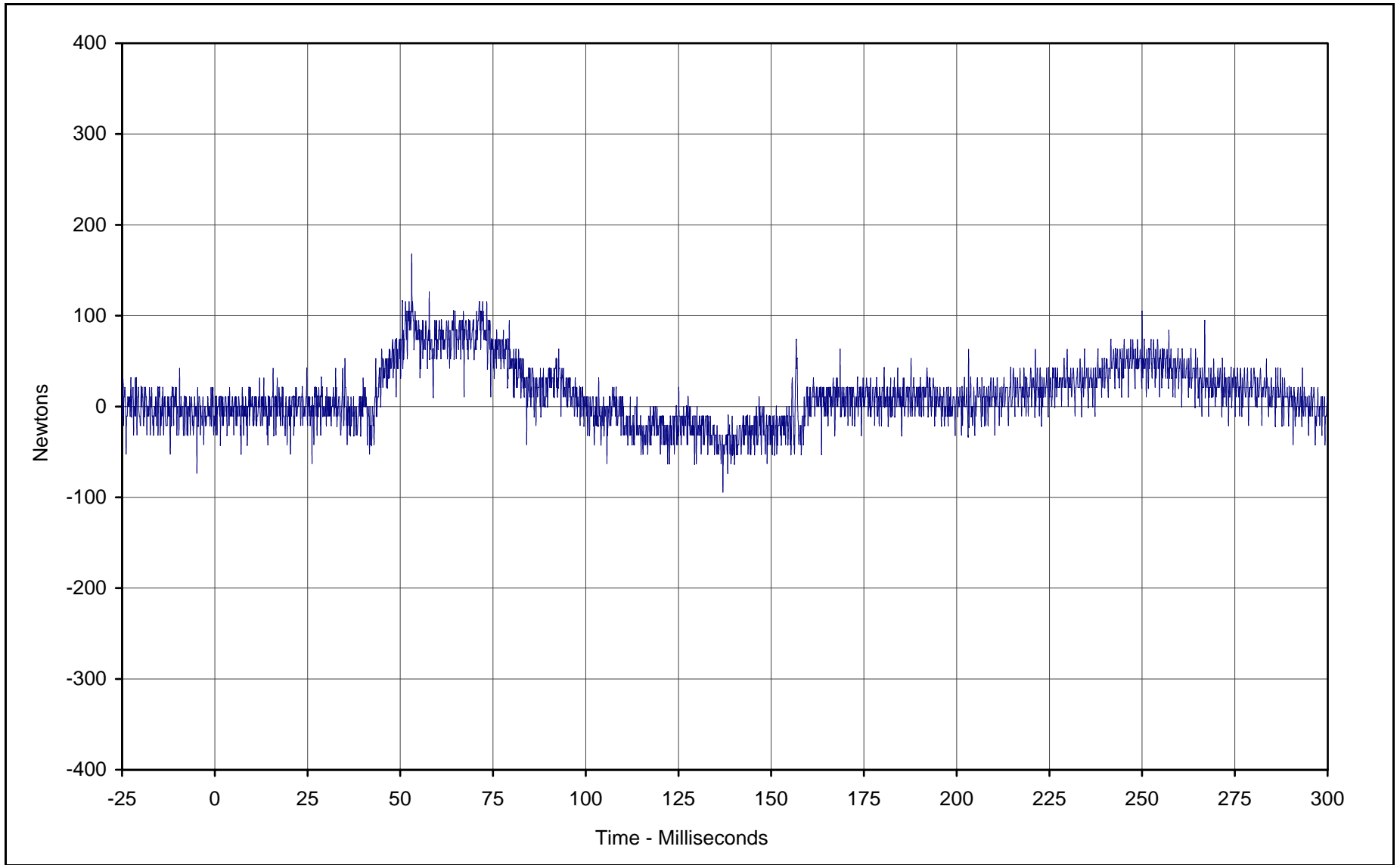

Curve Description: Driver Neck Force Y  
Maximum Value: 168.0 at 53.1 Milliseconds  
Minimum Value: -94.5 at 137.0 Milliseconds  
SAE Filter Class: 1000  
Date of Test: 1/29/02  
Curve Number: FIL-008

Test Program: 2002 NHTSA 35mph NCAP No.: HO5300  
Test Vehicle: 2002 Honda CR-V LX 4WD SUV



KAR21061-01

B-15

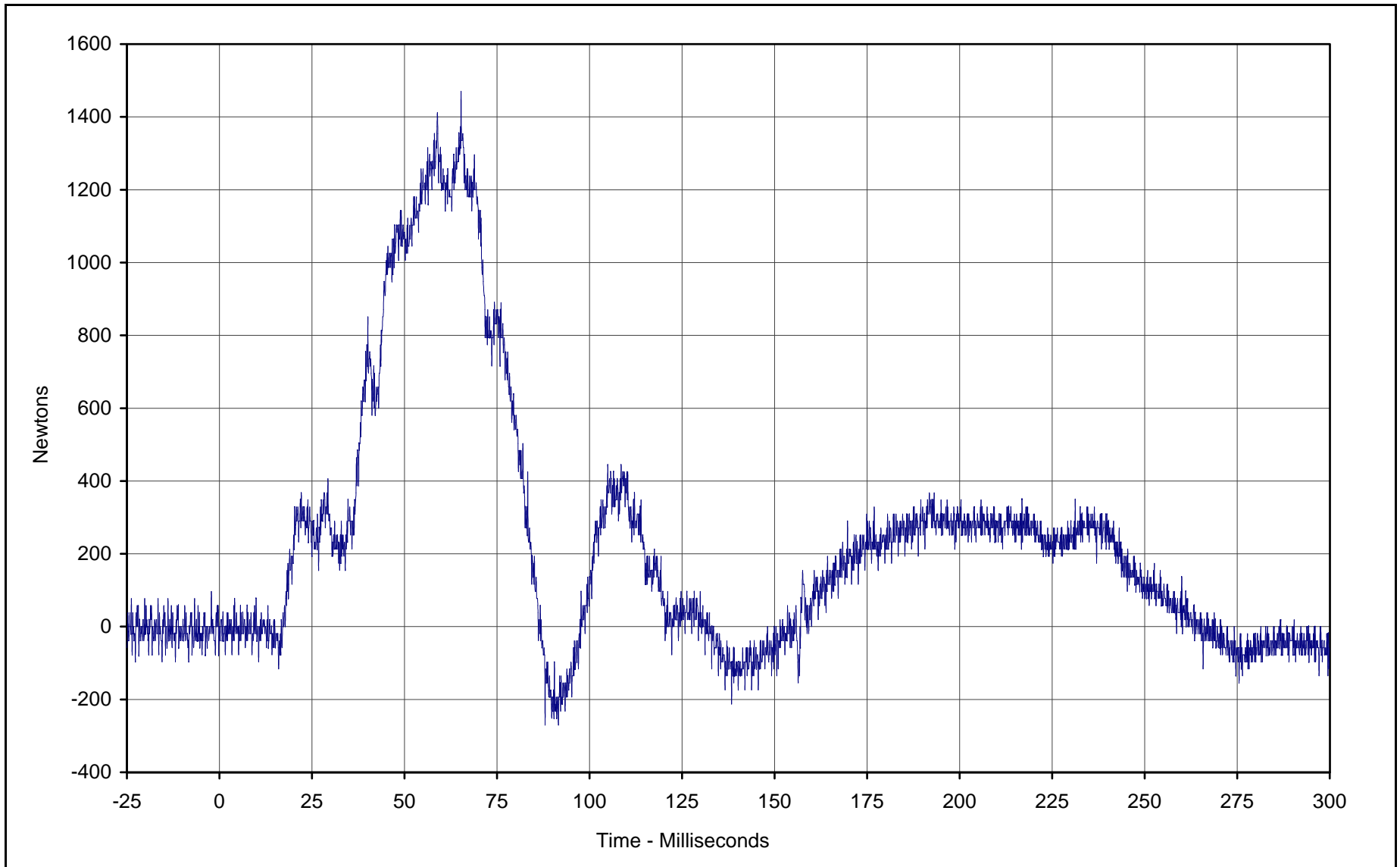

Curve Description: Driver Neck Force Z  
Maximum Value: 1470.4 at 65.3 Milliseconds  
Minimum Value: -270.9 at 88.0 Milliseconds  
SAE Filter Class: 1000  
Date of Test: 1/29/02  
Curve Number: FIL-009

Test Program: 2002 NHTSA 35mph NCAP No.: HO5300  
Test Vehicle: 2002 Honda CR-V LX 4WD SUV



KAR21061-01

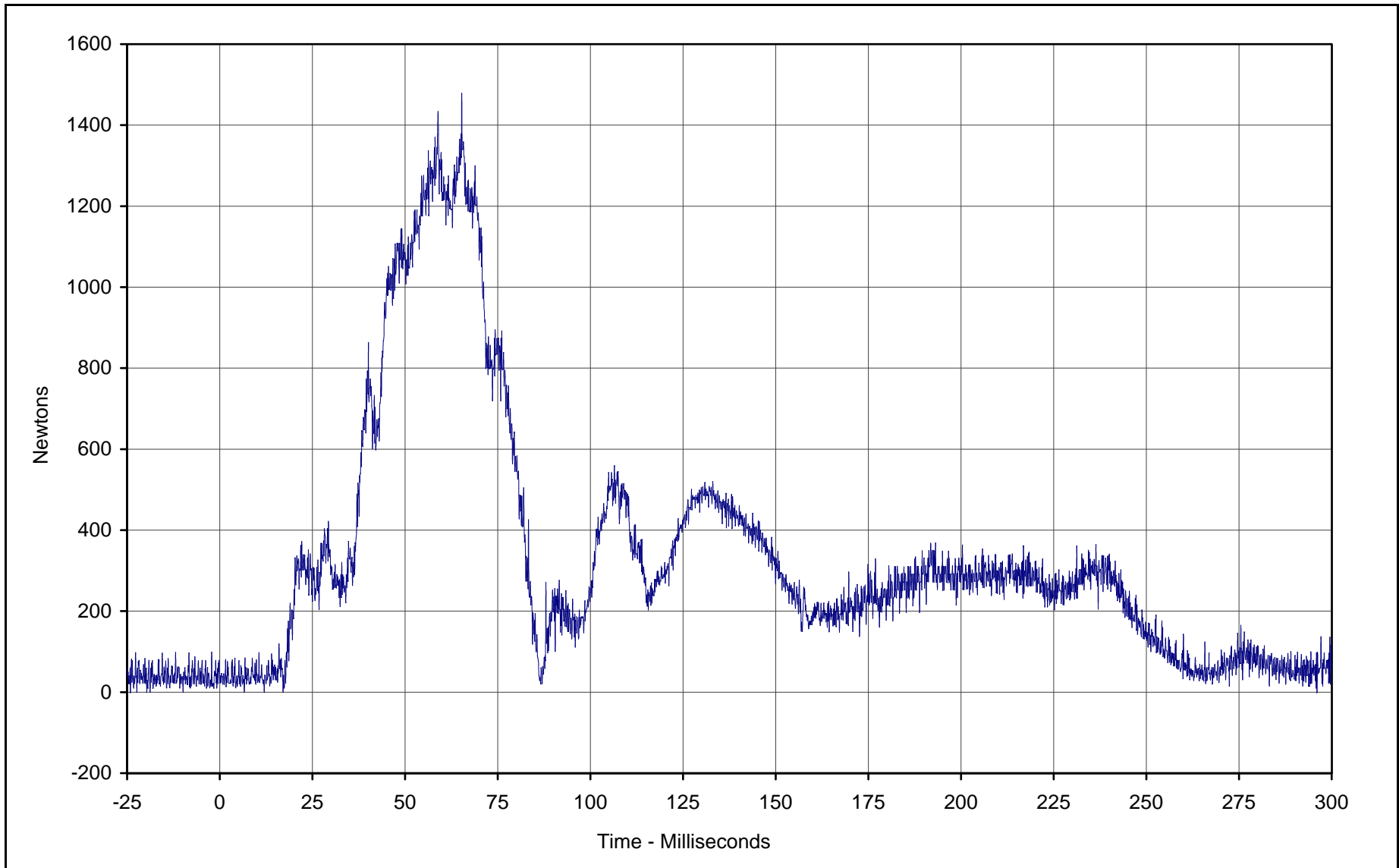

Curve Description: Driver Neck Force Resultant  
 Maximum Value: 1479.3 at 65.3 Milliseconds  
 Minimum Value: 0.0 at 6.6 Milliseconds  
 SAE Filter Class: 1000  
 Date of Test: 1/29/02  
 Curve Number: RES-007

Test Program: 2002 NHTSA 35mph NCAP No.: HO5300  
 Test Vehicle: 2002 Honda CR-V LX 4WD SUV



B-17

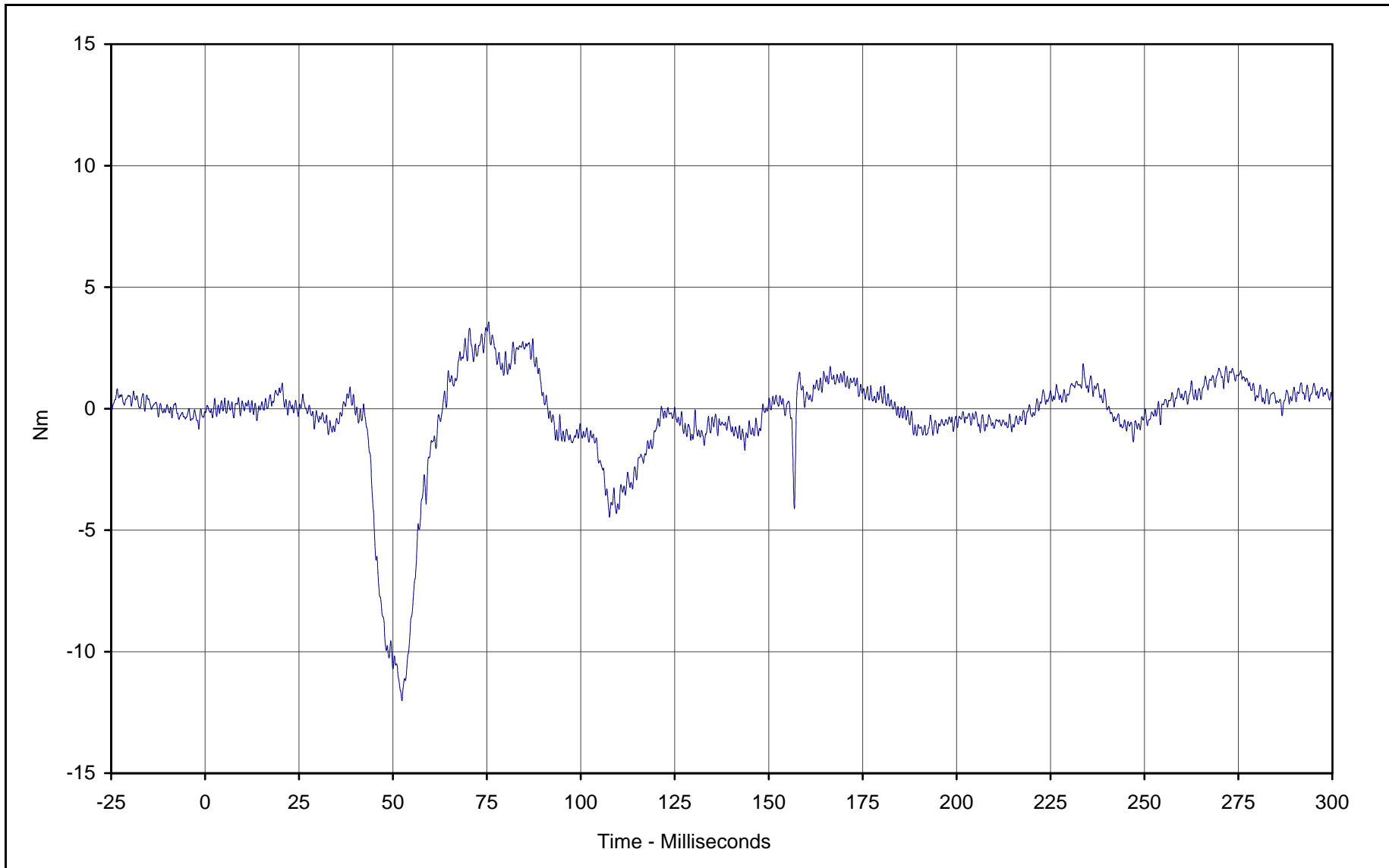

Curve Description: Driver Neck Moment X  
Maximum Value: 3.6 at 75.5 Milliseconds  
Minimum Value: -12.0 at 52.4 Milliseconds  
SAE Filter Class: 600  
Date of Test: 1/29/02  
Curve Number: FIL-010

Test Program: 2002 NHTSA 35mph NCAP No.: HO5300  
Test Vehicle: 2002 Honda CR-V LX 4WD SUV



KAR21061-01

B-18

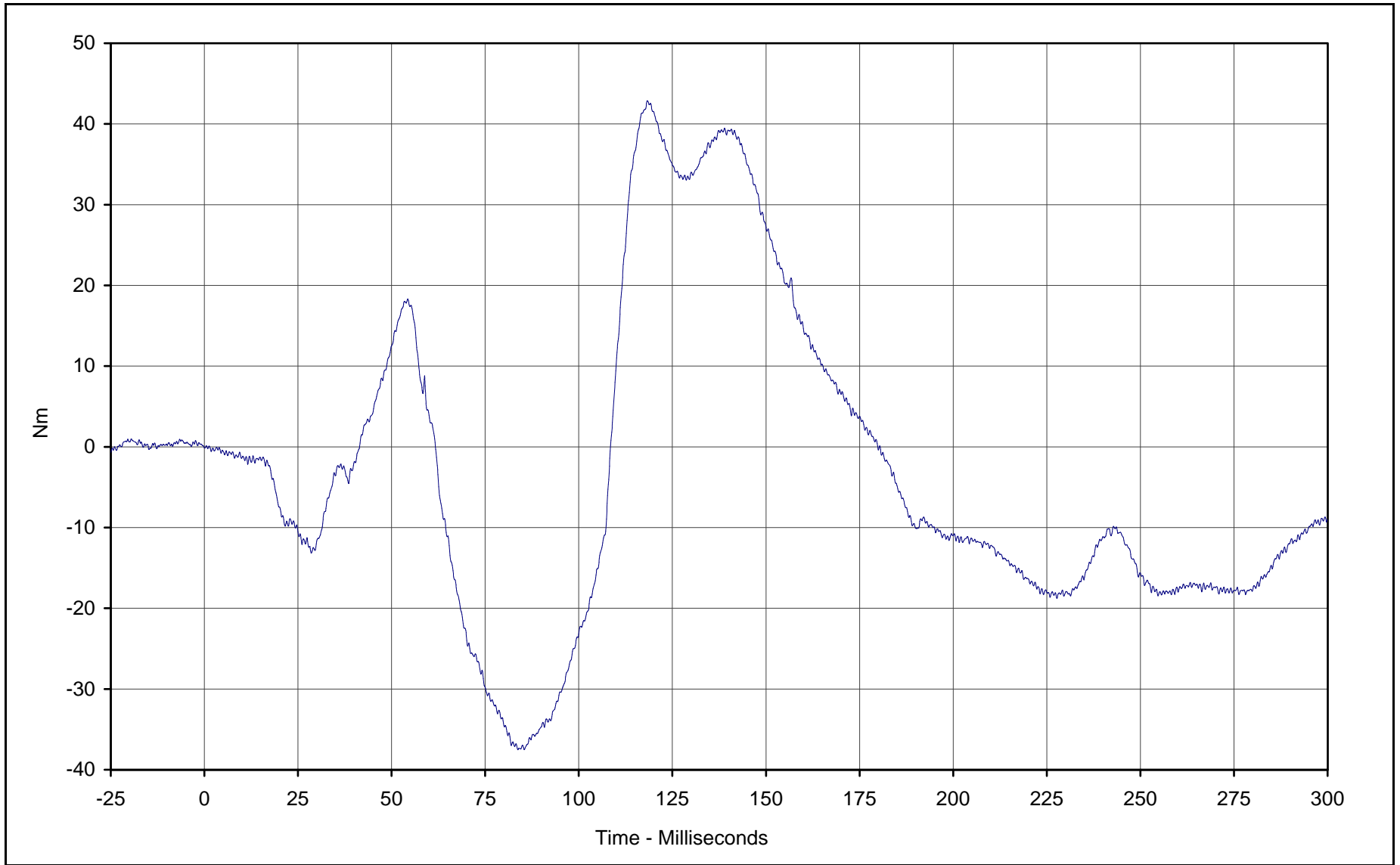

Curve Description: Driver Neck Moment Y  
Maximum Value: 42.9 at 118.3 Milliseconds  
Minimum Value: -37.5 at 83.7 Milliseconds  
SAE Filter Class: 600  
Date of Test: 1/29/02  
Curve Number: FIL-011

Test Program: 2002 NHTSA 35mph NCAP No.: HO5300  
Test Vehicle: 2002 Honda CR-V LX 4WD SUV



KAR21061-01

B-19

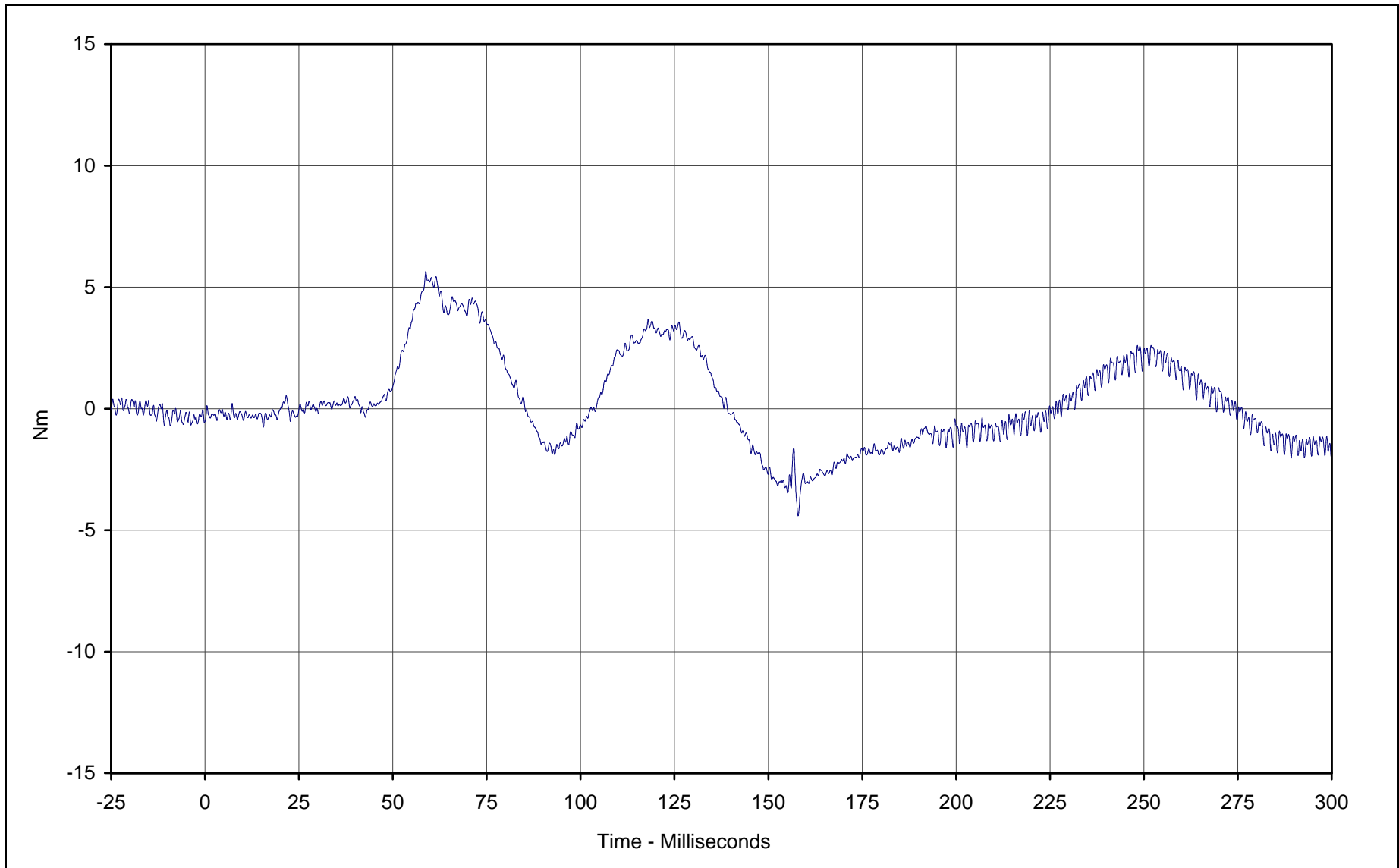

Curve Description: Driver Neck Moment Z  
Maximum Value: 5.7 at 58.8 Milliseconds  
Minimum Value: -4.4 at 157.9 Milliseconds  
SAE Filter Class: 600  
Date of Test: 1/29/02  
Curve Number: FIL-012

Test Program: 2002 NHTSA 35mph NCAP No.: HO5300  
Test Vehicle: 2002 Honda CR-V LX 4WD SUV



KAR21061-01

B-20

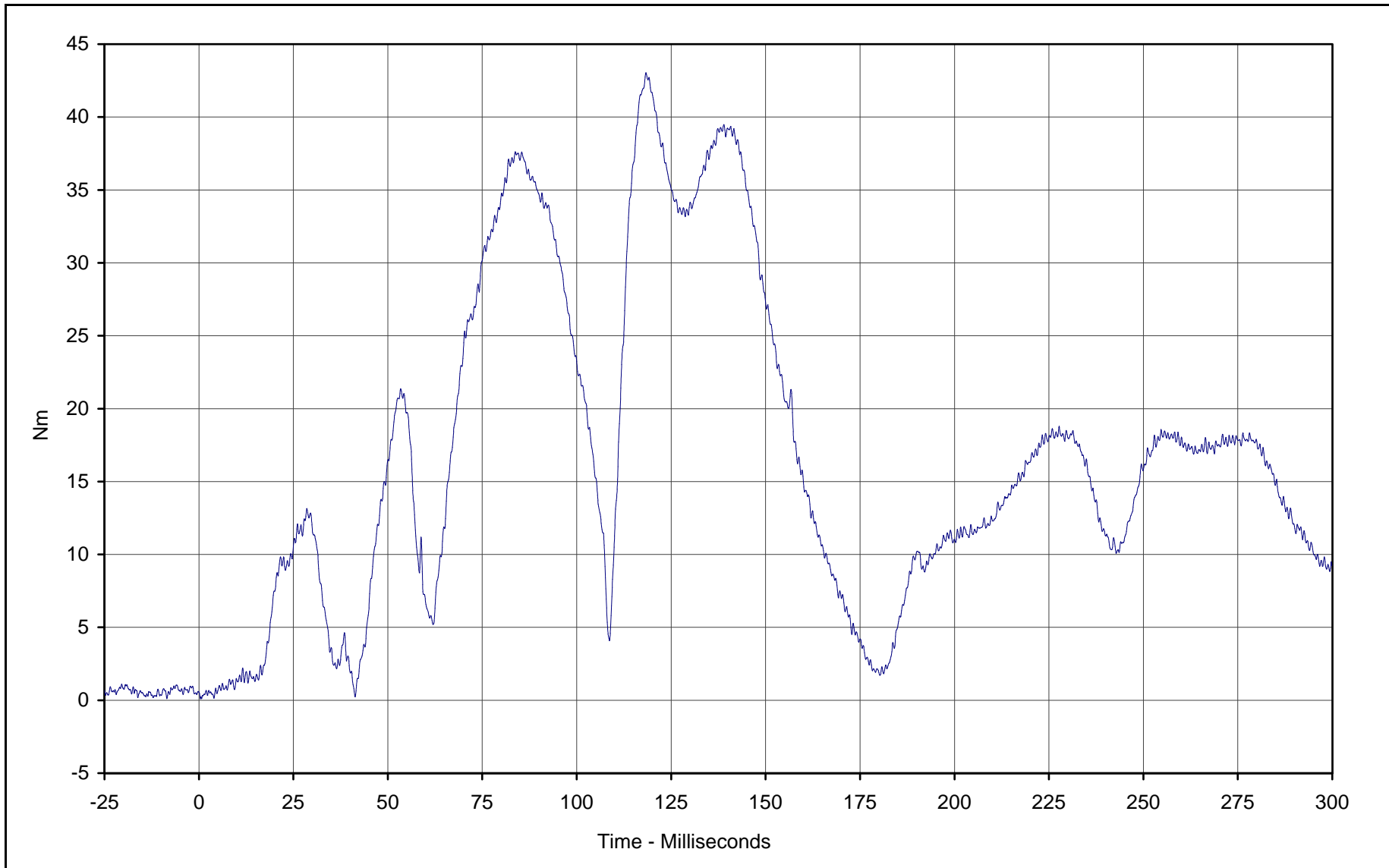

Curve Description: Driver Neck Moment Resultant  
Maximum Value: 43.0 at 118.3 Milliseconds  
Minimum Value: 0.1 at 0.4 Milliseconds  
SAE Filter Class: 600  
Date of Test: 1/29/02  
Curve Number: RES-010

Test Program: 2002 NHTSA 35mph NCAP No.: HO5300  
Test Vehicle: 2002 Honda CR-V LX 4WD SUV



KAR21061-01

B-21

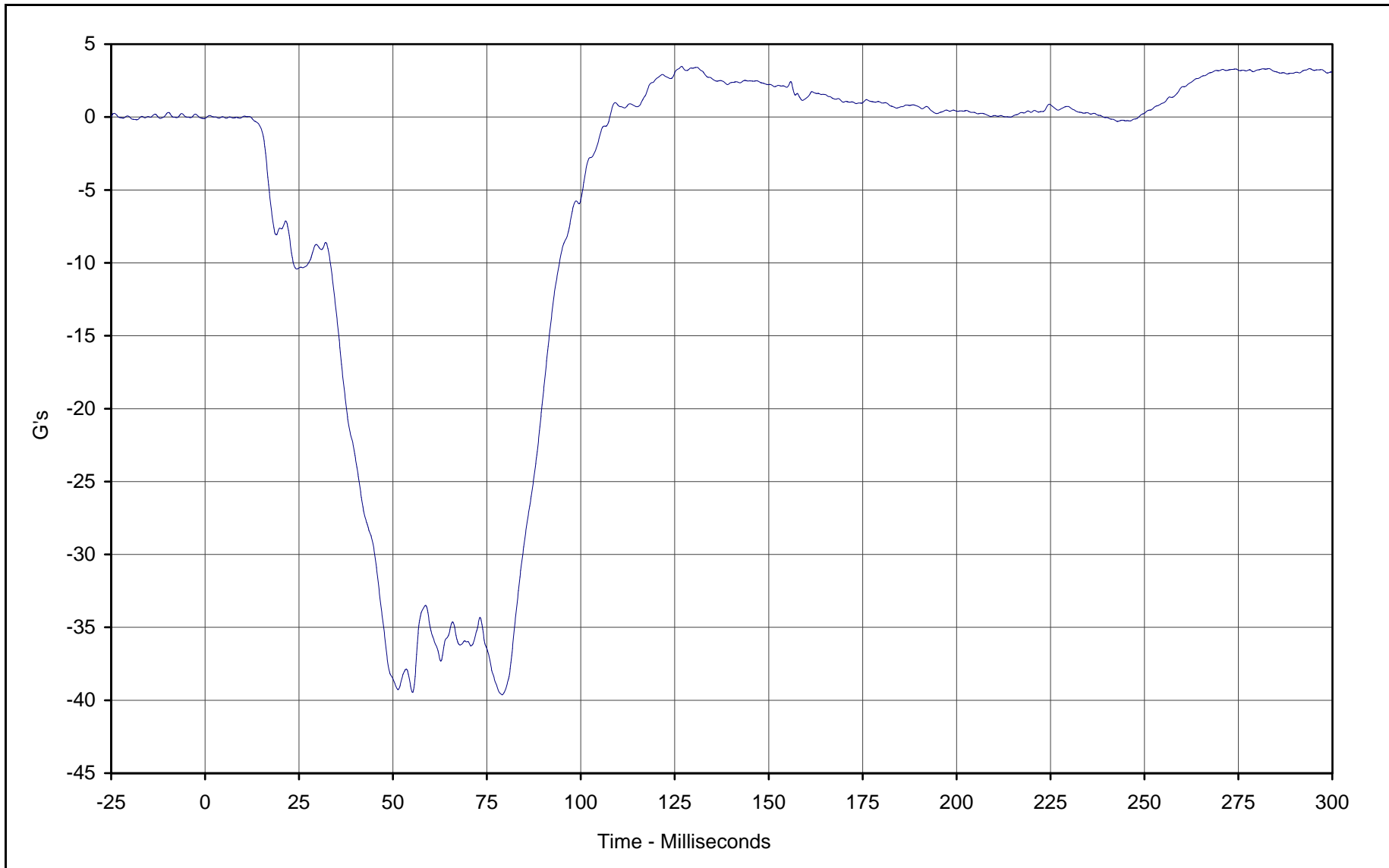

Curve Description: Driver Chest Primary X  
Maximum Value: 3.5 at 126.8 Milliseconds  
Minimum Value: -39.6 at 79.1 Milliseconds  
SAE Filter Class: 180  
Date of Test: 1/29/02  
Curve Number: FIL-013

Test Program: 2002 NHTSA 35mph NCAP No.: HO5300  
Test Vehicle: 2002 Honda CR-V LX 4WD SUV



KAR21061-01

B-22

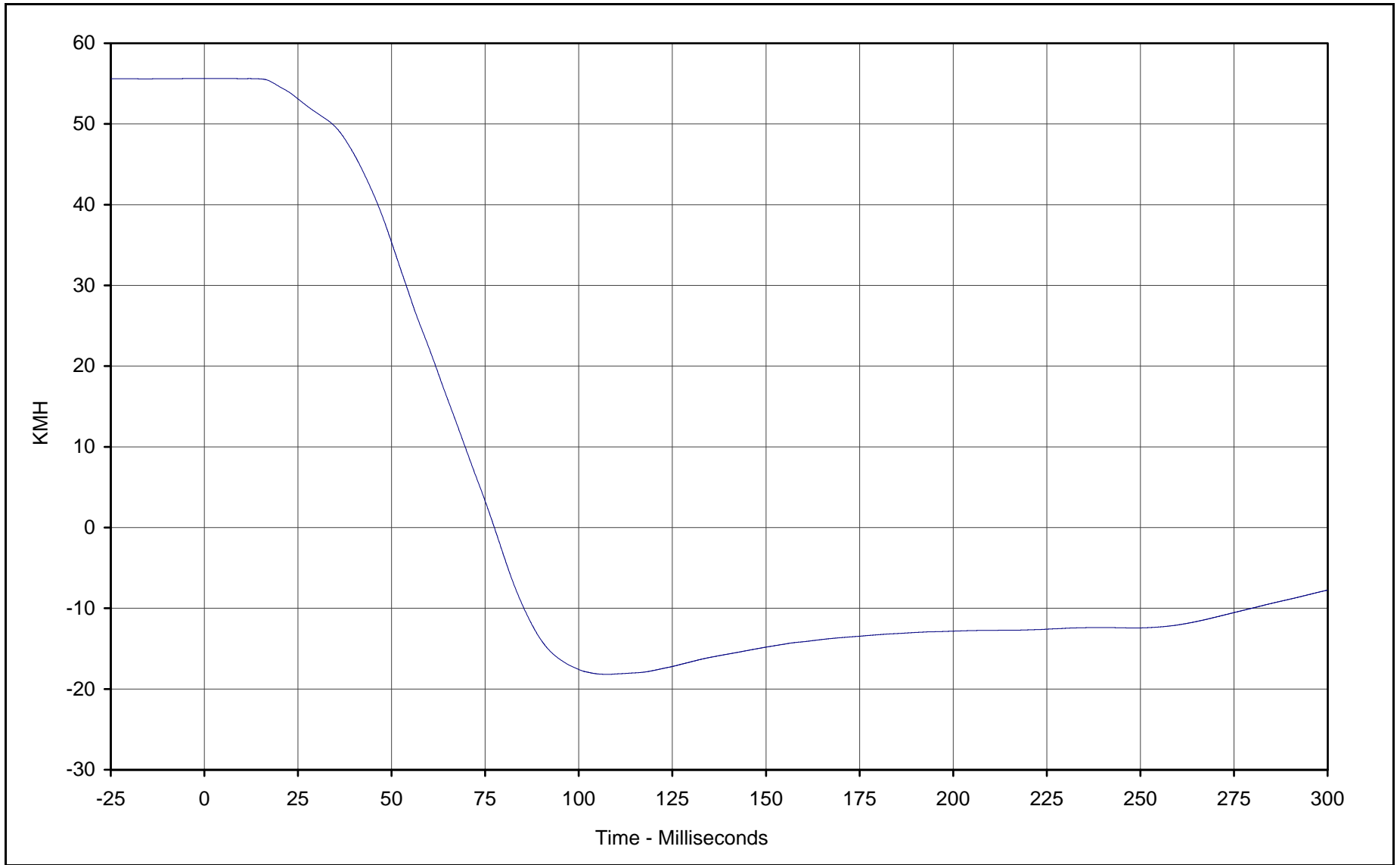

Curve Description: Driver Chest Primary X Velocity  
Maximum Value: 55.6 at 2.9 Milliseconds  
Minimum Value: -18.2 at 107.7 Milliseconds  
SAE Filter Class: 180  
Date of Test: 1/29/02  
Curve Number: IN1-013

Test Program: 2002 NHTSA 35mph NCAP No.: HO5300  
Test Vehicle: 2002 Honda CR-V LX 4WD SUV



KAR21061-01

B-23

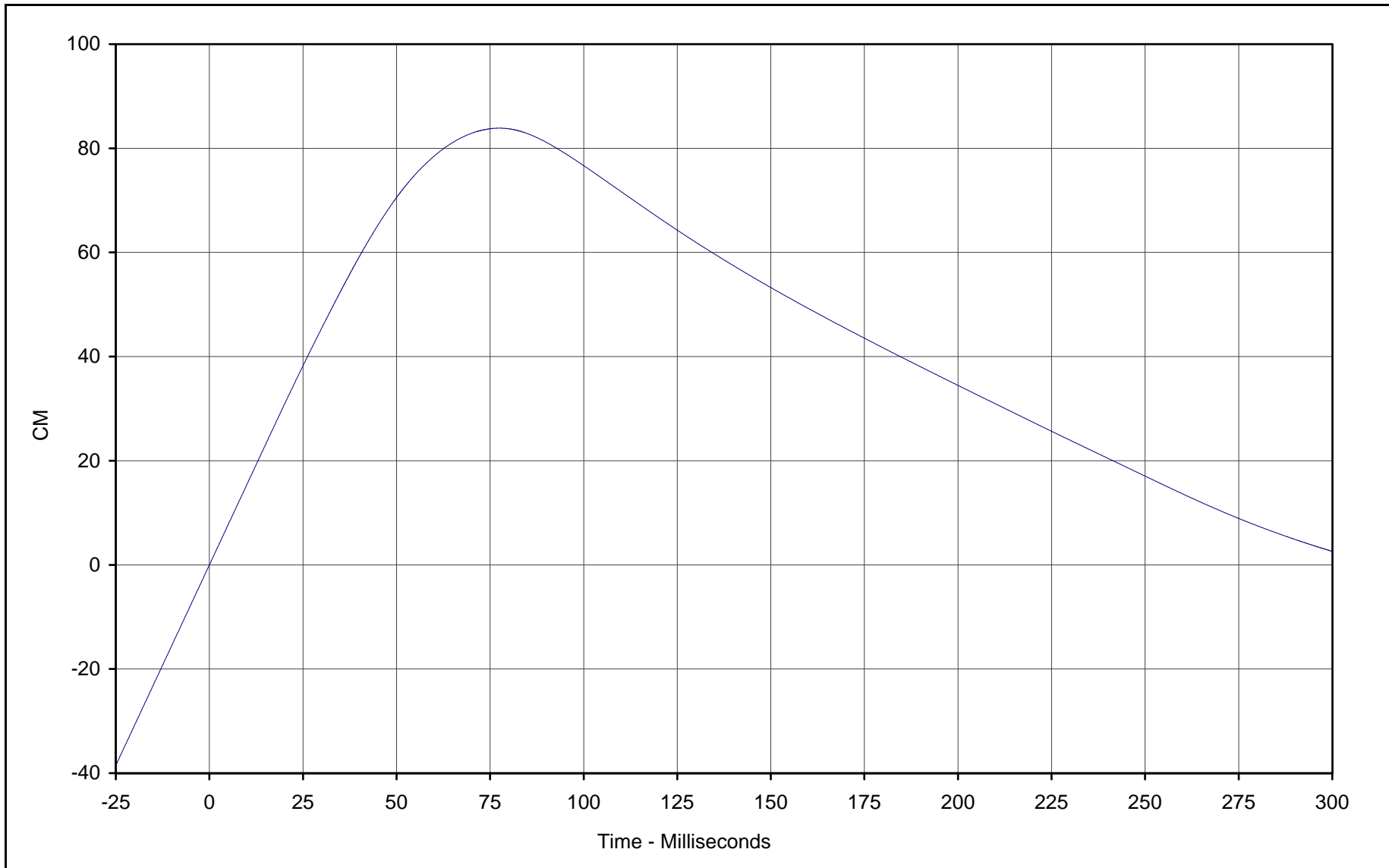

Curve Description: Driver Chest Primary X Displ.  
Maximum Value: 83.9 at 77.5 Milliseconds  
Minimum Value: 0.0 at 0.0 Milliseconds  
SAE Filter Class: 180  
Date of Test: 1/29/02  
Curve Number: IN2-013

Test Program: 2002 NHTSA 35mph NCAP No.: HO5300  
Test Vehicle: 2002 Honda CR-V LX 4WD SUV



KAR21061-01

B-24

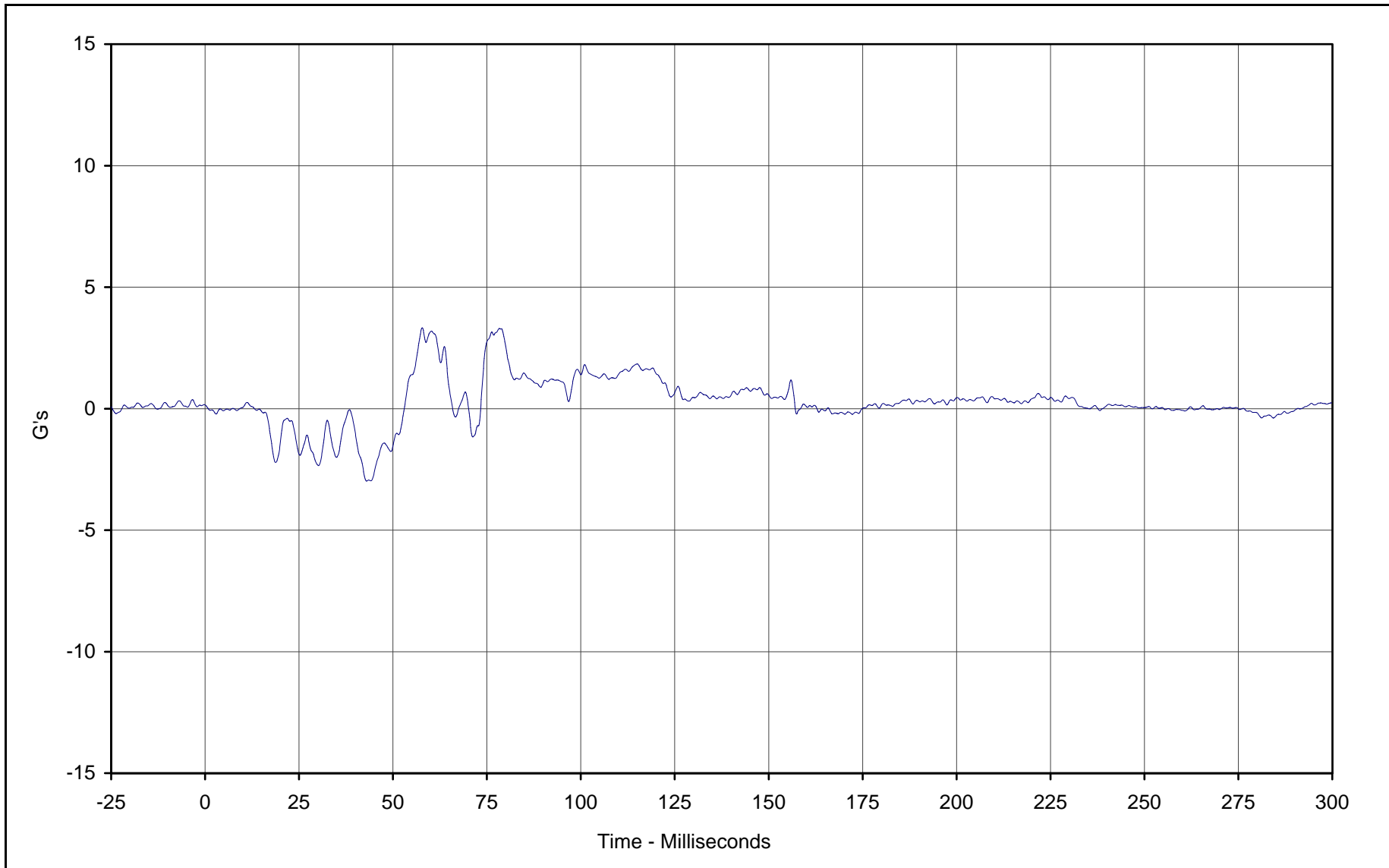

Curve Description: Driver Chest Primary Y  
Maximum Value: 3.3 at 57.8 Milliseconds  
Minimum Value: -3.0 at 43.0 Milliseconds  
SAE Filter Class: 180  
Date of Test: 1/29/02  
Curve Number: FIL-014

Test Program: 2002 NHTSA 35mph NCAP No.: HO5300  
Test Vehicle: 2002 Honda CR-V LX 4WD SUV



KAR21061-01

B-25

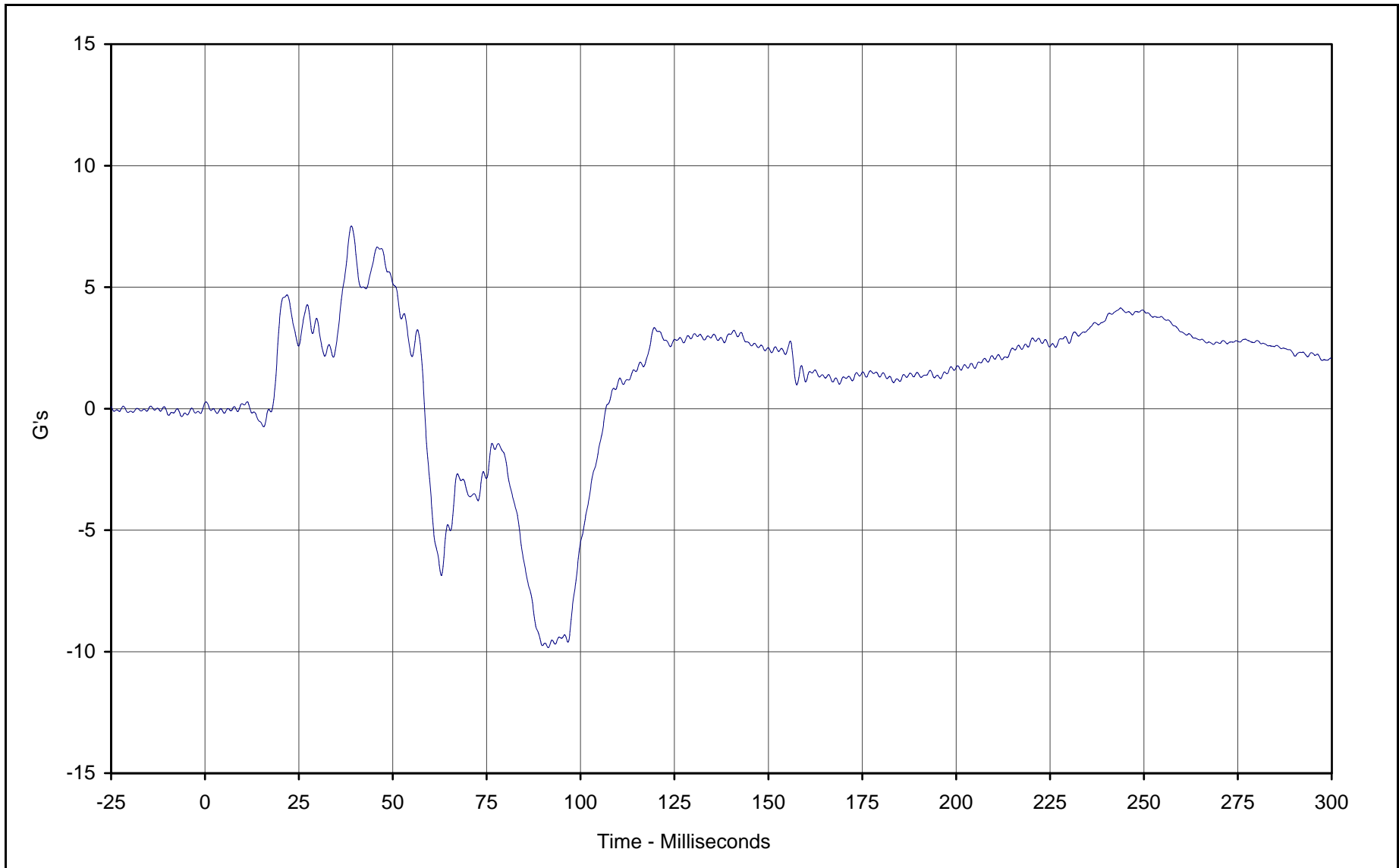

Curve Description: Driver Chest Primary Z  
Maximum Value: 7.5 at 39.0 Milliseconds  
Minimum Value: -9.8 at 91.4 Milliseconds  
SAE Filter Class: 180  
Date of Test: 1/29/02  
Curve Number: FIL-015

Test Program: 2002 NHTSA 35mph NCAP No.: HO5300  
Test Vehicle: 2002 Honda CR-V LX 4WD SUV



KAR21061-01

B-26

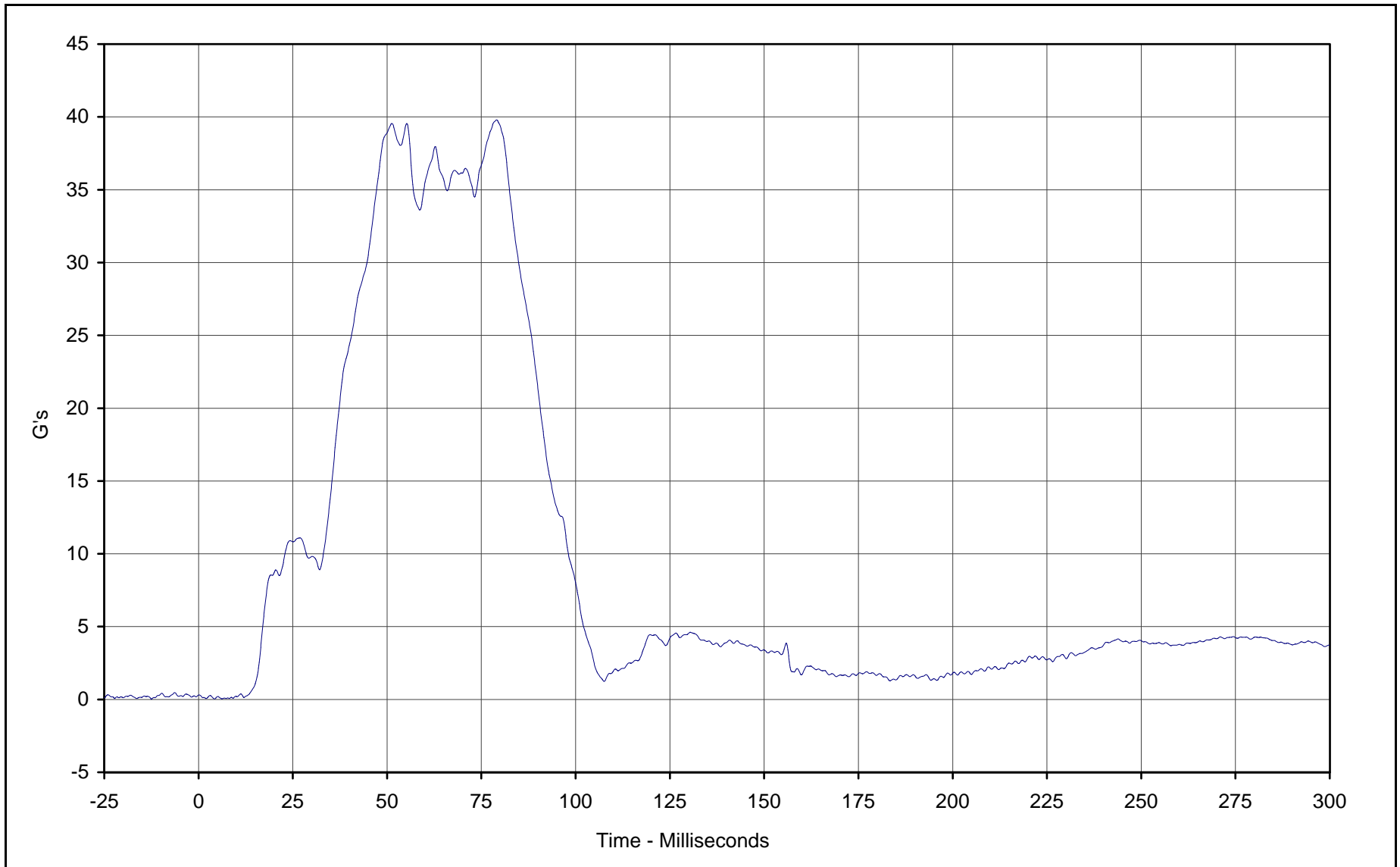

Curve Description: Driver Chest Resultant Primary  
Maximum Value: 39.8 at 79.1 Milliseconds  
Minimum Value: 0.0 at 4.3 Milliseconds  
SAE Filter Class: 180  
Date of Test: 1/29/02  
Curve Number: RES-013

Test Program: 2002 NHTSA 35mph NCAP No.: HO5300  
Test Vehicle: 2002 Honda CR-V LX 4WD SUV



KAR21061-01

B-27

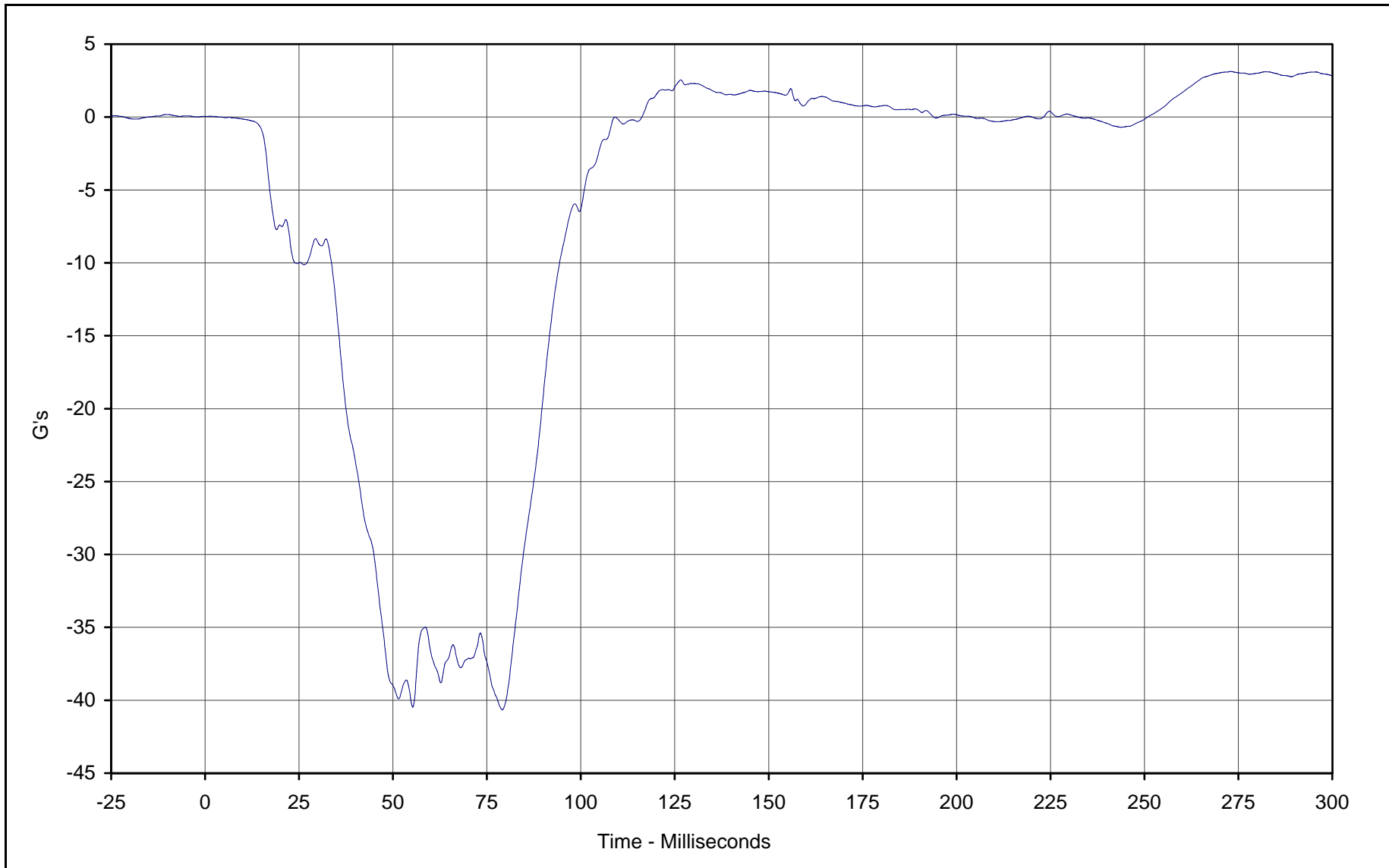

Curve Description: Driver Chest Redundant X  
Maximum Value: 3.1 at 273.0 Milliseconds  
Minimum Value: -40.7 at 79.1 Milliseconds  
SAE Filter Class: 180  
Date of Test: 1/29/02  
Curve Number: FIL-016

Test Program: 2002 NHTSA 35mph NCAP No.: HO5300  
Test Vehicle: 2002 Honda CR-V LX 4WD SUV



KAR21061-01

B-28

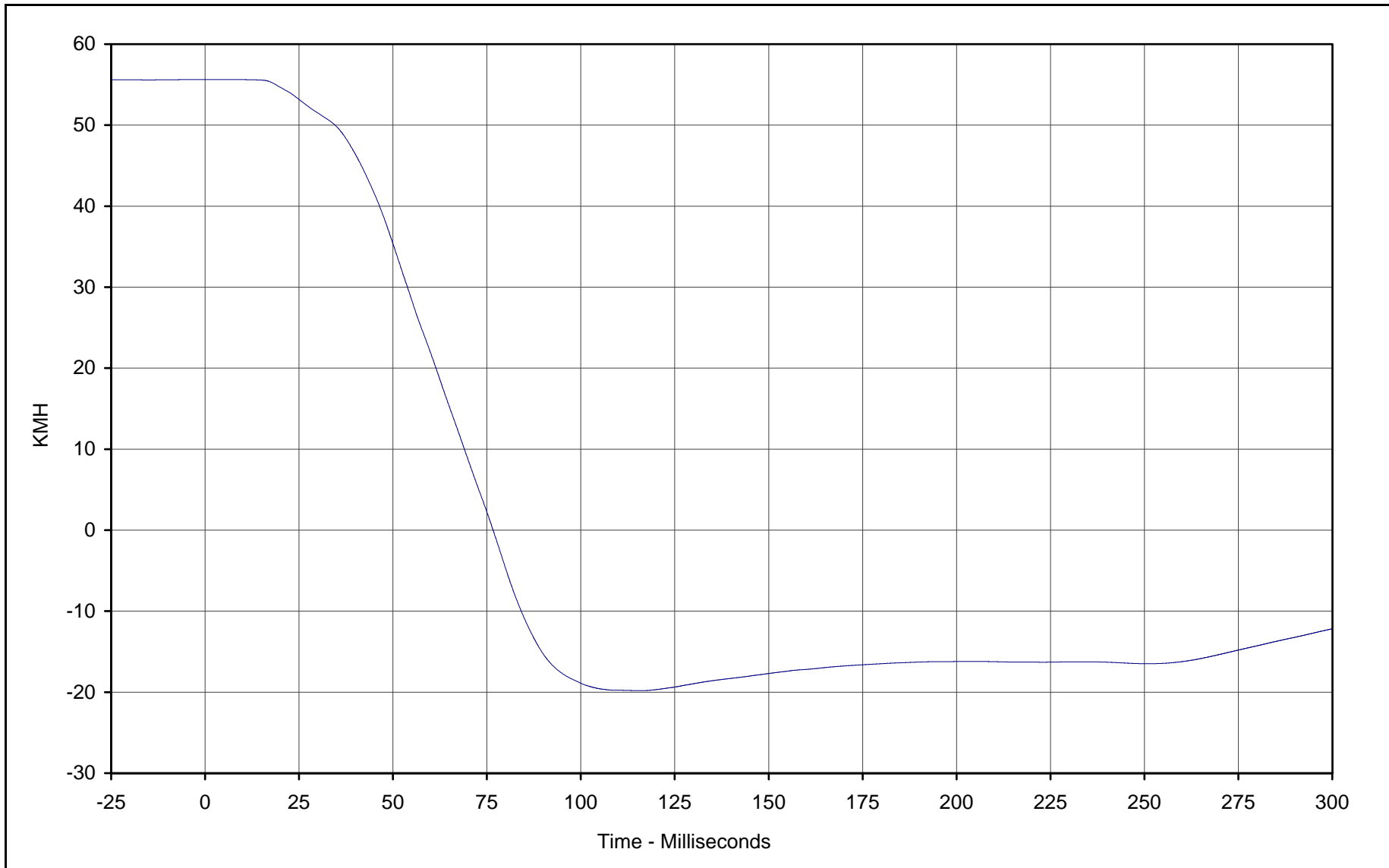

Curve Description: Driver Chest Redundant X Velocity

Maximum Value: 55.6 at 3.6 Milliseconds

Minimum Value: -19.8 at 116.2 Milliseconds

SAE Filter Class: 180

Date of Test: 1/29/02

Curve Number: IN1-016

Test Program: 2002 NHTSA 35mph NCAP No.: HO5300

Test Vehicle: 2002 Honda CR-V LX 4WD SUV

KAR21061-01



B-29

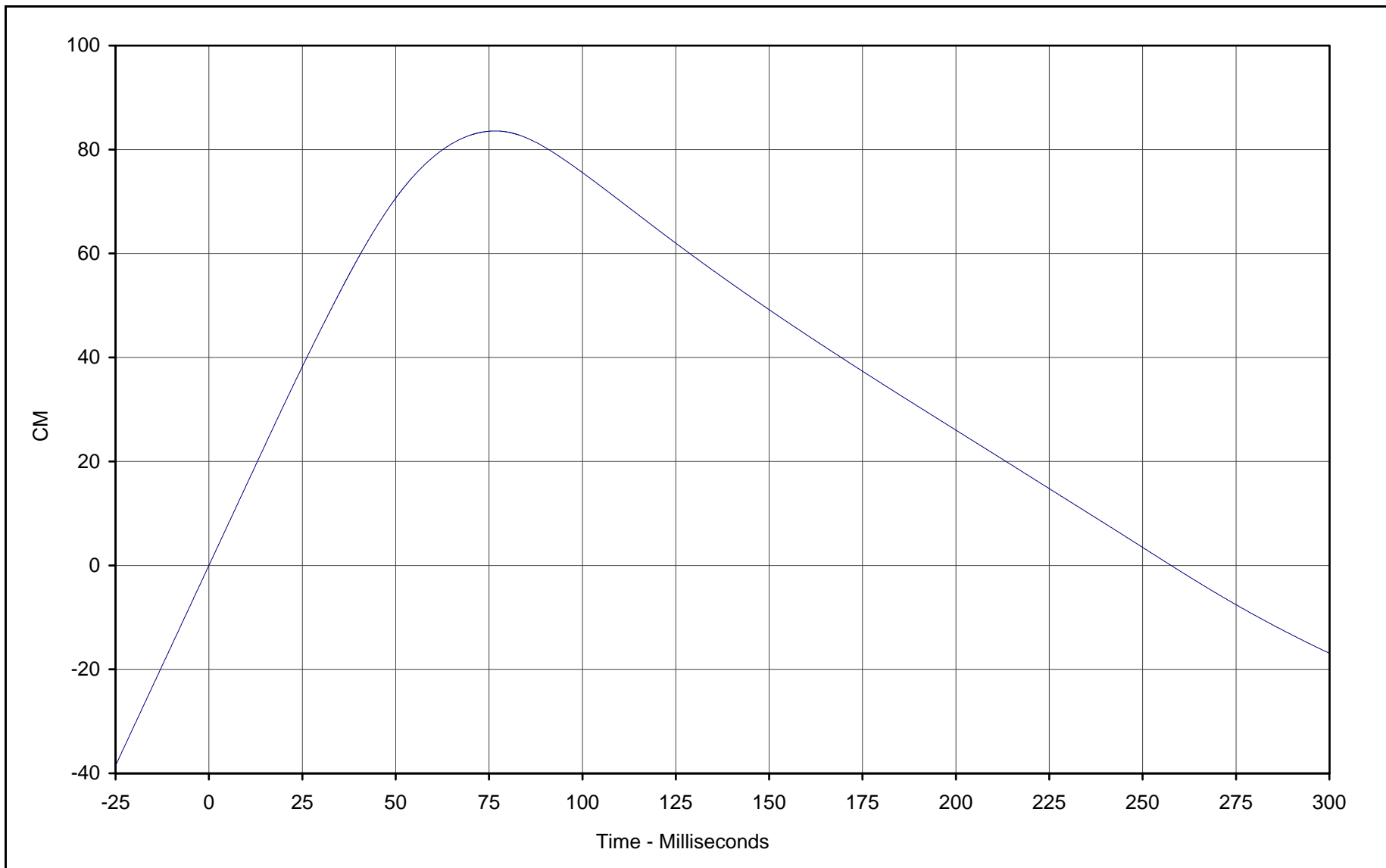

Curve Description: Driver Chest Redundant X Displ.  
Maximum Value: 83.6 at 76.7 Milliseconds  
Minimum Value: -16.9 at 299.9 Milliseconds  
SAE Filter Class: 180  
Date of Test: 1/29/02  
Curve Number: IN2-016

Test Program: 2002 NHTSA 35mph NCAP No.: HO5300  
Test Vehicle: 2002 Honda CR-V LX 4WD SUV



KAR21061-01

B-30

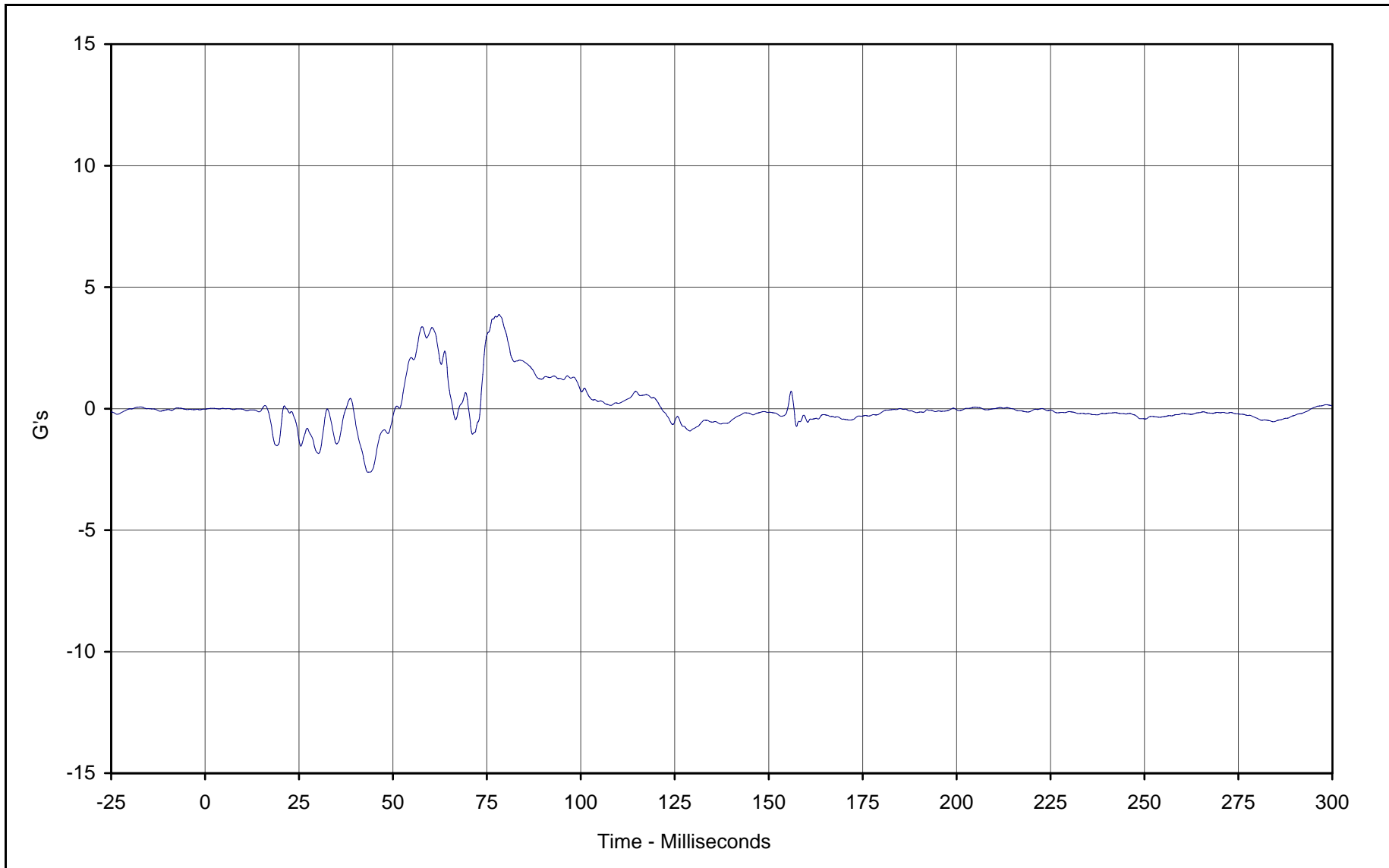

Curve Description: Driver Chest Redundant Y  
Maximum Value: 3.9 at 78.2 Milliseconds  
Minimum Value: -2.6 at 43.4 Milliseconds  
SAE Filter Class: 180  
Date of Test: 1/29/02  
Curve Number: FIL-017

Test Program: 2002 NHTSA 35mph NCAP No.: HO5300  
Test Vehicle: 2002 Honda CR-V LX 4WD SUV

KAR21061-01



B-31

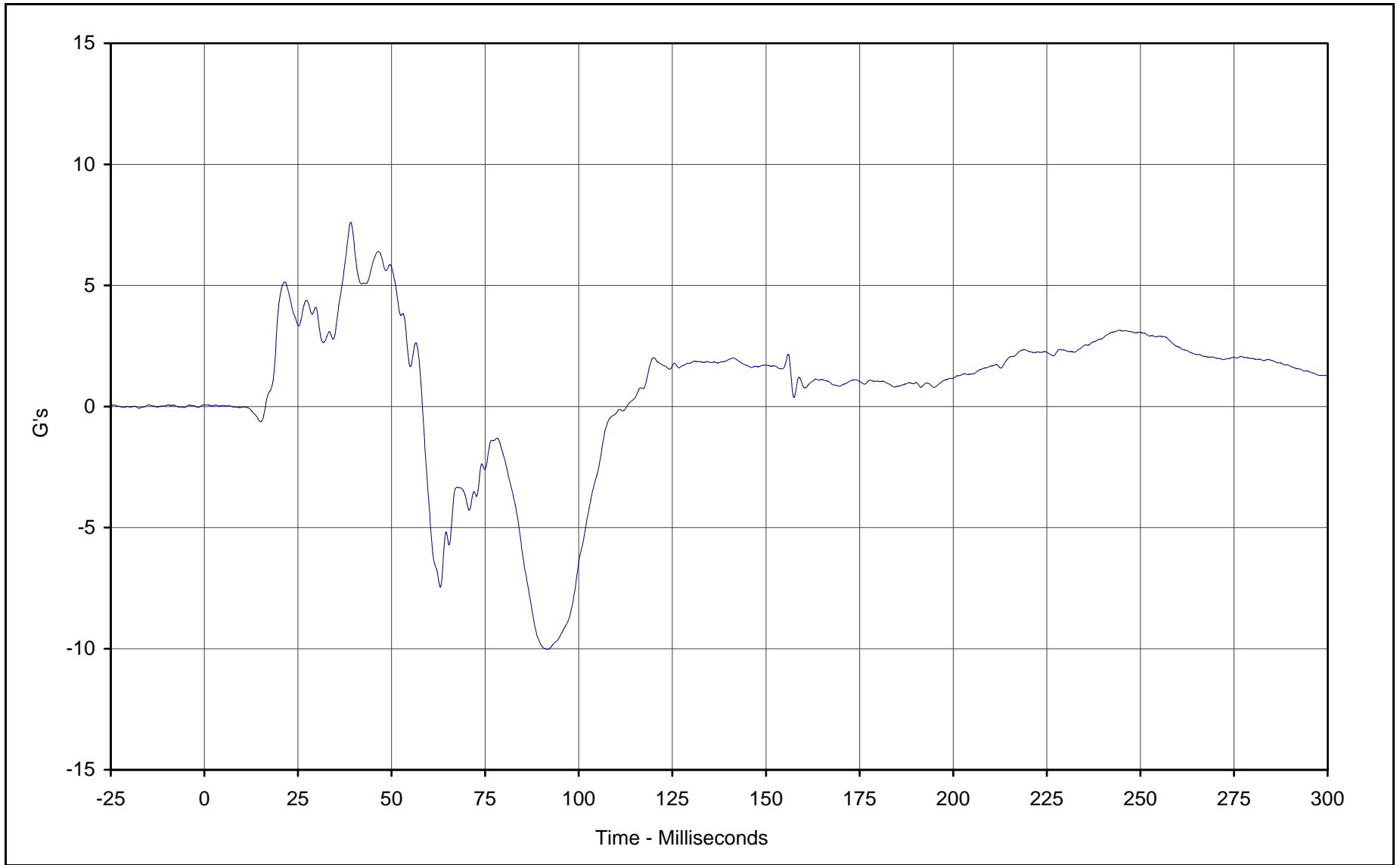

Curve Description: Driver Chest Redundant Z  
Maximum Value: 7.6 at 39.1 Milliseconds  
Minimum Value: -10.0 at 91.7 Milliseconds  
SAE Filter Class: 180  
Date of Test: 1/29/02  
Curve Number: FIL-018

Test Program: 2002 NHTSA 35mph NCAP No.: HO5300  
Test Vehicle: 2002 Honda CR-V LX 4WD SUV



KAR21061-01

B-32

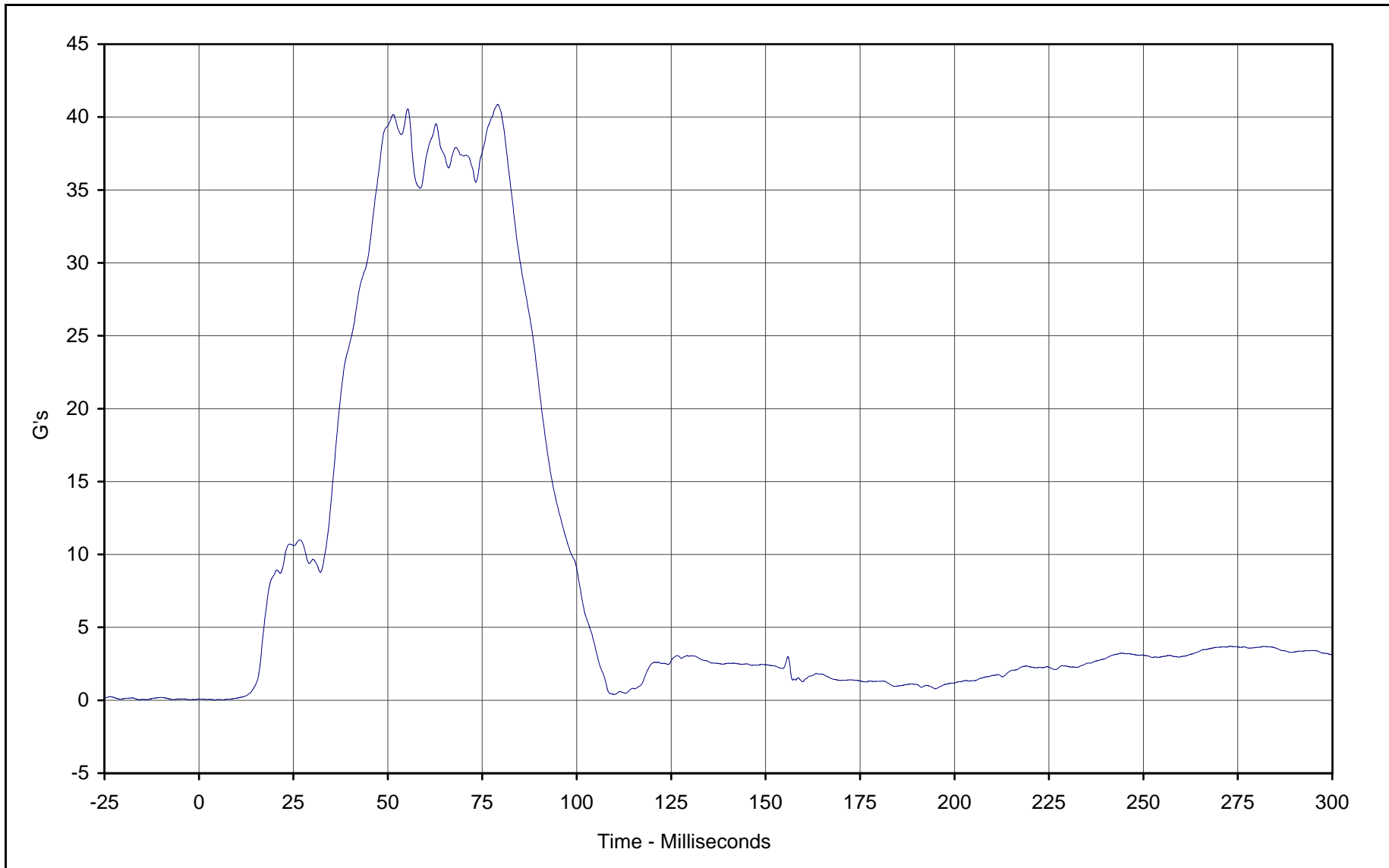

Curve Description: Driver Chest Resultant Redundant  
Maximum Value: 40.9 at 79.1 Milliseconds  
Minimum Value: 0.0 at 4.1 Milliseconds  
SAE Filter Class: 180  
Date of Test: 1/29/02  
Curve Number: RES-016

Test Program: 2002 NHTSA 35mph NCAP No.: HO5300  
Test Vehicle: 2002 Honda CR-V LX 4WD SUV



KAR21061-01

B-33

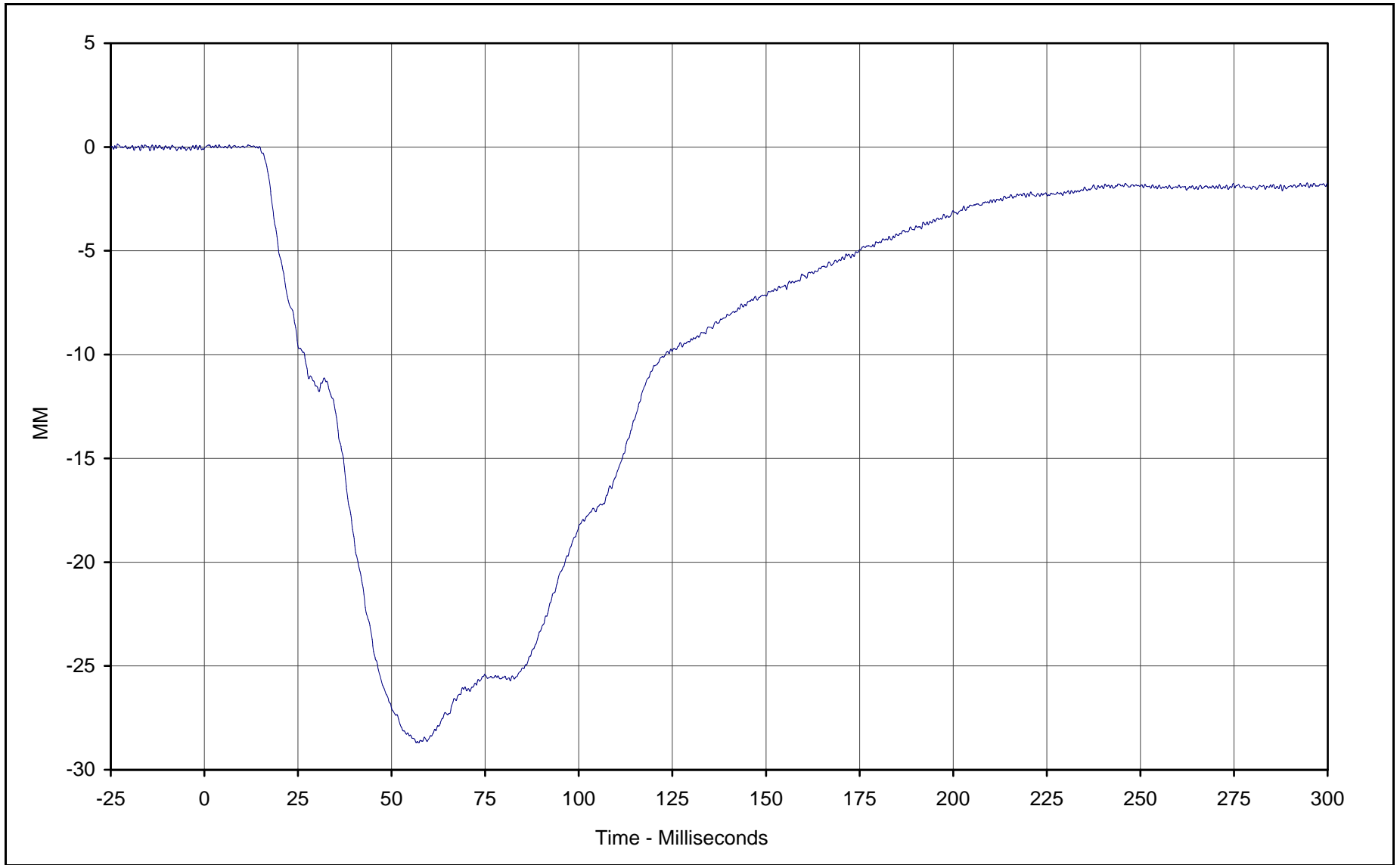

Curve Description: Driver Chest Displacement X  
Maximum Value: 0.1 at 3.9 Milliseconds  
Minimum Value: -28.7 at 57.2 Milliseconds  
SAE Filter Class: 600  
Date of Test: 1/29/02  
Curve Number: FIL-019

Test Program: 2002 NHTSA 35mph NCAP No.: HO5300  
Test Vehicle: 2002 Honda CR-V LX 4WD SUV



KAR21061-01

B-34

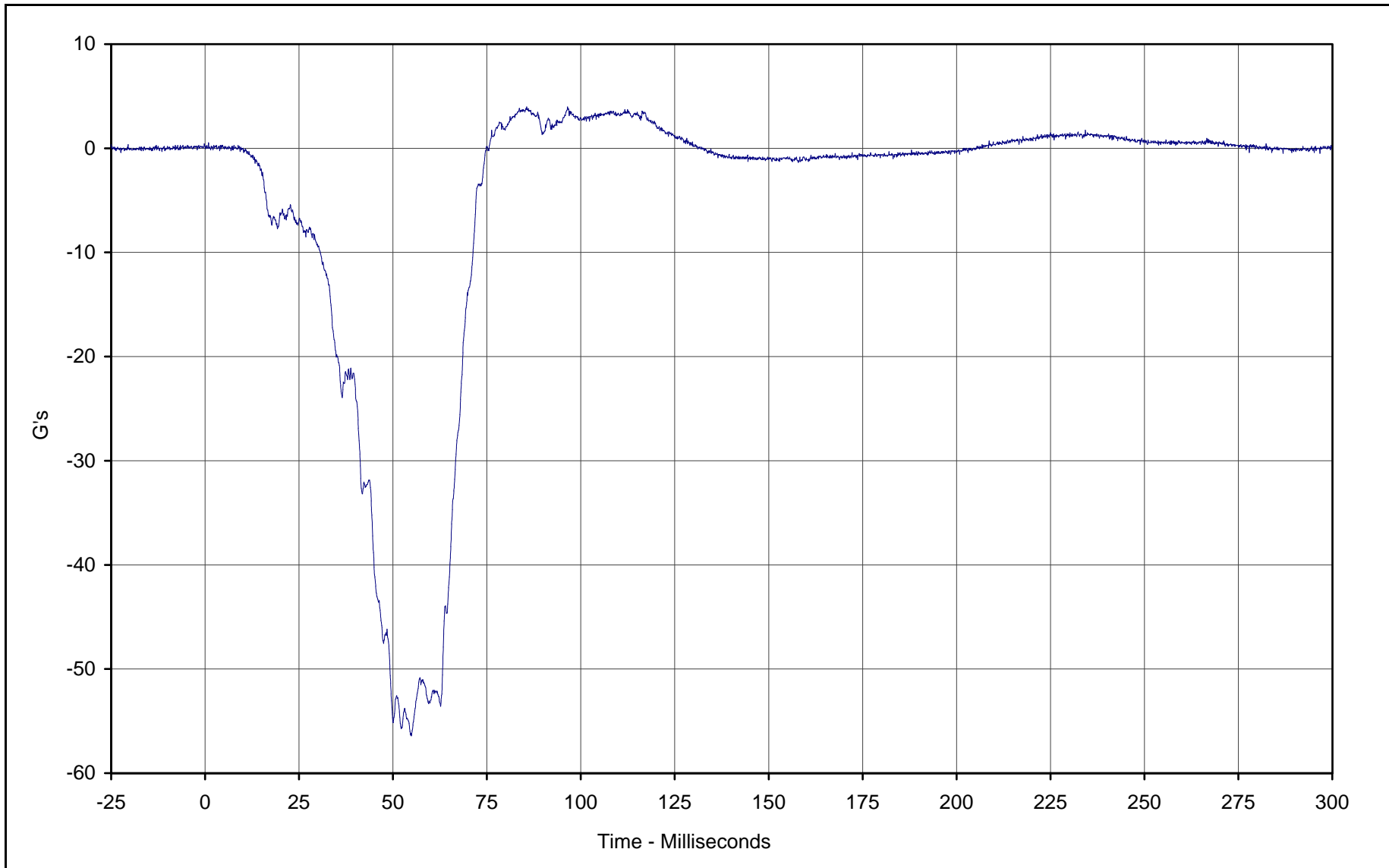

Curve Description: Driver Pelvis X  
Maximum Value: 4.0 at 85.6 Milliseconds  
Minimum Value: -56.4 at 54.9 Milliseconds  
SAE Filter Class: 1000  
Date of Test: 1/29/02  
Curve Number: FIL-020

Test Program: 2002 NHTSA 35mph NCAP No.: HO5300  
Test Vehicle: 2002 Honda CR-V LX 4WD SUV



KAR21061-01

B-35

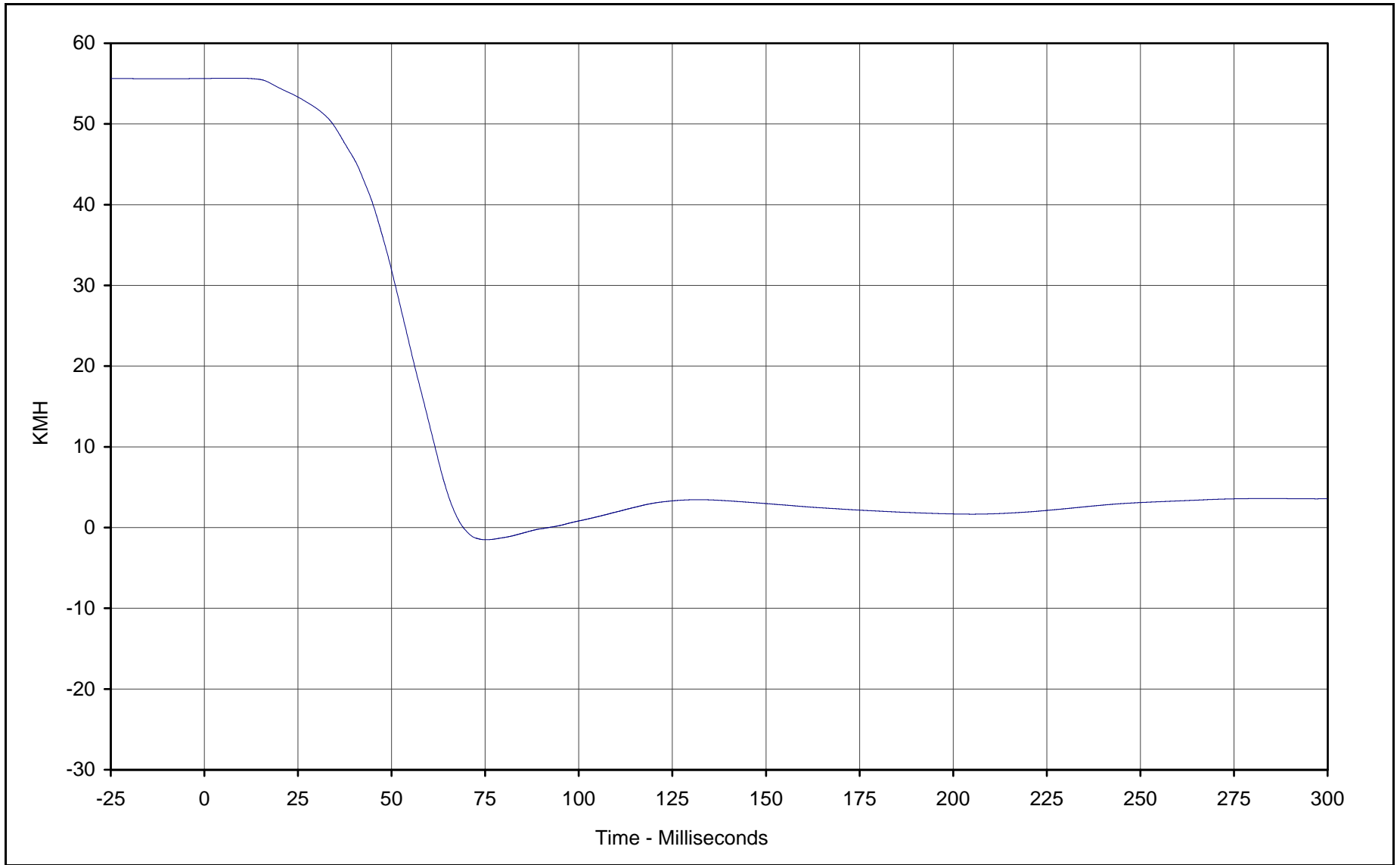

Curve Description: Driver Pelvis X Velocity  
Maximum Value: 55.7 at 9.3 Milliseconds  
Minimum Value: -1.5 at 75.2 Milliseconds  
SAE Filter Class: 180  
Date of Test: 1/29/02  
Curve Number: IN1-020

Test Program: 2002 NHTSA 35mph NCAP No.: HO5300  
Test Vehicle: 2002 Honda CR-V LX 4WD SUV



KAR21061-01

B-36

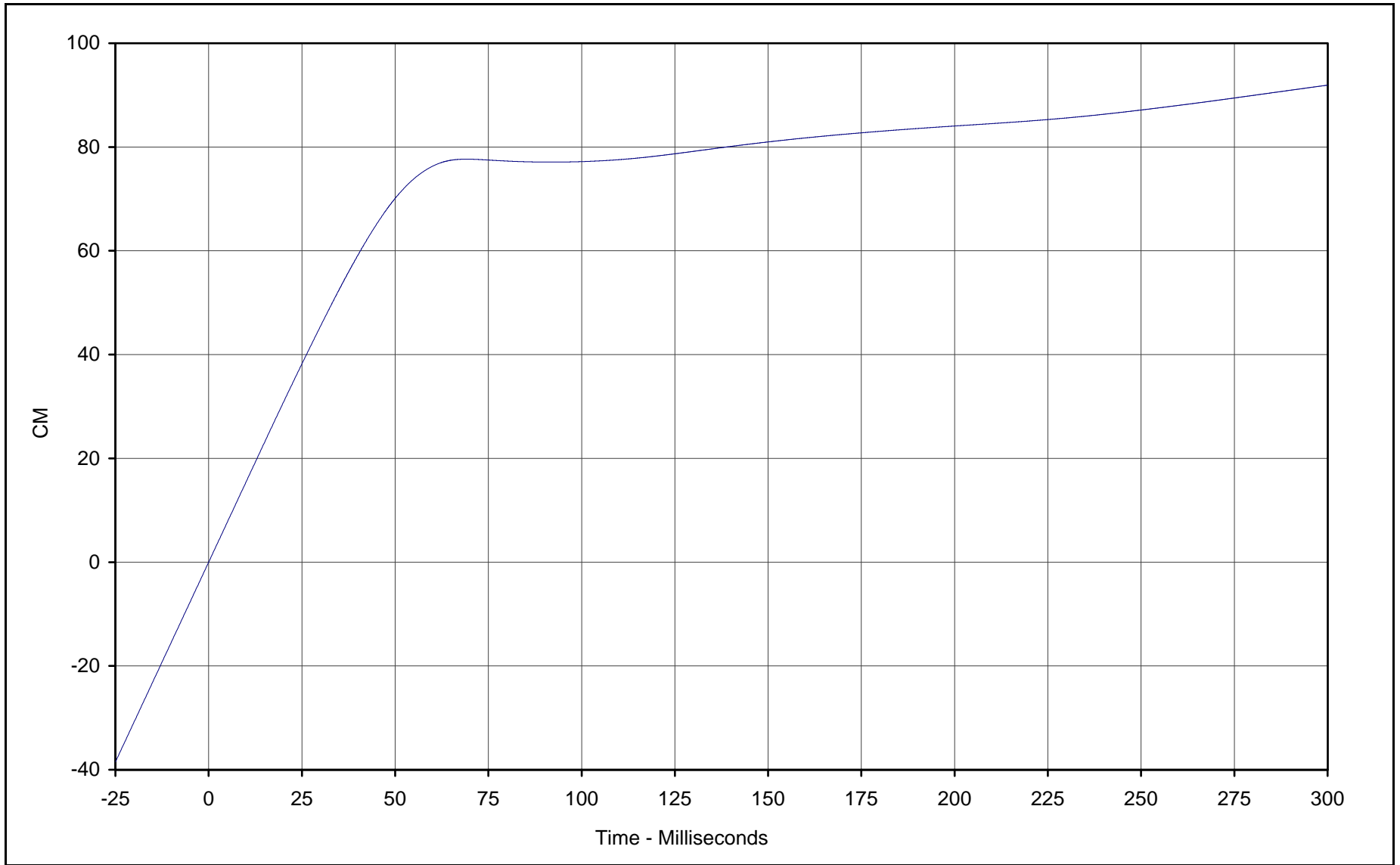

Curve Description: Driver Pelvis X Displ.  
Maximum Value: 91.9 at 299.9 Milliseconds  
Minimum Value: 0.0 at 0.0 Milliseconds  
SAE Filter Class: 180  
Date of Test: 1/29/02  
Curve Number: IN2-020

Test Program: 2002 NHTSA 35mph NCAP No.: HO5300  
Test Vehicle: 2002 Honda CR-V LX 4WD SUV



KAR21061-01

B-37

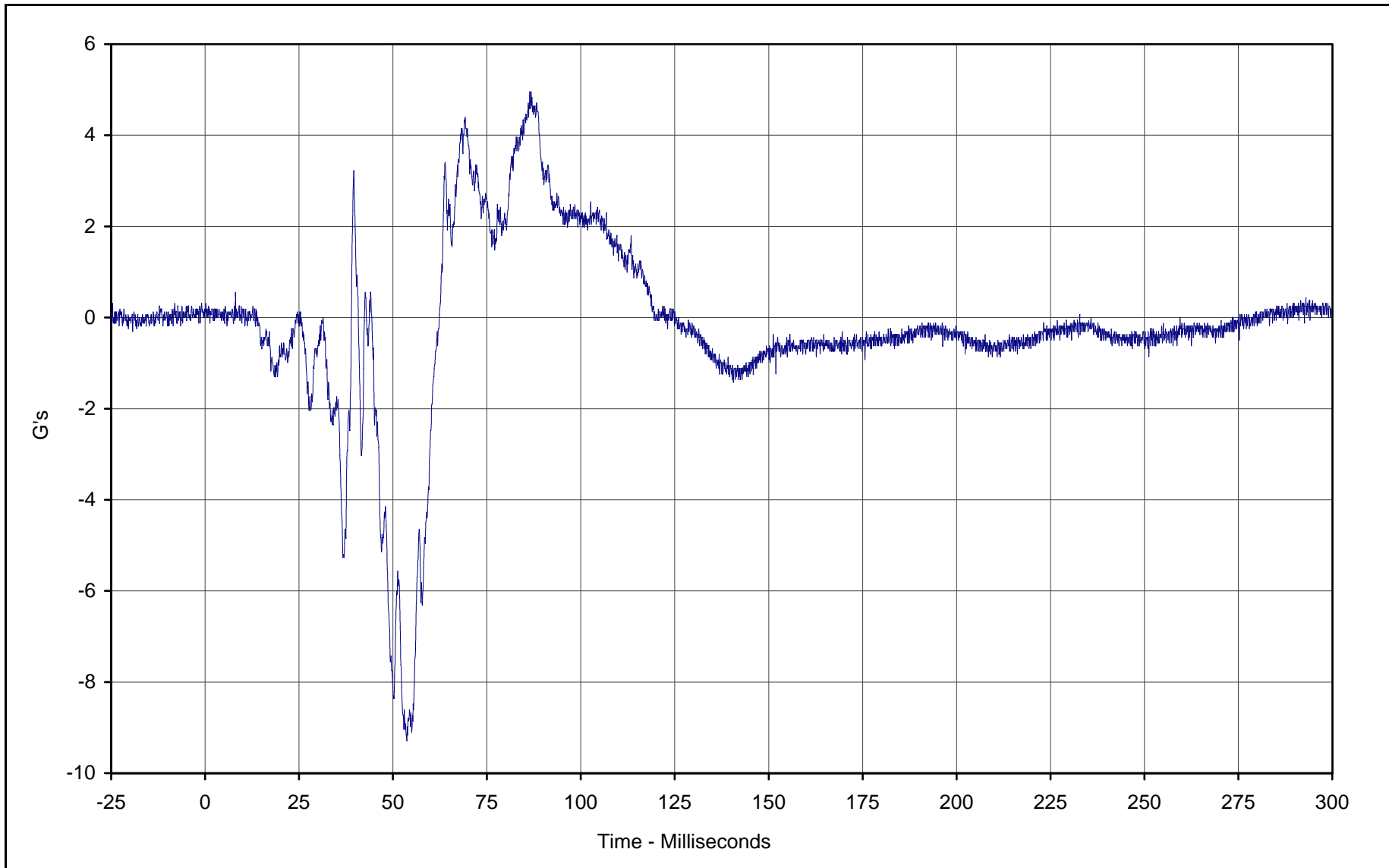

Curve Description: Driver Pelvis Y  
Maximum Value: 5.0 at 86.4 Milliseconds  
Minimum Value: -9.3 at 53.7 Milliseconds  
SAE Filter Class: 1000  
Date of Test: 1/29/02  
Curve Number: FIL-021

Test Program: 2002 NHTSA 35mph NCAP No.: HO5300  
Test Vehicle: 2002 Honda CR-V LX 4WD SUV



KAR21061-01

B-38

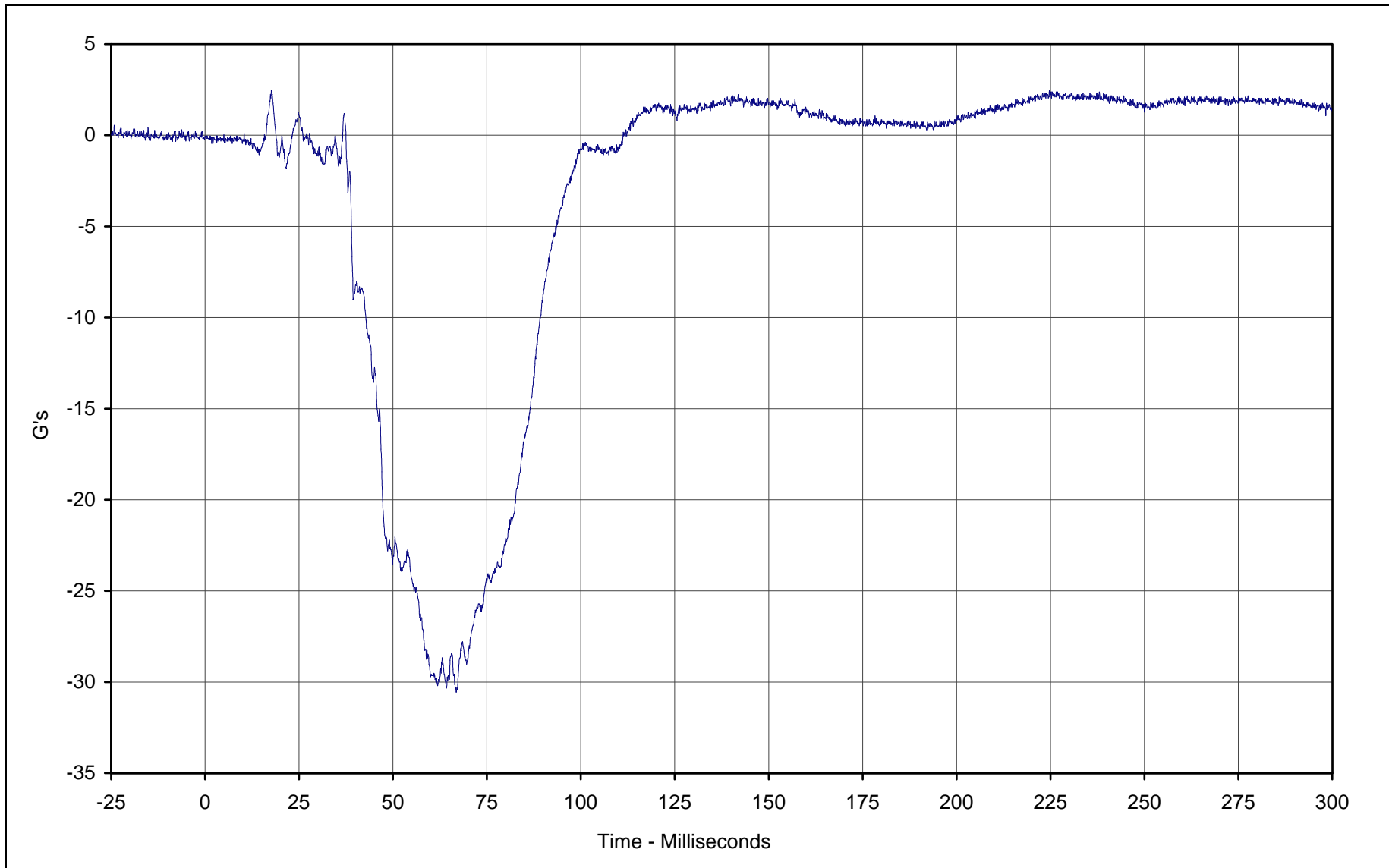

Curve Description: Driver Pelvis Z  
Maximum Value: 2.4 at 17.6 Milliseconds  
Minimum Value: -30.5 at 66.8 Milliseconds  
SAE Filter Class: 1000  
Date of Test: 1/29/02  
Curve Number: FIL-022

Test Program: 2002 NHTSA 35mph NCAP No.: HO5300  
Test Vehicle: 2002 Honda CR-V LX 4WD SUV



KAR21061-01

B-39

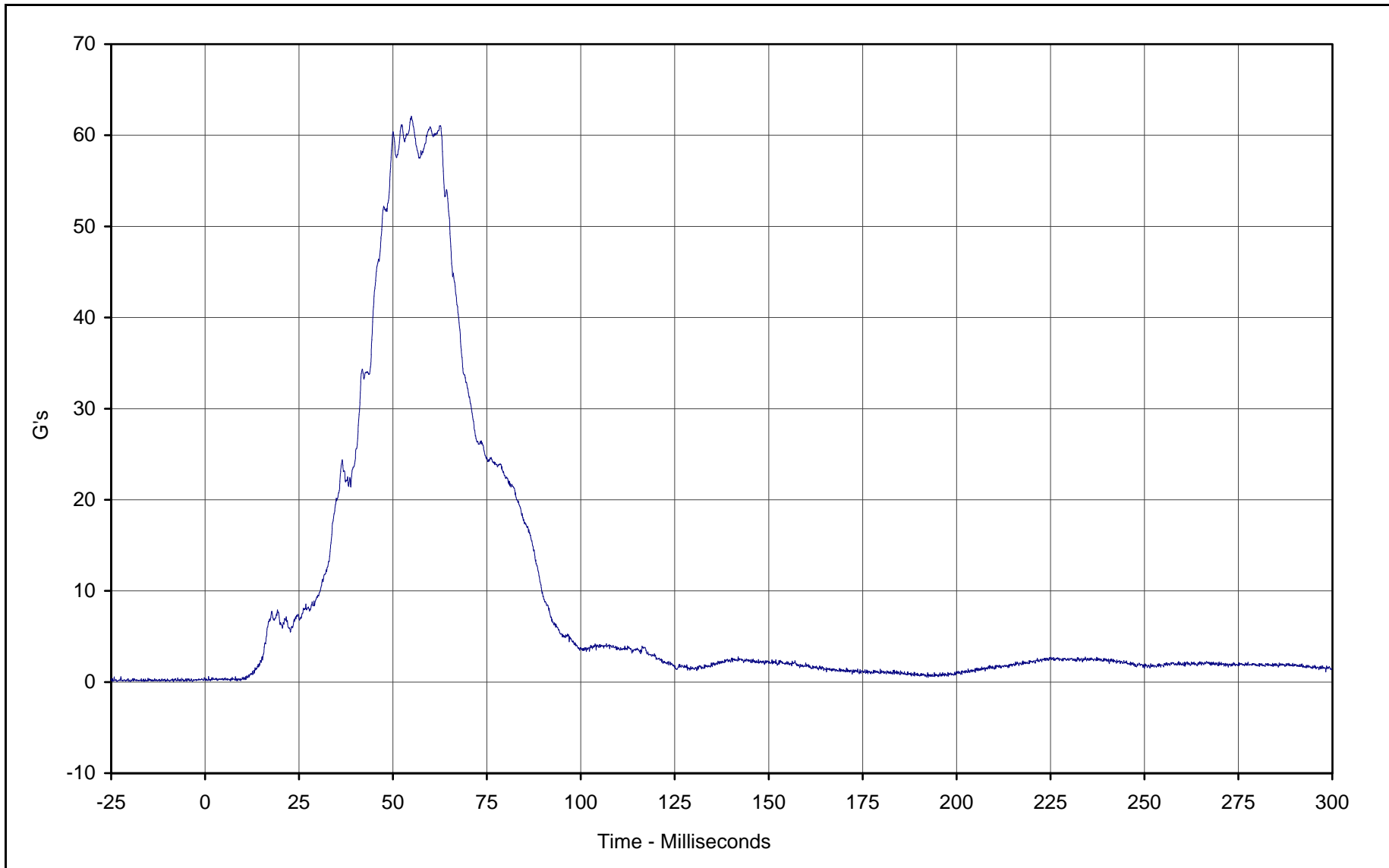

Curve Description: Driver Pelvis Resultant  
Maximum Value: 62.1 at 54.9 Milliseconds  
Minimum Value: 0.1 at 1.4 Milliseconds  
SAE Filter Class: 1000  
Date of Test: 1/29/02  
Curve Number: RES-020

Test Program: 2002 NHTSA 35mph NCAP No.: HO5300  
Test Vehicle: 2002 Honda CR-V LX 4WD SUV



KAR21061-01

B-40

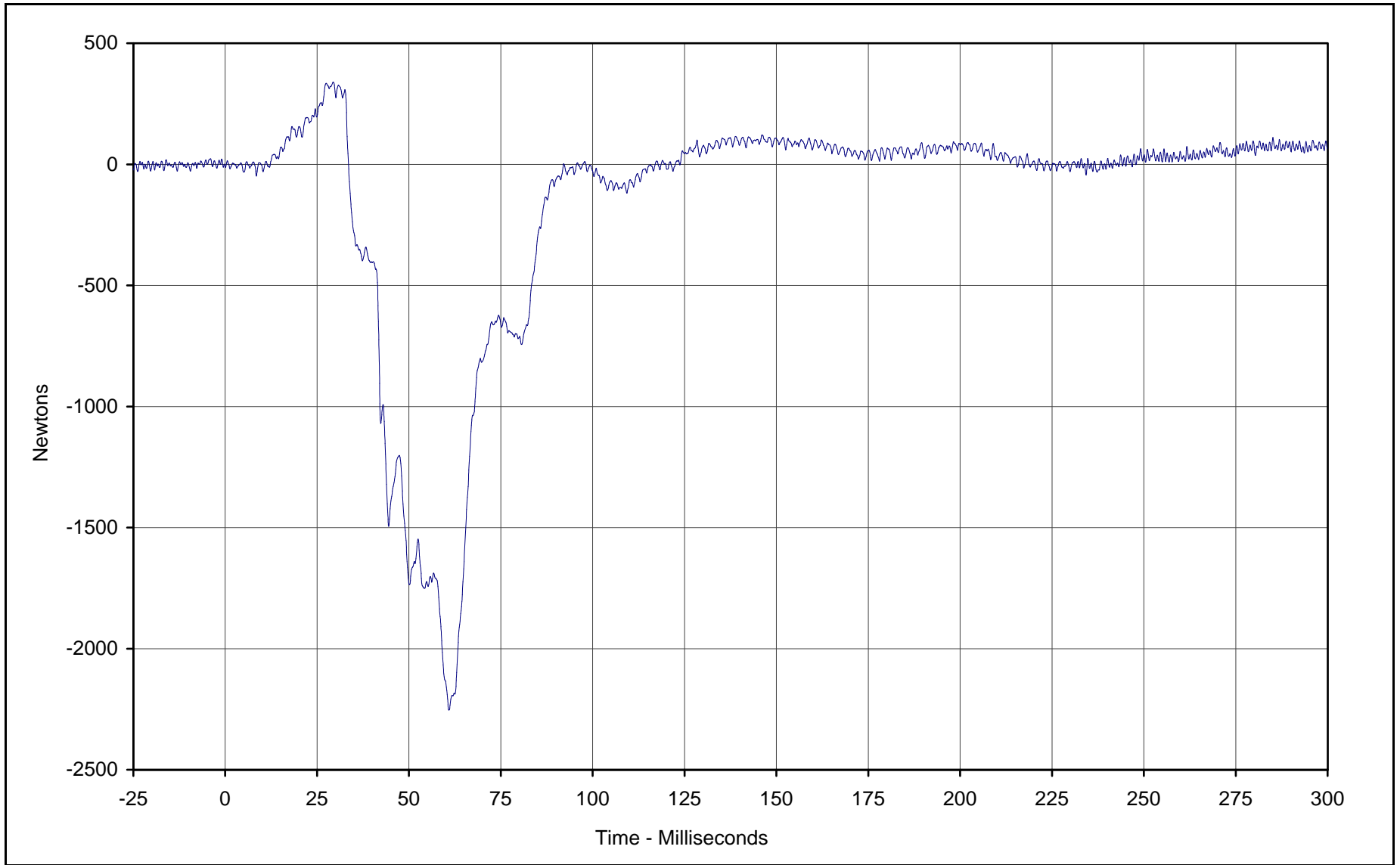

Curve Description: Driver Left Femur Force  
Maximum Value: 339.9 at 29.4 Milliseconds  
Minimum Value: -2253.6 at 60.9 Milliseconds  
SAE Filter Class: 600  
Date of Test: 1/29/02  
Curve Number: FIL-023

Test Program: 2002 NHTSA 35mph NCAP No.: HO5300  
Test Vehicle: 2002 Honda CR-V LX 4WD SUV



KAR21061-01

B-41

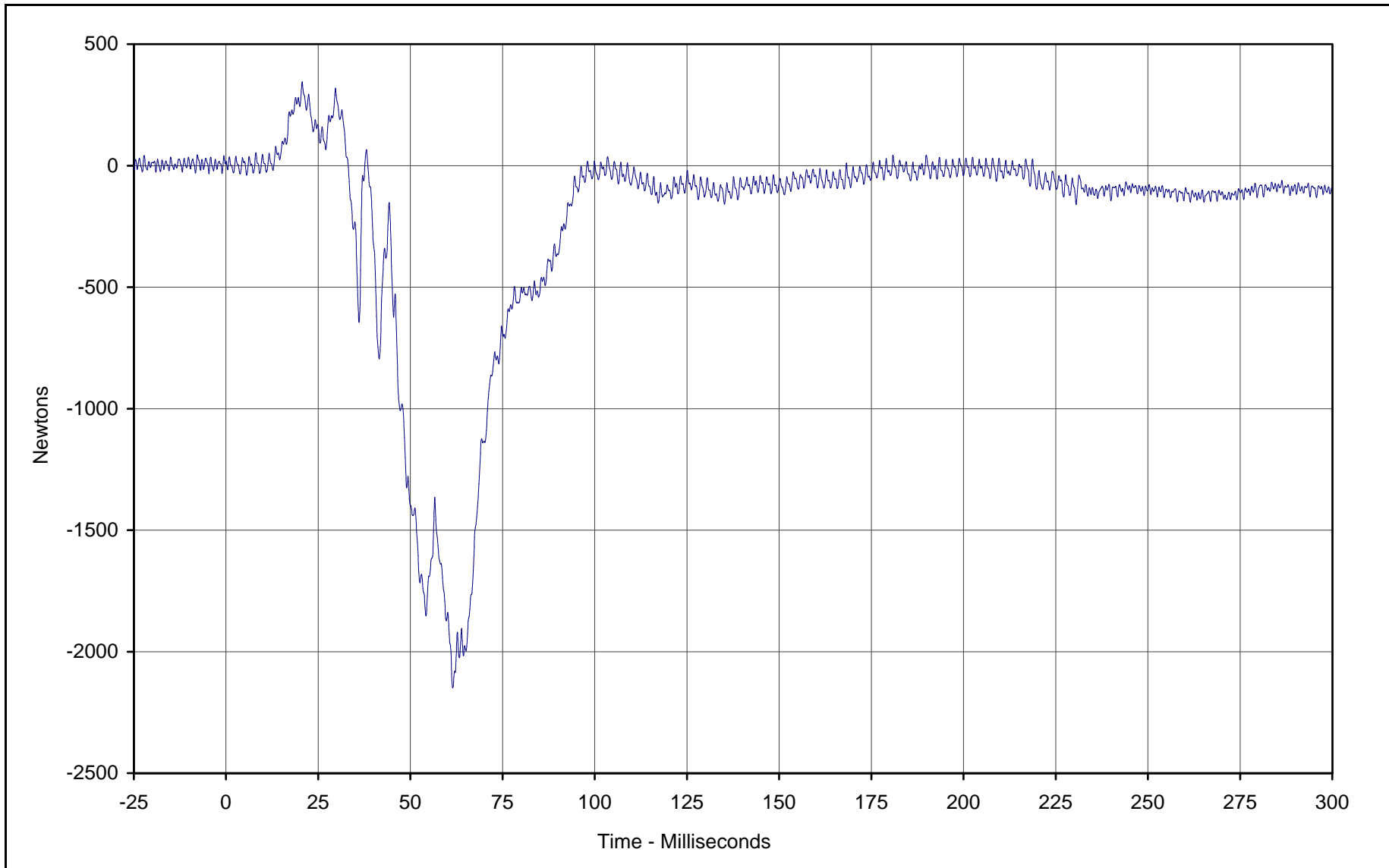

Curve Description: Driver Right Femur Force  
Maximum Value: 344.4 at 20.7 Milliseconds  
Minimum Value: -2149.4 at 61.5 Milliseconds  
SAE Filter Class: 600  
Date of Test: 1/29/02  
Curve Number: FIL-024

Test Program: 2002 NHTSA 35mph NCAP No.: HO5300  
Test Vehicle: 2002 Honda CR-V LX 4WD SUV



KAR21061-01

B-42

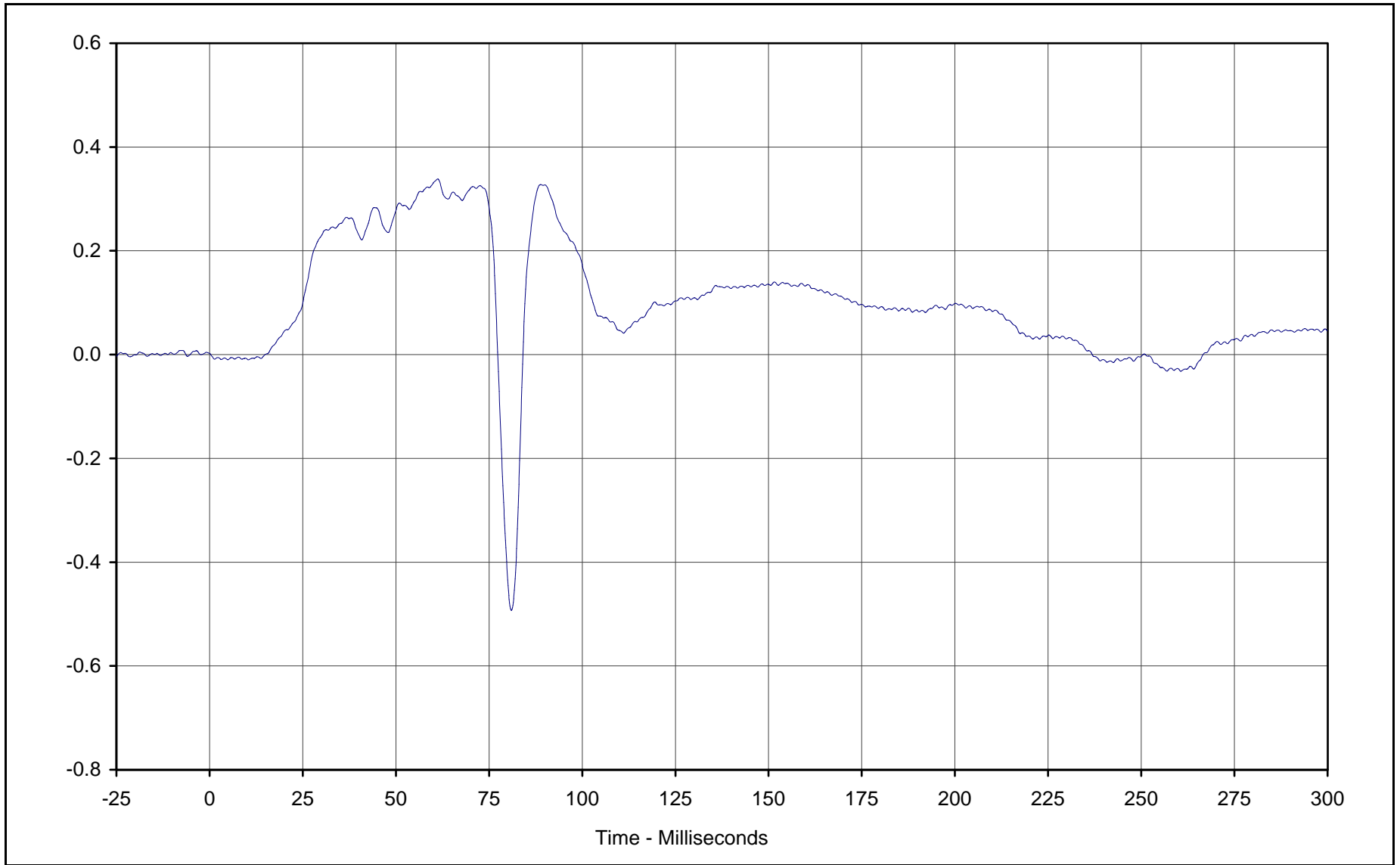

Curve Description: Driver Left Knee Slider  
Maximum Value: 0.34 at 61.2 Milliseconds  
Minimum Value: -0.49 at 81.0 Milliseconds  
SAE Filter Class: 180  
Date of Test: 1/29/02  
Curve Number: FIL-025

Test Program: 2002 NHTSA 35mph NCAP No.: HO5300  
Test Vehicle: 2002 Honda CR-V LX 4WD SUV



KAR21061-01

B-43

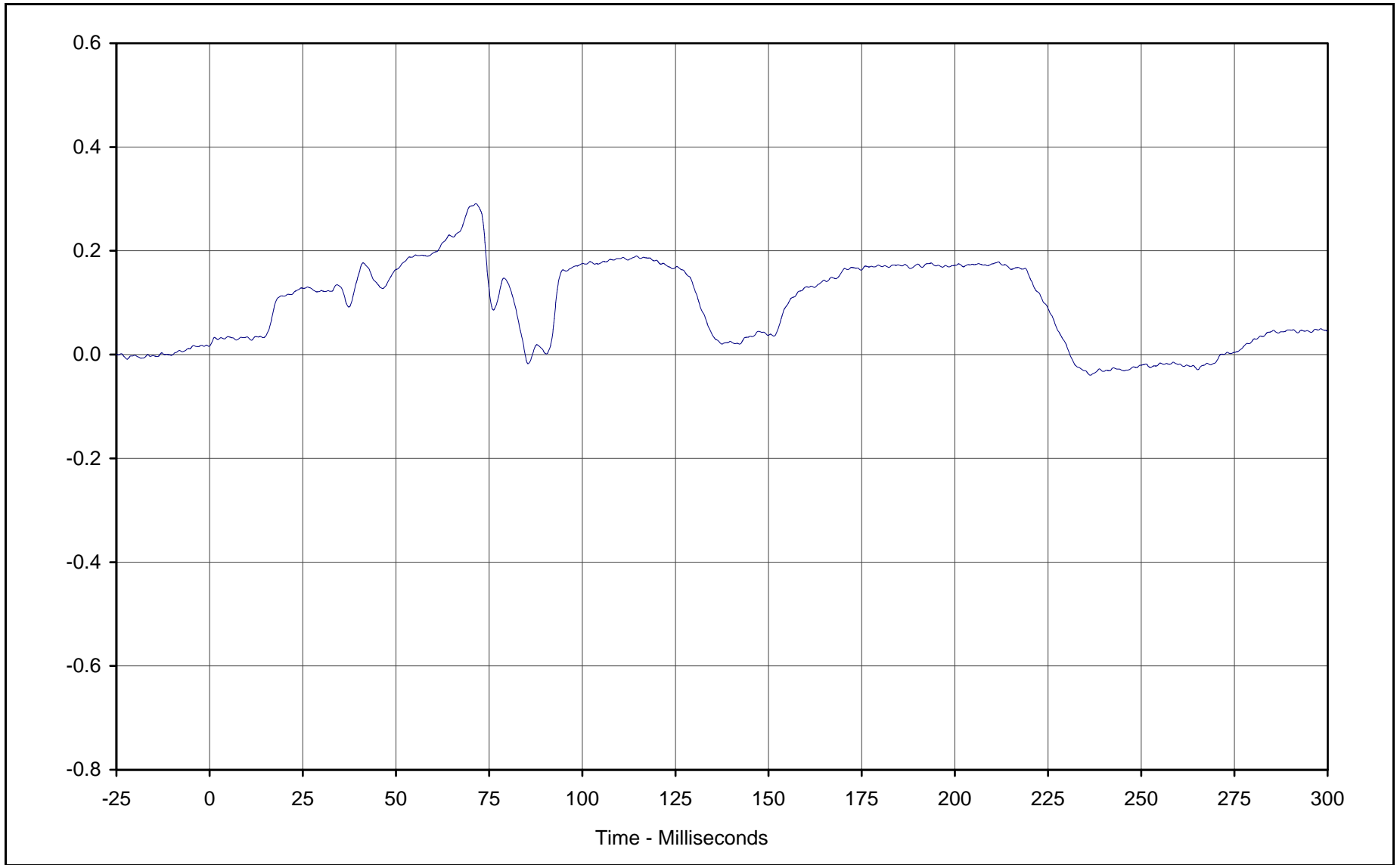

Curve Description: Driver Right Knee Slider  
Maximum Value: 0.29 at 71.5 Milliseconds  
Minimum Value: -0.04 at 236.4 Milliseconds  
SAE Filter Class: 180  
Date of Test: 1/29/02  
Curve Number: FIL-026

Test Program: 2002 NHTSA 35mph NCAP No.: HO5300  
Test Vehicle: 2002 Honda CR-V LX 4WD SUV



KAR21061-01

B-44

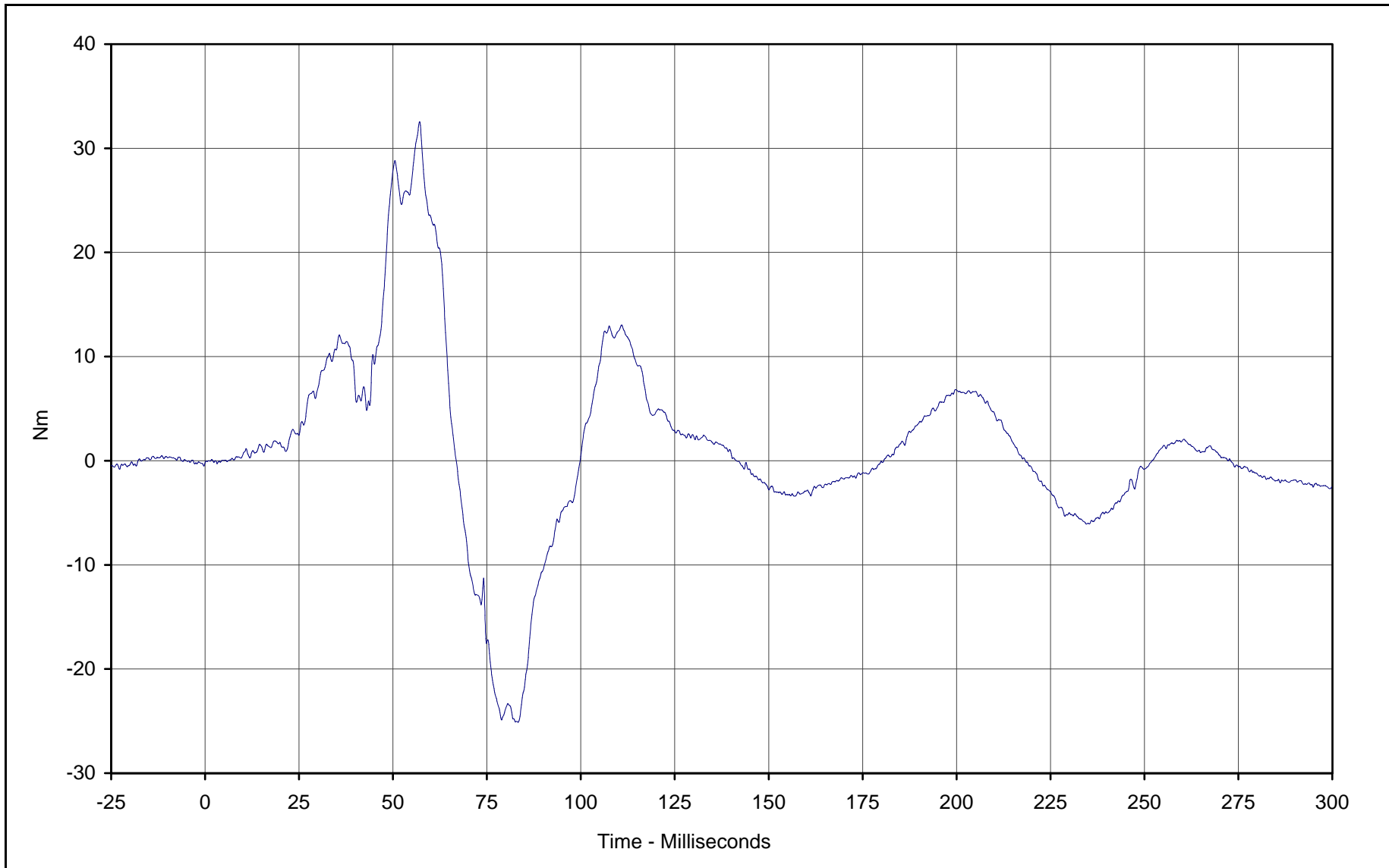

Curve Description: Driver Left Upper Tibia Moment X  
Maximum Value: 32.6 at 57.1 Milliseconds  
Minimum Value: -25.1 at 83.3 Milliseconds  
SAE Filter Class: 600  
Date of Test: 1/29/02  
Curve Number: FIL-027

Test Program: 2002 NHTSA 35mph NCAP No.: HO5300  
Test Vehicle: 2002 Honda CR-V LX 4WD SUV

KAR21061-01



B-45

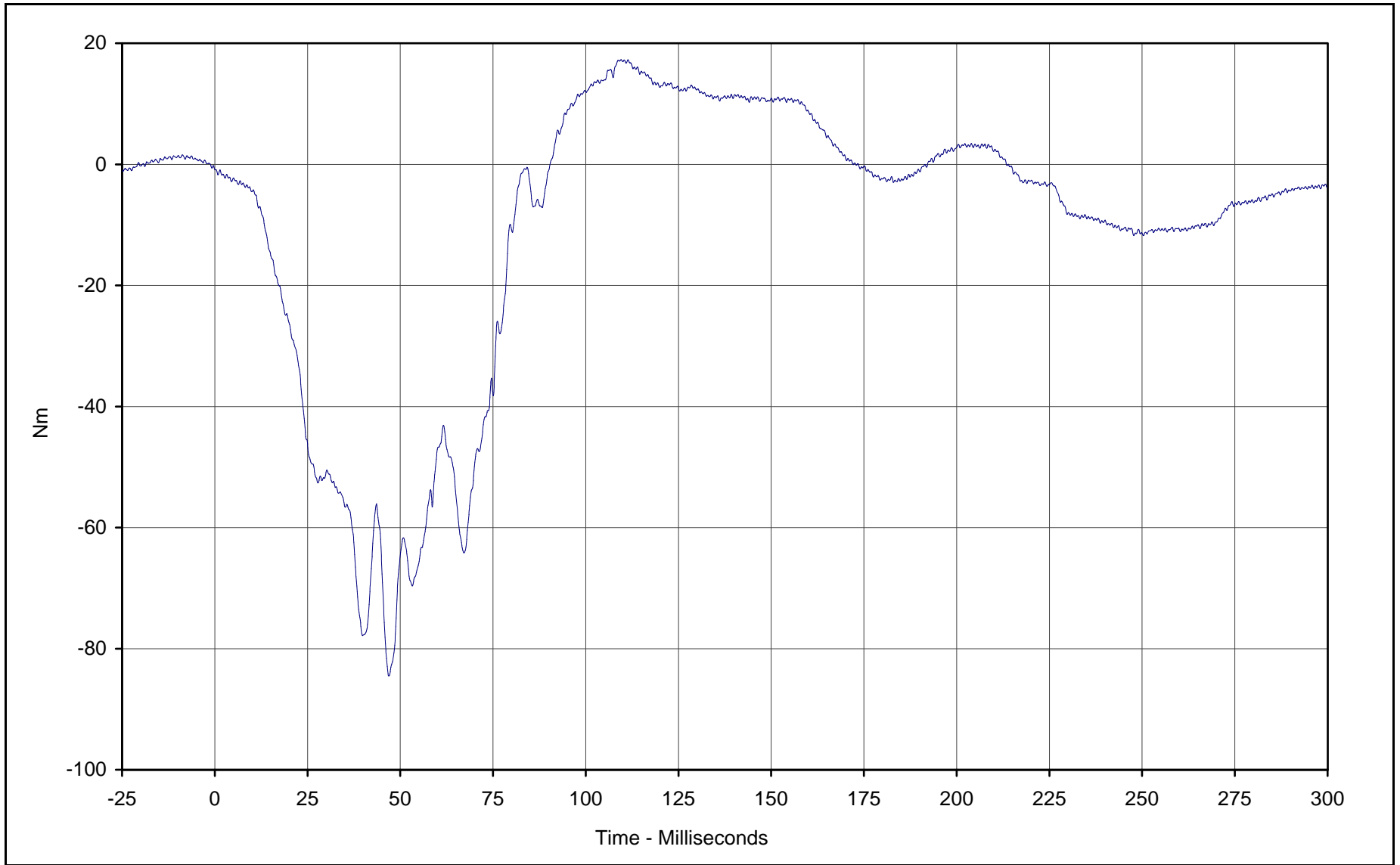

Curve Description: Driver Left Upper Tibia Moment Y  
Maximum Value: 17.3 at 109.5 Milliseconds  
Minimum Value: -84.5 at 46.9 Milliseconds  
SAE Filter Class: 600  
Date of Test: 1/29/02  
Curve Number: FIL-028

Test Program: 2002 NHTSA 35mph NCAP No.: HO5300  
Test Vehicle: 2002 Honda CR-V LX 4WD SUV



KAR21061-01

B-46

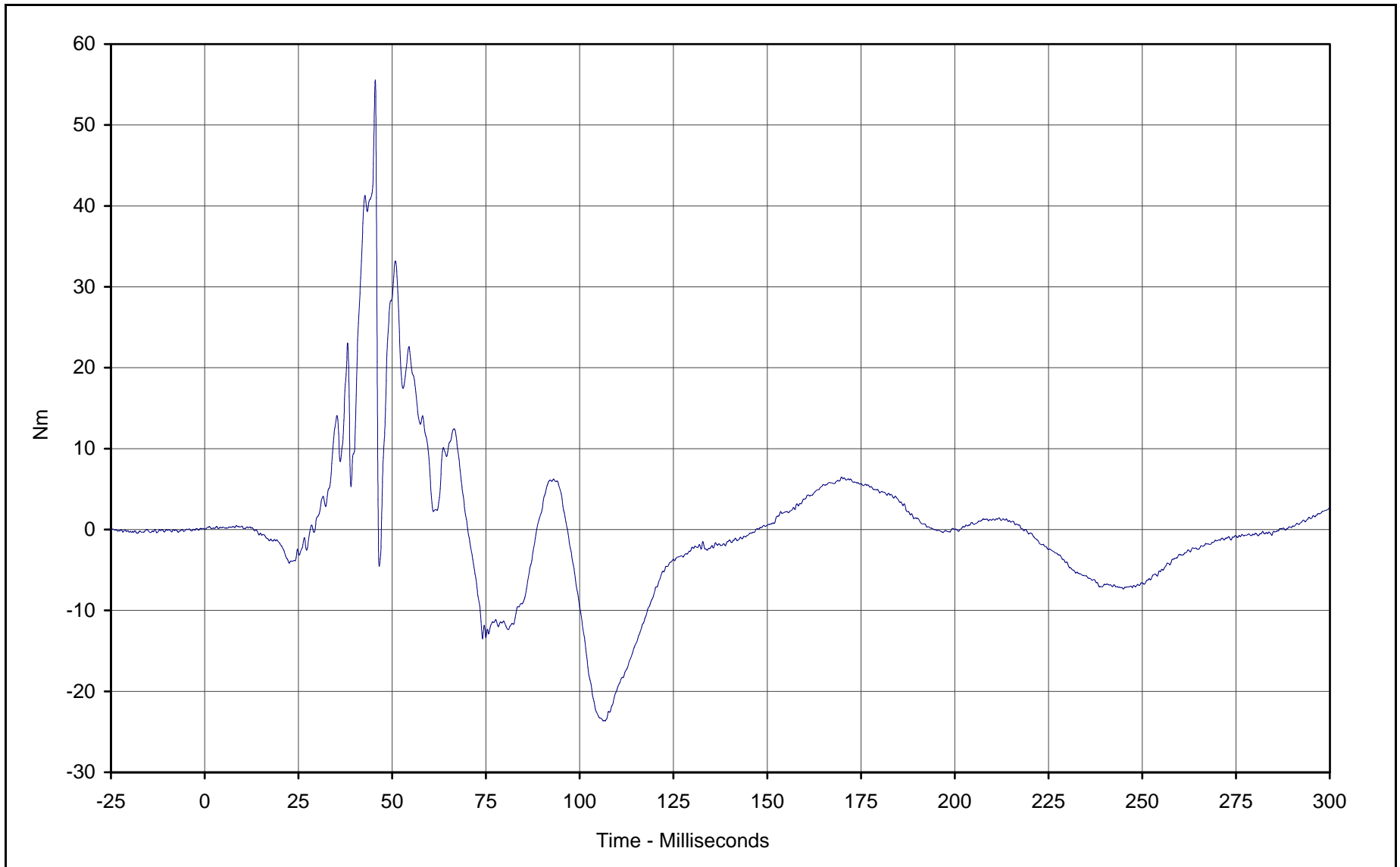

Curve Description: Driver Right Upper Tibia Moment X  
Maximum Value: 55.5 at 45.5 Milliseconds  
Minimum Value: -23.7 at 106.8 Milliseconds  
SAE Filter Class: 600  
Date of Test: 1/29/02  
Curve Number: FIL-029

Test Program: 2002 NHTSA 35mph NCAP No.: HO5300  
Test Vehicle: 2002 Honda CR-V LX 4WD SUV

KAR21061-01



B-47

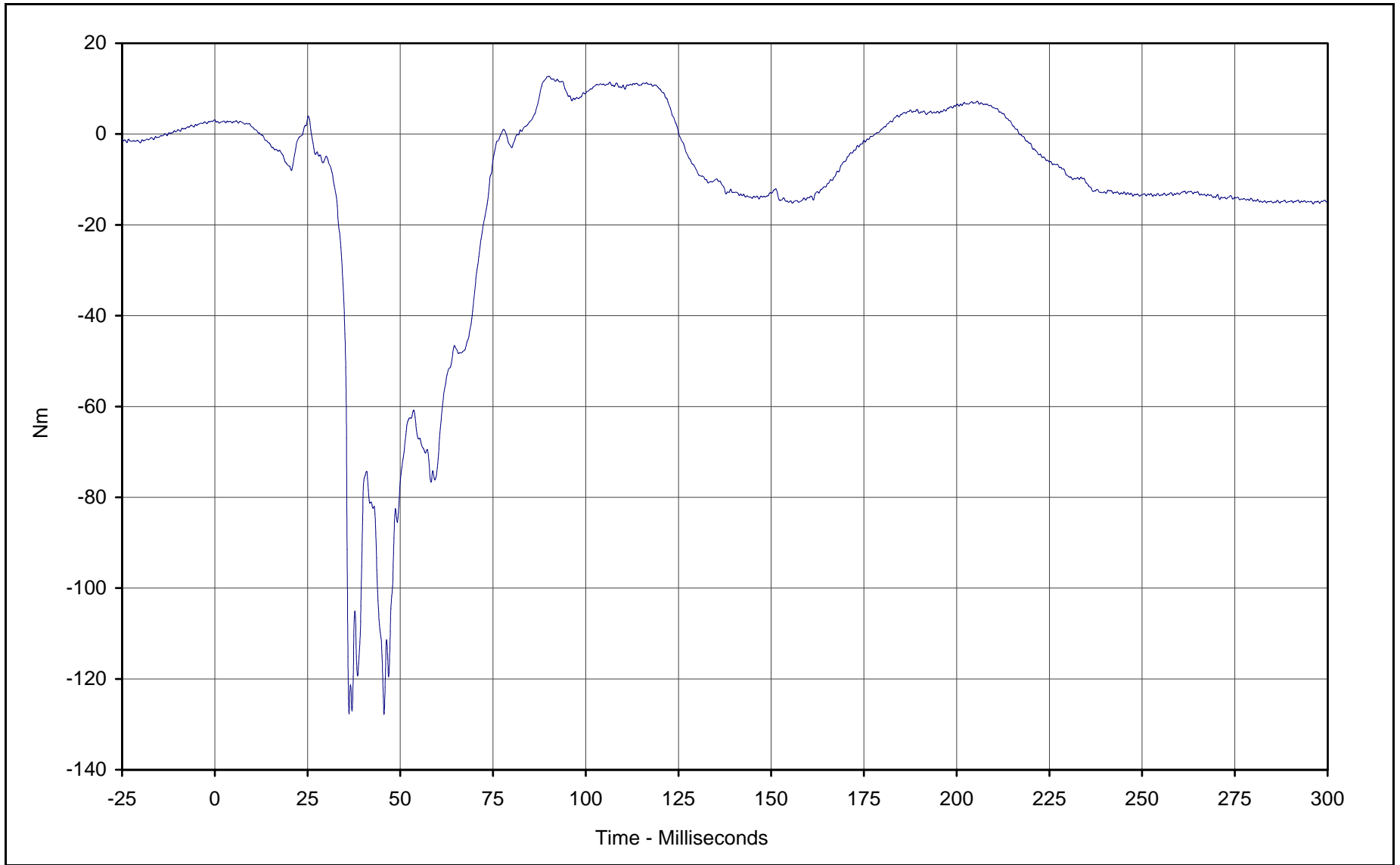

Curve Description: Driver Right Upper Tibia Moment Y  
Maximum Value: 12.7 at 90.1 Milliseconds  
Minimum Value: -127.8 at 45.6 Milliseconds  
SAE Filter Class: 600  
Date of Test: 1/29/02  
Curve Number: FIL-030

Test Program: 2002 NHTSA 35mph NCAP No.: HO5300  
Test Vehicle: 2002 Honda CR-V LX 4WD SUV

KAR21061-01



B-48

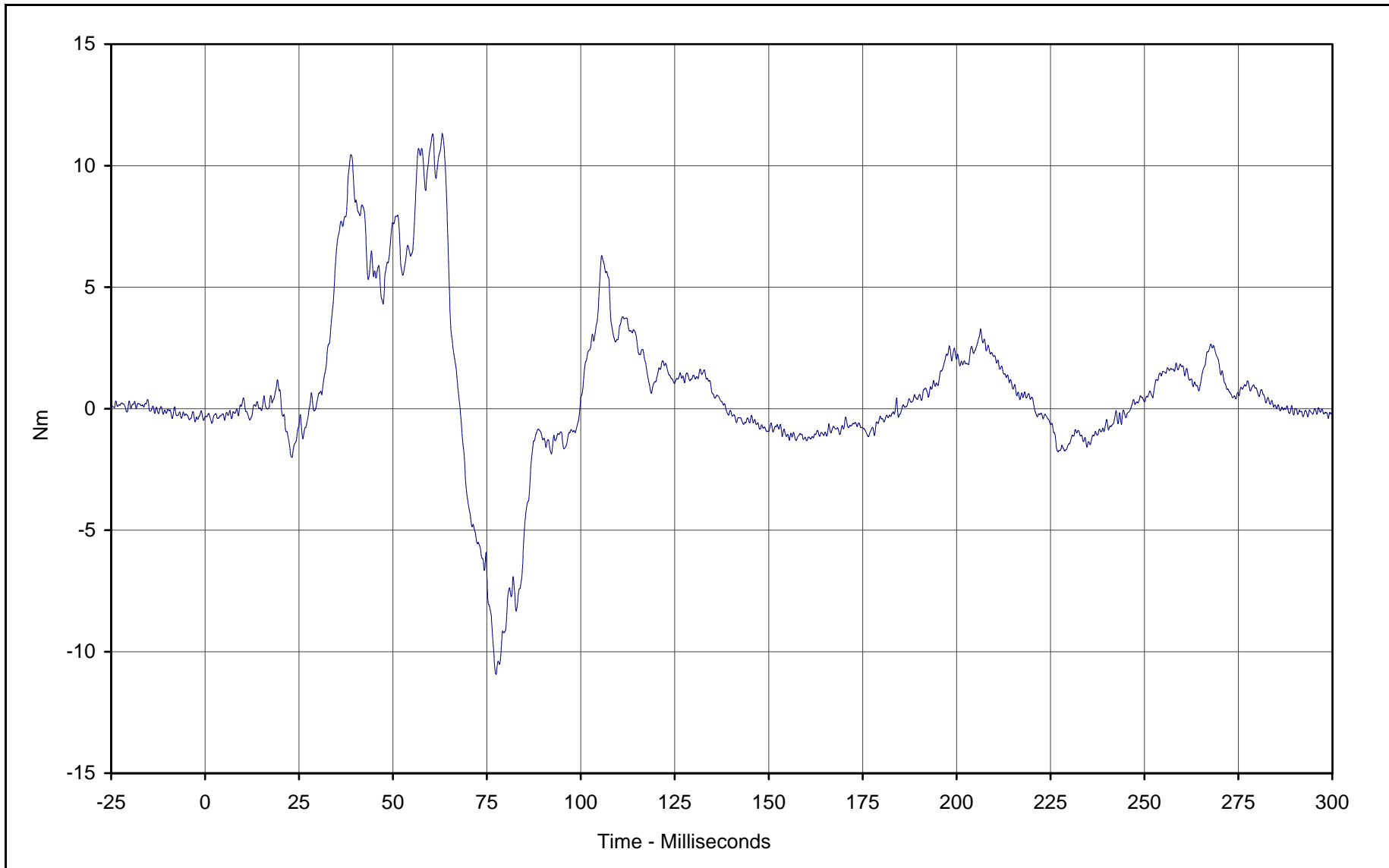

Curve Description: Driver Left Lower Tibia Moment X  
Maximum Value: 11.3 at 63.1 Milliseconds  
Minimum Value: -10.9 at 77.4 Milliseconds  
SAE Filter Class: 600  
Date of Test: 1/29/02  
Curve Number: FIL-031

Test Program: 2002 NHTSA 35mph NCAP No.: HO5300  
Test Vehicle: 2002 Honda CR-V LX 4WD SUV



KAR21061-01

B-49

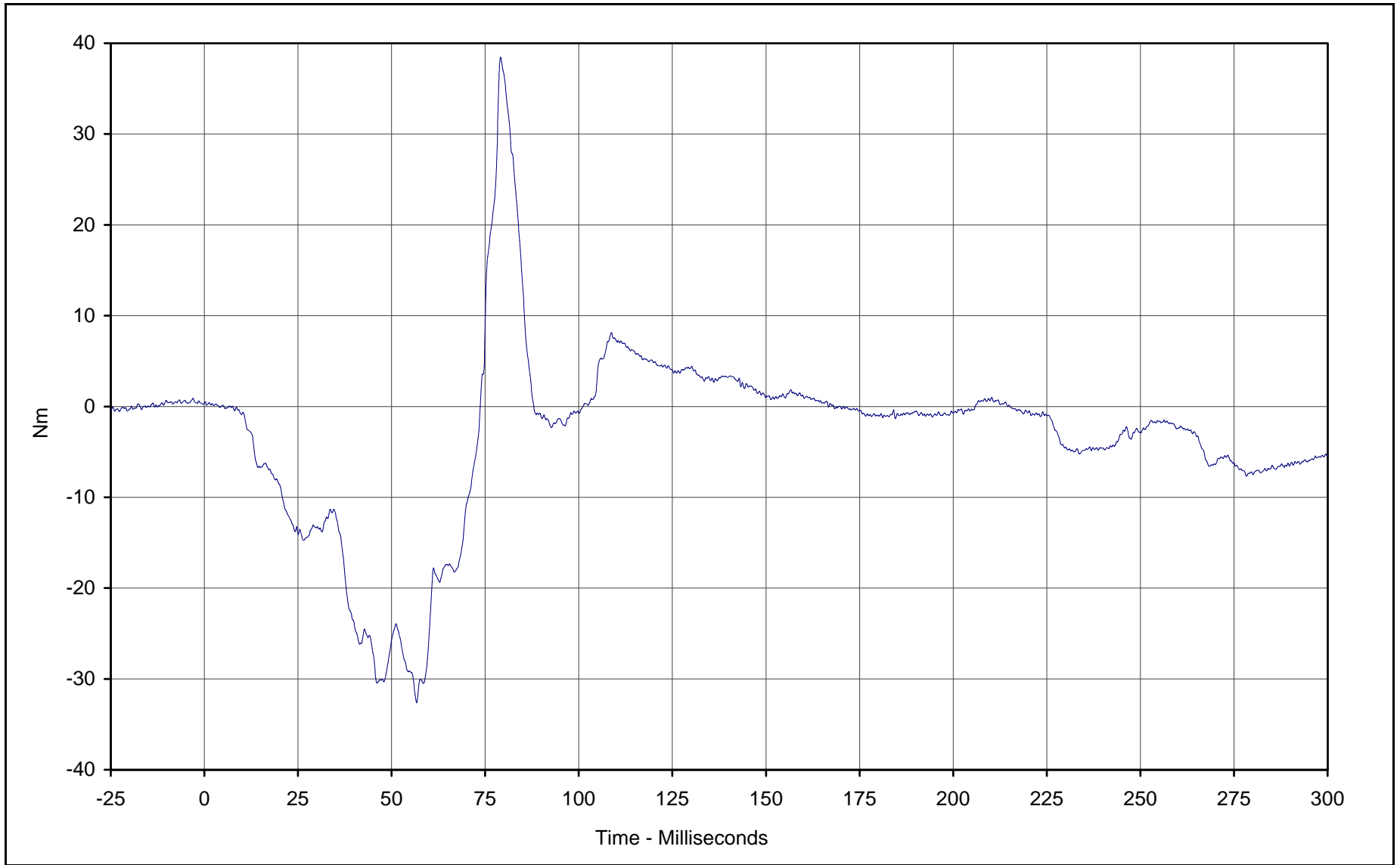

Curve Description: Driver Left Lower Tibia Moment Y  
Maximum Value: 38.5 at 79.1 Milliseconds  
Minimum Value: -32.6 at 56.7 Milliseconds  
SAE Filter Class: 600  
Date of Test: 1/29/02  
Curve Number: FIL-032

Test Program: 2002 NHTSA 35mph NCAP No.: HO5300  
Test Vehicle: 2002 Honda CR-V LX 4WD SUV



KAR21061-01

B-50

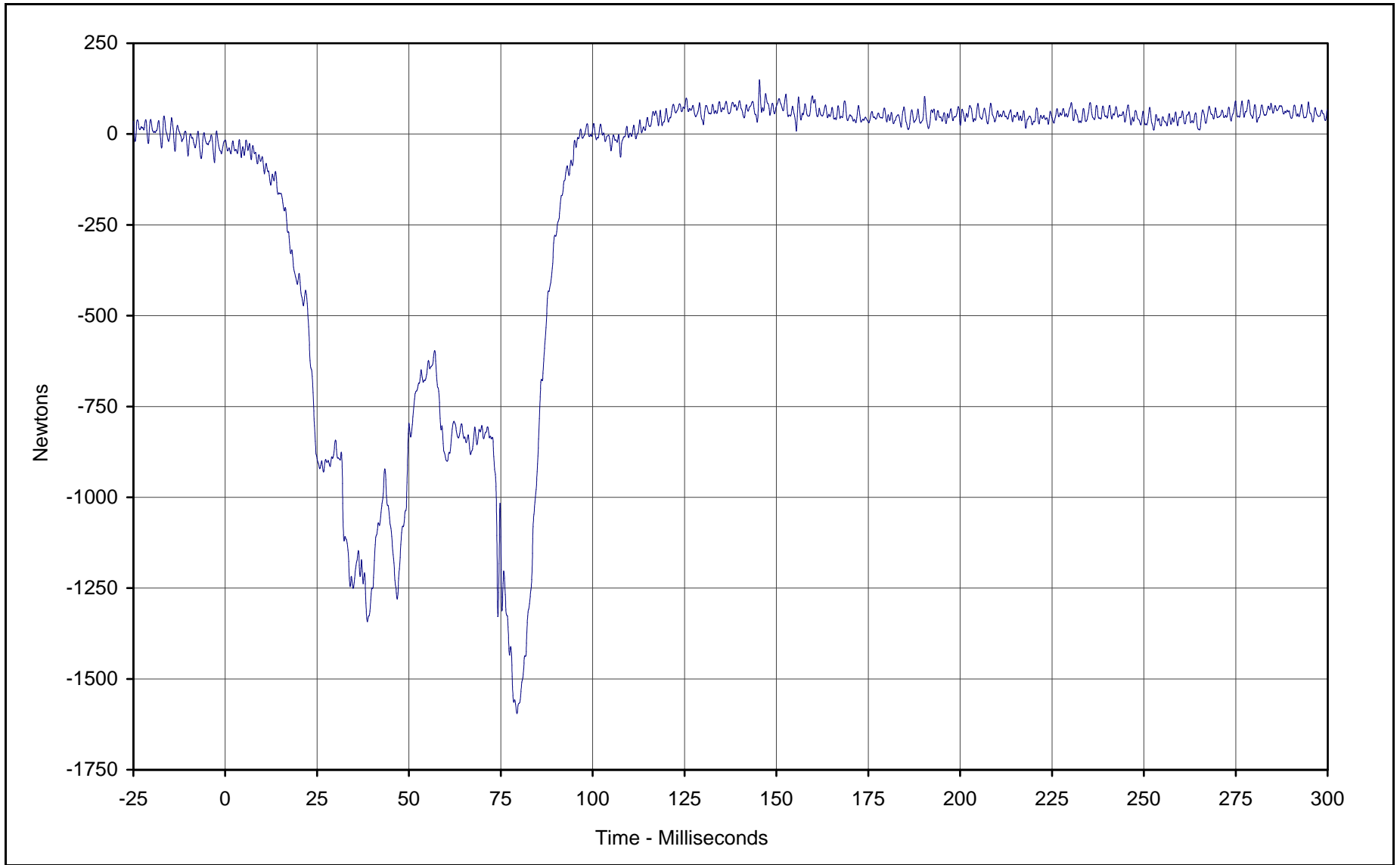

Curve Description: Driver Left Lower Tibia Force Z  
Maximum Value: 149.7 at 145.4 Milliseconds  
Minimum Value: -1595.5 at 79.4 Milliseconds  
SAE Filter Class: 600  
Date of Test: 1/29/02  
Curve Number: FIL-033

Test Program: 2002 NHTSA 35mph NCAP No.: HO5300  
Test Vehicle: 2002 Honda CR-V LX 4WD SUV



KAR21061-01

B-51

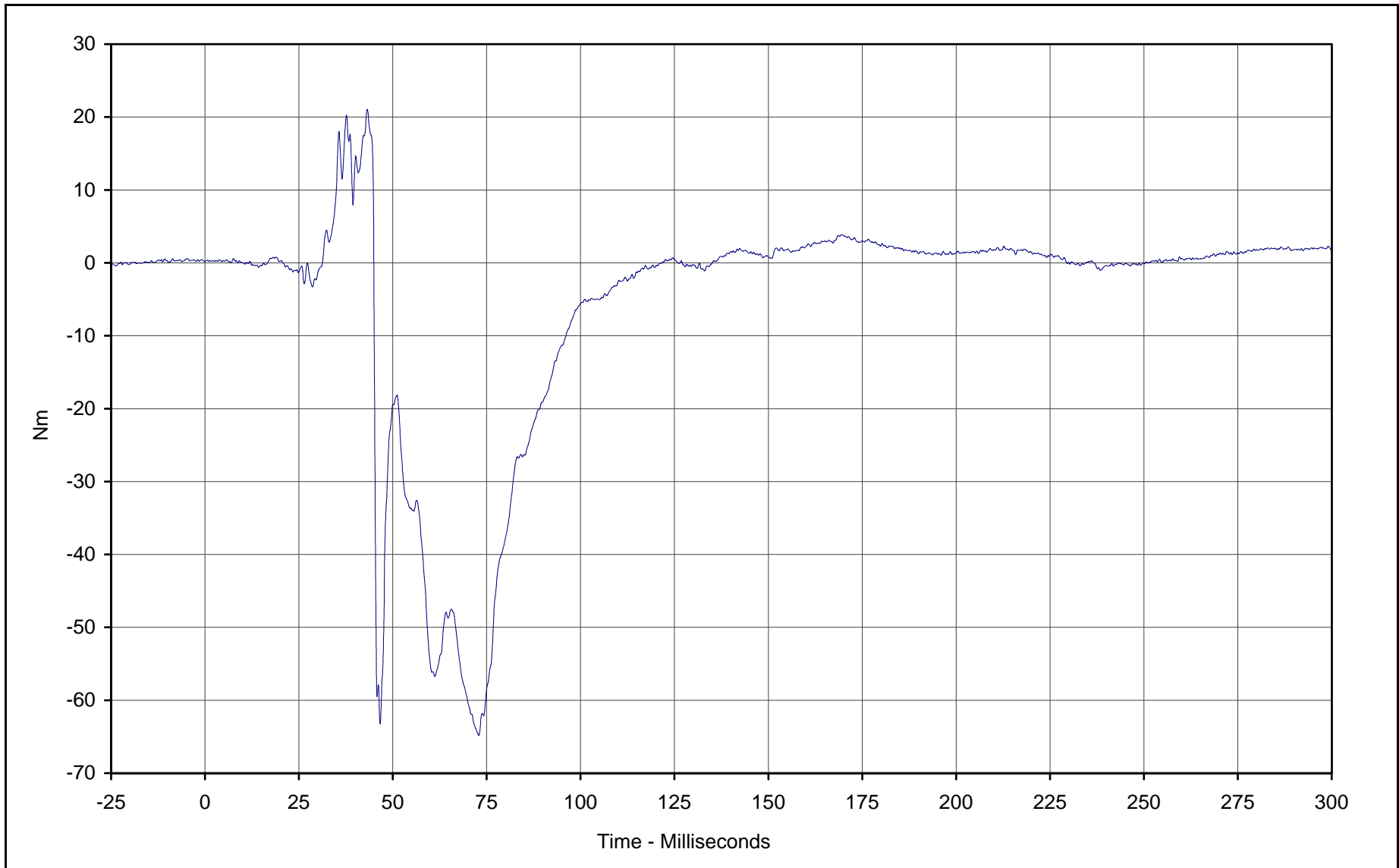

Curve Description: Driver Right Lower Tibia Moment X  
Maximum Value: 21.1 at 43.2 Milliseconds  
Minimum Value: -64.8 at 72.9 Milliseconds  
SAE Filter Class: 600  
Date of Test: 1/29/02  
Curve Number: FIL-034

Test Program: 2002 NHTSA 35mph NCAP No.: HO5300  
Test Vehicle: 2002 Honda CR-V LX 4WD SUV



KAR21061-01

B-52

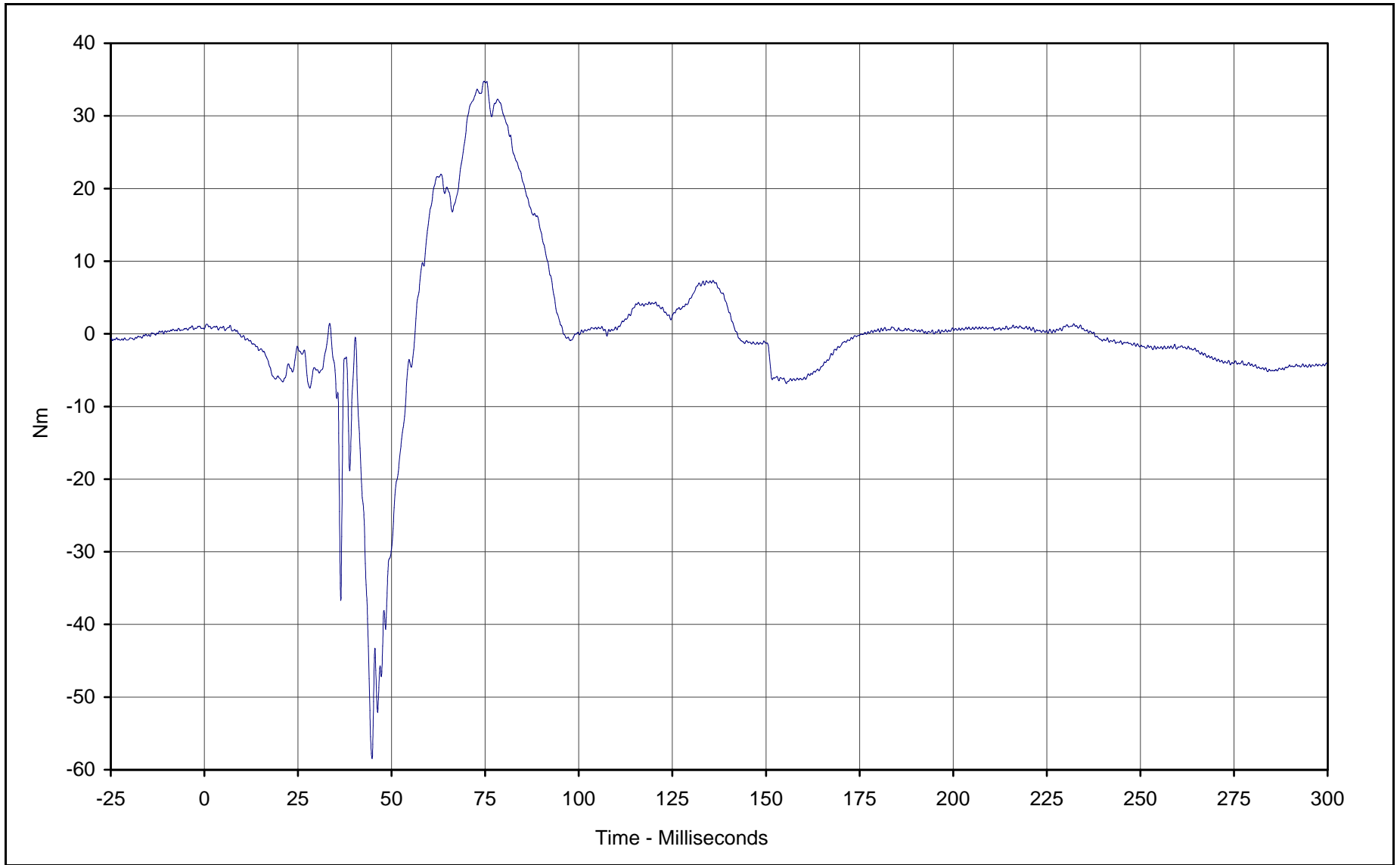

Curve Description: Driver Right Lower Tibia Moment Y  
Maximum Value: 34.8 at 74.7 Milliseconds  
Minimum Value: -58.5 at 44.8 Milliseconds  
SAE Filter Class: 600  
Date of Test: 1/29/02  
Curve Number: FIL-035

Test Program: 2002 NHTSA 35mph NCAP No.: HO5300  
Test Vehicle: 2002 Honda CR-V LX 4WD SUV

KAR21061-01



B-53

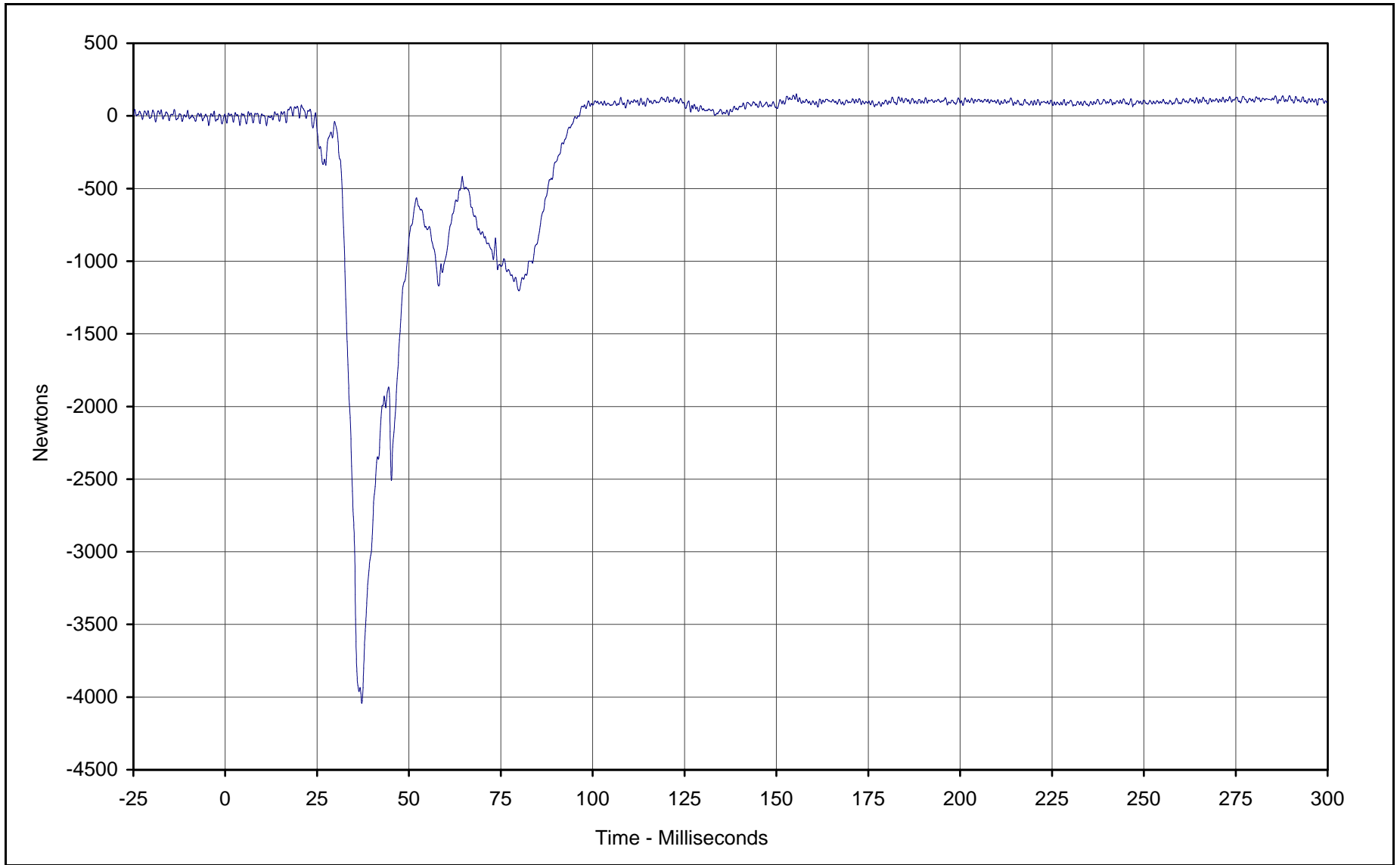

Curve Description: Driver Right Lower Tibia Force Z  
Maximum Value: 152.1 at 155.4 Milliseconds  
Minimum Value: -4042.8 at 37.2 Milliseconds  
SAE Filter Class: 600  
Date of Test: 1/29/02  
Curve Number: FIL-036

Test Program: 2002 NHTSA 35mph NCAP No.: HO5300  
Test Vehicle: 2002 Honda CR-V LX 4WD SUV



KAR21061-01

B-54

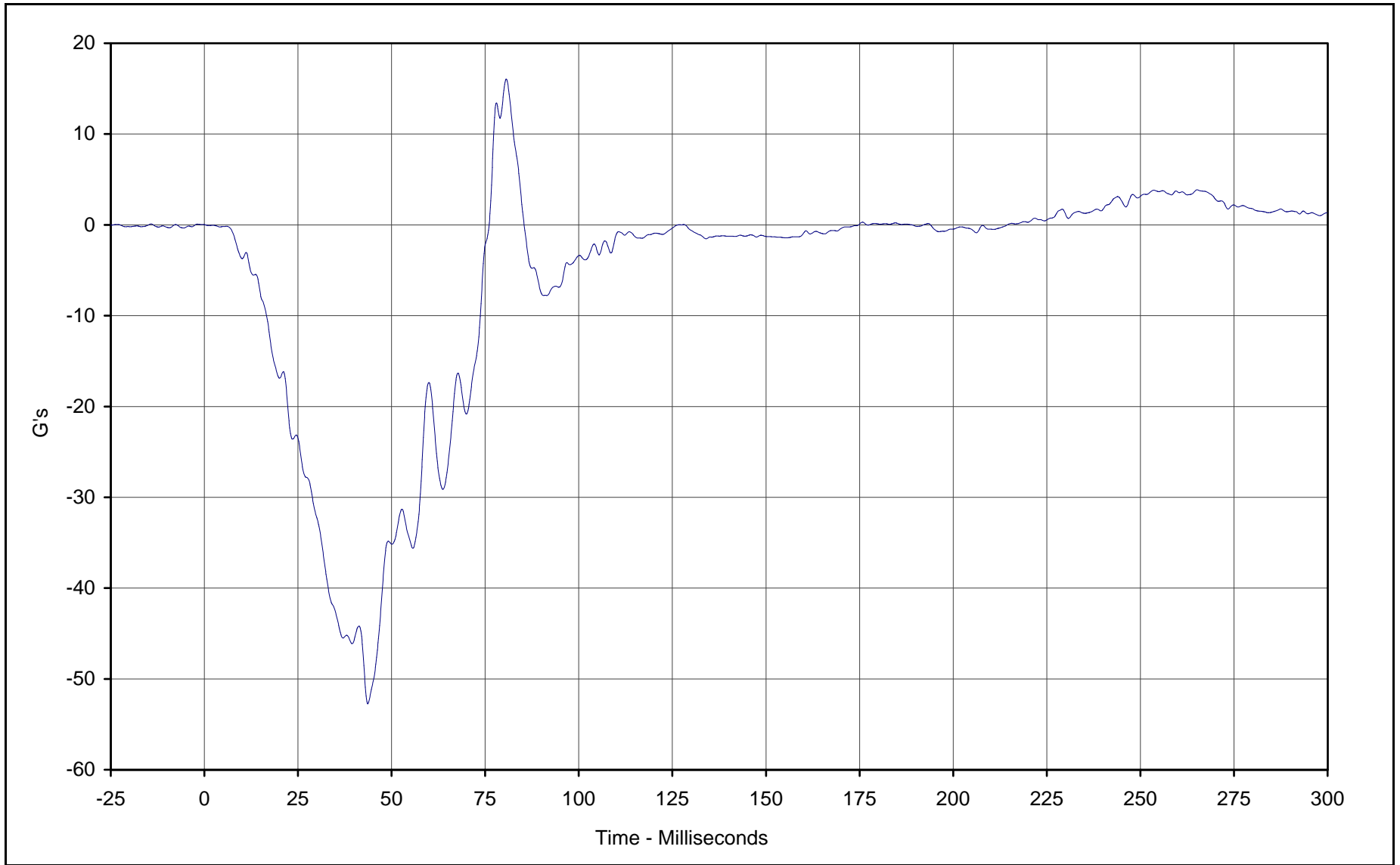

Curve Description: Driver Left Foot Aft X  
Maximum Value: 16.1 at 80.6 Milliseconds  
Minimum Value: -52.7 at 43.6 Milliseconds  
SAE Filter Class: 180  
Date of Test: 1/29/02  
Curve Number: FIL-037

Test Program: 2002 NHTSA 35mph NCAP No.: HO5300  
Test Vehicle: 2002 Honda CR-V LX 4WD SUV



KAR21061-01

B-55

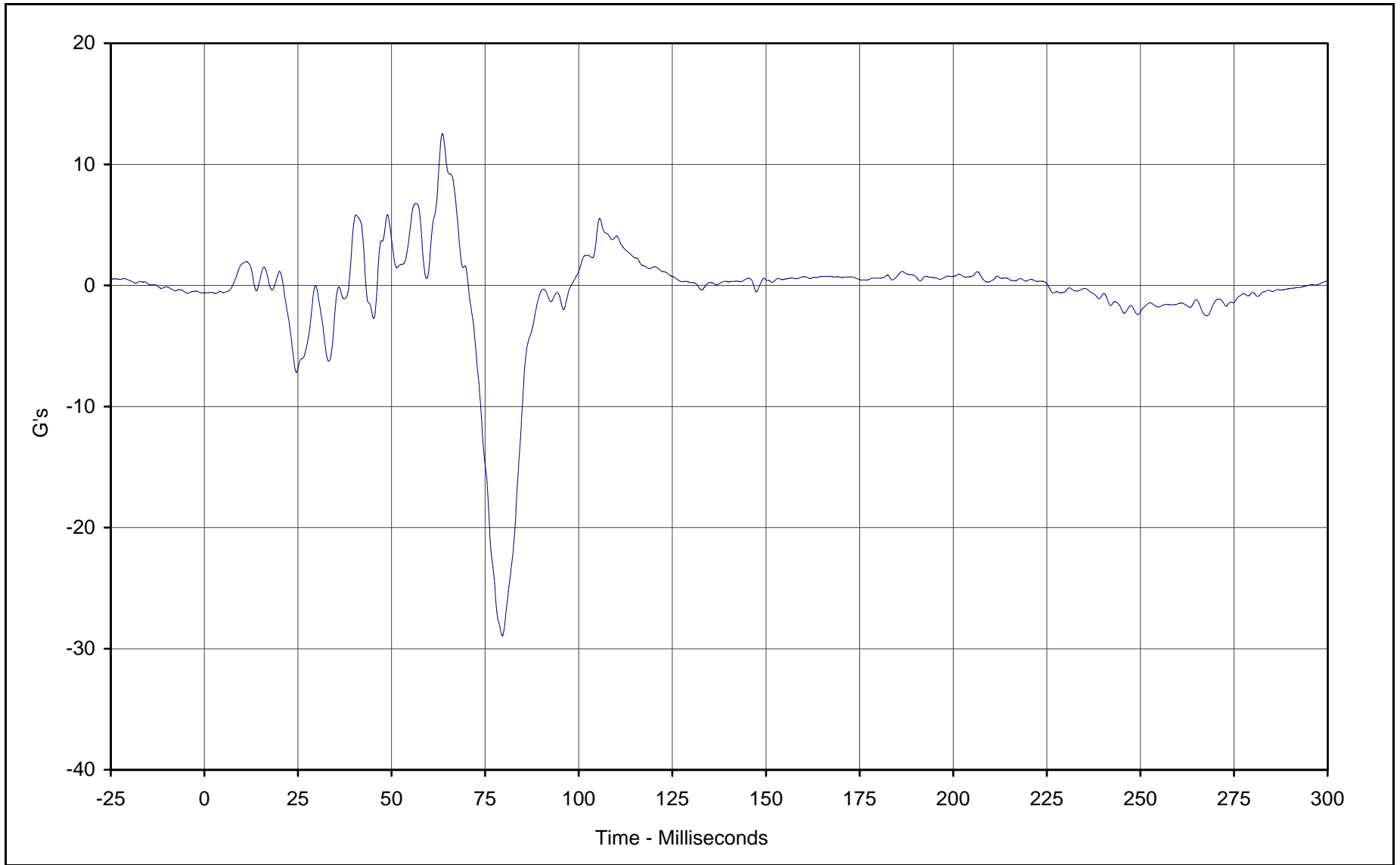

Curve Description: Driver Left Foot Aft Z  
Maximum Value: 12.5 at 63.6 Milliseconds  
Minimum Value: -29.0 at 79.6 Milliseconds  
SAE Filter Class: 180  
Date of Test: 1/29/02  
Curve Number: FIL-038

Test Program: 2002 NHTSA 35mph NCAP No.: HO5300  
Test Vehicle: 2002 Honda CR-V LX 4WD SUV



KAR21061-01

B-56

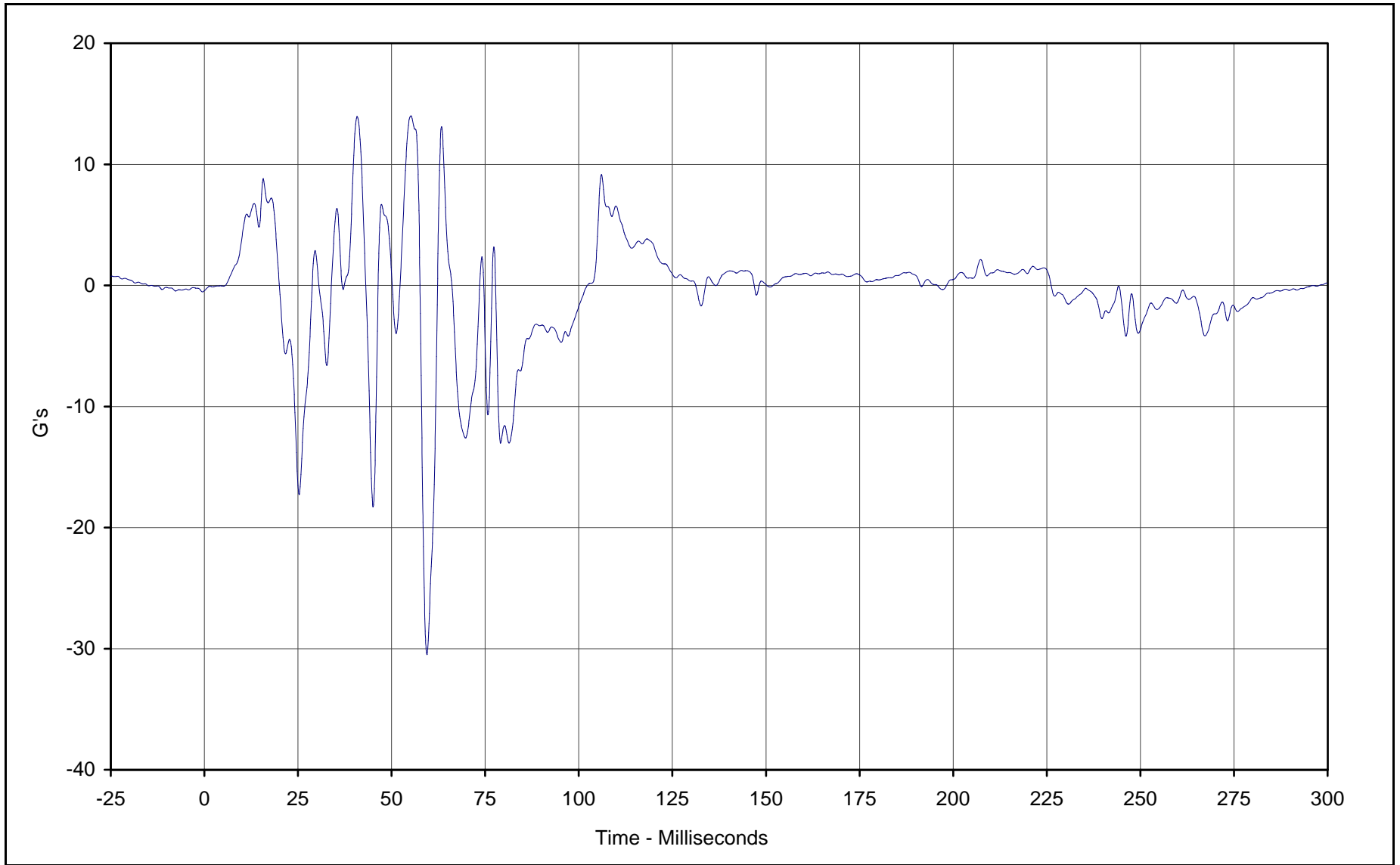

Curve Description: Driver Left Foot Fore Z  
Maximum Value: 14.0 at 55.2 Milliseconds  
Minimum Value: -30.5 at 59.4 Milliseconds  
SAE Filter Class: 180  
Date of Test: 1/29/02  
Curve Number: FIL-039

Test Program: 2002 NHTSA 35mph NCAP No.: HO5300  
Test Vehicle: 2002 Honda CR-V LX 4WD SUV



KAR21061-01

B-57

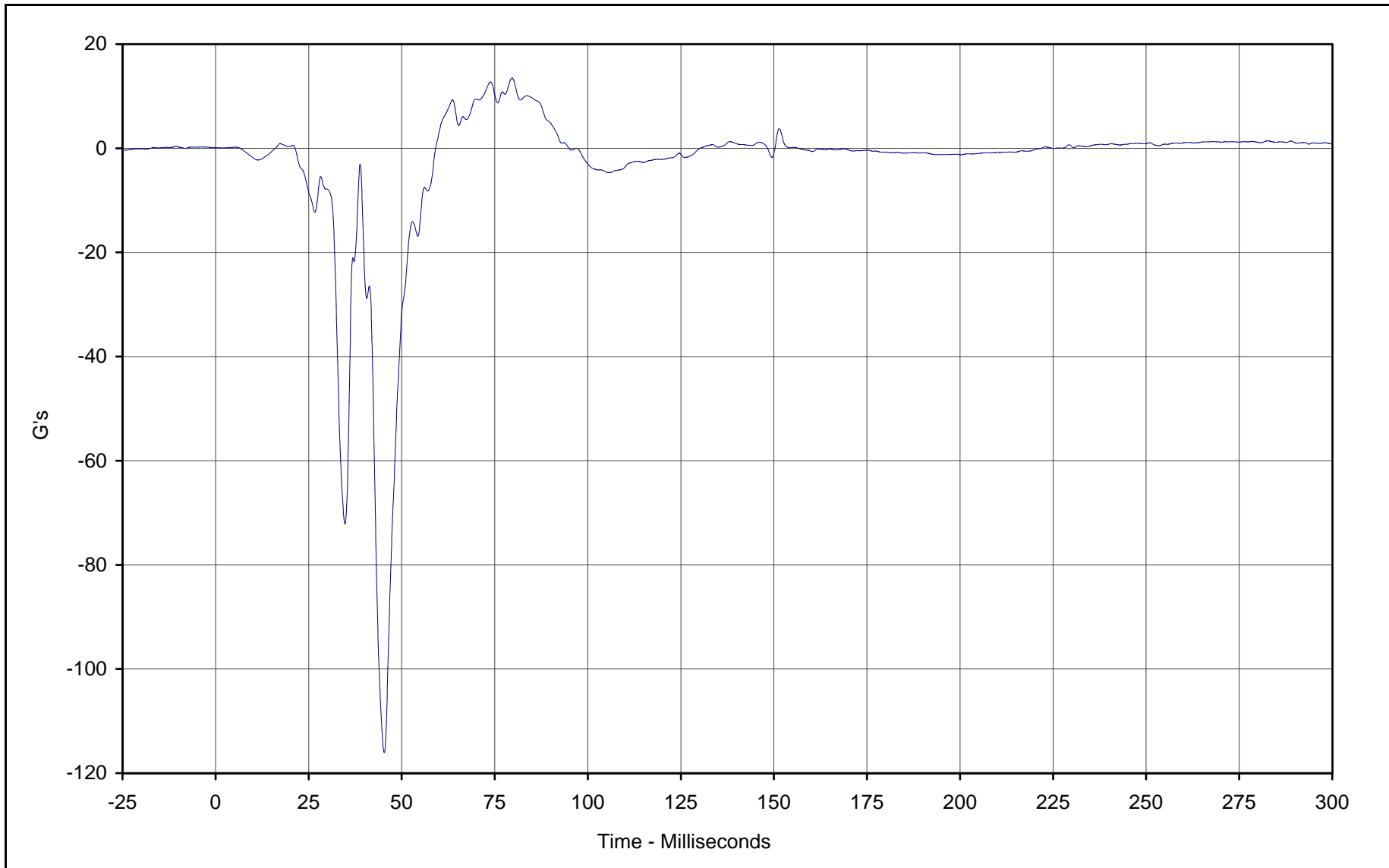

Curve Description: Driver Right Foot Aft X  
Maximum Value: 13.5 at 79.6 Milliseconds  
Minimum Value: -116.0 at 45.3 Milliseconds  
SAE Filter Class: 180  
Date of Test: 1/29/02  
Curve Number: FIL-040

Test Program: 2002 NHTSA 35mph NCAP No.: HO5300  
Test Vehicle: 2002 Honda CR-V LX 4WD SUV



KAR21061-01

B-58

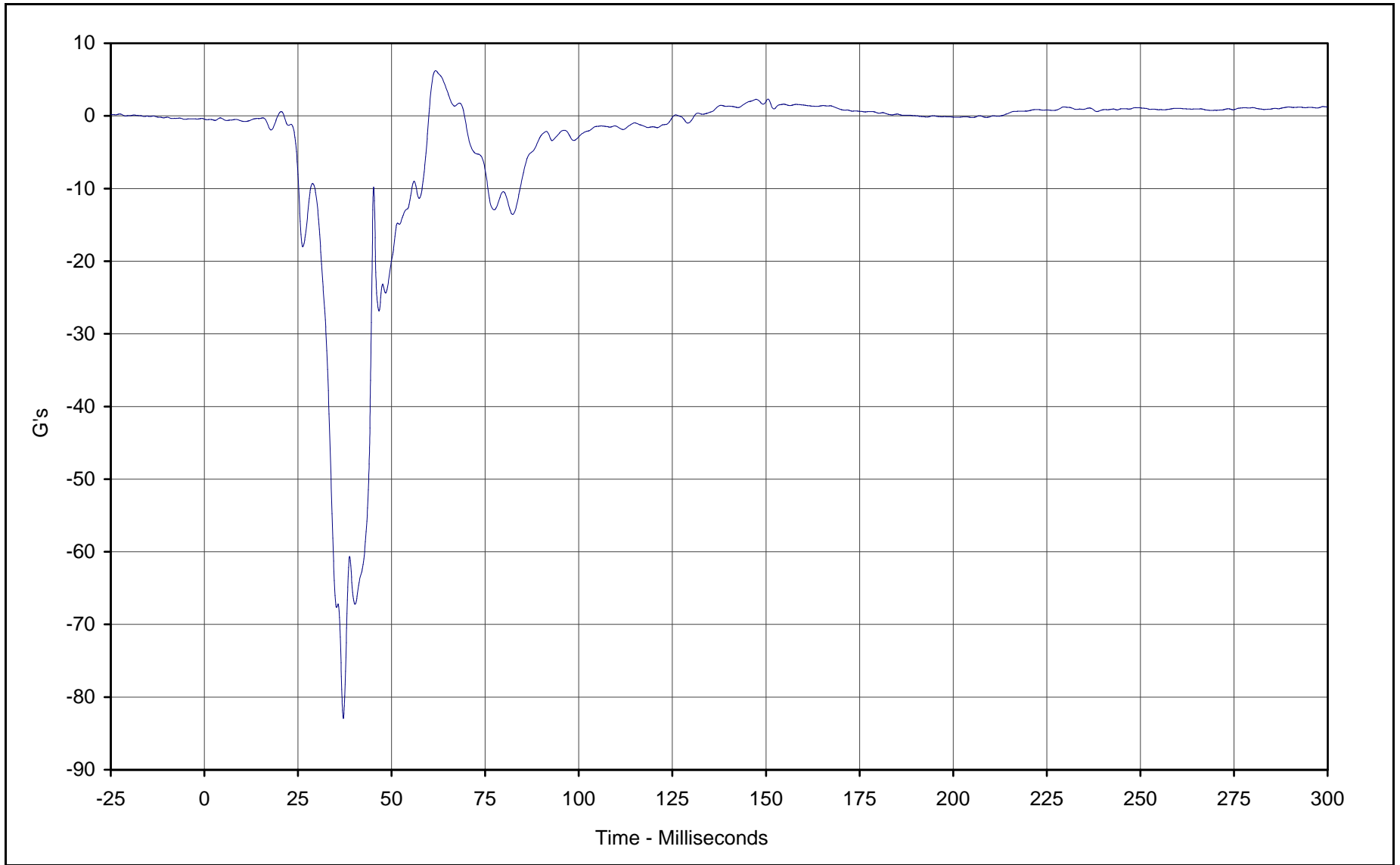

Curve Description: Driver Right Foot Aft Z  
Maximum Value: 6.2 at 61.7 Milliseconds  
Minimum Value: -82.9 at 37.1 Milliseconds  
SAE Filter Class: 180  
Date of Test: 1/29/02  
Curve Number: FIL-041

Test Program: 2002 NHTSA 35mph NCAP No.: HO5300  
Test Vehicle: 2002 Honda CR-V LX 4WD SUV



KAR21061-01

B-59

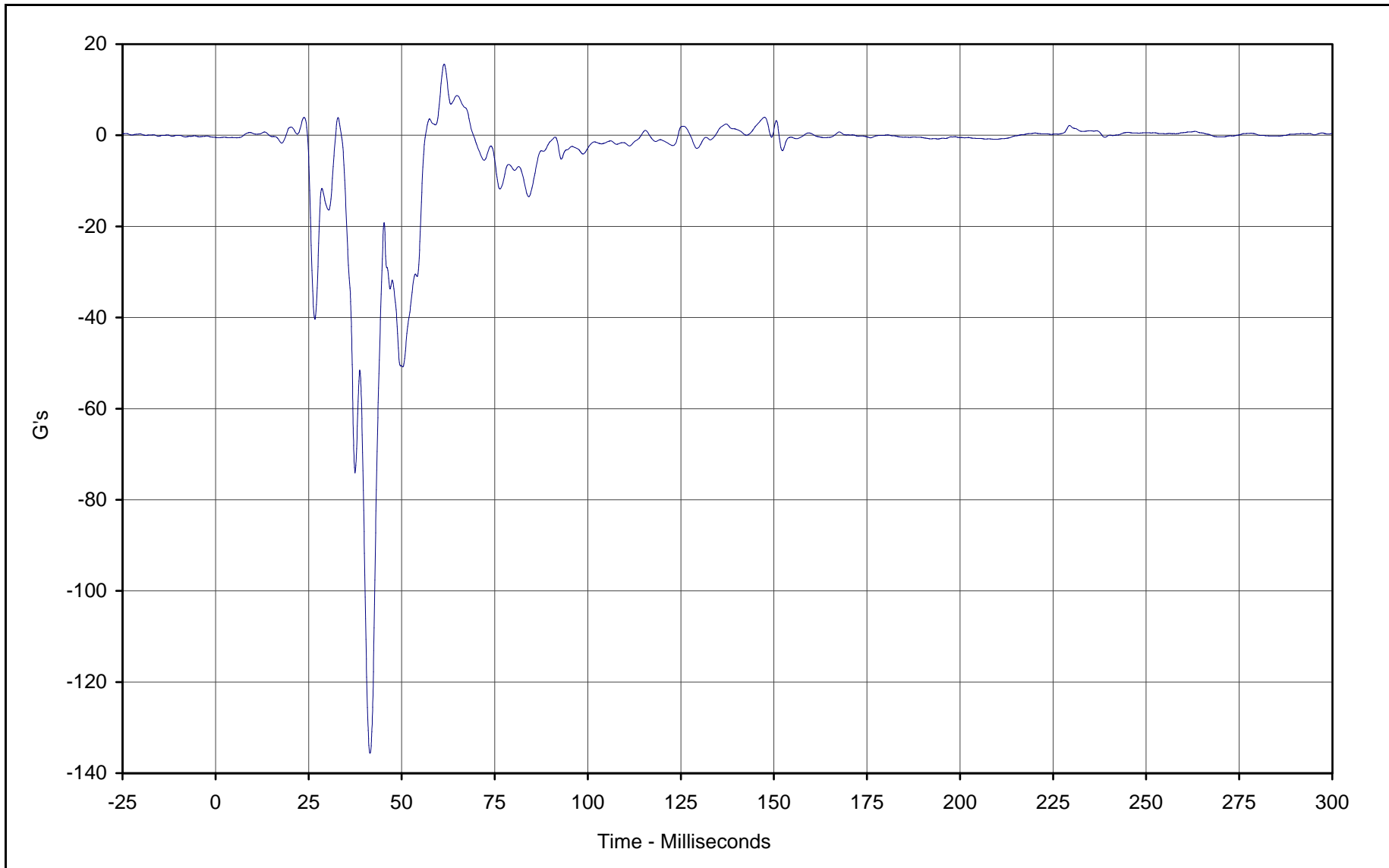

Curve Description: Driver Right Foot Fore Z  
Maximum Value: 15.6 at 61.4 Milliseconds  
Minimum Value: -135.6 at 41.5 Milliseconds  
SAE Filter Class: 180  
Date of Test: 1/29/02  
Curve Number: FIL-042

Test Program: 2002 NHTSA 35mph NCAP No.: HO5300  
Test Vehicle: 2002 Honda CR-V LX 4WD SUV



KAR21061-01

B-60

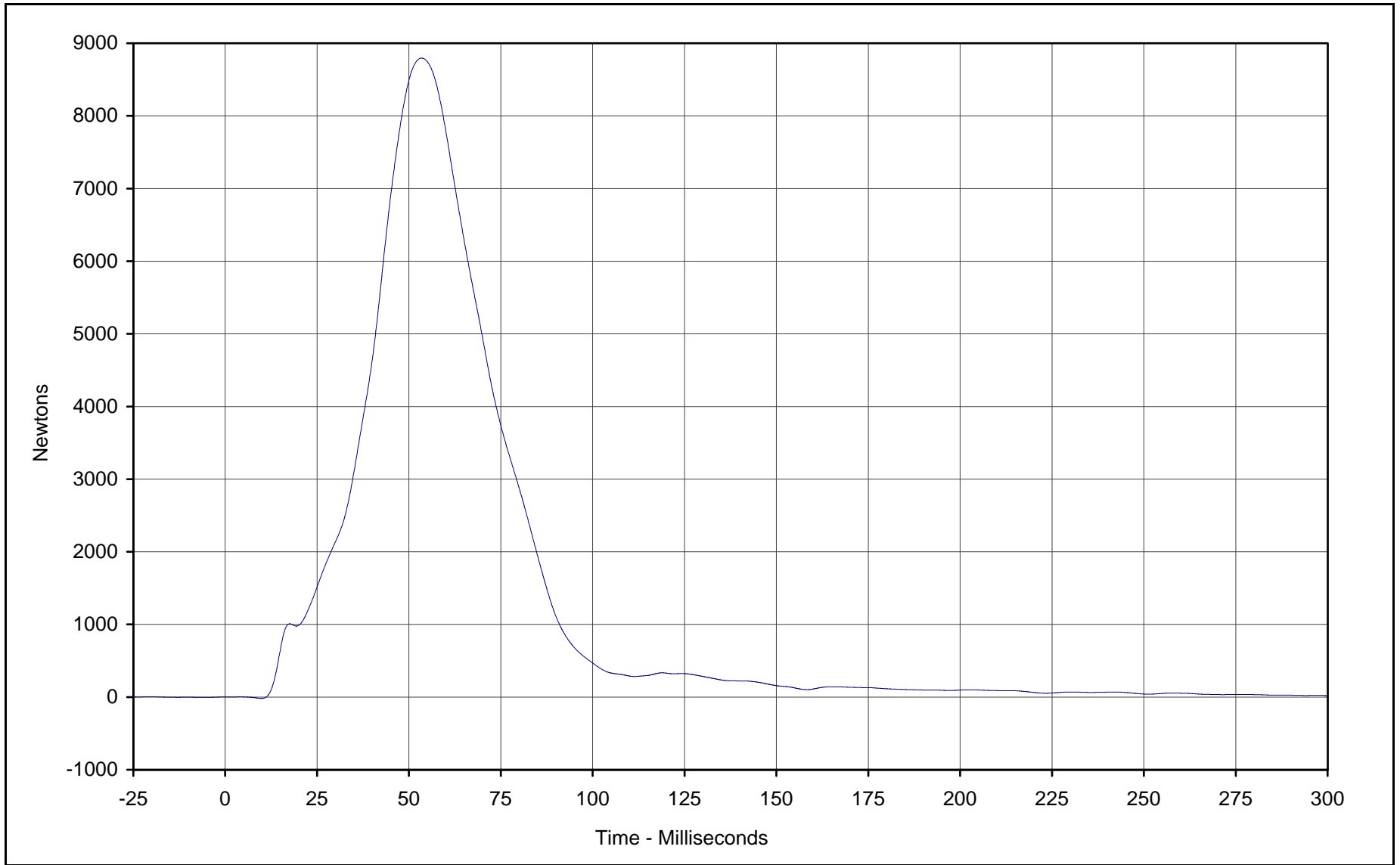

Curve Description: Driver Lap Belt Force  
Maximum Value: 8794.4 at 53.4 Milliseconds  
Minimum Value: -19.0 at 9.9 Milliseconds  
SAE Filter Class: 60  
Date of Test: 1/29/02  
Curve Number: FIL-043

Test Program: 2002 NHTSA 35mph NCAP No.: HO5300  
Test Vehicle: 2002 Honda CR-V LX 4WD SUV



KAR21061-01

B-61

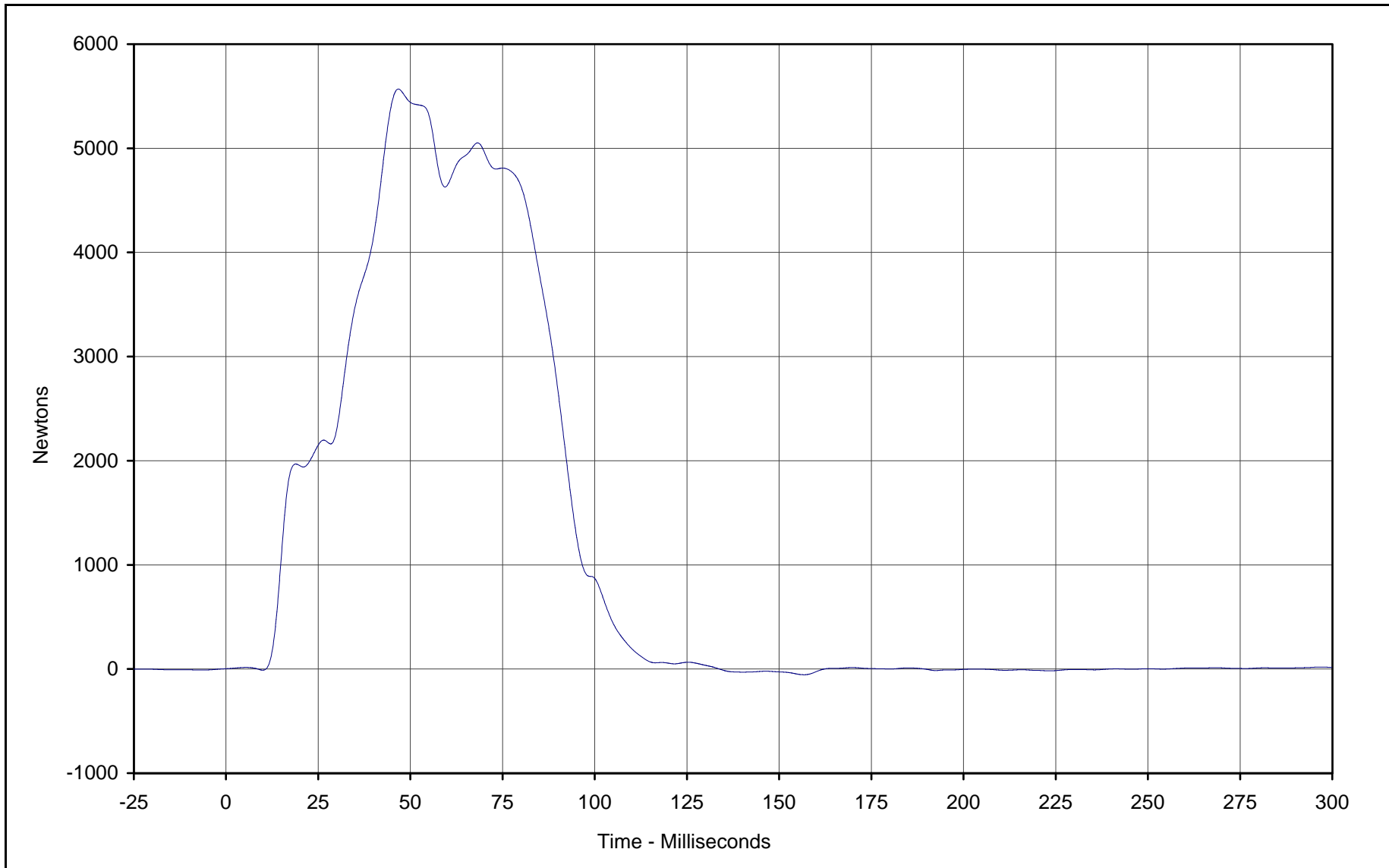

Curve Description: Driver Shoulder Belt Force  
Maximum Value: 5569.1 at 46.7 Milliseconds  
Minimum Value: -55.0 at 156.8 Milliseconds  
SAE Filter Class: 60  
Date of Test: 1/29/02  
Curve Number: FIL-044

Test Program: 2002 NHTSA 35mph NCAP No.: HO5300  
Test Vehicle: 2002 Honda CR-V LX 4WD SUV



KAR21061-01

B-62

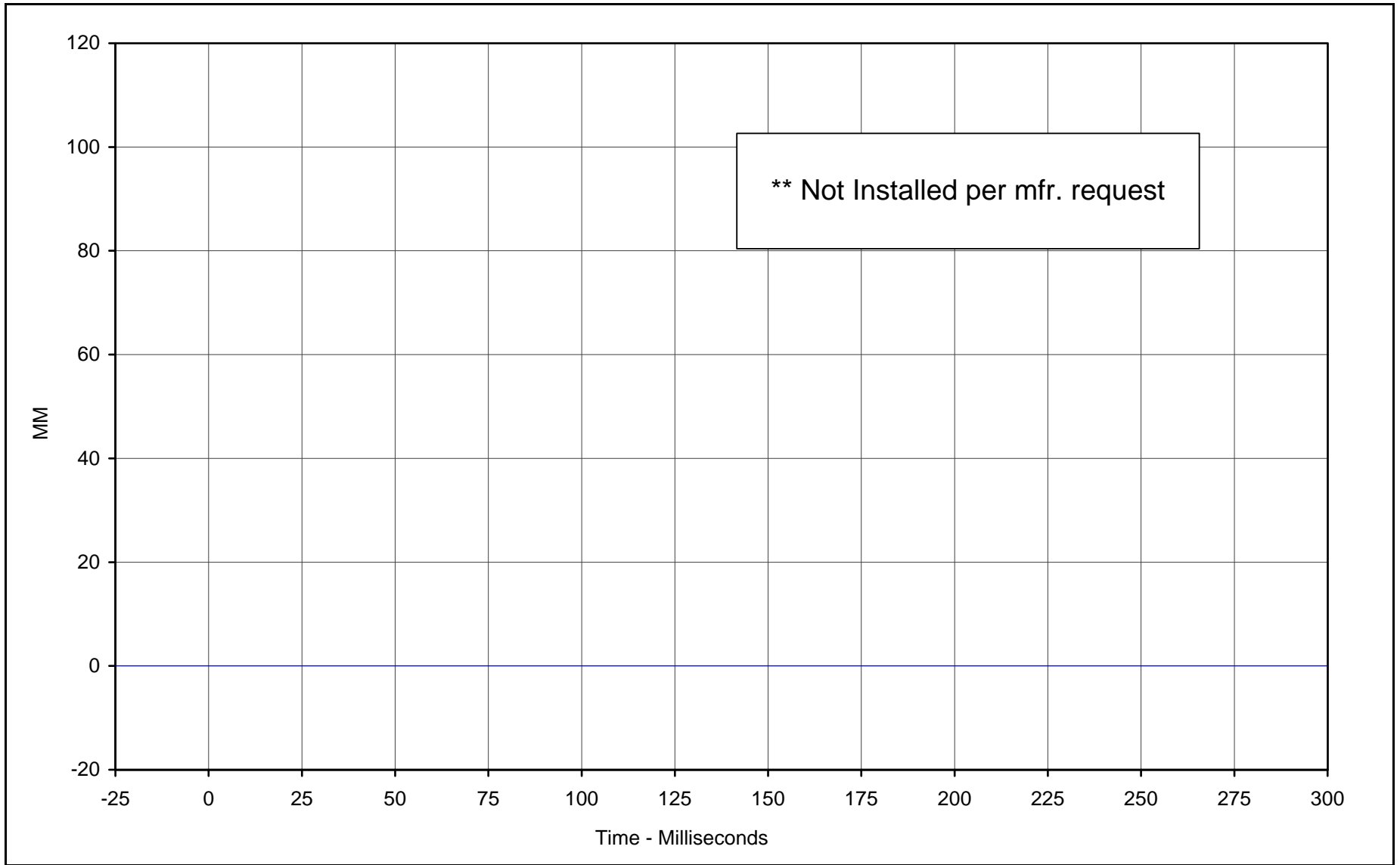

Curve Description: Driver Shoulder Belt Pullout \*\*  
Maximum Value: 0.0 at 0.0 Milliseconds  
Minimum Value: 0.0 at 0.0 Milliseconds  
SAE Filter Class: 60  
Date of Test: 1/29/02  
Curve Number: FIL-045

Test Program: 2002 NHTSA 35mph NCAP No.: HO5300  
Test Vehicle: 2002 Honda CR-V LX 4WD SUV

\*\* Not Installed per mfr. request



KAR21061-01

B-63

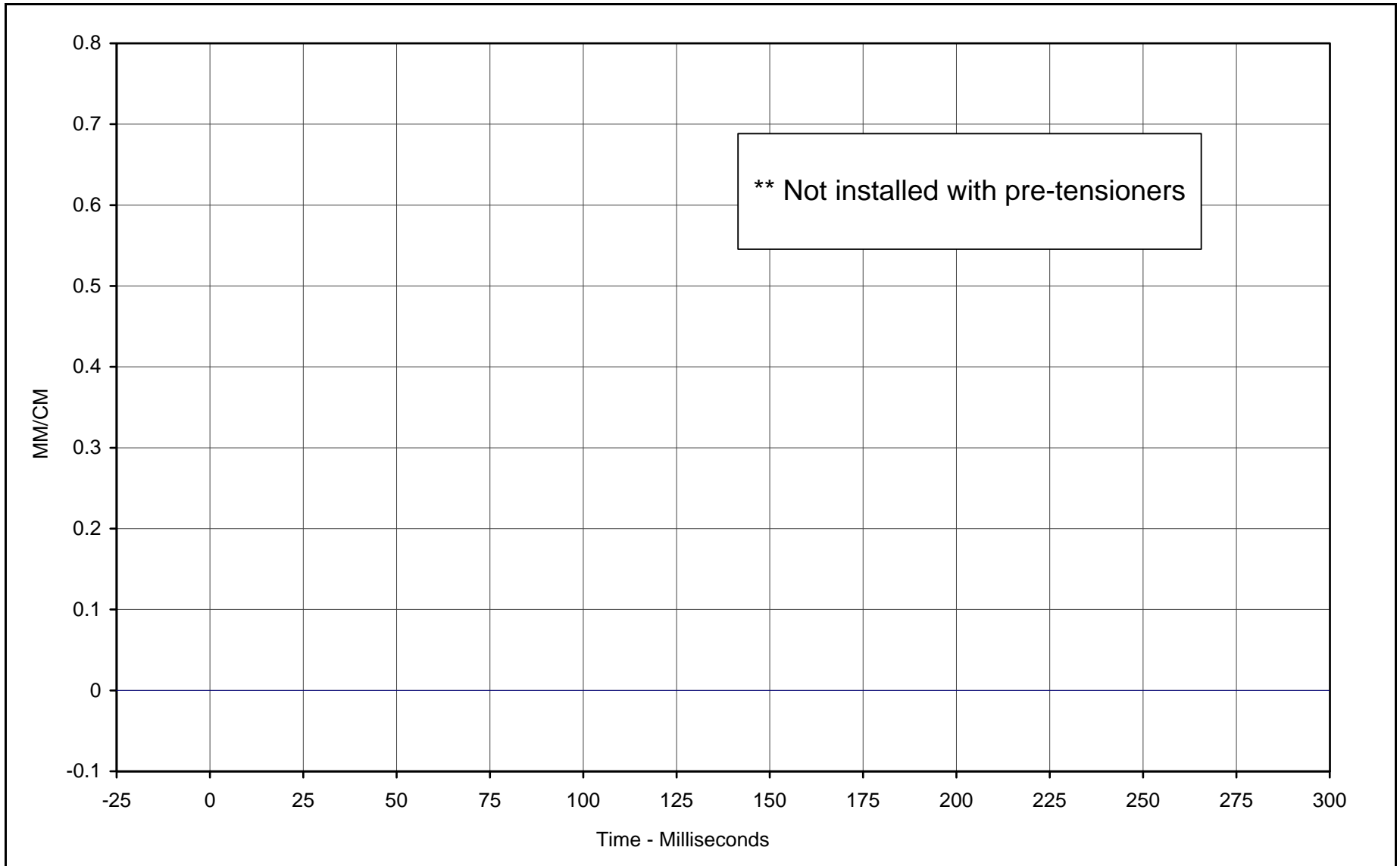

Curve Description: Driver Shoulder Belt Elongation \*\*

Test Program: 2002 NHTSA 35mph NCAP No.: HO5300

Maximum Value: 0.0 at 0.0 Milliseconds

Test Vehicle: 2002 Honda CR-V LX 4WD SUV

Minimum Value: 0.0 at 0.0 Milliseconds

SAE Filter Class: 60

Date of Test: 1/29/02

Curve Number: FIL-046

\*\* Not installed with pre-tensioners



KAR21061-01

B-64

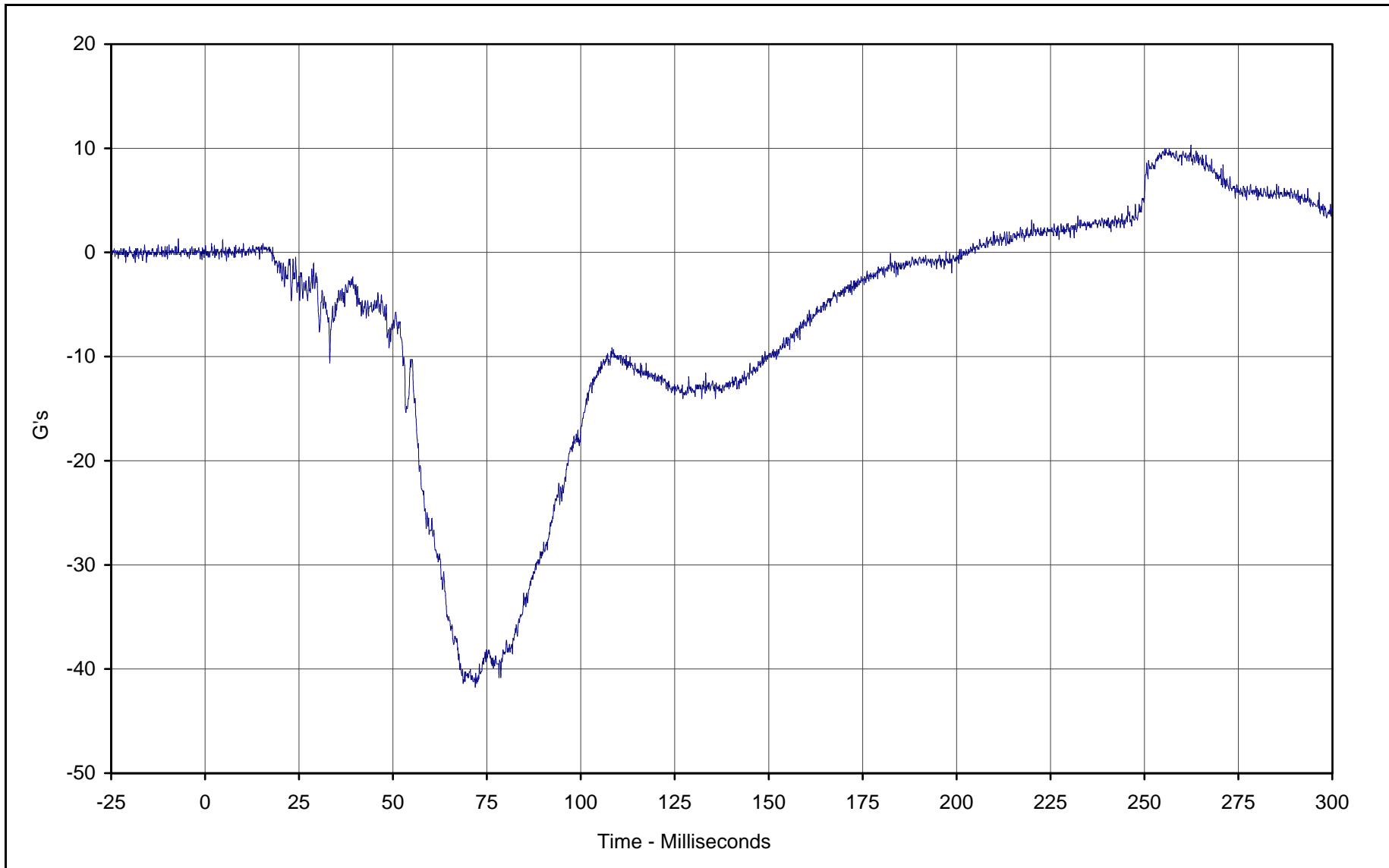

Curve Description: Passenger Head Primary X  
Maximum Value: 10.3 at 262.4 Milliseconds  
Minimum Value: -41.8 at 71.9 Milliseconds  
SAE Filter Class: 1000  
Date of Test: 1/29/02  
Curve Number: FIL-047

Test Program: 2002 NHTSA 35mph NCAP No.: HO5300  
Test Vehicle: 2002 Honda CR-V LX 4WD SUV



KAR21061-01

B-65

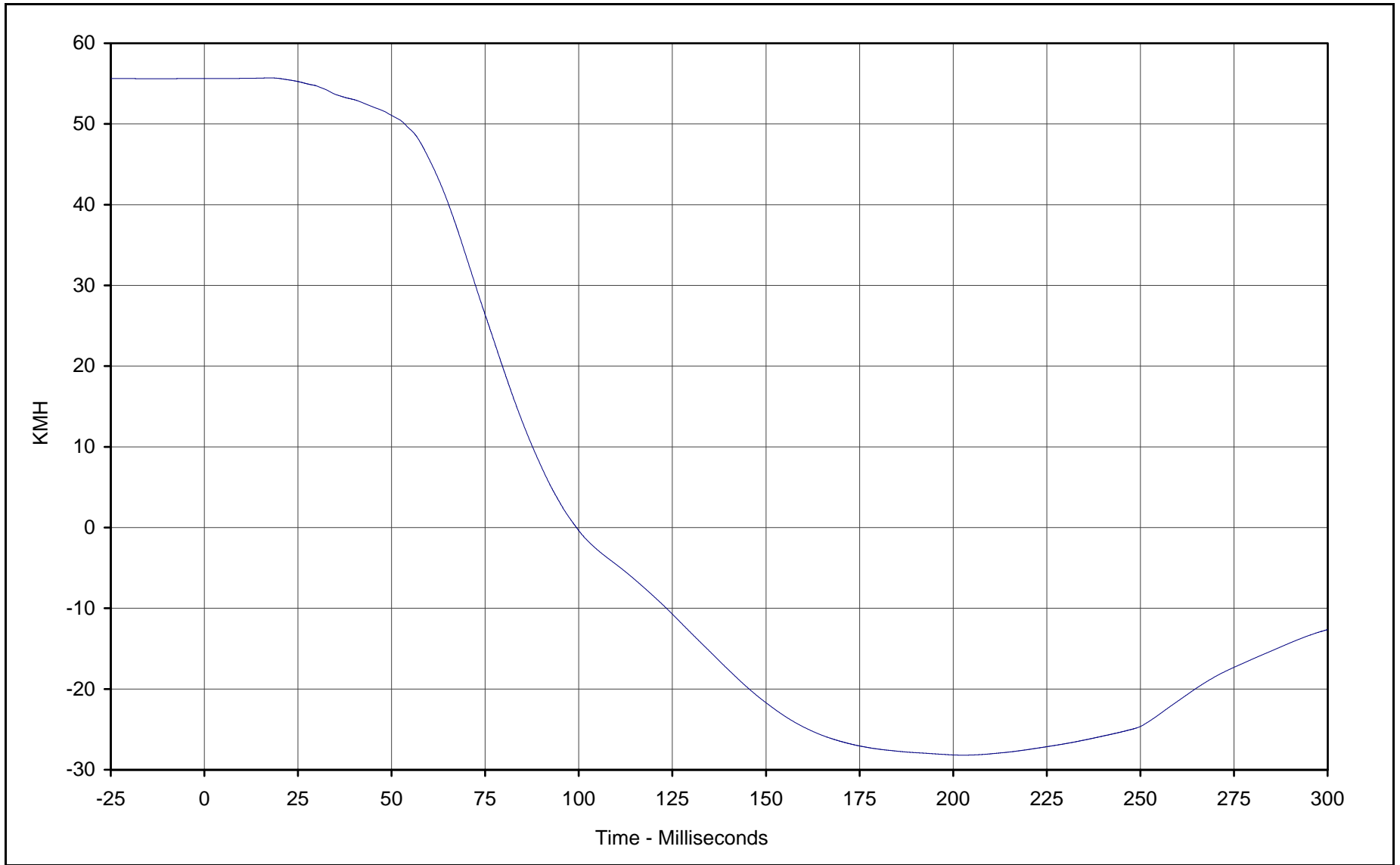

Curve Description: Passenger Head Primary X Velocity  
Maximum Value: 55.7 at 17.6 Milliseconds  
Minimum Value: -28.2 at 202.9 Milliseconds  
SAE Filter Class: 180  
Date of Test: 1/29/02  
Curve Number: IN1-047

Test Program: 2002 NHTSA 35mph NCAP No.: HO5300  
Test Vehicle: 2002 Honda CR-V LX 4WD SUV



KAR21061-01

B-66

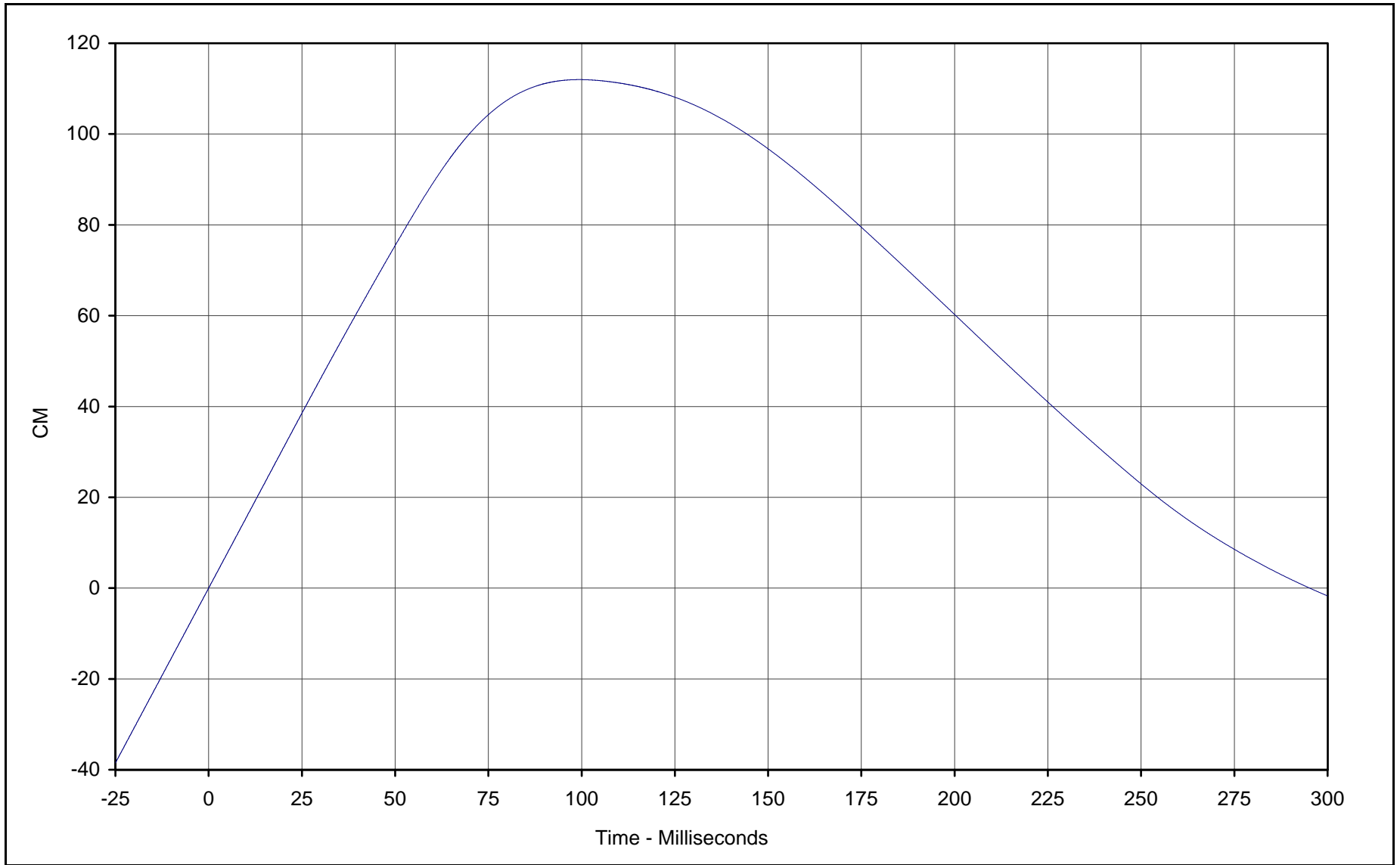

Curve Description: Passenger Head Primary X Displ.  
Maximum Value: 112.0 at 99.4 Milliseconds  
Minimum Value: -1.7 at 299.9 Milliseconds  
SAE Filter Class: 180  
Date of Test: 1/29/02  
Curve Number: IN2-047

Test Program: 2002 NHTSA 35mph NCAP No.: HO5300  
Test Vehicle: 2002 Honda CR-V LX 4WD SUV

KAR21061-01



B-67

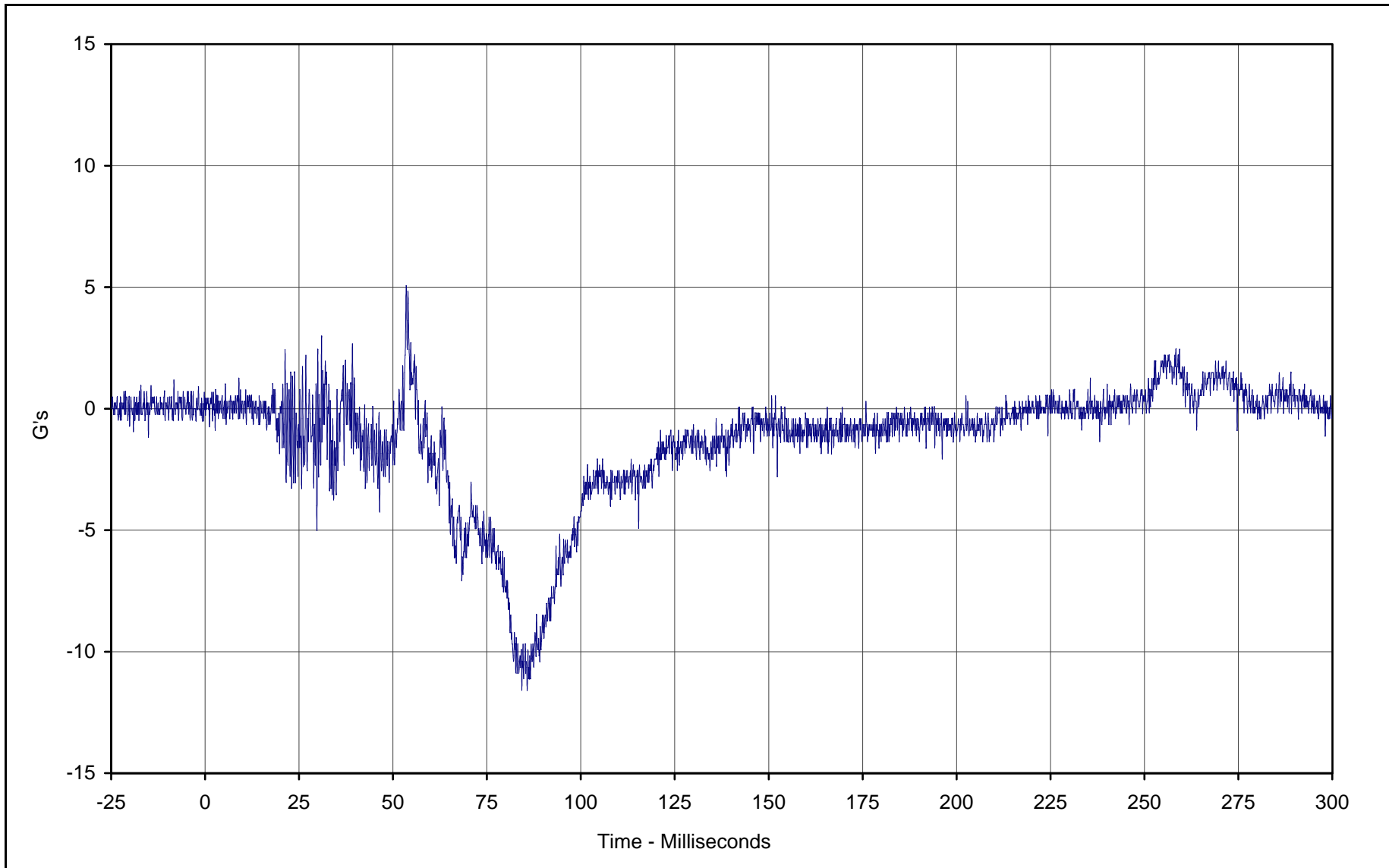

Curve Description: Passenger Head Primary Y  
Maximum Value: 5.1 at 53.5 Milliseconds  
Minimum Value: -11.6 at 84.3 Milliseconds  
SAE Filter Class: 1000  
Date of Test: 1/29/02  
Curve Number: FIL-048

Test Program: 2002 NHTSA 35mph NCAP No.: HO5300  
Test Vehicle: 2002 Honda CR-V LX 4WD SUV



KAR21061-01

B-68

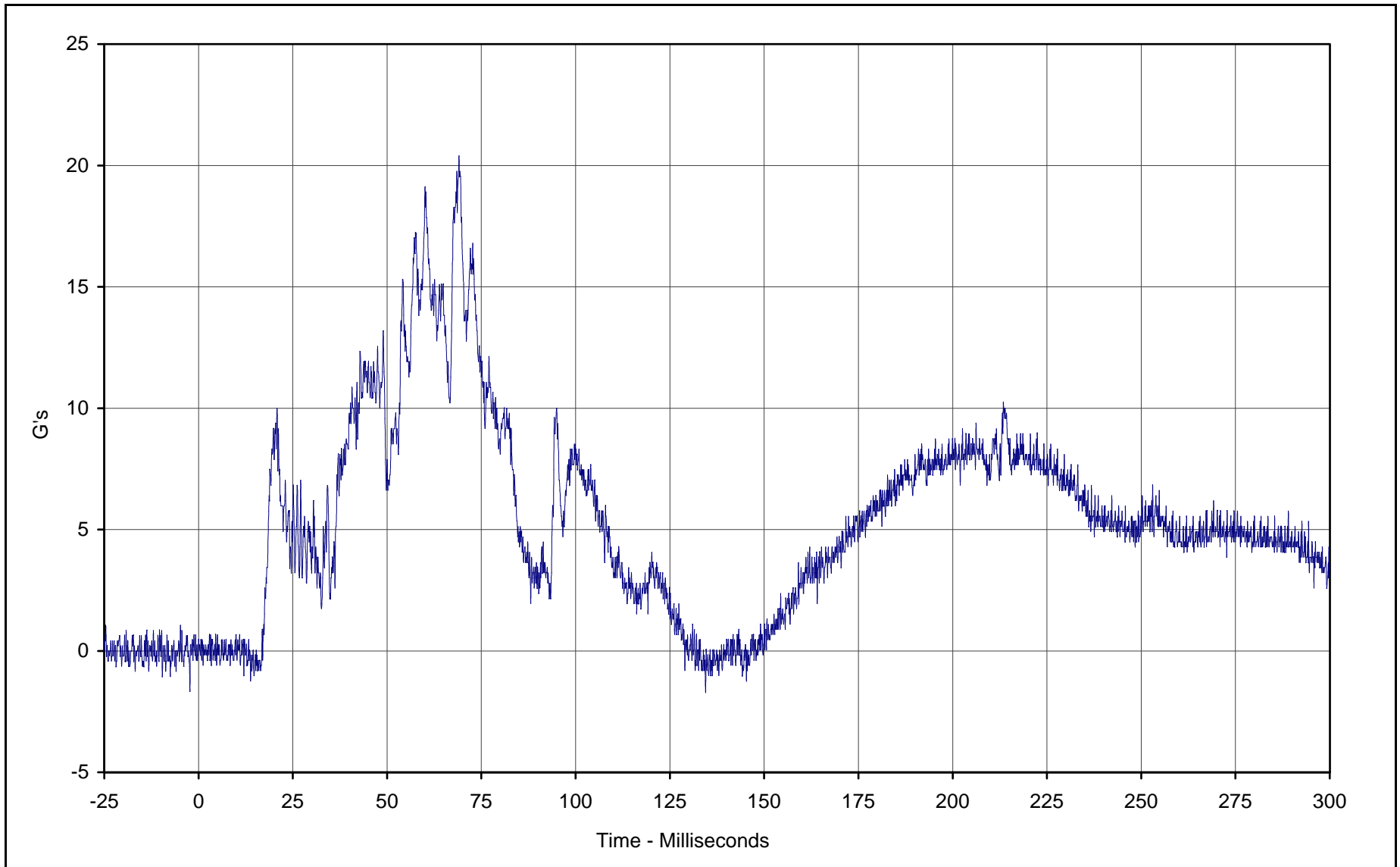

Curve Description: Passenger Head Primary Z  
Maximum Value: 20.4 at 69.1 Milliseconds  
Minimum Value: -1.7 at 134.5 Milliseconds  
SAE Filter Class: 1000  
Date of Test: 1/29/02  
Curve Number: FIL-048

Test Program: 2002 NHTSA 35mph NCAP No.: HO5300  
Test Vehicle: 2002 Honda CR-V LX 4WD SUV



KAR21061-01

B-69

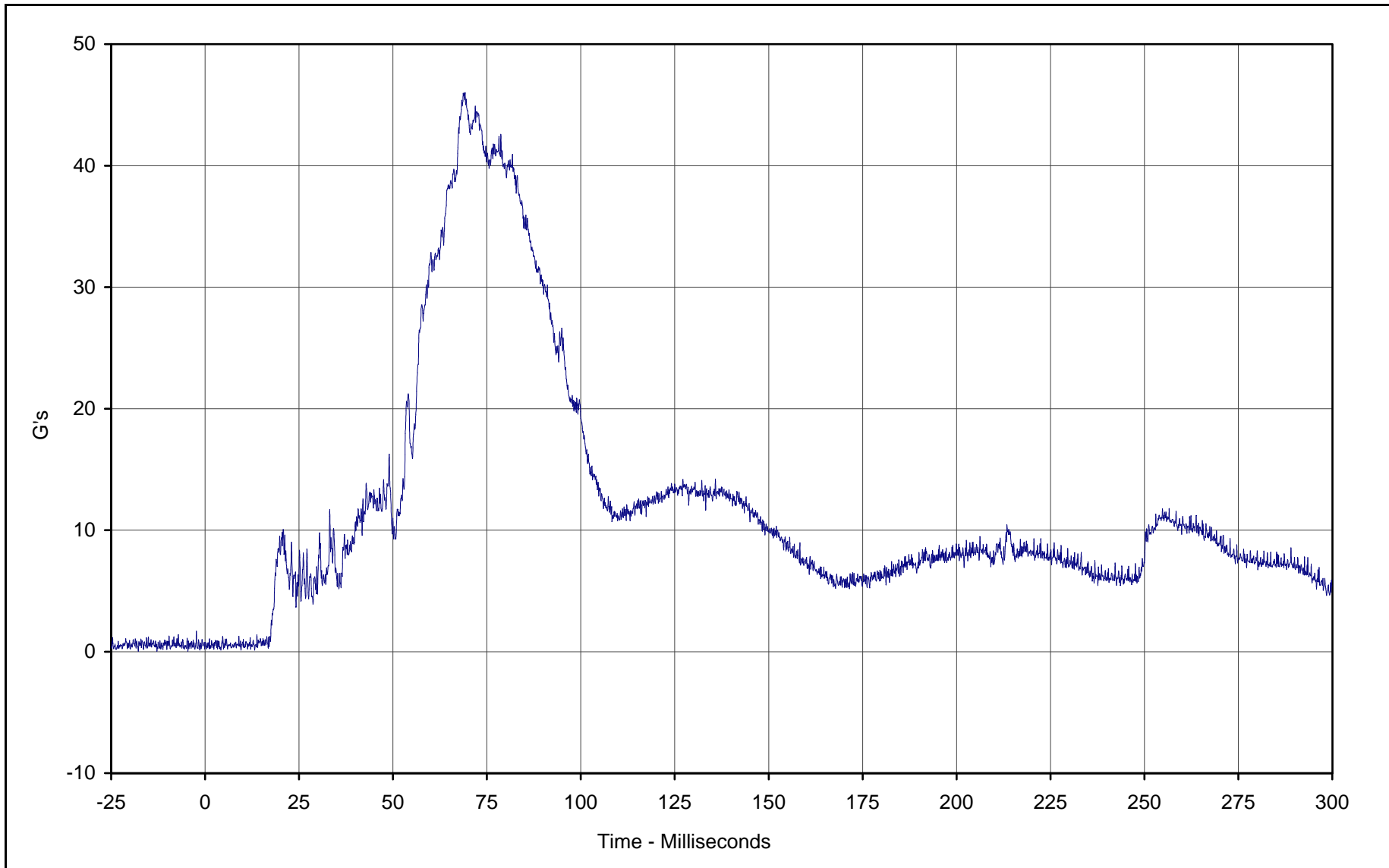

Curve Description: Passenger Head Resultant Primary  
Maximum Value: 46.0 at 69.2 Milliseconds  
Minimum Value: 0.1 at 4.2 Milliseconds  
SAE Filter Class: 1000  
Date of Test: 1/29/02  
Curve Number: RES-047

Test Program: 2002 NHTSA 35mph NCAP No.: HO5300  
Test Vehicle: 2002 Honda CR-V LX 4WD SUV



KAR21061-01

B-70

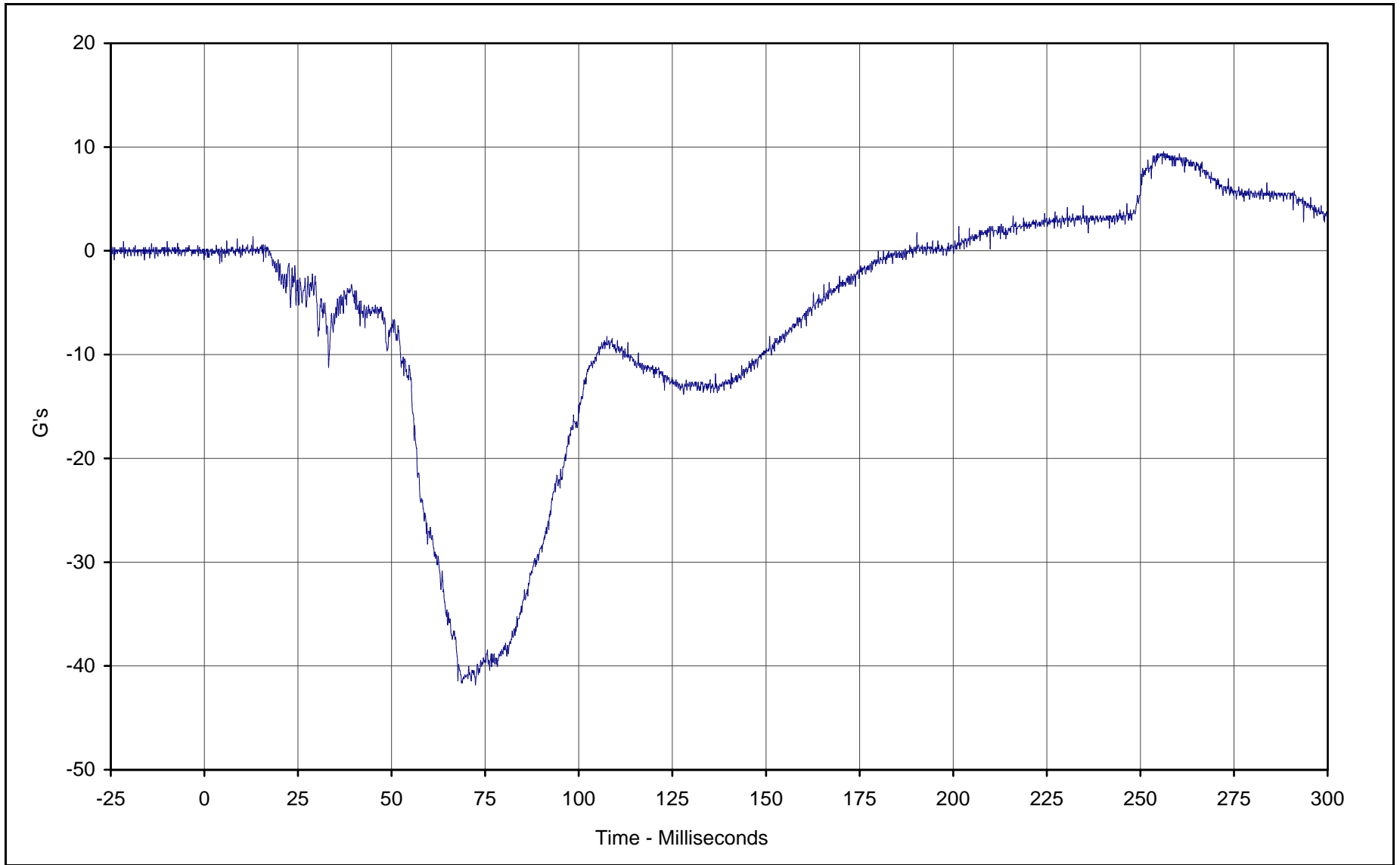

Curve Description: Passenger Head Redundant X  
Maximum Value: 9.6 at 256.2 Milliseconds  
Minimum Value: -41.8 at 72.4 Milliseconds  
SAE Filter Class: 1000  
Date of Test: 1/29/02  
Curve Number: FIL-050

Test Program: 2002 NHTSA 35mph NCAP No.: HO5300  
Test Vehicle: 2002 Honda CR-V LX 4WD SUV



KAR21061-01

B-71

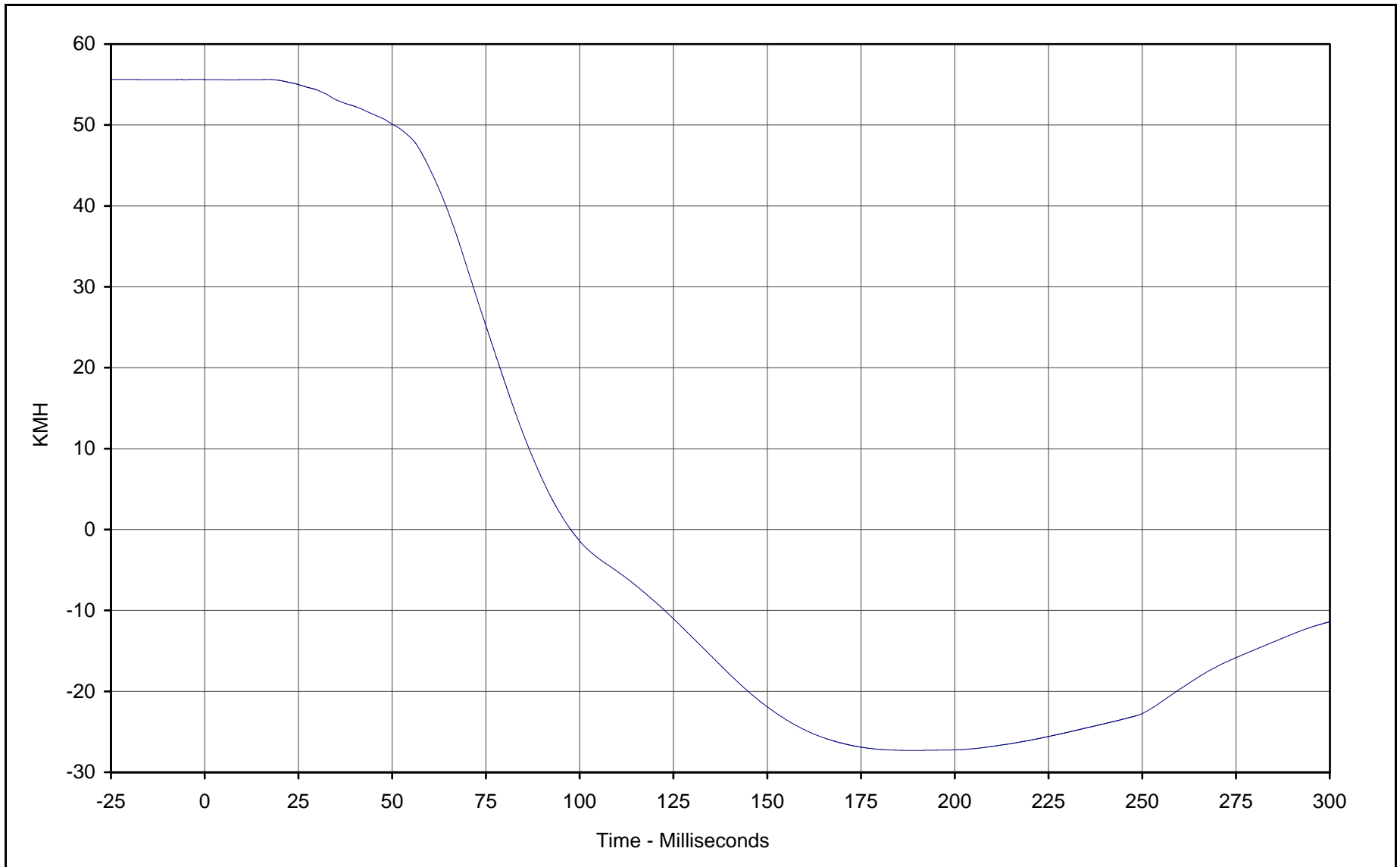

Curve Description: Passenger Head Redundant X Velocity

Maximum Value: 55.6 at 17.0 Milliseconds

Minimum Value: -27.3 at 188.7 Milliseconds

SAE Filter Class: 180

Date of Test: 1/29/02

Curve Number: IN1-050

Test Program: 2002 NHTSA 35mph NCAP No.: HO5300

Test Vehicle: 2002 Honda CR-V LX 4WD SUV

KAR21061-01



B-72

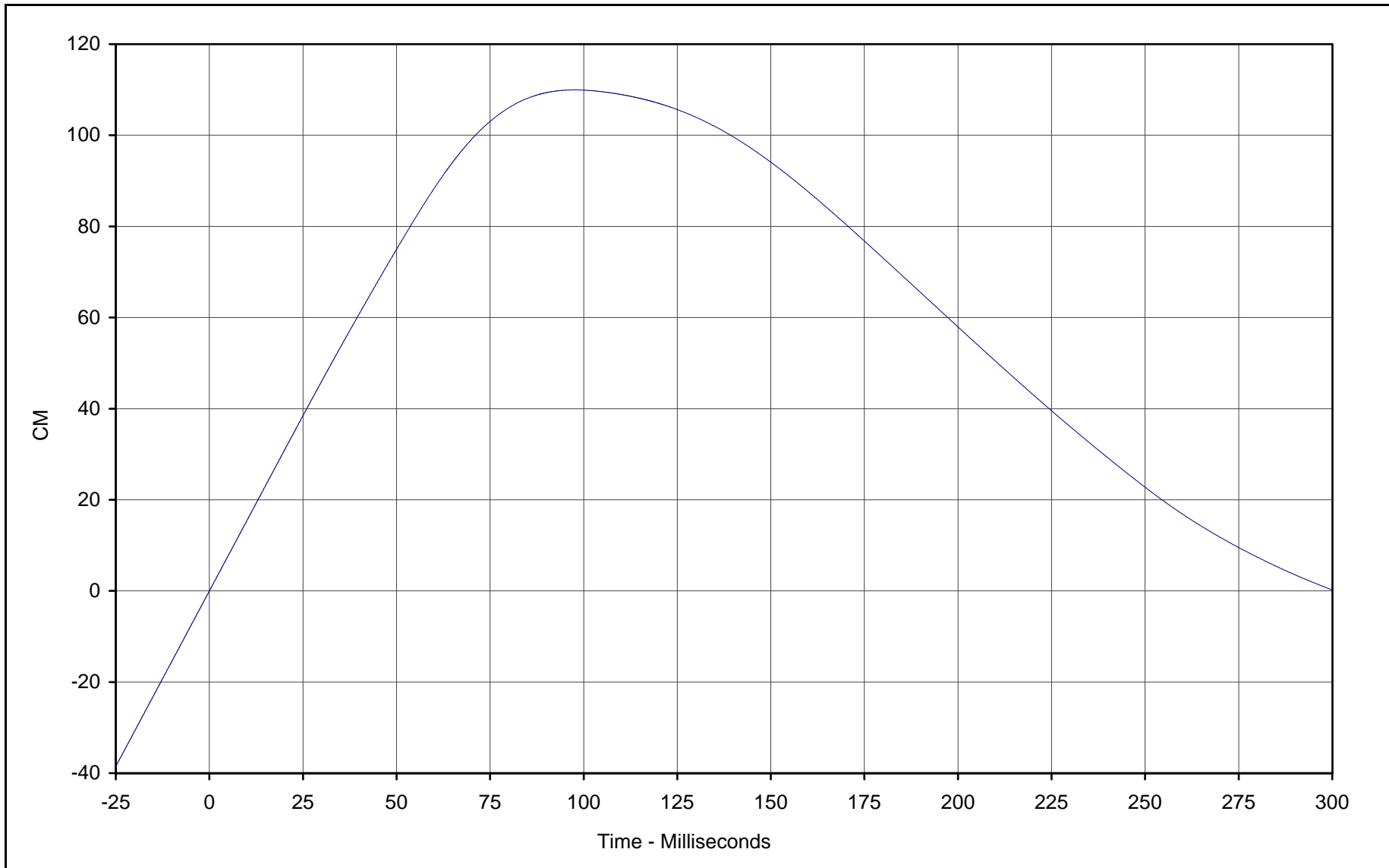

Curve Description: Passenger Head Redundant X Displ.

Test Program: 2002 NHTSA 35mph NCAP No.: HO5300

Maximum Value: 110.0 at 97.6 Milliseconds

Test Vehicle: 2002 Honda CR-V LX 4WD SUV

Minimum Value: 0.0 at 0.0 Milliseconds

SAE Filter Class: 180

Date of Test: 1/29/02

Curve Number: IN2-050



KAR21061-01

B-73

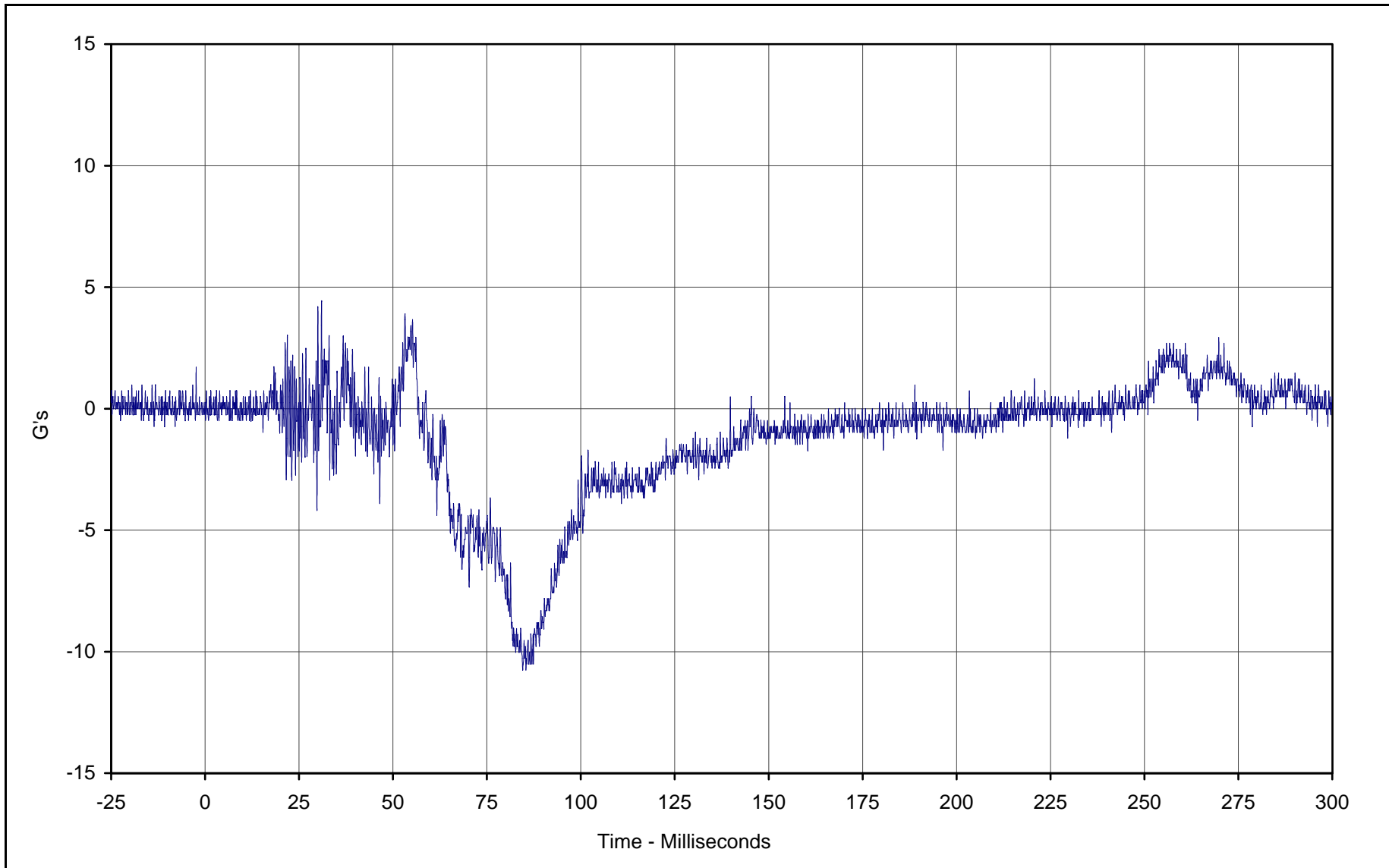

Curve Description: Passenger Head Redundant Y  
Maximum Value: 4.4 at 31.0 Milliseconds  
Minimum Value: -10.8 at 84.5 Milliseconds  
SAE Filter Class: 1000  
Date of Test: 1/29/02  
Curve Number: FIL-051

Test Program: 2002 NHTSA 35mph NCAP No.: HO5300  
Test Vehicle: 2002 Honda CR-V LX 4WD SUV



KAR21061-01

B-74

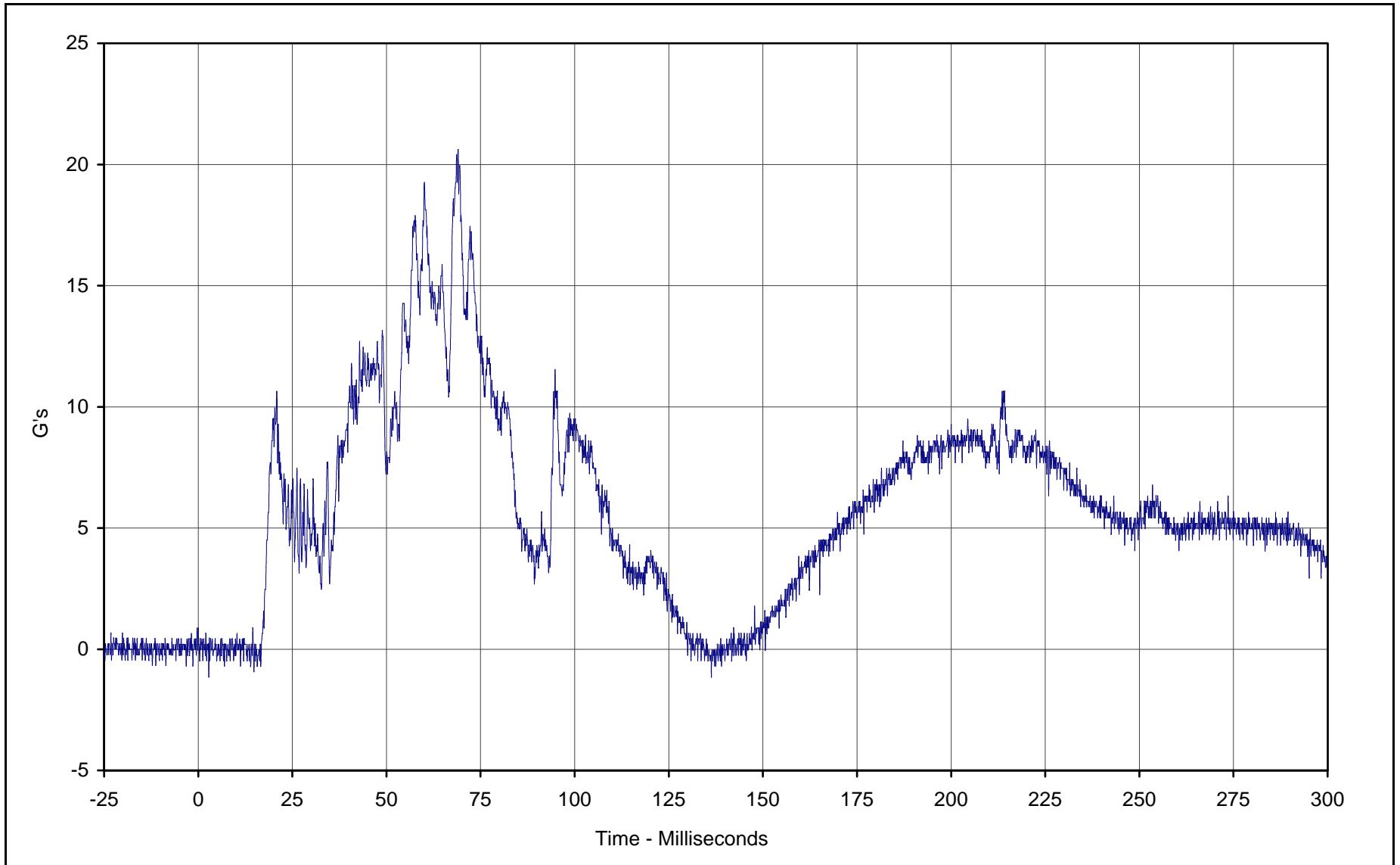

Curve Description: Passenger Head Redundant Z  
Maximum Value: 20.6 at 69.0 Milliseconds  
Minimum Value: -1.2 at 2.8 Milliseconds  
SAE Filter Class: 1000  
Date of Test: 1/29/02  
Curve Number: FIL-052

Test Program: 2002 NHTSA 35mph NCAP No.: HO5300  
Test Vehicle: 2002 Honda CR-V LX 4WD SUV



KAR21061-01

B-75

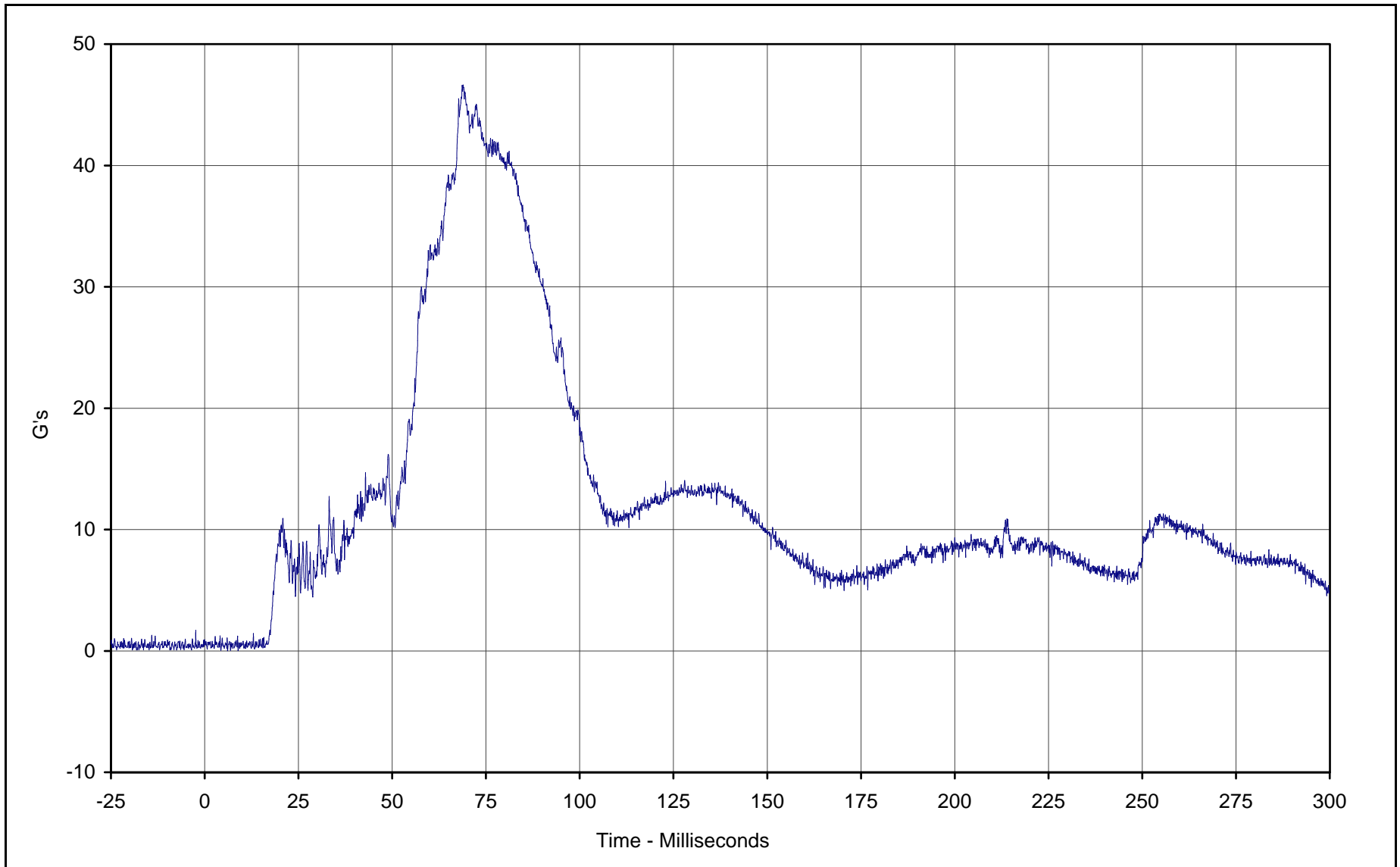

Curve Description: Passenger Head Resultant Redundant

Maximum Value: 46.6 at 68.9 Milliseconds

Minimum Value: 0.0 at 4.3 Milliseconds

SAE Filter Class: 1000

Date of Test: 1/29/02

Curve Number: RES-050

Test Program: 2002 NHTSA 35mph NCAP No.: HO5300

Test Vehicle: 2002 Honda CR-V LX 4WD SUV



KAR21061-01

B-76

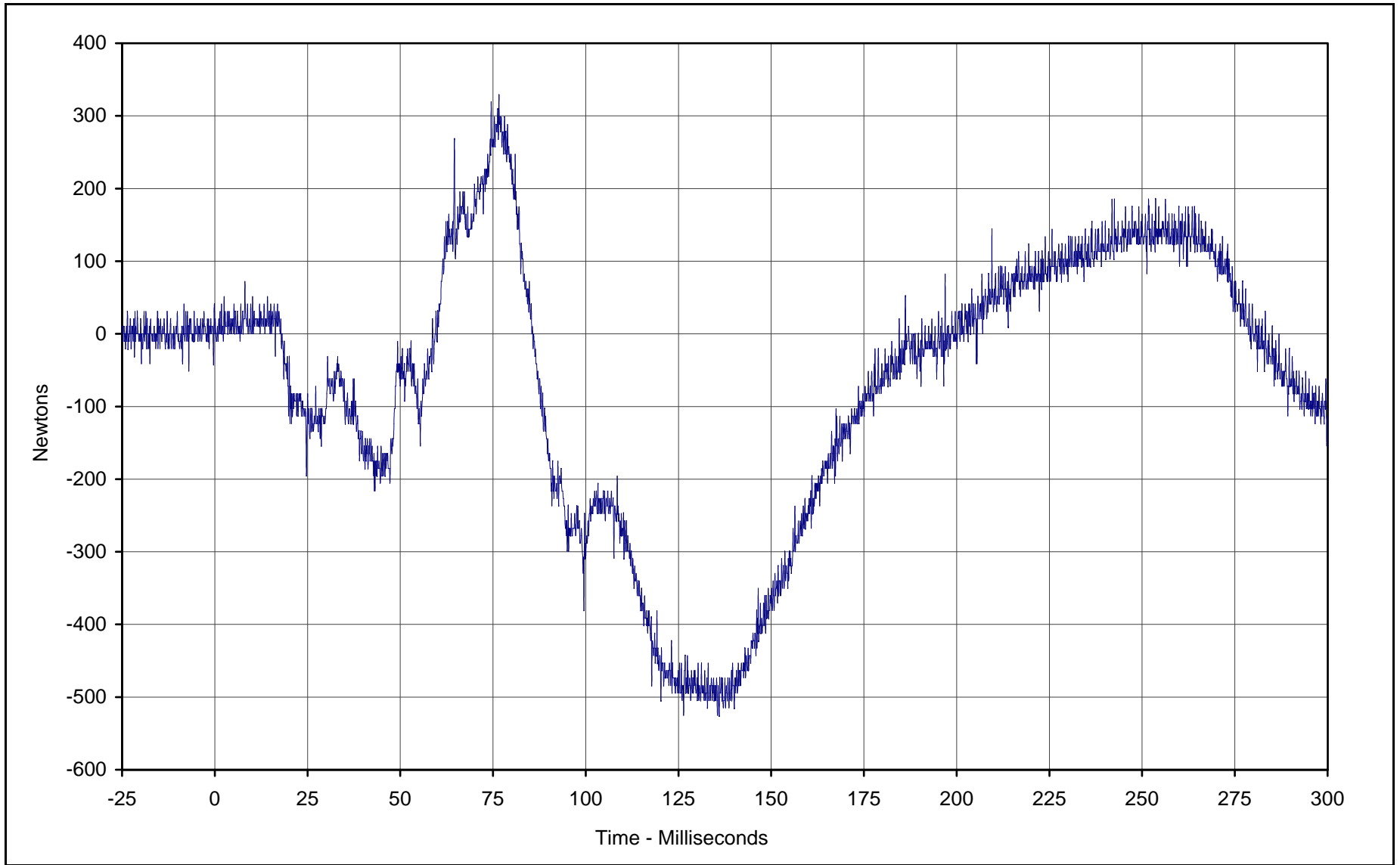

Curve Description: Passenger Neck Force X  
Maximum Value: 329.6 at 76.6 Milliseconds  
Minimum Value: -525.4 at 126.4 Milliseconds  
SAE Filter Class: 1000  
Date of Test: 1/29/02  
Curve Number: FIL-053

Test Program: 2002 NHTSA 35mph NCAP No.: HO5300  
Test Vehicle: 2002 Honda CR-V LX 4WD SUV



KAR21061-01

B-77

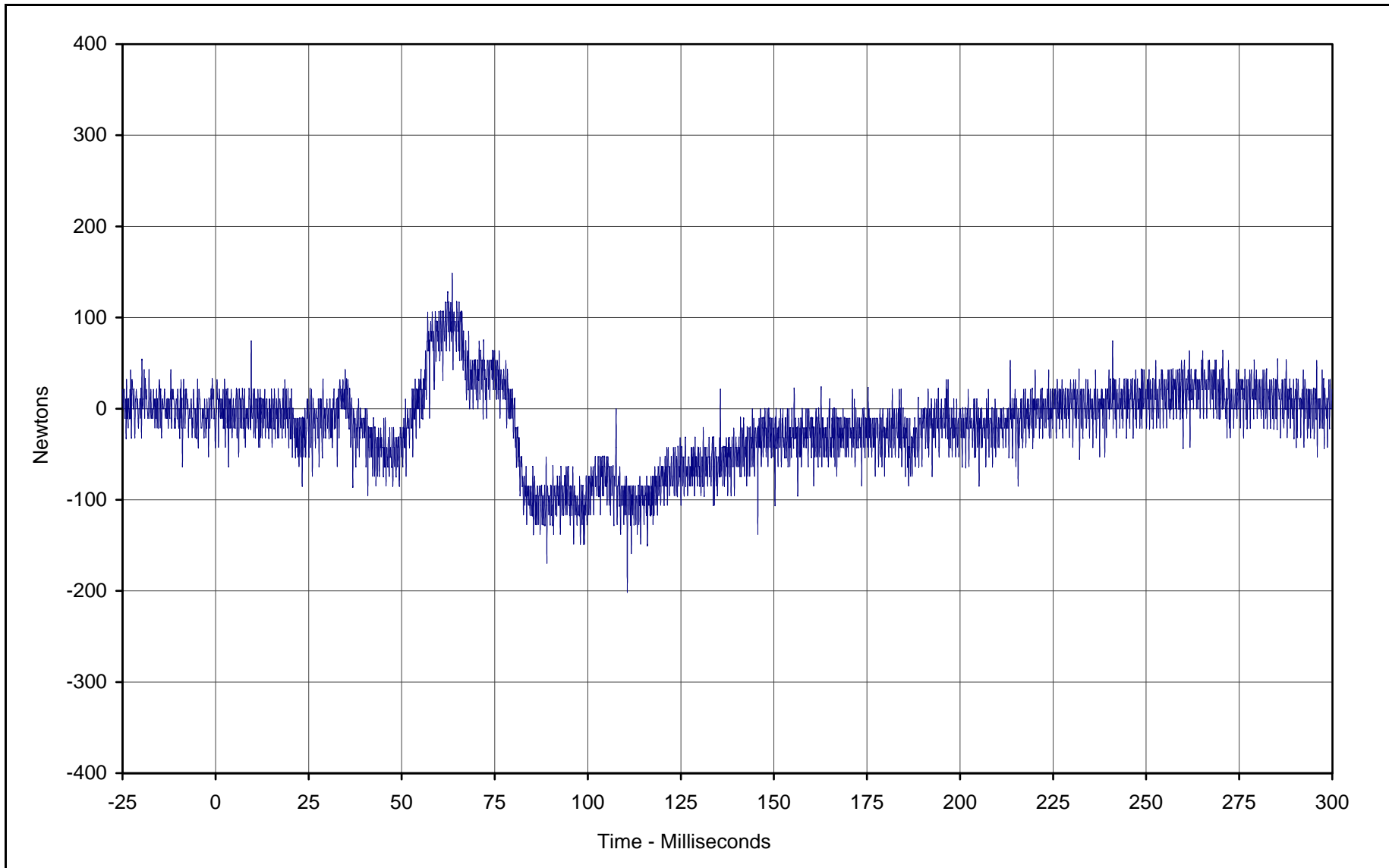

Curve Description: Passenger Neck Force Y  
Maximum Value: 148.6 at 63.6 Milliseconds  
Minimum Value: -201.6 at 110.6 Milliseconds  
SAE Filter Class: 1000  
Date of Test: 1/29/02  
Curve Number: FIL-054

Test Program: 2002 NHTSA 35mph NCAP No.: HO5300  
Test Vehicle: 2002 Honda CR-V LX 4WD SUV



KAR21061-01

B-78

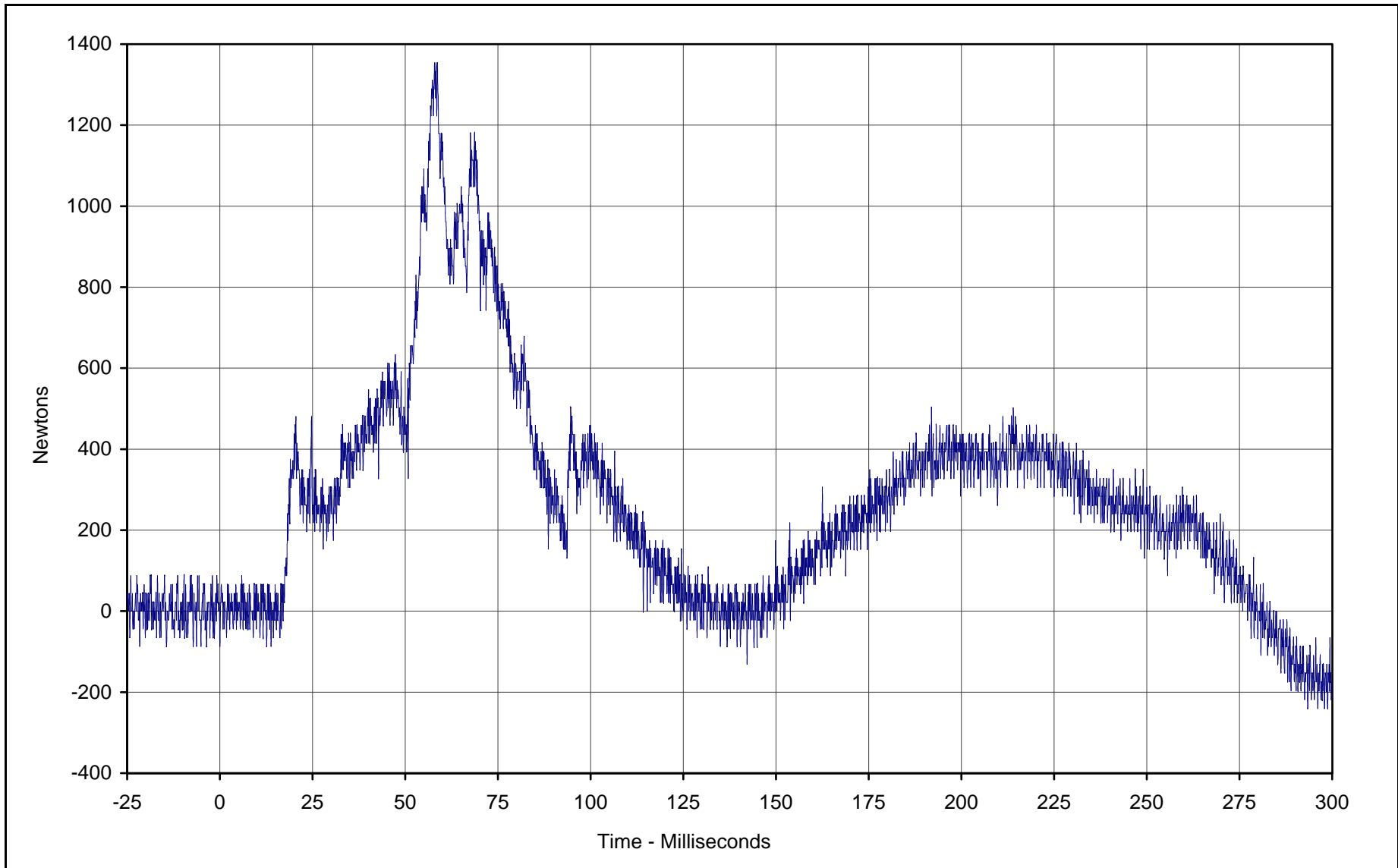

Curve Description: Passenger Neck Force Z  
Maximum Value: 1354.3 at 57.9 Milliseconds  
Minimum Value: -240.3 at 293.4 Milliseconds  
SAE Filter Class: 1000  
Date of Test: 1/29/02  
Curve Number: FIL-055

Test Program: 2002 NHTSA 35mph NCAP No.: HO5300  
Test Vehicle: 2002 Honda CR-V LX 4WD SUV



KAR21061-01

B-79

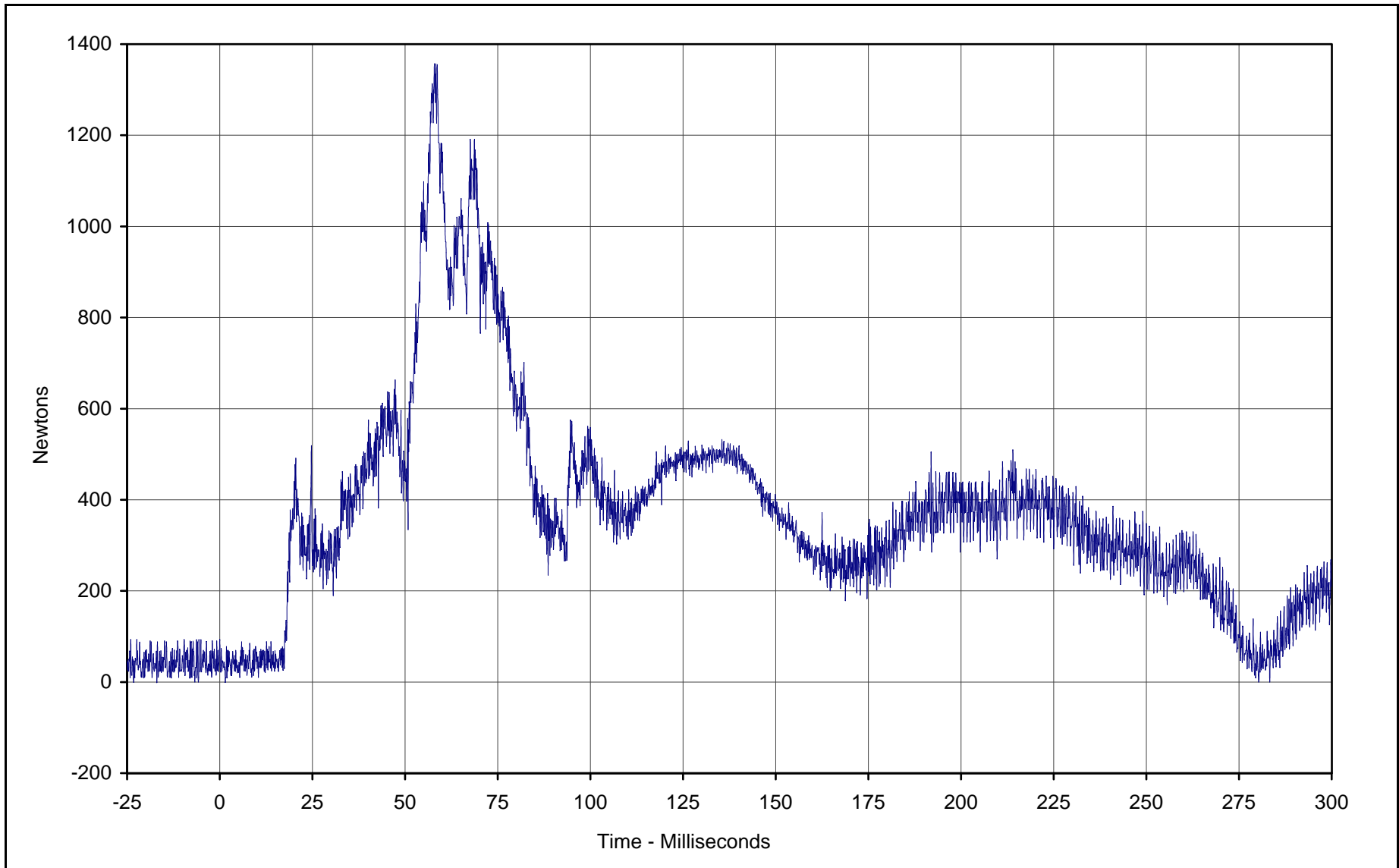

Curve Description: Passenger Neck Force Resultant  
Maximum Value: 1357.1 at 58.3 Milliseconds  
Minimum Value: 0.0 at 1.5 Milliseconds  
SAE Filter Class: 1000  
Date of Test: 1/29/02  
Curve Number: RES-053

Test Program: 2002 NHTSA 35mph NCAP No.: HO5300  
Test Vehicle: 2002 Honda CR-V LX 4WD SUV



KAR21061-01

B-80

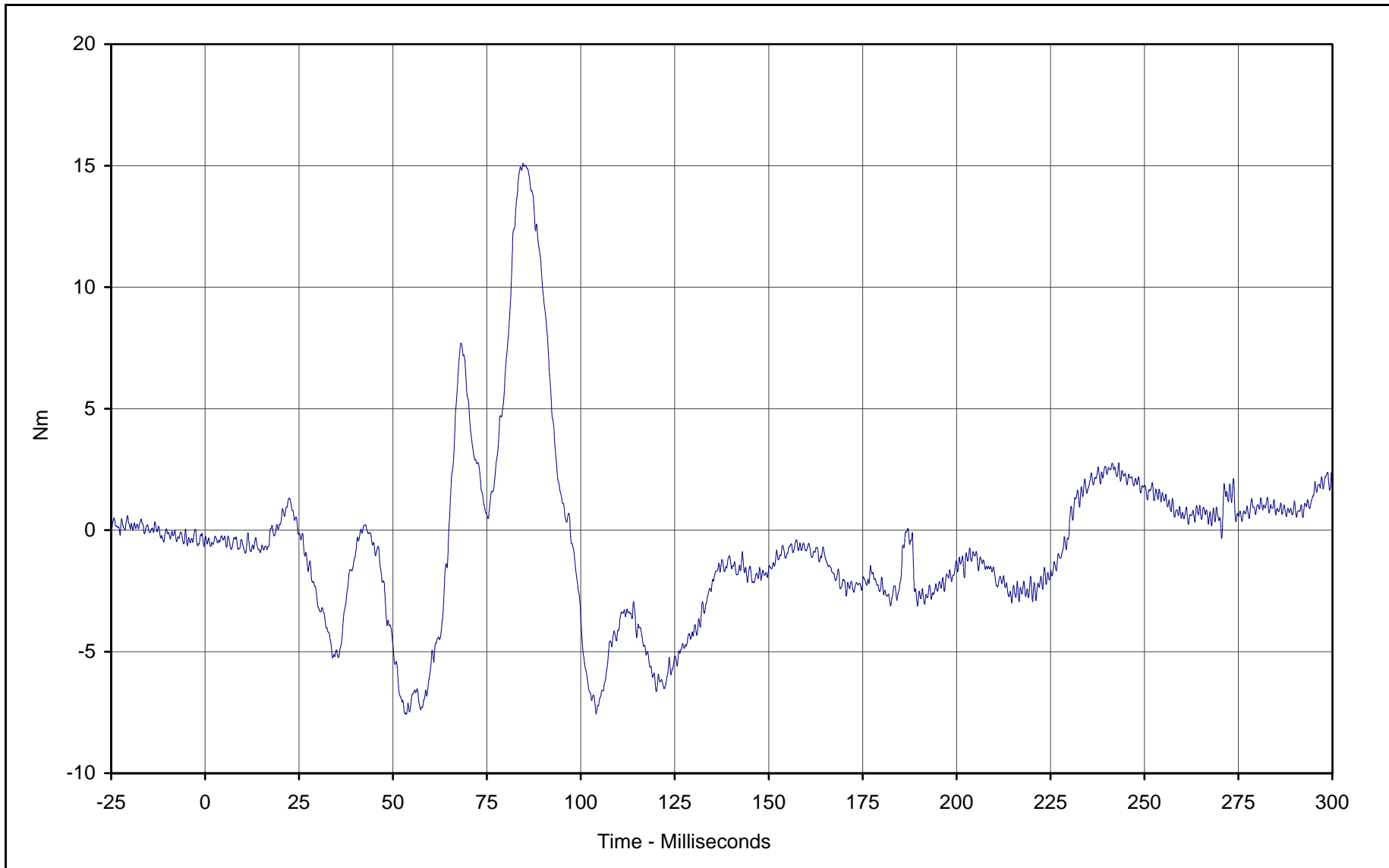

Curve Description: Passenger Neck Moment X  
Maximum Value: 15.1 at 84.6 Milliseconds  
Minimum Value: -7.6 at 53.6 Milliseconds  
SAE Filter Class: 600  
Date of Test: 1/29/02  
Curve Number: FIL-056

Test Program: 2002 NHTSA 35mph NCAP No.: HO5300  
Test Vehicle: 2002 Honda CR-V LX 4WD SUV



KAR21061-01

B-81

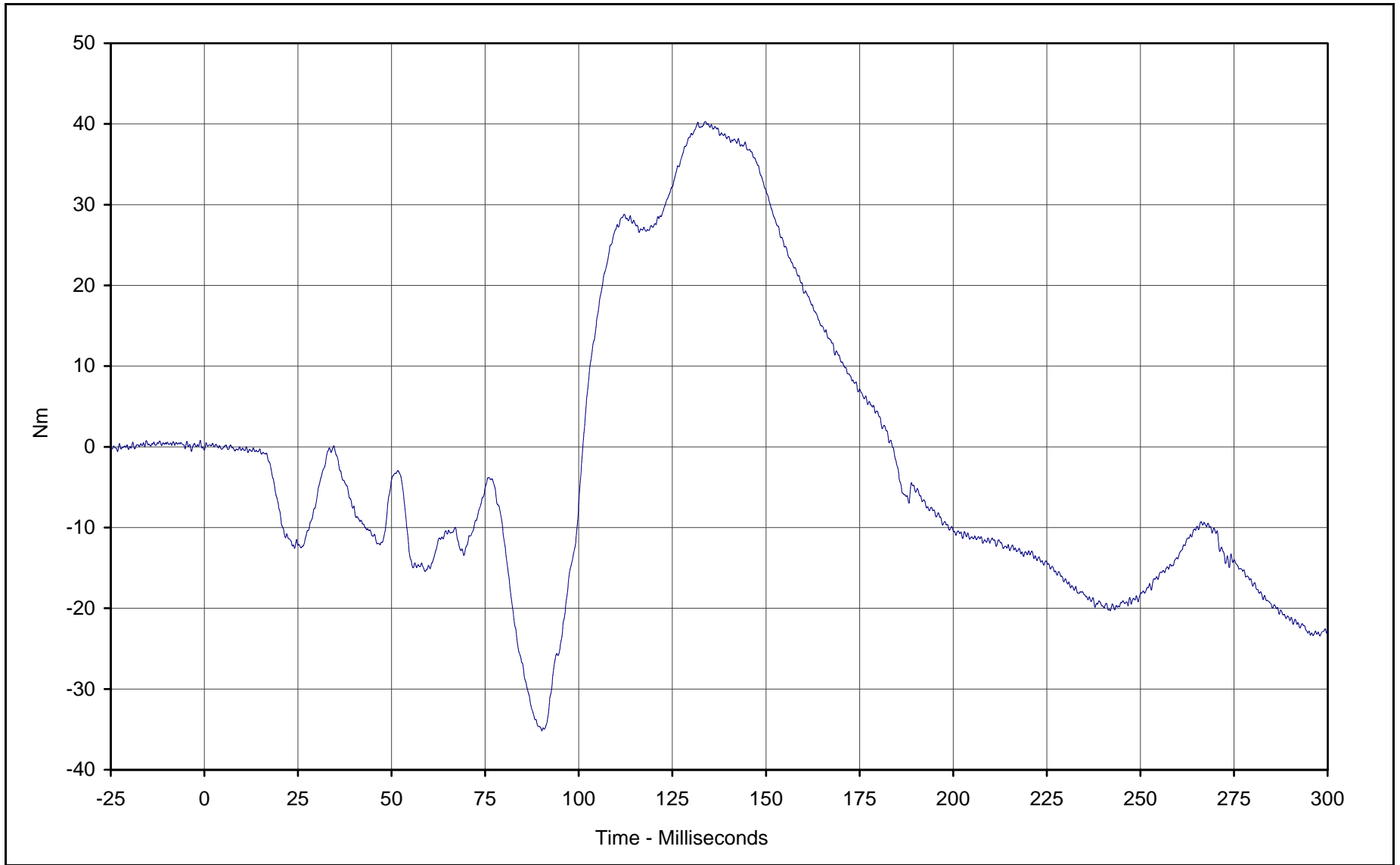

Curve Description: Passenger Neck Moment Y  
Maximum Value: 40.3 at 133.8 Milliseconds  
Minimum Value: -35.2 at 90.1 Milliseconds  
SAE Filter Class: 600  
Date of Test: 1/29/02  
Curve Number: FIL-057

Test Program: 2002 NHTSA 35mph NCAP No.: HO5300  
Test Vehicle: 2002 Honda CR-V LX 4WD SUV



KAR21061-01

B-82

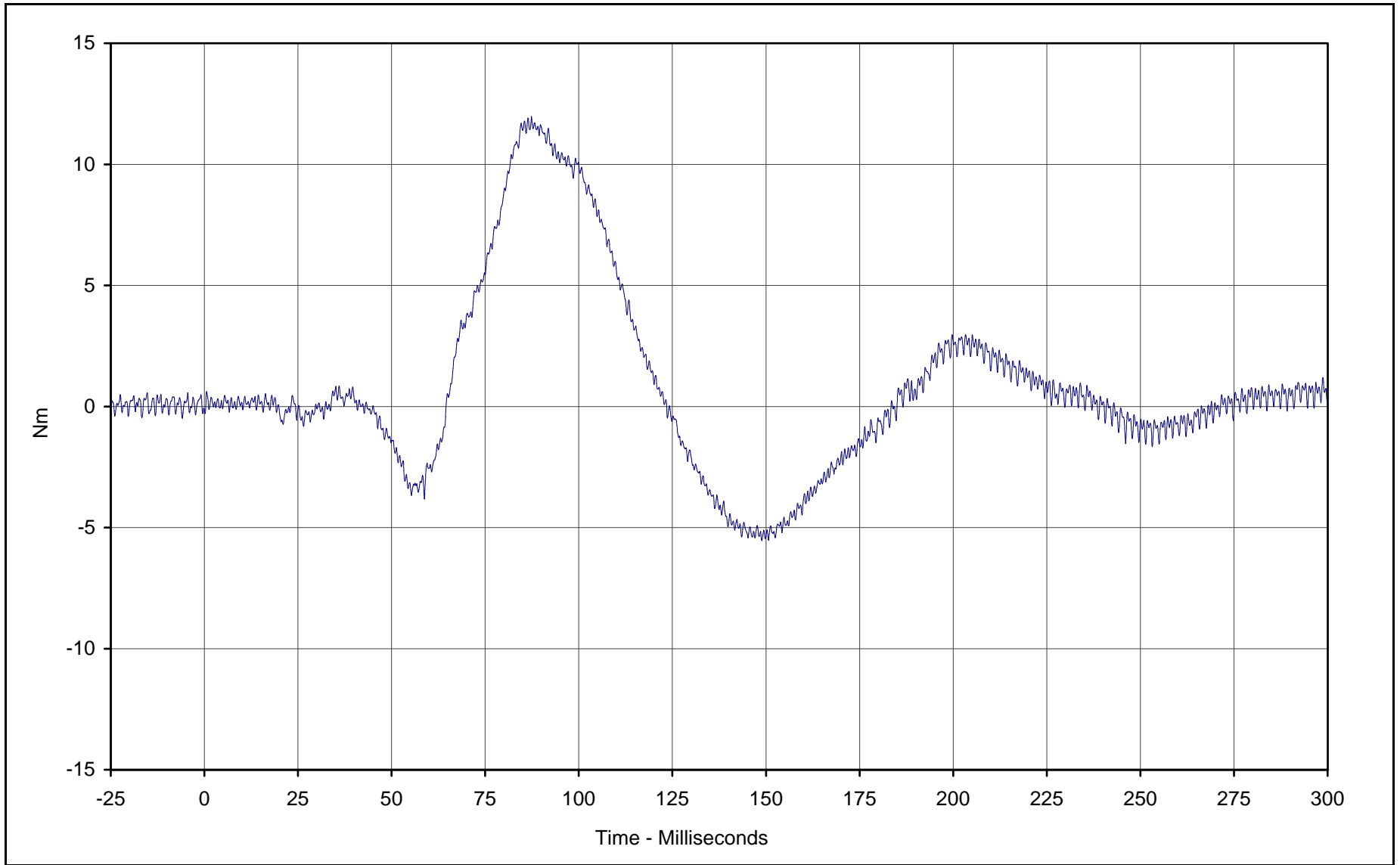

Curve Description: Passenger Neck Moment Z  
Maximum Value: 12.0 at 87.4 Milliseconds  
Minimum Value: -5.5 at 148.9 Milliseconds  
SAE Filter Class: 600  
Date of Test: 1/29/02  
Curve Number: FIL-058

Test Program: 2002 NHTSA 35mph NCAP No.: HO5300  
Test Vehicle: 2002 Honda CR-V LX 4WD SUV



KAR21061-01

B-83

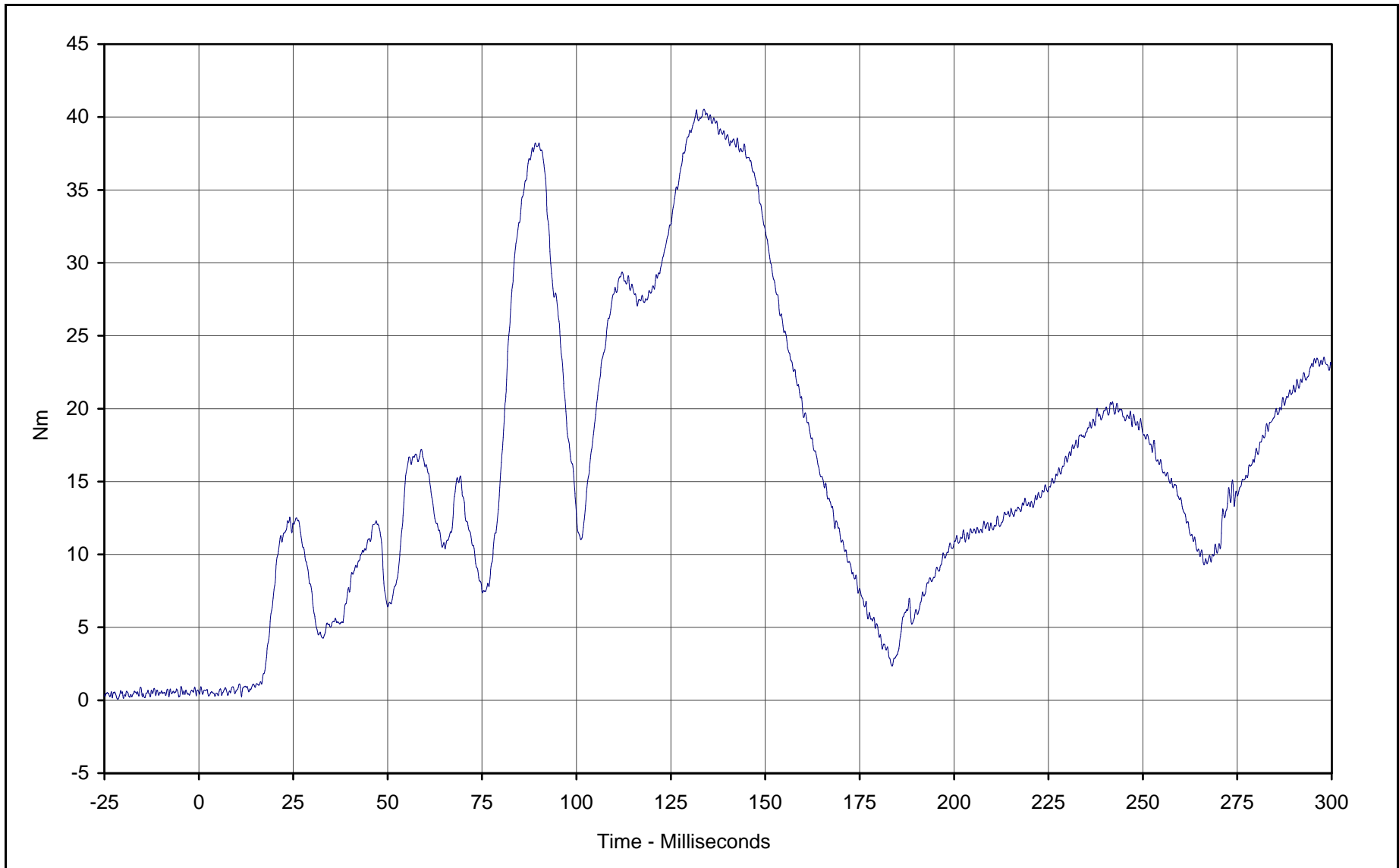

Curve Description: Passenger Neck Moment Resultant  
Maximum Value: 40.5 at 133.8 Milliseconds  
Minimum Value: 0.2 at 11.3 Milliseconds  
SAE Filter Class: 600  
Date of Test: 1/29/02  
Curve Number: RES-056

Test Program: 2002 NHTSA 35mph NCAP No.: HO5300  
Test Vehicle: 2002 Honda CR-V LX 4WD SUV



KAR21061-01

B-84

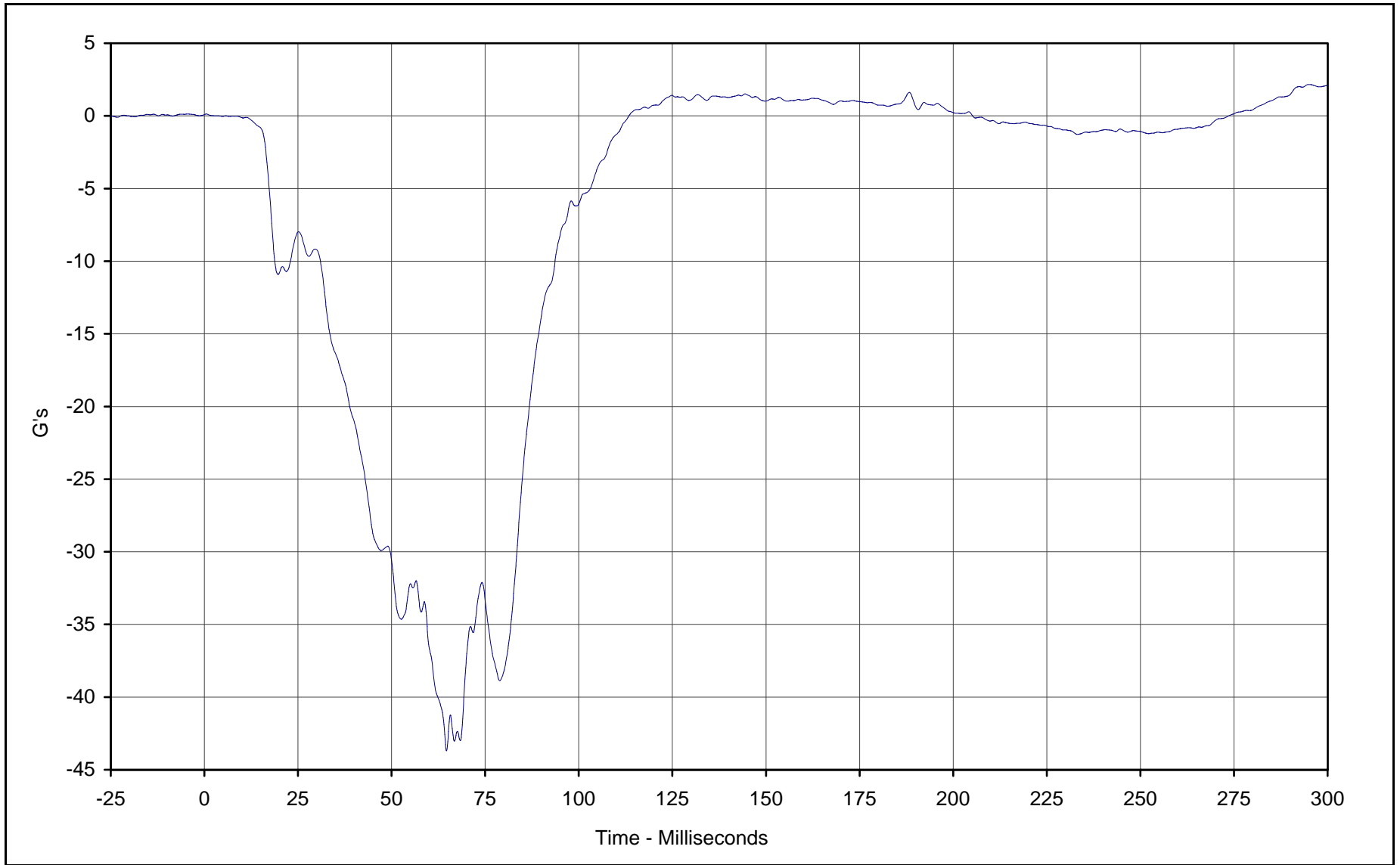

Curve Description: Passenger Chest Primary X  
Maximum Value: 2.2 at 295.1 Milliseconds  
Minimum Value: -43.7 at 64.7 Milliseconds  
SAE Filter Class: 180  
Date of Test: 1/29/02  
Curve Number: FIL-059

Test Program: 2002 NHTSA 35mph NCAP No.: HO5300  
Test Vehicle: 2002 Honda CR-V LX 4WD SUV



KAR21061-01

B-85

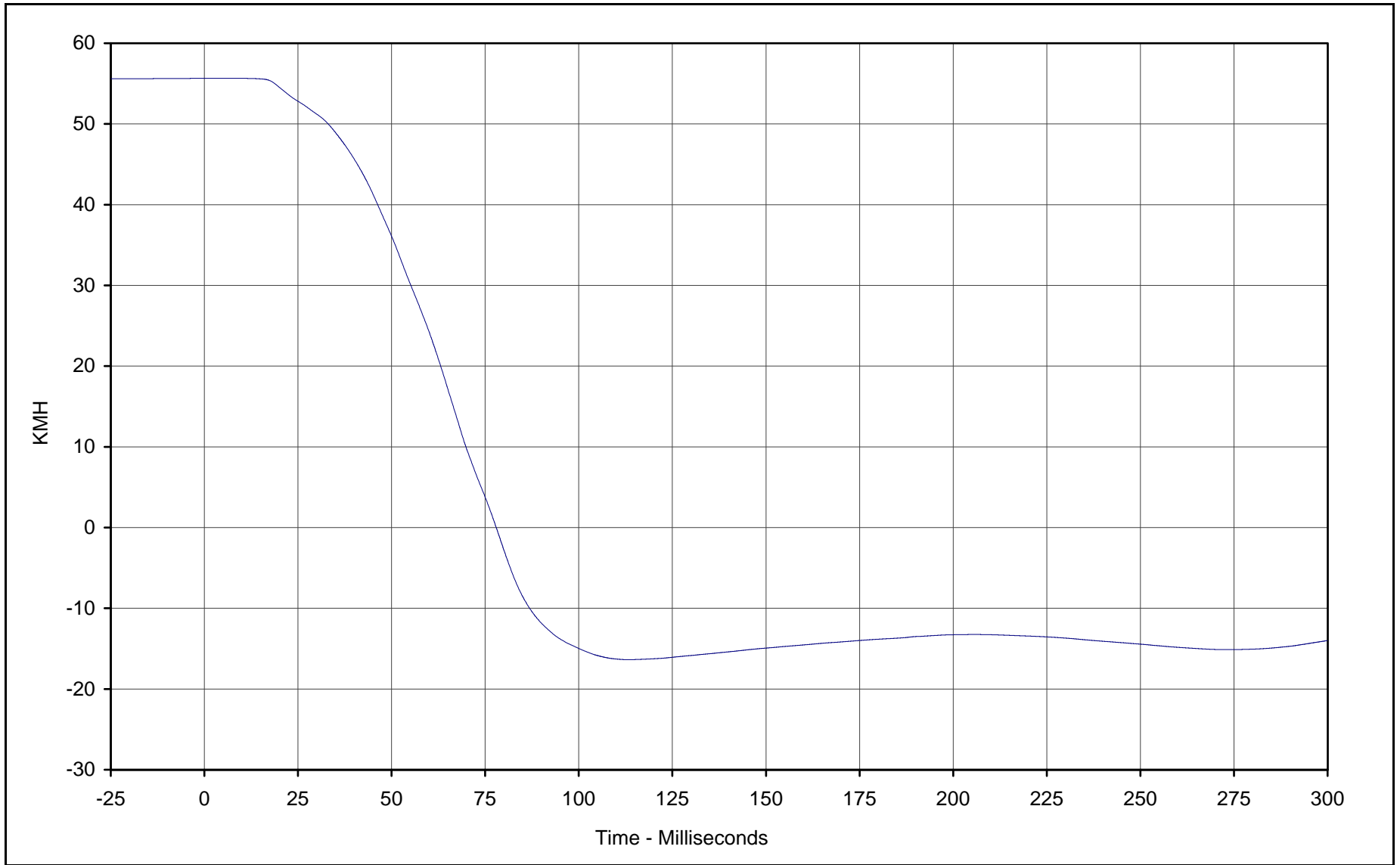

Curve Description: Passenger Chest Primary X Velocity

Maximum Value: 55.7 at 3.9 Milliseconds

Minimum Value: -16.4 at 113.4 Milliseconds

SAE Filter Class: 180

Date of Test: 1/29/02

Curve Number: IN1-059

Test Program: 2002 NHTSA 35mph NCAP No.: HO5300

Test Vehicle: 2002 Honda CR-V LX 4WD SUV

KAR21061-01



B-86

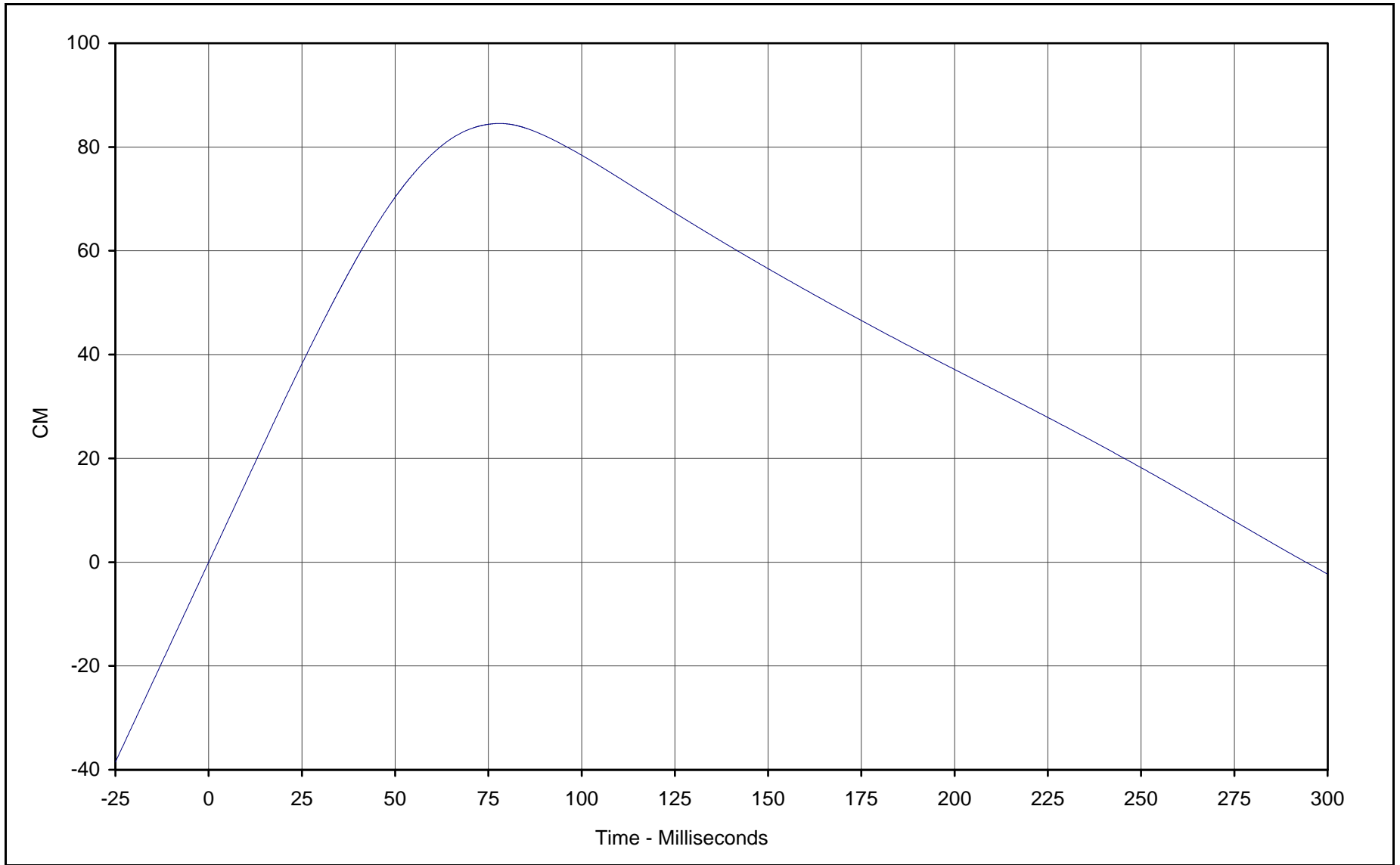

Curve Description: Passenger Chest Primary X Displ.  
Maximum Value: 84.5 at 78.0 Milliseconds  
Minimum Value: -2.3 at 299.9 Milliseconds  
SAE Filter Class: 180  
Date of Test: 1/29/02  
Curve Number: IN2-059

Test Program: 2002 NHTSA 35mph NCAP No.: HO5300  
Test Vehicle: 2002 Honda CR-V LX 4WD SUV



KAR21061-01

B-87

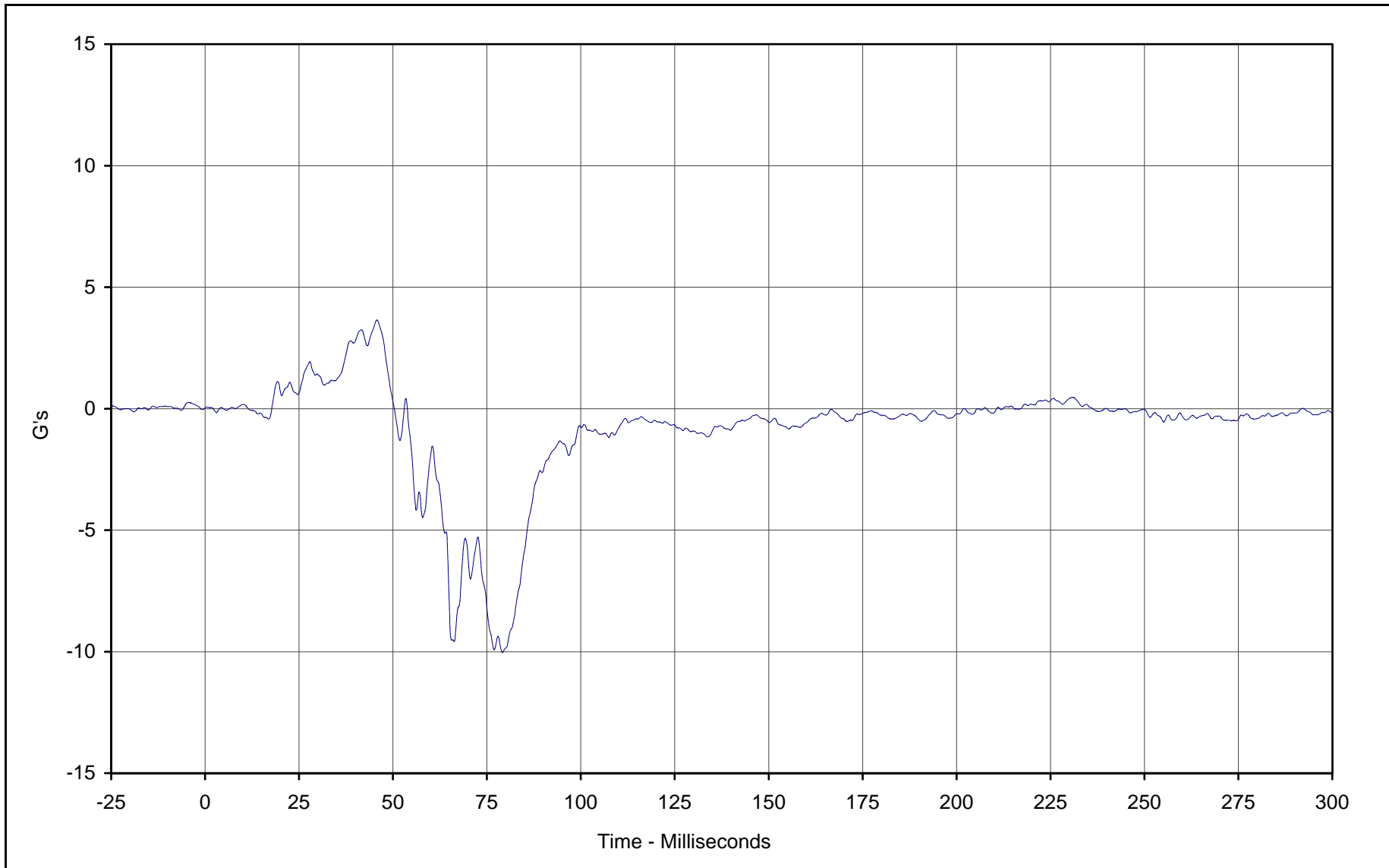

Curve Description: Passenger Chest Primary Y  
Maximum Value: 3.7 at 45.7 Milliseconds  
Minimum Value: -10.0 at 79.1 Milliseconds  
SAE Filter Class: 180  
Date of Test: 1/29/02  
Curve Number: FIL-060

Test Program: 2002 NHTSA 35mph NCAP No.: HO5300  
Test Vehicle: 2002 Honda CR-V LX 4WD SUV



KAR21061-01

B-88

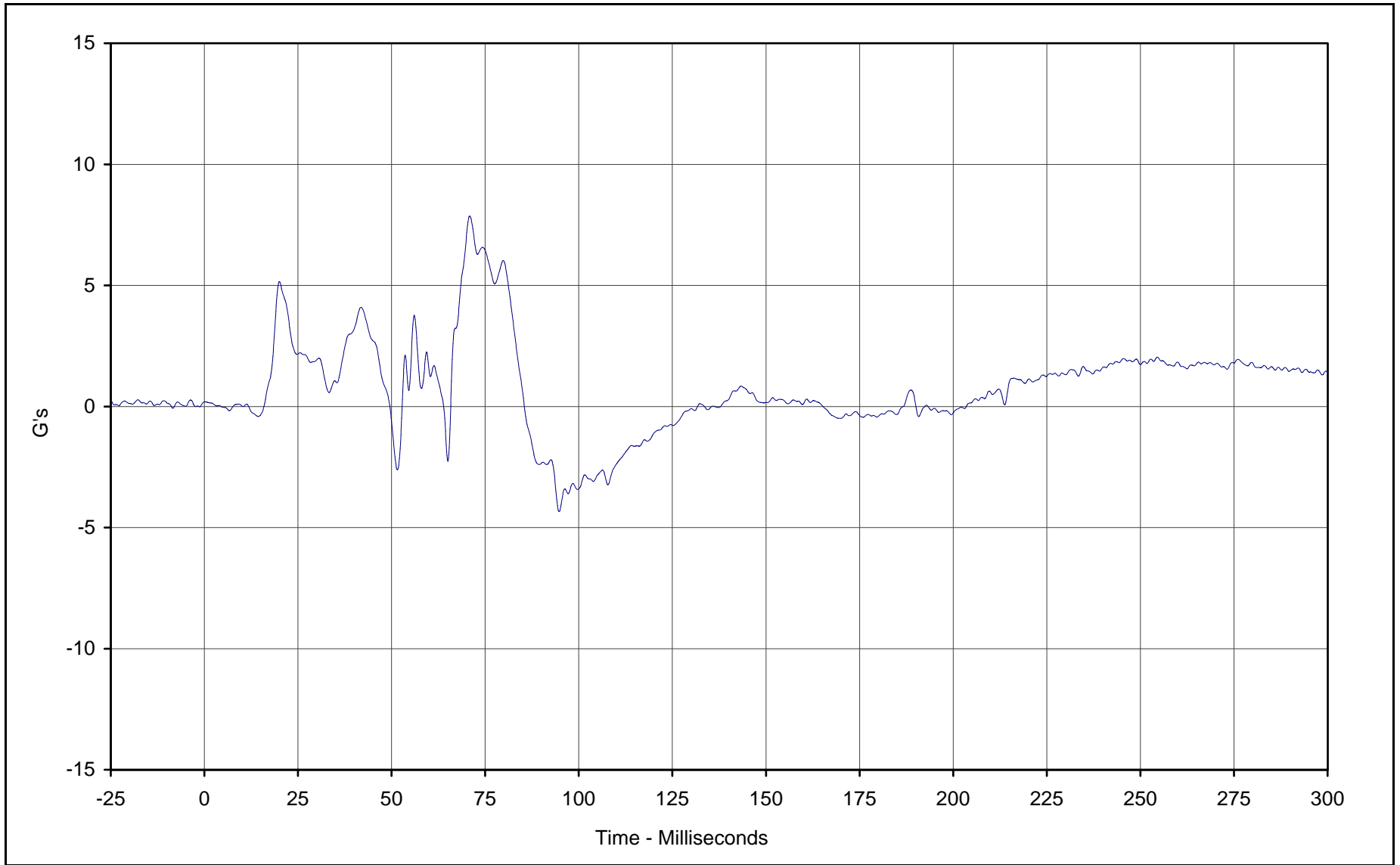

Curve Description: Passenger Chest Primary Z  
Maximum Value: 7.9 at 70.9 Milliseconds  
Minimum Value: -4.3 at 94.7 Milliseconds  
SAE Filter Class: 180  
Date of Test: 1/29/02  
Curve Number: FIL-061

Test Program: 2002 NHTSA 35mph NCAP No.: HO5300  
Test Vehicle: 2002 Honda CR-V LX 4WD SUV



KAR21061-01

B-89

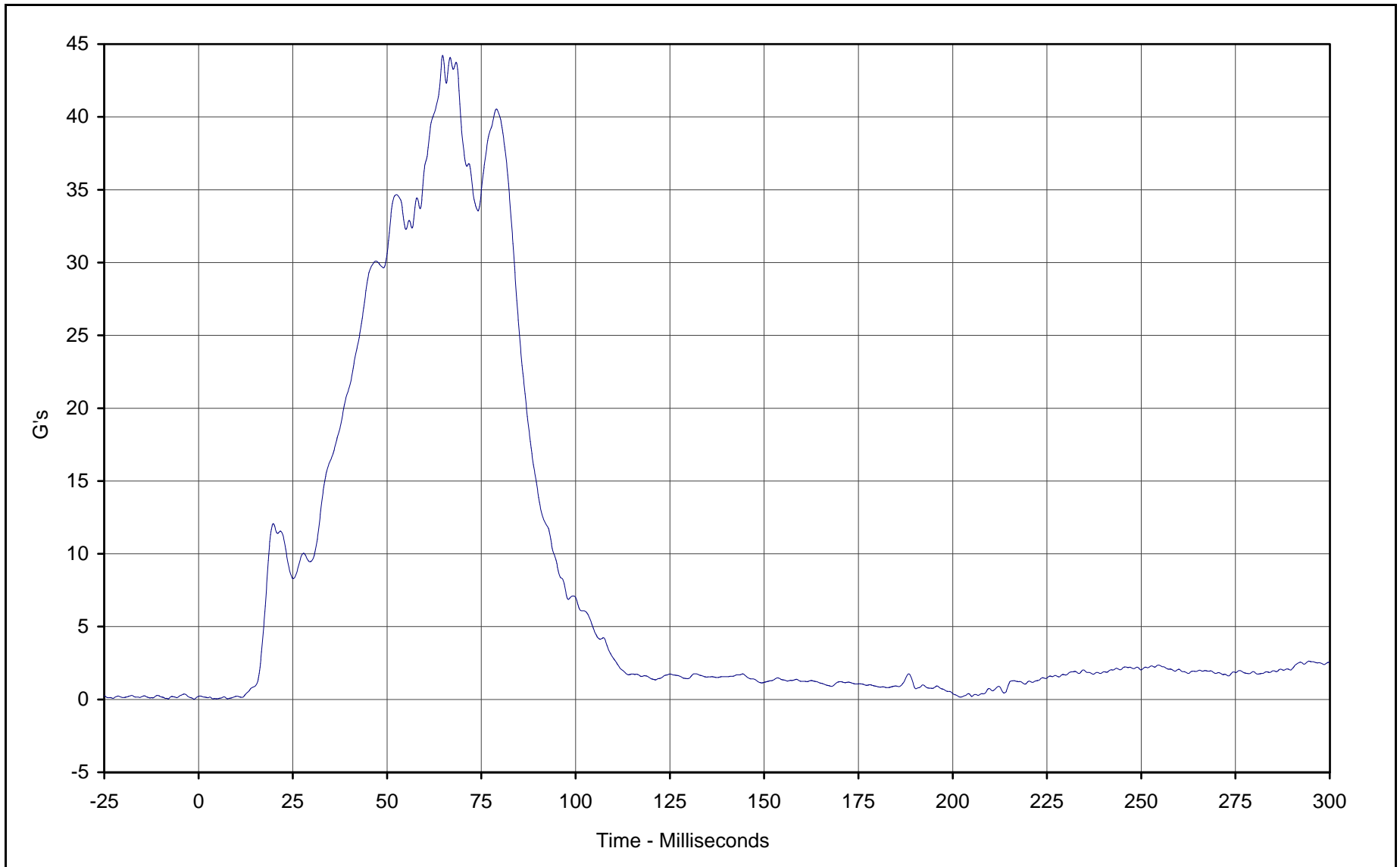

Curve Description: Passenger Chest Resultant Primary  
Maximum Value: 44.2 at 64.7 Milliseconds  
Minimum Value: 0.0 at 7.7 Milliseconds  
SAE Filter Class: 180  
Date of Test: 1/29/02  
Curve Number: RES-059

Test Program: 2002 NHTSA 35mph NCAP No.: HO5300  
Test Vehicle: 2002 Honda CR-V LX 4WD SUV



KAR21061-01

B-90

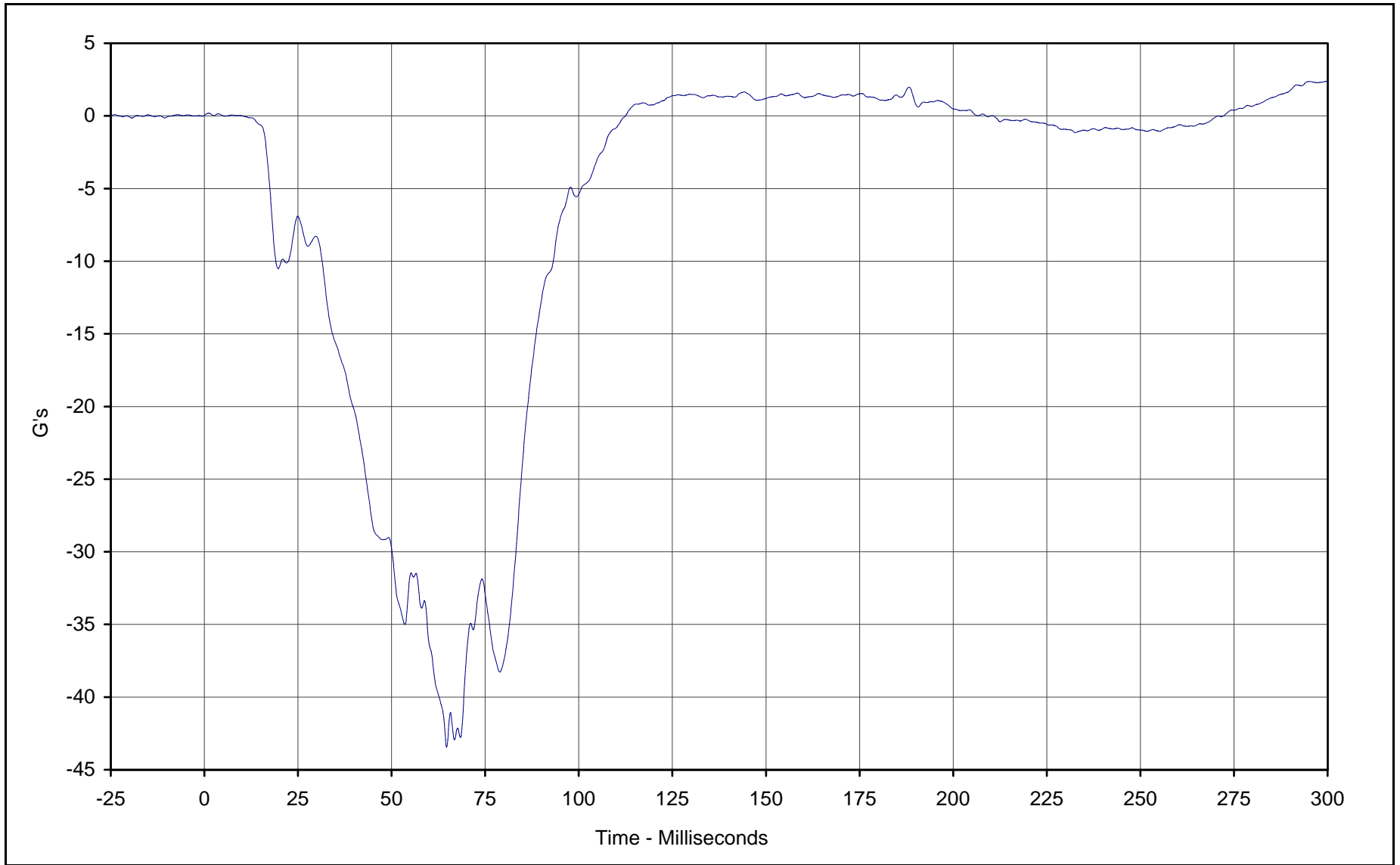

Curve Description: Passenger Chest Redundant X  
Maximum Value: 2.4 at 299.5 Milliseconds  
Minimum Value: -43.4 at 64.7 Milliseconds  
SAE Filter Class: 180  
Date of Test: 1/29/02  
Curve Number: FIL-062

Test Program: 2002 NHTSA 35mph NCAP No.: HO5300  
Test Vehicle: 2002 Honda CR-V LX 4WD SUV



KAR21061-01

B-91

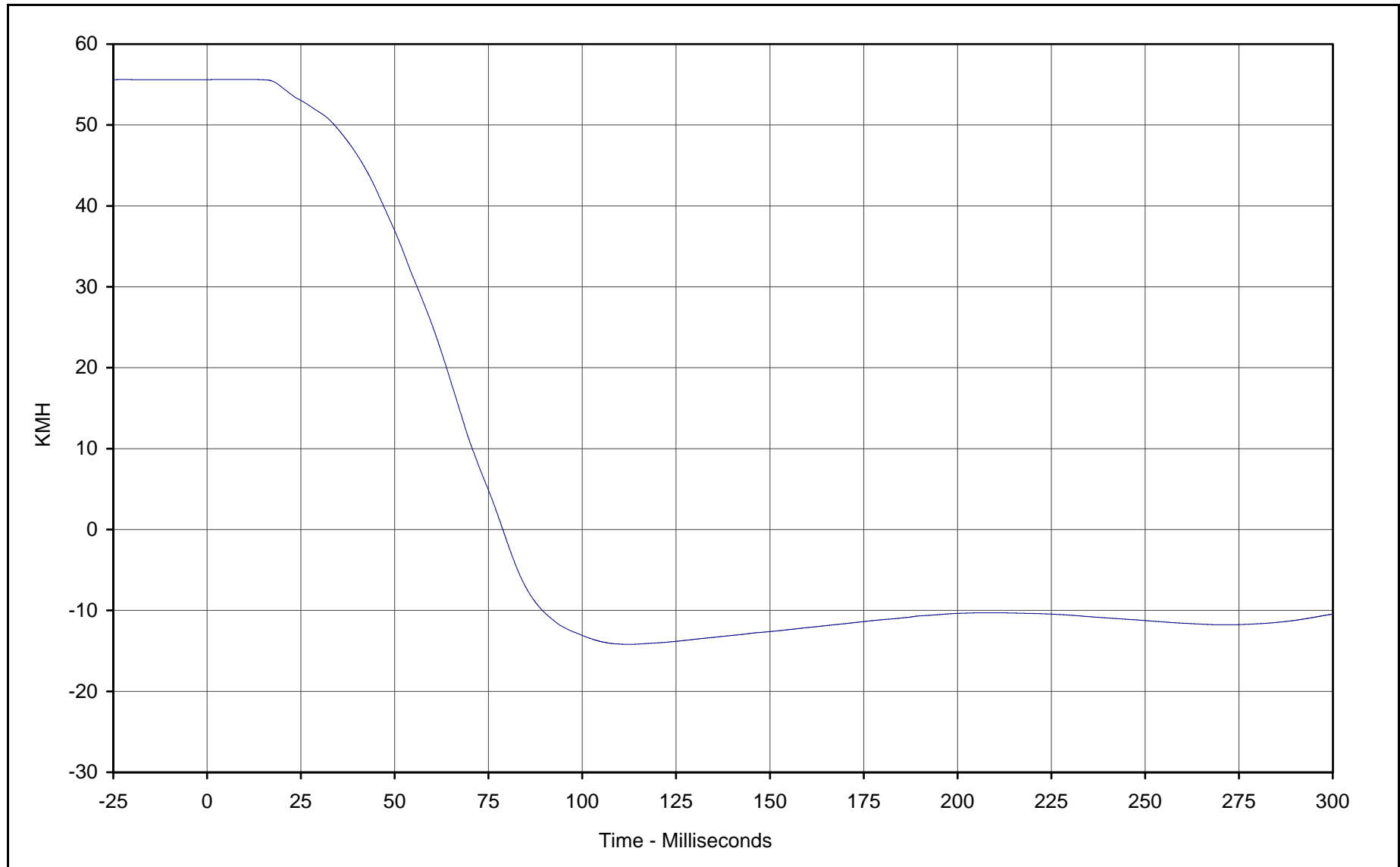

Curve Description: Passenger Chest Redundant X Velocity

Maximum Value: 55.6 at 10.1 Milliseconds

Minimum Value: -14.2 at 112.5 Milliseconds

SAE Filter Class: 180

Date of Test: 1/29/02

Curve Number: IN1-062

Test Program: 2002 NHTSA 35mph NCAP No.: HO5300

Test Vehicle: 2002 Honda CR-V LX 4WD SUV

KAR21061-01



B-92

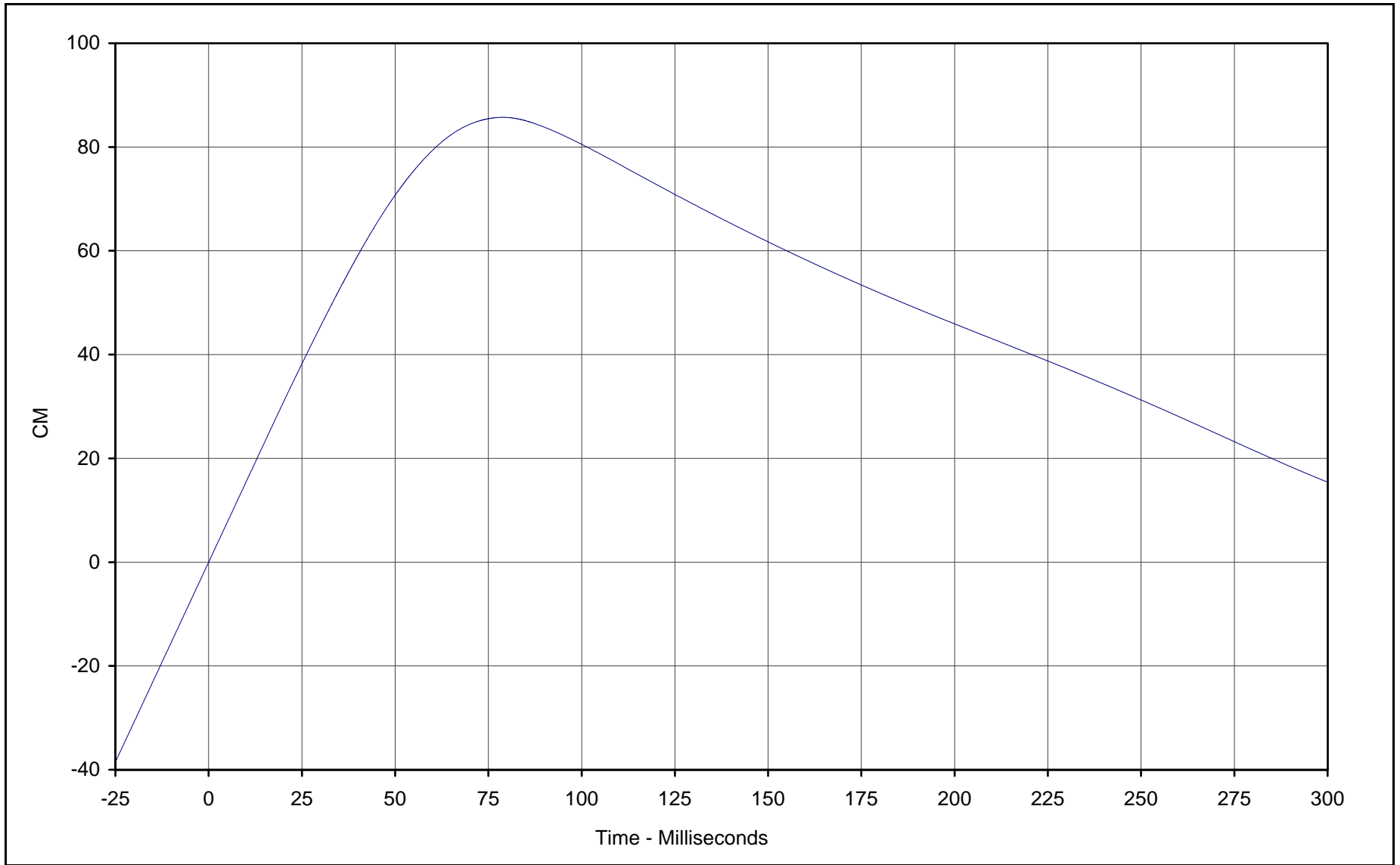

Curve Description: Passenger Chest Redundant X Displ.

Maximum Value: 85.7 at 78.8 Milliseconds

Minimum Value: 0.0 at 0.0 Milliseconds

SAE Filter Class: 180

Date of Test: 1/29/02

Curve Number: IN2-062

Test Program: 2002 NHTSA 35mph NCAP No.: HO5300

Test Vehicle: 2002 Honda CR-V LX 4WD SUV

KAR21061-01



B-93

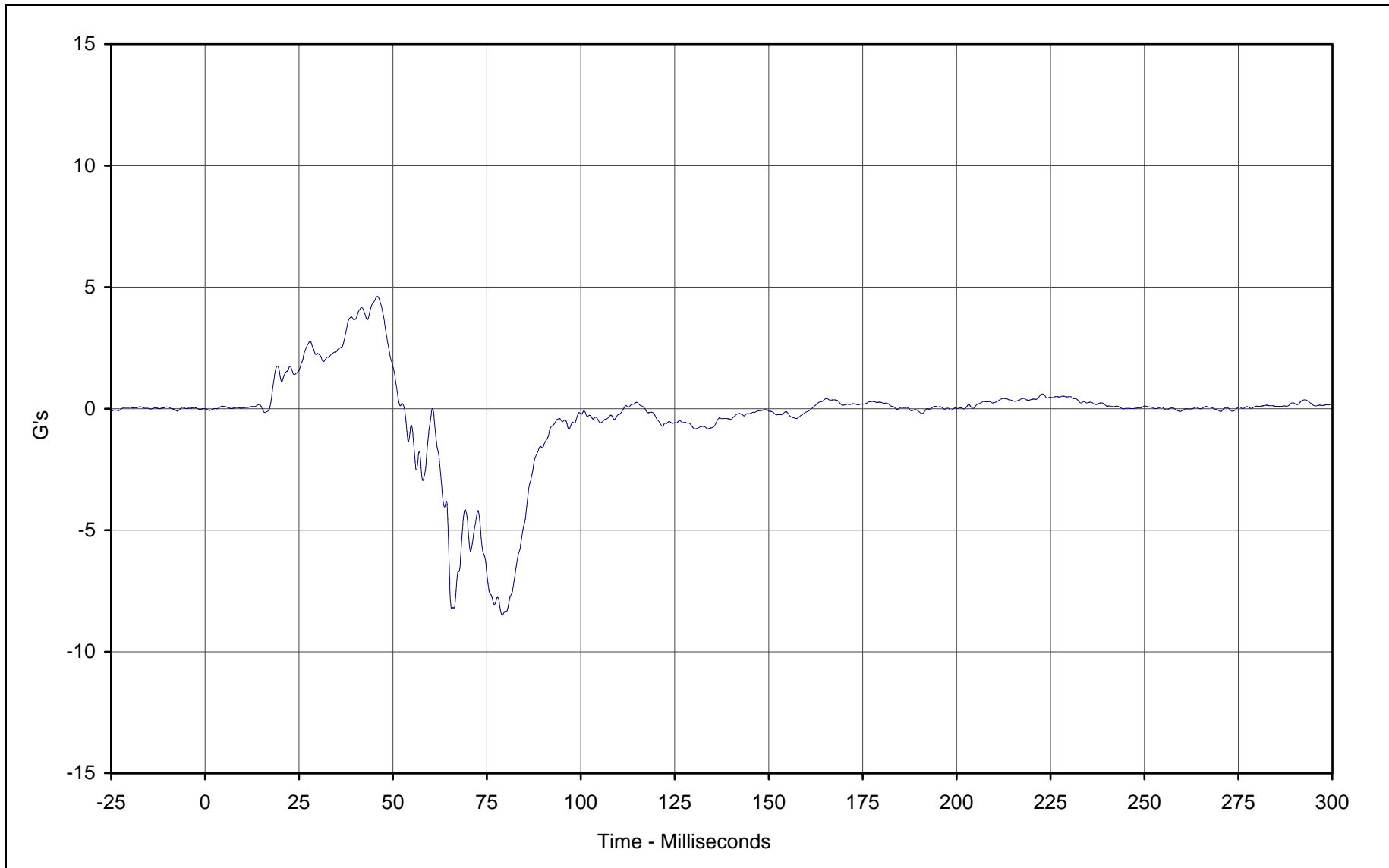

Curve Description: Passenger Chest Redundant Y  
Maximum Value: 4.6 at 45.8 Milliseconds  
Minimum Value: -8.5 at 79.1 Milliseconds  
SAE Filter Class: 180  
Date of Test: 1/29/02  
Curve Number: FIL-063

Test Program: 2002 NHTSA 35mph NCAP No.: HO5300  
Test Vehicle: 2002 Honda CR-V LX 4WD SUV

KAR21061-01



B-94

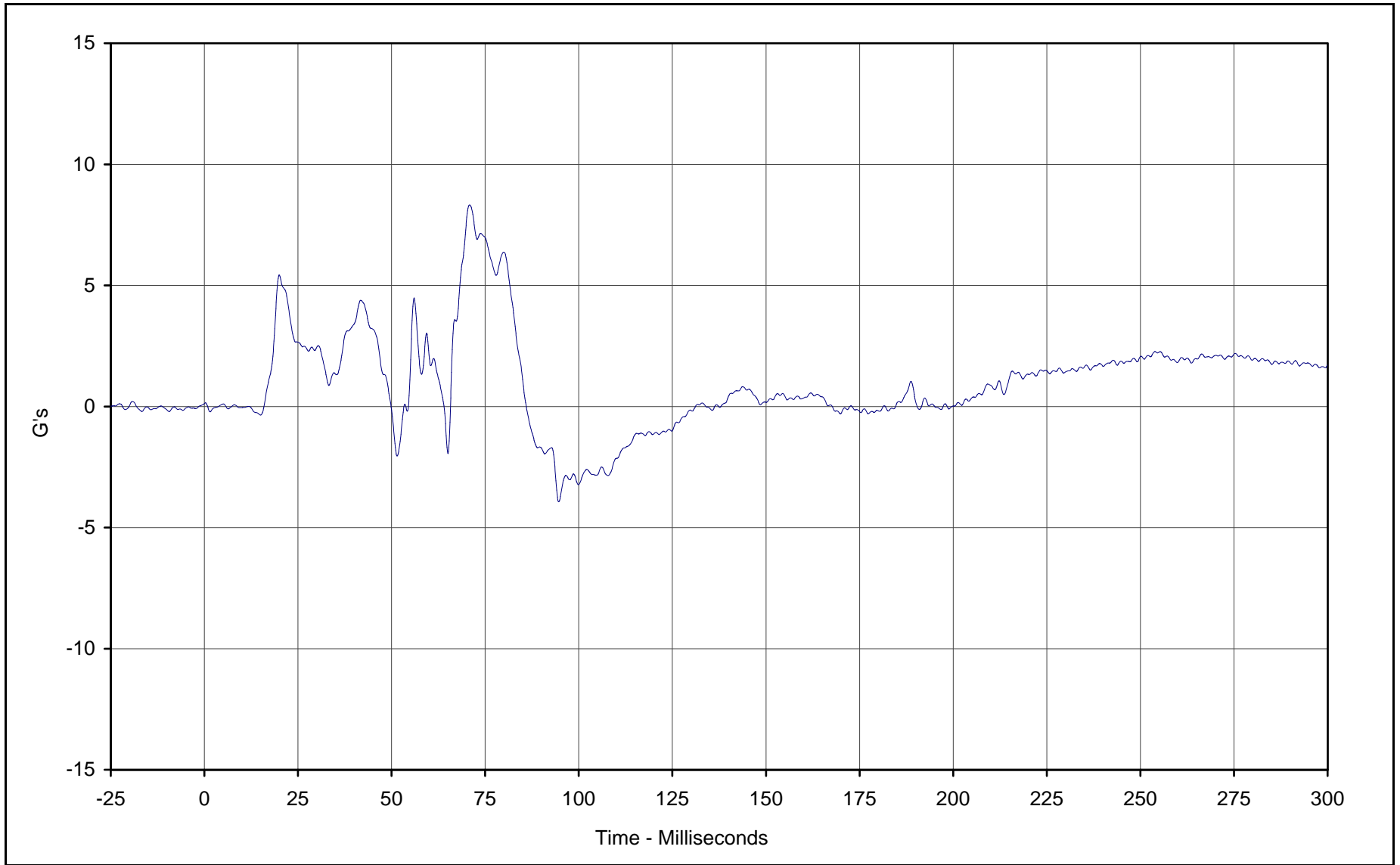

Curve Description: Passenger Chest Redundant Z  
Maximum Value: 8.3 at 70.8 Milliseconds  
Minimum Value: -3.9 at 94.6 Milliseconds  
SAE Filter Class: 180  
Date of Test: 1/29/02  
Curve Number: FIL-064

Test Program: 2002 NHTSA 35mph NCAP No.: HO5300  
Test Vehicle: 2002 Honda CR-V LX 4WD SUV

KAR21061-01



B-95

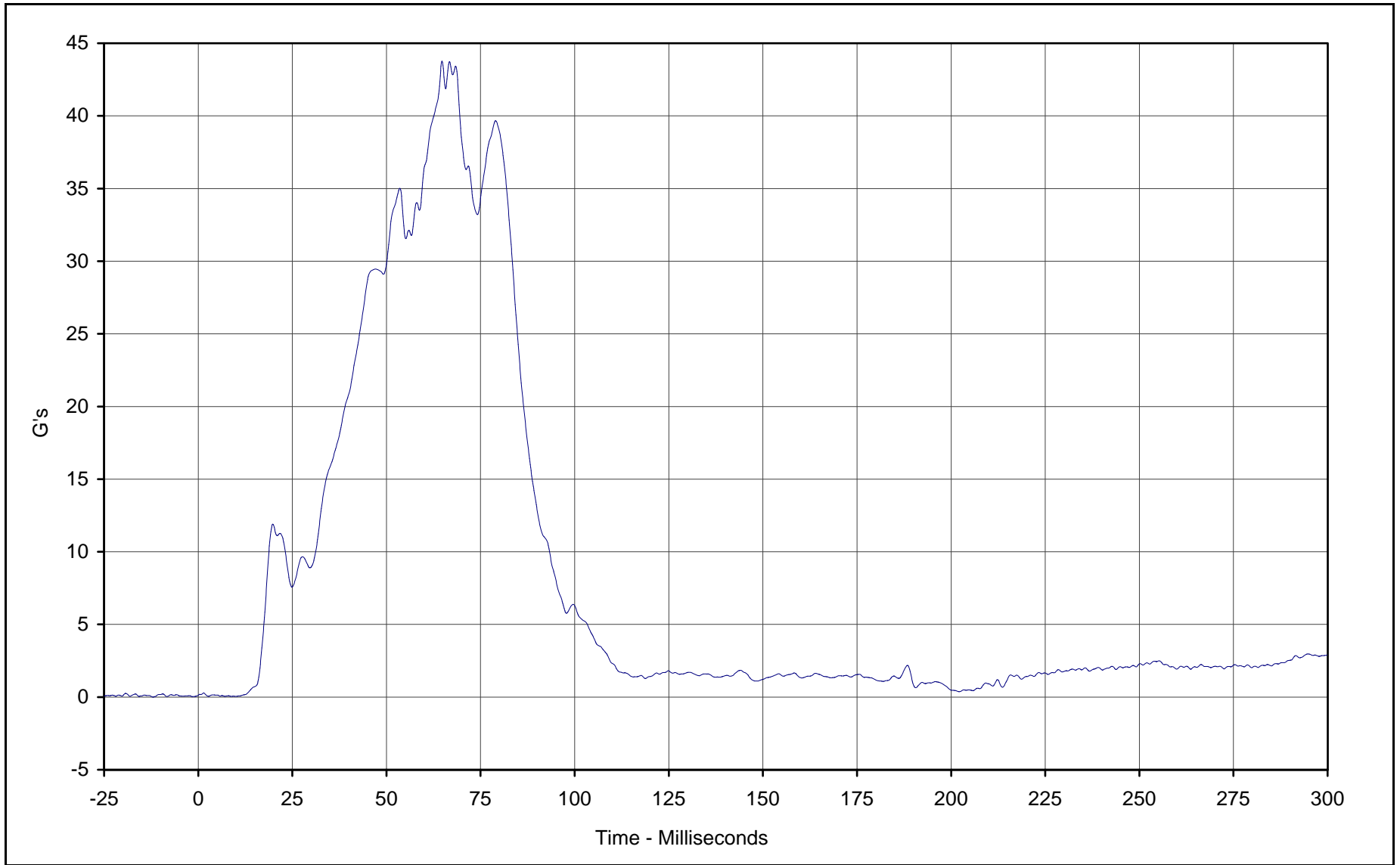

Curve Description: Passenger Chest Resultant Redundant

Maximum Value: 43.8 at 64.8 Milliseconds

Minimum Value: 0.1 at 8.8 Milliseconds

SAE Filter Class: 180

Date of Test: 1/29/02

Curve Number: RES-062

Test Program: 2002 NHTSA 35mph NCAP No.: HO5300

Test Vehicle: 2002 Honda CR-V LX 4WD SUV

KAR21061-01



B-96

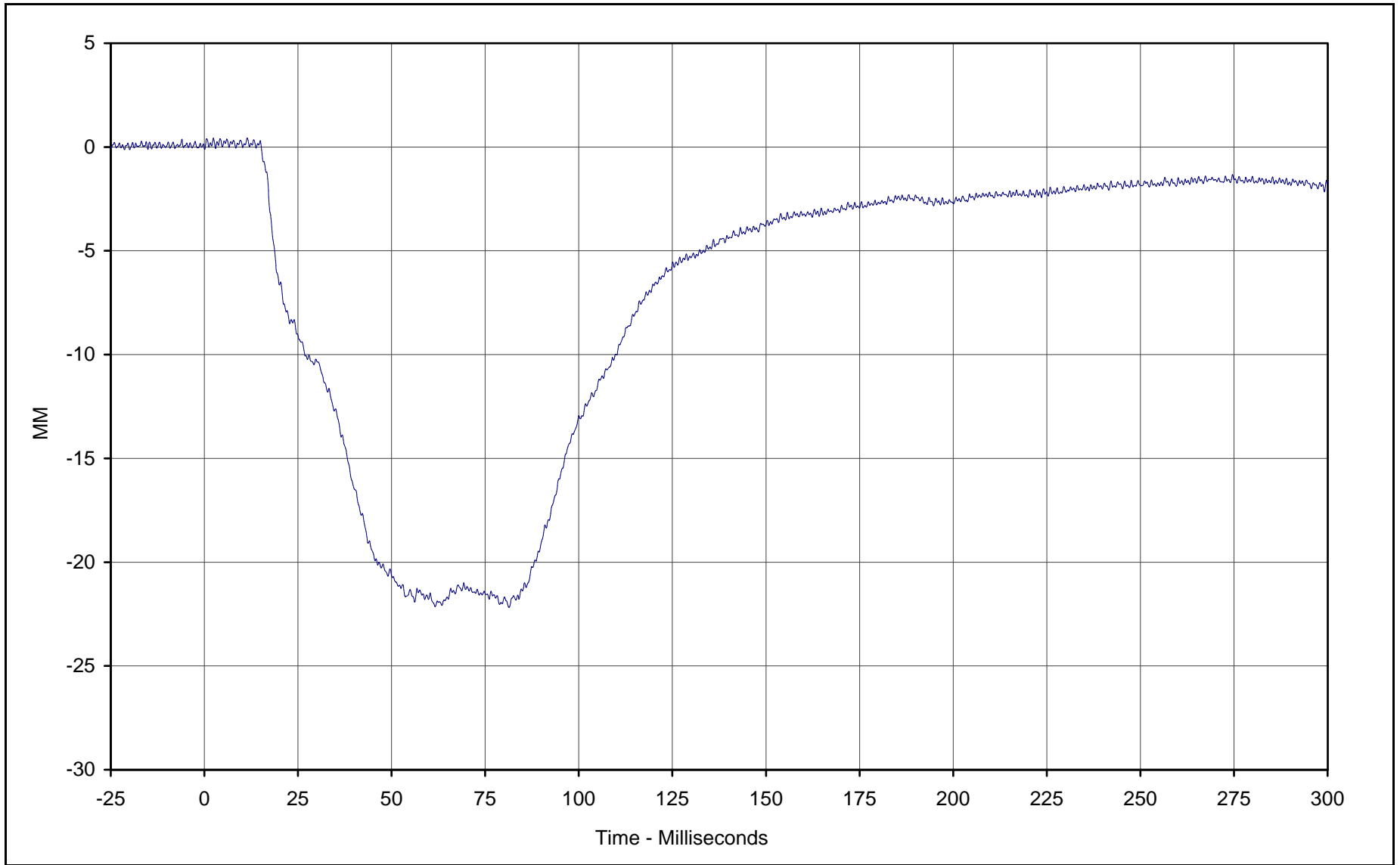

Curve Description: Passenger Chest Displacement X  
Maximum Value: 0.4 at 11.4 Milliseconds  
Minimum Value: -22.2 at 81.4 Milliseconds  
SAE Filter Class: 600  
Date of Test: 1/29/02  
Curve Number: FIL-065

Test Program: 2002 NHTSA 35mph NCAP No.: HO5300  
Test Vehicle: 2002 Honda CR-V LX 4WD SUV



KAR21061-01

B-97

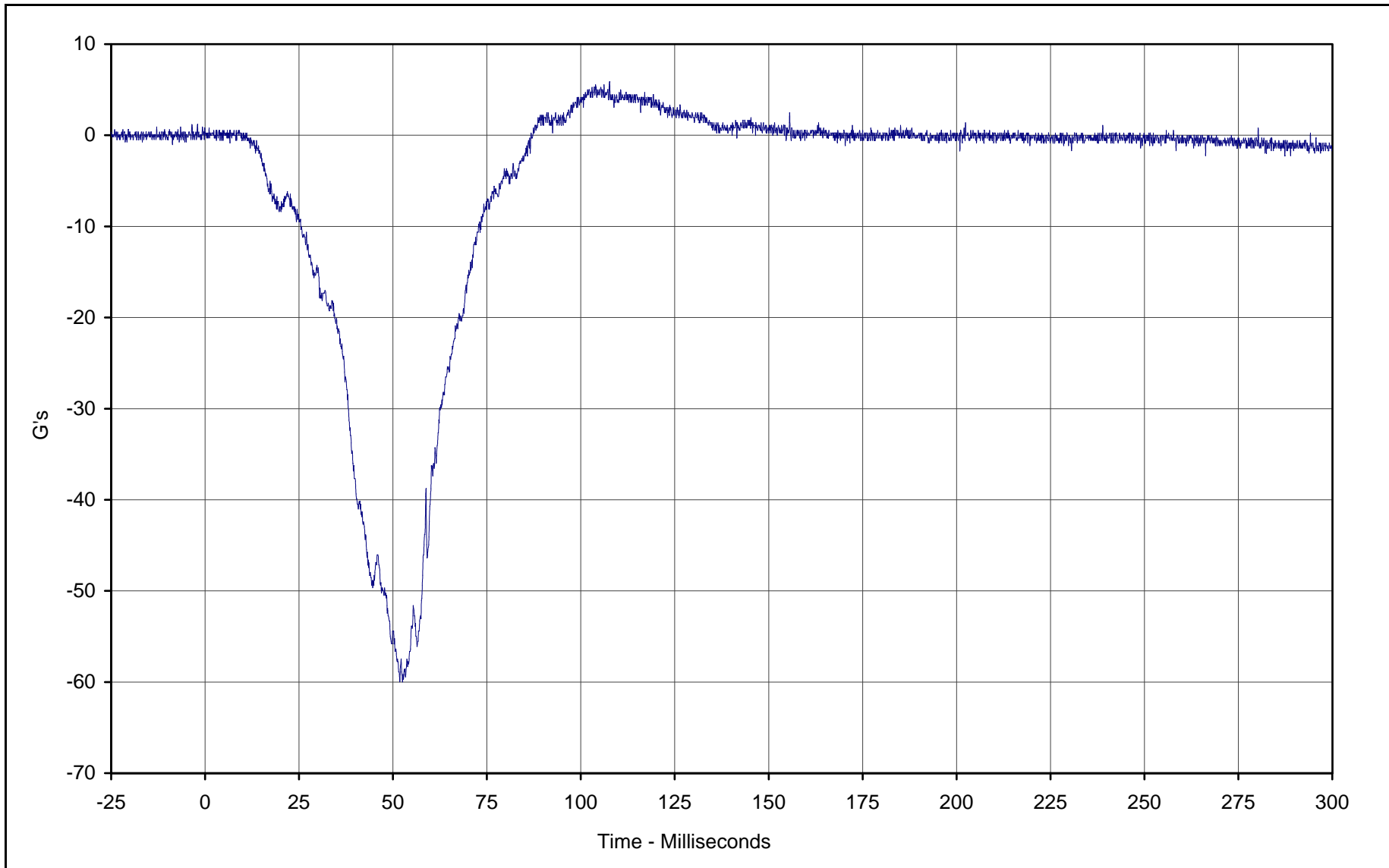

Curve Description: Passenger Pelvis X  
Maximum Value: 5.8 at 107.7 Milliseconds  
Minimum Value: -60.0 at 51.8 Milliseconds  
SAE Filter Class: 1000  
Date of Test: 1/29/02  
Curve Number: FIL-066

Test Program: 2002 NHTSA 35mph NCAP No.: HO5300  
Test Vehicle: 2002 Honda CR-V LX 4WD SUV

KAR21061-01



B-98

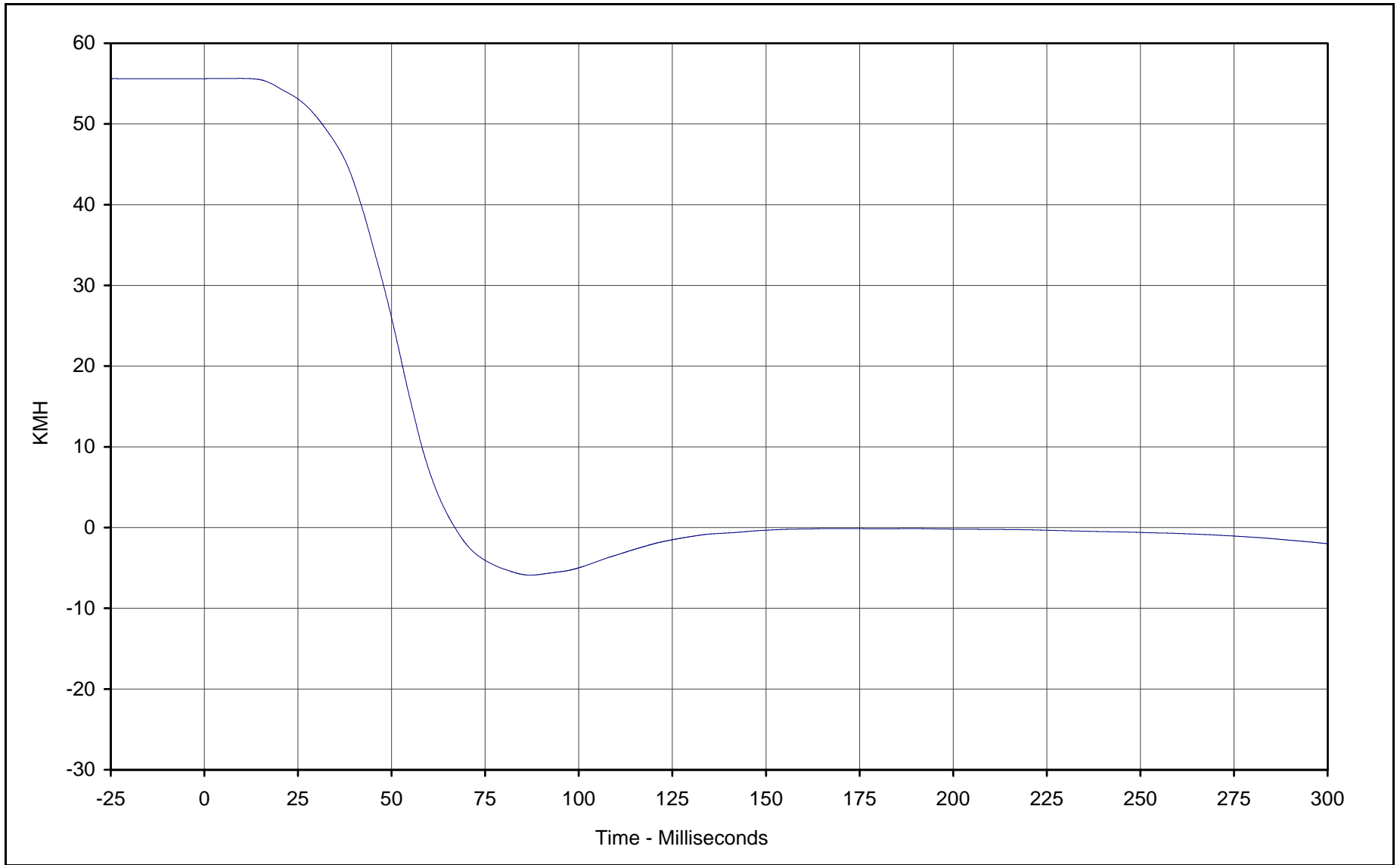

Curve Description: Passenger Pelvis X Velocity  
Maximum Value: 55.6 at 9.7 Milliseconds  
Minimum Value: -5.9 at 87.1 Milliseconds  
SAE Filter Class: 180  
Date of Test: 1/29/02  
Curve Number: IN1-066

Test Program: 2002 NHTSA 35mph NCAP No.: HO5300  
Test Vehicle: 2002 Honda CR-V LX 4WD SUV



KAR21061-01

B-99

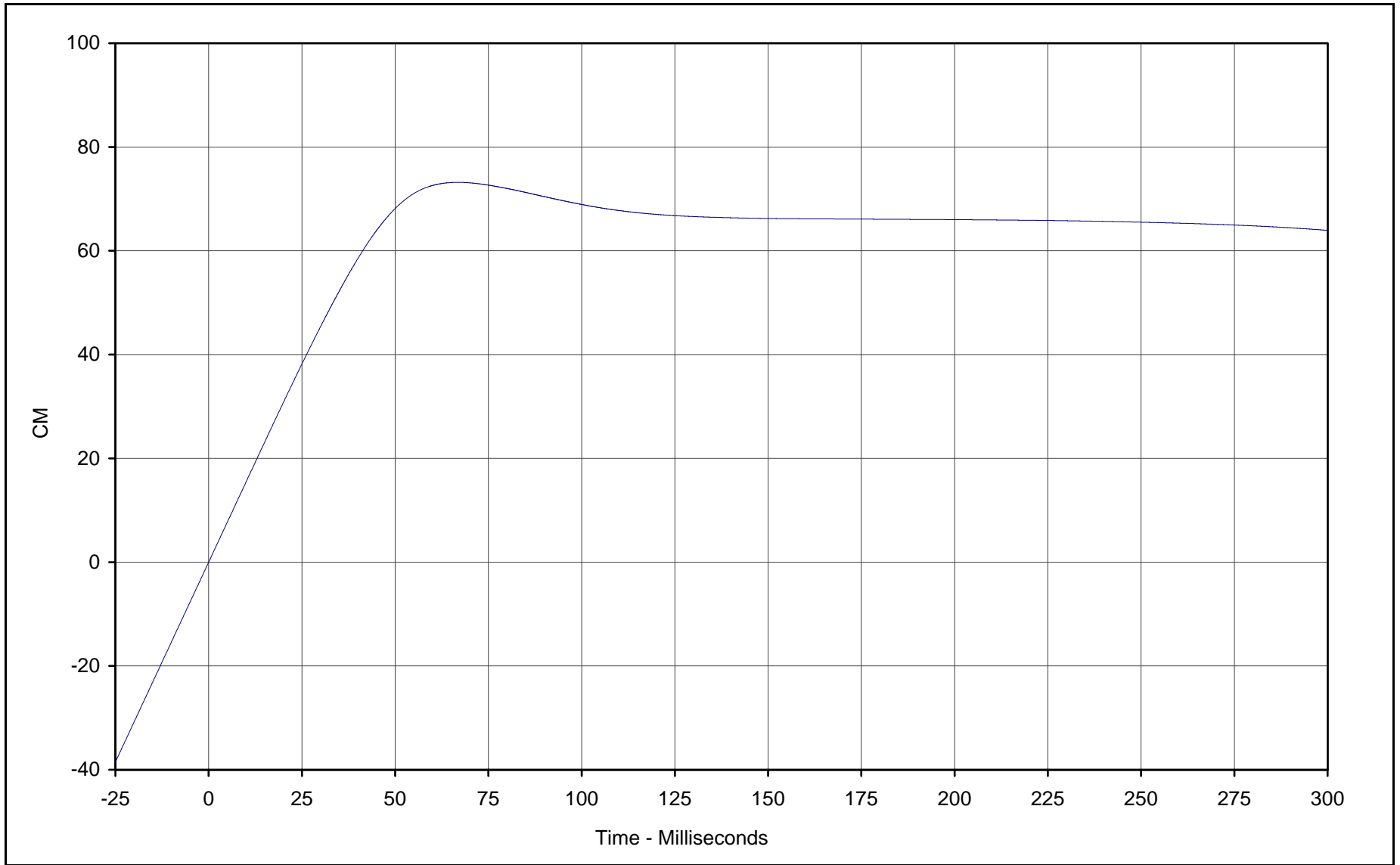

Curve Description: Passenger Pelvis X Displ.  
Maximum Value: 73.2 at 66.9 Milliseconds  
Minimum Value: 0.0 at 0.0 Milliseconds  
SAE Filter Class: 180  
Date of Test: 1/29/02  
Curve Number: IN2-066

Test Program: 2002 NHTSA 35mph NCAP No.: HO5300  
Test Vehicle: 2002 Honda CR-V LX 4WD SUV

KAR21061-01



B-100

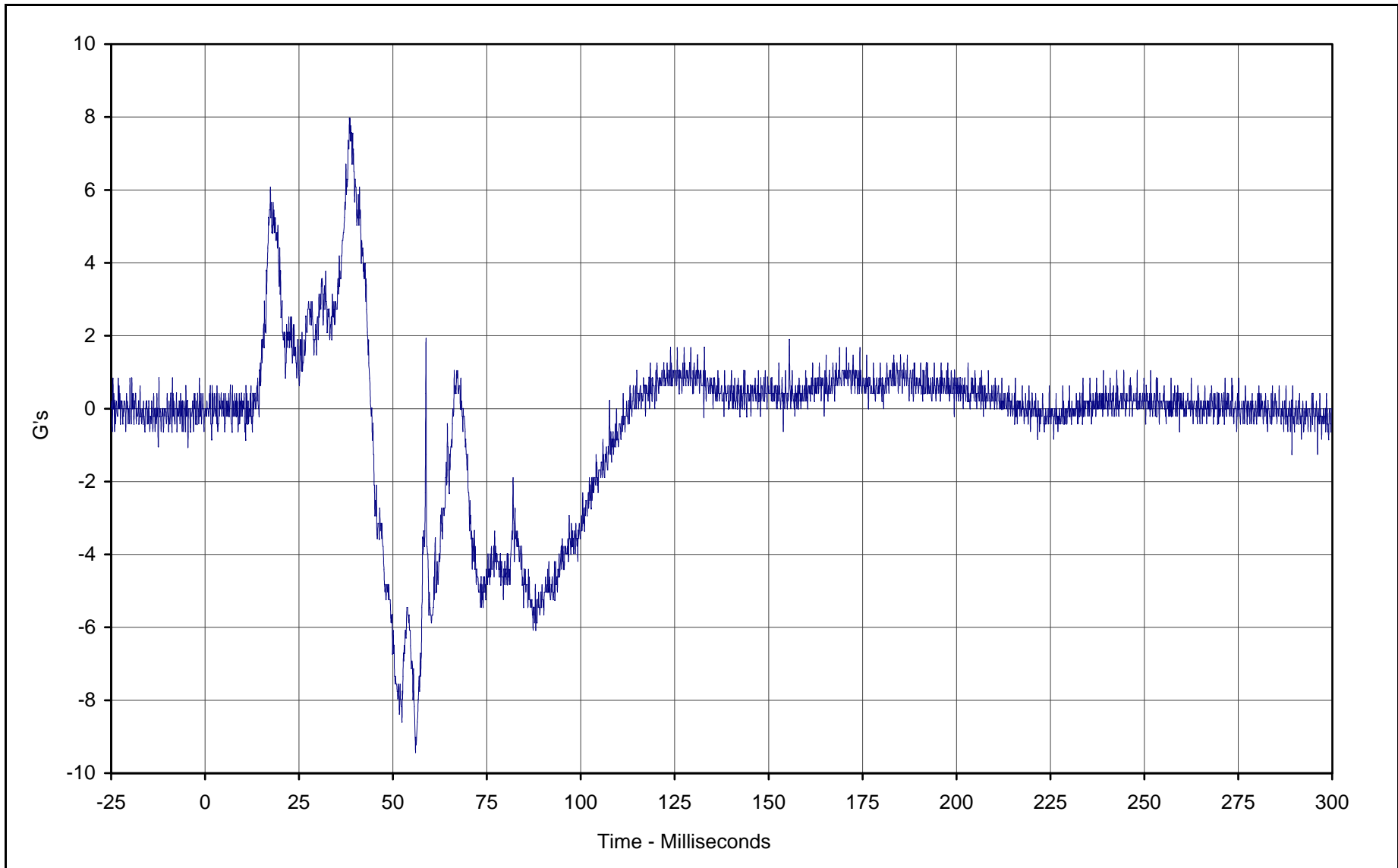

Curve Description: Passenger Pelvis Y  
Maximum Value: 8.0 at 38.4 Milliseconds  
Minimum Value: -9.4 at 56.0 Milliseconds  
SAE Filter Class: 1000  
Date of Test: 1/29/02  
Curve Number: FIL-067

Test Program: 2002 NHTSA 35mph NCAP No.: HO5300  
Test Vehicle: 2002 Honda CR-V LX 4WD SUV



KAR21061-01

B-101

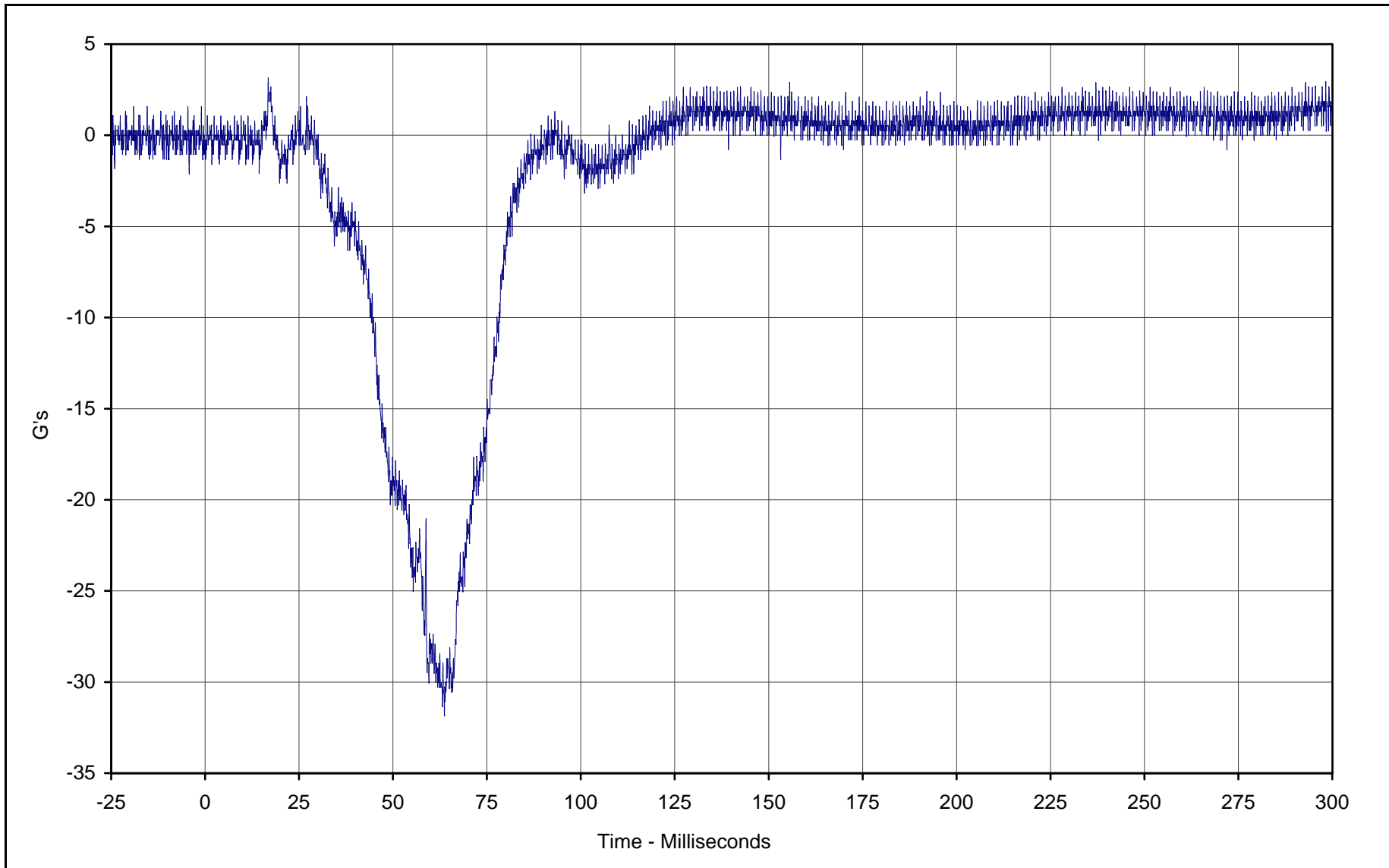

Curve Description: Passenger Pelvis Z  
Maximum Value: 3.2 at 16.8 Milliseconds  
Minimum Value: -31.9 at 63.7 Milliseconds  
SAE Filter Class: 1000  
Date of Test: 1/29/02  
Curve Number: FIL-068

Test Program: 2002 NHTSA 35mph NCAP No.: HO5300  
Test Vehicle: 2002 Honda CR-V LX 4WD SUV



KAR21061-01

B-102

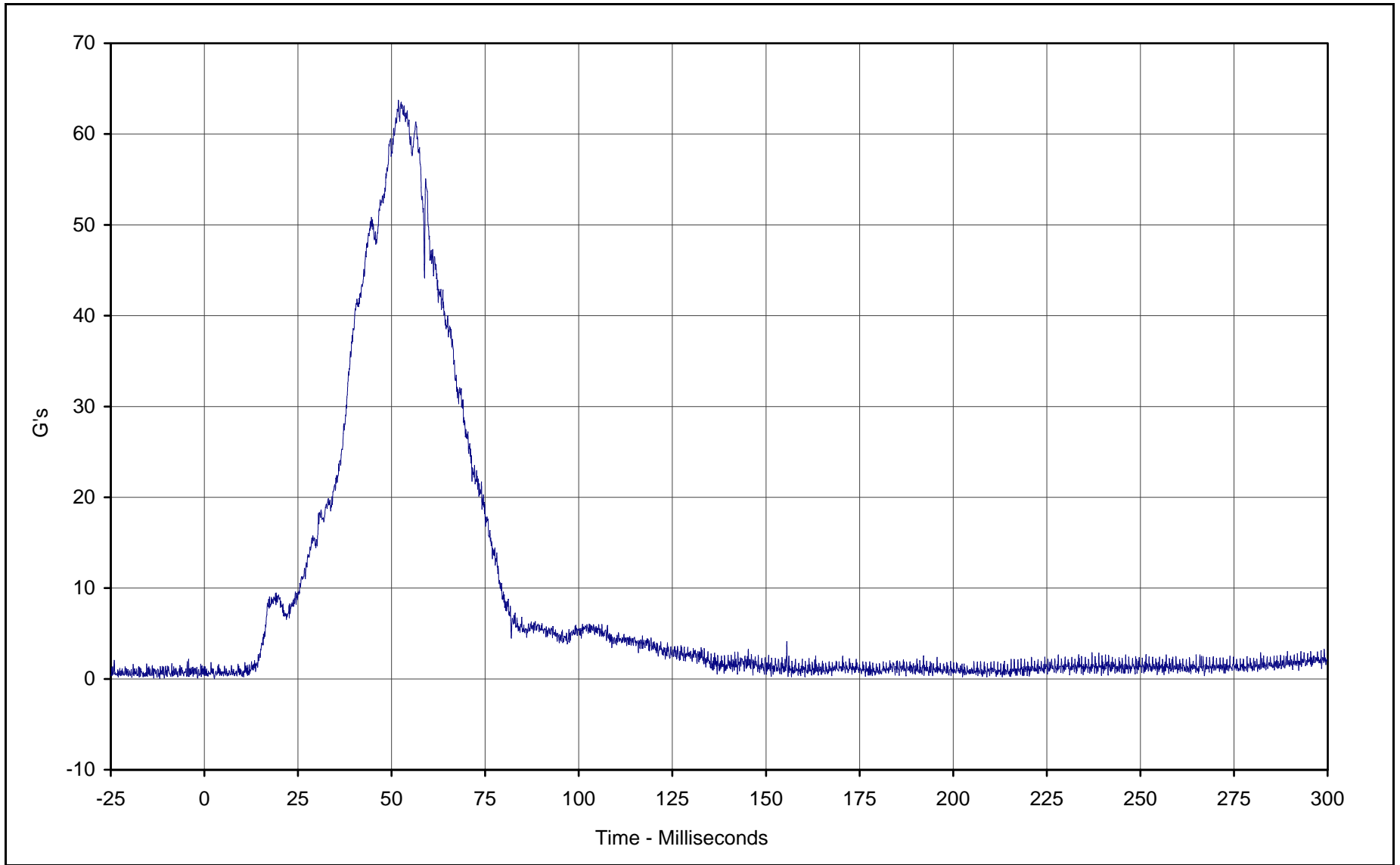

Curve Description: Passenger Pelvis Resultant  
Maximum Value: 63.7 at 51.8 Milliseconds  
Minimum Value: 0.0 at 2.7 Milliseconds  
SAE Filter Class: 1000  
Date of Test: 1/29/02  
Curve Number: RES-066

Test Program: 2002 NHTSA 35mph NCAP No.: HO5300  
Test Vehicle: 2002 Honda CR-V LX 4WD SUV



KAR21061-01

B-103

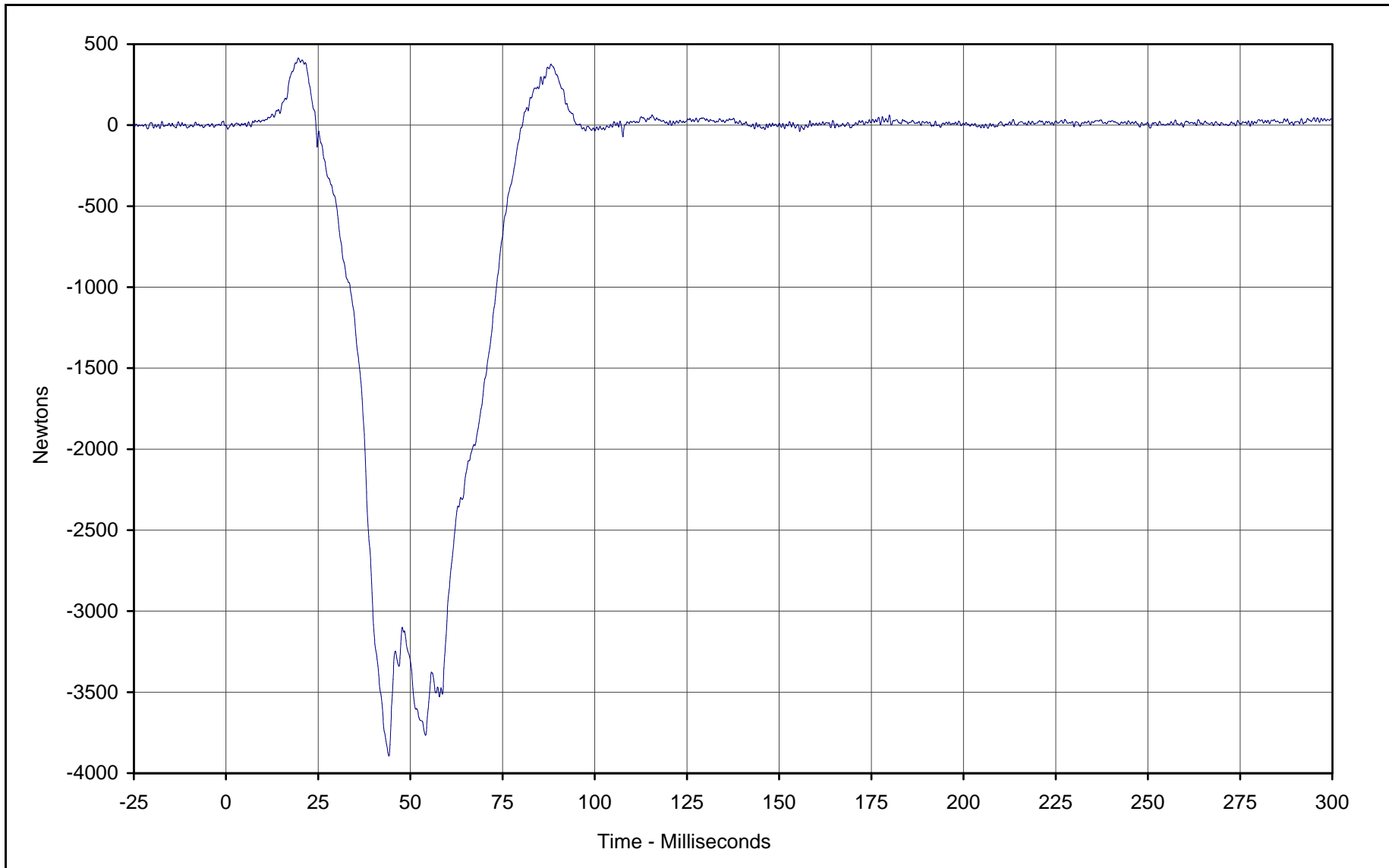

Curve Description: Passenger Left Femur Force  
Maximum Value: 415.5 at 19.6 Milliseconds  
Minimum Value: -3893.3 at 44.2 Milliseconds  
SAE Filter Class: 600  
Date of Test: 1/29/02  
Curve Number: FIL-069

Test Program: 2002 NHTSA 35mph NCAP No.: HO5300  
Test Vehicle: 2002 Honda CR-V LX 4WD SUV



KAR21061-01

B-104

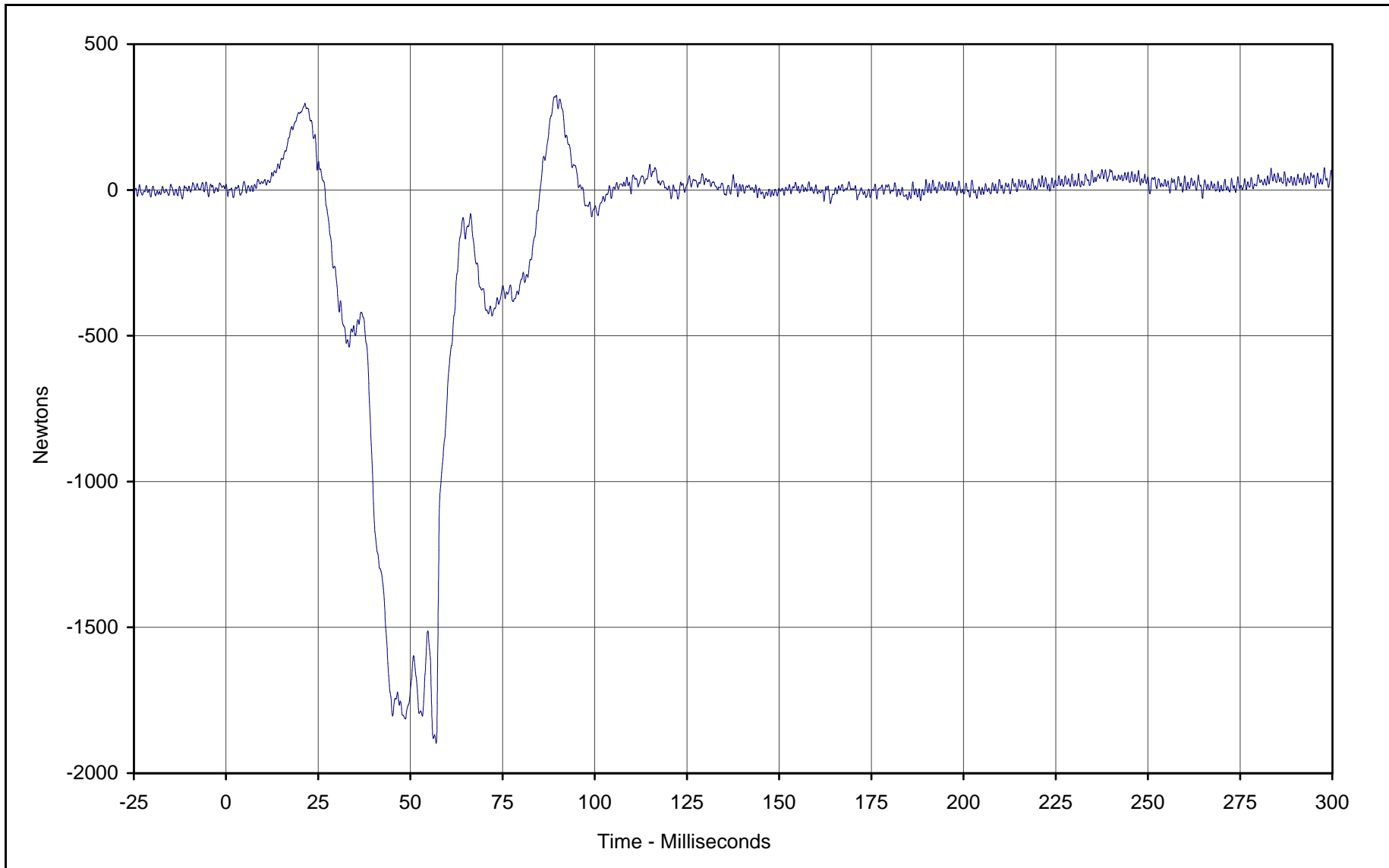

Curve Description: Passenger Right Femur Force  
Maximum Value: 324.3 at 89.6 Milliseconds  
Minimum Value: -1897.8 at 57.0 Milliseconds  
SAE Filter Class: 600  
Date of Test: 1/29/02  
Curve Number: FIL-070

Test Program: 2002 NHTSA 35mph NCAP No.: HO5300  
Test Vehicle: 2002 Honda CR-V LX 4WD SUV



KAR21061-01

B-105

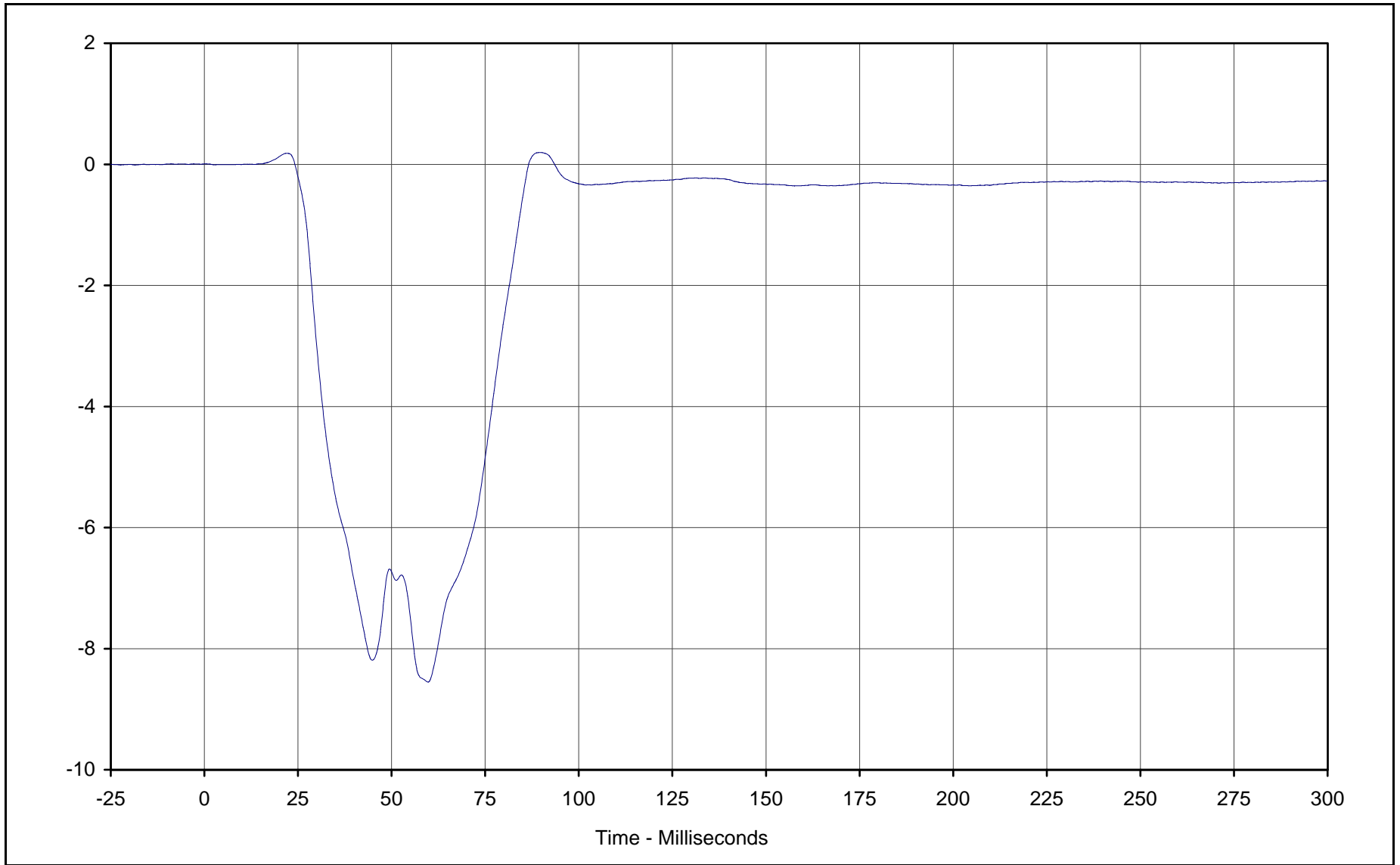

Curve Description: Passenger Left Knee Slider  
Maximum Value: 0.20 at 89.8 Milliseconds  
Minimum Value: -8.55 at 59.7 Milliseconds  
SAE Filter Class: 180  
Date of Test: 1/29/02  
Curve Number: FIL-071

Test Program: 2002 NHTSA 35mph NCAP No.: HO5300  
Test Vehicle: 2002 Honda CR-V LX 4WD SUV



KAR21061-01

B-106

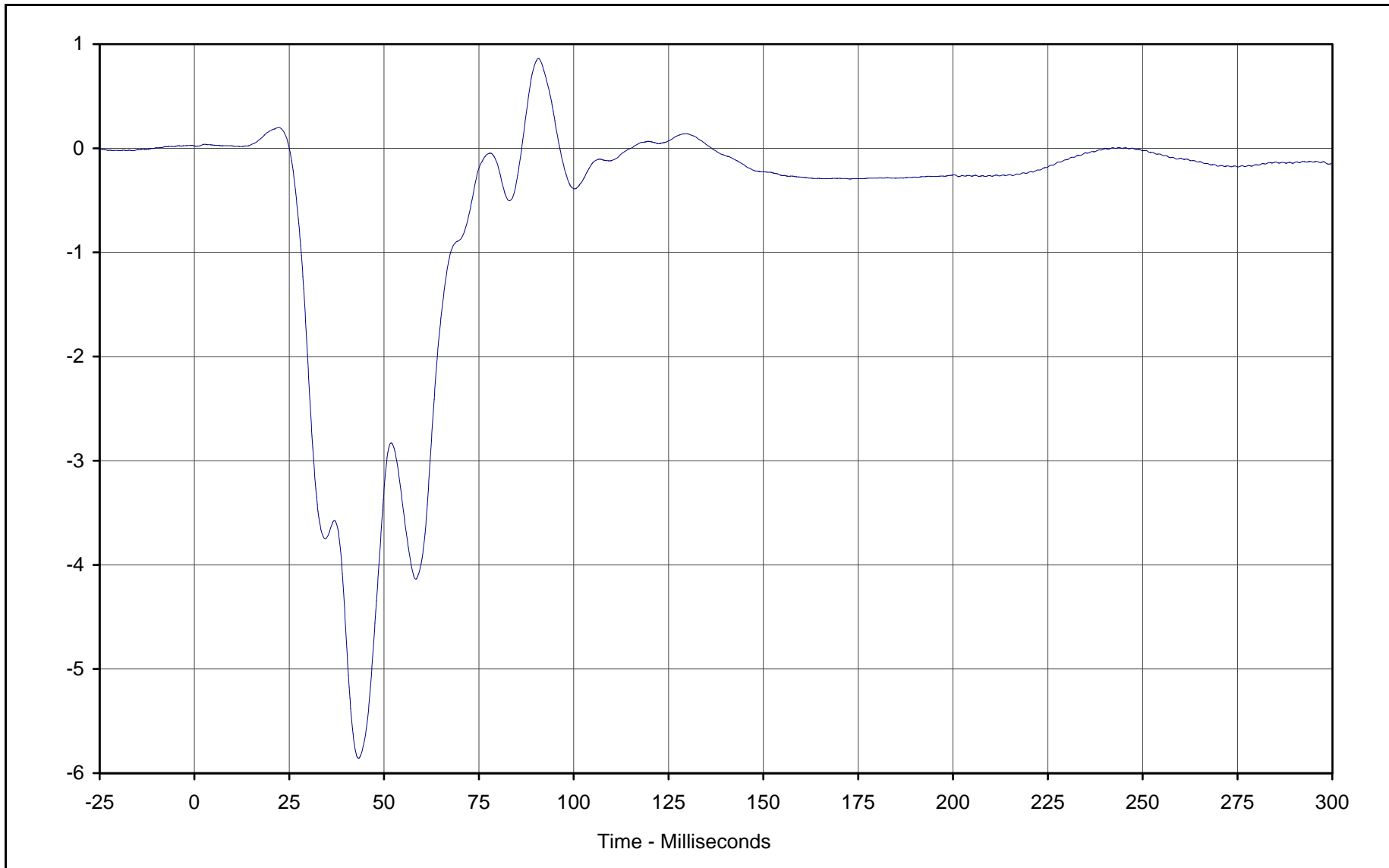

Curve Description: Passenger Right Knee Slider  
Maximum Value: 0.86 at 90.7 Milliseconds  
Minimum Value: -5.86 at 43.3 Milliseconds  
SAE Filter Class: 180  
Date of Test: 1/29/02  
Curve Number: FIL-072

Test Program: 2002 NHTSA 35mph NCAP No.: HO5300  
Test Vehicle: 2002 Honda CR-V LX 4WD SUV



KAR21061-01

B-107

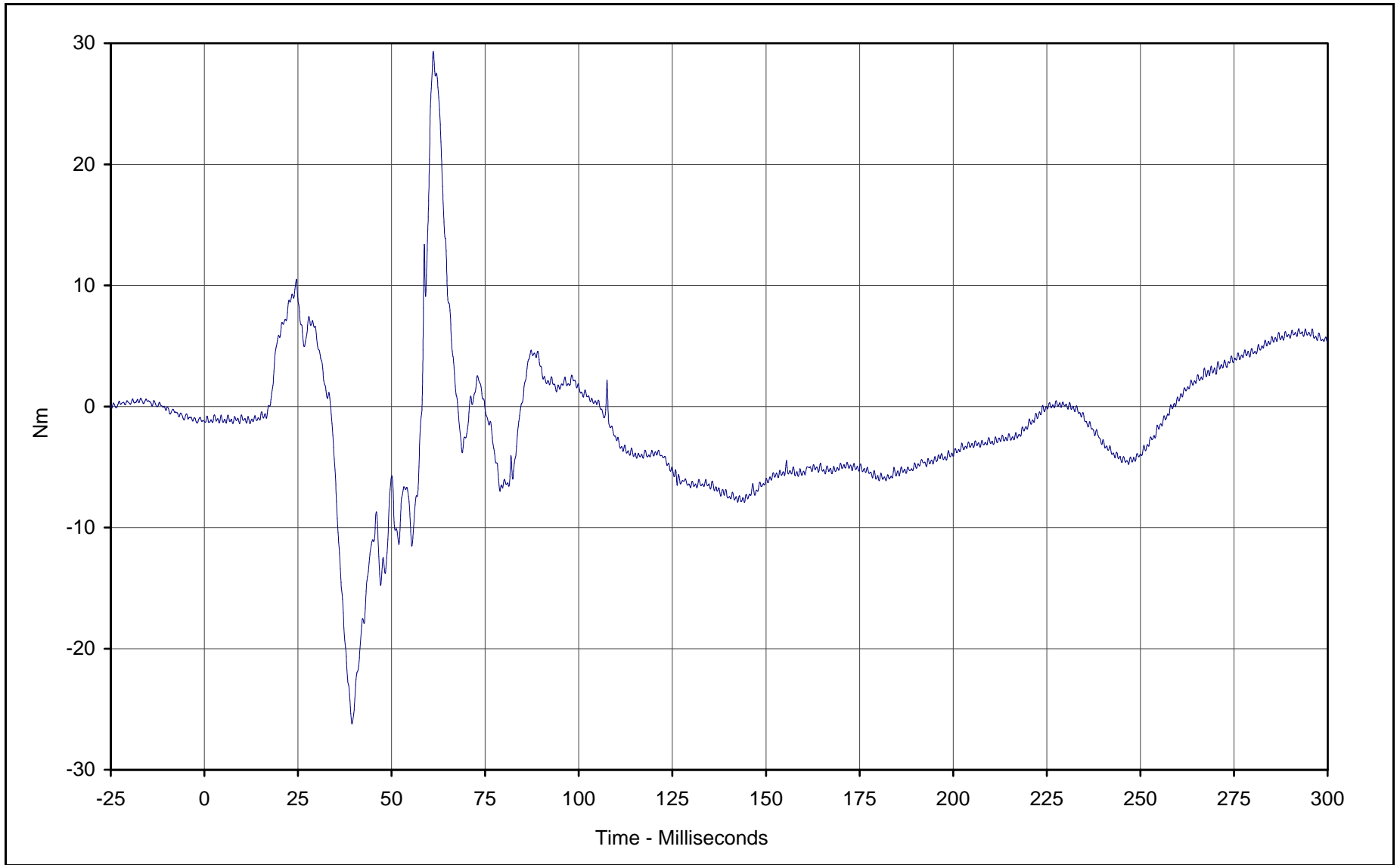

Curve Description: Passenger Left Upper Tibia Moment X

Maximum Value: 29.3 at 61.2 Milliseconds

Minimum Value: -26.2 at 39.4 Milliseconds

SAE Filter Class: 600

Date of Test: 1/29/02

Curve Number: FIL-073

Test Program: 2002 NHTSA 35mph NCAP No.: HO5300

Test Vehicle: 2002 Honda CR-V LX 4WD SUV

KAR21061-01



B-108

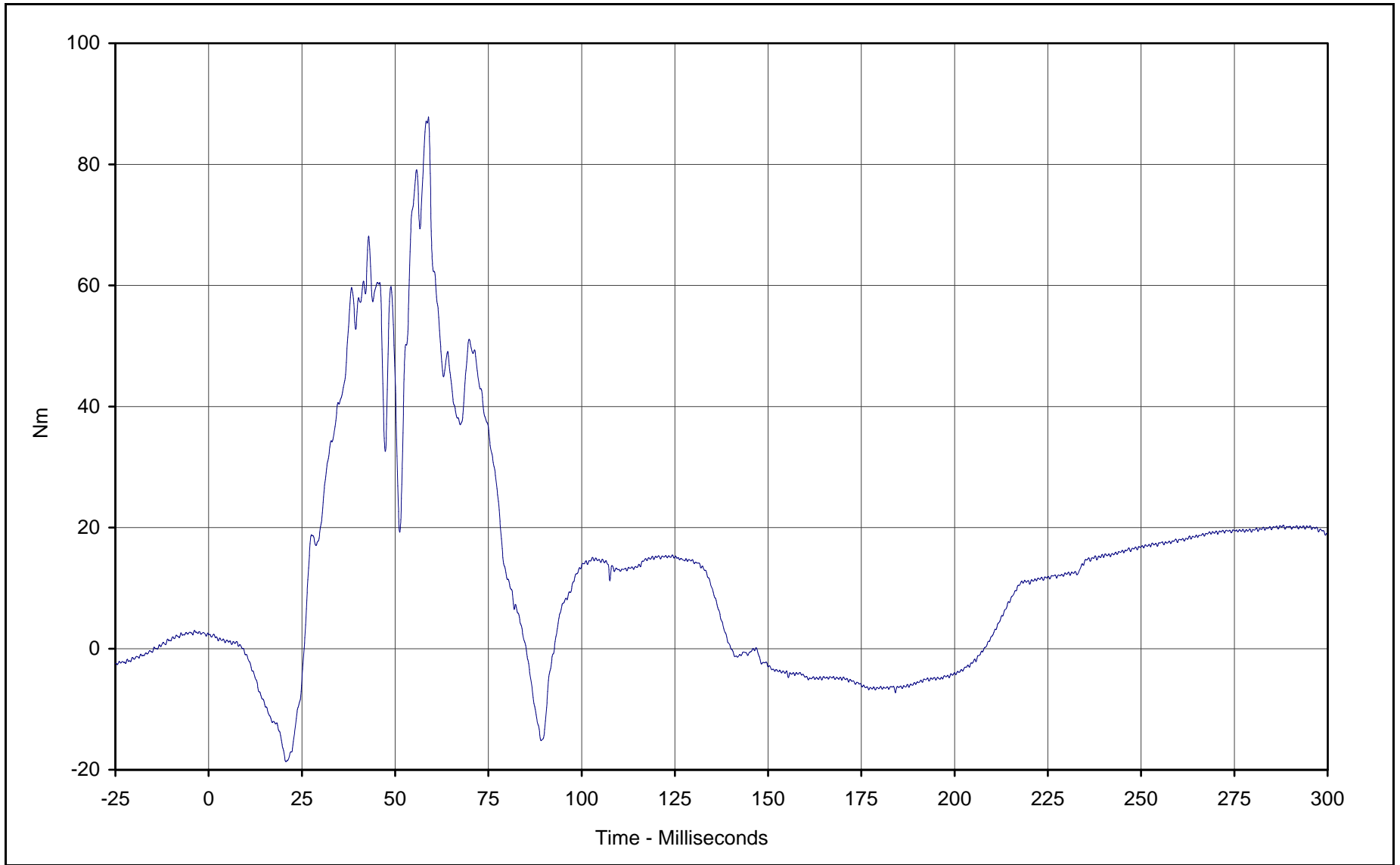

Curve Description: Passenger Left Upper Tibia Moment Y

Maximum Value: 87.8 at 58.9 Milliseconds

Minimum Value: -18.7 at 20.7 Milliseconds

SAE Filter Class: 600

Date of Test: 1/29/02

Curve Number: FIL-074

Test Program: 2002 NHTSA 35mph NCAP No.: HO5300

Test Vehicle: 2002 Honda CR-V LX 4WD SUV

KAR21061-01



B-109

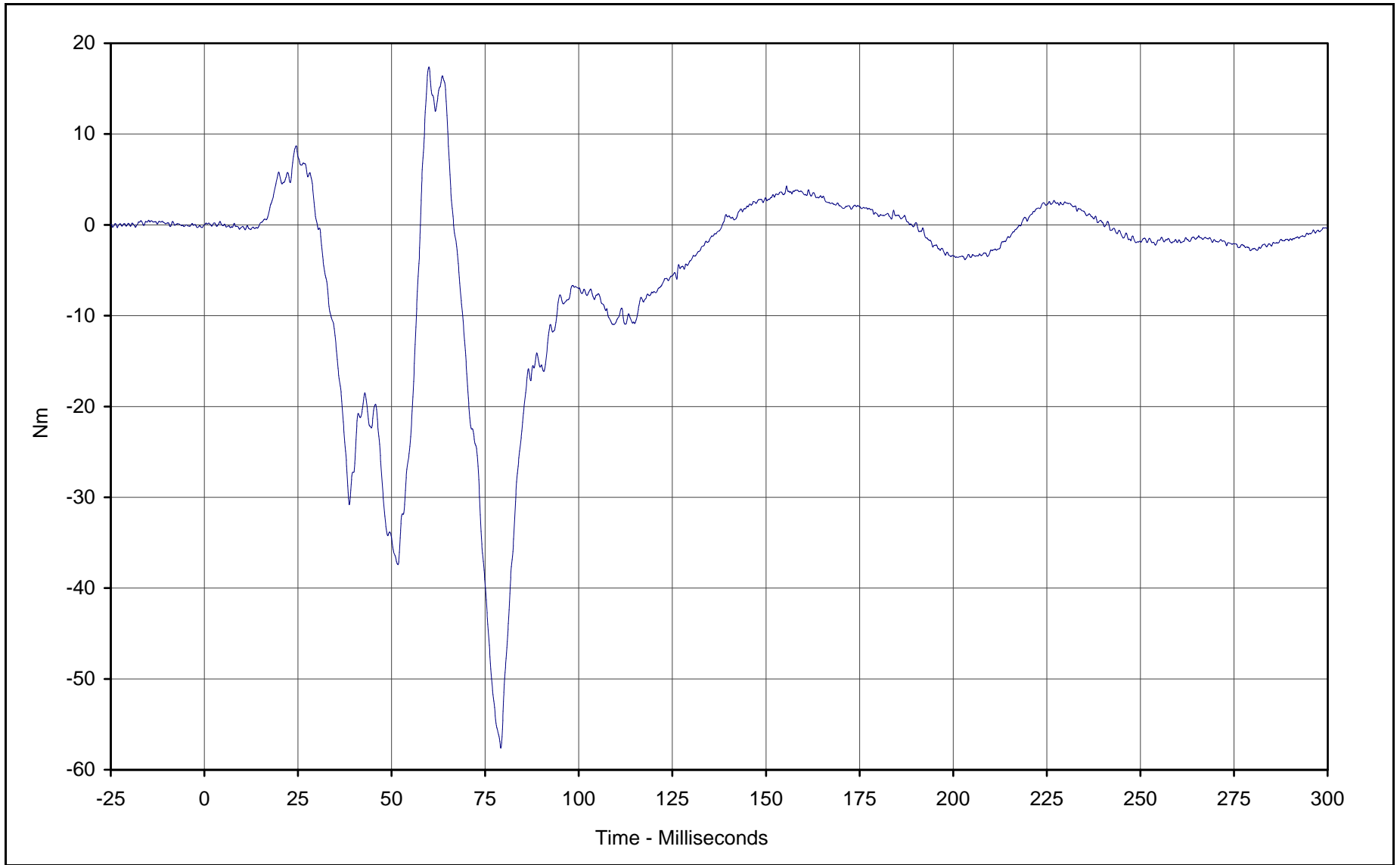

Curve Description: Passenger Right Upper Tibia Moment X

Maximum Value: 17.4 at 60.0 Milliseconds

Minimum Value: -57.6 at 79.2 Milliseconds

SAE Filter Class: 600

Date of Test: 1/29/02

Curve Number: FIL-075

Test Program: 2002 NHTSA 35mph NCAP No.: HO5300

Test Vehicle: 2002 Honda CR-V LX 4WD SUV

KAR21061-01



B-110

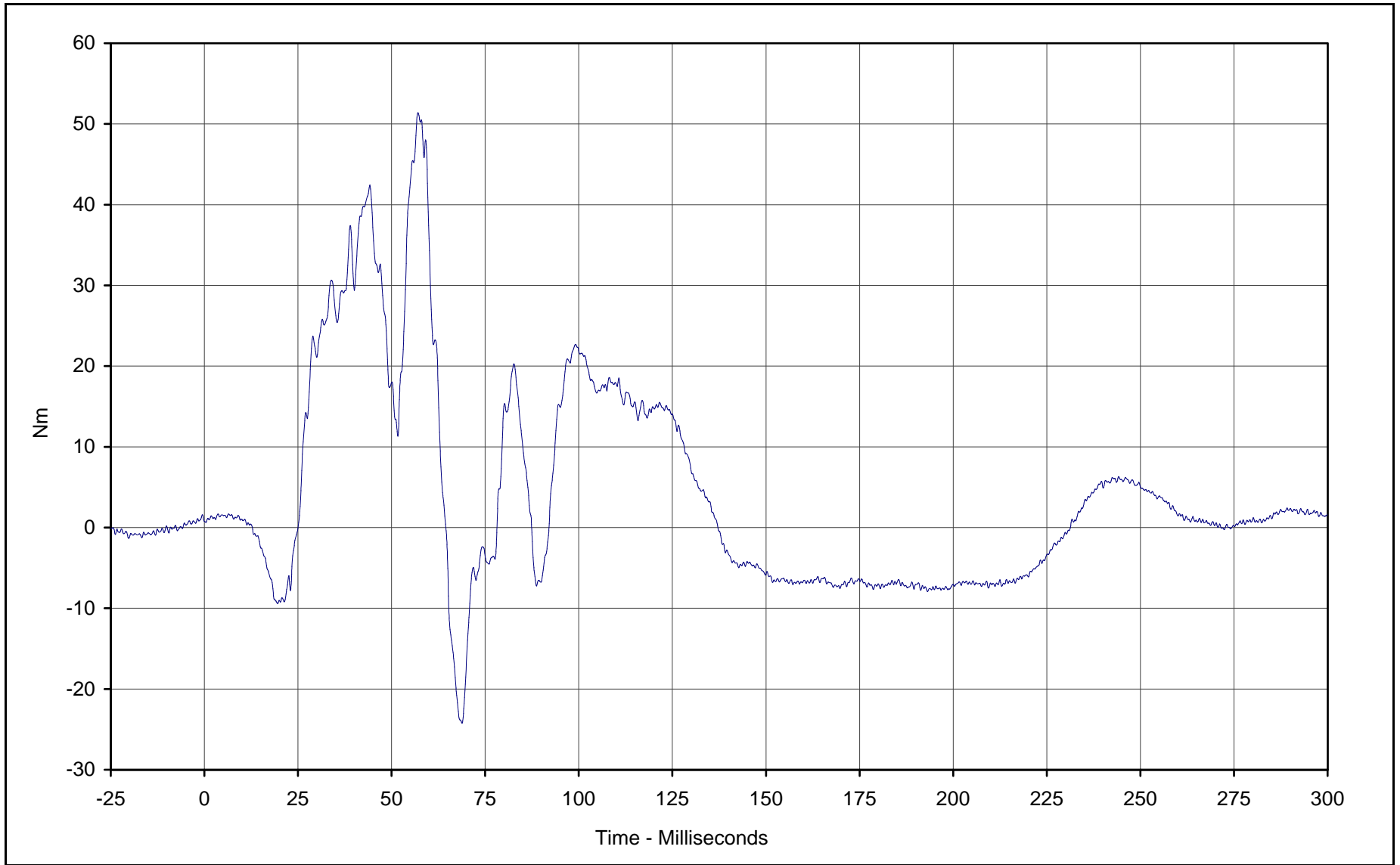

Curve Description: Passenger Right Upper Tibia Moment Y

Maximum Value: 51.4 at 57.0 Milliseconds

Minimum Value: -24.2 at 68.8 Milliseconds

SAE Filter Class: 600

Date of Test: 1/29/02

Curve Number: FIL-076

Test Program: 2002 NHTSA 35mph NCAP No.: HO5300

Test Vehicle: 2002 Honda CR-V LX 4WD SUV

KAR21061-01



B-111

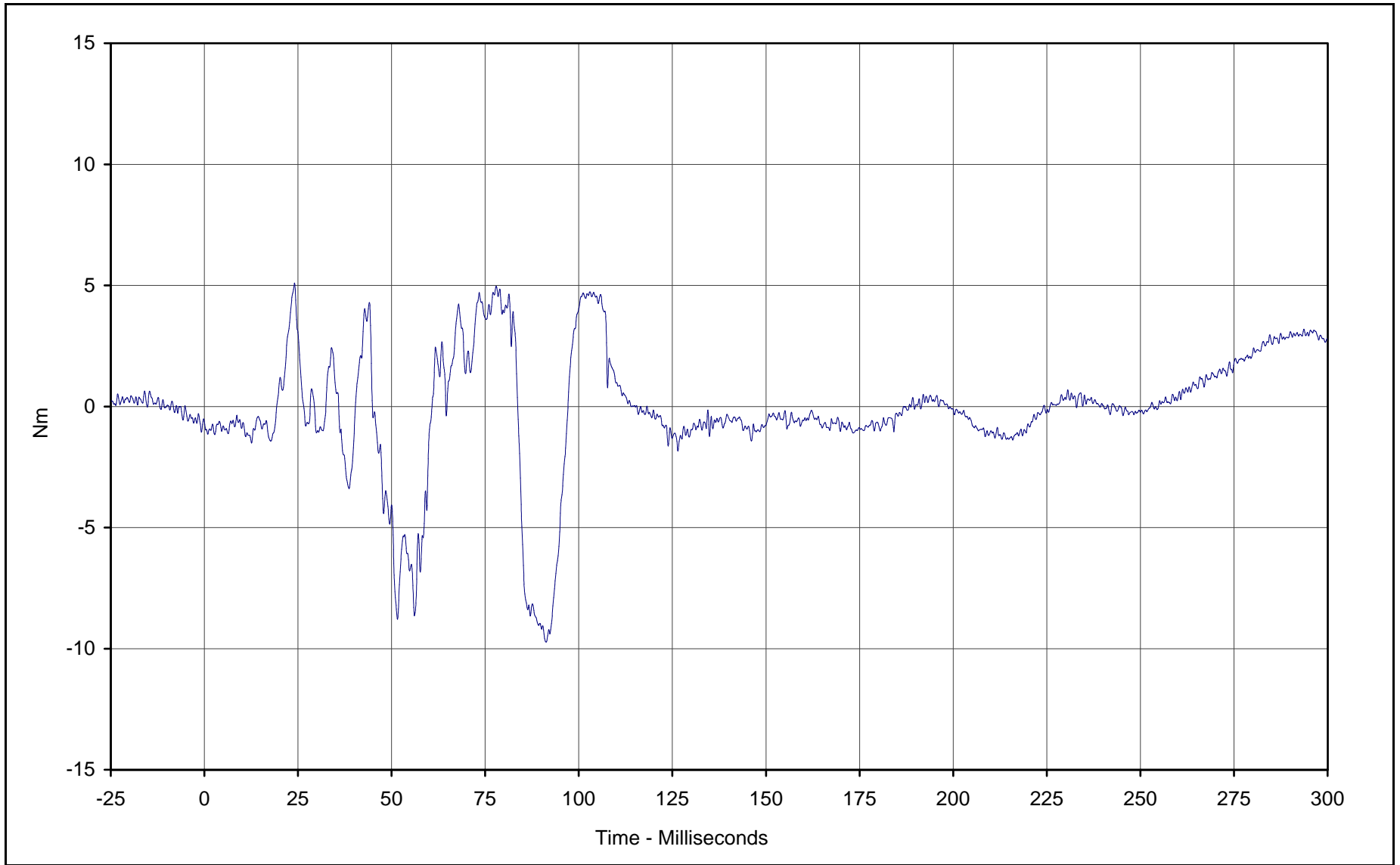

Curve Description: Passenger Left Lower Tibia Moment X

Maximum Value: 5.1 at 24.1 Milliseconds

Minimum Value: -9.7 at 91.2 Milliseconds

SAE Filter Class: 600

Date of Test: 1/29/02

Curve Number: FIL-077

Test Program: 2002 NHTSA 35mph NCAP No.: HO5300

Test Vehicle: 2002 Honda CR-V LX 4WD SUV

KAR21061-01



B-112

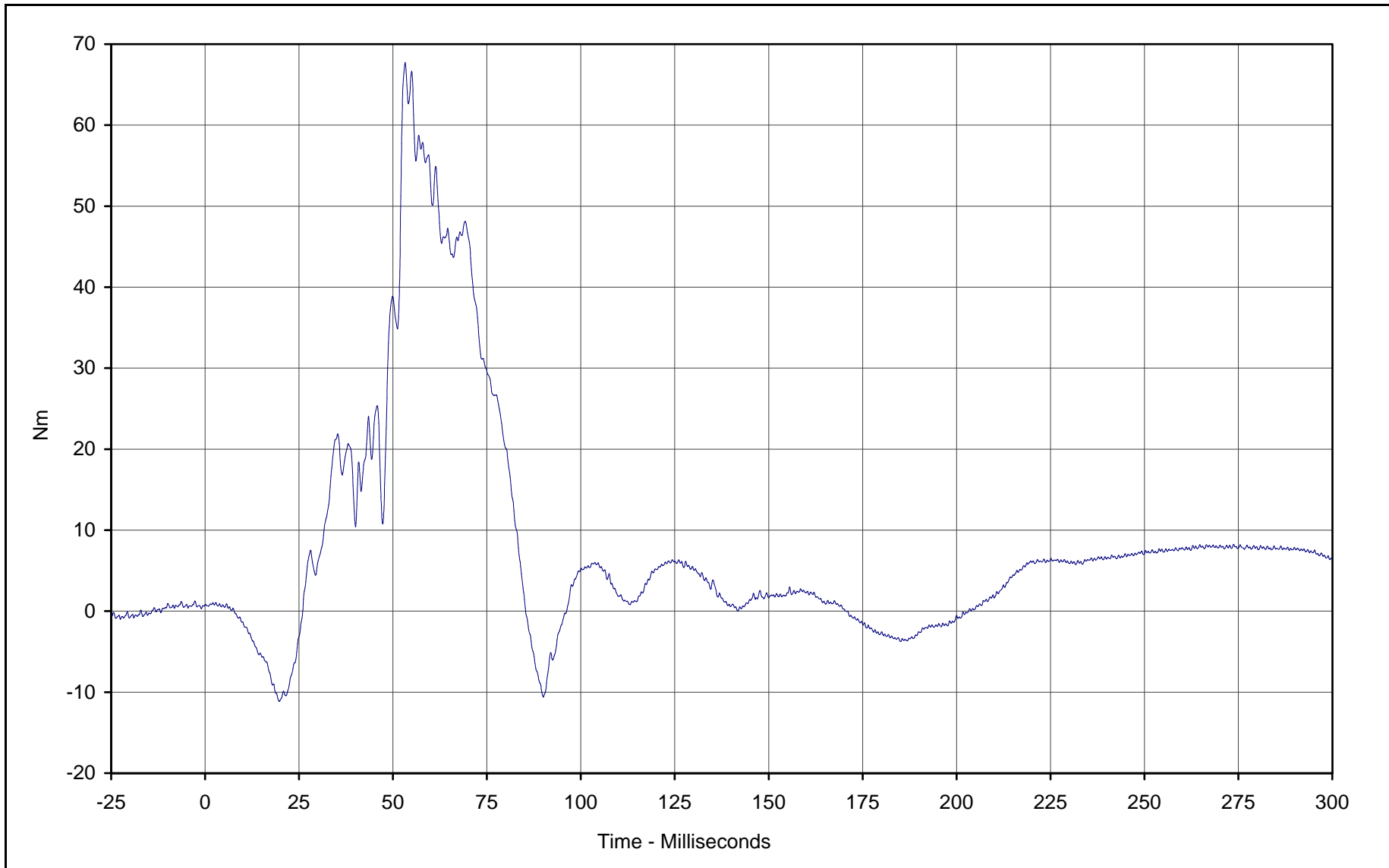

Curve Description: Passenger Left Lower Tibia Moment Y

Maximum Value: 67.7 at 53.3 Milliseconds

Minimum Value: -11.2 at 19.8 Milliseconds

SAE Filter Class: 600

Date of Test: 1/29/02

Curve Number: FIL-078

Test Program: 2002 NHTSA 35mph NCAP No.: HO5300

Test Vehicle: 2002 Honda CR-V LX 4WD SUV

KAR21061-01



B-113

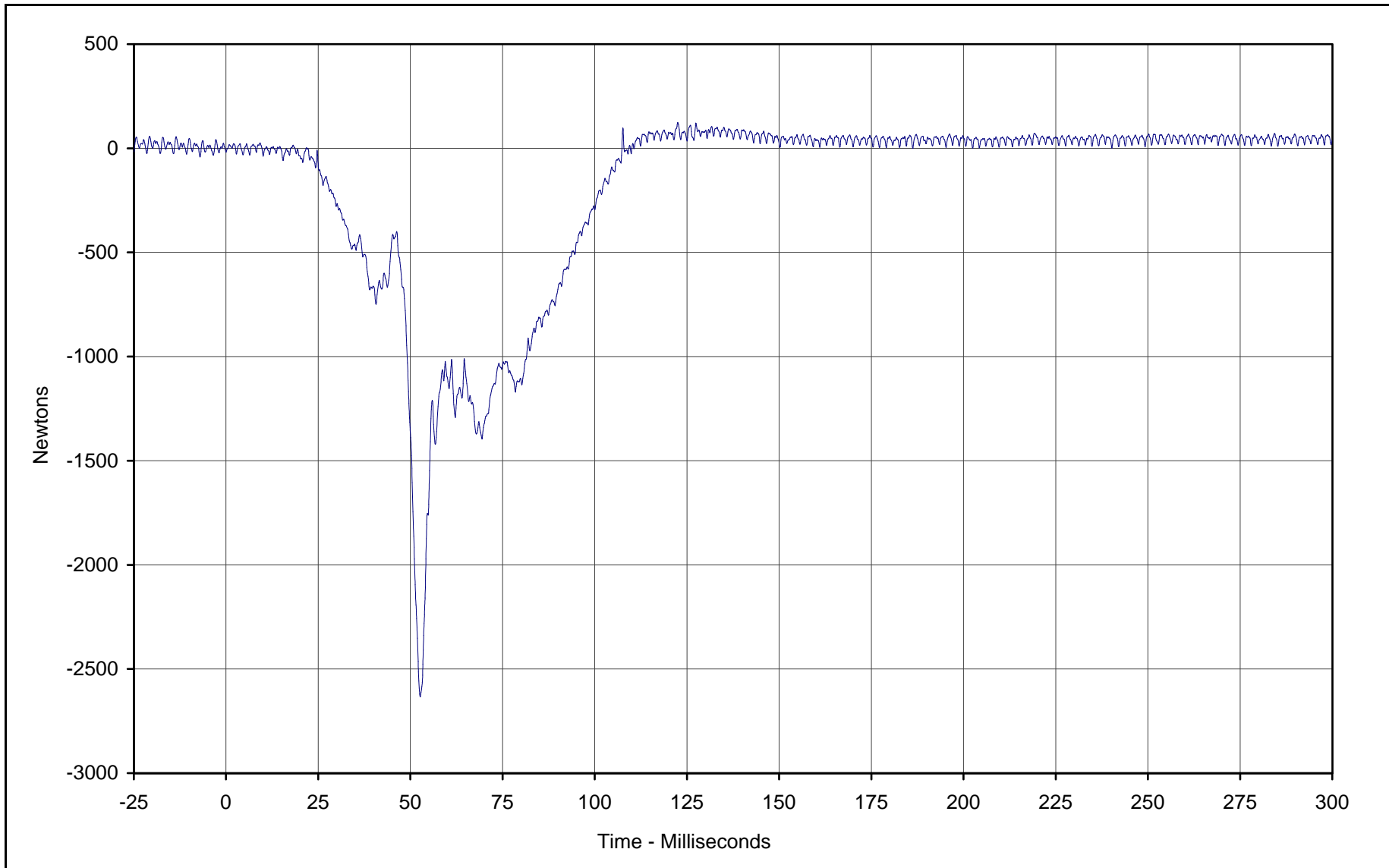

Curve Description: Passenger Left Lower Tibia Force Z  
Maximum Value: 123.9 at 122.5 Milliseconds  
Minimum Value: -2633.1 at 52.7 Milliseconds  
SAE Filter Class: 600  
Date of Test: 1/29/02  
Curve Number: FIL-079

Test Program: 2002 NHTSA 35mph NCAP No.: HO5300  
Test Vehicle: 2002 Honda CR-V LX 4WD SUV



KAR21061-01

B-114

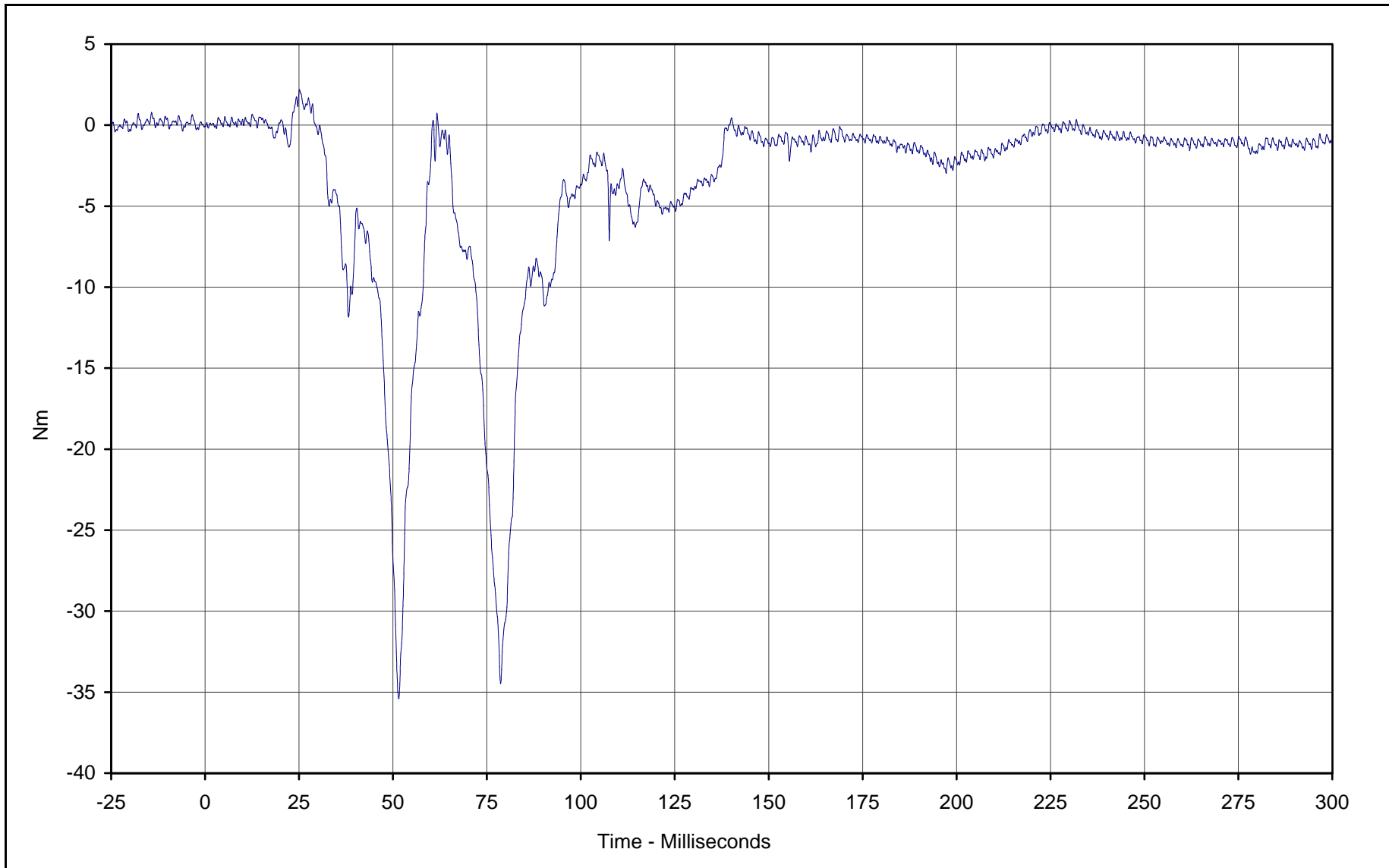

Curve Description: Passenger Right Lower Tibia Moment X

Maximum Value: 2.2 at 25.1 Milliseconds

Minimum Value: -35.4 at 51.5 Milliseconds

SAE Filter Class: 600

Date of Test: 1/29/02

Curve Number: FIL-080

Test Program: 2002 NHTSA 35mph NCAP No.: HO5300

Test Vehicle: 2002 Honda CR-V LX 4WD SUV

KAR21061-01



B-115

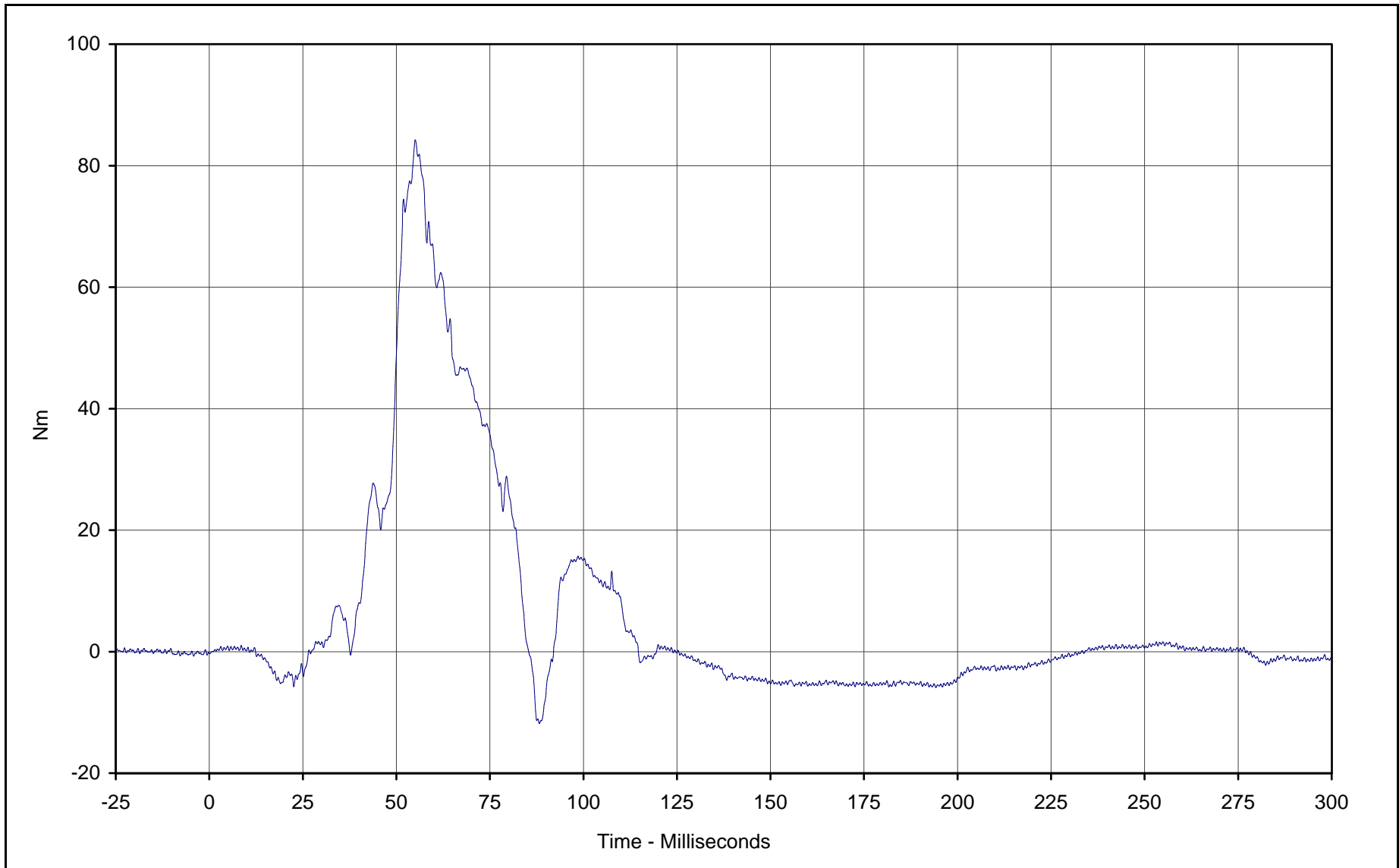

Curve Description: Passenger Right Lower Tibia Moment Y

Maximum Value: 84.2 at 55.1 Milliseconds

Minimum Value: -11.8 at 88.2 Milliseconds

SAE Filter Class: 600

Date of Test: 1/29/02

Curve Number: FIL-081

Test Program: 2002 NHTSA 35mph NCAP No.: HO5300

Test Vehicle: 2002 Honda CR-V LX 4WD SUV

KAR21061-01



B-116

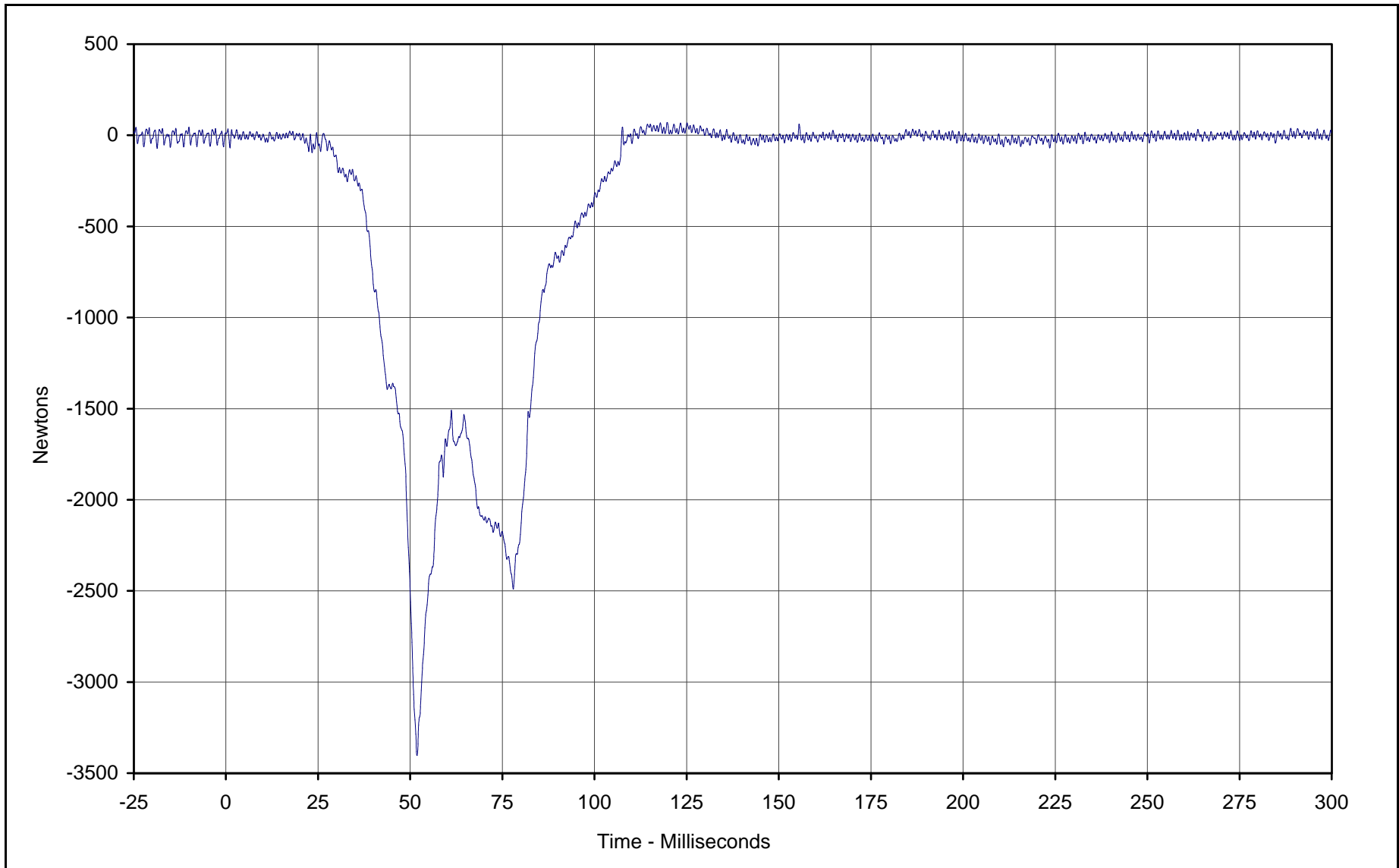

Curve Description: Passenger Right lower Tibia Force Z

Maximum Value: 70.3 at 119.7 Milliseconds

Minimum Value: -3402.8 at 51.8 Milliseconds

SAE Filter Class: 600

Date of Test: 1/29/02

Curve Number: FIL-082

Test Program: 2002 NHTSA 35mph NCAP No.: HO5300

Test Vehicle: 2002 Honda CR-V LX 4WD SUV

KAR21061-01



B-117

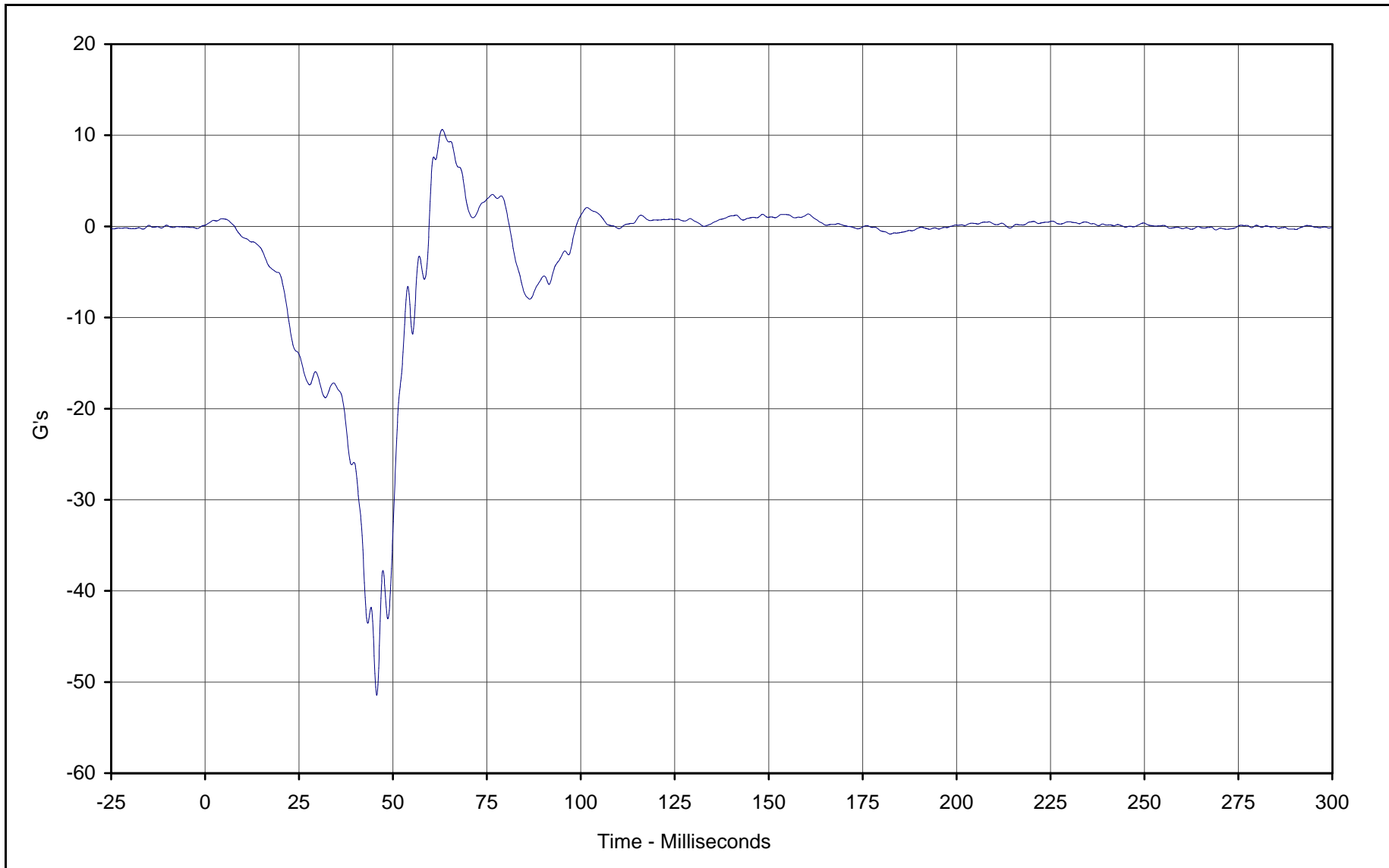

Curve Description: Passenger Left Foot Aft X  
Maximum Value: 10.6 at 63.1 Milliseconds  
Minimum Value: -51.5 at 45.7 Milliseconds  
SAE Filter Class: 180  
Date of Test: 1/29/02  
Curve Number: FIL-083

Test Program: 2002 NHTSA 35mph NCAP No.: HO5300  
Test Vehicle: 2002 Honda CR-V LX 4WD SUV



KAR21061-01

B-118

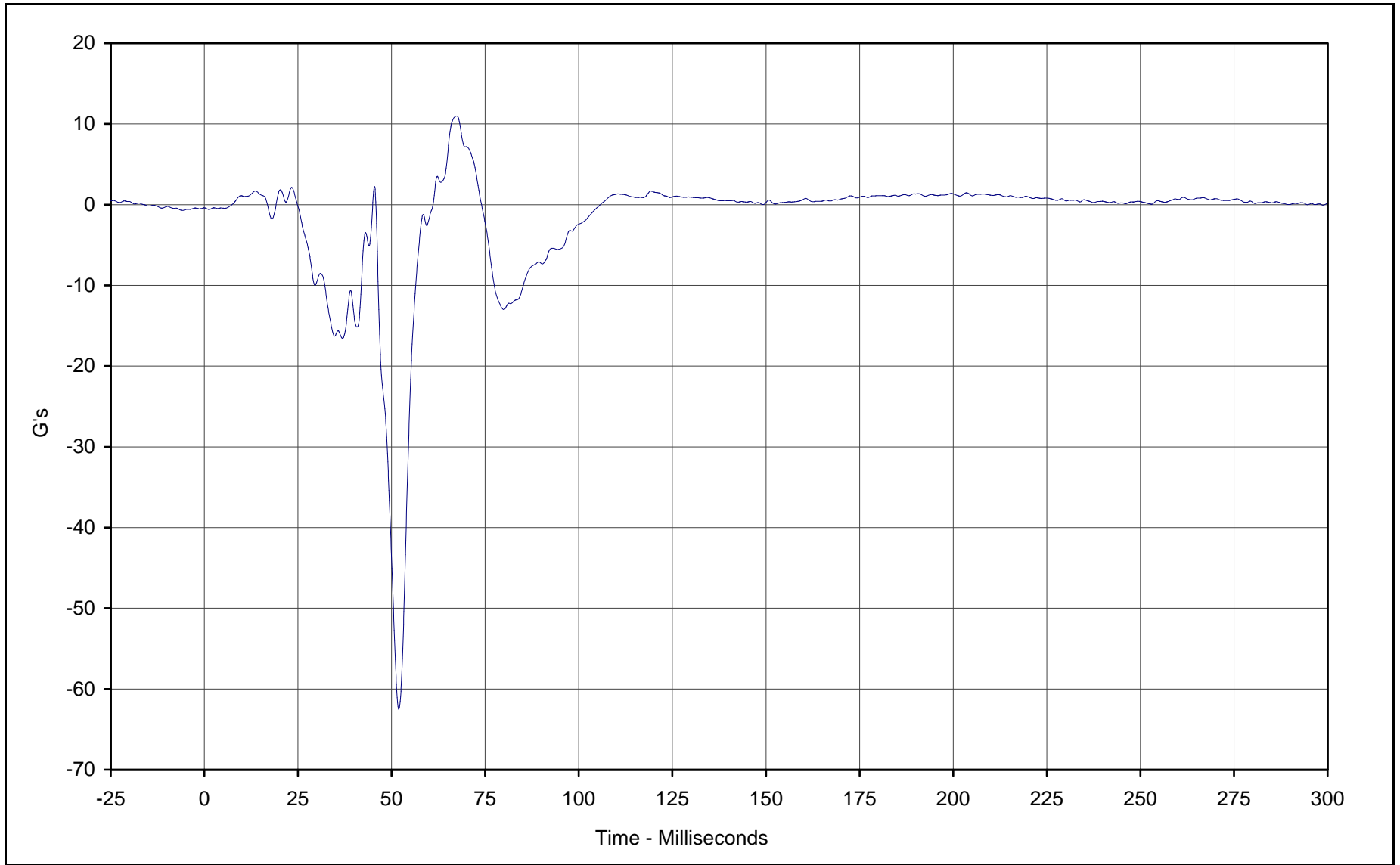

Curve Description: Passenger Left Foot Aft Z  
Maximum Value: 11.0 at 67.4 Milliseconds  
Minimum Value: -62.5 at 51.9 Milliseconds  
SAE Filter Class: 180  
Date of Test: 1/29/02  
Curve Number: FIL-084

Test Program: 2002 NHTSA 35mph NCAP No.: HO5300  
Test Vehicle: 2002 Honda CR-V LX 4WD SUV



KAR21061-01

B-119

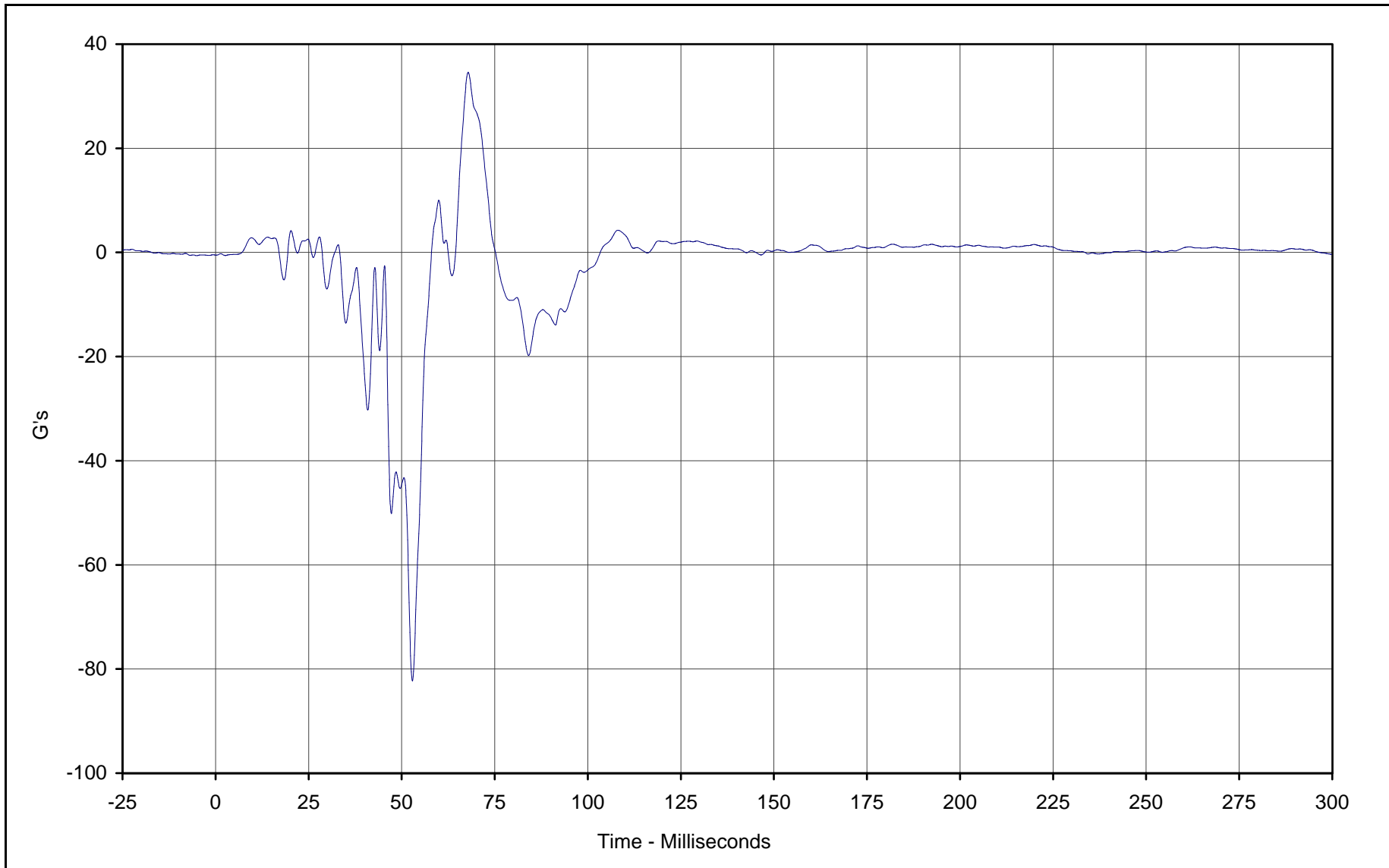

Curve Description: Passenger Left Foot Fore Z  
Maximum Value: 34.6 at 67.9 Milliseconds  
Minimum Value: -82.3 at 52.9 Milliseconds  
SAE Filter Class: 180  
Date of Test: 1/29/02  
Curve Number: FIL-085

Test Program: 2002 NHTSA 35mph NCAP No.: HO5300  
Test Vehicle: 2002 Honda CR-V LX 4WD SUV



KAR21061-01

B-120

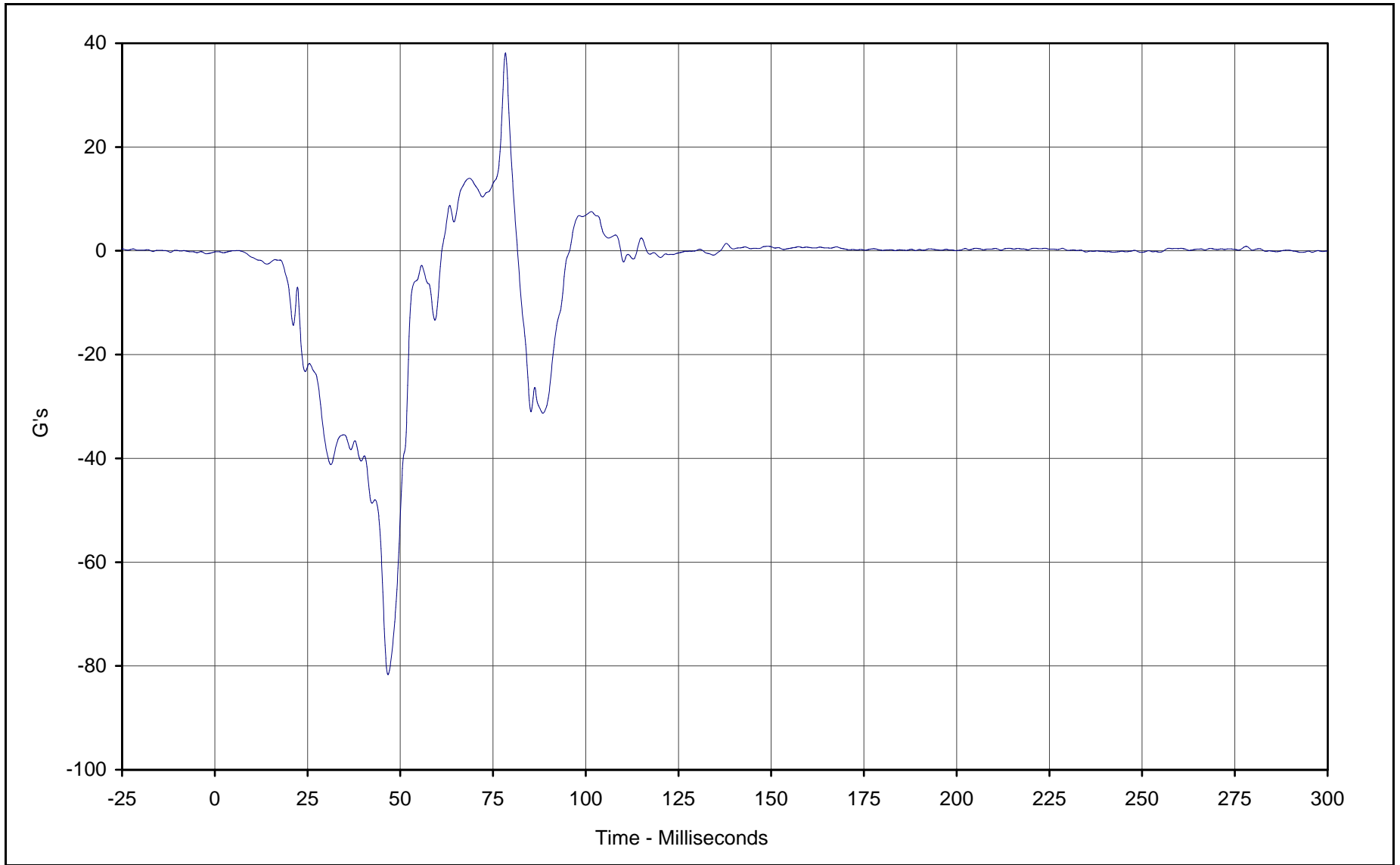

Curve Description: Passenger Right Foot Aft X  
Maximum Value: 38.1 at 78.4 Milliseconds  
Minimum Value: -81.7 at 46.7 Milliseconds  
SAE Filter Class: 180  
Date of Test: 1/29/02  
Curve Number: FIL-086

Test Program: 2002 NHTSA 35mph NCAP No.: HO5300  
Test Vehicle: 2002 Honda CR-V LX 4WD SUV



KAR21061-01

B-121

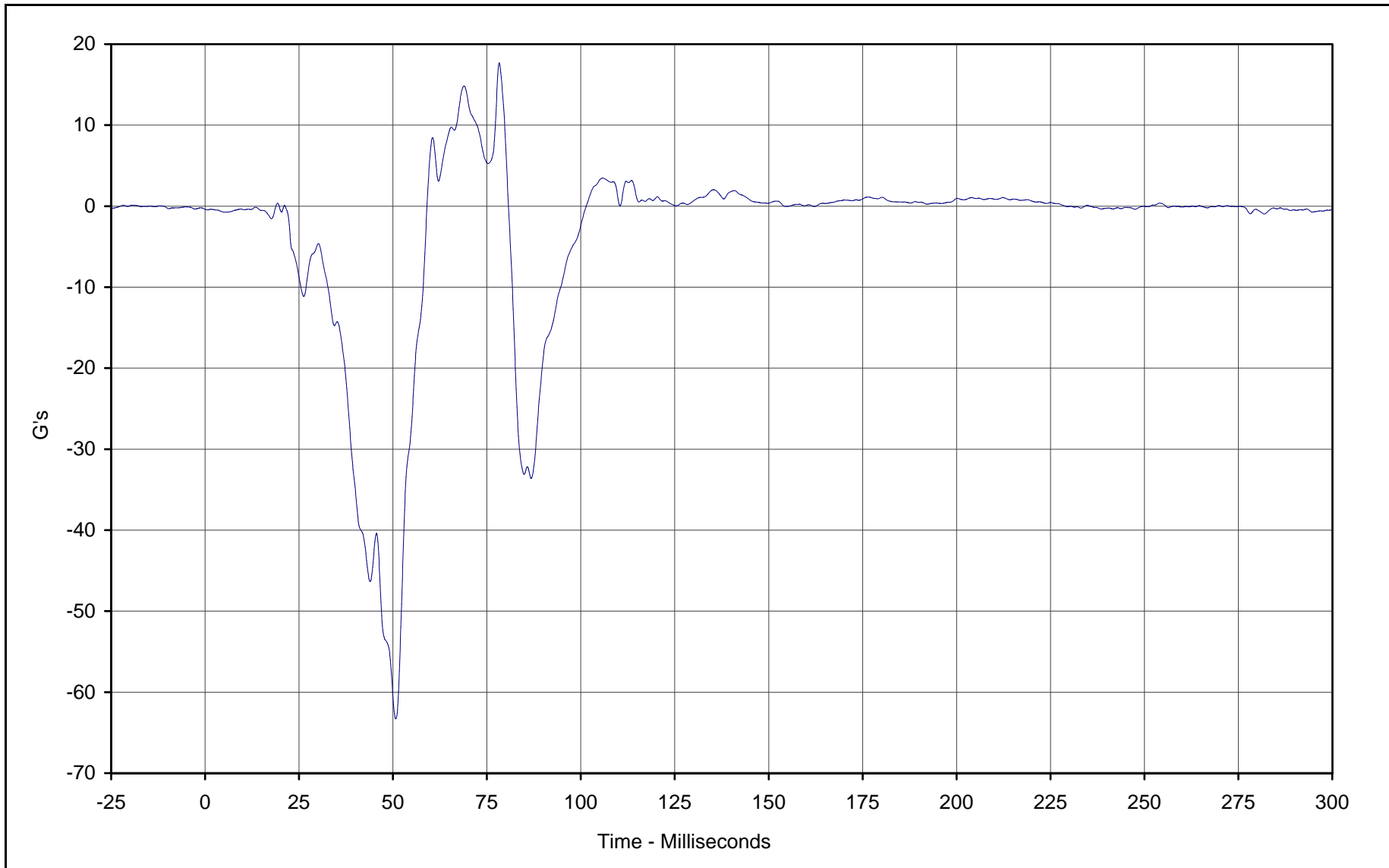

Curve Description: Passenger Right Foot Aft Z  
Maximum Value: 17.7 at 78.3 Milliseconds  
Minimum Value: -63.3 at 50.7 Milliseconds  
SAE Filter Class: 180  
Date of Test: 1/29/02  
Curve Number: FIL-087

Test Program: 2002 NHTSA 35mph NCAP No.: HO5300  
Test Vehicle: 2002 Honda CR-V LX 4WD SUV

KAR21061-01



B-122

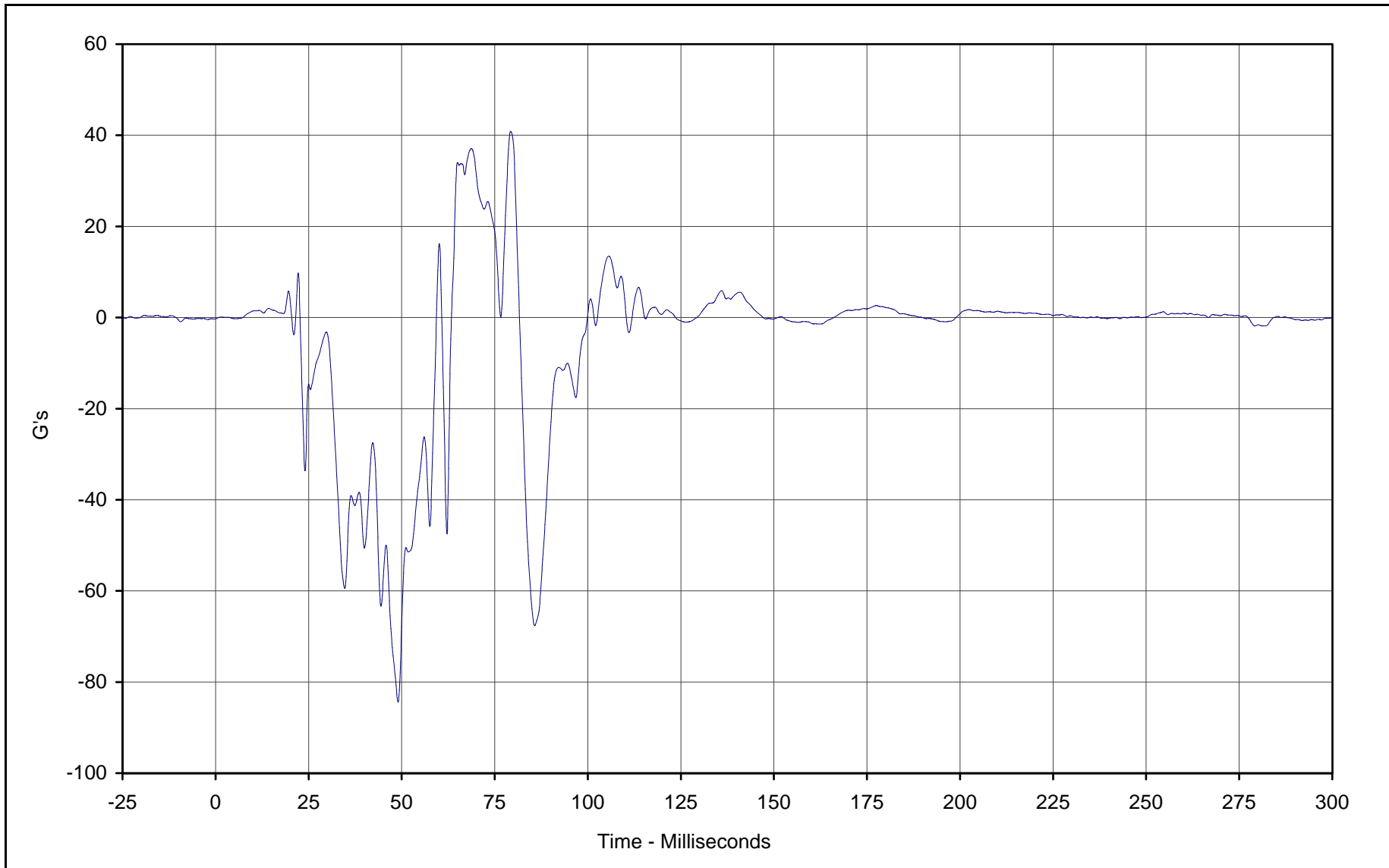

Curve Description: Passenger Right Foot Fore Z  
Maximum Value: 40.9 at 79.3 Milliseconds  
Minimum Value: -84.4 at 49.0 Milliseconds  
SAE Filter Class: 180  
Date of Test: 1/29/02  
Curve Number: FIL-088

Test Program: 2002 NHTSA 35mph NCAP No.: HO5300  
Test Vehicle: 2002 Honda CR-V LX 4WD SUV

KAR21061-01



B-123

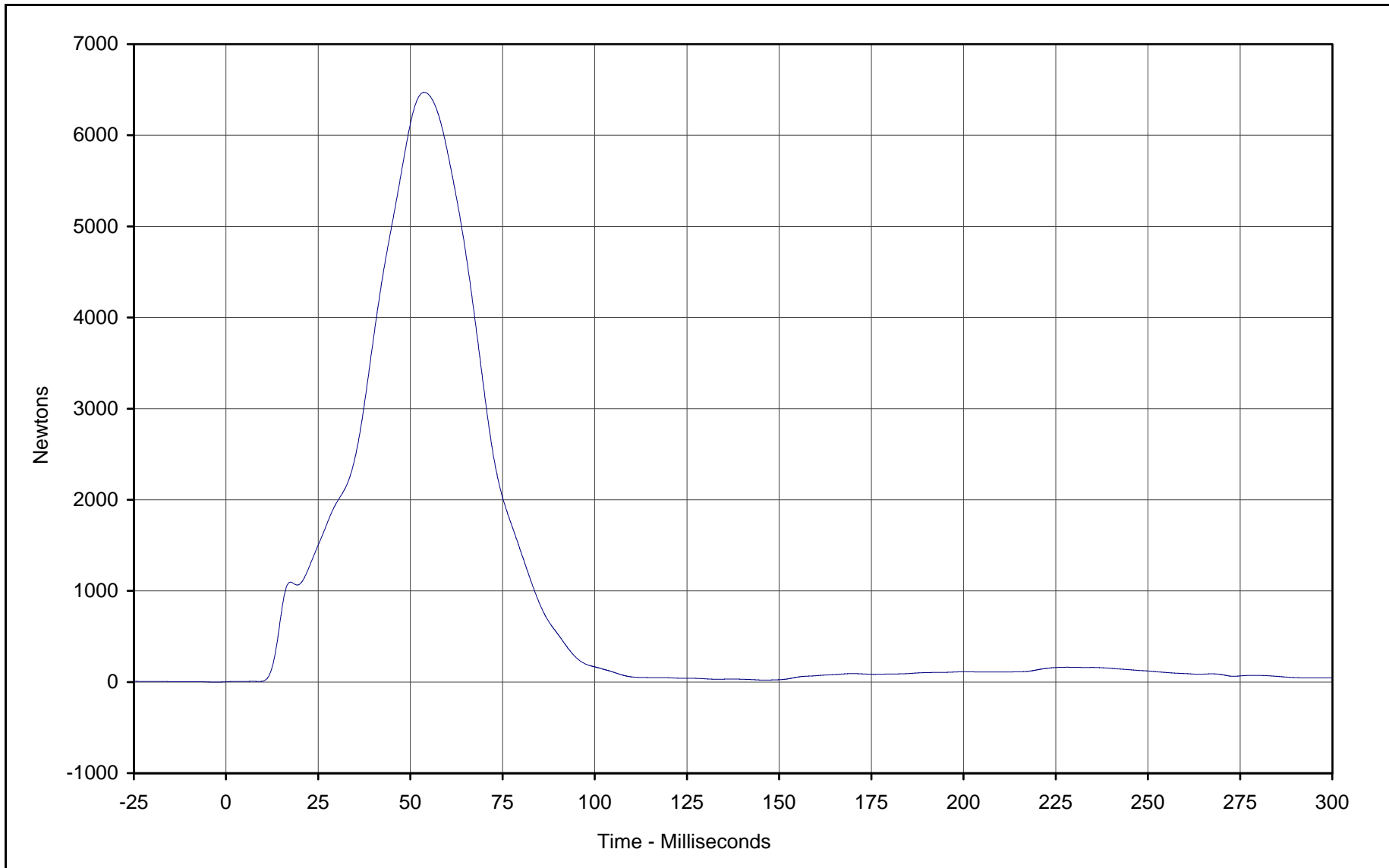

Curve Description: Passenger Lap Belt Force  
Maximum Value: 6471.6 at 53.8 Milliseconds  
Minimum Value: 2.6 at 0.0 Milliseconds  
SAE Filter Class: 60  
Date of Test: 1/29/02  
Curve Number: FIL-089

Test Program: 2002 NHTSA 35mph NCAP No.: HO5300  
Test Vehicle: 2002 Honda CR-V LX 4WD SUV



KAR21061-01

B-124

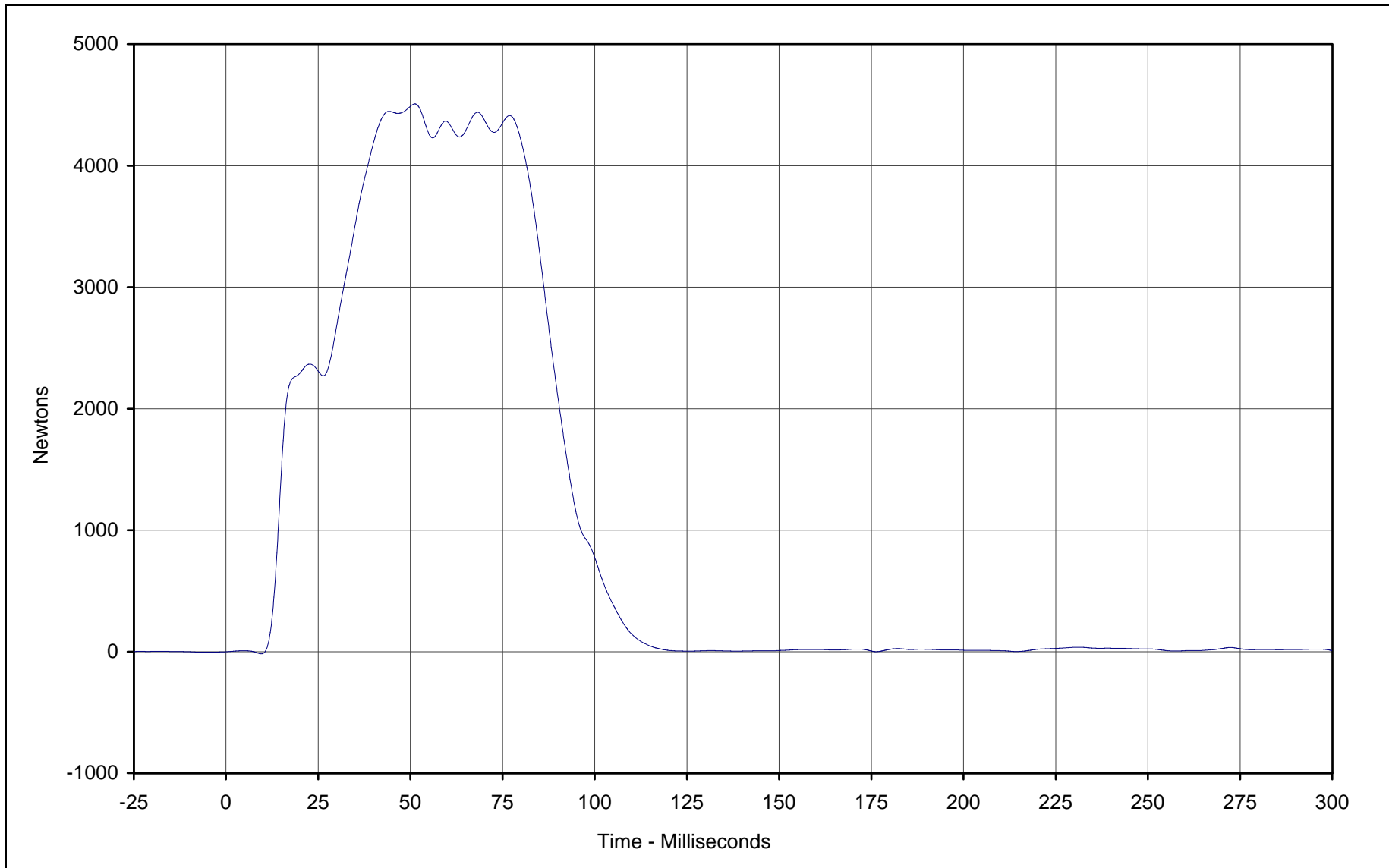

Curve Description: Passenger Shoulder Belt Force  
Maximum Value: 4508.2 at 51.2 Milliseconds  
Minimum Value: -17.7 at 9.6 Milliseconds  
SAE Filter Class: 60  
Date of Test: 1/29/02  
Curve Number: FIL-090

Test Program: 2002 NHTSA 35mph NCAP No.: HO5300  
Test Vehicle: 2002 Honda CR-V LX 4WD SUV

KAR21061-01



B-125

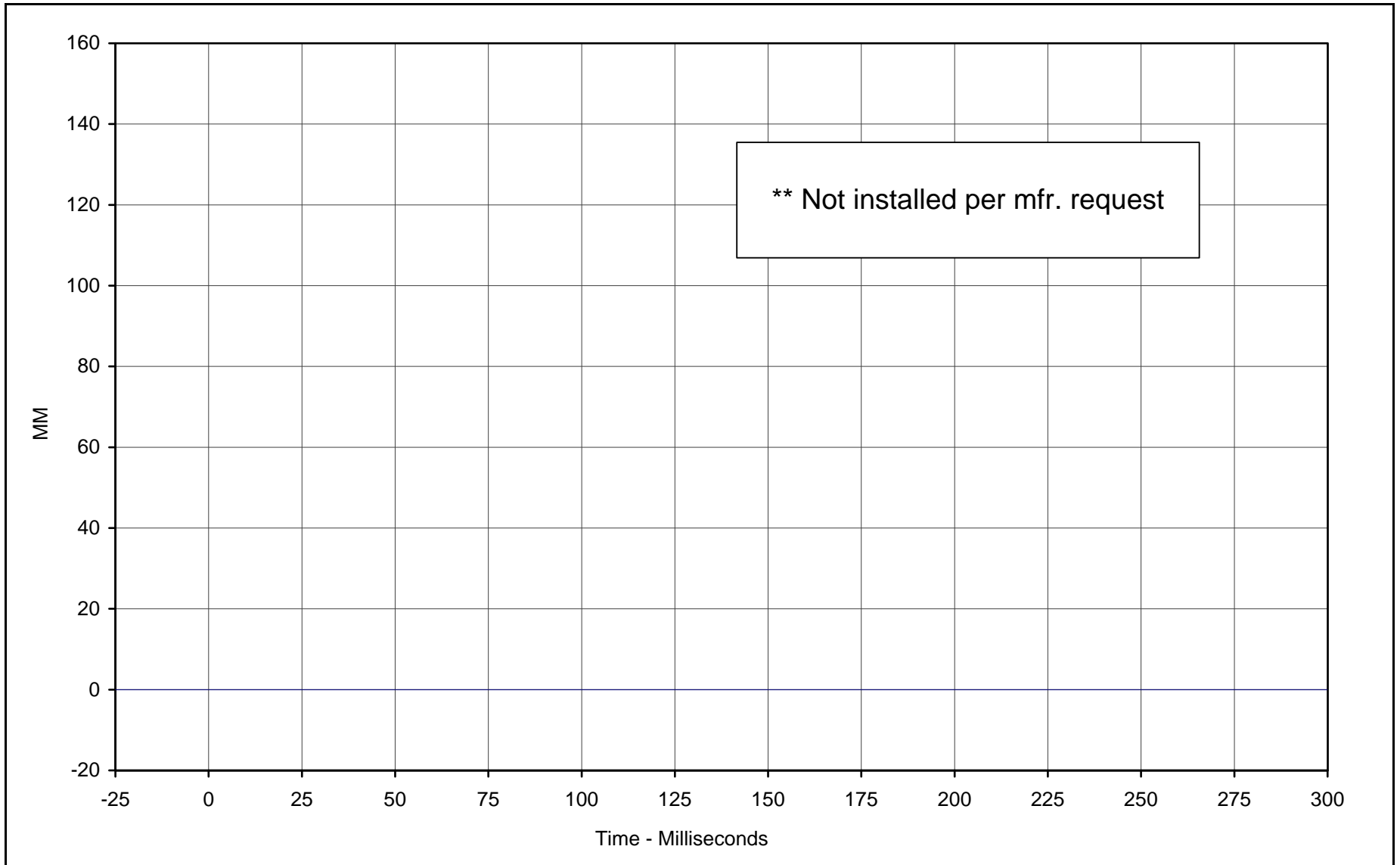

Curve Description: Passenger Shoulder Belt Pullout \*\*

Test Program: 2002 NHTSA 35mph NCAP No.: HO5300

Maximum Value: 0.0 at 0.0 Milliseconds

Test Vehicle: 2002 Honda CR-V LX 4WD SUV

Minimum Value: 0.0 at 0.0 Milliseconds

SAE Filter Class: 60

Date of Test: 1/29/02

Curve Number: FIL-091

\*\* Not installed per mfr. request



KAR21061-01

B-126

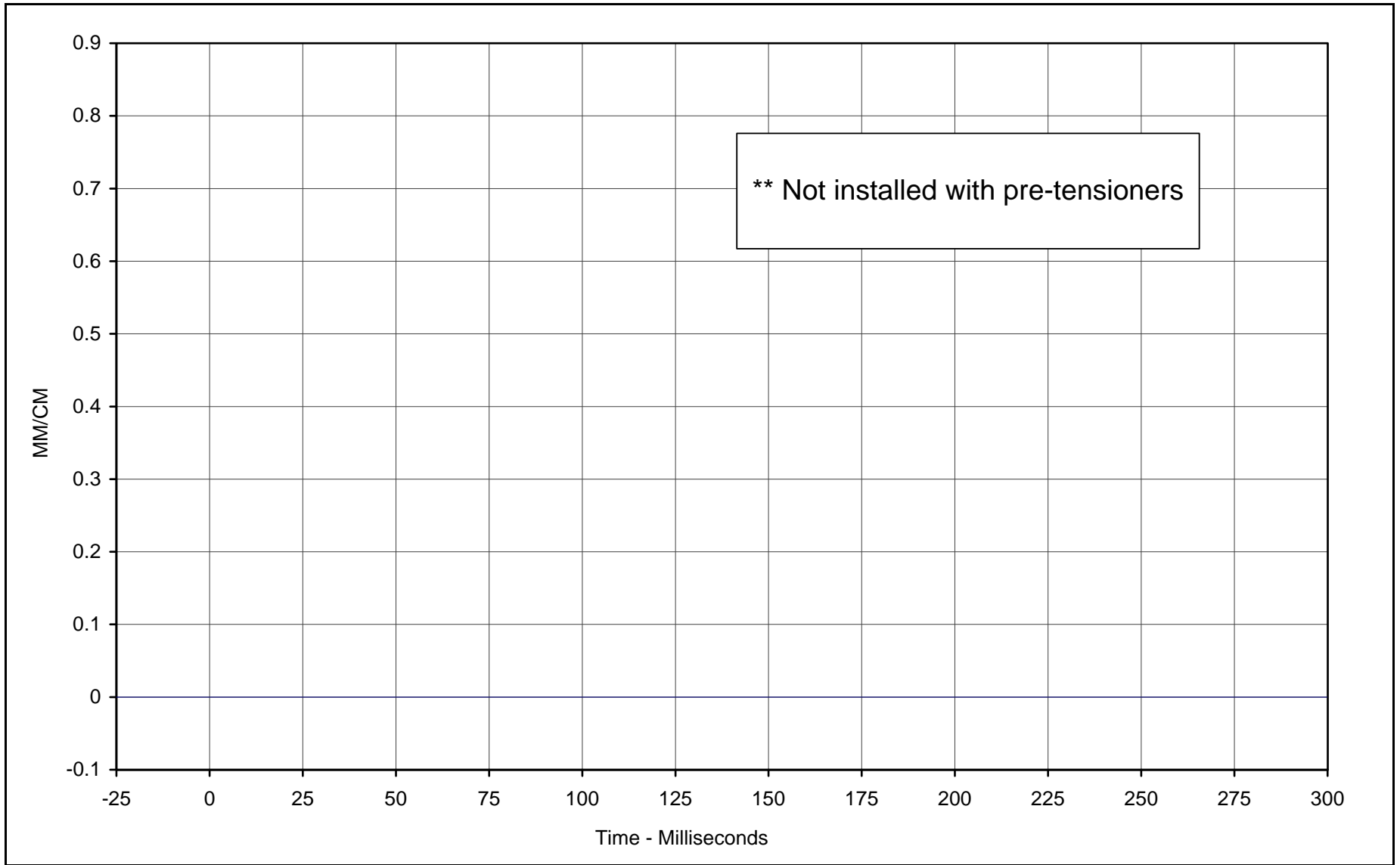

Curve Description: Passenger Shoulder Belt Elongation \*\*

Maximum Value: 0.0 at 0.0 Milliseconds

Minimum Value: 0.0 at 0.0 Milliseconds

SAE Filter Class: 60

Date of Test: 1/29/02

Curve Number: FIL-092

Test Program: 2002 NHTSA 35mph NCAP No.: HO5300

Test Vehicle: 2002 Honda CR-V LX 4WD SUV

\*\* Not installed with pre-tensioners



KAR21061-01

B-127

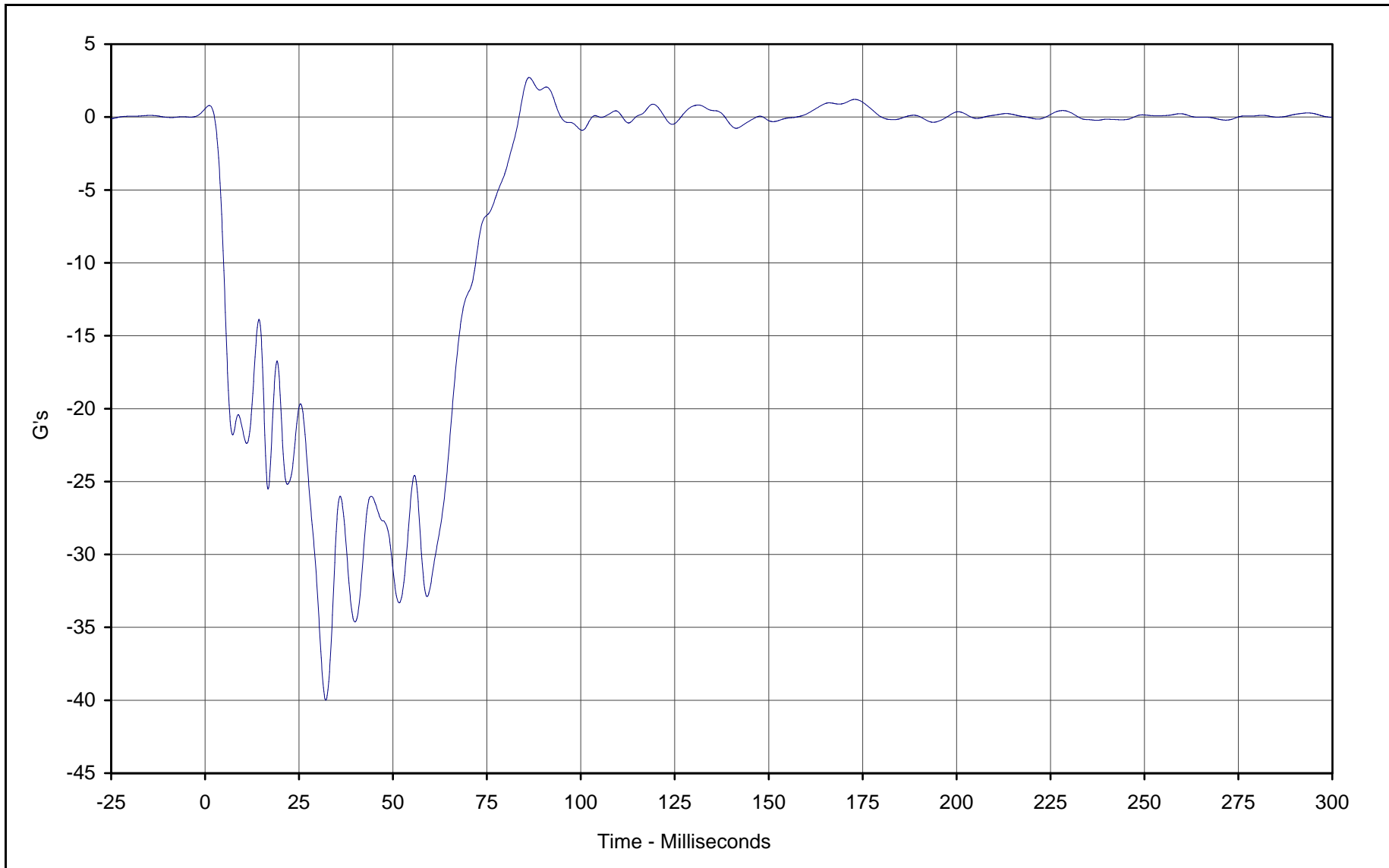

Curve Description: Vehicle Left Rear X  
Maximum Value: 2.7 at 86.3 Milliseconds  
Minimum Value: -40.0 at 32.1 Milliseconds  
SAE Filter Class: 60  
Date of Test: 1/29/02  
Curve Number: FIL-093

Test Program: 2002 NHTSA 35mph NCAP No.: HO5300  
Test Vehicle: 2002 Honda CR-V LX 4WD SUV



KAR21061-01

B-128

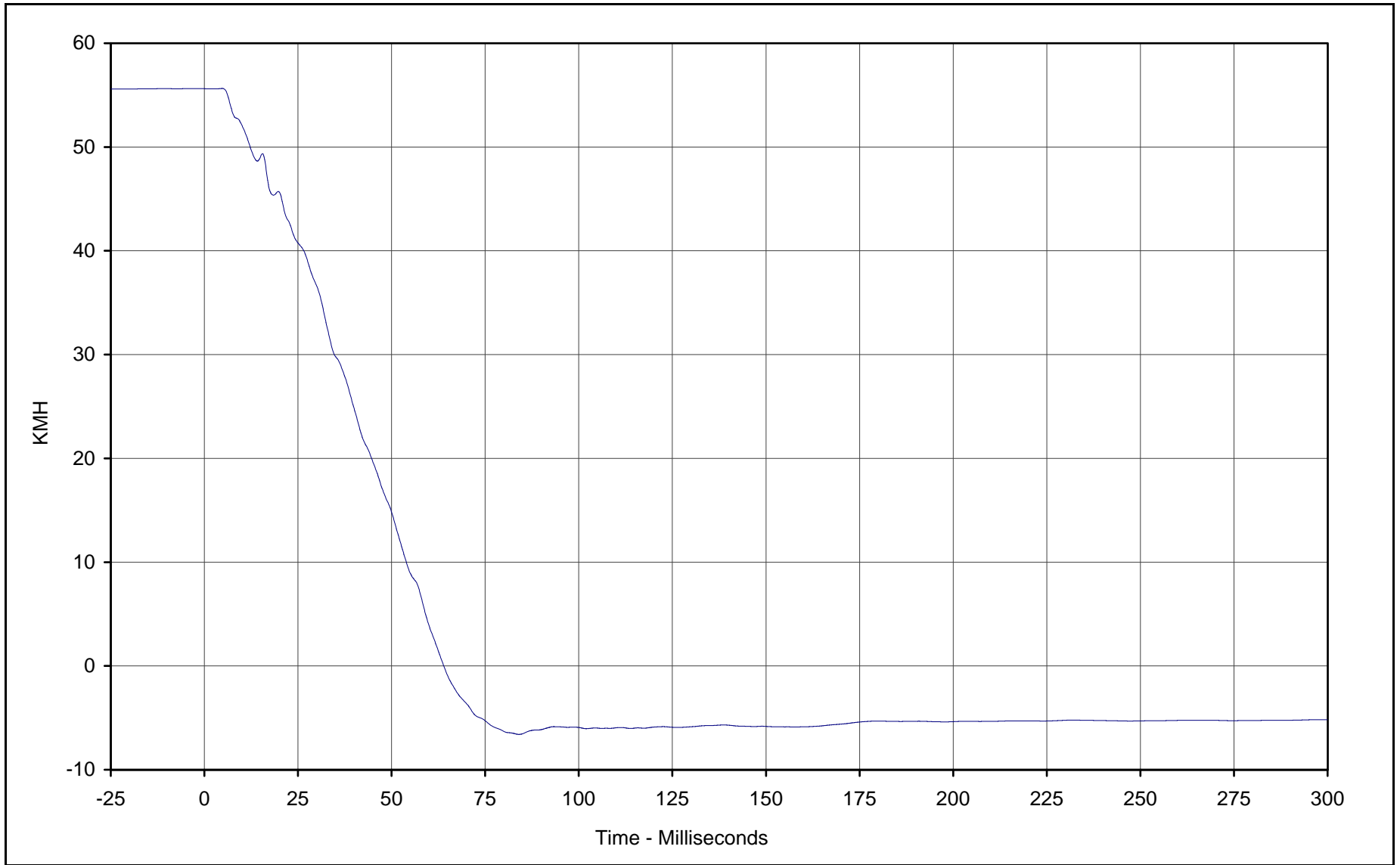

Curve Description: Vehicle Left Rear X Velocity  
Maximum Value: 55.6 at 4.8 Milliseconds  
Minimum Value: -6.6 at 84.0 Milliseconds  
SAE Filter Class: 180  
Date of Test: 1/29/02  
Curve Number: IN1-093

Test Program: 2002 NHTSA 35mph NCAP No.: HO5300  
Test Vehicle: 2002 Honda CR-V LX 4WD SUV

KAR21061-01



B-129

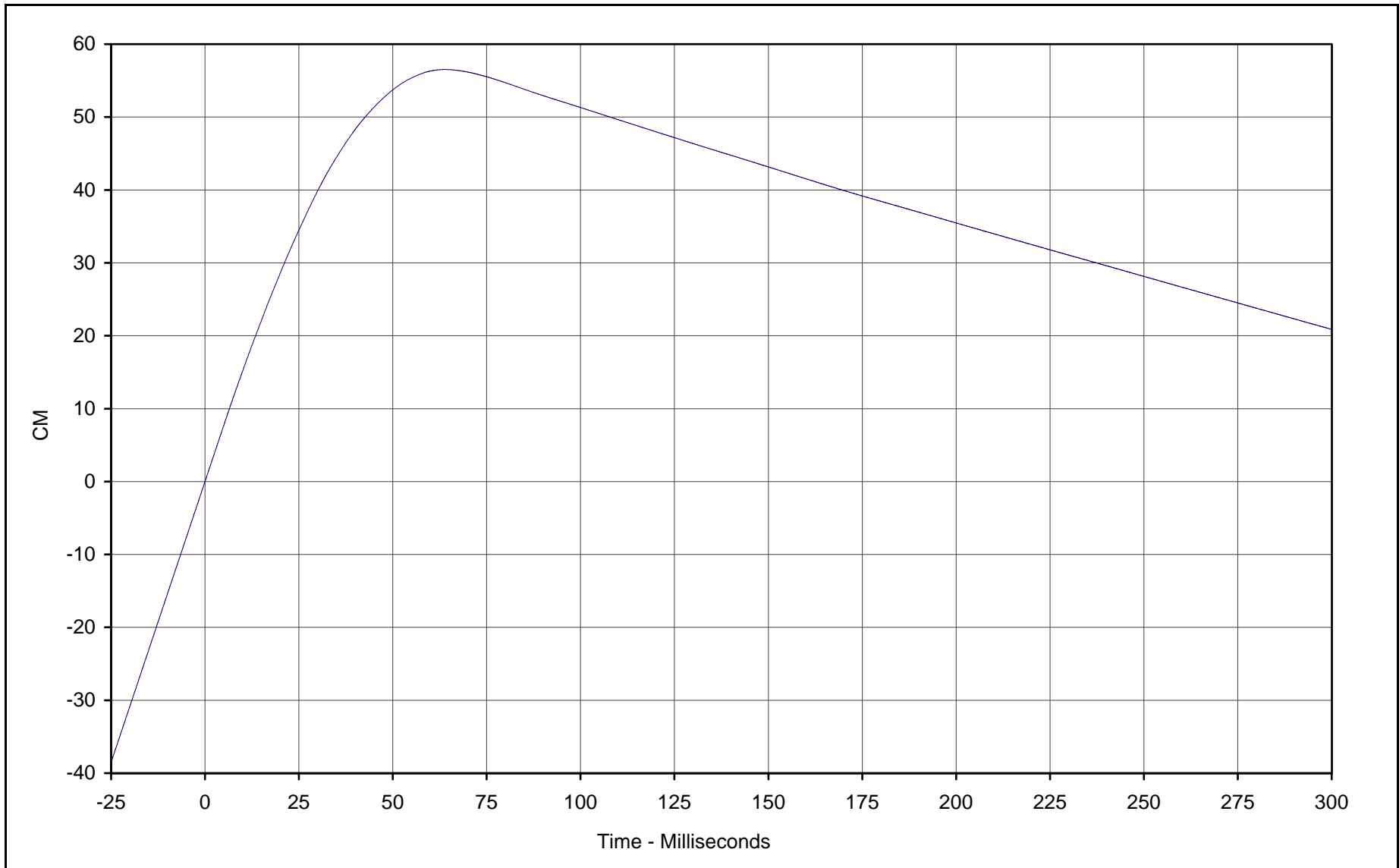

Curve Description: Vehicle Left Rear X Displ.  
Maximum Value: 56.5 at 63.9 Milliseconds  
Minimum Value: 0.0 at 0.0 Milliseconds  
SAE Filter Class: 180  
Date of Test: 1/29/02  
Curve Number: IN2-093

Test Program: 2002 NHTSA 35mph NCAP No.: HO5300  
Test Vehicle: 2002 Honda CR-V LX 4WD SUV



KAR21061-01

B-130

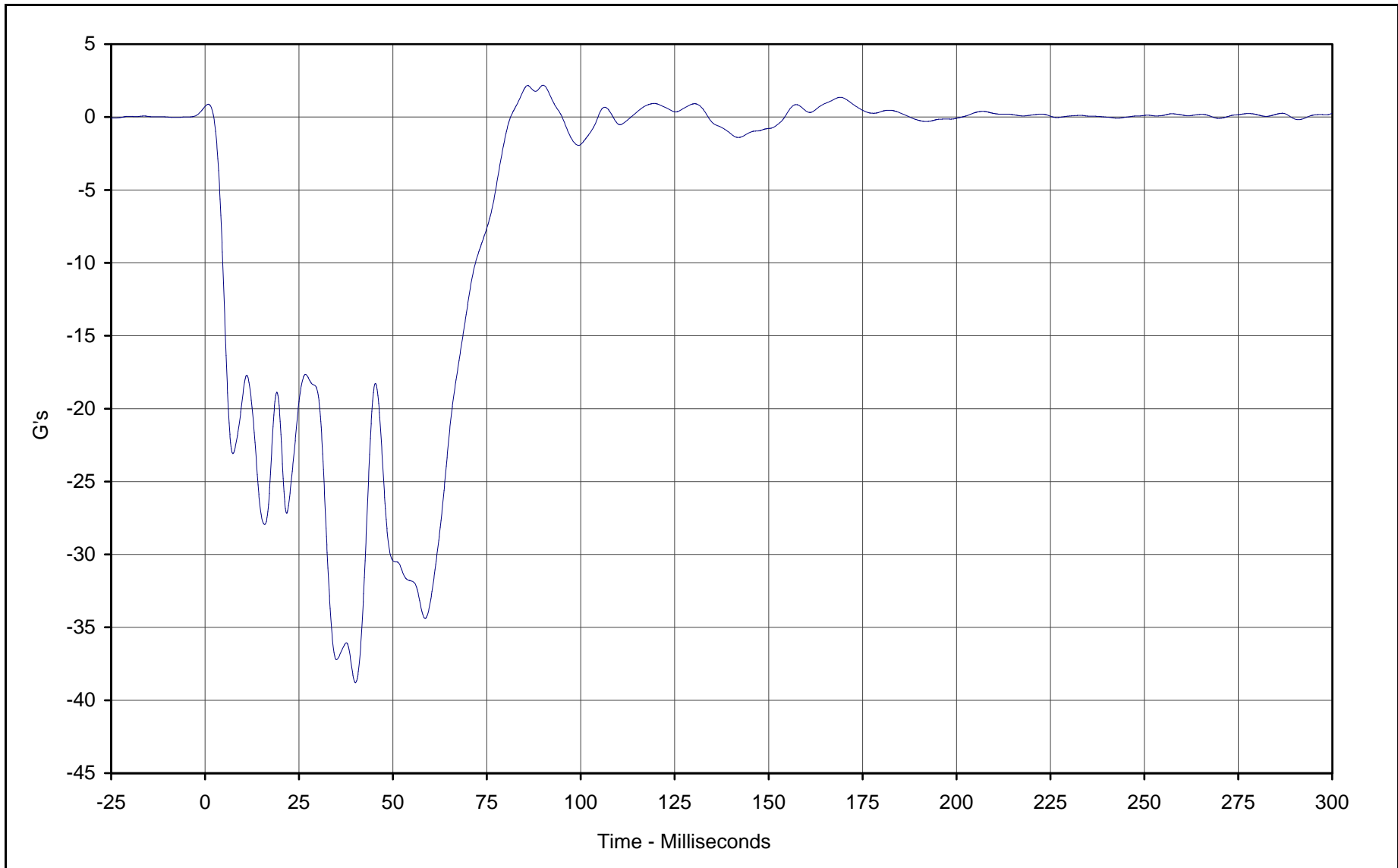

Curve Description: Vehicle Right Rear X  
Maximum Value: 2.2 at 90.0 Milliseconds  
Minimum Value: -38.8 at 40.0 Milliseconds  
SAE Filter Class: 60  
Date of Test: 1/29/02  
Curve Number: FIL-094

Test Program: 2002 NHTSA 35mph NCAP No.: HO5300  
Test Vehicle: 2002 Honda CR-V LX 4WD SUV



KAR21061-01

B-131

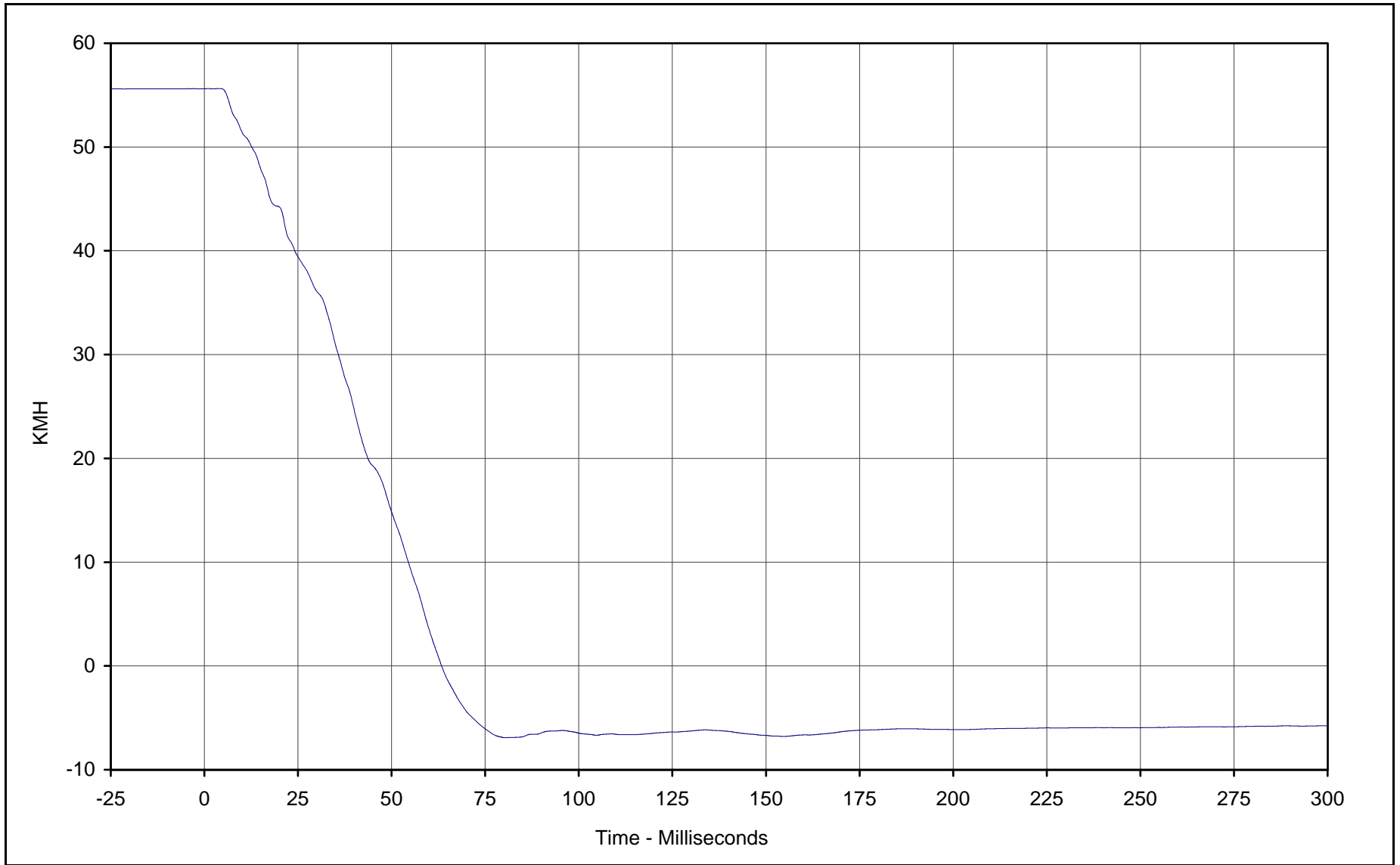

Curve Description: Vehicle Right Rear X Velocity  
Maximum Value: 55.6 at 4.2 Milliseconds  
Minimum Value: -6.9 at 80.4 Milliseconds  
SAE Filter Class: 180  
Date of Test: 1/29/02  
Curve Number: IN1-094

Test Program: 2002 NHTSA 35mph NCAP No.: HO5300  
Test Vehicle: 2002 Honda CR-V LX 4WD SUV

KAR21061-01



B-132

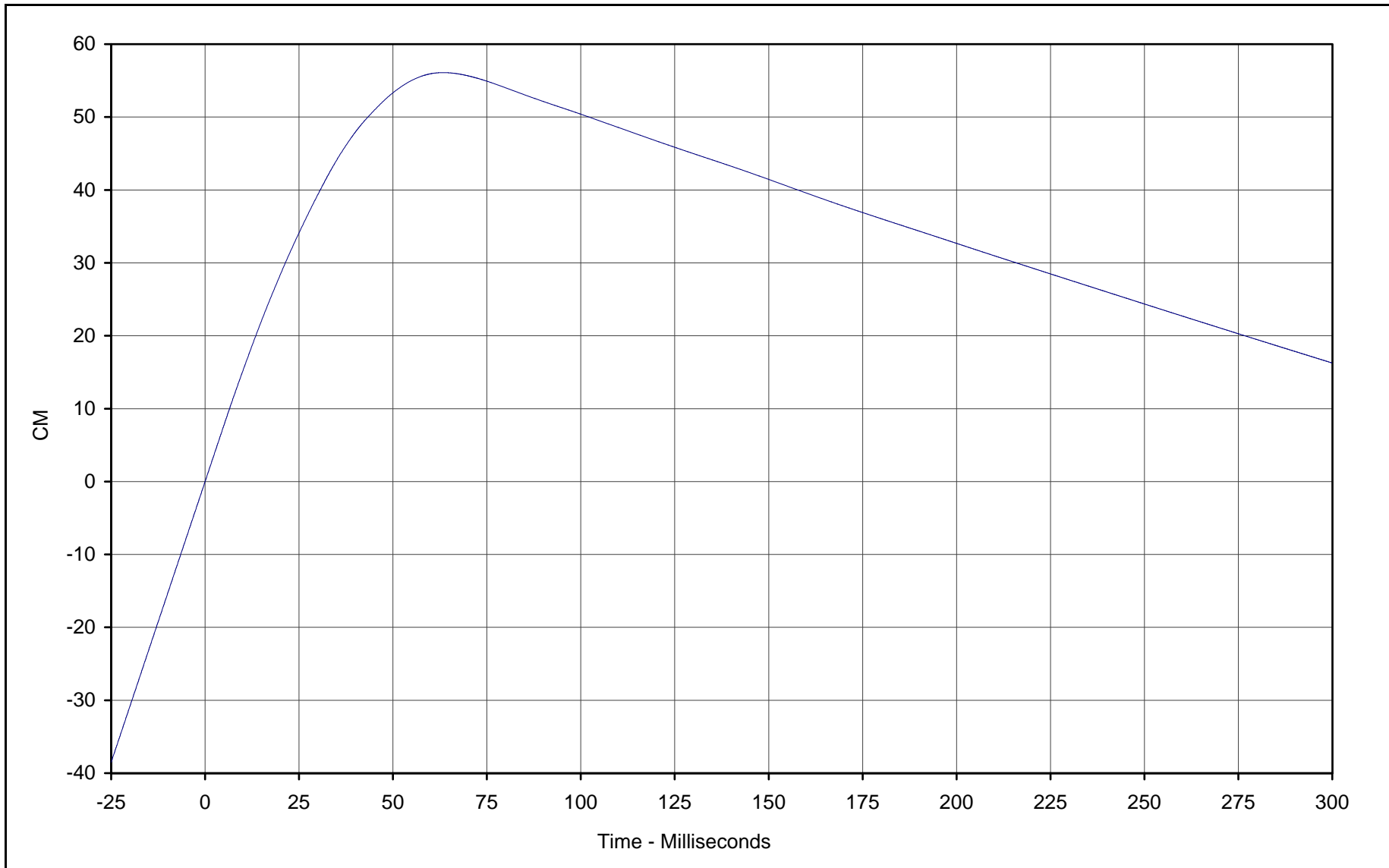

Curve Description: Vehicle Right Rear X Displ.  
Maximum Value: 56.1 at 63.4 Milliseconds  
Minimum Value: 0.0 at 0.0 Milliseconds  
SAE Filter Class: 180  
Date of Test: 1/29/02  
Curve Number: IN2-094

Test Program: 2002 NHTSA 35mph NCAP No.: HO5300  
Test Vehicle: 2002 Honda CR-V LX 4WD SUV

KAR21061-01



B-133

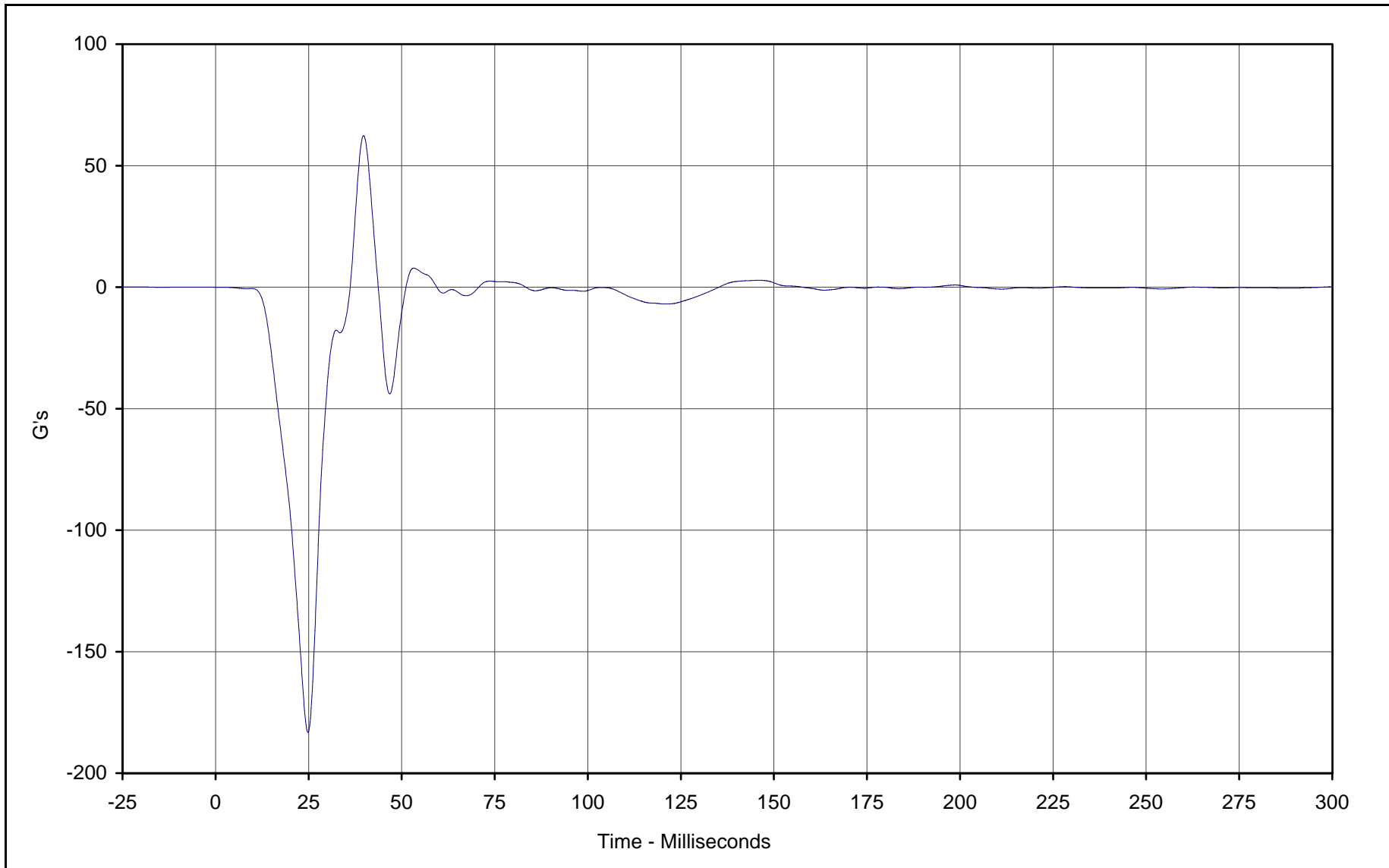

Curve Description: Vehicle Engine Top  
Maximum Value: 62.4 at 39.8 Milliseconds  
Minimum Value: -183.2 at 24.8 Milliseconds  
SAE Filter Class: 60  
Date of Test: 1/29/02  
Curve Number: FIL-095

Test Program: 2002 NHTSA 35mph NCAP No.: HO5300  
Test Vehicle: 2002 Honda CR-V LX 4WD SUV

KAR21061-01



B-134

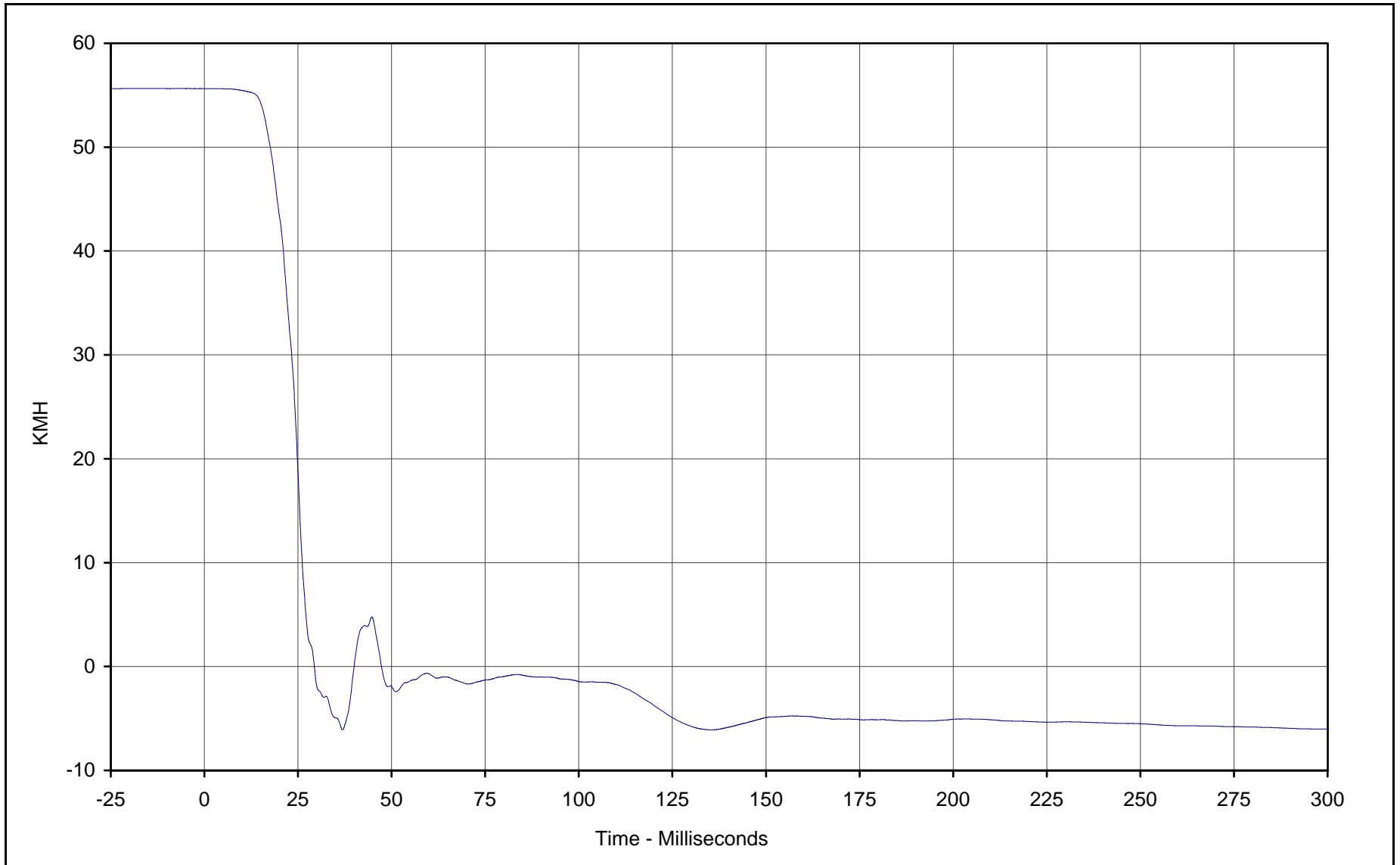

Curve Description: Vehicle Engine Top Velocity  
Maximum Value: 55.6 at 0.2 Milliseconds  
Minimum Value: -6.1 at 135.4 Milliseconds  
SAE Filter Class: 180  
Date of Test: 1/29/02  
Curve Number: IN1-095

Test Program: 2002 NHTSA 35mph NCAP No.: HO5300  
Test Vehicle: 2002 Honda CR-V LX 4WD SUV



KAR21061-01

B-135

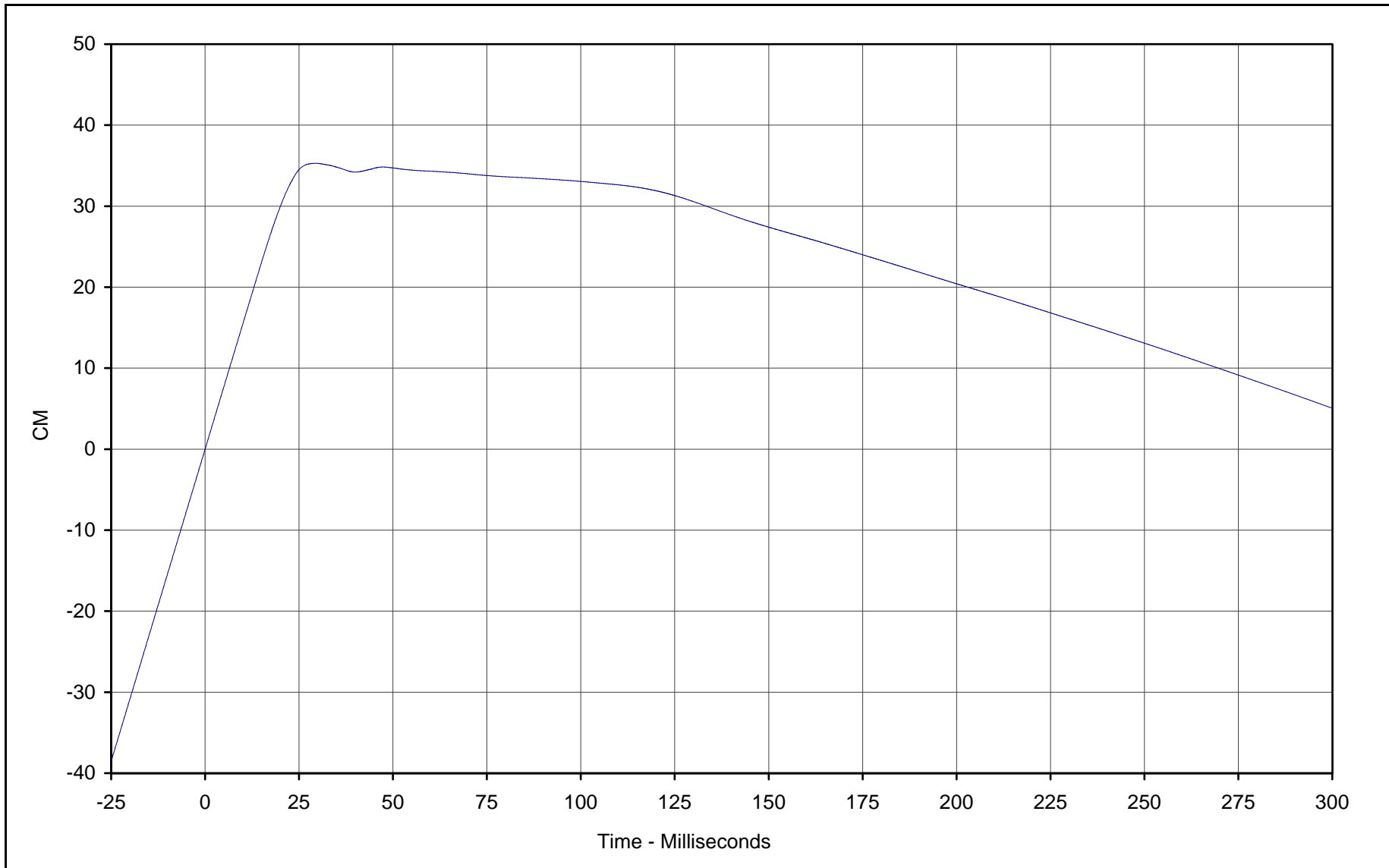

Curve Description: Vehicle Engine Top Displacement  
Maximum Value: 35.3 at 29.4 Milliseconds  
Minimum Value: 0.0 at 0.0 Milliseconds  
SAE Filter Class: 180  
Date of Test: 1/29/02  
Curve Number: IN2-095

Test Program: 2002 NHTSA 35mph NCAP No.: HO5300  
Test Vehicle: 2002 Honda CR-V LX 4WD SUV

KAR21061-01



B-136

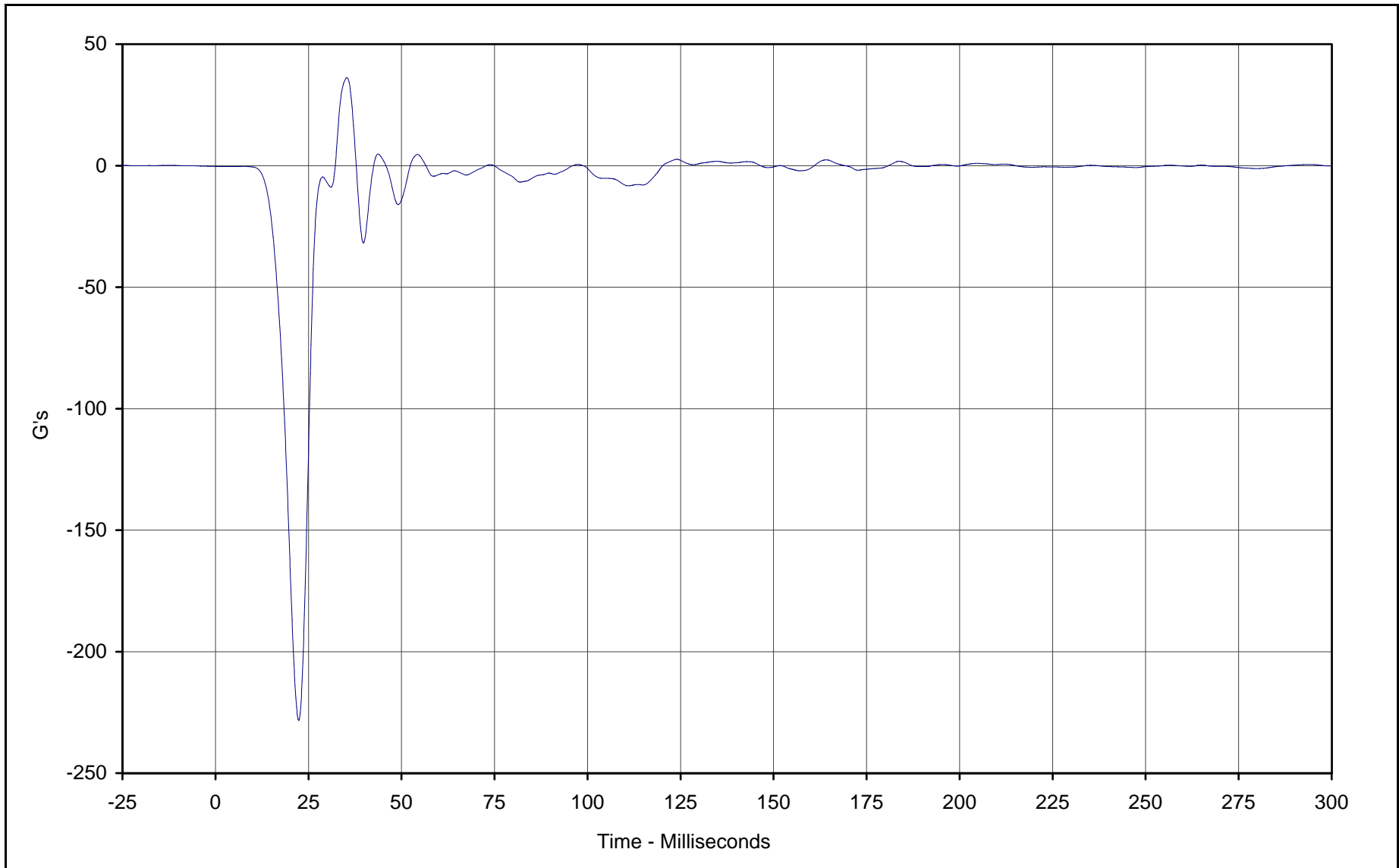

Curve Description: Vehicle Engine Bottom  
Maximum Value: 36.2 at 35.4 Milliseconds  
Minimum Value: -228.3 at 22.4 Milliseconds  
SAE Filter Class: 60  
Date of Test: 1/29/02  
Curve Number: FIL-096

Test Program: 2002 NHTSA 35mph NCAP No.: HO5300  
Test Vehicle: 2002 Honda CR-V LX 4WD SUV

KAR21061-01



B-137

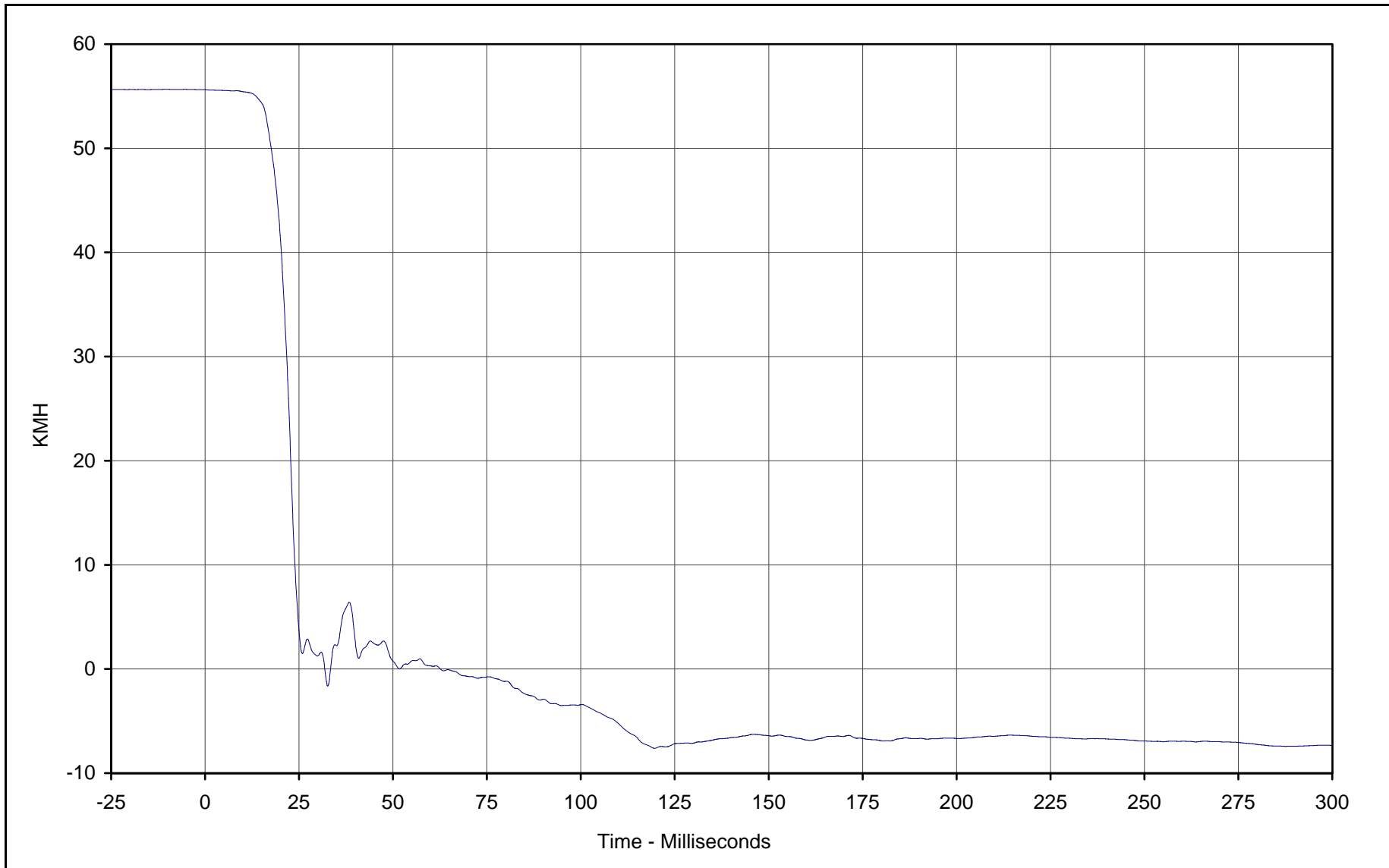

Curve Description: Vehicle Engine Bottom Velocity  
Maximum Value: 55.6 at 0.0 Milliseconds  
Minimum Value: -7.6 at 119.6 Milliseconds  
SAE Filter Class: 180  
Date of Test: 1/29/02  
Curve Number: IN1-096

Test Program: 2002 NHTSA 35mph NCAP No.: HO5300  
Test Vehicle: 2002 Honda CR-V LX 4WD SUV

KAR21061-01



B-138

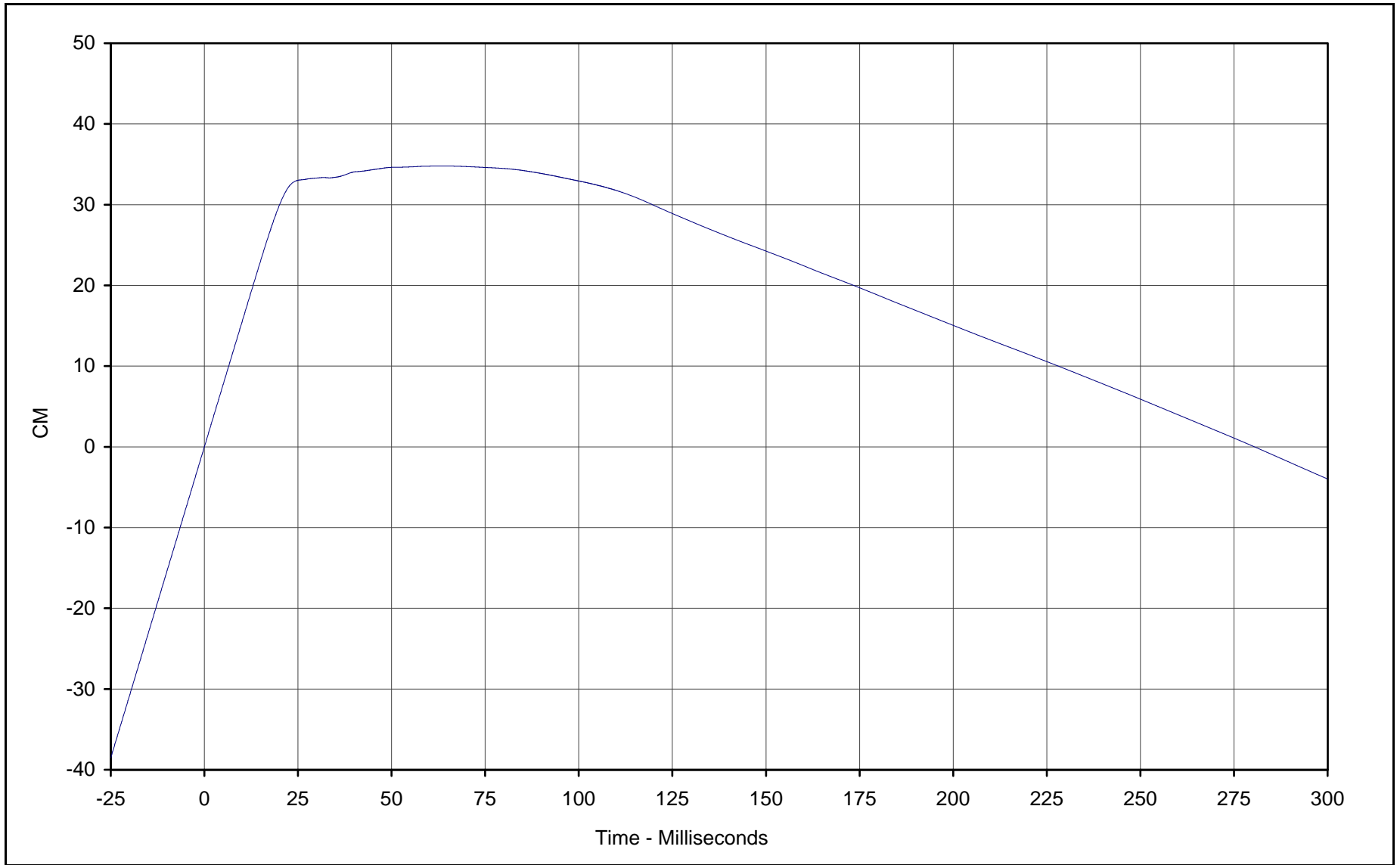

Curve Description: Vehicle Engine Bottom Displacement

Maximum Value: 34.8 at 62.6 Milliseconds

Minimum Value: -4.0 at 299.9 Milliseconds

SAE Filter Class: 180

Date of Test: 1/29/02

Curve Number: IN2-096

Test Program: 2002 NHTSA 35mph NCAP No.: HO5300

Test Vehicle: 2002 Honda CR-V LX 4WD SUV

KAR21061-01



B-139

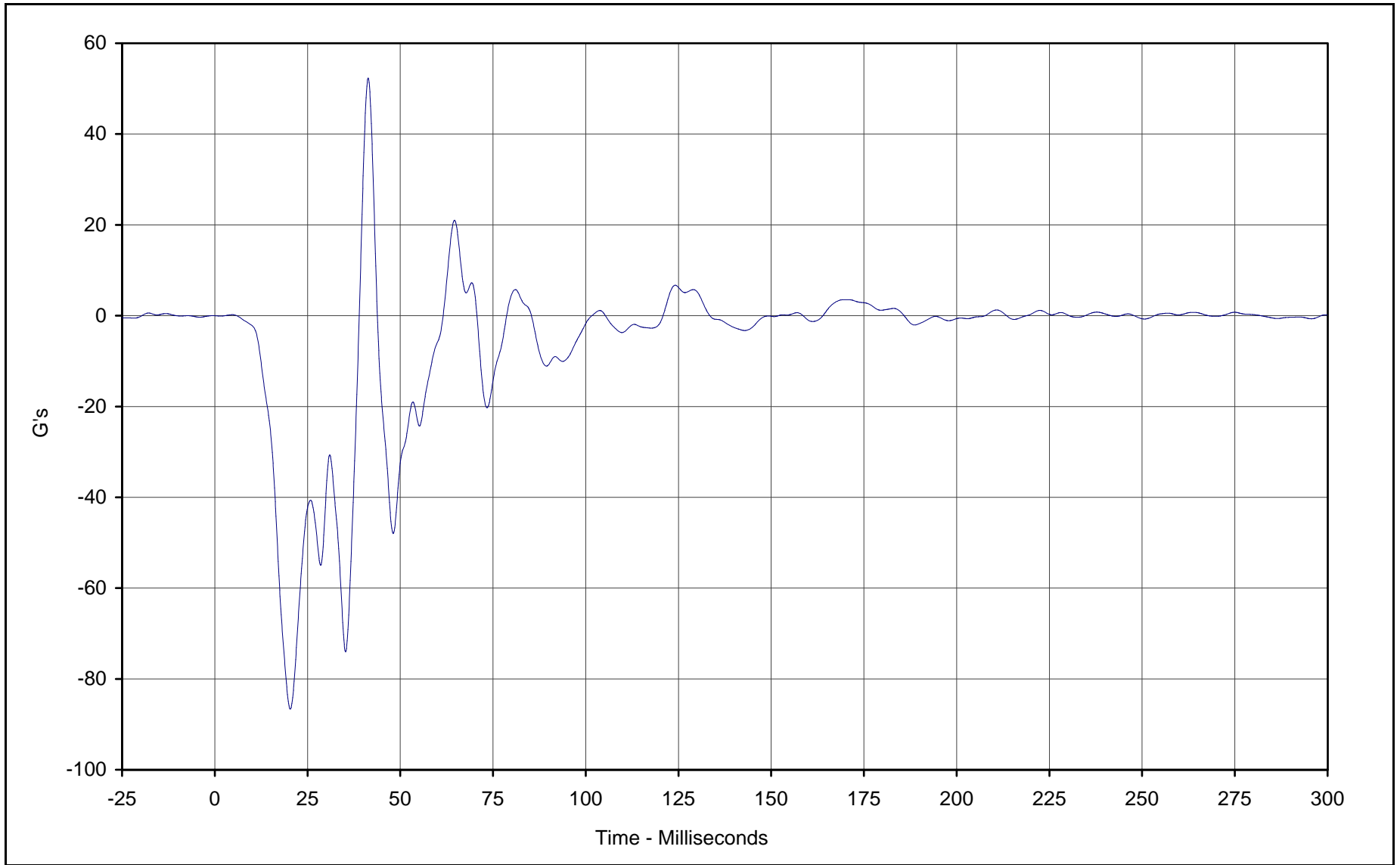

Curve Description: Vehicle Left Brake Caliper  
Maximum Value: 52.3 at 41.3 Milliseconds  
Minimum Value: -86.6 at 20.3 Milliseconds  
SAE Filter Class: 60  
Date of Test: 1/29/02  
Curve Number: FIL-097

Test Program: 2002 NHTSA 35mph NCAP No.: HO5300  
Test Vehicle: 2002 Honda CR-V LX 4WD SUV



KAR21061-01

B-140

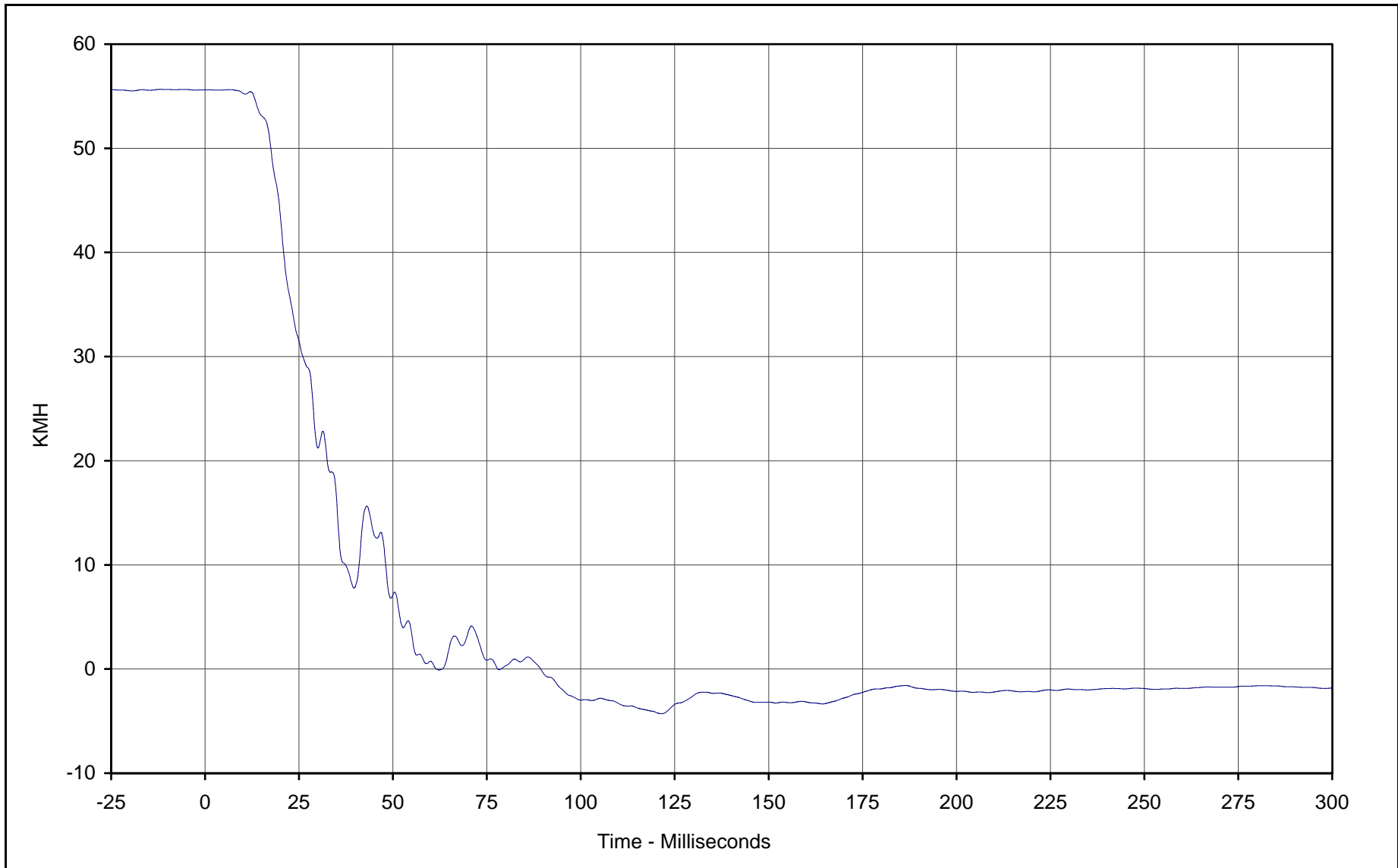

Curve Description: Vehicle Left Brake Caliper Velocity  
Maximum Value: 55.6 at 6.8 Milliseconds  
Minimum Value: -4.3 at 121.5 Milliseconds  
SAE Filter Class: 180  
Date of Test: 1/29/02  
Curve Number: IN1-097

Test Program: 2002 NHTSA 35mph NCAP No.: HO5300  
Test Vehicle: 2002 Honda CR-V LX 4WD SUV

KAR21061-01



B-141

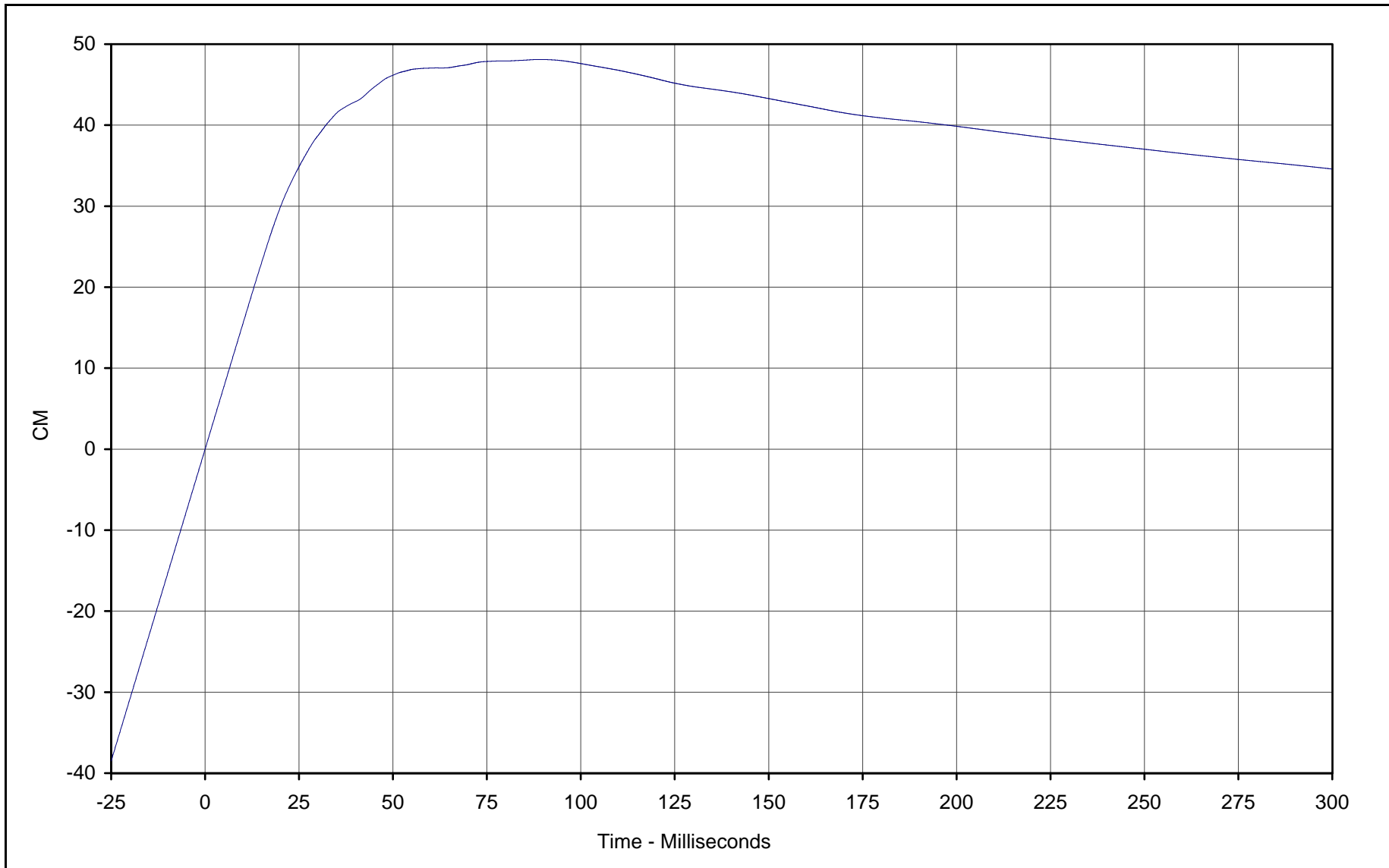

Curve Description: Vehicle Left Brake Caliper Displ.  
Maximum Value: 48.1 at 89.3 Milliseconds  
Minimum Value: 0.0 at 0.0 Milliseconds  
SAE Filter Class: 180  
Date of Test: 1/29/02  
Curve Number: IN2-097

Test Program: 2002 NHTSA 35mph NCAP No.: HO5300  
Test Vehicle: 2002 Honda CR-V LX 4WD SUV

KAR21061-01



B-142

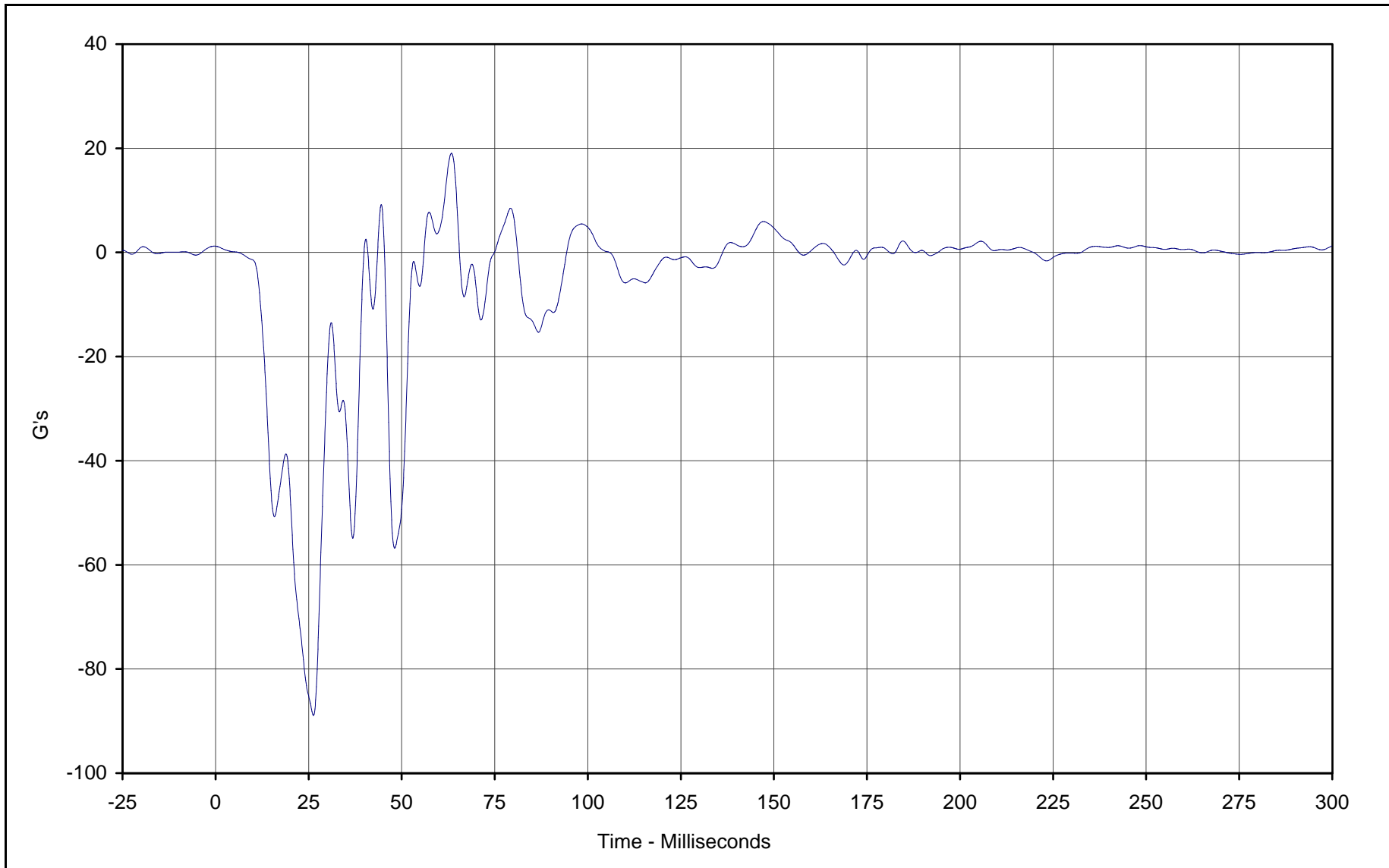

Curve Description: Vehicle Right Brake Caliper  
Maximum Value: 19.0 at 63.4 Milliseconds  
Minimum Value: -88.9 at 26.3 Milliseconds  
SAE Filter Class: 60  
Date of Test: 1/29/02  
Curve Number: FIL-098

Test Program: 2002 NHTSA 35mph NCAP No.: HO5300  
Test Vehicle: 2002 Honda CR-V LX 4WD SUV

KAR21061-01



B-143

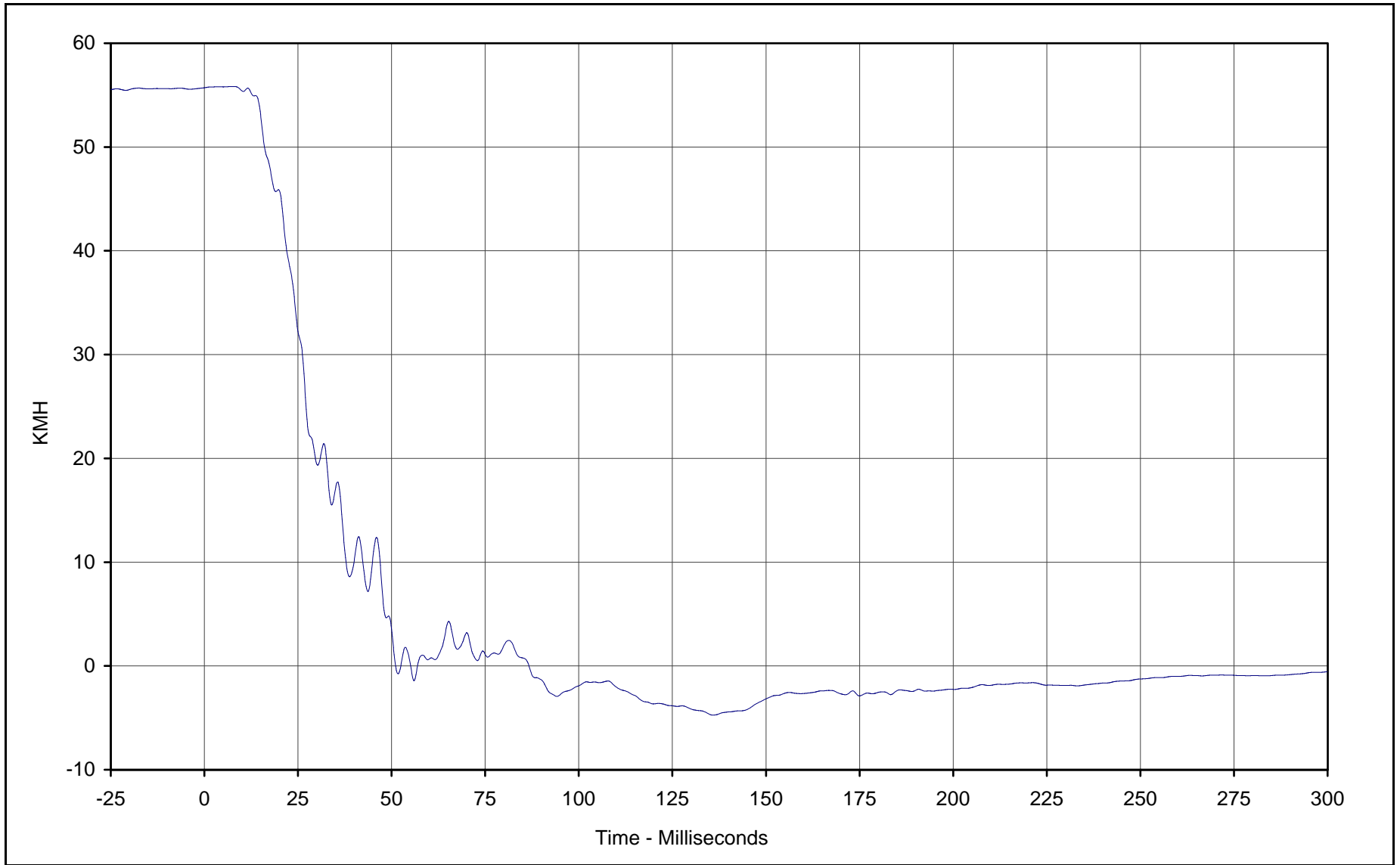

Curve Description: Vehicle Right Brake Caliper Velocity  
Maximum Value: 55.8 at 7.8 Milliseconds  
Minimum Value: -4.7 at 135.9 Milliseconds  
SAE Filter Class: 180  
Date of Test: 1/29/02  
Curve Number: IN1-098

Test Program: 2002 NHTSA 35mph NCAP No.: HO5300  
Test Vehicle: 2002 Honda CR-V LX 4WD SUV



KAR21061-01

B-144

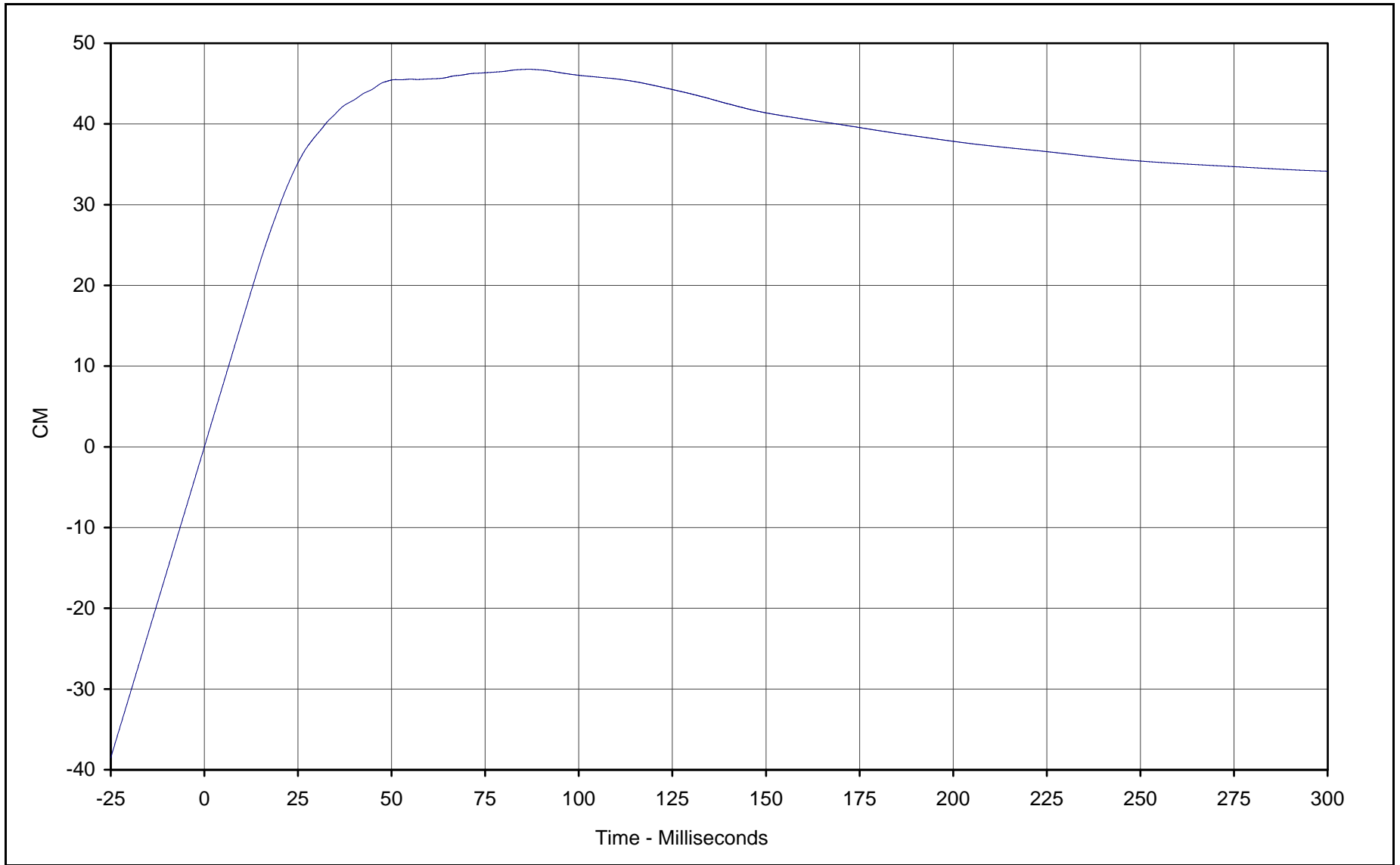

Curve Description: Vehicle Right Brake Caliper Displ.  
Maximum Value: 46.8 at 86.7 Milliseconds  
Minimum Value: 0.0 at 0.0 Milliseconds  
SAE Filter Class: 180  
Date of Test: 1/29/02  
Curve Number: IN2-098

Test Program: 2002 NHTSA 35mph NCAP No.: HO5300  
Test Vehicle: 2002 Honda CR-V LX 4WD SUV



KAR21061-01

B-145

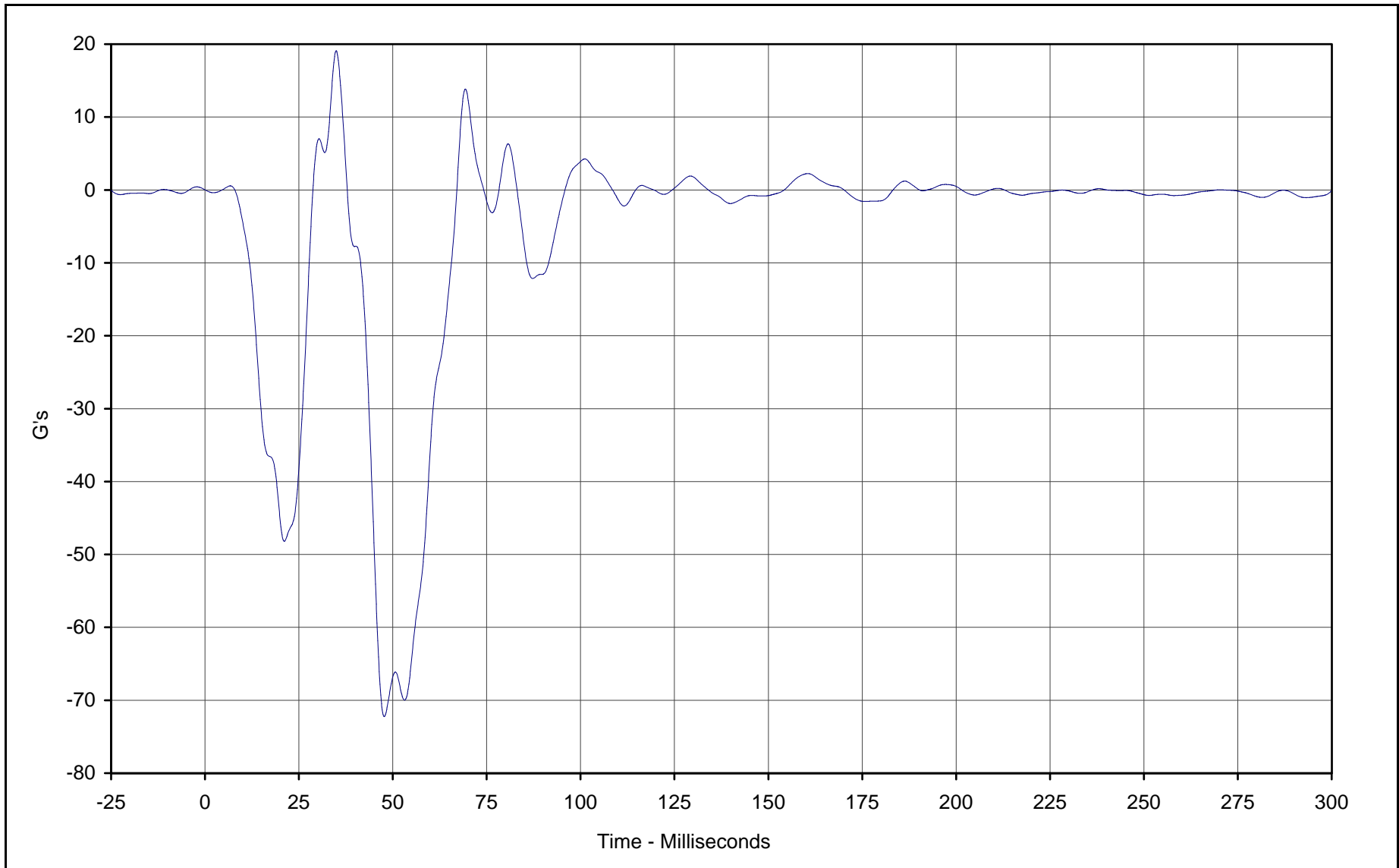

Curve Description: Vehicle Instrument Panel  
Maximum Value: 19.1 at 34.9 Milliseconds  
Minimum Value: -72.3 at 47.7 Milliseconds  
SAE Filter Class: 60  
Date of Test: 1/29/02  
Curve Number: FIL-099

Test Program: 2002 NHTSA 35mph NCAP No.: HO5300  
Test Vehicle: 2002 Honda CR-V LX 4WD SUV



KAR21061-01

B-146

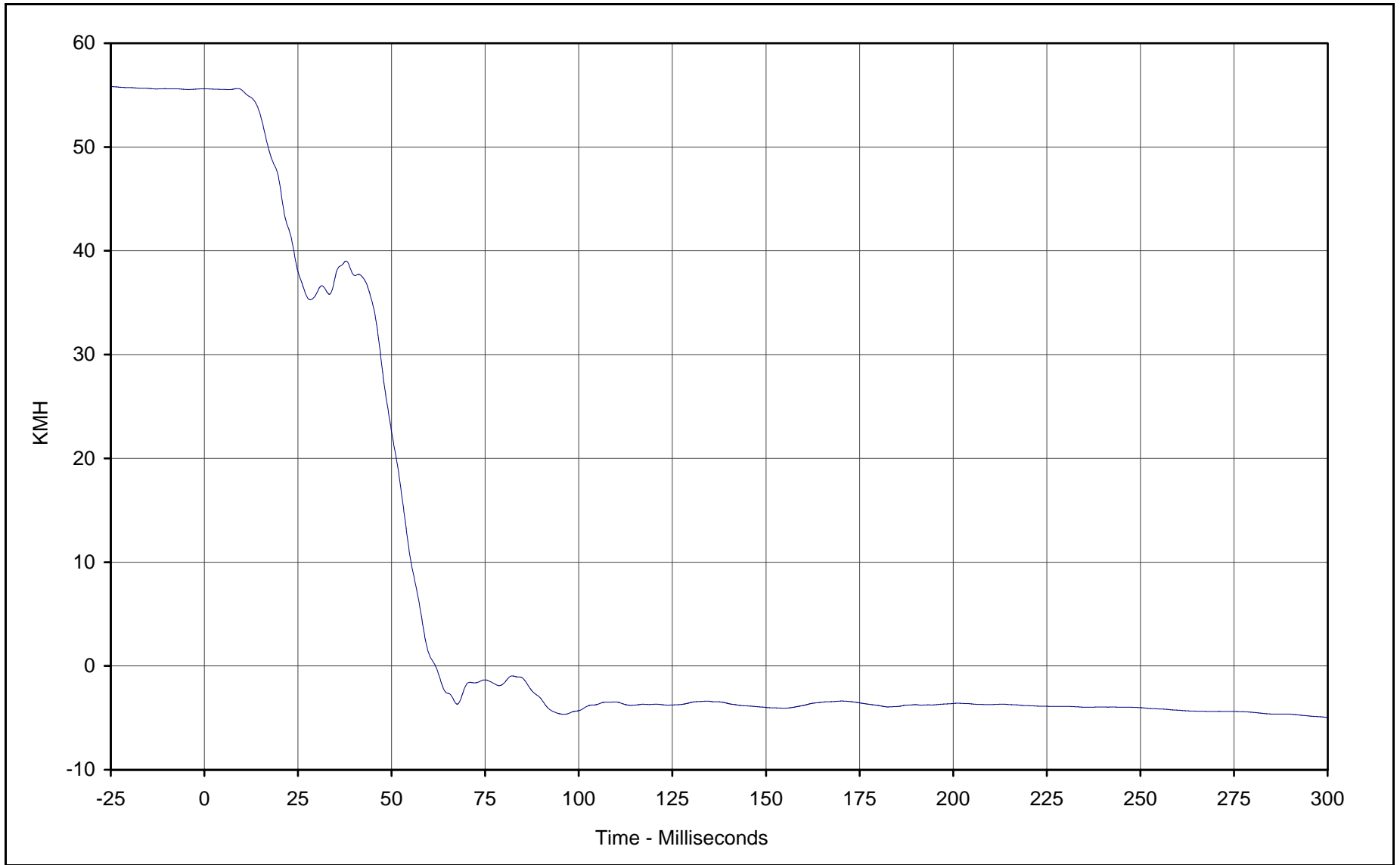

Curve Description: Vehicle Instrument Panel Velocity  
Maximum Value: 55.6 at 8.9 Milliseconds  
Minimum Value: -5.0 at 299.9 Milliseconds  
SAE Filter Class: 180  
Date of Test: 1/29/02  
Curve Number: IN1-099

Test Program: 2002 NHTSA 35mph NCAP No.: HO5300  
Test Vehicle: 2002 Honda CR-V LX 4WD SUV



KAR21061-01

B-147

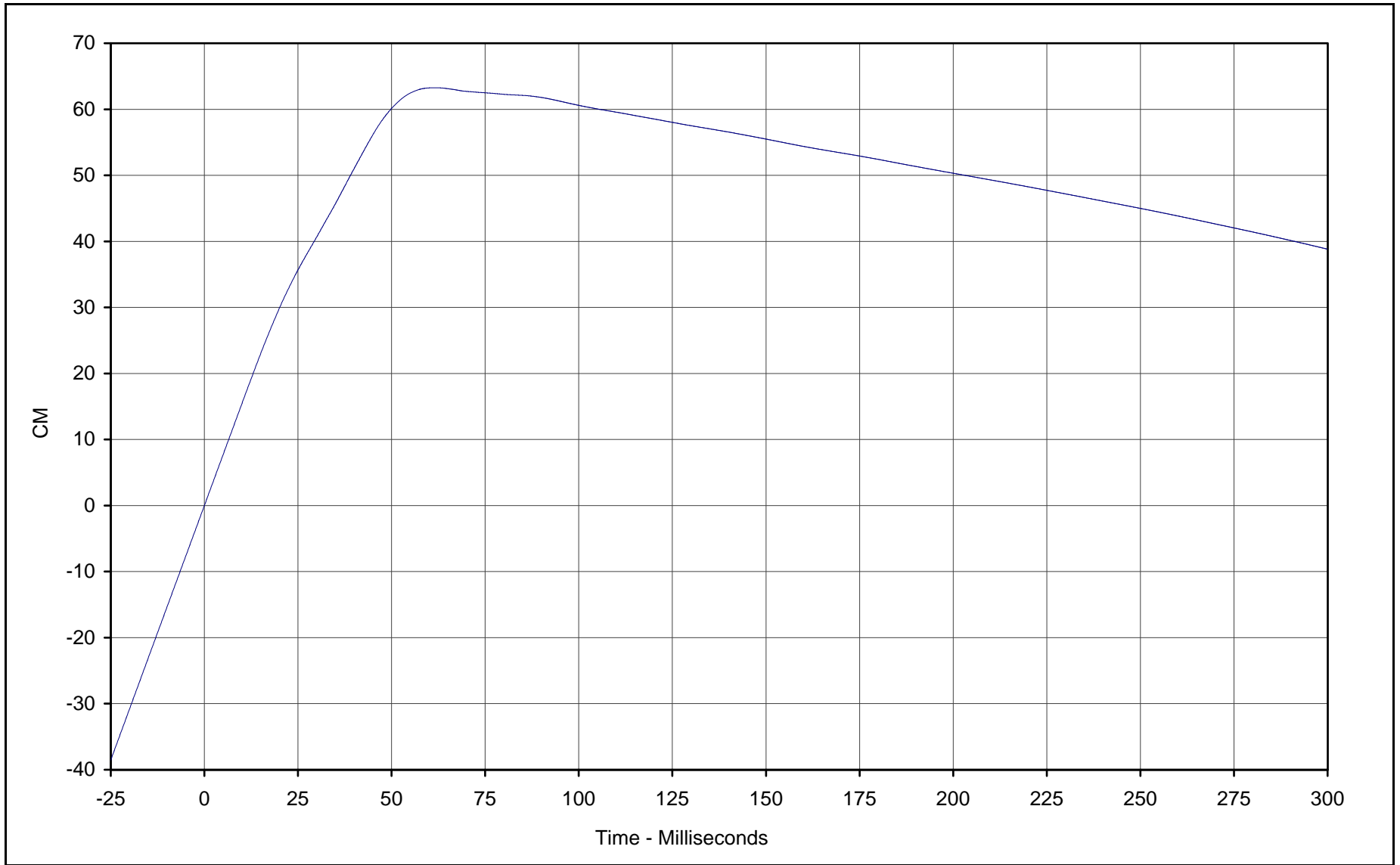

Curve Description: Vehicle Instrument Panel Displacement

Maximum Value: 63.3 at 61.7 Milliseconds

Minimum Value: 0.0 at 0.0 Milliseconds

SAE Filter Class: 180

Date of Test: 1/29/02

Curve Number: IN2-099

Test Program: 2002 NHTSA 35mph NCAP No.: HO5300

Test Vehicle: 2002 Honda CR-V LX 4WD SUV

KAR21061-01



B-148

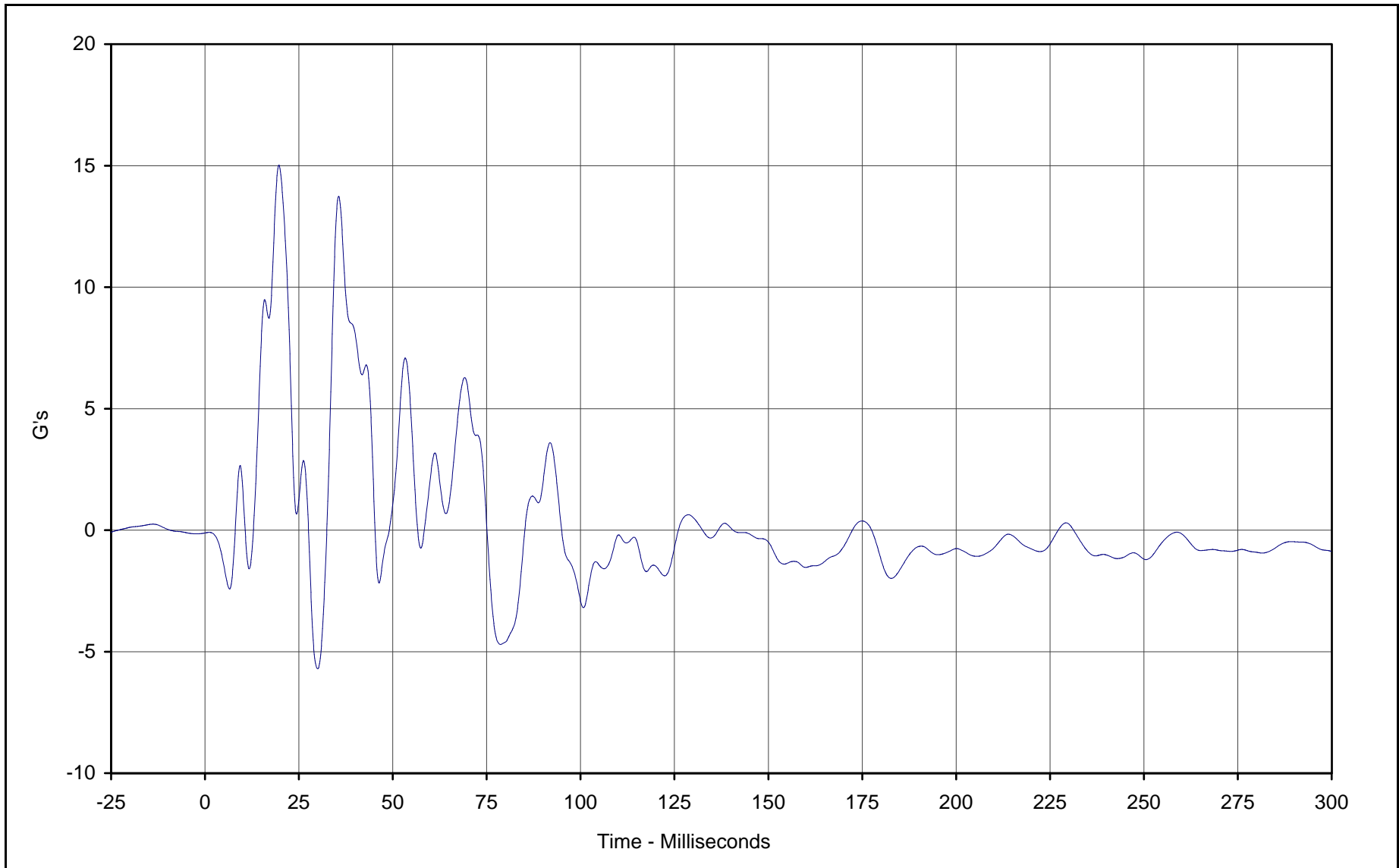

Curve Description: Vehicle Left Rear Z  
Maximum Value: 15.0 at 19.7 Milliseconds  
Minimum Value: -5.7 at 30.0 Milliseconds  
SAE Filter Class: 60  
Date of Test: 1/29/02  
Curve Number: FIL-100

Test Program: 2002 NHTSA 35mph NCAP No.: HO5300  
Test Vehicle: 2002 Honda CR-V LX 4WD SUV



KAR21061-01

B-149

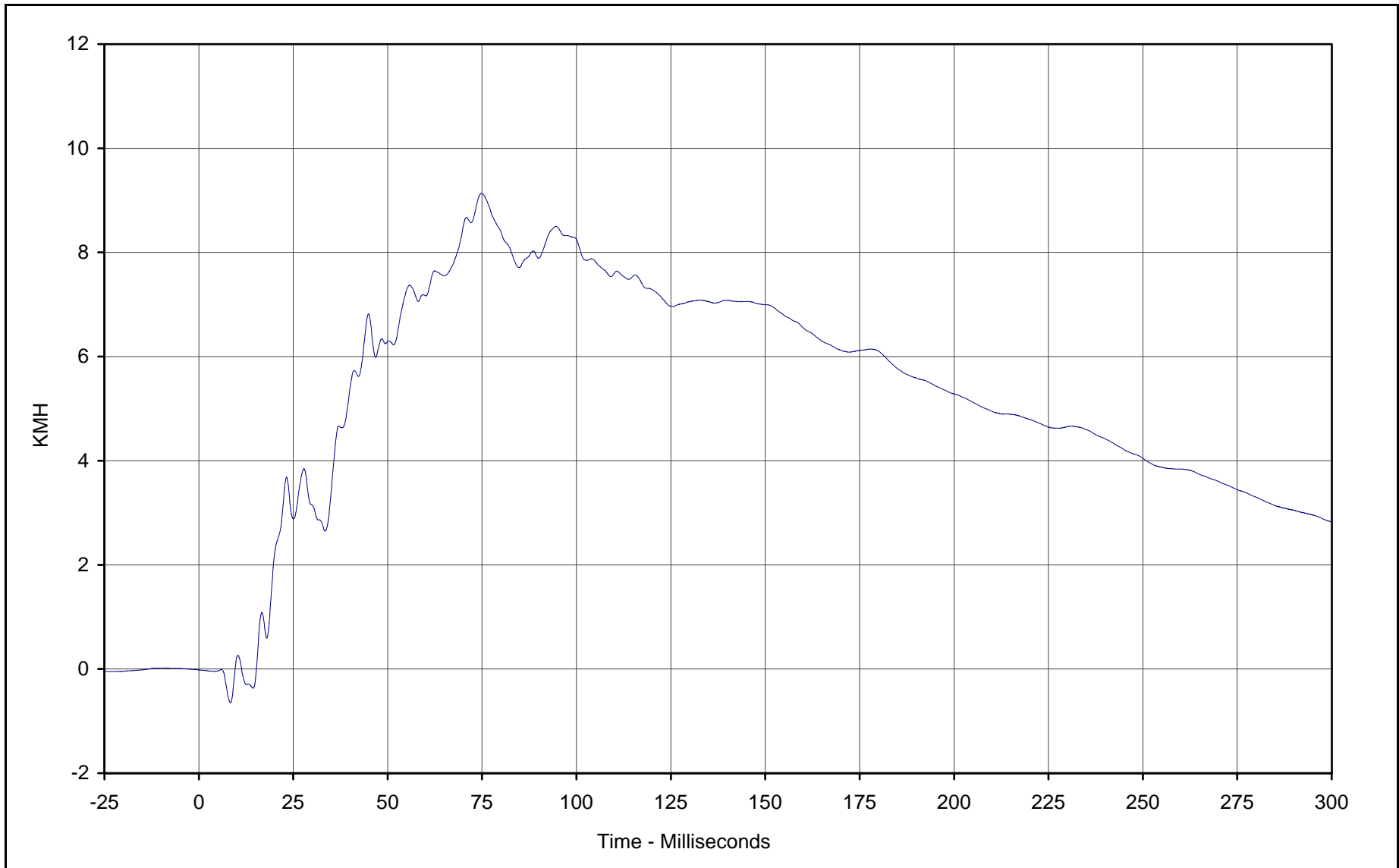

Curve Description: Vehicle Left Rear Z Velocity  
Maximum Value: 9.1 at 74.9 Milliseconds  
Minimum Value: -0.6 at 8.4 Milliseconds  
SAE Filter Class: 180  
Date of Test: 1/29/02  
Curve Number: IN1-100

Test Program: 2002 NHTSA 35mph NCAP No.: HO5300  
Test Vehicle: 2002 Honda CR-V LX 4WD SUV



KAR21061-01

B-150

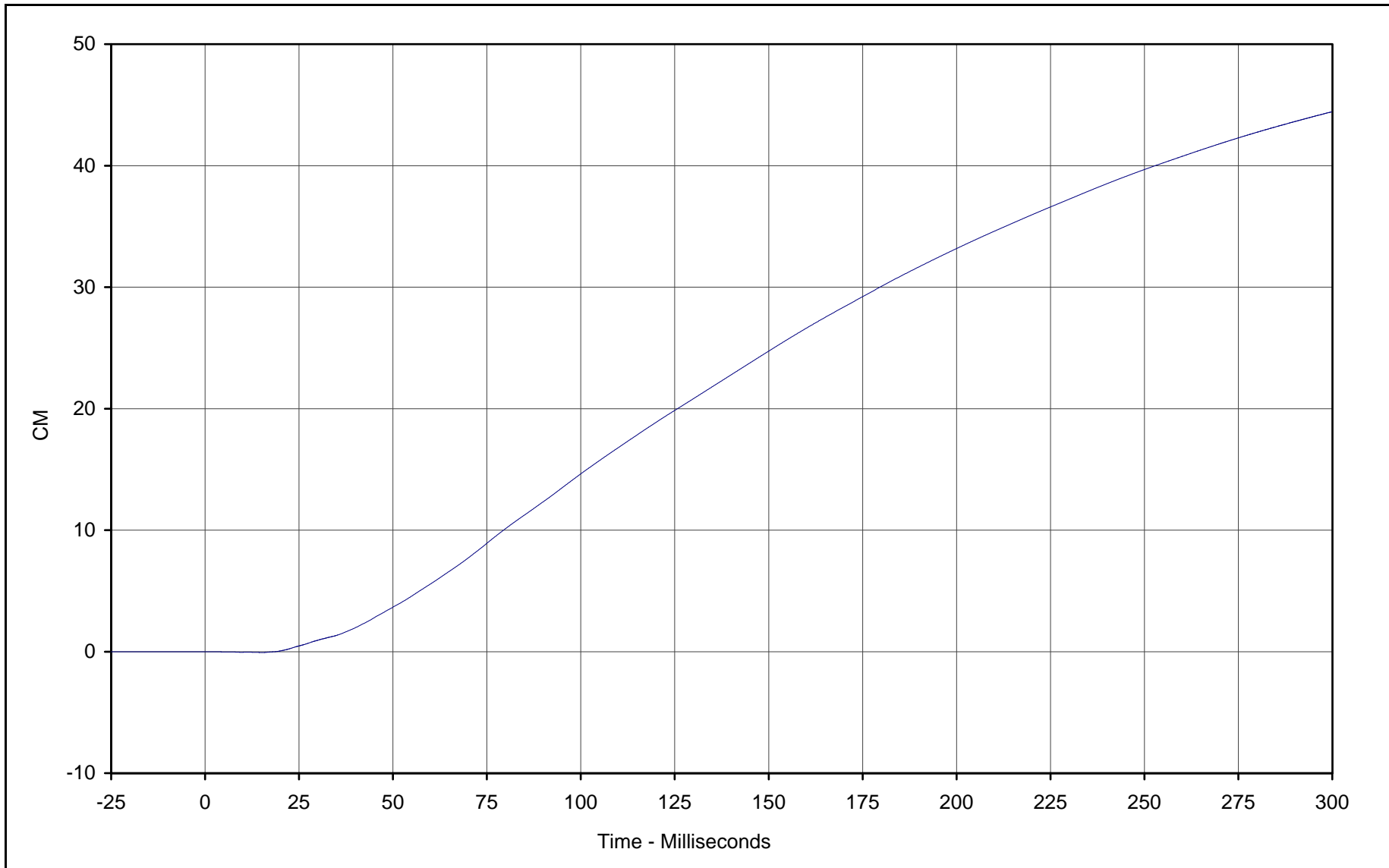

Curve Description: Vehicle Left Rear Z Displ.  
Maximum Value: 44.4 at 299.9 Milliseconds  
Minimum Value: -0.1 at 15.3 Milliseconds  
SAE Filter Class: 180  
Date of Test: 1/29/02  
Curve Number: IN2-100

Test Program: 2002 NHTSA 35mph NCAP No.: HO5300  
Test Vehicle: 2002 Honda CR-V LX 4WD SUV

KAR21061-01



B-151

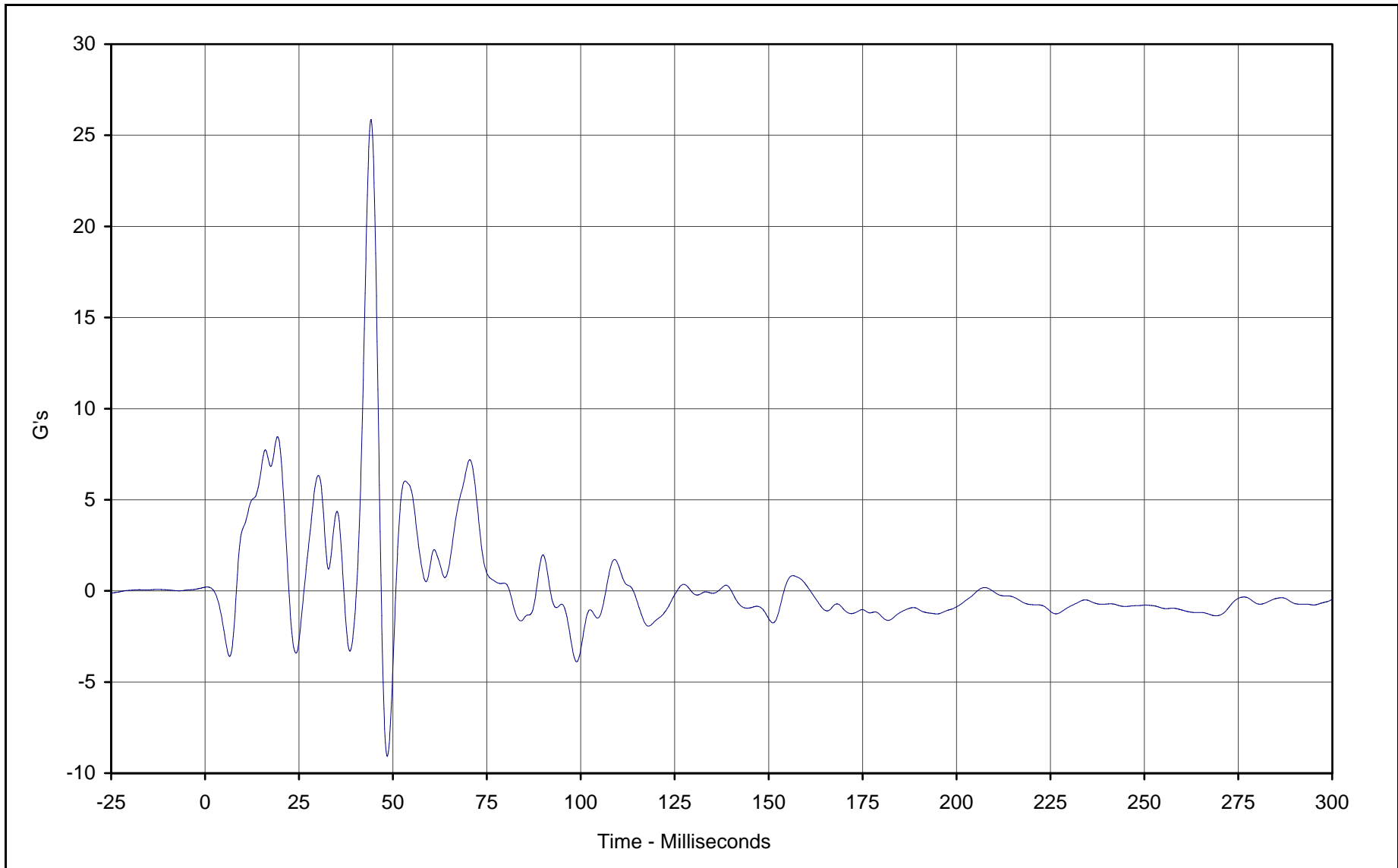

Curve Description: Vehicle Right Rear Z  
Maximum Value: 25.9 at 44.2 Milliseconds  
Minimum Value: -9.1 at 48.5 Milliseconds  
SAE Filter Class: 60  
Date of Test: 1/29/02  
Curve Number: FIL-101

Test Program: 2002 NHTSA 35mph NCAP No.: HO5300  
Test Vehicle: 2002 Honda CR-V LX 4WD SUV

KAR21061-01



B-152

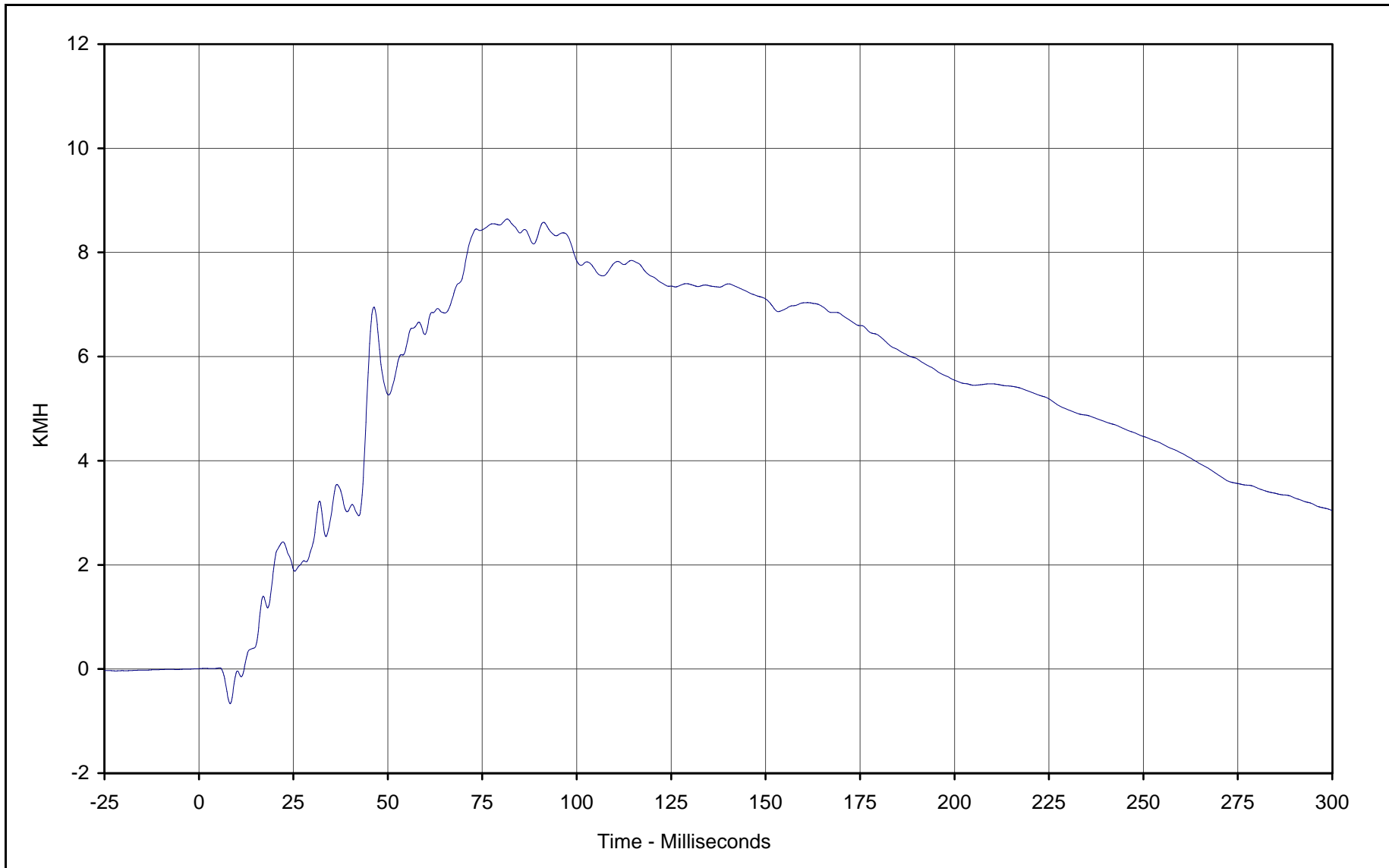

Curve Description: Vehicle Right Rear Z Velocity  
Maximum Value: 8.6 at 81.6 Milliseconds  
Minimum Value: -0.7 at 8.3 Milliseconds  
SAE Filter Class: 180  
Date of Test: 1/29/02  
Curve Number: IN1-101

Test Program: 2002 NHTSA 35mph NCAP No.: HO5300  
Test Vehicle: 2002 Honda CR-V LX 4WD SUV

KAR21061-01



B-153

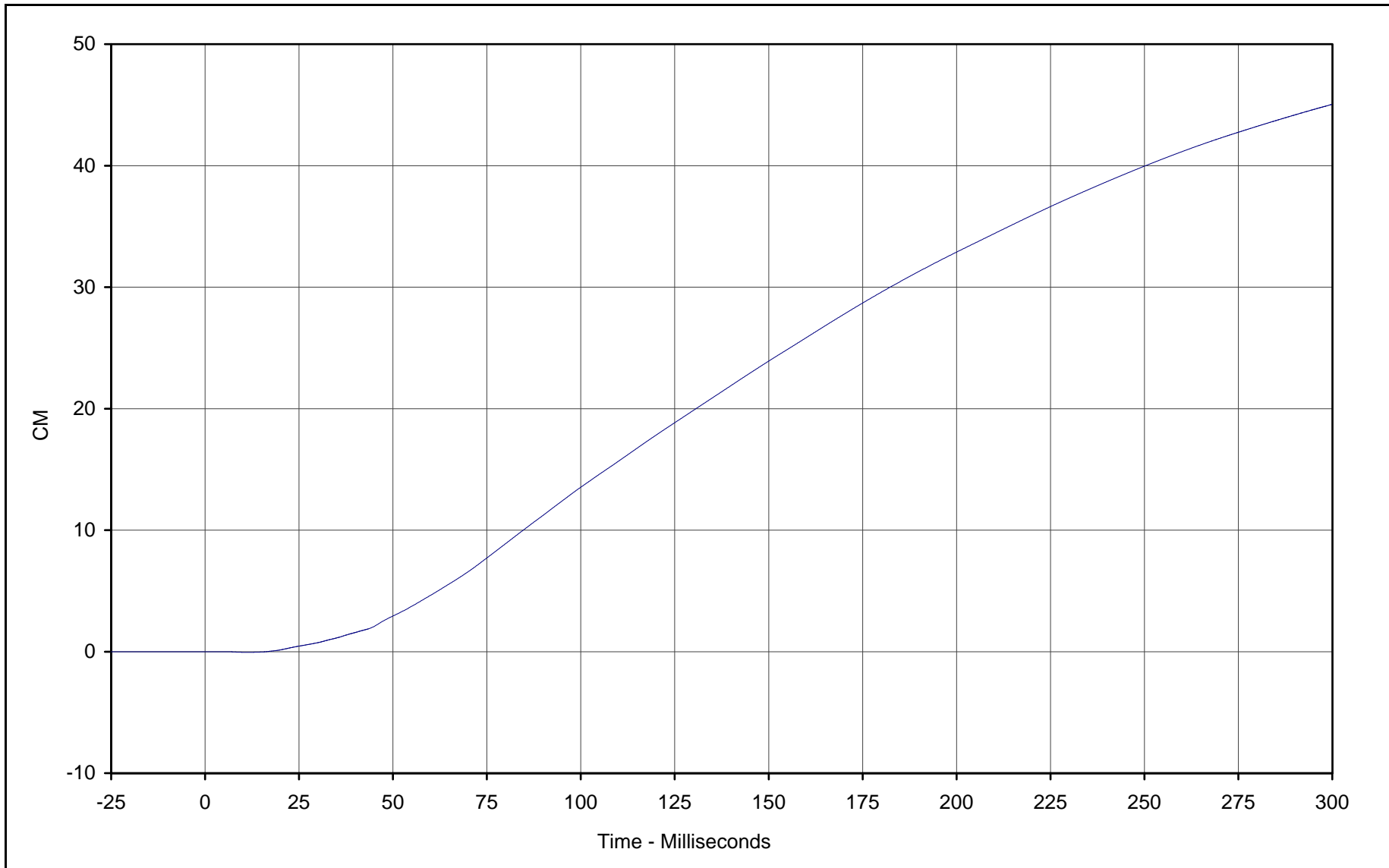

Curve Description: Vehicle Right Rear Z Displ.  
Maximum Value: 45.0 at 299.9 Milliseconds  
Minimum Value: -0.1 at 12.0 Milliseconds  
SAE Filter Class: 180  
Date of Test: 1/29/02  
Curve Number: IN2-101

Test Program: 2002 NHTSA 35mph NCAP No.: HO5300  
Test Vehicle: 2002 Honda CR-V LX 4WD SUV

KAR21061-01



## **APPENDIX C**

### **LOAD CELL BARRIER DATA PLOTS**

C-1

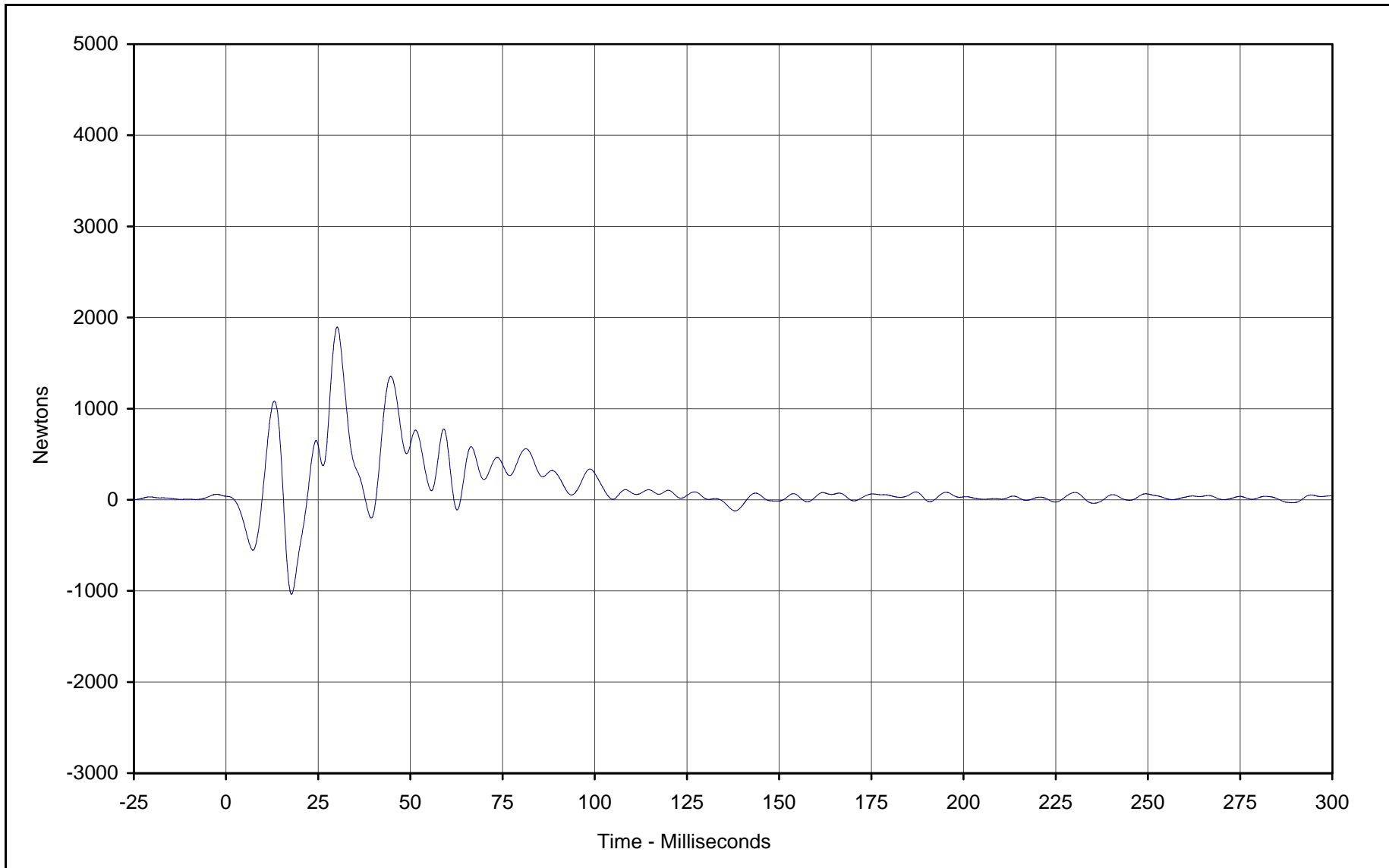

Curve Description: Barrier Force A2  
Maximum Value: 1896.5 at 30.2 Milliseconds  
Minimum Value: -1036.2 at 17.8 Milliseconds  
SAE Filter Class: 60  
Date of Test: 1/29/02  
Curve Number: FIL-103

Test Program: 2002 NHTSA 35mph NCAP No.: HO5300  
Test Vehicle: 2002 Honda CR-V LX 4WD SUV

KAR21061-01



C-2

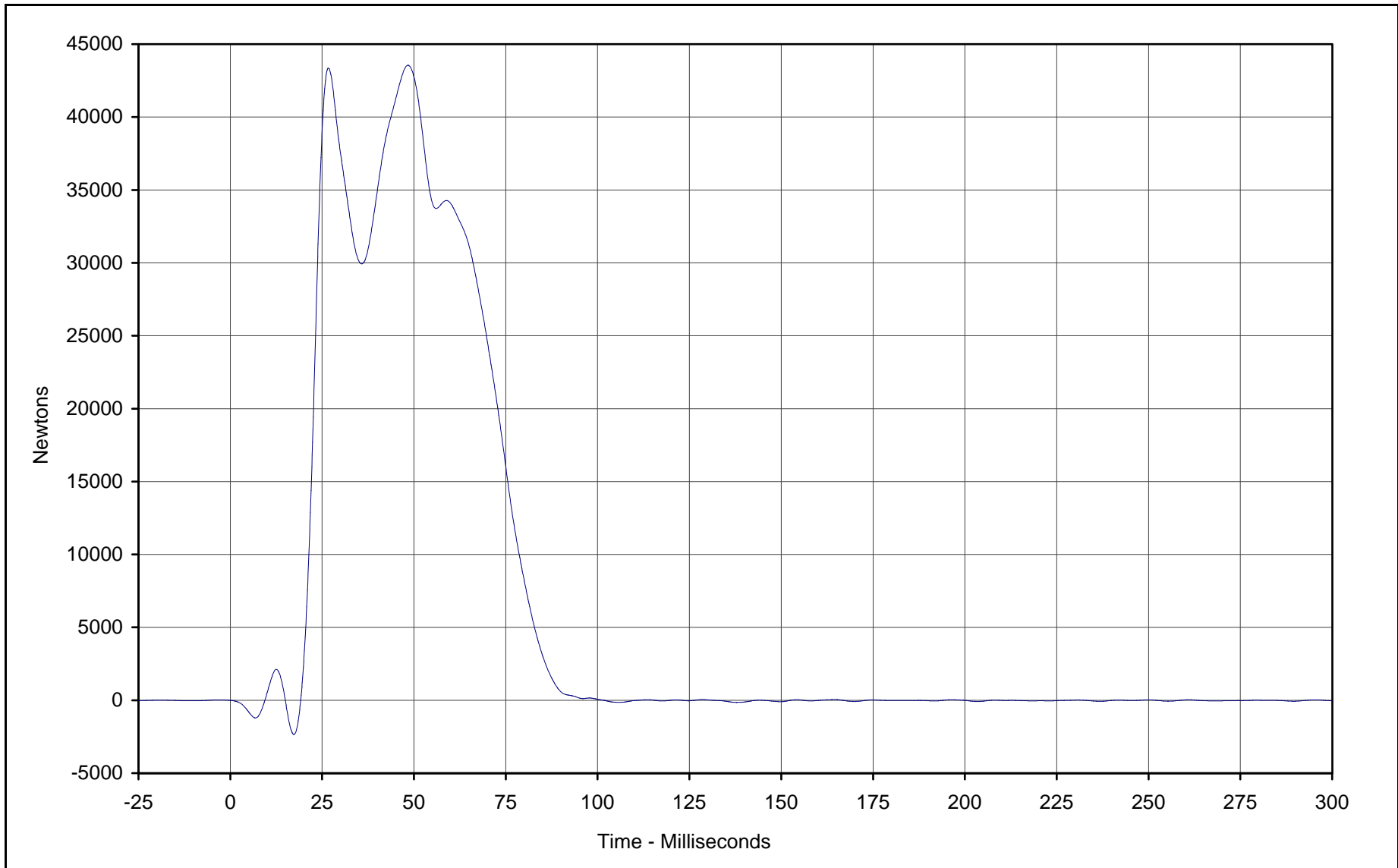

Curve Description: Barrier Force A3  
Maximum Value: 43552.8 at 48.4 Milliseconds  
Minimum Value: -2344.6 at 17.3 Milliseconds  
SAE Filter Class: 60  
Date of Test: 1/29/02  
Curve Number: FIL-104

Test Program: 2002 NHTSA 35mph NCAP No.: HO5300  
Test Vehicle: 2002 Honda CR-V LX 4WD SUV



KAR21061-01

C-3

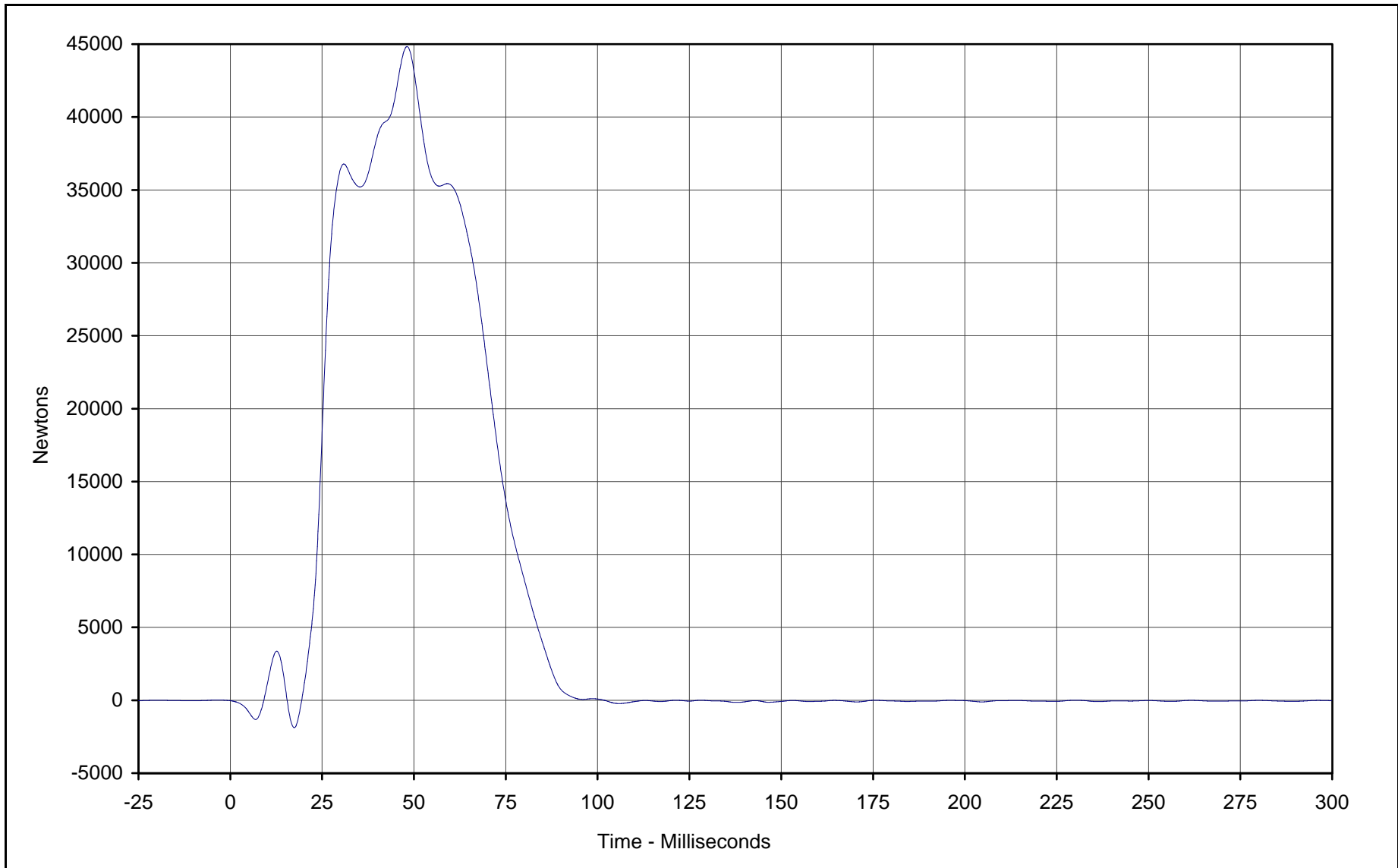

Curve Description: Barrier Force A4  
Maximum Value: 44835.8 at 48.1 Milliseconds  
Minimum Value: -1881.1 at 17.4 Milliseconds  
SAE Filter Class: 60  
Date of Test: 1/29/02  
Curve Number: FIL-105

Test Program: 2002 NHTSA 35mph NCAP No.: HO5300  
Test Vehicle: 2002 Honda CR-V LX 4WD SUV



KAR21061-01

C-4

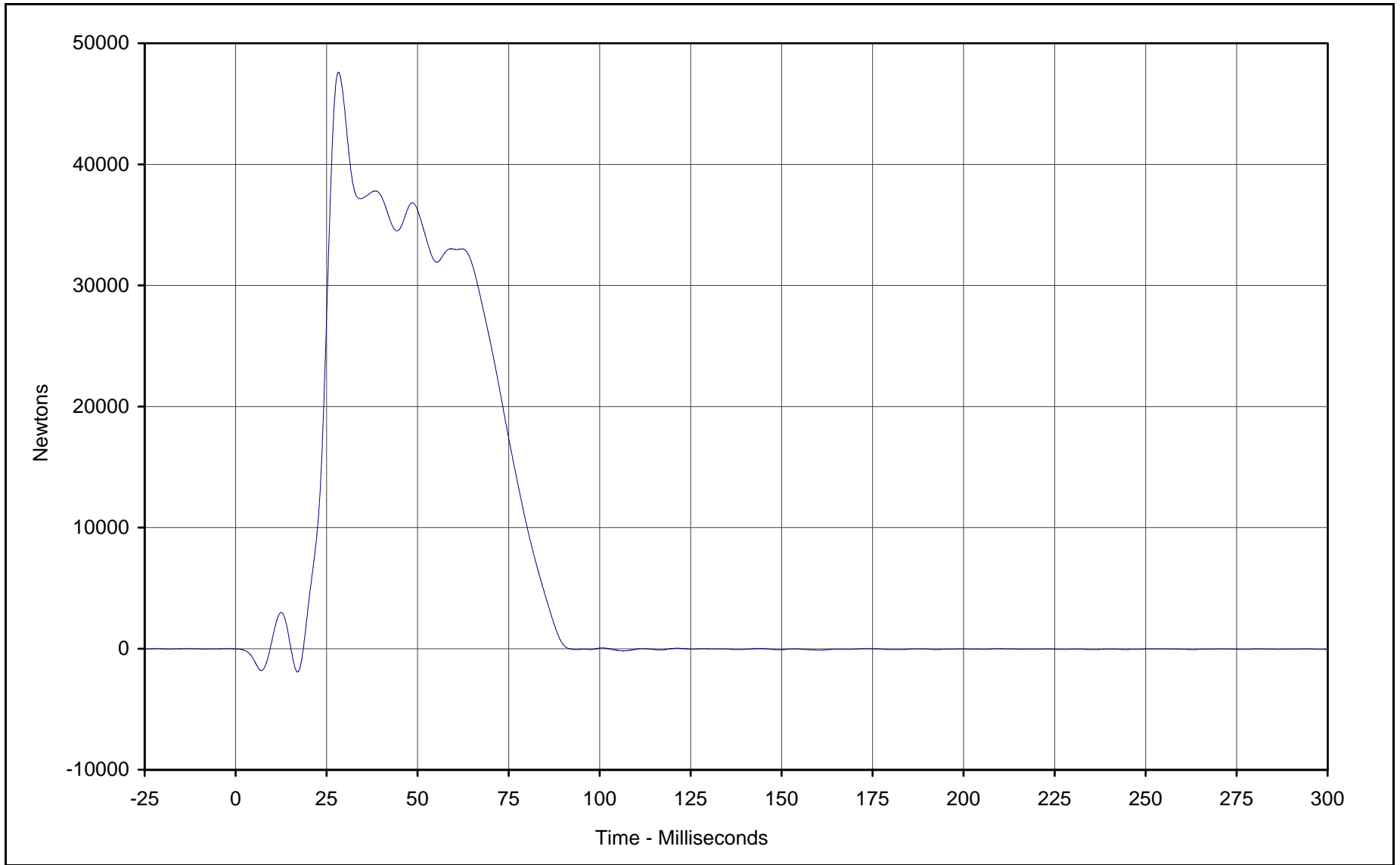

Curve Description: Barrier Force A5  
Maximum Value: 47608.8 at 28.3 Milliseconds  
Minimum Value: -1930.1 at 17.0 Milliseconds  
SAE Filter Class: 60  
Date of Test: 1/29/02  
Curve Number: FIL-106

Test Program: 2002 NHTSA 35mph NCAP No.: HO5300  
Test Vehicle: 2002 Honda CR-V LX 4WD SUV



KAR21061-01

C-5

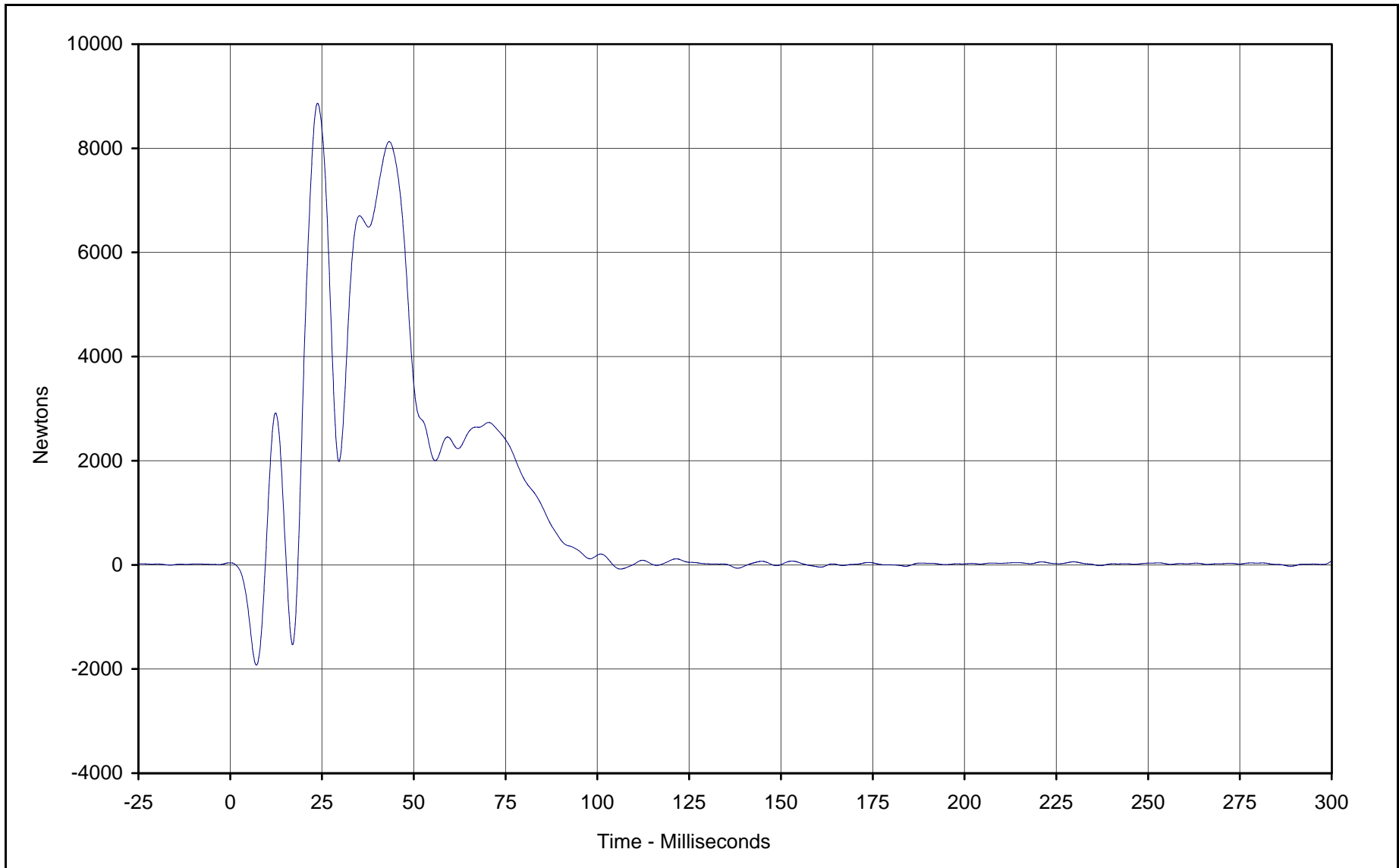

Curve Description: Barrier Force A6  
Maximum Value: 8866.9 at 23.8 Milliseconds  
Minimum Value: -1926.2 at 7.1 Milliseconds  
SAE Filter Class: 60  
Date of Test: 1/29/02  
Curve Number: FIL-107

Test Program: 2002 NHTSA 35mph NCAP No.: HO5300  
Test Vehicle: 2002 Honda CR-V LX 4WD SUV



KAR21061-01

C-6

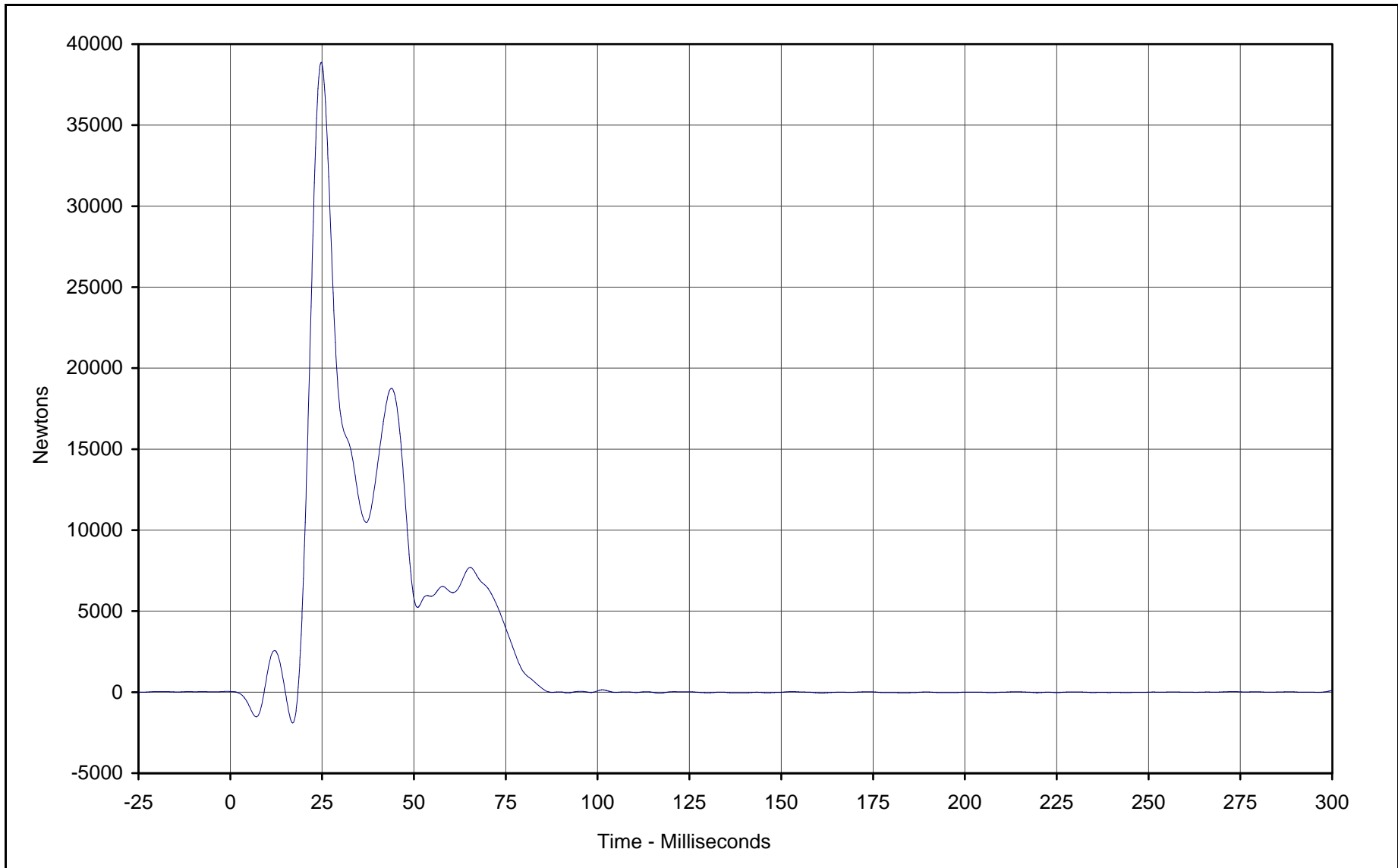

Curve Description: Barrier Force A7  
Maximum Value: 38872.6 at 24.8 Milliseconds  
Minimum Value: -1898.5 at 17.0 Milliseconds  
SAE Filter Class: 60  
Date of Test: 1/29/02  
Curve Number: FIL-108

Test Program: 2002 NHTSA 35mph NCAP No.: HO5300  
Test Vehicle: 2002 Honda CR-V LX 4WD SUV



KAR21061-01

C-7

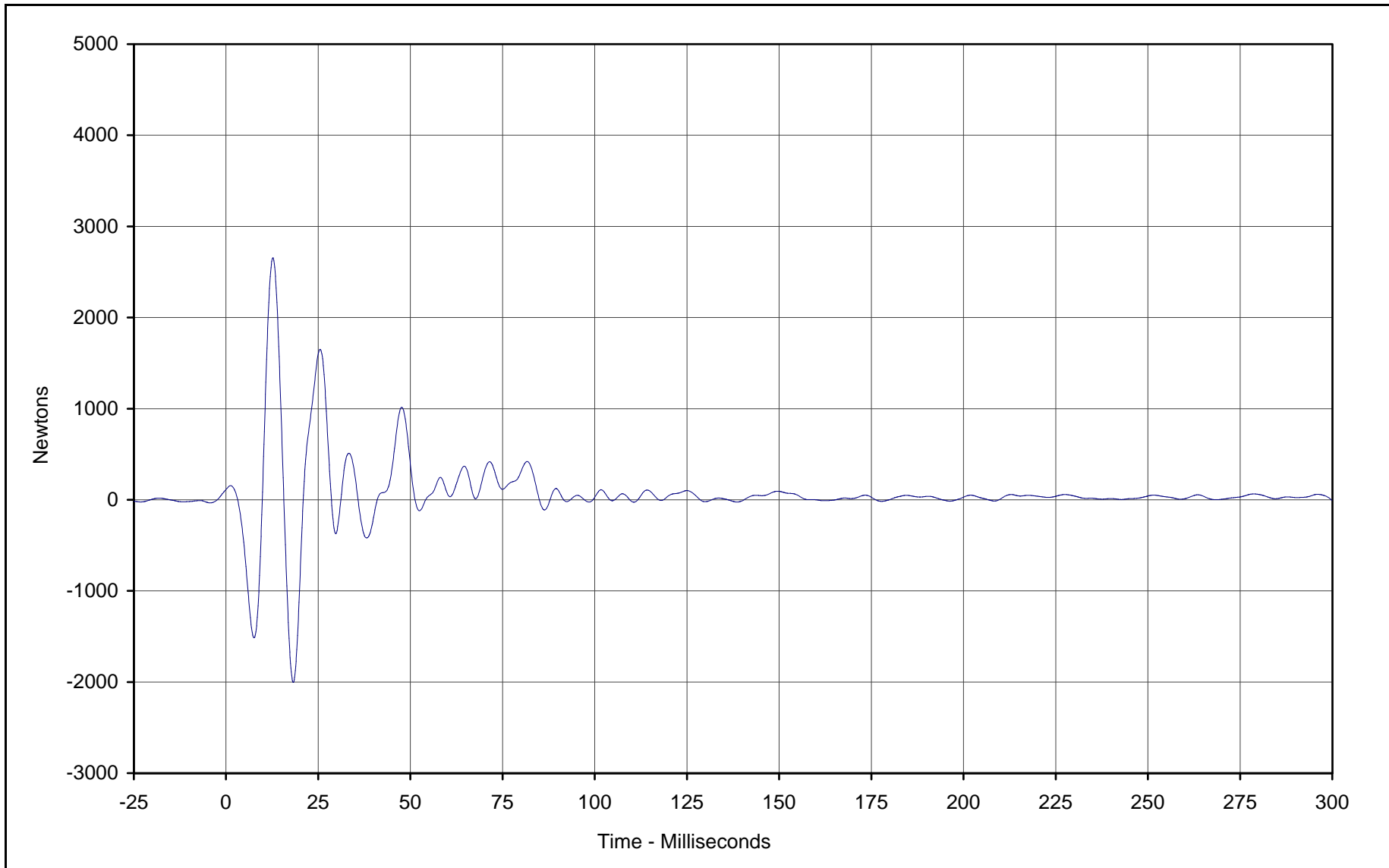

Curve Description: Barrier Force A8  
Maximum Value: 2656.3 at 12.7 Milliseconds  
Minimum Value: -2003.4 at 18.2 Milliseconds  
SAE Filter Class: 60  
Date of Test: 1/29/02  
Curve Number: FIL-109

Test Program: 2002 NHTSA 35mph NCAP No.: HO5300  
Test Vehicle: 2002 Honda CR-V LX 4WD SUV



KAR21061-01

C-8

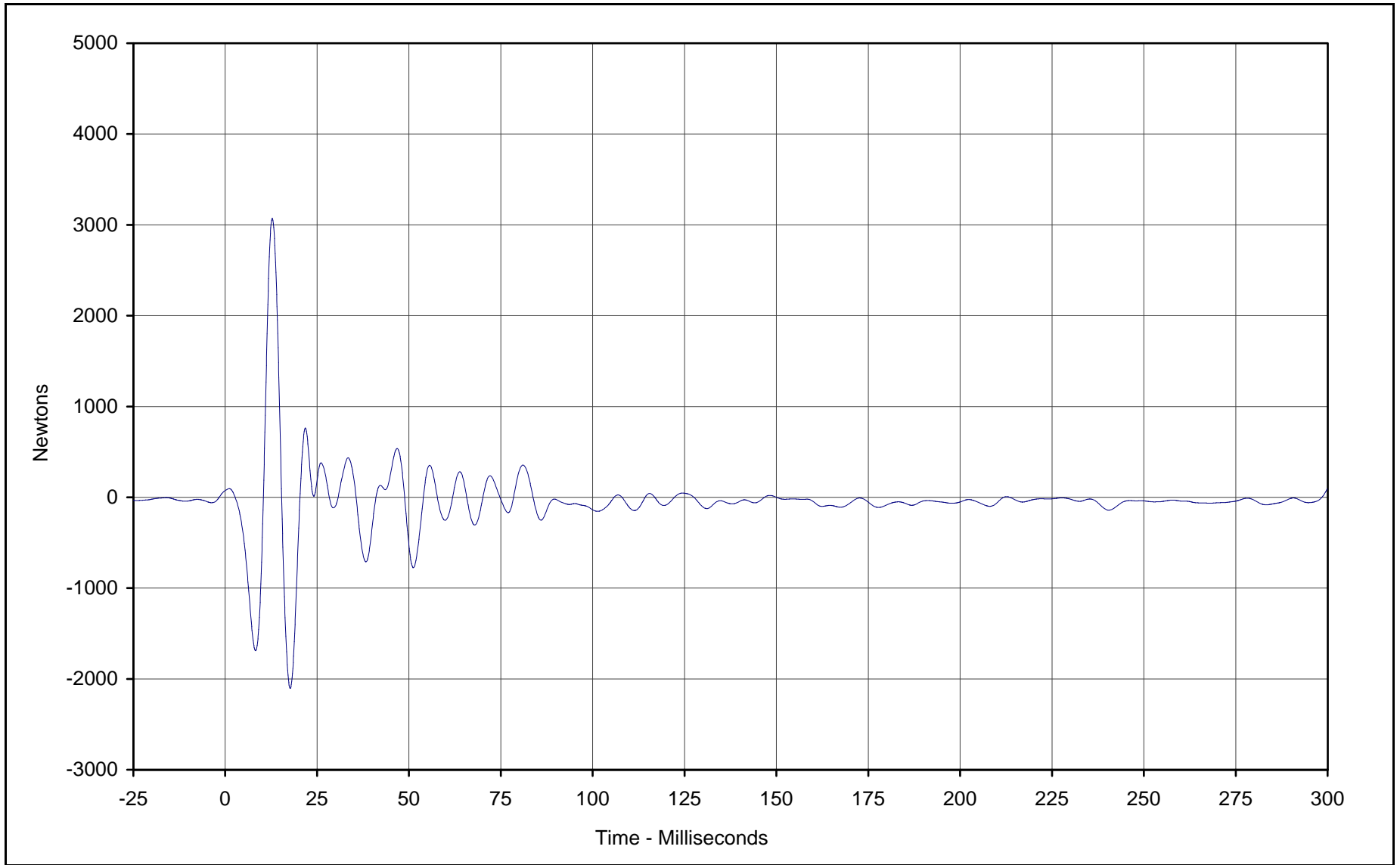

Curve Description: Barrier Force A9  
Maximum Value: 3073.1 at 12.8 Milliseconds  
Minimum Value: -2104.2 at 17.7 Milliseconds  
SAE Filter Class: 60  
Date of Test: 1/29/02  
Curve Number: FIL-110

Test Program: 2002 NHTSA 35mph NCAP No.: HO5300  
Test Vehicle: 2002 Honda CR-V LX 4WD SUV



KAR21061-01

C-9

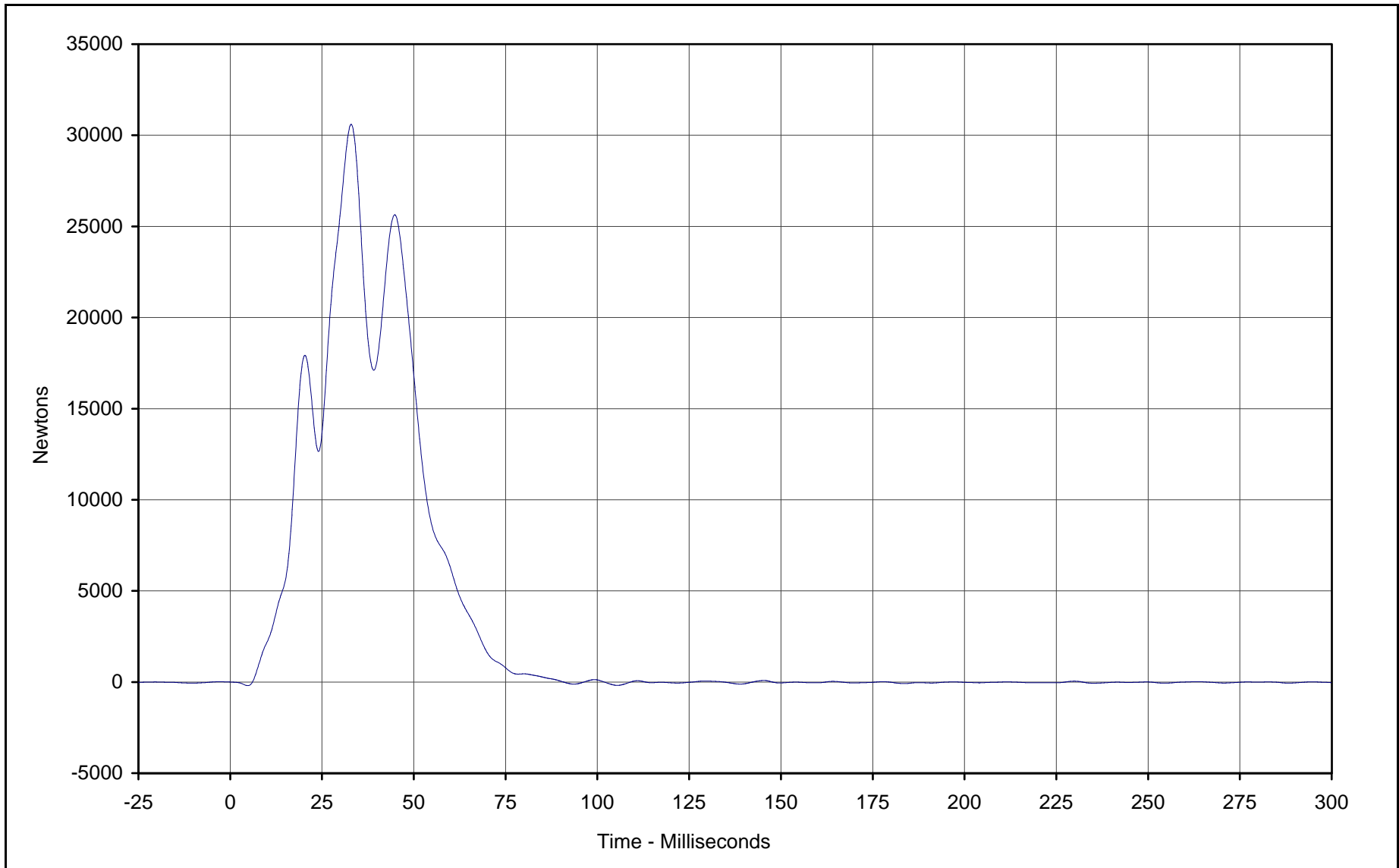

Curve Description: Barrier Force B2  
Maximum Value: 30602.5 at 32.9 Milliseconds  
Minimum Value: -197.4 at 4.7 Milliseconds  
SAE Filter Class: 60  
Date of Test: 1/29/02  
Curve Number: FIL-112

Test Program: 2002 NHTSA 35mph NCAP No.: HO5300  
Test Vehicle: 2002 Honda CR-V LX 4WD SUV



KAR21061-01

C-10

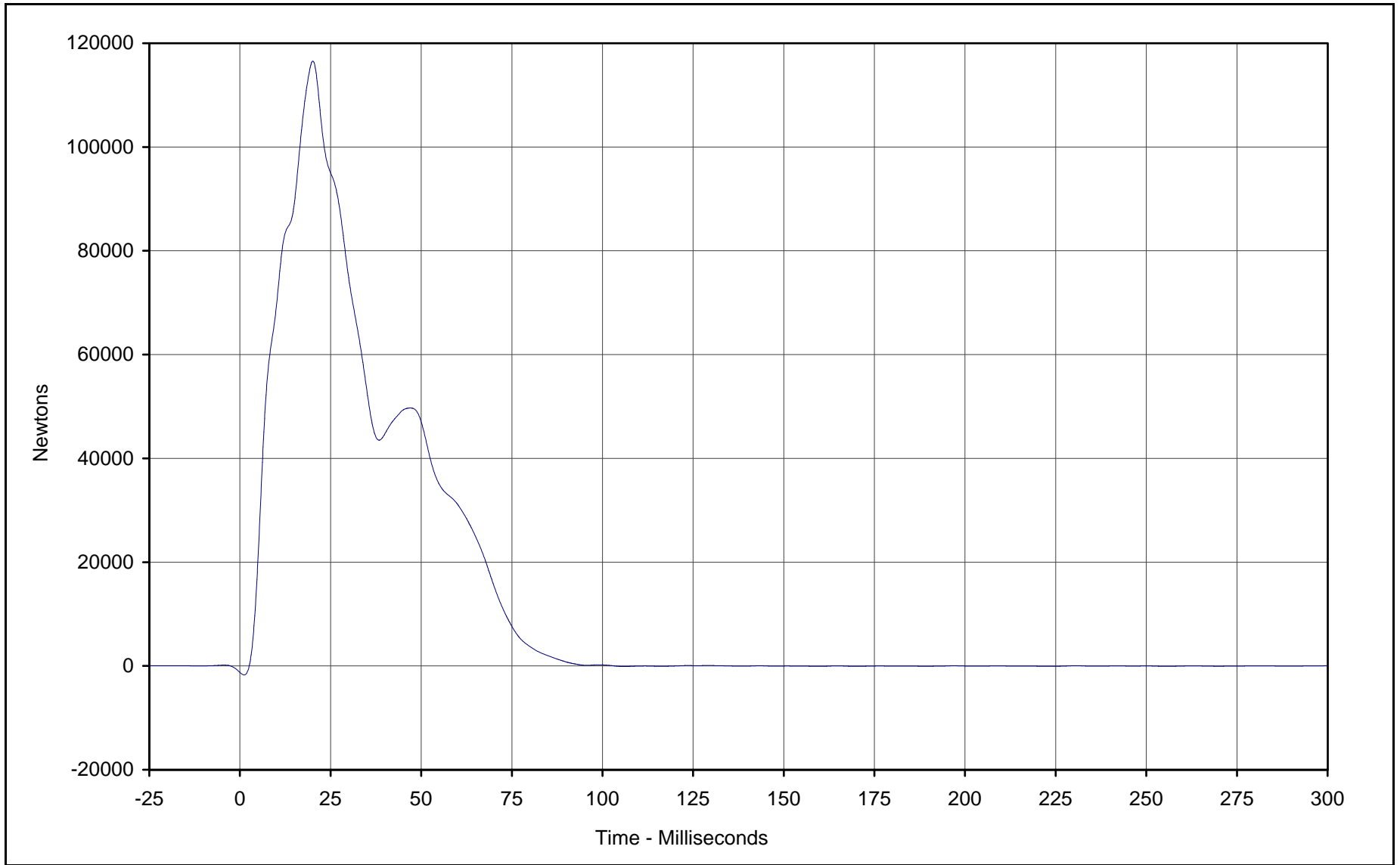

Curve Description: Barrier Force B3  
Maximum Value: 116581.3 at 20.1 Milliseconds  
Minimum Value: -1737.1 at 1.2 Milliseconds  
SAE Filter Class: 60  
Date of Test: 1/29/02  
Curve Number: FIL-113

Test Program: 2002 NHTSA 35mph NCAP No.: HO5300  
Test Vehicle: 2002 Honda CR-V LX 4WD SUV



KAR21061-01

C-11

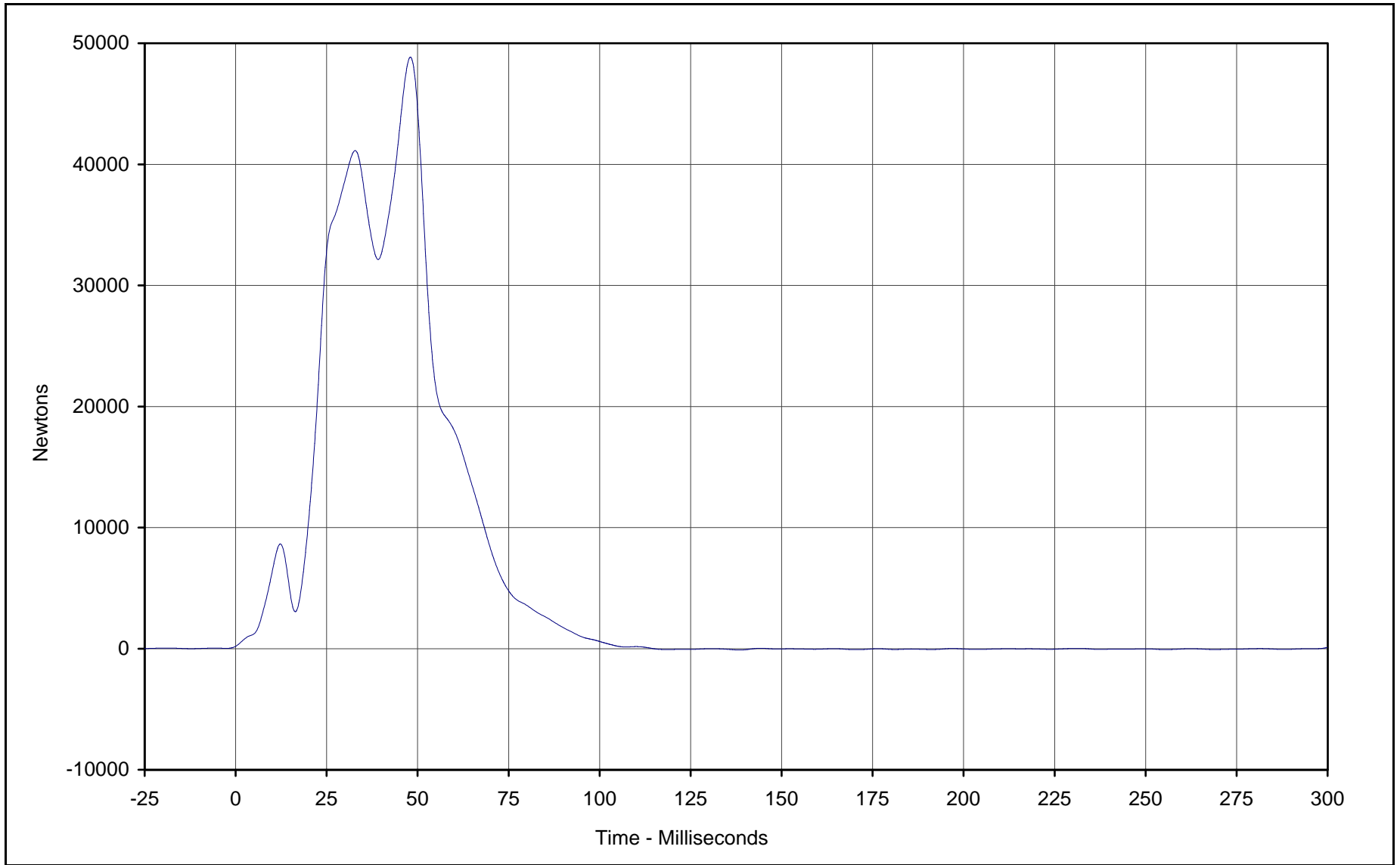

Curve Description: Barrier Force B4  
Maximum Value: 48855.0 at 48.0 Milliseconds  
Minimum Value: -113.0 at 138.4 Milliseconds  
SAE Filter Class: 60  
Date of Test: 1/29/02  
Curve Number: FIL-114

Test Program: 2002 NHTSA 35mph NCAP No.: HO5300  
Test Vehicle: 2002 Honda CR-V LX 4WD SUV



KAR21061-01

C-12

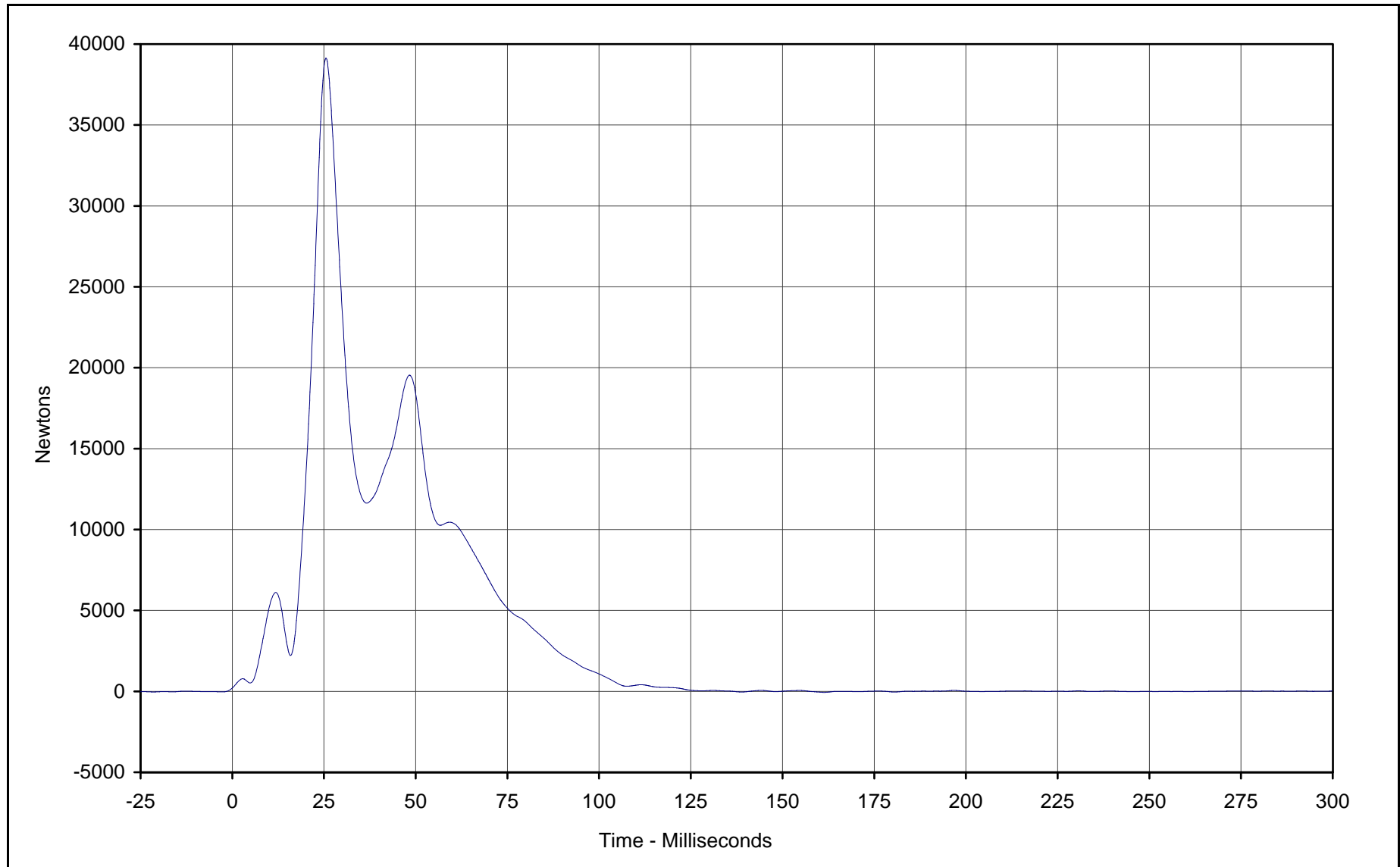

Curve Description: Barrier Force B5  
Maximum Value: 39143.5 at 25.5 Milliseconds  
Minimum Value: -62.4 at 161.3 Milliseconds  
SAE Filter Class: 60  
Date of Test: 1/29/02  
Curve Number: FIL-115

Test Program: 2002 NHTSA 35mph NCAP No.: HO5300  
Test Vehicle: 2002 Honda CR-V LX 4WD SUV



KAR21061-01

C-13

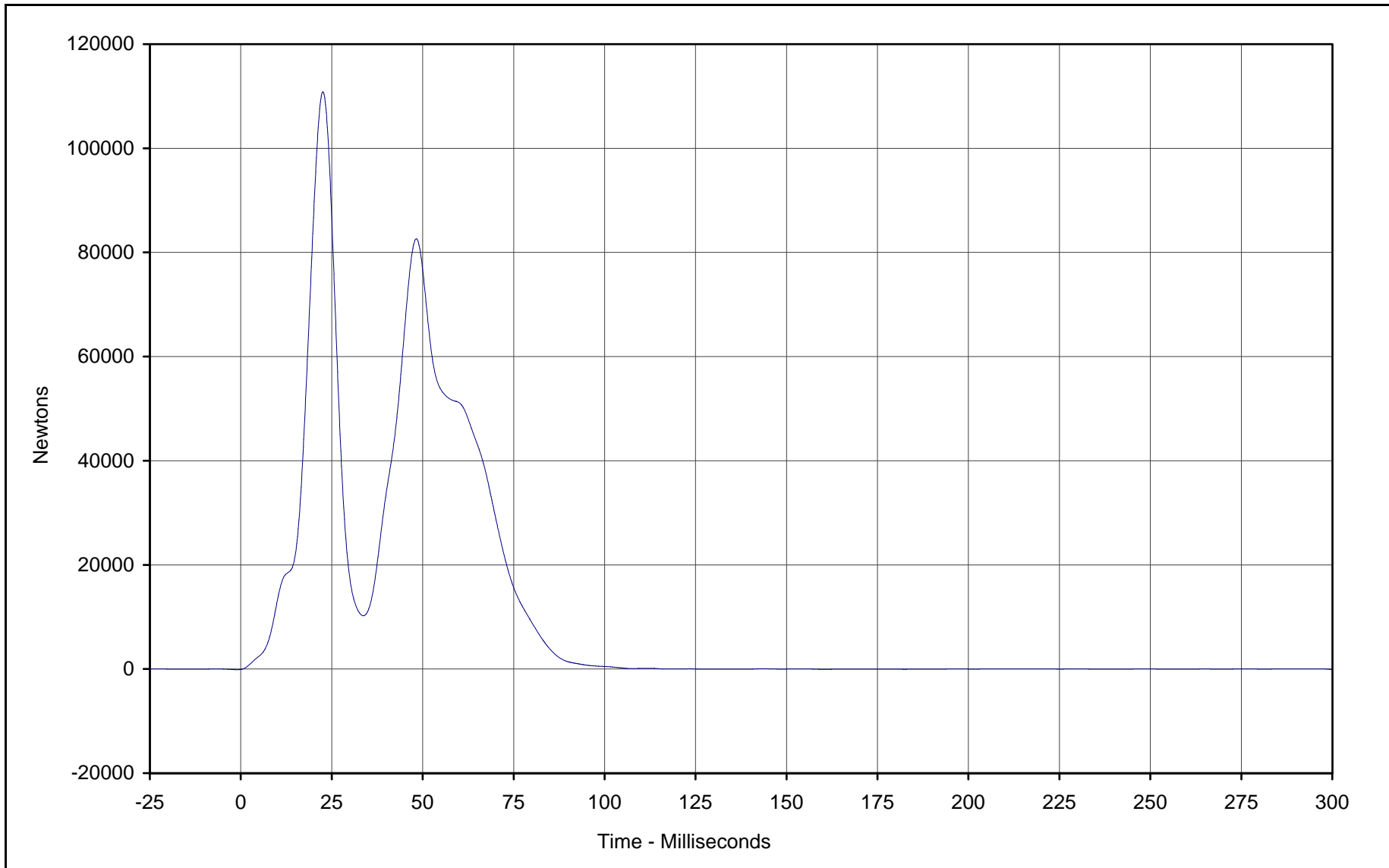

Curve Description: Barrier Force B6  
Maximum Value: 110844.8 at 22.6 Milliseconds  
Minimum Value: -103.0 at 299.9 Milliseconds  
SAE Filter Class: 60  
Date of Test: 1/29/02  
Curve Number: FIL-116

Test Program: 2002 NHTSA 35mph NCAP No.: HO5300  
Test Vehicle: 2002 Honda CR-V LX 4WD SUV



KAR21061-01

C-14

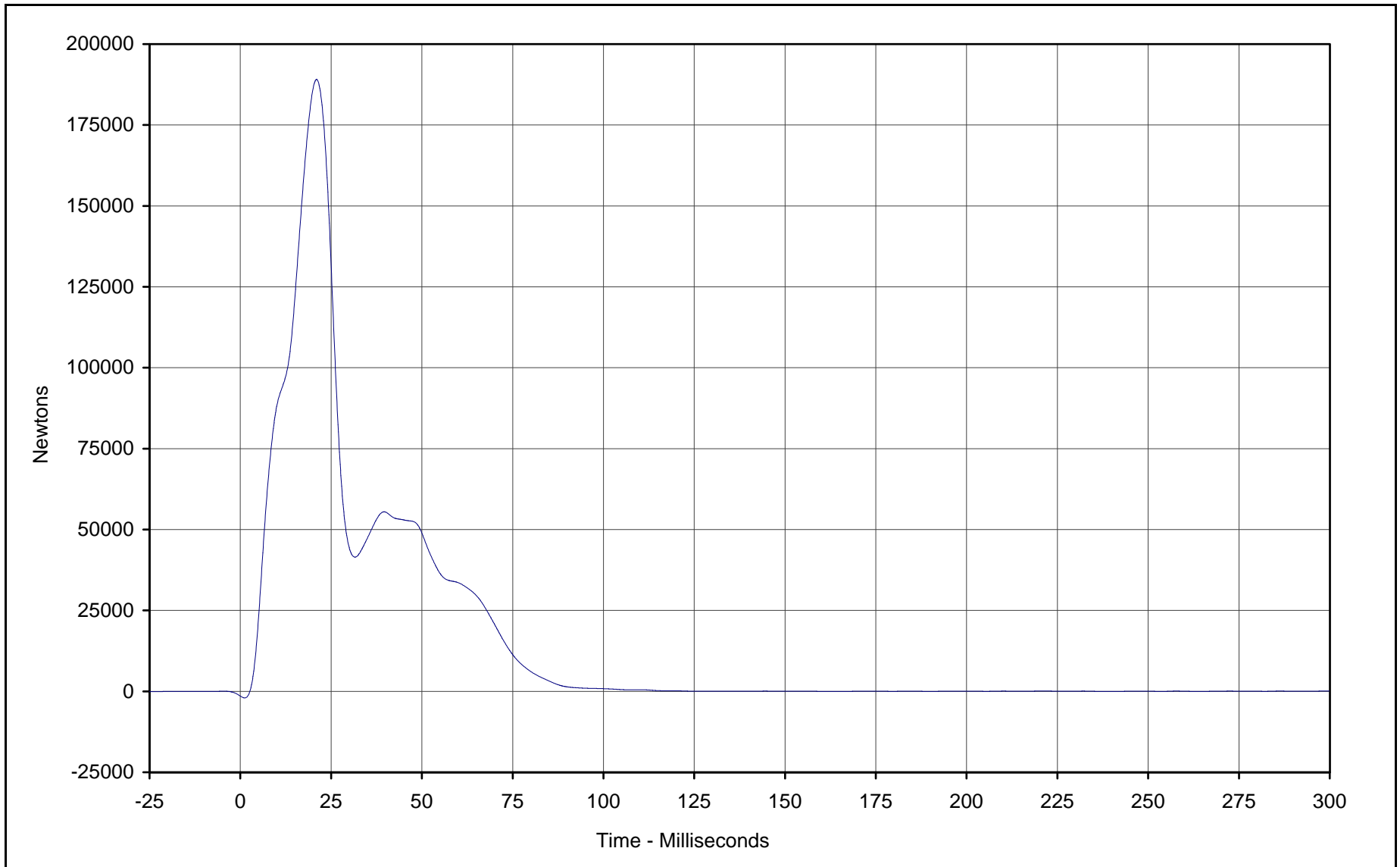

Curve Description: Barrier Force B7  
Maximum Value: 189079.7 at 21.0 Milliseconds  
Minimum Value: -2020.6 at 1.2 Milliseconds  
SAE Filter Class: 60  
Date of Test: 1/29/02  
Curve Number: FIL-117

Test Program: 2002 NHTSA 35mph NCAP No.: HO5300  
Test Vehicle: 2002 Honda CR-V LX 4WD SUV



KAR21061-01

C-15

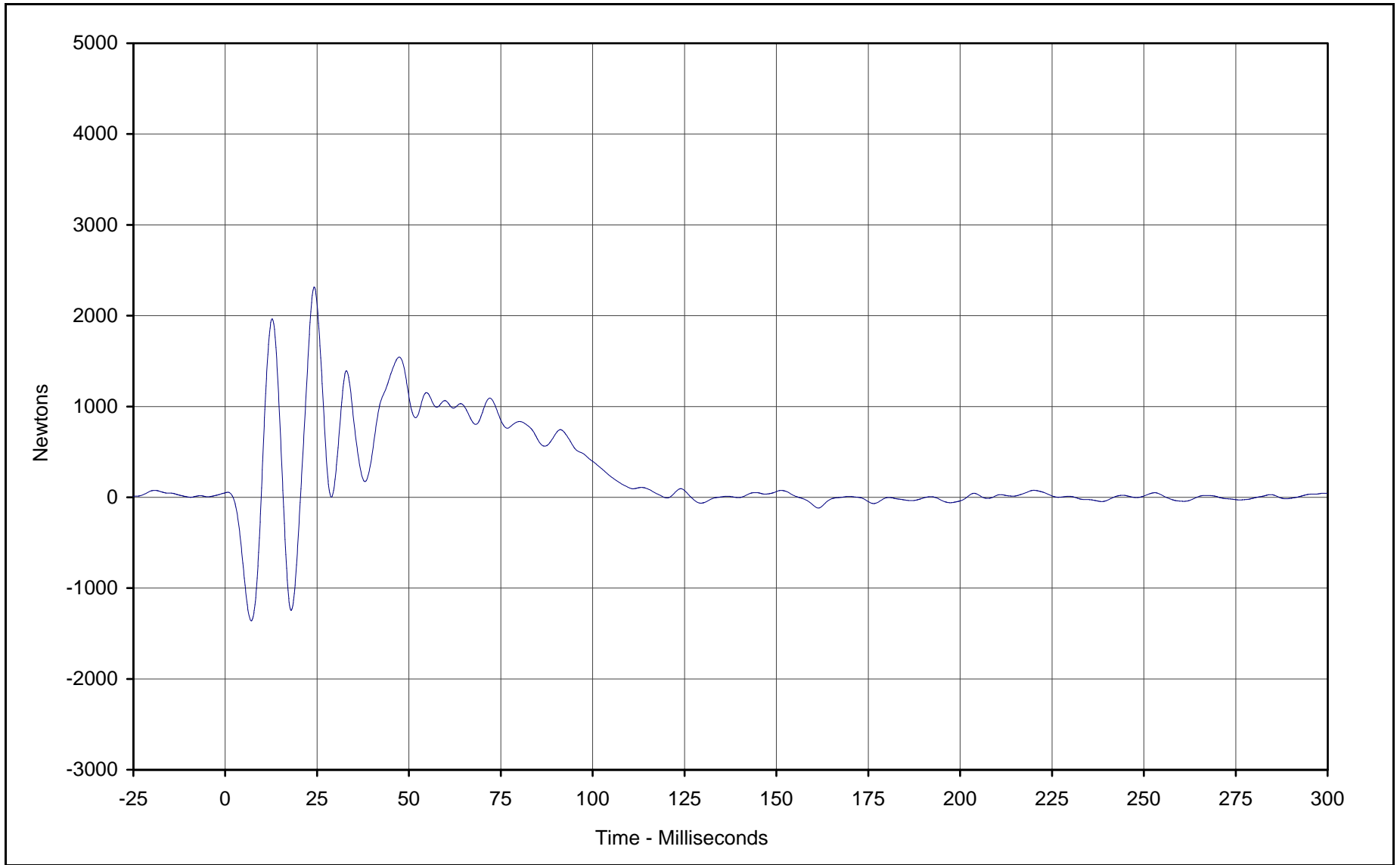

Curve Description: Barrier Force B8  
Maximum Value: 2315.1 at 24.2 Milliseconds  
Minimum Value: -1360.6 at 7.1 Milliseconds  
SAE Filter Class: 60  
Date of Test: 1/29/02  
Curve Number: FIL-118

Test Program: 2002 NHTSA 35mph NCAP No.: HO5300  
Test Vehicle: 2002 Honda CR-V LX 4WD SUV



KAR21061-01

C-16

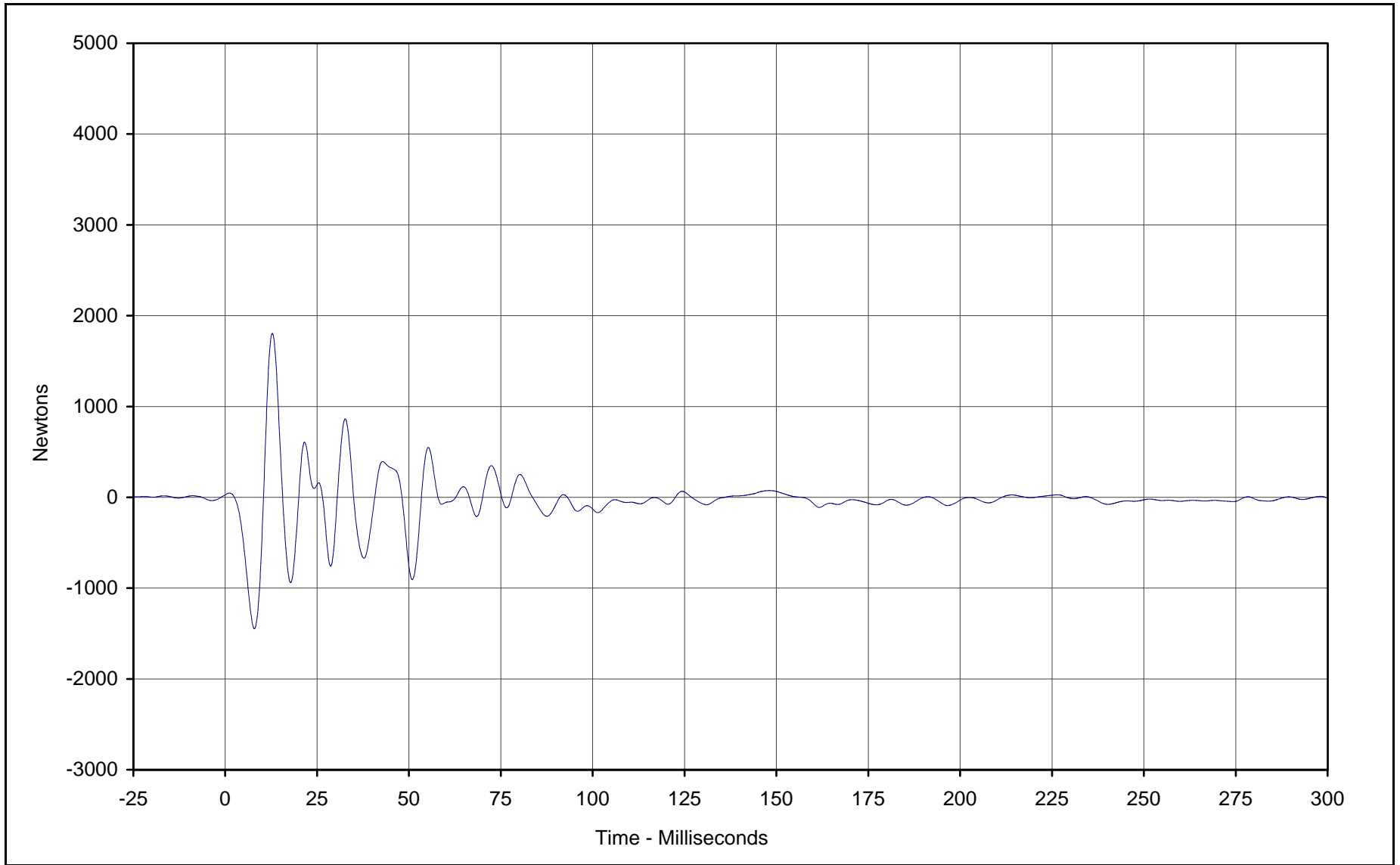

Curve Description: Barrier Force B9  
Maximum Value: 1805.8 at 12.8 Milliseconds  
Minimum Value: -1447.8 at 7.9 Milliseconds  
SAE Filter Class: 60  
Date of Test: 1/29/02  
Curve Number: FIL-119

Test Program: 2002 NHTSA 35mph NCAP No.: HO5300  
Test Vehicle: 2002 Honda CR-V LX 4WD SUV



KAR21061-01

C-17

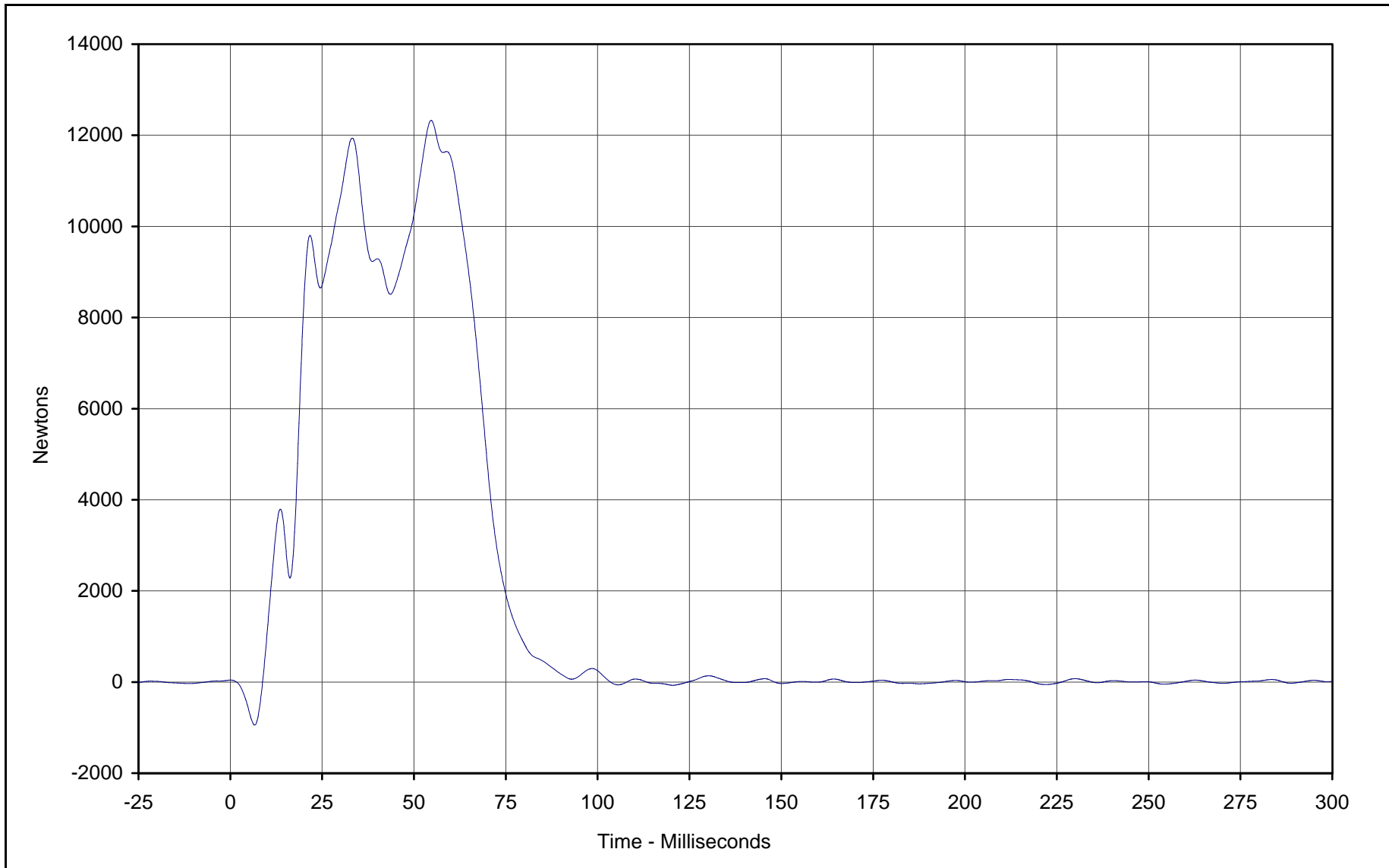

Curve Description: Barrier Force C2  
Maximum Value: 12328.0 at 54.7 Milliseconds  
Minimum Value: -942.8 at 6.6 Milliseconds  
SAE Filter Class: 60  
Date of Test: 1/29/02  
Curve Number: FIL-121

Test Program: 2002 NHTSA 35mph NCAP No.: HO5300  
Test Vehicle: 2002 Honda CR-V LX 4WD SUV



KAR21061-01

C-18

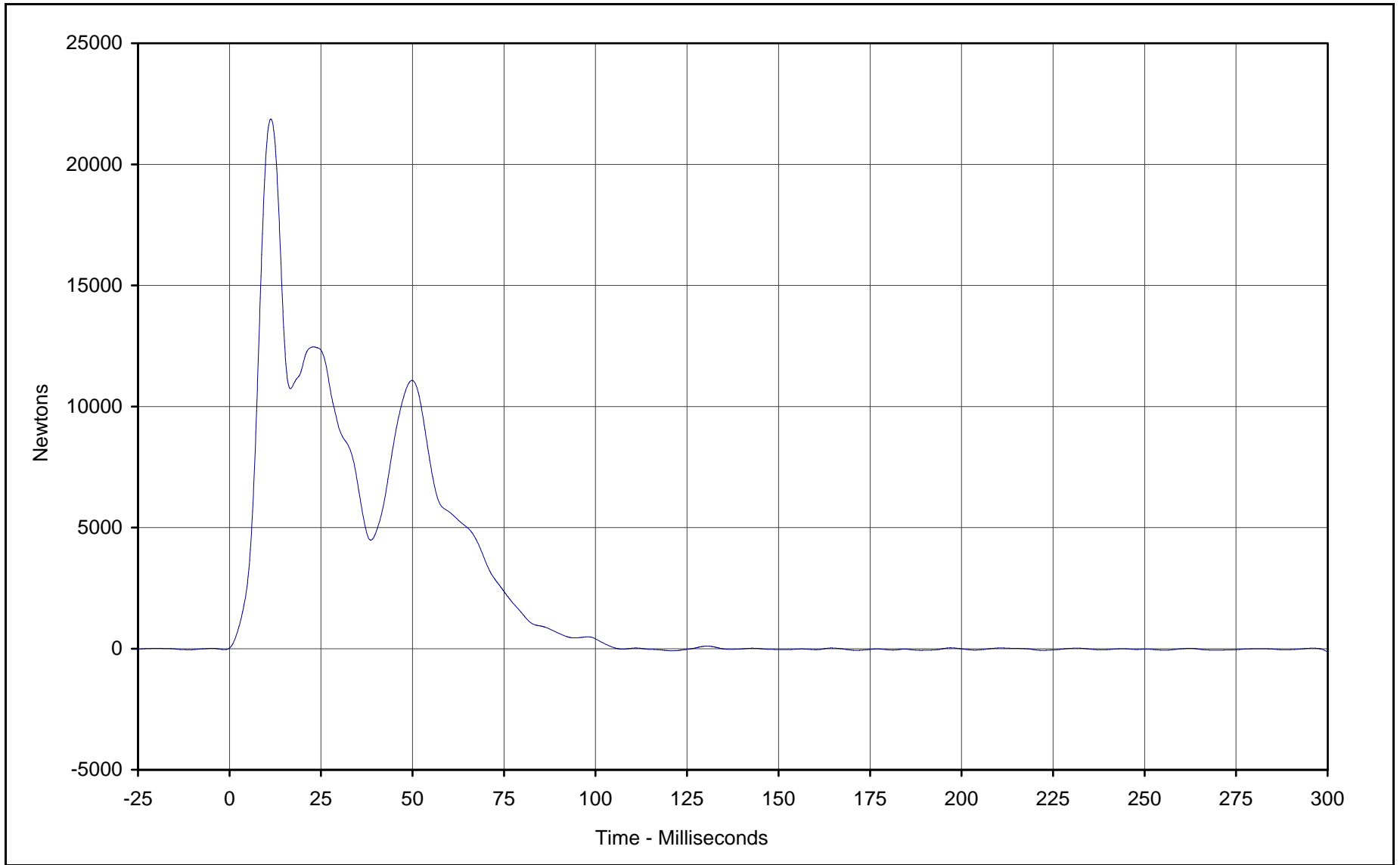

Curve Description: Barrier Force C3  
Maximum Value: 21873.2 at 11.3 Milliseconds  
Minimum Value: -126.8 at 299.9 Milliseconds  
SAE Filter Class: 60  
Date of Test: 1/29/02  
Curve Number: FIL-122

Test Program: 2002 NHTSA 35mph NCAP No.: HO5300  
Test Vehicle: 2002 Honda CR-V LX 4WD SUV



KAR21061-01

C-19

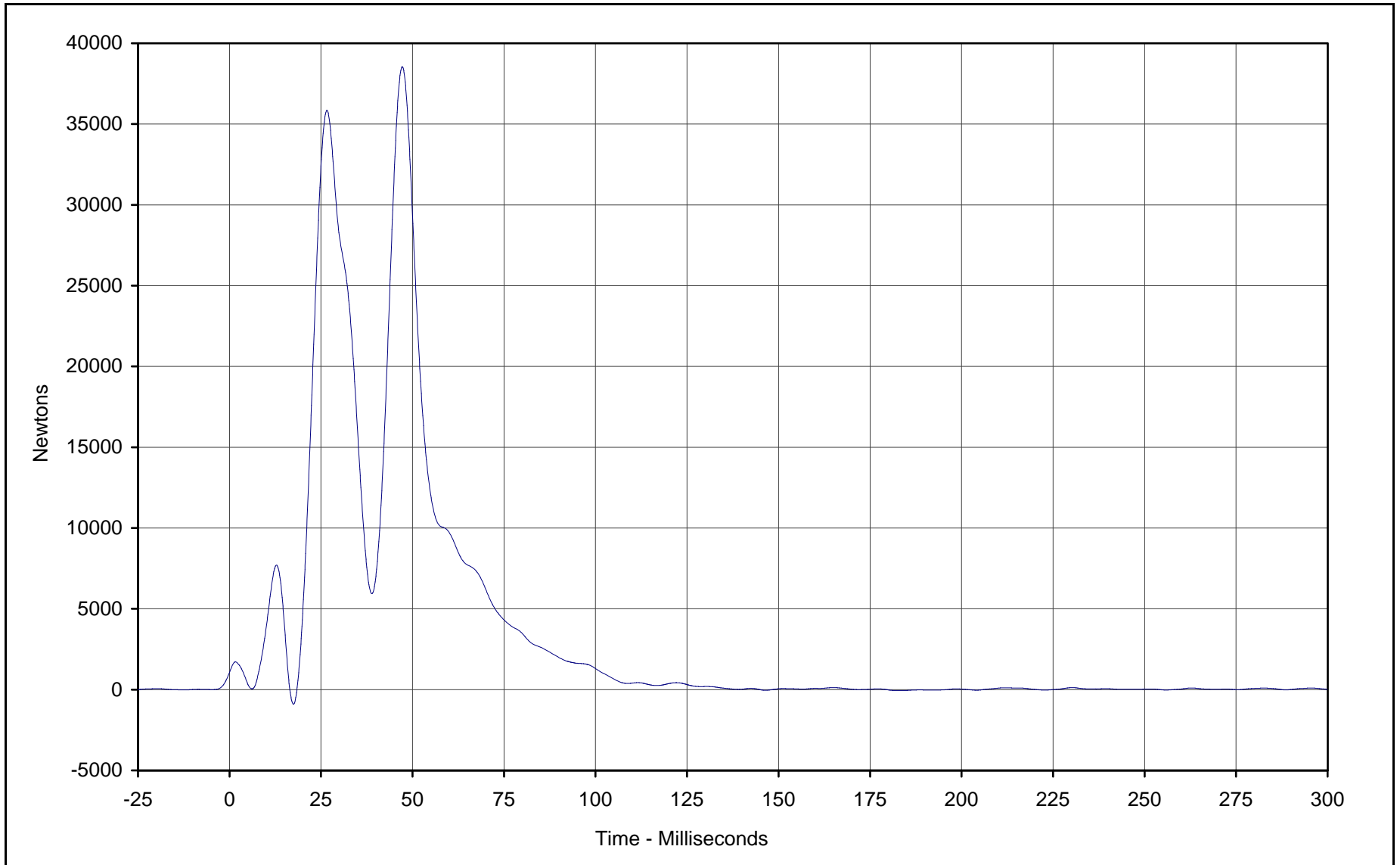

Curve Description: Barrier Force C4  
Maximum Value: 38548.1 at 47.2 Milliseconds  
Minimum Value: -903.8 at 17.5 Milliseconds  
SAE Filter Class: 60  
Date of Test: 1/29/02  
Curve Number: FIL-123

Test Program: 2002 NHTSA 35mph NCAP No.: HO5300  
Test Vehicle: 2002 Honda CR-V LX 4WD SUV



KAR21061-01

C-20

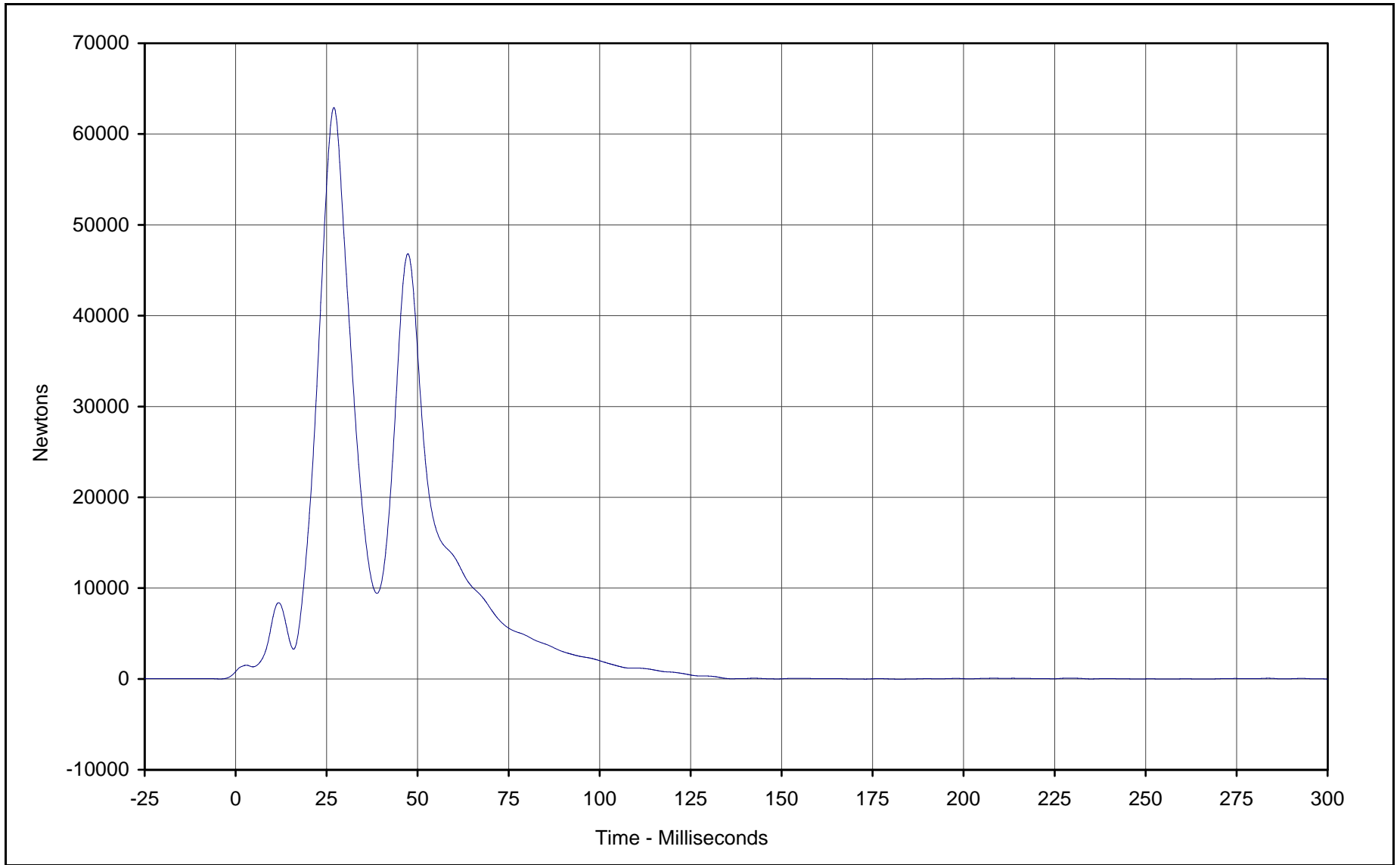

Curve Description: Barrier Force C5  
Maximum Value: 62919.9 at 27.0 Milliseconds  
Minimum Value: -27.2 at 182.7 Milliseconds  
SAE Filter Class: 60  
Date of Test: 1/29/02  
Curve Number: FIL-124

Test Program: 2002 NHTSA 35mph NCAP No.: HO5300  
Test Vehicle: 2002 Honda CR-V LX 4WD SUV



KAR21061-01

C-21

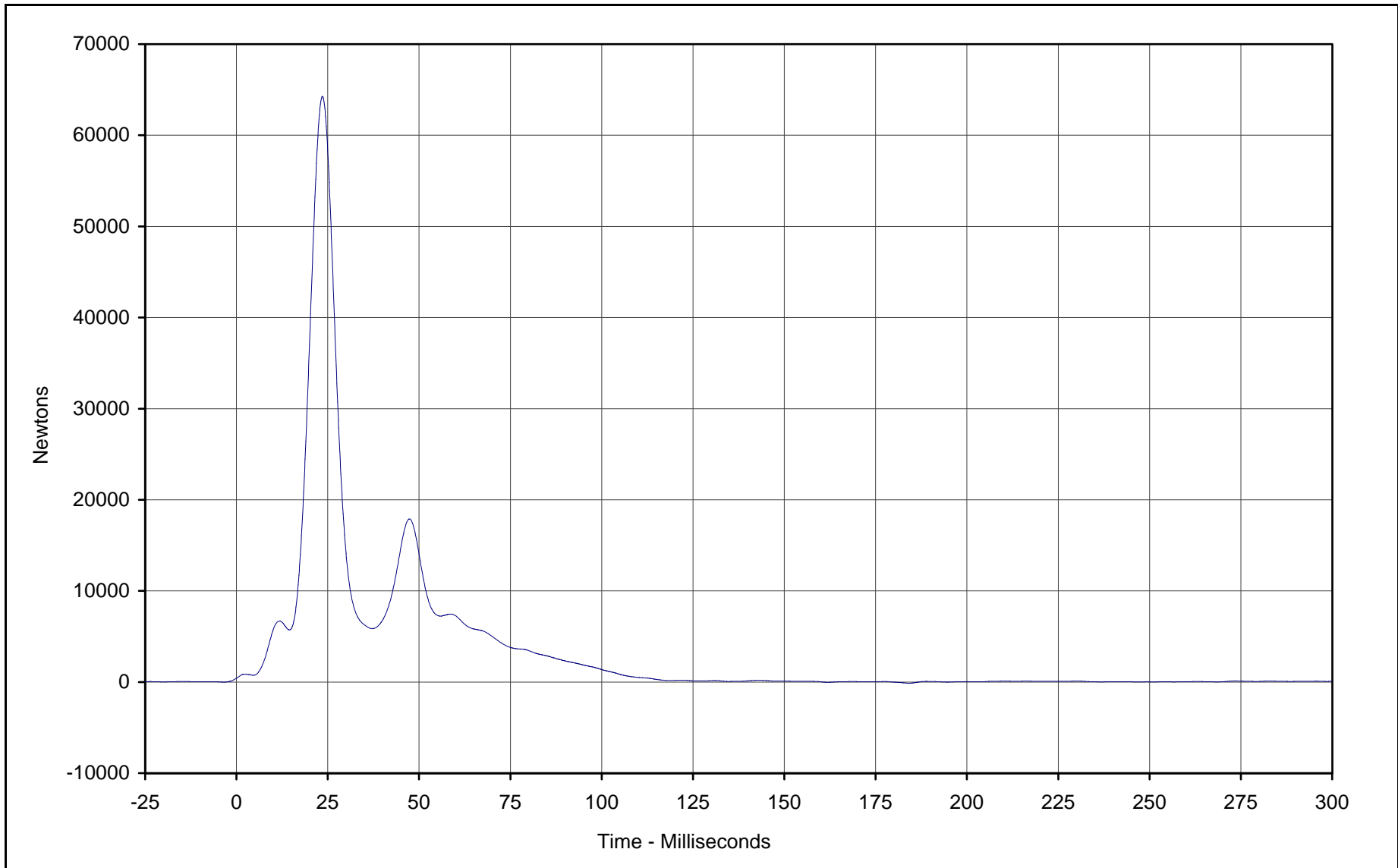

Curve Description: Barrier Force C6  
Maximum Value: 64266.5 at 23.5 Milliseconds  
Minimum Value: -135.6 at 184.2 Milliseconds  
SAE Filter Class: 60  
Date of Test: 1/29/02  
Curve Number: FIL-125

Test Program: 2002 NHTSA 35mph NCAP No.: HO5300  
Test Vehicle: 2002 Honda CR-V LX 4WD SUV



KAR21061-01

C-22

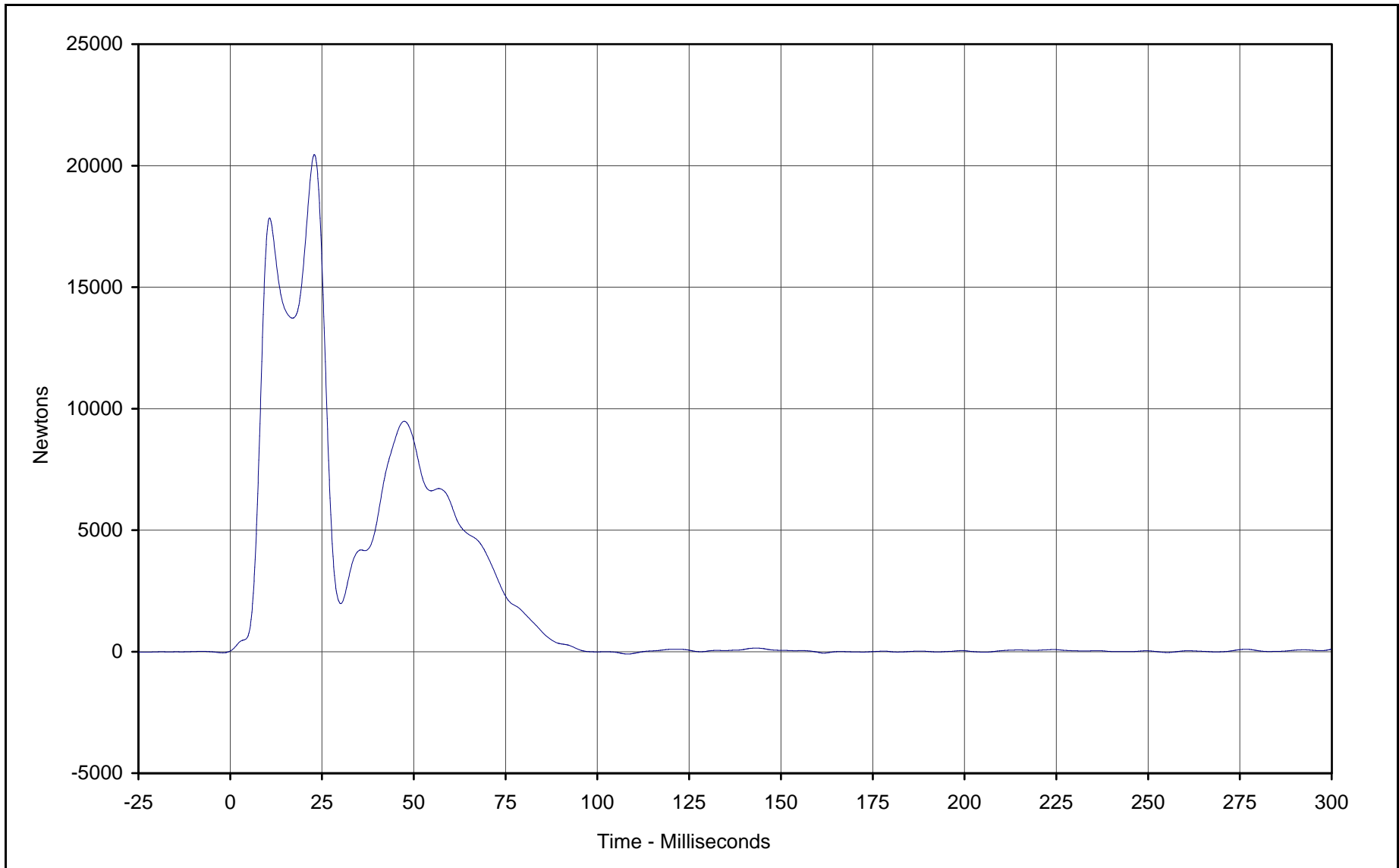

Curve Description: Barrier Force C7  
Maximum Value: 20455.6 at 22.9 Milliseconds  
Minimum Value: -98.5 at 108.2 Milliseconds  
SAE Filter Class: 60  
Date of Test: 1/29/02  
Curve Number: FIL-126

Test Program: 2002 NHTSA 35mph NCAP No.: HO5300  
Test Vehicle: 2002 Honda CR-V LX 4WD SUV



KAR21061-01

C-23

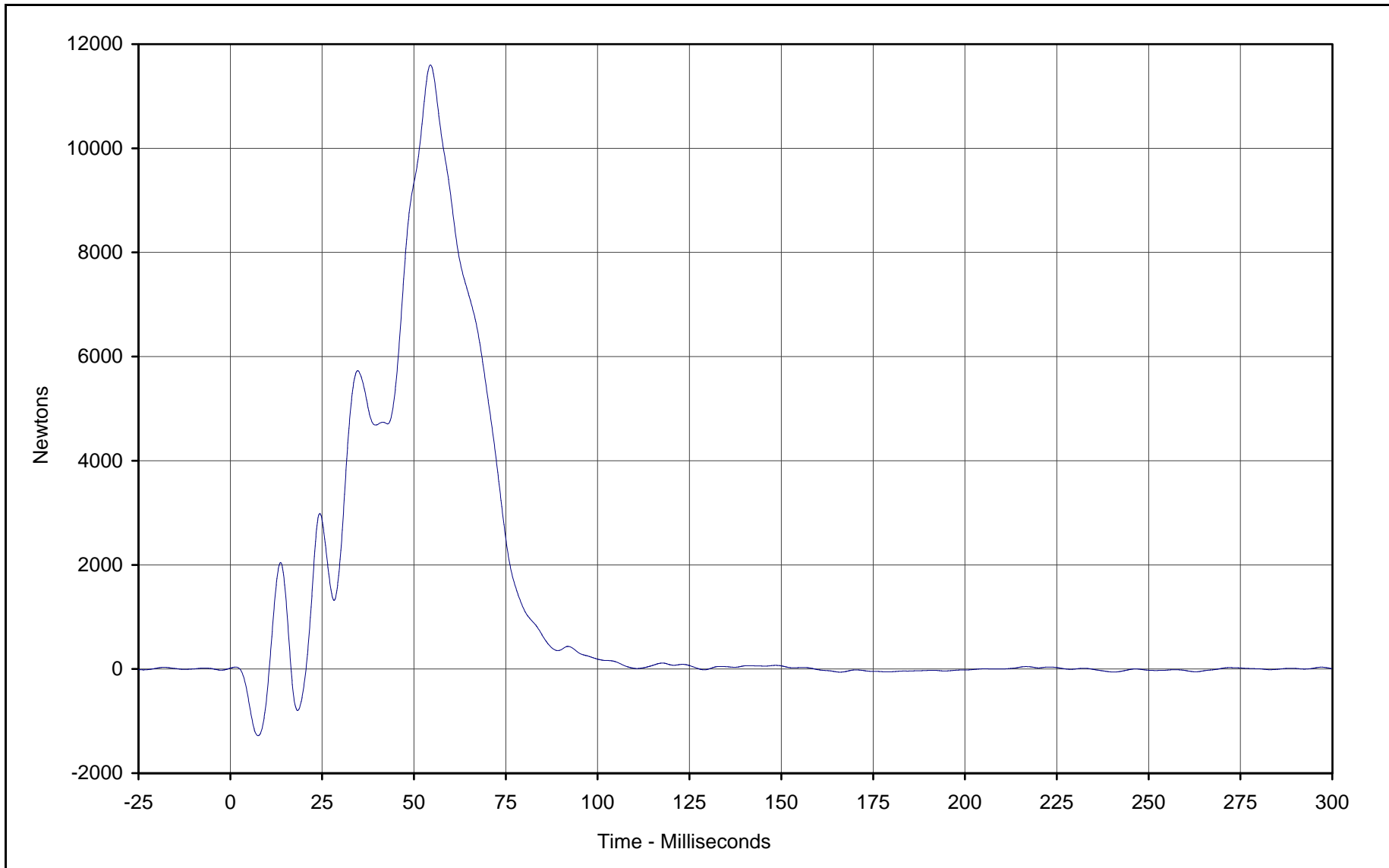

Curve Description: Barrier Force C8  
Maximum Value: 11601.0 at 54.5 Milliseconds  
Minimum Value: -1280.5 at 7.6 Milliseconds  
SAE Filter Class: 60  
Date of Test: 1/29/02  
Curve Number: FIL-127

Test Program: 2002 NHTSA 35mph NCAP No.: HO5300  
Test Vehicle: 2002 Honda CR-V LX 4WD SUV



KAR21061-01

C-24

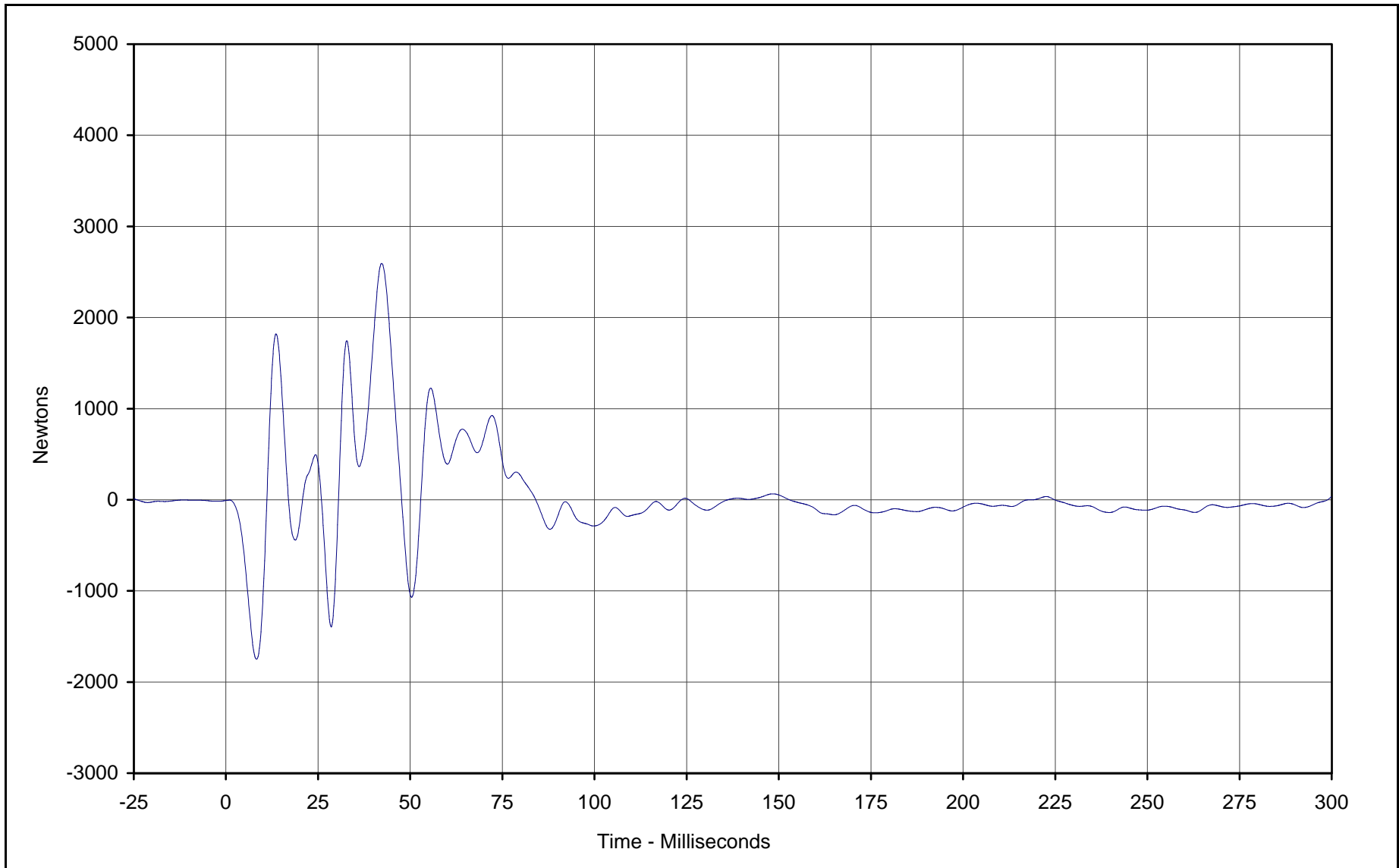

Curve Description: Barrier Force C9  
Maximum Value: 2594.1 at 42.3 Milliseconds  
Minimum Value: -1750.7 at 8.3 Milliseconds  
SAE Filter Class: 60  
Date of Test: 1/29/02  
Curve Number: FIL-128

Test Program: 2002 NHTSA 35mph NCAP No.: HO5300  
Test Vehicle: 2002 Honda CR-V LX 4WD SUV



KAR21061-01

C-25

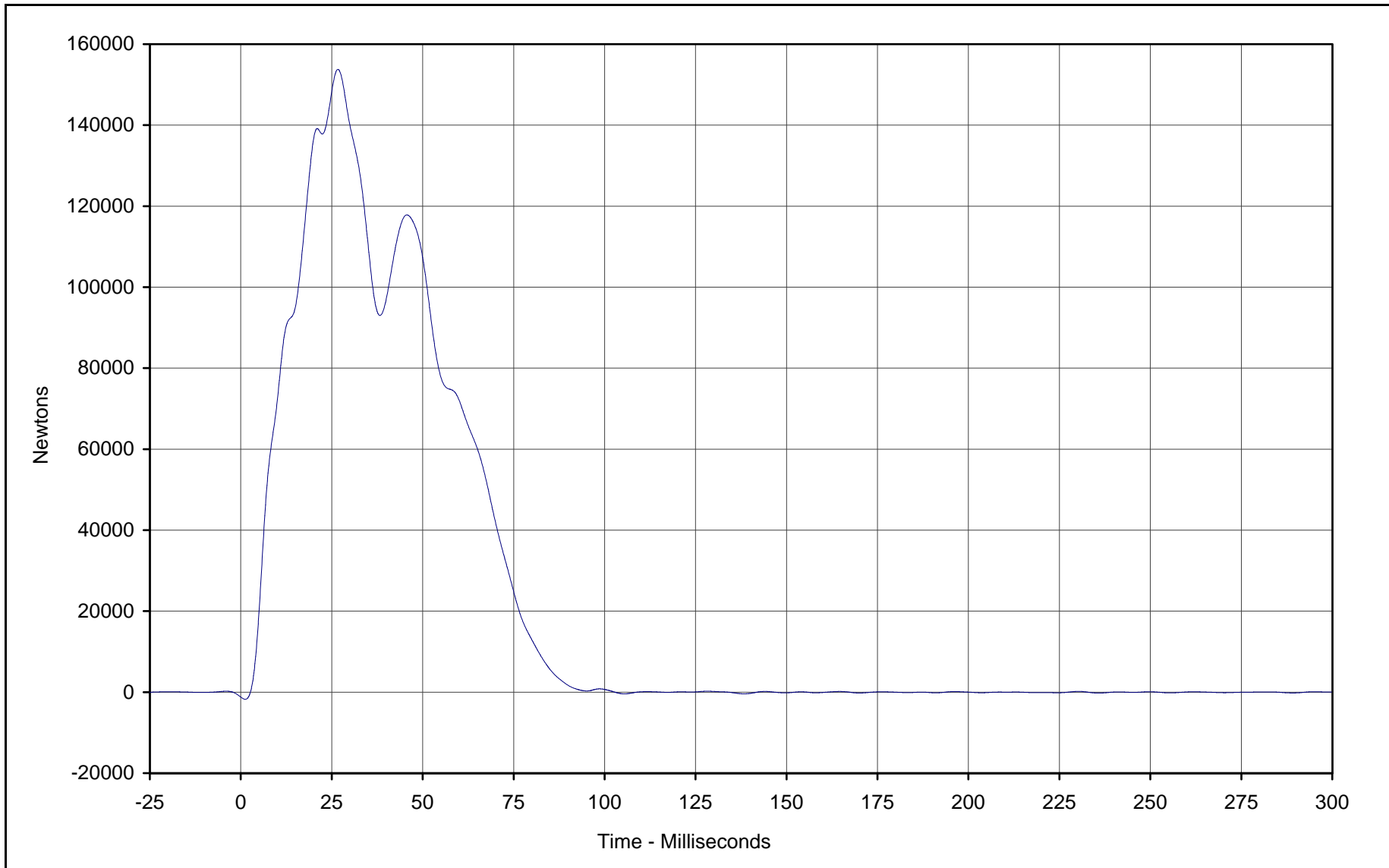

Curve Description: Barrier Force Sum Group 1  
Maximum Value: 153771.1 at 26.7 Milliseconds  
Minimum Value: -1771.5 at 1.2 Milliseconds  
SAE Filter Class: 60  
Date of Test: 1/29/02  
Curve Number: SUM-001

Test Program: 2002 NHTSA 35mph NCAP No.: HO5300  
Test Vehicle: 2002 Honda CR-V LX 4WD SUV



KAR21061-01

C-26

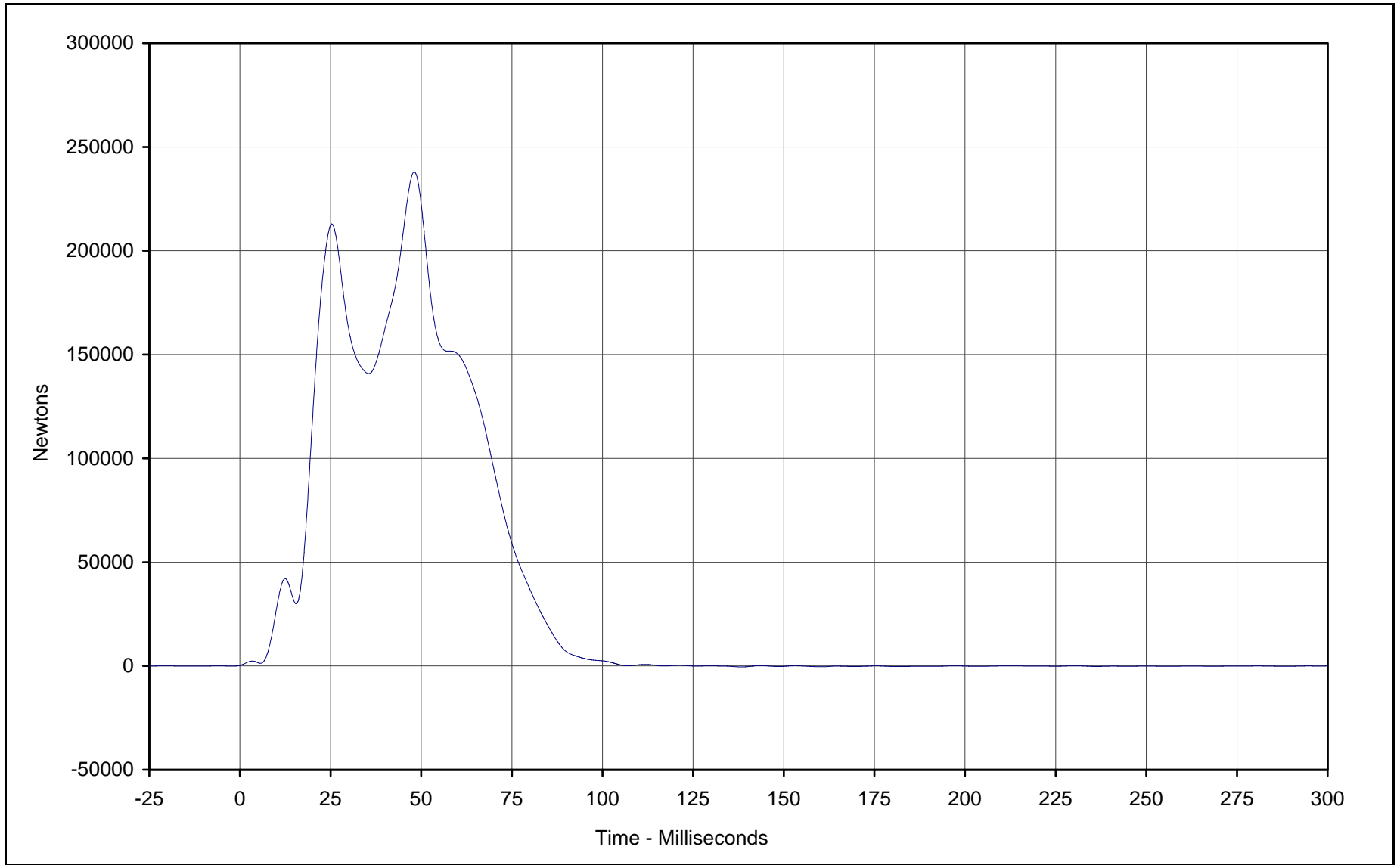

Curve Description: Barrier Force Sum Group 2  
Maximum Value: 238011.0 at 48.1 Milliseconds  
Minimum Value: -471.5 at 138.3 Milliseconds  
SAE Filter Class: 60  
Date of Test: 1/29/02  
Curve Number: SUM-002

Test Program: 2002 NHTSA 35mph NCAP No.: HO5300  
Test Vehicle: 2002 Honda CR-V LX 4WD SUV

KAR21061-01



C-27

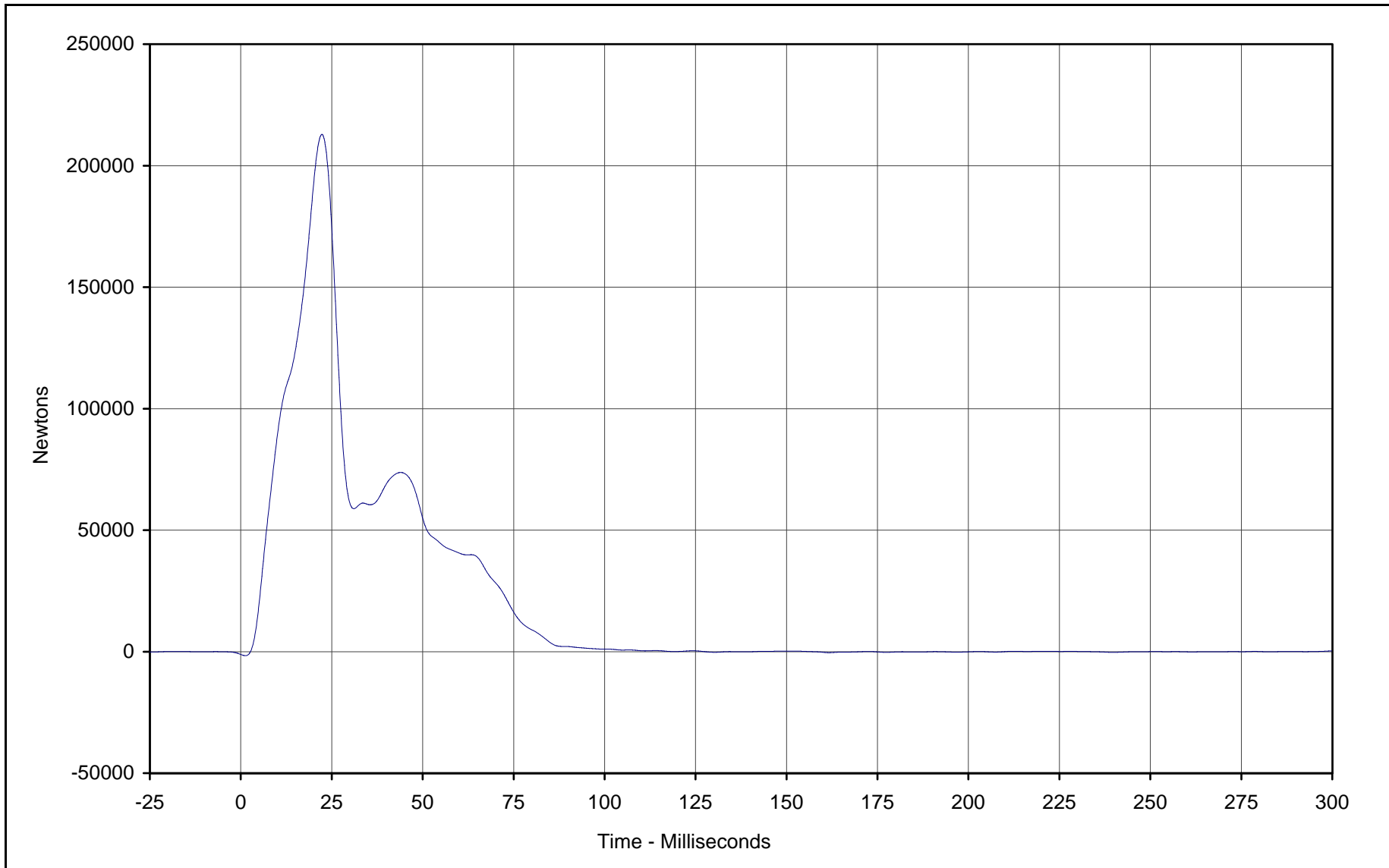

Curve Description: Barrier Force Sum Group 3  
Maximum Value: 212855.4 at 22.3 Milliseconds  
Minimum Value: -1658.6 at 1.3 Milliseconds  
SAE Filter Class: 60  
Date of Test: 1/29/02  
Curve Number: SUM-003

Test Program: 2002 NHTSA 35mph NCAP No.: HO5300  
Test Vehicle: 2002 Honda CR-V LX 4WD SUV



KAR21061-01

C-28

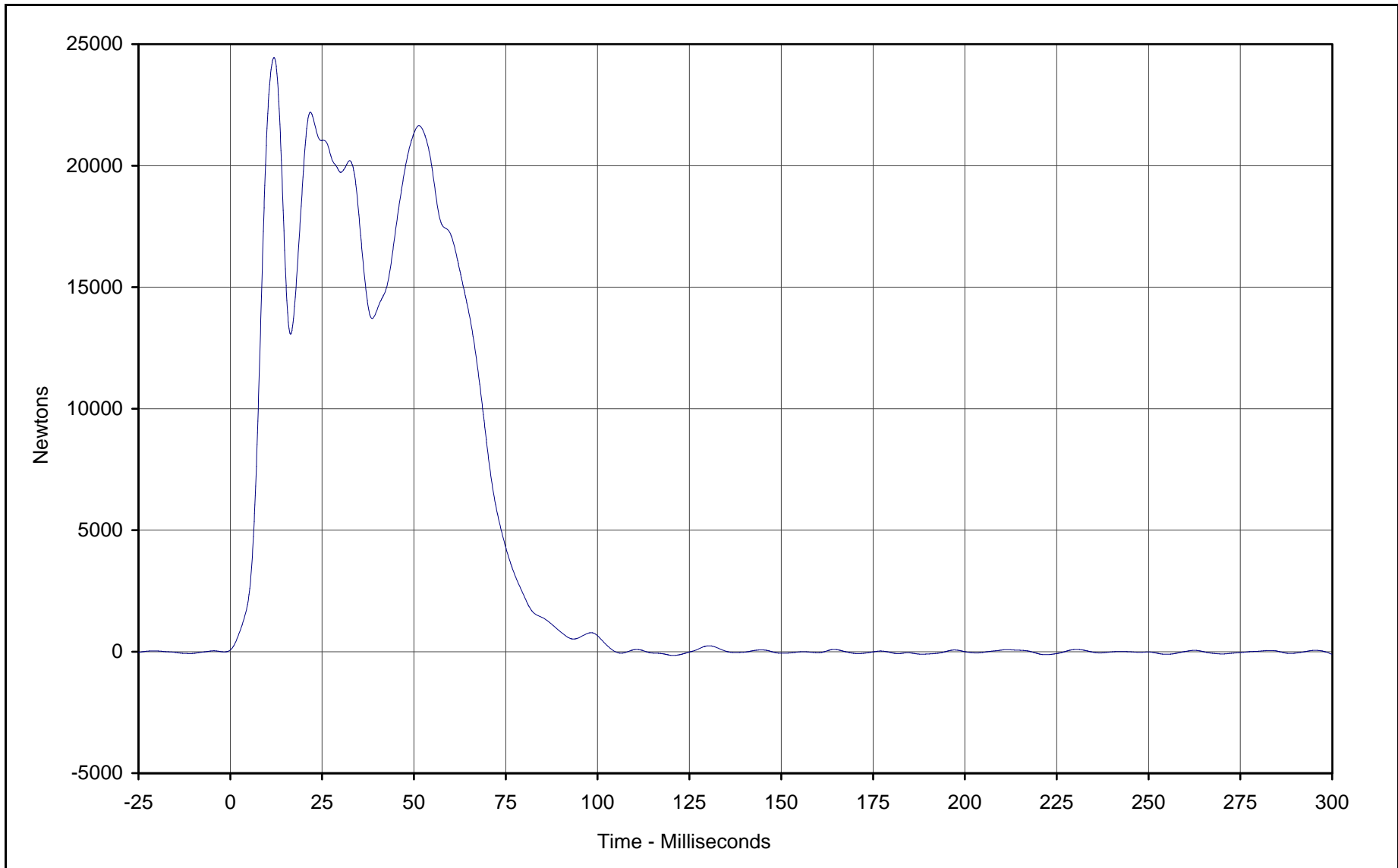

Curve Description: Barrier Force Sum Group 4  
Maximum Value: 24448.5 at 11.9 Milliseconds  
Minimum Value: -157.9 at 120.6 Milliseconds  
SAE Filter Class: 60  
Date of Test: 1/29/02  
Curve Number: SUM-004

Test Program: 2002 NHTSA 35mph NCAP No.: HO5300  
Test Vehicle: 2002 Honda CR-V LX 4WD SUV



KAR21061-01

C-29

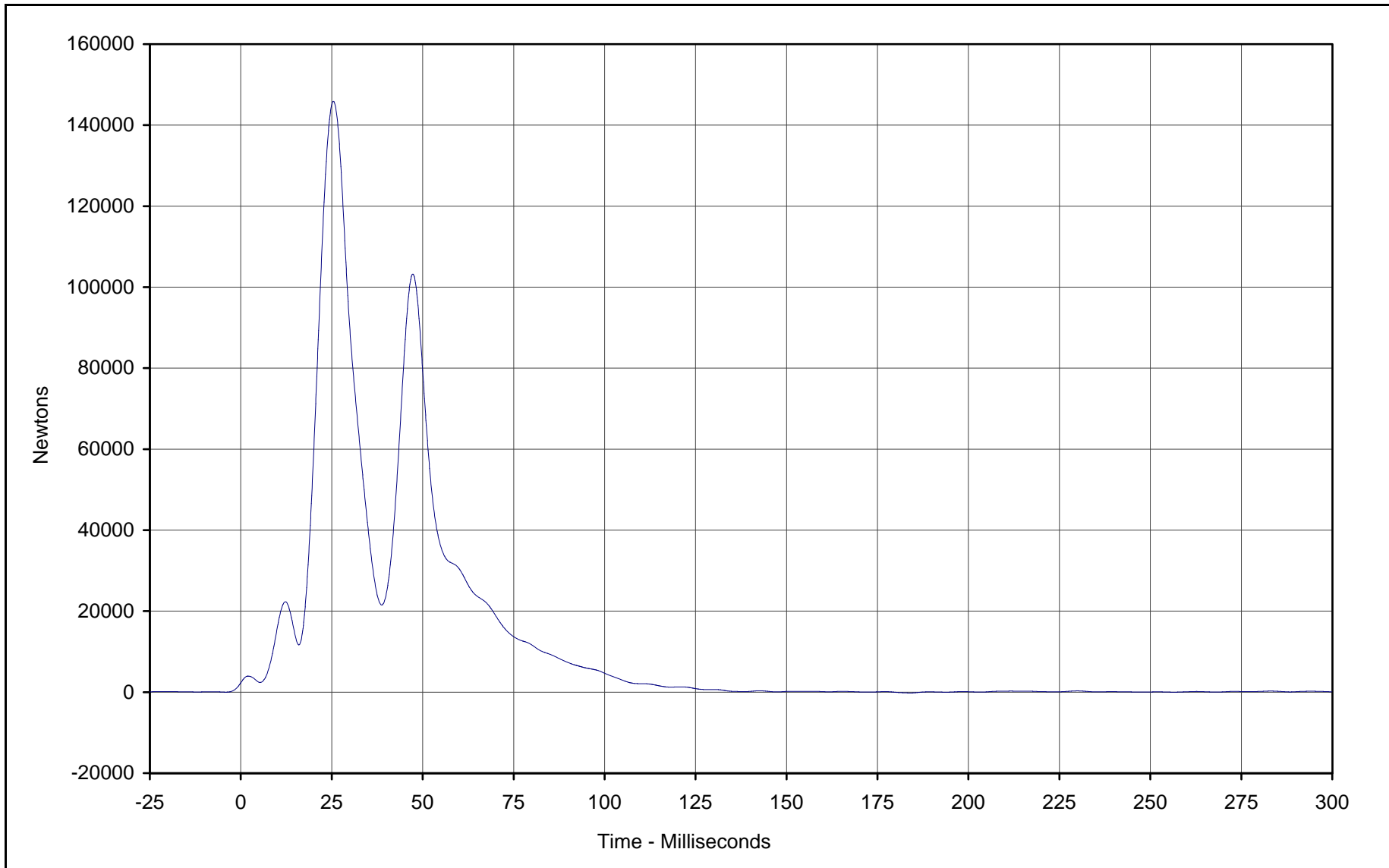

Curve Description: Barrier Force Sum Group 5  
Maximum Value: 145905.3 at 25.4 Milliseconds  
Minimum Value: -209.7 at 184.0 Milliseconds  
SAE Filter Class: 60  
Date of Test: 1/29/02  
Curve Number: SUM-005

Test Program: 2002 NHTSA 35mph NCAP No.: HO5300  
Test Vehicle: 2002 Honda CR-V LX 4WD SUV



KAR21061-01

C-30

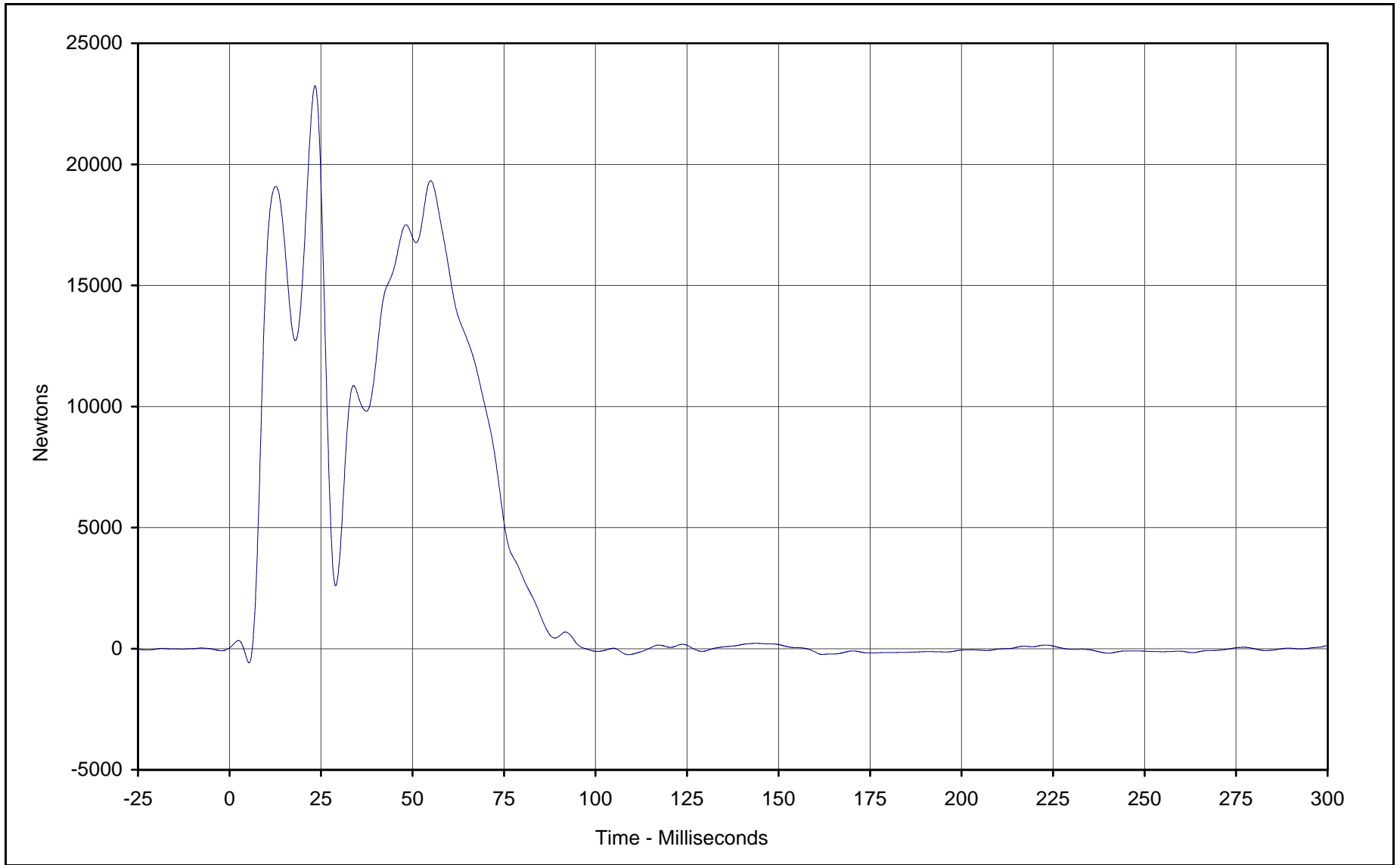

Curve Description: Barrier Force Sum Group 6  
Maximum Value: 23247.7 at 23.4 Milliseconds  
Minimum Value: -583.6 at 5.3 Milliseconds  
SAE Filter Class: 60  
Date of Test: 1/29/02  
Curve Number: SUM-006

Test Program: 2002 NHTSA 35mph NCAP No.: HO5300  
Test Vehicle: 2002 Honda CR-V LX 4WD SUV



KAR21061-01

C-31

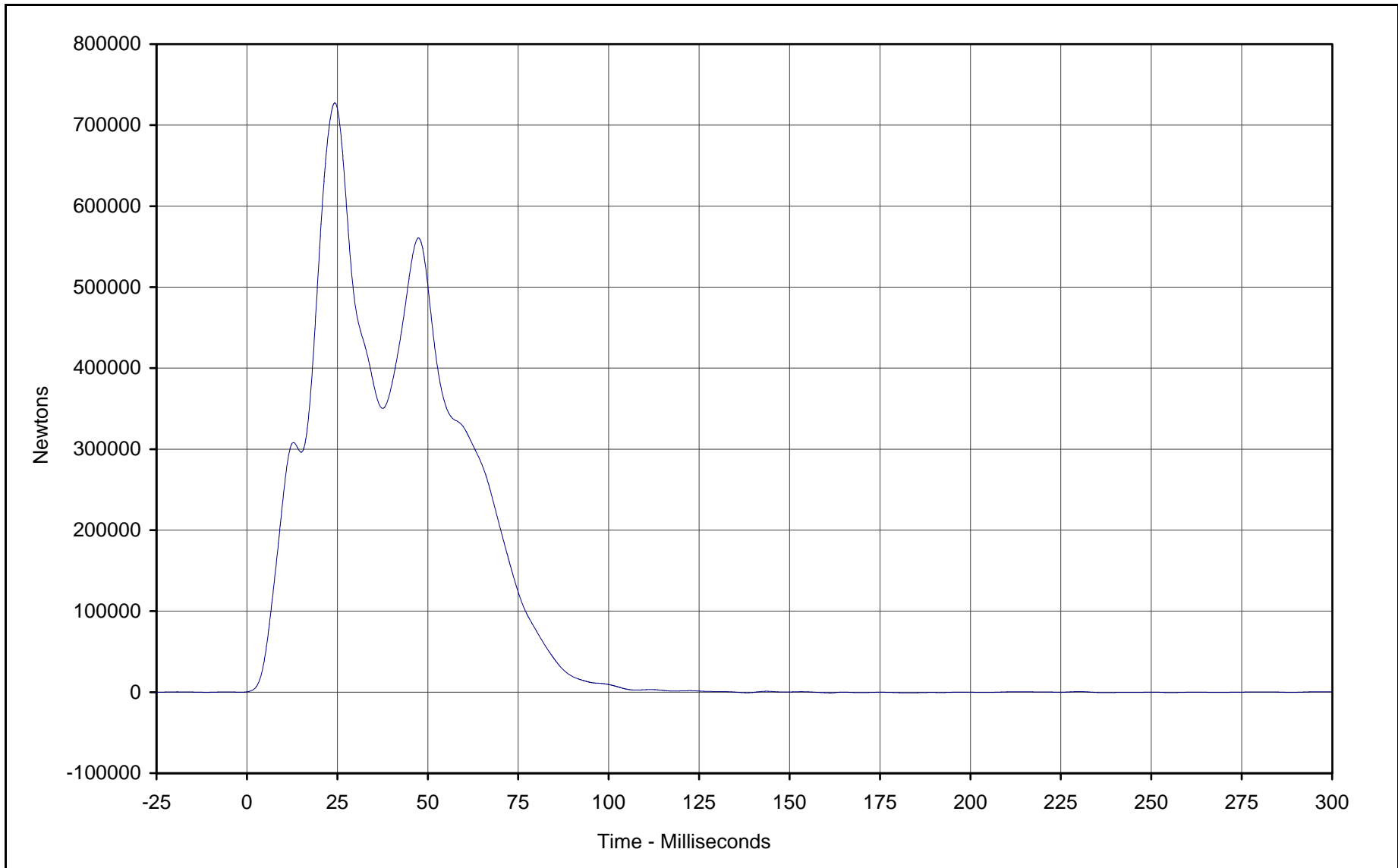

Curve Description: Barrier Force Sum Total  
Maximum Value: 727481.2 at 24.3 Milliseconds  
Minimum Value: -969.6 at 161.2 Milliseconds  
SAE Filter Class: 60  
Date of Test: 1/29/02  
Curve Number: SUM-007

Test Program: 2002 NHTSA 35mph NCAP No.: HO5300  
Test Vehicle: 2002 Honda CR-V LX 4WD SUV

KAR21061-01



C-32

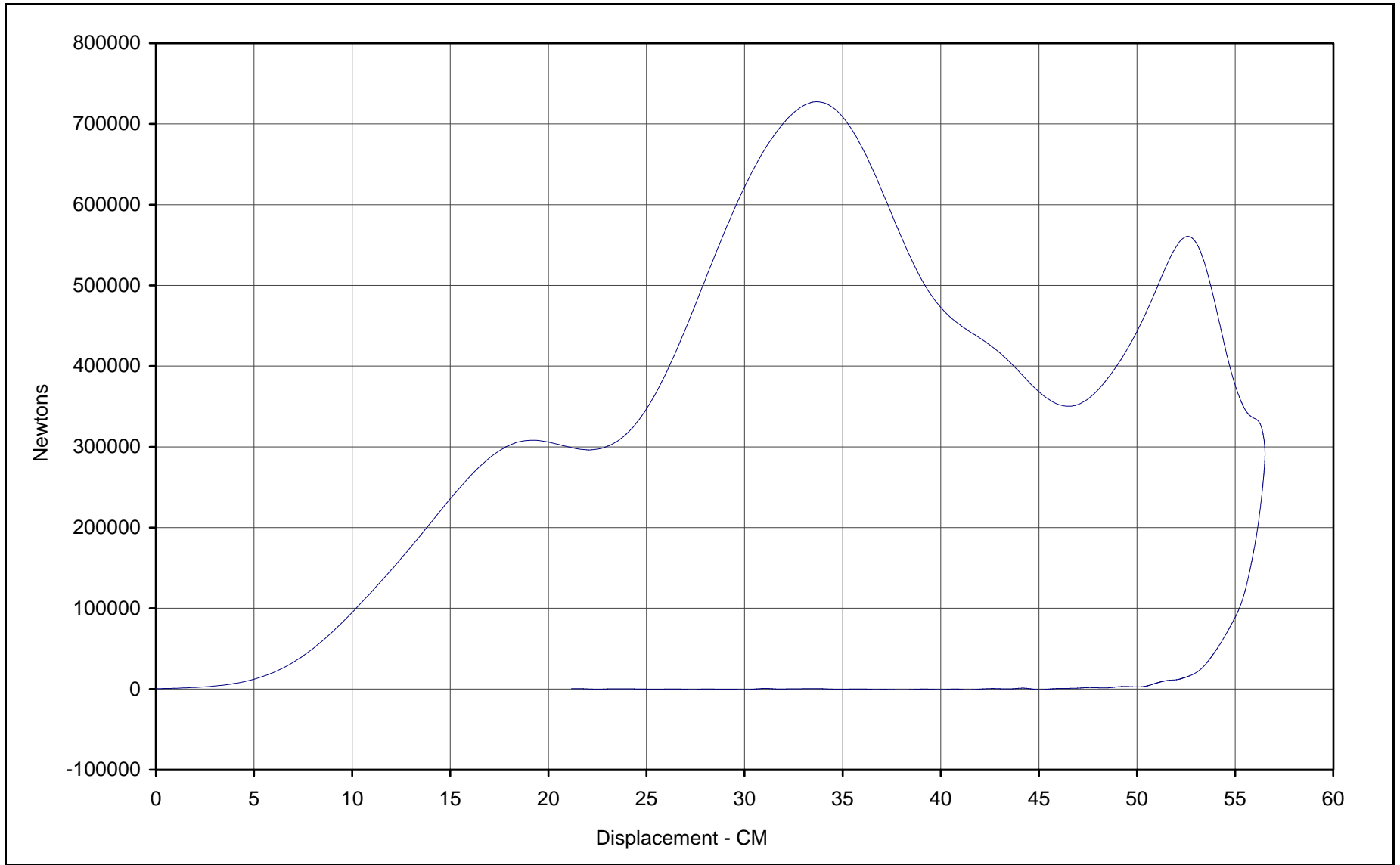

Curve Description: Sum Force Total vs. Dynamic Crush

Maximum Displ.: 56.5 at 63.9 Milliseconds

Maximum Force: 727,481 at 24.3 Milliseconds

Measured Energy: 194,910 joules

Date of Test: 1/29/02

Curve Number: XVY-001

Test Program: 2002 NHTSA 35mph NCAP No.: HO5300

Test Vehicle: 2002 Honda CR-V LX 4WD SUV

KAR21061-01



## BARRIER LOAD CELL SUMMARY DATA

Test Vehicle: 2002 Honda CR-V LX 4WD SUV

NHTSA No.: HO5300

Test Program: 2002 NHTSA 35mph NCAP

Test Date: 1/29/02

### BARRIER LOAD CELL PEAK FORCES

Location	Units	Max	Time	Min	Time
Barrier Force A2	Newtons	1896.5	30.2	-1036.2	17.8
Barrier Force A3	Newtons	43552.8	48.4	-2344.6	17.3
Barrier Force A4	Newtons	44835.8	48.1	-1881.1	17.4
Barrier Force A5	Newtons	47608.8	28.3	-1930.1	17.0
Barrier Force A6	Newtons	8866.9	23.8	-1926.2	7.1
Barrier Force A7	Newtons	38872.6	24.8	-1898.5	17.0
Barrier Force A8	Newtons	2656.3	12.7	-2003.4	18.2
Barrier Force A9	Newtons	3073.1	12.8	-2104.2	17.7
Barrier Force B2	Newtons	30602.5	32.9	-197.4	4.7
Barrier Force B3	Newtons	116581.3	20.1	-1737.1	1.2
Barrier Force B4	Newtons	48855.0	48.0	-113.0	138.4
Barrier Force B5	Newtons	39143.5	25.5	-62.4	161.3
Barrier Force B6	Newtons	110844.8	22.6	-103.0	299.9
Barrier Force B7	Newtons	189079.7	21.0	-2020.6	1.2
Barrier Force B8	Newtons	2315.1	24.2	-1360.6	7.1
Barrier Force B9	Newtons	1805.8	12.8	-1447.8	7.9
Barrier Force C2	Newtons	12328.0	54.7	-942.8	6.6
Barrier Force C3	Newtons	21873.2	11.3	-126.8	299.9
Barrier Force C4	Newtons	38548.1	47.2	-903.8	17.5
Barrier Force C5	Newtons	62919.9	27.0	-27.2	182.7
Barrier Force C6	Newtons	64266.5	23.5	-135.6	184.2
Barrier Force C7	Newtons	20455.6	22.9	-98.5	108.2
Barrier Force C8	Newtons	11601.0	54.5	-1280.5	7.6
Barrier Force C9	Newtons	2594.1	42.3	-1750.7	8.3
Barrier Force Sum Group 1	Newtons	153771.1	26.7	-1771.5	1.2
Barrier Force Sum Group 2	Newtons	238011.0	48.1	-471.5	138.3
Barrier Force Sum Group 3	Newtons	212855.4	22.3	-1658.6	1.3
Barrier Force Sum Group 4	Newtons	24448.5	11.9	-157.9	120.6
Barrier Force Sum Group 5	Newtons	145905.3	25.4	-209.7	184.0
Barrier Force Sum Group 6	Newtons	23247.7	23.4	-583.6	5.3
Barrier Force Sum Total	Newtons	727481.2	24.3	-969.6	161.2

Barrier Load cells A1,B1,C1, and D1 through D9 (12 locations) were not recorded.

## **APPENDIX D**

### **INSTRUMENTATION DATA CHANNEL ASSIGNMENTS**

**2002 NHTSA 35mph NCAP  
Instrumentation Data Channel Assignments  
Driver A.T.D. Serial Number 34  
1/29/02  
2002 Honda CR-V LX 4WD SUV**

CH.	LOCATION	AXIS	IDENT. NO.	DESCRIPTION	MFR	MODEL	UNITS
1	HEAD, PRIMARY	X	KEAC039	Accel., 1/2 bridge	Endevco	7264-2000	G
2	HEAD, PRIMARY	Y	KEAC038	Accel., 1/2 bridge	Endevco	7264-2000	G
3	HEAD, PRIMARY	Z	KEAC027	Accel., 1/2 bridge	Endevco	7264-2000	G
4	HEAD, REDUNDANT	X	KEAC031	Accel., 1/2 bridge	Endevco	7264-2000	G
5	HEAD, REDUNDANT	Y	KEAC032	Accel., 1/2 bridge	Endevco	7264-2000	G
6	HEAD, REDUNDANT	Z	KEAC026	Accel., 1/2 bridge	Endevco	7264-2000	G
7	NECK FORCE	X	GPUN02FX	Load cell, six axis neck	R. A. Denton	1716A	N
8	NECK FORCE	Y	GPUN02FY	Load cell, six axis neck	R. A. Denton	1716A	N
9	NECK FORCE	Z	GPUN02FZ	Load cell, six axis neck	R. A. Denton	1716A	N
10	NECK MOMENT	X	GPUN02MX	Load cell, six axis neck	R. A. Denton	1716A	Nm
11	NECK MOMENT	Y	GPUN02MY	Load cell, six axis neck	R. A. Denton	1716A	Nm
12	NECK MOMENT	Z	GPUN02MZ	Load cell, six axis neck	R. A. Denton	1716A	Nm
13	CHEST , PRIMARY	X	GPAC031	Accel., 1/2 bridge	Endevco	7264-2000	G
14	CHEST , PRIMARY	Y	GPAC024	Accel., 1/2 bridge	Endevco	7264-2000	G
15	CHEST , PRIMARY	Z	GPAC029	Accel., 1/2 bridge	Endevco	7264-2000	G
16	CHEST , REDUNDANT	X	KEAC023	Accel., 1/2 bridge	Endevco	7264-200	G
17	CHEST , REDUNDANT	Y	KEAC022	Accel., 1/2 bridge	Endevco	7264-200	G
18	CHEST , REDUNDANT	Z	KEAC024	Accel., 1/2 bridge	Endevco	7264-200	G
19	CHEST DISPLACEMENT	X	GPCP001	Rotary Pot Chest	Servo	14CBI	MM
20	PELVIS, PRIMARY	X	KEAC019	Accel., 1/2 bridge	Endevco	7264-200	G
21	PELVIS, PRIMARY	Y	KEAC020	Accel., 1/2 bridge	Endevco	7264-200	G
22	PELVIS, PRIMARY	Z	KEAC021	Accel., 1/2 bridge	Endevco	7264-200	G
23	LEFT FEMUR FORCE	Z	KEFF001	Load cell, Femur	R.A. Denton	2121	N
24	RIGHT FEMUR FORCE	Z	KEFF002	Load cell, Femur	R.A. Denton	2121	N

D-1

KAR21061-01

**2002 NHTSA 35mph NCAP  
Instrumentation Data Channel Assignments  
Driver A.T.D. Serial Number 34  
1/29/02  
2002 Honda CR-V LX 4WD SUV**

CH.	LOCATION	AXIS	IDENT. NO.	DESCRIPTION	MFR	MODEL	UNITS
25	Left Knee Slider	X	SLIDER	Rotary Potentiometer	Bourns	150-0121V	MM
26	Right Knee Slider	X	SLIDER	Rotary Potentiometer	Bourns	150-0121V	MM
27	UP. TIBIA LEFT MOM.	X	GPUT09MX	2 ch., Upper tibia gage	R. A. Denton	1583	Nm
28	UP. TIBIA LEFT MOM.	Y	GPUT09MY	2 ch., Upper tibia gage	R. A. Denton	1583	Nm
29	UP. TIBIA RIGHT MOM.	X	GPUT09MX	2 ch., Upper tibia gage	R. A. Denton	1583	Nm
30	UP. TIBIA RIGHT MOM.	Y	GPUT09MY	2 ch., Upper tibia gage	R. A. Denton	1583	Nm
31	LWR. TIBIA LEFT MOM.	X	GPLT09MX	3 ch., lower tibia gage	R. A. Denton	3093	Nm
32	LWR. TIBIA LEFT MOM.	Y	GPLT09MY	3 ch., lower tibia gage	R. A. Denton	3093	Nm
33	LWR. TIBIA LEFT FORCE	Z	GPLT09FZ	3 ch., lower tibia gage	R. A. Denton	3093	N
34	LWR. TIBIA RIGHT MOM.	X	GPLT09MX	3 ch., lower tibia gage	R. A. Denton	3093	Nm
35	LWR. TIBIA RIGHT MOM.	Y	GPLT09MY	3 ch., lower tibia gage	R. A. Denton	3093	Nm
36	LWR. TIBIA RIGHT FORCE	Z	GPLT09FZ	3 ch., lower tibia gage	R. A. Denton	3093	N
37	FOOT LEFT, AFT	X	KEIC003X	Accel., Foot Triax	I.C. Sensor	3031-500	G
38	FOOT LEFT, AFT	Z	KEIC003Y	Accel., Foot Triax	I.C. Sensor	3031-500	G
39	FOOT LEFT, FORE	Z	KEIC003Z	Accel., Foot Triax	I.C. Sensor	3031-500	G
40	FOOT RIGHT, AFT	X	KEIC004X	Accel., Foot Triax	I.C. Sensor	3031-500	G
41	FOOT RIGHT, AFT	Z	KEIC004Y	Accel., Foot Triax	I.C. Sensor	3031-500	G
42	FOOT RIGHT, FORE	Z	KEIC004Z	Accel., Foot Triax	I.C. Sensor	3031-500	G
43	LAP BELT FORCE	X	KELC003	Load cell, Seat belt	Lebow	3371	N
44	SHOULDER BELT FORCE	X	KELC004	Load cell, Seat belt	Lebow	3371	N
45	SHOULDER BELT SPOOL	X	KEPP001	Pullout pot	Celesco	PTX101-0030	CM
46	SHOULDER BELT ELONG.	X	KEEP001	Linear pot., belt stretch	E.T.I.	LCP8-10 10K	MM/CM

D-2

KAR21061-01

**2002 NHTSA 35mph NCAP  
Instrumentation Data Channel Assignments  
Passenger A.T.D. Serial Number 35  
1/29/02  
2002 Honda CR-V LX 4WD SUV**

CH.	LOCATION	AXIS	IDENT. NO.	DESCRIPTION	MFR	MODEL	UNITS
47	HEAD, PRIMARY	X	GPAC027	Accel., 1/2 bridge	Endevco	7264-2000	G
48	HEAD, PRIMARY	Y	GPAC002	Accel., 1/2 bridge	Endevco	7264-2000	G
49	HEAD, PRIMARY	Z	GPAC003	Accel., 1/2 bridge	Endevco	7264-2000	G
50	HEAD, REDUNDANT	X	GPAC032	Accel., 1/2 bridge	Endevco	7264-2000	G
51	HEAD, REDUNDANT	Y	GPAC021	Accel., 1/2 bridge	Endevco	7264-2000	G
52	HEAD, REDUNDANT	Z	GPAC026	Accel., 1/2 bridge	Endevco	7264-2000	G
53	NECK FORCE	X	GPUN01FX	Load cell, six axis neck	R. A. Denton	1716A	N
54	NECK FORCE	Y	GPUN01FY	Load cell, six axis neck	R. A. Denton	1716A	N
55	NECK FORCE	Z	GPUN01FZ	Load cell, six axis neck	R. A. Denton	1716A	N
56	NECK MOMENT	X	GPUN01MX	Load cell, six axis neck	R. A. Denton	1716A	Nm
57	NECK MOMENT	Y	GPUN01MY	Load cell, six axis neck	R. A. Denton	1716A	Nm
58	NECK MOMENT	Z	GPUN01MZ	Load cell, six axis neck	R. A. Denton	1716A	Nm
59	CHEST , PRIMARY	X	GPAC005	Accel., 1/2 bridge	Endevco	7264-2000	G
60	CHEST , PRIMARY	Y	GPAC011	Accel., 1/2 bridge	Endevco	7264-2000	G
61	CHEST , PRIMARY	Z	GPAC010	Accel., 1/2 bridge	Endevco	7264-2000	G
62	CHEST , REDUNDANT	X	GPAC034	Accel., 1/2 bridge	Endevco	7264-2000	G
63	CHEST , REDUNDANT	Y	GPAC023	Accel., 1/2 bridge	Endevco	7264-2000	G
64	CHEST , REDUNDANT	Z	GPAC020	Accel., 1/2 bridge	Endevco	7264-2000	G
65	CHEST DISPLACEMENT	X	GPCP002	Rotary Pot Chest	Servo	14CBI	MM
66	PELVIS, PRIMARY	X	GPAC025	Accel., 1/2 bridge	Endevco	7264-2000	G
67	PELVIS, PRIMARY	Y	GPAC022	Accel., 1/2 bridge	Endevco	7264-2000	G
68	PELVIS, PRIMARY	Z	GPAC019	Accel., 1/2 bridge	Endevco	7264-2000	G
69	LEFT FEMUR FORCE	Z	KEFF003	Load cell, Femur	R.A. Denton	2121	N
70	RIGHT FEMUR FORCE	Z	KEFF004	Load cell, Femur	R.A. Denton	2121	N

**2002 NHTSA 35mph NCAP  
Instrumentation Data Channel Assignments  
Passenger A.T.D. Serial Number 35  
1/29/02  
2002 Honda CR-V LX 4WD SUV**

CH.	LOCATION	AXIS	IDENT. NO.	DESCRIPTION	MFR	MODEL	UNITS
71	Left Knee Slider	X	SLIDER	Rotary Potentiometer	Bourns	150-0121V	MM
72	Right Knee Slider	X	SLIDER	Rotary Potentiometer	Bourns	150-0121V	MM
73	UP. TIBIA LEFT MOM.	X	GPUT09MX	2 ch., Upper tibia gage	R. A. Denton	1583	Nm
74	UP. TIBIA LEFT MOM.	Y	GPUT09MY	2 ch., Upper tibia gage	R. A. Denton	1583	Nm
75	UP. TIBIA RIGHT MOM.	X	GPUT09MX	2 ch., Upper tibia gage	R. A. Denton	1583	Nm
76	UP. TIBIA RIGHT MOM.	Y	GPUT09MY	2 ch., Upper tibia gage	R. A. Denton	1583	Nm
77	LWR. TIBIA LEFT MOM.	X	GPLT09MX	3 ch., lower tibia gage	R. A. Denton	3093	Nm
78	LWR. TIBIA LEFT MOM.	Y	GPLT09MY	3 ch., lower tibia gage	R. A. Denton	3093	Nm
79	LWR. TIBIA LEFT FORCE	Z	GPLT09FZ	3 ch., lower tibia gage	R. A. Denton	3093	N
80	LWR. TIBIA RIGHT MOM.	X	GPLT09MX	3 ch., lower tibia gage	R. A. Denton	3093	Nm
81	LWR. TIBIA RIGHT MOM.	Y	GPLT09MY	3 ch., lower tibia gage	R. A. Denton	3093	Nm
82	LWR. TIBIA RIGHT FORCE	Z	GPLT09FZ	3 ch., lower tibia gage	R. A. Denton	3093	N
83	FOOT LEFT, AFT	X	KEIC002X	Accel., Foot Triax	I.C. Sensor	3031-500	G
84	FOOT LEFT, AFT	Z	KEIC002Y	Accel., Foot Triax	I.C. Sensor	3031-500	G
85	FOOT LEFT, FORE	Z	KEIC002Z	Accel., Foot Triax	I.C. Sensor	3031-500	G
86	FOOT RIGHT, AFT	X	KEIC001X	Accel., Foot Triax	I.C. Sensor	3031-500	G
87	FOOT RIGHT, AFT	Z	KEIC001Y	Accel., Foot Triax	I.C. Sensor	3031-500	G
88	FOOT RIGHT, FORE	Z	KEIC001Z	Accel., Foot Triax	I.C. Sensor	3031-500	G
89	LAP BELT FORCE	X	KELC001	Load cell, Seat belt	Lebow	3371	N
90	SHOULDER BELT FORCE	X	KELC002	Load cell, Seat belt	Lebow	3371	N
91	SHOULDER BELT SPOOL	X	KEPP001	Pullout pot	Celesco	PTX101-0030	MM
92	SHOULDER BELT ELONG.	X	KEEP001	Linear pot., belt stretch	E.T.I.	LCP8-10 10K	MM/CM

D-4

KAR21061-01

**2002 NHTSA 35mph NCAP  
Instrumentation Data Channel Assignments  
Vehicle Accelerometers  
1/29/02  
2002 Honda CR-V LX 4WD SUV**

CH.	LOCATION	AXIS	IDENT. NO.	DESCRIPTION	MFR	MODEL	UNITS
93	Left Rear	X	KEVA002	Accel., Pre-Amp	I.C.S/Karco	3031-500	G
94	Right Rear	X	KEVA010	Accel., Vehicle block	I.C. Sensor	3031-200	G
95	Engine Top	X	KEVA012	Accel., Vehicle block	I.C. Sensor	3031-500	G
96	Engine Bottom	X	KEVA008	Accel., Vehicle block	I.C. Sensor	3031-500	G
97	Left Brake Caliper	X	KEVA007	Accel., Vehicle block	I.C. Sensor	3031-500	G
98	Right Brake Caliper	X	KEVA001	Accel., Vehicle block	I.C. Sensor	3031-500	G
99	Instrument Panel	X	KEVA011	Accel., Vehicle block	I.C. Sensor	3031-200	G
100	Left Rear	Z	KEVA005	Accel., Vehicle block	I.C. Sensor	3031-500	G
101	Right Rear	Z	KEVA006	Accel., Vehicle block	I.C. Sensor	3031-200	G

**2002 NHTSA 35mph NCAP  
Instrumentation Data Channel Assignments  
Rigid Load Cell Barrier  
1/29/02  
2002 Honda CR-V LX 4WD SUV**

CH.	LOCATION	AXIS	IDENT. NO.	DESCRIPTION	MFR	MODEL	UNITS
102	BARRIER FORCE A1	X	BARRIER	Not Used	N/A	N/A	N/A
103	BARRIER FORCE A2	X	BARRIER	Load Cell, LCB	Lebow	1220-FS	N
104	BARRIER FORCE A3	X	BARRIER	Load Cell, LCB	Lebow	1220-FS	N
105	BARRIER FORCE A4	X	BARRIER	Load Cell, LCB	Lebow	1220-FS	N
106	BARRIER FORCE A5	X	BARRIER	Load Cell, LCB	Lebow	1220-FS	N
107	BARRIER FORCE A6	X	BARRIER	Load Cell, LCB	Lebow	1220-FS	N
108	BARRIER FORCE A7	X	BARRIER	Load Cell, LCB	Lebow	1220-FS	N
109	BARRIER FORCE A8	X	BARRIER	Load Cell, LCB	Lebow	1220-FS	N
110	BARRIER FORCE A9	X	BARRIER	Load Cell, LCB	Lebow	1220-FS	N
111	BARRIER FORCE B1	X	BARRIER	Not Used	N/A	N/A	N/A
112	BARRIER FORCE B2	X	BARRIER	Load Cell, LCB	Lebow	1220-FS	N
113	BARRIER FORCE B3	X	BARRIER	Load Cell, LCB	Lebow	1220-FS	N
114	BARRIER FORCE B4	X	BARRIER	Load Cell, LCB	Lebow	1220-FS	N
115	BARRIER FORCE B5	X	BARRIER	Load Cell, LCB	Lebow	1220-FS	N
116	BARRIER FORCE B6	X	BARRIER	Load Cell, LCB	Lebow	1220-FS	N
117	BARRIER FORCE B7	X	BARRIER	Load Cell, LCB	Lebow	1220-FS	N
118	BARRIER FORCE B8	X	BARRIER	Load Cell, LCB	Lebow	1220-FS	N
119	BARRIER FORCE B9	X	BARRIER	Load Cell, LCB	Lebow	1220-FS	N

**2002 NHTSA 35mph NCAP  
Instrumentation Data Channel Assignments  
Rigid Load Cell Barrier  
1/29/02  
2002 Honda CR-V LX 4WD SUV**

CH.	LOCATION	AXIS	IDENT. NO.	DESCRIPTION	MFR	MODEL	UNITS
120	BARRIER FORCE C1	X	BARRIER	Not Used	N/A	N/A	N/A
121	BARRIER FORCE C2	X	BARRIER	Load Cell, LCB	Lebow	1220-FS	N
122	BARRIER FORCE C3	X	BARRIER	Load Cell, LCB	Lebow	1220-FS	N
123	BARRIER FORCE C4	X	BARRIER	Load Cell, LCB	Lebow	1220-FS	N
124	BARRIER FORCE C5	X	BARRIER	Load Cell, LCB	Lebow	1220-FS	N
125	BARRIER FORCE C6	X	BARRIER	Load Cell, LCB	Lebow	1220-FS	N
126	BARRIER FORCE C7	X	BARRIER	Load Cell, LCB	Lebow	1220-FS	N
127	BARRIER FORCE C8	X	BARRIER	Load Cell, LCB	Lebow	1220-FS	N
128	BARRIER FORCE C9	X	BARRIER	Load Cell, LCB	Lebow	1220-FS	N
129	BARRIER FORCE D1	X	BARRIER	Not Used	N/A	N/A	N/A
130	BARRIER FORCE D2	X	BARRIER	Not Used	N/A	N/A	N/A
131	BARRIER FORCE D3	X	BARRIER	Not Used	N/A	N/A	N/A
132	BARRIER FORCE D4	X	BARRIER	Not Used	N/A	N/A	N/A
133	BARRIER FORCE D5	X	BARRIER	Not Used	N/A	N/A	N/A
134	BARRIER FORCE D6	X	BARRIER	Not Used	N/A	N/A	N/A
135	BARRIER FORCE D7	X	BARRIER	Not Used	N/A	N/A	N/A
136	BARRIER FORCE D8	X	BARRIER	Not Used	N/A	N/A	N/A
137	BARRIER FORCE D9	X	BARRIER	Not Used	N/A	N/A	N/A

**2002 NHTSA 35mph NCAP  
Instrumentation Data Channel Assignments  
Nine Accelerometer Head Array Channels  
1/29/02  
2002 Honda CR-V LX 4WD SUV**

CH.	LOCATION	AXIS	IDENT. NO.	DESCRIPTION	MFR	MODEL	UNITS
138	Driver Head CG	X	KEAC039	Accel., 1/2 bridge	Endevco	7264-2000	G *
139	Driver Head CG	Y	KEAC038	Accel., 1/2 bridge	Endevco	7264-2000	G *
140	Driver Head CG	Z	KEAC027	Accel., 1/2 bridge	Endevco	7264-2000	G *
141	Driver Y-arm	Z	GPAC016	Accel., 1/2 bridge	Endevco	7264-2000	G
142	Driver Y-arm	X	GPAC015	Accel., 1/2 bridge	Endevco	7264-2000	G
143	Driver X-arm	Z	GPAC004	Accel., 1/2 bridge	Endevco	7264-2000	G
144	Driver X-arm	Y	GPAC018	Accel., 1/2 bridge	Endevco	7264-2000	G
145	Driver Z-arm	X	GPAC006	Accel., 1/2 bridge	Endevco	7264-2000	G
146	Driver Z-arm	Y	GPAC007	Accel., 1/2 bridge	Endevco	7264-2000	G
147	Passenger Head CG	X	GPAC027	Accel., 1/2 bridge	Endevco	7264-2000	G *
148	Passenger Head CG	Y	GPAC002	Accel., 1/2 bridge	Endevco	7264-2000	G *
149	Passenger Head CG	Z	GPAC003	Accel., 1/2 bridge	Endevco	7264-2000	G *
150	Passenger Y-arm	Z	GPAC012	Accel., 1/2 bridge	Endevco	7264-2000	G
151	Passenger Y-arm	X	GPAC001	Accel., 1/2 bridge	Endevco	7264-2000	G
152	Passenger X-arm	Z	GPAC036	Accel., 1/2 bridge	Endevco	7264-2000	G
153	Passenger X-arm	Y	GPAC014	Accel., 1/2 bridge	Endevco	7264-2000	G
154	Passenger Z-arm	X	GPAC030	Accel., 1/2 bridge	Endevco	7264-2000	G
155	Passenger Z-arm	Y	GPAC037	Accel., 1/2 bridge	Endevco	7264-2000	G

\* Duplicate of Head CG Primary Channels

**APPENDIX E**

**DUMMY CALIBRATION DATA**



# Hybrid III Calibration Data Sheet

## Hybrid III 50th Percentile Male Knee Impact Test

ATD Serial No.: 034

Location: Left Knee

Test I.D.: LK10C

Tested Parameter	Units	Specification	Result	Pass/Fail
Laboratory Temperature	°C	18.9 to 25.5	21.1	Pass
Laboratory Relative Humidity	%	10 to 70	30	Pass
Pendulum Velocity at T=0	m/sec	2.07 to 2.13	2.09	Pass
Peak Probe Force	N	4715 to 5782	5526	Pass
Overall Test Results				Pass

ATD Serial No.: 034

Location: Right Knee

Test I.D.: LK10D

Tested Parameter	Units	Specification	Result	Pass/Fail
Laboratory Temperature	°C	18.9 to 25.5	21.1	Pass
Laboratory Relative Humidity	%	10 to 70	30	Pass
Pendulum Velocity at T=0	m/sec	2.07 to 2.13	2.10	Pass
Peak Probe Force	N	4715 to 5782	5723	Pass
Overall Test Results				Pass

\_\_\_\_\_  
Laboratory Technician

January 15, 2002  
\_\_\_\_\_  
Test Date

E-1

KAR21061-01

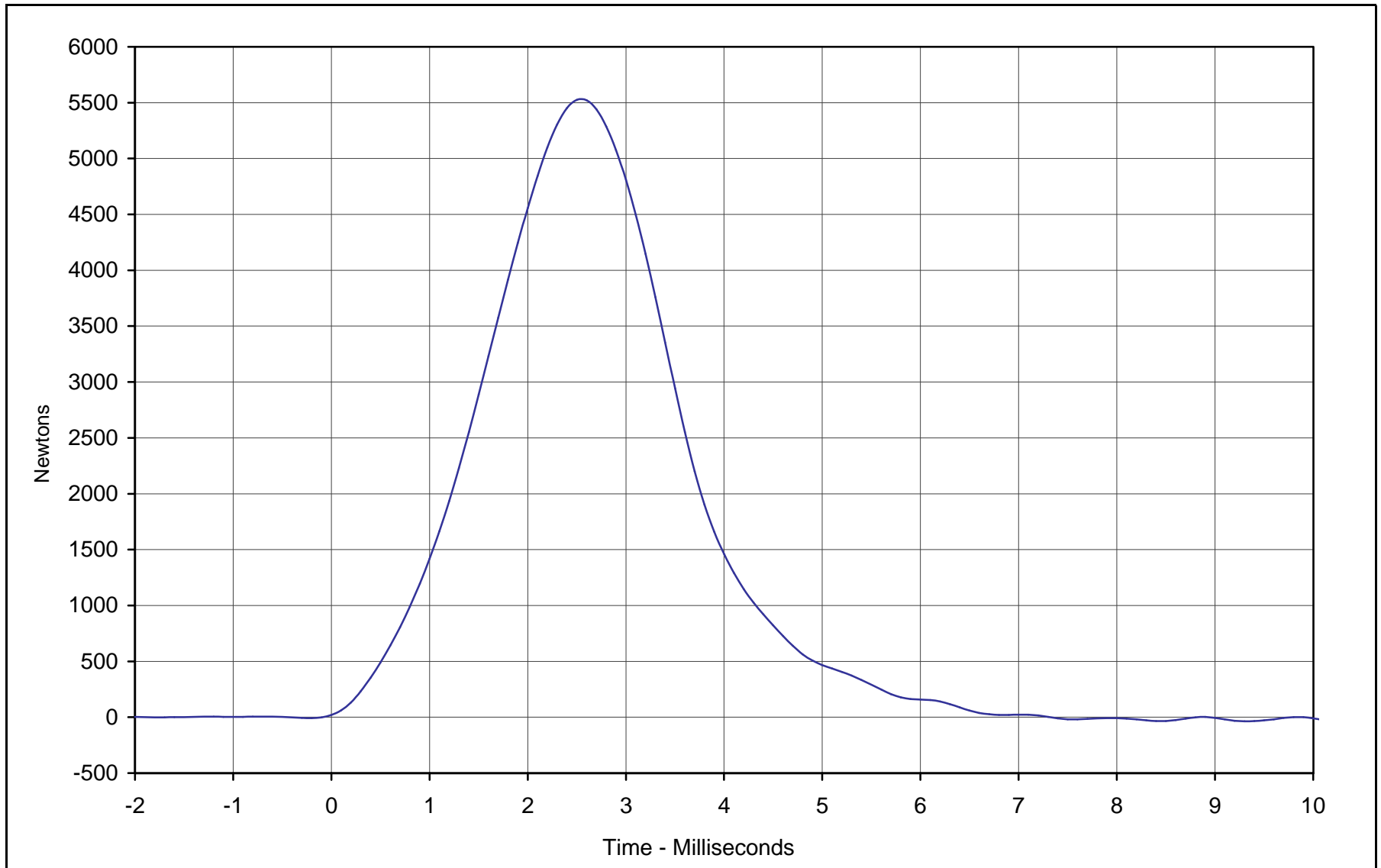

Curve Description: Probe Force  
Maximum Value: 5525.7 at 2.5 Milliseconds  
Minimum Value: -18.8 at 7.6 Milliseconds  
SAE Filter Class: 600  
Date of Test: 1/15/02  
ATD Serial No.: 034

Test Program: Hybrid III Knee Impact Test  
Test Information: Location: Left Knee Test I.D.: LK10C



E-3

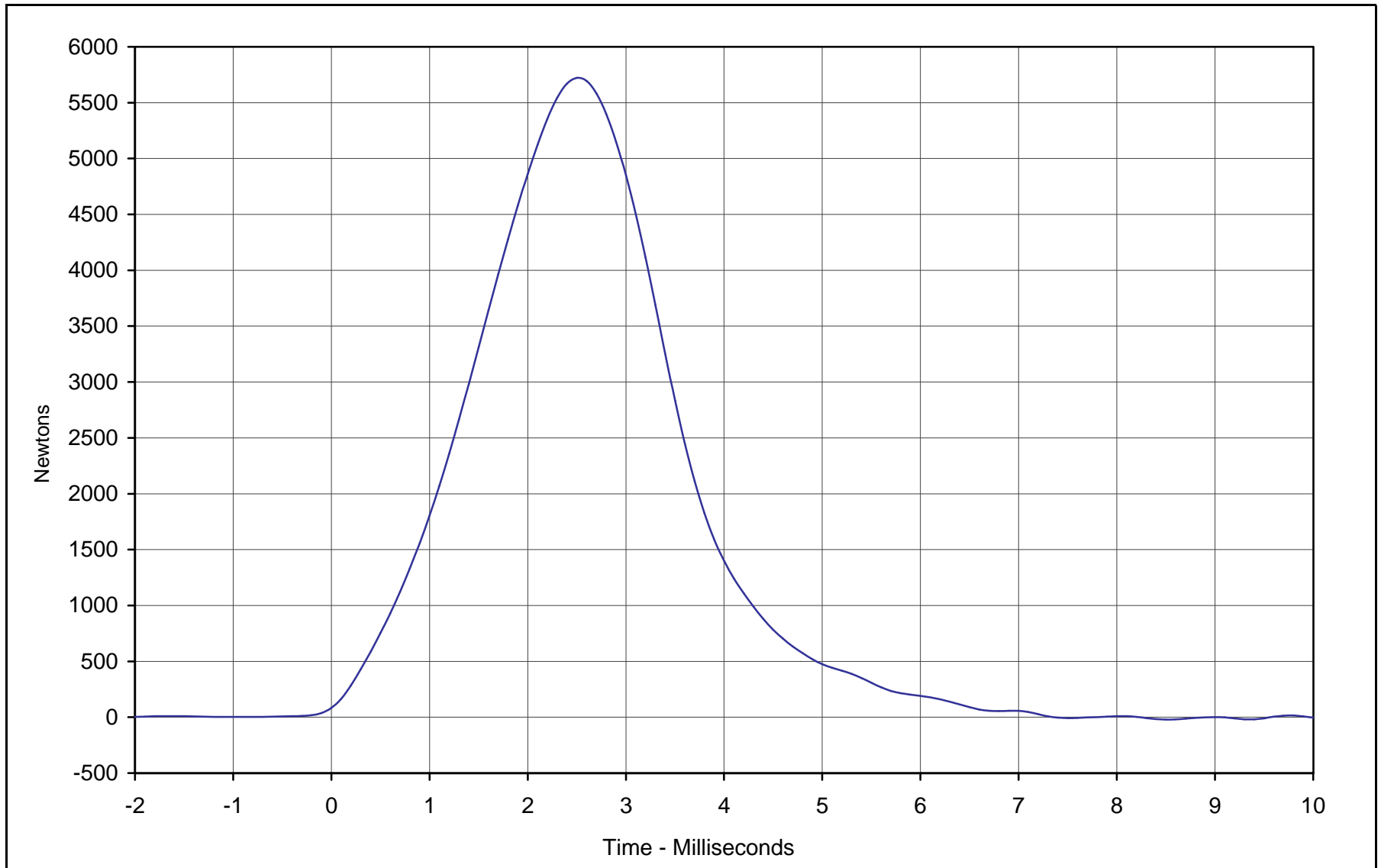

Curve Description: Probe Force  
Maximum Value: 5722.6 at 2.5 Milliseconds  
Minimum Value: -7.4 at 7.5 Milliseconds  
SAE Filter Class: 600  
Date of Test: 1/15/02  
ATD Serial No.: 034

Test Program: Hybrid III Knee Impact Test  
Test Information: Location: Right Knee Test I.D.: LK10D



KAR21061-01



## Hybrid III Calibration Data Sheet Hybrid III 50th Percentile Male Knee Slider Test

ATD Serial No.: 034

Location: Left Knee

Test I.D.: LS001

Tested Parameter		Units	Specification	Result	Pass/Fail
Laboratory Temperature		°C	20.6 to 22.2	21.1	Pass
Laboratory Relative Humidity		%	10 to 70	30	Pass
Pendulum Velocity at T=0		m/sec	2.70 to 2.80	2.77	Pass
Impact Force at:	10 mm	kN	1.26 to 1.72	1.66	Pass
	18 mm	kN	2.27 to 3.096	3.02	Pass
Overall Test Results					Pass

E-4

ATD Serial No.: 034

Location: Right Knee

Test I.D.: RS001

Tested Parameter		Units	Specification	Result	Pass/Fail
Laboratory Temperature		°C	20.6 to 22.2	21.1	Pass
Laboratory Relative Humidity		%	10 to 70	30	Pass
Pendulum Velocity at T=0		m/sec	2.70 to 2.80	2.78	Pass
Impact Force at:	10 mm	kN	1.26 to 1.72	1.54	Pass
	18 mm	kN	2.27 to 3.096	2.96	Pass
Overall Test Results					Pass

KAR21061-01

\_\_\_\_\_  
Laboratory Technician

January 17, 2002

\_\_\_\_\_  
Test Date

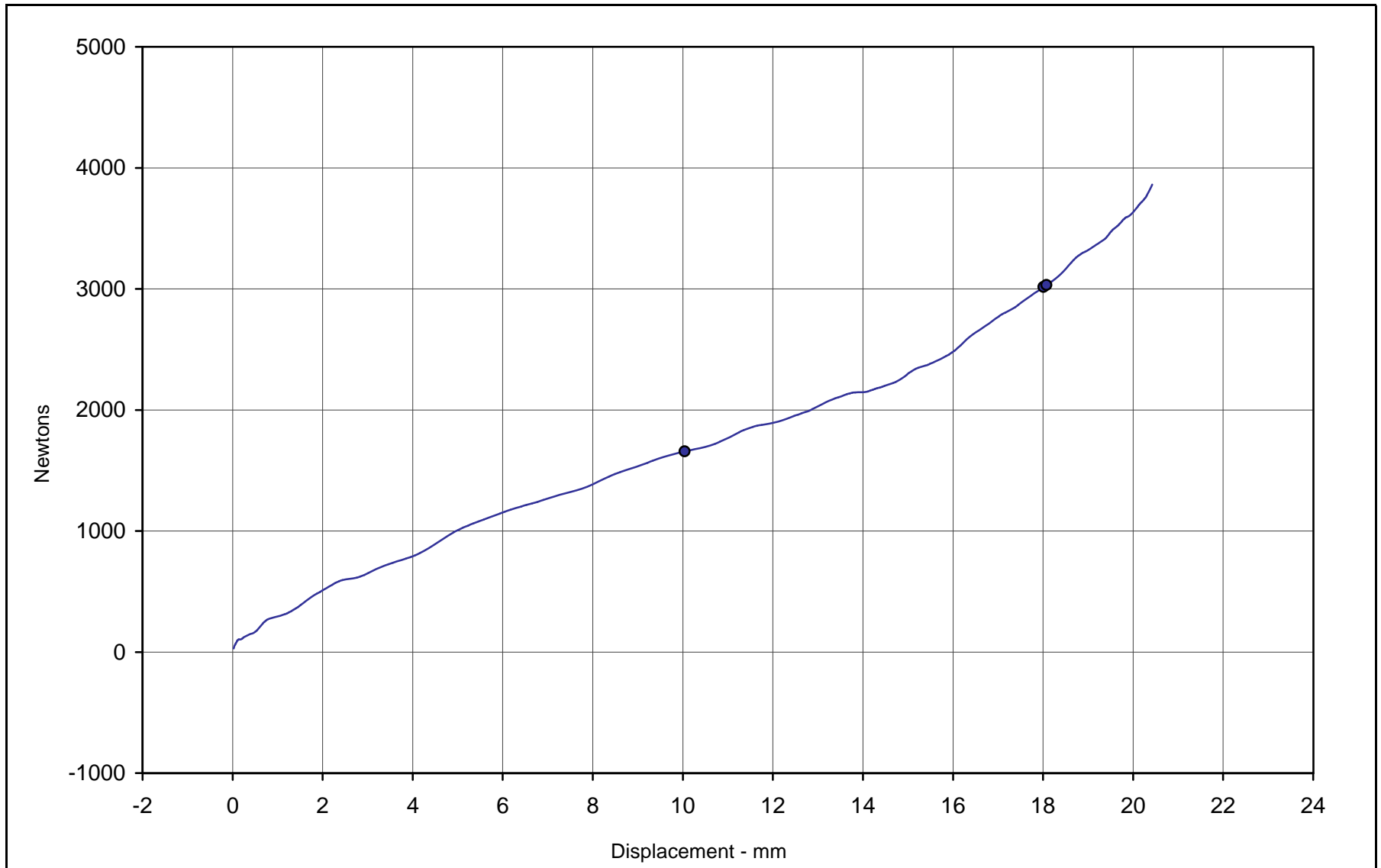

Curve Description: Femur Force vs. Knee Displacement

Test Program: Hybrid III Knee Shear Test

Femur Force: 1657 at 10.0 mm

Test Information: Location: Left Knee Test I.D.: LS001

Femur Force: 3016 at 18.0 mm

SAE Filter Class: 600

Date of Test: 1/17/02

ATD Serial No.: 034



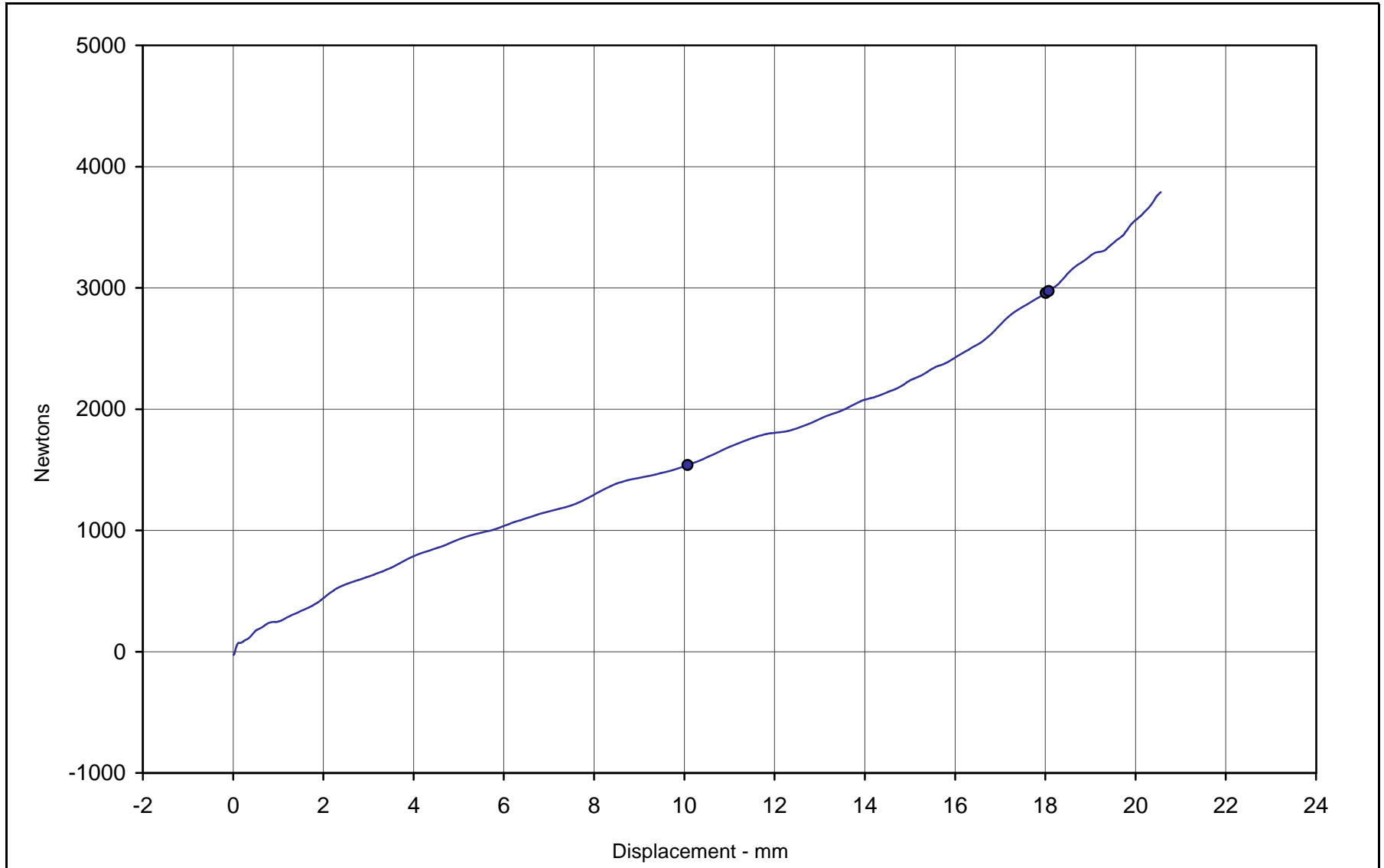

Curve Description: Femur Force vs. Knee Displacement

Test Program: Hybrid III Knee Shear Test

Femur Force: 1538 at 10.0 mm

Test Information: Location: Right Knee Test I.D.: RS001

Femur Force: 2957 at 18.0 mm

SAE Filter Class: 600

Date of Test: 11/28/01

ATD Serial No.: 034





# Hybrid III Calibration Data Sheet

## 50<sup>TH</sup> Percentile Male

### Head Drop Calibration

ATD Serial No.: 034

Part Serial No.: N/A

Test I.D.: HD10B

Tested Parameter	Units	Specification	Result	Pass/Fail
Laboratory Temperature	°C	18.9 to 25.6	21.1	Pass
Laboratory Relative Humidity	%	10 to 70	30	Pass
Peak Resultant Acceleration	G's	225.0 to 275.0	257.2	Pass
Peak Lateral Acceleration	G's	≤15.0	12.7	Pass
Is Acceleration Unimodal?	Yes/No	Yes	Yes	Pass
Overall Test Results				Pass

\_\_\_\_\_  
Laboratory Technician

January 16, 2002  
Test Date

E-8

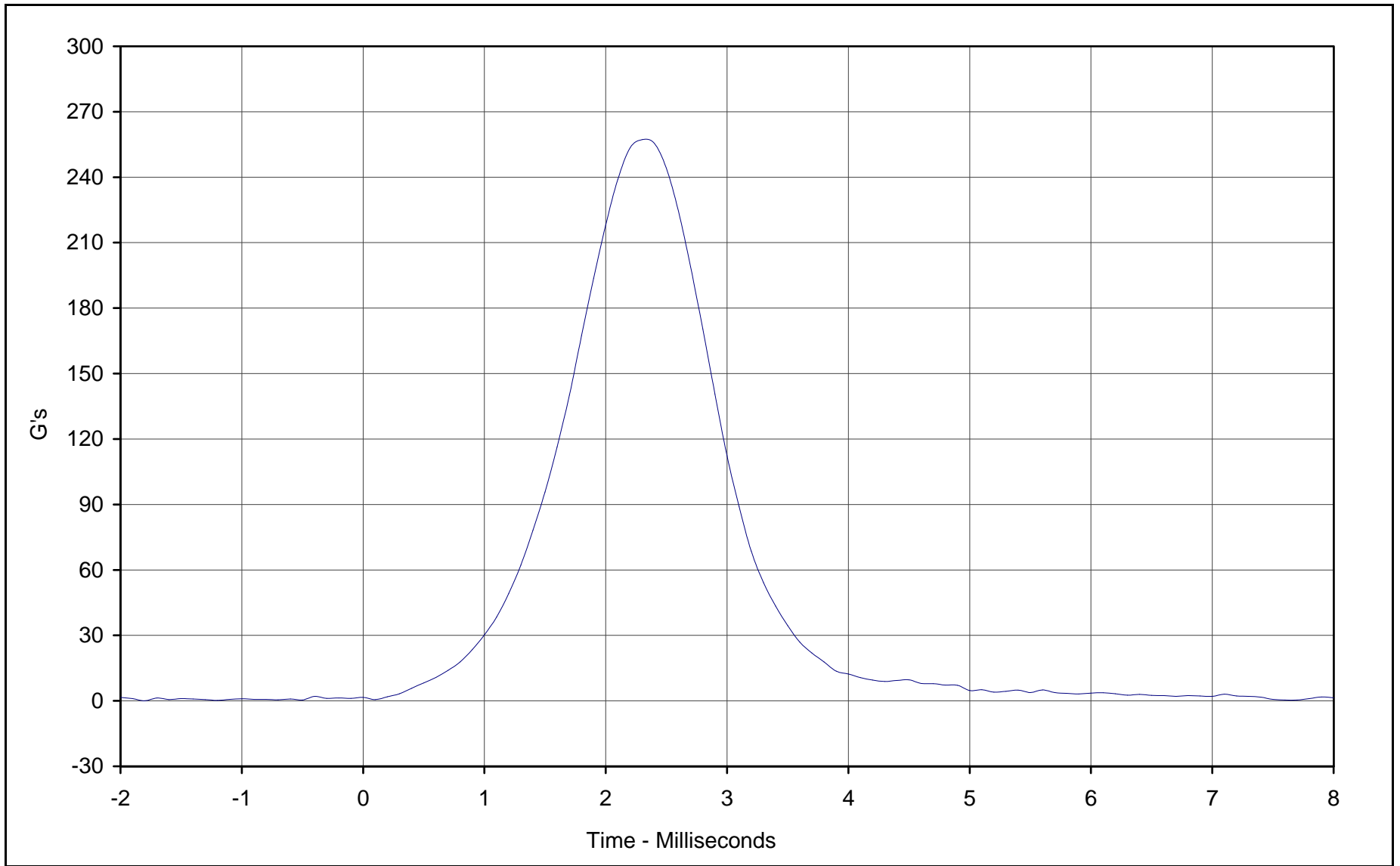

Curve Description: Head Resultant Acceleration

Maximum Value: 257.2 at 2.3 Milliseconds

Minimum Value: 0.0 at -1.8 Milliseconds

SAE Filter Class: 1000

Date of Test: 1/16/02

ATD Serial No.: 034

Testing Program: Hybrid III Head Drop Calibration (Male)

Test Information: S/N of Part: N/A Test I.D.: HD10B



KAR21061-01

E-9

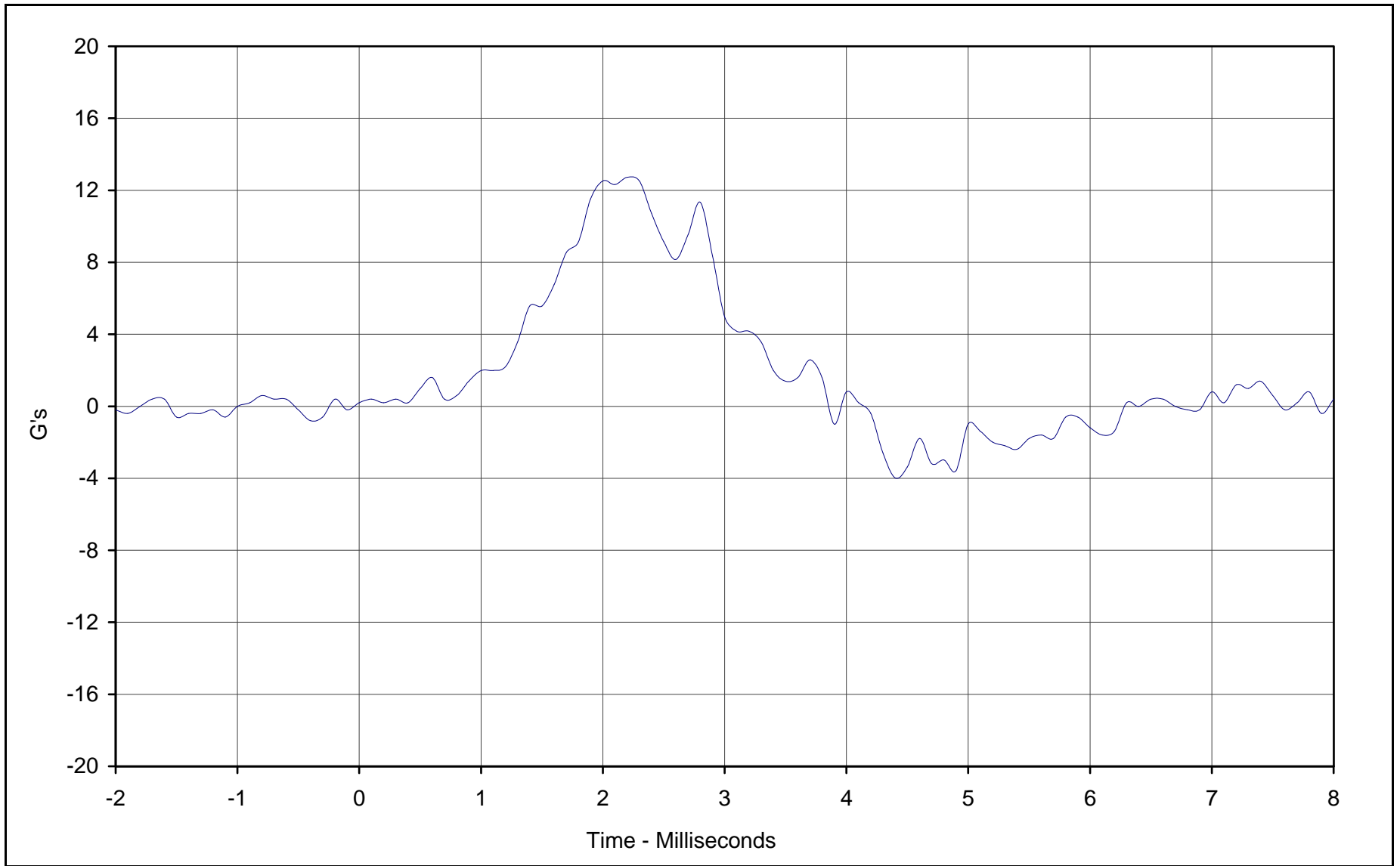

Curve Description: Head Acceleration Y Axis

Maximum Value: 12.7 at 2.2 Milliseconds

Minimum Value: -4.0 at 4.4 Milliseconds

SAE Filter Class: 1000

Date of Test: 1/16/02

ATD Serial No.: 034

Testing Program: Hybrid III Head Drop Calibration (Male)

Test Information: S/N of Part: N/A Test I.D.: HD10B

KAR21061-01





# Hybrid III Calibration Data Sheet

## 50<sup>TH</sup> Percentile Male

### Thorax Impact Test

ATD Serial No.: 034

Part Serial No.: N/A

Test I.D.: CH01A

Tested Parameter	Units	Specification	Result	Pass/Fail
Laboratory Temperature	°C	20.6 to 22.2	21.2	Pass
Laboratory Relative Humidity	%	10 to 70	30	Pass
Probe Velocity	m/s	6.58 to 6.82	6.74	Pass
Peak Probe Force	Newtons	5159 to 5893	5653	Pass
Peak Sternum Displacement	CM	6.35 to 7.26	6.83	Pass
Internal Hysteresis	%	69 to 85	76.5	Pass
Overall Test Results				Pass

\_\_\_\_\_  
Laboratory Technician

January 24, 2002  
\_\_\_\_\_  
Test Date

E-11

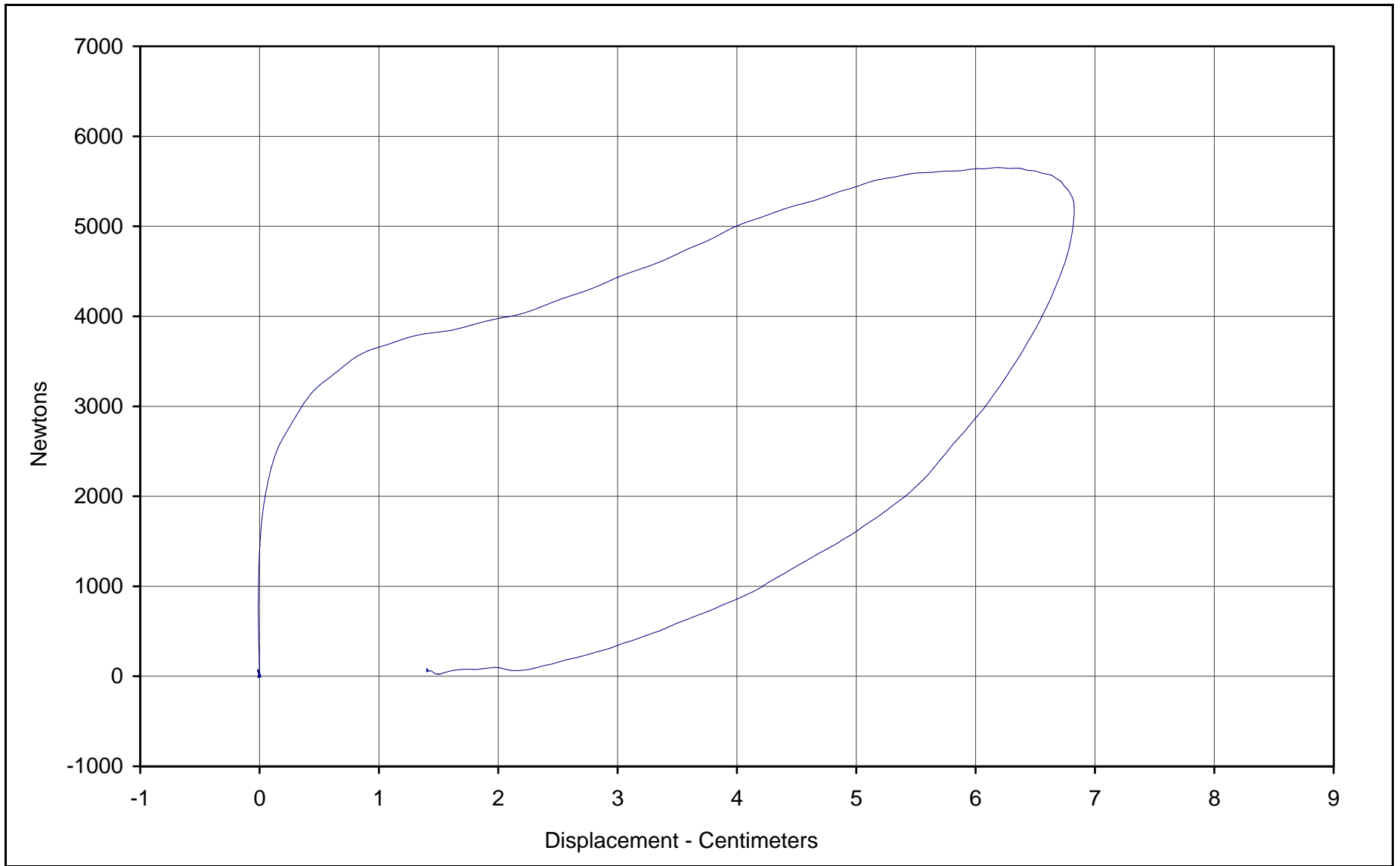

Curve Description: Probe Force vs. Chest Displacement

Testing Program: Hybrid III Thorax Impact Test

Probe Force: 5653.1 Newtons

Test Information: S/N of Part: N/A Test I.D.: CH01A

Chest Displ.: 6.83 Centimeters

SAE Filter Class: 180

Date of Test: 1/24/02

ATD Serial No.: 034



KAR21061-01



# Hybrid III Calibration Data Sheet

## 50<sup>TH</sup> Percentile Male

### Neck Flexion Test

ATD Serial No.: 034

Part Serial No.: N/A

Test I.D.: NF01A

Tested Parameter	Units	Specification	Result	Pass/Fail	
Laboratory Temperature	°C	20.6 to 22.2	21.1	Pass	
Laboratory Relative Humidity	%	10 to 70	30	Pass	
Pendulum Velocity	m/s	6.89 to 7.13	6.95	Pass	
Pendulum Deceleration	10 Msec.	G's	22.5 to 27.5	23.8	Pass
	20 Msec.	G's	17.6 to 22.6	20.2	Pass
	30 Msec.	G's	12.5 to 18.5	17.0	Pass
Peak Pendulum Decel. after 30 Msec.	G's	≤ 29.0	17.0	Pass	
Deceleration Decay, Time to Cross 5 G's	Msec.	34.0 to 42.0	37.2	Pass	
Maximum "D" Plane Rotation	Maximum	Degrees	64.0 to 78.0	70.4	Pass
	Time	Msec.	57.0 to 64.0	61.0	Pass
"D" Plane Rotation Decay, Time To Zero Crossing	Msec.	113.0 to 128.0	118.7	Pass	
Moment About Occipital Condyle	Maximum	N·m	84.1 to 108.5	87.6	Pass
	Time	Msec.	47.0 to 58.0	53.6	Pass
Positive Moment Decay, Time To Zero Crossing	Msec.	97.0 to 107.0	99.8	Pass	
Overall Test Results				Pass	

\_\_\_\_\_  
Laboratory Technician

\_\_\_\_\_  
January 24, 2002  
Test Date

E-13

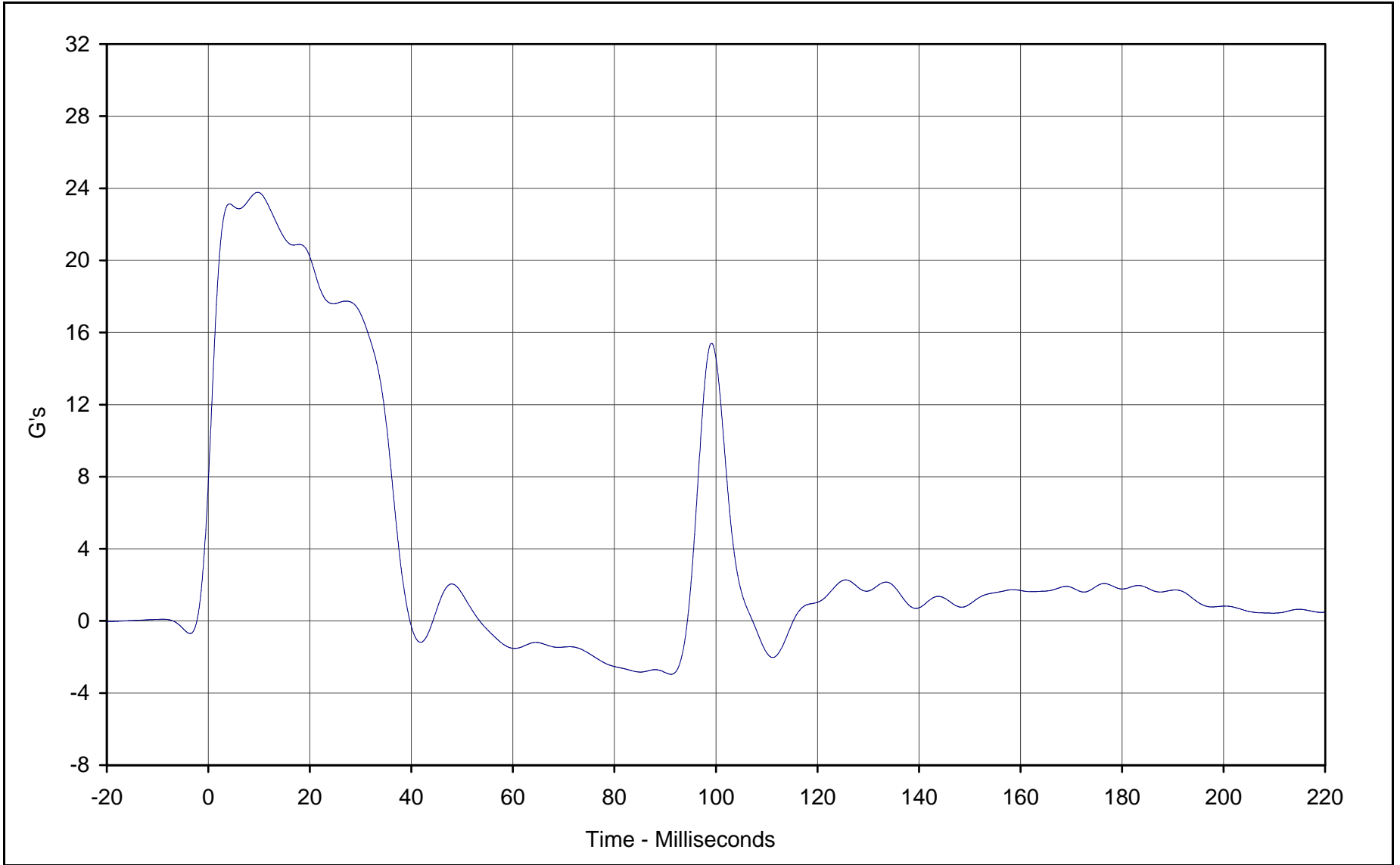

Curve Description: Pendulum Deceleration  
Maximum Value: 23.8 at 9.7 Milliseconds  
Minimum Value: -3.0 at 91.1 Milliseconds  
SAE Filter Class: 60  
Date of Test: 1/24/02  
ATD Serial No.: 034

Testing Program: Hybrid III Neck Flexion Test (Male)  
Test Information: S/N of Part: N/A Test I.D.: NF01A

KAR21061-01



E-14

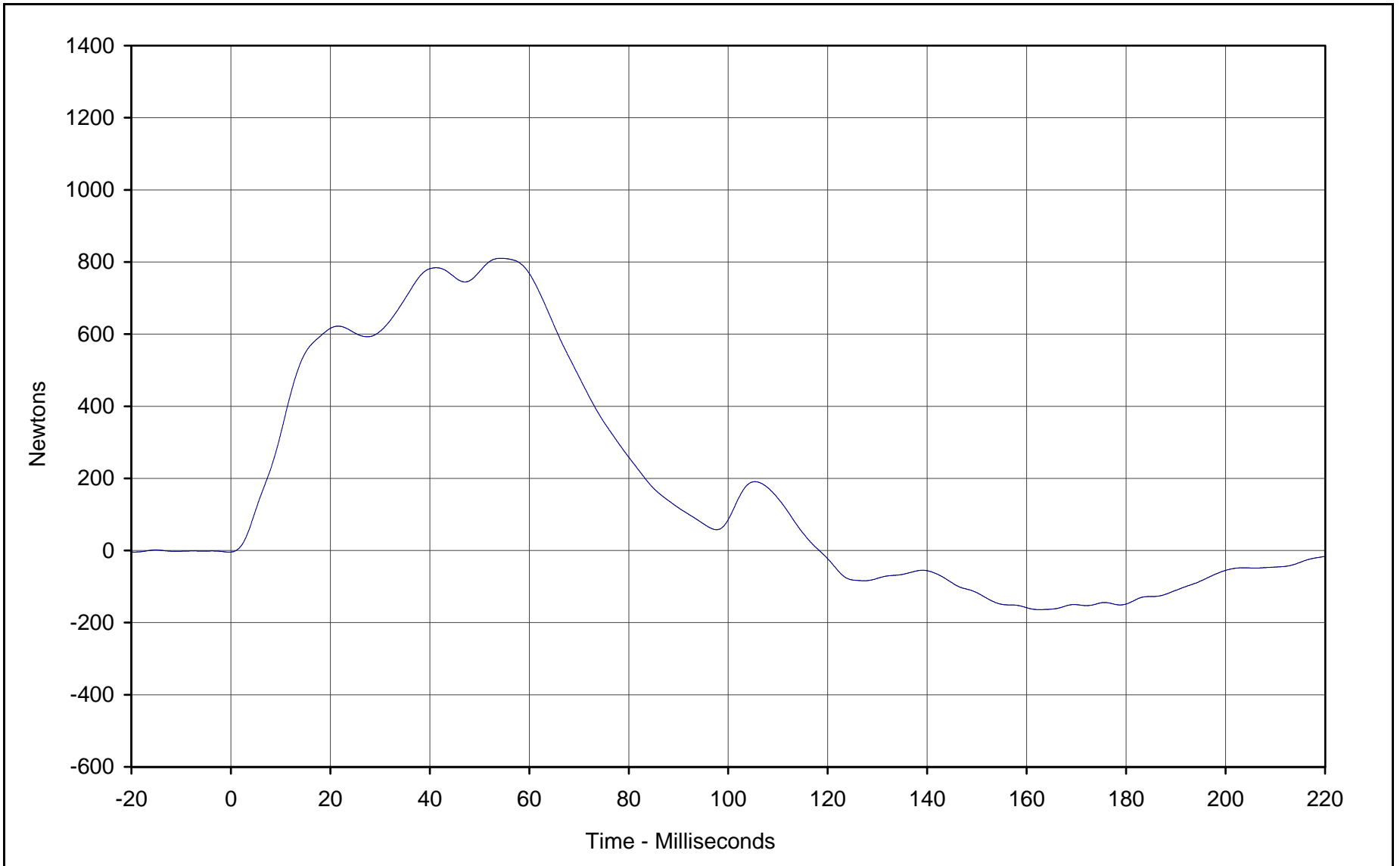

Curve Description: Neck Force X  
Maximum Value: 810.3 at 54.3 Milliseconds  
Minimum Value: -164.0 at 162.5 Milliseconds  
SAE Filter Class: 60  
Date of Test: 1/24/02  
ATD Serial No.: 034

Testing Program: Hybrid III Neck Flexion Test (Male)  
Test Information: S/N of Part: N/A Test I.D.: NF01A



KARR21061-01

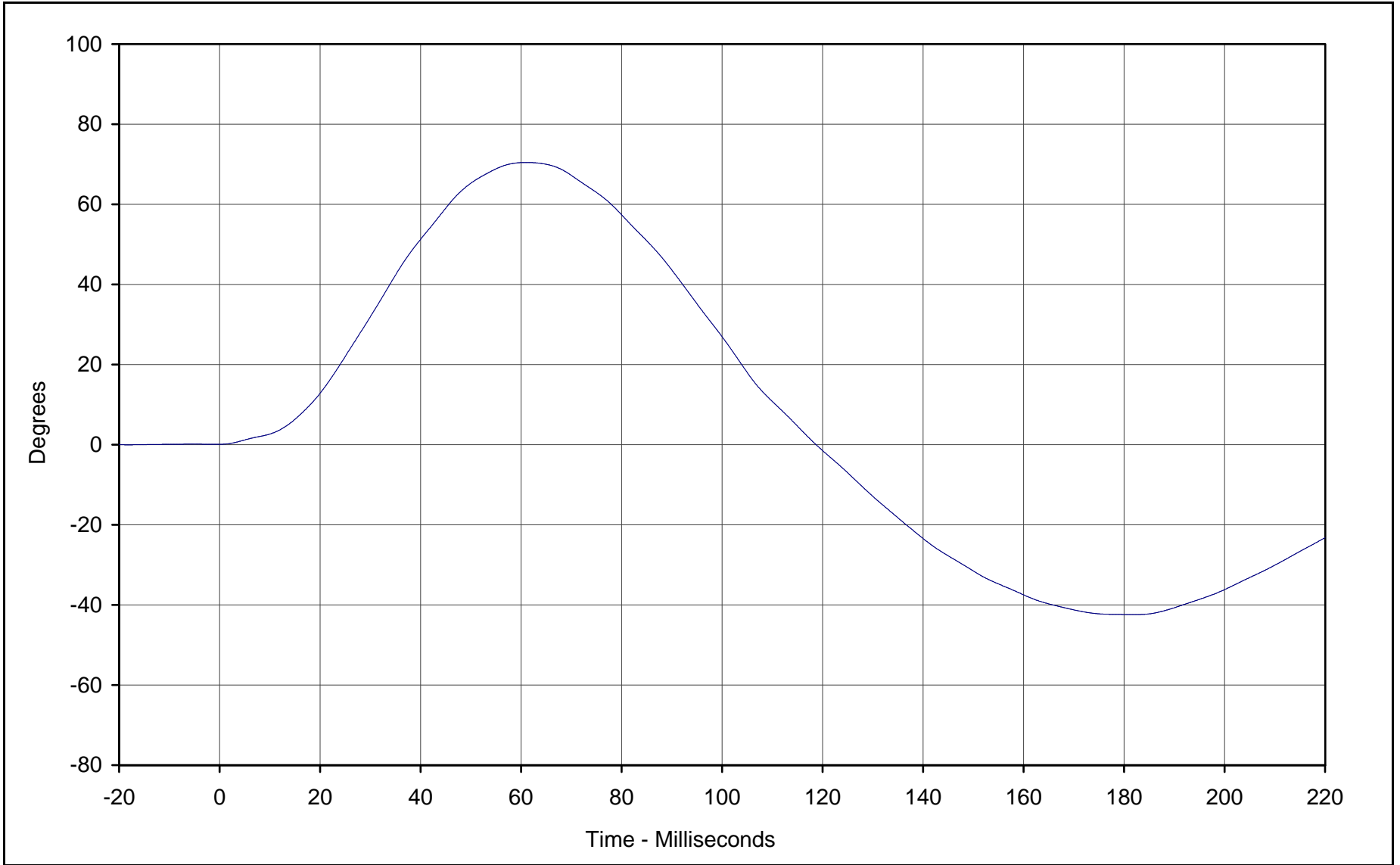

Curve Description: "D" Plane Rotation  
Maximum Value: 70.4 at 61.0 Milliseconds  
Minimum Value: -42.4 at 181.9 Milliseconds  
SAE Filter Class: 60  
Date of Test: 1/24/02  
ATD Serial No.: 034

Testing Program: Hybrid III Neck Flexion Test (Male)  
Test Information: S/N of Part: N/A Test I.D.: NF01A



E-16

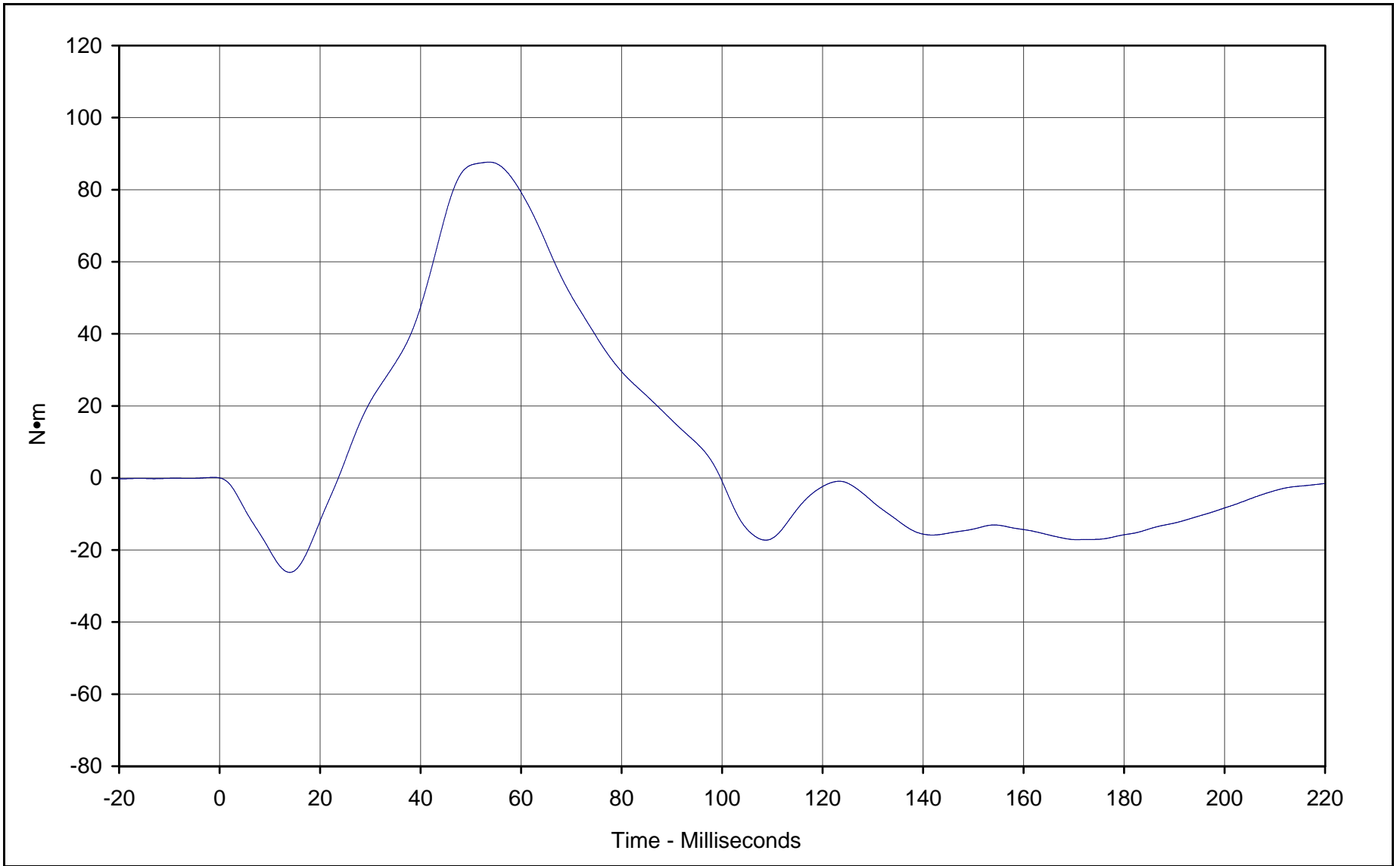

Curve Description: Moment About Occipital Condyles  
Maximum Value: 87.6 at 53.6 Milliseconds  
Minimum Value: -26.2 at 14.0 Milliseconds  
SAE Filter Class: 60  
Date of Test: 1/24/02  
ATD Serial No.: 034

Testing Program: Hybrid III Neck Flexion Test (Male)  
Test Information: S/N of Part: N/A Test I.D.: NF01A



KARR21061-01



# Hybrid III Calibration Data Sheet

## 50<sup>TH</sup> Percentile Male

### Neck Extension Test

ATD Serial No.: 034

Part Serial No.: N/A

Test I.D.: NE01A

Tested Parameter	Units	Specification	Result	Pass/Fail	
Laboratory Temperature	°C	20.6 to 22.2	21.1	Pass	
Laboratory Relative Humidity	%	10 to 70	30	Pass	
Pendulum Velocity	m/s	5.95 to 6.19	6.09	Pass	
Pendulum Deceleration	10 Msec.	G's	17.2 to 21.2	17.5	Pass
	20 Msec.	G's	14.0 to 19.0	17.4	Pass
	30 Msec.	G's	11.0 to 16.0	15.8	Pass
Peak Pendulum Decel. after 30 Msec.	G's	≤ 22.0	15.8	Pass	
Deceleration Decay, Time to Cross 5 G's	Msec.	38.0 to 46.0	40.6	Pass	
Maximum "D" Plane Rotation	Maximum	Degrees	81.0 to 106.0	97.2	Pass
	Time	Msec.	72.0 to 82.0	76.4	Pass
"D" Plane Rotation Decay, Time To Zero Crossing	Msec.	147.0 to 174.0	151.5	Pass	
Moment About Occipital Condyle	Maximum	N·m	-52.9 to- 79.9	-69.0	Pass
	Time	Msec.	65.0 to 79.0	68.4	Pass
Negative Moment Decay, Time To Zero Crossing	Msec.	120.0 to 148.0	137.7	Pass	
Overall Test Results				Pass	

\_\_\_\_\_  
Laboratory Technician

\_\_\_\_\_  
January 24, 2002  
Test Date

E-18

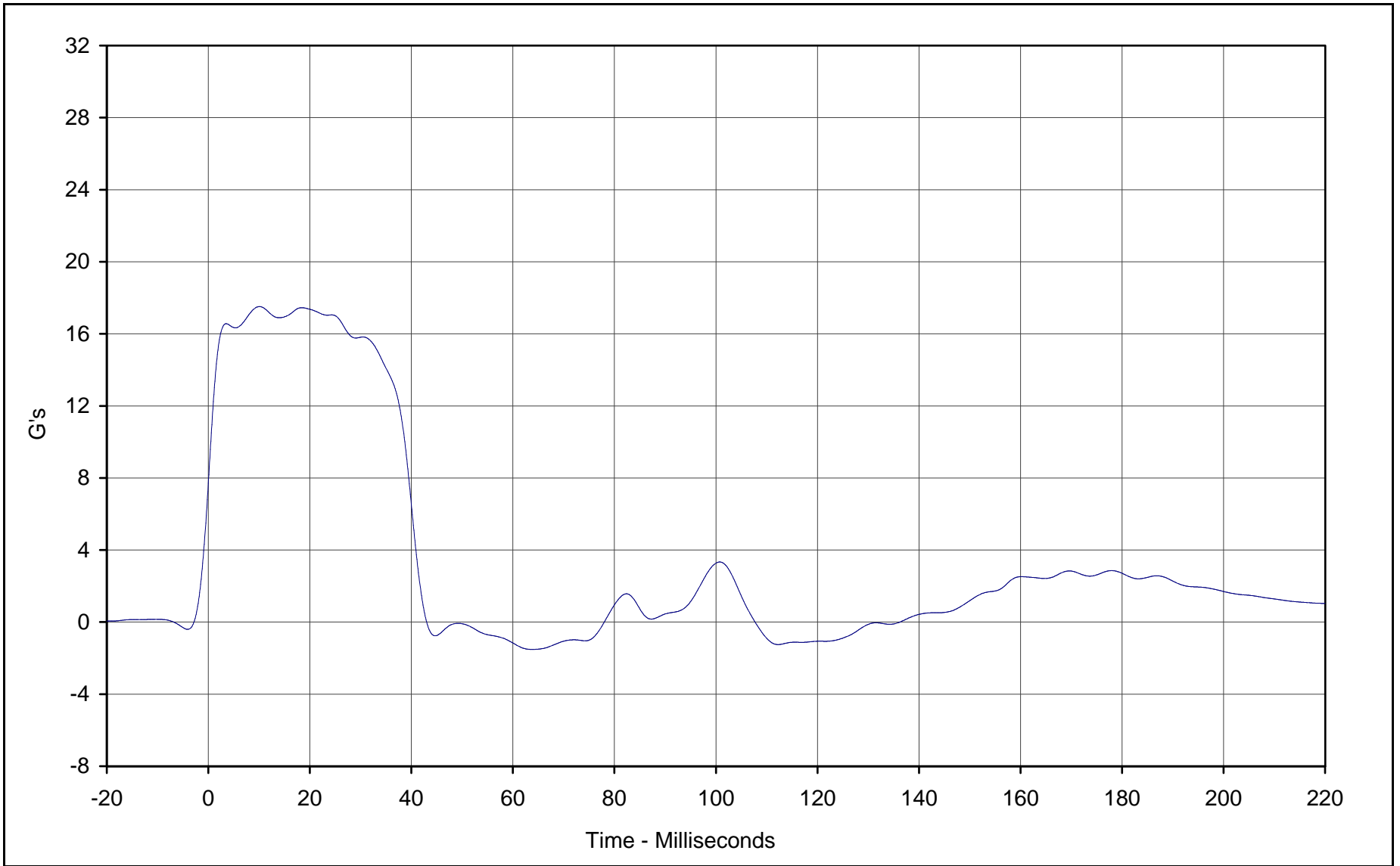

Curve Description: Pendulum Deceleration  
Maximum Value: 17.5 at 10.1 Milliseconds  
Minimum Value: -1.5 at 63.8 Milliseconds  
SAE Filter Class: 60  
Date of Test: 1/24/02  
ATD Serial No.: 034

Testing Program: Hybrid III Neck Extension Test (Male)  
Test Information: S/N of Part: N/A Test I.D.: NE01A



KAR21061-01

E-19

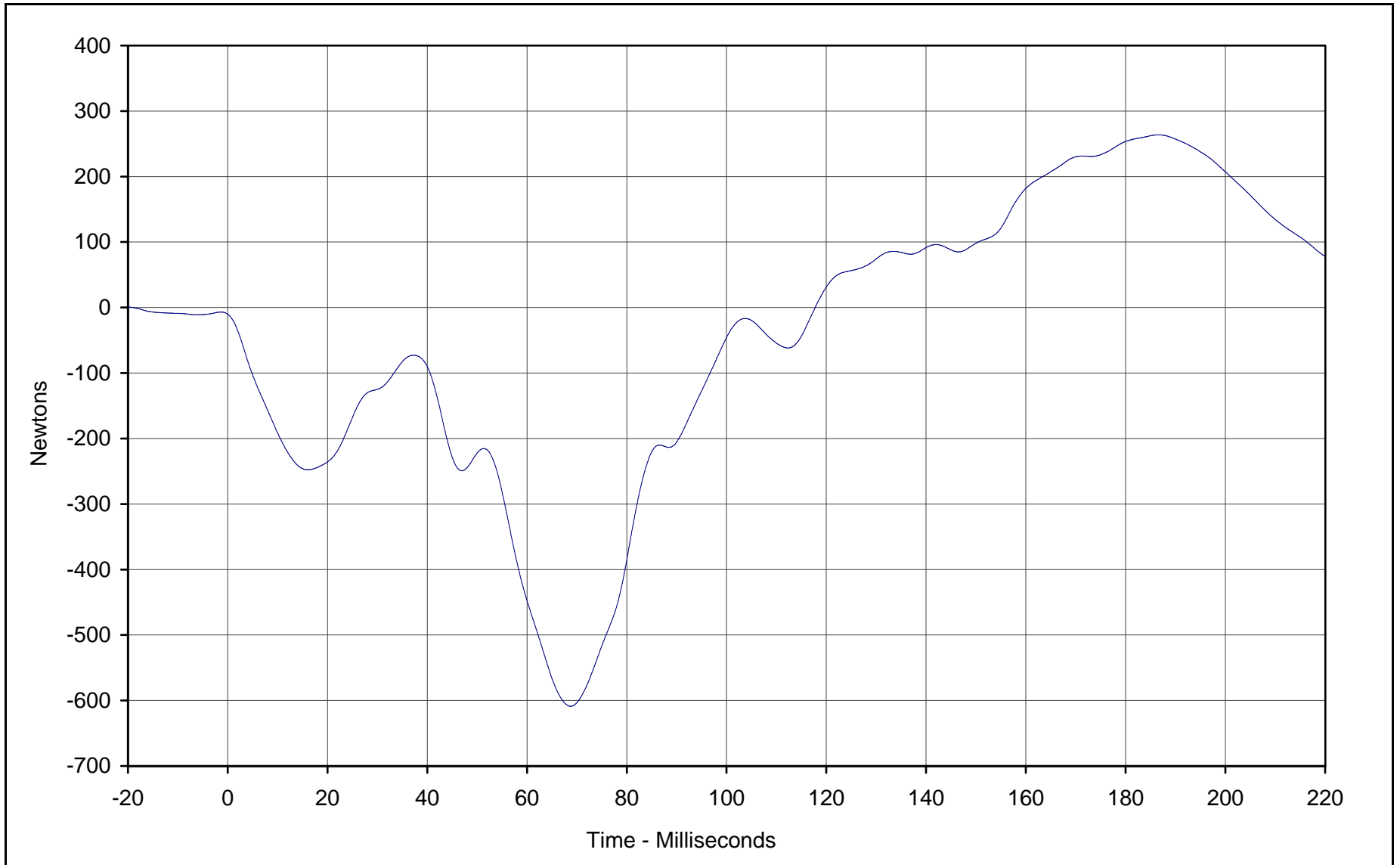

Curve Description: Neck Force X  
Maximum Value: 263.7 at 186.6 Milliseconds  
Minimum Value: -608.9 at 68.8 Milliseconds  
SAE Filter Class: 60  
Date of Test: 1/24/02  
ATD Serial No.: 034

Testing Program: Hybrid III Neck Extension Test (Male)  
Test Information: S/N of Part: N/A Test I.D.: NE01A

KARR21061-01



E-20

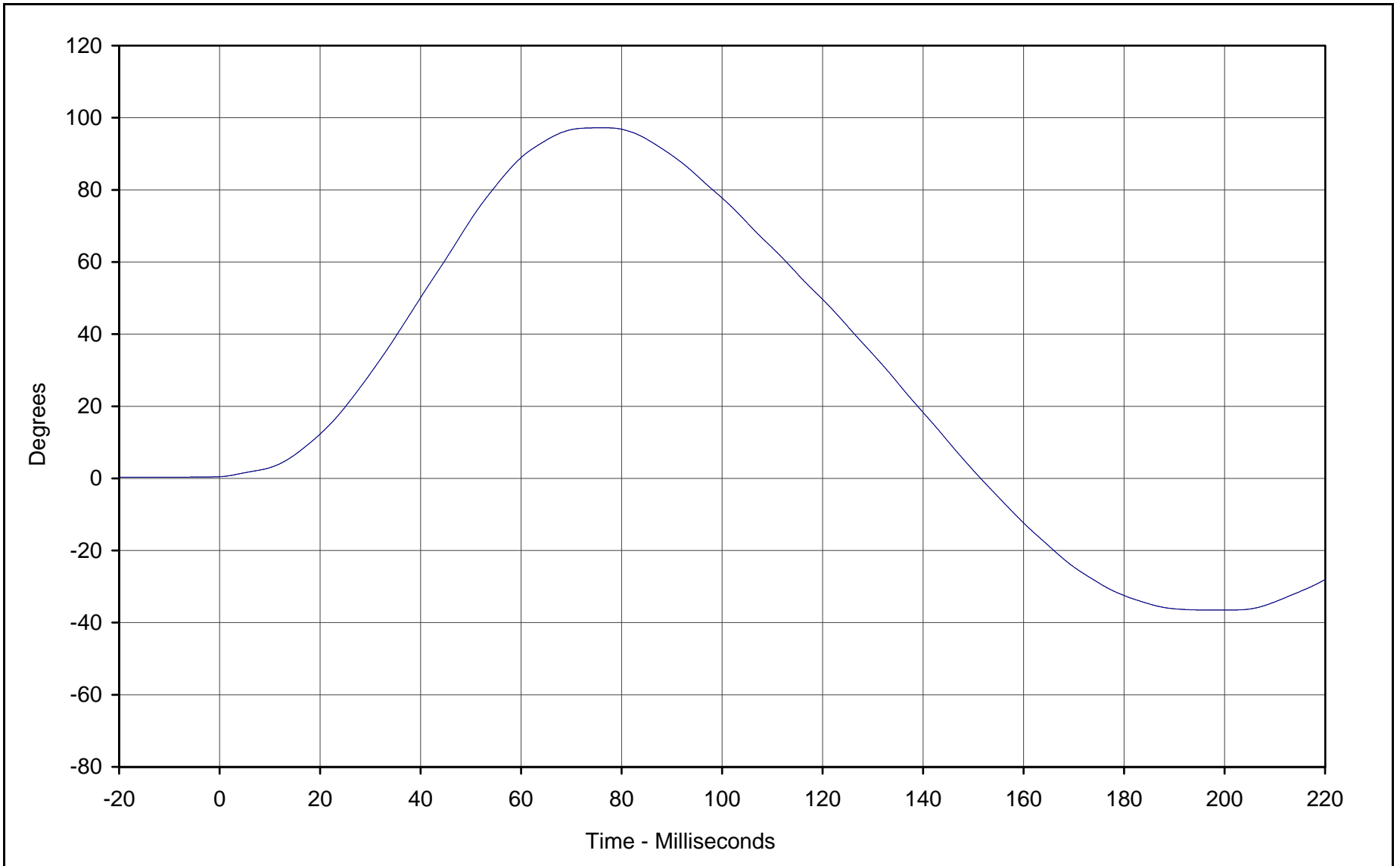

Curve Description: "D" Plane Rotation  
Maximum Value: 97.2 at 76.4 Milliseconds  
Minimum Value: -36.5 at 201.2 Milliseconds  
SAE Filter Class: 60  
Date of Test: 1/24/02  
ATD Serial No.: 034

Testing Program: Hybrid III Neck Extension Test (Male)  
Test Information: S/N of Part: N/A Test I.D.: NE01A

KAR21061-01



E-21

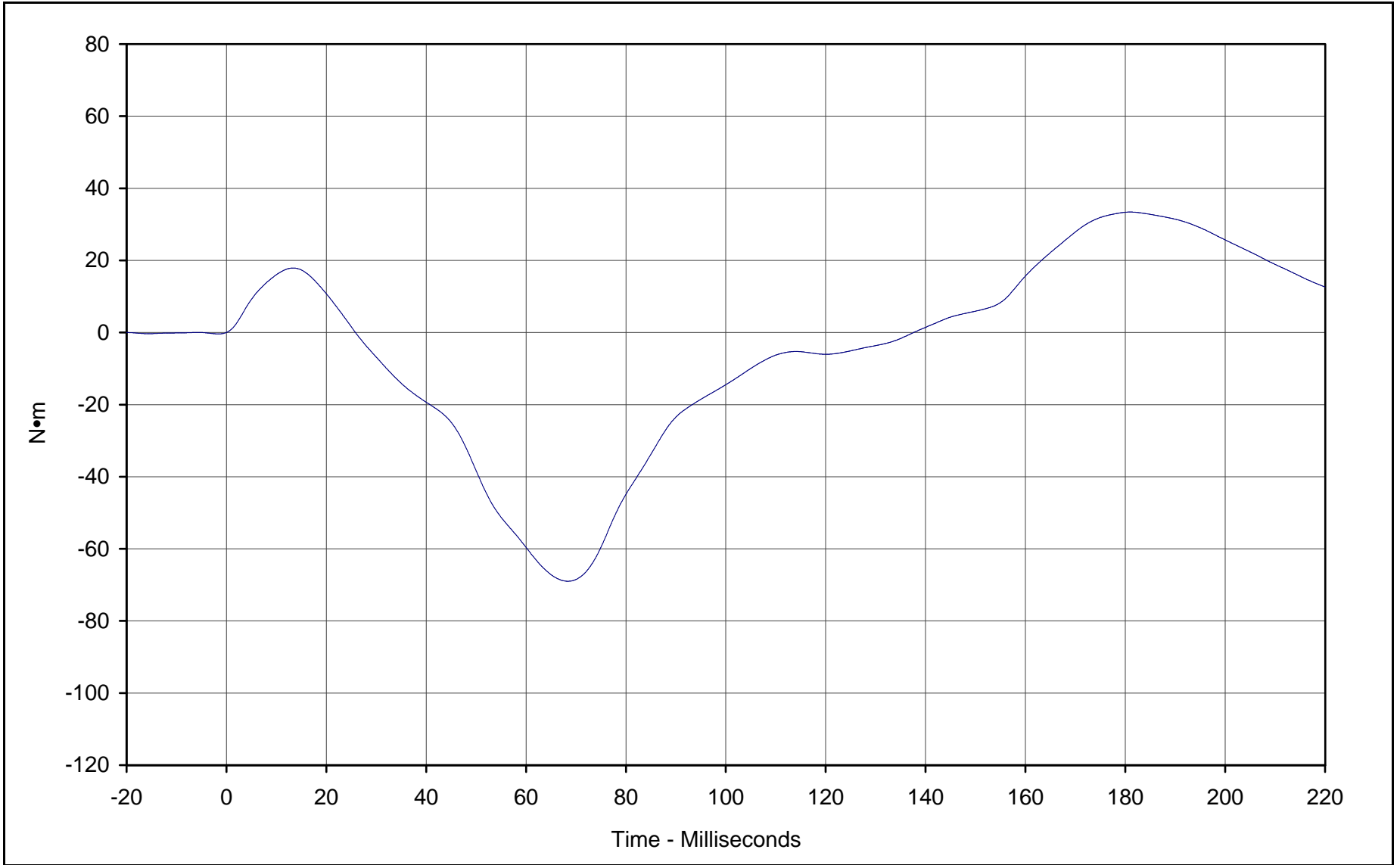

Curve Description: Moment About Occipital Condyles  
Maximum Value: 33.4 at 180.9 Milliseconds  
Minimum Value: -69.0 at 68.4 Milliseconds  
SAE Filter Class: 60  
Date of Test: 1/24/02  
ATD Serial No.: 034

Testing Program: Hybrid III Neck Extension Test (Male)  
Test Information: S/N of Part: N/A Test I.D.: NE01A

KARR21061-01





# Hybrid III Calibration Data Sheet

## 50<sup>TH</sup> Percentile Male

### External Measurements

ATD Serial No.: 034

Part Serial No.: N/A

Test I.D.: N/A

External Measurement Data				
Tested Parameter	Units	Specification	Result	Pass/Fail
Laboratory temperature	°C	20.4 to 22.1	20.9	Pass
Laboratory relative humidity	%	10 to 70	43	Pass
A - Total sitting height	mm	879 to 889	880	Pass
B - Shoulder pivot height	mm	505 to 521	520	Pass
C - "H" point height	mm	84 to 89	85	Pass
D - "H" point from seat back	mm	135 to 140	135	Pass
E - Shoulder pivot from back	mm	84 to 94	90	Pass
F - Thigh clearance	mm	140 to 155	150	Pass
G - Elbow back to wrist pivot	mm	290 to 305	295	Pass
H - Skull cap to back line	mm	41 to 46	45	Pass
I - Shoulder to elbow length	mm	330 to 345	340	Pass
J - Elbow rest height	mm	190 to 211	210	Pass
K - Buttock to knee length	mm	579 to 604	600	Pass
L - Popliteal length	mm	429 to 455	440	Pass
M - Knee pivot height	mm	485 to 500	495	Pass
N - Buttock popliteal length	mm	452 to 477	460	Pass
O - Chest depth	mm	213 to 229	220	Pass
P - Foot length	mm	251 to 267	260	Pass
V - Shoulder breadth	mm	422 to 437	425	Pass
W - Foot breadth	mm	91 to 107	100	Pass
Y - Chest circumference	mm	970 to 1001	980	Pass
Z - Waist circumference	mm	836 to 866	860	Pass
AA - Location for chest circumference	mm	429 to 434	430	Pass
BB - Location for waist circumference	mm	226 to 231	230	Pass
Overall Test Results				Pass

\_\_\_\_\_  
Laboratory Technician

\_\_\_\_\_  
January 26, 2002  
Test Date



# Hybrid III Calibration Data Sheet

## Hybrid III 50th Percentile Male

### Knee Impact Test

ATD Serial No.: 035

Location: Left Knee

Test I.D.: LK10B

Tested Parameter	Units	Specification	Result	Pass/Fail
Laboratory Temperature	°C	18.9 to 25.5	21.1	Pass
Laboratory Relative Humidity	%	10 to 70	30	Pass
Pendulum Velocity at T=0	m/sec	2.07 to 2.13	2.10	Pass
Peak Probe Force	N	4715 to 5782	5181	Pass
Overall Test Results				Pass

ATD Serial No.: 035

Location: Right Knee

Test I.D.: RK10C

Tested Parameter	Units	Specification	Result	Pass/Fail
Laboratory Temperature	°C	18.9 to 25.5	21.1	Pass
Laboratory Relative Humidity	%	10 to 70	30	Pass
Pendulum Velocity at T=0	m/sec	2.07 to 2.13	2.10	Pass
Peak Probe Force	N	4715 to 5782	5554	Pass
Overall Test Results				Pass

\_\_\_\_\_  
Laboratory Technician

January 15, 2002  
\_\_\_\_\_  
Test Date

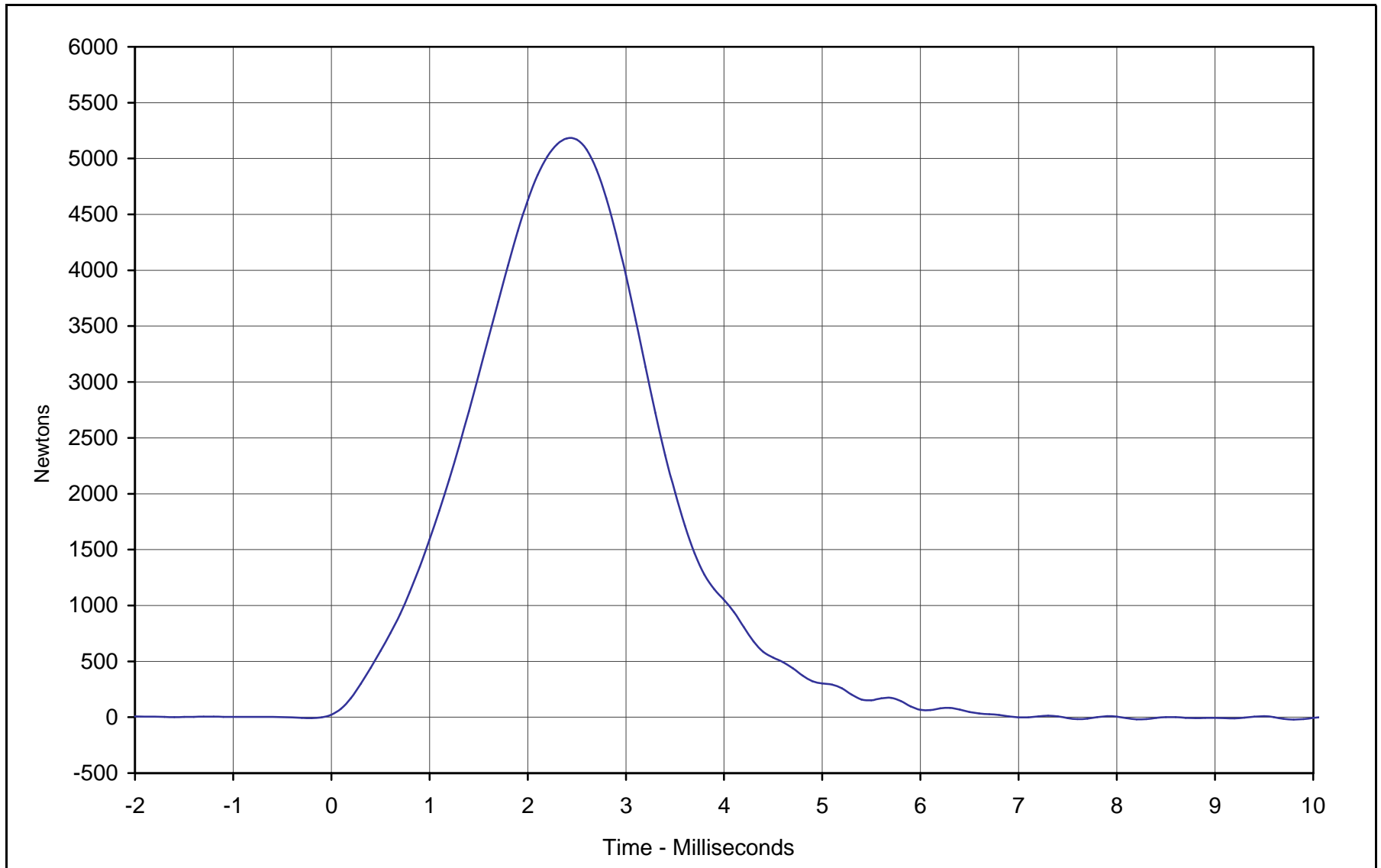

Curve Description: Probe Force  
Maximum Value: 5181.0 at 2.4 Milliseconds  
Minimum Value: -17.7 at 7.6 Milliseconds  
SAE Filter Class: 600  
Date of Test: 1/15/02  
ATD Serial No.: 035

Test Program: Hybrid III Knee Impact Test  
Test Information: Location: Left Knee Test I.D.: LK10B



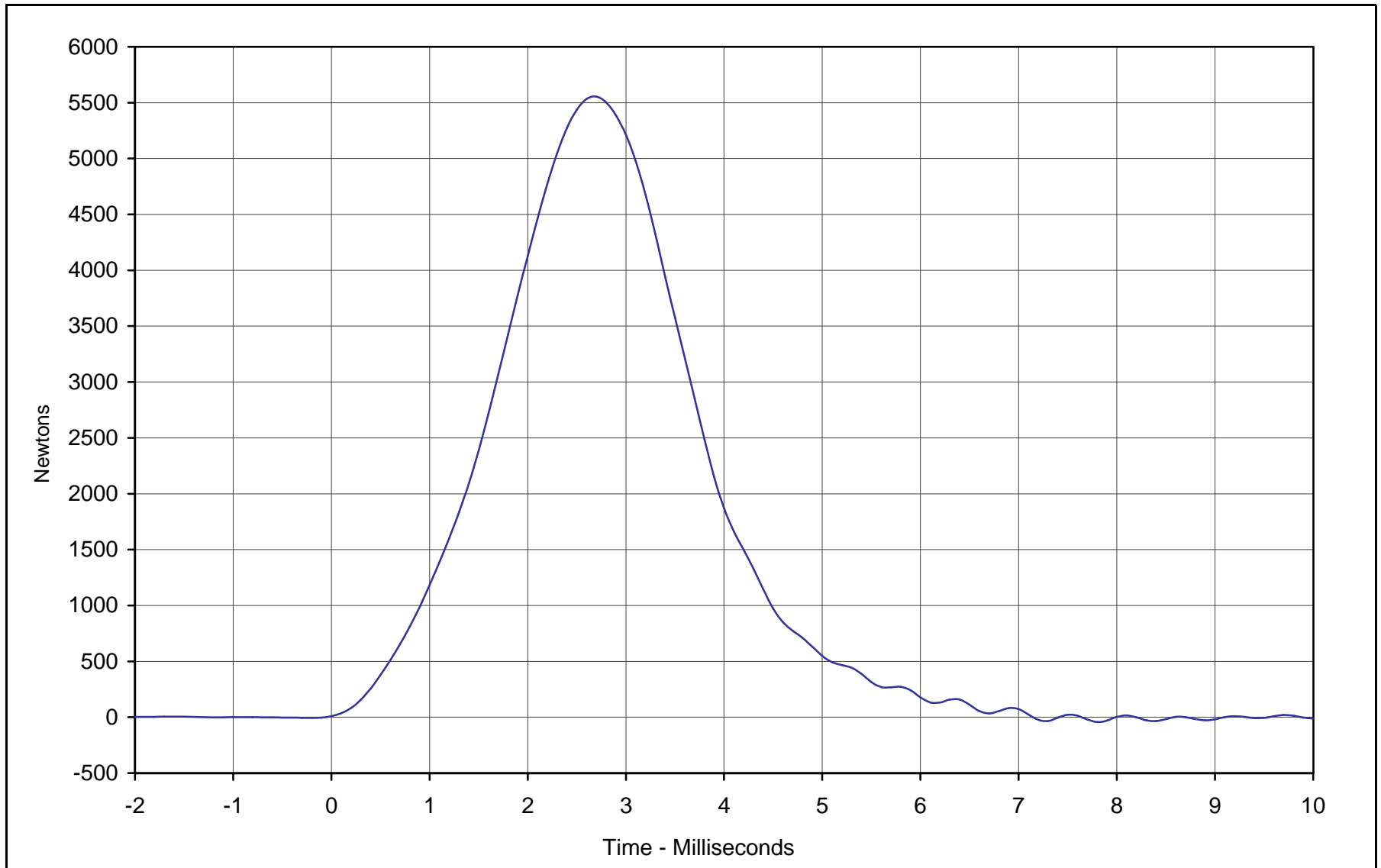

Curve Description: Probe Force  
Maximum Value: 5554.4 at 2.7 Milliseconds  
Minimum Value: -42.7 at 7.8 Milliseconds  
SAE Filter Class: 600  
Date of Test: 1/15/02  
ATD Serial No.: 035

Test Program: Hybrid III Knee Impact Test  
Test Information: Location: Right Knee Test I.D.: RK10C





# Hybrid III Calibration Data Sheet

## Hybrid III 50th Percentile Male

### Knee Slider Test

ATD Serial No.: 035

Location: Left Knee

Test I.D.: LS002

Tested Parameter		Units	Specification	Result	Pass/Fail
Laboratory Temperature		°C	20.6 to 22.2	21.1	Pass
Laboratory Relative Humidity		%	10 to 70	30	Pass
Pendulum Velocity at T=0		m/sec	2.70 to 2.80	2.74	Pass
Impact Force at:	10 mm	kN	1.26 to 1.72	1.65	Pass
	18 mm	kN	2.27 to 3.096	3.03	Pass
Overall Test Results					Pass

ATD Serial No.: 035

Location: Right Knee

Test I.D.: RS002

Tested Parameter		Units	Specification	Result	Pass/Fail
Laboratory Temperature		°C	20.6 to 22.2	21.1	Pass
Laboratory Relative Humidity		%	10 to 70	30	Pass
Pendulum Velocity at T=0		m/sec	2.70 to 2.80	2.78	Pass
Impact Force at:	10 mm	kN	1.26 to 1.72	1.54	Pass
	18 mm	kN	2.27 to 3.096	2.98	Pass
Overall Test Results					Pass

\_\_\_\_\_  
Laboratory Technician

\_\_\_\_\_  
January 17, 2002

\_\_\_\_\_  
Test Date

E-26

KAR21061-01

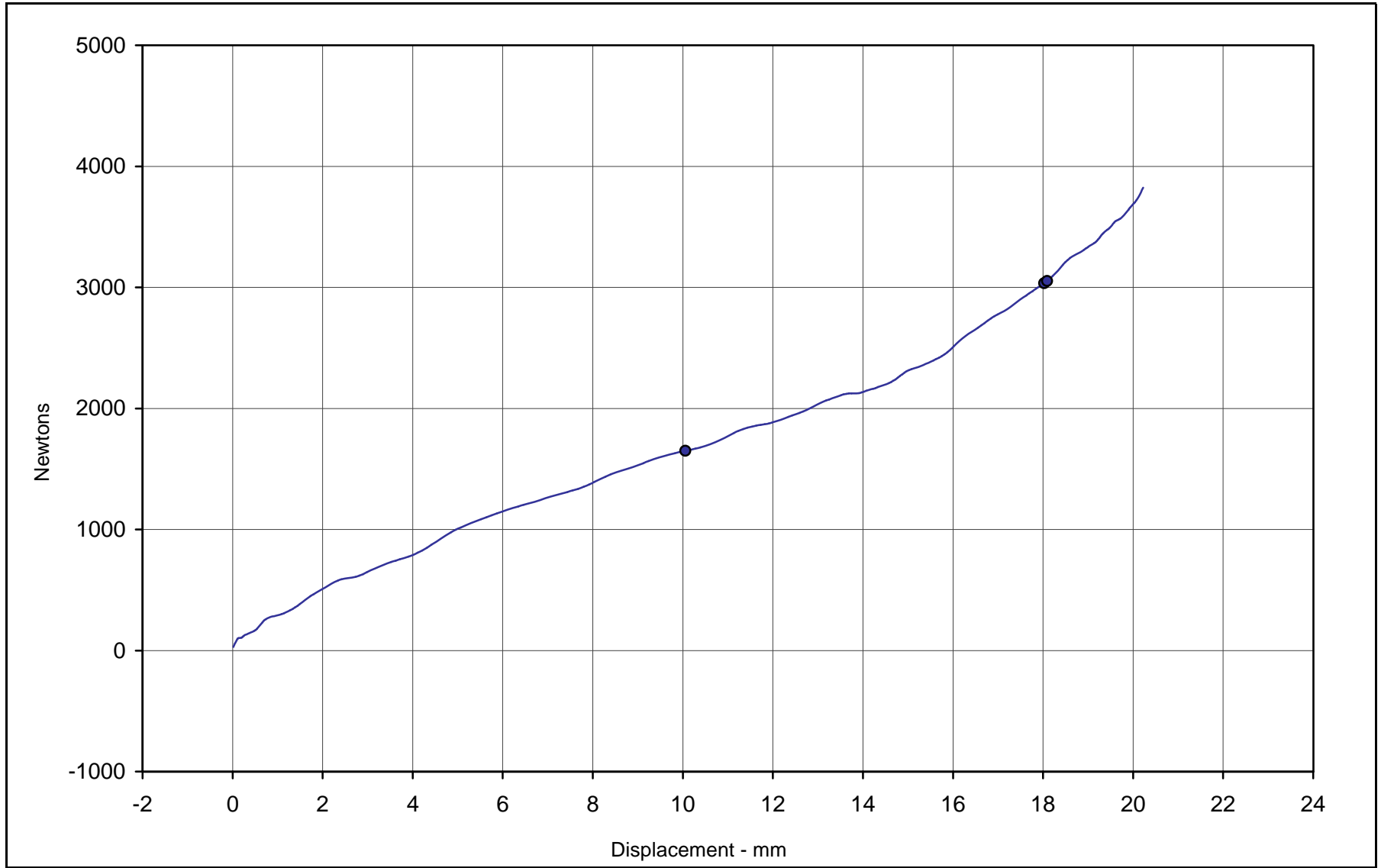

Curve Description: Femur Force vs. Knee Displacement

Test Program: Hybrid III Knee Shear Test

Femur Force: 1650 at 10.0 mm

Test Information: Location: Left Knee Test I.D.: LS002

Femur Force: 3035 at 18.0 mm

SAE Filter Class: 600

Date of Test: 1/17/02

ATD Serial No.: 035



E-28

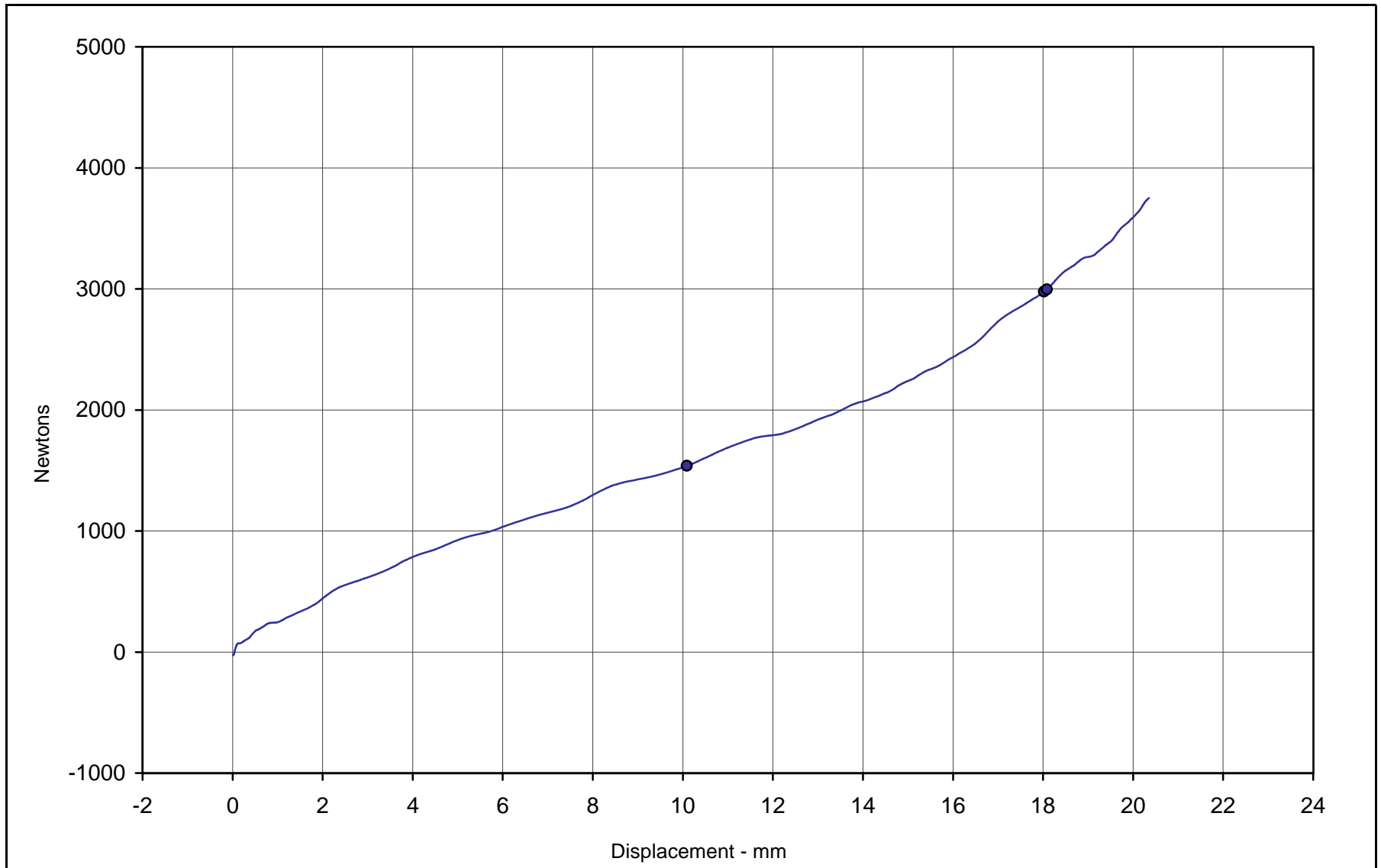

Curve Description: Femur Force vs. Knee Displacement

Test Program: Hybrid III Knee Shear Test

Femur Force: 1539 at 10.0 mm

Test Information: Location: Right Knee Test I.D.: RS002

Femur Force: 2977 at 18.0 mm

SAE Filter Class: 600

Date of Test: 11/28/01

ATD Serial No.: 035



KAR21061-01



# Hybrid III Calibration Data Sheet

## 50<sup>TH</sup> Percentile Male

### Head Drop Calibration

ATD Serial No.: 035

Part Serial No.: N/A

Test I.D.: HD10C

Tested Parameter	Units	Specification	Result	Pass/Fail
Laboratory Temperature	°C	18.9 to 25.6	21.1	Pass
Laboratory Relative Humidity	%	10 to 70	30	Pass
Peak Resultant Acceleration	G's	225.0 to 275.0	229.6	Pass
Peak Lateral Acceleration	G's	≤15.0	3.8	Pass
Is Acceleration Unimodal?	Yes/No	Yes	Yes	Pass
Overall Test Results				Pass

\_\_\_\_\_  
Laboratory Technician

January 16, 2002  
Test Date

E-30

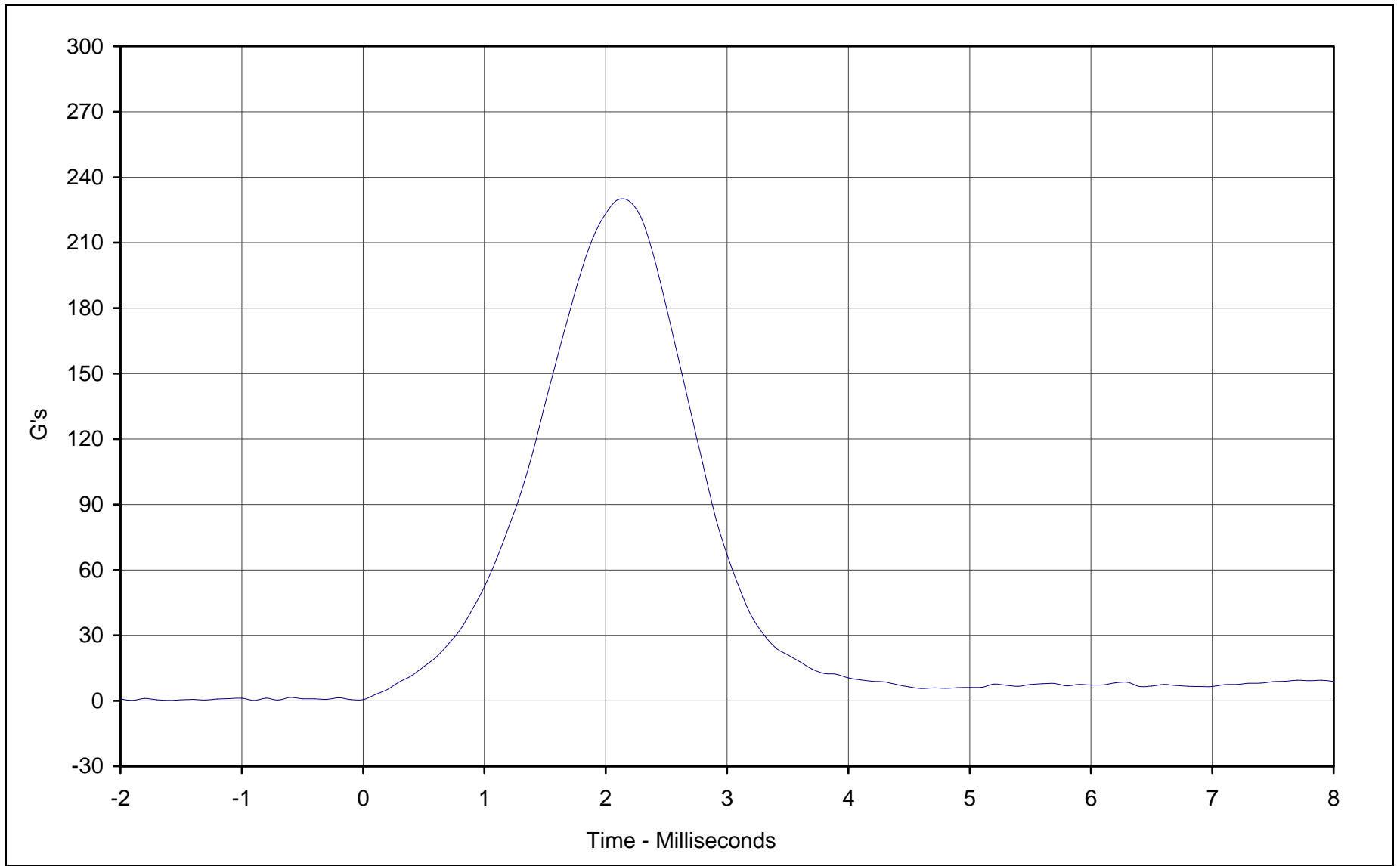

Curve Description: Head Resultant Acceleration  
Maximum Value: 229.6 at 2.1 Milliseconds  
Minimum Value: 0.2 at -1.6 Milliseconds  
SAE Filter Class: 1000  
Date of Test: 1/16/02  
ATD Serial No.: 035

Testing Program: Hybrid III Head Drop Calibration (Male)  
Test Information: S/N of Part: N/A Test I.D.: HD10C



KAR21061-01

E-31

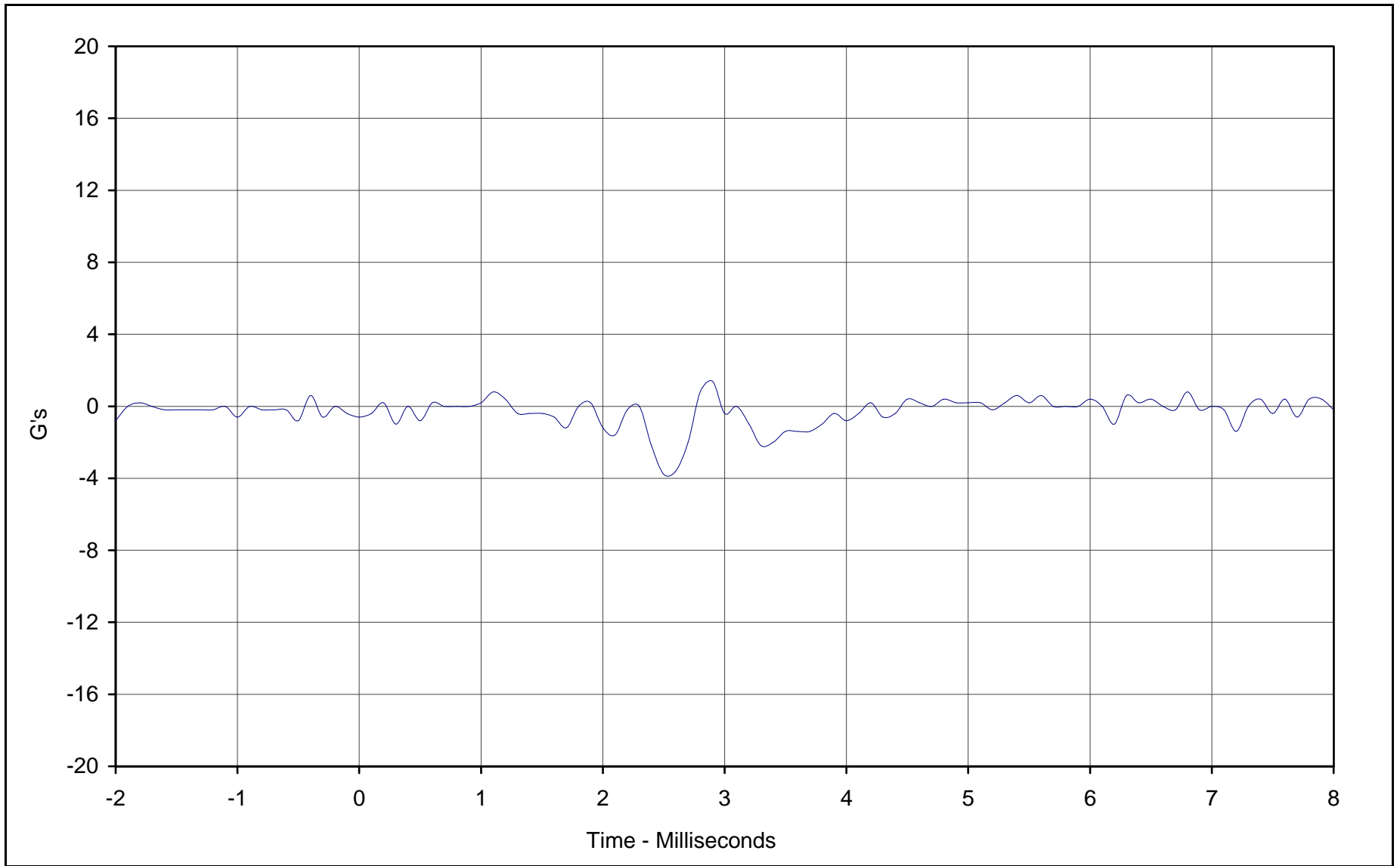

Curve Description: Head Acceleration Y Axis

Maximum Value: 1.4 at 2.9 Milliseconds

Minimum Value: -3.8 at 2.5 Milliseconds

SAE Filter Class: 1000

Date of Test: 1/16/02

ATD Serial No.: 035

Testing Program: Hybrid III Head Drop Calibration (Male)

Test Information: S/N of Part: N/A Test I.D.: HD10C

KAR21061-01





# Hybrid III Calibration Data Sheet

## 50<sup>TH</sup> Percentile Male

### Thorax Impact Test

ATD Serial No.: 035

Part Serial No.: N/A

Test I.D.: CH01A

Tested Parameter	Units	Specification	Result	Pass/Fail
Laboratory Temperature	°C	20.6 to 22.2	21.2	Pass
Laboratory Relative Humidity	%	10 to 70	30	Pass
Probe Velocity	m/s	6.58 to 6.82	6.68	Pass
Peak Probe Force	Newtons	5159 to 5893	5766	Pass
Peak Sternum Displacement	CM	6.35 to 7.26	6.96	Pass
Internal Hysteresis	%	69 to 85	76.5	Pass
Overall Test Results				Pass

\_\_\_\_\_  
Laboratory Technician

January 24, 2002  
\_\_\_\_\_  
Test Date

E-33

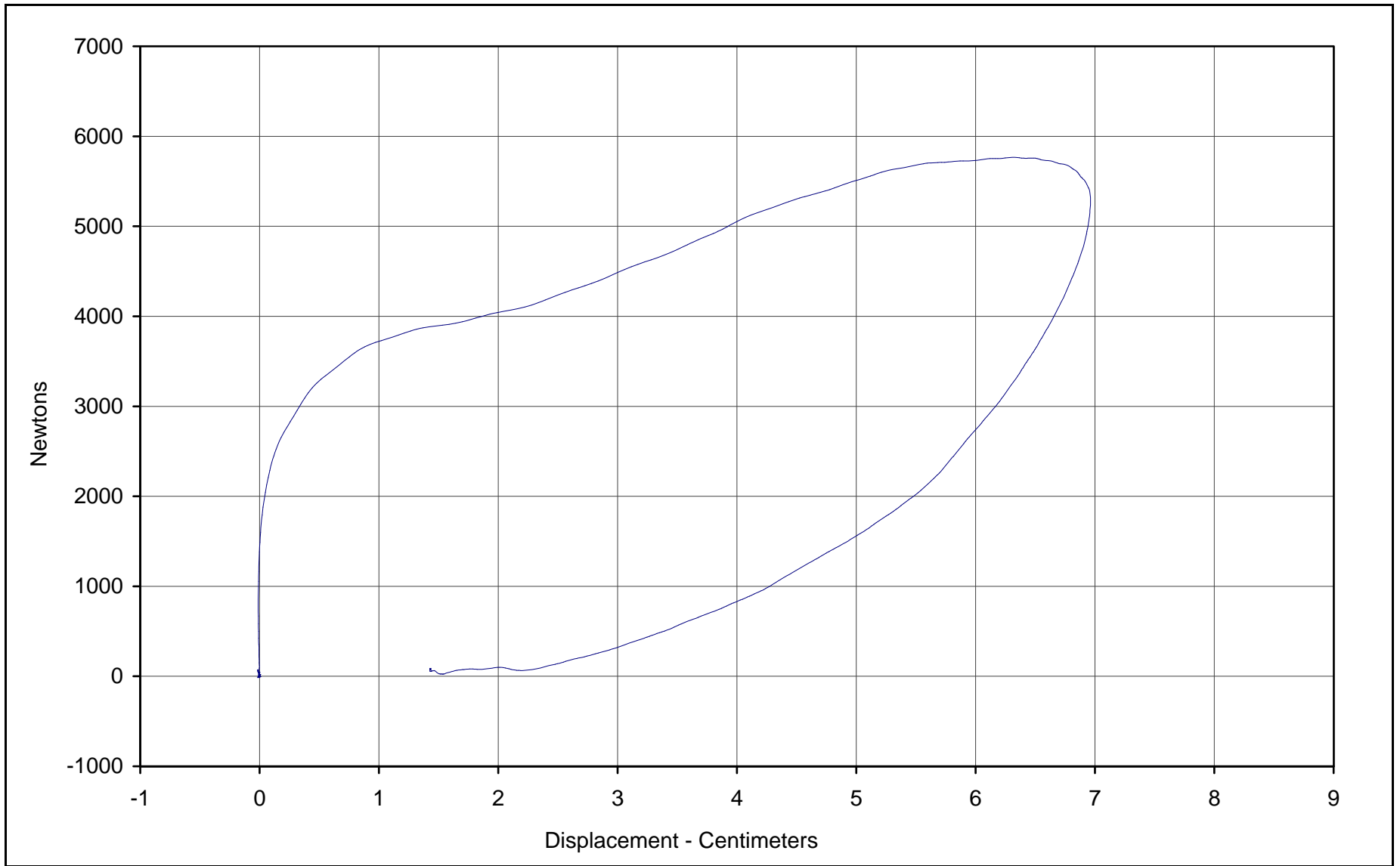

Curve Description: Probe Force vs. Chest Displacement

Testing Program: Hybrid III Thorax Impact Test

Probe Force: 5766.2 Newtons

Test Information: S/N of Part: N/A Test I.D.: CH01A

Chest Displ.: 6.96 Centimeters

SAE Filter Class: 180

Date of Test: 1/24/02

ATD Serial No.: 035

KAR21061-01





# Hybrid III Calibration Data Sheet

## 50<sup>TH</sup> Percentile Male

### Neck Flexion Test

ATD Serial No.: 035

Part Serial No.: N/A

Test I.D.: NF01B

Tested Parameter	Units	Specification	Result	Pass/Fail	
Laboratory Temperature	°C	20.6 to 22.2	21.1	Pass	
Laboratory Relative Humidity	%	10 to 70	30	Pass	
Pendulum Velocity	m/s	6.89 to 7.13	6.95	Pass	
Pendulum Deceleration	10 Msec.	G's	22.5 to 27.5	23.3	Pass
	20 Msec.	G's	17.6 to 22.6	20.4	Pass
	30 Msec.	G's	12.5 to 18.5	18.3	Pass
Peak Pendulum Decel. after 30 Msec.	G's	≤ 29.0	18.3	Pass	
Deceleration Decay, Time to Cross 5 G's	Msec.	34.0 to 42.0	38.0	Pass	
Maximum "D" Plane Rotation	Maximum	Degrees	64.0 to 78.0	71.8	Pass
	Time	Msec.	57.0 to 64.0	63.6	Pass
"D" Plane Rotation Decay, Time To Zero Crossing	Msec.	113.0 to 128.0	119.5	Pass	
Moment About Occipital Condyle	Maximum	N·m	84.1 to 108.5	88.3	Pass
	Time	Msec.	47.0 to 58.0	53.8	Pass
Positive Moment Decay, Time To Zero Crossing	Msec.	97.0 to 107.0	101.1	Pass	
Overall Test Results				Pass	

\_\_\_\_\_  
Laboratory Technician

\_\_\_\_\_  
January 24, 2002  
Test Date

E-35

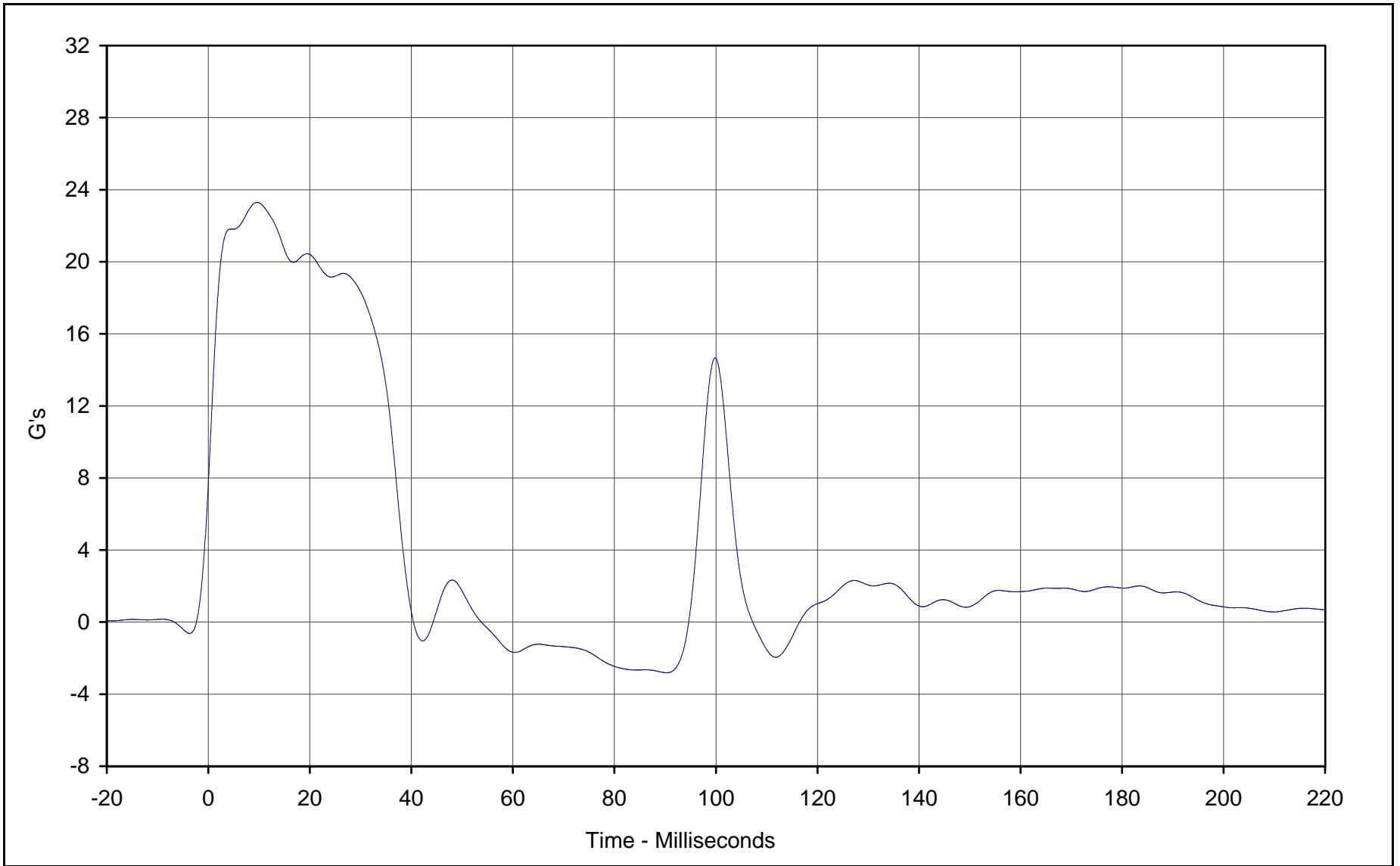

Curve Description: Pendulum Deceleration  
Maximum Value: 23.3 at 9.6 Milliseconds  
Minimum Value: -2.8 at 90.3 Milliseconds  
SAE Filter Class: 60  
Date of Test: 1/24/02  
ATD Serial No.: 035

Testing Program: Hybrid III Neck Flexion Test (Male)  
Test Information: S/N of Part: N/A Test I.D.: NF01B



KAR21061-01

E-36

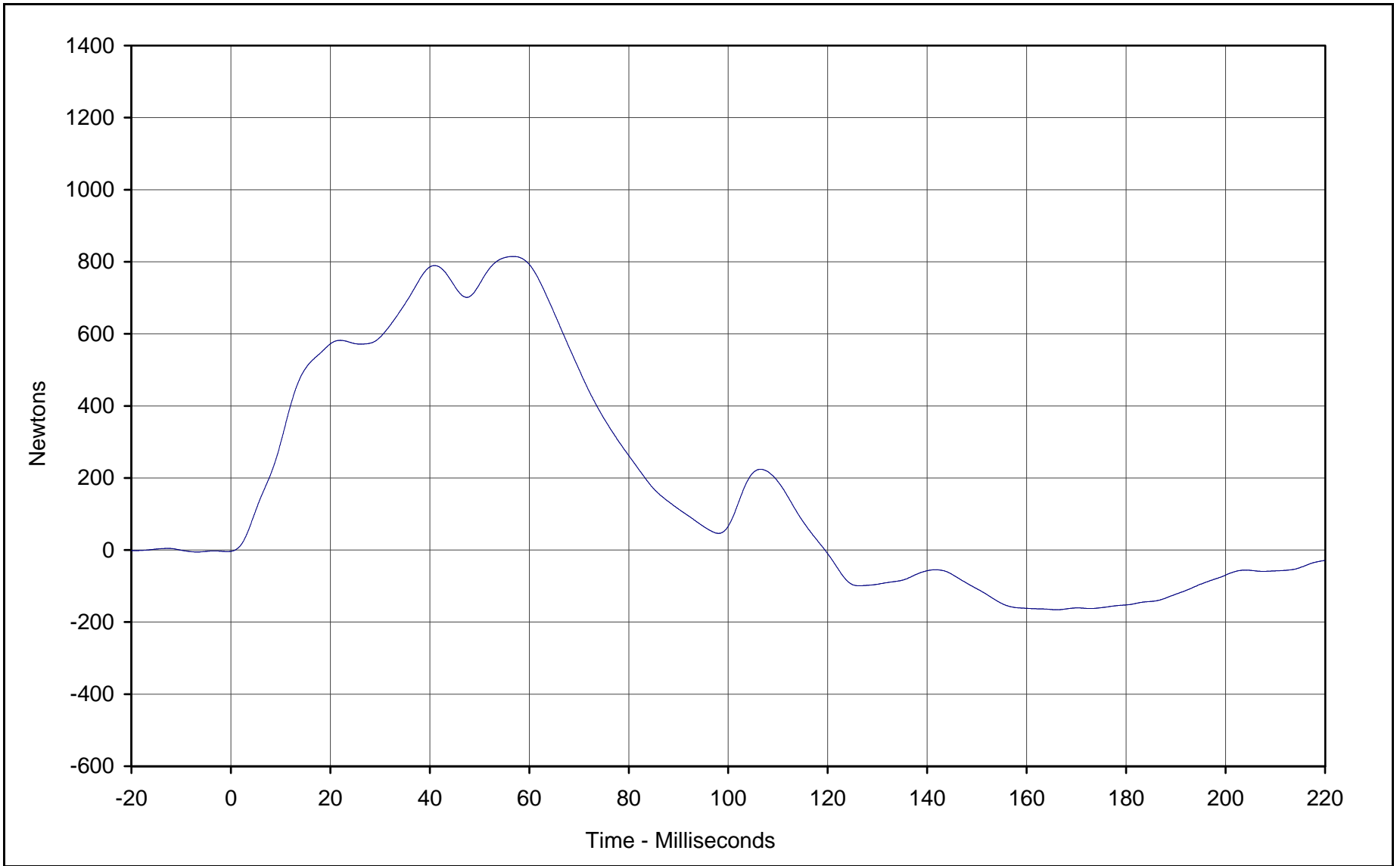

Curve Description: Neck Force X  
Maximum Value: 814.8 at 56.8 Milliseconds  
Minimum Value: -165.8 at 166.0 Milliseconds  
SAE Filter Class: 60  
Date of Test: 1/24/02  
ATD Serial No.: 035

Testing Program: Hybrid III Neck Flexion Test (Male)  
Test Information: S/N of Part: N/A Test I.D.: NF01B



KARR21061-01

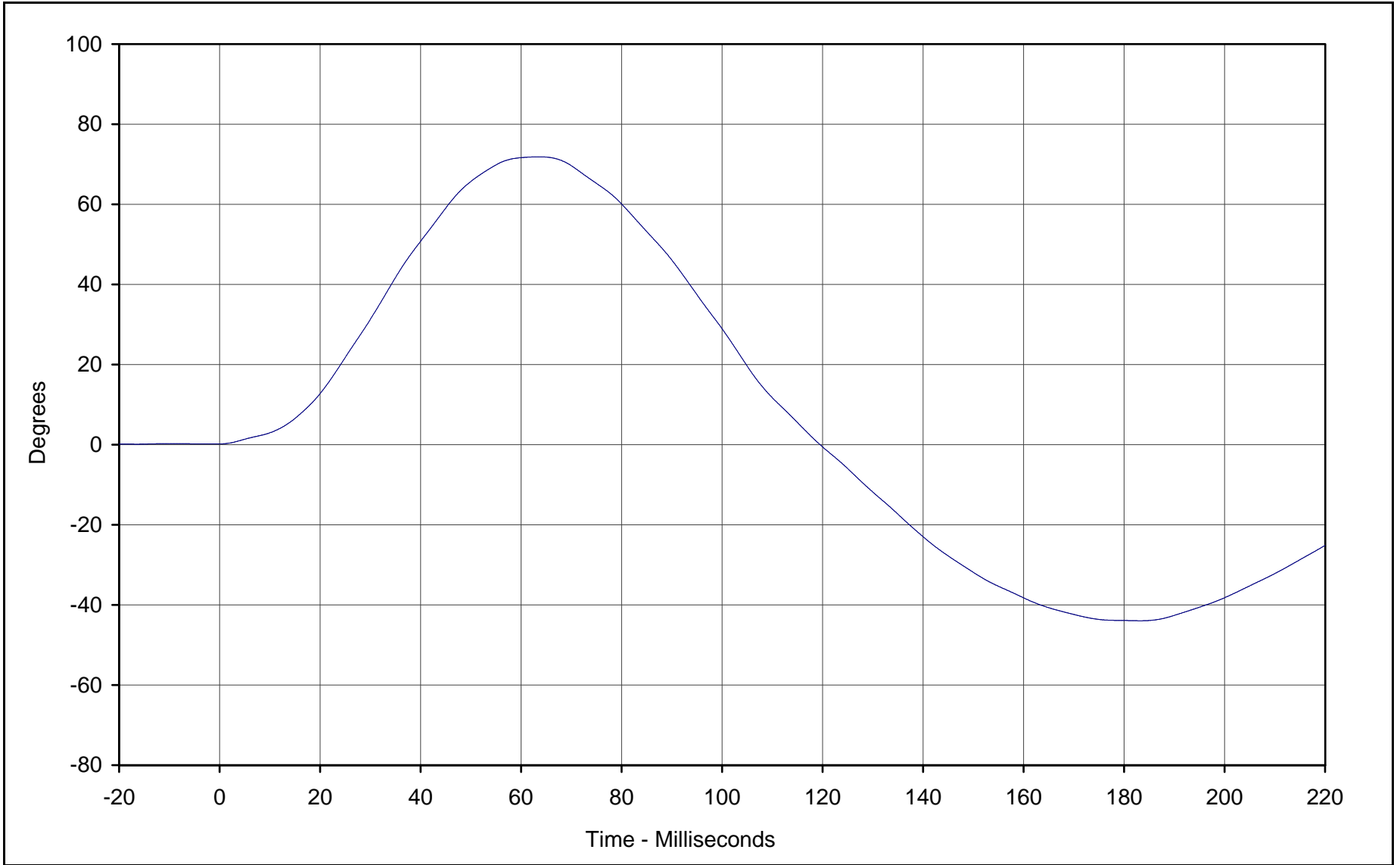

Curve Description: "D" Plane Rotation  
Maximum Value: 71.8 at 63.6 Milliseconds  
Minimum Value: -44.0 at 183.3 Milliseconds  
SAE Filter Class: 60  
Date of Test: 1/24/02  
ATD Serial No.: 035

Testing Program: Hybrid III Neck Flexion Test (Male)  
Test Information: S/N of Part: N/A Test I.D.: NF01B



E-38

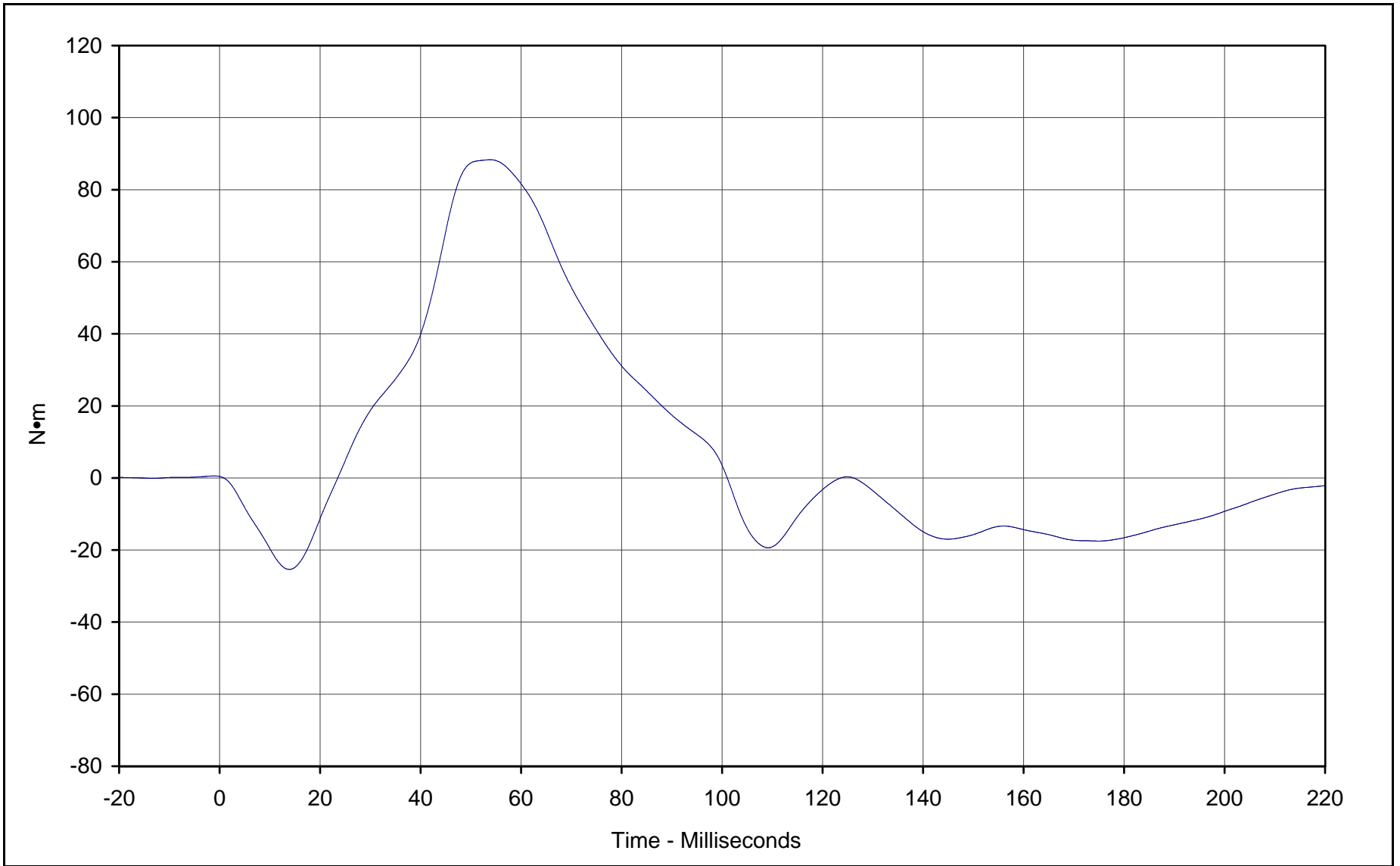

Curve Description: Moment About Occipital Condyles  
Maximum Value: 88.3 at 53.8 Milliseconds  
Minimum Value: -25.4 at 13.9 Milliseconds  
SAE Filter Class: 60  
Date of Test: 1/24/02  
ATD Serial No.: 035

Testing Program: Hybrid III Neck Flexion Test (Male)  
Test Information: S/N of Part: N/A Test I.D.: NF01B

KARR21061-01





# Hybrid III Calibration Data Sheet

## 50<sup>TH</sup> Percentile Male

### Neck Extension Test

ATD Serial No.: 035

Part Serial No.: N/A

Test I.D.: NE01B

Tested Parameter	Units	Specification	Result	Pass/Fail	
Laboratory Temperature	°C	20.6 to 22.2	21.1	Pass	
Laboratory Relative Humidity	%	10 to 70	30	Pass	
Pendulum Velocity	m/s	5.95 to 6.19	6.09	Pass	
Pendulum Deceleration	10 Msec.	G's	17.2 to 21.2	18.5	Pass
	20 Msec.	G's	14.0 to 19.0	16.8	Pass
	30 Msec.	G's	11.0 to 16.0	14.8	Pass
Peak Pendulum Decel. after 30 Msec.	G's	≤ 22.0	14.8	Pass	
Deceleration Decay, Time to Cross 5 G's	Msec.	38.0 to 46.0	40.9	Pass	
Maximum "D" Plane Rotation	Maximum	Degrees	81.0 to 106.0	97.9	Pass
	Time	Msec.	72.0 to 82.0	77.9	Pass
"D" Plane Rotation Decay, Time To Zero Crossing	Msec.	147.0 to 174.0	152.4	Pass	
Moment About Occipital Condyle	Maximum	N·m	-52.9 to- 79.9	-67.9	Pass
	Time	Msec.	65.0 to 79.0	68.8	Pass
Negative Moment Decay, Time To Zero Crossing	Msec.	120.0 to 148.0	139.0	Pass	
Overall Test Results				Pass	

\_\_\_\_\_  
Laboratory Technician

\_\_\_\_\_  
January 24, 2002  
Test Date

E-40

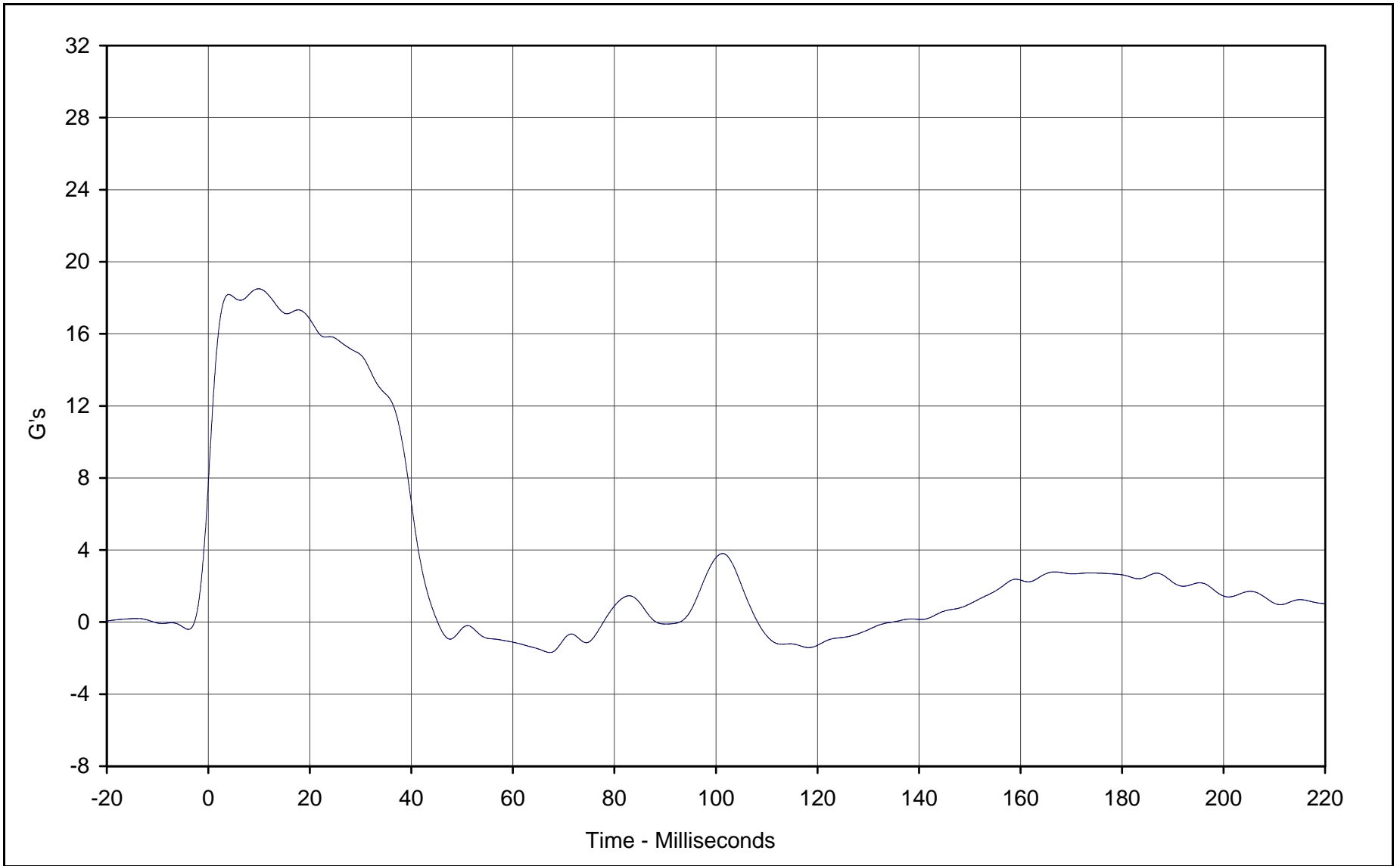

Curve Description: Pendulum Deceleration  
Maximum Value: 18.5 at 9.9 Milliseconds  
Minimum Value: -1.7 at 67.3 Milliseconds  
SAE Filter Class: 60  
Date of Test: 1/24/02  
ATD Serial No.: 035

Testing Program: Hybrid III Neck Extension Test (Male)  
Test Information: S/N of Part: N/A Test I.D.: NE01B

KAR21061-01



E-41

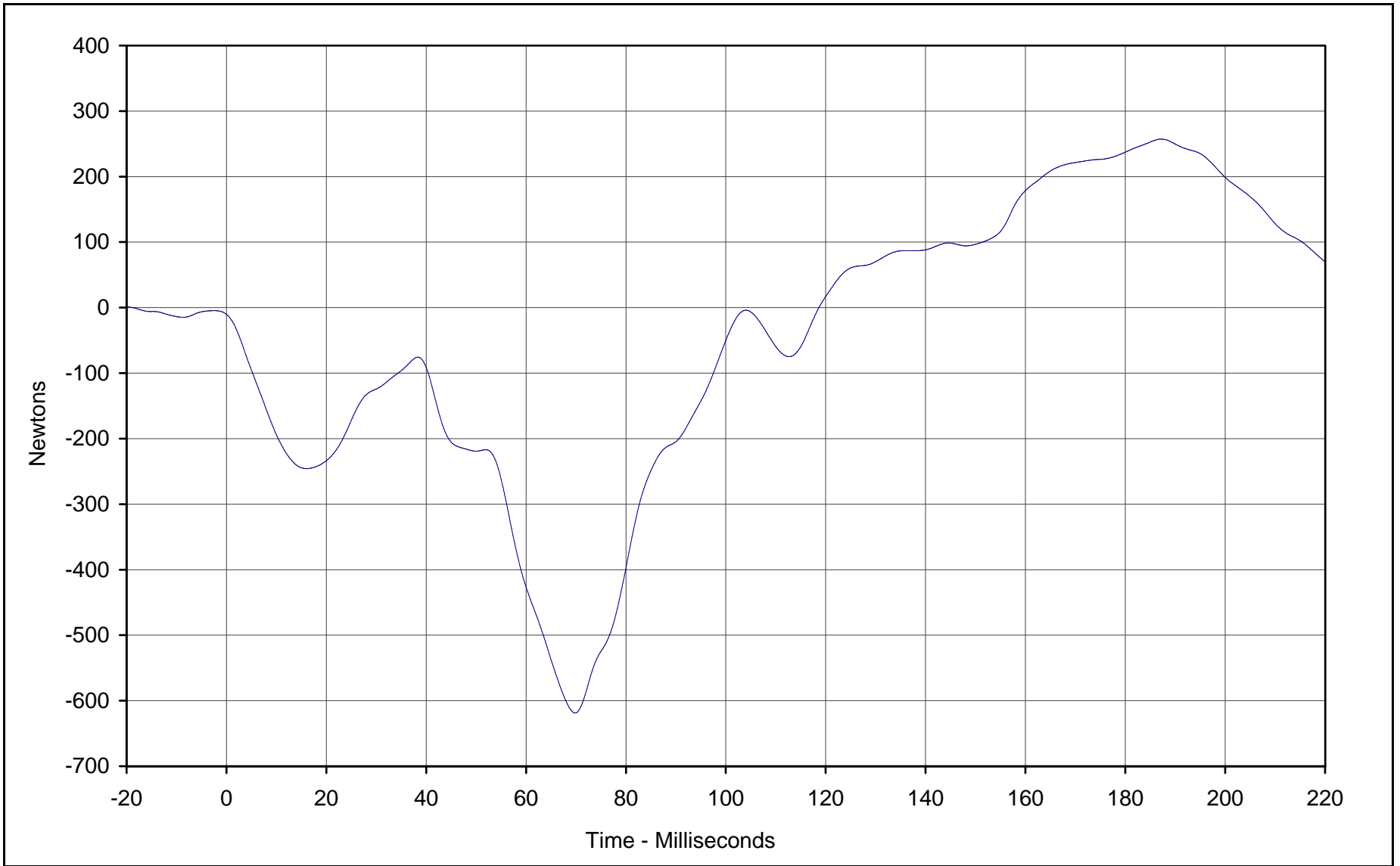

Curve Description: Neck Force X  
Maximum Value: 257.3 at 187.2 Milliseconds  
Minimum Value: -618.7 at 69.8 Milliseconds  
SAE Filter Class: 60  
Date of Test: 1/24/02  
ATD Serial No.: 035

Testing Program: Hybrid III Neck Extension Test (Male)  
Test Information: S/N of Part: N/A Test I.D.: NE01B



KARR21061-01

E-42

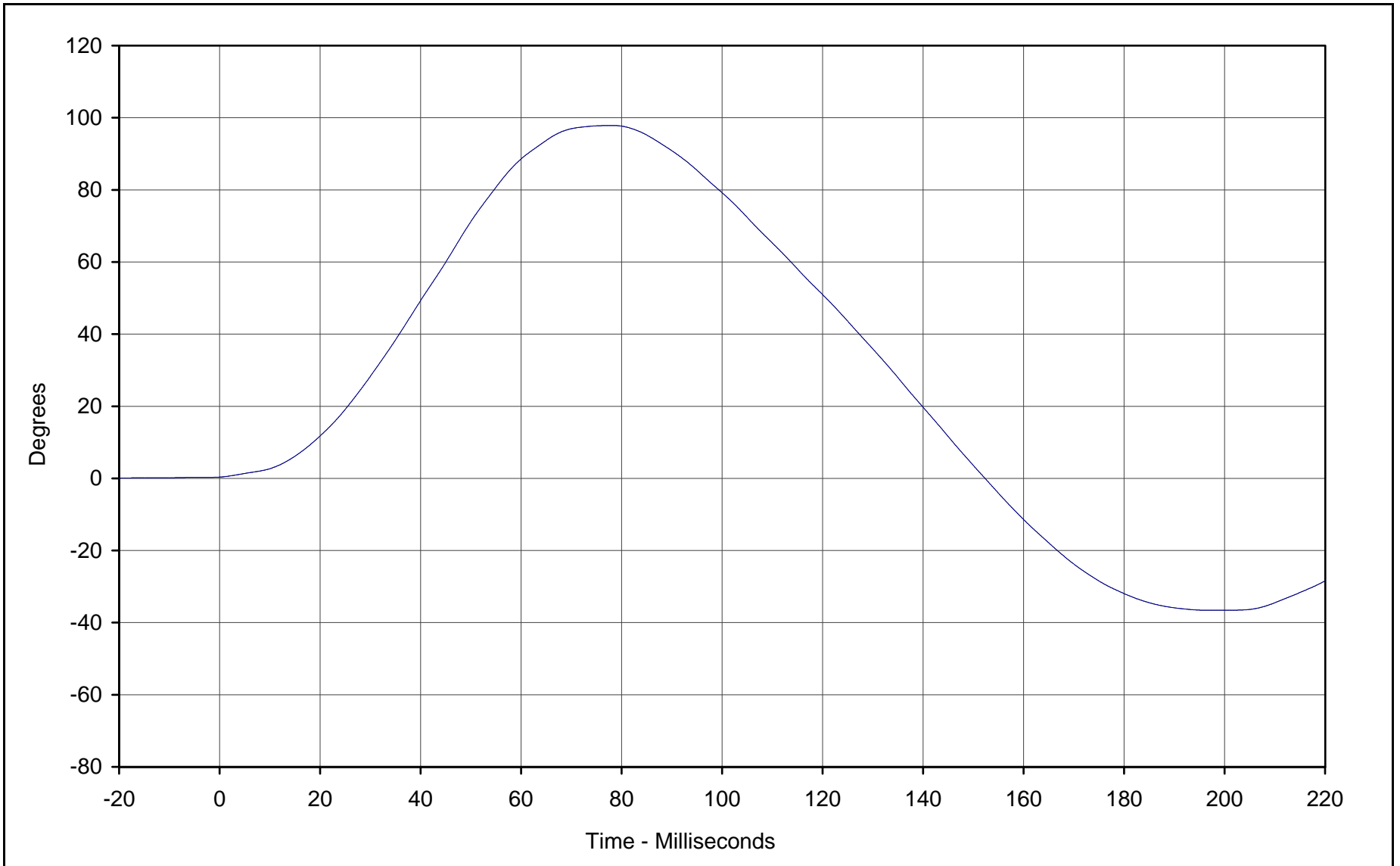

Curve Description: "D" Plane Rotation  
Maximum Value: 97.9 at 77.9 Milliseconds  
Minimum Value: -36.6 at 197.0 Milliseconds  
SAE Filter Class: 60  
Date of Test: 1/24/02  
ATD Serial No.: 035

Testing Program: Hybrid III Neck Extension Test (Male)  
Test Information: S/N of Part: N/A Test I.D.: NE01B

KARR21061-01



E-43

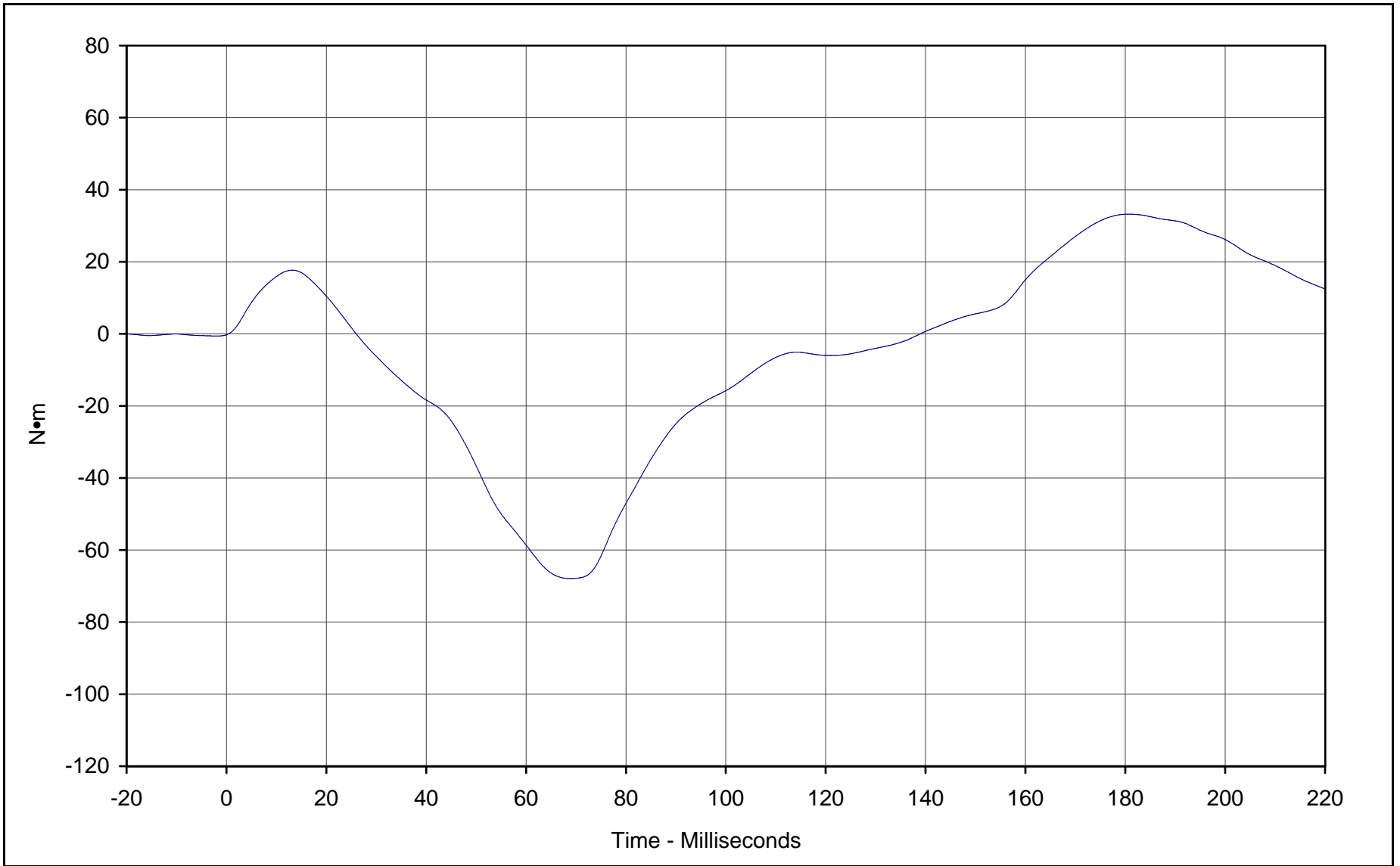

Curve Description: Moment About Occipital Condyles  
Maximum Value: 33.2 at 180.7 Milliseconds  
Minimum Value: -67.9 at 68.8 Milliseconds  
SAE Filter Class: 60  
Date of Test: 1/24/02  
ATD Serial No.: 035

Testing Program: Hybrid III Neck Extension Test (Male)  
Test Information: S/N of Part: N/A Test I.D.: NE01B



KARR21061-01



# Hybrid III Calibration Data Sheet

## 50<sup>TH</sup> Percentile Male

### External Measurements

ATD Serial No.: 035

Part Serial No.: N/A

Test I.D.: N/A

External Measurement Data				
Tested Parameter	Units	Specification	Result	Pass/Fail
Laboratory temperature	°C	20.4 to 22.1	20.9	Pass
Laboratory relative humidity	%	10 to 70	43	Pass
A - Total sitting height	mm	879 to 889	885	Pass
B - Shoulder pivot height	mm	505 to 521	515	Pass
C - "H" point height	mm	84 to 89	85	Pass
D - "H" point from seat back	mm	135 to 140	135	Pass
E - Shoulder pivot from back	mm	84 to 94	90	Pass
F - Thigh clearance	mm	140 to 155	145	Pass
G - Elbow back to wrist pivot	mm	290 to 305	300	Pass
H - Skull cap to back line	mm	41 to 46	45	Pass
I - Shoulder to elbow length	mm	330 to 345	335	Pass
J - Elbow rest height	mm	190 to 211	210	Pass
K - Buttock to knee length	mm	579 to 604	580	Pass
L - Popliteal length	mm	429 to 455	435	Pass
M - Knee pivot height	mm	485 to 500	495	Pass
N - Buttock popliteal length	mm	452 to 477	465	Pass
O - Chest depth	mm	213 to 229	225	Pass
P - Foot length	mm	251 to 267	265	Pass
V - Shoulder breadth	mm	422 to 437	430	Pass
W - Foot breadth	mm	91 to 107	100	Pass
Y - Chest circumference	mm	970 to 1001	990	Pass
Z - Waist circumference	mm	836 to 866	850	Pass
AA - Location for chest circumference	mm	429 to 434	430	Pass
BB - Location for waist circumference	mm	226 to 231	230	Pass
Overall Test Results				Pass

\_\_\_\_\_  
Laboratory Technician

January 26, 2002  
\_\_\_\_\_  
Test Date

**APPENDIX F**

**VEHICLE OWNER'S MANUAL**

**OCCUPANT RESTRAINT INSTRUCTIONS**

# Section 1 Seats and Restraint Systems

Here you'll find information about the seats in your vehicle and how to use your safety belts properly. You can also learn about some things you should *not* do with air bags and safety belts.

1-2	Seats and Seat Controls	1-36	Rear Safety Belt Comfort Guides for Children and Small Adults (4-Door Models)
1-10	Safety Belts: They're for Everyone	1-38	Center Rear Passenger Position (4-Door Models)
1-15	Here Are Questions Many People Ask About Safety Belts -- and the Answers	1-40	Children
1-16	How to Wear Safety Belts Properly	1-43	Restraint Systems for Children
1-16	Driver Position	1-55	Older Children
1-22	Safety Belt Use During Pregnancy	1-58	Safety Belt Extender
1-23	Right Front Passenger Position	1-58	Checking Your Restraint Systems
1-23	Air Bag System	1-59	Replacing Restraint System Parts After a Crash
1-31	Center Front Passenger Position (Four-Door Models with Front Bench Seat)		
1-32	Rear Seat Passengers		

1-1

## Manual Lumbar Support (If Equipped)

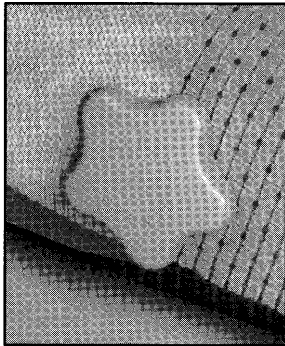

If your vehicle has this feature, there will be a knob on the outboard side of the driver's bucket seat.

Turn the knob counterclockwise to increase lumbar support and clockwise to decrease lumbar support.

## Power Seats (If Equipped)

If your vehicle has this feature, there will be a control pad on the outboard side of your seat.

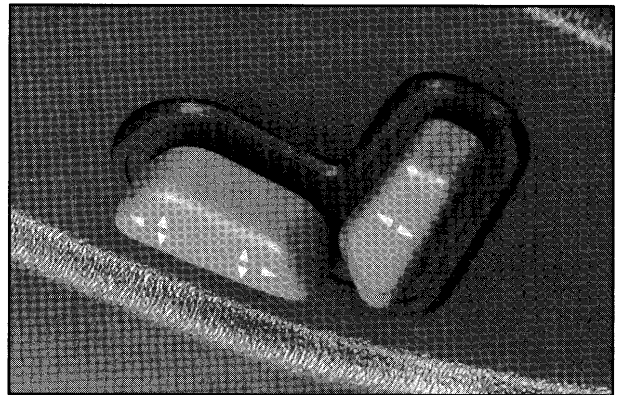

**Horizontal Control:** Raise or lower the front of the seat by raising or lowering the forward edge of the control.

Raise or lower the rear of the seat by raising or lowering the rear edge of the control. Move the seat forward or rearward by moving the whole control toward the front or the rear of the vehicle.

Moving the whole control up or down raises or lowers the whole seat.

**Vertical Control:** Move the reclining front seatback forward or rearward by moving the control toward the front or rear of the vehicle.

1-3

## Seats and Seat Controls

This section tells you about the seats -- how to adjust them, and fold them up and down.

### Manual Front Seat

#### CAUTION:

You can lose control of the vehicle if you try to adjust a manual driver's seat while the vehicle is moving. The sudden movement could startle and confuse you, or make you push a pedal when you don't want to. Adjust the driver's seat only when the vehicle is not moving.

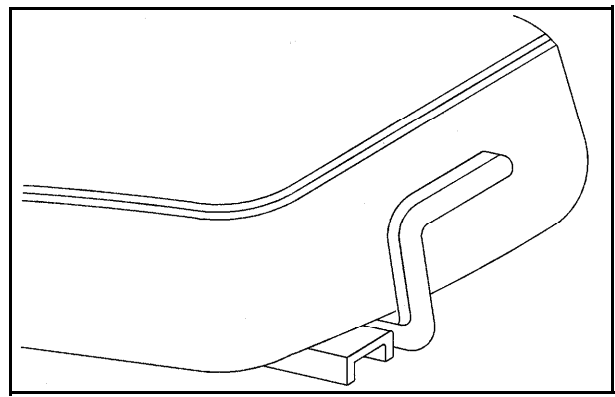

---

1-2

### Power Lumbar Control (If Equipped)

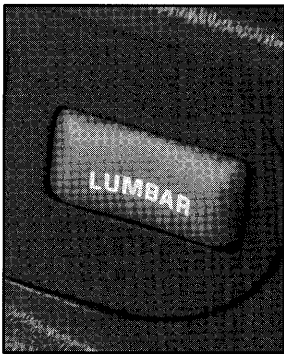

If your vehicle has this feature, it is located on the outboard side of the seat(s).

Press and hold the front of the control until you have the desired lumbar support. To decrease lumbar support, press and hold the rear of the control.

### Memory Seat (If Equipped)

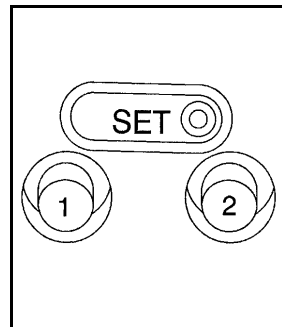

If your vehicle has this feature, the control located on the outboard side of the driver's seat looks like this.

Use this memory function to save your seat cushion and seatback settings by using the following procedure:

1. Adjust the driver's seat to a safe and comfortable driving position.
2. Press the SET button and then press and hold button 1 (for driver 1) for three seconds. A chime will sound to let you know that the position has been stored.

A second seating and mirror position can be programmed by repeating the procedure with a second driver and pressing button 2 for three seconds. Each time button 1 or 2 is pressed and released while the vehicle is in **PARK (P)**, the memory position will be recalled. Each time a memory button is pressed, a single chime will sound.

---

1-4

- To program your keyless entry transmitter, if equipped, press the UNLOCK button within five seconds of programming the memory button. You will hear a chime to confirm programming of the transmitter.

When your vehicle is in PARK (P) for an automatic transmission or the parking brake is engaged for a manual transmission, press and release the numbered memory button you just stored. The seat will move to the set position. You will hear one chime.

Pressing the UNLOCK button of a keyless entry transmitter will adjust the seat to the corresponding stored memory position. You will hear one chime.

Repeat Steps 1 and 2 to readjust the seat. The transmitter need not be reprogrammed unless it needs to correspond to the other numbered memory button.

If there is a third driver, use the seat adjuster switch to adjust the seat. Pressing any of the seat adjuster switches, the SET button or pressing the desired memory button twice will cause the seat to stop moving.

If you press the numbered button to adjust the seat and start the vehicle while the seat is still adjusting, adjustment will pause while the ignition is in START. Adjustment will resume after the ignition is in RUN.

## Heated Front Seats (If Equipped)

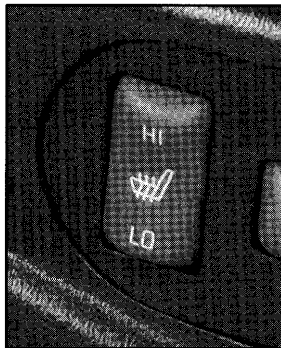

If your vehicle has this feature, the controls are located on the outboard side of the seats.

This feature will quickly heat the lower cushion and lower back of the driver's and front passenger's seats for added comfort.

Press the lower part of the switch to turn the heater on low. Press the upper part of the switch to turn the heater on high. Put the switch in the center position to turn the heater off.

The passenger's safety belt must be engaged for the heated seat feature to work on the passenger's seat.

### CAUTION:

**Sitting in a reclined position when your vehicle is in motion can be dangerous. Even if you buckle up, your safety belts can't do their job when you're reclined like this.**

**The shoulder belt can't do its job because it won't be against your body. Instead, it will be in front of you. In a crash you could go into it, receiving neck or other injuries.**

**The lap belt can't do its job either. In a crash the belt could go up over your abdomen. The belt forces would be there, not at your pelvic bones. This could cause serious internal injuries.**

**For proper protection when the vehicle is in motion, have the seatback upright. Then sit well back in the seat and wear your safety belt properly.**

## Head Restraints



Head restraints are fixed on some models and adjustable on others. Slide an adjustable head restraint up or down so that the top of the restraint is closest to the top of your head. This position reduces the chance of a neck injury in a crash.

## Reclining Front Seatbacks

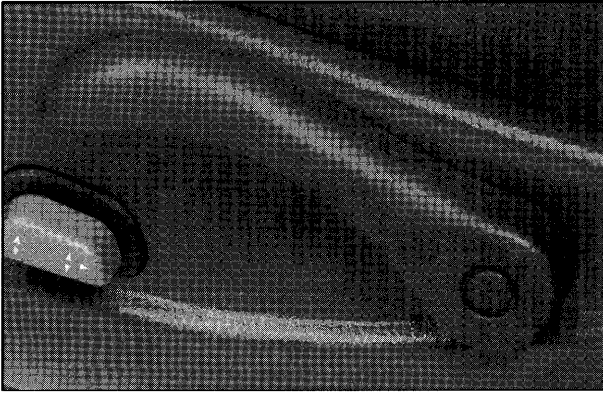

To adjust a manual seatback, lift the lever on the outboard side of the seat.

Release the lever to lock the seatback where you want it. Pull up on the lever and without pushing on the seatback the seat will go to an upright position.

If your vehicle is equipped with the vertical power seat control described earlier, it allows the seatback to recline also.



But don't have a seatback reclined if your vehicle is moving.

---

1-6

## Seatback Latches

The front seatbacks fold forward to let people get into the back seat or to access the storage area behind the seat.

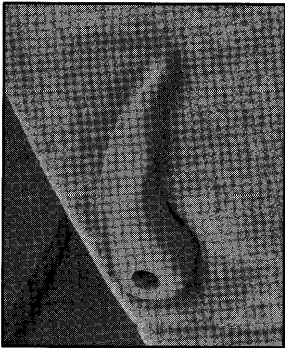

To fold a front seatback forward, move the lever located on the side of the seat rearward and pull the seatback forward.

To return the seatback to the upright position, push the seatback all the way back until the latch catches. If the seatback was reclined before being folded forward, it will return to the reclined position.

### CAUTION:

**If the seatback isn't locked, it could move forward in a sudden stop or crash. That could cause injury to the person sitting there. Always press rearward on the seatback to be sure it is locked.**

---

1-8

## Easy Entry Seat (2-Door Models)

The right front seat of your vehicle makes it easy to get in and out of the rear seat.

1. Tilt the right front seatback completely forward and the whole seat will slide forward.
2. Move the seatback to its original position after someone gets into the rear seat area. Then move the seat rearward until it locks.

### CAUTION:

**If an easy entry right front seat isn't locked, it can move. In a sudden stop or crash, the person sitting there could be injured. After you've used it, be sure to push rearward on an easy entry seat to be sure it is locked.**

Tilt the seatback completely forward and slide the whole seat forward again to get out of the rear seat.

## Rear Seats

Your vehicle has a folding rear seat which lets you fold the seatbacks down for more cargo space.

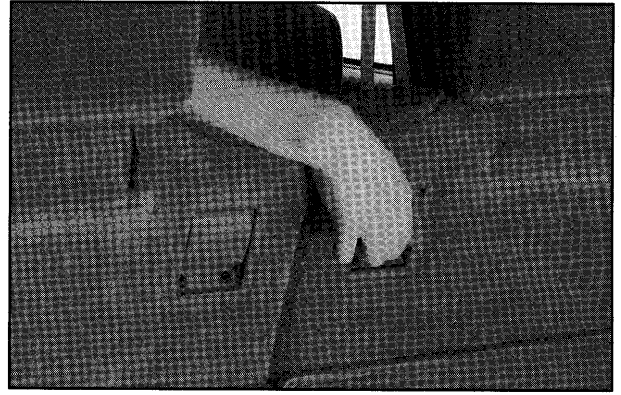

The rear seat release handles are located on the rear of the seatbacks. Push back on the seatbacks as you pull up on the handles. The head restraint will automatically fold out of the way when the seatback is folded down.

To raise the seatbacks, just lift up the seatbacks and push until they lock in the upright position. Push and pull on the seatbacks to check that the latches have locked in the upright position. If they haven't, see your dealer for service.

1-9

### CAUTION:

**It is extremely dangerous to ride in a cargo area, inside or outside of a vehicle. In a collision, people riding in these areas are more likely to be seriously injured or killed. Do not allow people to ride in any area of your vehicle that is not equipped with seats and safety belts. Be sure everyone in your vehicle is in a seat and using a safety belt properly.**



Your vehicle has a light that comes on as a reminder to buckle up. See "Safety Belt Reminder Light" in the Index.

In most states and Canadian provinces, the law says to wear safety belts. Here's why: *They work.*

You never know if you'll be in a crash. If you do have a crash, you don't know if it will be a bad one.

A few crashes are mild, and some crashes can be so serious that even buckled up a person wouldn't survive. But most crashes are in between. In many of them, people who buckle up can survive and sometimes walk away. Without belts they could have been badly hurt or killed.

After more than 30 years of safety belts in vehicles, the facts are clear. In most crashes buckling up does matter . . . a lot!

1-11

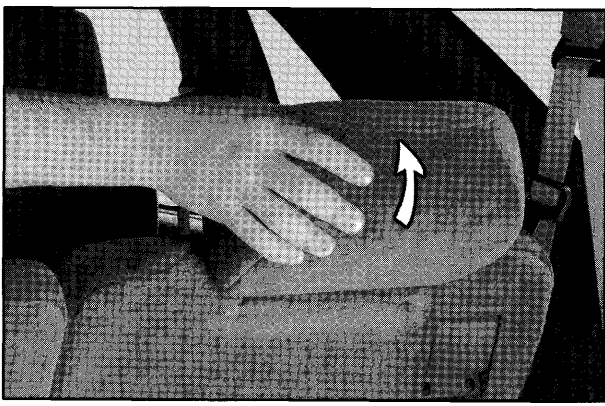

To return the head restraints to the upright position, reach behind the seats and pull the head restraint up until it locks into position.

On two-door models with an inside mounted spare tire, the driver's side rear seat head restraint must be lifted and held upright as the seatback is raised. Otherwise, the head restraint will hit the spare tire and prevent the seatback from properly latching.

Push and pull on the head restraints to check that they have locked in the upright position. If they haven't, see your dealer for service.

1-10

---

## Why Safety Belts Work

When you ride in or on anything, you go as fast as it goes.

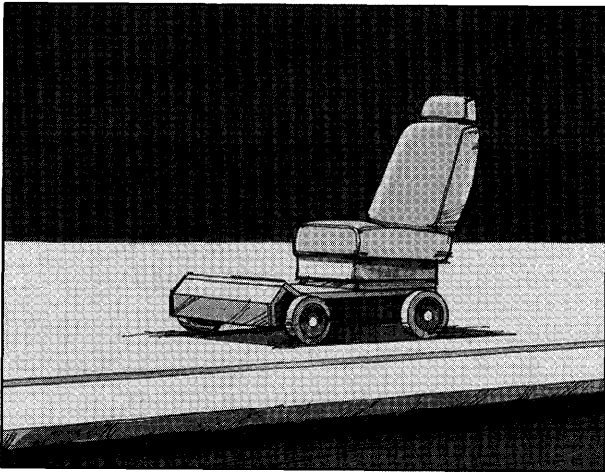

Take the simplest vehicle. Suppose it's just a seat on wheels.

1-12

---

## Safety Belts: They're for Everyone

This part of the manual tells you how to use safety belts properly. It also tells you some things you should not do with safety belts.

And it explains the air bag system.

### CAUTION:

**Don't let anyone ride where he or she can't wear a safety belt properly. If you are in a crash and you're not wearing a safety belt, your injuries can be much worse. You can hit things inside the vehicle or be ejected from it. You can be seriously injured or killed. In the same crash, you might not be if you are buckled up. Always fasten your safety belt, and check that your passengers' belts are fastened properly too.**

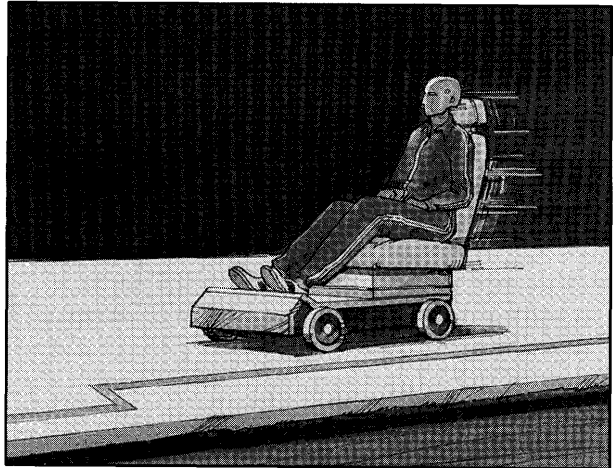

Put someone on it.

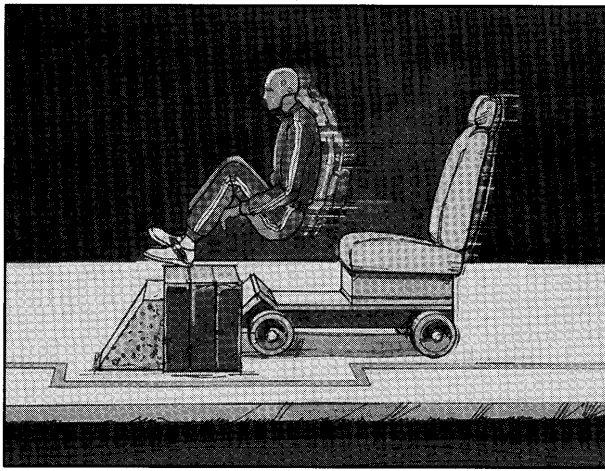

Get it up to speed. Then stop the vehicle. The rider doesn't stop.

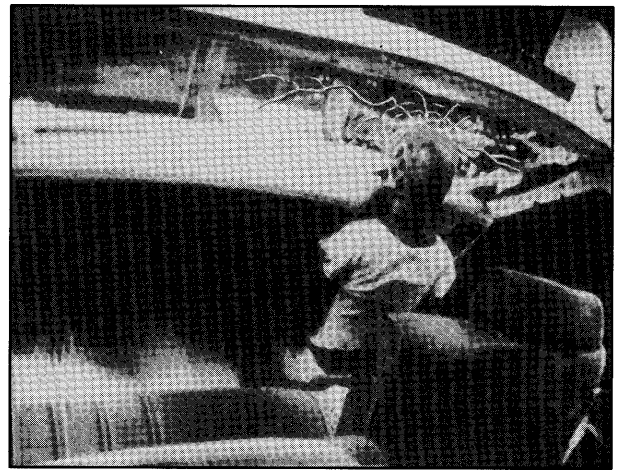

The person keeps going until stopped by something. In a real vehicle, it could be the windshield . . .

## Here Are Questions Many People Ask About Safety Belts -- and the Answers

**Q:** Won't I be trapped in the vehicle after an accident if I'm wearing a safety belt?

**A:** You *could* be -- whether you're wearing a safety belt or not. But you can unbuckle a safety belt, even if you're upside down. And your chance of being conscious during and after an accident, so you *can* unbuckle and get out, is *much* greater if you are belted.

**Q:** If my vehicle has air bags, why should I have to wear safety belts?

**A:** Air bags are in many vehicles today and will be in most of them in the future. But they are supplemental systems only; so they work *with* safety belts -- not instead of them. Every air bag system ever offered for sale has required the use of safety belts. Even if you're in a vehicle that has air bags, you still have to buckle up to get the most protection. That's true not only in frontal collisions, but especially in side and other collisions.

**Q:** If I'm a good driver, and I never drive far from home, why should I wear safety belts?

**A:** You may be an excellent driver, but if you're in an accident -- even one that isn't your fault -- you and your passengers can be hurt. Being a good driver doesn't protect you from things beyond your control, such as bad drivers.

Most accidents occur within 25 miles (40 km) of home. And the greatest number of serious injuries and deaths occur at speeds of less than 40 mph (65 km/h).

Safety belts are for everyone.

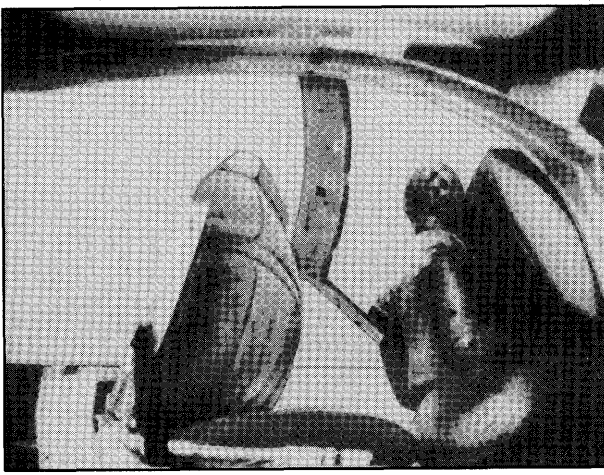

or the instrument panel . . .

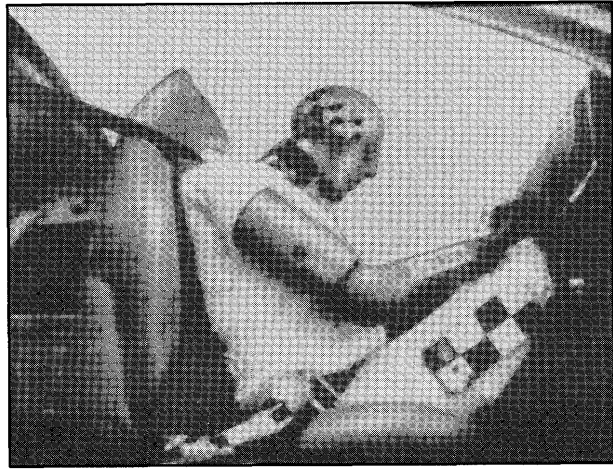

or the safety belts!

With safety belts, you slow down as the vehicle does. You get more time to stop. You stop over more distance, and your strongest bones take the forces. That's why safety belts make such good sense.

---

**I-14**

---

## How to Wear Safety Belts Properly

### Adults

This part is only for people of adult size.

Be aware that there are special things to know about safety belts and children. And there are different rules for smaller children and babies. If a child will be riding in your vehicle, see the part of this manual called "Children." Follow those rules for everyone's protection.

First, you'll want to know which restraint systems your vehicle has.

We'll start with the driver position.

### Driver Position

This part describes the driver's restraint system.

#### Lap-Shoulder Belt

The driver has a lap-shoulder belt. Here's how to wear it properly.

1. Close and lock the door.
2. Adjust the seat so you can sit up straight. To see how, see "Seats" in the Index.



3. Pick up the latch plate and pull the belt across you. Don't let it get twisted.

The shoulder belt may lock if you pull the belt across you very quickly. If this happens, let the belt go back slightly to unlock it. Then pull the belt across you more slowly.

---

**I-16**

---

4. Push the latch plate into the buckle until it clicks.

Pull up on the latch plate to make sure it is secure. If the belt isn't long enough, see "Safety Belt Extender" at the end of this section.

Make sure the release button on the buckle is positioned so you would be able to unbuckle the safety belt quickly if you ever had to.

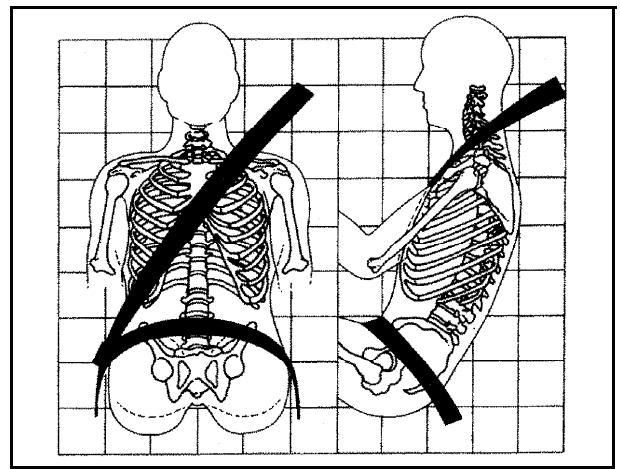
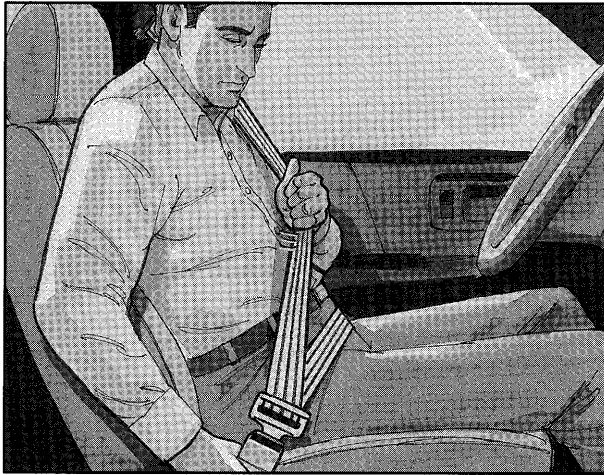

5. To make the lap part tight, pull down on the buckle end of the belt as you pull up on the shoulder belt.

The lap part of the belt should be worn low and snug on the hips, just touching the thighs. In a crash, this applies force to the strong pelvic bones. And you'd be less likely to slide under the lap belt. If you slid under it, the belt would apply force at your abdomen. This could cause serious or even fatal injuries. The shoulder belt should go over the shoulder and across the chest. These parts of the body are best able to take belt restraining forces.

The safety belt locks if there's a sudden stop or crash, or if you pull the belt very quickly out of the retractor.

**Q:** What's wrong with this?

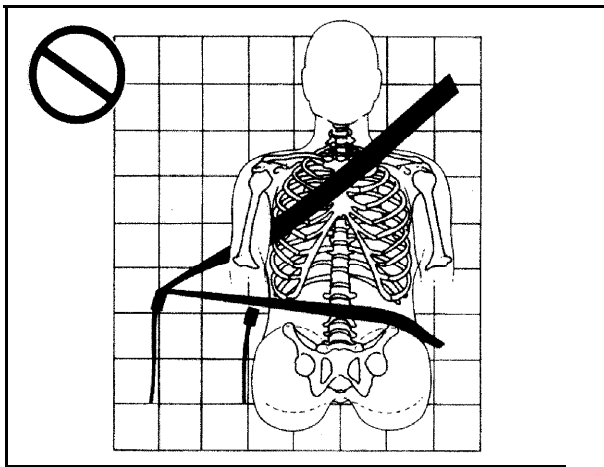

**⚠ CAUTION:**

**You can be seriously injured if your belt is buckled in the wrong place like this. In a crash, the belt would go up over your abdomen. The belt forces would be there, not at the pelvic bones. This could cause serious internal injuries. Always buckle your belt into the buckle nearest you.**

**A:** The belt is buckled in the wrong place.

**Q:** What's wrong with this?

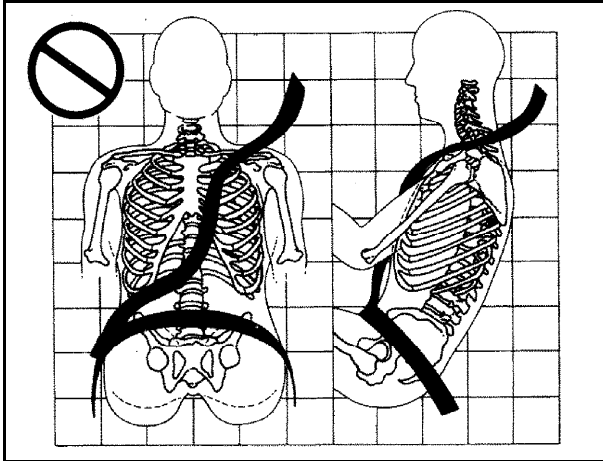

**A:** The shoulder belt is too loose. It won't give nearly as much protection this way.

1-18

**Q:** What's wrong with this?

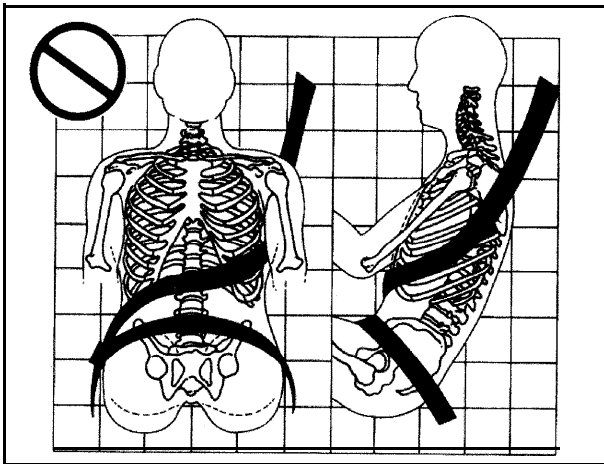

**A:** The shoulder belt is worn under the arm. It should be worn over the shoulder at all times.

1-20

**! CAUTION:**

You can be seriously hurt if your shoulder belt is too loose. In a crash, you would move forward too much, which could increase injury. The shoulder belt should fit against your body.

**! CAUTION:**

You can be seriously injured if you wear the shoulder belt under your arm. In a crash, your body would move too far forward, which would increase the chance of head and neck injury. Also, the belt would apply too much force to the ribs, which aren't as strong as shoulder bones. You could also severely injure internal organs like your liver or spleen.

**Q:** What's wrong with this?

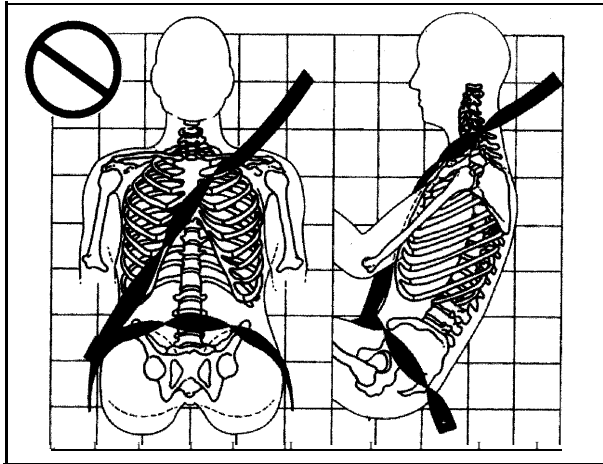

**A:** The belt is twisted across the body.

**⚠ CAUTION:**

You can be seriously injured by a twisted belt. In a crash, you wouldn't have the full width of the belt to spread impact forces. If a belt is twisted, make it straight so it can work properly, or ask your dealer to fix it.

The best way to protect the fetus is to protect the mother. When a safety belt is worn properly, it's more likely that the fetus won't be hurt in a crash. For pregnant women, as for anyone, the key to making safety belts effective is wearing them properly.

### Right Front Passenger Position

To learn how to wear the right front passenger's safety belt properly, see "Driver Position" earlier in this section.

The right front passenger's safety belt works the same way as the driver's safety belt -- except for one thing. If you ever pull the shoulder portion of the belt out all the way, you will engage the child restraint locking feature. If this happens, just let the belt go back all the way and start again.

### Air Bag System

This part explains the air bag system.

Your vehicle has air bags -- one air bag for the driver and another air bag for the right front passenger.

Frontal air bags are designed to help reduce the risk of injury from the force of an inflating air bag. But these air bags must inflate very quickly to do their job and comply with federal regulations.

Here are the most important things to know about the air bag system:

**⚠ CAUTION:**

You can be severely injured or killed in a crash if you aren't wearing your safety belt -- even if you have air bags. Wearing your safety belt during a crash helps reduce your chance of hitting things inside the vehicle or being ejected from it. Air bags are designed to work with safety belts, but don't replace them. Air bags are designed to work only in moderate to severe crashes where the front of your vehicle hits something. They aren't designed to inflate at all in rollover, rear or low-speed frontal crashes, or in many side crashes. And, for some unrestrained occupants, air bags may provide less protection in frontal crashes than more forceful air bags have provided in the past. Everyone in your vehicle should wear a safety belt properly -- whether or not there's an air bag for that person.



To unclasp the belt, just push the button on the buckle. The belt should go back out of the way.

Before you close the door, be sure the belt is out of the way. If you slam the door on it, you can damage both the belt and your vehicle.

## Safety Belt Use During Pregnancy

Safety belts work for everyone, including pregnant women. Like all occupants, they are more likely to be seriously injured if they don't wear safety belts.

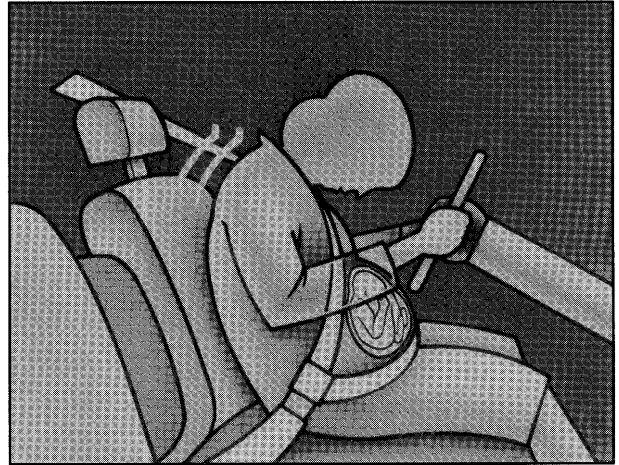

A pregnant woman should wear a lap-shoulder belt, and the lap portion should be worn as low as possible, below the rounding, throughout the pregnancy.

1-22

### CAUTION:

**Air bags inflate with great force, faster than the blink of an eye. If you're too close to an inflating air bag, as you would be if you were leaning forward, it could seriously injure you. Safety belts help keep you in position before and during a crash. Always wear your safety belt, even with air bags. The driver should sit as far back as possible while still maintaining control of the vehicle.**

### CAUTION:

**Anyone who is up against, or very close to, any air bag when it inflates can be seriously injured or killed. Air bags plus lap-shoulder belts offer the best protection for adults, but not for young children and infants. Neither the vehicle's safety belt system nor its air bag system is designed for them. Young children and infants need the protection that a child restraint system can provide. Always secure children properly in your vehicle. To read how, see the part of this manual called "Children."**

1-24

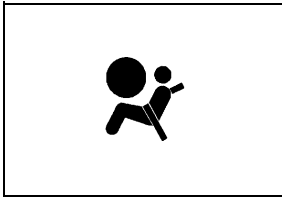

There is an air bag readiness light on the instrument panel, which shows the air bag symbol.

The system checks the air bag electrical system for malfunctions. The light tells you if there is an electrical problem. See “Air Bag Readiness Light” in the Index for more information.

## How the Air Bag System Works

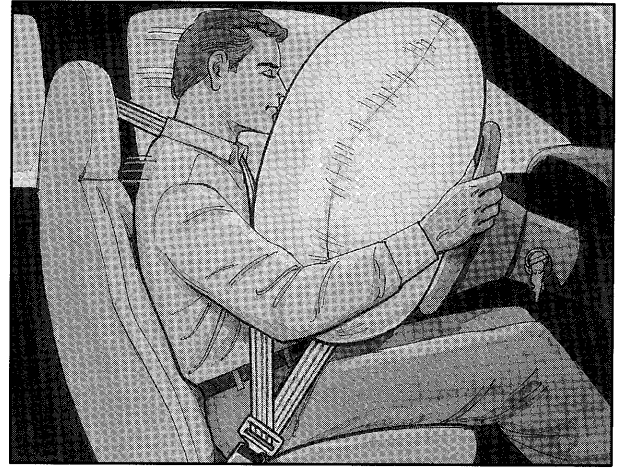

### Where are the air bags?

The driver's air bag is in the middle of the steering wheel.

### When should an air bag inflate?

An air bag is designed to inflate in a moderate to severe frontal or near-frontal crash. The air bag will inflate only if the impact speed is above the system's designed “threshold level.” If your vehicle goes straight into a wall that doesn't move or deform, the threshold level is about 9 to 16 mph (14 to 26 km/h). The threshold level can vary, however, with specific vehicle design, so that it can be somewhat above or below this range. If your vehicle strikes something that will move or deform, such as a parked car, the threshold level will be higher. The air bag is not designed to inflate in rollovers, rear impacts, or in many side impacts because inflation would not help the occupant.

In any particular crash, no one can say whether an air bag should have inflated simply because of the damage to a vehicle or because of what the repair costs were. Inflation is determined by the angle of the impact and how quickly the vehicle slows down in frontal or near-frontal impacts.

The air bag system is designed to work properly under a wide range of conditions, including off-road usage. Observe safe driving speeds, especially on rough terrain. As always, wear your safety belt. See “Off-Road Driving” in the Index for more tips on off-road driving.

### What makes an air bag inflate?

In an impact of sufficient severity, the air bag sensing system detects that the vehicle is in a crash. The sensing system triggers a release of gas from the inflator, which inflates the air bag. The inflator, air bag and related hardware are all part of the air bag modules inside the steering wheel and in the instrument panel in front of the right front passenger.

### How does an air bag restrain?

In moderate to severe frontal or near-frontal collisions, even belted occupants can contact the steering wheel or the instrument panel. Air bags supplement the protection provided by safety belts. Air bags distribute the force of the impact more evenly over the occupant's upper body, stopping the occupant more gradually. But air bags would not help you in many types of collisions, including rollovers, rear impacts and many side impacts, primarily because an occupant's motion is not toward those air bags. Air bags should never be regarded as anything more than a supplement to safety belts, and then only in moderate to severe frontal or near-frontal collisions.

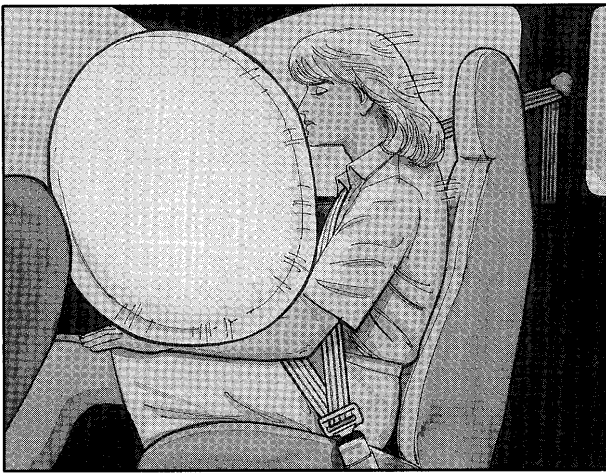

The right front passenger's air bag is in the instrument panel on the passenger's side.

**⚠ CAUTION:**

If something is between an occupant and an air bag, the bag might not inflate properly or it might force the object into that person causing severe injury or even death. The path of an inflating air bag must be kept clear. Don't put anything between an occupant and an air bag, and don't attach or put anything on the steering wheel hub or on or near any other air bag covering.

1-26

**What will you see after an air bag inflates?**

After an air bag inflates, it quickly deflates, so quickly that some people may not even realize the air bag inflated. Some components of the air bag module -- the steering wheel hub for the driver's air bag, or the instrument panel for the right front passenger's bag -- will be hot for a short time. The parts of the bag that come into contact with you may be warm, but not too hot to touch. There will be some smoke and dust coming from vents in the deflated air bags. Air bag inflation doesn't prevent the driver from seeing or from being able to steer the vehicle, nor does it stop people from leaving the vehicle.

**⚠ CAUTION:**

**When an air bag inflates, there is dust in the air. This dust could cause breathing problems for people with a history of asthma or other breathing trouble. To avoid this, everyone in the vehicle should get out as soon as it is safe to do so. If you have breathing problems but can't get out of the vehicle after an air bag inflates, then get fresh air by opening a window or door.**

- Air bags are designed to inflate only once. After they inflate, you'll need some new parts for your air bag system. If you don't get them, the air bag system won't be there to help protect you in another crash. A new system will include air bag modules and possibly other parts. The service manual for your vehicle covers the need to replace other parts.
- Your vehicle is equipped with a diagnostic module, which records information about the air bag system. The module records information about the readiness of the system, when the system commands air bag inflation and driver's safety belt usage at deployment.
- Let only qualified technicians work on your air bag system. Improper service can mean that your air bag system won't work properly. See your dealer for service.

1-28

**NOTICE:**

If you damage the covering for the driver's or the right front passenger's air bag, the bag may not work properly. You may have to replace the air bag module in the steering wheel or both the air bag module and the instrument panel for the right front passenger's air bag. Do not open or break the air bag coverings.

**Servicing Your Air Bag-Equipped Vehicle**

Air bags affect how your vehicle should be serviced. There are parts of the air bag system in several places around your vehicle. You don't want the system to inflate while someone is working on your vehicle. Your dealer and the service manual have information about servicing your vehicle and the air bag system. To purchase a service manual, see "Service and Owner Publications" in the Index.

**CAUTION:**

For up to 10 minutes after the ignition key is turned off and the battery is disconnected, an air bag can still inflate during improper service. You can be injured if you are close to an air bag when it inflates. Avoid wires wrapped with yellow tape or yellow connectors. They are probably part of the air bag system. Be sure to follow proper service procedures, and make sure the person performing work for you is qualified to do so.

The air bag system does not need regular maintenance.

## Adding Equipment to Your Air Bag-Equipped Vehicle

**If I add a push bumper or a bicycle rack to the front of my vehicle, will it keep the air bags from working properly?**

As long as the push bumper or bicycle rack is attached to your vehicle so that the vehicle's basic structure isn't changed, it's not likely to keep the air bags from working properly in a crash.

**Q:** Is there anything I might add to the front of the vehicle that could keep the air bags from working properly?

**A:** Yes. If you add things that change your vehicle's frame, bumper system, front end sheet metal or height, they may keep the air bag system from working properly. Also, the air bag system may not work properly if you relocate any of the air bag sensors. If you have any questions about this, you should contact Customer Assistance before you modify your vehicle. The phone numbers and addresses for Customer Assistance are in Step Two of the Customer Satisfaction Procedure in this manual. See "Customer Satisfaction Procedure" in the Index.

**APPENDIX G**

**NINE ACCELEROMETER**

**HEAD ARRAY DATA**

G-1

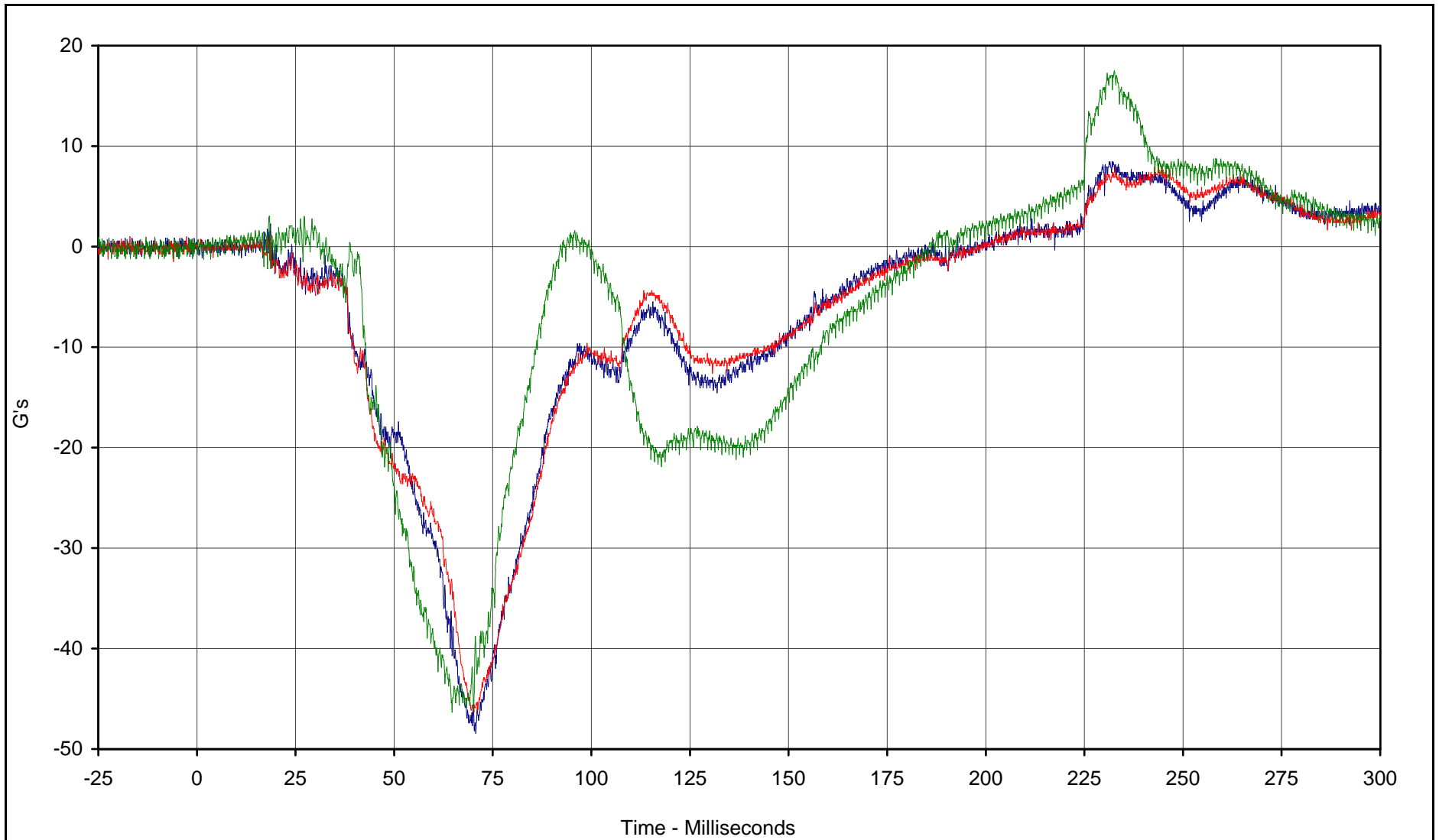

Curve Description	CURNO	Type	Units	Max	Time	Min	Time	SAE Class
Driver Head Primary X	138	FIL	G's	8.4	231.3	-48.4	70.7	1000
Driver Yarm-X	142	FIL	G's	7.9	232.8	-46.4	70.2	1000
Driver Zarm-X	145	FIL	G's	17.5	232.6	-46.3	64.7	1000



Test Vehicle: 2002 Honda CR-V LX 4WD SUV

Test Date: 1/29/02

Test Program: 2002 NHTSA 35mph NCAP

NHTSA No.: HO5300

KAR21061-01

G-2

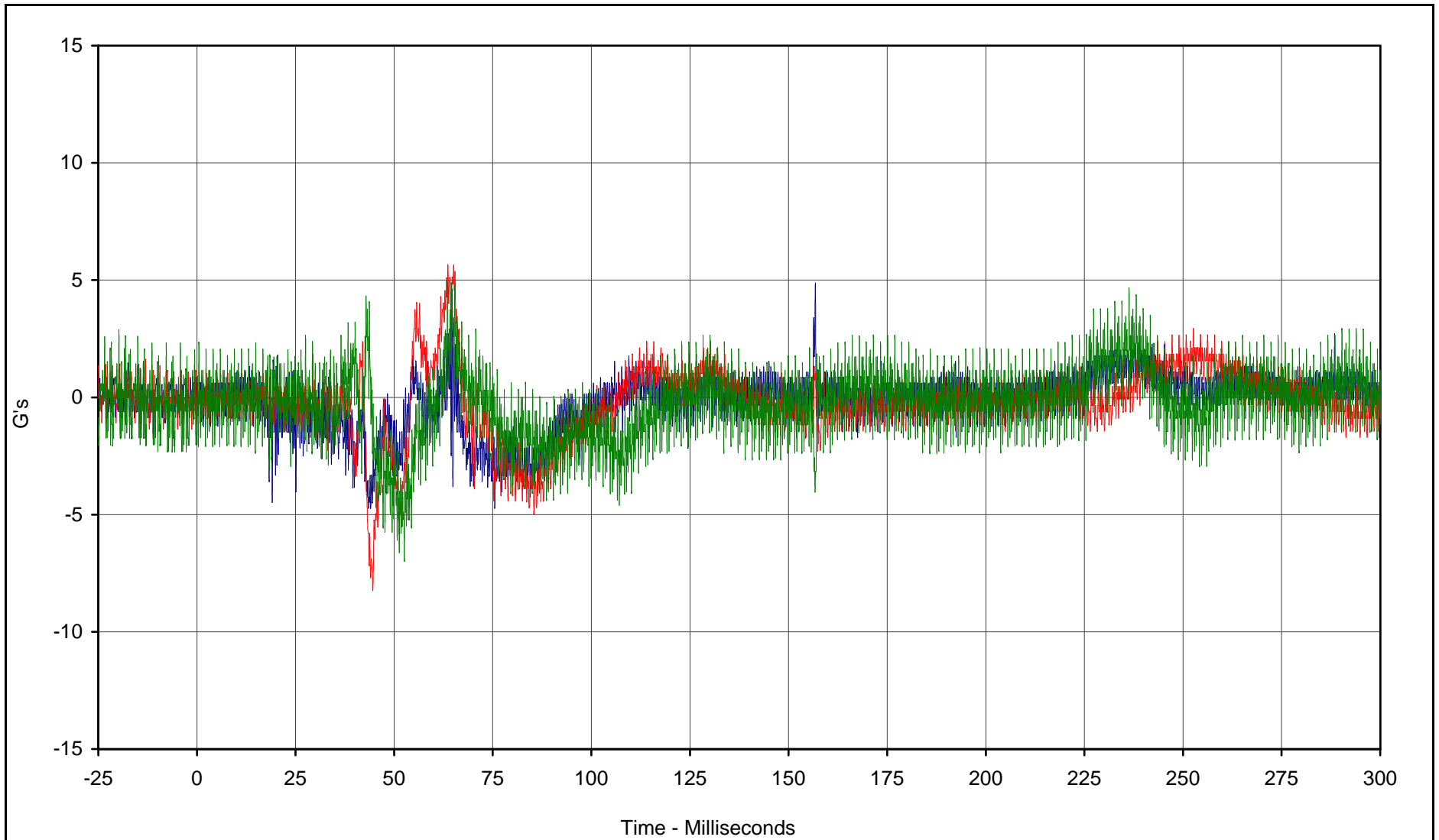

Curve Description	CURNO	Type	Units	Max	Time	Min	Time	SAE Class
Driver Head Primary Y	139	FIL	G's	4.8	156.8	-4.7	43.5	1000
Driver Xarm-Y	144	FIL	G's	5.6	63.6	-8.2	44.6	1000
Driver Zarm-Y	146	FIL	G's	4.9	63.5	-6.9	52.6	1000



Test Vehicle: 2002 Honda CR-V LX 4WD SUV

Test Date: 1/29/02

Test Program: 2002 NHTSA 35mph NCAP

NHTSA No.: HO5300

KAR21061-01

G-3

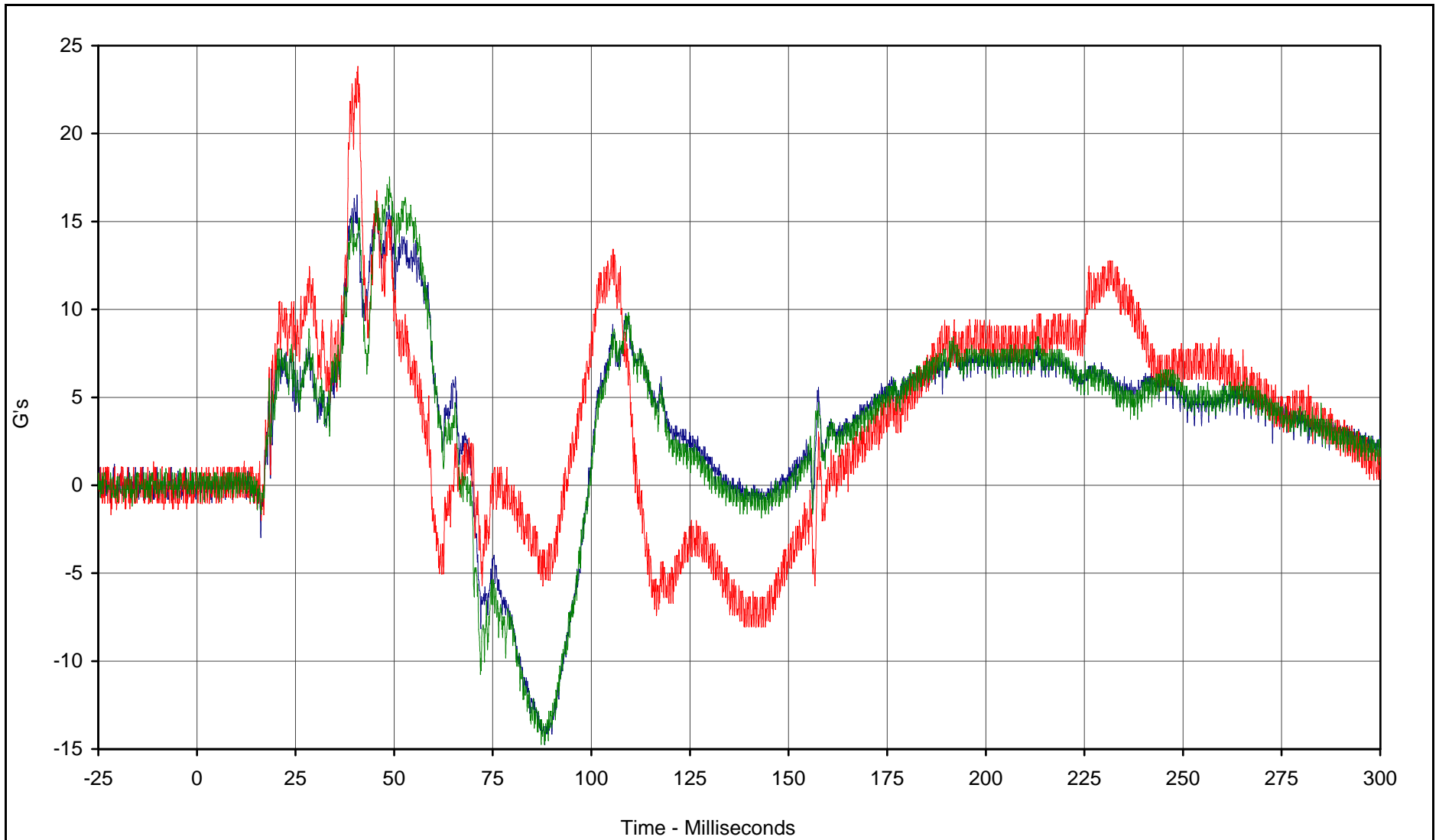

Curve Description	CURNO	Type	Units	Max	Time	Min	Time	SAE Class
Driver Head Primary Z	140	FIL	G's	16.5	40.6	-14.7	88.2	1000
Driver Xarm-Z	143	FIL	G's	23.8	40.8	-8.0	138.7	1000
Driver Yarm-Z	141	FIL	G's	17.5	48.8	-14.7	87.3	1000



Test Vehicle: 2002 Honda CR-V LX 4WD SUV  
 Test Program: 2002 NHTSA 35mph NCAP

Test Date: 1/29/02  
 NHTSA No.: HO5300

KAR21061-01

G-4

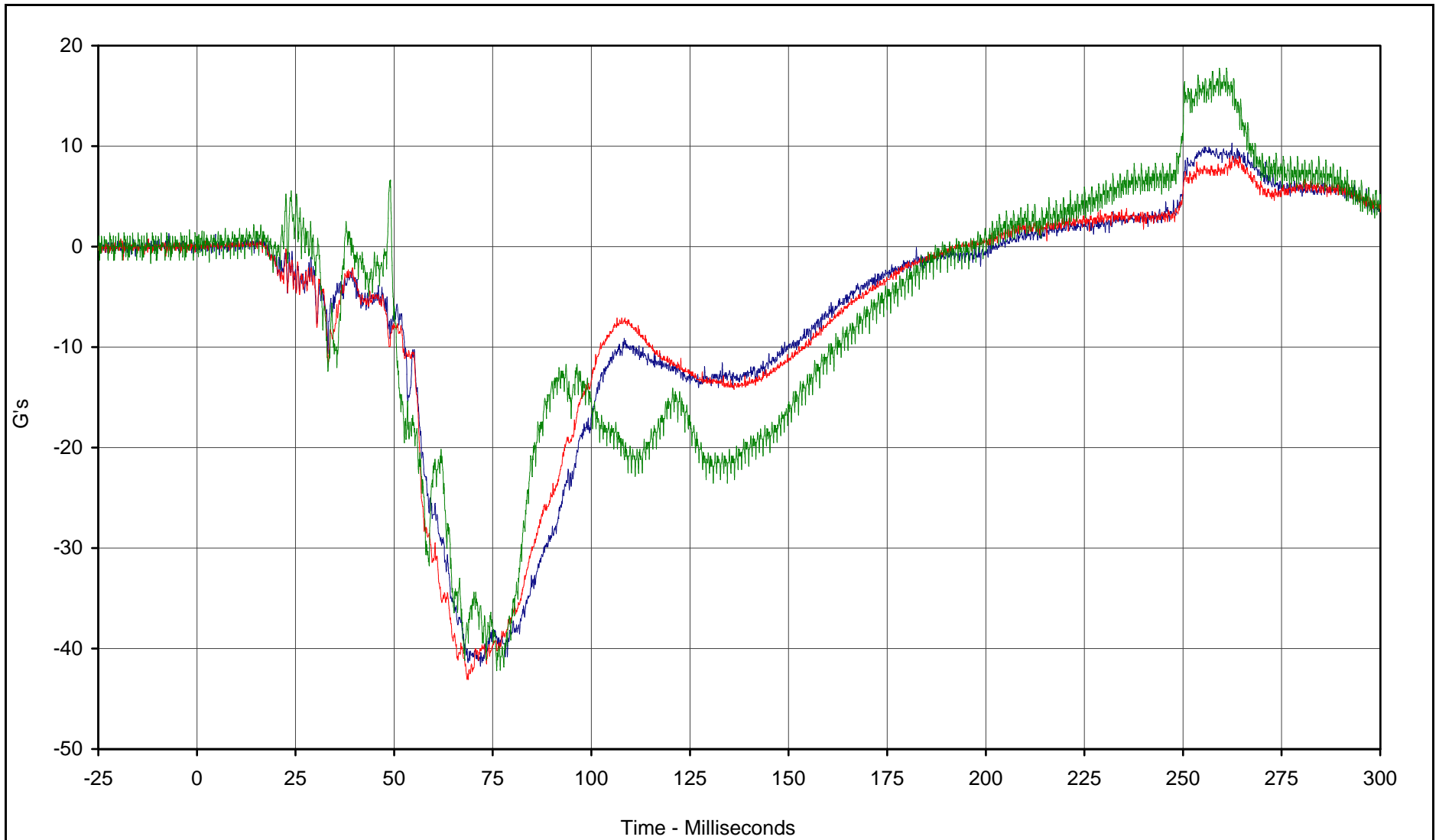

Curve Description	CURNO	Type	Units	Max	Time	Min	Time	SAE Class
Passenger Head Primary X	147	FIL	G's	10.3	262.4	-41.8	71.9	1000
Passenger Yarm-X	151	FIL	G's	9.0	262.5	-43.1	68.5	1000
Passenger Zarm-X	154	FIL	G's	17.7	259.2	-42.2	76.0	1000



Test Vehicle: 2002 Honda CR-V LX 4WD SUV

Test Date: 1/29/02

Test Program: 2002 NHTSA 35mph NCAP

NHTSA No.: HO5300

KAR21061-01

G-5

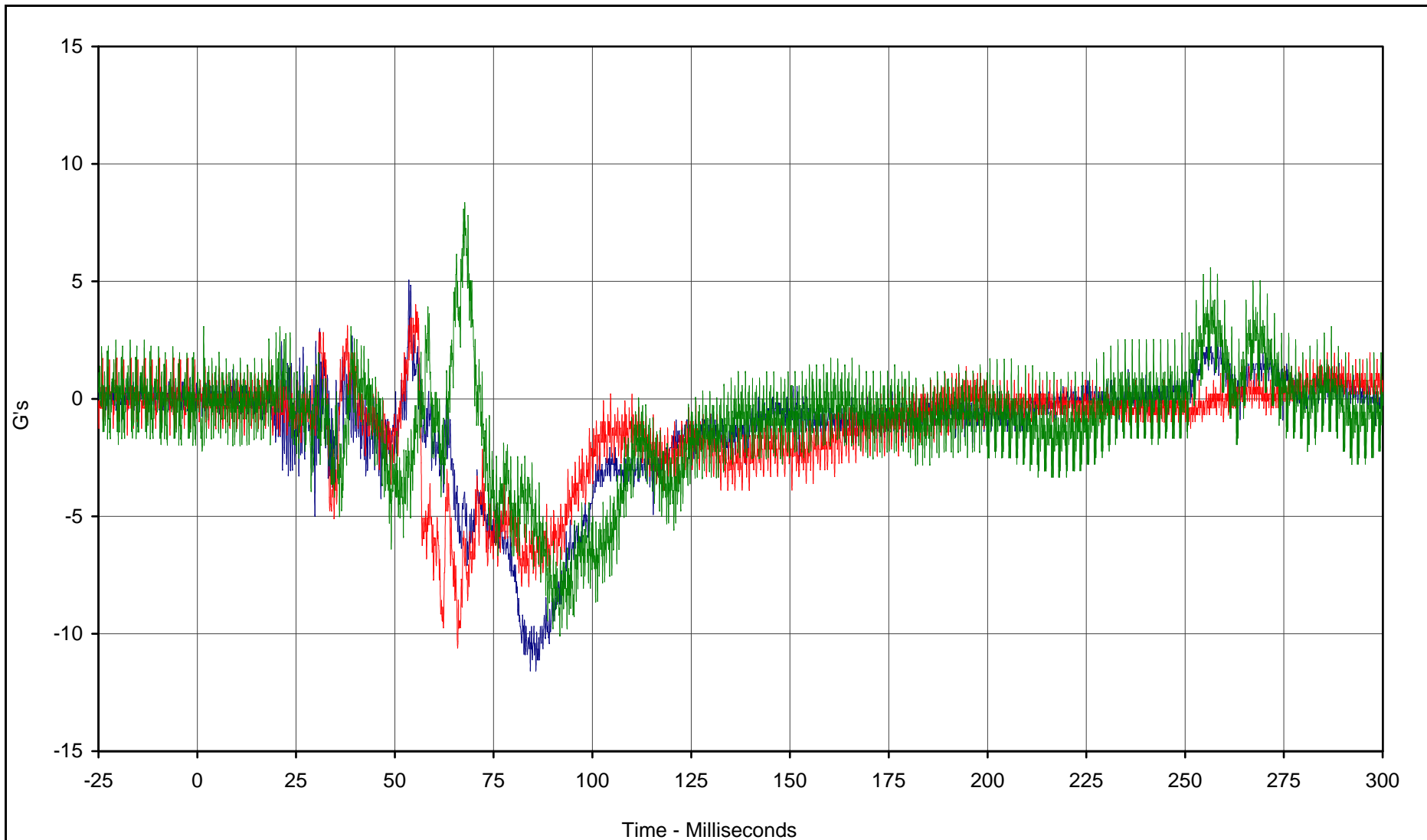

Curve Description	CURNO	Type	Units	Max	Time	Min	Time	SAE Class
Passenger Head Primary Y	148	FIL	G's	5.1	53.5	-11.6	84.3	1000
Passenger Xarm-Y	153	FIL	G's	4.0	55.3	-10.6	65.9	1000
Passenger Zarm-Y	155	FIL	G's	8.4	67.7	-10.0	91.8	1000



Test Vehicle: 2002 Honda CR-V LX 4WD SUV

Test Date: 1/29/02

Test Program: 2002 NHTSA 35mph NCAP

NHTSA No.: HO5300

KAR21061-01

G-6

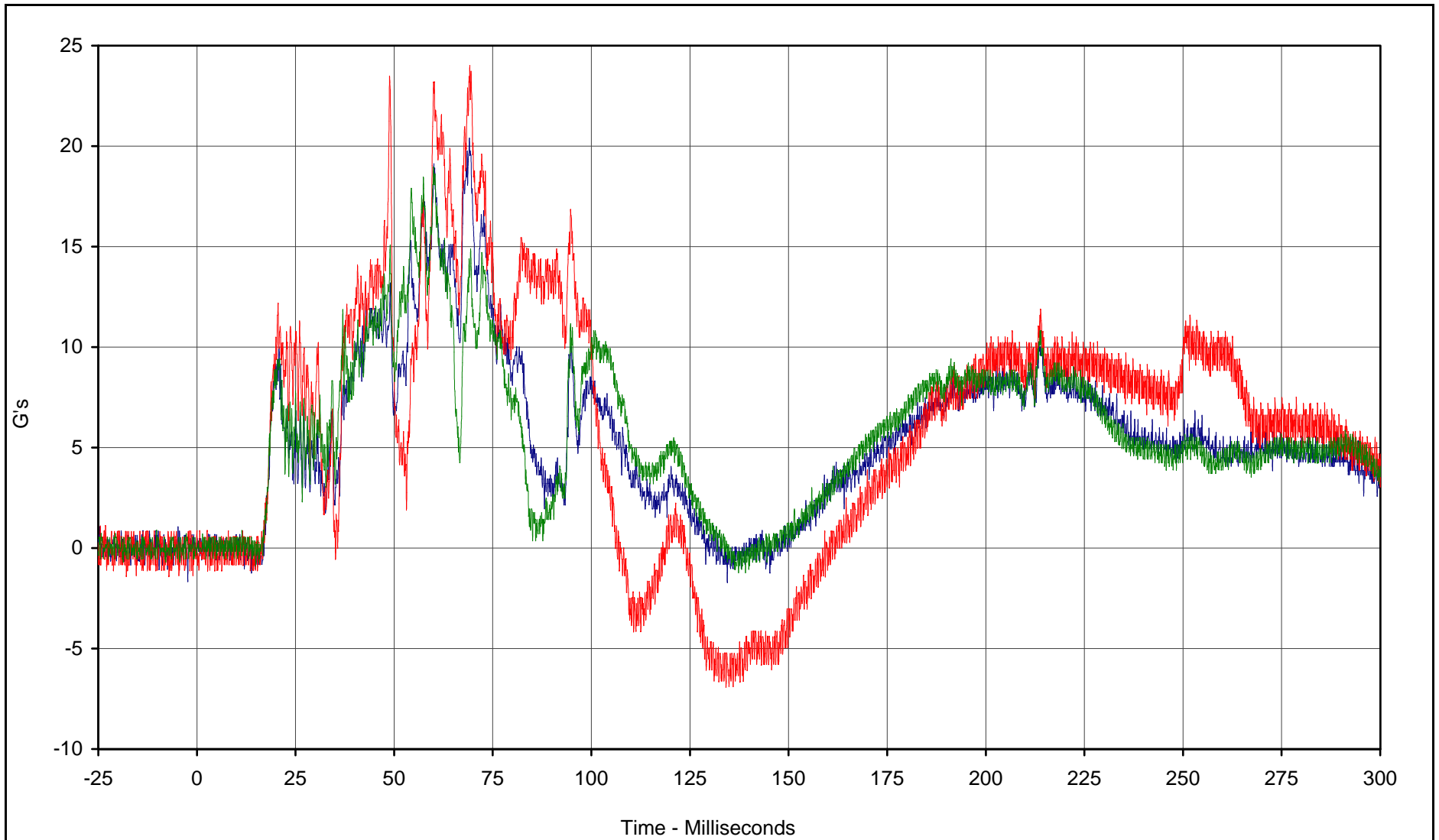

Curve Description	CURNO	Type	Units	Max	Time	Min	Time	SAE Class
Passenger Head Primary Z	149	FIL	G's	20.4	69.1	-1.7	134.5	1000
Passenger Xarm-Z	152	FIL	G's	24.0	69.2	-6.9	134.1	1000
Passenger Yarm-Z	150	FIL	G's	19.0	60.0	-1.2	137.3	1000



Test Vehicle: 2002 Honda CR-V LX 4WD SUV

Test Date: 1/29/02

Test Program: 2002 NHTSA 35mph NCAP

NHTSA No.: HO5300

KAR21061-01