

Report Number: NCAP-TRC-01-003

New Car Assessment Program (NCAP)

Frontal Barrier Impact Test

Nissan Motor Co.

2001 Nissan Maxima 4-door Sedan

NHTSA Number: NI0002

TRC Inc. Test Number: 010618

Prepared By:

Transportation Research Center Inc.

10820 State Route 347

East Liberty, OH 43319



Test Date: June 18, 2001

Report Date: July 11, 2001

Final Report

Prepared For:

U. S. Department of Transportation

National Highway Traffic Safety Administration

Safety Performance Standards

Office of Crashworthiness Standards

Mail Code: NPS-10

400 Seventh Street, S.W., Room 5313

Washington, DC 20590

1. Report No. NCAP-TRC-01-003	2. Government Accession No.	3. Recipient's Catalog No.			
4. Title and Subtitle Final Report of New Car Assessment Program (NCAP)		5. Report Date July 11, 2001			
Frontal Barrier Impact Test of a 2001 Nissan Maxima 4-door sedan, NHTSA No. NI0002		6. Performing Organization Code TRC Inc.			
7. Author(s) Virginia L. Watters, Project Manager		8. Performing Organization Report No. NCAP-TRC-01-003			
9. Performing Organization Name and Address Transportation Research Center Inc.		10. Work Unit No. (TRAIS)			
10820 State Route 347 East Liberty, OH 43319-0367		11. Contract or Grant No. N/A			
12. Sponsoring Agency Name and Address U. S. Department of Transportation National Highway Traffic Safety Administration		13. Type of Report and Period Covered Final Report June - July 2001			
Office of Crashworthiness Standards Mail Code NPS-10 400 Seventh Street, S. W., Room 5313, Washington, DC 20590		14. Sponsoring Agency Code NPS-10			
15. Supplemental Notes					
16. Abstract A 35 mph (56.3 km/h) frontal barrier impact was conducted on a 2001 Nissan Maxima 4-door sedan at Transportation Research Center Inc. on 06/18/01. This test was conducted to obtain data indicant of FMVSS 208, 212, 219 (partial), 301 and footwell intrusion performance. The impact velocity is 56.3 km/h. The ambient temperature at the barrier face at the time of impact is 21 degrees Celcius. The vehicle's maximum post test static crush is 551 mm. The test vehicle is equipped with a 3-point continuous belt system and second generation supplemental airbags in both front outboard seating positions. With respect to FMVSS 208 "Occupant Crash Protection", the occupant injury criteria summary is as follows:					
Measurement Description		Units	Threshold	Driver ATD	Passenger ATD
Head Injury Criteria (HIC)		N/A	1000	526	534
Max. Thorax Accel. (3 msec Clip)		G's	60	46.9	42.8
Left Femur Force		Newtons	10009	-237	-3739
Right Femur Force		Newtons	10009	-2918	-819
17. Key Words 56.3 kph (35 mph) Frontal Barrier Impact Test New Car Assessment Program (NCAP) 2001 Nissan Maxima 4-door sedan NHTSA No. NI0002			18. Distribution Statement Copies of this report are available from: National Highway Traffic Safety Admin. NHTSA Technical Reference Division 400 Seventh Street, S. W., Room 5108 Washington, DC 20590		
19. Security Classif. (of this report) Unclassified	20. Security Classif. (of this page) Unclassified	21. Number of Pages 393		22. Price	

Table of Contents

<u>Section</u>	<u>Description</u>	<u>Page</u>
1.0	Purpose and Summary of NCAP Test NI0002	1-1
2.0	Occupant, Camera and Vehicle Information/Data Sheets	2-1
3.0	Photographs	3-1
4.0	Dummy, Vehicle and Load Cell Barrier Data Plots	4-1
5.0	Dummy Configuration and Performance Verification Data	5-1
6.0	Test Equipment and Instrumentation Calibration Information	6-1

Data Sheets

<u>Number</u>	<u>Title</u>	<u>Page</u>
1	Crash Test Summary	2-2
2	General Test and Vehicle Parameter Data	2-3
3	Post-Impact Data	2-7
4	Test Vehicle Information	2-9
5	Dummy Measurement Data for Front Seat Occupants	2-12
6	Seat Belt Positioning Data	2-16
7	Vehicle Accelerometer Locations and Data Summary	2-18
8	Dummy Injury Criteria Data	2-19
9	Seat Belt Performance Assessment Test Data	2-24
10	FMVSS 212 Data	2-25
11	FMVSS 219 (Partial) Data	2-26
12	FMVSS 301 Post-Impact Test Data	2-27
13	FMVSS 301 Static Rollover Test Data	2-28
14	Vehicle Measurements	2-33
15	Motion Picture Camera Locations	2-41
16	Vehicle Reference Photo Target Locations	2-42
17	Load Cell Locations on Fixed Barrier	2-43
18	Post-Test Airbag Data	2-44
19	Accident Investigation Division Data	2-45

List of Figures

<u>Number</u>	<u>Title</u>	<u>Page</u>
1	Impact Velocity Measurement System	2-8
2	Dummy Measurement Locations For Front Seat Occupants	2-11
3	Vehicle Accelerometer Placement	2-17
4	Pre-Test and Post-Test Measurement Points	2-32
5	Camera Positions	2-39

List of Photographs

Figure 3-1	Pre-Test Front View
Figure 3-2	Post-Test Front View
Figure 3-3	Pre-Test Left Side View
Figure 3-4	Post-Test Left Side View
Figure 3-5	Pre-Test Rear View
Figure 3-6	Post-Test Rear View
Figure 3-7	Pre-Test Right Side View
Figure 3-8	Post-Test Right Side View
Figure 3-9	Pre-Test Right Front Three-Quarter View
Figure 3-10	Post-Test Right Front Three-Quarter View
Figure 3-11	Pre-Test Left Rear Three-Quarter View
Figure 3-12	Post-Test Left Rear Three-Quarter View
Figure 3-13	Pre-Test Windshield View
Figure 3-14	Post-Test Windshield - View 1
Figure 3-15	Post-Test Windshield - View 2
Figure 3-16	Pre-Test Engine Compartment View
Figure 3-17	Post-Test Engine Compartment View
Figure 3-18	Pre-Test Fuel Filler Cap View
Figure 3-19	Post-Test Fuel Filler Cap View
Figure 3-20	Pre-Test Fuel Filler Neck View
Figure 3-21	Post-Test Fuel Filler Neck View
Figure 3-22	Pre-Test Fuel Tank View
Figure 3-23	Post-Test Fuel Tank View
Figure 3-24	Pre-Test Front Underbody View
Figure 3-25	Post-Test Front Underbody View
Figure 3-26	Pre-Test Rear Underbody View
Figure 3-27	Post-Test Rear Underbody View
Figure 3-28	Pre-Test Driver Dummy Position - View 1
Figure 3-29	Post-Test Driver Dummy Position - View 1

List Of Photographs, Cont'd.

- Figure 3-30 Pre-Test Driver Dummy Position - View 2
- Figure 3-31 Post-Test Driver Dummy Position - View 2
- Figure 3-32 Pre-Test Passenger Dummy Position - View 1
- Figure 3-33 Post-Test Passenger Dummy Position - View 1
- Figure 3-34 Pre-Test Passenger Dummy Position - View 2
- Figure 3-35 Post-Test Passenger Dummy Position - View 2
- Figure 3-36 Pre-Test Driver Dummy & Vehicle Interior - View 1
- Figure 3-37 Post-Test Driver Dummy & Vehicle Interior - View 1
- Figure 3-38 Pre-Test Driver Dummy & Vehicle Interior - View 2
- Figure 3-39 Post-Test Driver Dummy & Vehicle Interior - View 2
- Figure 3-40 Pre-Test Passenger Dummy & Vehicle Interior - View 1
- Figure 3-41 Post-Test Passenger Dummy & Vehicle Interior - View 1
- Figure 3-42 Pre-Test Passenger Dummy & Vehicle Interior - View 2
- Figure 3-43 Post-Test Passenger Dummy & Vehicle Interior - View 2
- Figure 3-44 Post-Test Driver Dummy Overall View
- Figure 3-45 Post-Test Driver Dummy Head Contact - View 1
- Figure 3-46 Post-Test Driver Dummy Head Contact - View 2
- Figure 3-47 Post-Test Driver Dummy Head Contact - View 3
- Figure 3-48 Post-Test Driver Dummy Knee Contact - View 1
- Figure 3-49 Post-Test Driver Dummy Knee Contact - View 2
- Figure 3-50 Post-Test Passenger Dummy Overall View
- Figure 3-51 Post-Test Passenger Dummy Head Contact - View 1
- Figure 3-52 Post-Test Passenger Dummy Head Contact - View 2
- Figure 3-53 Post-Test Passenger Dummy Head Contact - View 3
- Figure 3-54 Post-Test Passenger Dummy Knee Contact - View 1
- Figure 3-55 Post-Test Passenger Dummy Knee Contact - View 2
- Figure 3-56 Pre-Test Vehicle Certification Label View
- Figure 3-57 Pre-Test Tire Label View
- Figure 3-58 Post-Test Vehicle On Static Rollover Machine View

Section 1.0

Purpose and Summary of NCAP Test NI0002

Purpose

This 56 km/h (35 mph) frontal barrier impact test is part of the New Car Assessment Program (NCAP) conducted for the National Highway Traffic Safety Administration's (NHTSA) Office of Crashworthiness Standards by Transportation Research Center Inc. (TRC Inc.) as an optional NCAP test.

The purpose of this test was to obtain vehicle crashworthiness and occupant restraint system performance data for the subject vehicle, a 2001 Nissan Maxima 4-door sedan, NHTSA Number NI0002, at an impact speed in excess of the current 48 km/h (30 mph) FMVSS 208, 212, 219, and 301 requirements.

Test Procedure

This 56 km/h (35 mph) test was conducted in accordance with Office of Crashworthiness Standards Laboratory Test Procedure for New Car Assessment Program, dated December 1999. Data was obtained indicant of FMVSS 208, "Occupant Crash Protection"; FMVSS 212, "Windshield Retention"; FMVSS 219, "Windshield Zone Intrusion"; and FMVSS 301, "Fuel System Integrity," performance.

The test vehicle was instrumented with nine (9) accelerometers to measure longitudinal axis accelerations. The driver's and passenger's restraint systems were instrumented with load cells to measure lap and shoulder belt forces and potentiometers to measure shoulder belt stretch and spoolout. The vehicle impacted a frontal load cell barrier instrumented with thirty-six (36) barrier face load cells. The vehicle's specified impact velocity range was 55.5 to 57.1 km/h.

The test vehicle contained two (2) Part 572E 50th percentile adult male anthropomorphic test devices (dummies). The dummies were positioned in the front outboard designated seating positions according to the dummy placement procedures specified in Appendix B of the Laboratory Indicant Test Procedure. This test was the first use of the driver dummy and the first use of the passenger dummy following dummy calibration.

Both dummies were instrumented with primary and redundant head and chest, and pelvis, accelerometers to measure longitudinal, lateral, and vertical accelerations, and with left and right femur load cells to measure axial forces. The dummies were also instrumented with neck moment and force load cells, chest deflection potentiometers, foot accelerometers to measure longitudinal and vertical axis accelerations, and upper and lower tibia load cells to measure forces and moments.

The 141 data channels were digitally sampled and recorded at 12,500 samples per second and processed per Section 11.13 of the Laboratory Indicant Test Procedure.

The crash event was recorded by one (1) real-time panning motion picture camera and fifteen (15) high-speed motion picture cameras. The pre- and post-test conditions were recorded by one (1) real-time motion picture camera.

The occupant, camera, and vehicle data sheets are presented in Section 2.0. Section 3.0 contains the still photographic prints. Section 4 contains the dummy, vehicle, and load cell barrier data plots. Section 5 contains the dummy certification data. Section 6 contains test equipment and instrumentation calibration information.

Test Results Summary

This frontal load cell barrier test was conducted by TRC Inc. on June 18, 2001.

The test vehicle, a 2001 Nissan Maxima 4-door sedan, NHTSA Number NI0002, was equipped with a 3.0-liter transverse engine, automatic transmission, power steering, and power brakes. The vehicle's test weight was 1673.8 kg. The vehicle's impact speed was 56.3 km/h. The vehicle sustained 551 mm of static crush during the impact.

The driver's 36 millisecond Head Injury Criteria (HIC) was 526. The driver's chest maximum resultant acceleration with three (3) milliseconds minimum duration was 46.9 g¹. The driver's maximum chest deflection was 39 mm. The driver's left and right femur maximum axial compressive forces were 237 N and 2918 N, respectively.

The right front passenger's 36 millisecond HIC was 534. The passenger's chest maximum resultant acceleration with three (3) milliseconds minimum duration was 42.8 g. The passenger's maximum chest deflection was 25 mm. The passenger's left and right femur maximum axial compressive forces were 3739 N and 819 N, respectively.

There was 99.6% windshield periphery retention.

There was no penetration through the windshield.

Following the impact, no fluid spilled from the vehicle's fuel system prior to the static rollover test or during the static rollover test.

¹ See Data Acquisition Explanations

Data Acquisition Explanations

The driver dummy's chest X-axis and Y-axis acceleration data channels, CSTXG1 and CSTYG1, recorded no valid data during the event. This affected the chest resultant and chest three-millisecond clip calculations. This data is not included in Data Sheet 8, but the plot traces are included in Section 4.0. The three-millisecond clip calculated from the redundant chest accelerometers is reported for injury criteria evaluation.

The passenger dummy's lower tibia Z-axis force data channel, ANLZF2, exceeded the data channel's full-scale at approximately 44 milliseconds.

The passenger dummy's seat belt extension data channel, SBED2, recorded no valid data after approximately 232 milliseconds.

The vehicle's engine bottom X-axis acceleration data channel, ENGXG2, exceeded the data channel's full-scale at approximately 40 milliseconds.

The vehicle's left brake caliper X-axis acceleration data channel, BCLXG1, exceeded full-scale at approximately 40 milliseconds and failed to record valid data after 80 milliseconds.

The barrier load cell channel row A cell 2, BA2F, did not fully return to the zero level following impact. This affected the Group No. 1 total for the barrier load cell.

Section 2.0

Occupant, Camera and Vehicle Information

Data Sheet 1 Crash Test Summary

Vehicle NHTSA number:	NI0002		
Test mode:	Frontal load cell barrier		
Test date:	06/18/01		
Test time:	1517		
Ambient temperature:	21° C		
Vehicle year/make/ model/body style:	2001/Nissan/Maxima/4-door sedan		
Vehicle test weight:	1673.8 kg		
Impact angle ¹ :	0°		
Impact velocity ² :	56.3 km/h		
Maximum static crush:	551 mm		
Average rebound:	551 mm		
Number of data channels:	141		
Number of cameras:	High-speed	15	Real-time 1
<u>Dummies:</u>	<u>Driver #142</u>		<u>Passenger #192</u>
Type:	Part 572E		Part 572E
Restraint:	Airbag/3-pt. seatbelt		Airbag/3-pt. seatbelt
<u>Door Opening Data:</u>			
Left Front	Easy		Easy
Right Front	Easy		Easy
<u>Front Seat Data:</u>	<u>Driver</u>		<u>Passenger</u>
Seat Track Shift	None		None
Seat Back Failure	None		None
<u>Visible Dummy Contact Points:</u>	<u>Driver</u>		<u>Passenger</u>
Head	Airbag/headrest		Airbag/headrest
Chest	Airbag		Airbag
Abdomen	None		None
Left knee	Instrument panel		Instrument panel
Right knee	Instrument panel		Instrument panel

¹ With respect to tow track centerline.

² Speed trap measurement (± .08 km/h accuracy)

Data Sheet 2 General Test and Vehicle Parameter Data

Vehicle year/make/
model/body style: 2001/Nissan/Maxima/4-door sedan

Vehicle NHTSA number: NI0002

VIN: JN1CA31D91T624427

Color: Sunlit Sand (pale gold)

Engine data:

 Cylinders: 6

 Displacement 3.0 liters

 Cylinder placement: V

 Engine placement: Transverse

Transmission data: 4 speed, ___ manual, X automatic, ___ overdrive

 Final drive: X FWD, ___ RWD, ___ 4WD

Major Options:

 Air conditioning Yes

 Power steering Yes

 Power brakes Yes

 Power windows Yes

 Power door locks Yes

 Tilting steering wheel Yes

Date vehicle received: 06/13/2001

Odometer reading: 73

Dealer's name Ricart Nissan
and address: 4255 S. Hamilton Rd.
Columbus, Ohio 43227

Certification data from vehicle's label:

Vehicle manufactured by: Nissan Motor Co., Ltd.

Date of manufacture: 02/01

VIN: JN1CA31D91T624427

GVWR: 4310 lbs.

GAWR: Front: 2313 lbs.
Rear: 2013 lbs.

Data Sheet 2 General Test and Vehicle Parameter Data, Cont'd.

Data from Tires:

Tire pressure with maximum capacity vehicle load:

Front:	35 psi	(240 kPa)
Rear:	35 psi	(240 kPa)

Size of tires on test vehicle: P215/55R16

Manufacturer of tires: Toyo

Tire & capacity data from vehicle's label:

Recommended tire size: P215/55R16

Recommended cold tire pressure:

Front:	33 psi	(230 kPa)
Rear:	30 psi	(210 kPa)

Vehicle Capacity Data:

Type of front seats: Bucket

Number of Occupants (Designated seating capacity):

Front	2
Rear	3
Total	5

Vehicle capacity weight: 400 kg

No. of Occupants X 68 kg: 340 kg

Rated Cargo/Luggage Weight (RCLW)¹ 60 kg

¹ Cargo weight for multipurpose passenger vehicles, trucks, and buses is the vehicle's rated cargo and luggage weight from the vehicle's label or 136 kilograms, whichever is less.

Data Sheet 2 General Test and Vehicle Parameter Data Cont'd

Weight of test vehicle as received (with maximum fluids)=UDW:

Right front	447.0 kg	Right rear	283.0 kg
Left front	462.0 kg	Left rear	274.5 kg
Total front weight	909.0 kg	(62.0 % of total vehicle weight)	
Total rear weight	557.5 kg	(38.0 % of total vehicle weight)	
Total delivered weight	1466.5 kg		

Calculation of test vehicle's target test weight:

Total Delivered Weight (UDW) =	1466.5 kg
Rated Cargo/Luggage Weight (RCLW) ¹ =	60 kg
Weight of 2 Part 572 Dummies @ 76 kg each =	152 kg
Target test weight =	1678.5 kg

Weight of test vehicle with required dummies and 55 kg of cargo weight:

Right front	482.0 kg	Right rear	343.8 kg
Left front	499.6 kg	Left rear	348.4 kg
Total front weight	981.6 kg	(58.6 % of total vehicle weight)	
Total rear weight	692.2 kg	(41.4 % of total vehicle weight)	
Total test weight	1673.8 kg	(0.3 % under target test weight)	

Weight of ballast secured in vehicle: None

Components removed to meet target test weight: Taillights, rear seat & seat belts, trunk lid, rear door glass & motors, muffler, rear bumper beam & fascia

Test vehicle attitude:

Delivered attitude:	LF	715 mm;	RF	714 mm;	LR	695 mm;	RR	685 mm
Fully loaded attitude:	LF	693 mm;	RF	692 mm;	LR	661 mm;	RR	652 mm
Pre-test attitude:	LF	694 mm;	RF	693 mm;	LR	665 mm;	RR	657 mm
Post-test attitude:	LF	705 mm;	RF	725 mm;	LR	657 mm;	RR	655 mm

Vehicle's Wheelbase: 2752 mm

Location of Vehicle's CG: 1138 mm rearward of front wheel centerline

¹ Cargo weight for multipurpose passenger vehicles, trucks, and buses is the vehicle's rated cargo and luggage weight from the vehicle's label or 136 kilograms, whichever is less.

Data Sheet 2 General Test and Vehicle Parameter Data Cont'd

Fuel system capacity:	70.0 liters (from owner's manual)
Usable capacity:	70.0 liters (furnished by COTR)
Test volume range:	64.4 to 65.8 liters (92-94% of usable)
Actual test volume:	65.1 liters (with entire fuel system filled)
Test fluid type:	Stoddard
Specific gravity:	0.764
Kinematic viscosity:	0.99 centistoke
Test fluid color:	Purple
Type of fuel pump:	Electric
Did electric fuel pump operate with ignition switch "on" and the engine not operating?	Yes
Details of fuel system:	Tank in front of rear suspension; fill neck runs out to left rear behind and above wheel well; cap at end of neck; fuel lines run inside left frame.

Data Sheet 3 Post-Impact Data

Test type: Frontal load cell barrier

Impact angle: 0°

Test date: 06/18/01

Test time: 1517

Ambient temperature
at impact area: 21° C

Vehicle NHTSA number: NI0002

Required impact velocity range: 55.5 to 57.1 km/h

Barrier impact velocity:

Primary: 56.3 km/h

Secondary: 56.3 km/h

Distance from vehicle to barrier:

Entering velocity trap: 661 mm

Exiting velocity trap: 51 mm

Vehicle static crush:

Overall length of test vehicle:

Pre-test: L 4663 mm; C 4833 mm; R 4664 mm

Post-test: L 4209 mm; C 4285 mm; R 4282 mm

Total crush: L 454 mm; C 548 mm; R 382 mm

Average crush: 461 mm

Vehicle rebound from flat rigid barrier:

Distance from test vehicle to barrier impact point:

Post-test: L 580 mm; C 527 mm; R 545 mm

Average rebound: 551 mm

Figure 1 Impact Velocity Measurement System

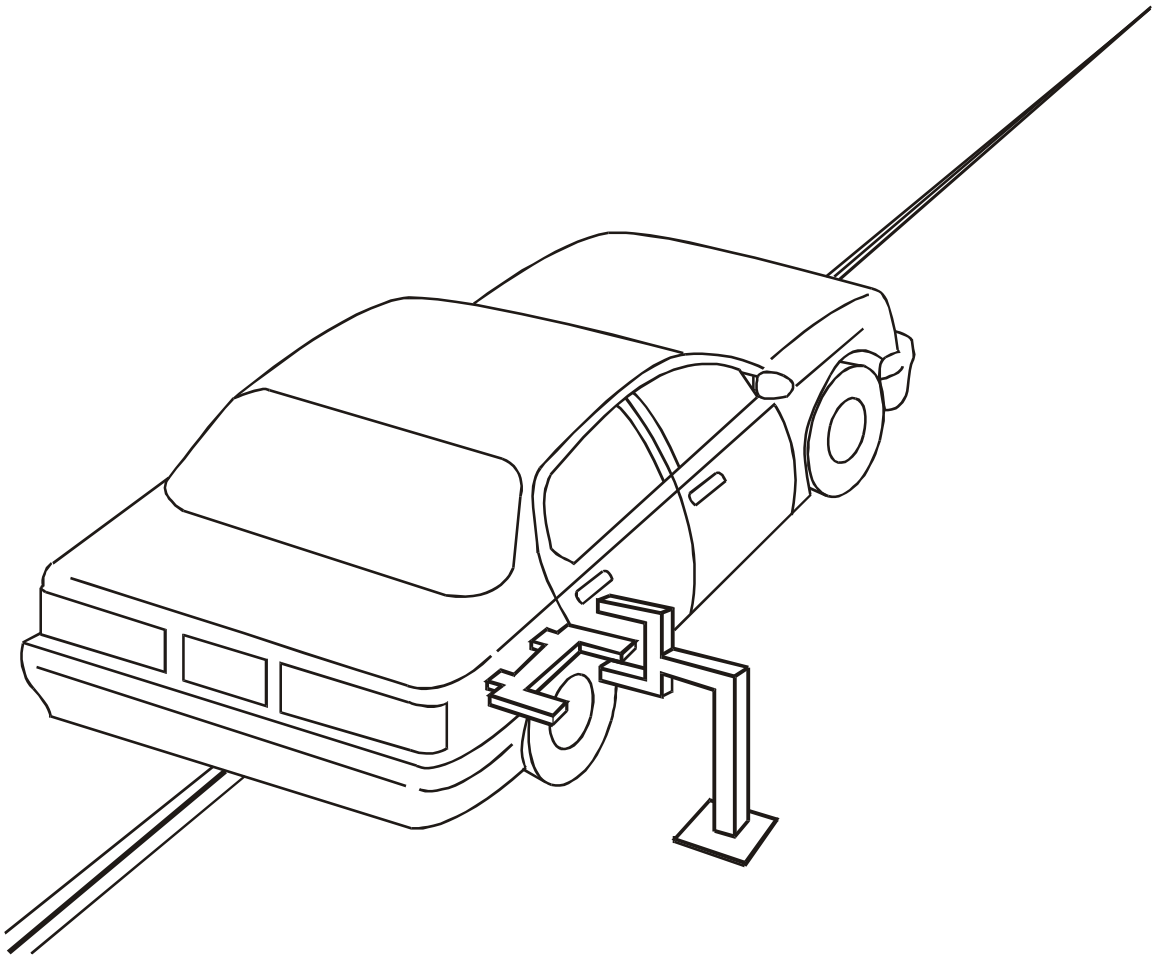

The final vane clears the final emitter/receiver pair 51 millimeters before impact.

The vanes have 610-millimeter spacing.

Data Sheet 4 Test Vehicle Information

Vehicle year/make/model/body style: 2001/Nissan/Maxima/4-door sedan

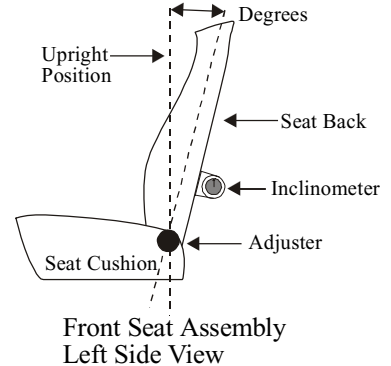

Nominal Design Riding Position:

Seat back angle for driver's seat: 21°

Measurement instructions: Power seat: Removed the seat cover. Adjusted the notch as shown below.

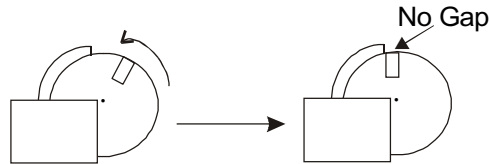

The angle was checked by removing the cover from the seat back and placing an inclinometer on the lower inboard seat back frame. At this point the inclinometer read 10 degrees (per customer, this corresponds to the 21 degree seat back angle).

Seat Back Angle for Passenger Seat: 21°

Measurement instructions: Manual seat: Pulled the folded seat back until the lock position was attained. Released the lock by actuating the reclining lever and pushed the seat back to the 5th rearward notch from the 1st locking position. The angle was check by removing the cover from the seat back and placing an inclinometer on the lower inboard seat back frame. At this point the inclinometer read 10 degrees (per customer, this corresponds to the 21 degree seat back angle).

Data Sheet 4 Test Vehicle Information, Cont'd.

Vehicle year/make/model/body style: 2001/Nissan/Maxima/4-door sedan

Seat Fore and Aft Positions:

Positioning of the driver's seat: The seat track was positioned ten notches rearward from the forwardmost position with the forwardmost position as zero.

Positioning of the passenger's seat: The seat track was positioned ten notches rearward from the forwardmost position with forwardmost position as zero.

Fuel Tank Capacity Data:

Usable capacity of standard tank: 70.0 liters

Usable capacity of optional tank: N/A

Usable capacity of test vehicle's tank: 70.0 liters

Test volume: 65.1 liters

Type of fuel pump: Electric

Did electric fuel pump operate with ignition switch "on" and the engine not operating? Yes

Steering Column Adjustments: 23° degrees

Operational instructions: An inclinometer was placed on the steering column cover. The angle was measured with the column in its highest position and in its lowest position. The steering column was adjusted to the mid position.

Seat Belt Upper Anchorage:

Nominal design riding position: Full up

Figure 2 Dummy Measurement Locations for Front Seat Occupants

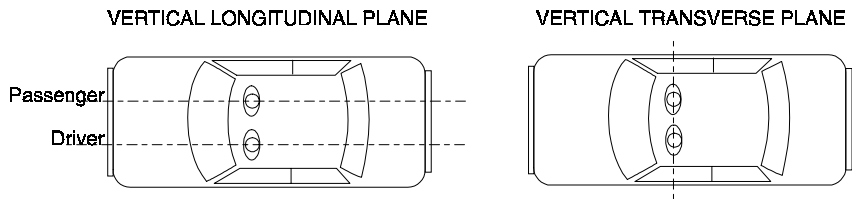
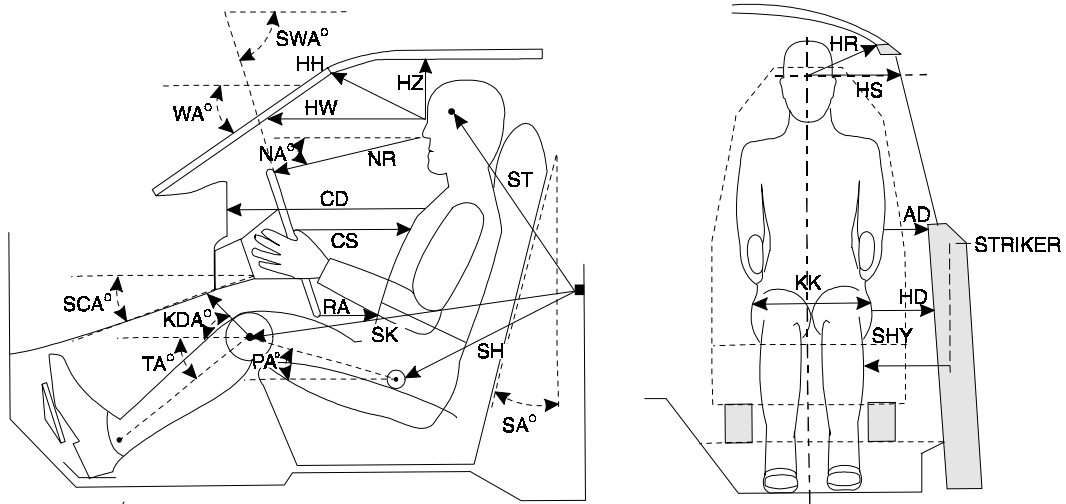

Data Sheet 5 Dummy Measurement Data For Front Seat Occupants

Designation	Type of Measurement	Driver (Serial # 142)	Passenger (Serial # 192)
WA	Windshield angle	27.1°	27.1°
SWA	Steering wheel angle	23°	N/A
SCA	Steering column angle	67°	N/A
SA	Seat back angle	21°	21°
HZ	Head to roof	190 mm	105 mm
HH	Head to header	312 mm	295 mm
HW	Head to windshield	557 mm	593 mm
HR	Head to side header	205 mm	205 mm
NR	Nose to rim	400 mm	N/A
NA	Nose to rim angle	12.3°	N/A
CD	Chest to dash	540 mm	561 mm
CS	Steering wheel to chest	315 mm	N/A
RA	Rim to abdomen	195 mm	N/A
KDL	Left knee to dash	199 mm	166 mm
KDR	Right knee to dash	194 mm	166 mm
KDA	Outboard knee to dash angle	30.3°	22.0°
PA	Pelvic angle	23.4°	24.0°
TA	Tibia angle	40.7°	37.0°
KK	Knee to knee	330 mm	270 mm
ST ¹	Striker to head	514 mm	523 mm
	Striker to head angle	-77.3°	-74.0°
SK ¹	Striker to knee	612 mm	645 mm
	Striker to knee angle	-0.9°	1.8°
SH ¹	Striker to H-point	253 mm	269 mm
	Striker to H-point angle	30.4°	33.1°
SHY	Striker to H-point (Y dir.)	248 mm	265 mm
HS	Head to side window	257 mm	280 mm
HD	H-point to door	136 mm	116 mm
AD	Arm to door	116 mm	123 mm

The seat back angle (SA°) is measured relative to vertical, all other angles are measured relative to horizontal.

¹ A negative angle indicates the measurement point was above the striker.

Descriptions of Dummy Measurements

When a level is to be used, it is to ensure that the line containing the two points described is either parallel or perpendicular to the ground. If a measurement to be made is less than 10 inches ignore the directions to use a level and approximate a level measurement. Also, when a measurement is to be taken to or from the center of a bolt on the dummy, take the measurement from the center of the bolt hole if the bolt is recessed.

The following measurements are to be made within a vertical longitudinal plane.

- * HH Head to Header, taken from the point where the dummy's nose meets his forehead (between his eyes) to the furthest point forward on the header.
- * HW Head to Windshield, taken from the point where the dummy's nose meets his forehead (between his eyes) to a point on the windshield. Use a level.
- HZ Head to Roof, taken from the point where the dummy's nose meets his forehead (between his eyes) to the point on the roof directly above it. Use a level.
- * CS Steering Wheel to Chest, taken from the center of the steering wheel hub to the dummy's chest. Use a level.
- * CD Chest to Dash, place a tape measure on the tip of the dummy's chin and rotate five inches of it downward toward the dummy to the point of contact on the transverse center of the dummy's chest. Then measure from this point to the closest point on the dashboard either between the upper part of the steering wheel between the hub and the rim, or measure to the dashboard placing the tape measure above the rim, whichever is a shorter measurement. See diagram.
- RA Steering Wheel Rim to Abdomen, taken from the bottommost point of the steering wheel rim horizontally rearward to the dummy. Use a level.
- NR Nose to Rim, taken from the tip of the dummy's nose to the closest point on the top of the steering wheel rim. Also indicate the angle this line makes with respect to the horizontal (NA).
- *¹ KDL, Left and Right Knees to Dashboard, taken from the center of the knee pivot bolt's
KDR outer surface to the closest point forward acquired by swinging the tape measure in continually larger arcs until it contacts the dashboard. Also reference the angle of this measurement with respect to the horizontal for the outboard knee (KDA). See diagram.

* Measurement used in Data Tape Reference Guide

¹ Only outboard measurement is referenced in Data Tape Reference Guide

Descriptions of Dummy Measurements, Cont'd.

SH, Striker to Hip, Knee, and Head, these measurements are to be taken in the X-Z
SK, plane measured from the forward most center point on the striker to the center of
ST the H-point, outer knee bolt, and head target. When taking this measurement a
firm device that can be rigidly connected to the striker should be used. Use a
level. The angles of these measurements with respect to the horizontal should
also be recorded. The measurement in the Y (transverse) direction from the
striker to the H-point should also be taken (SHY). See diagram.

The following measurements are to be made within a vertical transverse plane.

- HS Head to Side Window, taken from the point where the dummy's nose meets his
forehead (between his eyes) to the outside of the side window. In order to make
this measurement, roll the window down to the exact height which allows a level
measurement. Use a level. See diagram.
- * AD Arm to Door, taken from the outer surface of the elbow pivot bolt on a Hybrid II
dummy to the first point it hits on the door. In the case of a Hybrid III dummy,
measure from the bolt on the outer biceps. When a SID is used make the
measurement from the center of the bottom of the arm segment where it meets the
dummy's torso.
- * HD H-point to Door, taken from the H-point on the dummy to the closest point on the
door. Use a level.
- * HR Head to Side Header, measure the shortest distance from the point where the
dummy's nose meets his forehead (between his eyes) to the side edge of the
header just above the window frame, directly adjacent to the dummy.
- SHY Striker to H-point, taken from a rod rigidly connected to the forward most center
point on the striker to the H-point. Use a level. See diagram.
- KK Knee to Knee, for Hybrid II dummies measure the distance between knee pivot
bolt head outer surfaces. For Hybrid III dummies measure the distance between
the outboard knee clevis flange surfaces. (This measurement may not be exactly
transverse.)

Angles

SA Seat Back Angle, find this angle using the instructions provided by the
manufacturer. If the manufacturer doesn't provide clear instructions contact the
COTR.

* Measurement used in Data Tape Reference Guide

Descriptions of Dummy Measurements, Cont'd.

- PA Pelvic or Femur Angle, taken by inserting the pelvic angle gauge into the H-point gauging hole on the SID or the Hybrid III dummies and taking this angle with respect to the horizontal. Measure the angle of the line connecting the H-point hole and the outer knee pivot bolt hole on a Hybrid II dummy with respect to the horizontal, to find the femur angle.
- SWA Steering Wheel Angle, find this by placing a straight edge against the steering wheel rim along the longitudinal plane. Then measure the acute angle of the straight edge with respect to the horizontal.
- SCA Steering Column Angle, measured with respect to the horizontal by placing an inclinometer on the center of the underside of the steering column.
- NA Measure the angle made when taking the measurement NR with respect to the horizontal.
- KDA Knee to Dash Angle, the angle that the measurement KD is taken at with respect to the horizontal. Only get this angle for the outboard knee. See diagram.
- WA Windshield Angle, place an inclinometer along the transverse center of the windshield exterior (measurement is made with respect to horizontal).
- TA Tibia Angle, use a straight edge to connect the dummy's knee and ankle bolts. Then place an inclinometer on the straight edge and measure the angle with respect to the horizontal.

Data Sheet 6 Seat Belt Positioning Data

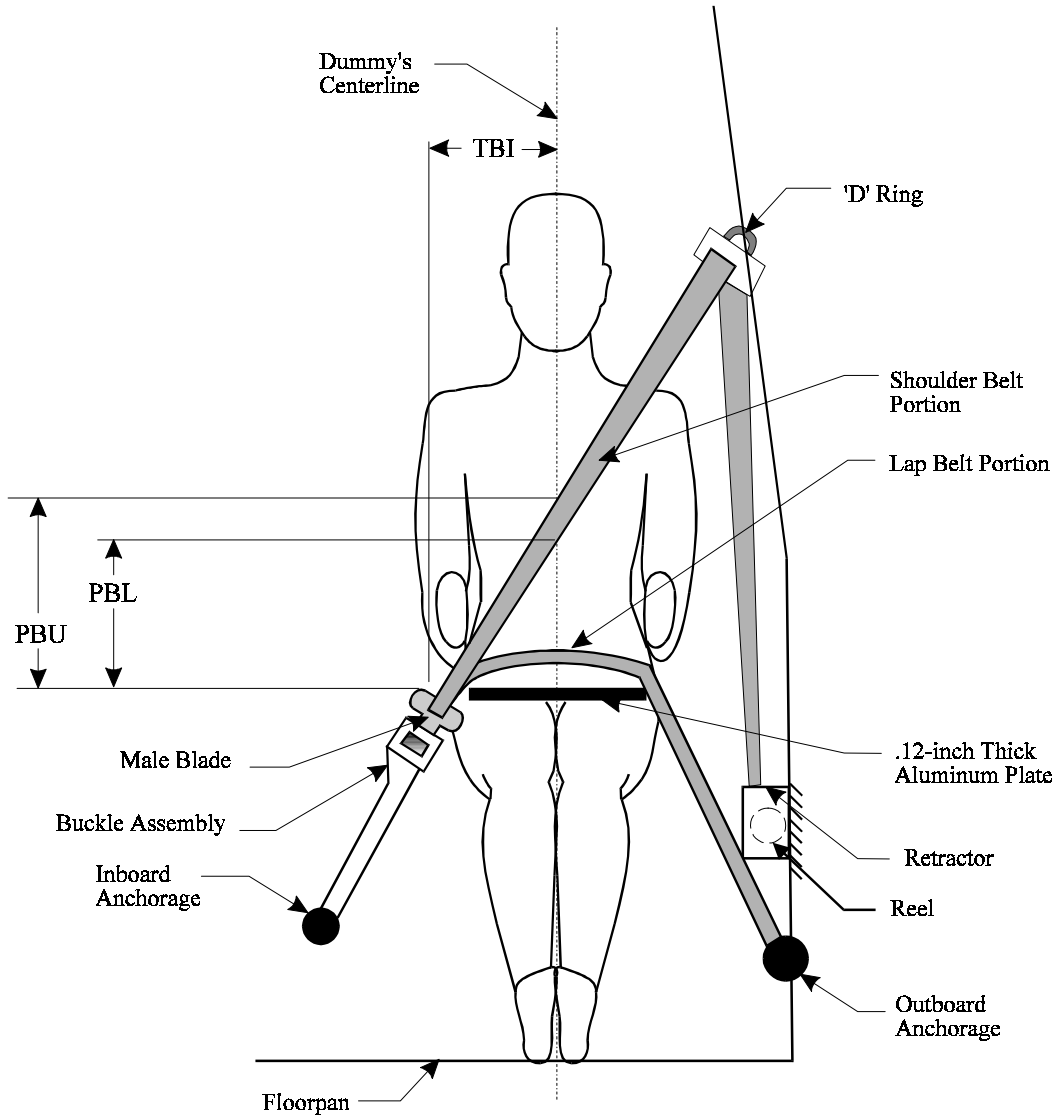

	Driver	Passenger
PBU - Top surface of aluminum plate to belt upper edge	320 mm	340 mm
PBL - Top surface of aluminum plate to belt lower edge	240 mm	245 mm
TBI - Dummy centerline to intersection of upper torso belt and lap belt	220 mm	225 mm
Lap Belt Tension	15.6 N	13.3 N
Shoulder Belt Tension	13.3 N	13.3 N

Figure 3 Vehicle Accelerometer Placement

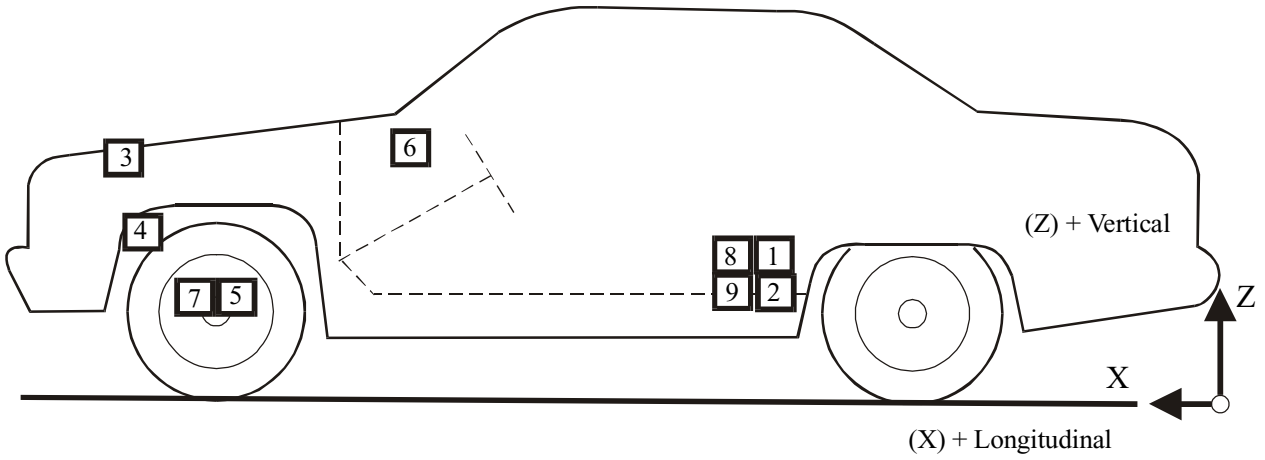

Side View

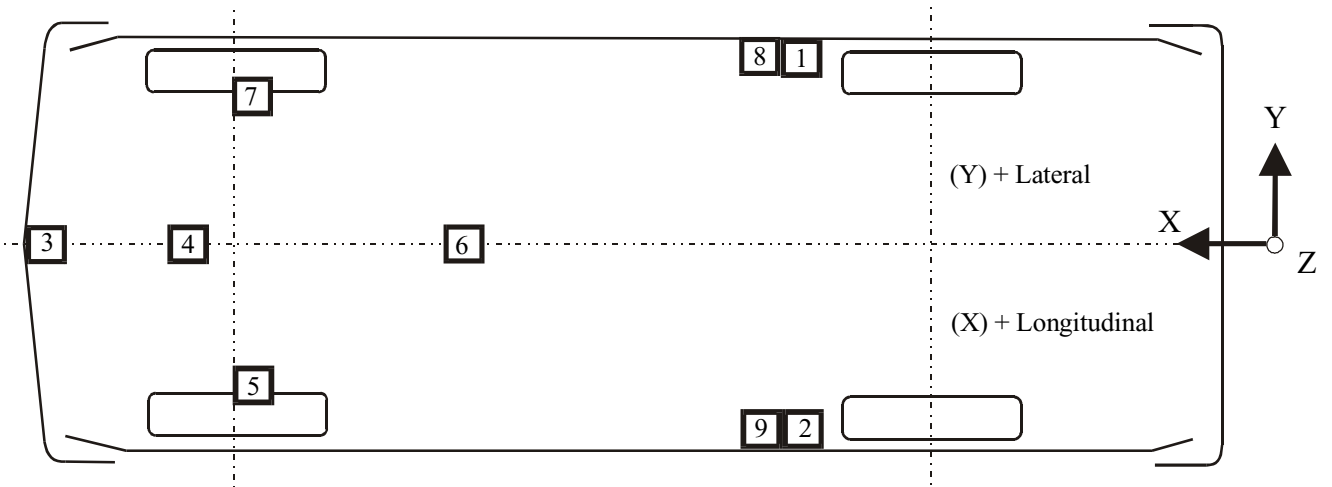

Bottom View

Data Sheet 7 Vehicle Accelerometer Locations and Data Summary

Measurement	Pre-Test Length
A Left Rear Seat Crossmember Y	650 mm
B Right Rear Seat Crossmember Y	650 mm
C Top of Engine X	4546 mm
D Bottom of Engine X	4000 mm
E Disk Brake Calipers X	4075 mm
F Disc Brake Calipers Y	660 mm
G Instrument Panel X	3550 mm
H Rear Seat Crossmember X	2090 mm

No.	Description	Peak Data			
		Positive	Time	Negative	Time
1	Left Rear Seat Crossmember	3.5 g	118.3 ms	34.7 g	64.6 ms
2	Right Rear Seat Crossmember	4.0 g	117.1 ms	38.1 g	67.4 ms
3	Top of Engine	28.7 g	42.1 ms	96.1 g	35.4 ms
4	Bottom of Engine ¹	35.4 g	38.3 ms	152.1 g	31.8 ms
5	Right Brake Disk Caliper	140.2 g	59.0 ms	146.8 g	43.1 ms
6	Instrument Panel	61.7 g	64.0 ms	96.1 g	50.9 ms
7	Left Disk Brake Caliper ¹	N/A	N/A	N/A	N/A
8	Left Rear Seat Crossmember-Red.	3.7 g	118.4 ms	34.8 g	64.6 ms
9	Right Rear Seat Crossmember-Red.	4.1 g	116.9 ms	38.2 g	67.2 ms

¹ See Data Acquisition Explanations

Data Sheet 8 Dummy Injury Criteria Data

Vehicle year/make/
model/body style:

2001/Nissan/Maxima/4-door sedan

Vehicle NHTSA number: NI0002

Test date: 06/18/01

Description	Unit	Maximum Values							
		Driver				Passenger			
		Positive	Time, ms	Negative	Time, ms	Positive	Time, ms	Negative	Time, ms
Head X	g	17.8	208.2	51.8	73.9	17.0	203.6	57.4	79.2
Head Y	g	2.9	174.1	17.8	81.3	8.3	62.4	4.2	89.0
Head Z	g	18.9	48.2	2.9	102.2	17.6	59.4	9.7	97.1
Head Resultant	g	56.9	76.2	----	----	57.9	79.2	----	----
Redundant Head X	g	17.5	207.1	52.5	74.6	17.0	204.6	58.2	79.0
Redundant Head Y	g	2.7	174.2	19.1	82.3	8.3	61.8	4.6	89.0
Redundant Head Z	g	19.8	74.1	5.4	102.5	17.0	59.4	9.7	99.4
Redun Head Resultant	g	58.9	76.0	----	----	58.7	79.0	----	----
Upper Neck Fx	N	680.5	70.8	371.2	51.4	388.2	88.9	241.3	35.8
Upper Neck Fy	N	98.8	49.7	161.7	107.7	80.5	77.4	114.9	88.9
Upper Neck Fz	N	1450.3	65.8	152.9	226.0	1030.0	55.6	384.6	223.0
Upper Neck Mx	Nm	7.4	162.5	18.4	110.9	20.8	87.9	16.1	59.7
Upper Neck My	Nm	50.9	70.3	13.4	227.9	11.2	53.9	24.8	230.0
Upper Neck Mz	Nm	21.2	87.2	12.0	151.4	7.5	119.5	13.5	233.7
Occipital Neck M	Nm	38.9	69.9	12.4	228.1	12.9	309.7	23.4	231.0
Chest X ¹	g	N/A	N/A	N/A	N/A	4.6	178.2	44.3	74.0
Chest Y ¹	g	N/A	N/A	N/A	N/A	5.8	50.5	9.6	85.4
Chest Z	g	8.3	47.2	10.5	100.8	6.6	50.7	8.4	107.0
Chest Resultant ¹	g	N/A	N/A	----	----	44.6	74.1	----	----
Redundant Chest X	g	5.0	160.1	47.0	64.8	4.8	177.5	45.2	73.9
Redundant Chest Y	g	2.9	94.9	8.4	112.2	6.0	50.5	9.2	85.4
Redundant Chest Z	g	8.6	47.2	6.5	98.2	6.9	50.6	8.4	106.1
Redun Chest Resultant	g	47.5	59.4	----	----	45.4	74.0	----	----
Chest Deflection	mm	0.0	8.2	38.8	75.1	0.0	5.7	25.3	71.4

¹ See Data Acquisition Explanations

Data Sheet 8 Dummy Injury Criteria Data, Cont'd.

Vehicle year/make/
model/body style:

2001/Nissan/Maxima/4-door sedan

Vehicle NHTSA number: NI0002

Test date: 06/18/01

Description	Unit	Maximum Values							
		Driver				Passenger			
		Positive	Time, ms	Negative	Time, ms	Positive	Time, ms	Negative	Time, ms
Pelvis X	g	4.7	176.1	62.1	60.0	4.8	124.2	54.8	59.8
Pelvis Y	g	6.7	80.2	19.4	45.4	14.3	44.2	8.8	47.0
Pelvis Z	g	5.6	45.3	28.6	56.6	4.6	43.8	22.1	84.1
Pelvis Resultant	g	68.3	60.1	----	----	57.3	59.8	----	----
Left Femur	N	1162.9	54.3	236.7	61.8	445.1	75.3	3738.6	61.4
Right Femur	N	1254.6	73.5	2918.5	60.1	747.3	45.8	819.0	56.8
Left Tibia - Femur DX	mm	0.1	92.4	0.3	191.7	0.4	87.6	0.7	61.5
Right Tibia Femur DX	mm	1.2	49.1	15.0	63.0	0.6	59.5	0.1	80.3
Left Upper Tibia Mx	Nm	64.9	62.6	6.4	45.5	23.1	66.7	29.6	43.3
Left Upper Tibia My	Nm	22.9	137.2	73.6	64.4	22.4	125.8	284.7	44.0
Left Upper Tibia Fz	N	114.4	115.3	1331.1	37.8	79.5	25.1	8484.7	44.1
Left Lower Tibia Mx	Nm	36.7	45.0	127.9	47.0	30.3	59.2	23.1	43.6
Left Lower Tibia My	Nm	159.7	58.6	76.2	44.7	254.2	59.3	74.3	41.4
Left Lower Tibia Fz	N	79.2	139.6	10030.9	46.5	55.4	25.0	11166.8 ¹	43.9 ¹
Right Upper Tibia Mx	Nm	70.5	58.2	70.2	47.2	36.8	47.3	51.3	53.9
Right Upper Tibia My	Nm	48.9	66.2	293.4	45.3	23.6	122.2	72.5	48.4
Right Upper Tibia Fz	N	82.6	24.3	7284.7	46.6	97.8	137.8	2379.9	50.1
Right Lower Tibia Mx	Nm	48.3	59.9	9.8	81.8	37.6	58.5	74.9	50.0
Right Lower Tibia My	Nm	38.2	65.0	28.7	45.2	200.0	74.7	28.7	36.2
Right Lower Tibia Fz	N	99.7	117.9	1835.1	38.0	179.9	137.6	3289.2	50.0
Left Foot Aft X	g	9.2	61.7	53.6	46.9	71.8	51.8	296.1	42.8
Left Foot Aft Z	g	4.5	179.4	51.2	44.0	70.3	58.9	288.2	43.6
Left Foot Fore Z	g	6.7	179.7	58.4	23.6	271.7	51.8	224.0	45.4
Right Foot Aft X	g	93.2	42.1	264.3	44.1	16.5	60.2	58.6	39.4

¹ See Data Acquisition Explanations

Data Sheet 8 Dummy Injury Criteria Data, Cont'd.

Vehicle year/make/
model/body style:

2001/Nissan/Maxima/4-door sedan

Vehicle NHTSA number: NI0002

Test date: 06/18/01

Description	Unit	Maximum Values							
		Driver				Passenger			
		Positive	Time, ms	Negative	Time, ms	Positive	Time, ms	Negative	Time, ms
Right Foot Aft Z	g	108.9	54.4	321.4	44.2	5.0	27.0	77.7	46.4
Right Foot Fore Z	g	161.4	56.3	634.7	42.0	55.2	55.6	90.8	44.1
Lap Belt	N	7113.9	59.1	10.9	308.3	6821.4	61.0	9.6	172.4
Torso Belt	N	6033.3	57.0	14.6	163.5	6094.3	58.7	26.9	235.0
Belt Spoolout	Mm	5.7	83.0	52.1	51.4	102.1	92.4	26.7	44.9
Belt Extension	Mm/ m	29.3	115.4	0.0	0.0	20.8	68.9	N/A ¹	N/A ¹

¹ See Data Acquisition Explanations

Data Sheet 8 Dummy Injury Criteria Data, Cont'd.

Vehicle year/make/
model/body style: 2001/Nissan/Maxima/4-door sedan

Vehicle NHTSA number: NI0002 Test date: 06/18/01

	Head Injury Criteria (HIC) Data			
	HIC ¹	t ₁ , ms	t ₂ , ms	Average acceleration t ₁ to t ₂
Driver	526	54.7	90.7	-42.2
Passenger	534	59.0	95.0	-41.1

¹ HIC as defined in FMVSS 208. The maximum time interval from t₁ to t₂ is 36 ms.

	3 ms Chest Resultant Acceleration (Clip) Data ²			
	Clip, g	t ₁ , ms	t ₂ , ms	Chest Severity Index (CSI)
Driver ³	N/A	N/A	N/A	N/A
Passenger	42.8	72.5	75.5	430

² The maximum chest resultant acceleration is defined as the maximum acceleration which exceeds .003 seconds duration.

³ See Data Acquisition Explanations.

Data Sheet 8 Dummy Injury Criteria Data, Cont'd.

Redundant Data

Vehicle year/make/

model/body style: 2001/Nissan/Maxima/4-door sedan

Vehicle NHTSA number: NI0002

Test date: 06/18/01

Head Injury Criteria (HIC) Redundant Data				
	HIC ¹	t ₁ , ms	t ₂ , ms	Average acceleration t ₁ to t ₂
Driver	558	54.8	90.8	-42.2
Passenger	545	58.9	94.9	-41.2

¹ HIC as defined in FMVSS 208. The maximum time interval from t₁ to t₂ is 36 ms.

3 ms Chest Resultant Acceleration (Clip) Redundant Data ²				
	Clip, g	t ₁ , ms	t ₂ , ms	Chest Severity Index (CSI)
Driver	46.9	58.4	61.4	473
Passenger	43.6	72.5	75.5	446

² The maximum chest resultant acceleration is defined as the maximum acceleration which exceeds .003 seconds duration.

Data Sheet 9 Seat Belt Performance Assessment Test Data

	Driver	Passenger
<hr/>		
<u>Belt length data:</u>		
Belt length from trim panel exit to bolt hole anchor point for continuous webbing systems.	2502 mm	2500 mm
Shoulder belt length as measured on Part 572 dummy.	880 mm	855 mm
Lap belt length as measured on Part 572 dummy.	830 mm	835 mm
<hr/>		
<u>Shoulder belt spool-off length:</u>		
As determined by film analysis	11 mm	N/A mm
As determined mechanically	N/A mm	N/A mm
As determined electronically	5.7 mm	102.1 mm
<hr/>		
<u>Belt stretch length:</u>		
As measured mechanically	0 mm/m	0 mm/m
As measured electronically	29 mm/m	21 mm/m
<hr/>		

Data Sheet 10 FMVSS 212 Test Data

Details of windshield mounting such as retention method, trim type, etc.: Plastic trim

FMVSS 212 requirements: The post-test periphery retention amount must be at least 75% of the pre-test periphery measurement for vehicles NOT equipped with automatic restraints, and 50% for each side of windshield for vehicles equipped with automatic restraint systems for front occupants.

Windshield periphery measurements:

	<u>Pre-test</u>	<u>Post-test</u>	<u>Percent retention</u>
Right side	2170 mm	2170 mm	100.0
Left side	2170 mm	2153 mm	99.2
Total	4340 mm	4323 mm	99.6

Pre-test windshield mounting material temperature: N/A

- A = 1157 mm
- B = 1480 mm
- C = 830 mm
- D = 15 mm

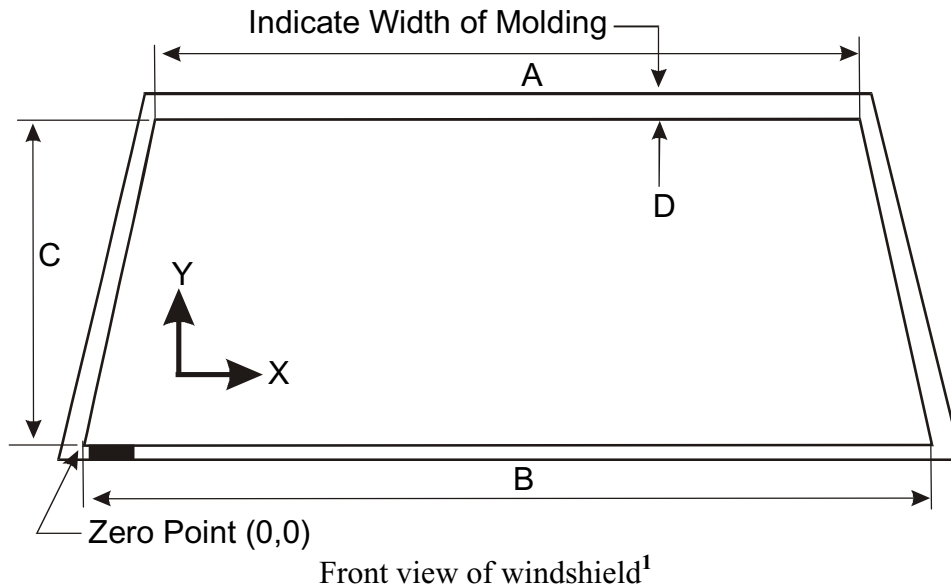

Loss of windshield retention lengths: 17 mm lower left corner

¹ Indicate areas of loss of retention, if any, on windshield diagram.

Data Sheet 11 FMVSS 219 (Partial) Test Data

Protected zone lower edge requirement:

The lower edge of the protected zone is determined by placing a 165-millimeter diameter rigid sphere weighing 6.8 kg in a position such that it simultaneously contacts the inner surface of the windshield and the top surface of the instrument panel including padding. Draw the locus of points on the inner surface of the windshield contactable by the sphere across the width of the instrument panel. From the outermost contactable points, extend the locus line horizontally to the edges of the windshield, and then draw a line on the inner surface of the windshield below and 13 millimeters from the locus line. The **lower edge of the protected zone** is the longitudinal projection onto the outer surface of the windshield of this line.

Windshield measurements:

- A = 1157 mm
- B = 575 mm
- C = 1480 mm
- D = 830 mm
- E = 560 mm
- F = 590 mm

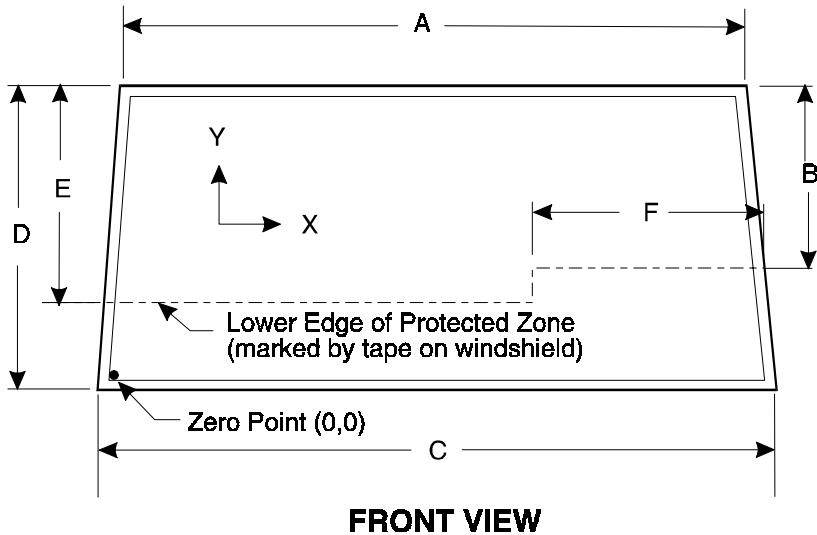

Method of adhering protected zone template to windshield: N/A

Areas of windshield template penetration greater than 6 mm: N/A

Coordinates, mm	
X	Y
1. N/A	N/A
2.	
3.	

Areas of windshield penetration, below the protected zone, through the inner surface of the windshield: None

1. N/A	N/A
2.	
3.	

Data Sheet 12 FMVSS 301 Post-Impact Test Data

Vehicle NHTSA number: NI0002
Test date: 06/18/01
Vehicle year/make/
model/body style: 2001/Nissan/Maxima/4-door sedan

Test requirements:

Test vehicle fuel tank filled to 92 to 94% of manufacturer's usable capacity and with electric fuel pump operating (if it will operate without engine operation). Part 572 test dummies located at each front designated seating position.

Test vehicle impact type:

- Frontal (56 km/h)
- Oblique (48 km/h) with ___° barrier face first contacting ___ (driver/pass.) side
- Rear moving barrier (48 km/h)
- Lateral moving barrier (32 km/h)

Fuel system fluid spillage measurements:

	<u>Test Results</u>	<u>Maximum Allowable</u>
1. From impact until vehicle motion ceases	0 g	28 g
2. 5-minute period after vehicle motion ceases	0 g	142 g
3. Next 25 minutes after 5-minute period	0 g	28 g/min

Fuel system fluid spillage location(s): None

Data Sheet 13 FMVSS 301 Static Rollover Test Data

Vehicle NHTSA number: NI0002

Test phase

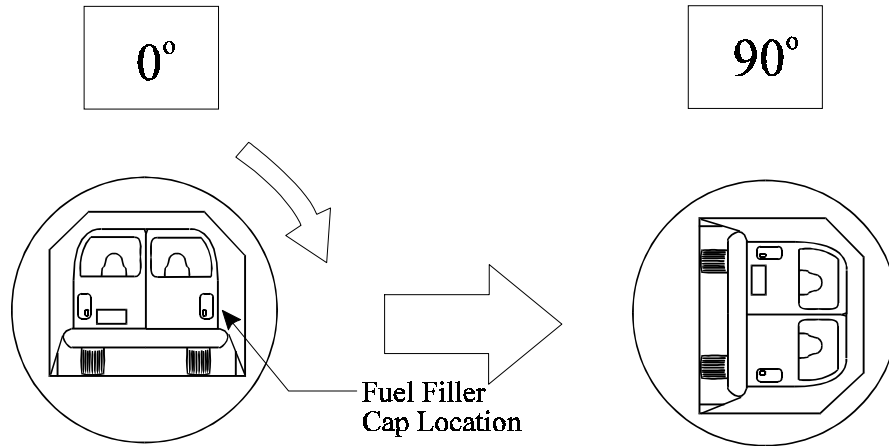

Static rollover machine rotation time information: (specified range is 1-3 minutes)

Time required for machine to rotate 90° = 2 minutes, 0 seconds
 FMVSS 301 position hold time = 5 minutes, 0 seconds
 Total = 7 minutes, 0 seconds
 Next whole minute interval = 7 minutes

Fuel system fluid spillage measurements:

	Test Results	Maximum Allowable
<u>0° to 90° rotation (fuel filler cap down)</u>		
1. First five minutes from onset of rotation	0 g	142 g
2. Sixth minute from onset of rotation	0 g	28 g
3. Seventh minute from onset of rotation	0 g	28 g

Fuel system fluid spillage location(s): None

Data Sheet 13 FMVSS 301 Static Rollover Test Data, Cont'd.

Test phase

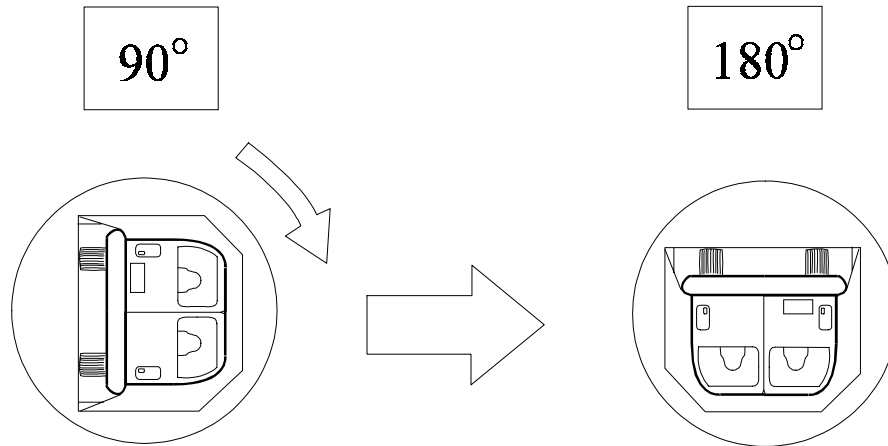

Static rollover machine rotation time information: (specified range is 1-3 minutes)

Time required for machine to rotate 90° = 2 minutes, 0 seconds
 FMVSS 301 position hold time = 5 minutes, 0 seconds
 Total = 7 minutes, 0 seconds
 Next whole minute interval = 14 minutes

Fuel system fluid spillage measurements:

<u>90° to 180° rotation</u>	<u>Test Results</u>	<u>Maximum Allowable</u>
1. First five minutes from onset of rotation	0 g	142 g
2. Sixth minute from onset of rotation	0 g	28 g
3. Seventh minute from onset of rotation	0 g	28 g

Fuel system fluid spillage location(s): None

Data Sheet 13 FMVSS 301 Static Rollover Test Data, Cont'd.

Test phase

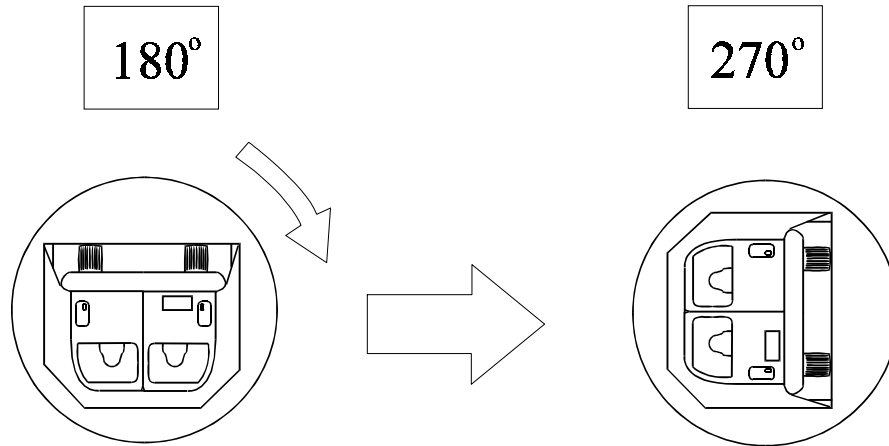

Static rollover machine rotation time information: (specified range is 1-3 minutes)

Time required for machine to rotate 90° = 2 minutes, 0 seconds
 FMVSS 301 position hold time = 5 minutes, 0 seconds
 Total = 7 minutes, 0 seconds
 Next whole minute interval = 21 minutes

Fuel system fluid spillage measurements:

<u>180° to 270° rotation</u>	<u>Test Results</u>	<u>Maximum Allowable</u>
1. First five minutes from onset of rotation	0 g	142 g
2. Sixth minute from onset of rotation	0 g	28 g
3. Seventh minute from onset of rotation	0 g	28 g

Fuel system fluid spillage location(s): None

Data Sheet 13 FMVSS 301 Static Rollover Test Data, Cont'd.

Test phase

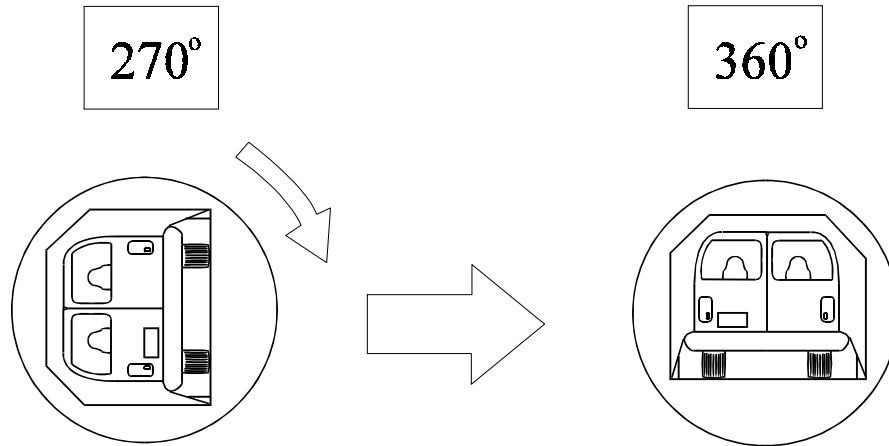

Static rollover machine rotation time information: (specified range is 1-3 minutes)

Time required for machine to rotate 90° = 2 minutes, 0 seconds
 FMVSS 301 position hold time = 5 minutes, 0 seconds
 Total = 7 minutes, 0 seconds
 Next whole minute interval = 28 minutes

Fuel system fluid spillage measurements:

<u>270° to 360° rotation</u>	Test Results	Maximum Allowable
1. First five minutes from onset of rotation	0 g	142 g
2. Sixth minute from onset of rotation	0 g	28 g
3. Seventh minute from onset of rotation	0 g	28 g

Fuel system fluid spillage location(s): None

Figure 4 Pre-Test And Post-Test Measurement Points

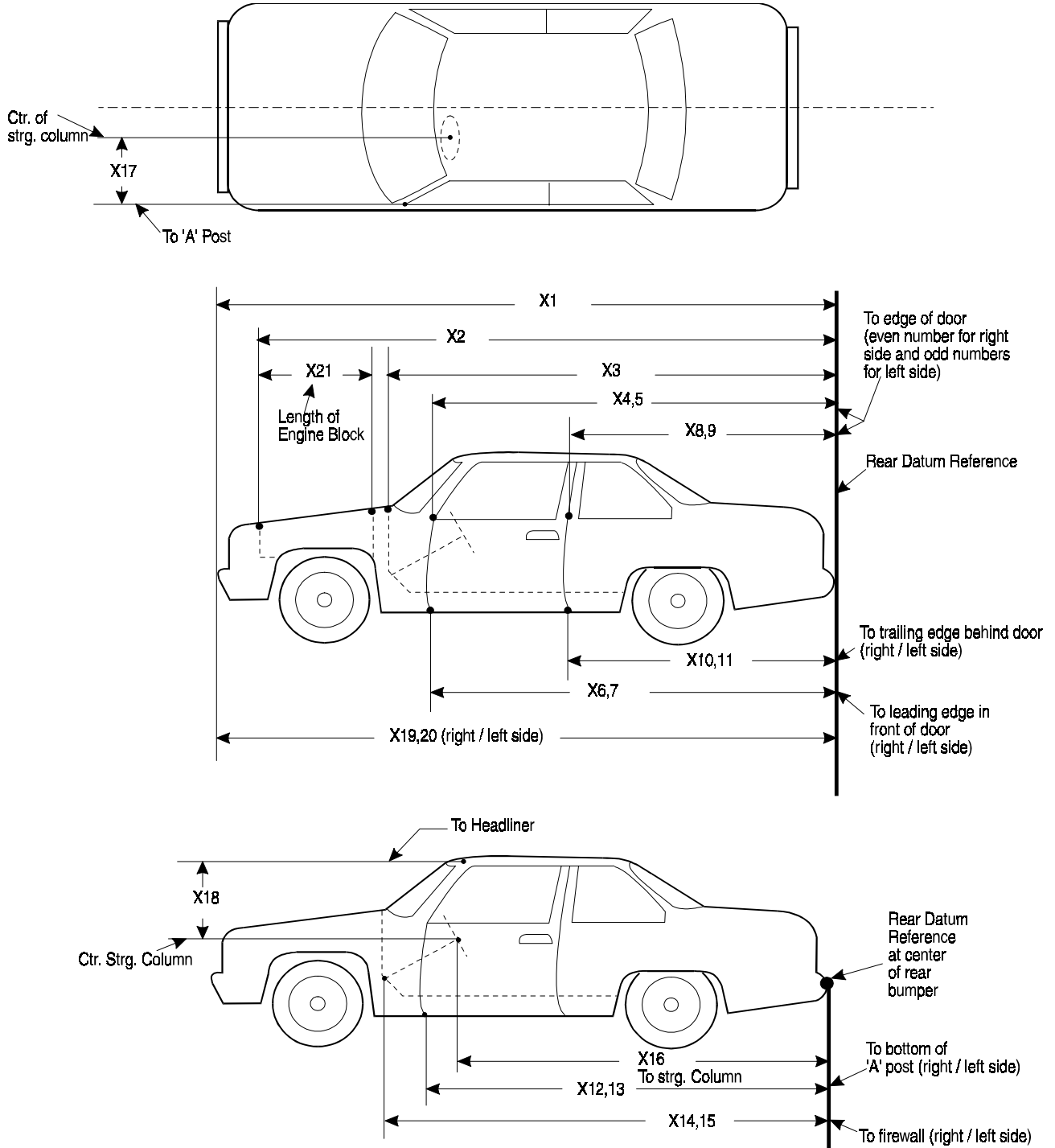

Data Sheet 14 Impacted Vehicle Measurements

Test number: 010618

Vehicle year/make/model/body style: 2001/Nissan/Maxima/4-door sedan

No.	Type of measurement	Pre-Test	Post-Test	Difference
X1	Total Length of Vehicle at Centerline	4833	4285	548
X2	Rear Surface of Vehicle to Front of Engine Block	4337	4099	238
X3	Rear Surface of Vehicle to Firewall	3683	3499	184
X4	Rear Surface of Veh. to Upper Leading Edge of Right Door	3333	3331	2
X5	Rear Surface of Veh. to Upper Leading Edge of Left Door	3346	3345	1
X6	Rear Surface of Veh. to Lower Leading Edge of Right Door	3317	3299	18
X7	Rear Surface of Veh. to Lower Leading Edge of Left Door	3323	3307	16
X8	Rear Surface of Veh. to Upper Trailing Edge of Right Door	2278	2279	-1
X9	Rear Surface of Veh. to Upper Trailing Edge of Left Door	2282	2274	8
X10	Rear Surface of Veh. to Lower Trailing Edge of Right Door	2279	2263	16
X11	Rear Surface of Veh. to Lower Trailing Edge of Left Door	2292	2276	16
X12	Rear Surface of Veh. to Bottom of " A " Post on Right Side	3337	3315	22
X13	Rear Surface of Veh. to Bottom of " A " Post on Left Side	3343	3328	15
X14	Rear Surface of Vehicle to Firewall--Right Side	3618	3539	79
X15	Rear Surface of Vehicle to Firewall --Left Side	3608	3569	39
X16	Rear Surface of Vehicle to Steering Wheel Center	2905	2831	74
X17	Center of Steering Column to " A " Post	300	298	2
X18	Center of Steering Column to Headliner	450	423	27
X19	Rear Surface of Vehicle to Right Side of Front Bumper	4664	4282	382
X20	Rear Surface of Vehicle to Left Side of Front Bumper	4663	4209	454
X21	Length of Engine Block	470	470	0
RD	Rear Surface of Vehicle to Right Side of Dash Panel	3081	3065	16
CD	Rear Surface of Vehicle to Center of Dash Panel	3090	3029	61
LD	Rear Surface of Vehicle to Left Side of Dash Panel	3080	3065	15

All distance measurements are in millimeters.

Data Sheet 14 Vehicle Measurements, Cont'd.

Vehicle Intrusion Measurements

Door Opening Width

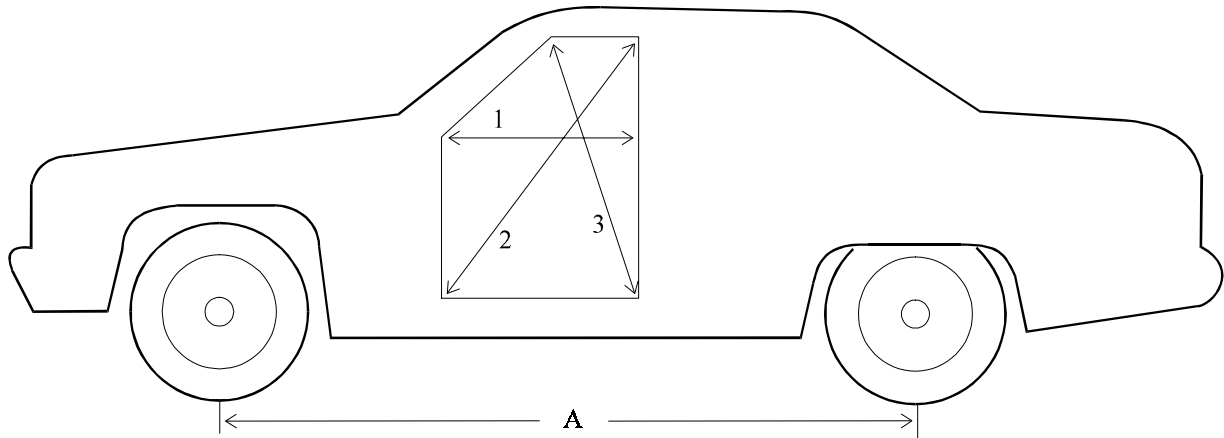

Units (mm)	Left			Right		
Measurement	1	2	3	1	2	3
Pre-Test	1120 mm	1435 mm	960 mm	1027 mm	1433 mm	982 mm
Post-Test	1014 mm	1438 mm	960 mm	1020 mm	1437 mm	988 mm
Difference	106 mm	-3 mm	0 mm	7 mm	-4 mm	-6 mm

Units (mm)	A = Wheelbase Left	A = Wheelbase Right
Pre-Test	2752 mm	2750 mm
Post-Test	2664 mm	2625 mm
Difference	88 mm	125 mm

Data Sheet 14 Vehicle Measurements, Cont'd.

Vehicle Intrusion Measurements

Static Footwell Deformation

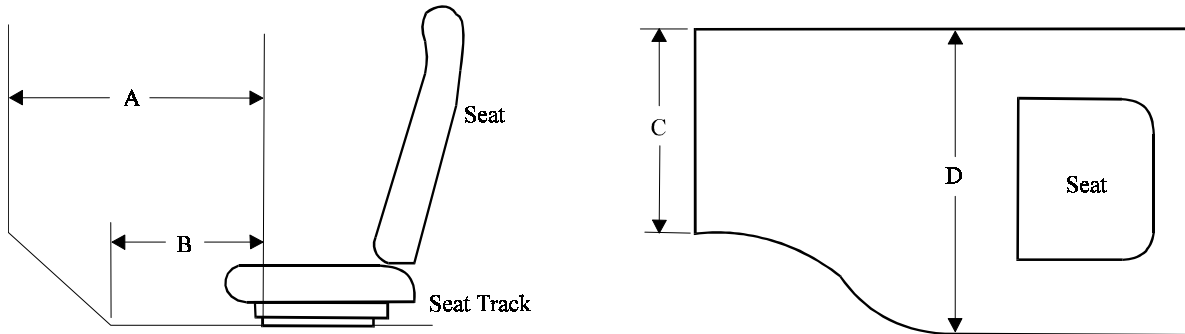

Driver's Side

Measurement	Pre-Test	Post-Test	Difference
A	670 mm	502 mm	168 mm
B	790 mm	642 mm	148 mm
C	340 mm	372 mm	-32 mm
D	443 mm	444 mm	-1 mm

Passenger's Side

Measurement	Pre-Test	Post-Test	Difference
A	660 mm	467 mm	193 mm
B	655 mm	561 mm	94 mm
C	390 mm	371 mm	19 mm
D	435 mm	425 mm	10 mm

Data Sheet 14 Vehicle Measurements, Cont'd.

Vehicle Intrusion Measurements

Static Passenger Compartment Intrusion

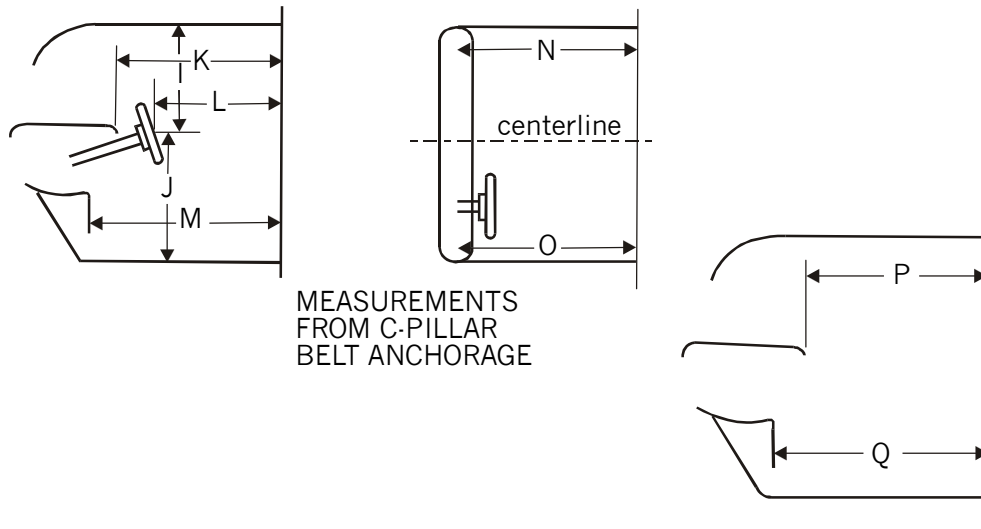

Measurement	Pre-Test	Post-Test	Difference
I	470 mm	430 mm	40 mm
J	615 mm	610 mm	5 mm
K (driver's side)	1630 mm	1596 mm	34 mm
L	1410 mm	1324 mm	86 mm
M (driver's side)	1740 mm	1731 mm	9 mm
N	1600 mm	1594 mm	6 mm
O	1605 mm	1600 mm	5 mm
P (passenger's side)	1695 mm	1681 mm	14 mm
Q (passenger's side)	1800 mm	1791 mm	9 mm

Data Sheet 14 Vehicle Measurements, Cont'd.

Floorboard Deformation

DRIVERS SIDE

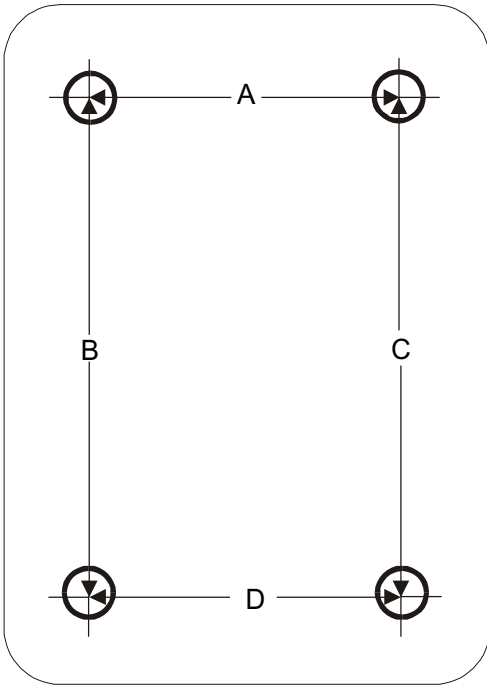

PASSENGERS SIDE

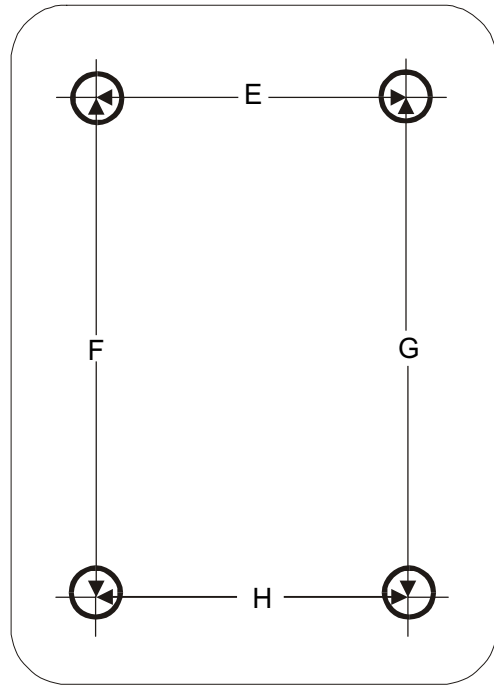

Measurement	Pre-Test	Post-Test	Difference
A	580 mm	395 mm	185 mm
B	540 mm	471 mm	69 mm
C	580 mm	444 mm	136 mm
D	500 mm	470 mm	30 mm
E	480 mm	400 mm	80 mm
F	550 mm	432 mm	118 mm
G	550 mm	521 mm	29 mm
H	495 mm	421 mm	74 mm

Data Sheet 14 Vehicle Measurements, Cont'd.

Driver Toeboard Measurements

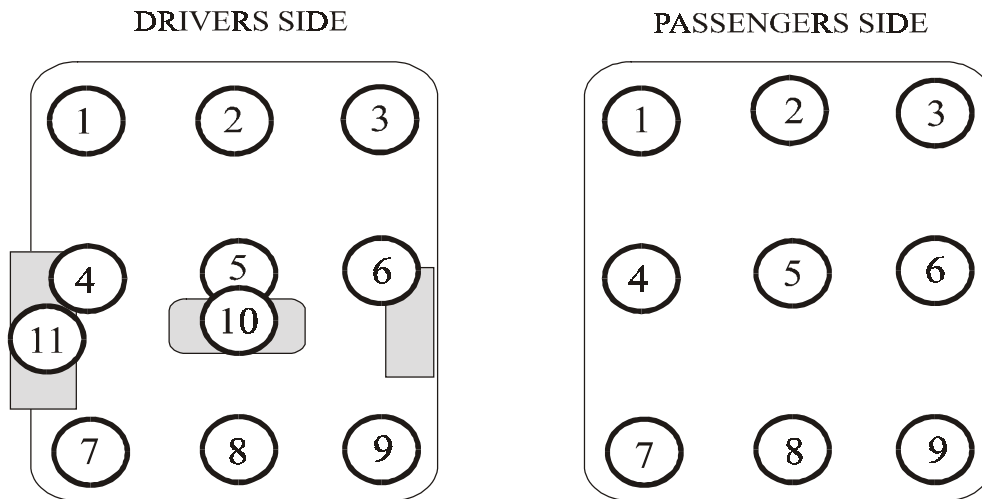

Driver's Side Floorpan Measurements

Floorpan Location	X			Z		
	Pre-Test	Post-Test	Difference	Pre-Test	Post-Test	Difference
1	3881 mm	3738	143 mm	437 mm	510 mm	-73 mm
2	3865 mm	3710	155 mm	405 mm	474 mm	-69 mm
3	3820 mm	3699	121 mm	423 mm	480 mm	-57 mm
4	3818 mm	3682	136 mm	327 mm	395 mm	-68 mm
5	3790 mm	3639	151 mm	305 mm	380 mm	-75 mm
6	3780 mm	3630	150 mm	303 mm	365 mm	-62 mm
7	3718 mm	3608	110 mm	255 mm	282 mm	-27 mm
8	3700 mm	3571	129 mm	252 mm	275 mm	-23 mm
9	3705 mm	3594	111 mm	255 mm	285 mm	-30 mm
10	3650 mm	3593	57 mm	402 mm	464 mm	-62 mm
11	3708 mm	3669	39 mm	375 mm	399 mm	-24 mm

Passenger's Side Floorpan Measurements

Floorpan Location	X			Z		
	Pre-Test	Post-Test	Difference	Pre-Test	Post-Test	Difference
1	3793 mm	3687	106 mm	417 mm	465 mm	-48 mm
2	3800 mm	3679	121 mm	420 mm	448 mm	-28 mm
3	3768 mm	3668	100 mm	440 mm	480 mm	-40 mm
4	3708 mm	3588	120 mm	305 mm	366 mm	-61 mm
5	3715 mm	3609	106 mm	303 mm	350 mm	-47 mm
6	3733 mm	3679	54 mm	308 mm	325 mm	-17 mm
7	3622 mm	3570	52 mm	253 mm	220 mm	33 mm
8	3625 mm	3574	51 mm	255 mm	225 mm	30 mm
9	3658 mm	3668	-10 mm	252 mm	190 mm	62 mm

Reference: +X forward from rear bumper; +Z upward from ground level

Figure 5 Camera Positions

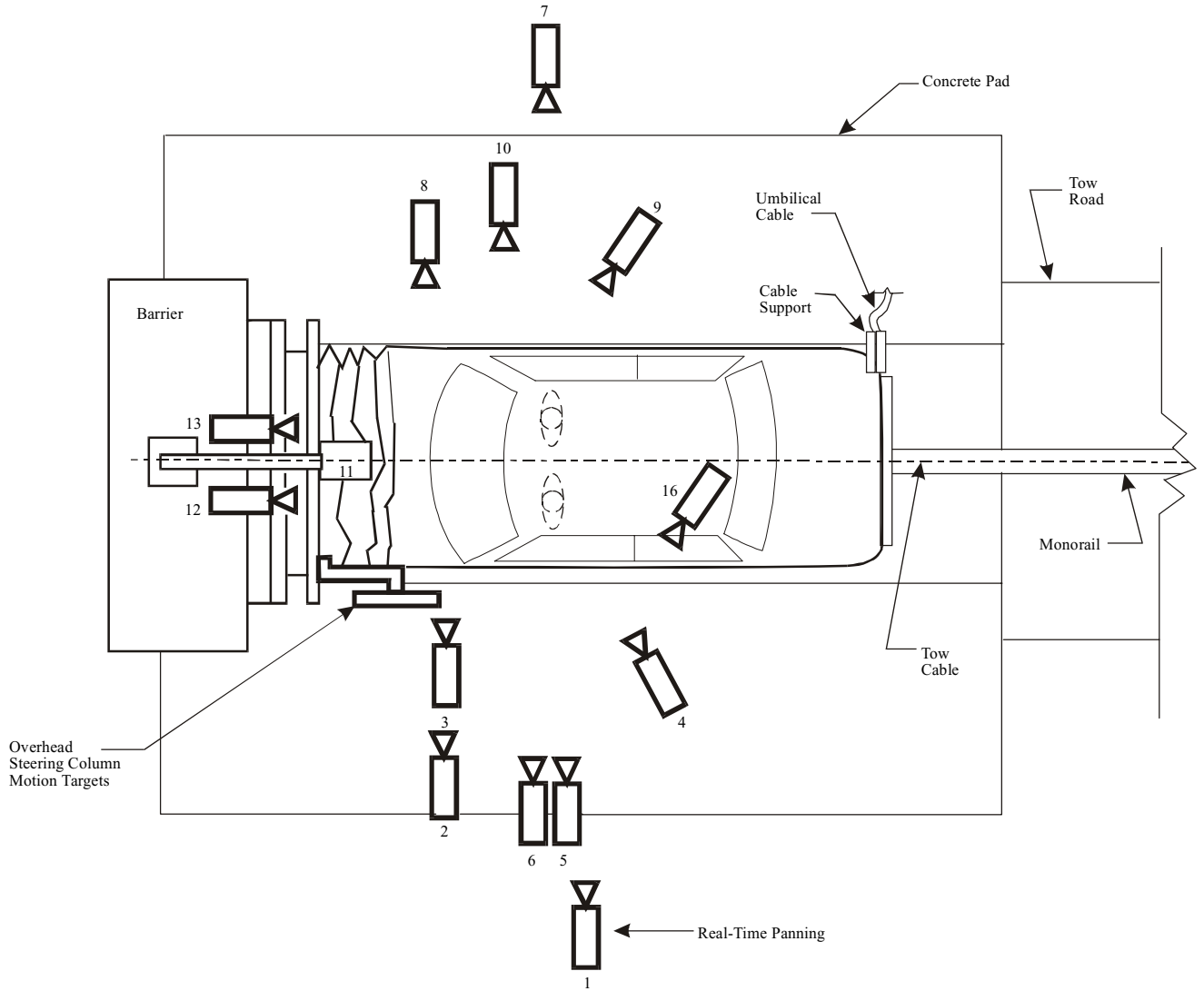
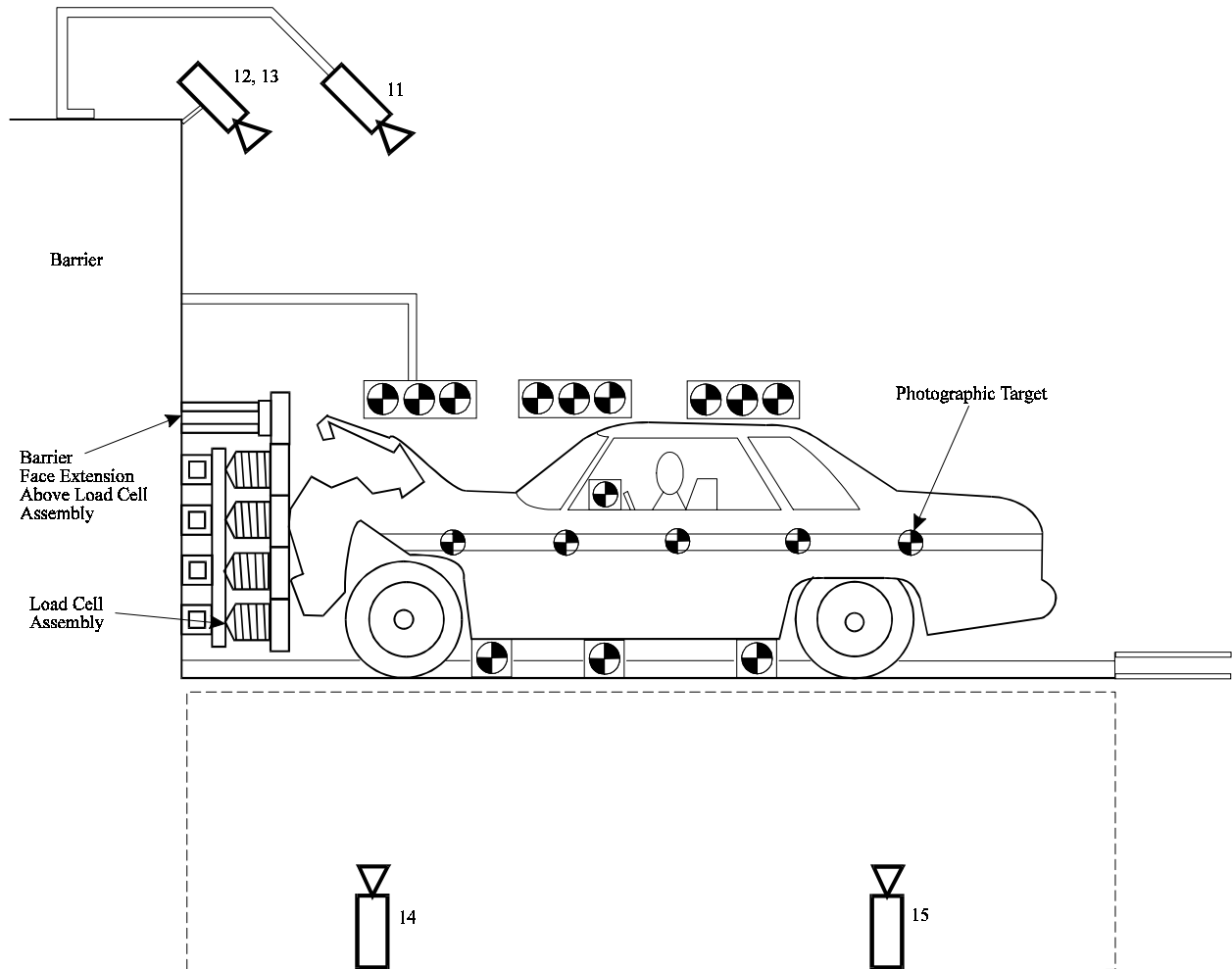

Figure 5 Camera Positions, Cont'd.



Data Sheet 15 Motion Picture Camera Locations

Test Number: 010618 Vehicle Year/Make/Model/Body Style: 2001/Nissan/Maxima/4-door sedan

No.	View	Camera Positions ¹			Angle ²	Film Plane to Head Target	Lens	Film Speed
		X	Y	Z				
1	Real-time panning	N/A	N/A	N/A	N/A	N/A	16 mm	24 frames/s
2	Left side medium tight	-1372 mm	6807 mm	1486 mm	N/A	N/A	25 mm	1030 frames/s
3	Left side windshield and dummy	-1372 mm	6096 mm	1422 mm	N/A	N/A	50 mm	1000 frames/s
4	Dummy and interior angled view	-3658 mm	2515 mm	2153 mm	N/A	N/A	25 mm	1010 frames/s
5	Column movement - upper	-2134 mm	8433 mm	2705 mm	N/A	N/A	25 mm	1007 frames/s
6	Column movement - lower	-2134 mm	8433 mm	1651 mm	N/A	N/A	25 mm	1002 frames/s
7	Right side overall	-3048 mm	-8230 mm	1524 mm	N/A	N/A	13 mm	1002 frames/s
8	Right side windshield and dummy	-914 mm	-6706 mm	1524 mm	N/A	N/A	50 mm	990 frames/s
9	Passenger and interior angled view	-3962 mm	-2311 mm	2134 mm	N/A	N/A	25 mm	997 frames/s
10	Right medium tight	-1524 mm	-2311 mm	2134 mm	N/A	N/A	25 mm	1007 frames/s
11	Windshield - barrier center	N/A	N/A	N/A	N/A	N/A	13 mm	1007 frames/s
12	Driver - barrier view	N/A	N/A	N/A	N/A	N/A	17 mm	1005 frames/s
13	Passenger - barrier view	N/A	N/A	N/A	N/A	N/A	17 mm	1000 frames/s
14	Front pit - engine	N/A	N/A	N/A	N/A	N/A	13 mm	1002 frames/s
15	Rear pit - fuel tank	N/A	N/A	N/A	N/A	N/A	13 mm	995 frames/s
16	Driver seat belt movement	N/A	N/A	N/A	N/A	N/A	13 mm	1000 frames/s
17	Passenger seat belt movement ³							

¹ +X = Film plane forward of barrier face
+Y = Film plane to left of monorail centerline
+Z = Film plane above ground level
² +Angle = Film plane angled upward from horizontal plane
³ Deleted from test

Data Sheet 16 Vehicle Reference Photo Target Locations

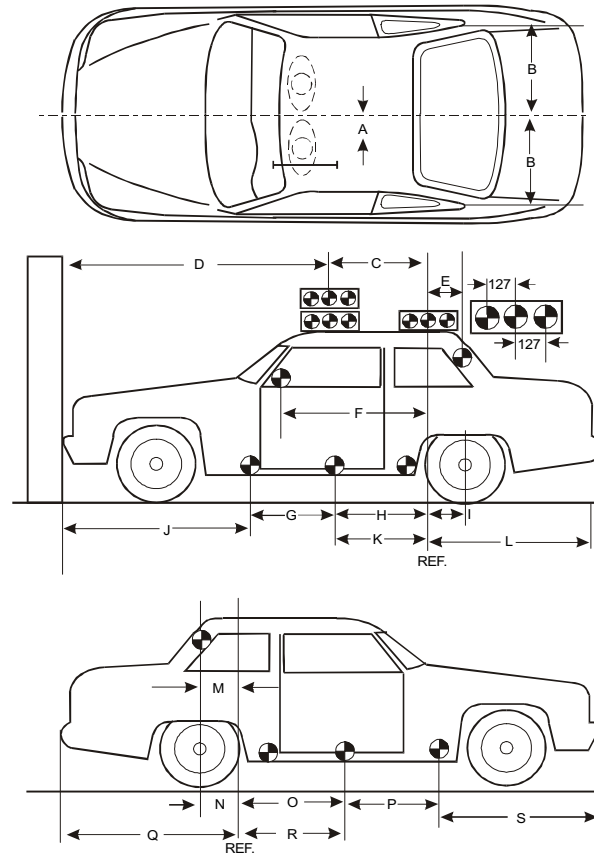

Measurement	Pre-Test
A	343 mm
B	715 mm
C	610 mm
D	522 mm
E	735 mm
F	1945 mm
G	905 mm
H	905 mm
I	275 mm
J	1485 mm
K	620 mm
L	2131 mm
M	738 mm
N	265 mm
O	905 mm
P	905 mm
Q	2131 mm
R	620 mm
S	1485 mm

Data Sheet 17 Load Cell Locations on Fixed Barrier

36 LOAD CELLS
4 ROWS
9 COLUMNS
FRONT VIEW

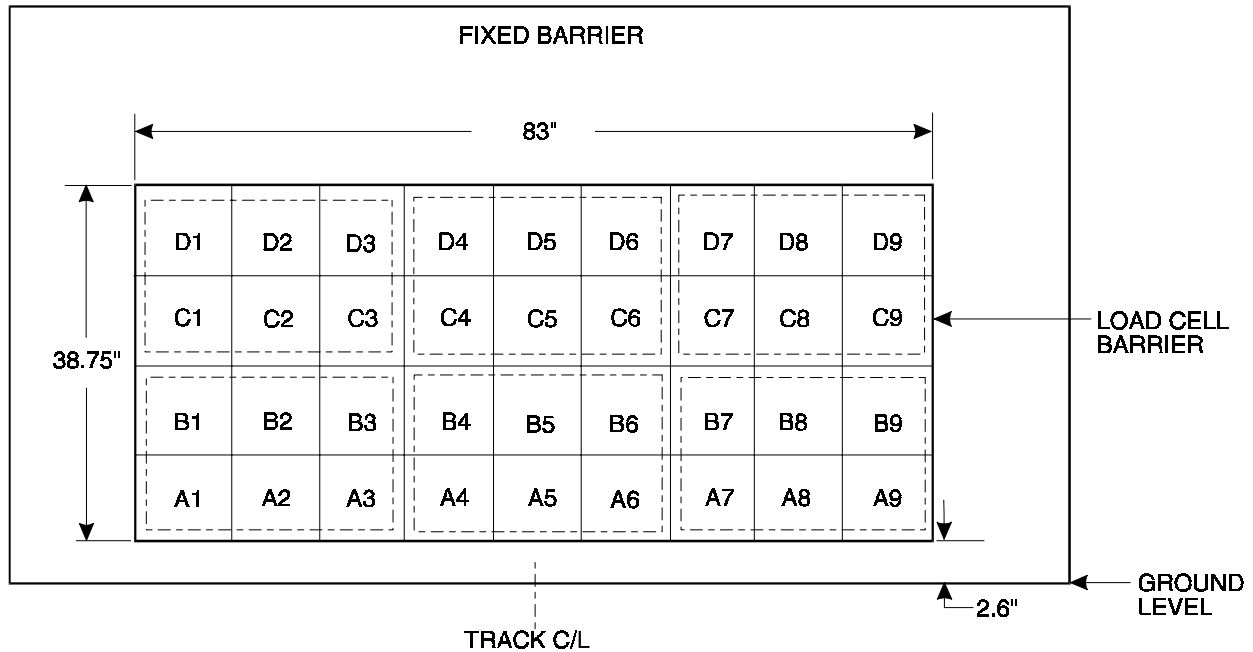

- Group 1: A1 through B3
- Group 2: A4 through B6
- Group 3: A7 through B9
- Group 4: C1 through D3
- Group 5: C4 through D6
- Group 6: C7 through D9

The following data is presented as data plots at the end of Section 4.0:

- 1) Data from 36 individual load cells
- 2) Total of 36 individual load cells
- 3) Data from 6 groupings shown above (6 cells/groups)

Data Sheet 18 Post-Test Airbag Data

Vehicle NHTSA number: NI0002
 Test date: 06/18/01
 Technician: Jason D. Jenkins/Virginia Watters
 Vehicle year/make/
 model/body style: 2001/Nissan/Maxima/4-door sedan

	<u>Driver</u>	<u>Passenger</u>
A. Number of airbag vent holes:	2	2
B. Size of airbag vent holes:	35 mm	40 mm
C. Total airbag vent area:	1923 mm ²	2512 mm ²
D. Deflated airbag length and width dimensions or, if round, diameter		
Driver: Diameter	660 mm	
Passenger: Diameter:	780 mm; width between top seams: 400 mm	
E. Is the airbag tethered?		
Driver: No		If yes, record length of tether: N/A
Passenger: No		If yes, record length of tether: N/A

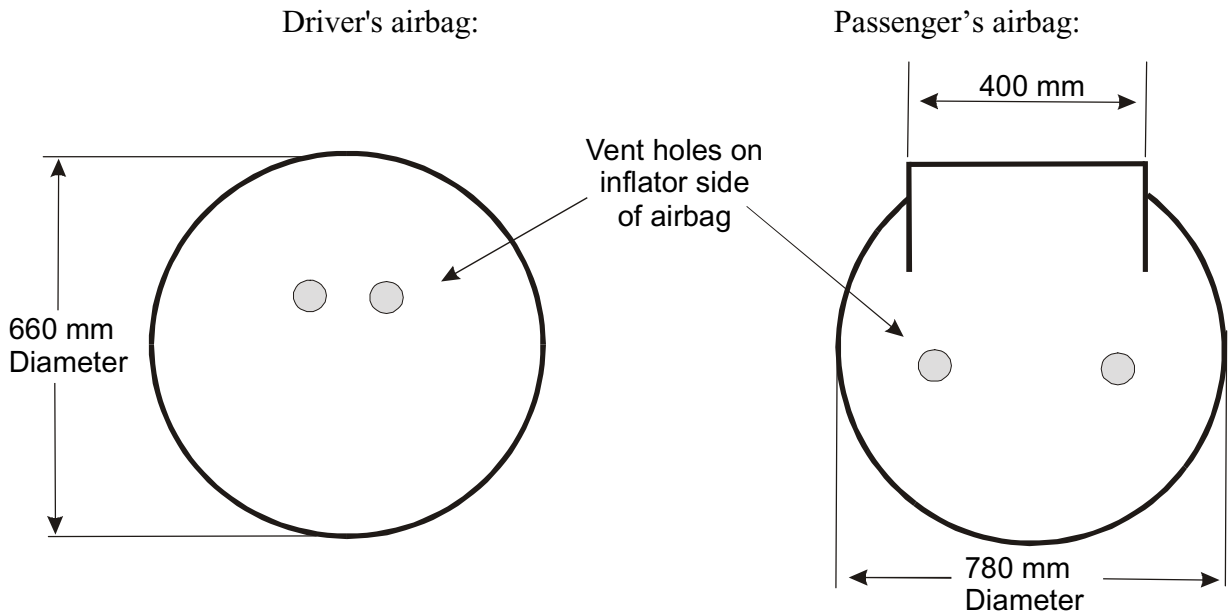

F. Airbag and gas generator part numbers and manufacturer's names.

Driver: Manufacturer:	N/A
Airbag:	PMY90012140306
Inflator:	SG860011290458
Passenger: Manufacturer:	N/A
Airbag:	KPY90012080194
Inflator:	N/A

Data Sheet 19 Accident Investigation Division Data

Vehicle year/make/
model/body style: 2001/Nissan/Maxima/4-door sedan

Vehicle NHTSA number: NI0002

VIN: JN1CA31D91T624427

Build date: 02/01

Test date: 06/18/01

Vehicle size category: Mid size car

Test weight: 1673.8 kg

Vehicle wheelbase: 2752 mm

Maximum width: 1780 mm

Front overhang: 4186 mm

Collision Deformation
Classification (CDC) code: 12FDEW2

Crush depth measurements:

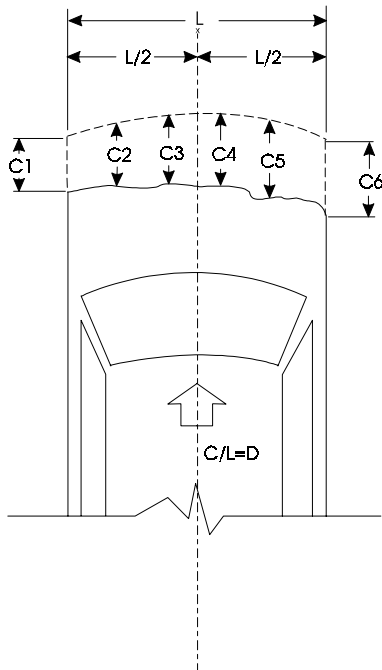

Location	Pre-test	Post-test	Difference
C1	4663 mm	4209 mm	454 mm
C2	4795 mm	4244 mm	551 mm
C3	4833 mm	4291 mm	542 mm
C4	4833 mm	4280 mm	553 mm
C5	4794 mm	4248 mm	546 mm
C6	4664 mm	4282 mm	382 mm
CL	4833 mm	4285 mm	548 mm

Midpoint of damage: D: Vehicle Longitudinal Centerline

Length of damaged region: L: 1525 mm

L/2: 762 mm

Section 3.0

Photographs

Section 4.0

Dummy, Vehicle, and Load Cell Barrier Response Data Plots

Section 5.0

Dummy Configuration and Performance Verification Data

Pre-Test Dummy Configuration and Performance Verification Data

Driver Dummy S/N: 142

Pre-Test Dummy Configuration and Performance Verification Data

Passenger Dummy S/N: 192

Section 6.0

Test Equipment and Instrumentation Calibration Information

Dummy Instrument Calibrations
Driver Dummy # 142

	Serial Number	Model Number	Manufacturer	Calibration Date	
				Last	Due
Head X-axis accelerometer	AGAG0	7264-2000LC	Endevco	05/25/01	11/25/01
Head Y-axis accelerometer	AAJY4	7264-2000LC	Endevco	05/25/01	11/25/01
Head Z-axis accelerometer	AAKE2	7264-2000LC	Endevco	05/25/01	11/25/01
Head X-axis accelerometer-redundant	AF9Y3	7264-2000LC	Endevco	05/25/01	11/25/01
Head Y-axis accelerometer-redundant	AF973	7264-2000LC	Endevco	05/25/01	11/25/01
Head Z-axis accelerometer-redundant	AGN47	7264-2000LC	Endevco	05/25/01	11/25/01
Chest X-axis accelerometer	J27466	7264-2KM5T	Endevco	05/25/01	11/25/01
Chest Y-axis accelerometer	J27470	7264-2KM5T	Endevco	05/25/01	11/25/01
Chest Z-axis accelerometer	J27509	7264-2KM5T	Endevco	05/25/01	11/25/01
Chest X-axis accelerometer-redundant	AAL32	7264-2KM5T	Endevco	05/25/01	11/25/01
Chest Y-axis accelerometer-redundant	AGT82	7264-2KM5T	Endevco	05/25/01	11/25/01
Chest Z-axis accelerometer-redundant	AGR67	7264-2KM5T	Endevco	05/25/01	11/25/01
Left femur force load cell	257	2121	Denton	06/07/01	12/07/01
Right femur force load cell	258	2121	Denton	06/07/01	12/07/01
Neck X-axis force load cell	260-FX	IF-205	FTSS	05/23/01	11/23/01
Neck Y-axis force load cell	260-FY	IF-205	FTSS	05/23/01	11/23/01
Neck Z-axis force load cell	260-FZ	IF-205	FTSS	05/23/01	11/23/01
Neck Moment about X-axis load cell	260-MX	IF-205	FTSS	05/23/01	11/23/01
Neck Moment about Y-axis load cell	260-MY	IF-205	FTSS	05/23/01	11/23/01
Neck Moment about Z-axis load cell	260-MZ	IF-205	FTSS	05/23/01	11/23/01
Pelvis X-axis accelerometer	J23918	7264-2KM5T	Endevco	05/25/01	11/25/01
Pelvis Y-axis accelerometer	EH75J	7264-2KM5T	Endevco	05/25/01	11/25/01
Pelvis Z-axis accelerometer	FJ66J	7264-2KM5T	Endevco	05/25/01	11/25/01
Chest deflection potentiometer	142	14CB1-2981	Servo	06/15/01	12/15/01
Left tibia to femur displacement	1469	150-0121VR	Space Age	05/31/01	11/30/01
Right tibia to femur displacement	1468	150-0121VL	Space Age	05/31/01	11/30/01

Dummy Instrument Calibrations, Cont'd.
Driver Dummy # 142

	Serial Number	Model Number	Manufacturer	Calibration Date	
				Last	Due
Left upper tibia moment about X-axis load cell	107-MX	3292	Denton	06/06/01	12/06/01
Left upper tibia moment about Y-axis load cell	107-MY	3292	Denton	06/06/01	12/06/01
Left upper tibia Z-axis force load cell	107-FZ	3292	Denton	06/06/01	12/06/01
Right upper tibia moment about X-axis load cell	108-MX	3292	Denton	06/06/01	12/06/01
Right upper tibia moment about Y-axis load cell	108-MY	3292	Denton	06/06/01	12/06/01
Right upper tibia Z-axis force load cell	108-FZ	3292	Denton	06/06/01	12/06/01
Left Lower tibia X-axis moment about X-axis load cell	137-MX	3093	Denton	06/06/01	12/06/01
Left Lower tibia moment about Y-axis load cell	137-MY	3093	Denton	06/06/01	12/06/01
Left Lower tibia Z-axis force load cell	137-FZ	3093	Denton	06/06/01	12/06/01
Right Lower tibia X-axis moment about X-axis load cell	136-MX	3093	Denton	06/06/01	12/06/01
Right Lower tibia moment about Y-axis load cell	136-MY	3093	Denton	06/06/01	12/06/01
Right Lower tibia Z-axis force load cell	136-FZ	3093	Denton	06/06/01	12/06/01
Left foot heel X-axis accelerometer	AAKA1	7264-2000LC	Endevco	05/25/01	11/25/01
Left foot heel Z-axis accelerometer	AAKA2	7264-2000LC	Endevco	05/25/01	11/25/01
Left foot toe Z-axis accelerometer	AF9Y5	7264-2000LC	Endevco	05/25/01	11/25/01
Right foot heel X-axis accelerometer	J14232	7264-2000LC	Endevco	05/25/01	11/25/01
Right foot heel Z-axis accelerometer	AJ453	7264-2000LC	Endevco	05/25/01	11/25/01
Right foot toe Z-axis accelerometer	J17988	7264-2000LC	Endevco	05/25/01	11/25/01

Dummy Instrument Calibrations, Cont'd.
Passenger Dummy # 192

	Serial Number	Model Number	Manufacturer	Calibration Date	
				Last	Due
Head X-axis accelerometer	ACCP9	7264-2000LC	Endevco	05/25/01	11/25/01
Head Y-axis accelerometer	AGMY3	7264-2000LC	Endevco	05/25/01	11/25/01
Head Z-axis accelerometer	AGRY2	7264-2000LC	Endevco	05/25/01	11/25/01
Head X-axis accelerometer-redundant	AGRP4	7264-2000LC	Endevco	05/25/01	11/25/01
Head Y-axis accelerometer-redundant	AAKB3	7264-2000LC	Endevco	05/25/01	11/25/01
Head Z-axis accelerometer-redundant	AFW91	7264-2000LC	Endevco	05/25/01	11/25/01
Chest X-axis accelerometer	J29006	7264-2KM5T	Endevco	05/25/01	11/25/01
Chest Y-axis accelerometer	J27523	7264-2KM5T	Endevco	05/25/01	11/25/01
Chest Z-axis accelerometer	J29023	7264-2KM5T	Endevco	05/25/01	11/25/01
Chest X-axis accelerometer-redundant	J27457	7264-2KM5T	Endevco	05/25/01	11/25/01
Chest Y-axis accelerometer-redundant	J27461	7264-2KM5T	Endevco	05/25/01	11/25/01
Chest Z-axis accelerometer-redundant	J35562	7264-2000LC	Endevco	05/25/01	11/25/01
Left femur force load cell	0263	2121	Denton	06/07/01	12/07/01
Right femur force load cell	0264	2121	Denton	06/07/01	12/07/01
Neck X-axis force load cell	261-FX	IF-205	FTSS	05/23/01	11/23/01
Neck Y-axis force load cell	261-FY	IF-205	FTSS	05/23/01	11/23/01
Neck Z-axis force load cell	261-FZ	IF-205	FTSS	05/23/01	11/23/01
Neck Moment about X-axis load cell	261-MX	IF-205	FTSS	05/23/01	11/23/01
Neck Moment about Y-axis load cell	261-MY	IF-205	FTSS	05/23/01	11/23/01
Neck Moment about Z-axis load cell	261-MZ	IF-205	FTSS	05/23/01	11/23/01
Pelvis X-axis accelerometer	J19873	7264-2KM5T	Endevco	05/25/01	11/25/01
Pelvis Y-axis accelerometer	J19236	7264-2KM5T	Endevco	05/25/01	11/25/01
Pelvis Z-axis accelerometer	J23772	7264-2KM5T	Endevco	05/25/01	11/25/01
Chest deflection potentiometer	87313-96	14CB1-2981	Servo	06/06/01	12/06/01
Left tibia to femur displacement	1469	150-0121VR	Space Age	05/31/01	11/30/01
Right tibia to femur displacement	1467	150-0121VL	Space Age	05/31/01	11/30/01

Dummy Instrument Calibrations, Cont'd.
Passenger Dummy # 192

	Serial Number	Model Number	Manufacturer	Calibration Date	
				Last	Due
Left upper tibia moment about X-axis load cell	110-MX	3292	Denton	06/06/01	12/06/01
Left upper tibia moment about Y-axis load cell	110-MY	3292	Denton	06/06/01	12/06/01
Left upper tibia Z-axis force load cell	110-FZ	3292	Denton	06/06/01	12/06/01
Right upper tibia moment about X-axis load cell	111-MX	3292	Denton	06/06/01	12/06/01
Right upper tibia moment about Y-axis load cell	111-MY	3292	Denton	06/06/01	12/06/01
Right upper tibia Z-axis force load cell	111-FZ	3292	Denton	06/06/01	12/06/01
Left Lower tibia X-axis force load cell	139-MX	3093	Denton	06/06/01	12/06/01
Left Lower tibia moment about Y-axis load cell	139-MY	3093	Denton	06/06/01	12/06/01
Left Lower tibia Z-axis force load cell	139-FZ	3093	Denton	06/06/01	12/06/01
Right Lower tibia X-axis force load cell	142-MX	3093	Denton	06/06/01	12/06/01
Right Lower tibia moment about Y-axis load cell	142-MY	3093	Denton	06/06/01	12/06/01
Right Lower tibia Z-axis force load cell	142-FZ	3093	Denton	06/06/01	12/06/01
Left foot heel X-axis accelerometer	AJ507	7264-2KM5T	Endevco	05/25/01	11/25/01
Left foot heel Z-axis accelerometer	J35564	7264-2000LC	Endevco	05/25/01	11/25/01
Left foot toe Z-axis accelerometer	J14232	7264-2KM5T	Endevco	05/25/01	11/25/01
Right foot heel X-axis accelerometer	J19925	7264-2KM5T	Endevco	05/25/01	11/25/01
Right foot heel Z-axis accelerometer	J17988	7264-2KM5T	Endevco	05/25/01	11/25/01
Right foot toe Z-axis accelerometer	AJ4R3	7264-2KM5T	Endevco	05/25/01	11/25/01

Vehicle and Calibration Laboratory Instrument Calibrations

Vehicle Accelerometers

	Serial Number	Model Number	Manufacturer	Calibration Date	
				Last	Due
Left rear seat crossmember X-axis	J34515	7264-2000TZ	Endevco	06/13/01	12/13/01
Left rear seat crossmember X-axis redundant	J31017	7264-2000TZ	Endevco	16/13/01	12/13/01
Right rear seat crossmember X-axis	J30423	7264-2000TZ	Endevco	03/08/01	09/08/01
Right rear seat crossmember X-axis redundant	J36177	7264-2000TZ	Endevco	01/30/01	07/30/01
Engine top X-axis	J36555	7264-2000TZ	Endevco	06/13/01	12/13/01
Engine bottom X-axis	J28978	7264-2000TZ	Endevco	03/28/01	09/28/01
Right brake caliper X-axis	J36279	7264-2000TZ	Endevco	06/13/01	12/13/01
Left brake caliper X-axis	J15372	7264-2000TZ	Endevco	03/08/01	09/08/01
Instrument panel center X-axis	J36783	7264-2000TZ	Endevco	06/13/01	12/13/01

Seat Belt Transducers

	Serial Number	Model Number	Manufacturer	Calibration Date	
				Last	Due
Driver:					
Lap belt force load cell	808	3419T	Lebow	05/08/01	11/08/01
Shoulder belt force load cell	805	3419T	Lebow	05/01/01	11/01/01
Shoulder belt displacement	A12889	PT-101-60A	Celesco	03/09/01	09/09/01
Shoulder belt extension	ST3	205141410	Bourns	06/18/01	12/18/01
Passenger:					
Lap belt force load cell	804	3419T	Lebow	05/09/01	11/09/01
Shoulder belt force load cell	809	3419T	Lebow	05/01/01	11/01/01
Shoulder belt displacement	A23306	PT-101-60A	Celesco	02/09/01	08/09/01
Shoulder belt extension	2091	205141410	Bourns	06/18/01	12/18/01

Dummy Laboratory Instrument Calibrations

	Serial Number	Model Number	Manufacturer	Calibration Date	
				Last	Due
Neck bending pendulum accelerometer	A079	7231C	Endevco	06/06/01	12/06/01
Neck bending rotary potentiometer	9439EG (Beta3)	6657S-1-102	Bourns	04/30/01	10/30/01
Neck bending rotary potentiometer	9618EL (Theta)	6657S-1-102	Bourns	06/30/01	12/30/01
Thorax/Hybrid III pendulum accelerometer	CC64	7232	Endevco	04/23/01	10/23/01
Hybrid III femur pendulum accelerometer	CB35	7232	Endevco	04/23/01	10/23/01
Hip flexion torque transducer	940	2110-5K	Eaton	04/13/01	10/13/01
Hip flexion rotary pot	0218	6209-2038	JDK	04/10/01	10/10/01
Hybrid III knee slider test load cell	964	2430	GSE	04/28/01	10/28/01

Sign Convention
SAE J211 Sign Convention
(used for NHTSA format data diskettes)

<u>Accelerometers:</u>	+X: Forward
	+Y: Rightward
	+Z: Downward
<u>Potentiometers:</u>	+Chest longitudinal deflection: Outward ¹
	+Chest lateral deflection: Rightward
	+Seat belt displacement: Outward
	+Seat belt extension: Elongation
	+Knee slider displacement: Distance between femur and tibia increased (in relation to a seated dummy)
<u>Load cells:</u>	+Femur force: Tension
	+Seat belt force: Tension
	+Barrier force: Tension
<u>Neck load cells:</u>	+X force: Head rearward, chest forward
	+Y force: Head leftward, chest rightward
	+Z force: Head pulled upward (tension on neck), chest downward
	+X moment: Left ear rotating toward left shoulder
	+Y moment: Chin rotating toward chest
	+Z moment: Chin rotating toward left shoulder
<u>Tibia load cells:</u>	+X force: Ankle forward, knee rearward
	+Y force: Ankle rightward, knee leftward
	+Z force: Ankle downward, femur upward (tension)
	+X moment: Ankle leftward, holding knee in place
	+Y moment: Ankle forward, bottom of knee clevis rearward

¹ Exception: Dummy Calibration Laboratory thorax test chest displacement data is presented as positive = inward (rearward).

Frequency Response Classes
SAE J211 MAR95¹

<u>Typical Test Measurements</u>	<u>Channel Class</u>
Vehicle Structural Accelerations for use in:	
Total vehicle comparison	60
Collision simulation input	60
Component analysis	600
Integration for velocity or displacement	180
Barrier Face Forces	60
Belt Restraint System Loads	60
Anthropomorphic Test Device	
Head accelerations (linear and angular)	1000
Neck	
Forces	1000
Moments	600
Thorax	
Spine accelerations	180
Rib accelerations	1000
Sternum accelerations	1000
Deflections	180 ¹
Lumbar	
Forces	1000
Moments	1000
Pelvis	
Accelerations	1000
Forces	1000
Moments	1000
Femur/Knee/Tibia/Ankle	
Forces	600
Moments	600
Displacements	180
Sled Accelerations	60
Steering Column Loads	600
Head form Accelerations	1000

¹ Exception to J211: NCAP procedure requires Channel Class 180 for chest deflection instead of the J211 recommended Channel Class 600.

Type: HIII S/N: 142 Mfr: Humanoid Test Date: 06/18/01
 Proj./Seg. No.: 20010281-1000 Test Eng.: Ginny Watters

Item	Pre-Use
Head:	
Head Ballast Condition	X
Accelerometer Mount Bolts and Cables	X
Skull Cap Bolts	X
Accelerometer Cable Exit (left or right)	X
Neck:	
* Bracket at specified setting, Serration Alignment, Bolt 0°	X
* Condyle Pin, Set Screws	X
* Rubber Condition	X
* Neck Cable Torque (50 th 9.6 - 14.4 in-lb/5 th 12 in-lb/6YO 1.8 - 2.2 in/lbs)	X
* Nodding Blocks Condition and Position	X
Arms and Hands:	
Clavicle and Shoulder Bumpers Condition	X
Range of Motion Stops: Elbow, Top and Rear Shoulder	X
Thorax:	
Front and Rear Rib Bolts, Rib Ends Position, Rib Spacing	X
Chest Pot Arm, Ball Movement, Set Screws	X
Sternum Bolts and Sternum Bumpers Condition	X
Jacket Condition	X
Abdominal Insert Condition	X
Rib Damping Material and Stiffeners Condition	X
Rib Minimum Depth (Use Chest Depth Gauge)	X
Accelerometer Mount Bolts	X
Lumbar Spine Rubber Condition, Spine Angle, (4) Attachment Bolts	X
Pelvis:	
Illioc Crest Bone	X
Flesh Condition	X
Accelerometer Mount Bolt	X
Lumbar Block Bolts	X
Legs and Feet:	
* Femur Load Cell Bolts (30 ft/lbs.)	X
Knee Joint Function and Range of Motion	X
Knee Skins, Inserts and Castings Condition	X
Knee Slider Zero Position	X
Ankle Range of Motion, Bumper Condition	X
Foot Condition	X
Other:	
Cleanliness/Skin Condition & Position	X
Target Position	X
Clothes Blue	X
Shoes	X
One G Joint Adjustments	X

* Items to be checked during calibration.

Inspection Completed By: J. Clarridge Date: 06/15/01

Type: HIII S/N: 192 Mfr: Alderson Test Date: 06/18/01
 Proj./Seg. No.: 20010281-1000 Test Eng.: Ginny Watters

Item	Pre-Use
Head:	
Head Ballast Condition	X
Accelerometer Mount Bolts and Cables	X
Skull Cap Bolts	X
Accelerometer Cable Exit (left or right)	X
Neck:	
* Bracket at specified setting, Serration Alignment, Bolt 0°	X
* Condyle Pin, Set Screws	X
* Rubber Condition	X
* Neck Cable Torque (50 th 9.6 - 14.4 in-lb/5 th 12 in-lb/6YO 1.8 - 2.2 in/lbs)	X
* Nodding Blocks Condition and Position	X
Arms and Hands:	
Clavicle and Shoulder Bumpers Condition	X
Range of Motion Stops: Elbow, Top and Rear Shoulder	X
Thorax:	
Front and Rear Rib Bolts, Rib Ends Position, Rib Spacing	X
Chest Pot Arm, Ball Movement, Set Screws	X
Sternum Bolts and Sternum Bumpers Condition	X
Jacket Condition	X
Abdominal Insert Condition	X
Rib Damping Material and Stiffeners Condition	X
Rib Minimum Depth (Use Chest Depth Gauge)	X
Accelerometer Mount Bolts	X
Lumbar Spine Rubber Condition, Spine Angle, (4) Attachment Bolts	X
Pelvis:	
Iliac Crest Bone	X
Flesh Condition	X
Accelerometer Mount Bolt	X
Lumbar Block Bolts	X
Legs and Feet:	
* Femur Load Cell Bolts (30 ft/lbs.)	X
Knee Joint Function and Range of Motion	X
Knee Skins, Inserts and Castings Condition	X
Knee Slider Zero Position	X
Ankle Range of Motion, Bumper Condition	X
Foot Condition	X
Other:	
Cleanliness/Skin Condition & Position	X
Target Position	X
Clothes Pink	X
Shoes	X
One G Joint Adjustments	X

* Items to be checked during calibration.

Inspection Completed By: J. Clarridge Date: 06/15/01

Type: HIII S/N: 142 Mfr: Humanoid Test Date: 06/18/01
 Proj./Seg. No.: 20010281-1000 Test Eng.: Ginny Watters

Item	Post-Use
Head:	
Head Skin Condition	X
Neck:	
Rubber Condition	X
Arms and Hands:	
Skin Condition	X
Thorax:	
Jacket Condition	X
Rib Damping Material and Stiffeners Condition	X
Chest Pot Arm and Ball Movement	X
Spine Condition	X
Sternum Assembly Condition	X
Pelvis:	
Iliac Crest Bone	X
Flesh Condition	X
Range of Motion Bumpers and Leg Cavity	X
Legs and Feet:	
Knee Skins, Inserts, and Castings Condition	X
Leg Skin Condition and Position	X
Foot Condition	X

Notes: No damage to report.

Inspection Completed By: J. Clarridge Date: 06/19/01

Type: HIII S/N: 192 Mfr: Alderson Test Date: 06/18/01
 Proj./Seg. No.: 20010281-1000 Test Eng.: Ginny Watters

Item	Post-Use
Head:	
Head Skin Condition	X
Neck:	
Rubber Condition	X
Arms and Hands:	
Skin Condition	X
Thorax:	
Jacket Condition	X
Rib Damping Material and Stiffeners Condition	X
Chest Pot Arm and Ball Movement	X
Spine Condition	X
Sternum Assembly Condition	X
Pelvis:	
Iliac Crest Bone	X
Flesh Condition	X
Range of Motion Bumpers and Leg Cavity	X
Legs and Feet:	
Knee Skins, Inserts, and Castings Condition	X
Leg Skin Condition and Position	X
Foot Condition	See Note

Notes: Replaced missing stop pin retainer from ankle (supplied by VRTC).

 No other damage to report.

Inspection Completed By: J. Clarridge Date: 06/18/01

Temperature Data - NHTSA NCAP Veh. No. NI0002- Test Date 6/18/01

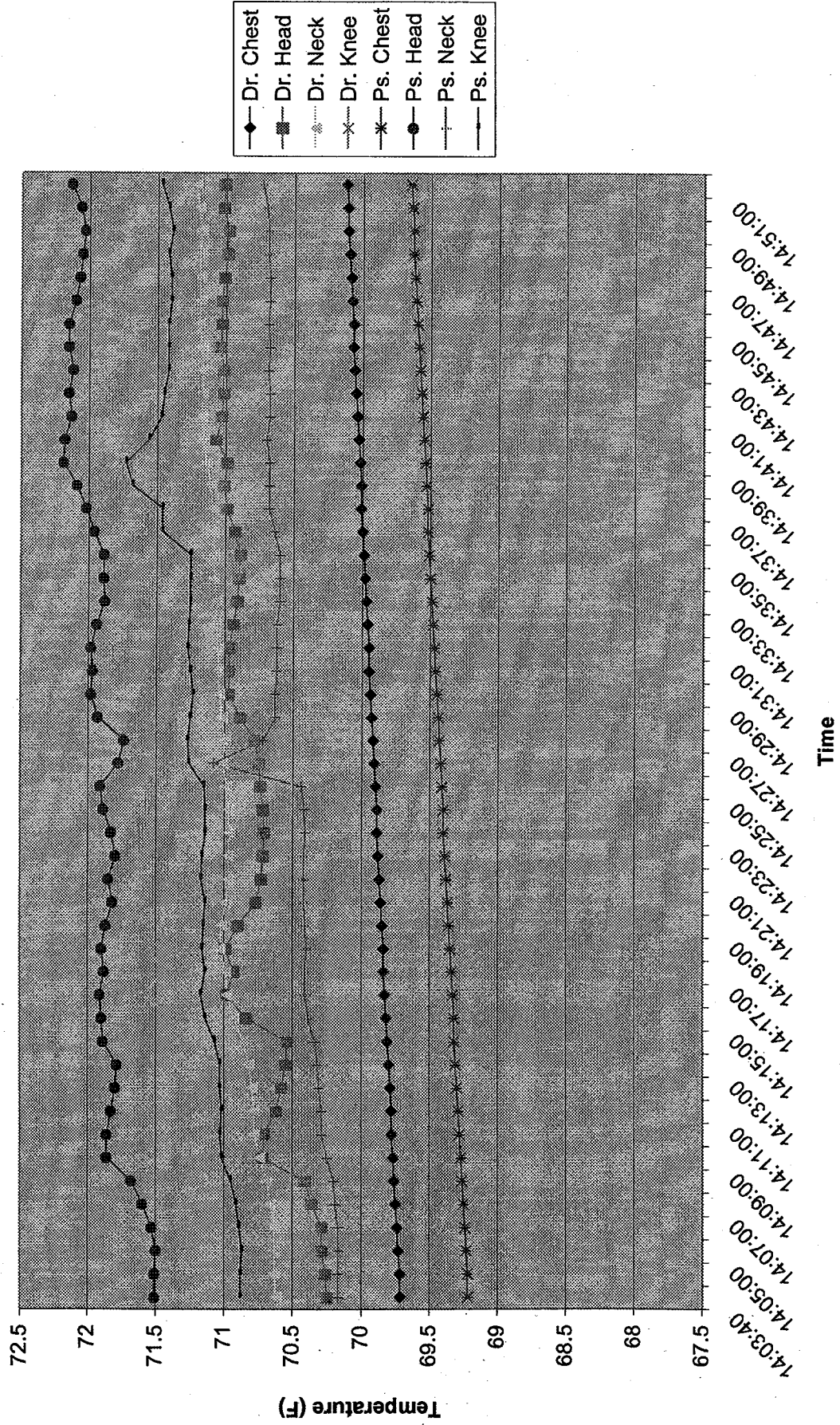

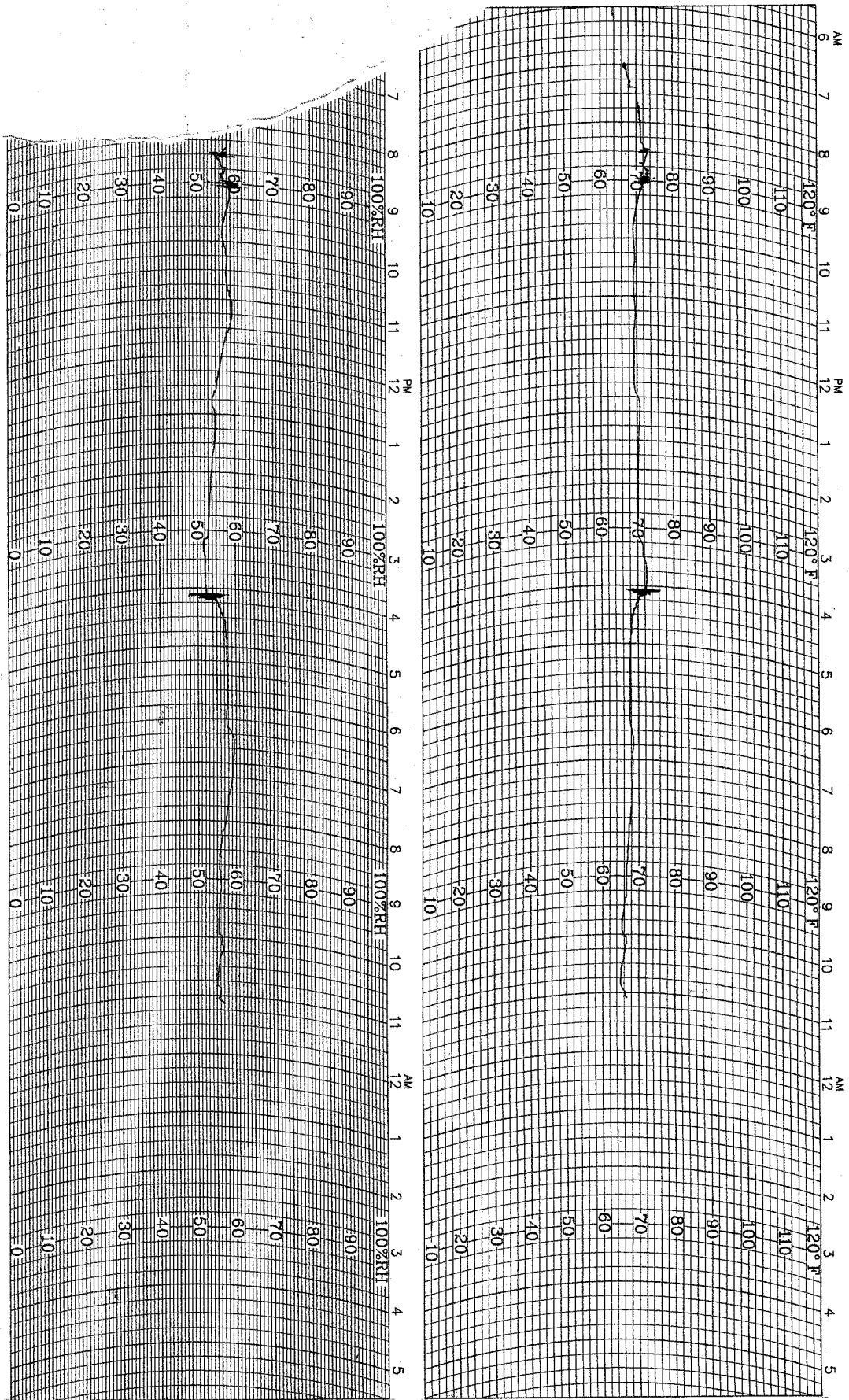

Weather Measure
WEATHERtronics
 Division of QUALLMETRICS, Inc.

P.O. BOX 41039
 SACRAMENTO, CA 95841
 PHONE: (916) 923-0055

HYGROTHERMOGRAPH
 1 DAY

CHART NO. M699123
 C311-D-HF
 ECN 2717
 6-9-87

20010287-1000
 STATION NHTSA NCAP DATE ON 6-18-01 DATE OFF _____



Figure 3-1 Pre-Test Front View
3-2

010618

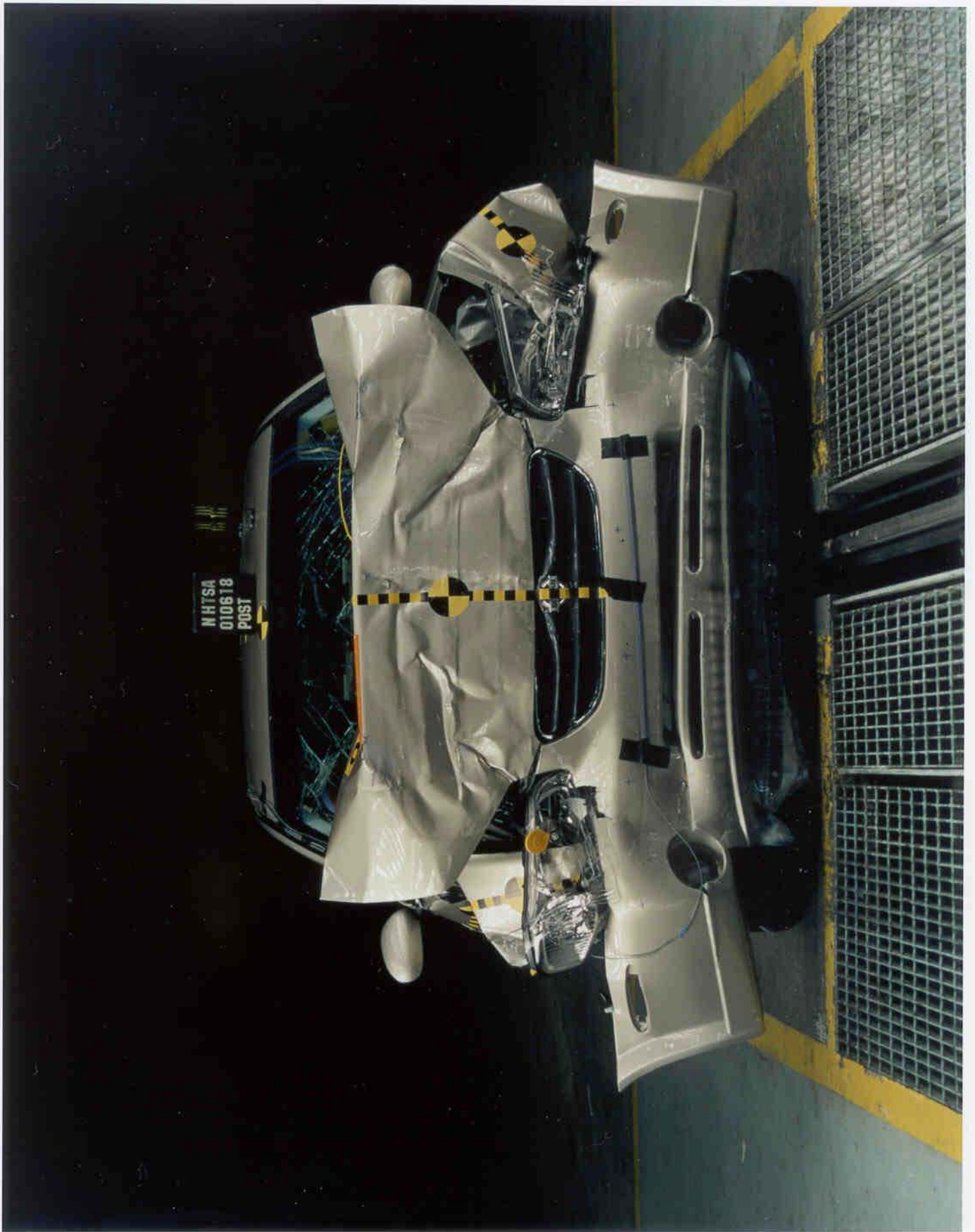

Figure 3-2 Post-Test Front View
3-3

010618

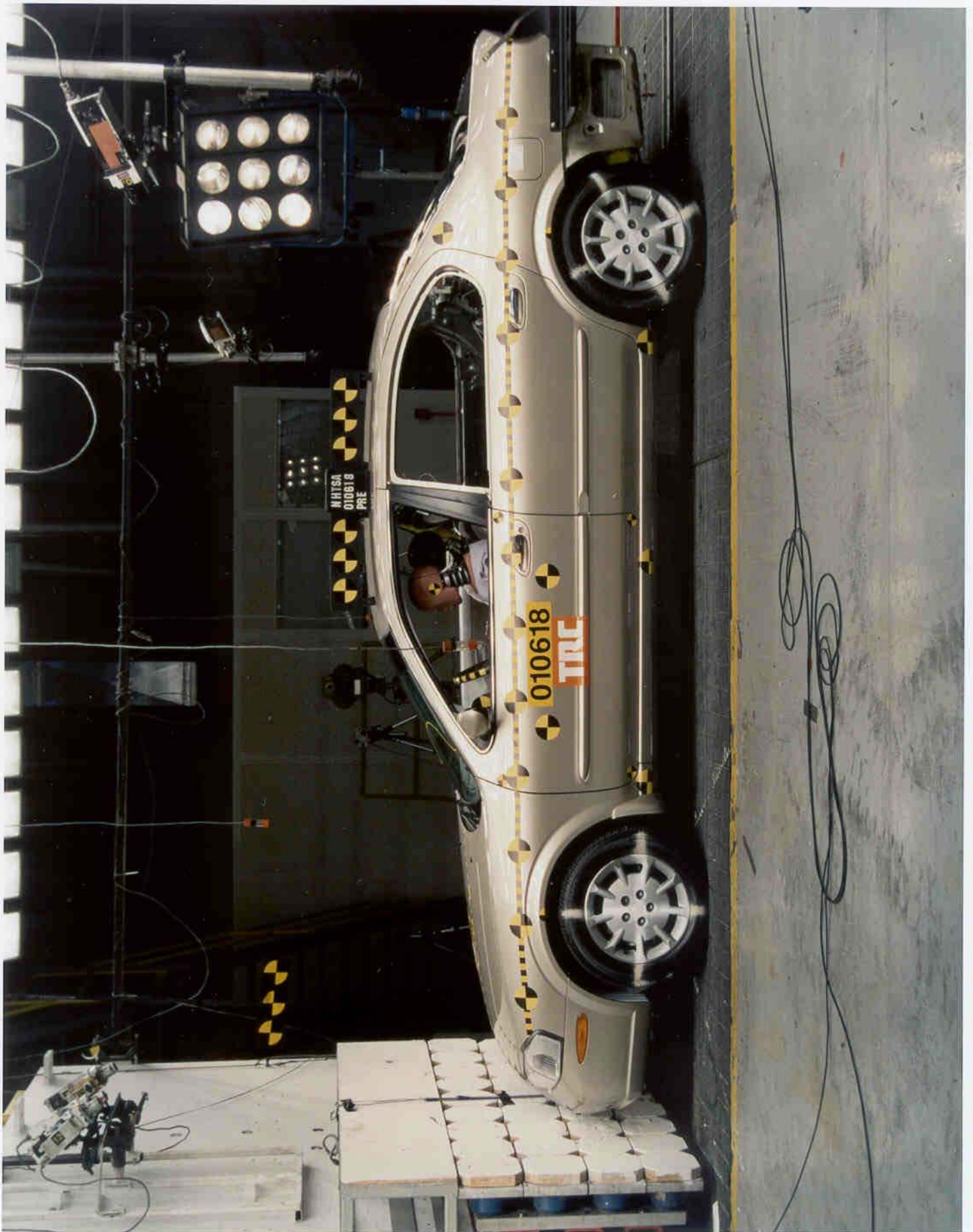

Figure 3-3 Pre-Test Left Side View

3-4

010618

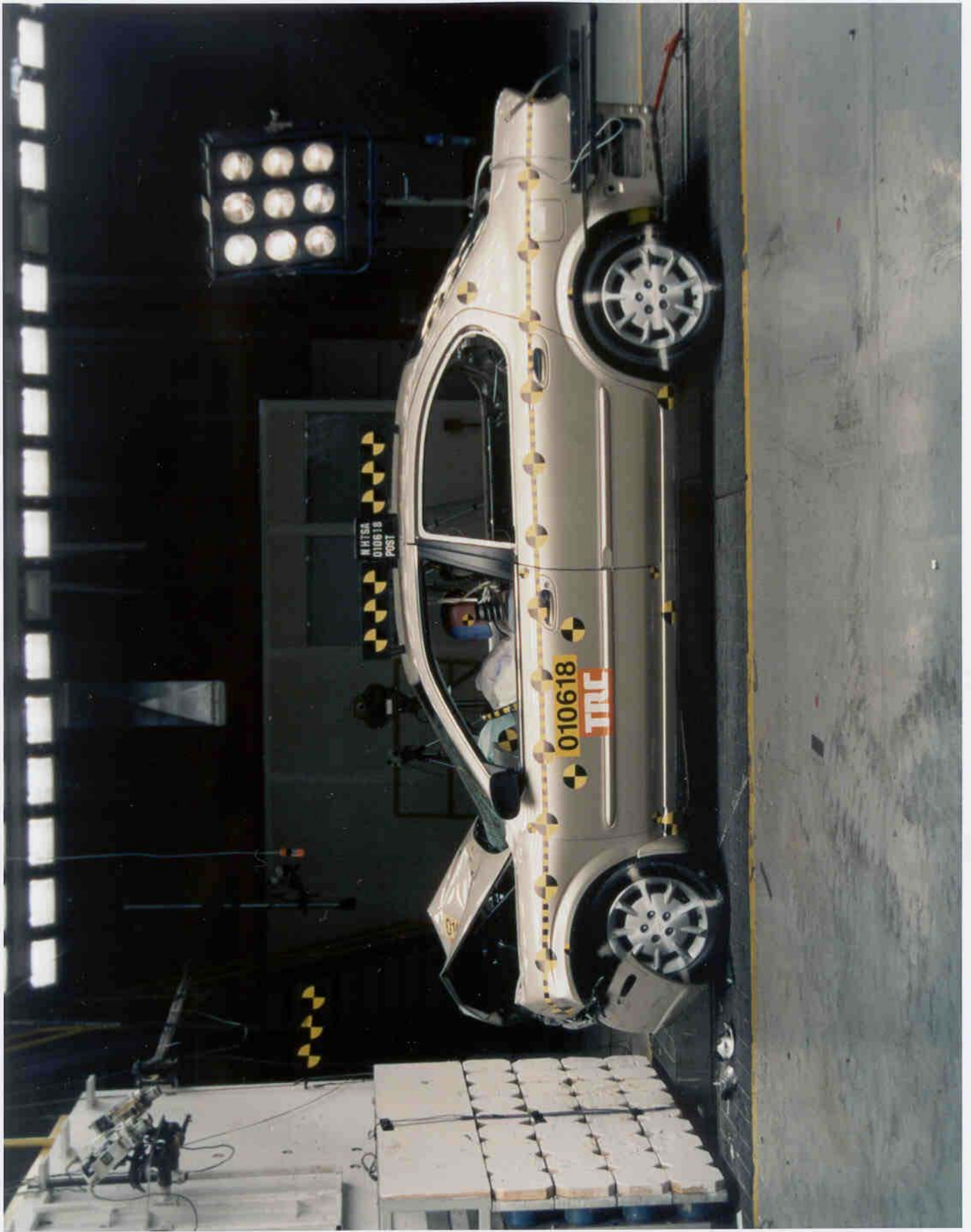

Figure 3-4 Post-Test Left Side View
3-5

010618

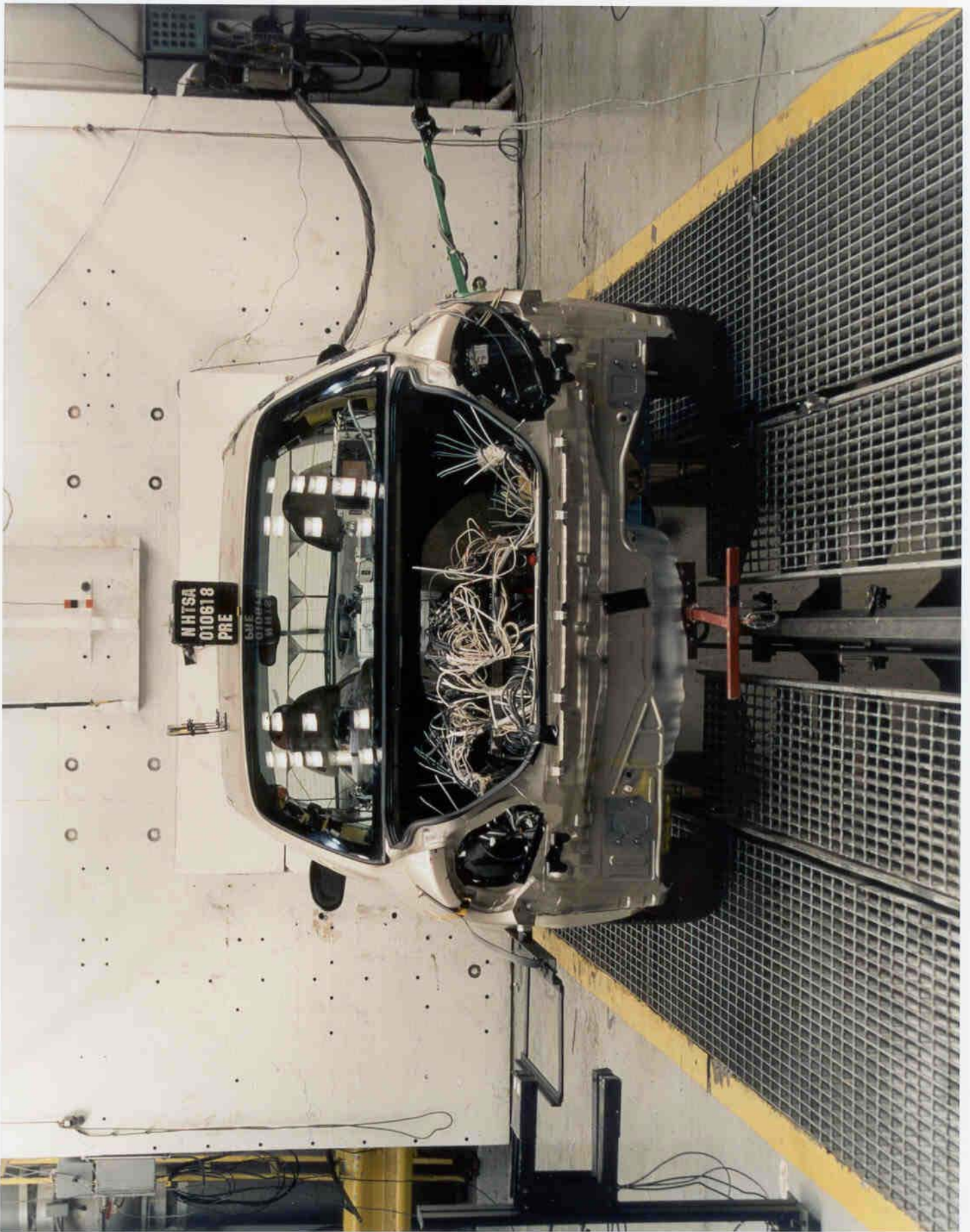

Figure 3-5 Pre-Test Rear View
3-6

010618

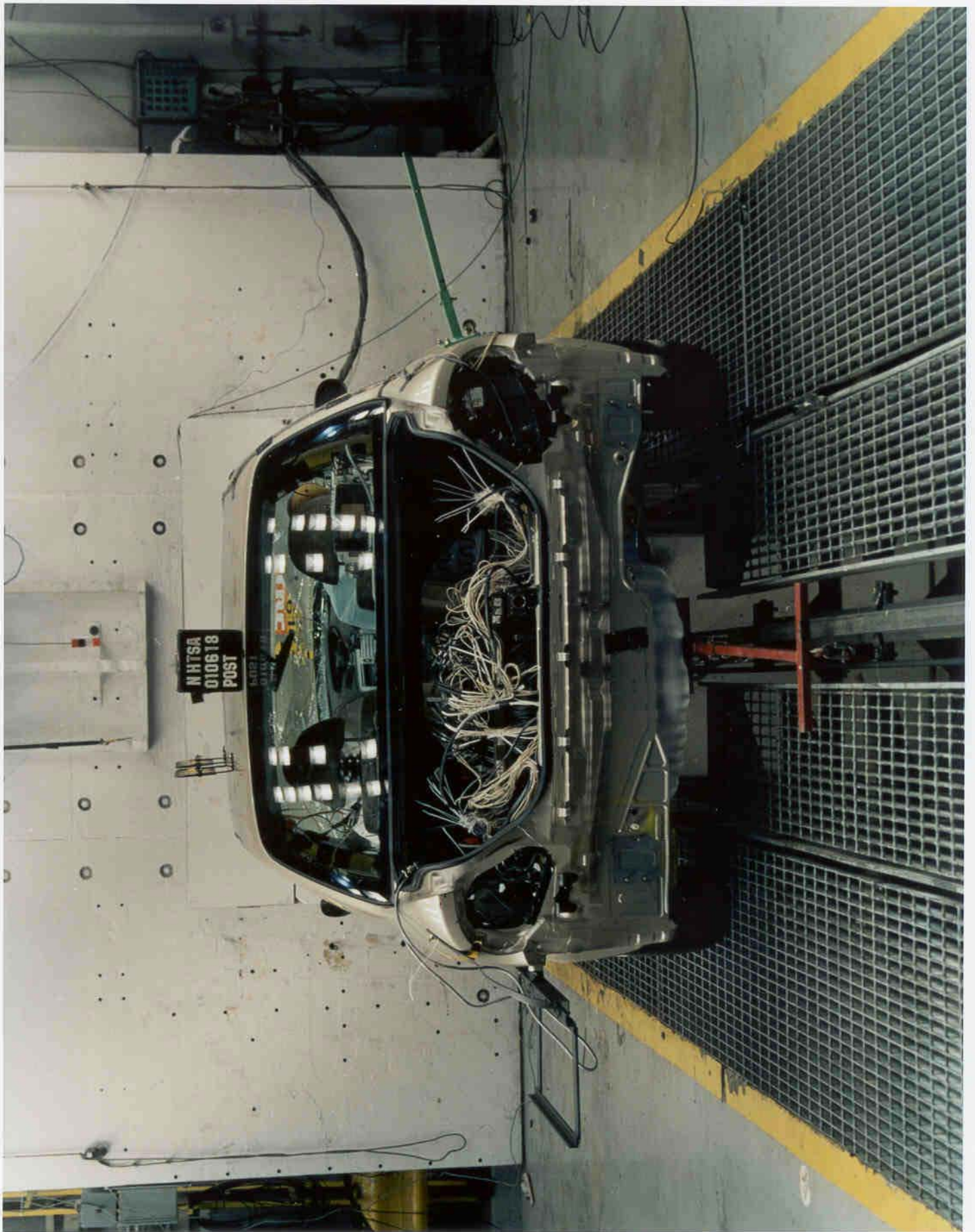

Figure 3-6 Post-Test Rear View
3-7

010618

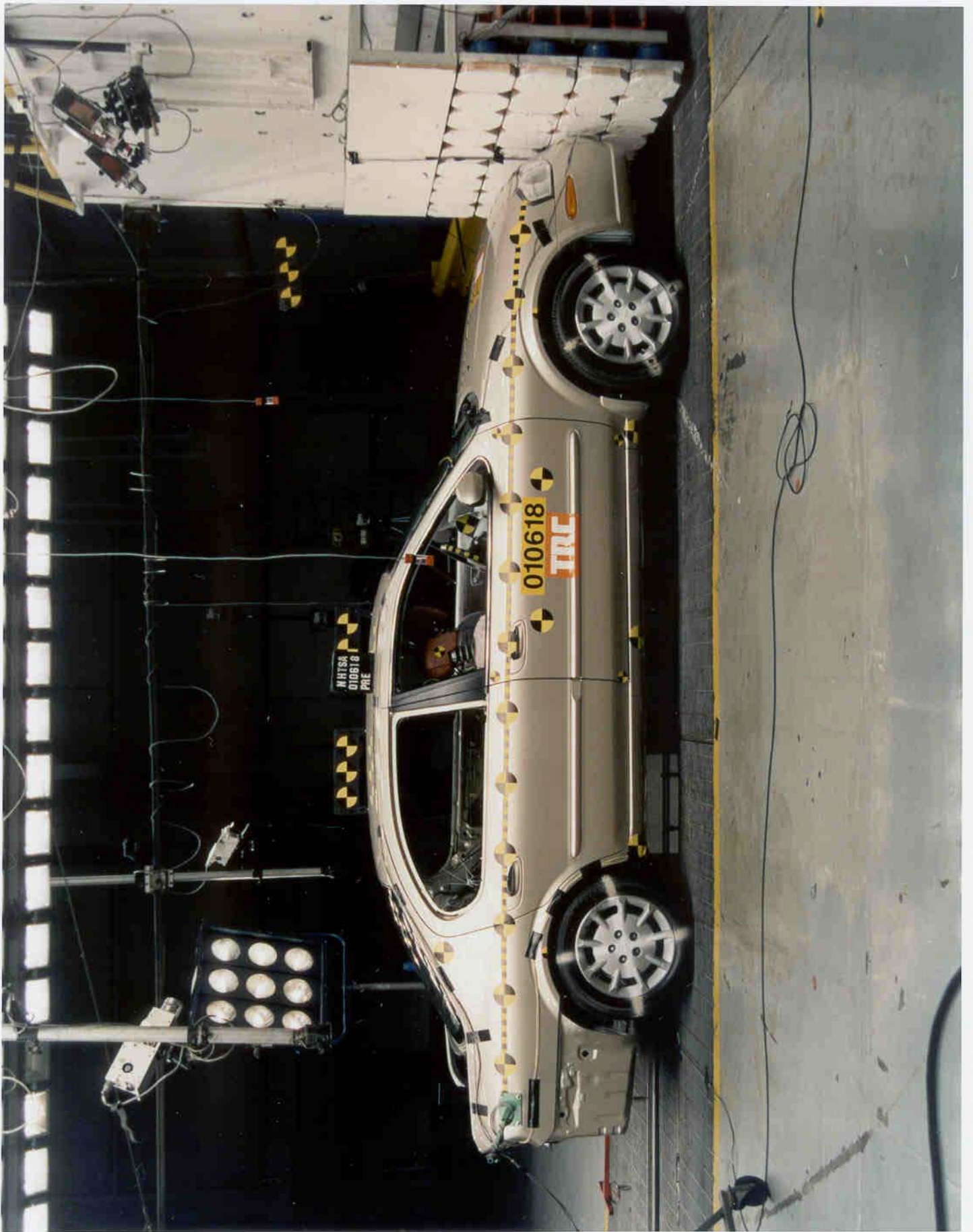

Figure 3-7 Pre-Test Right Side View
3-8

010618



Figure 3-8 Post-Test Right Side View
3-9

010618

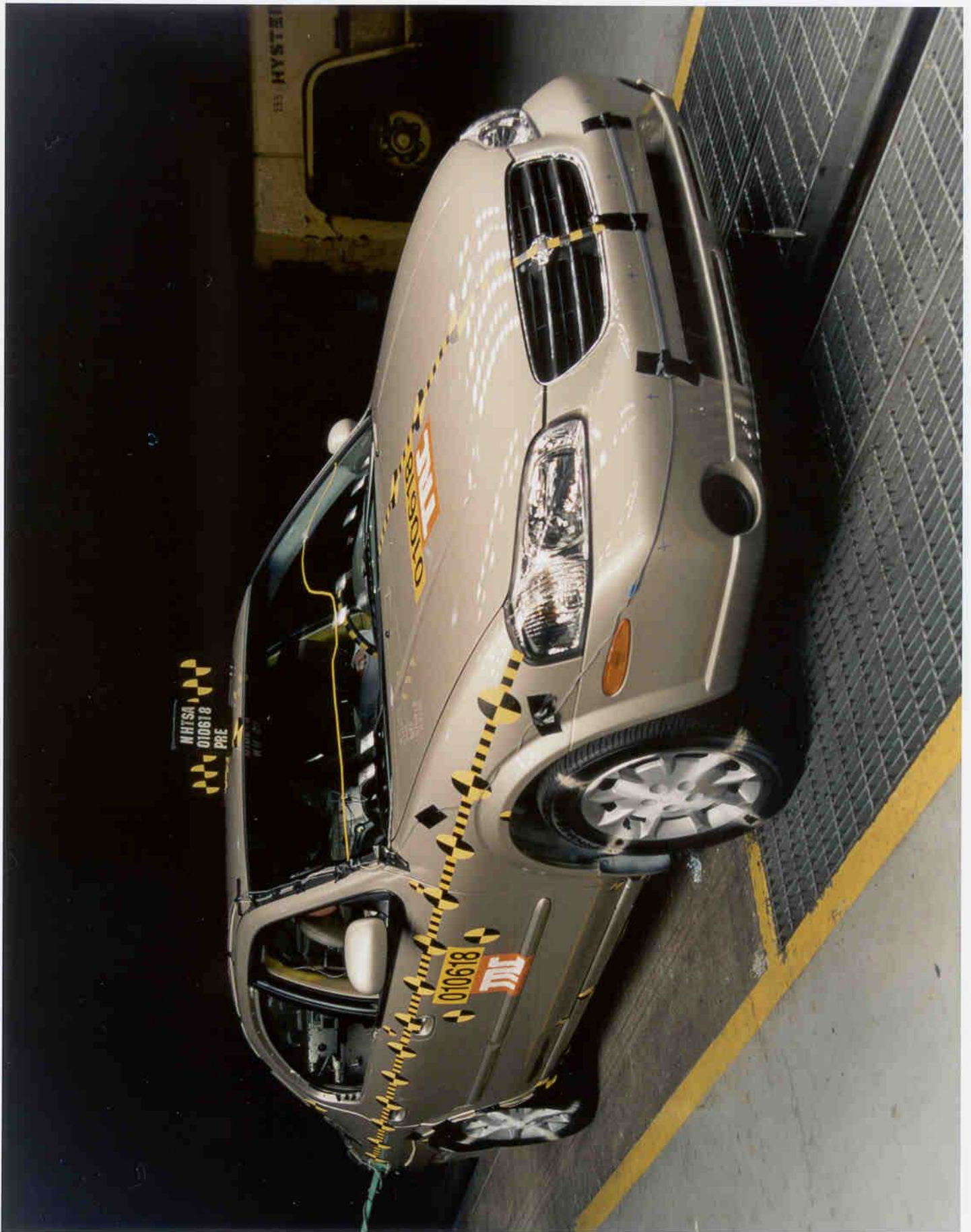

Figure 3-9 Pre-Test Right Front Three-Quarter View

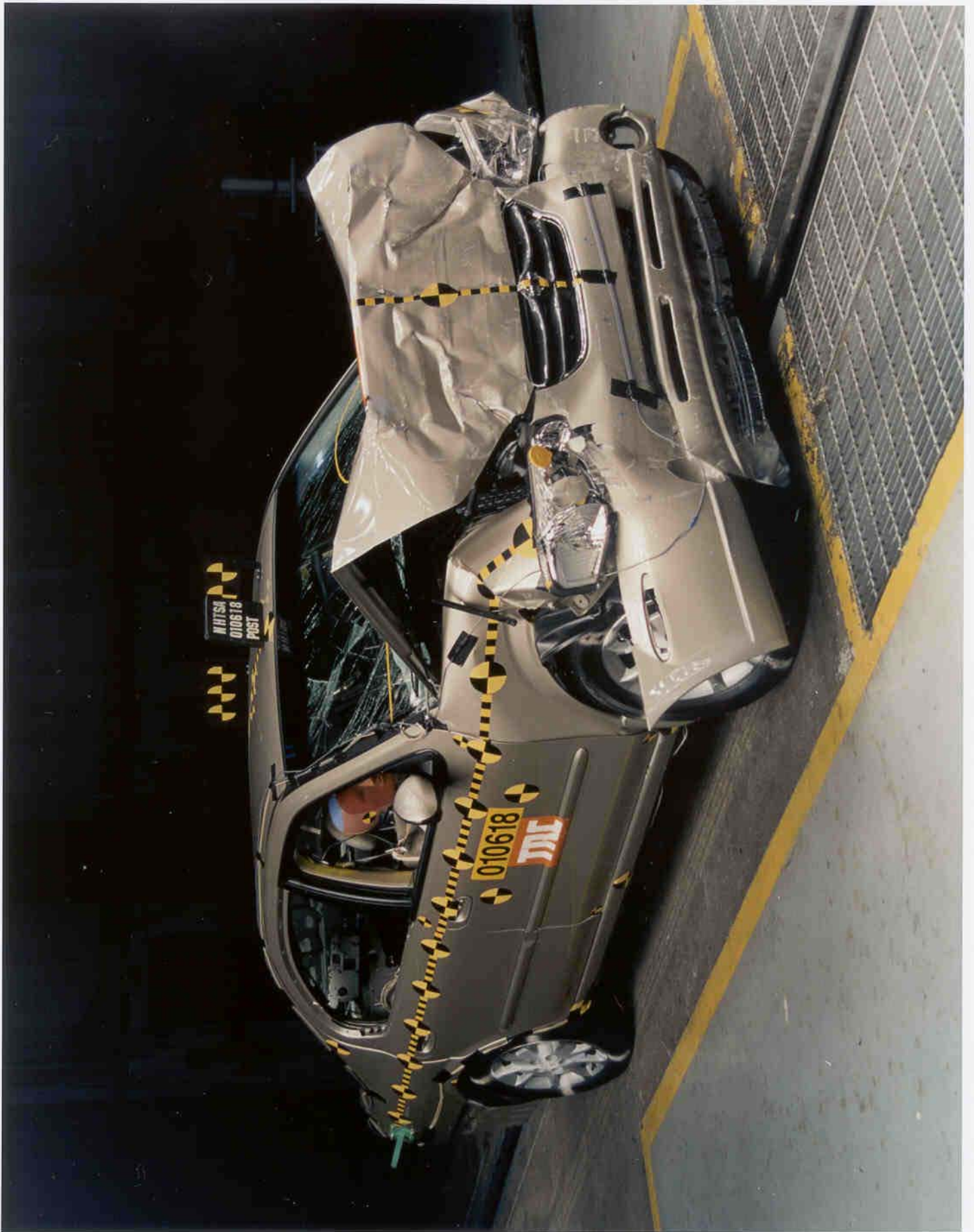

Figure 3-10 Post-Test Right Front Three-Quarter View



Figure 3-11 Pre-Test Left Rear Three-Quarter View

3-12

010618



Figure 3-12 Post-Test Left Rear Three-Quarter View

3-13

010618

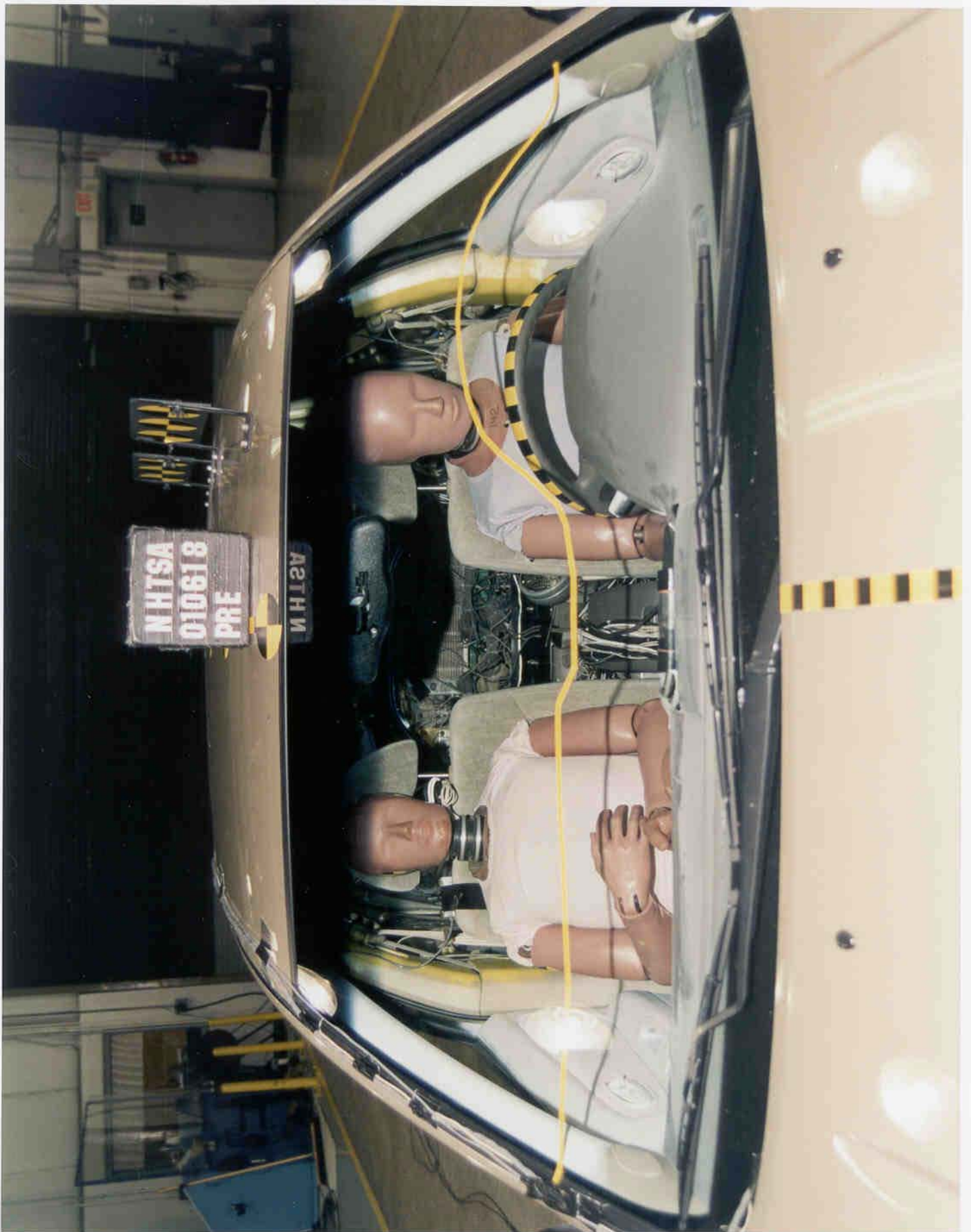

Figure 3-13 Pre-Test Windshield View
3-14

010618



Figure 3-14 Post-Test Windshield - View 1
3-15

010618

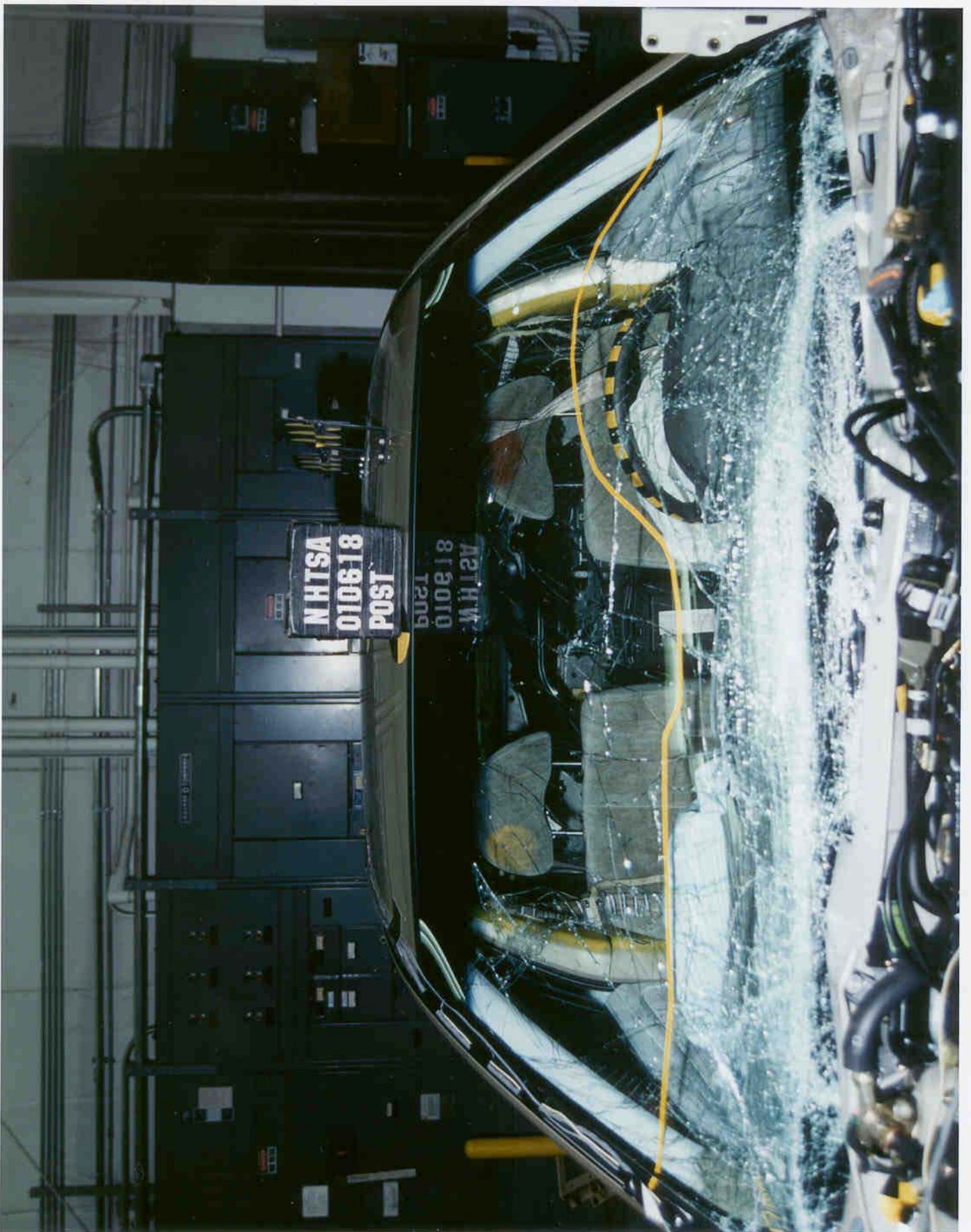

Figure 3-15 Post-Test Windshield - View 2
3-16

010618

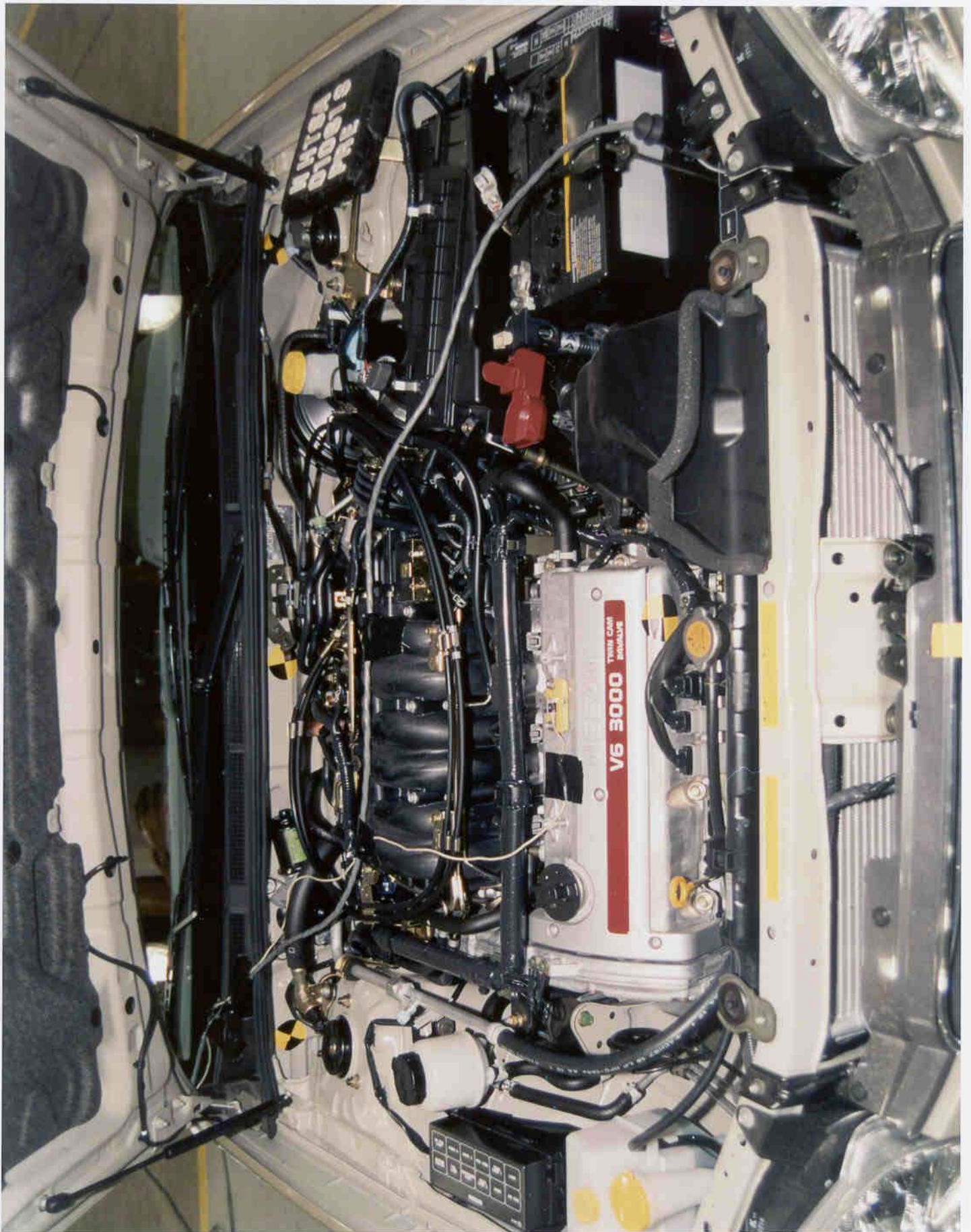

Figure 3-16 Pre-Test Engine Compartment View
3-17

010618

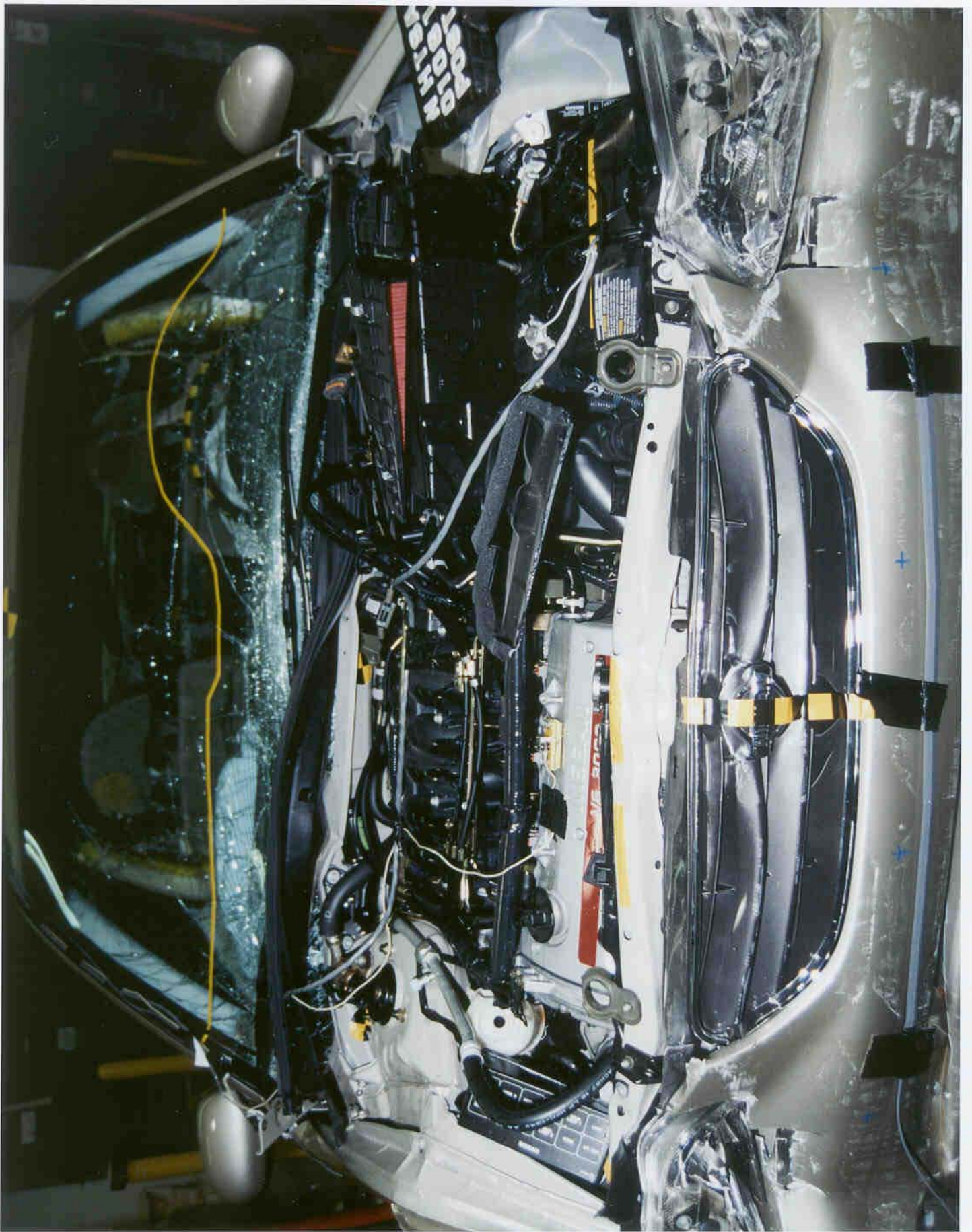

Figure 3-17 Post-Test Engine Compartment View
3-18

010618



Figure 3-18 Pre-Test Fuel Filler Cap View



Figure 3-19 Post-Test Fuel Filler Cap View

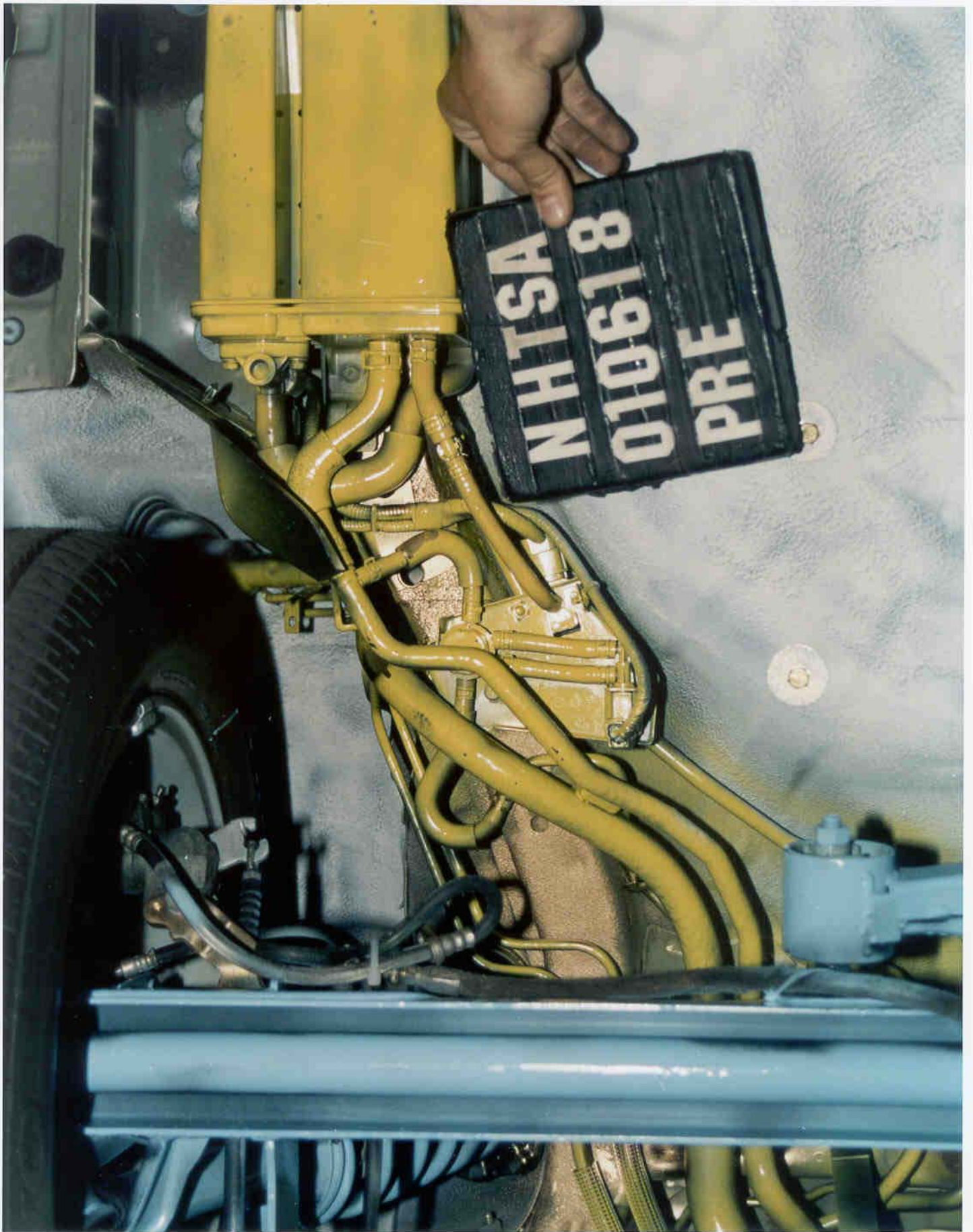

Figure 3-20 Pre-Test Fuel Filler Neck View
3-21

010618

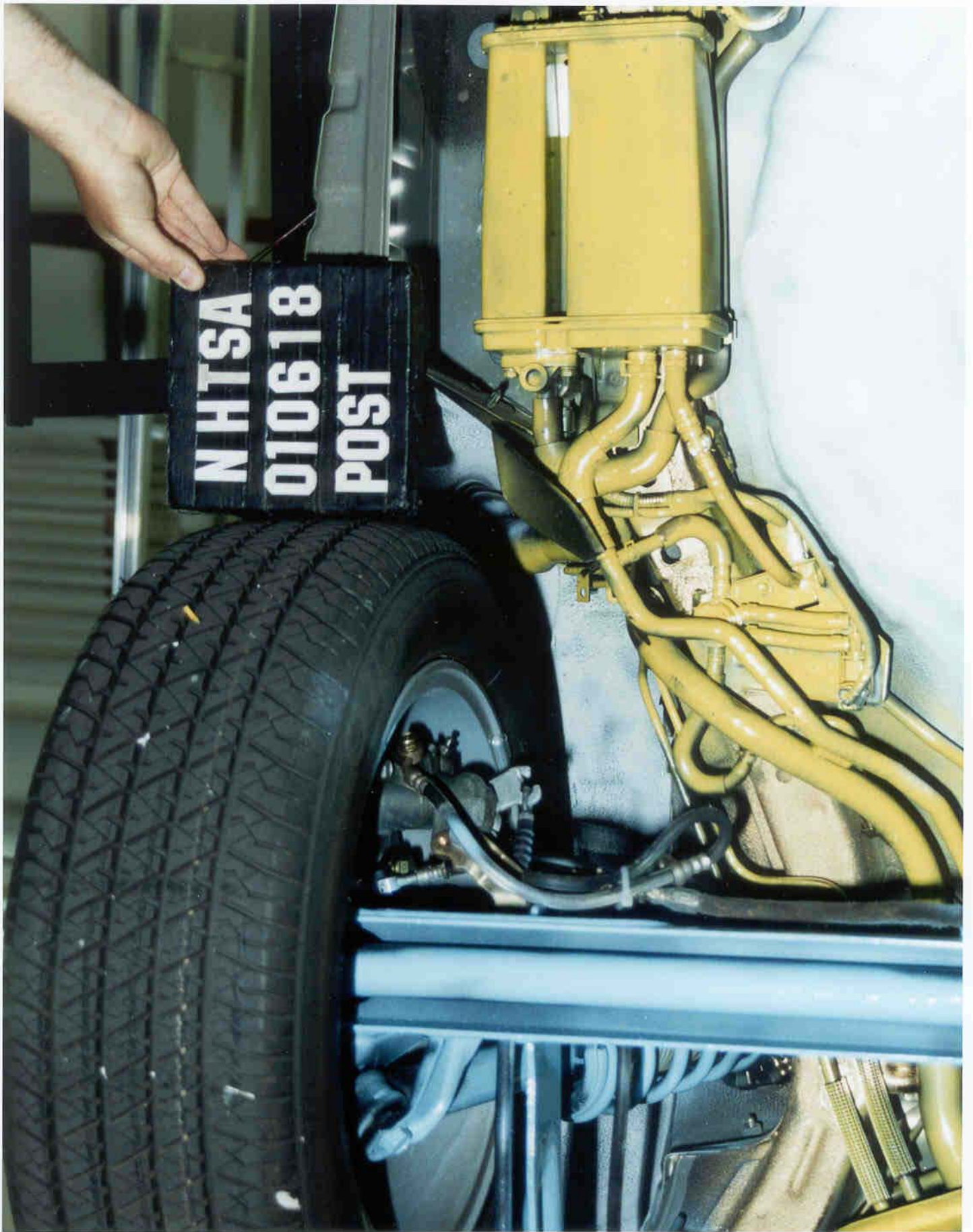

Figure 3-21 Post-Test Fuel Filler Neck View
3-22

010618

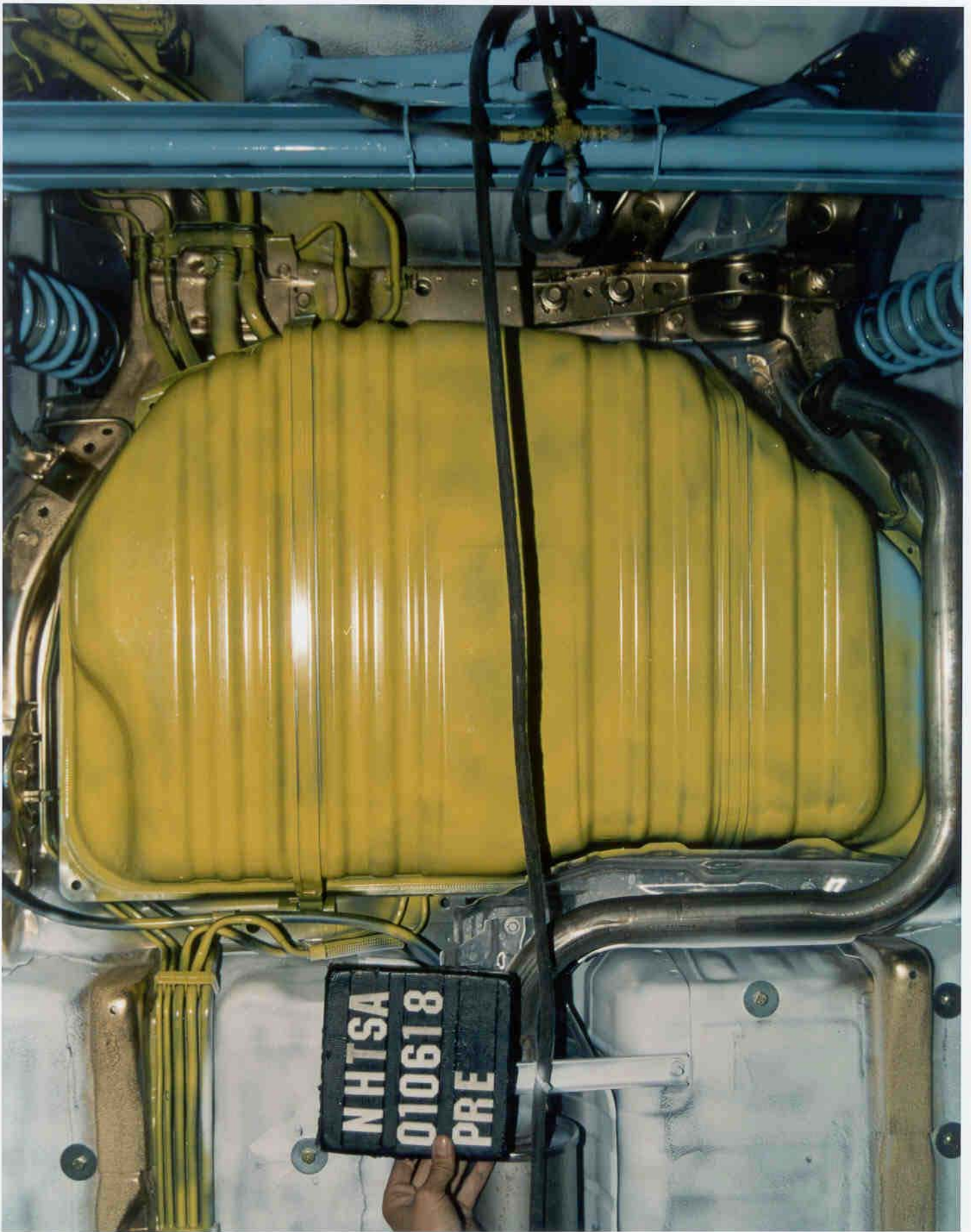

Figure 3-22 Pre-Test Fuel Tank View
3-23

010618

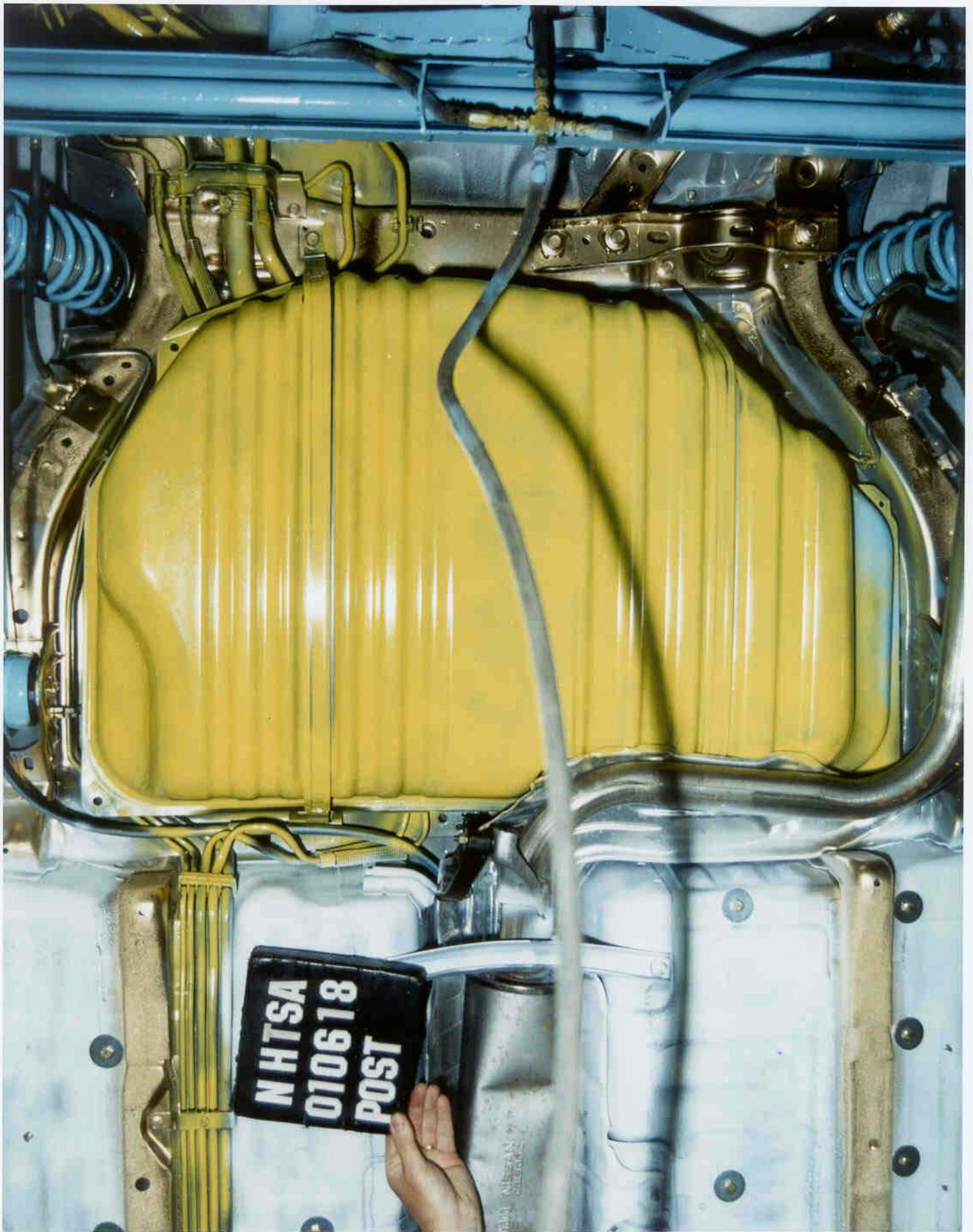

Figure 3-23 Post-Test Fuel Tank View

3-24

010618

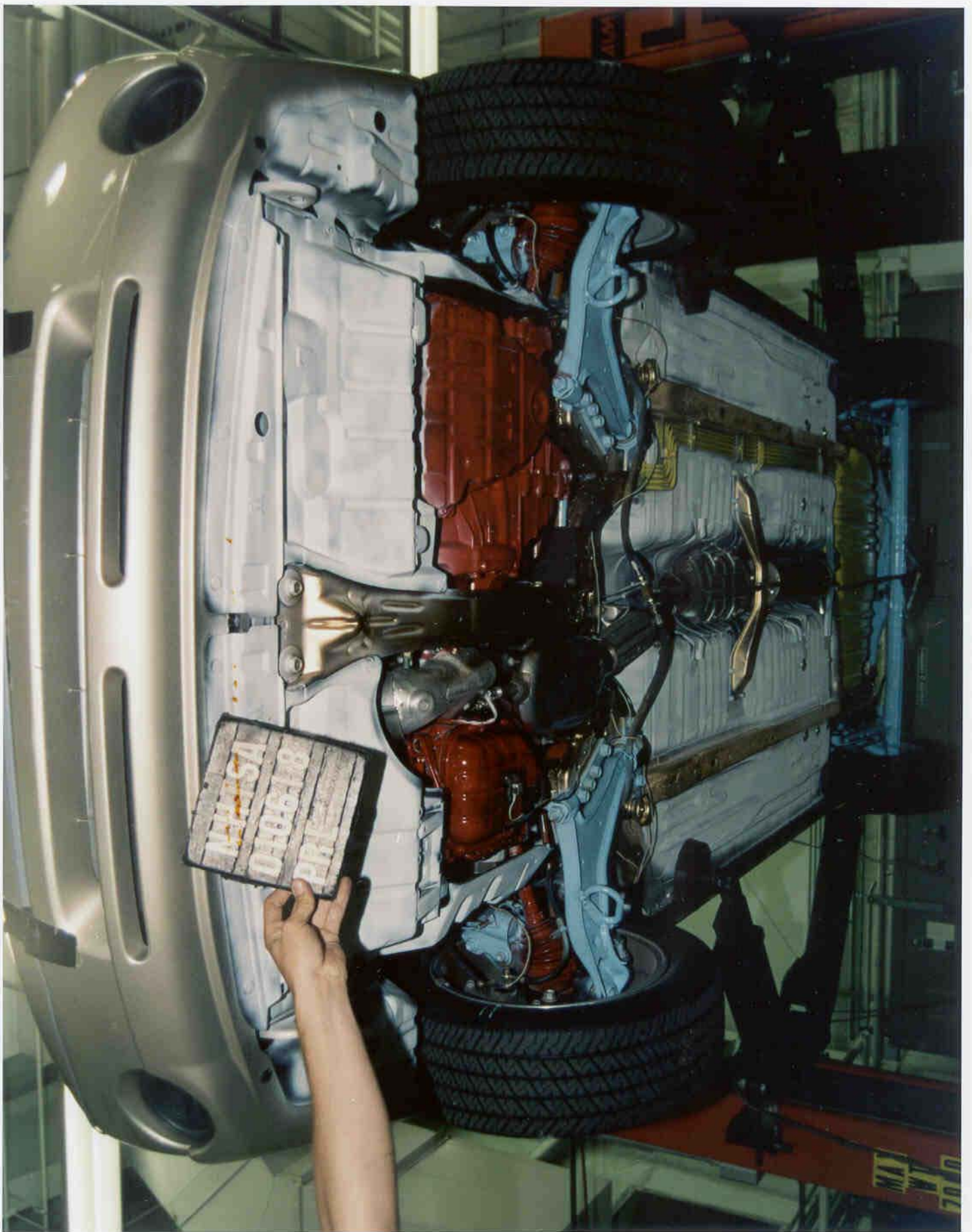

Figure 3-24 Pre-Test Front Underbody View

3-25

010618

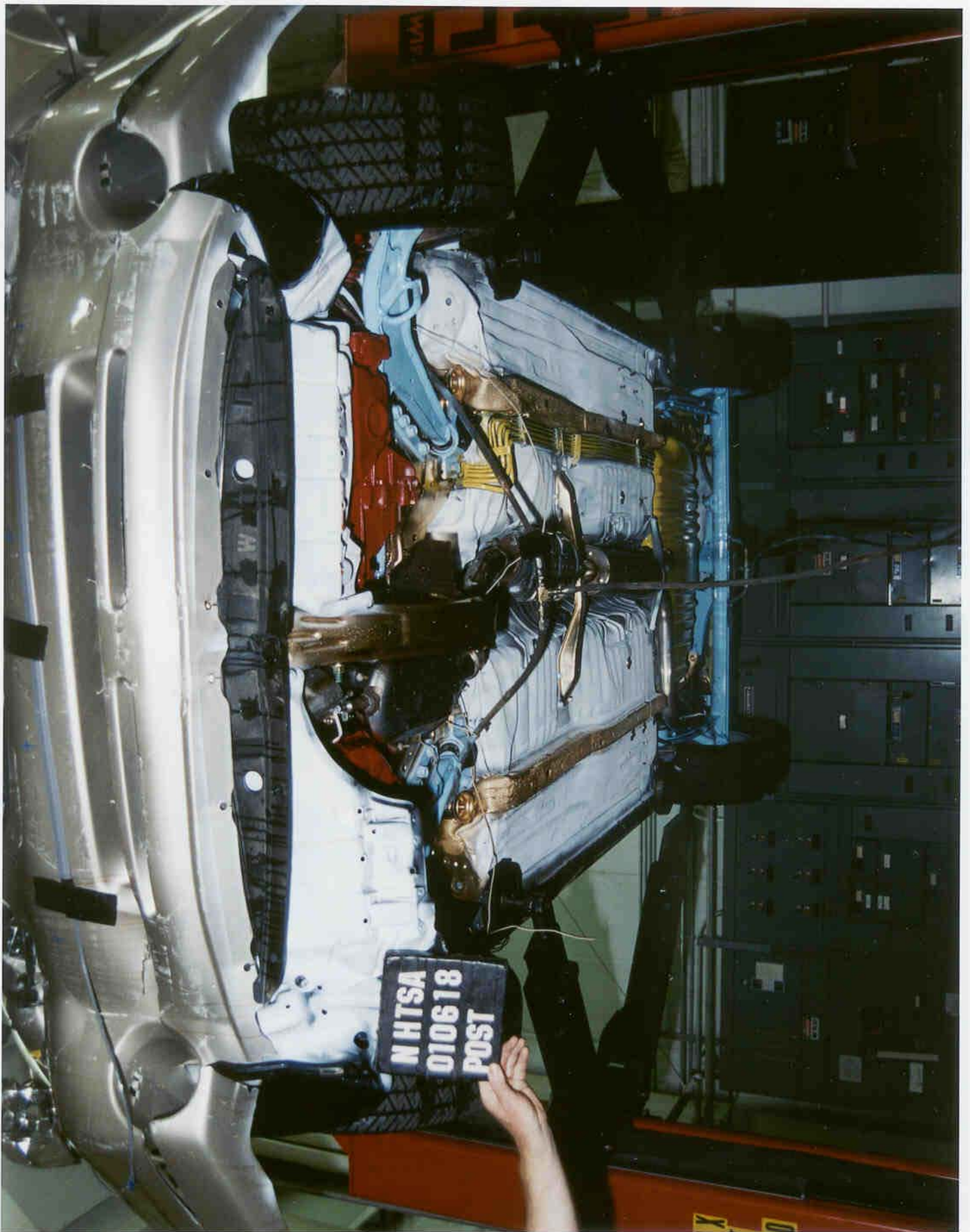

Figure 3-25 Post-Test Front Underbody View

3-26

010618

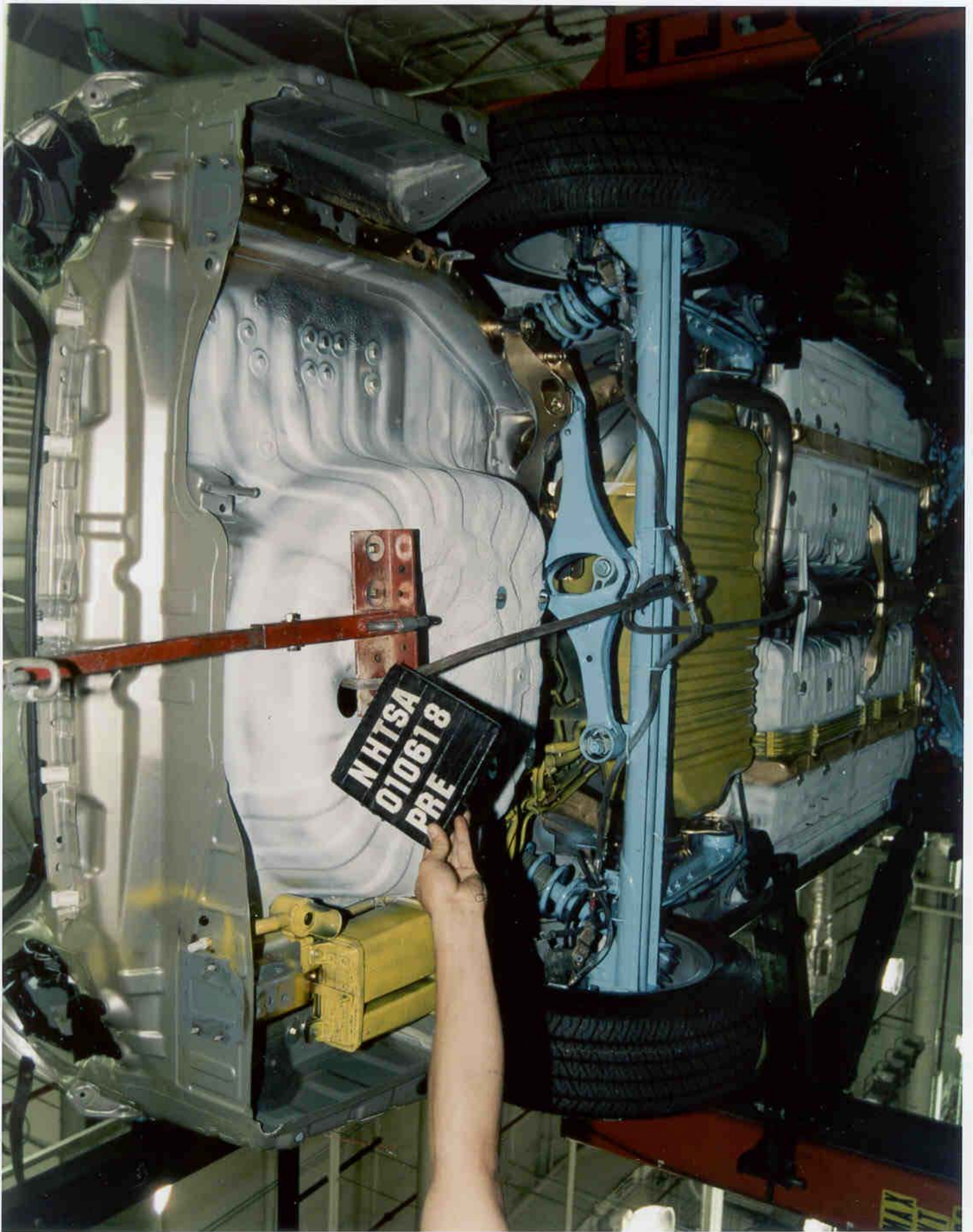

Figure 3-26 Pre-Test Rear Underbody View

3-27

010618

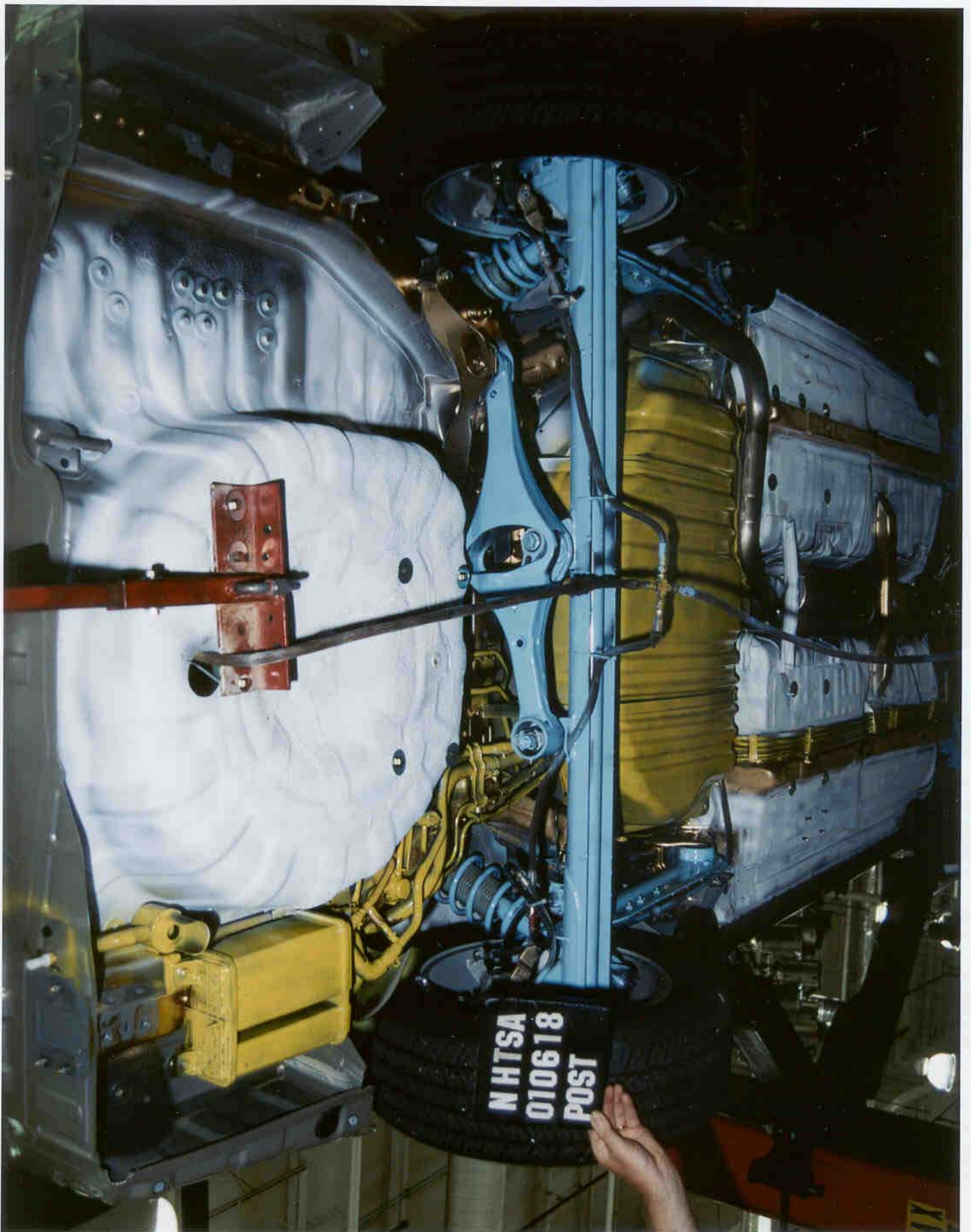

Figure 3-27 Post-Test Rear Underbody View
3-28

010618

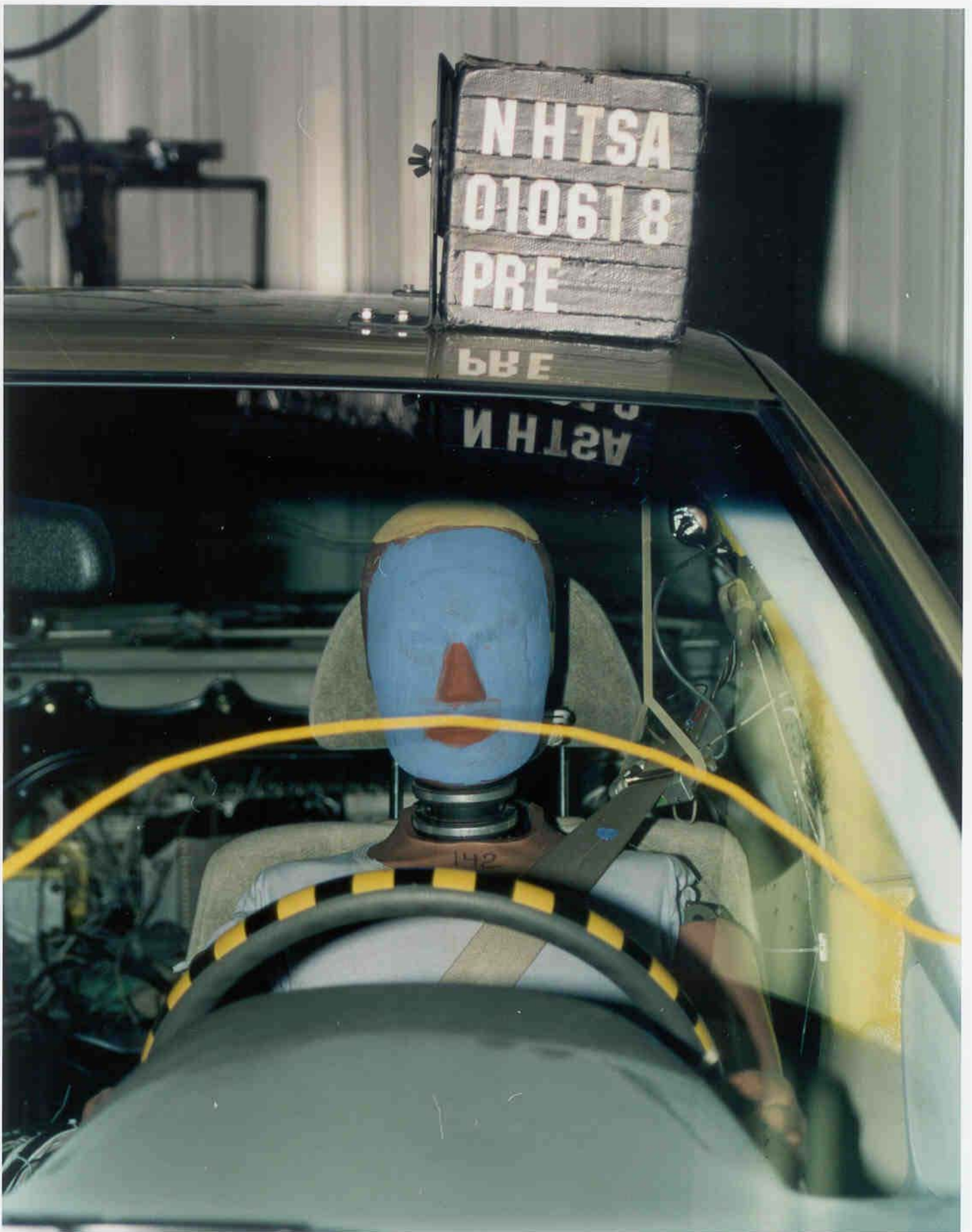

Figure 3-28 Pre-Test Driver Dummy Position - View 1
3-29

010618

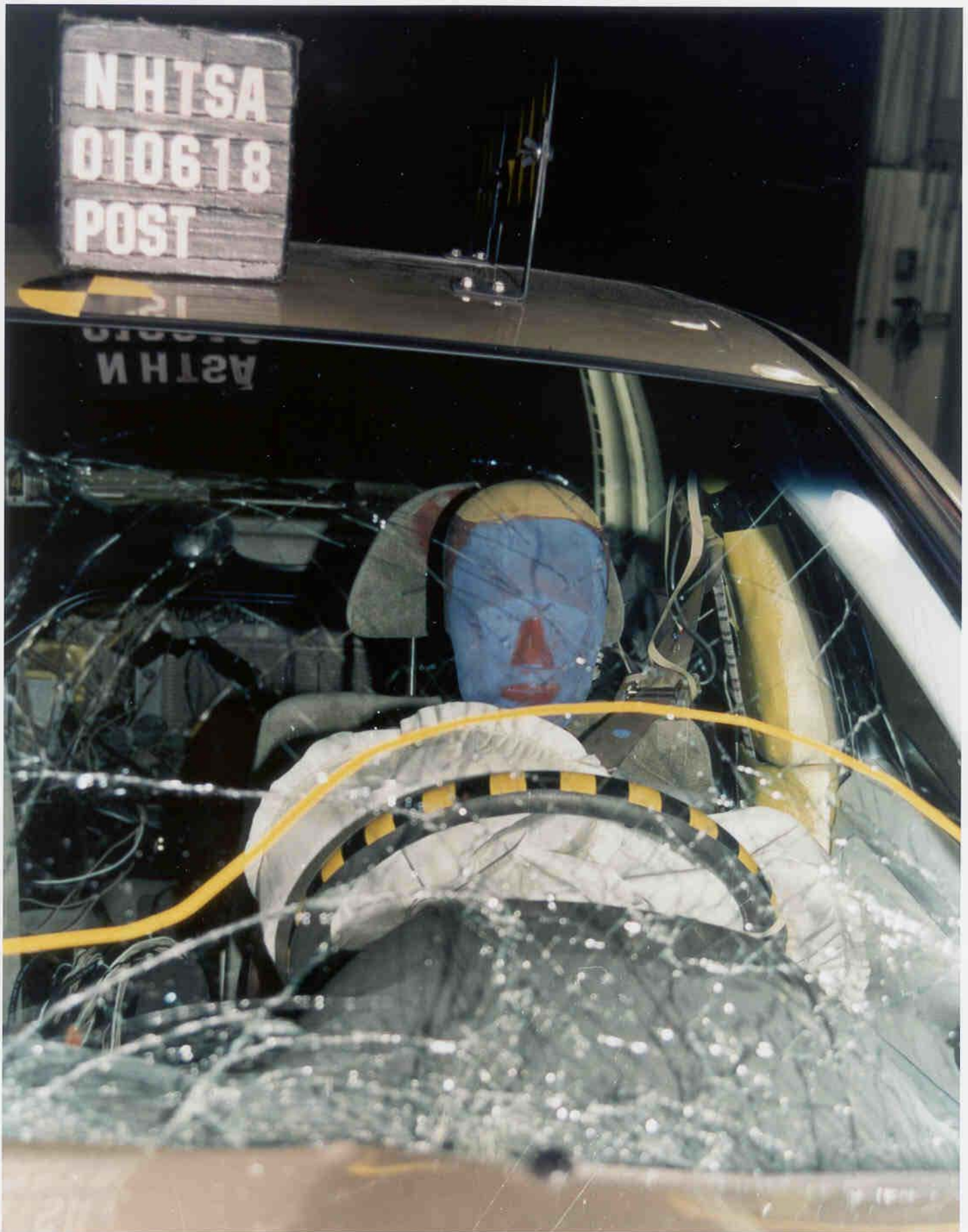

Figure 3-29 Post-Test Driver Dummy Position - View 1
3-30

010618



Figure 3-30 Pre-Test Driver Dummy Position - View 2



Figure 3-31 Post-Test Driver Dummy Position - View 2

3-32

010618

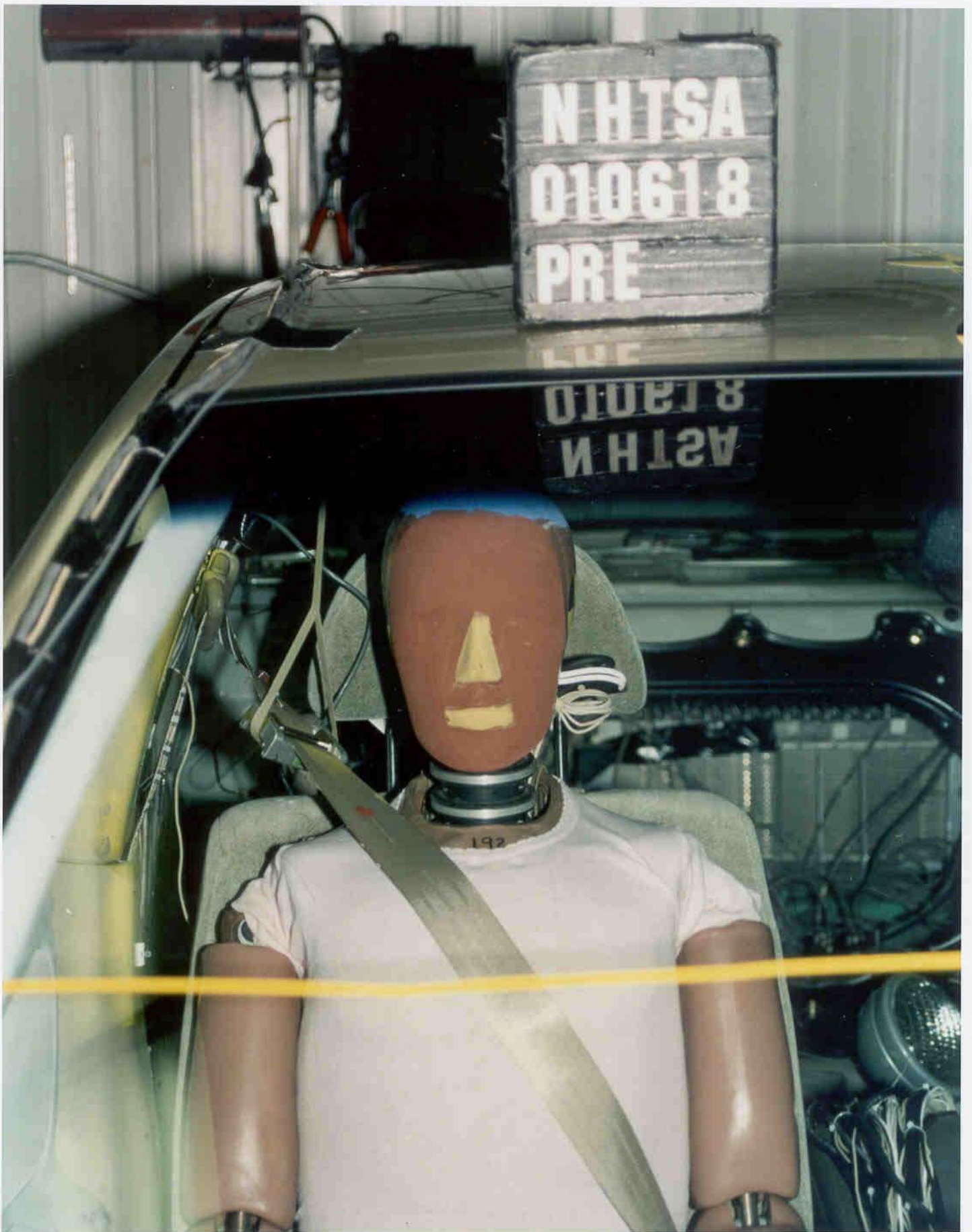

Figure 3-32 Pre-Test Passenger Dummy Position - View 1



Figure 3-33 Post-Test Passenger Dummy Position - View 1



Figure 3-34 Pre-Test Passenger Dummy Position - View 2
3-35

010618



Figure 3-35 Post-Test Passenger Dummy Position - View 2

3-36

010618



Figure 3-36 Pre-Test Driver Dummy & Vehicle Interior - View 1

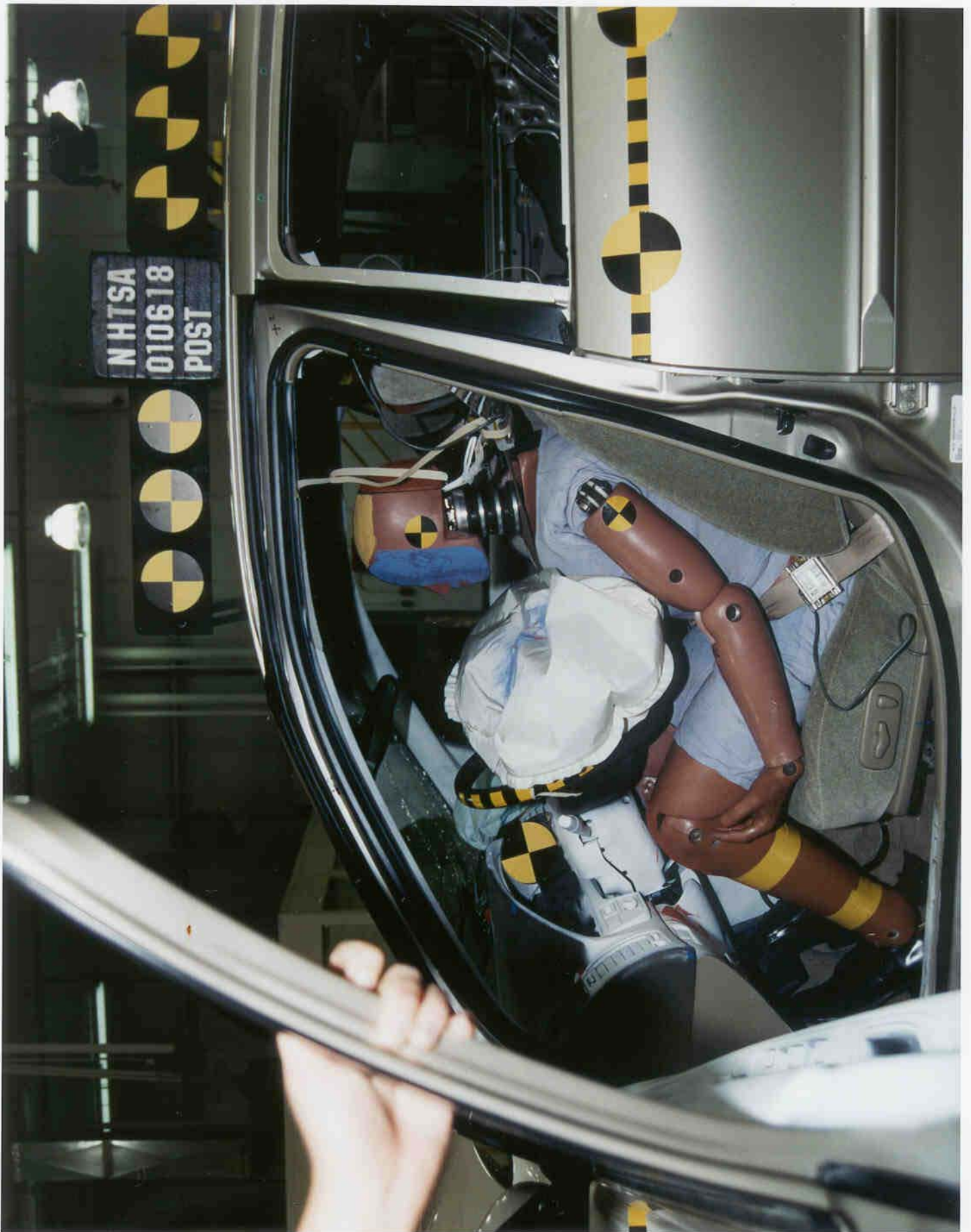

Figure 3-37 Post-Test Driver Dummy & Vehicle Interior - View 1



Figure 3-38 Pre-Test Driver Dummy & Vehicle Interior - View 2



Figure 3-39 Post-Test Driver Dummy & Vehicle Interior - View 2

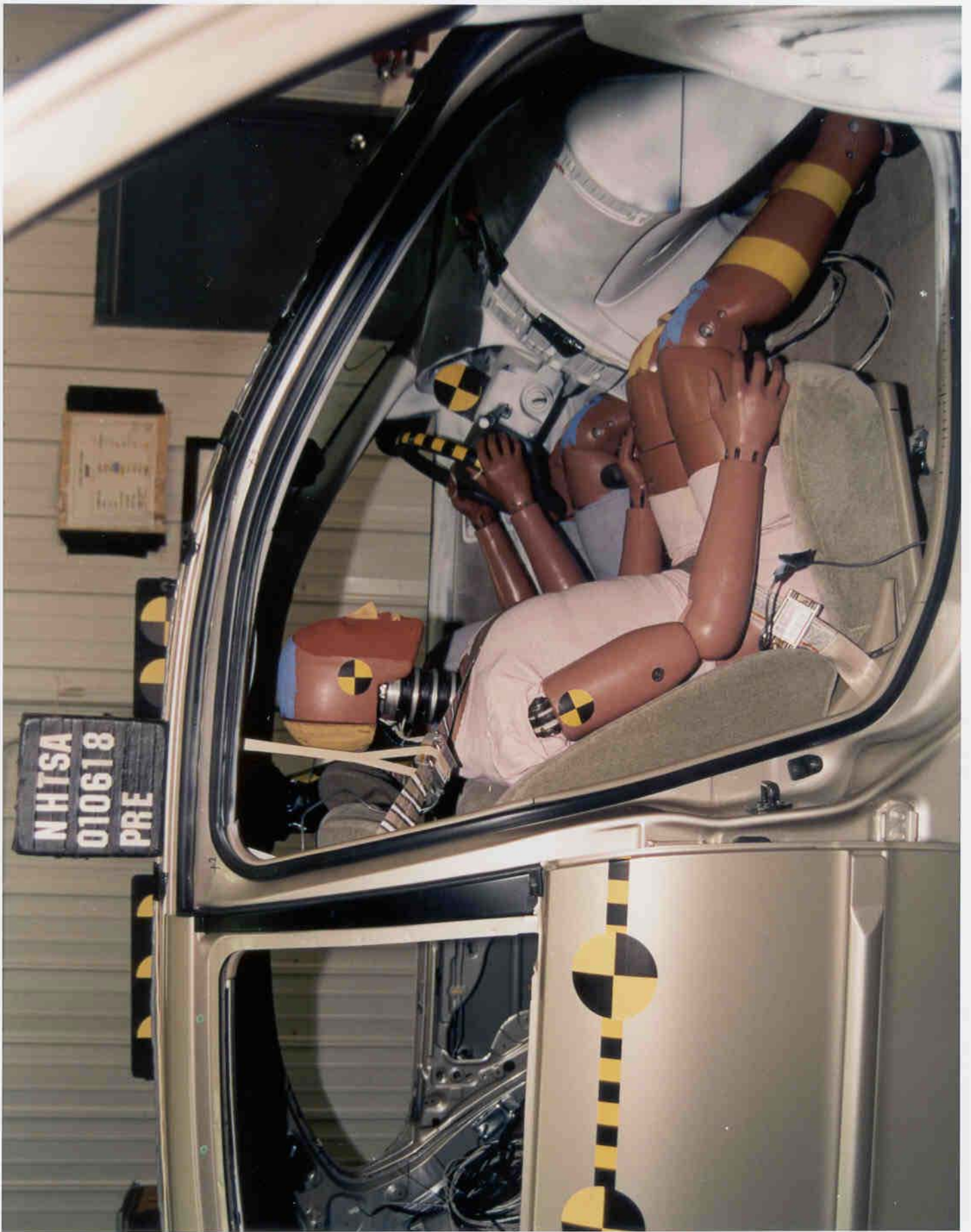

Figure 3-40 Pre-Test Passenger Dummy & Vehicle Interior - View 1

3-41

010618



Figure 3-41 Post-Test Passenger Dummy & Vehicle Interior - View 1



Figure 3-42 Pre-Test Passenger Dummy & Vehicle Interior - View 2

3-43

010618



Figure 3-43 Post-Test Passenger Dummy & Vehicle Interior - View 2



Figure 3-44 Post-Test Driver Dummy Overall View
3-45

010618



Figure 3-45 Post-Test Driver Dummy Head Contact - View 1
3-46

010618



Figure 3-46 Post-Test Driver Dummy Head Contact - View 2

3-47

010618



Figure 3-47 Post-Test Driver Dummy Head Contact - View 3
3-48

010618



Figure 3-48 Post-Test Driver Dummy Knee Contact - View 1



Figure 3-49 Post-Test Driver Dummy Knee Contact - View 2

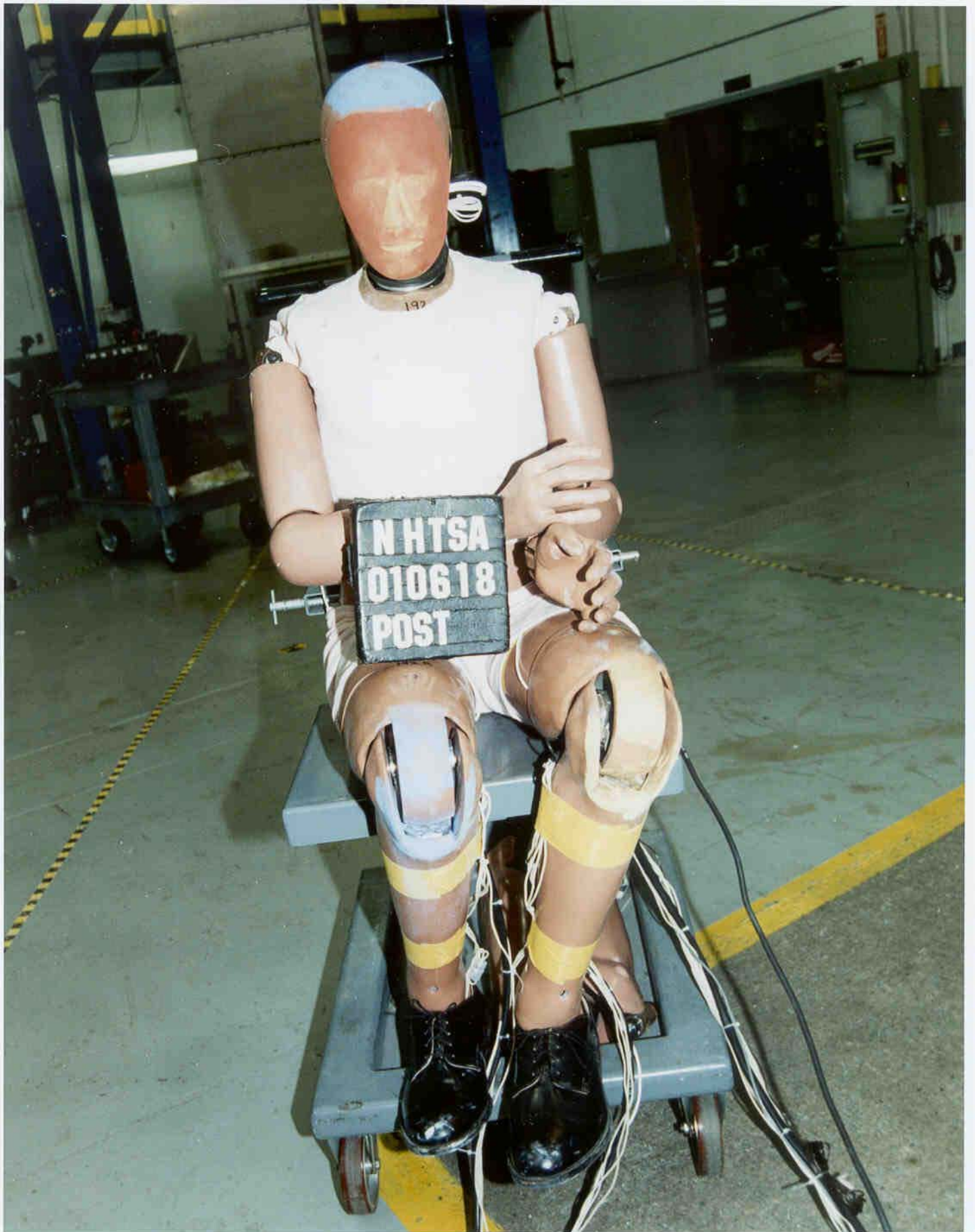

Figure 3-50 Post-Test Passenger Dummy Overall View
3-51

010618



Figure 3-51 Post-Test Passenger Dummy Head Contact - View 1

3-52

010618



Figure 3-52 Post-Test Passenger Dummy Head Contact - View 2

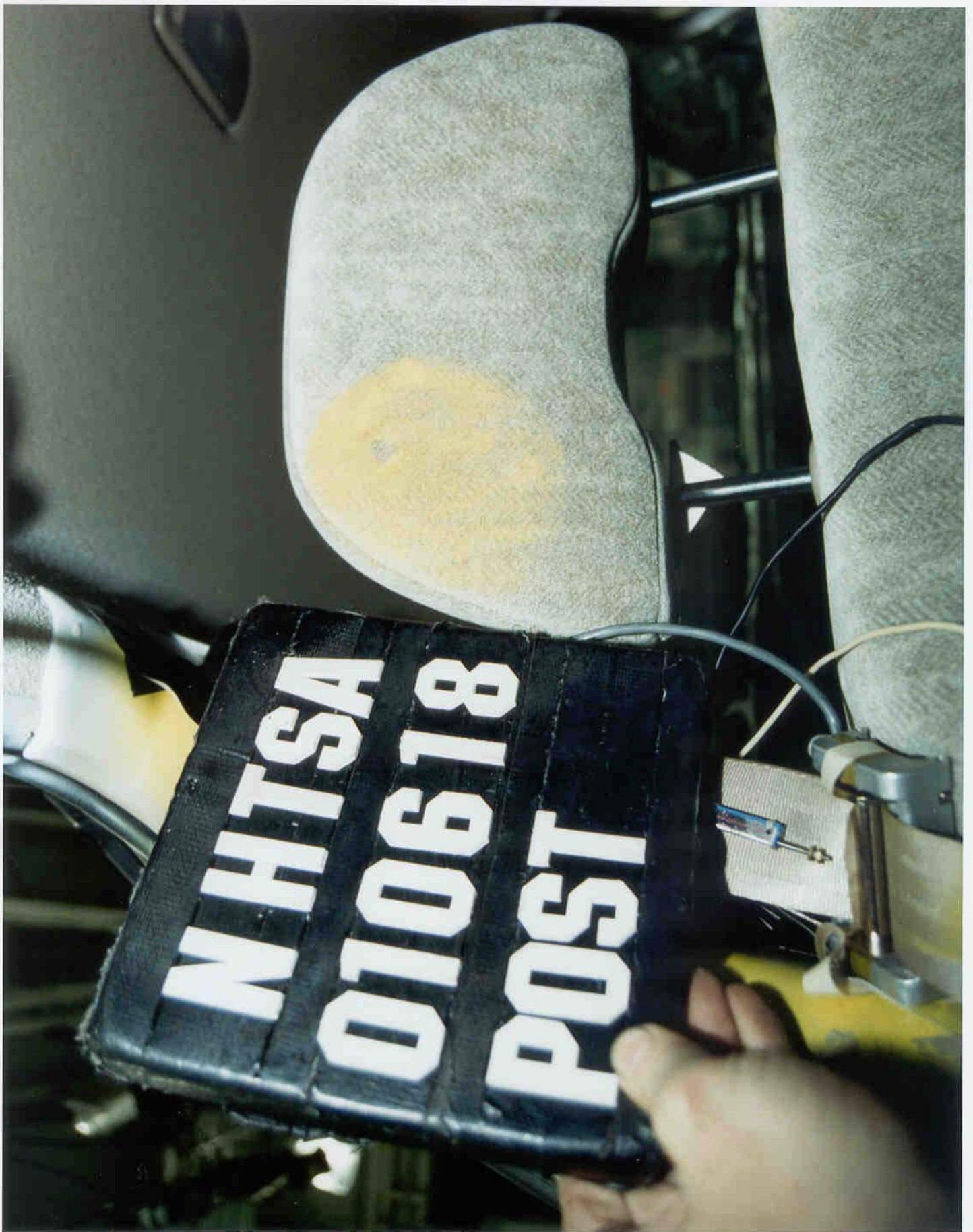

Figure 3-53 Post-Test Passenger Dummy Head Contact - View 3



Figure 3-54 Post-Test Passenger Dummy Knee Contact - View 1

3-55

010618



Figure 3-55 Post-Test Passenger Dummy Knee Contact - View 2

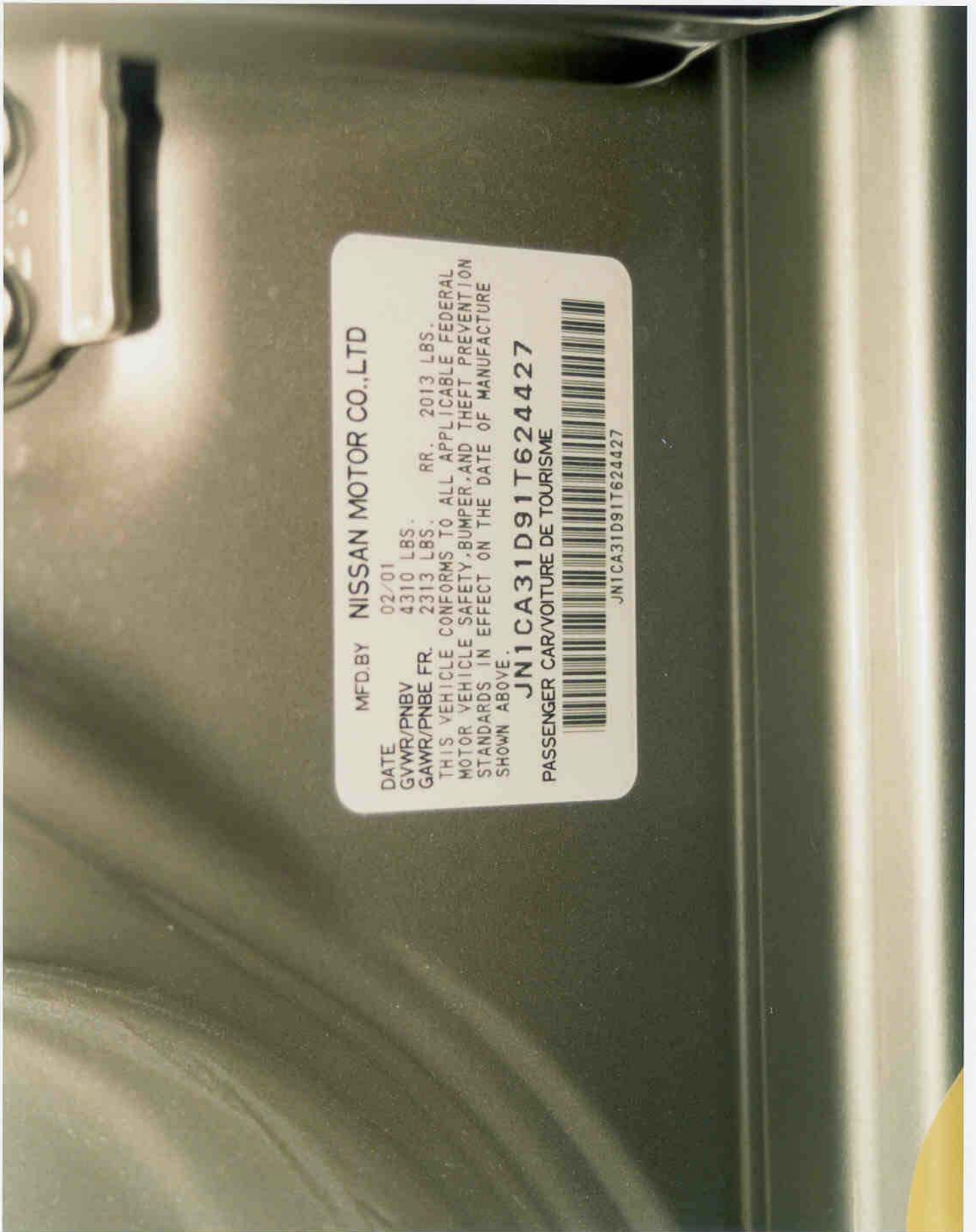

MFD.BY NISSAN MOTOR CO.,LTD

DATE

02/01

GVWR/PNBV

4310 LBS.

GAWR/PNBE FR.

2313 LBS.

RR. 2013 LBS.

THIS VEHICLE CONFORMS TO ALL APPLICABLE FEDERAL MOTOR VEHICLE SAFETY, BUMPER, AND THEFT PREVENTION STANDARDS IN EFFECT ON THE DATE OF MANUFACTURE SHOWN ABOVE.

JN1CA31D91T624427

PASSENGER CAR/VOITURE DE TOURISME



JN1CA31D91T624427

Figure 3-56 Pre-Test Vehicle Certification Label View

VEHICLE CAPACITY WEIGHT POIDS UTILE DU VEHICULE	882 lbs 400 kg	SEATING CAPACITY NOMBRE DE PLACES	FRONT AVANT	2	TOTAL TOTAL	SPARE TIRE ROUE DE SECOURS	PSI kPa
			REAR ARRIERE	3	5	T125/70D16	60 (420)
RECOMMENDED COLD TIRE INFLATION PRESSURE PRESSION DE GONFLAGE RECOMMANDEE DES PNEUS FROIDS.							
TIRE SIZE DIMENSIONS		FRONT PSI AVANT (kPa)		REAR PSI ARRIERE (kPa)		DO NOT USE IN EXCESS OF 50MPH, 80km/h SEE OWNER'S MANUAL FOR ADDITIONAL INFORMATION UTILISATION A UNE VITESSE MAX 50MPH, 80km/h POUR LES DETAILS SE REFERER AU MANUEL DU CONDUCTEUR	
P215-55R16 91W		33 (230)		30 (210)			
							27400

Figure 3-57 Pre-Test Tire Label View
3-58

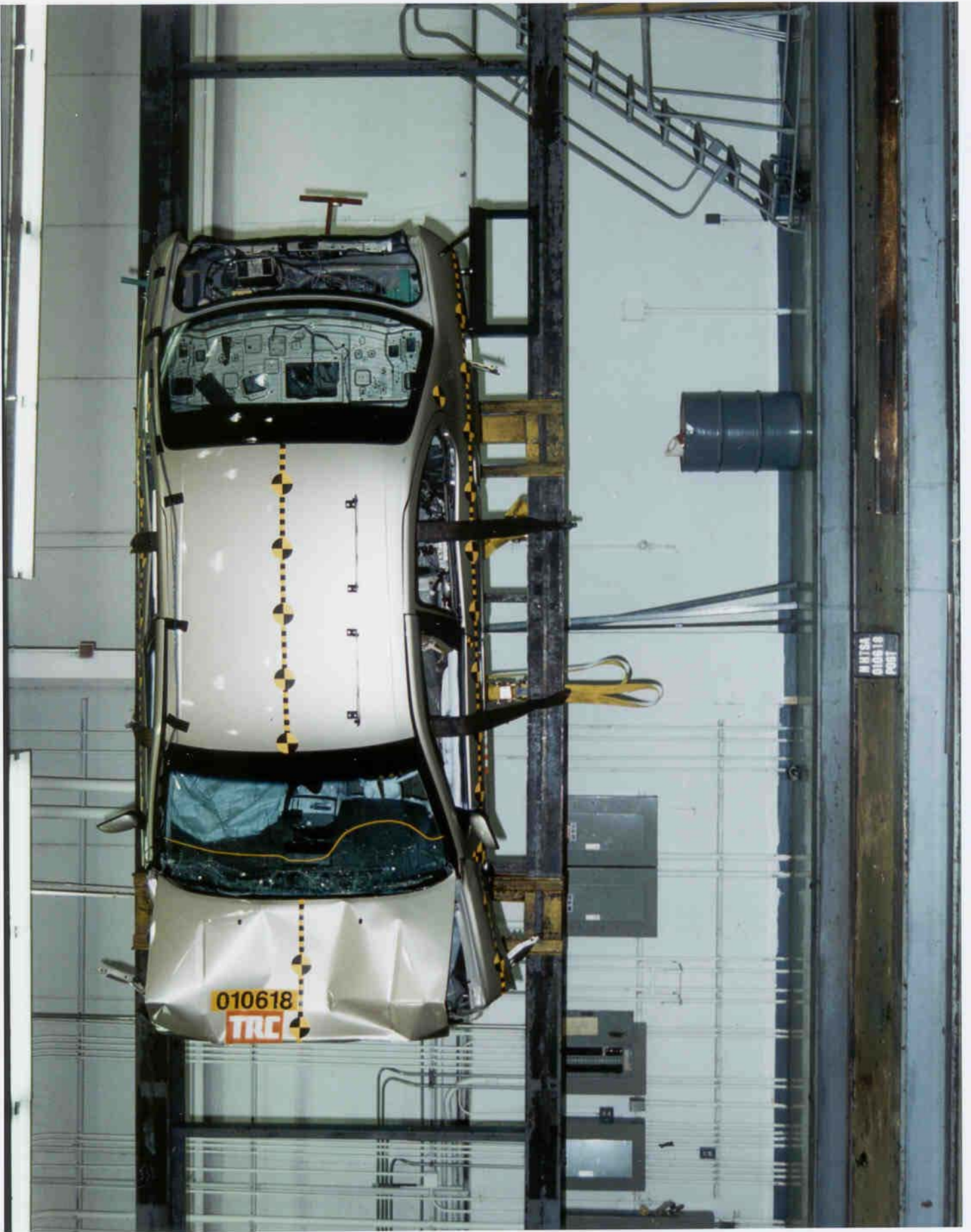
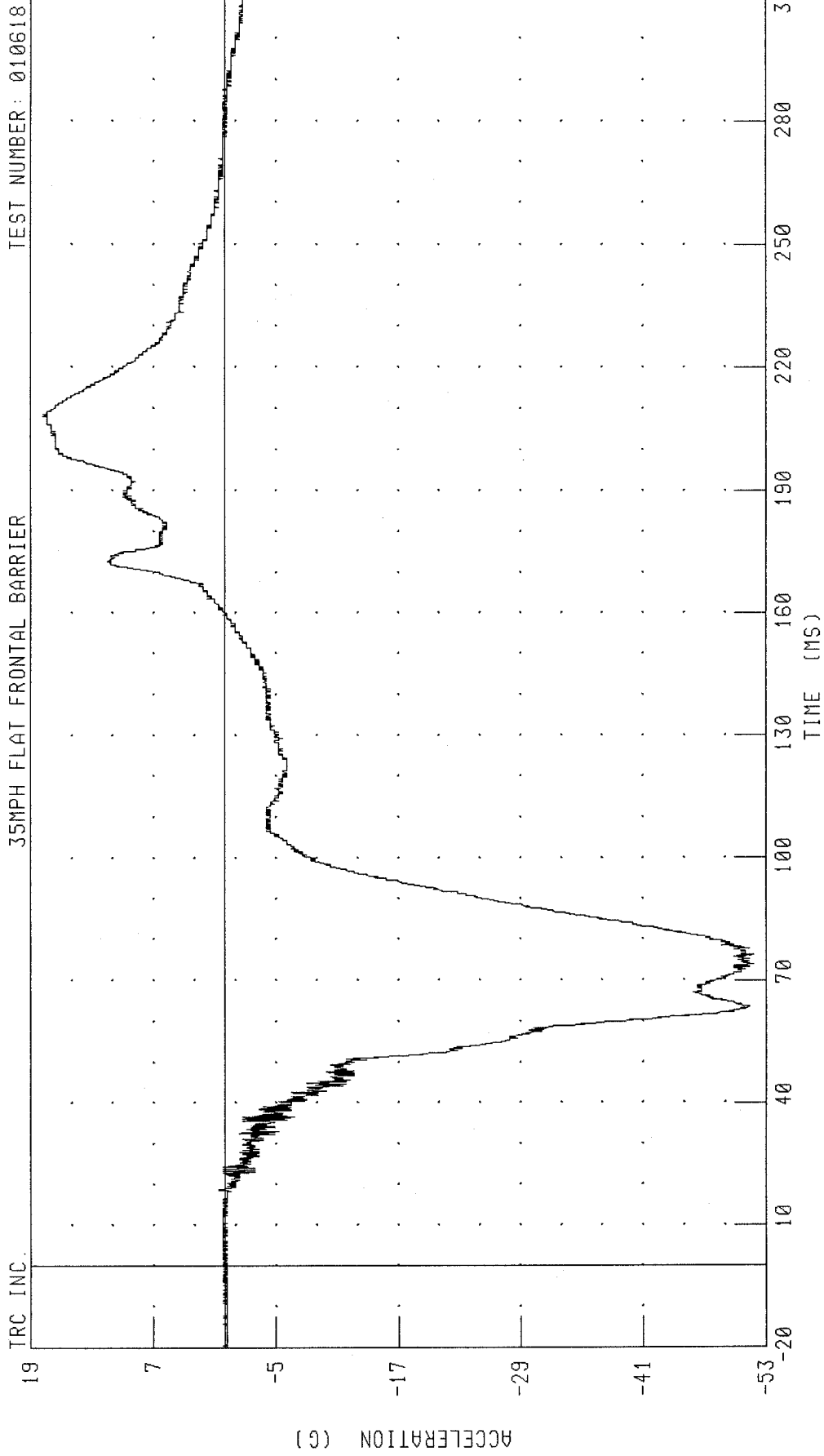

Figure 3-58 Post-Test Vehicle on Static Rollover Machine View

3-59

010618

2001 NISSAN MAXIMA INTO FRONTAL LOAD CELL BARRIER
DRIVER HEAD X-AXIS ACCELERATION
35MPH FLAT FRONTAL BARRIER



CHANNEL: HEDXC1 FILTER: CH. CLASS 1000

PEAK DATA: 17.80 G @ 208.16 MS; -51.78 G @ 73.92 MS

2001 NISSAN MAXIMA INTO FRONTAL LOAD CELL BARRIER
DRIVER HEAD Y-AXIS ACCELERATION
35MPH FLAT FRONTAL BARRIER

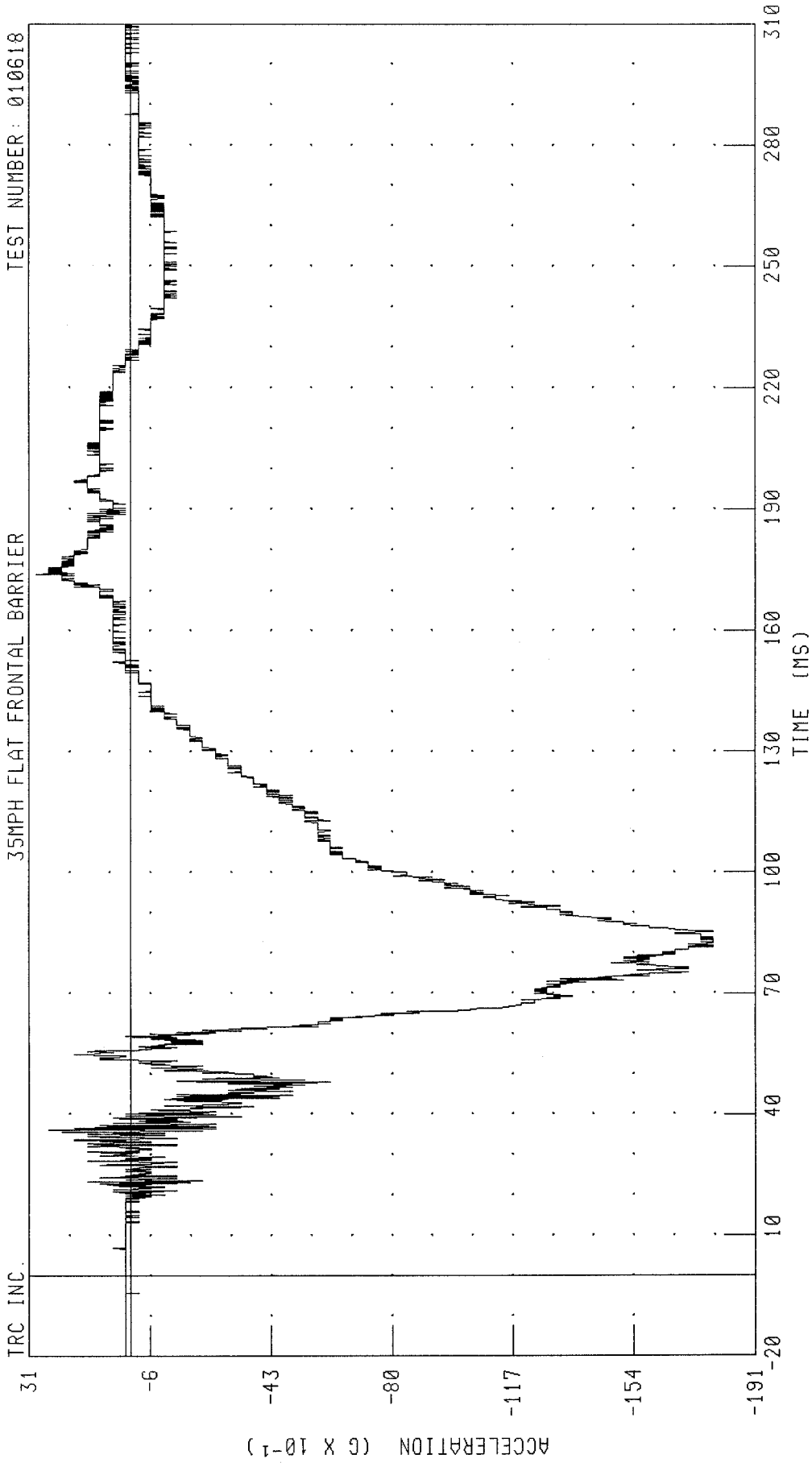

CHANNEL: HEDYG1 FILTER: CH. CLASS 1000

2001 NISSAN MAXIMA INTO FRONTAL LOAD CELL BARRIER
DRIVER HEAD Z-AXIS ACCELERATION
35MPH FLAT FRONTAL BARRIER

TEST NUMBER: 010618

TRC INC.

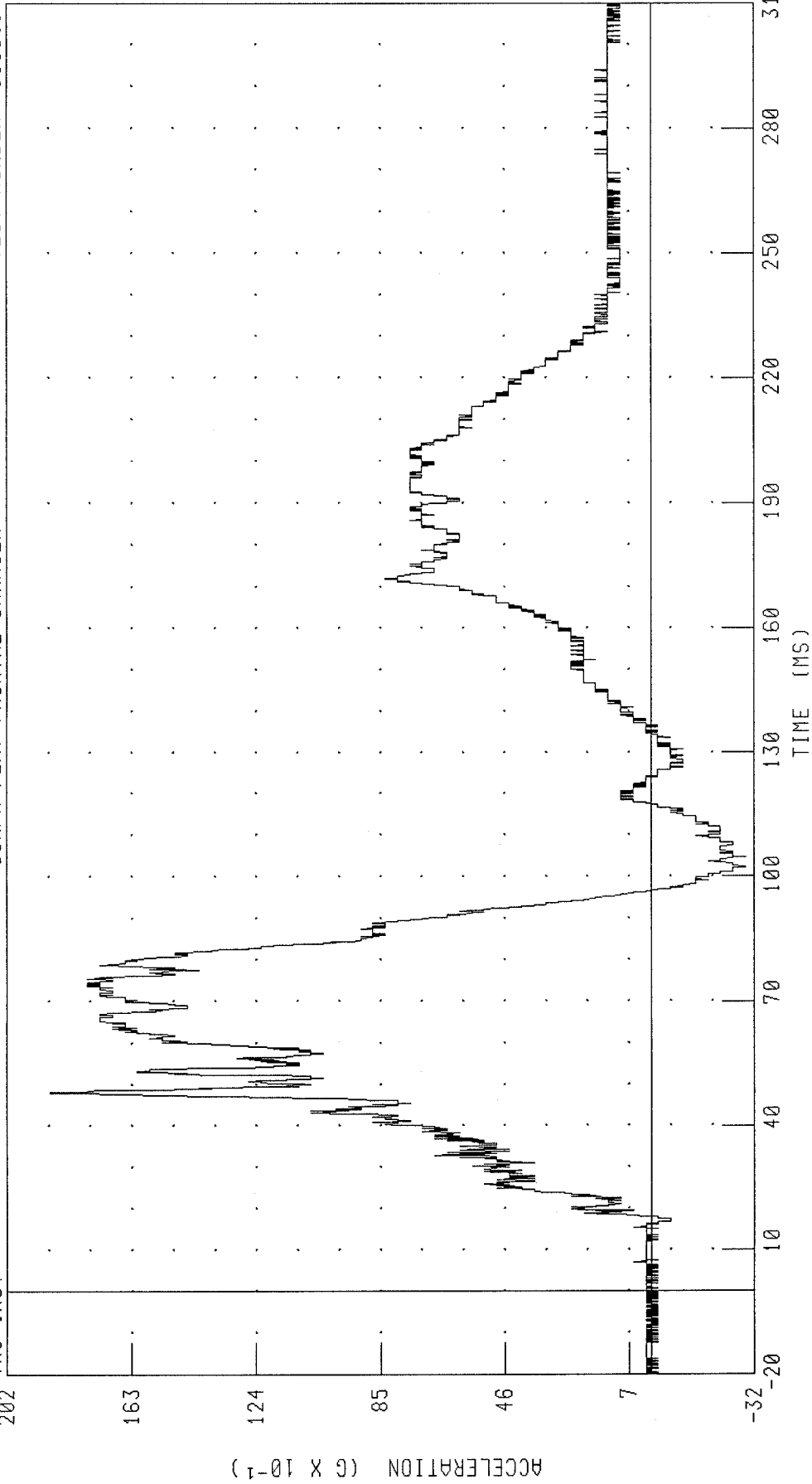

PEAK DATA: 18.86 G @ 48.16 MS; -2.94 G @ 102.24 MS

CHANNEL: HEDZG1 FILTER: CH. CLASS 1000

2001 NISSAN MAXIMA INTO FRONTAL LOAD CELL BARRIER
DRIVER HEAD RESULTANT ACCELERATION
35MPH FLAT FRONTAL BARRIER

TEST NUMBER: 010618

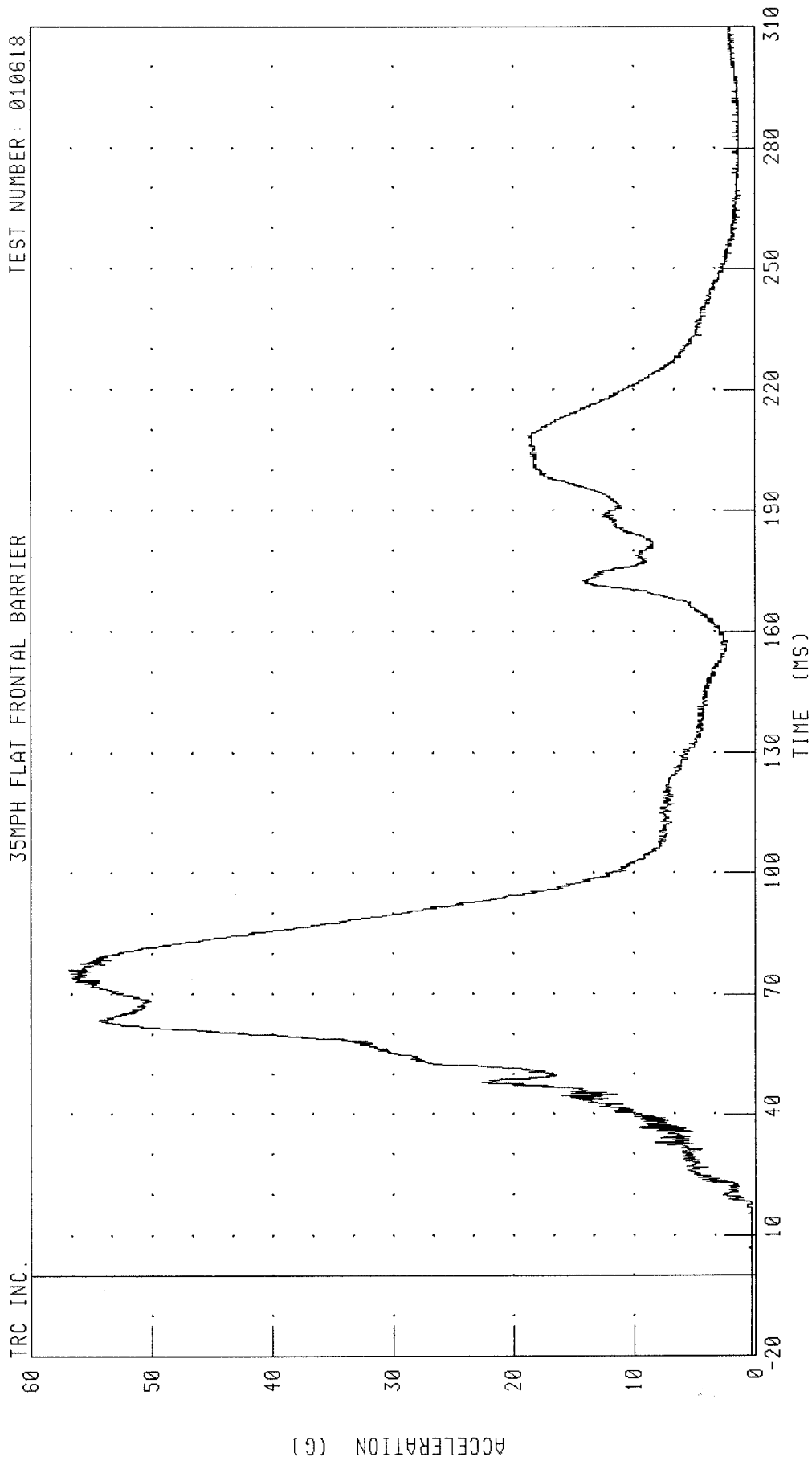

CHANNEL: HEDRG1 FILTER: CH. CLASS 1000 PEAK DATA: 56.85 G @ 76.16 MS; 0.29 G @ -20.00 MS

2001 NISSAN MAXIMA INTO FRONTAL LOAD CELL BARRIER
DRIVER HEAD X-AXIS ACCELERATION - REDUNDANT
35MPH FLAT FRONTAL BARRIER

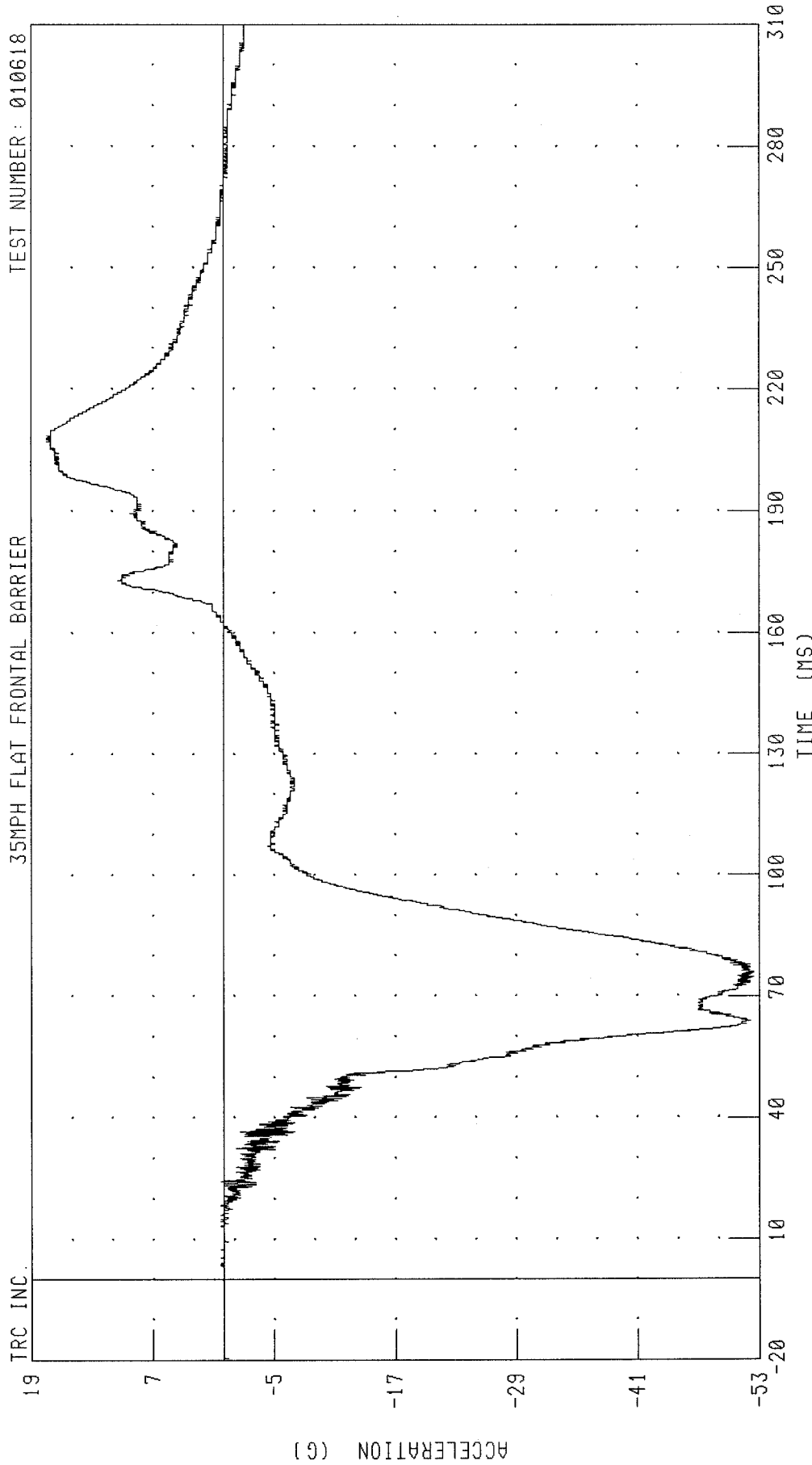

CHANNEL: HEDXR1 FILTER: CH. CLASS 1000 PEAK DATA: 17.46 G @ 207.12 MS; -52.45 G @ 74.64 MS

2001 NISSAN MAXIMA INTO FRONTAL LOAD CELL BARRIER
DRIVER HEAD Y-AXIS ACCELERATION - REDUNDANT
35MPH FLAT FRONTAL BARRIER

TEST NUMBER: 010618

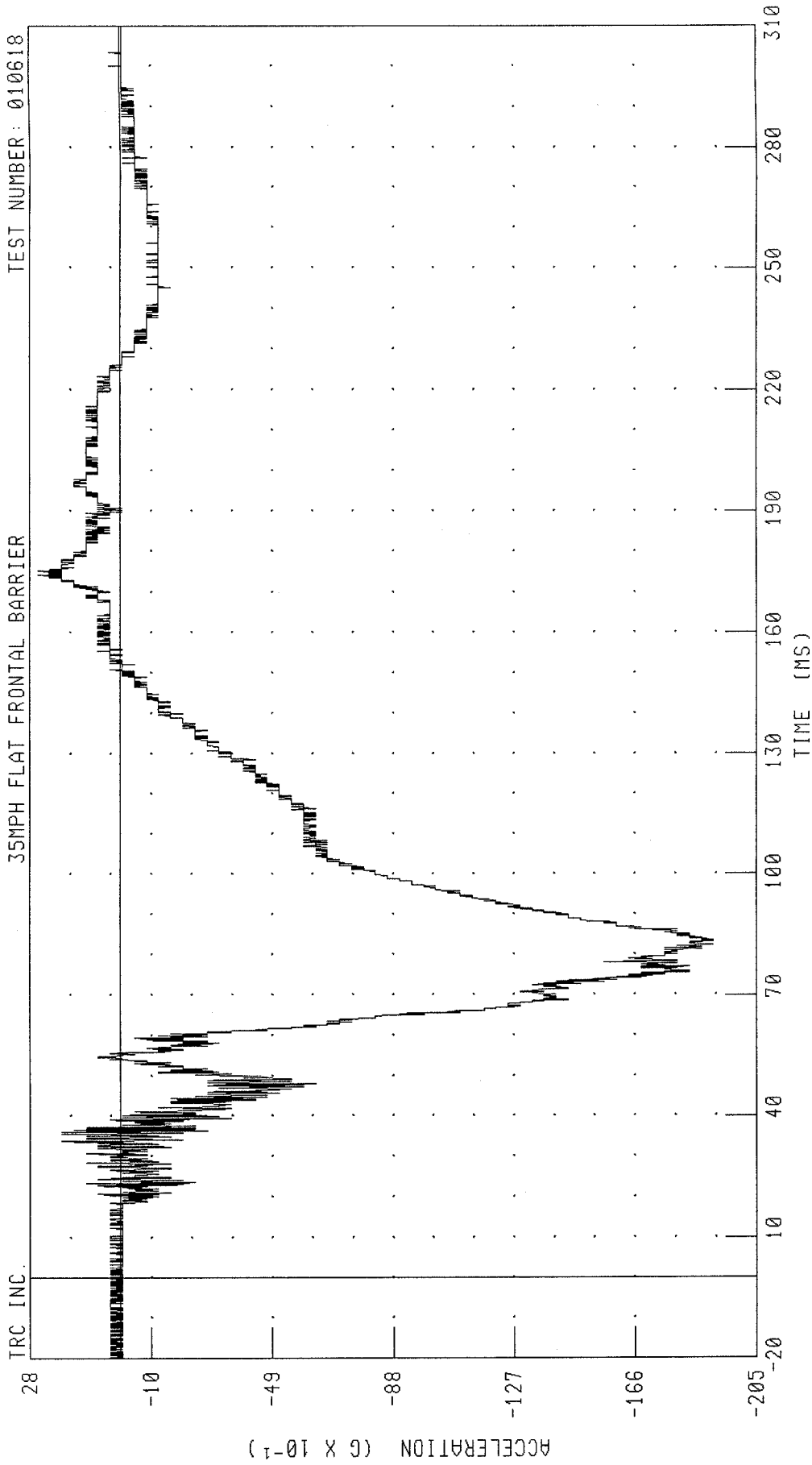

PEAK DATA: 2.66 G @ 174.16 MS; -19.13 G @ 82.32 MS

CHANNEL: HEDYR1 FILTER: CH. CLASS 1000

2001 NISSAN MAXIMA INTO FRONTAL LOAD CELL BARRIER
DRIVER HEAD Z-AXIS ACCELERATION - REDUNDANT
35MPH FLAT FRONTAL BARRIER

TEST NUMBER: 010618

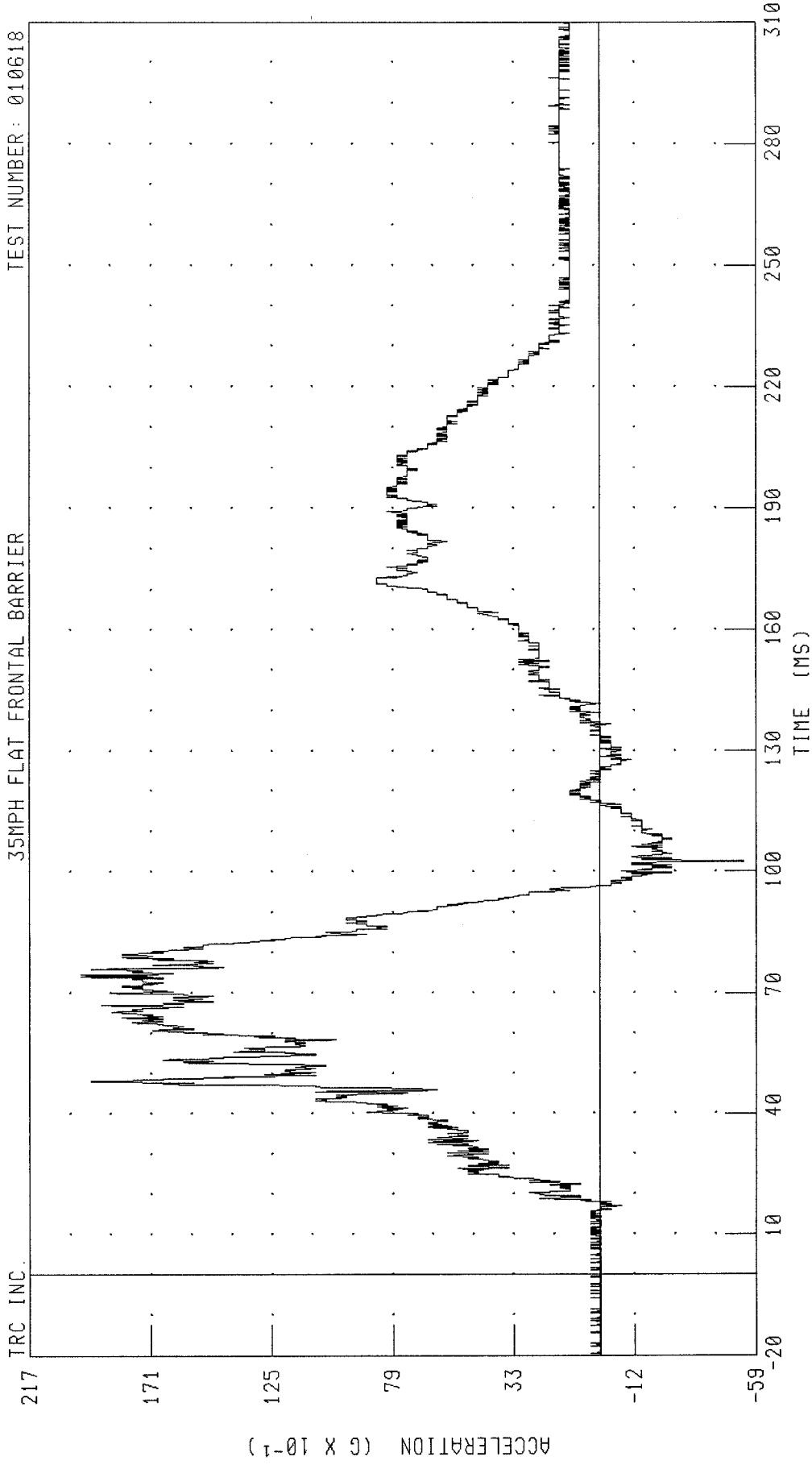

CHANNEL: HEDZR1 FILTER: CH. CLASS 1000

PEAK DATA: 19.76 G @ 74.08 MS; -5.44 G @ 102.48 MS

2001 NISSAN MAXIMA INTO FRONTAL LOAD CELL BARRIER
DRIVER HEAD RESULTANT ACCELERATION - REDUNDANT
35MPH FLAT FRONTAL BARRIER

TEST NUMBER : 010618

TRC INC.

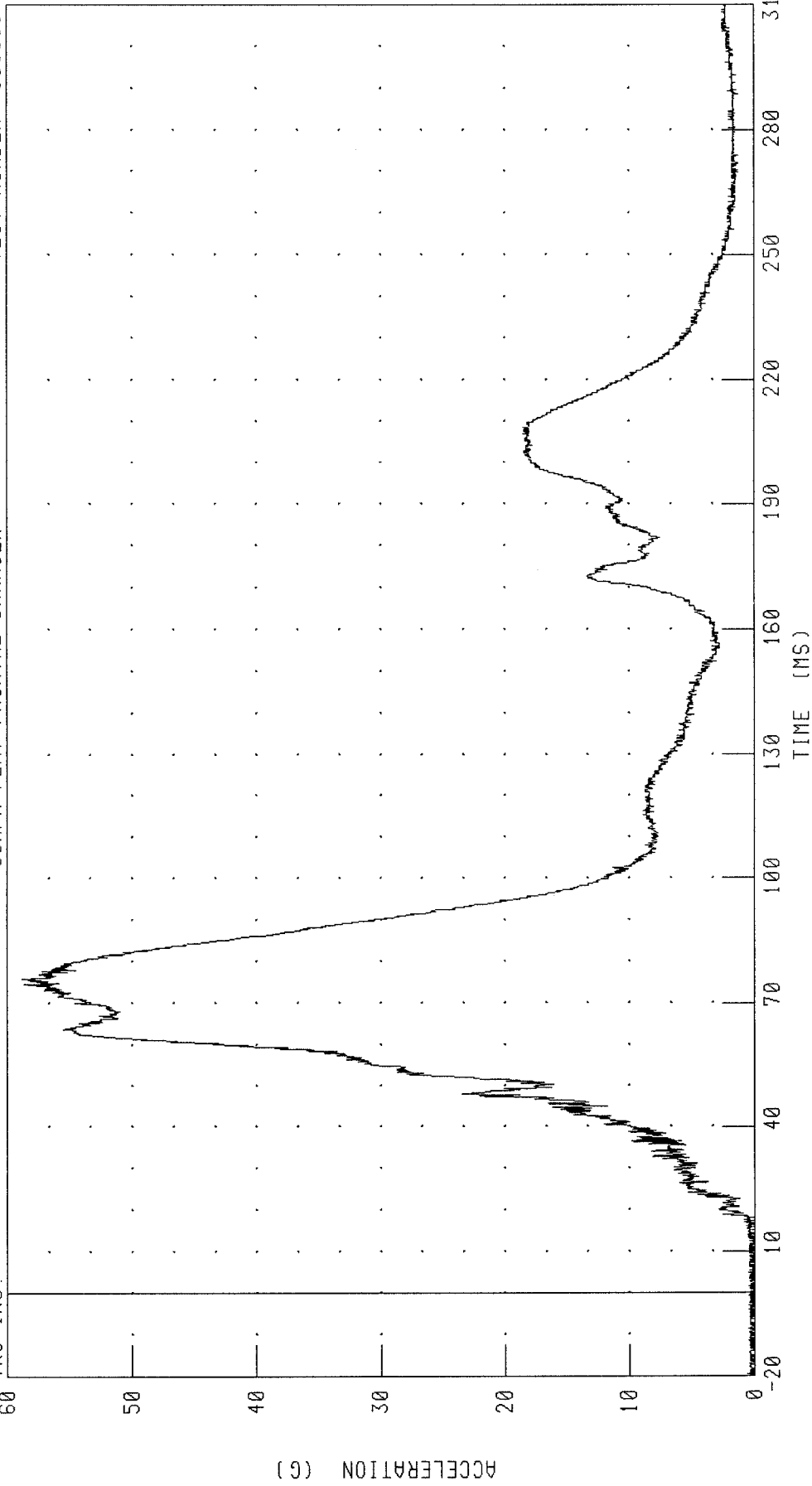

CHANNEL : HEDRR1 FILTER : CH. CLASS 1000

PEAK DATA : 58.85 G @ 76.00 MS ; 0.07 G @ -20.00 MS

2001 NISSAN MAXIMA INTO FRONTAL LOAD CELL BARRIER
DRIVER NECK X-AXIS SHEAR FORCE
35MPH FLAT FRONTAL BARRIER

TEST NUMBER: 010618

TRC INC.

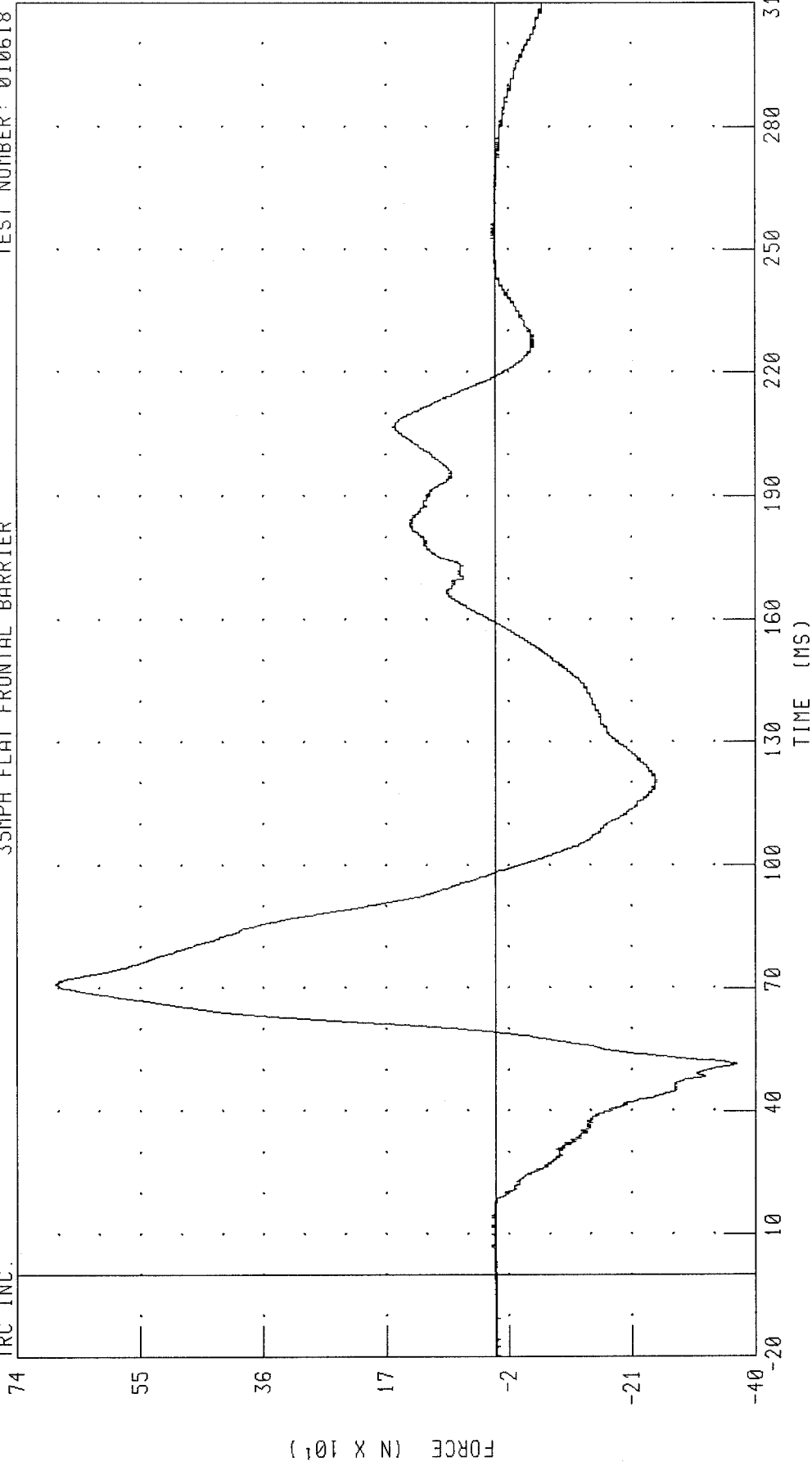

PEAK DATA: 680.52 N @ 70.80 MS; -371.23 N @ 51.44 MS

CHANNEL: NEKXF1 FILTER: CH. CLASS 1000

2001 NISSAN MAXIMA INTO FRONTAL LOAD CELL BARRIER
DRIVER NECK Y-AXIS SHEAR FORCE
35MPH FLAT FRONTAL BARRIER

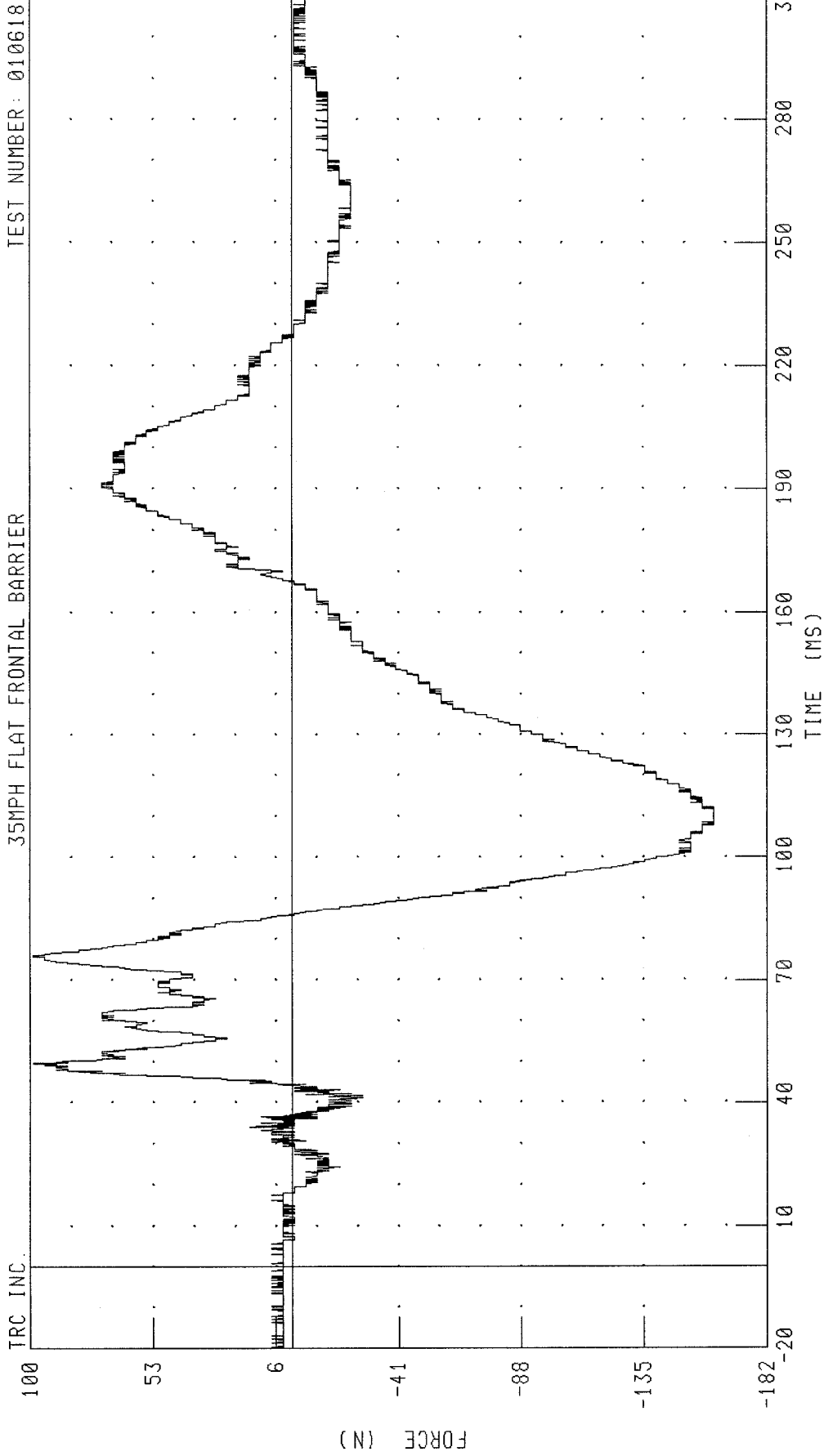

CHANNEL: NEKYF1 FILTER: CH. CLASS 1000

PEAK DATA: 98.75 N @ 49.68 MS; -161.68 N @ 107.68 MS

2001 NISSAN MAXIMA INTO FRONTAL LOAD CELL BARRIER
DRIVER NECK Z-AXIS AXIAL FORCE
35MPH FLAT FRONTAL BARRIER

TEST NUMBER: 010618

TRC INC.

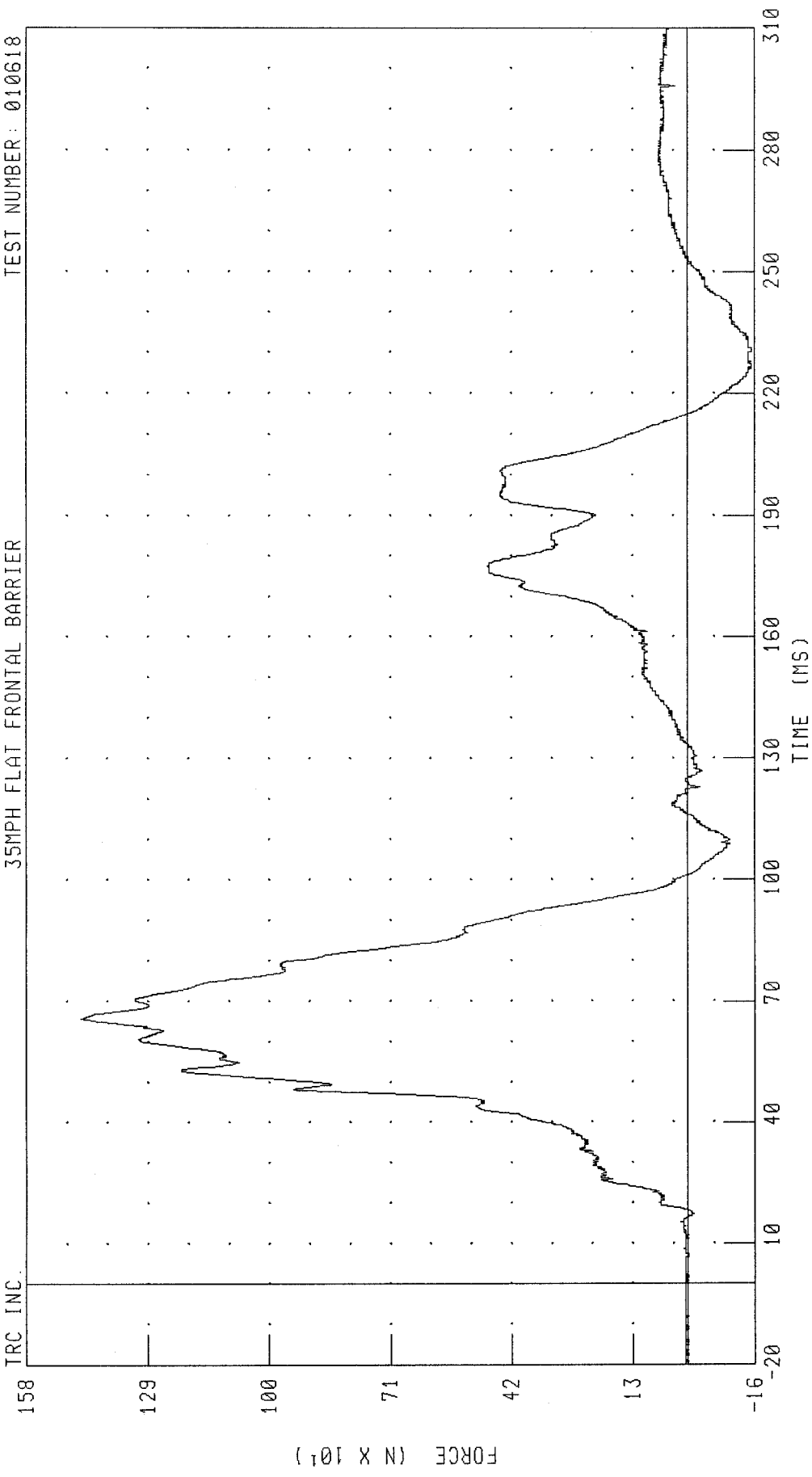

CHANNEL: NEKZF1 FILTER: CH. CLASS 1000

PEAK DATA: 1450.31 N @ 65.84 MS; -152.88 N @ 226.00 MS

2001 NISSAN MAXIMA INTO FRONTAL LOAD CELL BARRIER
DRIVER NECK MOMENT ABOUT X AXIS
35MPH FLAT FRONTAL BARRIER

TEST NUMBER: 010618

TRC INC.

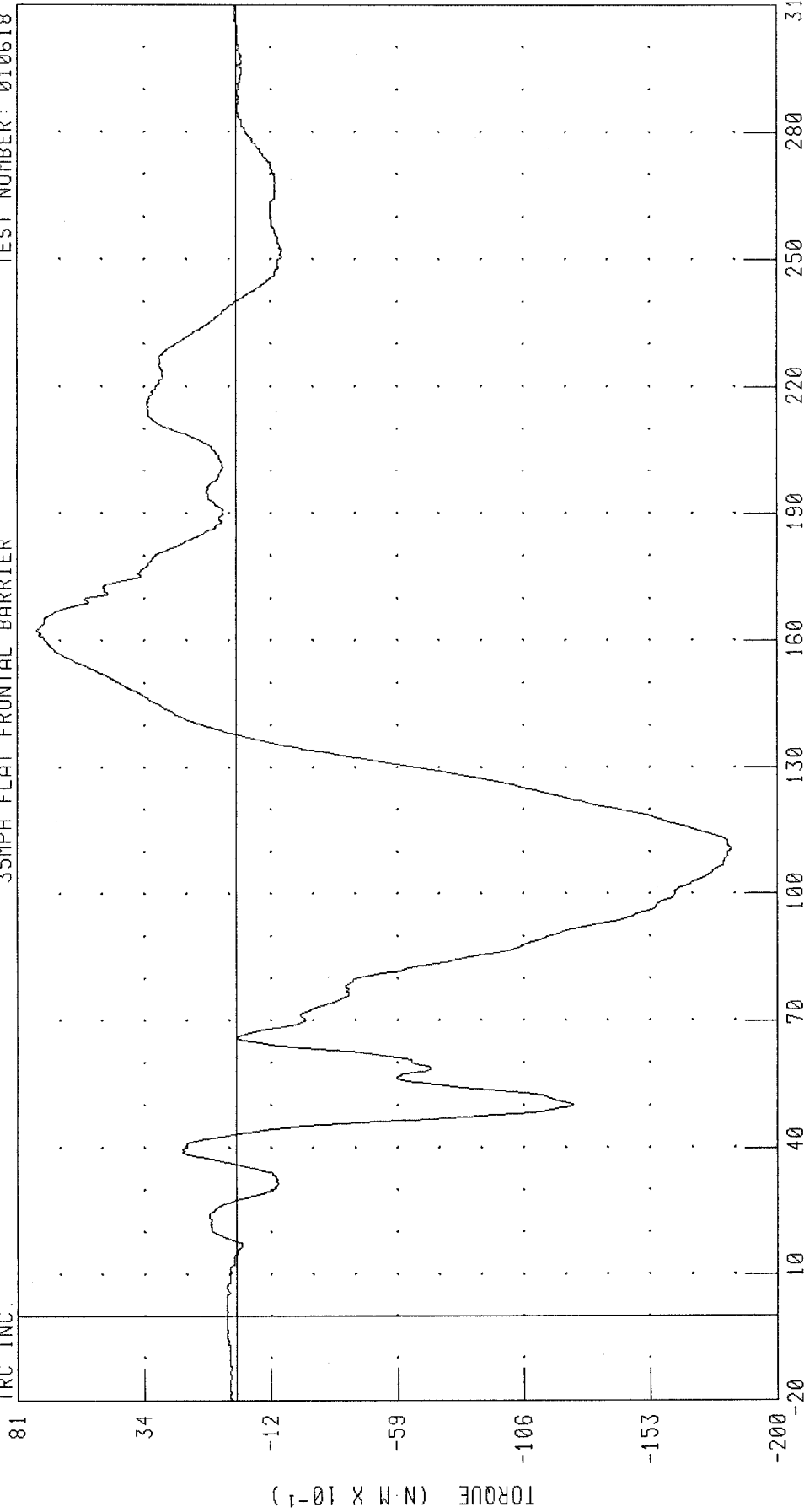

TIME (MS)

PEAK DATA: 7.39 N·M @ 162.48 MS; -18.41 N·M @ 110.88 MS

CHANNEL: NEKX11 FILTER: CH. CLASS 600

2001 NISSAN MAXIMA INTO FRONTAL LOAD CELL BARRIER
DRIVER NECK MOMENT ABOUT Y AXIS
35MPH FLAT FRONTAL BARRIER

TEST NUMBER: 010618

TRC INC.

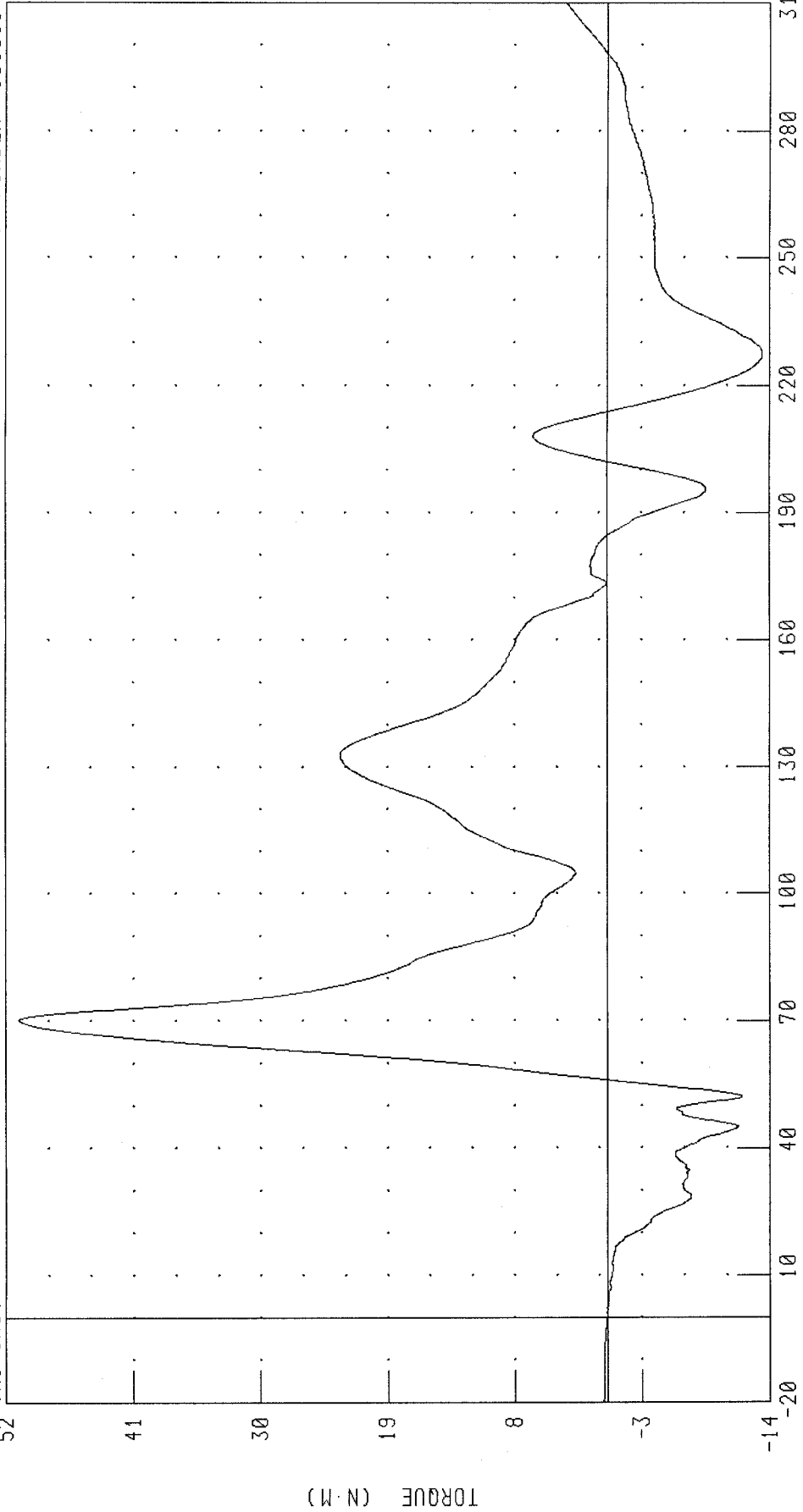

TIME (MS)

CHANNEL: NEKYM1 FILTER: CH. CLASS 600 PEAK DATA: 50.90 N.M @ 70.32 MS, -13.37 N.M @ 227.92 MS

TORQUE (N-M)

2001 NISSAN MAXIMA INTO FRONTAL LOAD CELL BARRIER
DRIVER NECK MOMENT ABOUT Z AXIS
35MPH FLAT FRONTAL BARRIER

TEST NUMBER: 010618

TRC INC.

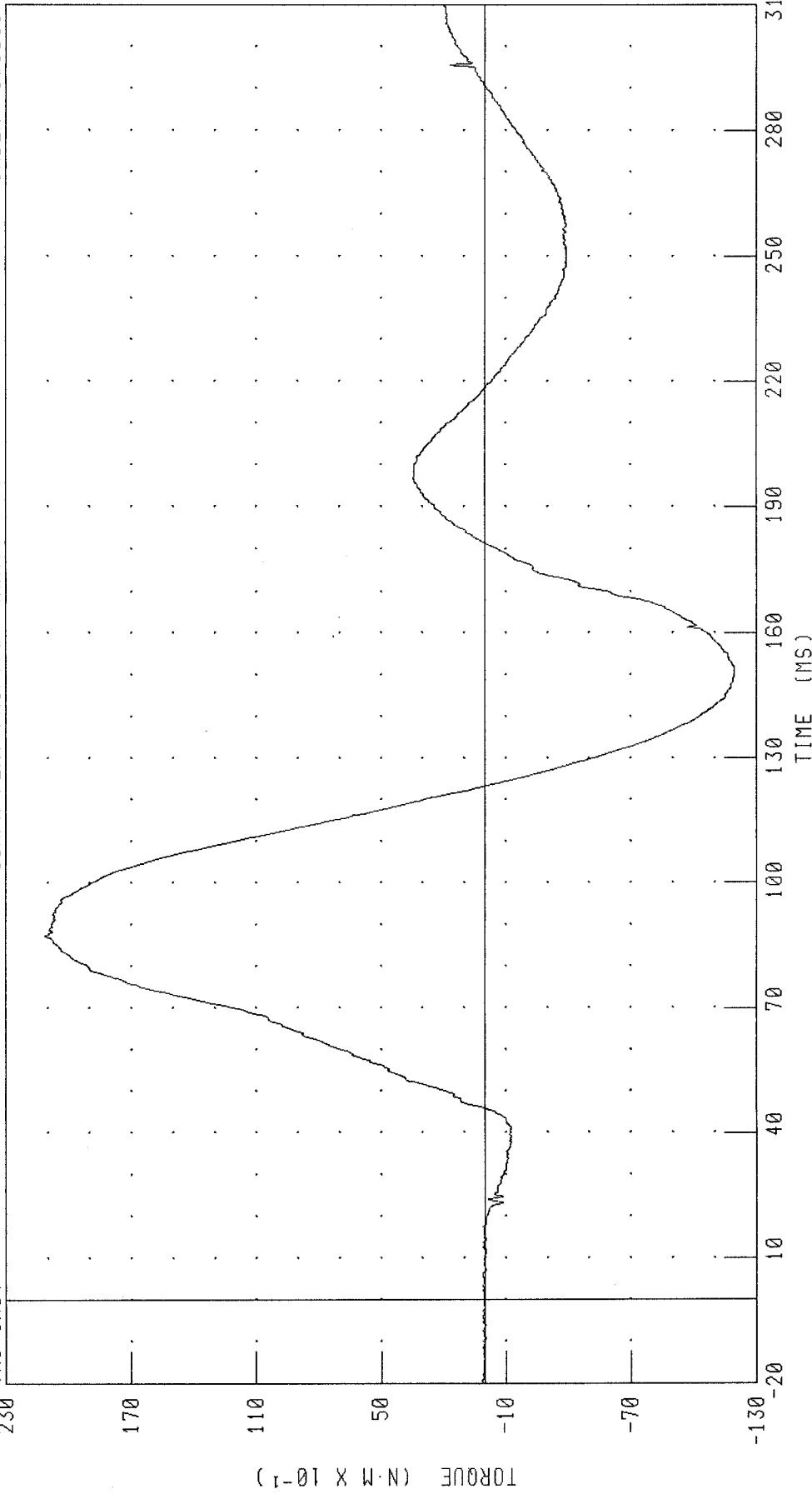

TIME (MS)

PEAK DATA: 21.15 N·M @ 87.20 MS; -11.95 N·M @ 151.44 MS

CHANNEL: NEKZM1 FILTER: CH. CLASS 600

2001 NISSAN MAXIMA INTO FRONTAL LOAD CELL BARRIER
DRIVER NECK MOMENT OCCIPITAL CONDYLE ABOUT Y AXIS
35MPH FLAT FRONTAL BARRIER

TEST NUMBER: 010618

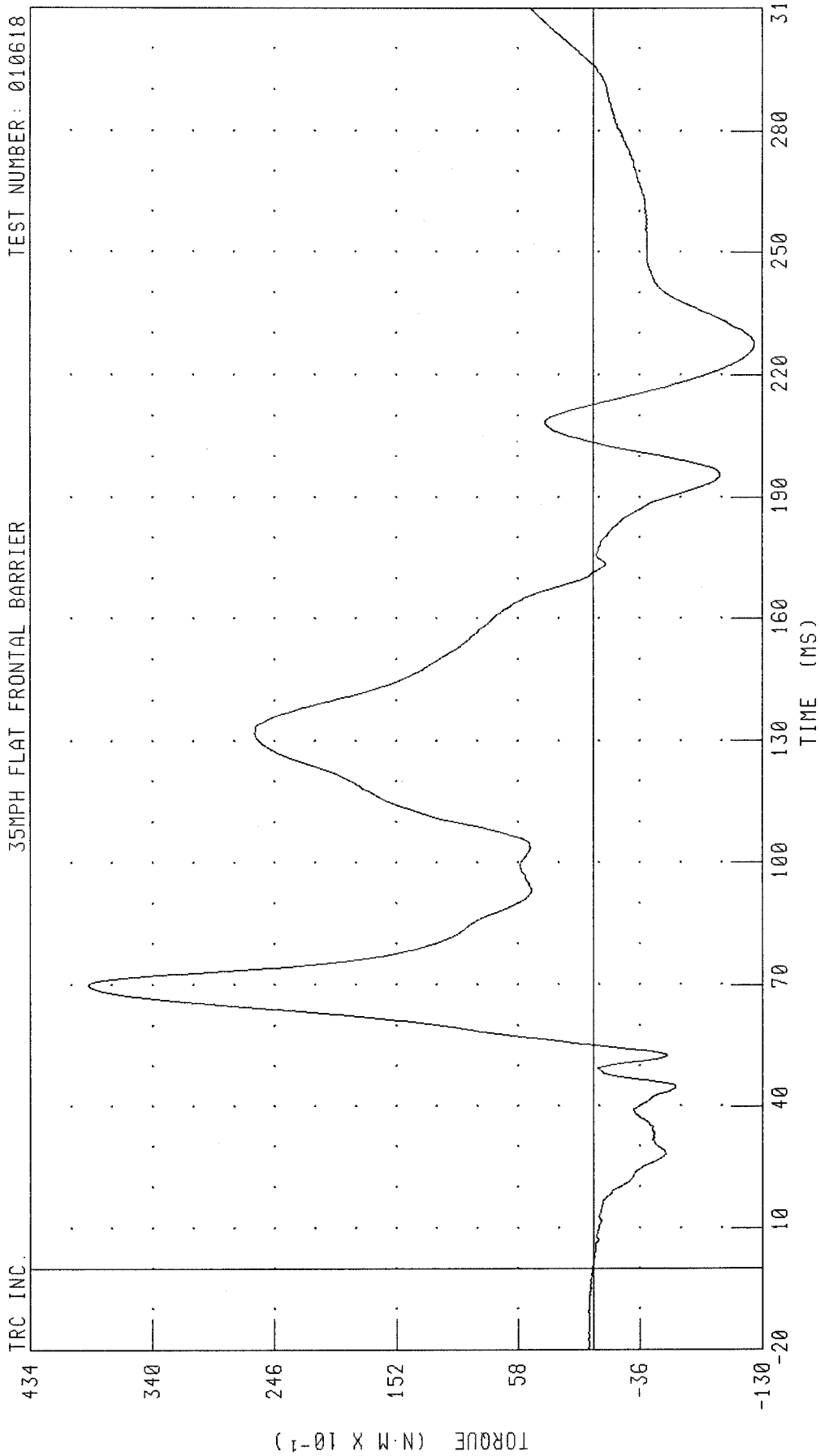

PEAK DATA: 38.93 N·M @ 69.92 MS; -12.39 N·M @ 228.08 MS

CHANNEL: NEKOM1 FILTER: CH. CLASS 600

2001 NISSAN MAXIMA INTO FRONTAL LOAD CELL BARRIER
DRIVER CHEST X-AXIS ACCELERATION
35MPH FLAT FRONTAL BARRIER

TEST NUMBER: 010618

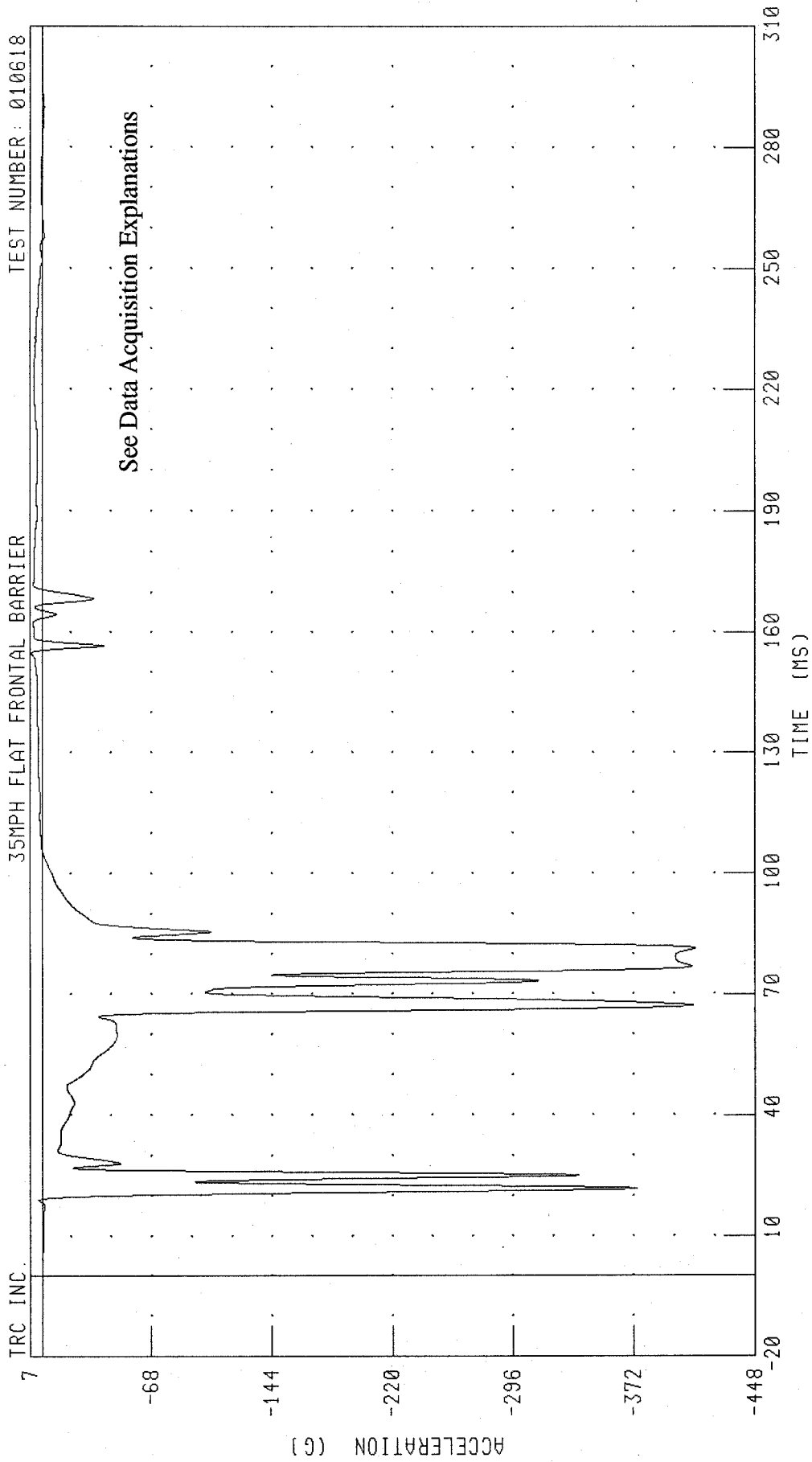

CHANNEL: CSTXC1 FILTER: CH. CLASS 180 PEAK DATA: 7.05 G @ 154.96 MS; -411.03 G @ 81.44 MS

2001 NISSAN MAXIMA INTO FRONTAL LOAD CELL BARRIER
DRIVER CHEST Y-AXIS ACCELERATION
35MPH FLAT FRONTAL BARRIER

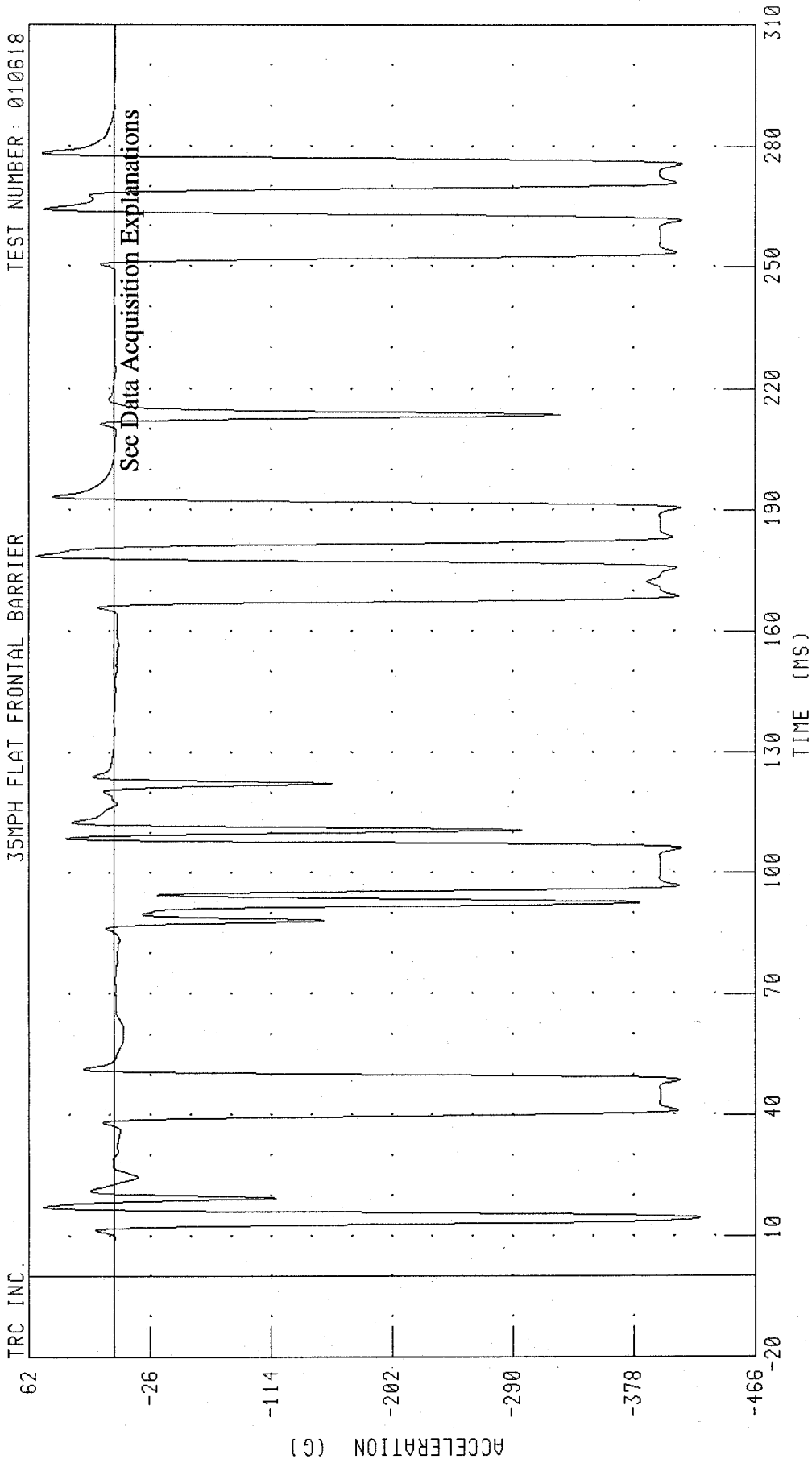

CHANNEL: CSTYC1 FILTER: CH. CLASS 180 PEAK DATA: 56.62 G @ 178.64 MS, -425.89 G @ 14.40 MS

2001 NISSAN MAXIMA INTO FRONTAL LOAD CELL BARRIER
DRIVER CHEST Z-AXIS ACCELERATION
35MPH FLAT FRONTAL BARRIER

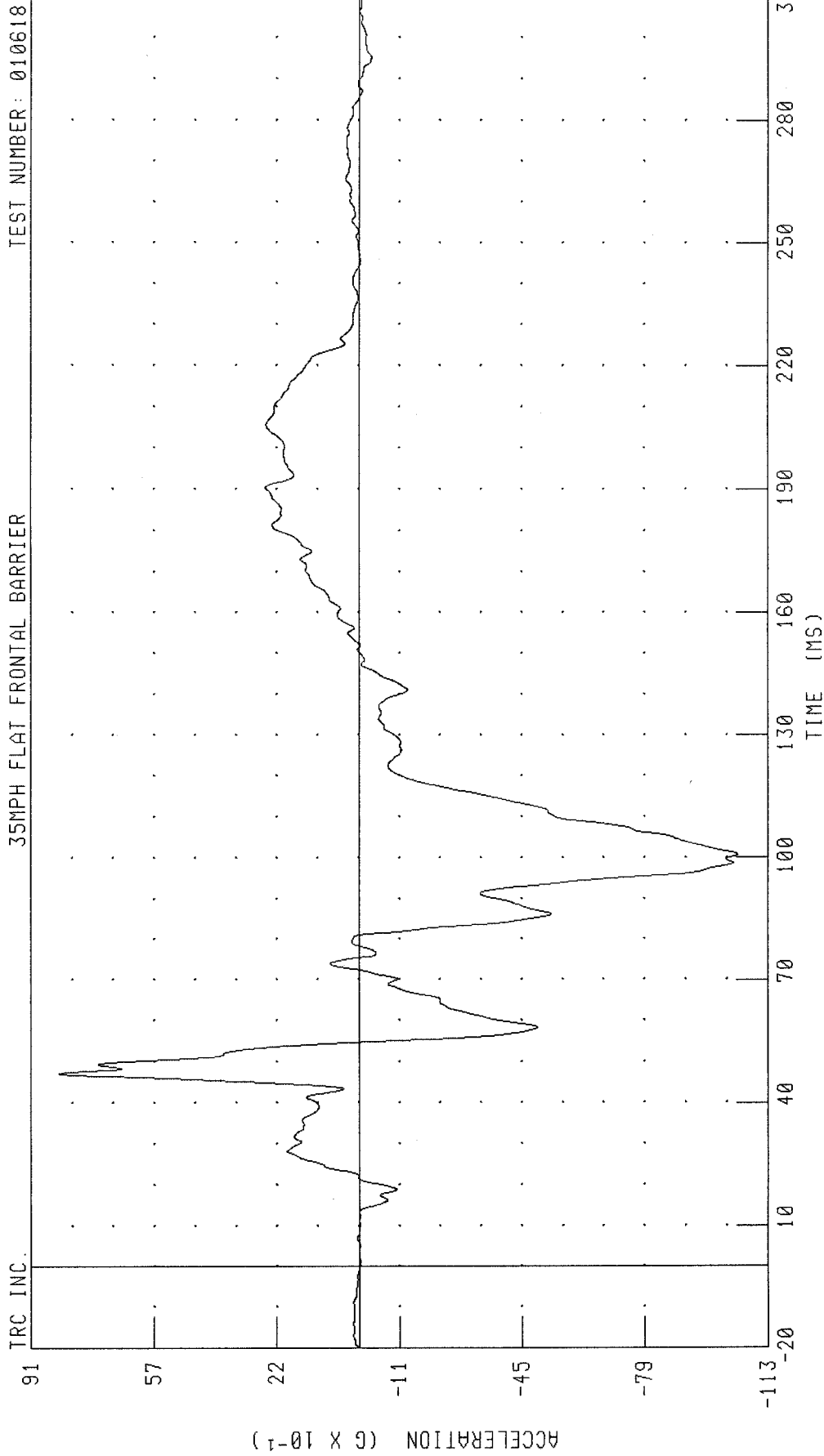

CHANNEL: CSTZG1 FILTER: CH. CLASS 180 PEAK DATA: 8.33 G @ 47.20 MS; -10.47 G @ 100.80 MS

2001 NISSAN MAXIMA INTO FRONTAL LOAD CELL BARRIER
DRIVER CHEST RESULTANT ACCELERATION
35MPH FLAT FRONTAL BARRIER

TEST NUMBER: 010618

TRC INC.

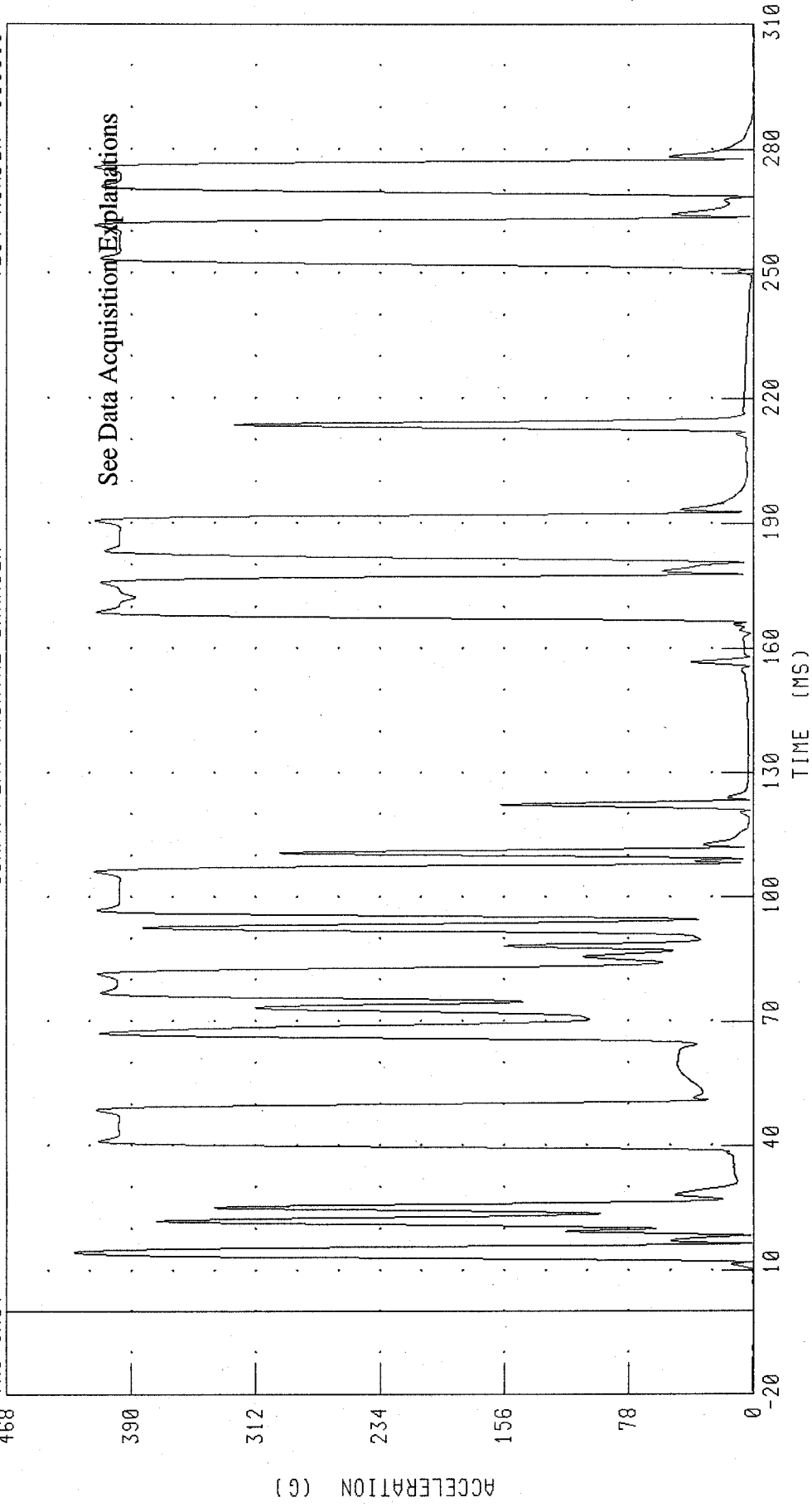

CHANNEL: CSTRG1 FILTER: CH. CLASS 180 PEAK DATA: 425.89 G @ 14.40 MS, 0.02 G @ -20.00 MS

2001 NISSAN MAXIMA INTO FRONTAL LOAD CELL BARRIER
DRIVER CHEST X-AXIS ACCELERATION - REDUNDANT
35MPH FLAT FRONTAL BARRIER

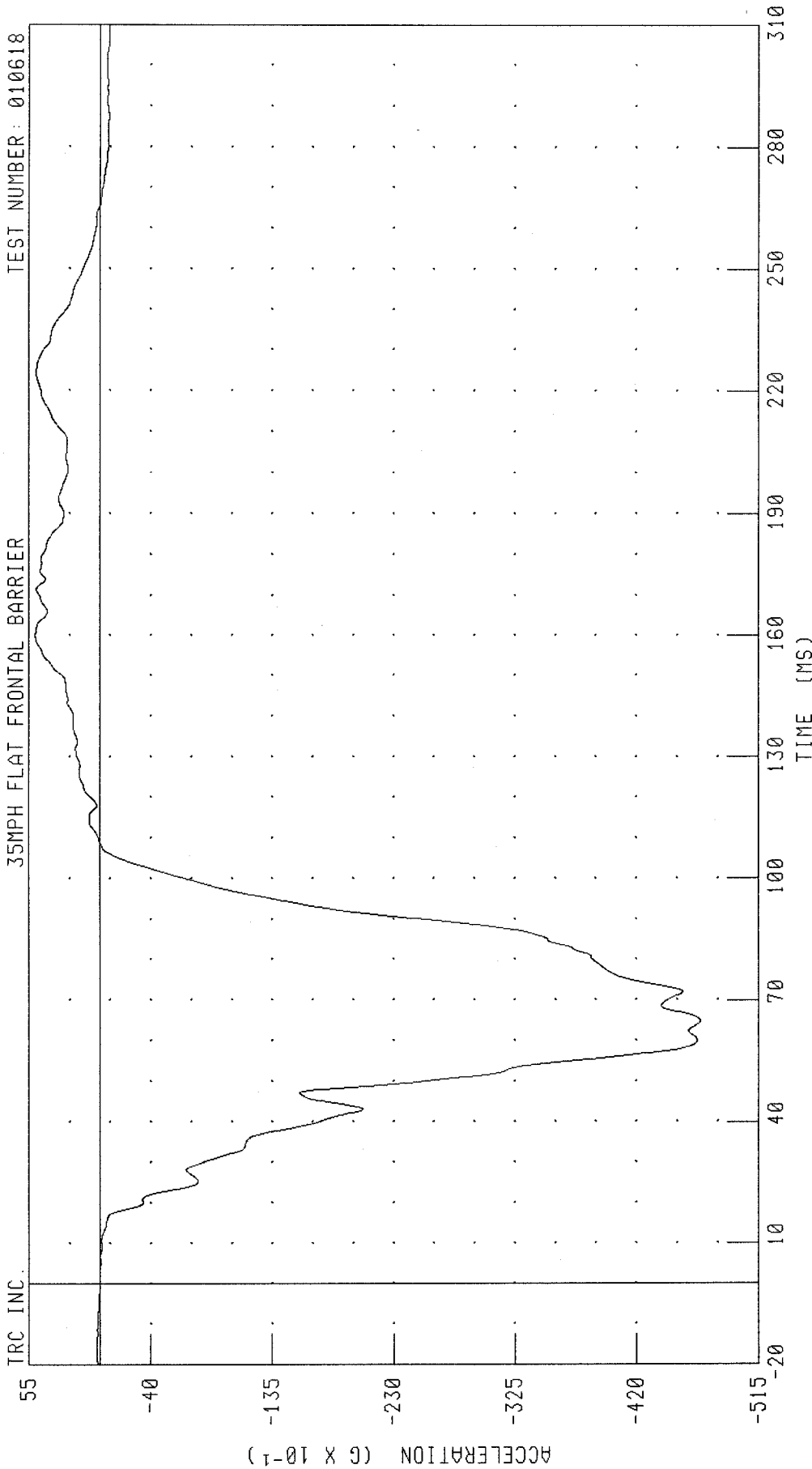

CHANNEL: CSTXR1 FILTER: CH. CLASS 180 PEAK DATA: 5.01 G @ 160.08 MS, -46.98 G @ 64.80 MS

2001 NISSAN MAXIMA INTO FRONTAL LOAD CELL BARRIER
DRIVER CHEST Y-AXIS ACCELERATION - REDUNDANT
35MPH FLAT FRONTAL BARRIER

TEST NUMBER: 010618

TRC INC.

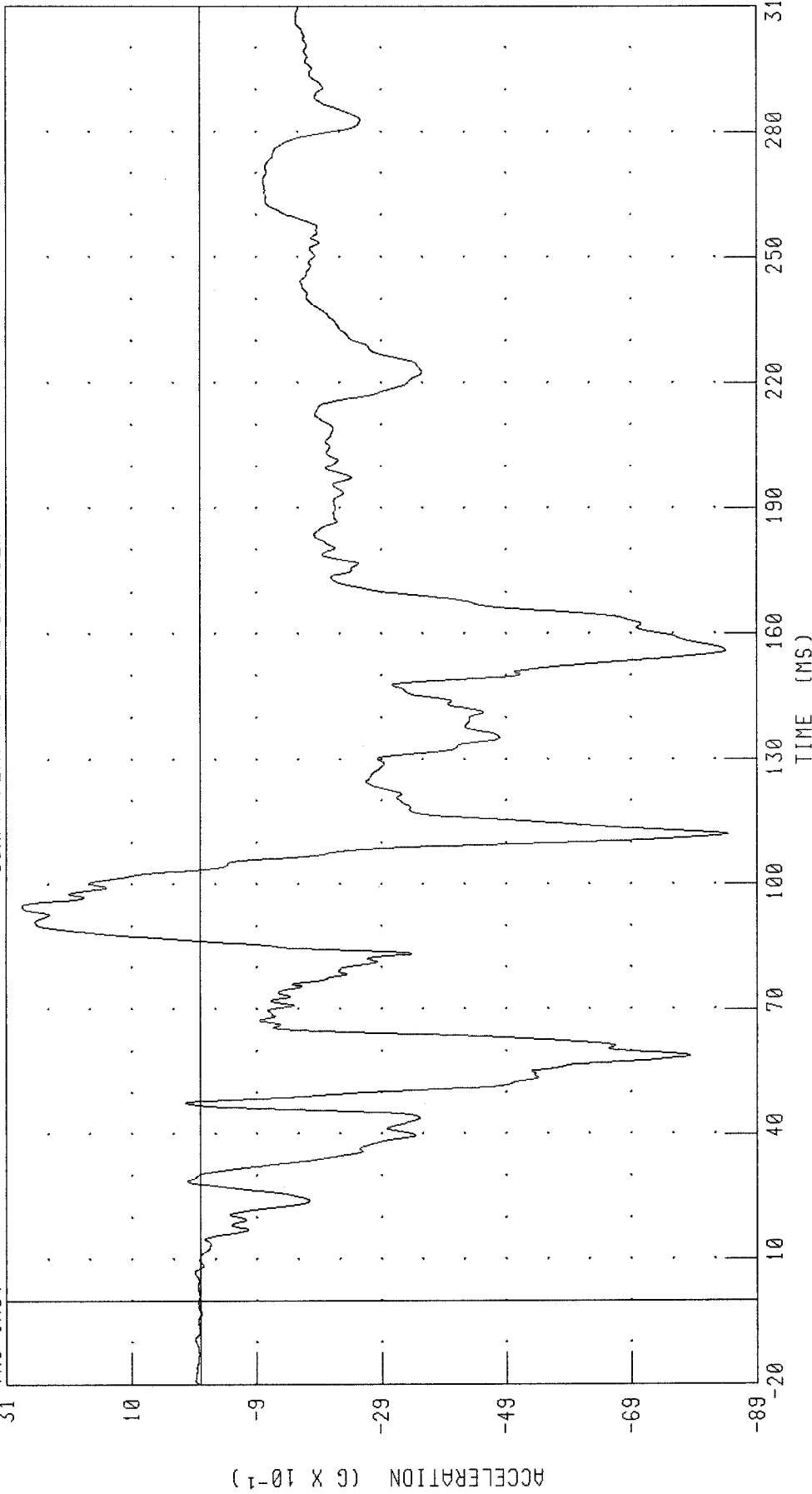

CHANNEL: CSTYR1

FILTER: CH. CLASS 180

PEAK DATA: 2.85 G @ 94.88 MS; -8.45 G @ 112.16 MS

2001 NISSAN MAXIMA INTO FRONTAL LOAD CELL BARRIER
DRIVER CHEST Z-AXIS ACCELERATION - REDUNDANT
35MPH FLAT FRONTAL BARRIER

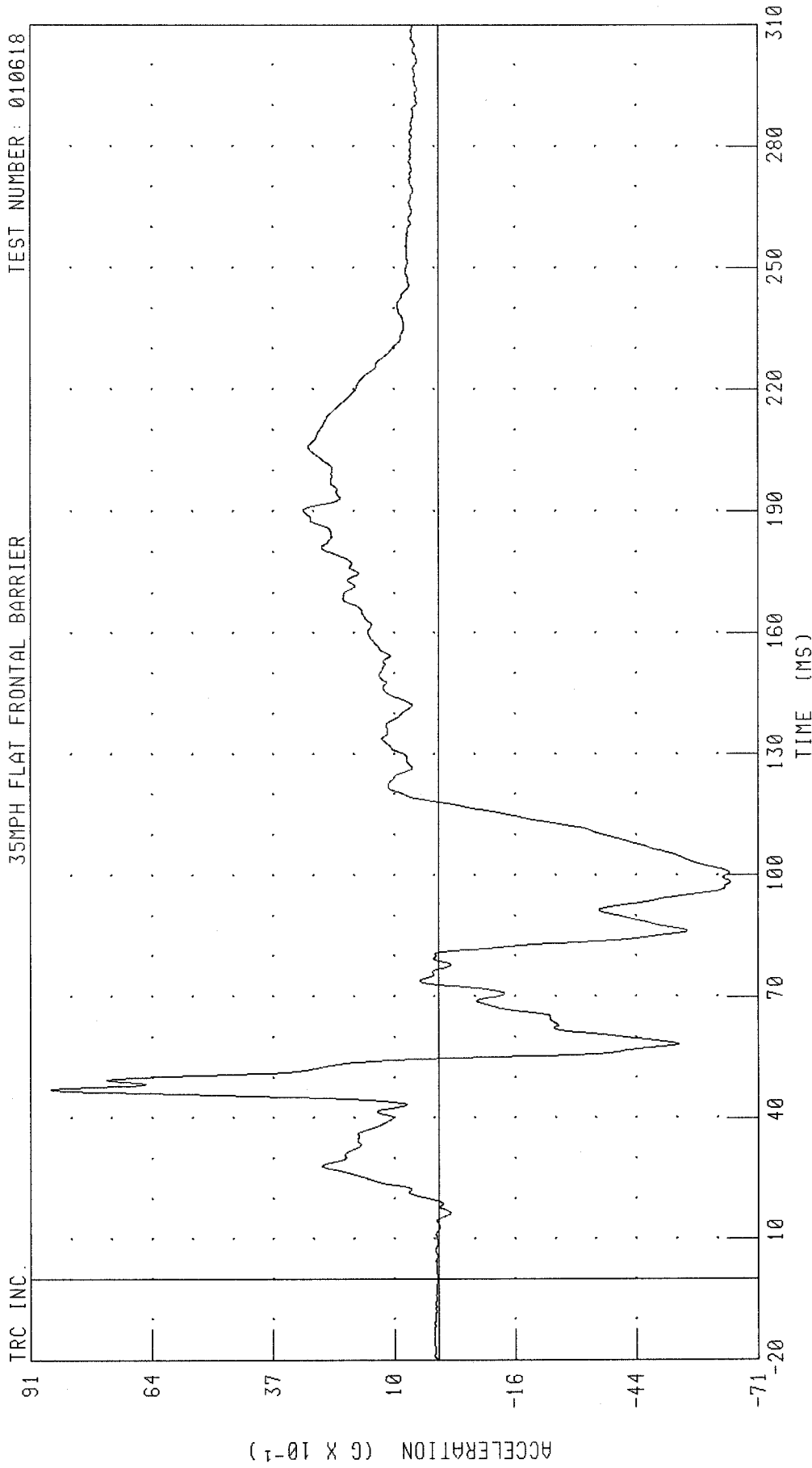

CHANNEL: CSTZR1 FILTER: CH. CLASS 180 PEAK DATA: 8.64 G @ 47.20 MS, -6.50 G @ 98.24 MS

2001 NISSAN MAXIMA INTO FRONTAL LOAD CELL BARRIER
DRIVER CHEST RESULTANT ACCELERATION - REDUNDANT
35MPH FLAT FRONTAL BARRIER

TEST NUMBER: 010618

TRC INC.

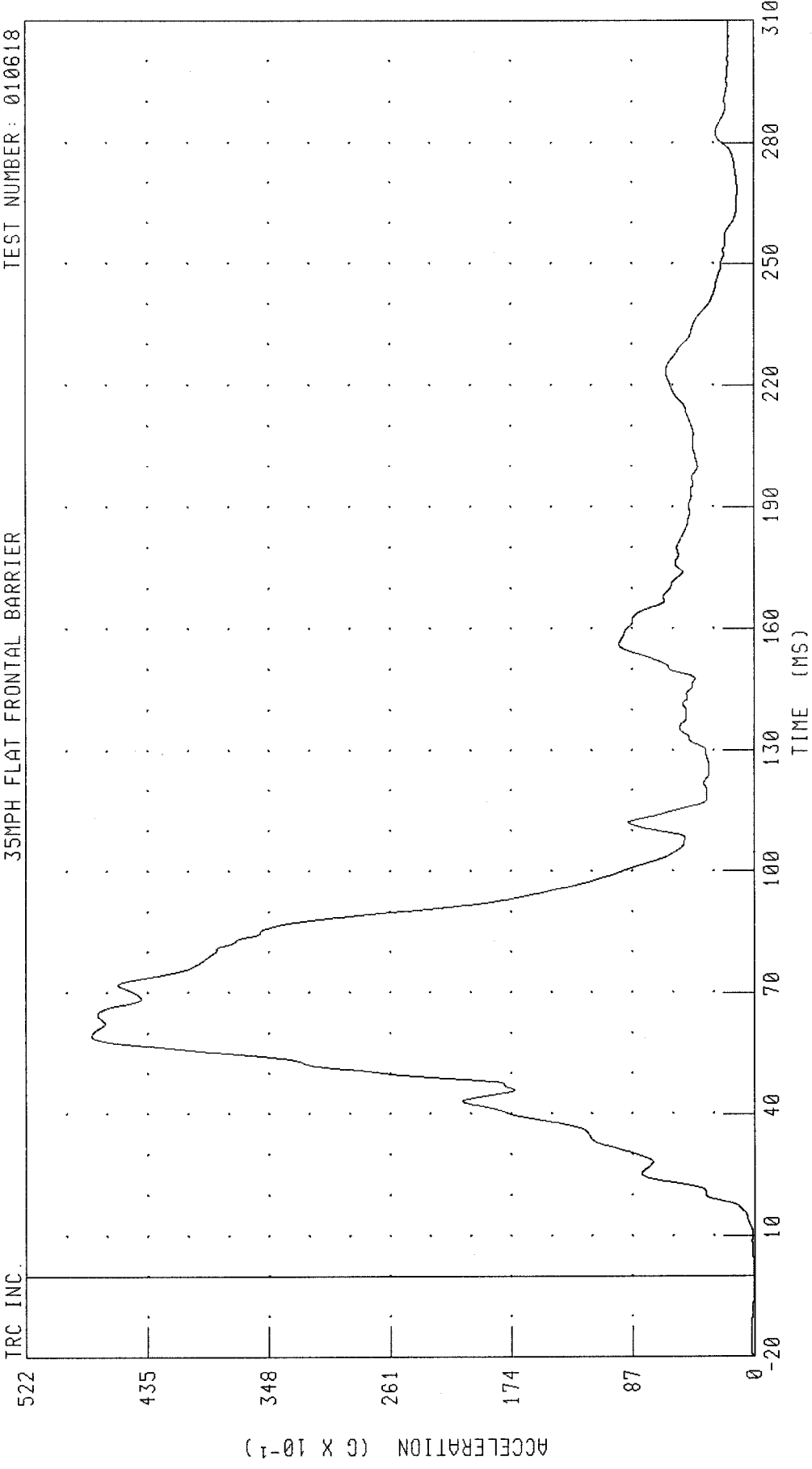

CHANNEL: CSTRR1 FILTER: CH. CLASS 180 PEAK DATA: 47.50 G @ 59.44 MS; 0.01 G @ -20.00 MS

2001 NISSAN MAXIMA INTO FRONTAL LOAD CELL BARRIER
DRIVER CHEST DEFLECTION
35MPH FLAT FRONTAL BARRIER

TEST NUMBER: 010618

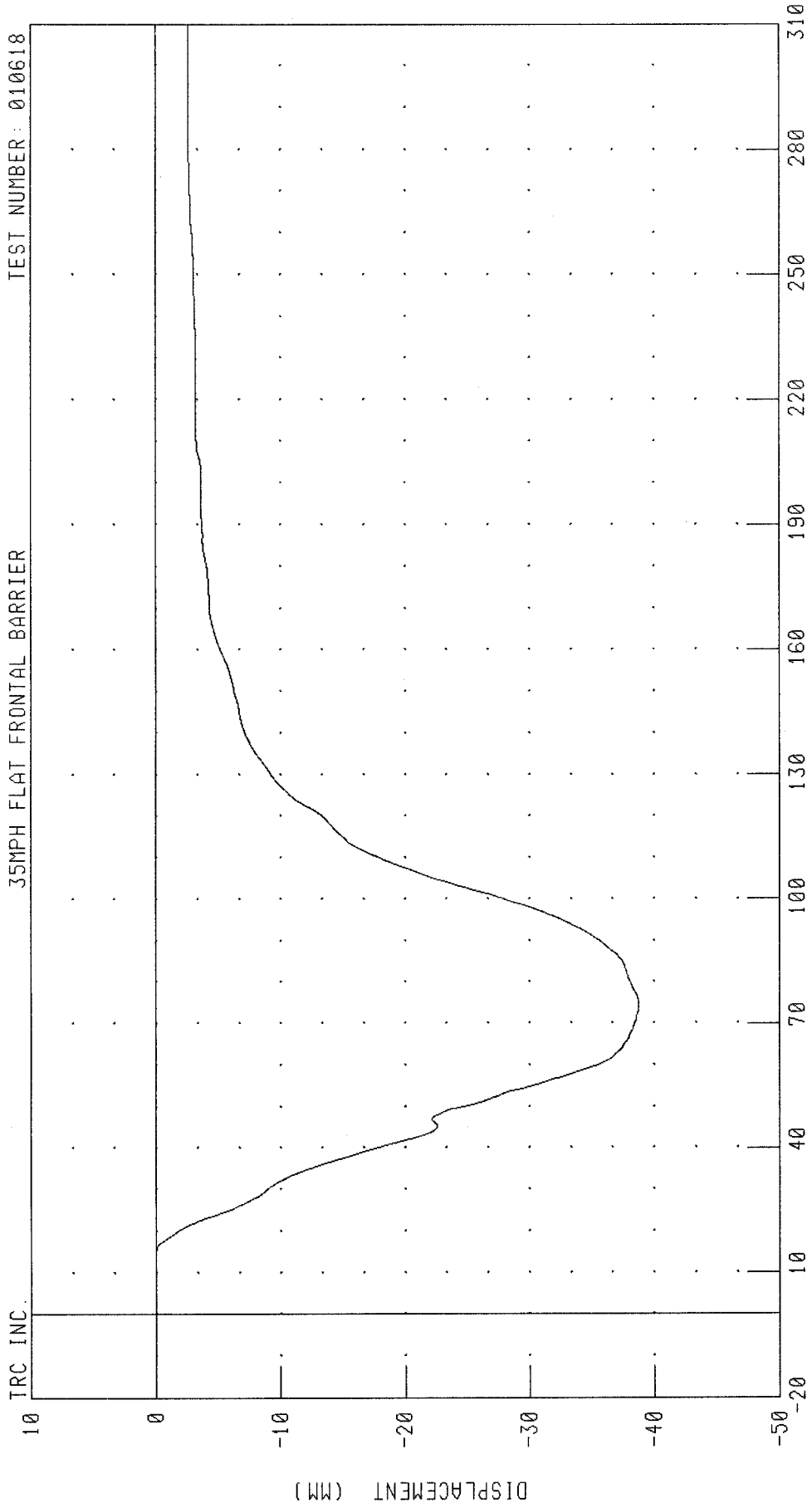

TRC INC.

CHANNEL: CSTXD1 FILTER: CH. CLASS 180

PEAK DATA: 0.01 MM @ 8.16 MS; -38.76 MM @ 75.12 MS

2001 NISSAN MAXIMA INTO FRONTAL LOAD CELL BARRIER
DRIVER PELVIS X-AXIS ACCELERATION
35MPH FLAT FRONTAL BARRIER

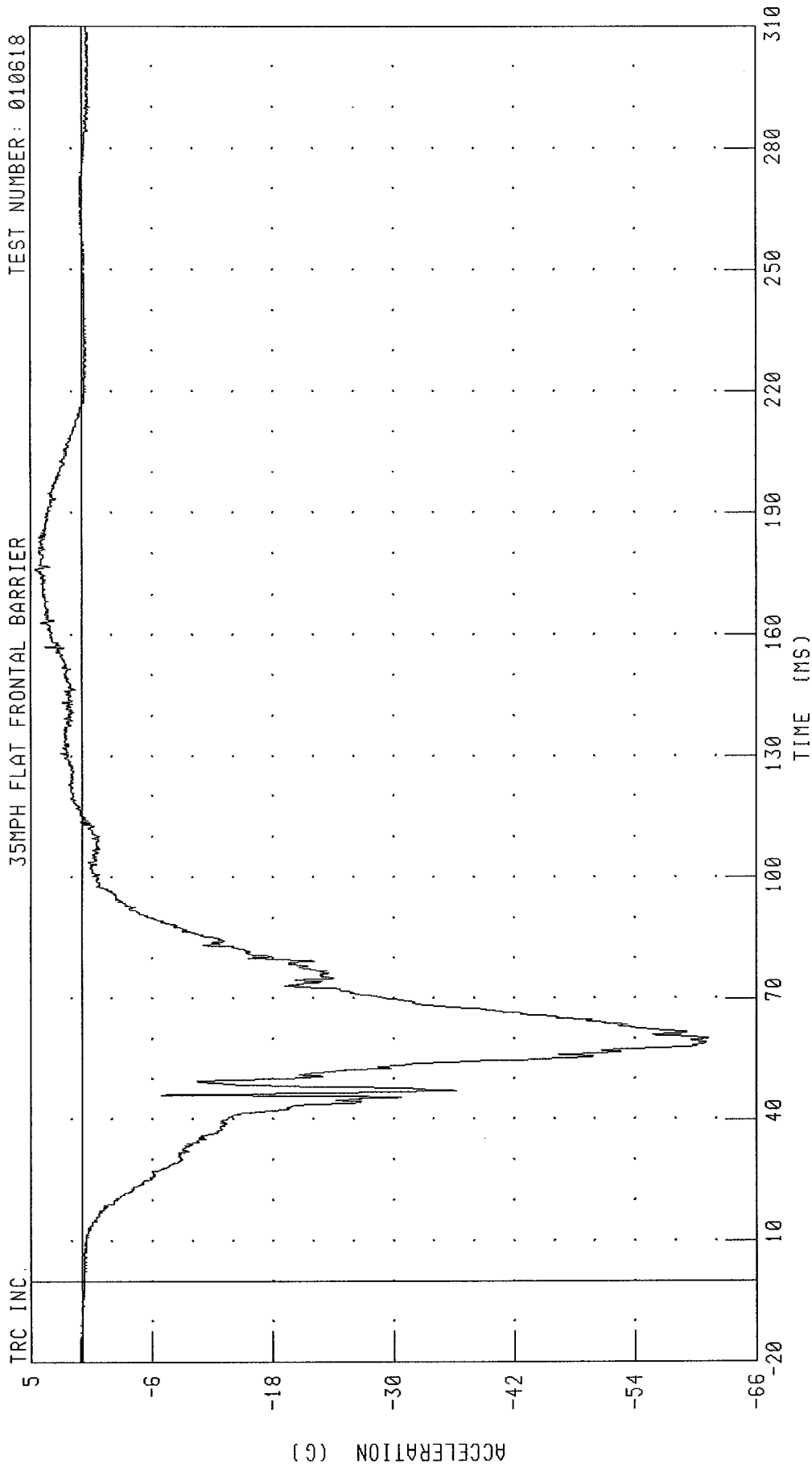

CHANNEL: PEVXC1 FILTER: CH. CLASS 1000 PEAK DATA: 4.72 G @ 176.08 MS; -62.15 G @ 60.00 MS

2001 NISSAN MAXIMA INTO FRONTAL LOAD CELL BARRIER
DRIVER PELVIS Y-AXIS ACCELERATION
35MPH FLAT FRONTAL BARRIER

TEST NUMBER: 010618

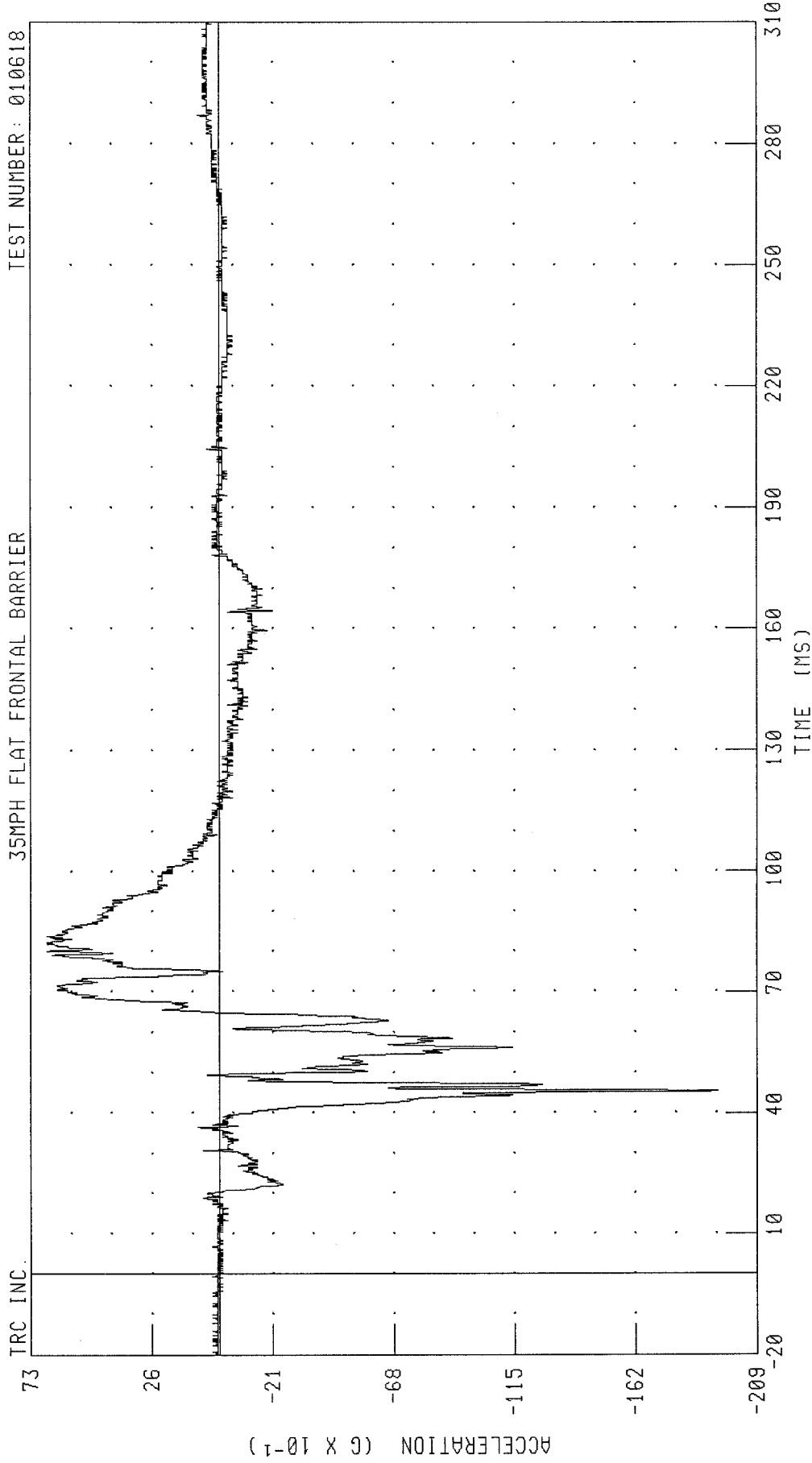

CHANNEL: PEVYG1 FILTER: CH. CLASS 1000 PEAK DATA: 6.67 G @ 80.16 MS; -19.40 G @ 45.44 MS

2001 NISSAN MAXIMA INTO FRONTAL LOAD CELL BARRIER
DRIVER PELVIS Z-AXIS ACCELERATION
35MPH FLAT FRONTAL BARRIER

TEST NUMBER: 010618

TRC INC.

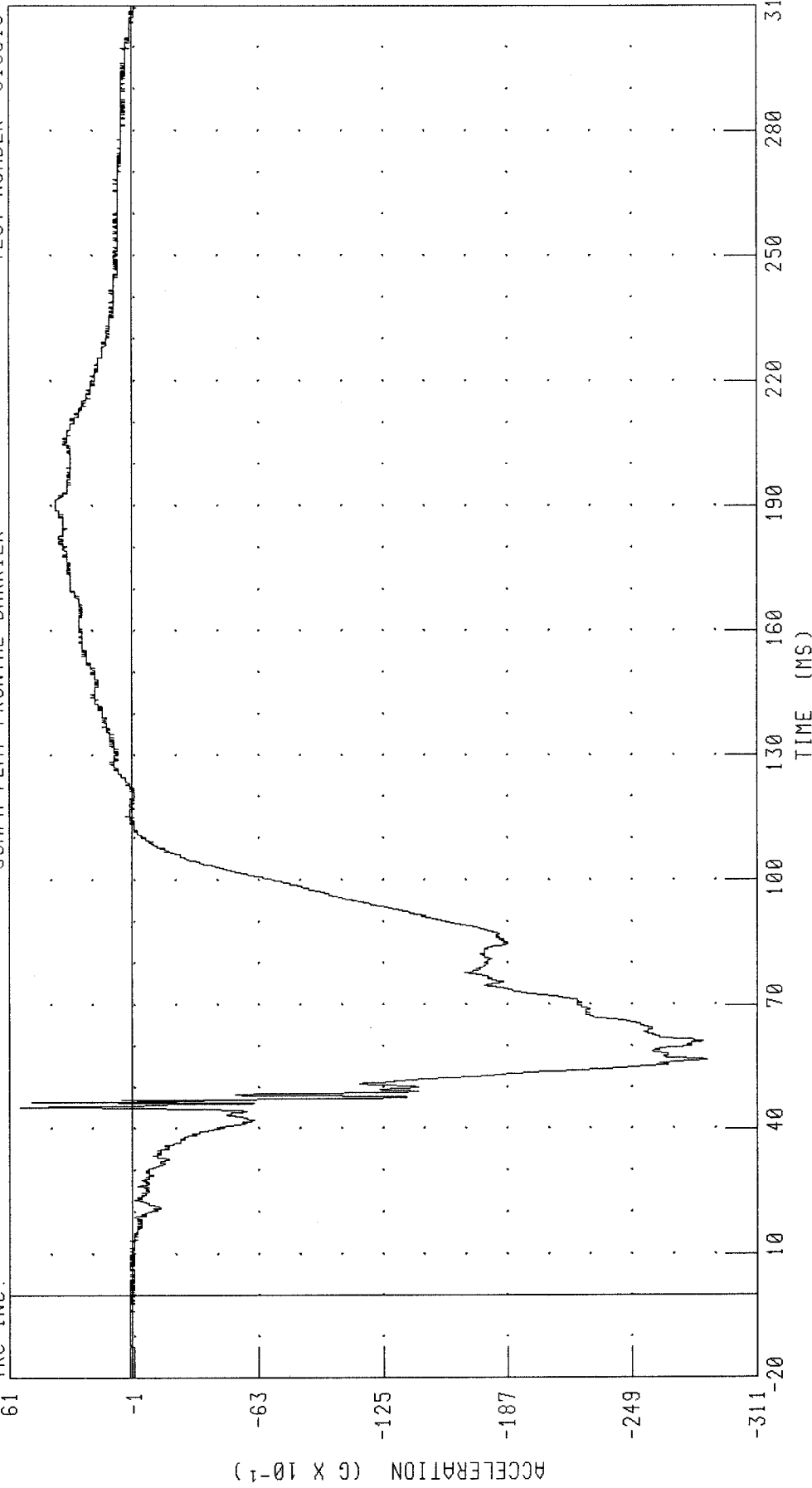

PEAK DATA: 5.57 G @ 45.28 MS; -28.61 G @ 56.64 MS

CHANNEL: PEVZG1 FILTER: CH. CLASS 1000

2001 NISSAN MAXIMA INTO FRONTAL LOAD CELL BARRIER
DRIVER PELVIS RESULTANT ACCELERATION
35MPH FLAT FRONTAL BARRIER

TEST NUMBER: 010618

TRC INC.

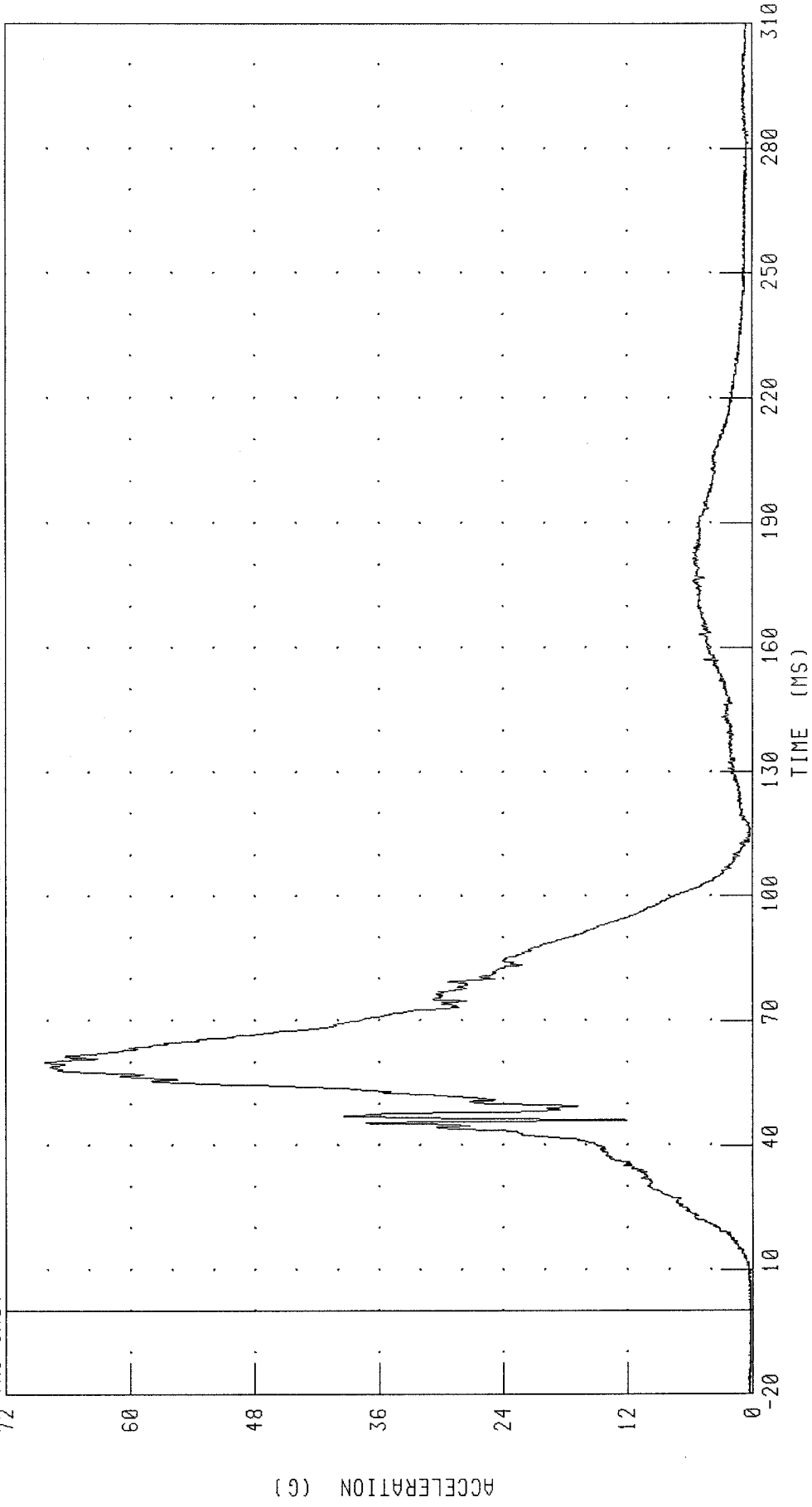

CHANNEL: PEVRG1 FILTER: CH. CLASS 1000 PEAK DATA: 68.31 G @ 60.08 MS; 0.09 G @ -12.32 MS

2001 NISSAN MAXIMA INTO FRONTAL LOAD CELL BARRIER
DRIVER LEFT FEMUR FORCE
35MPH FLAT FRONTAL BARRIER

TEST NUMBER: 010618

TRC INC.

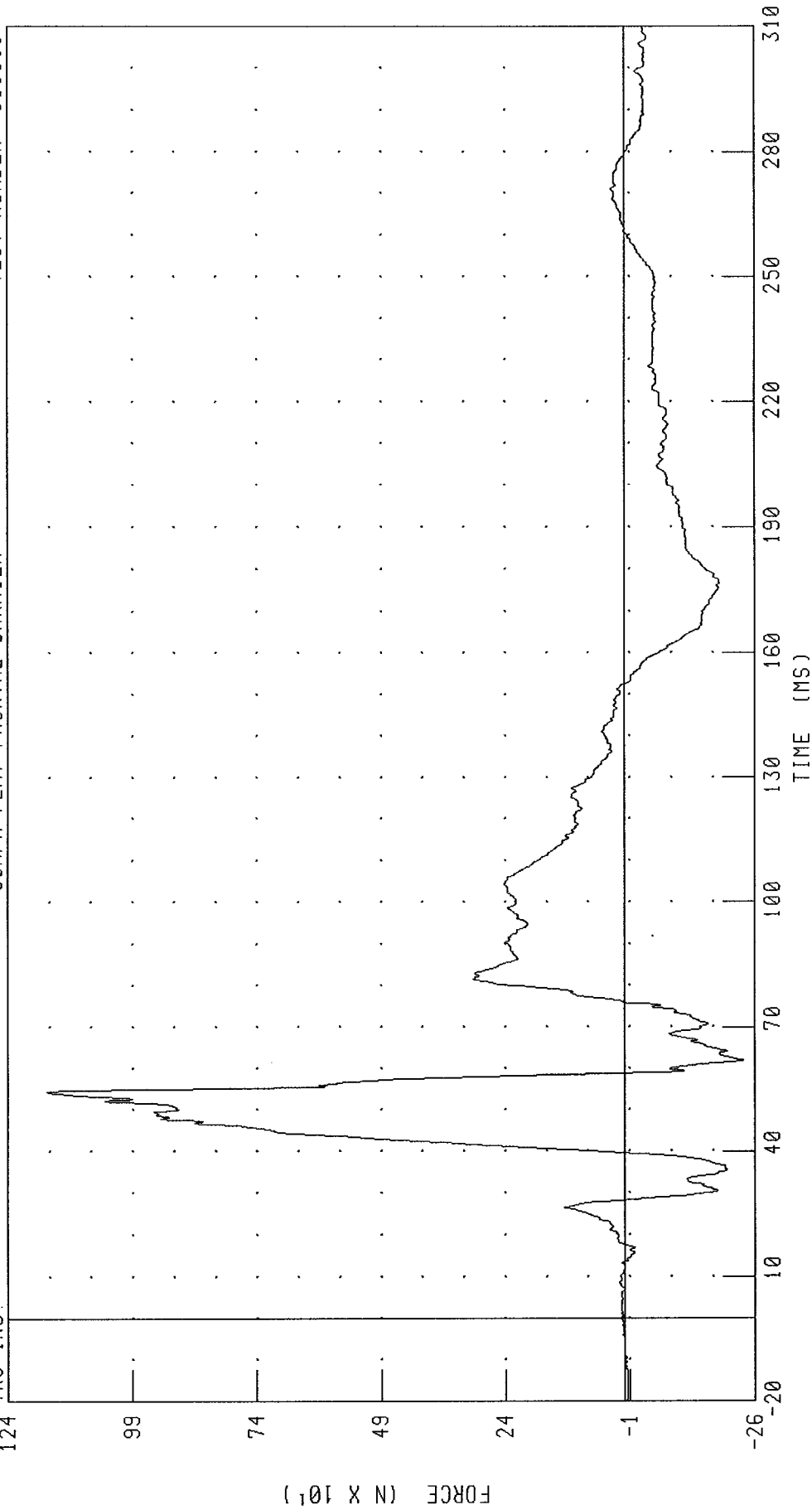

PEAK DATA: 1162.88 N @ 54.32 MS; -236.70 N @ 61.84 MS

CHANNEL: LFMZF1 FILTER: CH. CLASS 600

2001 NISSAN MAXIMA INTO FRONTAL LOAD CELL BARRIER
DRIVER RIGHT FEMUR FORCE
35MPH FLAT FRONTAL BARRIER

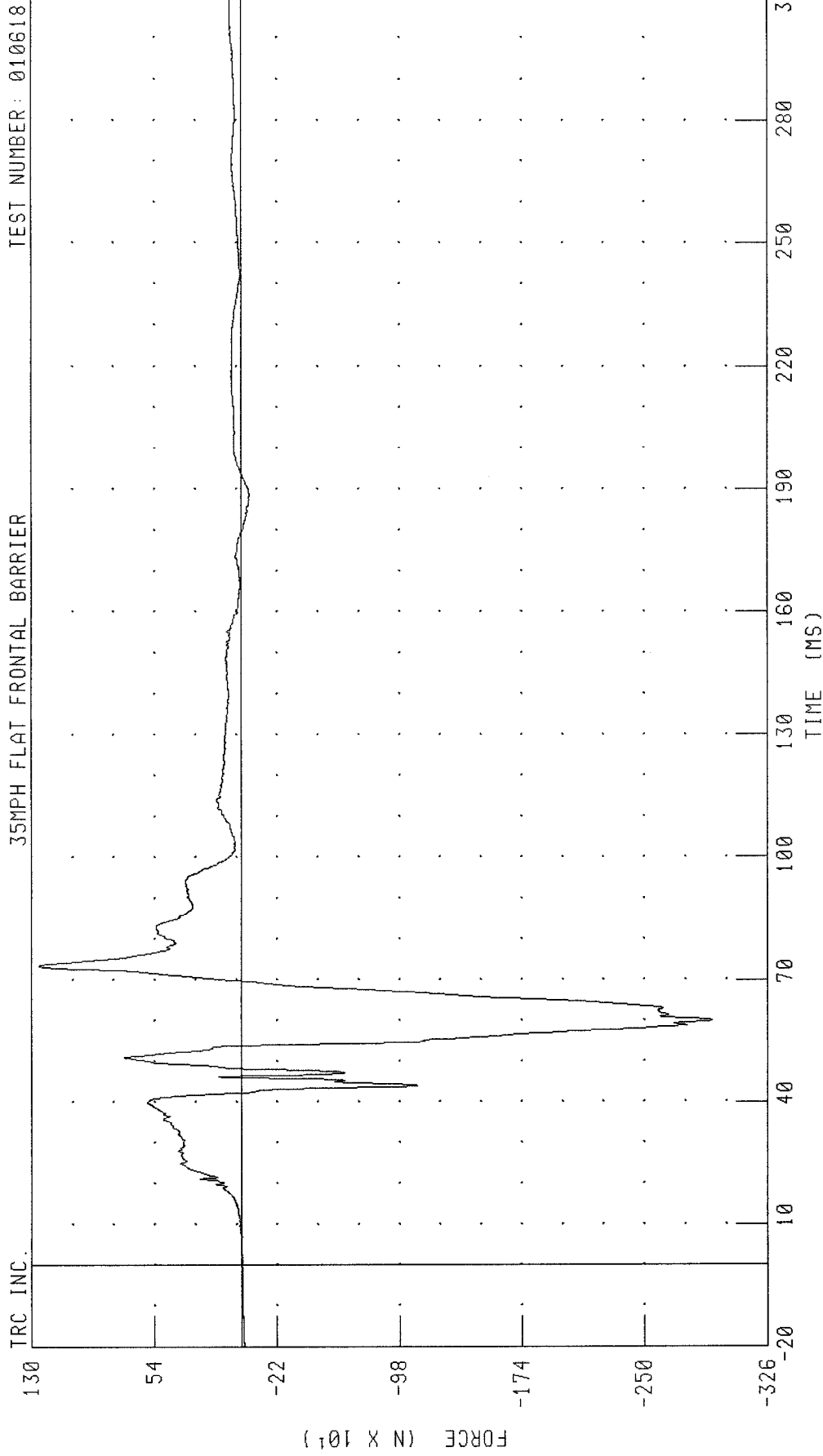

CHANNEL: RFMZF1 FILTER: CH. CLASS 600 PEAK DATA: 1254.63 N @ 73.52 MS; -2918.46 N @ 60.08 MS

2001 NISSAN MAXIMA INTO FRONTAL LOAD CELL BARRIER
DRIVER LEFT TIBIA TO FEMUR DISPLACEMENT
35MPH FLAT FRONTAL BARRIER

TEST NUMBER: 010618

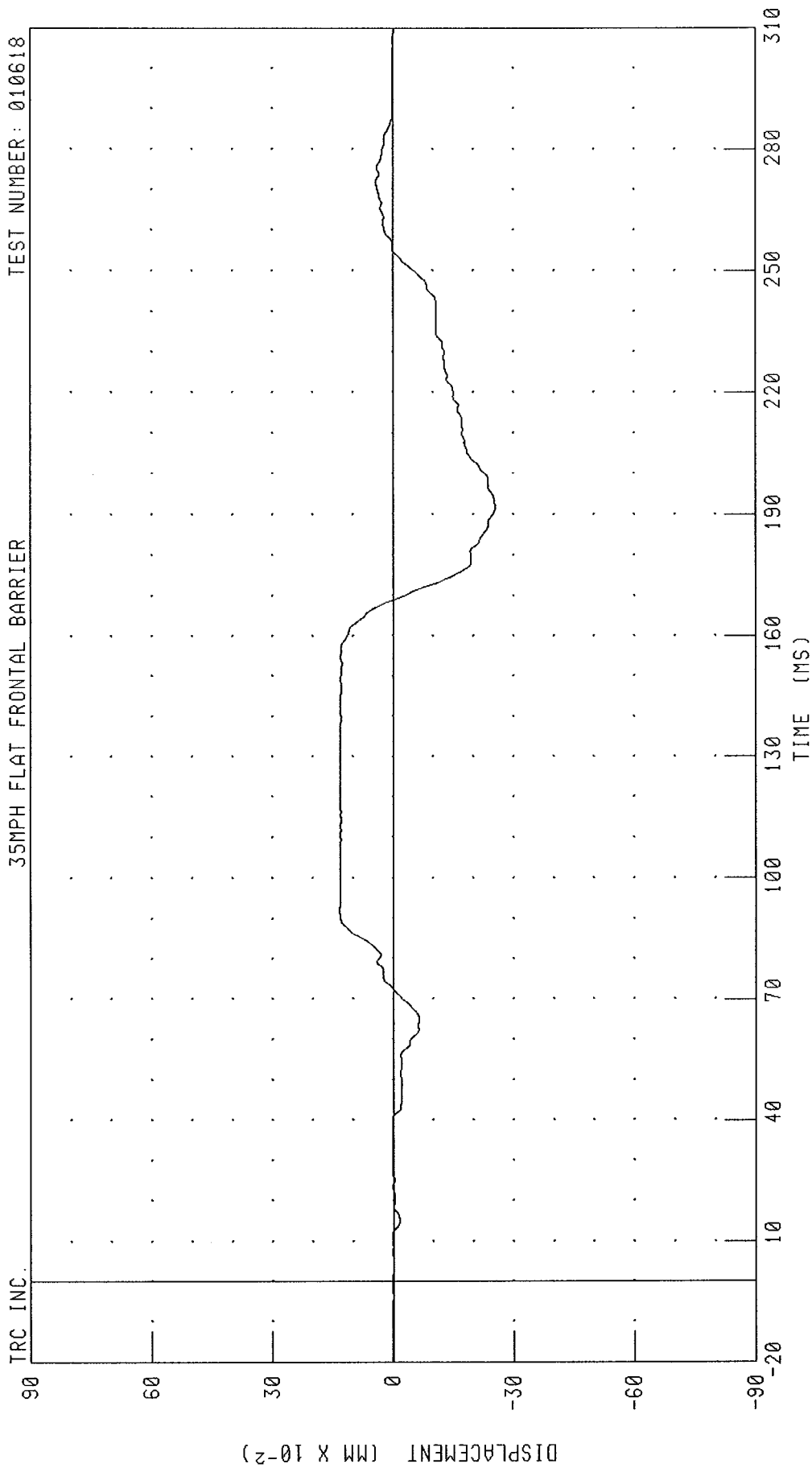

TRC INC.

CHANNEL: KNLXD1 FILTER: CH. CLASS 180

PEAK DATA: 0.13 MM @ 92.40 MS; -0.26 MM @ 191.68 MS

2001 NISSAN MAXIMA INTO FRONTAL LOAD CELL BARRIER
DRIVER RIGHT TIBIA TO FEMUR DISPLACEMENT
35MPH FLAT FRONTAL BARRIER

TEST NUMBER: 010618

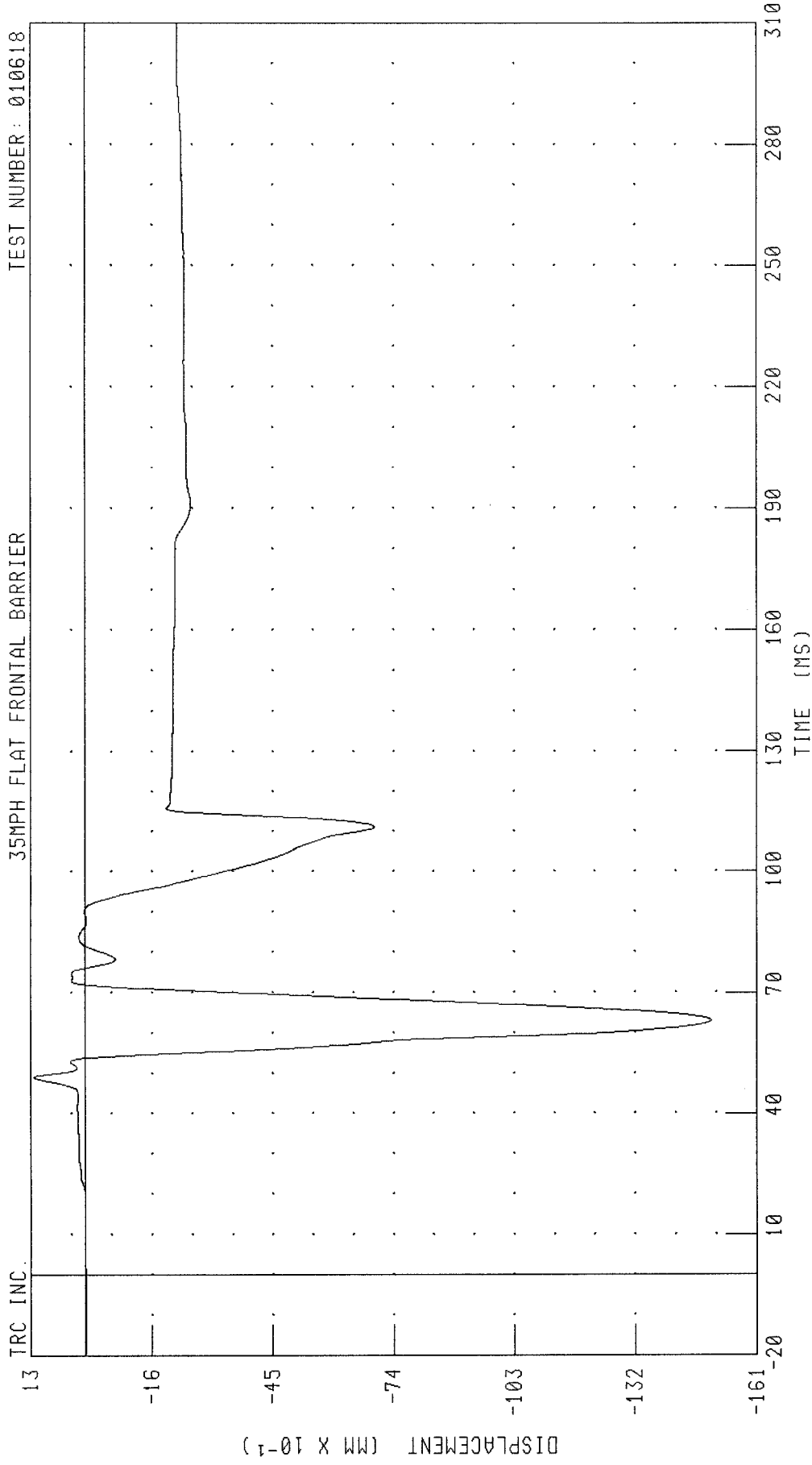

CHANNEL: KNRXD1 FILTER: CH. CLASS 180

PEAK DATA: 1.22 MM @ 49.12 MS, -15.01 MM @ 63.04 MS

2001 NISSAN MAXIMA INTO FRONTAL LOAD CELL BARRIER
DRIVER LEFT UPPER TIBIA MOMENT ABOUT X AXIS
35MPH FLAT FRONTAL BARRIER

TEST NUMBER: 010618

TRC INC.

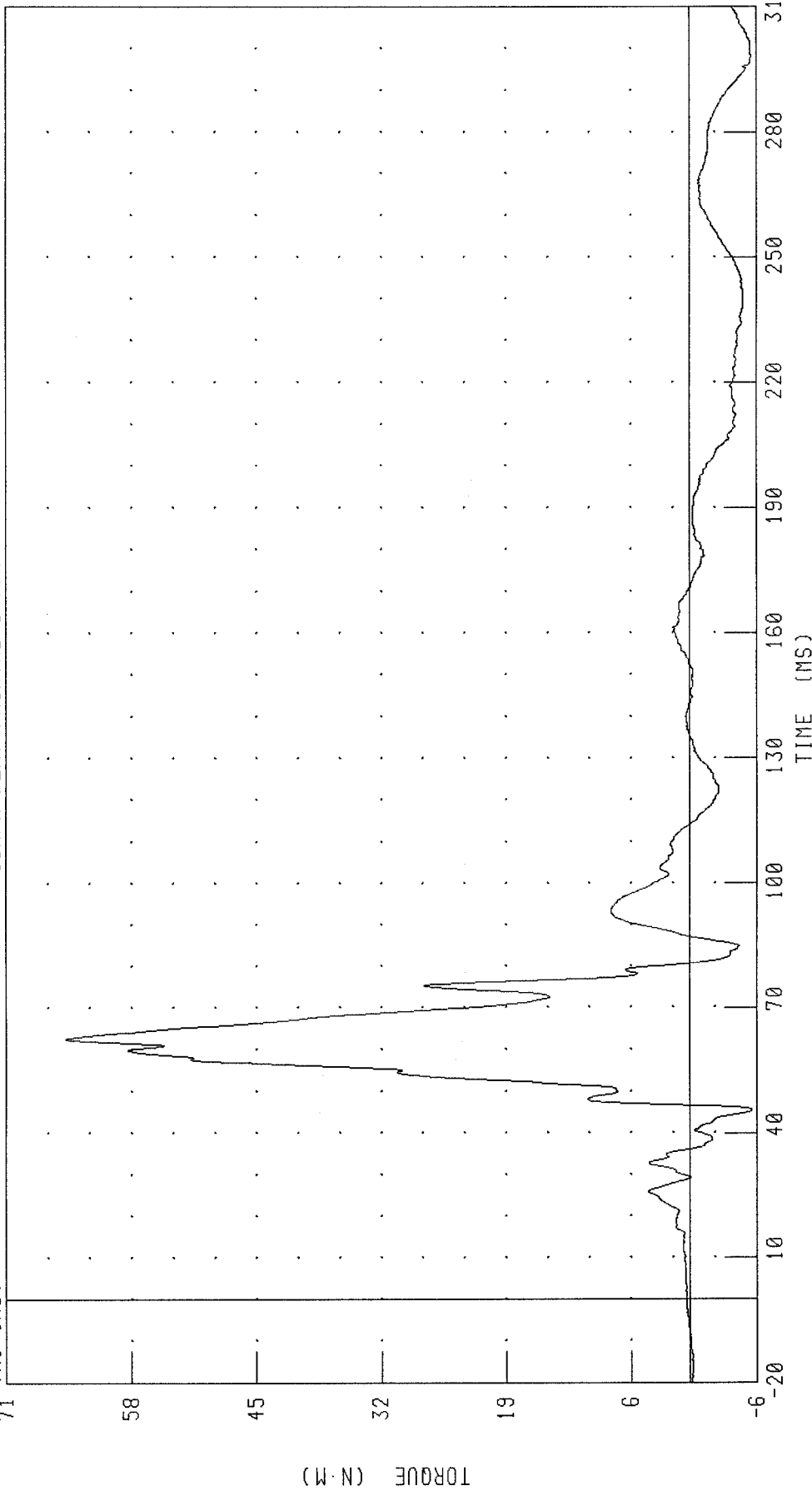

PEAK DATA: 64.92 N·M @ 62.56 MS; -6.35 N·M @ 45.52 MS

CHANNEL: TBLXM1 FILTER: CH. CLASS 600

2001 NISSAN MAXIMA INTO FRONTAL LOAD CELL BARRIER
DRIVER LEFT UPPER TIBIA MOMENT ABOUT Y AXIS
35MPH FLAT FRONTAL BARRIER

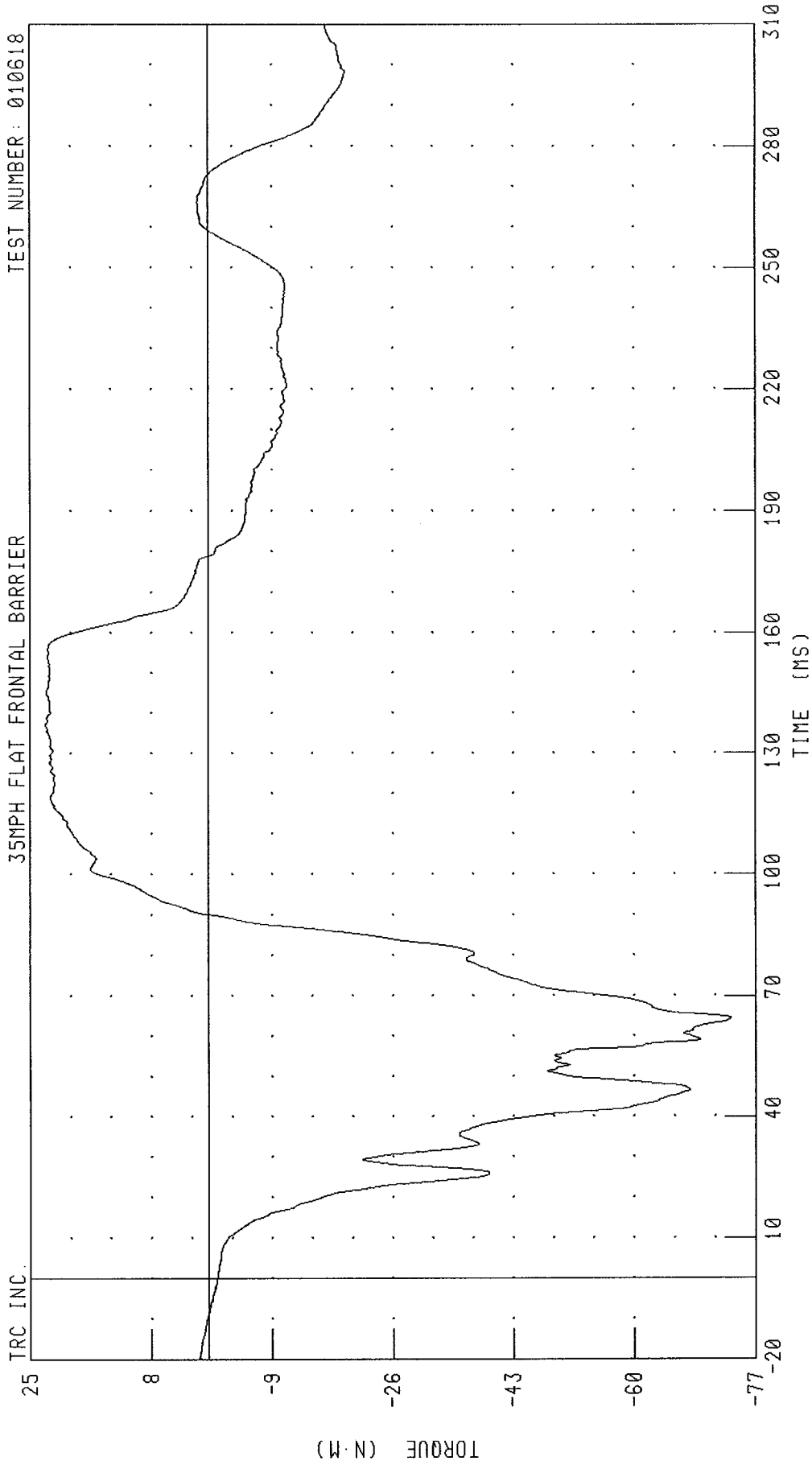

CHANNEL: TBLYM1 FILTER: CH. CLASS 600 PEAK DATA: 22.92 N·M @ 137.20 MS; -73.62 N·M @ 64.40 MS

2001 NISSAN MAXIMA INTO FRONTAL LOAD CELL BARRIER
DRIVER LEFT UPPER TIBIA Z-AXIS FORCE
35MPH FLAT FRONTAL BARRIER

TEST NUMBER: 010618

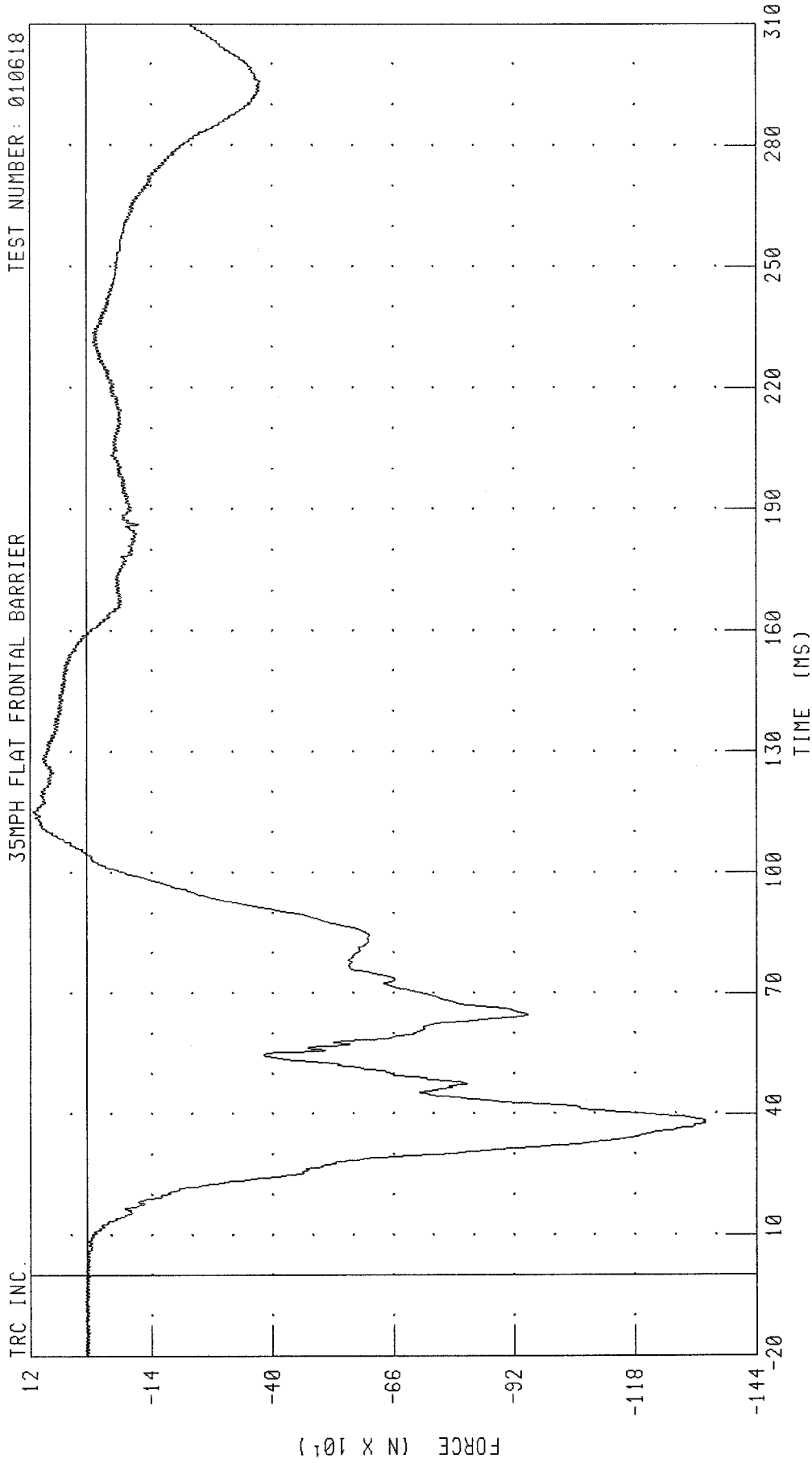

CHANNEL: TBLZF1 FILTER: CH. CLASS 600

PEAK DATA: 114.36 N @ 115.28 MS; -1331.13 N @ 37.76 MS

2001 NISSAN MAXIMA INTO FRONTAL LOAD CELL BARRIER
DRIVER LEFT LOWER TIBIA MOMENT ABOUT X AXIS
35MPH FLAT FRONTAL BARRIER

TEST NUMBER: 010618

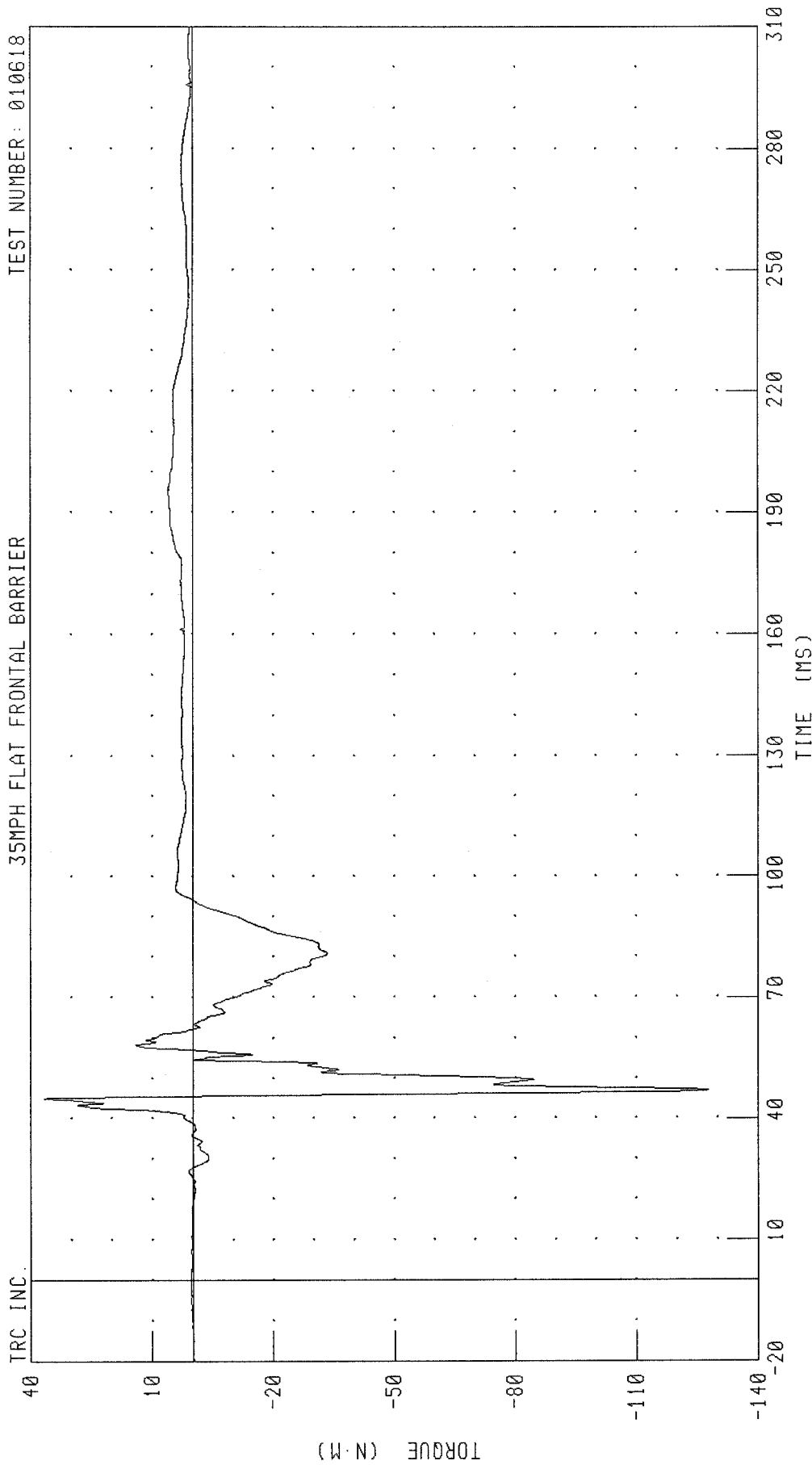

CHANNEL: ANLXM1 FILTER: CH. CLASS 600 PEAK DATA: 36.71 N·M @ 45.04 MS; -127.87 N·M @ 46.96 MS

2001 NISSAN MAXIMA INTO FRONTAL LOAD CELL BARRIER
DRIVER LEFT LOWER TIBIA MOMENT ABOUT Y AXIS
35MPH FLAT FRONTAL BARRIER

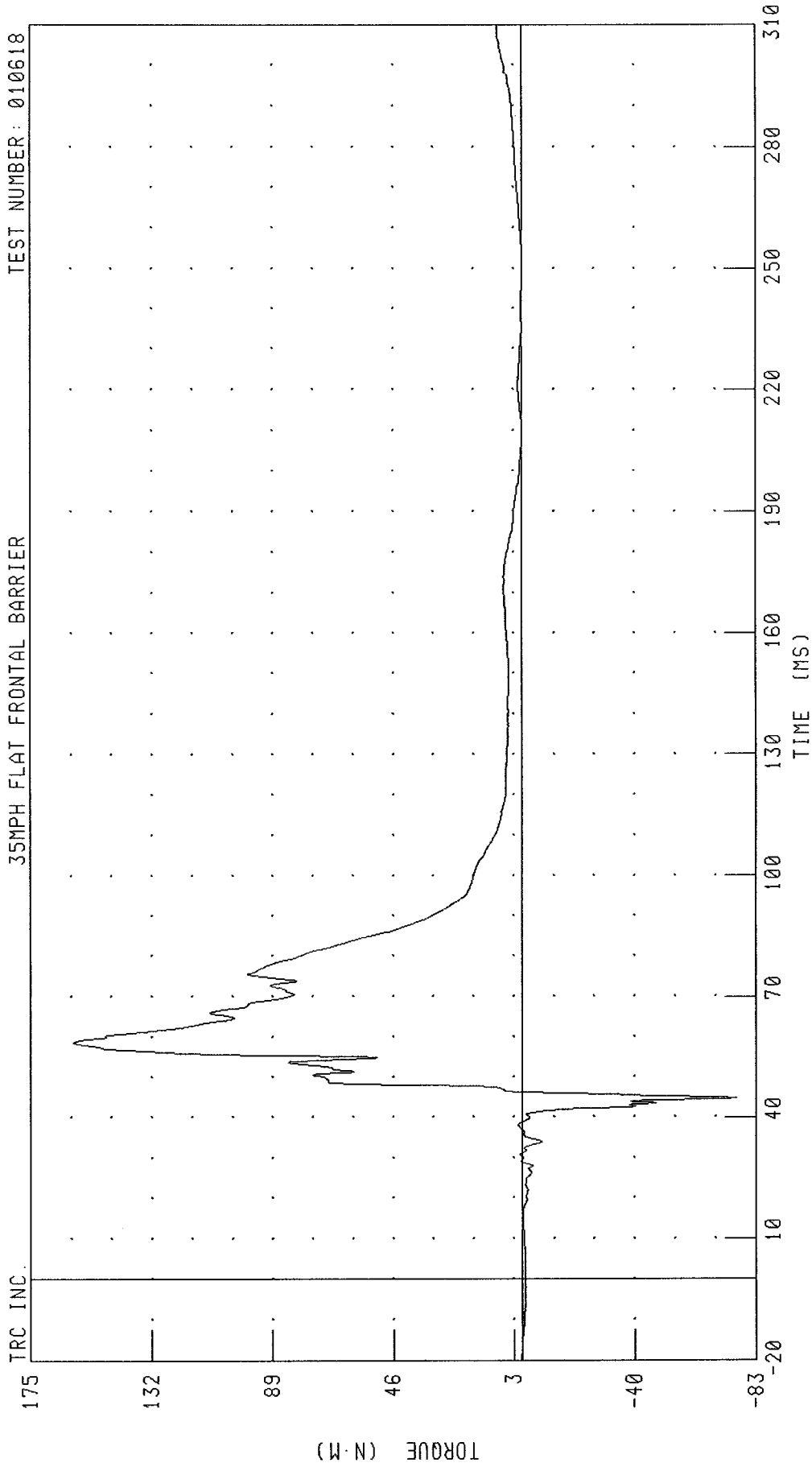

CHANNEL: ANLYM1 FILTER: CH. CLASS 600 PEAK DATA: 159.72 N·M @ 58.56 MS; -76.20 N·M @ 44.72 MS

2001 NISSAN MAXIMA INTO FRONTAL LOAD CELL BARRIER
 DRIVER LEFT LOWER TIBIA Z-AXIS FORCE
 35MPH FLAT FRONTAL BARRIER

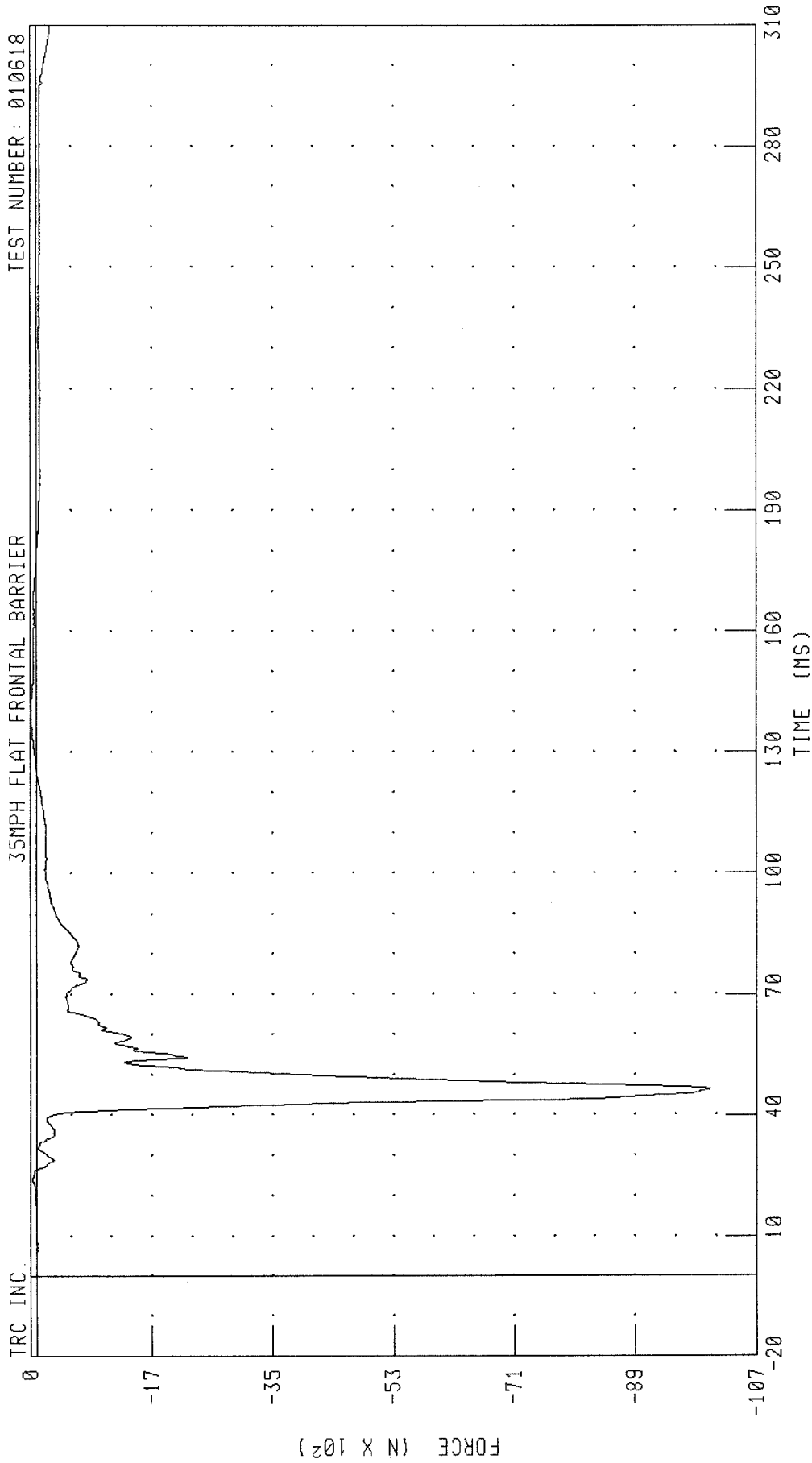

CHANNEL: ANLZF1 FILTER: CH. CLASS 600 PEAK DATA: 79.25 N @ 139.60 MS; -10030.94 N @ 46.48 MS

2001 NISSAN MAXIMA INTO FRONTAL LOAD CELL BARRIER
DRIVER RIGHT UPPER TIBIA MOMENT ABOUT X AXIS
35MPH FLAT FRONTAL BARRIER

TEST NUMBER: 010618

TRC INC.

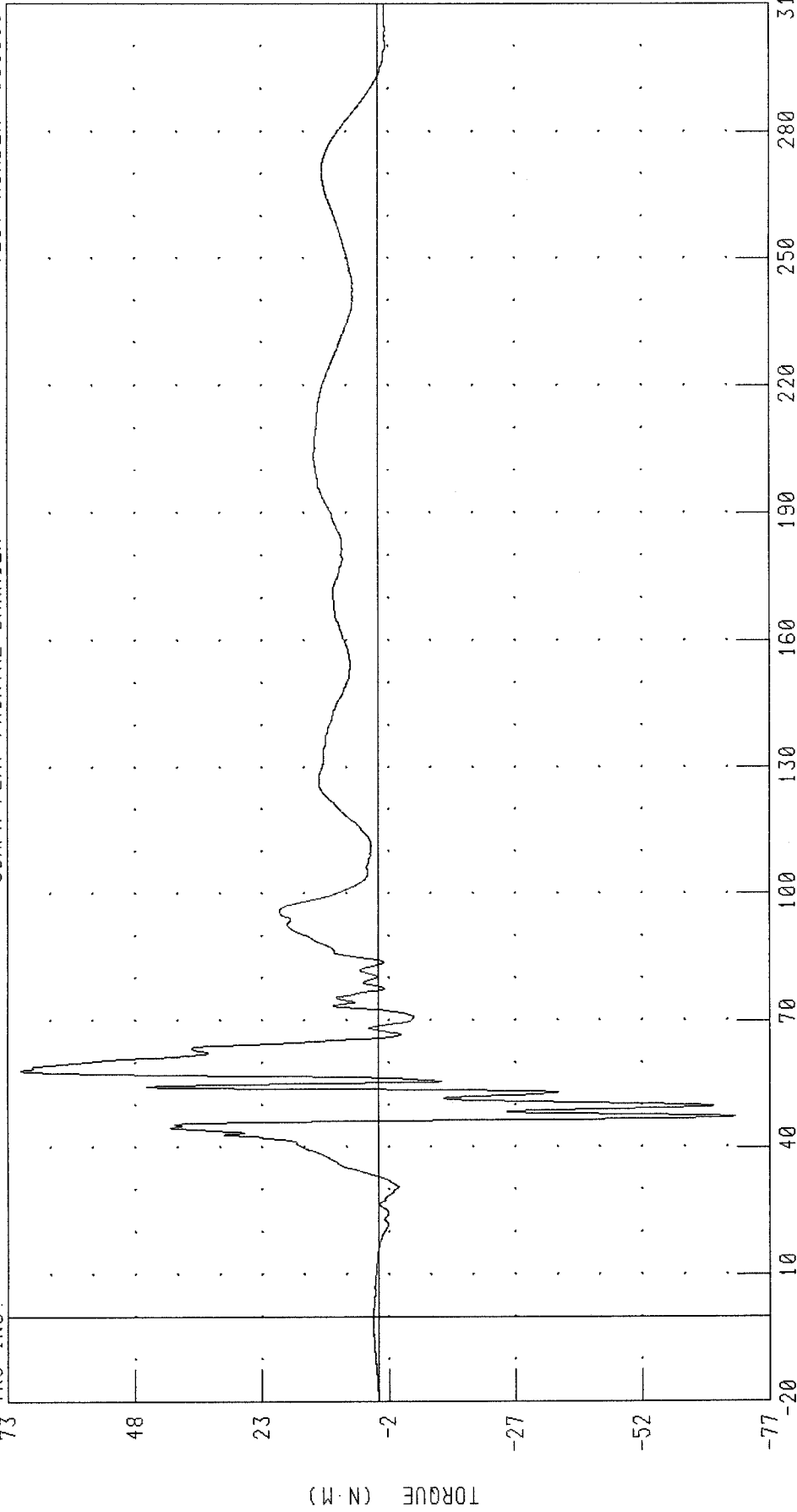

PEAK DATA: 70.53 N·M @ 58.16 MS; -70.23 N·M @ 47.20 MS

CHANNEL: TBRXM1 FILTER: CH. CLASS 600

2001 NISSAN MAXIMA INTO FRONTAL LOAD CELL BARRIER
DRIVER RIGHT UPPER TIBIA MOMENT ABOUT Y AXIS
35MPH FLAT FRONTAL BARRIER

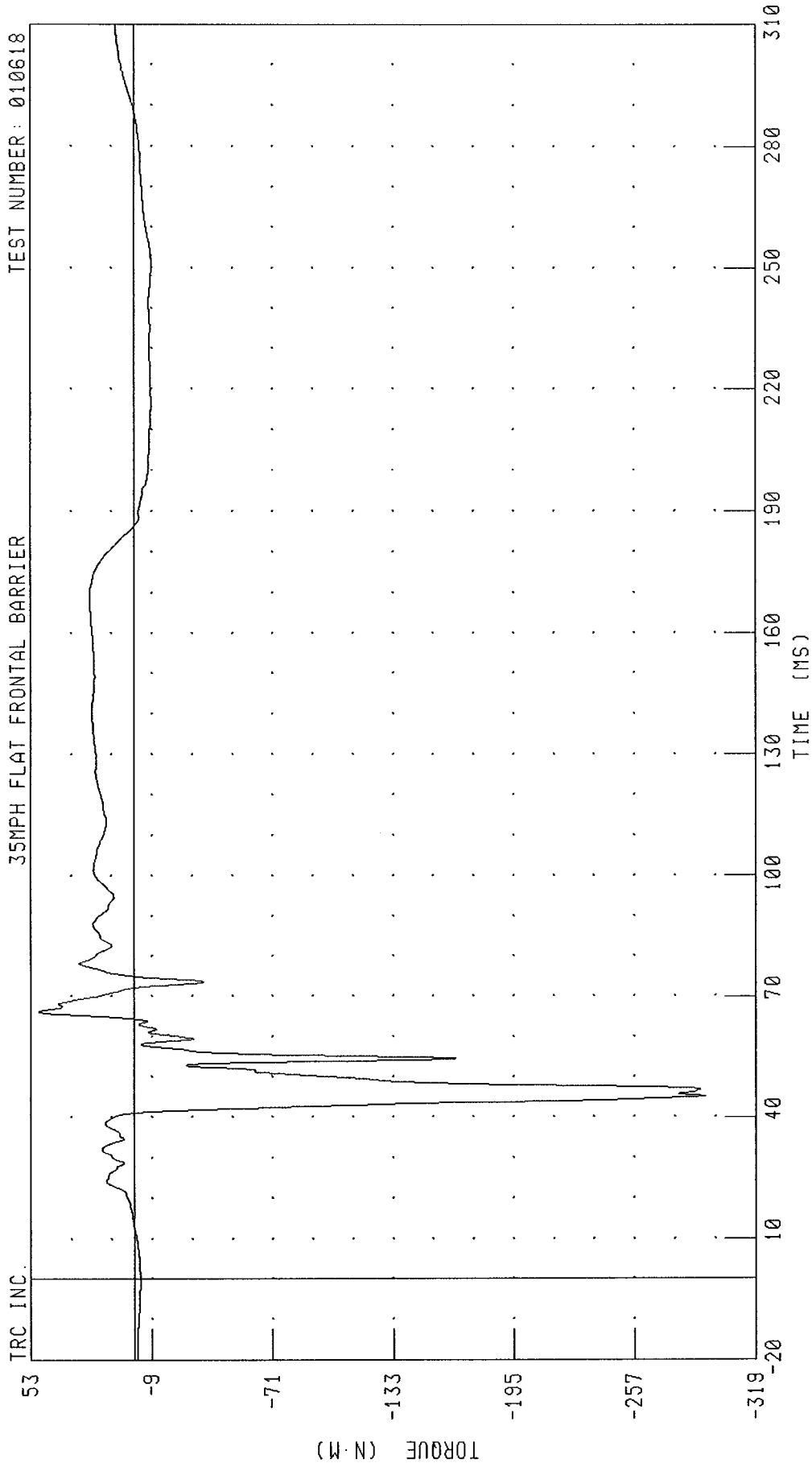

CHANNEL: TBRYM1 FILTER: CH. CLASS 600 PEAK DATA: 48.87 N·M @ 66.24 MS; -293.42 N·M @ 45.28 MS

2001 NISSAN MAXIMA INTO FRONTAL LOAD CELL BARRIER
DRIVER RIGHT UPPER TIBIA Z-AXIS FORCE
35MPH FLAT FRONTAL BARRIER

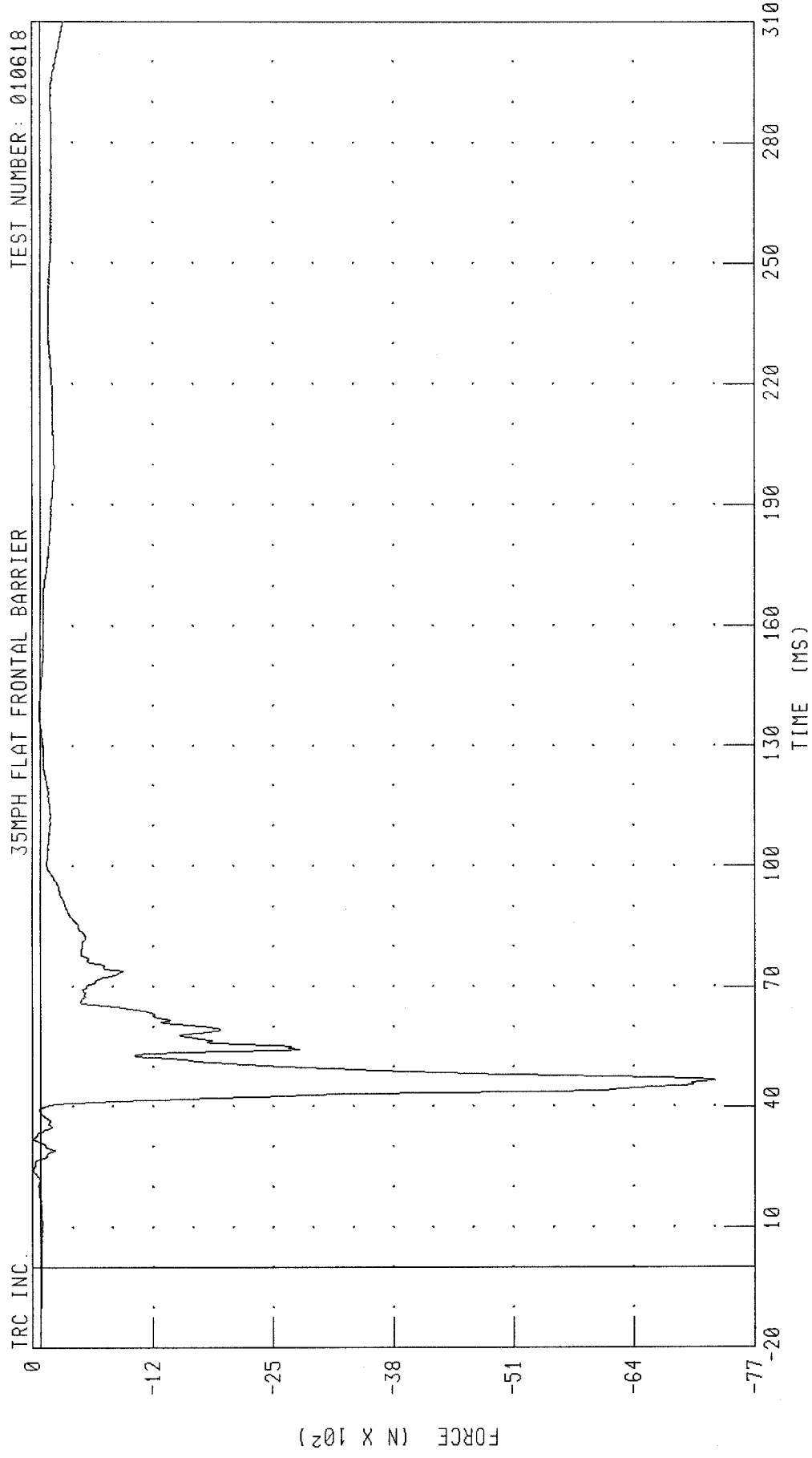

CHANNEL: TBRZF1 FILTER: CH. CLASS 600 PEAK DATA: 82.59 N @ 24.32 MS; -7284.69 N @ 46.64 MS

2001 NISSAN MAXIMA INTO FRONTAL LOAD CELL BARRIER
DRIVER RIGHT LOWER TIBIA MOMENT ABOUT X AXIS
35MPH FLAT FRONTAL BARRIER

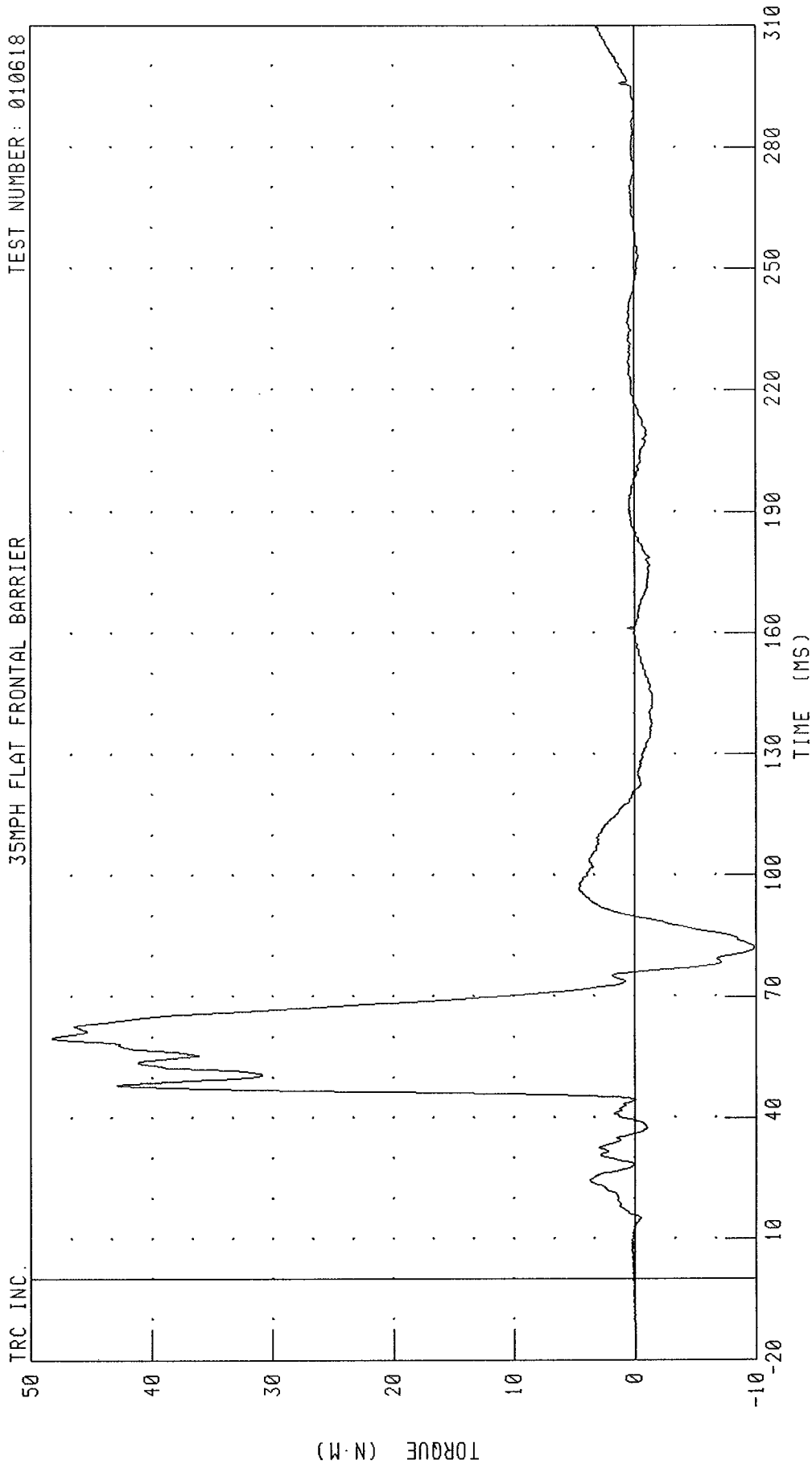

CHANNEL: ANRXM1 FILTER: CH. CLASS 600 PEAK DATA: 48.28 N·M @ 59.92 MS; -9.83 N·M @ 81.76 MS

2001 NISSAN MAXIMA INTO FRONTAL LOAD CELL BARRIER
DRIVER RIGHT LOWER TIBIA MOMENT ABOUT Y AXIS
35MPH FLAT FRONTAL BARRIER

TEST NUMBER: 010618

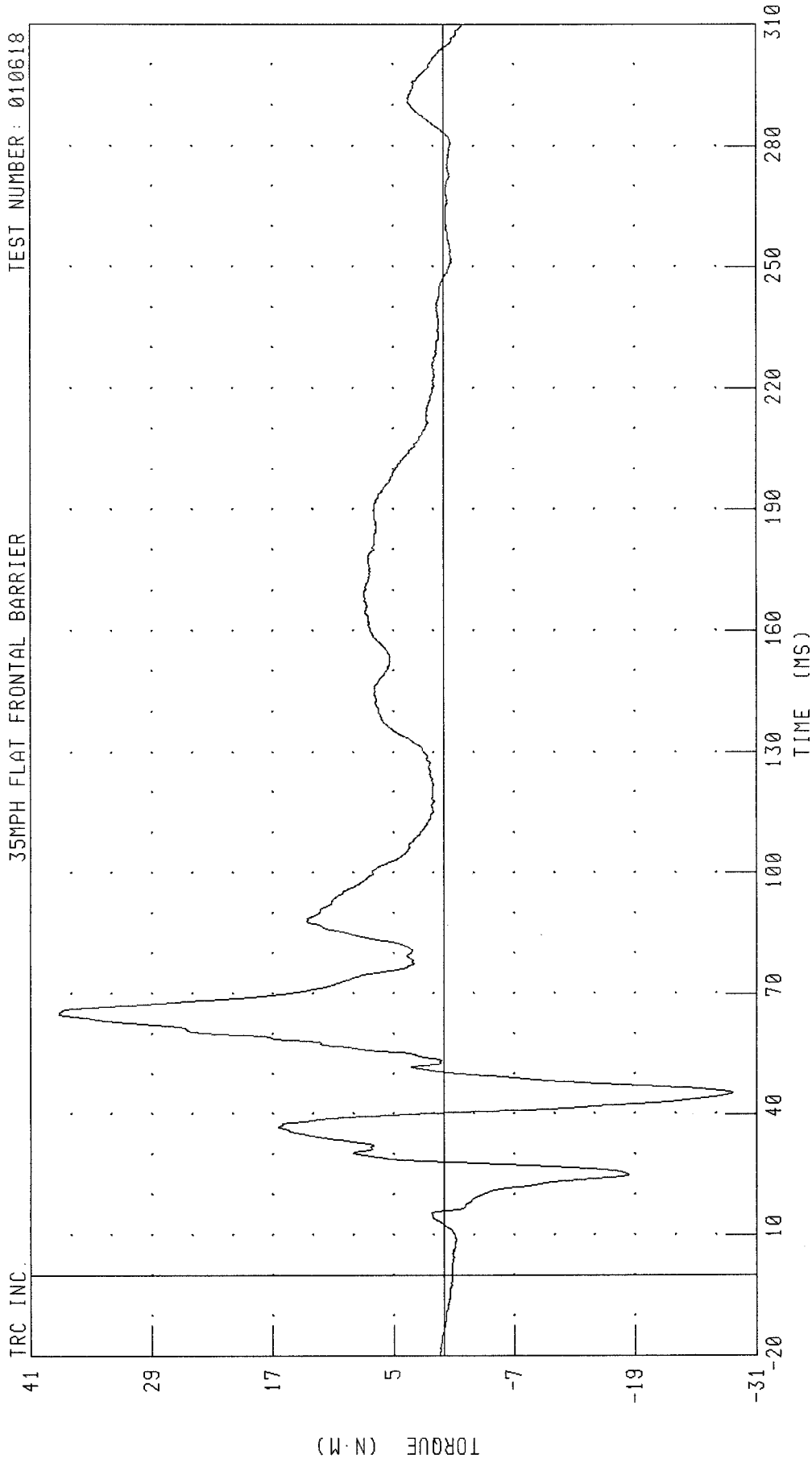

CHANNEL: ANRYM1 FILTER: CH. CLASS 600 PEAK DATA: 38.21 N-M @ 65.04 MS, -28.66 N-M @ 45.20 MS

2001 NISSAN MAXIMA INTO FRONTAL LOAD CELL BARRIER
DRIVER RIGHT LOWER TIBIA Z-AXIS FORCE
35MPH FLAT FRONTAL BARRIER

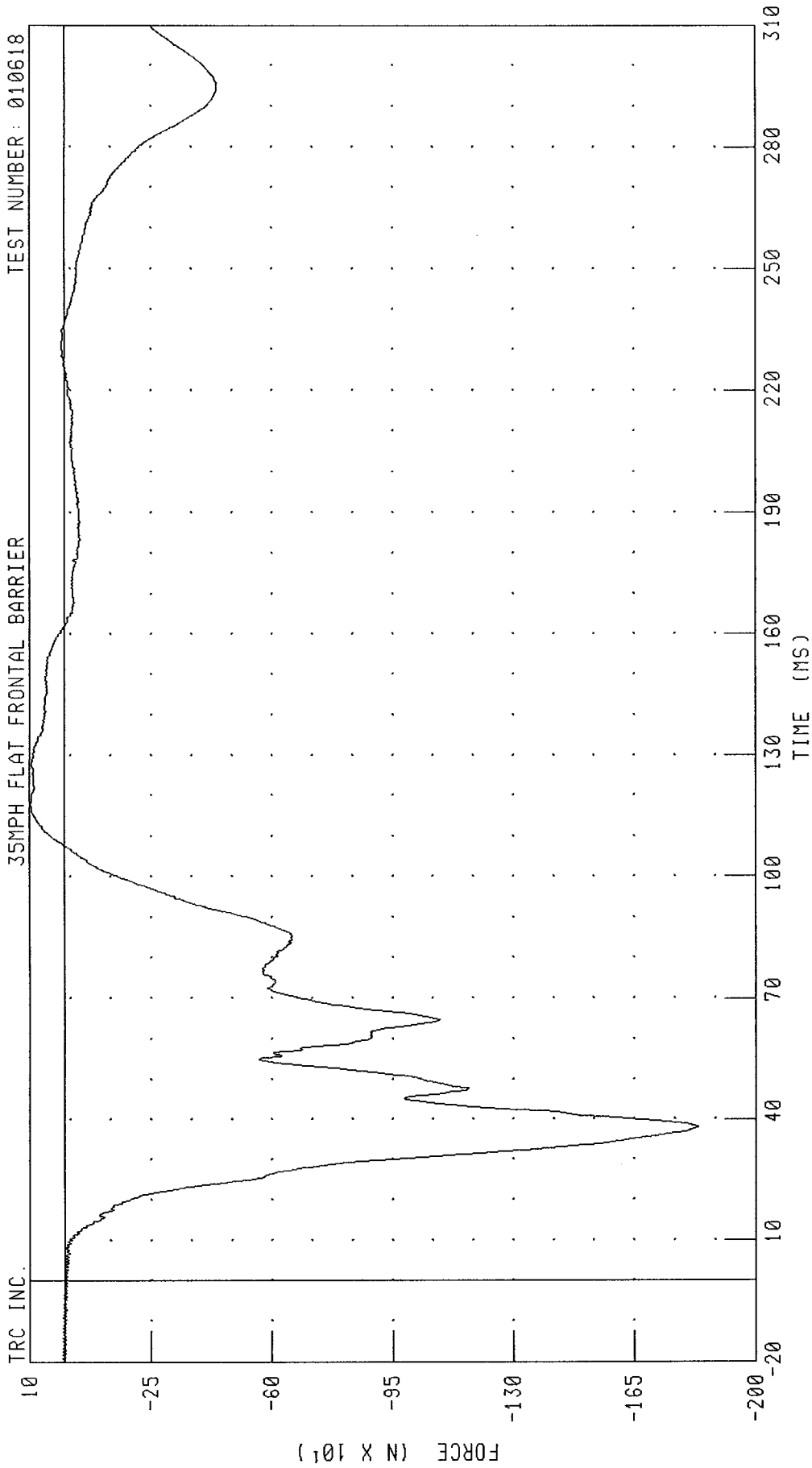

CHANNEL: ANRZF1 FILTER: CH. CLASS 600
PEAK DATA: 99.74 N @ 117.92 MS; -1835.14 N @ 38.00 MS

2001 NISSAN MAXIMA INTO FRONTAL LOAD CELL BARRIER
DRIVER LEFT FOOT X-AXIS ACCELERATION AT HEEL
35MPH FLAT FRONTAL BARRIER

TEST NUMBER: 010618

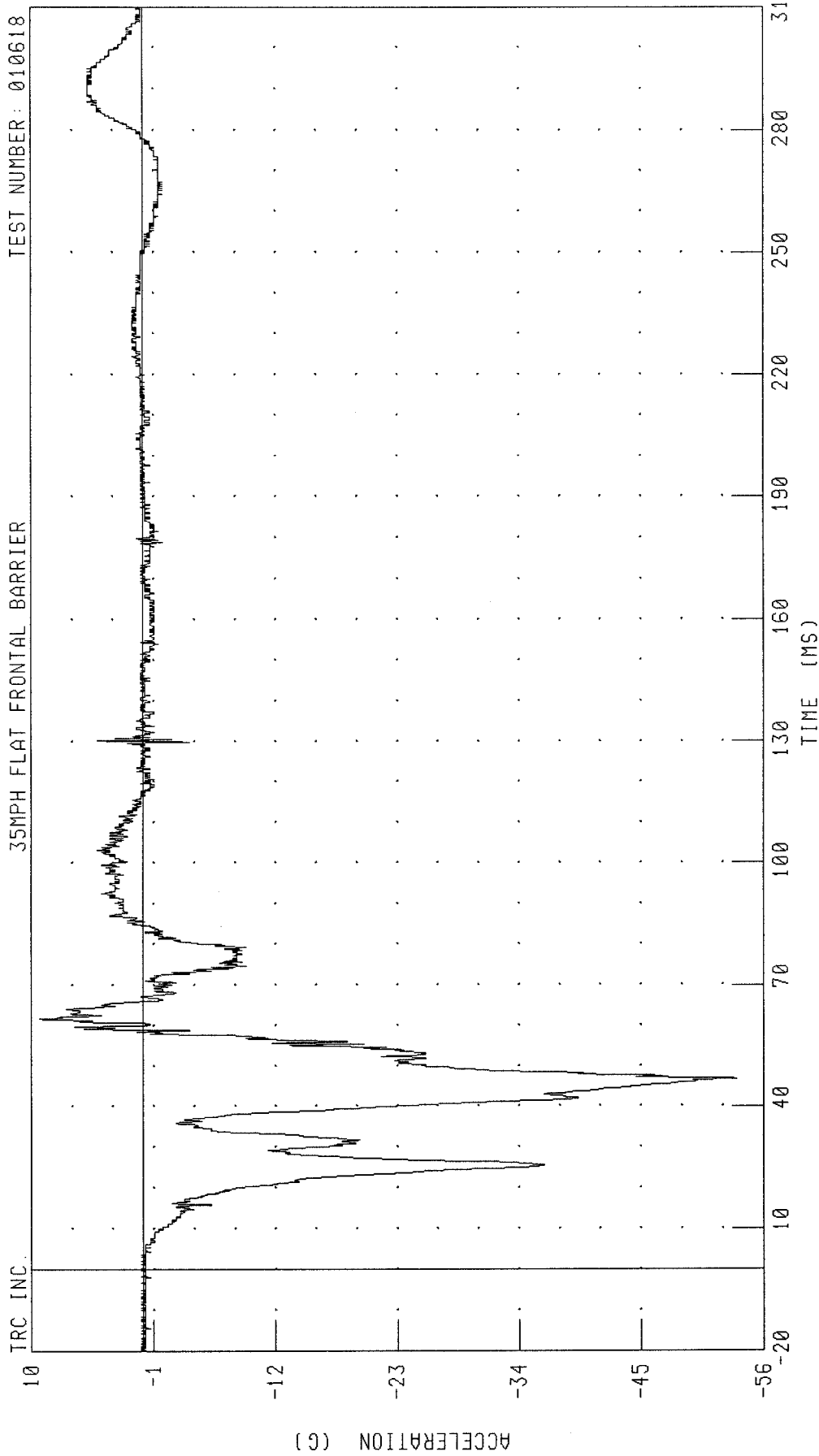

CHANNEL: FLHXG1 FILTER: CH. CLASS 1000

PEAK DATA: 9.24 G @ 61.68 MS; -53.61 G @ 46.88 MS

2001 NISSAN MAXIMA INTO FRONTAL LOAD CELL BARRIER
DRIVER LEFT FOOT Z-AXIS ACCELERATION AT HEEL
35MPH FLAT FRONTAL BARRIER

TEST NUMBER: 010618

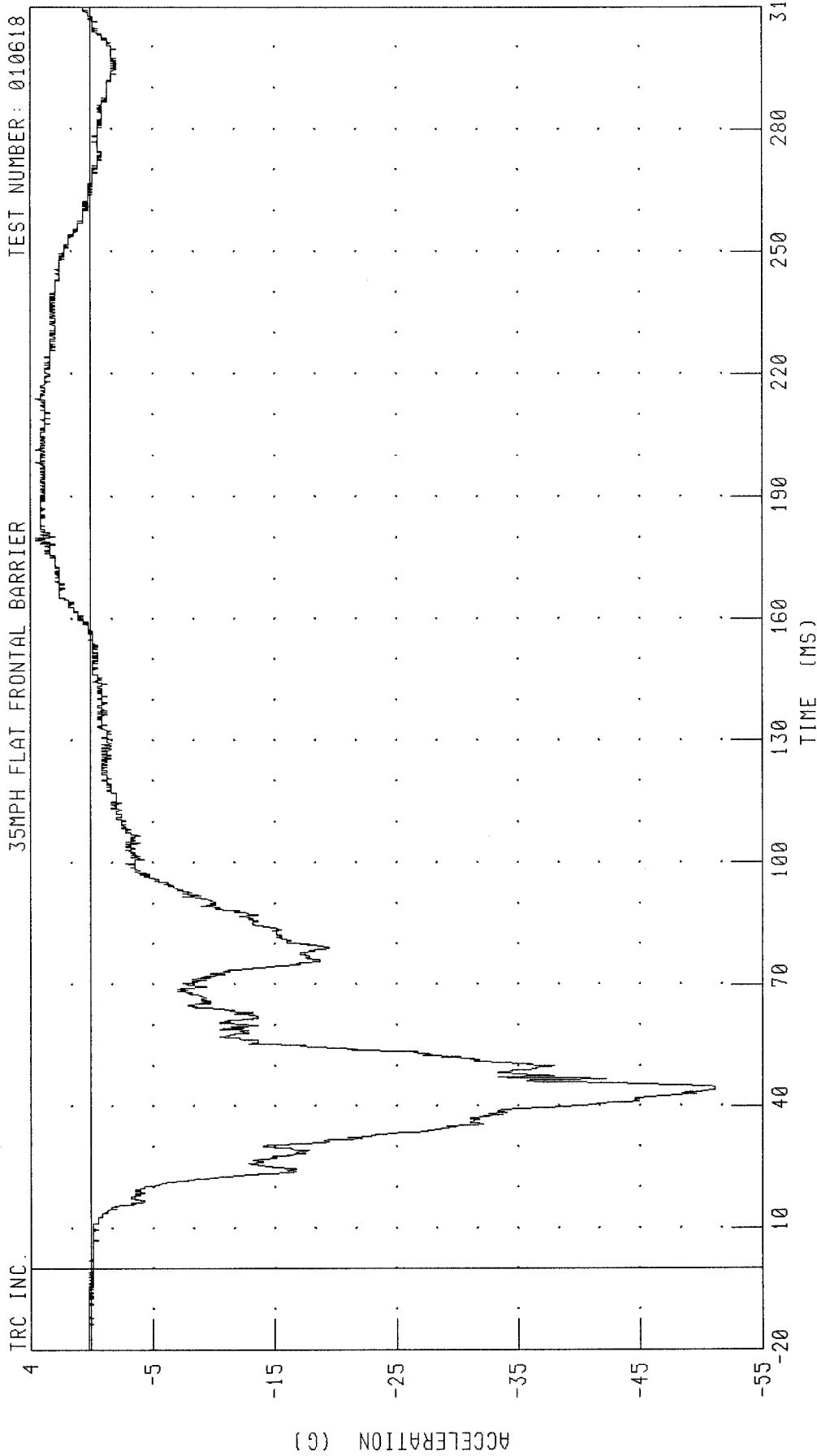

TRC INC.

CHANNEL: FLHZG1 FILTER: CH. CLASS 1000

010618

2001 NISSAN MAXIMA INTO FRONTAL LOAD CELL BARRIER
DRIVER LEFT TOE Z-AXIS ACCELERATION AT TOE
35MPH FLAT FRONTAL BARRIER

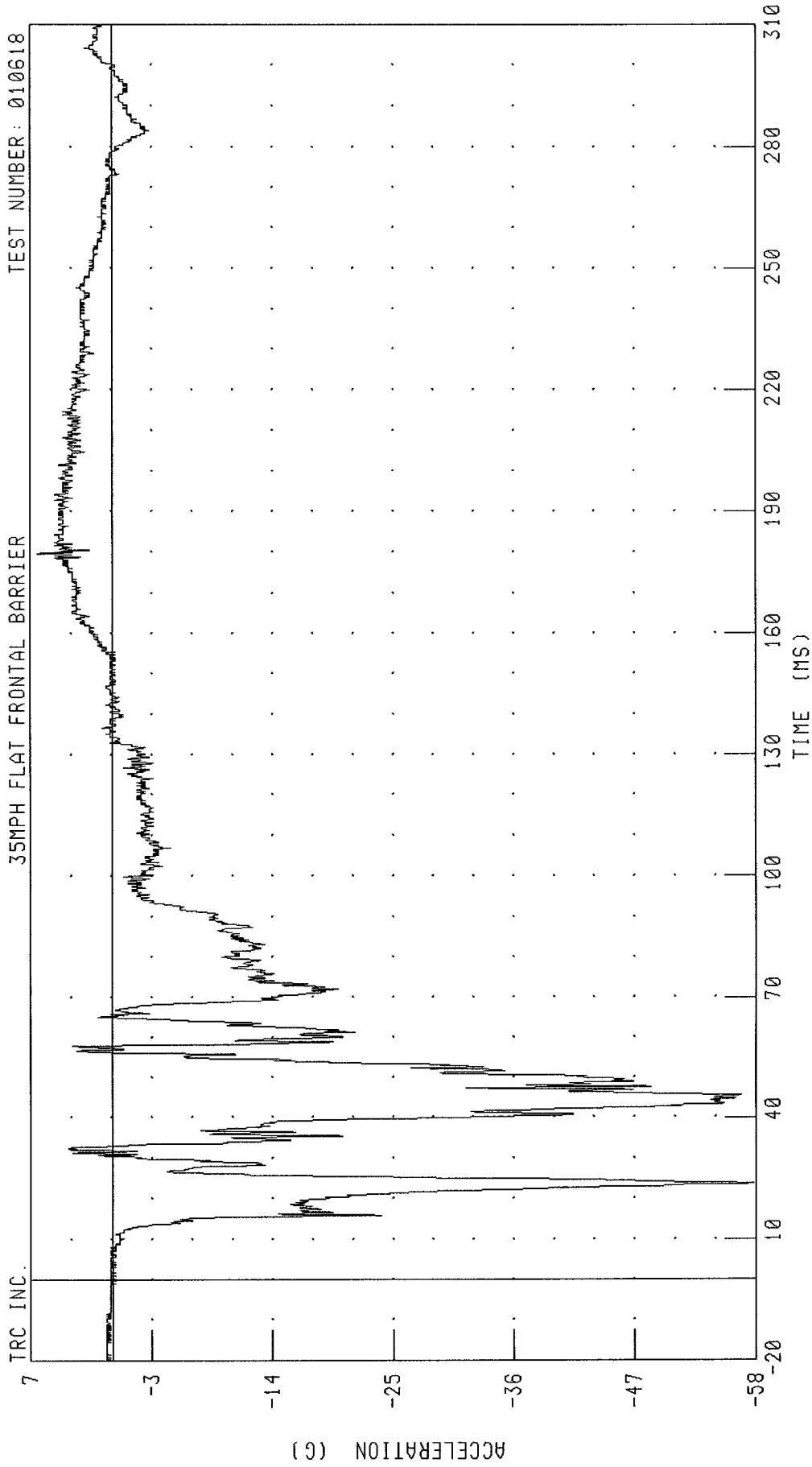

CHANNEL: FLTZG1 FILTER: CH. CLASS 1000 PEAK DATA: 6.75 G @ 179.68 MS; -58.43 G @ 23.60 MS

2001 NISSAN MAXIMA INTO FRONTAL LOAD CELL BARRIER
DRIVER RIGHT FOOT X-AXIS ACCELERATION AT HEEL
35MPH FLAT FRONTAL BARRIER

TEST NUMBER: 010618

TRC INC.

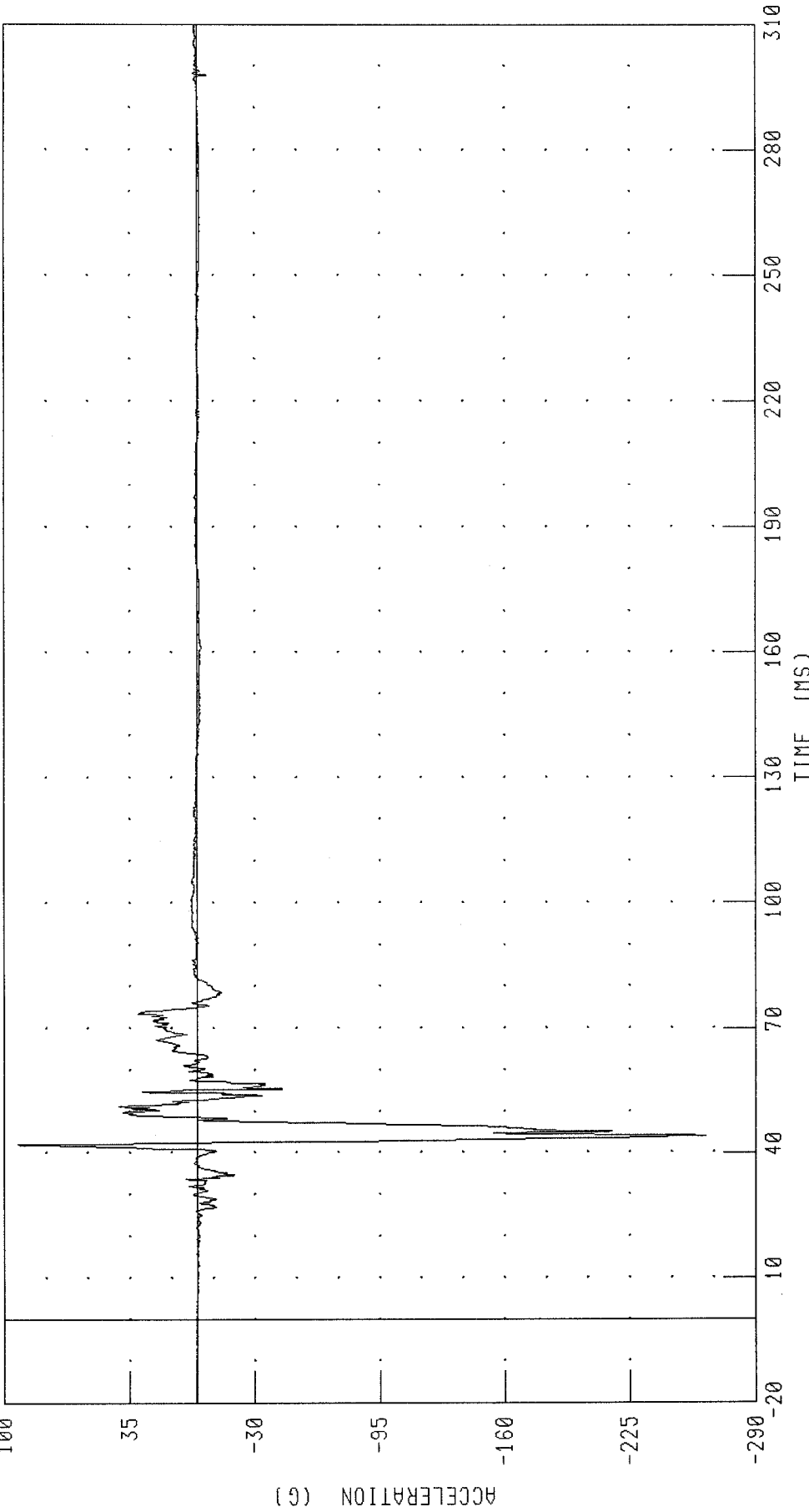

CHANNEL: FRHXG1 FILTER: CH. CLASS 1000

PEAK DATA: 93.25 G @ 42.08 MS; -264.35 G @ 44.08 MS

2001 NISSAN MAXIMA INTO FRONTAL LOAD CELL BARRIER
DRIVER RIGHT FOOT Z-AXIS ACCELERATION AT HEEL
35MPH FLAT FRONTAL BARRIER

TEST NUMBER: 010618

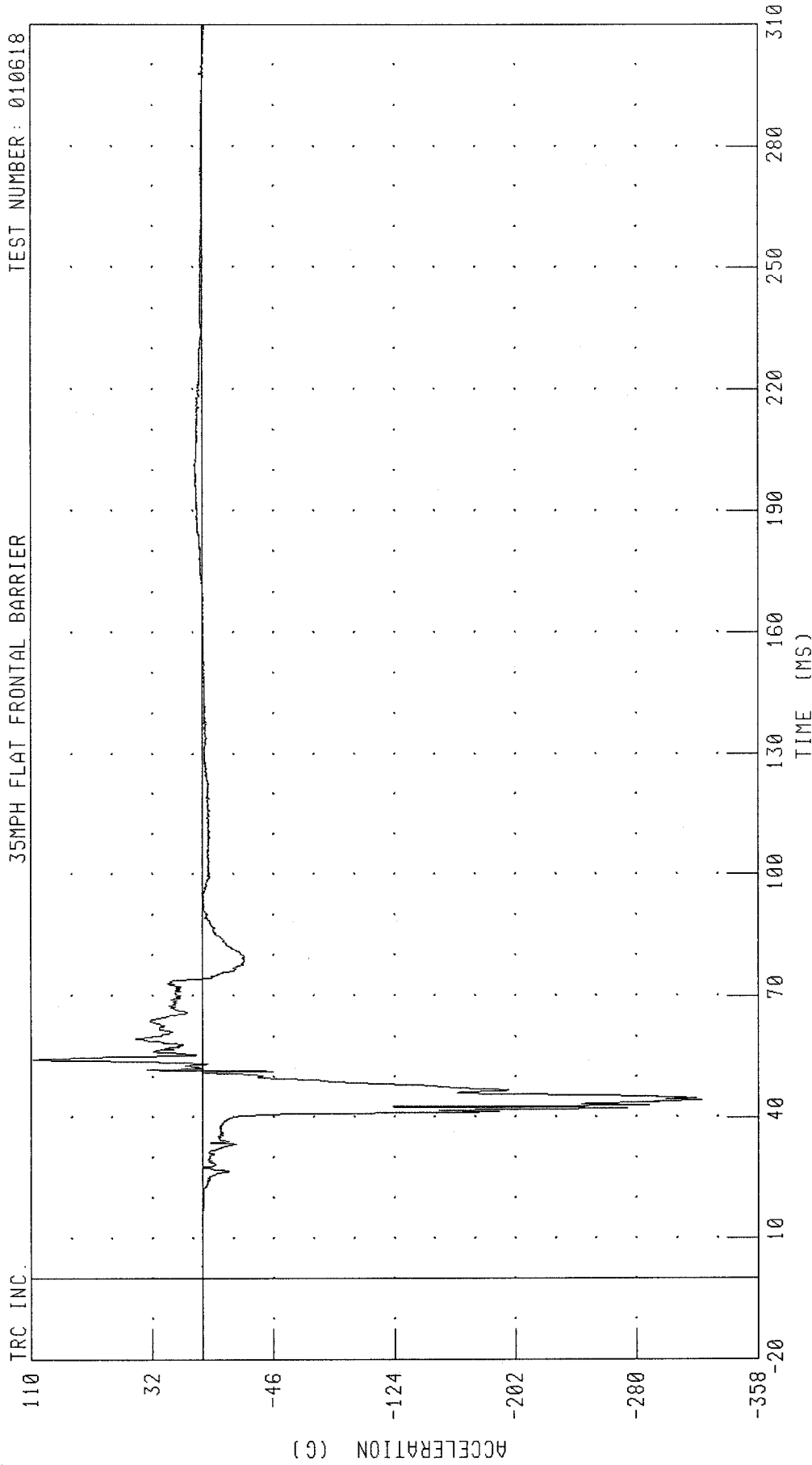

CHANNEL: FRHZG1 FILTER: CH. CLASS 1000

PEAK DATA: 108.93 G @ 54.40 MS, -321.45 G @ 44.24 MS

2001 NISSAN MAXIMA INTO FRONTAL LOAD CELL BARRIER
DRIVER RIGHT TOE Z-AXIS ACCELERATION AT TOE
35MPH FLAT FRONTAL BARRIER

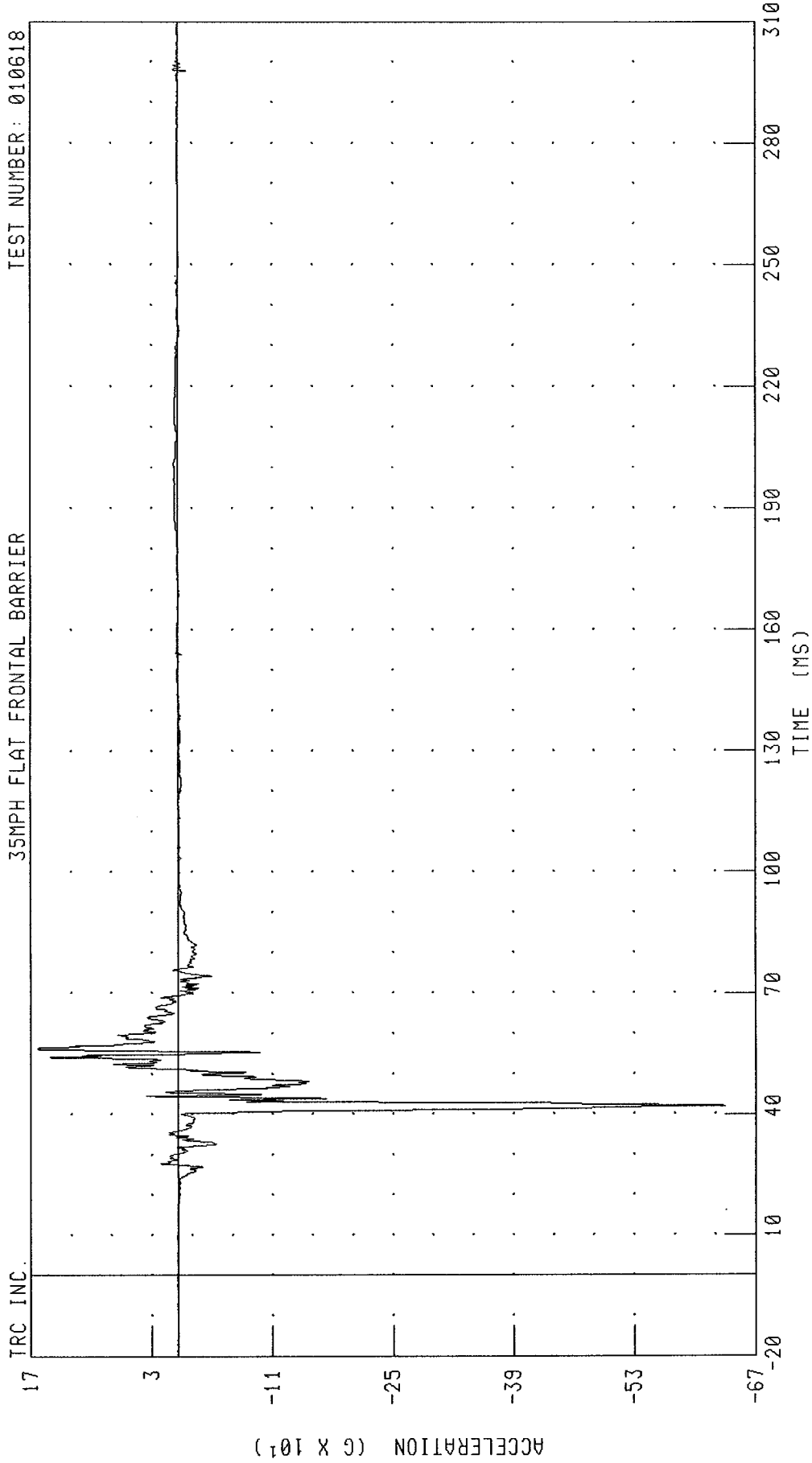

CHANNEL: FRTZG1 FILTER: CH. CLASS 1000 PEAK DATA: 161.45 G @ 56.32 MS; -634.72 G @ 42.00 MS

2001 NISSAN MAXIMA INTO FRONTAL LOAD CELL BARRIER
DRIVER LAP BELT OUTBOARD FORCE
35MPH FLAT FRONTAL BARRIER

TEST NUMBER: 010618

TRC INC.

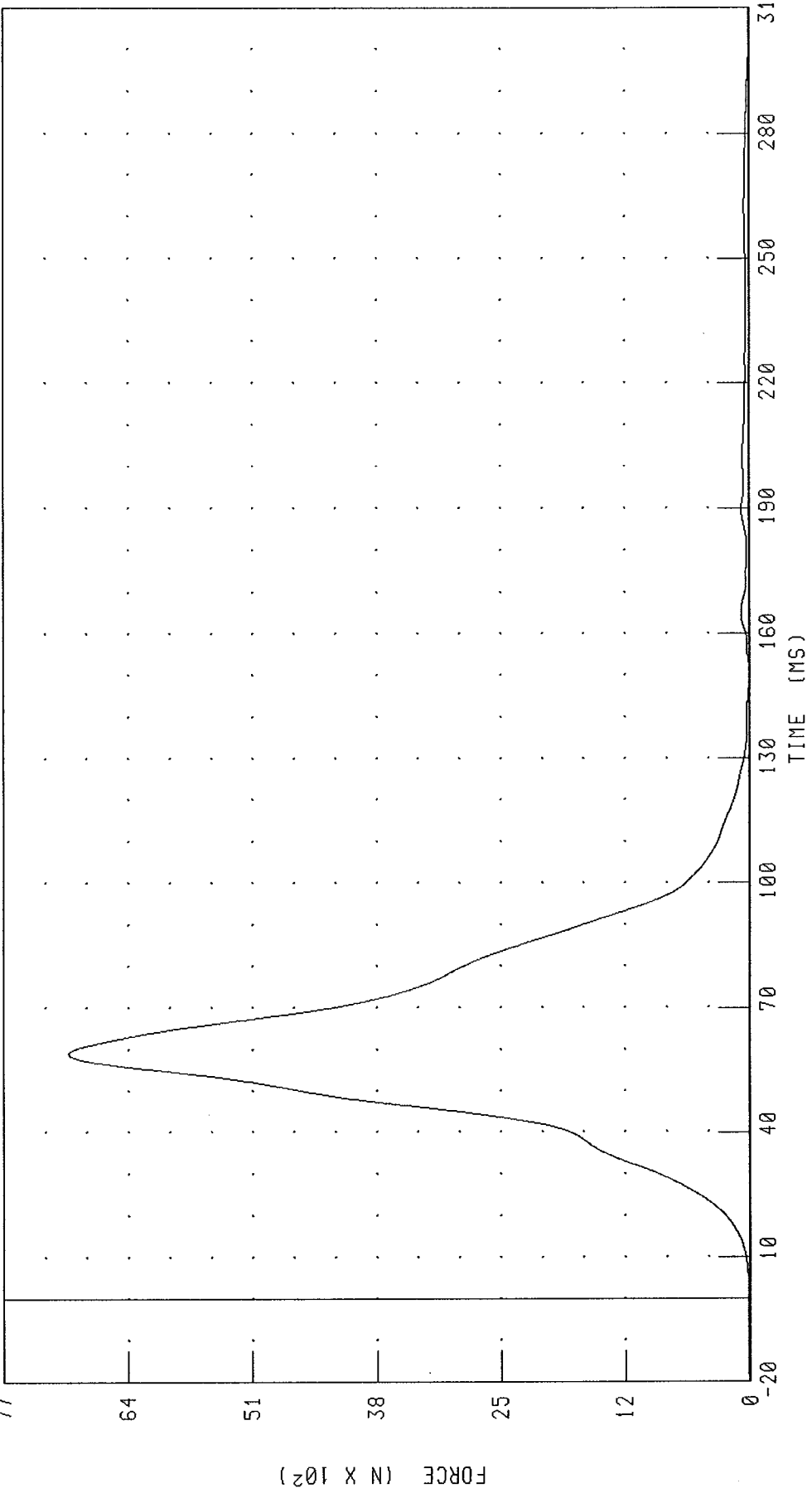

CHANNEL: LBOF1 FILTER: CH. CLASS 60 PEAK DATA: 7113.86 N @ 59.12 MS; -10.93 N @ 308.32 MS

2001 NISSAN MAXIMA INTO FRONTAL LOAD CELL BARRIER
DRIVER SHOULDER BELT FORCE
35MPH FLAT FRONTAL BARRIER

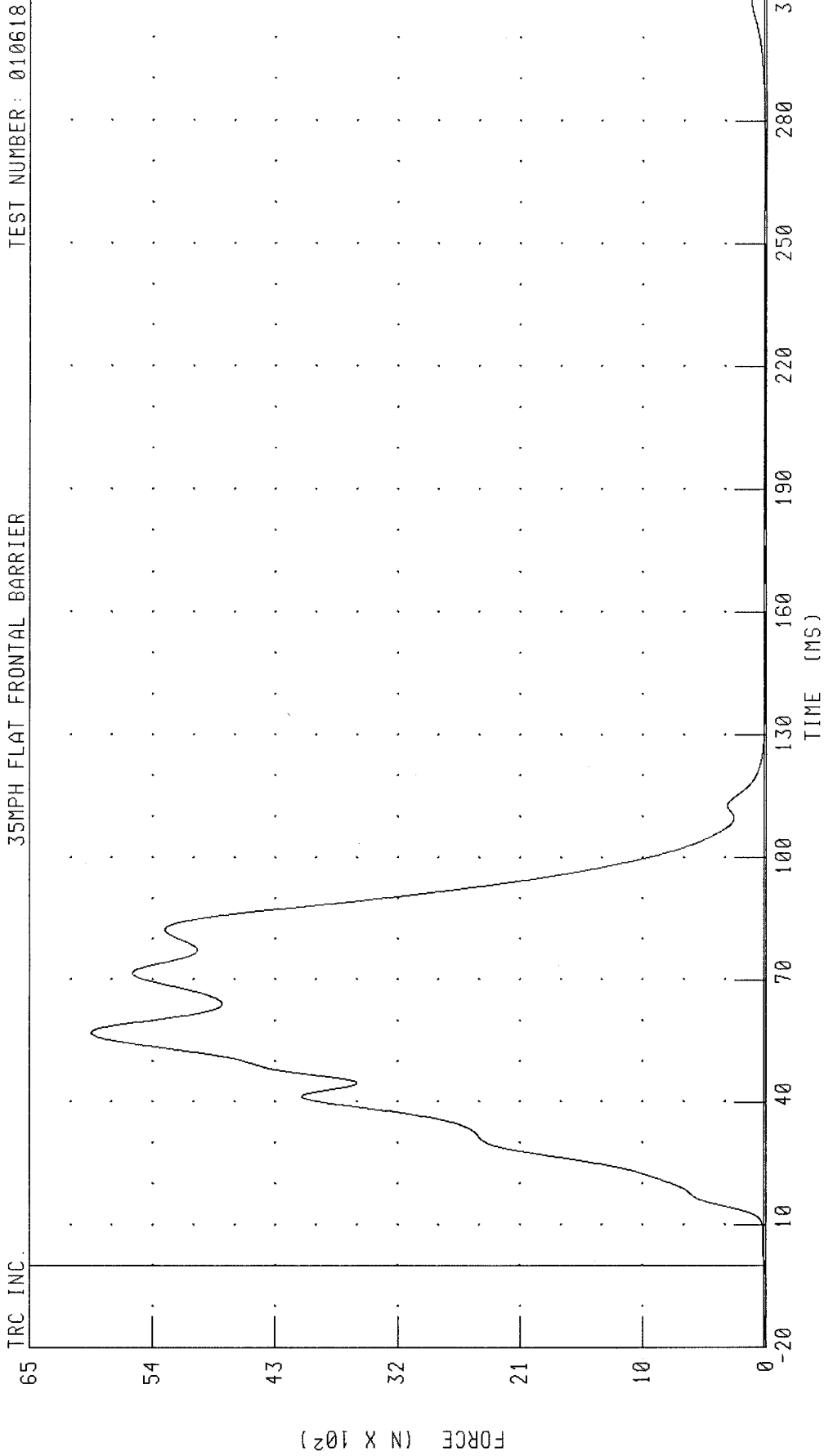

CHANNEL: SHBF1 FILTER: CH. CLASS 60 PEAK DATA: 6033.30 N @ 57.04 MS; -14.62 N @ 163.52 MS

2001 NISSAN MAXIMA INTO FRONTAL LOAD CELL BARRIER
DRIVER SHOULDER BELT DISPLACEMENT
35MPH FLAT FRONTAL BARRIER

TEST NUMBER: 010618

TRC INC.

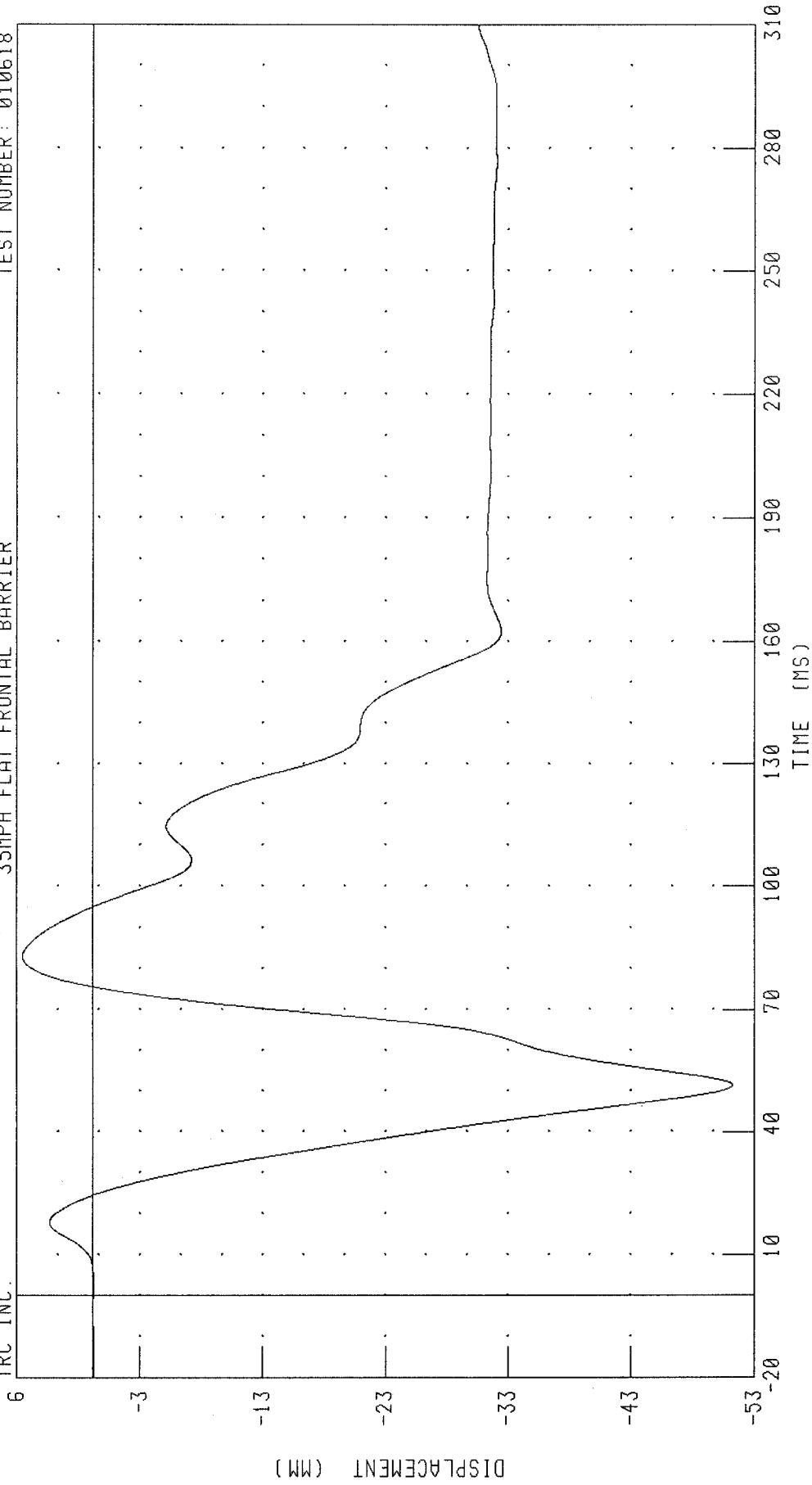

CHANNEL: SHBD1 FILTER: CH. CLASS 60

PEAK DATA: 5.72 MM @ 82.96 MS; -52.07 MM @ 51.36 MS

2001 NISSAN MAXIMA INTO FRONTAL LOAD CELL BARRIER
DRIVER SEAT BELT EXTENSION MEASURED OVER 16 MM
35MPH FLAT FRONTAL BARRIER

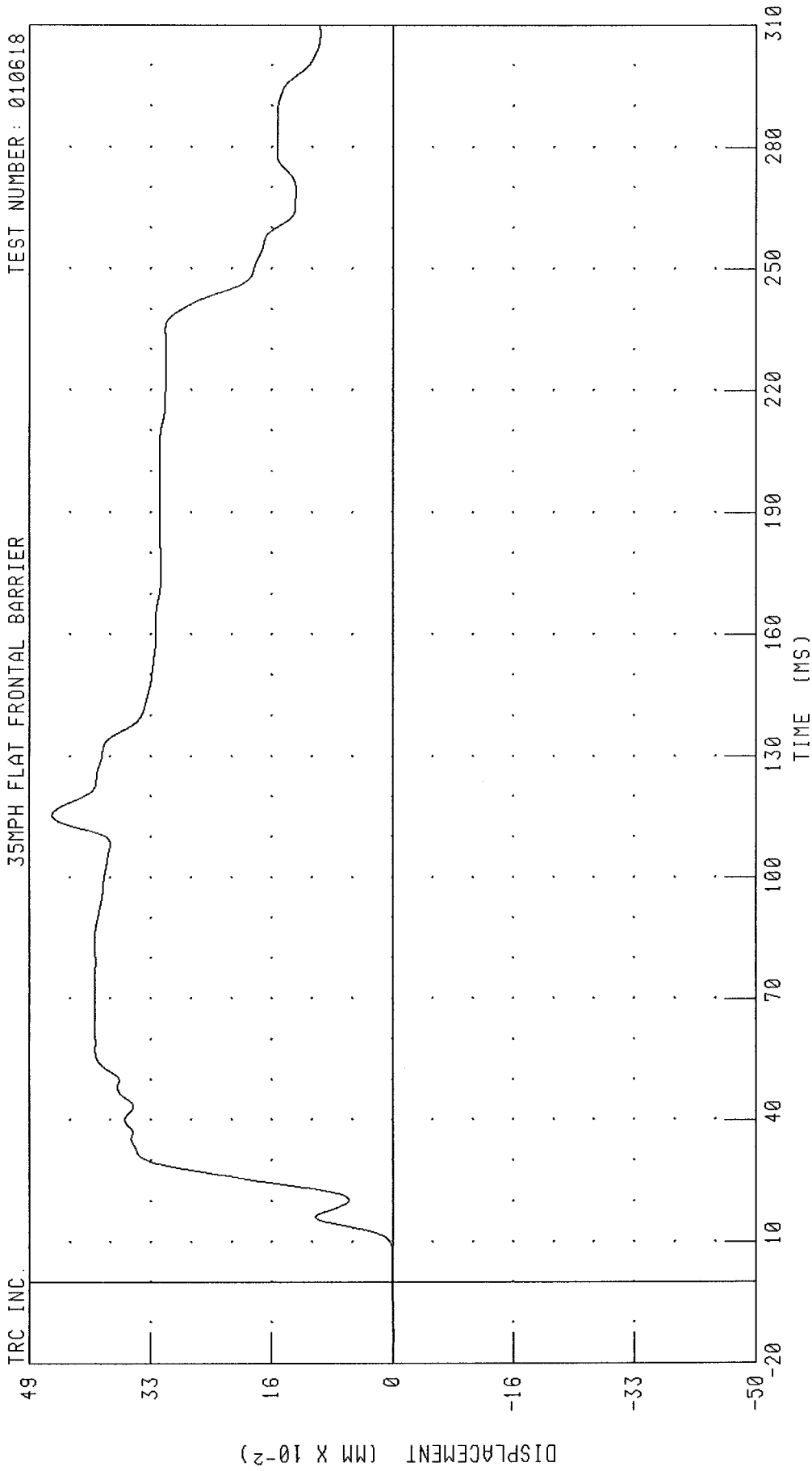

CHANNEL: SBED1 FILTER: CH. CLASS 60 PEAK DATA: 0.47 MM @ 115.44 MS; 0.00 MM @ -13.36 MS

2001 NISSAN MAXIMA INTO FRONTAL LOAD CELL BARRIER
PASSENGER HEAD X-AXIS ACCELERATION
35MPH FLAT FRONTAL BARRIER

TEST NUMBER: 010618

TRC INC.

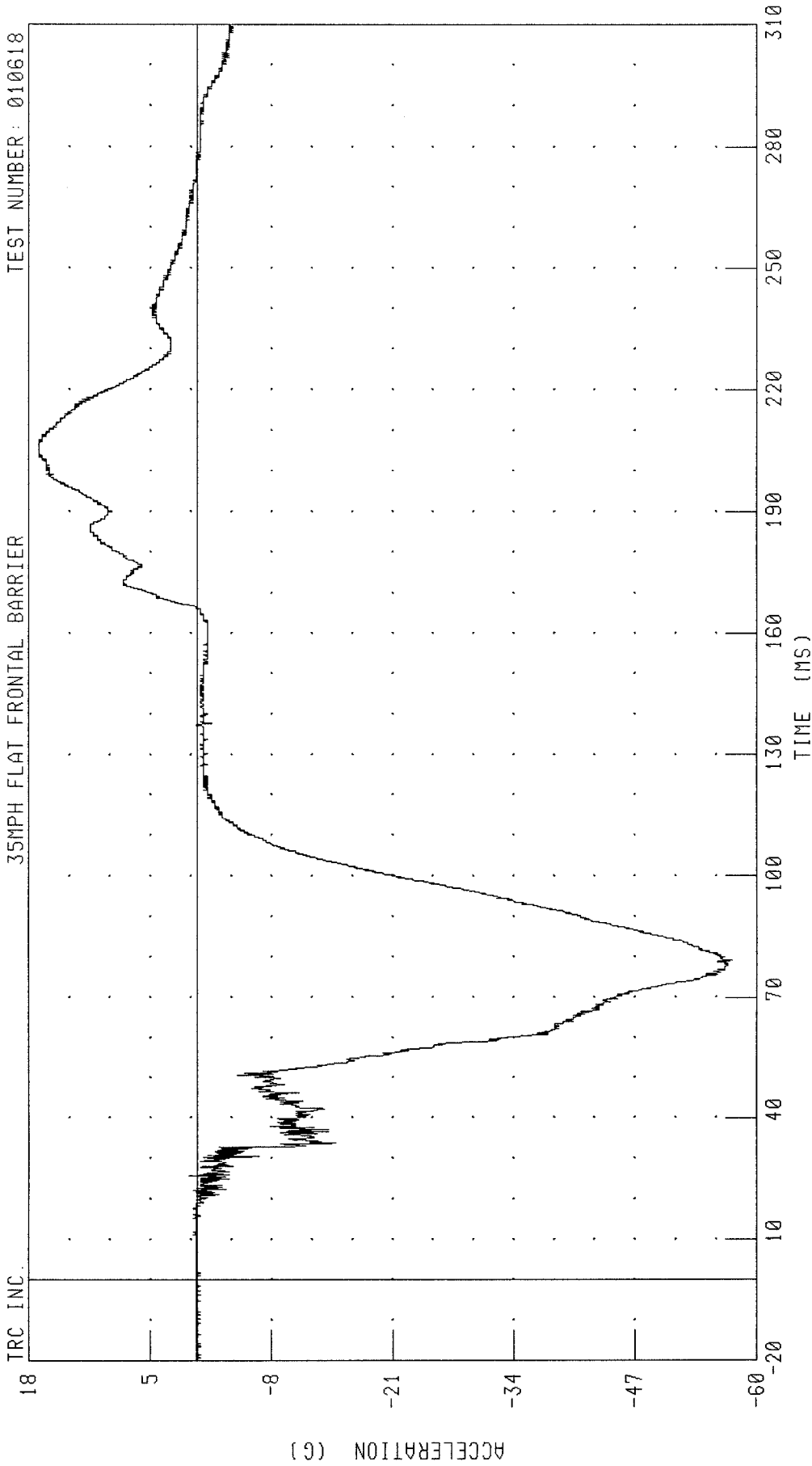

TIME (MS)

CHANNEL: HEDXC2 FILTER: CH. CLASS 1000

PEAK DATA: 16.97 G @ 203.60 MS; -57.36 G @ 79.20 MS

2001 NISSAN MAXIMA INTO FRONTAL LOAD CELL BARRIER
PASSENGER HEAD Y-AXIS ACCELERATION
35MPH FLAT FRONTAL BARRIER

TEST NUMBER: 010618

TRC INC.

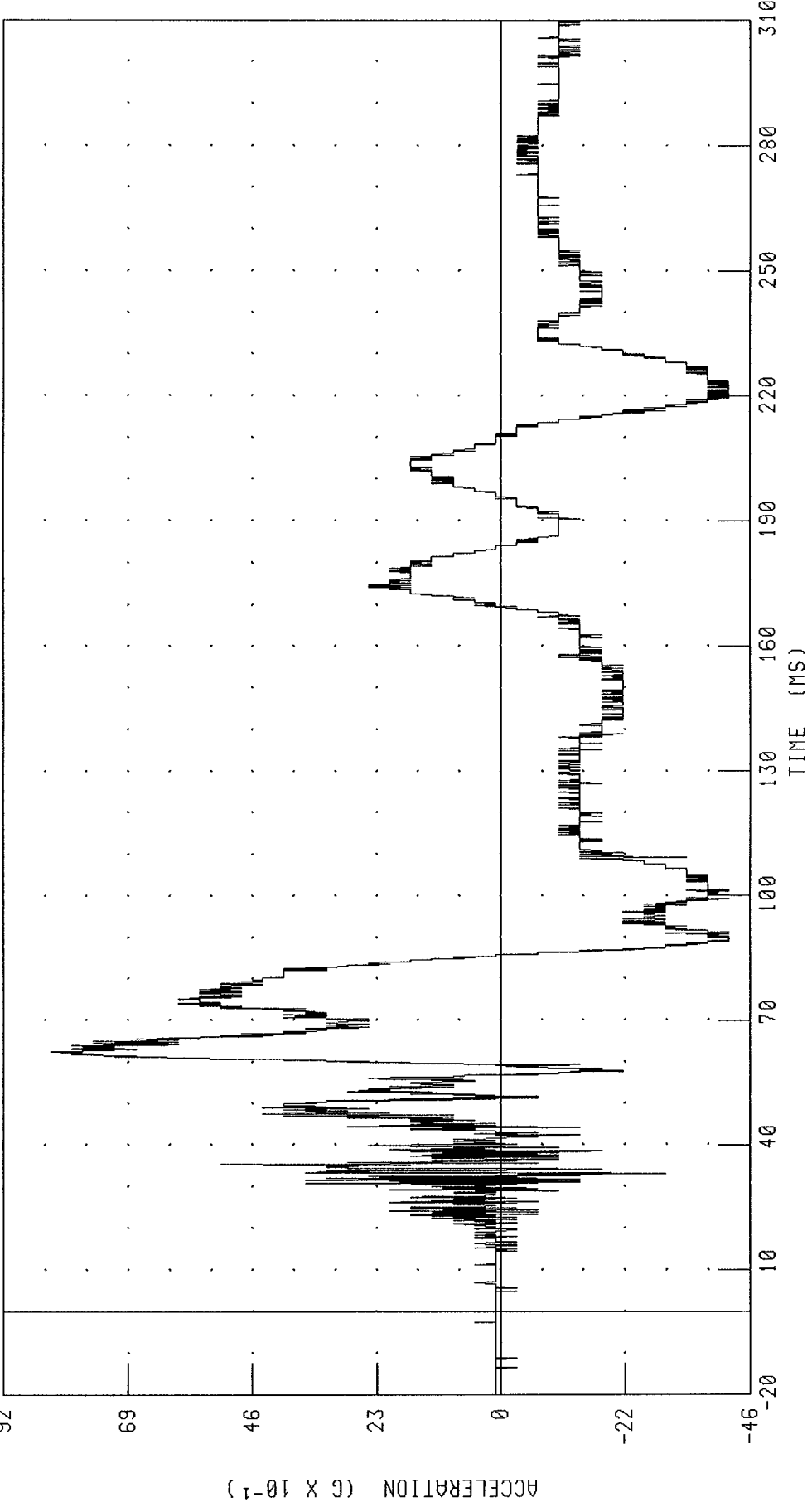

CHANNEL: HEDYC2 FILTER: CH. CLASS 1000 PEAK DATA: 8.33 G @ 62.40 MS; -4.22 G @ 88.96 MS

2001 NISSAN MAXIMA INTO FRONTAL LOAD CELL BARRIER
PASSENGER HEAD Z-AXIS ACCELERATION
35MPH FLAT FRONTAL BARRIER

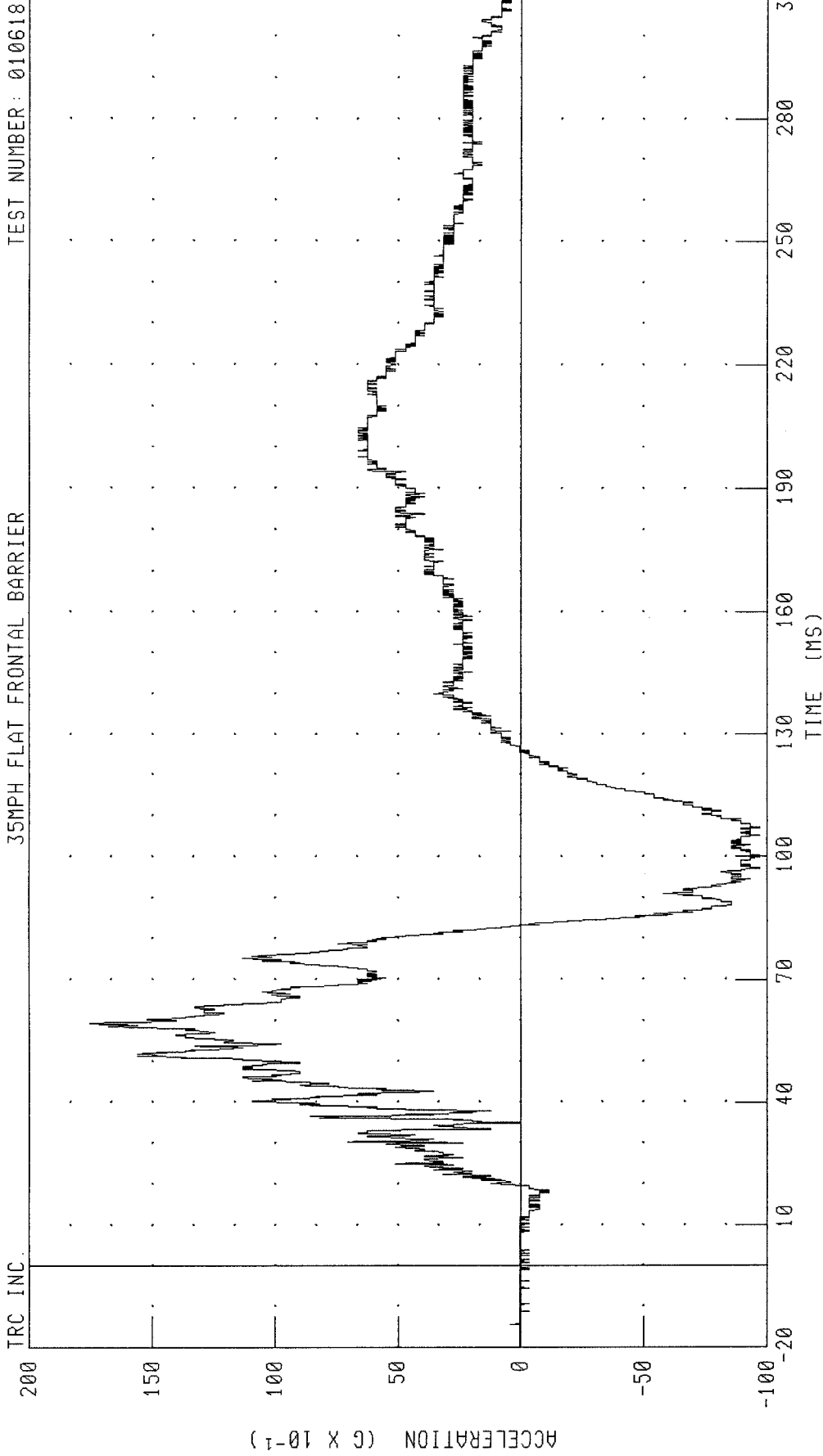

CHANNEL: HEDZG2 FILTER: CH. CLASS 1000

PEAK DATA: 17.56 G @ 59.44 MS; -9.72 G @ 97.12 MS

2001 NISSAN MAXIMA INTO FRONTAL LOAD CELL BARRIER
PASSENGER HEAD RESULTANT ACCELERATION
35MPH FLAT FRONTAL BARRIER

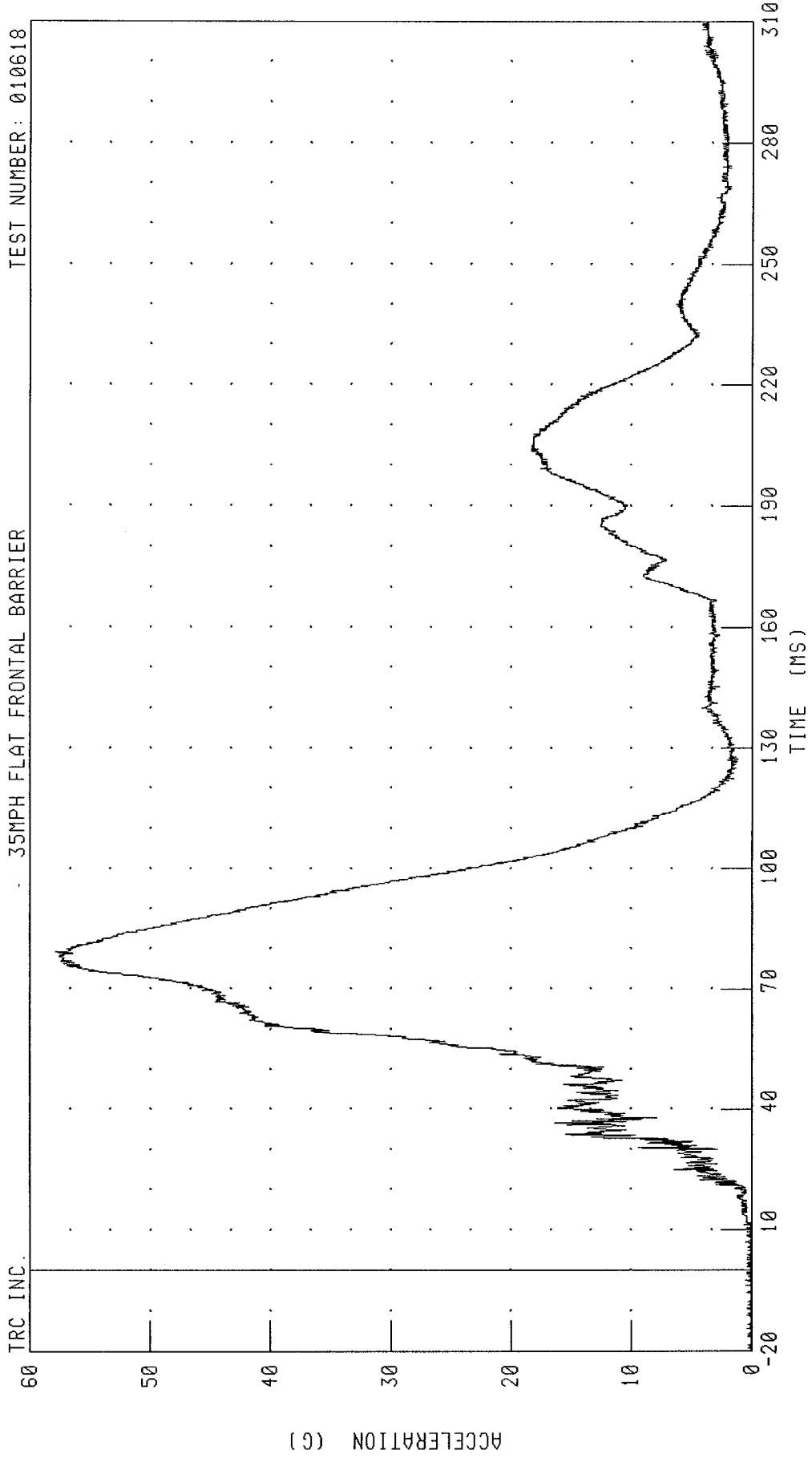

TRC INC.

TEST NUMBER: 010618

CHANNEL: HEDRG2 FILTER: CH. CLASS 1000 PEAK DATA: 57.87 G @ 79.20 MS, 0.11 G @ -20.00 MS

2001 NISSAN MAXIMA INTO FRONTAL LOAD CELL BARRIER
PASSENGER HEAD X-AXIS ACCELERATION - REDUNDANT
35MPH FLAT FRONTAL BARRIER

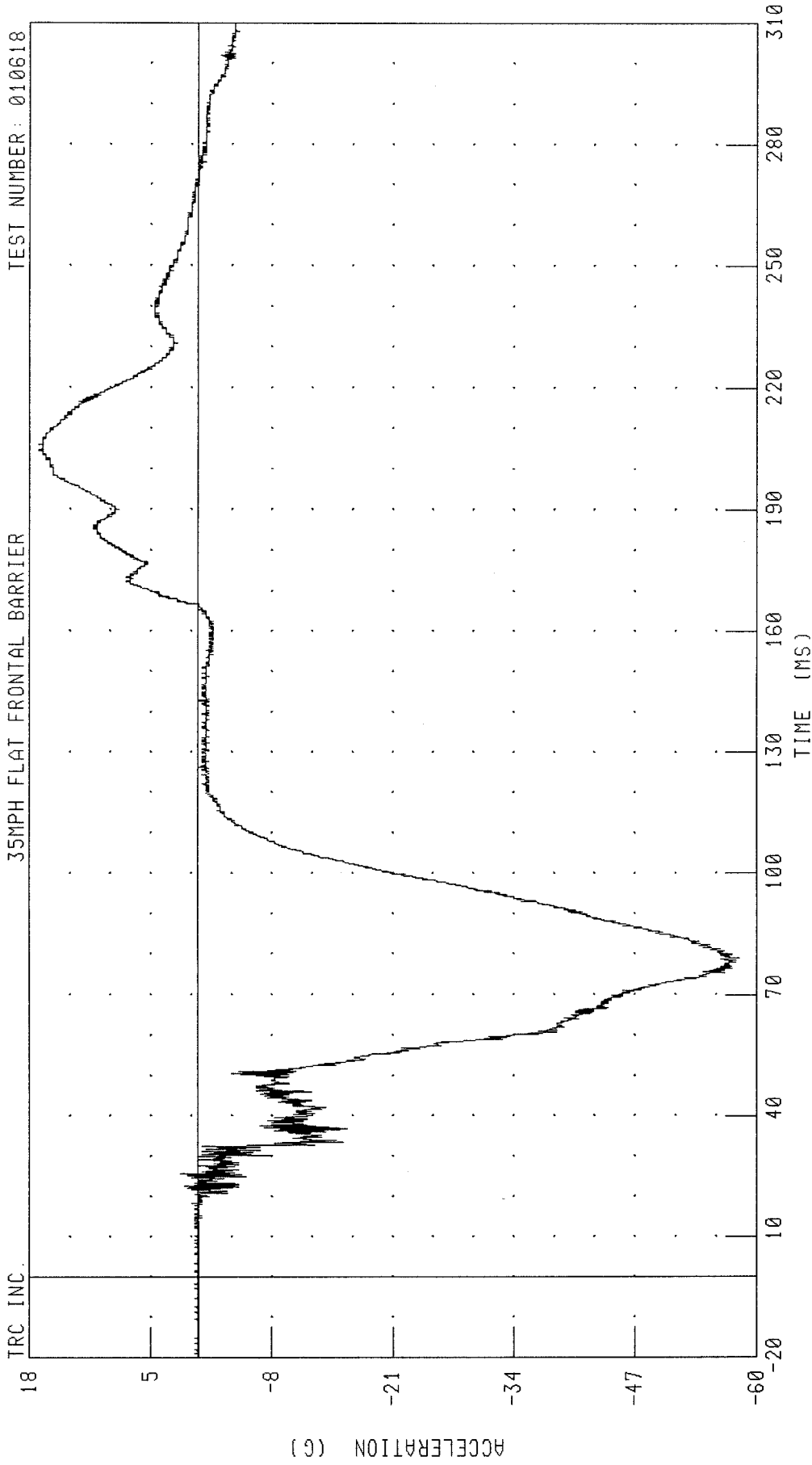

CHANNEL: HEDXR2 FILTER: CH. CLASS 1000

PEAK DATA: 17.03 G @ 204.56 MS; -58.16 G @ 79.04 MS

2001 NISSAN MAXIMA INTO FRONTAL LOAD CELL BARRIER
PASSENGER HEAD Y-AXIS ACCELERATION - REDUNDANT
35MPH FLAT FRONTAL BARRIER

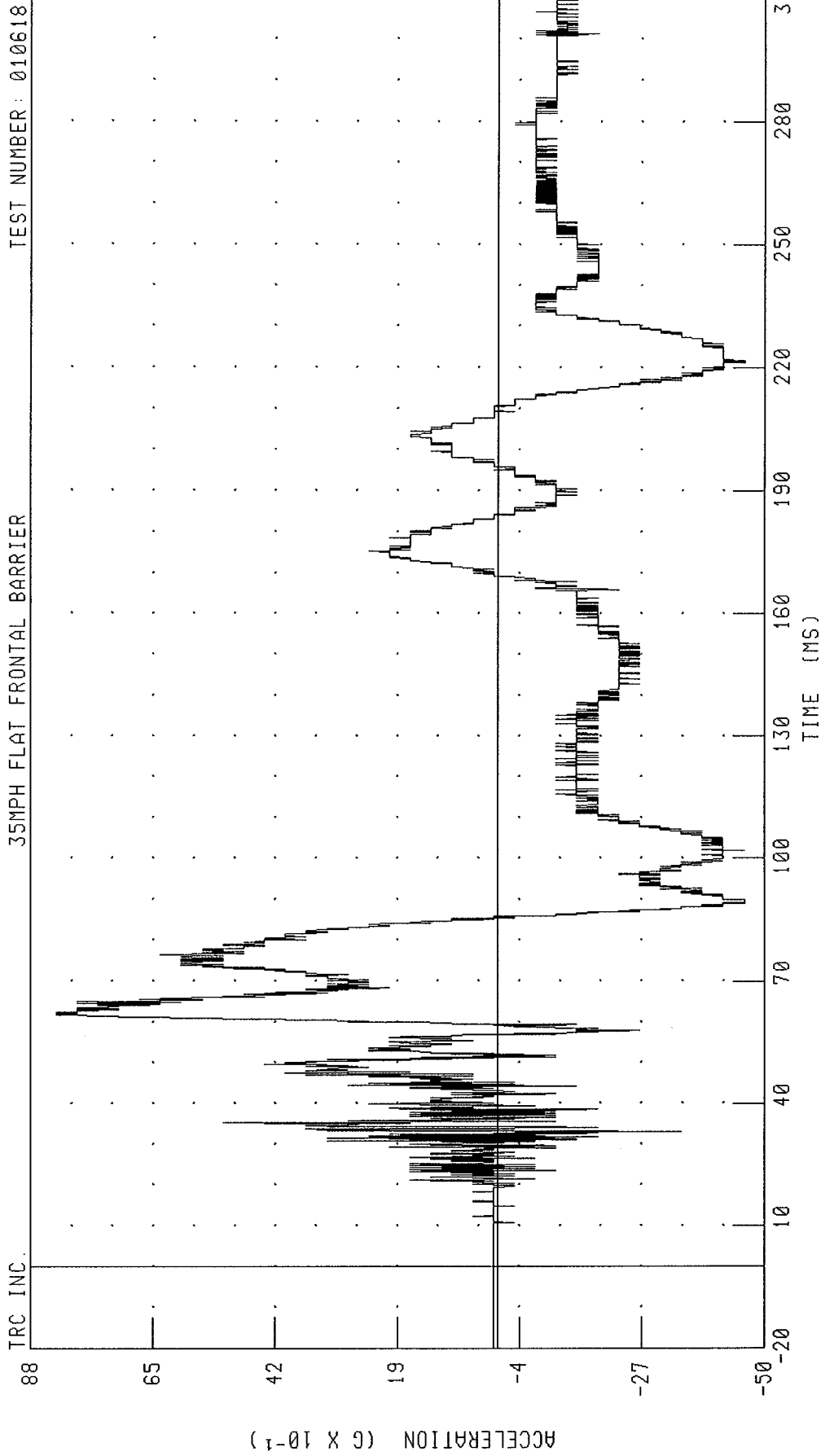

2001 NISSAN MAXIMA INTO FRONTAL LOAD CELL BARRIER
PASSENGER HEAD Z-AXIS ACCELERATION - REDUNDANT
35MPH FLAT FRONTAL BARRIER

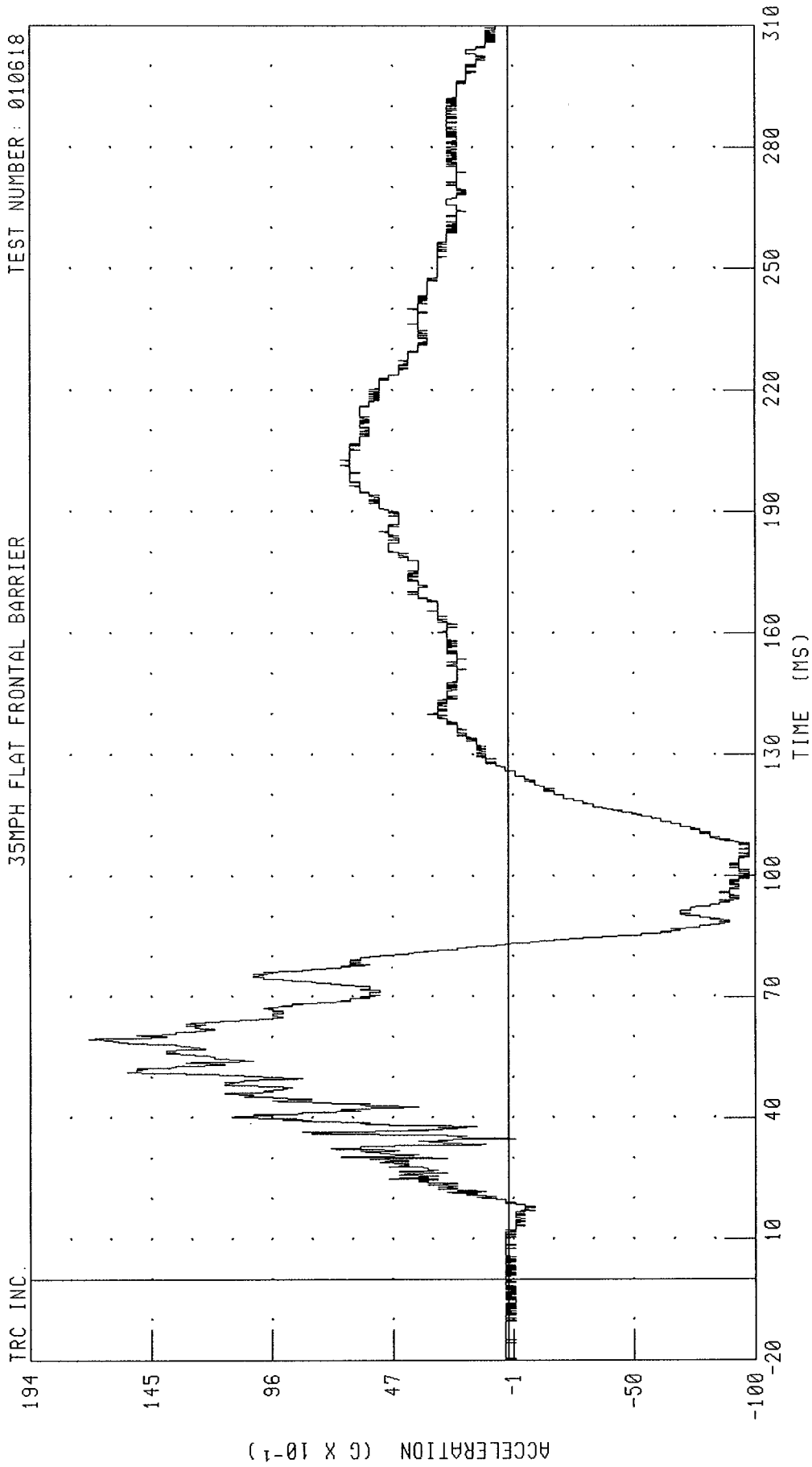

PEAK DATA: 17.04 G @ 59.44 MS; -9.74 G @ 99.36 MS

CHANNEL: HEDZR2 FILTER: CH. CLASS 1000

2001 NISSAN MAXIMA INTO FRONTAL LOAD CELL BARRIER
PASSENGER HEAD RESULTANT ACCELERATION - REDUNDANT
35MPH FLAT FRONTAL BARRIER

TEST NUMBER: 010618

TRC INC.

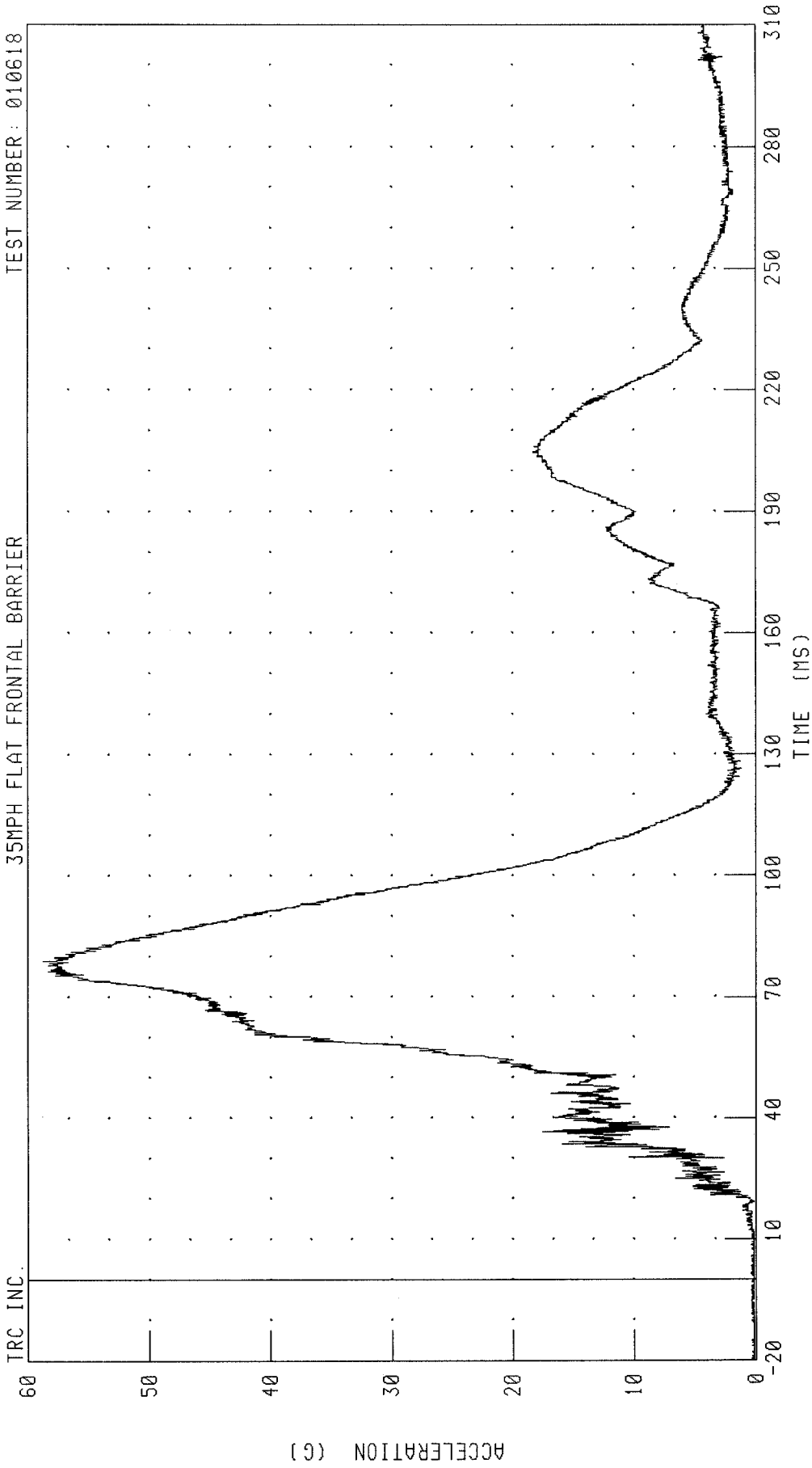

CHANNEL: HEDRR2 FILTER: CH. CLASS 1000

PEAK DATA: 58.71 G @ 79.04 MS; 0.18 G @ -20.00 MS

2001 NISSAN MAXIMA INTO FRONTAL LOAD CELL BARRIER
PASSENGER NECK X-AXIS SHEAR FORCE
35MPH FLAT FRONTAL BARRIER

TEST NUMBER: 010618

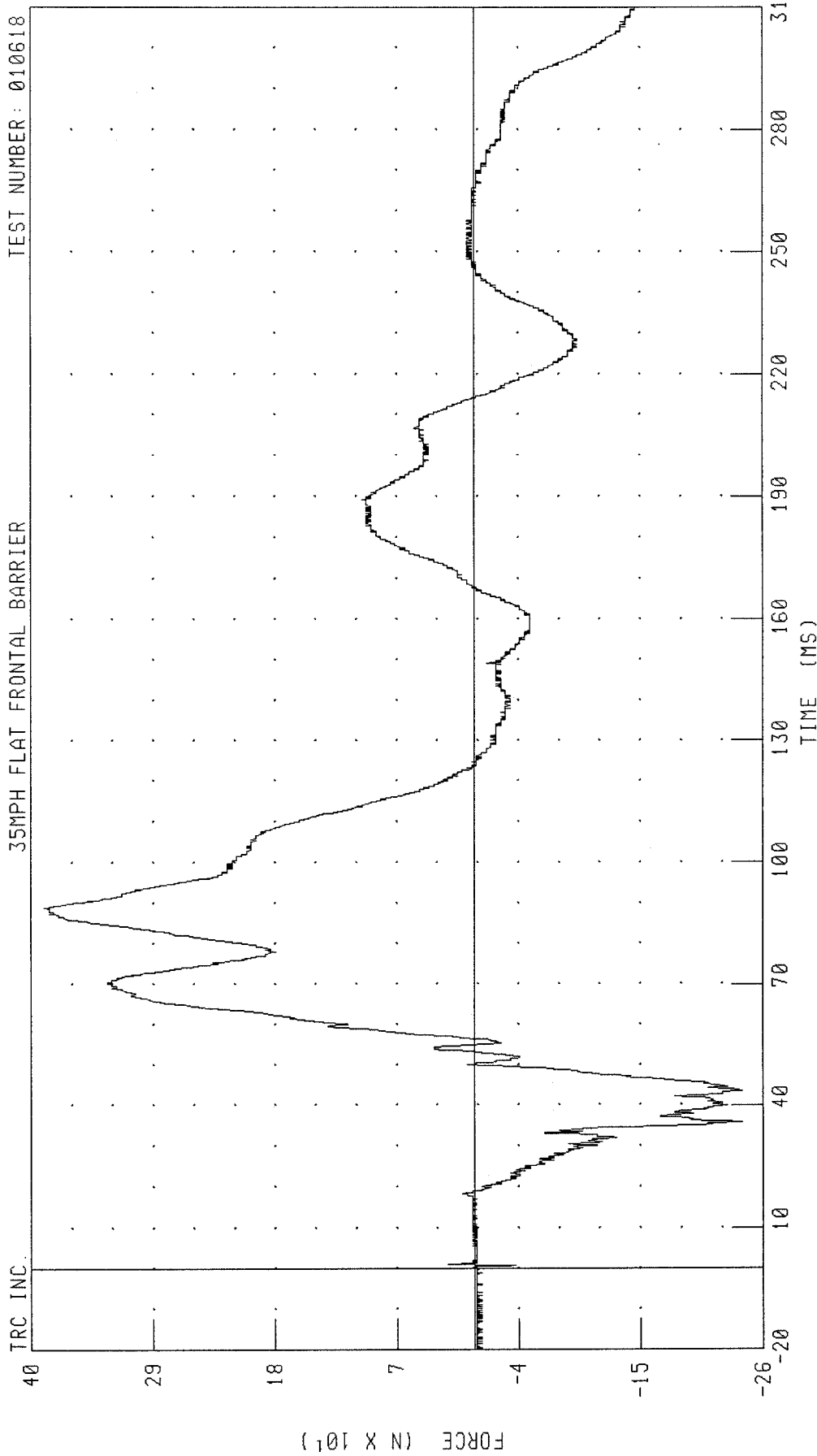

CHANNEL: NEKXF2 FILTER: CH. CLASS 1000
PEAK DATA: 388.17 N @ 88.88 MS; -241.30 N @ 35.84 MS

2001 NISSAN MAXIMA INTO FRONTAL LOAD CELL BARRIER
PASSENGER NECK Y-AXIS SHEAR FORCE
35MPH FLAT FRONTAL BARRIER

TEST NUMBER: 010618

TRC INC.

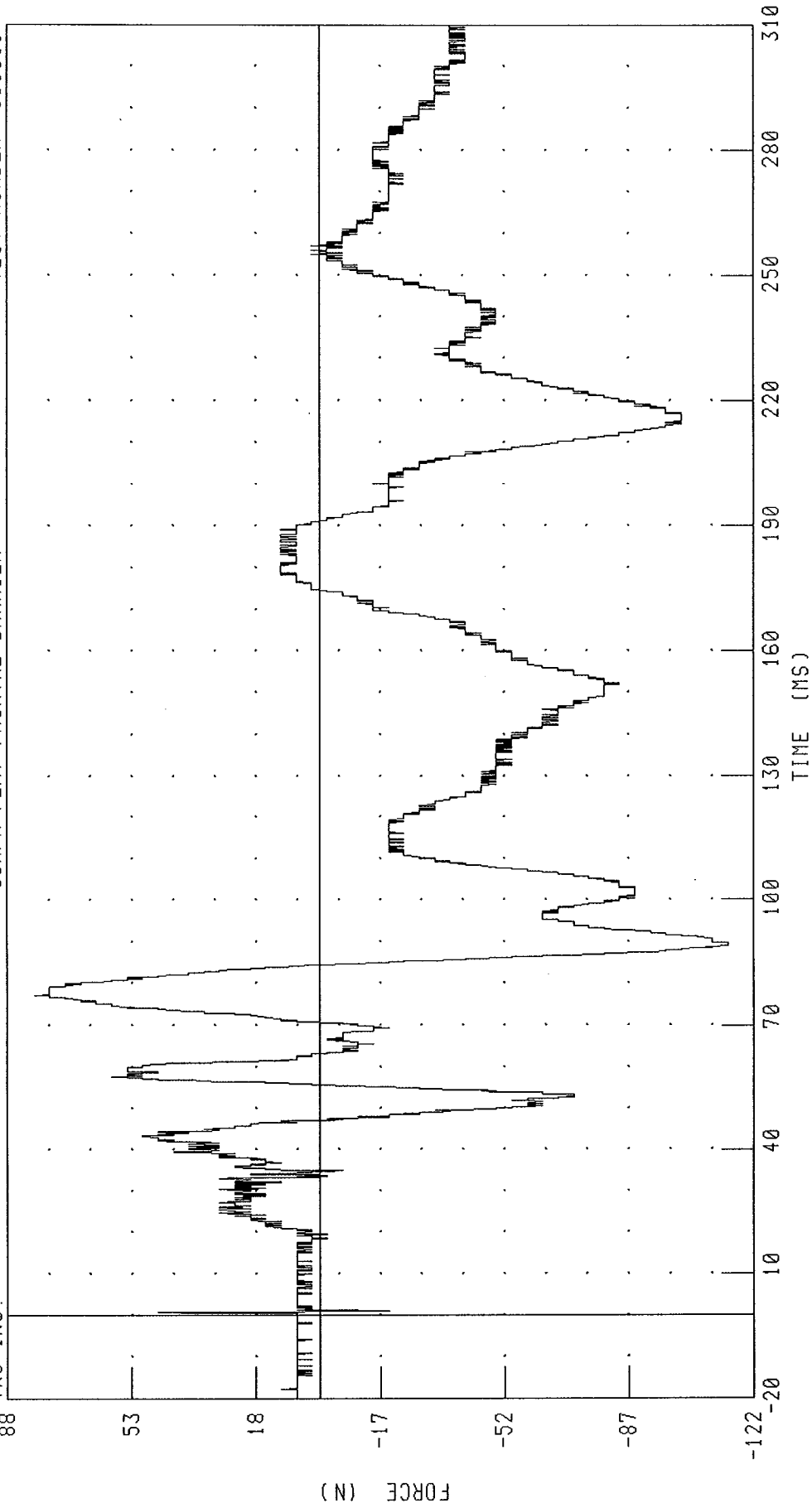

PEAK DATA: 80.48 N @ 77.36 MS; -114.95 N @ 88.88 MS

CHANNEL: NEKYF2 FILTER: CH. CLASS 1000

2001 NISSAN MAXIMA INTO FRONTAL LOAD CELL BARRIER
PASSENGER NECK Z-AXIS AXIAL FORCE
35MPH FLAT FRONTAL BARRIER

TEST NUMBER: 010618

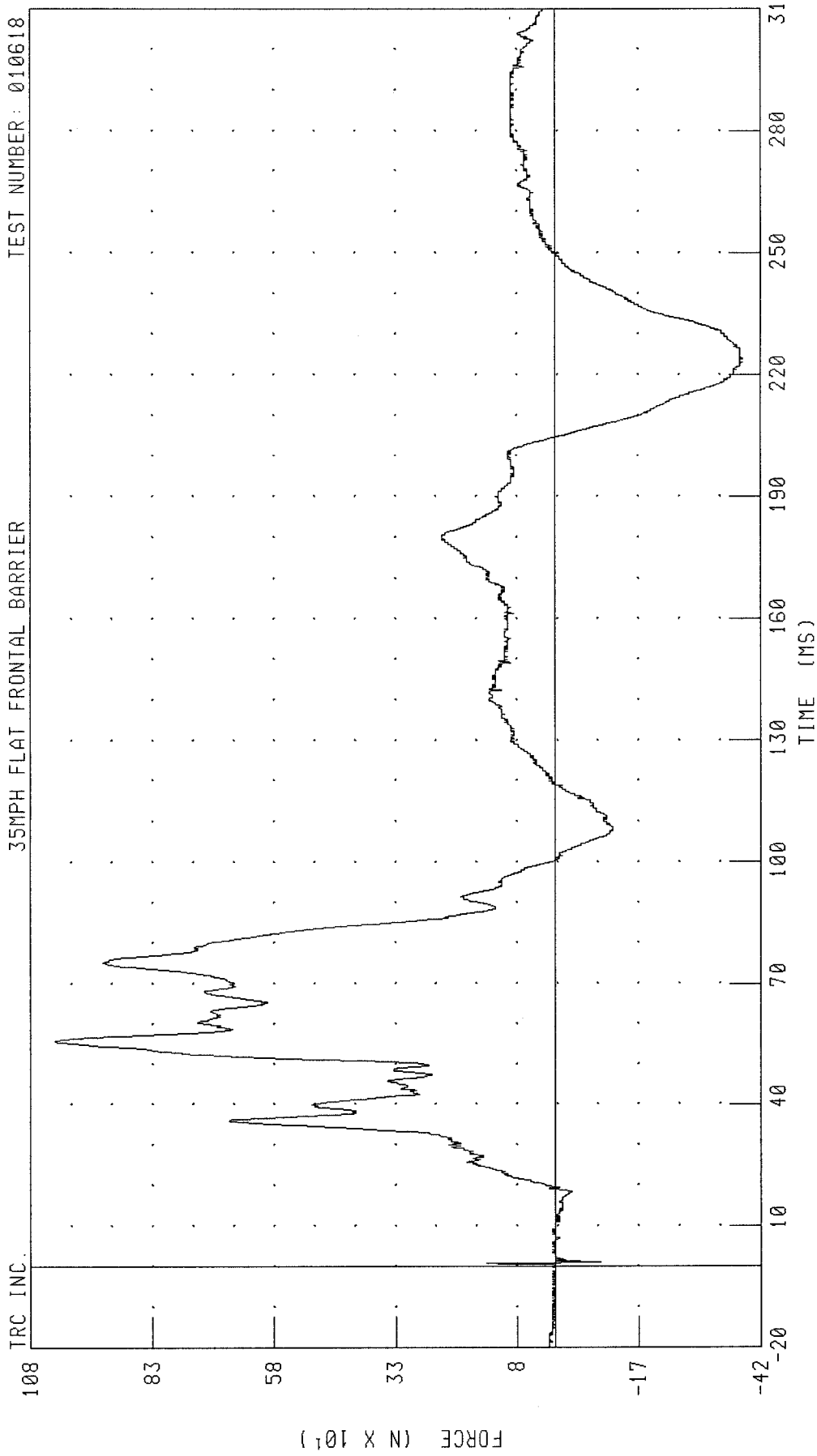

CHANNEL: NEKZF2 FILTER: CH. CLASS 1000

PEAK DATA: 1029.99 N @ 55.60 MS; -384.61 N @ 222.96 MS

2001 NISSAN MAXIMA INTO FRONTAL LOAD CELL BARRIER
PASSENGER NECK MOMENT ABOUT X AXIS
35MPH FLAT FRONTAL BARRIER

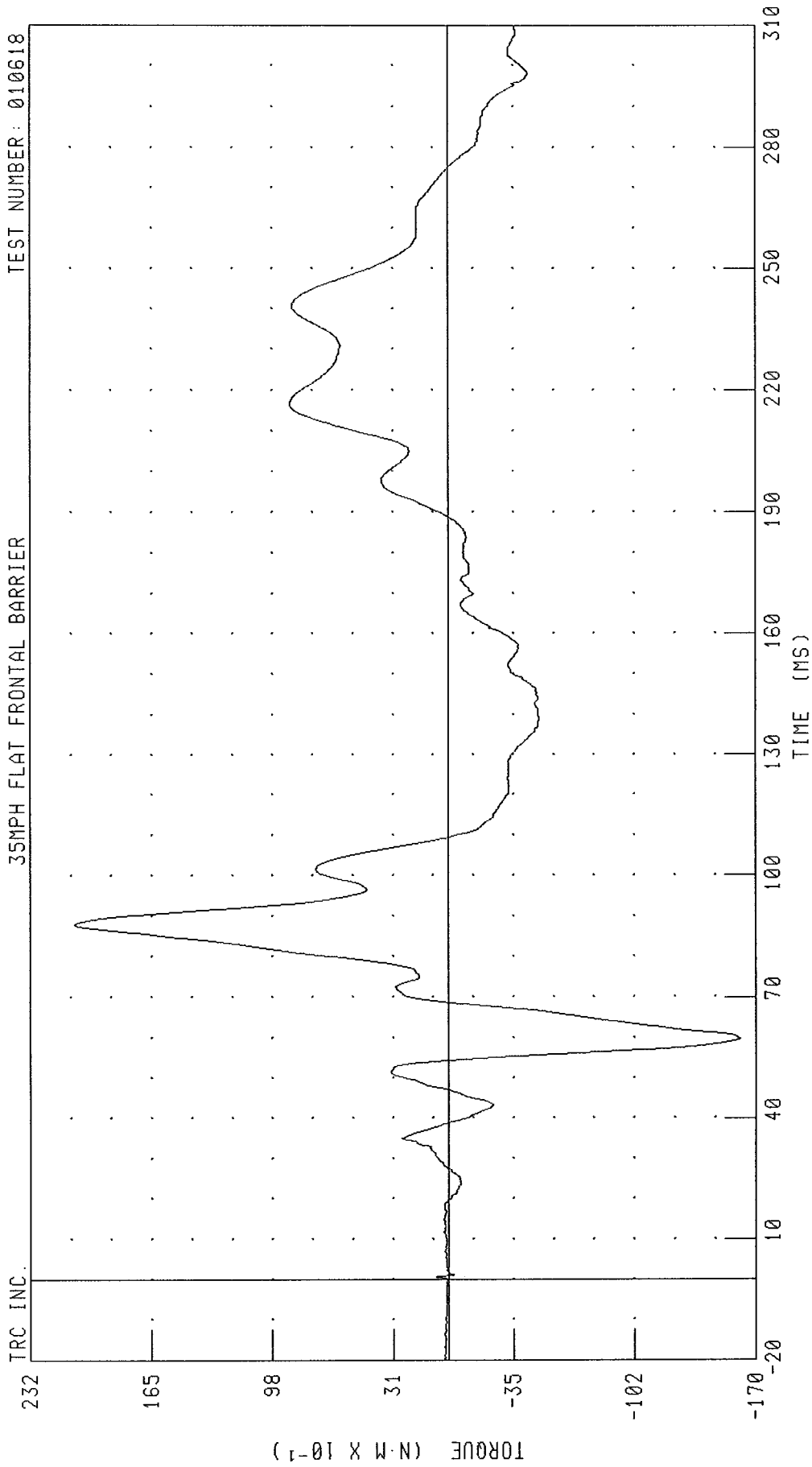

CHANNEL: NEKX12 FILTER: CH. CLASS 600

PEAK DATA: 20.76 N.M @ 87.92 MS; -16.14 N.M @ 59.68 MS

2001 NISSAN MAXIMA INTO FRONTAL LOAD CELL BARRIER
PASSENGER NECK MOMENT ABOUT Y AXIS
35MPH FLAT FRONTAL BARRIER

TEST NUMBER: 010618

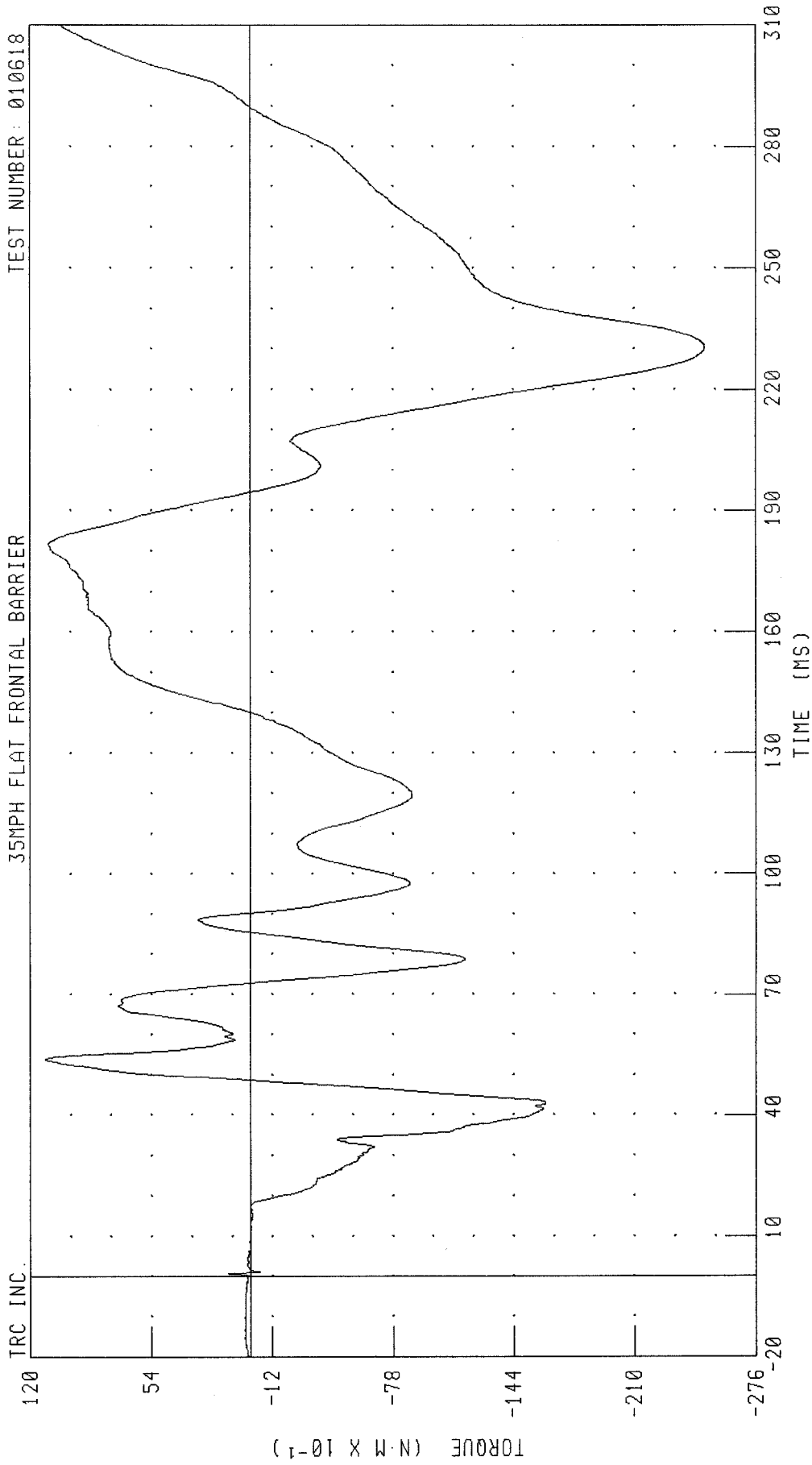

TRC INC.

CHANNEL: NEKYM2 FILTER: CH. CLASS 600

PEAK DATA: 11.20 N·M @ 53.92 MS, -24.82 N·M @ 230.00 MS

2001 NISSAN MAXIMA INTO FRONTAL LOAD CELL BARRIER
PASSENGER NECK MOMENT ABOUT Z AXIS
35MPH FLAT FRONTAL BARRIER

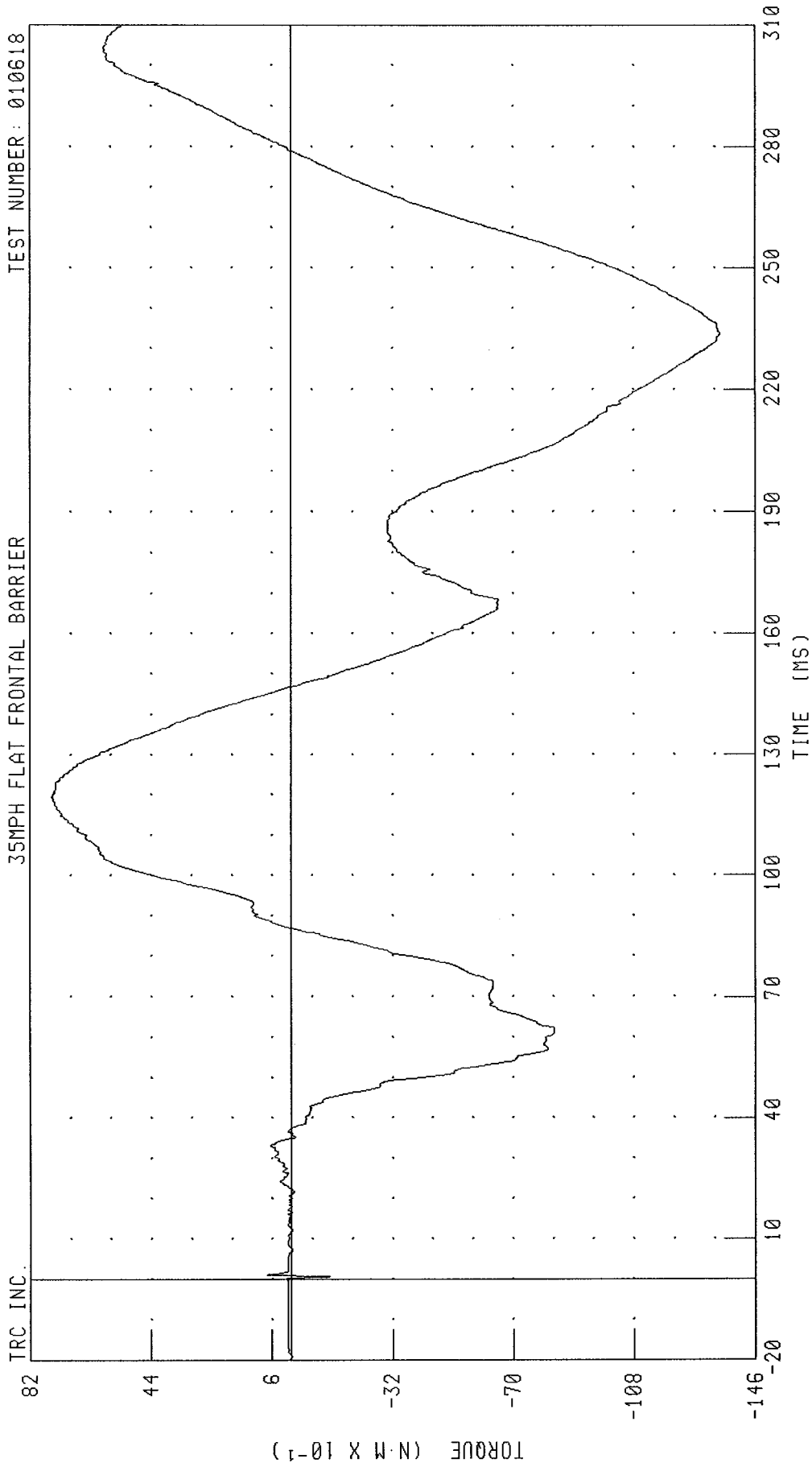

CHANNEL: NEKZM2 FILTER: CH. CLASS 600 PEAK DATA: 7.52 N·M @ 119.52 MS; -13.52 N·M @ 233.68 MS

2001 NISSAN MAXIMA INTO FRONTAL LOAD CELL BARRIER
PASSENGER NECK MOMENT OCCIPITAL CONDYLE ABOUT Y AXIS
35MPH FLAT FRONTAL BARRIER

TEST NUMBER: 010618

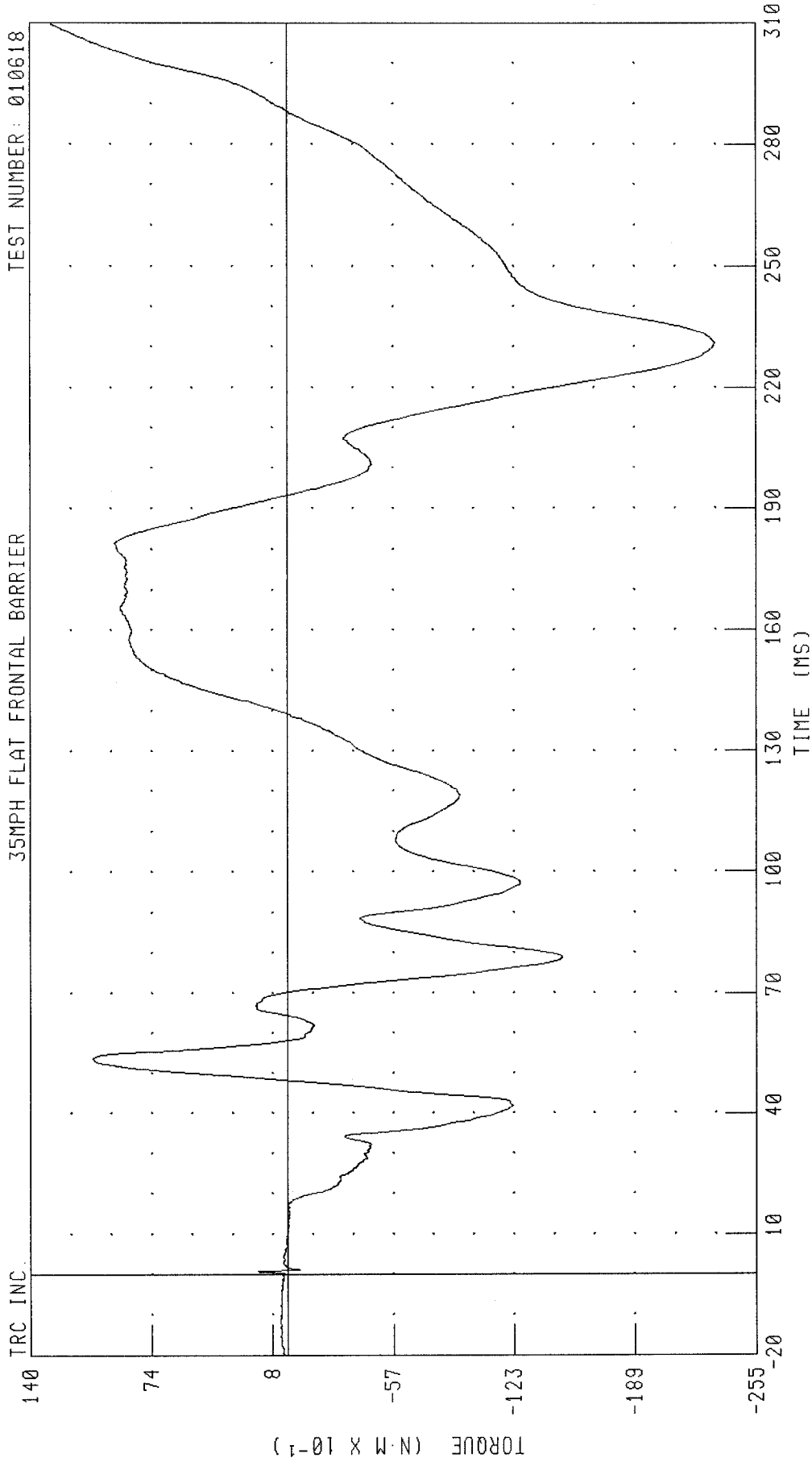

CHANNEL: NEKOM2 FILTER: CH. CLASS 600

PEAK DATA: 12.86 N·M @ 309.68 MS; -23.36 N·M @ 231.04 MS

2001 NISSAN MAXIMA INTO FRONTAL LOAD CELL BARRIER
PASSENGER CHEST X-AXIS ACCELERATION
35MPH FLAT FRONTAL BARRIER

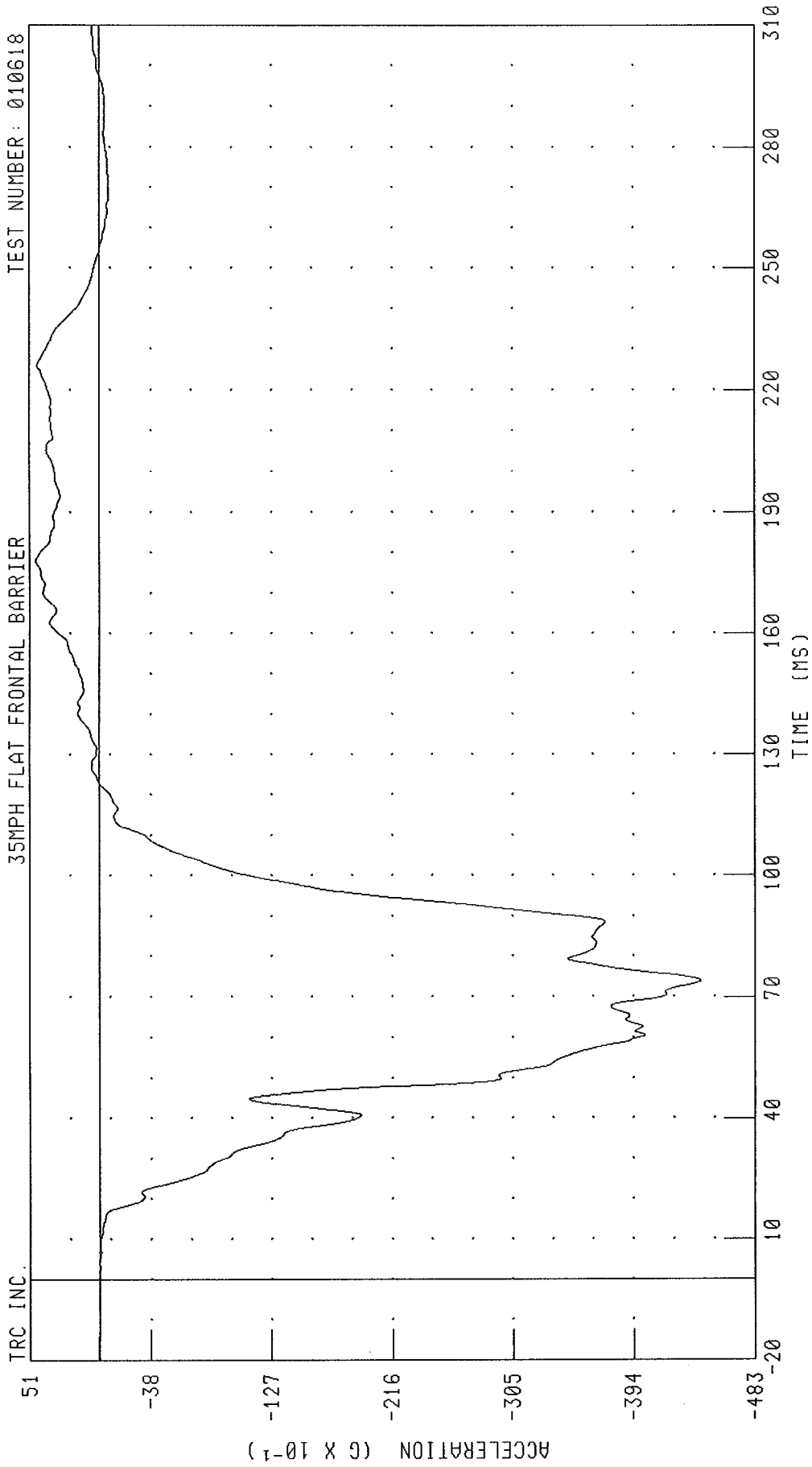

CHANNEL: CSTXG2 FILTER: CH. CLASS 180 PEAK DATA: 4.65 G @ 178.16 MS; -44.33 G @ 74.00 MS

2001 NISSAN MAXIMA INTO FRONTAL LOAD CELL BARRIER
PASSENGER CHEST Y-AXIS ACCELERATION
35MPH FLAT FRONTAL BARRIER

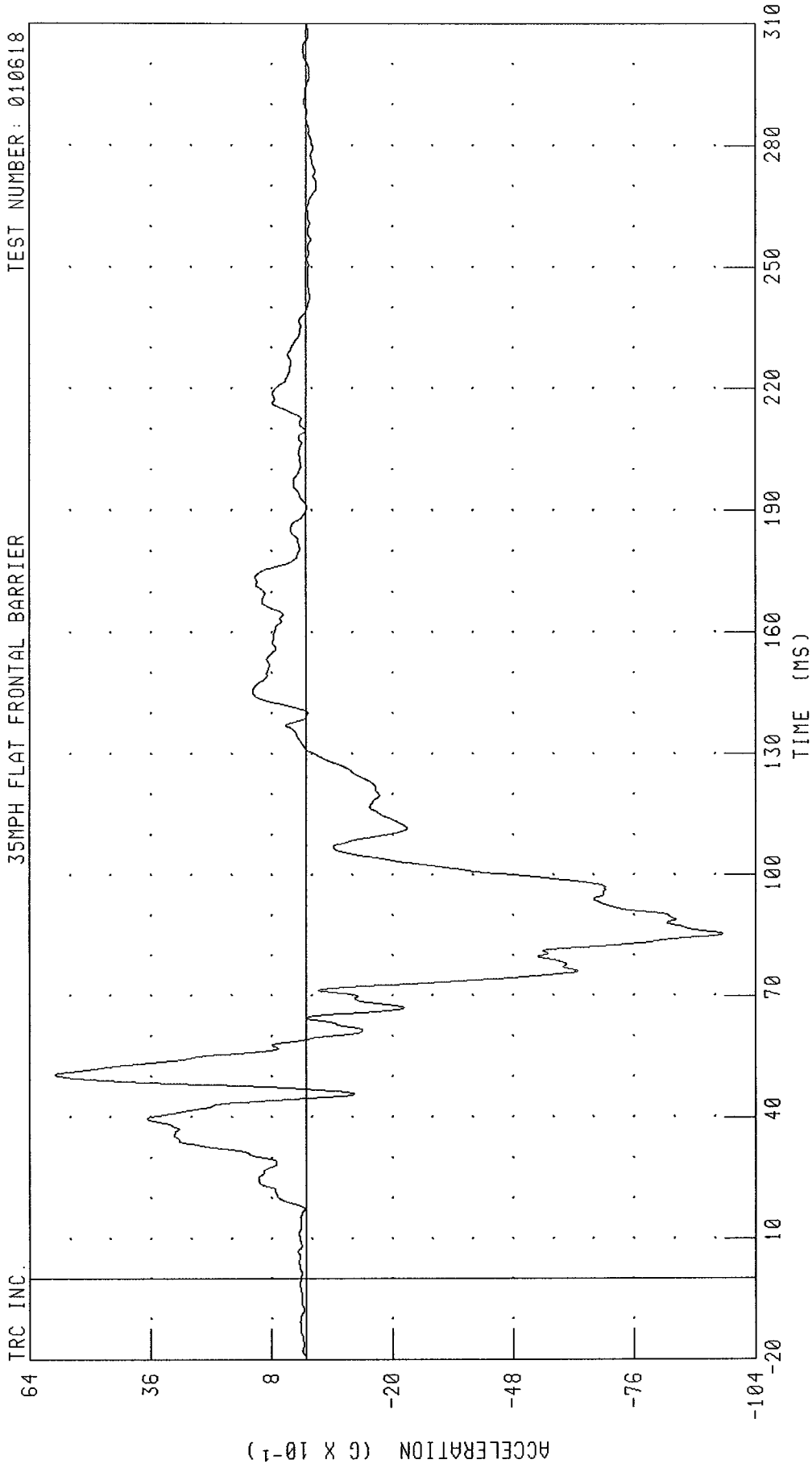

CHANNEL: CSTYC2 FILTER: CH. CLASS 180

PEAK DATA: 5.82 G @ 50.48 MS; -9.64 G @ 85.36 MS

2001 NISSAN MAXIMA INTO FRONTAL LOAD CELL BARRIER
PASSENGER CHEST Z-AXIS ACCELERATION
35MPH FLAT FRONTAL BARRIER

TEST NUMBER: 010618

TRC INC.

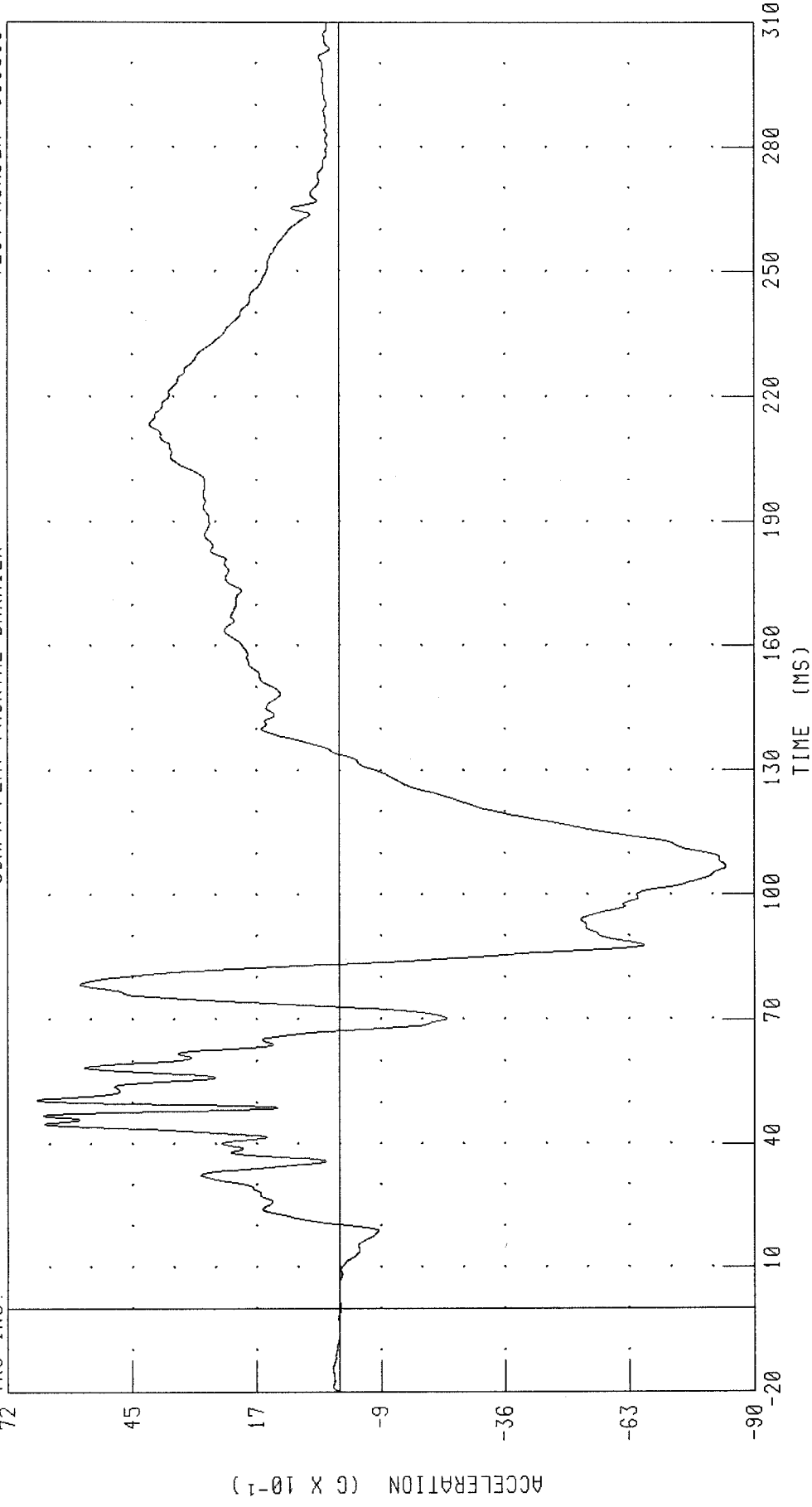

CHANNEL: CSTZG2 FILTER: CH. CLASS 180 PEAK DATA: 6.57 G @ 50.72 MS; -8.38 G @ 106.96 MS

2001 NISSAN MAXIMA INTO FRONTAL LOAD CELL BARRIER
PASSENGER CHEST RESULTANT ACCELERATION
35MPH FLAT FRONTAL BARRIER

TEST NUMBER: 010618

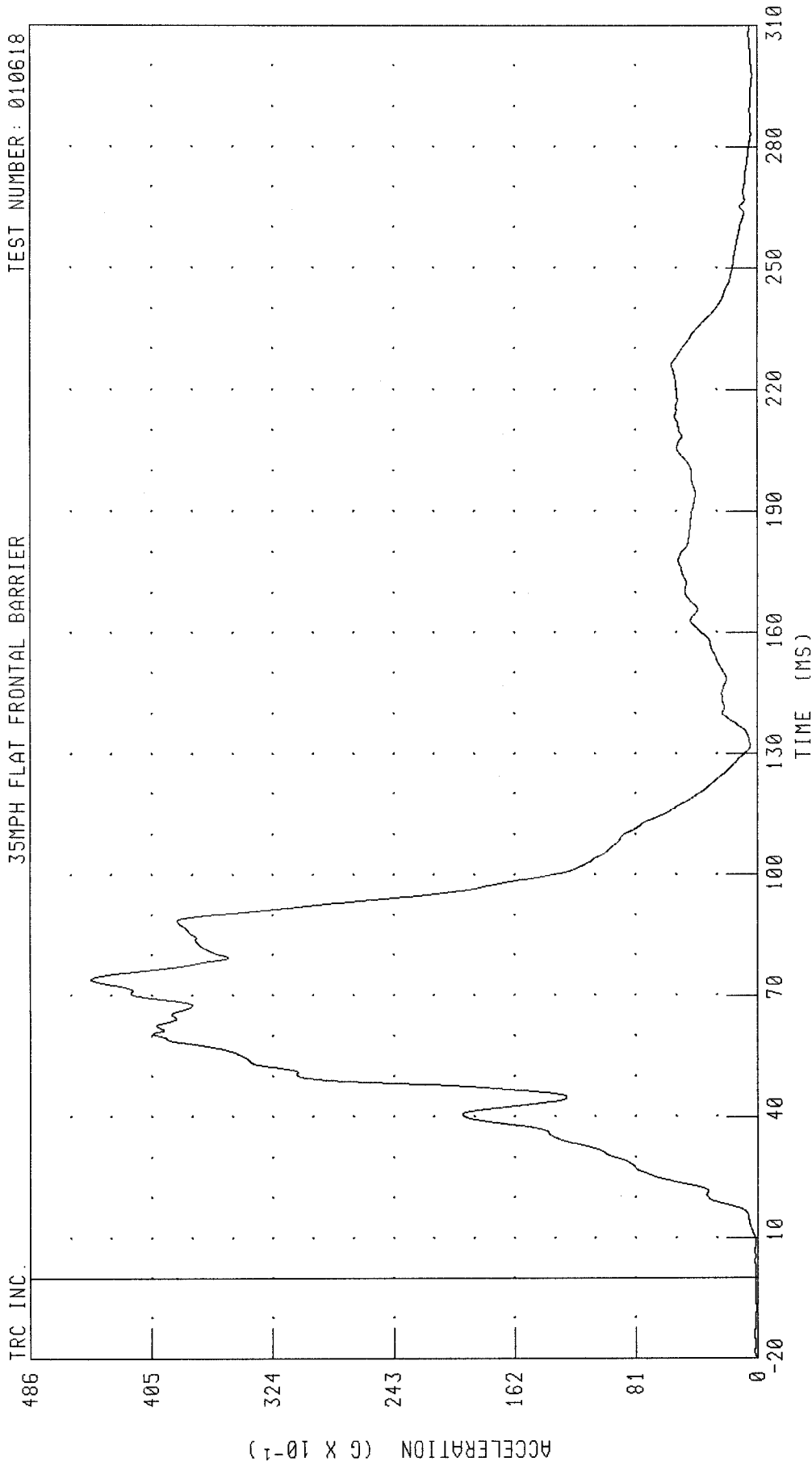

CHANNEL: CSTRG2 FILTER: CH. CLASS 180 PEAK DATA: 44.56 G @ 74.08 MS; 0.01 G @ -20.00 MS

2001 NISSAN MAXIMA INTO FRONTAL LOAD CELL BARRIER
PASSENGER CHEST X-AXIS ACCELERATION - REDUNDANT
35MPH FLAT FRONTAL BARRIER

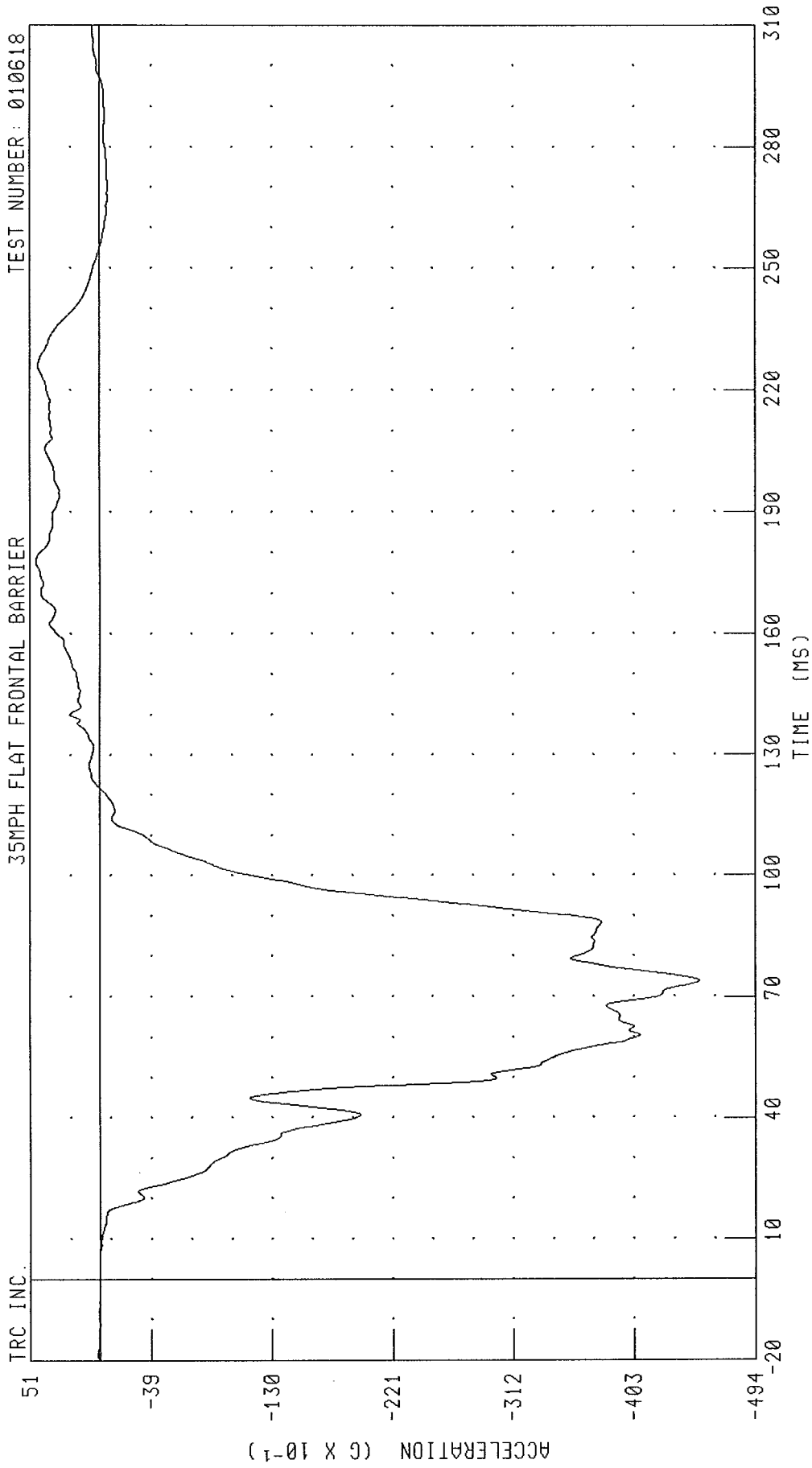

CHANNEL: CSTXR2 FILTER: CH. CLASS 180 PEAK DATA: 4.76 G @ 177.52 MS; -45.22 G @ 73.92 MS

2001 NISSAN MAXIMA INTO FRONTAL LOAD CELL BARRIER
PASSENGER CHEST Y-AXIS ACCELERATION - REDUNDANT
35MPH FLAT FRONTAL BARRIER

TEST NUMBER: 010618

TRC INC.

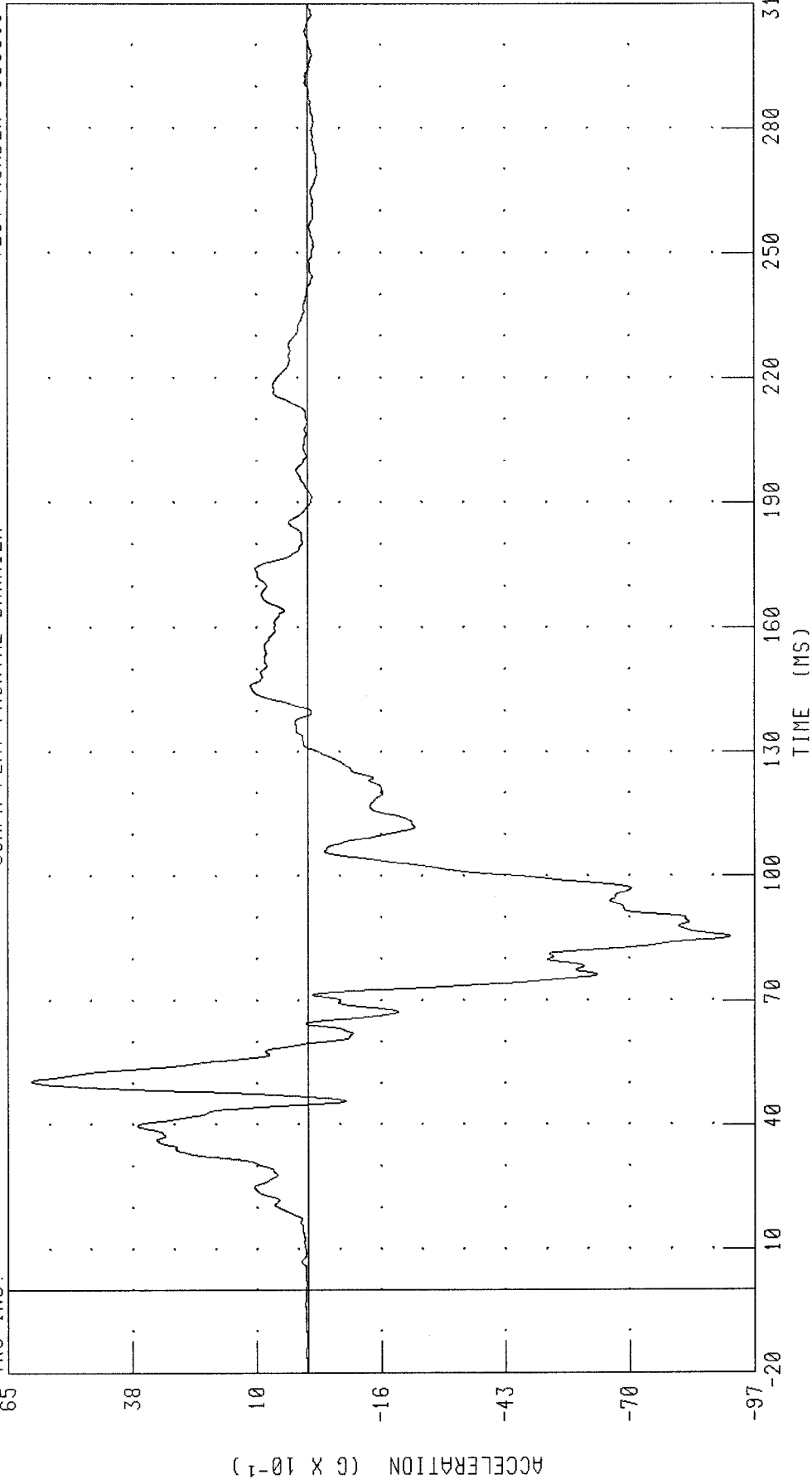

PEAK DATA: 5.99 G @ 50.48 MS; -9.18 G @ 85.36 MS

CHANNEL: CSTYR2 FILTER: CH. CLASS 180

2001 NISSAN MAXIMA INTO FRONTAL LOAD CELL BARRIER
PASSENGER CHEST Z-AXIS ACCELERATION - REDUNDANT
35MPH FLAT FRONTAL BARRIER

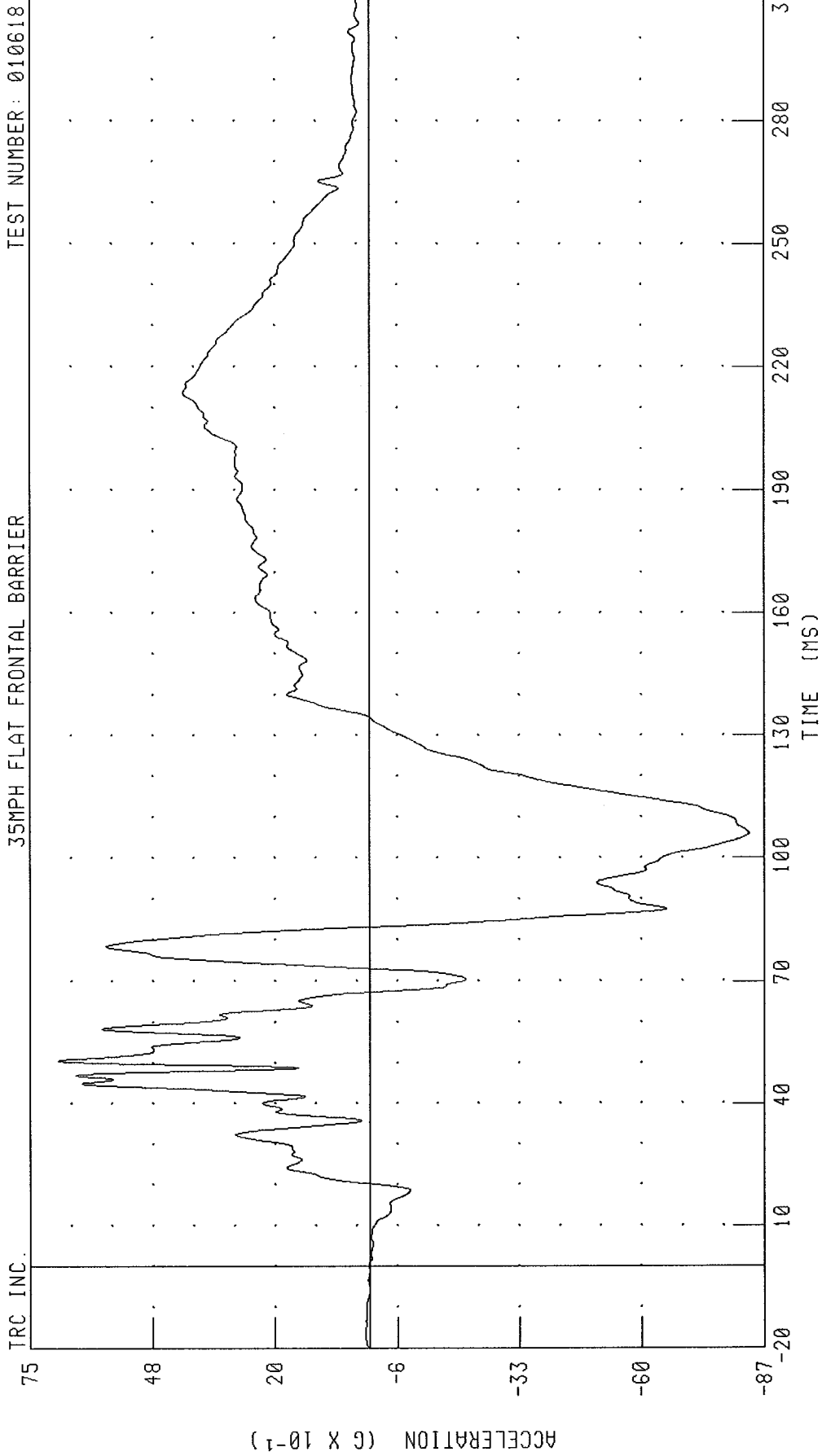

CHANNEL: CSTZR2 FILTER: CH. CLASS 180 PEAK DATA: 6.88 G @ 50.64 MS; -8.37 G @ 106.08 MS

2001 NISSAN MAXIMA INTO FRONTAL LOAD CELL BARRIER
PASSENGER CHEST RESULTANT ACCELERATION - REDUNDANT
35MPH FLAT FRONTAL BARRIER

TEST NUMBER: 010618

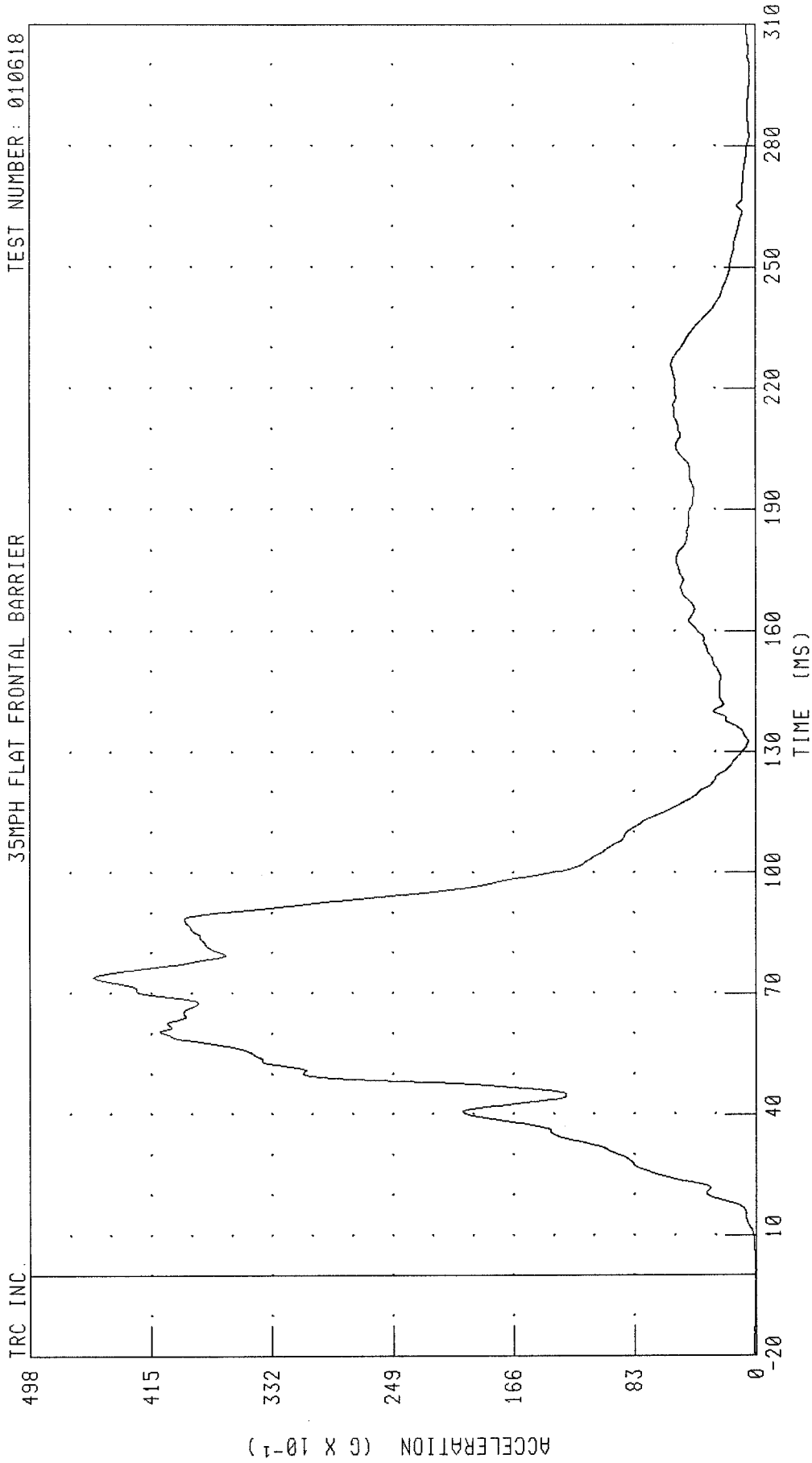

PEAK DATA: 45.42 G @ 74.00 MS; 0.01 G @ -20.00 MS

CHANNEL: CSTR2 FILTER: CH. CLASS 180

TRC INC.

498

415

332

249

166

83

0

-20

10

40

70

100

130

160

190

220

250

280

310

TIME (MS)

2001 NISSAN MAXIMA INTO FRONTAL LOAD CELL BARRIER
PASSENGER CHEST DEFLECTION
35MPH FLAT FRONTAL BARRIER

TEST NUMBER: 010618

TRC INC.

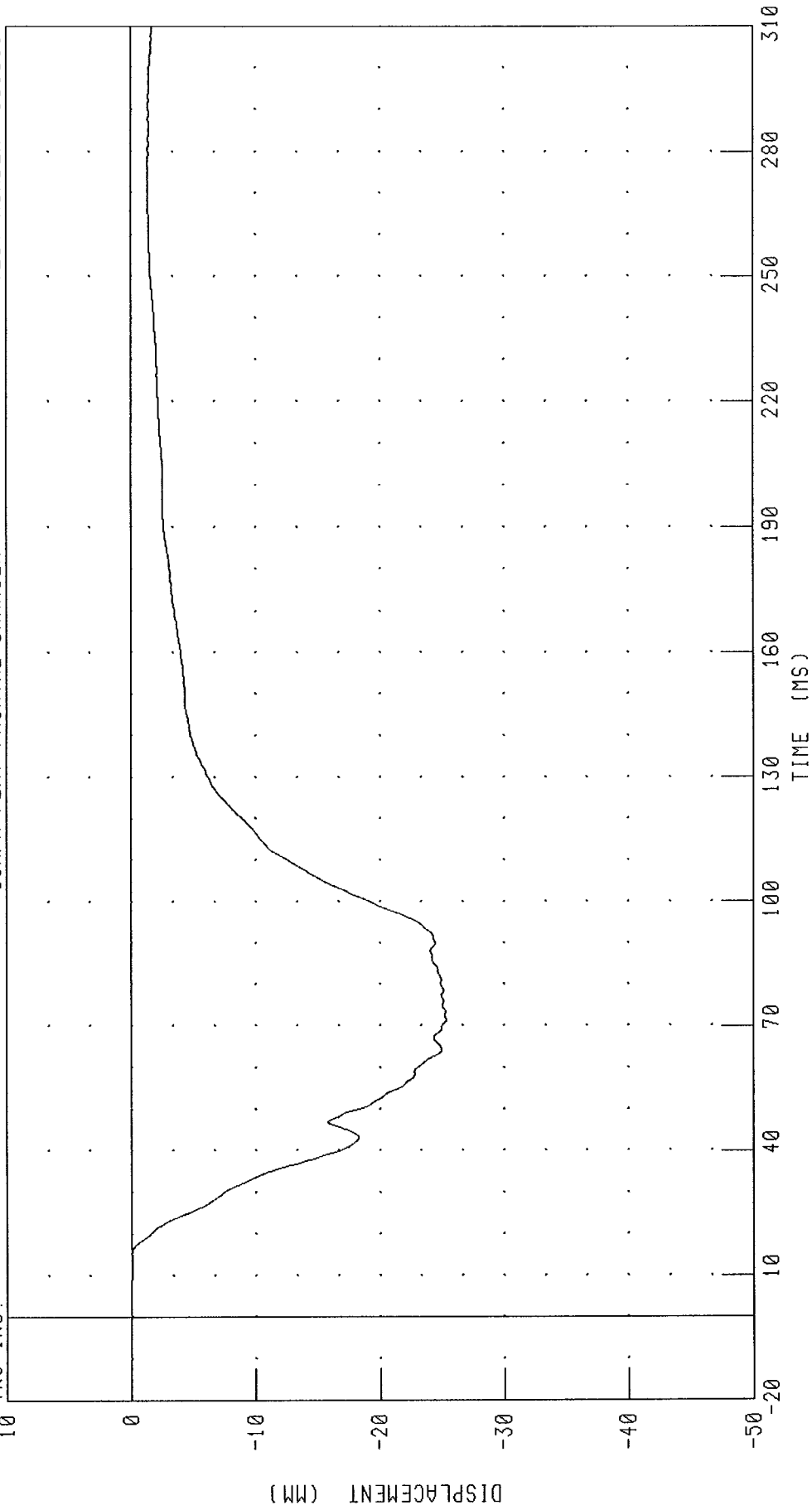

CHANNEL: CSTXD2 FILTER: CH. CLASS 180
PEAK DATA: 0.01 MM @ -17.84 MS; -25.34 MM @ 71.44 MS

2001 NISSAN MAXIMA INTO FRONTAL LOAD CELL BARRIER
PASSENGER PELVIS X-AXIS ACCELERATION
35MPH FLAT FRONTAL BARRIER

TEST NUMBER: 010618

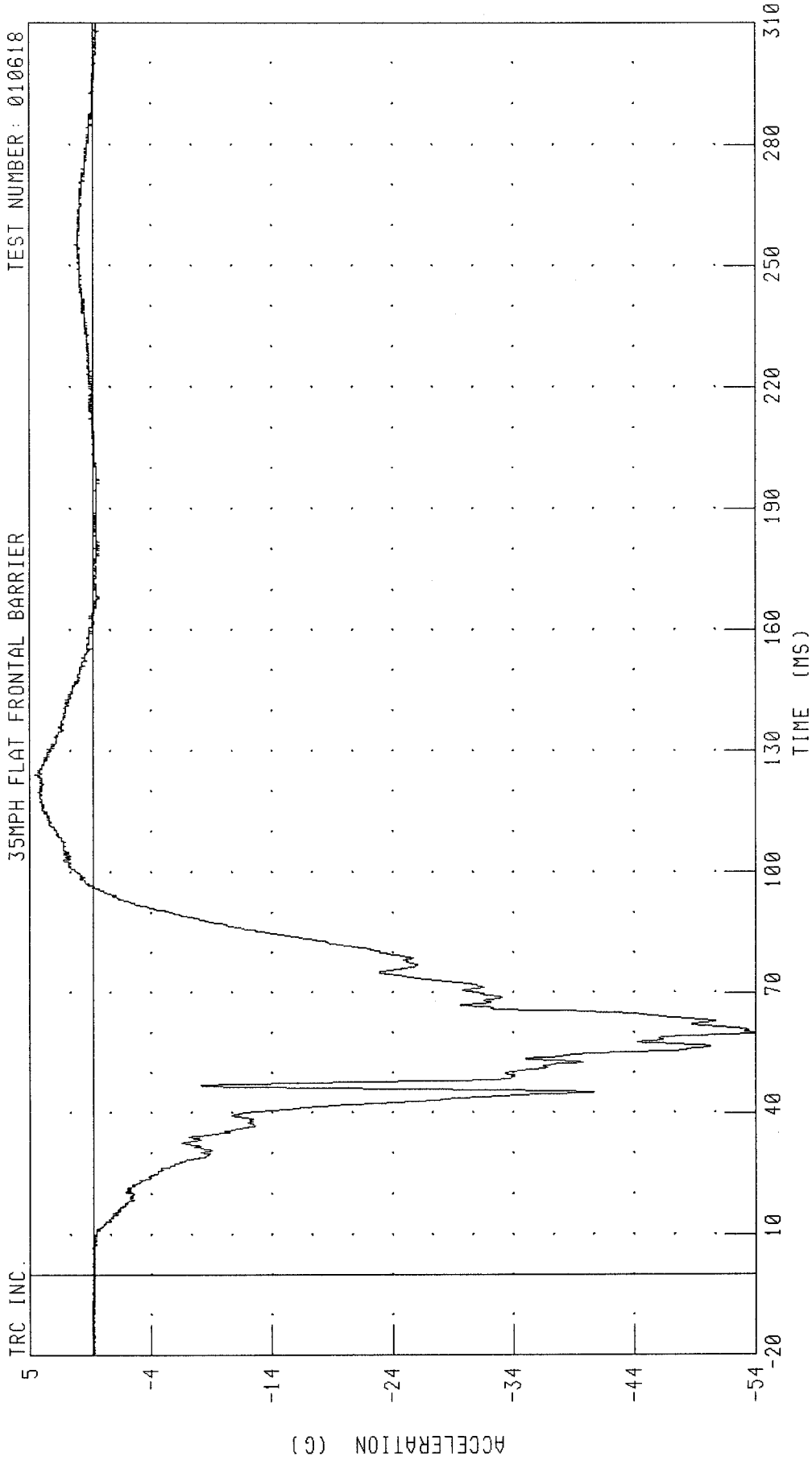

PEAK DATA: 4.78 G @ 124.24 MS, -54.83 G @ 59.84 MS

CHANNEL: PEVXC2 FILTER: CH. CLASS 1000

2001 NISSAN MAXIMA INTO FRONTAL LOAD CELL BARRIER
PASSENGER PELVIS Y-AXIS ACCELERATION
35MPH FLAT FRONTAL BARRIER

TEST NUMBER: 010618

TRC INC.

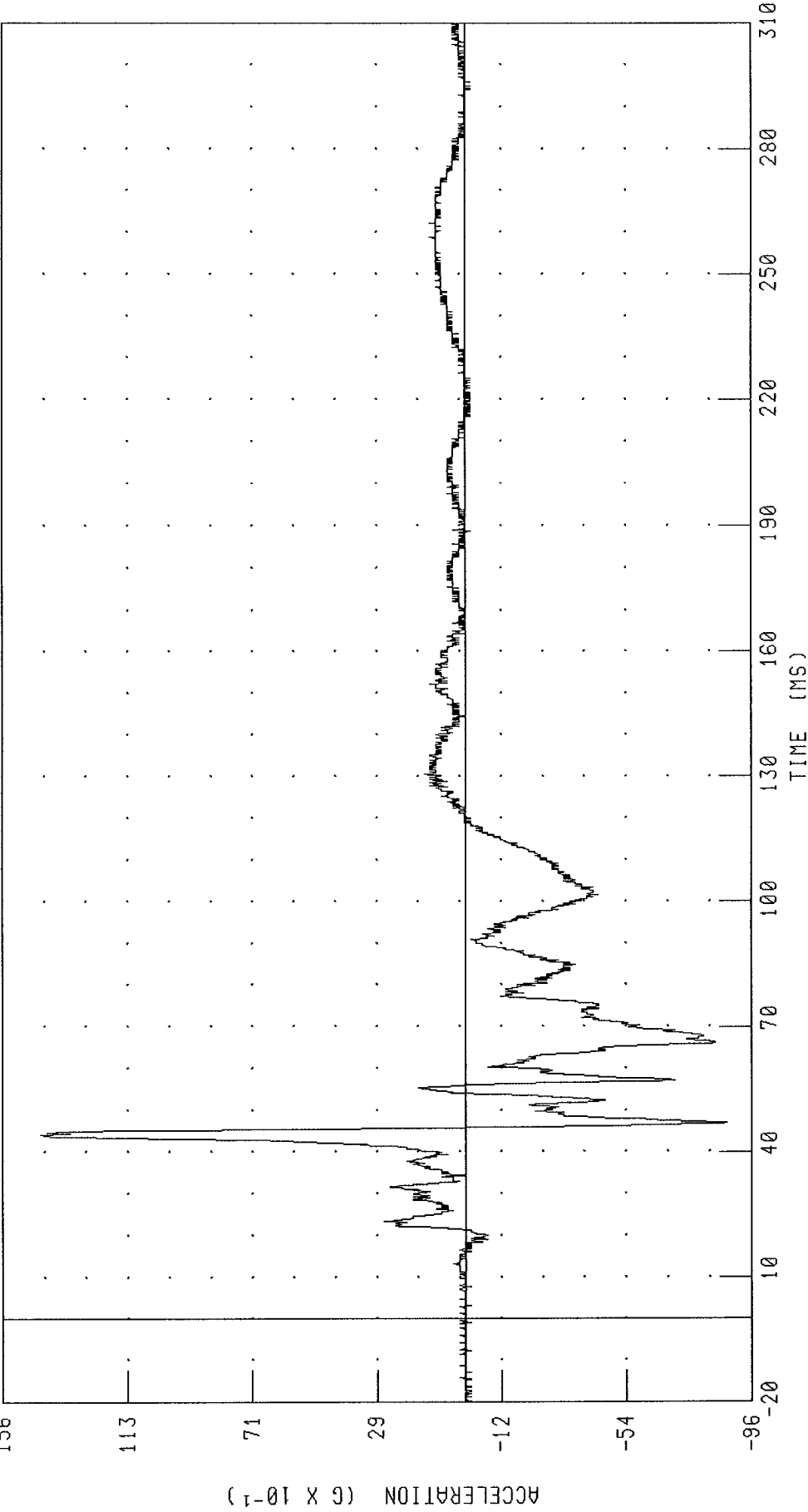

CHANNEL: PEVYC2 FILTER: CH. CLASS 1000 PEAK DATA: 14.32 G @ 44.16 MS; -8.80 G @ 46.96 MS

2001 NISSAN MAXIMA INTO FRONTAL LOAD CELL BARRIER
PASSENGER PELVIS Z-AXIS ACCELERATION
35MPH FLAT FRONTAL BARRIER

TEST NUMBER: 010618

TRC INC.

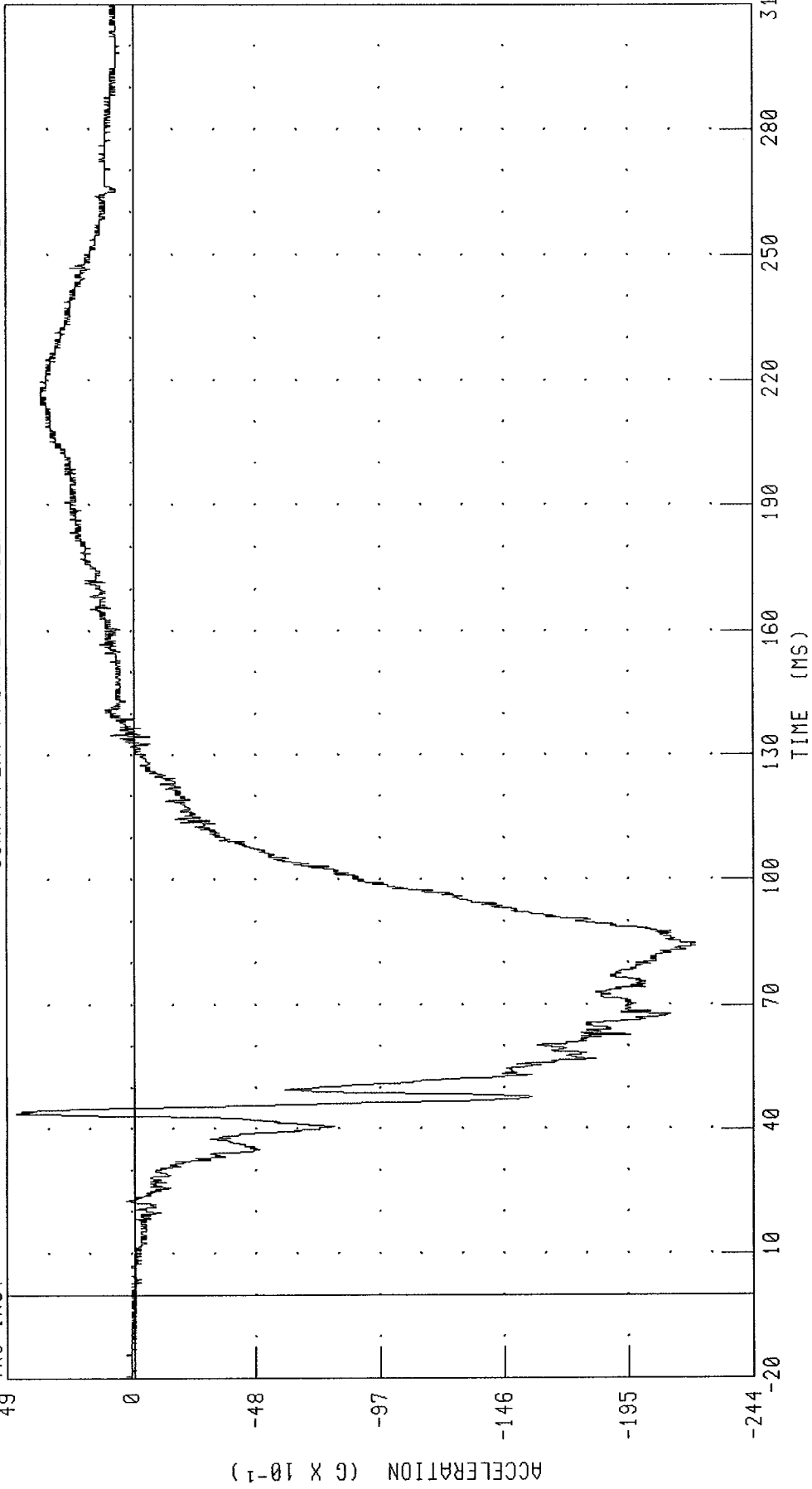

CHANNEL: PEVZG2 FILTER: CH. CLASS 1000

PEAK DATA: 4.62 G @ 43.84 MS; -22.13 G @ 84.08 MS

2001 NISSAN MAXIMA INTO FRONTAL LOAD CELL BARRIER
PASSENGER PELVIS RESULTANT ACCELERATION
35MPH FLAT FRONTAL BARRIER

TEST NUMBER: 010618

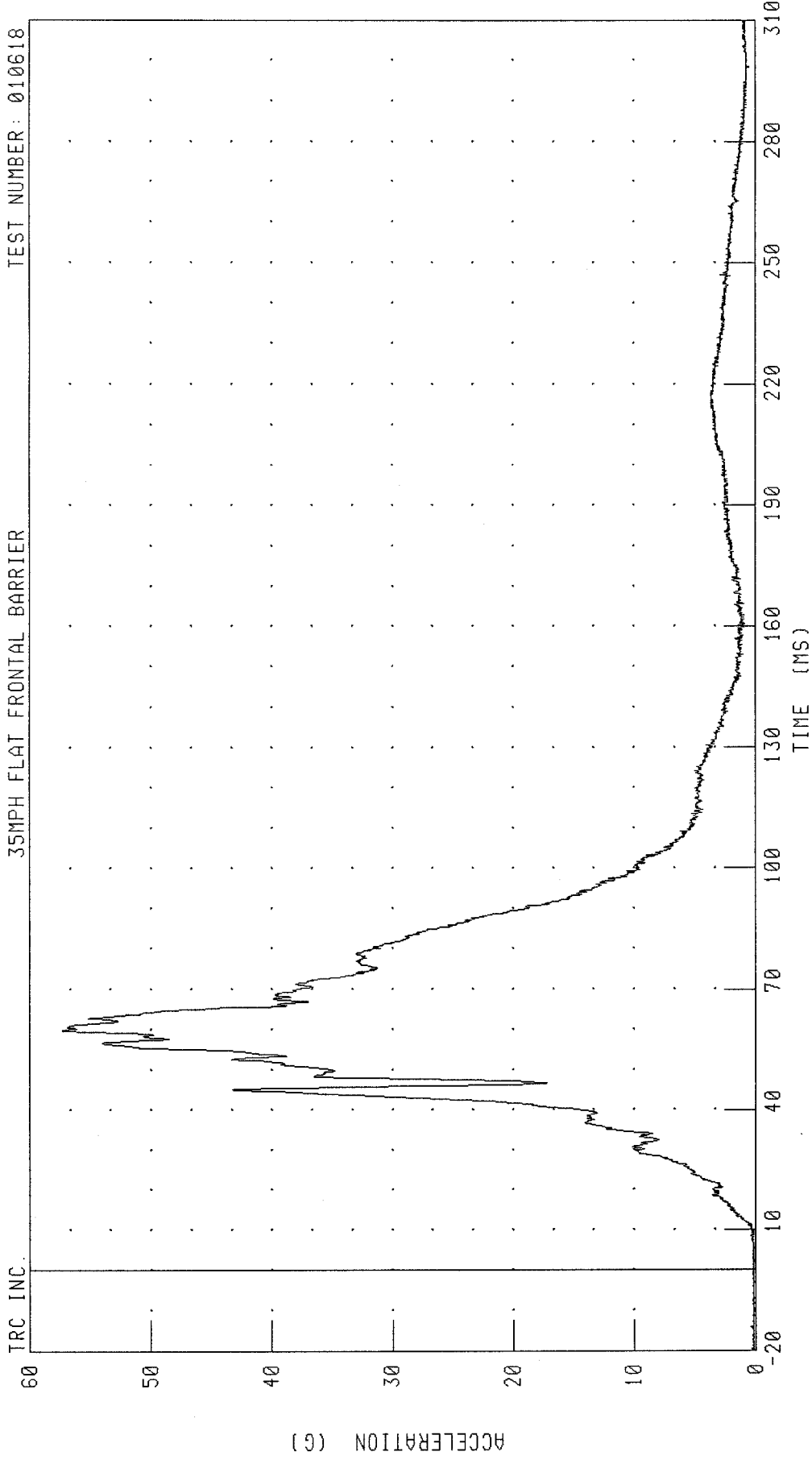

PEAK DATA: 57.31 G @ 59.84 MS; 0.11 G @ -11.28 MS

CHANNEL: PEVRG2 FILTER: CH. CLASS 1000

2001 NISSAN MAXIMA INTO FRONTAL LOAD CELL BARRIER
PASSENGER LEFT FEMUR FORCE
35MPH FLAT FRONTAL BARRIER

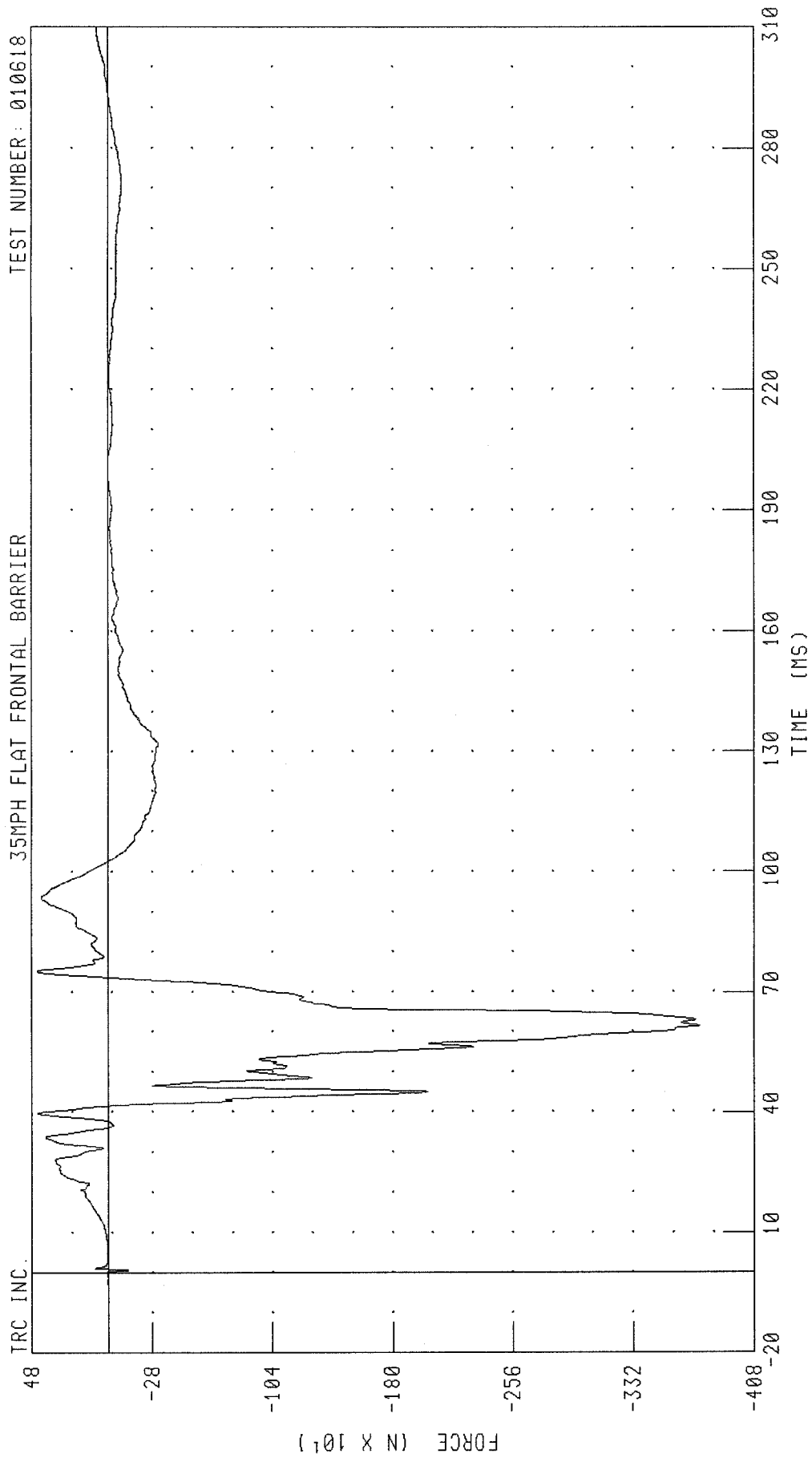

CHANNEL: LFMZF2 FILTER: CH. CLASS 600 PEAK DATA: 445.14 N @ 75.28 MS; -3738.56 N @ 61.44 MS

2001 NISSAN MAXIMA INTO FRONTAL LOAD CELL BARRIER
PASSENGER RIGHT FEMUR FORCE
35MPH FLAT FRONTAL BARRIER

TEST NUMBER: 010618

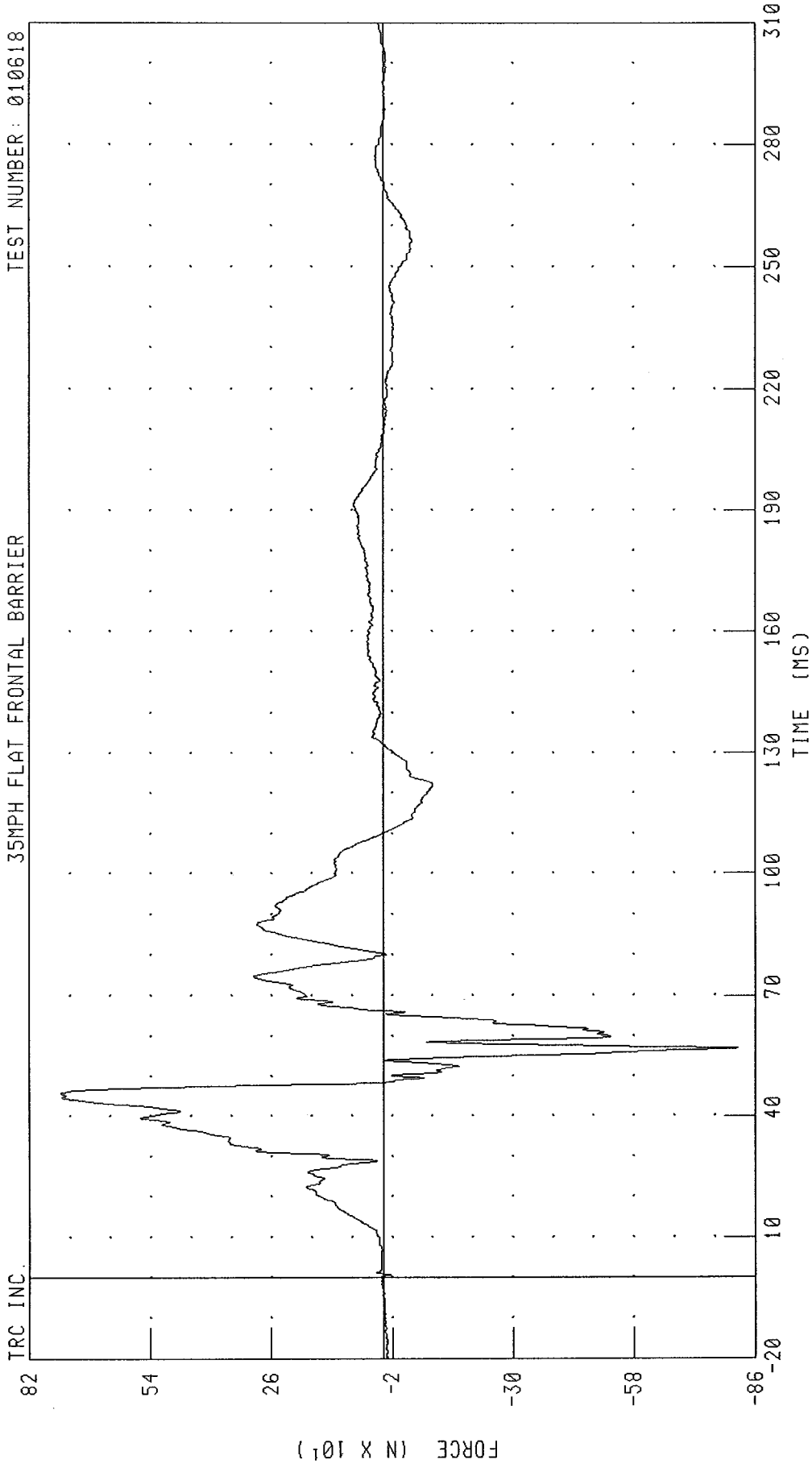

TRC INC.

CHANNEL: RFMZF2 FILTER: CH. CLASS 600

PEAK DATA: 747.28 N @ 45.84 MS; -818.99 N @ 56.80 MS

2001 NISSAN MAXIMA INTO FRONTAL LOAD CELL BARRIER
PASSENGER LEFT TIBIA TO FEMUR DISPLACEMENT
35MPH FLAT FRONTAL BARRIER

TEST NUMBER: 010618

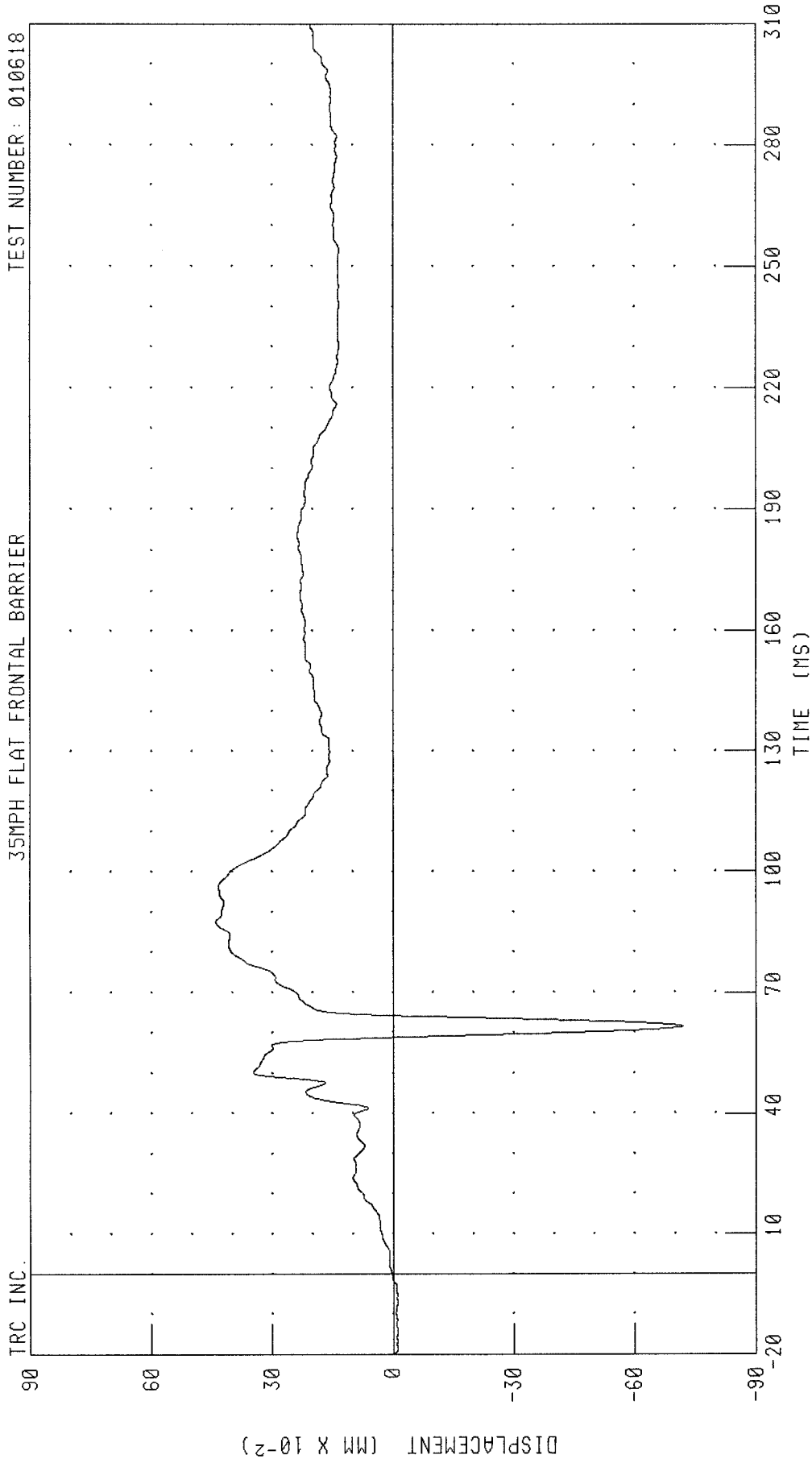

CHANNEL: KNLXD2 FILTER: CH. CLASS 180 PEAK DATA: 0.44 MM @ 87.60 MS; -0.72 MM @ 61.52 MS

2001 NISSAN MAXIMA INTO FRONTAL LOAD CELL BARRIER
PASSENGER RIGHT TIBIA TO FEMUR DISPLACEMENT
35MPH FLAT FRONTAL BARRIER

TEST NUMBER: 010618

TRC INC.

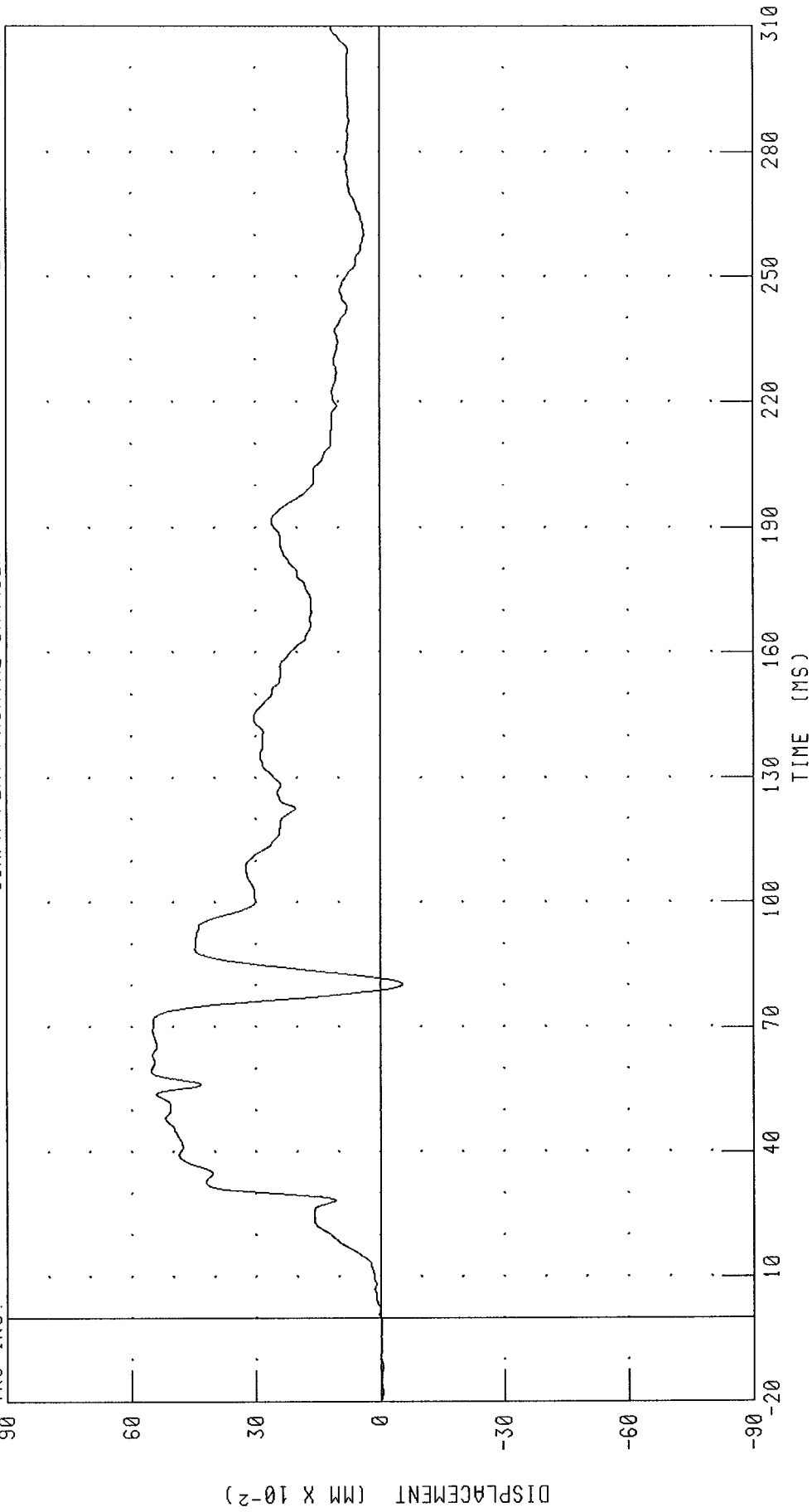

CHANNEL: KNRXD2 FILTER: CH. CLASS 180 PEAK DATA: 0.55 MM @ 59.52 MS; -0.05 MM @ 80.32 MS

2001 NISSAN MAXIMA INTO FRONTAL LOAD CELL BARRIER
PASSENGER LEFT UPPER TIBIA MOMENT ABOUT X AXIS
35MPH FLAT FRONTAL BARRIER

TEST NUMBER: 010618

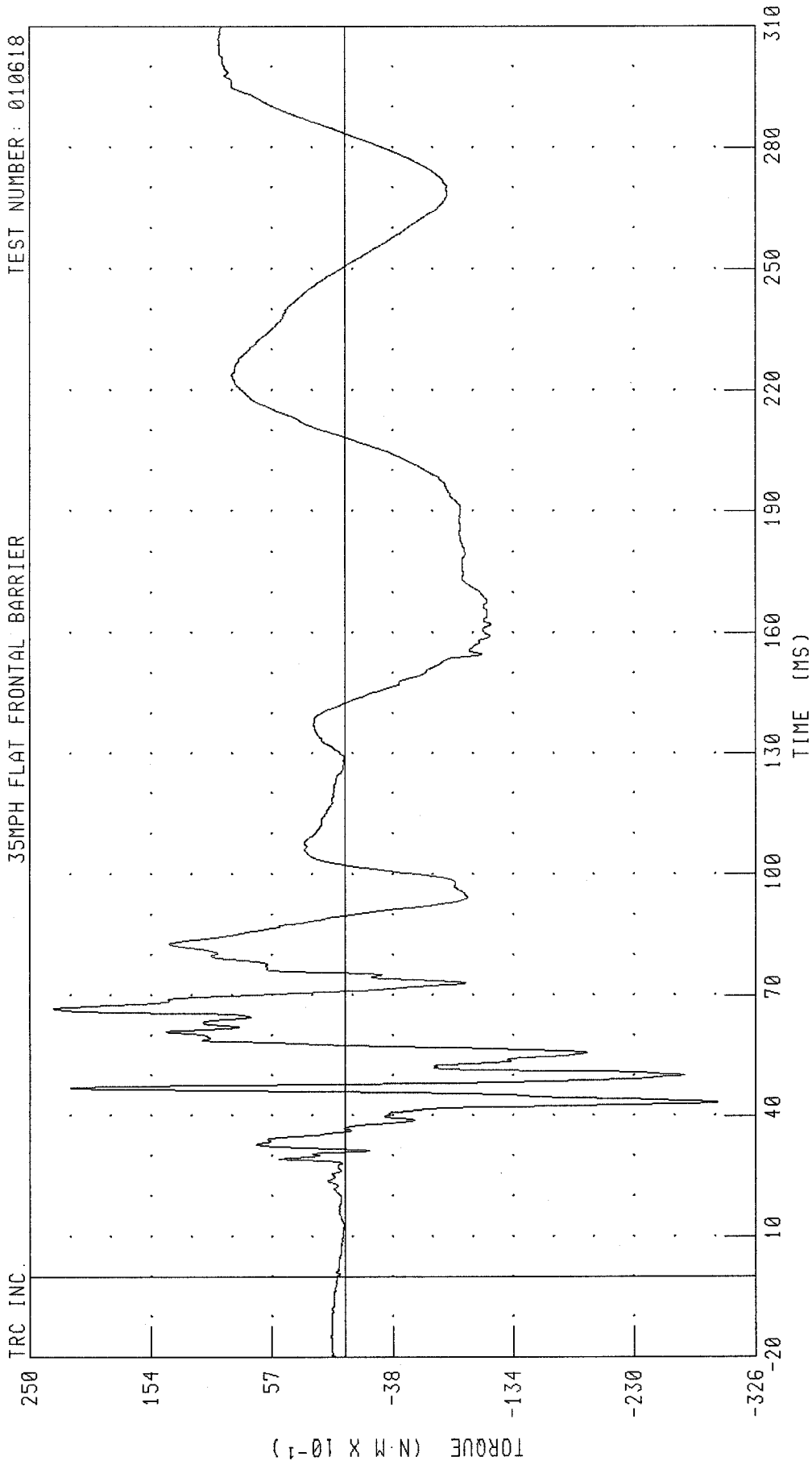

CHANNEL: TBLXM2 FILTER: CH. CLASS 600

PEAK DATA: 23.13 N·M @ 66.72 MS, -29.63 N·M @ 43.28 MS

2001 NISSAN MAXIMA INTO FRONTAL LOAD CELL BARRIER
PASSENGER LEFT UPPER TIBIA MOMENT ABOUT Y AXIS
35MPH FLAT FRONTAL BARRIER

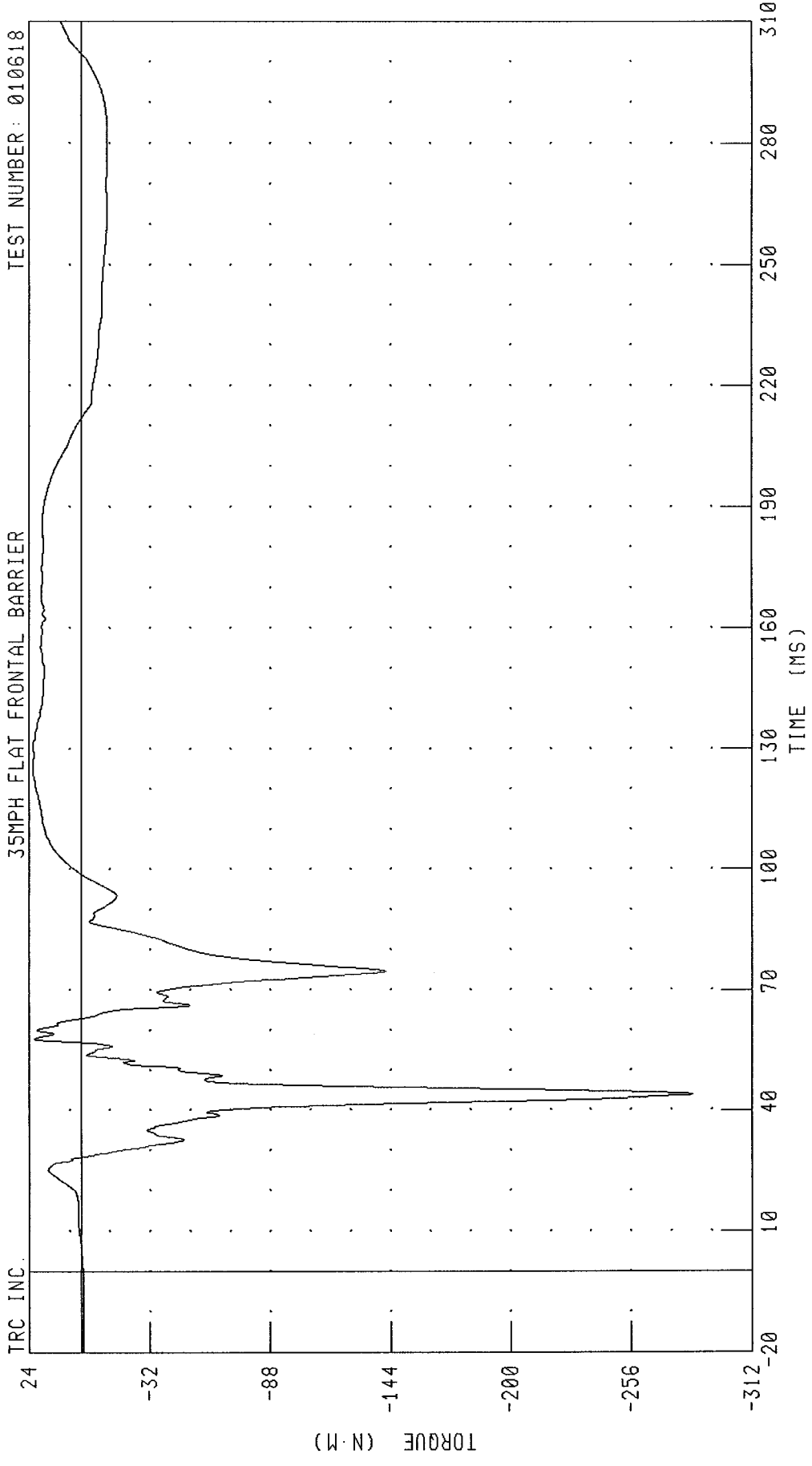

CHANNEL: TBLYM2 FILTER: CH. CLASS 600
PEAK DATA: 22.44 N·M @ 125.76 MS; -284.66 N·M @ 44.00 MS

2001 NISSAN MAXIMA INTO FRONTAL LOAD CELL BARRIER
PASSENGER LEFT UPPER TIBIA Z-AXIS FORCE
35MPH FLAT FRONTAL BARRIER

TEST NUMBER: 010618

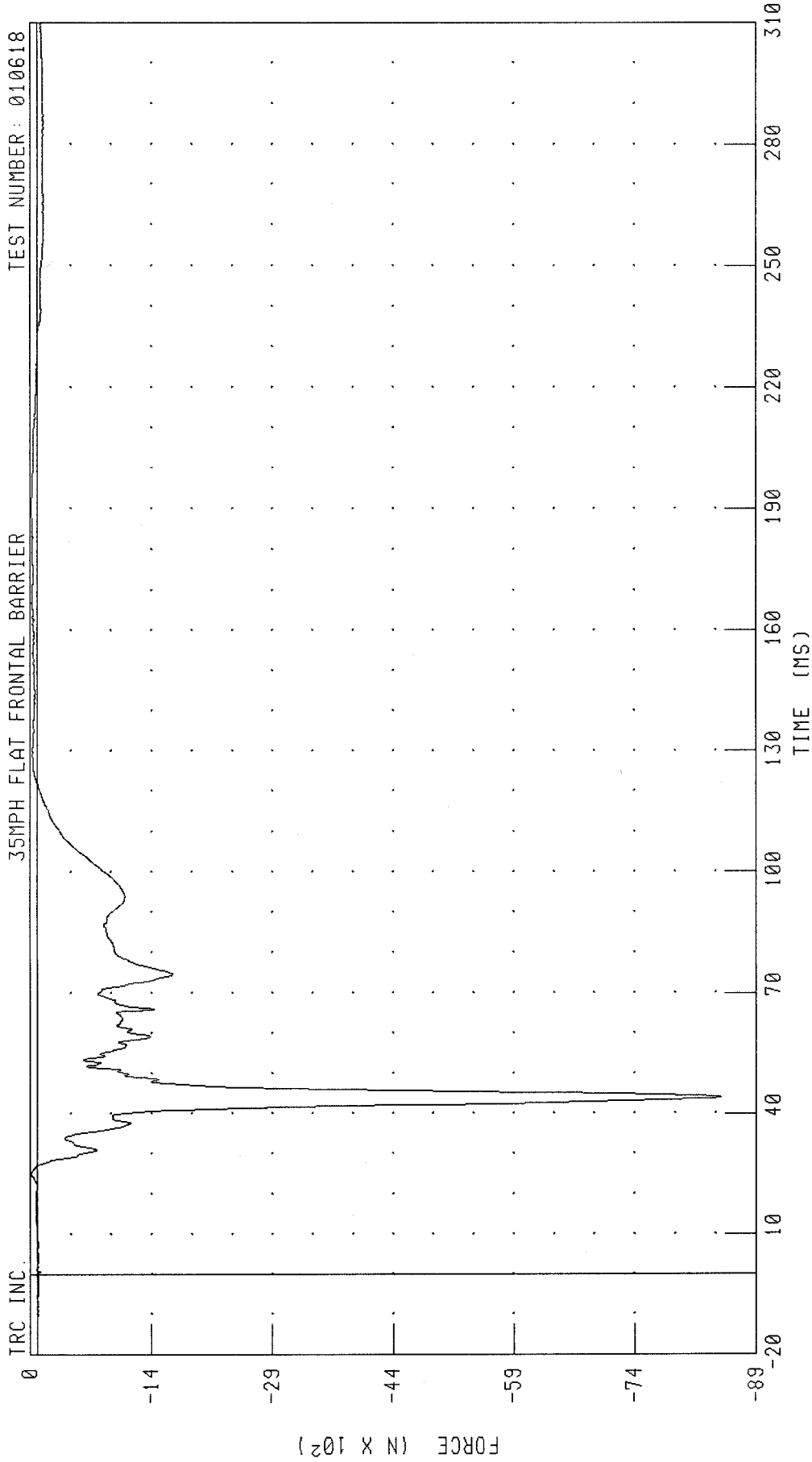

CHANNEL: TBLZF2 FILTER: CH. CLASS 600

PEAK DATA: 79.47 N @ 25.12 MS, -8484.68 N @ 44.08 MS

2001 NISSAN MAXIMA INTO FRONTAL LOAD CELL BARRIER
PASSENGER LEFT LOWER TIBIA MOMENT ABOUT X AXIS
35MPH FLAT FRONTAL BARRIER

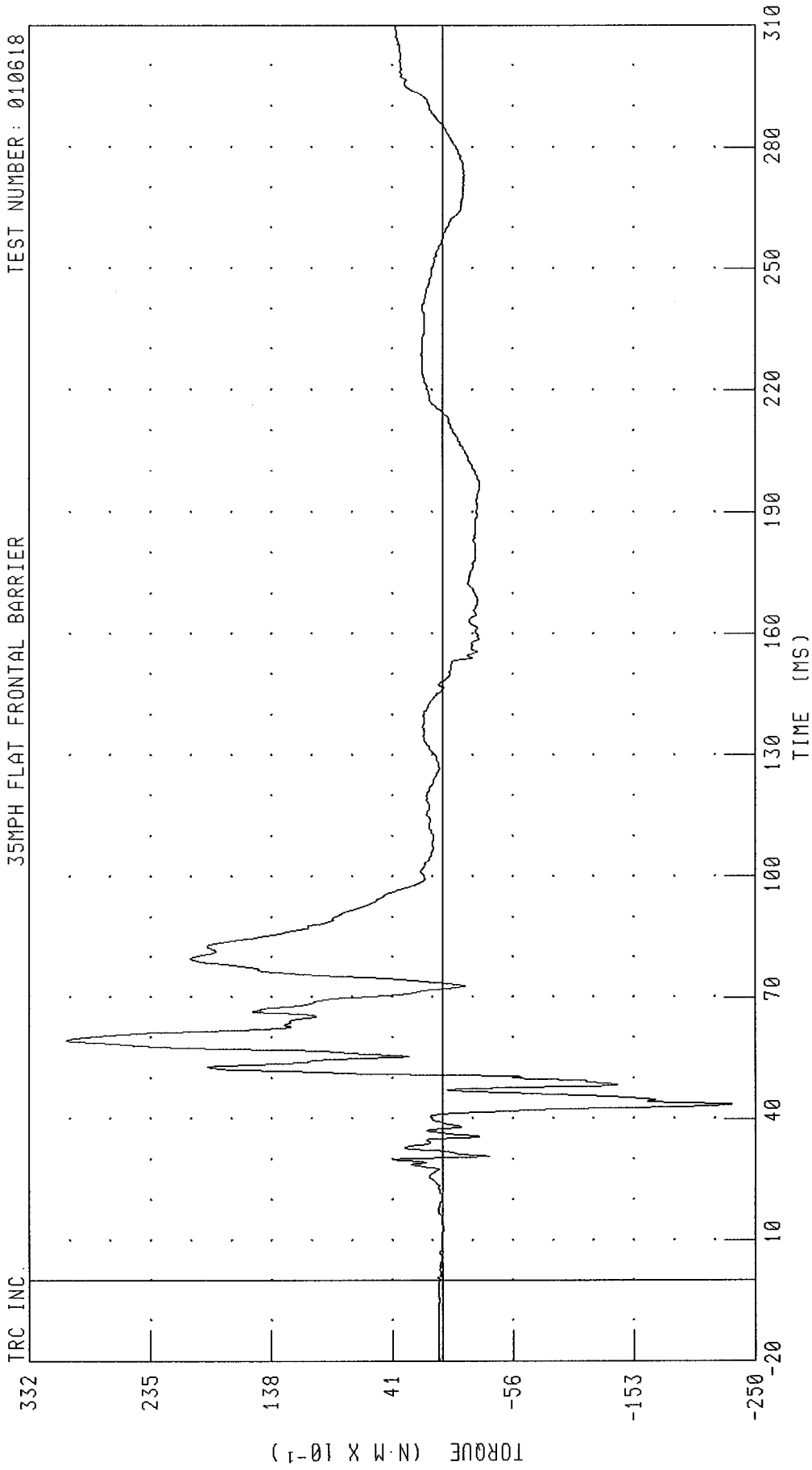

CHANNEL: ANLXM2 FILTER: CH. CLASS 600 PEAK DATA: 30.27 N·M @ 59.20 MS; -23.15 N·M @ 43.60 MS

2001 NISSAN MAXIMA INTO FRONTAL LOAD CELL BARRIER
PASSENGER LEFT LOWER TIBIA MOMENT ABOUT Y AXIS
35MPH FLAT FRONTAL BARRIER

TEST NUMBER: 010618

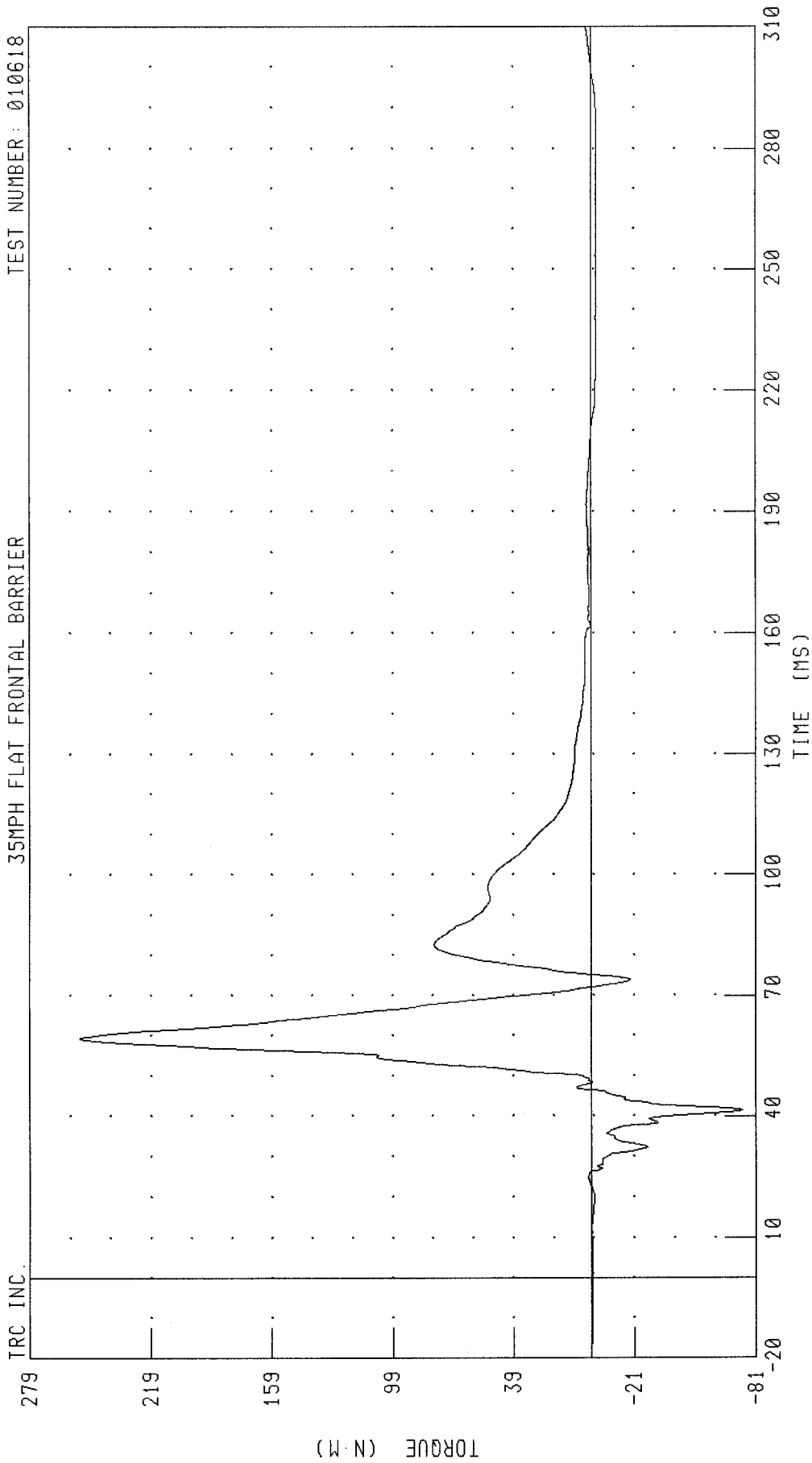

CHANNEL: ANLYM2 FILTER: CH. CLASS 600 PEAK DATA: 254.24 N·M @ 59.28 MS; -74.35 N·M @ 41.44 MS

2001 NISSAN MAXIMA INTO FRONTAL LOAD CELL BARRIER
PASSENGER LEFT LOWER TIBIA Z-AXIS FORCE
35MPH FLAT FRONTAL BARRIER

TEST NUMBER: 010618

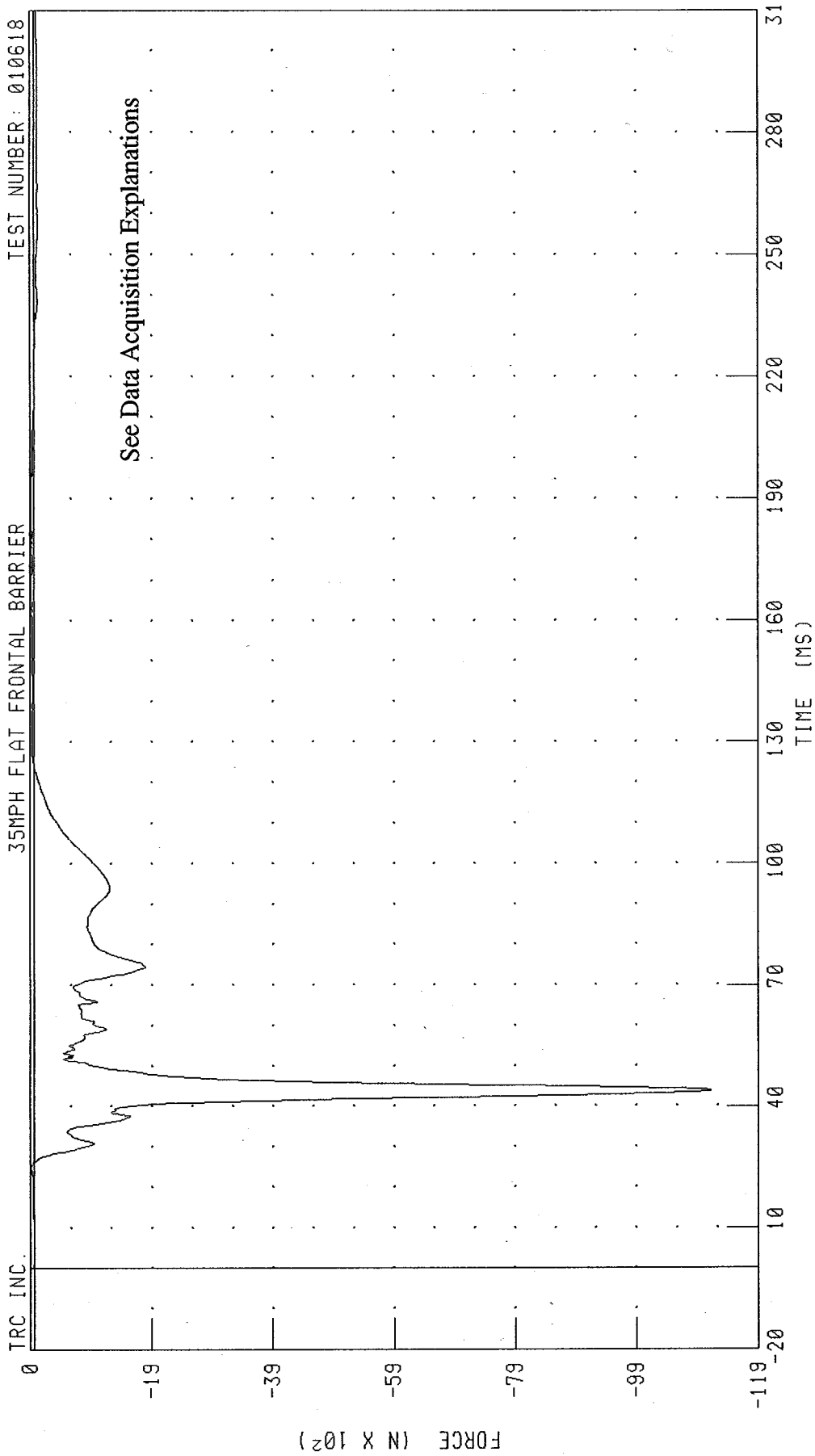

CHANNEL: ANLZF2 FILTER: CH. CLASS 600
PEAK DATA: 55.36 N @ 25.04 MS; -11166.83 N @ 43.92 MS

2001 NISSAN MAXIMA INTO FRONTAL LOAD CELL BARRIER
PASSENGER RIGHT UPPER TIBIA MOMENT ABOUT X AXIS
35MPH FLAT FRONTAL BARRIER

TEST NUMBER: 010618

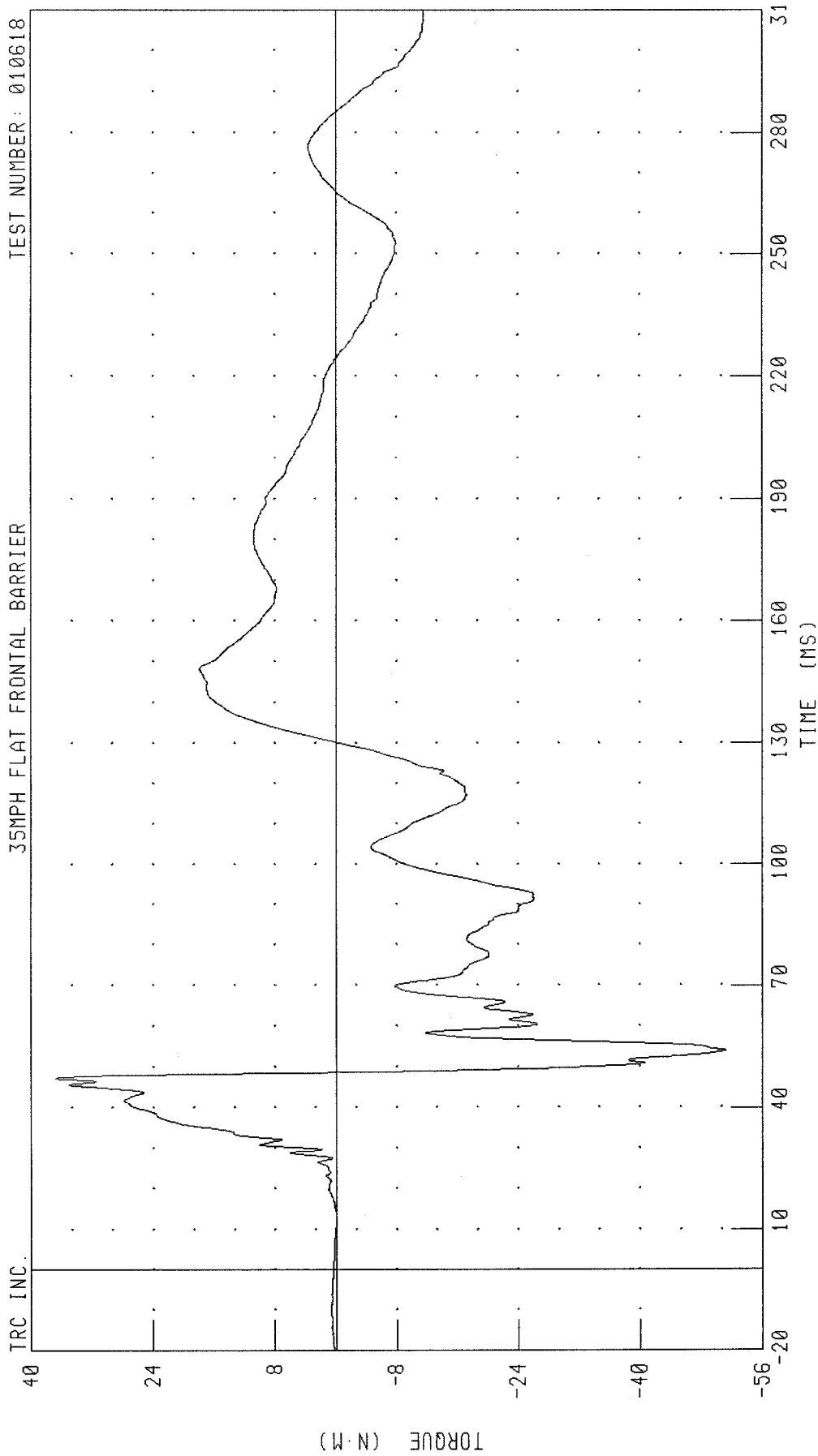

CHANNEL: TBRXM2 FILTER: CH. CLASS 600 PEAK DATA: 36.84 N·M @ 47.28 MS; -51.29 N·M @ 53.92 MS

2001 NISSAN MAXIMA INTO FRONTAL LOAD CELL BARRIER
PASSENGER RIGHT UPPER TIBIA MOMENT ABOUT Y AXIS
35MPH FLAT FRONTAL BARRIER

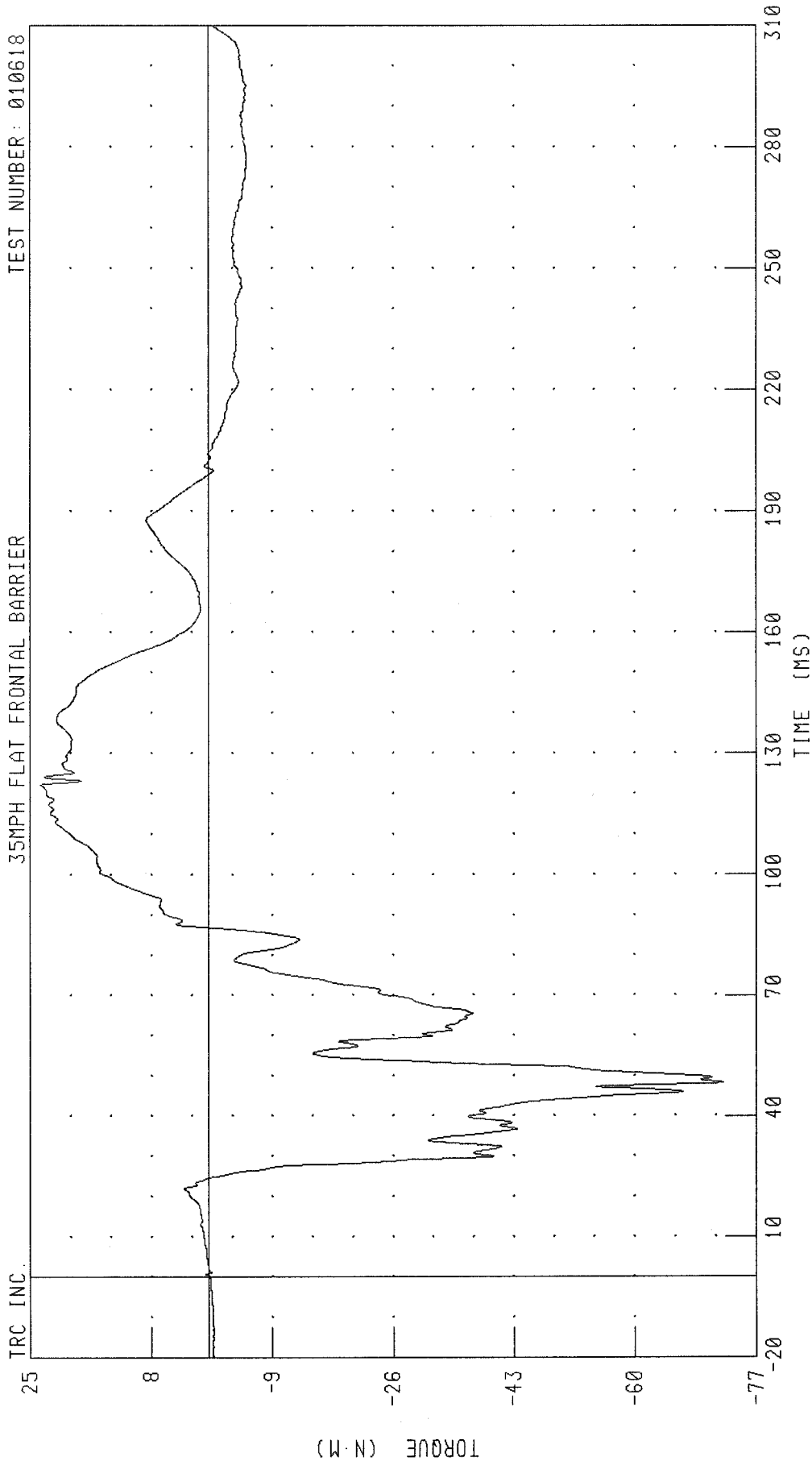

CHANNEL: TBRYM2 FILTER: CH. CLASS 600 PEAK DATA: 23.60 N·M @ 122.24 MS, -72.46 N·M @ 48.40 MS

2001 NISSAN MAXIMA INTO FRONTAL LOAD CELL BARRIER
PASSENGER RIGHT UPPER TIBIA Z-AXIS FORCE
35MPH FLAT FRONTAL BARRIER

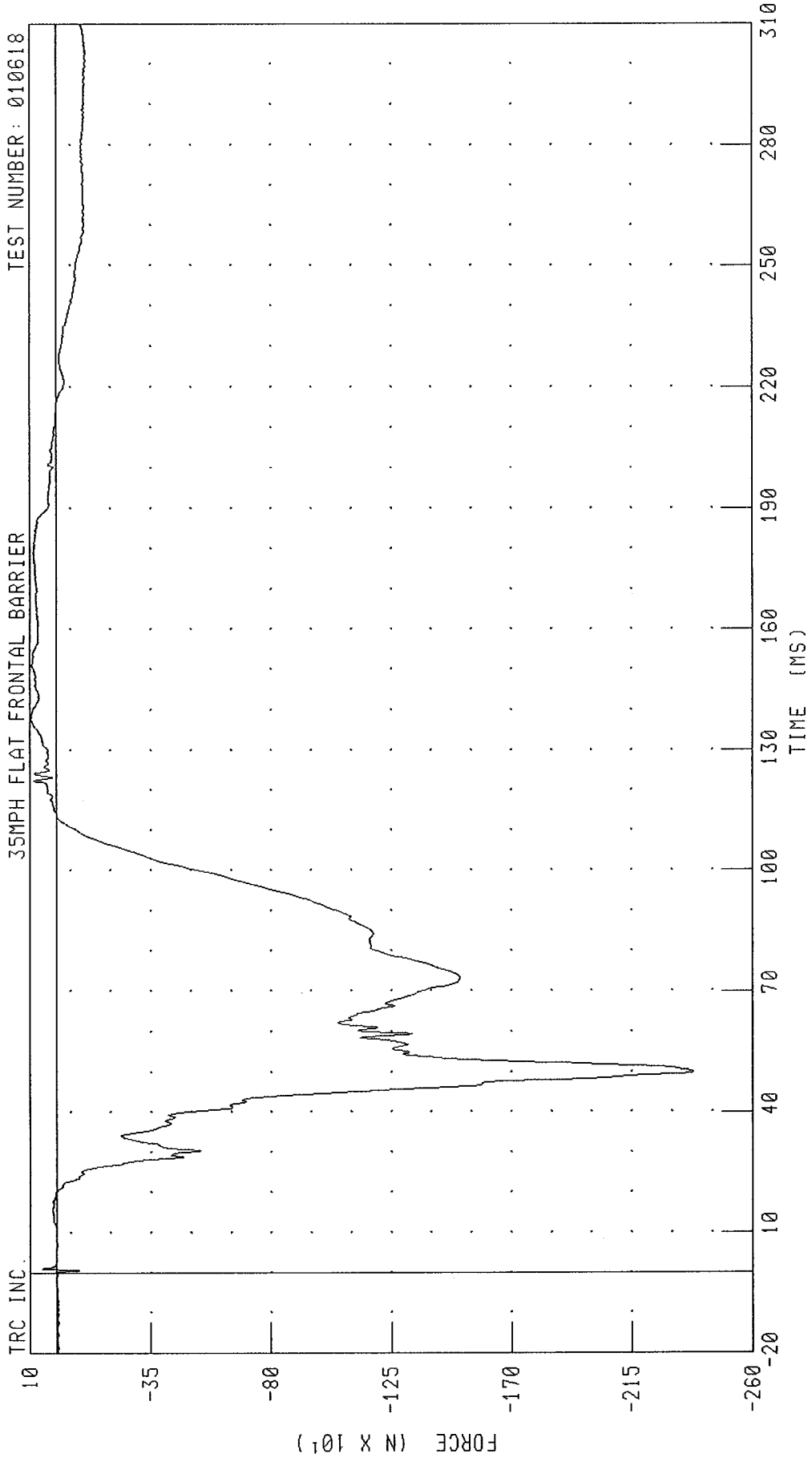

CHANNEL: TBRZF2 FILTER: CH. CLASS 600 PEAK DATA: 97.77 N @ 137.76 MS; -2379.92 N @ 50.08 MS

2001 NISSAN MAXIMA INTO FRONTAL LOAD CELL BARRIER
PASSENGER RIGHT LOWER TIBIA MOMENT ABOUT X AXIS
35MPH FLAT FRONTAL BARRIER

TEST NUMBER: 010618

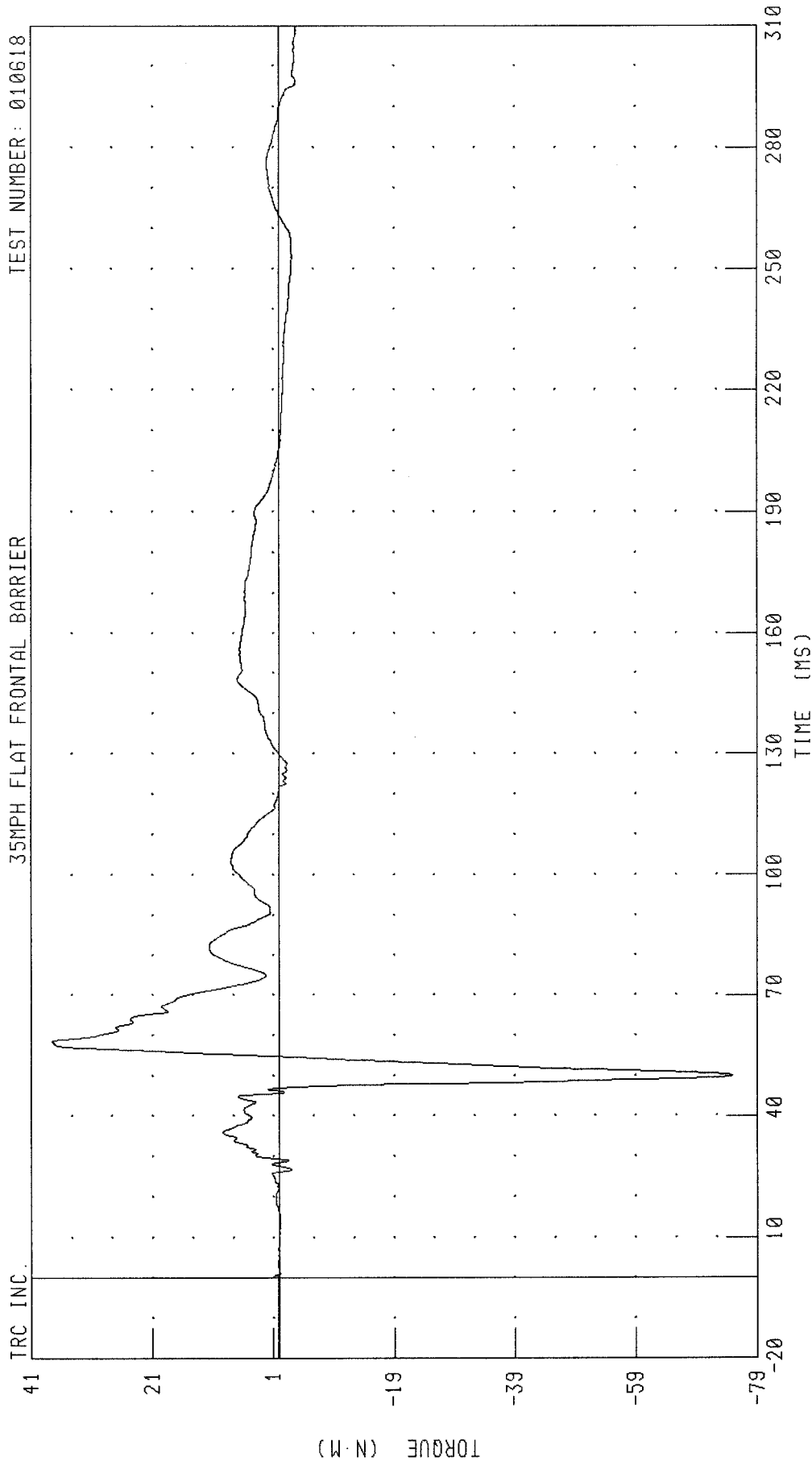

CHANNEL: ANRXM2 FILTER: CH. CLASS 600 PEAK DATA: 37.62 N·M @ 58.48 MS; -74.93 N·M @ 50.00 MS

2001 NISSAN MAXIMA INTO FRONTAL LOAD CELL BARRIER
PASSENGER RIGHT LOWER TIBIA MOMENT ABOUT Y AXIS
35MPH FLAT FRONTAL BARRIER

TEST NUMBER: 010618

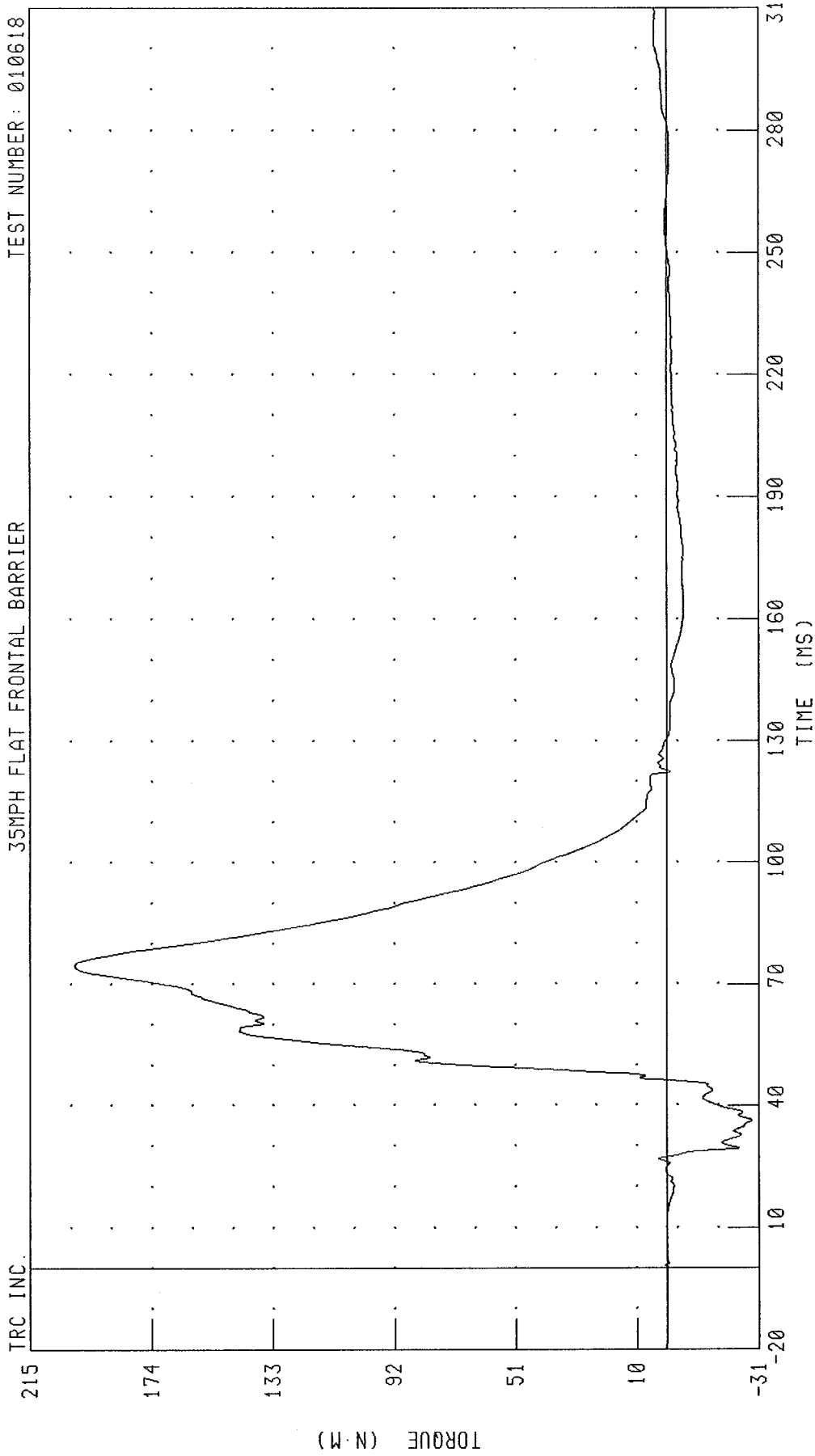

TRC INC.

CHANNEL: ANRYM2 FILTER: CH. CLASS 600 PEAK DATA: 199.98 N.M @ 74.72 MS; -28.69 N.M @ 36.24 MS

2001 NISSAN MAXIMA INTO FRONTAL LOAD CELL BARRIER
PASSENGER RIGHT LOWER TIBIA Z-AXIS FORCE
35MPH FLAT FRONTAL BARRIER

TEST NUMBER : 010618

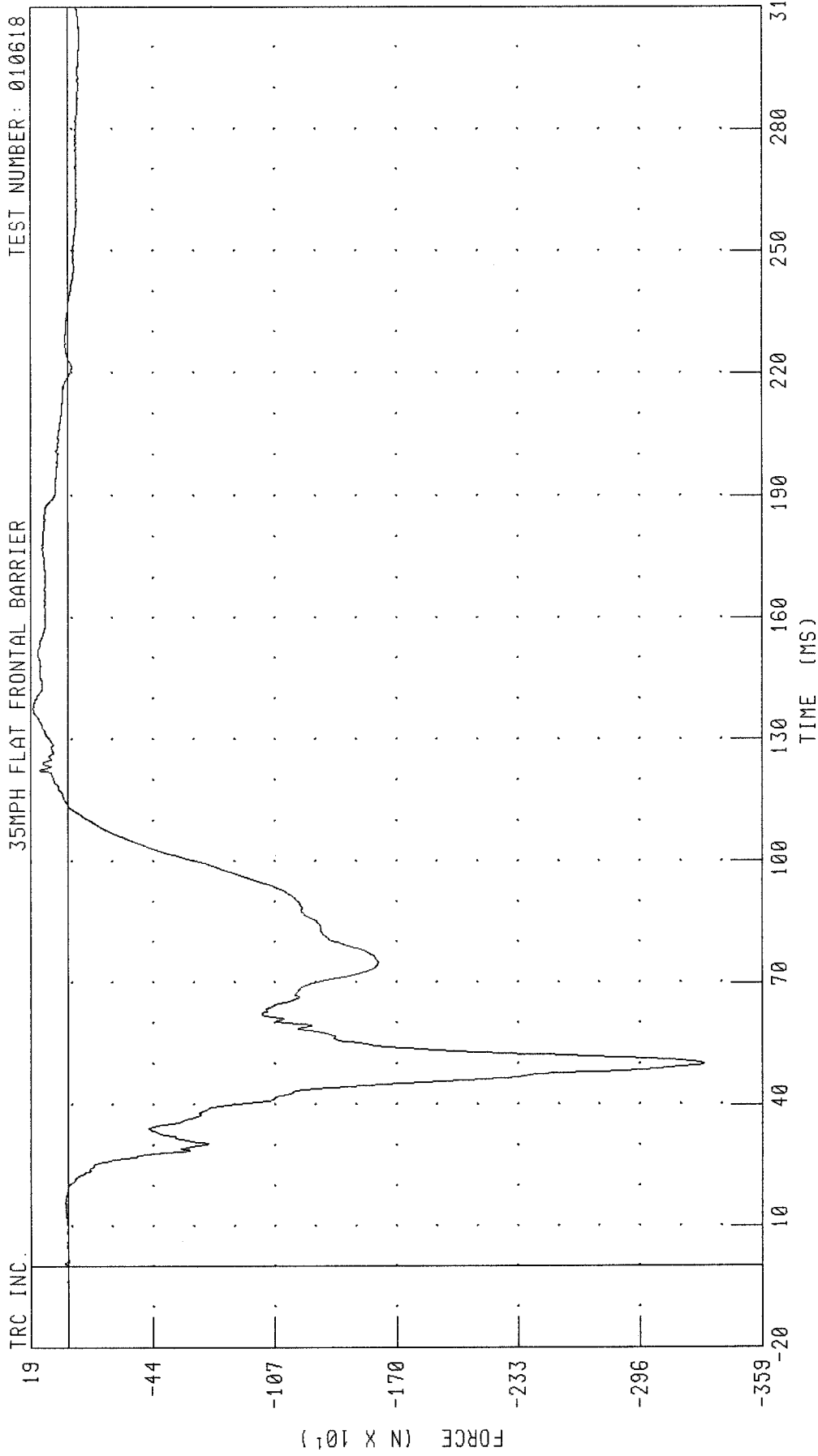

CHANNEL : ANRZF2 FILTER : CH. CLASS 600 PEAK DATA : 179.92 N @ 137.60 MS; -3289.24 N @ 50.00 MS

2001 NISSAN MAXIMA INTO FRONTAL LOAD CELL BARRIER
PASSENGER LEFT FOOT X-AXIS ACCELERATION AT HEEL
35MPH FLAT FRONTAL BARRIER

TRC INC.

TEST NUMBER: 010618

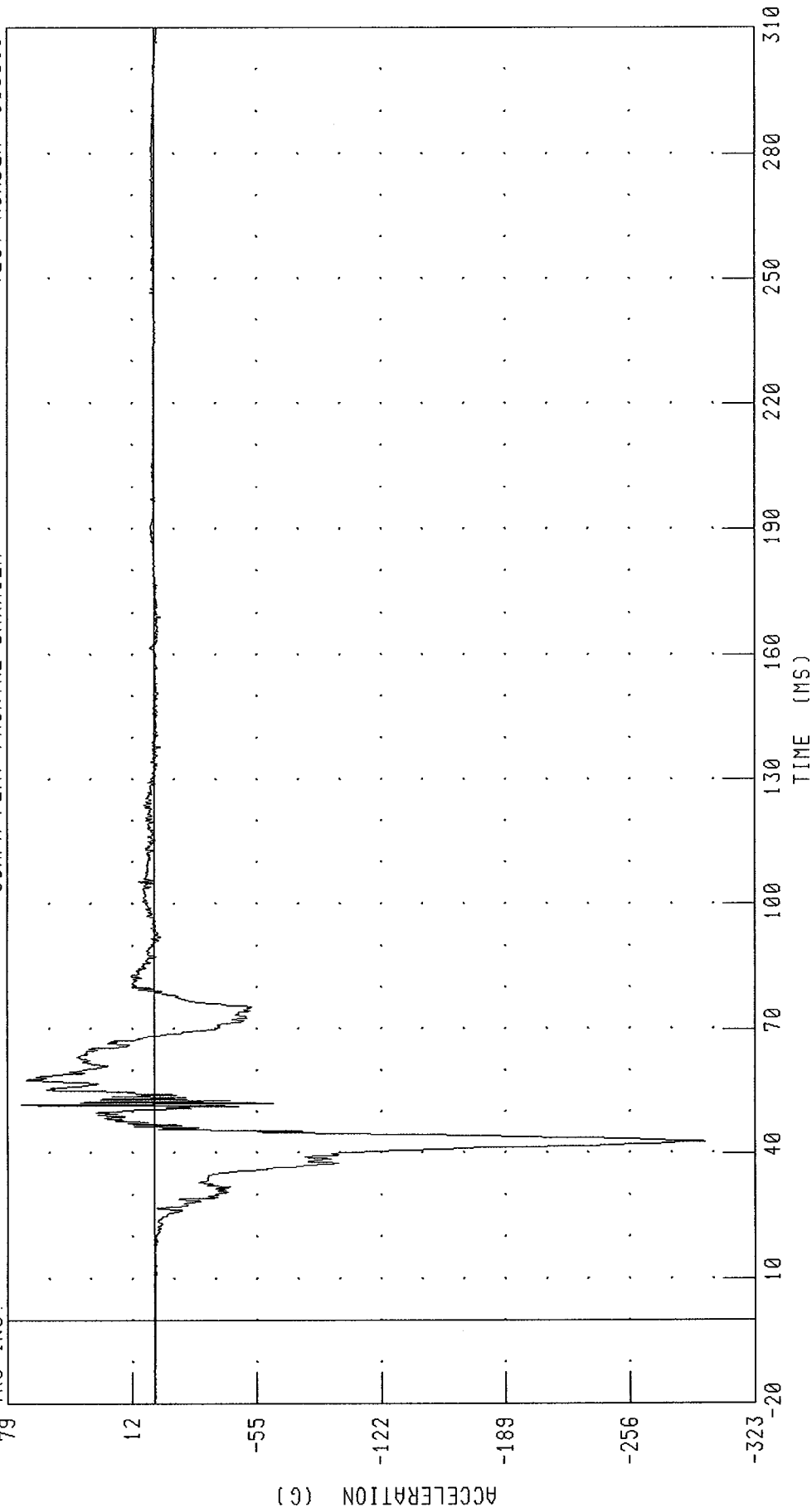

CHANNEL: FLHXG2 FILTER: CH. CLASS 1000 PEAK DATA: 71.82 G @ 51.76 MS; -296.13 G @ 42.80 MS

2001 NISSAN MAXIMA INTO FRONTAL LOAD CELL BARRIER
PASSENGER LEFT FOOT Z-AXIS ACCELERATION AT HEEL
35MPH FLAT FRONTAL BARRIER

TEST NUMBER: 010618

TRC INC.
77

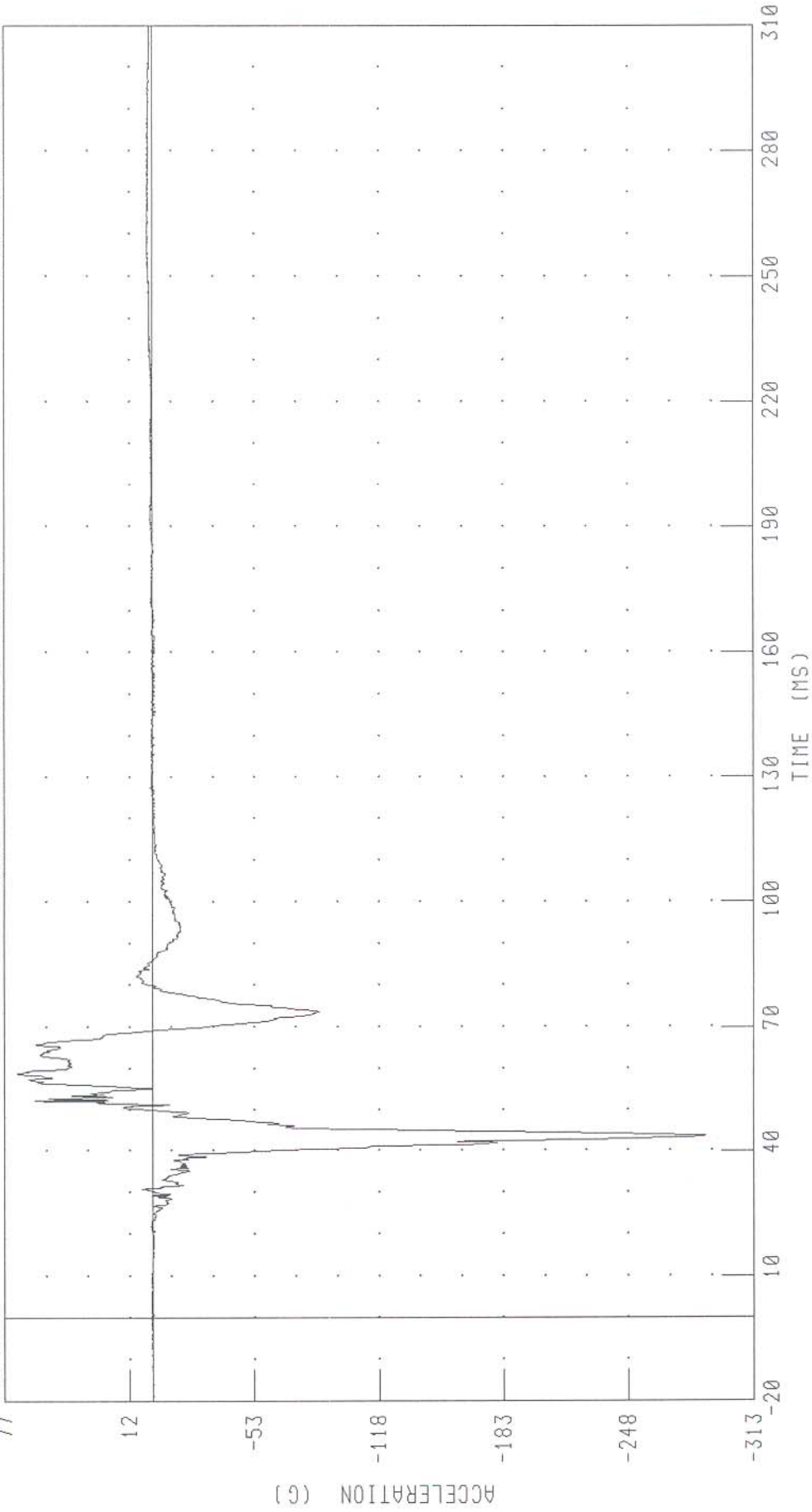

CHANNEL: FLHZG2 FILTER: CH. CLASS 1000

PEAK DATA: 70.26 G @ 58.88 MS; -288.19 G @ 43.60 MS

2001 NISSAN MAXIMA INTO FRONTAL LOAD CELL BARRIER
PASSENGER LEFT TOE Z-AXIS ACCELERATION AT TOE
35MPH FLAT FRONTAL BARRIER

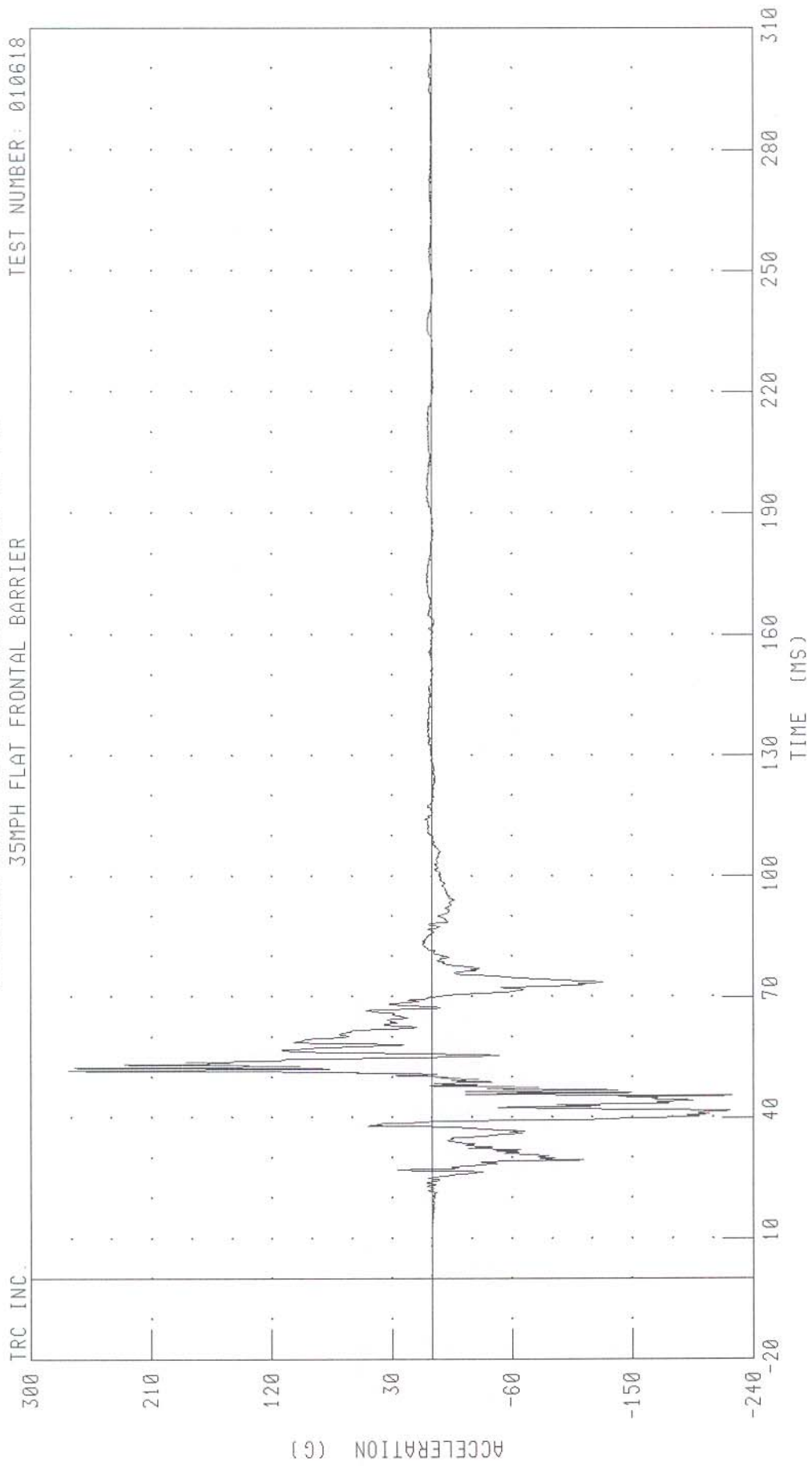

2001 NISSAN MAXIMA INTO FRONTAL LOAD CELL BARRIER
PASSENGER RIGHT FOOT X-AXIS ACCELERATION AT HEEL
35MPH FLAT FRONTAL BARRIER

TEST NUMBER: 010618

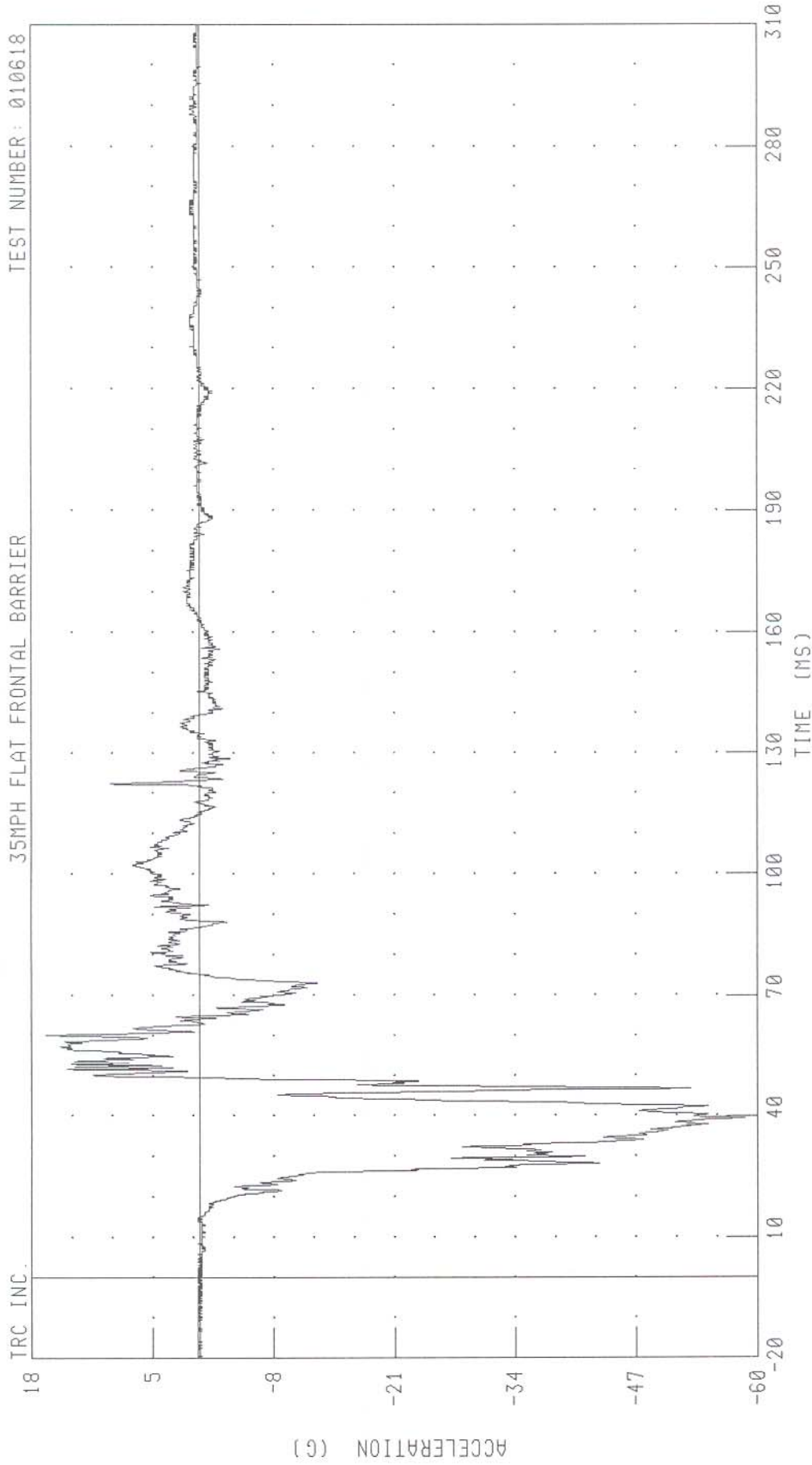

CHANNEL: FRHXG2 FILTER: CH. CLASS 1000

PEAK DATA: 16.50 G @ 60.24 MS; -58.64 G @ 39.36 MS

2001 NISSAN MAXIMA INTO FRONTAL LOAD CELL BARRIER
PASSENGER RIGHT FOOT Z-AXIS ACCELERATION AT HEEL
35MPH FLAT FRONTAL BARRIER

TEST NUMBER: 010618

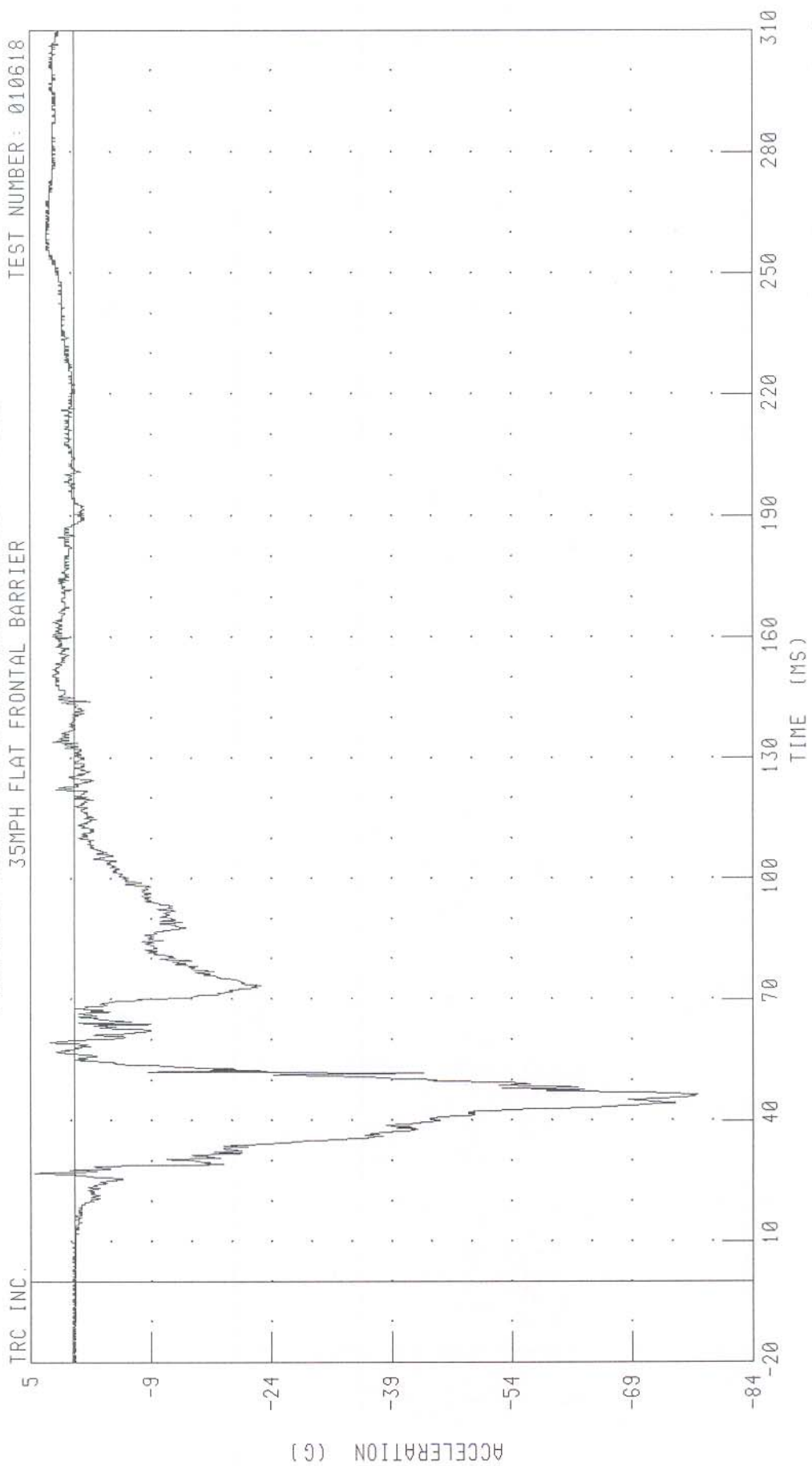

TRC INC.

CHANNEL: FRHZ02 FILTER: CH, CLASS 1000 PEAK DATA: 4.97 G @ 27.04 MS, -77.73 G @ 46.40 MS

2001 NISSAN MAXIMA INTO FRONTAL LOAD CELL BARRIER
PASSENGER RIGHT TOE Z-AXIS ACCELERATION AT TOE
35MPH FLAT FRONTAL BARRIER

TEST NUMBER : 010618

TRC INC.

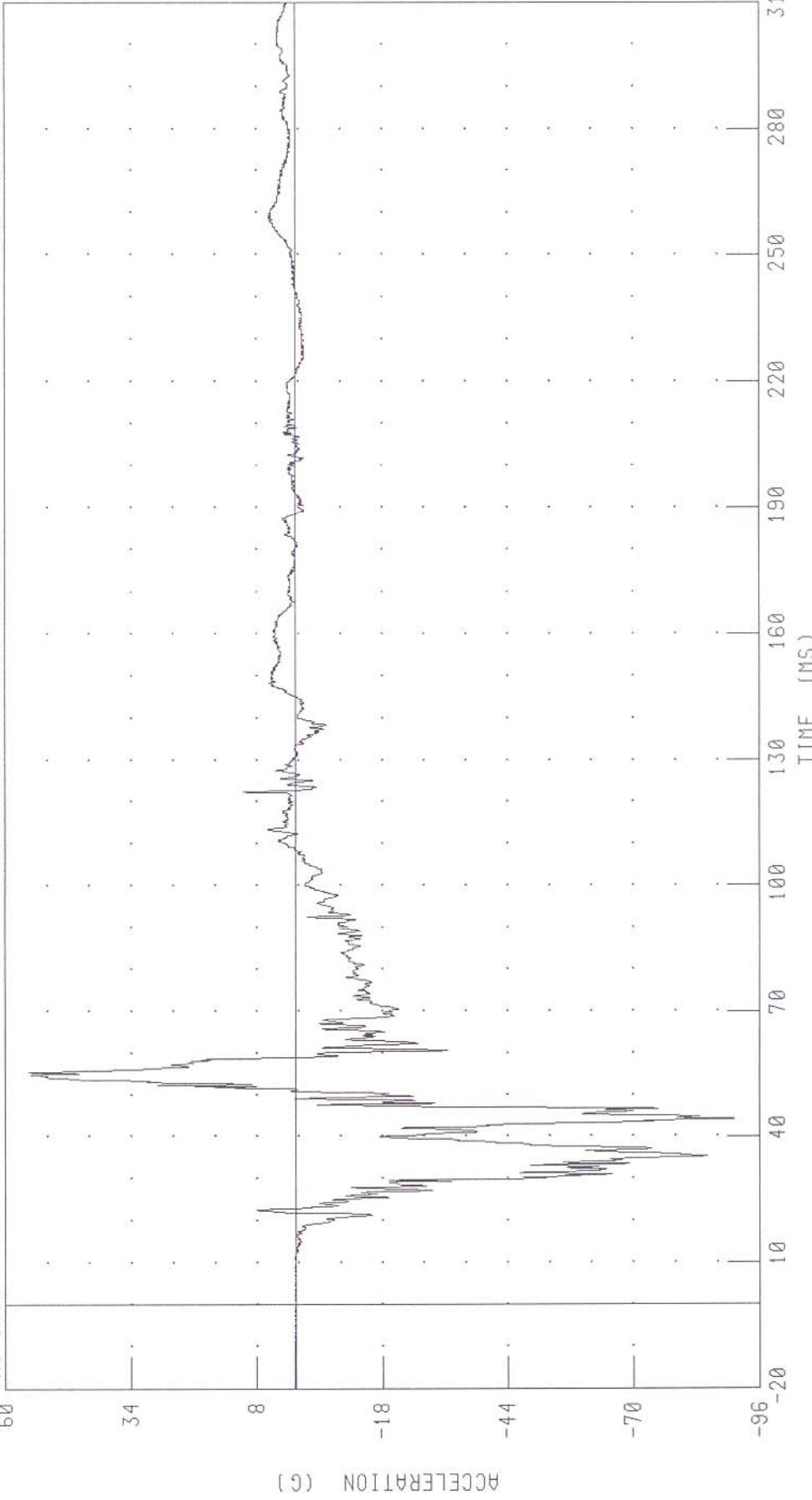

PEAK DATA: 55.16 G @ 55.60 MS, -90.76 G @ 44.08 MS

CHANNEL: FRTZG2 FILTER: CH. CLASS 1000

2001 NISSAN MAXIMA INTO FRONTAL LOAD CELL BARRIER
PASSENGER LAP BELT OUTBOARD FORCE
35MPH FLAT FRONTAL BARRIER

TEST NUMBER: 010618

TRC INC.

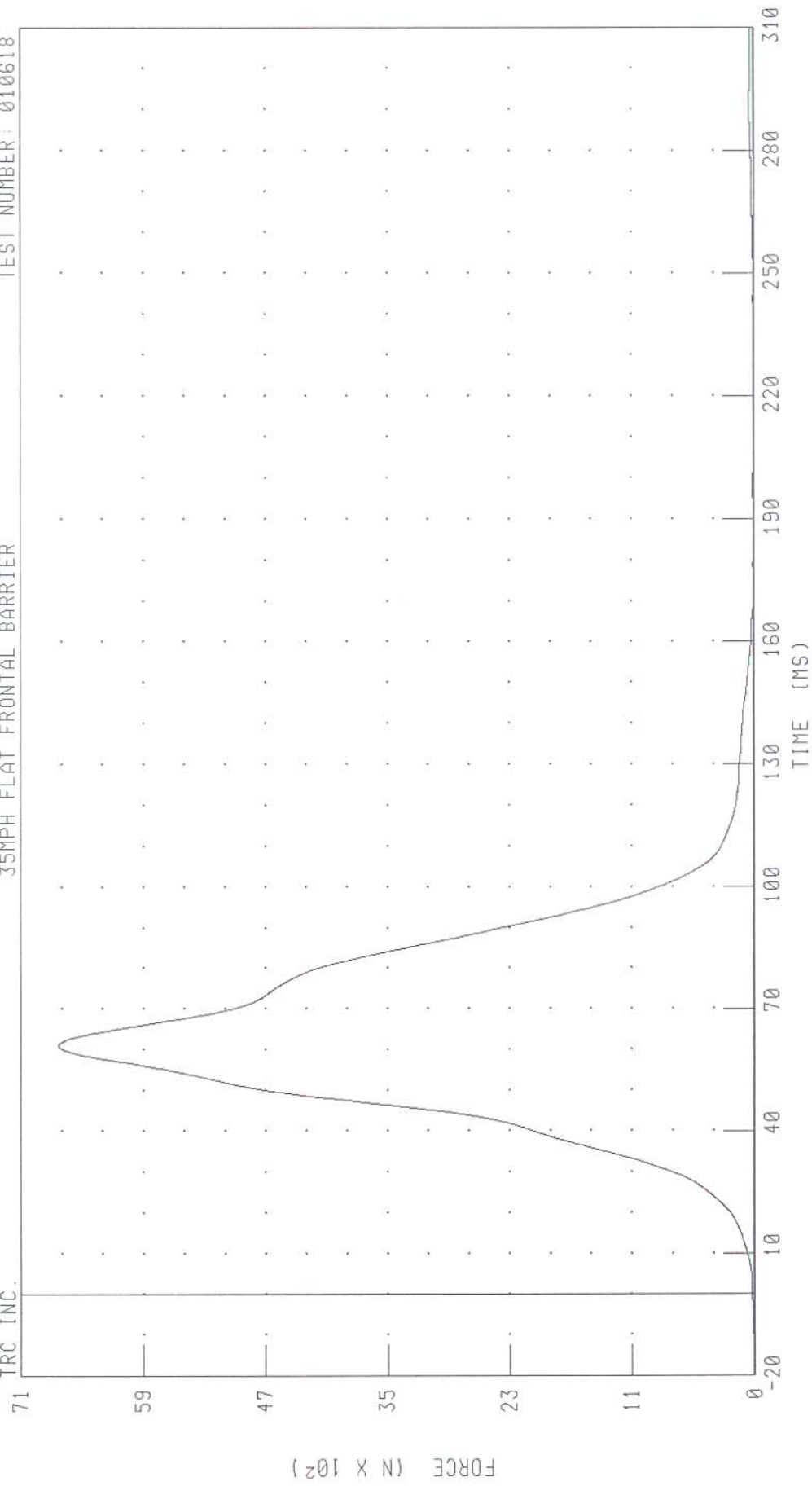

CHANNEL: LBOF2 FILTER: CH. CLASS 60

PEAK DATA: 6821.42 N @ 60.96 MS; -9.63 N @ 172.40 MS

2001 NISSAN MAXIMA INTO FRONTAL LOAD CELL BARRIER
PASSENGER SHOULDER BELT FORCE
35MPH FLAT FRONTAL BARRIER

TEST NUMBER: 010618

TRC INC.

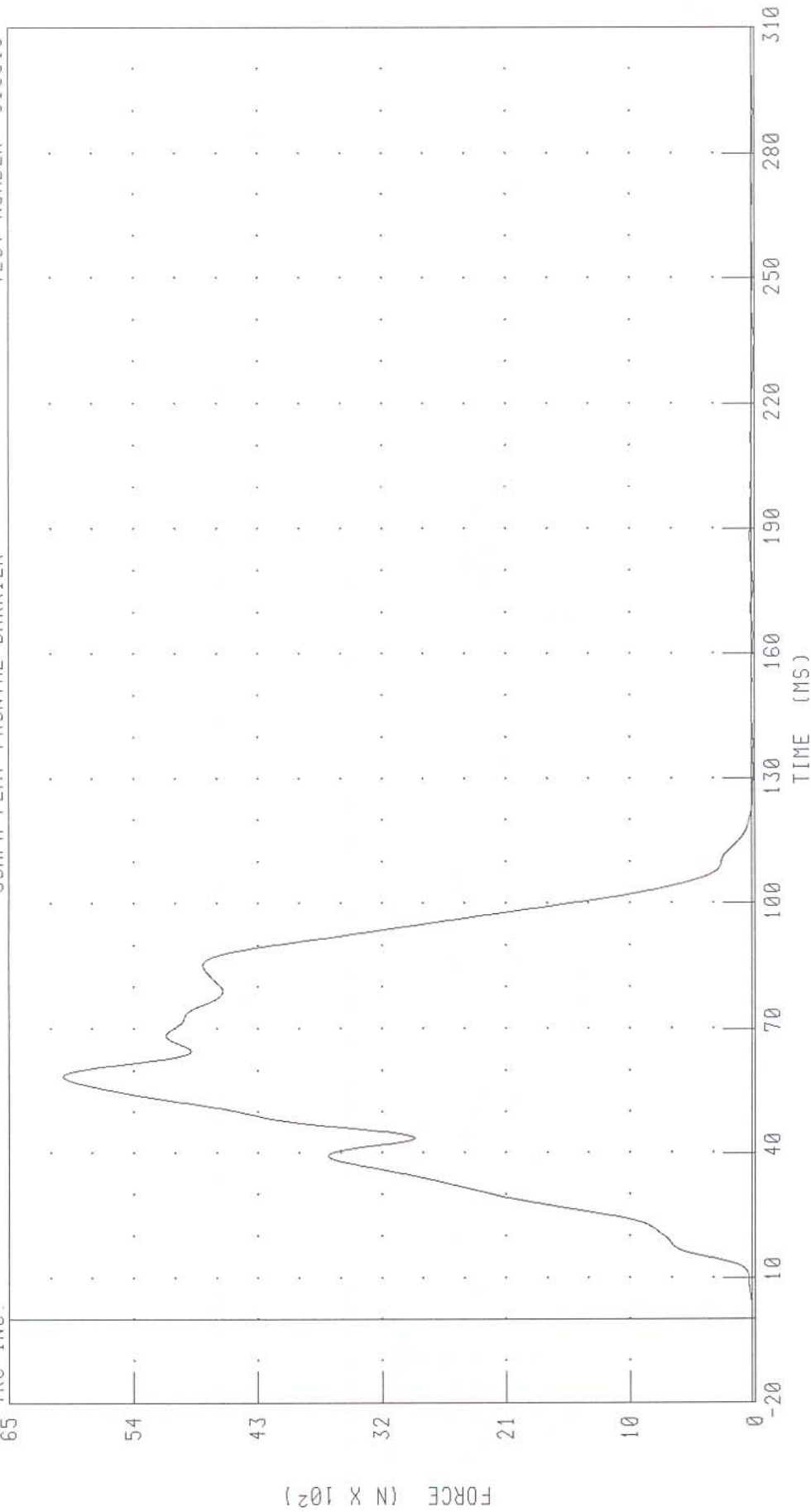

PEAK DATA: 6094.30 N @ 58.72 MS, -26.88 N @ 235.04 MS

CHANNEL: SHBF2 FILTER: CH. CLASS 60

2001 NISSAN MAXIMA INTO FRONTAL LOAD CELL BARRIER
PASSENGER SHOULDER BELT DISPLACEMENT
35MPH FLAT FRONTAL BARRIER

TEST NUMBER: 010618

TRC INC.

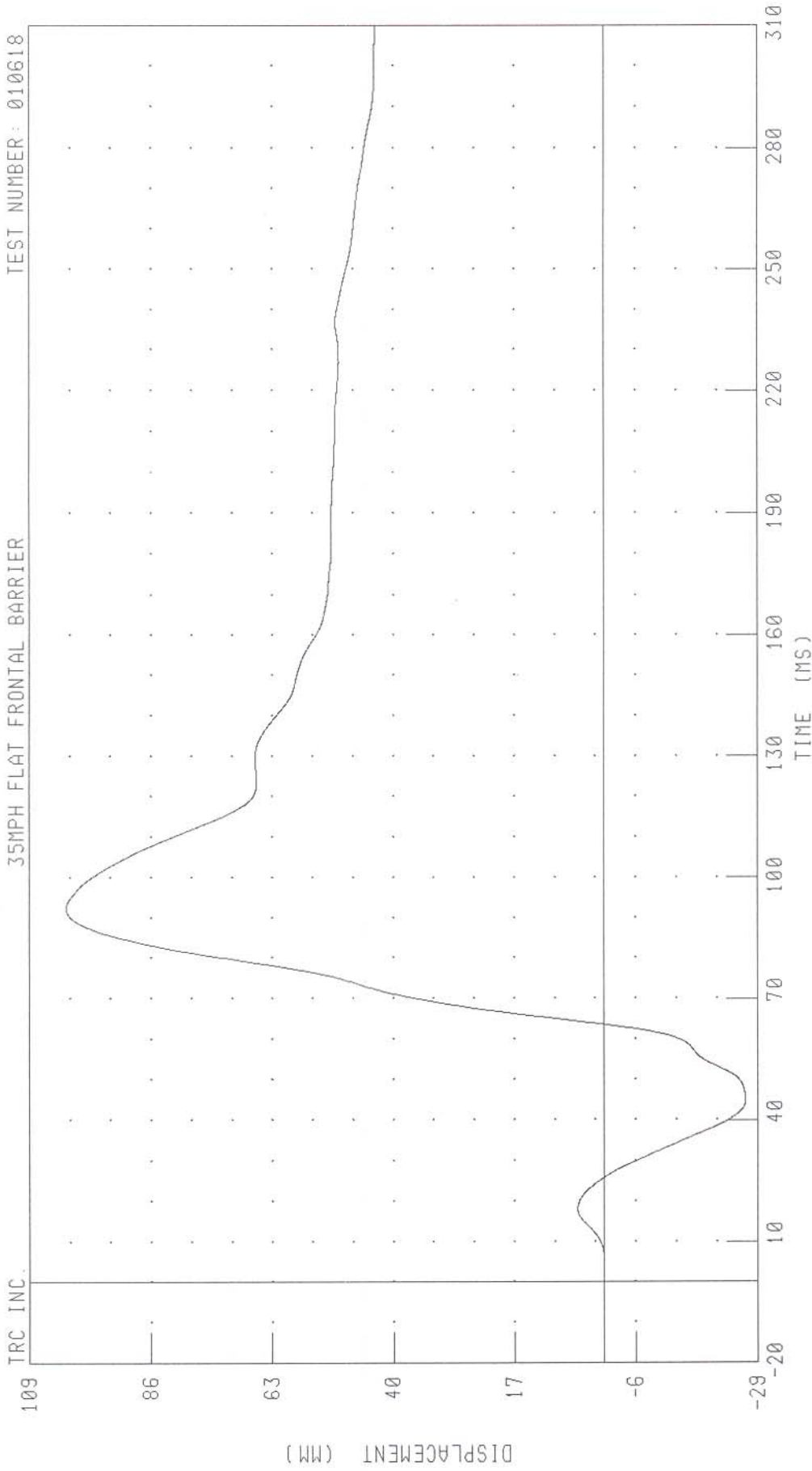

CHANNEL: SHBD2 FILTER: CH, CLASS 60

PEAK DATA: 102.05 MM @ 92.40 MS, -26.73 MM @ 44.88 MS

2001 NISSAN MAXIMA INTO FRONTAL LOAD CELL BARRIER
PASSENGER SEAT BELT EXTENSION MEASURED OVER 19 MM
35MPH FLAT FRONTAL BARRIER

TEST NUMBER: 010618

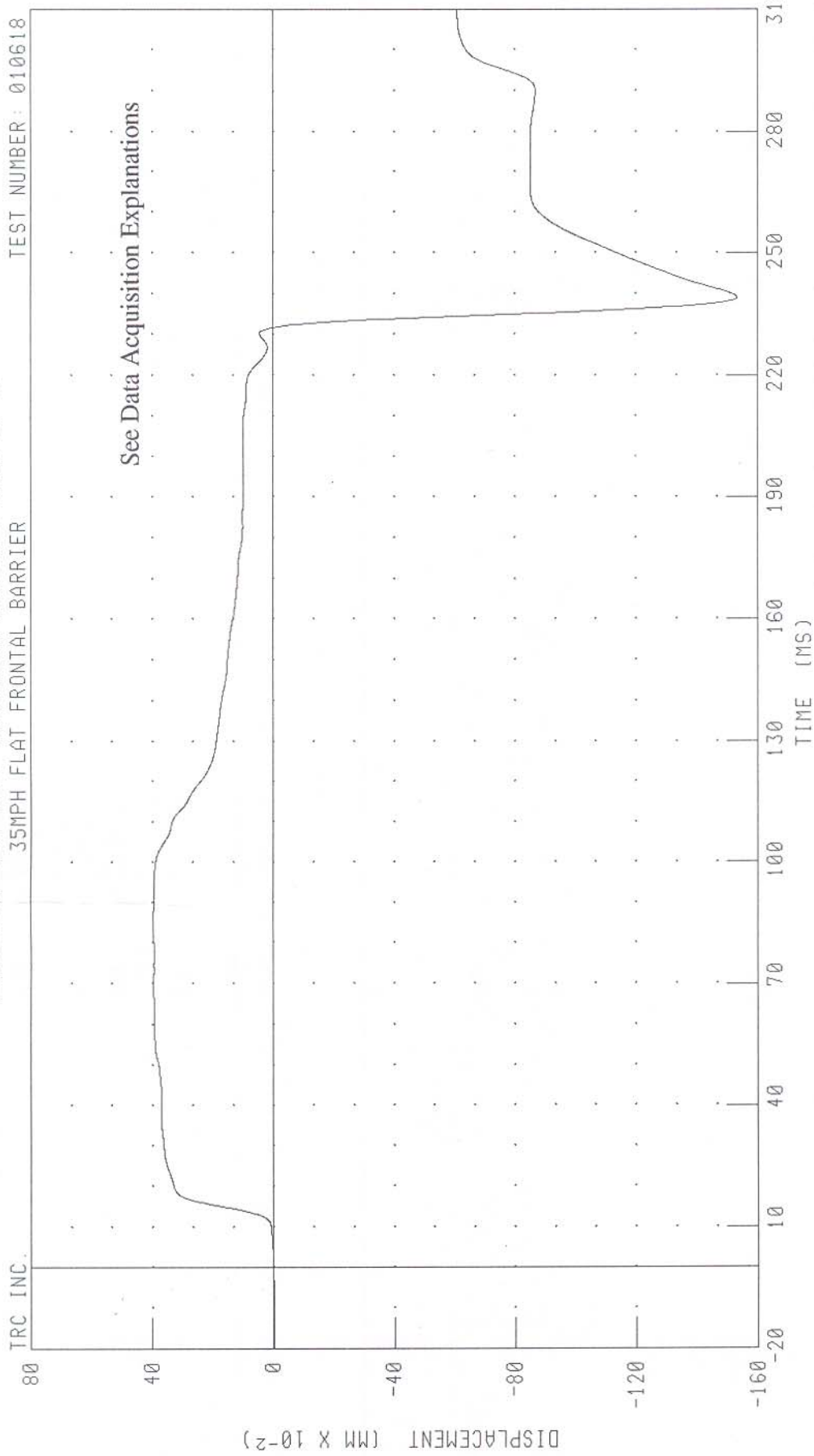

CHANNEL: SBED2 FILTER: CH. CLASS 60 PEAK DATA: 0.40 MM @ 68.88 MS, -1.53 MM @ 239.12 MS

2001 NISSAN MAXIMA INTO FRONTAL LOAD CELL BARRIER
LEFT REAR SEAT X-AXIS ACCELERATION
35MPH FLAT FRONTAL BARRIER

TEST NUMBER: 010618

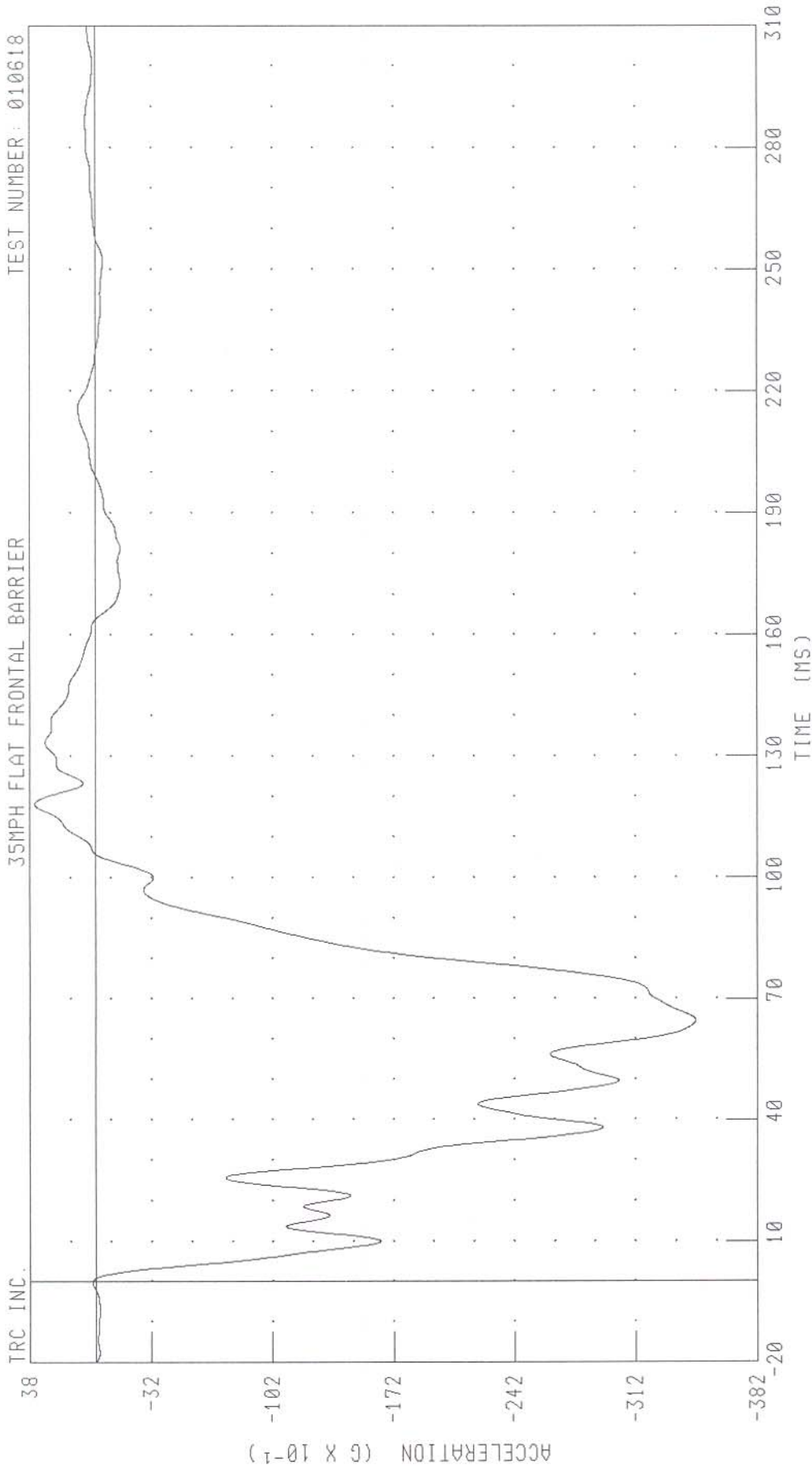

PEAK DATA: 3.52 G @ 118.32 MS; -34.67 G @ 64.56 MS

CHANNEL: TLRXG1 FILTER: CH. CLASS 60

2001 NISSAN MAXIMA INTO FRONTAL LOAD CELL BARRIER
 LEFT REAR SEAT X-AXIS VELOCITY
 35MPH FLAT FRONTAL BARRIER

TEST NUMBER: 010618

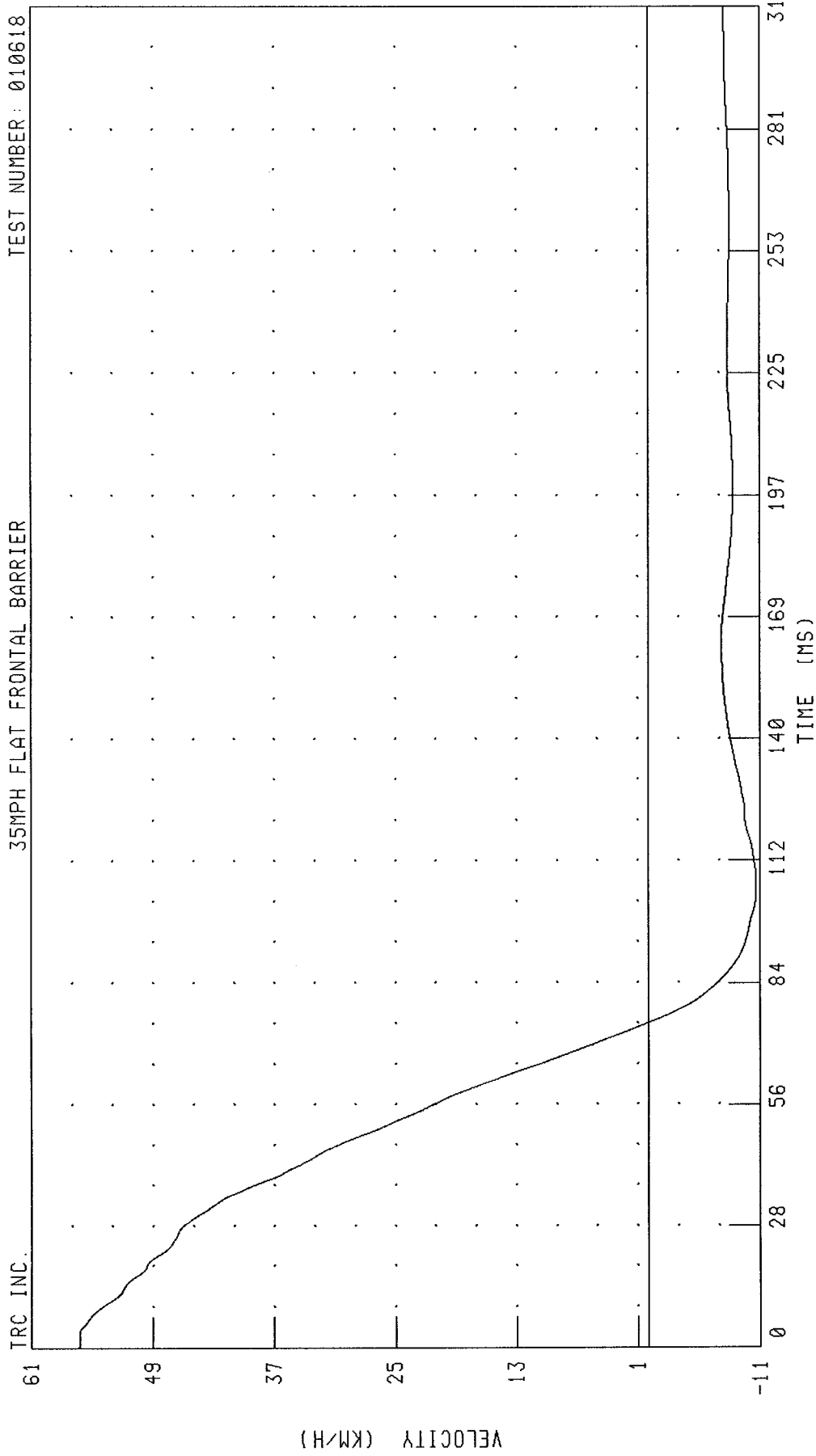

CHANNEL: TLRXV1 FILTER: CH. CLASS 180 PEAK DATA: 56.30 KM/H @ 0.00 MS; -10.63 KM/H @ 105.04 MS

2001 NISSAN MAXIMA INTO FRONTAL LOAD CELL BARRIER
LEFT REAR SEAT X-AXIS DISPLACEMENT
35MPH FLAT FRONTAL BARRIER

TEST NUMBER: 010618

TRC INC.

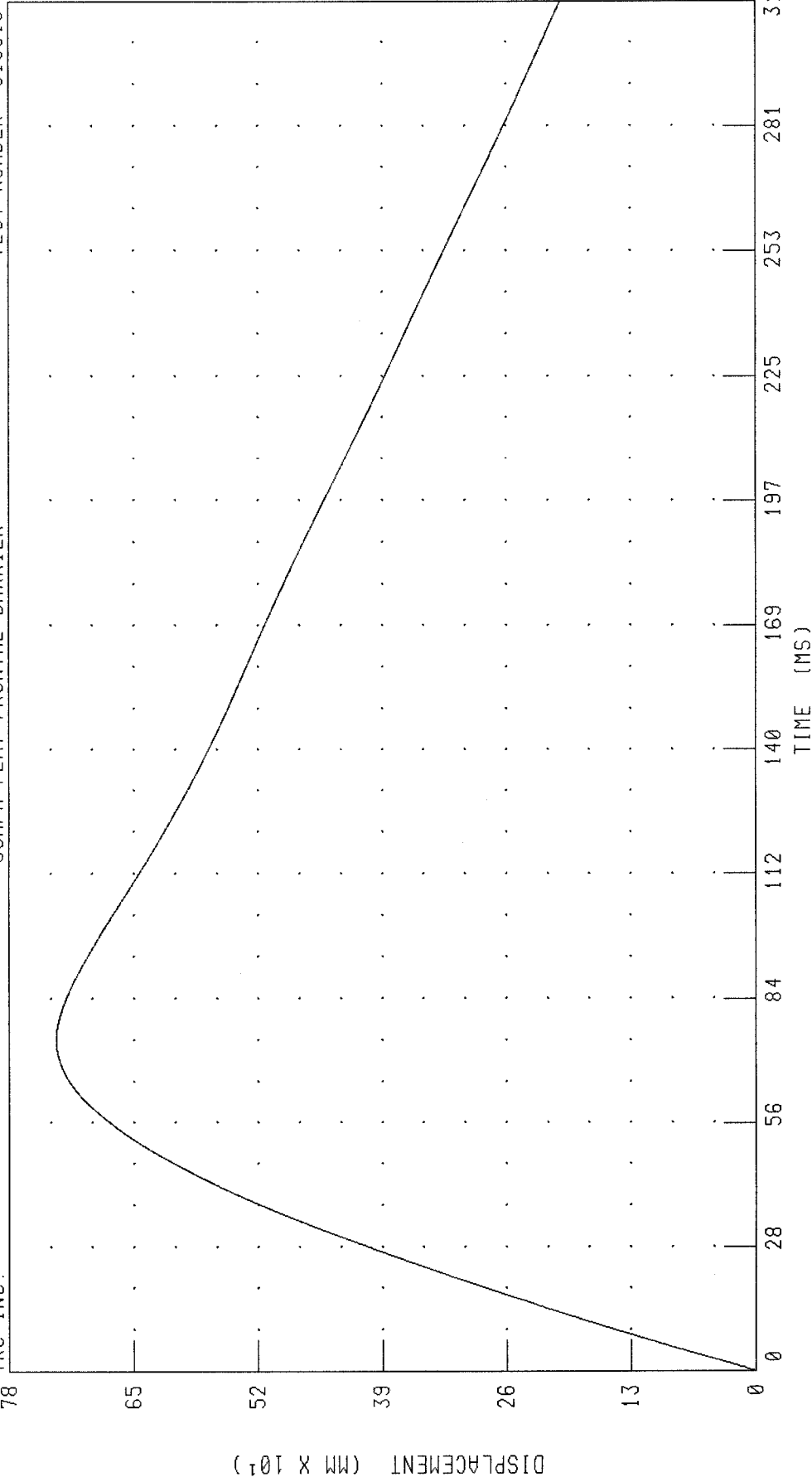

PEAK DATA: 731.06 MM @ 75.20 MS; 0.00 MM @ 0.00 MS

CHANNEL: TLRXD1 FILTER: CH. CLASS 180

2001 NISSAN MAXIMA INTO FRONTAL LOAD CELL BARRIER
RIGHT REAR SEAT X-AXIS ACCELERATION
35MPH FLAT FRONTAL BARRIER

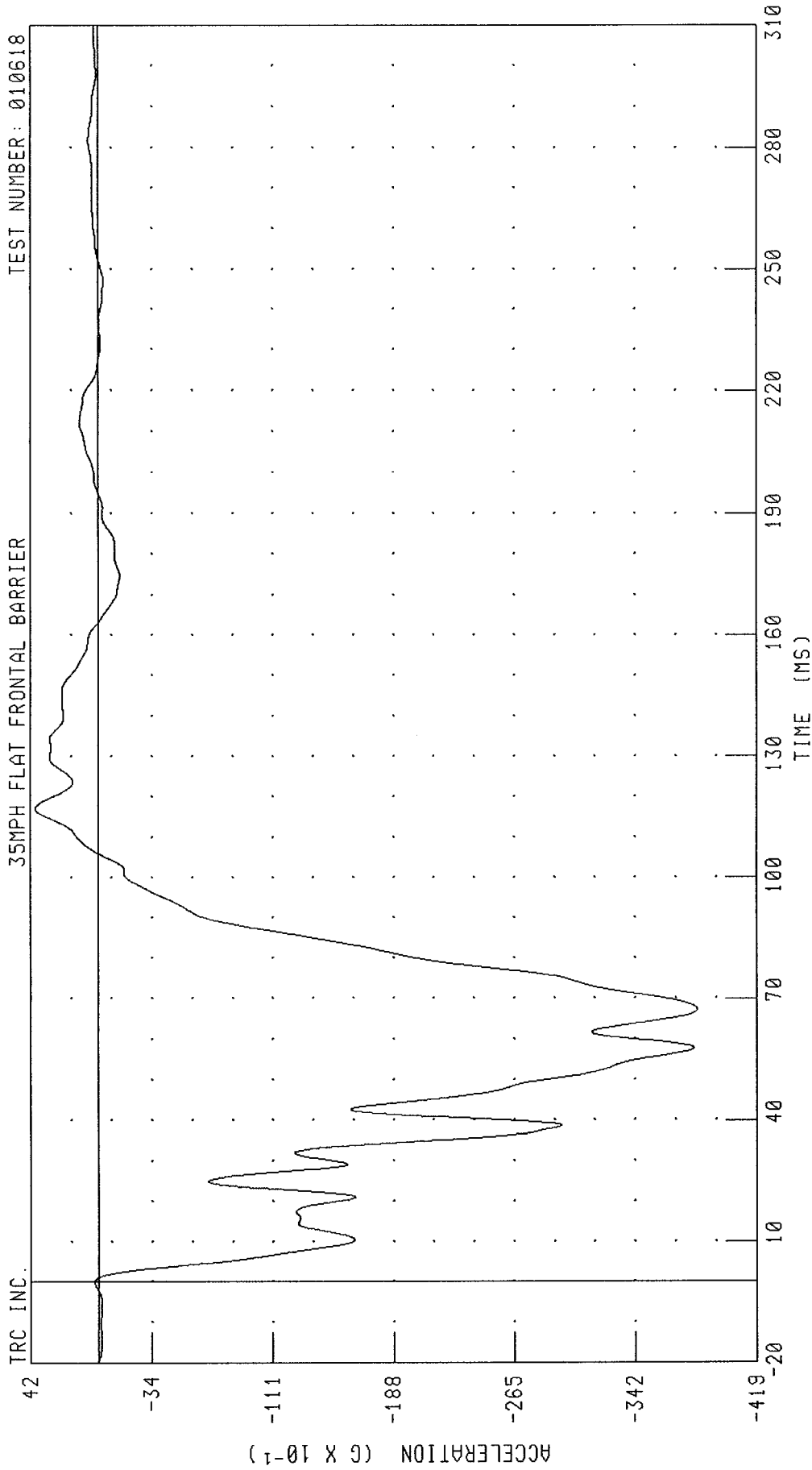

CHANNEL: TRRXG1 FILTER: CH. CLASS 60

PEAK DATA: 3.99 G @ 117.12 MS; -38.15 G @ 67.36 MS

2001 NISSAN MAXIMA INTO FRONTAL LOAD CELL BARRIER
RIGHT REAR SEAT X-AXIS VELOCITY
35MPH FLAT FRONTAL BARRIER

TEST NUMBER: 010618

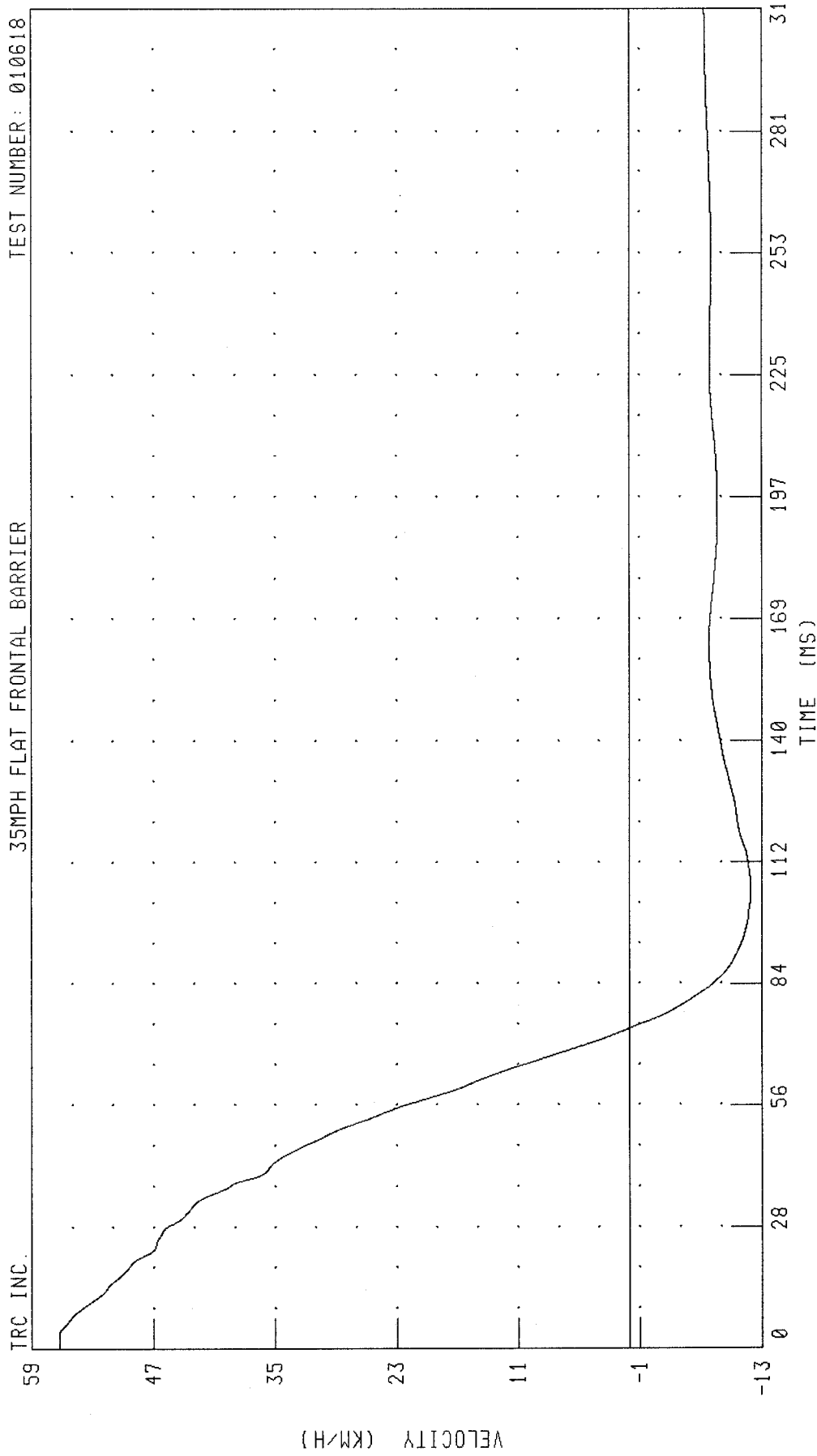

CHANNEL: TRRXV1 FILTER: CH. CLASS 180

PEAK DATA: 56.30 KM/H @ 2.72 MS; -11.93 KM/H @ 106.08 MS

2001 NISSAN MAXIMA INTO FRONTAL LOAD CELL BARRIER
RIGHT REAR SEAT X-AXIS DISPLACEMENT
35MPH FLAT FRONTAL BARRIER

TEST NUMBER: 010618

TRC INC.

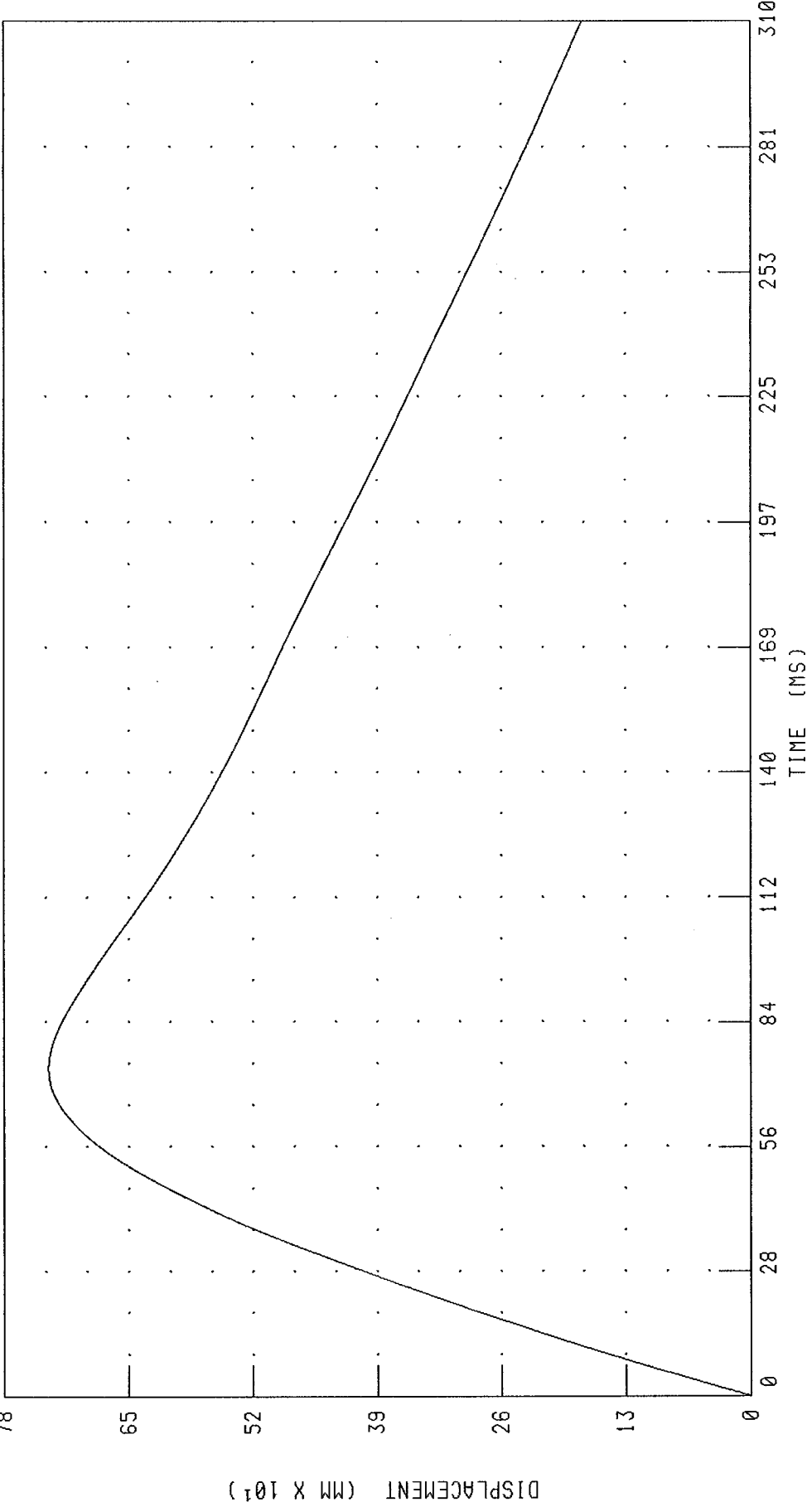

CHANNEL: TRRXD1 FILTER: CH. CLASS 180 PEAK DATA: 733.53 MM @ 74.16 MS; 0.00 MM @ 0.00 MS

2001 NISSAN MAXIMA INTO FRONTAL LOAD CELL BARRIER
ENGINE TOP X-AXIS ACCELERATION
35MPH FLAT FRONTAL BARRIER

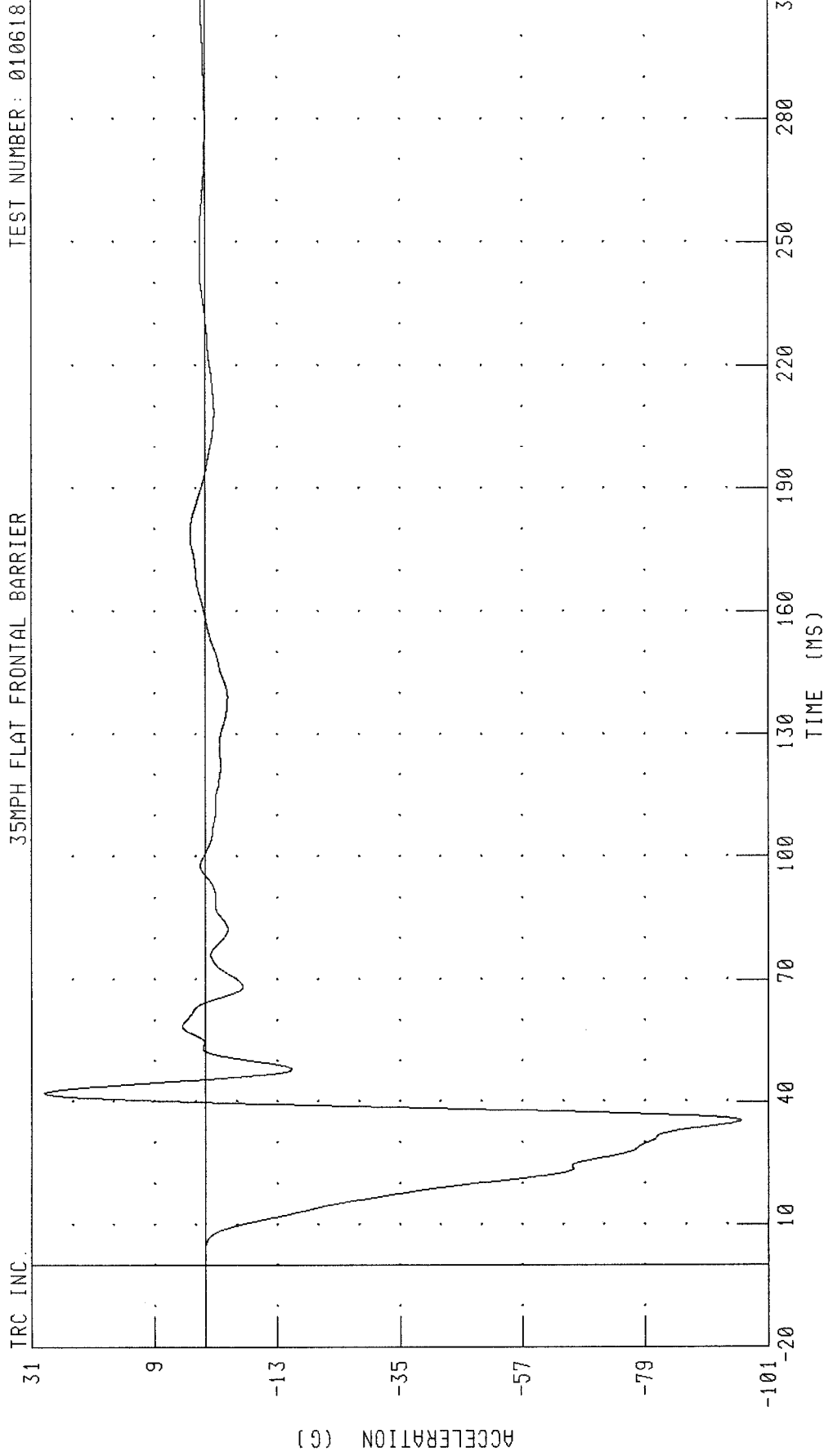

CHANNEL: ENGXC1 FILTER: CH. CLASS 60 PEAK DATA: 28.74 G @ 42.08 MS; -96.13 G @ 35.36 MS

2001 NISSAN MAXIMA INTO FRONTAL LOAD CELL BARRIER
ENGINE BOTTOM X-AXIS ACCELERATION
35MPH FLAT FRONTAL BARRIER

TEST NUMBER: 010618

TRC INC.

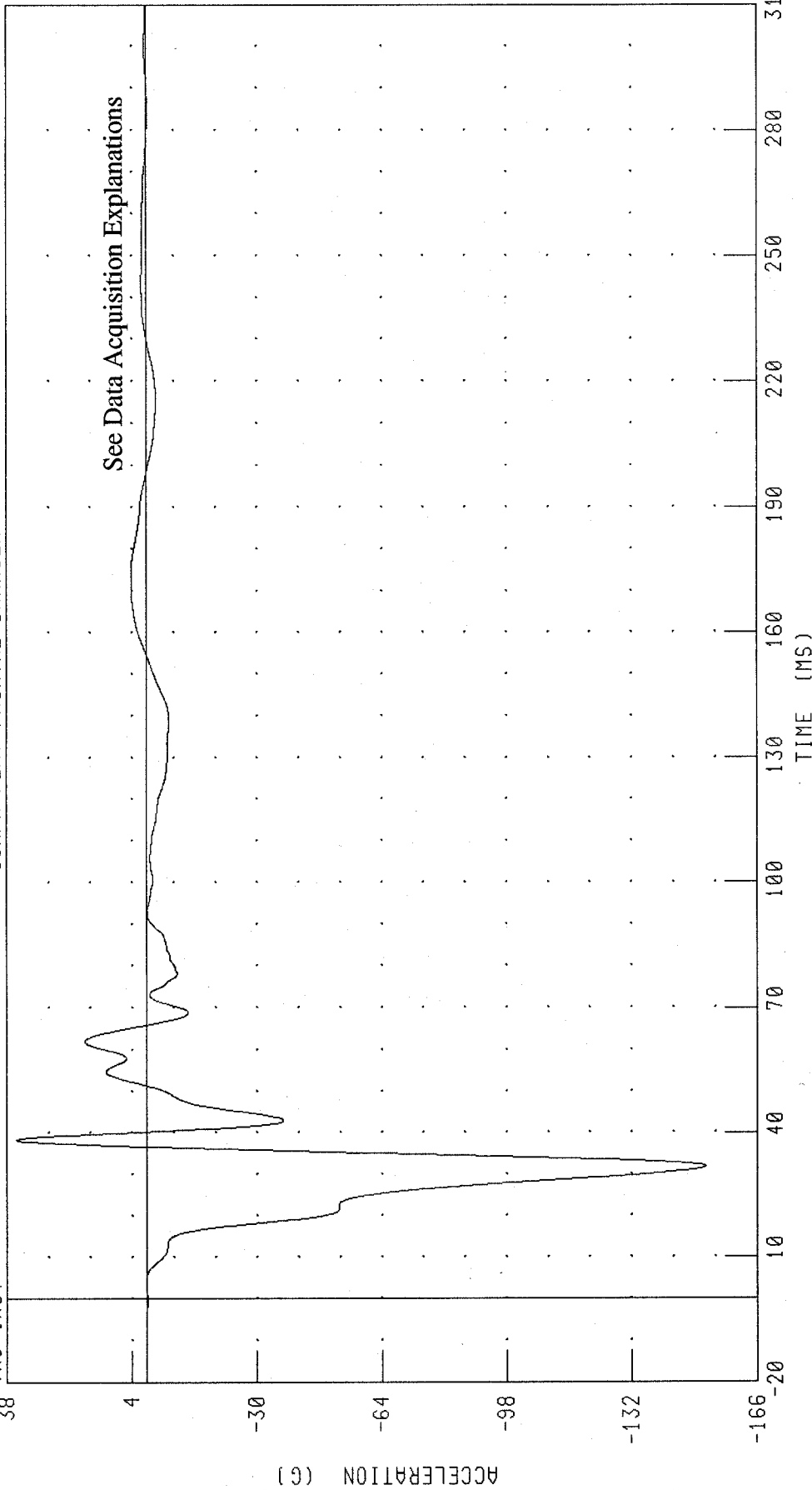

CHANNEL: ENGXC2 FILTER: CH. CLASS 60

PEAK DATA: 35.37 G @ 38.32 MS; -152.08 G @ 31.76 MS

2001 NISSAN MAXIMA INTO FRONTAL LOAD CELL BARRIER
LEFT BRAKE CALIPER X-AXIS ACCELERATION
35MPH FLAT FRONTAL BARRIER

TEST NUMBER: 010618

TRC INC.

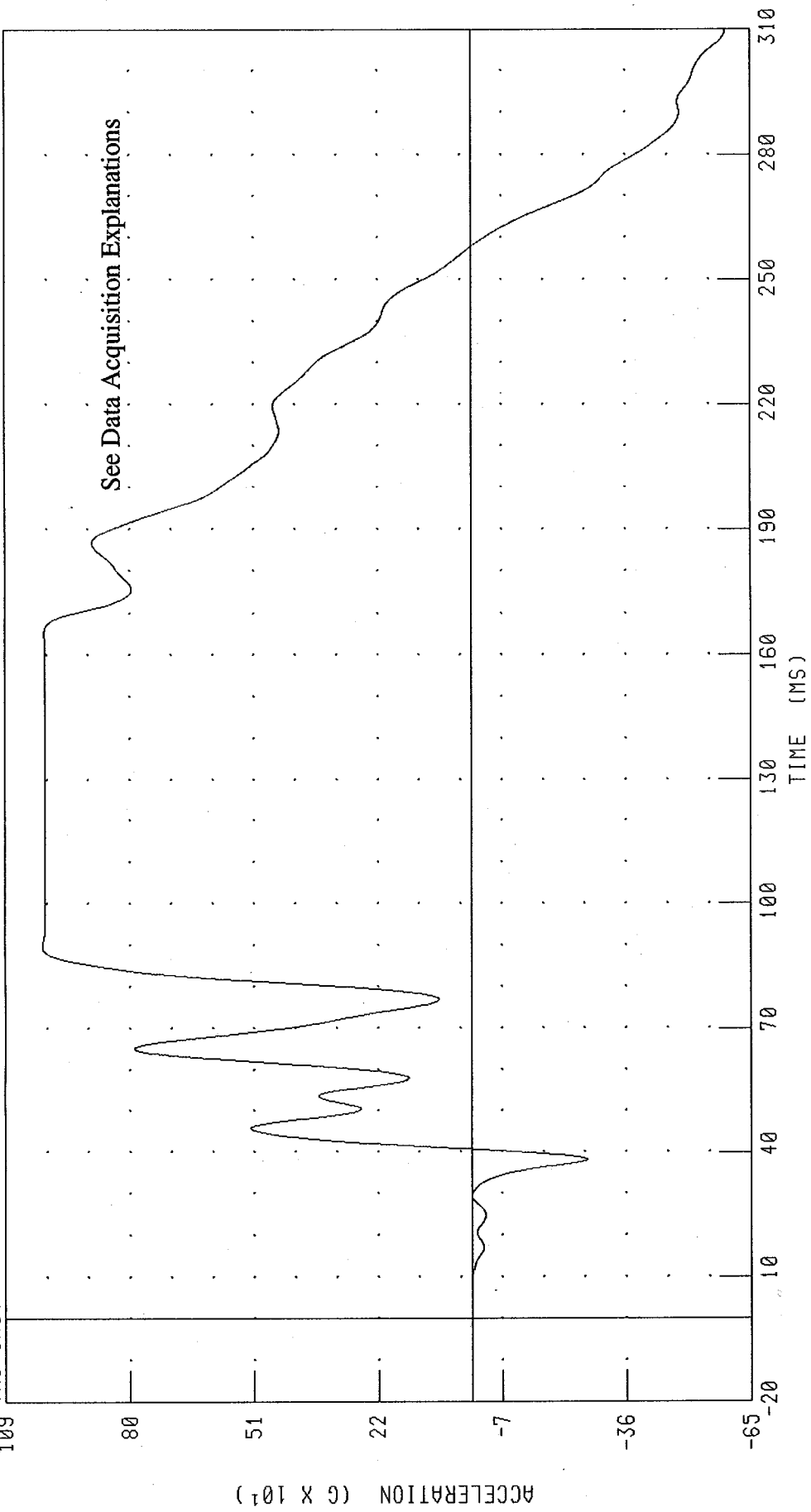

CHANNEL: BCLXG1 FILTER: CH. CLASS 60 PEAK DATA: 1003.30 G @ 89.68 MS; -591.09 G @ 309.36 MS

2001 NISSAN MAXIMA INTO FRONTAL LOAD CELL BARRIER
RIGHT BRAKE CALIPER X-AXIS ACCELERATION
35MPH FLAT FRONTAL BARRIER

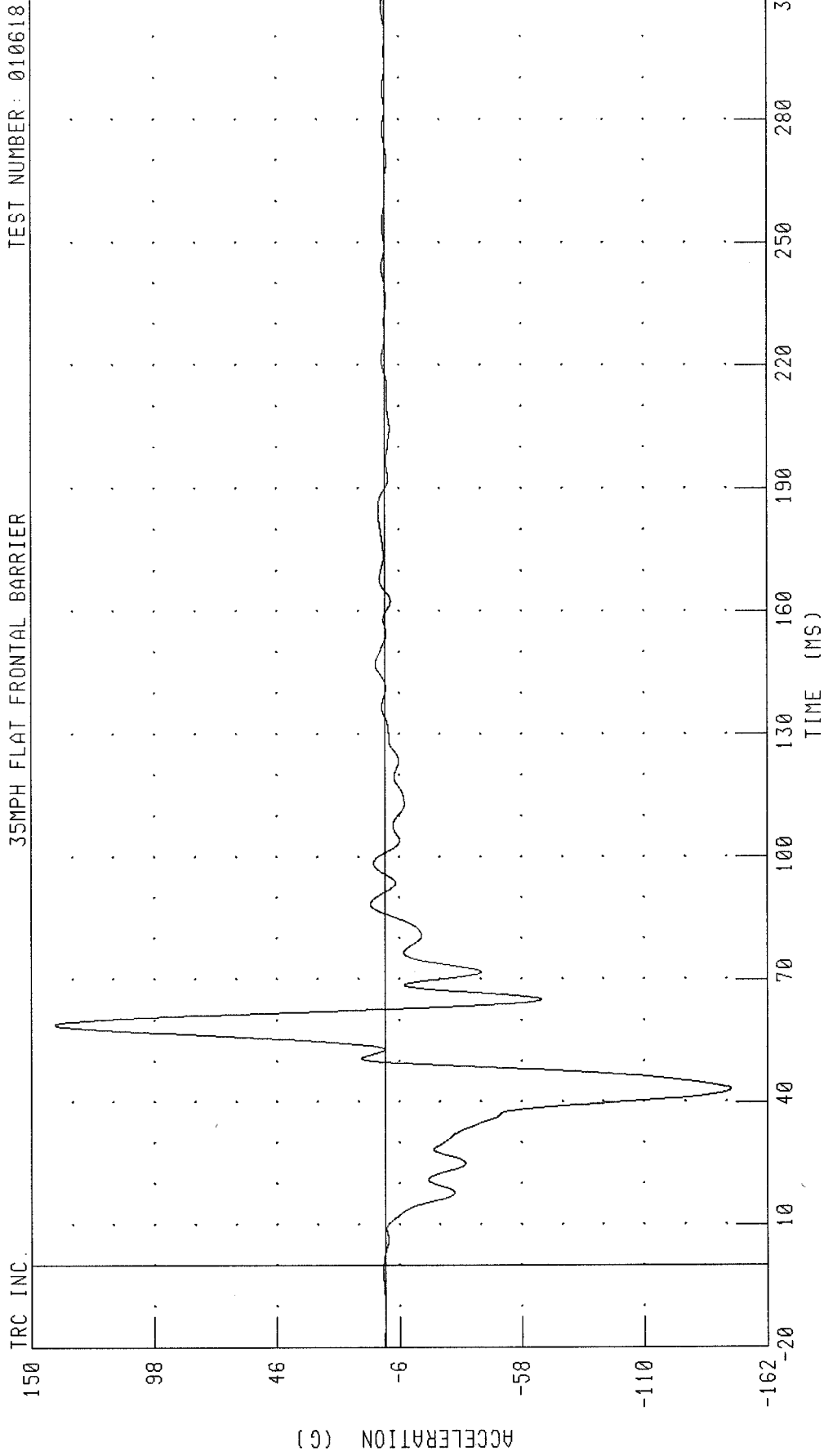

CHANNEL: BCRXG1 FILTER: CH. CLASS 60

PEAK DATA: 140.18 G @ 58.96 MS; -146.84 G @ 43.12 MS

2001 NISSAN MAXIMA INTO FRONTAL LOAD CELL BARRIER
INSTRUMENT PANEL CENTER X-AXIS ACCELERATION
35MPH FLAT FRONTAL BARRIER

TEST NUMBER: 010618

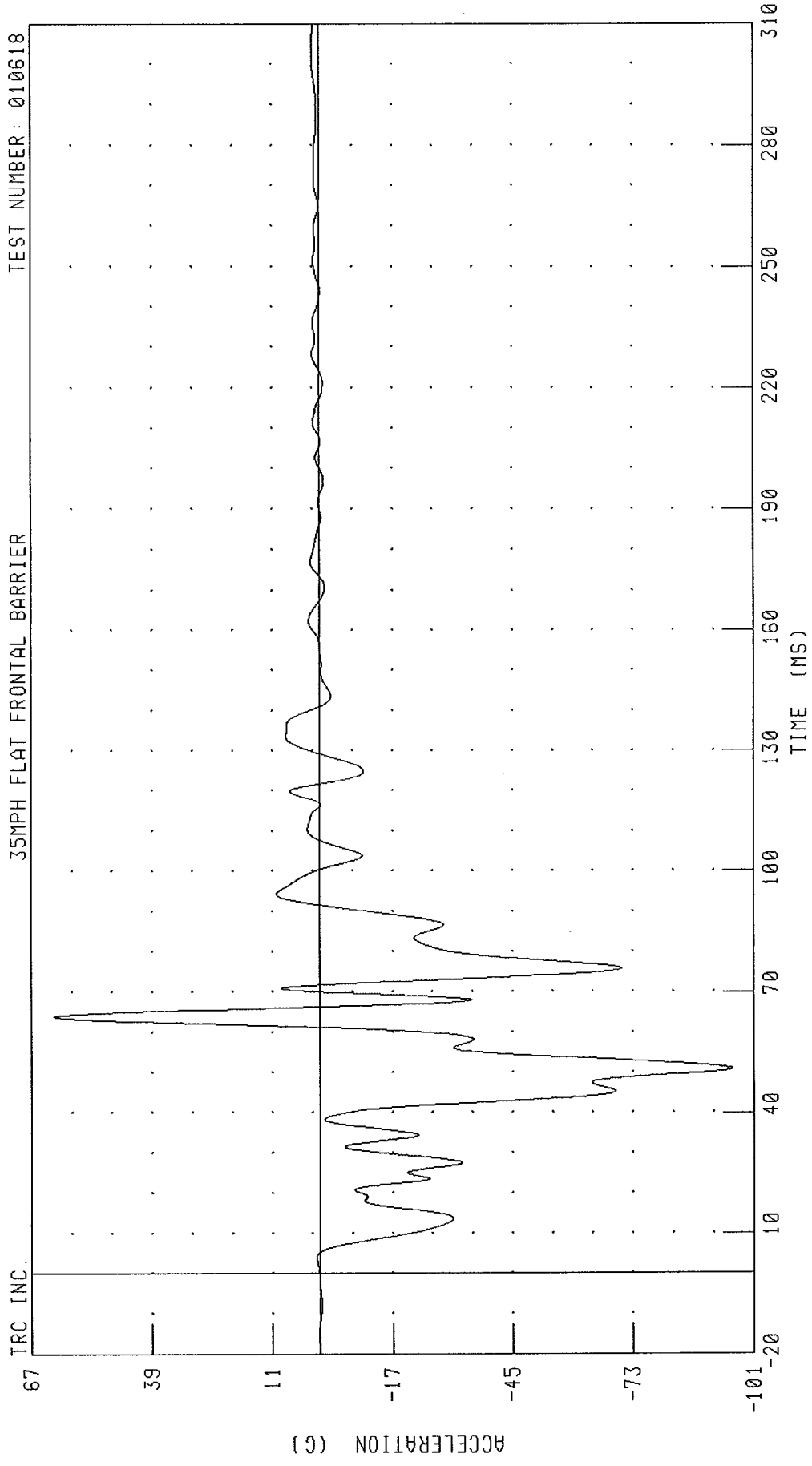

TRC INC.

CHANNEL: DPCXG1 FILTER: CH. CLASS 60 PEAK DATA: 61.72 G @ 64.00 MS; -96.11 G @ 50.88 MS

2001 NISSAN MAXIMA INTO FRONTAL LOAD CELL BARRIER
LEFT REAR SEAT REDUNDANT X-AXIS ACCELERATION
35MPH FLAT FRONTAL BARRIER

TEST NUMBER: 010618

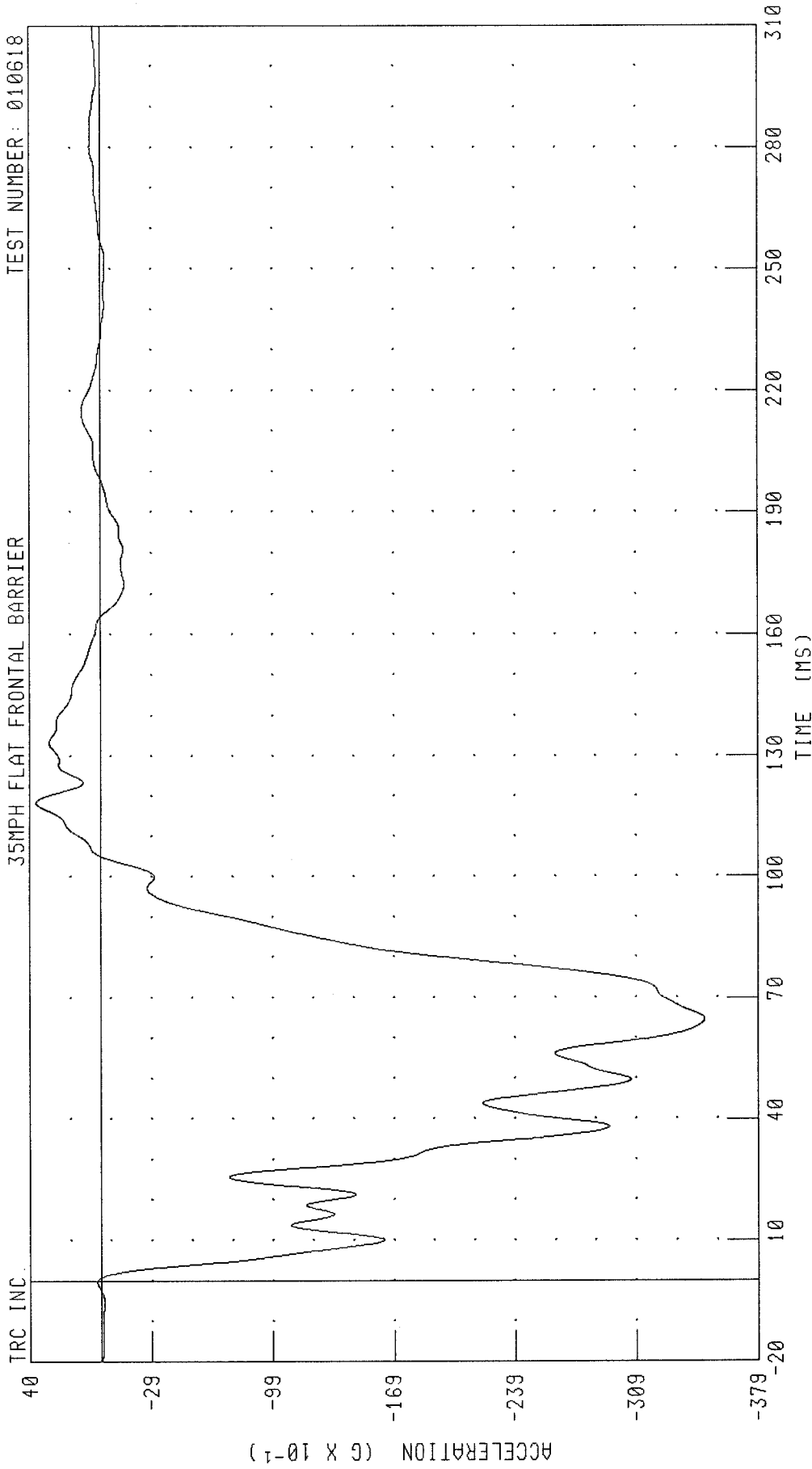

CHANNEL: TLRXGA FILTER: CH. CLASS 60 PEAK DATA: 3.74 G @ 118.40 MS; -34.84 G @ 64.64 MS

2001 NISSAN MAXIMA INTO FRONTAL LOAD CELL BARRIER
RIGHT REAR SEAT REDUNDANT X-AXIS ACCELERATION
35MPH FLAT FRONTAL BARRIER

TEST NUMBER: 010618

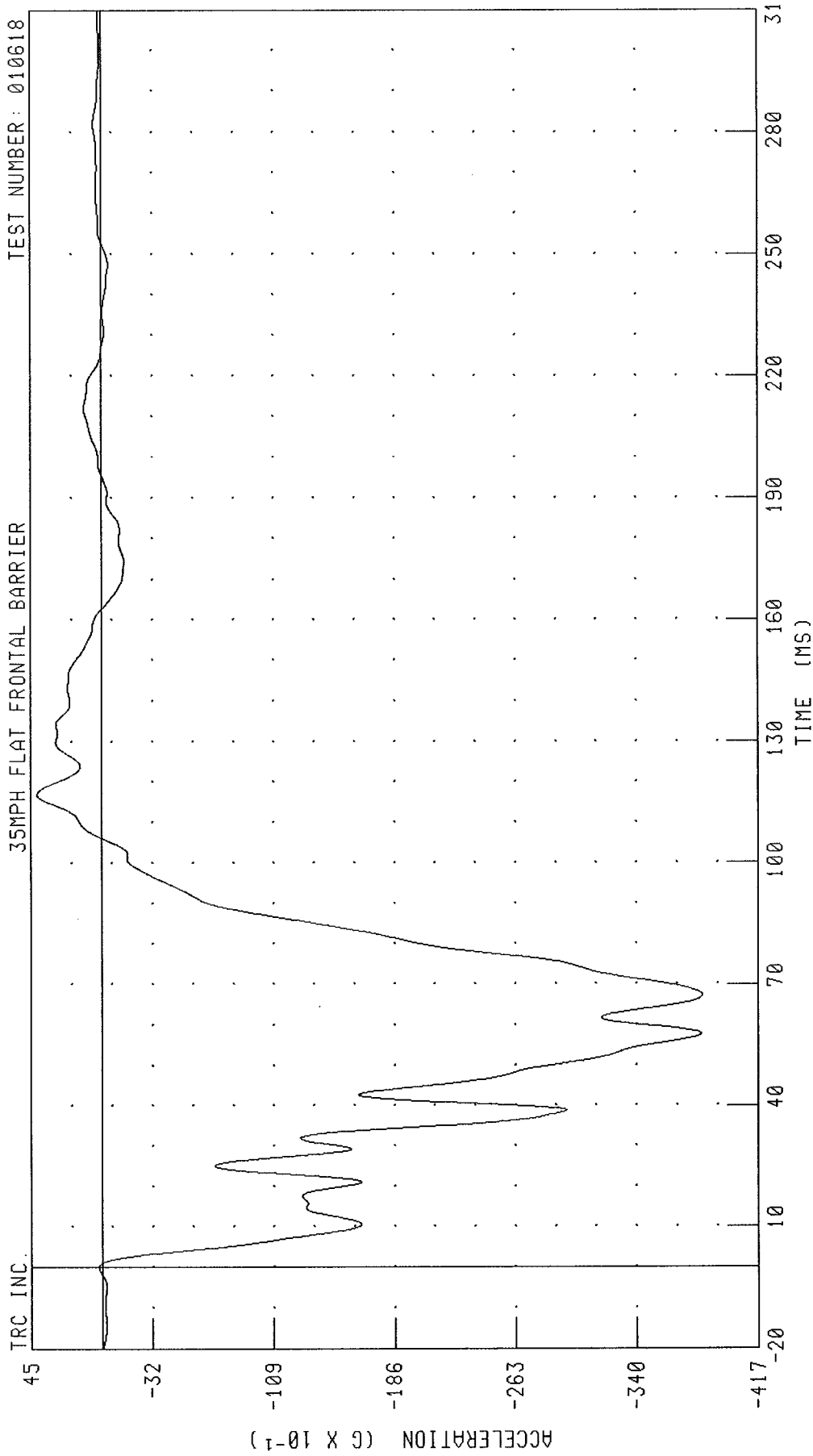

CHANNEL: TRRXGA FILTER: CH. CLASS 60 PEAK DATA: 4.11 G @ 116.88 MS; -381.98 G @ 67.20 MS

2001 NISSAN MAXIMA INTO FRONTAL LOAD CELL BARRIER
LOAD CELL BARRIER POSITION A1 FORCE
35MPH FLAT FRONTAL BARRIER

TEST NUMBER: 010618

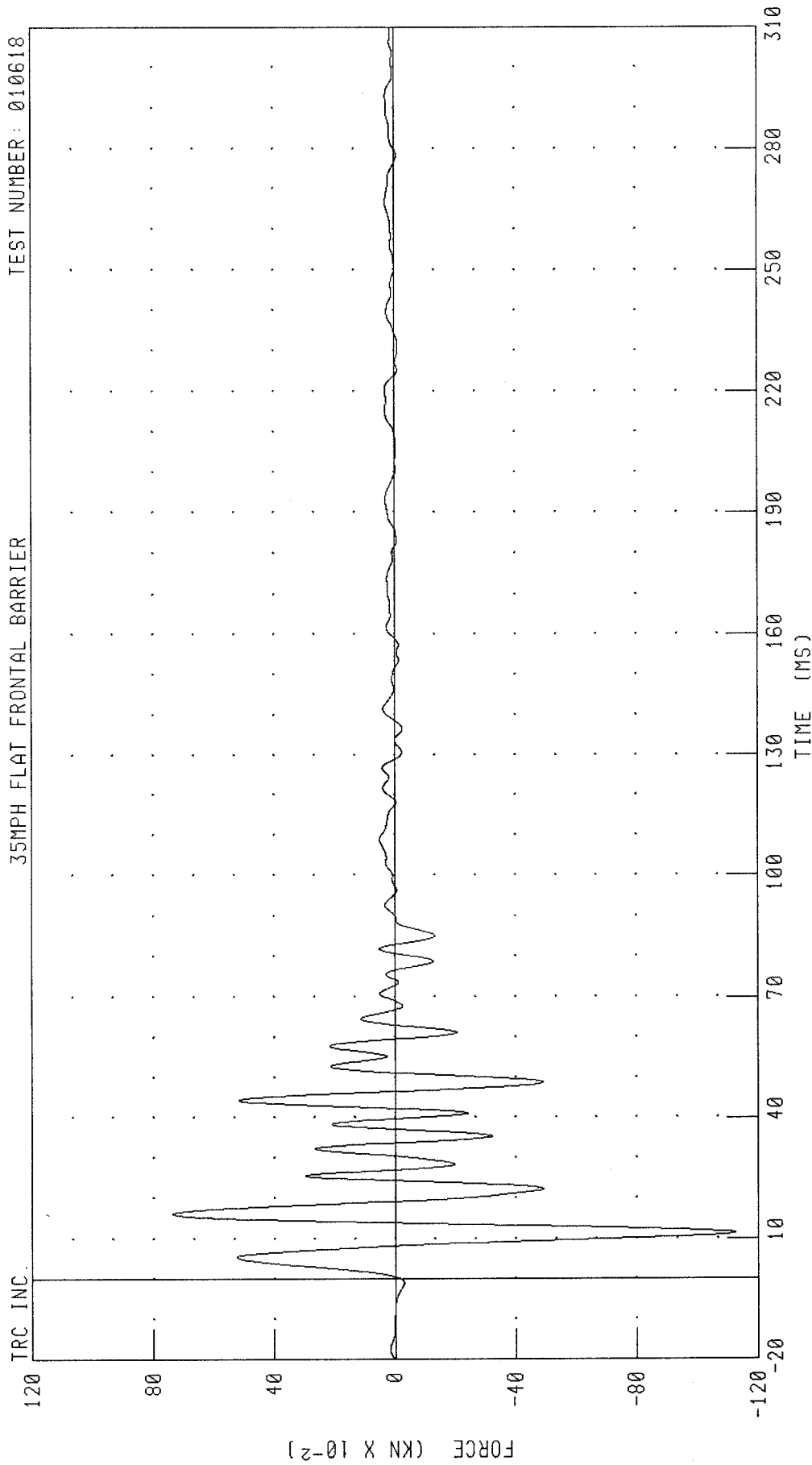

CHANNEL: BA1F FILTER: CH. CLASS 60 PEAK DATA: 0.74 KN @ 16.16 MS; -1.13 KN @ 11.36 MS

2001 NISSAN MAXIMA INTO FRONTAL LOAD CELL BARRIER
LOAD CELL BARRIER POSITION A2 FORCE
35MPH FLAT FRONTAL BARRIER

TEST NUMBER: 010618

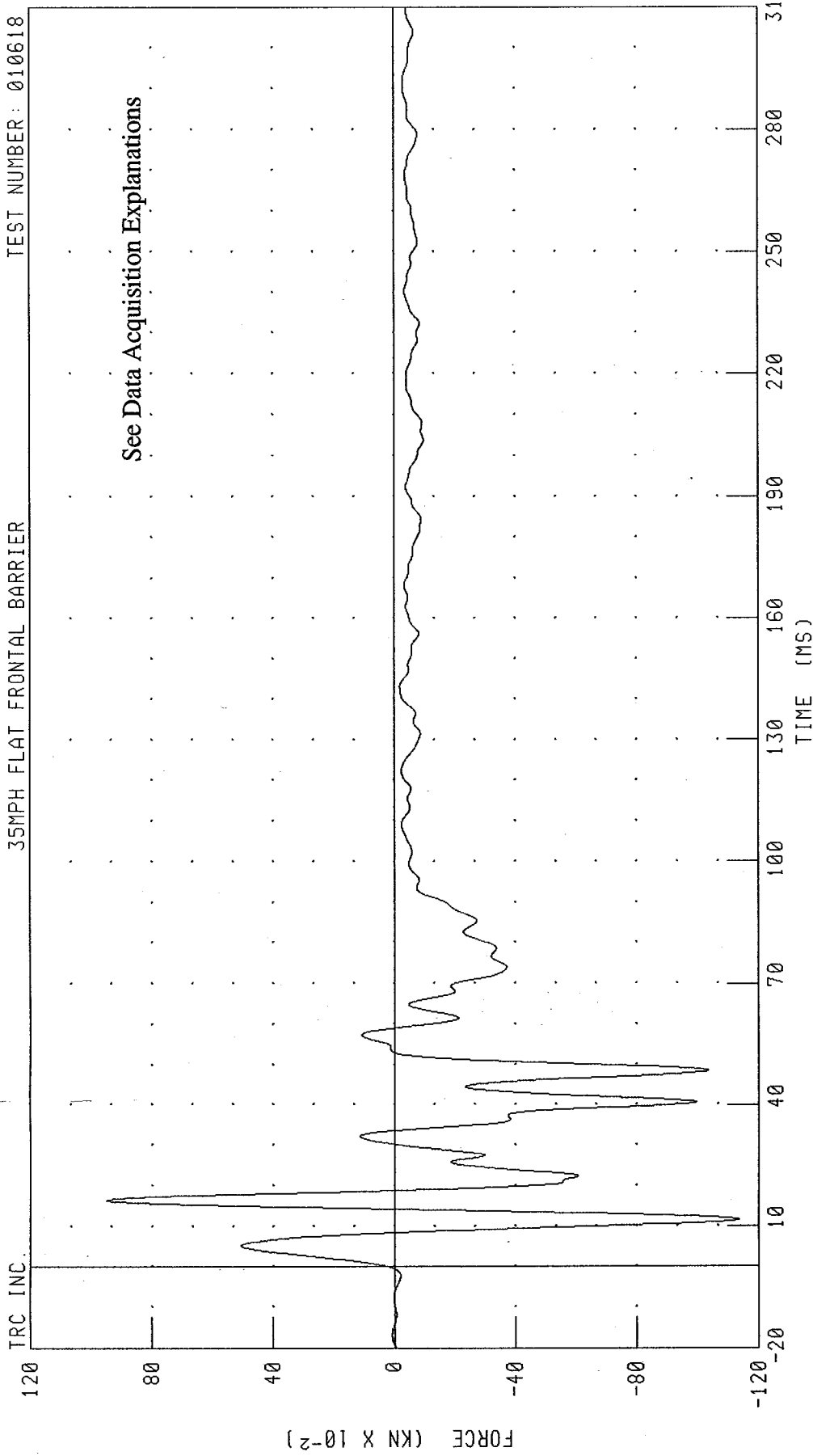

CHANNEL: BA2F FILTER: CH. CLASS 60

PEAK DATA: 0.95 KN @ 16.40 MS; -1.14 KN @ 11.52 MS

2001 NISSAN MAXIMA INTO FRONTAL LOAD CELL BARRIER
LOAD CELL BARRIER POSITION A3 FORCE
35MPH FLAT FRONTAL BARRIER

TEST NUMBER: 010618

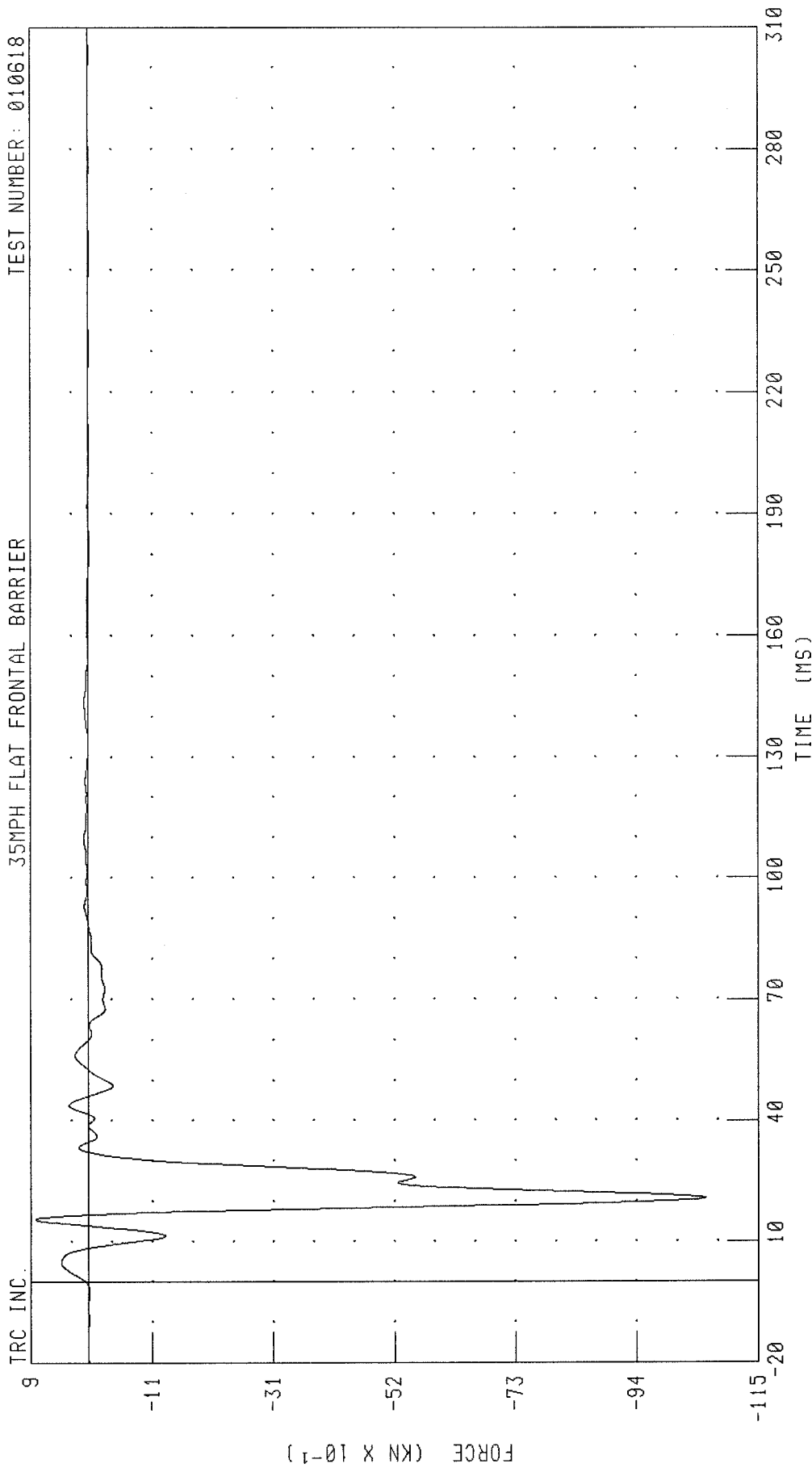

CHANNEL: BA3F FILTER: CH. CLASS 60 PEAK DATA: 0.92 KN @ 15.60 MS, -10.69 KN @ 20.80 MS

2001 NISSAN MAXIMA INTO FRONTAL LOAD CELL BARRIER
LOAD CELL BARRIER POSITION A4 FORCE
35MPH FLAT FRONTAL BARRIER

TEST NUMBER: 010618

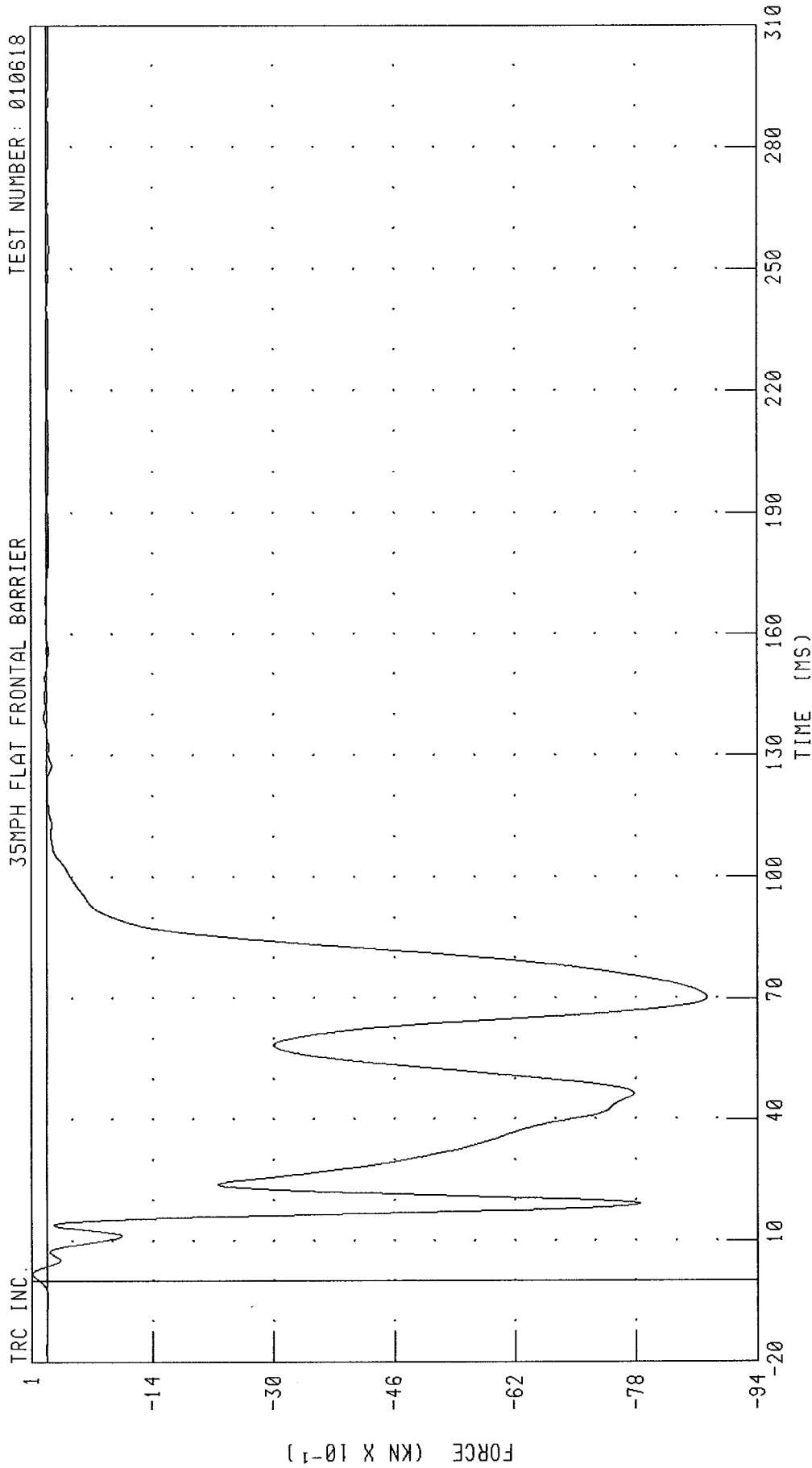

TRC INC. CHANNEL: BA4F FILTER: CH. CLASS 60
PEAK DATA: 0.19 KN @ 1.84 MS; -8.74 KN @ 70.24 MS

2001 NISSAN MAXIMA INTO FRONTAL LOAD CELL BARRIER
LOAD CELL BARRIER POSITION A5 FORCE
35MPH FLAT FRONTAL BARRIER

TEST NUMBER: 010618

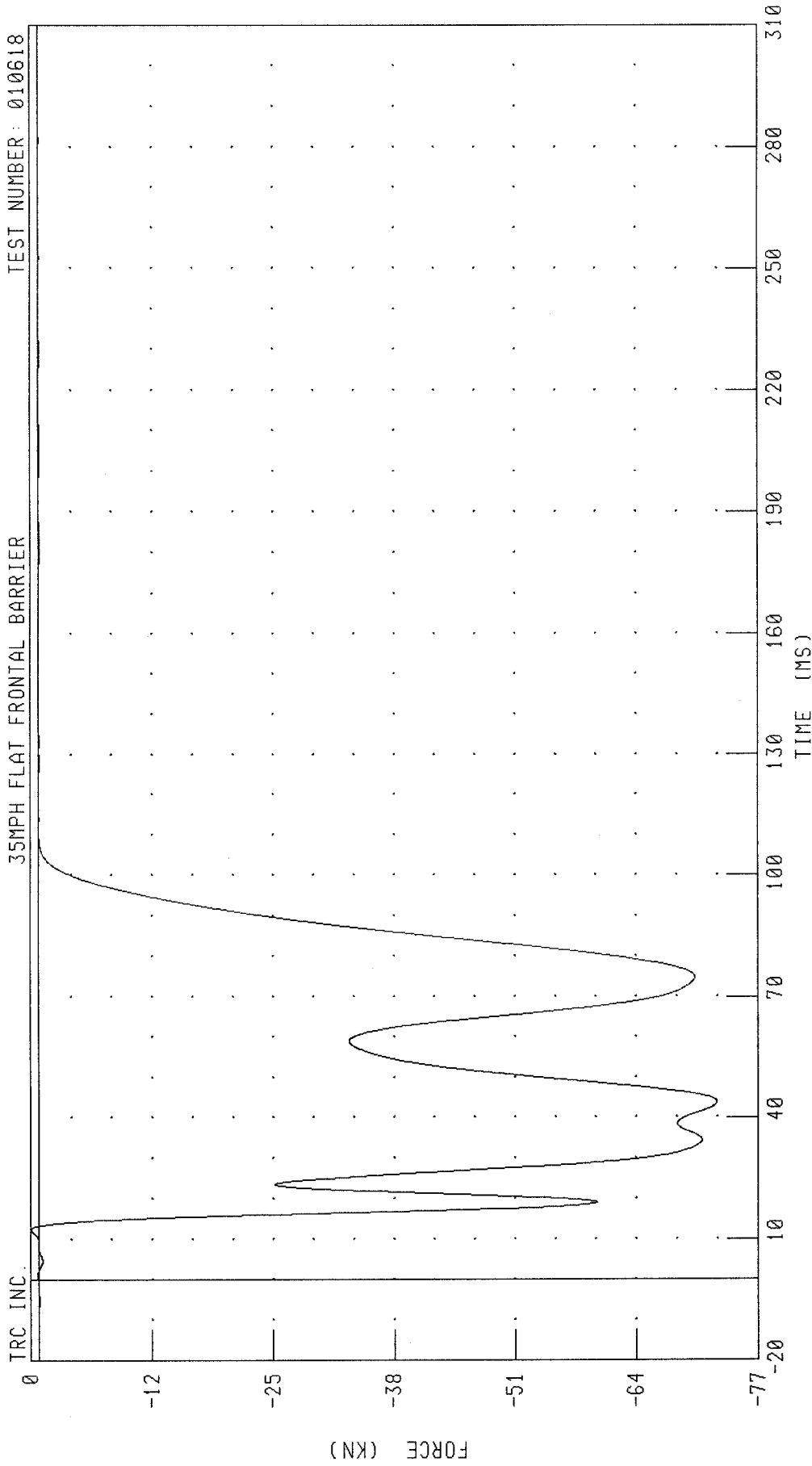

TRC INC. CHANNEL: BA5F FILTER: CH. CLASS 60
PEAK DATA: 0.88 KN @ 12.48 MS; -72.76 KN @ 43.76 MS

2001 NISSAN MAXIMA INTO FRONTAL LOAD CELL BARRIER
LOAD CELL BARRIER POSITION A6 FORCE
35MPH FLAT FRONTAL BARRIER

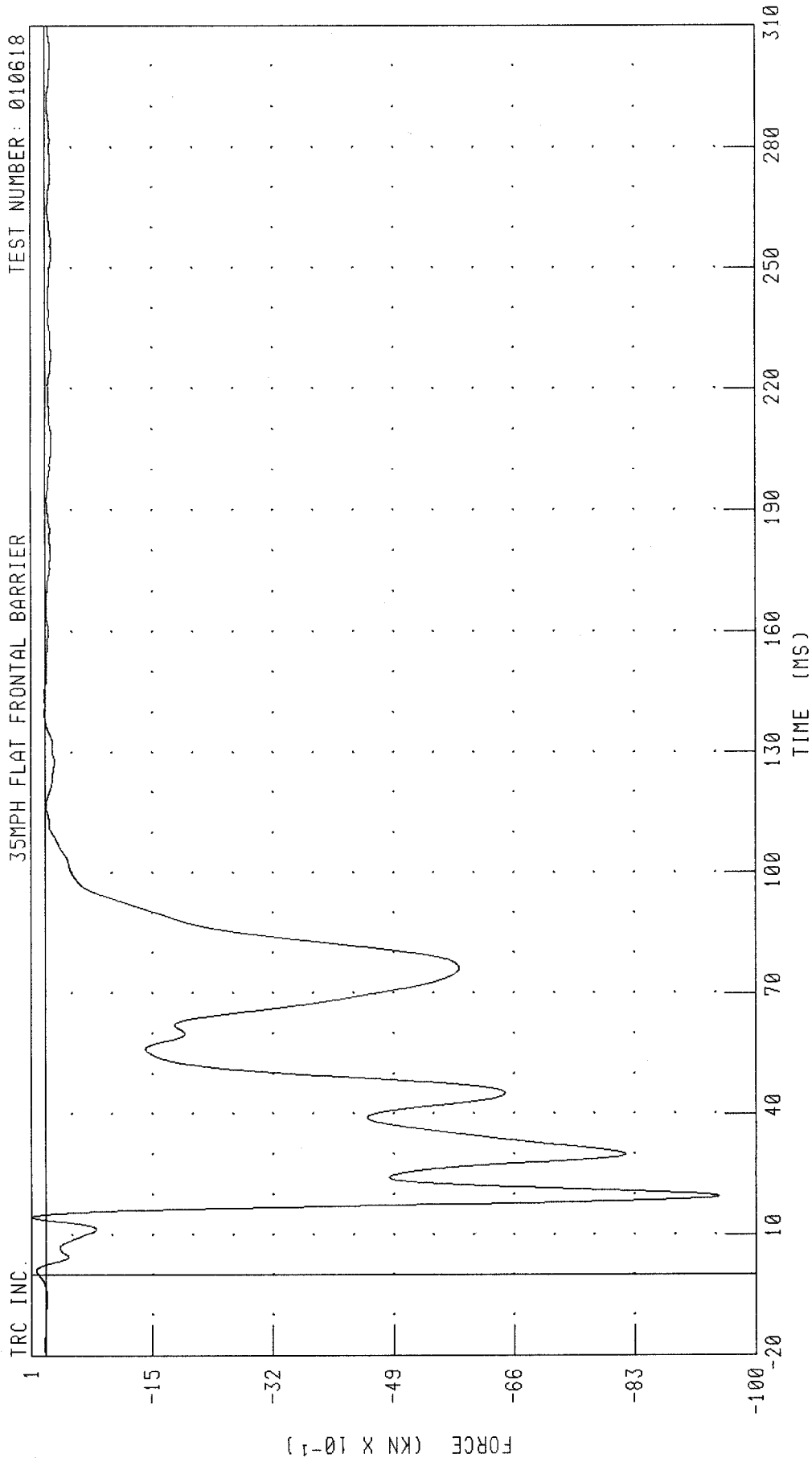

CHANNEL: BA6F FILTER: CH. CLASS 60

2001 NISSAN MAXIMA INTO FRONTAL LOAD CELL BARRIER
LOAD CELL BARRIER POSITION A7 FORCE
35MPH FLAT FRONTAL BARRIER

TEST NUMBER: 010618

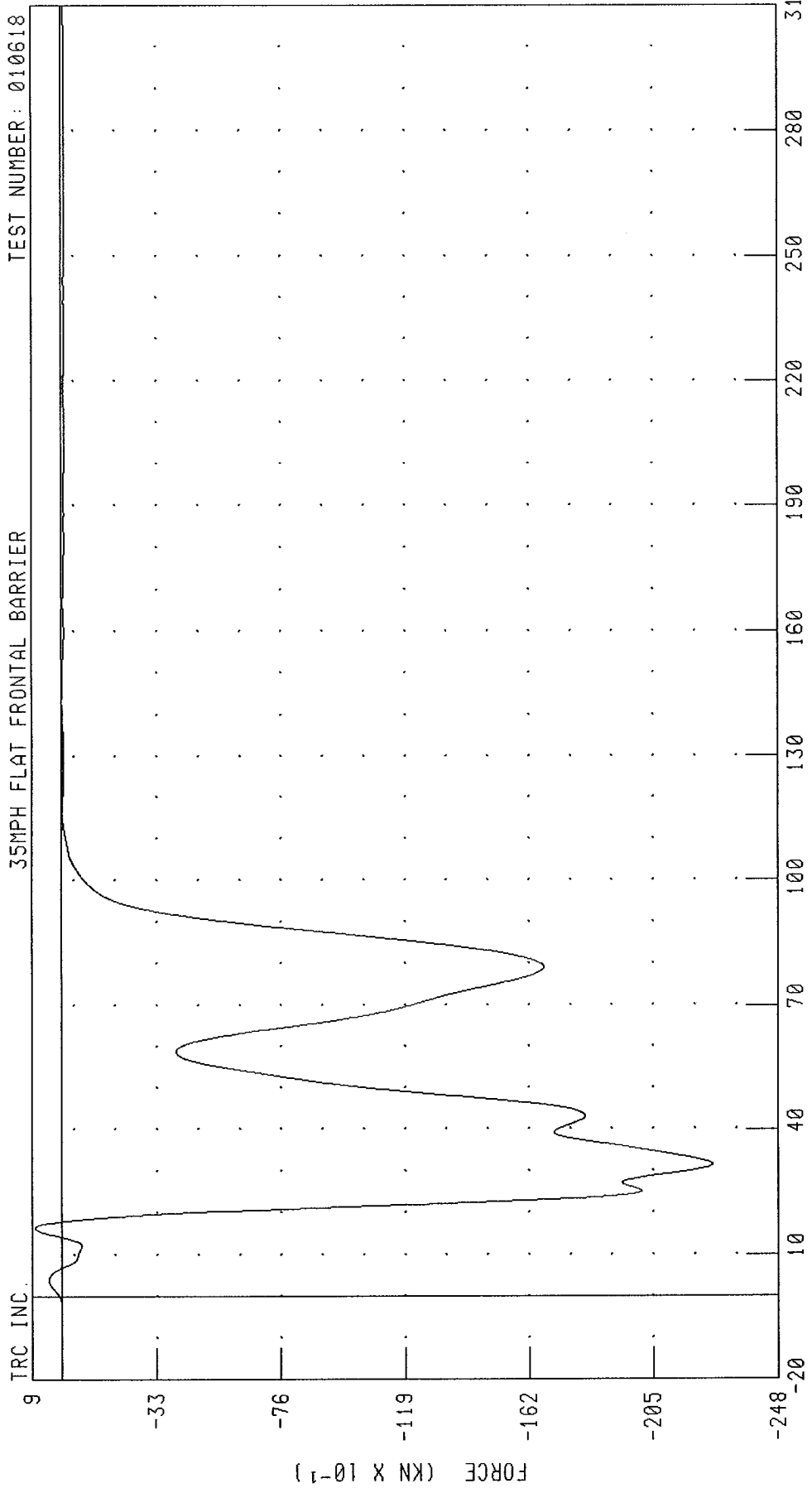

TRC INC. CHANNEL: BA7F FILTER: CH. CLASS 60
PEAK DATA: 0.91 KN @ 16.32 MS; -22.55 KN @ 31.52 MS

2001 NISSAN MAXIMA INTO FRONTAL LOAD CELL BARRIER
LOAD CELL BARRIER POSITION A8 FORCE
35MPH FLAT FRONTAL BARRIER

TEST NUMBER: 010618

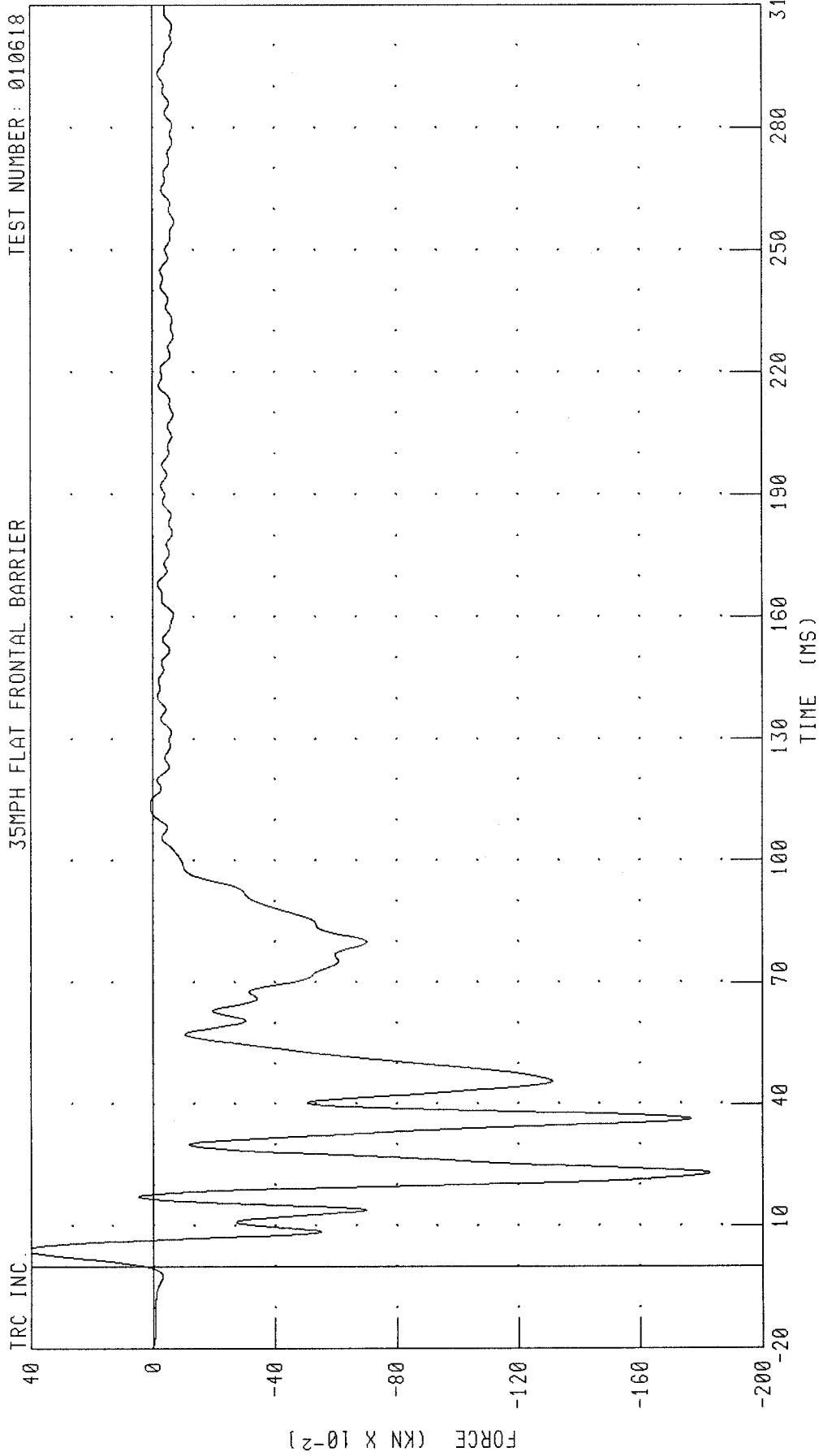

PEAK DATA: 0.42 KN @ 4.00 MS; -1.83 KN @ 22.88 MS

CHANNEL: BA8F FILTER: CH. CLASS 60

2001 NISSAN MAXIMA INTO FRONTAL LOAD CELL BARRIER
LOAD CELL BARRIER POSITION A9 FORCE
35MPH FLAT FRONTAL BARRIER

TEST NUMBER: 010618

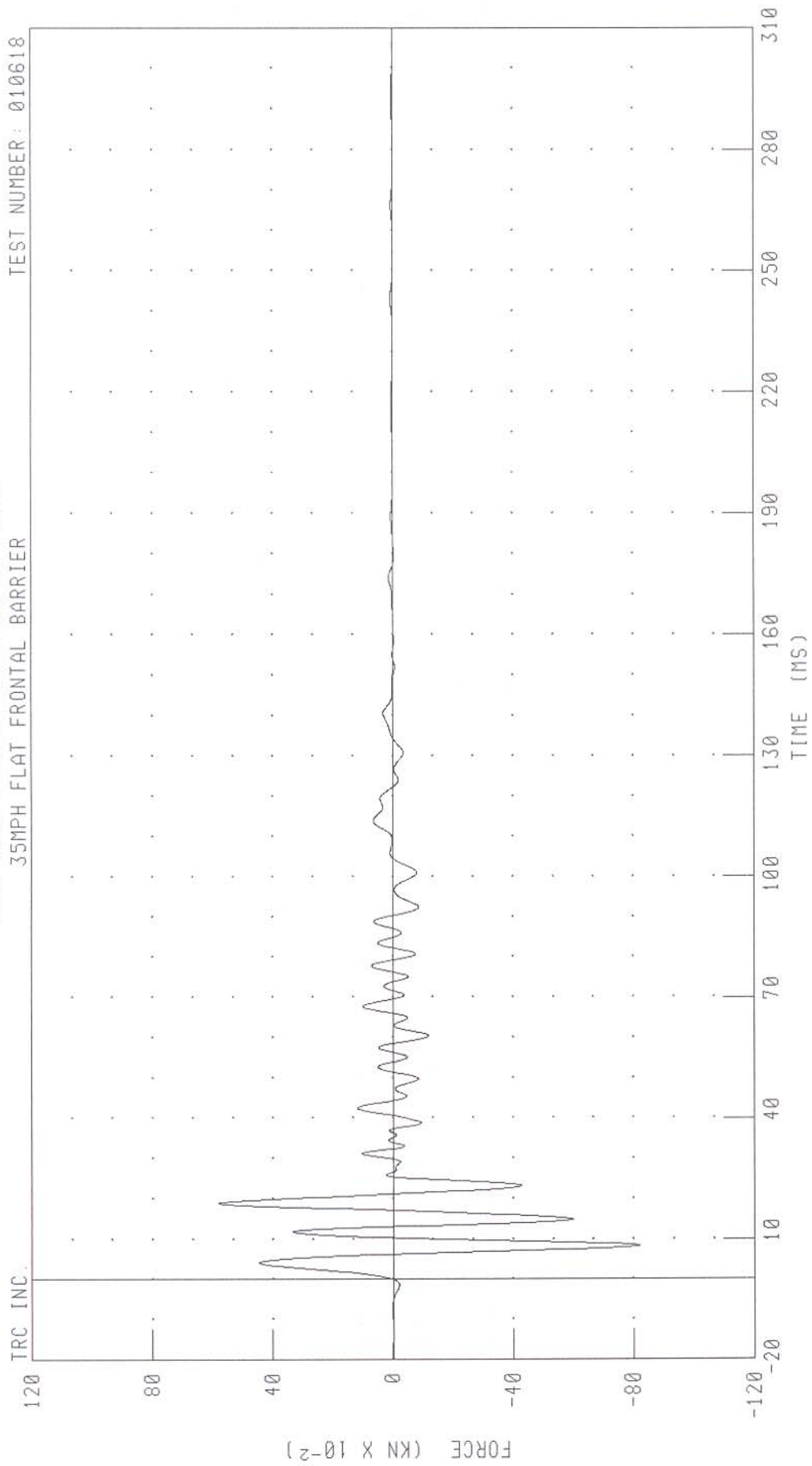

CHANNEL: BA9F FILTER: CH. CLASS 60 PEAK DATA: 0.58 KN @ 18.88 MS, -0.82 KN @ 8.32 MS

2001 NISSAN MAXIMA INTO FRONTAL LOAD CELL BARRIER
LOAD CELL BARRIER POSITION B1 FORCE
35MPH FLAT FRONTAL BARRIER

TEST NUMBER: 010618

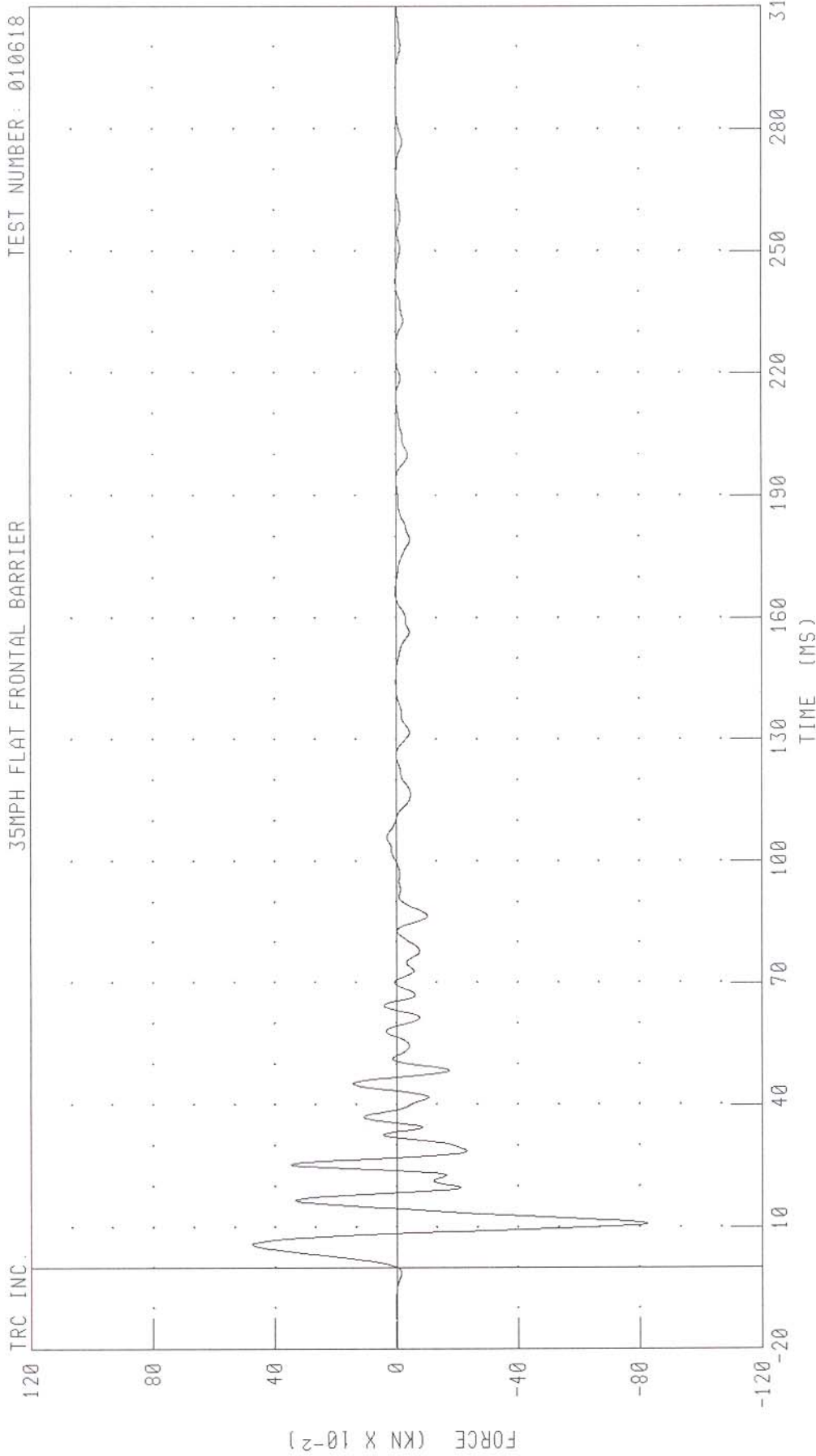

PEAK DATA: 0.47 KN @ 5.76 MS; -0.83 KN @ 10.88 MS

CHANNEL: BB1F FILTER: CH. CLASS 60

2001 NISSAN MAXIMA INTO FRONTAL LOAD CELL BARRIER
LOAD CELL BARRIER POSITION B2 FORCE
35MPH FLAT FRONTAL BARRIER

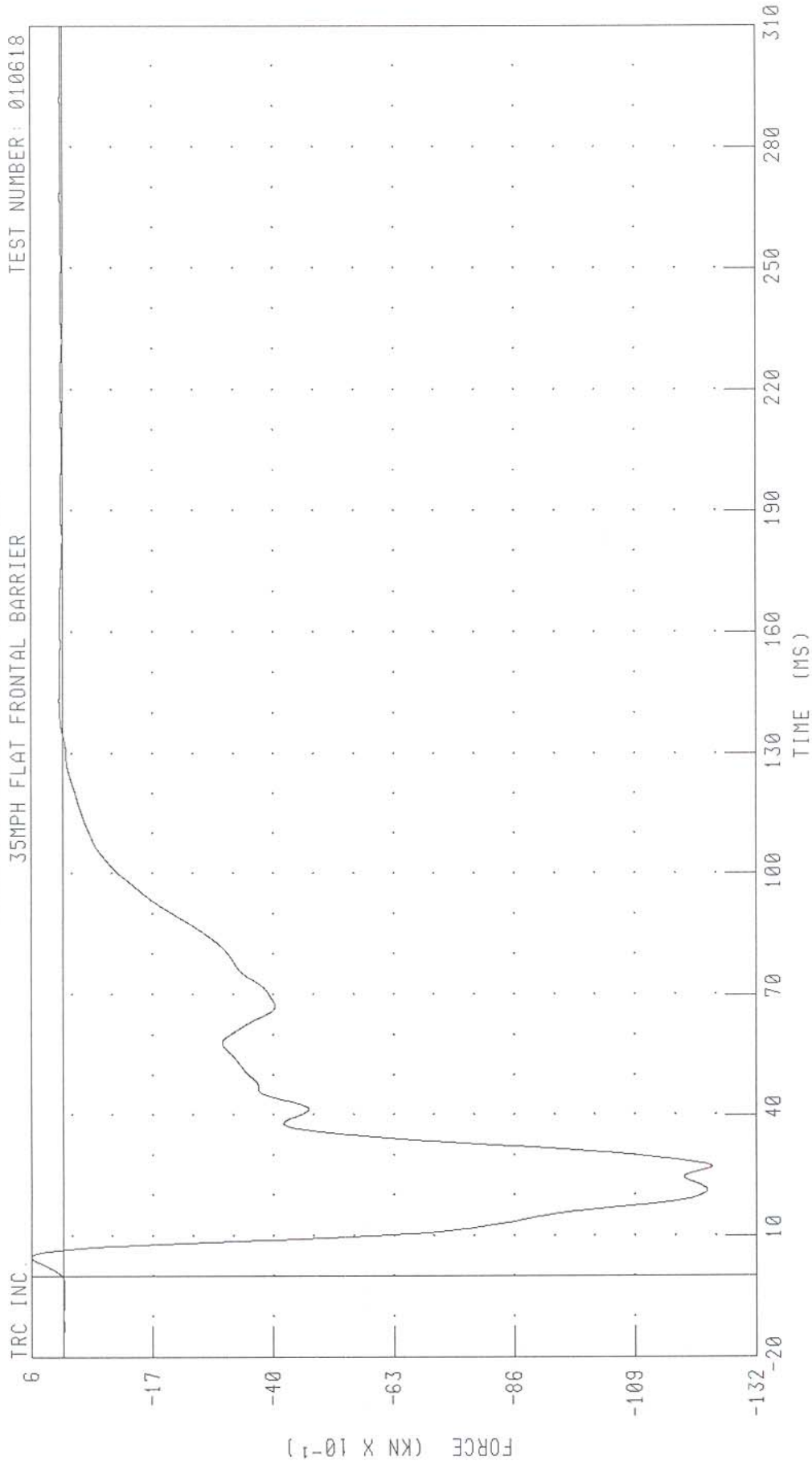

CHANNEL: BB2F FILTER: CH. CLASS 60

PEAK DATA: 0.61 KN @ 4.72 MS; -12.36 KN @ 27.12 MS

2001 NISSAN MAXIMA INTO FRONTAL LOAD CELL BARRIER
LOAD CELL BARRIER POSITION B3 FORCE
35MPH FLAT FRONTAL BARRIER

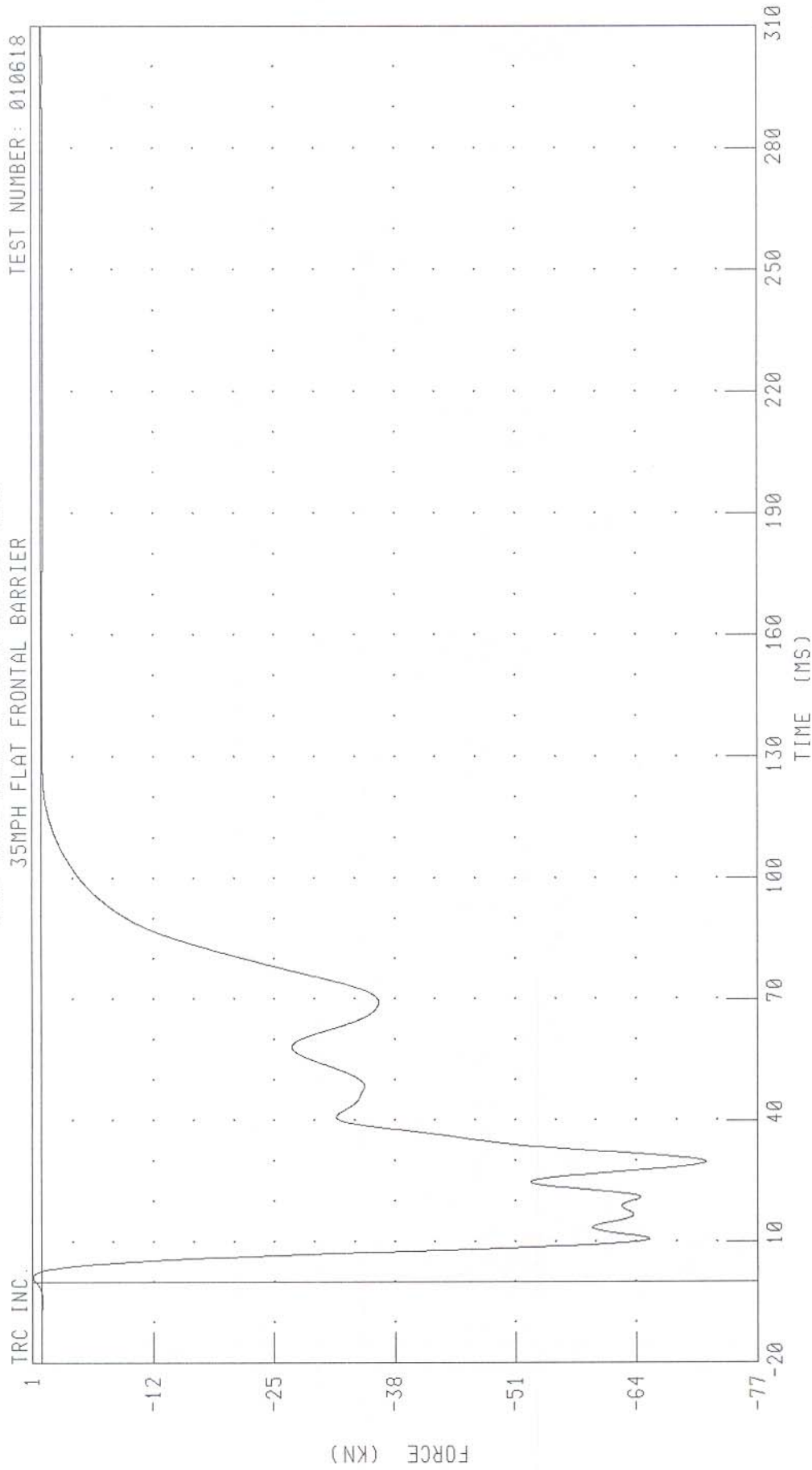

CHANNEL: BB3F FILTER: CH CLASS 60 PEAK DATA: 0.97 KN @ 1.36 MS, -71.47 KN @ 29.68 MS

2001 NISSAN MAXIMA INTO FRONTAL LOAD CELL BARRIER
 LOAD CELL BARRIER POSITION B4 FORCE
 35MPH FLAT FRONTAL BARRIER

TEST NUMBER : 010618

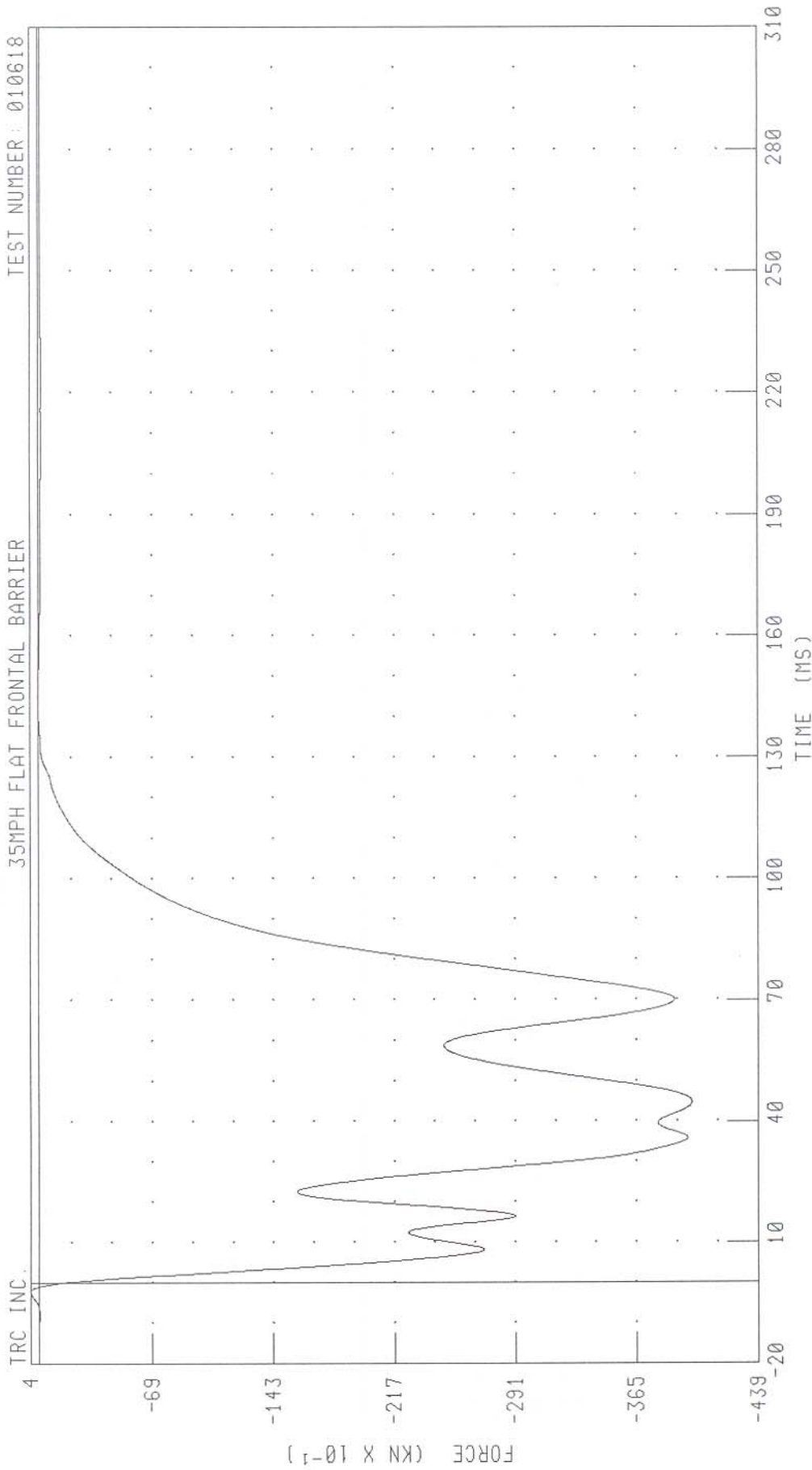

PEAK DATA : 0.52 KN @ -2.32 MS; -39.87 KN @ 44.80 MS

CHANNEL : BB4F FILTER : CH. CLASS 60

2001 NISSAN MAXIMA INTO FRONTAL LOAD CELL BARRIER
 LOAD CELL BARRIER POSITION B5 FORCE
 35MPH FLAT FRONTAL BARRIER

TEST NUMBER: 010618

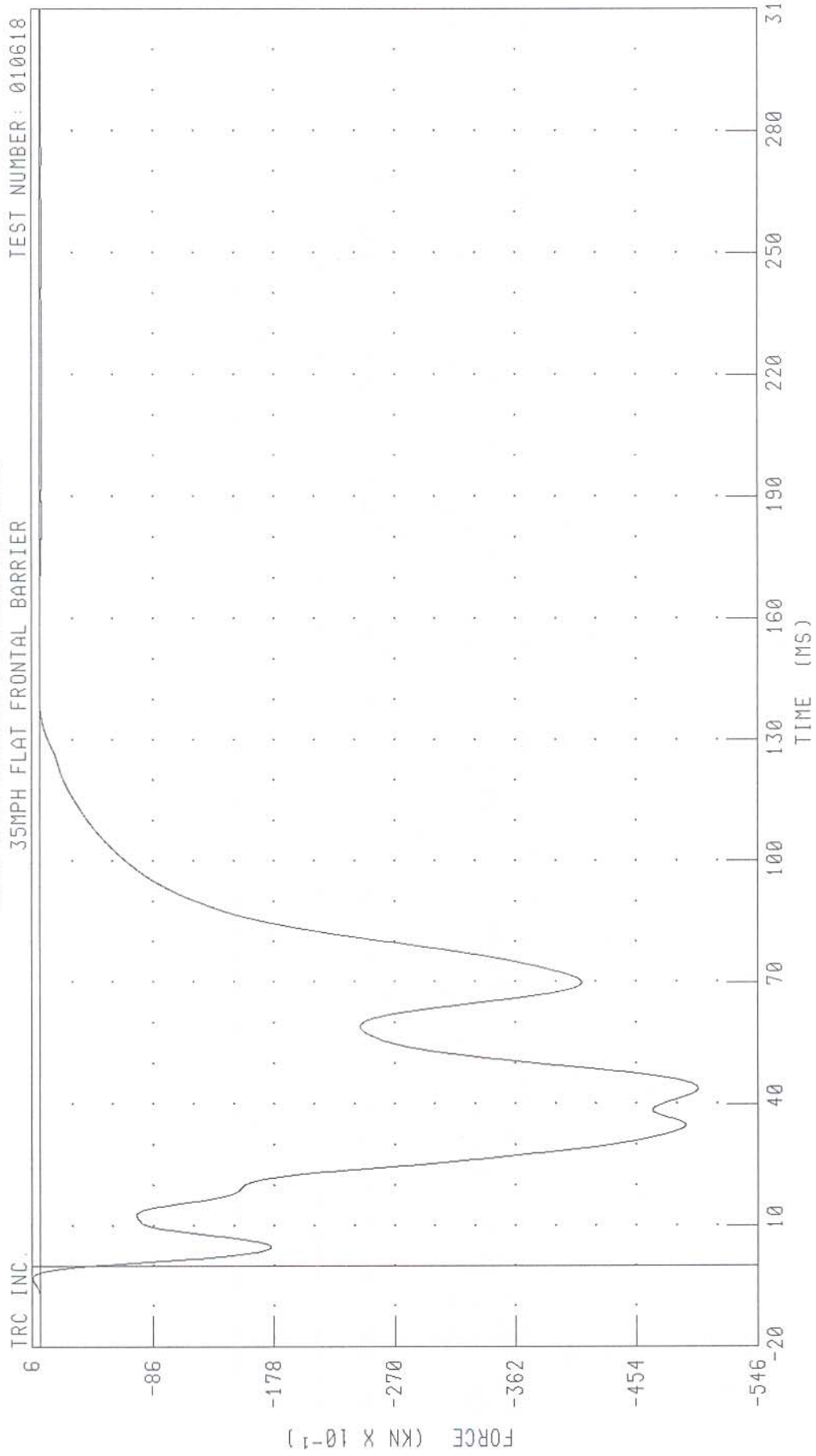

CHANNEL: BB5F FILTER: CH CLASS 60 PEAK DATA: 0.56 KN @ -3.12 MS, -50.09 KN @ 43.84 MS

2001 NISSAN MAXIMA INTO FRONTAL LOAD CELL BARRIER
 LOAD CELL BARRIER POSITION B6 FORCE
 35MPH FLAT FRONTAL BARRIER

TEST NUMBER: 010618

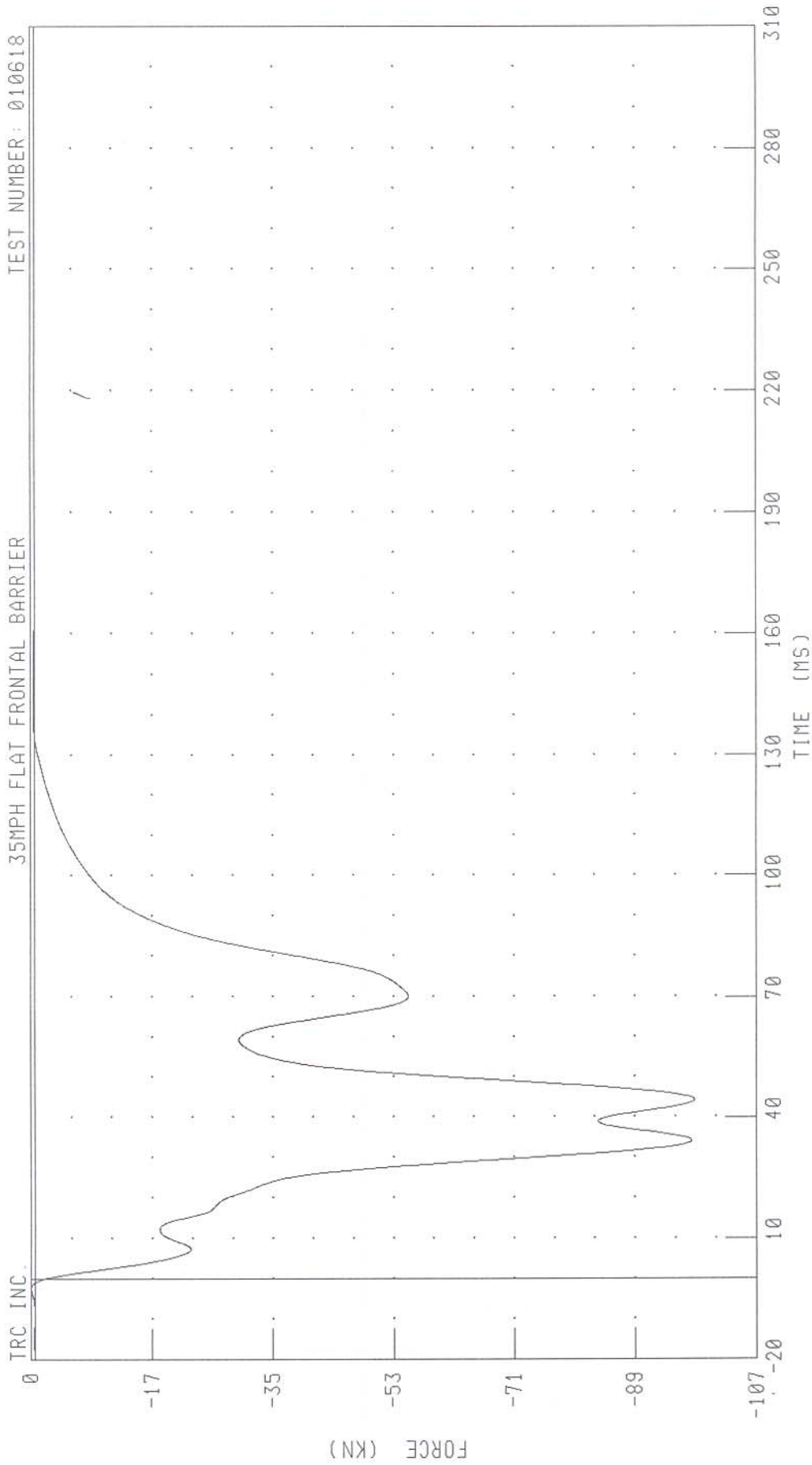

CHANNEL: BB6F FILTER: CH. CLASS 60

PEAK DATA: 0.53 KN @ -2.40 MS; -98.36 KN @ 44.32 MS

2001 NISSAN MAXIMA INTO FRONTAL LOAD CELL BARRIER
LOAD CELL BARRIER POSITION B7 FORCE
35MPH FLAT FRONTAL BARRIER

TEST NUMBER: 010618

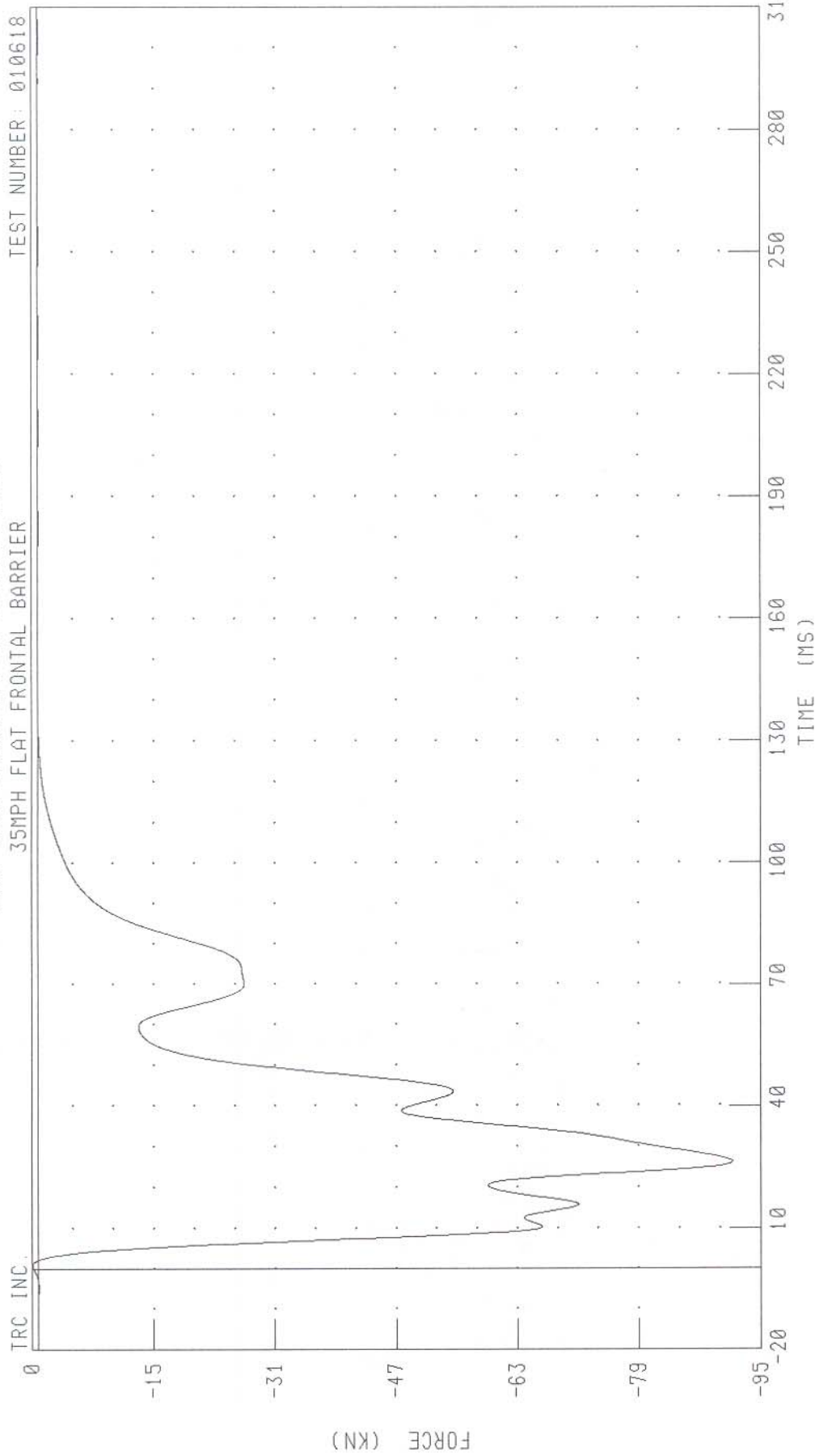

PEAK DATA: 0.74 KN @ 0.80 MS, -91.54 KN @ 26.16 MS

CHANNEL: BB7F FILTER: CH. CLASS 60

2001 NISSAN MAXIMA INTO FRONTAL LOAD CELL BARRIER
LOAD CELL BARRIER POSITION B8 FORCE
35MPH FLAT FRONTAL BARRIER

TEST NUMBER: 010618

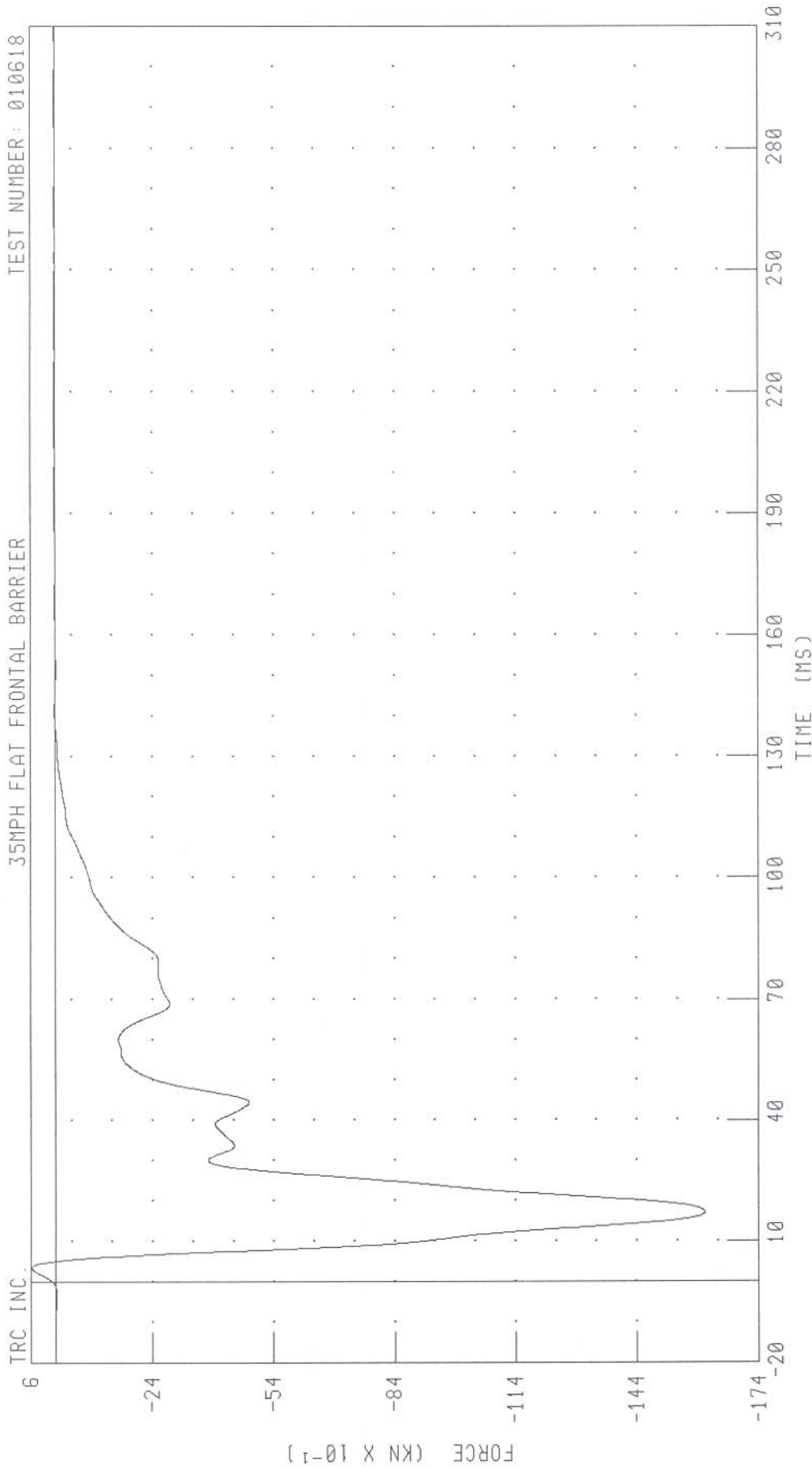

PEAK DATA: 0.58 KN @ 3.44 MS; -16.08 KN @ 17.12 MS

FILTER: CH. CLASS 60

CHANNEL: BB8F

2001 NISSAN MAXIMA INTO FRONTAL LOAD CELL BARRIER
LOAD CELL BARRIER POSITION B9 FORCE
35MPH FLAT FRONTAL BARRIER

TEST NUMBER: 010618

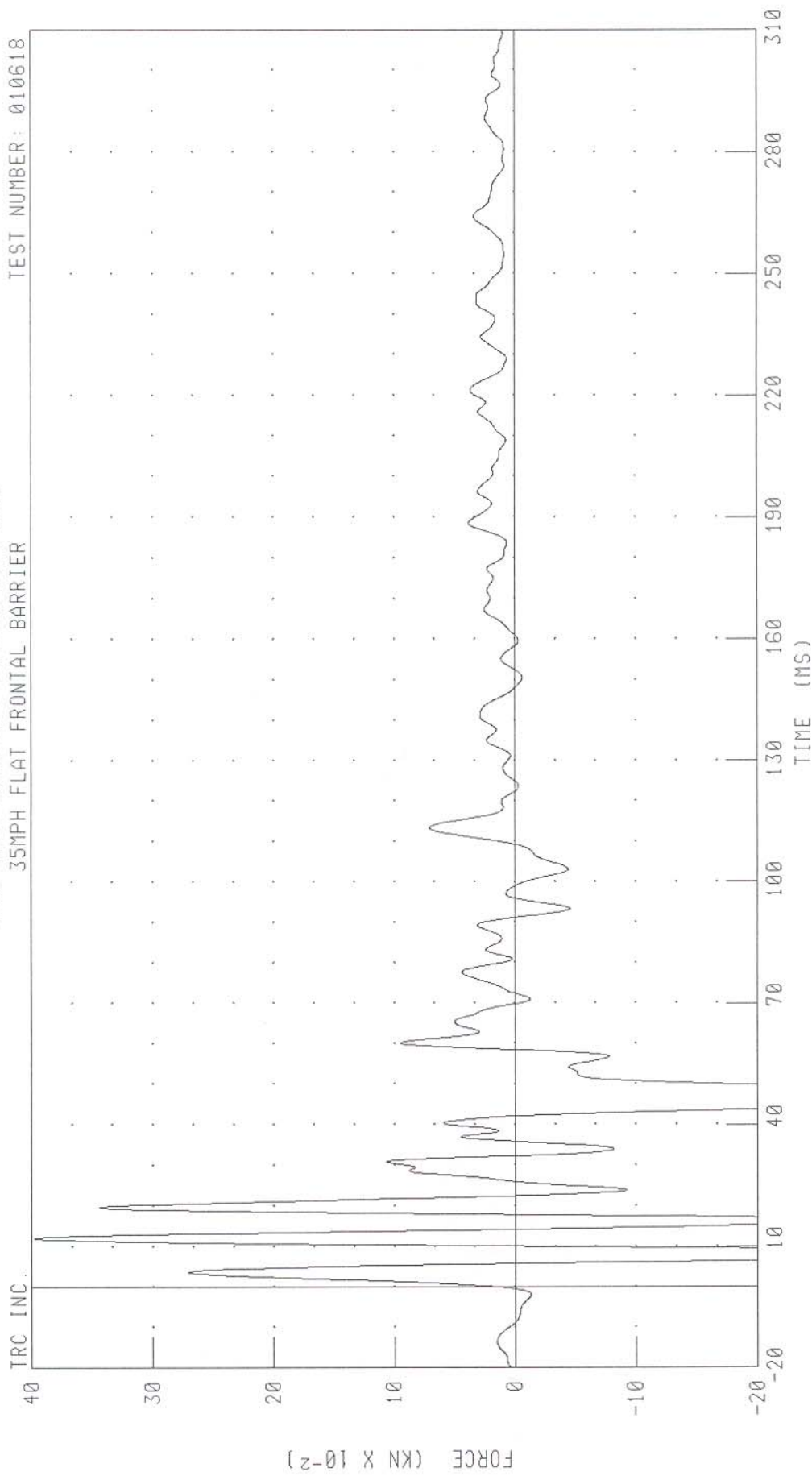

CHANNEL: BB9F FILTER: CH. CLASS 60 PEAK DATA: 0.40 KN @ 12.08 MS, -0.56 KN @ 8.08 MS

2001 NISSAN MAXIMA INTO FRONTAL LOAD CELL BARRIER
LOAD CELL BARRIER POSITION C1 FORCE
35MPH FLAT FRONTAL BARRIER

TEST NUMBER: 010618

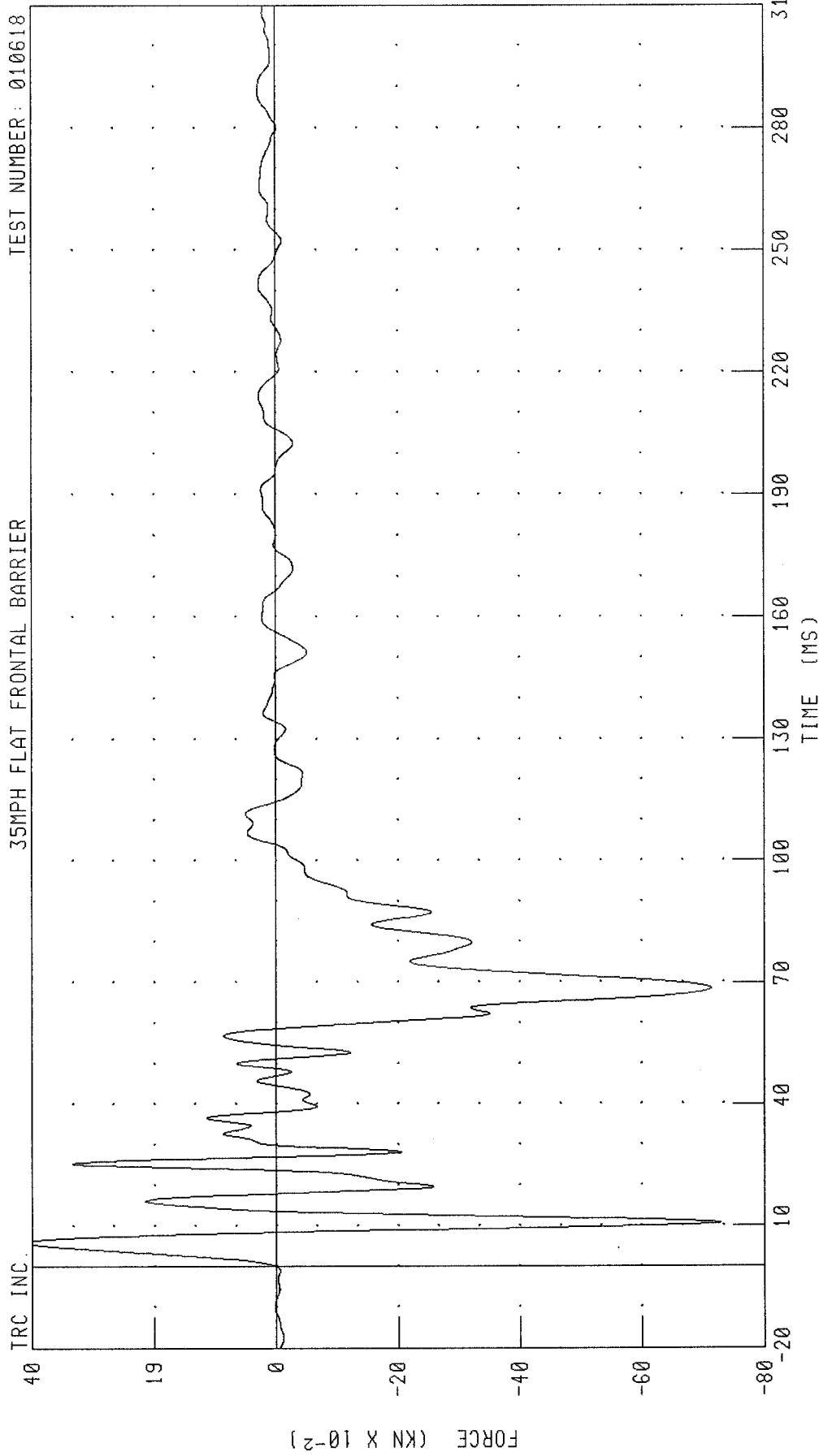

CHANNEL: BC1F FILTER: CH. CLASS 60 PEAK DATA: 0.41 KN @ 5.92 MS; -0.73 KN @ 10.64 MS

2001 NISSAN MAXIMA INTO FRONTAL LOAD CELL BARRIER
 LOAD CELL BARRIER POSITION C2 FORCE
 35MPH FLAT FRONTAL BARRIER

TEST NUMBER: 010618

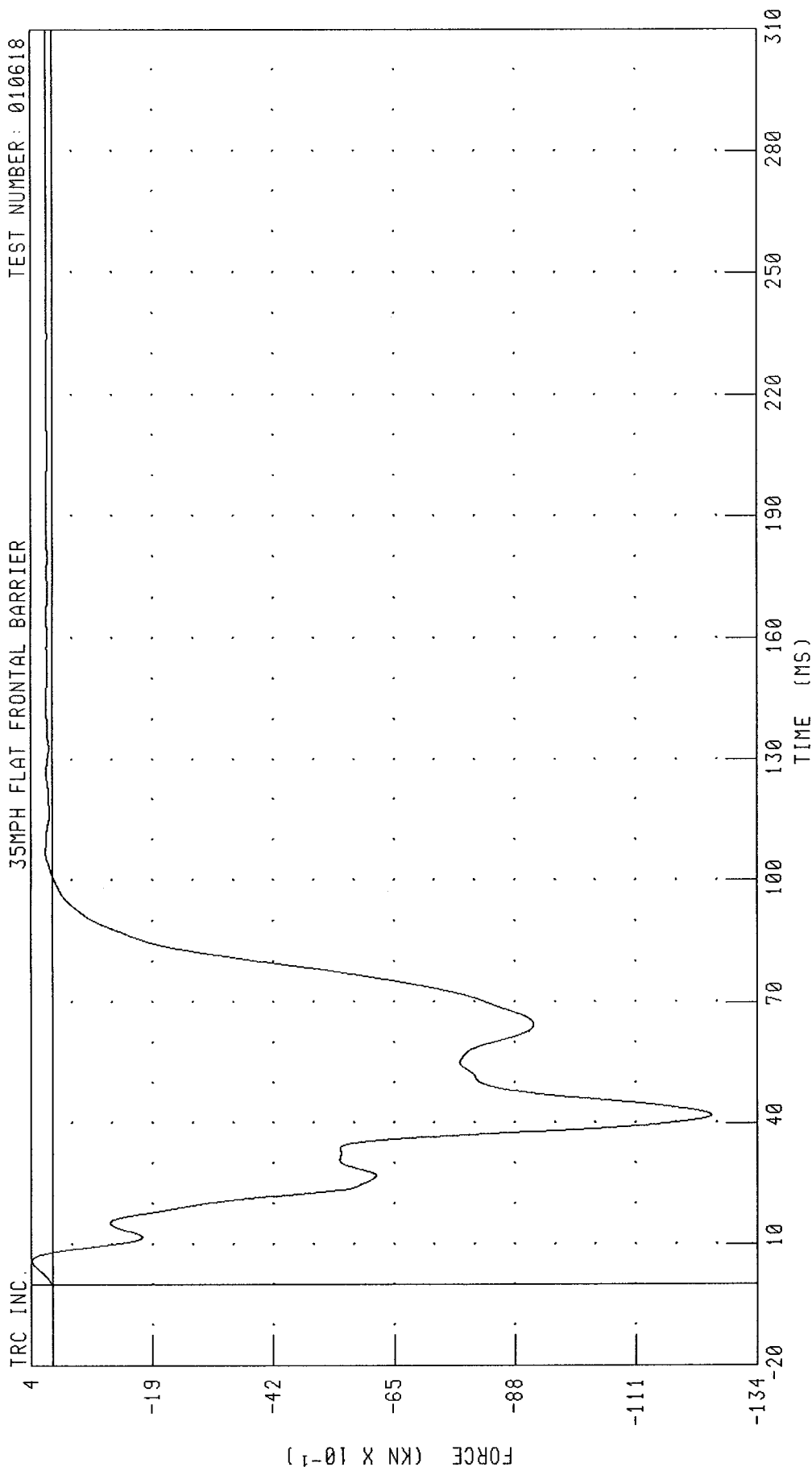

CHANNEL: BC2F FILTER: CH. CLASS 60 PEAK DATA: 0.39 KN @ 5.92 MS; -12.54 KN @ 42.00 MS

2001 NISSAN MAXIMA INTO FRONTAL LOAD CELL BARRIER
LOAD CELL BARRIER POSITION C3 FORCE
35MPH FLAT FRONTAL BARRIER

TEST NUMBER: 010618

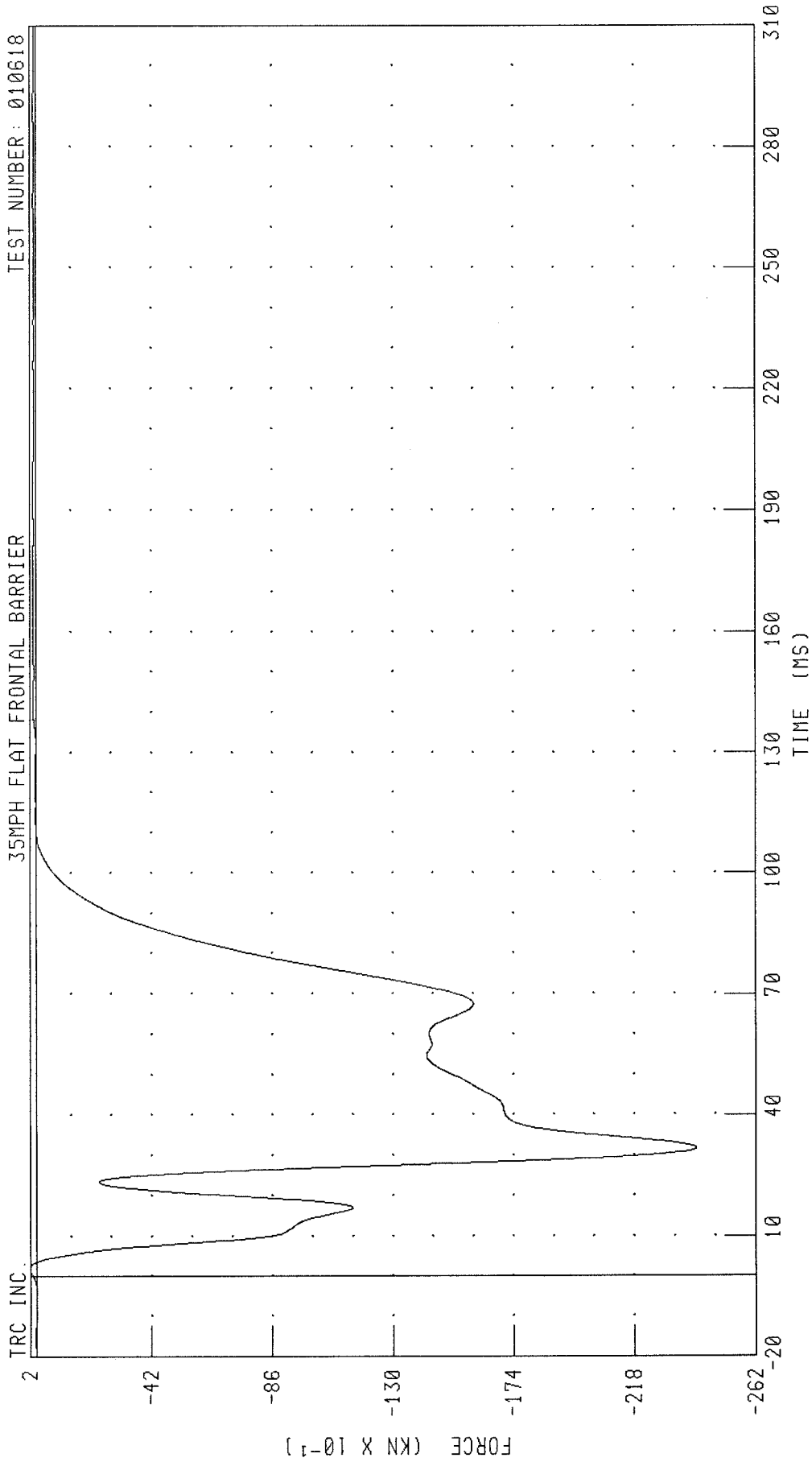

CHANNEL: BC3F FILTER: CH. CLASS 60

PEAK DATA: 0.25 KN @ 1.92 MS; -24.05 KN @ 31.76 MS

2001 NISSAN MAXIMA INTO FRONTAL LOAD CELL BARRIER
LOAD CELL BARRIER POSITION C4 FORCE
35MPH FLAT FRONTAL BARRIER

TEST NUMBER: 010618

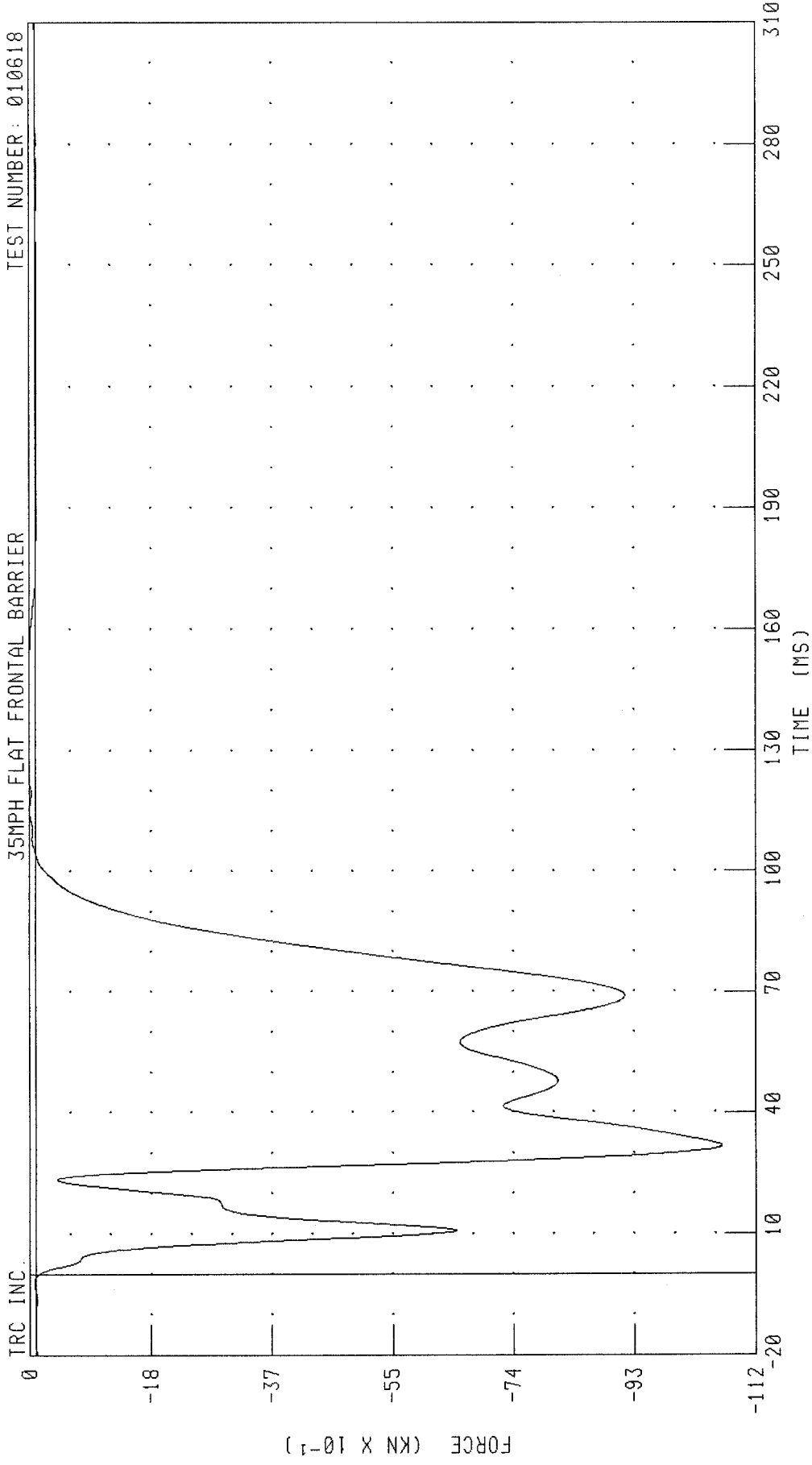

CHANNEL: BC4F FILTER: CH. CLASS 60 PEAK DATA: 0.13 KN @ 140.00 MS, -10.77 KN @ 31.76 MS

2001 NISSAN MAXIMA INTO FRONTAL LOAD CELL BARRIER
 LOAD CELL BARRIER POSITION C5 FORCE
 35MPH FLAT FRONTAL BARRIER

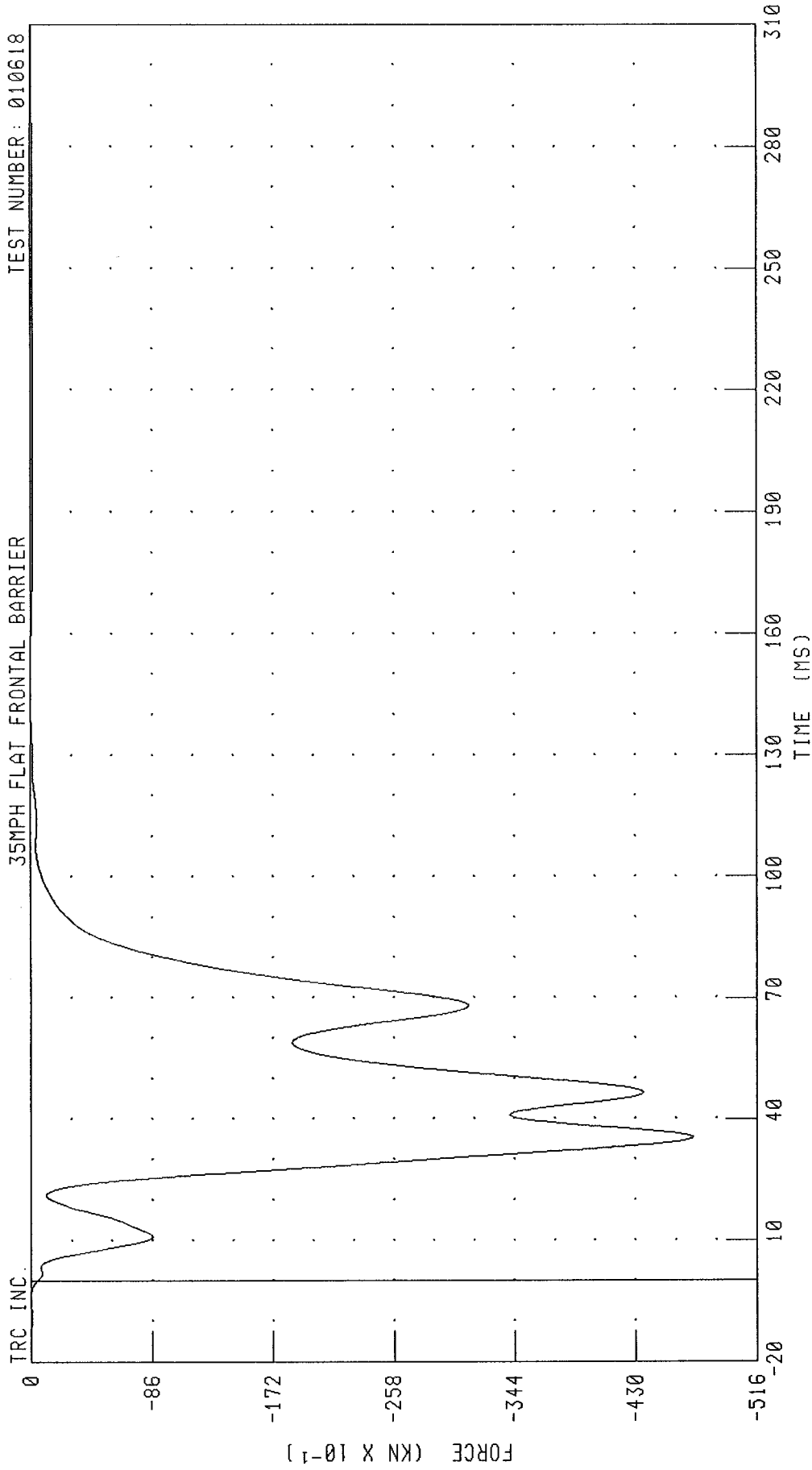

CHANNEL: BC5F FILTER: CH. CLASS 60

PEAK DATA: 0.02 KN @ 144.08 MS; -47.08 KN @ 35.36 MS

2001 NISSAN MAXIMA INTO FRONTAL LOAD CELL BARRIER
 LOAD CELL BARRIER POSITION C6 FORCE
 35MPH FLAT FRONTAL BARRIER

TEST NUMBER: 010618

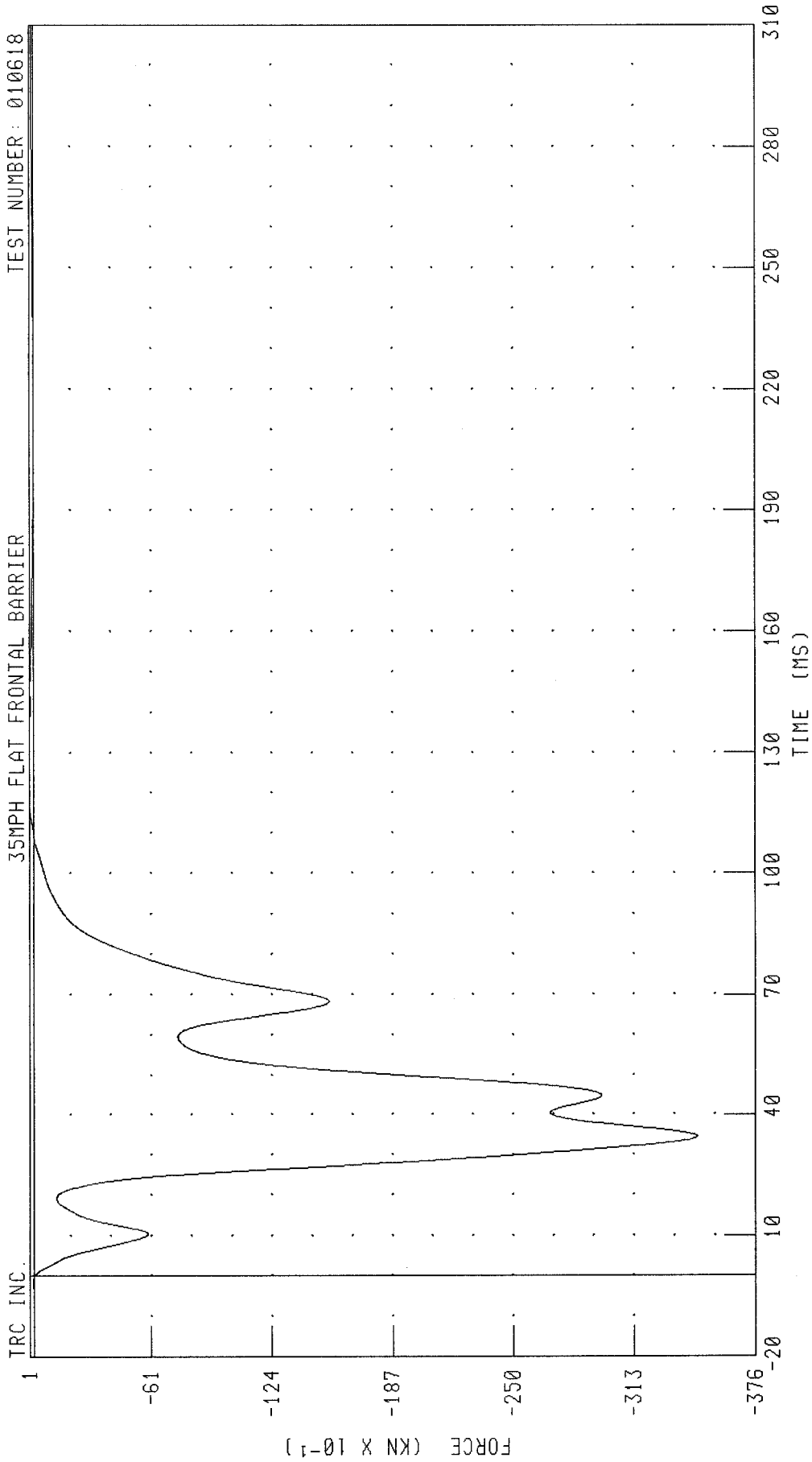

CHANNEL: BC6F FILTER: CH. CLASS 60

PEAK DATA: 0.26 KN @ 123.28 MS; -34.60 KN @ 34.48 MS

2001 NISSAN MAXIMA INTO FRONTAL LOAD CELL BARRIER
LOAD CELL BARRIER POSITION C7 FORCE
35MPH FLAT FRONTAL BARRIER

TEST NUMBER: 010618

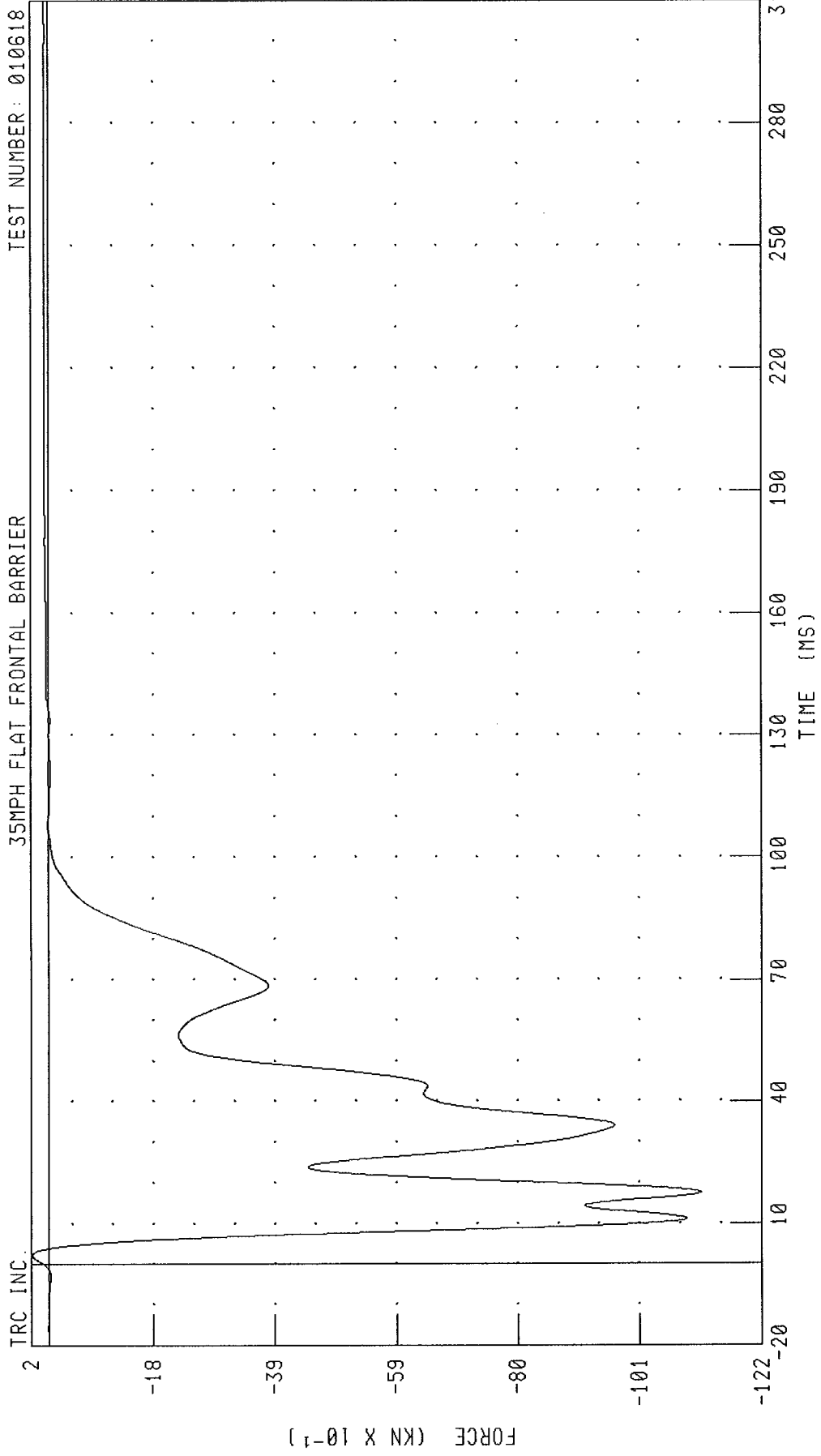

CHANNEL: BC7F FILTER: CH. CLASS 60 PEAK DATA: 0.29 KN @ 2.16 MS; -11.26 KN @ 17.68 MS

2001 NISSAN MAXIMA INTO FRONTAL LOAD CELL BARRIER
LOAD CELL BARRIER POSITION C8 FORCE
35MPH FLAT FRONTAL BARRIER

TEST NUMBER: 010618

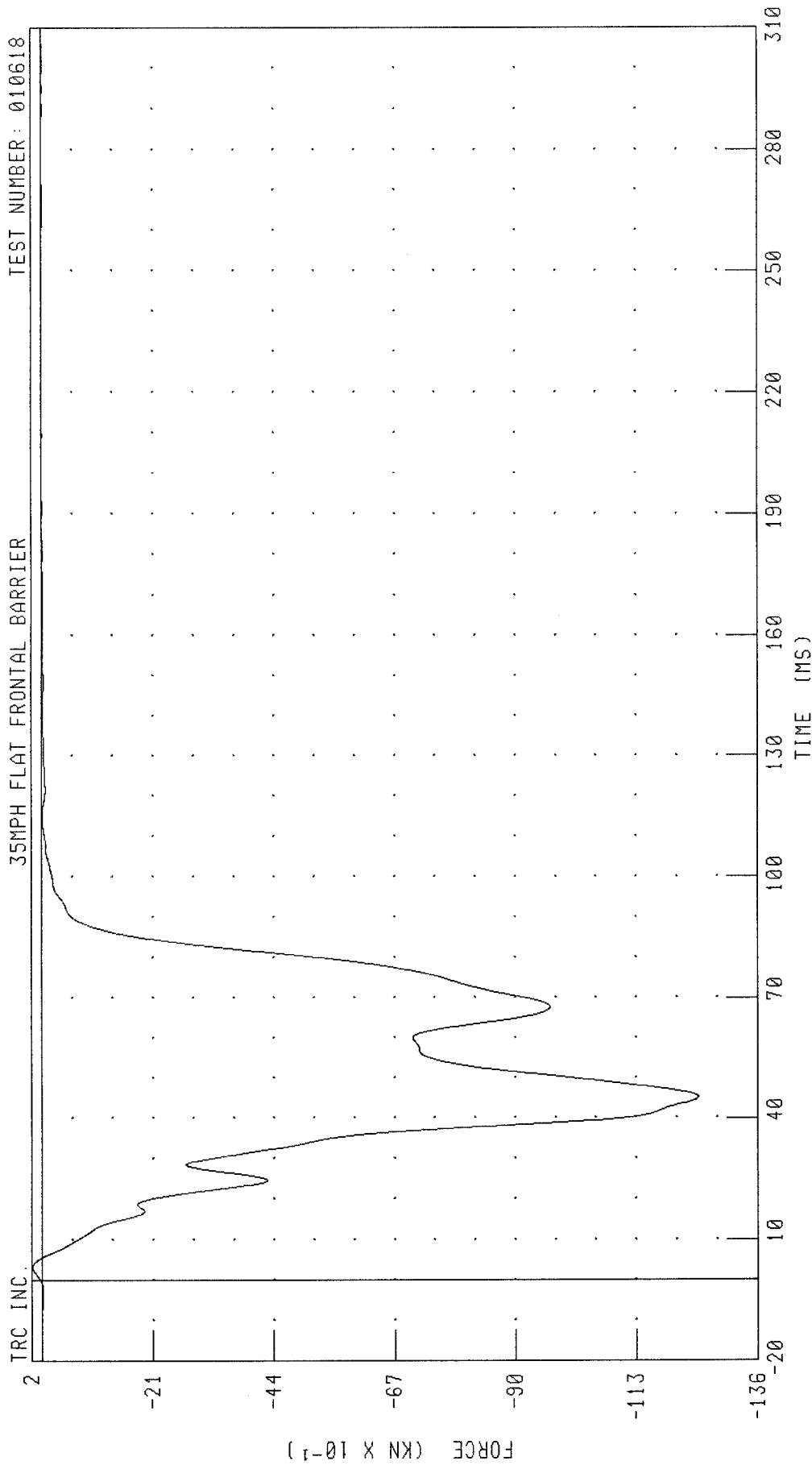

CHANNEL: BC8F FILTER: CH. CLASS 60 PEAK DATA: 0.18 KN @ 3.20 MS; -12.48 KN @ 45.20 MS

2001 NISSAN MAXIMA INTO FRONTAL LOAD CELL BARRIER
LOAD CELL BARRIER POSITION C9 FORCE
35MPH FLAT FRONTAL BARRIER

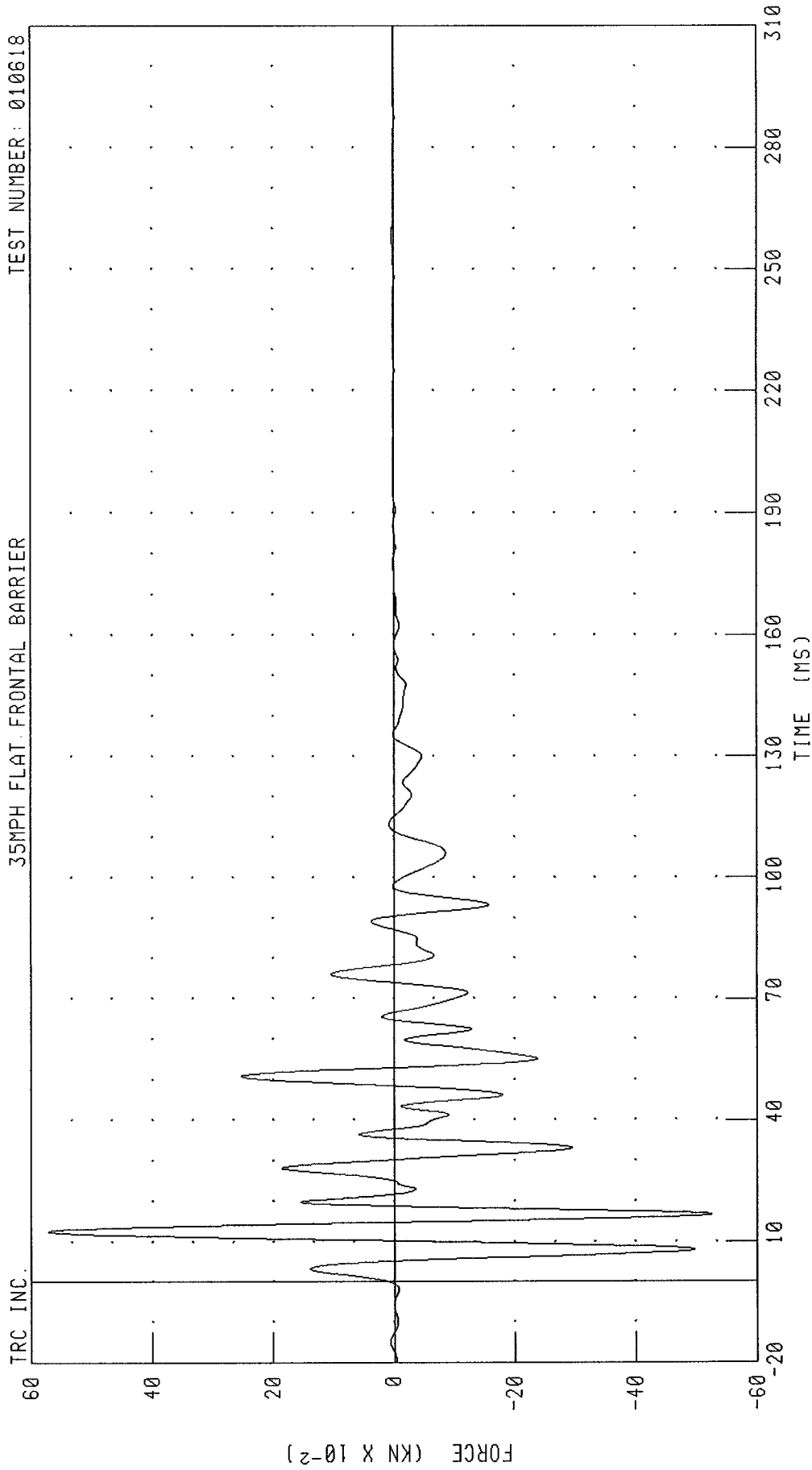

CHANNEL: BC9F FILTER: CH. CLASS 60 PEAK DATA: 0.57 KN @ 12.64 MS; -0.53 KN @ 16.72 MS

2001 NISSAN MAXIMA INTO FRONTAL LOAD CELL BARRIER
LOAD CELL BARRIER POSITION D1 FORCE
35MPH FLAT FRONTAL BARRIER

TEST NUMBER: 010618

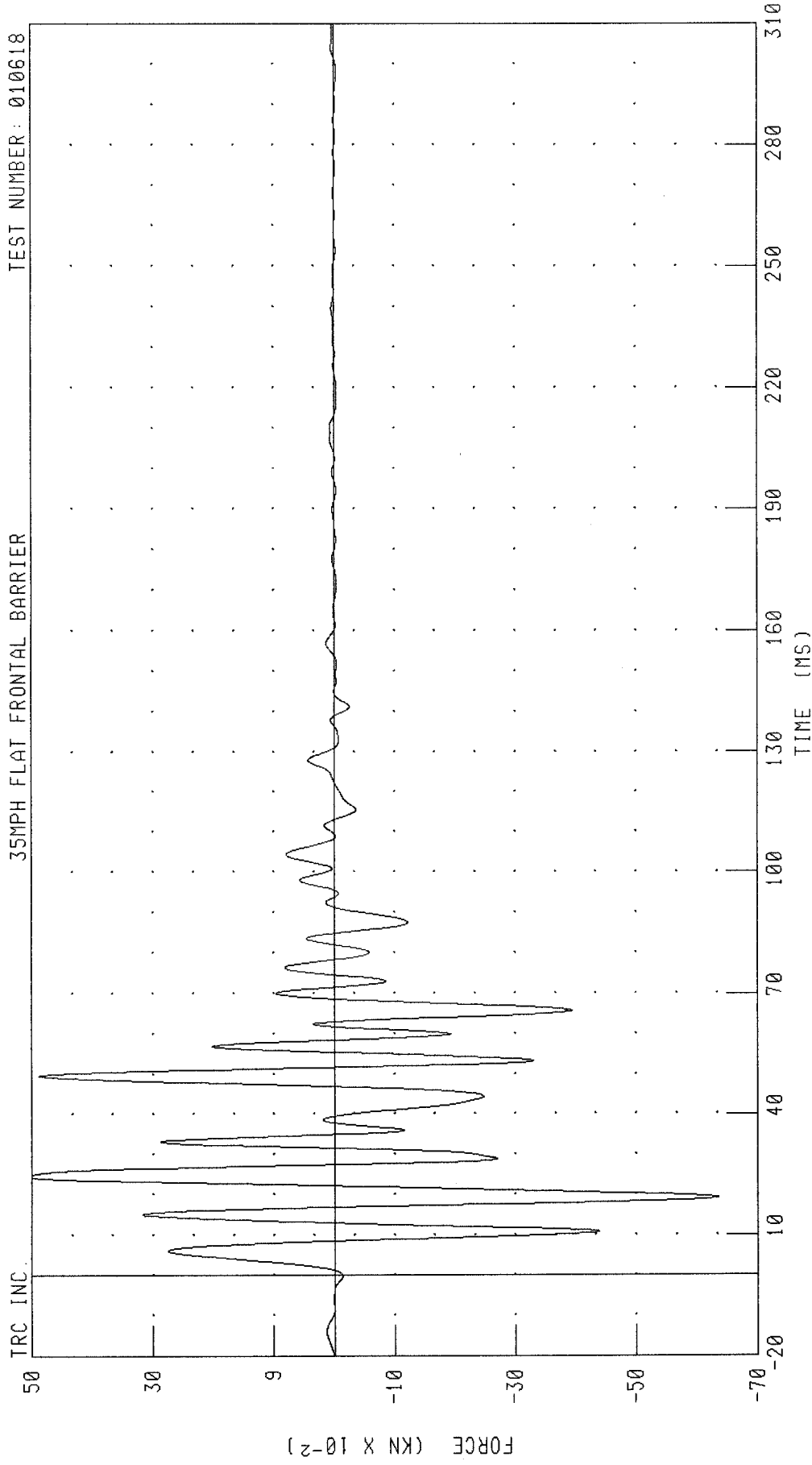

PEAK DATA: 0.51 KN @ 24.56 MS, -0.64 KN @ 19.20 MS

CHANNEL: BD1F FILTER: CH. CLASS 60

2001 NISSAN MAXIMA INTO FRONTAL LOAD CELL BARRIER
LOAD CELL BARRIER POSITION D2 FORCE
35MPH FLAT FRONTAL BARRIER

TEST NUMBER: 010618

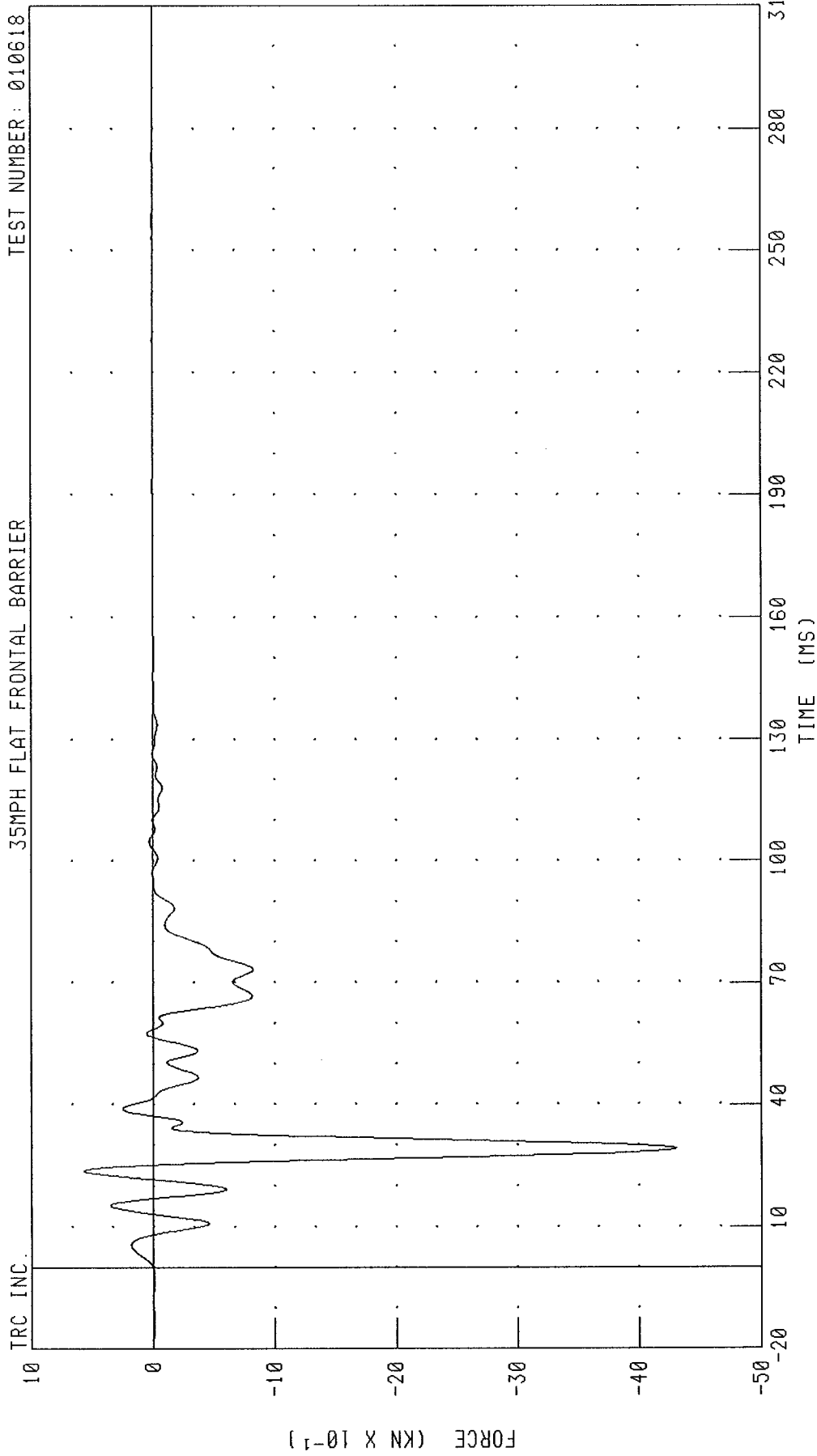

TRC INC.

CHANNEL: BD2F

FILTER: CH. CLASS 60

PEAK DATA: 0.57 KN @ 23.84 MS; -4.31 KN @ 29.20 MS

2001 NISSAN MAXIMA INTO FRONTAL LOAD CELL BARRIER
LOAD CELL BARRIER POSITION D3 FORCE
35MPH FLAT FRONTAL BARRIER

TEST NUMBER : 010618

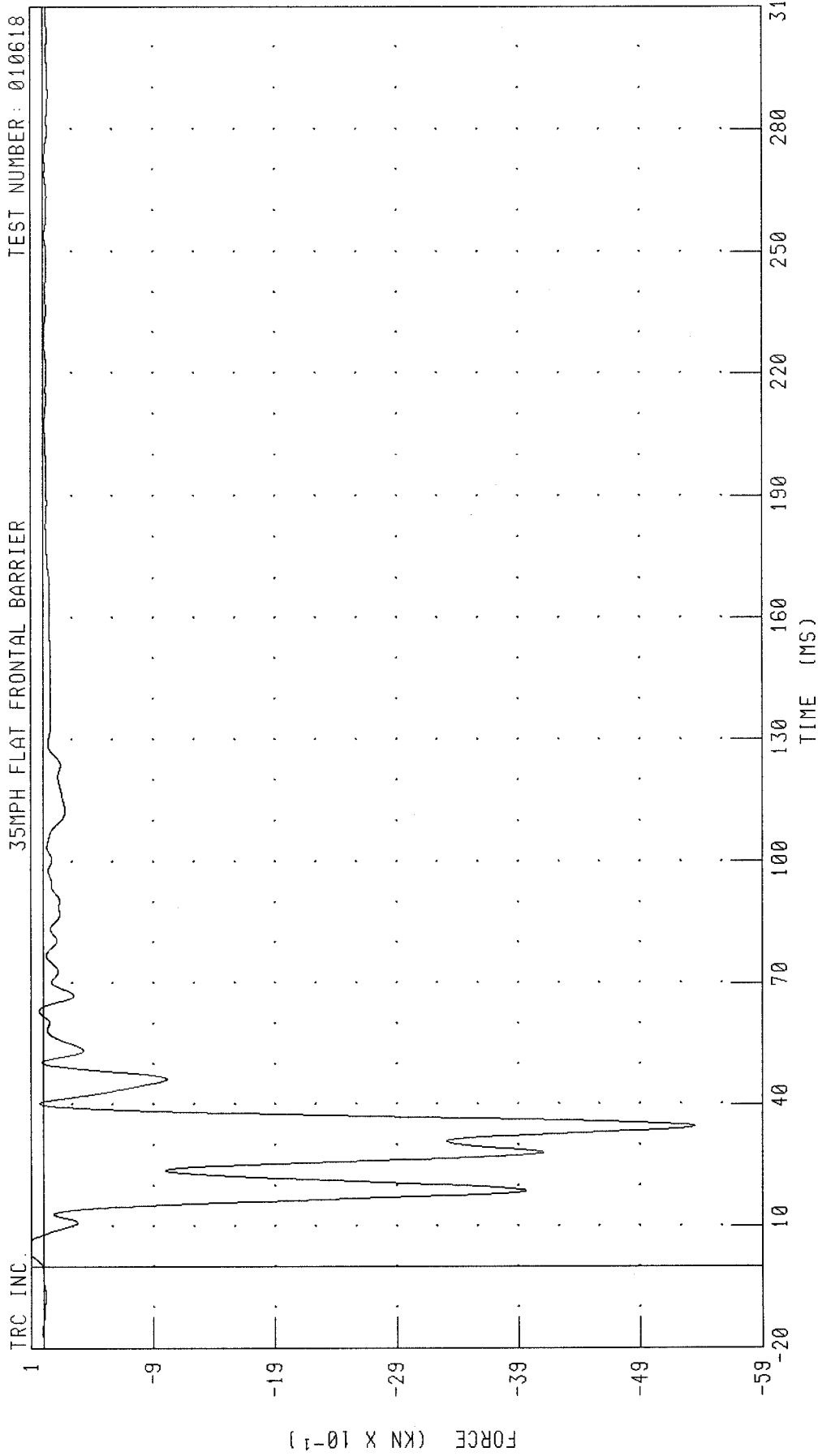

CHANNEL : BD3F FILTER : CH. CLASS 60 PEAK DATA : 0.15 KN @ 4.88 MS; -5.35 KN @ 34.64 MS

2001 NISSAN MAXIMA INTO FRONTAL LOAD CELL BARRIER
LOAD CELL BARRIER POSITION D4 FORCE
35MPH FLAT FRONTAL BARRIER

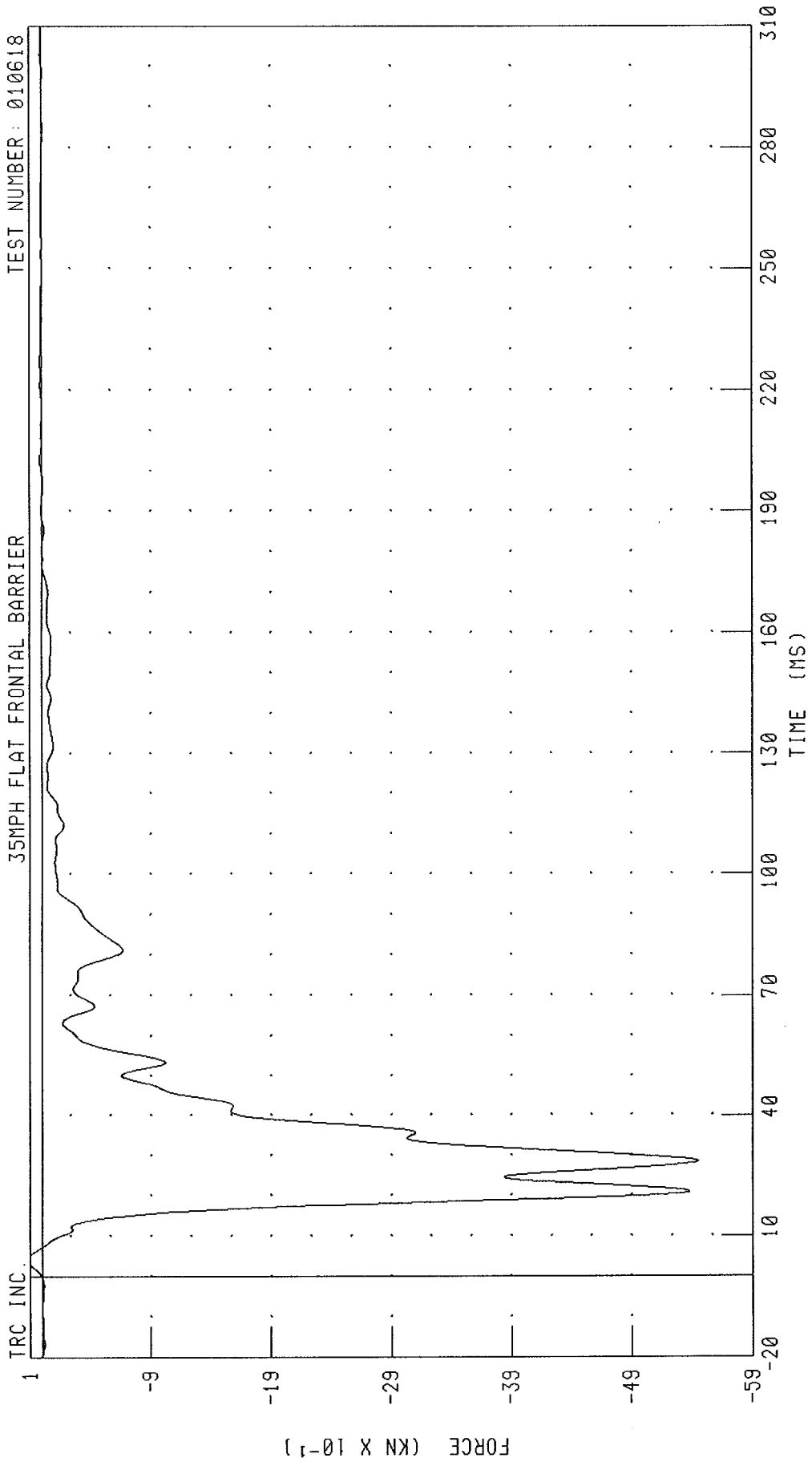

2001 NISSAN MAXIMA INTO FRONTAL LOAD CELL BARRIER
LOAD CELL BARRIER POSITION D5 FORCE
35MPH FLAT FRONTAL BARRIER

TEST NUMBER: 010618

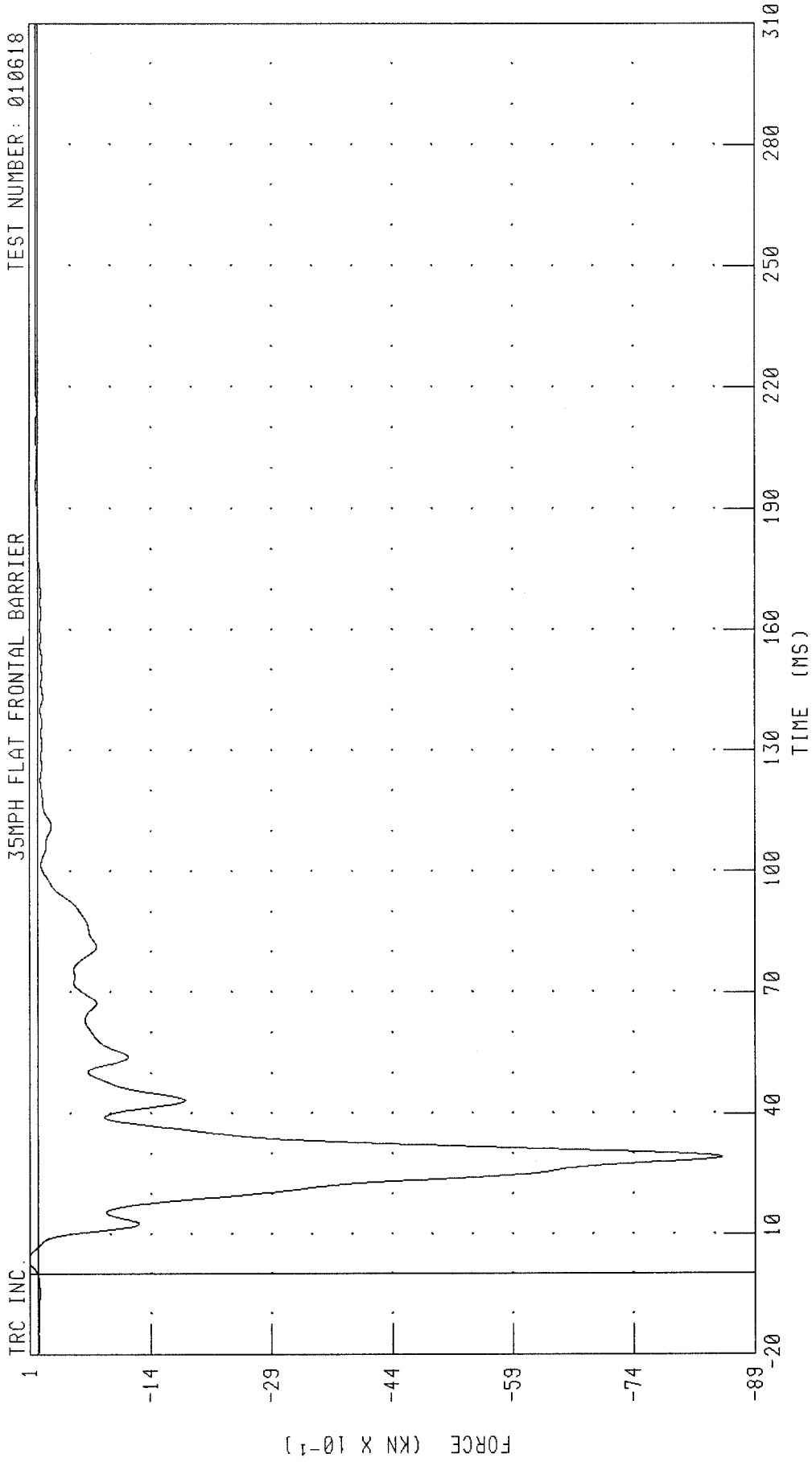

PEAK DATA: 0.12 KN @ 3.68 MS; -8.50 KN @ 29.20 MS

FILTER: CH. CLASS 60

CHANNEL: BD5F

2001 NISSAN MAXIMA INTO FRONTAL LOAD CELL BARRIER
LOAD CELL BARRIER POSITION D6 FORCE
35MPH FLAT FRONTAL BARRIER

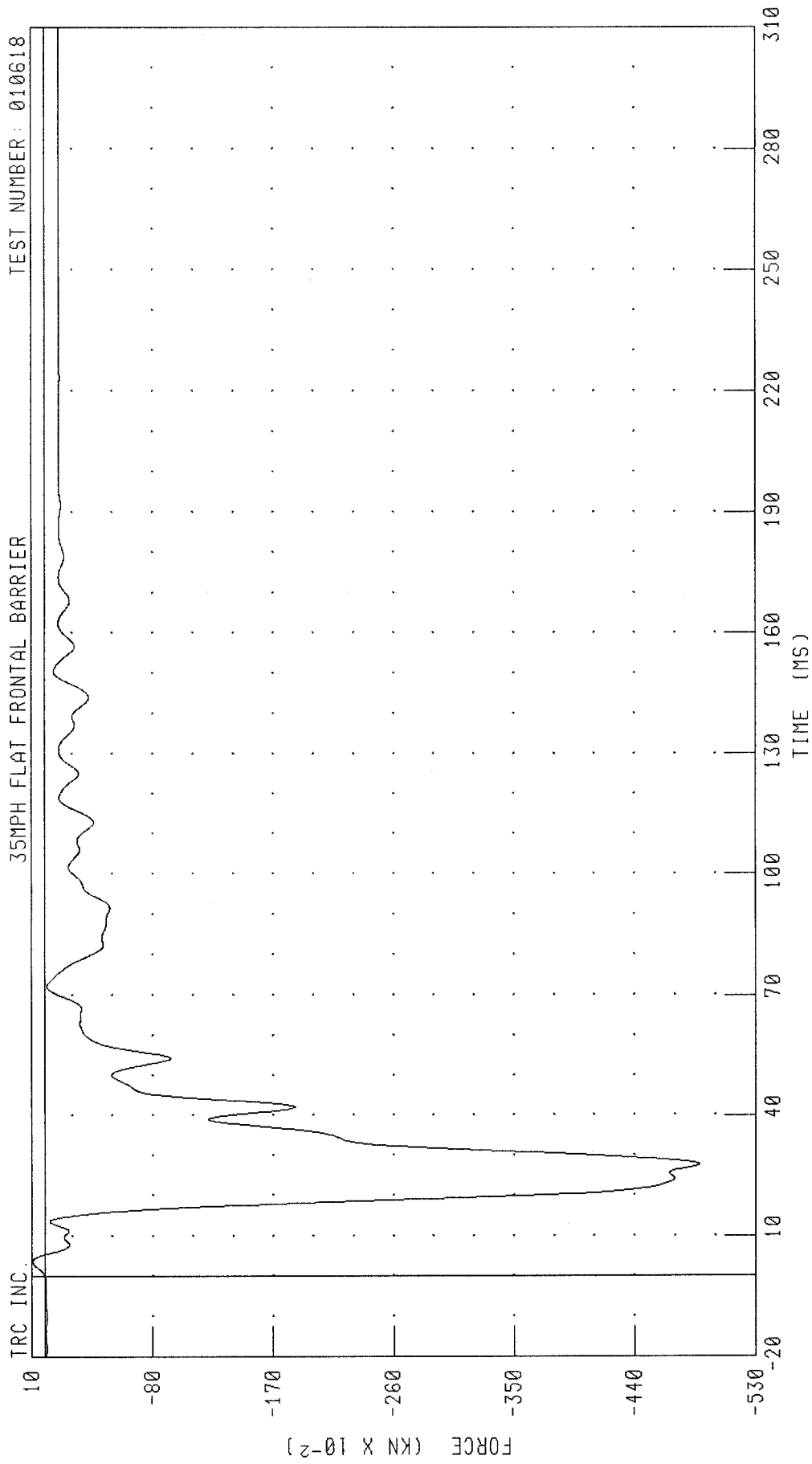

CHANNEL: BD6F FILTER: CH. CLASS 60 PEAK DATA: 0.09 KN @ 3.68 MS; -4.88 KN @ 27.68 MS

2001 NISSAN MAXIMA INTO FRONTAL LOAD CELL BARRIER
LOAD CELL BARRIER POSITION D7 FORCE
35MPH FLAT FRONTAL BARRIER

TEST NUMBER: 010618

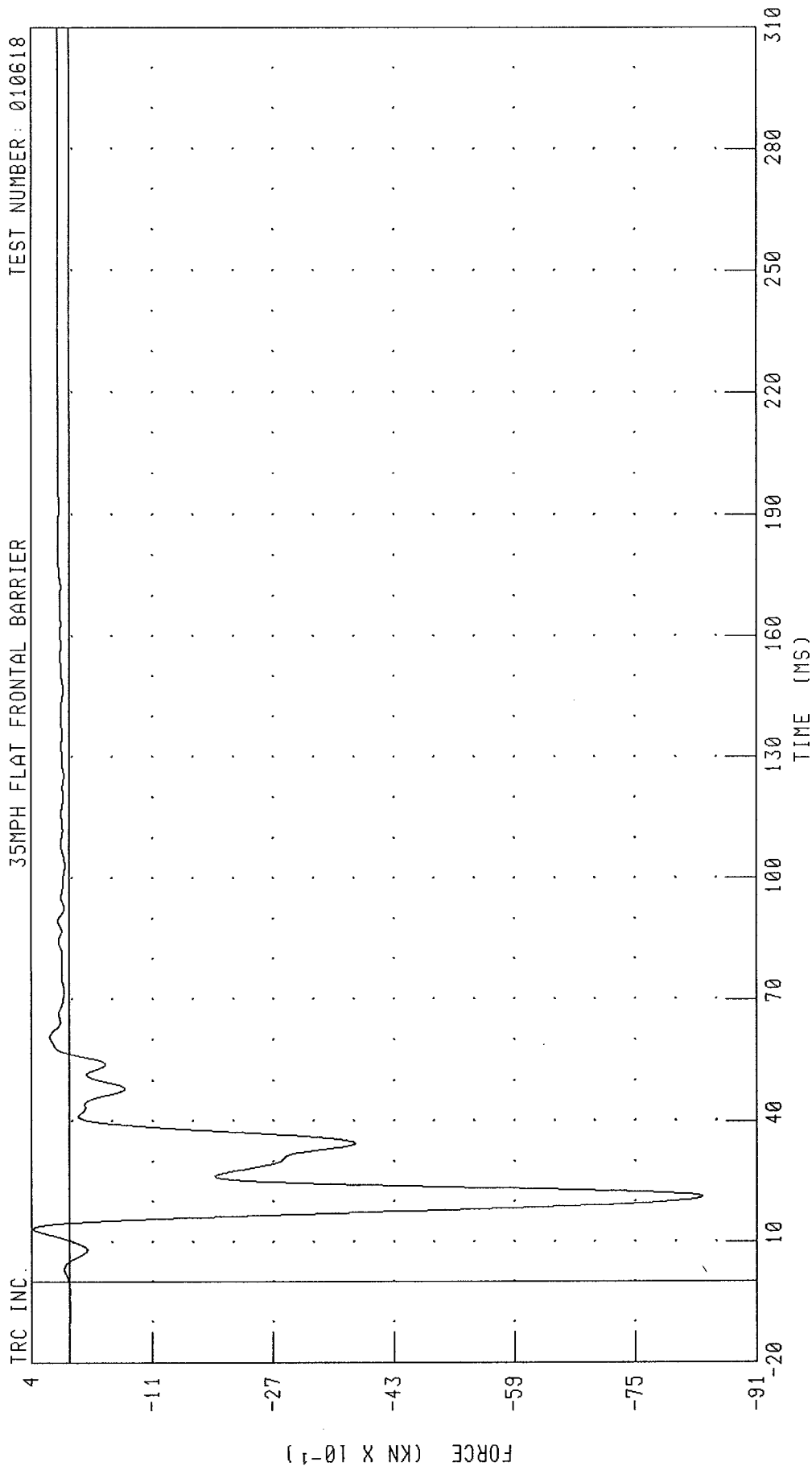

CHANNEL: BD7F FILTER: CH. CLASS 60 PEAK DATA: 0.49 KN @ 13.28 MS; -8.39 KN @ 21.20 MS

2001 NISSAN MAXIMA INTO FRONTAL LOAD CELL BARRIER
LOAD CELL BARRIER POSITION D8 FORCE
35MPH FLAT FRONTAL BARRIER

TEST NUMBER: 010618

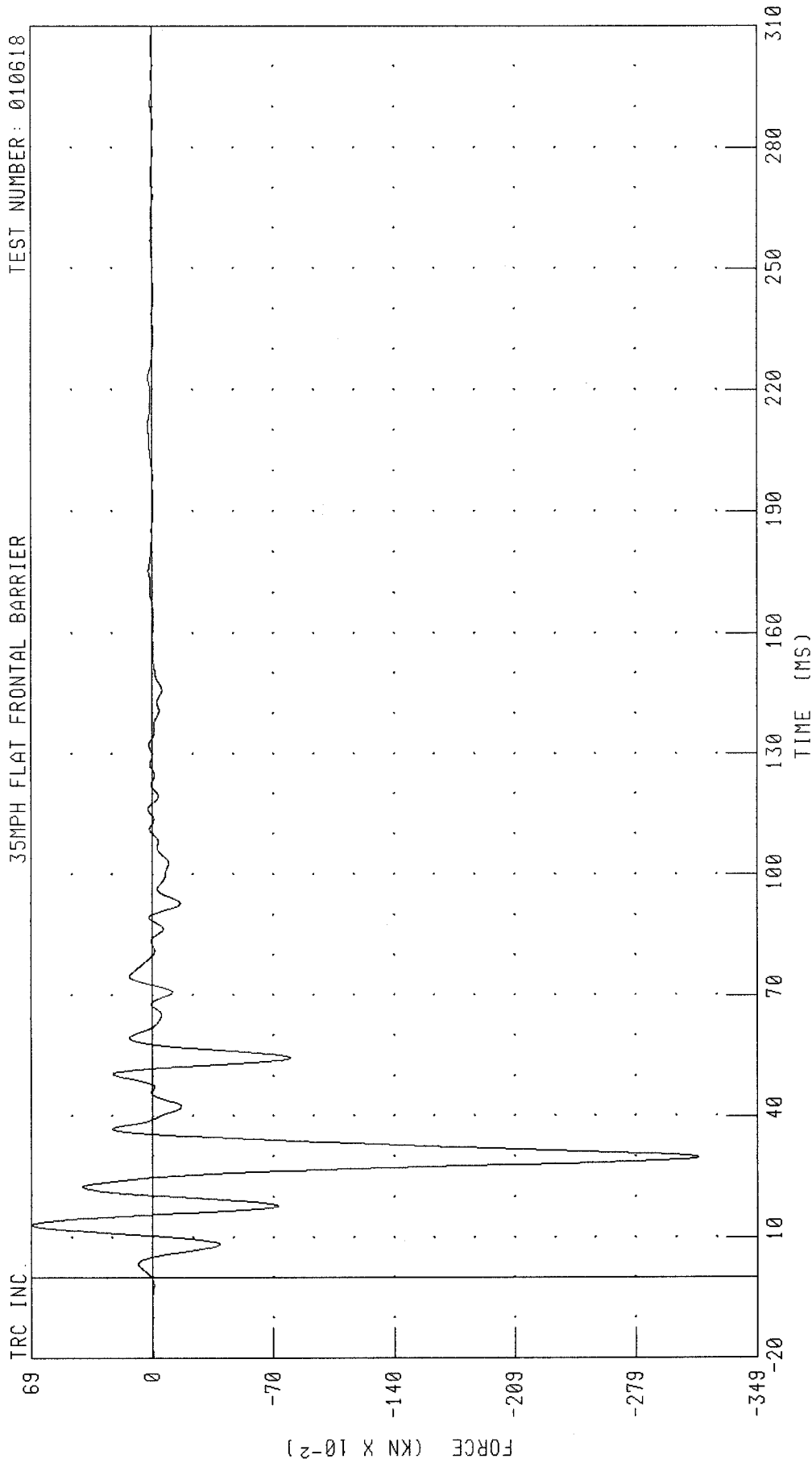

CHANNEL: BD8F FILTER: CH. CLASS 60

PEAK DATA: 0.70 KN @ 13.12 MS; -3.16 KN @ 29.76 MS

2001 NISSAN MAXIMA INTO FRONTAL LOAD CELL BARRIER
LOAD CELL BARRIER POSITION D9 FORCE
35MPH FLAT FRONTAL BARRIER

TEST NUMBER: 010618

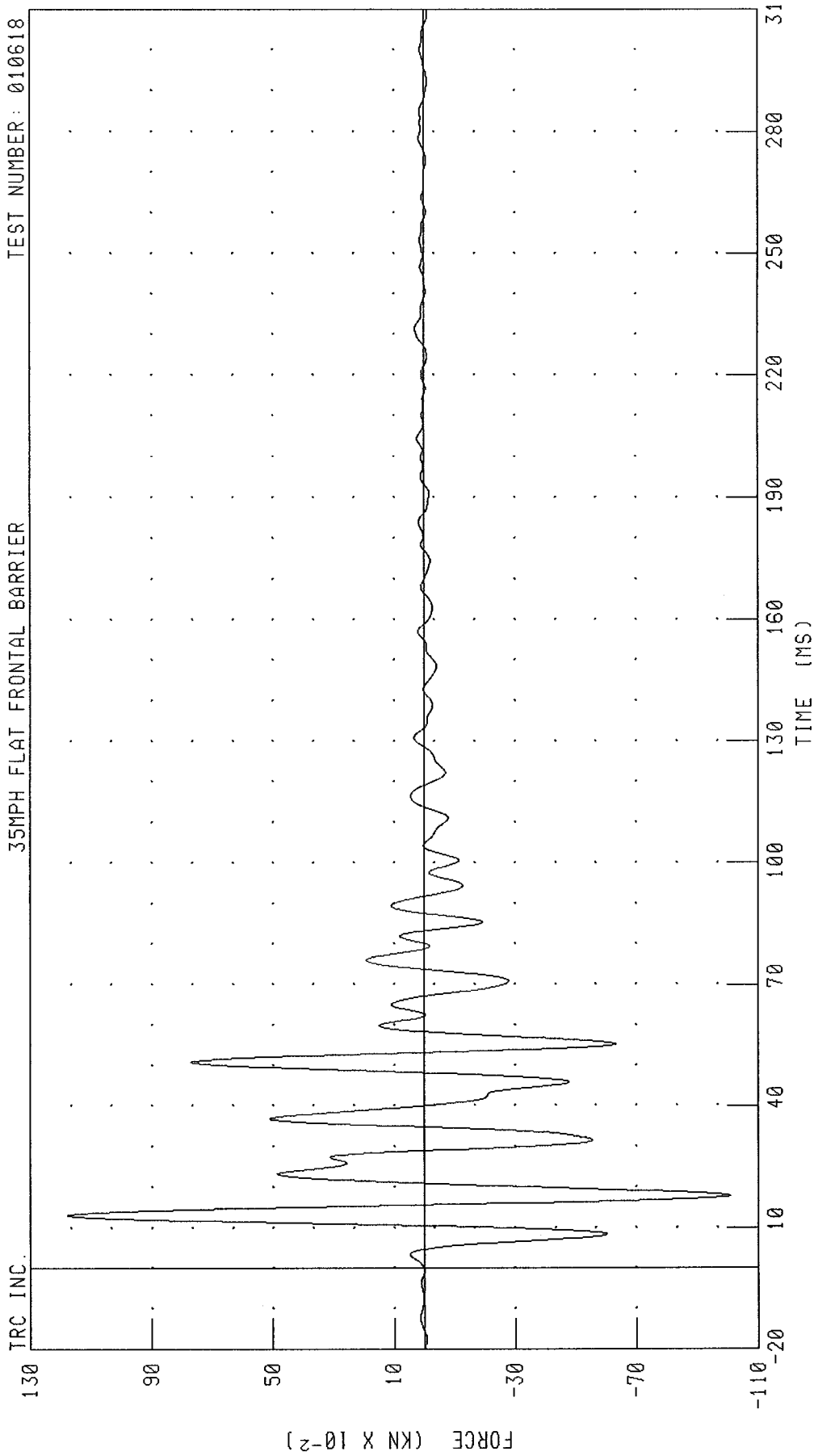

CHANNEL: BD9F FILTER: CH. CLASS 60 PEAK DATA: 1.18 KN @ 13.12 MS; -1.01 KN @ 17.84 MS

2001 NISSAN MAXIMA INTO FRONTAL LOAD CELL BARRIER
LOAD CELL BARRIER GROUP # 1 FORCE TOTAL
35MPH FLAT FRONTAL BARRIER

TEST NUMBER : 010618

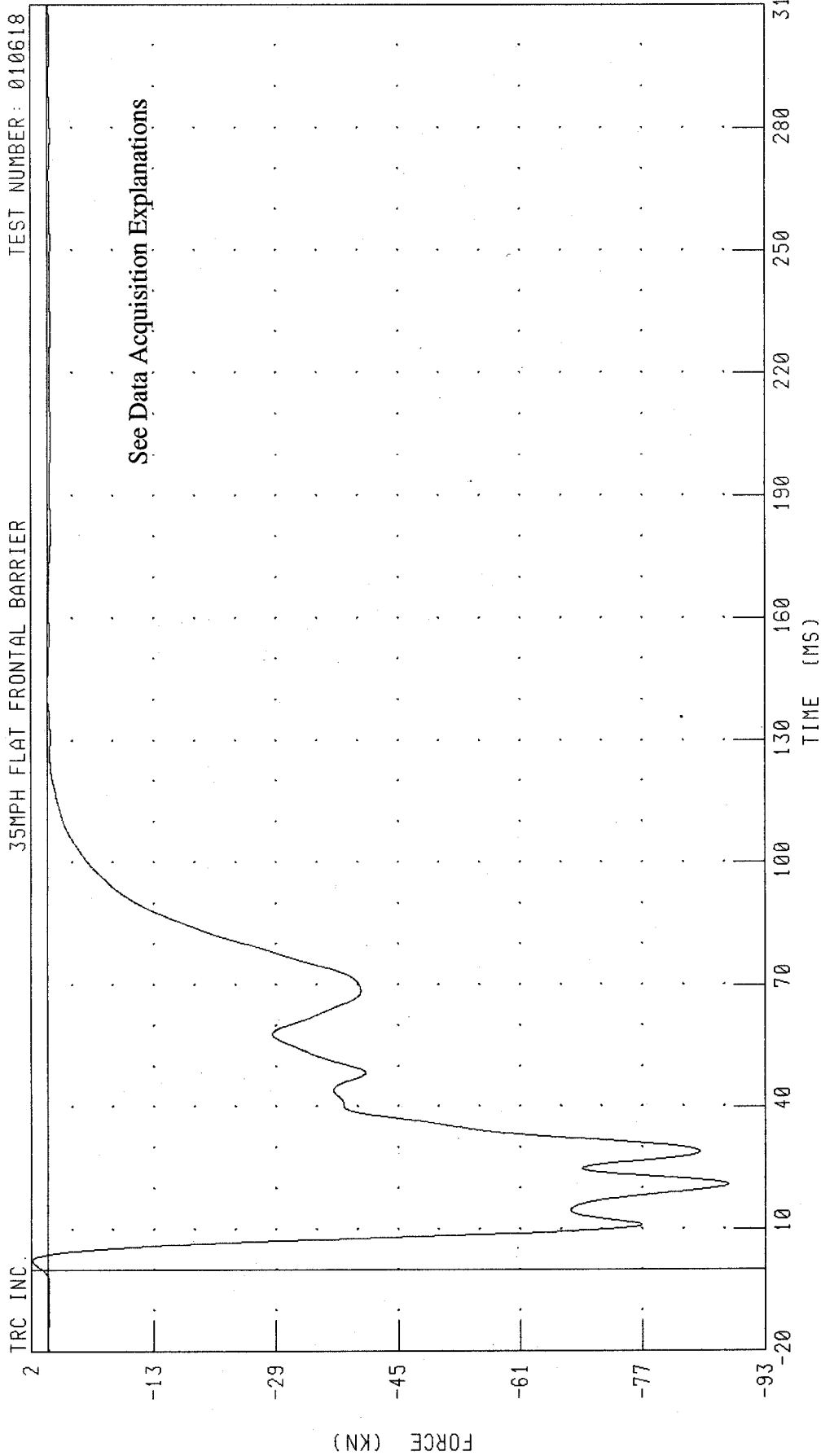

CHANNEL : LCBC1F FILTER : CH. CLASS 60

PEAK DATA : 2.06 KN @ 2.24 MS; -89.02 KN @ 20.88 MS

2001 NISSAN MAXIMA INTO FRONTAL LOAD CELL BARRIER
LOAD CELL BARRIER GROUP # 2 FORCE TOTAL
35MPH FLAT FRONTAL BARRIER

TEST NUMBER: 010618

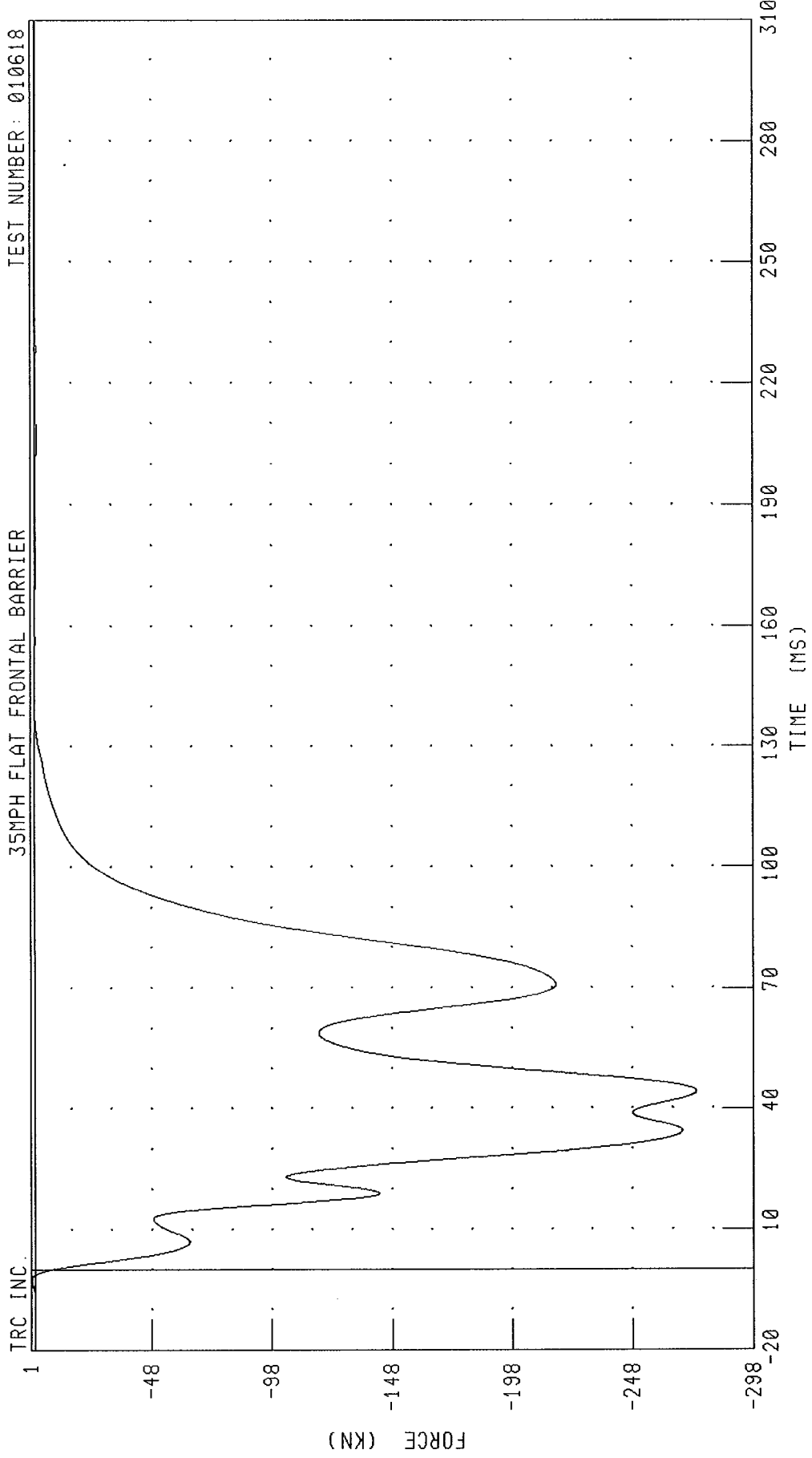

TRC INC. CHANNEL: LCBG2F FILTER: CH. CLASS 60 PEAK DATA: 1.55 KN @ -2.64 MS; -274.82 KN @ 44.24 MS

2001 NISSAN MAXIMA INTO FRONTAL LOAD CELL BARRIER
LOAD CELL BARRIER GROUP # 3 FORCE TOTAL
35MPH FLAT FRONTAL BARRIER

TEST NUMBER: 010618

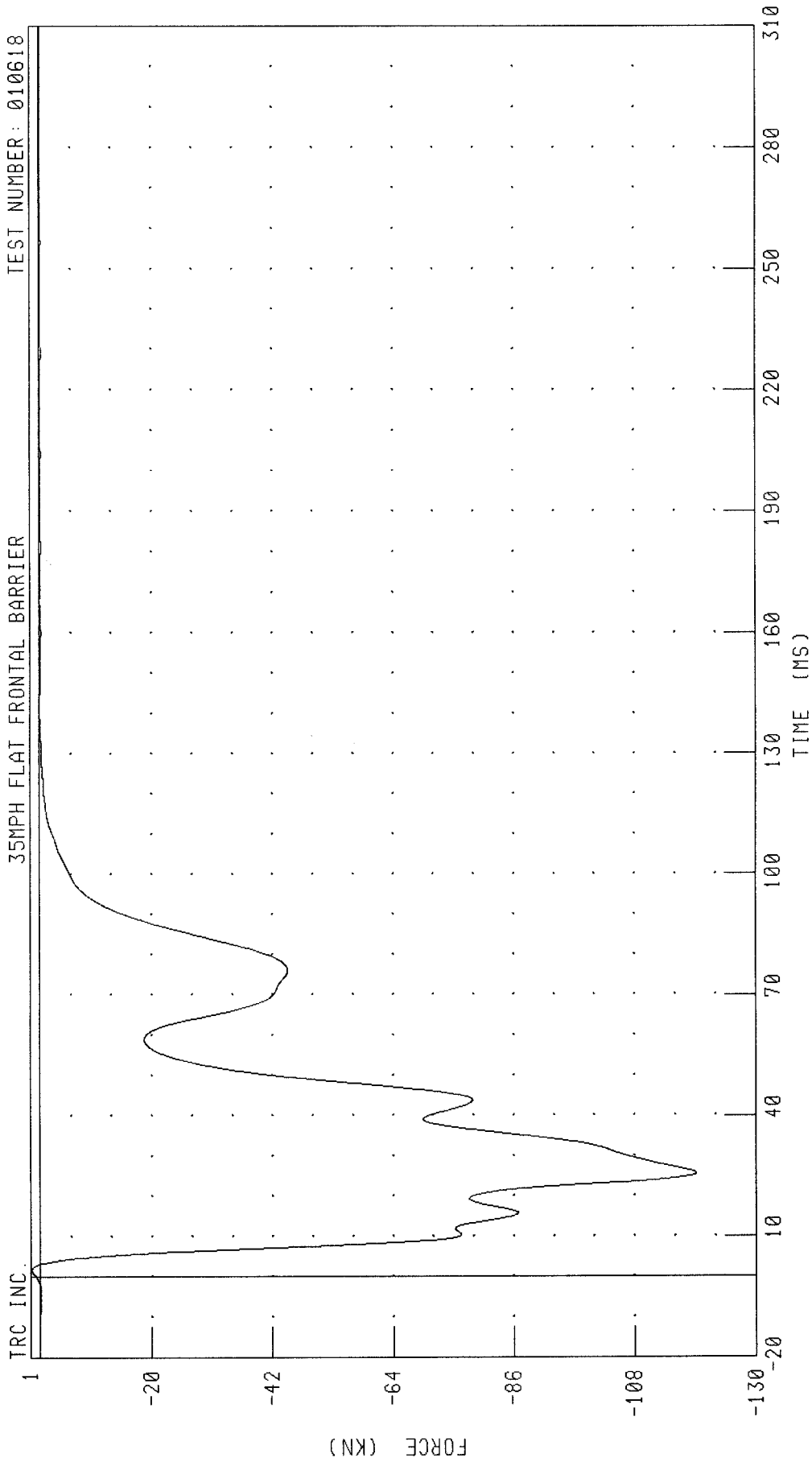

PEAK DATA: 1.56 KN @ 1.76 MS; -119.49 KN @ 25.60 MS

CHANNEL: LCBG3F FILTER: CH. CLASS 60

2001 NISSAN MAXIMA INTO FRONTAL LOAD CELL BARRIER
LOAD CELL BARRIER GROUP # 4 FORCE TOTAL
35MPH FLAT FRONTAL BARRIER

TEST NUMBER: 010618

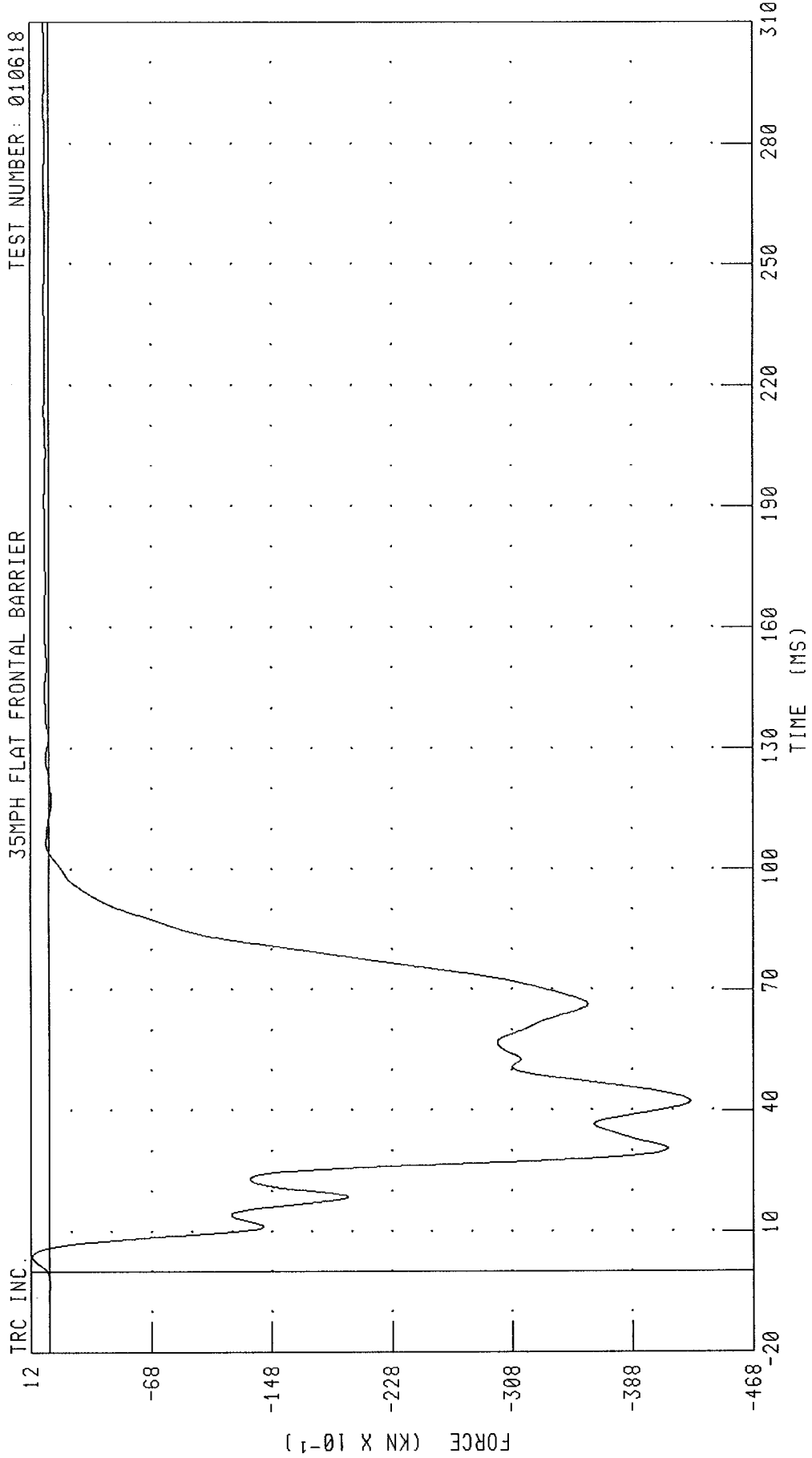

TRC INC. CHANNEL: LCBC4F FILTER: CH. CLASS 60
PEAK DATA: 1.14 KN @ 3.76 MS; -42.66 KN @ 42.32 MS

2001 NISSAN MAXIMA INTO FRONTAL LOAD CELL BARRIER
LOAD CELL BARRIER GROUP # 5 FORCE TOTAL
35MPH FLAT FRONTAL BARRIER

TEST NUMBER: 010618

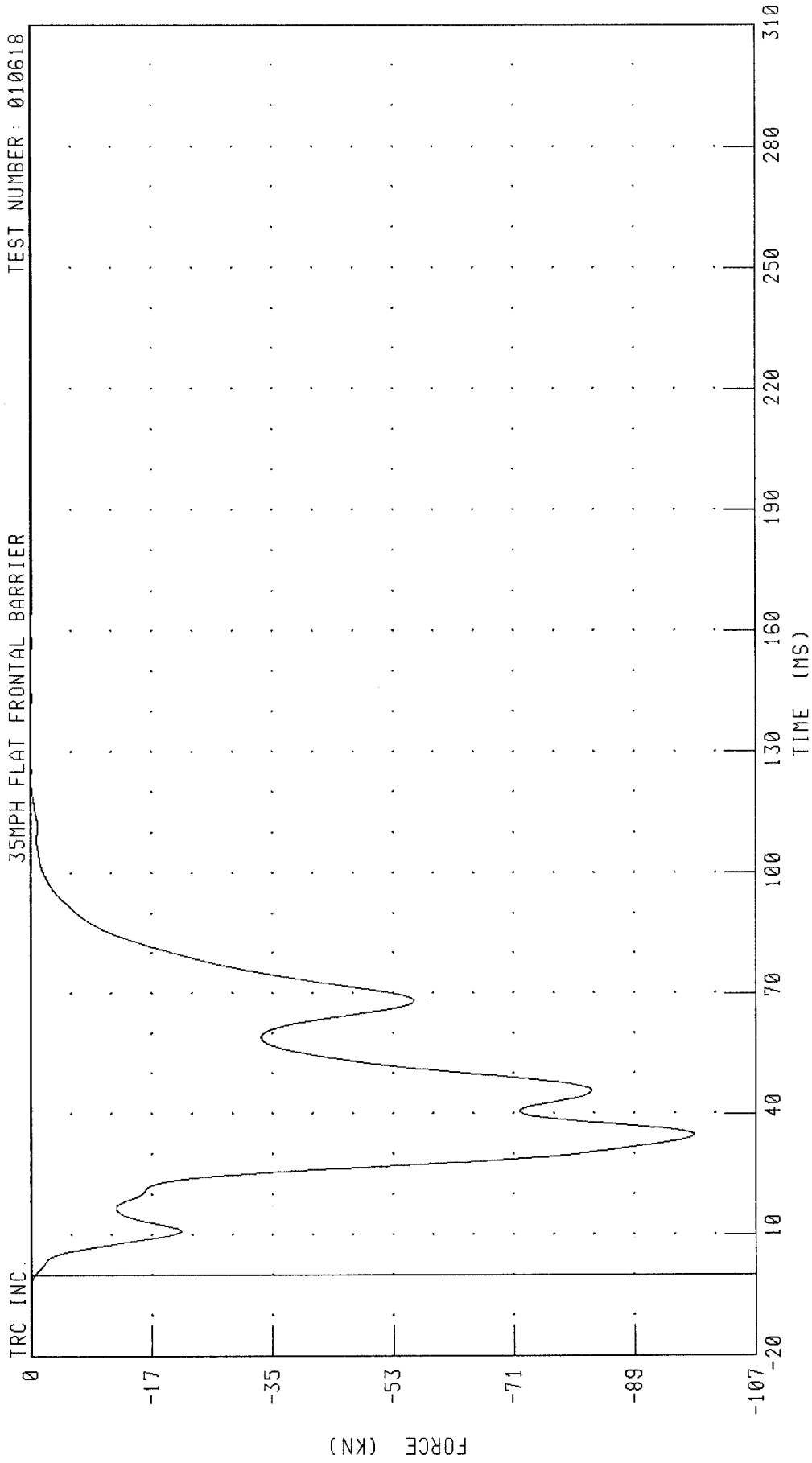

CHANNEL: LCBG5F FILTER: CH. CLASS 60

PEAK DATA: 0.10 KN @ 150.32 MS; -98.78 KN @ 34.80 MS

2001 NISSAN MAXIMA INTO FRONTAL LOAD CELL BARRIER
LOAD CELL BARRIER GROUP # 6 FORCE TOTAL
35MPH FLAT FRONTAL BARRIER

TEST NUMBER: 010618

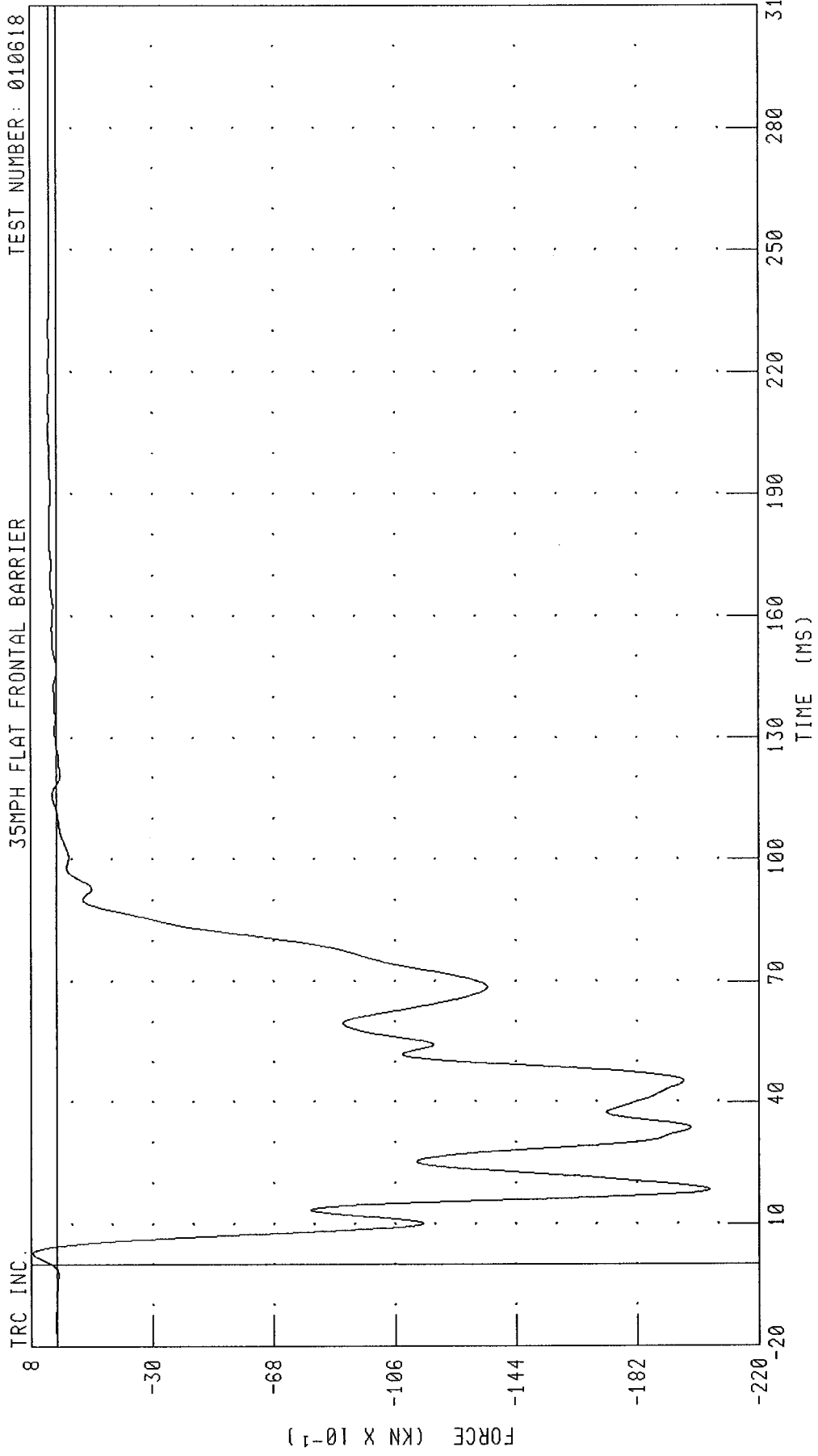

CHANNEL: LCBC6F FILTER: CH. CLASS 60 PEAK DATA: 0.76 KN @ 2.72 MS; -20.46 KN @ 18.48 MS

2001 NISSAN MAXIMA INTO FRONTAL LOAD CELL BARRIER
TOTAL LOAD CELL BARRIER FORCE
35MPH FLAT FRONTAL BARRIER

TEST NUMBER: 010618

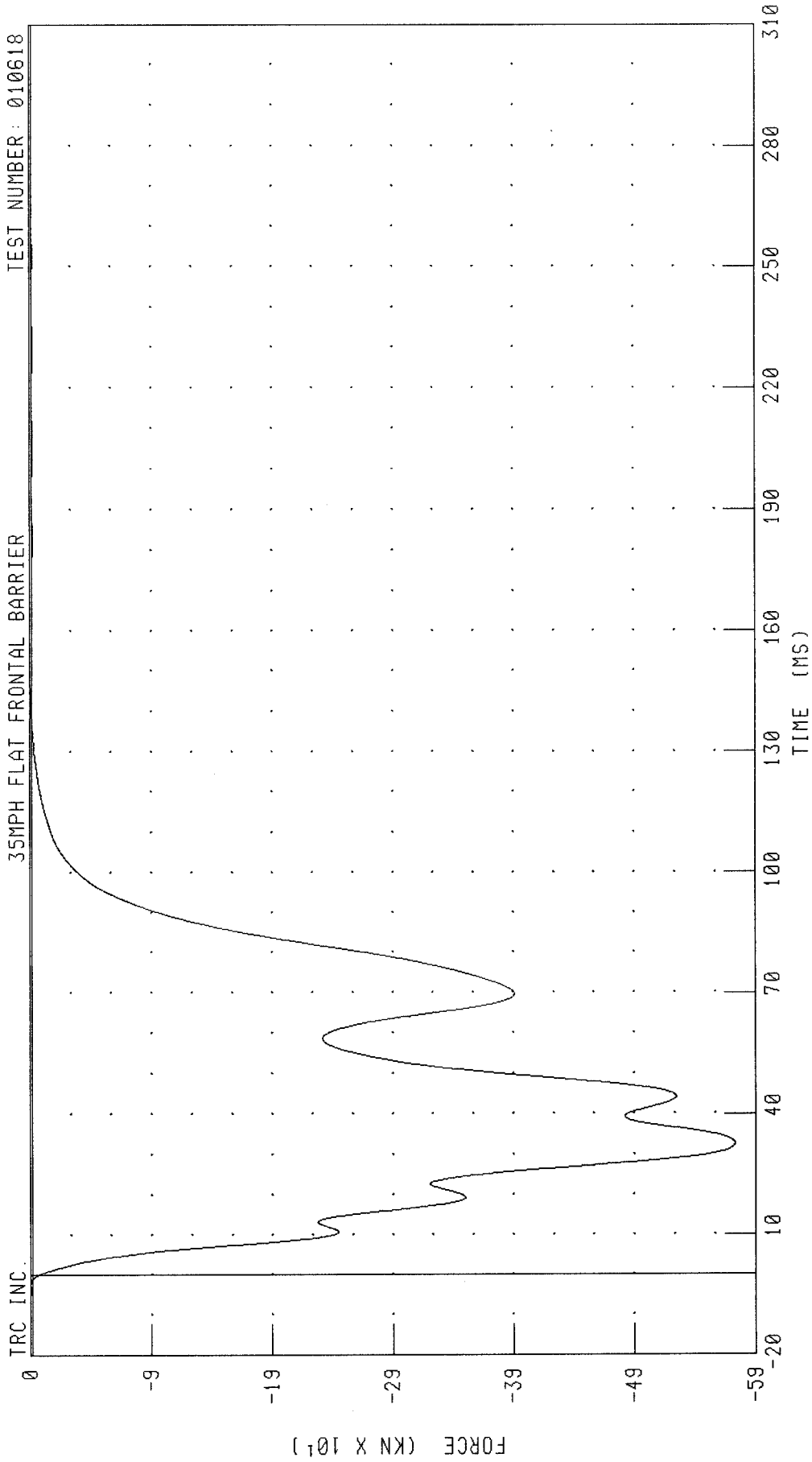

PEAK DATA: 1.33 KN @ -2.48 MS; -581.64 KN @ 32.64 MS

CHANNEL: LCBGT FILTER: CH. CLASS 60

2001 NISSAN MAXIMA INTO FRONTAL LOAD CELL BARRIER
 TOTAL LOAD CELL BARRIER FORCE VS AVERAGE VEHICLE X-AXIS DISPLACEMENT
 35MPH FLAT FRONTAL BARRIER

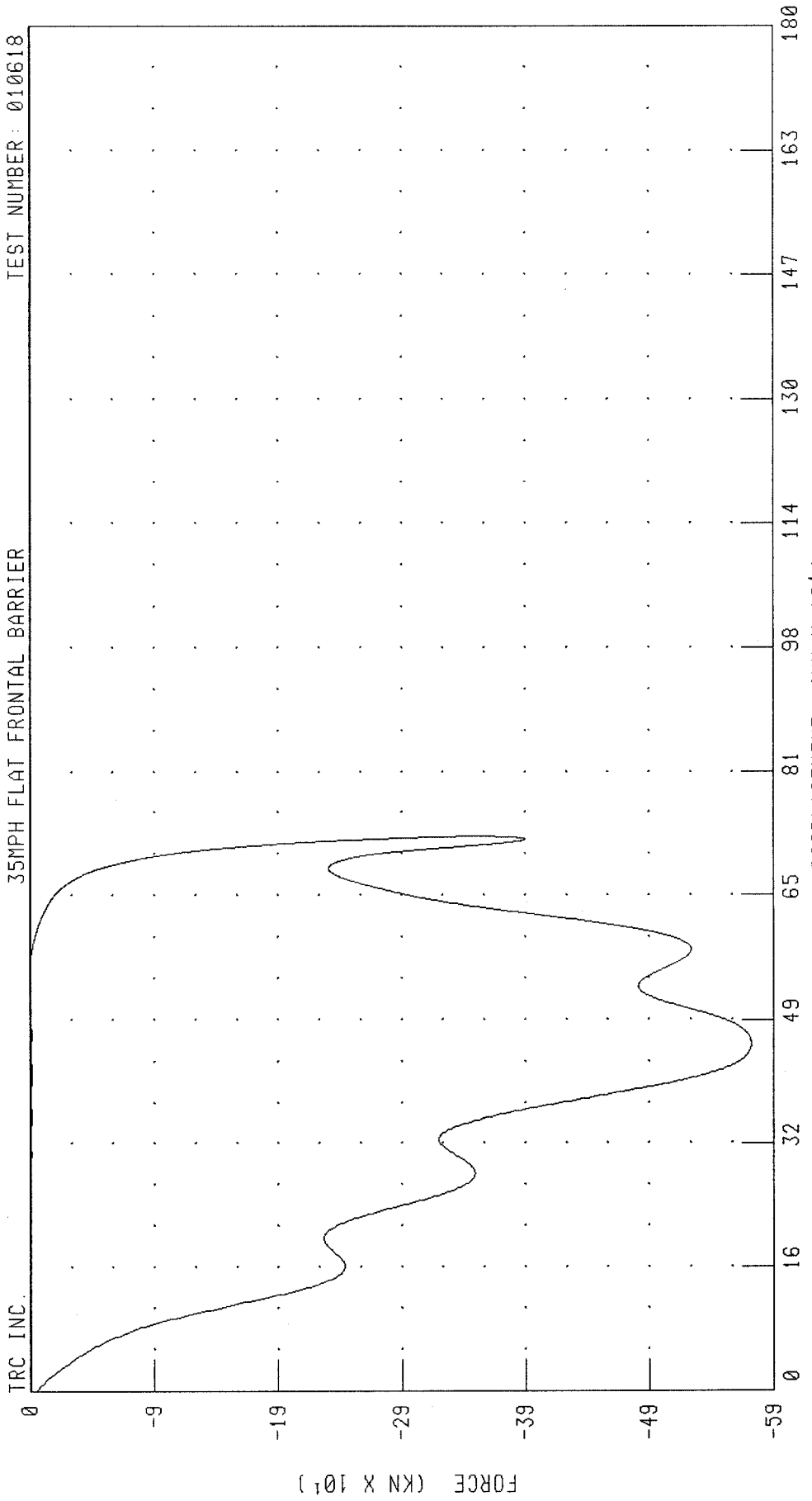

CHANNEL: OTHXD FILTER: CH. CLASS 180
 LCBGT CH. CLASS 60

PEAK DATA: 732.27 MM @ 74.64 MS;
 0.53 KN @ 140.56 MS; -581.64 KN @ 32.64 MS

TRANSPORTATION RESEARCH CENTER INC.
HYBRID III EXTERNAL DIMENSIONS

142

15-JUN-01

TRC INC. TEST NO: 142C45ED1 572E SN142 EXT.DIMENSION CAL45

TEST PARAMETER (DIMEN.)	SPECIFICATION	TEST RESULTS
LOCATION FOR CHEST CIRCUMFERENCE (AA)	429 - 434 MM	432. MM
LOCATION FOR WAIST CIRCUMFERENCE (BB)	226 - 231 MM	229. MM
CHEST CIRCUMFERENCE (Y)	970 -1001 MM	993. MM
WAIST CIRCUMFERENCE (Z)	836 - 866 MM	856. MM
CHEST DEPTH (O)	213 - 229 MM	221. MM
H-POINT HEIGHT (C)	84 - 89 MM	86. MM
H-POINT FROM SEATBACK (D)	135 - 140 MM	137. MM
SKULL CAP TO BACKLINE (H)	41 - 46 MM	43. MM
TOTAL SITTING HEIGHT (A)	879 - 889 MM	884. MM
THIGH CLEARANCE (F)	140 - 155 MM	145. MM
BUTTOCK KNEE LENGTH (K)	579 - 605 MM	599. MM
BUTTOCK POPLITEAL LENGTH (N)	452 - 478 MM	470. MM
POPLITEAL HEIGHT (L)	429 - 455 MM	445. MM
KNEE PIVOT HEIGHT (M)	485 - 500 MM	490. MM
FOOT LENGTH (P)	252 - 267 MM	254. MM
FOOT BREADTH (W)	91 - 107 MM	102. MM
SHOULDER PIVOT FROM BACKLINE (E)	84 - 94 MM	91. MM
SHOULDER BREADTH (V)	422 - 437 MM	434. MM
SHOULDER PIVOT HEIGHT (B)	506 - 521 MM	516. MM
ELBOW REST HEIGHT (J)	191 - 211 MM	206. MM
SHOULDER-ELBOW LENGTH (I)	330 - 345 MM	335. MM
BACK OF ELBOW TO WRIST PIVOT (G)	290 - 305 MM	297. MM

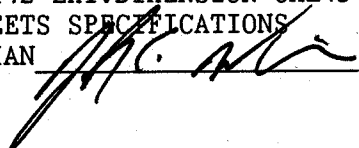
572E SN142 EXT.DIMENSION CAL45
DUMMY MEETS SPECIFICATIONS
TECHNICIAN 

RUN NUMBER: 061801.0659

TRANSPORTATION RESEARCH CENTER INC.

HEAD DROP TEST

HYBRID III 50th

07-JUN-01

TRC INC.

TEST NO: 142C45HD1

572E SN142 HEAD DROP CAL 45

TEST PARAMETER	SPECIFICATION	TEST RESULTS
TEMPERATURE	18.9-25.6 DEG. C	21.1 DEG. C
RELATIVE HUMIDITY	10 - 70 %	55.0 %
PEAK RESULTANT ACCELERATION	225 - 275 G	258.88 G
PEAK LATERAL ACCELERATION	15 G MAX	-4.68 G
IS ACCELERATION CURVE UNIMODAL?	YES	YES

TEST MEETS SPECIFICATIONS

TECHNICIAN

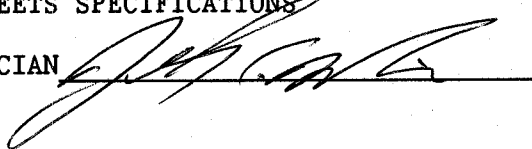

RUN NUMBER: 060801.0917;5

PART 572-E HYBRID III HEAD CALIBRATION

HEAD ACCELERATION X AXIS

572E SN142 HEAD DROP CAL 45

RUN NUMBER: 060801.0917,5

TRC TEST NUMBER: 142C45HD1

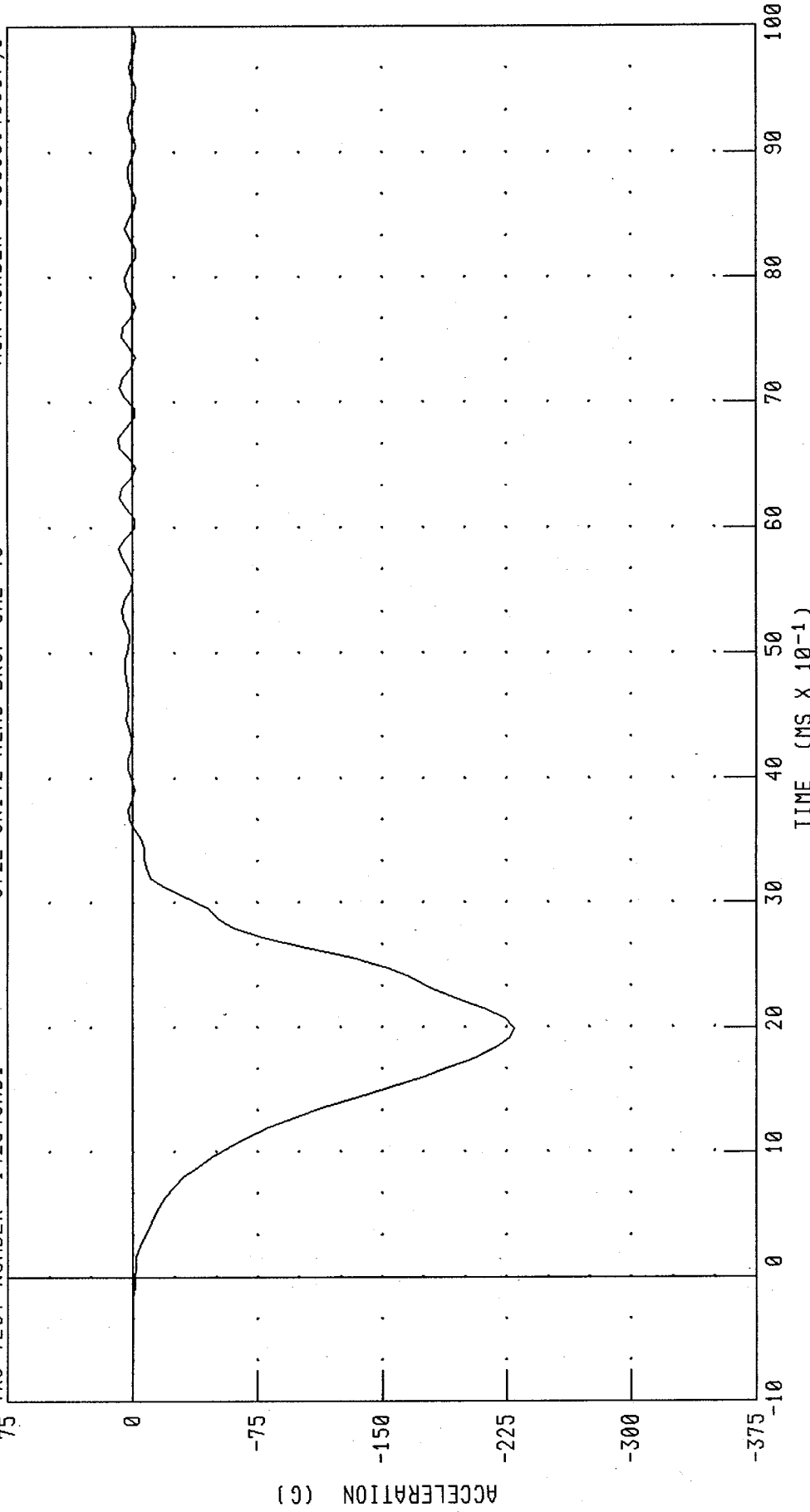

PEAK DATA: 8.68 G @ 5.84 MS, -229.81 G @ 2.00 MS

CHANNEL: HEDXC FILTER: CH. CLASS 1000

PART 572-E HYBRID III HEAD CALIBRATION
HEAD ACCELERATION Y AXIS

TRC TEST NUMBER: 142C45HD1 572E SN142 HEAD DROP CAL 45 RUN NUMBER: 060801.0917.5

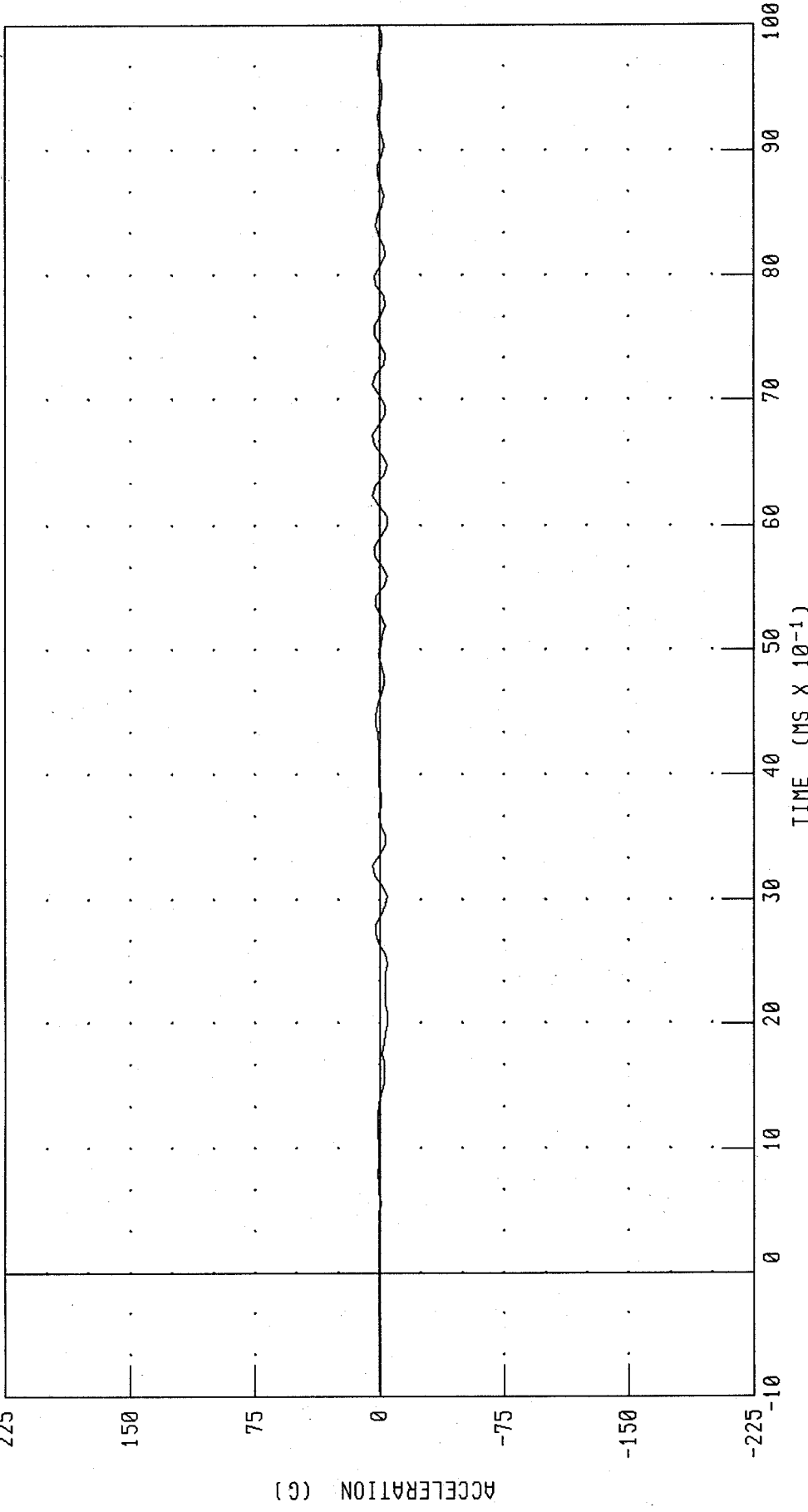

CHANNEL: HEDYG FILTER: CH. CLASS 1000 PEAK DATA: 4.20 G @ 3.28 MS; -4.69 G @ 2.00 MS

PART 572-E HYBRID III HEAD CALIBRATION
HEAD ACCELERATION Z AXIS

TRC TEST NUMBER: 142C45HD1

572E SN142 HEAD DROP CAL 45

RUN NUMBER: 060801.0917,5

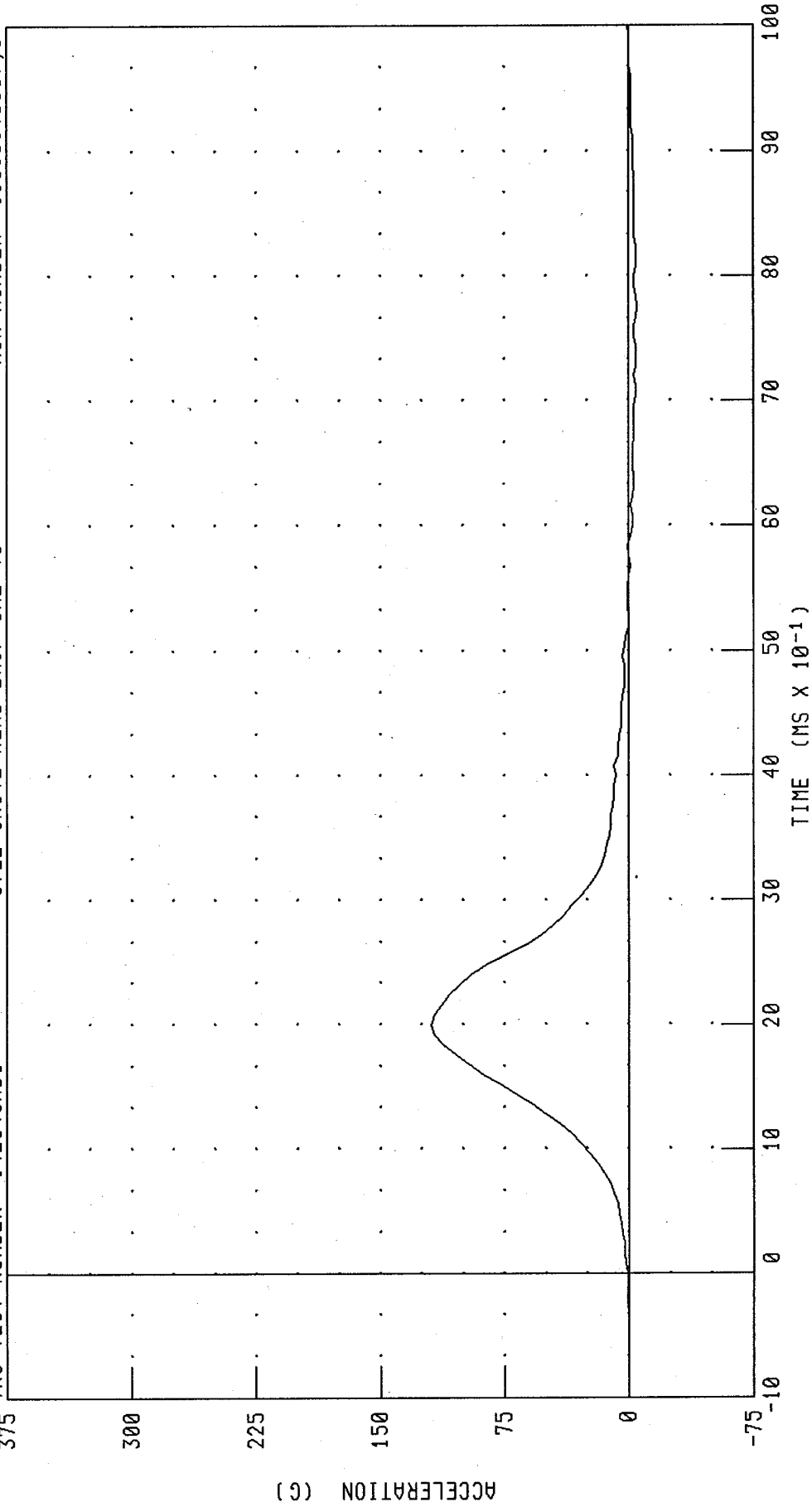

CHANNEL: HEDZG FILTER: CH. CLASS 1000

PEAK DATA: 119.11 G @ 2.00 MS; -5.43 G @ 7.76 MS

PART 572-E HYBRID III HEAD CALIBRATION
HEAD RESULTANT ACCELERATION

TRC TEST NUMBER: 142C45HD1 RUN NUMBER: 060801 0917,5

572E SN142 HEAD DROP CAL 45

375

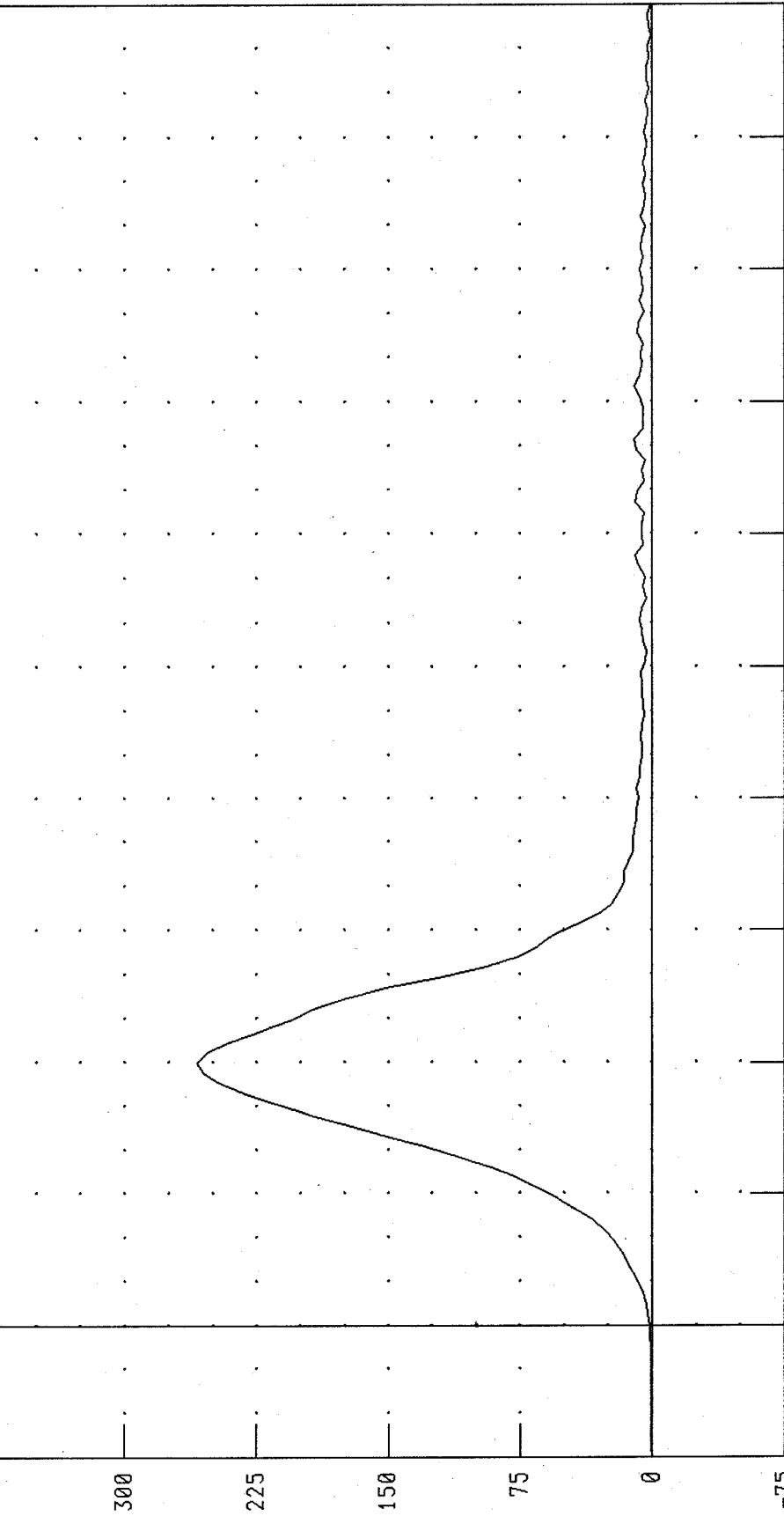

-75 0 10 20 30 40 50 60 70 80 90 100

TIME (MS X 10⁻¹)

CHANNEL: HEDRG FILTER: CH. CLASS 1000 PEAK DATA: 258.88 G @ 2.00 MS; 0.52 G @ -0.96 MS

TRANSPORTATION RESEARCH CENTER INC.

HYBRID III 50th

11-JUN-01

NECK FLEXION TEST - 6 CHANNEL TRANSDUCER

TRC INC. TEST NO: 142C45NF1 572E SN142 NECK FLEXION CAL45

TEST PARAMETER	SPECIFICATION	TEST RESULTS
TEMPERATURE	20.6-22.2 DEG. C	21.7 DEG. C
RELATIVE HUMIDITY	10 - 70 %	55.0 %
IMPACT VELOCITY	6.89 - 7.13 M/S	7.06 M/S
PENDULUM DECELERATION	10 MS 22.50 - 27.50 G	23.66 G
	20 MS 17.60 - 22.60 G	21.60 G
	30 MS 12.50 - 18.50 G	18.38 G
MAX PENDULUM G	29 G MAX	24.40 G
MAX PENDULUM G ABOVE 30 MS	29 G MAX	18.30 G
DECELERATION-TIME CURVE DECAY TIME TO 5 G	34 - 42 MS	37.84 MS
D PLANE	MAX 64 - 78 DEG.	71.95 DEG.
ROTATION	TIME 57 - 64 MS	59.92 MS
MOMENT ABOUT OCCIPITAL CONDYLE	MAX 88.2 - 108.5 NM	97.58 NM
	TIME 47 - 58 MS	51.44 MS
ROTATION ANGLE-TIME CURVE DECAY TIME TO ZERO	113 - 128 MS	116.64 MS
POSITIVE MOMENT-TIME CURVE DECAY TIME TO ZERO	97 - 107 MS	97.36 MS

TEST MEETS SPECIFICATIONS

TECHNICIAN

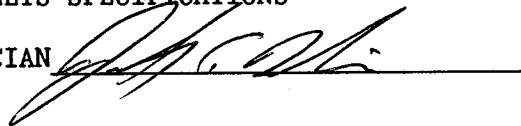

RUN NUMBER: 061101.1228;2

PART 572-E HYBRID III NECK FLEXION CALIBRATION
PENDULUM DECELERATION

TRC TEST NUMBER: 142C45NF1 572E SN142 NECK FLEXION CAL45 RUN NUMBER: 061101 1228;2

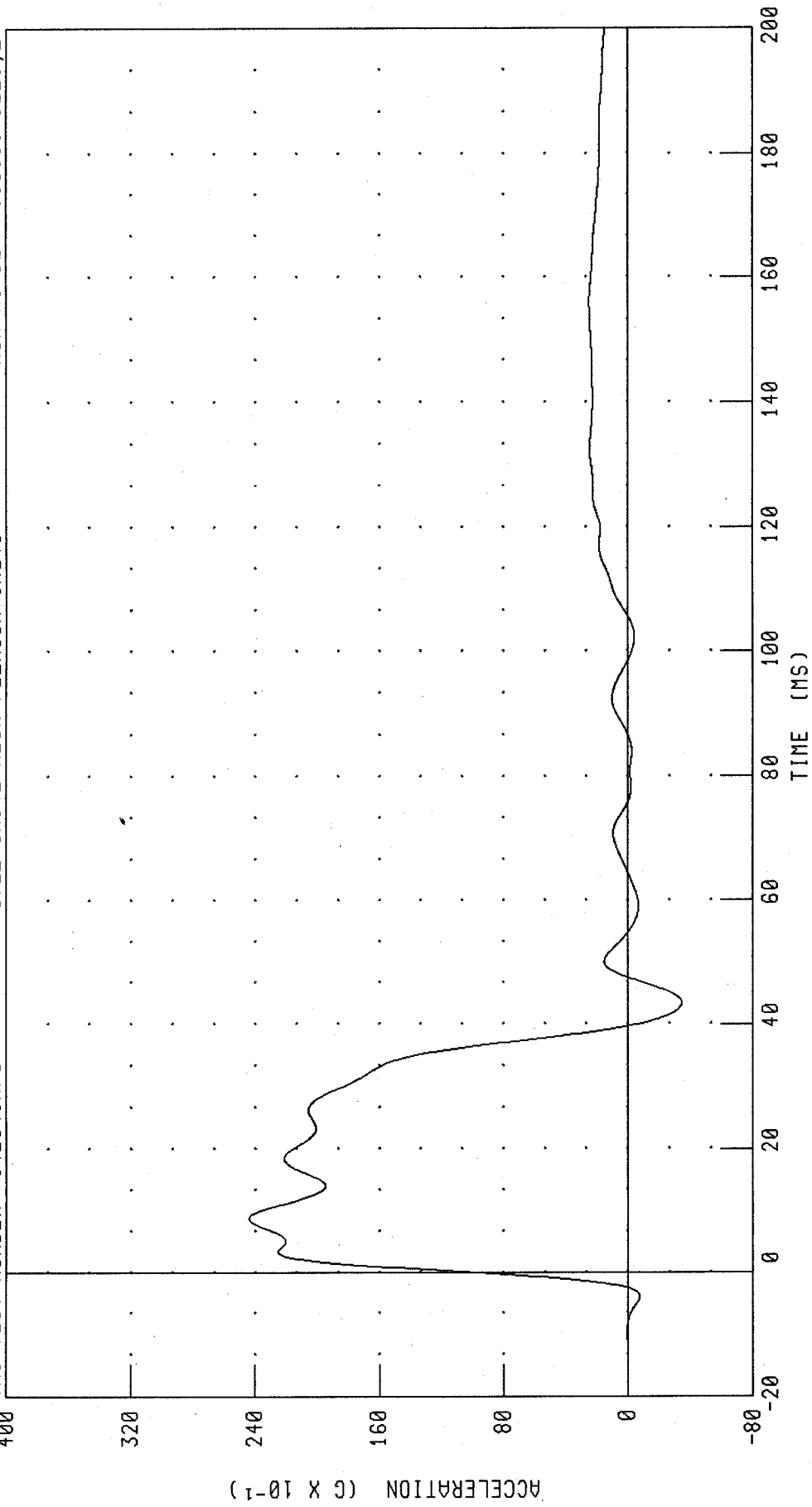

CHANNEL: PENXC FILTER: CH. CLASS 60 PEAK DATA: 24.40 G @ 8.80 MS; -3.47 G @ 43.36 MS

PART 572-E HYBRID III NECK FLEXION CALIBRATION

ROTATION ABOUT BASE OF NECK

TRC TEST NUMBER: 142C45NF1

572E SN142 NECK FLEXION CAL45

RUN NUMBER: 061101.1228;2

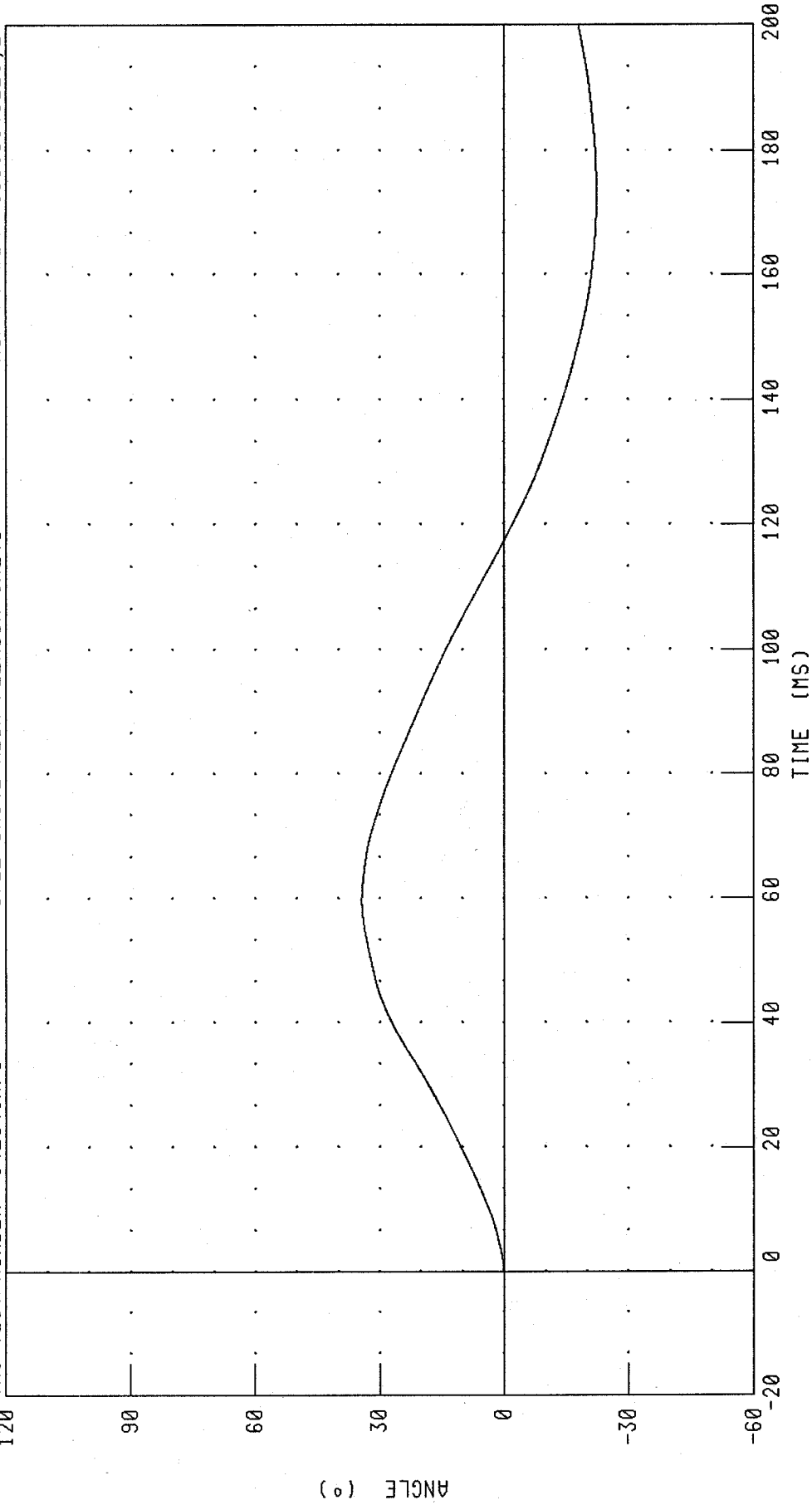

CHANNEL: BETA FILTER: CH. CLASS 60

PEAK DATA: 34.35 ° @ 59.60 MS; -22.41 ° @ 172.72 MS

PART 572-E HYBRID III NECK FLEXION CALIBRATION

ROTATION ABOUT OCCIPITAL CONDYLE

TRC TEST NUMBER: 142C45NF1

RUN NUMBER: 061101.1228;2

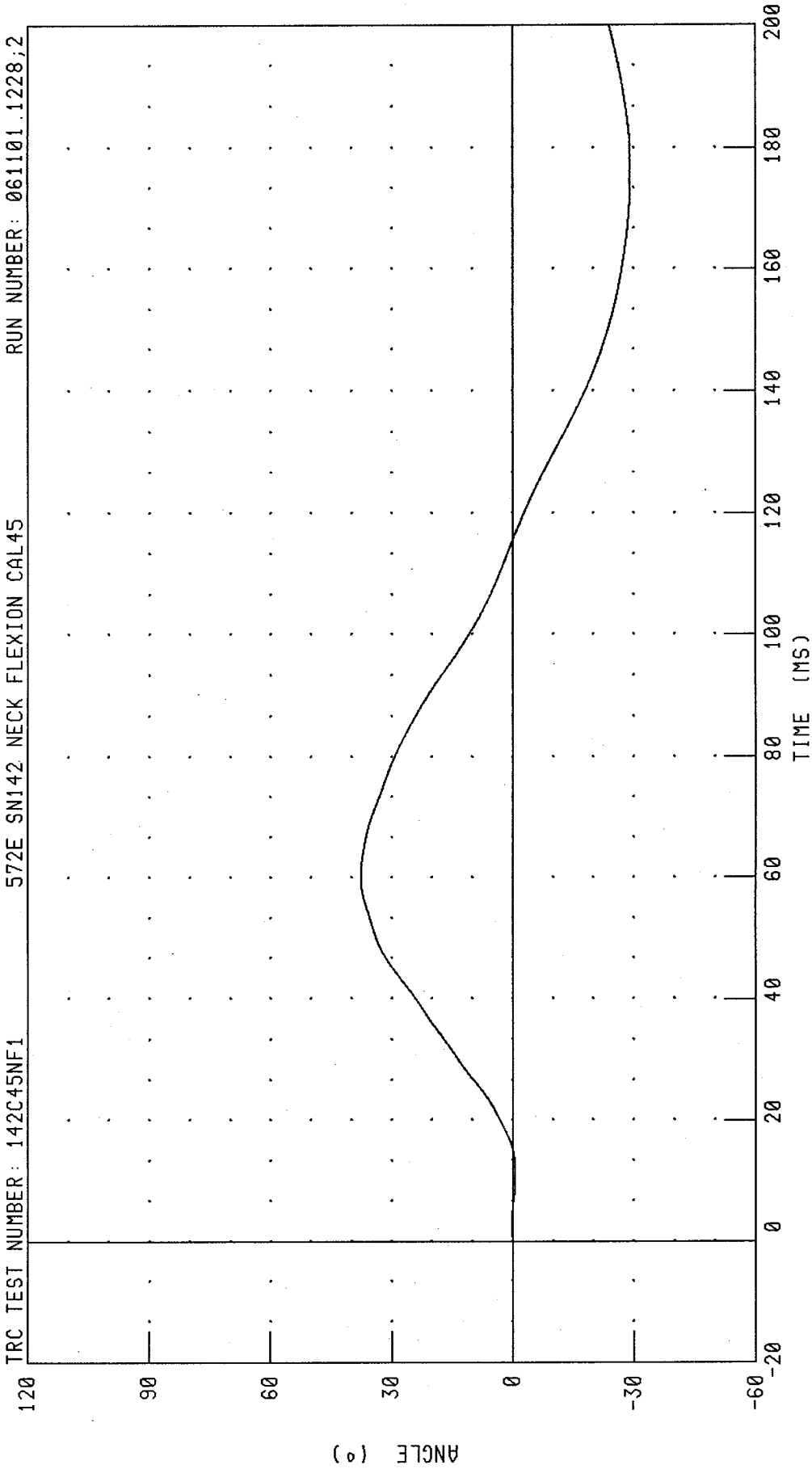

CHANNEL: THETA FILTER: CH. CLASS 60

PEAK DATA: 37.62 ° @ 60.16 MS; -29.14 ° @ 177.20 MS

PART 572-E HYBRID III NECK FLEXION CALIBRATION

TOTAL ROTATION

TRC TEST NUMBER: 142C45NF1

572E SN142 NECK FLEXION CAL45

RUN NUMBER: 061101.1228;2

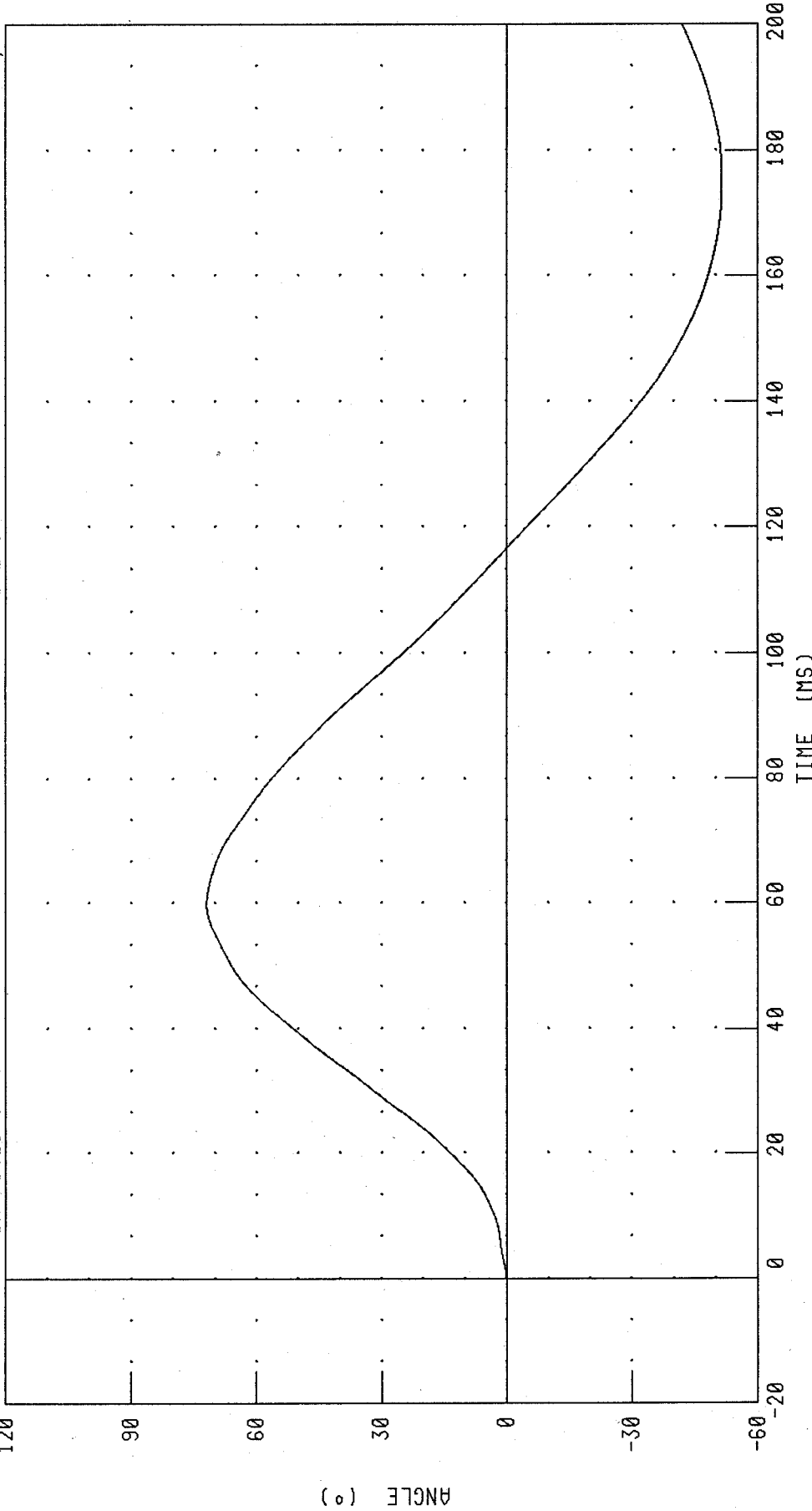

CHANNEL: TOTAN FILTER: CH. CLASS 60 PEAK DATA: 71.95 ° @ 59.92 MS; -51.50 ° @ 174.48 MS

PART 572-E HYBRID III NECK FLEXION CALIBRATION

NECK FORCE X AXIS

TRC TEST NUMBER: 142C45NF1

572E SN142 NECK FLEXION CAL45

RUN NUMBER: 061101.1228;2

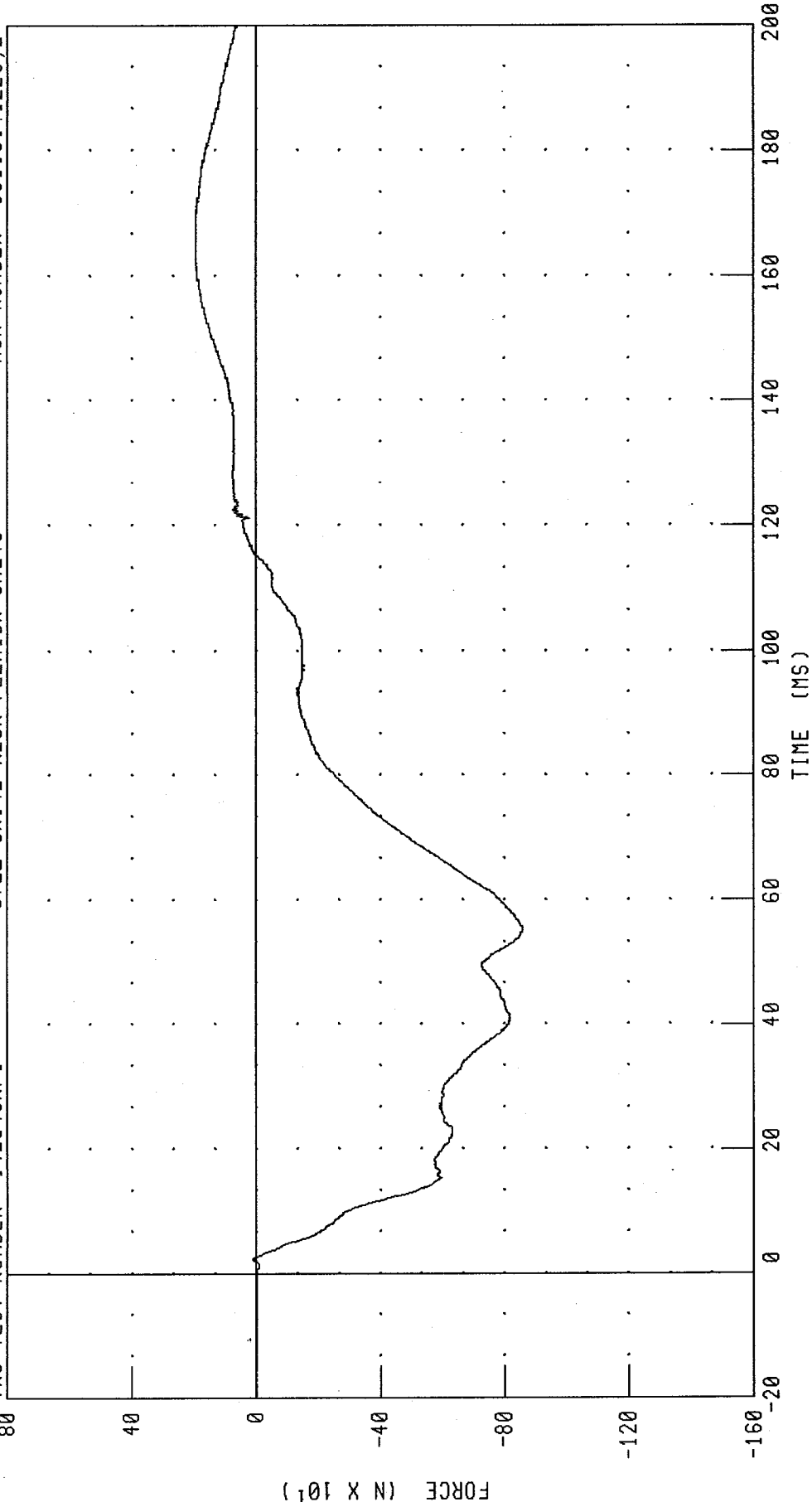

CHANNEL: NEKXF FILTER: CH. CLASS 1000

PEAK DATA: 194.48 N @ 161.04 MS; -857.26 N @ 54.88 MS

PART 572-E HYBRID III NECK FLEXION CALIBRATION
NECK FORCE X AXIS FILTERED FOR USE IN OCCIPITAL MOMENT CALCULATION

IRC TEST NUMBER: 142C45NF1 572E SN142 NECK FLEXION CAL45 RUN NUMBER: 061101.1228;2

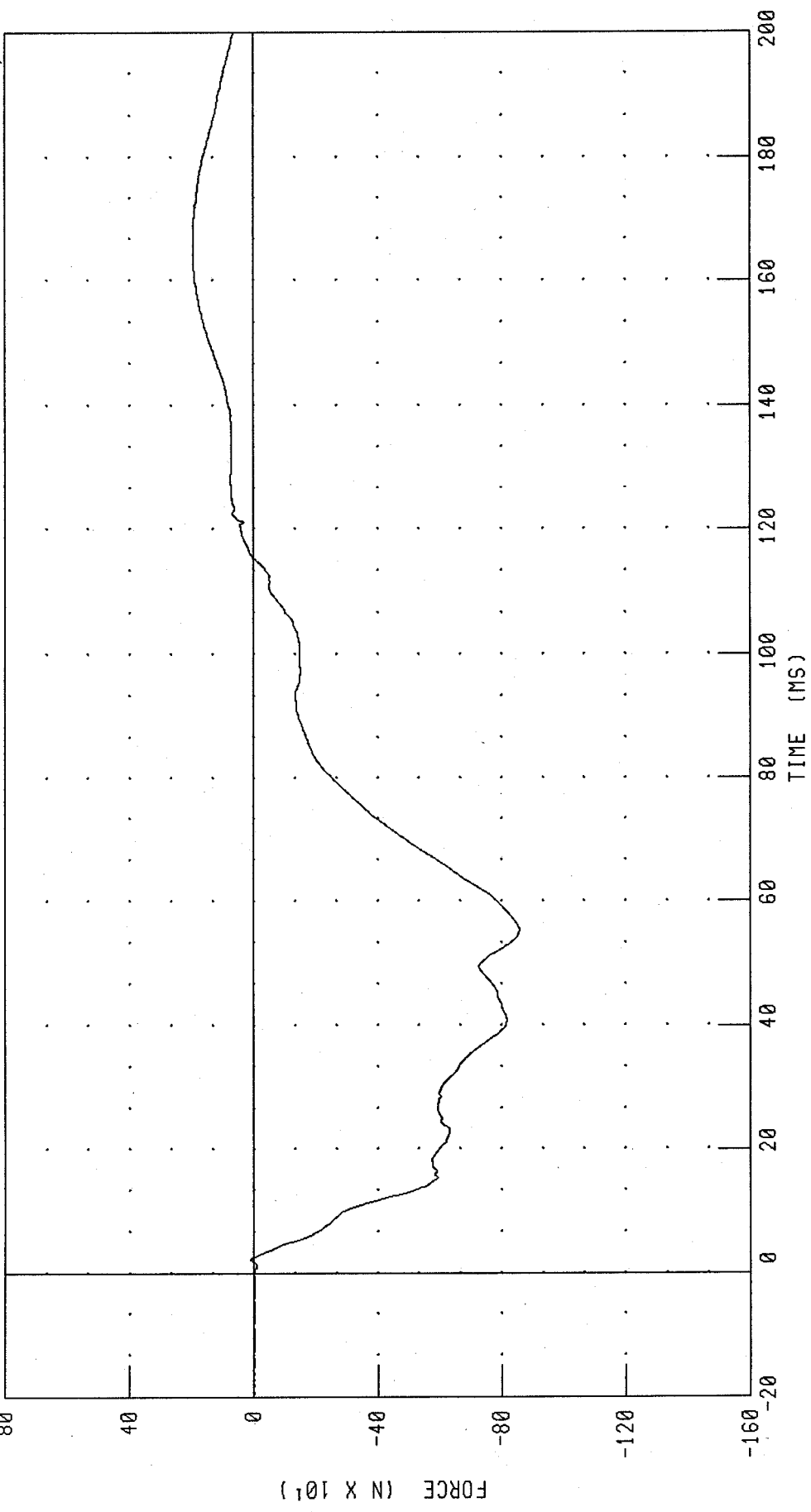

CHANNEL: NEKXFC FILTER: CH. CLASS 600 PEAK DATA: 194.58 N @ 169.68 MS; -857.53 N @ 55.36 MS

PART 572-E HYBRID III NECK FLEXION CALIBRATION
NECK MOMENT Y AXIS

TRC TEST NUMBER: 142C45NF1 572E SN142 NECK FLEXION CAL45 RUN NUMBER: 061101.1228;2

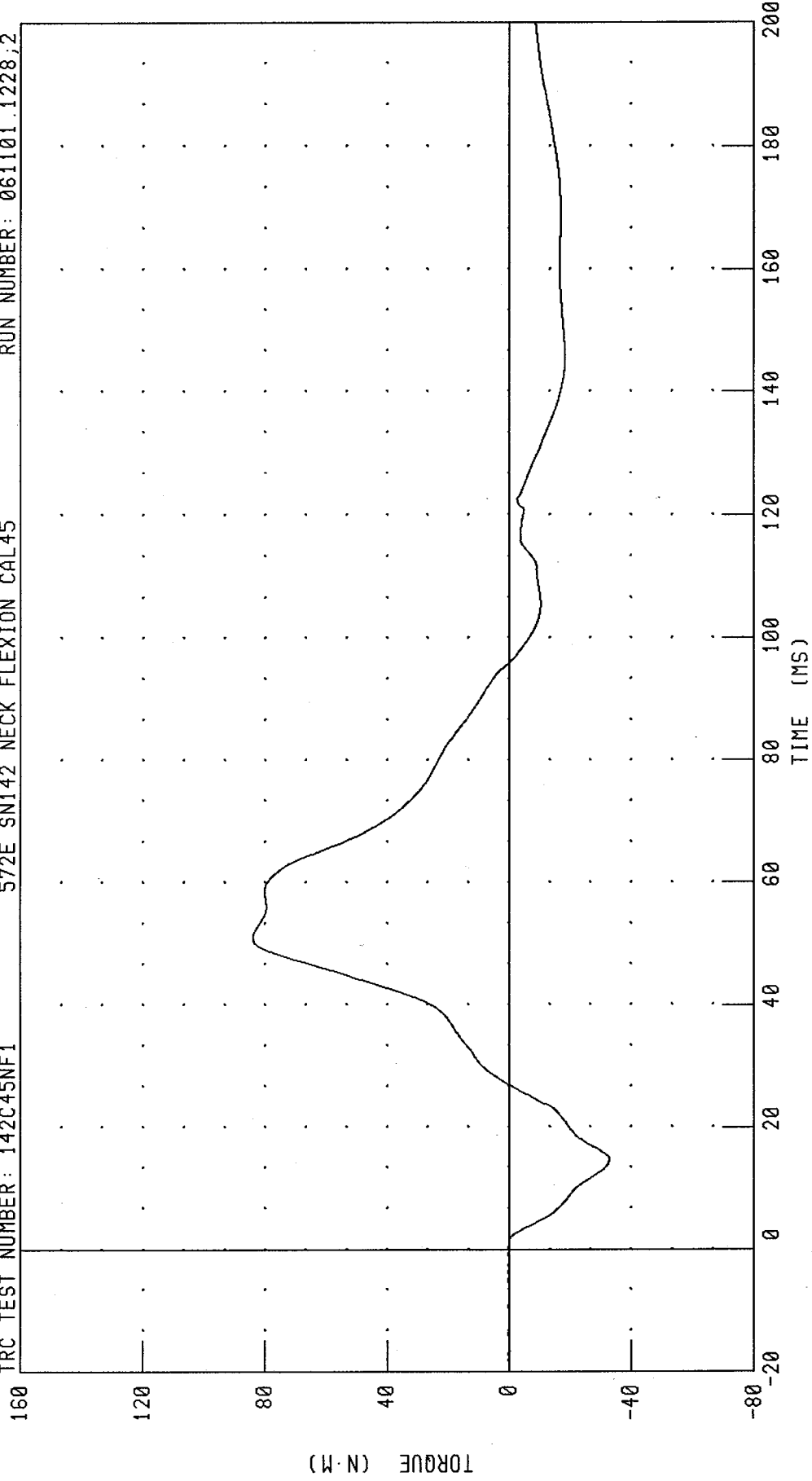

CHANNEL: NEKYM FILTER: CH. CLASS 600 PEAK DATA: 84.03 N·M @ 51.12 MS; -32.84 N·M @ 14.72 MS

PART 572-E HYBRID III NECK FLEXION CALIBRATION

TOTAL MOMENT ABOUT OCCIPITAL CONDYLE

TRC TEST NUMBER: 142C45NF1

572E SN142 NECK FLEXION CAL45

RUN NUMBER: 061101.1228;2

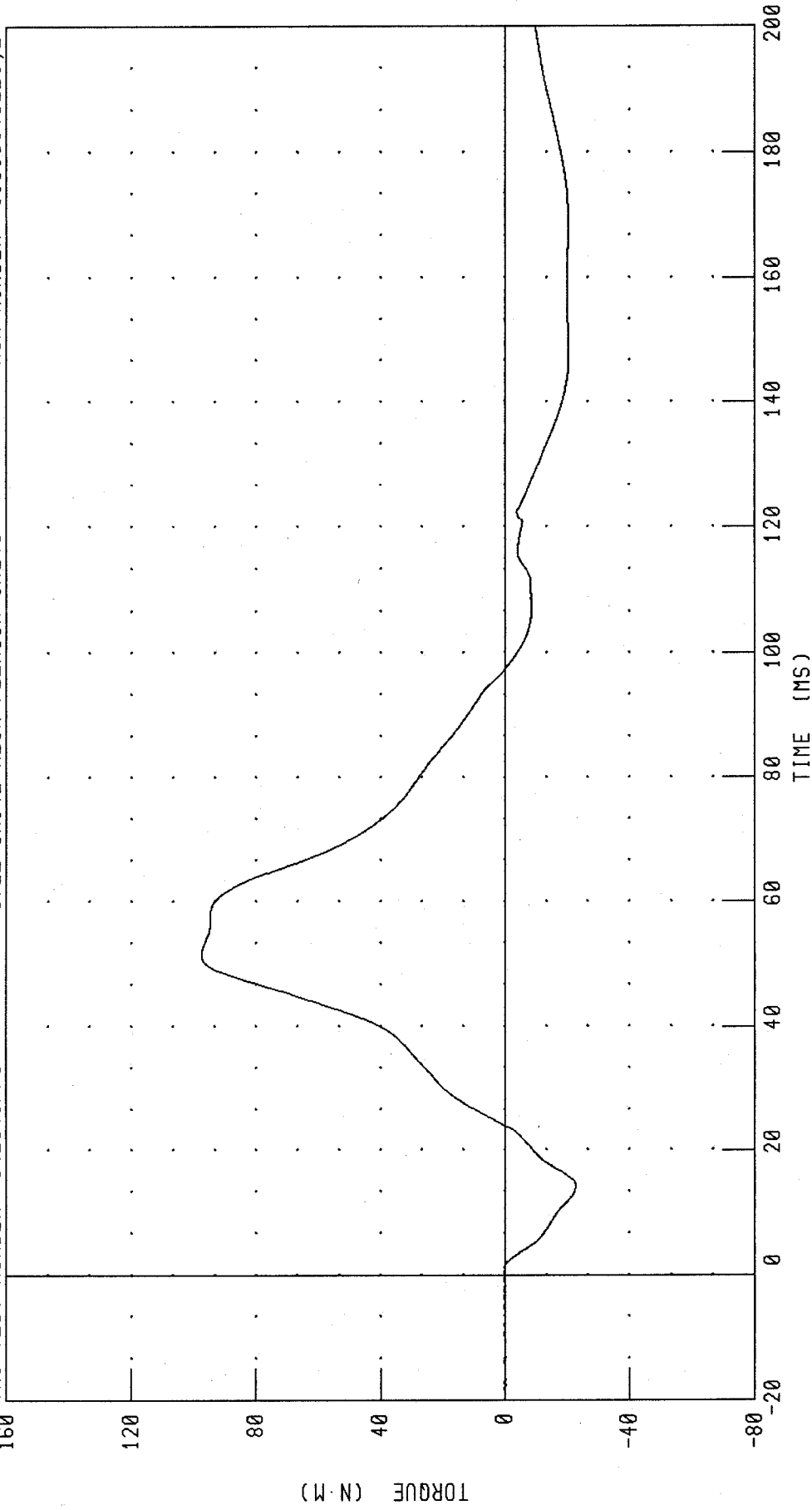

CHANNEL: NEKOM FILTER: CH. CLASS 600

PEAK DATA: 97.58 N-M @ 51.44 MS; -22.74 N-M @ 14.24 MS

PART 572-E HYBRID III NECK EXTENSION CALIBRATION
PENDULUM DECELERATION

TRC TEST NUMBER: 142C45NE1

572E SN142 NECK EXT CAL45

RUN NUMBER: 061101.1354.1

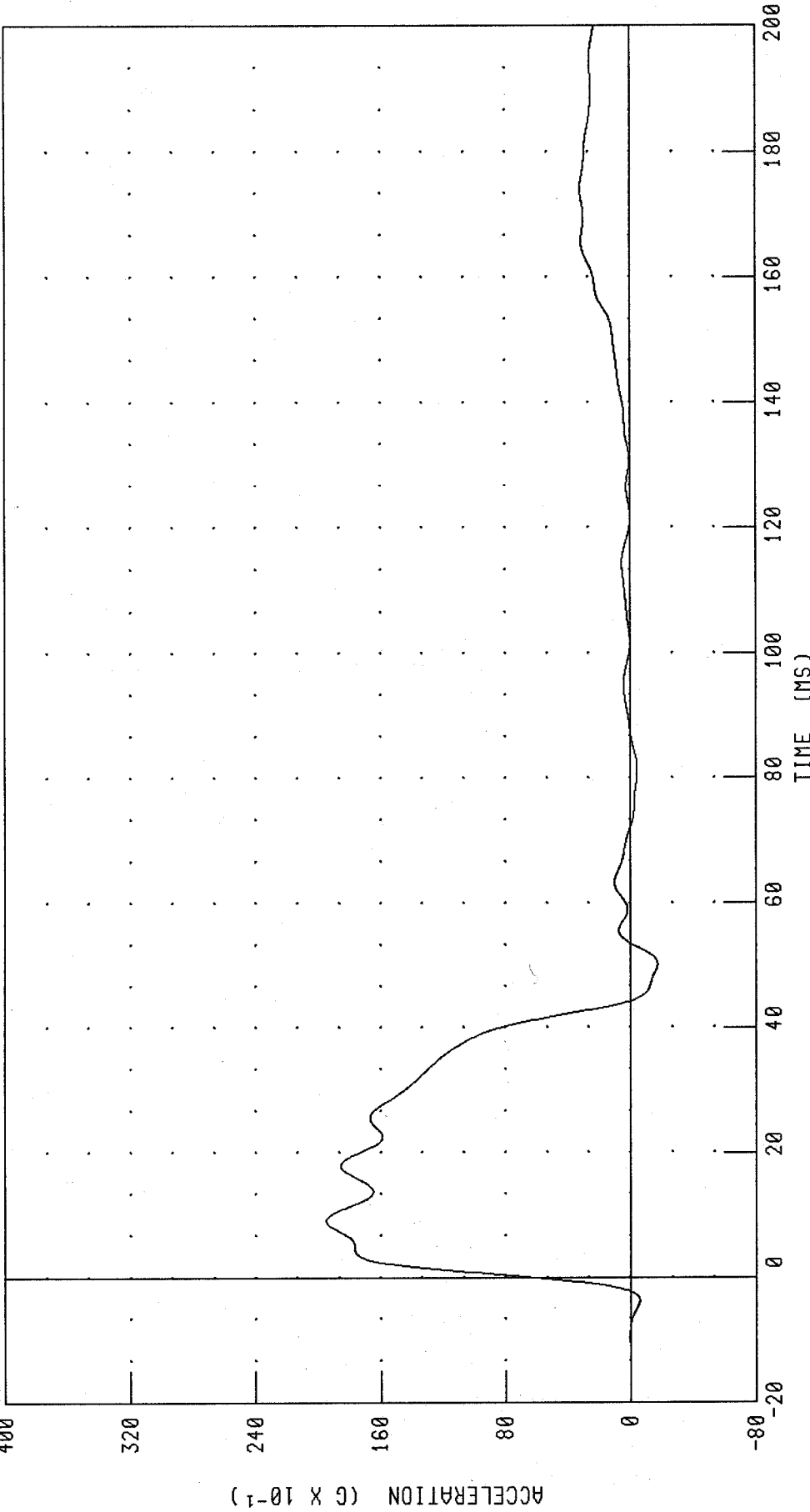

CHANNEL: PENXG FILTER: CH. CLASS 60

PEAK DATA: 19.48 G @ 9.04 MS; -1.75 G @ 50.16 MS

PART 572-E HYBRID III NECK EXTENSION CALIBRATION

ROTATION ABOUT BASE OF NECK

TRC TEST NUMBER: 142C45NE1

572E SN142 NECK EXT CAL45

RUN NUMBER: 061101.1354;1

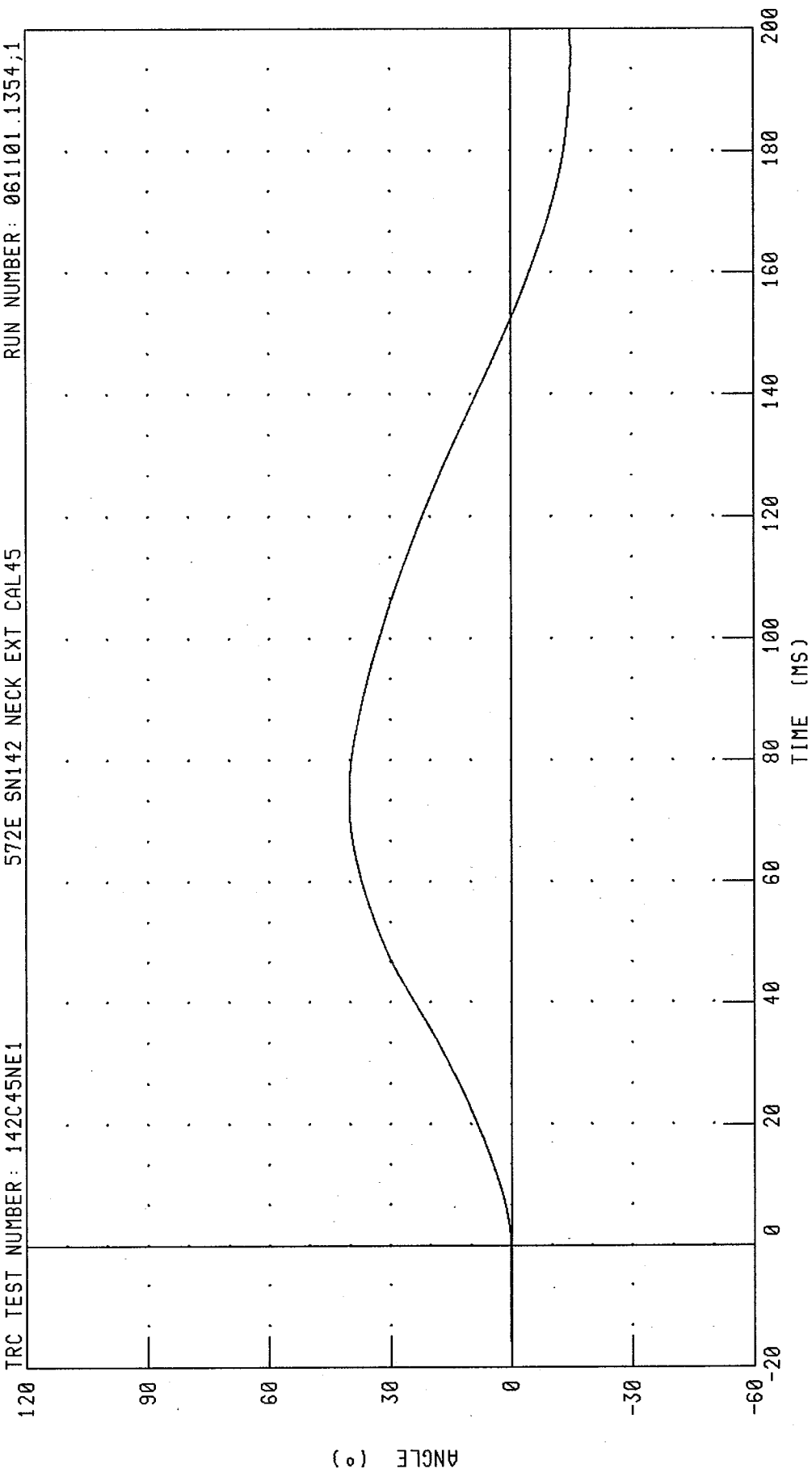

CHANNEL: BETA FILTER: CH. CLASS 60 PEAK DATA: 40.13 ° @ 74.56 MS; -14.96 ° @ 195.52 MS

PART 572-E HYBRID III NECK EXTENSION CALIBRATION
ROTATION ABOUT OCCIPITAL CONDYLE

TRC TEST NUMBER: 142C45NE1 572E SN142 NECK EXT CAL45 RUN NUMBER: 061101.1354;1

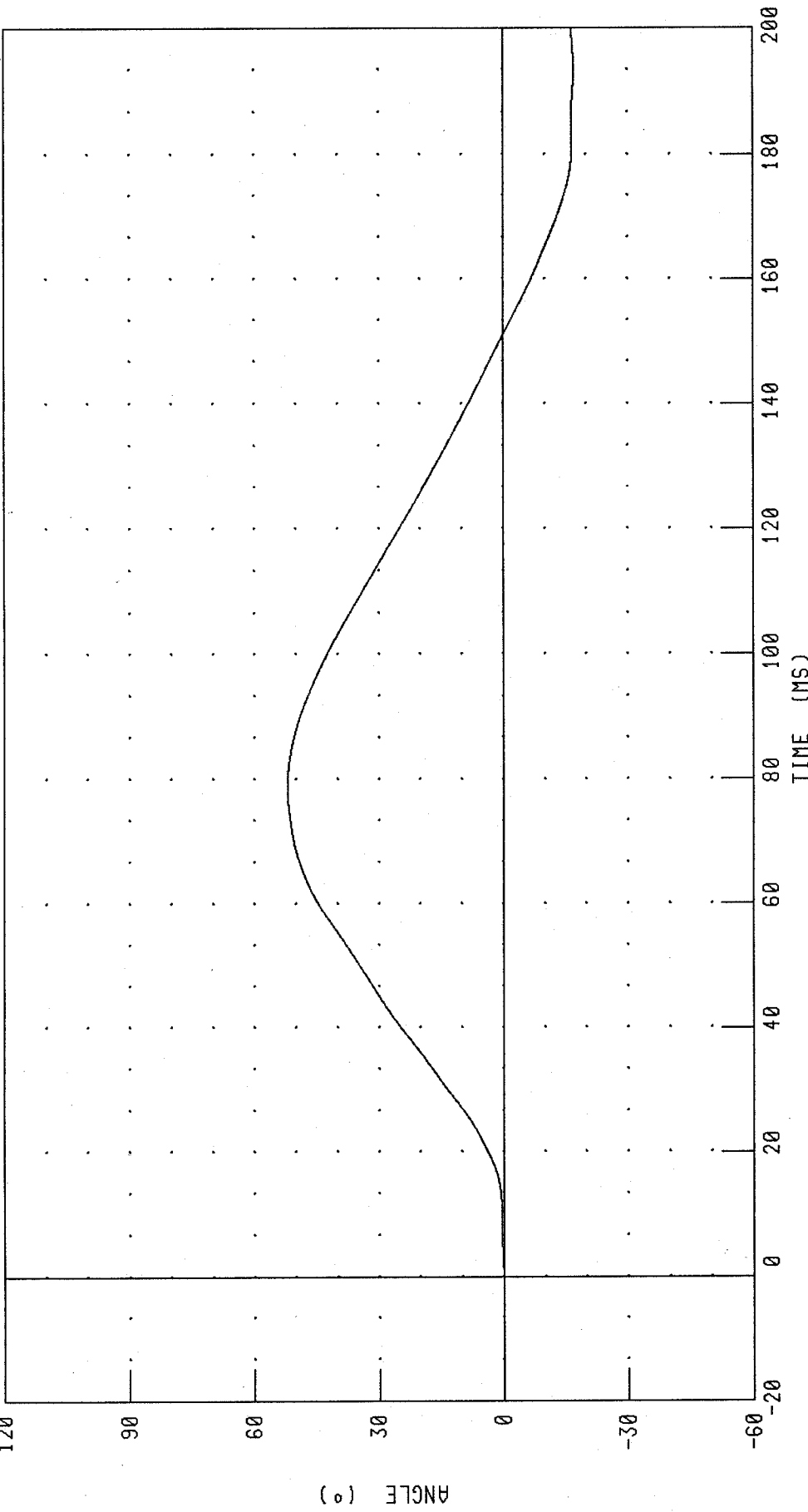

CHANNEL: THETA FILTER: CH. CLASS 60 PEAK DATA: 52.08 ° @ 78.56 MS; -17.09 ° @ 193.20 MS

PART 572-E HYBRID III NECK EXTENSION CALIBRATION

TOTAL ROTATION

TRC TEST NUMBER: 142C45NE1

572E SN142 NECK EXT CAL45

RUN NUMBER: 061101.1354;1

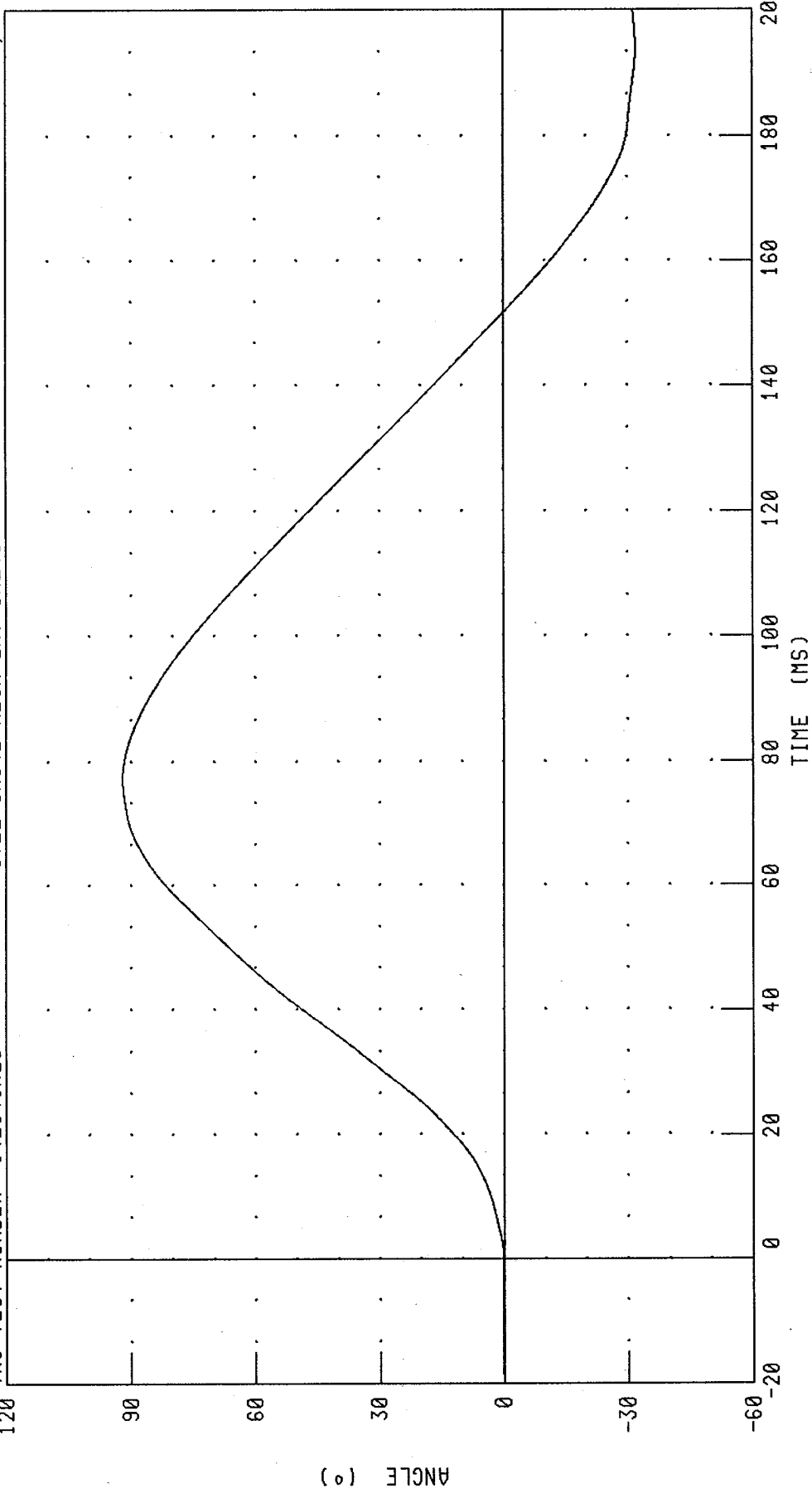

CHANNEL: TOTAN FILTER: CH. CLASS 60 PEAK DATA: 92.04 ° @ 77.28 MS; -32.02 ° @ 193.92 MS

PART 572-E HYBRID III NECK EXTENSION CALIBRATION
NECK FORCE X AXIS

TRC TEST NUMBER: 142C45NE1 572E SN142 NECK EXT CAL45 RUN NUMBER: 061101.1354;1

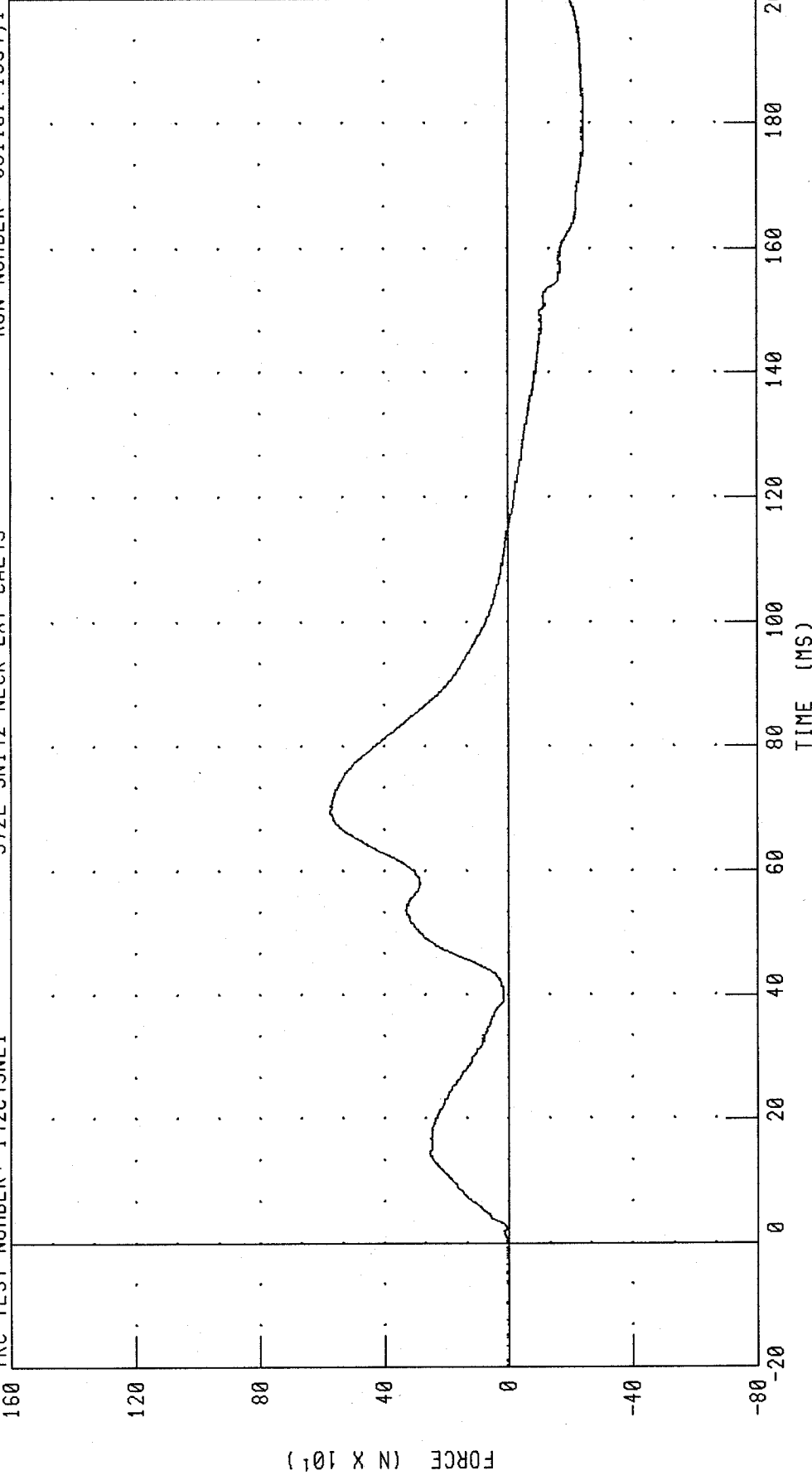

CHANNEL: NEKXF FILTER: CH. CLASS 1000 PEAK DATA: 573.60 N @ 69.28 MS; -243.46 N @ 174.72 MS

PART 572-E HYBRID III NECK EXTENSION CALIBRATION
 NECK FORCE X AXIS FILTERED FOR USE IN OCCIPITAL MOMENT CALCULATION
 TRC TEST NUMBER: 142C45NE1 572E SN142 NECK EXT CAL45 RUN NUMBER: 061101.1354;1

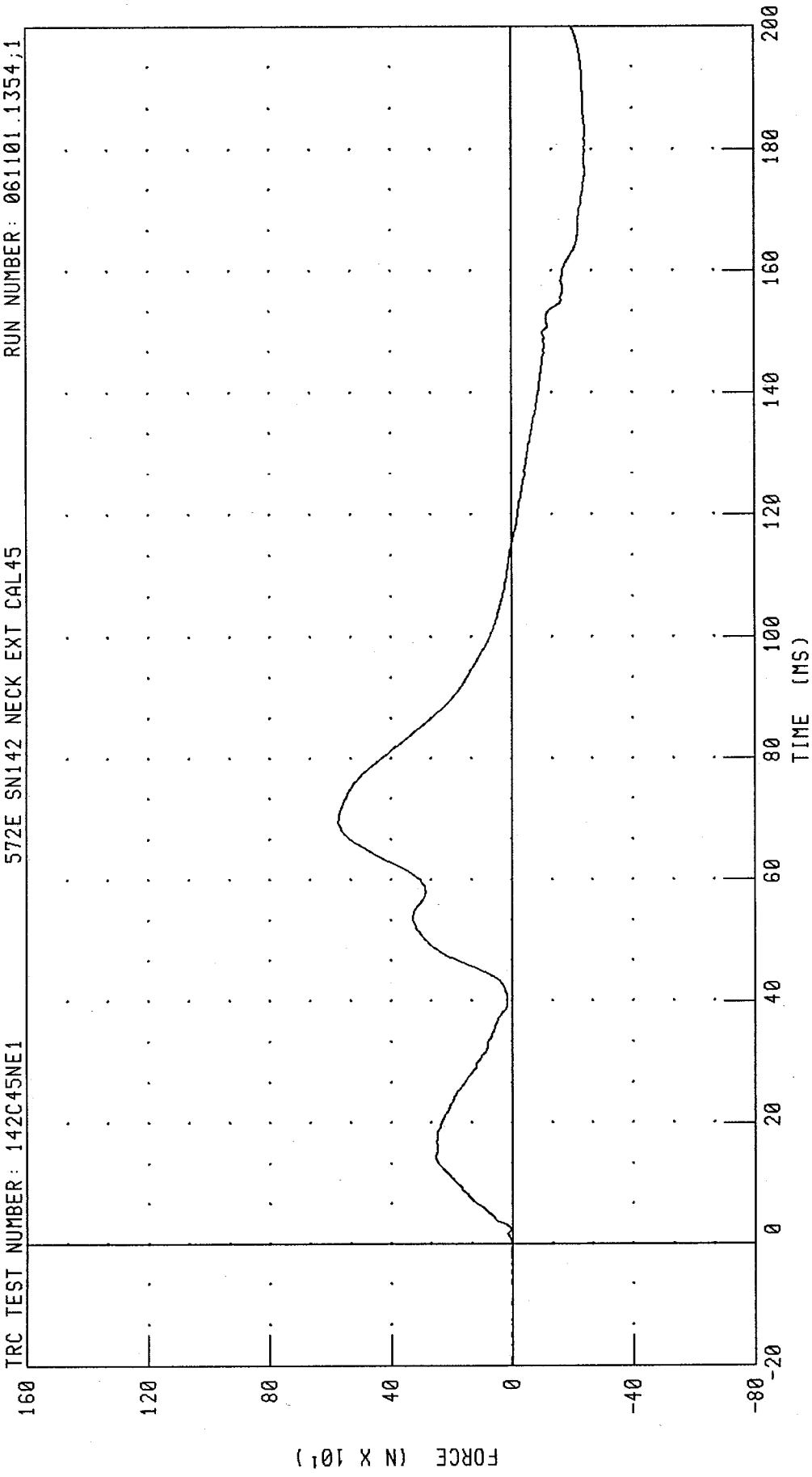

CHANNEL: NEKXFC FILTER: CH. CLASS 600 PEAK DATA: 573.88 N @ 69.60 MS; -243.58 N @ 183.92 MS

PART 572-E HYBRID III NECK EXTENSION CALIBRATION
NECK MOMENT Y AXIS

TRC TEST NUMBER: 142C45NE1 572E SN142 NECK EXT CAL45 RUN NUMBER: 061101.1354;1

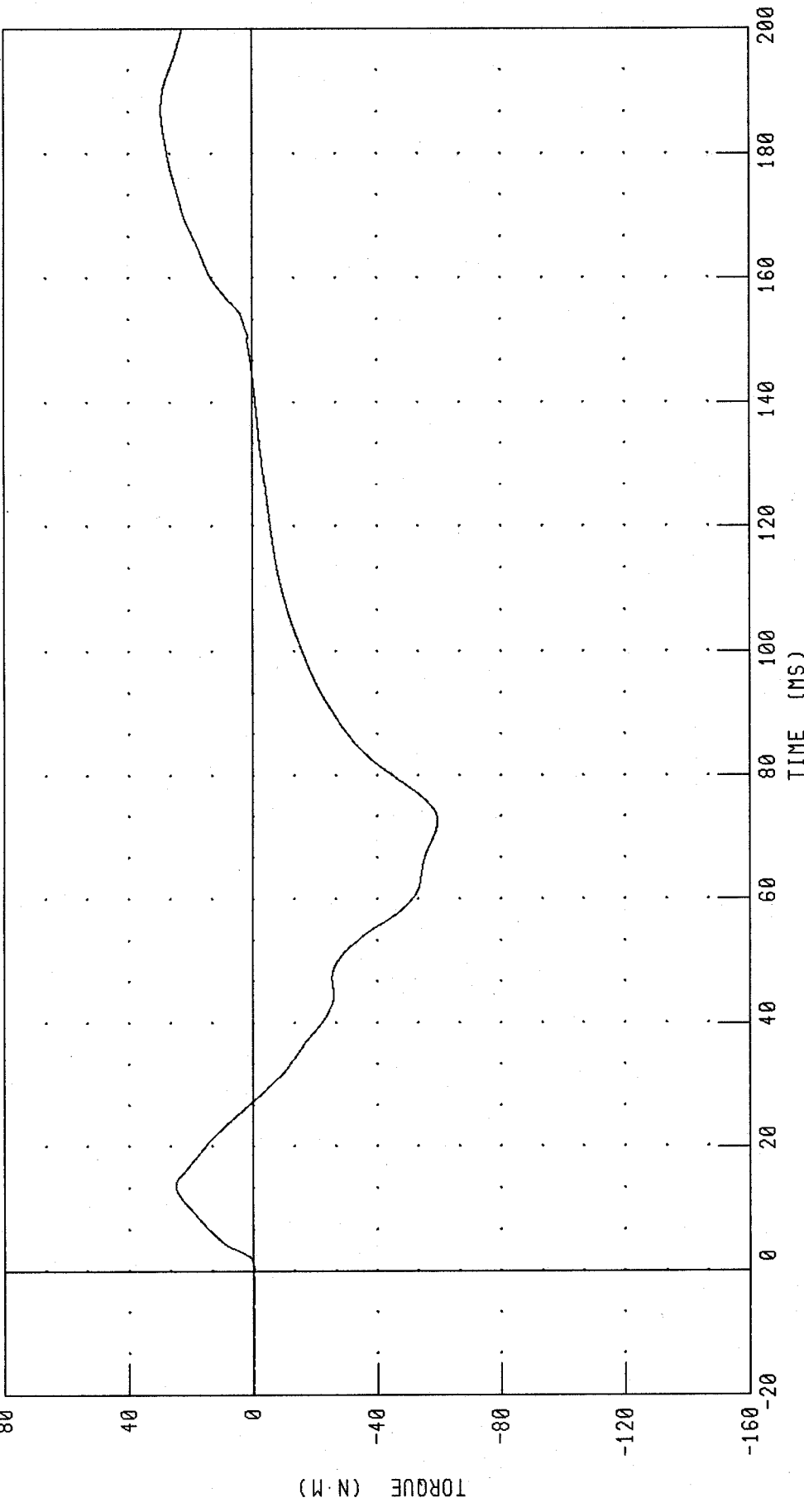

CHANNEL: NEKYM FILTER: CH. CLASS 600 PEAK DATA: 29.47 N·M @ 186.32 MS; -59.47 N·M @ 72.88 MS

PART 572-E HYBRID III NECK EXTENSION CALIBRATION
TOTAL MOMENT ABOUT OCCIPITAL CONDYLE

TRC TEST NUMBER: 142C45NE1

572E SN142 NECK EXT CAL45

RUN NUMBER: 061101.1354;1

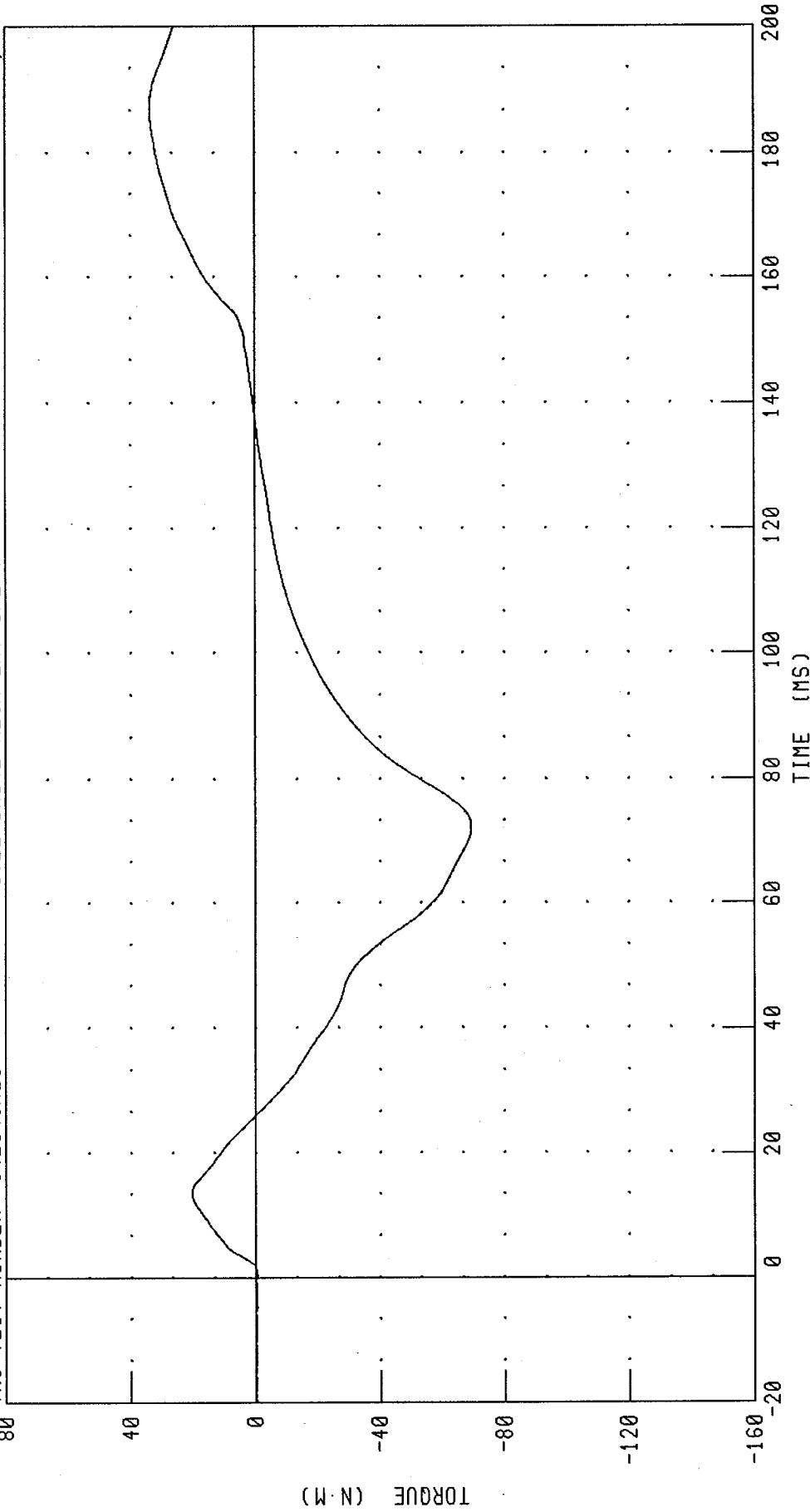

CHANNEL: NEKOM FILTER: CH. CLASS 600

PEAK DATA: 33.72 N·M @ 186.32 MS; -69.44 N·M @ 72.08 MS

TRANSPORTATION RESEARCH CENTER INC.

THORAX IMPACT TEST

HYBRID III 50th

15-JUN-01

TRC INC.

TEST NO: 142C45TH1

572E SN142 H.S.THORAX CAL45

TEST PARAMETER	HIGH SPEED TEST	TEST RESULTS
	SPECIFICATION	
TEMPERATURE	20.6-22.2 DEG. C	21.7 DEG. C
RELATIVE HUMIDITY	10 - 70 %	55.0 %
PENDULUM VELOCITY	6.59 - 6.83 M/S	6.59 M/S
MAXIMUM DEFLECTION	63.5 - 72.6 MM	69.1 MM
MAXIMUM RESISTIVE FORCE	5159 - 5894 N	5683. N
INTERNAL HYSTERESIS	69% - 85%	74.1%

TEST MEETS SPECIFICATIONS

TECHNICIAN

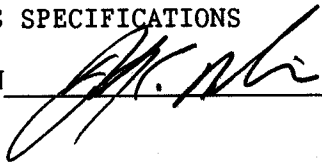

RUN NUMBER: 061501.1429;1

PART 572-E HYBRID III THORAX CALIBRATION

PENDULUM DECELERATION

TRC TEST NUMBER: 142C45TH1

572E SN142 H.S.THORAX CAL45

RUN NUMBER: 061801.0702;1

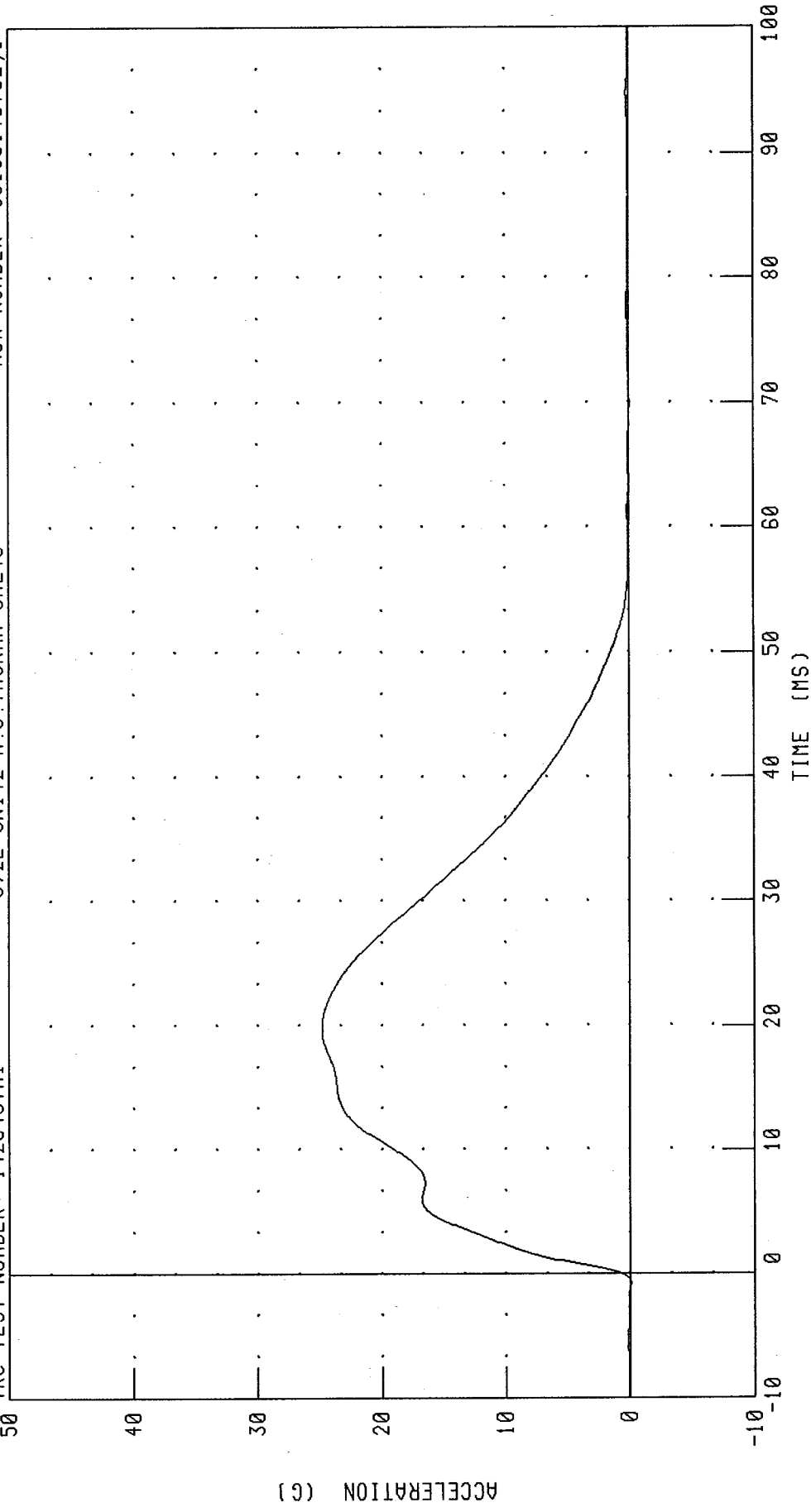

CHANNEL: PENXC FILTER: CH. CLASS 180 PEAK DATA: 24.81 G @ 19.68 MS; -0.07 G @ 69.92 MS

PART 572-E HYBRID III THORAX CALIBRATION
PENDULUM FORCE

TRC TEST NUMBER: 142C45TH1

572E SN142 H.S. THORAX CAL45

RUN NUMBER: 061801 0702;1

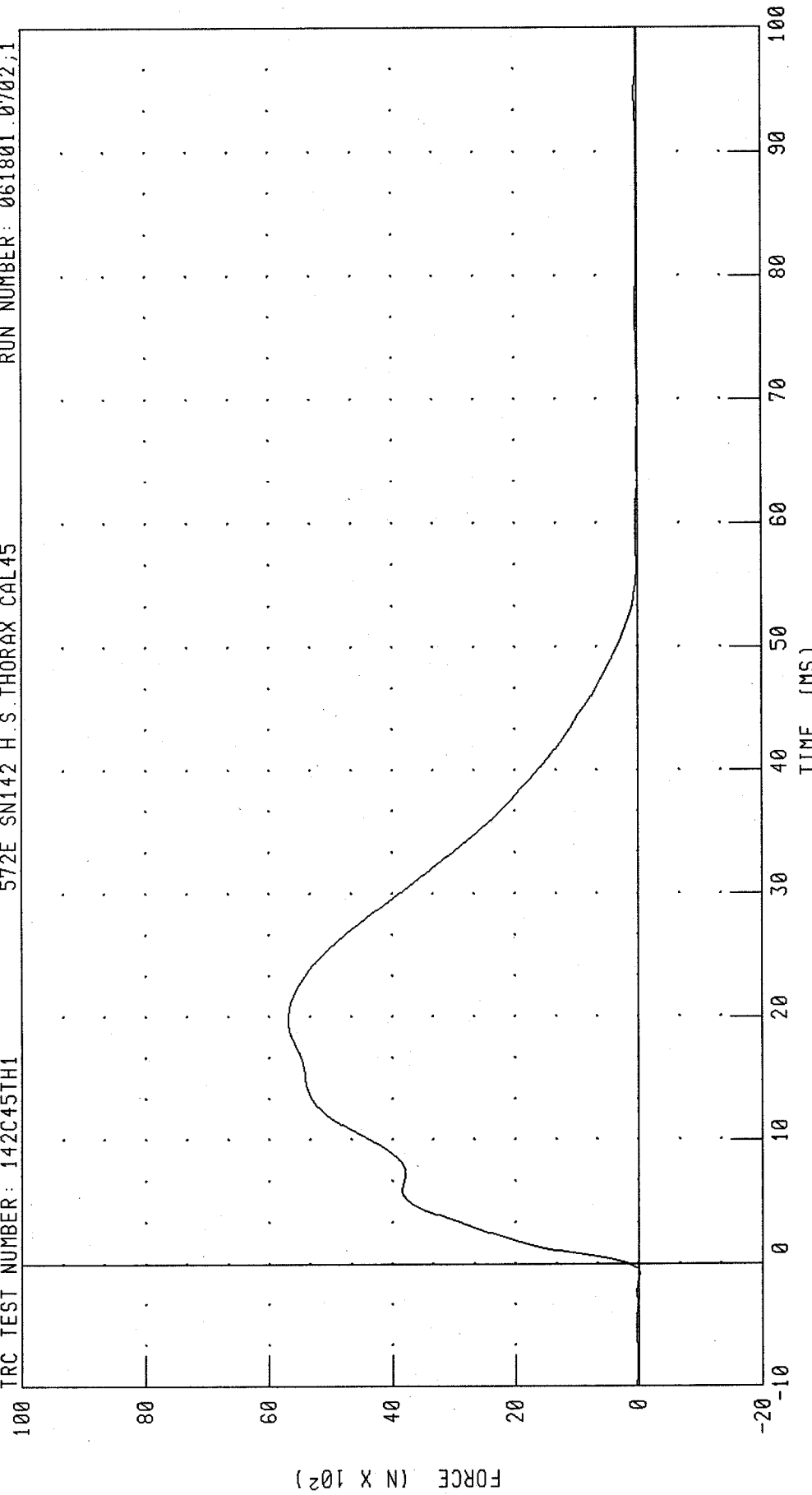

CHANNEL: PENXF FILTER: CH. CLASS 180 PEAK DATA: 5683.57 N @ 19.68 MS; -16.42 N @ 69.92 MS

PART 572-E HYBRID III THORAX CALIBRATION
STERNUM DISPLACEMENT

TRC TEST NUMBER: 142C45TH1

572E SN142 H.S. THORAX CAL45

RUN NUMBER: 061801.0702;1

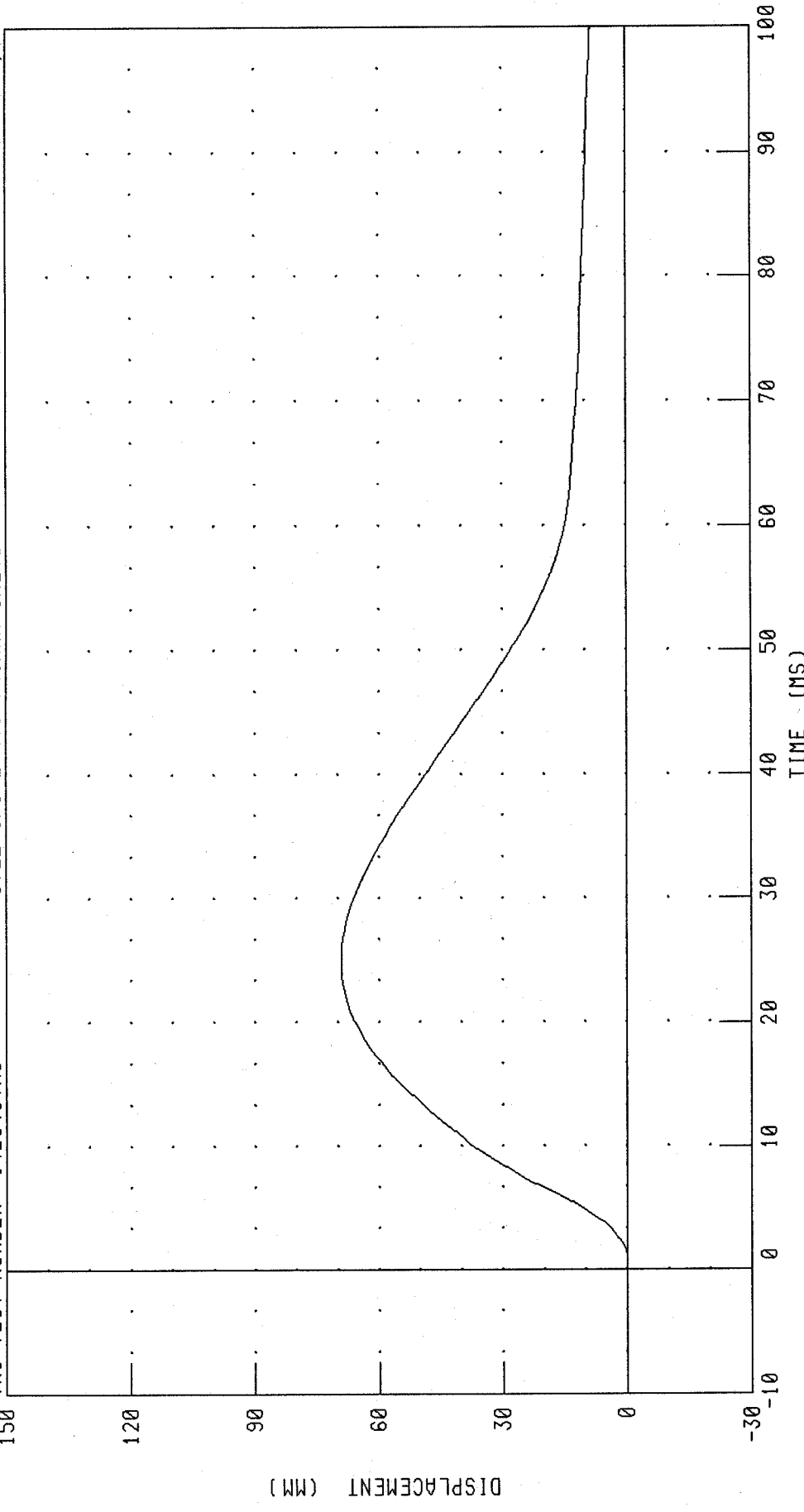

CHANNEL: CSTXD FILTER: CH. CLASS 180

PEAK DATA: 69.12 MM @ 25.28 MS; -0.06 MM @ 0.72 MS

PART 572-E HYBRID III THORAX CALIBRATION
 CHEST DISPLACEMENT VS PENDULUM FORCE

TRC TEST NUMBER: 142C45TH1 RUN NUMBER: 061801.0702;1

572E SN142 H.S.THORAX CAL45

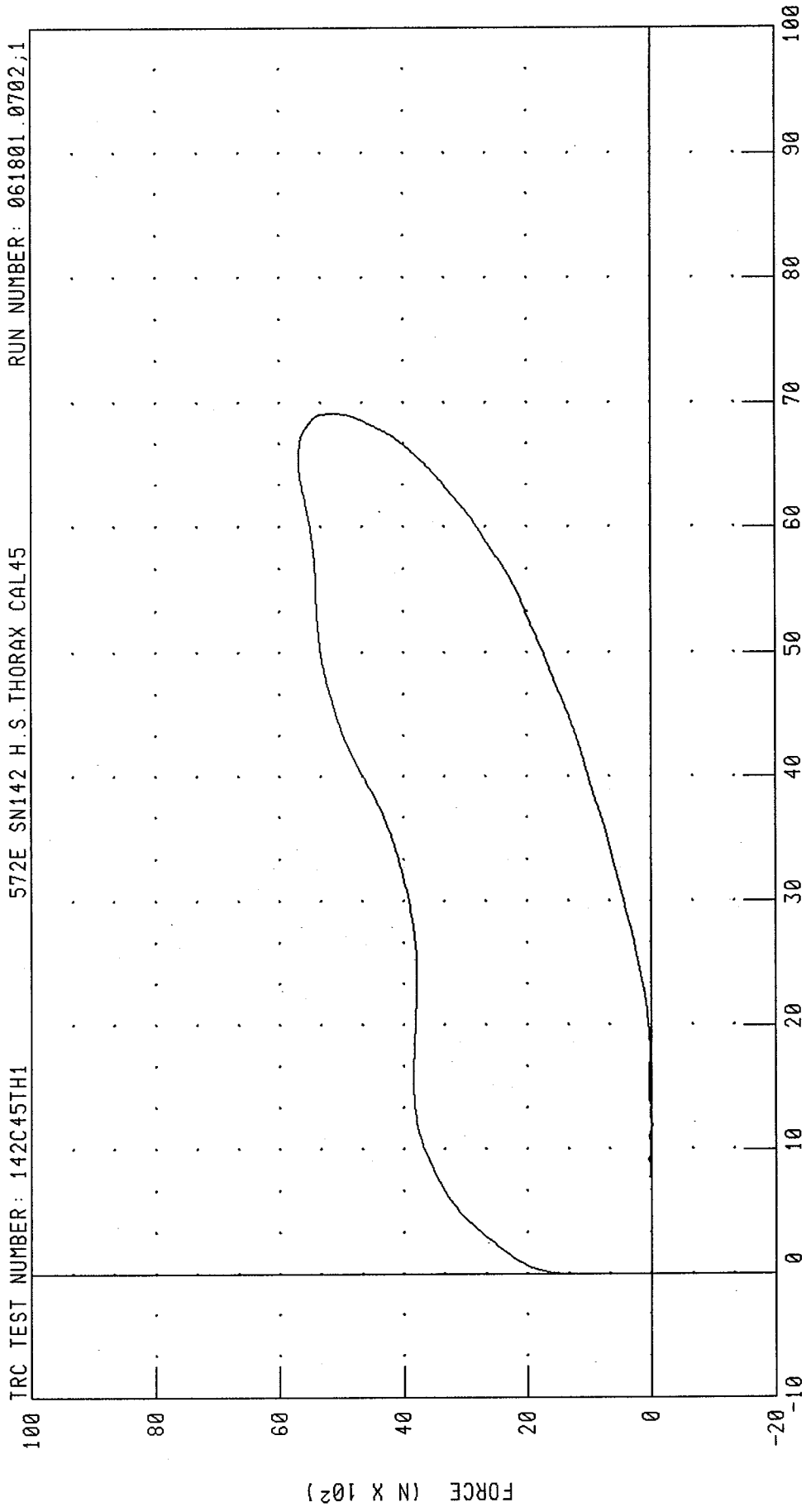

CHANNEL: CSTXD FILTER: CH: CLASS 180
 PENXF CH: CLASS 180

DISPLACEMENT (MM) PEAK DATA: 69.12 MM @ 25.28 MS; -0.06 MM @ 0.72 MS
 5683.57 N @ 19.68 MS; -16.42 N @ 69.92 MS

Transportation Research Center Inc

Hybrid III Hip Range of Motion

Serial Number: 142C45

Date: 06/07/2001

Test Number: 142L

Time: 08:01

Comments:

TEST PARAMETER	SPECIFICATION	TEST RESULTS	
Temperature	18.9 - 25.6	21.1 °C	Pass
Humidity	10 - 70	55 %	Pass
Moment at 30 deg	<= 94.9	74.5 Nm	Pass
Angle at 203 Nm	40.0 - 50.0	41.9 deg	Pass
Average Velocity	5.0 - 10.0	7.4 deg/sec	Pass

Moment About H-Point
Peak Moment: 211.5 Nm at 42.3 deg
Peak Angle: 42.3 deg at 211.5 Nm

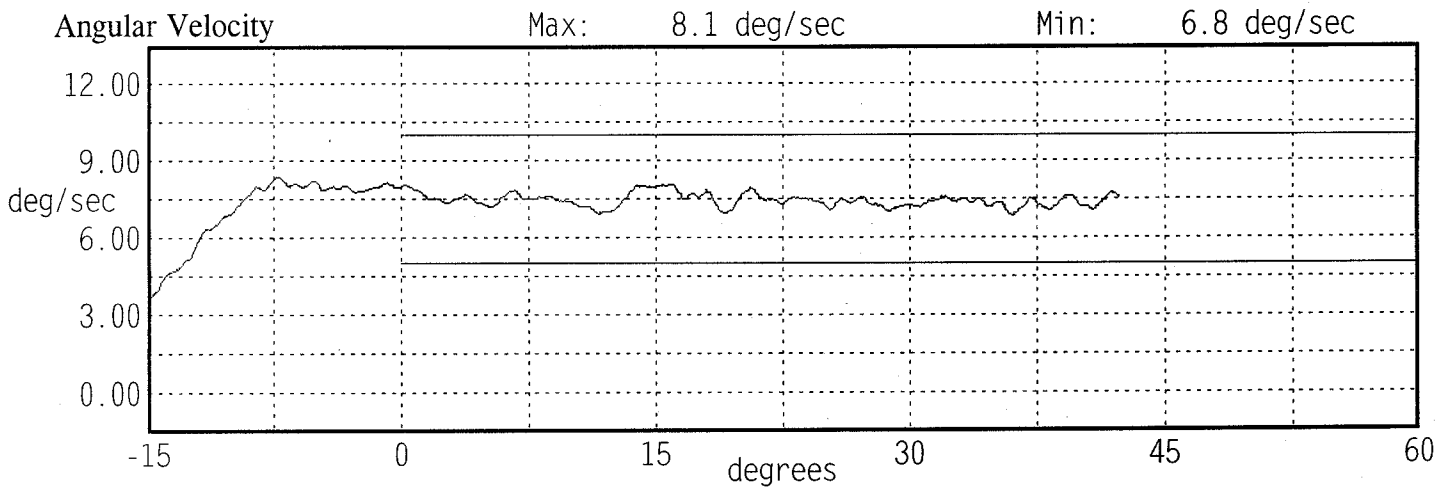
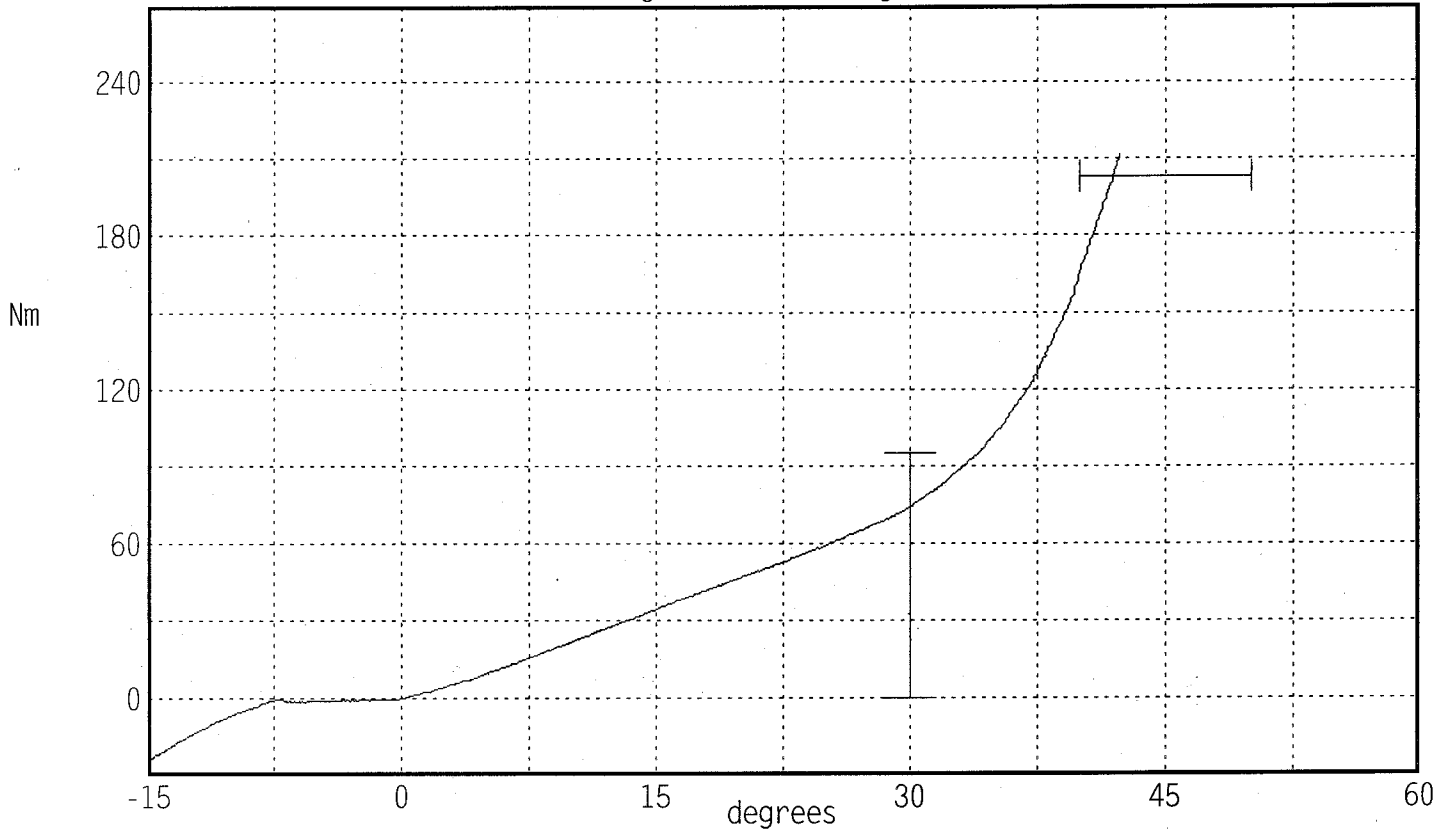

Transportation Research Center Inc

Hybrid III Hip Range of Motion

Serial Number: 142C45

Date: 06/07/2001

Test Number: 142R

Time: 07:50

Comments:

TEST PARAMETER	SPECIFICATION	TEST RESULTS	
Temperature	18.9 - 25.6	21.1 °C	Pass
Humidity	10 - 70	55 %	Pass
Moment at 30 deg	<= 94.9	75.2 Nm	Pass
Angle at 203 Nm	40.0 - 50.0	43.7 deg	Pass
Average Velocity	5.0 - 10.0	7.4 deg/sec	Pass

Moment About H-Point
 Peak Moment: 210.9 Nm at 44.0 deg
 Peak Angle: 44.0 deg at 210.9 Nm

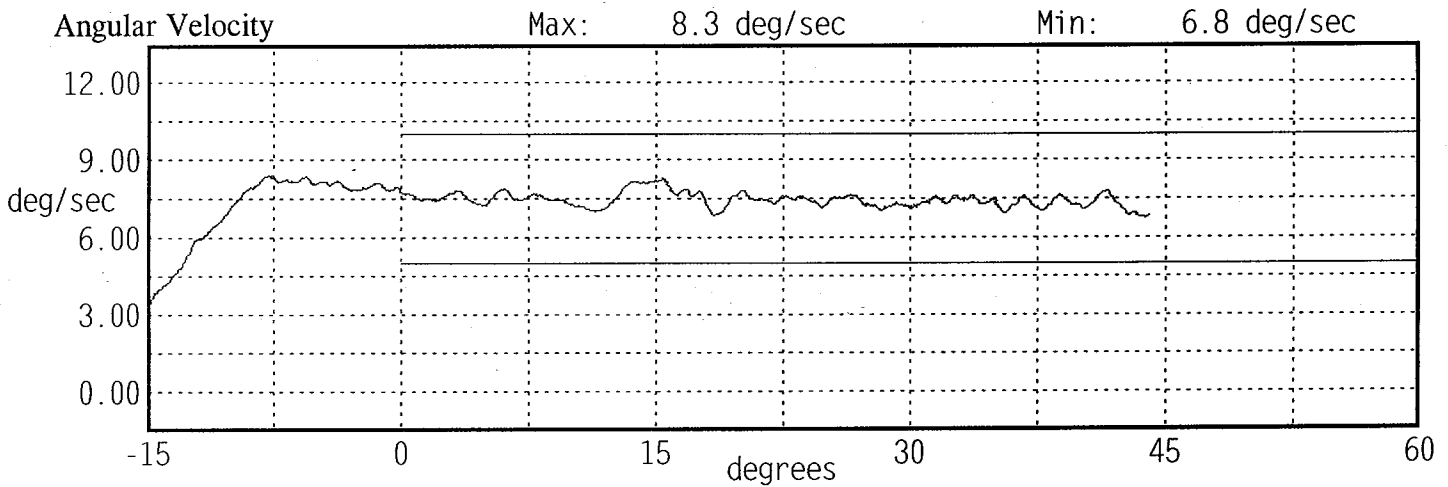
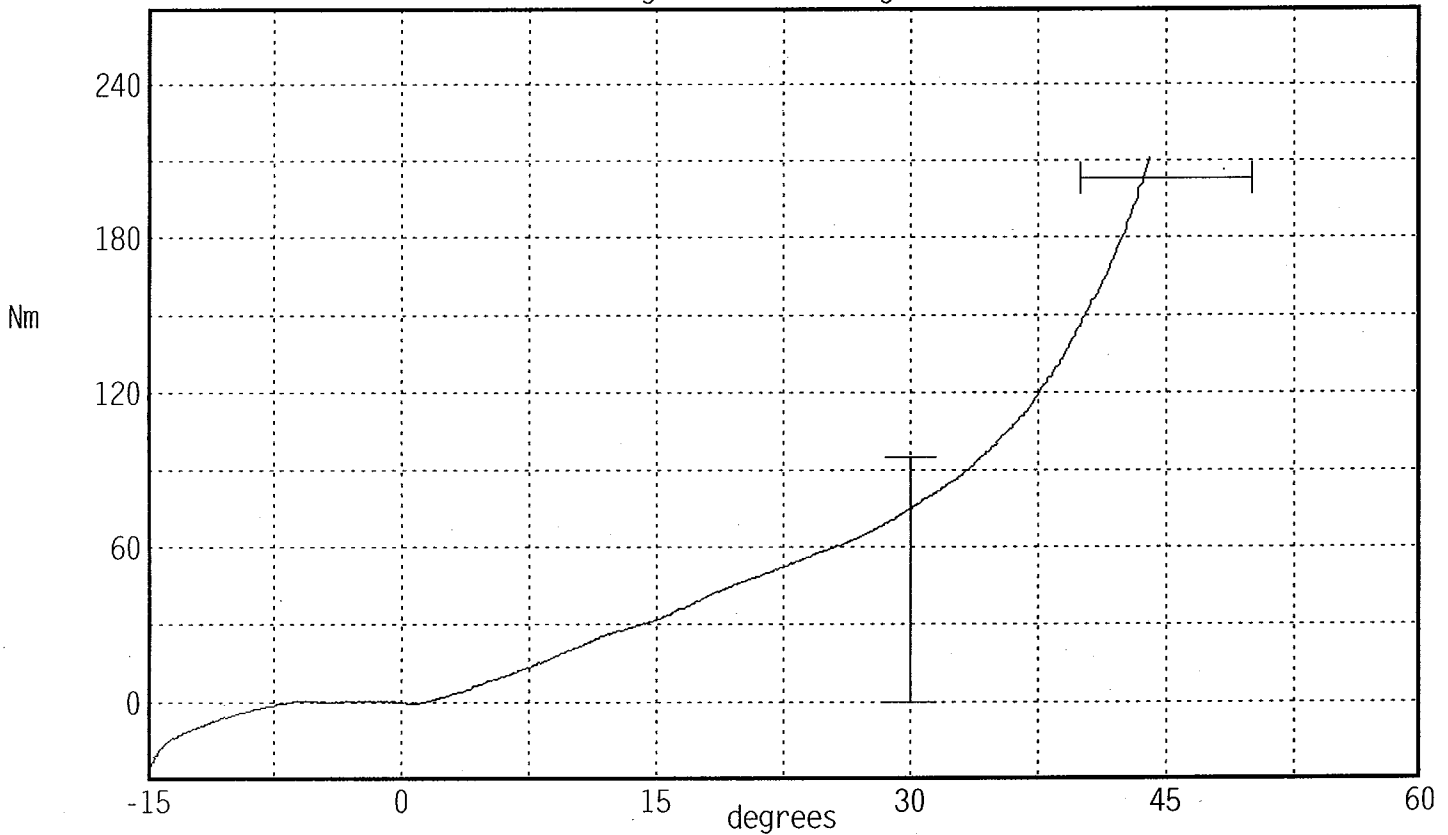

TRANSPORTATION RESEARCH CENTER INC.

LEFT KNEE IMPACT TEST

HYBRID III 50th

08-JUN-01

TRC INC.

TEST NO: 142C45LK1

572E SN142 LEFT KNEE CAL 45

TEST PARAMETER	SPECIFICATION	TEST RESULTS
TEMPERATURE	18.9-25.6 DEG. C	21.1 DEG. C
RELATIVE HUMIDITY	10 - 70 %	58.0 %
PROBE VELOCITY	2.07 - 2.13 M/S	2.09 M/S
PEAK KNEE IMPACT FORCE 5.0 KG PENDULUM	4715 - 5782 N	5352.7 N

TEST MEETS SPECIFICATIONS

TECHNICIAN

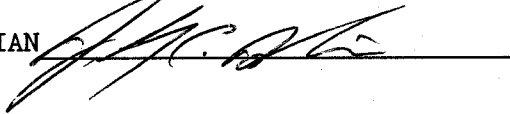

RUN NUMBER: 060801.0912;1

PART 572-E HYBRID III LEFT KNEE CALIBRATION
PENDULUM DECELERATION (5 KG PEND.)

TRC TEST NUMBER: 142C45LK1

572E SN142 LEFT KNEE CAL 45

RUN NUMBER: 060801.0913;1

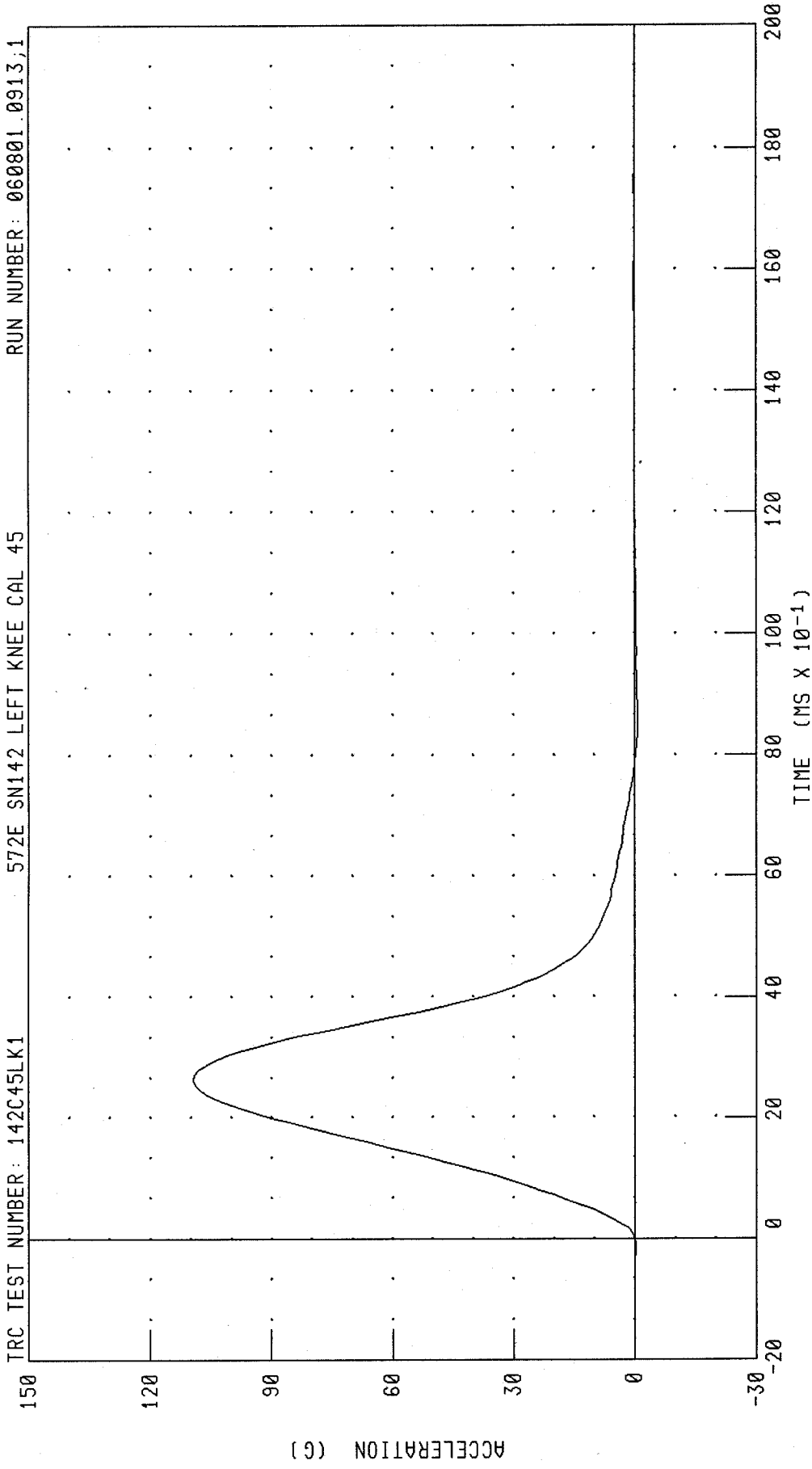

CHANNEL: PENXC FILTER: CH. CLASS 600 PEAK DATA: 109.40 G @ 2.64 MS; -0.76 G @ 8.48 MS

PART 572-E HYBRID III LEFT KNEE CALIBRATION

PENDULUM FORCE (5 KG PEND.)

TRC TEST NUMBER: 142C45LK1

572E SN142 LEFT KNEE CAL 45

RUN NUMBER: 060801.0913.1

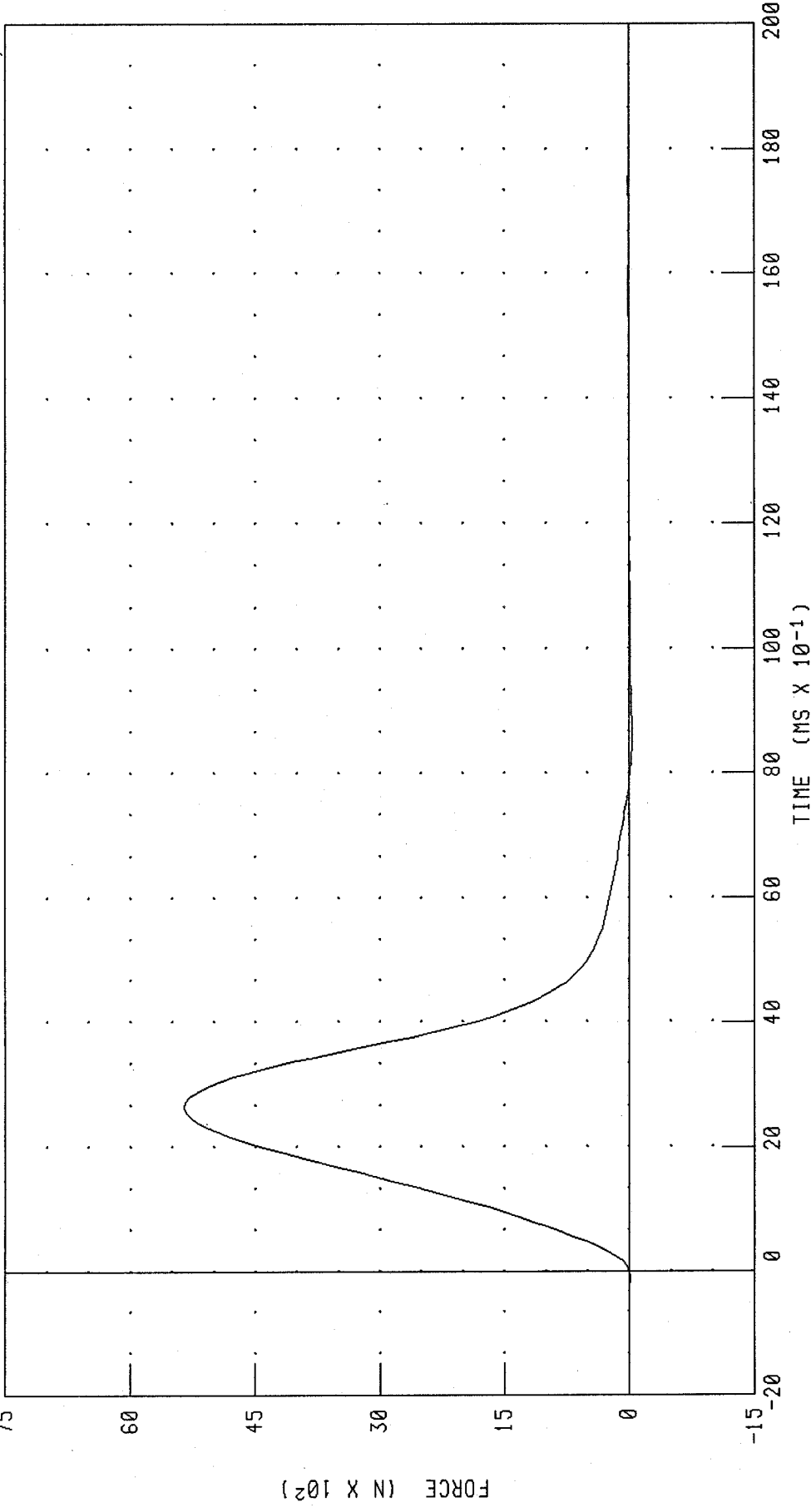

CHANNEL: PENXF FILTER: CH. CLASS 600 PEAK DATA: 5352.74 N @ 2.64 MS; -37.37 N @ 8.48 MS

TRANSPORTATION RESEARCH CENTER INC.

RIGHT KNEE IMPACT TEST

HYBRID III 50th

08-JUN-01

TRC INC.

TEST NO: 142C45RK2

572E SN142 RIGHT KNEE CAL 45

TEST PARAMETER	SPECIFICATION	TEST RESULTS
TEMPERATURE	18.9-25.6 DEG. C	21.1 DEG. C
RELATIVE HUMIDITY	10 - 70 %	58.0 %
PROBE VELOCITY	2.07 - 2.13 M/S	2.07 M/S
PEAK KNEE IMPACT FORCE 5.0 KG PENDULUM	4715 - 5782 N	5092.0 N

TEST MEETS SPECIFICATIONS

TECHNICIAN

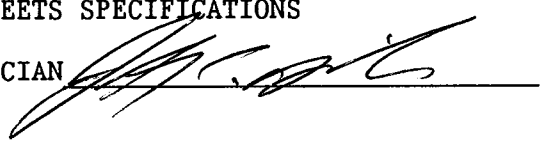

RUN NUMBER: 060801.0805;1

PART 572-E HYBRID III RIGHT KNEE CALIBRATION
PENDULUM DECELERATION (5 KG PEND.)

TRC TEST NUMBER: 142C45RK2 RUN NUMBER: 060801.0805,1

572E SN142 RIGHT KNEE CAL 45

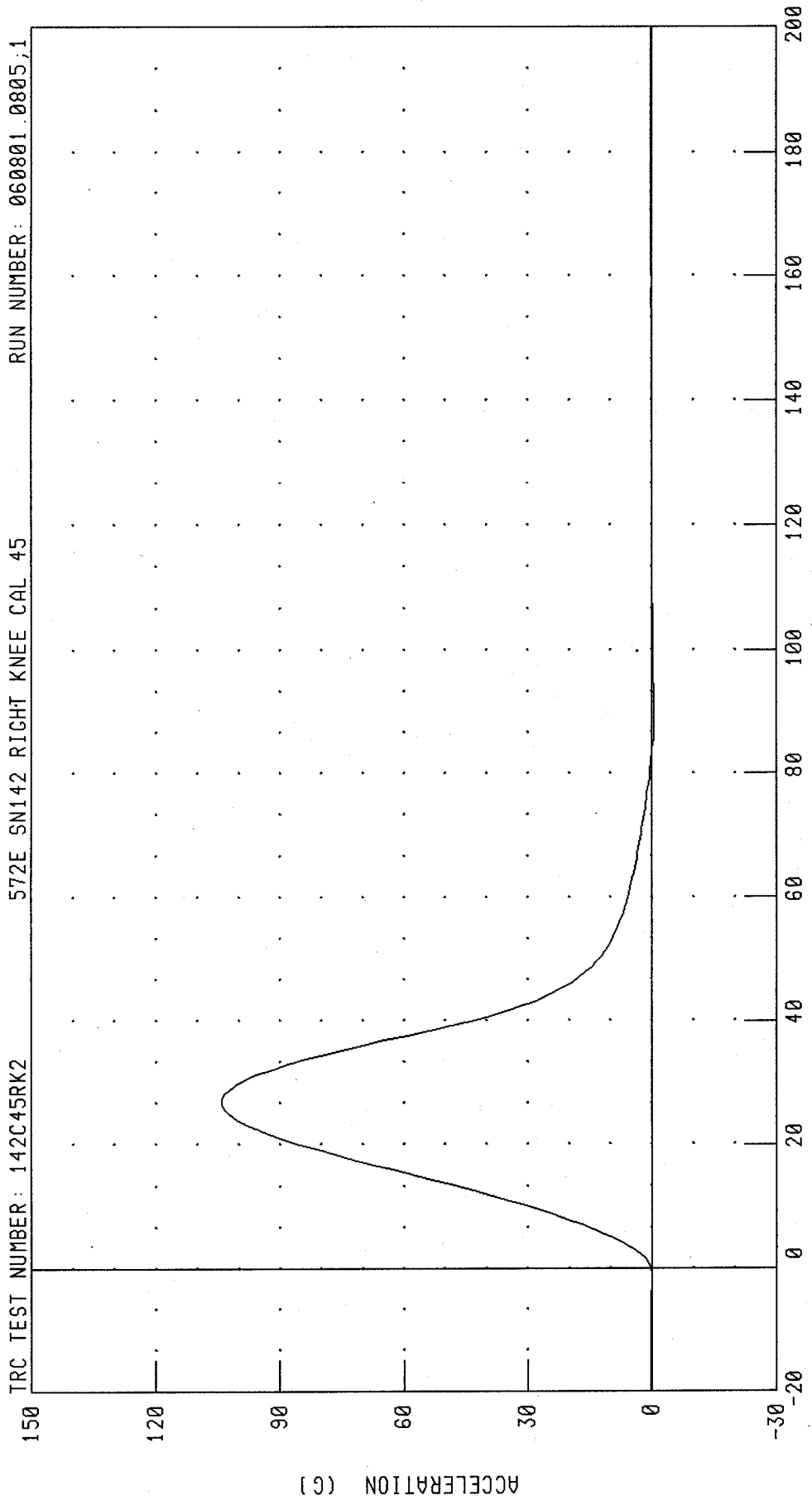

CHANNEL: PENXC FILTER: CH. CLASS 600 PEAK DATA: 104.07 G @ 2.72 MS; -0.67 G @ 8.96 MS

PART 572-E HYBRID III RIGHT KNEE CALIBRATION

PENDULUM FORCE (5 KG PEND.)

572E SN142 RIGHT KNEE CAL 45

RUN NUMBER: 060801.0805;1

TRC TEST NUMBER: 142C45RK2

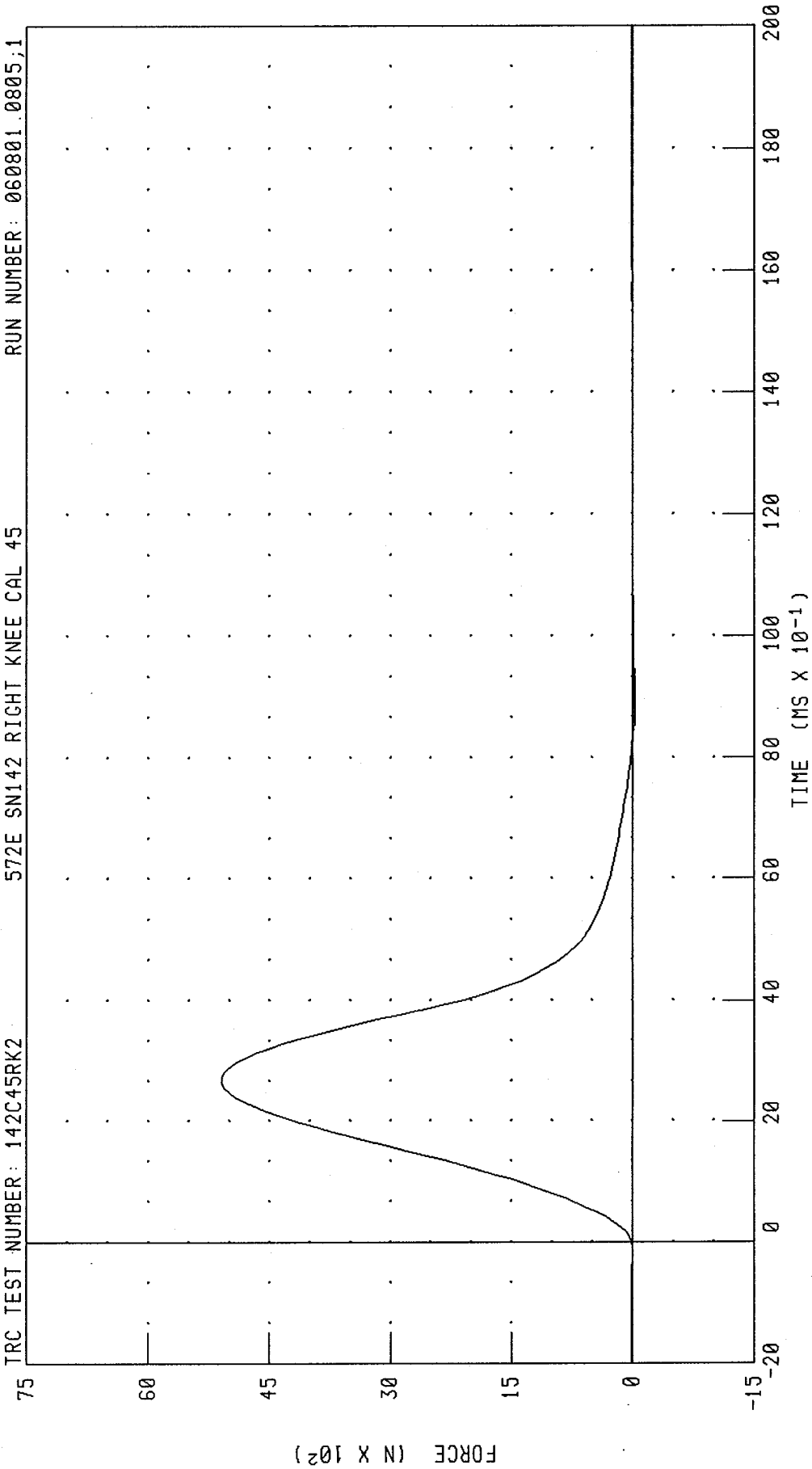

CHANNEL: PENXF FILTER: CH. CLASS 600 PEAK DATA: 5092.00 N @ 2.72 MS; -32.59 N @ 8.96 MS

TRANSPORTATION RESEARCH CENTER INC.

KNEE SLIDER TEST

HYBRID III 50th

12-JUN-01

LEFT KNEE

TRC INC.

TEST NO: 142C45LS3

572E SN142 LEFT SLIDER CAL 45

TEST PARAMETER	SPECIFICATION	TEST RESULTS
TEMPERATURE	18.9-25.6 DEG. C	21.7 DEG. C
RELATIVE HUMIDITY	10 - 70 %	58.0 %
PENDULUM VELOCITY	2.70-2.80 M/S	2.75 M/S
FORCE AT 10.0 MM DISPLACEMENT	1259 - 1721 N	-1418. N
FORCE AT 18.0 MM DISPLACEMENT	2268 - 3096 N	-2487. N

TEST MEETS SPECIFICATIONS

TECHNICIAN

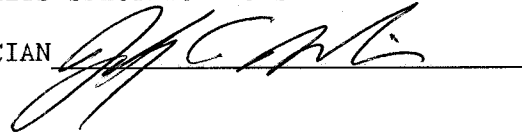

RUN NUMBER: 062101.1317;1

PART 572-E HYBRID III LEFT KNEE SLIDER CALIBRATION

LEFT FEMUR FORCE

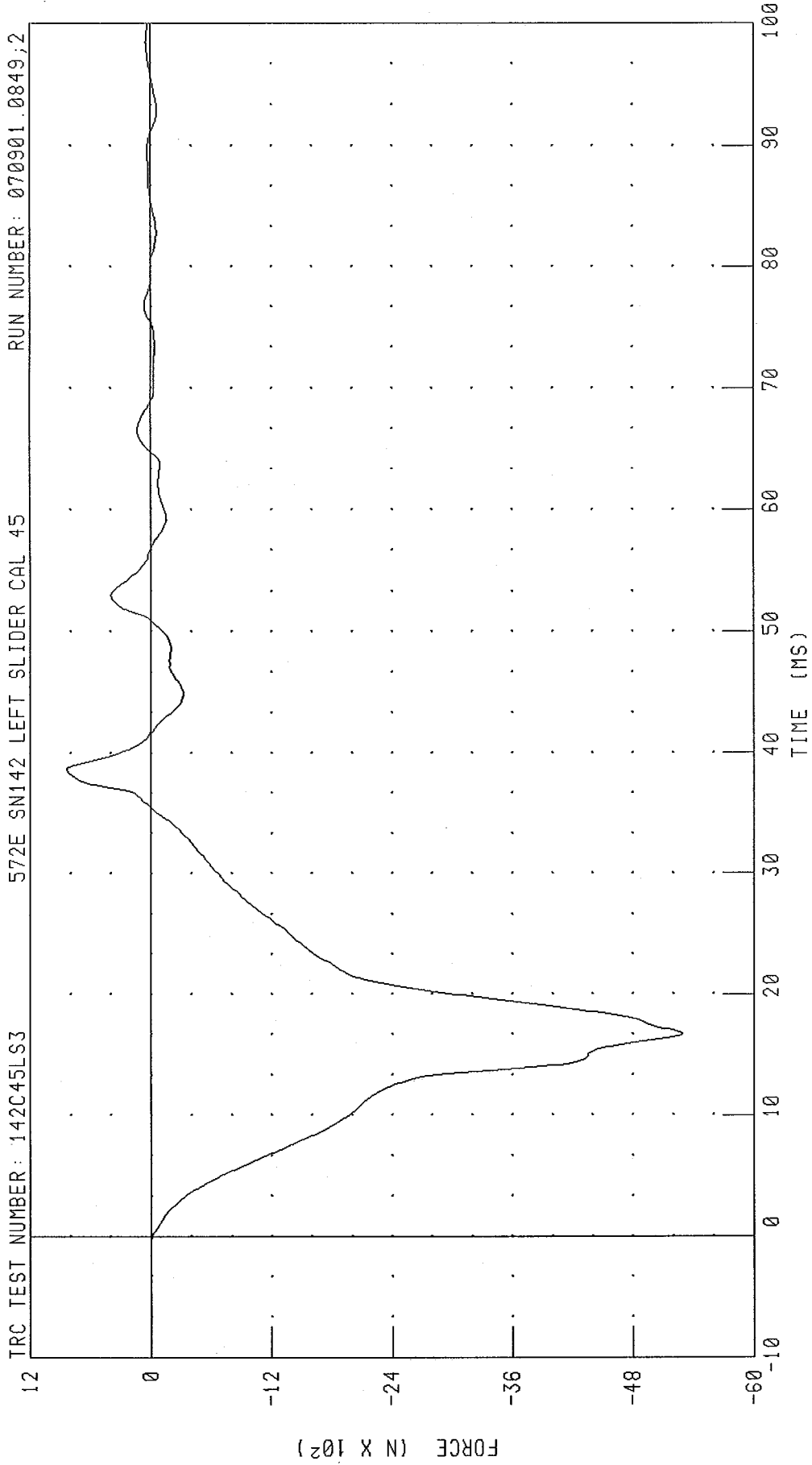

TRC TEST NUMBER: 142C45LS3

572E SN142 LEFT SLIDER CAL 45

RUN NUMBER: 070901.0849;2

CHANNEL: LFMF FILTER: CH. CLASS 600

PEAK DATA: 839.10 N @ 38.64 MS; -5292.37 N @ 16.64 MS

PART 572-E HYBRID III LEFT KNEE SLIDER CALIBRATION

KNEE DISPLACEMENT

TRC TEST NUMBER: 142C45LS3

572E SN142 LEFT SLIDER CAL 45

RUN NUMBER: 070901.0849,2

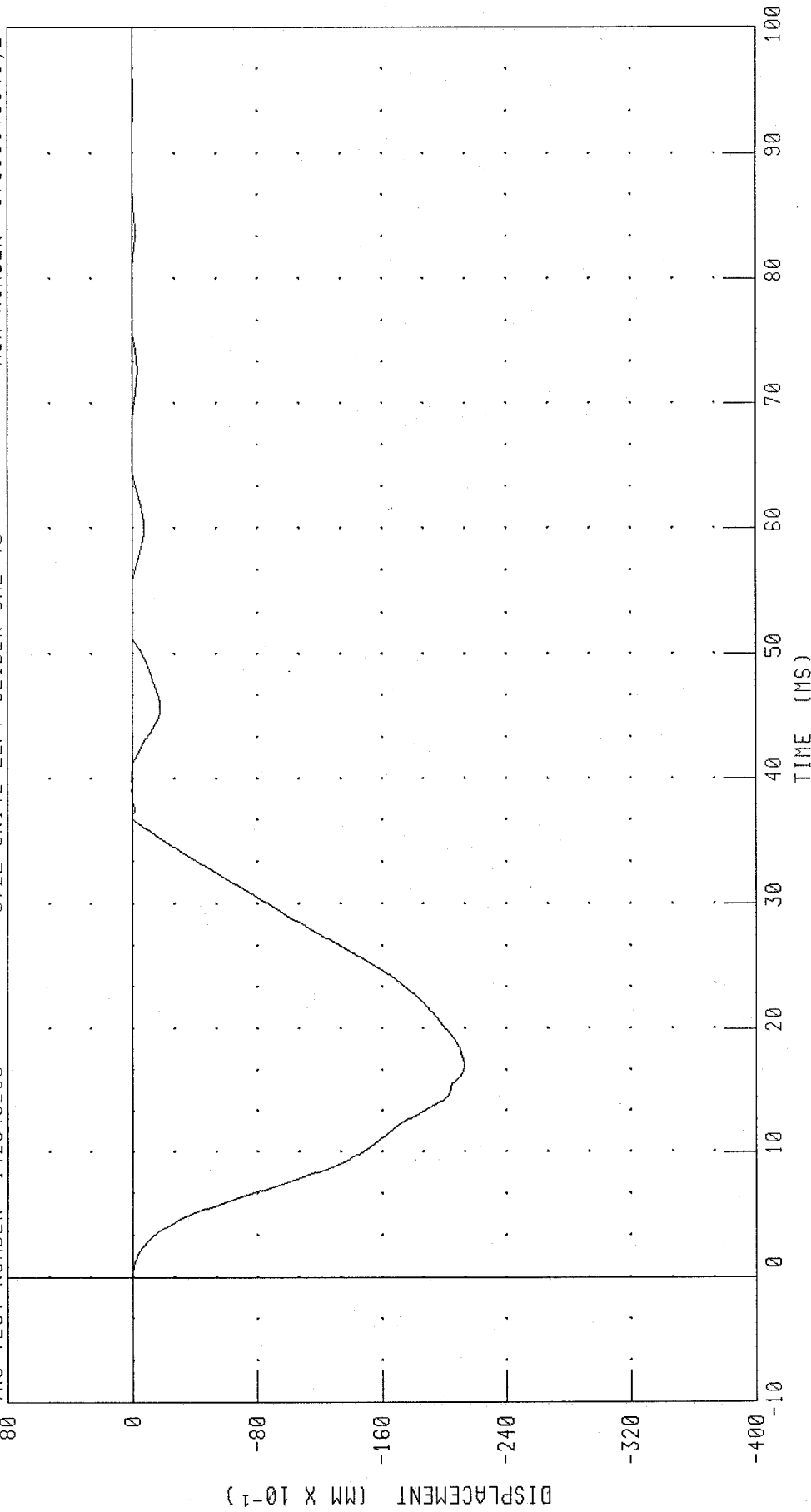

CHANNEL: KNLXD FILTER: CH. CLASS 600

PEAK DATA: 0.11 MM @ 40.16 MS; -21.31 MM @ 17.04 MS

PART 572-E HYBRID III LEFT KNEE SLIDER CALIBRATION
 LEFT KNEE DISPLACEMENT VS FEMUR FORCE

TRC TEST NUMBER: 142C45LS3 572E SN142 LEFT SLIDER CAL 45 RUN NUMBER: 070901.0940;2

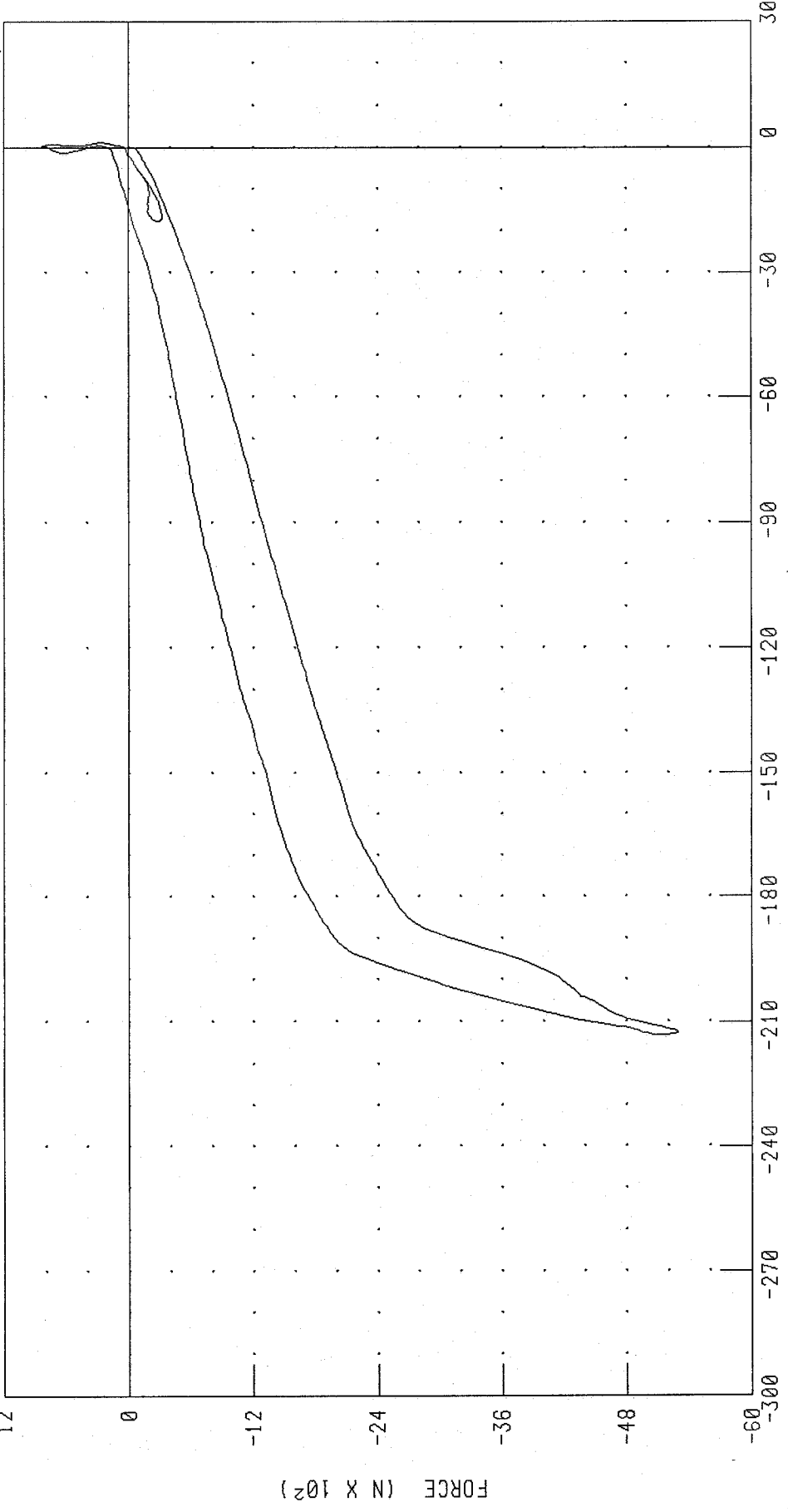

CHANNEL: KNLXD FILTER: CH: CLASS 600
 LFMF CH: CLASS 600
 DISPLACEMENT (MM X 10⁻¹) PEAK DATA: 0.11 MM @ 40.16 MS; -21.31 MM @ 17.04 MS
 839.10 N @ 38.64 MS; -5292.37 N @ 16.64 MS

TRANSPORTATION RESEARCH CENTER INC.

KNEE SLIDER TEST

HYBRID III 50th

12-JUN-01

RIGHT KNEE

TRC INC.

TEST NO: 142C45RS1

572E SN142 RIGHT SLIDER CAL 45

TEST PARAMETER	SPECIFICATION	TEST RESULTS
TEMPERATURE	18.9-25.6 DEG. C	21.7 DEG. C
RELATIVE HUMIDITY	10 - 70 %	58.0 %
PENDULUM VELOCITY	2.70-2.80 M/S	2.81 M/S
FORCE AT 10.0 MM DISPLACEMENT	1259 - 1721 N	-1558. N
FORCE AT 18.0 MM DISPLACEMENT	2268 - 3096 N	-2914. N

TEST MEETS SPECIFICATIONS

TECHNICIAN



RUN NUMBER: 070901.0844;1

PART 572-E HYBRID III RIGHT KNEE SLIDER CALIBRATION

RIGHT FEMUR FORCE

TRC TEST NUMBER: 142C45RS1 572E SN142 RIGHT SLIDER CAL 45 RUN NUMBER: 070901.0939,3

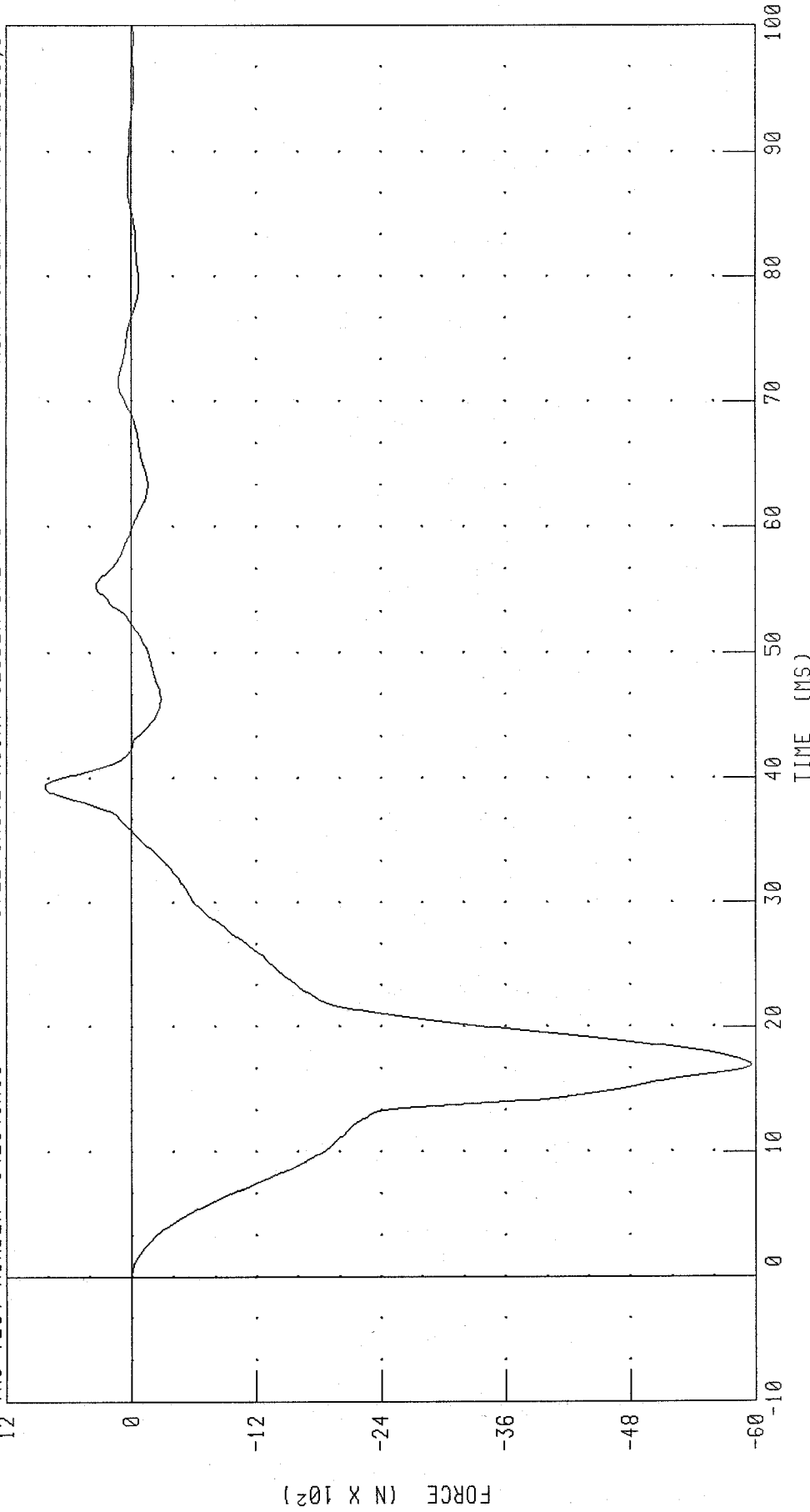

CHANNEL: RFMF FILTER: CH. CLASS 600 PEAK DATA: 829.29 N @ 39.36 MS; -5955.54 N @ 16.88 MS

PART 572-E HYBRID III RIGHT KNEE SLIDER CALIBRATION

RIGHT KNEE DISPLACEMENT

TRC TEST NUMBER: 142C45RS1

572E SN142 RIGHT SLIDER CAL 45

RUN NUMBER: 070901.0939;3

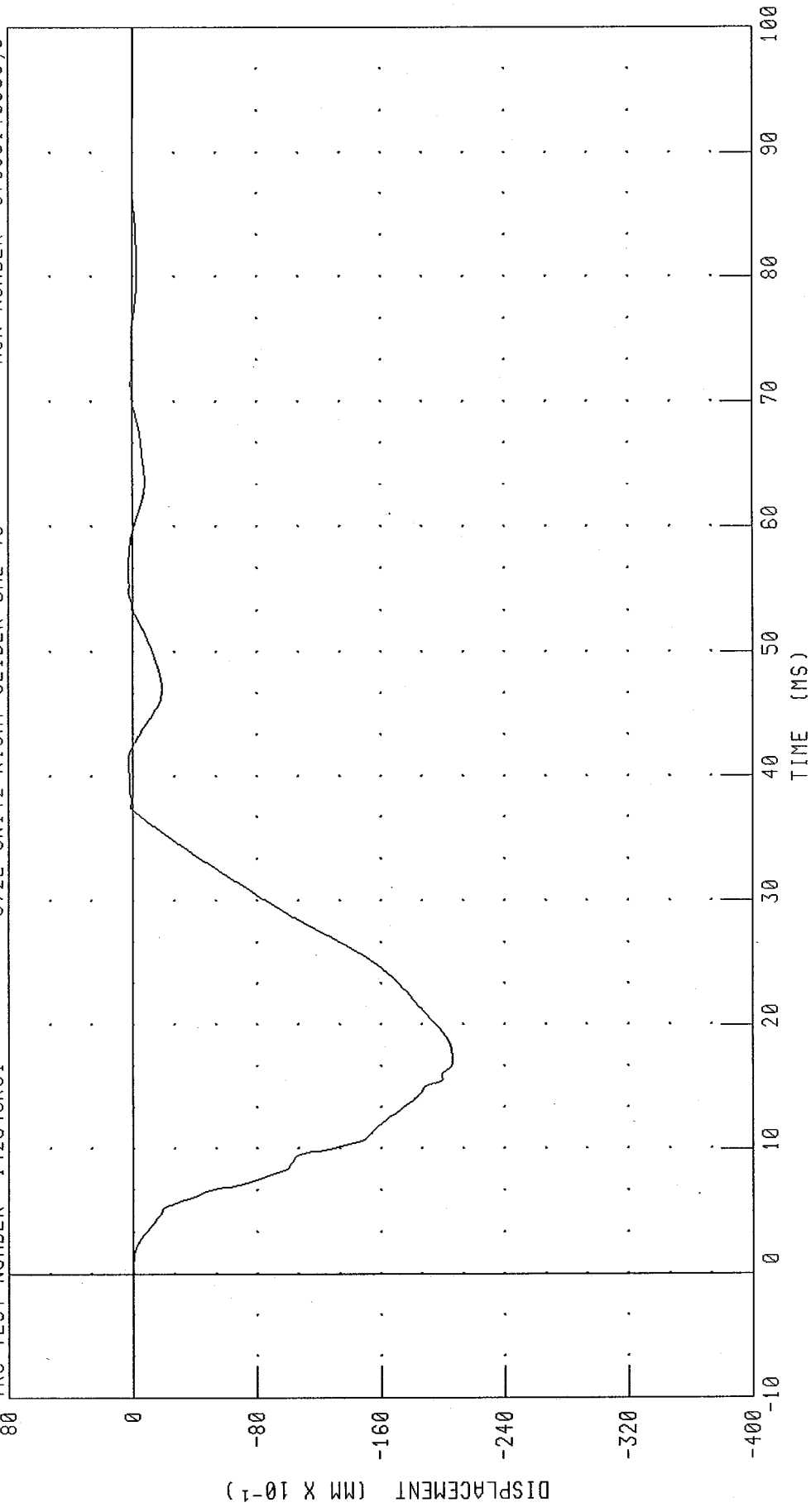

CHANNEL: KNRXD FILTER: CH. CLASS 600

PEAK DATA: 0.32 MM @ 41.36 MS; -20.66 MM @ 17.20 MS

PART 572-E HYBRID III RIGHT KNEE SLIDER CALIBRATION
 RIGHT KNEE DISPLACEMENT VS FEMUR FORCE

TRC TEST NUMBER: 142C45RS1 572E SN142 RIGHT SLIDER CAL 45 RUN NUMBER: 070901.0939;3

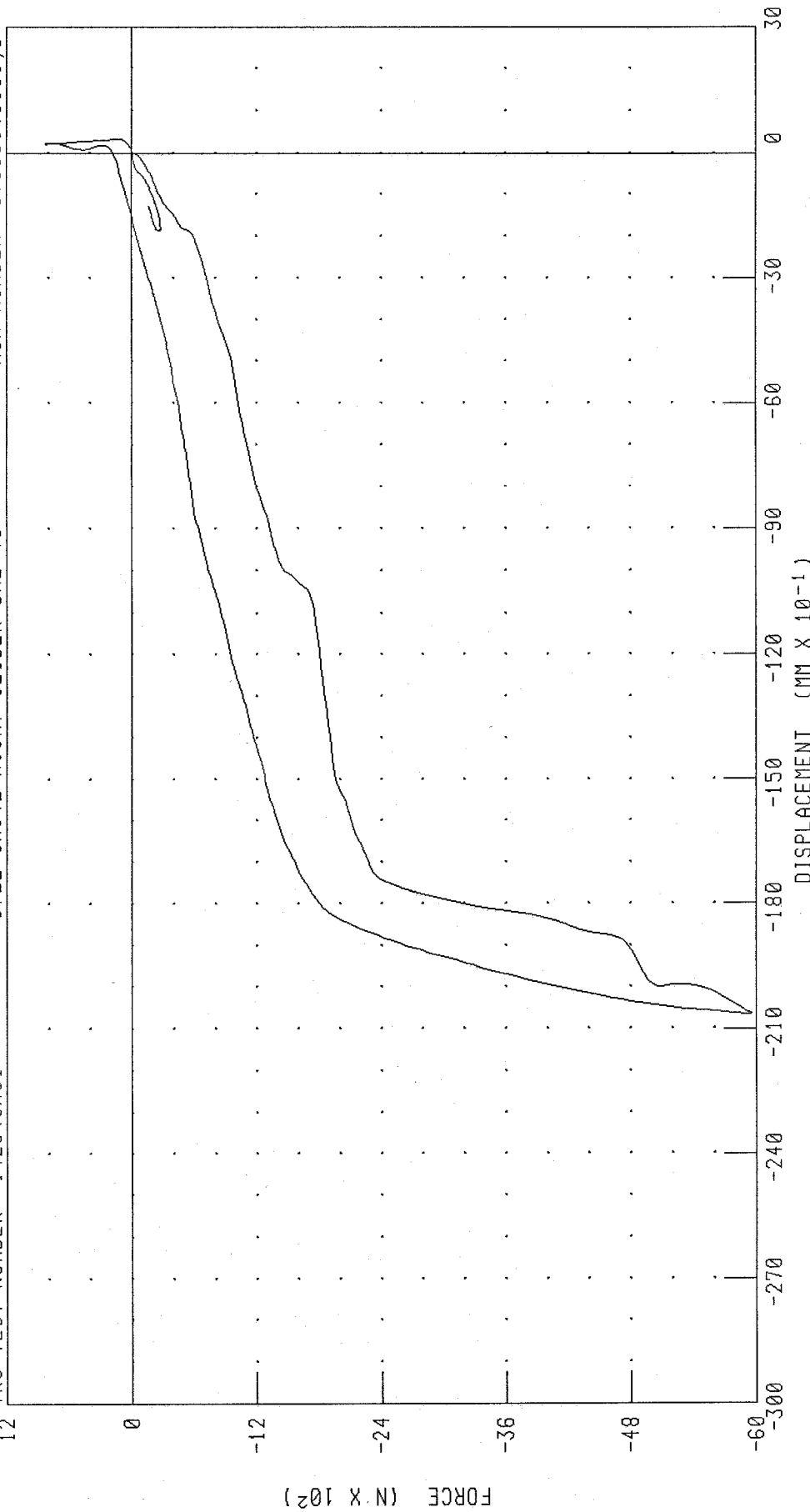

CHANNEL: KNRXD FILTER: CH: CLASS 600
 RFMF CH: CLASS 600
 PEAK DATA: 0.32 MM @ 41.36 MS; -20.66 MM @ 17.20 MS
 829.29 N @ 39.36 MS; -59.55 N @ 16.88 MS

TRANSPORTATION RESEARCH CENTER INC.
HYBRID III EXTERNAL DIMENSIONS

192

14-JUN-01

TRC INC. TEST NO: 192C44ED1 572E SN192 EXT.DIMENSION CAL44

TEST PARAMETER (DIMEN.)	SPECIFICATION	TEST RESULTS
LOCATION FOR CHEST CIRCUMFERENCE (AA)	429 - 434 MM	432. MM
LOCATION FOR WAIST CIRCUMFERENCE (BB)	226 - 231 MM	229. MM
CHEST CIRCUMFERENCE (Y)	970 - 1001 MM	988. MM
WAIST CIRCUMFERENCE (Z)	836 - 866 MM	856. MM
CHEST DEPTH (O)	213 - 229 MM	221. MM
H-POINT HEIGHT (C)	84 - 89 MM	89. MM
H-POINT FROM SEATBACK (D)	135 - 140 MM	137. MM
SKULL CAP TO BACKLINE (H)	41 - 46 MM	43. MM
TOTAL SITTING HEIGHT (A)	879 - 889 MM	886. MM
THIGH CLEARANCE (F)	140 - 155 MM	147. MM
BUTTOCK KNEE LENGTH (K)	579 - 605 MM	597. MM
BUTTOCK POPLITEAL LENGTH (N)	452 - 478 MM	470. MM
POPLITEAL HEIGHT (L)	429 - 455 MM	445. MM
KNEE PIVOT HEIGHT (M)	485 - 500 MM	490. MM
FOOT LENGTH (P)	252 - 267 MM	254. MM
FOOT BREADTH (W)	91 - 107 MM	102. MM
SHOULDER PIVOT FROM BACKLINE (E)	84 - 94 MM	91. MM
SHOULDER BREADTH (V)	422 - 437 MM	434. MM
SHOULDER PIVOT HEIGHT (B)	506 - 521 MM	516. MM
ELBOW REST HEIGHT (J)	191 - 211 MM	206. MM
SHOULDER-ELBOW LENGTH (I)	330 - 345 MM	335. MM
BACK OF ELBOW TO WRIST PIVOT (G)	290 - 305 MM	297. MM

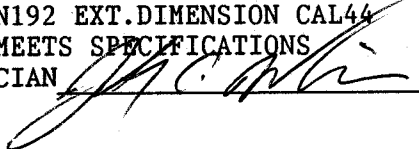
572E SN192 EXT.DIMENSION CAL44
DUMMY MEETS SPECIFICATIONS
TECHNICIAN 

RUN NUMBER: 061401.1210

TRANSPORTATION RESEARCH CENTER INC.

HEAD DROP TEST

HYBRID III 50th

11-JUN-01

TRC INC.

TEST NO: 192C44HD1

572E SN192 HEAD DROP CAL 44

TEST PARAMETER	SPECIFICATION	TEST RESULTS
TEMPERATURE	18.9-25.6 DEG. C	21.7 DEG. C
RELATIVE HUMIDITY	10 - 70 %	55.0 %
PEAK RESULTANT ACCELERATION	225 - 275 G	233.54 G
PEAK LATERAL ACCELERATION	15 G MAX	-6.08 G
IS ACCELERATION CURVE UNIMODAL?	YES	YES

TEST MEETS SPECIFICATIONS

TECHNICIAN

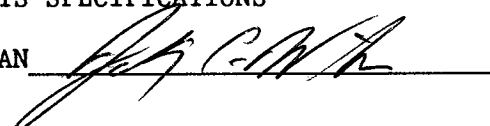

RUN NUMBER: 061101.1244;1

PART 572-E HYBRID III HEAD CALIBRATION
HEAD ACCELERATION X AXIS

TRC TEST NUMBER: 192C44HD1 572E SN192 HEAD DROP CAL 44 RUN NUMBER: 061101.1245;1

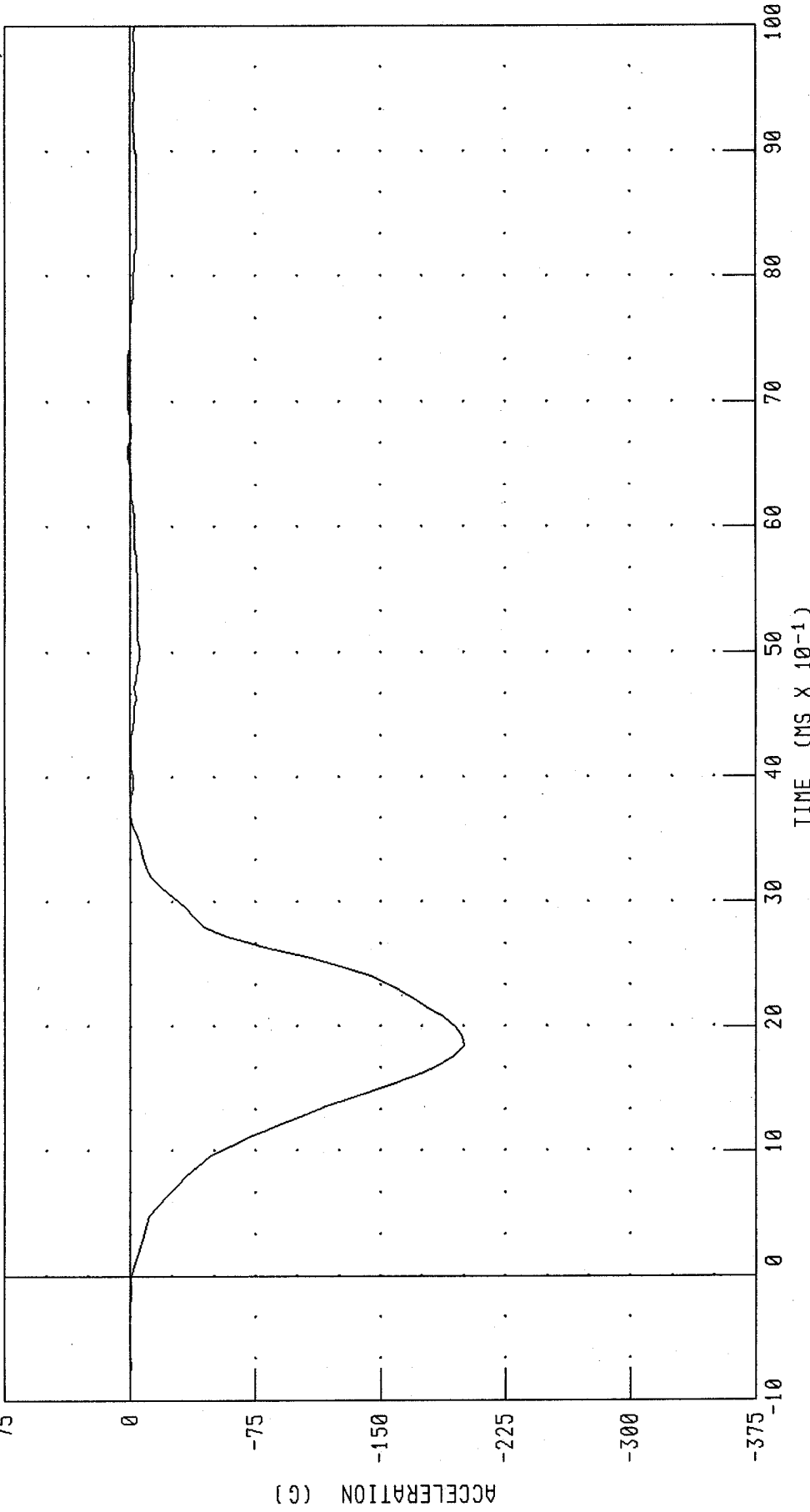

CHANNEL: HEDXC FILTER: CH CLASS 1000 PEAK DATA: 1.45 G @ 6.56 MS; -200.13 G @ 1.84 MS

PART 572-E HYBRID III HEAD CALIBRATION
HEAD ACCELERATION Y AXIS

TRC TEST NUMBER: 192C44HD1

572E SN192 HEAD DROP CAL 44

RUN NUMBER: 061101.1245;1

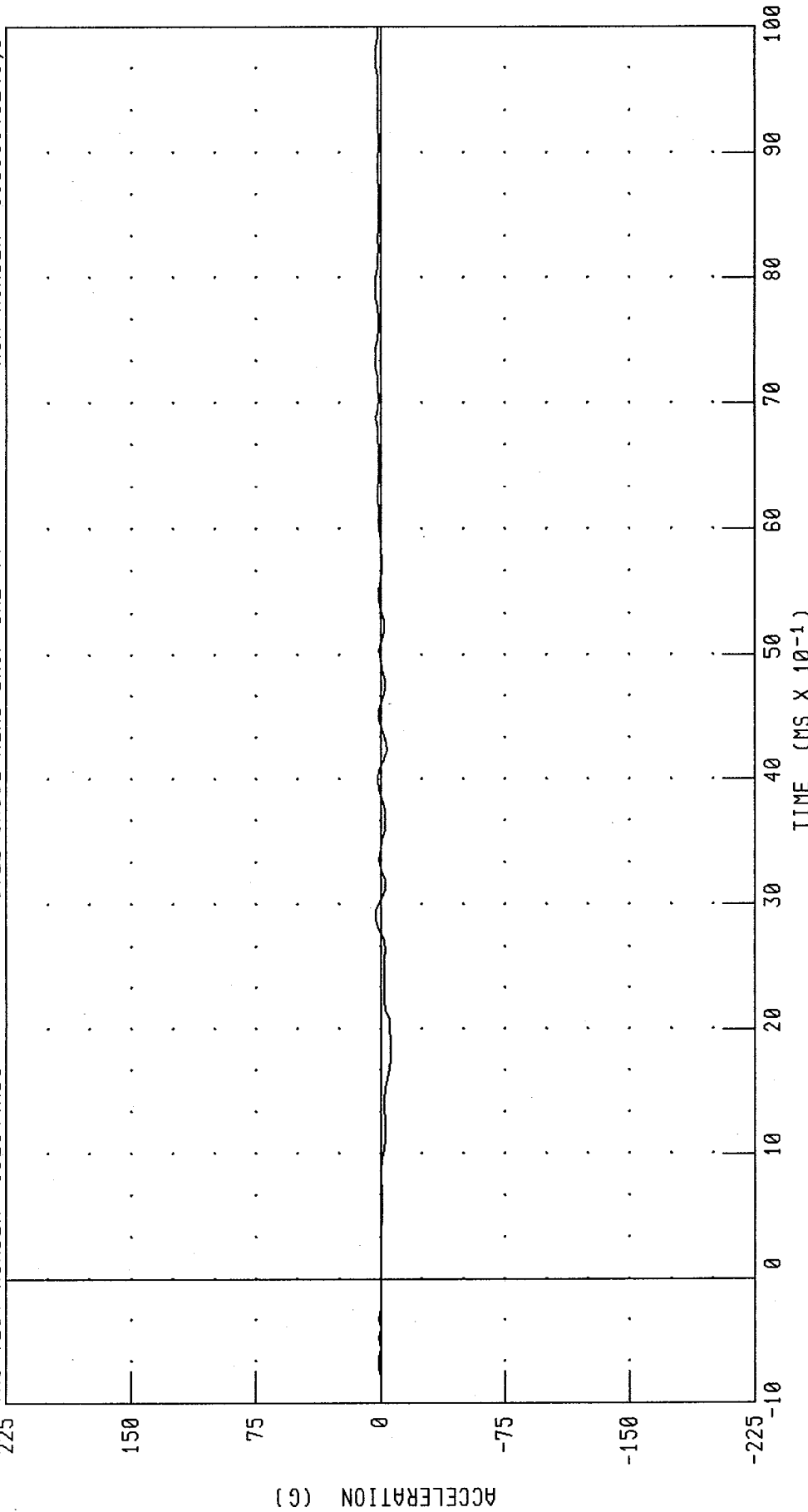

CHANNEL: HEDYG FILTER: CH. CLASS 1000

PEAK DATA: 2.89 G @ 2.88 MS; -6.09 G @ 1.76 MS

PART 572-E HYBRID III HEAD CALIBRATION

HEAD ACCELERATION Z AXIS

TRC TEST NUMBER: 192C44HD1

572E SN192 HEAD DROP CAL 44

RUN NUMBER: 061101.1245;1

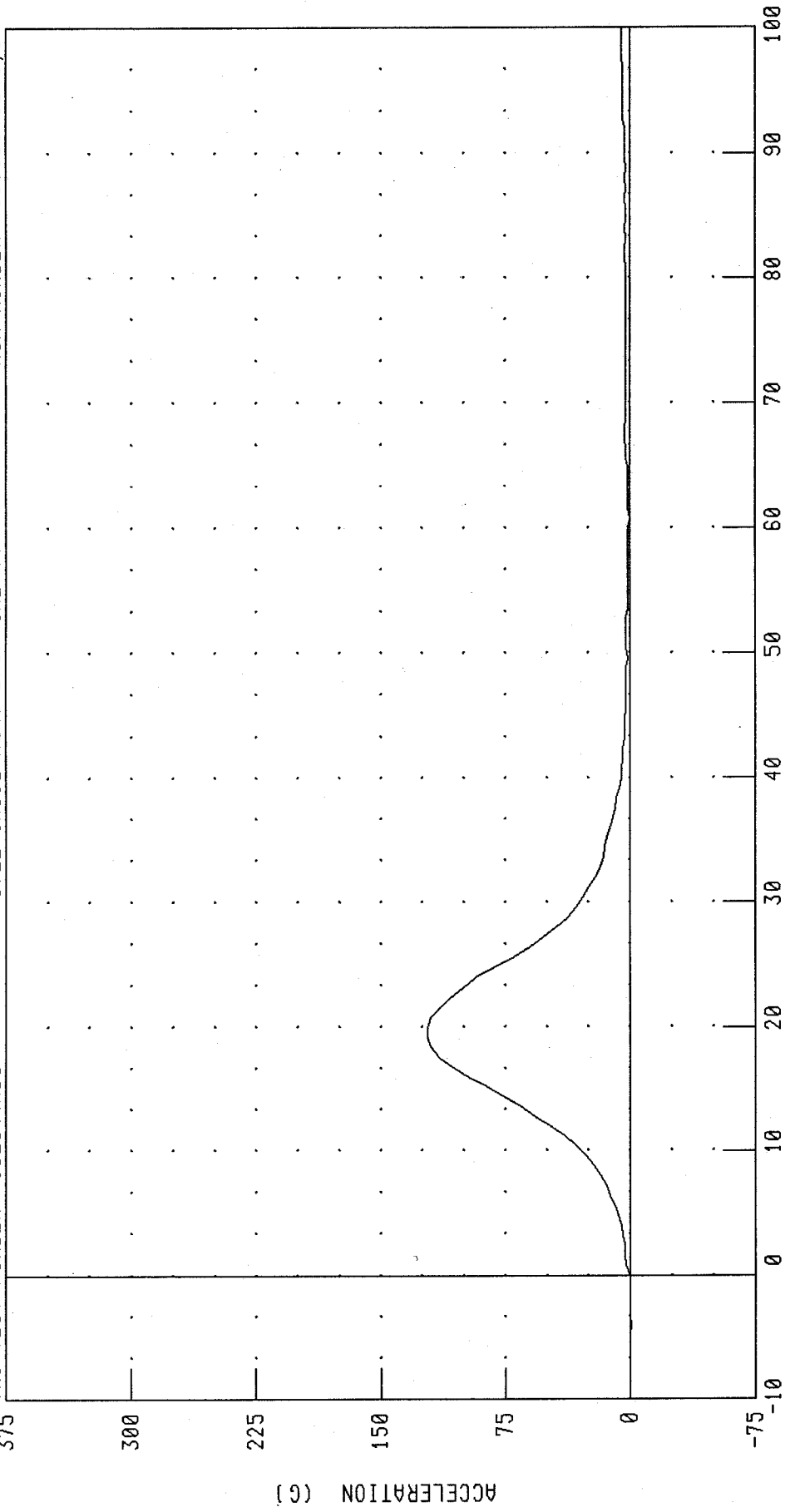

PEAK DATA: 121.82 G @ 1.92 MS; -0.82 G @ -0.40 MS

CHANNEL: HEDZG FILTER: CH. CLASS 1000

PART 572-E HYBRID III HEAD CALIBRATION
HEAD RESULTANT ACCELERATION

TRC TEST NUMBER: 192C44HD1 RUN NUMBER: 061101.1245;1

572E SN192 HEAD DROP CAL 44

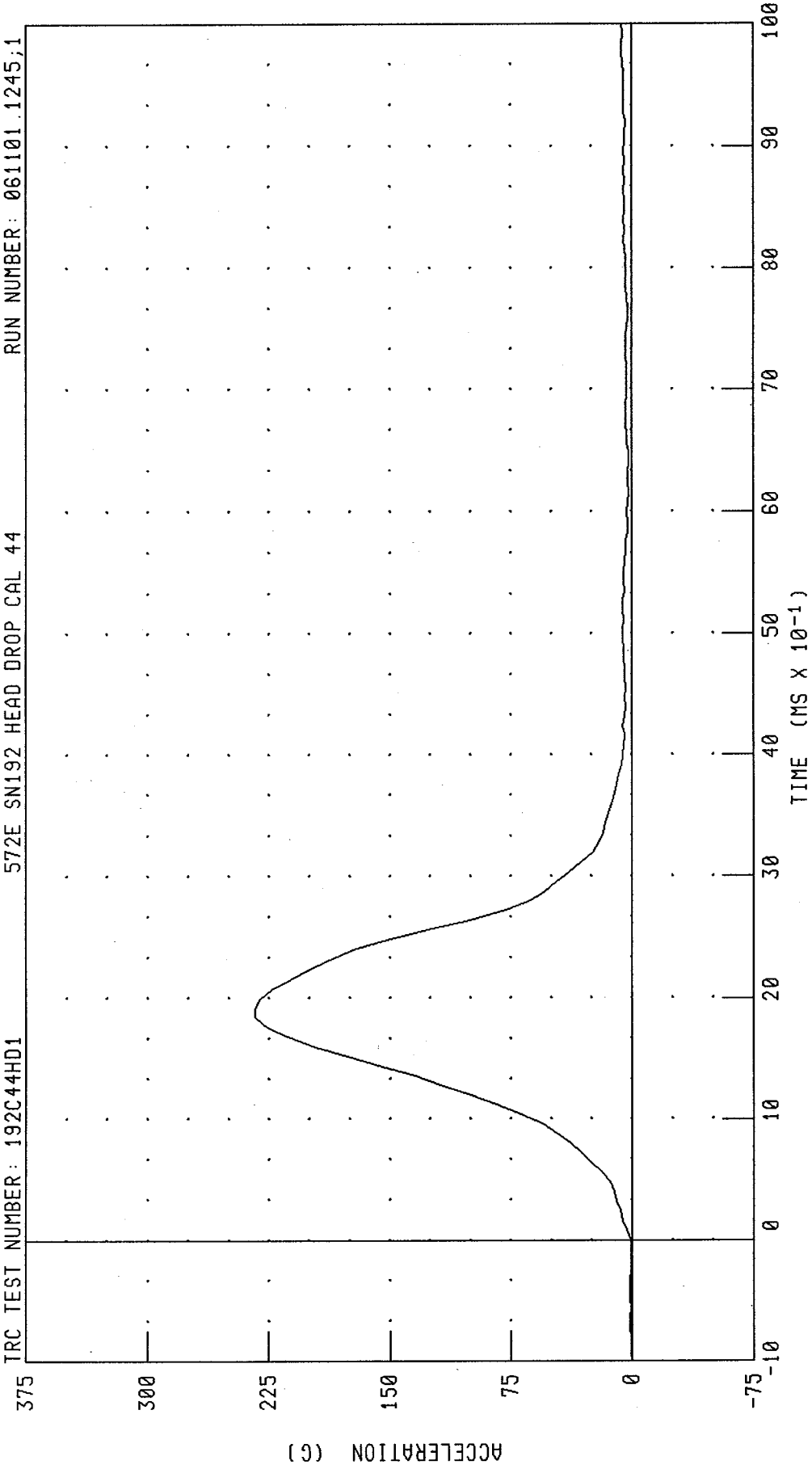

CHANNEL: HEDRG FILTER: CH. CLASS 1000 PEAK DATA: 233.54 G @ 1.92 MS; 0.51 G @ -0.96 MS

TRANSPORTATION RESEARCH CENTER INC.

HYBRID III 50th

13-JUN-01

NECK FLEXION TEST - 6 CHANNEL TRANSDUCER

TRC INC. TEST NO: 192C44NF1 572E SN192 NECK FLEXION CAL44

TEST PARAMETER	SPECIFICATION	TEST RESULTS
TEMPERATURE	20.6-22.2 DEG. C	21.7 DEG. C
RELATIVE HUMIDITY	10 - 70 %	58.0 %
IMPACT VELOCITY	6.89 - 7.13 M/S	7.06 M/S
PENDULUM DECELERATION	10 MS 22.50 - 27.50 G	24.59 G
	20 MS 17.60 - 22.60 G	21.11 G
	30 MS 12.50 - 18.50 G	17.58 G
MAX PENDULUM G	29 G MAX	24.68 G
MAX PENDULUM G ABOVE 30 MS	29 G MAX	17.53 G
DECELERATION-TIME CURVE DECAY TIME TO 5 G	34 - 42 MS	38.80 MS
D PLANE	MAX 64 - 78 DEG.	72.27 DEG.
ROTATION	TIME 57 - 64 MS	59.12 MS
MOMENT ABOUT OCCIPITAL CONDYLE	MAX 88.2 - 108.5 NM	95.93 NM
	TIME 47 - 58 MS	51.36 MS
ROTATION ANGLE-TIME CURVE DECAY TIME TO ZERO	113 - 128 MS	114.64 MS
POSITIVE MOMENT-TIME CURVE DECAY TIME TO ZERO	97 - 107 MS	97.04 MS

TEST MEETS SPECIFICATIONS

TECHNICIAN 

RUN NUMBER: 061301.1038;1

PART 572-E HYBRID III NECK FLEXION CALIBRATION
PENDULUM DECELERATION

TRC TEST NUMBER: 192C44NF1 572E SN192 NECK FLEXION CAL44 RUN NUMBER: 061301.1038;1

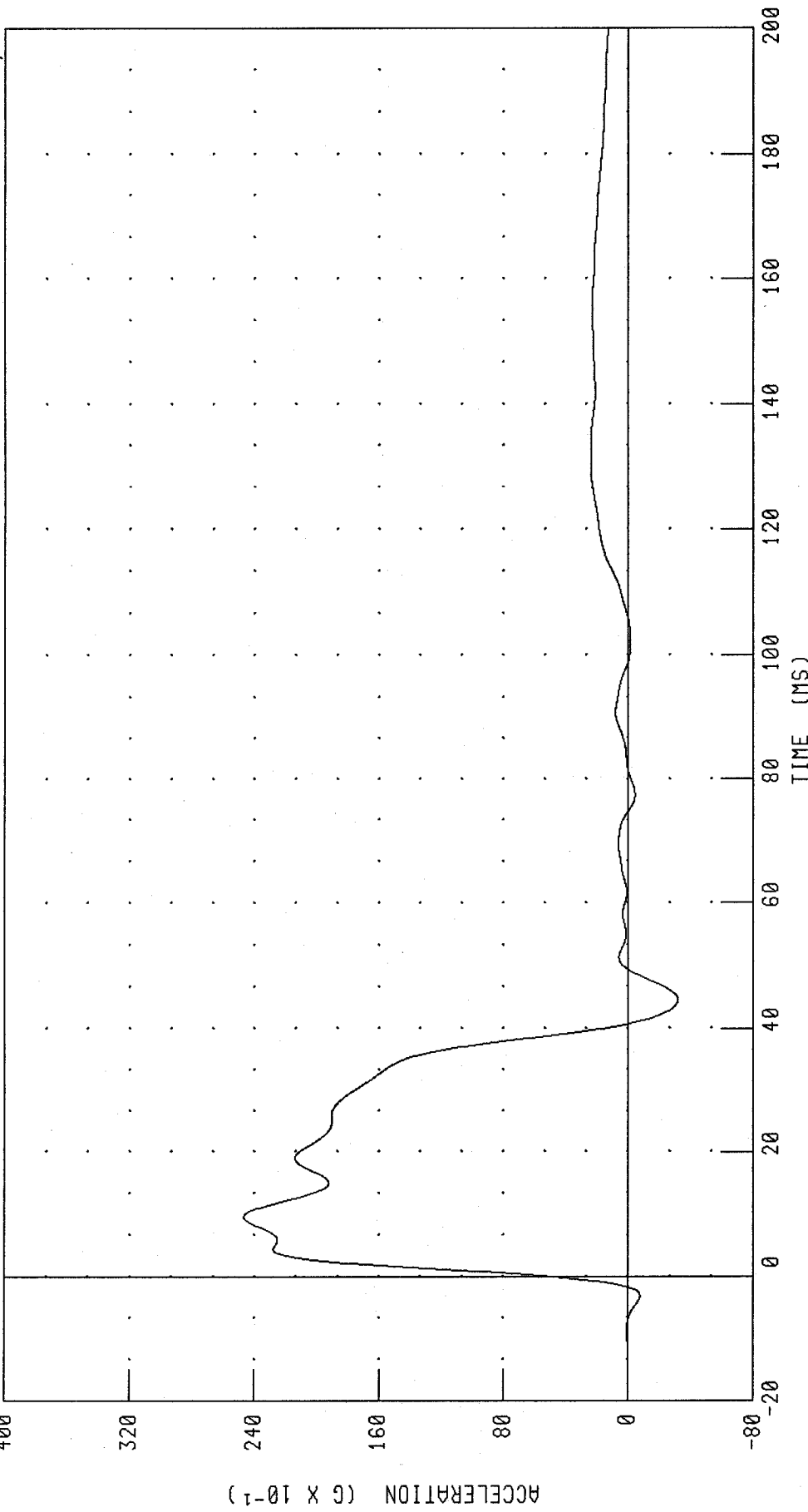

CHANNEL: PENXG FILTER: CH. CLASS 60 PEAK DATA: 24.68 G @ 9.60 MS; -3.20 G @ 44.56 MS

PART 572-E HYBRID III NECK FLEXION CALIBRATION

ROTATION ABOUT BASE OF NECK

TRC TEST NUMBER: 192C44NF1

572E SN192 NECK FLEXION CAL44

RUN NUMBER: 061301.1038;1

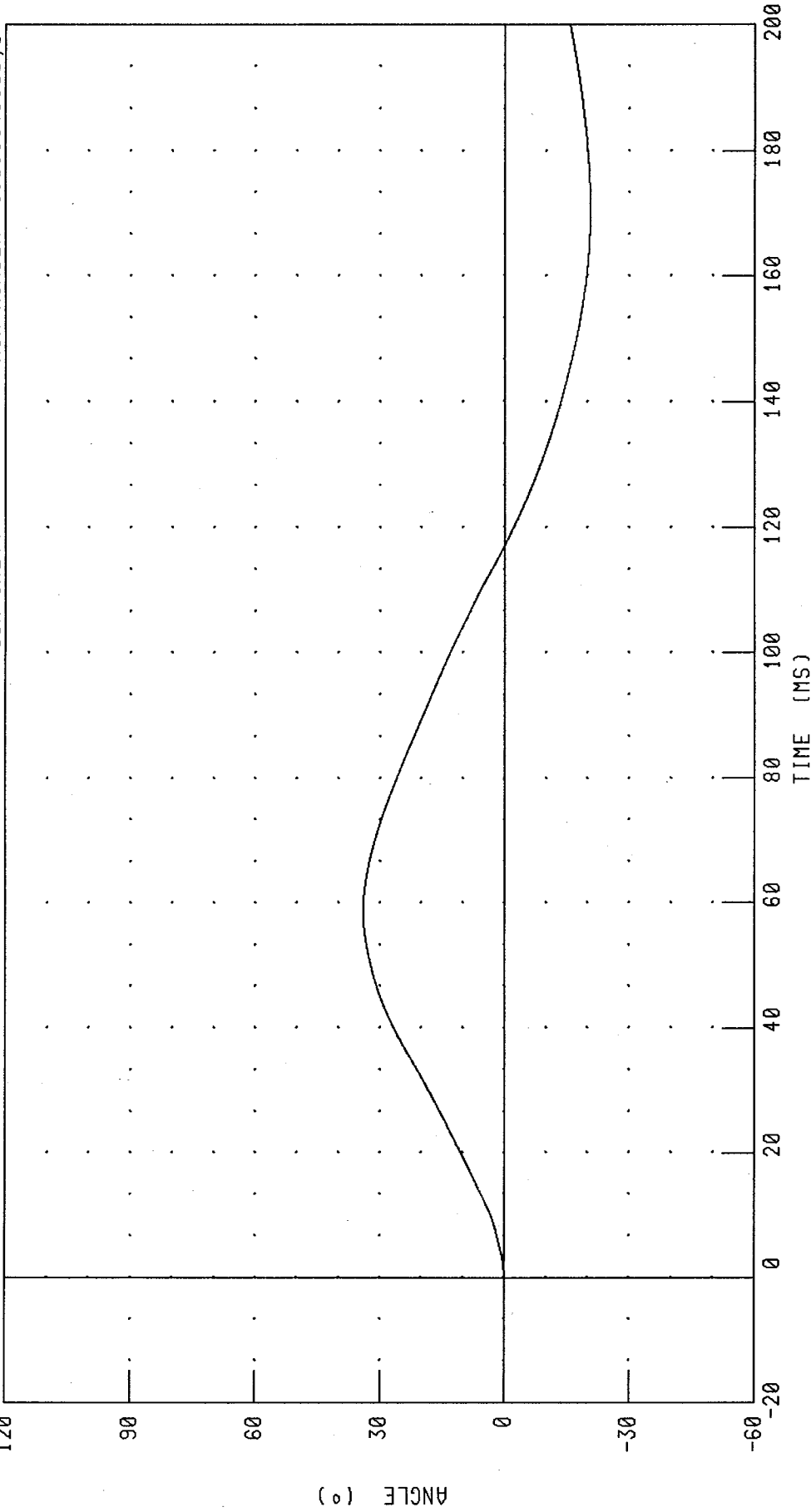

PEAK DATA: 34.03 ° @ 58.64 MS; -20.63 ° @ 170.72 MS

CHANNEL: BETA FILTER: CH. CLASS 60

PART 572-E HYBRID III NECK FLEXION CALIBRATION
ROTATION ABOUT OCCIPITAL CONDYLE

TRC TEST NUMBER: 192C44NF1

572E SN192 NECK FLEXION CAL44

RUN NUMBER: 061301.1038;1

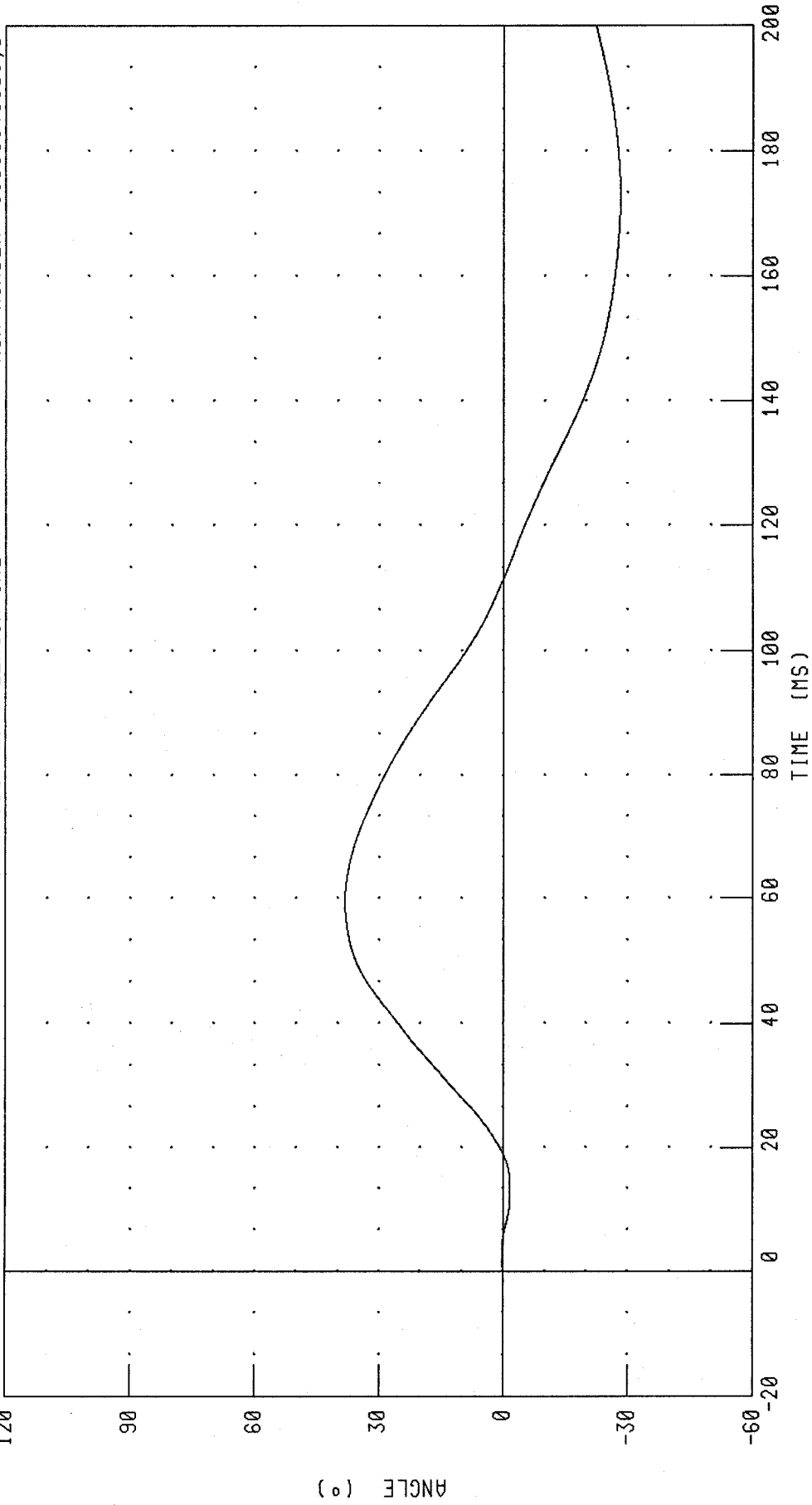

CHANNEL: THETA FILTER: CH. CLASS 60 PEAK DATA: 38.26 ° @ 59.44 MS; -28.24 ° @ 172.88 MS

PART 572-E HYBRID III NECK FLEXION CALIBRATION

TOTAL ROTATION

TRC TEST NUMBER: 192C44NF1

572E SN192 NECK FLEXION CAL44

RUN NUMBER: 061301.1038;1

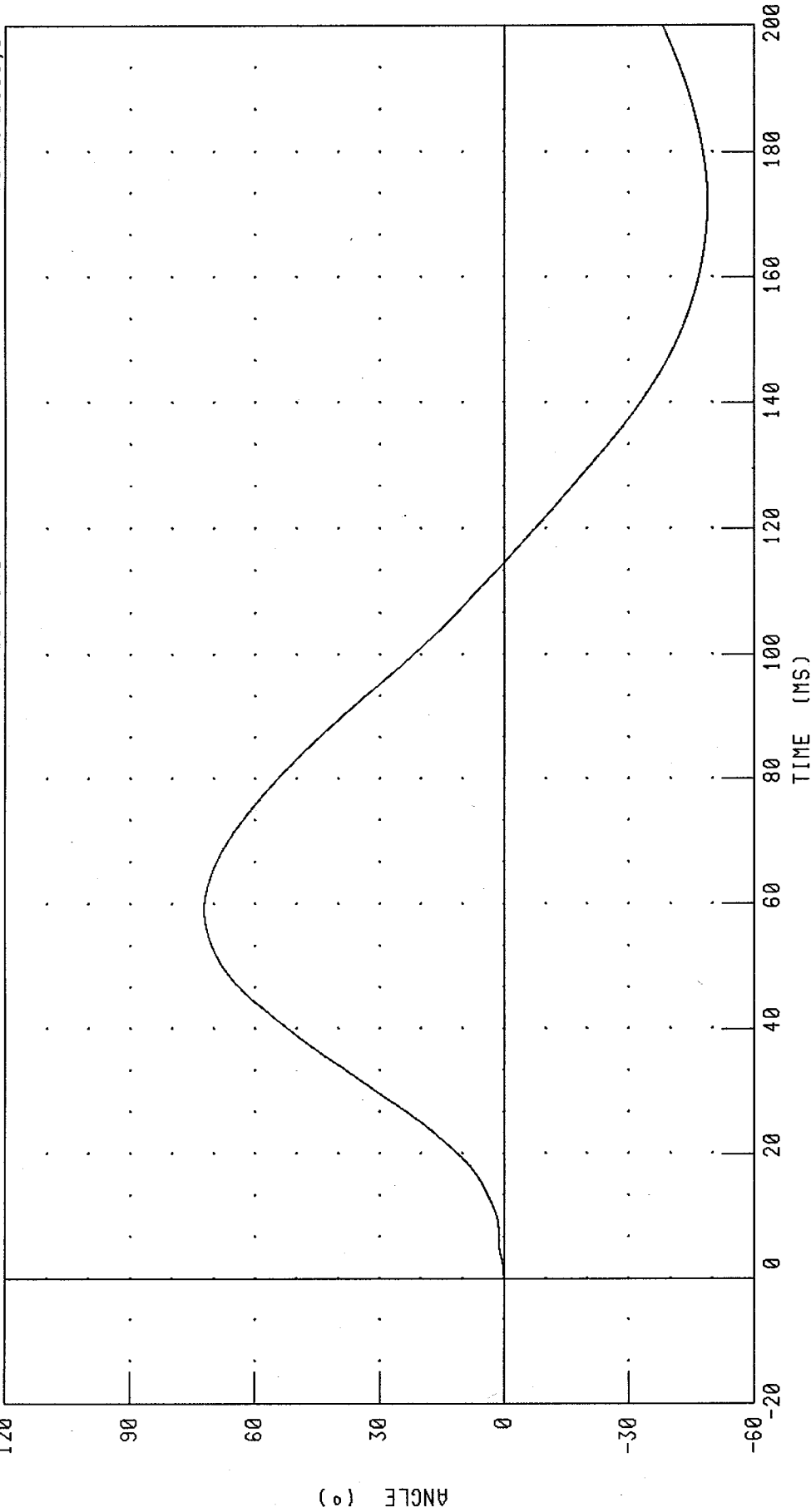

CHANNEL: TOTAN FILTER: CH. CLASS 60

PEAK DATA: 72.27 ° @ 59.12 MS; -48.86 ° @ 172.08 MS

PART 572-E HYBRID III NECK FLEXION CALIBRATION

NECK FORCE X AXIS

TRC TEST NUMBER: 192C44NF1

572E SN192 NECK FLEXION CAL44

RUN NUMBER: 061301.1038;1

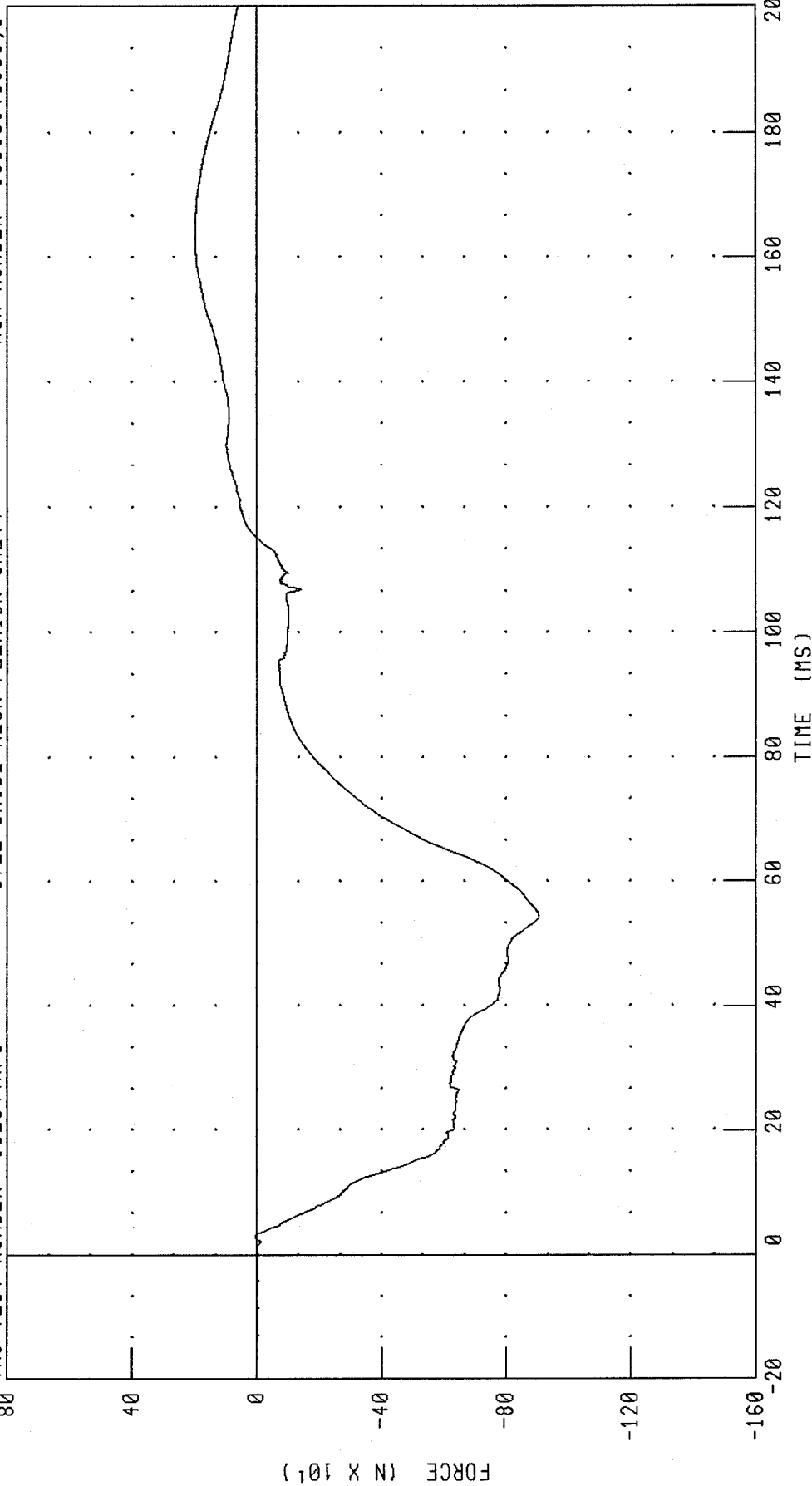

CHANNEL: NEKXF FILTER: CH. CLASS 1000 PEAK DATA: 198.22 N @ 161.76 MS; -907.57 N @ 54.40 MS

PART 572-E HYBRID III NECK FLEXION CALIBRATION
NECK FORCE X AXIS FILTERED FOR USE IN OCCIPITAL MOMENT CALCULATION

TRC TEST NUMBER: 192C44NF1 572E SN192 NECK FLEXION CAL44 RUN NUMBER: 061301.1038;1

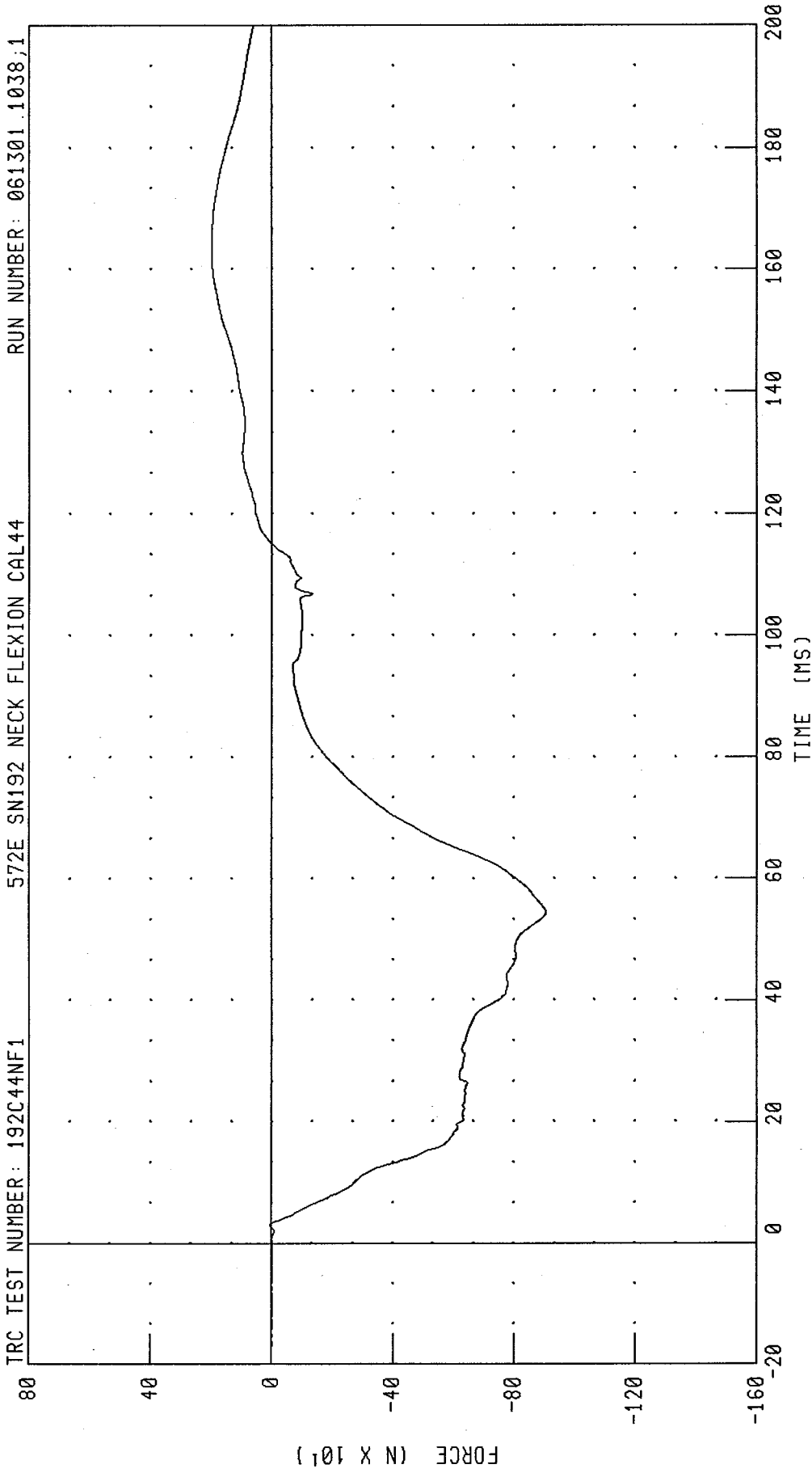

CHANNEL: NEKXFC FILTER: CH. CLASS 600

PEAK DATA: 198.03 N @ 163.76 MS; -907.61 N @ 54.48 MS

PART 572-E HYBRID III NECK FLEXION CALIBRATION

NECK MOMENT Y AXIS

IRC TEST NUMBER: 192C44NF1

572E SN192 NECK FLEXION CAL44

RUN NUMBER: 061301.1038;1

160

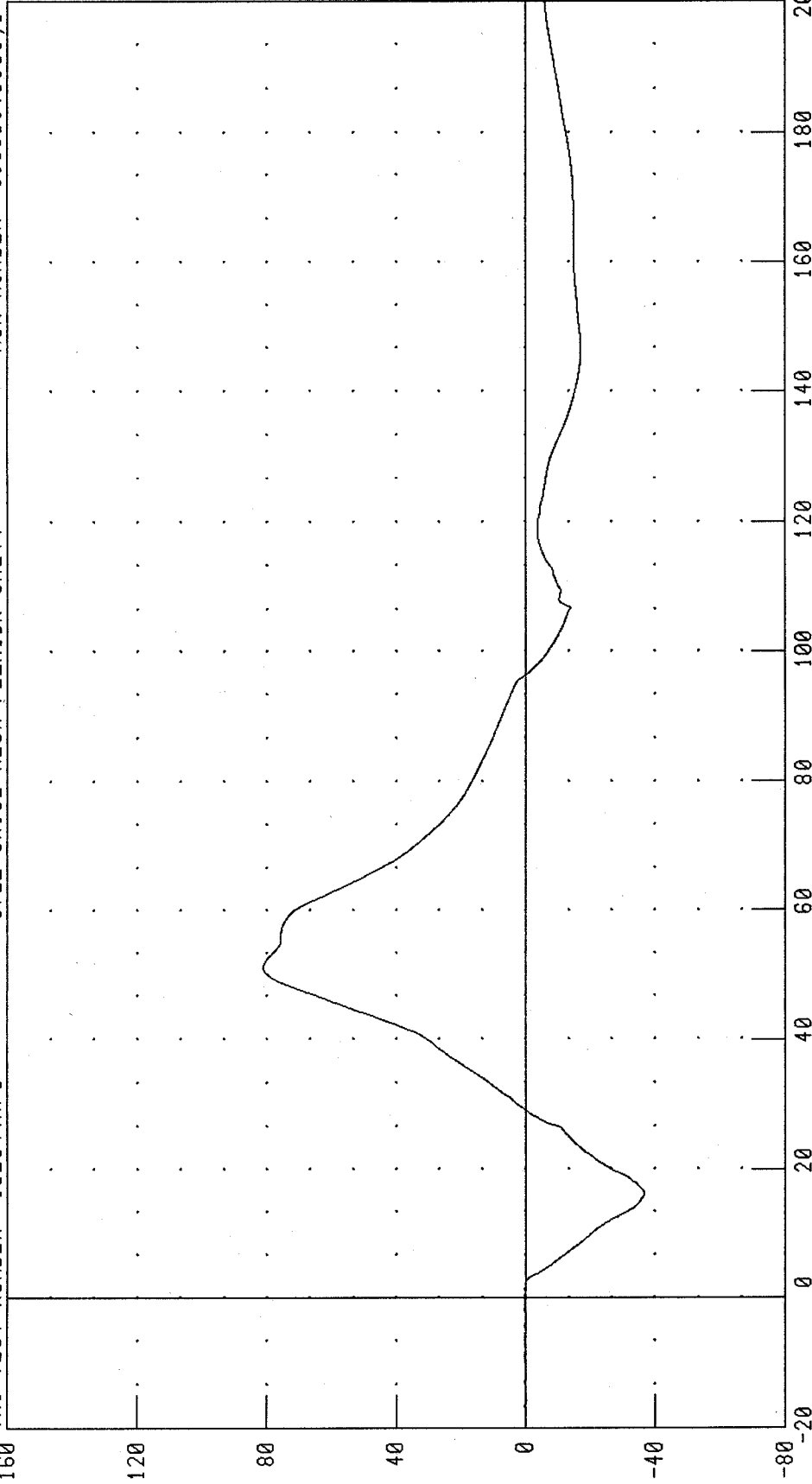

TIME (MS)

PEAK DATA: 81.15 N·M @ 51.12 MS; -36.74 N·M @ 16.08 MS

CHANNEL: NEKYM FILTER: CH. CLASS 600

TORQUE (N·M)

PART 572-E HYBRID III NECK FLEXION CALIBRATION
TOTAL MOMENT ABOUT OCCIPITAL CONDYLE

TRC TEST NUMBER: 192C44NF1

572E SN192 NECK FLEXION CAL44

RUN NUMBER: 061301.1038;1

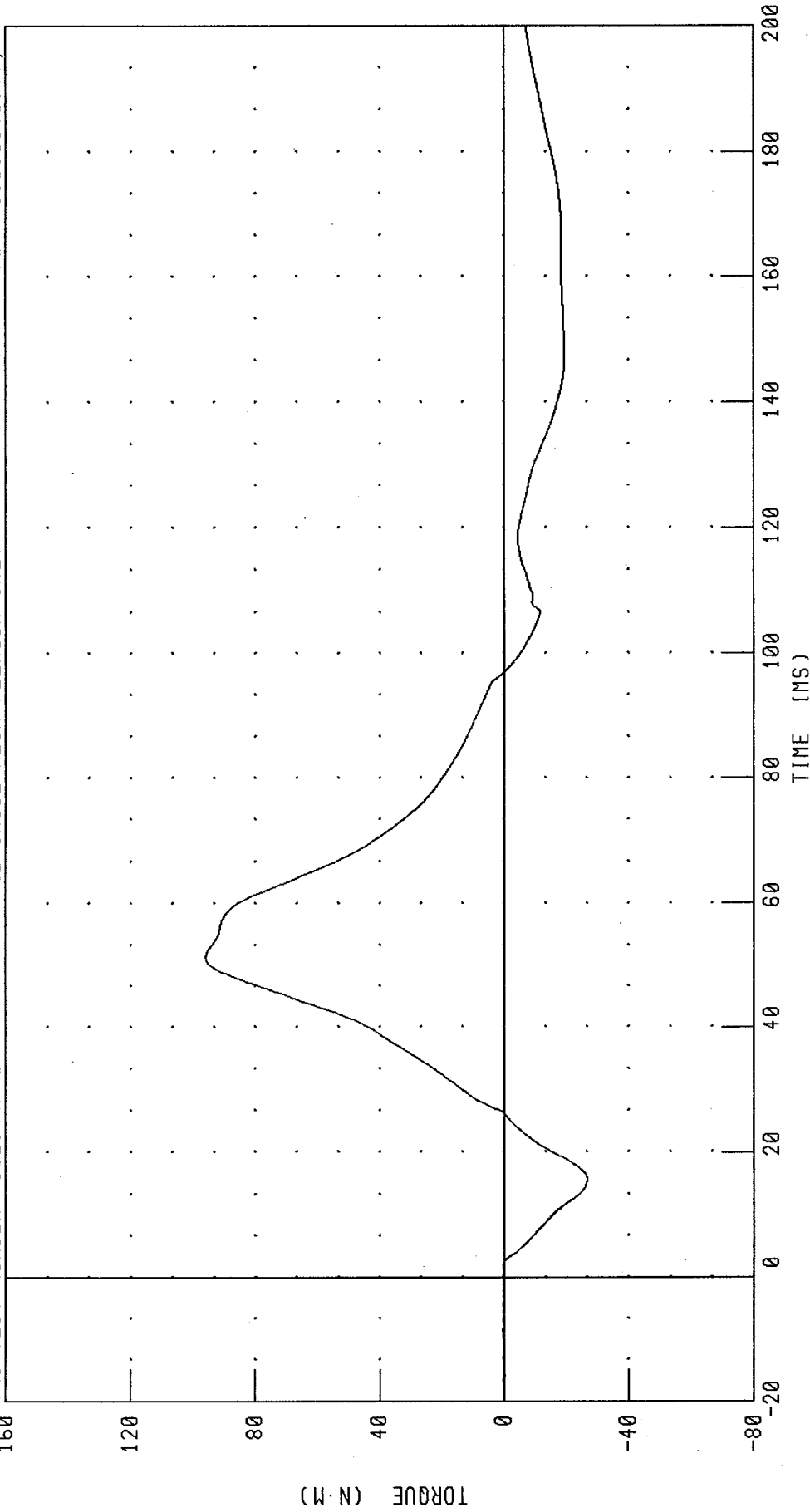

CHANNEL: NEKOM FILTER: CH. CLASS 600

PEAK DATA: 95.93 N·M @ 51.36 MS; -26.78 N·M @ 15.76 MS

TRANSPORTATION RESEARCH CENTER INC.

HYBRID III 50th

13-JUN-01

NECK EXTENSION TEST - 6 CHANNEL TRANSDUCER

TRC INC.

TEST NO: 192C44NE1

572E SN192 NECK EXT CAL44

TEST PARAMETER	SPECIFICATION	TEST RESULTS
TEMPERATURE	20.6 - 22.2 DEG. C	21.1 DEG. C
RELATIVE HUMIDITY	10 - 70 %	58.0 %
IMPACT VELOCITY	5.95 - 6.19 M/S	6.10 M/S
PENDULUM DECELERATION	10 MS 17.20 - 21.20 G	17.88 G
	20 MS 14.00 - 19.00 G	16.17 G
	30 MS 11.00 - 16.00 G	14.56 G
MAX PENDULUM G	22 G MAX	18.14 G
MAX PENDULUM G ABOVE 30 MS	22 G MAX	14.52 G
DECELERATION-TIME CURVE DECAY TIME TO 5 G	38 - 46 MS	42.16 MS
D PLANE	MAX 81 - 106 DEG.	93.19 DEG.
ROTATION	TIME 72 - 82 MS	76.56 MS
MOMENT ABOUT OCCIPITAL CONDYLE	MIN -80.0/-52.9 NM	-61.12 NM
ROTATION ANGLE-TIME CURVE DECAY TIME TO ZERO	65 - 79 MS	73.04 MS
NEGATIVE MOMENT-TIME CURVE DECAY TIME TO ZERO	147 - 174 MS	155.68 MS
	120 - 148 MS	134.88 MS

TEST MEETS SPECIFICATIONS

TECHNICIAN 

RUN NUMBER: 061301.1118;1

PART 572-E HYBRID III NECK EXTENSION CALIBRATION

PENDULUM DECELERATION

TRC TEST NUMBER: 192C44NE1

572E SN192 NECK EXT CAL44

RUN NUMBER: 061301.1119;1

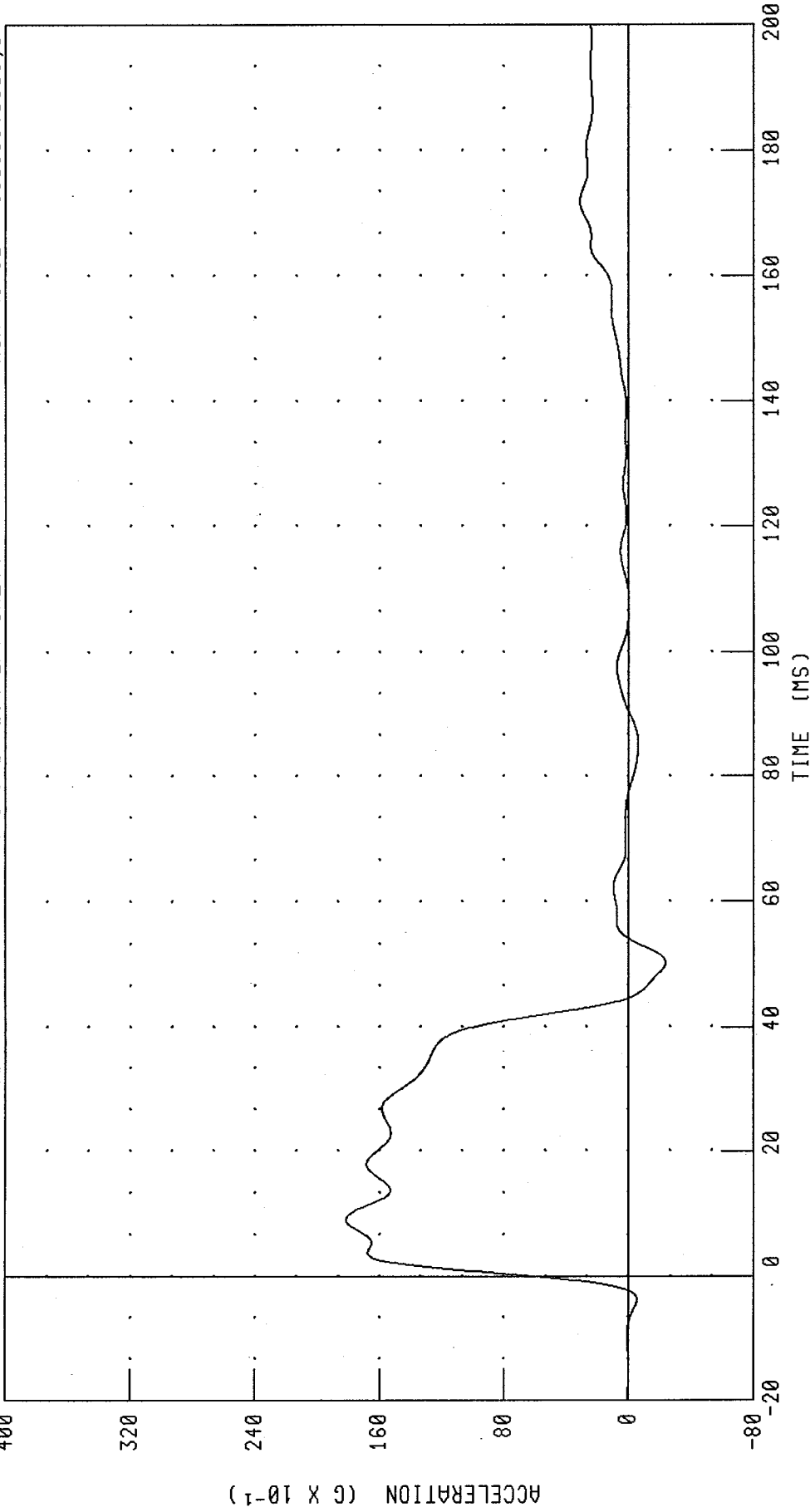

CHANNEL: PENXC FILTER: CH. CLASS 60

PEAK DATA: 18.15 C @ 9.04 MS; -2.38 C @ 50.32 MS

PART 572-E HYBRID III NECK EXTENSION CALIBRATION

ROTATION ABOUT BASE OF NECK

TRC TEST NUMBER: 192C44NE1

572E SN192 NECK EXT CAL44

RUN NUMBER: 061301.1119;1

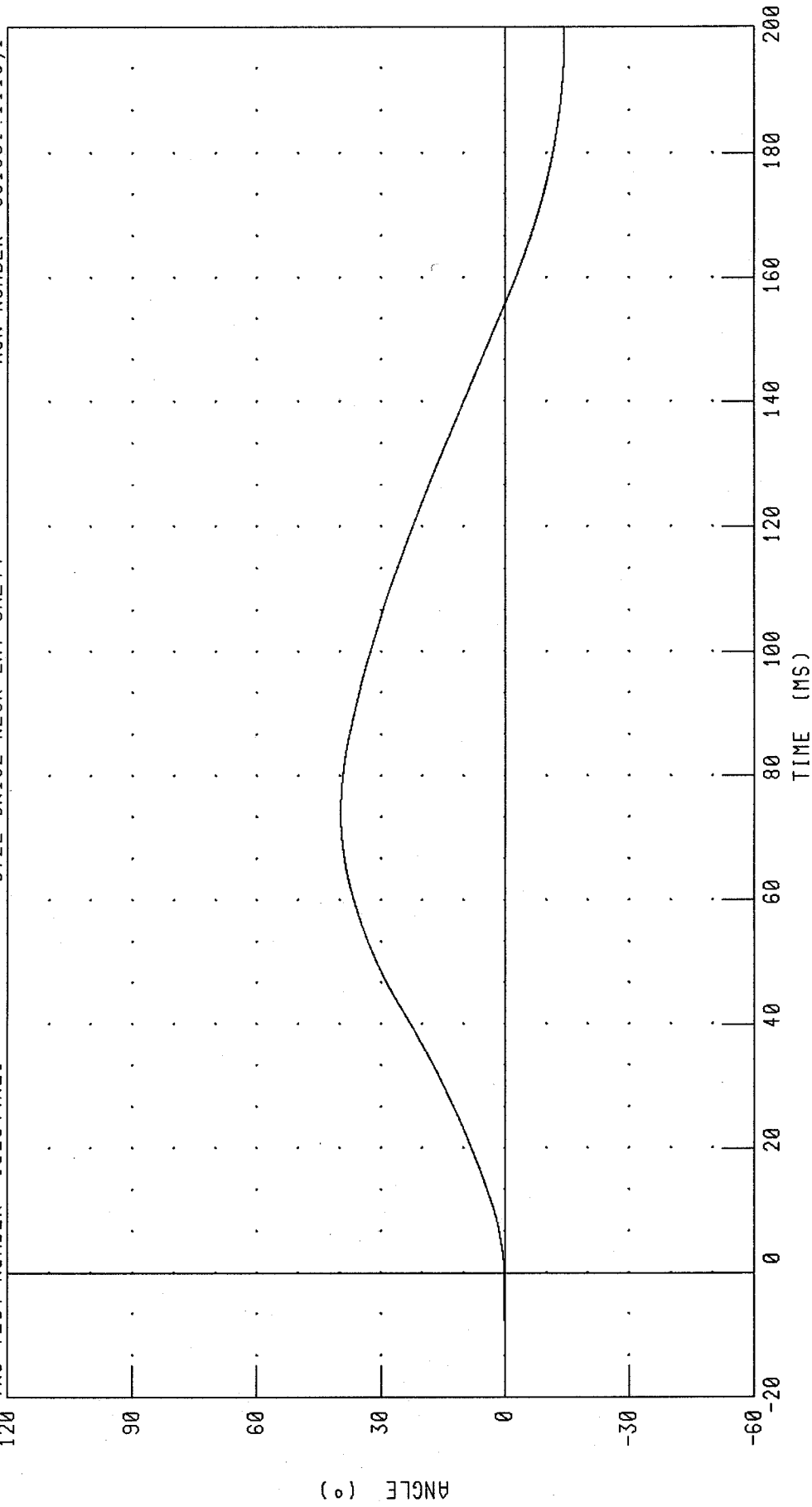

CHANNEL: BETA FILTER: CH. CLASS 60 PEAK DATA: 39.73 ° @ 73.84 MS; -14.41 ° @ 199.04 MS

PART 572-E HYBRID III NECK EXTENSION CALIBRATION
ROTATION ABOUT OCCIPITAL CONDYLE

TRC TEST NUMBER: 192C44NE1

572E SN192 NECK EXT CAL44

RUN NUMBER: 061301.1119;1

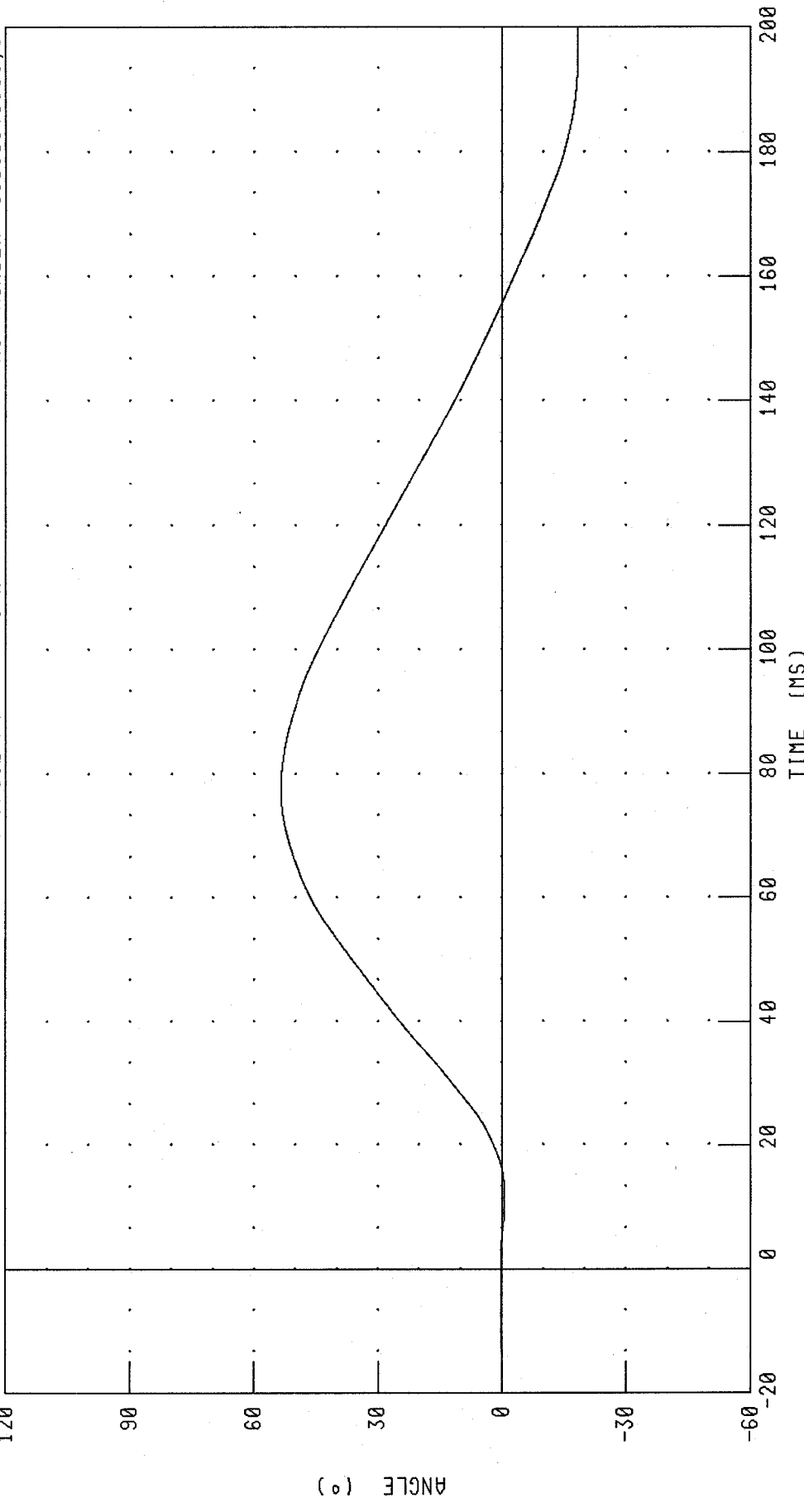

CHANNEL: THETA FILTER: CH. CLASS 60 PEAK DATA: 53.59 ° @ 77.84 MS; -18.49 ° @ 196.24 MS

PART 572-E HYBRID III NECK EXTENSION CALIBRATION

TOTAL ROTATION

TRC TEST NUMBER: 192C44NE1

572E SN192 NECK EXT CAL44

RUN NUMBER: 061301.1119;1

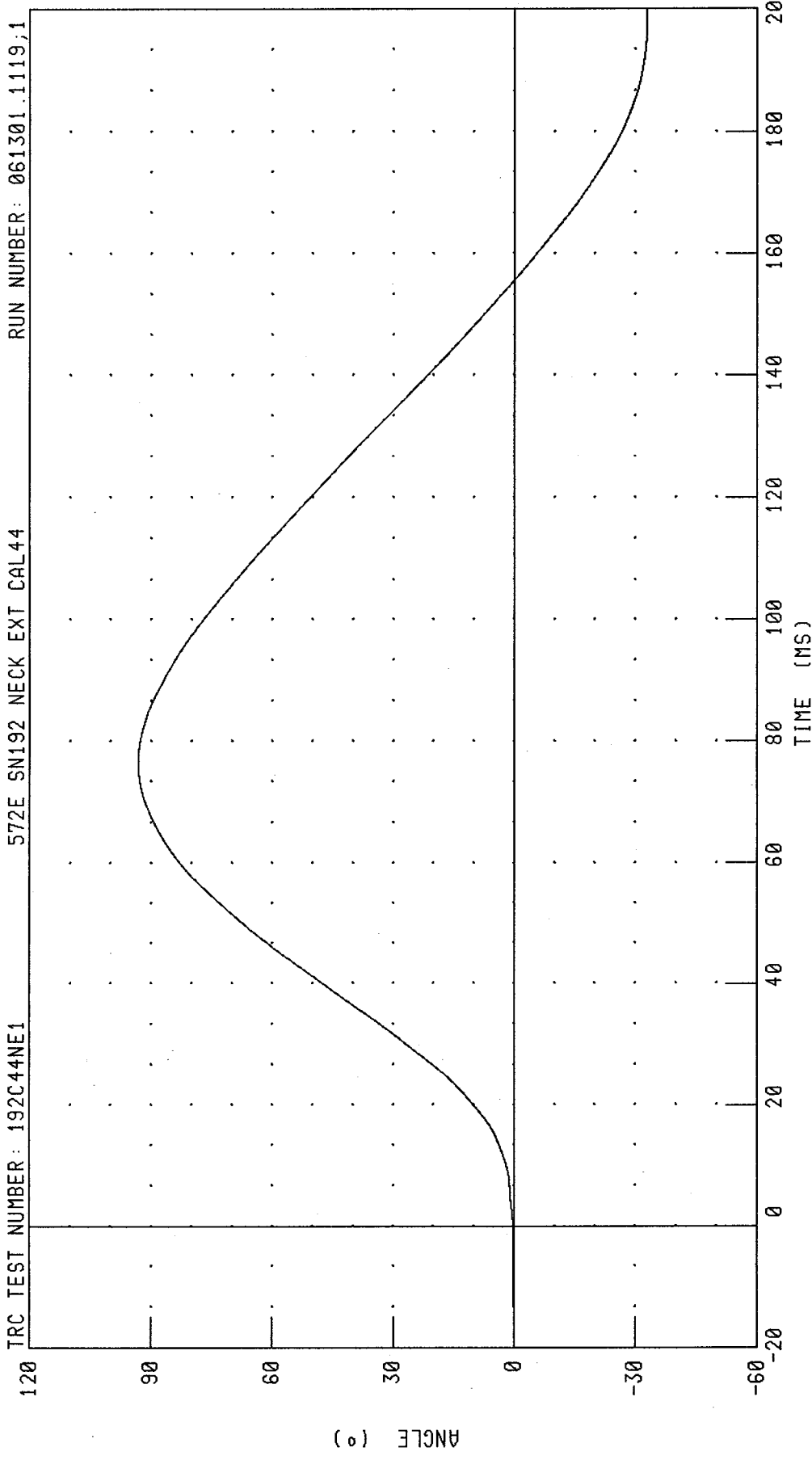

CHANNEL: TOTAN FILTER: CH. CLASS 60 PEAK DATA: 93.19 ° @ 76.56 MS; -32.87 ° @ 197.20 MS

PART 572-E HYBRID III NECK EXTENSION CALIBRATION

NECK FORCE X AXIS

TRC TEST NUMBER: 192C44NE1

572E SN192 NECK EXT CAL44

RUN NUMBER: 061301.1119;1

160

120

80

40

0

-40

-80

FORCE (N X 10⁴)

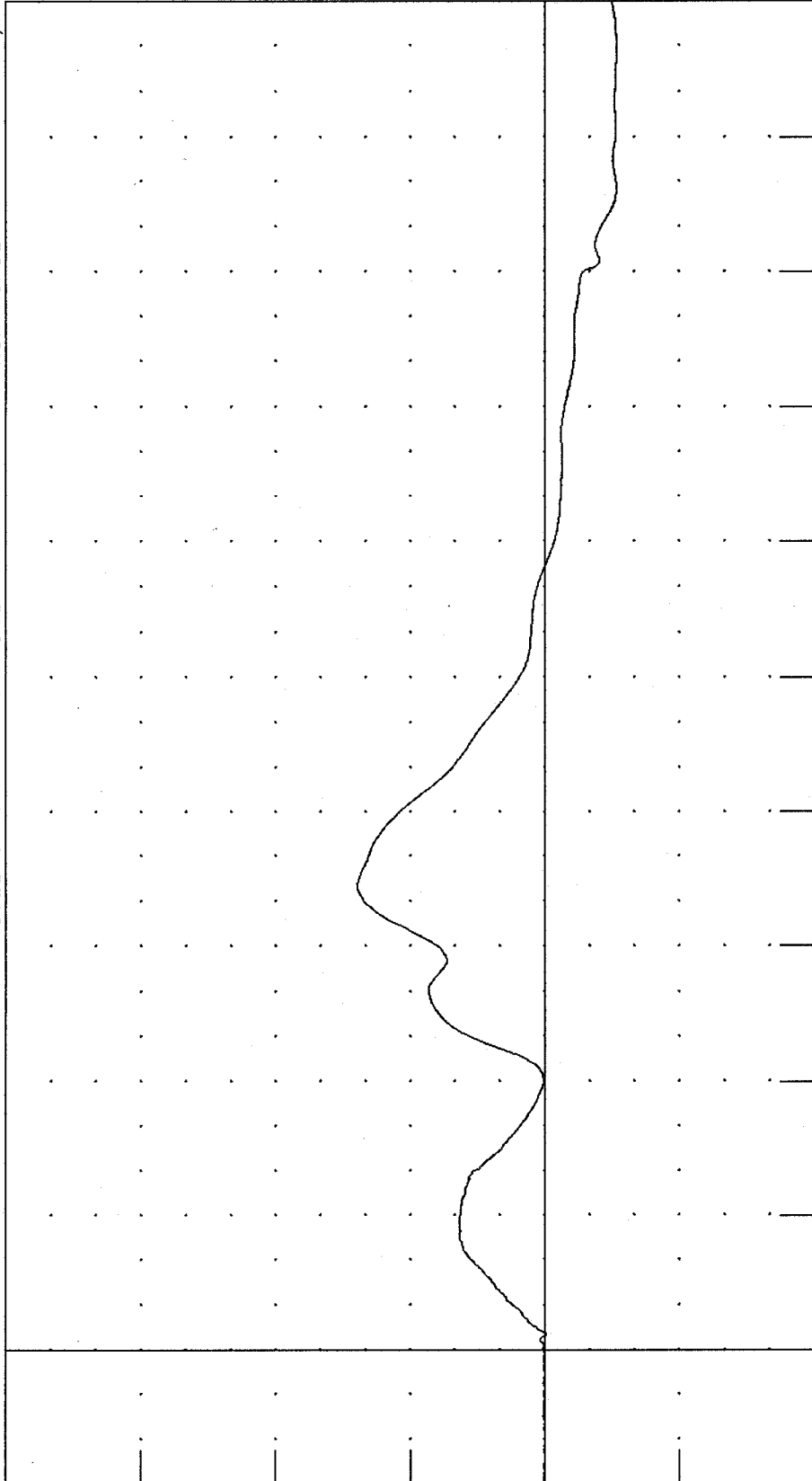

TIME (MS)

PEAK DATA: 557.04 N @ 68.48 MS; -215.65 N @ 172.00 MS

CHANNEL: NEKXF FILTER: CH. CLASS 1000

PART 572-E HYBRID III NECK EXTENSION CALIBRATION
 NECK FORCE X AXIS FILTERED FOR USE IN OCCIPITAL MOMENT CALCULATION
 TRC TEST NUMBER: 192C44NE1 572E SN192 NECK EXT CAL44 RUN NUMBER: 061301.1119;1

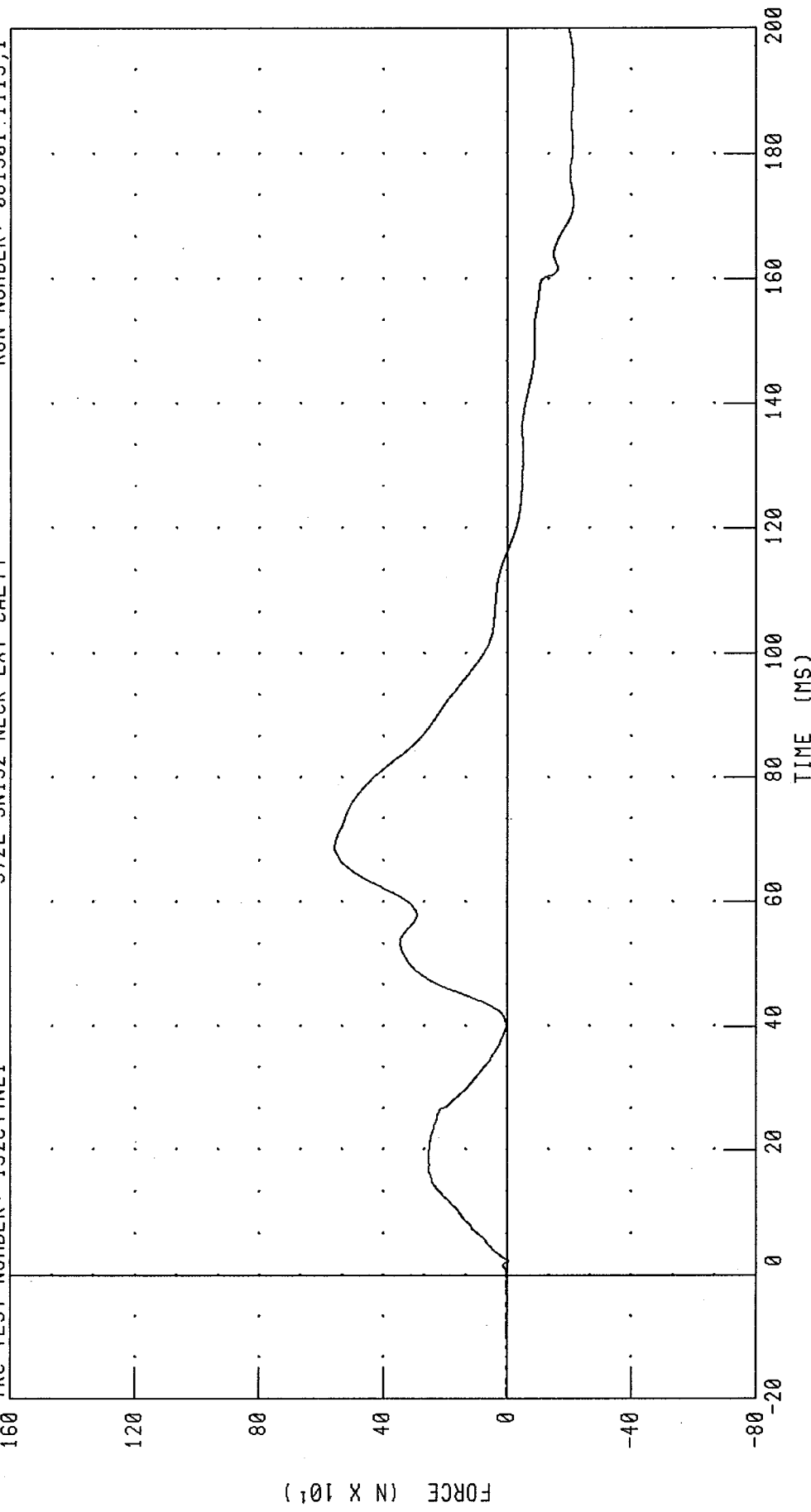

CHANNEL: NEKXFC FILTER: CH. CLASS 600 PEAK DATA: 557.17 N @ 68.80 MS; -214.93 N @ 172.00 MS

PART 572-E HYBRID III NECK EXTENSION CALIBRATION

NECK MOMENT Y AXIS

TRC TEST NUMBER: 192C44NE1

572E SN192 NECK EXT CAL44

RUN NUMBER: 061301.1119,1

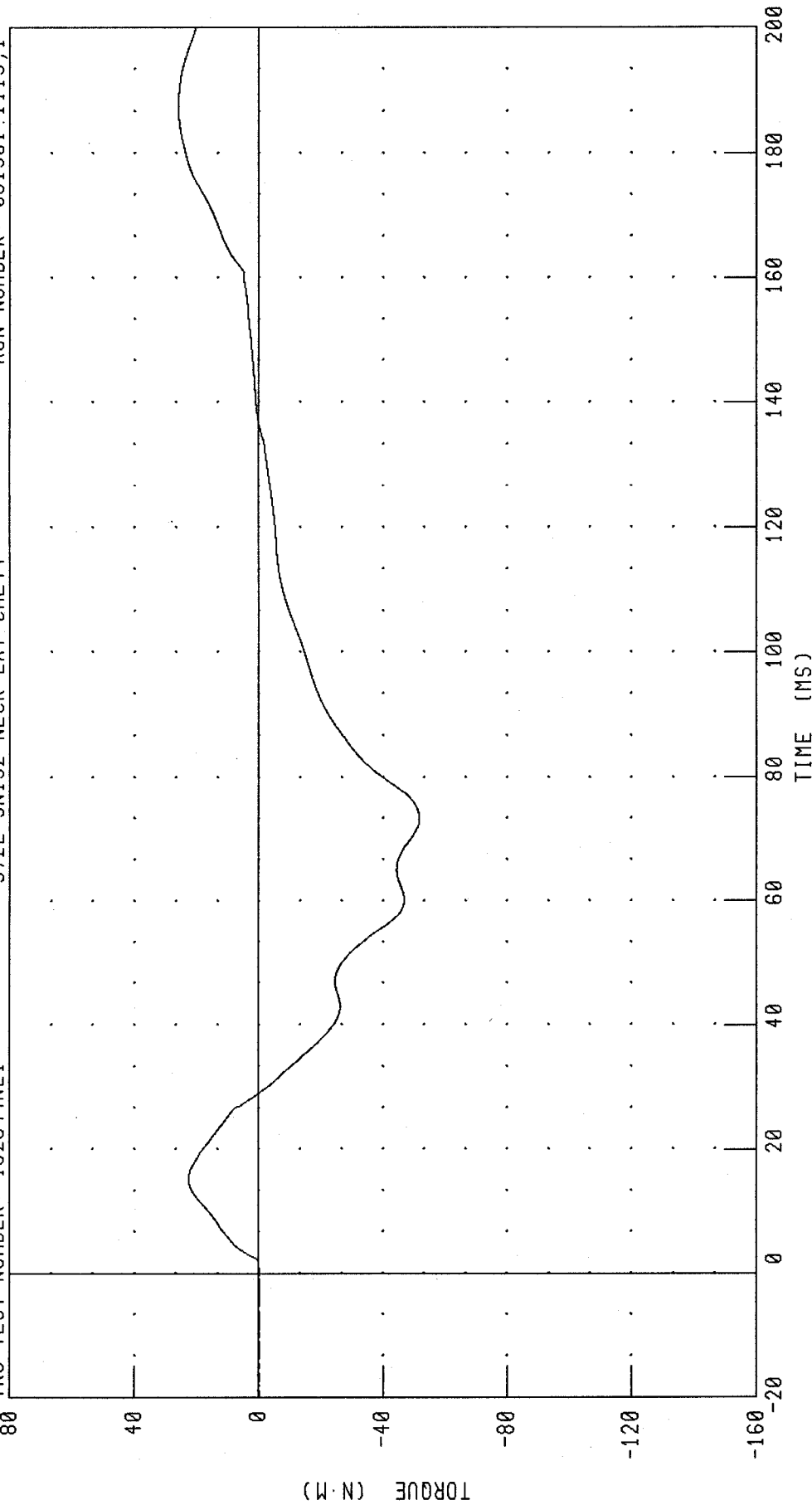

CHANNEL: NEKYM FILTER: CH. CLASS 600 PEAK DATA: 25.91 N·M @ 187.68 MS; -51.78 N·M @ 73.28 MS

PART 572-E HYBRID III NECK EXTENSION CALIBRATION
TOTAL MOMENT ABOUT OCCIPITAL CONDYLE

TRC TEST NUMBER: 192C44NE1

572E SN192 NECK EXT CAL44

RUN NUMBER: 061301.1119,1

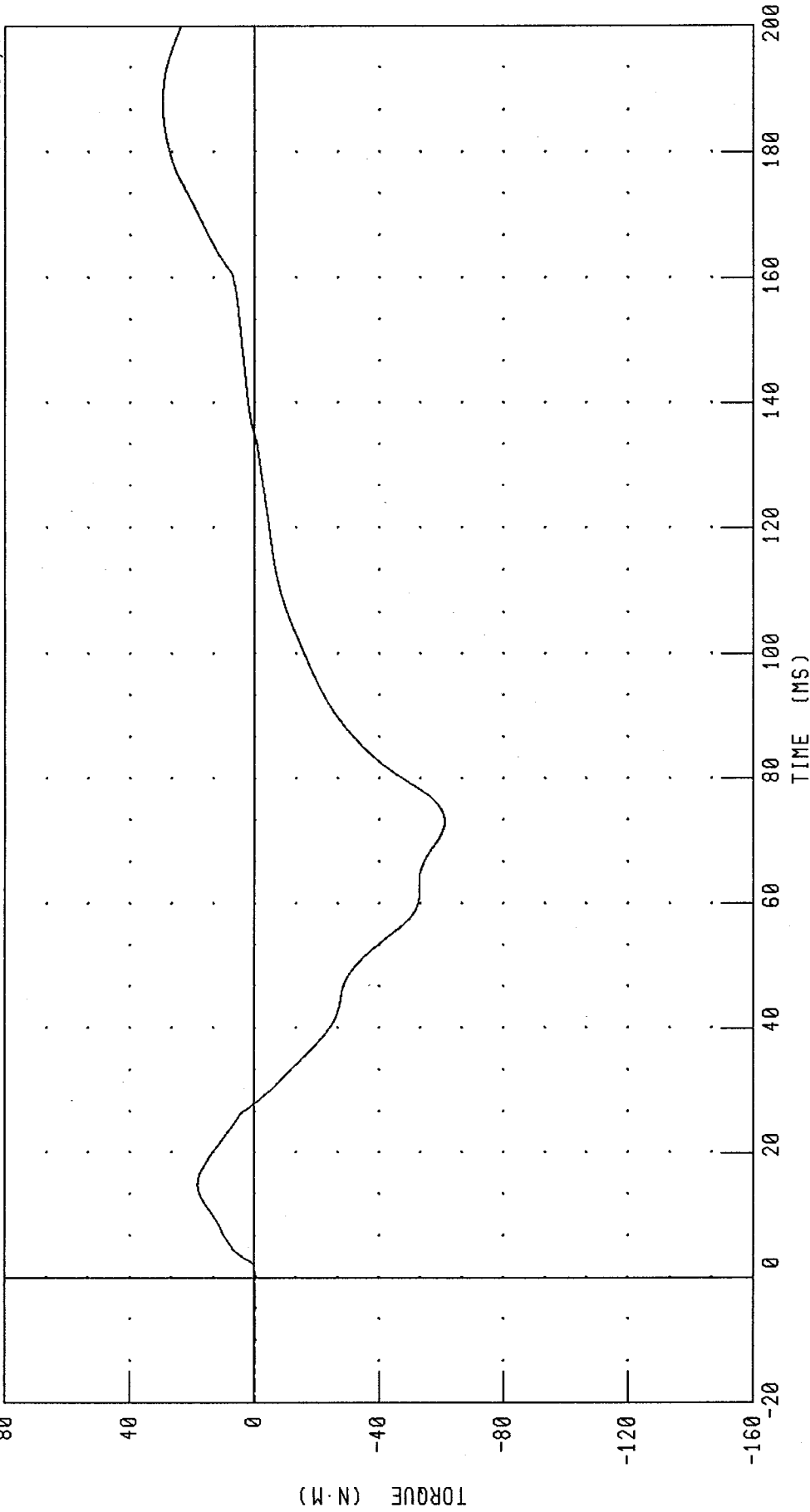

CHANNEL: NEKOM FILTER: CH. CLASS 600 PEAK DATA: 29.64 N·M @ 187.68 MS; -61.12 N·M @ 73.04 MS

TRANSPORTATION RESEARCH CENTER INC.

THORAX IMPACT TEST

HYBRID III 50th

05-JUN-01

TRC INC.

TEST NO: 192C44TH1

572E SN192 H.S.THORAX CAL44

TEST PARAMETER	HIGH SPEED TEST	TEST RESULTS
	SPECIFICATION	
TEMPERATURE	20.6-22.2 DEG. C	21.7 DEG. C
RELATIVE HUMIDITY	10 - 70 %	58.0 %
PENDULUM VELOCITY	6.59 - 6.83 M/S	6.62 M/S
MAXIMUM DEFLECTION	63.5 - 72.6 MM	70.1 MM
MAXIMUM RESISTIVE FORCE	5159 - 5894 N	5614. N
INTERNAL HYSTERESIS	69% - 85%	73.5%

TEST MEETS SPECIFICATIONS

TECHNICIAN

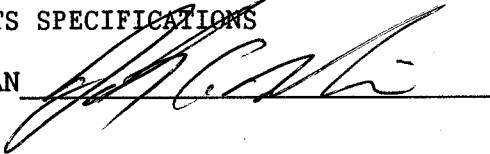

RUN NUMBER: 061401.1058;1

PART 572-E HYBRID III THORAX CALIBRATION
PENDULUM DECELERATION

TRC TEST NUMBER: 192C44TH1

572E SN192 H.S.THORAX CAL44

RUN NUMBER: 061401.1059;1

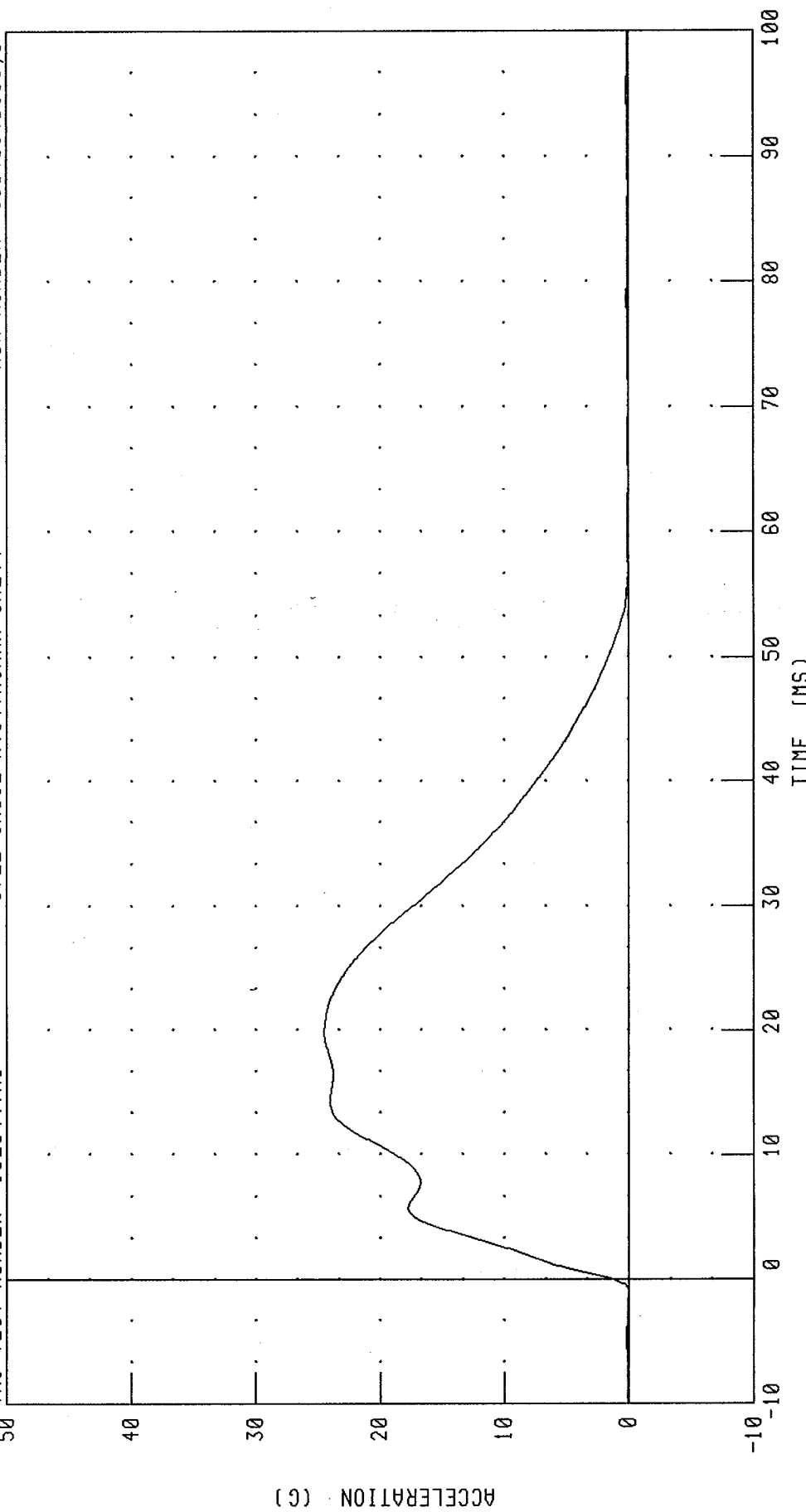

CHANNEL: PENXC FILTER: CH. CLASS 180 PEAK DATA: 24.51 G @ 19.76 MS; -0.06 G @ 70.64 MS

PART 572-E HYBRID III THORAX CALIBRATION
PENDULUM FORCE

TRC TEST NUMBER: 192C44TH1 572E SN192 H.S.THORAX CAL44 RUN NUMBER: 061401.1059,1

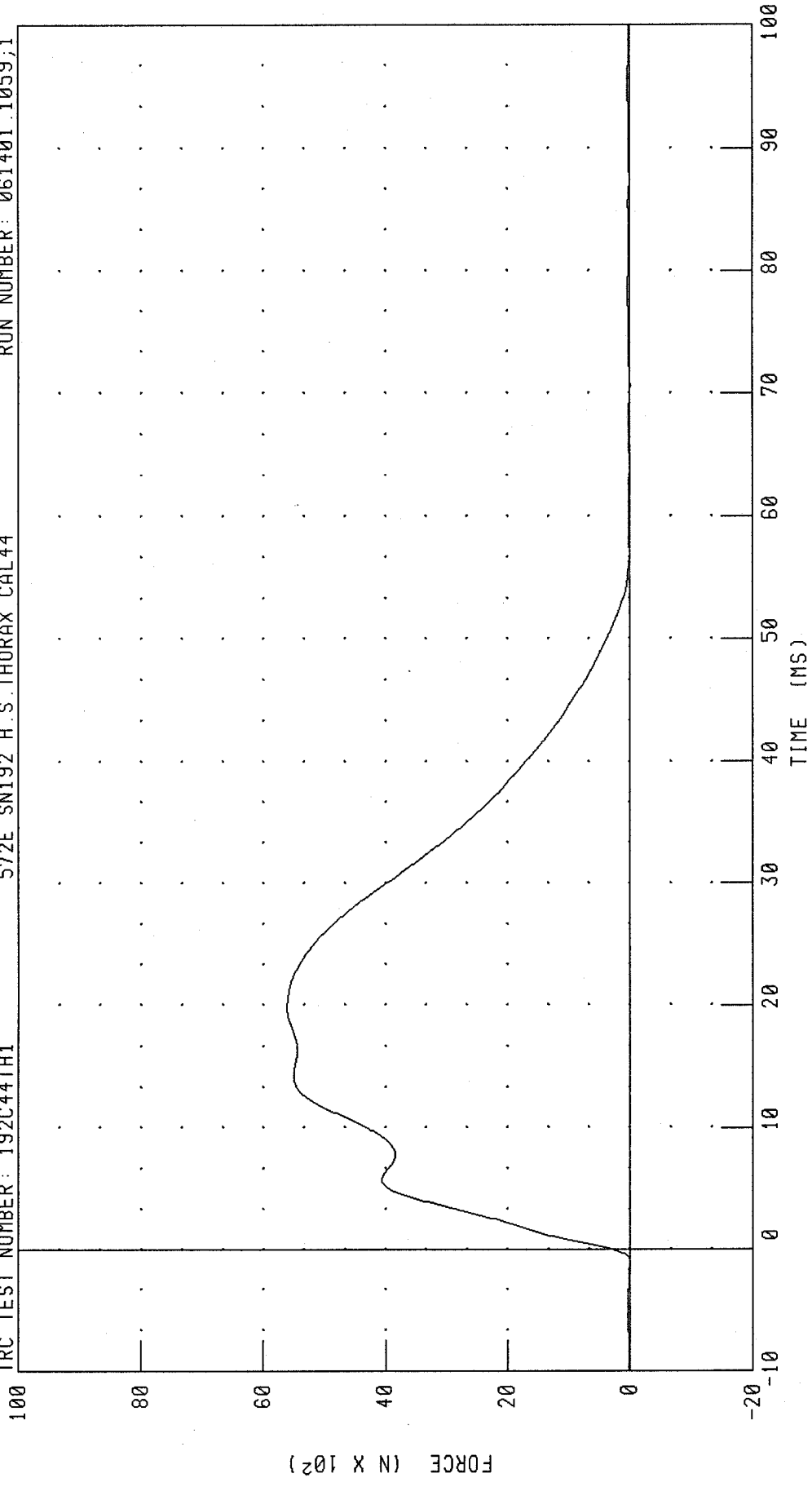

CHANNEL: PENXF FILTER: CH. CLASS 180 PEAK DATA: 5614.43 N @ 19.76 MS; -13.28 N @ 70.64 MS

PART 572-E HYBRID III THORAX CALIBRATION
STERNUM DISPLACEMENT

TRC TEST NUMBER: 192C44TH1 572E SN192 H.S. THORAX CAL44 RUN NUMBER: 061401.1059;1

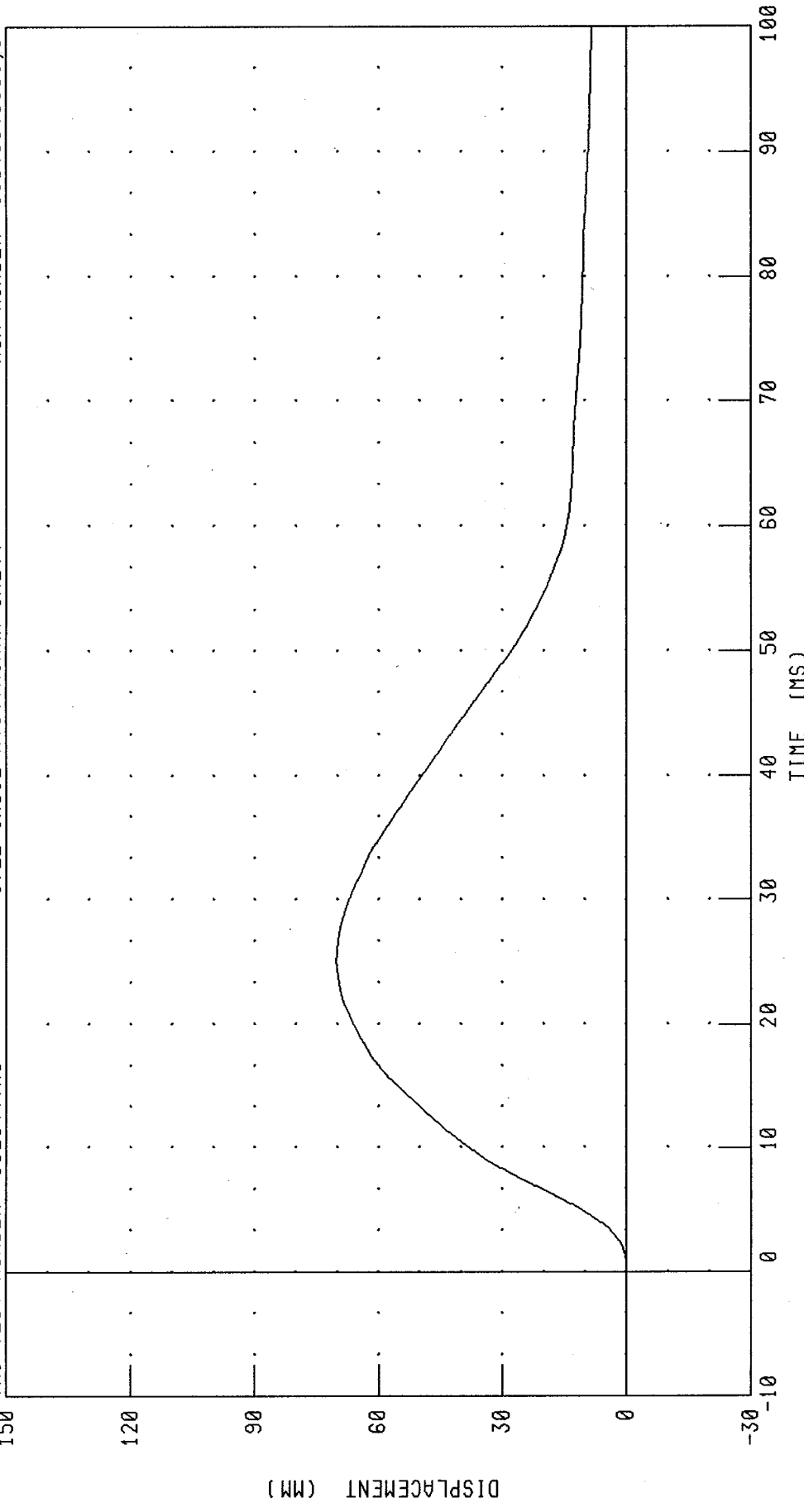

CHANNEL: CSTXD FILTER: CH. CLASS 180 PEAK DATA: 70.20 MM @ 25.12 MS; -0.04 MM @ 0.40 MS

PART 572-E HYBRID III THORAX CALIBRATION
CHEST DISPLACEMENT VS PENDULUM FORCE

TRC TEST NUMBER: 192C44TH1

572E SN192 H.S.THORAX CAL44

RUN NUMBER: 061401.1059;1

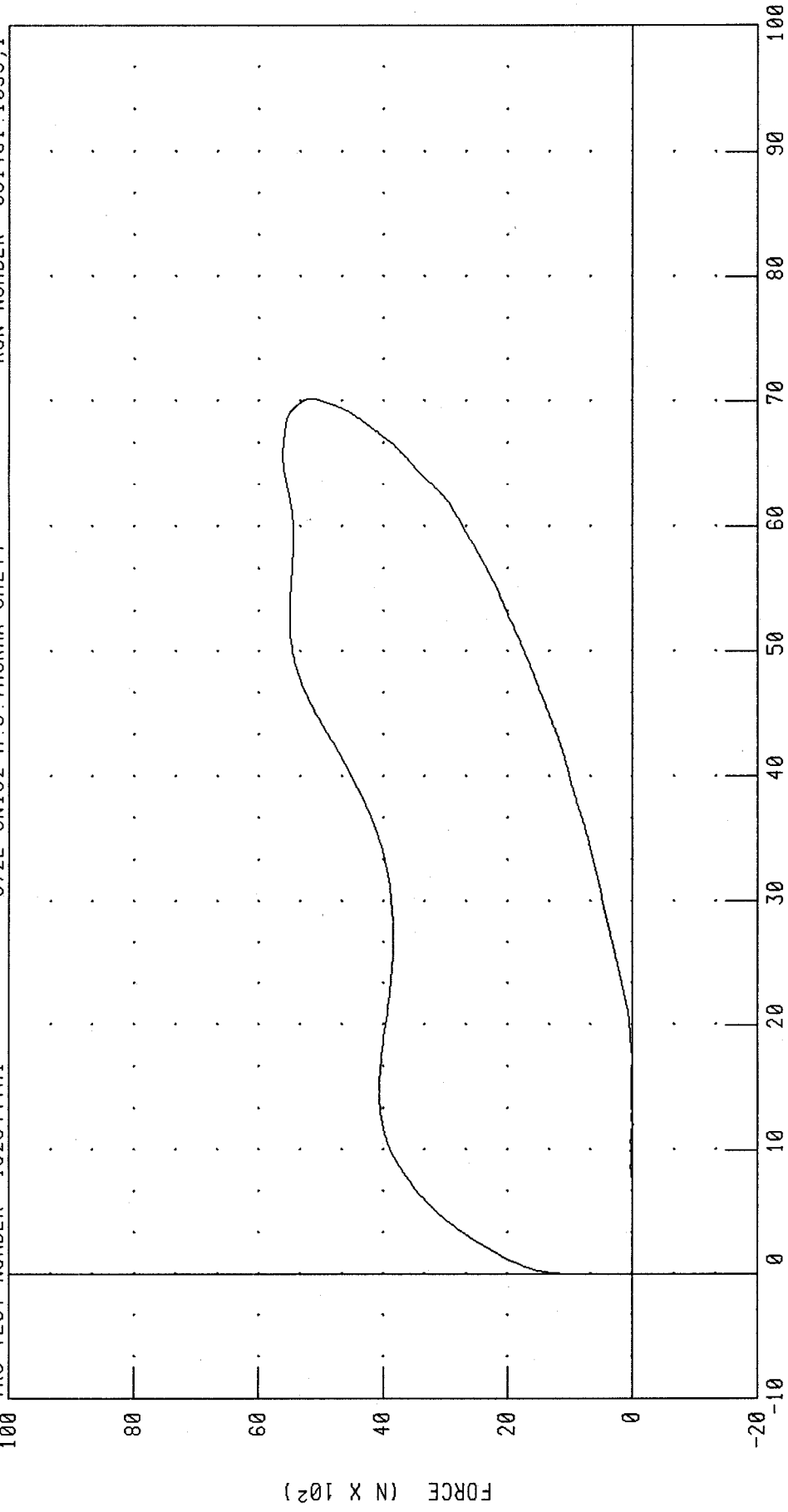

DISPLACEMENT (MM)

PEAK DATA: 70.20 MM @ 25.12 MS; -0.04 MM @ 0.40 MS
5614.43 N @ 19.76 MS; -13.28 N @ 70.64 MS

CHANNEL: CSTXD FILTER: CH. CLASS 180
PENXF CH. CLASS 180

Transportation Research Center Inc

Hybrid III Hip Range of Motion

Serial Number: 192C44

Date: 06/07/2001

Test Number: 192L

Time: 09:47

Comments:

TEST PARAMETER	SPECIFICATION	TEST RESULTS
Temperature	18.9 - 25.6	21.1 °C Pass
Humidity	10 - 70	55 % Pass
Moment at 30 deg	<= 94.9	85.4 Nm Pass
Angle at 203 Nm	40.0 - 50.0	40.2 deg Pass
Average Velocity	5.0 - 10.0	7.4 deg/sec Pass

Peak Moment: 211.1 Nm at 40.6 deg
Peak Angle: 40.6 deg at 211.1 Nm

Moment About H-Point

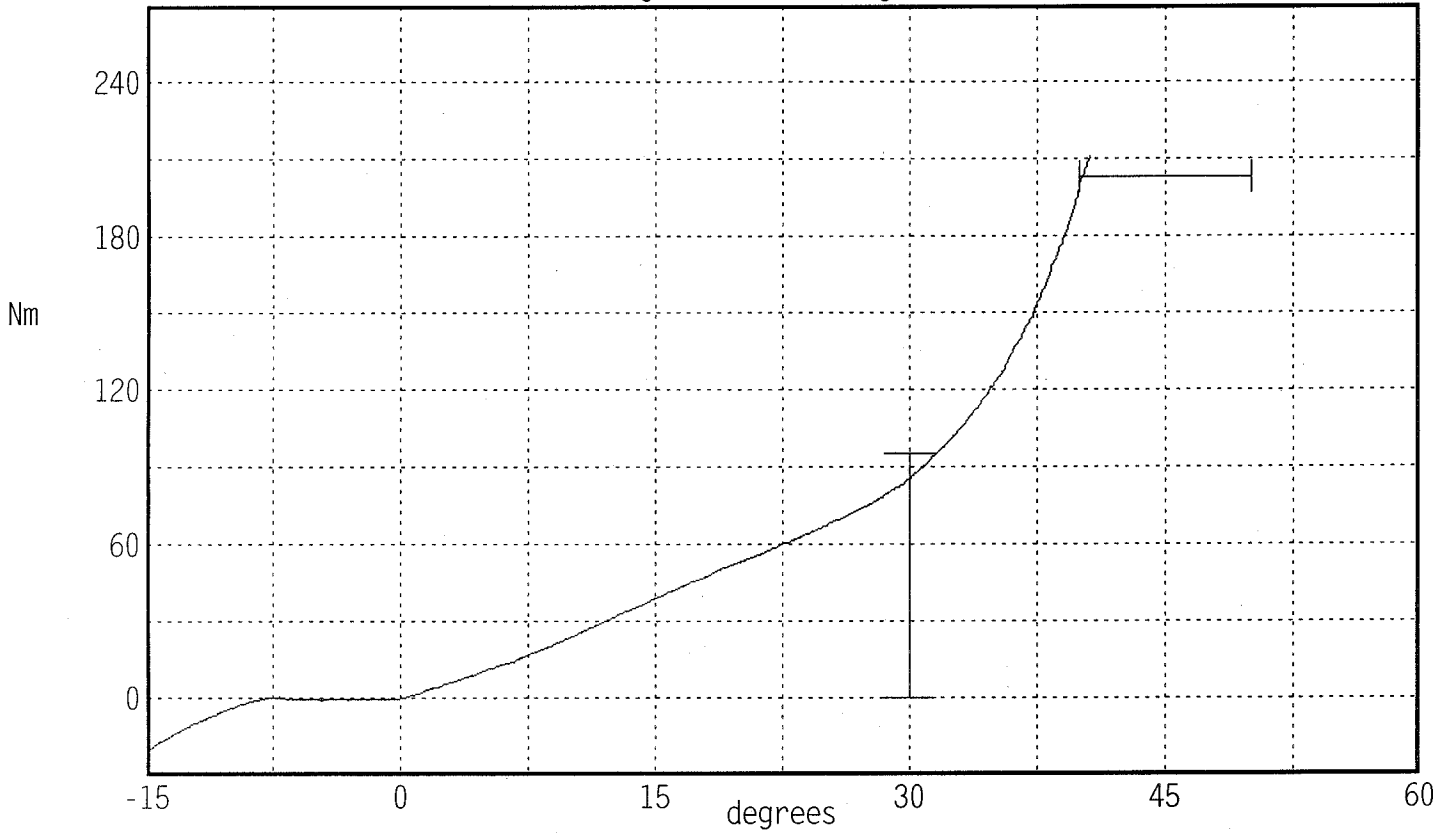

Angular Velocity

Max: 8.1 deg/sec

Min: 6.7 deg/sec

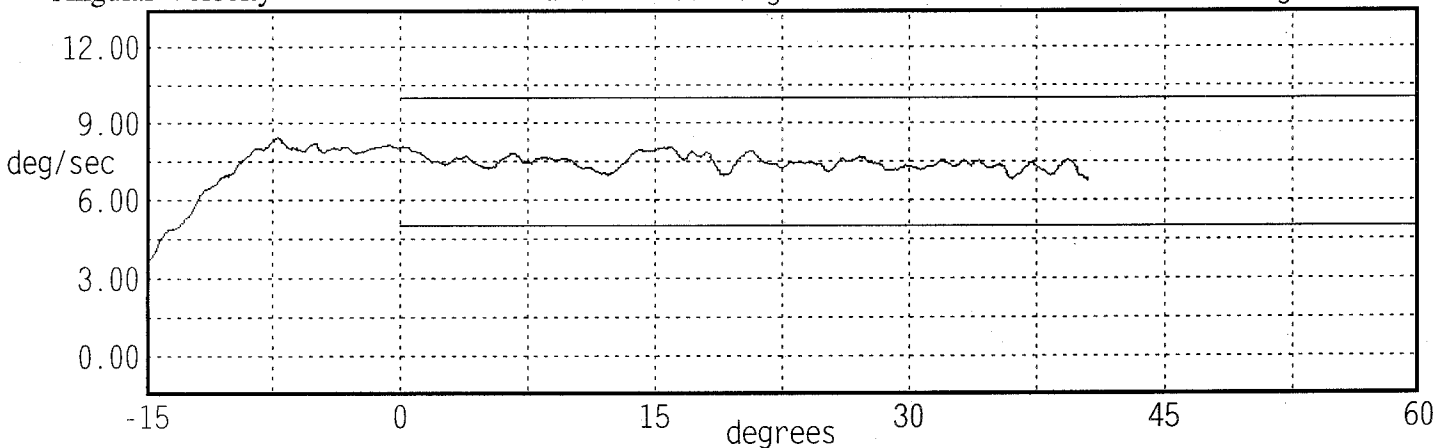

Transportation Research Center Inc

Hybrid III Hip Range of Motion

Serial Number: 192C44

Date: 06/07/2001

Test Number: 192R

Time: 11:59

Comments:

TEST PARAMETER	SPECIFICATION	TEST RESULTS
Temperature	18.9 - 25.6	21.1 °C Pass
Humidity	10 - 70	55 % Pass
Moment at 30 deg	<= 94.9	93.9 Nm Pass
Angle at 203 Nm	40.0 - 50.0	42.8 deg Pass
Average Velocity	5.0 - 10.0	7.4 deg/sec Pass

Moment About H-Point
Peak Moment: 211.2 Nm at 43.2 deg
Peak Angle: 43.2 deg at 211.2 Nm

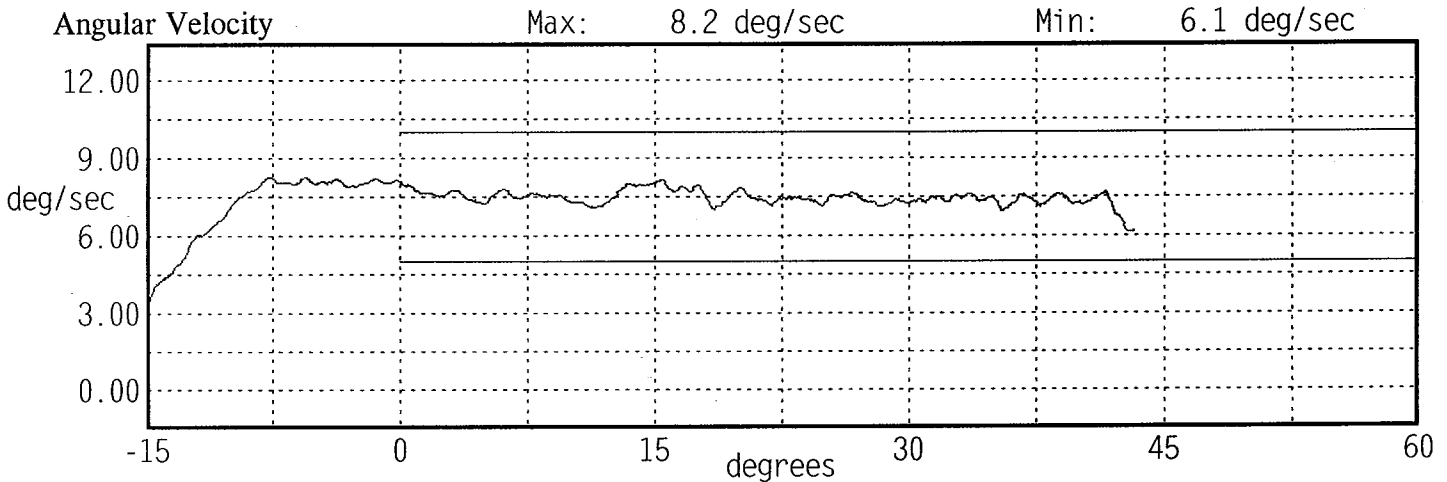
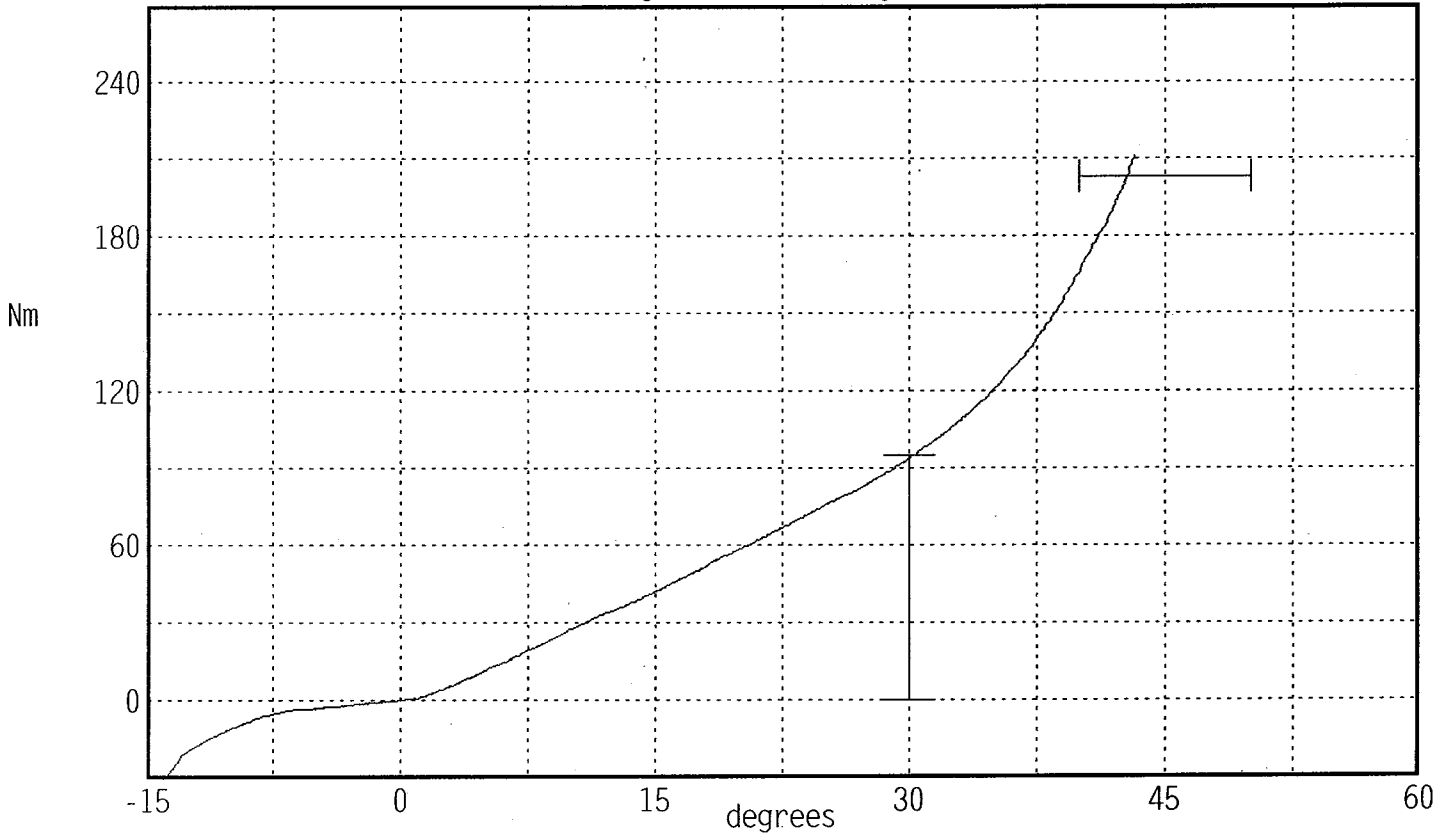

TRANSPORTATION RESEARCH CENTER INC.

LEFT KNEE IMPACT TEST

HYBRID III 50th

07-JUN-01

TRC INC.

TEST NO: 192C44LK3

572E SN192 LEFT KNEE CAL 44

TEST PARAMETER	SPECIFICATION	TEST RESULTS
TEMPERATURE	18.9-25.6 DEG. C	21.1 DEG. C
RELATIVE HUMIDITY	10 - 70 %	55.0 %
PROBE VELOCITY	2.07 - 2.13 M/S	2.07 M/S
PEAK KNEE IMPACT FORCE 5.0 KG PENDULUM	4715 - 5782 N	5019.0 N

TEST MEETS SPECIFICATIONS

TECHNICIAN

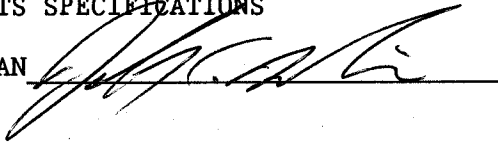

RUN NUMBER: 060701.1409;2

PART 572-E HYBRID III LEFT KNEE CALIBRATION
PENDULUM DECELERATION (5 KG PEND.)

TRC TEST NUMBER: 192C44LK3

572E SN192 LEFT KNEE CAL 44

RUN NUMBER: 060701.1409;2

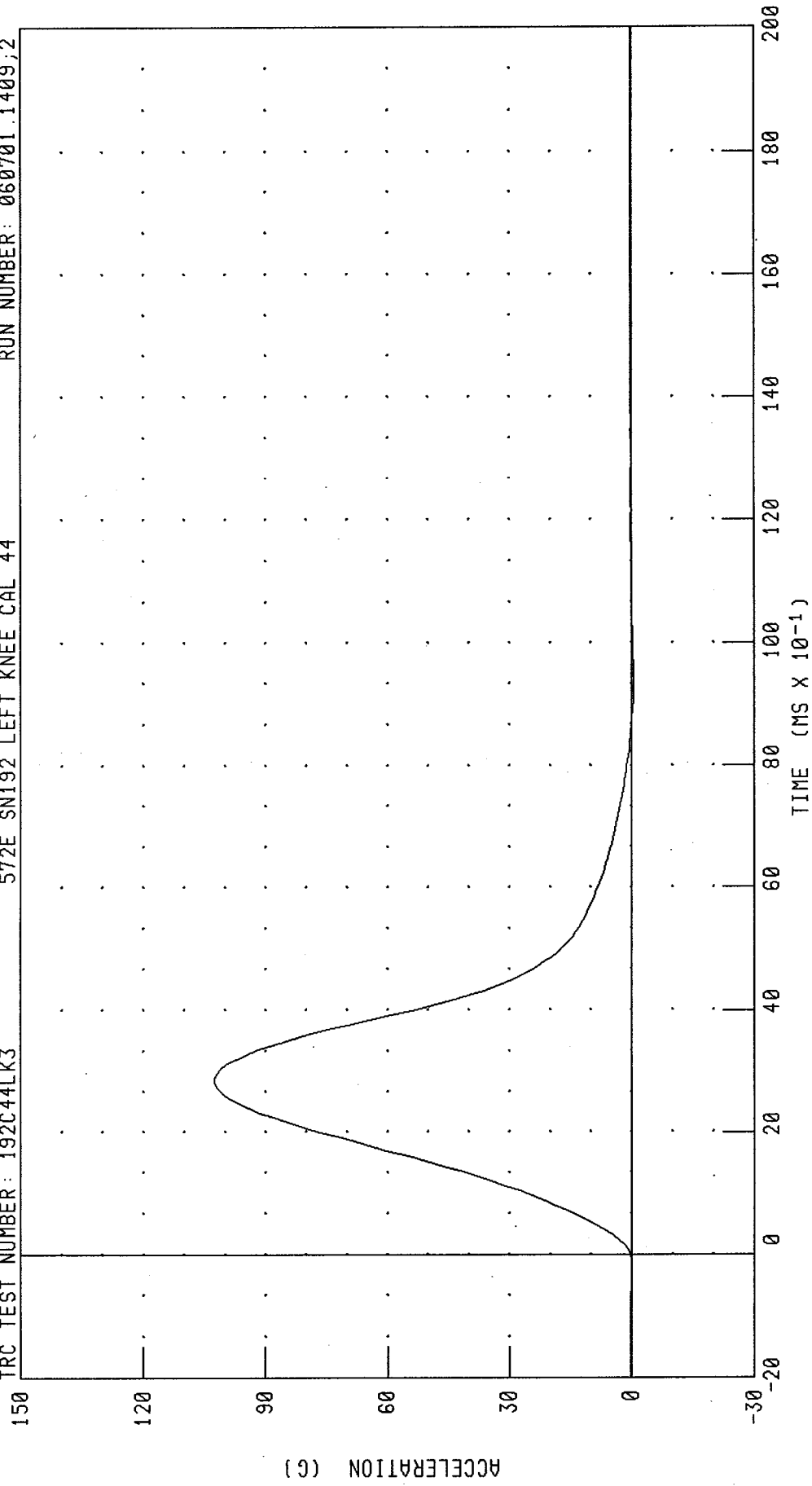

CHANNEL: PENXG FILTER: CH. CLASS 600

PEAK DATA: 102.58 G @ 2.88 MS; -0.55 G @ 9.20 MS

PART 572-E HYBRID III LEFT KNEE CALIBRATION

PENDULUM FORCE (5 KG PEND.)

TRC TEST NUMBER: 192C44LK3

572E SN192 LEFT KNEE CAL 44

RUN NUMBER: 060701.1409;2

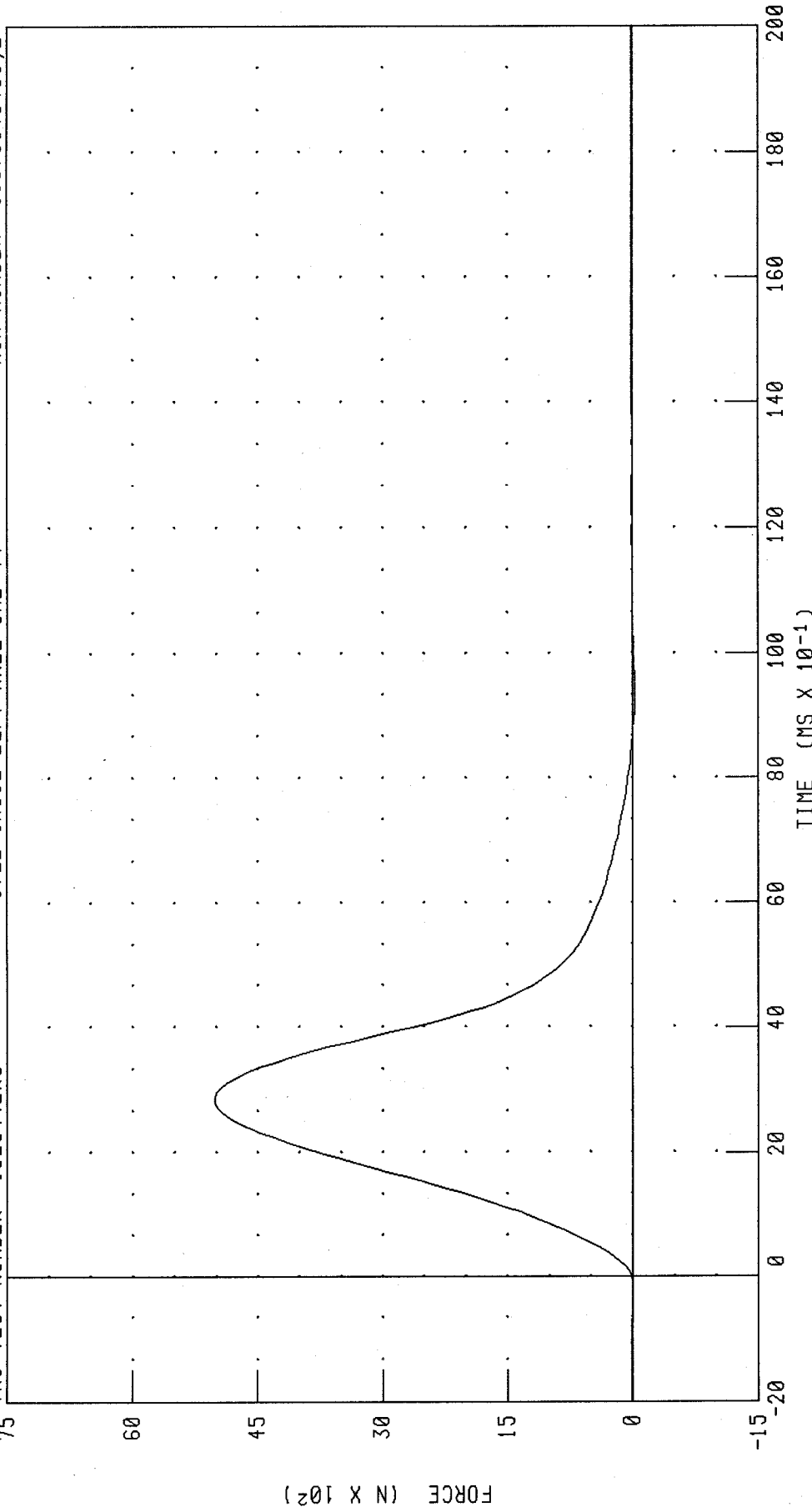

CHANNEL: PENXF FILTER: CH. CLASS 600

PEAK DATA: 5019.10 N @ 2.88 MS; -27.05 N @ 9.20 MS

TRANSPORTATION RESEARCH CENTER INC.

RIGHT KNEE IMPACT TEST

HYBRID III 50th

07-JUN-01

TRC INC.

TEST NO: 192C44RK2

572E SN192 RIGHT KNEE CAL 44

TEST PARAMETER	SPECIFICATION	TEST RESULTS
TEMPERATURE	18.9-25.6 DEG. C	21.1 DEG. C
RELATIVE HUMIDITY	10 - 70 %	55.0 %
PROBE VELOCITY	2.07 - 2.13 M/S	2.07 M/S
PEAK KNEE IMPACT FORCE 5.0 KG PENDULUM	4715 - 5782 N	4738.5 N

TEST MEETS SPECIFICATIONS

TECHNICIAN

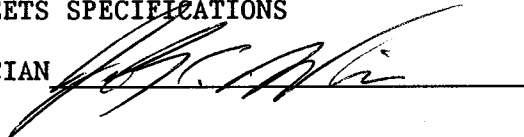

RUN NUMBER: 060701.1422;1

PART 572-E HYBRID III RIGHT KNEE CALIBRATION
PENDULUM DECELERATION (5 KG PEND.)

TRC TEST NUMBER: 192C44RK2 RUN NUMBER: 060701.1422.1

572E SN192 RIGHT KNEE CAL 44

150

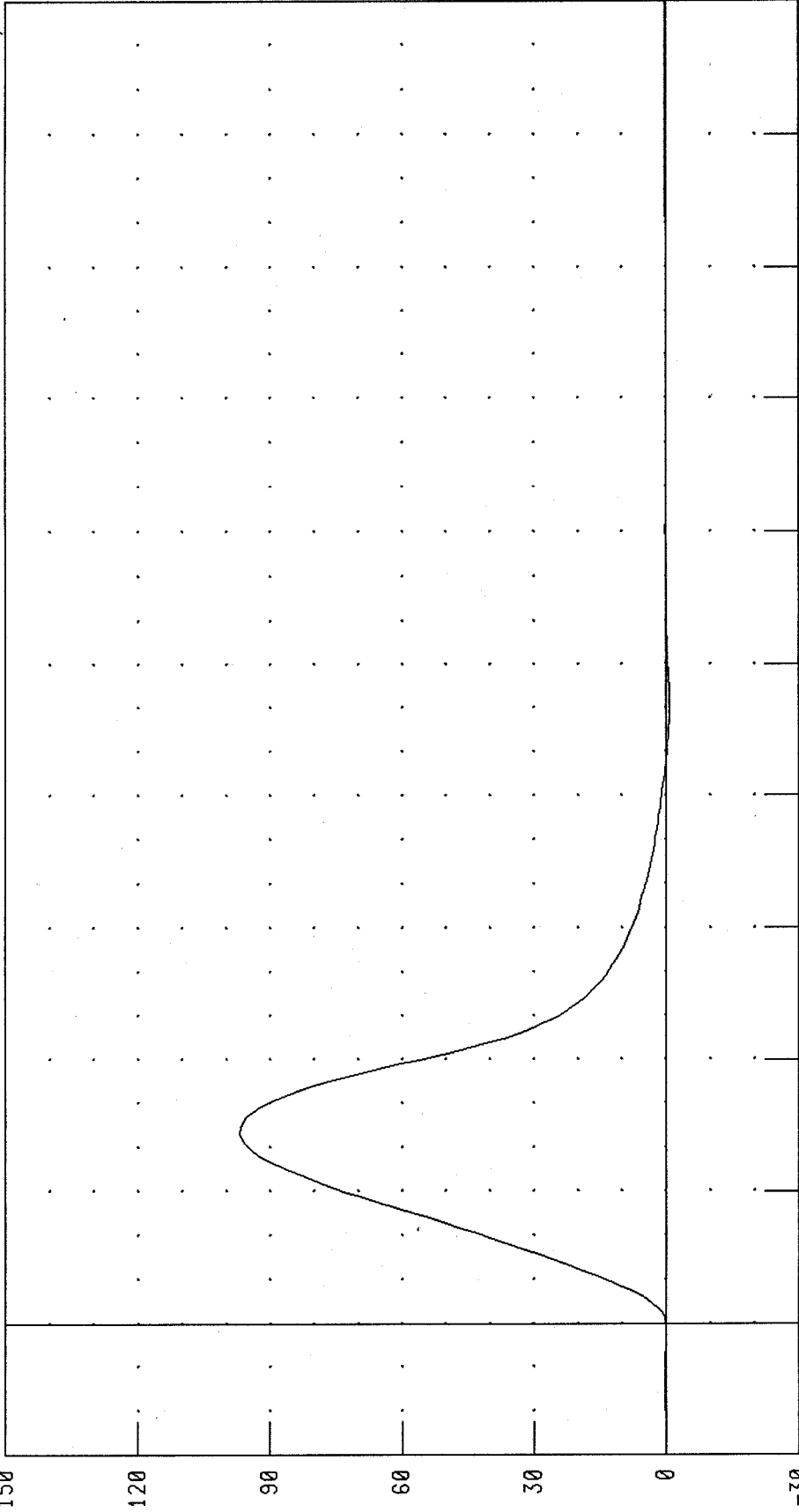

ACCELERATION (G)

TIME (MS X 10⁻¹)

CHANNEL: PENXC FILTER: CH. CLASS 600

PEAK DATA: 96.85 G @ 2.88 MS; -0.77 G @ 9.28 MS

PART 572-E HYBRID III RIGHT KNEE CALIBRATION

PENDULUM FORCE (5 KG PEND.)

TRC TEST NUMBER: 192C44RK2

572E SN192 RIGHT KNEE CAL 44

RUN NUMBER: 060701.1422;1

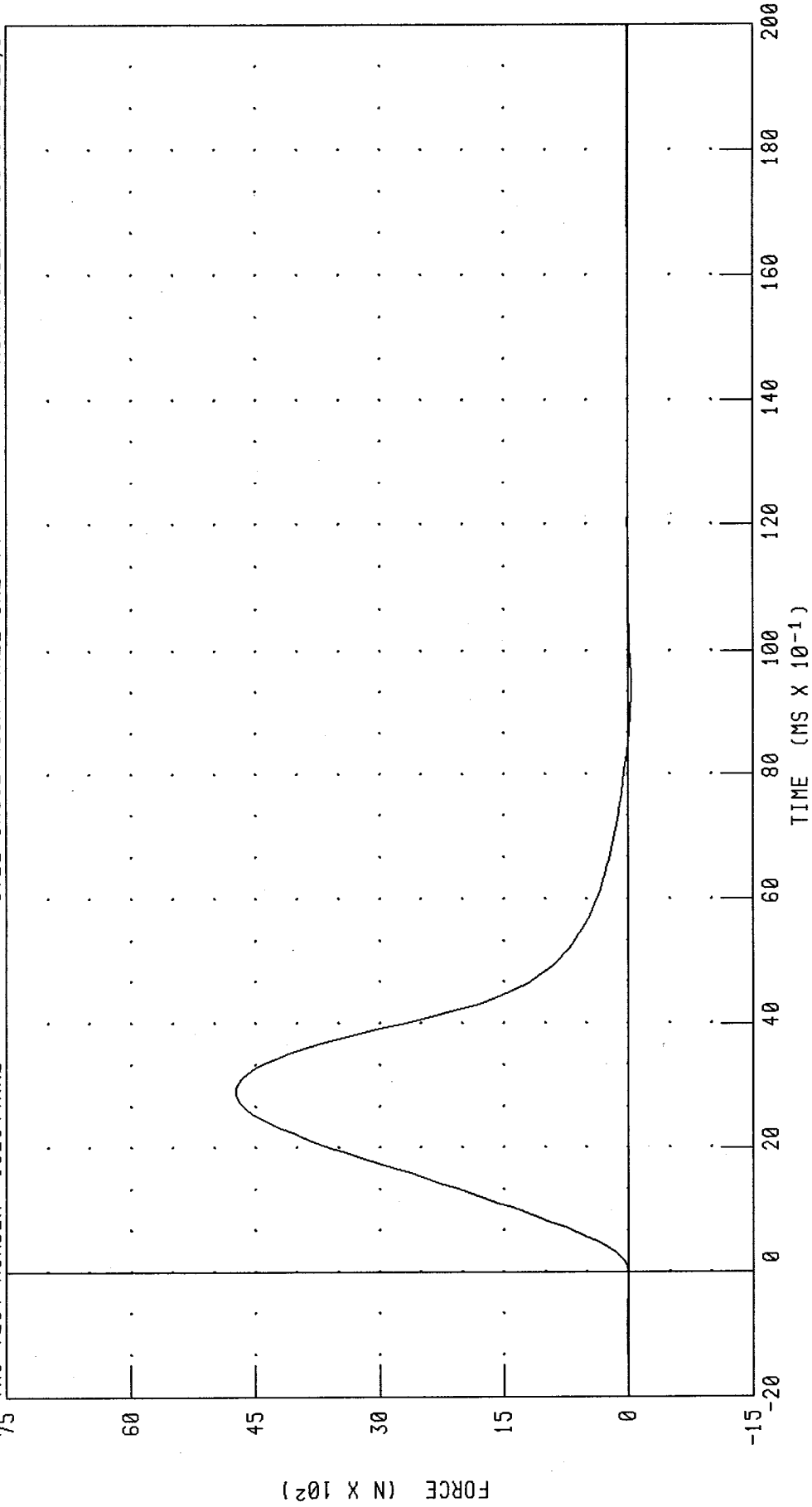

CHANNEL: PENXF FILTER: CH. CLASS 600

PEAK DATA: 4738.55 N @ 2.88 MS; -37.87 N @ 9.28 MS

TRANSPORTATION RESEARCH CENTER INC.

KNEE SLIDER TEST

HYBRID III 50th

12-JUN-01

LEFT KNEE

TRC INC.

TEST NO: 192C44LS1

572E SN192 LEFT SLIDER CAL 44

TEST PARAMETER	SPECIFICATION	TEST RESULTS
TEMPERATURE	18.9-25.6 DEG. C	21.7 DEG. C
RELATIVE HUMIDITY	10 - 70 %	58.0 %
PENDULUM VELOCITY	2.70-2.80 M/S	2.80 M/S
FORCE AT 10.0 MM DISPLACEMENT	1259 - 1721 N	- 1357. N
FORCE AT 18.0 MM DISPLACEMENT	2268 - 3096 N	-2314. N

TEST MEETS SPECIFICATIONS

TECHNICIAN

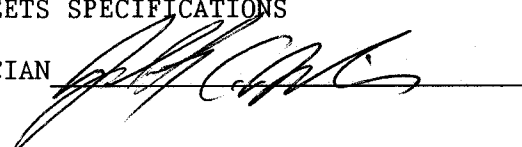

RUN NUMBER: 070901.0907;1

PART 572-E HYBRID III LEFT KNEE SLIDER CALIBRATION

LEFT FEMUR FORCE

TRC TEST NUMBER: 192C44LS1

572E SN192 LEFT SLIDER CAL 44

RUN NUMBER: 070901.0910;2

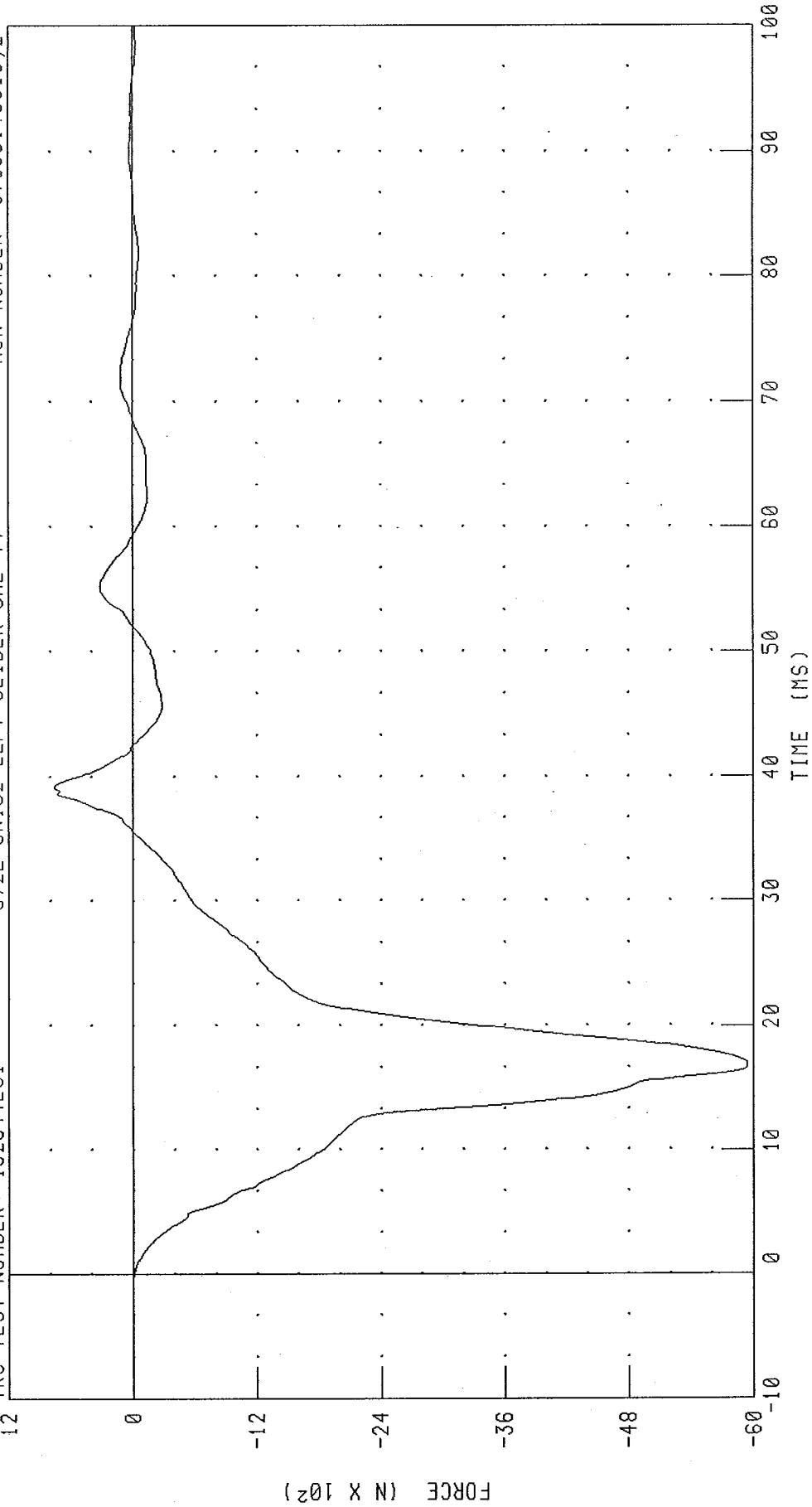

CHANNEL: LFMF FILTER: CH. CLASS 600

PEAK DATA: 759.51 N @ 39.20 MS; -5943.88 N @ 16.96 MS

PART 572-E HYBRID III LEFT KNEE SLIDER CALIBRATION
KNEE DISPLACEMENT

TRC TEST NUMBER: 192C44LS1

572E SN192 LEFT SLIDER CAL 44

RUN NUMBER: 070901.0910;2

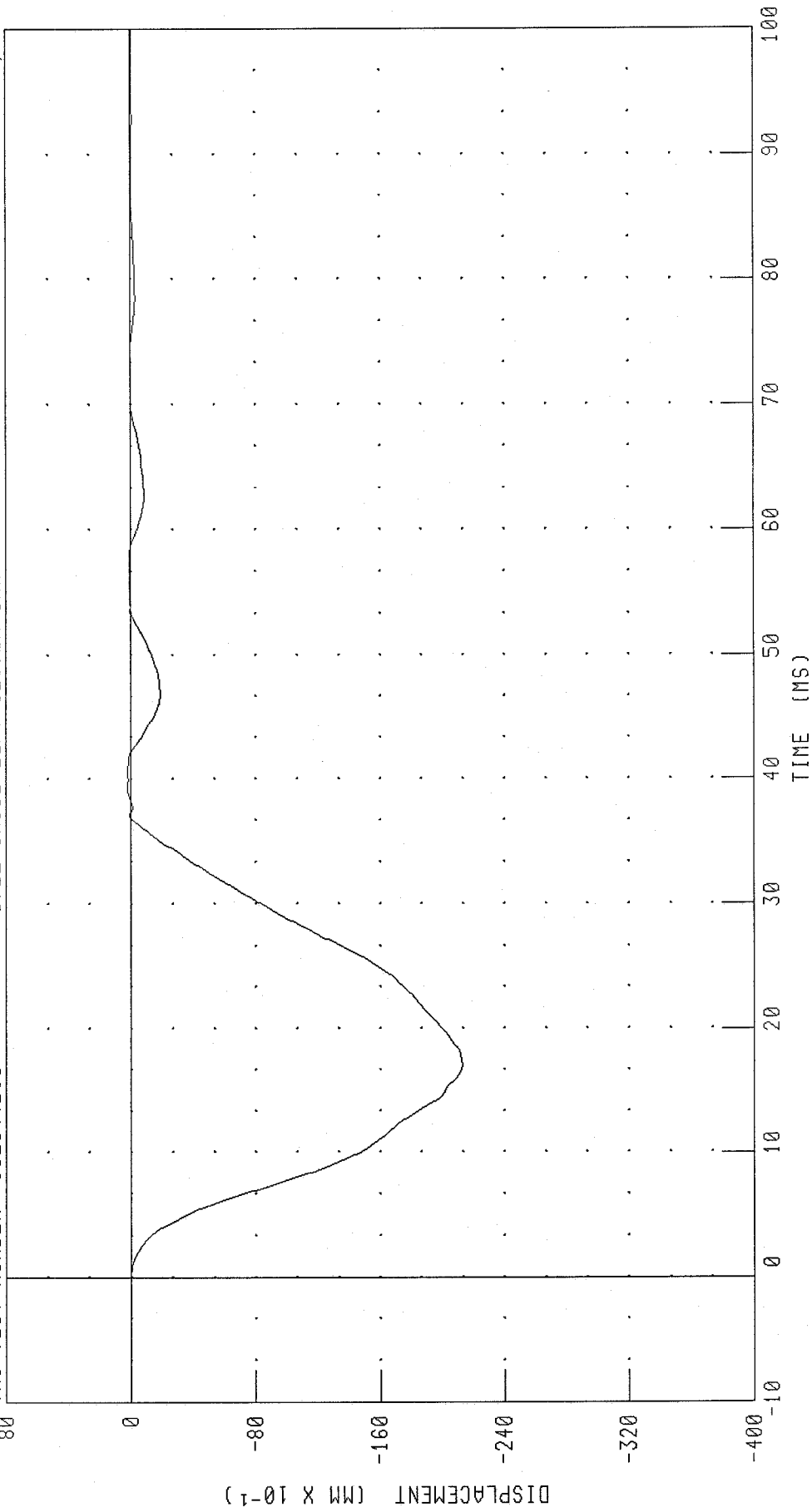

CHANNEL: KNLXD FILTER: CH. CLASS 600 PEAK DATA: 0.25 MM @ 39.28 MS; -21.29 MM @ 17.04 MS

PART 572-E HYBRID III LEFT KNEE SLIDER CALIBRATION
 LEFT KNEE DISPLACEMENT VS FEMUR FORCE

TRC TEST NUMBER: 192C44LS1 572E SN192 LEFT SLIDER CAL 44 RUN NUMBER: 070901.0942;2

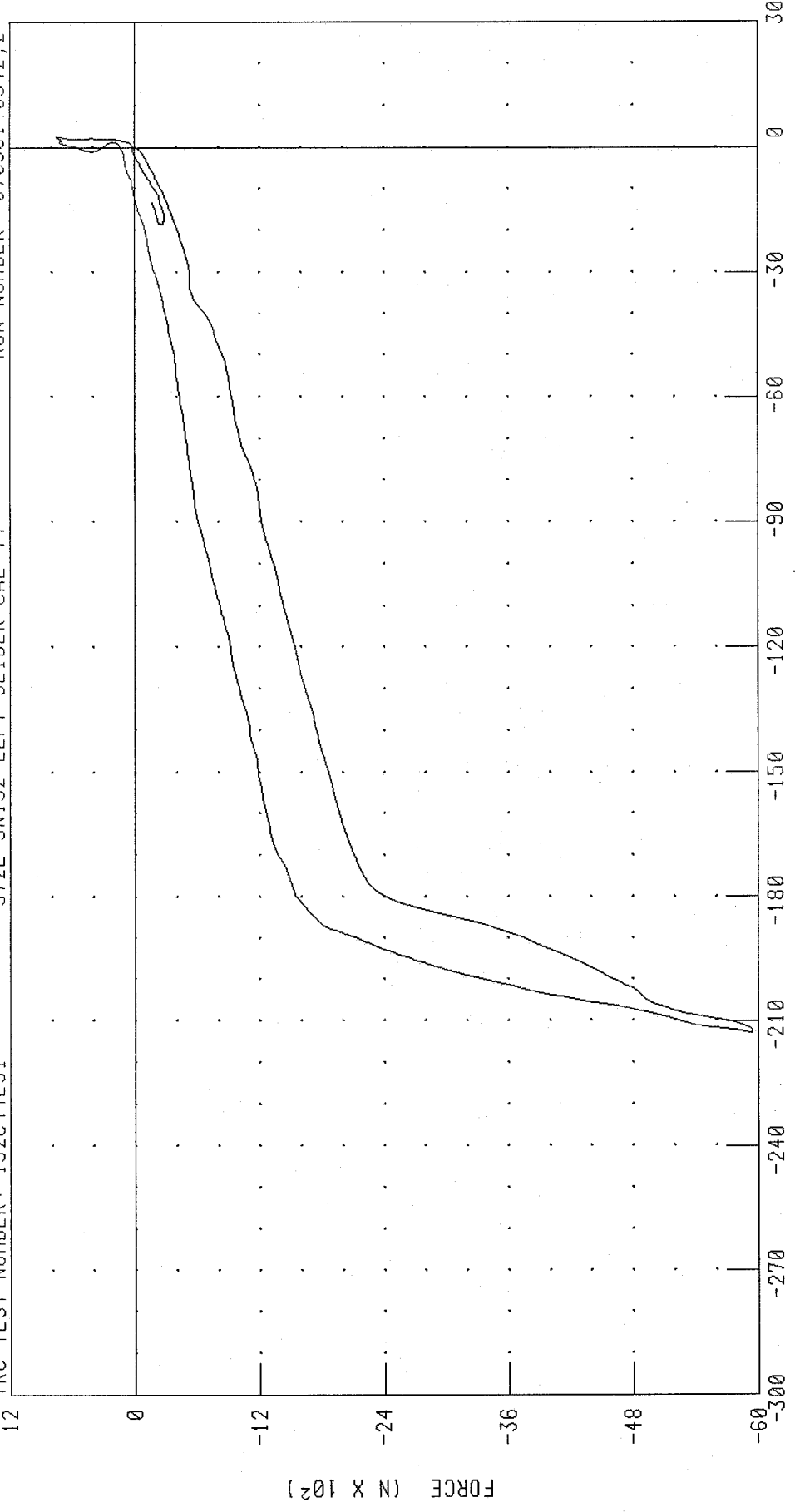

CHANNEL: KNLXD FILTER: CH. CLASS 600
 LFHF CH. CLASS 600
 DISPLACEMENT (MM X 10⁻¹) PEAK DATA: 0.25 MM @ 39.28 MS; -21.29 MM @ 17.04 MS
 759.51 N @ 39.20 MS; -5943.88 N @ 16.96 MS

TRANSPORTATION RESEARCH CENTER INC.

KNEE SLIDER TEST

HYBRID III 50th

12-JUN-01

RIGHT KNEE

TRC INC.

TEST NO: 192C44RS1

572E SN192 RIGHT SLIDER CAL 44

TEST PARAMETER	SPECIFICATION	TEST RESULTS
TEMPERATURE	18.9-25.6 DEG. C	21.7 DEG. C
RELATIVE HUMIDITY	10 - 70 %	58.0 %
PENDULUM VELOCITY	2.70-2.80 M/S	2.80 M/S
FORCE AT 10.0 MM DISPLACEMENT	1259 - 1721 N	-1450. N
FORCE AT 18.0 MM DISPLACEMENT	2268 - 3096 N	-2613. N

TEST MEETS SPECIFICATIONS

TECHNICIAN

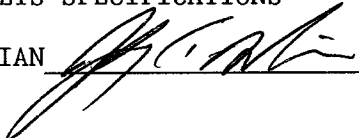

RUN NUMBER: 070901.0913;1

PART 572-E HYBRID III RIGHT KNEE SLIDER CALIBRATION

RIGHT FEMUR FORCE

TRC TEST NUMBER: 192C44RS1 572E SN192 RIGHT SLIDER CAL 44 RUN NUMBER: 070901.0914;2

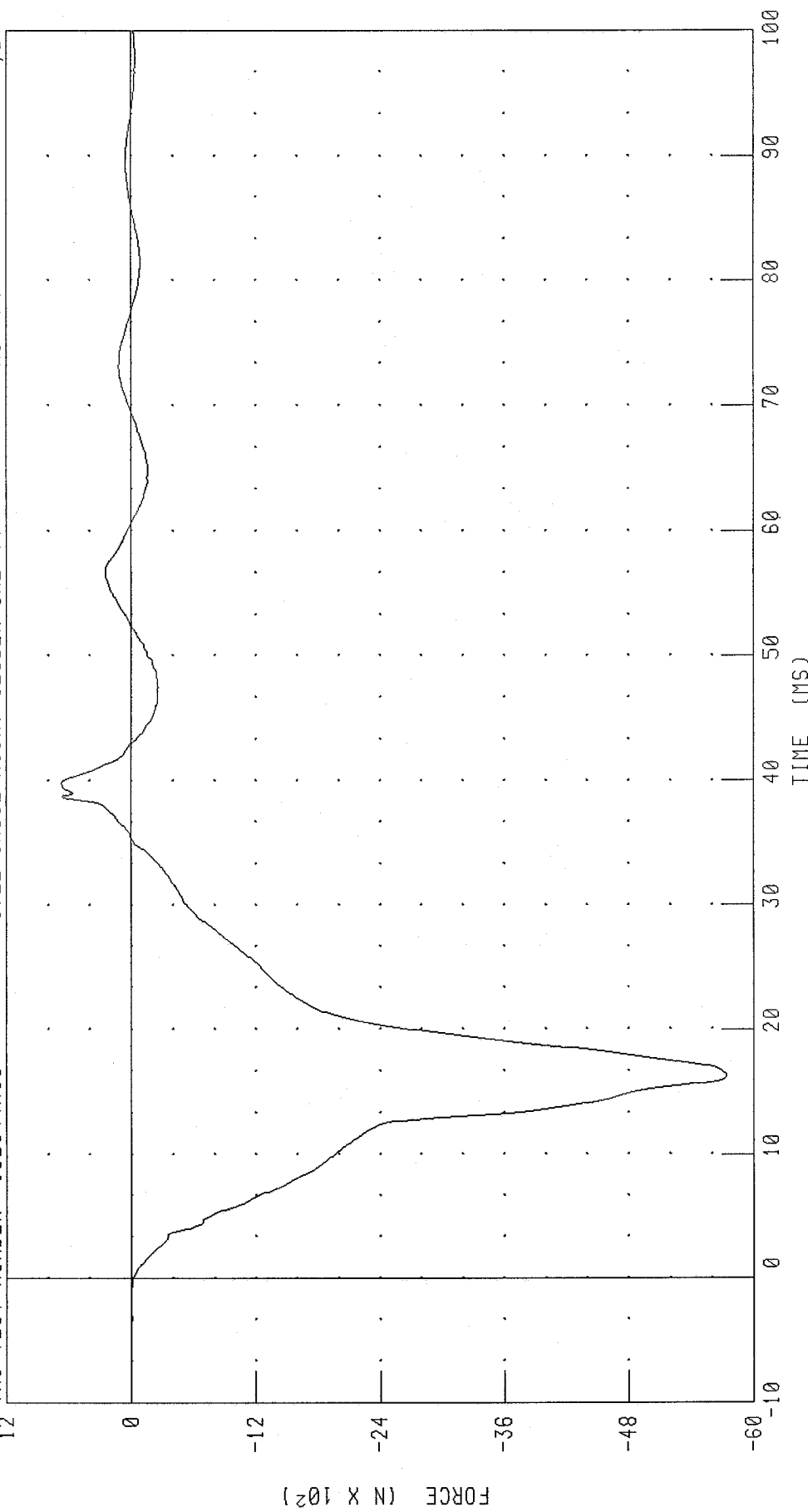

CHANNEL: RFMF FILTER: CH. CLASS 600 PEAK DATA: 669.72 N @ 39.76 MS; -5740.13 N @ 16.24 MS

PART 572-E HYBRID III RIGHT KNEE SLIDER CALIBRATION

RIGHT KNEE DISPLACEMENT

TRC TEST NUMBER: 192C44RS1

572E SN192 RIGHT SLIDER CAL 44

RUN NUMBER: 070901.0914;2

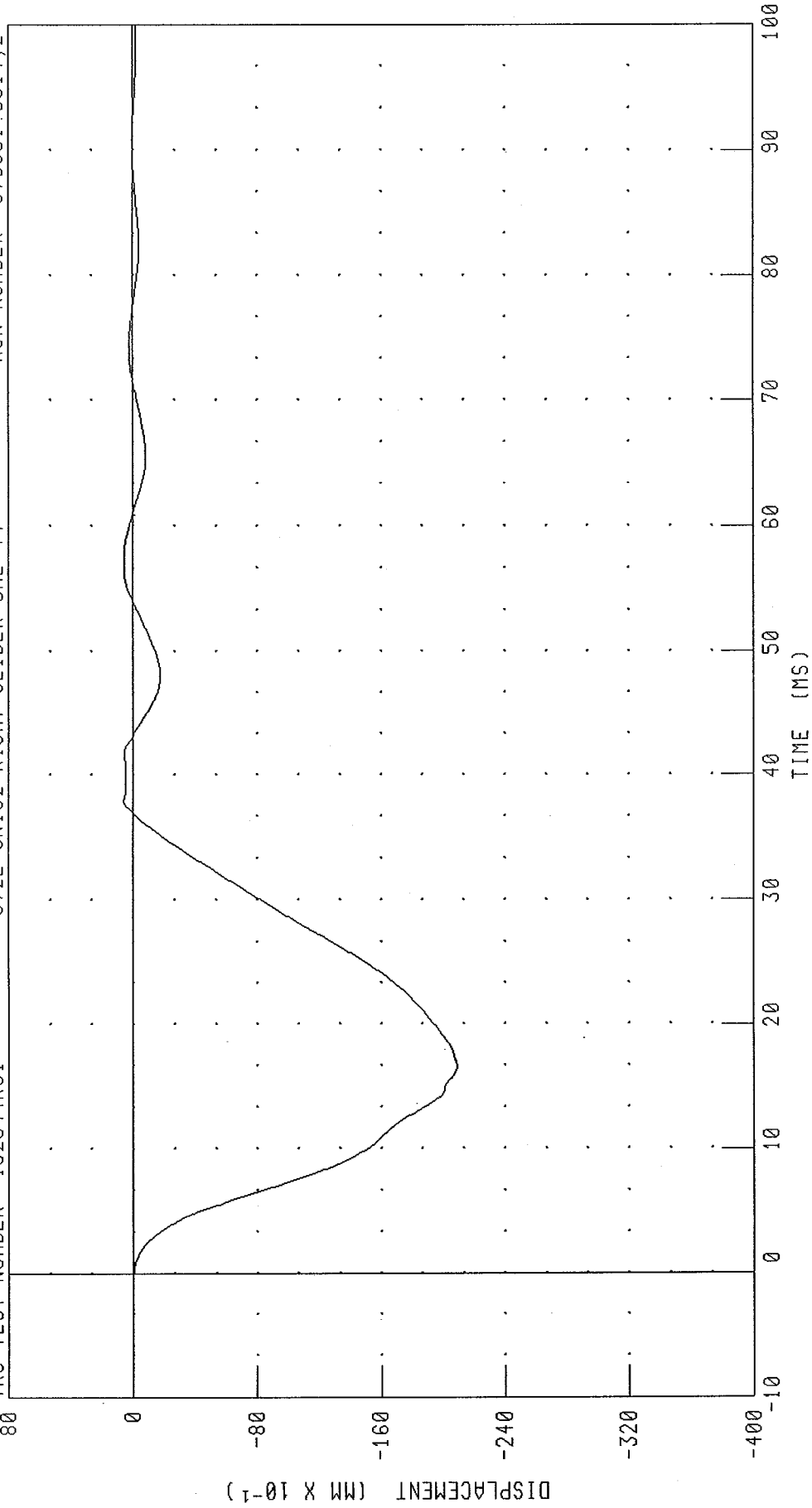

CHANNEL: KNRXD FILTER: CH. CLASS 600 PEAK DATA: 0.62 MM @ 37.92 MS; -20.89 MM @ 16.56 MS

PART 572-E HYBRID III RIGHT KNEE SLIDER CALIBRATION
 RIGHT KNEE DISPLACEMENT VS FEMUR FORCE

TRC TEST NUMBER: 192C44RS1 572E SN192 RIGHT SLIDER CAL 44 RUN NUMBER: 070901.0942;2

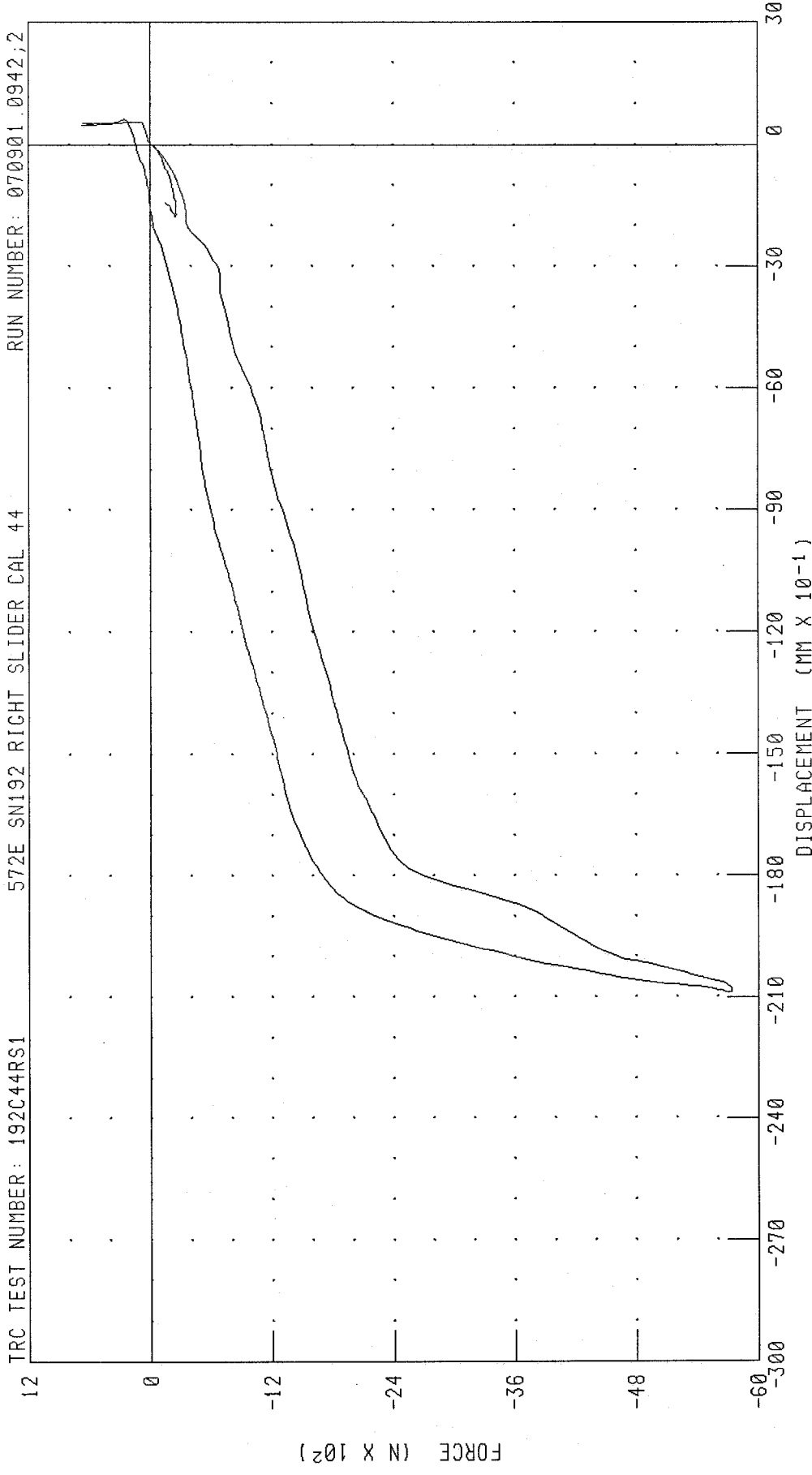

CHANNEL: KNRXD FILTER: CH: CLASS 600
 RFMF CH: CLASS 600
 DISPLACEMENT (MM X 10⁻¹) PEAK DATA: 0.62 MM @ 37.92 MS; -20.89 MM @ 16.56 MS
 669.72 N @ 39.76 MS; -5740.13 N @ 16.24 MS