

V3460

REPORT NUMBER: CAL-00-2-2

**NATIONAL HIGHWAY TRAFFIC SAFETY ADMINISTRATION  
FRONTAL BARRIER 40% OFFSET IMPACT TEST**

**NISSAN MOTOR CORPORATION  
2000 NISSAN ALTIMA  
4-DOOR SEDAN**

NHTSA NUMBER: RY5211

VERIDIAN TEST NUMBER: 8413-58

VERIDIAN ENGINEERING  
TRANSPORTATION SCIENCES CENTER  
P.O. BOX 400  
BUFFALO, NEW YORK 14225

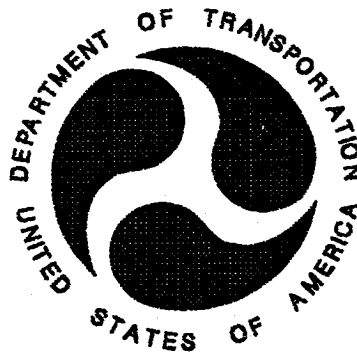

October 20, 2000

FINAL REPORT

PREPARED FOR:

U.S. DEPARTMENT OF TRANSPORTATION  
National Highway Traffic Safety Administration  
Research and Development  
Crashworthiness Research Division  
Mail Code: NRD-11  
400 Seventh Street, SW, Room No. 6226  
Washington, DC 20590

This publication is distributed by the U. S. Department of Transportation, National Highway Traffic Safety Administration, in the interest of information exchange. The opinions, findings and conclusions expressed in this publication are those of the author(s) and not necessarily those of the Department of Transportation or the National Highway Traffic Safety Administration. The United States Government assumes no liability for its contents or use thereof. If trade or manufacturers' names or products are mentioned, it is only because they are considered essential to the object of the publication and should not be construed as an endorsement. The United States Government does not endorse products or manufacturers.

Prepared by: Patrick G. MacDiarmid, Jr.  
Patrick G. MacDiarmid, Jr., Project Engineer

Approved by: David J. Travate  
David J. Travate, Program Manager  
Transportation Science Center

Approval Date: November 15, 2000

FINAL REPORT ACCEPTANCE BY OCS:

\_\_\_\_\_  
Contracting Officer's Technical Representative (COTR),  
NHTSA, Office of Crashworthiness Standards

\_\_\_\_\_  
Date of Report Acceptance

\_\_\_\_\_  
Project Engineer  
NHTSA, Research and Development

\_\_\_\_\_  
Date of Report Acceptance

**TECHNICAL REPORT STANDARD TITLE PAGE**

1. <i>Report No.</i> CAL-00-2-2		2. <i>Government Accession No.</i>		3. <i>Recipient's Catalog No.</i>	
4. <i>Title and Subtitle</i> Final Report of Frontal Barrier 40% Offset Testing of a 2000 Nissan Altima 4-Door Sedan NHTSA No. RY5211			5. <i>Report Date</i> October 20, 2000		
			6. <i>Performing Organization Code</i> CAL		
7. <i>Author(s)</i> Patrick G. MacDiarmid, Jr., Project Engineer David J. Travale, Program Manager			8. <i>Performing Organization Report No.</i> 8413-58		
9. <i>Performing Organization Name and Address</i> Veridian Engineering 4455 Genesee Street Buffalo, New York 14225			10. <i>Work Unit No.</i>		
			11. <i>Contract or Grant No.</i> DTNH22-96-D-02010		
12. <i>Sponsoring Agency Name and Address</i> U.S. DEPARTMENT OF TRANSPORTATION National Highway Traffic Safety Administration Research and Development Crashworthiness Research Division Mail Code: NRD-11 400 Seventh Street, SW, Room No. 6226 Washington, DC 20590			13. <i>Type of Report and Period Covered</i> Final Report October - November 2000		
			14. <i>Sponsoring Agency Code</i> NRD-11		
15. <i>Supplementary Notes</i>					
16. <i>Abstract</i> This frontal 40% offset deformable barrier impact test of a 2000 Nissan Altima 4-Door Sedan was to evaluate the use of the Thor Advanced Lower Extremity (Thor-Lx). This test was performed at Veridian Engineering crash test facility in Buffalo, New York, on October 20, 2000 The impact velocity was 63.6 kph and the temperature at the barrier face was 21 °C. The maximum post-test vehicle crush was 700 mm. The test vehicle was equipped with 3-point restraint systems with torso belt pre-tensioners, knee bolsters, and airbags at both the driver and right outboard passenger seating positions. With respect to FMVSS 208 "Occupant Crash Protection - Injury Criteria" both the driver and passenger appeared to comply with head, chest, and femur requirements.					
<b>ATD Position</b>	<b>HIC</b>	<b>Clip (g's)</b>	<b>Chest Disp (mm)</b>	<b>Left Femur (N)</b>	<b>Right Femur (N)</b>
<b>Driver (202)</b>	264.8	32.1	23.6	2701.9	2214.5
<b>Passenger (206)</b>	195.0	31.7	27.4	3825.0	231.3
17. <i>Key Words</i> Frontal 40% Offset Barrier Impact test THOR LX/HIIIr			18. <i>Distribution Statement</i> <u>Copies of this report are available from:</u> NHTSA Technical Reference Division National Highway Traffic Safety Admin. 400 Seventh St., SW, Room 5108 Washington, DC 20590		
19. <i>Security Classif. (of this report)</i> UNCLASSIFIED		20. <i>Security Classif. (of this page)</i> UNCLASSIFIED		21. <i>No. of Pages</i> 374	22. <i>Price</i>

**Form DOT F1700.7 (8-69)**

## TABLE OF CONTENTS

<u>Section</u>		<u>Page No.</u>
1	PURPOSE AND SUMMARY OF NCAP TEST	1-1
2	OCCUPANT AND VEHICLE INFORMATION	2-1
<u>Data Sheet</u>	<u>Description</u>	
1.	CRASH TEST SUMMARY	2-1
2.	GENERAL TEST AND VEHICLE PARAMETER DATA	2-2
3.	POST IMPACT DATA	2-4
4.	TEST VEHICLE INFORMATION	2-5
5.	DUMMY POSITIONING IN VEHICLE	2-7
6.	SEAT BELT POSITIONING DATA	2-9
7.	VEHICLE ACCELEROMETER LOCATION AND DATA SUMMARY	2-10
8.	DUMMY INJURY CRITERIA VALUES	2-12
9.	SEAT BELT PERFORMANCE DATA	2-18
10.	SUMMARY OF FMVSS 212 DATA	2-19
11.	WINDSHIELD ZONE INTRUSION FMVSS 219 DATA	2-20
12.	FMVSS 301 FUEL SYSTEM INTEGRITY DATA	2-21
13.	FMVSS 310 ROLLOVER DATA	2-22
14.	TEST VEHICLE MEASUREMENTS	2-26
15.	HIGH SPEED CAMERA LOCATIONS	2-33
16.	VEHICLE REFERENCE PHOTO TARGET LOCATIONS	2-35
17.	LOAD CELL LOCATIONS RELATIVE TO FIXED BARRIER AND DEFORMABLE BARRIER FACE	2-36
18.	POST TEST AIR BAG DATA	2-37
19.	ACCIDENT INVESTIGATION DIVISION DATA	2-38
20.	OFFSET BARRIER AND VEHICLE ORIENTATION	2-39
21.	OFFSET BARRIER DEFORMATION	2-40
APPENDIX A	PHOTOGRAPHS	A-1
APPENDIX B	VEHICLE, LOAD CELL BARRIER AND DUMMY RESPONSE DATA	B-1
APPENDIX C	PART 572 BVE DUMMY CONFIGURATION AND PERFORMANCE VERIFICATION TESTS	C-1
APPENDIX D	DUMMY, VEHICLE AND LABORATORY INSTRUMENT CALIBRATION	D-1

## SECTION 1

### PURPOSE AND SUMMARY OF TEST RY5211

#### PURPOSE

This 63.6 kph frontal 40% offset barrier impact test is part of the Test Procedure Development Program sponsored by the National Highway Traffic Safety Administration (NHTSA) under Contract No. DTNH22-96-D-02010. The purpose of this test was to evaluate the performance of Thor-Lx Hybrid III retrofit (Thor-Lx/HIIIr) lower legs and obtain vehicle crashworthiness and occupant and restraint system performance data .

The 63.6 kph frontal 40% offset barrier impact test was conducted in accordance with the Office of Crashworthiness Standards Laboratory Indicant Test procedure.

#### SUMMARY

A deformable honeycomb barrier mounted to a load cell barrier consisting of 30 load cells was impacted by a 2000 Nissan Altima 4-Door Sedan at 40% overlap at a velocity of 63.6 kph. The test was performed at Veridian Engineering on October 20, 2000. Pre- and post-test photographs of the vehicle and dummies can be found in Appendix A.

The frontal 40% offset barrier impact event was documented by 1 real-time camera and 16 high-speed cameras. Camera locations and other pertinent camera information can be found in this report.

Two Part 572E, 50th percentile male anthropomorphic test devices (ATDs), were placed in the driver and right-front passenger seating positions according to dummy placement instructions specified in the Laboratory Indicant Test Procedure.

Both ATDs were fully instrumented with primary and redundant head and chest accelerometers, pelvis triaxial accelerometers, chest displacement potentiometers, upper neck transducers, right/left femur triaxial force and moment load cells, and knee sliders. The driver ATD was equipped with Thor-Lx Hybrid III retrofit (Thor-Lx/HIIIr) lower legs and feet. The passenger ATD was equipped with VTRC lower leg instrumentation. Seat belt load cells were also on the driver's and passenger's lap belts to measure dummy pelvic section loading. The driver (position 1) ATD (Serial No. 202) and the right-front passenger (position 2) ATD (Serial No. 206) were used in one test (RY5502) previous to this test. Certification details, along with instrumentation calibration data, are found in Appendix C.

The 201 channels of data were recorded on a PC-based and on-board data acquisition system. Appendix B contains the vehicle, load cell barrier and dummy response data traces.

The driver's HIC was 264.8. The maximum chest deceleration over 3 milliseconds was 32.1 g's and maximum chest deflection was 23.6 mm. Compressive femur loads were 2701.9 Newtons on the left and 2214.5 Newtons on the right.

The right front passenger's HIC was 195.0. Maximum chest deceleration over 3 milliseconds was 31.7 g's and maximum chest deflection was 27.4 mm. Compressive femur loads were 3825.0 Newtons on the left and 231.3 Newtons on the right.

**SECTION 2**

**GENERAL TEST AND VEHICLE PARAMETER DATA**

DATA SHEET NO. 1 CRASH TEST SUMMARY

Vehicle NHTSA No. : RY5211 Test Mode : 64.0 kph Offset Frontal Barrier

Test Date : October 20, 2000 Time: 11:52 Temperature : 20 °C

Vehicle Make/Model/Body Style : 2000 Nissan Altima 4-Door Sedan

Vehicle Test Weight : 1599.0 kg

Vehicle/Barrier Impact Angle : 0 °

Impact Velocity : 63.6 kph

Maximum Static Crush : 700.0 mm

Actual Vehicle Offset : 40 %

DUMMIES:

DRIVER

PASSENGER

Type : 572E 572E/Lx

Restraint System : Seatbelt with pretensioner, Airbag Seatbelt with pretensioner, Airbag

Number of Data Channels : 201

Number of Cameras : 1 Real Time

16 High Speed

DOOR OPENING DATA : Closed/Inoperable - Left Front

Closed/Operable - Right Front

Front Seat(s) Data :

DRIVER

PASSENGER

Seat Track Failure :(mm of shift) 0 0

Seat Back Failure : None None

VISIBLE DUMMY CONTACT POINTS :

DRIVER

PASSENGER

Head : Face to the Left of Center of the Airbag, Back of the Head to the Left side of the Headrest and the B-Pillar Face to the Left of Center of the Airbag, Back of the Head to the Right side of the Headrest

Abdomen : - -

Chest Airbag Airbag

Knees Knee Bolster Knee Bolster

DATA SHEET NO. 2 GENERAL TEST AND VEHICLE PARAMETER DATA

TEST VEHICLE INFORMATION :

Year/Make/Model/Body Style : 2000 Nissan Altima 4-Door Sedan  
NHTSA No. : RY5211 ; VIN: 1N4DL01D4YC101391 ; Color : Blue  
Engine Data: 4 cylinders; - CID; 2.4 Liters; - cc  
Placement : - Longitudinal or In-Line; X Transverse or Lateral  
Transmission Data : 4 speeds; - Manual; X Automatic; X Overdrive  
Final Drive : - Rear Wheel Drive; X Front Wheel Drive; - Four Wheel Drive  
Major Options : X A/C; X Pwr.Strg.; X Pwr. Brakes  
X Pwr. Windows; X Pwr. Door Locks; X Tilt Wheel  
Date Received : August 31, 2000 ; Odometer Reading 16887 km  
Selling Dealer : Ray Laks Honda  
& Address: Orchard Park, New York

DATA FROM TIRE VEHICLE'S CERTIFICATION LABEL:

Vehicle Manufactured by : Nissan Motor Corporation  
Date of Manufacture 8/99  
GVWR : 1810 kg; GAWR: 976 kg FRONT; 845 kg REAR

DATA FROM TIRE PLACARD:

Tire Pressure with Maximum Capacity Vehicle Load : 300 kpa FRONT  
300 kpa REAR

Recommended Tire Size : P205/60R15

\* Recommended Cold Tire Pressure : 200 kpa FRONT; 200 kpa REAR

Size of Tires on Test Vehicle: P205/60R15 ; Manufacturer: General

Vehicle Capacity Data :

Type of Front Seats: - Bench; X Bucket; - Split Bench

Number of Occupants: 2 Front; 3 Rear; 5 Total

Vehicle Capacity Weight (VCW) = 390.0 kg

No. of Occupants x 68 kg = 340.2 kg

Rated Cargo/Luggage Weight (RCLW) = 49.8 kg

\*Tire pressure used for test

DATA SHEET NO. 2 GENERAL TEST AND VEHICLE PARAMETER DATA ( cont. )

WEIGHT OF TEST VEHICLE AS RECEIVED FROM DEALER (with maximum fluids)= UDW:

Right Front	=	<u>428.5</u>	kg	Right Rear	=	<u>256.0</u>	kg
Left Front	=	<u>425.0</u>	kg	Left Rear	=	<u>265.5</u>	kg
TOTAL FRONT	=	<u>853.5</u>	kg	TOTAL REAR	=	<u>521.5</u>	kg
TOTAL DELIVERED WEIGHT	=	<u>1375.0</u>	kg				
% of Total Front of Vehicle Weight	=	<u>62.1</u>	%	% of Total Rear Weight	=	<u>37.9</u>	%

CALCULATION OF VEHICLE'S TARGET TEST WEIGHT :

Weight of Vehicle and Driver	=	<u>1505.0</u>	kg
Total Delivered Weight (UDW)	=	<u>1375.0</u>	kg
Rated Cargo/Luggage Weight (RCLW)	=	<u>49.8</u>	kg
Weight of 2 p.572 Dummies @ 76 each	=	<u>152.0</u>	kg
TARGET TEST WEIGHT	=	<u>1576.8</u>	kg

WEIGHT OF TEST VEHICLE WITH TWO DUMMIES AND 72 KG OF CARGO WEIGHT:

Right Front	=	<u>463.0</u>	kg	Right Rear	=	<u>333.0</u>	kg
Left Front	=	<u>452.0</u>	kg	Left Rear	=	<u>351.0</u>	kg
TOTAL FRONT	=	<u>915.0</u>	kg	TOTAL REAR	=	<u>684.0</u>	kg
TOTAL TEST WEIGHT	=	<u>1599.0</u>	kg (approved by COTR prior to testing)				
% of Total Front Weight	=	<u>57.2</u>	%	% of Total Rear Weight	=	<u>42.8</u>	%
Weight of Ballast Secured in Vehicle Trunk Area	=	<u>0</u>	kg				
Vehicle Components Removed for Weight Reduction:		<u>None</u>					

VEHICLE ATTITUDE (all dimension in millimeters):

AS DELIVERED :	RF	<u>675</u>	LF	<u>676</u>	RR	<u>690</u>	LR	<u>690</u>
FULLY LOADED :	RF	<u>664</u>	LF	<u>666</u>	RR	<u>661</u>	LR	<u>661</u>
AS TESTED :	RF	<u>665</u>	LF	<u>667</u>	RR	<u>672</u>	LR	<u>668</u>
Vehicle's Wheel Base :		<u>2616</u>	mm					
Location of Vehicle's C.G. :		<u>1119.0</u>	mm rearward of front wheel center.					

FUEL SYSTEM DATA :

Fuel System Capacity From Owner's Manual	=	<u>59.8</u>	liters
Usable Capacity Figure Furnished by COTR	=	<u>59.8</u>	liters
Test Volume Range (92 to 94% of Usable Capacity)	=	<u>55.0</u>	to <u>56.2</u> liters
ACTUAL TEST VOLUME	=	<u>55.0</u>	liters (with entire fuel system filled)
Test Fluid Type:	<u>Stoddard Solution</u> ;	Spec. Grav. =	<u>0.764</u>
	Kinematic Viscosity =	<u>0.96</u>	centistokes; Color = <u>Orange</u>
Type of Fuel Pump:	Electric- <u>X</u> ;	Mechanical-	<u>-</u>
Does Electric Pump operate with ignition switch "ON" & engine "OFF"		Yes- <u>X</u>	No- <u>-</u>
Details of Fuel System	<u>Tank - centered ahead of axle; Lines - inside left body stiffener; Filler- left side behind rear axle.</u>		

DATA SHEET NO. 3 POST IMPACT DATA

TYPE OF TEST:

Type of Test : Frontal Barrier Impact Angle : 0°

Test Date : October 20, 2000 Time: 11:52 Temperature: 20 °C

Vehicle NHTSA No. : RY5211

Required Impact Velocity Range : 63.2 to 64.8 kph

BARRIER IMPACT VELOCITY: (Speed traps within 5 feet of impact plane.)

Trap No. 1 = 63.6 kph; Trap No. 2 = 63.6 kph

Distance from vehicle to barrier : (1) entering trap = 813 mm

(2) exiting trap = 305 mm

VEHICLE STATIC CRUSH: (mm) (For frontal and rear impacts only.)

Vehicle Length:

Pre-Test Right = 4565 ; C/L = 4674 ; Left = 4566

Post-Test Right = 4551 ; C/L = 4275 ; Left = 3912

Crush Right = 14.0 ; C/L = 399.0 ; Left = 654.0

AVERAGE = 355.7 mm

VEHICLE OFFSET DATA: (mm)

Vehicle Width = 1750 mm

Desired Vehicle Offset = 700.0 mm

Actual Vehicle Offset = 700 mm (from film analysis)

Offset Difference = 0.0 mm

Actual Percent Offset = 40.00 %

DATA SHEET NO. 4 TEST VEHICLE INFORMATION

VEHICLE IDENTIFICATION:

Model Year : 2000 Vehicle Model: Nissan Altima Body Style : 4-Door Sedan

1. Nominal Design Riding Position for adjustable driver and passenger seat backs. Please describe how to position the inclinometer to measure the seat back angle. Include description of the location of the adjustment latch detent, if applicable.

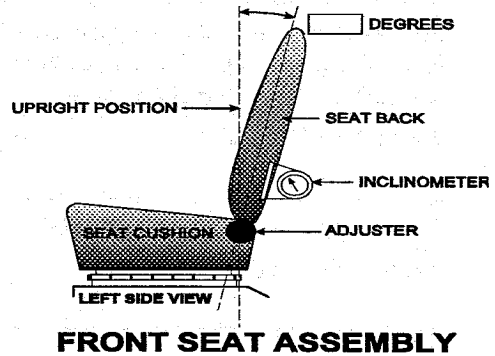

Seat back angle for driver's seat: 15°

Measurement instructions: Adjust seat to 7<sup>th</sup> detent rearward from full up position (0).

Seat back angle for passenger's seat: 15°

Measurement instructions: Same as the driver's seat.

2. Seat Fore and Aft Positioning

Positioning of the driver's seat: There are 21 total detents. The seat was placed at detent 10 from the first detent labeled 0.

Positioning of the passenger's seat: Same as the driver's seat

3. Fuel Tank Capacity Data

3.1 A. "Usable Capacity" of the standard equipment fuel tank is 59.8 liters

B. "Usable Capacity" of the optional equipment fuel tank is - liters

C. "Usable Capacity" of the vehicle(s) used for certification testing to requirements of FMVSS 301 = 59.8 liters

3.2 Amount of Stoddard solvent added to vehicle(s) used for certification test(s) = 55.0 liters

3.3 Is vehicle equipped with electric fuel pump? Yes- X ; No- -

If YES, explain the vehicle operating conditions under which the fuel pump will pump fuel.

For 5 seconds after the ignition is switched on, while the engine is running, and for 1.5 seconds after the engine stops running.

DATA SHEET NO. 4 TEST VEHICLE INFORMATION (cont.)

4. STEERING COLUMN ADJUSTMENTS :

Steering wheel and column adjustments are made so that the steering wheel hub is at the geometric center of the locus it describes when it is moved through its full range of driving positions. If the tested vehicle has any of these adjustments, does your company use any specific procedures to determine the geometric center.

Operational Instructions: Adjust steering column to its middle position. The angle should be 24°.

---

5. SEAT BELT UPPER ANCHORAGE

Nominal design riding position: Adjust D-ring to one position above lowermost position.

---

DUMMY MEASUREMENT FOR FRONT SEAT PASSENGERS

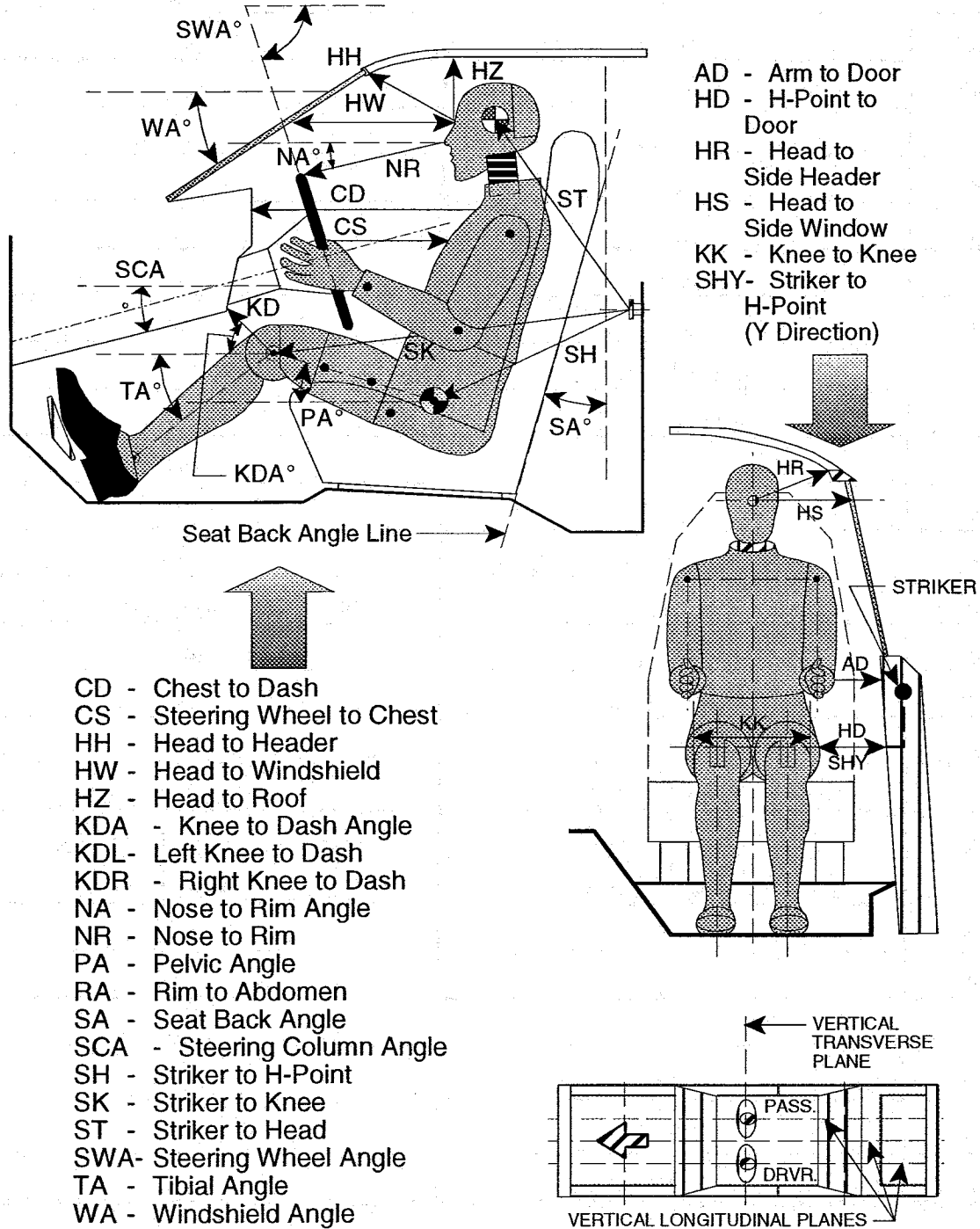

DATA SHEET NO. 5 FRONT SEAT DUMMY POSITIONING MEASUREMENTS IN VEHICLE (cont.)

	DRIVER (Serial #202)			PASS. (Serial # 206)		
WA°	28.3 deg.			N/A		
SWA°	24 deg.			N/A		
SCA°	66 deg.			N/A		
SA°	15 deg.			15 deg.		
HZ	166			161		
HH	291			330		
HW	571			557		
HR	217			210		
NR	383	Angle	-12 deg.	N/A		
CD	497 / 610 (level)			575		
CS	285			N/A		
RA	184			N/A		
KDL	175	Angle (KDA)	22 deg.	159		
KDR	155			181	Angle (KDA)	30 deg.
PA°	22.9 deg.			24.3 deg.		
TA°	L: 38.4° / R: 38.0°			42 deg.		
KK	260			270		
ST	504	Angle	9 deg.	505	Angle	6 deg.
SK	610	Angle	95 deg.	600	Angle	94 deg.
SH	276	Angle	132 deg.	260	Angle	134 deg.
SHY	265			250		
HS	332			344		
HD	150			140		
AD	109			108		
AA	235			243		
Foot °	L: 46.3° / R: 53.3°			-		

Dimensions in millimeters

DATA SHEET NO. 6 SEAT BELT POSITIONING DATA

SEAT BELT POSITIONING DATA

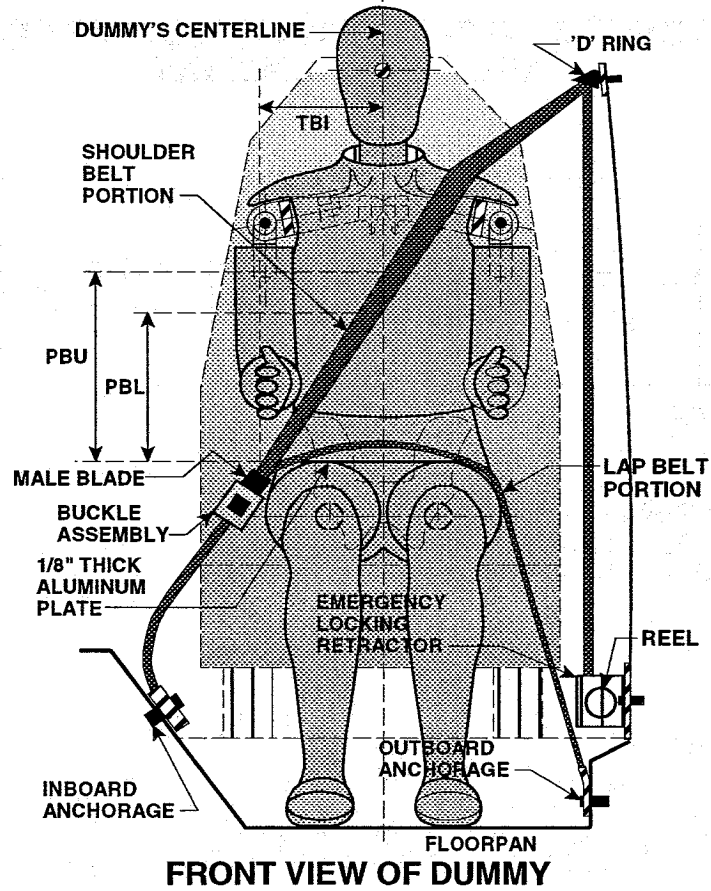

FRONT VIEW OF DUMMY

	DRIVER DUMMY (mm)	PASSENGER DUMMY** (mm)
PBU -- Top surface of alum. plate to upper edge	340	345
PBL-- Top surface of alum. plate to belt lower edge	265	270
LAP BELT TENSION	10 N	10 N
SHOULDER BELT TENSION	Retractor	Retractor

\*\* Passenger Belt was delivered with a twist that could not be corrected without detaching belt system.

### VEHICLE ACCELEROMETER LOCATION AND DATA SUMMARY

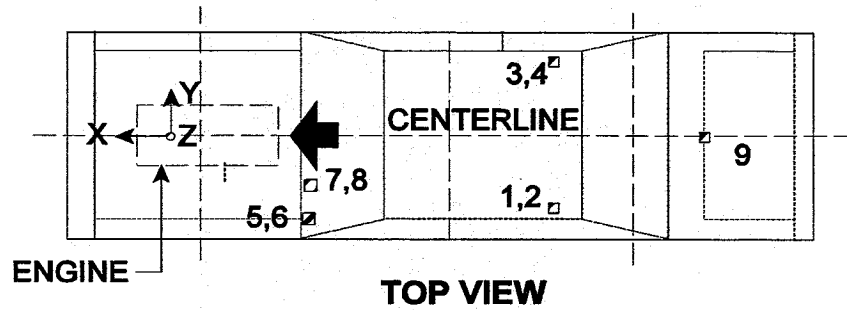

REAR SEAT CUSHION  
ASSY. FRONT ATTACHMENT  
BRACKET SUPPORT

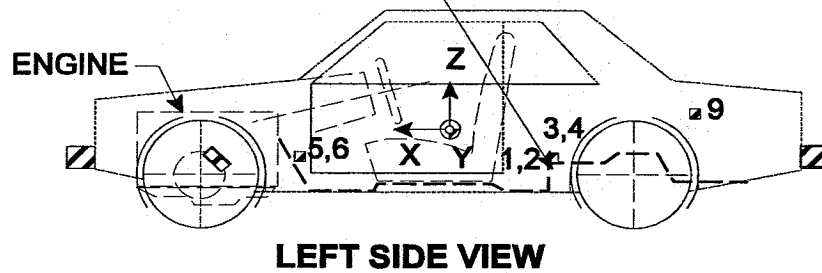

Note: Vehicle accelerometer location and data summary shown in DATA SHEET NO. 7

DATA SHEET NO. 7 VEHICLE ACCELEROMETER LOCATIONS AND DATA SUMMARY (cont.)

Accelerometer Location	X-Direction (mm)	Y-Direction (mm)	Z-Direction (mm)
Left Rear Seat Crossmember	1788	-632	-323
Right Rear Seat Crossmember	1777	615	-331
Driver Left Side Toe Pan	3369	-445	-349
Driver Right Side Toe Pan	3387	-293	-300
Trunk	1171	-6	-482

X-Direction is referenced from vehicle rear bumper (positive forward)

Y-Direction is referenced from vehicle centerline (positive to right)

Z-Direction is referenced from ground plane (positive down)

LOCATION NUMBER	DESCRIPTION	MAXIMUM VALUE (g's)			
		Pos.	msec.	Neg.	msec.
1	Rear Seat X-Member @ Left Side X	1.7	201.0	-26.2	81.8
2	Rear Seat X-Member @ Left Side Y	10.2	70.9	-3.4	97.5
3	Rear Seat X-Member @ Right Side X	1.2	495.5	-25.2	84.3
4	Rear Seat X-Member @ Right Side Y	10.8	72.6	-3.8	125.8
5	Driver Toe Pan @ Left Side X	*	*	*	*
6	Driver Toe Pan @ Left Side Z	62.8	82.4	-51.8	64.2
7	Driver Toe Pan @ Right Side X	27.9	29.7	-63.8	66.3
8	Driver Toe Pan @ Right Side Z	23.2	80.0	-20.2	57.8
9	Trunk Z	6.4	154.9	-6.2	79.5

\* Not Accurate after 277 ms.

**DATA SHEET NO. 8 DUMMY INJURY CRITERIA VALUES**

Vehicle Year/Make/Model/Body Style: 2000 Nissan Altima 4-Door Sedan

NHTSA Test No.: RY5211 Test Date: October 20, 2000

DESCRIPTION	Unit	MAXIMUM VALUE							
		Driver				Passenger			
		Pos	msec	Neg	msec	Pos	msec	Neg	msec
Head X	g	4.7	165.7	-39.7	104.0	4.5	366.9	-29.5	115.6
Head Y	g	8.8	180.9	-3.0	293.8	7.7	116.3	-3.5	243.7
Head Z	g	15.7	104.4	-4.9	132.7	30.4	110.8	-1.1	29.7
Head Resultant	g	42.4	104.0	0.0	-39.9	40.3	111.0	0.0	4.5
Redundant Head X	g	4.3	160.5	-39.8	104.0	4.7	368.6	-29.3	115.8
Redundant Head Y	g	9.2	181.6	-3.0	305.0	8.1	116.8	-3.6	235.5
Redundant Head Z	g	15.2	104.4	-4.3	132.7	30.1	111.0	-1.0	29.7
Redundant Head Resultant	g	42.6	104.4	0.0	-39.9	40.0	111.0	0.0	-49.4
Upper Neck Fx	N	337.7	107.9	-320.2	74.3	93.4	351.3	-463.5	116.7
Upper Neck Fy	N	317.6	182.5	-113.7	298.4	141.8	133.9	-144.5	237.6
Upper Neck Fz	N	1022.0	112.3	-54.4	30.0	1071.9	110.8	-47.4	29.4
Upper Neck F Resultant	N	1096.4	112.3	1.2	-0.2	1130.0	110.8	0.4	6.7
Upper Neck Mx	N-m	15.5	171.3	-15.3	115.3	10.1	168.3	-15.5	116.8
Upper Neck My	N-m	20.2	107.3	-12.9	50.9	19.2	100.9	-9.8	258.9
Upper Neck Mz	N-m	9.2	231.8	-17.4	147.7	2.4	382.9	-13.4	113.3
Upper Neck M Resultant	N-m	21.6	153.8	0.1	-73.1	23.2	106.8	0.1	-100.0
Chest X	g	1.4	277.0	-31.9	108.8	1.5	345.5	-32.5	109.8
Chest Y	g	16.1	126.0	-1.8	31.8	11.6	101.5	-4.3	166.1
Chest Z	g	5.0	90.5	-8.7	131.1	3.8	106.9	-5.7	97.8
Chest Resultant	g	32.8	108.7	0.0	-100.0	33.2	110.0	0.0	-100.0
Redundant Chest X	g	1.5	275.2	-31.6	109.0	1.5	345.6	-32.4	109.7
Redundant Chest Y	g	16.4	126.1	-1.9	31.9	12.0	101.9	-4.4	162.4
Redundant Chest Z	g	4.6	90.5	-8.6	131.7	4.1	106.9	-5.9	97.9
Redundant Chest Resultant	g	32.6	111.3	0.0	-100.0	33.2	109.8	0.0	-100.0
Chest Displacement	mm	0.0	-98.9	-23.6	101.1	0.0	4.0	-27.4	90.2

DATA SHEET NO. 8 DUMMY INJURY CRITERIA VALUES (cont.)

Vehicle Year/Make/Model/Body Style: 2000 Nissan Altima 4-Door Sedan

NHTSA Test No.: RY5211 Test Date: October 20, 2000

DESCRIPTION	Unit	MAXIMUM VALUE							
		Driver				Passenger			
		Pos	msec	Neg	msec	Pos	msec	Neg	msec
Pelvic X	g	1.2	223.9	-33.8	97.0	1.0	216.5	-36.0	97.4
Pelvic Y	g	15.9	98.5	-2.8	71.0	10.0	86.2	-9.7	149.5
Pelvic Z	g	2.6	250.7	-17.1	108.4	1.5	371.6	-19.1	100.0
Pelvic Resultant	g	38.6	97.1	0.0	-16.4	40.5	97.4	0.0	-6.7
Left Femur Fx	N	1229.8	108.2	-17.7	38.1	664.6	107.1	-207.6	173.1
Left Femur Fy	N	655.3	114.9	-127.7	74.4	362.1	102.9	-140.5	83.3
Left Femur Fz	N	1005.5	74.5	-2701.9	112.5	536.7	81.9	-3825.0	106.7
Left Femur Force Resultant	N	3011.0	112.4	0.3	-100.0	3895.2	106.7	0.1	-97.0
Left Femur Mx	N-m	39.6	140.7	-128.4	103.3	63.2	379.3	-122.9	88.1
Left Femur My	N-m	101.3	107.4	-29.1	84.8	96.8	117.3	-20.2	88.5
Left Femur Mz	N-m	20.0	230.7	-28.6	110.5	15.0	340.9	-40.4	89.1
Left Femur Moment Res.	N-m	147.3	103.4	0.0	-100.0	129.0	88.2	0.1	-100.0
Right Femur Fx	N	761.0	110.9	-65.4	250.5	284.1	110.6	-94.8	213.5
Right Femur Fy	N	888.1	107.0	-94.6	69.5	177.5	110.9	-127.2	88.9
Right Femur Fz	N	297.5	58.0	-2214.5	88.5	1001.7	92.0	-231.3	96.9
Right Femur Force Resultant	N	2371.8	107.3	0.2	-68.2	1008.7	92.0	0.3	-100.0
Right Femur Mx	N-m	13.7	63.1	-112.2	72.9	5.1	326.2	-88.4	97.5
Right Femur My	N-m	74.4	89.5	-24.4	79.3	50.6	119.2	-9.5	287.4
Right Femur Mz	N-m	33.2	78.0	-24.2	95.6	10.7	204.7	-63.2	125.6
Right Femur Moment Res.	N-m	114.7	72.9	0.0	-100.0	96.5	97.5	0.0	-100.0
Left Knee Shear Dx	mm	0.4	76.5	-11.2	102.1	0.3	99.7	-0.7	194.2
Right Knee Shear Dx	mm	4.5	498.5	-6.0	65.7	0.3	124.5	-0.3	225.9

DATA SHEET NO. 8 DUMMY INJURY CRITERIA VALUES (cont.)

Vehicle Year/Make/Model/Body Style: 2000 Nissan Altima 4-Door Sedan

NHTSA Test No.: RY5211 Test Date: October 20, 2000

DESCRIPTION	Unit	MAXIMUM VALUE							
		Driver				Passenger			
		Pos	msec	Neg	msec	Pos	msec	Neg	msec
Left Upper Tibia Fx	N	753.9	91.9	-83.3	85.2	63.0	171.6	-206.9	107.2
Left Upper Tibia Fy	N	‡	‡	‡	‡	111.4	141.1	-172.0	87.1
Left Upper Tibia Fz	N	682.9	146.1	-1915.3	70.1	135.9	129.7	-981.6	89.6
Left Upper Tibia FR	N	‡	‡	‡	‡	988.6	89.6	0.1	-100.0
Left Upper Tibia Mx	N-m	35.2	108.2	-62.5	139.9	12.2	342.0	-61.6	88.2
Left Upper Tibia My	N-m	120.8	100.4	-46.9	74.9	17.4	161.4	-85.2	89.9
Left Lower Tibia Fx	N	123.7	111.3	-557.2	90.0	176.8	111.5	-489.6	89.6
Left Lower Tibia Fy	N	257.6	134.9	-57.9	108.8	315.3	87.8	-32.7	339.9
Left Lower Tibia Fz	N	33.9	344.8	-2642.1	69.5	201.7	115.8	-1047.7	78.8
Left Lower Tibia FR	N	2659.9	69.5	0.4	-100.0	1158.7	89.7	0.1	-100.0
Left Lower Tibia Mx	N-m	8.1	229.0	-28.5	89.2	13.1	119.7	-30.2	90.2
Left Lower Tibia My	N-m	41.5	101.0	-47.4	72.3	8.3	111.6	-22.9	89.6
Right Upper Tibia Fx	N	596.5	70.8	-280.7	91.7	140.4	95.9	-82.7	132.7
Right Upper Tibia Fy	N	‡	‡	‡	‡	232.1	134.0	-79.5	97.8
Right Upper Tibia Fz	N	710.8	106.8	-2485.8	80.3	42.7	178.9	-751.6	133.3
Right Upper Tibia FR	N	‡	‡	‡	‡	783.2	133.3	0.1	-100.0
Right Upper Tibia Mx	N-m	63.3	74.5	-11.0	92.7	9.0	200.2	-63.1	129.8
Right Upper Tibia My	N-m	91.2	89.5	-22.3	54.8	5.5	217.3	-55.1	97.7
Right Lower Tibia Fx	N	122.3	128.9	-1224.6	105.6	32.0	218.5	-354.1	94.1
Right Lower Tibia Fy	N	87.3	30.5	-384.5	73.4	264.0	130.6	-43.6	205.3
Right Lower Tibia Fz	N	4.9	-98.3	-3653.0	79.9	107.3	259.3	-966.8	132.2
Right Lower Tibia FR	N	3846.3	79.9	0.4	-60.6	1003.5	132.1	0.2	-100.0
Right Lower Tibia Mx	N-m	32.4	124.6	-119.1	81.3	16.1	134.4	-16.8	97.5
Right Lower Tibia My	N-m	41.7	91.2	-34.2	78.3	6.8	138.1	-25.5	97.1

‡ ATD not Equipped with this Instrument

**DATA SHEET NO. 8 DUMMY INJURY CRITERIA VALUES (cont.)**

Vehicle Year/Make/Model/Body Style: 2000 Nissan Altima 4-Door Sedan  
 NHTSA Test No.: RY5211 Test Date: October 20, 2000

DESCRIPTION	Unit	MAXIMUM VALUE							
		Driver				Passenger			
		Pos	msec	Neg	msec	Pos	msec	Neg	msec
Left Tibia Ax	g	7.3	120.2	-64.4	89.9	‡	‡	‡	‡
Left Tibia Ay	g	29.0	89.4	-19.4	138.2	‡	‡	‡	‡
Right Tibia Ax	g	16.7	91.6	-43.2	78.6	‡	‡	‡	‡
Right Tibia Ay	g	43.3	77.6	-37.5	100.1	‡	‡	‡	‡
Left Ankle Rotation X	Deg	21.0	70.7	-13.2	173.4	‡	‡	‡	‡
Left Ankle Rotation Y	Deg	19.5	104.6	-19.7	37.4	‡	‡	‡	‡
Left Ankle Rotation Z	Deg	19.5	99.5	0.3	-100.0	‡	‡	‡	‡
Right Ankle Rotation X	Deg	-0.2	-100.0	-35.4	87.5	‡	‡	‡	‡
Right Ankle Rotation Y	Deg	25.0	153.2	-9.9	35.3	‡	‡	‡	‡
Right Ankle Rotation Z	Deg	9.0	84.7	-6.1	153.9	‡	‡	‡	‡
Left Foot Ax	g	14.8	103.1	-56.3	71.3	4.5	165.4	-42.1	78.0
Left Foot Ay	g	25.2	98.8	-24.2	144.3	‡	‡	‡	‡
Left Foot Az	g	15.6	127.0	-51.0	72.8	2.4	61.9	-21.8	91.3
Left Foot A Resultant	g	74.9	71.3	0.0	499.9	‡	‡	‡	‡
Left Toe Az	g	‡	‡	‡	‡	14.7	201.5	-33.8	72.4
Right Foot Ax	g	29.7	97.6	-65.4	74.6	4.6	179.9	-33.9	89.7
Right Foot Ay	g	67.7	71.8	-26.6	85.2	‡	‡	‡	‡
Right Foot Az	g	23.5	85.8	-30.5	102.6	2.3	164.8	-10.9	95.6
Right Foot A Resultant	g	83.5	77.1	0.0	-100.0	‡	‡	‡	‡
Right Toe Az	g	‡	‡	‡	‡	12.9	164.6	-19.3	99.1
Lap Belt Force	N	4927.1	94.7	-9.5	497.1	4595.5	98.9	-3.5	-10.5

‡ ATD not Equipped with this Instrument

DATA SHEET NO. 8 DUMMY INJURY CRITERIA VALUES (cont.)

Vehicle Year/Make/Model/Body Style: 2000 Nissan Altima 4-Door Sedan

NHTSA Test No.: RY5211 Test Date: October 20, 2000

HEAD INJURY CRITERIA (HIC)				
	HIC**	t <sub>1</sub> (msec)	t <sub>2</sub> (msec)	Average Acceleration t <sub>1</sub> to t <sub>2</sub>
Position #1 - Driver	264.8	87.8	123.8	35.2
Position #2 - Passenger	195.0	95.7	131.6	31.2

\*\* HIC is as defined in FMVSS 208. The maximum time interval from t<sub>1</sub> to t<sub>2</sub> is 36 milliseconds.

CLIP SUMMARY*				
	CLIP (g's)	t <sub>1</sub> (msec)	t <sub>2</sub> (msec)	CSI
Position #1 - Driver	32.1	107.8	112.0	229.4
Position #2 - Passenger	31.7	108.5	111.5	171.4

\* The maximum chest resultant acceleration is defined as the maximum acceleration which exceeds 0.003 seconds in duration.

**DATA SHEET NO. 8 DUMMY INJURY CRITERIA VALUES (cont.)**  
**REDUNDANT DATA**

Vehicle Year/Make/Model/Body Style: 2000 Nissan Altima 4-Door Sedan

NHTSA Test No.: RY5211 Test Date: October 20, 2000

HEAD INJURY CRITERIA (HIC) REDUNDANT				
	HIC**	t <sub>1</sub> (msec)	t <sub>2</sub> (msec)	Average Acceleration t <sub>1</sub> to t <sub>2</sub>
Position #1 - Driver	265.7	87.8	123.8	35.3
Position #2 - Passenger	189.0	95.6	131.6	30.8

\*\* HIC is as defined in FMVSS 208. The maximum time interval from t<sub>1</sub> to t<sub>2</sub> is 36 milliseconds.

CLIP SUMMARY* REDUNDANT				
	CLIP (g's)	t <sub>1</sub> (msec)	t <sub>2</sub> (msec)	CSI
Position #1 - Driver	32.0	107.9	112.0	228.3
Position #2 - Passenger	31.6	108.5	111.5	166.7

\* The maximum chest resultant acceleration is defined as the maximum acceleration which exceeds 0.003 seconds in duration.

DATA SHEET NO. 9 SEAT BELT PERFORMANCE ASSESSMENT TEST DATA

BELT LENGTH DATA:

Belt length from trim panel exit  
to bolt hole anchor point for  
continuous webbing systems.

Driver

Passenger

1895

1875

Shoulder belt length as measured  
on Part 572 Dummy.

880

870

Lap belt length as measured  
on Part 572 Dummy.

840

830

SHOULDER BELT SPOOL-OFF DATA:

As determined by film analysis.

-

-

As determined mechanically.

-

-

As determined electronically.

52.0

50.3

BELT STRETCH DATA:

Measured electronically between shoulder  
belt load cell and the "D" ring.

-

-

Measured mechanically.

-

-

Dimensions in millimeters

DATA SHEET NO.10 SUMMARY OF FMVSS 212 DATA

FMVSS NO. 212 - "WINDSHIELD MOUNTING" DATA

DETAILS OF WINDSHIELD MOUNTING SUCH AS RETENTION METHOD, TRIM TYPE, ETC.:

Windshield is bonded in place and covered with a 19 mm molding.

FMVSS 212 REQUIREMENTS:

The Post-Test periphery retention amount must be at least 75% of the Pre-Test periphery measurement for vehicles NOT equipped with automatic restraints, and 50% for each side of the windshield for vehicles equipped with automatic restraint systems for front occupants,

FMVSS 212 TEST DATA

	WINDSHIELD PERIPHERY		% OF RETENTION
	PRE-TEST (mm)	POST-TEST(mm)	
RIGHT SIDE	2101	2101	100
LEFT SIDE	2101	2101	100
TOTAL	4202	4202	100

AREA OF RETENTION FAILURE: None

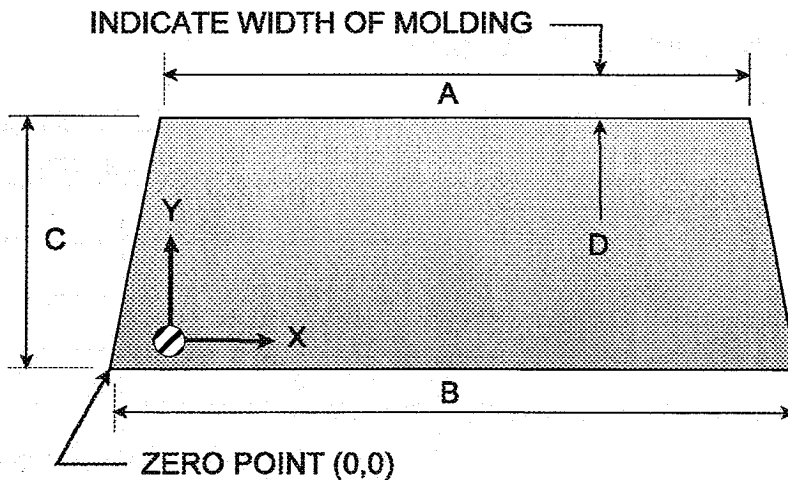

DIMENSIONS (mm)	
A	1142
B	1470
C	795
D	19

**FRONT VIEW OF WINDSHIELD**

FAILURE DETAILS: None

DATA SHEET NO. 11 FMVSS NO. 219 (PARTIAL) - "WINDSHIELD ZONE INTRUSION" DATA

PROTECTED ZONE LOWER EDGE REQUIREMENT:

The lower edge of the protected zone is determined by placing a 165 mm diameter rigid sphere weighing 6.8 kg in a position such that it simultaneously contacts the inner surface of the windshield and the top surface of the instrument panel including padding. The locus of points is drawn on the inner surface of the windshield contacted by the sphere across the width of the instrument panel. From the outermost contactable points extend the locus line horizontally to the edges of the windshield, then draw a line on the inner surface of the windshield below and 13 mm distant from the locus line. The LOWER EDGE OF THE PROTECTED ZONE is the longitudinal projection of this line onto the outer surface of the windshield.

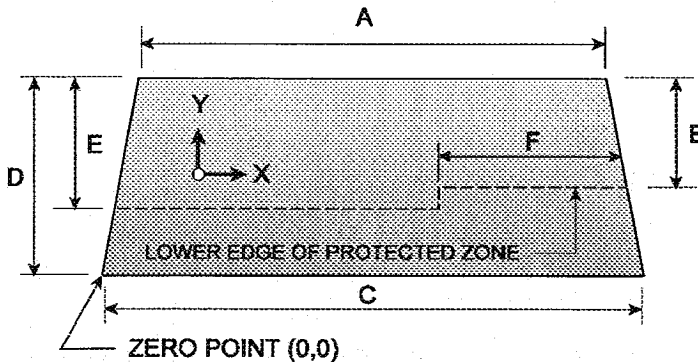

**FRONT VIEW OF WINDSHIELD**

FMVSS 219 TEST DATA:

DIMENSIONS (mm)	
A	1142
B	465
C	1470
D	795
E	540
F	833

DETAILS OF WINDSHIELD GLASS PENETRATION GREATER THAN 6 mm:

None

(Show location of penetration on the above sketch)

	COORDINATES	
	X	Y
1.	-	-
2.	-	-
3.	-	-
4.	-	-

DATA SHEET NO. 12 FMVSS NO. 301-75 "FUEL SYSTEM INTEGRITY" POST IMPACT TEST DATA

NHTSA TEST No.: RY5211 TEST DATE: October 20, 2000

VEHICLE MAKE/MODEL: 2000 Nissan Altima

The test vehicle was filled from 92% to 94% of the manufacture's "usable" capacity. The electric fuel pump was operating if it will operate without engine operation. Two Part 572 anthropomorphic test devices were located at each of the front designated seating positions.

=====

TEST VEHICLE IMPACT TYPE: X Offset Frontal (64 kph)  
- Oblique (48 kph) with \_\_\_\_\_ deg. barrier face first contacting \_\_\_\_\_ (driver/passenger) side  
- Rear Moving Barrier (48 kph)  
- Lateral Moving Barrier (32 kph)

FUEL SPILLAGE MEASUREMENT:

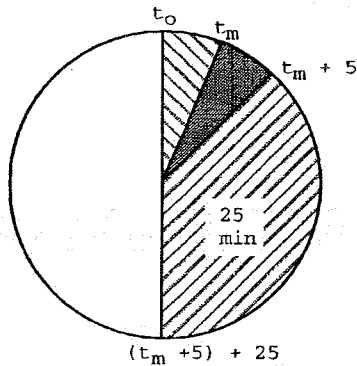

1. From impact until vehicle motion ceases
2. For 5 minute period after vehicle motion ceases
3. For next 25 minutes

ACTUAL	MAX ALLOWED
0	28 g
0	141 g
0	28 g/min.

SOLVENT SPILLAGE DETAILS: None

DATA SHEET 13

FMVSS NO. 301 STATIC ROLLOVER DATA SHEET

Vehicle: 2000 Nissan Altima

NHTSA No. RY5211

0 - 90 Degrees

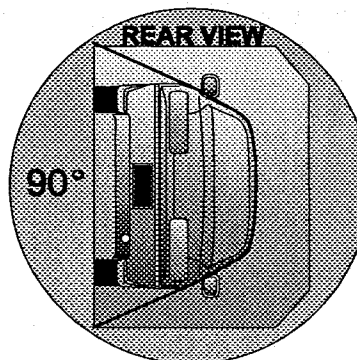
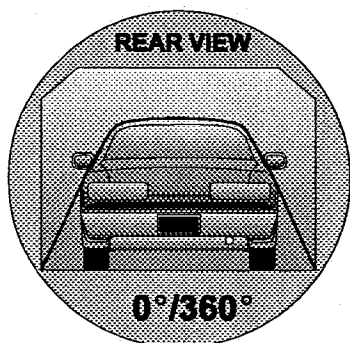

I. DETERMINATION OF SOLVENT COLLECTION TIME PERIOD :

Rollover Fixture 90° Rotation Time (Spec. Range = 1 to 3 minutes)	<u>1</u>	minutes	<u>19</u>	seconds
FMVSS 301 Position Hold Time +	<u>5</u>	minutes	<u>0</u>	seconds
TOTAL	<u>6</u>	minutes	<u>19</u>	seconds
Next whole minute interval	<u>7</u>	minutes		

II. FMVSS 301 REQUIREMENTS :

(1) Time Period

First 5 minutes FROM onset of rotation	6th min.	7th min.	8th min. (if required)
--	----------	----------	------------------------

(2) Maximum Allowable Solvent Spillage

142 g	28 g	28 g	28 g
-------	------	------	------

III. ACTUAL TEST VEHICLE SOLVENT SPILLAGE:

0 g	0 g	0 g	N/A
-----	-----	-----	-----

Note: Record spillage for whole minute intervals only as determined above.

IV. SOLVENT SPILLAGE LOCATION(S) :

None

---

DATA SHEET 13

FMVSS NO. 301 STATIC ROLLOVER DATA SHEET (CONTINUED)

Vehicle: 2000 Nissan Altima

NHTSA No. RY5211

90 - 180 Degrees

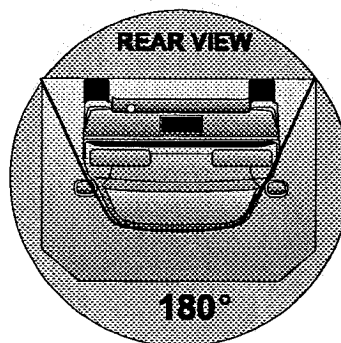
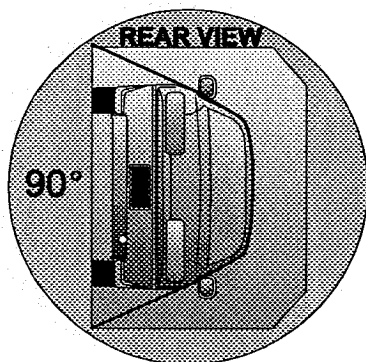

I. DETERMINATION OF SOLVENT COLLECTION TIME PERIOD :

Rollover Fixture 90° Rotation Time (Spec. Range = 1 to 3 minutes)	<u>1</u> minutes	<u>04</u> seconds
FMVSS 301 Position Hold Time +	<u>5</u> minutes	<u>0</u> seconds
TOTAL	<u>6</u> minutes	<u>4</u> seconds
Next whole minute interval	<u>7</u> minutes	

II. FMVSS 301 REQUIREMENTS :

(1) Time Period

First 5 minutes FROM onset of rotation	6th min.	7th min.	8th min. (if required)
--	----------	----------	------------------------

(2) Maximum Allowable Solvent Spillage

142 g	28 g	28 g	28 g
-------	------	------	------

III. ACTUAL TEST VEHICLE SOLVENT SPILLAGE:

0 g	0 g	0 g	N/A
-----	-----	-----	-----

Note: Record spillage for whole minute intervals only as determined above.

IV. SOLVENT SPILLAGE LOCATION(S) :

None

DATA SHEET 13

FMVSS NO. 301 STATIC ROLLOVER DATA SHEET (CONTINUED)

Vehicle: 2000 Nissan Altima

NHTSA No. RY5211

180 - 270 Degrees

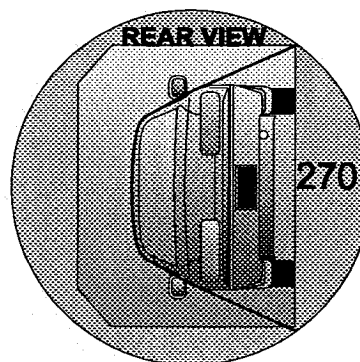
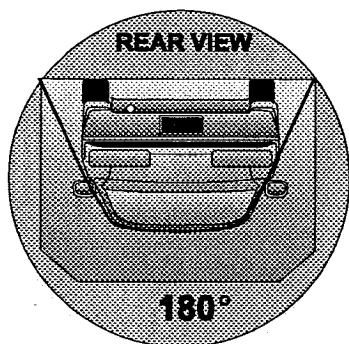

I. DETERMINATION OF SOLVENT COLLECTION TIME PERIOD :

Rollover Fixture 90° Rotation Time (Spec. Range = 1 to 3 minutes)	<u>1</u> minutes	<u>07</u> seconds
FMVSS 301 Position Hold Time +	<u>5</u> minutes	<u>0</u> seconds
TOTAL	<u>6</u> minutes	<u>7</u> seconds
Next whole minute interval	<u>7</u> minutes	

II. FMVSS 301 REQUIREMENTS :

(1) Time Period

First 5 minutes FROM onset of rotation	6th min.	7th min.	8th min. (if required)
--	----------	----------	------------------------

(2) Maximum Allowable Solvent Spillage

142 g	28 g	28 g	28 g
-------	------	------	------

III. ACTUAL TEST VEHICLE SOLVENT SPILLAGE:

0 g	0 g	0 g	N/A
-----	-----	-----	-----

Note: Record spillage for whole minute intervals only as determined above.

IV. SOLVENT SPILLAGE LOCATION(S) :

None

DATA SHEET 13

FMVSS NO. 301 STATIC ROLLOVER DATA SHEET (CONTINUED)

Vehicle: 2000 Nissan Altima

NHTSA No. RY5211

270 - 360 Degrees

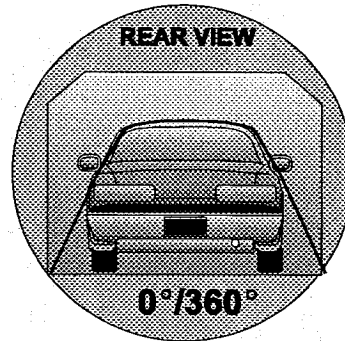
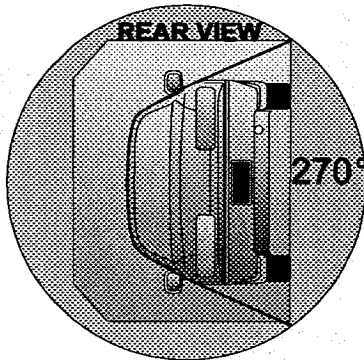

I. DETERMINATION OF SOLVENT COLLECTION TIME PERIOD :

Rollover Fixture 90° Rotation Time (Spec. Range = 1 to 3 minutes)	<u>1</u>	minutes	<u>11</u>	seconds
FMVSS 301 Position Hold Time +	<u>5</u>	minutes	<u>0</u>	seconds
TOTAL	<u>6</u>	minutes	<u>11</u>	seconds
Next whole minute interval	<u>7</u>	minutes		

II. FMVSS 301 REQUIREMENTS :

(1) Time Period

First 5 minutes FROM onset of rotation	6th min.	7th min.	8th min. (if required)
--	----------	----------	------------------------

(2) Maximum Allowable Solvent Spillage

142 g	28 g	28 g	28 g
-------	------	------	------

III. ACTUAL TEST VEHICLE SOLVENT SPILLAGE:

0 g	0 g	0 g	N/A
-----	-----	-----	-----

Note: Record spillage for whole minute intervals only as determined above.

IV. SOLVENT SPILLAGE LOCATION(S) :

None

DATA SHEET NO. 14 TEST VEHICLE MEASUREMENTS

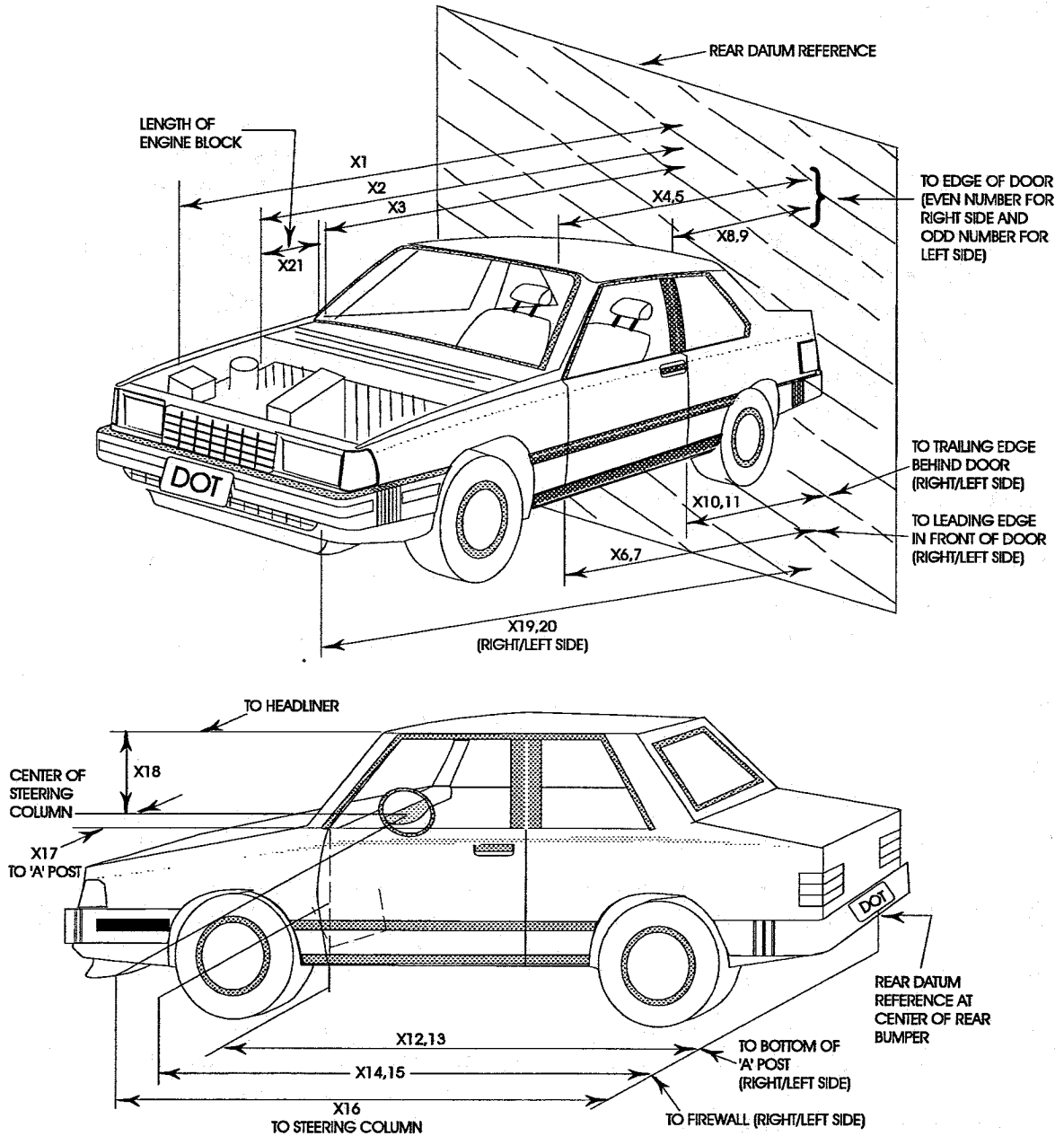

DATA SHEET NO.14      VEHICLE MEASUREMENTS (cont.)

No.		Pre-Test	Post-Test	Differences
X1	Total Length of Vehicle at Centerline	4674	4275	399
X2	Rear Surface of Vehicle to Front of Engine	4103	3936	167
X3	Rear Surface of Vehicle to Firewall	3526	3408	118
X4	Rear Surface of Vehicle to Upper Leading Edge of Right Door	3184	3188	-4
X5	Rear Surface of Vehicle to Upper Leading Edge of Left Door	3191	3100	91
X6	Rear Surface of Vehicle to Lower Leading Edge of Right Door	3183	3202	-19
X7	Rear Surface of Vehicle to Lower Leading Edge of Left Door	3194	3088	106
X8	Rear Surface of Vehicle to Upper Trailing Edge of Right Door	2146	2151	-5
X9	Rear Surface of Vehicle to Upper Trailing Edge of Left Door	2151	2141	10
X10	Rear Surface of Vehicle to Lower Trailing Edge of Right Door	2136	2158	-22
X11	Rear Surface of Vehicle to Lower Trailing Edge of Left Door	2166	2105	61
X12	Rear Surface of Vehicle to Bottom of "A" Post of Right Side	3319	3347	-28
X13	Rear Surface of Vehicle to Bottom of "A" Post of Left Side	3328	3127	201
X14	Rear Surface of Vehicle to Firewall, Right Side	3523	3488	35
X15	Rear Surface of Vehicle to Firewall, Left Side	3472	3241	231
X16	Rear Surface of Vehicle to Steering Column	2756	2668	88
X17	Center of Steering Column to "A" Post	296	317	-21
X18	Center of Steering Column to Headliner	414	367	47
X19	Rear Surface of Vehicle to Right Side of Front Bumper	4565	4551	14
X20	Rear Surface of Vehicle to Left Side of Front Bumper	4566	3912	654
X21	Length of Engine Block	435	435	0
RD	Rear Surface of Vehicle to Right Side of Dash Panel	2949	2954	-5
CD	Rear Surface of Vehicle to Center of Dash Panel	2977	2899	78
LD	Rear Surface of Vehicle to Left Side of Dash Panel	2962	2814	148

All Dimensions in mm

DATA SHEET NO.14 VEHICLE MEASUREMENTS (cont.)  
**VEHICLE INTRUSION MEASUREMENTS**  
**DOOR OPENING WIDTH**

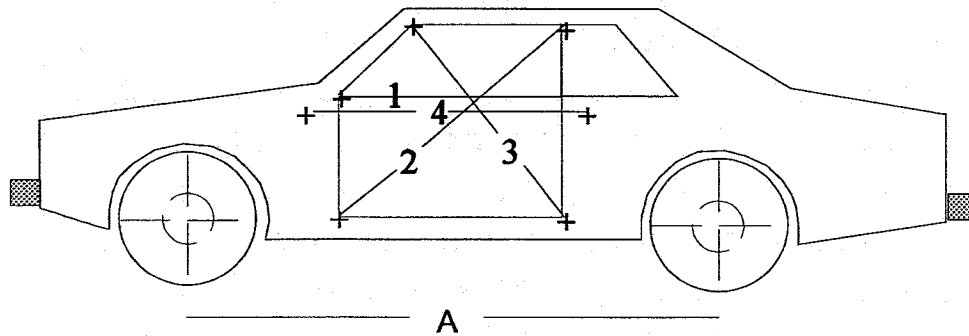

UNITS (mm)	LEFT				RIGHT		
MEASUREMENT	1	2	3	4*	1	2	3
BEFORE TEST	979	1448	954	1088	975	1405	938
AFTER TEST	858	1325	1055	945	976	1438	935
DIFFERENCE	121	123	-101	143	-1	-33	3

\* Measurement for driver's side only

UNITS (mm)	A = WHEELBASE LEFT	A = WHEELBASE RIGHT
BEFORE TEST	2615	2616
AFTER TEST	2259	2703
DIFFERENCE	356	-87

**DATA SHEET NO.14 VEHICLE MEASUREMENTS (cont.)**  
**VEHICLE INTRUSION MEASUREMENTS**  
**STATIC FOOTWELL DEFORMATION**

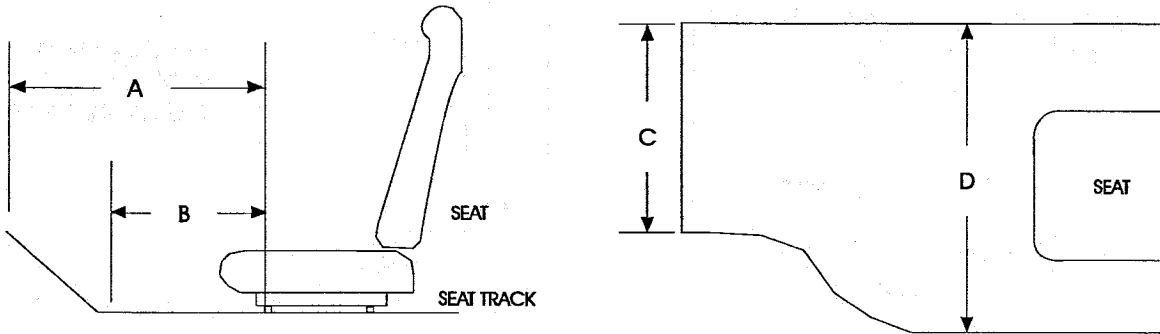

**DRIVER**

Measurement	Pre-Test	Post-Test	Difference
A	750	488	262
B	666	424	242
C	460	438	22
D	474	382	92

**PASSENGER**

Measurement	Pre-Test	Post-Test	Difference
A	743	678	65
B	533	505	28
C	440	439	1
D	407	435	-28

Units = mm

**DATA SHEET NO.14 VEHICLE MEASUREMENTS (cont.)**  
**VEHICLE INTRUSION MEASUREMENTS**  
**STATIC PASSENGER COMPARTMENT INTRUSION**

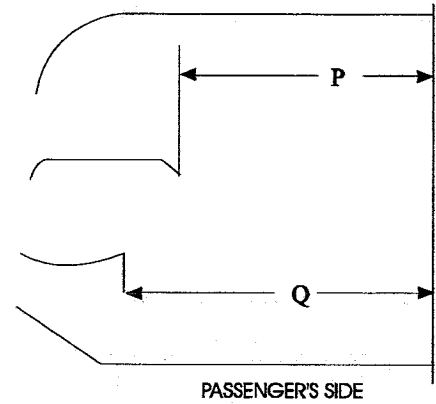
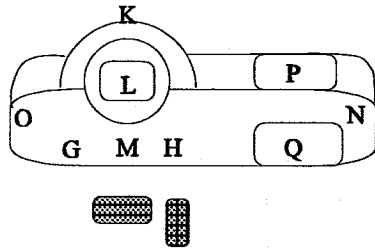
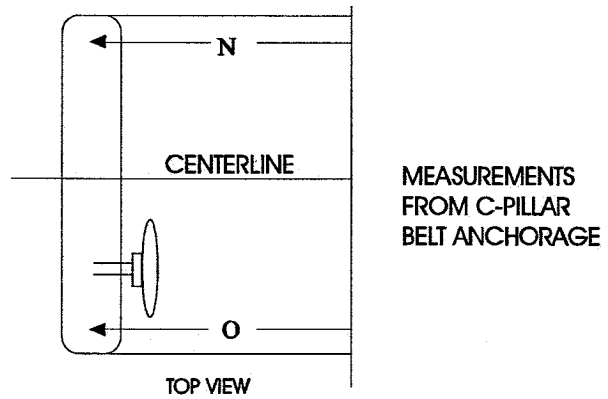
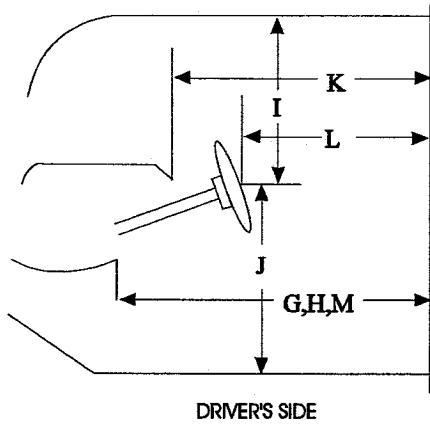

Measurement	Pre-Test	Post-Test	Difference
G*	1870	1728	142
H*	1860	1774	86
I	414	367	47
J	644	697	-53
K	1824	1707	117
L	1635	1544	91
M	1834	1706	128
N	1831	1835	-4
O	353	286	67
P = K (PASS.)	1937	1903	34
Q = M (PASS.)	1860	1834	26

\* IIHS measurement locations; 15 cm left and right of steering wheel center 45 cm from floor.

Units = mm

**DATA SHEET NO.14 VEHICLE MEASUREMENTS (cont.)**  
**TOE-PAN INTRUSION**

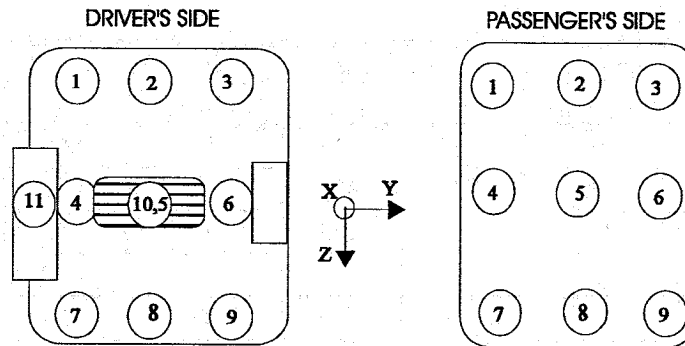

**Driver Side Toe-pan Measurements**

Toe-pan Location	X Deformation (mm)			Y Deformation (mm)			Z Deformation (mm)		
	Pre	Post	$\Delta$	Pre	Post	$\Delta$	Pre	Post	$\Delta$
1	3423	3099	-324	-502	-497	5	-506	-541	-35
2	3442	3180	-262	-362	-358	4	-489	-515	-26
3	3449	3169	-280	-224	-227	-3	-464	-524	-60
4*	3405	3129	-276	-506	-459	47	-405	-492	-87
5* <sup>A</sup>	3435	3170	-265	-362	-330	32	-402	-515	-113
6*	3434	3207	-227	-220	-196	24	-401	-479	-78
7	3359	3123	-236	-508	-456	52	-324	-406	-82
8	3358	3115	-243	-347	-319	28	-286	-375	-89
9	3344	3169	-175	-191	-187	4	-318	-369	-51
10	3240	3013	-227	-330	-349	-19	-422	-517	-95
11*	3347	3084	-263	-605	-509	96	-429	-426	3

**Passenger Side Toe-pan Measurements**

Toe-pan Location	X Deformation (mm)			Y Deformation (mm)			Z Deformation (mm)		
	Pre	Post	$\Delta$	Pre	Post	$\Delta$	Pre	Post	$\Delta$
1	3433	3353	-80	218	204	-14	-384	-474	-90
2	3425	3384	-41	352	317	-35	-392	-462	-70
3	3399	3396	-3	507	470	-37	-421	-506	-85
4	3322	3281	-41	204	206	2	-283	-372	-89
5	3328	3315	-13	346	349	3	-306	-374	-68
6	3344	3357	13	507	495	-12	-307	-373	-66
7	3206	3165	-41	228	246	18	-219	-289	-70
8	3215	3211	-4	382	388	6	-221	-261	-40
9	3237	3249	12	509	552	43	-247	-269	-22

Reference: (SAE) X = Rear Bumper (pos: forward); Y = Vehicle Centerline (pos: right); Z = Ground (pos: down)

\* IIHS measurement locations

\*<sup>A</sup> IIHS measurement located directly behind 10 (brake pedal center) on the vehicle floorpan in same vertical plane.

**DATA SHEET NO.14 VEHICLE MEASUREMENTS (cont.)**  
**INSURANCE INSTITUTE MEASUREMENT LOCATION AND FLOOR PAN DEFORMATION DATA**

**IHS Measurement Location Data**

Meas. Loc*	X Measurement (mm)			Y Measurement (mm)			Z Measurement (mm)		
	Pre	Post	Difference	Pre	Post	Difference	Pre	Post	Difference
1	2756	2668	-88	-366	-336	30	-864	-995	-131
2	2991	2852	-139	-502	-495	7	-672	-740	-68
3	2981	2899	-82	-212	-225	-13	-667	-722	-55
4	3240	3013	-227	-330	-349	-19	-422	-517	-95
5	3405	3129	-276	-506	-459	47	-405	-492	-87
6	3435	3170	-265	-362	-330	32	-402	-515	-113
7	3434	3207	-227	-220	-196	24	-401	-479	-78
8	3347	3084	-263	-605	-509	96	-429	-426	3
17	3226	3072	-154	-803	-802	1	-885	-924	-39
18	2138	2128	-10	-827	-833	-6	-887	-902	-15

**Floor Pan Deformation Measurement Data**

Meas. Loc**	X Measurement (mm)			Y Measurement (mm)			Z Measurement (mm)		
	Pre	Post	Difference	Pre	Post	Difference	Pre	Post	Difference
1	3313	3060	-253	-493	-455	38	-221	-288	-67
2	3313	3057	-256	-343	-309	34	-221	-313	-92
3	3313	3054	-259	-193	-196	-3	-243	-285	-42
4	3188	2997	-191	-493	-477	16	-221	-257	-36
5	3188	2995	-193	-343	-342	1	-221	-223	-2
6	3188	2970	-218	-193	-219	-26	-221	-246	-25
7	3063	2968	-95	-493	-450	43	-221	-249	-28
8	3063	2962	-101	-343	-360	-17	-221	-280	-59
9	3063	2959	-104	-193	-243	-50	-243	-325	-82

Reference: (SAE) X = Rear Bumper (pos: forward); Y = Vehicle Centerline (pos: right); Z = Ground (pos: down)

**Measurement Location Descriptions\***

1. Steering Column - Geometric center of the steering wheel on airbag door.
2. Lower Instrument Panel Left - Taken 45 cm above floorpan and 15 cm to the left of the steering wheel center.
3. Lower Instrument Panel Right - Taken 45 cm above floorpan and 15 cm to the right of the steering wheel center.
4. Brake Pedal - Geometric center of the brake pedal.
5. Toepan Left - Taken 15 cm to the left of the brake pedal center on the same vertical plane on the vehicle toepan.
6. Toepan Center - Taken directly behind the brake pedal center on the same vertical plane on the vehicle toepan.
7. Toepan Right - Taken 15 cm to the right of the brake pedal center on the same vertical plane on the vehicle toepan.
8. Left Footrest - Taken 25 cm to the left of the brake pedal center on the same vertical plane on the vehicle toepan.
17. A-pillar - Taken on the vehicle exterior at the same vertical coordinate as the base on the left front window.
18. B-pillar - Taken on the vehicle exterior at the same vertical coordinate as the lower A-pillar mark.

\*\* There is an equal spaced 3 x 3 floor pan matrix. Position 1 is floor pan left side forwardmost position; Position 9 is located on the right side rearmost position of the 3 x 3 grid.

**DATA SHEET NO.15 HIGH-SPEED CAMERA LOCATIONS**

NOTE: Camera information shown in DATA SHEET NO. 15.

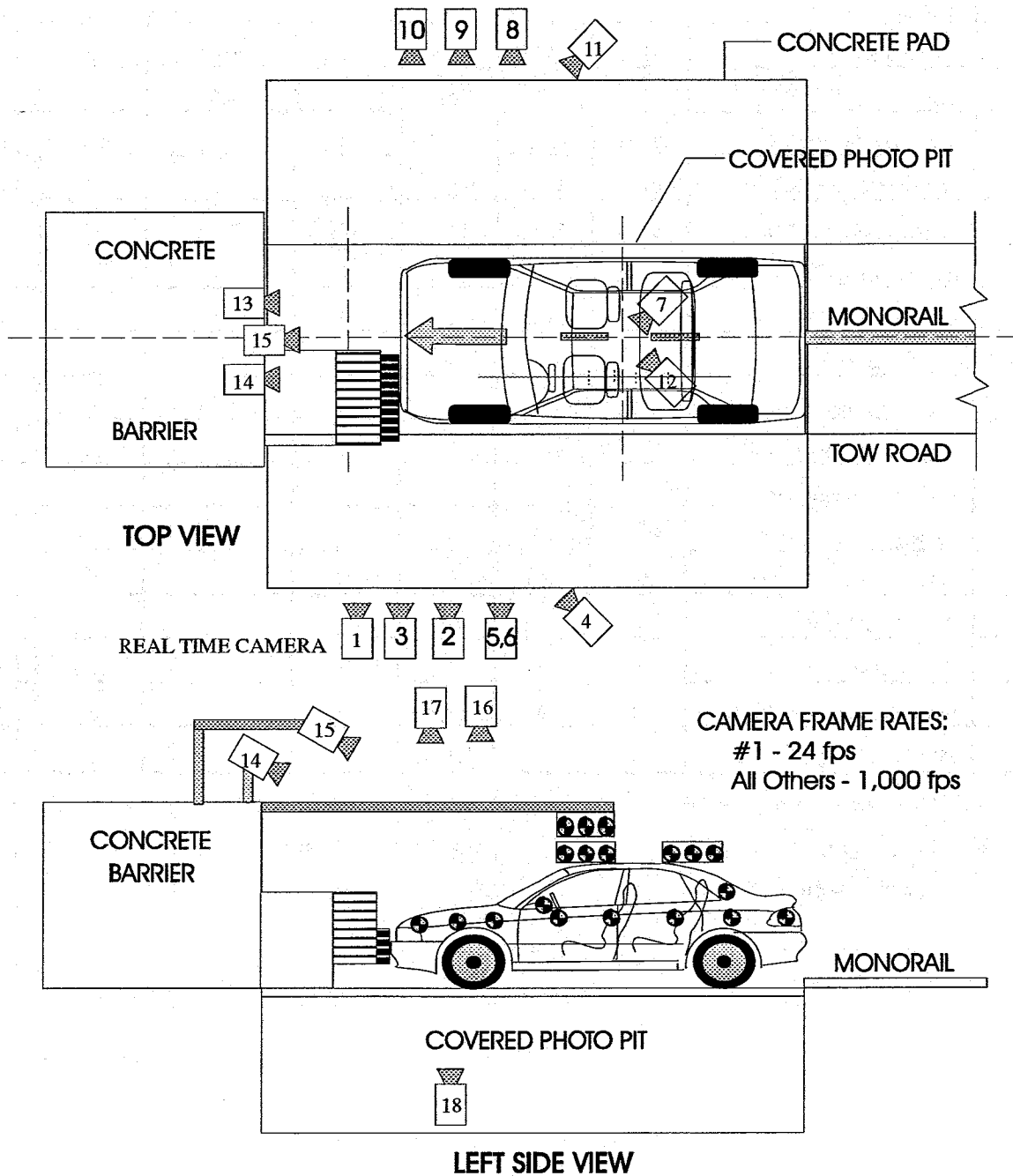

DATA SHEET NO. 17    LOAD CELL LOCATIONS RELATIVE TO FIXED BARRIER AND DEFORMABLE BARRIER FACE

30    Load Cells  
 5    Rows  
 6    Columns

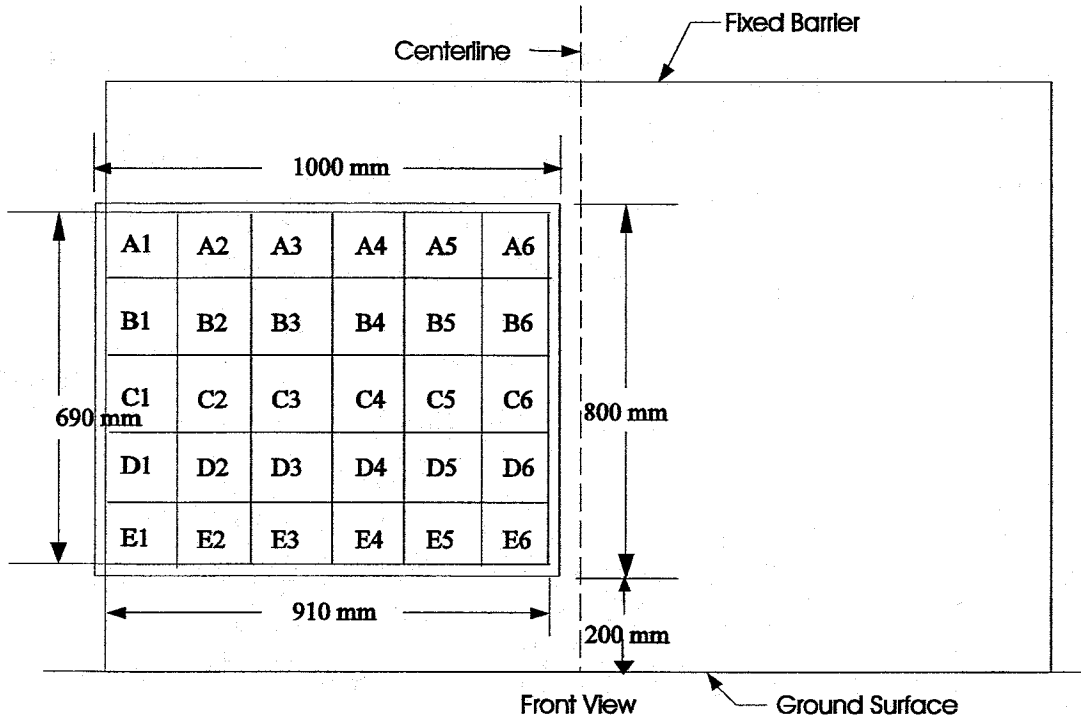

Load cell width	146 mm
Load cell height	133 mm
Vertical gap between load cells	6 mm
Horizontal gap between load cells	6 mm
Vertical filler block width	55 mm

The following data is presented in Appendix B:

- (1) X Direction Data from load cells A1 through A6
- (2) X and Y Direction Data from load cells B1 through E6

DATA SHEET NO. 18 POST TEST AIR BAG DATA

NHTSA No. : RY5211; Test Date: October 20, 2000; Technician: Patrick G. MacDiarmid

Vehicle Model Year/Make/Model: 2000 Nissan Altima

A. No. of vent holes: 2 -Driver 2 -Passenger

B. Size of vent holes: (mm<sup>2</sup>) 490.87 -Driver 490.87 -Passenger

C. Total vent area: (mm<sup>2</sup>) 981.77 -Driver 981.77 -Passenger

D. Deflated air bag length and width dimensions or, if round, diameter. (mm)

Driver: 480 -Height; 600 -Width; 310 -Depth

Passenger: 750 -Height; 700 -Width; 625 -Depth

E. Is the air bag tethered?

Driver: X -Yes; - -No; If yes, record length of tether- 200

Passenger: - -Yes; X -No; If yes, record length of tether- -

Sketch the air bag showing the location of the vent holes, how the bag is tethered, and where the bag is tethered. Also describe how the tethers are attached to the bag and the steering wheel.

(Note: Not to scale; V<sub>n</sub> = Vent hole<sub>n</sub>, T<sub>n</sub> = Tether<sub>n</sub>).

**Driver**

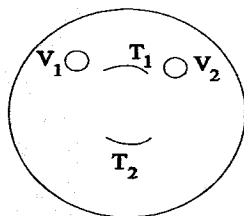

**Passenger**

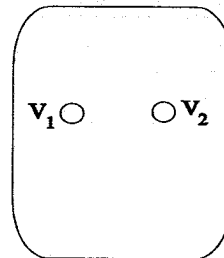

F. Record part numbers and manufacturer name of the air bag and gas generator.

Driver: Air bag: Nissan 2Q 98570-89912-C1 0004758 25 06 99  
Generator: KM9E0997216735

Passenger: Air bag: -  
Generator: NP800997270199 NFFK7U4PALC

DATA SHEET NO. 19 ACCIDENT INVESTIGATION DIVISION DATA

FOR 56.3 KPH FRONTAL BARRIER IMPACT

Vehicle Make/Model/Body Style: Nissan Altima 4-Door Sedan

NHTSA Test No.: RY5211 VIN: 1N4DL01D4YC101391

Model Year: 2000 Build Date: 8/99 Test Date: October 20, 2000

Vehicle Size Category: Compact Test Weight: 1599.0 kg

Vehicle Wheelbase: 2616 mm; Baseline: 1148 mm; Overall Width: 1750 mm

Collision Deformation Classification (CDC) Code: 12FDEW3

Crush Depth Dimensions:

	PRE	POST	DIFF	
C1 =	4494	3794	-700.0	mm
C2 =	4611	4002	-609.0	mm
C3 =	4666	4169	-497.0	mm
C4 =	4667	4349	-318.0	mm
C5 =	4608	4491	-117.0	mm
C6 =	4489	4574	85.0	mm

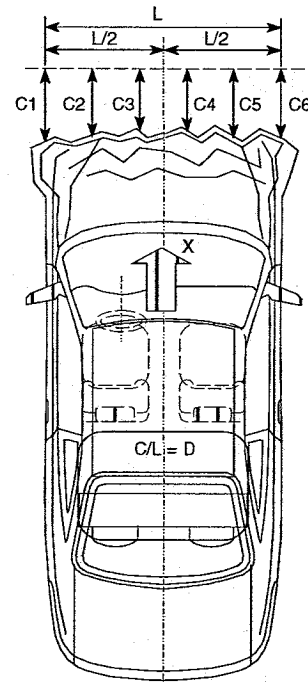

Midpoint of Damage: D = Vehicle Centerline (Longitudinal)

Length of Damaged Region:

L1= 1500 mm  
 L2= 750.0 mm  
 L3= 500.0 mm

**DATA SHEET NO. 20 OFFSET BARRIER AND VEHICLE ORIENTATION**

NHTSA Test No.: RY5211 Vehicle: 2000 Nissan Altima 4-Door Sedan  
 Barrier Manufacturer and Serial Number: Plascore, Inc. 211C0600-1C 199C0300

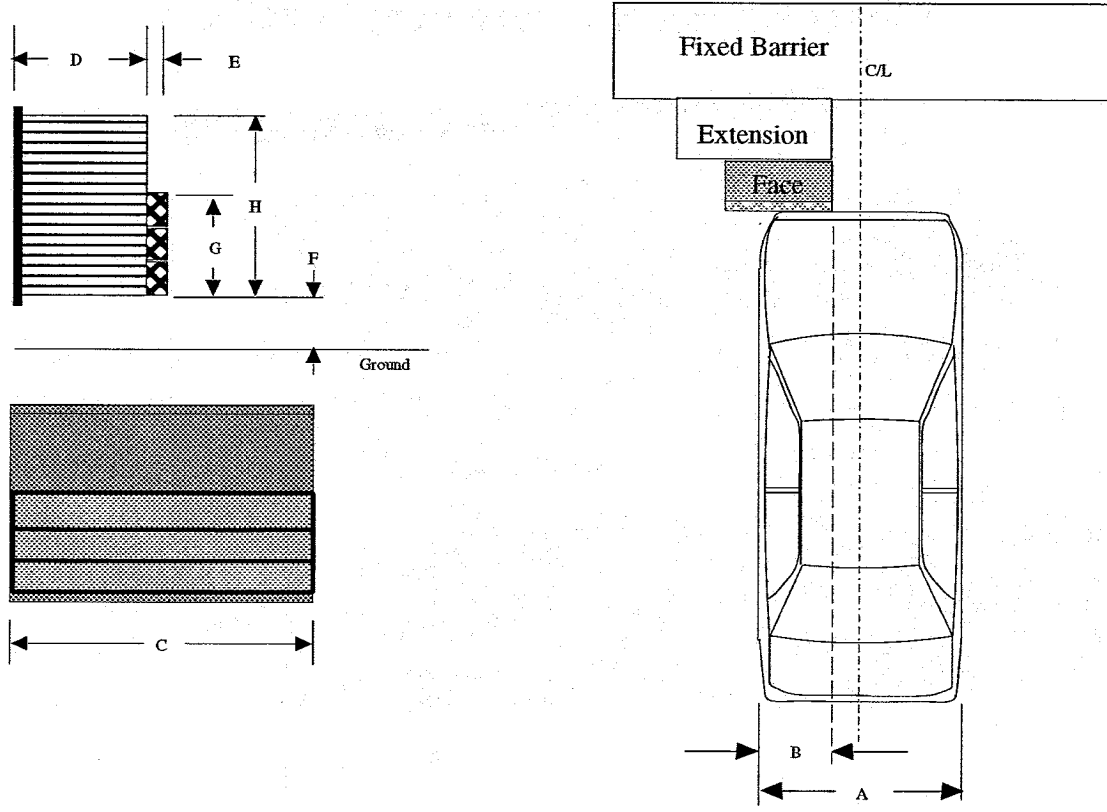

A	Total Vehicle Width	<u>1750</u>	mm
B	40% Overlap Distance	<u>700</u>	mm
C	Deformable Face Width	<u>1000</u>	mm
D	Single Stage Honeycomb Depth	<u>450</u>	mm
E	Bumper Element Depth	<u>90</u>	mm
F	Lower Edge Height From Ground	<u>200</u>	mm
G*	Bumper Element Height	<u>330</u>	mm
H	Deformable Barrier Honeycomb Height	<u>650</u>	mm

\* The bumper element consists of three 110 mm height blocks of 1.723 MPa honeycomb

### Offset Barrier Measurement Locations

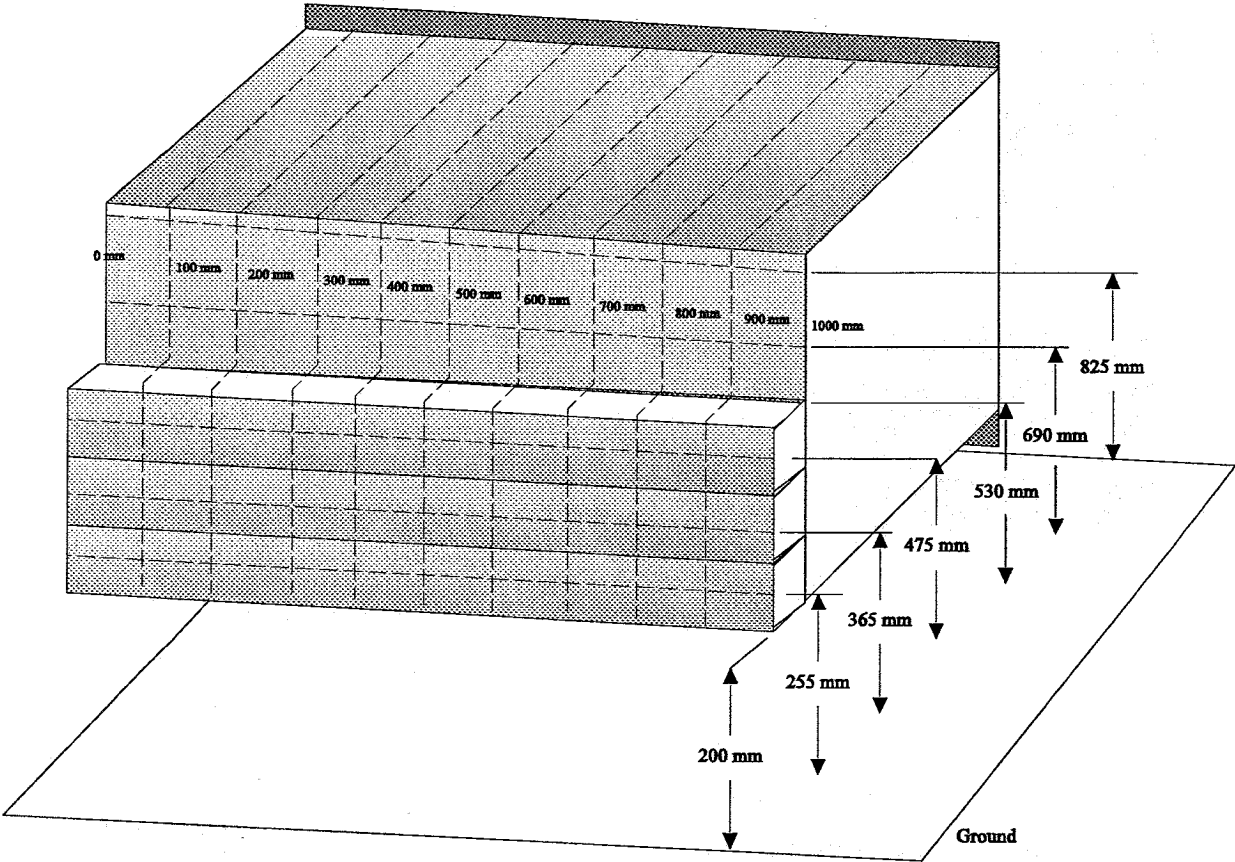

**EXTERIOR STATIC CRUSH FOR BARRIER FACE**  
(Grid as looking at barrier from front)

Vehicle: 2000 Nissan Altima

NHTSA No. RY5211

NOTE: All dimensions are in millimeters with a tolerance of  $\pm 3$  mm

LEVEL	HEIGHT AT CL (mm)*	DISTANCE RIGHT OF CENTER (mm)					0	DISTANCE LEFT OF CENTER (mm)				
		500	400	300	200	100		100	200	300	400	500
LEVEL 6		546	546	546	546	546	546	2572	546	546	546	546
TOP	913	517	533	545	551	579	641	707	750	787	840	840
STACK		-29	-13	-1	5	33	95	-1865	204	241	294	294
LEVEL 5		546	546	546	546	546	546	546	546	546	546	546
MID	687	461	511	551	567	625	691	796	836	857	913	913
STACK		-85	-35	5	21	79	145	250	290	311	367	367
LEVEL 4		546	546	546	546	546	546	546	546	546	546	546
TOP	530	458	523	581	629	721	781	865	895	905	936	936
BUMPER		-88	-23	35	83	175	235	319	349	359	390	390
LEVEL 3		456	456	456	456	456	456	456	456	456	456	456
BUMPER	475	384	450	521	592	654	723	806	869	901	905	948
TOP		-72	-6	65	136	198	273	350	413	445	449	492
LEVEL 2		456	456	456	456	456	456	456	456	456	456	456
BUMPER	365	383	454	528	594	651	713	786	847	864	892	938
MID		-73	-2	72	138	195	257	330	391	408	436	482
LEVEL 1		456	456	456	456	456	456	456	456	456	456	456
BUMPER	255	407	469	528	589	648	693	759	824	852	882	933
LOW		-49	13	72	133	192	237	303	368	396	426	477

\*Heights measured above ground level.

APPENDIX A  
PHOTOGRAPHS

TABLE OF PHOTOGRAPHS

<u>Figure</u>	<u>Title</u>	<u>Page</u>
A-1	PRE-TEST FRONT VIEW	A-3
A-2	POST-TEST FRONT VIEW	A-4
A-3	PRE-TEST LEFT SIDE VIEW	A-5
A-4	POST-TEST LEFT SIDE VIEW	A-6
A-5	PRE-TEST RIGHT SIDE VIEW	A-7
A-6	POST-TEST RIGHT SIDE VIEW	A-8
A-7	PRE-TEST RIGHT FRONT THREE-QUARTER VIEW	A-9
A-8	POST-TEST RIGHT FRONT THREE-QUARTER VIEW	A-10
A-9	PRE-TEST LEFT REAR THREE-QUARTER VIEW	A-11
A-10	POST-TEST LEFT REAR THREE-QUARTER VIEW	A-12
A-11	PRE-TEST WINDSHIELD VIEW	A-13
A-12	POST-TEST WINDSHIELD VIEW	A-14
A-13	PRE-TEST ENGINE COMPARTMENT VIEW	A-15
A-14	FUEL CAP VIEW	A-16
A-15	PRE-TEST FRONT UNDERBODY VIEW	A-17
A-16	POST-TEST FRONT UNDERBODY VIEW	A-18
A-17	PRE-TEST FRONT SIDE UNDERBODY VIEW	A-19
A-18	POST-TEST FRONT SIDE UNDERBODY VIEW	A-20
A-19	PRE-TEST REAR UNDERBODY VIEW	A-21
A-20	POST-TEST REAR UNDERBODY VIEW	A-22
A-21	PRE-TEST DRIVER POSITION VIEW	A-23
A-22	POST-TEST DRIVER POSITION VIEW	A-24
A-23	PRE-TEST PASSENGER POSITION VIEW	A-25
A-24	POST-TEST PASSENGER POSITION VIEW	A-26
A-25	PRE-TEST DRIVER AND INTERIOR VIEW	A-27
A-26	POST-TEST DRIVER AND INTERIOR VIEW	A-28
A-27	PRE-TEST PASSENGER AND INTERIOR VIEW	A-29
A-28	POST-TEST PASSENGER AND INTERIOR VIEW	A-30
A-29	PRE-TEST DRIVER HEAD LOCATION	A-31
A-30	POST-TEST DRIVER HEAD LOCATION	A-32
A-31	PRE-TEST PASSENGER HEAD LOCATION	A-33
A-32	POST-TEST PASSENGER HEAD LOCATION	A-34
A-33	PRE-TEST DRIVER FLOOR PAN VIEW	A-35
A-34	POST-TEST DRIVER FLOOR PAN VIEW	A-36
A-35	PRE-TEST PASSENGER FLOOR PAN VIEW	A-37
A-36	POST-TEST PASSENGER FLOOR PAN VIEW	A-38
A-37	PRE-TEST BARRIER FRONT VIEW	A-39
A-38	POST-TEST BARRIER FRONT VIEW	A-40
A-39	PRE-TEST BARRIER LEFT SIDE VIEW	A-41
A-40	POST-TEST BARRIER LEFT SIDE VIEW	A-42
A-41	PRE-TEST BARRIER RIGHT SIDE VIEW	A-43
A-42	POST-TEST BARRIER RIGHT SIDE VIEW	A-44
A-43	PRE-TEST BARRIER TOP VIEW	A-45
A-44	POST-TEST BARRIER TOP VIEW	A-46
A-45	POST-TEST OVERHEAD VIEW	A-47
A-46	ROLLOVER VIEW	A-48
A-47	IMPACT VIEW	A-49





Figure A-2 POST-TEST FRONT VIEW



Figure A-3 PRE-TEST LEFT SIDE VIEW



Figure A-4 POST-TEST LEFT SIDE VIEW



Figure A-5 PRE-TEST RIGHT SIDE VIEW

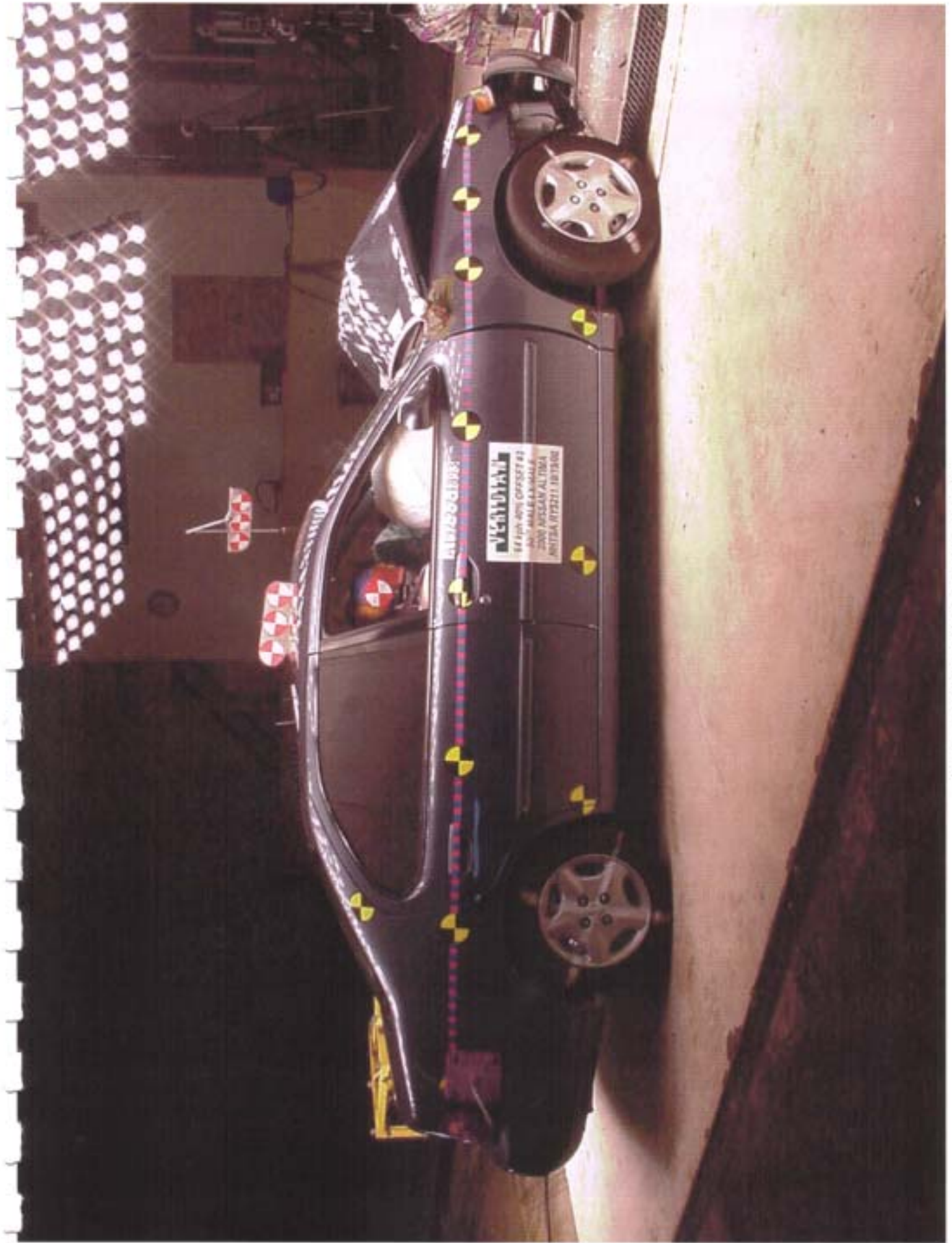

Figure A-6 POST-TEST RIGHT SIDE VIEW



Figure A-7 PRE-TEST RIGHT FRONT THREE-QUARTER VIEW

PHOTOGRAPH NOT AVAILABLE

Figure A-8 POST-TEST RIGHT FRONT THREE-QUARTER VIEW



Figure A-9 PRE-TEST LEFT REAR THREE-QUARTER VIEW



Figure A-10 POST-TEST LEFT REAR THREE-QUARTER VIEW



Figure A-11 PRE-TEST WINDSHIELD VIEW



Figure A-12 POST-TEST WINDSHIELD VIEW

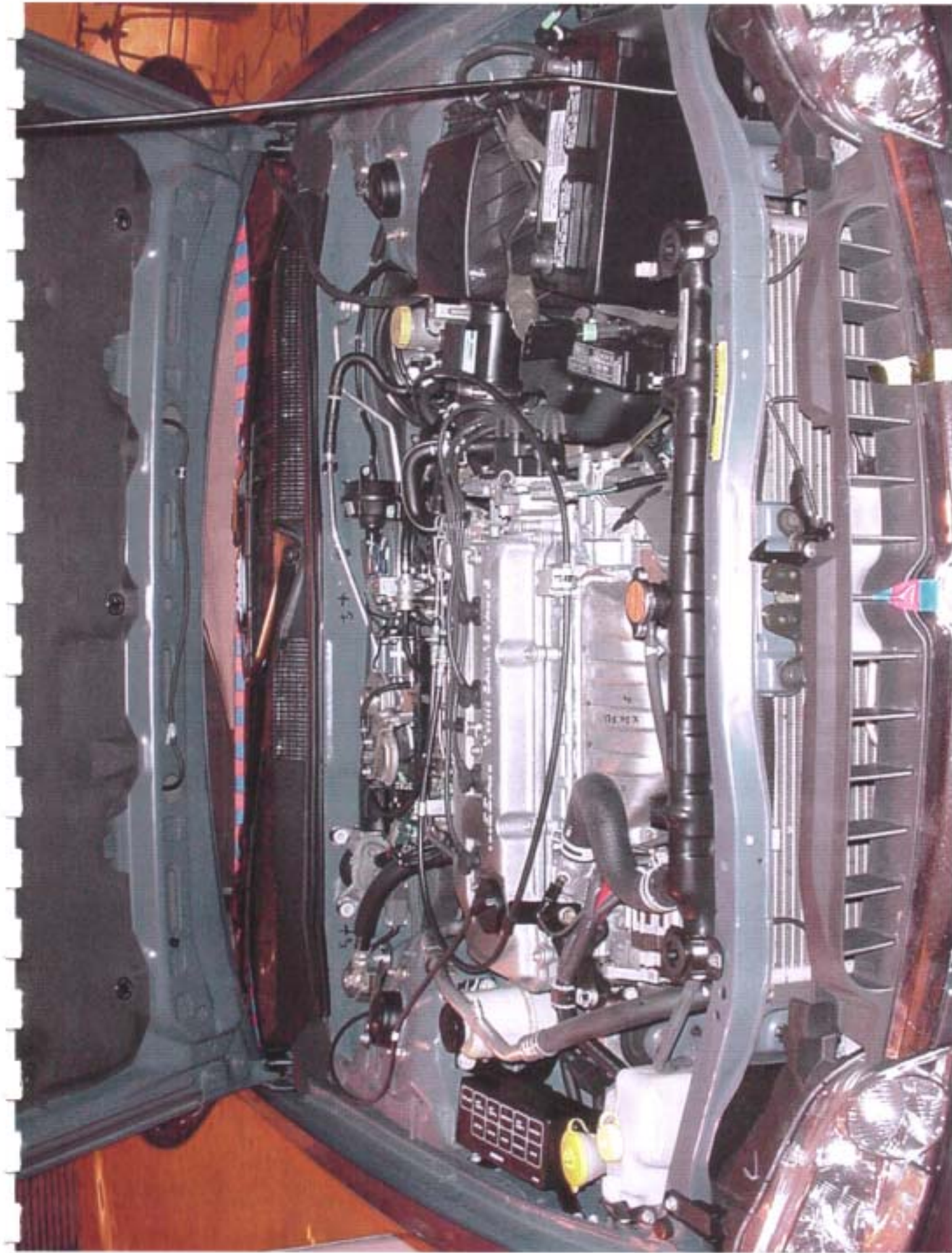

Figure A-13 PRE-TEST ENGINE COMPARTMENT VIEW

RY5211



Figure A-14 FUEL CAP VIEW



Figure A-15 PRE-TEST FRONT UNDERBODY VIEW



Figure A-16 POST-TEST FRONT UNDERBODY VIEW



Figure A-17 PRE-TEST FRONT SIDE UNDERBODY VIEW

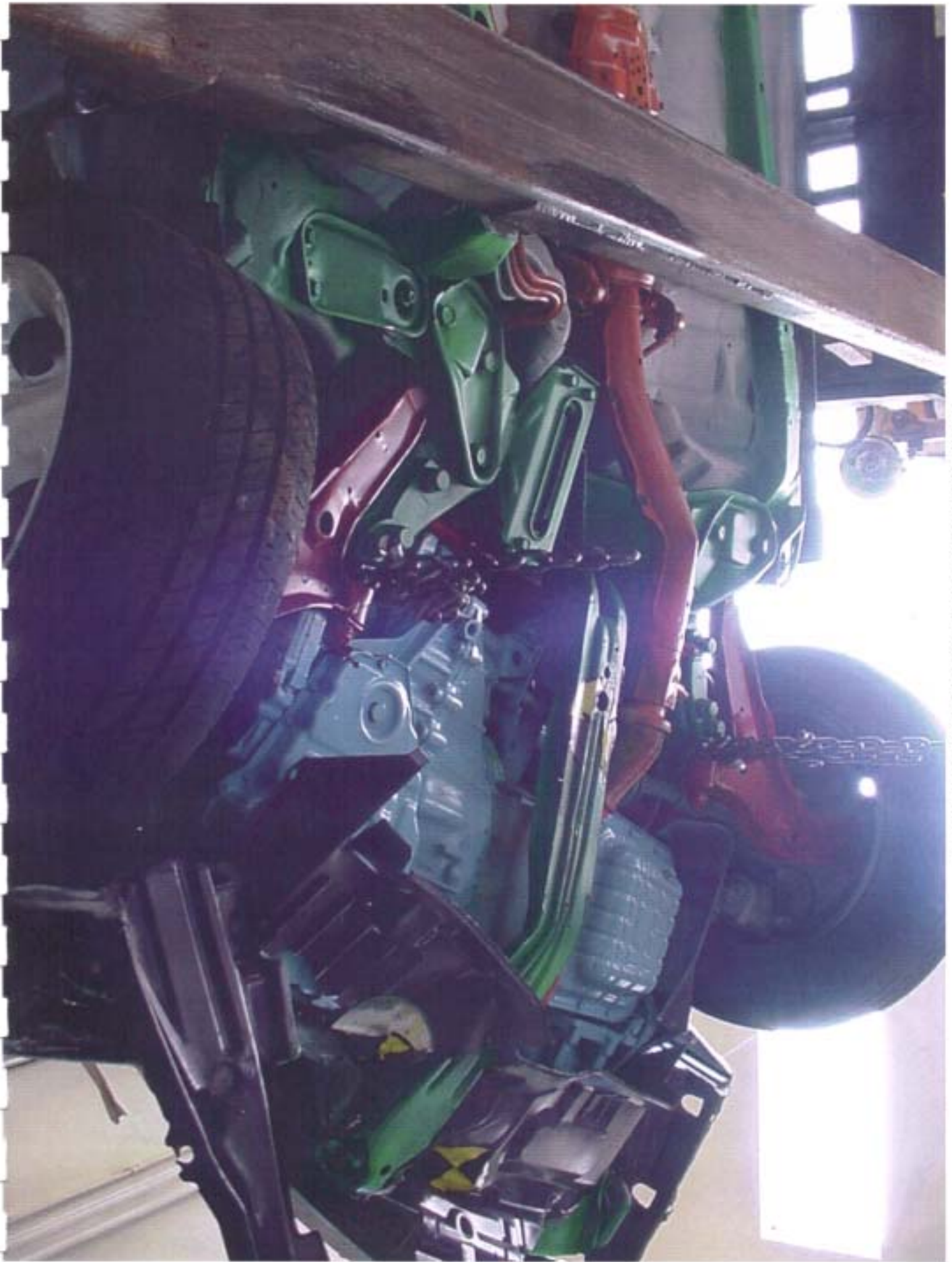

Figure A-18 POST-TEST FRONT SIDE UNDERBODY VIEW

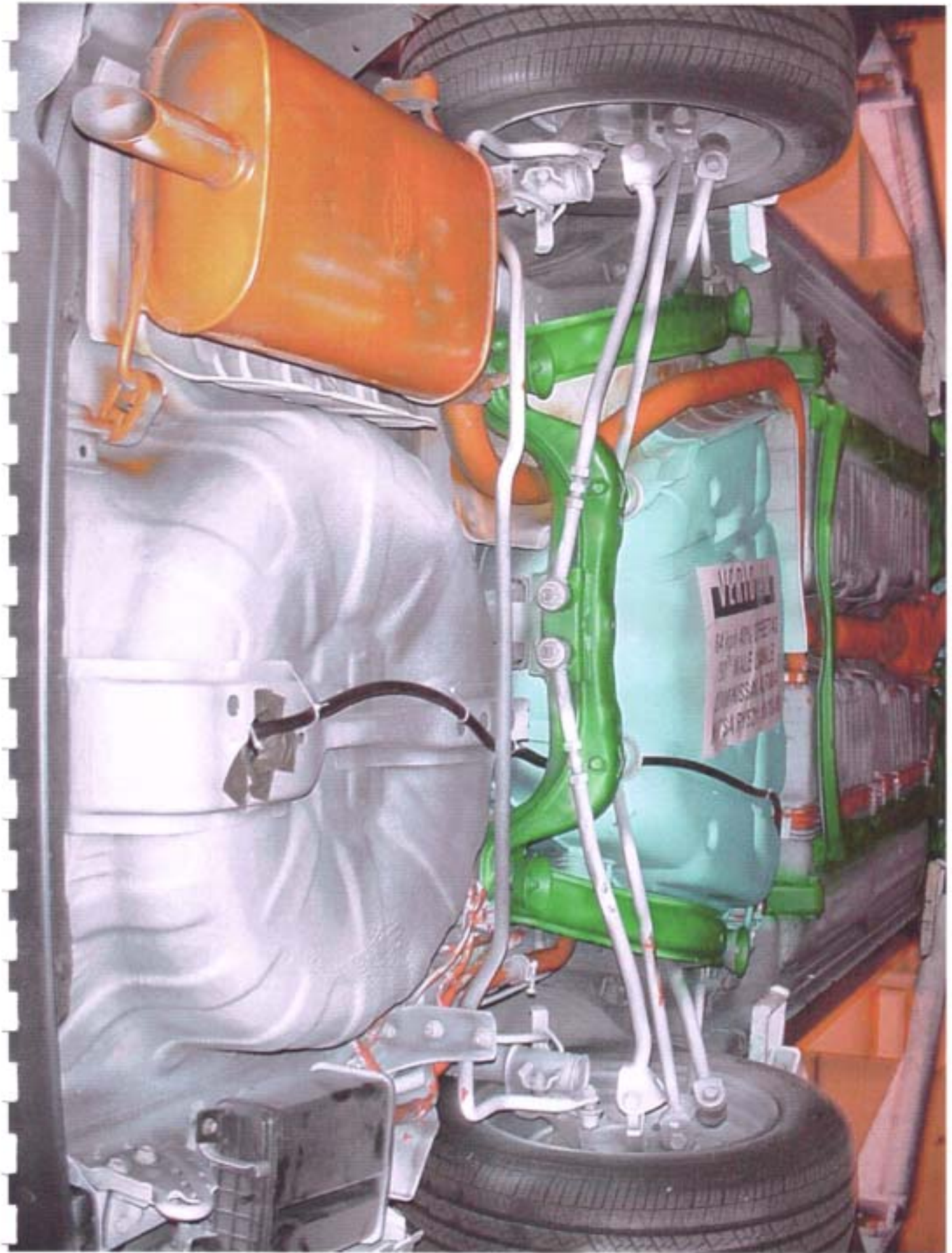

Figure A-19 PRE-TEST REAR UNDERBODY VIEW



Figure A-20 POST-TEST REAR UNDERBODY VIEW



Figure A-21 PRE-TEST DRIVER POSITION VIEW



Figure A-22 POST-TEST DRIVER POSITION VIEW



Figure A-23 PRE-TEST PASSENGER POSITION VIEW



Figure A-24 POST-TEST PASSENGER POSITION VIEW



Figure A-25 PRE-TEST DRIVER AND INTERIOR VIEW



Figure A-26 POST-TEST DRIVER AND INTERIOR VIEW

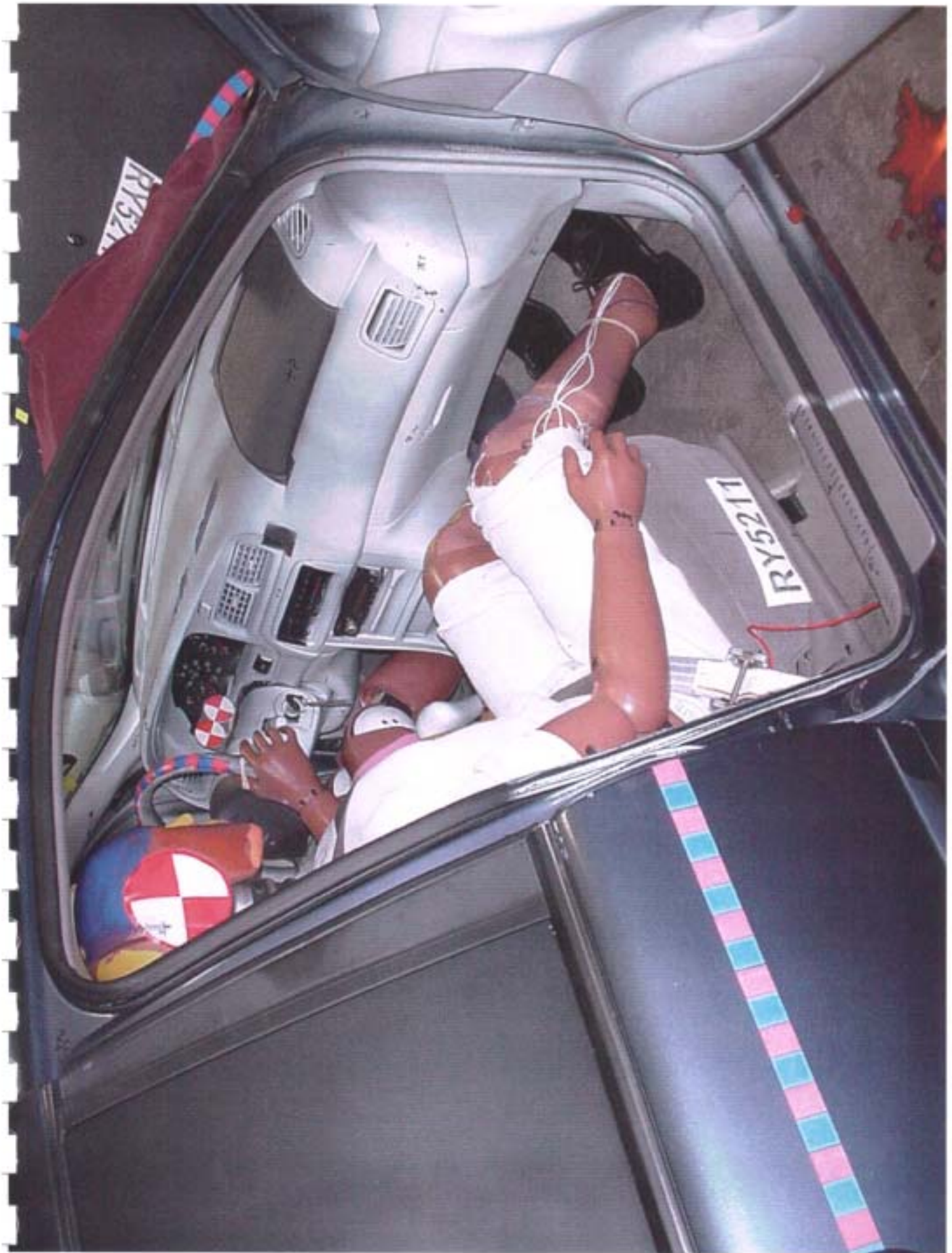

Figure A-27 PRE-TEST PASSENGER AND INTERIOR VIEW



Figure A-28 POST-TEST PASSENGER AND INTERIOR VIEW



Figure A-29 PRE-TEST DRIVER HEAD LOCATION

PHOTOGRAPH NOT AVAILABLE

Figure A-30 POST-TEST DRIVER HEAD LOCATION



Figure A-31 PRE-TEST PASSENGER HEAD LOCATION



Figure A-32 POST-TEST PASSENGER HEAD LOCATION



Figure A-33 PRE-TEST DRIVER FLOOR PAN VIEW



Figure A-34 POST-TEST DRIVER FLOOR PAN VIEW



Figure A-35 PRE-TEST PASSENGER FLOOR PAN VIEW



Figure A-36 POST-TEST PASSENGER FLOOR PAN VIEW



Figure A-37 PRE-TEST BARRIER FRONT VIEW

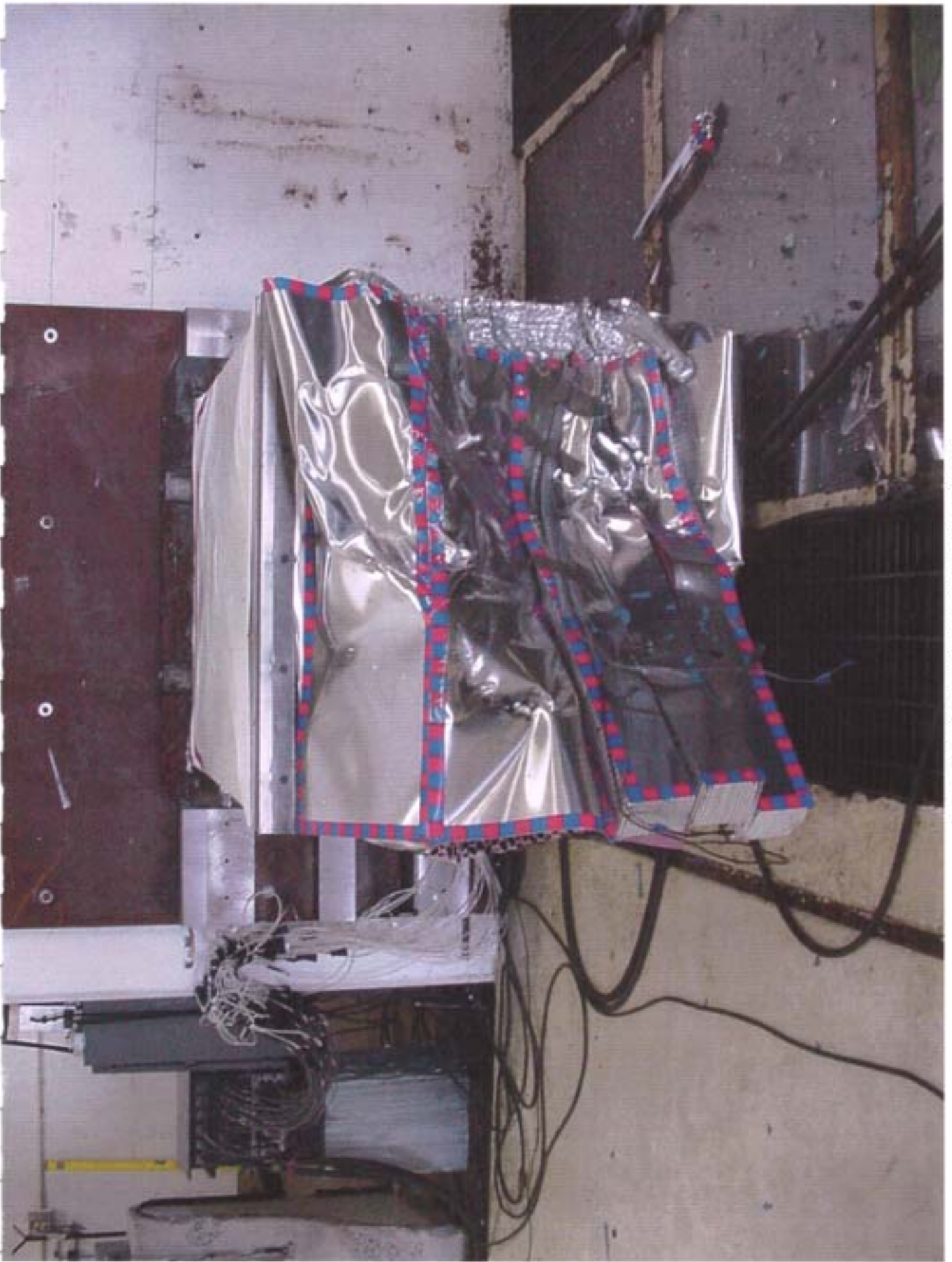

Figure A-38 POST-TEST BARRIER FRONT VIEW

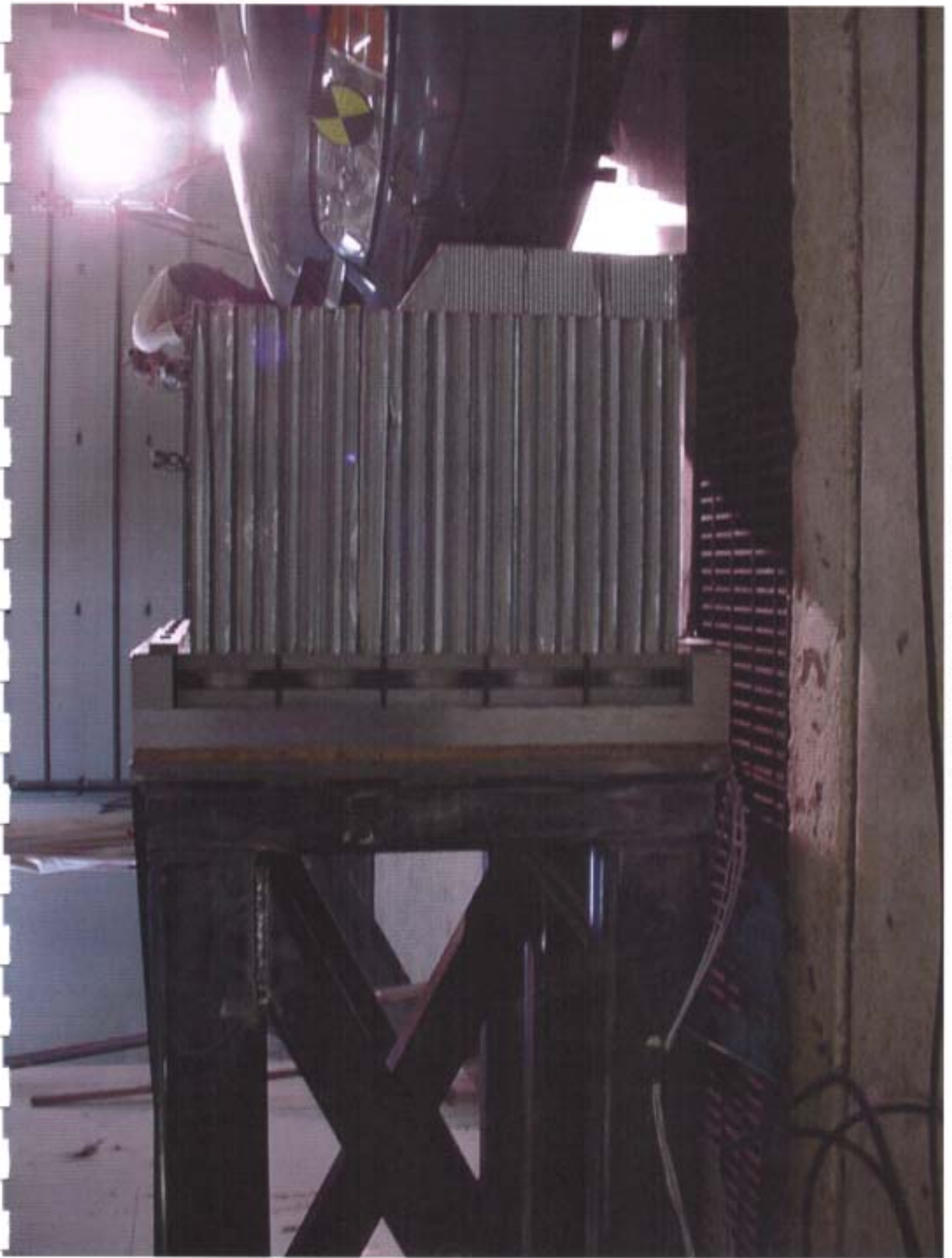

Figure A-39 PRE-TEST BARRIER LEFT SIDE VIEW



Figure A-40 POST-TEST BARRIER LEFTSIDE VIEW



Figure A-41 PRE-TEST BARRIER RIGHT SIDE VIEW



Figure A-42 POST-TESTBARRIER RIGHT SIDE VIEW

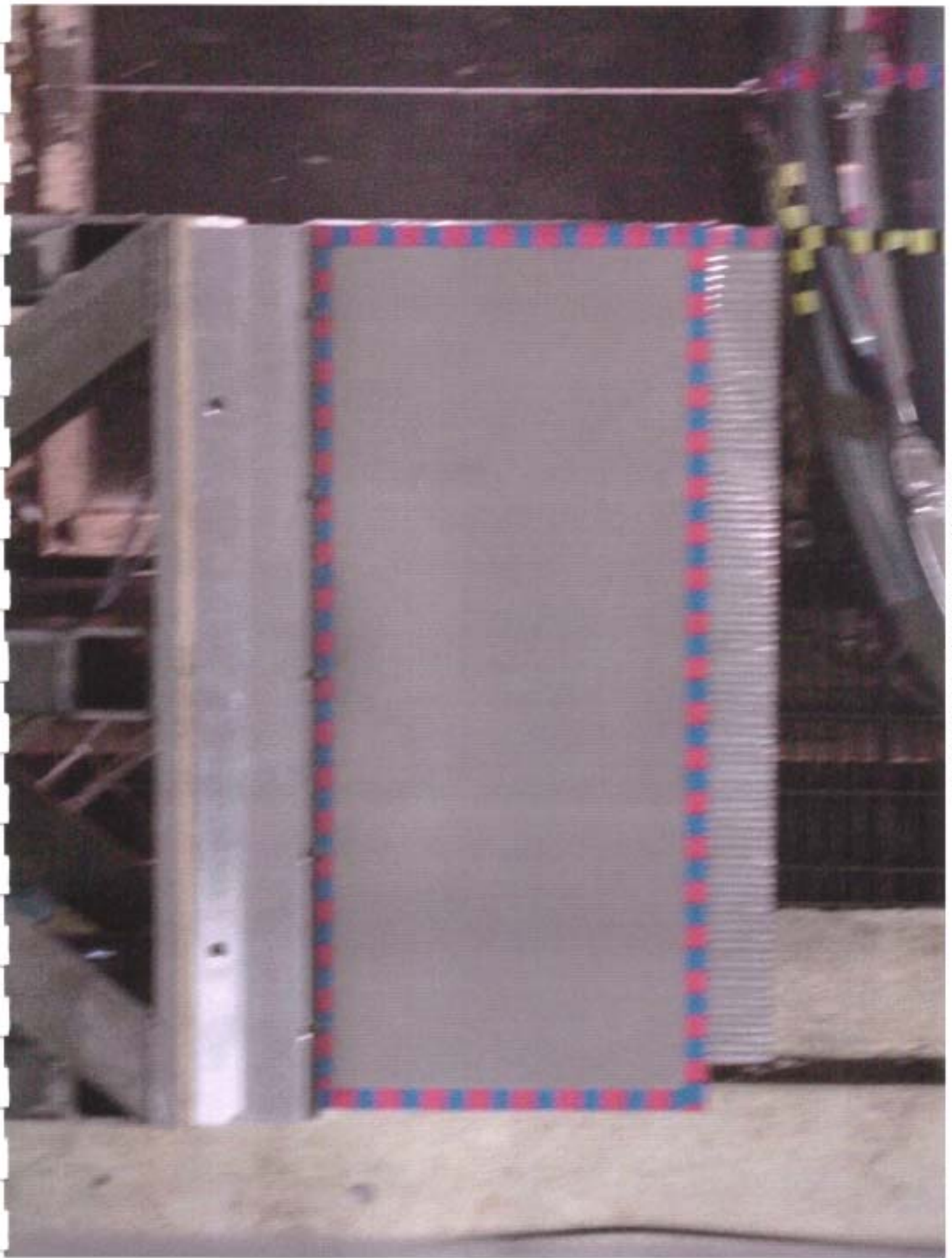

Figure A-43 PRE-TEST BARRIER TOP VIEW

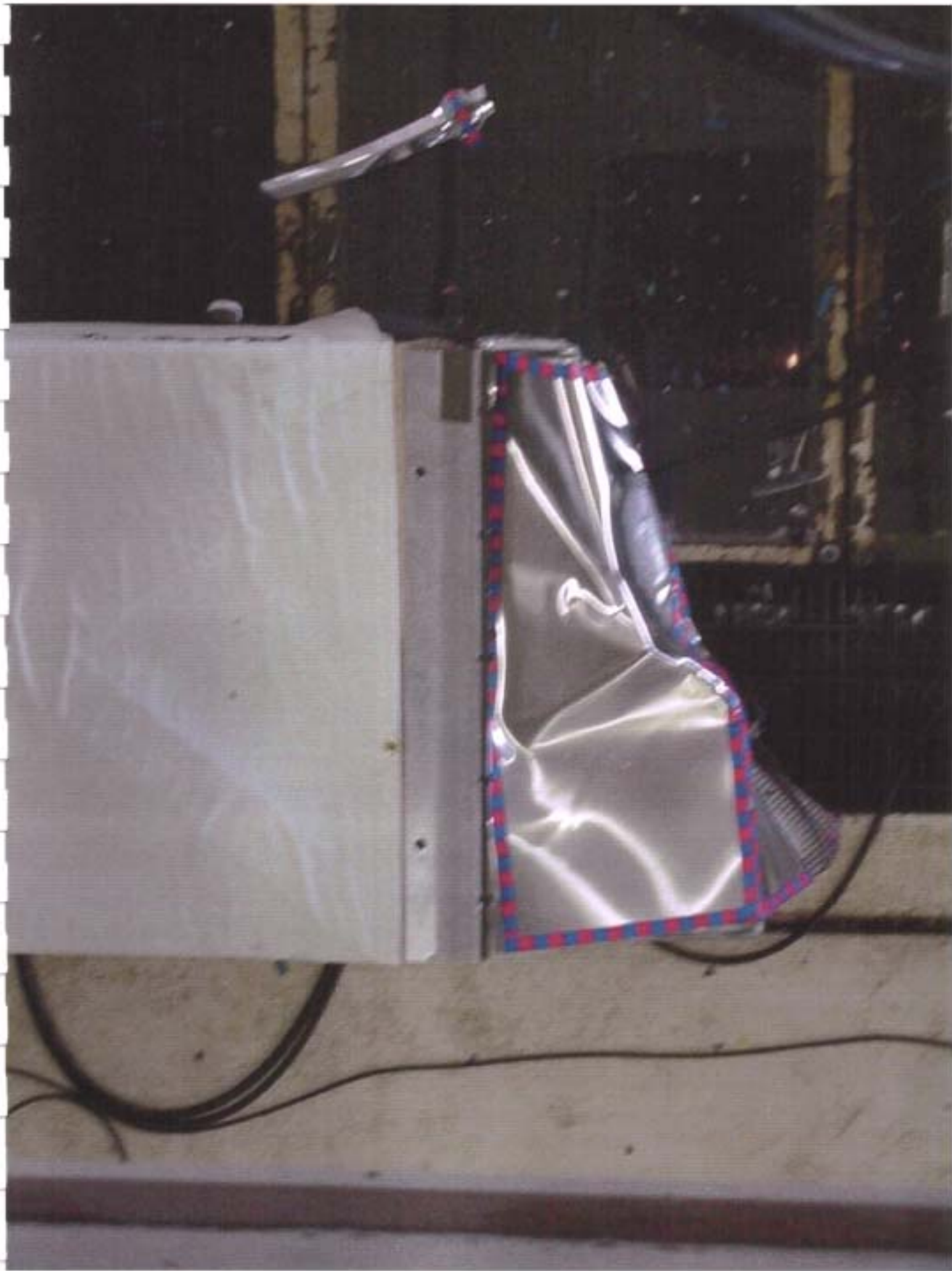

Figure A-44 POST-TEST BARRIER TOP VIEW



Figure A-45 POST-TEST OVERHEAD LEFT VIEW



Figure A-46 ROLLOVER VIEW

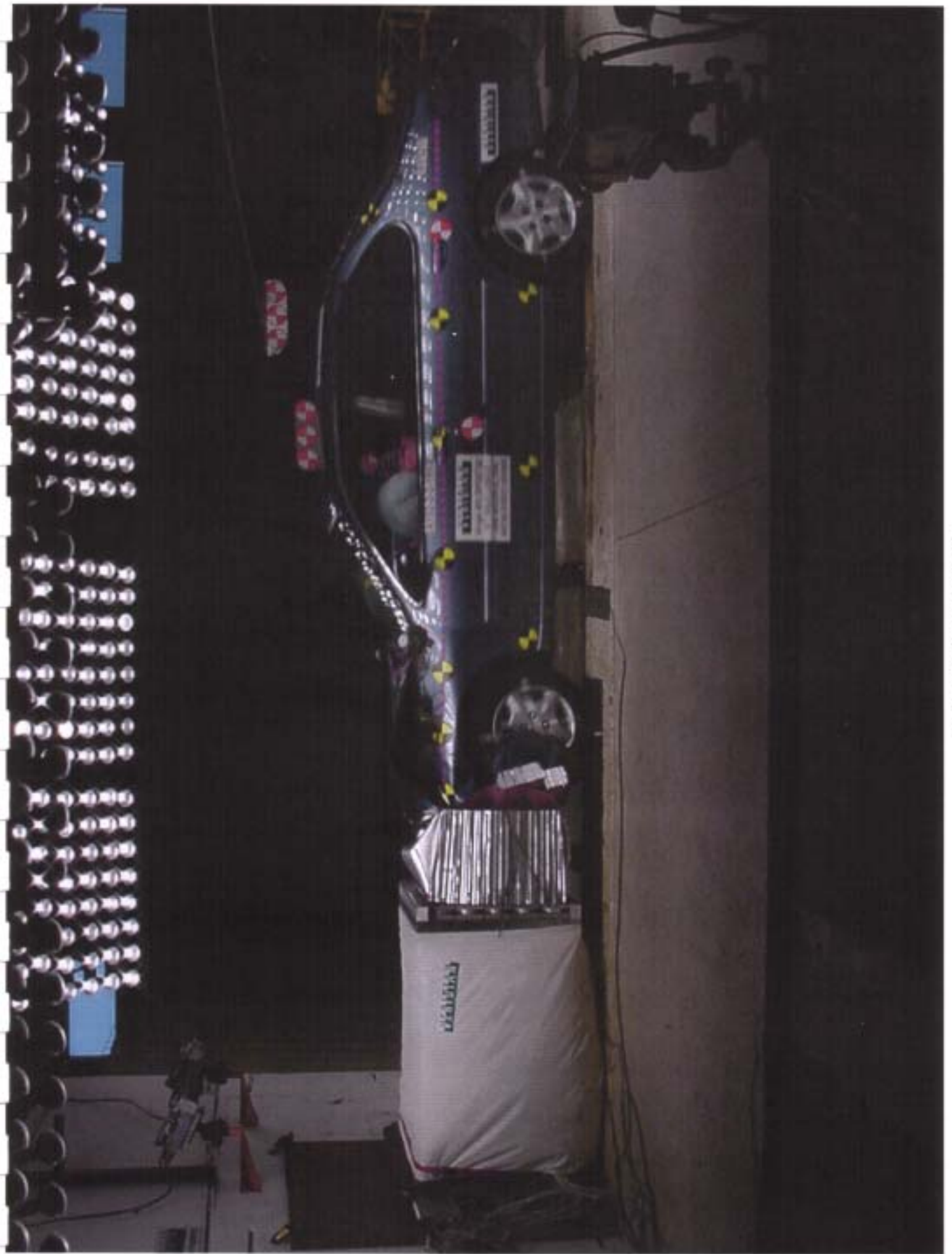

Figure A-47 IMPACT VIEW

**APPENDIX B**

**DUMMY, VEHICLE AND LOAD CELL BARRIER RESPONSE DATA**

**Hybrid III Dummy Sign Conventions  
Load Cells and Special Transducers**

Transducer	SAE Sign Convention (positive unless noted)
Upper Neck Load Cell	Fx Head rearward, Chest Froward Fy Head leftward, Chest rightward Fz Head Upward, Chest Downward Mx Left ear toward left shoulder My Chin toward sternum (flexion) Mz Chin toward left shoulder (look left)
Chest Displacement Potentiometer	Compression is negative
Pelvic Load Cell (Lower Lumbar)	Fx Chest rearward Fy Chest left Fz Spine in tension
Femur Load Cell (right and left leg)	Fx Knee Upward, Upper Femur Downward Fy Knee Rightward, Upper Femur Leftward Fz Knee Forward, Pelvis Rearward Mx Knee Leftward, Hold Upper Femur in Place My Knee Upward, Hold Upper Femur in Place Mz Tibia Leftward, Hold Pelvis in Place
Upper Tibia Load Cell (right and left leg)	Fx Ankle Forward, Knee Rearward Fy Ankle Rightward, Knee Leftward Fz Tibia Downward, Femur Upward Mx Ankle Leftward, Hold Knee in Place My Ankle Forward, Bottom of Knee Clevis Rearward
Lower Tibia Load Cell (right and left leg)	Fx Ankle Forward, Knee Rearward Fy Ankle Rightward, Knee Leftward Fz Tibia Downward, Femur Upward Mx Ankle Leftward, Hold Knee in Place My Ankle Forward, Bottom of Knee Clevis Rearward
Knee Shear Displacement	X Hold Femur Move Tibia Forward
Tibia Mid-Shaft Accelerometer	X Forward Y To the Right
Foot Rotations (left foot)	X Eversion Y Dorsi Flexion Z Internal Rotation
Foot Rotations (right foot)	X Inversion Y Dorsi Flexion Z External Rotation
Foot Accelerometer (right and left foot)	X Forward Y To the Right Z Down

## DATA CHANNEL FILTER CLASS SUMMARY

NHTSA TEST NO. RY5211

<b>DATA TYPE</b>	<b>SAE FILTER CLASS (Hz)</b>
Dummy Head Accelerations	1000
Dummy Neck Forces	1000
Dummy Neck Moments	600
Dummy Chest Accelerations	180
Dummy Chest Displacements	60
Dummy Femur Forces	600
Dummy Femur Moments	600
Dummy Knee Displacement	180
Dummy Tibia Accelerations	600
Dummy Tibia Forces	600
Dummy Tibia Moments	600
Dummy Ankle Rotations	180
Dummy Foot Accelerations	600
Dummy Belt Displacements	180
Dummy Belt Loads	60
Vehicle Accelerations	60
Vehicle Velocity Integrations	180
Vehicle Displacement Integrations	180
Load Cell Barrier Forces	60

### Table of Data Plots

PLOT	PLOT NAME [UNITS, CHANNEL FILTER CLASS]	PAGE
1	P1 Head x [g, CFC_1000]	B- 9
2	P1 Head y [g, CFC_1000]	B- 10
3	P1 Head z [g, CFC_1000]	B- 11
4	P1 Head Resultant [g, CFC_1000]	B- 12
5	P1 Head Red x [g, CFC_1000]	B- 13
6	P1 Head Red y [g, CFC_1000]	B- 14
7	P1 Head Red z [g, CFC_1000]	B- 15
8	P1 Head Red Resultant [g, CFC_1000]	B- 16
9	P1 Upper Neck Fx [N, CFC_1000]	B- 17
10	P1 Upper Neck Fy [N, CFC_1000]	B- 18
11	P1 Upper Neck Fz [N, CFC_1000]	B- 19
12	P1 Upper Neck F Resultant [N, CFC_1000]	B- 20
13	P1 Upper Neck Mx [Nm, CFC_600]	B- 21
14	P1 Upper Neck My [Nm, CFC_600]	B- 22
15	P1 Upper Neck Mz [Nm, CFC_600]	B- 23
16	P1 Upper Neck M Resultant [Nm, CFC_600]	B- 24
17	P1 Chest x [g, CFC_180]	B- 25
18	P1 Chest y [g, CFC_180]	B- 26
19	P1 Chest z [g, CFC_180]	B- 27
20	P1 Chest Resultant [g, CFC_180]	B- 28
21	P1 Chest Red x [g, CFC_180]	B- 29
22	P1 Chest Red y [g, CFC_180]	B- 30
23	P1 Chest Red z [g, CFC_180]	B- 31
24	P1 Chest Red Resultant [g, CFC_180]	B- 32
25	P1 Chest Compression [mm, CFC_600]	B- 33
26	P1 Pelvic x [g, CFC_1000]	B- 34
27	P1 Pelvic y [g, CFC_1000]	B- 35
28	P1 Pelvic z [g, CFC_1000]	B- 36
29	P1 Pelvic Resultant [g, CFC_1000]	B- 37
30	P1 Left Femur Fx [N, CFC_600]	B- 38
31	P1 Left Femur Fy [N, CFC_600]	B- 39
32	P1 Left Femur Fz [N, CFC_600]	B- 40
33	P1 Left Femur F Resultant [N, CFC_600]	B- 41
34	P1 Left Femur Mx [Nm, CFC_600]	B- 42
35	P1 Left Femur My [Nm, CFC_600]	B- 43
36	P1 Left Femur Mz [Nm, CFC_600]	B- 44
37	P1 Left Femur M Resultant [Nm, CFC_600]	B- 45
38	P1 Right Femur Fx [N, CFC_600]	B- 46
39	P1 Right Femur Fy [N, CFC_600]	B- 47
40	P1 Right Femur Fz [N, CFC_600]	B- 48
41	P1 Right Femur F Resultant [N, CFC_600]	B- 49
42	P1 Right Femur Mx [Nm, CFC_600]	B- 50
43	P1 Right Femur My [Nm, CFC_600]	B- 51
44	P1 Right Femur Mz [Nm, CFC_600]	B- 52
45	P1 Right Femur M Resultant [Nm, CFC_600]	B- 53
46	P1 Left Knee Shear Dx [mm, CFC_180]	B- 54
47	P1 Right Knee Shear Dx [mm, CFC_180]	B- 55
48	P1 Left Upper Tibia Fx [N, CFC_600]	B- 56
49	P1 Left Upper Tibia Fz [N, CFC_600]	B- 57
50	P1 Left Upper Tibia Mx [Nm, CFC_600]	B- 58

51	P1 Left Upper Tibia My [Nm, CFC_600]	B- 59
52	P1 Left Lower Tibia Fx [N, CFC_600]	B- 60
53	P1 Left Lower Tibia Fy [N, CFC_600]	B- 61
54	P1 Left Lower Tibia Fz [N, CFC_600]	B- 62
55	P1 Left Lower Tibia F Resultant [N, CFC_600]	B- 63
56	P1 Left Lower Tibia Mx [Nm, CFC_600]	B- 64
57	P1 Left Lower Tibia My [Nm, CFC_600]	B- 65
58	P1 Right Upper Tibia Fx [N, CFC_600]	B- 66
59	P1 Right Upper Tibia Fz [N, CFC_600]	B- 67
60	P1 Right Upper Tibia Mx [Nm, CFC_600]	B- 68
61	P1 Right Upper Tibia My [Nm, CFC_600]	B- 69
62	P1 Right Lower Tibia Fx [N, CFC_600]	B- 70
63	P1 Right Lower Tibia Fy [N, CFC_600]	B- 71
64	P1 Right Lower Tibia Fz [N, CFC_600]	B- 72
65	P1 Right Lower Tibia F Resultant [N, CFC_600]	B- 73
66	P1 Right Lower Tibia Mx [Nm, CFC_600]	B- 74
67	P1 Right Lower Tibia My [Nm, CFC_600]	B- 75
68	P1 Left Tibia Ax [g, CFC_600]	B- 76
69	P1 Left Tibia Ay [g, CFC_600]	B- 77
70	P1 Right Tibia Ax [g, CFC_600]	B- 78
71	P1 Right Tibia Ay [g, CFC_600]	B- 79
72	P1 Left Ankle Rotation x [Deg, CFC_180]	B- 80
73	P1 Left Ankle Rotation y [Deg, CFC_180]	B- 81
74	P1 Left Ankle Rotation z [Deg, CFC_180]	B- 82
75	P1 Right Ankle Rotation x [Deg, CFC_180]	B- 83
76	P1 Right Ankle Rotation y [Deg, CFC_180]	B- 84
77	P1 Right Ankle Rotation z [Deg, CFC_180]	B- 85
78	P1 Left Foot Ax [g, CFC_600]	B- 86
79	P1 Left Foot Ay [g, CFC_600]	B- 87
80	P1 Left Foot Az [g, CFC_600]	B- 88
81	P1 Left Foot A Resultant [g, CFC_600]	B- 89
82	P1 Right Foot Ax [g, CFC_600]	B- 90
83	P1 Right Foot Ay [g, CFC_600]	B- 91
84	P1 Right Foot Az [g, CFC_600]	B- 92
85	P1 Right Foot A Resultant [g, CFC_600]	B- 93
86	P1 Lap Belt Force [N, CFC_60]	B- 94
87	P1 Torso Belt Spoolout [mm, CFC_180]	B- 95
88	P2 Head x [g, CFC_1000]	B- 96
89	P2 Head y [g, CFC_1000]	B- 97
90	P2 Head z [g, CFC_1000]	B- 98
91	P2 Head Resultant [g, CFC_1000]	B- 99
92	P2 Head Red x [g, CFC_1000]	B- 100
93	P2 Head Red y [g, CFC_1000]	B- 101
94	P2 Head Red z [g, CFC_1000]	B- 102
95	P2 Head Red Resultant [g, CFC_1000]	B- 103
96	P2 Upper Neck Fx [N, CFC_1000]	B- 104
97	P2 Upper Neck Fy [N, CFC_1000]	B- 105
98	P2 Upper Neck Fz [N, CFC_1000]	B- 106
99	P2 Upper Neck F Resultant [N, CFC_1000]	B- 107
100	P2 Upper Neck Mx [Nm, CFC_600]	B- 108
101	P2 Upper Neck My [Nm, CFC_600]	B- 109
102	P2 Upper Neck Mz [Nm, CFC_600]	B- 110
103	P2 Upper Neck M Resultant [Nm, CFC_600]	B- 111
104	P2 Chest x [g, CFC_180]	B- 112

105	P2 Chest y [g, CFC_180]	B- 113
106	P2 Chest z [g, CFC_180]	B- 114
107	P2 Chest Resultant [g, CFC_180]	B- 115
108	P2 Chest Red x [g, CFC_180]	B- 116
109	P2 Chest Red y [g, CFC_180]	B- 117
110	P2 Chest Red z [g, CFC_180]	B- 118
111	P2 Chest Red Resultant [g, CFC_180]	B- 119
112	P2 Chest Compression [mm, CFC_600]	B- 120
113	P2 Pelvic x [g, CFC_1000]	B- 121
114	P2 Pelvic y [g, CFC_1000]	B- 122
115	P2 Pelvic z [g, CFC_1000]	B- 123
116	P2 Pelvic Resultant [g, CFC_1000]	B- 124
117	P2 Left Femur Fx [N, CFC_600]	B- 125
118	P2 Left Femur Fy [N, CFC_600]	B- 126
119	P2 Left Femur Fz [N, CFC_600]	B- 127
120	P2 Left Femur F Resultant [N, CFC_600]	B- 128
121	P2 Left Femur Mx [Nm, CFC_600]	B- 129
122	P2 Left Femur My [Nm, CFC_600]	B- 130
123	P2 Left Femur Mz [Nm, CFC_600]	B- 131
124	P2 Left Femur M Resultant [Nm, CFC_600]	B- 132
125	P2 Right Femur Fx [N, CFC_600]	B- 133
126	P2 Right Femur Fy [N, CFC_600]	B- 134
127	P2 Right Femur Fz [N, CFC_600]	B- 135
128	P2 Right Femur F Resultant [N, CFC_600]	B- 136
129	P2 Right Femur Mx [Nm, CFC_600]	B- 137
130	P2 Right Femur My [Nm, CFC_600]	B- 138
131	P2 Right Femur Mz [Nm, CFC_600]	B- 139
132	P2 Right Femur M Resultant [Nm, CFC_600]	B- 140
133	P2 Left Knee Shear Dx [mm, CFC_180]	B- 141
134	P2 Right Knee Shear Dx [mm, CFC_180]	B- 142
135	P2 Left Upper Tibia Fx [N, CFC_600]	B- 143
136	P2 Left Upper Tibia Fy [N, CFC_600]	B- 144
137	P2 Left Upper Tibia Fz [N, CFC_600]	B- 145
138	P2 Left Upper Tibia F Resultant [N, CFC_600]	B- 146
139	P2 Left Upper Tibia Mx [Nm, CFC_600]	B- 147
140	P2 Left Upper Tibia My [Nm, CFC_600]	B- 148
141	P2 Left Lower Tibia Fx [N, CFC_600]	B- 149
142	P2 Left Lower Tibia Fy [N, CFC_600]	B- 150
143	P2 Left Lower Tibia Fz [N, CFC_600]	B- 151
144	P2 Left Lower Tibia F Resultant [N, CFC_600]	B- 152
145	P2 Left Lower Tibia Mx [Nm, CFC_600]	B- 153
146	P2 Left Lower Tibia My [Nm, CFC_600]	B- 154
147	P2 Right Upper Tibia Fx [N, CFC_600]	B- 155
148	P2 Right Upper Tibia Fy [N, CFC_600]	B- 156
149	P2 Right Upper Tibia Fz [N, CFC_600]	B- 157
150	P2 Right Upper Tibia F Resultant [N, CFC_600]	B- 158
151	P2 Right Upper Tibia Mx [Nm, CFC_600]	B- 159
152	P2 Right Upper Tibia My [Nm, CFC_600]	B- 160
153	P2 Right Lower Tibia Fx [N, CFC_600]	B- 161
154	P2 Right Lower Tibia Fy [N, CFC_600]	B- 162
155	P2 Right Lower Tibia Fz [N, CFC_600]	B- 163
156	P2 Right Lower Tibia F Resultant [N, CFC_600]	B- 164
157	P2 Right Lower Tibia Mx [Nm, CFC_600]	B- 165
158	P2 Right Lower Tibia My [Nm, CFC_600]	B- 166

159	P2 Left Foot Ax [g, CFC_600]	B- 167
160	P2 Left Foot Az [g, CFC_600]	B- 168
161	P2 Left Toe Az [g, CFC_600]	B- 169
162	P2 Right Foot Ax [g, CFC_600]	B- 170
163	P2 Right Foot Az [g, CFC_600]	B- 171
164	P2 Right Toe Az [g, CFC_600]	B- 172
165	P2 Lap Belt Force [N, CFC_60]	B- 173
166	P2 Torso Belt Spoolout [mm, CFC_180]	B- 174
167	Acc 1 Rear XMBR Left X [g, CFC_60]	B- 175
168	Acc 1 Rear XMBR Left X Velocity [kph, CFC_180]	B- 176
169	Acc 1 Rear XMBR Left X Displacement [mm, CFC_180]	B- 177
170	Acc 2 Rear XMBR Left Y [g, CFC_60]	B- 178
171	Acc 2 Rear XMBR Left Y Velocity [kph, CFC_180]	B- 179
172	Acc 2 Rear XMBR Left Y Displacement [mm, CFC_180]	B- 180
173	Acc 3 Rear XMBR Right X [g, CFC_60]	B- 181
174	Acc 3 Rear XMBR Right X Velocity [kph, CFC_180]	B- 182
175	Acc 3 Rear XMBR Right X Displacement [mm, CFC_180]	B- 183
176	Acc 4 Rear XMBR Right Y [g, CFC_60]	B- 184
177	Acc 4 Rear XMBR Right Y Velocity [kph, CFC_180]	B- 185
178	Acc 4 Rear XMBR Right Y Displacement [mm, CFC_180]	B- 186
179	Acc 5 P1 Toepan Left X [g, CFC_60]	B- 187
180	Acc 5 P1 Toepan Left X Velocity [kph, CFC_180]	B- 188
181	Acc 5 P1 Toepan Left X Displacement [mm, CFC_180]	B- 189
182	Acc 6 P1 Toepan Left Z [g, CFC_60]	B- 190
183	Acc 6 P1 Toepan Left Z Velocity [kph, CFC_180]	B- 191
184	Acc 6 P1 Toepan Left Z Displacement [mm, CFC_180]	B- 192
185	Acc 7 P1 Toepan Right X [g, CFC_60]	B- 193
186	Acc 7 P1 Toepan Right X Velocity [kph, CFC_180]	B- 194
187	Acc 7 P1 Toepan Right X Displacement [mm, CFC_180]	B- 195
188	Acc 8 P1 Toepan Right Z [g, CFC_60]	B- 196
189	Acc 8 P1 Toepan Right Z Velocity [kph, CFC_180]	B- 197
190	Acc 8 P1 Toepan Right Z Displacement [mm, CFC_180]	B- 198
191	Acc 9 Trunk Z [g, CFC_60]	B- 199
192	Acc 9 Trunk Z Velocity [kph, CFC_180]	B- 200
193	Acc 9 Trunk Z Displacement [mm, CFC_180]	B- 201
194	Barrier Load Cell E1 FY [N, CFC_60]	B- 202
195	Barrier Load Cell E2 FY [N, CFC_60]	B- 203
196	Barrier Load Cell E3 FY [N, CFC_60]	B- 204
197	Barrier Load Cell E4 FY [N, CFC_60]	B- 205
198	Barrier Load Cell E5 FY [N, CFC_60]	B- 206
199	Barrier Load Cell E6 FY [N, CFC_60]	B- 207
200	Barrier Load Cell E1 FX [N, CFC_60]	B- 208
201	Barrier Load Cell E2 FX [N, CFC_60]	B- 209
202	Barrier Load Cell E3 FX [N, CFC_60]	B- 210
203	Barrier Load Cell E4 FX [N, CFC_60]	B- 211
204	Barrier Load Cell E5 FX [N, CFC_60]	B- 212
205	Barrier Load Cell E6 FX [N, CFC_60]	B- 213
206	Barrier Load Cell D1 FY [N, CFC_60]	B- 214
207	Barrier Load Cell D2 FY [N, CFC_60]	B- 215
208	Barrier Load Cell D3 FY [N, CFC_60]	B- 216
209	Barrier Load Cell D4 FY [N, CFC_60]	B- 217
210	Barrier Load Cell D5 FY [N, CFC_60]	B- 218
211	Barrier Load Cell D6 FY [N, CFC_60]	B- 219
212	Barrier Load Cell D1 FX [N, CFC_60]	B- 220

213	Barrier Load Cell D2 FX [N, CFC_60]	B- 221
214	Barrier Load Cell D3 FX [N, CFC_60]	B- 222
215	Barrier Load Cell D4 FX [N, CFC_60]	B- 223
216	Barrier Load Cell D5 FX [N, CFC_60]	B- 224
217	Barrier Load Cell D6 FX [N, CFC_60]	B- 225
218	Barrier Load Cell C1 FY [N, CFC_60]	B- 226
219	Barrier Load Cell C2 FY [N, CFC_60]	B- 227
220	Barrier Load Cell C3 FY [N, CFC_60]	B- 228
221	Barrier Load Cell C4 FY [N, CFC_60]	B- 229
222	Barrier Load Cell C5 FY [N, CFC_60]	B- 230
223	Barrier Load Cell C6 FY [N, CFC_60]	B- 231
224	Barrier Load Cell C1 FX [N, CFC_60]	B- 232
225	Barrier Load Cell C2 FX [N, CFC_60]	B- 233
226	Barrier Load Cell C3 FX [N, CFC_60]	B- 234
227	Barrier Load Cell C4 FX [N, CFC_60]	B- 235
228	Barrier Load Cell C5 FX [N, CFC_60]	B- 236
229	Barrier Load Cell C6 FX [N, CFC_60]	B- 237
230	Barrier Load Cell B1 FY [N, CFC_60]	B- 238
231	Barrier Load Cell B2 FY [N, CFC_60]	B- 239
232	Barrier Load Cell B3 FY [N, CFC_60]	B- 240
233	Barrier Load Cell B4 FY [N, CFC_60]	B- 241
234	Barrier Load Cell B5 FY [N, CFC_60]	B- 242
235	Barrier Load Cell B6 FY [N, CFC_60]	B- 243
236	Barrier Load Cell B1 FX [N, CFC_60]	B- 244
237	Barrier Load Cell B2 FX [N, CFC_60]	B- 245
238	Barrier Load Cell B3 FX [N, CFC_60]	B- 246
239	Barrier Load Cell B4 FX [N, CFC_60]	B- 247
240	Barrier Load Cell B5 FX [N, CFC_60]	B- 248
241	Barrier Load Cell B6 FX [N, CFC_60]	B- 249
242	Barrier Load Cell A1 FX [N, CFC_60]	B- 250
243	Barrier Load Cell A2 FX [N, CFC_60]	B- 251
244	Barrier Load Cell A3 FX [N, CFC_60]	B- 252
245	Barrier Load Cell A4 FX [N, CFC_60]	B- 253
246	Barrier Load Cell A5 FX [N, CFC_60]	B- 254
247	Barrier Load Cell A6 FX [N, CFC_60]	B- 255

40% Frontal Offset Test #2 - 2000 Nissan Altima

Max: 4.7 [g] at 0.166 [s]  
Min: -39.7 [g] at 0.104 [s]

P1 Head x

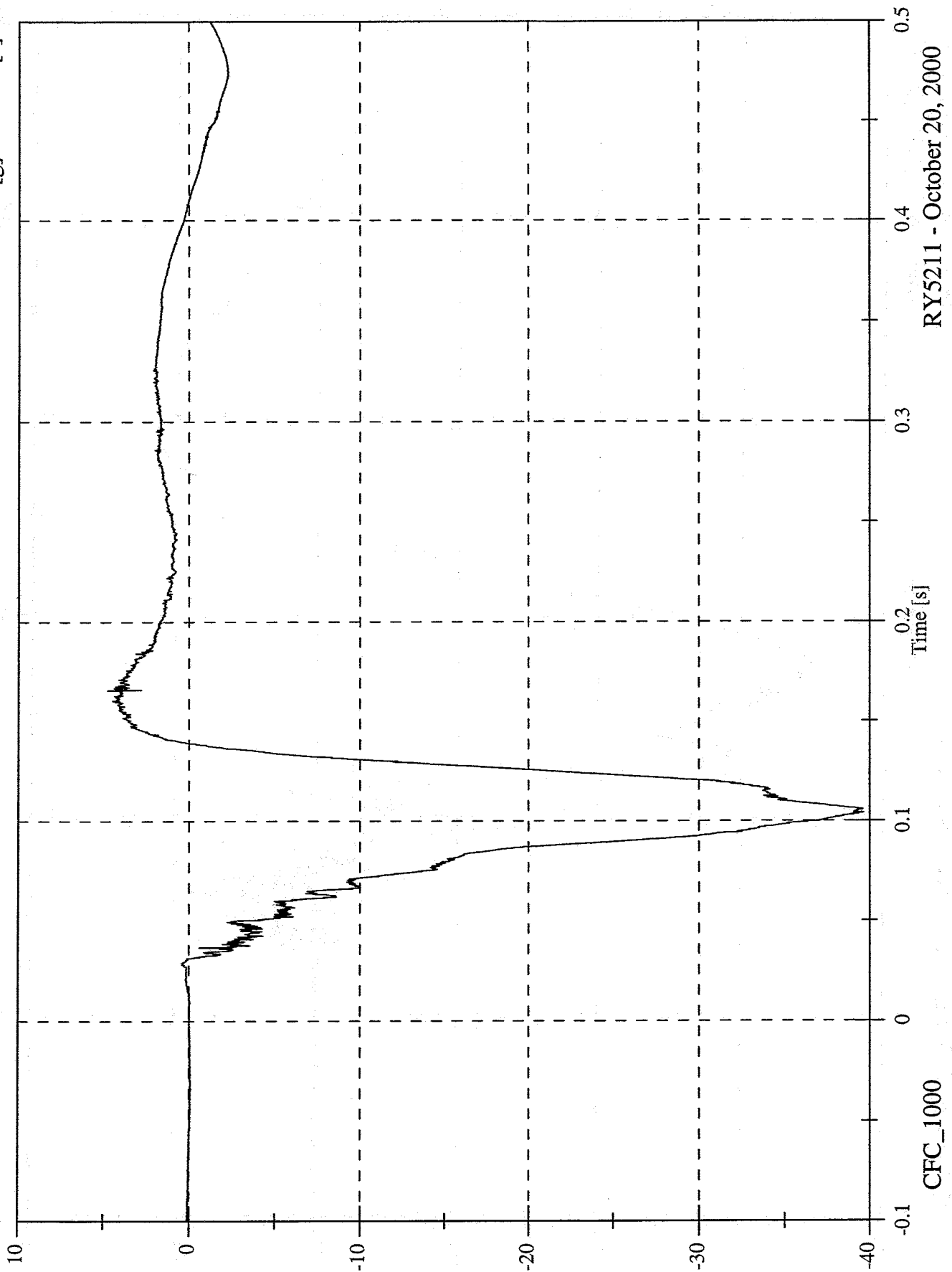

RYS211 - October 20, 2000

40% Frontal Offset Test #2 - 2000 Nissan Altima

Max: 8.8 [g] at 0.181 [s]  
Min: -3.0 [g] at 0.294 [s]

PI Head y

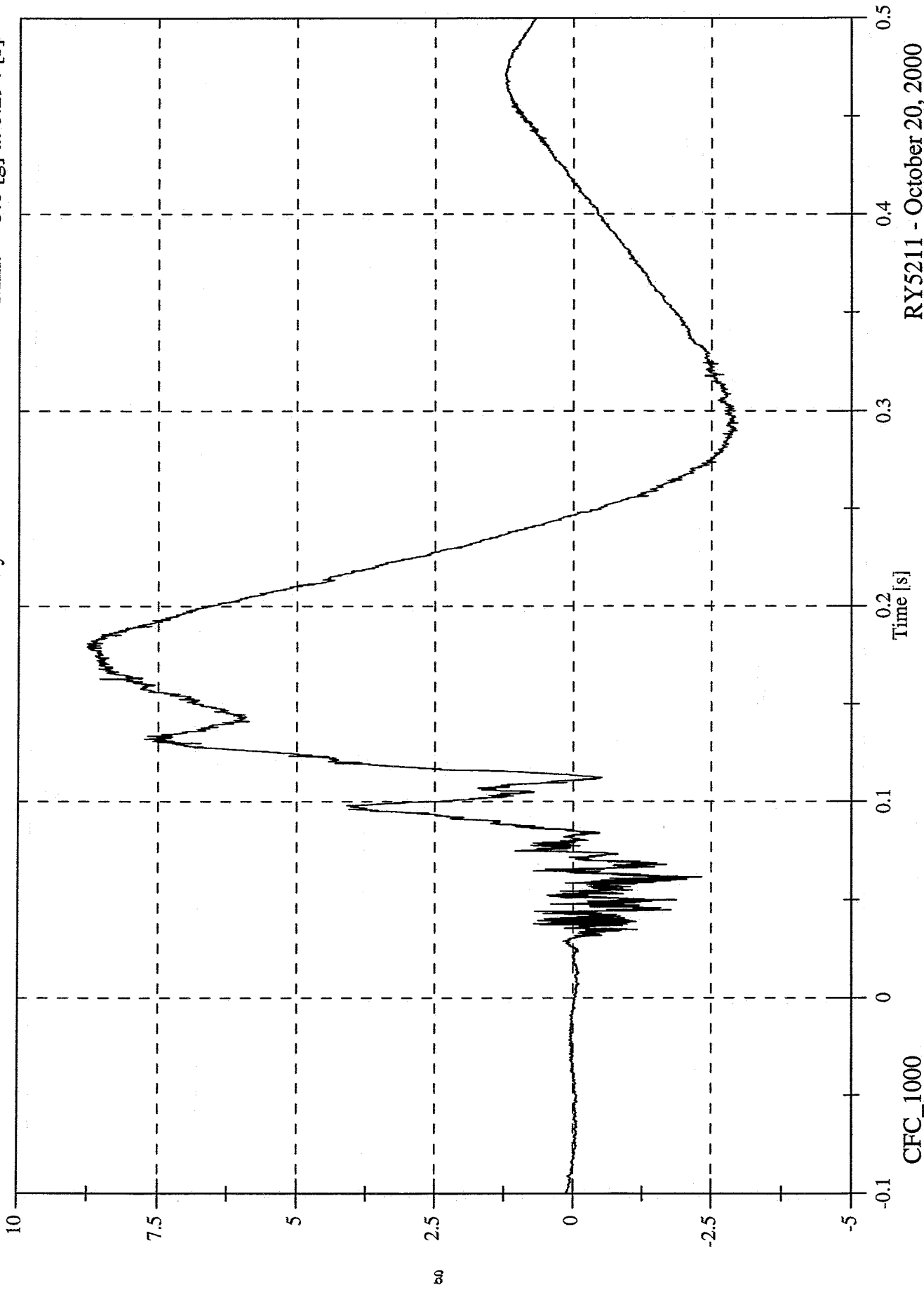

RY5211 - October 20, 2000

40% Frontal Offset Test #2 - 2000 Nissan Altima

Max: 15.7 [g] at 0.104 [s]  
Min: -4.9 [g] at 0.133 [s]

P1 Head z

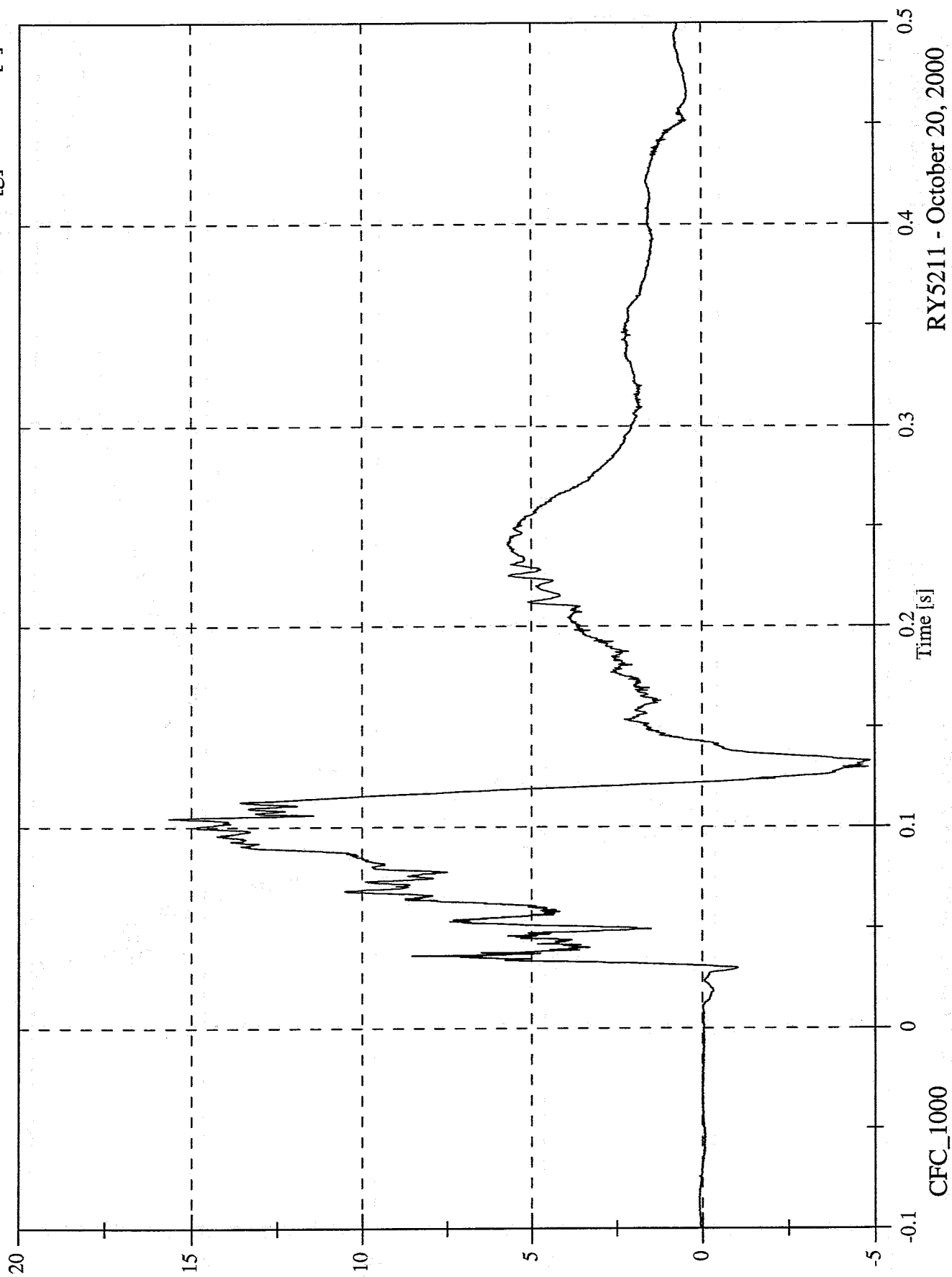

R Y5211 - October 20, 2000

40% Frontal Offset Test #2 - 2000 Nissan Altima

P1 Head Resultant

Max: 42.4 [g] at 0.104 [s]

Min: 0.0 [g] at -0.040 [s]

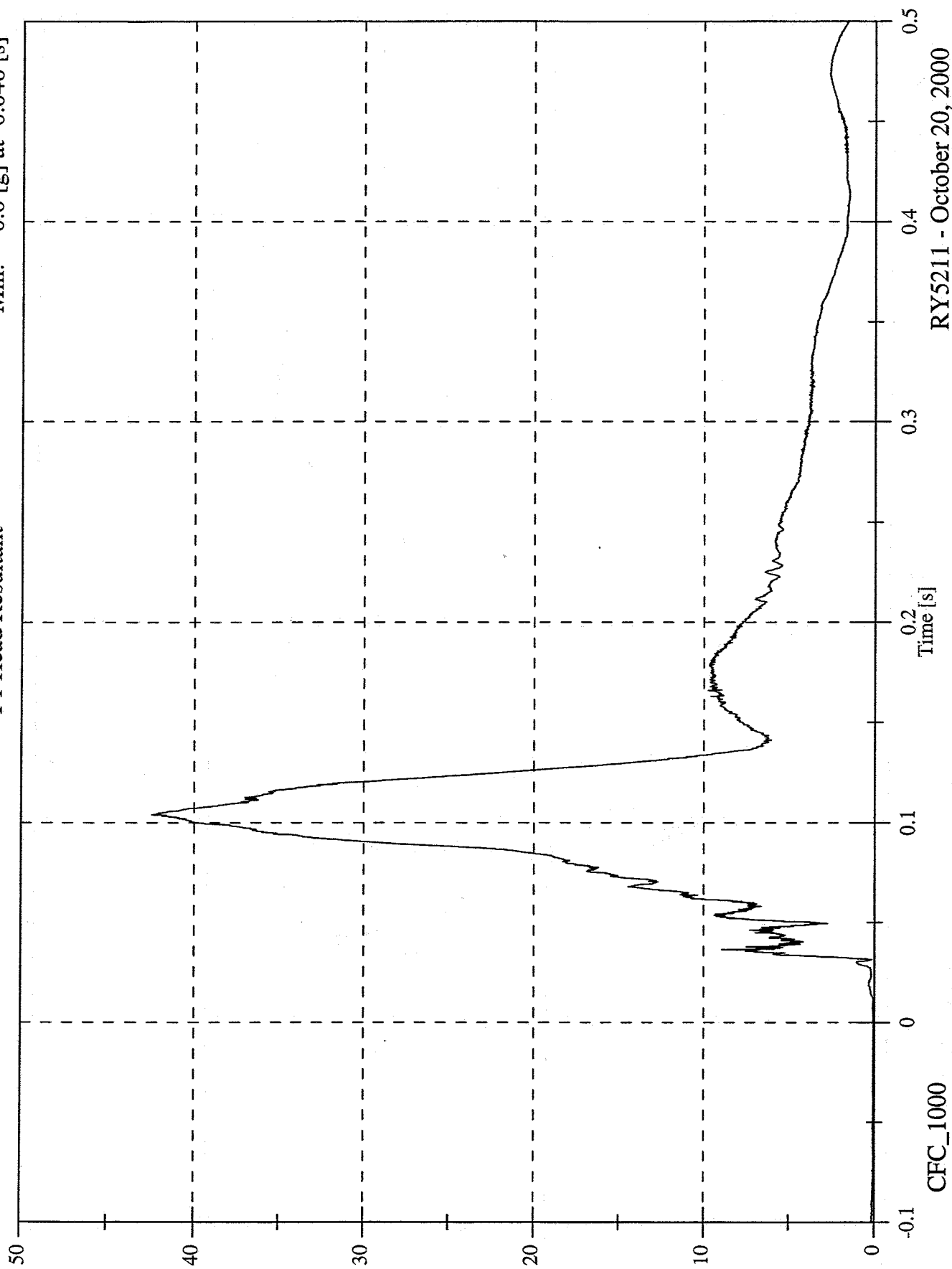

RYS211 - October 20, 2000

40% Frontal Offset Test #2 - 2000 Nissan Altima

Max: 4.3 [g] at 0.161 [s]  
Min: -39.8 [g] at 0.104 [s]

P1 Head Red x

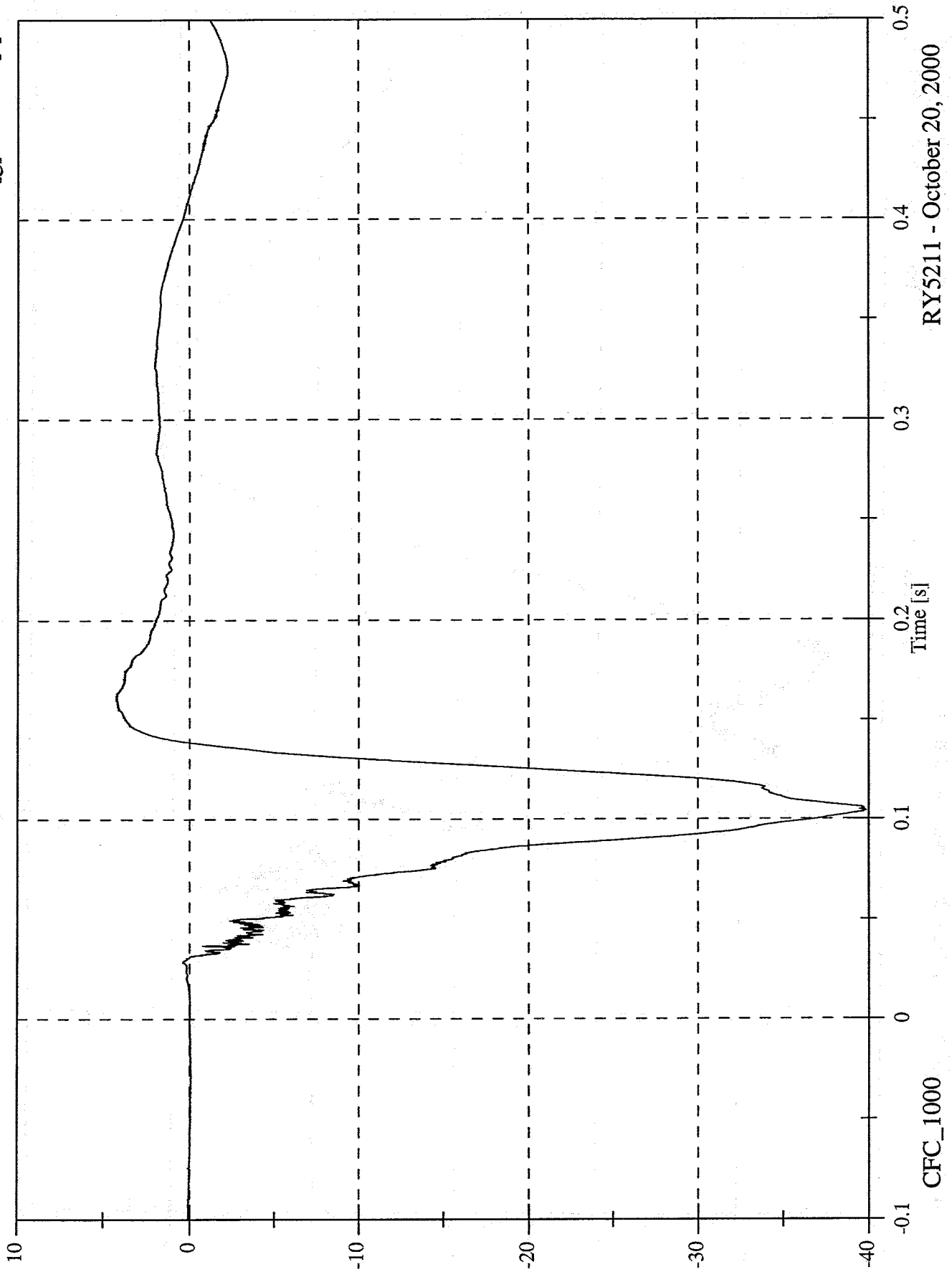

RY5211 - October 20, 2000

40% Frontal Offset Test #2 - 2000 Nissan Altima

Max: 9.2 [g] at 0.182 [s]  
Min: -3.0 [g] at 0.305 [s]

P1 Head Red y

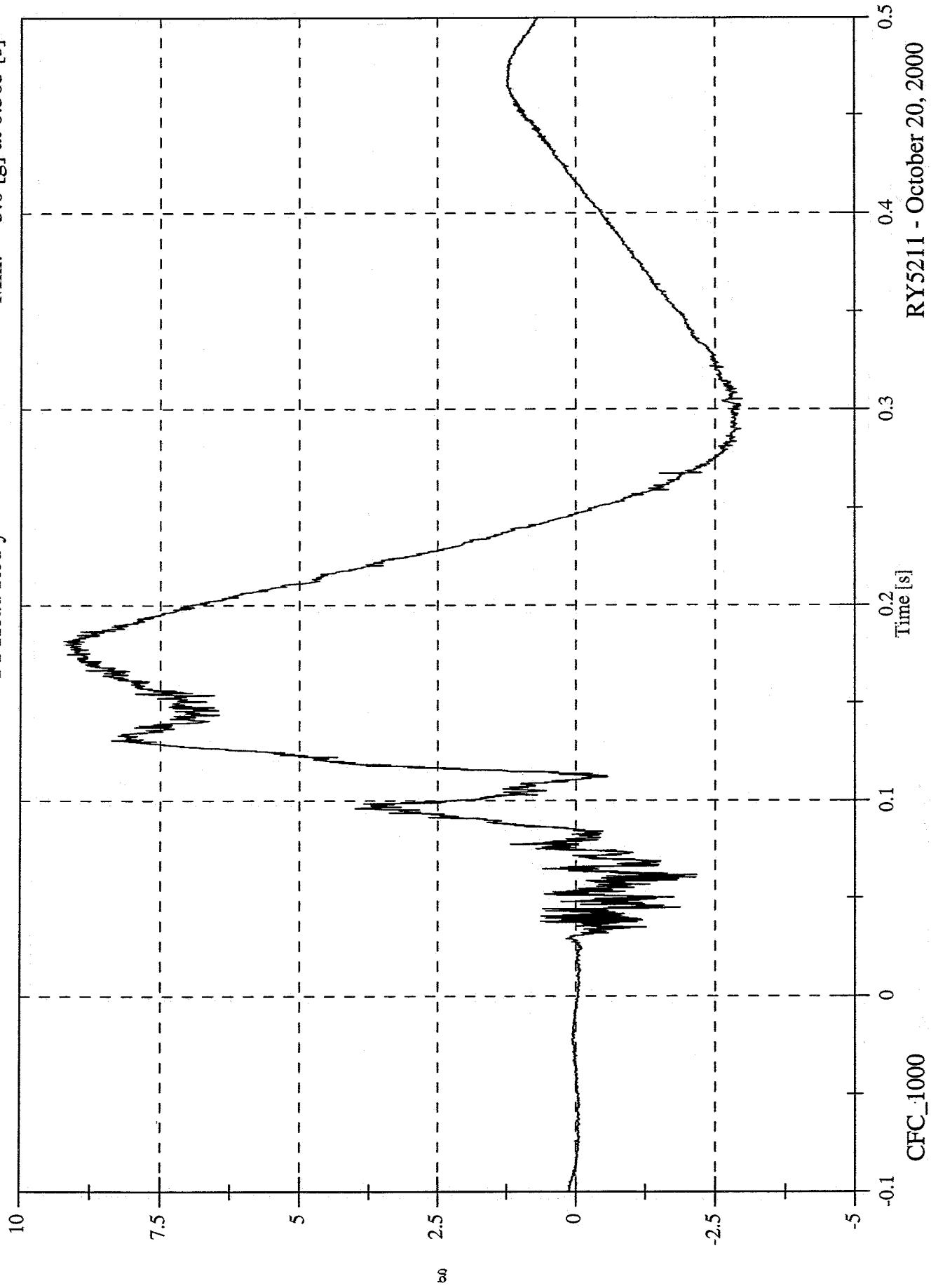

R Y5211 - October 20, 2000

40% Frontal Offset Test #2 - 2000 Nissan Altima

Max: 15.2 [g] at 0.104 [s]  
Min: -4.3 [g] at 0.133 [s]

P1 Head Red z

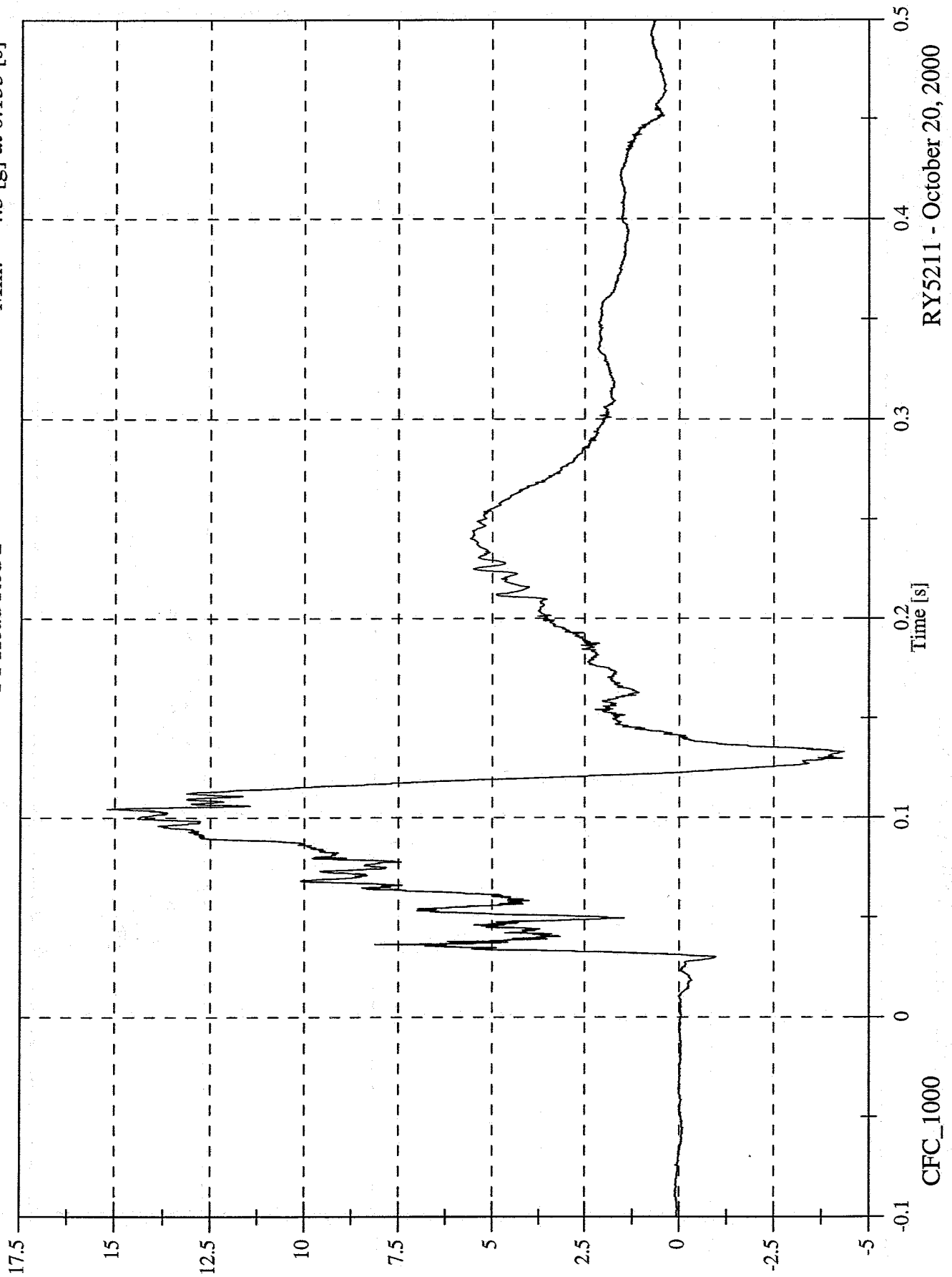

RY5211 - October 20, 2000

40% Frontal Offset Test #2 - 2000 Nissan Altima

Max: 42.6 [g] at 0.104 [s]

Min: 0.0 [g] at -0.040 [s]

P1 Head Red Resultant

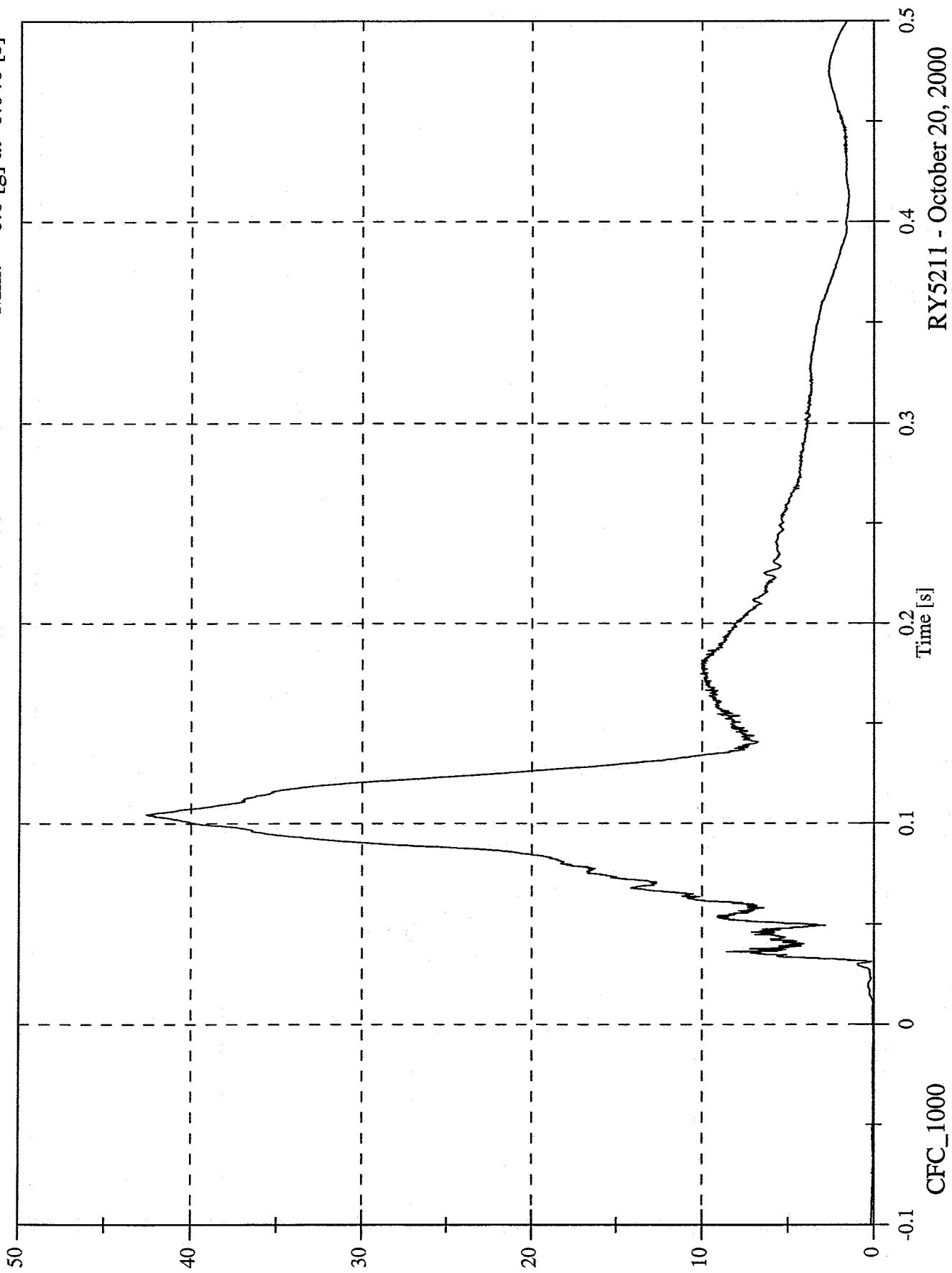

RYS211 - October 20, 2000

40% Frontal Offset Test #2 - 2000 Nissan Altima

Max: 337.7 [N] at 0.108 [s]

Min: -320.2 [N] at 0.074 [s]

P1 Upper Neck Fx

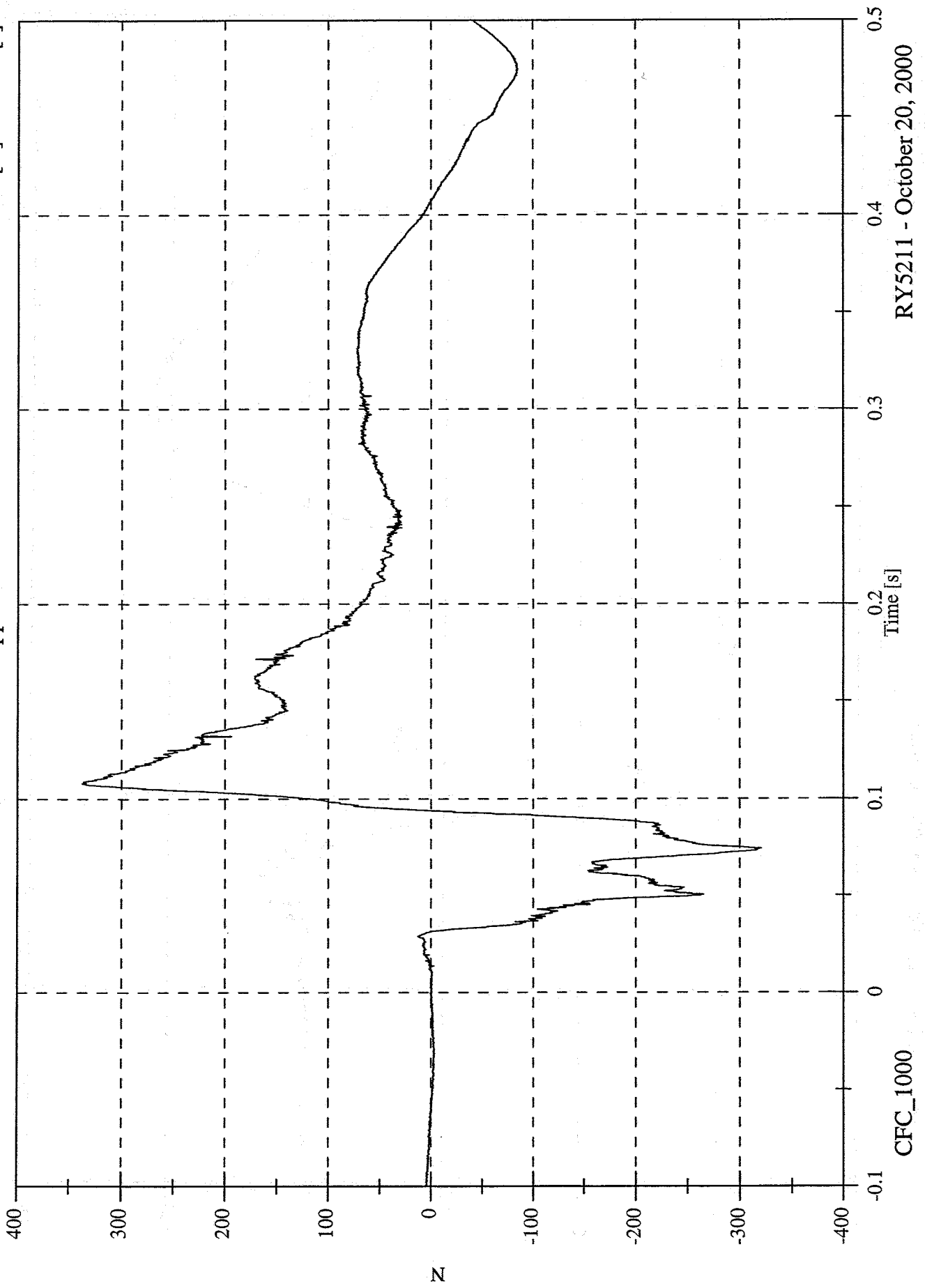

RY5211 - October 20, 2000

40% Frontal Offset Test #2 - 2000 Nissan Altima

Max: 317.6 [N] at 0.182 [s]  
Min: -113.7 [N] at 0.298 [s]

P1 Upper Neck Fy

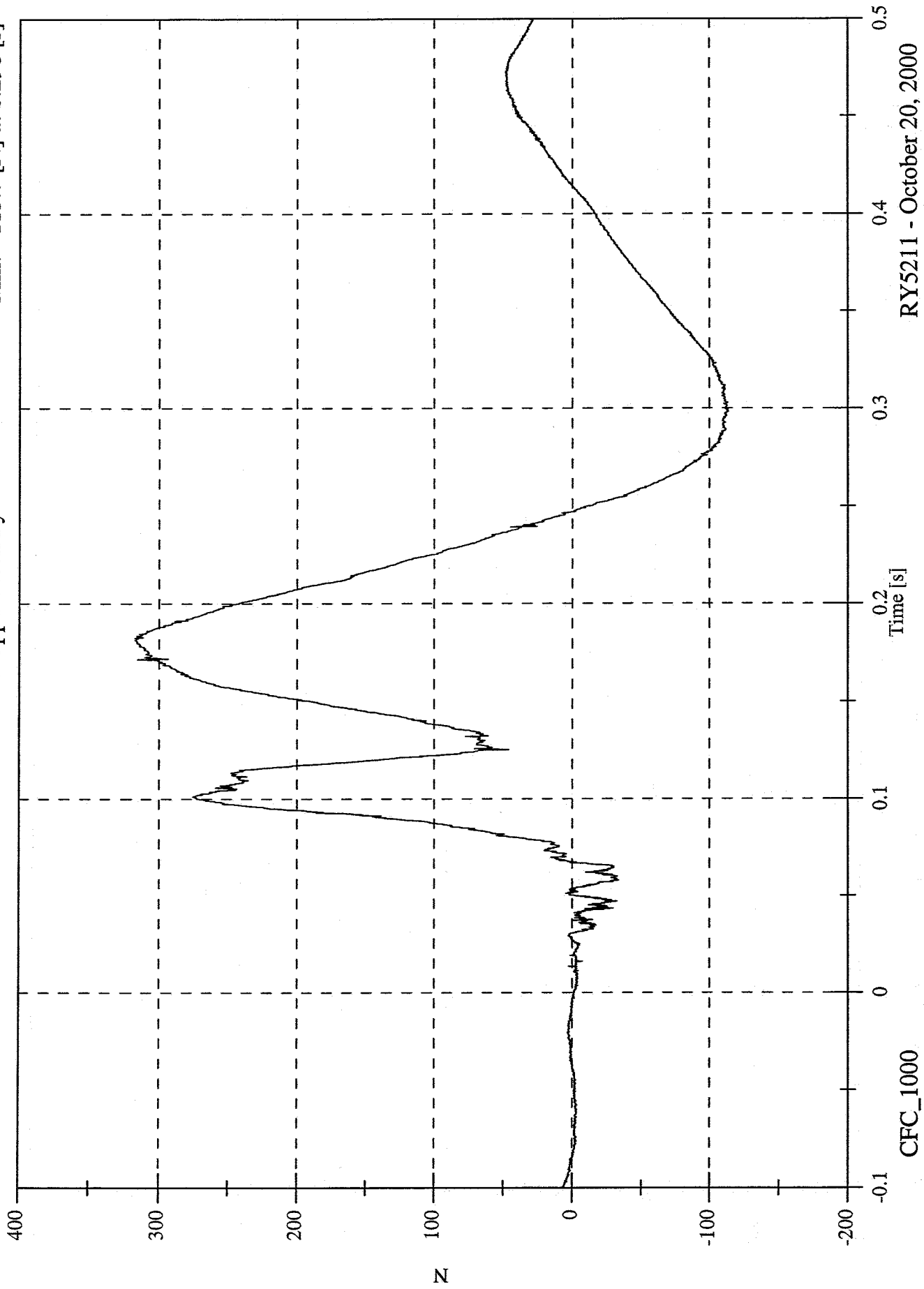

CFC\_1000

RY5211 - October 20, 2000

40% Frontal Offset Test #2 - 2000 Nissan Altima

Max: 1022.0 [N] at 0.112 [s]

Min: -54.4 [N] at 0.030 [s]

P1 Upper Neck Fz

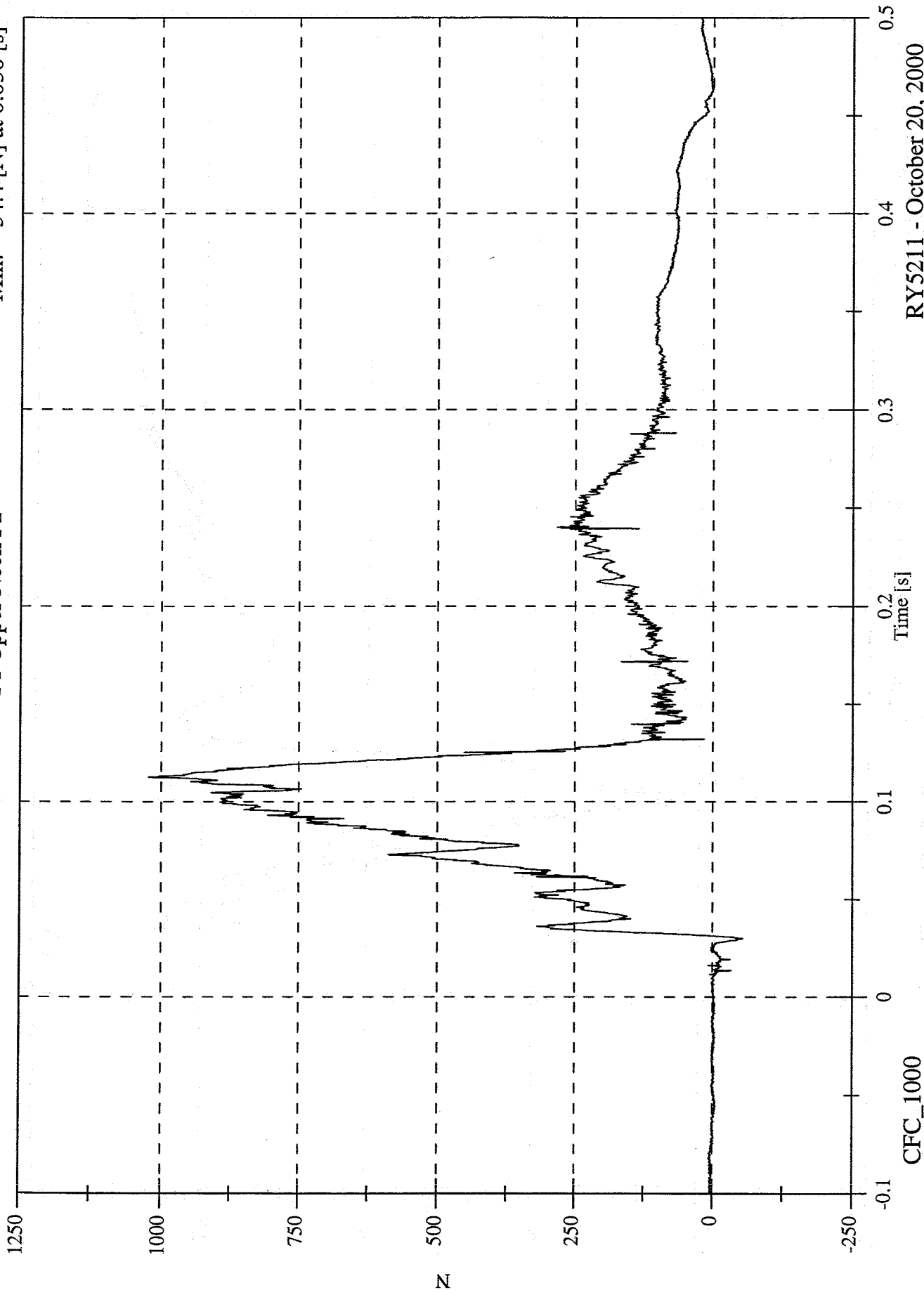

RY5211 - October 20, 2000

40% Frontal Offset Test #2 - 2000 Nissan Altima

Max: 1096.4 [N] at 0.112 [s]  
Min: 1.2 [N] at -0.000 [s]

P1 Upper Neck F Resultant

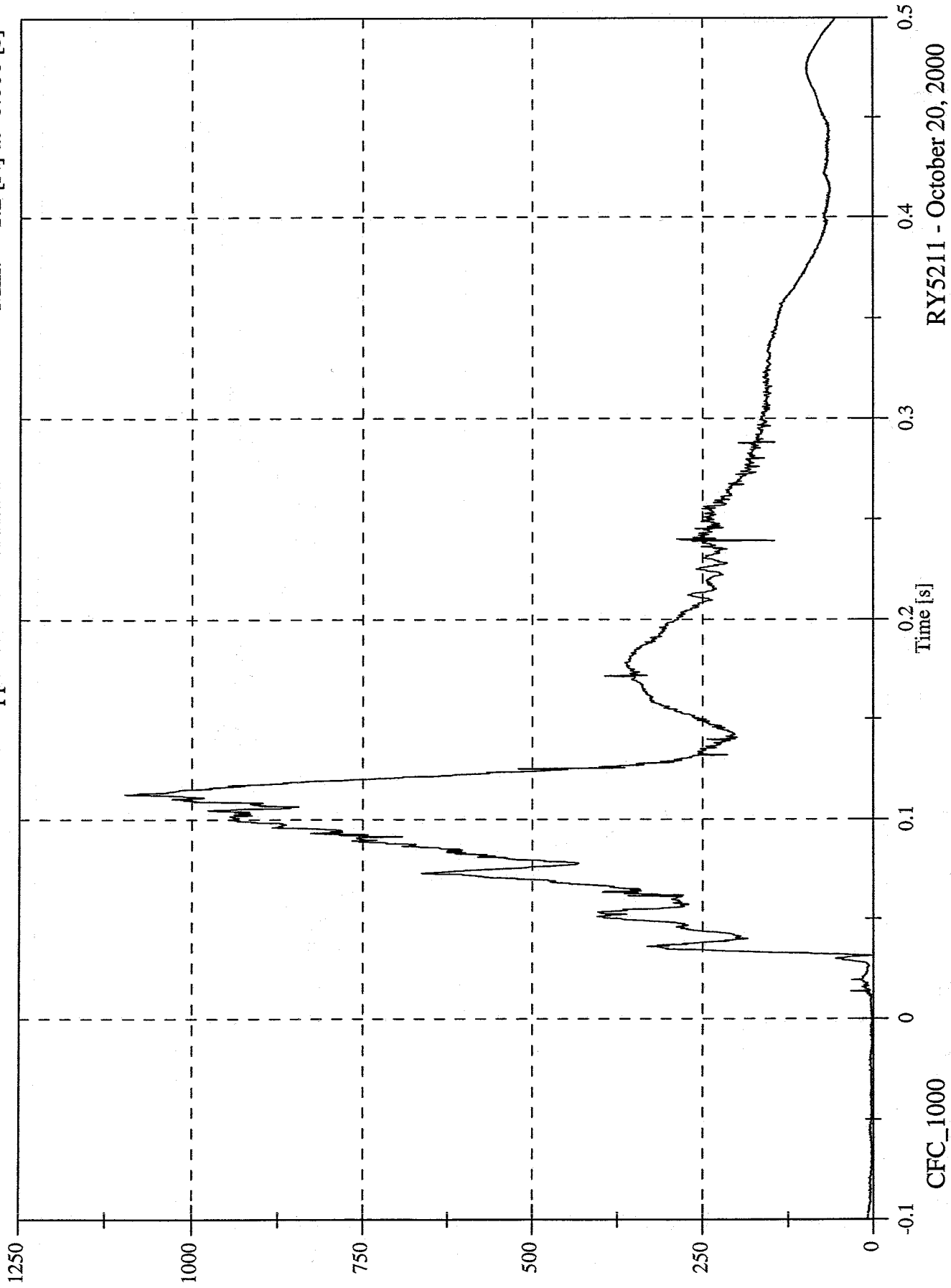

RY5211 - October 20, 2000

40% Frontal Offset Test #2 - 2000 Nissan Altima

P1 Upper Neck Mx

Max: 15.5 [Nm] at 0.171 [s]  
Min: -15.3 [Nm] at 0.115 [s]

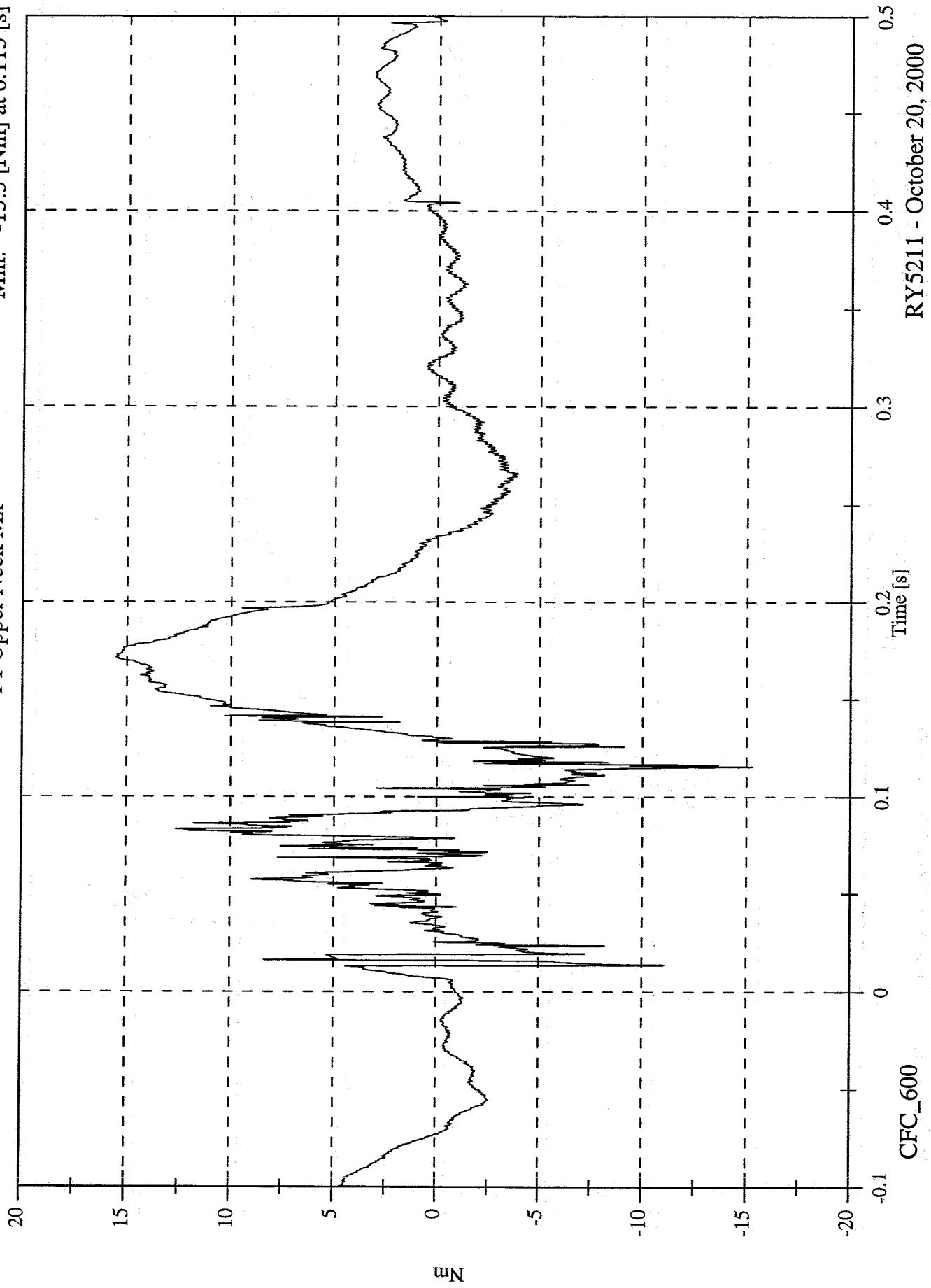

RY5211 - October 20, 2000

40% Frontal Offset Test #2 - 2000 Nissan Altima

Max: 20.2 [Nm] at 0.107 [s]  
Min: -12.9 [Nm] at 0.051 [s]

P1 Upper Neck My

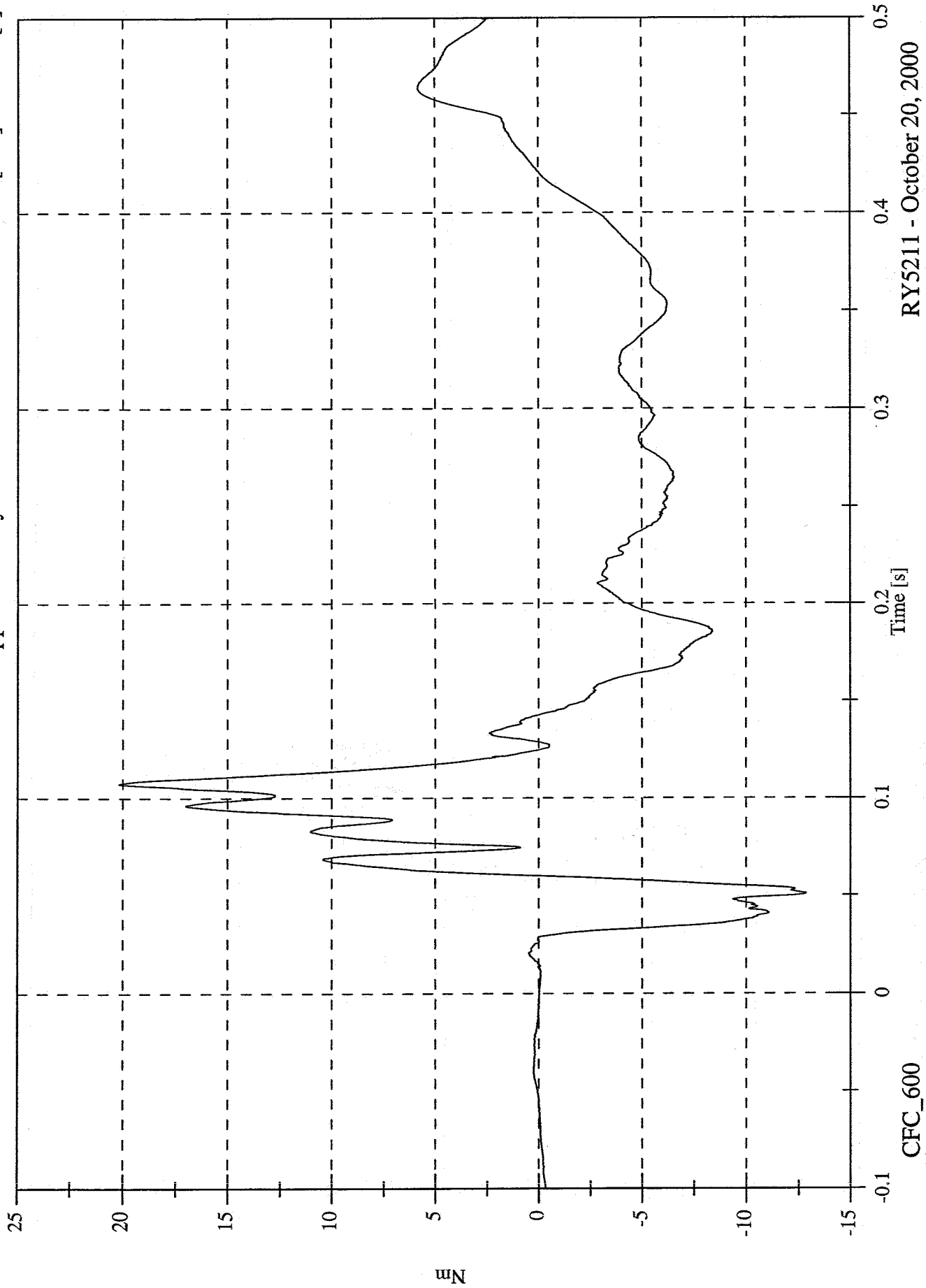

RY5211 - October 20, 2000

40% Frontal Offset Test #2 - 2000 Nissan Altima

Max: 9.2 [Nm] at 0.232 [s]  
Min: -17.4 [Nm] at 0.148 [s]

P1 Upper Neck Mz

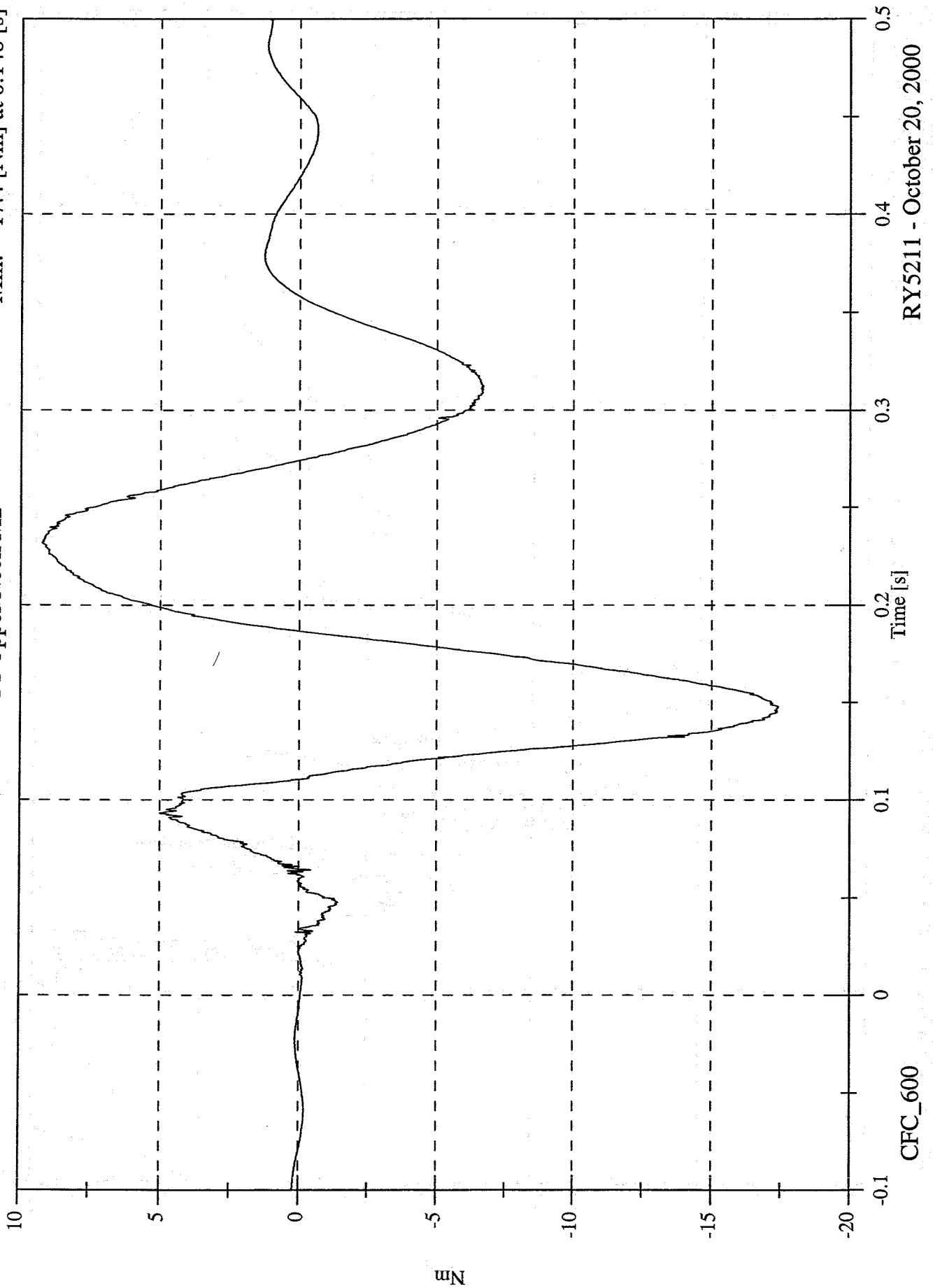

CFC\_600

RY5211 - October 20, 2000

40% Frontal Offset Test #2 - 2000 Nissan Altima

Max: 21.6 [Nm] at 0.154 [s]

Min: 0.1 [Nm] at -0.073 [s]

P1 Upper Neck M Resultant

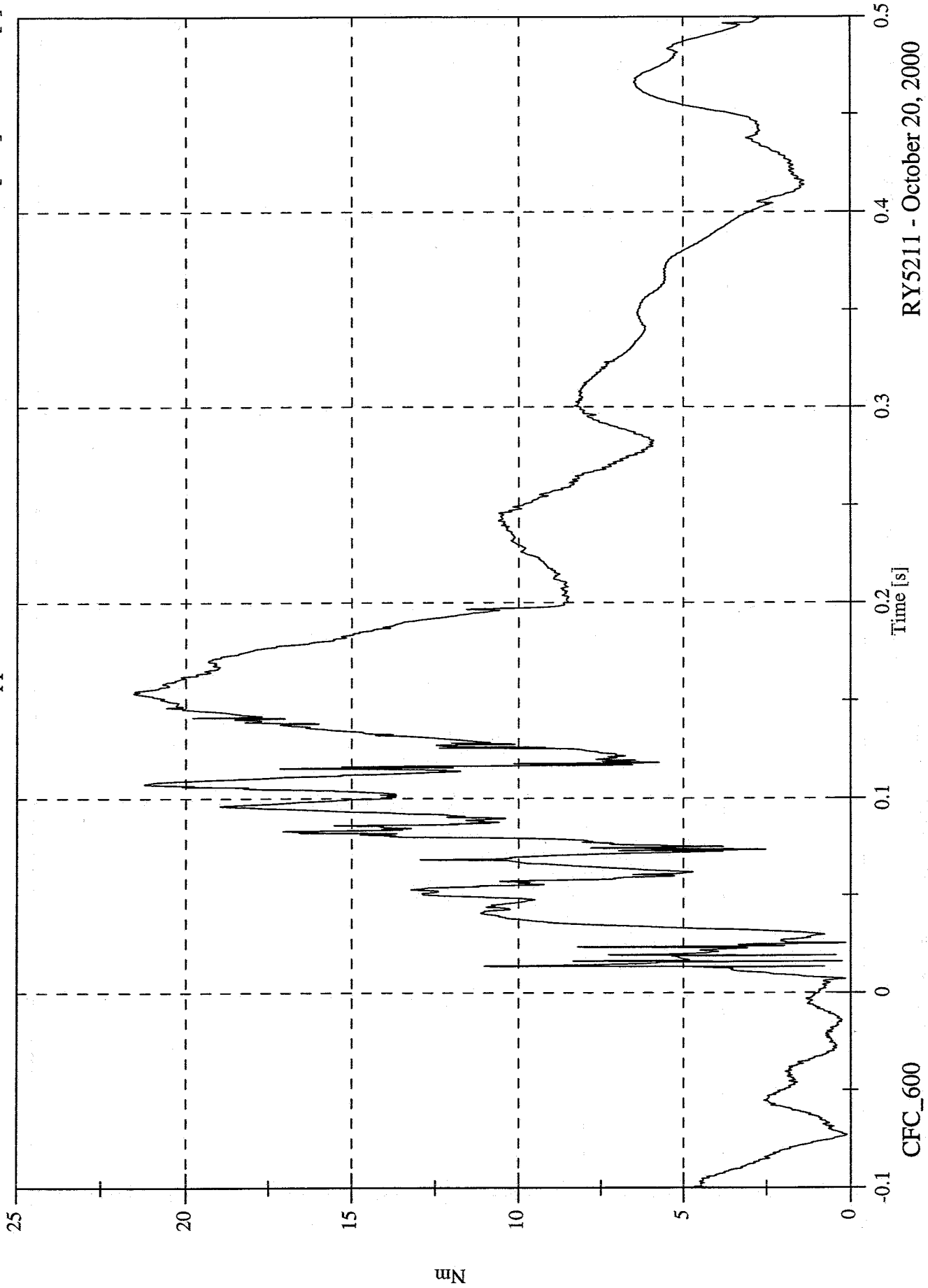

RY5211 - October 20, 2000

40% Frontal Offset Test #2 - 2000 Nissan Altima

Max: 1.4 [g] at 0.277 [s]  
Min: -31.9 [g] at 0.109 [s]

P1 Chest x

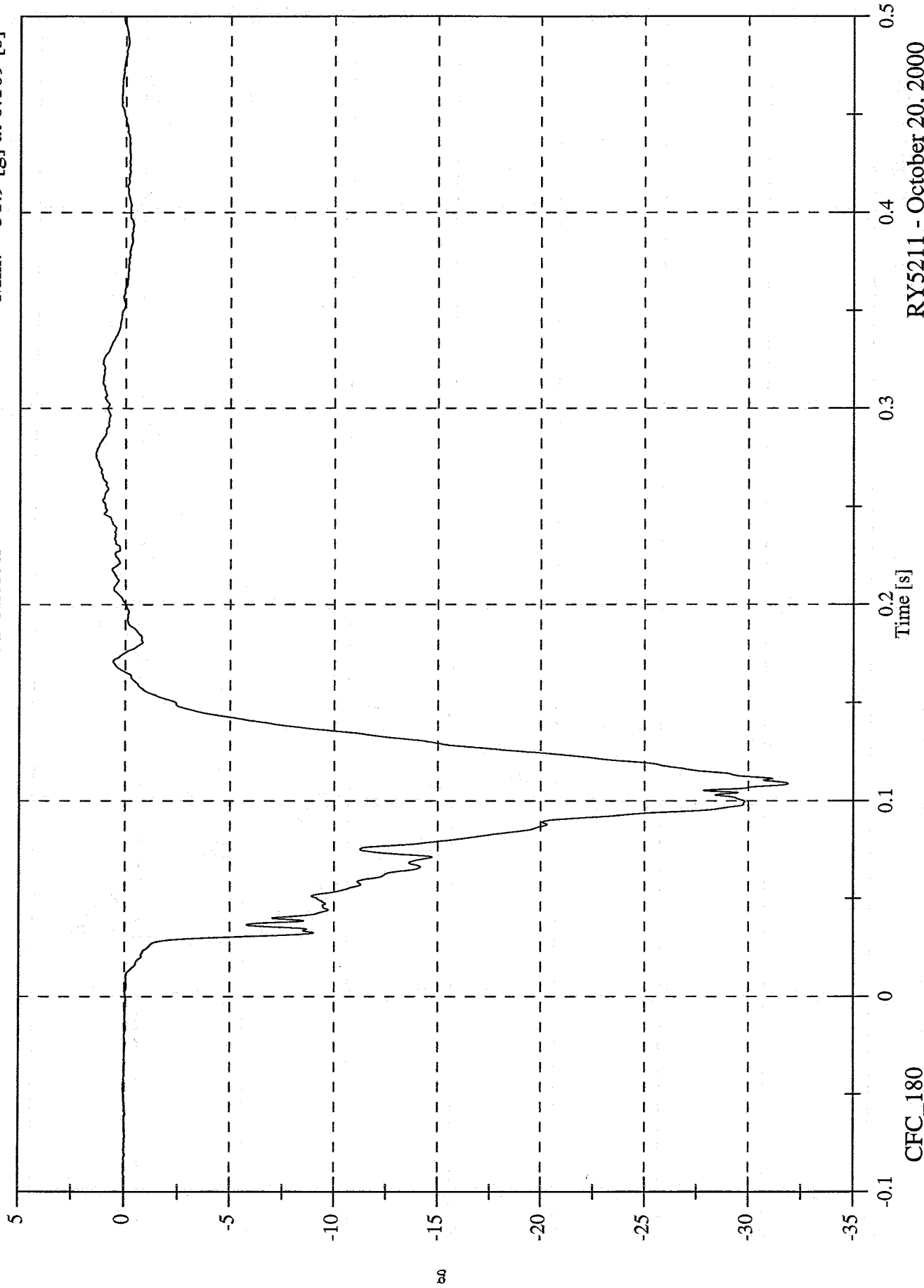

CFC\_180

RY5211 - October 20, 2000

40% Frontal Offset Test #2 - 2000 Nissan Altima

Max: 16.1 [g] at 0.126 [s]  
Min: -1.8 [g] at 0.032 [s]

P1 Chest y

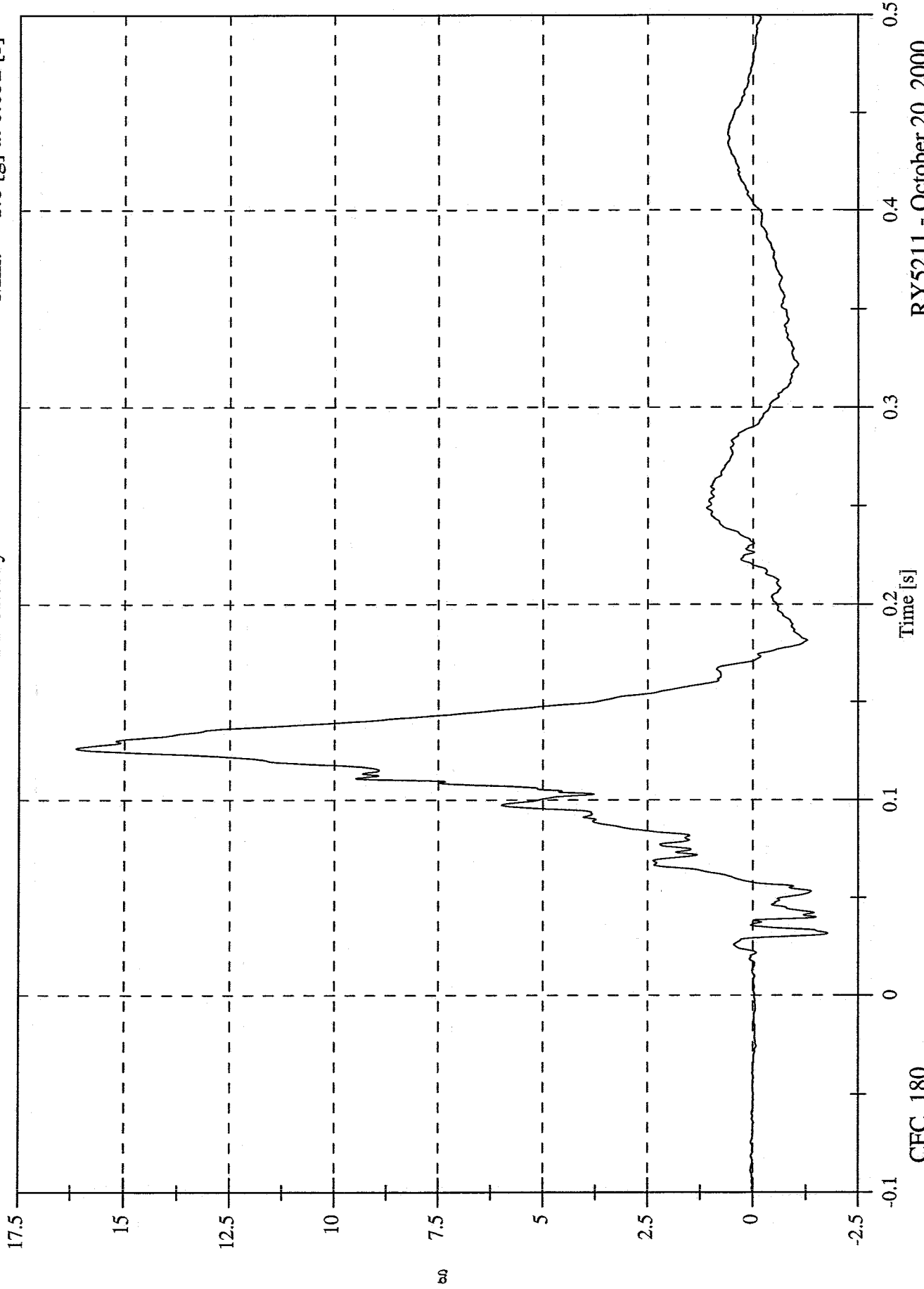

RY5211 - October 20, 2000

40% Frontal Offset Test #2 - 2000 Nissan Altima

Max: 5.0 [g] at 0.091 [s]  
Min: -8.7 [g] at 0.131 [s]

P1 Chest z

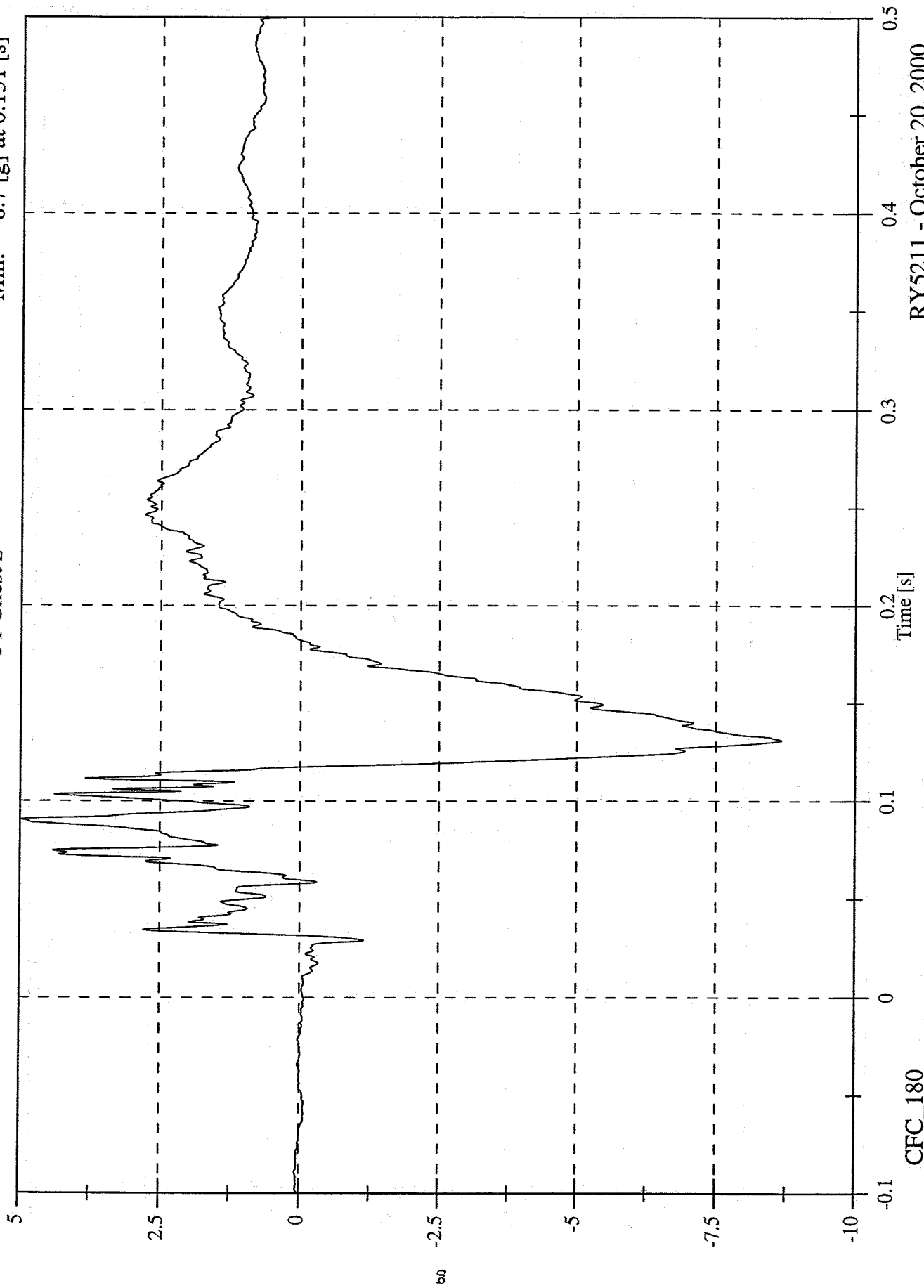

RY5211 - October 20, 2000

40% Frontal Offset Test #2 - 2000 Nissan Altima

Max: 32.8 [g] at 0.109 [s]

Min: 0.0 [g] at -0.100 [s]

P1 Chest Resultant

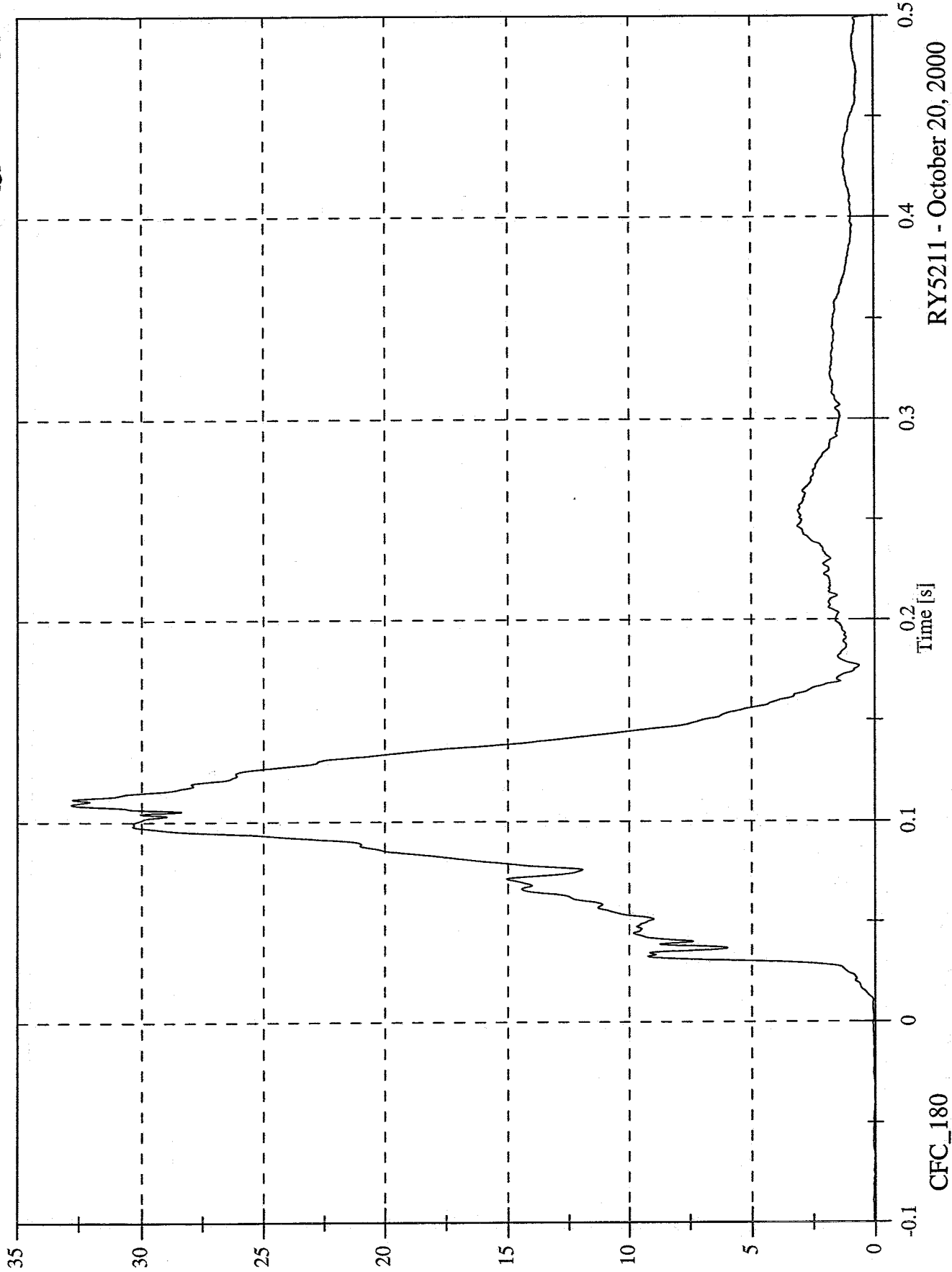

RY5211 - October 20, 2000

40% Frontal Offset Test #2 - 2000 Nissan Altima

Max: 1.5 [g] at 0.275 [s]  
Min: -31.6 [g] at 0.109 [s]

P1 Chest Red x

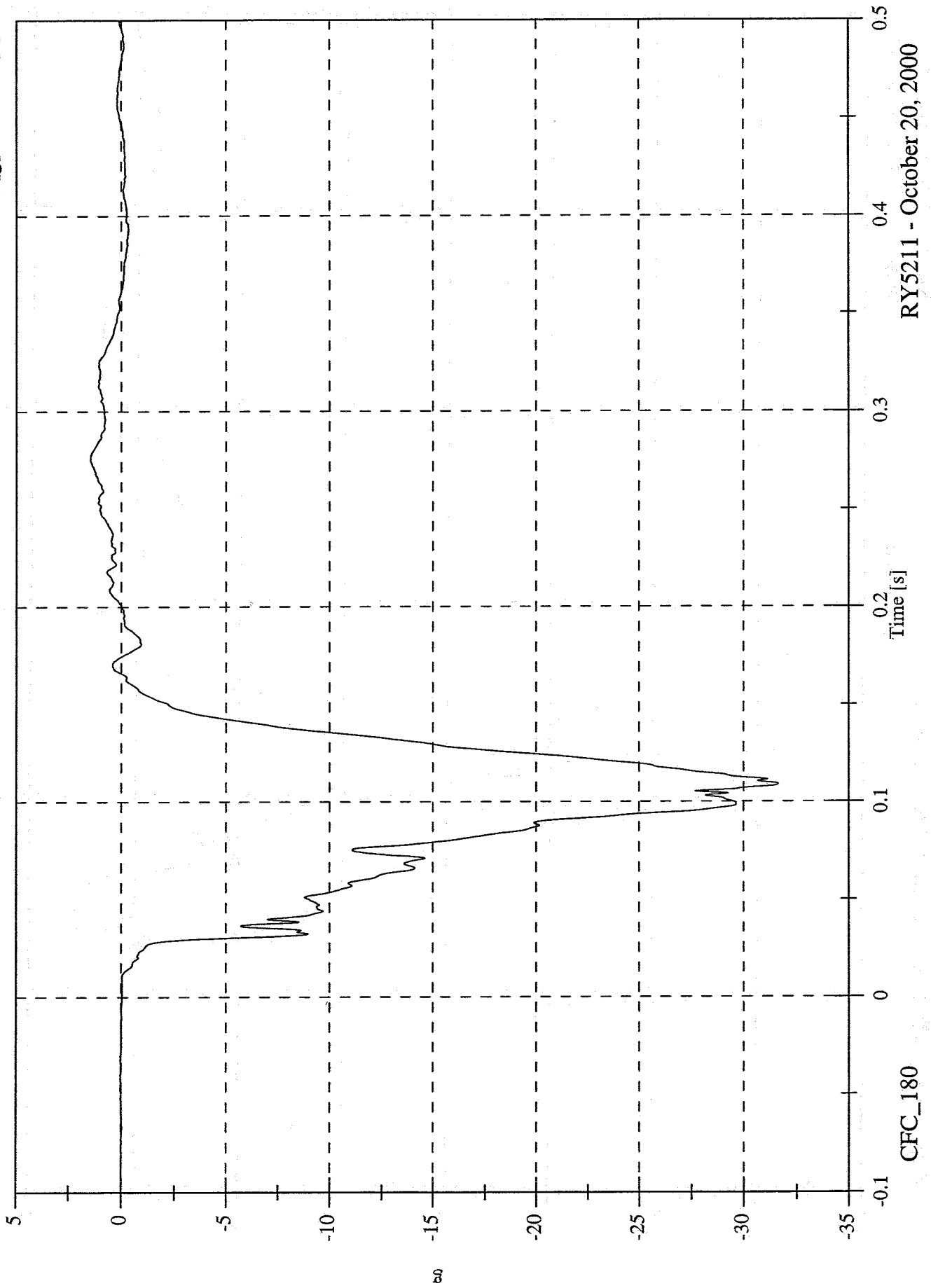

CFC\_180

RY5211 - October 20, 2000

40% Frontal Offset Test #2 - 2000 Nissan Altima

Max: 16.4 [g] at 0.126 [s]  
Min: -1.9 [g] at 0.032 [s]

P1 Chest Red y

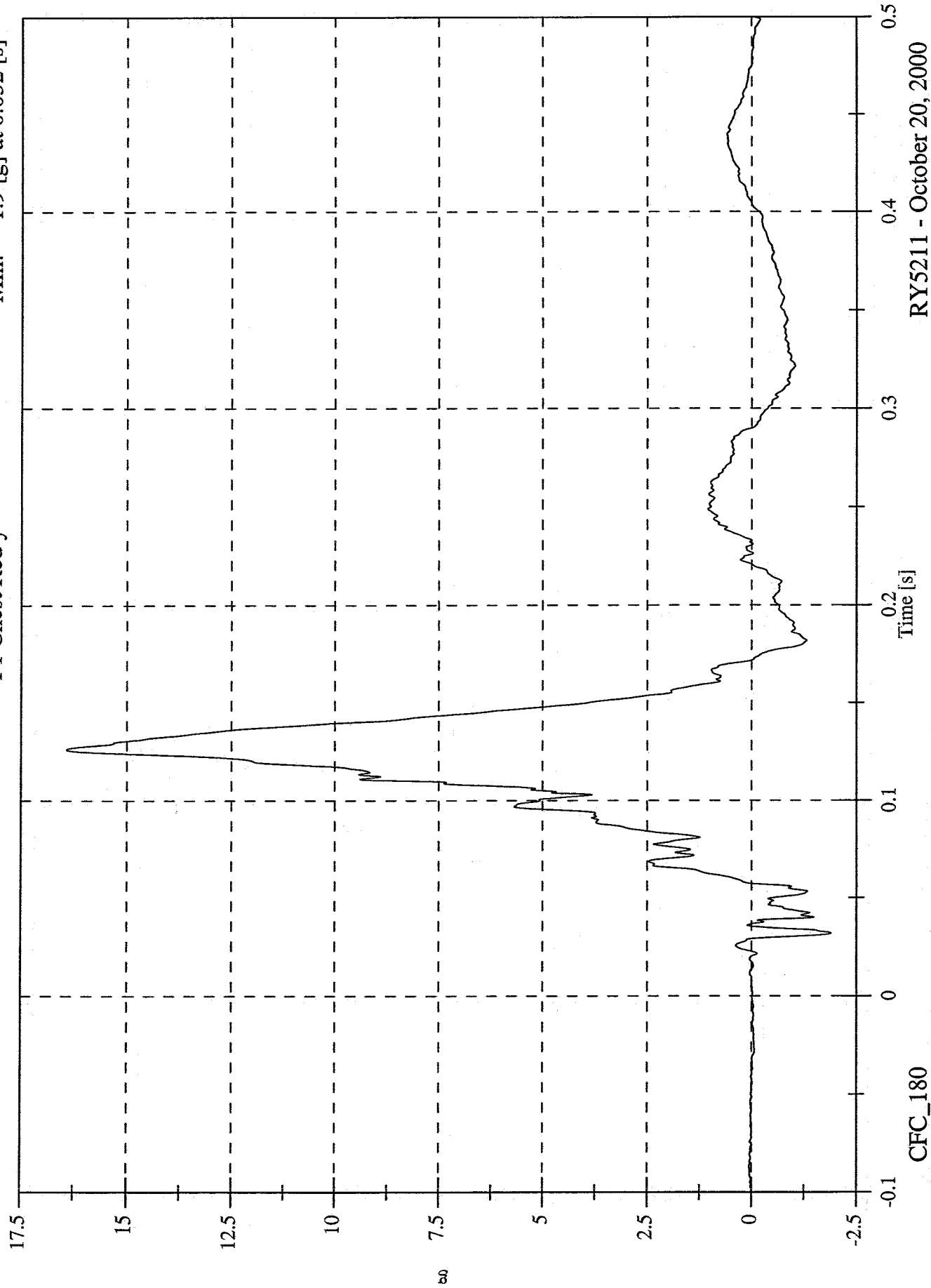

RY5211 - October 20, 2000

40% Frontal Offset Test #2 - 2000 Nissan Altima

Max: 4.6 [g] at 0.090 [s]  
Min: -8.6 [g] at 0.132 [s]

P1 Chest Red z

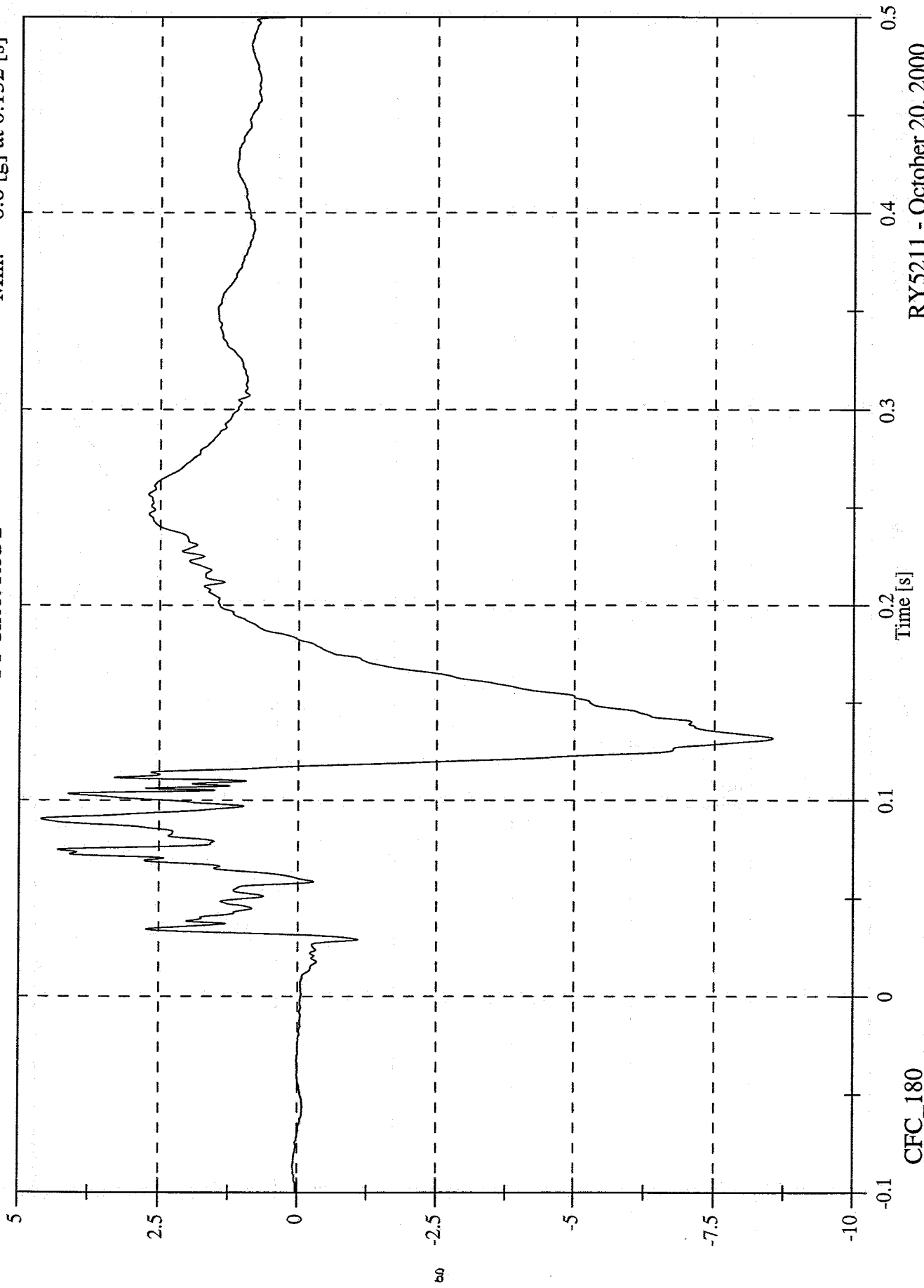

RY5211 - October 20, 2000

40% Frontal Offset Test #2 - 2000 Nissan Altima

Max: 32.6 [g] at 0.111 [s]

Min: 0.0 [g] at -0.100 [s]

P1 Chest Red Resultant

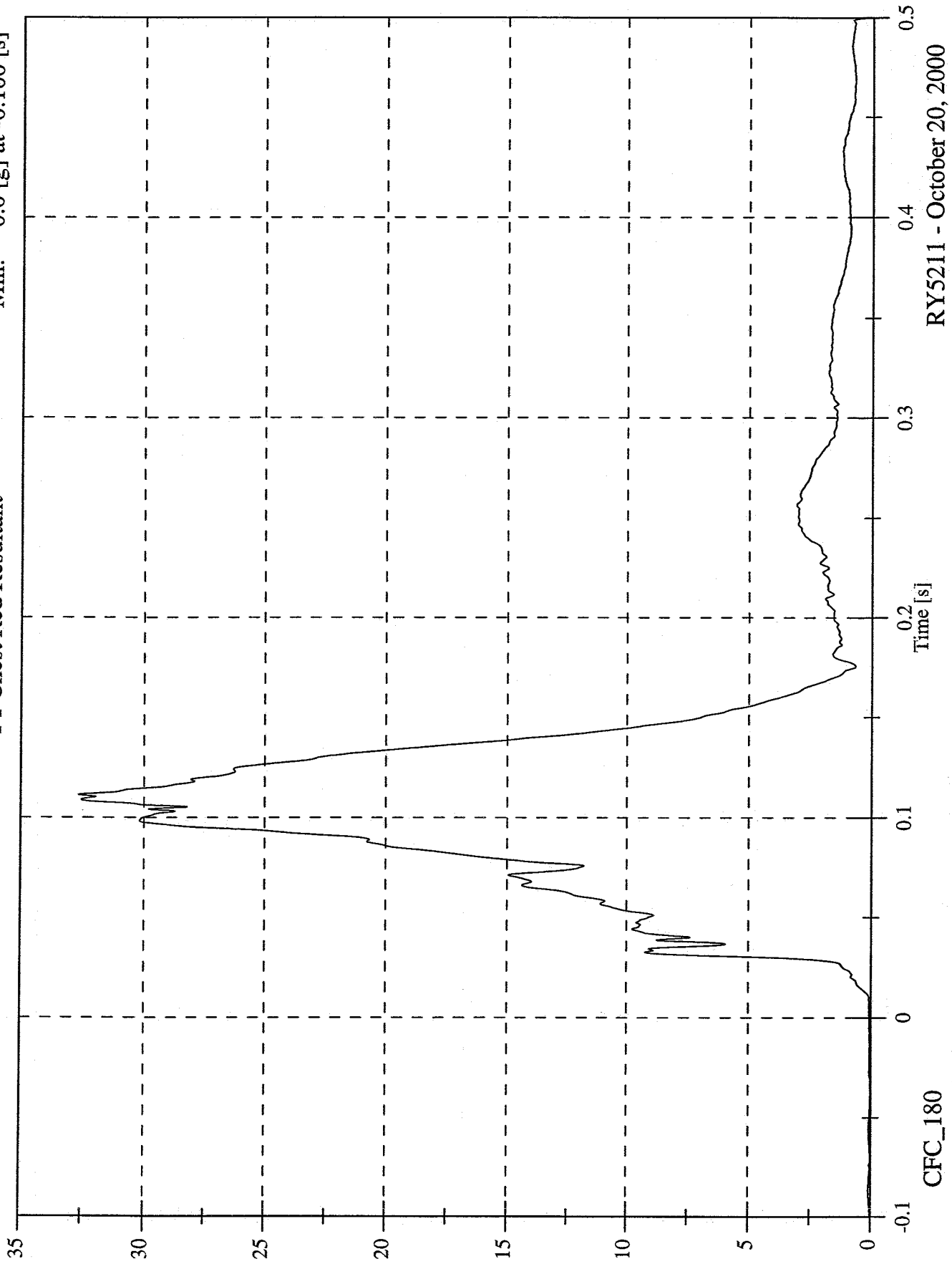

RYS211 - October 20, 2000

CFC\_180

40% Frontal Offset Test #2 - 2000 Nissan Altima

P1 Chest Compression

Max: 0.0 [mm] at -0.099 [s]  
Min: -23.6 [mm] at 0.101 [s]

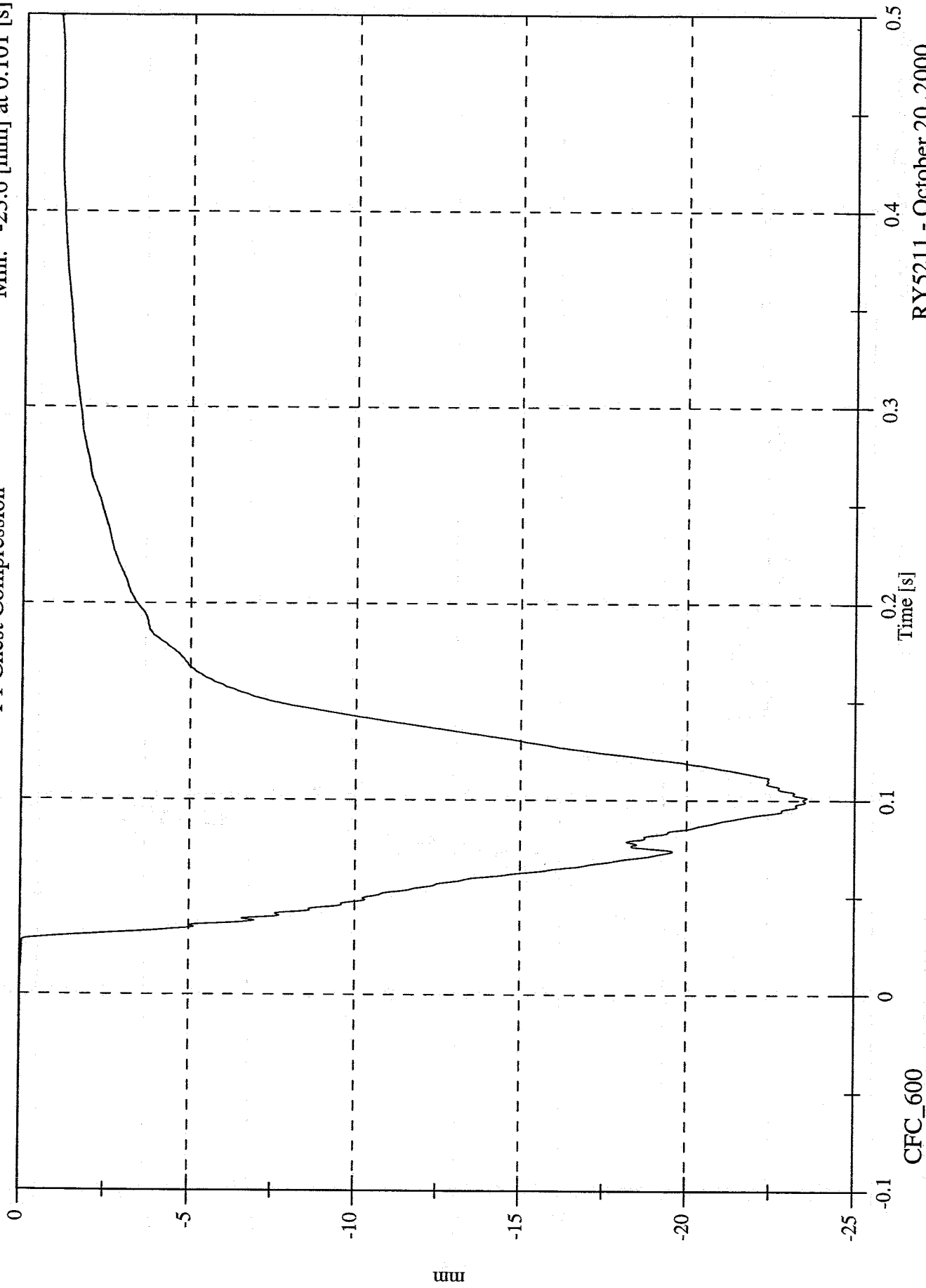

RYS211 - October 20, 2000

40% Frontal Offset Test #2 - 2000 Nissan Altima

Max: 1.2 [g] at 0.224 [s]  
Min: -33.8 [g] at 0.097 [s]

P1 Pelvic x

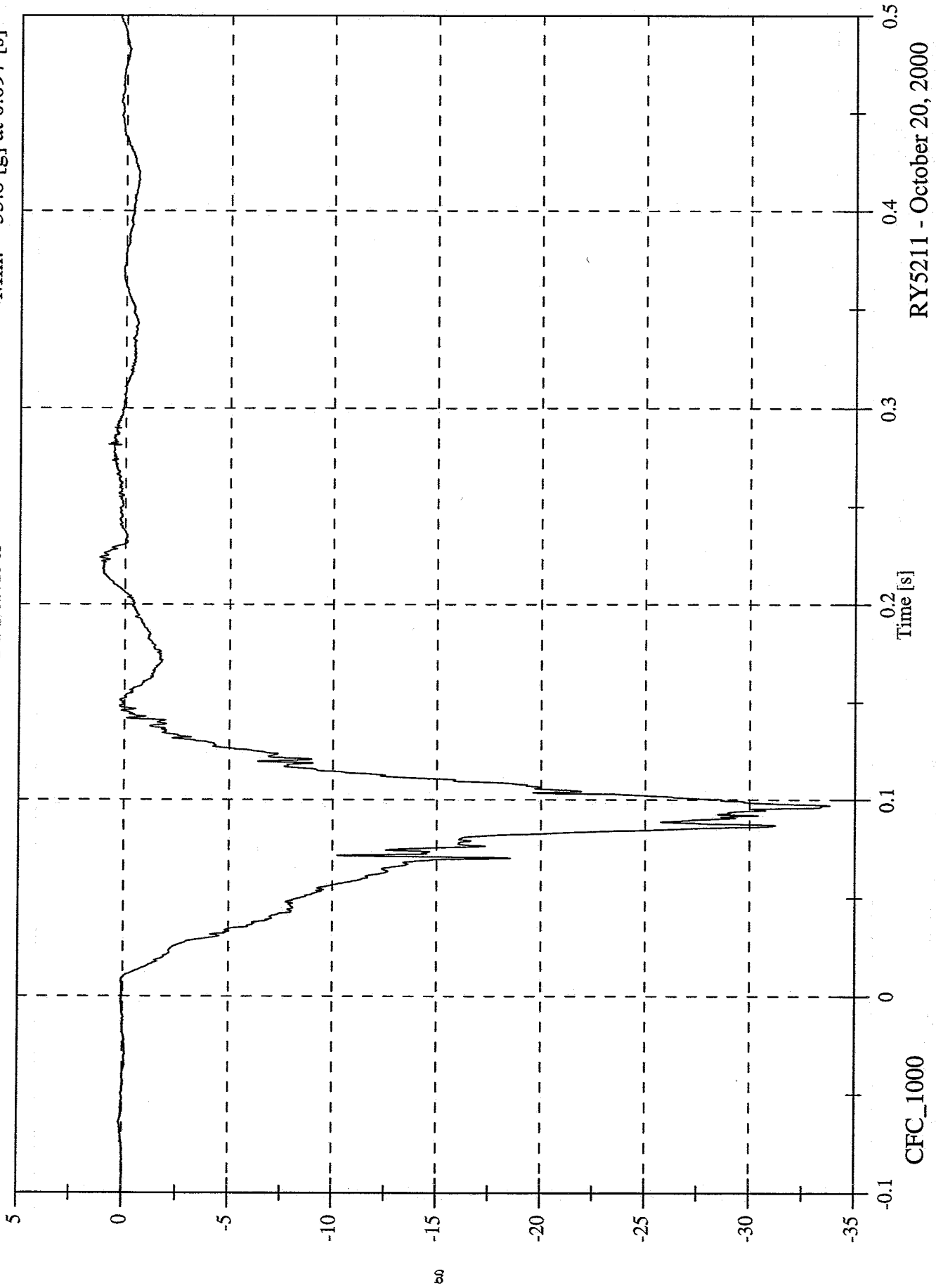

RY5211 - October 20, 2000

40% Frontal Offset Test #2 - 2000 Nissan Altima

P1 Pelvic y

Max: 15.9 [g] at 0.099 [s]  
Min: -2.8 [g] at 0.071 [s]

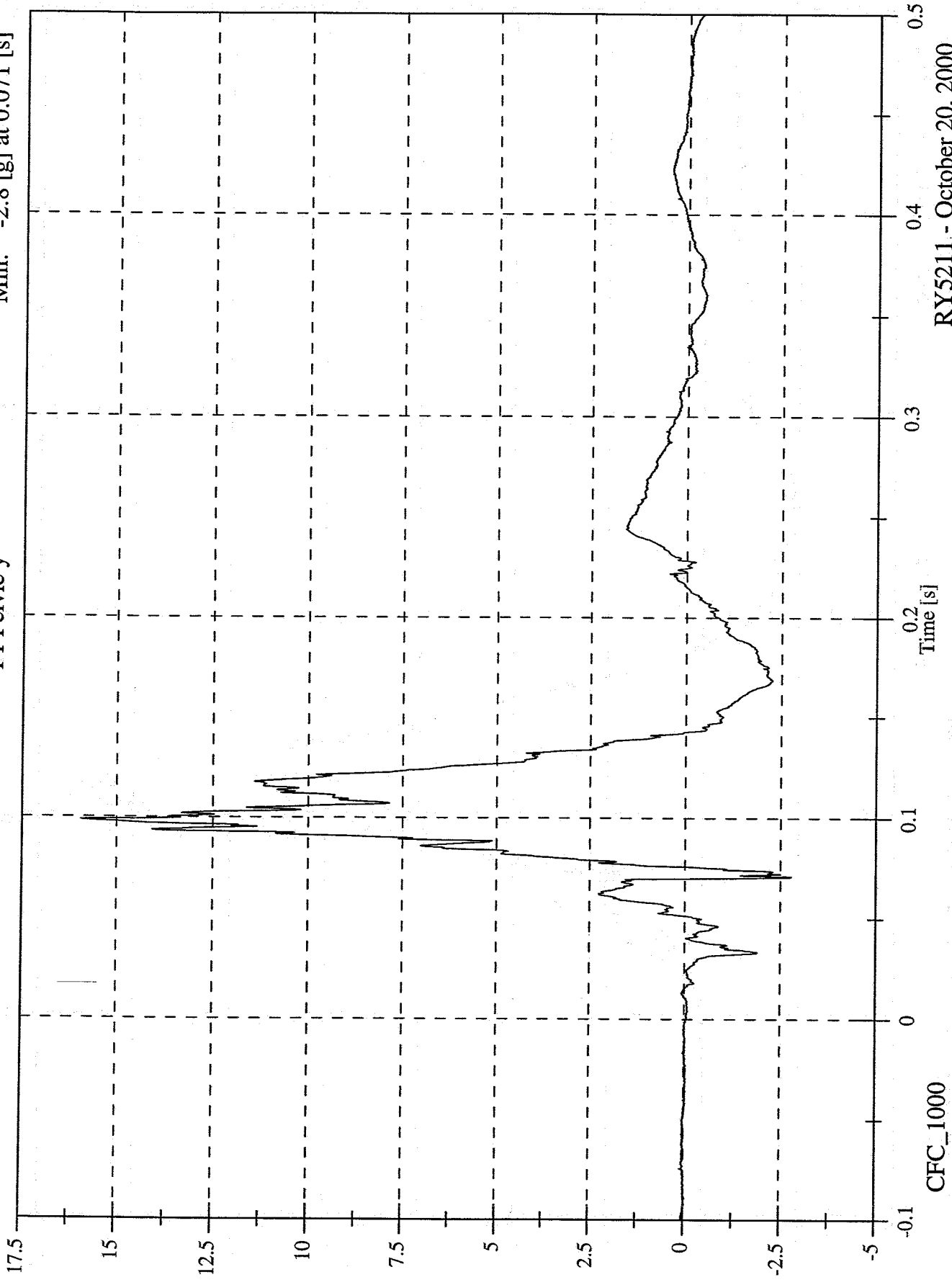

RY5211 - October 20, 2000

40% Frontal Offset Test #2 - 2000 Nissan Altima

Max: 2.6 [g] at 0.251 [s]  
Min: -17.1 [g] at 0.108 [s]

P1 Pelvic z

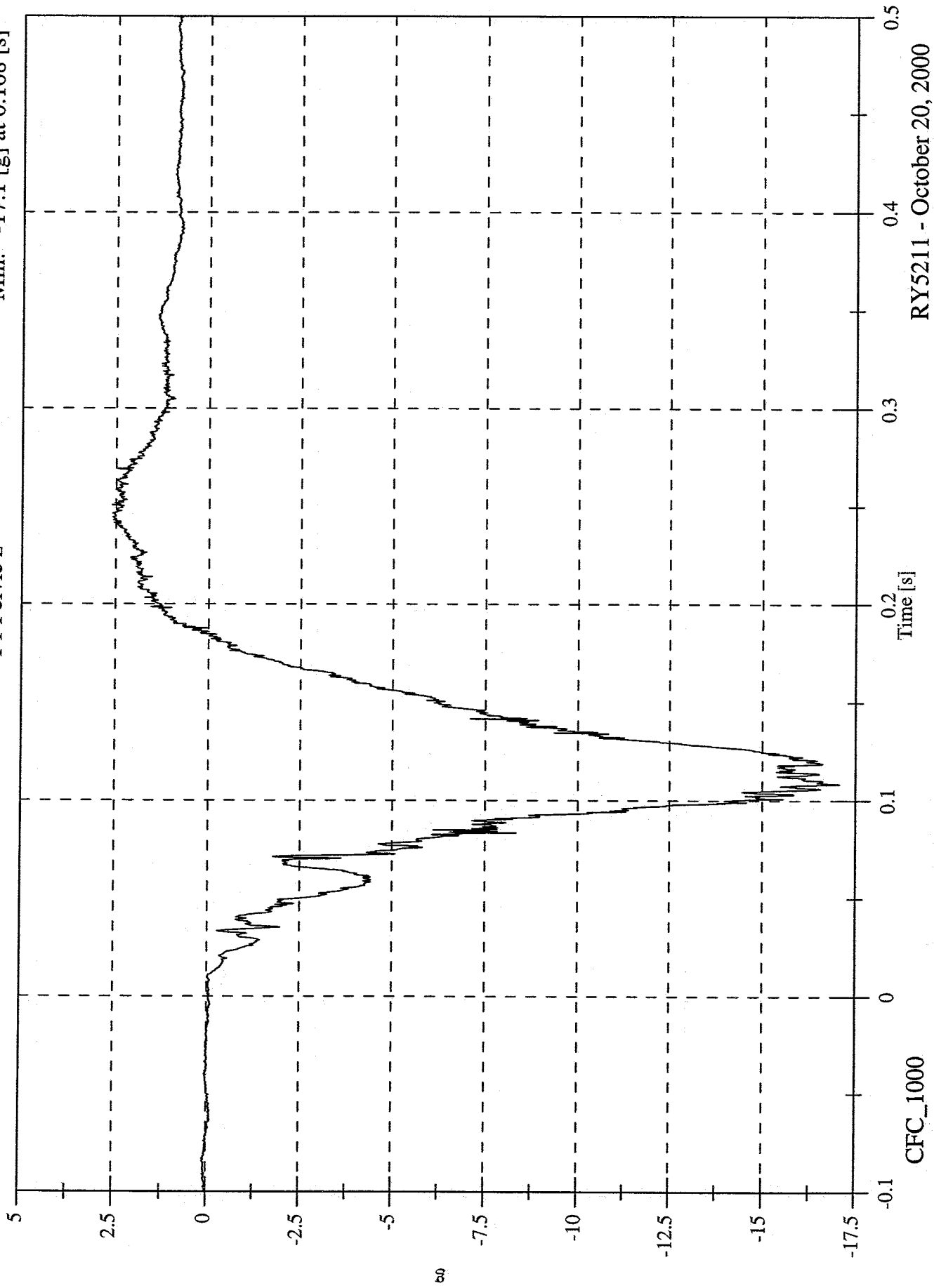

RYS211 - October 20, 2000

40% Frontal Offset Test #2 - 2000 Nissan Altima

Max: 38.6 [g] at 0.097 [s]  
Min: 0.0 [g] at -0.016 [s]

P1 Pelvic Resultant

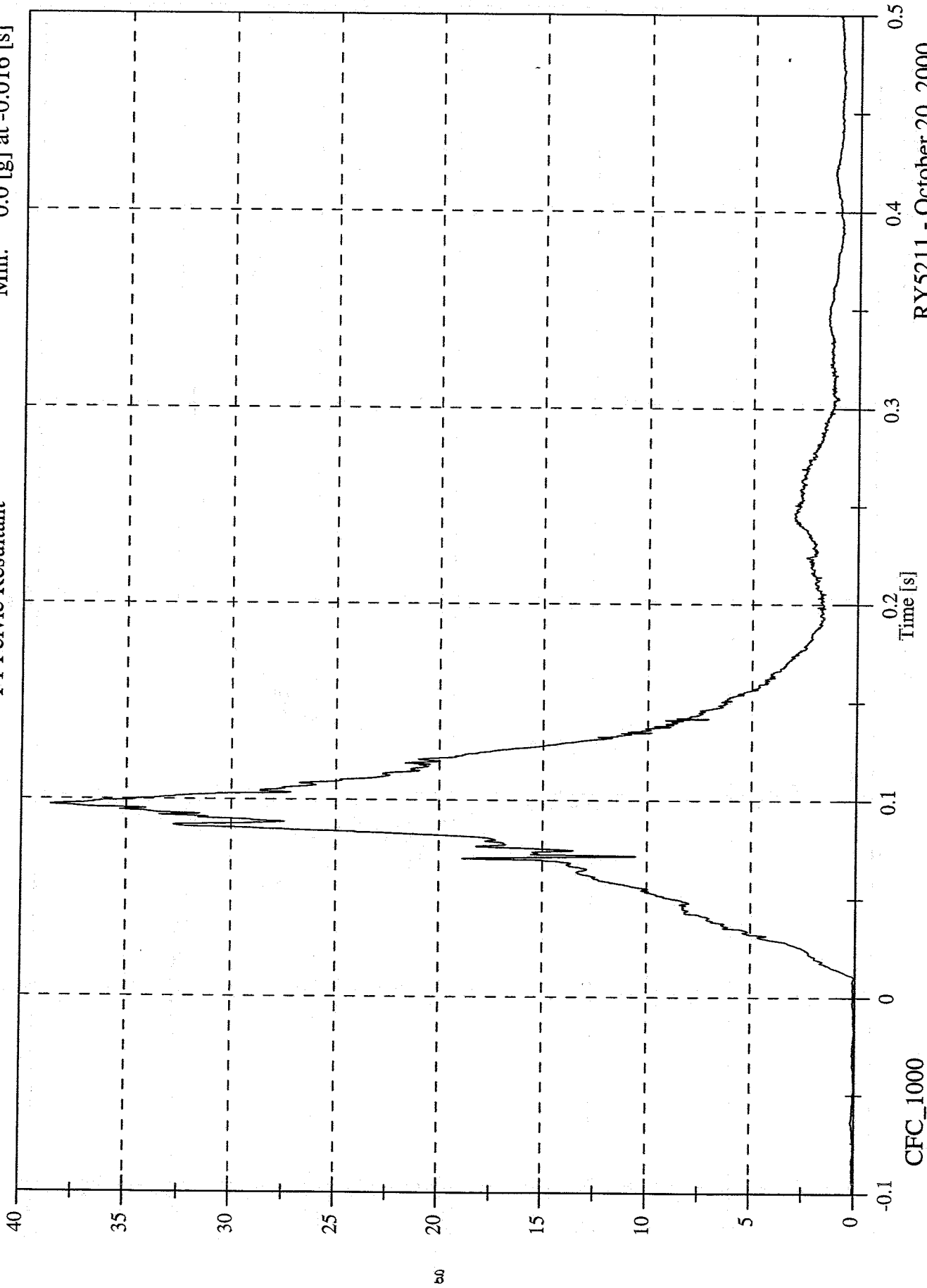

CFC\_1000

RY5211 - October 20, 2000

40% Frontal Offset Test #2 - 2000 Nissan Altima

Max: 1229.8 [N] at 0.108 [s]

Min: -17.7 [N] at 0.038 [s]

P1 Left Femur Fx

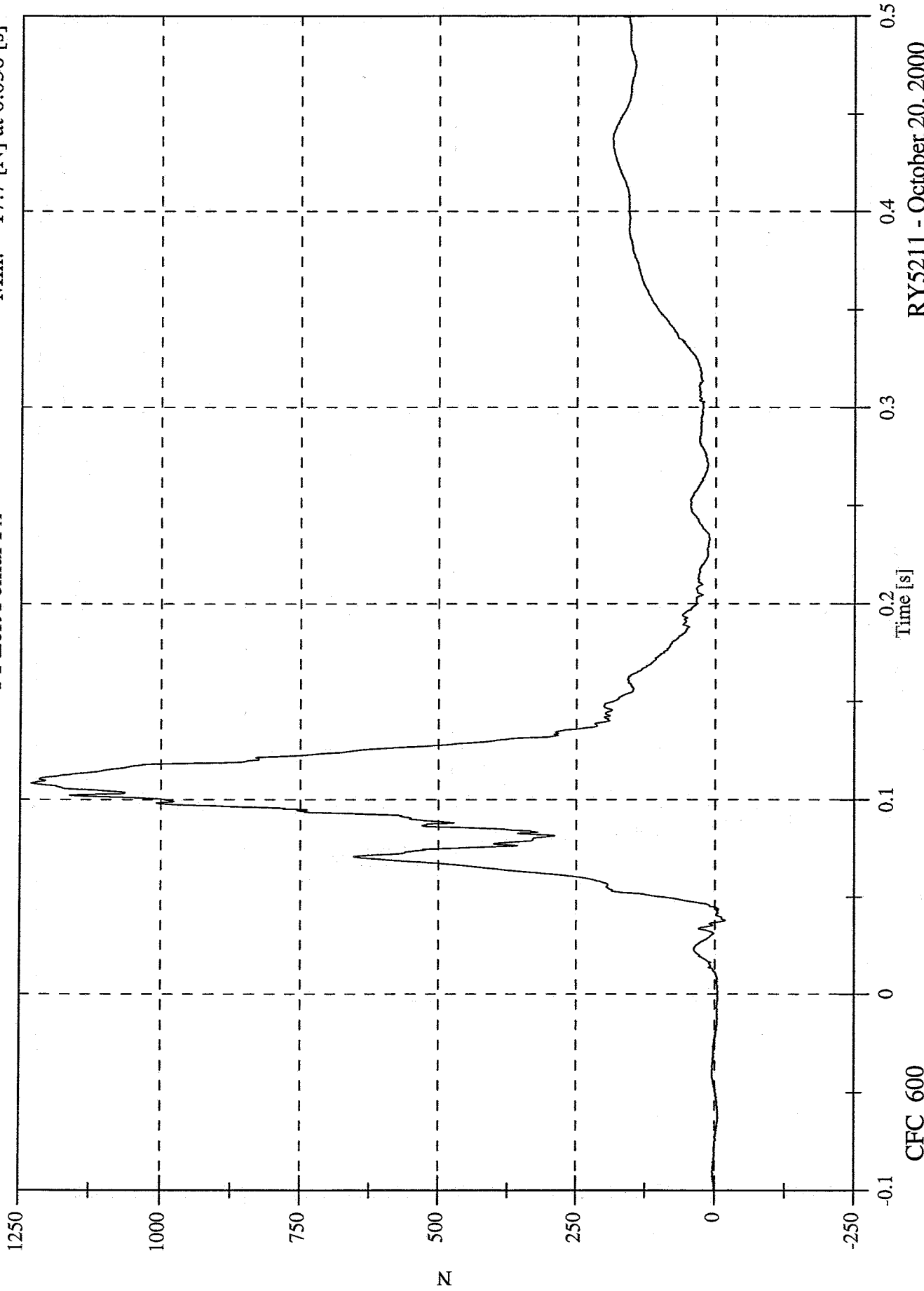

CFC\_600

RYS211 - October 20, 2000

40% Frontal Offset Test #2 - 2000 Nissan Altima

Max: 655.3 [N] at 0.115 [s]  
Min: -127.7 [N] at 0.074 [s]

P1 Left Femur Fy

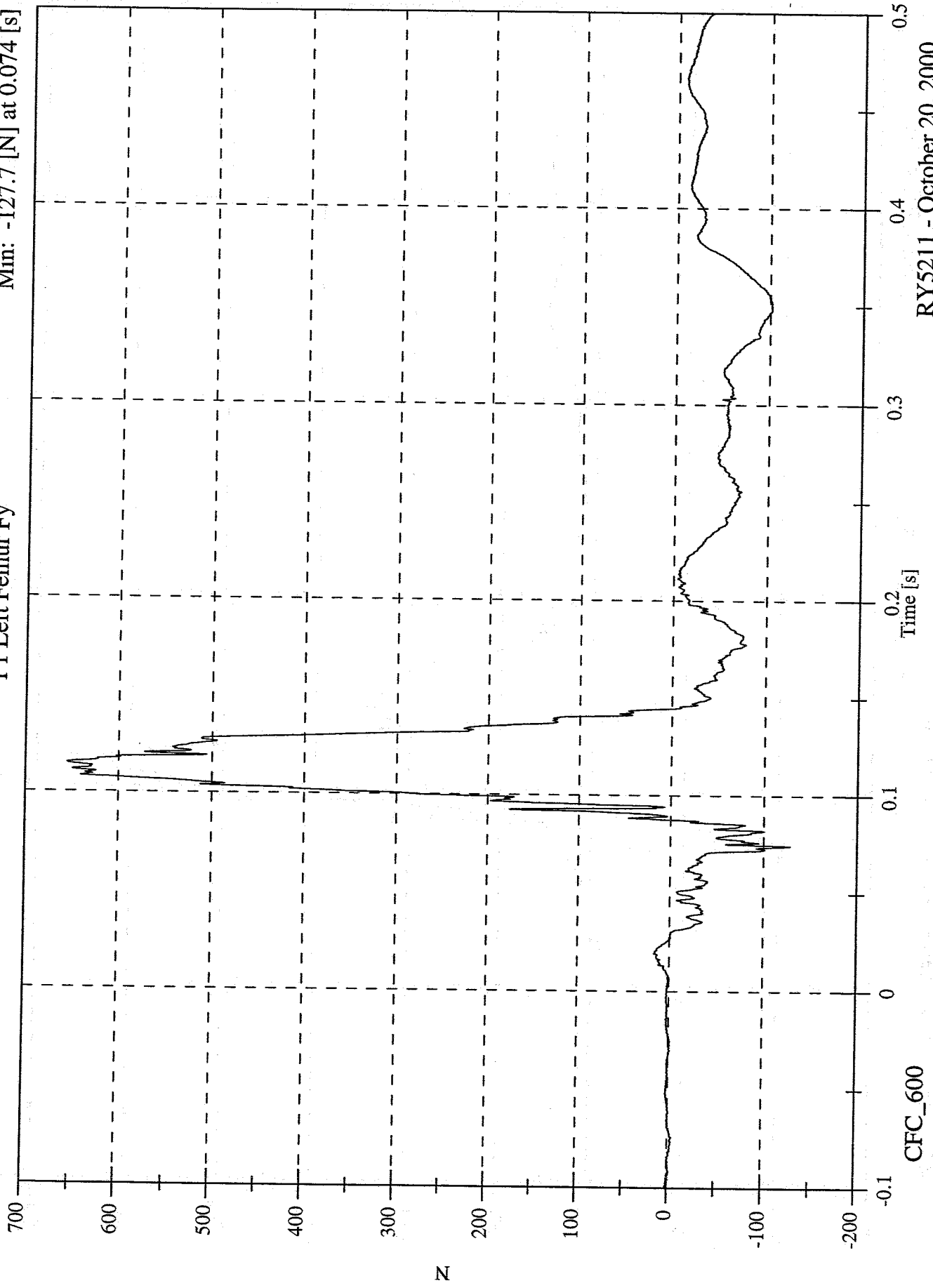

RYS211 - October 20, 2000

40% Frontal Offset Test #2 - 2000 Nissan Altima

P1 Left Femur Fz

Max: 1005.5 [N] at 0.074 [s]  
Min: -2701.9 [N] at 0.112 [s]

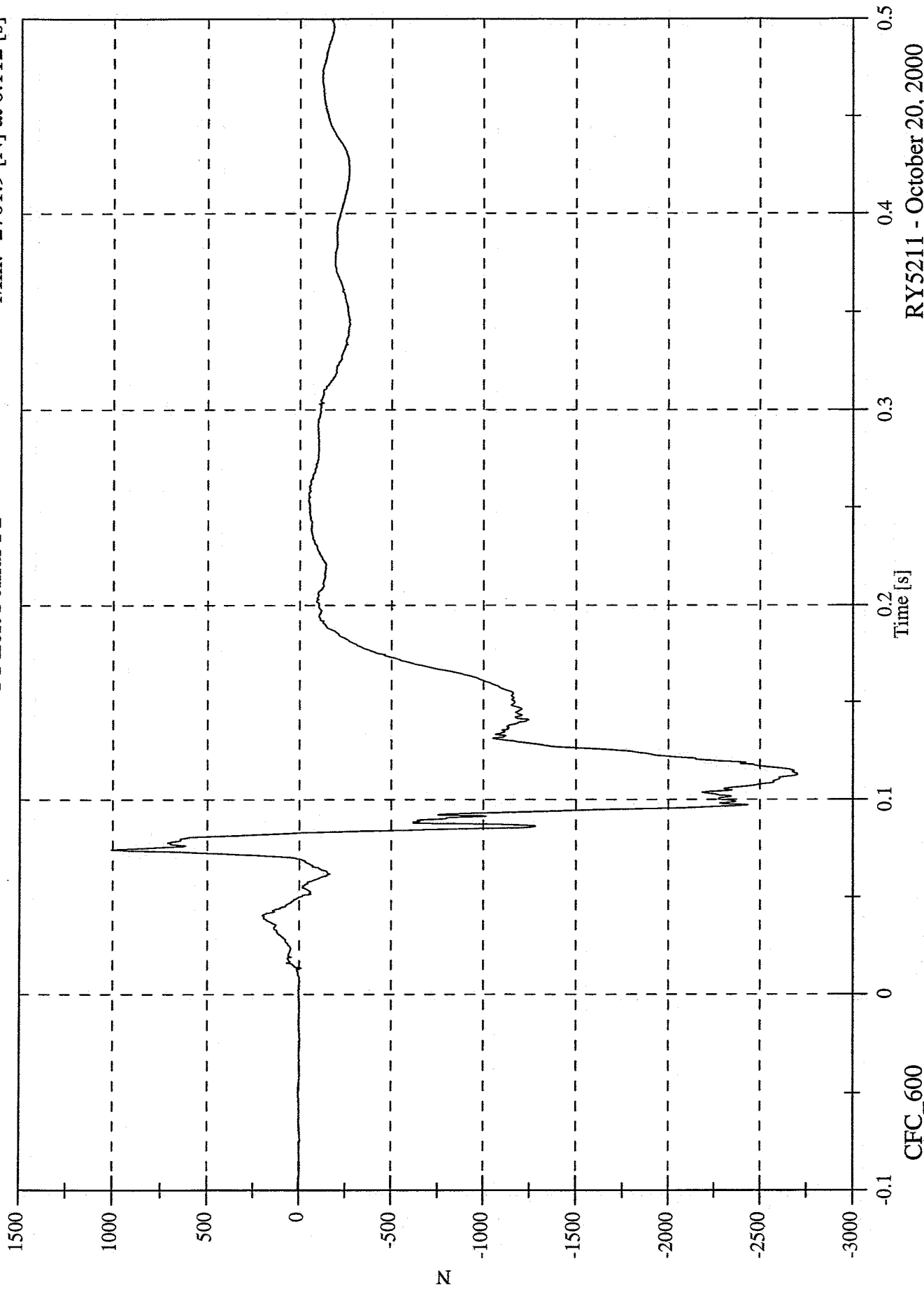

RYS211 - October 20, 2000

40% Frontal Offset Test #2 - 2000 Nissan Altima

Max: 3011.0 [N] at 0.112 [s]  
Min: 0.3 [N] at -0.100 [s]

P1 Left Femur F Resultant

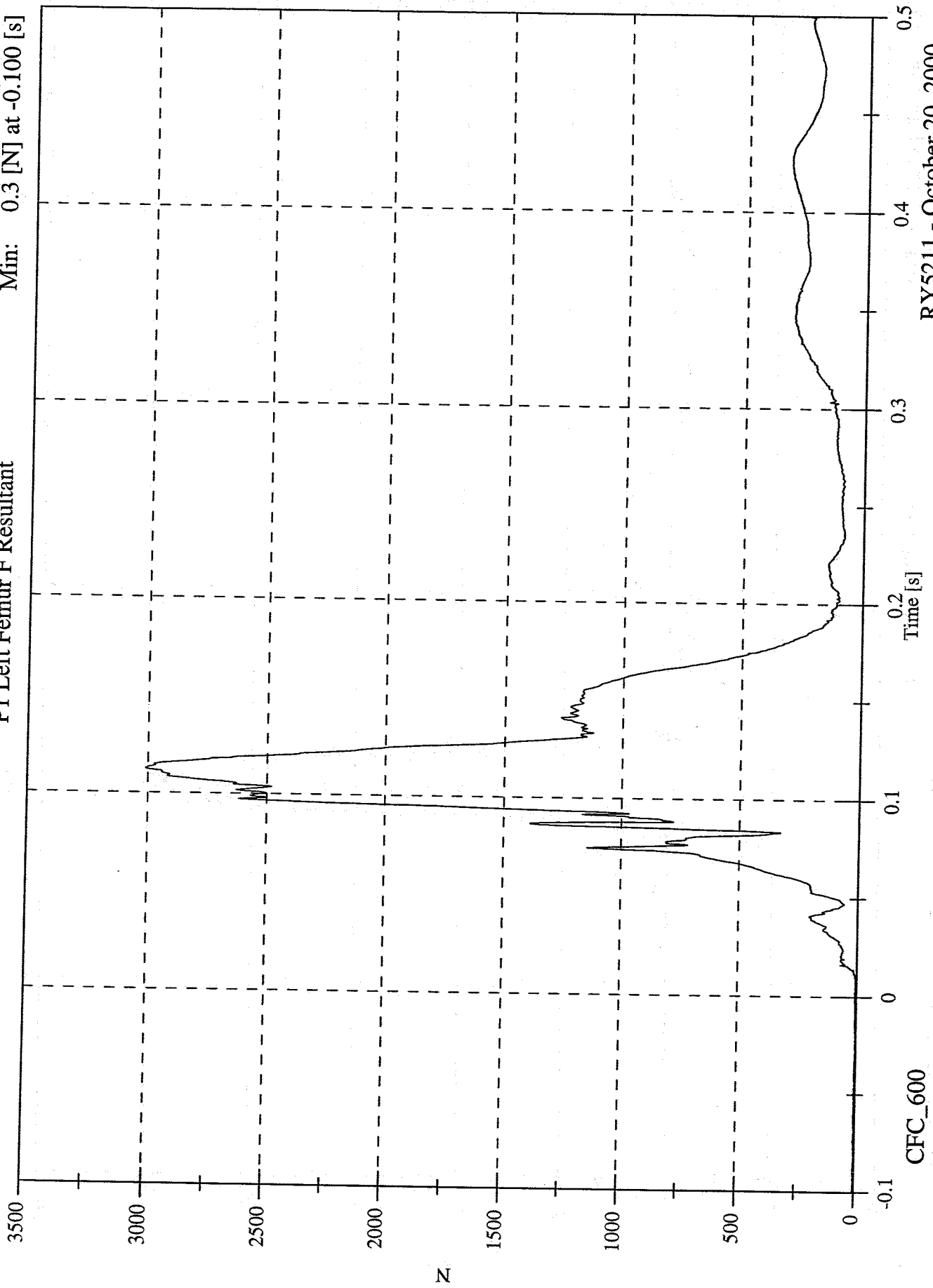

RY5211 - October 20, 2000

40% Frontal Offset Test #2 - 2000 Nissan Altima

Max: 39.6 [Nm] at 0.141 [s]  
Min: -128.4 [Nm] at 0.103 [s]

P1 Left Femur Mx

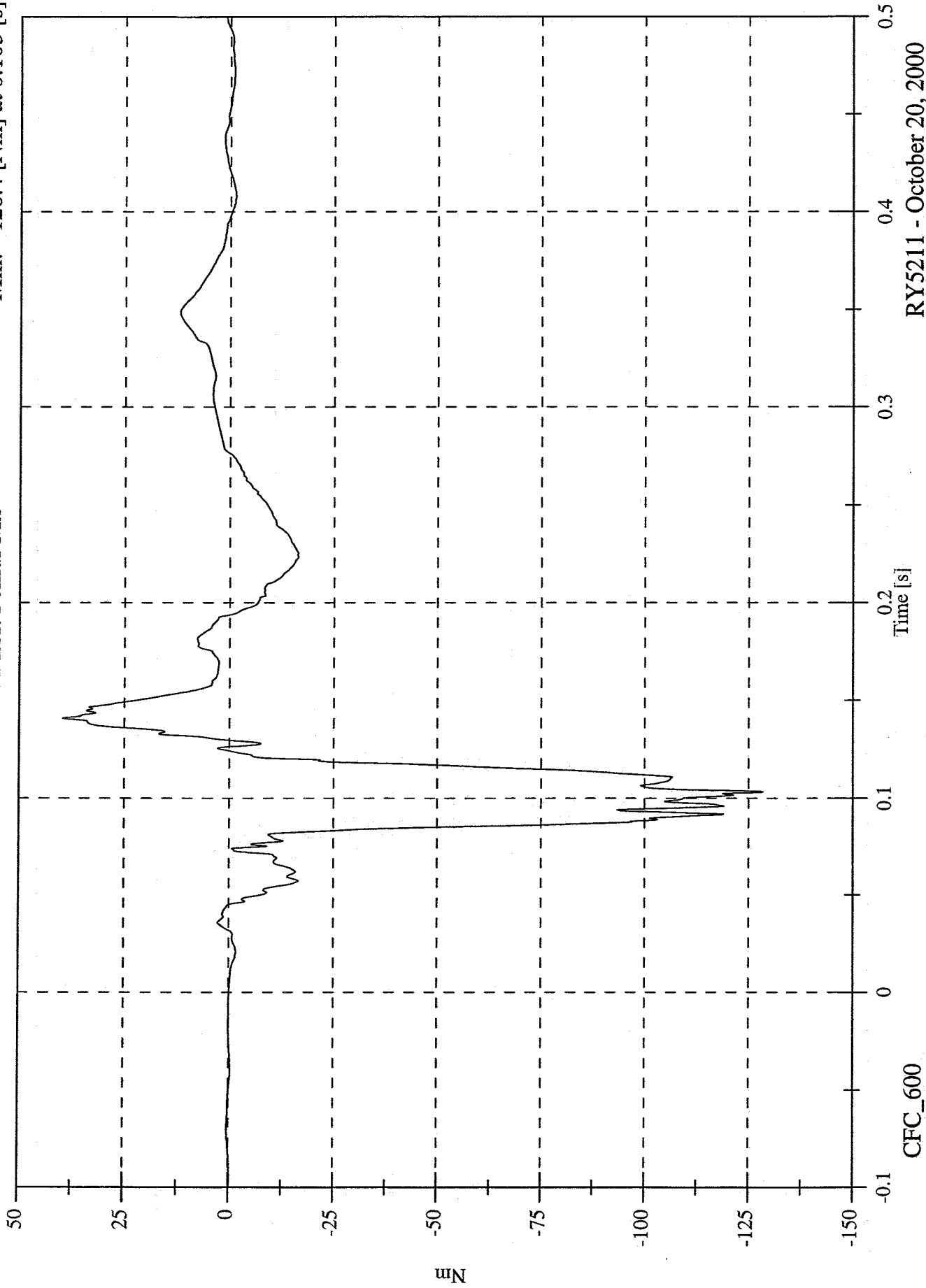

RYS211 - October 20, 2000

40% Frontal Offset Test #2 - 2000 Nissan Altima

Max: 101.3 [Nm] at 0.107 [s]  
Min: -29.1 [Nm] at 0.085 [s]

P1 Left Femur My

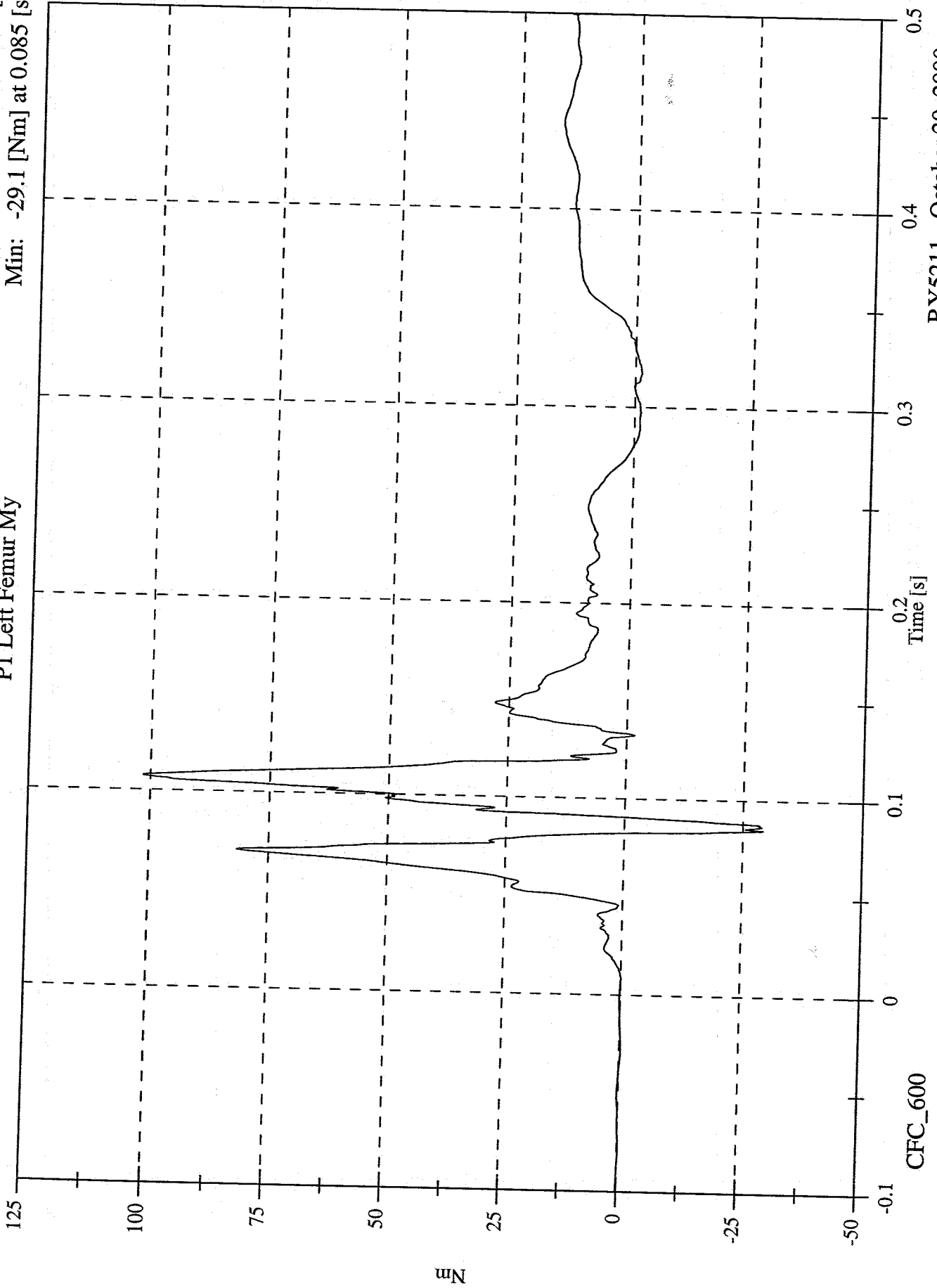

RY5211 - October 20, 2000

40% Frontal Offset Test #2 - 2000 Nissan Altima

Max: 20.0 [Nm] at 0.231 [s]  
Min: -28.6 [Nm] at 0.111 [s]

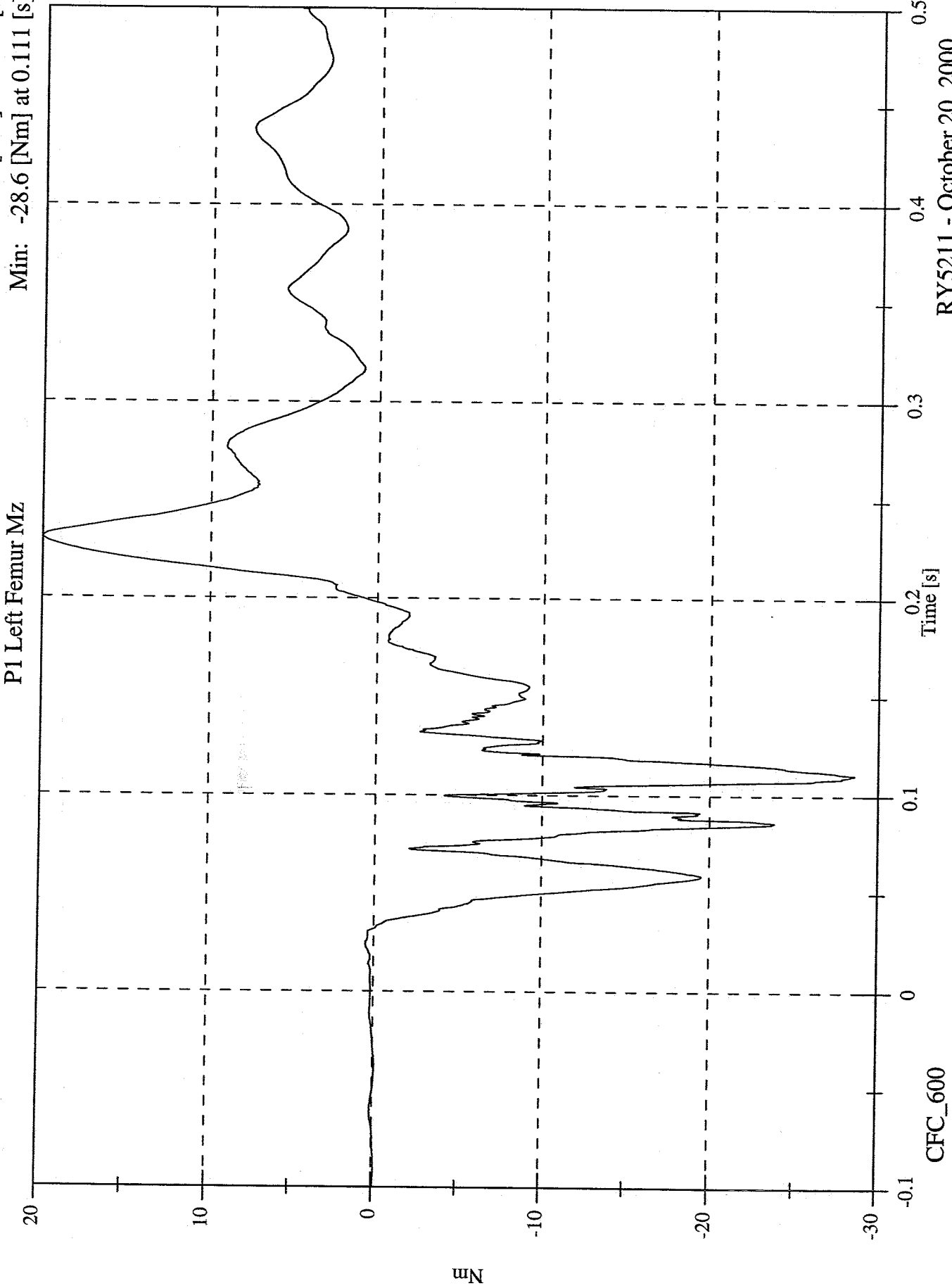

RY5211 - October 20, 2000

40% Frontal Offset Test #2 - 2000 Nissan Altima

Max: 147.3 [Nm] at 0.103 [s]

Min: 0.0 [Nm] at -0.100 [s]

P1 Left Femur M Resultant

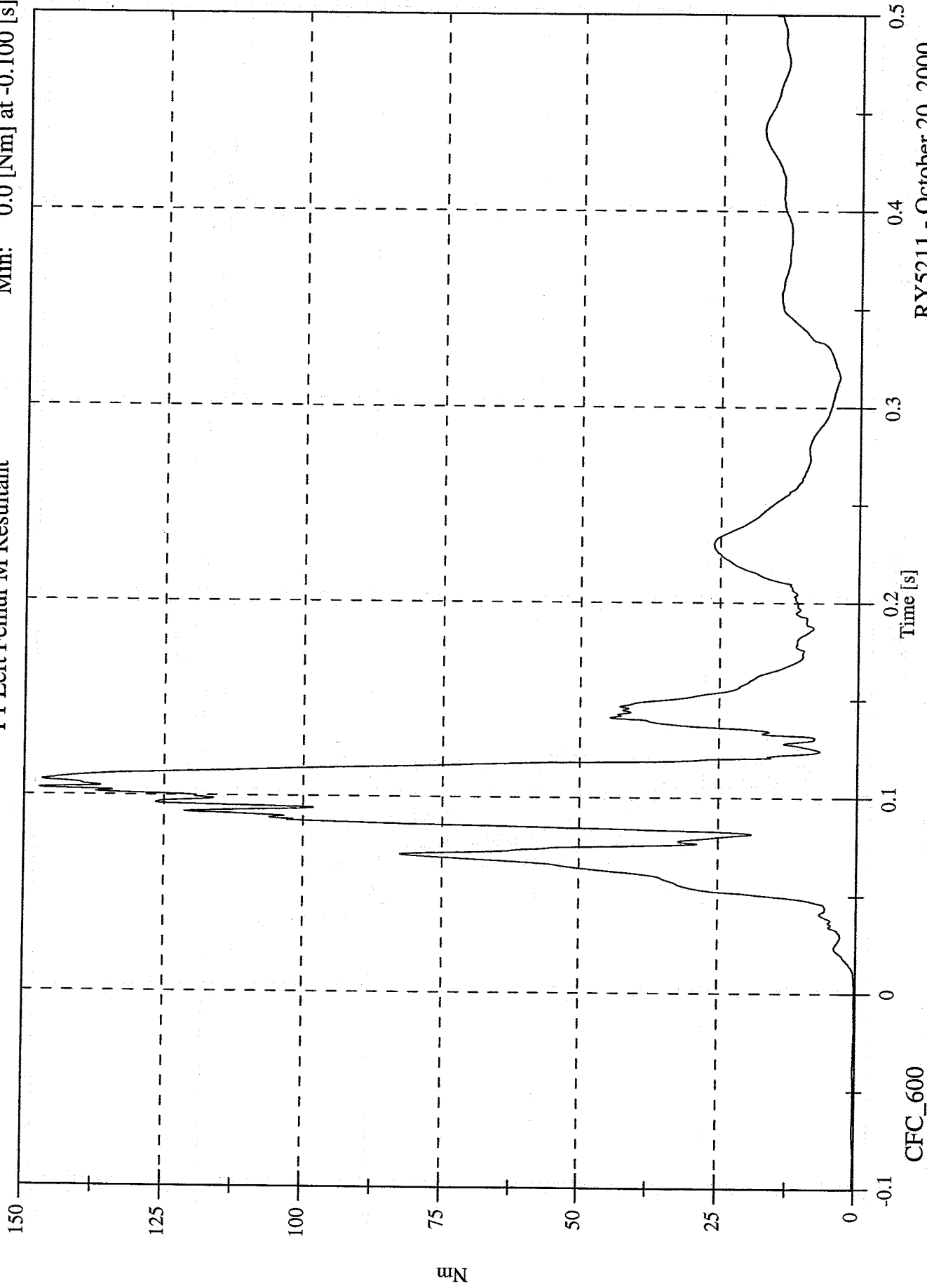

RY5211 - October 20, 2000

40% Frontal Offset Test #2 - 2000 Nissan Altima

Max: 761.0 [N] at 0.111 [s]  
Min: -65.4 [N] at 0.250 [s]

P1 Right Femur Fx

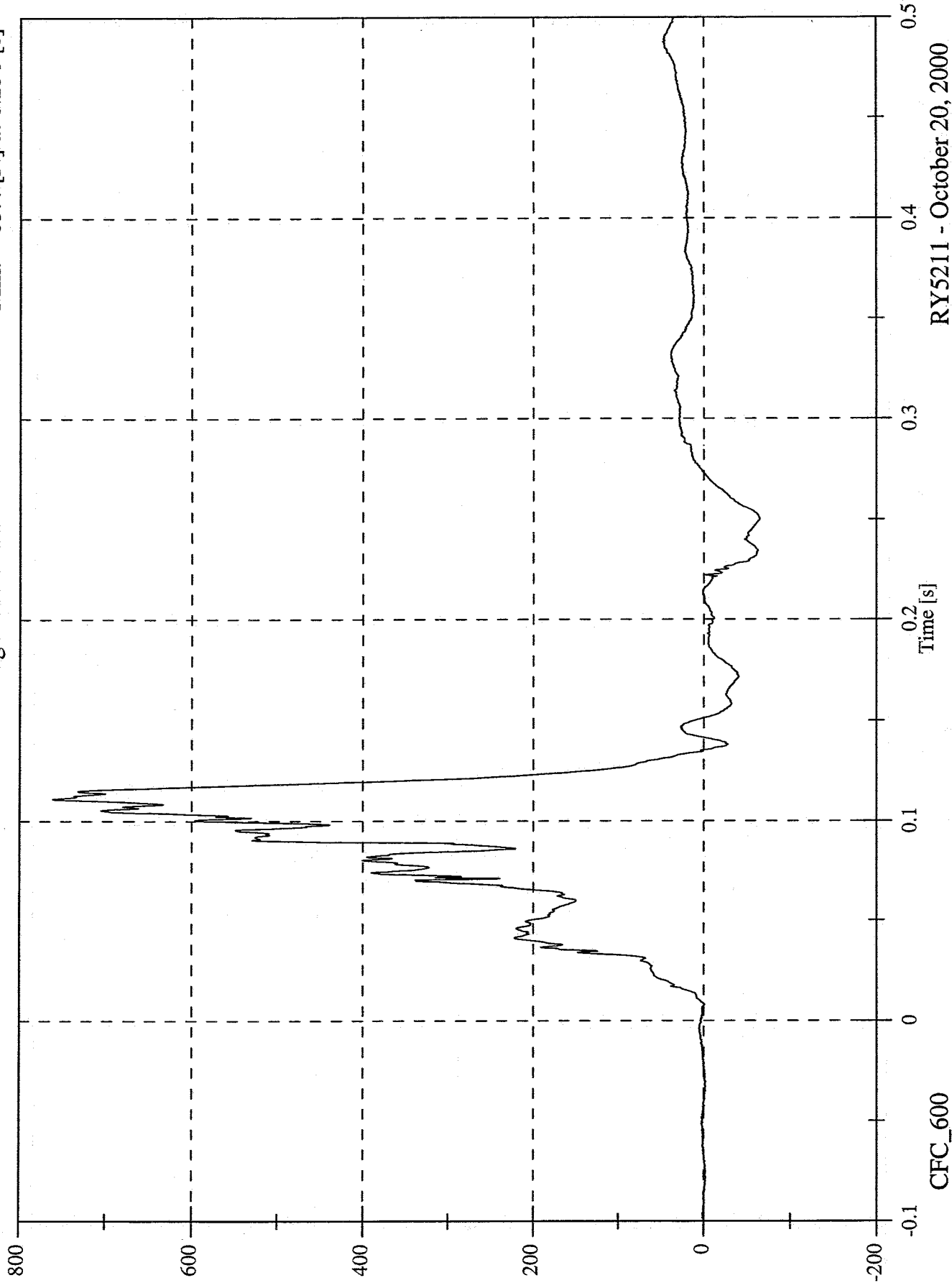

CFC\_600

RY5211 - October 20, 2000

40% Frontal Offset Test #2 - 2000 Nissan Altima

Max: 888.1 [N] at 0.107 [s]  
Min: -94.6 [N] at 0.069 [s]

P1 Right Femur Fy

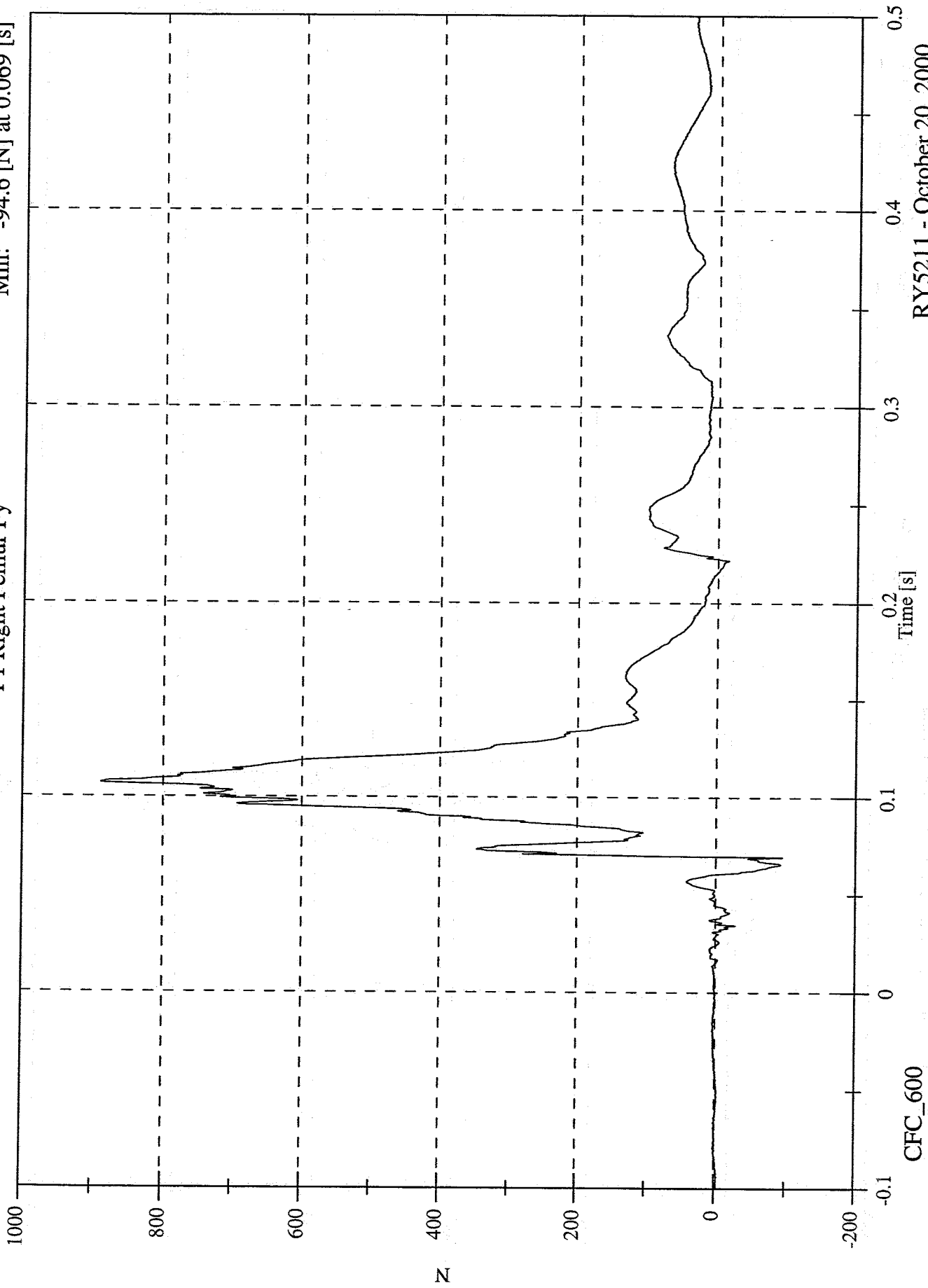

RY5211 - October 20, 2000

40% Frontal Offset Test #2 - 2000 Nissan Altima

Max: 297.5 [N] at 0.058 [s]  
Min: -2214.5 [N] at 0.089 [s]

P1 Right Femur Fz

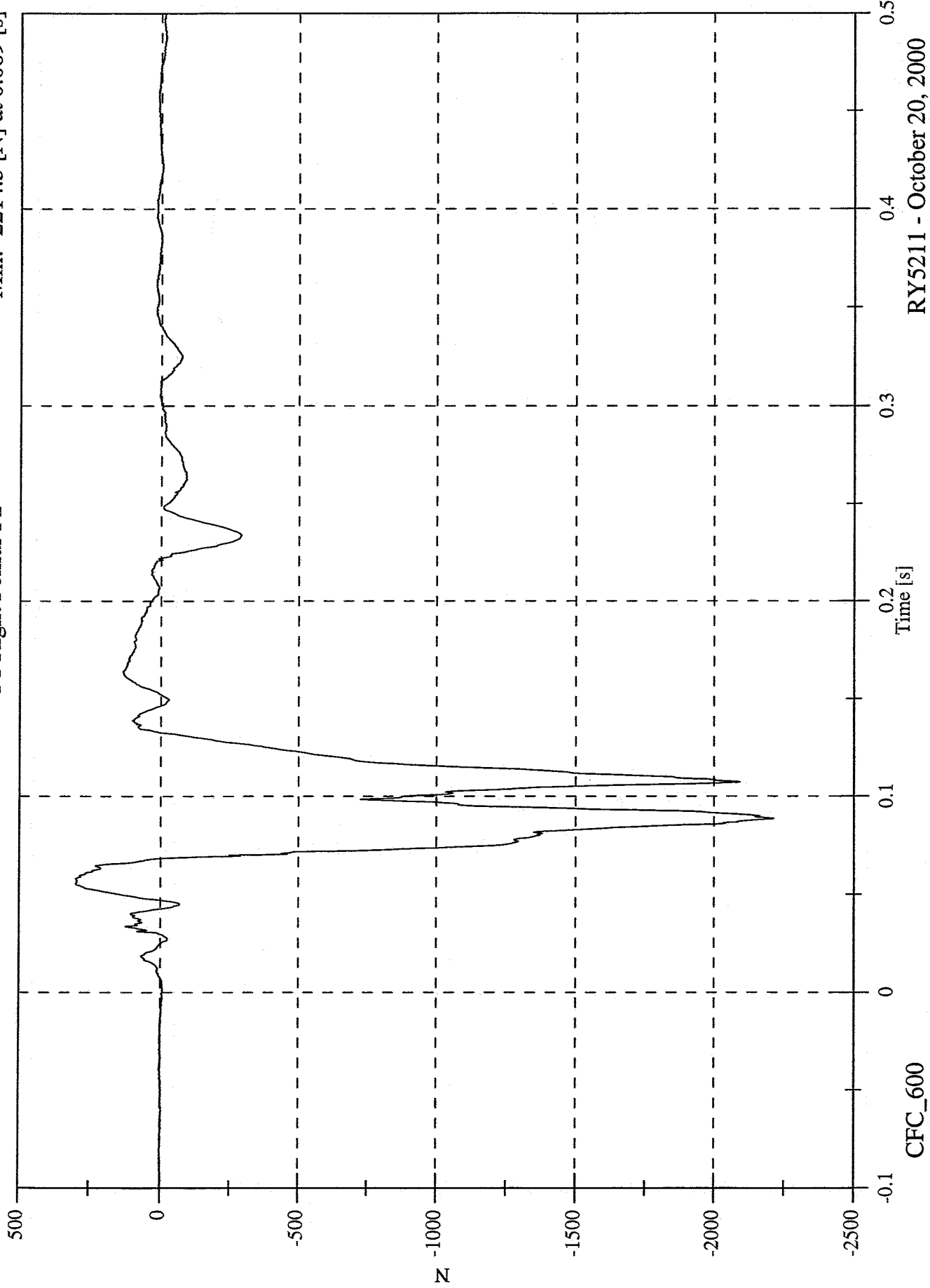

RY5211 - October 20, 2000

40% Frontal Offset Test #2 - 2000 Nissan Altima

P1 Right Femur F Resultant

Max: 2371.8 [N] at 0.107 [s]

Min: 0.2 [N] at -0.068 [s]

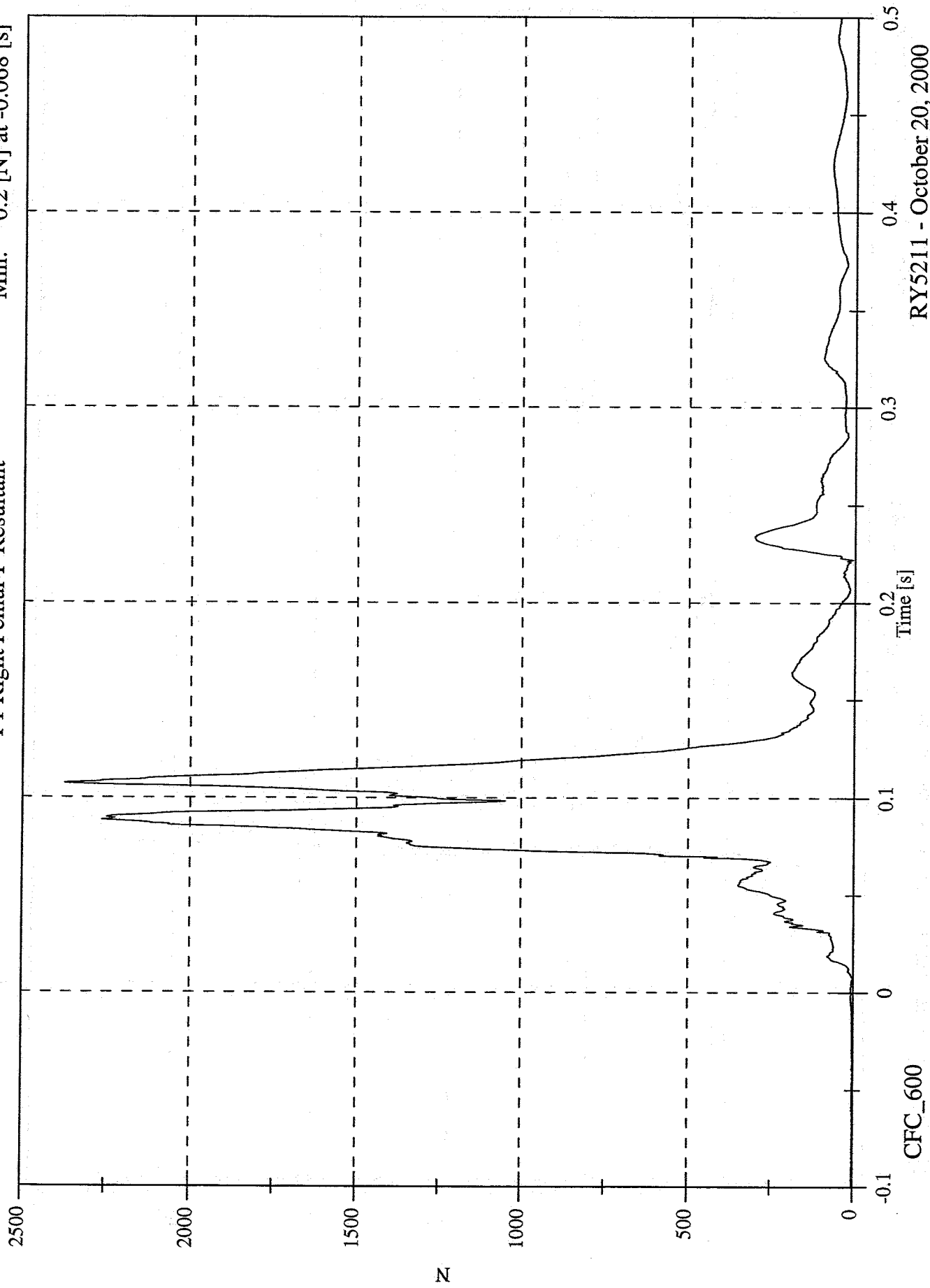

RY5211 - October 20, 2000

40% Frontal Offset Test #2 - 2000 Nissan Altima

Max: 13.7 [Nm] at 0.063 [s]  
Min: -112.2 [Nm] at 0.073 [s]

P1 Right Femur Mx

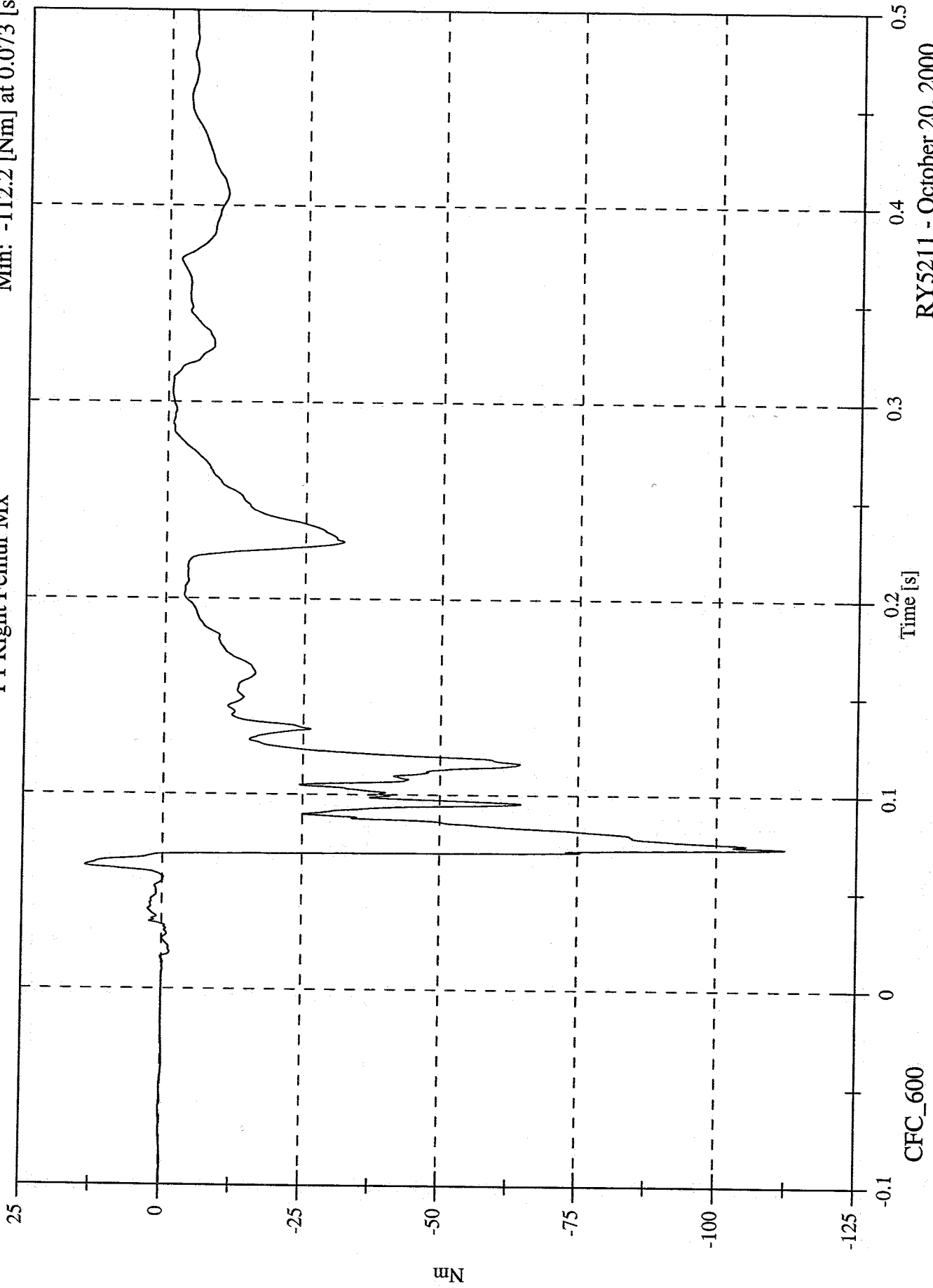

RY5211 - October 20, 2000

40% Frontal Offset Test #2 - 2000 Nissan Altima

Max: 74.4 [Nm] at 0.089 [s]  
Min: -24.4 [Nm] at 0.079 [s]

P1 Right Femur My

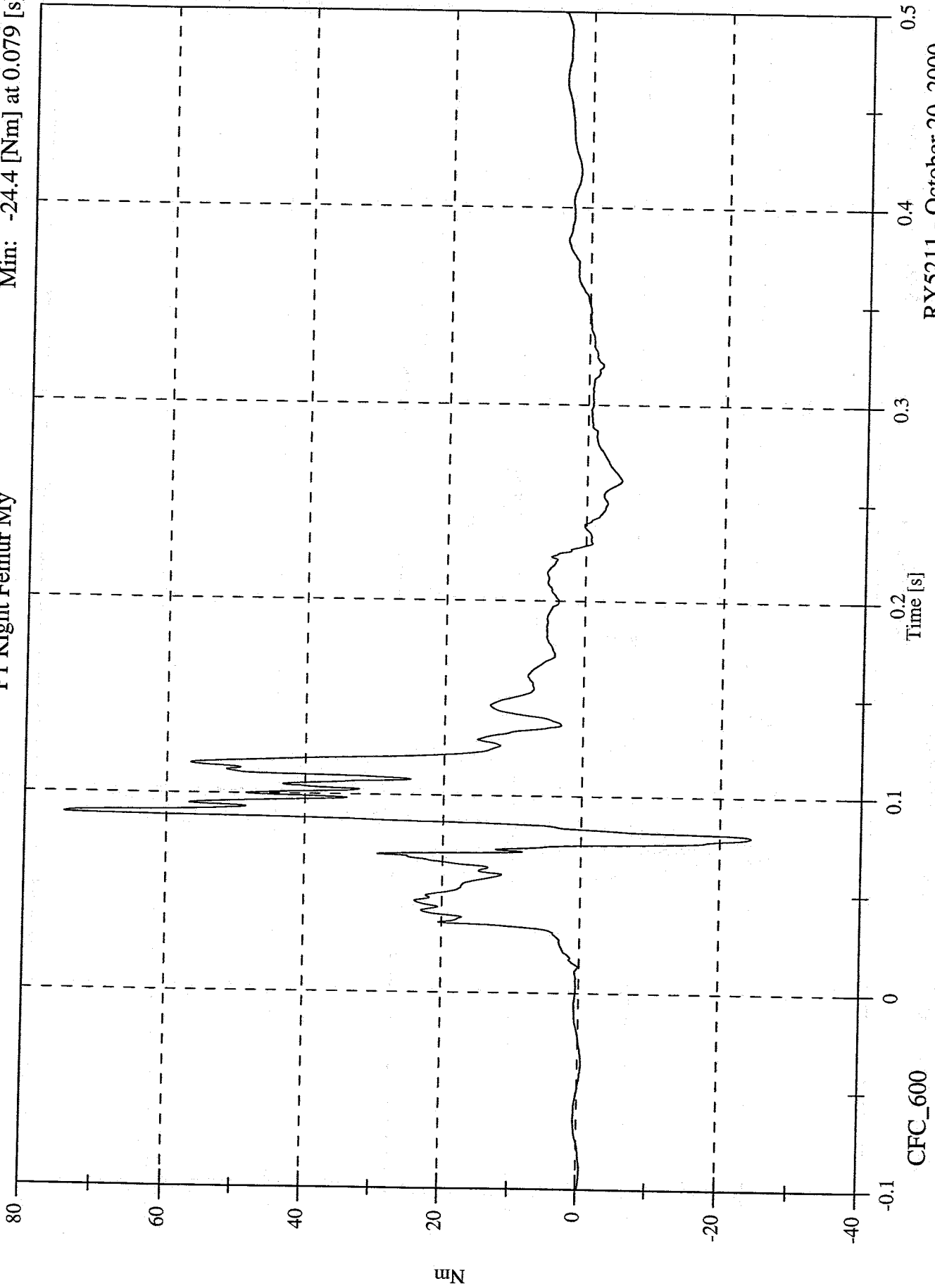

RY5211 - October 20, 2000

40% Frontal Offset Test #2 - 2000 Nissan Altima

Max: 33.2 [Nm] at 0.078 [s]

Min: -24.2 [Nm] at 0.096 [s]

P1 Right Femur Mz

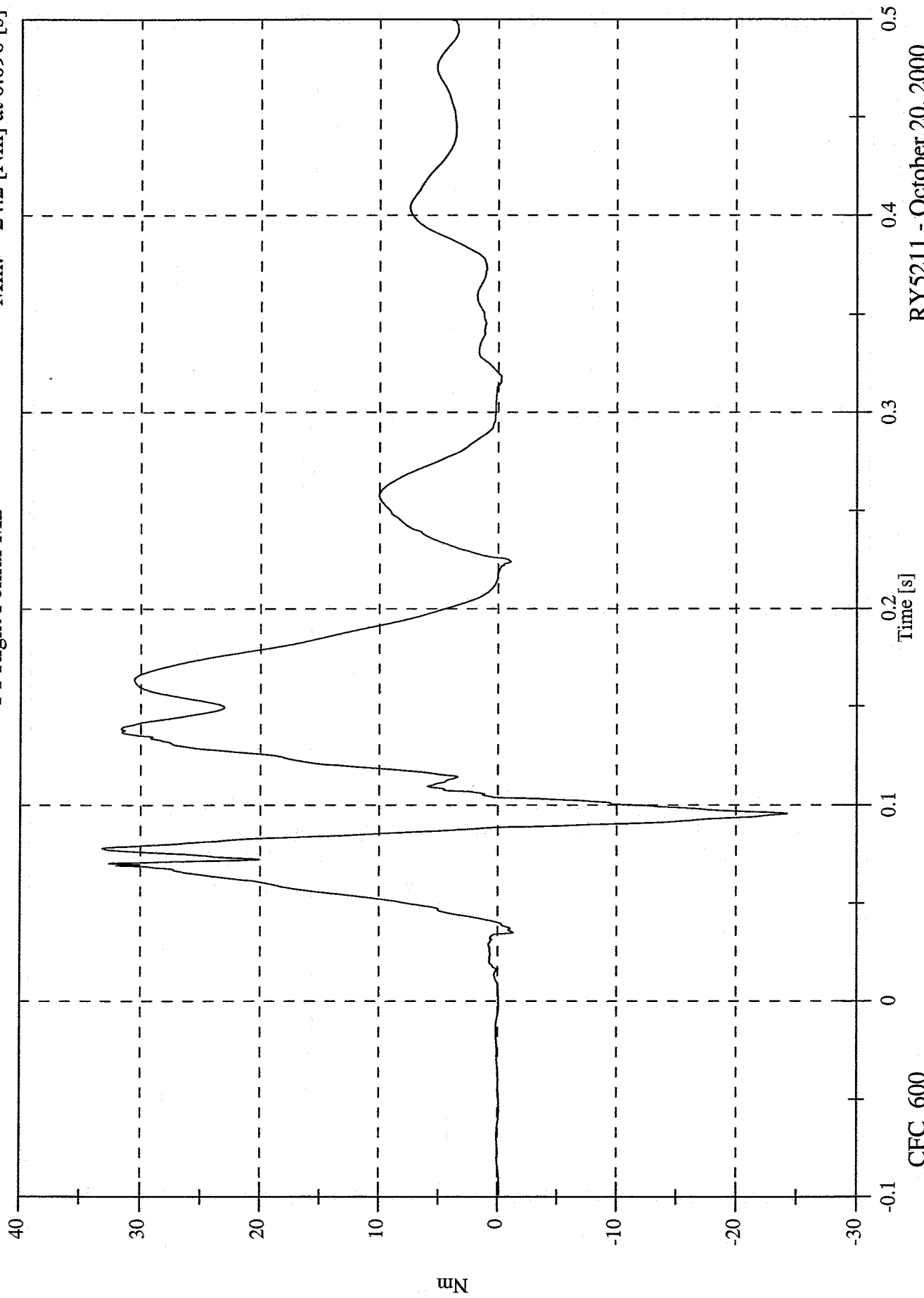

RY5211 - October 20, 2000

40% Frontal Offset Test #2 - 2000 Nissan Altima

Max: 114.7 [Nm] at 0.073 [s]  
Min: 0.0 [Nm] at -0.100 [s]

P1 Right Femur M Resultant

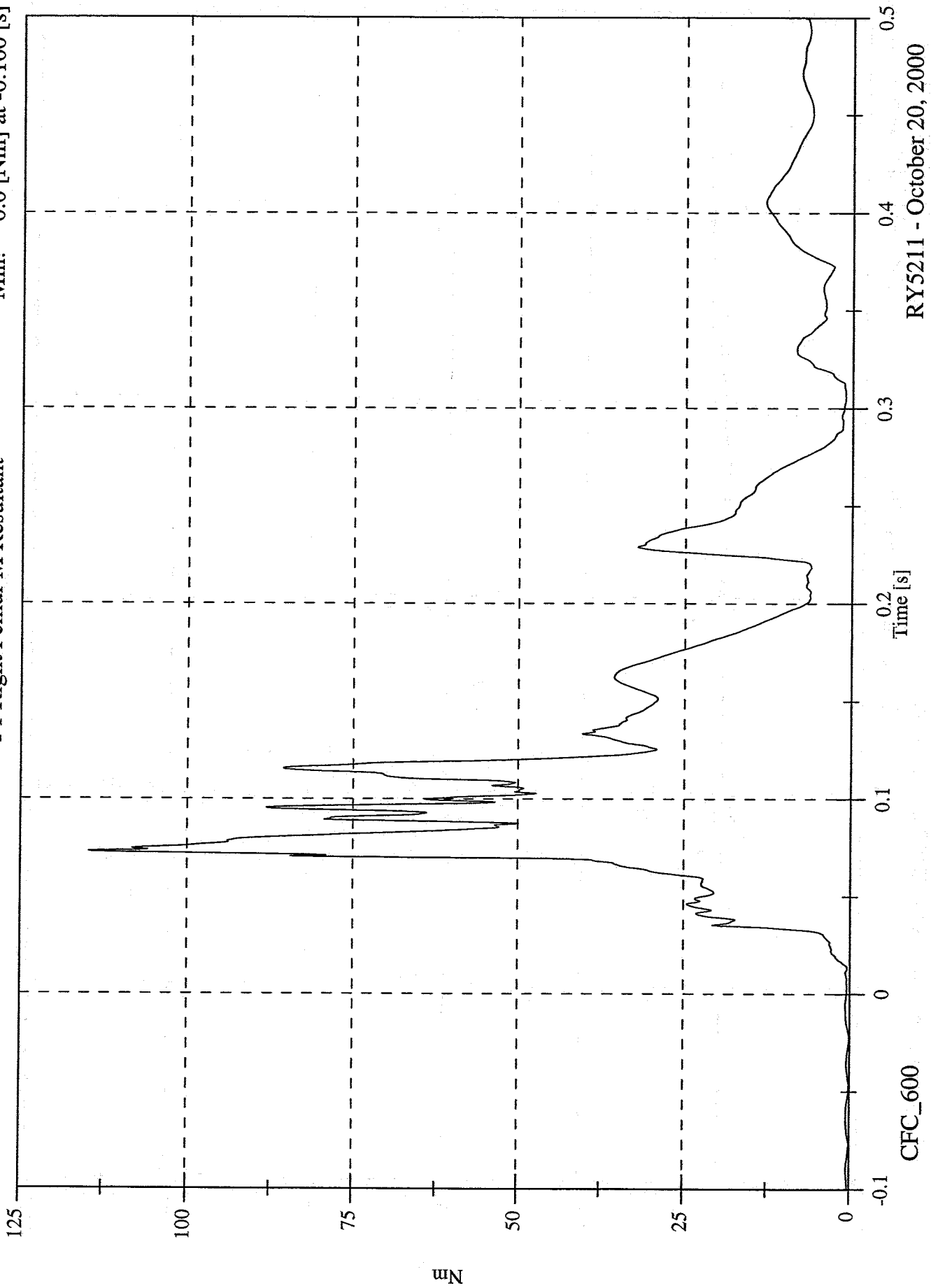

RX5211 - October 20, 2000

40% Frontal Offset Test #2 - 2000 Nissan Altima

P1 Left Knee Shear Dx

Max: 0.4 [mm] at 0.077 [s]

Min: -11.2 [mm] at 0.102 [s]

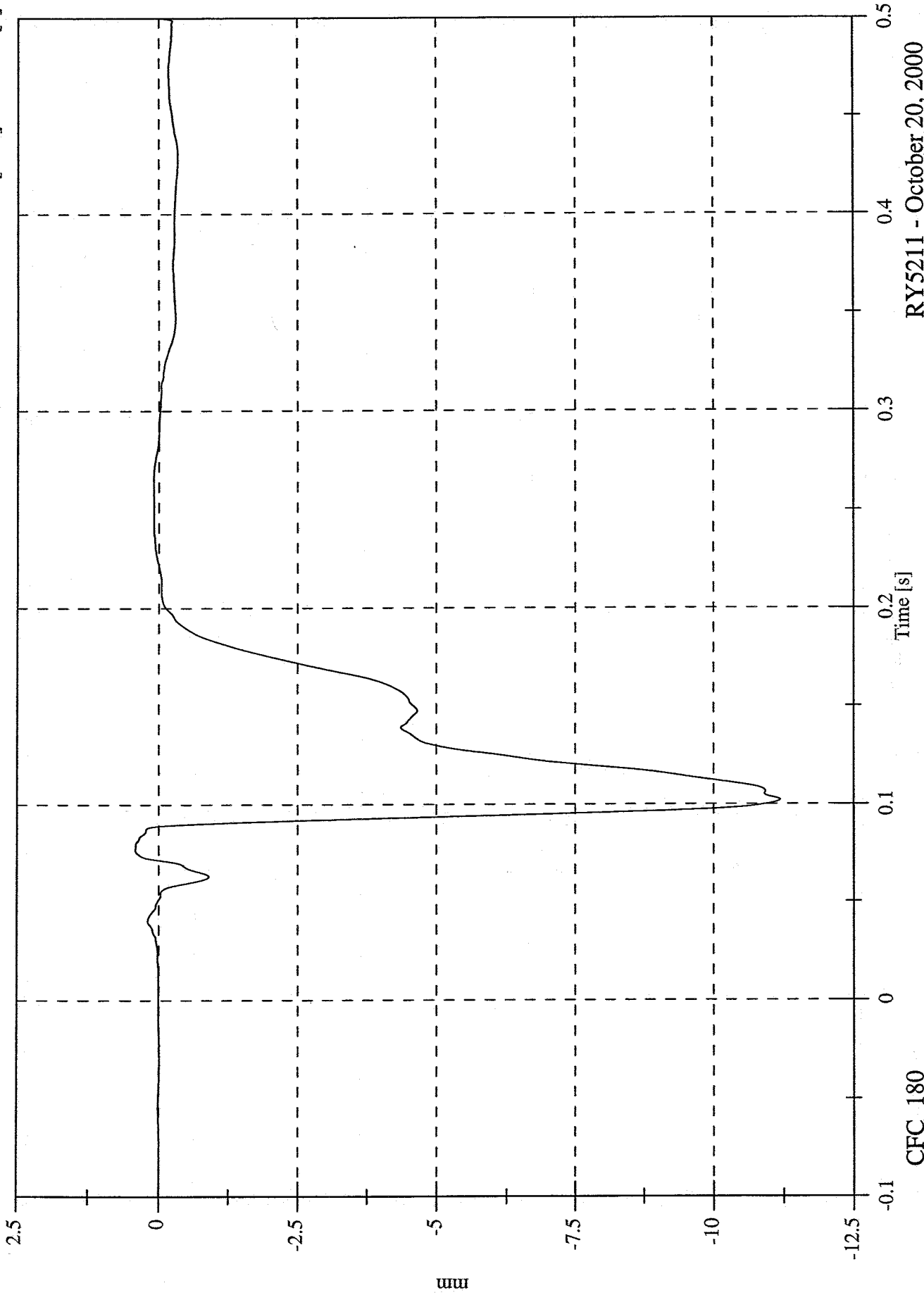

RY5211 - October 20, 2000

CFC\_180

40% Frontal Offset Test #2 - 2000 Nissan Altima

Max: 4.5 [mm] at 0.499 [s]  
Min: -6.0 [mm] at 0.066 [s]

P1 Right Knee Shear Dx

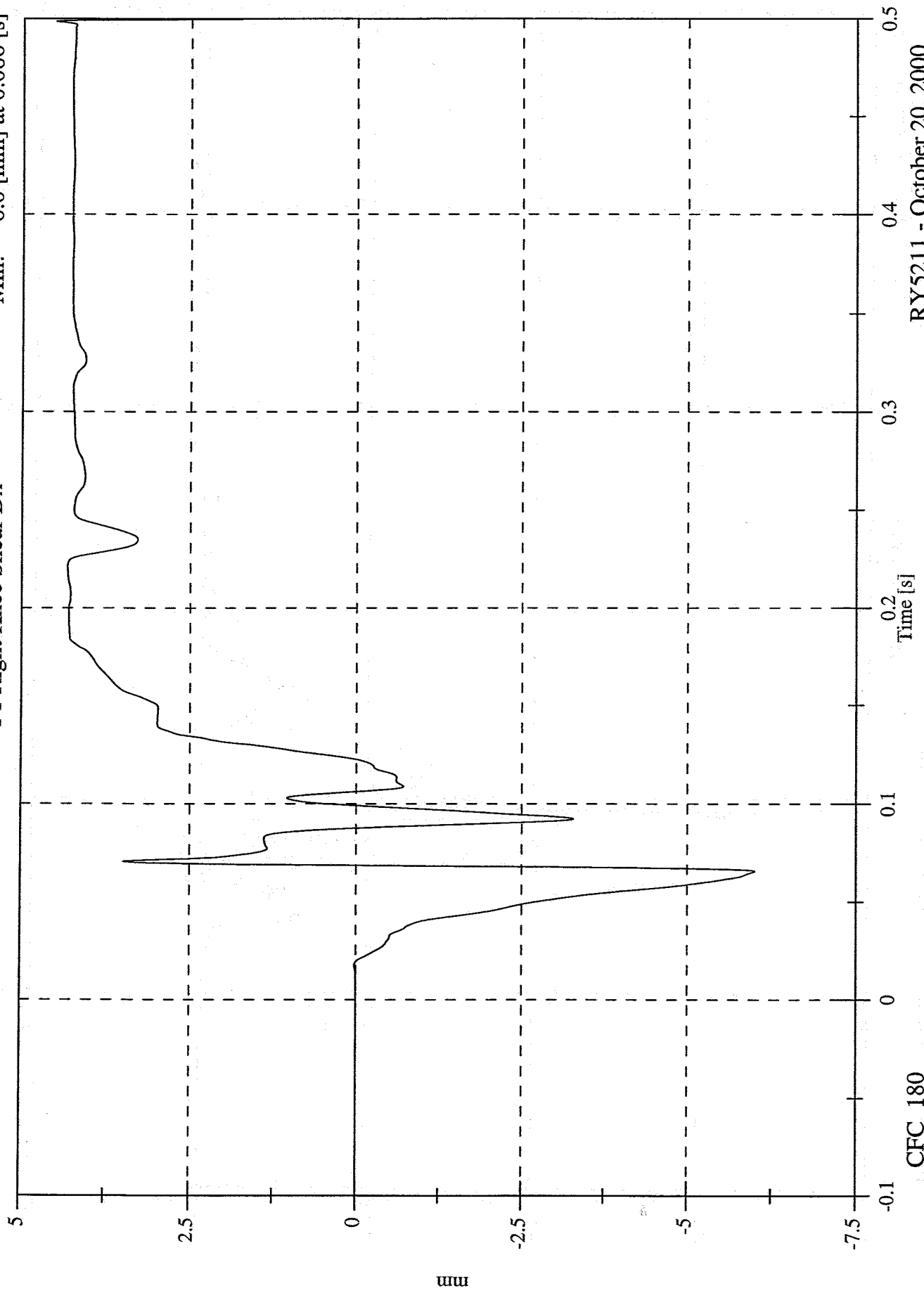

RYS211 - October 20, 2000

CFC\_180

40% Frontal Offset Test #2 - 2000 Nissan Altima

Max: 753.9 [N] at 0.092 [s]

Min: -83.3 [N] at 0.085 [s]

P1 Left Upper Tibia Fx

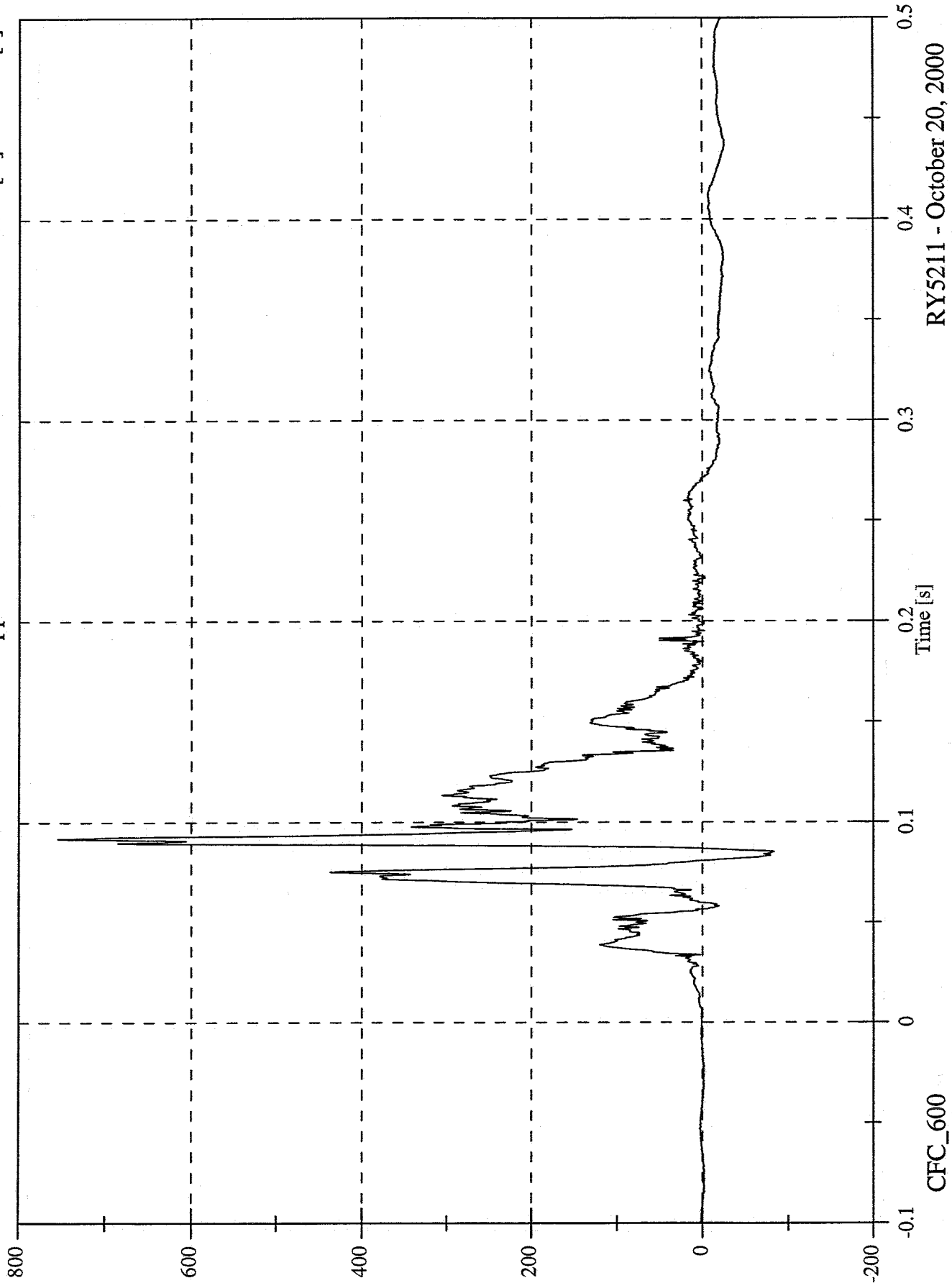

CFC\_600

RY5211 - October 20, 2000

40% Frontal Offset Test #2 - 2000 Nissan Altima

Max: 682.9 [N] at 0.146 [s]  
Min: -1915.3 [N] at 0.070 [s]

P1 Left Upper Tibia Fz

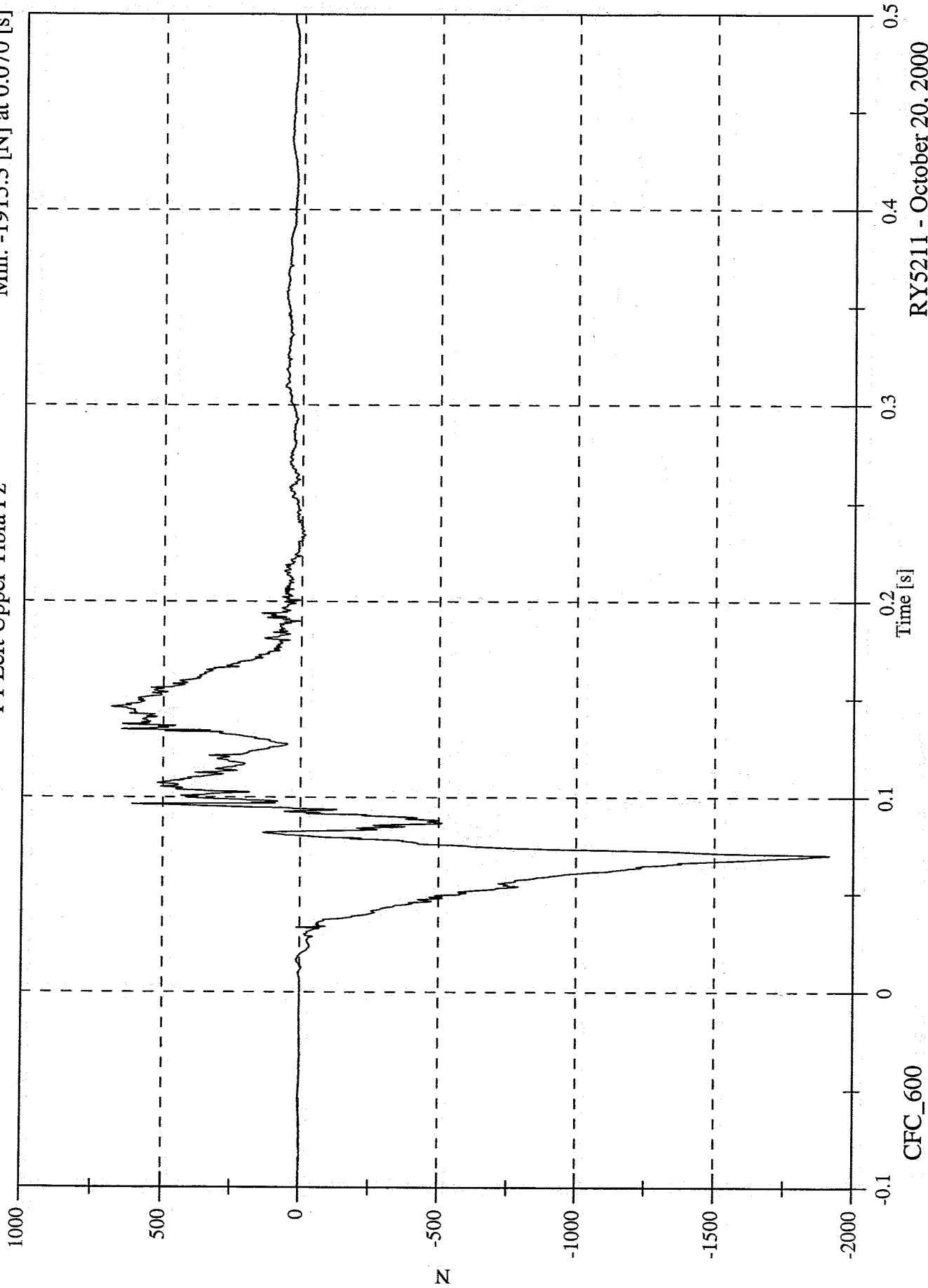

CFC\_600

RYS211 - October 20, 2000

40% Frontal Offset Test #2 - 2000 Nissan Altima

Max: 35.2 [Nm] at 0.108 [s]

Min: -62.5 [Nm] at 0.140 [s]

P1 Left Upper Tibia Mx

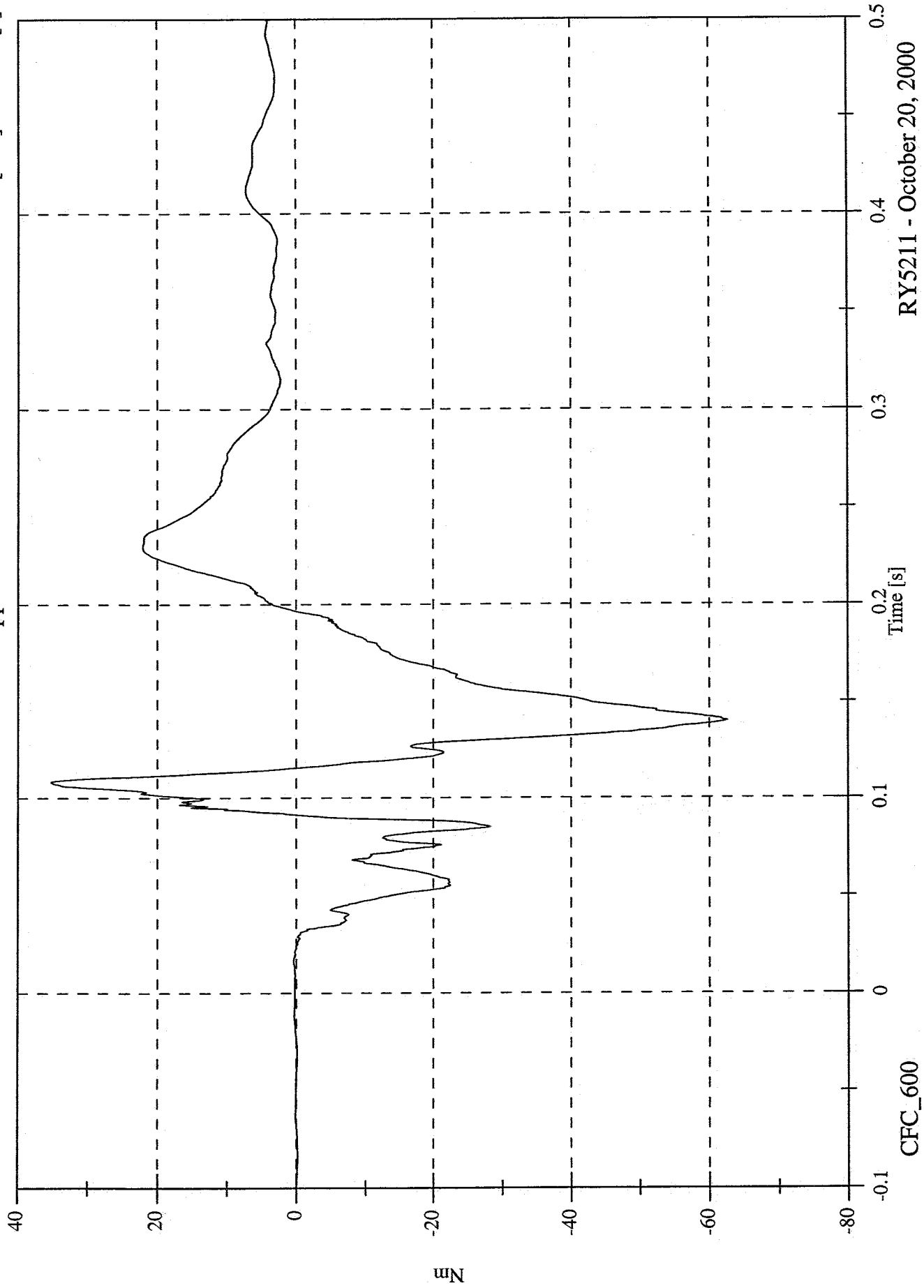

RYS211 - October 20, 2000

CFC\_600

40% Frontal Offset Test #2 - 2000 Nissan Altima

P1 Left Upper Tibia My

Max: 120.8 [Nm] at 0.100 [s]  
Min: -46.9 [Nm] at 0.075 [s]

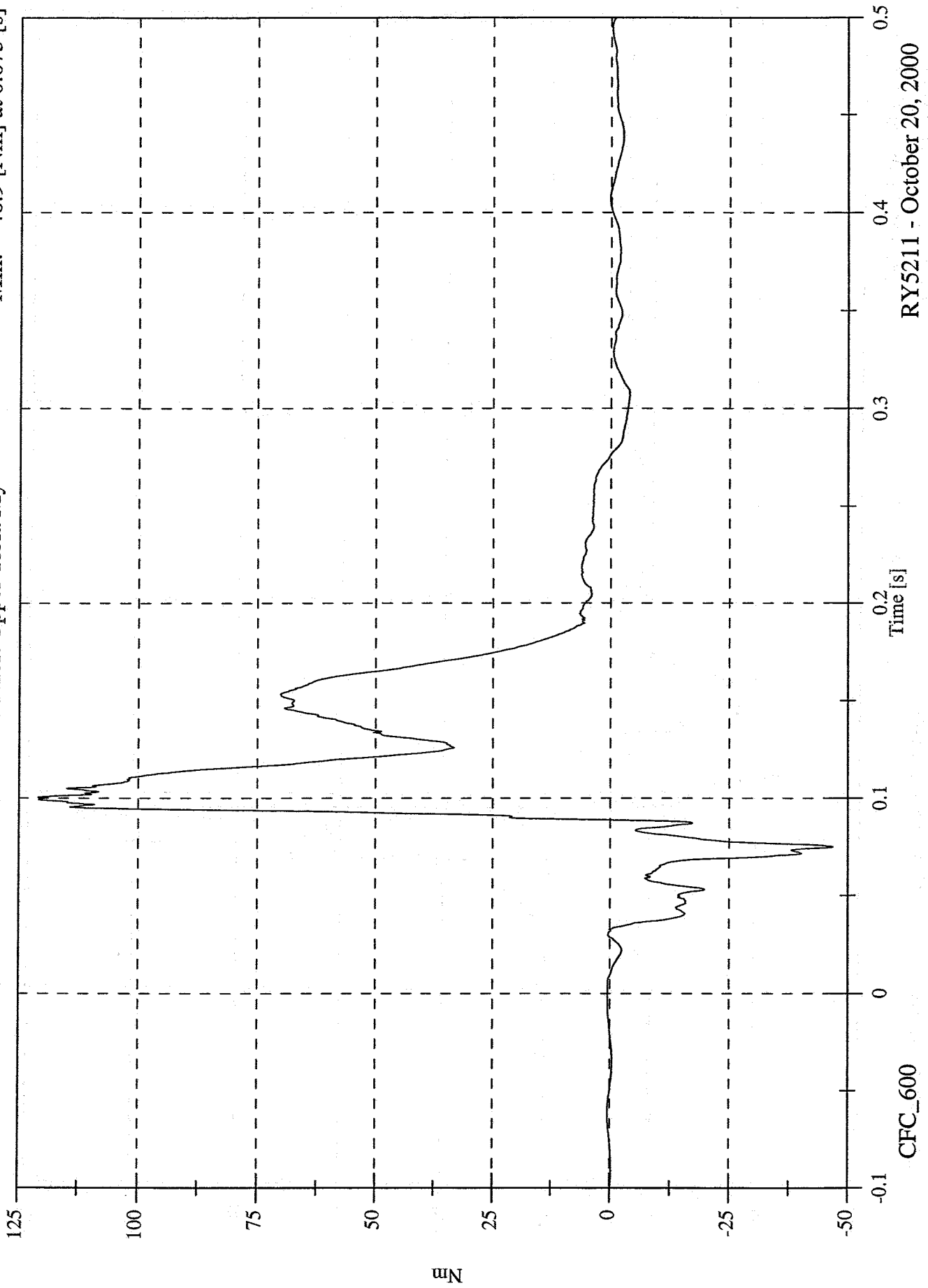

RY5211 - October 20, 2000

40% Frontal Offset Test #2 - 2000 Nissan Altima

Max: 123.7 [N] at 0.111 [s]

Min: -557.2 [N] at 0.090 [s]

P1 Left Lower Tibia Fx

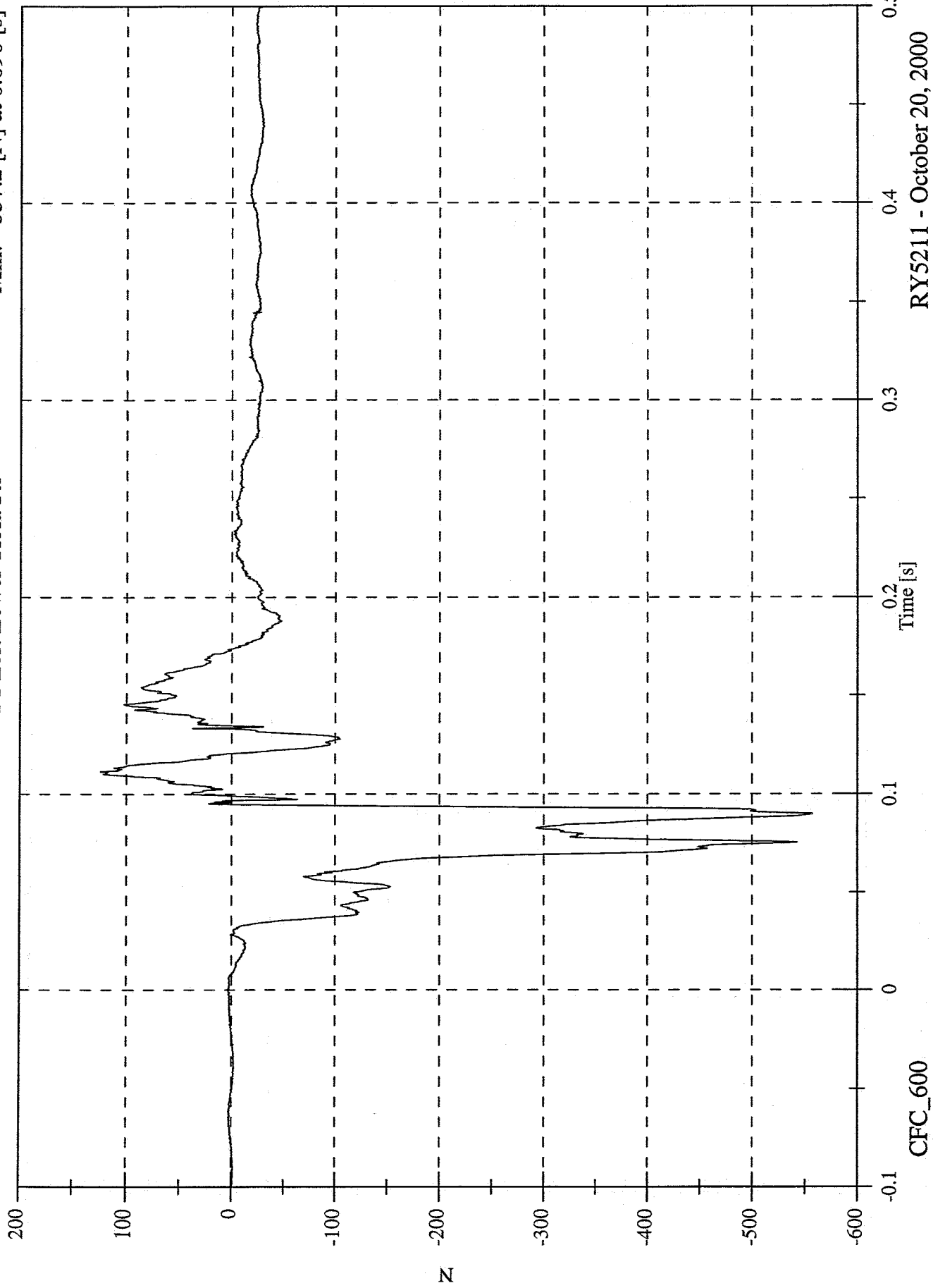

RYS211 - October 20, 2000

40% Frontal Offset Test #2 - 2000 Nissan Altima

Max: 257.6 [N] at 0.135 [s]  
Min: -57.9 [N] at 0.109 [s]

P1 Left Lower Tibia Fy

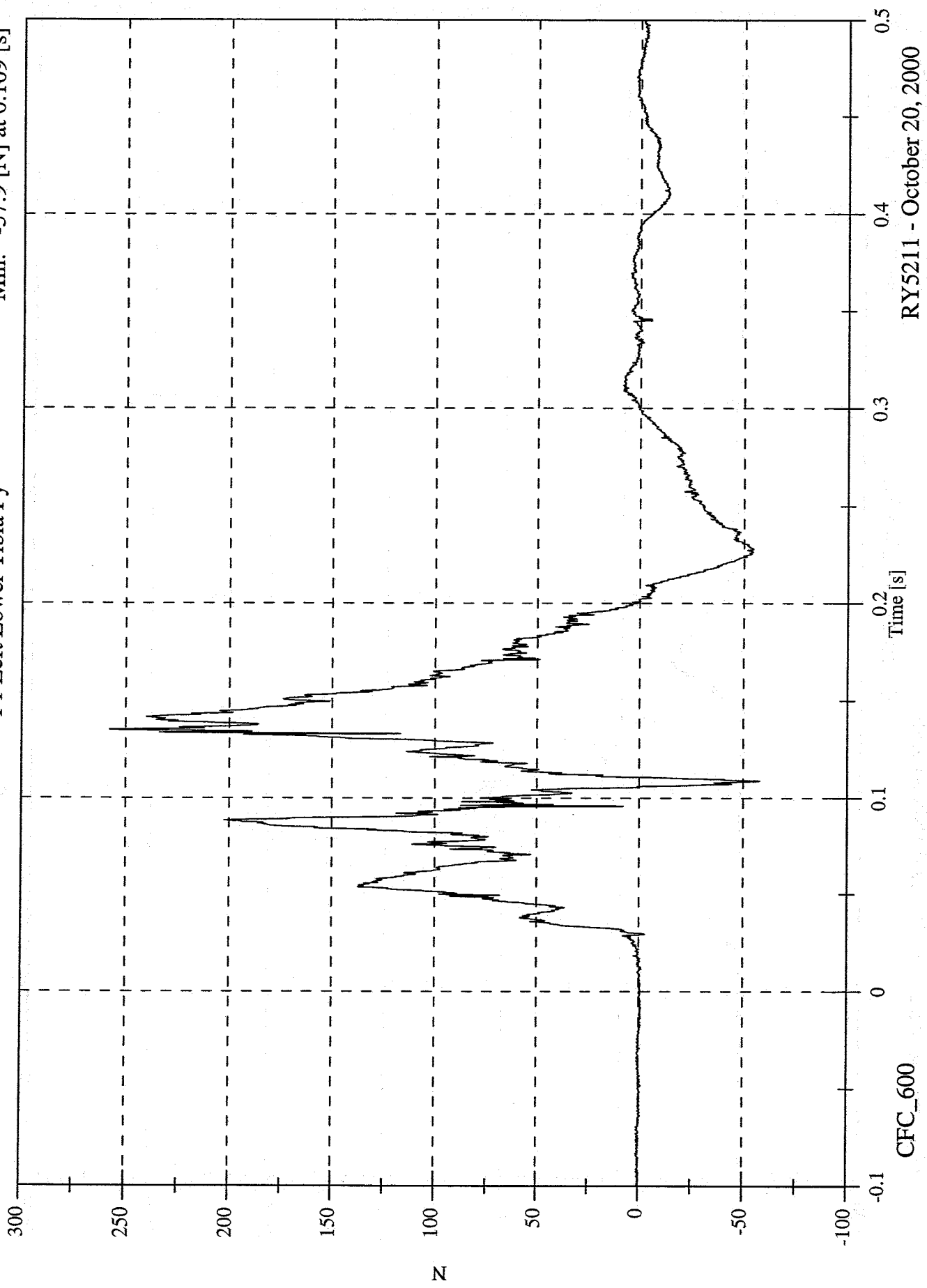

RYS211 - October 20, 2000

40% Frontal Offset Test #2 - 2000 Nissan Altima

Max: 33.9 [N] at 0.345 [s]  
Min: -2642.1 [N] at 0.069 [s]

P1 Left Lower Tibia Fz

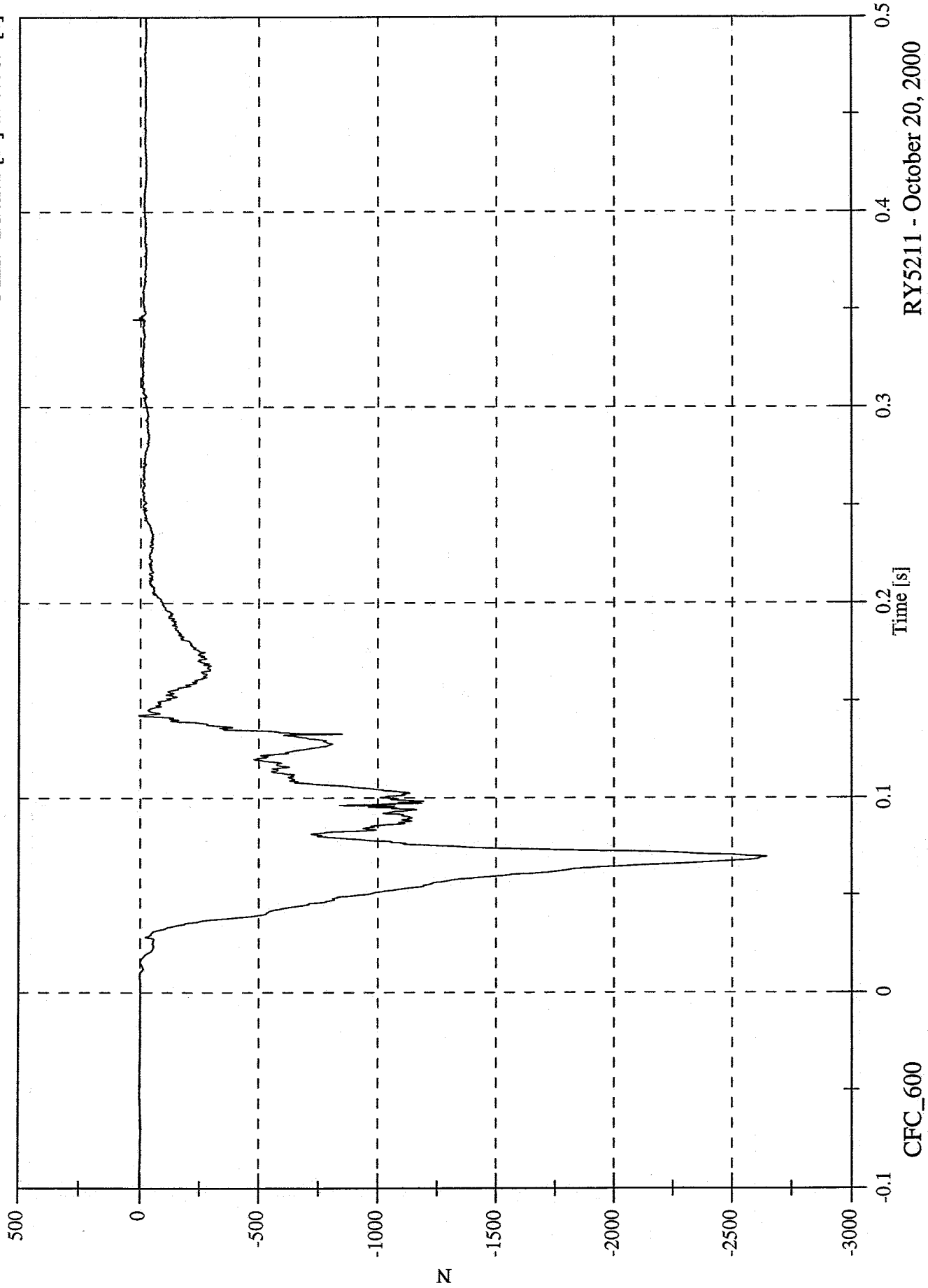

RYS211 - October 20, 2000

40% Frontal Offset Test #2 - 2000 Nissan Altima

P1 Left Lower Tibia F Resultant

Max: 2659.9 [N] at 0.069 [s]

Min: 0.4 [N] at -0.100 [s]

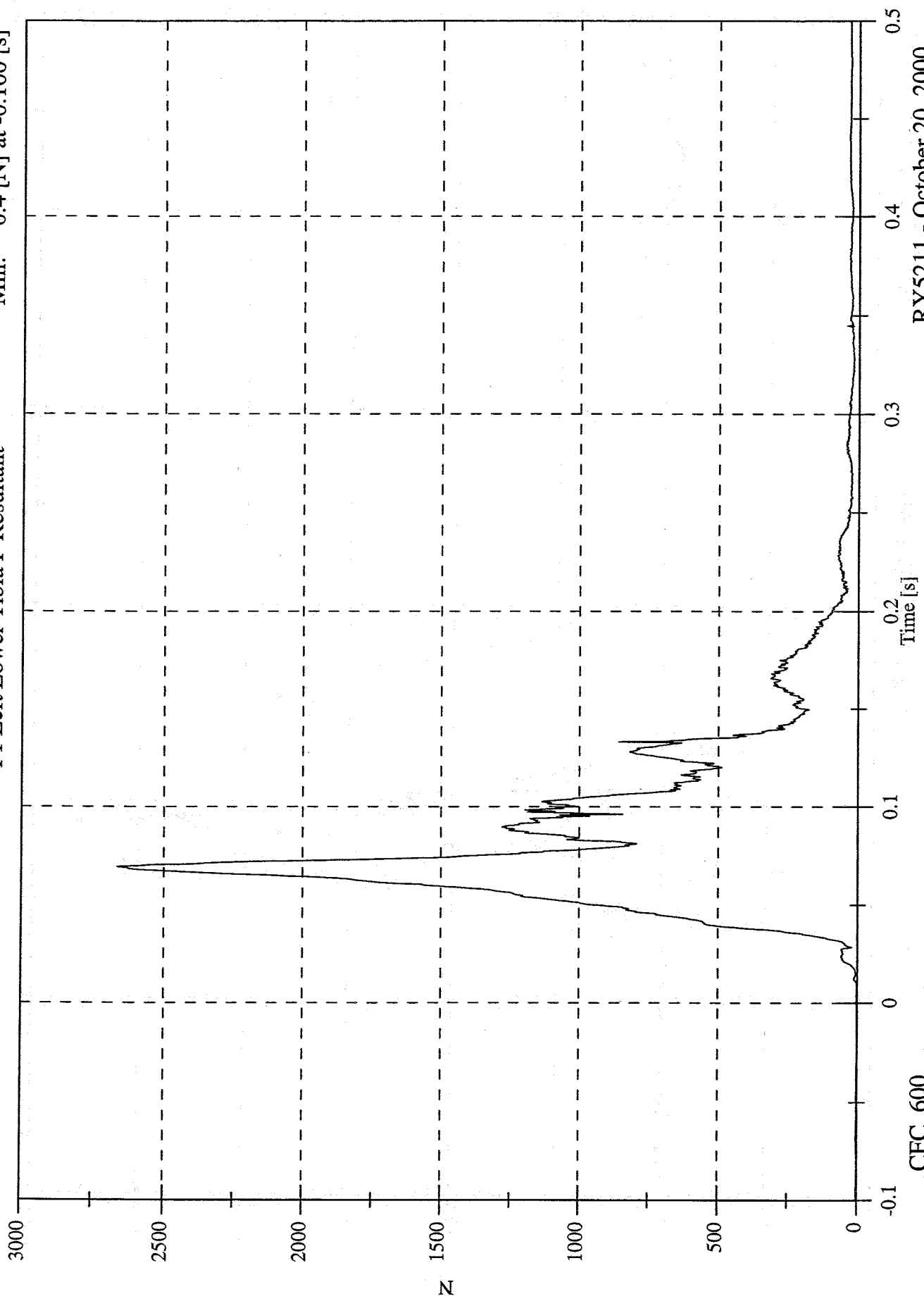

CFC\_600

RY5211 - October 20, 2000

40% Frontal Offset Test #2 - 2000 Nissan Altima

Max: 8.1 [Nm] at 0.229 [s]

Min: -28.5 [Nm] at 0.089 [s]

P1 Left Lower Tibia Mx

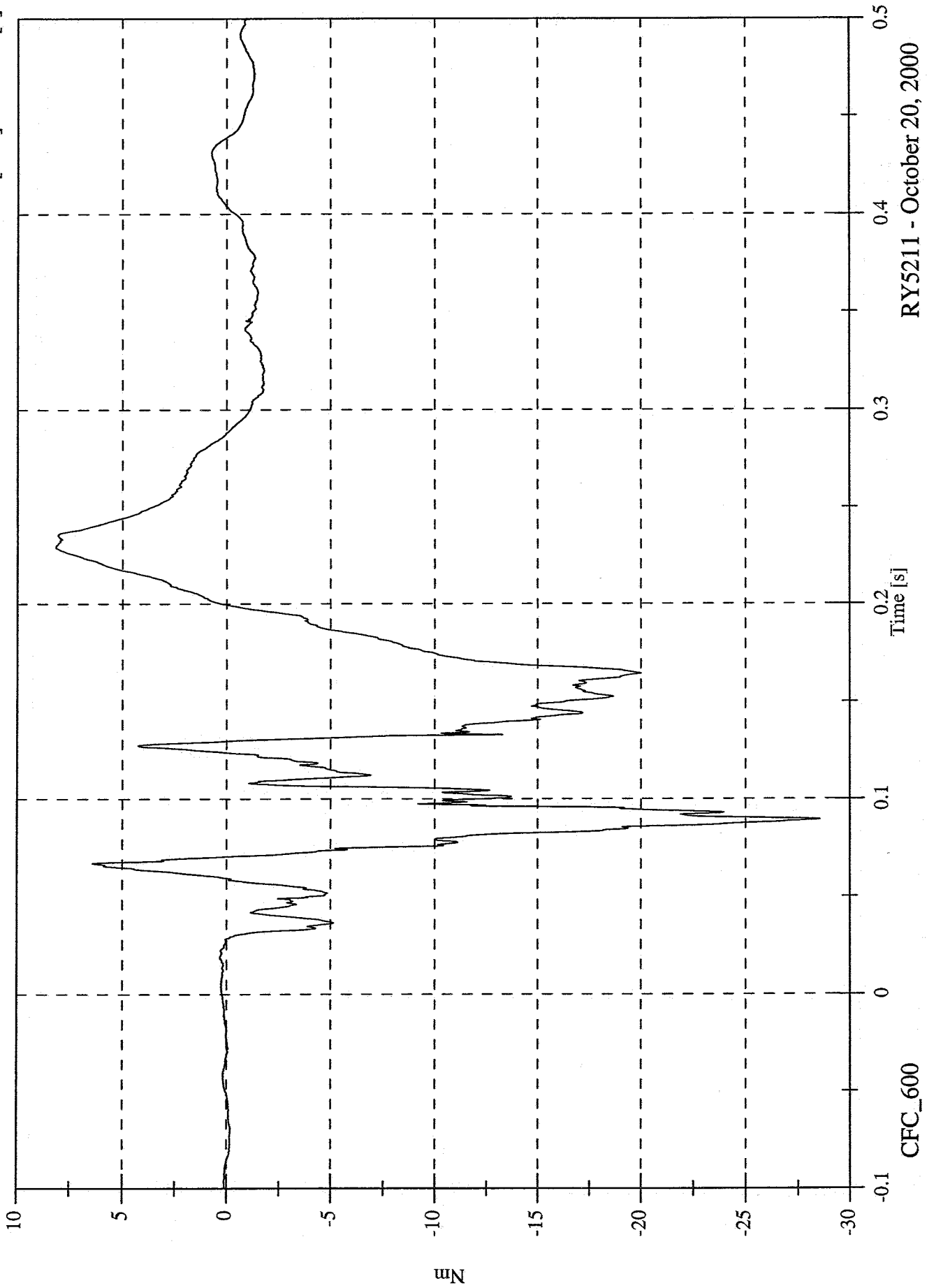

R Y 5 2 1 1 - O c t o b e r 2 0 , 2 0 0 0

40% Frontal Offset Test #2 - 2000 Nissan Altima

P1 Left Lower Tibia My

Max: 41.5 [Nm] at 0.101 [s]

Min: -47.4 [Nm] at 0.072 [s]

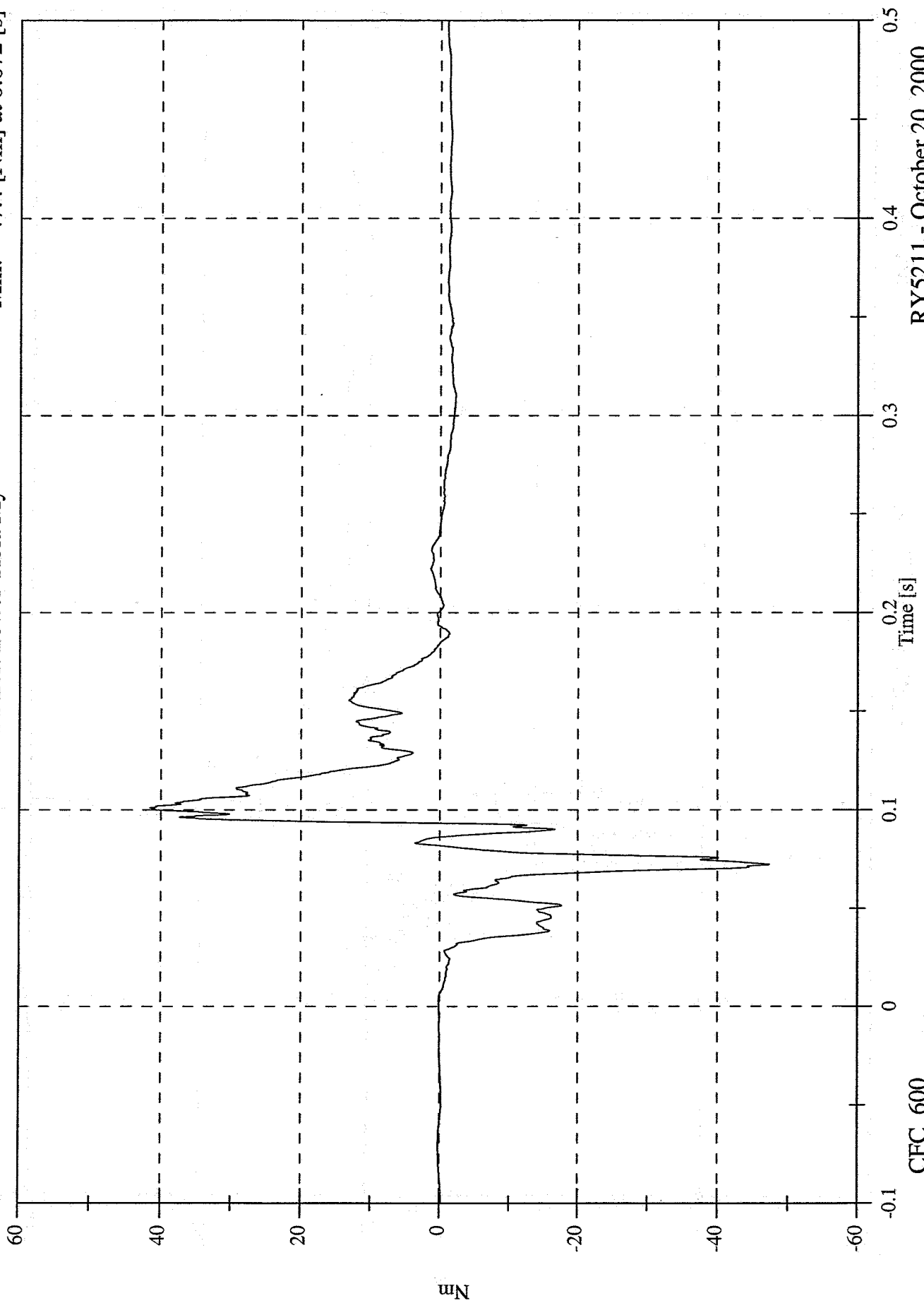

RY5211 - October 20, 2000

40% Frontal Offset Test #2 - 2000 Nissan Altima

Max: 596.5 [N] at 0.071 [s]  
Min: -280.7 [N] at 0.092 [s]

P1 Right Upper Tibia Fx

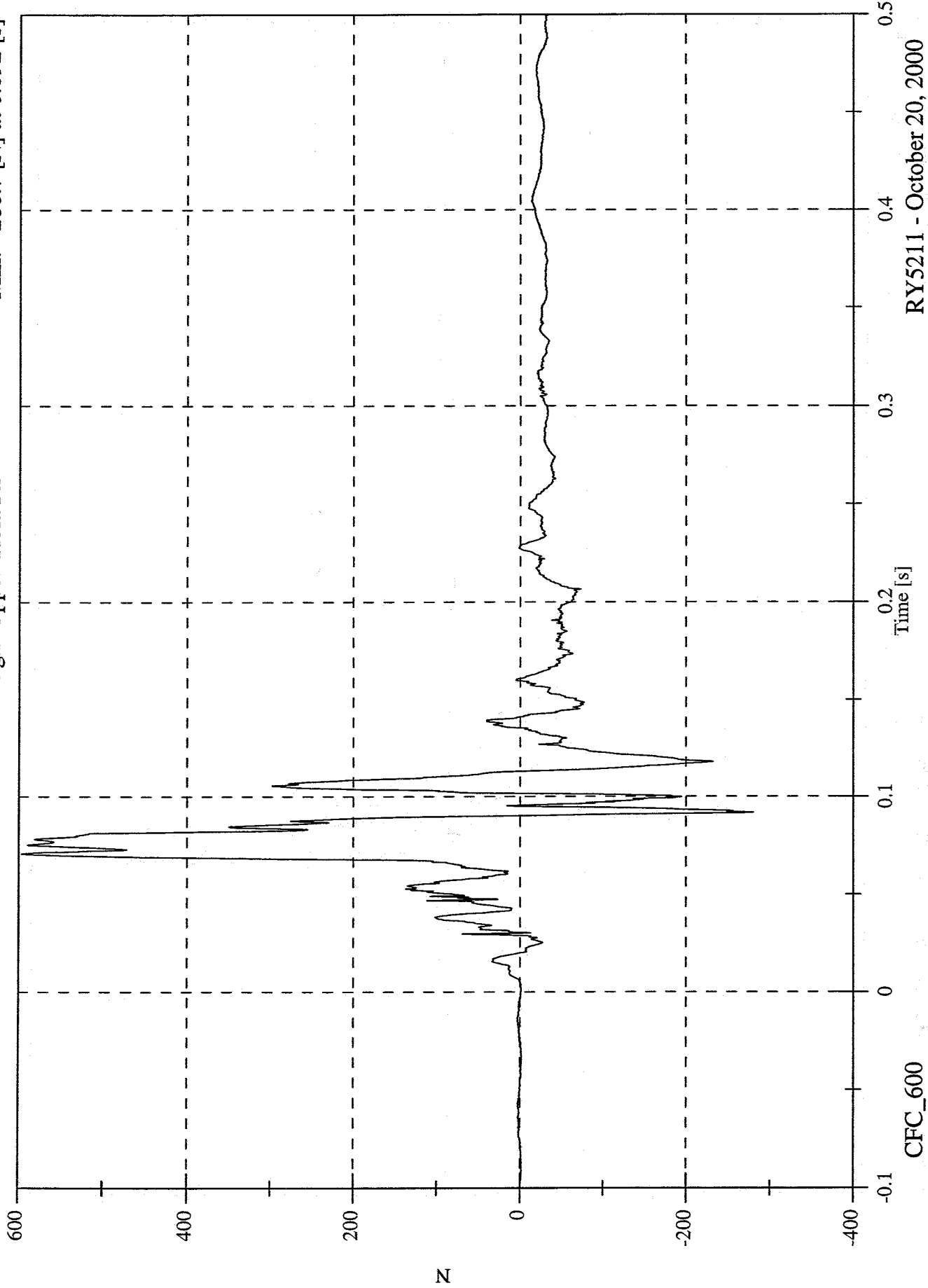

RY5211 - October 20, 2000

40% Frontal Offset Test #2 - 2000 Nissan Altima

P1 Right Upper Tibia Fz

Max: 710.8 [N] at 0.107 [s]  
Min: -2485.8 [N] at 0.080 [s]

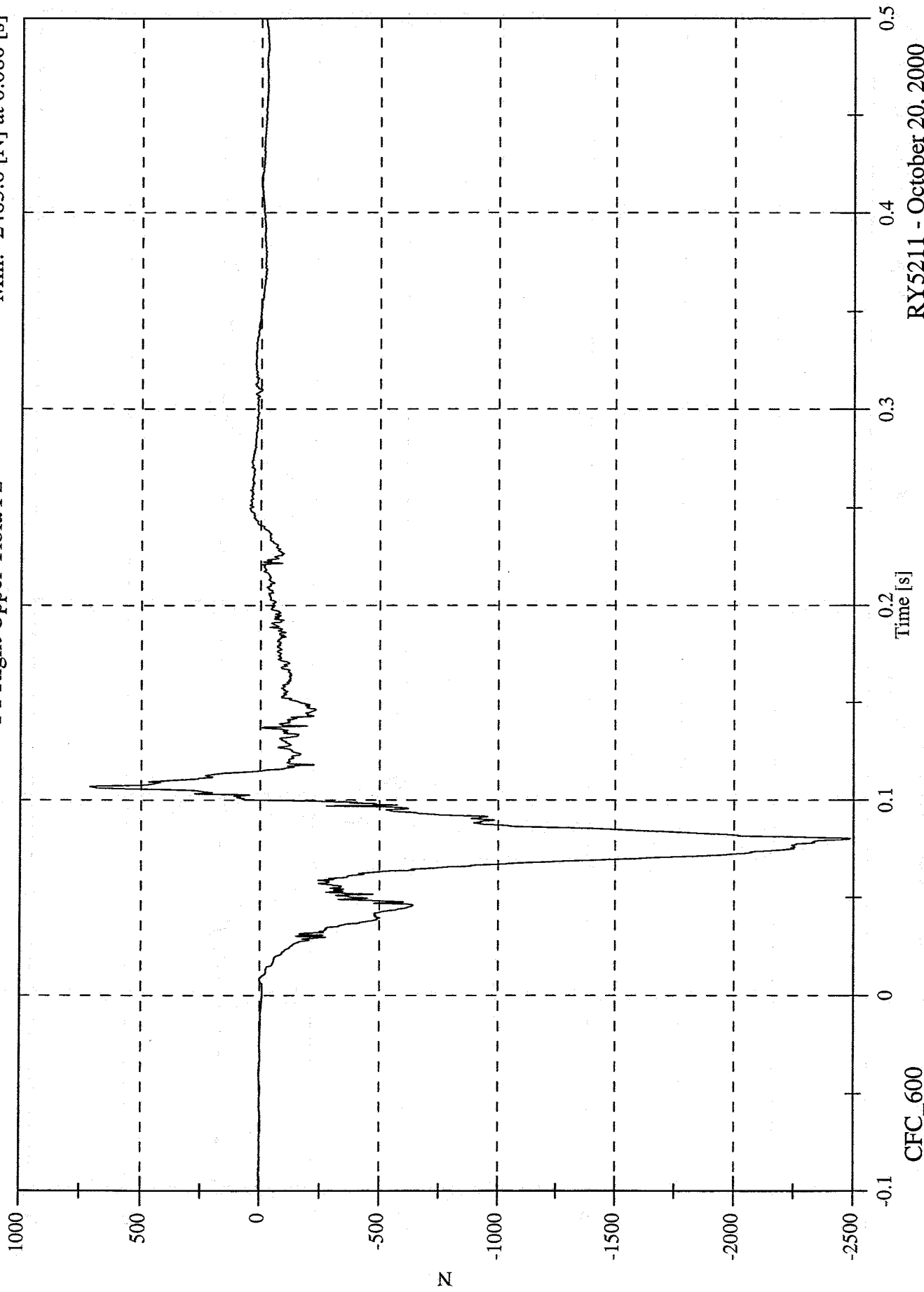

RYS211 - October 20, 2000

40% Frontal Offset Test #2 - 2000 Nissan Altima

Max: 63.3 [Nm] at 0.074 [s]

Min: -11.0 [Nm] at 0.093 [s]

P1 Right Upper Tibia Mx

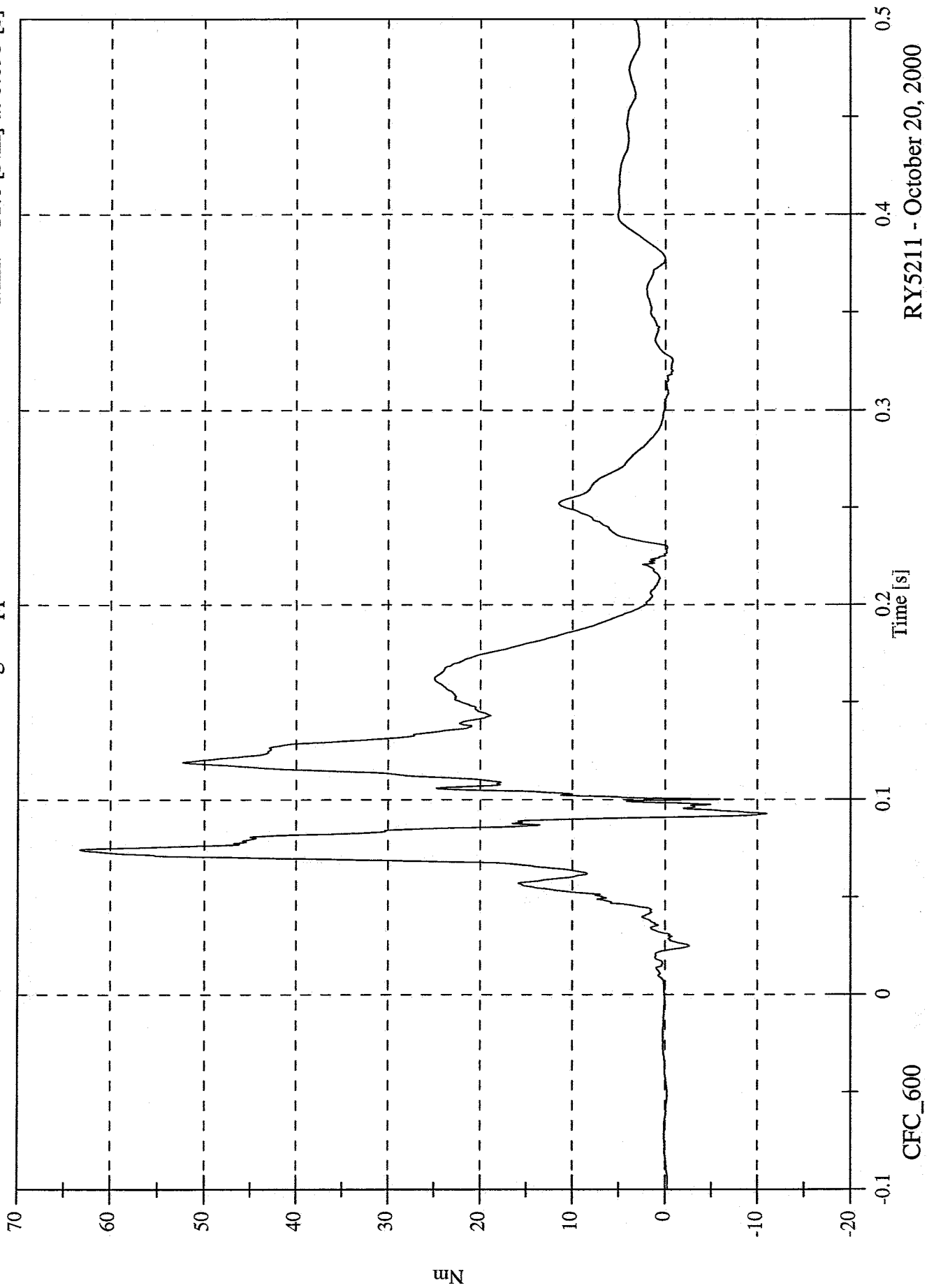

RY5211 - October 20, 2000

40% Frontal Offset Test #2 - 2000 Nissan Altima

Max: 91.2 [Nm] at 0.089 [s]  
Min: -22.3 [Nm] at 0.055 [s]

P1 Right Upper Tibia My

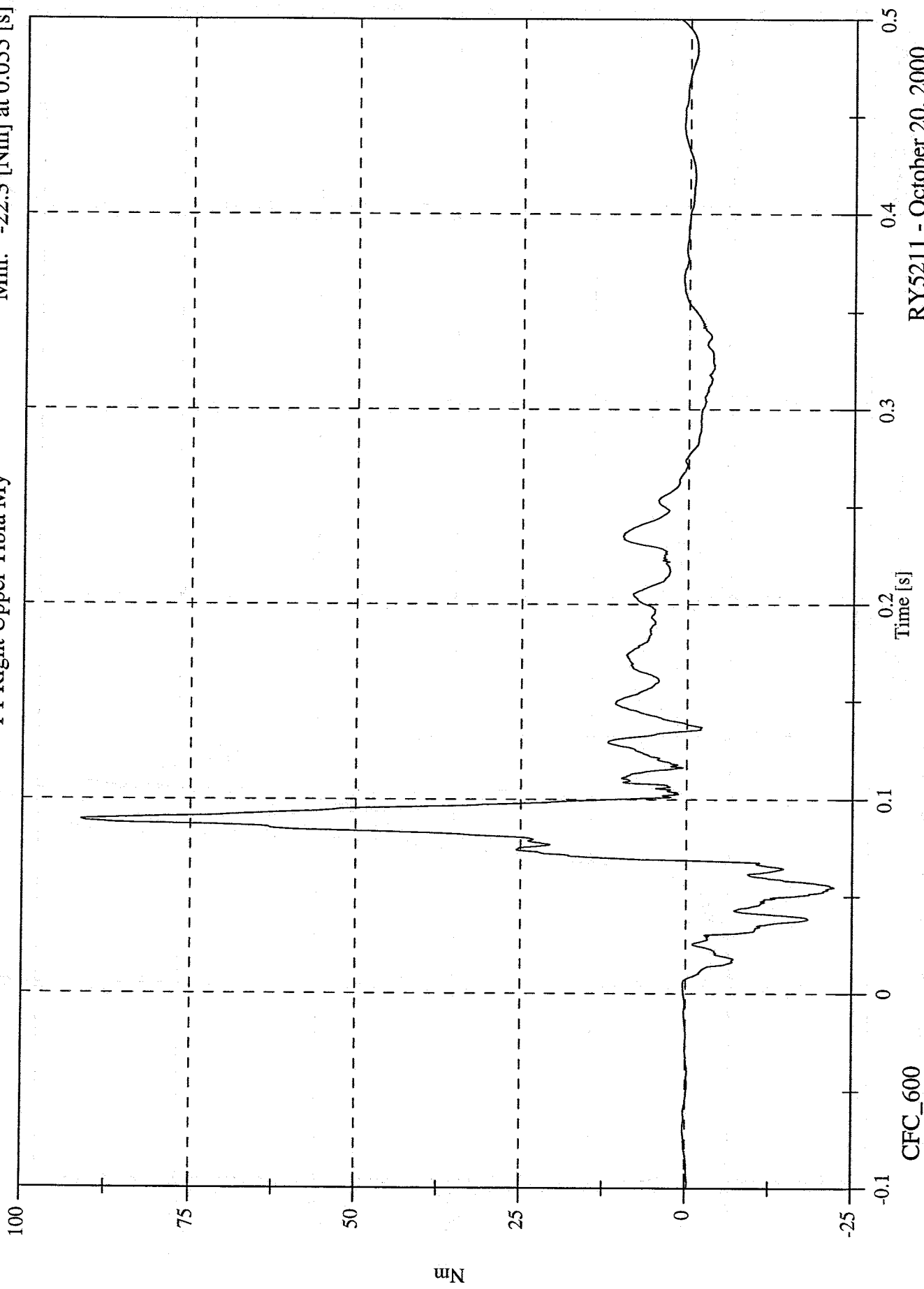

RY5211 - October 20, 2000

40% Frontal Offset Test #2 - 2000 Nissan Altima

Max: 122.3 [N] at 0.129 [s]  
Min: -1224.6 [N] at 0.106 [s]

P1 Right Lower Tibia Fx

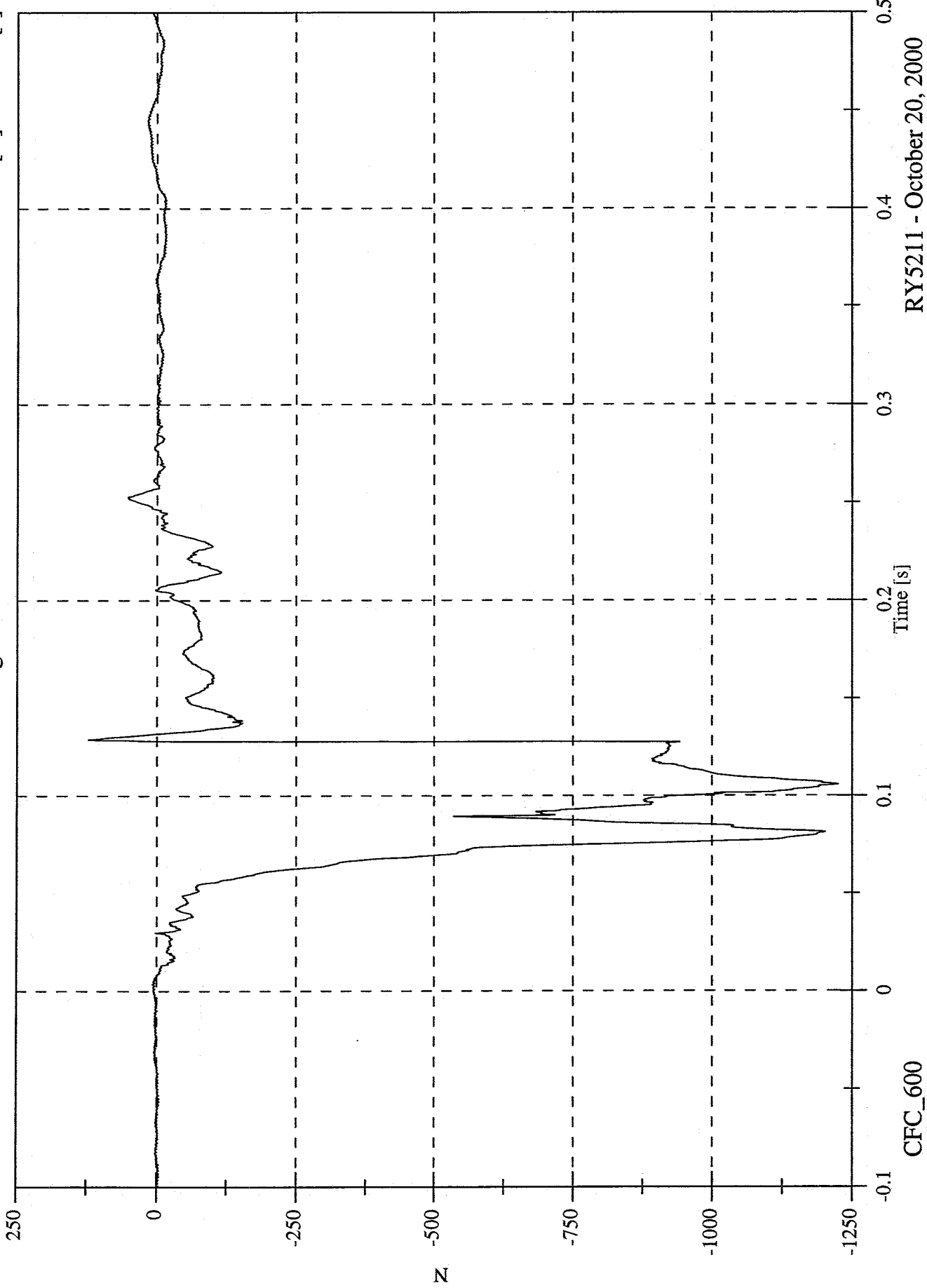

RY5211 - October 20, 2000

40% Frontal Offset Test #2 - 2000 Nissan Altima

Max: 87.3 [N] at 0.031 [s]

Min: -384.5 [N] at 0.073 [s]

P1 Right Lower Tibia Fy

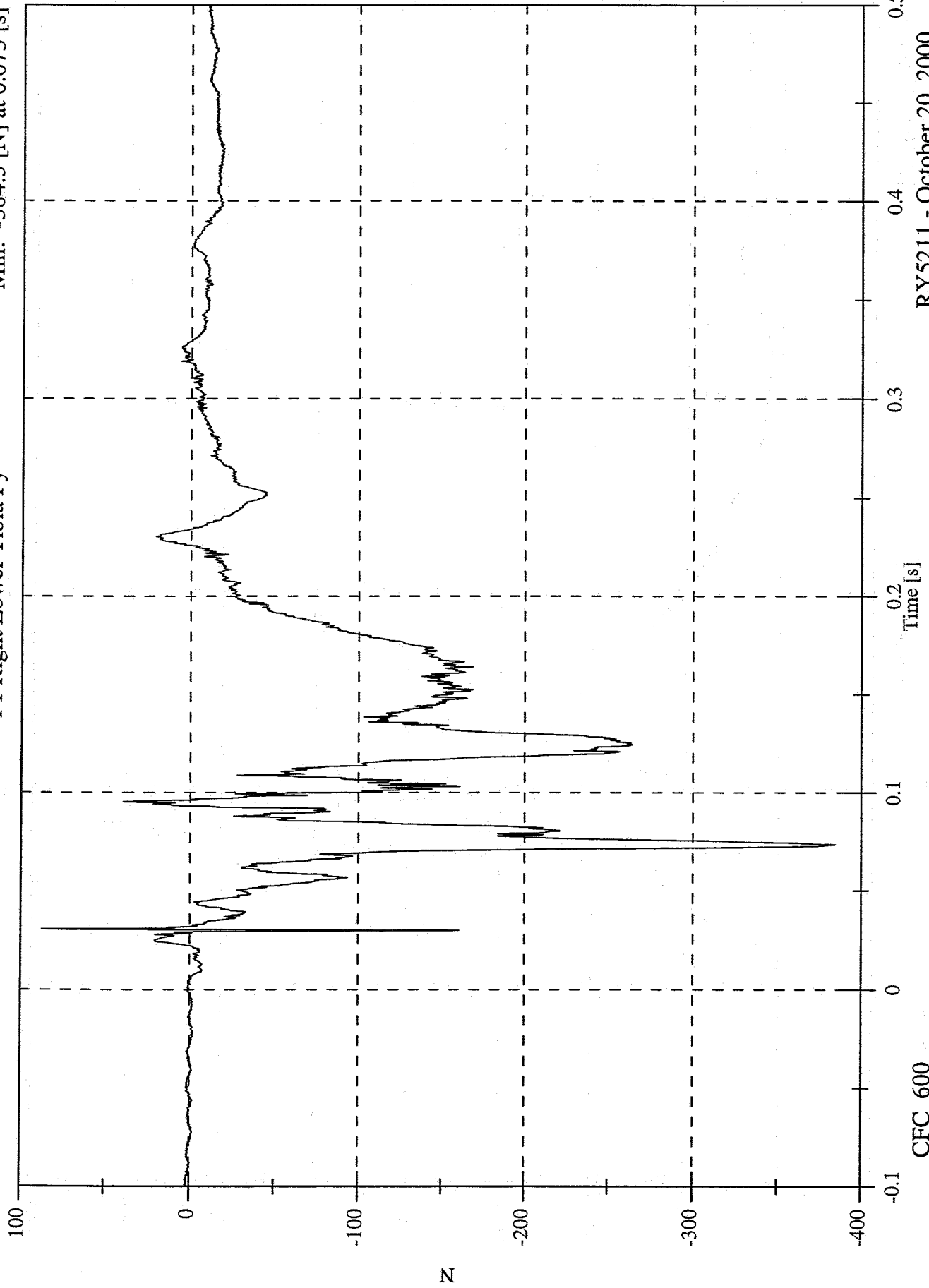

CFC\_600

RY5211 - October 20, 2000

40% Frontal Offset Test #2 - 2000 Nissan Altima

Max: 4.9 [N] at -0.098 [s]  
Min: -3653.0 [N] at 0.080 [s]

P1 Right Lower Tibia Fz

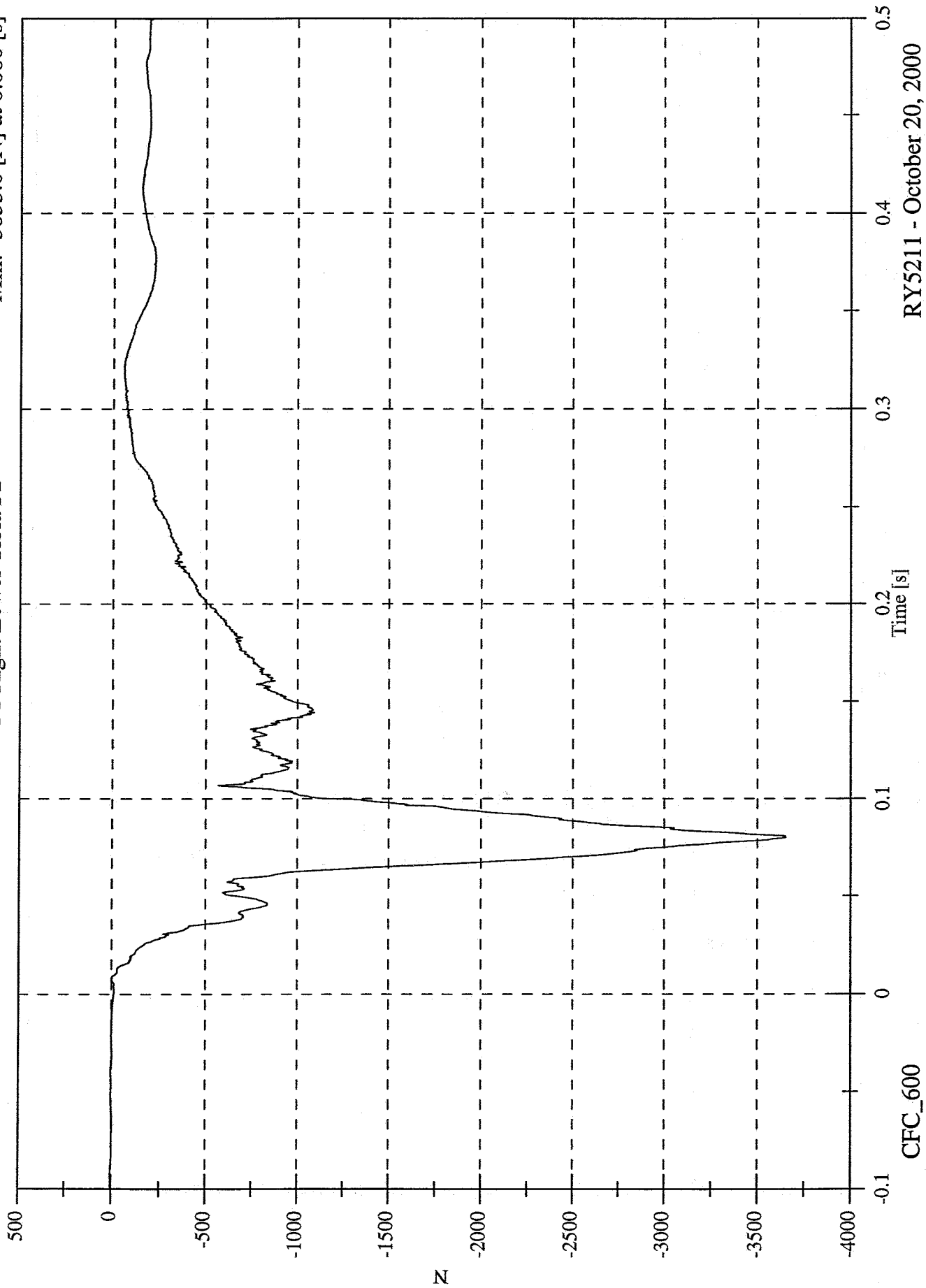

RY5211 - October 20, 2000

CFC\_600

40% Frontal Offset Test #2 - 2000 Nissan Altima

P1 Right Lower Tibia F Resultant

Max: 3846.3 [N] at 0.080 [s]  
Min: 0.4 [N] at -0.061 [s]

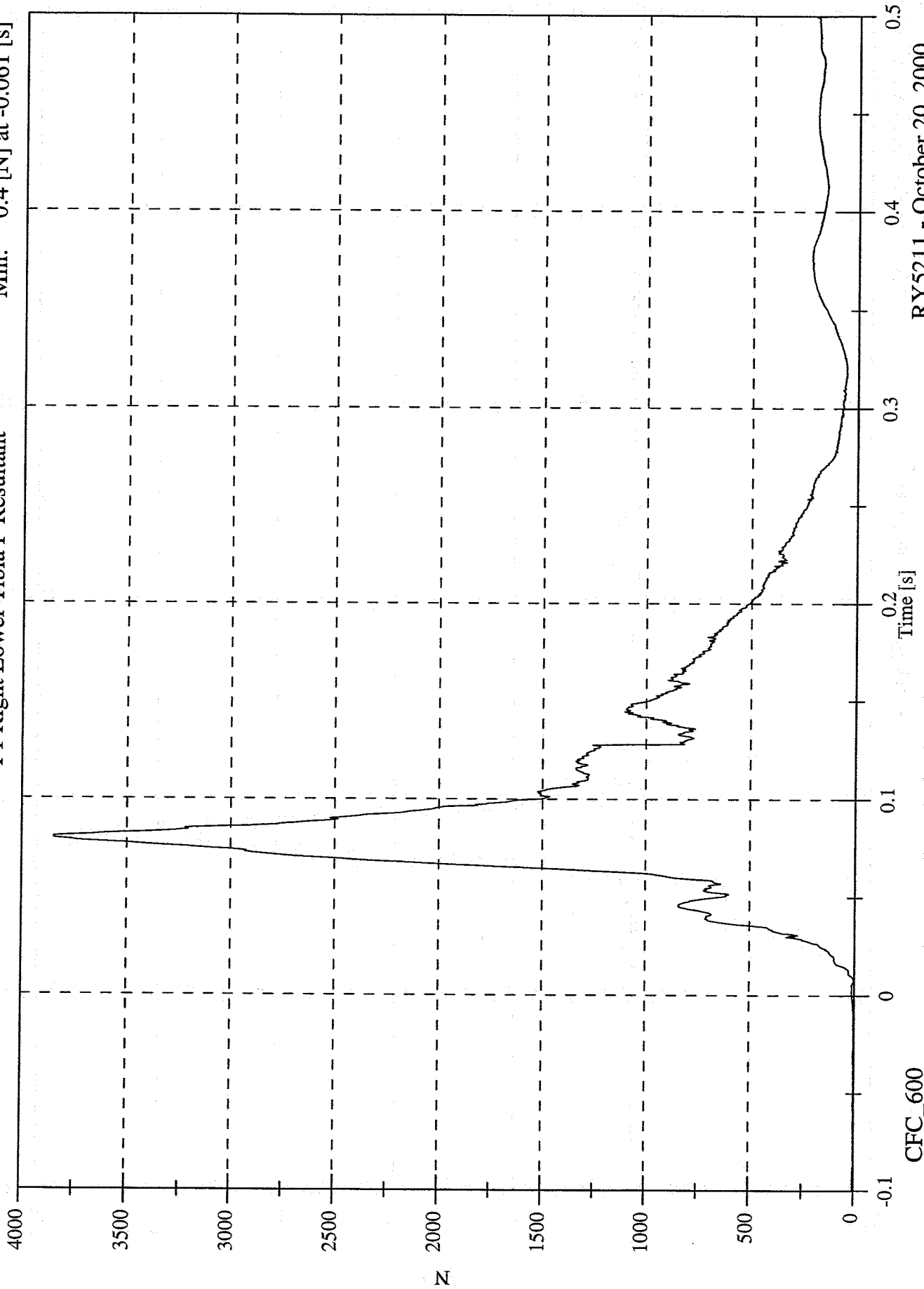

CFC\_600

RY5211 - October 20, 2000

40% Frontal Offset Test #2 - 2000 Nissan Altima

P1 Right Lower Tibia Mx

Max: 32.4 [Nm] at 0.125 [s]  
Min: -119.1 [Nm] at 0.081 [s]

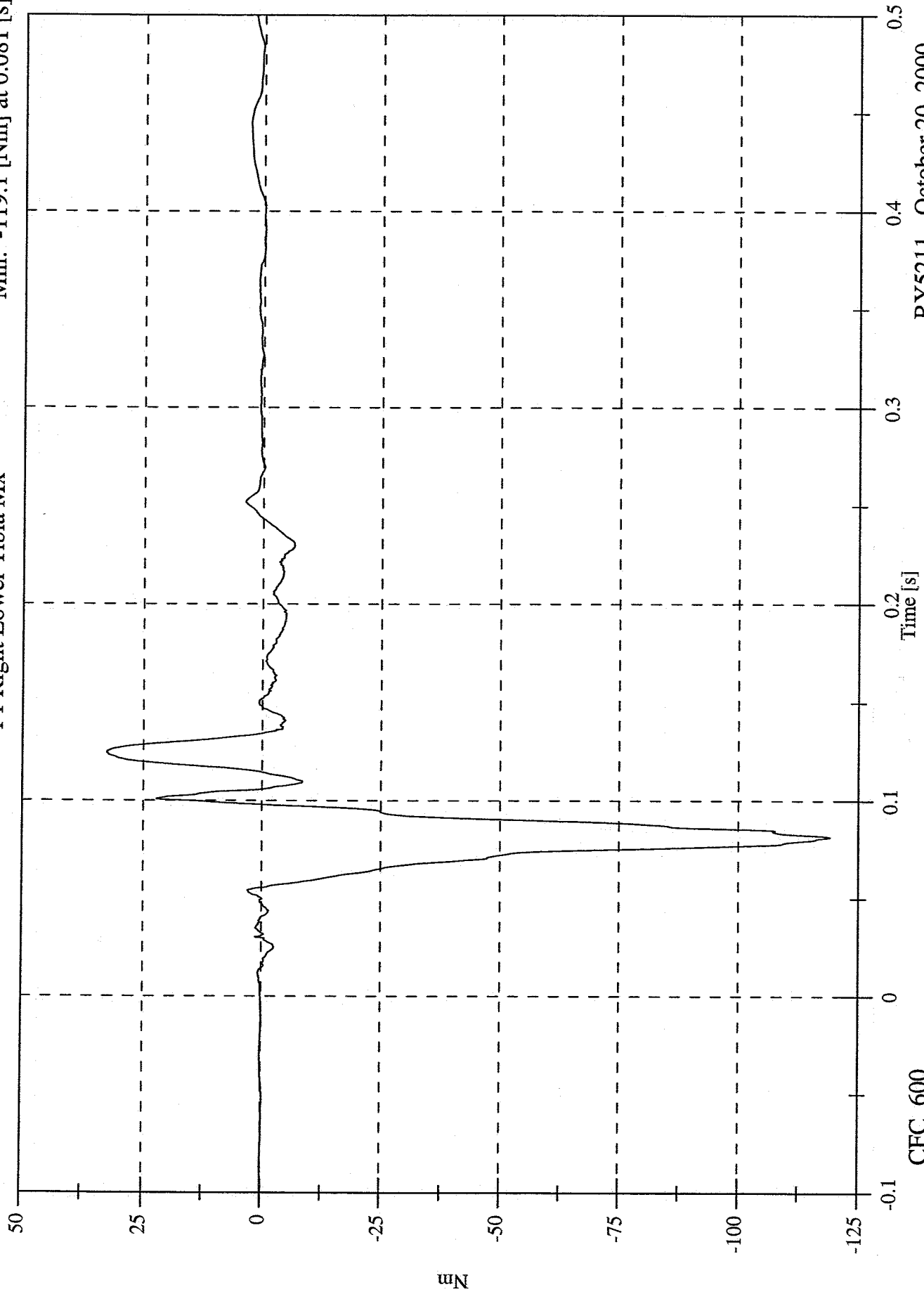

CFC\_600

RY5211 - October 20, 2000

40% Frontal Offset Test #2 - 2000 Nissan Altima

P1 Right Lower Tibia My

Max: 41.7 [Nm] at 0.091 [s]  
Min: -34.2 [Nm] at 0.078 [s]

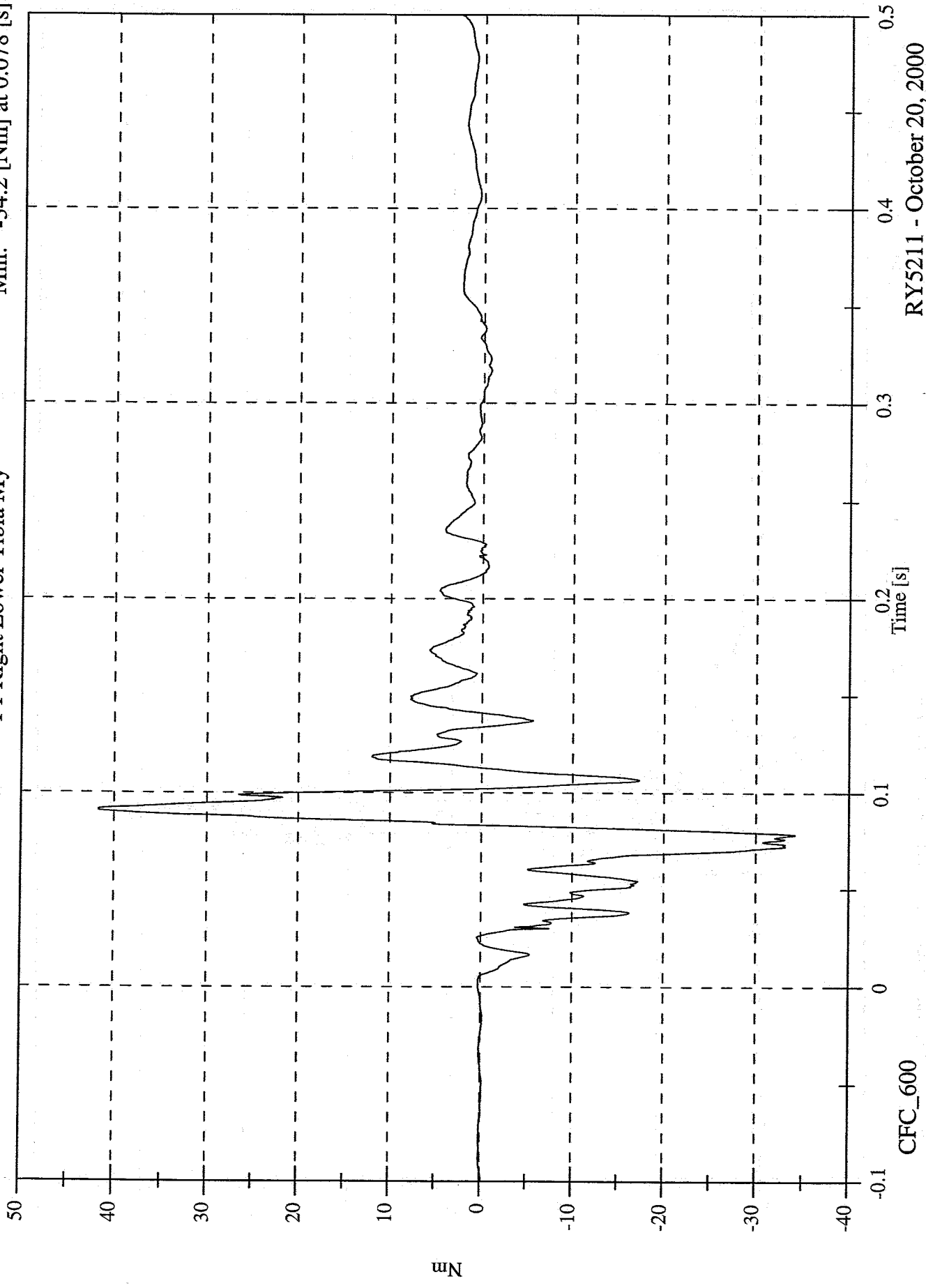

RYS211 - October 20, 2000

40% Frontal Offset Test #2 - 2000 Nissan Altima

Max: 7.3 [g] at 0.120 [s]  
Min: -64.4 [g] at 0.090 [s]

P1 Left Tibia Ax

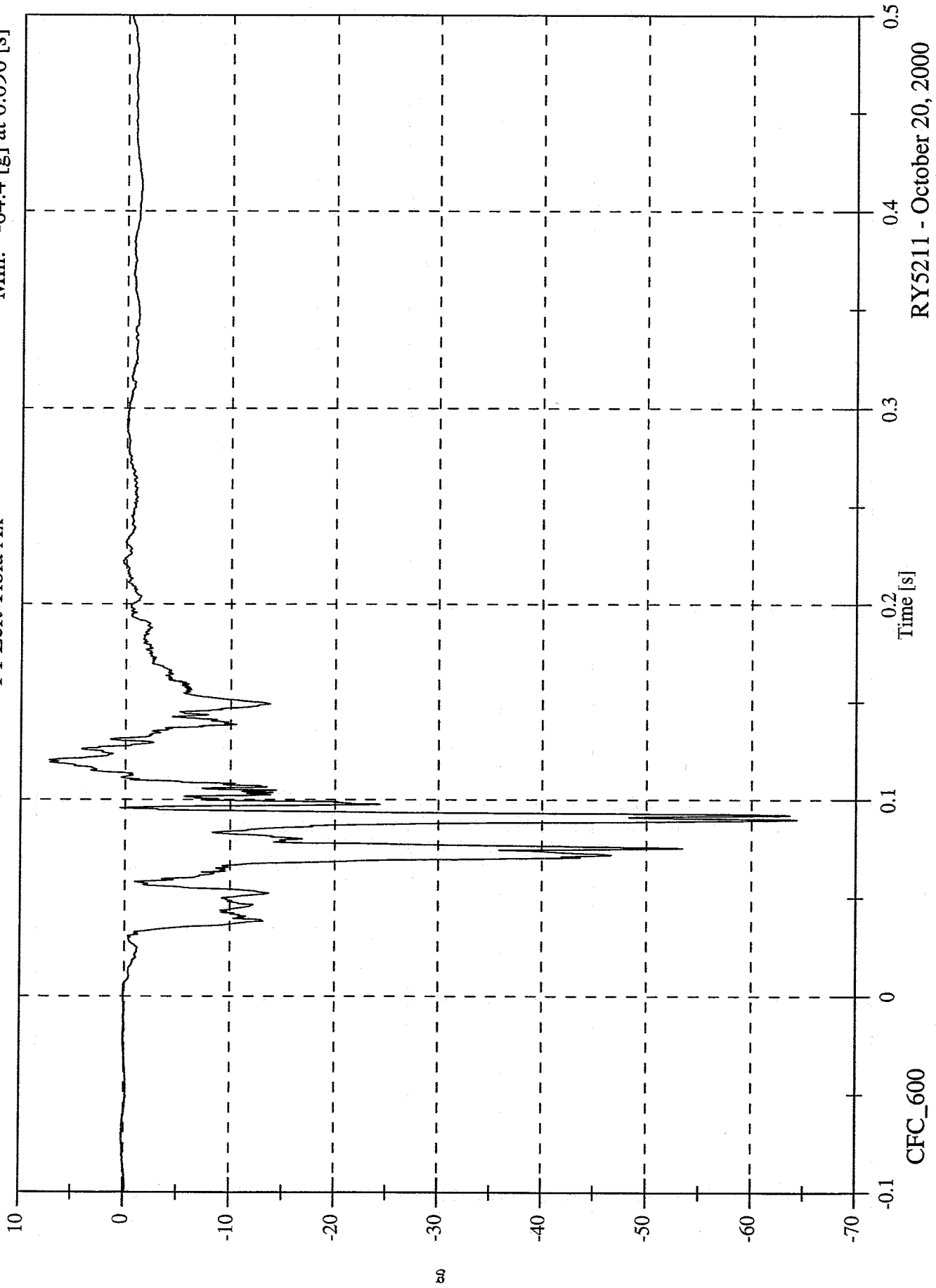

RYS211 - October 20, 2000

40% Frontal Offset Test #2 - 2000 Nissan Altima

Max: 29.0 [g] at 0.089 [s]  
Min: -19.4 [g] at 0.138 [s]

P1 Left Tibia Ay

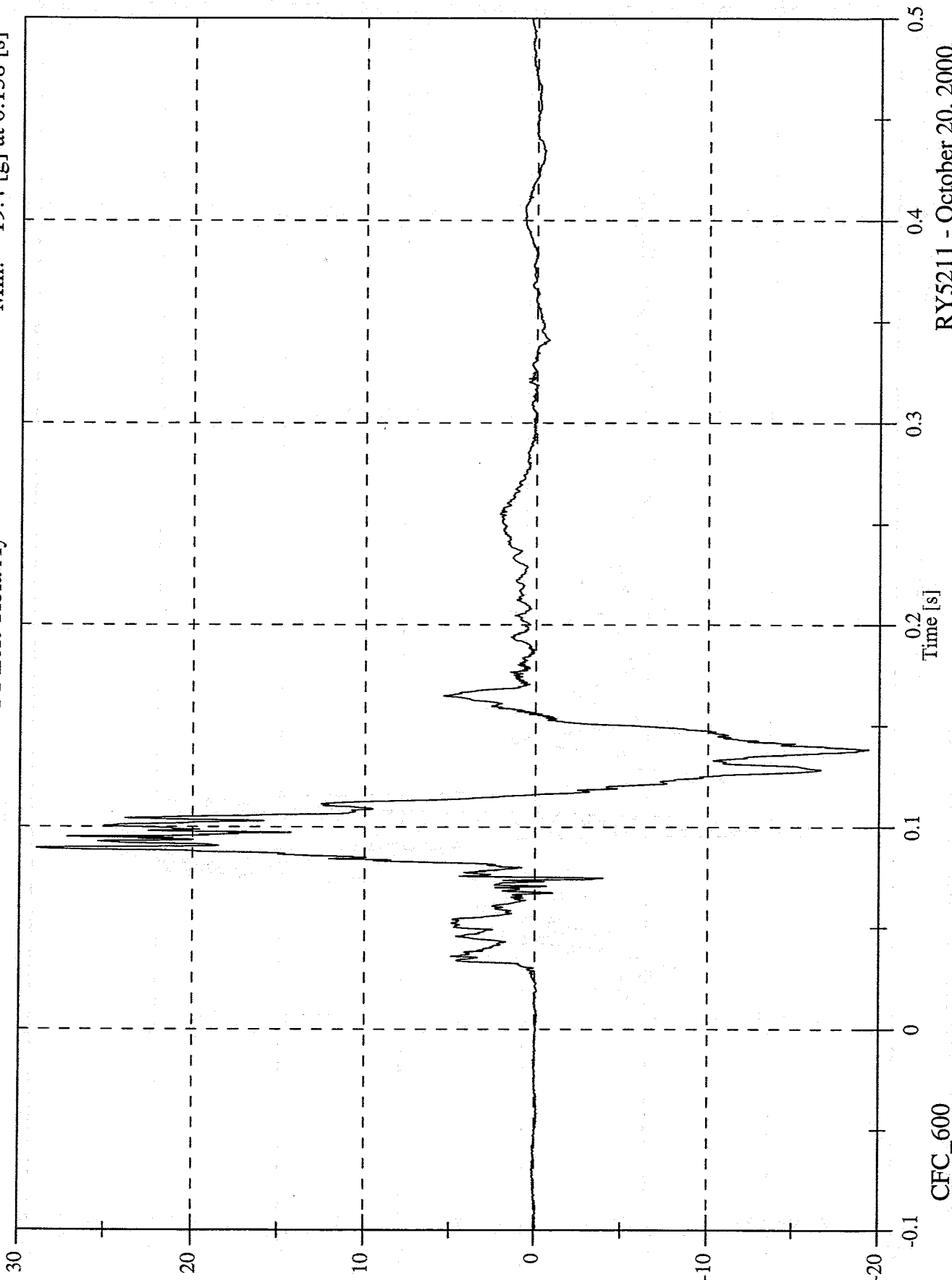

RY5211 - October 20, 2000

40% Frontal Offset Test #2 - 2000 Nissan Altima

Max: 16.7 [g] at 0.092 [s]  
Min: -43.2 [g] at 0.079 [s]

P1 Right Tibia Ax

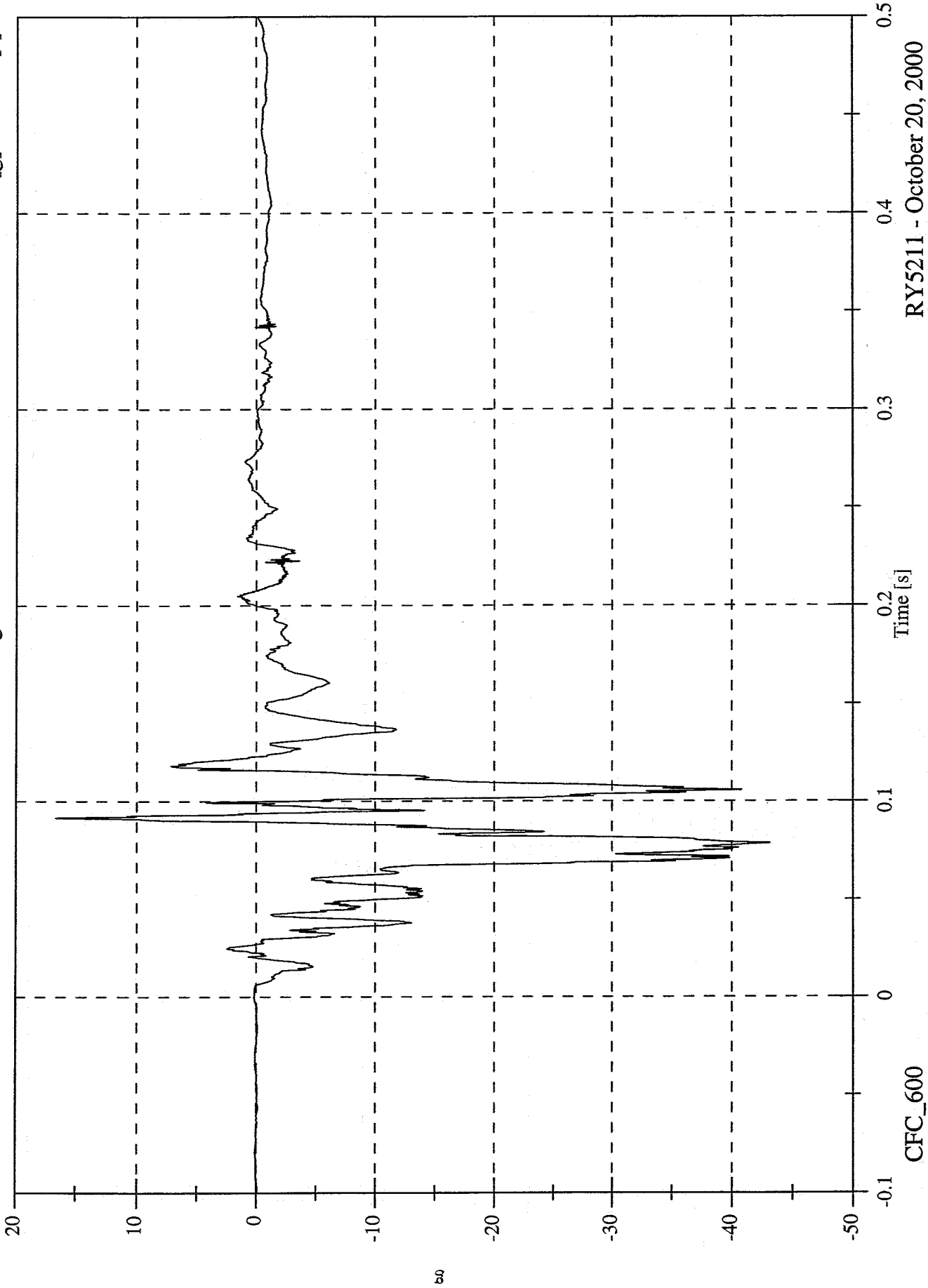

RYS211 - October 20, 2000

40% Frontal Offset Test #2 - 2000 Nissan Altima

Max: 43.3 [g] at 0.078 [s]  
Min: -37.5 [g] at 0.100 [s]

P1 Right Tibia Ay

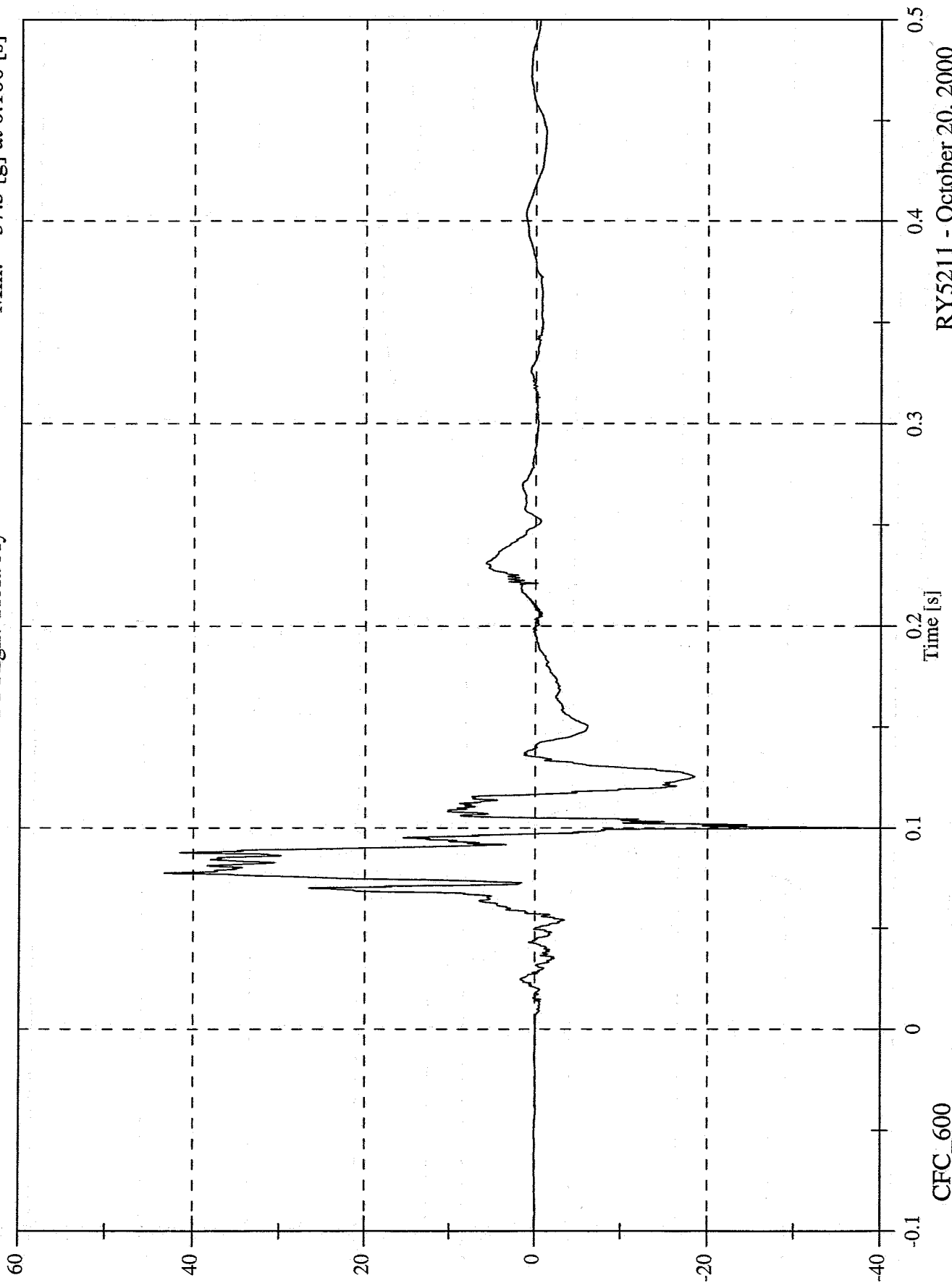

RY5211 - October 20, 2000

40% Frontal Offset Test #2 - 2000 Nissan Altima

Max: 21.0 [Deg] at 0.071 [s]

Min: -13.2 [Deg] at 0.173 [s]

P1 Left Ankle Rotation x

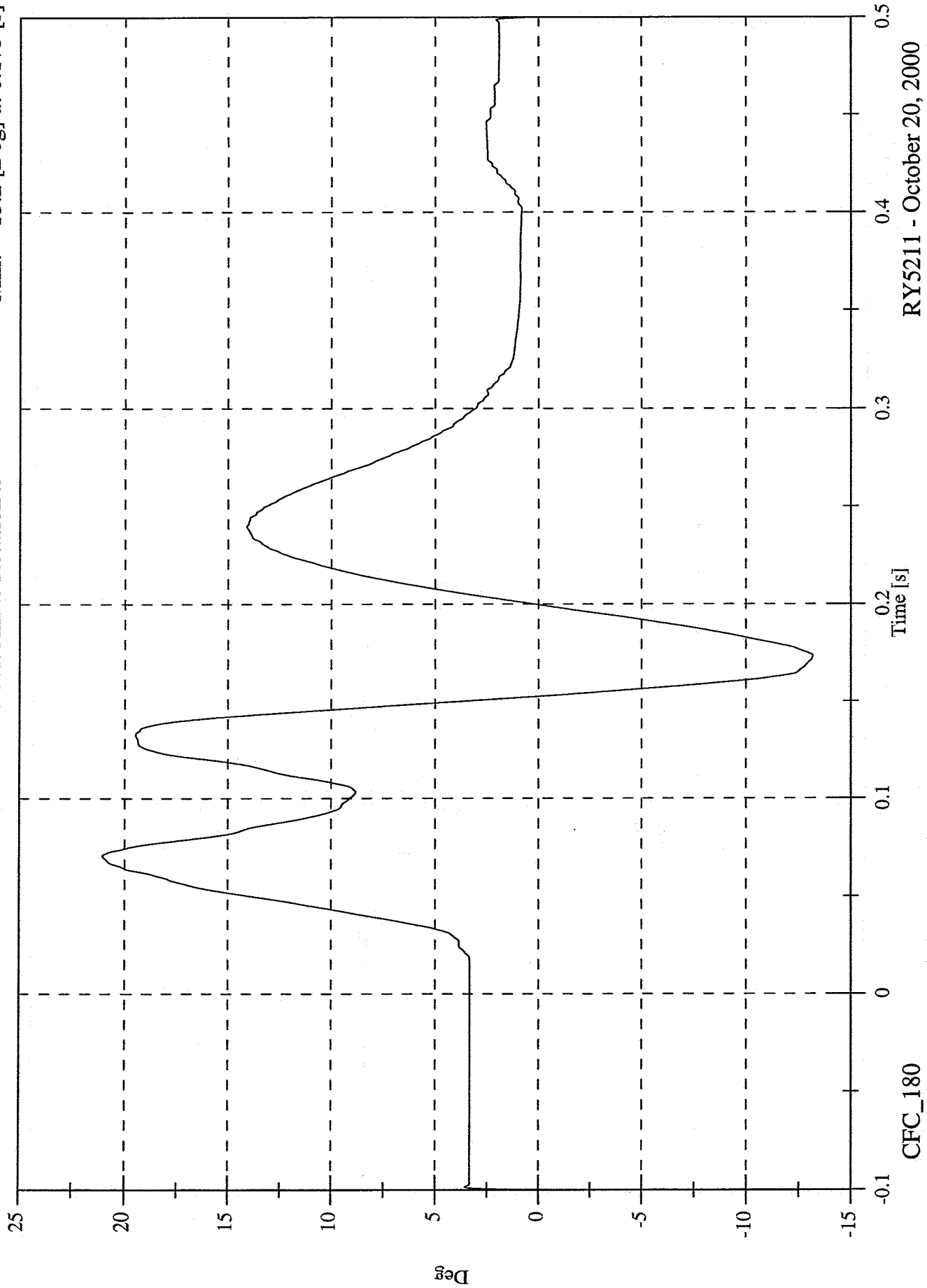

RY5211 - October 20, 2000

40% Frontal Offset Test #2 - 2000 Nissan Altima

Max: 19.5 [Deg] at 0.105 [s]

Min: -19.7 [Deg] at 0.037 [s]

P1 Left Ankle Rotation y

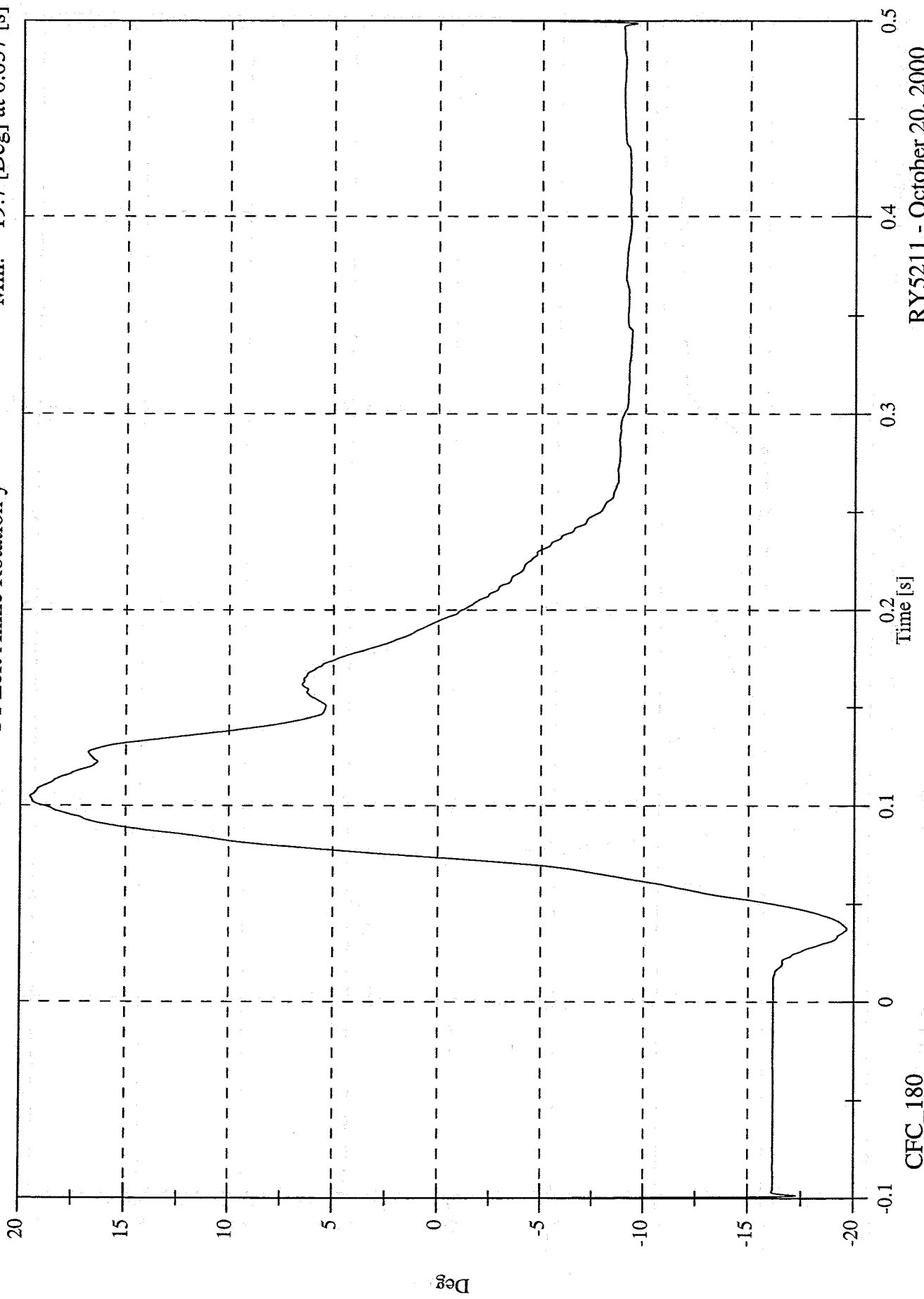

CFC\_180

RY5211 - October 20, 2000

40% Frontal Offset Test #2 - 2000 Nissan Altima

Max: 19.5 [Deg] at 0.099 [s]

Min: 0.3 [Deg] at -0.100 [s]

P1 Left Ankle Rotation z

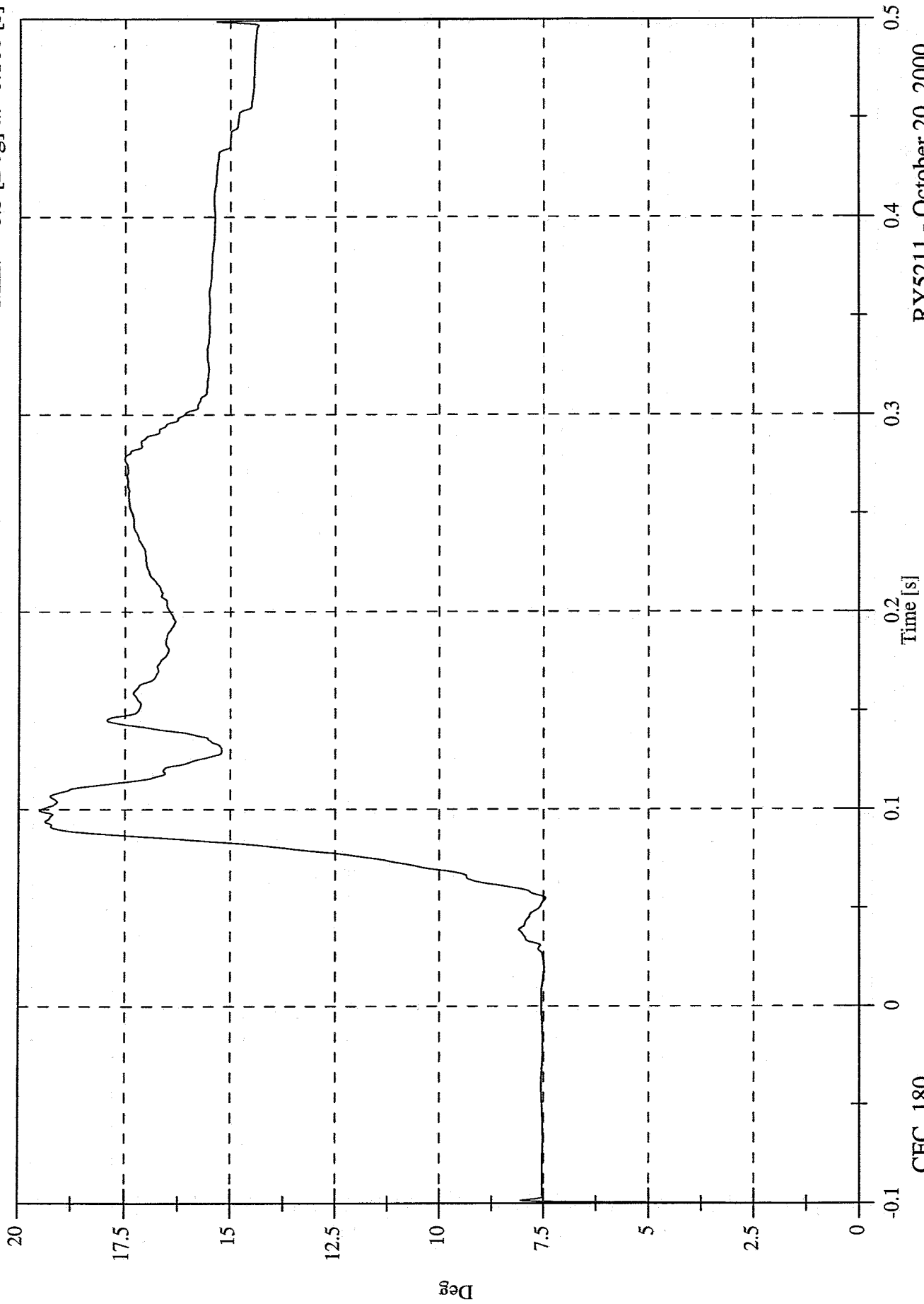

RY5211 - October 20, 2000

CFC\_180

40% Frontal Offset Test #2 - 2000 Nissan Altima

Max: -0.2 [Deg] at -0.100 [s]

Min: -35.4 [Deg] at 0.088 [s]

P1 Right Ankle Rotation x

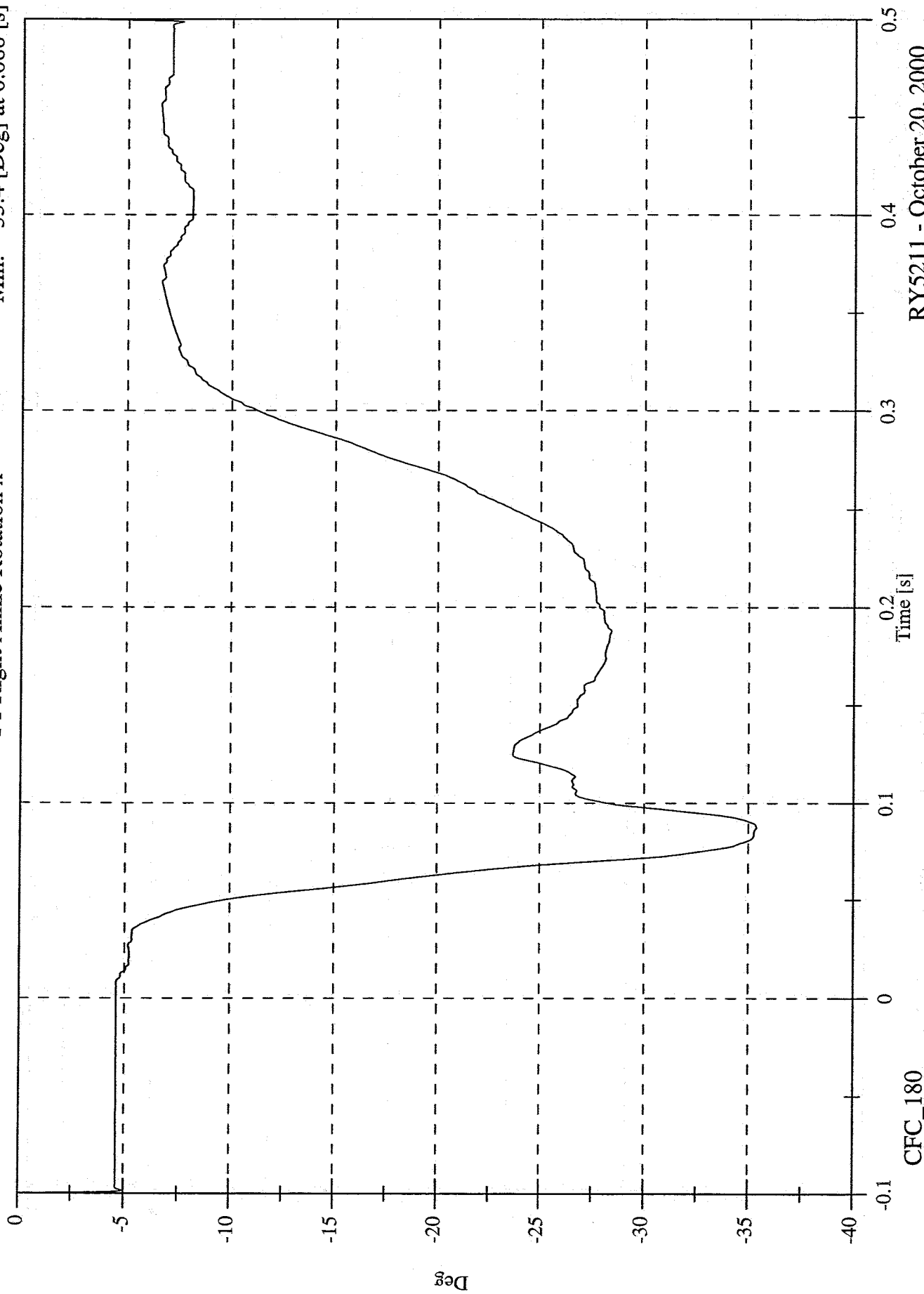

CFC\_180

RY5211 - October 20, 2000

40% Frontal Offset Test #2 - 2000 Nissan Altima

Max: 25.0 [Deg] at 0.153 [s]

Min: -9.9 [Deg] at 0.035 [s]

P1 Right Ankle Rotation y

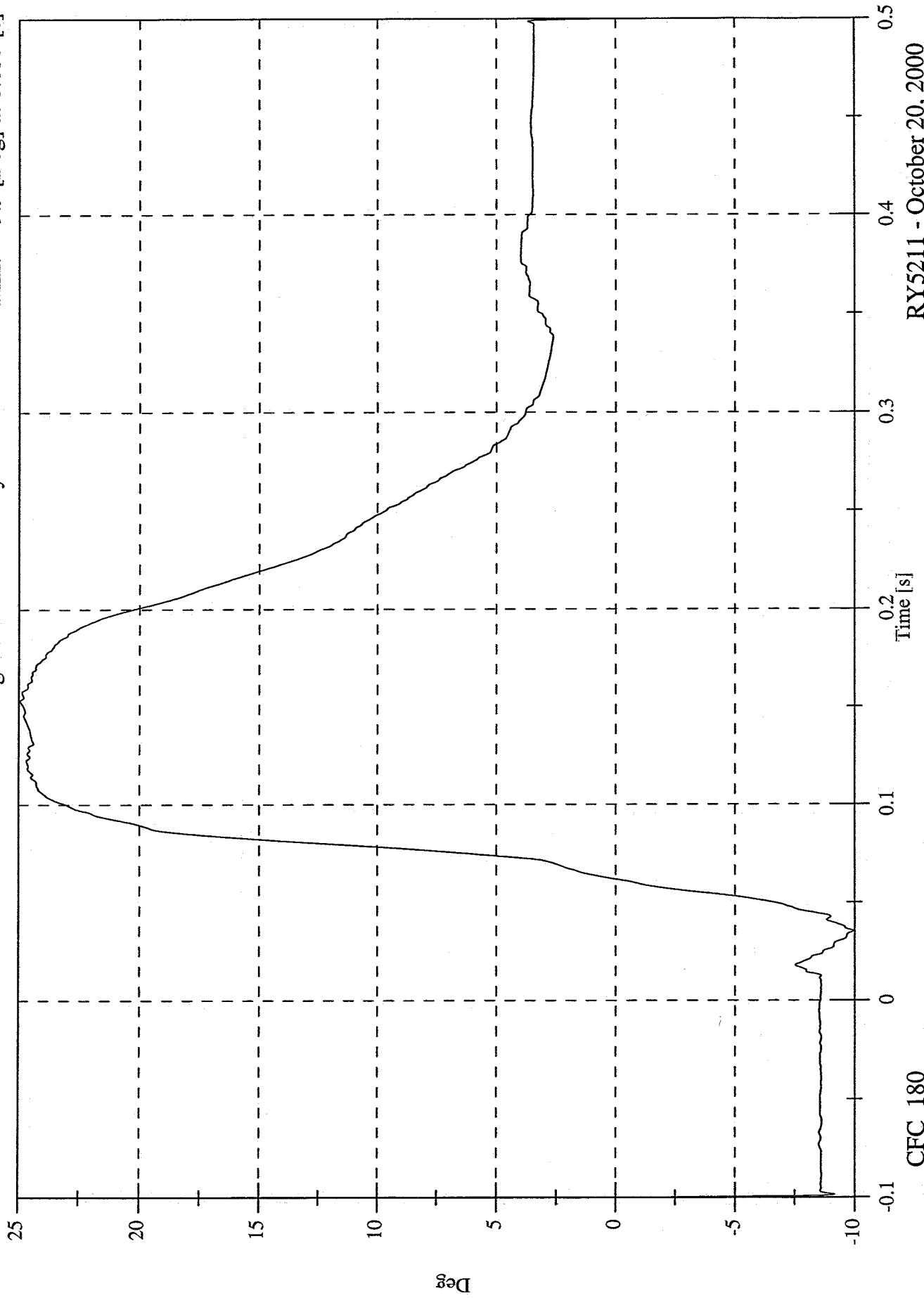

RYS211 - October 20, 2000

CFC\_180

40% Frontal Offset Test #2 - 2000 Nissan Altima

Max: 9.0 [Deg] at 0.085 [s]

Min: -6.1 [Deg] at 0.154 [s]

P1 Right Ankle Rotation z

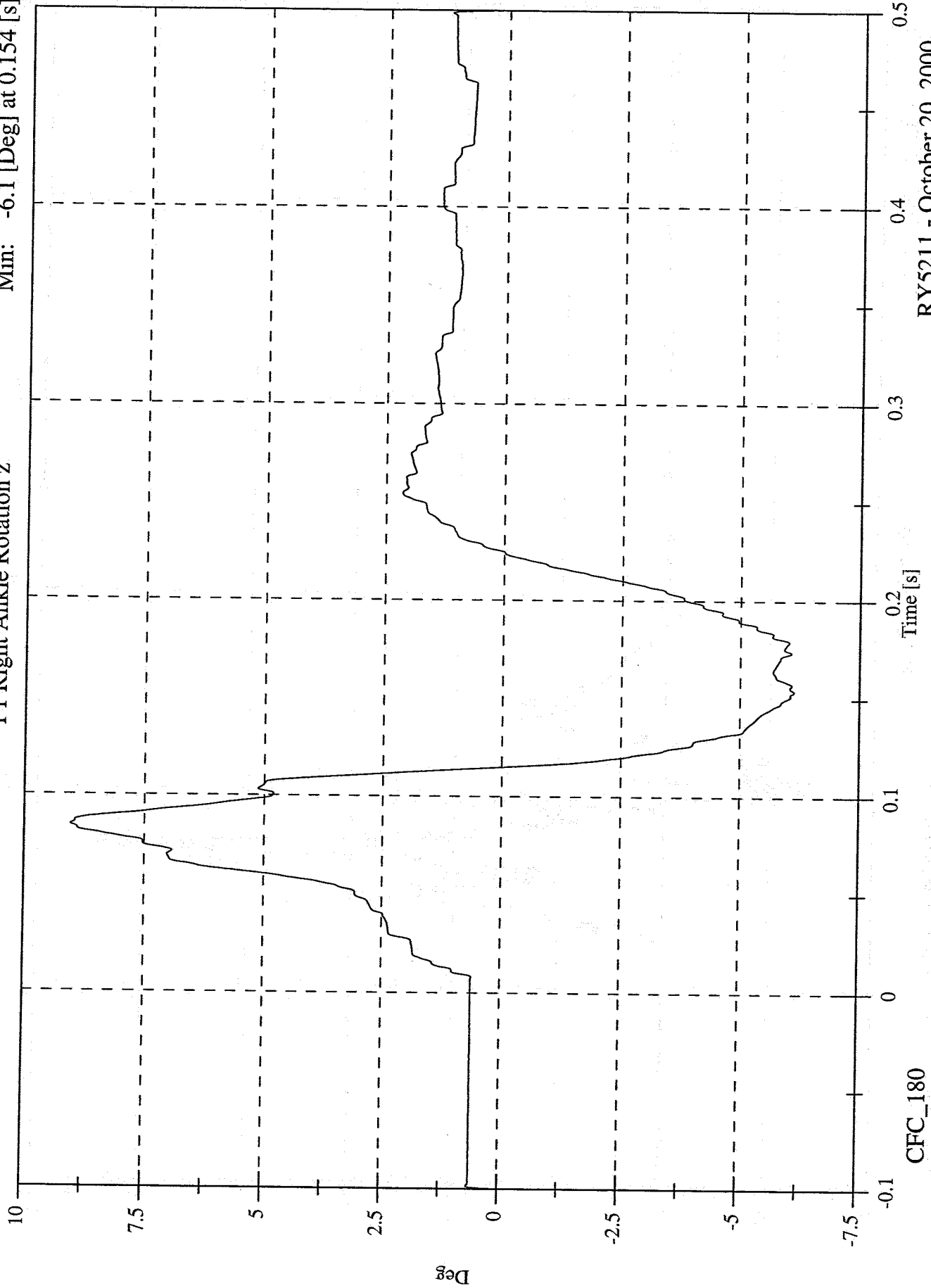

RY5211 - October 20, 2000

40% Frontal Offset Test #2 - 2000 Nissan Altima

Max: 14.8 [g] at 0.103 [s]  
Min: -56.3 [g] at 0.071 [s]

P1 Left Foot Ax

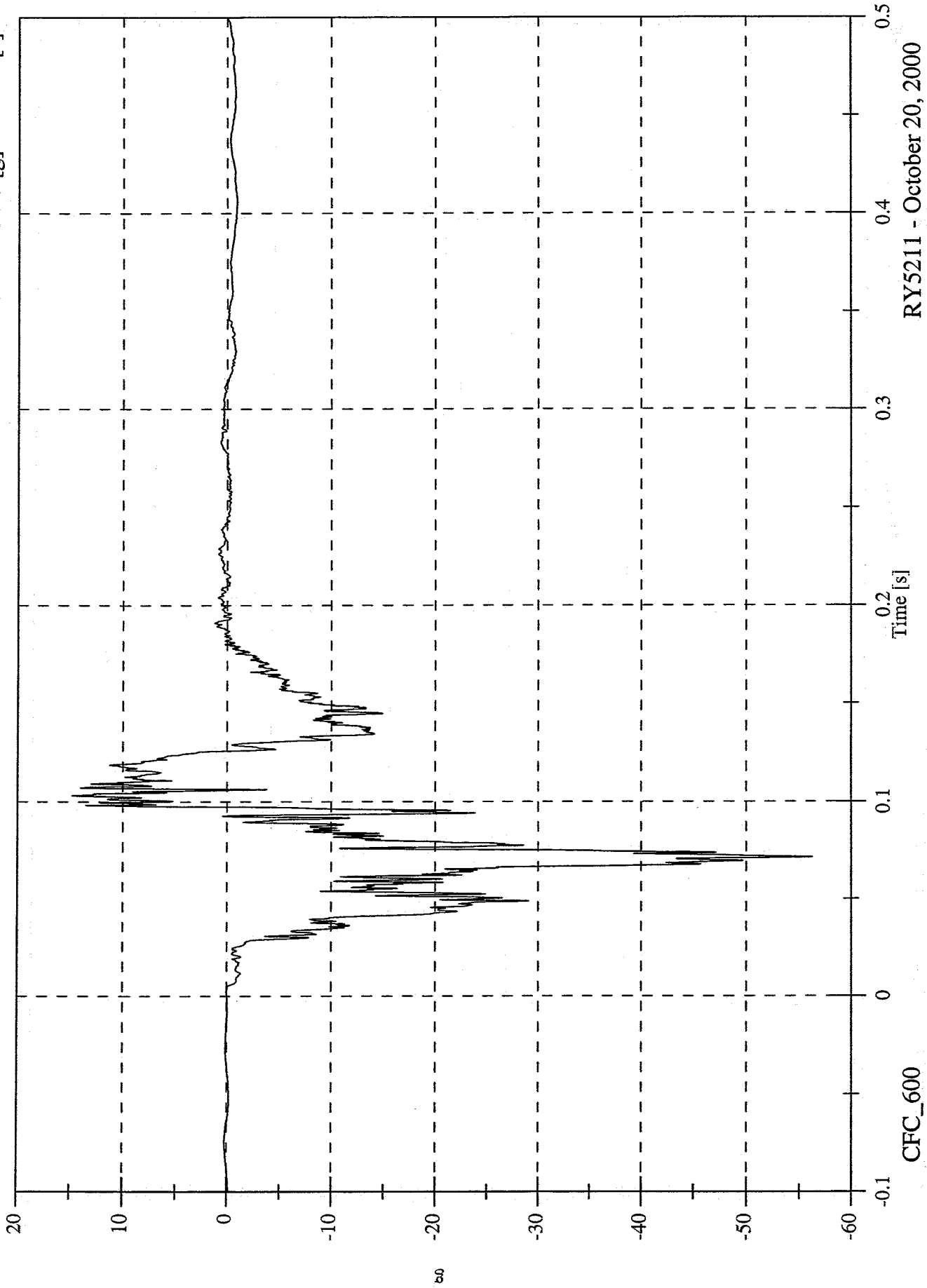

40% Frontal Offset Test #2 - 2000 Nissan Altima

Max: 25.2 [g] at 0.099 [s]  
Min: -24.2 [g] at 0.144 [s]

P1 Left Foot Ay

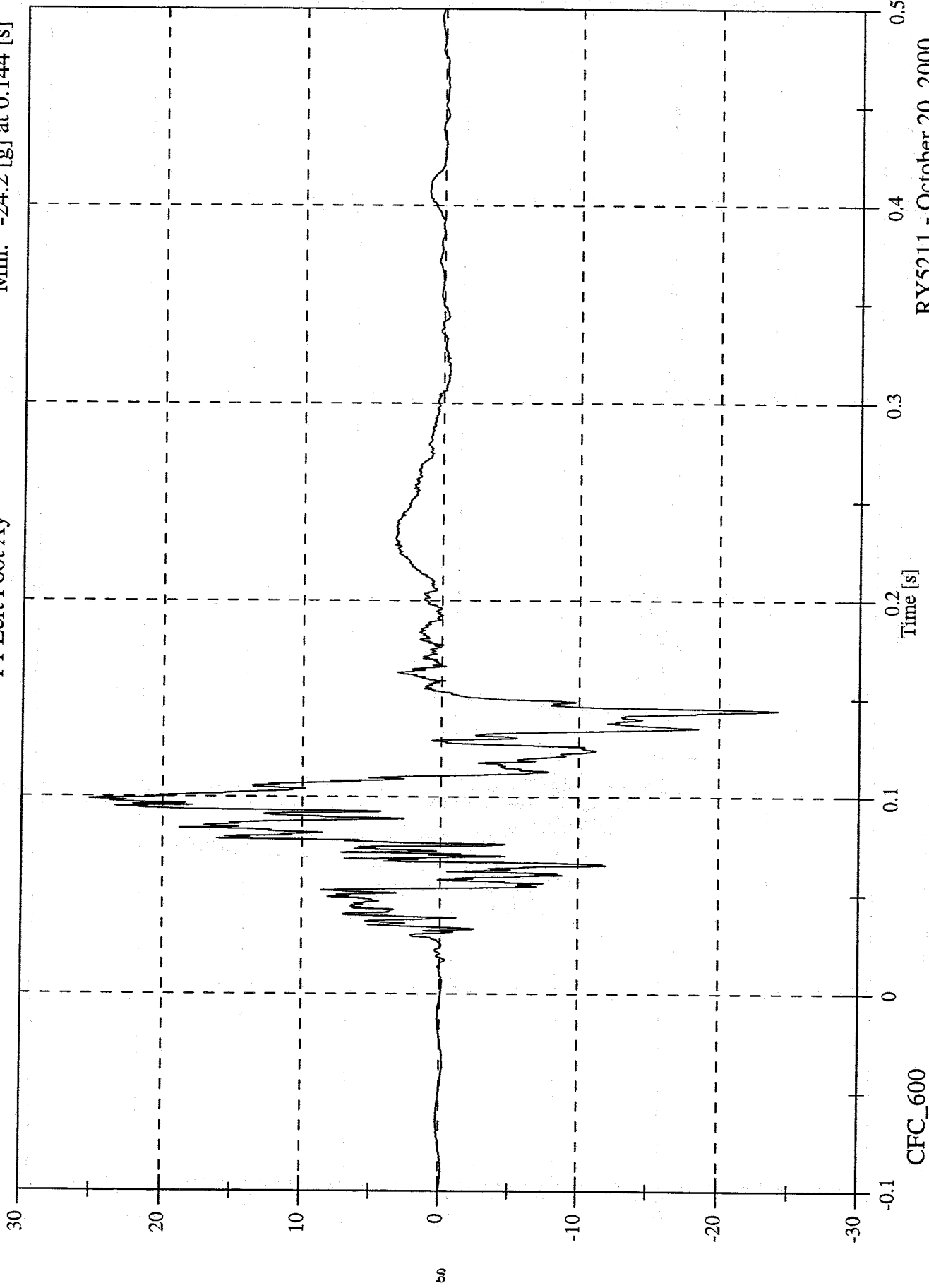

RYS211 - October 20, 2000

40% Frontal Offset Test #2 - 2000 Nissan Altima

Max: 15.6 [g] at 0.127 [s]  
Min: -51.0 [g] at 0.073 [s]

PI Left Foot Az

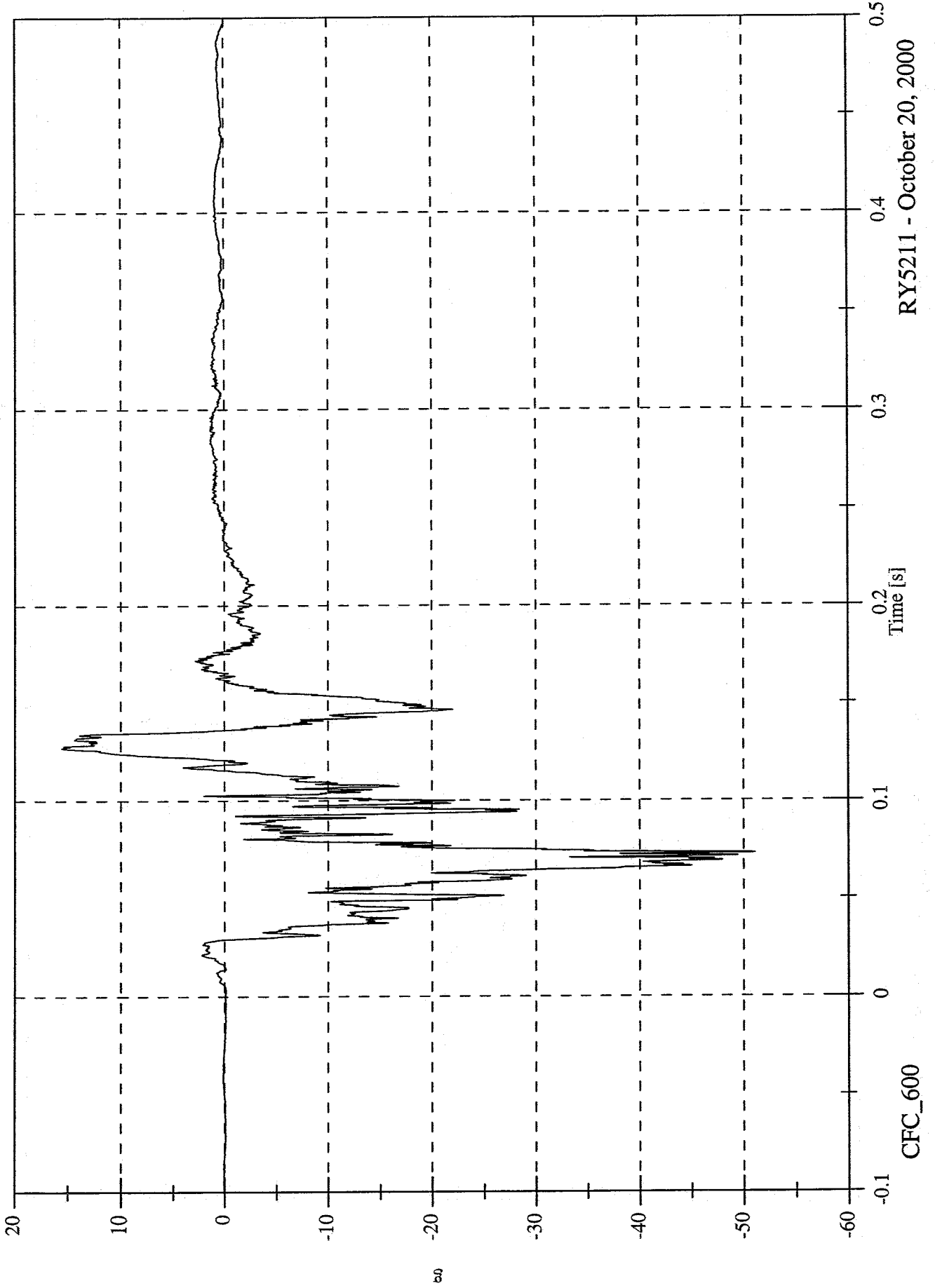

R Y5211 - October 20, 2000

40% Frontal Offset Test #2 - 2000 Nissan Altima

P1 Left Foot A Resultant

Max: 74.9 [g] at 0.071 [s]  
Min: 0.0 [g] at 0.500 [s]

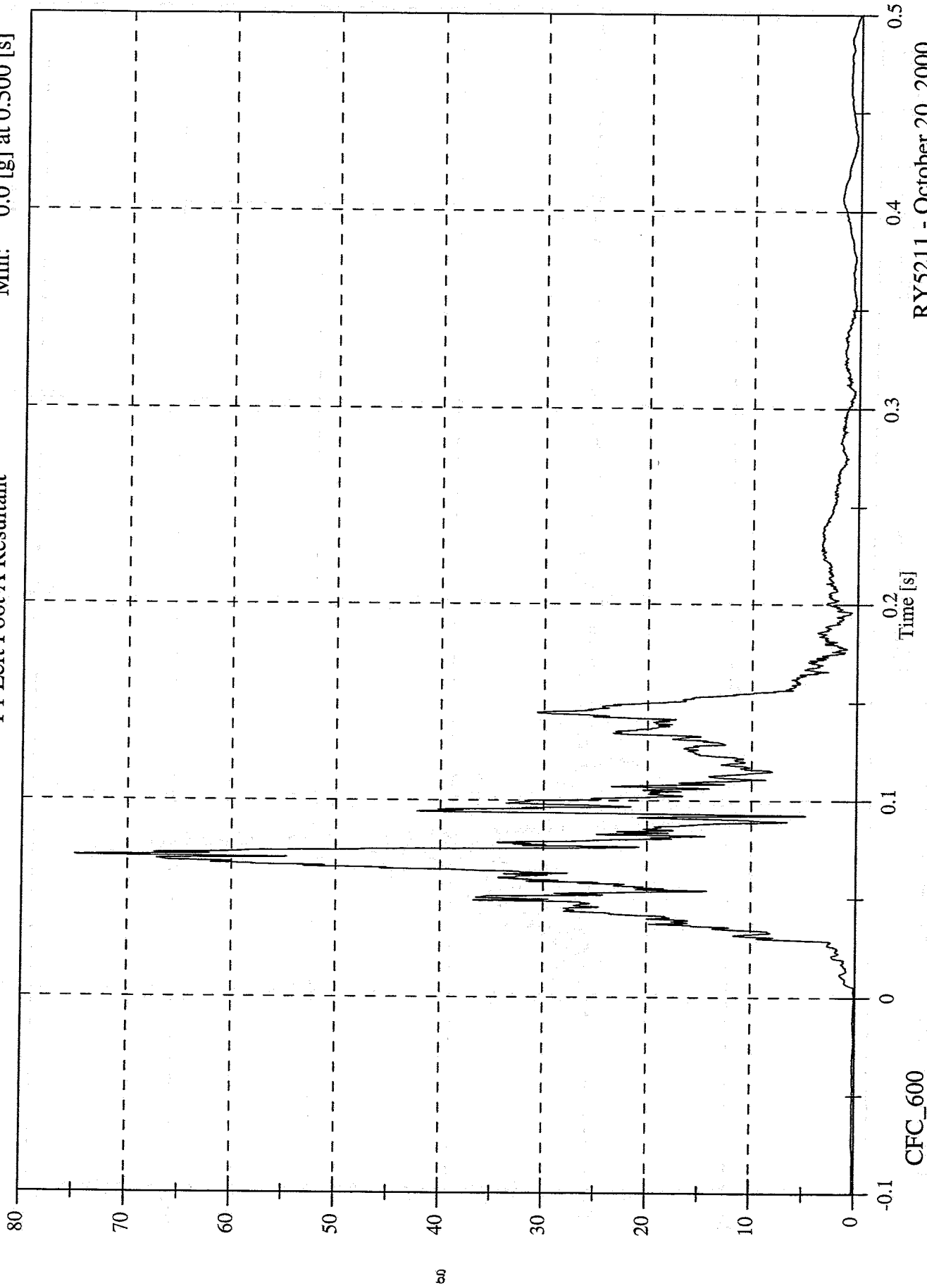

RY5211 - October 20, 2000

40% Frontal Offset Test #2 - 2000 Nissan Altima

Max: 29.7 [g] at 0.098 [s]  
Min: -65.4 [g] at 0.075 [s]

P1 Right Foot Ax

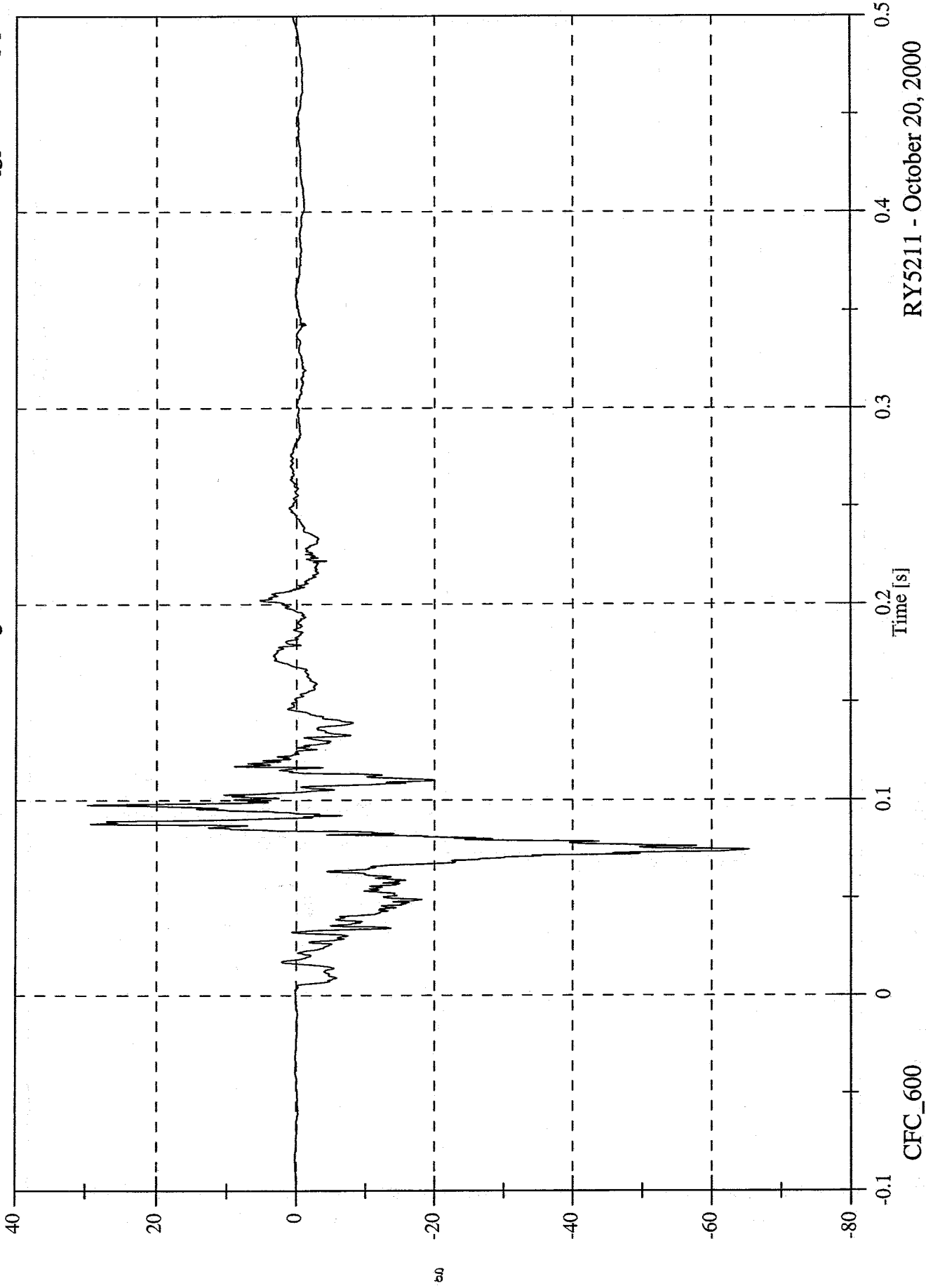

RY5211 - October 20, 2000

40% Frontal Offset Test #2 - 2000 Nissan Altima

Max: 67.7 [g] at 0.072 [s]  
Min: -26.6 [g] at 0.085 [s]

P1 Right Foot Ay

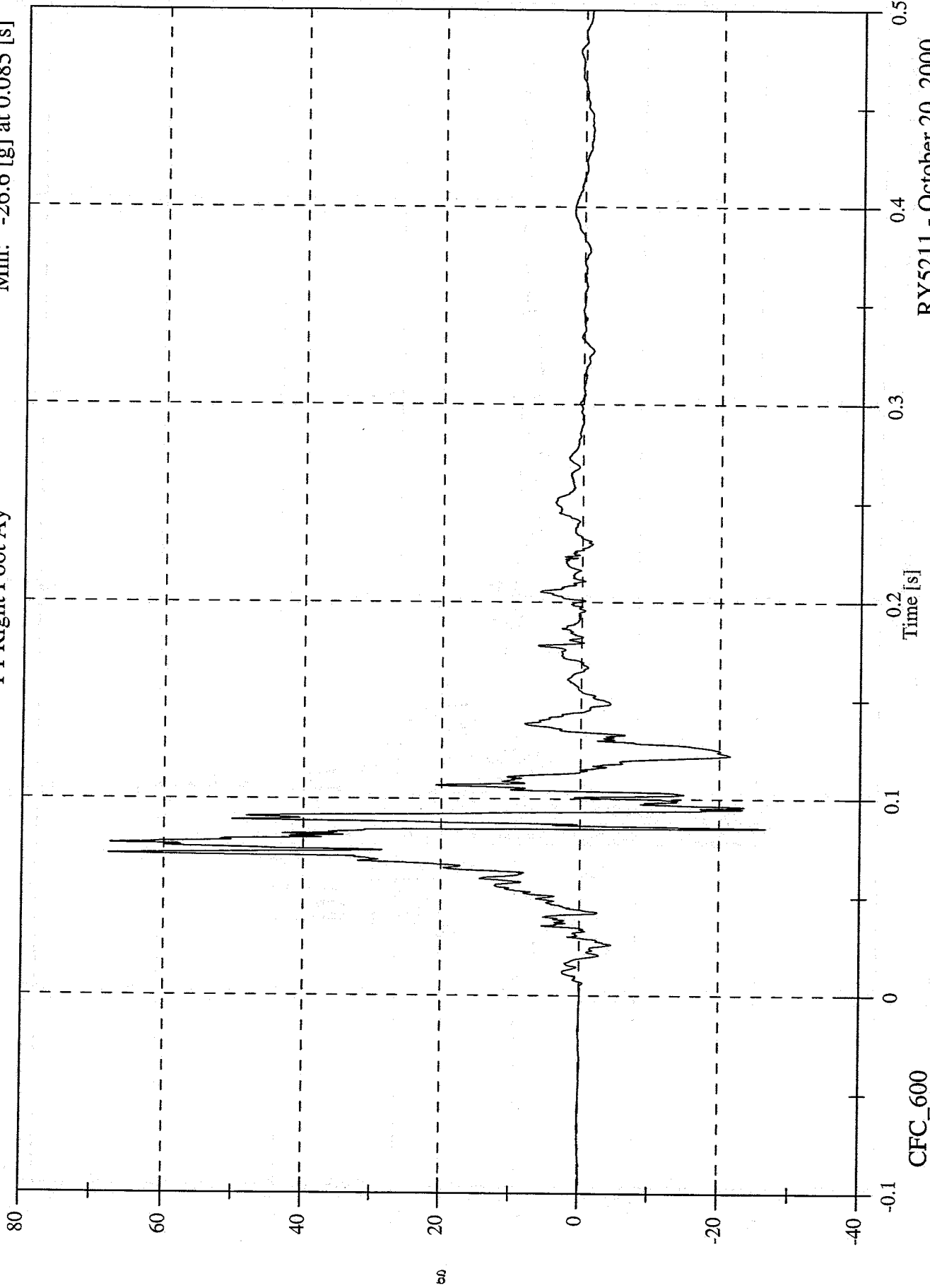

RY5211 - October 20, 2000

40% Frontal Offset Test #2 - 2000 Nissan Altima

Max: 23.5 [g] at 0.086 [s]  
Min: -30.5 [g] at 0.103 [s]

P1 Right Foot Az

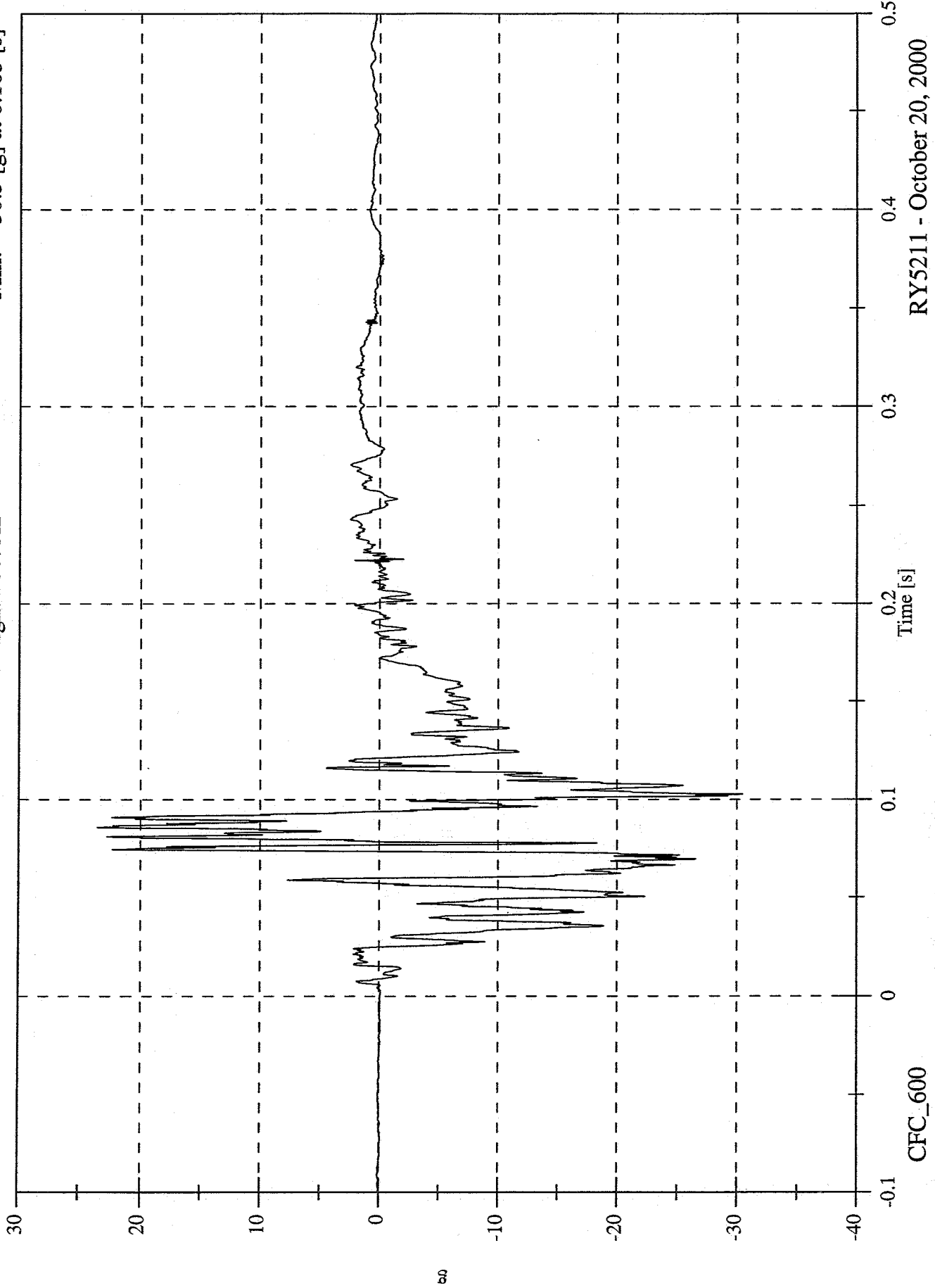

RYS211 - October 20, 2000

40% Frontal Offset Test #2 - 2000 Nissan Altima

P1 Right Foot A Resultant

Max: 83.5 [g] at 0.077 [s]  
Min: 0.0 [g] at -0.100 [s]

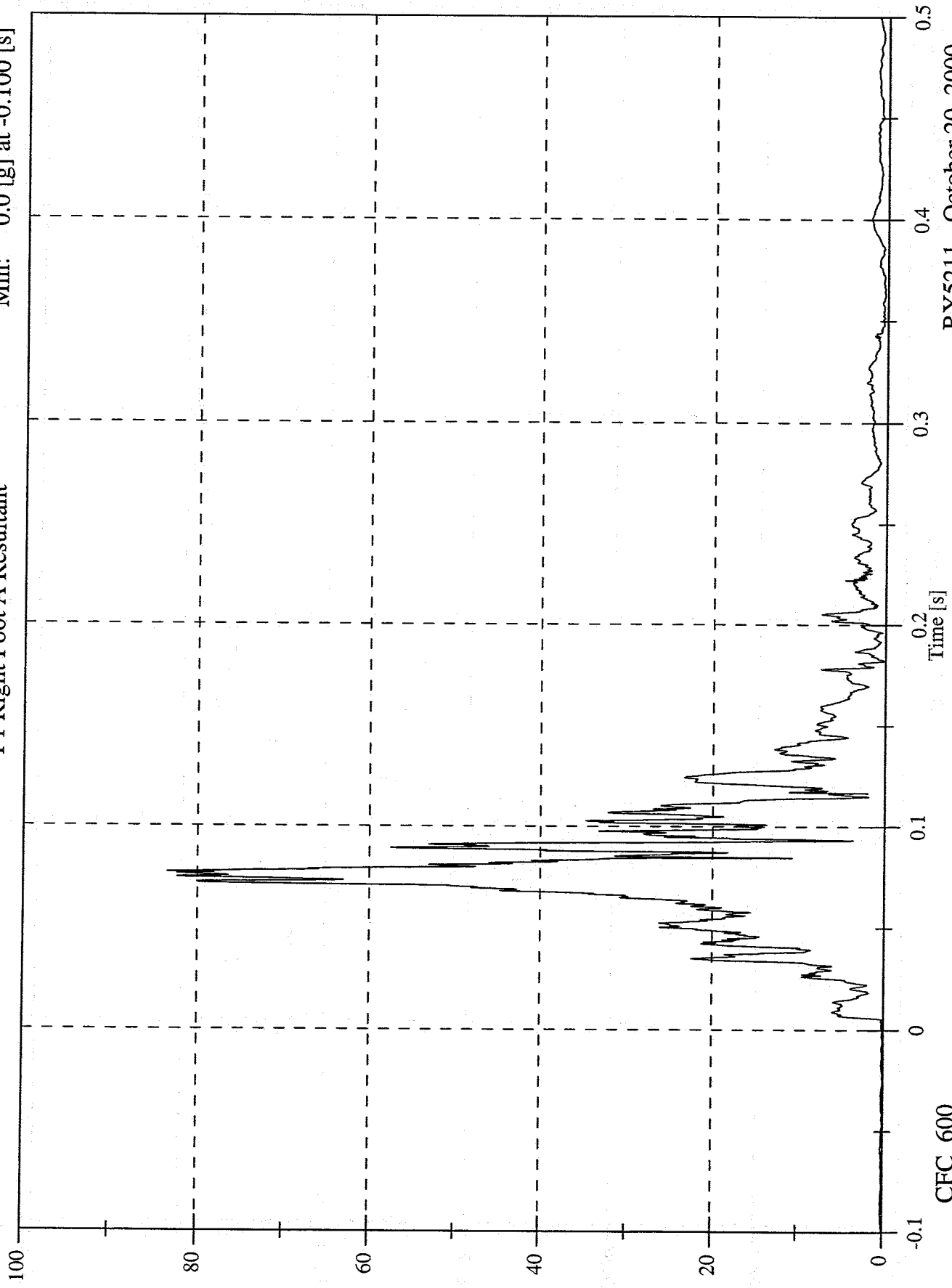

CFC\_600

RY5211 - October 20, 2000

40% Frontal Offset Test #2 - 2000 Nissan Altima

Max: 4927.1 [N] at 0.095 [s]

Min: -9.5 [N] at 0.497 [s]

P1 Lap Belt Force

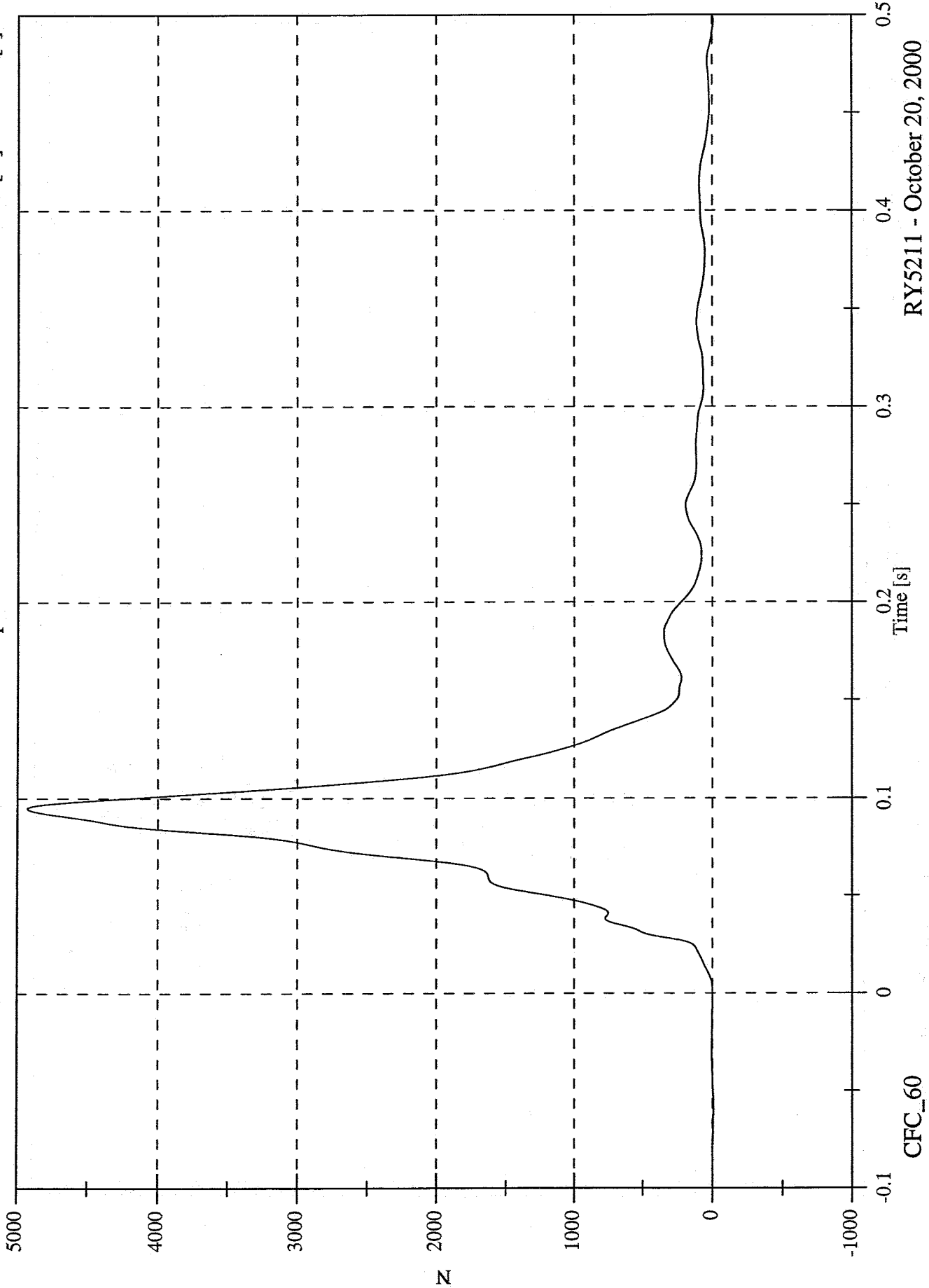

RY5211 - October 20, 2000

40% Frontal Offset Test #2 - 2000 Nissan Altima

P1 Torso Belt Spoolout

Max: 9.3 [mm] at 0.028 [s]  
Min: -52.0 [mm] at 0.499 [s]

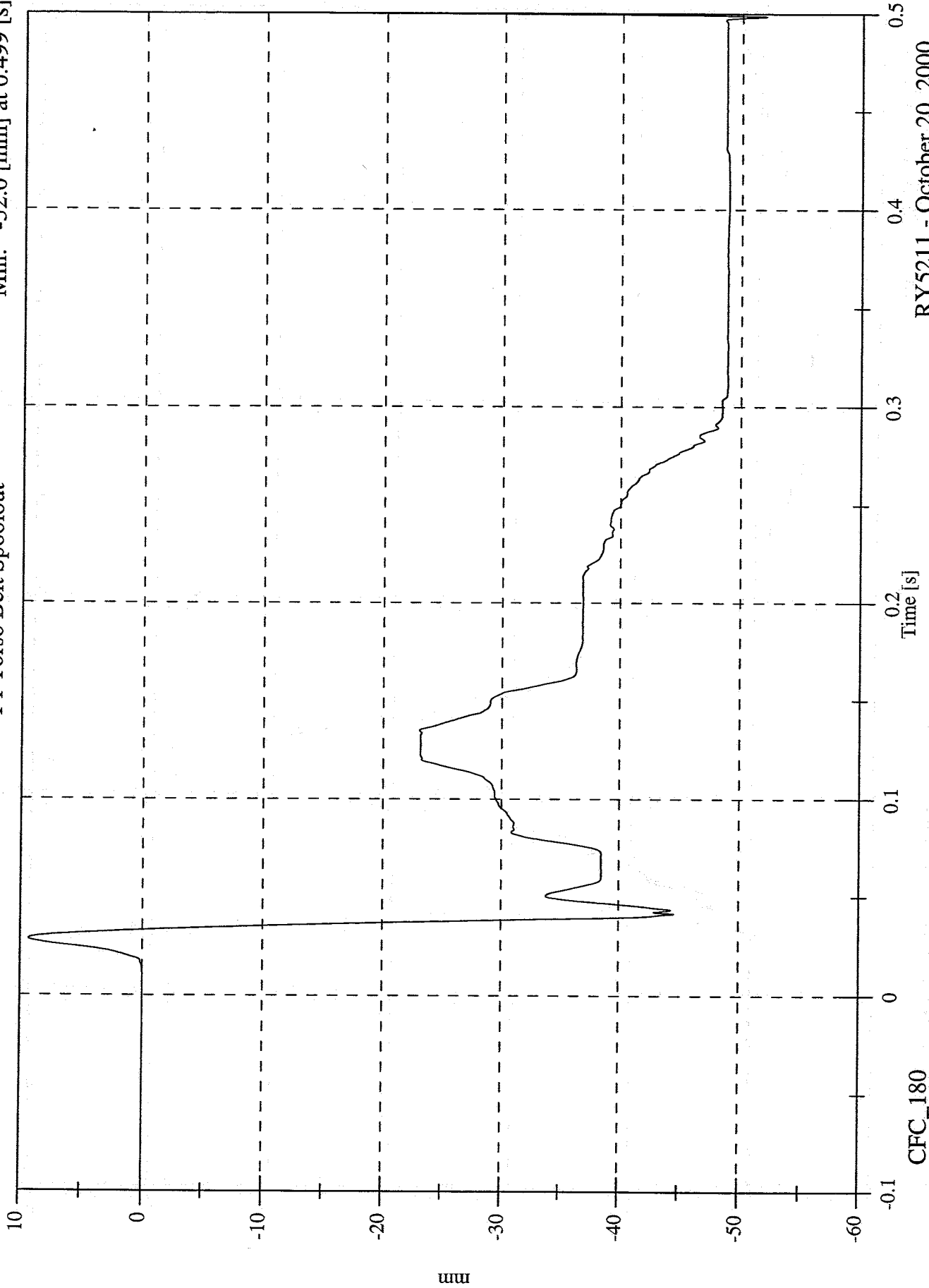

RY5211 - October 20, 2000

40% Frontal Offset Test #2 - 2000 Nissan Altima

Max: 4.5 [g] at 0.367 [s]  
Min: -29.5 [g] at 0.116 [s]

P2 Head x

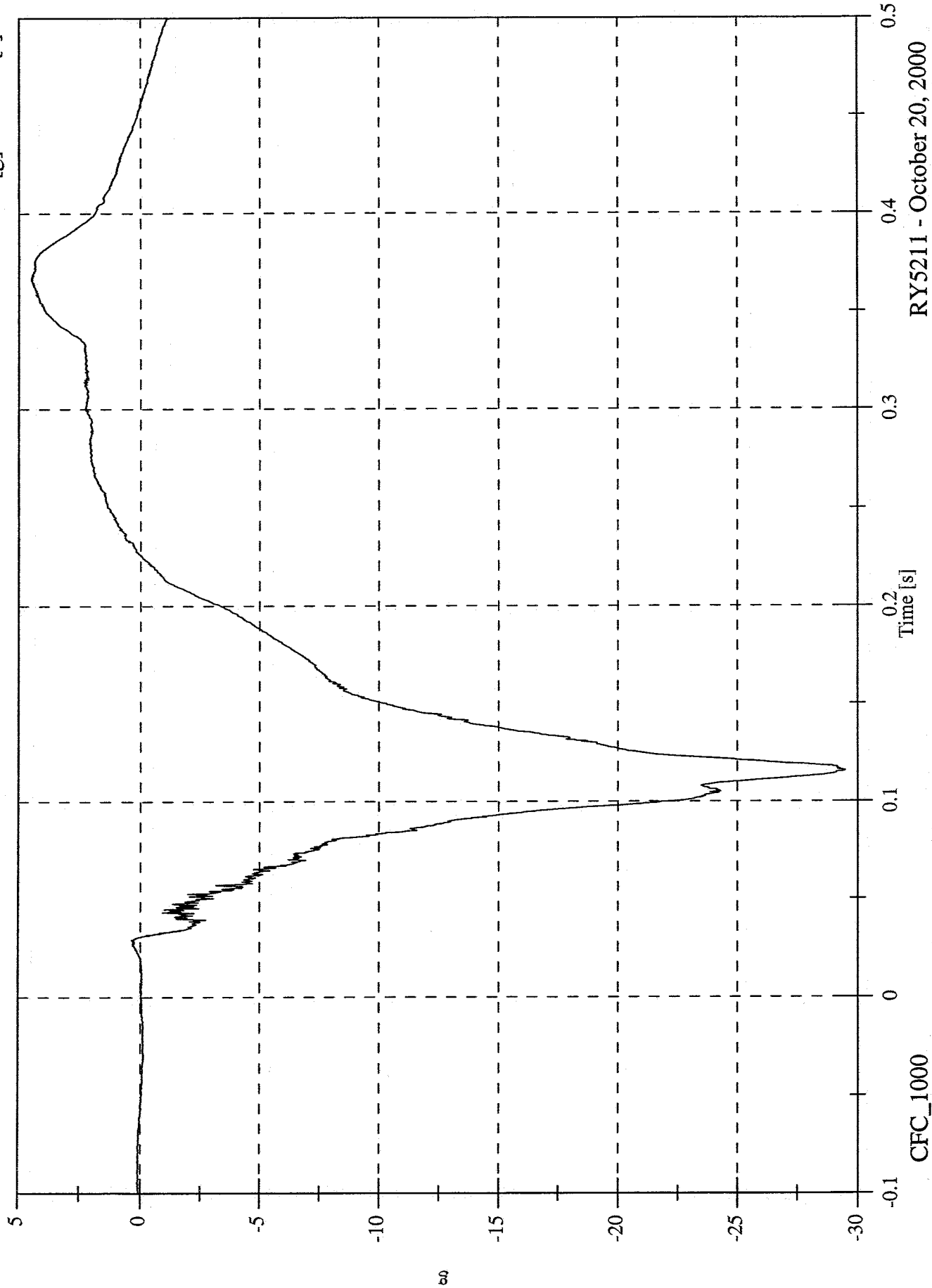

RYS211 - October 20, 2000

40% Frontal Offset Test #2 - 2000 Nissan Altima

P2 Head y

Max: 7.7 [g] at 0.116 [s]  
Min: -3.5 [g] at 0.244 [s]

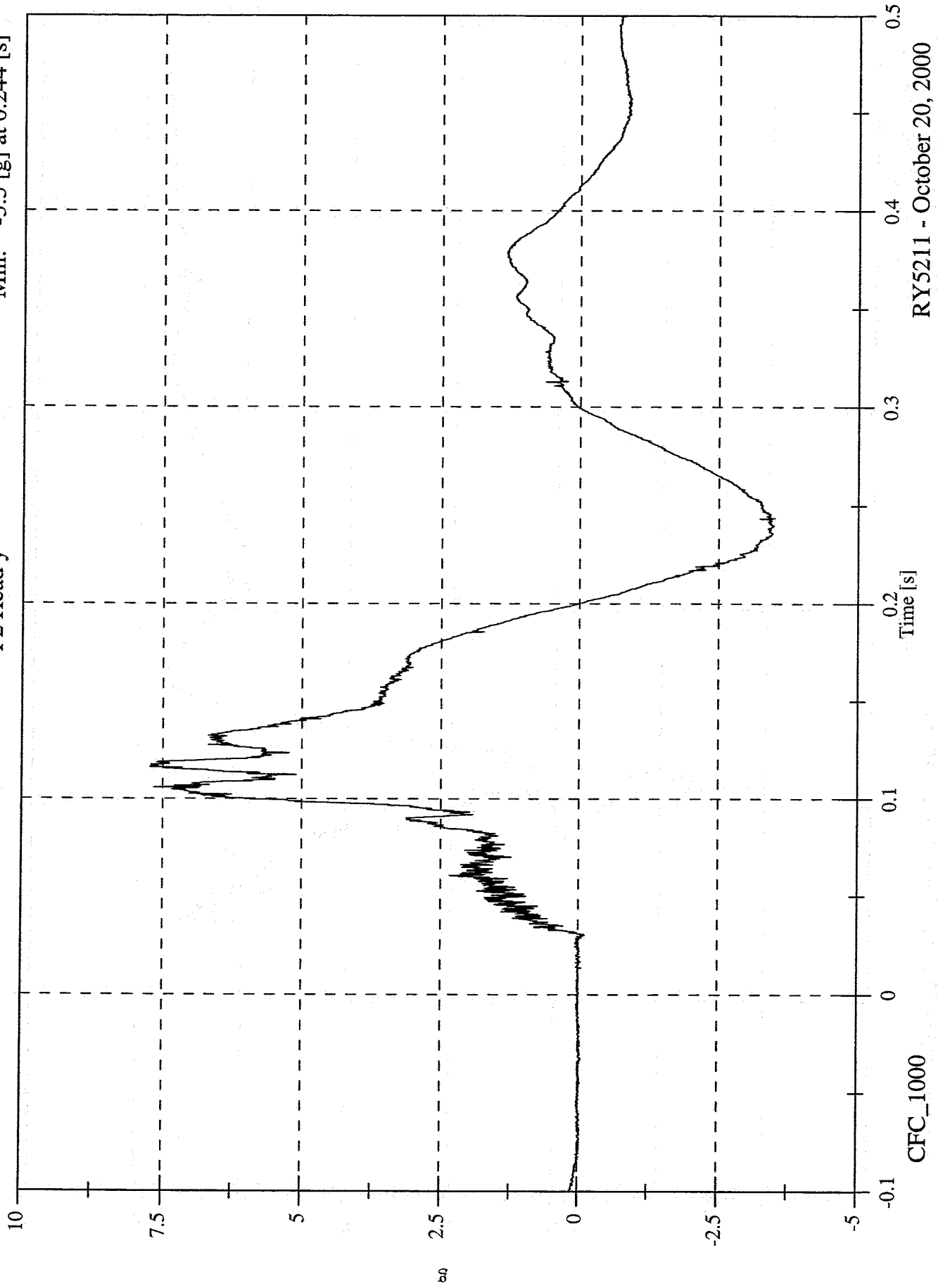

RYS211 - October 20, 2000

40% Frontal Offset Test #2 - 2000 Nissan Altima

Max: 30.4 [g] at 0.111 [s]  
Min: -1.1 [g] at 0.030 [s]

P2 Head z

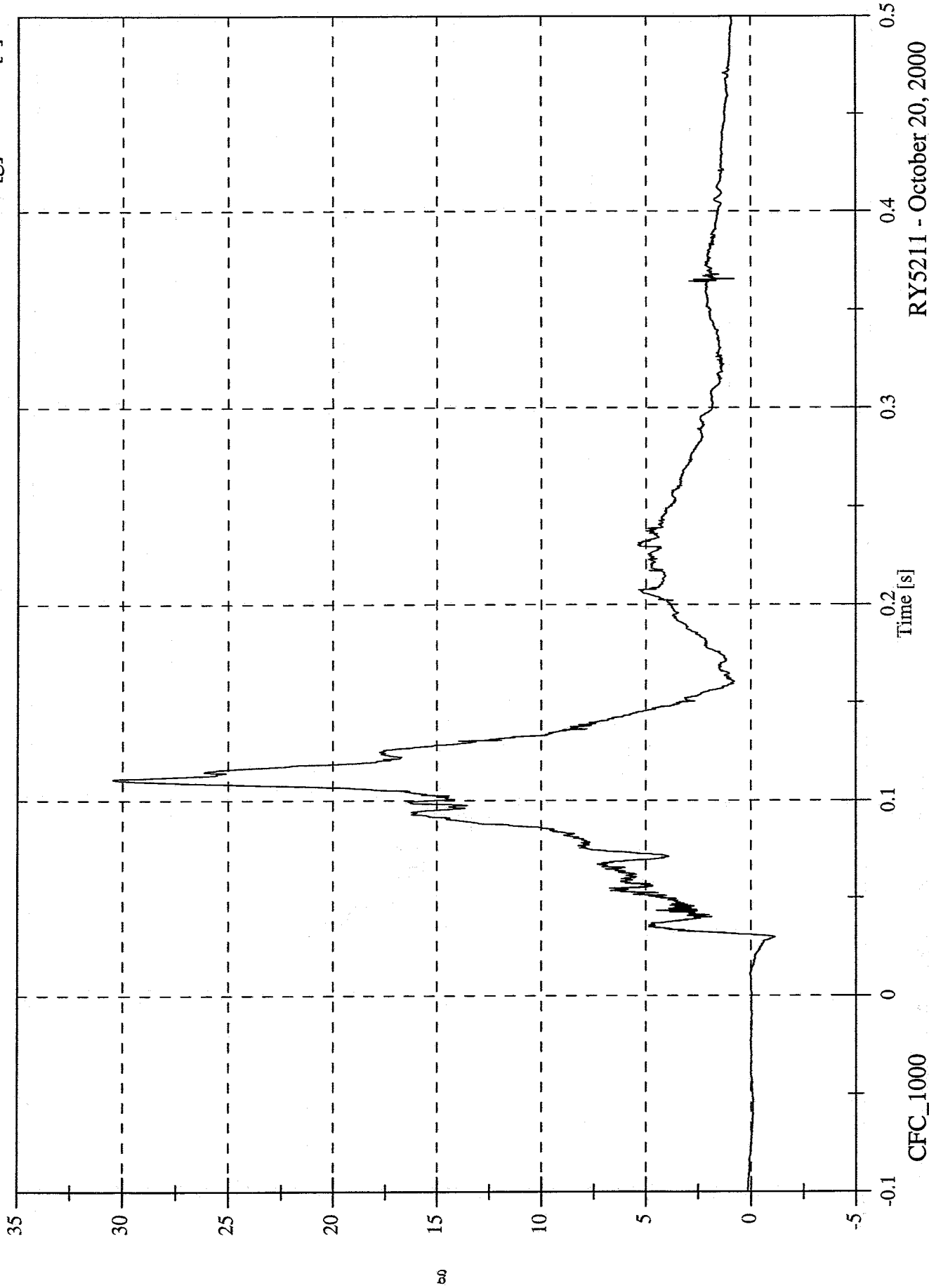

RY5211 - October 20, 2000

40% Frontal Offset Test #2 - 2000 Nissan Altima

Max: 40.3 [g] at 0.111 [s]  
Min: 0.0 [g] at 0.004 [s]

P2 Head Resultant

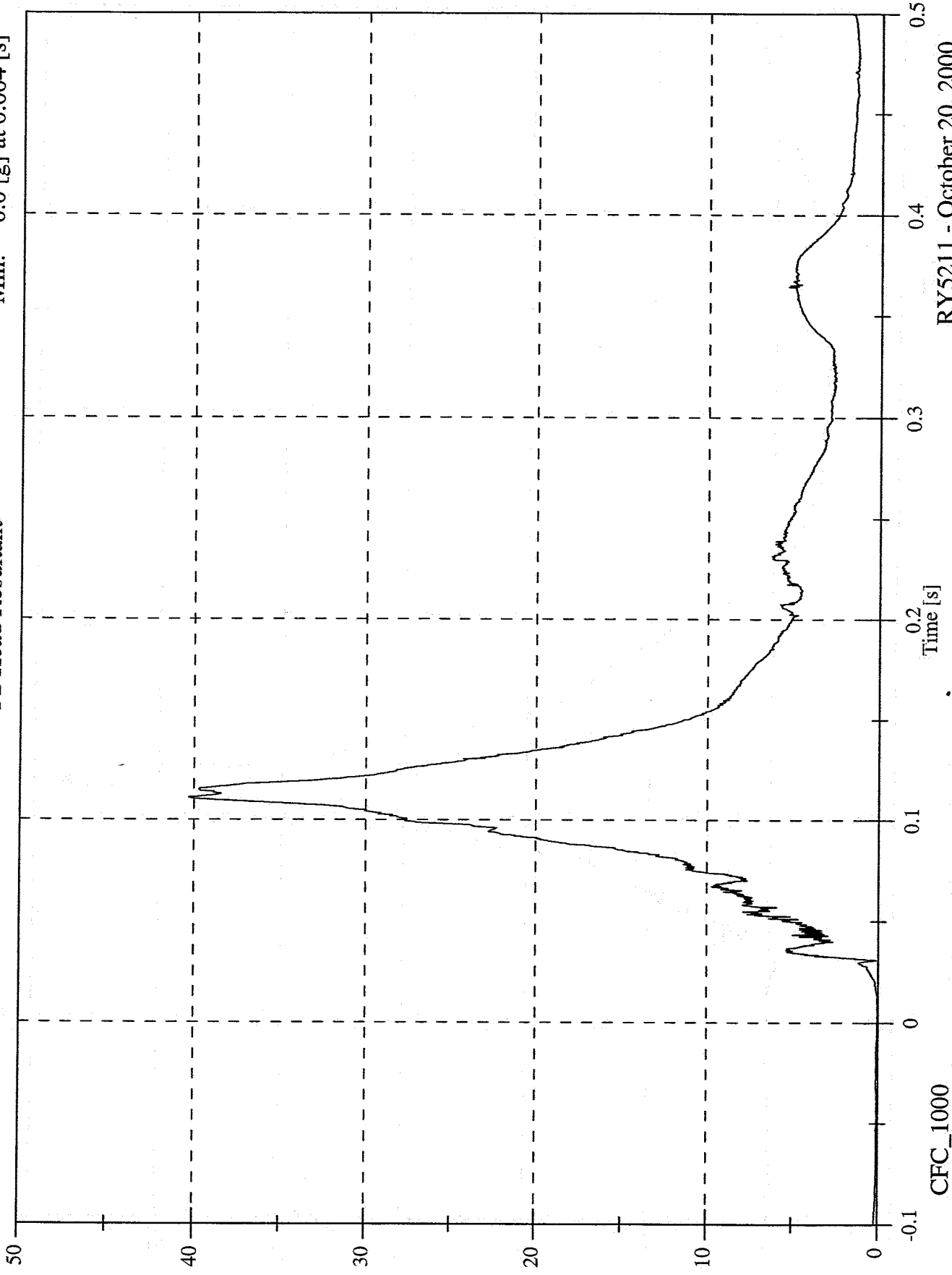

RYS211 - October 20, 2000

40% Frontal Offset Test #2 - 2000 Nissan Altima

Max: 4.7 [g] at 0.369 [s]  
Min: -29.3 [g] at 0.116 [s]

P2 Head Red x

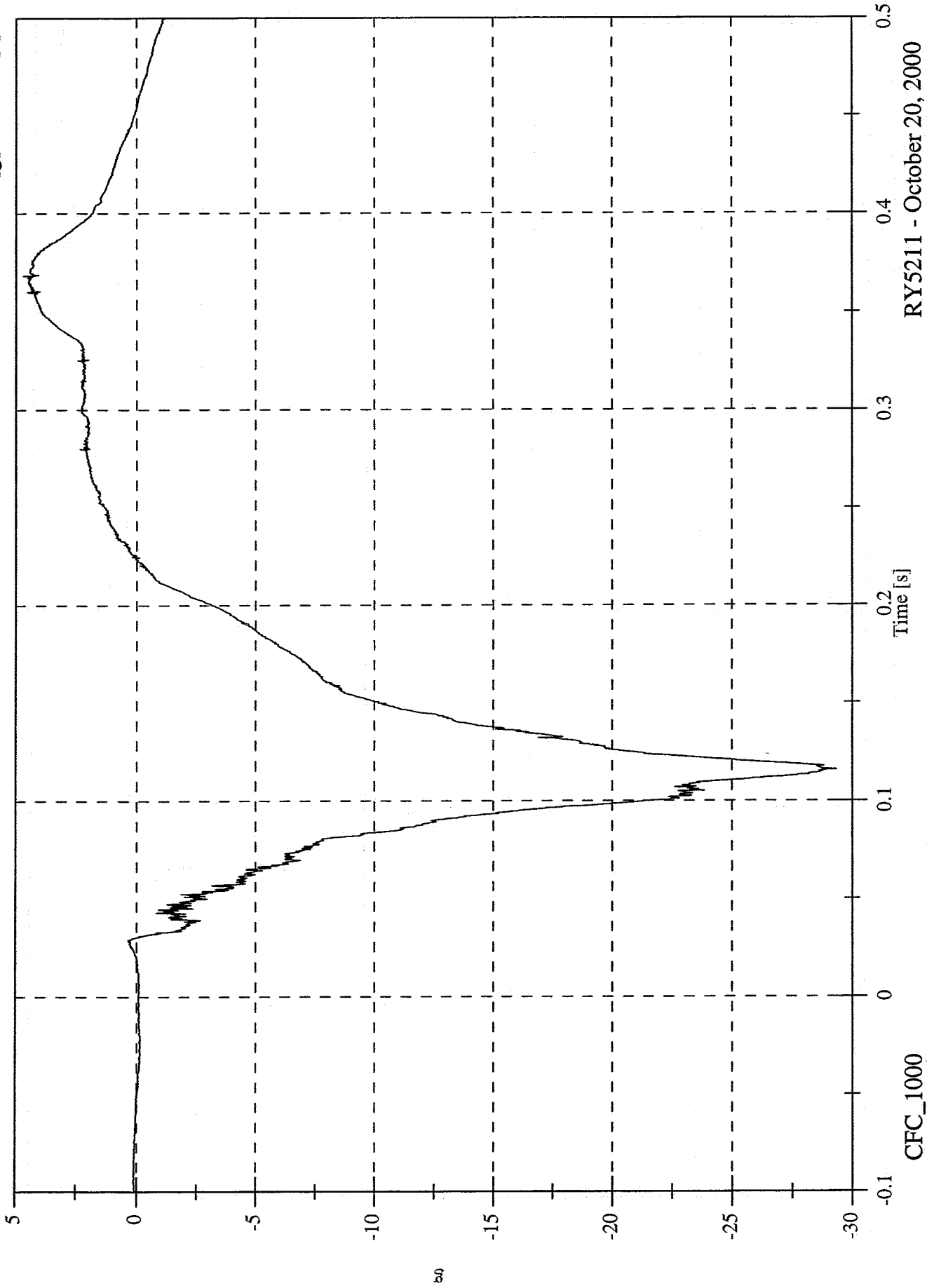

RY5211 - October 20, 2000

40% Frontal Offset Test #2 - 2000 Nissan Altima

Max: 8.1 [g] at 0.117 [s]  
Min: -3.6 [g] at 0.236 [s]

P2 Head Red y

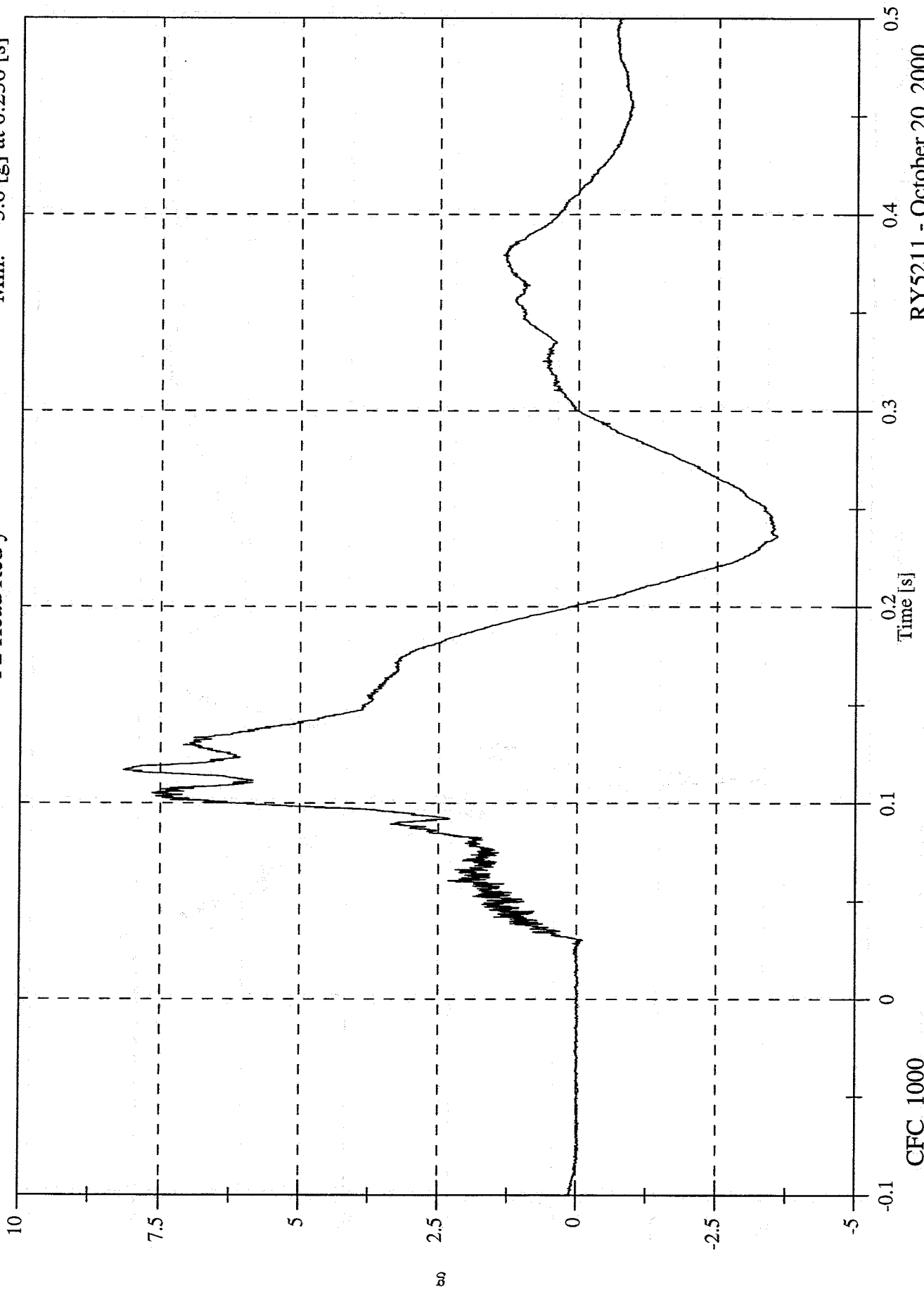

RY5211 - October 20, 2000

40% Frontal Offset Test #2 - 2000 Nissan Altima

Max: 30.1 [g] at 0.111 [s]  
Min: -1.0 [g] at 0.030 [s]

P2 Head Red z

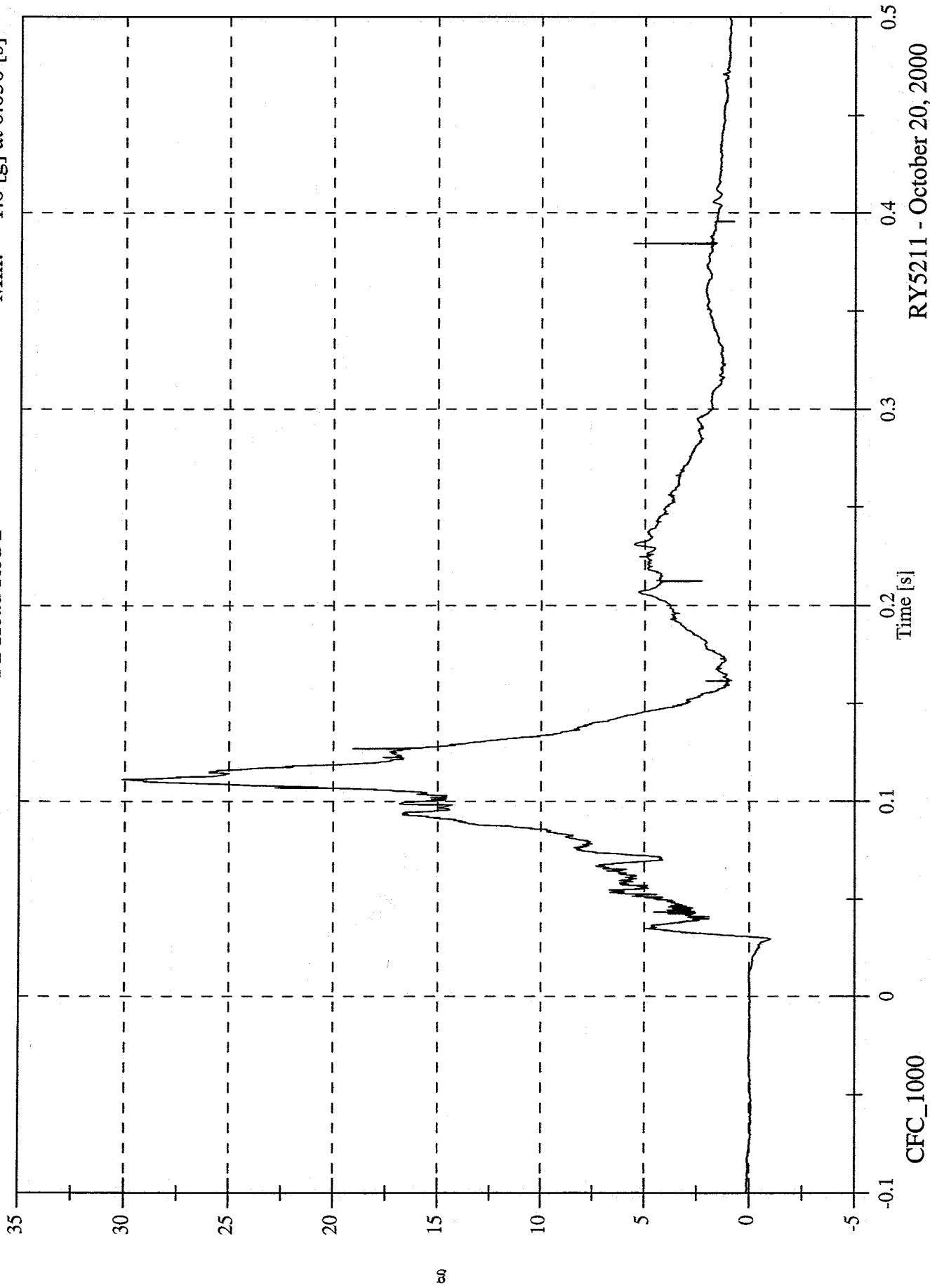

RY5211 - October 20, 2000

40% Frontal Offset Test #2 - 2000 Nissan Altima

Max: 40.0 [g] at 0.111 [s]

Min: 0.0 [g] at -0.049 [s]

P2 Head Red Resultant

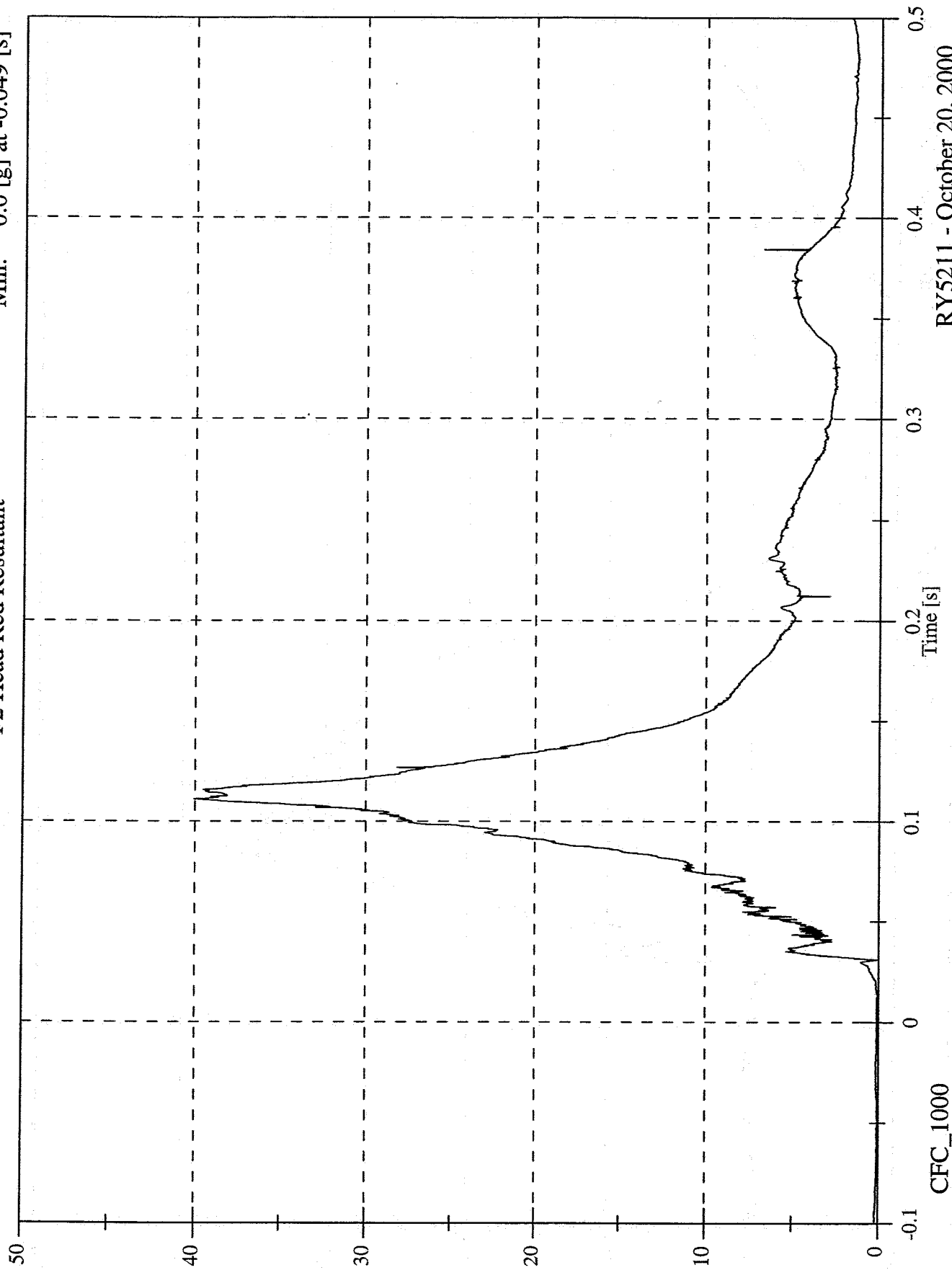

RY5211 - October 20, 2000

40% Frontal Offset Test #2 - 2000 Nissan Altima

Max: 93.4 [N] at 0.351 [s]  
Min: -463.5 [N] at 0.117 [s]

P2 Upper Neck Fx

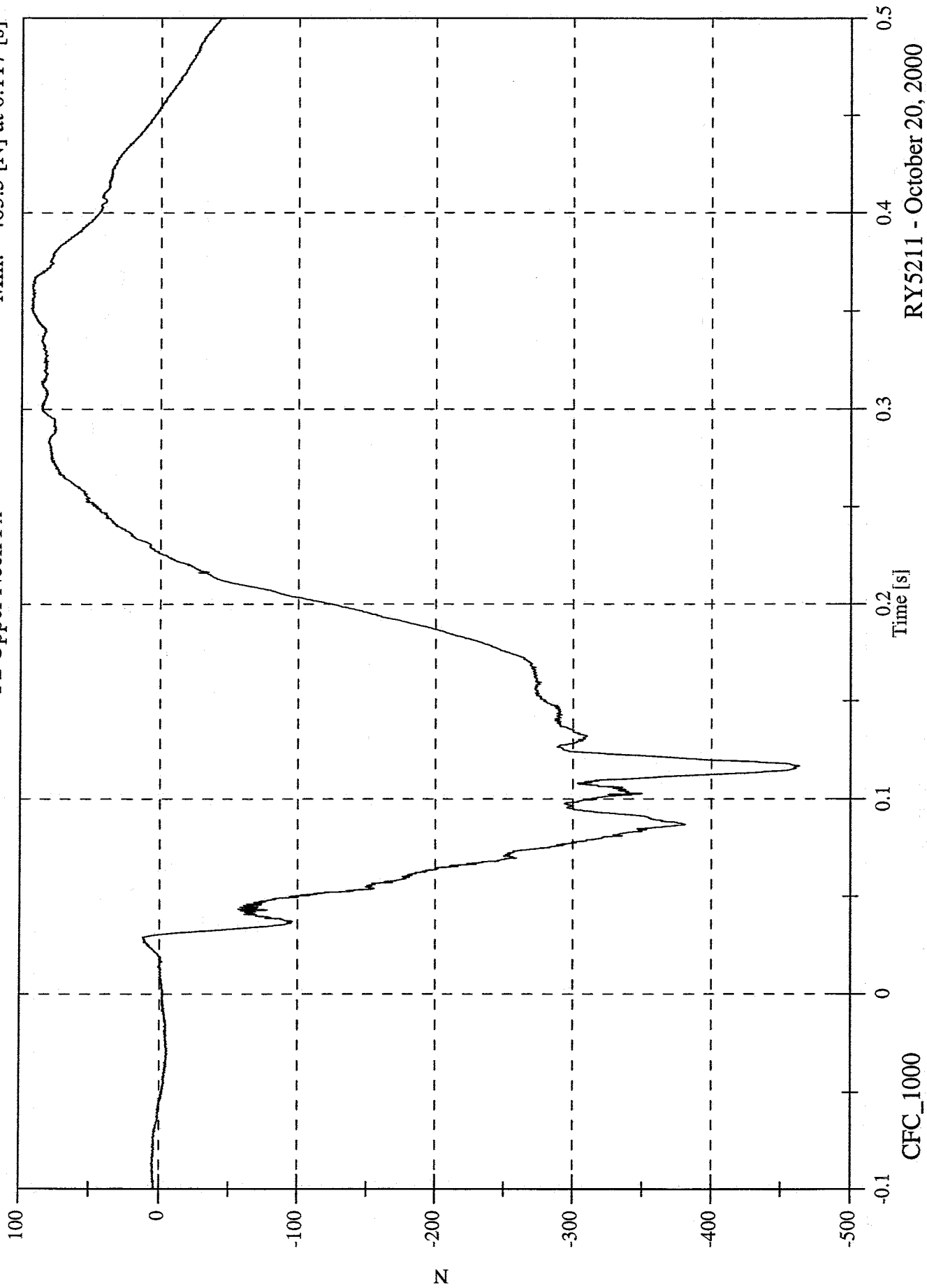

R Y 5 2 1 1 - O c t o b e r 2 0 , 2 0 0 0

40% Frontal Offset Test #2 - 2000 Nissan Altima

Max: 141.8 [N] at 0.134 [s]

Min: -144.5 [N] at 0.238 [s]

P2 Upper Neck Fy

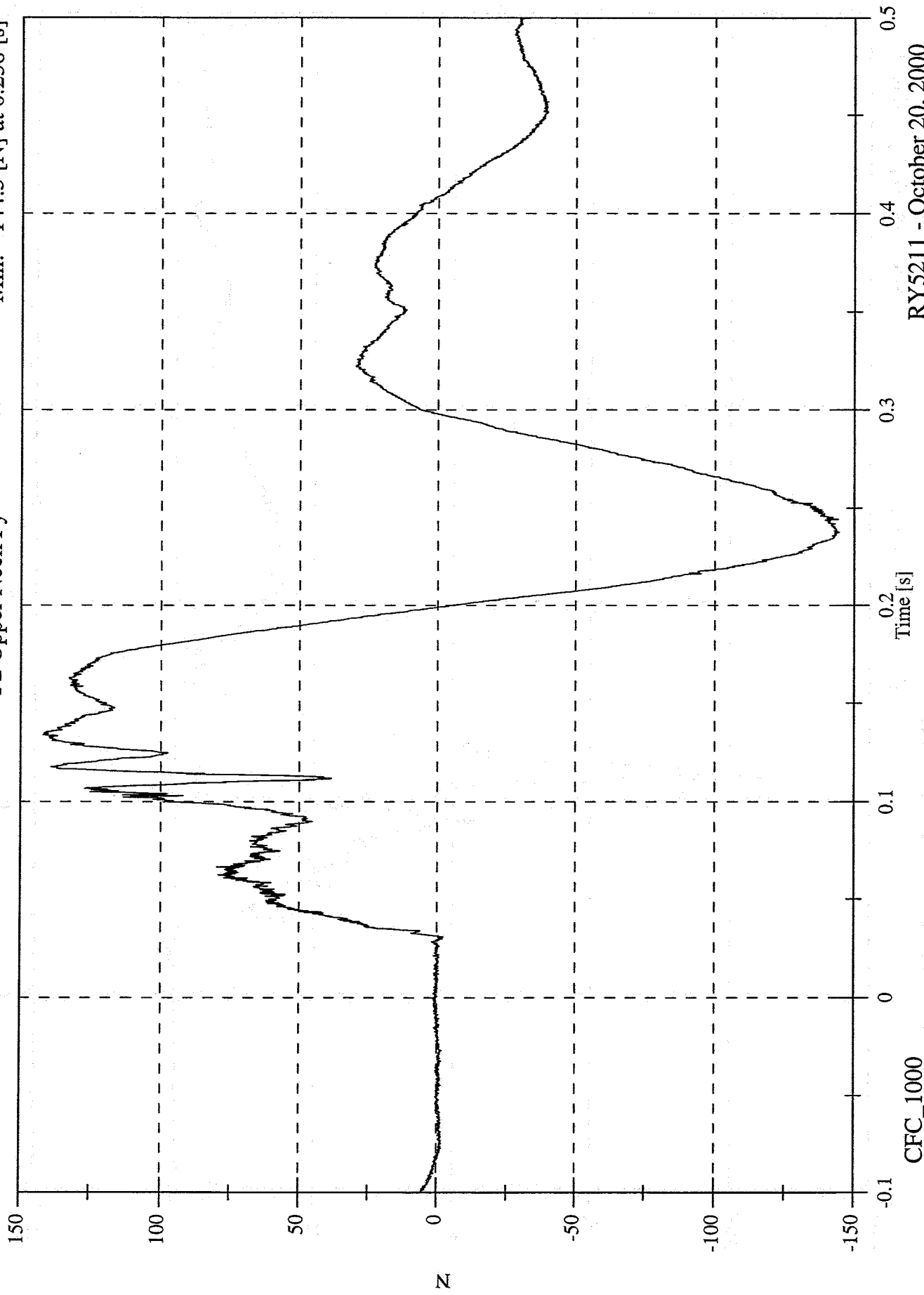

RY5211 - October 20, 2000

40% Frontal Offset Test #2 - 2000 Nissan Altima

Max: 1071.9 [N] at 0.111 [s]  
Min: -47.4 [N] at 0.029 [s]

P2 Upper Neck Fz

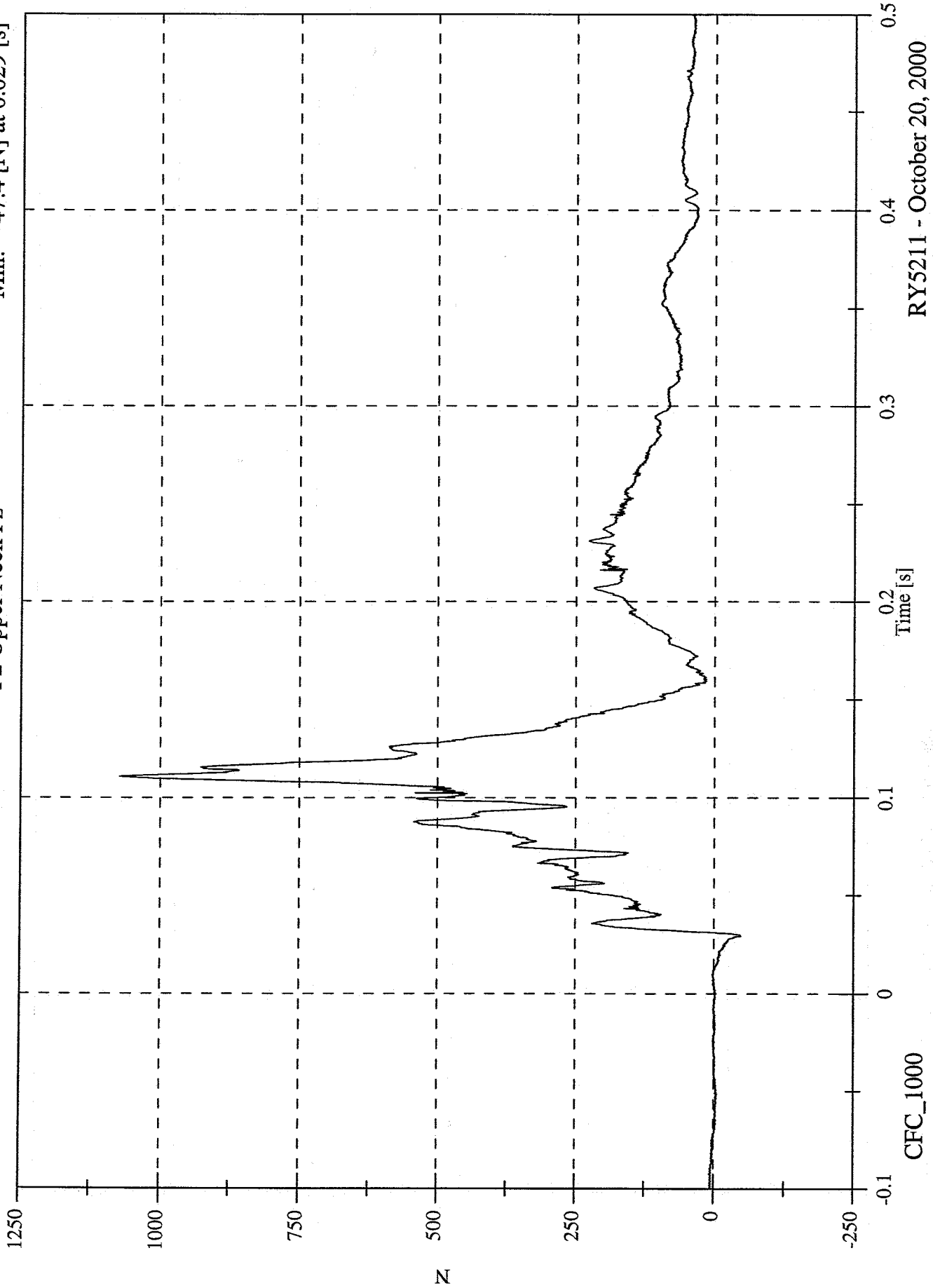

CFC\_1000

RYS211 - October 20, 2000

40% Frontal Offset Test #2 - 2000 Nissan Altima

Max: 1130.0 [N] at 0.111 [s]

Min: 0.4 [N] at 0.007 [s]

P2 Upper Neck F Resultant

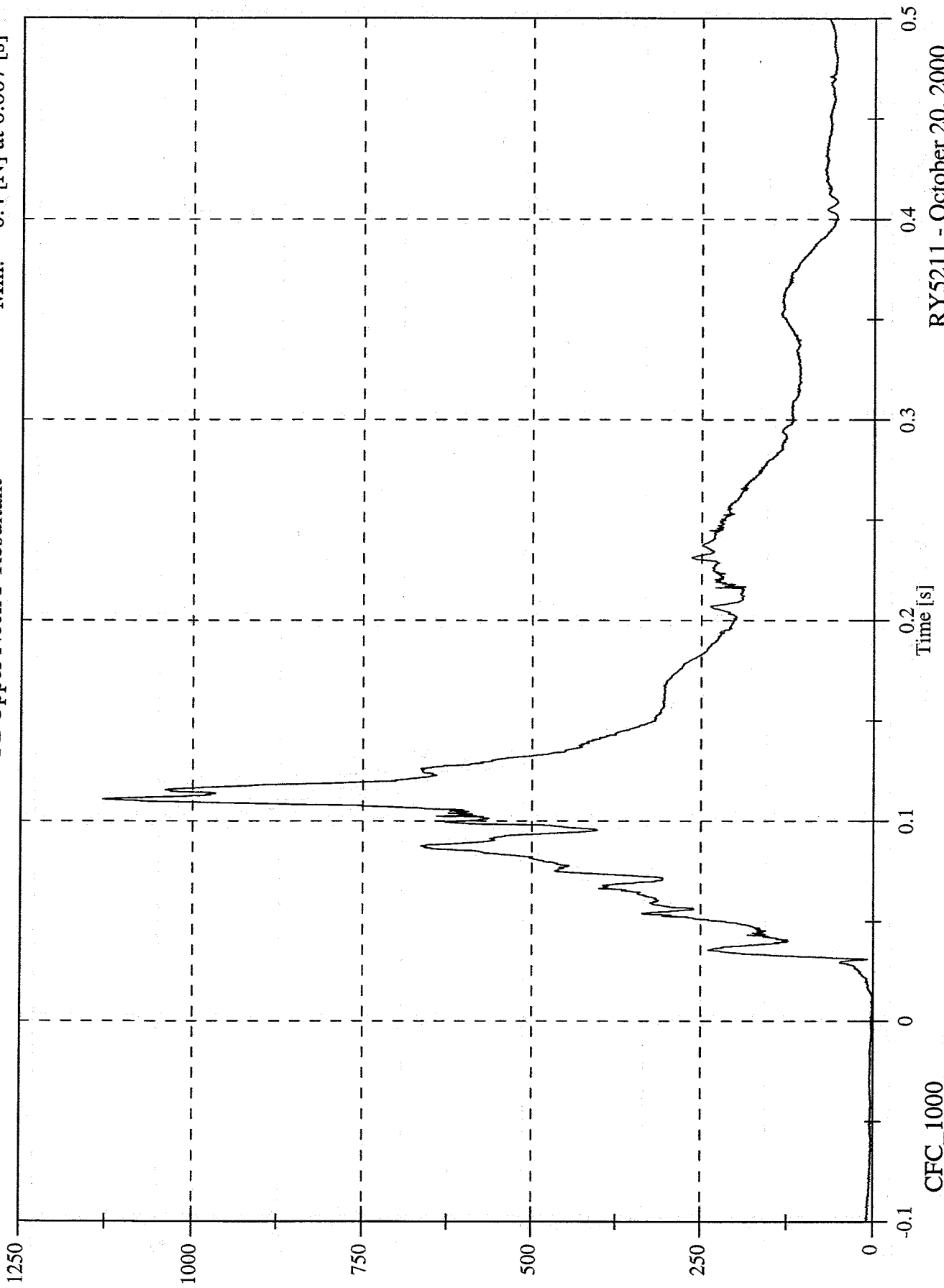

RYS211 - October 20, 2000

40% Frontal Offset Test #2 - 2000 Nissan Altima

P2 Upper Neck Mx

Max: 10.1 [Nm] at 0.168 [s]  
Min: -15.5 [Nm] at 0.117 [s]

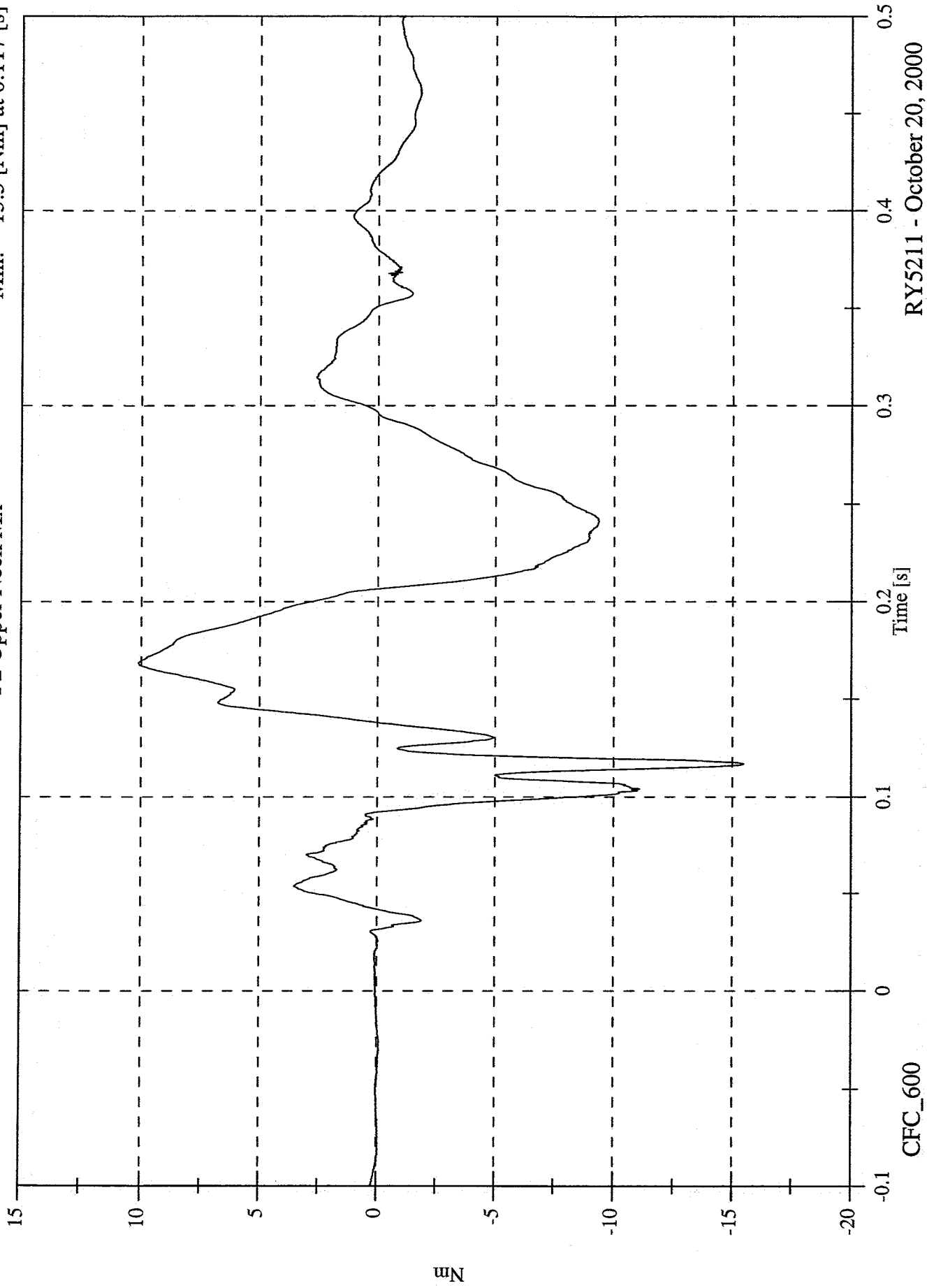

RY5211 - October 20, 2000

40% Frontal Offset Test #2 - 2000 Nissan Altima

Max: 19.2 [Nm] at 0.101 [s]

Min: -9.8 [Nm] at 0.259 [s]

P2 Upper Neck My

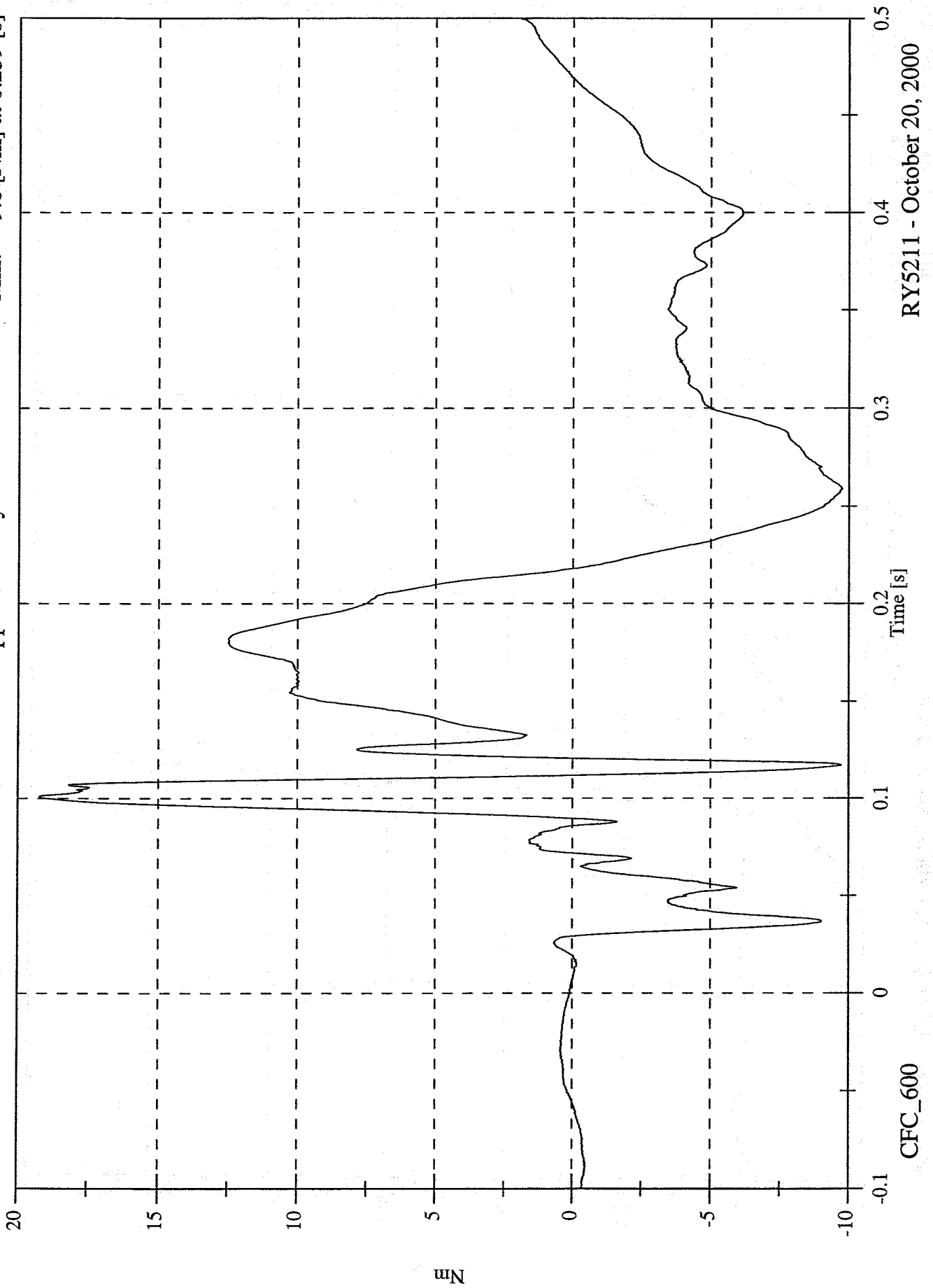

RY5211 - October 20, 2000

40% Frontal Offset Test #2 - 2000 Nissan Altima

Max: 2.4 [Nm] at 0.383 [s]  
Min: -13.4 [Nm] at 0.113 [s]

P2 Upper Neck Mz

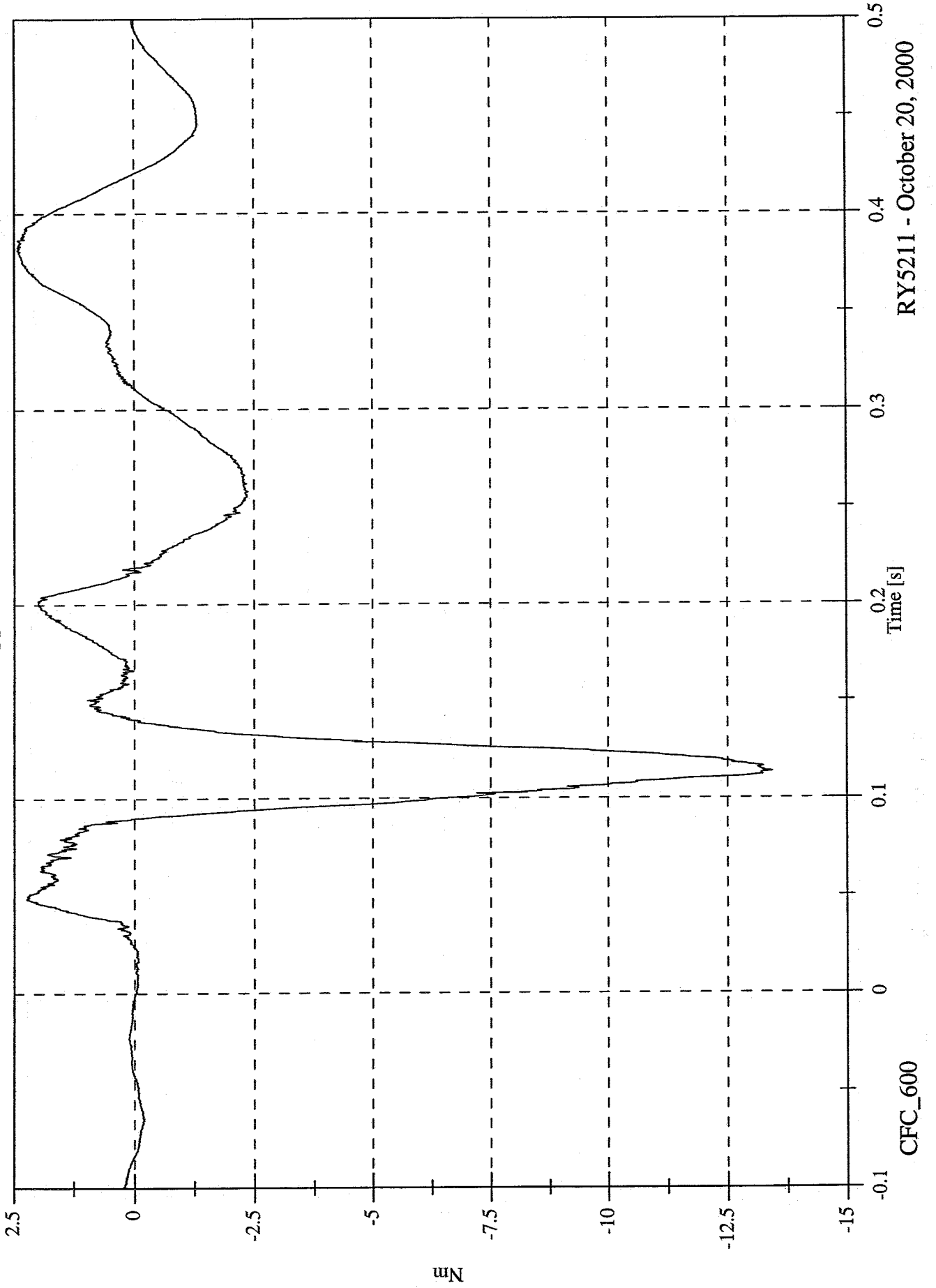

RYS211 - October 20, 2000

40% Frontal Offset Test #2 - 2000 Nissan Altima

Max: 23.2 [Nm] at 0.107 [s]

Min: 0.1 [Nm] at -0.100 [s]

P2 Upper Neck M Resultant

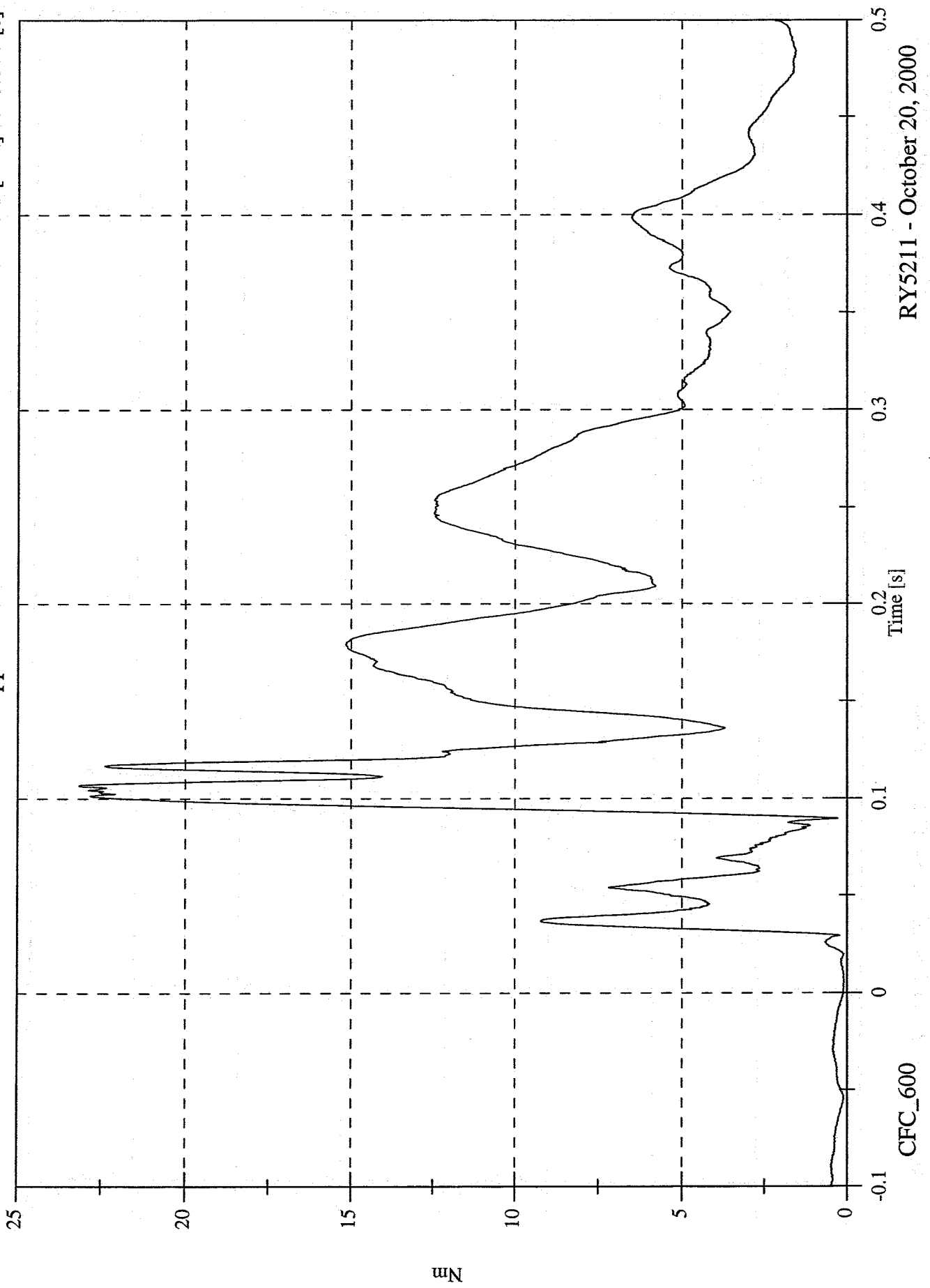

RYS211 - October 20, 2000

40% Frontal Offset Test #2 - 2000 Nissan Altima

Max: 1.5 [g] at 0.346 [s]  
Min: -32.5 [g] at 0.110 [s]

P2 Chest x

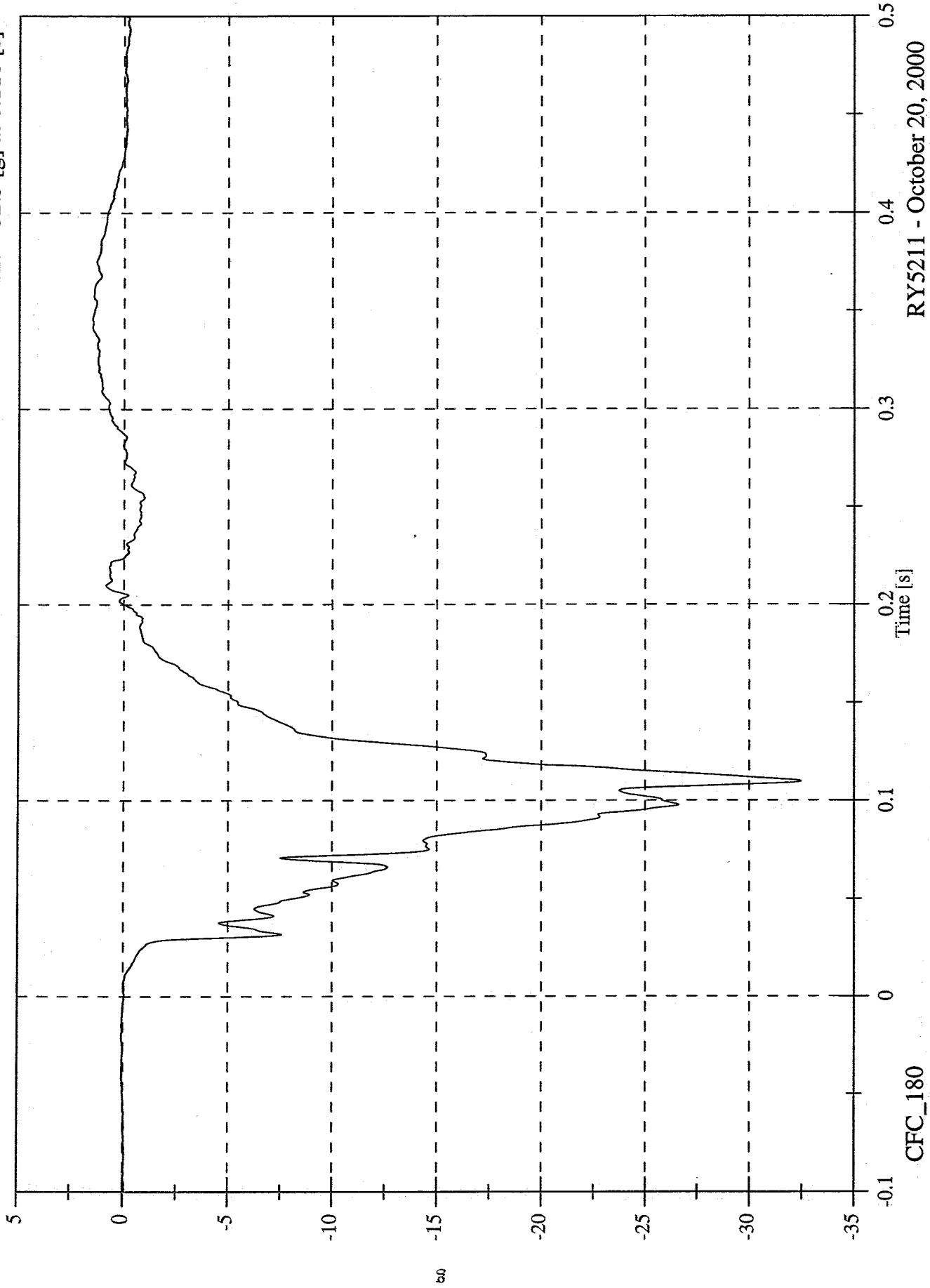

R Y 5 2 1 1 - O c t o b e r 2 0 , 2 0 0 0

40% Frontal Offset Test #2 - 2000 Nissan Altima

Max: 11.6 [g] at 0.102 [s]  
Min: -4.3 [g] at 0.166 [s]

P2 Chest y

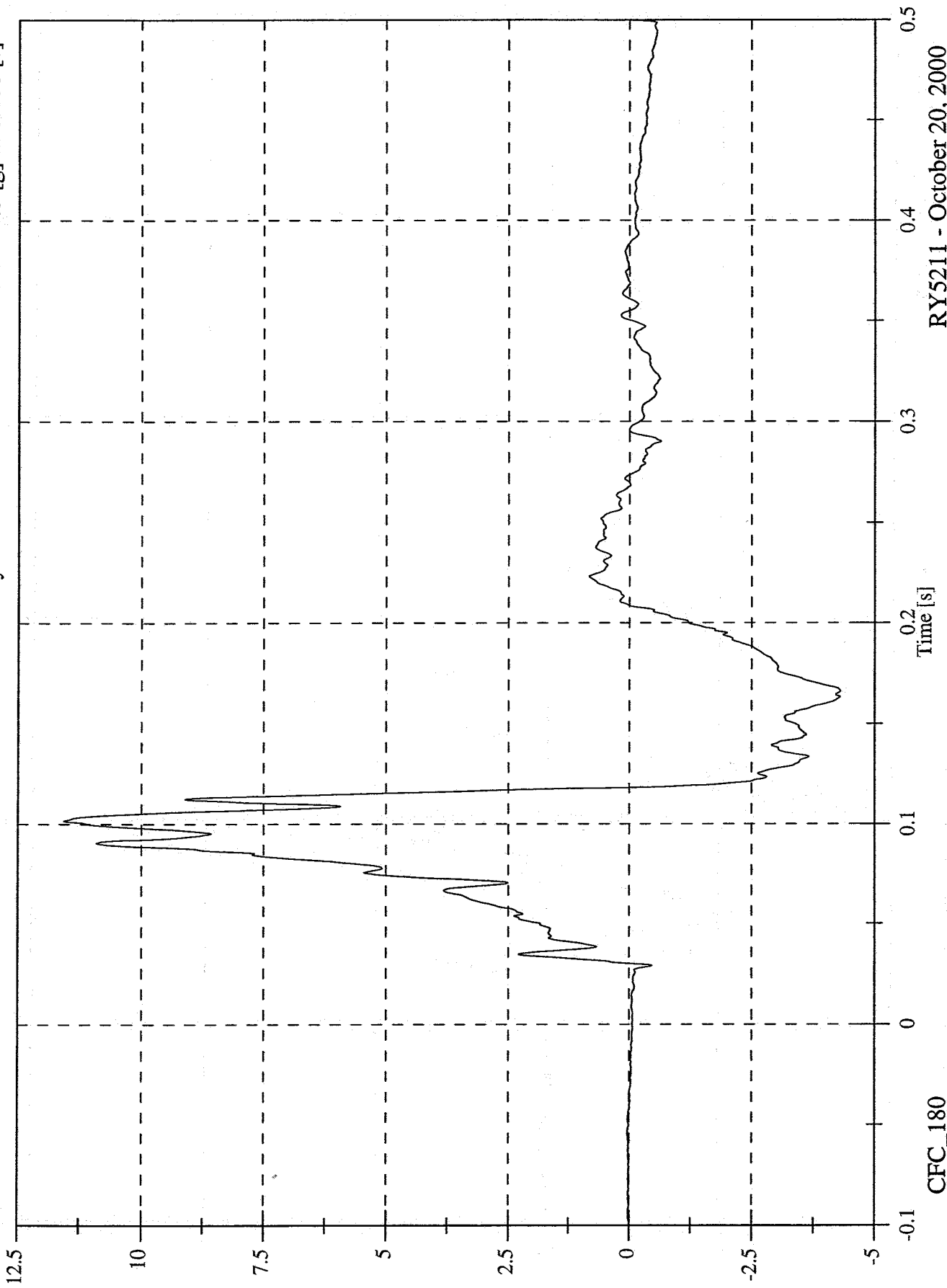

40% Frontal Offset Test #2 - 2000 Nissan Altima

Max: 3.8 [g] at 0.107 [s]  
Min: -5.7 [g] at 0.098 [s]

P2 Chest z

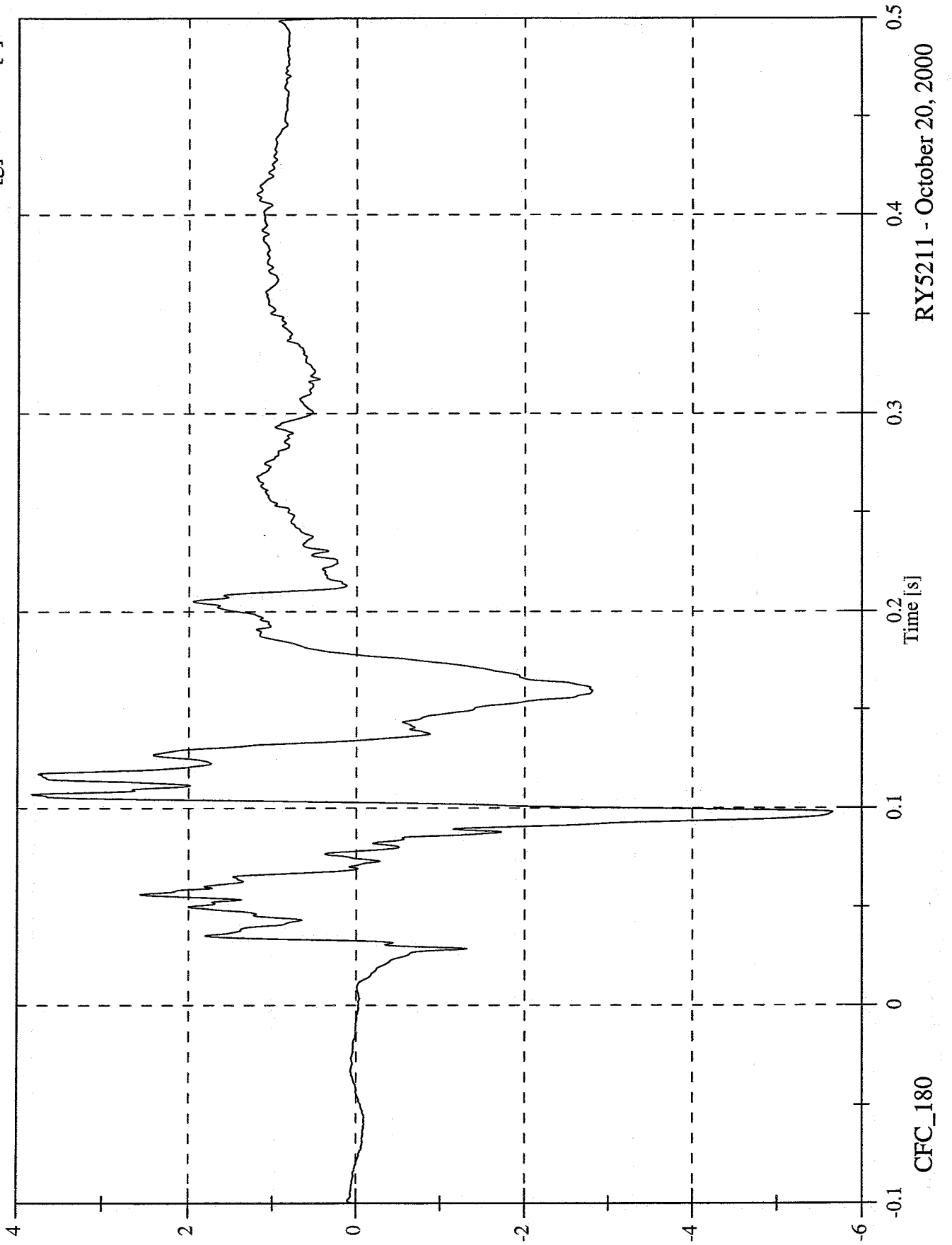

RY5211 - October 20, 2000

40% Frontal Offset Test #2 - 2000 Nissan Altima

Max: 33.2 [g] at 0.110 [s]  
Min: 0.0 [g] at -0.100 [s]

P2 Chest Resultant

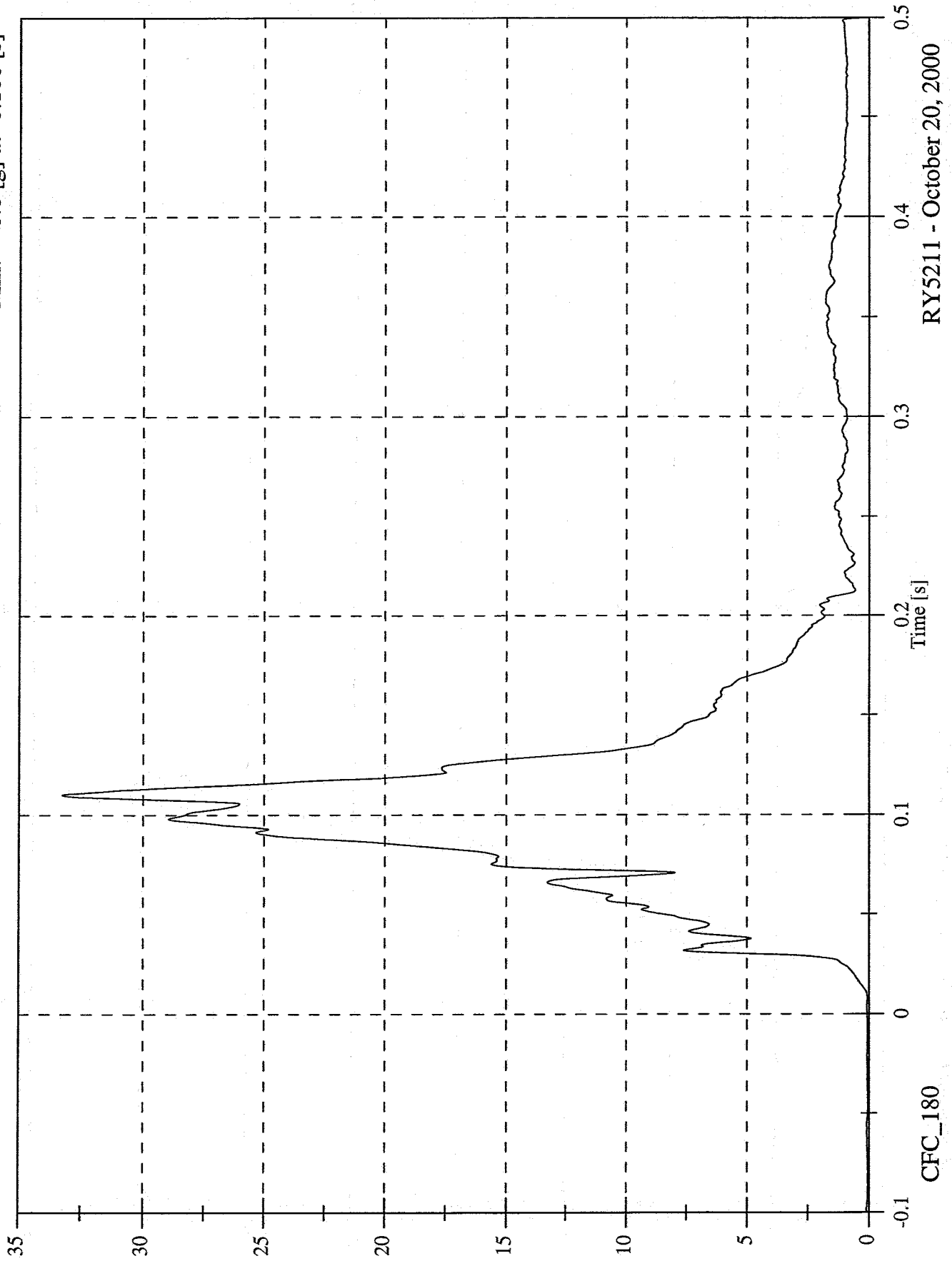

RY5211 - October 20, 2000

CFC\_180

40% Frontal Offset Test #2 - 2000 Nissan Altima

Max: 1.5 [g] at 0.346 [s]  
Min: -32.4 [g] at 0.110 [s]

P2 Chest Red x

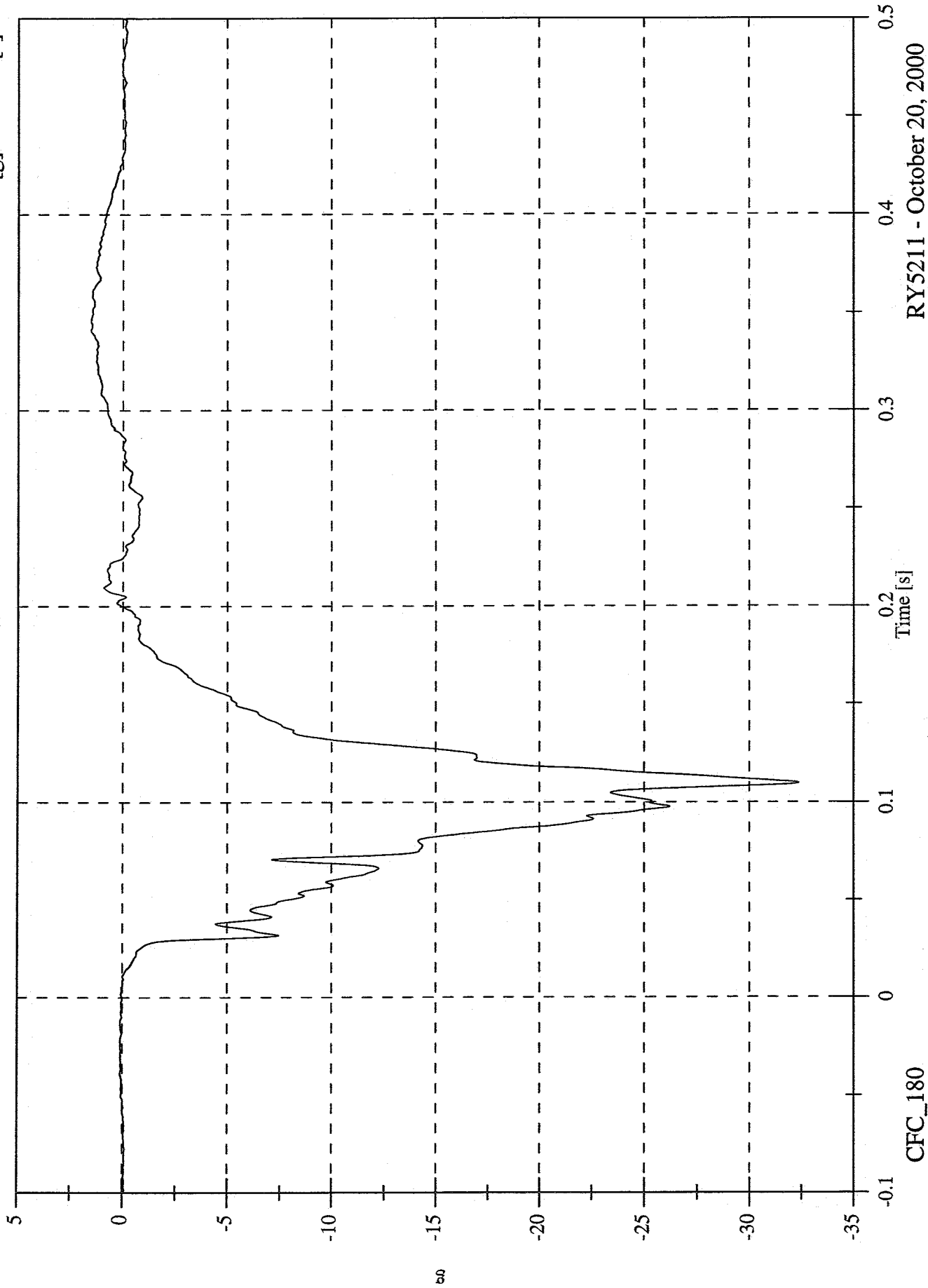

RYS211 - October 20, 2000

40% Frontal Offset Test #2 - 2000 Nissan Altima

Max: 12.0 [g] at 0.102 [s]  
Min: -4.4 [g] at 0.162 [s]

P2 Chest Red y

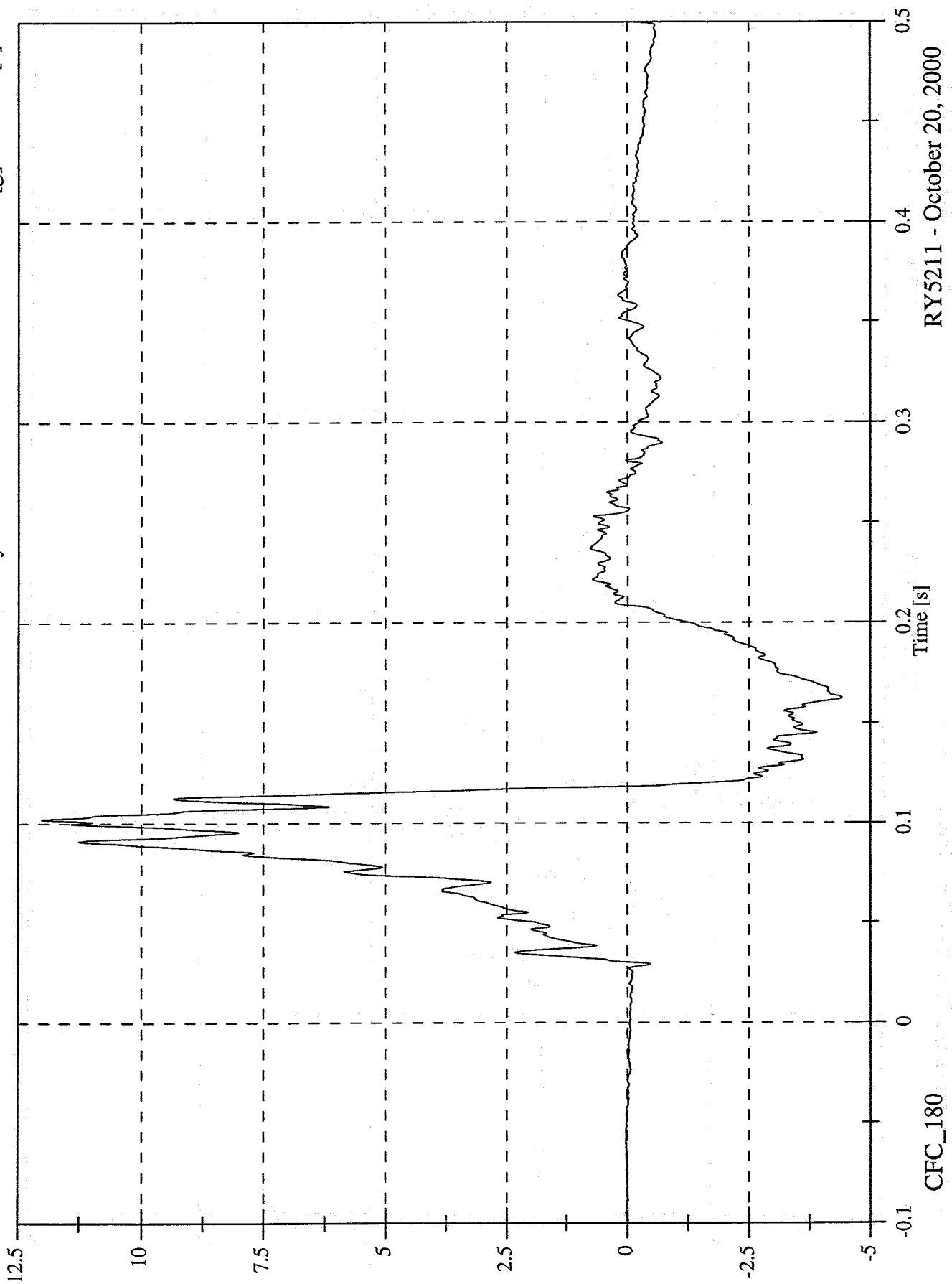

RY5211 - October 20, 2000

40% Frontal Offset Test #2 - 2000 Nissan Altima

Max: 4.1 [g] at 0.107 [s]  
Min: -5.9 [g] at 0.098 [s]

P2 Chest Red z

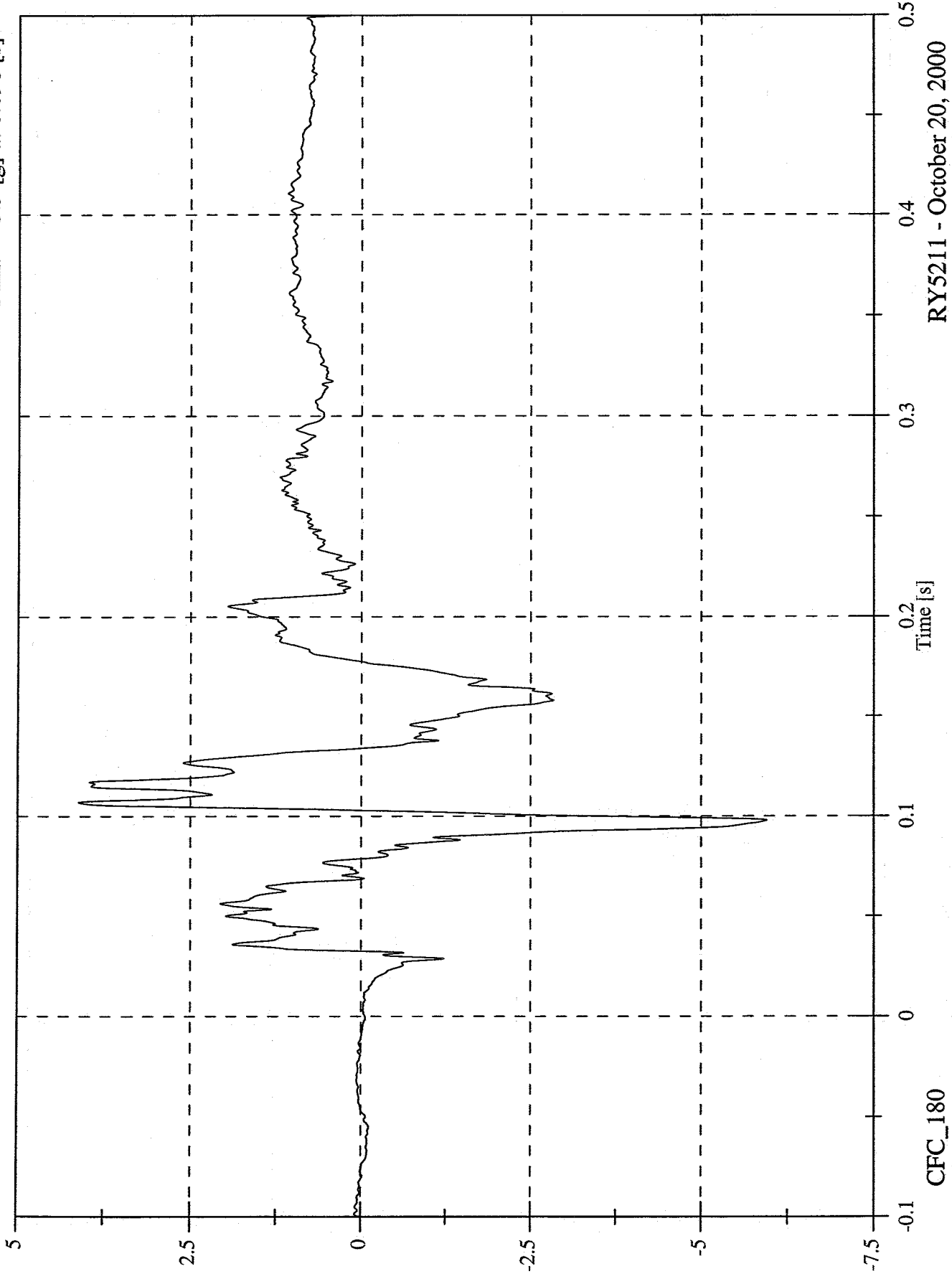

RY5211 - October 20, 2000

40% Frontal Offset Test #2 - 2000 Nissan Altima

Max: 33.2 [g] at 0.110 [s]

Min: 0.0 [g] at -0.100 [s]

P2 Chest Red Resultant

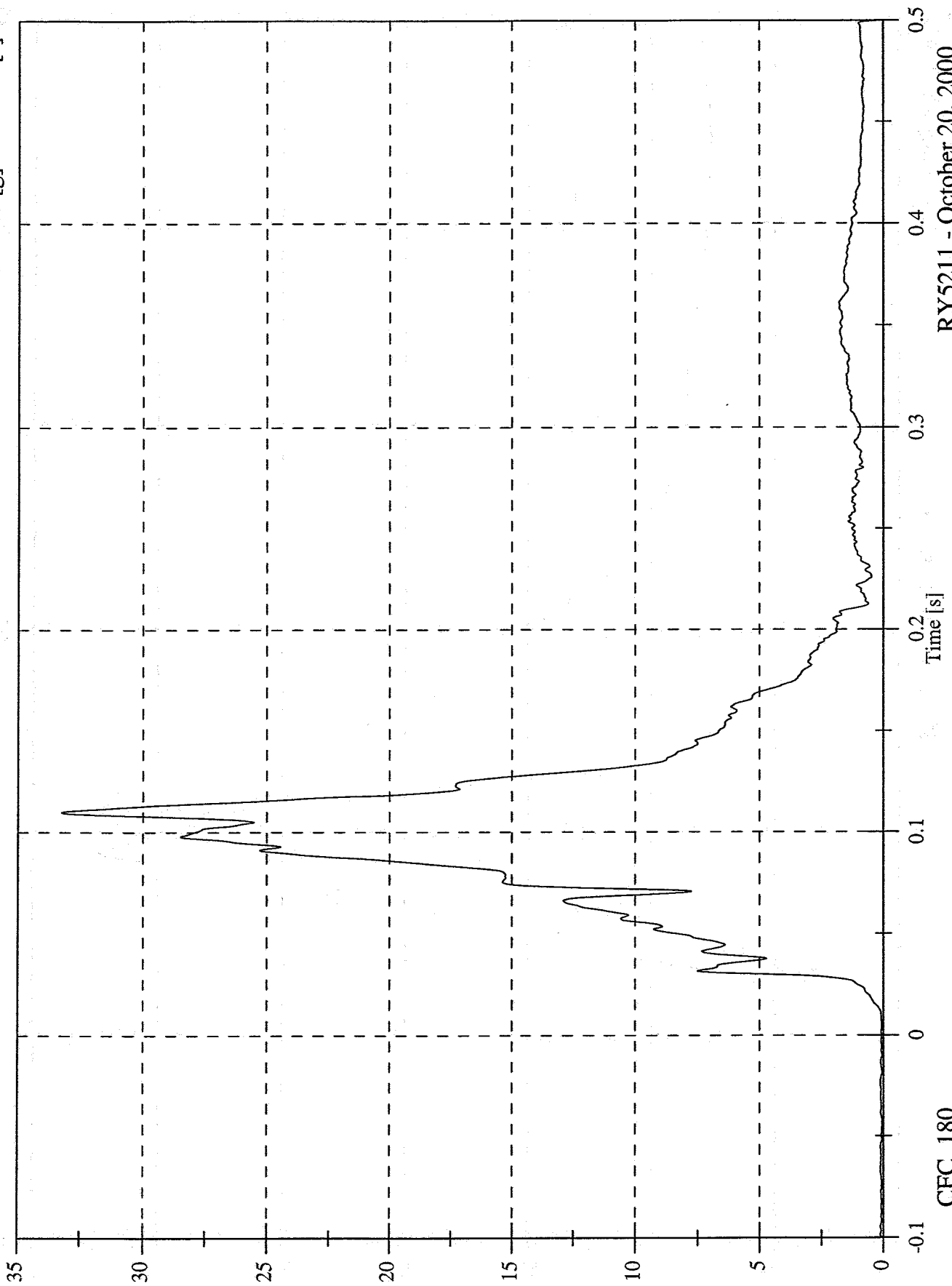

R Y 5 2 1 1 - O c t o b e r 2 0 , 2 0 0 0

40% Frontal Offset Test #2 - 2000 Nissan Altima

P2 Chest Compression

Max: 0.0 [mm] at 0.004 [s]  
Min: -27.4 [mm] at 0.090 [s]

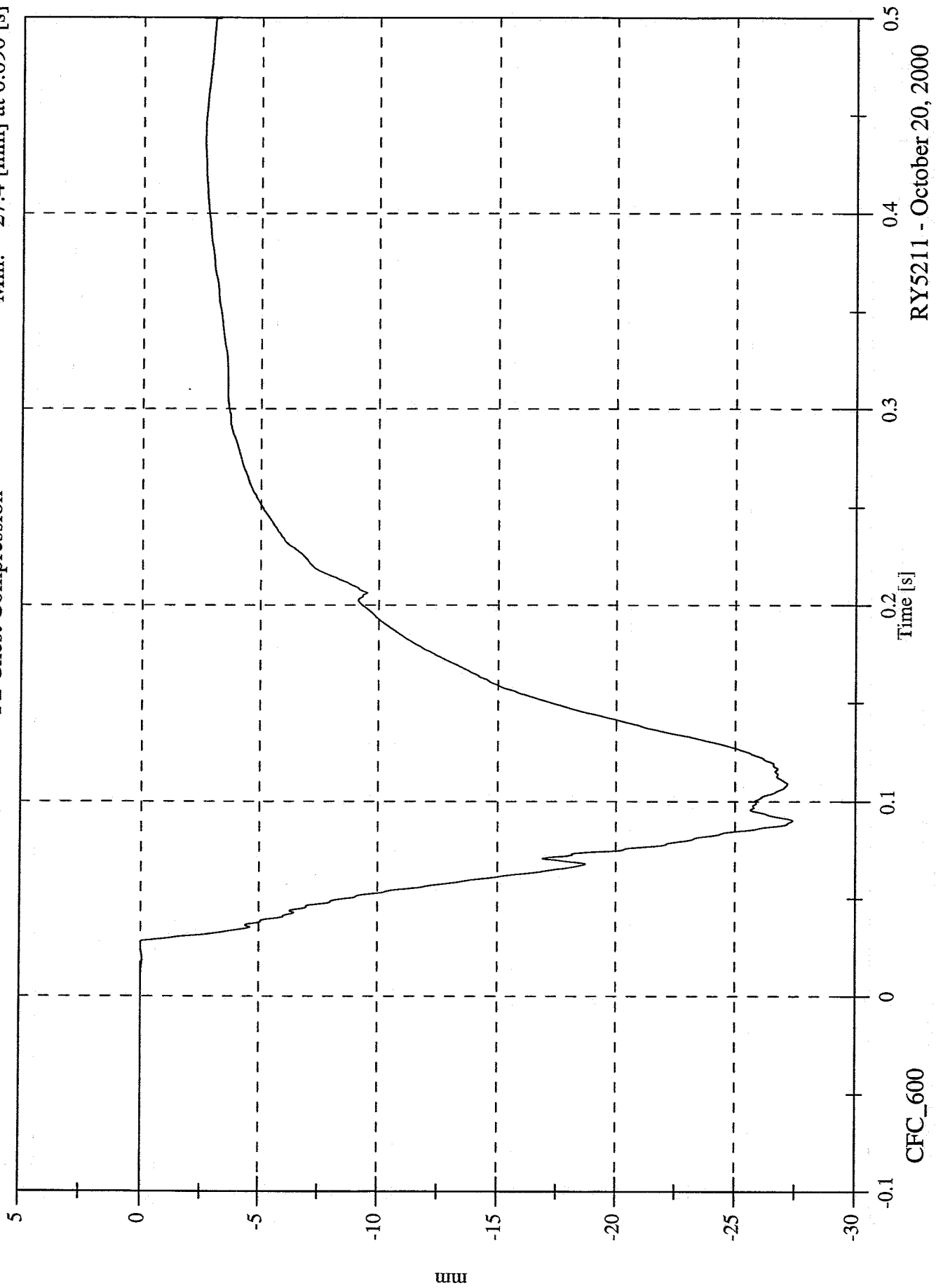

RY5211 - October 20, 2000

40% Frontal Offset Test #2 - 2000 Nissan Altima

Max: 1.0 [g] at 0.217 [s]  
Min: -36.0 [g] at 0.097 [s]

P2 Pelvic x

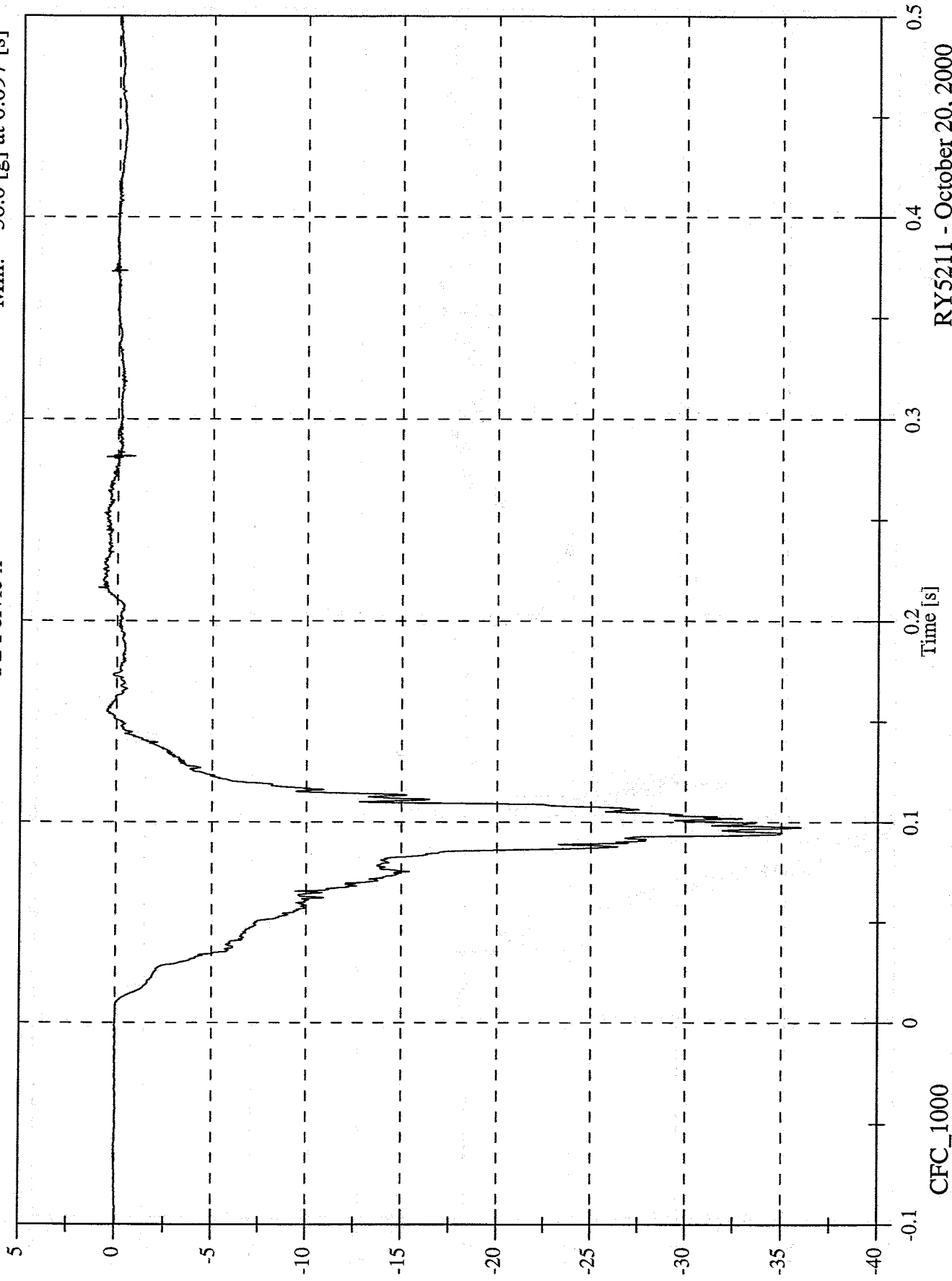

CFC\_1000

Time [s]

RY5211 - October 20, 2000

40% Frontal Offset Test #2 - 2000 Nissan Altima

Max: 10.0 [g] at 0.086 [s]  
Min: -9.7 [g] at 0.149 [s]

P2 Pelvic y

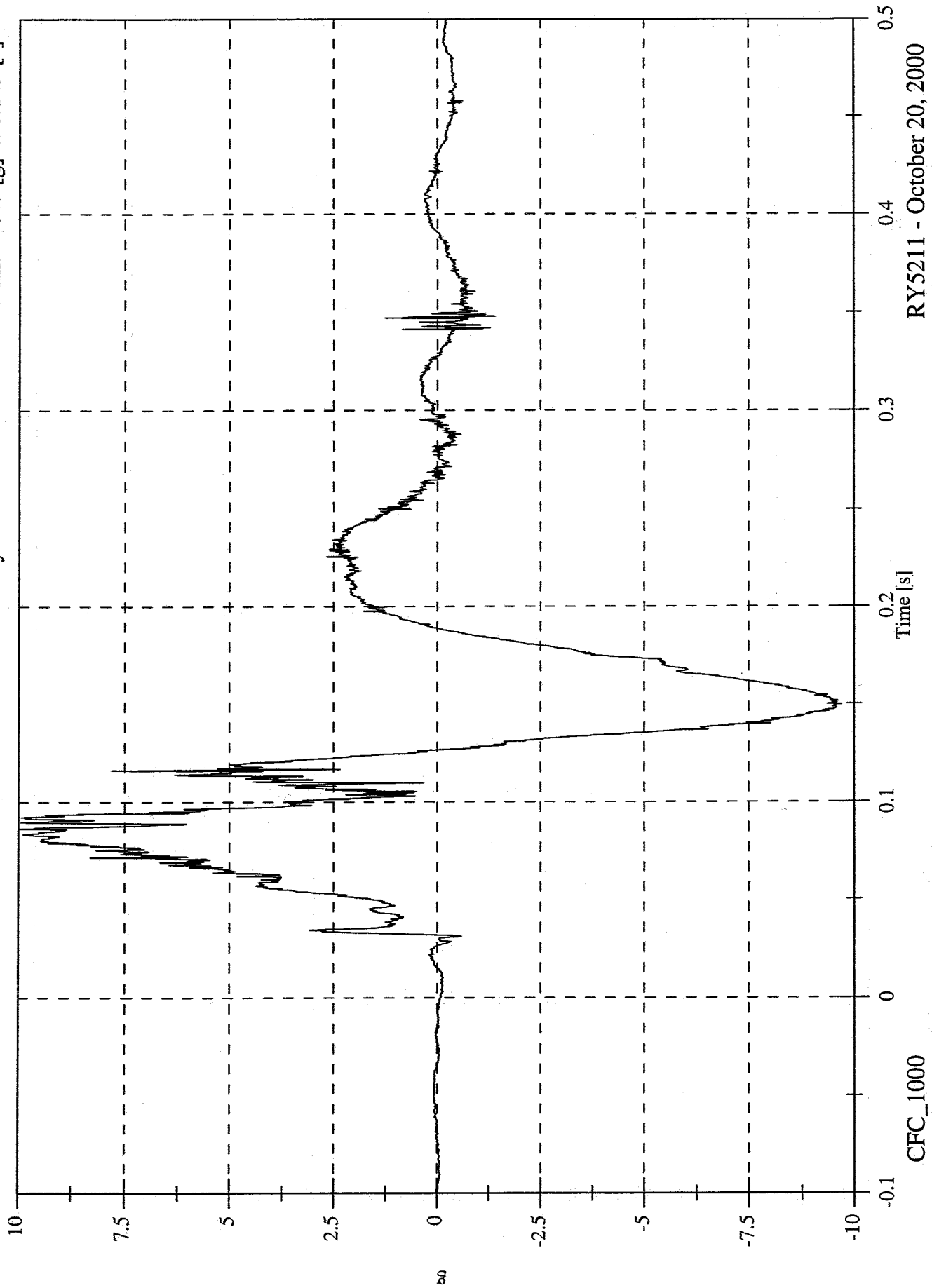

RY5211 - October 20, 2000

40% Frontal Offset Test #2 - 2000 Nissan Altima

Max: 1.5 [g] at 0.372 [s]  
Min: -19.1 [g] at 0.100 [s]

P2 Pelvic z

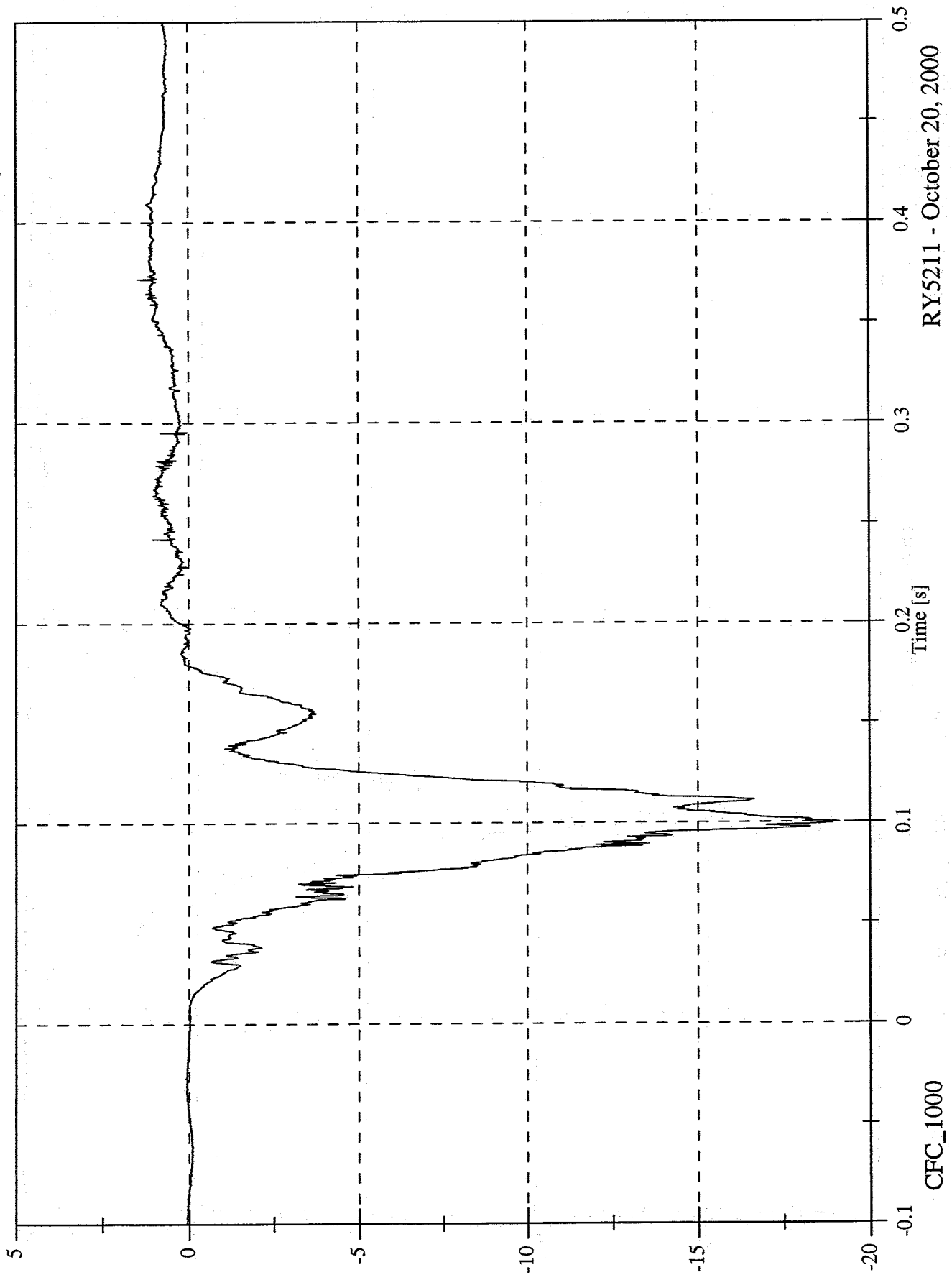

CFC\_1000

RY5211 - October 20, 2000

40% Frontal Offset Test #2 - 2000 Nissan Altima

Max: 40.5 [g] at 0.097 [s]  
Min: 0.0 [g] at -0.007 [s]

P2 Pelvic Resultant

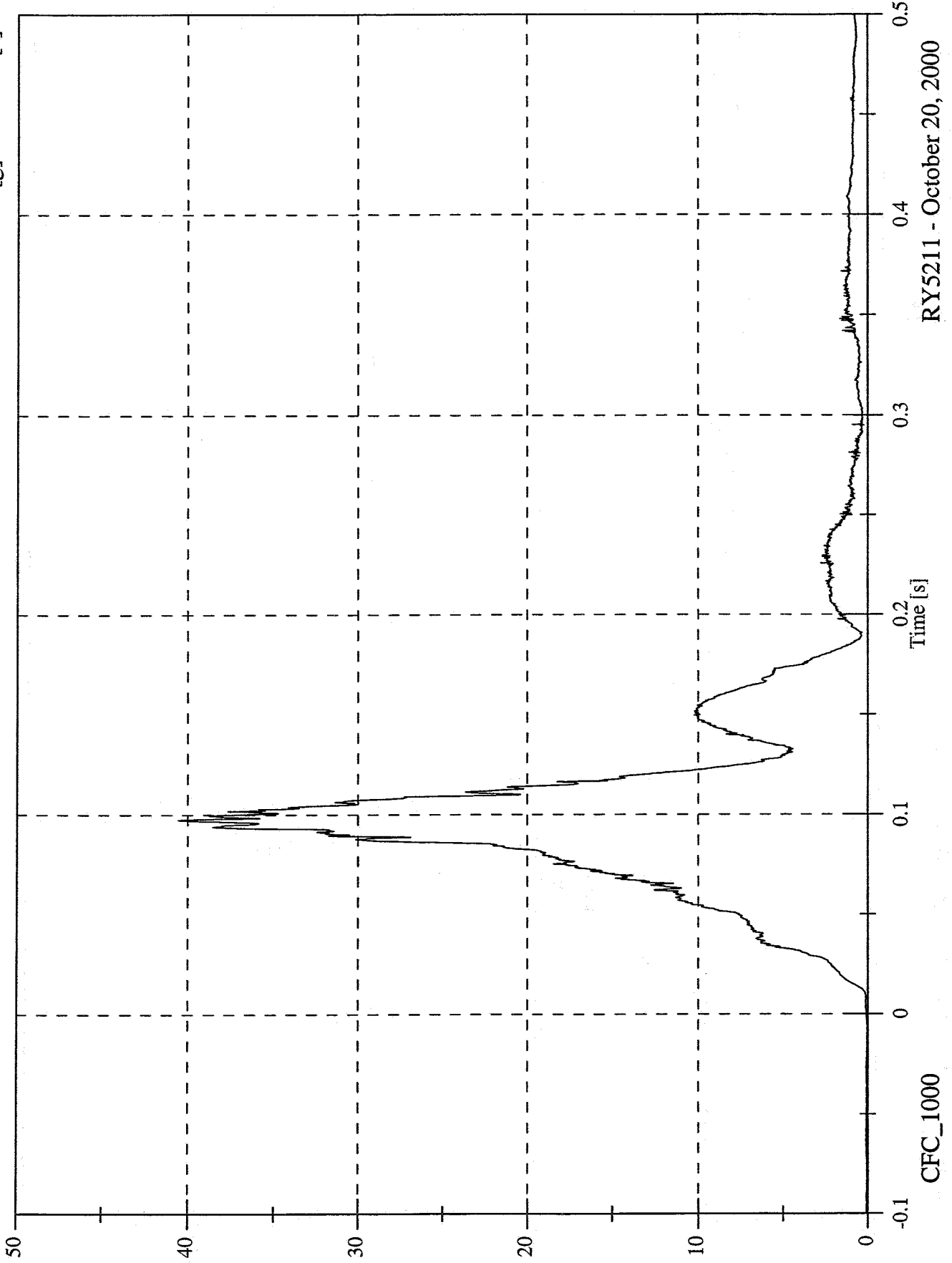

R Y 5 2 1 1 - O c t o b e r 2 0 , 2 0 0 0

40% Frontal Offset Test #2 - 2000 Nissan Altima

Max: 664.6 [N] at 0.107 [s]  
Min: -207.6 [N] at 0.173 [s]

P2 Left Femur Fx

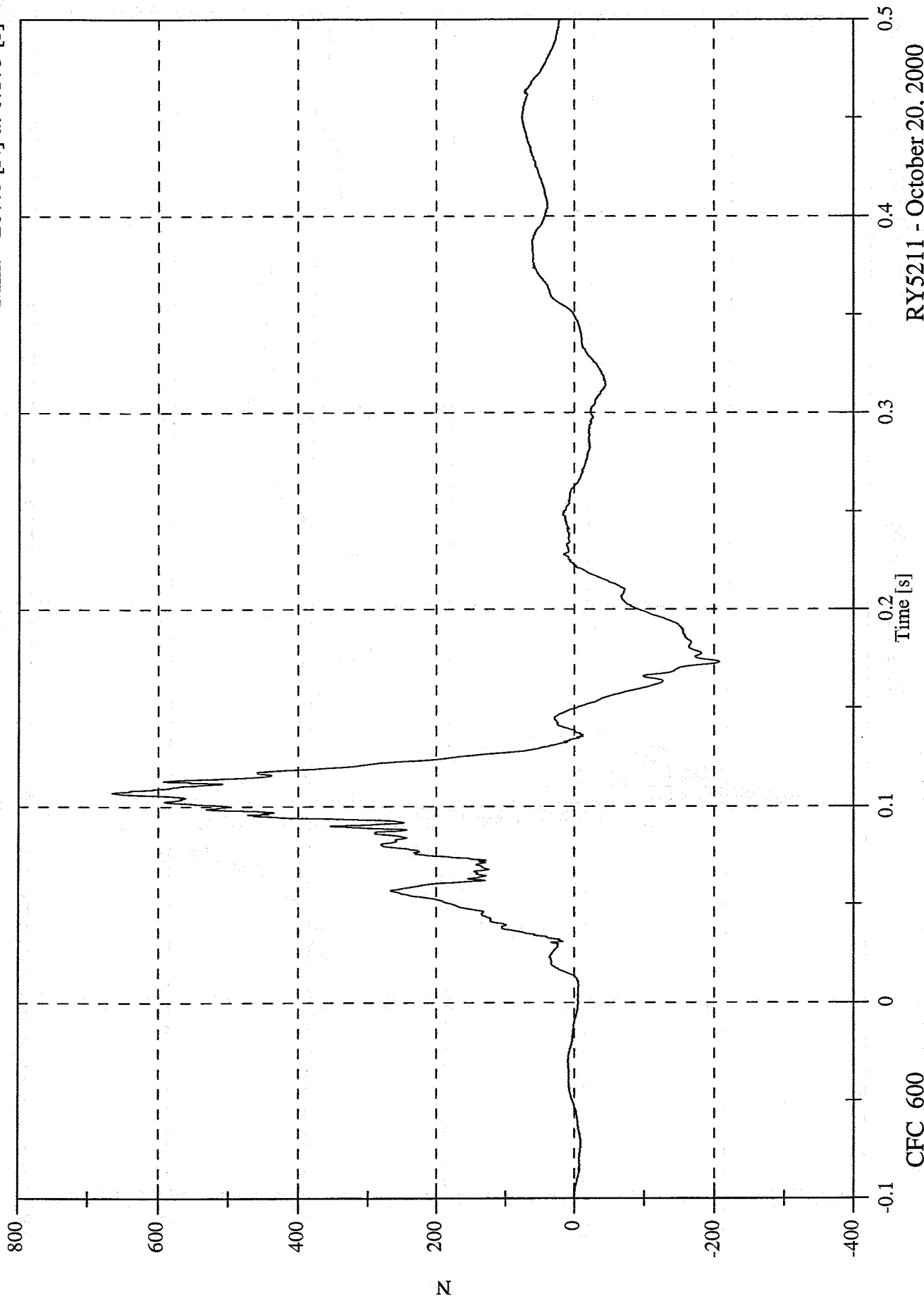

RY5211 - October 20, 2000

40% Frontal Offset Test #2 - 2000 Nissan Altima

Max: 362.1 [N] at 0.103 [s]  
Min: -140.5 [N] at 0.083 [s]

P2 Left Femur Fy

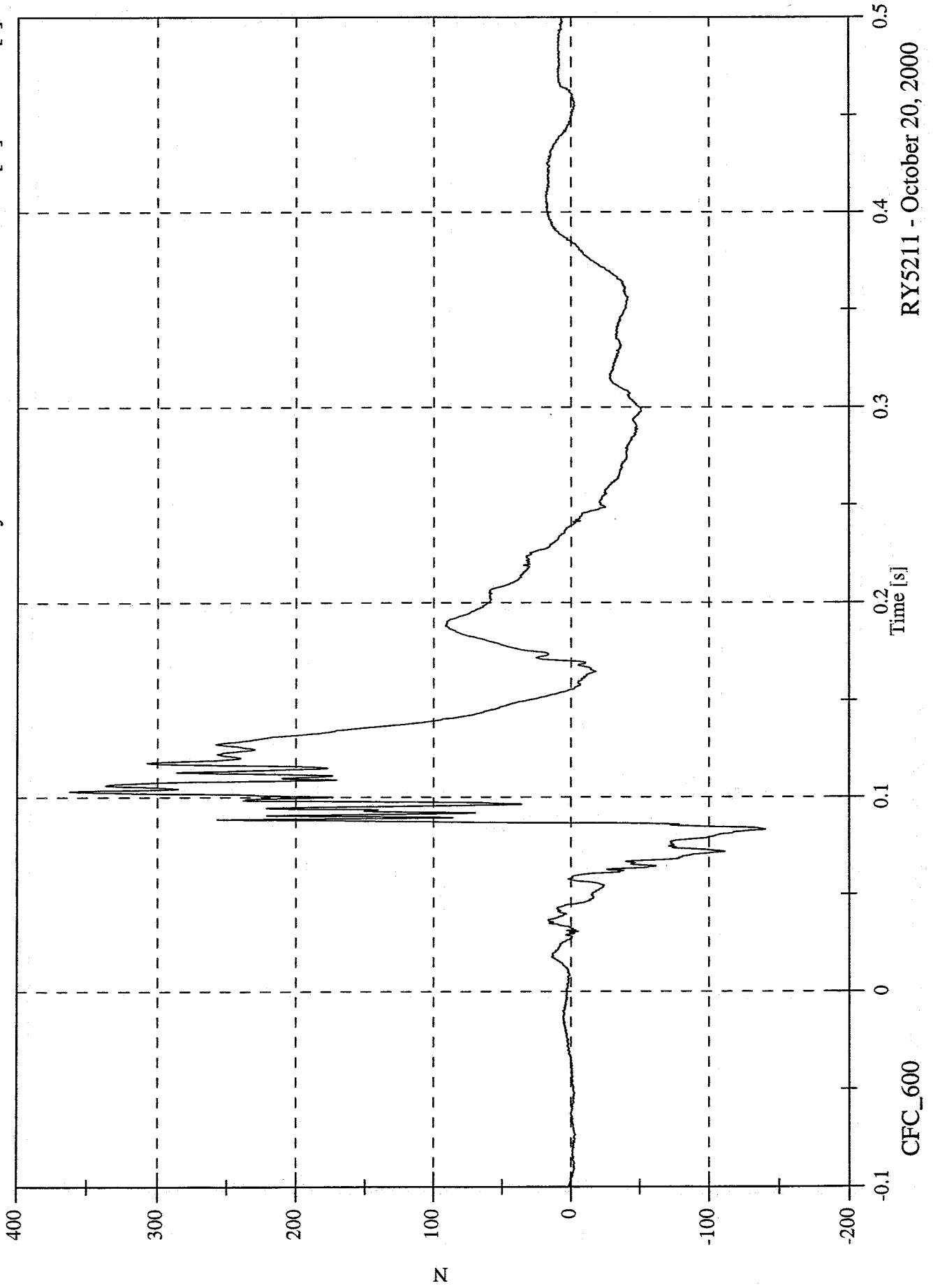

RY5211 - October 20, 2000

40% Frontal Offset Test #2 - 2000 Nissan Altima

Max: 536.7 [N] at 0.082 [s]  
Min: -3825.0 [N] at 0.107 [s]

P2 Left Femur Fz

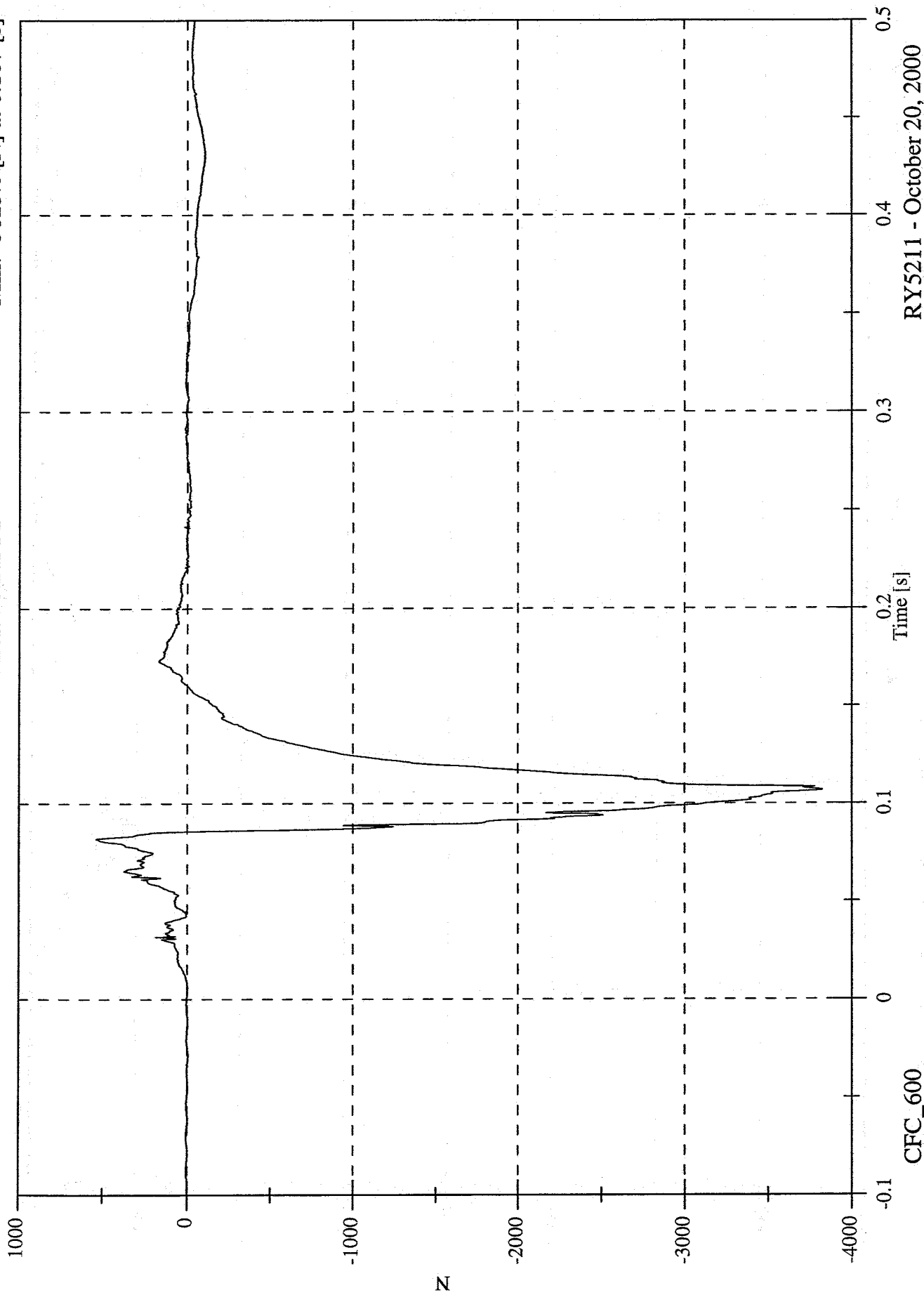

RY5211 - October 20, 2000

Max: 3895.2 [N] at 0.107 [s]  
Min: 0.1 [N] at -0.097 [s]

P2 Left Femur F Resultant

40% Frontal Offset Test #2 - 2000 Nissan Altima

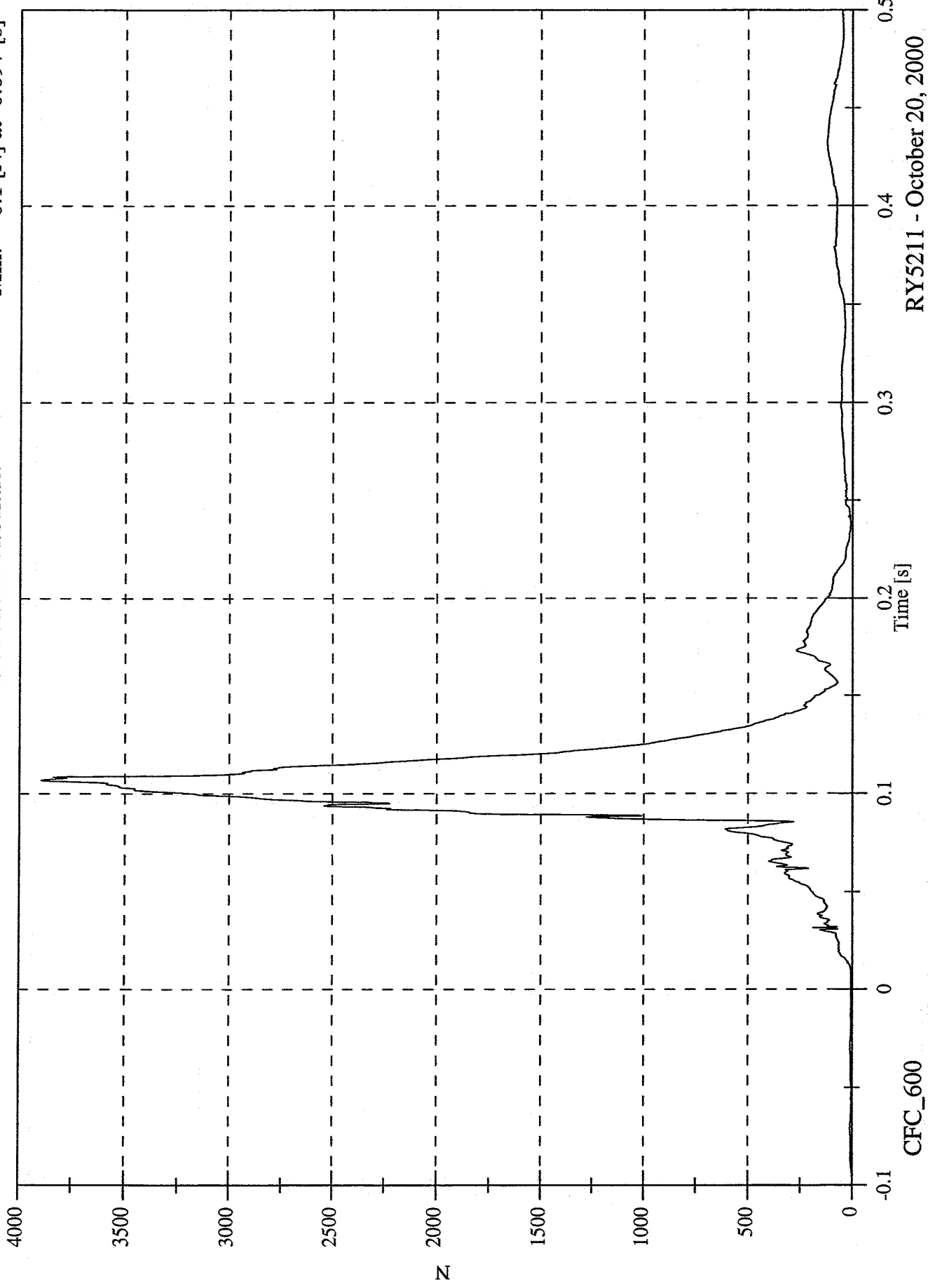

RY5211 - October 20, 2000

40% Frontal Offset Test #2 - 2000 Nissan Altima

Max: 63.2 [Nm] at 0.379 [s]  
Min: -122.9 [Nm] at 0.088 [s]

P2 Left Femur Mx

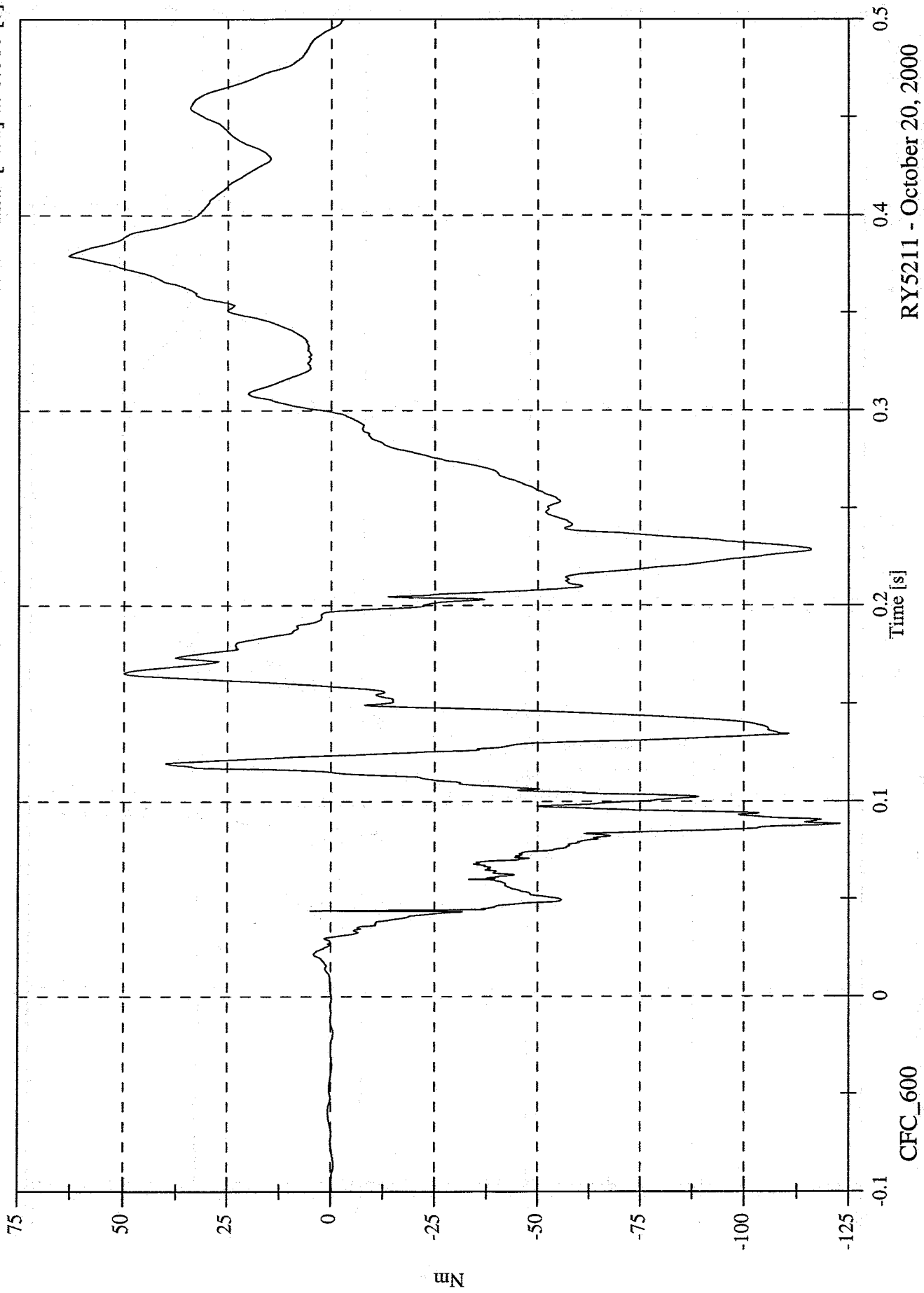

RY5211 - October 20, 2000

40% Frontal Offset Test #2 - 2000 Nissan Altima

P2 Left Femur My

Max: 96.8 [Nm] at 0.117 [s]  
Min: -20.2 [Nm] at 0.088 [s]

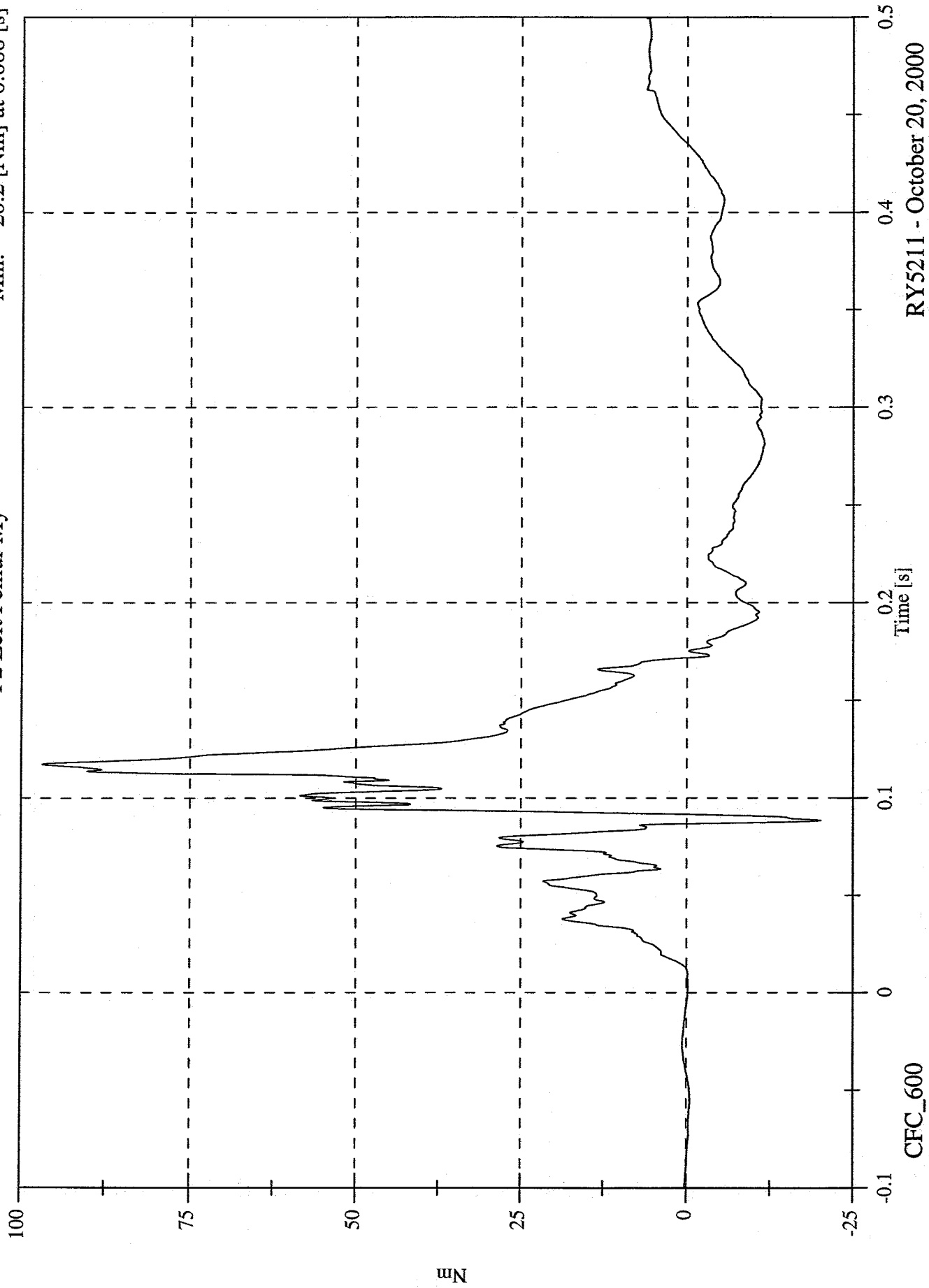

RY5211 - October 20, 2000

40% Frontal Offset Test #2 - 2000 Nissan Altima

Max: 15.0 [Nm] at 0.341 [s]  
Min: -40.4 [Nm] at 0.089 [s]

P2 Left Femur Mz

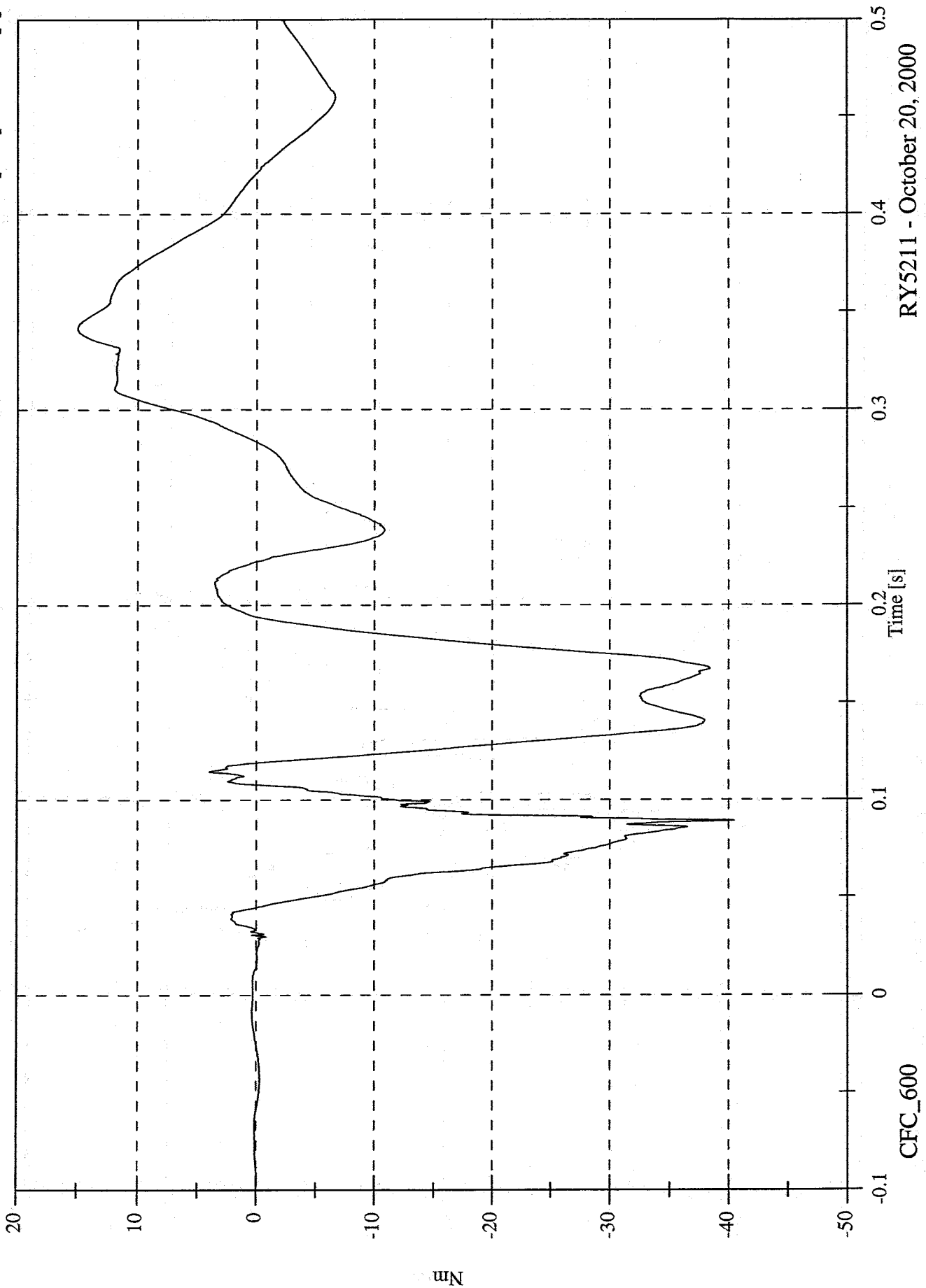

RY5211 - October 20, 2000

40% Frontal Offset Test #2 - 2000 Nissan Altima

Max: 129.0 [Nm] at 0.088 [s]

Min: 0.1 [Nm] at -0.100 [s]

P2 Left Femur M Resultant

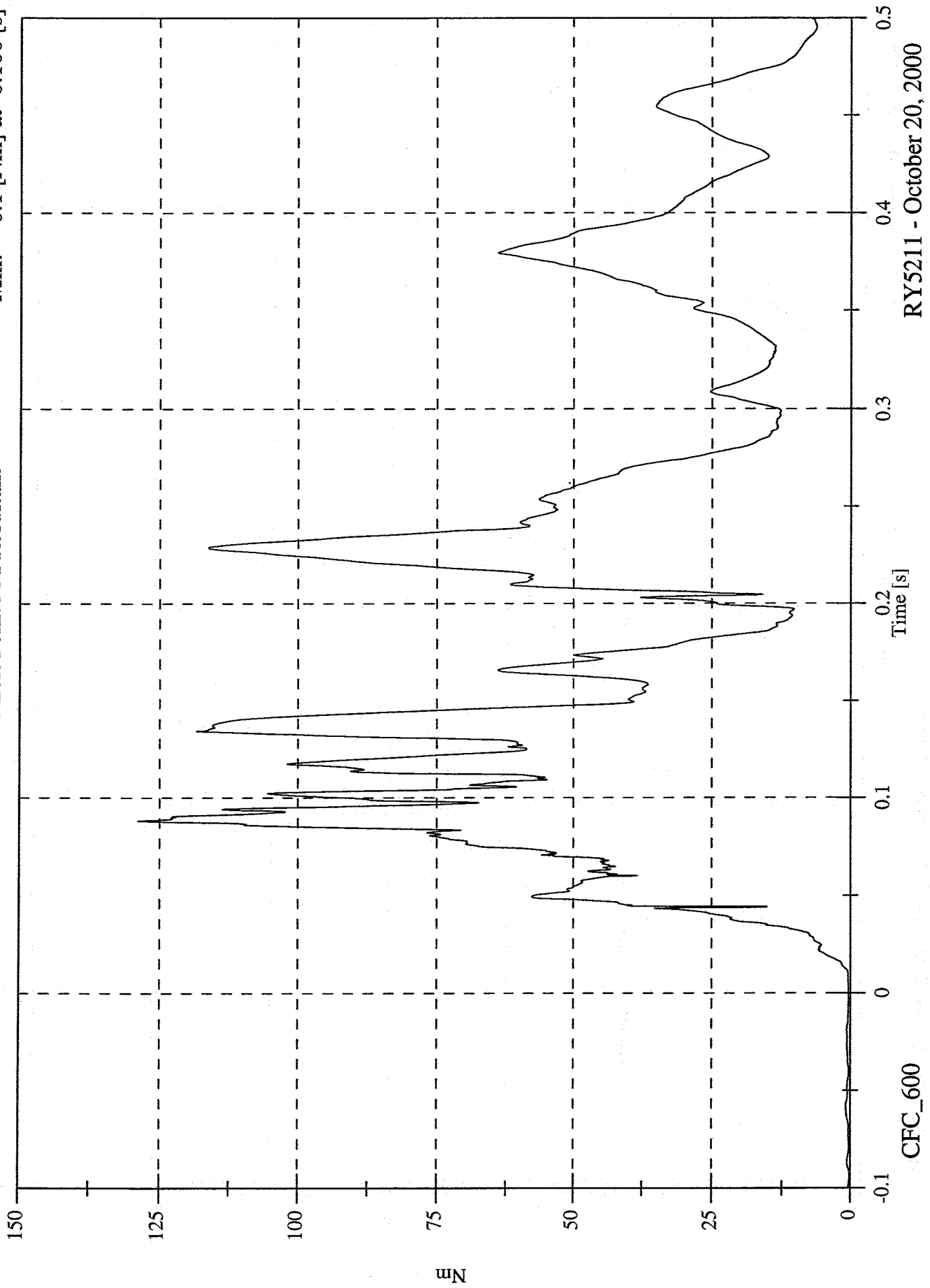

RY5211 - October 20, 2000

CFC\_600

40% Frontal Offset Test #2 - 2000 Nissan Altima

Max: 284.1 [N] at 0.111 [s]

Min: -94.8 [N] at 0.214 [s]

P2 Right Femur Fx

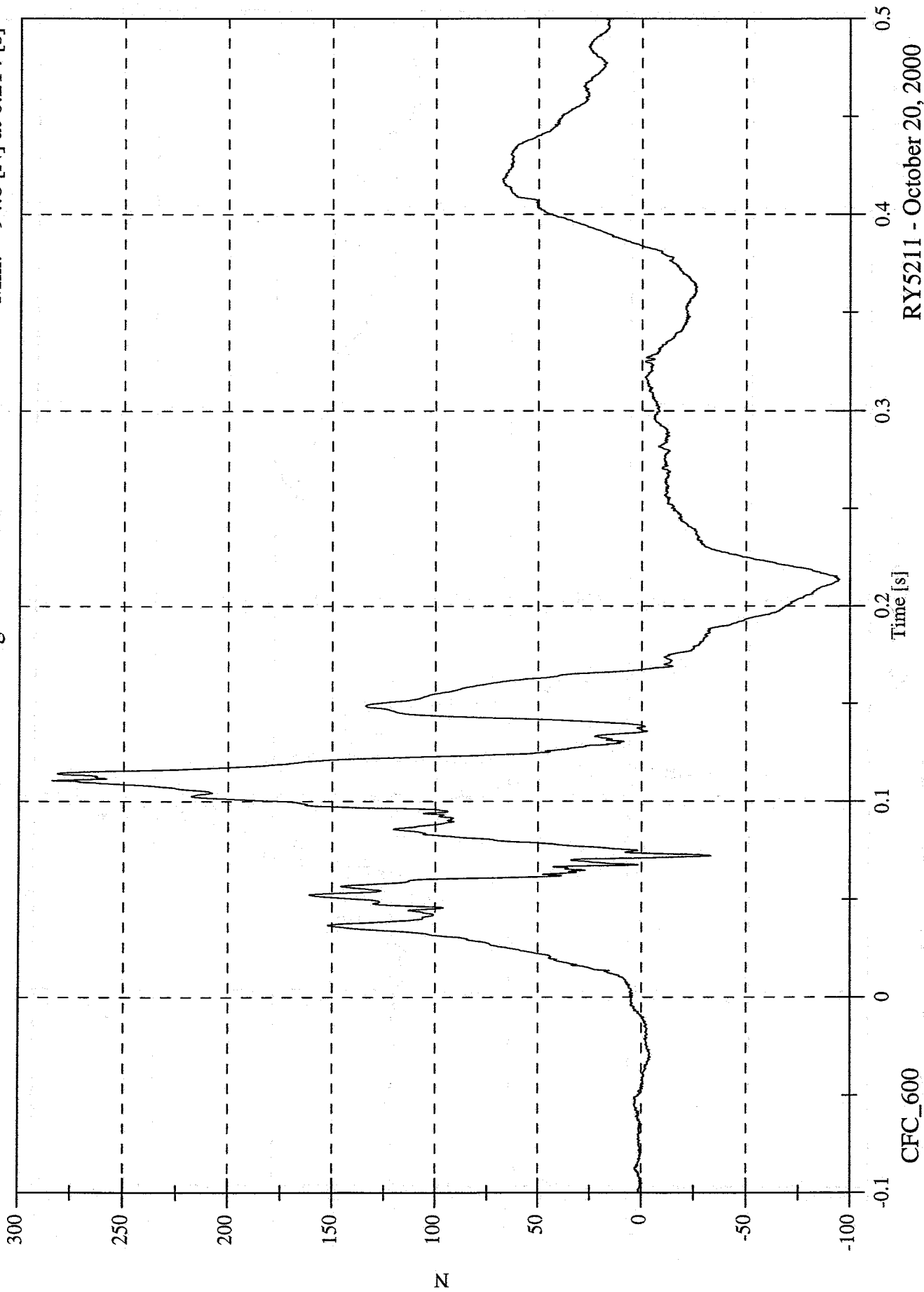

RYS211 - October 20, 2000

CFC\_600

40% Frontal Offset Test #2 - 2000 Nissan Altima

Max: 177.5 [N] at 0.111 [s]

Min: -127.2 [N] at 0.089 [s]

P2 Right Femur Fy

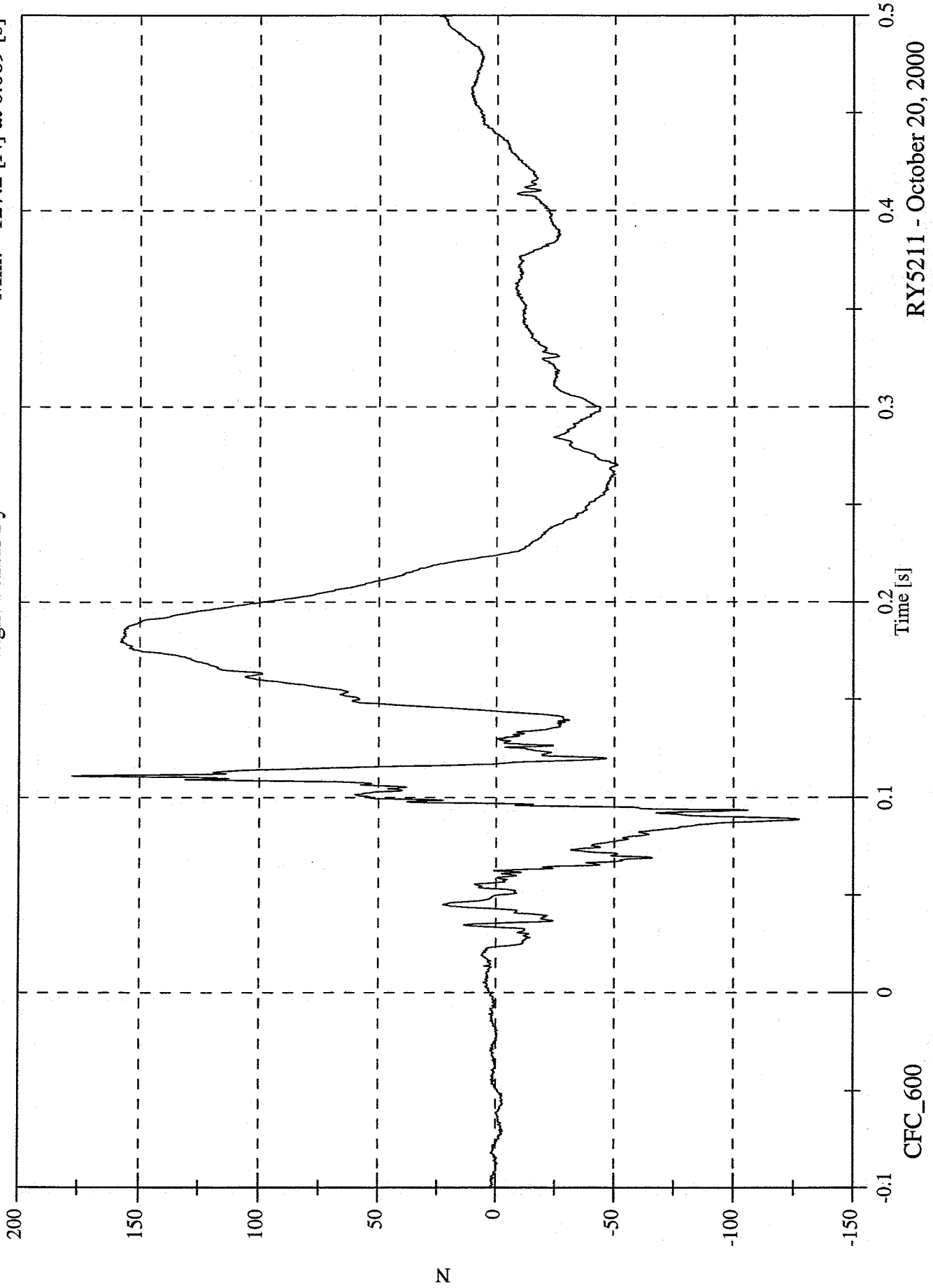

RY5211 - October 20, 2000

40% Frontal Offset Test #2 - 2000 Nissan Altima

Max: 1001.7 [N] at 0.092 [s]  
Min: -231.3 [N] at 0.097 [s]

P2 Right Femur Fz

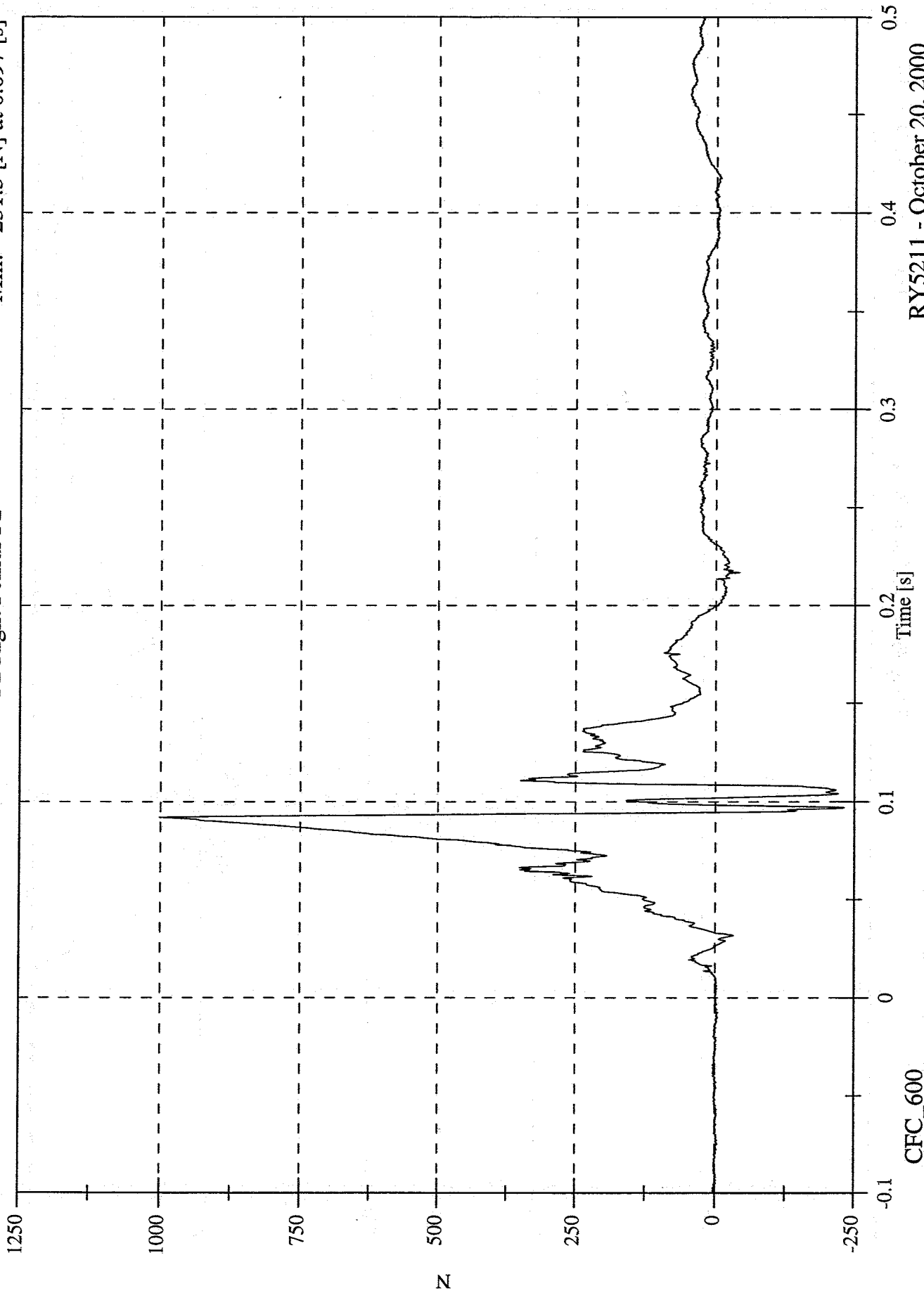

CFC\_600

RY5211 - October 20, 2000

40% Frontal Offset Test #2 - 2000 Nissan Altima

Max: 1008.7 [N] at 0.092 [s]

Min: 0.3 [N] at -0.100 [s]

P2 RightFemur F Resultant

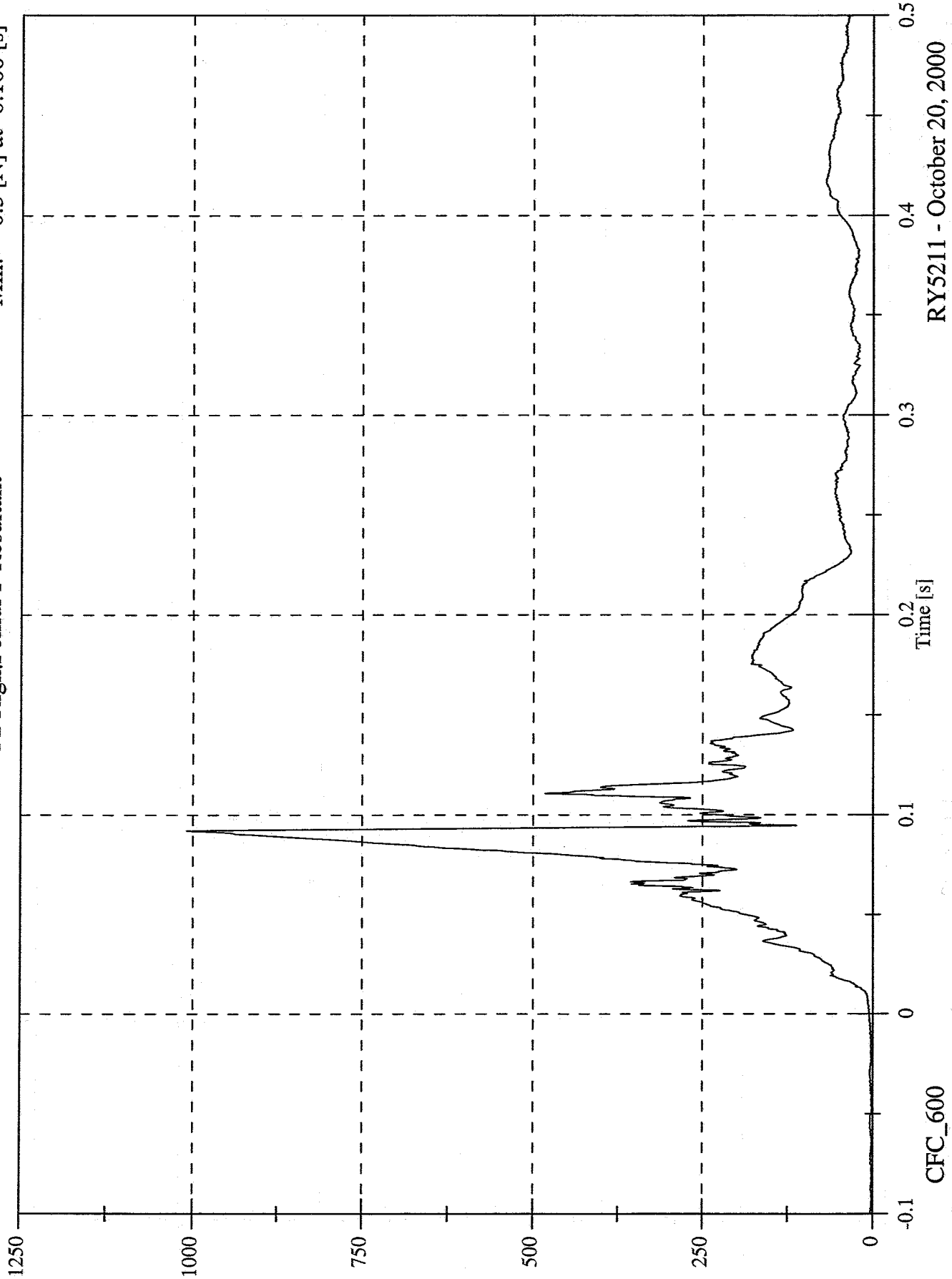

RY5211 - October 20, 2000

CFC\_600

40% Frontal Offset Test #2 - 2000 Nissan Altima

Max: 5.1 [Nm] at 0.326 [s]

Min: -88.4 [Nm] at 0.098 [s]

P2 Right Femur Mx

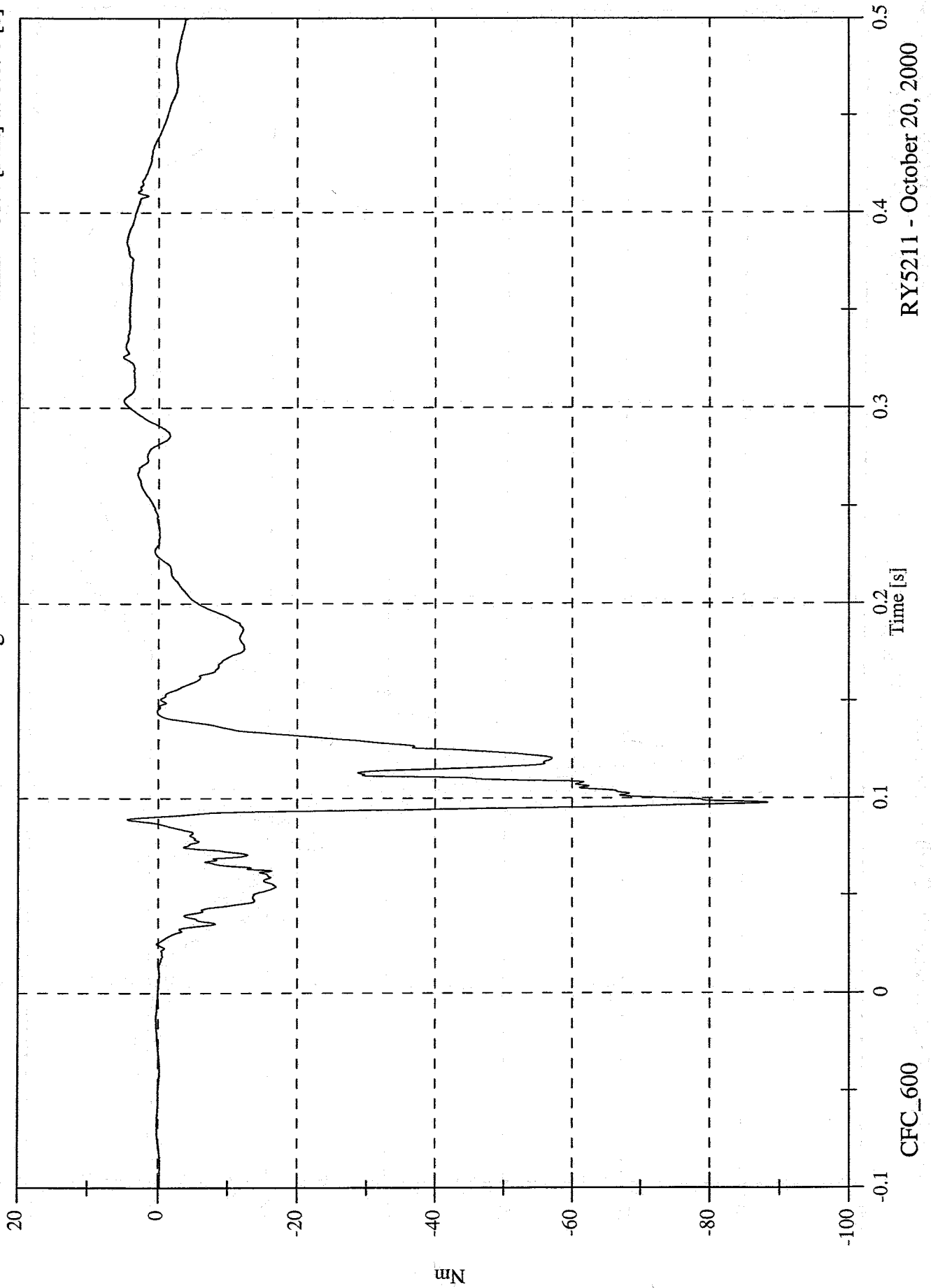

R Y5211 - October 20, 2000

CFC\_600

40% Frontal Offset Test #2 - 2000 Nissan Altima

Max: 50.6 [Nm] at 0.119 [s]

Min: -9.5 [Nm] at 0.287 [s]

P2 Right Femur My

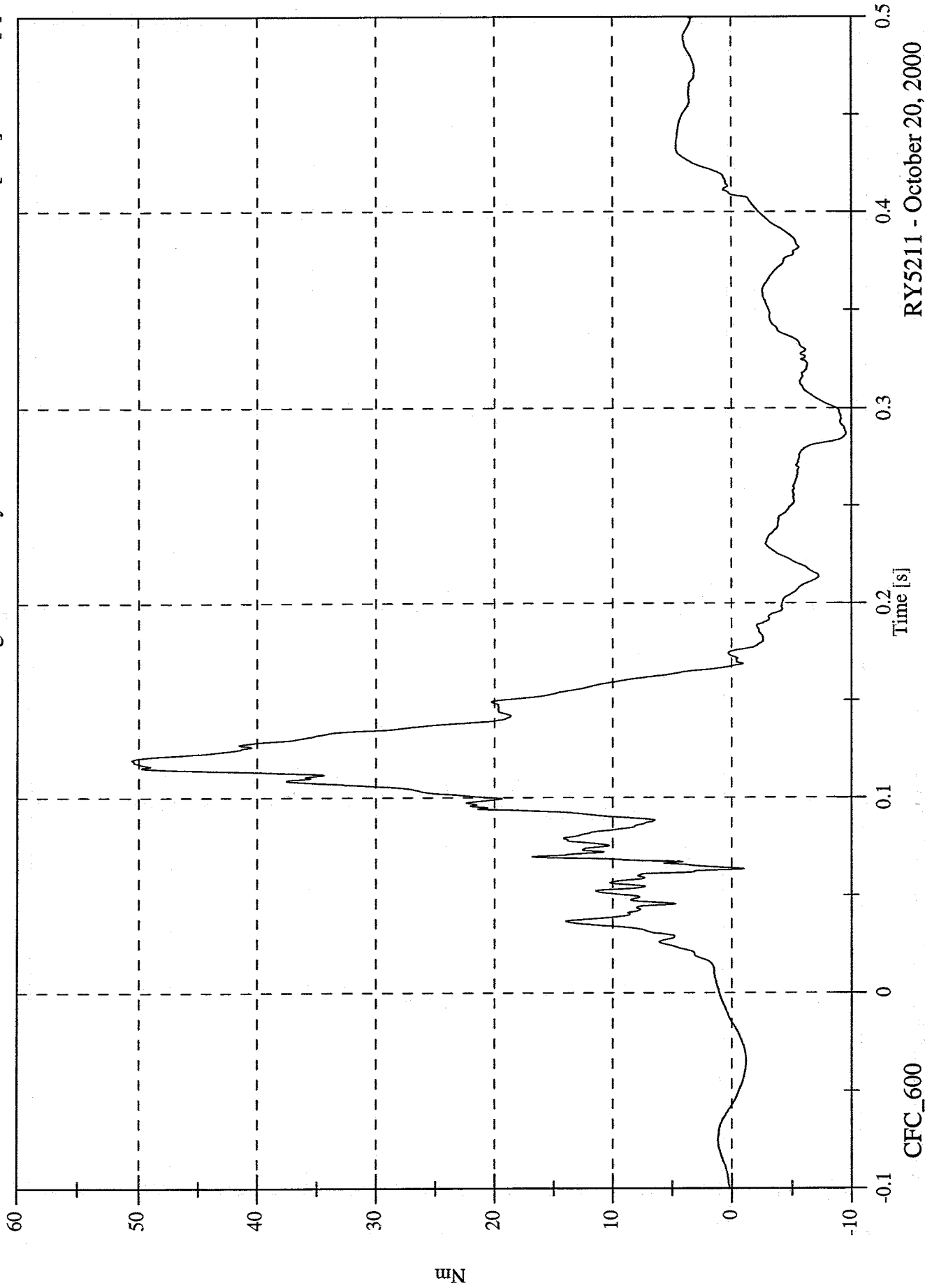

RY5211 - October 20, 2000

40% Frontal Offset Test #2 - 2000 Nissan Altima

Max: 10.7 [Nm] at 0.205 [s]  
Min: -63.2 [Nm] at 0.126 [s]

P2 Right Femur Mz

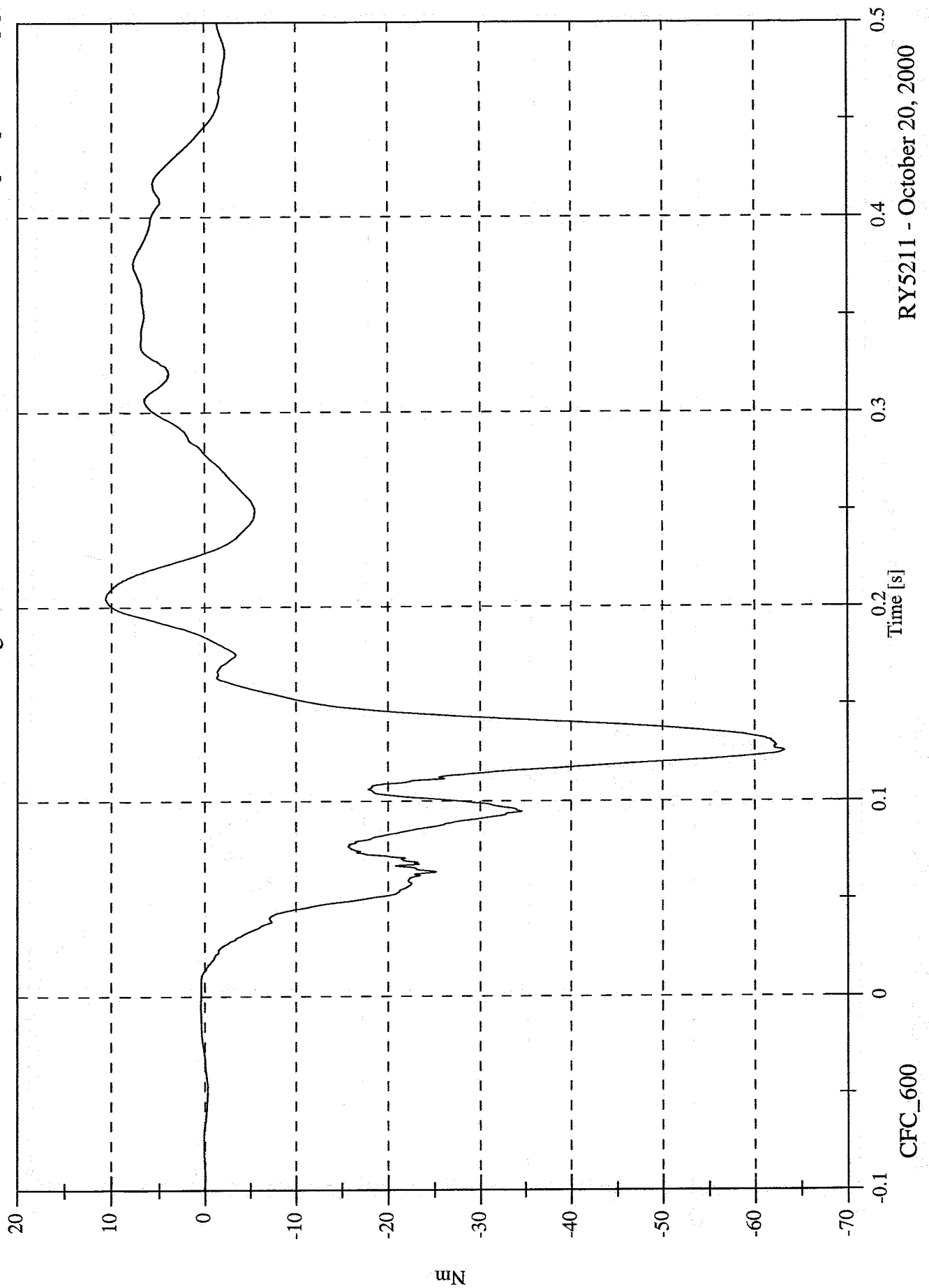

RY5211 - October 20, 2000

40% Frontal Offset Test #2 - 2000 Nissan Altima

Max: 96.5 [Nm] at 0.098 [s]

Min: 0.0 [Nm] at -0.100 [s]

P2 Right Femur M Resultant

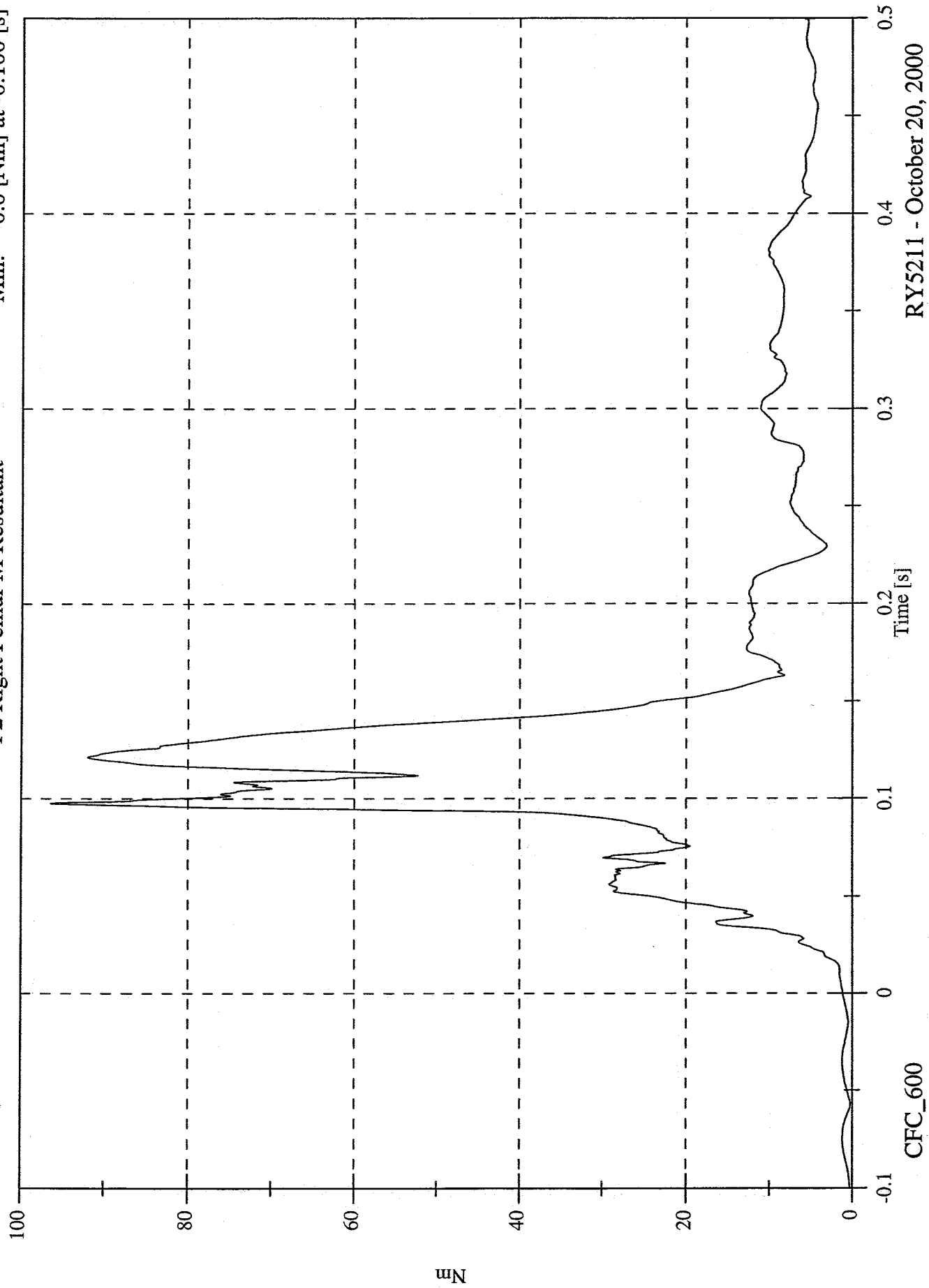

R5211 - October 20, 2000

40% Frontal Offset Test #2 - 2000 Nissan Altima

P2 Left Knee Shear Dx

Max: 0.3 [mm] at 0.100 [s]  
Min: -0.7 [mm] at 0.194 [s]

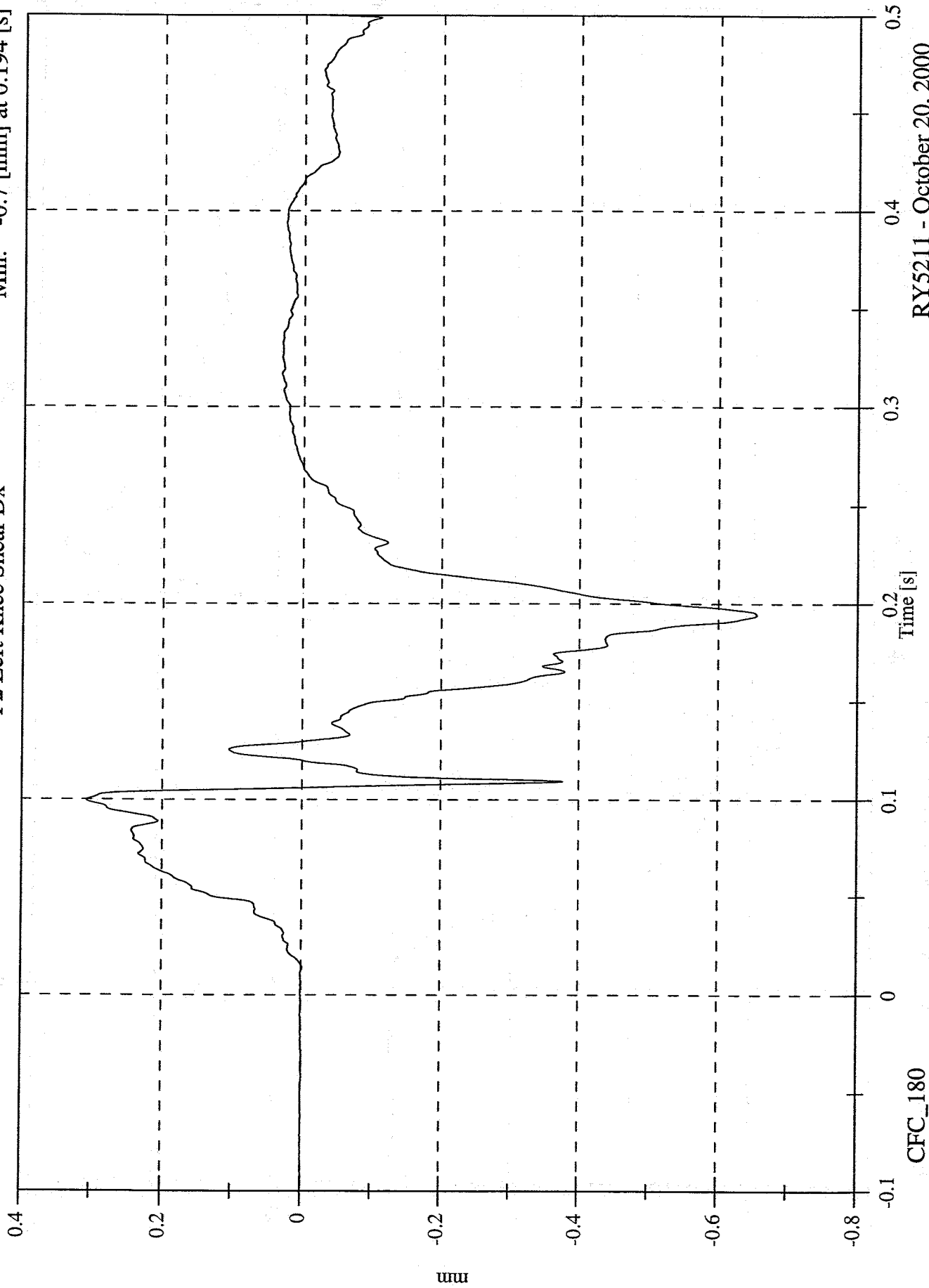

R Y5211 - October 20, 2000

40% Frontal Offset Test #2 - 2000 Nissan Altima

Max: 0.3 [mm] at 0.124 [s]  
Min: -0.3 [mm] at 0.226 [s]

P2 Right Knee Shear Dx

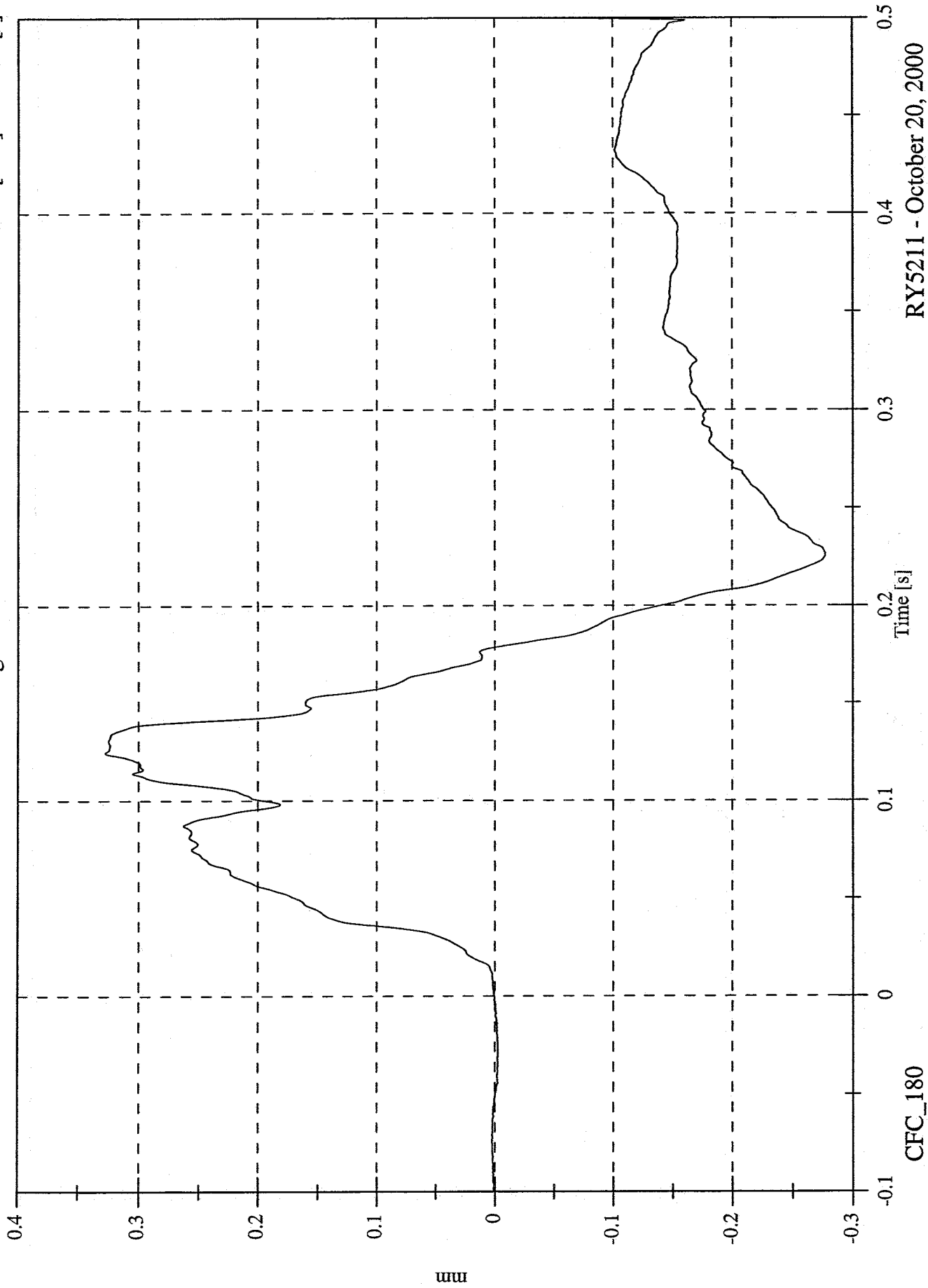

RY5211 - October 20, 2000

40% Frontal Offset Test #2 - 2000 Nissan Altima

Max: 63.0 [N] at 0.172 [s]  
Min: -206.9 [N] at 0.107 [s]

P2 Left Upper Tibia Fx

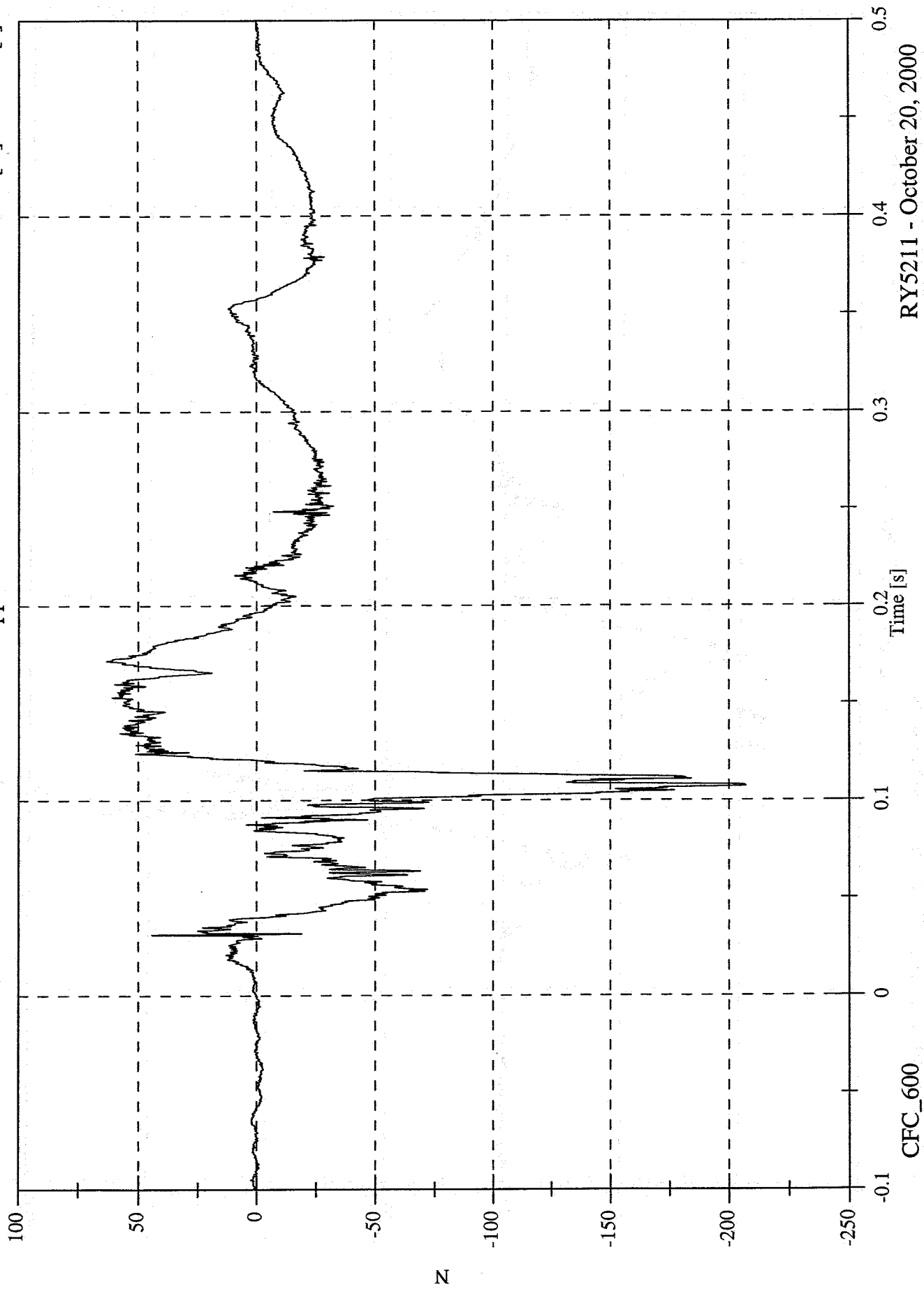

RY5211 - October 20, 2000

40% Frontal Offset Test #2 - 2000 Nissan Altima

Max: 111.4 [N] at 0.141 [s]  
Min: -172.0 [N] at 0.087 [s]

P2 Left Upper Tibia Fy

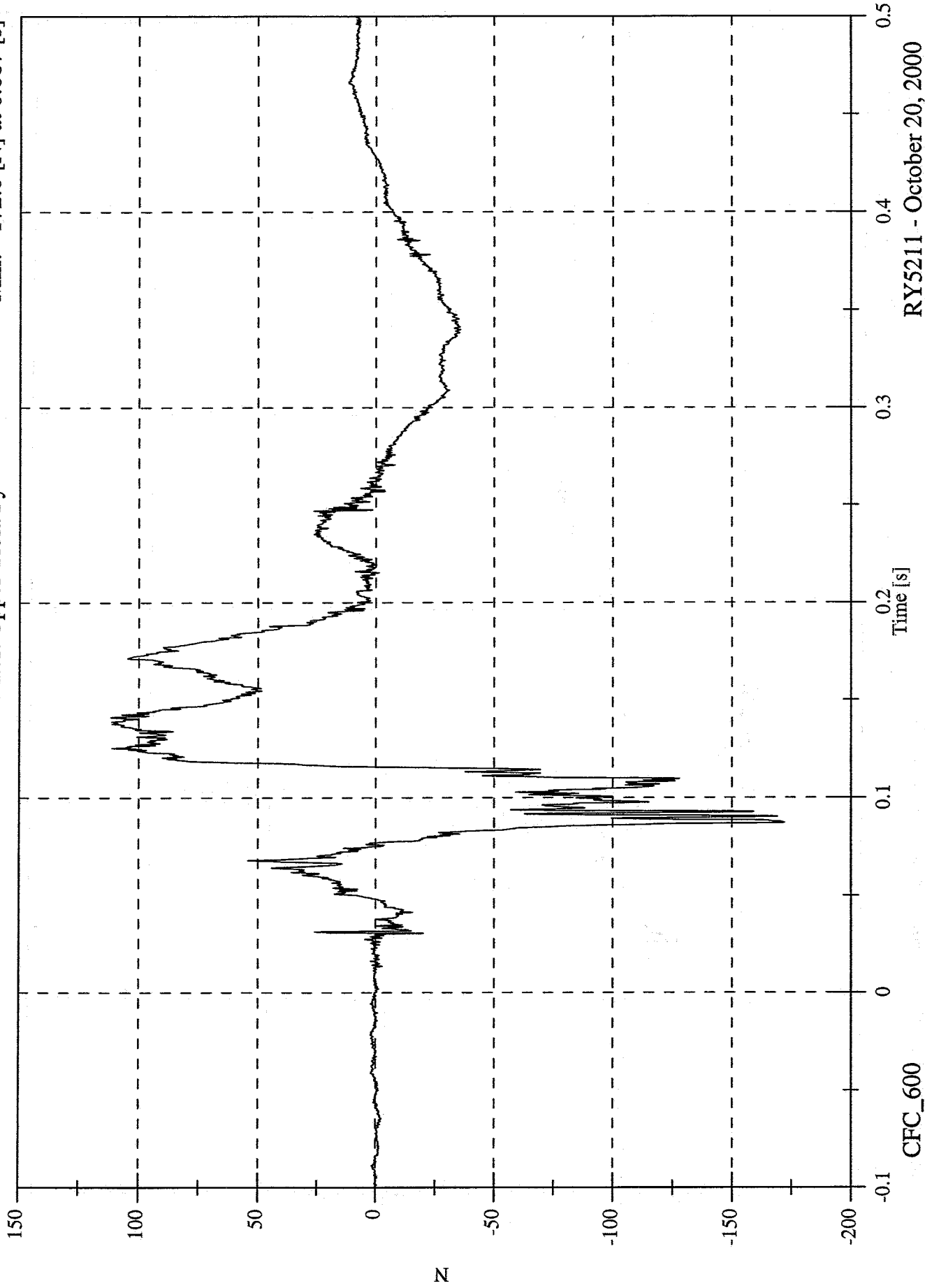

RY5211 - October 20, 2000

40% Frontal Offset Test #2 - 2000 Nissan Altima

Max: 135.9 [N] at 0.130 [s]

Min: -981.6 [N] at 0.090 [s]

P2 Left Upper Tibia Fz

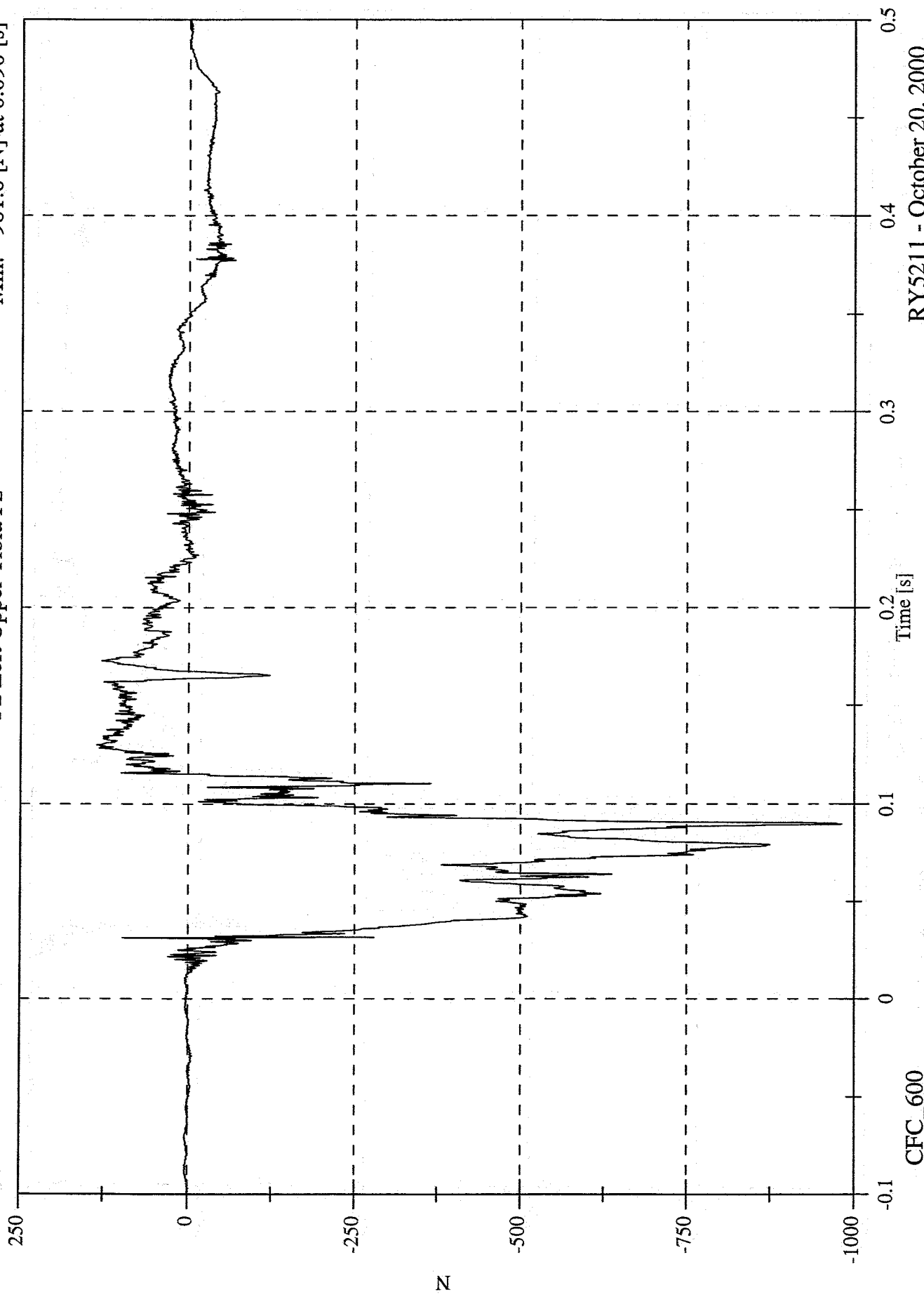

RY5211 - October 20, 2000

40% Frontal Offset Test #2 - 2000 Nissan Altima

Max: 988.6 [N] at 0.090 [s]

Min: 0.1 [N] at -0.100 [s]

P2 Left Upper Tibia F Resultant

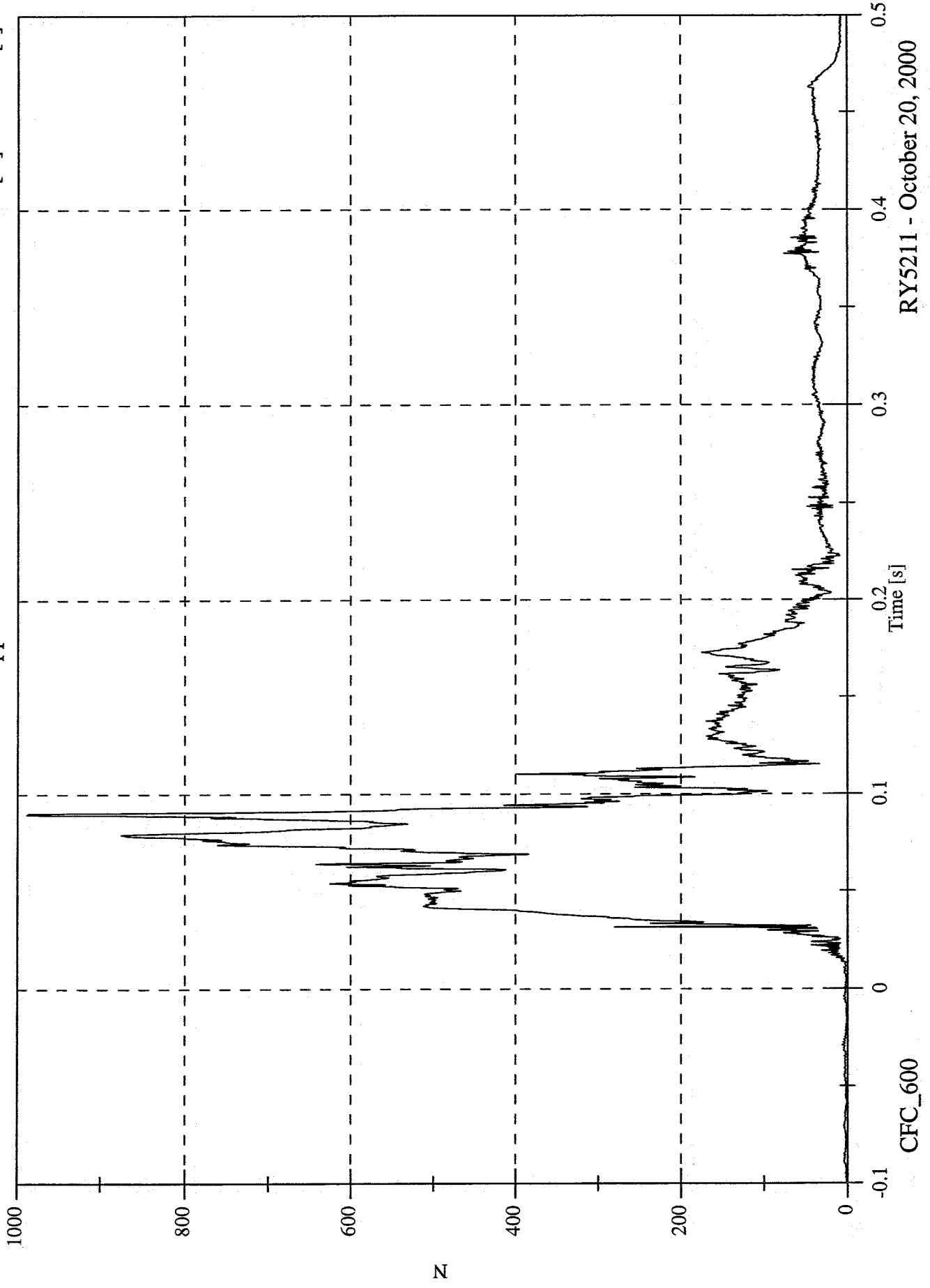

RY5211 - October 20, 2000

40% Frontal Offset Test #2 - 2000 Nissan Altima

Max: 12.2 [Nm] at 0.342 [s]

Min: -61.6 [Nm] at 0.088 [s]

P2 Left Upper Tibia Mx

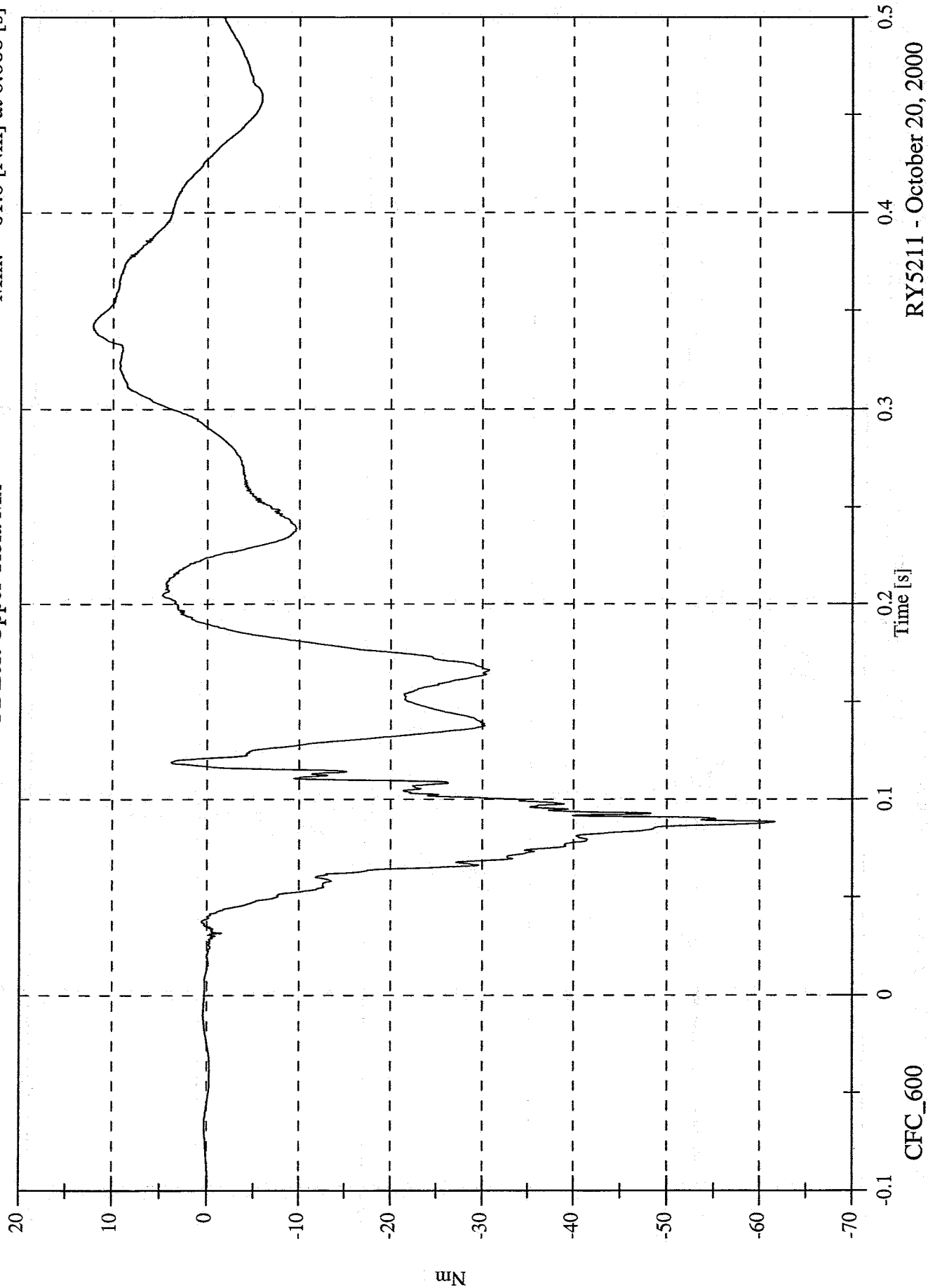

RY5211 - October 20, 2000

Max: 17.4 [Nm] at 0.161 [s]  
Min: -85.2 [Nm] at 0.090 [s]

P2 Left Upper Tibia My

40% Frontal Offset Test #2 - 2000 Nissan Altima

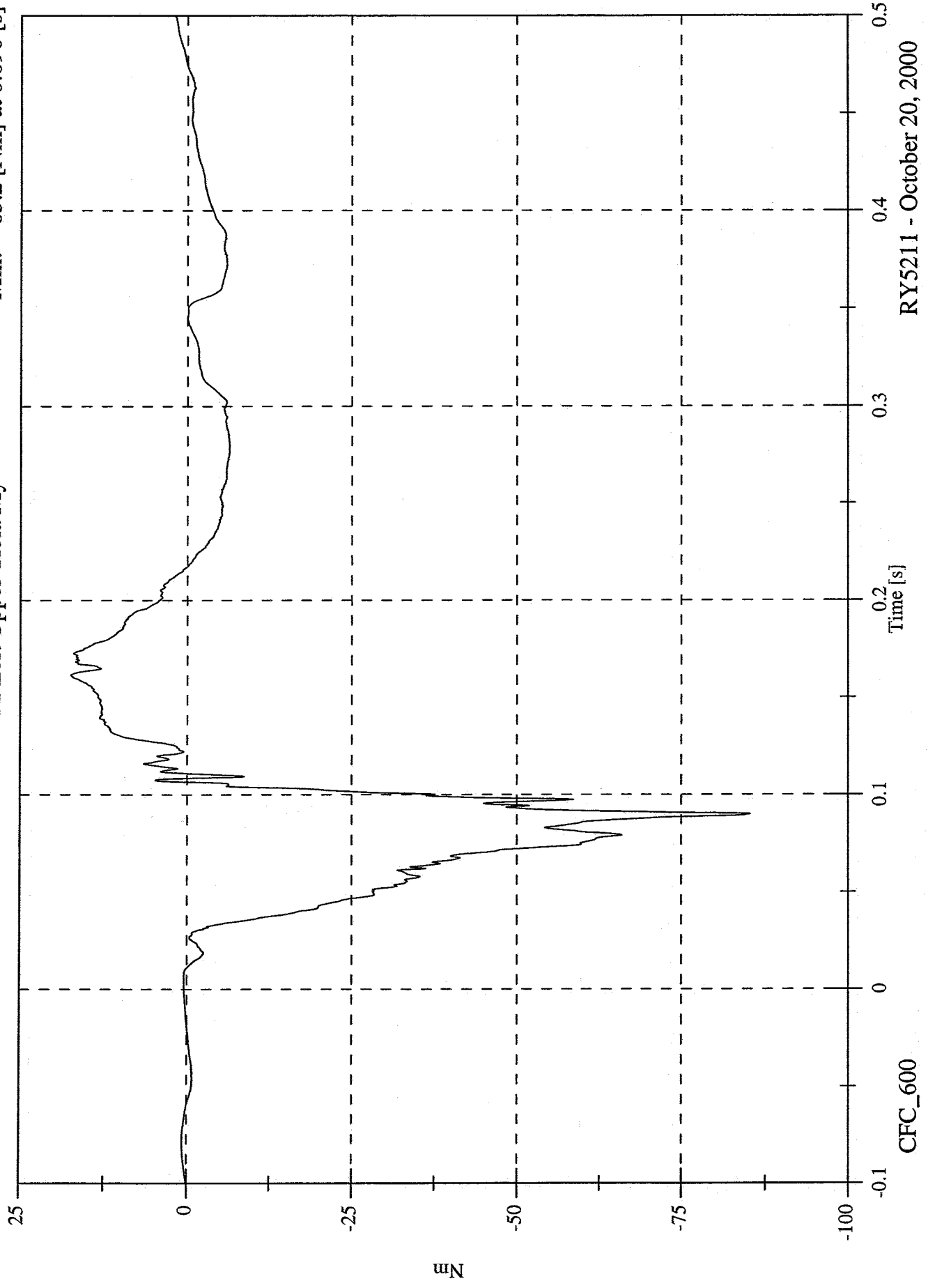

RYS211 - October 20, 2000

40% Frontal Offset Test #2 - 2000 Nissan Altima

Max: 176.8 [N] at 0.111 [s]  
Min: -489.6 [N] at 0.090 [s]

P2 Left Lower Tibia Fx

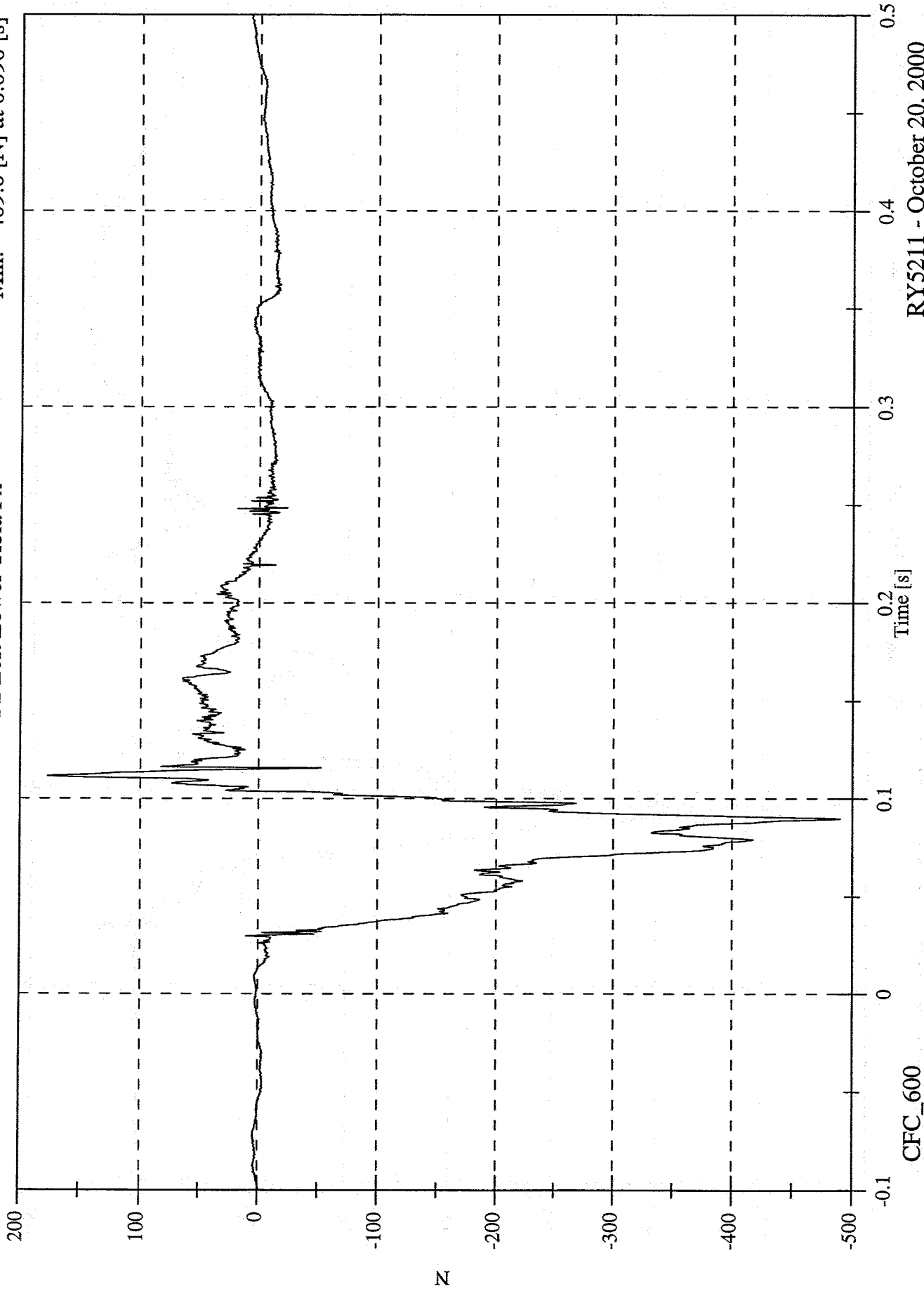

CFC\_600

RY5211 - October 20, 2000

40% Frontal Offset Test #2 - 2000 Nissan Altima

P2 Left Lower Tibia Fy

Max: 315.3 [N] at 0.088 [s]  
Min: -32.7 [N] at 0.340 [s]

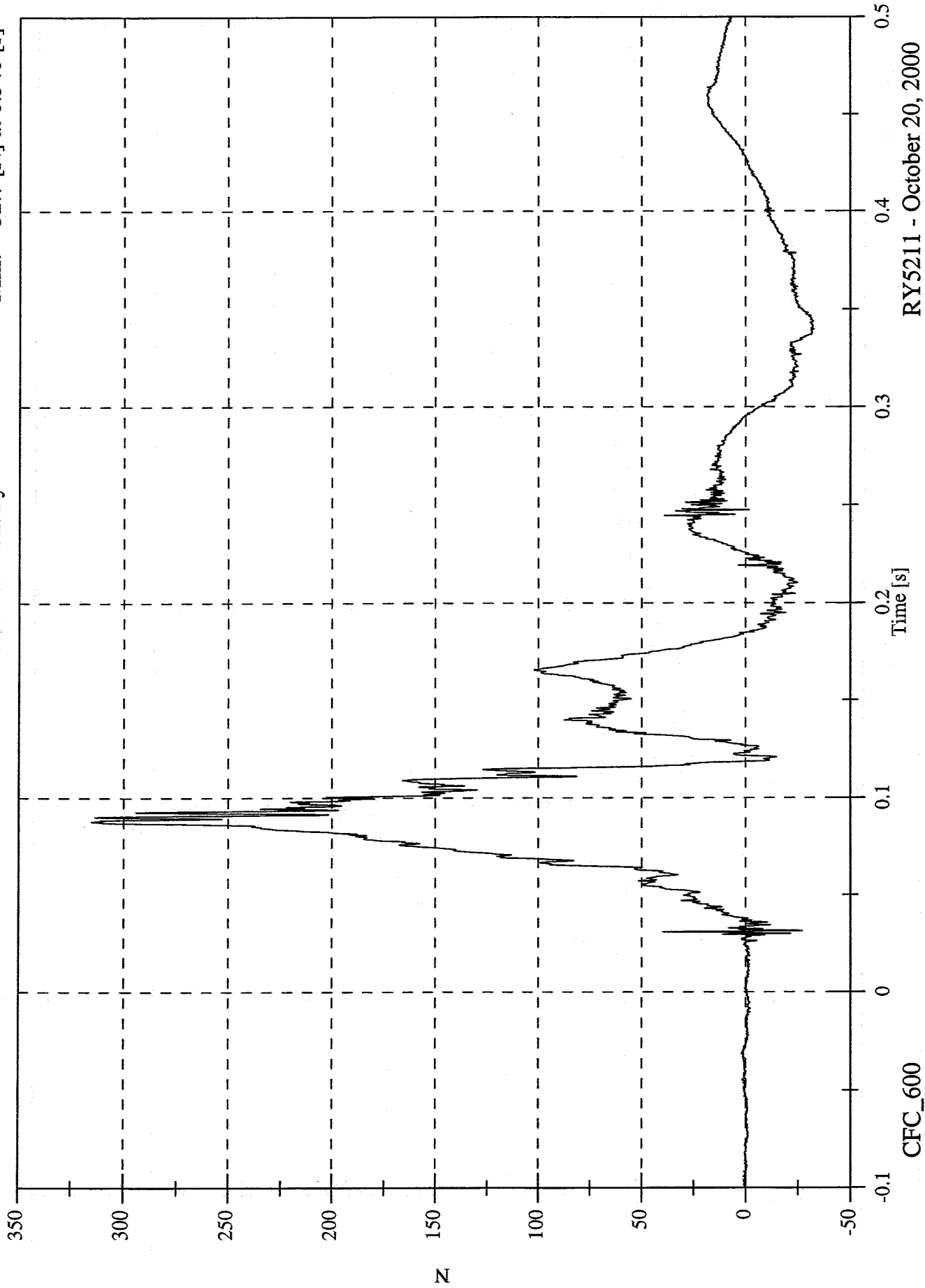

RY5211 - October 20, 2000

40% Frontal Offset Test #2 - 2000 Nissan Altima

Max: 201.7 [N] at 0.116 [s]  
Min: -1047.7 [N] at 0.079 [s]

P2 Left Lower Tibia Fz

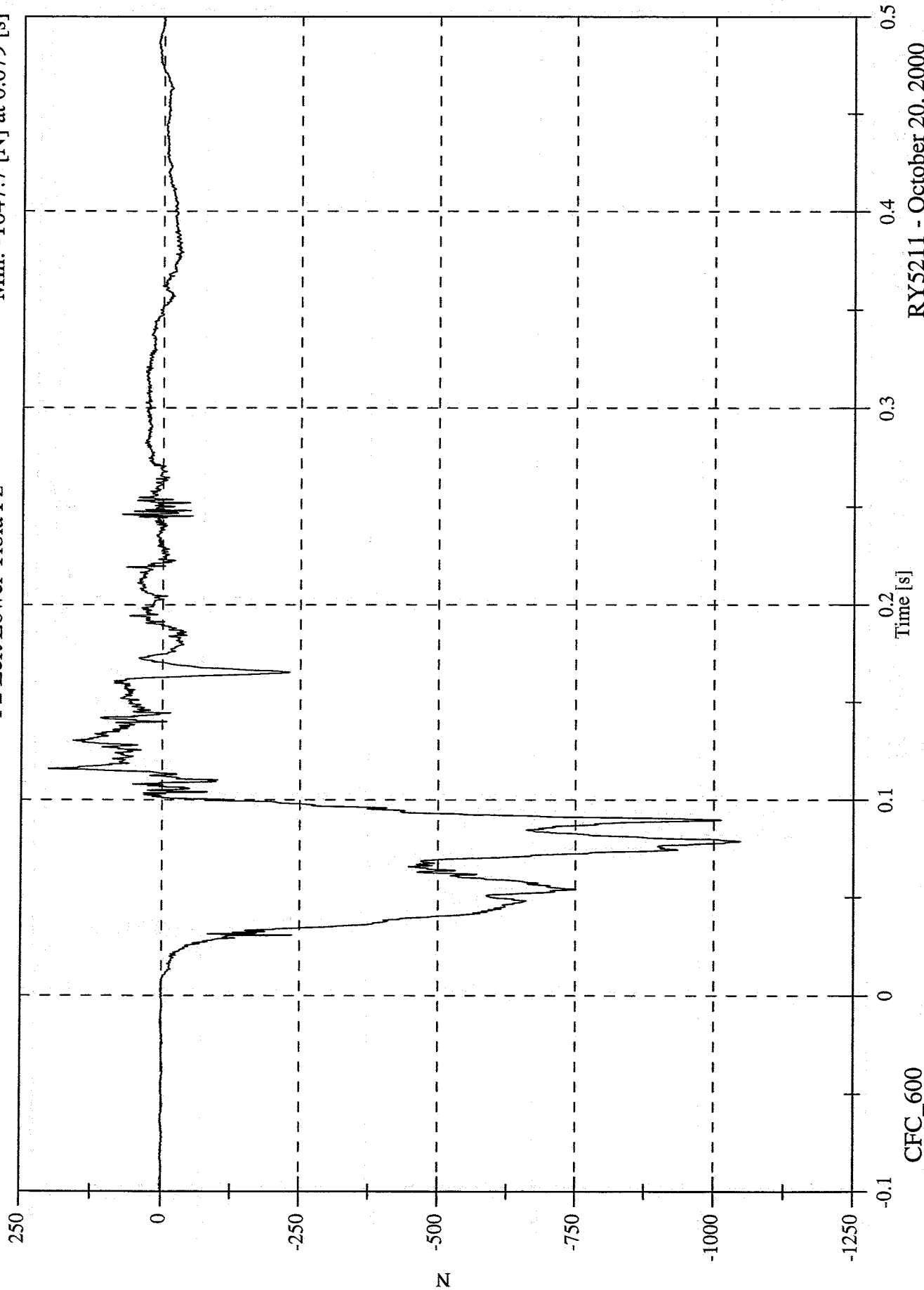

RYS211 - October 20, 2000

Max: 1158.7 [N] at 0.090 [s]  
Min: 0.1 [N] at -0.100 [s]

40% Frontal Offset Test #2 - 2000 Nissan Altima  
P2 Left Lower Tibia F Resultant

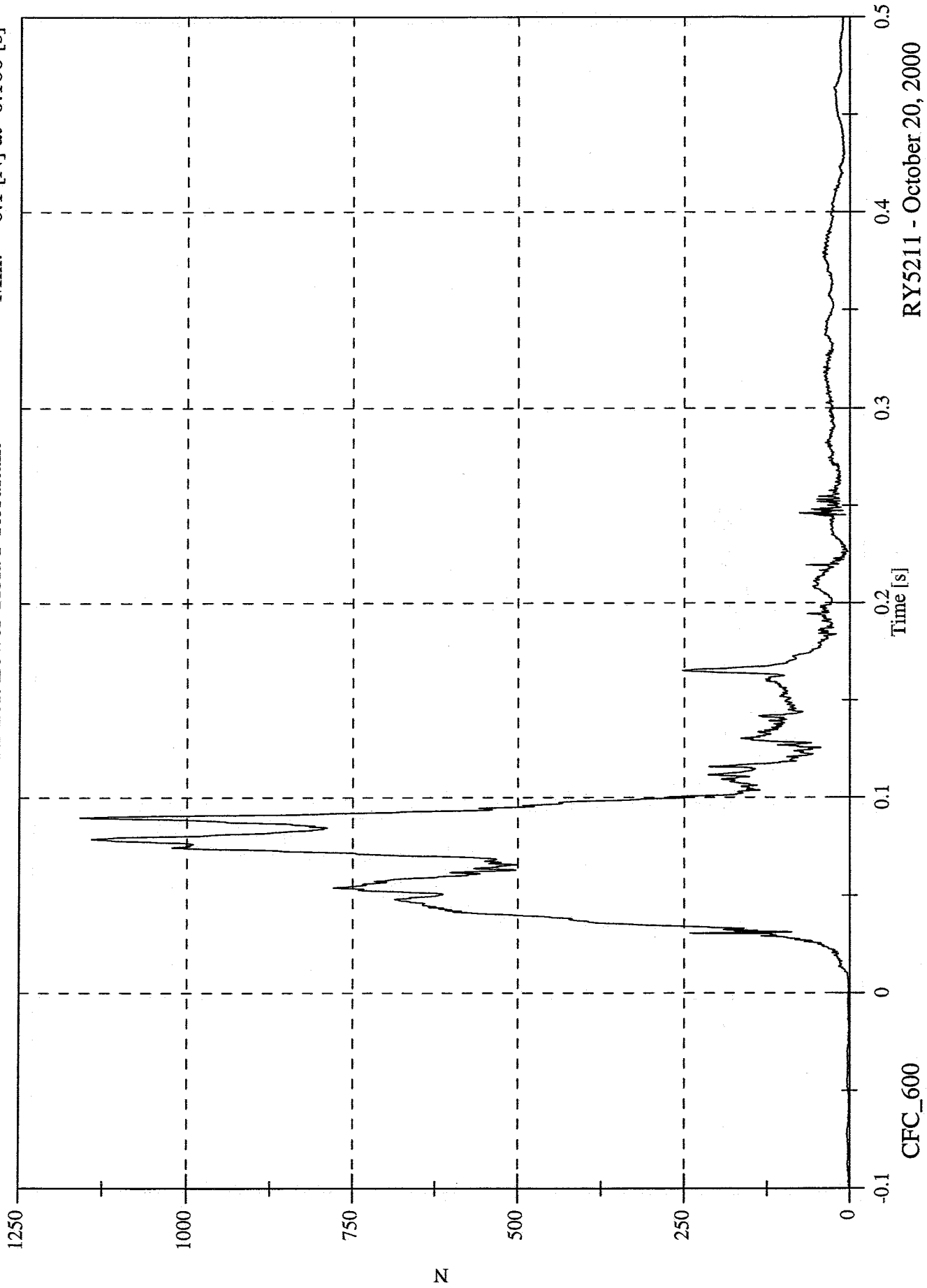

RYS211 - October 20, 2000

40% Frontal Offset Test #2 - 2000 Nissan Altima  
P2 Left Lower Tibia Mx

Max: 13.1 [Nm] at 0.120 [s]  
Min: -30.2 [Nm] at 0.090 [s]

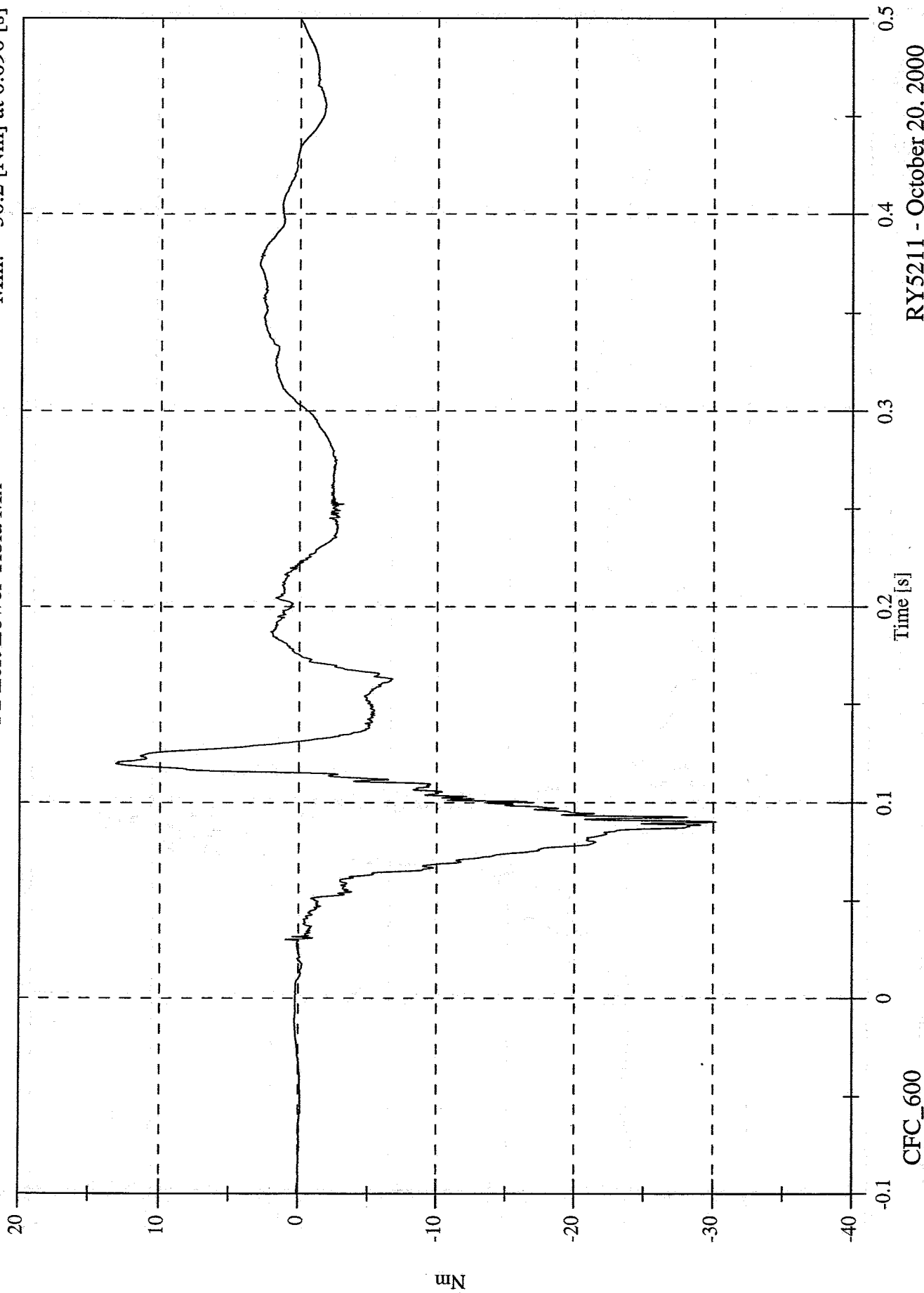

RYS211 - October 20, 2000

40% Frontal Offset Test #2 - 2000 Nissan Altima

Max: 8.3 [Nm] at 0.112 [s]  
Min: -22.9 [Nm] at 0.090 [s]

P2 Left Lower Tibia My

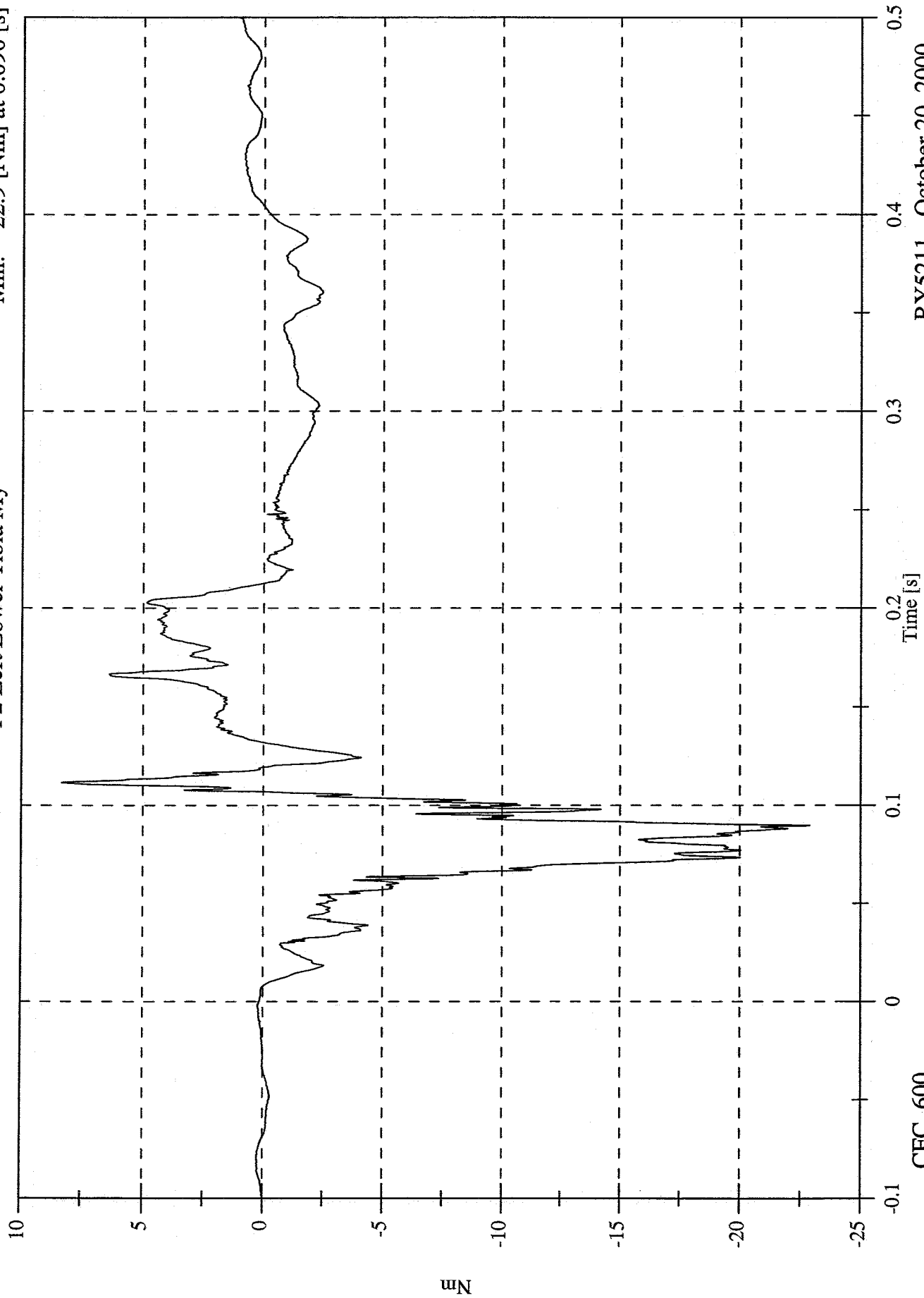

R5211 - October 20, 2000

40% Frontal Offset Test #2 - 2000 Nissan Altima

Max: 140.4 [N] at 0.096 [s]

Min: -82.7 [N] at 0.133 [s]

P2 Right Upper Tibia Fx

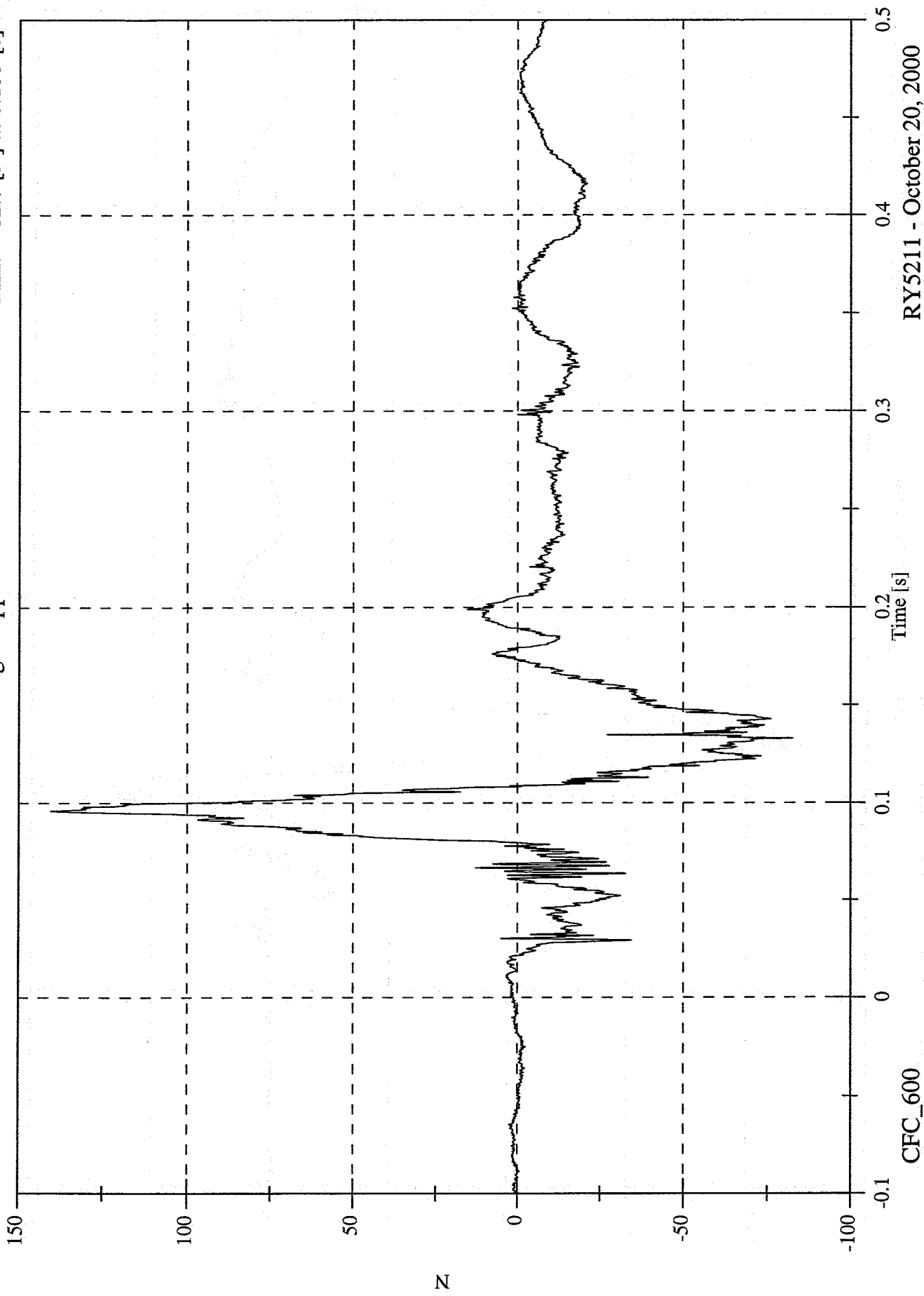

RYS211 - October 20, 2000

40% Frontal Offset Test #2 - 2000 Nissan Altima

Max: 232.1 [N] at 0.134 [s]

Min: -79.5 [N] at 0.098 [s]

P2 Right Upper Tibia Fy

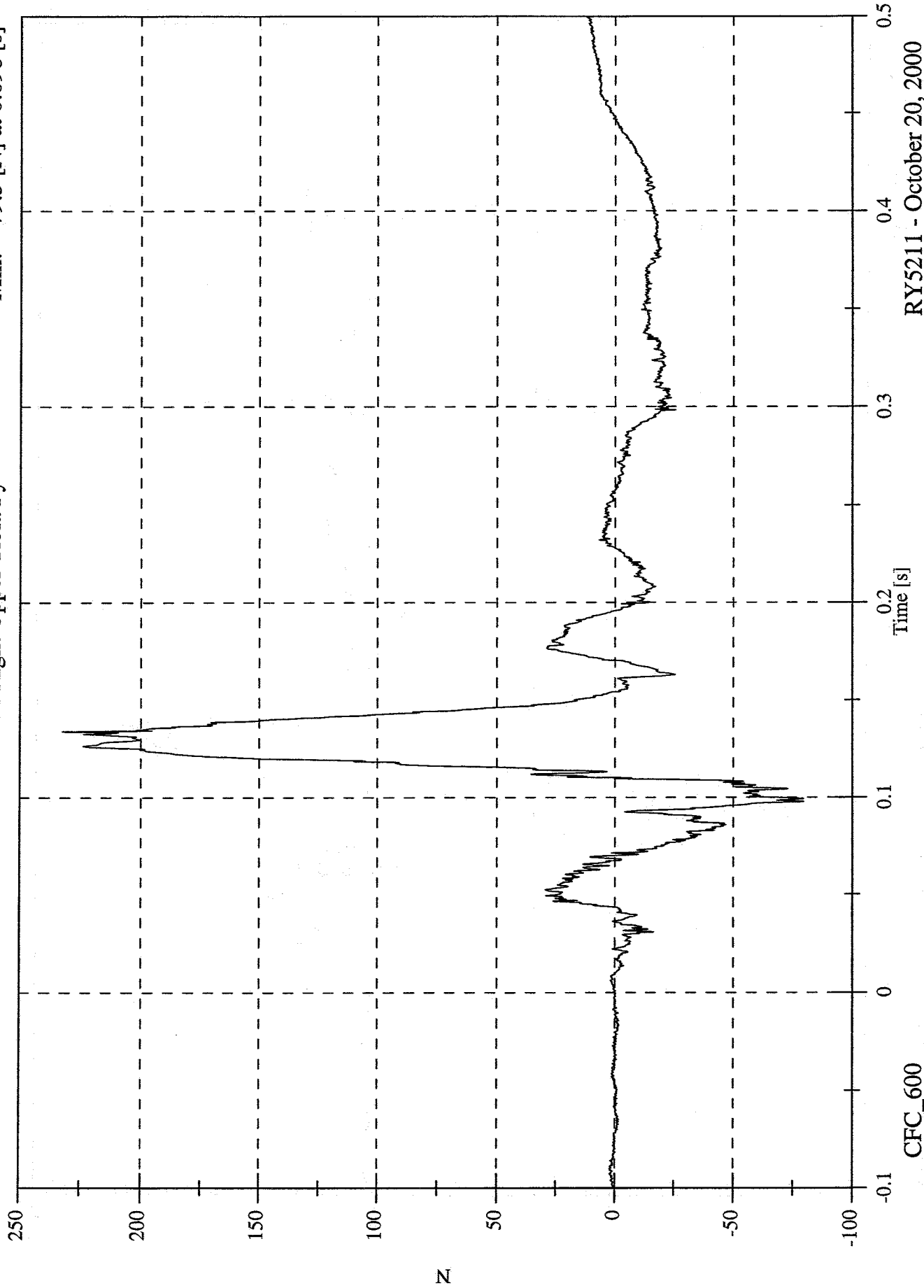

RY5211 - October 20, 2000

CFC\_600

40% Frontal Offset Test #2 - 2000 Nissan Altima

Max: 42.7 [N] at 0.179 [s]

Min: -751.6 [N] at 0.133 [s]

P2 Right Upper Tibia Fz

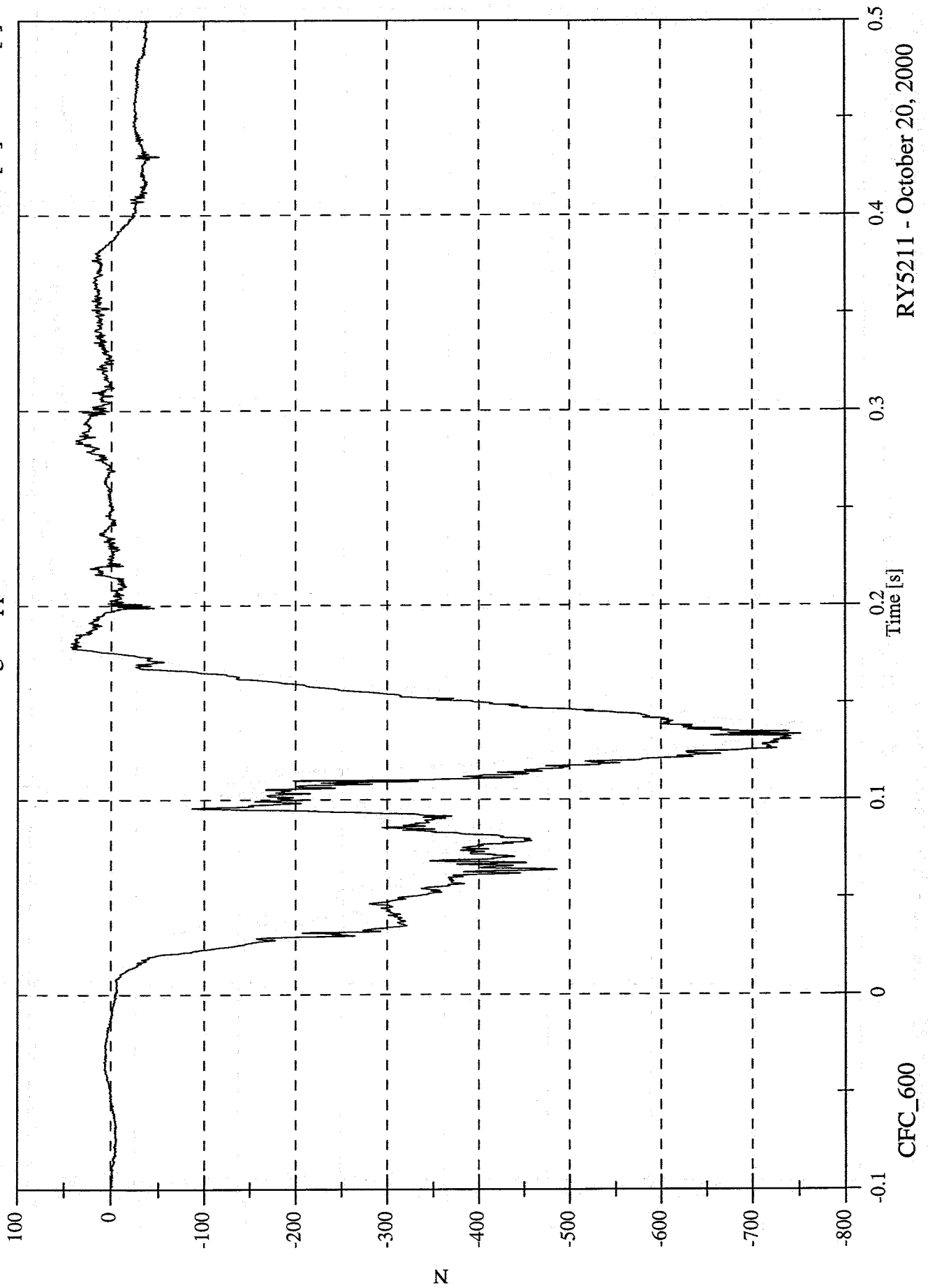

RY5211 - October 20, 2000

40% Frontal Offset Test #2 - 2000 Nissan Altima

Max: 783.2 [N] at 0.133 [s]

Min: 0.1 [N] at -0.100 [s]

P2 Right Upper Tibia F Resultant

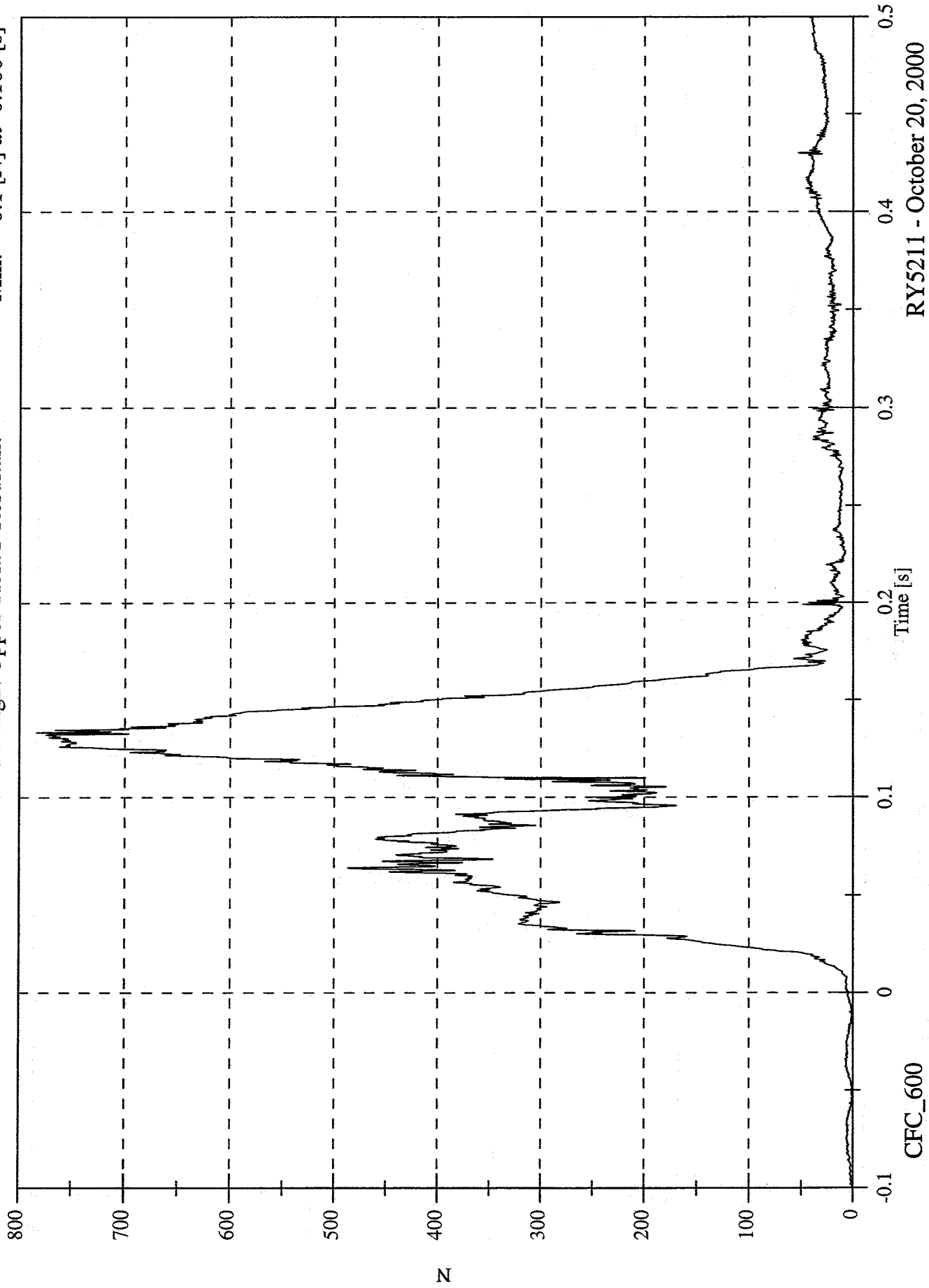

RY5211 - October 20, 2000

40% Frontal Offset Test #2 - 2000 Nissan Altima

P2 Right Upper Tibia Mx

Max: 9.0 [Nm] at 0.200 [s]  
Min: -63.1 [Nm] at 0.130 [s]

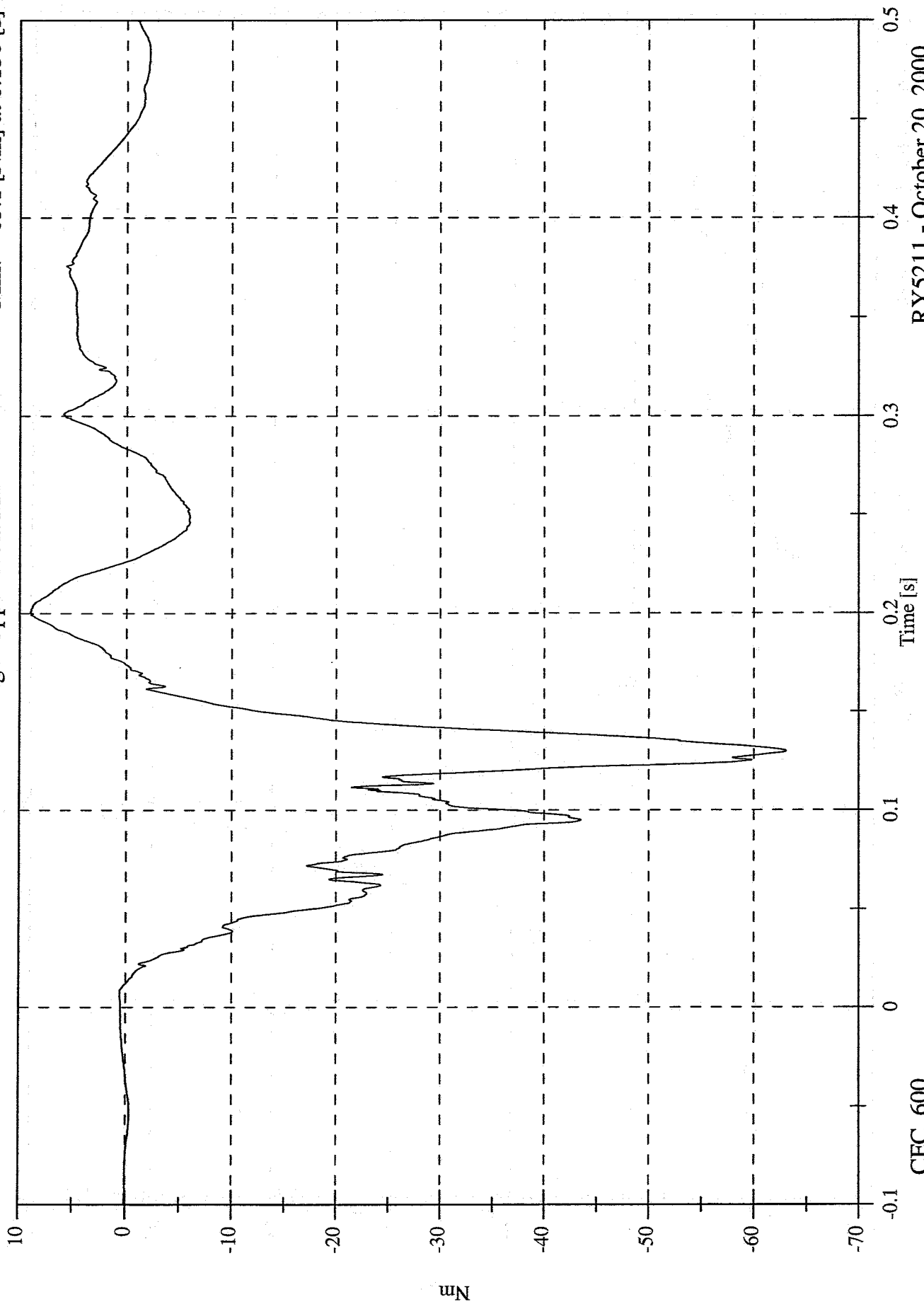

RY5211 - October 20, 2000

40% Frontal Offset Test #2 - 2000 Nissan Altima

P2 Right Upper Tibia My

Max: 5.5 [Nm] at 0.217 [s]  
Min: -55.1 [Nm] at 0.098 [s]

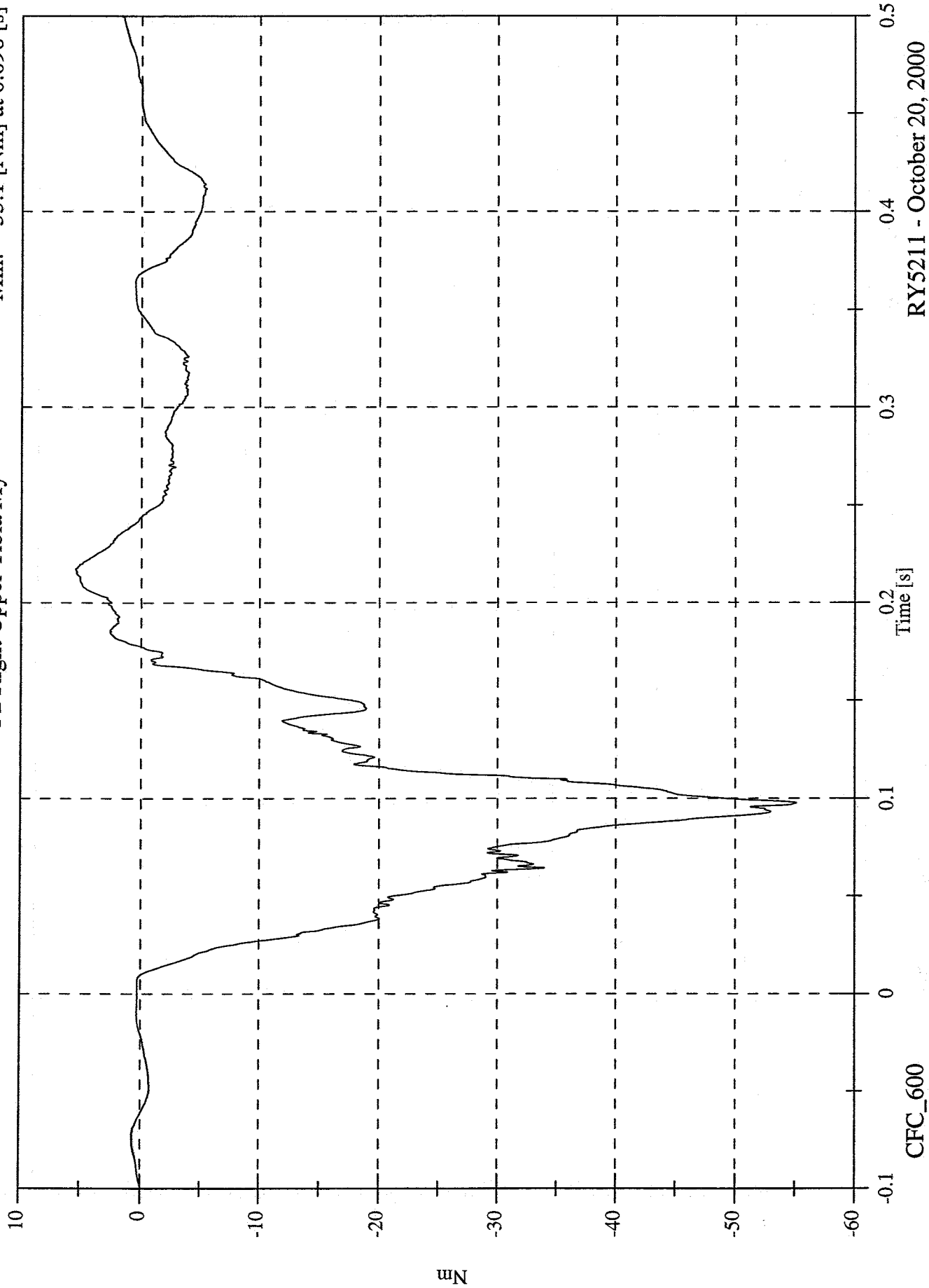

RY5211 - October 20, 2000

40% Frontal Offset Test #2 - 2000 Nissan Altima  
P2 Right Lower Tibia Fx

Max: 32.0 [N] at 0.218 [s]  
Min: -354.1 [N] at 0.094 [s]

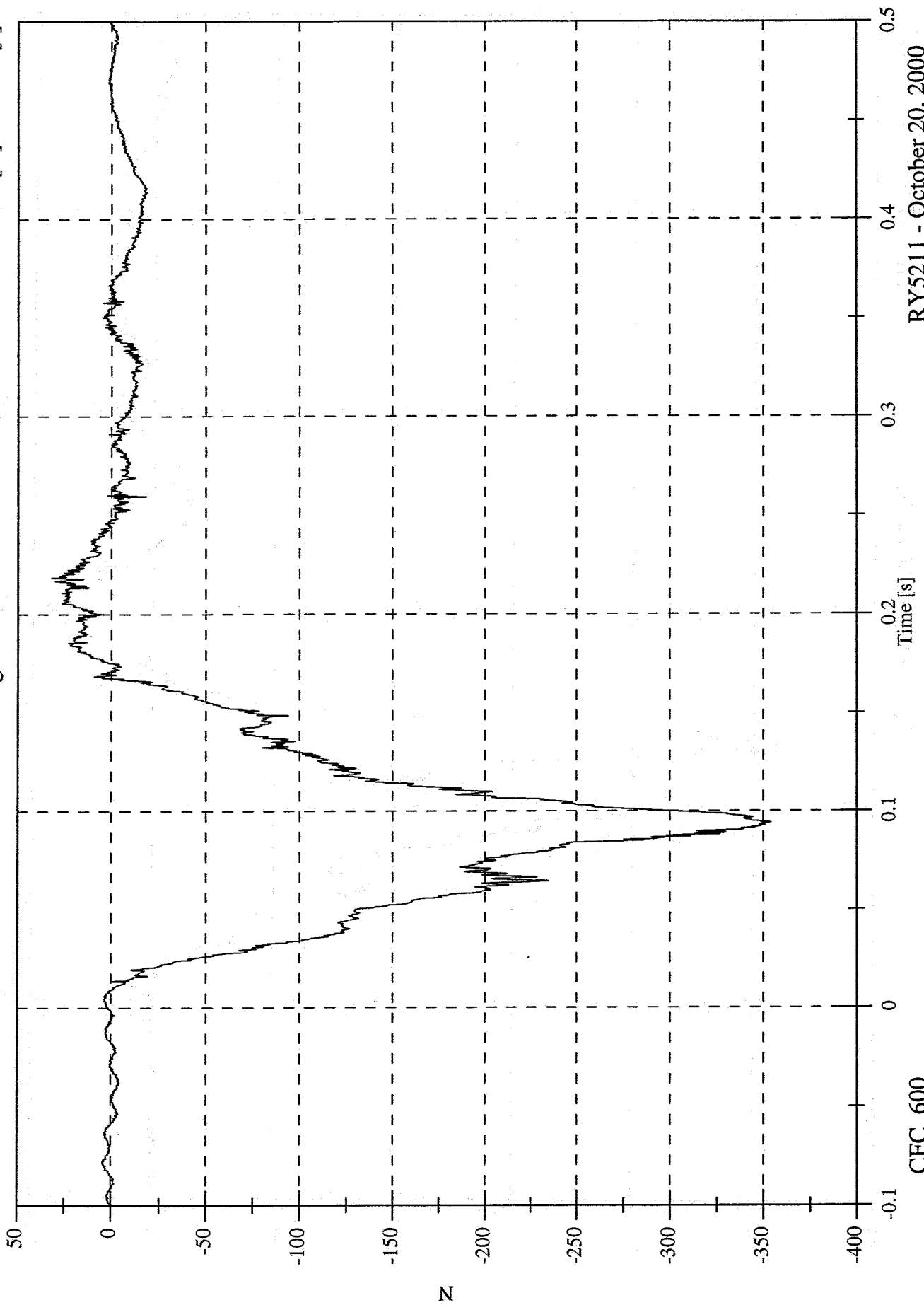

RY5211 - October 20, 2000

40% Frontal Offset Test #2 - 2000 Nissan Altima

Max: 264.0 [N] at 0.131 [s]

Min: -43.6 [N] at 0.205 [s]

P2 Right Lower Tibia Fy

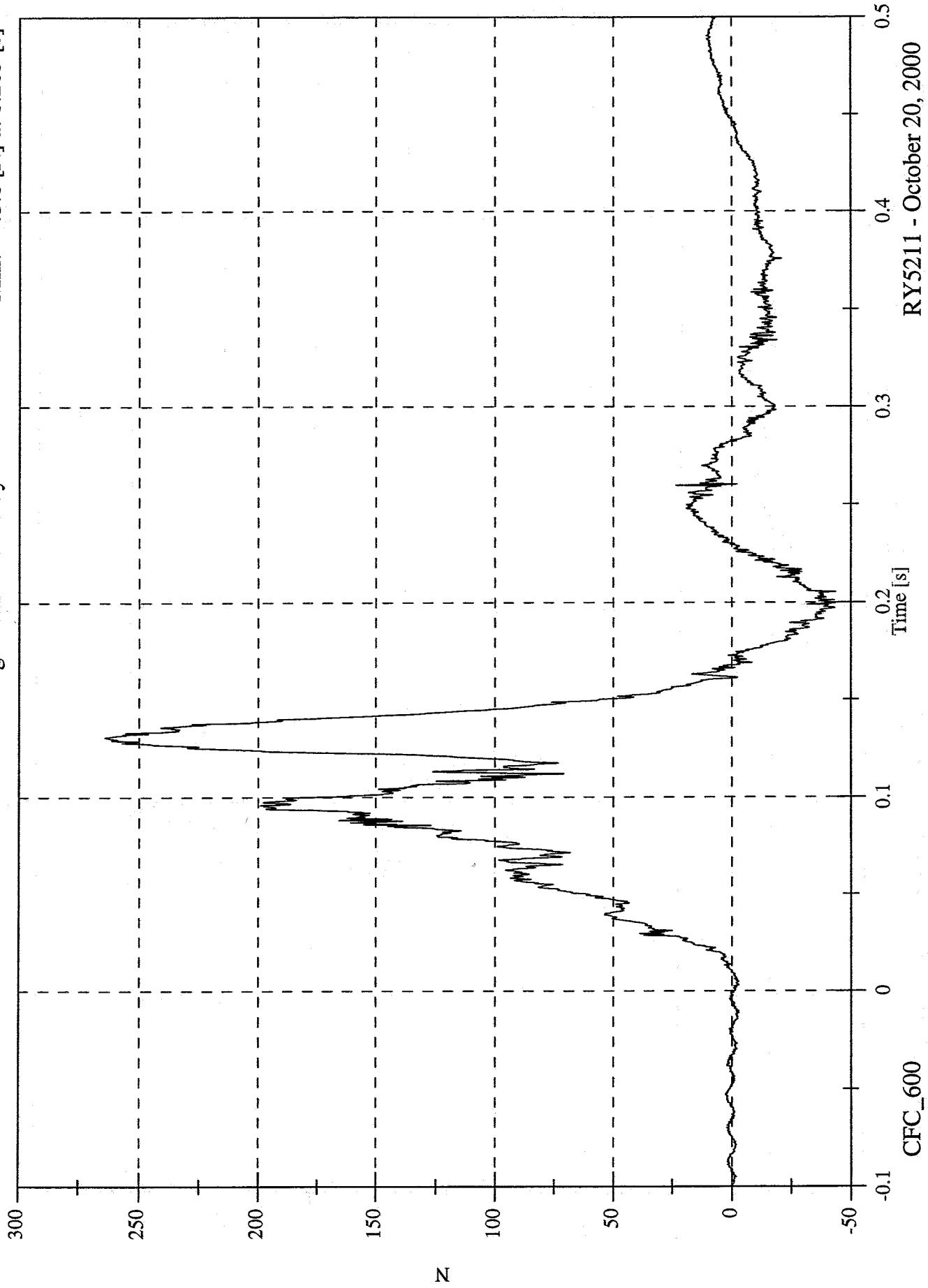

RY5211 - October 20, 2000

40% Frontal Offset Test #2 - 2000 Nissan Altima

Max: 107.3 [N] at 0.259 [s]

Min: -966.8 [N] at 0.132 [s]

P2 Right Lower Tibia Fz

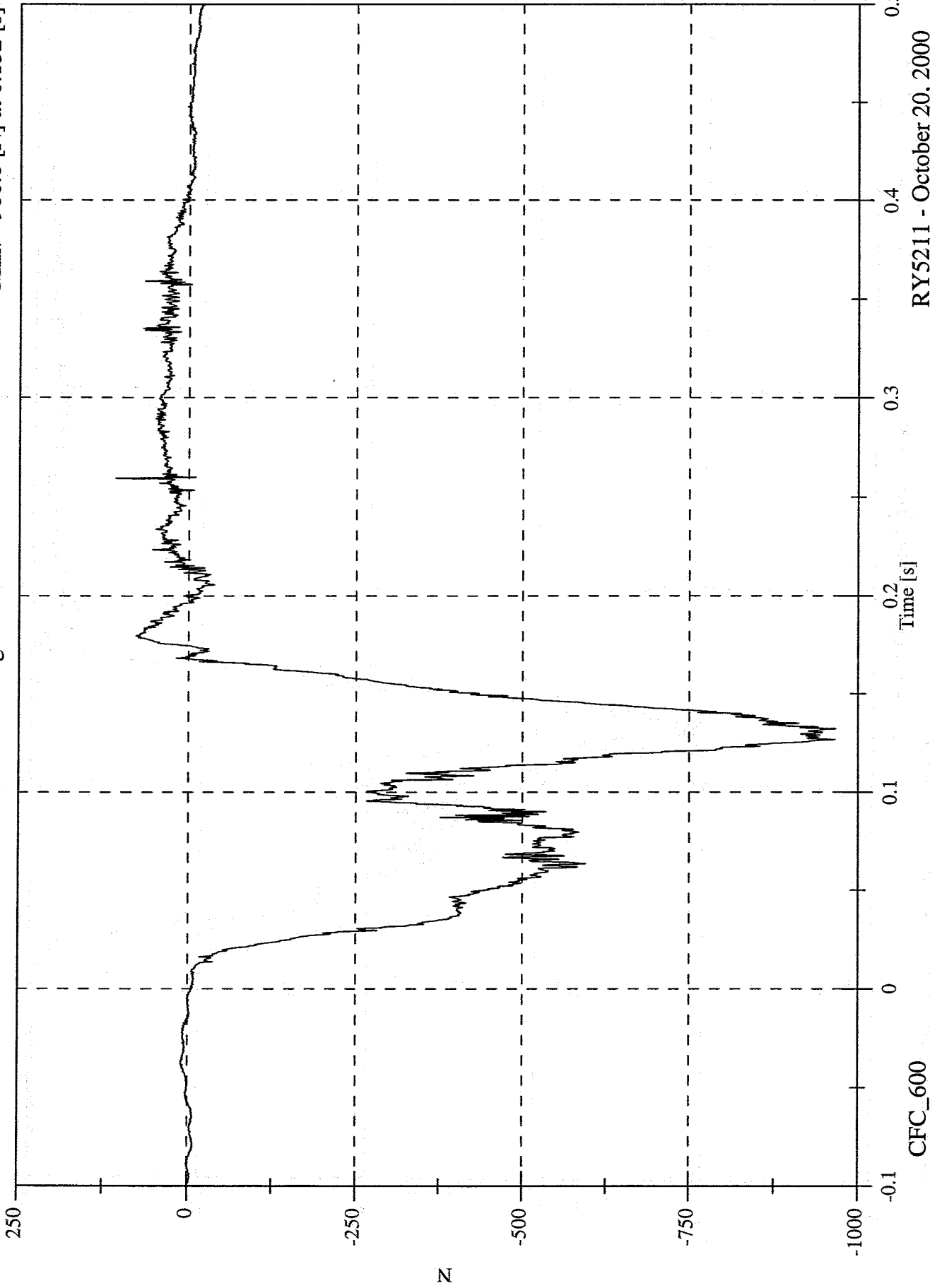

RYS211 - October 20, 2000

Max: 1003.5 [N] at 0.132 [s]  
Min: 0.2 [N] at -0.100 [s]

P2 Right Lower Tibia F Resultant

40% Frontal Offset Test #2 - 2000 Nissan Altima

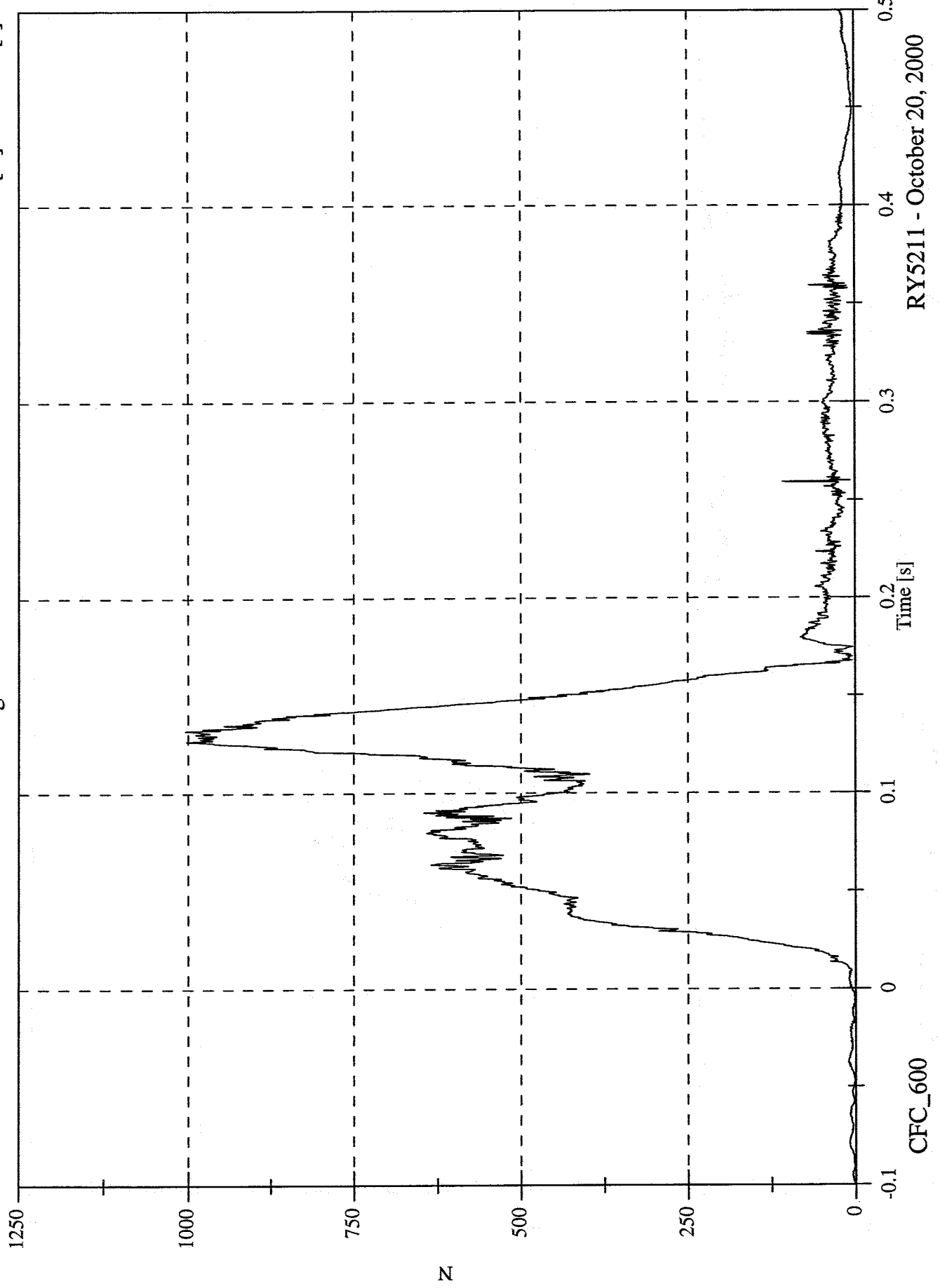

RY5211 - October 20, 2000

40% Frontal Offset Test #2 - 2000 Nissan Altima

P2 Right Lower Tibia Mx

Max: 16.1 [Nm] at 0.134 [s]

Min: -16.8 [Nm] at 0.098 [s]

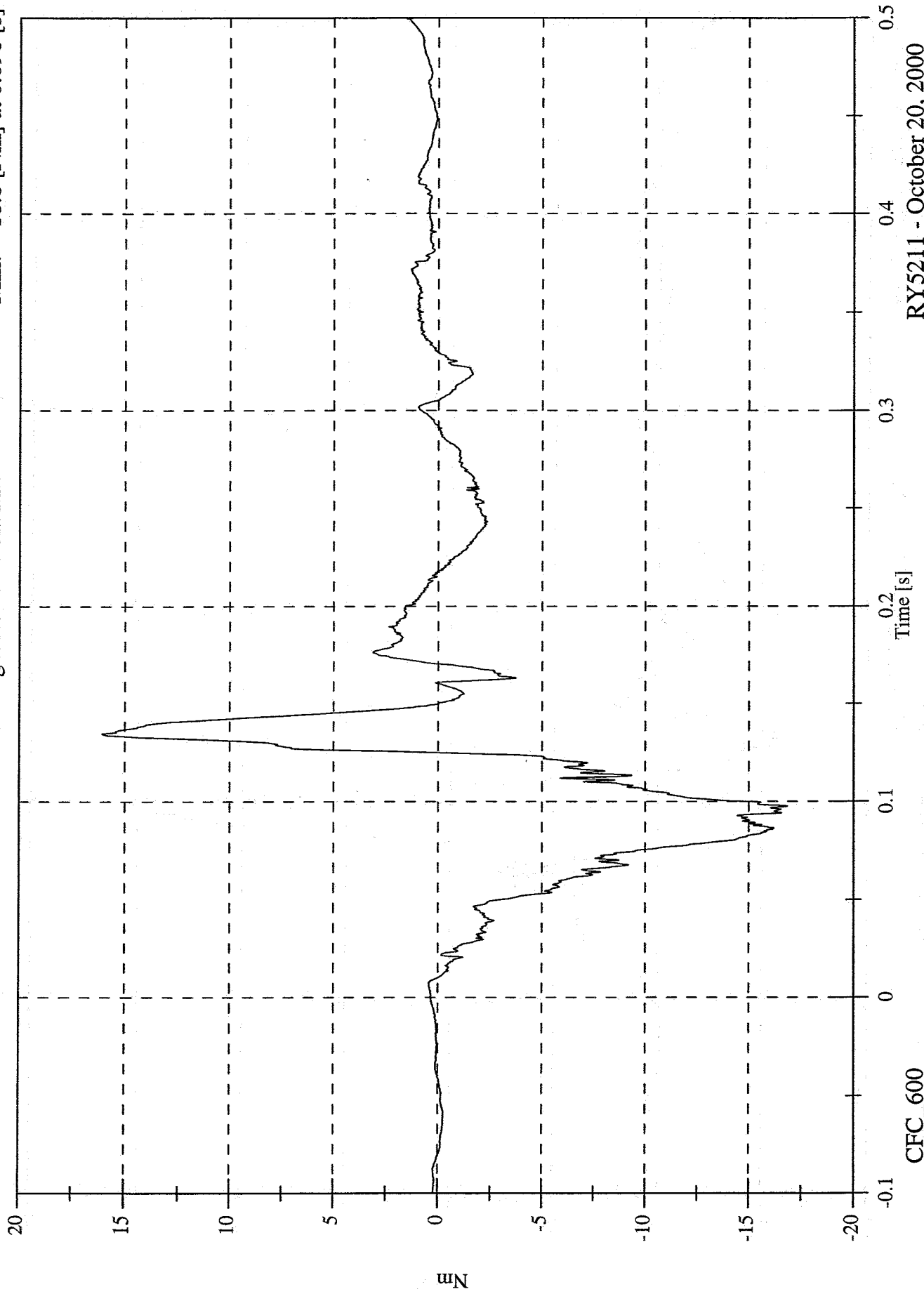

R Y5211 - October 20, 2000

40% Frontal Offset Test #2 - 2000 Nissan Altima

P2 Right Lower Tibia My

Max: 6.8 [Nm] at 0.138 [s]

Min: -25.5 [Nm] at 0.097 [s]

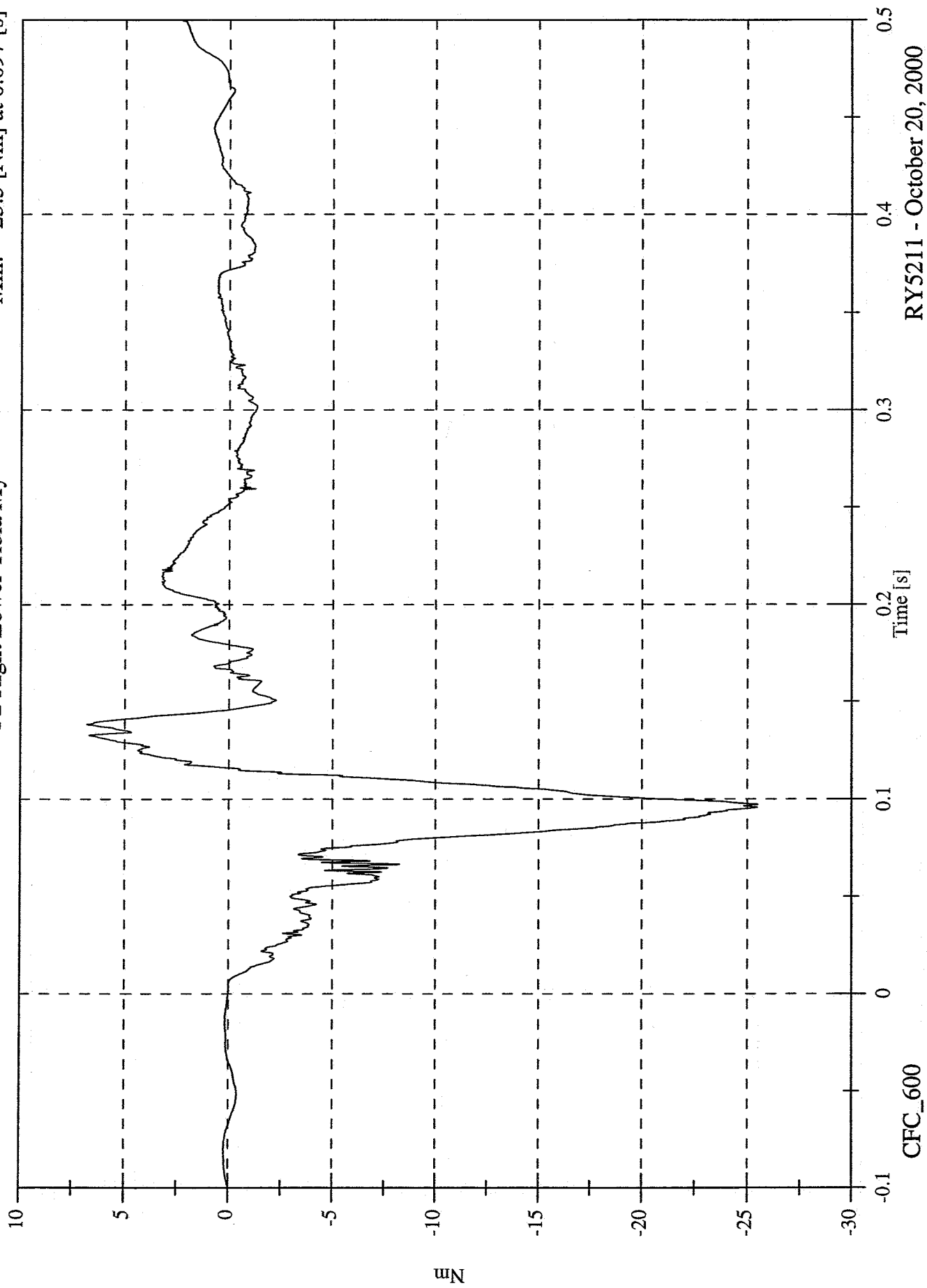

RYS211 - October 20, 2000

40% Frontal Offset Test #2 - 2000 Nissan Altima

Max: 4.5 [g] at 0.165 [s]  
Min: -42.1 [g] at 0.078 [s]

P2 Left Foot Ax

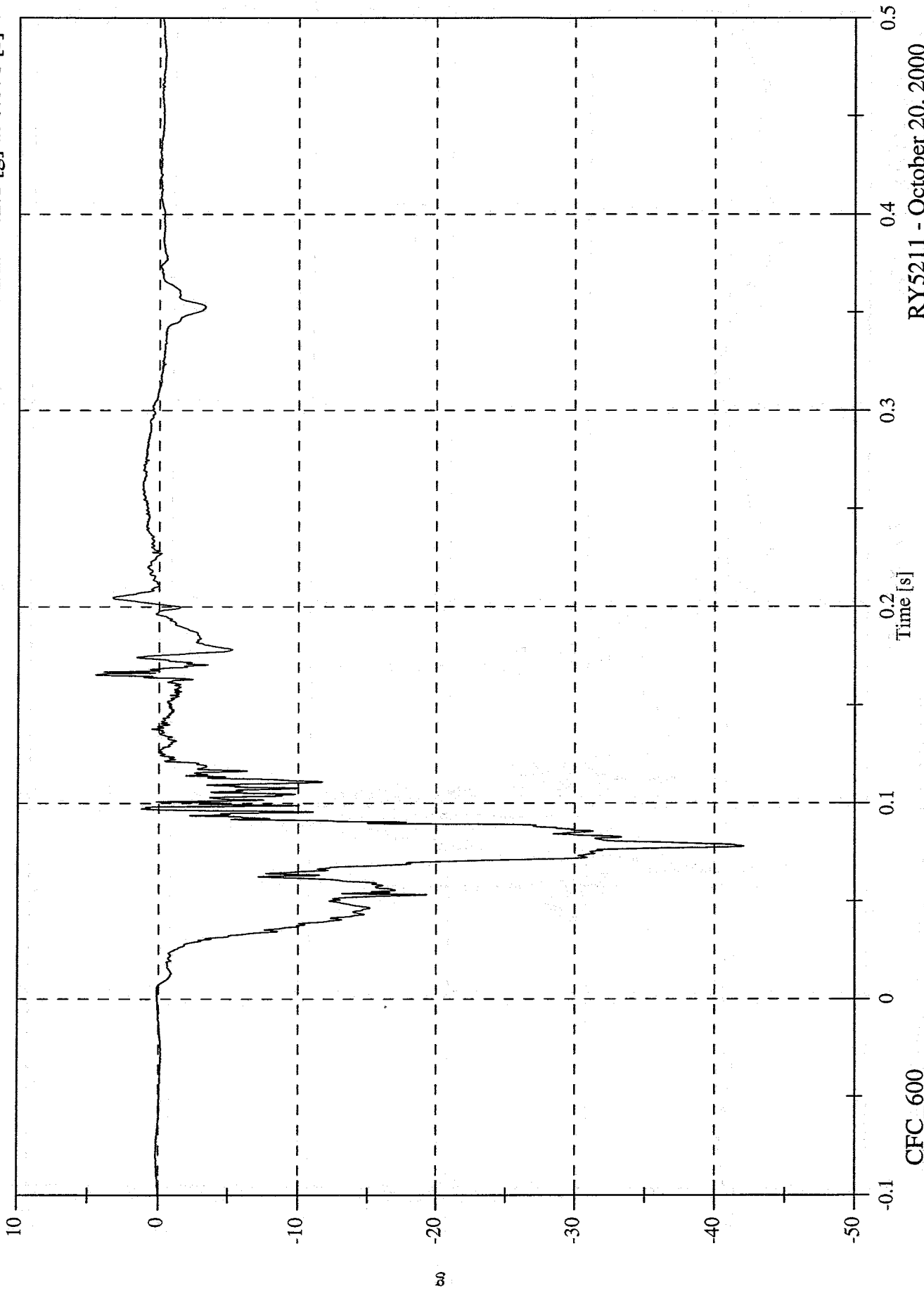

R5211 - October 20, 2000

40% Frontal Offset Test #2 - 2000 Nissan Altima

Max: 2.4 [g] at 0.062 [s]  
Min: -21.8 [g] at 0.091 [s]

P2 Left Foot Az

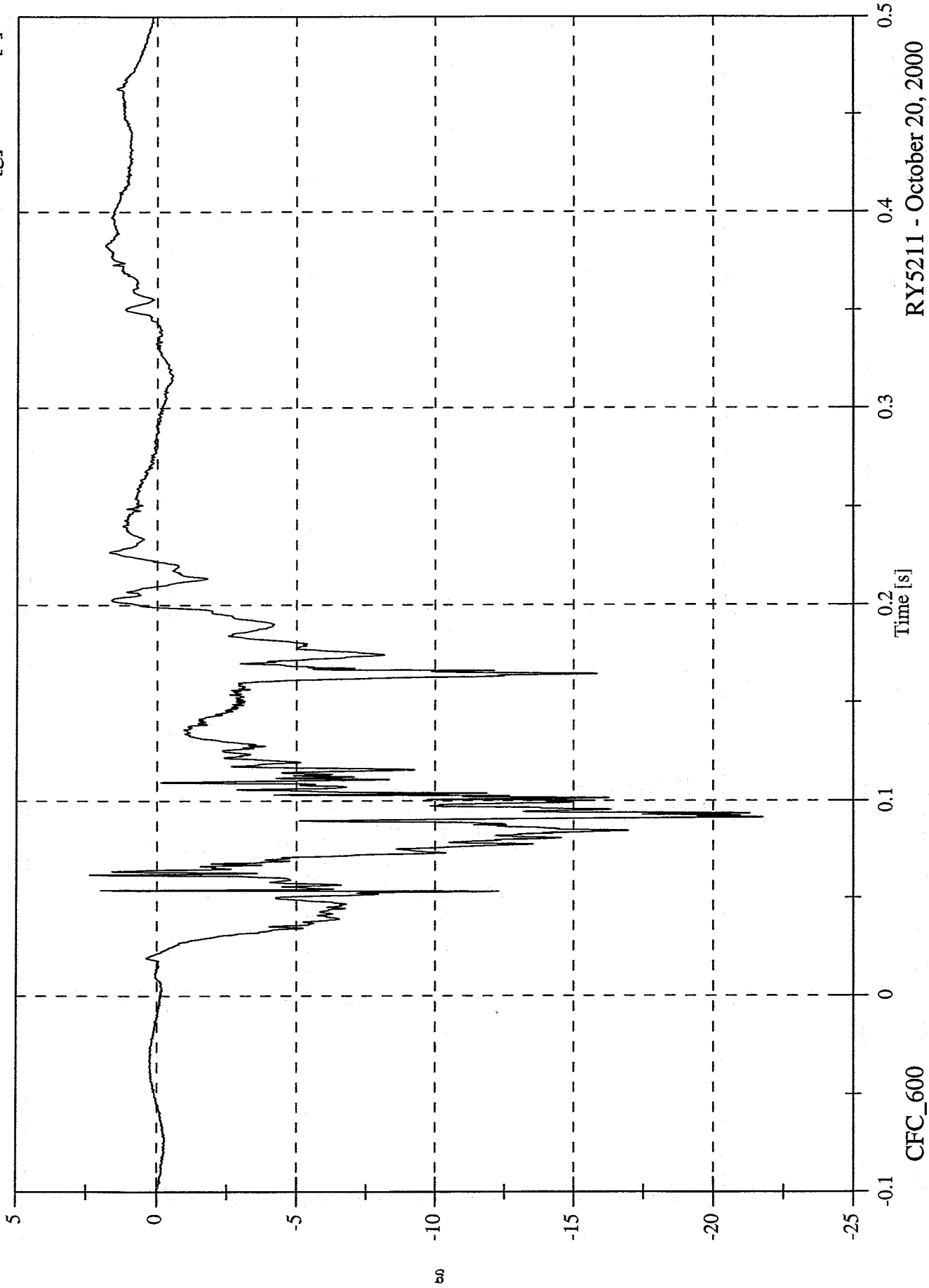

RY5211 - October 20, 2000

40% Frontal Offset Test #2 - 2000 Nissan Altima

Max: 14.7 [g] at 0.202 [s]  
Min: -33.8 [g] at 0.072 [s]

P2 Left Toe Az

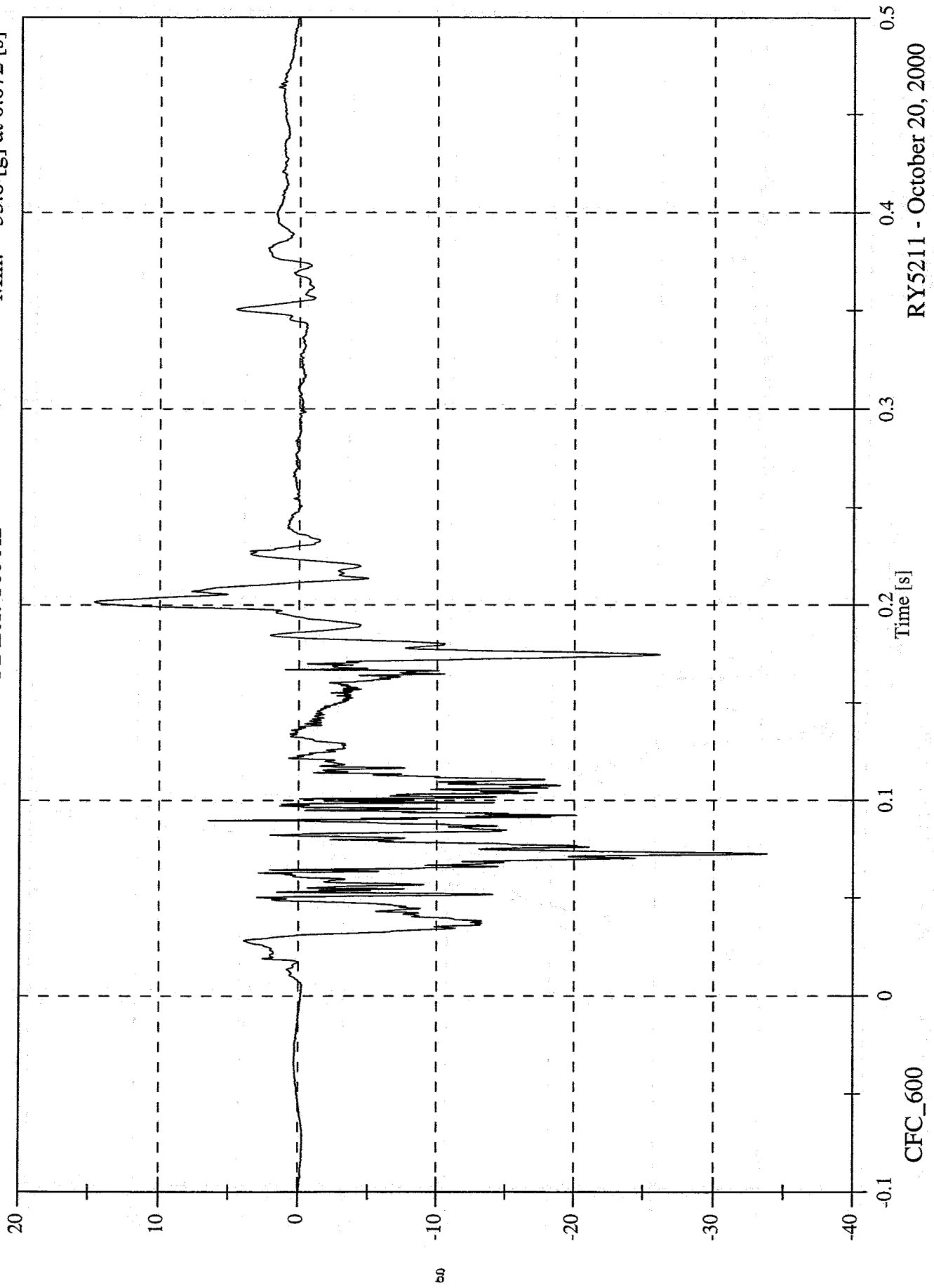

RY5211 - October 20, 2000

40% Frontal Offset Test #2 - 2000 Nissan Altima

Max: 4.6 [g] at 0.180 [s]  
Min: -33.9 [g] at 0.090 [s]

P2 Right Foot Ax

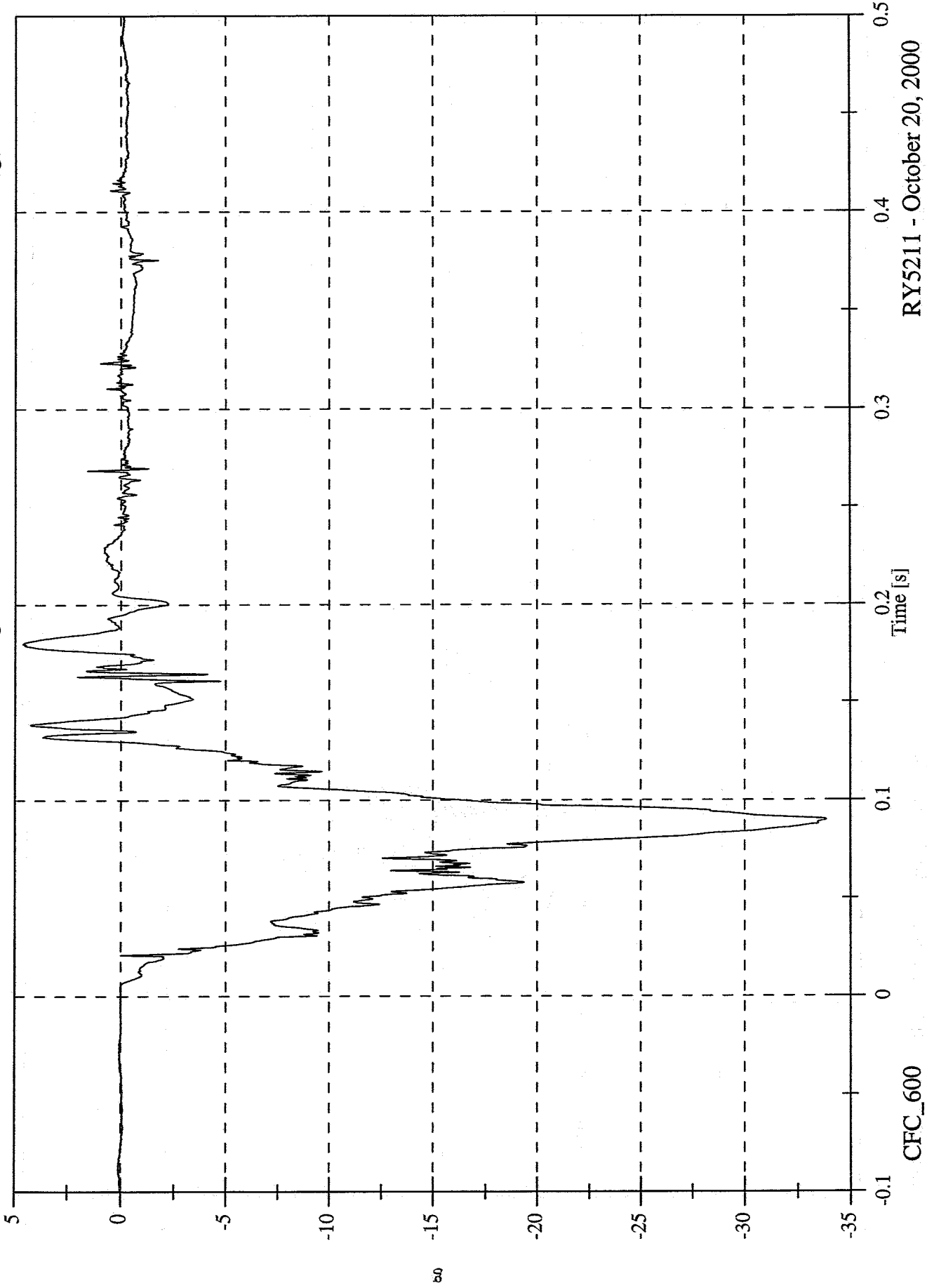

RY5211 - October 20, 2000

40% Frontal Offset Test #2 - 2000 Nissan Altima

Max: 2.3 [g] at 0.165 [s]  
Min: -10.9 [g] at 0.096 [s]

P2 Right Foot Az

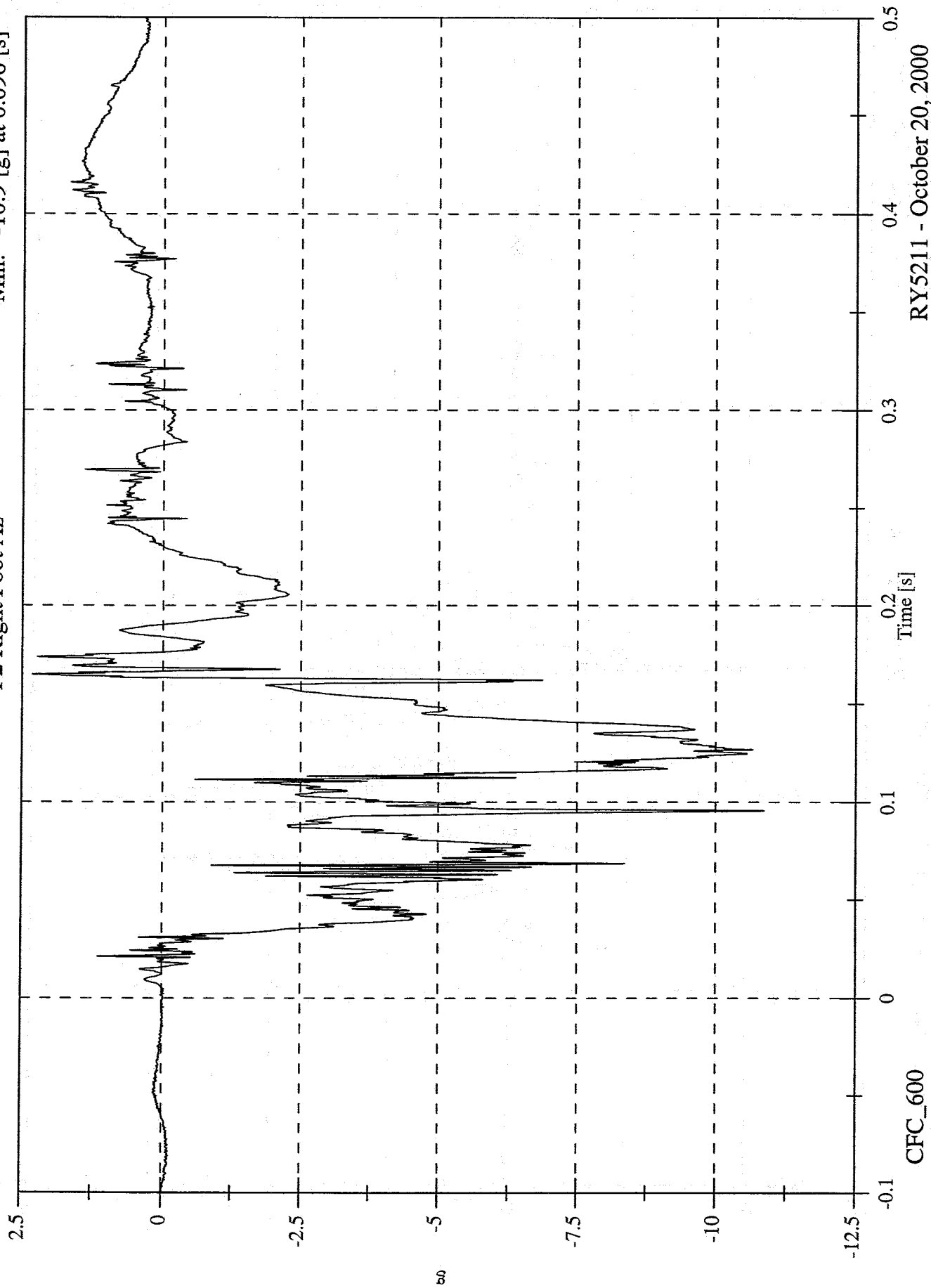

RY5211 - October 20, 2000

40% Frontal Offset Test #2 - 2000 Nissan Altima

Max: 12.9 [g] at 0.165 [s]  
Min: -19.3 [g] at 0.099 [s]

P2 Right Toe Az

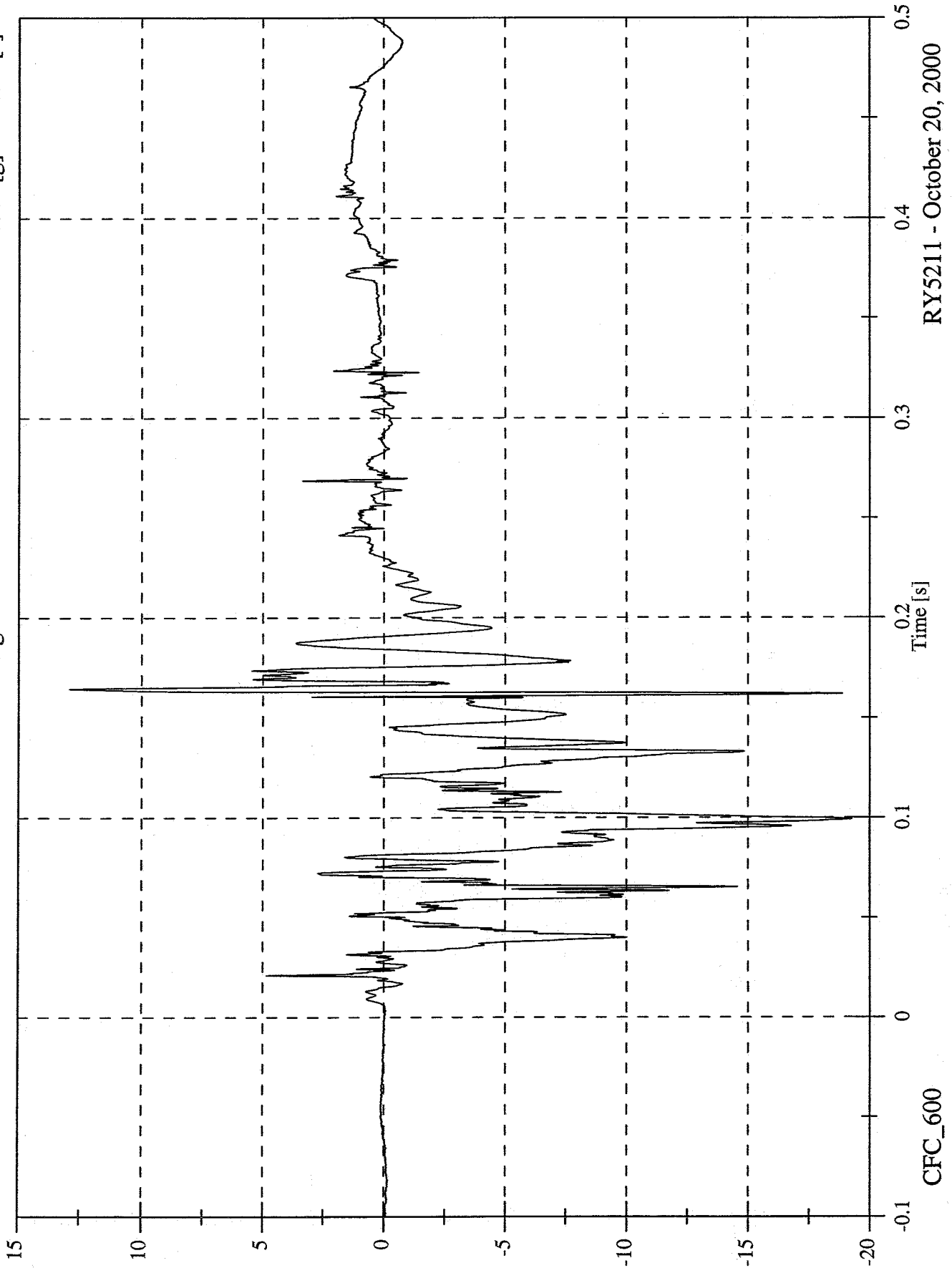

40% Frontal Offset Test #2 - 2000 Nissan Altima

P2 Lap Belt Force

Max: 4595.5 [N] at 0.099 [s]  
Min: -3.5 [N] at -0.011 [s]

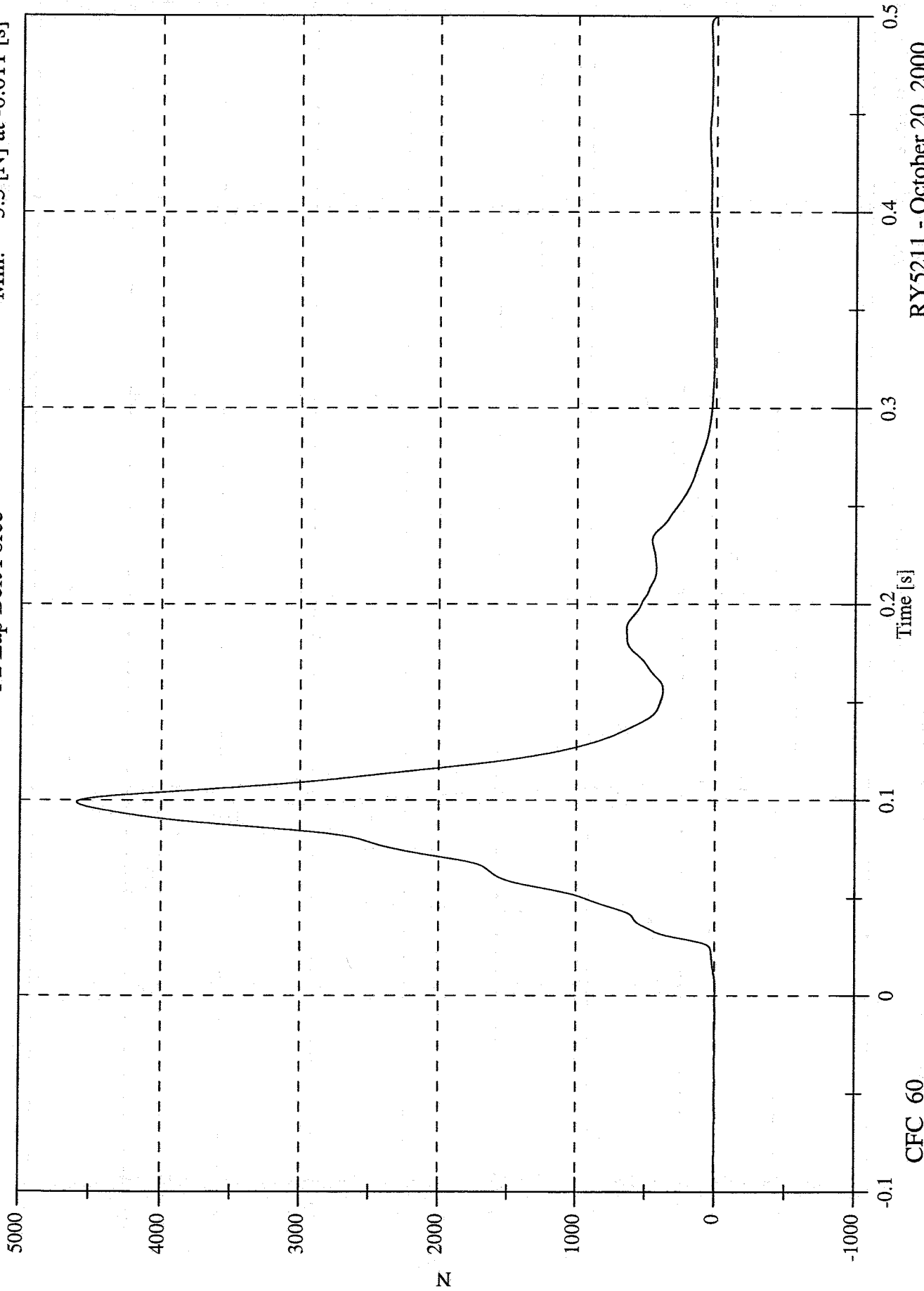

RY5211 - October 20, 2000

40% Frontal Offset Test #2 - 2000 Nissan Altima

P2 Torso Belt Spoolout

Max: 22.6 [mm] at 0.203 [s]  
Min: -50.3 [mm] at 0.047 [s]

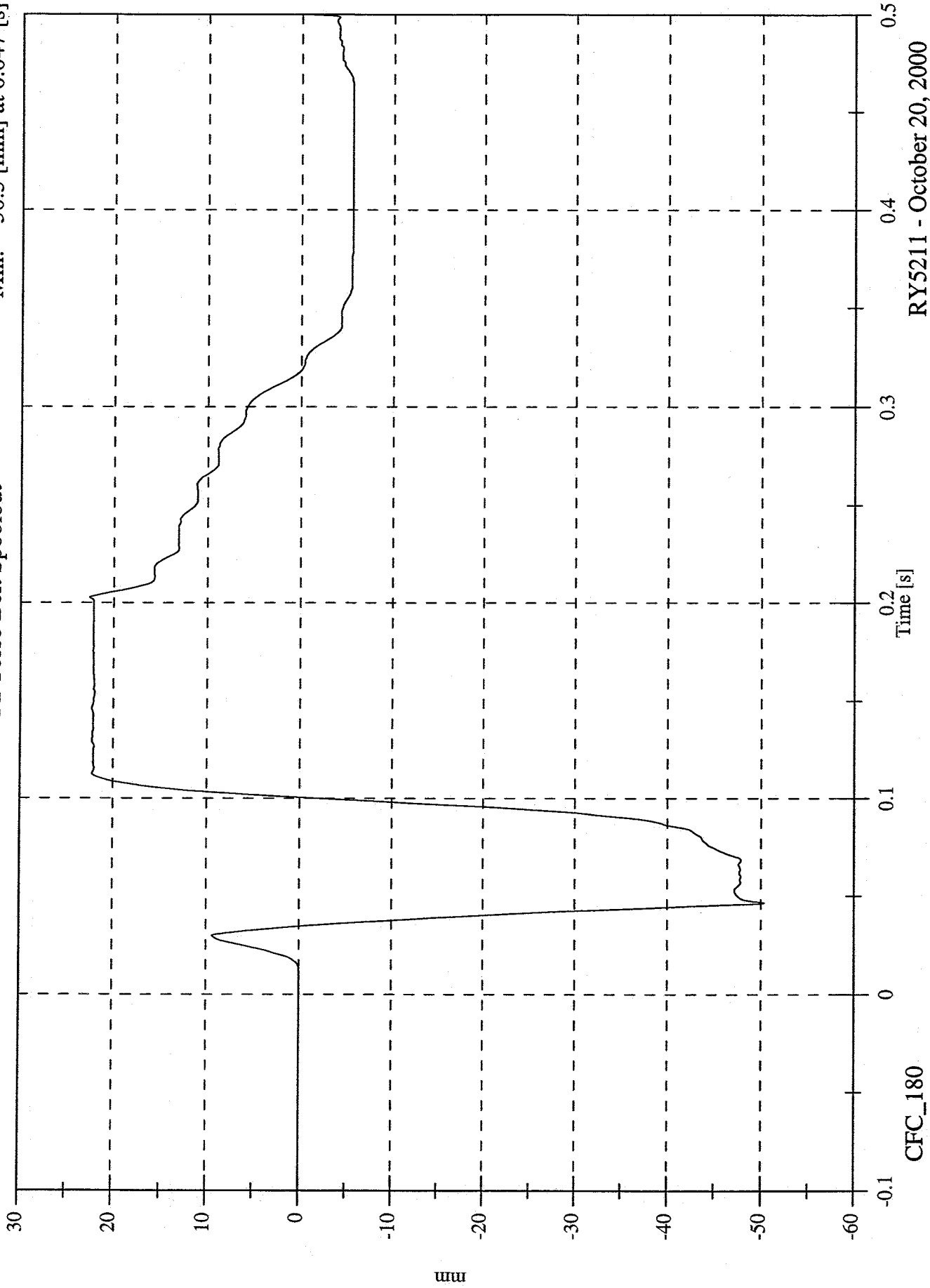

RY5211 - October 20, 2000

40% Frontal Offset Test #2 - 2000 Nissan Altima

Max: 1.7 [g] at 0.201 [s]  
Min: -26.2 [g] at 0.082 [s]

Acc 1 Rear XMBR Left X

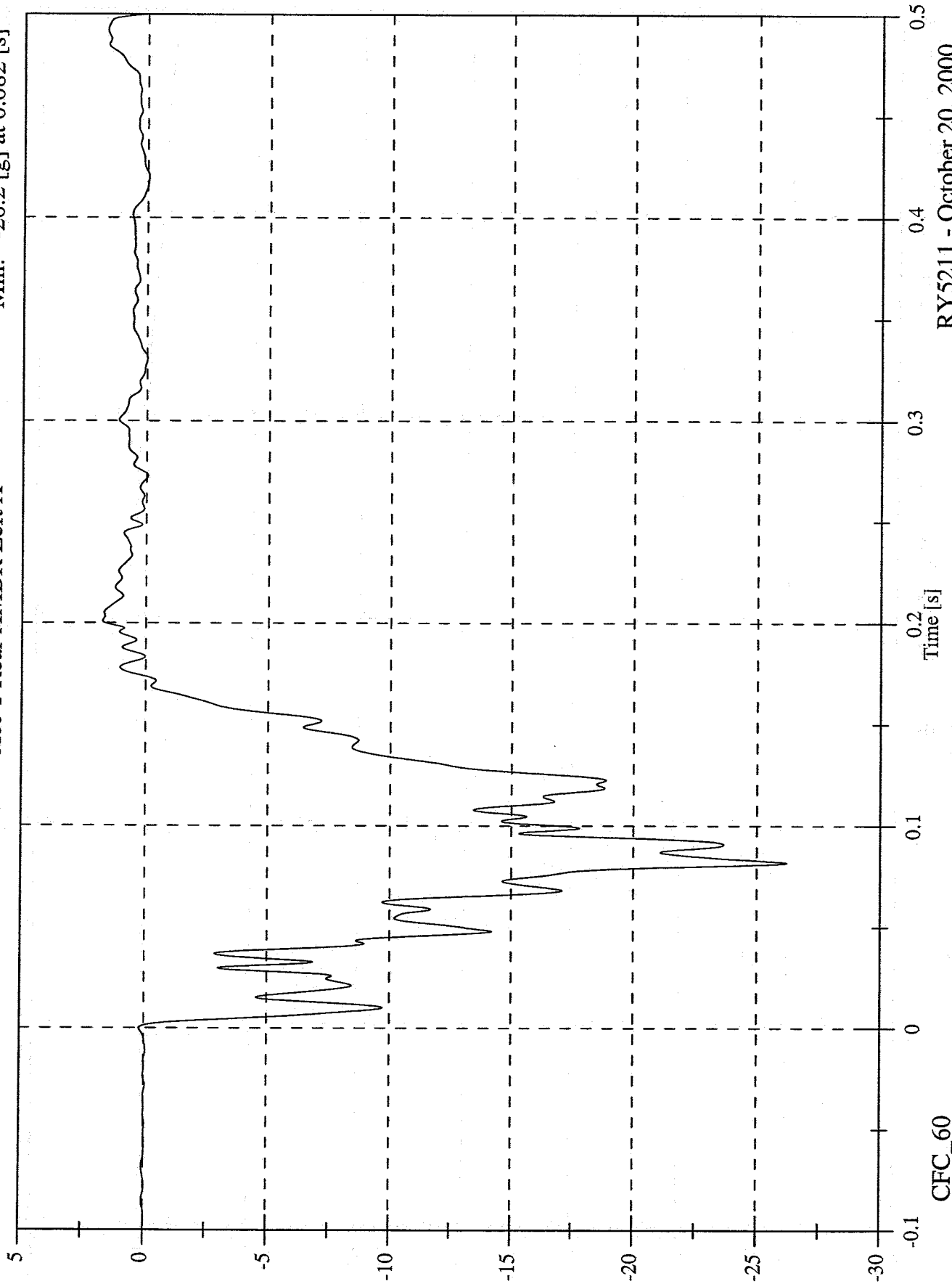

CFC\_60

Time [s]

RY5211 - October 20, 2000

40% Frontal Offset Test #2 - 2000 Nissan Altima

Max: 63.6 [kph] at -0.064 [s]

Min: -3.3 [kph] at 0.174 [s]

Acc 1 Rear XMBR Left X Velocity

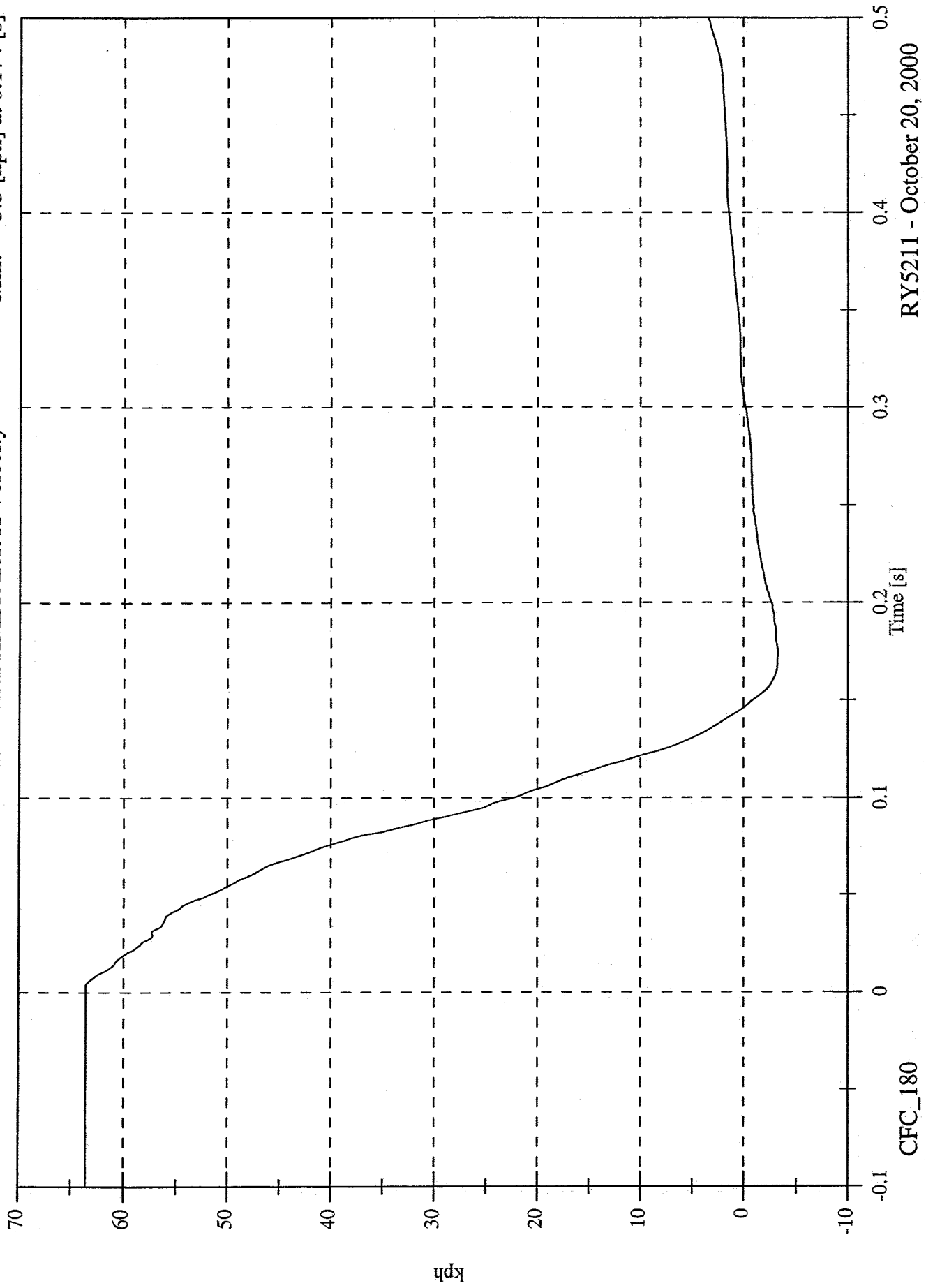

RY5211 - October 20, 2000

CFC\_180

40% Frontal Offset Test #2 - 2000 Nissan Altima

Max: 1481.0 [mm] at 0.500 [s]  
Min: -1766.0 [mm] at -0.100 [s]

Acc 1 Rear XMBR Left X Displacement

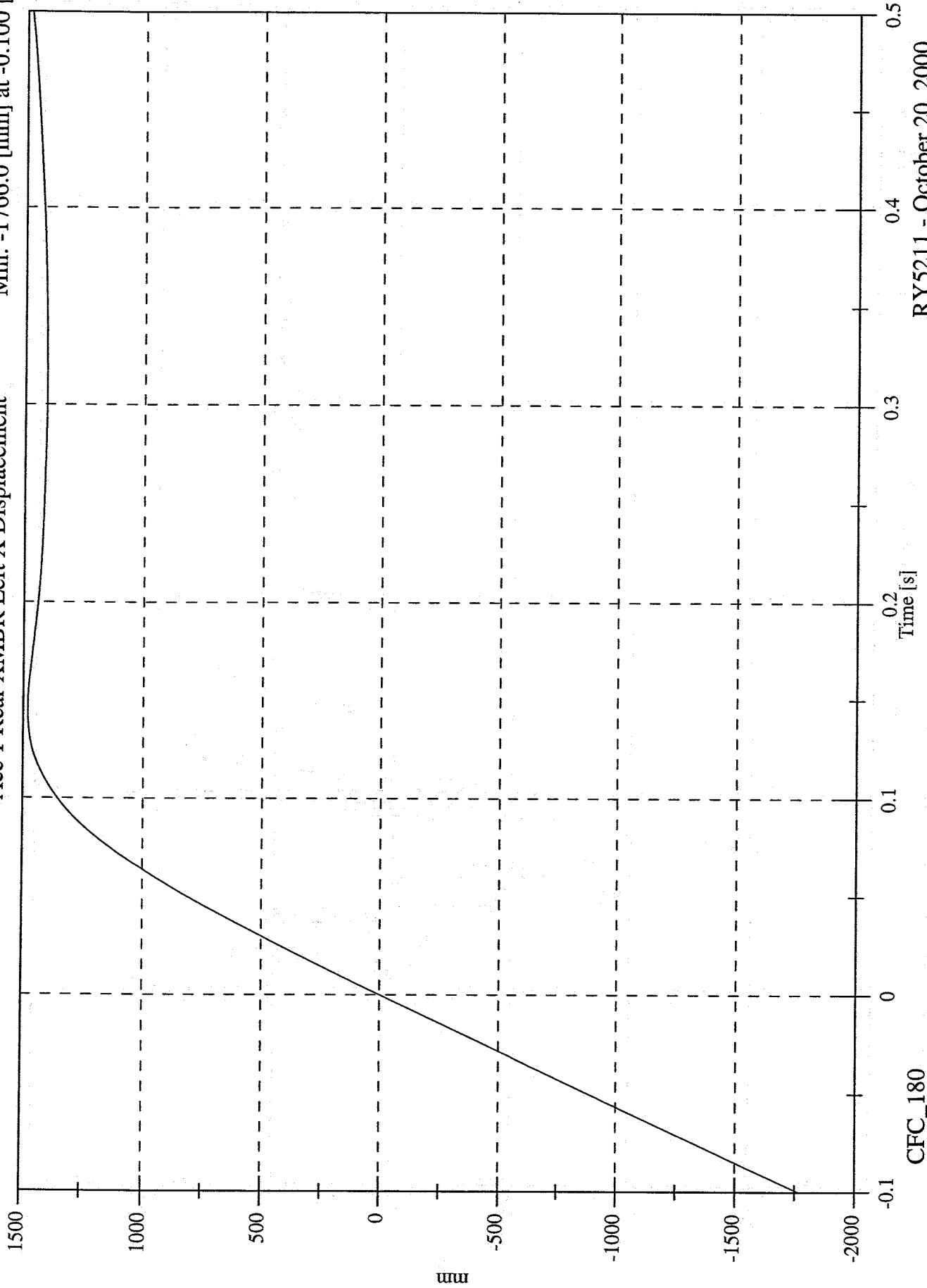

CFC\_180

RY5211 - October 20, 2000

40% Frontal Offset Test #2 - 2000 Nissan Altima  
Acc 2 Rear XMBR Left Y

Max: 10.2 [g] at 0.071 [s]  
Min: -3.4 [g] at 0.097 [s]

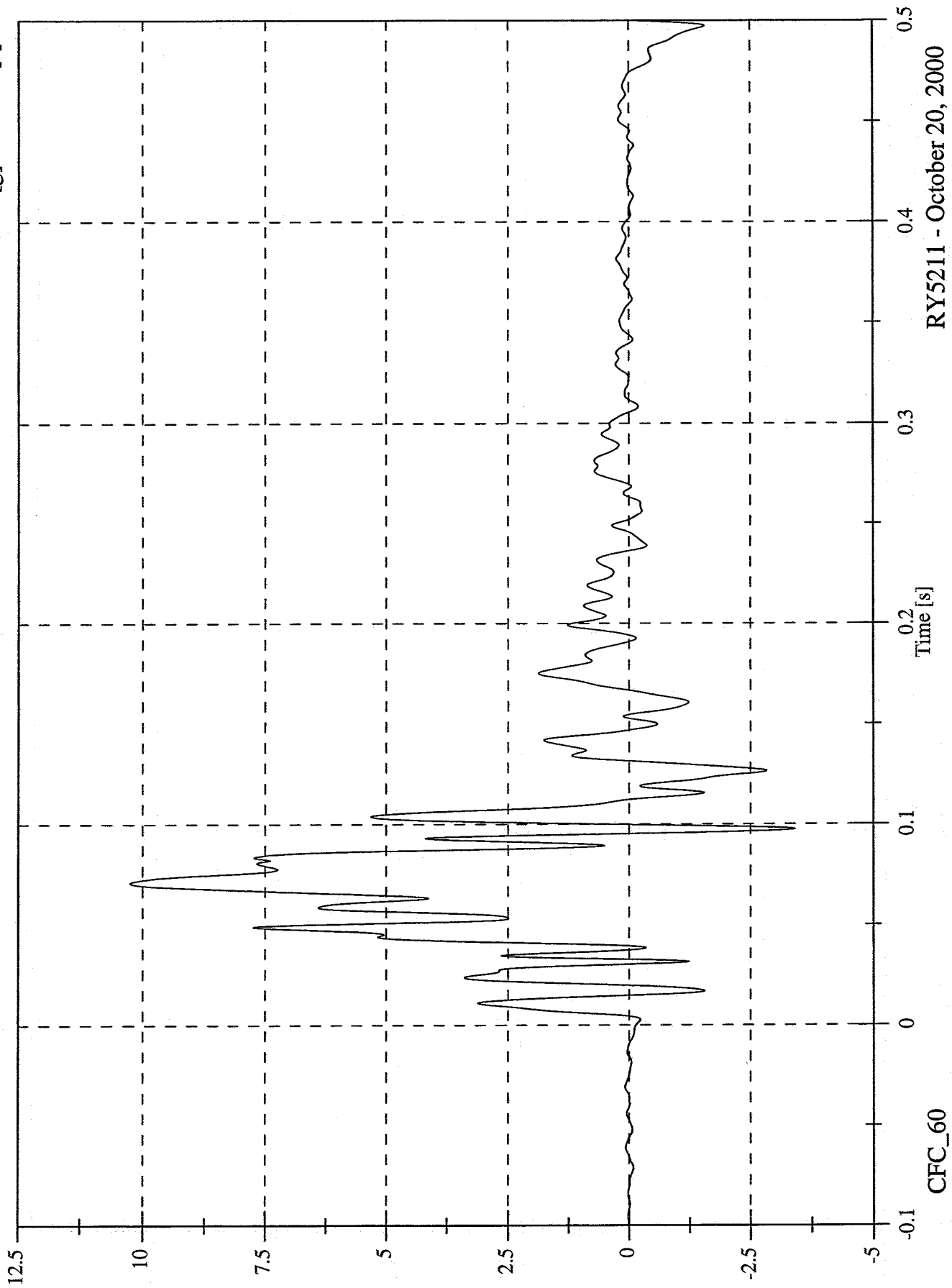

RYS211 - October 20, 2000

40% Frontal Offset Test #2 - 2000 Nissan Altima

Max: 15.3 [kph] at 0.475 [s]  
Min: -0.1 [kph] at 0.005 [s]

Acc 2 Rear XMBR Left Y Velocity

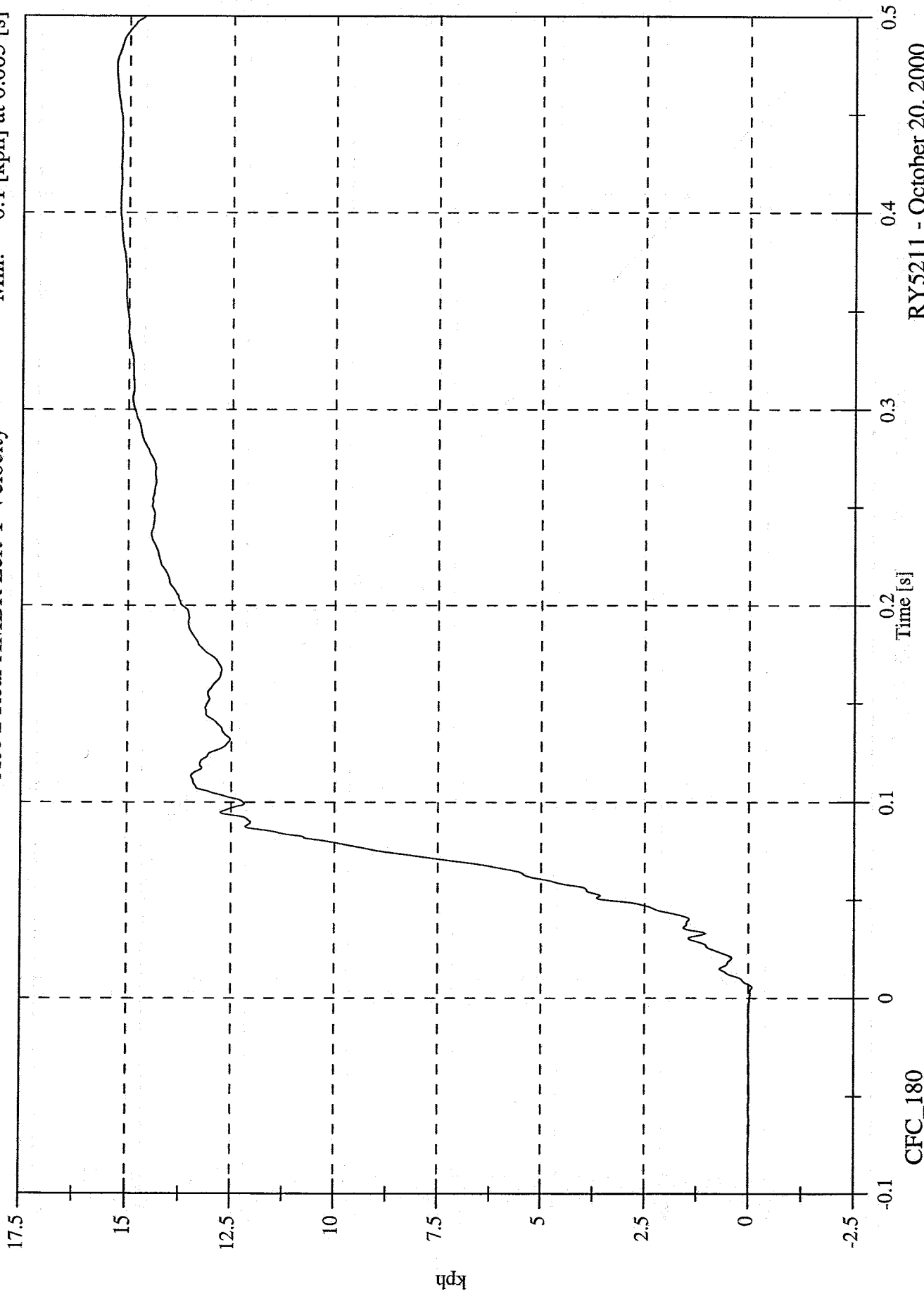

CFC\_180

RY5211 - October 20, 2000

40% Frontal Offset Test #2 - 2000 Nissan Altima

Max: 1732.5 [mm] at 0.500 [s]

Min: -0.1 [mm] at 0.007 [s]

Acc 2 Rear XMBR Left Y Displacement

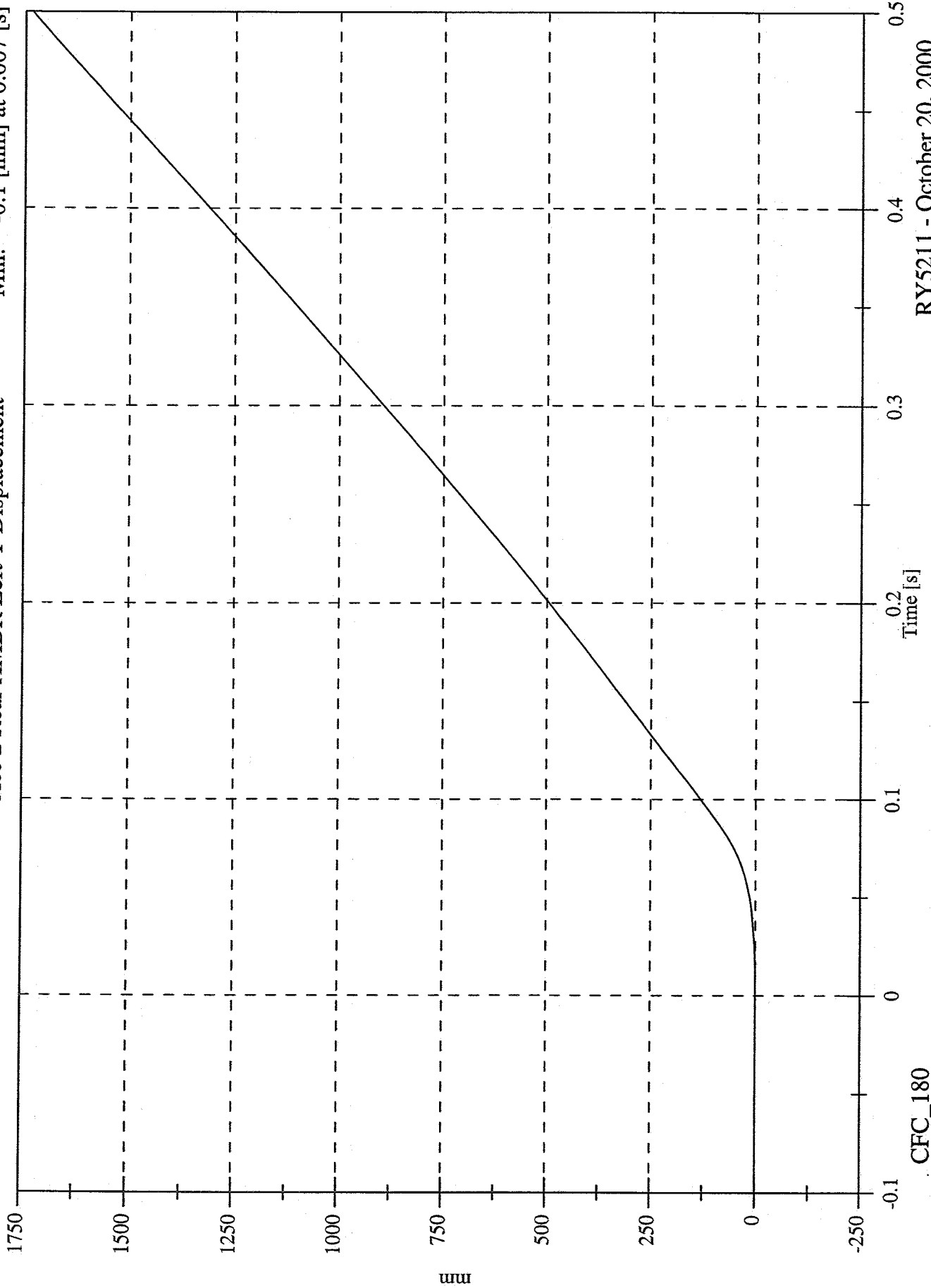

RYS211 - October 20, 2000

CFC\_180

40% Frontal Offset Test #2 - 2000 Nissan Altima

Acc 3 Rear XMBR Right X

Max: 1.2 [g] at 0.495 [s]

Min: -25.2 [g] at 0.084 [s]

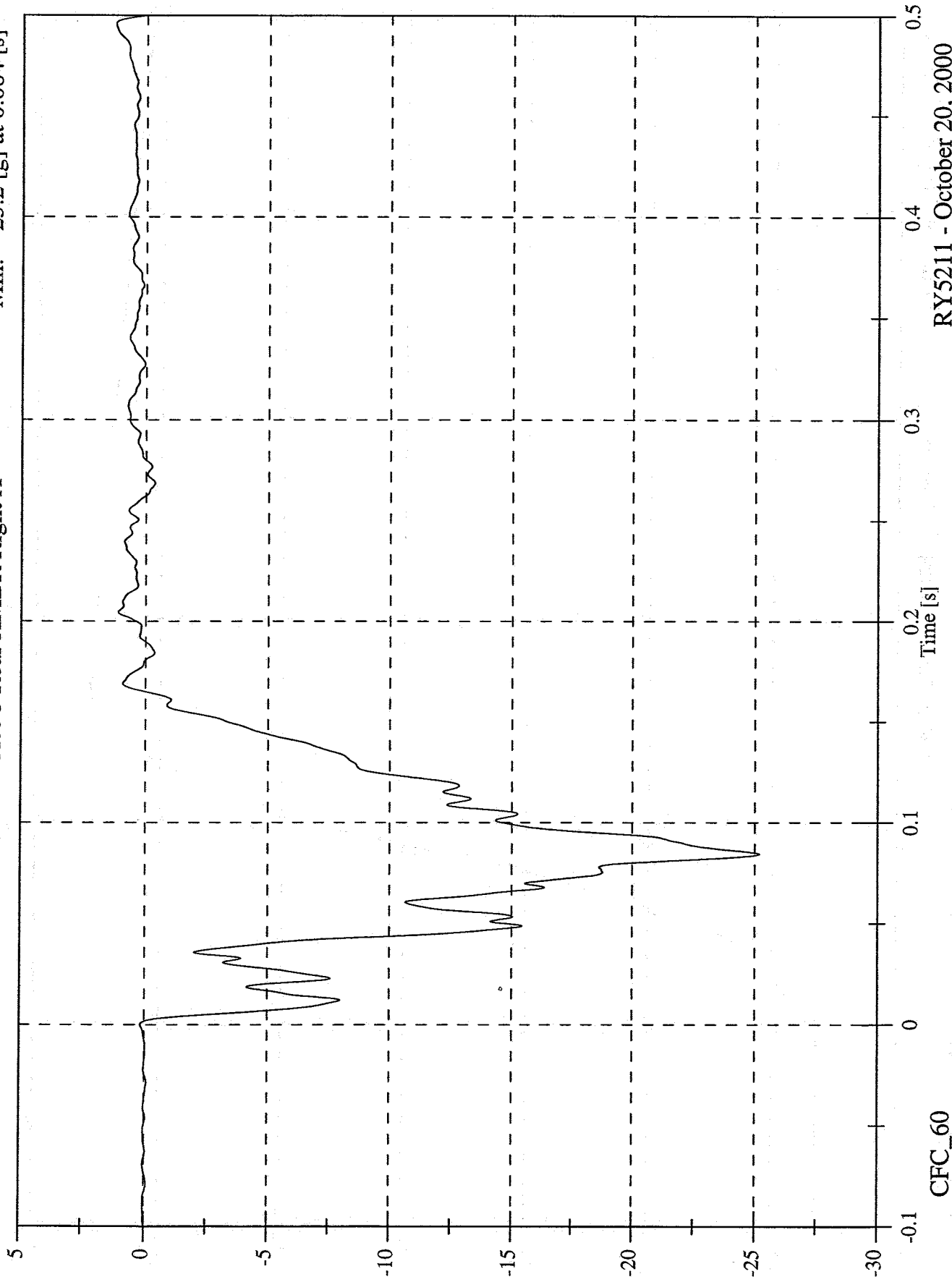

R Y5211 - October 20, 2000

40% Frontal Offset Test #2 - 2000 Nissan Altima

Max: 63.6 [kph] at -0.036 [s]

Min: 4.4 [kph] at 0.165 [s]

Acc 3 Rear XMBR Right X Velocity

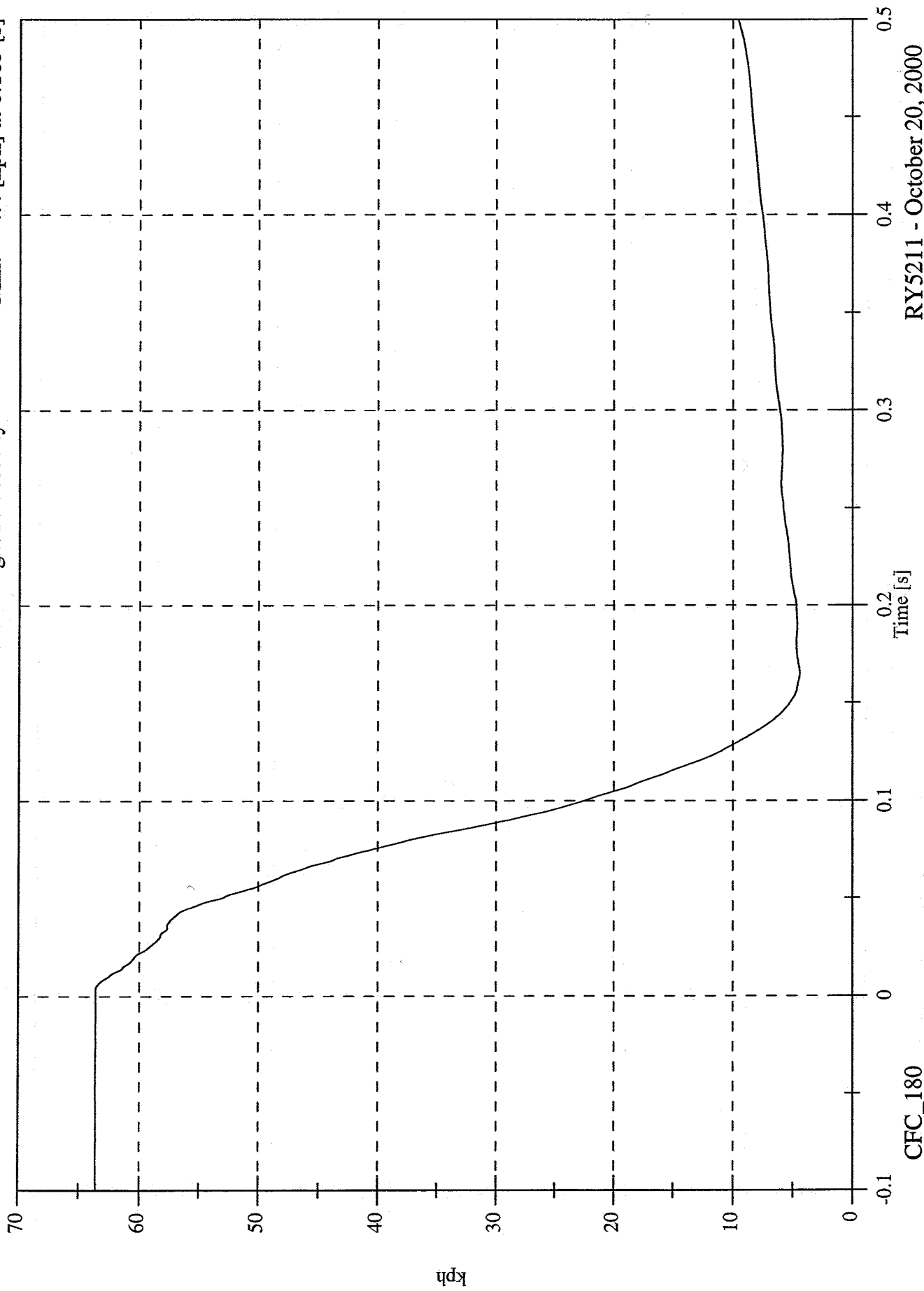

CFC\_180

RY5211 - October 20, 2000

40% Frontal Offset Test #2 - 2000 Nissan Altima

Max: 2181.8 [mm] at 0.500 [s]  
Min: -1766.0 [mm] at -0.100 [s]

Acc 3 Rear XMBR Right X Displacement

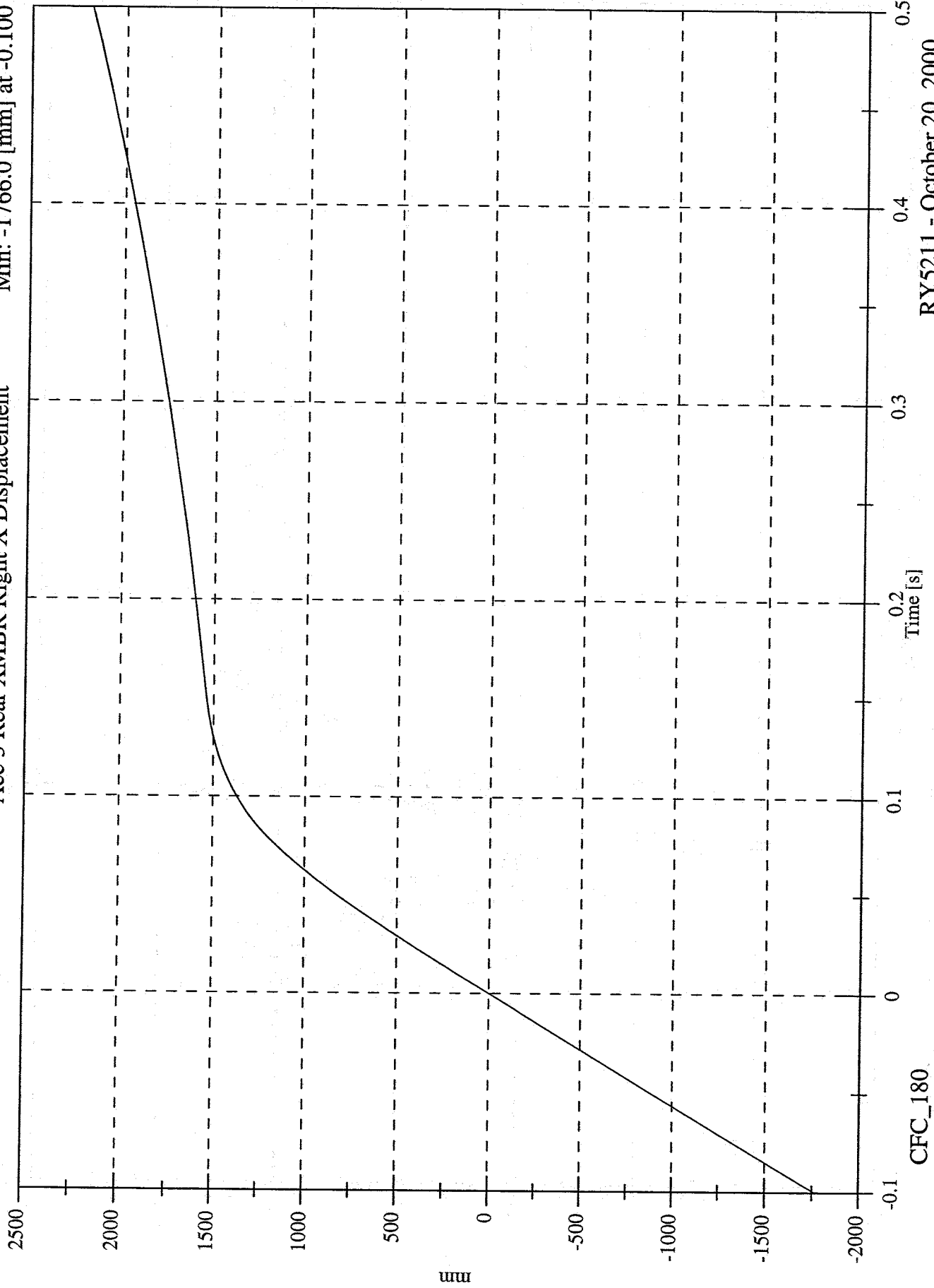

RY5211 - October 20, 2000

40% Frontal Offset Test #2 - 2000 Nissan Altima

Acc 4 Rear XMBR Right Y

Max: 10.8 [g] at 0.073 [s]

Min: -3.8 [g] at 0.126 [s]

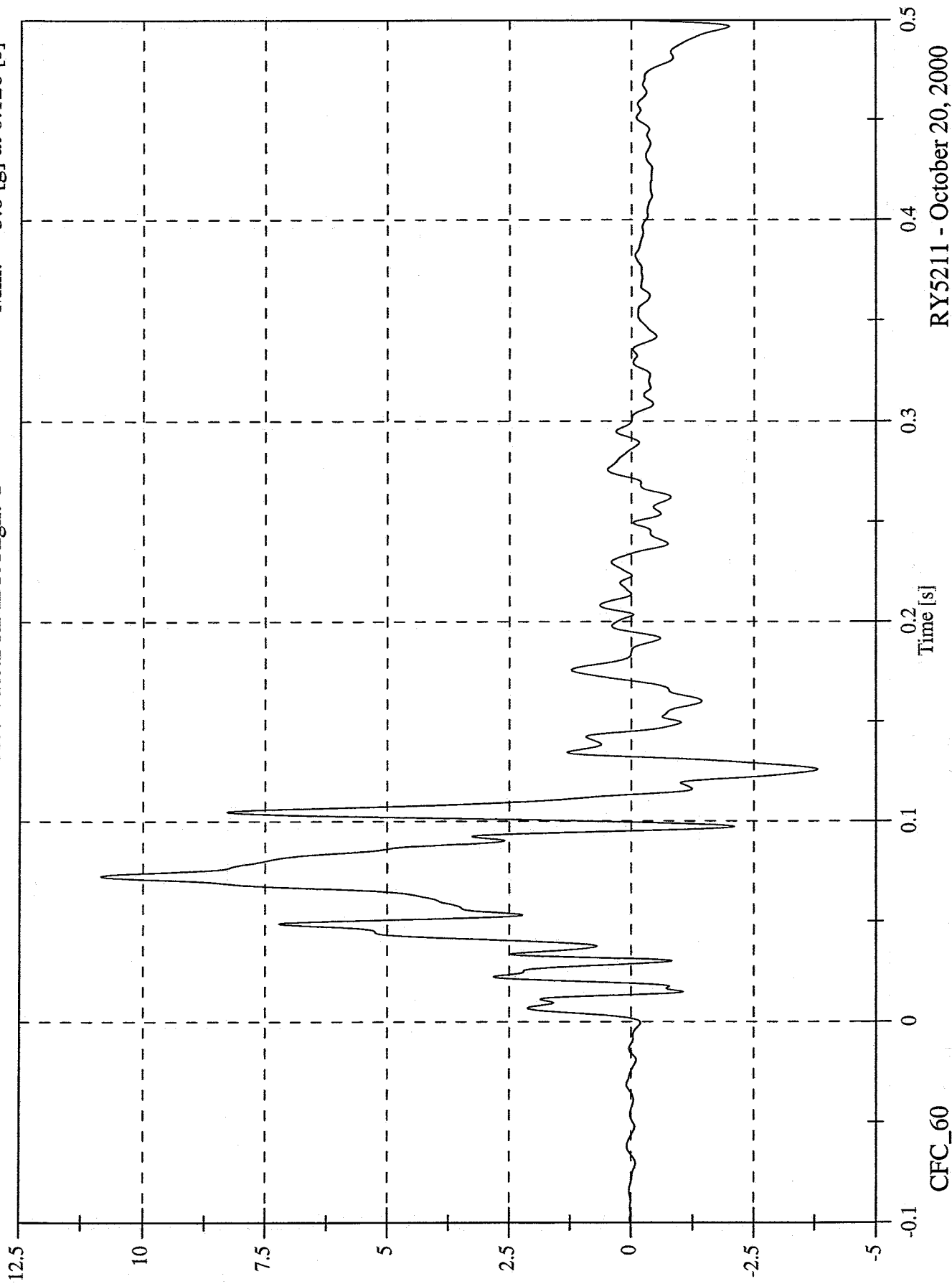

40% Frontal Offset Test #2 - 2000 Nissan Altima

Max: 13.9 [kph] at 0.114 [s]  
Min: -0.0 [kph] at 0.002 [s]

Acc 4 Rear XMBR Right Y Velocity

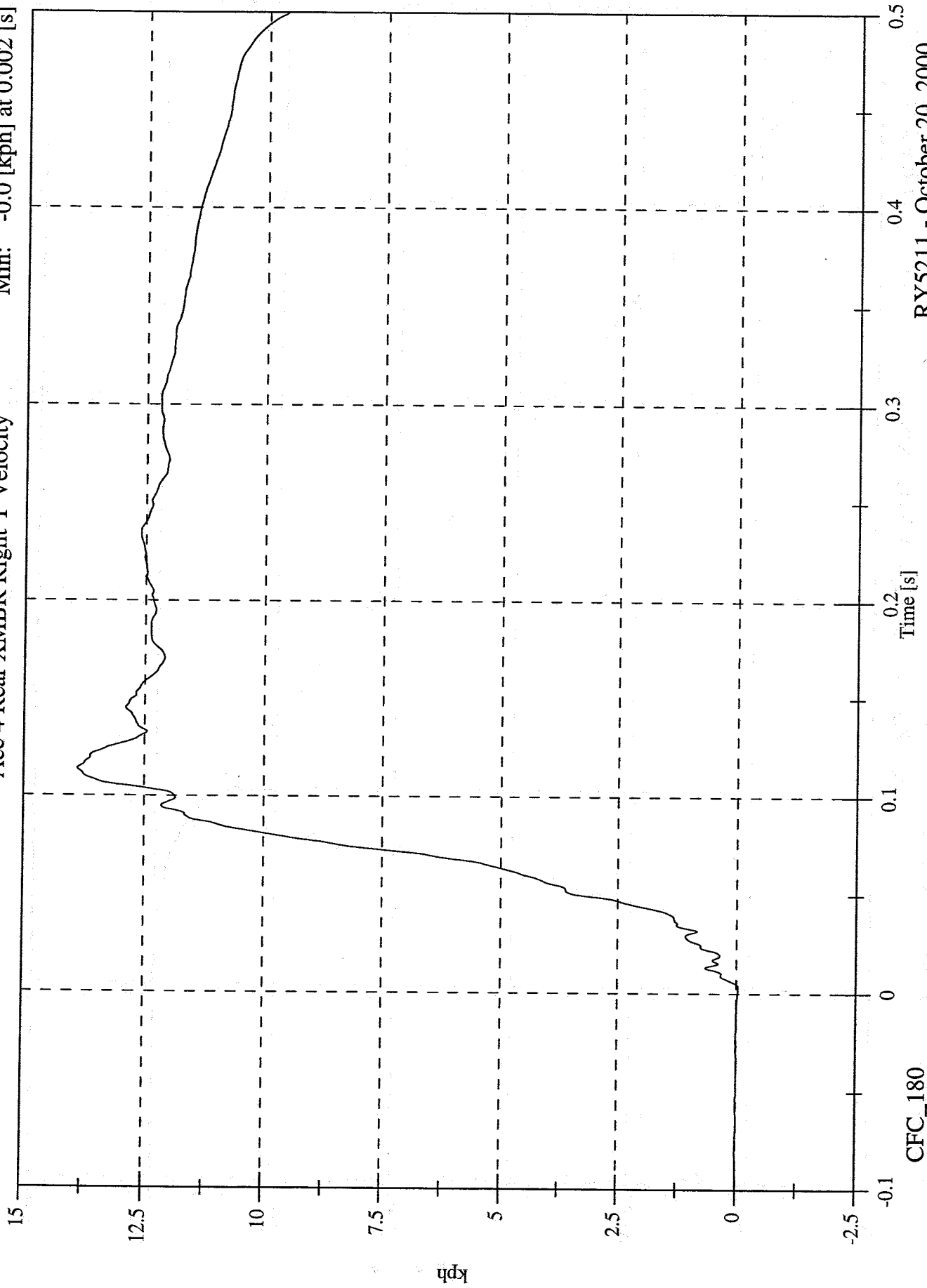

CFC\_180

RY5211 - October 20, 2000

40% Frontal Offset Test #2 - 2000 Nissan Altima  
Acc 4 Rear XMBR Right Y Displacement

Max: 1446.8 [mm] at 0.500 [s]  
Min: -0.1 [mm] at -0.100 [s]

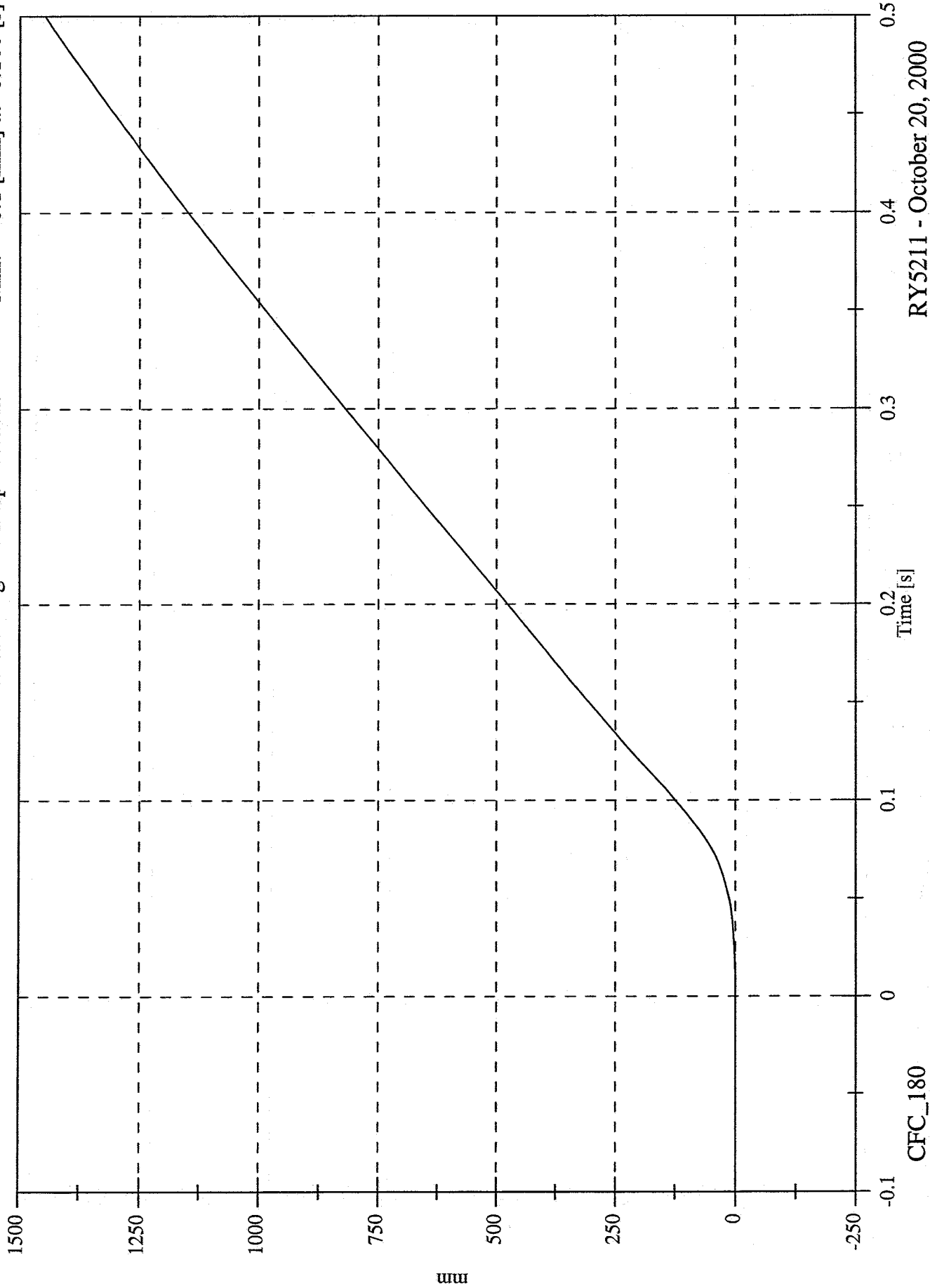

RYS211 - October 20, 2000

40% Frontal Offset Test #2 - 2000 Nissan Altima

Acc 5 P1 Toepan Left X

Max: 14.1 [g] at 0.081 [s]  
Min: -53.6 [g] at 0.307 [s]

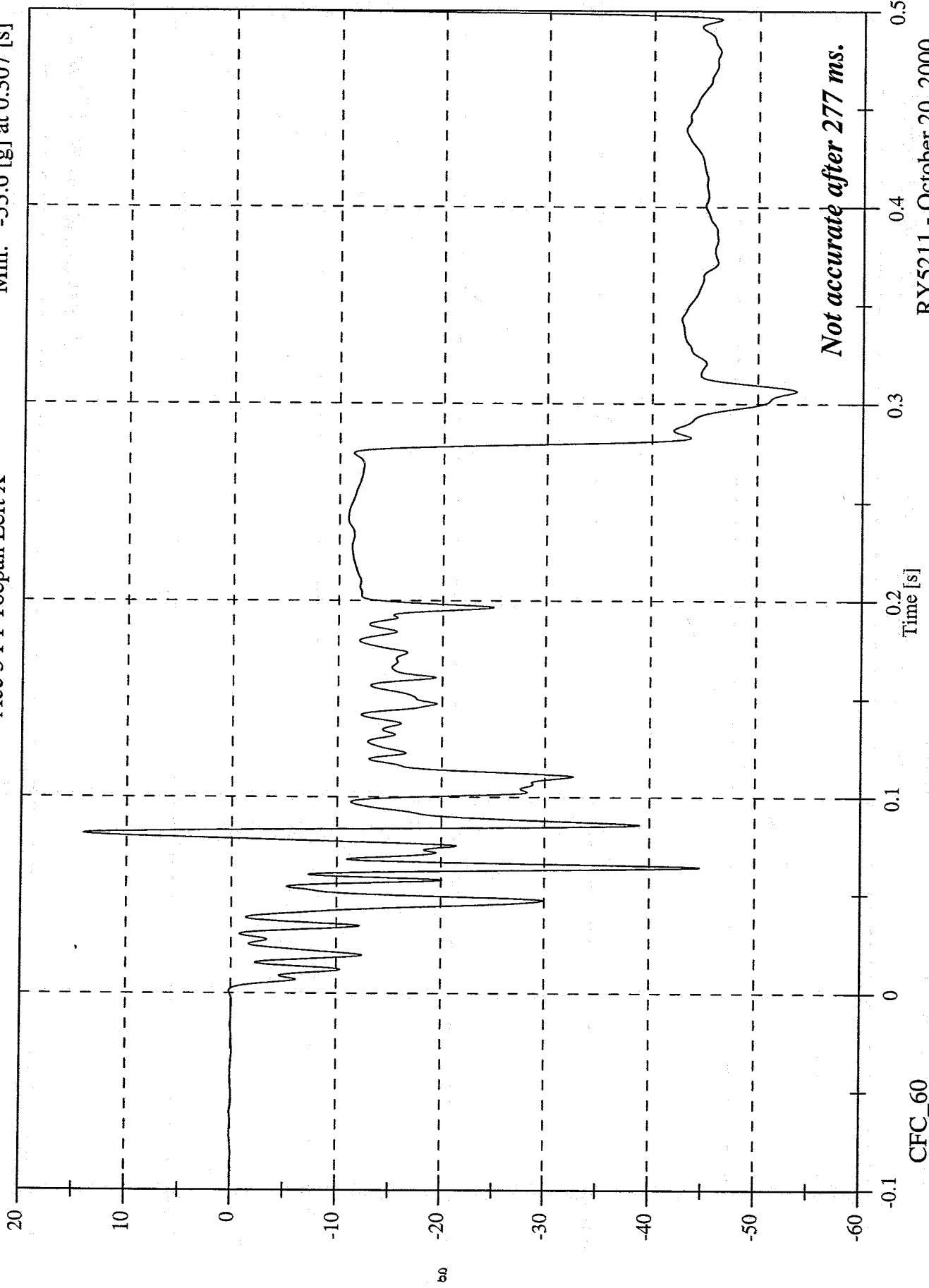

Not accurate after 277 ms.

RY5211 - October 20, 2000

40% Frontal Offset Test #2 - 2000 Nissan Altima

Max: 63.6 [kph] at -0.036 [s]

Min: -421.1 [kph] at 0.500 [s]

Acc 5 P1 Toe pan Left X Velocity

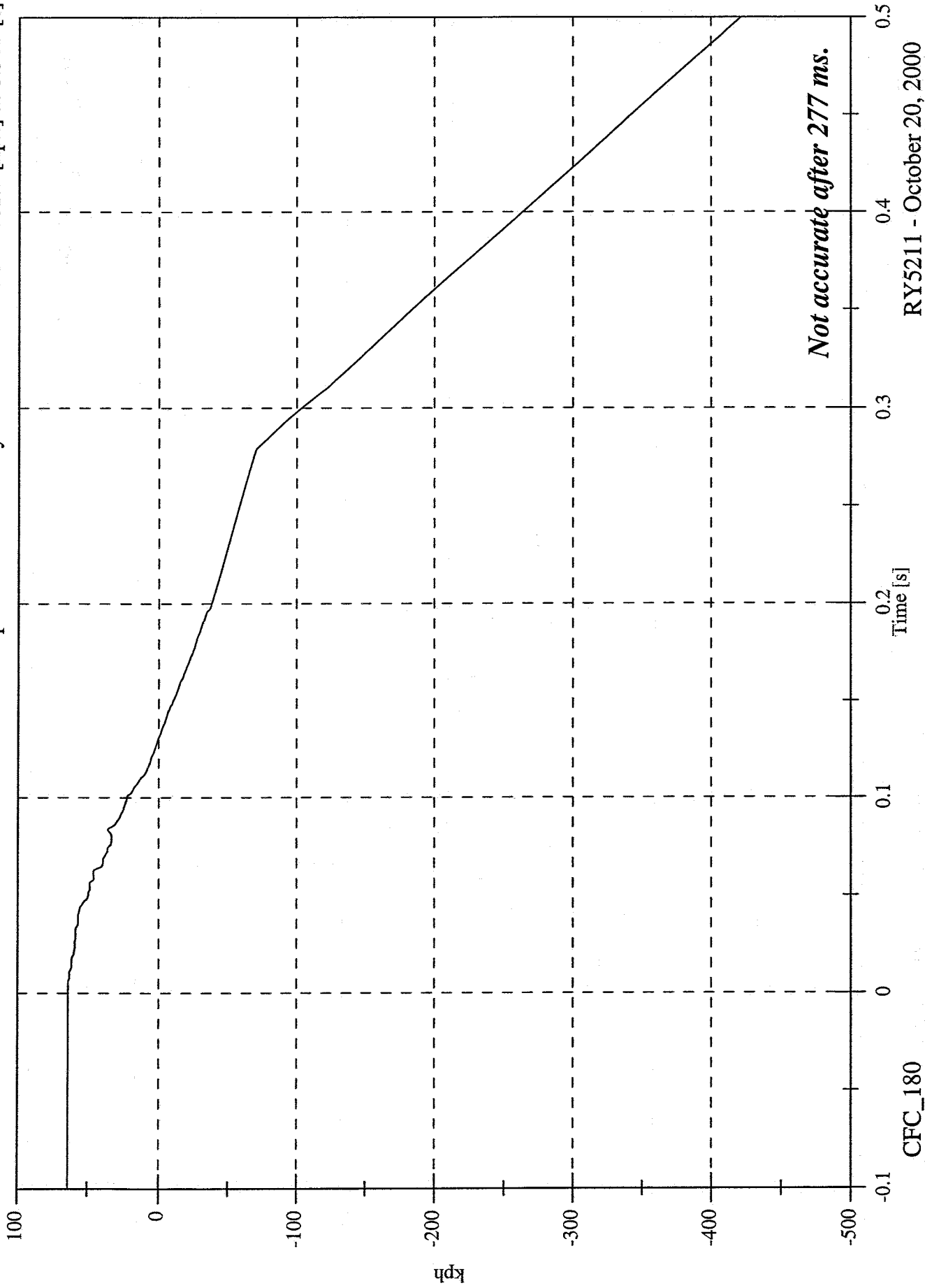

*Not accurate after 277 ms.*

RY5211 - October 20, 2000

40% Frontal Offset Test #2 - 2000 Nissan Altima

Acc 5 P1 Toe pan Left X Displacement

Max: 1405.8 [mm] at 0.131 [s]  
Min: -15280.8 [mm] at 0.500 [s]

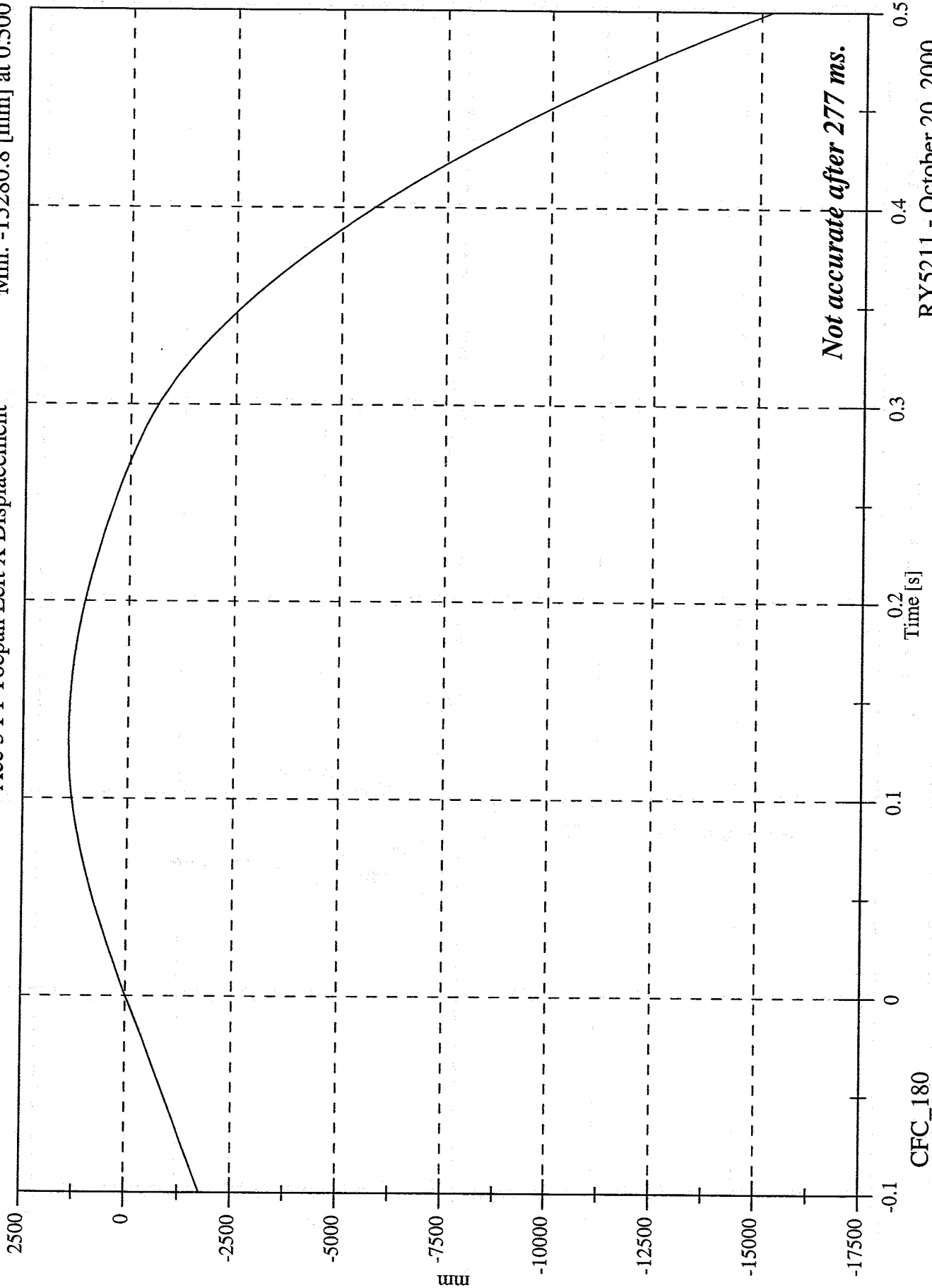

CFC\_180

RY5211 - October 20, 2000

40% Frontal Offset Test #2 - 2000 Nissan Altima

Max: 62.8 [g] at 0.082 [s]

Min: -51.8 [g] at 0.064 [s]

Acc 6 P1 Toepan Left Z

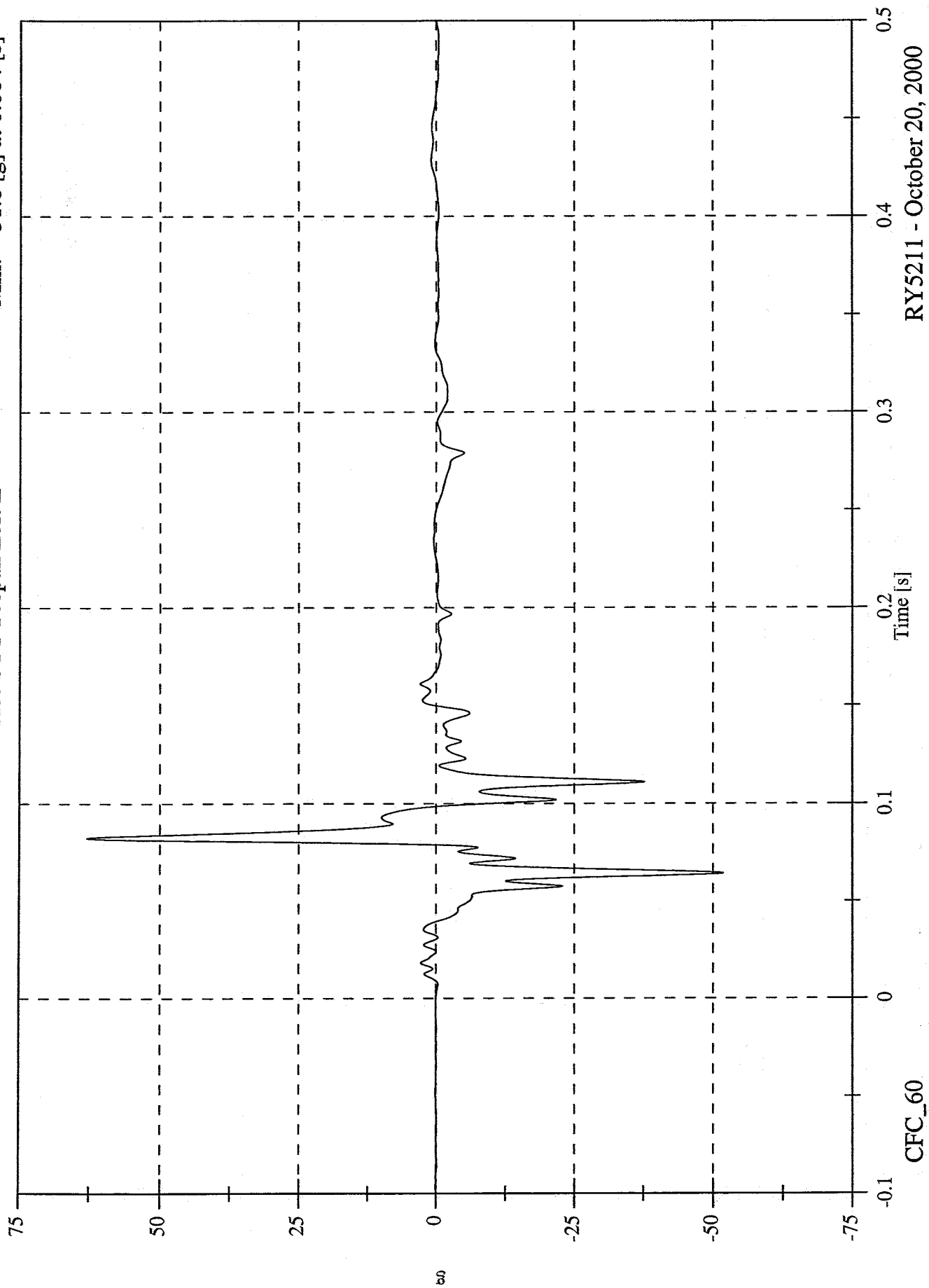

RYS211 - October 20, 2000

40% Frontal Offset Test #2 - 2000 Nissan Altima

Max: 1.3 [kph] at 0.040 [s]  
Min: -19.9 [kph] at 0.416 [s]

Acc 6 P1 Toe pan Left Z Velocity

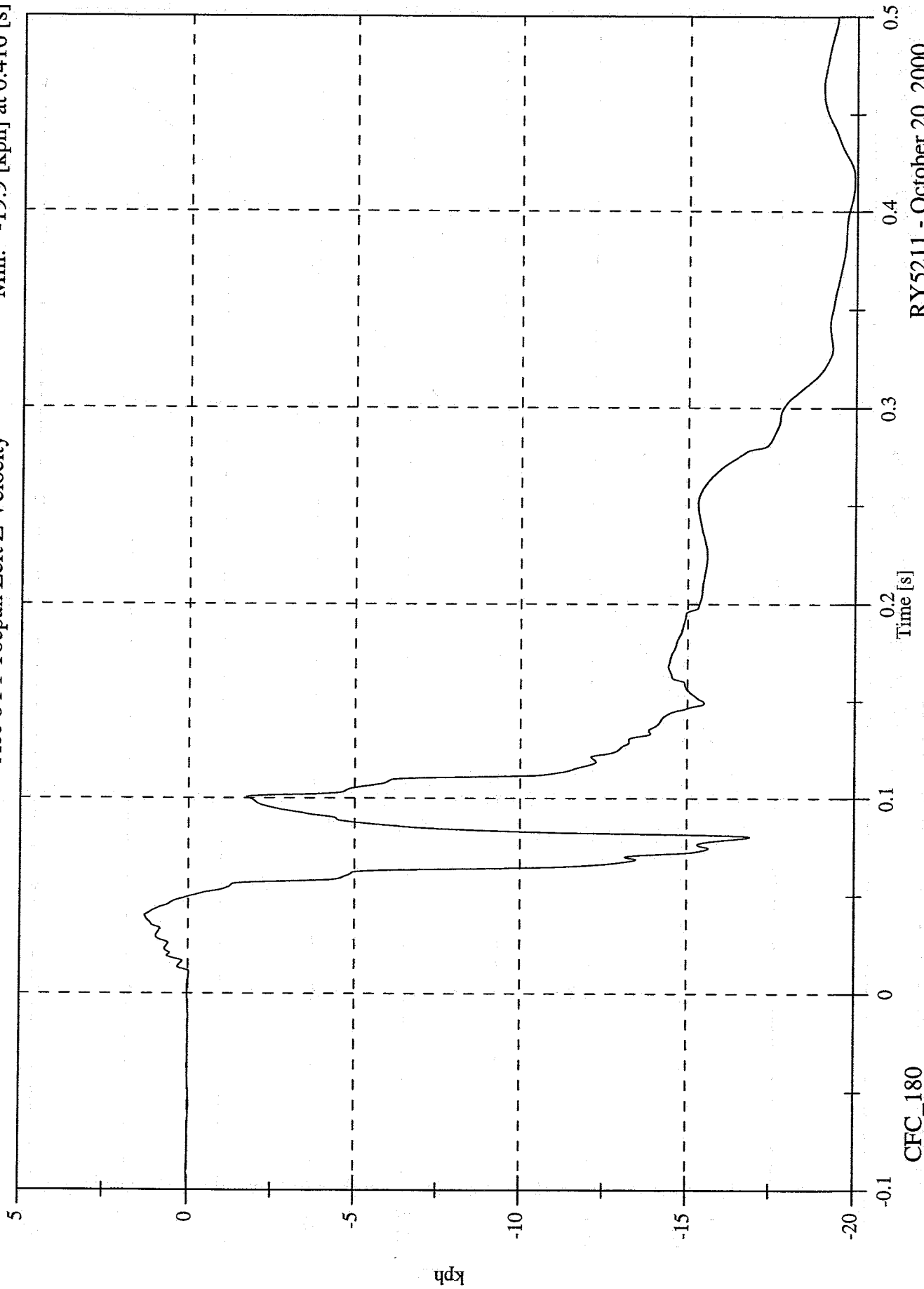

CFC\_180

RY5211 - October 20, 2000

40% Frontal Offset Test #2 - 2000 Nissan Altima

Max: 7.7 [mm] at 0.050 [s]  
Min: -1980.4 [mm] at 0.500 [s]

Acc 6 P1 Toe pan Left Z Displacement

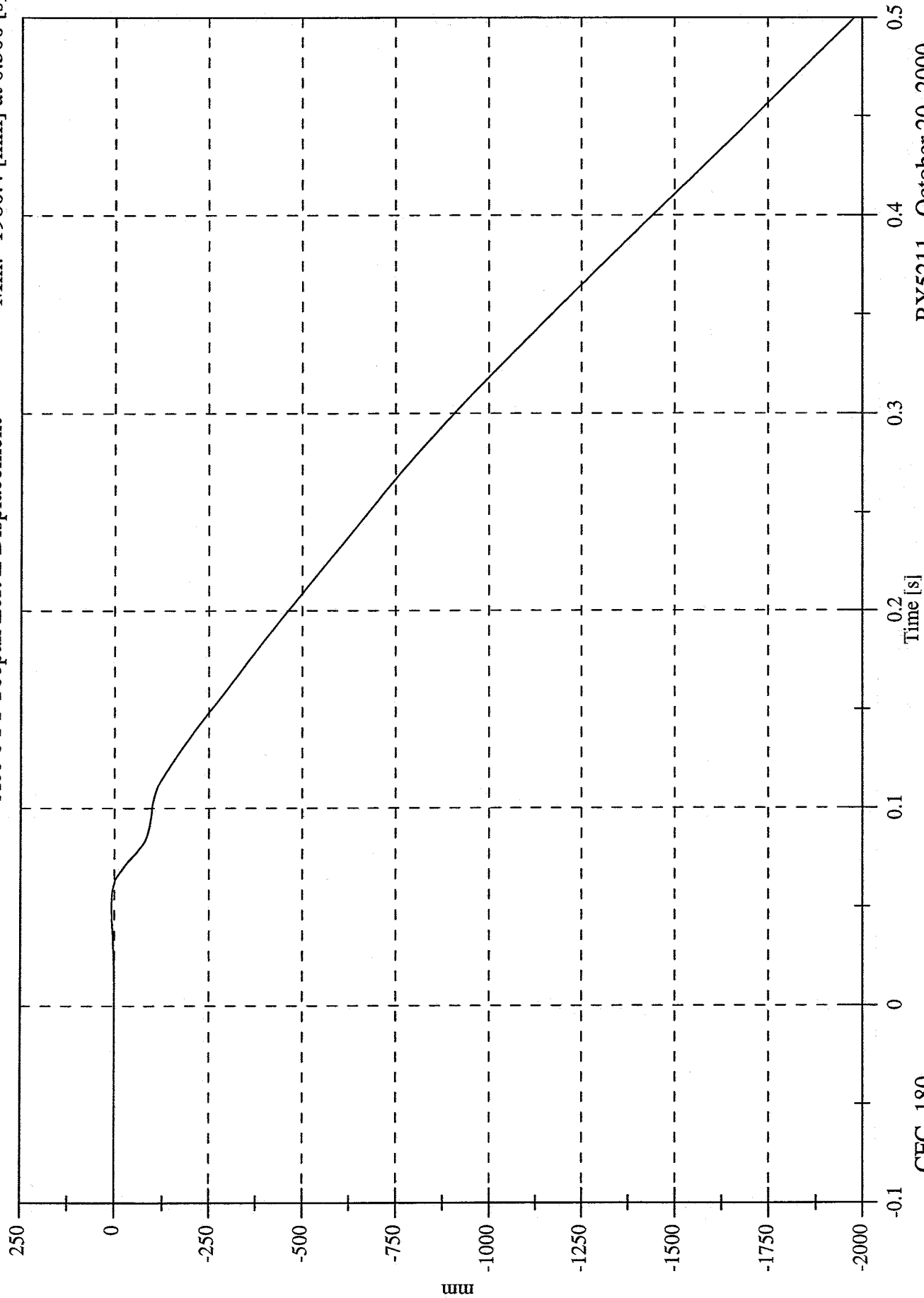

CFC\_180

RY5211 - October 20, 2000

40% Frontal Offset Test #2 - 2000 Nissan Altima

Acc 7 P1 Toe pan Right X

Max: 27.9 [g] at 0.030 [s]  
Min: -63.8 [g] at 0.066 [s]

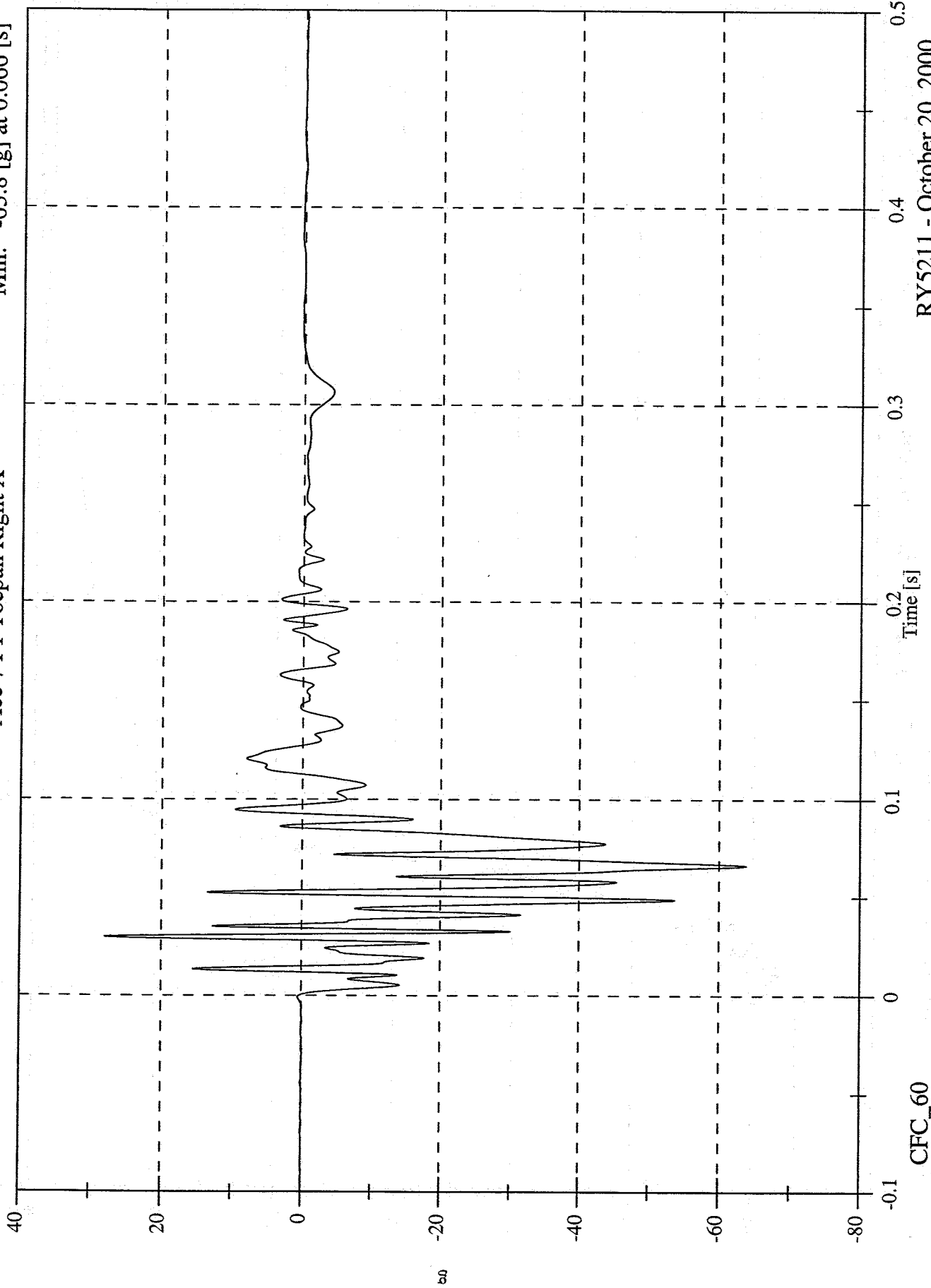

RY5211 - October 20, 2000

40% Frontal Offset Test #2 - 2000 Nissan Altima

Max: 63.6 [kph] at -0.036 [s]

Min: 0.5 [kph] at 0.327 [s]

Acc 7 P1 Toe pan Right X Velocity

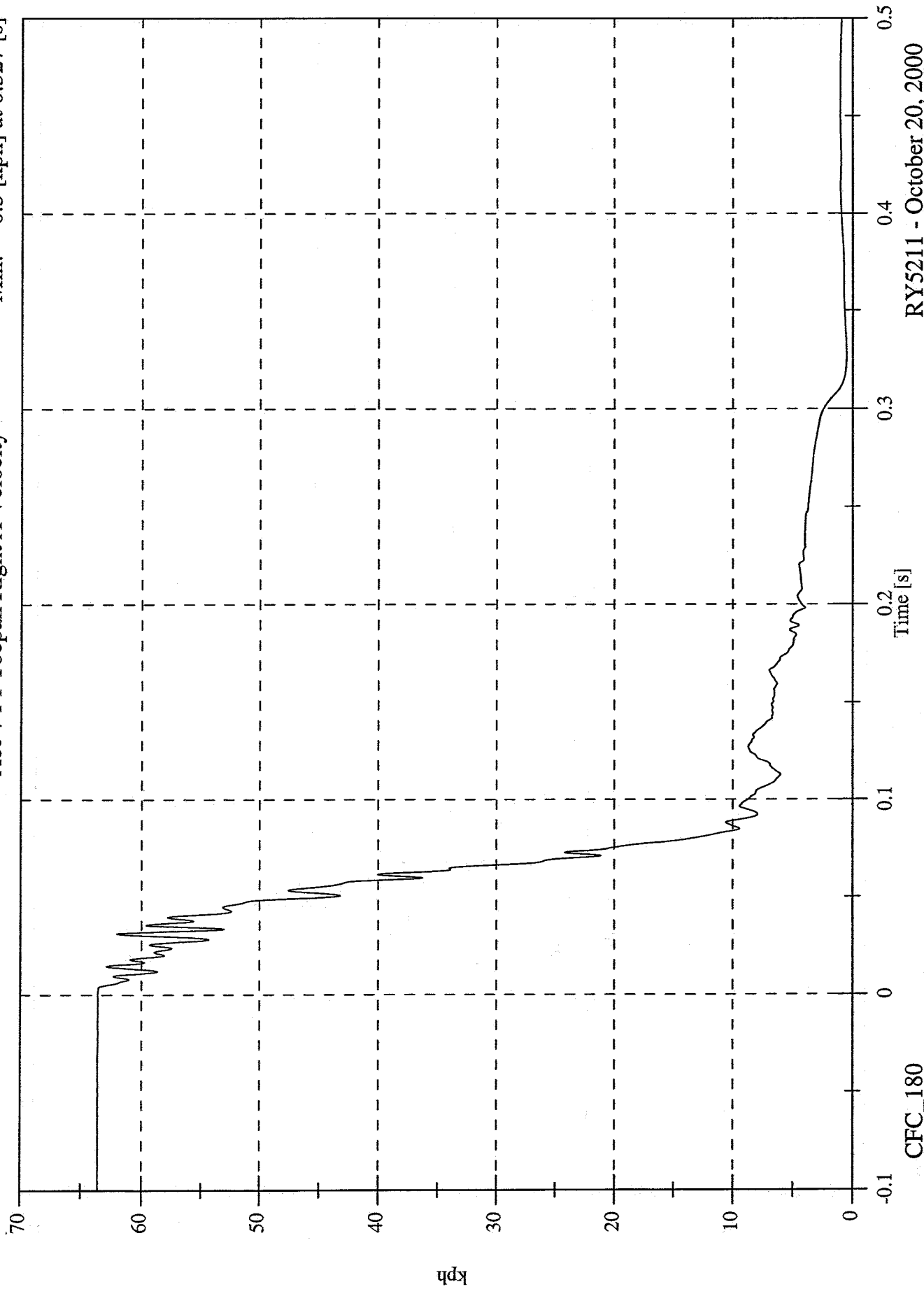

RY5211 - October 20, 2000

CFC\_180

40% Frontal Offset Test #2 - 2000 Nissan Altima

Acc 7 P1 Toe pan Right X Displacement

Max: 1459.2 [mm] at 0.500 [s]  
Min: -1766.1 [mm] at -0.100 [s]

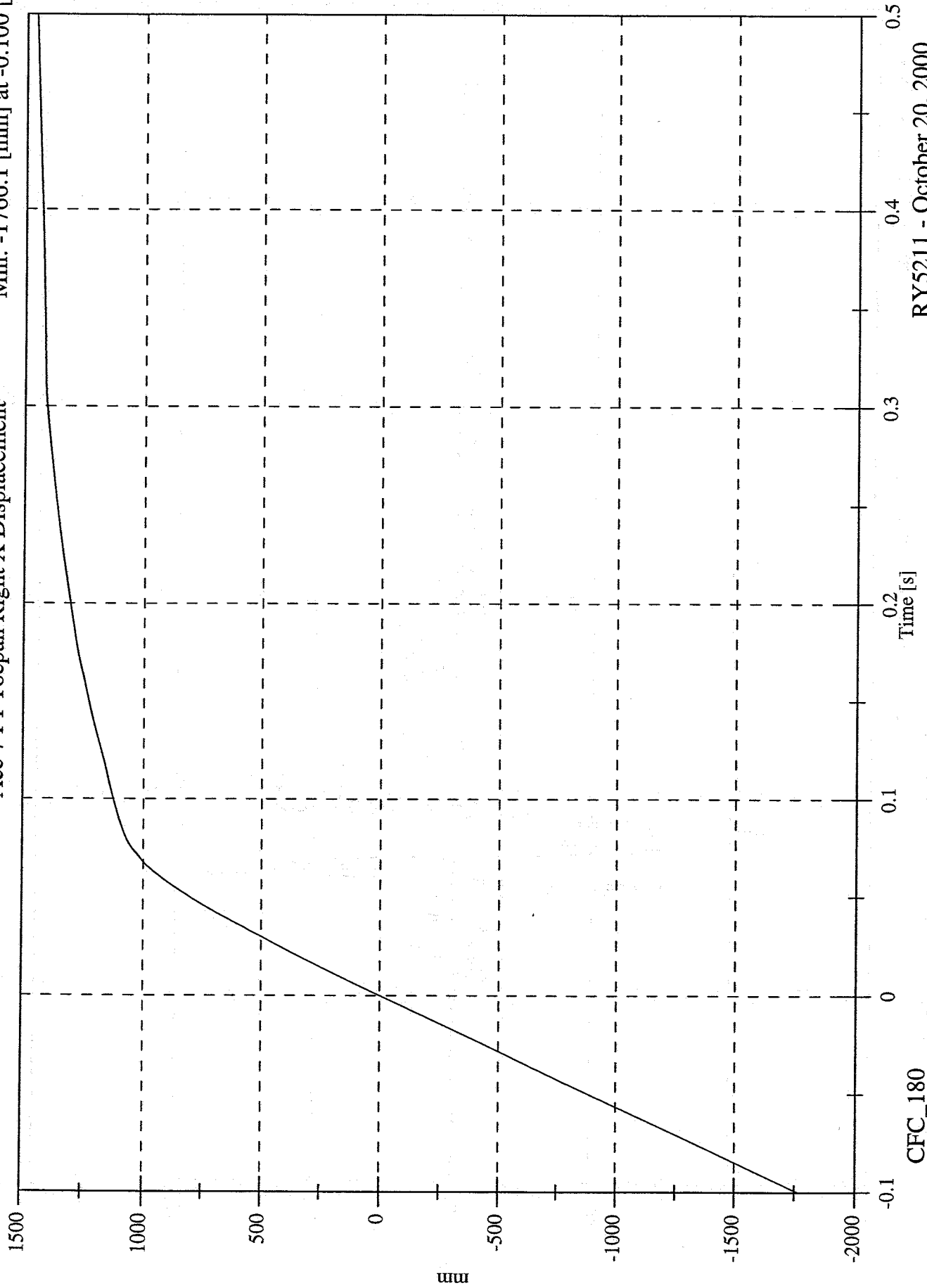

RYS211 - October 20, 2000

40% Frontal Offset Test #2 - 2000 Nissan Altima

Acc 8 P1 Toepan Right Z

Max: 23.2 [g] at 0.080 [s]  
Min: -20.2 [g] at 0.058 [s]

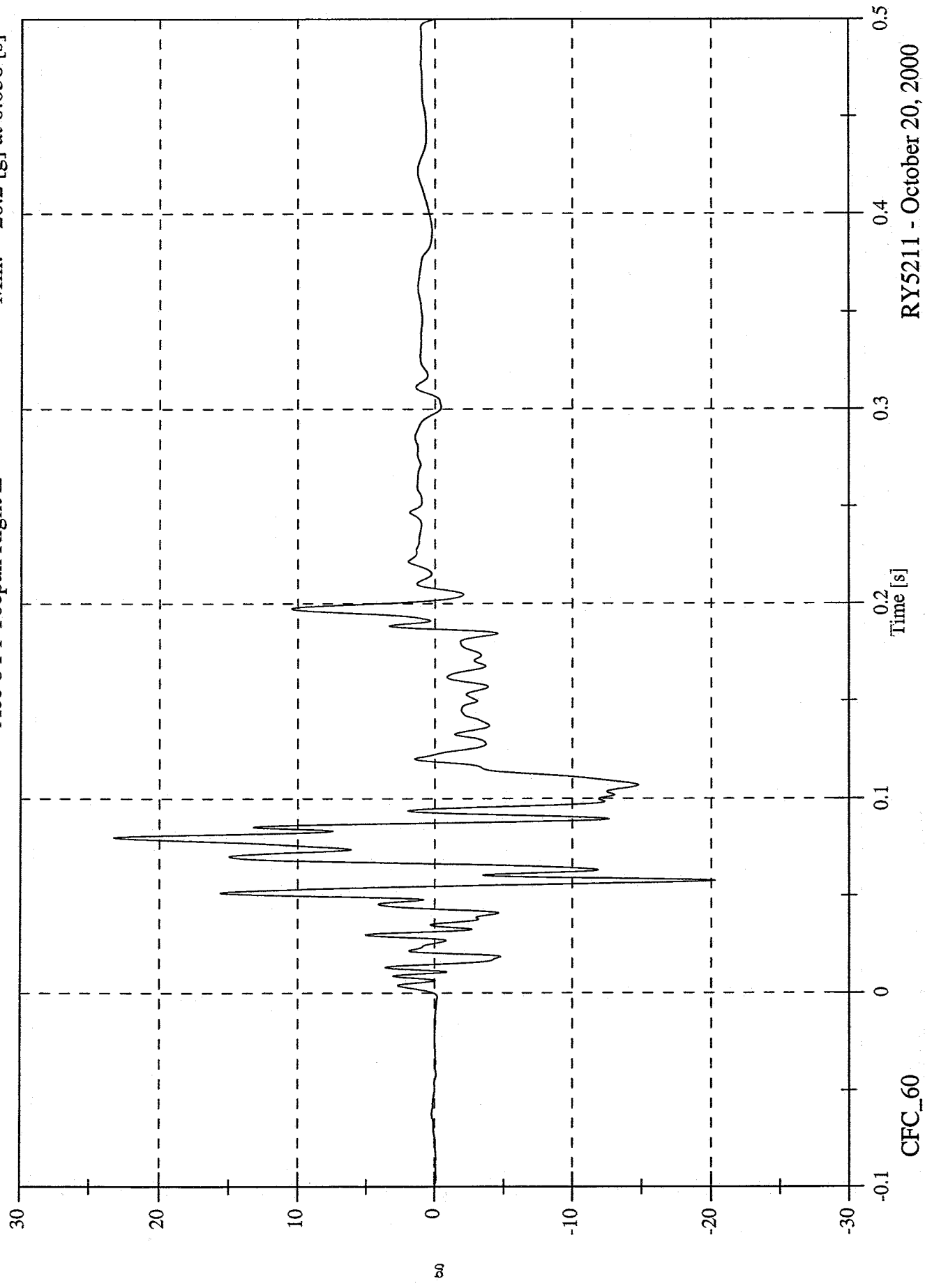

RY5211 - October 20, 2000

40% Frontal Offset Test #2 - 2000 Nissan Altima

Max: 7.9 [kph] at 0.088 [s]

Min: -8.1 [kph] at 0.187 [s]

Acc 8 P1 Toe Pan Right Z Velocity

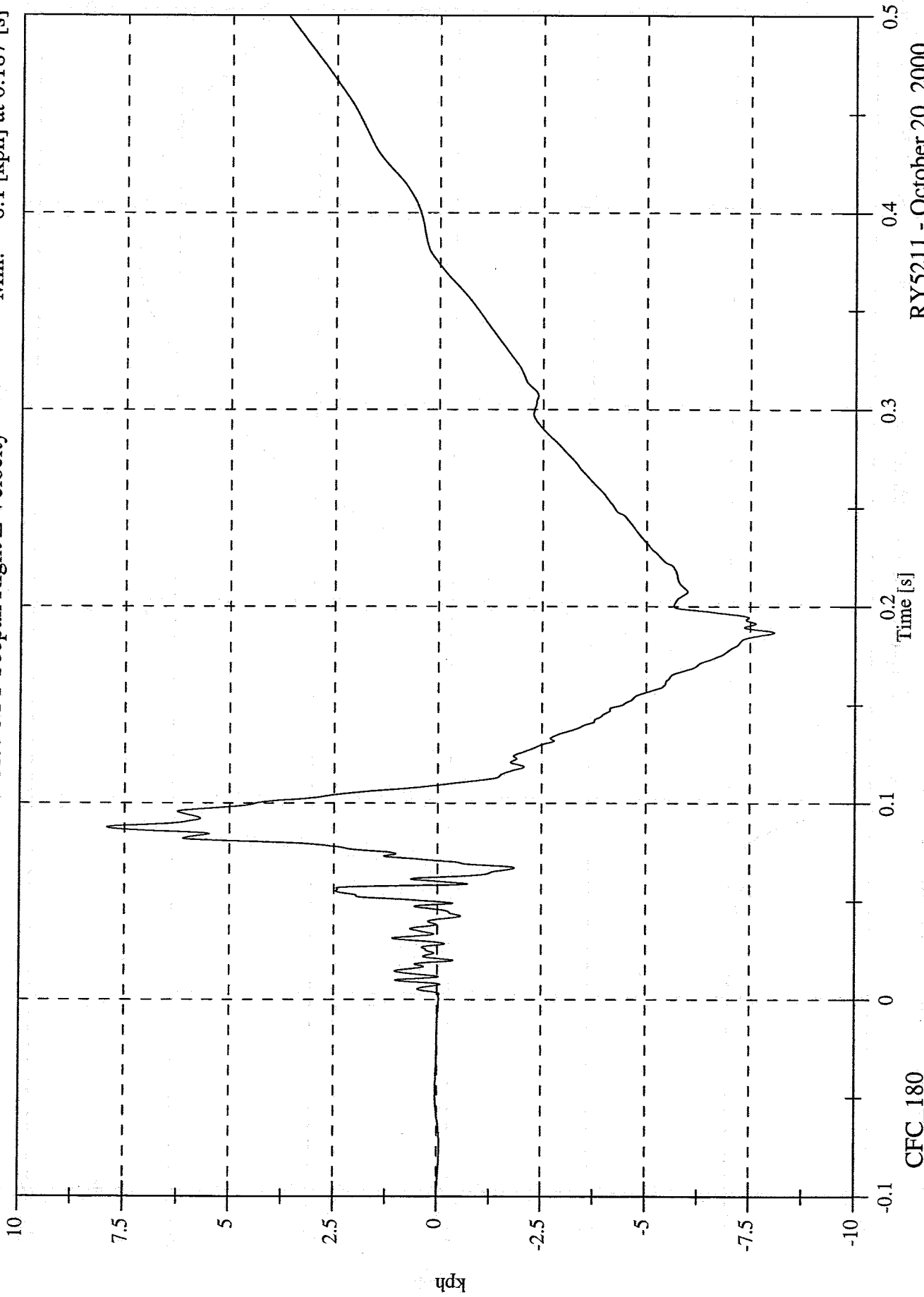

CFC\_180

RY5211 - October 20, 2000

40% Frontal Offset Test #2 - 2000 Nissan Altima

Max: 48.1 [mm] at 0.109 [s]  
Min: -214.1 [mm] at 0.373 [s]

Acc 8 P1 Toepan Right Z Displacement

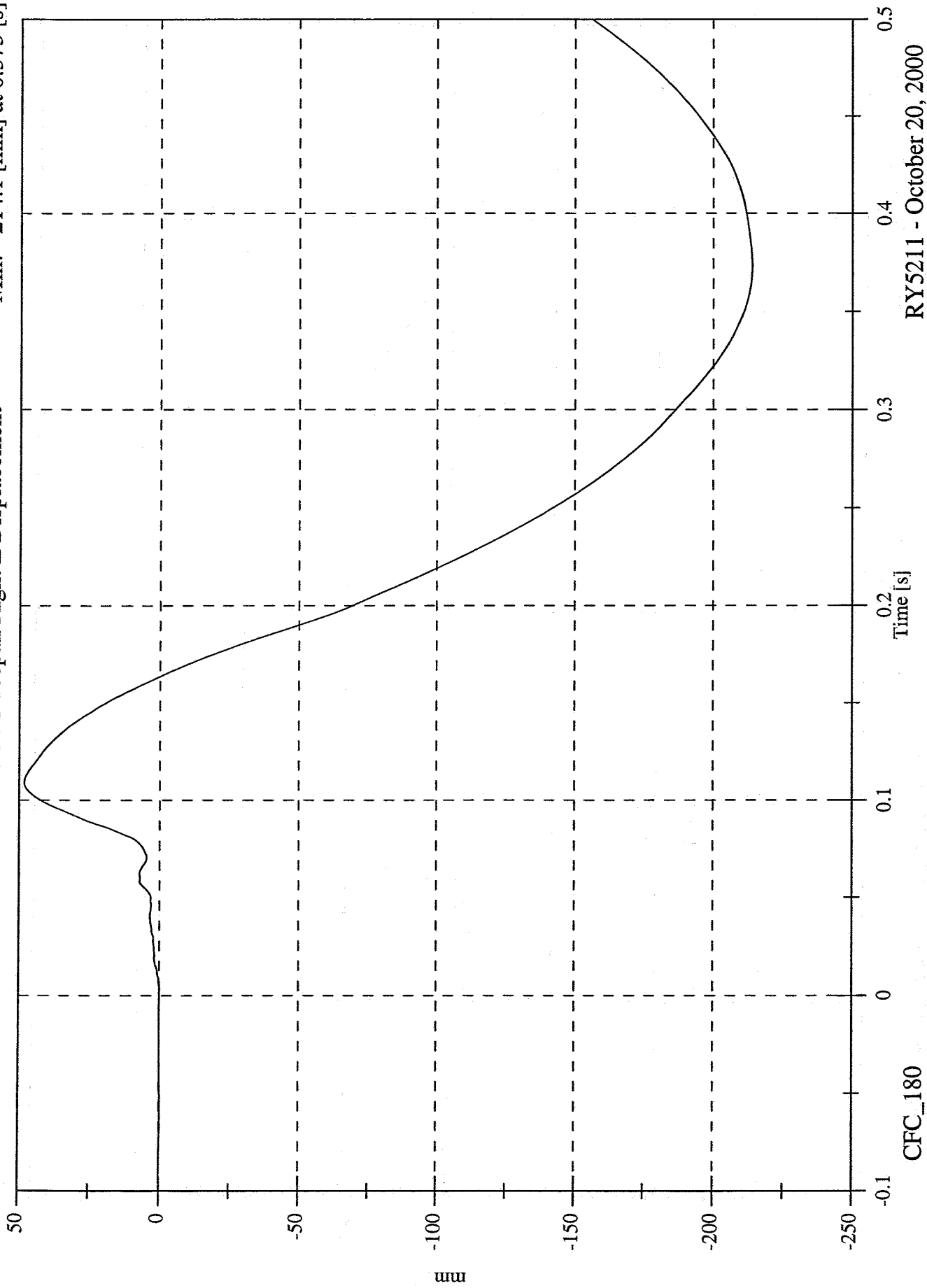

RY5211 - October 20, 2000

CFC\_180

40% Frontal Offset Test #2 - 2000 Nissan Altima

Max: 6.4 [g] at 0.155 [s]  
Min: -6.2 [g] at 0.079 [s]

Acc 9 Trunk Z

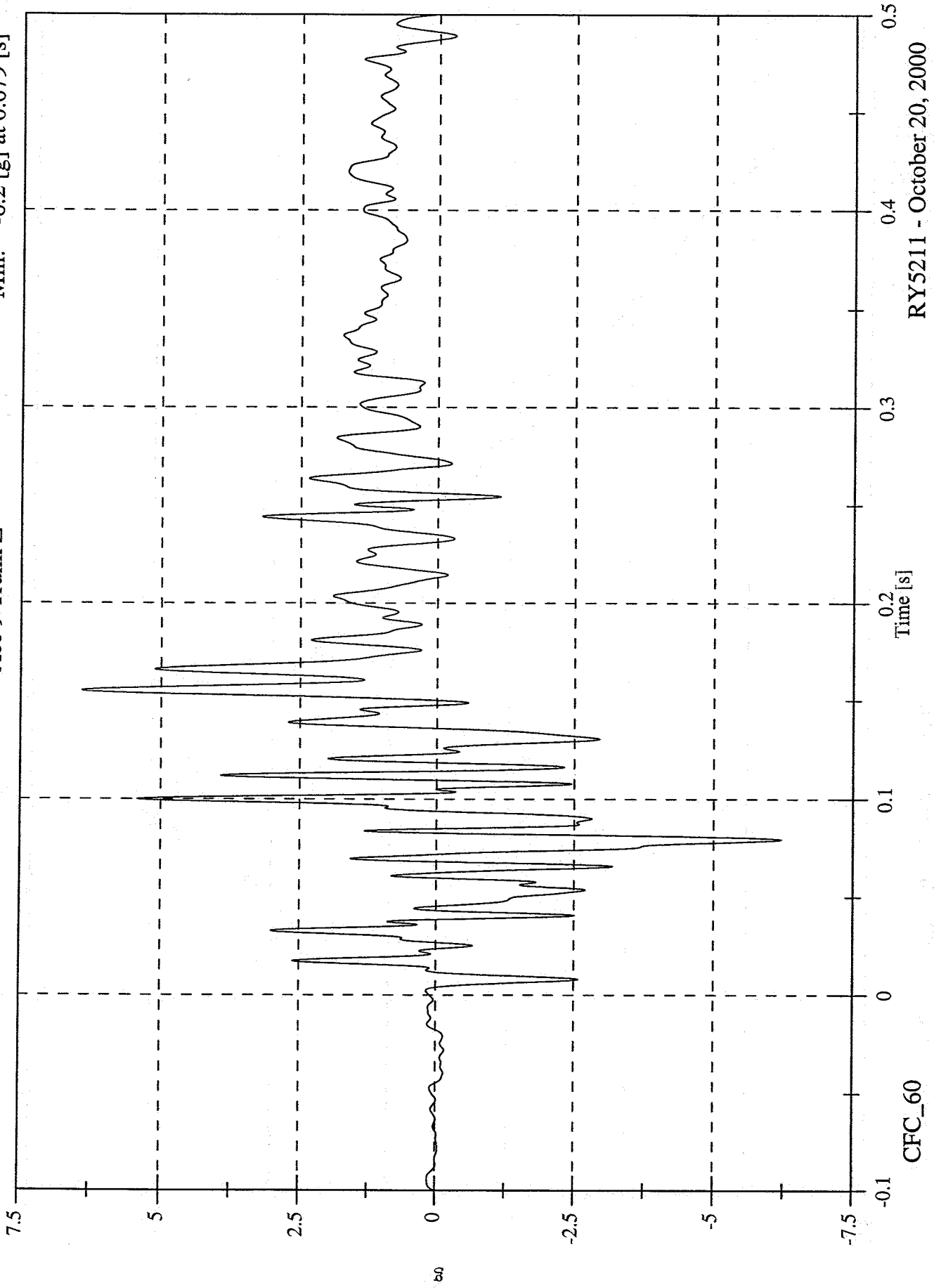

R Y5211 - October 20, 2000

40% Frontal Offset Test #2 - 2000 Nissan Altima

Max: 12.4 [kph] at 0.500 [s]  
Min: -2.7 [kph] at 0.093 [s]

Acc 9 Trunk Z Velocity

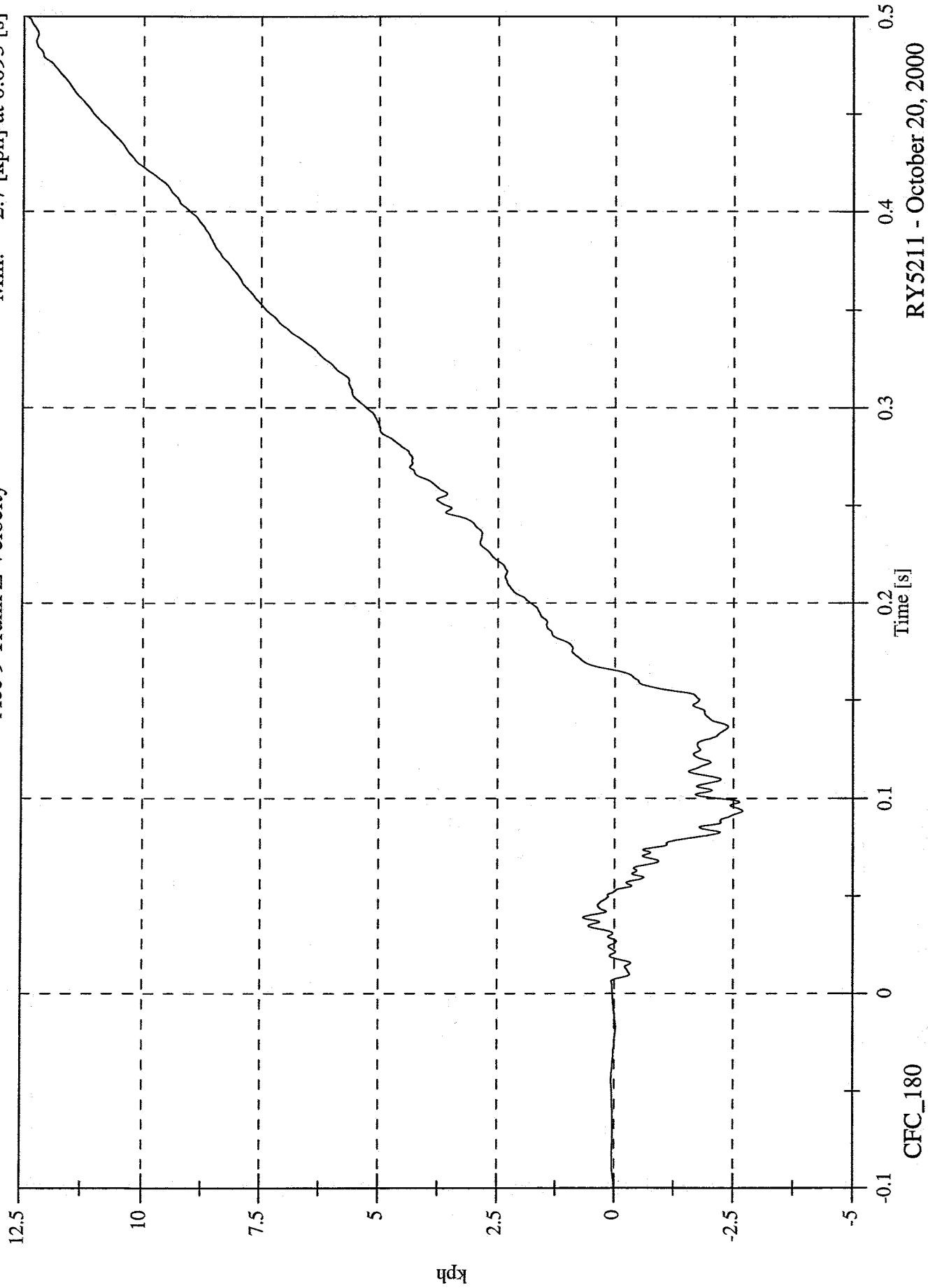

R Y 5 2 1 1 - O c t o b e r 2 0 , 2 0 0 0

40% Frontal Offset Test #2 - 2000 Nissan Altima

Acc 9 Trunk Z Displacement

Max: 567.1 [mm] at 0.500 [s]  
Min: -46.6 [mm] at 0.165 [s]

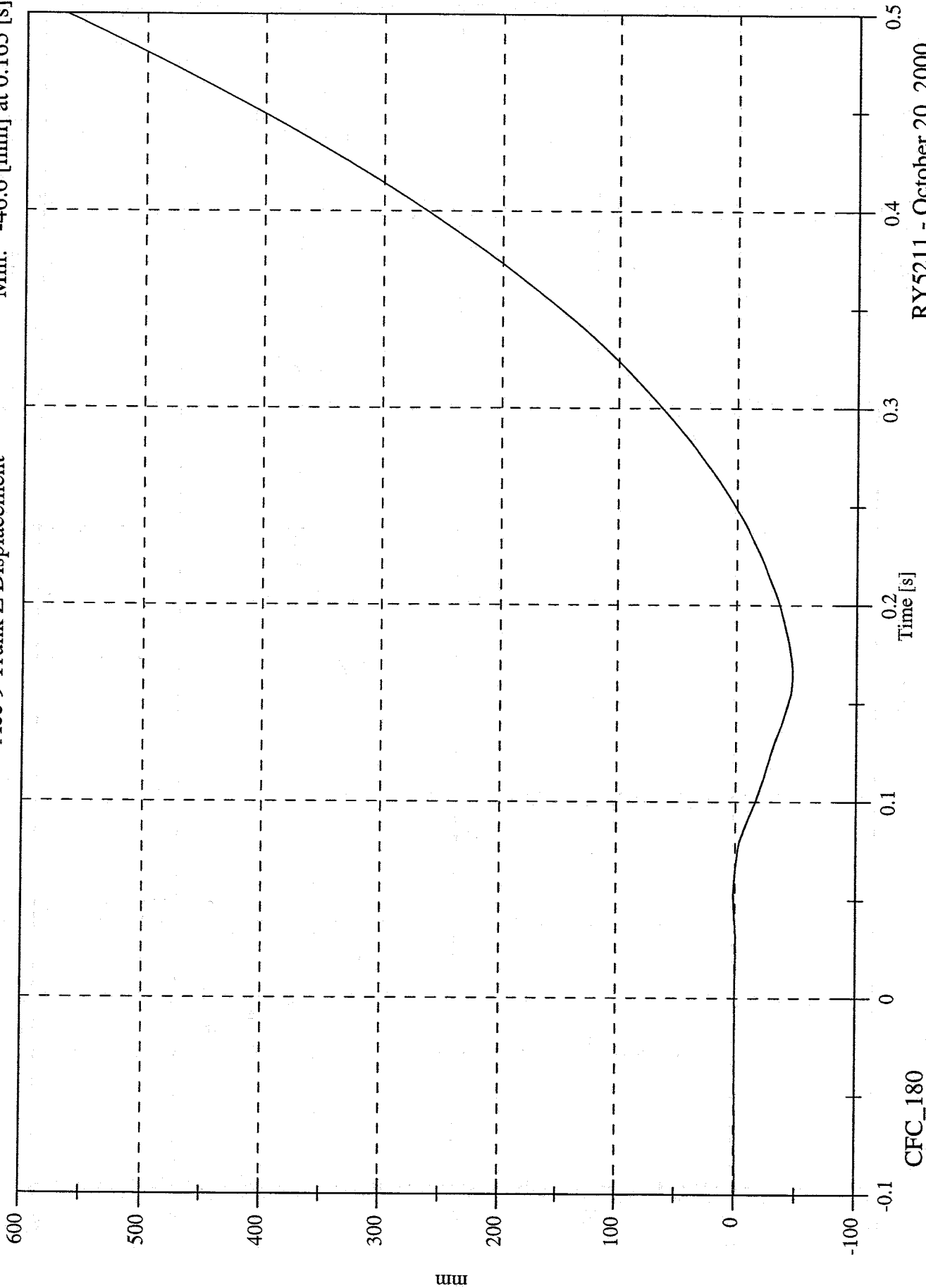

RY5211 - October 20, 2000

40% Offset Barrier Test #2 - 2000 Nissan Altima

Barrier Load Cell E1 FY

Max: 1507.7 [N] at 0.103 [S]

Min: -974.1 [N] at 0.054 [S]

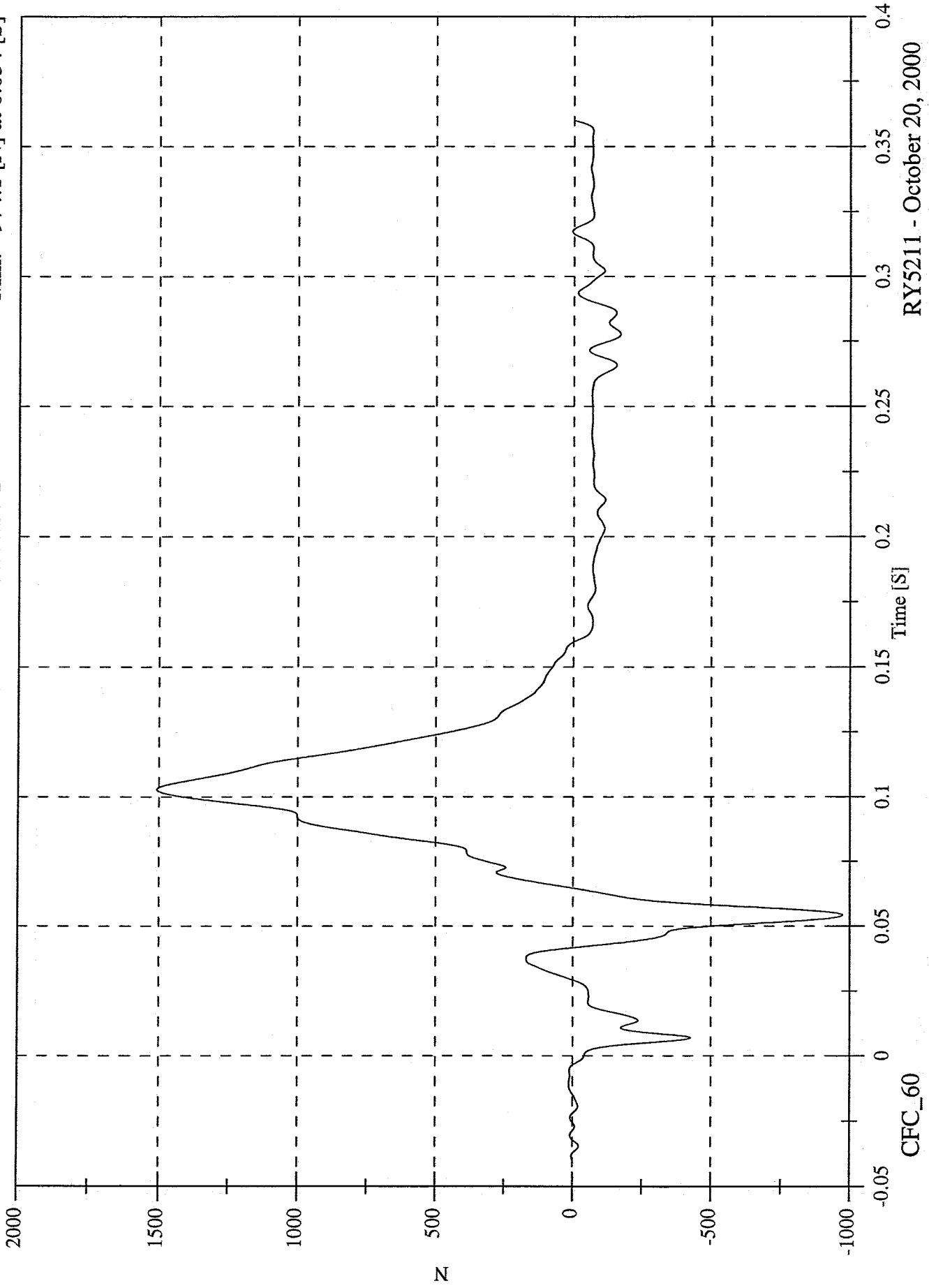

RY5211 - October 20, 2000

40% Offset Barrier Test #2 - 2000 Nissan Altima

Barrier Load Cell E2 FY

Max: 926.2 [N] at 0.101 [S]  
Min: -1557.9 [N] at 0.072 [S]

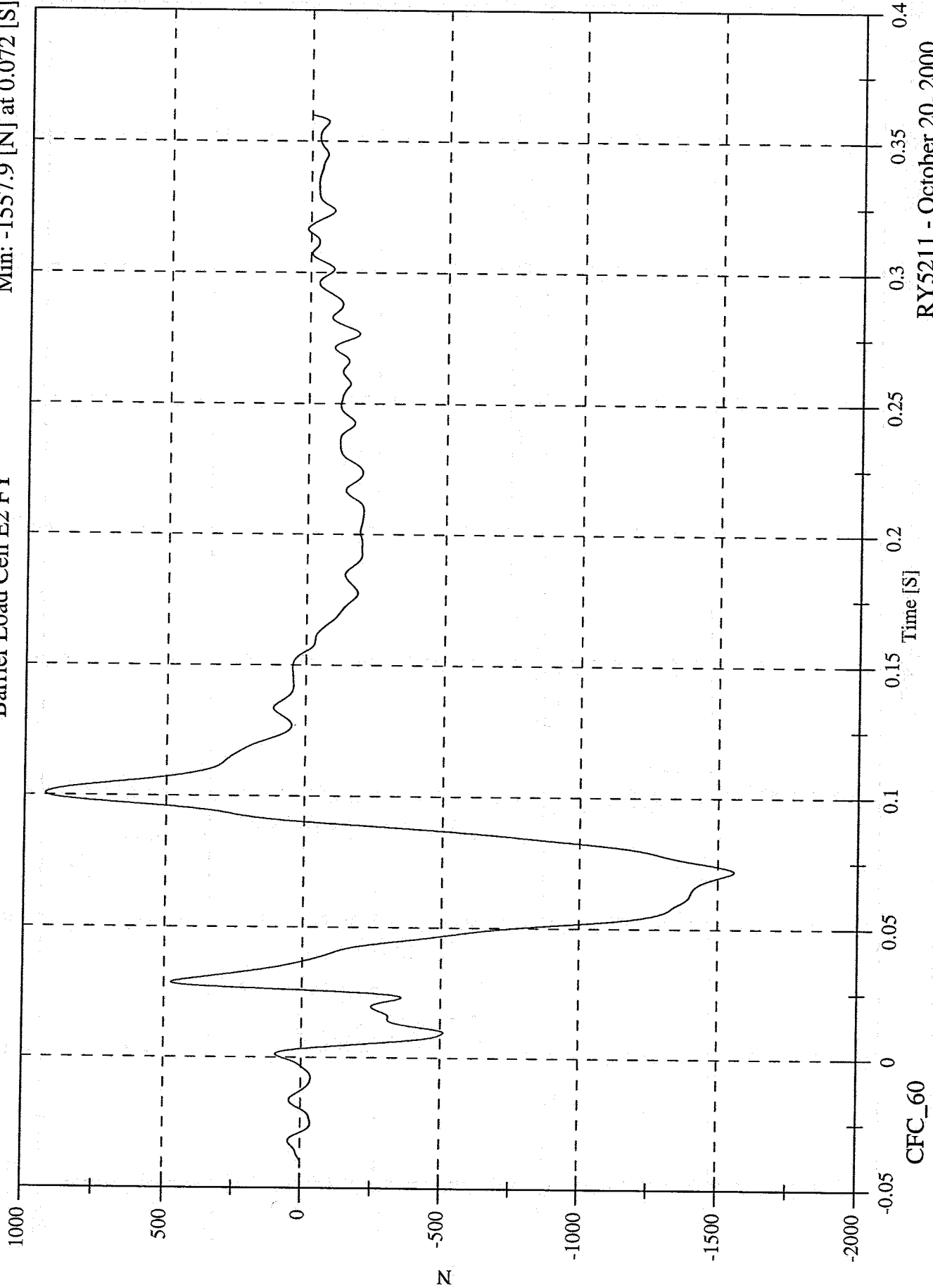

RY5211 - October 20, 2000

40% Offset Barrier Test #2 - 2000 Nissan Altima

Barrier Load Cell E3 FY

Max: 695.6 [N] at 0.099 [S]

Min: -1420.8 [N] at 0.071 [S]

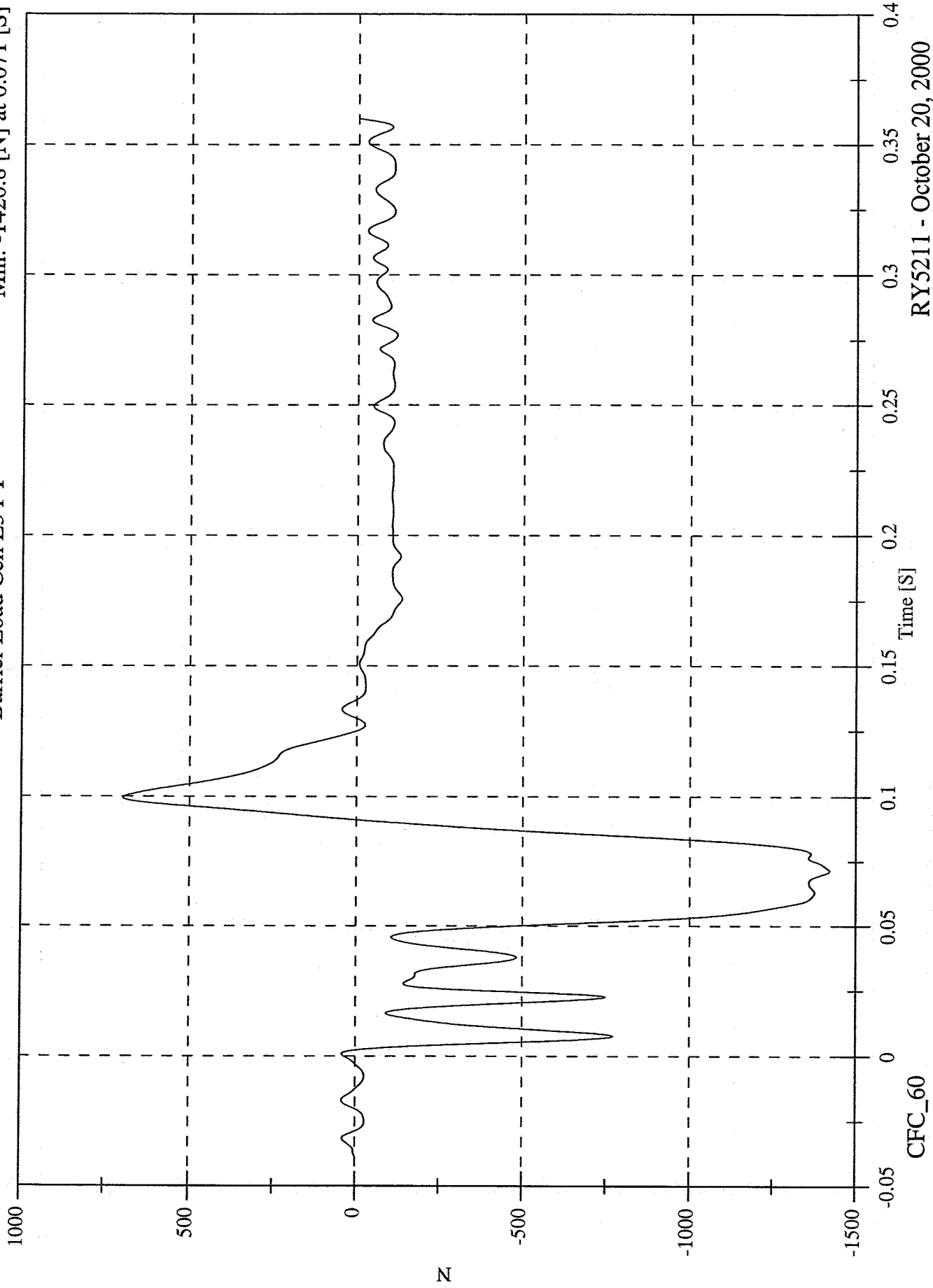

RY5211 - October 20, 2000

40% Offset Barrier Test #2 - 2000 Nissan Altima

Max: 768.8 [N] at 0.091 [S]  
Min: -1693.0 [N] at 0.078 [S]

Barrier Load Cell E4 FY

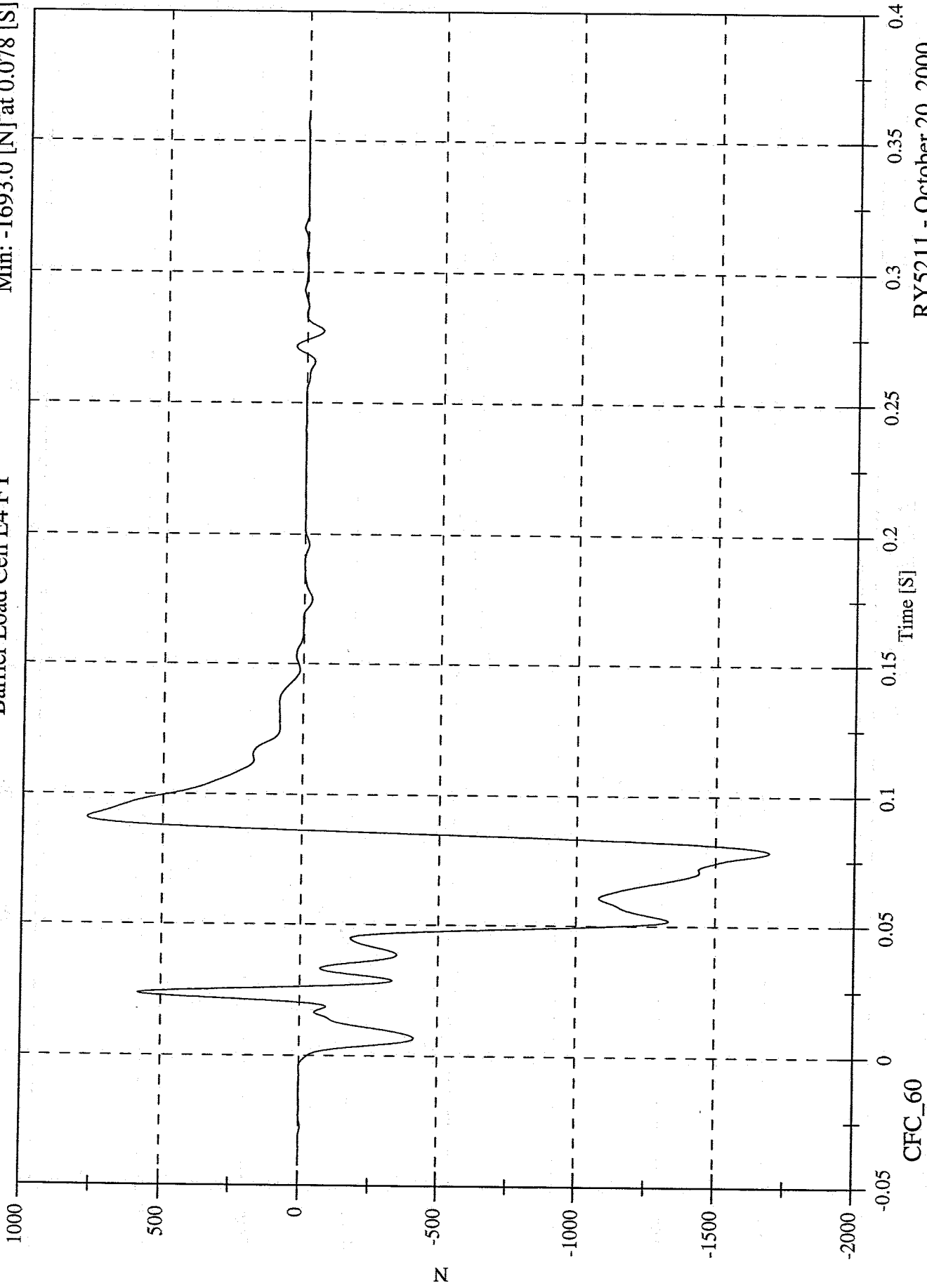

CFC\_60

RY5211 - October 20, 2000

40% Offset Barrier Test #2 - 2000 Nissan Altima

Max: 3192.4 [N] at 0.099 [S]

Min: -3121.7 [N] at 0.067 [S]

Barrier Load Cell E5 FY

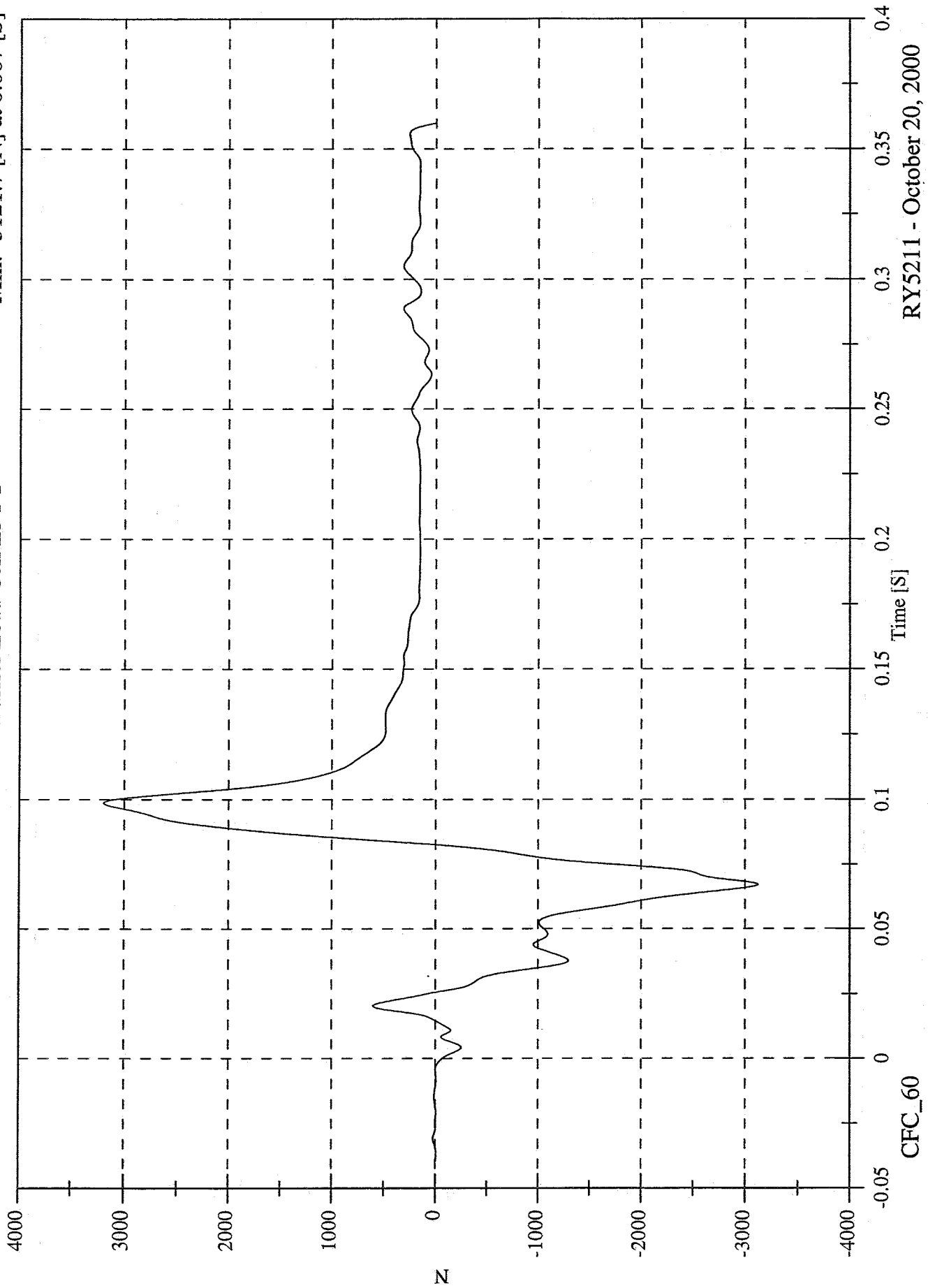

RY5211 - October 20, 2000

40% Offset Barrier Test #2 - 2000 Nissan Altima

Barrier Load Cell E6 FY

Max: 655.5 [N] at 0.227 [S]  
Min: -12517.5 [N] at 0.068 [S]

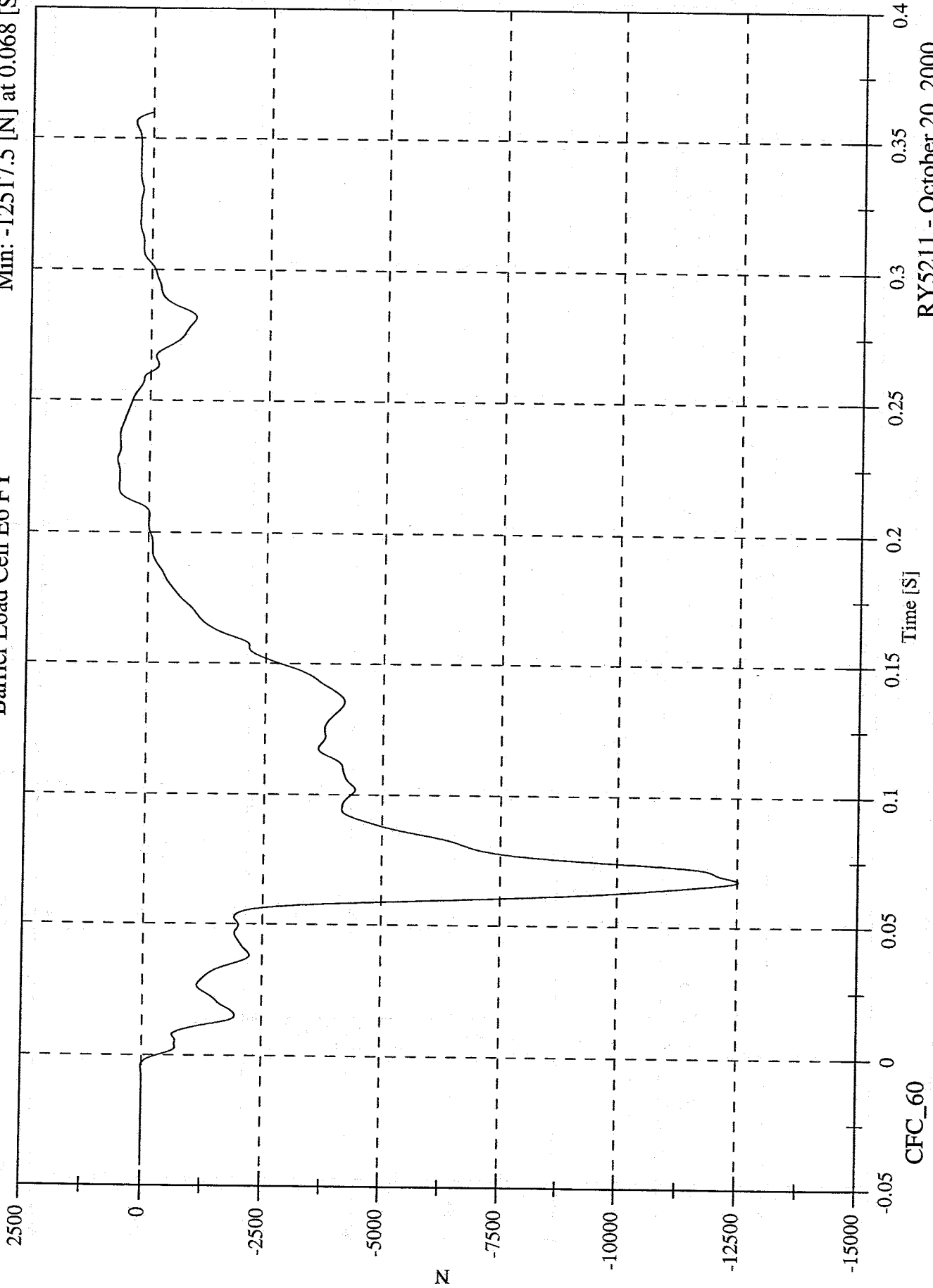

RY5211 - October 20, 2000

40% Offset Barrier Test #2 - 2000 Nissan Altima

Barrier Load Cell E1 FX

Max: 1123.9 [N] at 0.001 [S]

Min: -5006.4 [N] at 0.074 [S]

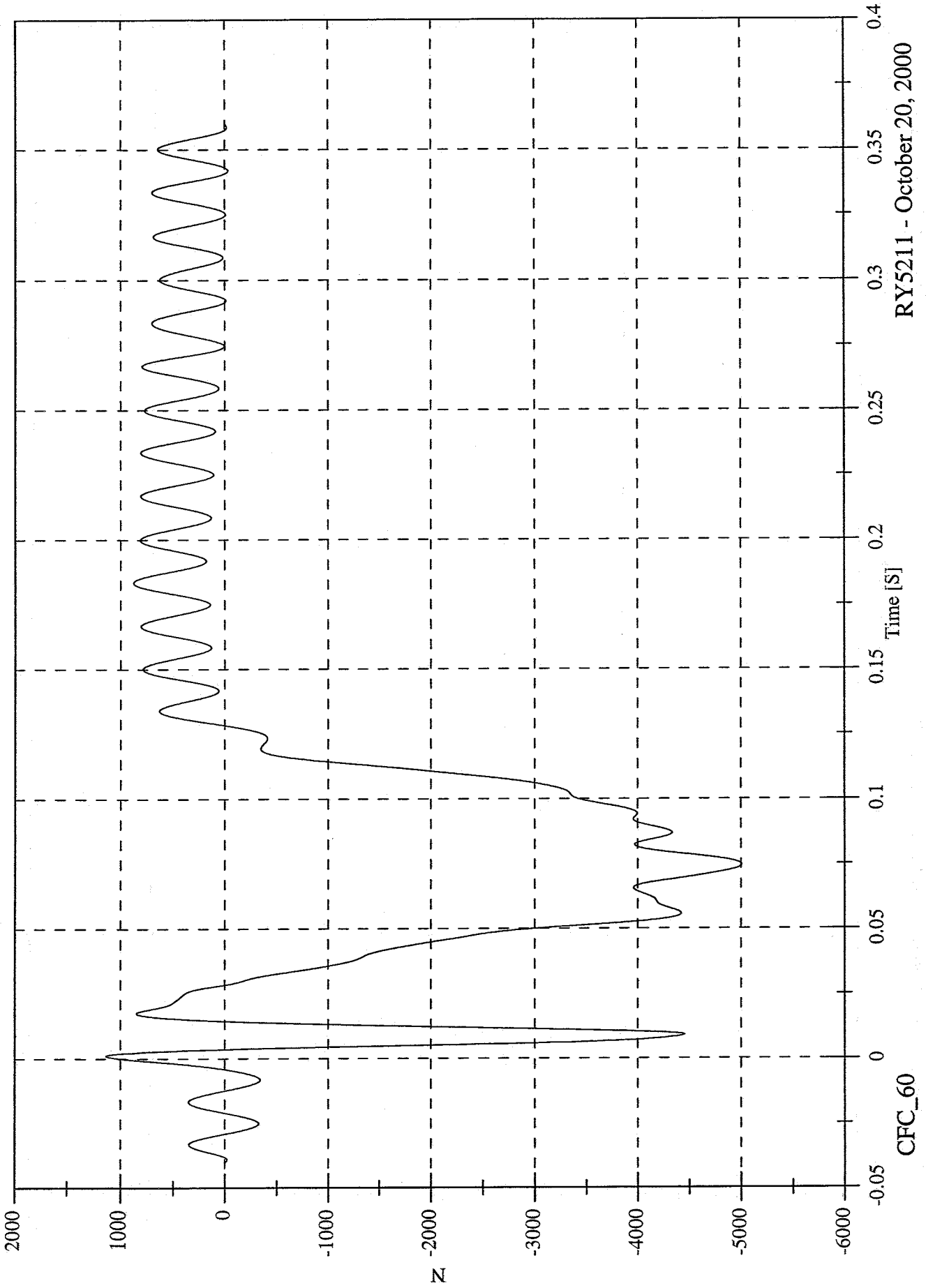

RY5211 - October 20, 2000

40% Offset Barrier Test #2 - 2000 Nissan Altima

Barrier Load Cell E2 FX

Max: 1202.5 [N] at 0.267 [S]  
Min: -6604.0 [N] at 0.075 [S]

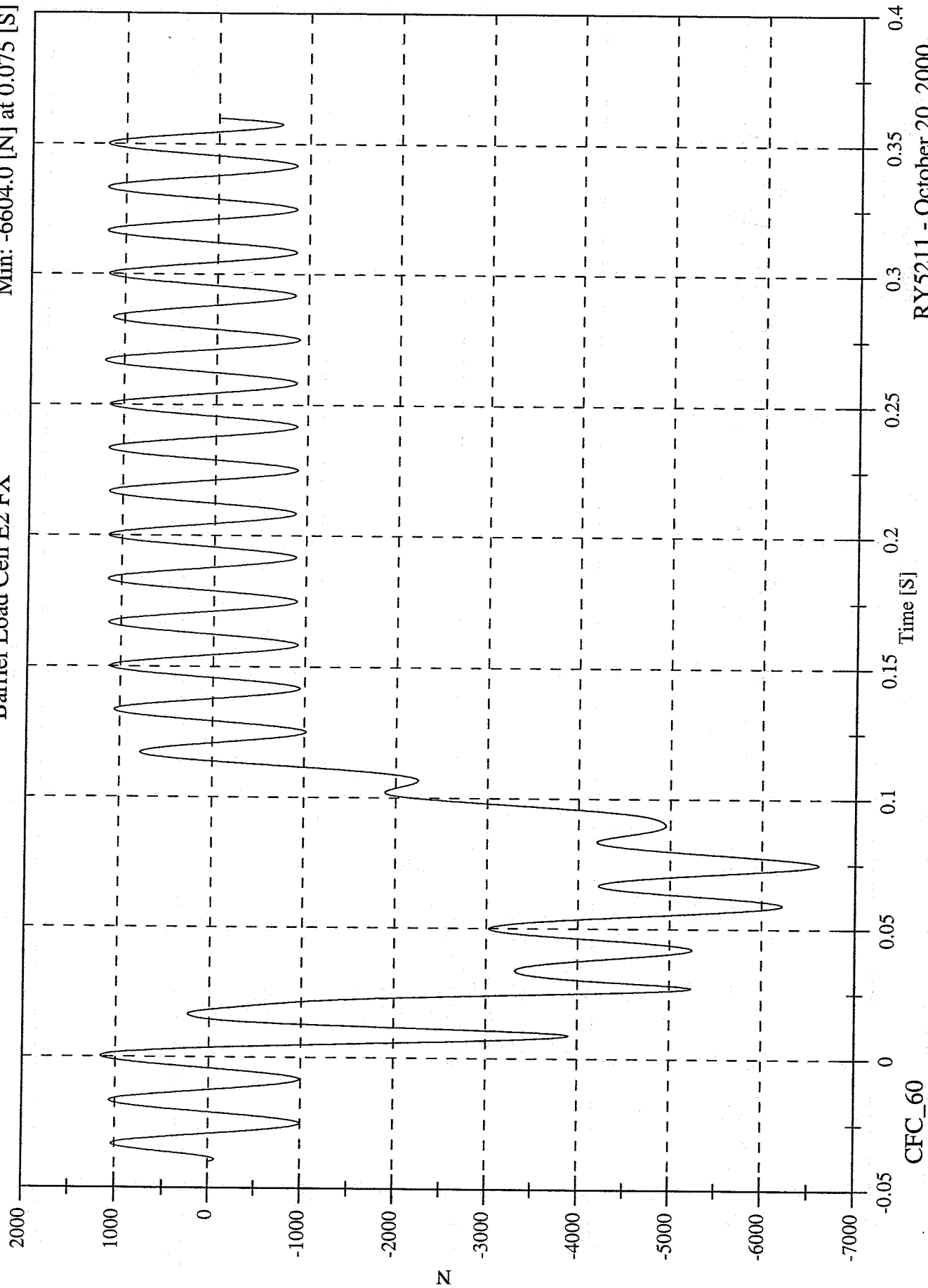

CFC\_60

40% Offset Barrier Test #2 - 2000 Nissan Altima

Max: 765.1 [N] at 0.317 [S]

Min: -10375.7 [N] at 0.024 [S]

Barrier Load Cell E3 FX

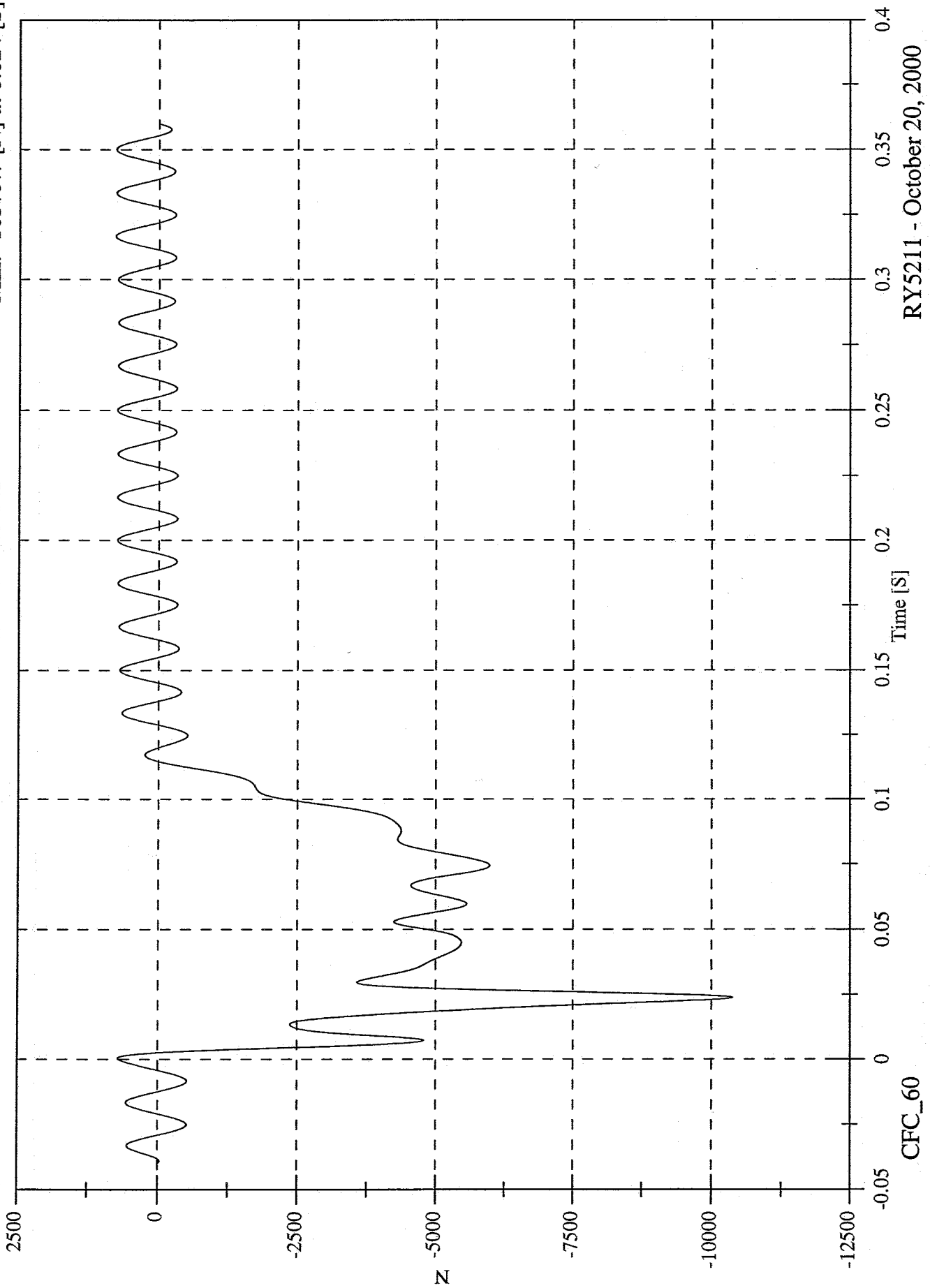

CFC\_60

RY5211 - October 20, 2000

40% Offset Barrier Test #2 - 2000 Nissan Altima

Barrier Load Cell E4 FX

Max: 1021.8 [N] at 0.333 [S]

Min: -10672.3 [N] at 0.023 [S]

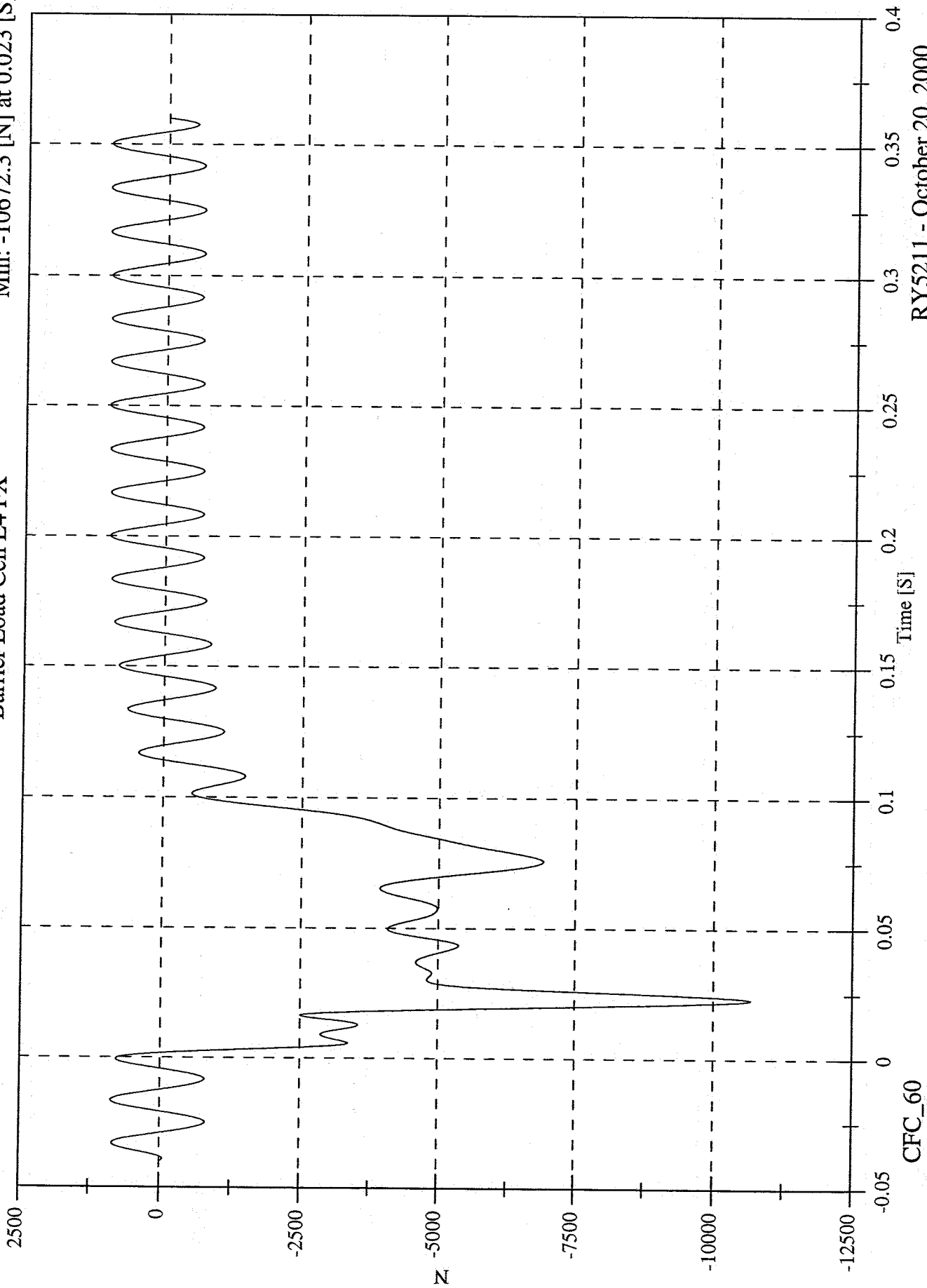

CFC\_60

RY5211 - October 20, 2000

40% Offset Barrier Test #2 - 2000 Nissan Altima

Max: 859.6 [N] at 0.183 [S]  
Min: -19217.7 [N] at 0.077 [S]

Barrier Load Cell E5 FX

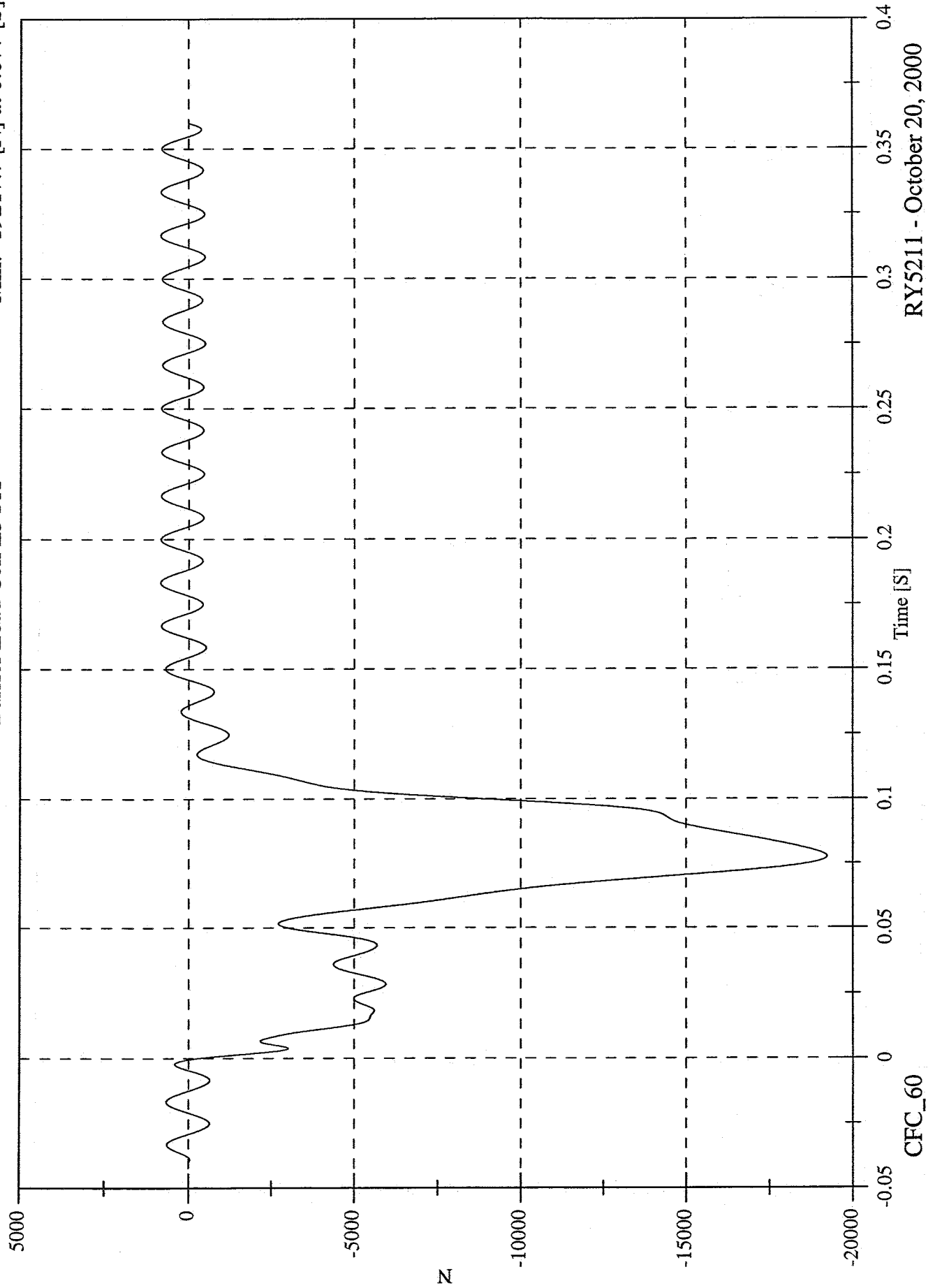

RYS211 - October 20, 2000

40% Offset Barrier Test #2 - 2000 Nissan Altima

Barrier Load Cell E6 FX

Max: 2481.0 [N] at 0.317 [S]  
Min: -22104.6 [N] at 0.094 [S]

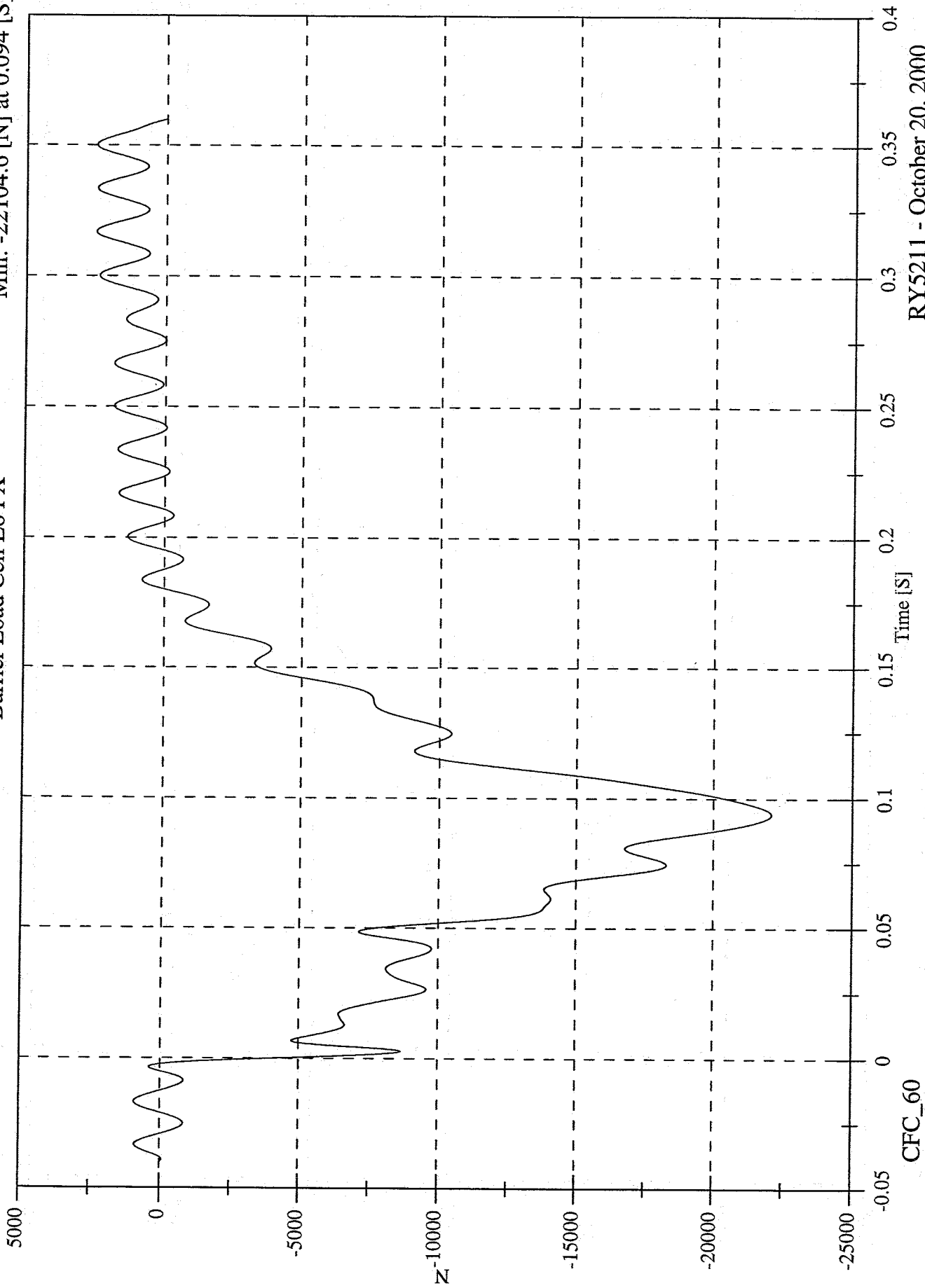

RY5211 - October 20, 2000

40% Offset Barrier Test #2 - 2000 Nissan Altima

Max: 1729.3 [N] at 0.099 [S]  
Min: -573.9 [N] at 0.049 [S]

Barrier Load Cell D1 FY

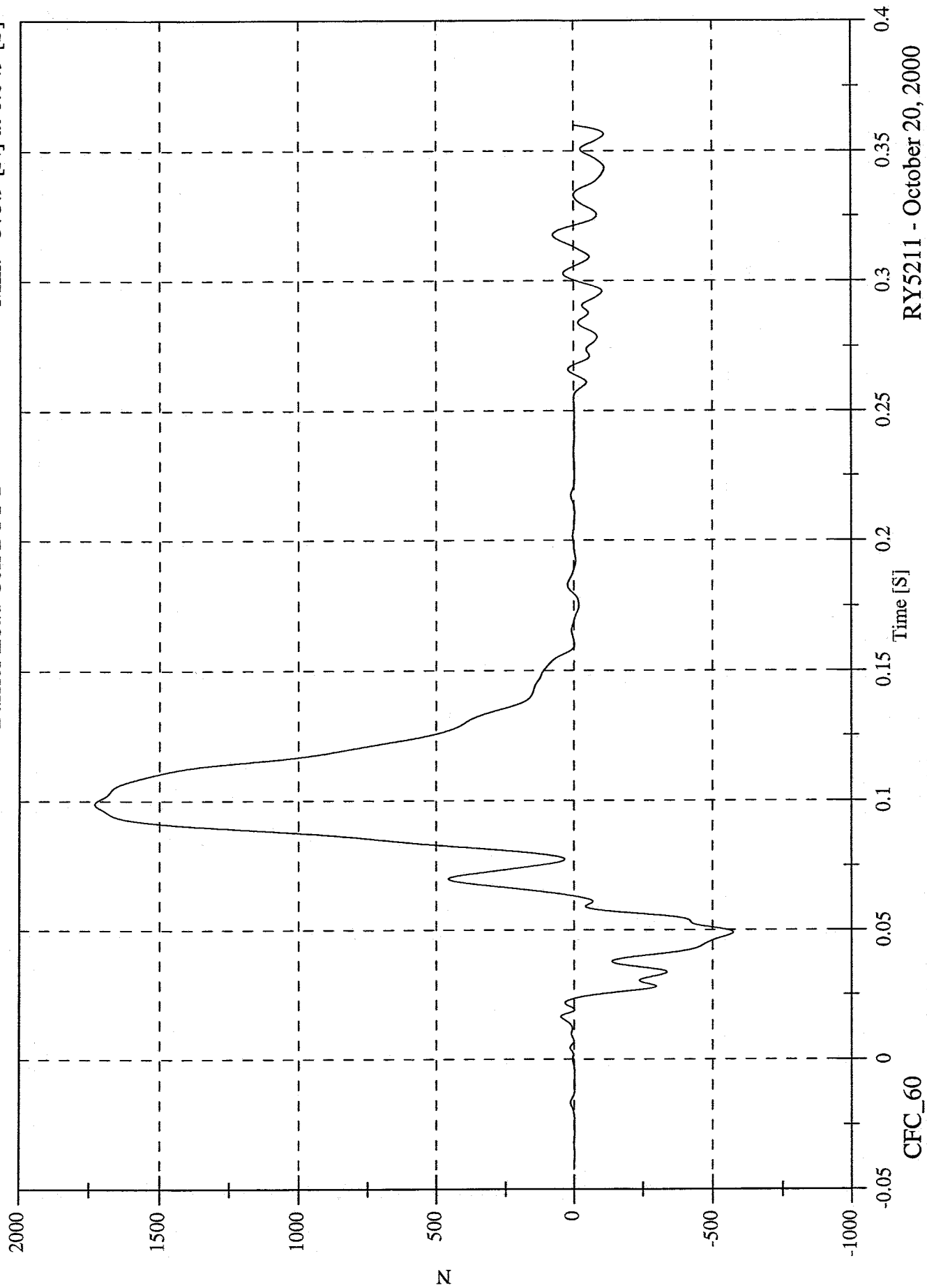

RY5211 - October 20, 2000

40% Offset Barrier Test #2 - 2000 Nissan Altima

Barrier Load Cell D2 FY

Max: 753.5 [N] at 0.096 [S]  
Min: -1713.3 [N] at 0.073 [S]

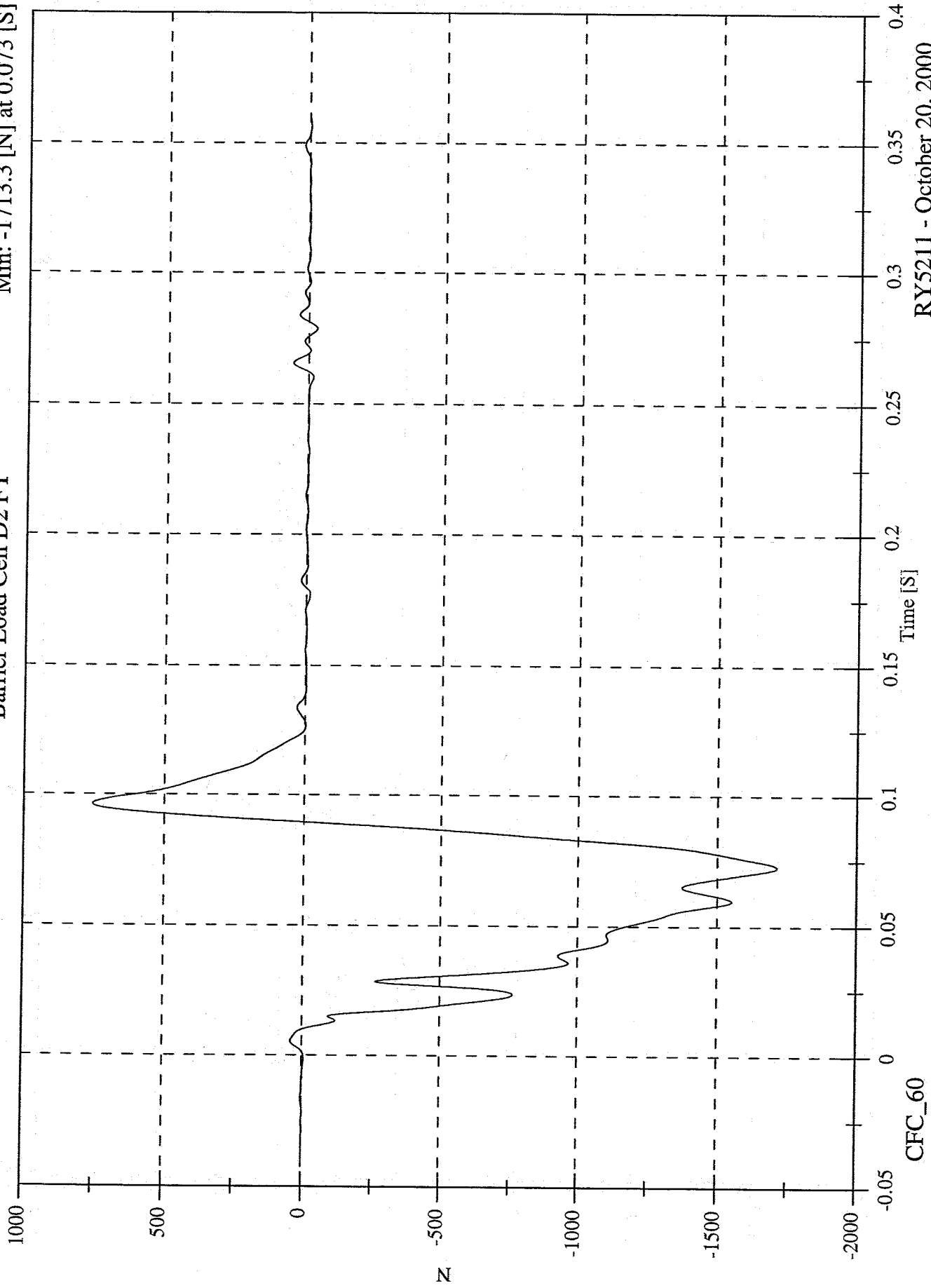

R5211 - October 20, 2000

40% Offset Barrier Test #2 - 2000 Nissan Altima

Max: 2045.7 [N] at 0.072 [S]  
Min: -814.6 [N] at 0.016 [S]

Barrier Load Cell D3 FY

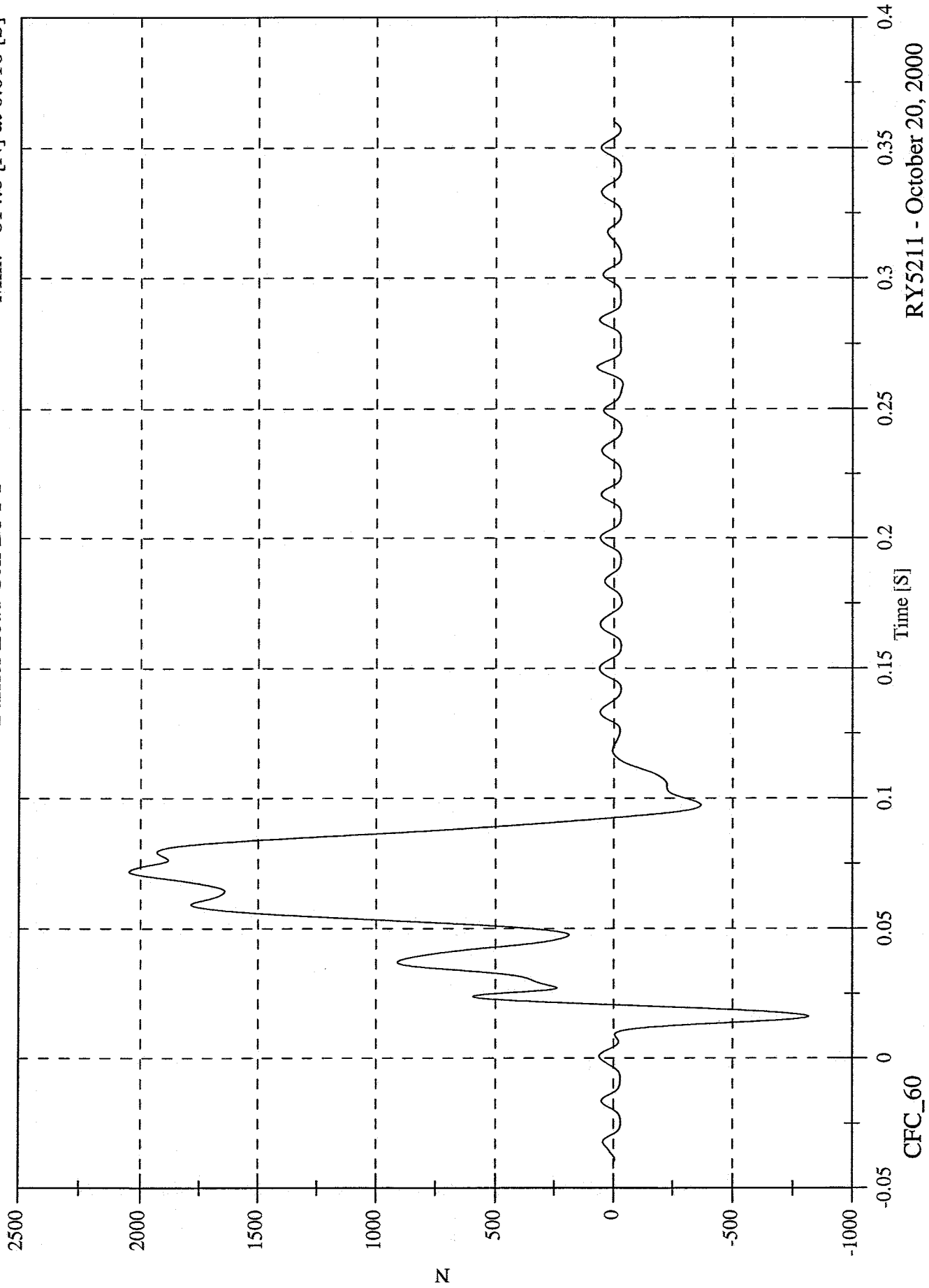

RY5211 - October 20, 2000

40% Offset Barrier Test #2 - 2000 Nissan Altima

Barrier Load Cell D4 FY

Max: 2434.9 [N] at 0.023 [S]  
Min: -2515.5 [N] at 0.079 [S]

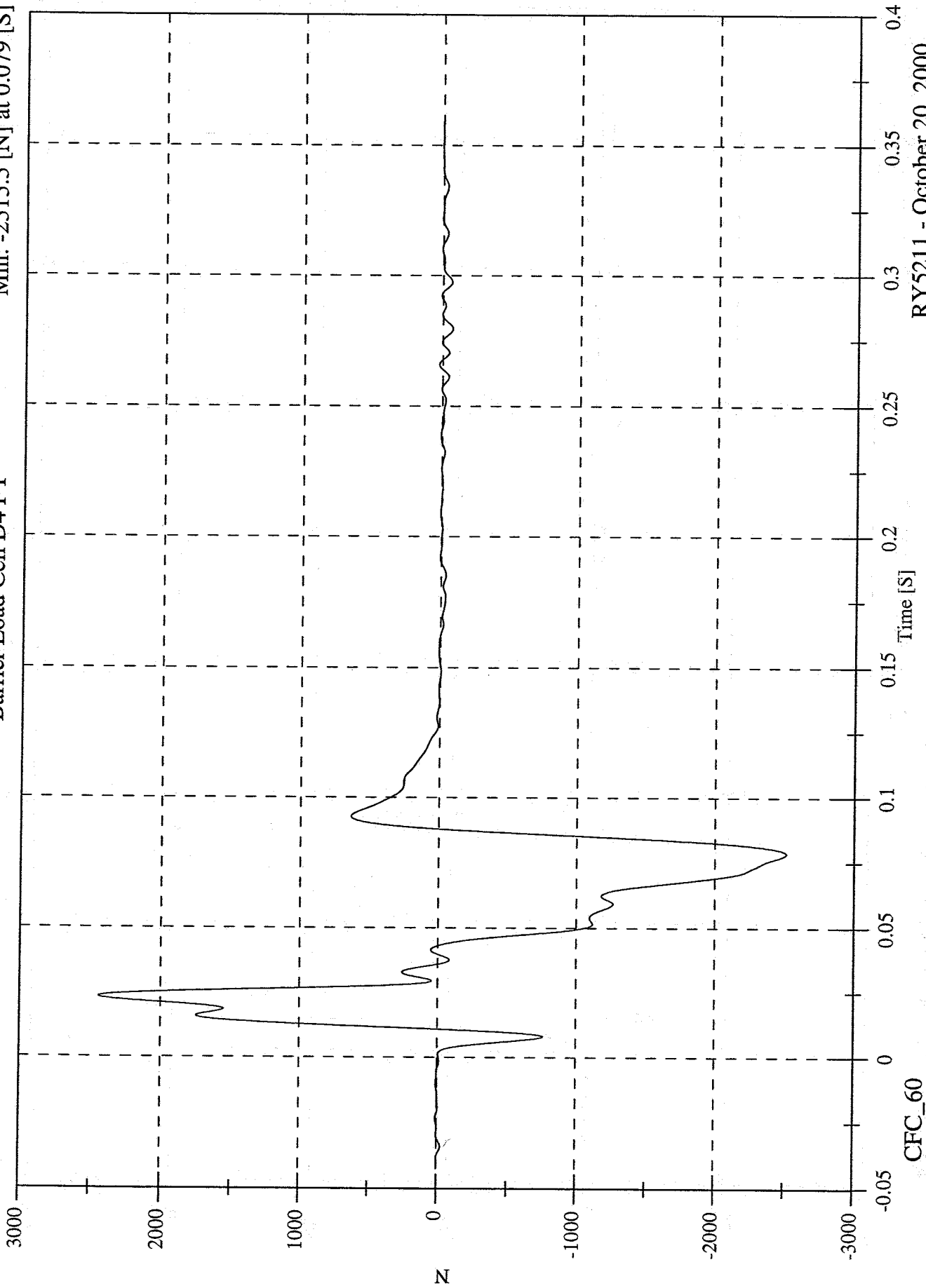

RY5211 - October 20, 2000

40% Offset Barrier Test #2 - 2000 Nissan Altima

Max: 2983.1 [N] at 0.102 [S]

Min: -8244.9 [N] at 0.080 [S]

Barrier Load Cell D5 FY

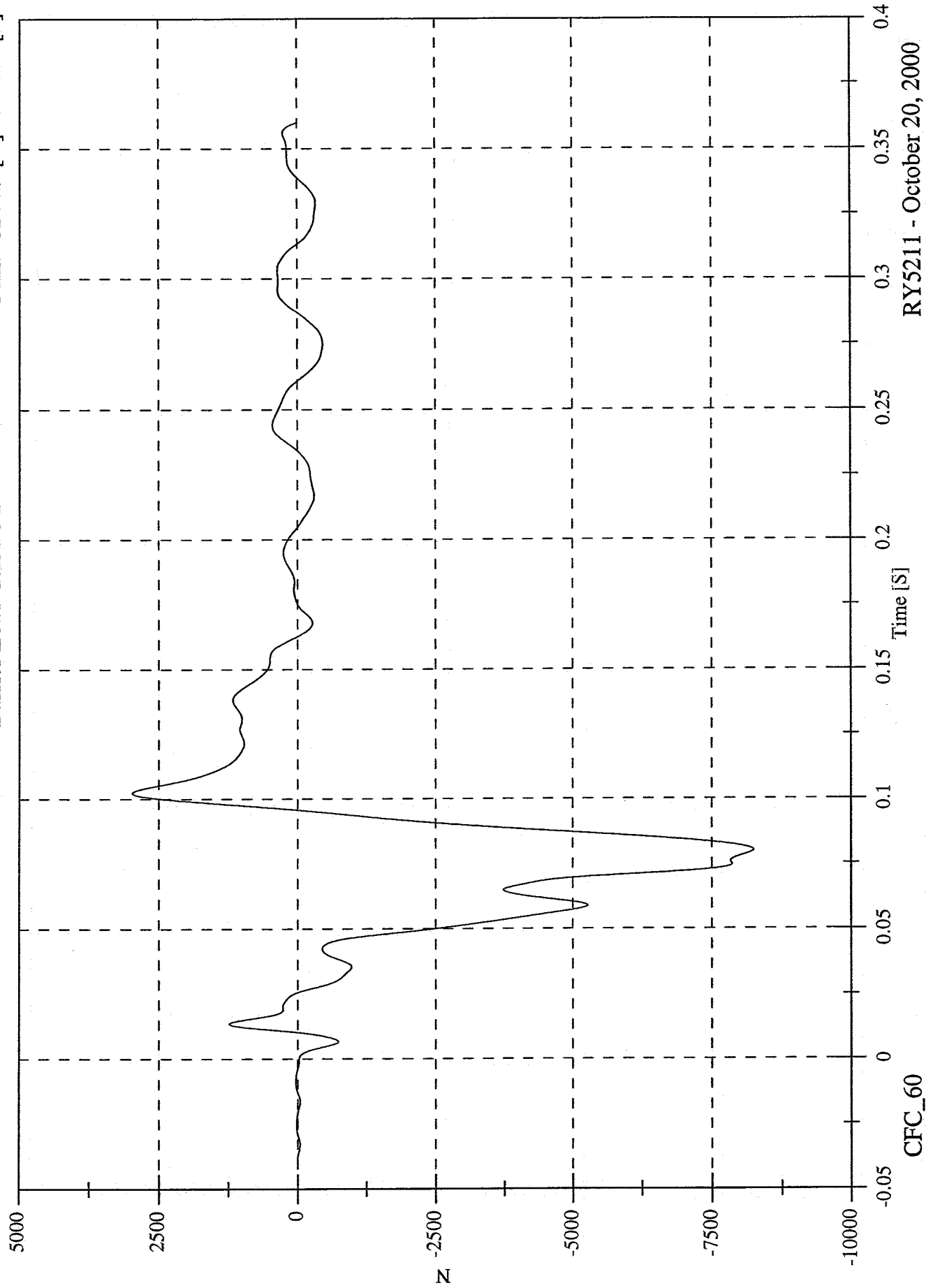

RYS211 - October 20, 2000

40% Offset Barrier Test #2 - 2000 Nissan Altima

Barrier Load Cell D6 FY

Max: 157.4 [N] at 0.352 [S]  
Min: -27490.8 [N] at 0.071 [S]

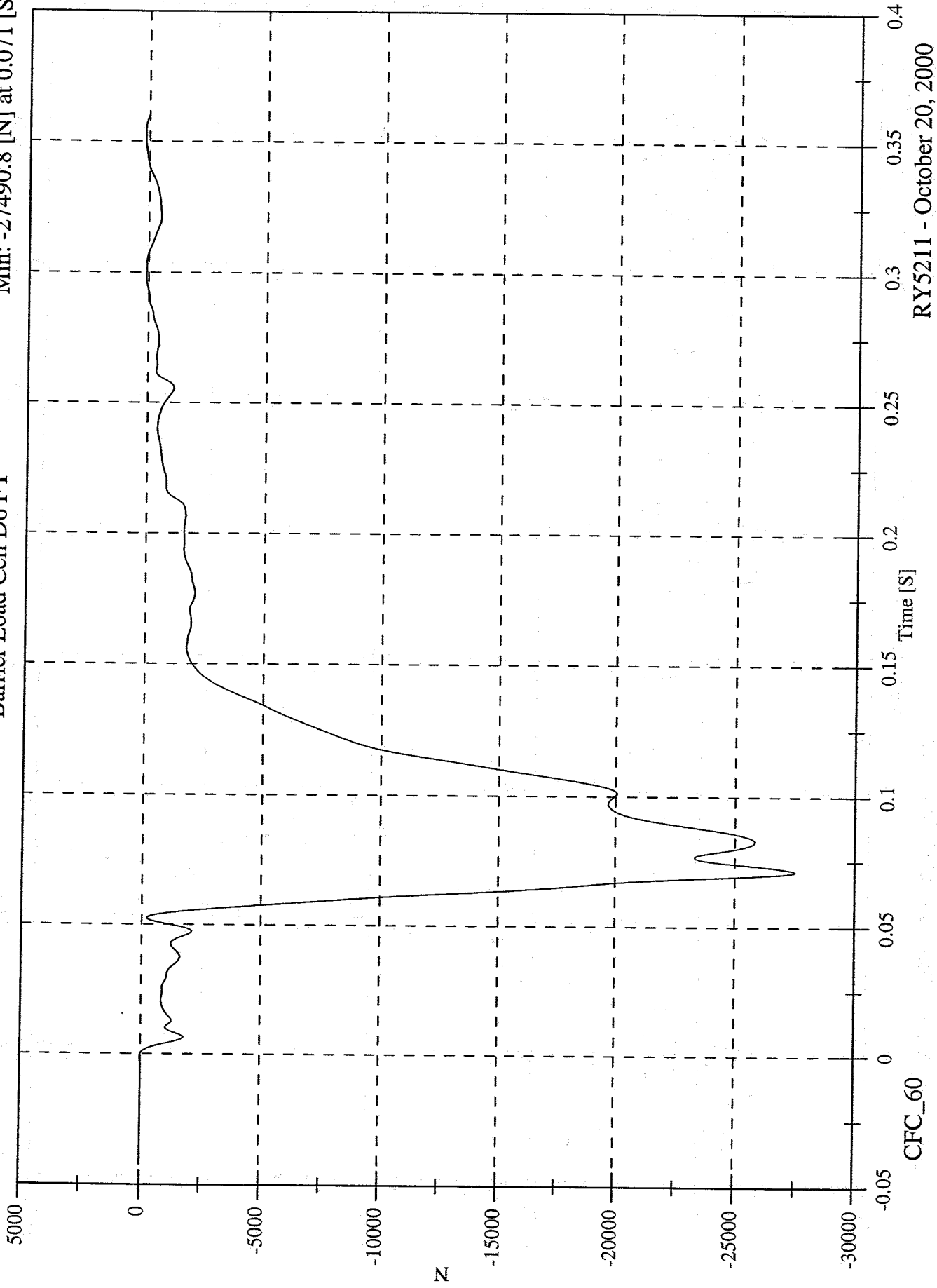

RY5211 - October 20, 2000

40% Offset Barrier Test #2 - 2000 Nissan Altima

Barrier Load Cell D1 FX

Max: 1075.5 [N] at 0.250 [S]

Min: -7575.6 [N] at 0.074 [S]

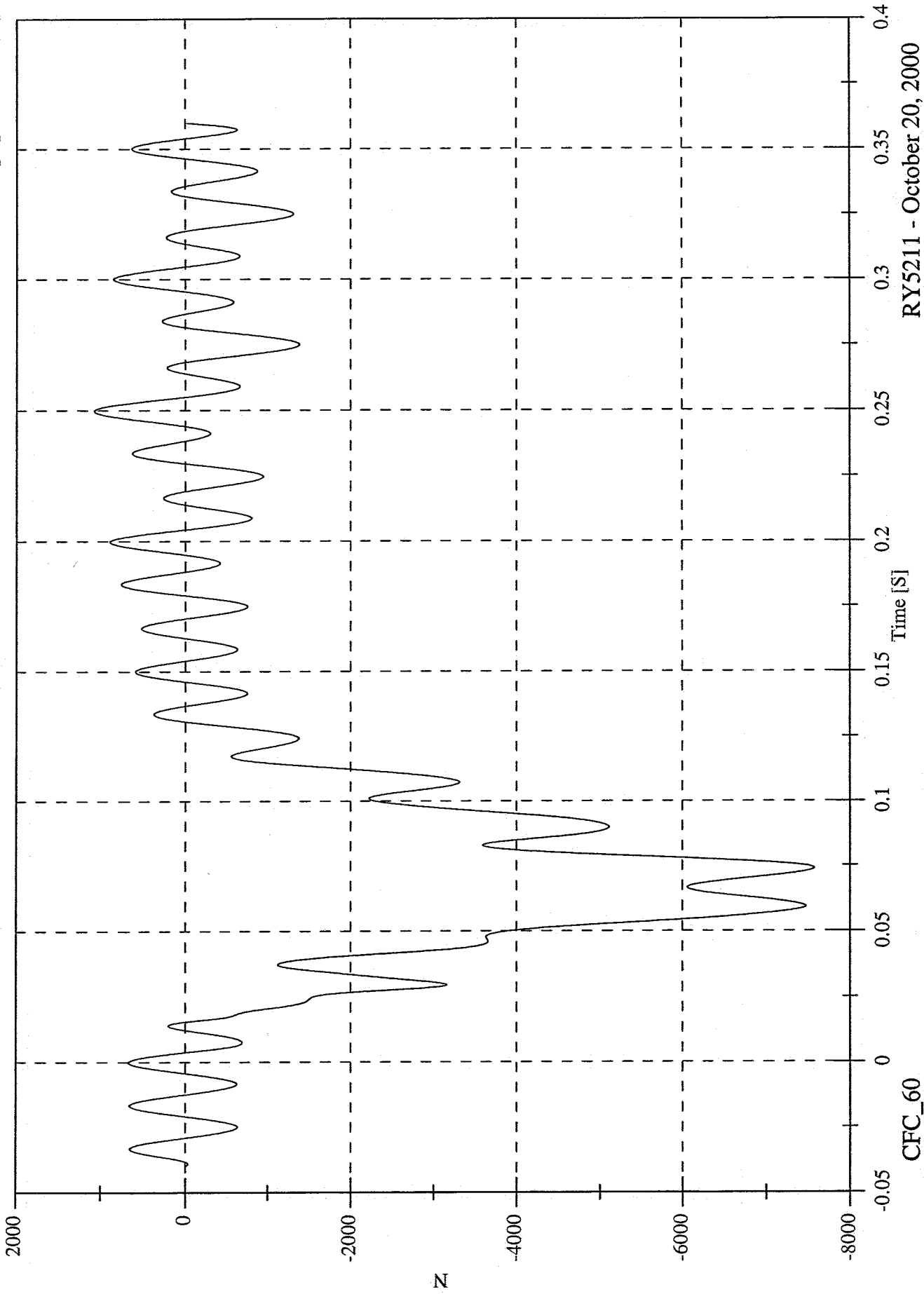

R5Y5211 - October 20, 2000

40% Offset Barrier Test #2 - 2000 Nissan Altima

Barrier Load Cell D2 FX

Max: 1061.5 [N] at 0.300 [S]  
Min: -7545.7 [N] at 0.075 [S]

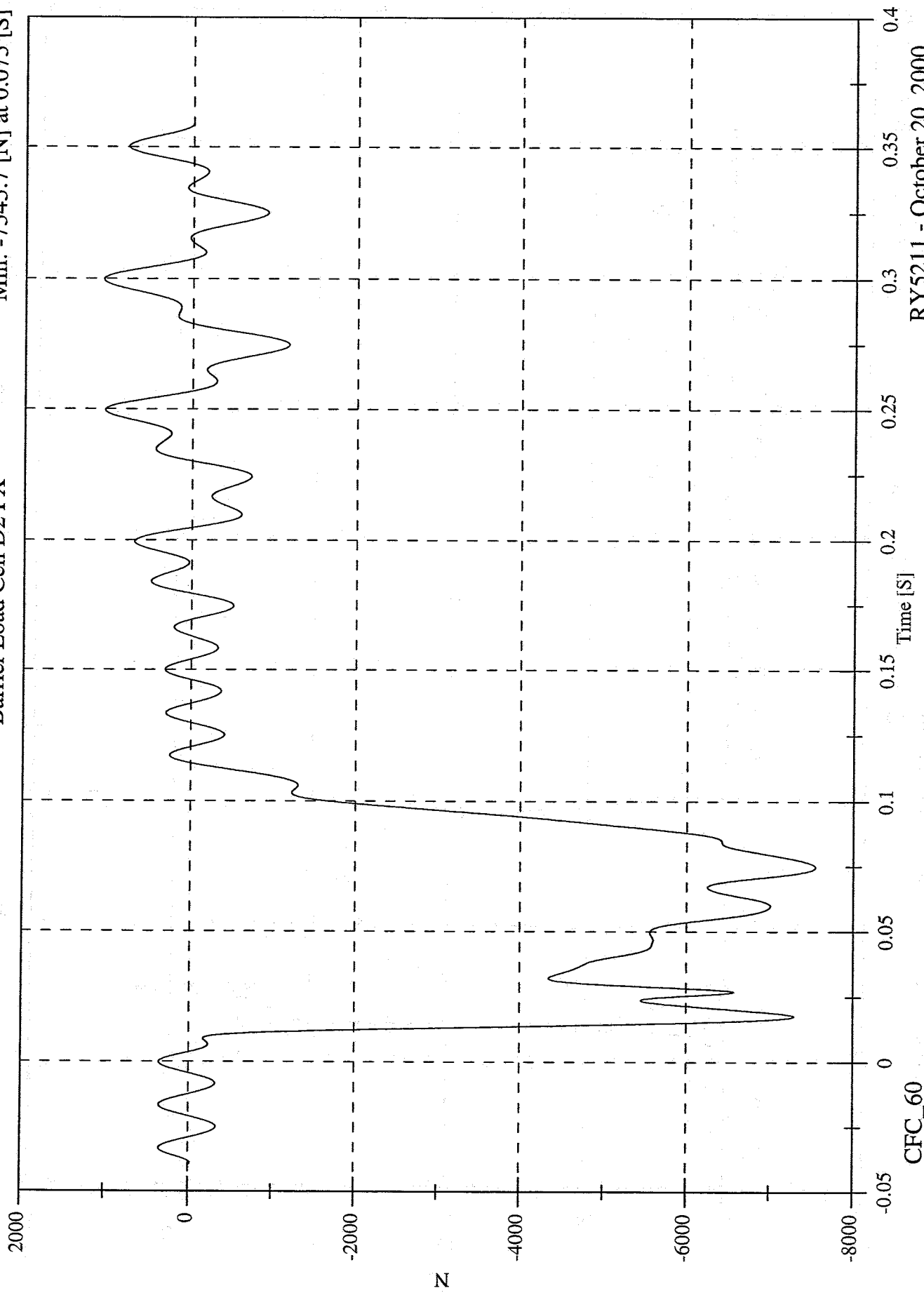

CFC\_60

RY5211 - October 20, 2000

40% Offset Barrier Test #2 - 2000 Nissan Altima

Max: 1853.0 [N] at 0.250 [S]  
Min: -10662.2 [N] at 0.025 [S]

Barrier Load Cell D3 FX

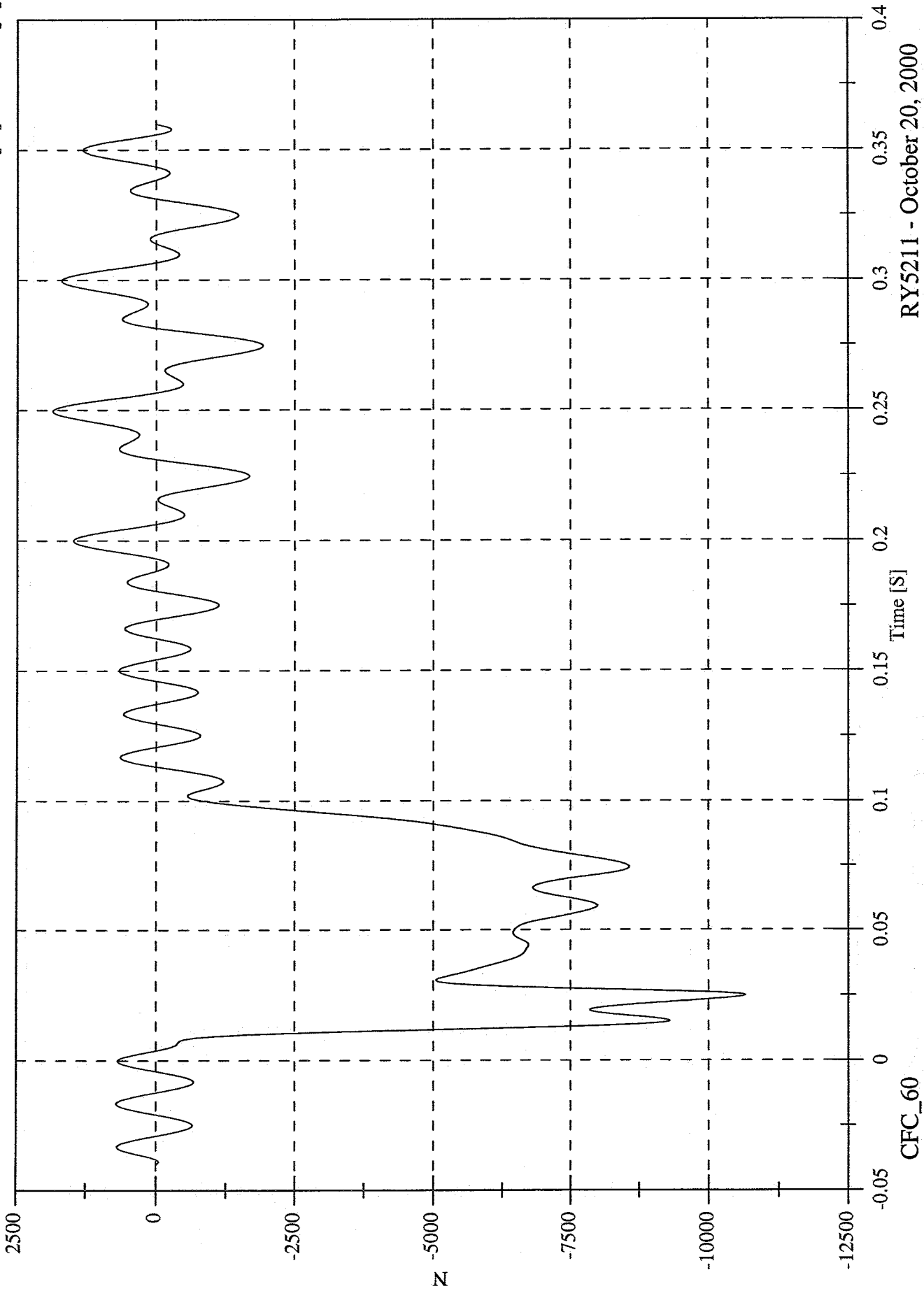

RY5211 - October 20, 2000

40% Offset Barrier Test #2 - 2000 Nissan Altima

Barrier Load Cell D4 FX

Max: 2107.6 [N] at 0.249 [S]  
Min: -13262.7 [N] at 0.013 [S]

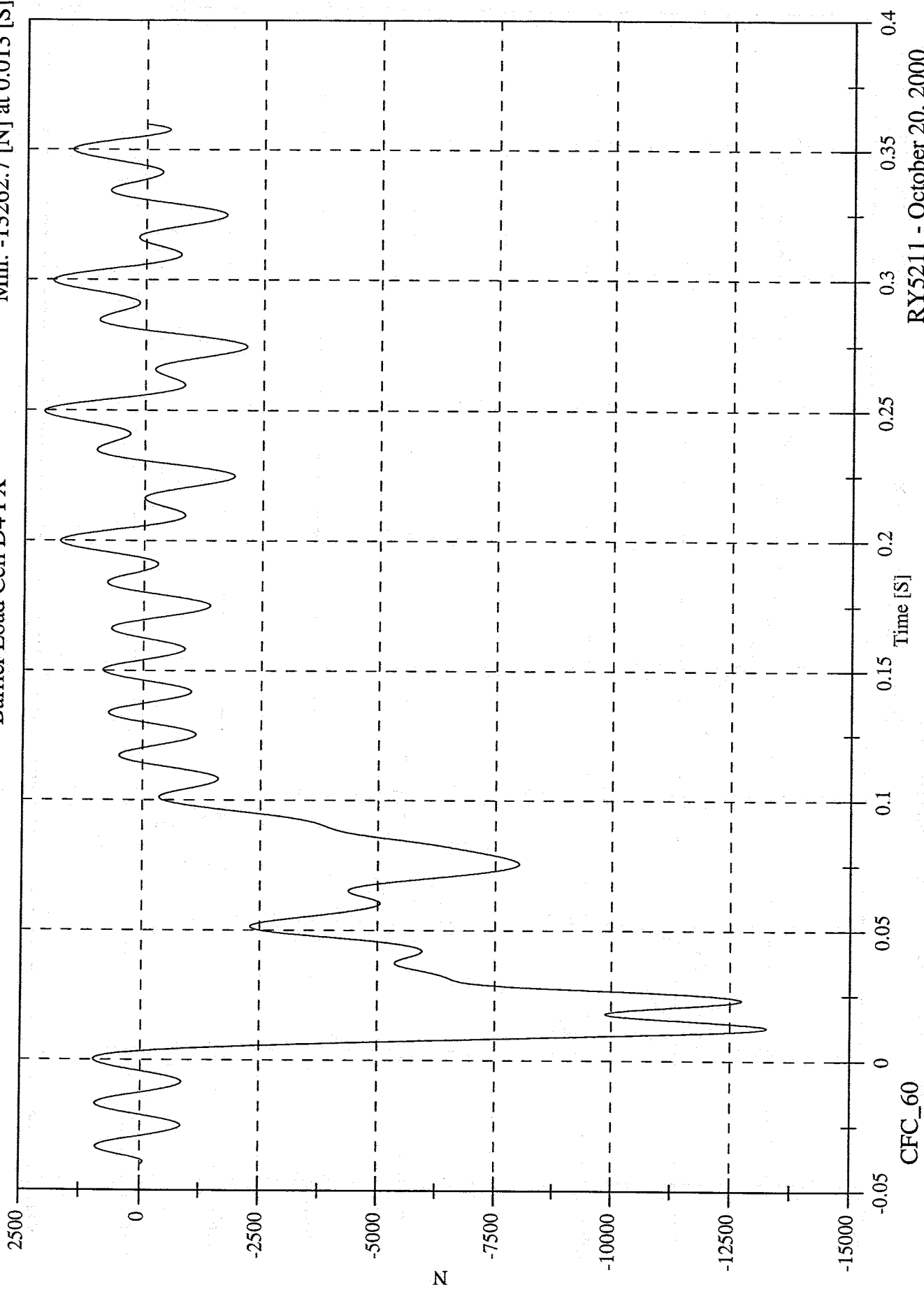

RY5211 - October 20, 2000

40% Offset Barrier Test #2 - 2000 Nissan Altima

Max: 1769.9 [N] at 0.249 [S]  
Min: -36566.6 [N] at 0.079 [S]

Barrier Load Cell D5 FX

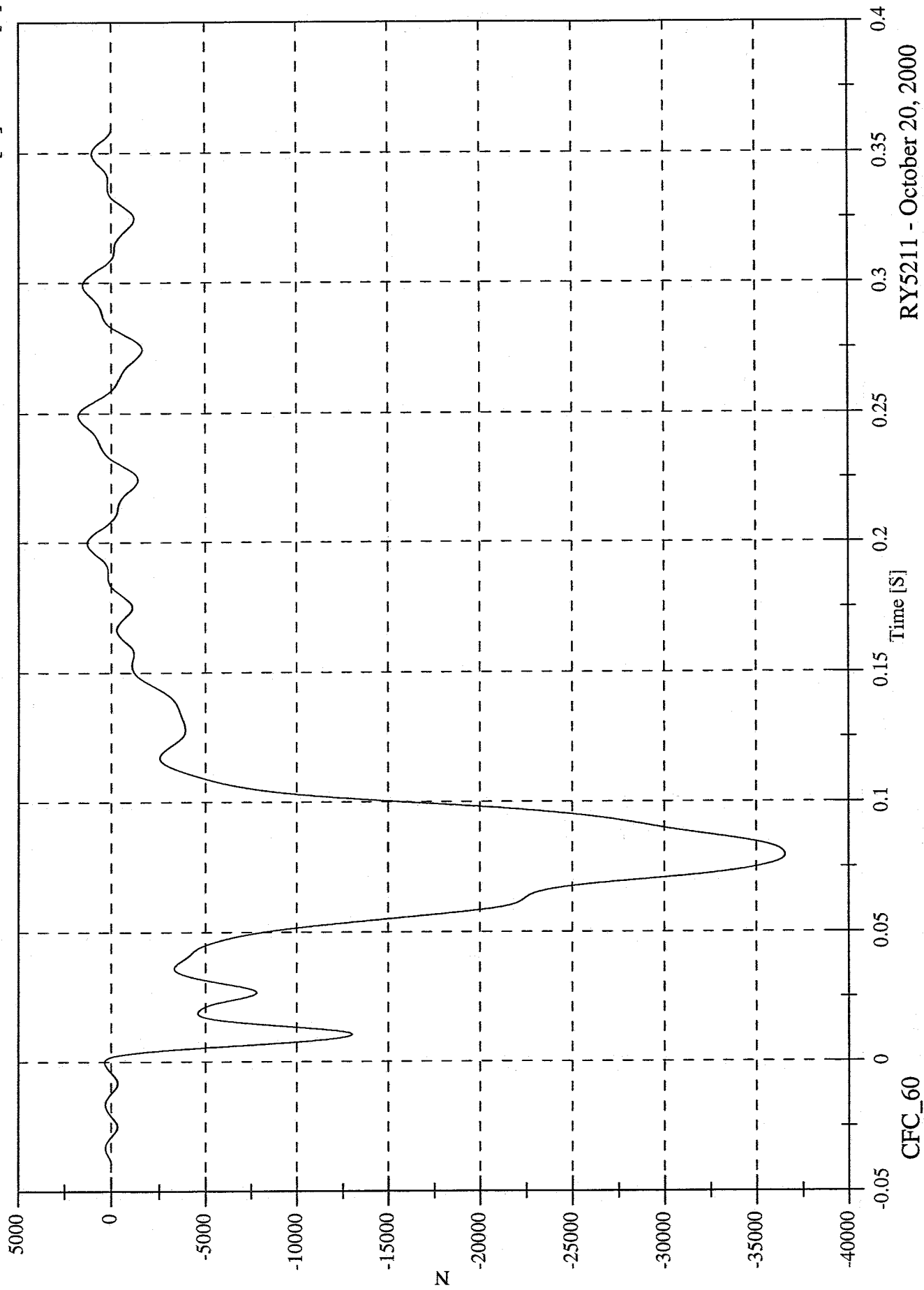

RYS211 - October 20, 2000

40% Offset Barrier Test #2 - 2000 Nissan Altima

Barrier Load Cell D6 FX

Max: 2544.1 [N] at 0.249 [S]  
Min: -41630.7 [N] at 0.095 [S]

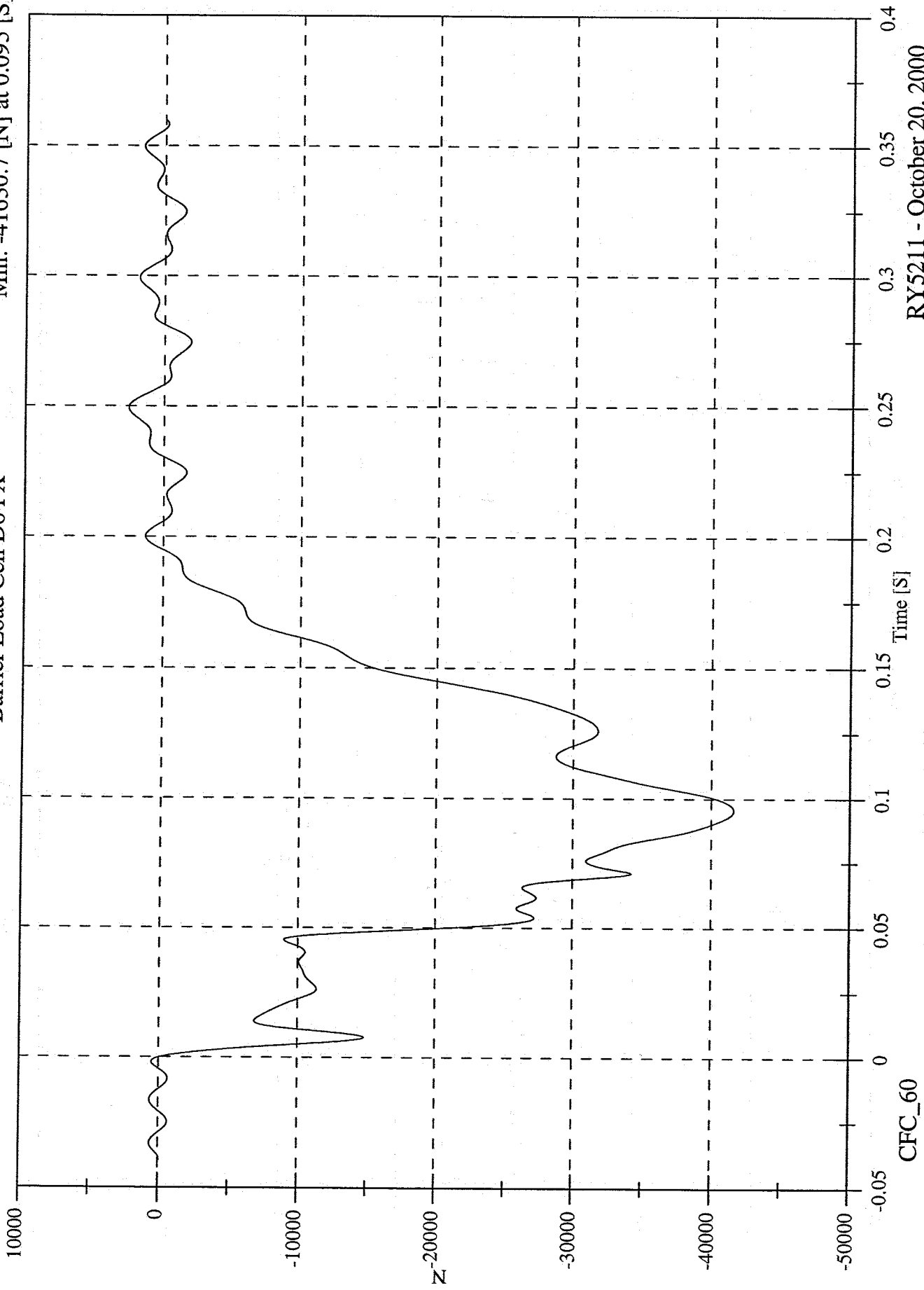

RY5211 - October 20, 2000

40% Offset Barrier Test #2 - 2000 Nissan Altima

Barrier Load Cell C1 FY

Max: 660.0 [N] at 0.302 [S]  
Min: -762.9 [N] at 0.278 [S]

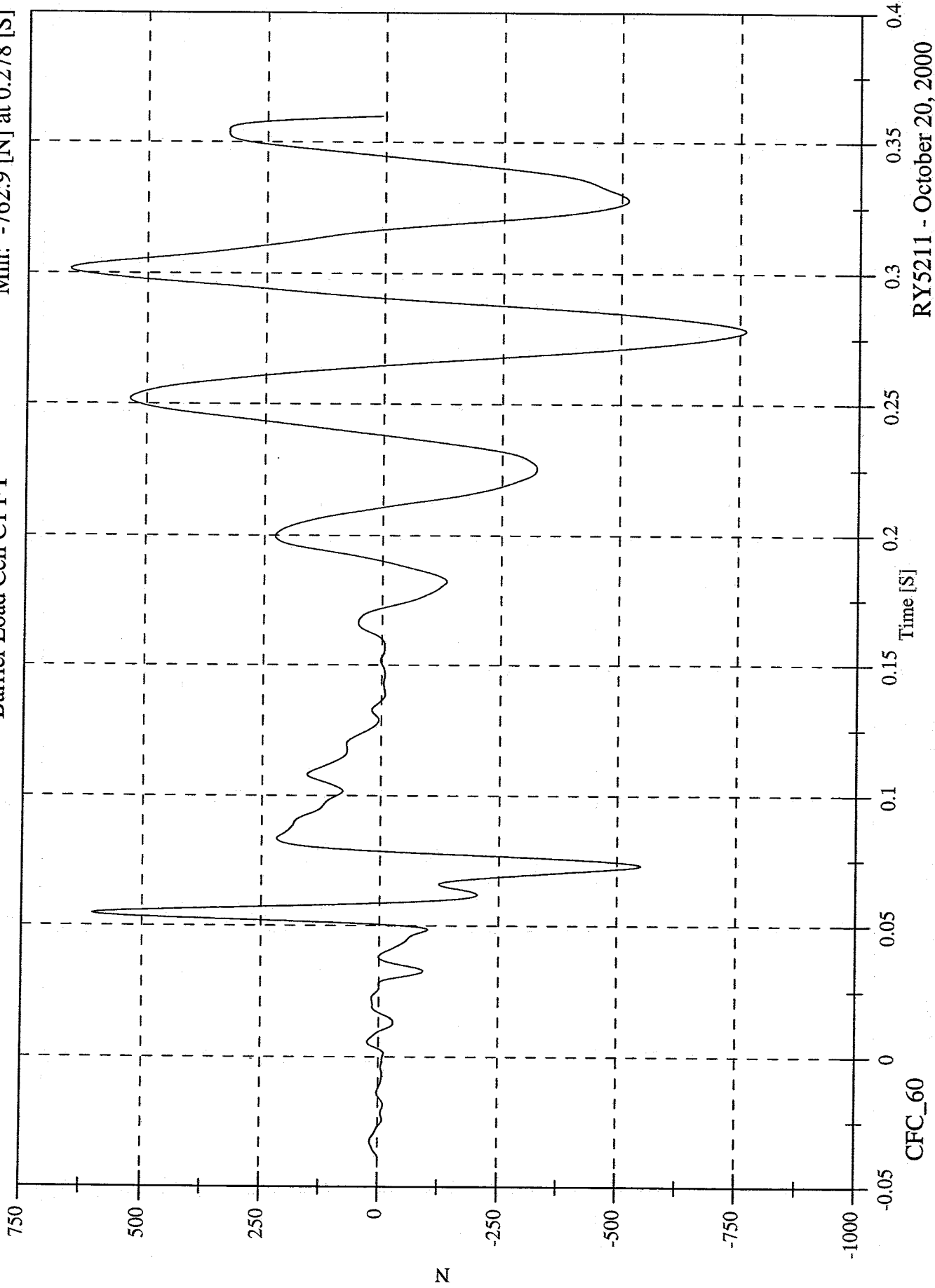

RYS211 - October 20, 2000

40% Offset Barrier Test #2 - 2000 Nissan Altima

Barrier Load Cell C2 FY

Max: 662.3 [N] at 0.301 [S]  
Min: -1631.7 [N] at 0.072 [S]

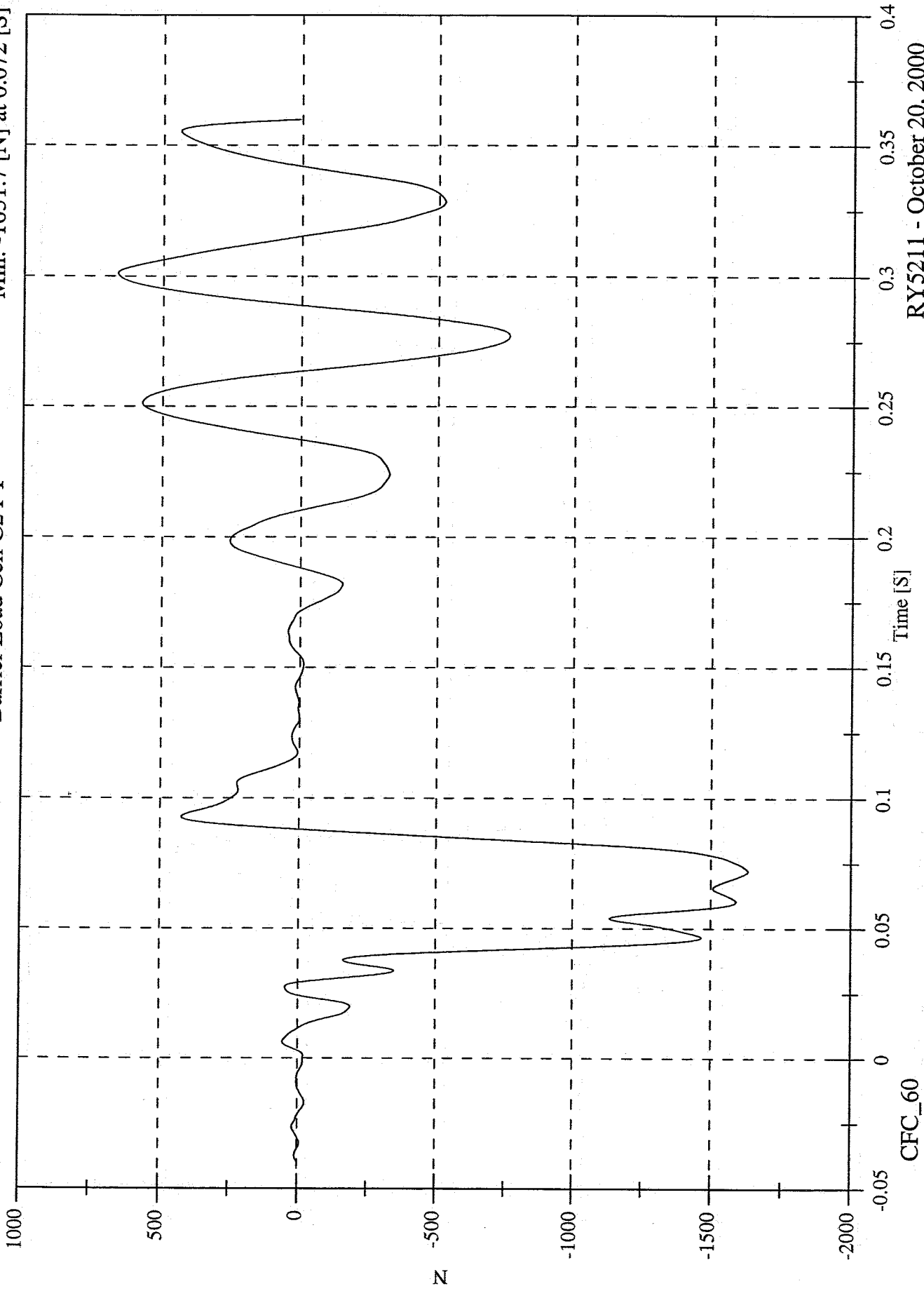

RY5211 - October 20, 2000

40% Offset Barrier Test #2 - 2000 Nissan Altima

Barrier Load Cell C3 FY

Max: 748.6 [N] at 0.302 [S]

Min: -1503.8 [N] at 0.073 [S]

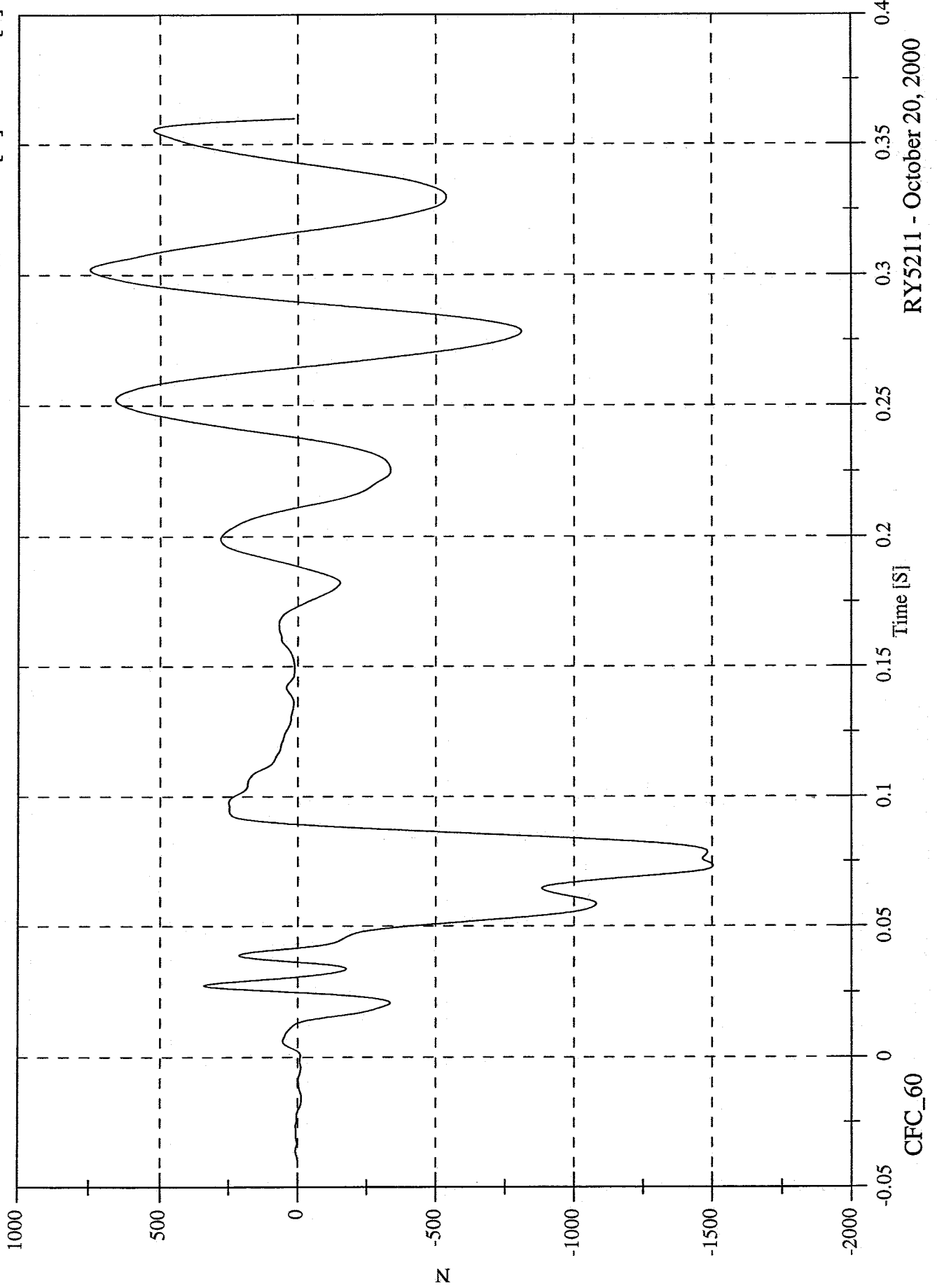

RY5211 - October 20, 2000

40% Offset Barrier Test #2 - 2000 Nissan Altima

Barrier Load Cell C4 FY

Max: 1315.6 [N] at 0.018 [S]  
Min: -1964.3 [N] at 0.078 [S]

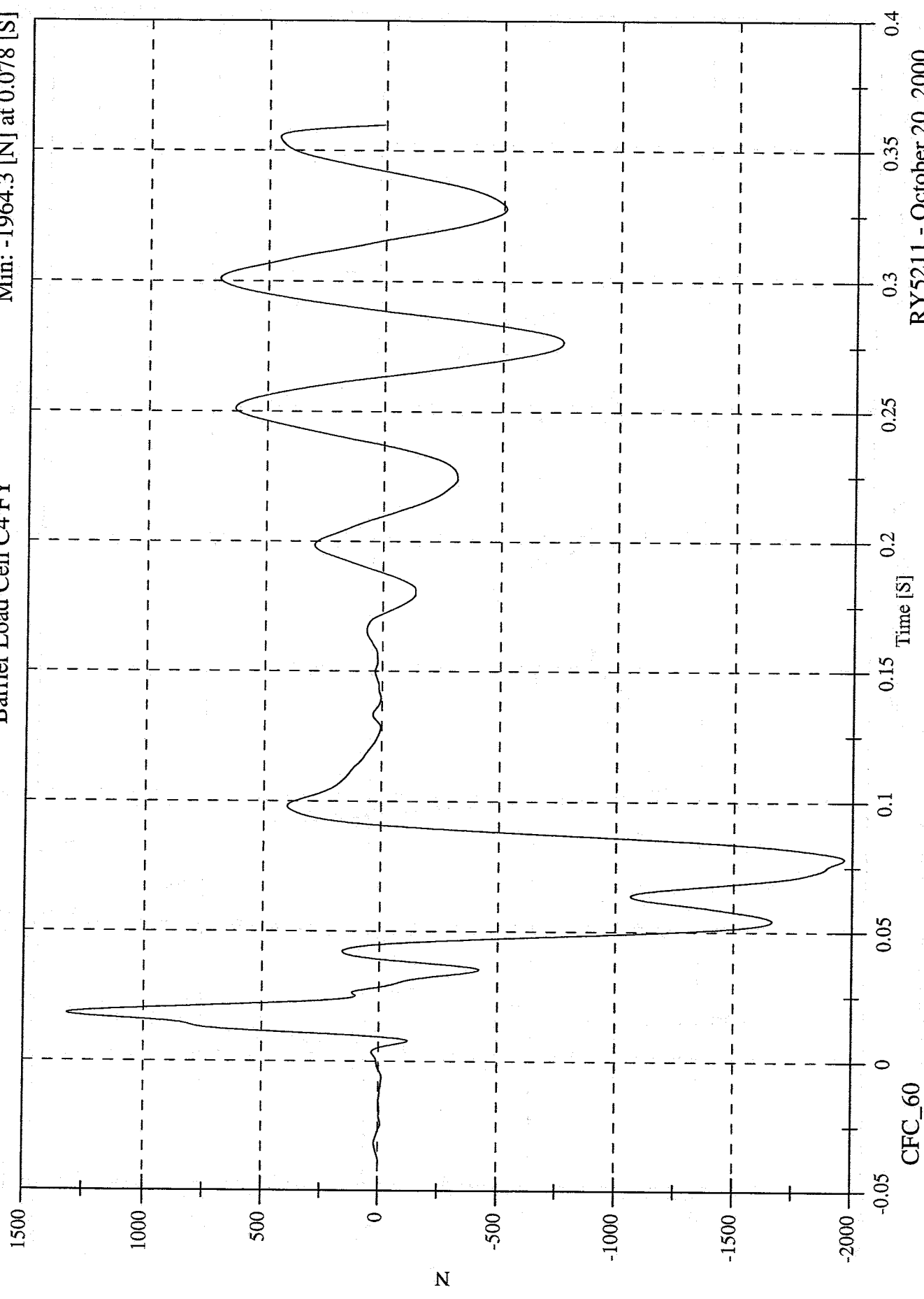

RY5211 - October 20, 2000

40% Offset Barrier Test #2 - 2000 Nissan Altima

Barrier Load Cell C5 FY

Max: 1316.0 [N] at 0.015 [S]

Min: -2955.1 [N] at 0.054 [S]

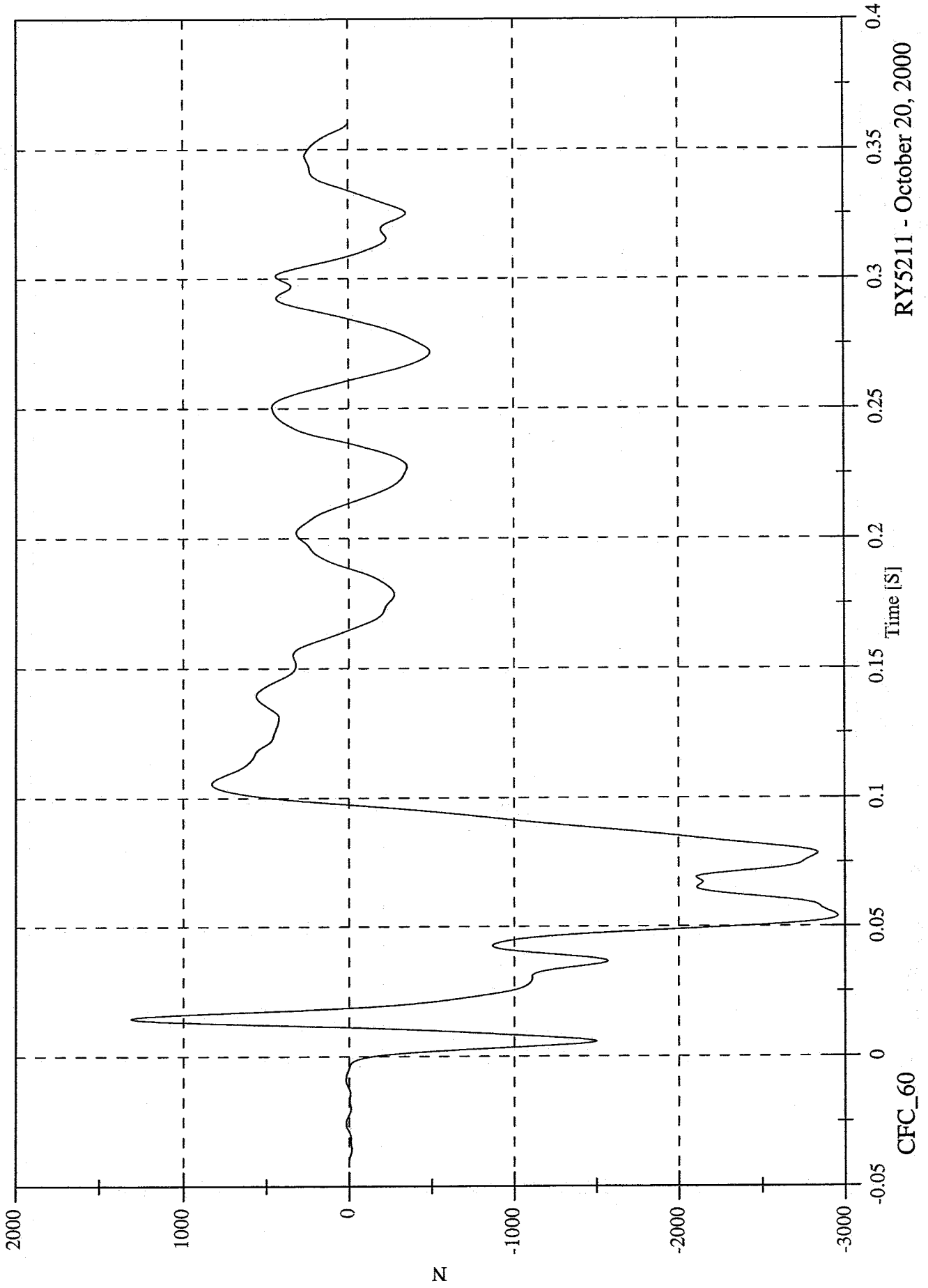

RY5211 - October 20, 2000

40% Offset Barrier Test #2 - 2000 Nissan Altima

Barrier Load Cell C6 FY

Max: 520.4 [N] at 0.135 [S]  
Min: -18364.1 [N] at 0.079 [S]

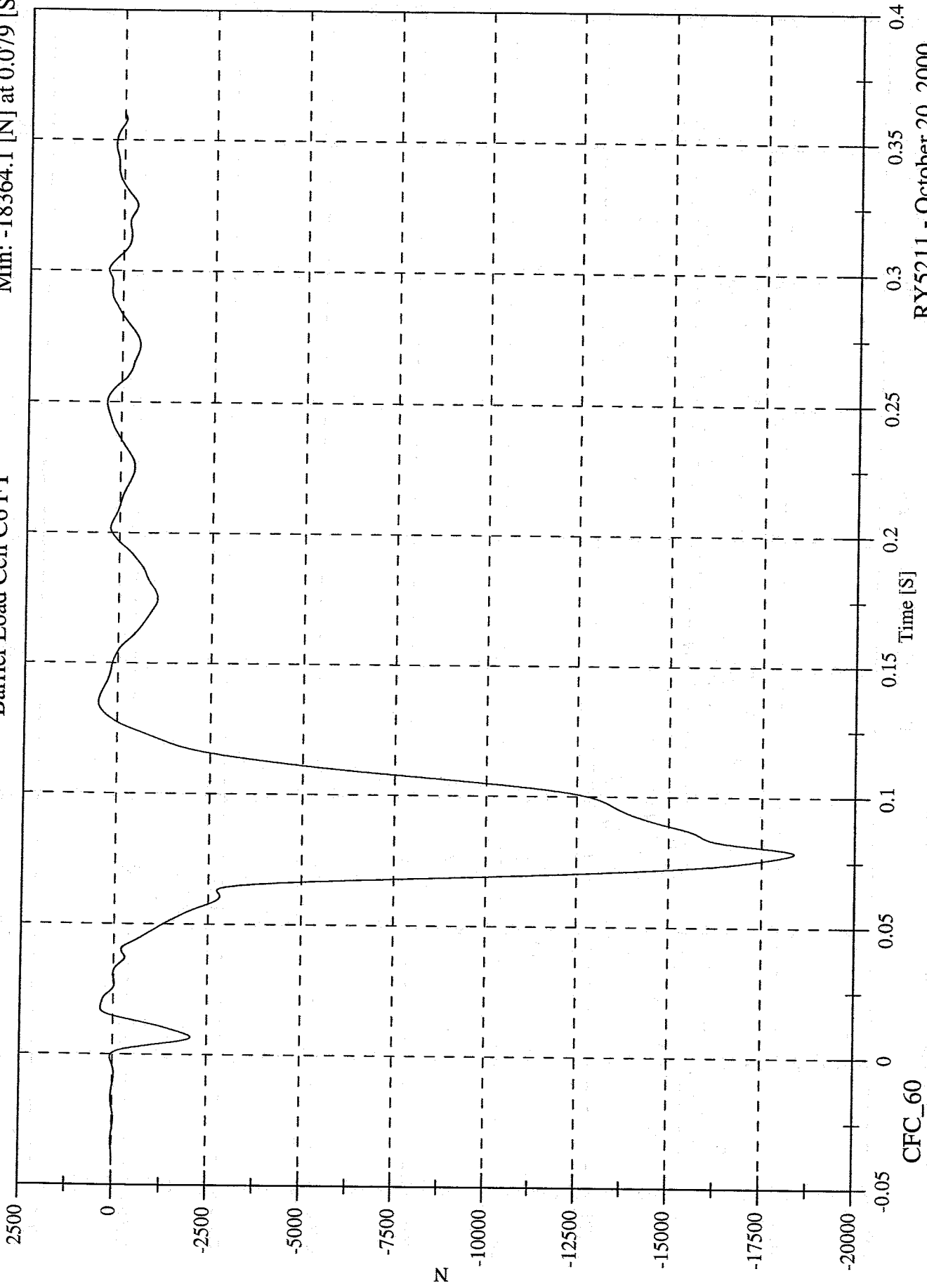

RY5211 - October 20, 2000

40% Offset Barrier Test #2 - 2000 Nissan Altima

Max: 1218.3 [N] at 0.250 [S]  
Min: -6163.3 [N] at 0.071 [S]

Barrier Load Cell C1 FX

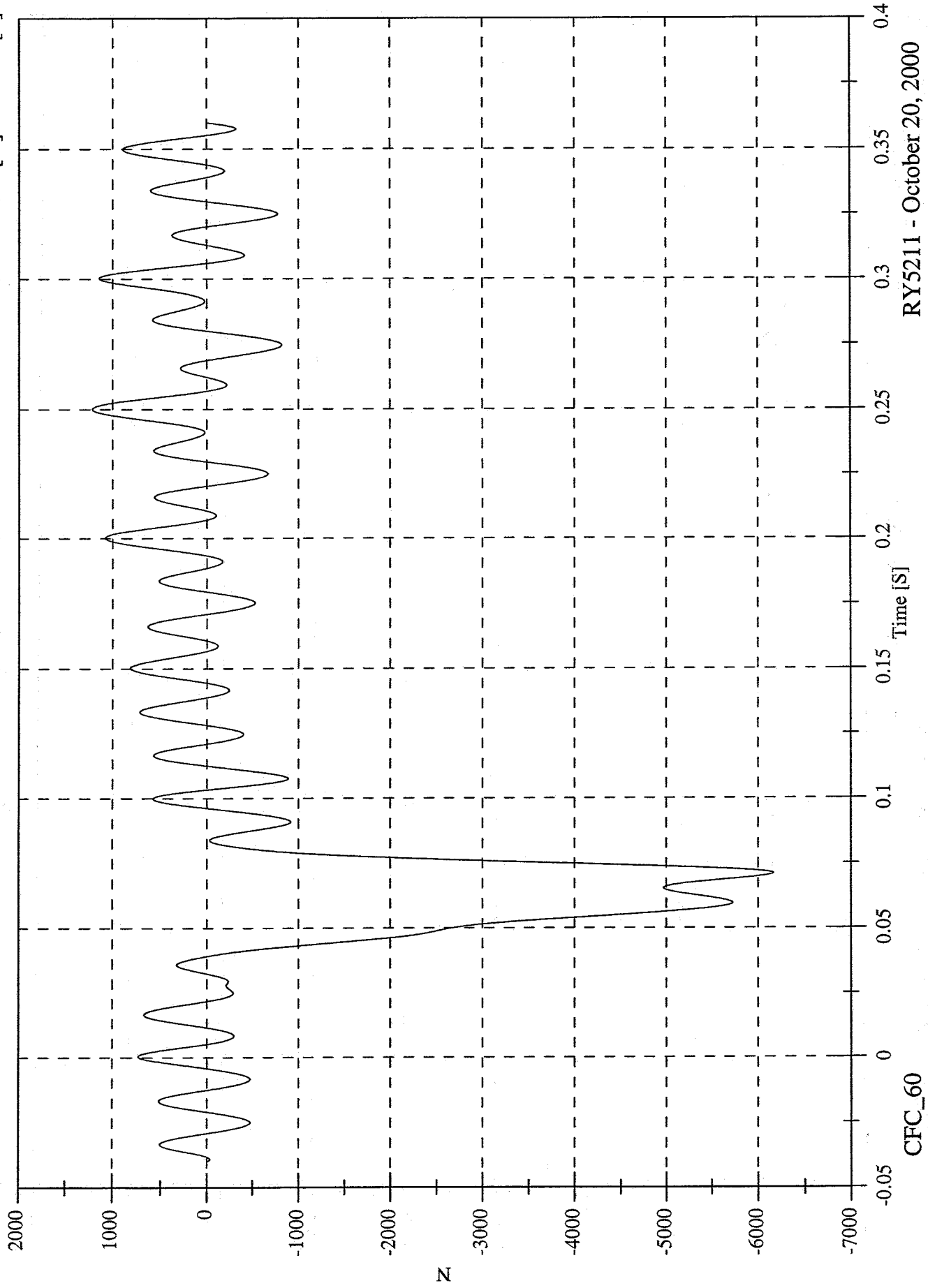

RY5211 - October 20, 2000

CFC\_60

40% Offset Barrier Test #2 - 2000 Nissan Altima

Barrier Load Cell C2 FX

Max: 1177.7 [N] at 0.300 [S]  
Min: -7448.3 [N] at 0.058 [S]

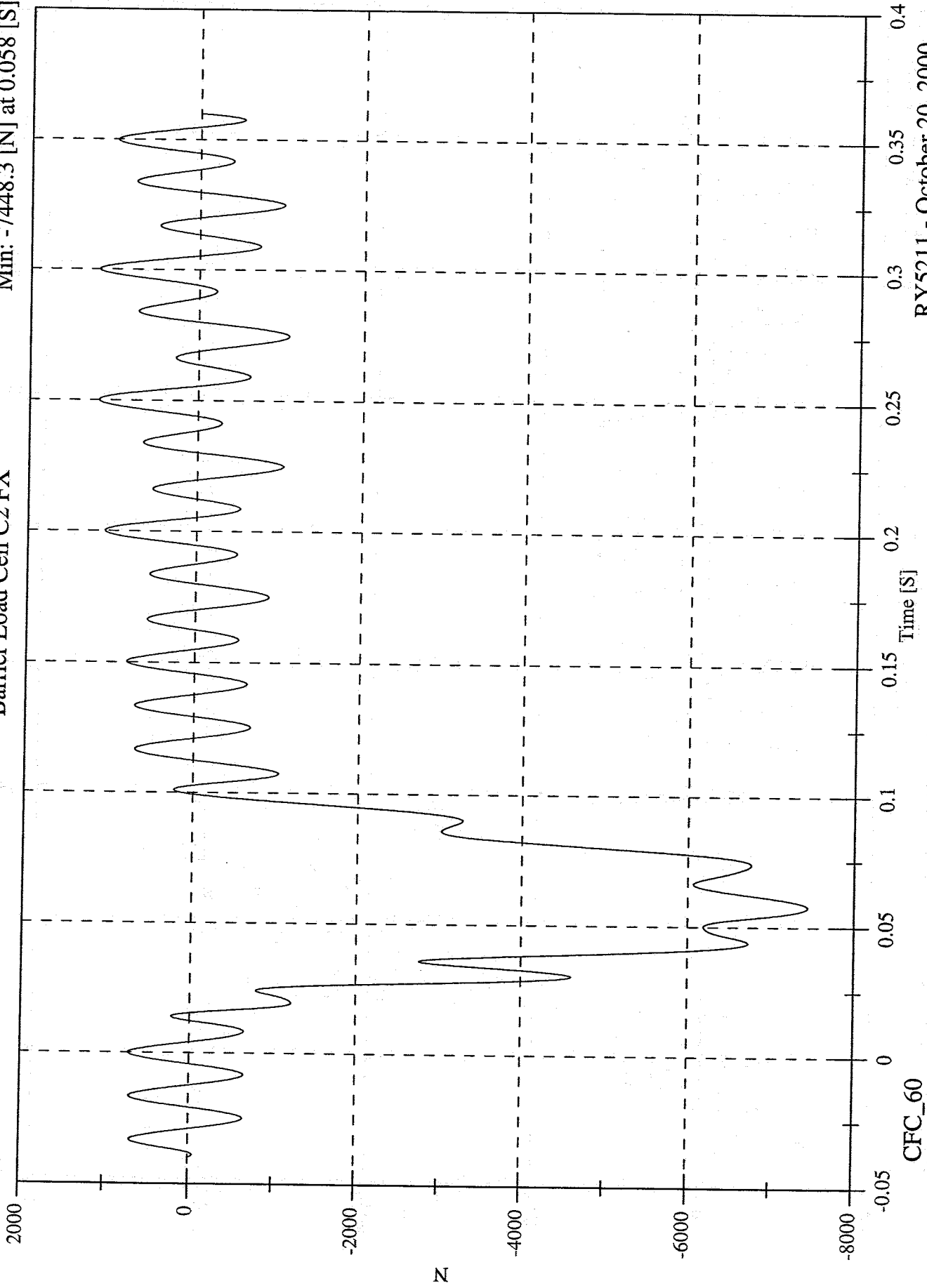

RY5211 - October 20, 2000

40% Offset Barrier Test #2 - 2000 Nissan Altima

Max: 1675.8 [N] at -0.000 [S]  
Min: -8403.0 [N] at 0.075 [S]

Barrier Load Cell C3 FX

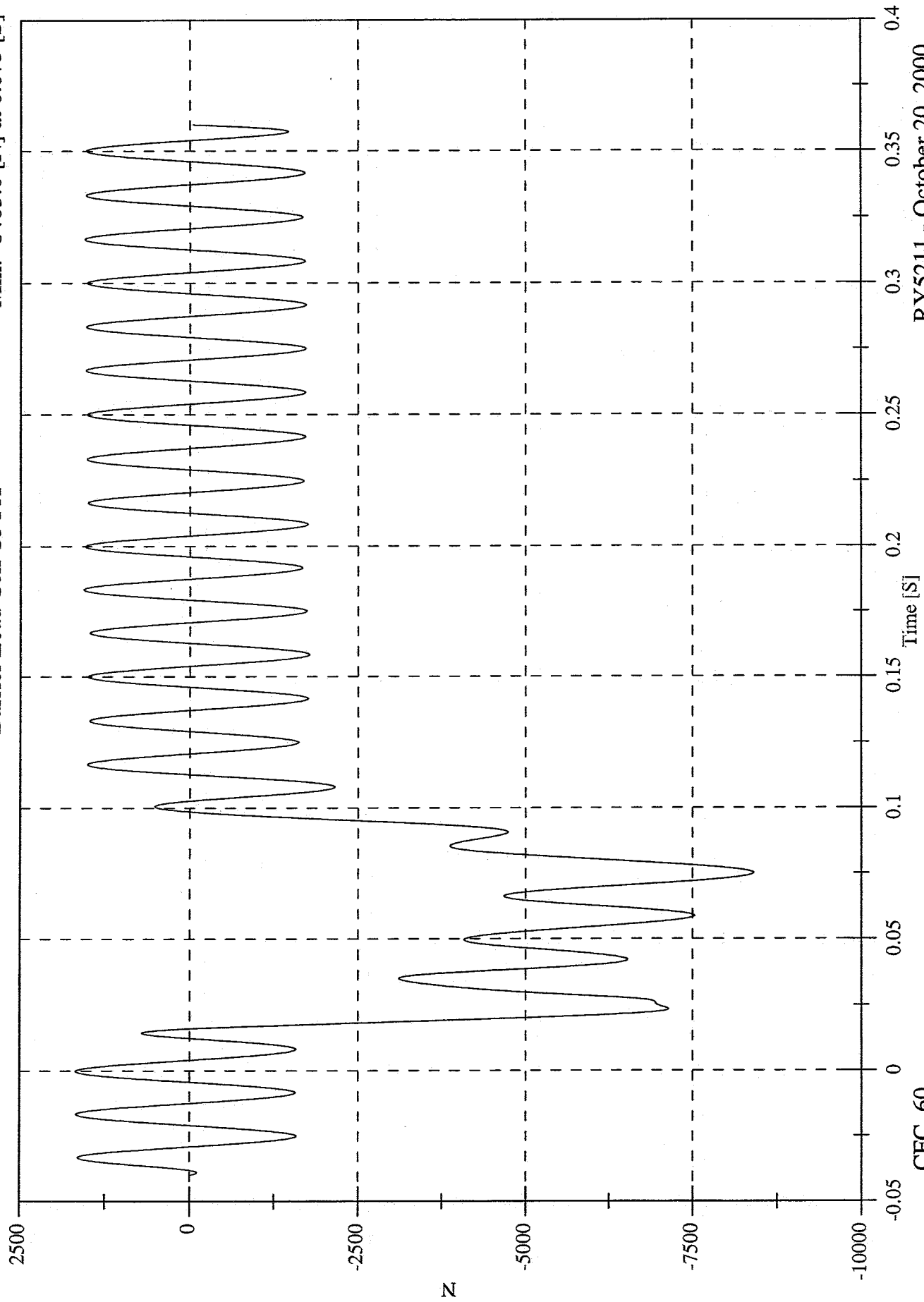

CFC\_60

RY5211 - October 20, 2000

40% Offset Barrier Test #2 - 2000 Nissan Altima

Barrier Load Cell C4 FX

Max: 1005.1 [N] at 0.267 [S]  
Min: -8674.7 [N] at 0.017 [S]

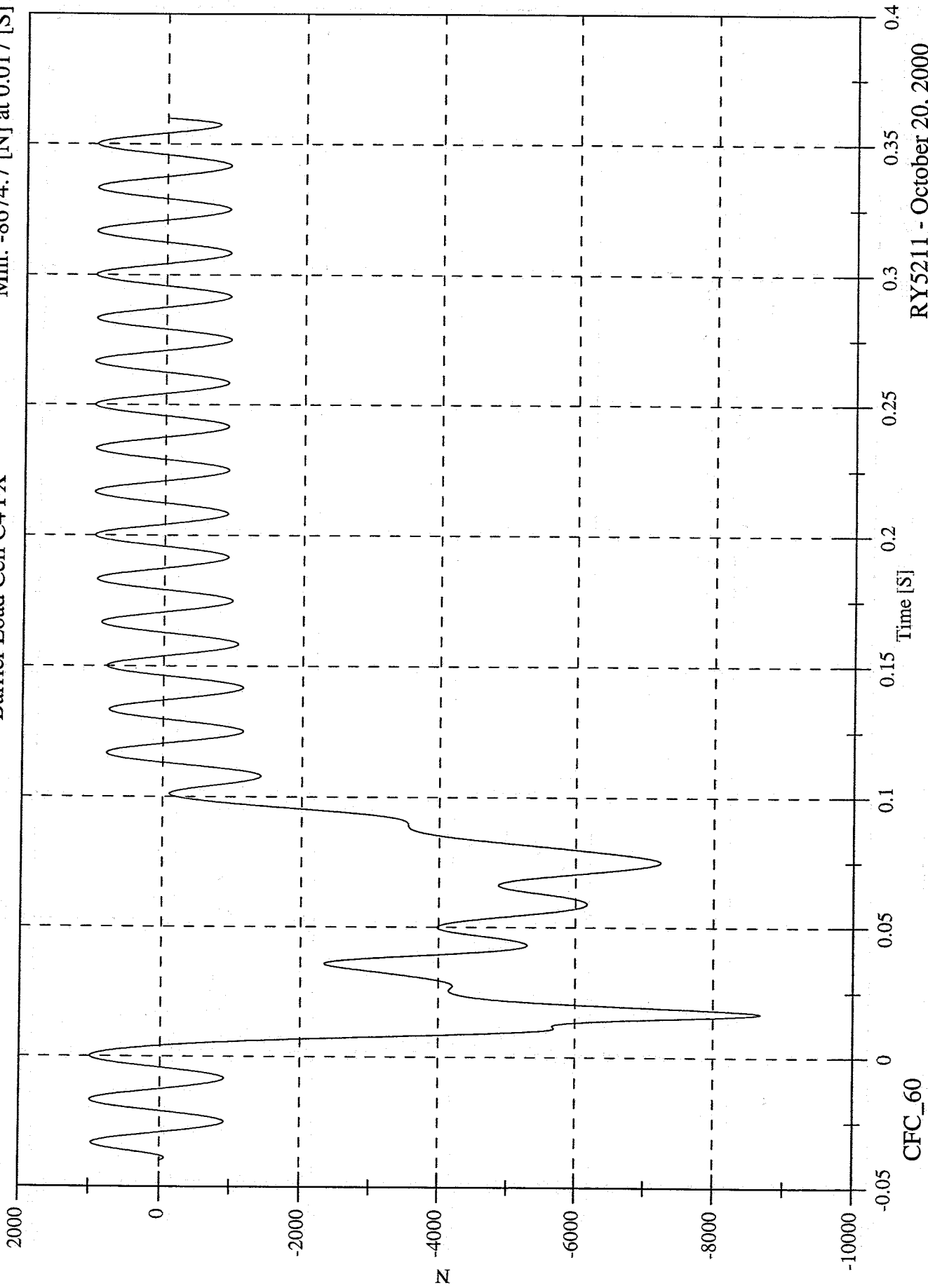

RY5211 - October 20, 2000

40% Offset Barrier Test #2 - 2000 Nissan Altima

Max: 775.1 [N] at 0.250 [S]  
Min: -12213.9 [N] at 0.010 [S]

Barrier Load Cell C5 FX

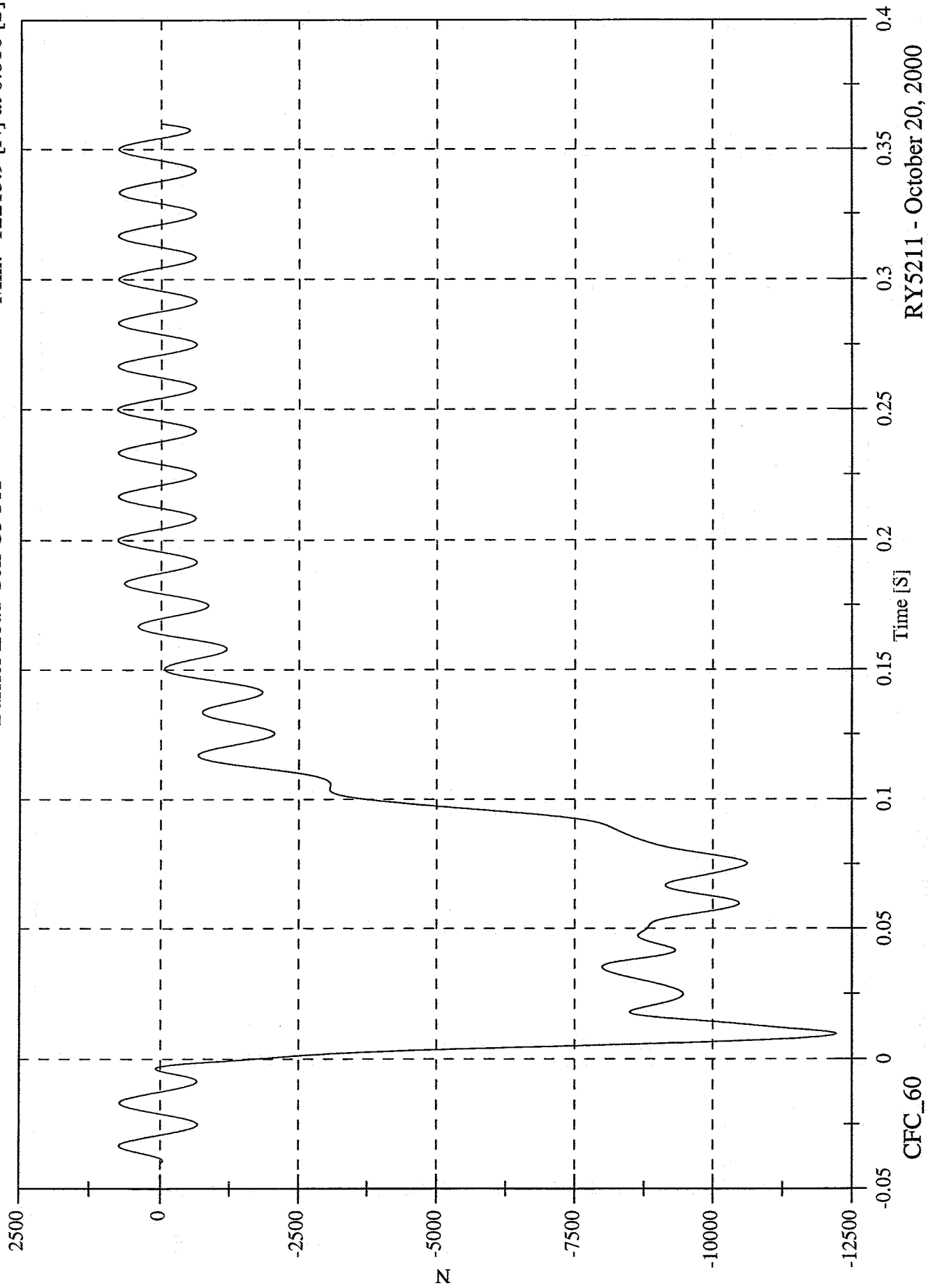

RY5211 - October 20, 2000

40% Offset Barrier Test #2 - 2000 Nissan Altima

Barrier Load Cell C6 FX

Max: 981.6 [N] at 0.250 [S]  
Min: -15903.0 [N] at 0.079 [S]

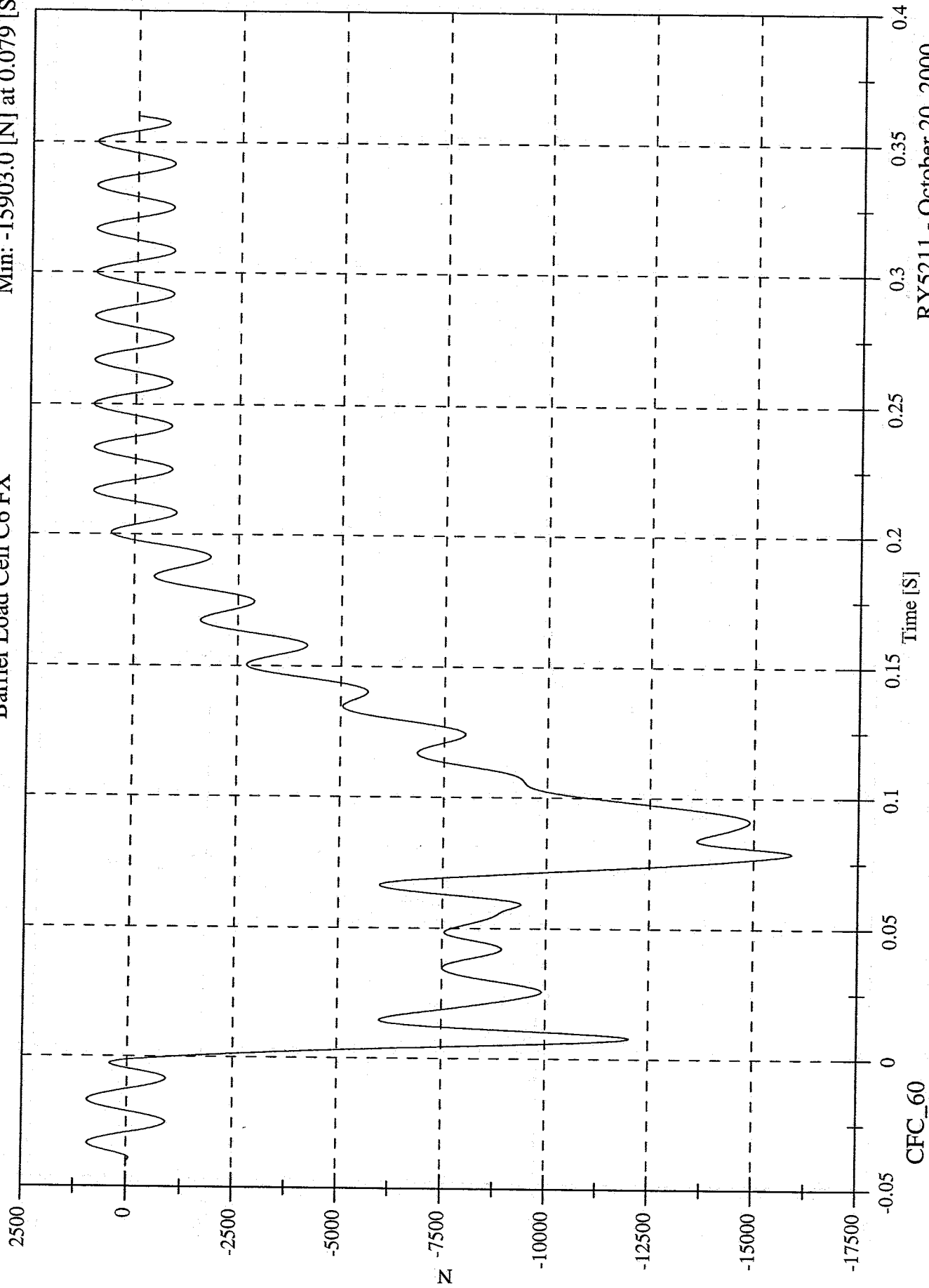

RY5211 - October 20, 2000

Max: 367.5 [N] at 0.106 [S]  
Min: -651.4 [N] at 0.071 [S]

Barrier Load Cell B1 FY

40% Offset Barrier Test #2 - 2000 Nissan Altima

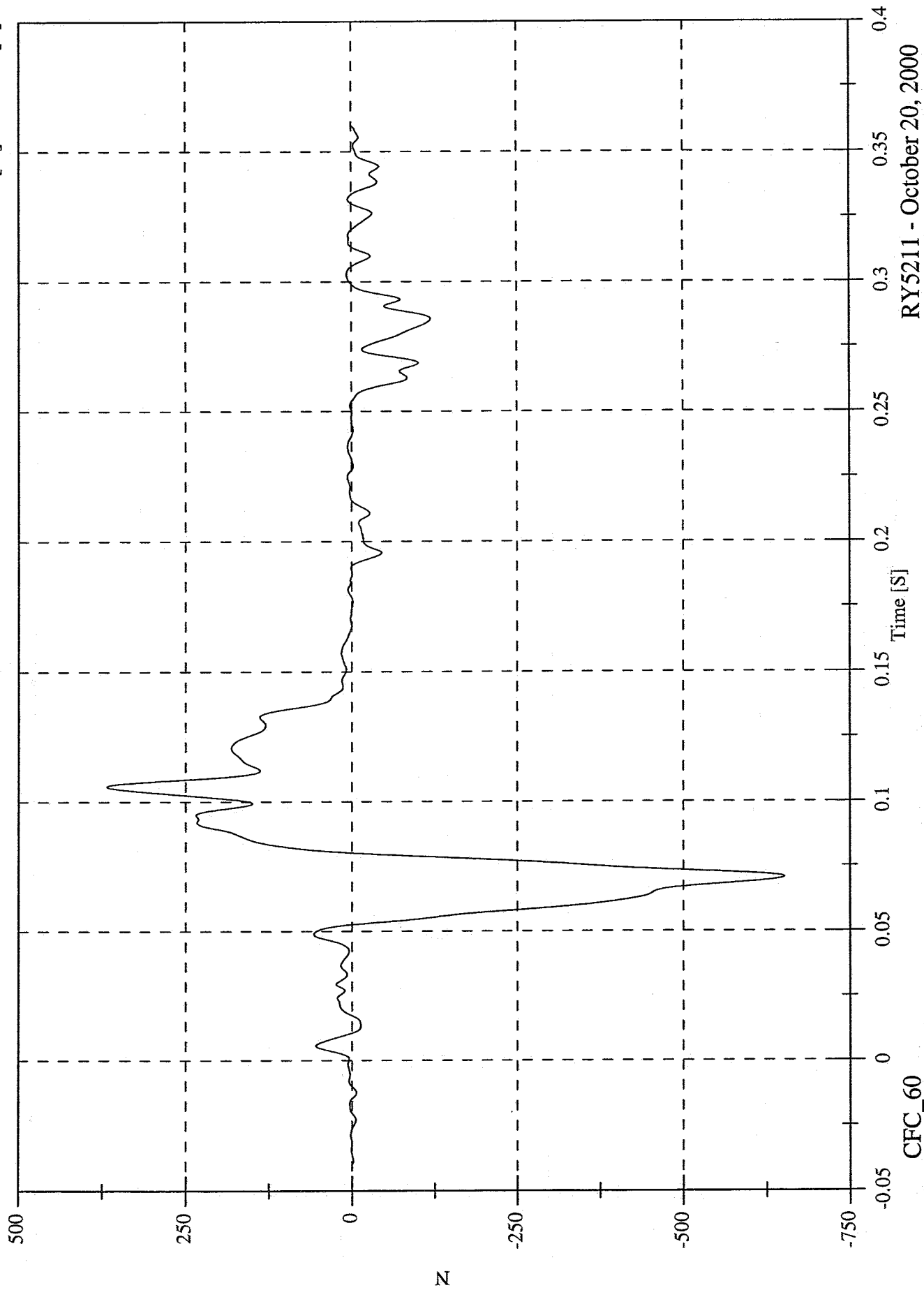

RYS211 - October 20, 2000

40% Offset Barrier Test #2 - 2000 Nissan Altima

Barrier Load Cell B2 FY

Max: 337.8 [N] at 0.090 [S]  
Min: -1207.4 [N] at 0.071 [S]

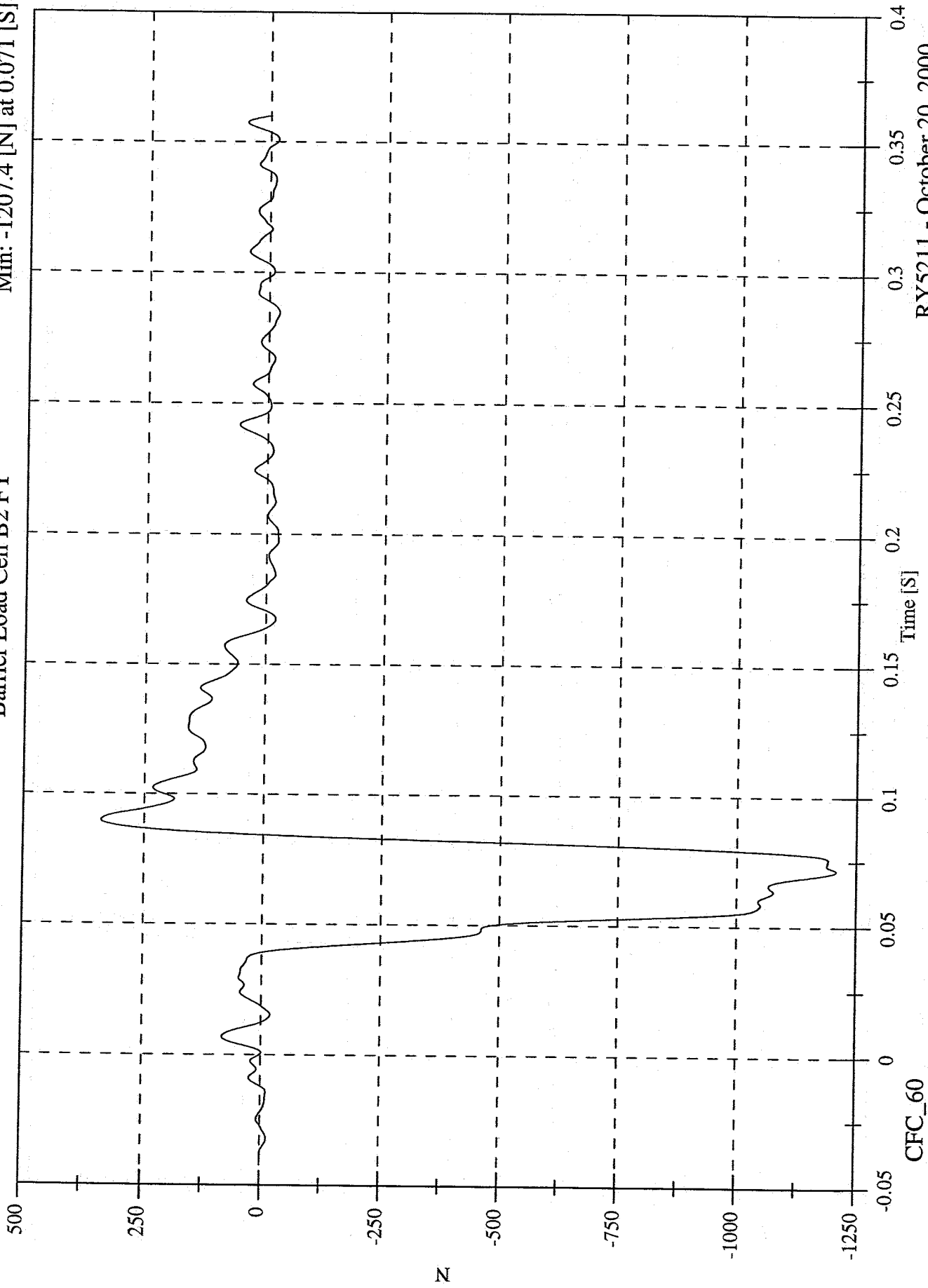

RYS211 - October 20, 2000

40% Offset Barrier Test #2 - 2000 Nissan Altima

Max: 510.3 [N] at 0.038 [S]  
Min: -1216.1 [N] at 0.057 [S]

Barrier Load Cell B3 FY

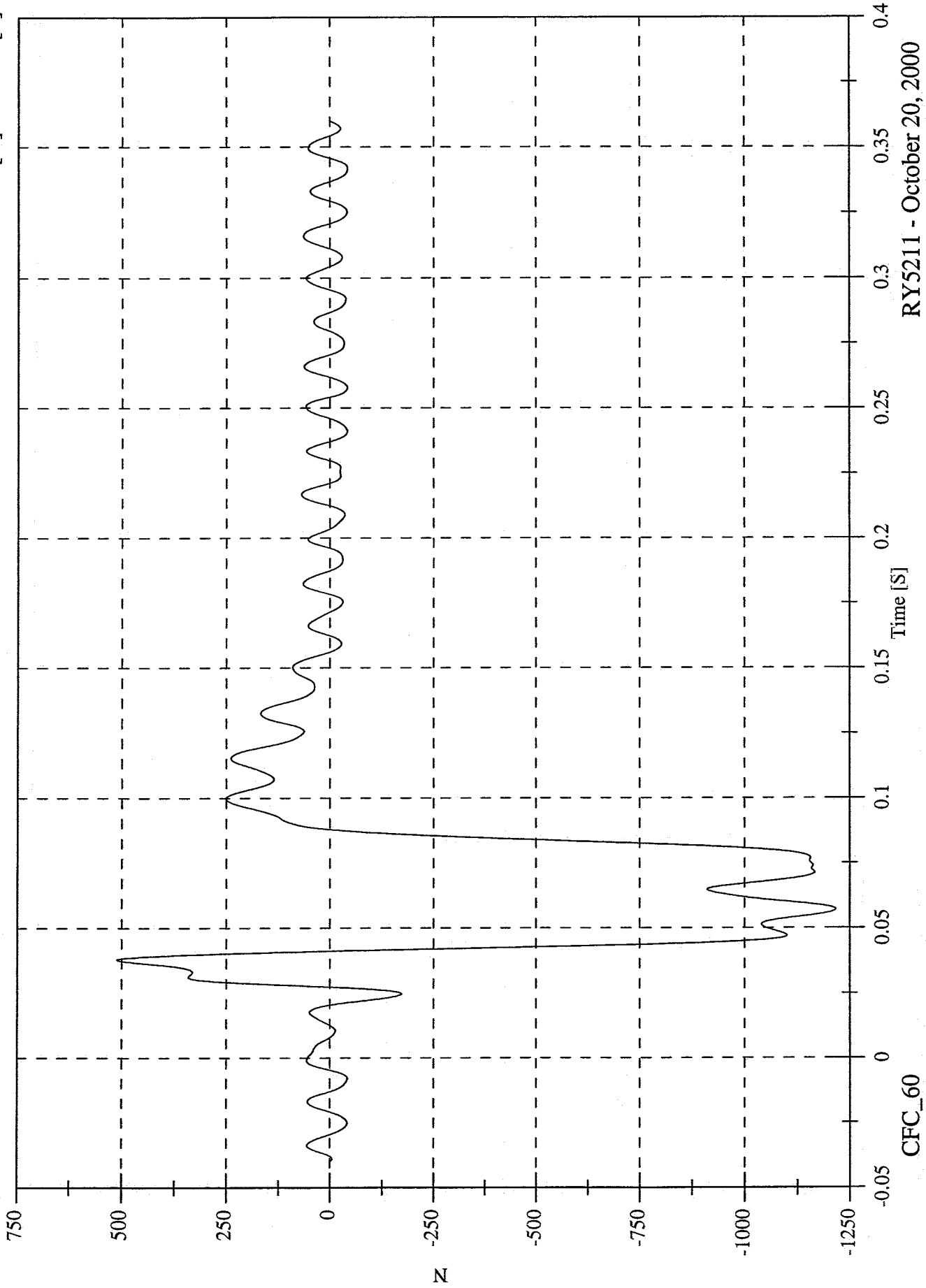

RY5211 - October 20, 2000

CFC\_60

40% Offset Barrier Test #2 - 2000 Nissan Altima

Barrier Load Cell B4 FY

Max: 240.2 [N] at 0.101 [S]  
Min: -1691.6 [N] at 0.075 [S]

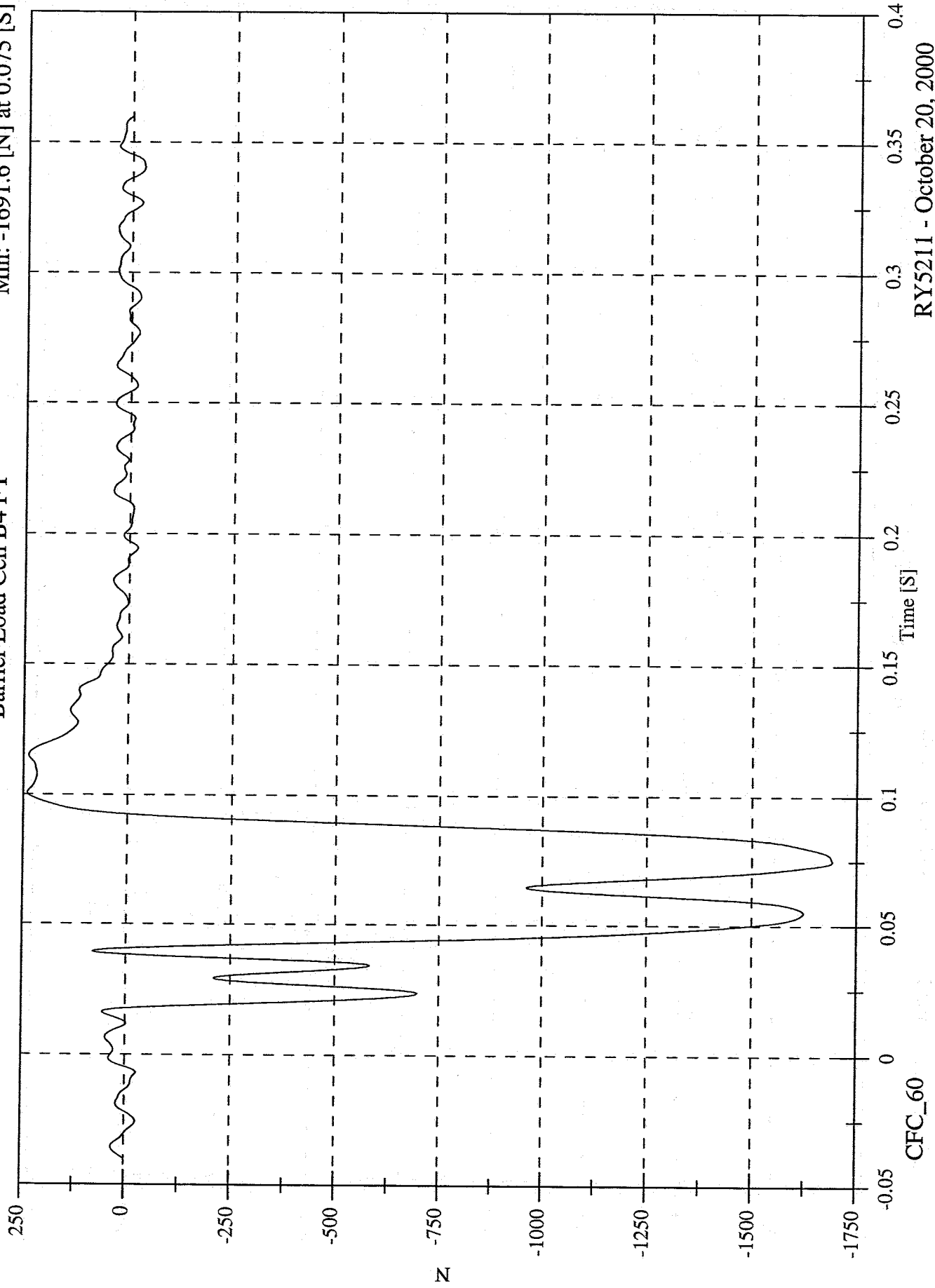

RY5211 - October 20, 2000

40% Offset Barrier Test #2 - 2000 Nissan Altima

Max: 270.0 [N] at 0.140 [S]  
Min: -1603.5 [N] at 0.054 [S]

Barrier Load Cell B5 FY

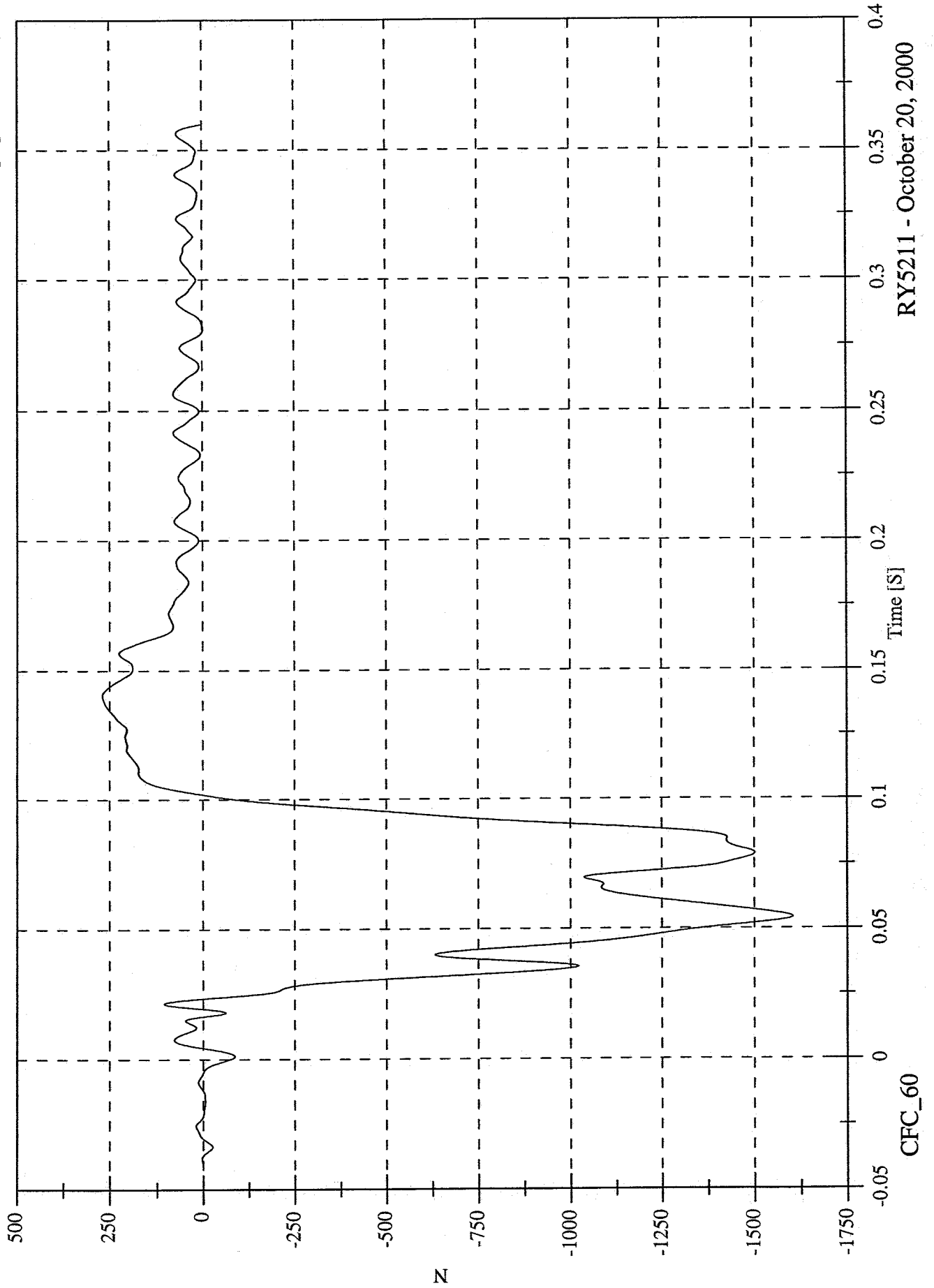

RY5211 - October 20, 2000

40% Offset Barrier Test #2 - 2000 Nissan Altima

Barrier Load Cell B6 FY

Max: 279.3 [N] at 0.141 [S]  
Min: -4886.0 [N] at 0.099 [S]

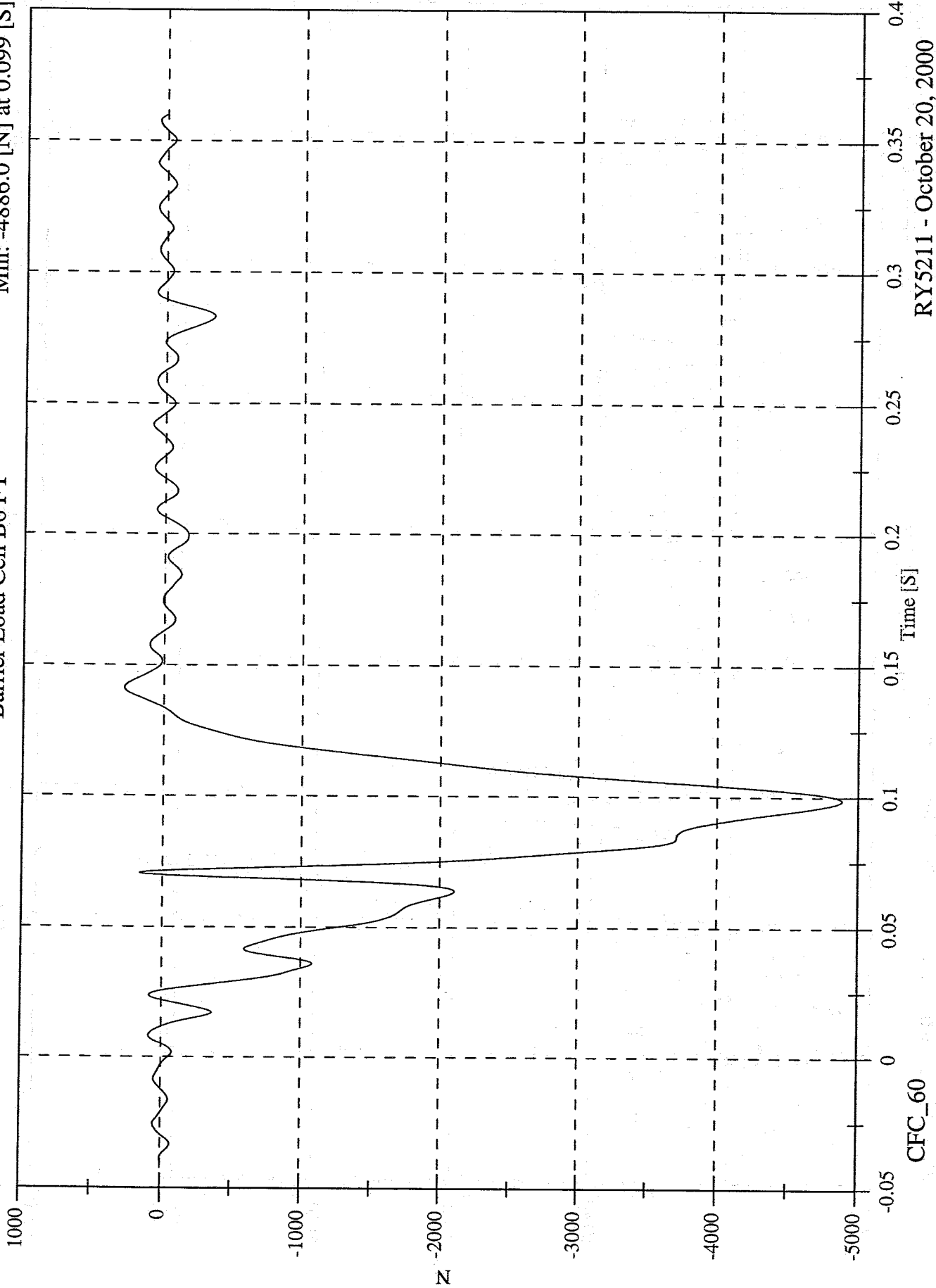

RY5211 - October 20, 2000

40% Offset Barrier Test #2 - 2000 Nissan Altima

Max: 853.4 [N] at -0.000 [S]

Min: -4330.1 [N] at 0.071 [S]

Barrier Load Cell B1 FX

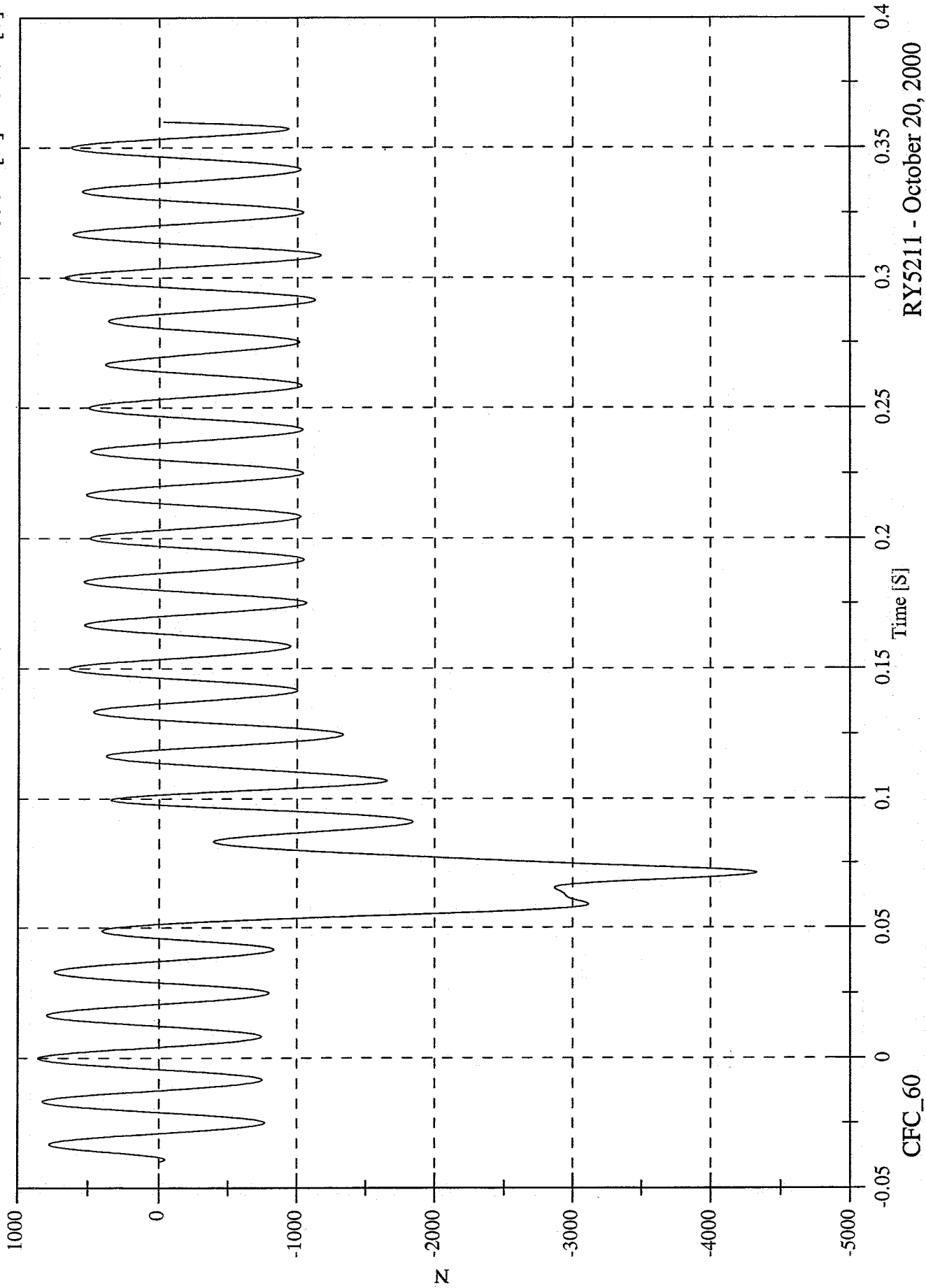

RYS211 - October 20, 2000

40% Offset Barrier Test #2 - 2000 Nissan Altima

Barrier Load Cell B2 FX

Max: 375.1 [N] at 0.317 [S]  
Min: -7194.4 [N] at 0.060 [S]

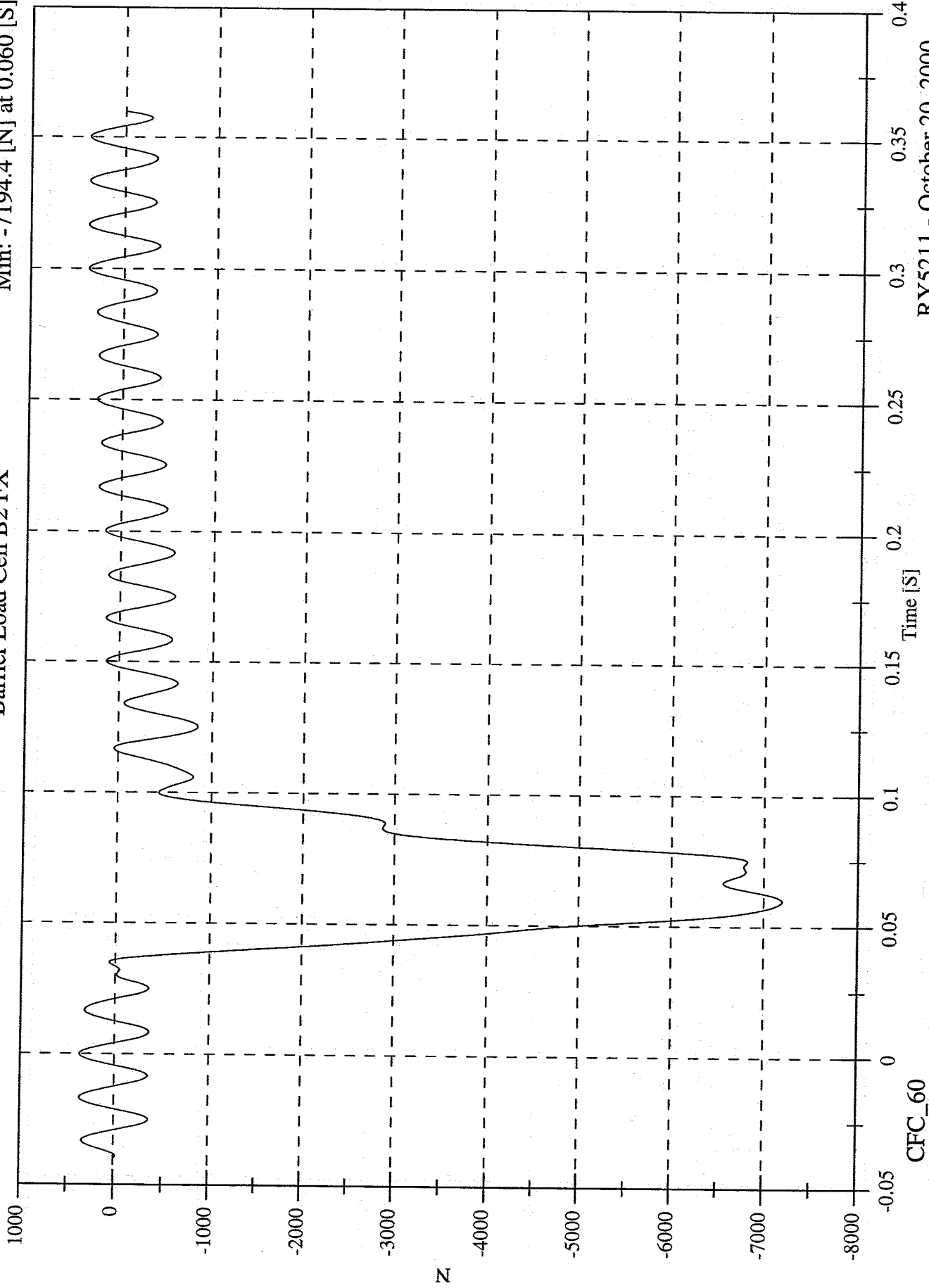

R5211 - October 20, 2000

40% Offset Barrier Test #2 - 2000 Nissan Altima

Max: 891.0 [N] at 0.350 [S]  
Min: -7606.6 [N] at 0.044 [S]

Barrier Load Cell B3 FX

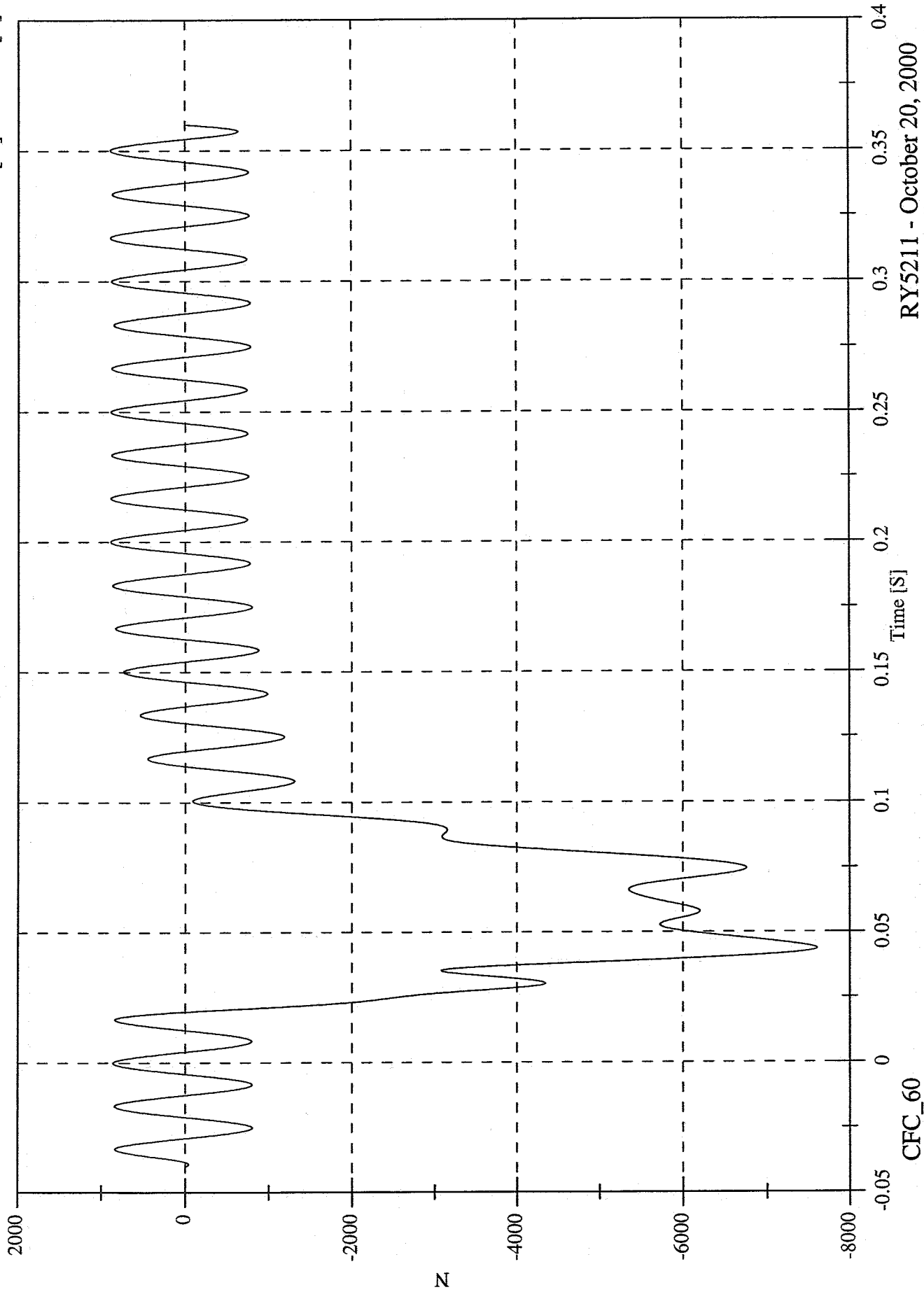

RYS211 - October 20, 2000

40% Offset Barrier Test #2 - 2000 Nissan Altima

Barrier Load Cell B4 FX

Max: 721.1 [N] at 0.317 [S]

Min: -8555.9 [N] at 0.042 [S]

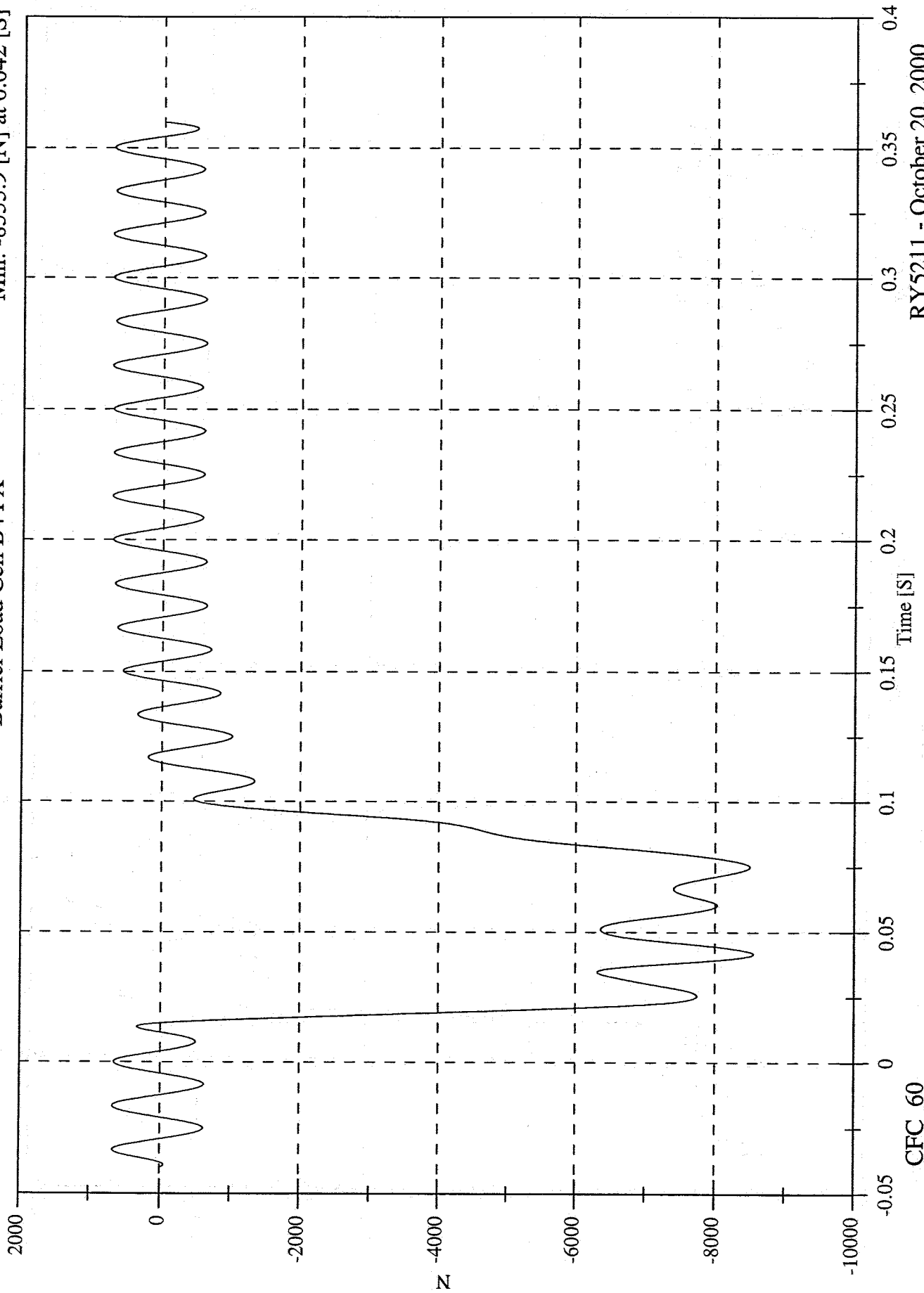

RY5211 - October 20, 2000

CFC\_60

40% Offset Barrier Test #2 - 2000 Nissan Altima

Barrier Load Cell B5 FX

Max: 1326.7 [N] at 0.267 [S]

Min: -7695.7 [N] at 0.075 [S]

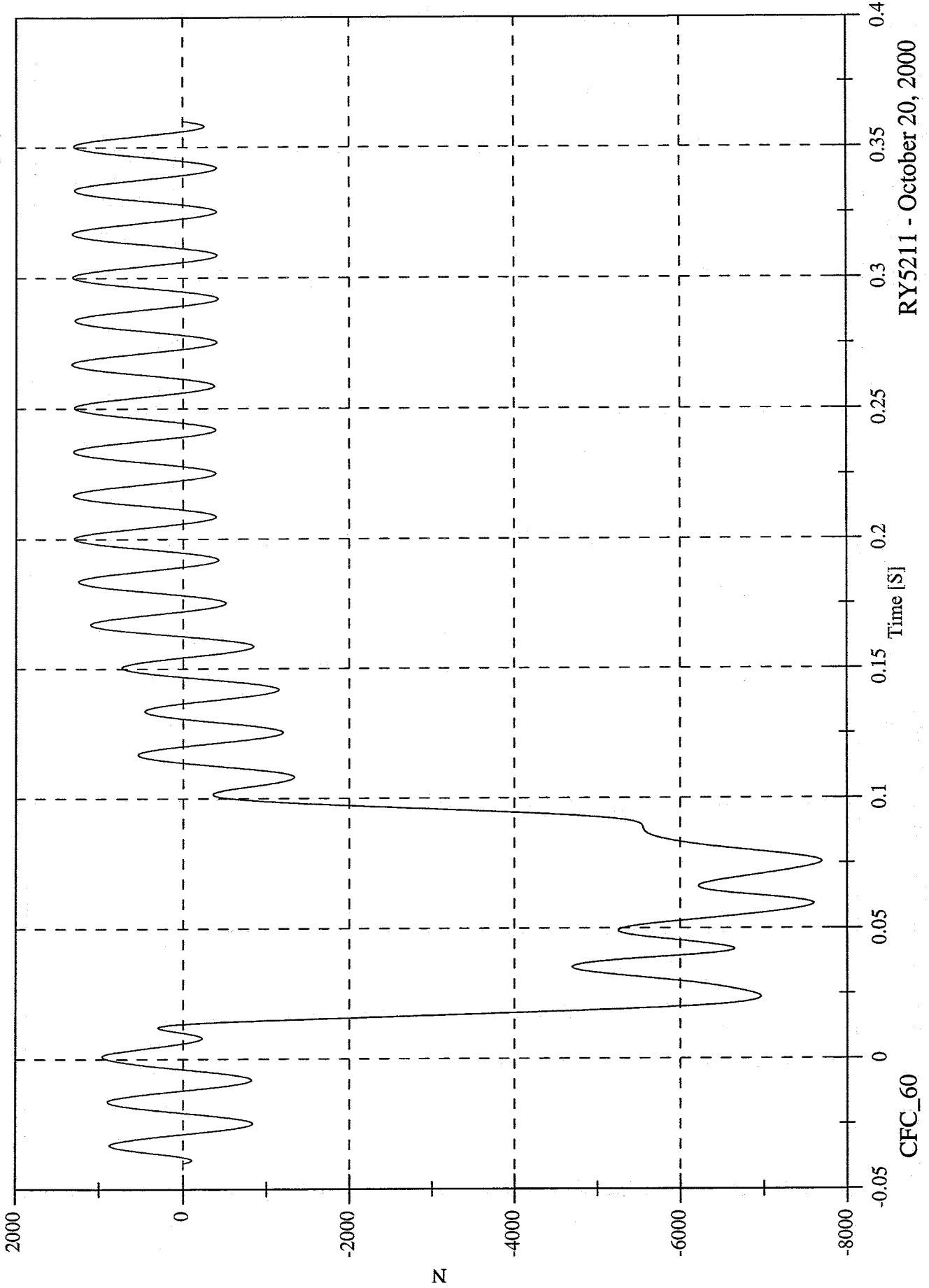

RY5211 - October 20, 2000

40% Offset Barrier Test #2 - 2000 Nissan Altima

Barrier Load Cell B6 FX

Max: 700.3 [N] at 0.267 [S]  
Min: -10897.1 [N] at 0.058 [S]

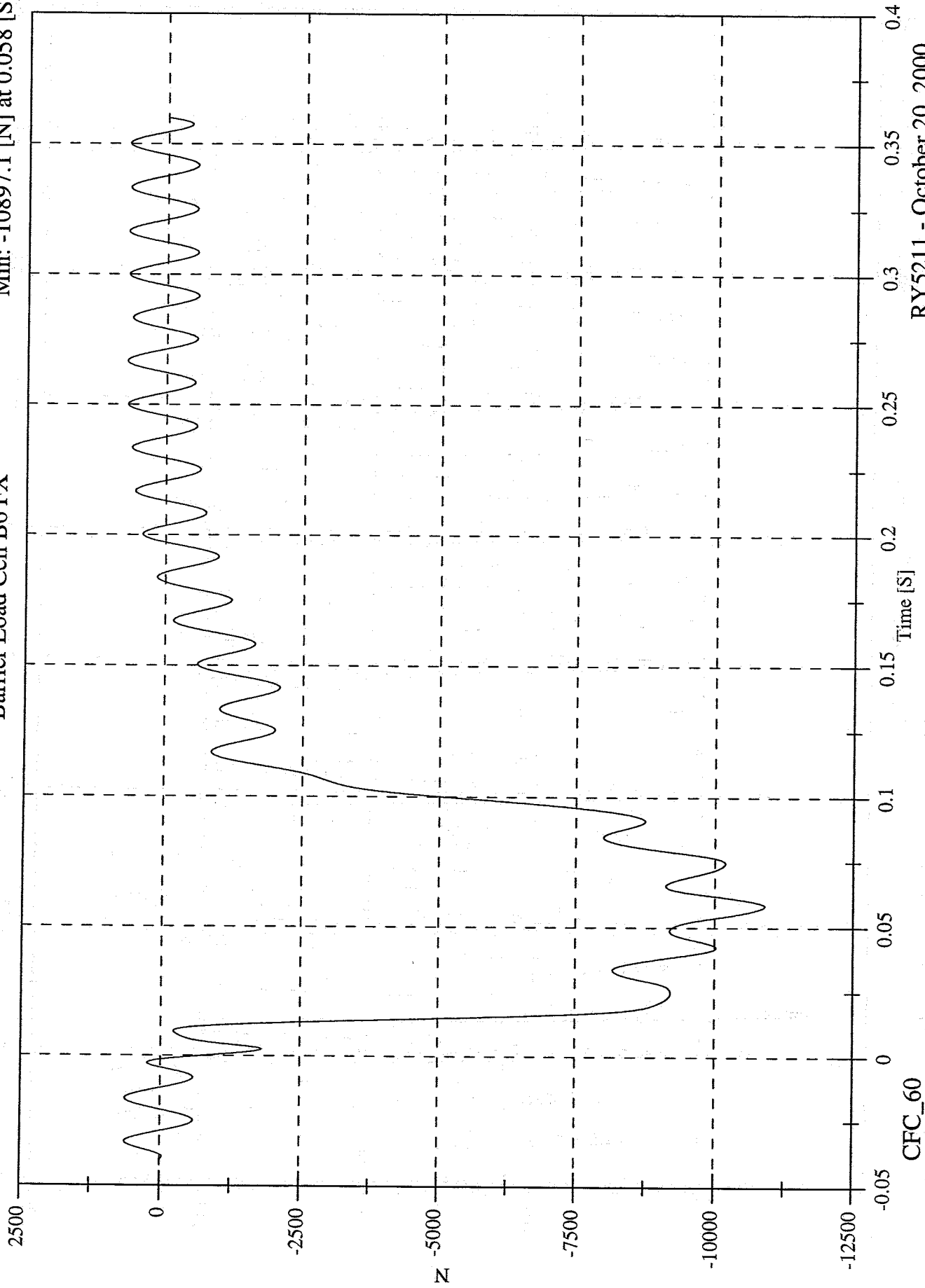

RY5211 - October 20, 2000

40% Offset Barrier Test #2 - 2000 Nissan Altima

Max: 1331.5 [N] at 0.016 [S]

Min: -776.4 [N] at 0.075 [S]

Barrier Load Cell A1 FX

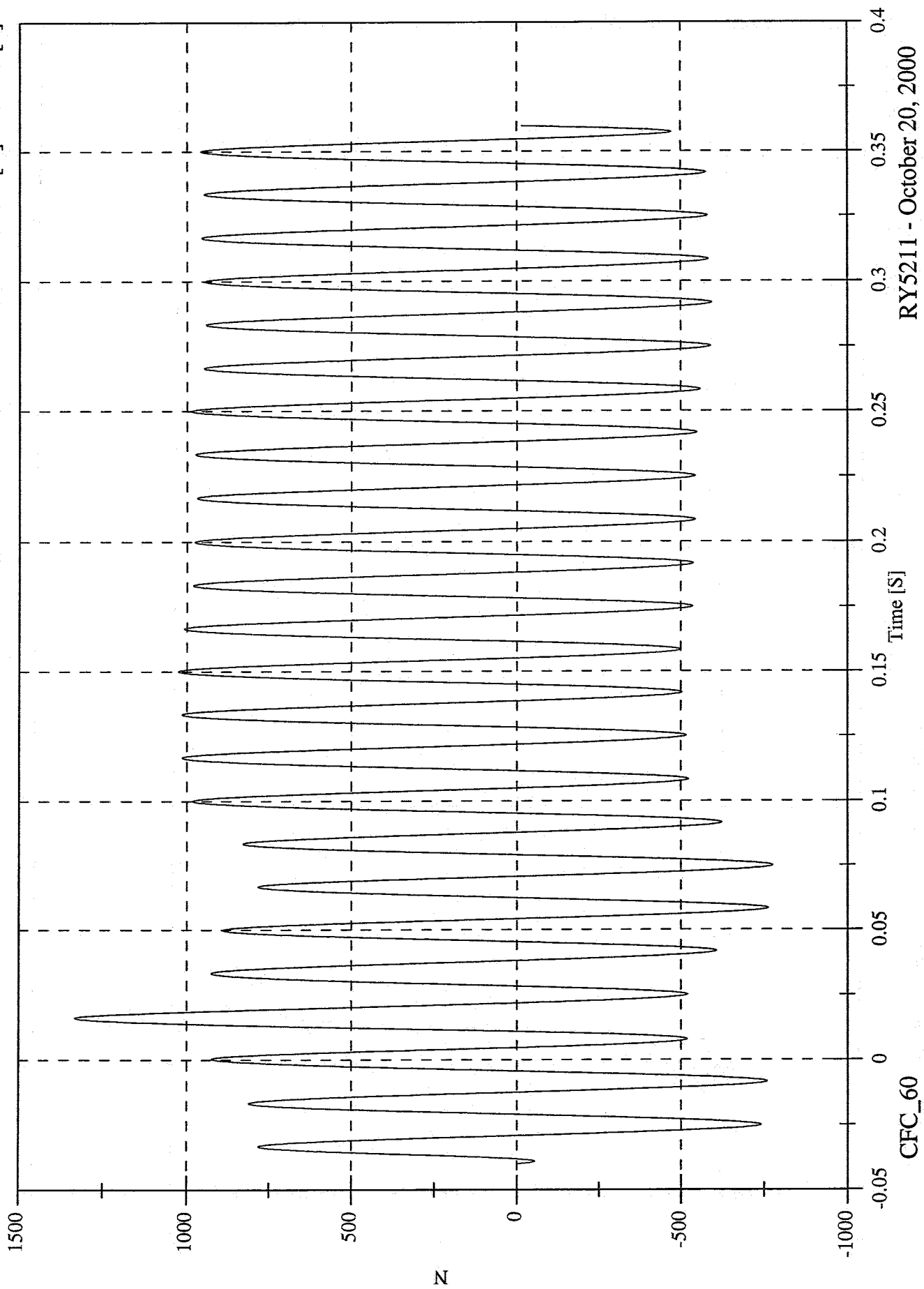

RY5211 - October 20, 2000

40% Offset Barrier Test #2 - 2000 Nissan Altima

Max: 933.6 [N] at 0.350 [S]  
Min: -2061.5 [N] at 0.076 [S]

Barrier Load Cell A2 FX

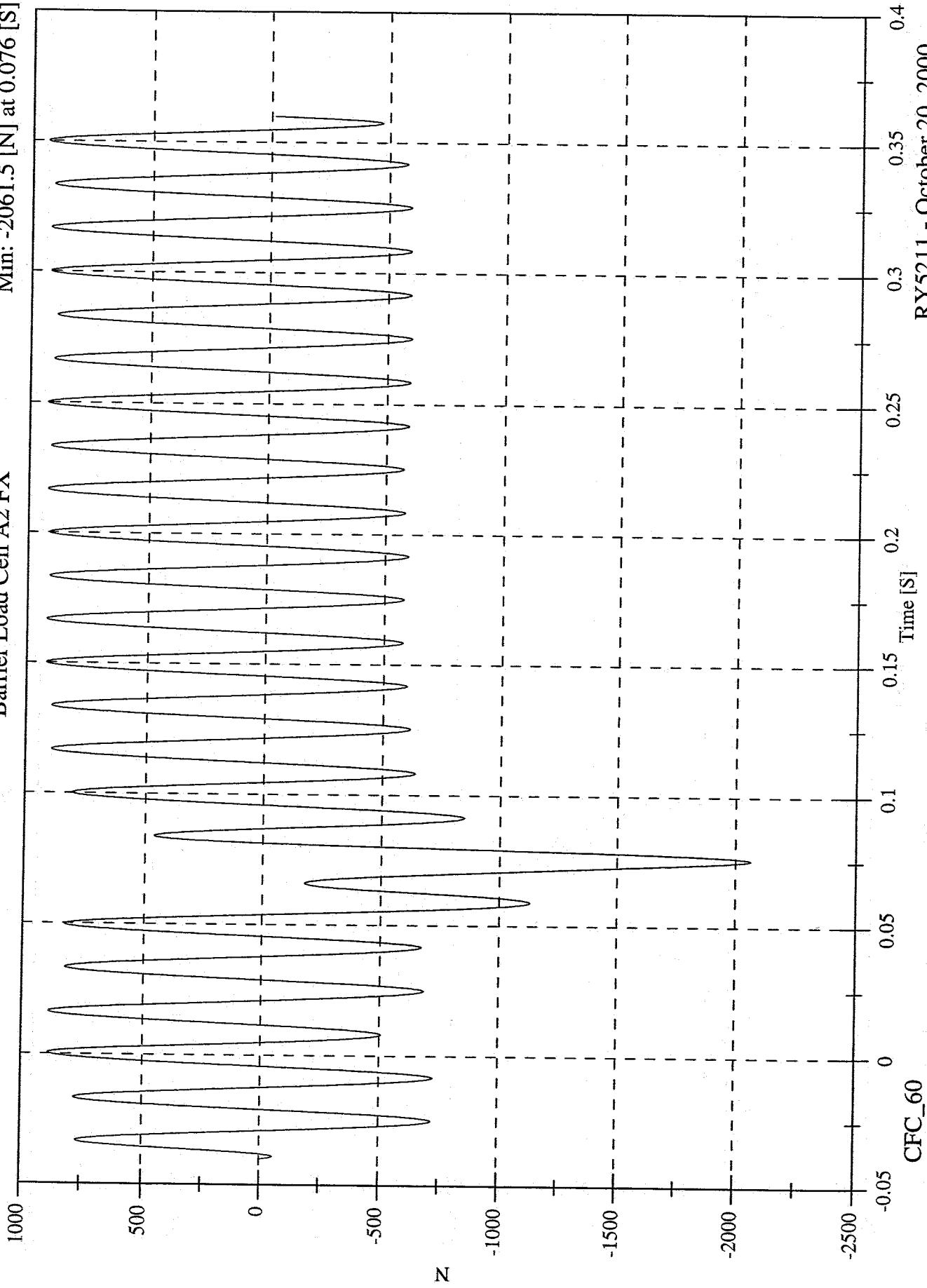

RY5211 - October 20, 2000

40% Offset Barrier Test #2 - 2000 Nissan Altima

Barrier Load Cell A3 FX

Max: 407.5 [N] at 0.350 [S]

Min: -4667.3 [N] at 0.076 [S]

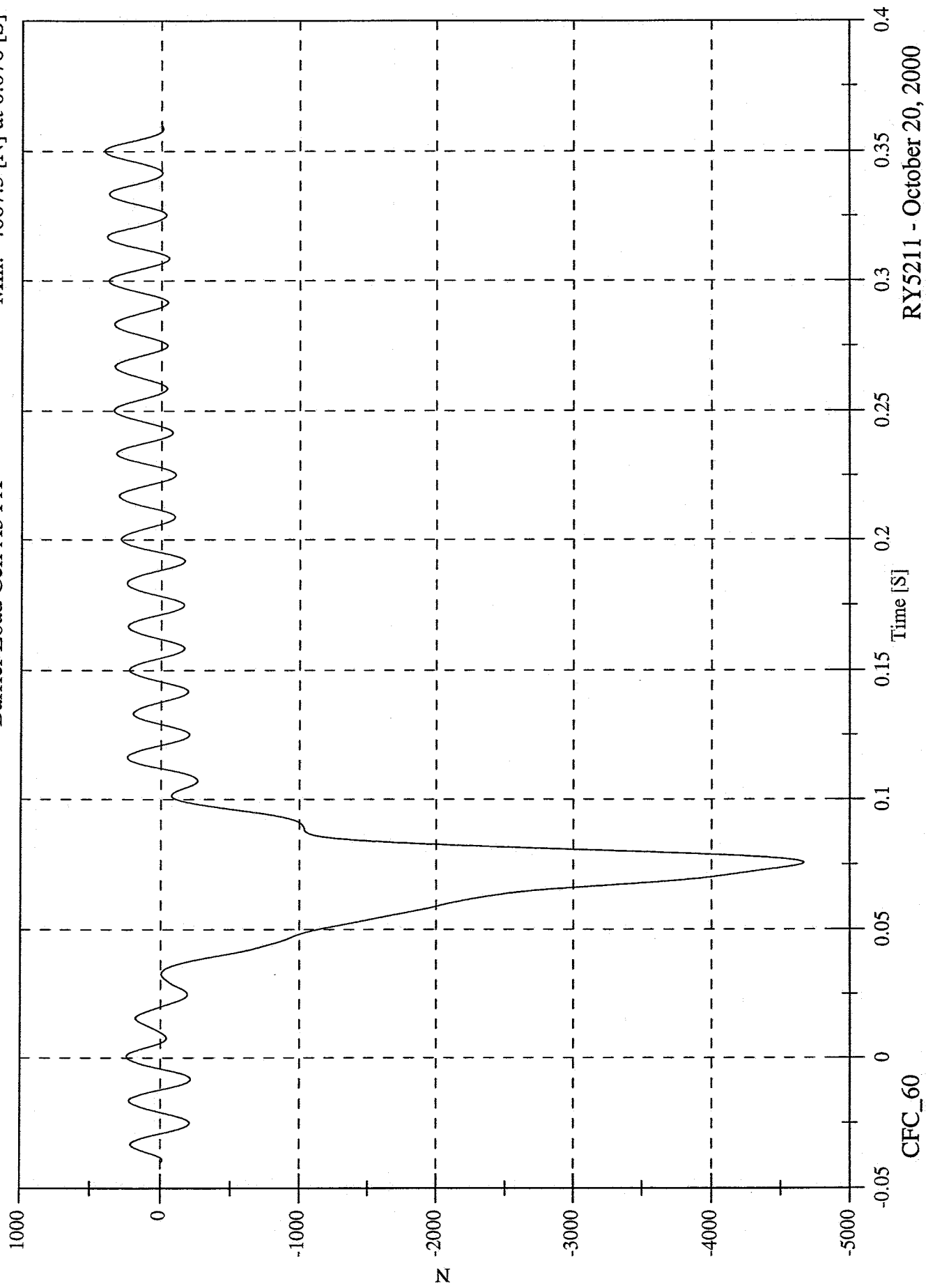

RYS211 - October 20, 2000

40% Offset Barrier Test #2 - 2000 Nissan Altima

Barrier Load Cell A4 FX

Max: 1311.7 [N] at 0.350 [S]

Min: -6900.8 [N] at 0.076 [S]

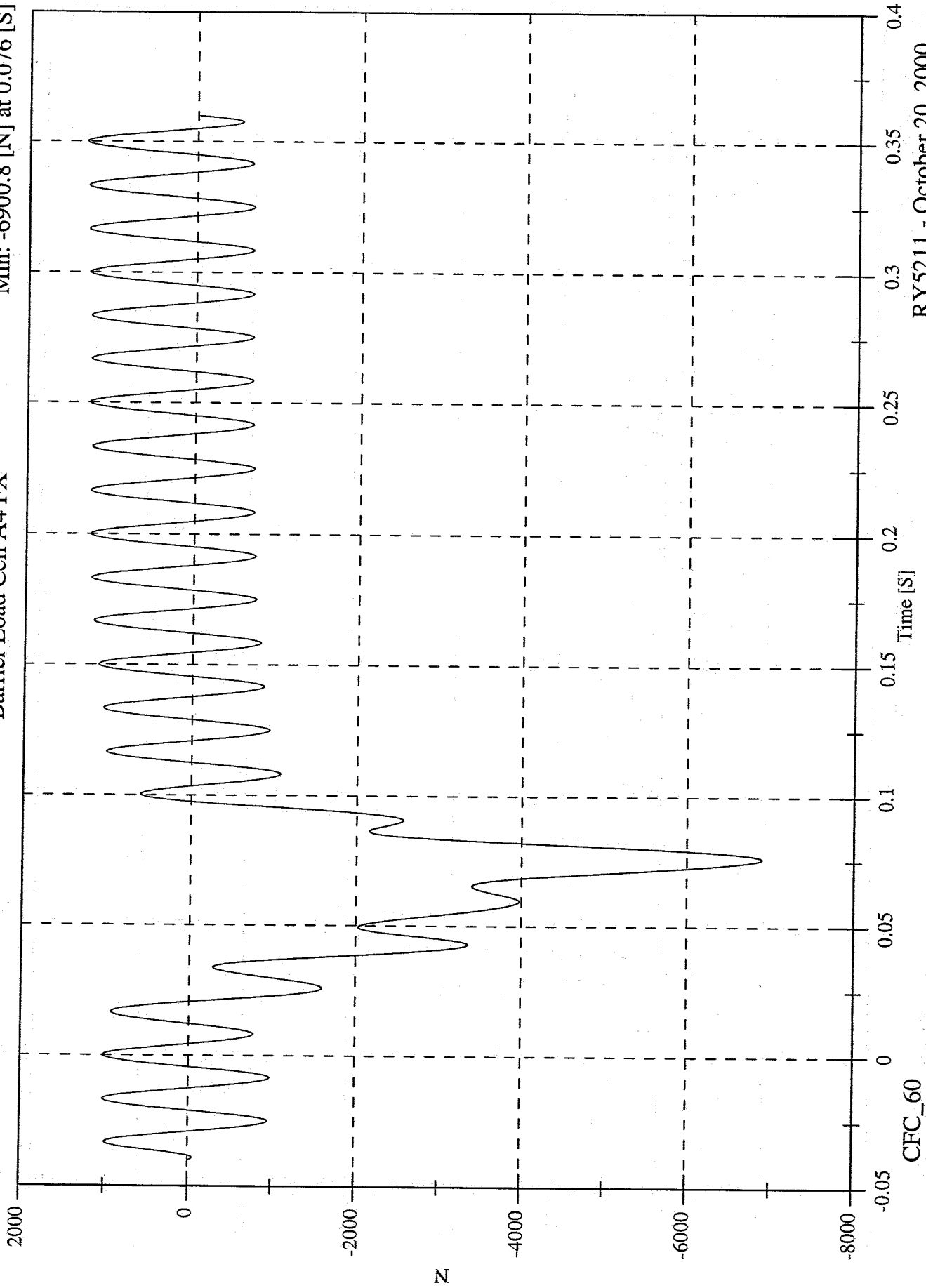

RY5211 - October 20, 2000

40% Offset Barrier Test #2 - 2000 Nissan Altima

Barrier Load Cell A5 FX

Max: 1016.4 [N] at 0.300 [S]

Min: -5260.4 [N] at 0.076 [S]

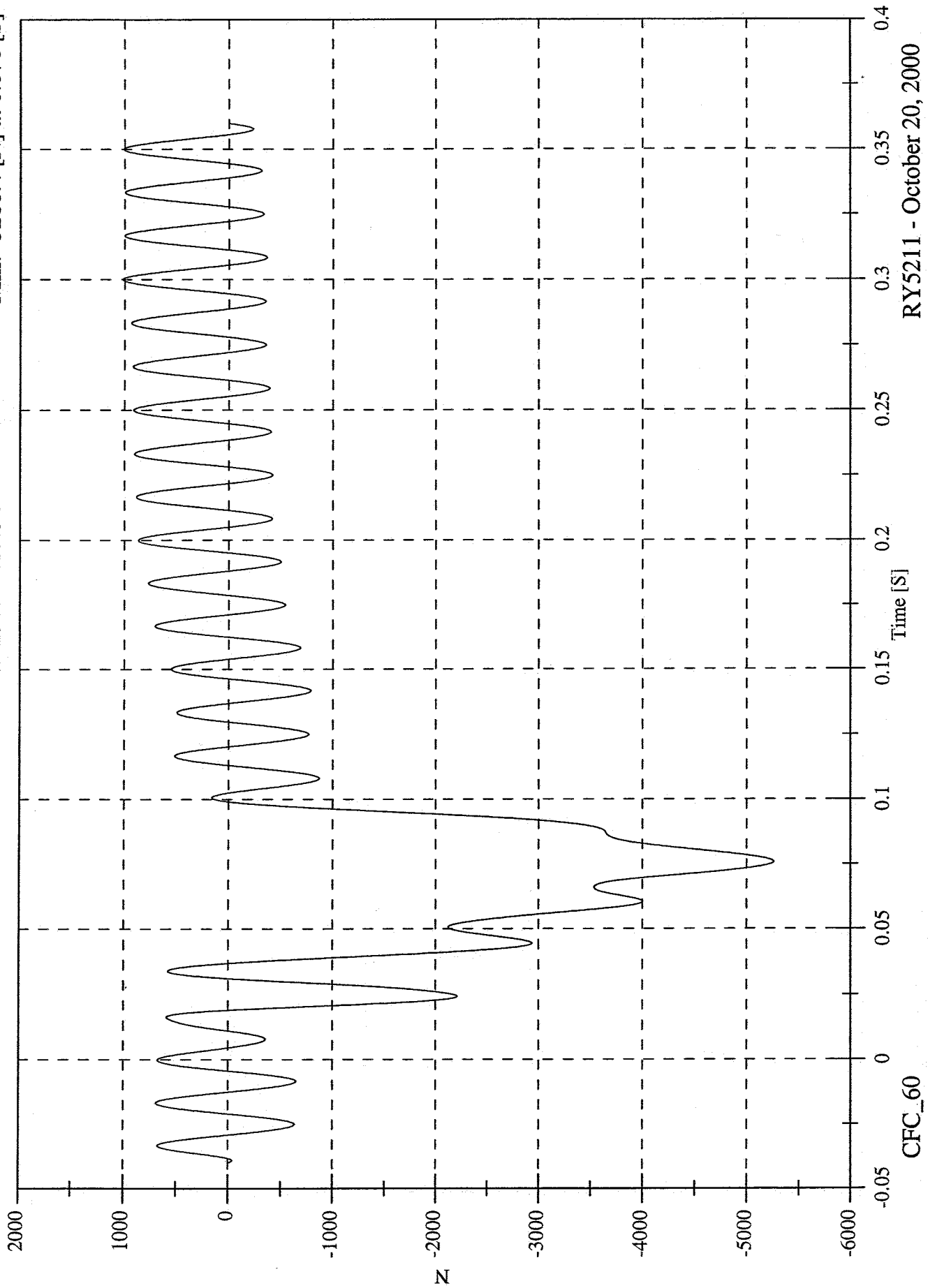

RYS211 - October 20, 2000

CFC\_60

40% Offset Barrier Test #2 - 2000 Nissan Altima

Max: 1670.6 [N] at 0.350 [S]  
Min: -7156.7 [N] at 0.075 [S]

Barrier Load Cell A6 FX

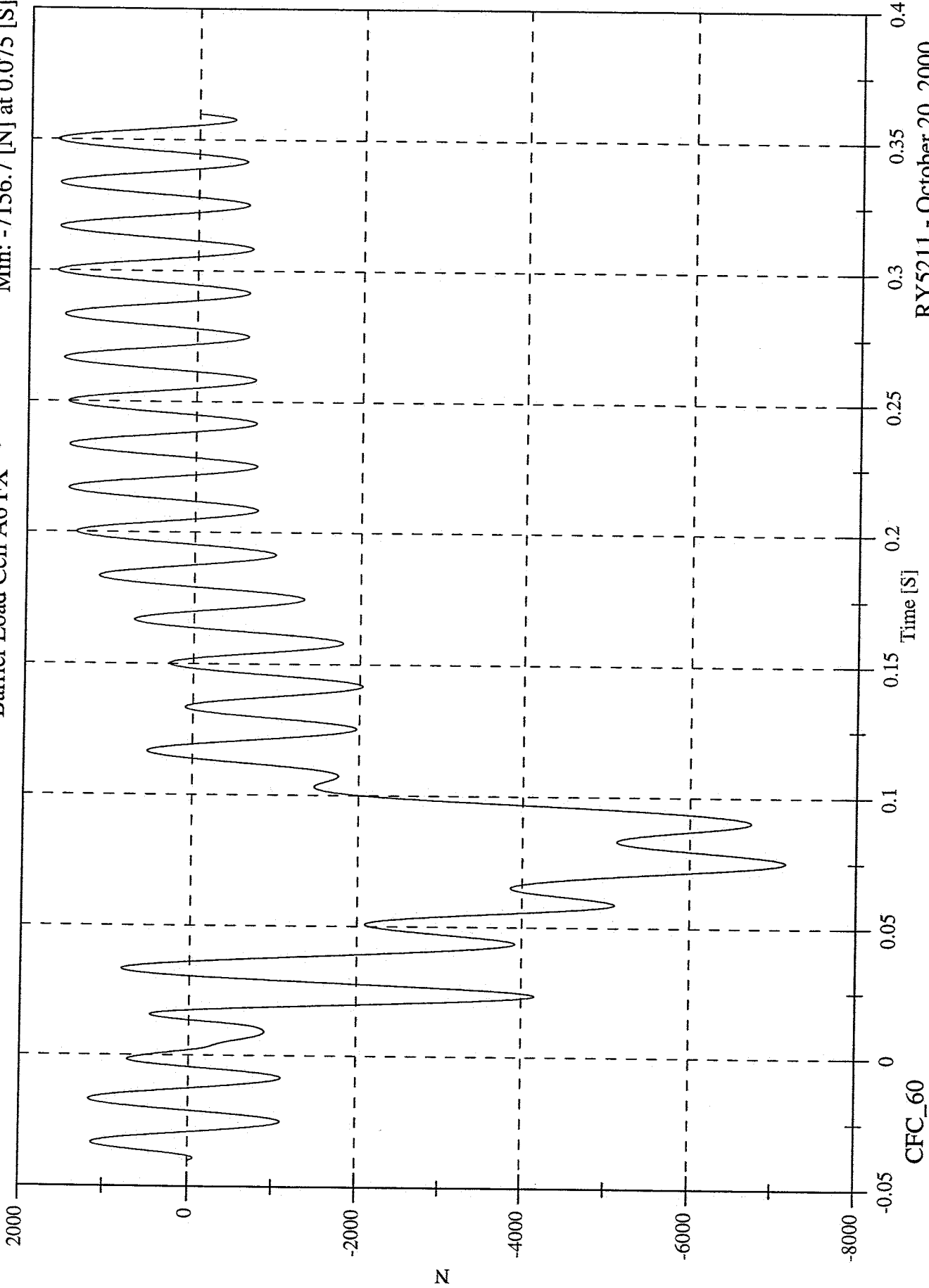

RY5211 - October 20, 2000

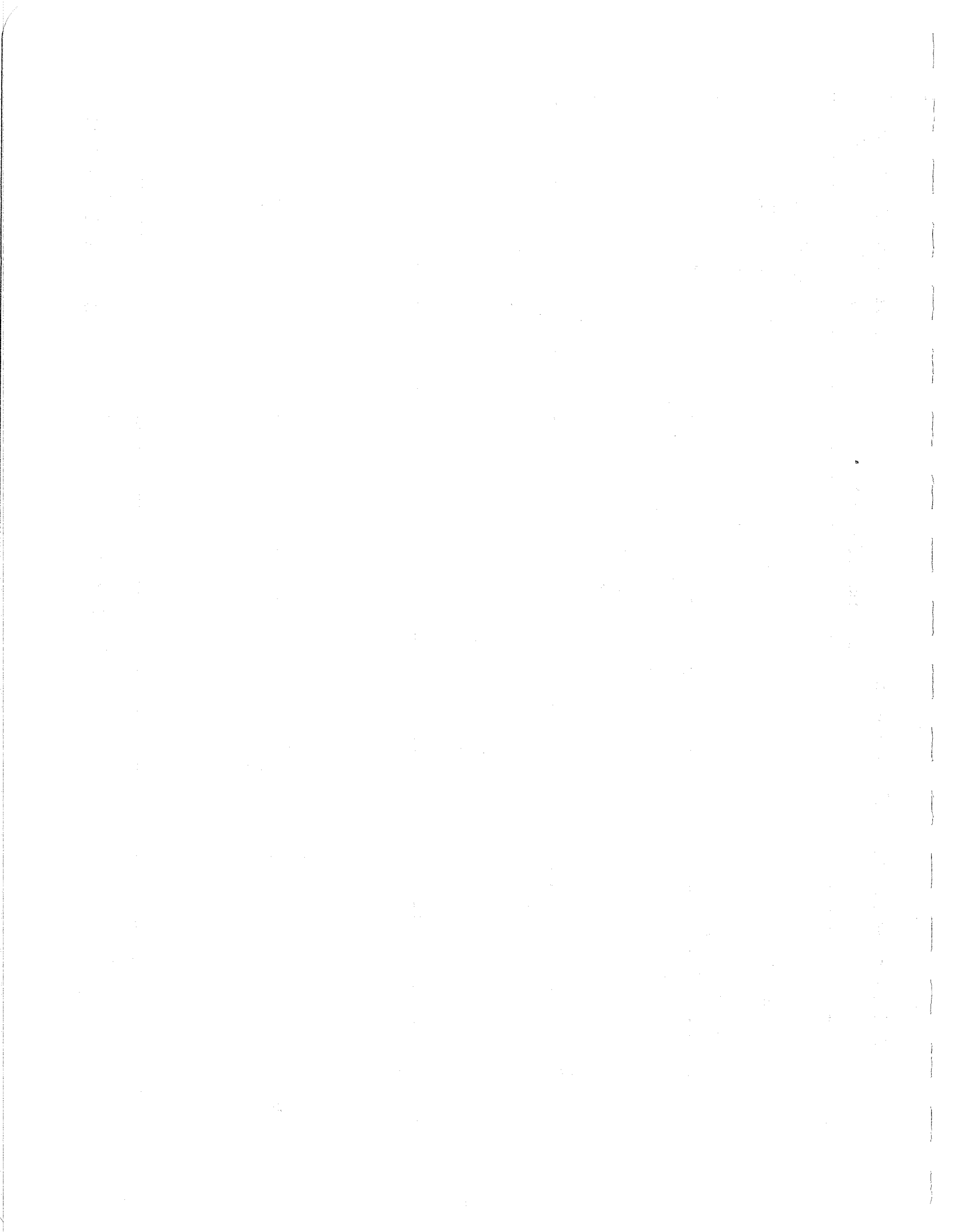

**APPENDIX C**

**PART 572B/E DUMMY CONFIGURATION  
AND PERFORMANCE VERIFICATION DATA SHEETS**

Appendix C contains the results from certification tests performed on the 50th percentile male anthropomorphic test devices utilized for this crash test. The results indicate that the dummies meet all of the performance requirements of the six standard tests as specified in 49 CFR Part 572, Federal Register, Volume 42, No. 25, dated February 7, 1977.

The tests were conducted at the Dummy Certification Test Facility of Veridian Engineering. A summary of the test results, and Part 572 specifications are included in this Appendix.

Dummy serial numbers and certification dates are:

<u>Position No./Location</u>	<u>Serial No.</u>	<u>Completion Date</u>
#1/Driver	202	10-6-2000
#2/Right Front Passenger	206	10-6-2000

#### Electronic Test Equipment

The complement of signal conditioning, recording and display equipment, in conjunction with dummy certification testing, can be found in New Car Assessment and Standards Indicant Testing Final Report No. 6525-V-1.

DUMMY CONFIGURATION DIMENSIONS

EXTERNAL DIMENSIONS SPECIFICATIONS

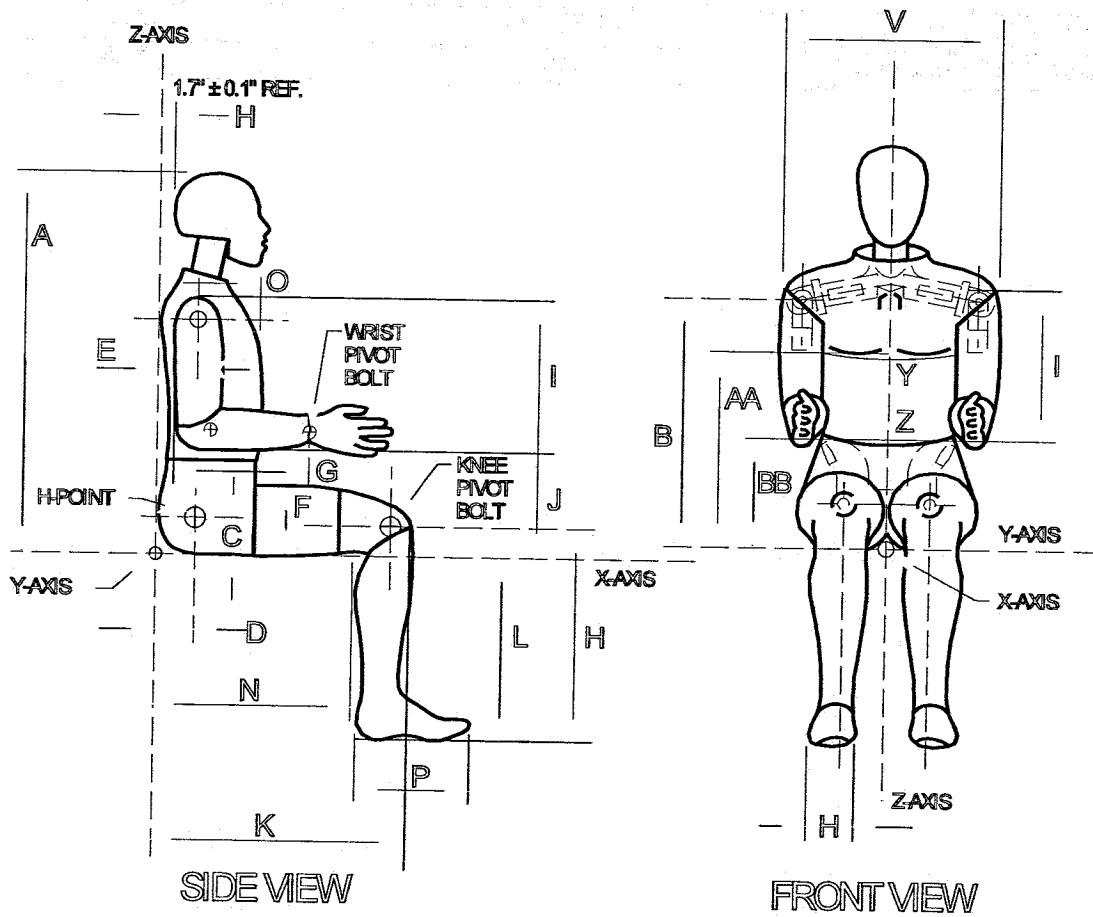

NOTE: Figure is referenced to the erect seated position. The curved lumbar does not allow the Hybrid III to be positioned in a perfect erect attitude. (REF: S572.31(A)(6))

PART 572E  
HEAD DROP TEST

Dummy Serial Number 202  
Sequential Test Number 1  
Date 10-4-2000  
Workfile 202100.hdp

TEST PARAMETER	SPECIFICATION	TEST RESULTS
Temperature	66-78 Deg F	71
Relative Humidity	10% - 70%	31
Peak Resultant Acceleration	225-275 G's	243.08
Peak Lateral Acceleration	15 G's Max	2.56
Is Acceleration Curve Unimodal?	YES	YES

Remarks:

Laboratory Technician: B. Swiecicki

PART 572E  
NECK FLEXION TEST

Dummy Serial Number            202  
 Sequential Test Number        1  
 Date                                10-5-2000  
 Workfile                         202100.nfl

6 Axis Neck Transducer

TEST PARAMETER		SPECIFICATION	TEST RESULTS
Temperature		69-72 Deg F	70
Relative Humidity		10% - 70%	31
Impact Velocity		22.60 - 23.40 Ft/s	23.32
Pendulum Deceleration	10 ms	22.50 - 27.50 G's	25.33
	20 ms	17.60 - 22.60 G's	21.08
	30 ms	12.50 - 18.50 G's	12.66
Max Pendulum G's Above 30 ms		29 G's Max	12.66
Deceleration - Time Curve Decay Time to 5 G's		34 - 42 ms	41.12
D Plane Rotation	Max	64 - 78 Deg	75.60
	Time	57 - 64 ms	57.00
Moment About Occipital Condyle	Max	65 - 80 Ft-Lbs	79.69
	Time	47 - 58 ms	55.00
Rotation Angle - Time Curve Decay Time to Zero		113 - 128 ms	126.25
Positive Moment - Time Curve Decay Time to Zero		97 - 107 ms	98.75

Remarks:

Laboratory Technician:           B. Swiecicki

PART 572E  
NECK EXTENSION TEST

Dummy Serial Number            202  
 Sequential Test Number        1  
 Date                                10-6-2000                                6 Axis Neck Transducer  
 Workfile                          202100.nex

TEST PARAMETER		SPECIFICATION	TEST RESULTS
Temperature		69-72 Deg F	70
Relative Humidity		10% - 70%	31
Impact Velocity		19.50 - 20.30 Ft/s	20.14
Pendulum Deceleration	10 ms	17.20 - 21.20 G's	18.40
	20 ms	14.00 - 19.00 G's	16.62
	30 ms	11.00 - 16.00 G's	13.64
Max Pendulum G's Above 30 ms		22 G's Max	13.64
Deceleration - Time Curve Decay Time to 5 G's		38 - 46 ms	44.75
D Plane Rotation	Max	81 - 106 Deg	97.44
	Time	72 - 82 ms	72.25
Moment About Occipital Condyle	Max	-59.0 - -39.0 Ft-Lbs	-58.35
	Time	65 - 79 ms	67.75
Rotation Angle - Time Curve Decay Time to Zero		147 - 174 ms	147.12
Positive Moment - Time Curve Decay Time to Zero		120 - 148 ms	137.62

Remarks:

Laboratory Technician:           B. Swiecicki

PART 572E  
THORAX IMPACT TEST

Dummy Serial Number 202  
Sequential Test Number 1  
Date 10-6-2000  
Workfile 202100.th3

TEST PARAMETER	SPECIFICATION	TEST RESULTS
Temperature	69-72 Deg F	70
Relative Humidity	10% - 70%	31
Pendulum Velocity	21.6 - 22.4 Ft/s	21.6
Maximum Deflection	2.50 - 2.86 in	2.70
Maximum Resistive Force	1160 - 1325 Lbs	1185.46
Internal Hysteresis	69 - 85 %	75.60

Remarks:

Laboratory Technician: B. Swiecicki

PART 572E  
KNEE IMPACT TEST

Dummy Serial Number            202  
 Sequential Test Number        1  
 Date                                10-5-2000  
 Workfile                         202100.lf/202100.rf

TEST PARAMETER	SPECIFICATION	TEST RESULTS
<b>LEFT KNEE</b>		
Temperature	66 - 78 Deg F	70
Relative Humidity	10% - 70%	31
Probe Velocity	6.8 - 7.0 Ft/s	7.0
Peak Knee Impact Force	1060 - 1300 Lbs	1241.41
<b>RIGHT KNEE</b>		
Temperature	66 - 78 Deg F	70
Relative Humidity	10% - 70%	31
Probe Velocity	6.8 - 7.0 Ft/s	7.0
Peak Knee Impact Force	1060 - 1300 Lbs	1258.87

Remarks:

Laboratory Technician:           B. Swiecicki

PART 572E  
EXTERNAL DIMENSIONS

Dummy Serial Number            202  
 Sequential Test Number        1  
 Date                                10-6-2000

TEST PARAMETER		SPECIFICATION	TEST RESULTS
Temperature			70
Relative Humidity			31
Location for Chest Circumference	AA	16.9 - 17.1 in	17.0
Location for Waist Circumference	BB	8.9 - 9.1 in	9.0
Chest Circumference (With Jacket)	Y	38.2 - 39.4 in	39.1
Waist Circumference	Z	32.9 - 34.1 in	33.4
Chest Depth	O	8.4 - 9.0 in	8.5
H-Point Height	C	3.3 - 3.5 in	3.4
H-Point from Backline	D	5.3 - 5.5 in	5.4
Skull Cap to Backline	H	1.6 - 1.8 in	1.7
Total Sitting Height	A	34.6 - 35.0 in	34.8
Thigh Clearance	F	5.5 - 6.1 in	6.1
Buttock Knee Length	K	22.8 - 23.8 in	23.6
Buttock Popliteal Length	N	17.8 - 18.8 in	18.6
Popliteal Height	L	16.9 - 17.9 in	17.2
Knee Pivot Height	M	19.1 - 19.7 in	19.4
Foot Length	P	9.9 - 10.5 in	10.2
Foot Breadth	W	3.6 - 4.2 in	3.9
Shoulder Pivot from Backline	E	3.3 - 3.7 in	3.7
Shoulder Breadth	V	16.6 - 17.2 in	16.9
Shoulder Pivot Height	B	19.9 - 20.5 in	20.3
Elbow Rest Height	J	7.5 - 8.3 in	7.9
Shoulder - Elbow Length	I	13.0 - 13.6 in	13.2
Back of Elbow to Wrist Pivot	G	11.4 - 12.0 in	11.6

Remarks:

Laboratory Technician:           B. Swiecicki

PART 572E  
HEAD DROP TEST

Dummy Serial Number 206  
Sequential Test Number 1  
Date 10-4-2000  
Workfile 206100.hdp

TEST PARAMETER	SPECIFICATION	TEST RESULTS
Temperature	66-78 Deg F	71
Relative Humidity	10% - 70%	31
Peak Resultant Acceleration	225-275 G's	234.33
Peak Lateral Acceleration	15 G's Max	3.00
Is Acceleration Curve Unimodal?	YES	YES

Remarks:

Laboratory Technician: B. Swiecicki

PART 572E  
NECK FLEXION TEST

Dummy Serial Number            206  
 Sequential Test Number        1  
 Date                                10-5-2000  
 Workfile                         206100.nfl

6 Axis Neck Transducer

TEST PARAMETER		SPECIFICATION	TEST RESULTS
Temperature		69-72 Deg F	70
Relative Humidity		10% - 70%	30
Impact Velocity		22.60 - 23.40 Ft/s	23.13
Pendulum Deceleration	10 ms	22.50 - 27.50 G's	25.42
	20 ms	17.60 - 22.60 G's	21.39
	30 ms	12.50 - 18.50 G's	15.47
Max Pendulum G's Above 30 ms		29 G's Max	15.47
Deceleration - Time Curve Decay Time to 5 G's		34 - 42 ms	37.88
D Plane Rotation	Max	64 - 78 Deg	75.45
	Time	57 - 64 ms	61.50
Moment About Occipital Condyle	Max	65 - 80 Ft-Lbs	74.23
	Time	47 - 58 ms	53.25
Rotation Angle - Time Curve Decay Time to Zero		113 - 128 ms	121.38
Positive Moment - Time Curve Decay Time to Zero		97 - 107 ms	101.62

Remarks:

Laboratory Technician:           B. Swiecicki

PART 572E  
NECK EXTENSION TEST

Dummy Serial Number            206  
 Sequential Test Number         1  
 Date                                 10-5-2000  
 Workfile                            206100.nex

6 Axis Neck Transducer

TEST PARAMETER		SPECIFICATION	TEST RESULTS
Temperature		69-72 Deg F	70
Relative Humidity		10% - 70%	30
Impact Velocity		19.50 - 20.30 Ft/s	20.14
Pendulum Deceleration	10 ms	17.20 - 21.20 G's	18.07
	20 ms	14.00 - 19.00 G's	15.89
	30 ms	11.00 - 16.00 G's	13.58
Max Pendulum G's Above 30 ms		22 G's Max	13.58
Deceleration - Time Curve Decay Time to 5 G's		38 - 46 ms	46.00
D Plane Rotation	Max	81 - 106 Deg	86.06
	Time	72 - 82 ms	74.75
Moment About Occipital Condyle	Max	-59.0 - -39.0 Ft-Lbs	-55.20
	Time	65 - 79 ms	66.12
Rotation Angle - Time Curve Decay Time to Zero		147 - 174 ms	148.75
Positive Moment - Time Curve Decay Time to Zero		120 - 148 ms	139.75

Remarks:

Laboratory Technician:           B. Swiecicki

PART 572E  
THORAX IMPACT TEST

Dummy Serial Number 206  
Sequential Test Number 1  
Date 10-5-2000  
Workfile 206100.th3

TEST PARAMETER	SPECIFICATION	TEST RESULTS
Temperature	69-72 Deg F	70
Relative Humidity	10% - 70%	30
Pendulum Velocity	21.6 - 22.4 Ft/s	21.6
Maximum Deflection	2.50 - 2.86 in	2.68
Maximum Resistive Force	1160 - 1325 Lbs	1190.34
Internal Hysteresis	69 - 85 %	75.95

Remarks:

Laboratory Technician: B. Swiecicki

PART 572E  
KNEE IMPACT TEST

Dummy Serial Number 206  
Sequential Test Number 1  
Date 10-6-2000  
Workfile 206100.lf/206100.rf

TEST PARAMETER	SPECIFICATION	TEST RESULTS
<b>LEFT KNEE</b>		
Temperature	66 - 78 Deg F	70
Relative Humidity	10% - 70%	31
Probe Velocity	6.8 - 7.0 Ft/s	7.0
Peak Knee Impact Force	1060 - 1300 Lbs	1223.64
<b>RIGHT KNEE</b>		
Temperature	66 - 78 Deg F	70
Relative Humidity	10% - 70%	31
Probe Velocity	6.8 - 7.0 Ft/s	7.0
Peak Knee Impact Force	1060 - 1300 Lbs	1223.50

Remarks:

Laboratory Technician: B. Swiecicki

PART 572E  
EXTERNAL DIMENSIONS

Dummy Serial Number            206  
 Sequential Test Number        1  
 Date                                10-6-2000

TEST PARAMETER		SPECIFICATION	TEST RESULTS
Temperature			71
Relative Humidity			31
Location for Chest Circumference	AA	16.9 - 17.1 in	17.0
Location for Waist Circumference	BB	8.9 - 9.1 in	9.0
Chest Circumference (With Jacket)	Y	38.2 - 39.4 in	39.4
Waist Circumference	Z	32.9 - 34.1 in	33.5
Chest Depth	O	8.4 - 9.0 in	8.5
H-Point Height	C	3.3 - 3.5 in	3.4
H-Point from Backline	D	5.3 - 5.5 in	5.4
Skull Cap to Backline	H	1.6 - 1.8 in	1.7
Total Sitting Height	A	34.6 - 35.0 in	34.8
Thigh Clearance	F	5.5 - 6.1 in	6.1
Buttock Knee Length	K	22.8 - 23.8 in	23.5
Buttock Popliteal Length	N	17.8 - 18.8 in	18.5
Popliteal Height	L	16.9 - 17.9 in	17.7
Knee Pivot Height	M	19.1 - 19.7 in	19.4
Foot Length	P	9.9 - 10.5 in	10.2
Foot Breadth	W	3.6 - 4.2 in	3.8
Shoulder Pivot from Backline	E	3.3 - 3.7 in	3.6
Shoulder Breadth	V	16.6 - 17.2 in	16.9
Shoulder Pivot Height	B	19.9 - 20.5 in	20.3
Elbow Rest Height	J	7.5 - 8.3 in	7.4
Shoulder - Elbow Length	I	13.0 - 13.6 in	13.4
Back of Elbow to Wrist Pivot	G	11.4 - 12.0 in	11.6

Remarks:

Laboratory Technician:           B. Swiecicki

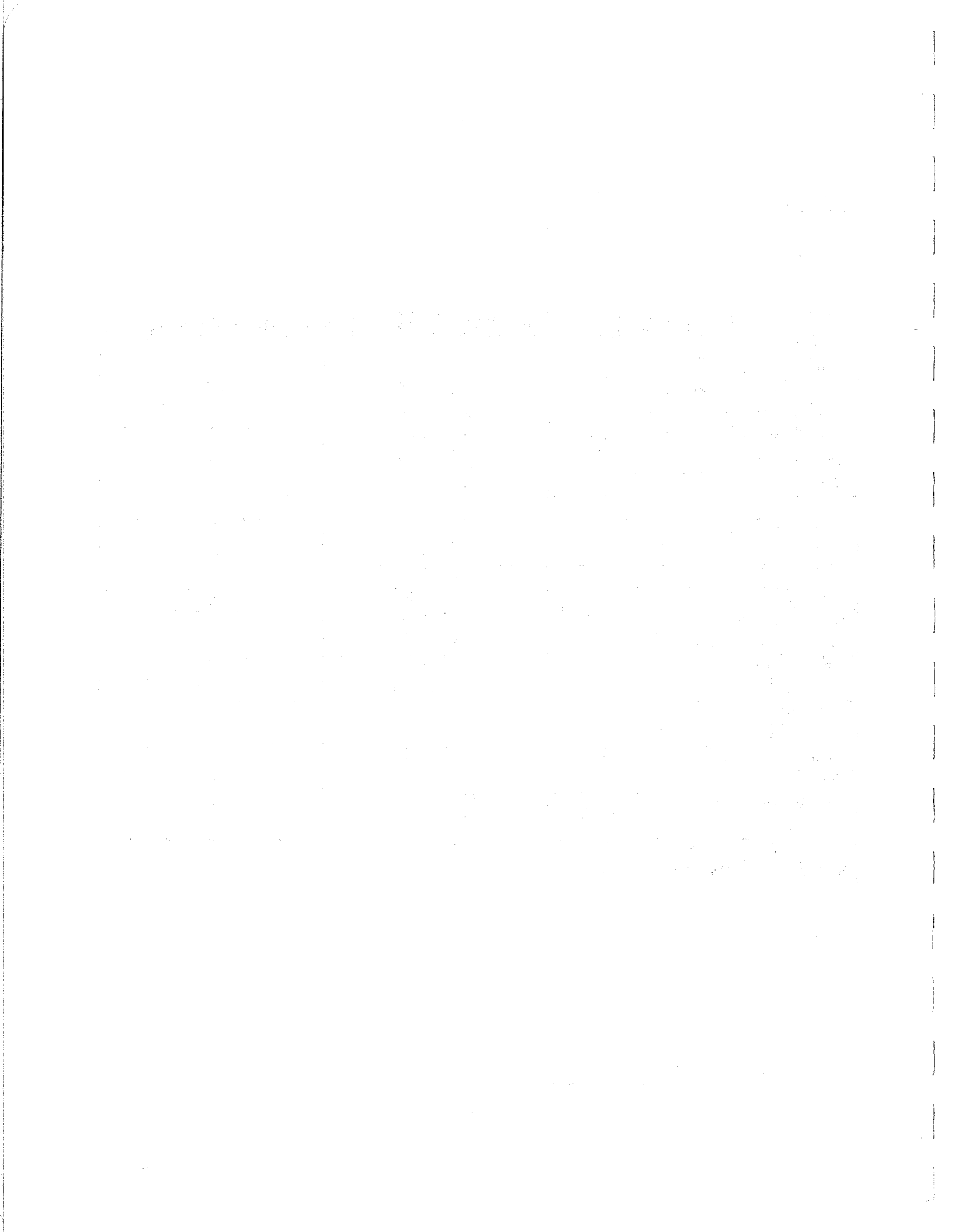

**APPENDIX D**

**DUMMY, VEHICLE AND LABORATORY INSTRUMENT CALIBRATION**

INSTRUMENT CALIBRATION FOR PASSENGER DUMMY  
( 6 Month Calibration Minimum )

DRIVER DUMMY (S/N 202)	Manufacturer	Serial #	Calibration		
			Last	Next	
Head	X	ENDEVCO	AC-J28988	12-Sep-00	12-Mar-01
	Y	ENDEVCO	AC-J28686	12-Sep-00	12-Mar-01
	Z	ENDEVCO	AC-P16625	02-Oct-00	02-Apr-01
Head	X (R)	ENDEVCO	AC-J20556	12-Sep-00	12-Mar-01
	Y (R)	ENDEVCO	AC-J28727	12-Sep-00	12-Mar-01
	Z (R)	ENDEVCO	AC-J20382	12-Sep-00	12-Mar-01
Neck Load Cell	X	DENTON	LC-425Fx	15-Sep-00	15-Mar-01
	Y	DENTON	LC-425Fy	15-Sep-00	15-Mar-01
	Z	DENTON	LC-425Fz	15-Sep-00	15-Mar-01
Neck Moment	X	DENTON	LC-425Mx	15-Sep-00	15-Mar-01
	Y	DENTON	LC-425My	15-Sep-00	15-Mar-01
	Z	DENTON	LC-425Mz	15-Sep-00	15-Mar-01
Chest	X	ENDEVCO	AC-J27072	12-Sep-00	12-Mar-01
	Y	ENDEVCO	AC-J28340	04-Aug-00	04-Feb-01
	Z	ENDEVCO	AC-J23946	12-Sep-00	12-Mar-01
Chest	X (R)	ENDEVCO	AC-CY06H	12-Sep-00	12-Mar-01
	Y (R)	ENDEVCO	AC-J27079	12-Sep-00	12-Mar-01
	Z (R)	ENDEVCO	AC-J20570	12-Sep-00	12-Mar-01
Chest Deflection Gauge Hybrid III Use Only		SERVO	DS-202	18-Sep-00	18-Mar-01
Pelvic	X	ENDEVCO	AC-EH88J	12-Sep-00	12-Mar-01
	Y	ENDEVCO	AC-BE39J	12-Sep-00	12-Mar-01
	Z	ENDEVCO	AC-J30041	04-Aug-00	04-Feb-01

INSTRUMENT CALIBRATION FOR PASSENGER DUMMY  
( 6 Month Calibration Minimum )

PASSENGER DUMMY (S/N 206)	Manufacturer	Serial #	Calibration		
			Last	Next	
Left Femur Load X	DENTON	LC-411FX	01-Sep-00	01-Mar-01	
	DENTON	LC-411FY	01-Sep-00	01-Mar-01	
	DENTON	LC-411FZ	01-Sep-00	01-Mar-01	
L. Femur Moment X	DENTON	LC-411MX	01-Sep-00	01-Mar-01	
	DENTON	LC-411MY	01-Sep-00	01-Mar-01	
	DENTON	LC-411MZ	01-Sep-00	01-Mar-01	
Right Femur Load X	DENTON	LC-412FX	01-Sep-00	01-Mar-01	
	DENTON	LC-412FY	01-Sep-00	01-Mar-01	
	DENTON	LC-412FZ	01-Sep-00	01-Mar-01	
R. Femur Moment X	DENTON	LC-412MX	01-Sep-00	01-Mar-01	
	DENTON	LC-412MY	01-Sep-00	01-Mar-01	
	DENTON	LC-412MZ	01-Sep-00	01-Mar-01	
Left Knee Shear Dx	ASTC	LX-102-LTKN	26-Sep-00	26-Mar-01	
Right Knee Shear Dx	ASTC	LX-101-RTKN	26-Sep-00	26-Mar-01	
Left Upper Tibia	Fx	DENTON	LX-102-UTLFX	26-Sep-00	26-Mar-01
	Fz	DENTON	LX-102-UTLFZ	26-Sep-00	26-Mar-01
	Mx	DENTON	LX-102-UTLMX	26-Sep-00	26-Mar-01
	My	DENTON	LX-102-UTLMY	26-Sep-00	26-Mar-01
Left Lower Tibia	Fx	DENTON	LX-102-LTLFX	26-Sep-00	26-Mar-01
	Fy	DENTON	LX-102-LTLFY	26-Sep-00	26-Mar-01
	Fz	DENTON	LX-102-LTLFZ	26-Sep-00	26-Mar-01
	Mx	DENTON	LX-102-LTLMX	26-Sep-00	26-Mar-01
	My	DENTON	LX-102-LTLMY	26-Sep-00	26-Mar-01
Right Upper Tibia	Fx	DENTON	LX-101-UTRFX	26-Sep-00	26-Mar-01
	Fz	DENTON	LX-101-UTRFZ	26-Sep-00	26-Mar-01
	Mx	DENTON	LX-101-UTRMX	26-Sep-00	26-Mar-01
	My	DENTON	LX-101-UTRMY	26-Sep-00	26-Mar-01

INSTRUMENT CALIBRATION FOR PASSENGER DUMMY  
( 6 Month Calibration Minimum )

PASSENGER DUMMY (S/N 206)	Manufacturer	Serial #	Calibration		
			Last	Next	
Right Lower Tibia	Fx	DENTON	LX-101-LTRFX	26-Sep-00	26-Mar-01
	Fy	DENTON	LX-101-LTRFY	26-Sep-00	26-Mar-01
	Fz	DENTON	LX-101-LTRFZ	26-Sep-00	26-Mar-01
	Mx	DENTON	LX-101-LTRMX	26-Sep-00	26-Mar-01
	My	DENTON	LX-101-LTRMY	26-Sep-00	26-Mar-01
Left Tibia	X	ENDEVCO	AC-P15638	27-Sep-00	27-Mar-01
	Y	ENDEVCO	AC-P16361	27-Sep-00	27-Mar-01
Right Tibia	X	ENDEVCO	AC-P16899	27-Sep-00	27-Mar-01
	Y	ENDEVCO	AC-P17297	27-Sep-00	27-Mar-01
Left Ankle	Rx	Contelec	LX-102-AXLRP	26-Sep-00	26-Mar-01
	Ry	Contelec	LX-102-AYLRP	26-Sep-00	26-Mar-01
	Rz	Contelec	LX-102-AZLRP	26-Sep-00	26-Mar-01
Right Ankle	Rx	Contelec	LX-101-AXRRP	26-Sep-00	26-Mar-01
	Ry	Contelec	LX-101-AYRRP	26-Sep-00	26-Mar-01
	Rz	Contelec	LX-101-AZRRP	26-Sep-00	26-Mar-01
Left Foot	Ax	ENDEVCO	AC-P17196	27-Sep-00	27-Mar-01
	Ay	ENDEVCO	AC-P17743	27-Sep-00	27-Mar-01
	Az	ENDEVCO	AC-P16281	27-Sep-00	27-Mar-01
Right Foot	Ax	ENDEVCO	AC-P13574	27-Sep-00	27-Mar-01
	Ay	ENDEVCO	AC-P17836	27-Sep-00	27-Mar-01
	Az	ENDEVCO	AC-P15831	27-Sep-00	27-Mar-01
Lap Belt Load Cells	LEBOW	LC-706	01-Jun-00	01-Dec-00	
Shoulder Belt Load Cells					
Spool-Out Potentiometer	PATRIOT	DS-M97	17-Jul-00	17-Jan-00	
Belt Stretch Transducer					

INSTRUMENT CALIBRATION FOR PASSENGER DUMMY  
( 6 Month Calibration Minimum )

PASSENGER DUMMY (S/N 206)		Manufacturer	Serial #	Calibration	
				Last	Next
Head	X	ENDEVCO	AC-J19865	12-Sep-00	12-Mar-01
	Y	ENDEVCO	AC-ACCT5	12-Sep-00	12-Mar-01
	Z	ENDEVCO	AC-J17976	12-Sep-00	12-Mar-01
Head	X (R)	ENDEVCO	AC-J22040	12-Sep-00	12-Mar-01
	Y (R)	ENDEVCO	AC-J19890	12-Sep-00	12-Mar-01
	Z (R)	ENDEVCO	AC-J27430	12-Sep-00	11-Mar-01
Neck Load Cell	X	DENTON	LC-441Fx	11-Sep-00	11-Mar-01
	Y	DENTON	LC-441Fy	11-Sep-00	11-Mar-01
	Z	DENTON	LC-441Fz	11-Sep-00	11-Mar-01
Neck Moment	X	DENTON	LC-441Mx	11-Sep-00	11-Mar-01
	Y	DENTON	LC-441My	11-Sep-00	11-Mar-01
	Z	DENTON	LC-441Mz	11-Sep-00	11-Mar-01
Chest	X	ENDEVCO	AC-J27474	08-Sep-00	08-Mar-01
	Y	ENDEVCO	AC-J28989	08-Sep-00	08-Mar-01
	Z	ENDEVCO	AC-J19934	09-Sep-00	09-Mar-01
Chest	X (R)	ENDEVCO	AC-AGAE7	08-Sep-00	08-Mar-01
	Y (R)	ENDEVCO	AC-J20165	08-Sep-00	08-Mar-01
	Z (R)	ENDEVCO	AC-J27387	08-Sep-00	08-Mar-01
Chest Deflection Gauge Hybrid III Use Only		SERVO	DS-206	18-Sep-00	18-Mar-01
Pelvic	X	ENDEVCO	AC-J27513	08-Sep-00	08-Mar-01
	Y	ENDEVCO	AC-J22036	08-Sep-00	08-Mar-01
	Z	ENDEVCO	AC-J28986	08-Sep-00	08-Mar-01

INSTRUMENT CALIBRATION FOR PASSENGER DUMMY  
( 6 Month Calibration Minimum )

PASSENGER DUMMY (S/N 206)	Manufacturer	Serial #	Calibration		
			Last	Next	
Left Femur Load	X	DENTON	LC-362FX	01-Sep-00	01-Mar-01
	Y	DENTON	LC-362FY	01-Sep-00	01-Mar-01
	Z	DENTON	LC-362FZ	01-Sep-00	01-Mar-01
L. Femur Moment	X	DENTON	LC-362MX	01-Sep-00	01-Mar-01
	Y	DENTON	LC-362MY	01-Sep-00	01-Mar-01
	Z	DENTON	LC-362MZ	01-Sep-00	01-Mar-01
Right Femur Load	X	DENTON	LC-363FX	01-Sep-00	01-Mar-01
	Y	DENTON	LC-363FY	01-Sep-00	01-Mar-01
	Z	DENTON	LC-363FZ	01-Sep-00	01-Mar-01
R. Femur Moment	X	DENTON	LC-363MX	01-Sep-00	01-Mar-01
	Y	DENTON	LC-363MY	01-Sep-00	01-Mar-01
	Z	DENTON	LC-363MZ	01-Sep-00	01-Mar-01
Left Knee Shear Dx		DENTON	DS-13739	19-Sep-00	19-Mar-01
Right Knee Shear Dx		DENTON	DS-13723	19-Sep-00	19-Mar-01
Left Upper Tibia	Fx	UNK	LC-91FX-UP	05-Sep-00	05-Mar-01
	Fy	UNK	LC-91FY-UP	05-Sep-00	05-Mar-01
	Fz	UNK	LC-91FZ-UP	05-Sep-00	05-Mar-01
	Mx	UNK	LC-91MX-UP	05-Sep-00	05-Mar-01
	My	UNK	LC-91MY-UP	05-Sep-00	05-Mar-01
Left Lower Tibia	Fx	UNK	LC-91FX-LO	05-Sep-00	05-Mar-01
	Fy	UNK	LC-91FY-LO	05-Sep-00	05-Mar-01
	Fz	UNK	LC-91FZ-LO	05-Sep-00	05-Mar-01
	Mx	UNK	LC-91MX-LO	05-Sep-00	05-Mar-01
	My	UNK	LC-91MY-LO	05-Sep-00	05-Mar-01

INSTRUMENT CALIBRATION FOR PASSENGER DUMMY  
( 6 Month Calibration Minimum )

PASSENGER DUMMY (S/N 206)	Manufacturer	Serial #	Calibration		
			Last	Next	
Right Upper Tibia	Fx	UNK	LC-93FX-UP	05-Sep-00	05-Mar-01
	Fy	UNK	LC-93FY-UP	05-Sep-00	05-Mar-01
	Fz	UNK	LC-93FZ-UP	05-Sep-00	05-Mar-01
	Mx	UNK	LC-93MX-UP	05-Sep-00	05-Mar-01
	My	UNK	LC-93MY-UP	05-Sep-00	05-Mar-01
Right Lower Tibia	Fx	UNK	LC-93FX-LO	05-Sep-00	05-Mar-01
	Fy	UNK	LC-93FY-LO	05-Sep-00	05-Mar-01
	Fz	UNK	LC-93FZ-LO	05-Sep-00	05-Mar-01
	Mx	UNK	LC-93MX-LO	05-Sep-00	05-Mar-01
	My	UNK	LC-93MY-LO	05-Sep-00	05-Mar-01
Left Foot	Ax	ENDEVCO	AC-P15341	27-Sep-00	27-Mar-01
	Az	ENDEVCO	AC-P16356	27-Sep-00	27-Mar-01
Left Toe	Az	ENDEVCO	AC-P15334	06-Oct-00	06-Apr-01
Right Foot	Ax	UNK	AC-P15321	06-Oct-00	06-Apr-01
	Az	UNK	AC-P16998	06-Oct-00	06-Apr-01
Left Toe	Az	UNK	AC-P16944	06-Oct-00	06-Apr-01
Lap Belt Load Cells	LEBOW	LC-711	01-Jun-00	01-Dec-00	
Shoulder Belt Load Cells					
Spool-Out Potentiometer	MAGNETEK	DS-M6	27-Jul-00	27-Jan-01	
Belt Stretch Transducer					

INSTRUMENT CALIBRATION FOR VEHICLE ACCELEROMETERS

( 6 Month Calibration Minimum )

	Manufacturer	Serial #	Calibration	
			Last	Next
Left Seat Rear Crossmember X	ICS	AC-D32	25-Aug-00	25-Feb-01
Left Seat Rear Crossmember Y	ICS	AC-D82	17-Aug-00	17-Feb-01
Right Seat Rear Crossmember X	ENDEVCO	AC-X93	10-Aug-00	10-Feb-01
Right Rear Seat Crossmember Y	ICS	AC-D36	14-Aug-00	14-Feb-01
Driver Left Side Toepan X	ENDEVCO	AC-A14342	12-Jun-00	12-Dec-00
Driver Left Side Toepan Z	ENDEVCO	AC-A14261	12-Jun-00	12-Dec-00
Driver Right Side Toepan X	ENDEVCO	AC-A13565	12-Jun-00	12-Dec-00
Driver Right Side Toepan Z	ENDEVCO	AC-A14510	13-Jun-00	13-Dec-00
Trunk Z	ICS	AC-Y171	31-Aug-00	28-Feb-01