

REPORT NUMBER KAR-20002-02

**40% OFFSET
FRONTAL BARRIER IMPACT TEST**

**FORD MOTOR COMPANY
2000 FORD EXPEDITION 4 WD
4 DOOR SUV**

NHTSA NUMBER: FORD01

**PREPARED BY:
KARCO ENGINEERING
9270 HOLLY ROAD
ADELANTO, CALIFORNIA 92301**



AUGUST 17, 2000

FINAL REPORT

**PREPARED FOR:
U.S. DEPARTMENT OF TRANSPORTATION
NATIONAL HIGHWAY TRAFFIC SAFETY ADMINISTRATION
SAFETY PERFORMANCE STANDARDS
OFFICE OF CRASHWORTHINESS STANDARDS
MAIL CODE: NPS-10
400 SEVENTH STREET, SW, ROOM 5313
WASHINGTON, D.C. 20590**

This final test report was prepared for the U.S. Department of Transportation, National Highway Traffic Safety Administration, in response to Contract Number DTNH22-97-D-02007.

This publication is distributed by the U.S. Department of Transportation, National Highway Traffic Safety Administration, in the interest of information exchange. The opinions, findings and conclusions expressed in this publication are those of the author(s) and not necessarily those of the Department of Transportation or the National Highway Traffic Safety Administration. The United States Government assumes no liability for its contents or use thereof. If trade or manufacturers' names or products are mentioned it is only because they are considered essential to the object of the publication and should not be construed as an endorsement. The United States Government does not endorse products or manufacturers.

Prepared by: _____
Mr. Kirubel Abebe, Test Engineer
KARCO Engineering

Date: August 17, 2000

Reviewed by: _____
Mr. Jerry L. Kratzke, Director of Operations
KARCO Engineering

Date: August 17, 2000

Approved by: _____
Mr. Frank D. Richardson, Program Manager
KARCO Engineering

Date: August 17, 2000

FINAL REPORT ACCEPTED BY:

Manager, New Car Assessment Program

Date of Acceptance

COTR, NCAP Frontal Impact Program

Date of Acceptance

Technical Report Documentation Page

1. Report No. KAR-2000-02	2. Government Accession No.	3. Recipients Catalog No.																										
4. Title and Subtitle Final Report of Frontal Barrier 40% Offset impact Test Testing of a 2000 Ford Expedition 4WD NHTSA No. FORD01		5. Report Date August 17, 2000																										
		6. Performing Organization Code KAR																										
7. Author(s) Mr. Kirubel Abebe, Test Engineer, Karco Mr. Frank Richardson, Project Manager, Karco		8. Performing Organization Report No. KAR-20002-02																										
9. Performing Organization Name and Address KARCO Engineering 9270 Holly Road Adelanto, CA 92301		10. Work Unit No.																										
		11. Contract or Grant No. DTNH22-97-D-02007																										
12. Sponsoring Agency Name and Address U.S. Department of Transportation National Highway Traffic Safety Administration Safety Performance Standards Office of Crashworthiness Standards Mail Code: NPS-10 400 Seventh Street, SW, Room 5313 Washington, D.C. 20590		13. Type of Report and Period Covered Final Test Report Option Year 1																										
		14. Sponsoring Agency Code DOT/NHTSA/NRM/OCS																										
15. Supplementary Notes																												
16. Abstract A 37.5mph (60.3 km/h) 40% offset impact was conducted on a 2000 Ford Expedition 4WD at KARCO Engineering on August 15, 2000. This test was conducted to obtain data indicant of FMVSS 208, 212, 219 (partial), 301 and footwell intrusion performance. The impact velocity is 59.82 km/h. The ambient temperature at the barrier face at the time of impact is 40.6 deg. Celcius. The vehicle's maximum post test static crush is 1040 mm at the left side of the vehicle. The test vehicle is equipped with a 3-point continuous belt system and second generation supplemental airbags in both front outboard seating positions. With respect to FMVSS 208 "Occupant Crash Protection", the occupant injury criteria summary is as follows:																												
<table border="1" style="width: 100%; border-collapse: collapse;"> <thead> <tr> <th style="width: 35%;">Measurement Description</th> <th style="width: 15%;">Units</th> <th style="width: 15%;">Threshold</th> <th style="width: 15%;">Driver ATD</th> <th style="width: 20%;">Passenger ATD</th> </tr> </thead> <tbody> <tr> <td>Head Injury Criteria (HIC)</td> <td>N/A</td> <td>1000</td> <td>293.5</td> <td>396.3</td> </tr> <tr> <td>Max. Thorax Accel. (3 msec Clip)</td> <td>G's</td> <td>60</td> <td>28.6</td> <td>35.9</td> </tr> <tr> <td>Left Femur force</td> <td>Newtons</td> <td>10009</td> <td>-3956.3</td> <td>-1410.8</td> </tr> <tr> <td>Right Femur Force</td> <td>Newtons</td> <td>10009</td> <td>-1873.7</td> <td>-937.8</td> </tr> </tbody> </table>				Measurement Description	Units	Threshold	Driver ATD	Passenger ATD	Head Injury Criteria (HIC)	N/A	1000	293.5	396.3	Max. Thorax Accel. (3 msec Clip)	G's	60	28.6	35.9	Left Femur force	Newtons	10009	-3956.3	-1410.8	Right Femur Force	Newtons	10009	-1873.7	-937.8
Measurement Description	Units	Threshold	Driver ATD	Passenger ATD																								
Head Injury Criteria (HIC)	N/A	1000	293.5	396.3																								
Max. Thorax Accel. (3 msec Clip)	G's	60	28.6	35.9																								
Left Femur force	Newtons	10009	-3956.3	-1410.8																								
Right Femur Force	Newtons	10009	-1873.7	-937.8																								
17. Key Words 60.3km/h 40% Offset Frontal Barrier Impact Test New Car Assessment Program (NCAP) 2000 Ford Expedition 4WD 4 Door SUV NHTSA No. FORD01		18. Distribution Statement Copies of this report are available from: NHTSA Technical Reference Division National Highway Traffic Safety Admin. 400 Seventh St., SW, Room 5108 Washington, DC 20590																										
19. Security Classification(of this report) UNCLASSIFIED	20. Security Classification(of this page) UNCLASSIFIED	21. No. of Pages 316	22. Price																									

Form DOT F1700.7 (8-72)

TABLE OF CONTENTS

<u>Section</u>		<u>Page</u>
1	Purpose, Test Procedures and Summary of Test FORD01	1
2	Occupant and Vehicle Information Data Sheets	3
<u>Data Sheet No.</u>		<u>Page</u>
1	Crash Test Summary	4
2	General Test and Vehicle Parameter Data	5
3	Post Impact Data	7
4	Test Vehicle Information	8
5	Dummy Positioning in Vehicle	10
6	Seat Belt Positioning Data	12
7	Vehicle Accelerometer Location and Data Summary	13
8	Hybrid III ATD Injury Criteria and Sensor Data	14
9	Seat Belt Assessment Test Data	17
10	Summary of FMVSS 212 Data	18
11	Windshield Zone Intrusion FMVSS 219 Data (Partial)	19
12	FMVSS 301 Fuel System Integrity Post Impact Data	20
13	FMVSS 301 Static Rollover Data	21
14	Vehicle Measurements	22
15	Camera Locations	24
16	Photographic Reference Target Locations	25
17	Vehicle Intrusion Measurements	26
18	Deformable Barrier Dimensions and Orientation	30
19	Accident Investigation Division Data	31
20	Dummy/Vehicle Temperature Stabilization Chart	32
<u>Appendix</u>		
A	Photographs	A
B	Dummy and Vehicle Response Data Traces	B
C	Deformable Barrier Crush Profile	C
D	Instrumentation Data Channel Assignments	D
E	Dummy Calibration Data	E
F	Vehicle Owner's Manual Restraint and Seating Instructions	F

SECTION 1

PURPOSE, TEST PROCEDURE AND SUMMARY OF TEST FORD01

1.1 PURPOSE

This 40% Offset Frontal Impact Test is part of the FY' 2000 crash worthiness evaluation program sponsored by the National Highway Traffic Safety Administration (NHTSA) under Contract Number DTNH22-97-D-02007. The purpose of this test is to obtain vehicle crashworthiness, occupant restraint system performance, and lower leg data for 40% offset barrier impacts.

1.2 TEST PROCEDURE

This 40% offset Frontal impact test was conducted in accordance with the Office of Crashworthiness Standards (OCS) New Car Assessment Program (NCAP) Laboratory Indicant Test Procedure, dated 01 October 1996 and the corresponding KARCO Engineering Test Procedure KTP-001, dated October 18, 1996. Data was obtained indicant of FMVSS 212, "Windshield Retention"; FMVSS 219, "Windshield Zone Intrusion (Partial)"; and FMVSS 301 "Fuel System Integrity" performance. Procedures for receiving, inspection testing and reporting of test results are described in the test procedures and are not repeated in this report.

The test was conducted at KARCO Engineering on August 15, 2000 at a speed of 59.82 km/h. The test vehicle was instrumented with eight (8) accelerometers to measure longitudinal and lateral accelerations. The driver and passenger's restraint systems were instrumented with four (4) seat belt load cells to measure lap and shoulder belt force. The 40% offset impact event was documented by; one (1) real-time panning motion picture camera and eighteen (18) high-speed motion picture cameras. The pre- and post-test conditions were recorded by one (1) real-time motion picture camera. Camera locations and pertinent camera information is documented in the data sheets. Pre- and post-test photographs of the vehicle and dummies can be found in Appendix A.

The test vehicle contained two (2) part 572E 50th percentile adult male anthropomorphic test devices (ATDs). The ATDs were positioned in the front outboard seating positions according to the dummy placement procedures specified in the Laboratory Indicant Test Procedure. Both ATDs were instrumented with head, chest, and pelvic tri-axial accelerometers, left and right femur load cells, upper and lower tibia sensors, and foot accelerometers. In addition, chest displacement and upper neck six-axis force and moment sensors were utilized. Ninety-six (96) channels of data were recorded with a PC based (TDAS) on-board data acquisition system. The data was digitally sampled at 10,000 samples per second and processed per section IP11 of the Laboratory Indicant Test Procedure.

The Driver ATD (Serial No. 34) and the right-front passenger ATD (Serial No. 35) were re-calibrated prior to this test. FMVSS 208 "Occupant Crash Protection" injury criteria were not exceeded by either ATD during this 40% offset frontal impact test.

1.3 SUMMARY OF FRONTAL BARRIER IMPACT TEST

A deformable barrier was mounted to a fixed barrier and was impacted by a 2000 Ford Expedition 4WD 4-door SUV traveling at velocity of 59.82 km/h. The test vehicle weight is 2742 kilograms with two (2) part 572E 50th percentile adult male ATDs, and instrumentation. The test vehicle is equipped with longitudinally mounted 4.6-liter, 8-cylinder engine and a 4-speed automatic transmission.

The driver Head Injury Criteria (HIC) is 293.5. The maximum resultant chest deceleration over three (3) milliseconds is 28.6 g's. The left and right femur loads are -3956.3 and -1873.7 Newtons, respectively. Chest deflection for the driver ATD peaked at -21.3 mm. The driver ATD head, chest, and abdomen contacted the airbag, and both knees contacted the knee bolster.

The right front passenger's HIC is 396.3. The maximum resultant chest deceleration over three (3) milliseconds is 35.9 g's. The left and right femur loads are -1410.8 and -937.8 Newtons respectively. Chest deflection for the passenger ATD peaked at -34.4 mm. The passenger ATD head contacted the airbag and headrest, the chest and abdomen contacted the airbag and both knees contacted the glove box.

Maximum shoulder belt spool out as measured by on-board potentiometers is 77.8 mm for the driver ATD and 62.2 mm for the passenger ATD. The shoulder belt stretch was 0.000 mm/cm for the driver ATD and 0.117 mm/cm for the passenger ATD.

There was 100 percent windshield retention (minimum 50 percent required for passive restraint systems). No intrusion occurred into the protected or unprotected zone of the windshield. Approximately 3200 ounces (by weight) of Stoddard leaked during the first thirty minutes after impact. An additional 57 ounces leaked during static rollover.

The test vehicle sustained a maximum static crush of 1040 mm located at the left side of the vehicle. The driver side door was jammed and passenger side doors opened without the aid of tools.

1.4 GENERAL COMMENTS

The 2000 Ford Expedition 4WD 4-door SUV passed the requirements of FMVSS 208, FMVSS 212, FMVSS 219. The tested vehicle failed to meet the test requirements of FMVSS 301. Data pertaining to these standards are presented in the data sheets.

The vehicle, occupant, camera and measurement data are presented in Section 2. Appendix A contains the still photograph prints. Appendix B contains the dummy and vehicle response data traces. Appendix C contains the deformable barrier crush profile. Appendix D contains the instrumentation data channel assignments. Appendix E contains the dummy calibration data and Appendix F contains the owner's manual instructions for the occupant seating and restraint systems.

SECTION 2

OCCUPANT AND VEHICLE INFORMATION/DATA SHEETS

Test Vehicle: 2000 Ford Expedition 4WD 4 door SUV

NHTSA No.: FORD01

Test Program: 2000 NHTSA 40% Offset

Test Date: 8/15/00

CONVERSION FACTORS USED IN THIS REPORT*

Quantity	Typical Application	Std Units	Metric Unit	Multiply By
Mass	Vehicle Weight	lb	kg	0.4536
Linear Velocity	Impact Velocity	mile/h	km/h	1.609
Length or Distance	Measurements	in	mm	25.4
Volume	Fuel Systems	gal	liter	3.785
Volume	Small Fluids	oz	mL	29.573
Pressure	Tire Pressures	lbf/in ²	kPa	7.0
Volume	Liquid	gal	liter	3.785
Temperature	General Use	°F	°C	=(tf -32)/1.8
Force	Dynamic Forces	lbf	N	4.448
Moment	Torque	lbf/ft	Nm	1.355

* Based on the Recommended Practice in SAE J916, May 85

**DATA SHEET NO. 1
CRASH TEST SUMMARY**

Test Vehicle: 2000 Ford Expedition 4WD 4 door SUV
 Test Program: 2000 NHTSA 40% Offset

NHTSA No.: FORD01
 Test Date: 8/15/00

PRIMARY IMPACT DATA

Measured Parameter	Units	Value
Velocity at Impact	km/h	59.82
Test Weight	kg	2742
Impact Angle	degrees	0
Maximum Static Crush	mm	1040

DOOR OPENING AND SEAT TRACK INFORMATION

Description	Driver	Passenger
Front Door Opening	Jammed	Opened
Rear Door Opening	Opened	Opened
Seat Track Shift (mm)	0	0
Seat Back Failure	None	None

TEST DUMMY INFORMATION

Description	Driver	Passenger
Dummy Type / Serial No.	50% Male Hybrid III / No. 34	50% Male Hybrid III / No. 35
Head Contact	Airbag/Headrest	Airbag/B-pillar/D-ring
Chest Contact	Airbag	Airbag
Abdomen Contact	Airbag	Airbag
Left Knee Contact	Knee Bolster	Glove Box
Right Knee Contact	Knee Bolster	Glove Box

16mm MOVIE COVERAGE

High Speed	18
Real Time	1
Total	19

Driver ATD Sensors	40
Passenger ATD Sensors	40
Belt Assessment Sensors	8
Vehicle Structure Accelerometers	8
Total	96

**DATA SHEET NO. 2
GENERAL TEST AND VEHICLE PARAMETER DATA**

Test Vehicle: 2000 Ford Expedition 4WD 4 door SUV
 Test Program: 2000 NHTSA 40% Offset

NHTSA No.: FORD01
 Test Date: 8/15/00

TEST VEHICLE INFORMATION

Manufacturer	Ford Motor Company
Model	Expedition 4WD
Body Style	4 Door SUV
NHTSA NO.	FORD01
VIN	1FMRU1665YLA82245
Color	Silver
Delivery Date	07/31/00
Odometer Reading (mile)	115
Dealer	Colley Ford
Transmission	4-Speed Automatic
Final Drive	Rear
Number of Cylinders	8
Engine Displacement (L)	4.6
Engine Placement	Longitudinal

TEST VEHICLE OPTIONS

Driver Airbag	Yes
Passenger Airbag	Yes
Power Windows	Yes
Power Steering	Yes
Power Door Locks	Yes
Tilt Wheel	Yes
Air Conditioning	Yes
Power Brakes	Yes
Disc Brakes, Front	Yes
Disc Brakes, Rear	Yes
Anti-lock Brakes	Yes
AM/FM/Cassette	Yes
Anti-Theft System	Yes
Cruise Control	Yes

DATA FROM CERTIFICATION LABEL

Manufactured By	Ford Motor Company	GVWR (kg)	3166
Date of Manufacture	December-99	GAWR Front (kg)	1587
		GAWR Rear (kg)	1769

DATA FROM TIRE PLACARD

Measured Parameter	Front	Rear
Maximum Tire Pressure (kPa)	207	241
Cold Pressure (kPa)	207	241
Recommend Tire Size	P255/70/R16 SL	P255/70/R16 SL
Tire Size on Vehicle	P255/70/R16	P255/70/R16
Tire Manufacturer	Firestone	Firestone

Measured Parameter	Front	Center	Rear	Total
Type of Seats	Bucket	Bucket	Bench	
Number of Occupants	2	2	3	7
Capacity Wt. (VCW) (kg)				N/A
Cargo Weight (RCLW) (kg)				136 *

* RCLW for SUV is 136 kg max.

DATA SHEET NO. 2...(continued)
GENERAL TEST AND VEHICLE PARAMETER DATA

Test Vehicle: 2000 Ford Expedition 4WD 4 door SUV
 Test Program: 2000 NHTSA 40% Offset

NHTSA No.: FORD01
 Test Date: 8/15/00

TEST VEHICLE WEIGHTS

	Units	As Delivered (UVW)			As Tested (ATW)		
		Front Axle	Rear Axle	Total	Front Axle	Rear Axle	Total
Left	kg	643	615		680	709	
Right	kg	610	593		652	699	
Ratio	%	50.9	49.1		48.6	51.4	
Totals	kg	1253	1208	2461	1332	1408	2740

TARGET TEST WEIGHT CALCULATION

Measured Parameter	Units	Value
Total Delivered Weight (UVW)	kg	2461
Weight of 2 P572 ATD's	kg	152
Rated Cargo/Luggage Weight (RCLW)	kg	136
Calculated Vehicle Target Weight (TVTW)	kg	2749

TEST VEHICLE ATTITUDE AND CG

	Units	LF	RF	LR	RR	CG (aft of front axle)
As Delivered	mm	943	957	909	921	1490
As Tested	mm	927	944	887	898	1560

Vehicle Wheel base (mm): 3035
 Weight of Ballast secured in cargo area (kg): 0 *
 Vehicle Components Removed: Left middle seat, jack, tools.

* Ballast weight does not include cameras, instrumentation, and brake abort system.

FUEL SYSTEM DATA

Fuel System Capacity From Owner's Manual (L): 113.6
 Usable Capacity Figure Furnished by COTR (L): 113.6
 Actual Test Volume with entire fuel System Filled (L): 105.6
 Test Fluid Type: Stoddard Solvent ; Specific Gravity: 0.764
 Is Vehicle Fuel Pump Electric or Mechanical?: Electric
 If electric, does pump operate with ignition switch "ON" & engine "OFF"? Yes
 Fuel System Particulars: Fuel pump operates for 2 seconds when ignition is turned on, then automatically shuts off if engine is not started.

**DATA SHEET NO. 3
POST IMPACT DATA**

Test Vehicle: 2000 Ford Expedition 4WD 4 door SUV
 Test Program: 2000 NHTSA 40% Offset

NHTSA No.: FORD01
 Test Date: 8/15/00

SPEED TRAP DATA

Measured Parameter	Units	Requirement	Value
Trap No. 1 Velocity (Primary)	km/h	59.5 to 61.1	59.82
Trap No. 1 Entry Distance	mm	< 1524	1524
Trap No. 1 Exit Distance	mm	< 1524	305
Trap No. 2 Velocity (Redundant)	km/h	59.5 to 61.1	59.97
Trap No. 2 Entry Distance	mm	< 1524	1524
Trap No. 2 Exit Distance	mm	< 1524	305

VEHICLE STATIC CRUSH

Measured Parameter	Units	Pre-Test	Post-Test	Difference
Left Side	mm	4910	3870	-1040
Center	mm	5190	4605	-585
Right Side	mm	4910	5205	295

VEHICLE REBOUND FROM BARRIER (mm)

Axis	Front Tire		Rear Tire	
	Left	Right	Left	Right
X-Axis	2560	1275	4885	3930
Y-axis	595	1675	1810	3205

Reference points

X-axis = Concrete barrier face

Y-axis = Monorail centerline

DATA SHEET NO. 4
TEST VEHICLE INFORMATION

Test Vehicle: 2000 Ford Expedition 4WD 4 door SUV
Test Program: 2000 NHTSA 40% Offset

NHTSA No.: FORD01
Test Date: 8/15/00

NOMINAL DESIGN RIDING POSITION

The driver and passenger seat backs are positioned to the manufacturers designated angle. The procedure is as follows: An inclinometer is inserted through a slit in the seat back the fabric, making contact with the rigid portion of the seat frame assembly, approximately 13 inches above the pivot point of the seat back. The inclinometer is placed against the flat surface of the seat back and the angle is measured directly from the dial face.

Driver seat back angle: 21° with a seated dummy
Passenger seat back angle: 21° with a seated dummy

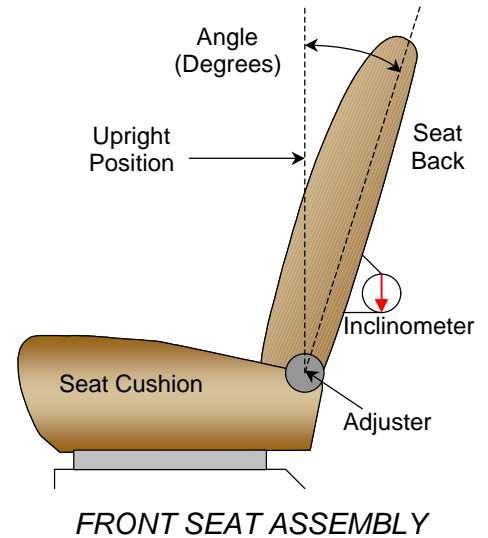

SEAT FORE/AFT POSITIONS

The driver seat is electrically adjusted and is set to middle position. The passenger seat is mechanically adjusted and has 19 positions or detents, and set to middle position. The first or forward most position is counted as number one (1).

Driver seat fore/aft total travel: 192 mm total travel
Driver seat fore/aft position: 96 mm aft of forward most
Passenger seat fore/aft total travel: 19 seating positions or detents
Passenger seat fore/aft position: 10th detent from forward most

SEAT BELT UPPER ANCHORAGE

The test vehicle was equipped with adjustable anchorages for both driver and passenger seat positions. There are 5 positions or detents. Anchors are set to middle position.

DATA SHEET NO. 4...(continued)

TEST VEHICLE INFORMATION

Test Vehicle: 2000 Ford Expedition 4WD 4 door SUV

NHTSA No.: FORD01

Test Program: 2000 NHTSA 40% Offset

Test Date: 8/15/00

FUEL TANK CAPACITY DATA

The "Usable Capacity" of the standard equipment fuel tank is: 113.6 liters

The "Usable Capacity" of any optional equipment fuel tank is: N/A liters

"Usable Capacity" used for certification tests FMVSS 301 requirements: 104.5 to 106.8 liters

Actual amount of Stoddard solvent added to vehicle for certification test: 105.6 liters

The test vehicle is equipped with an electric fuel pump. The fuel pump operates for approximately two seconds after the ignition is placed to the "ON" position, after which the fuel pump automatically shuts off. The fuel filler door is located on the left rear fender. The standard fuel tank occupies the area under the left center and rear seat. Fuel lines run along the left frame rail to the engine compartment.

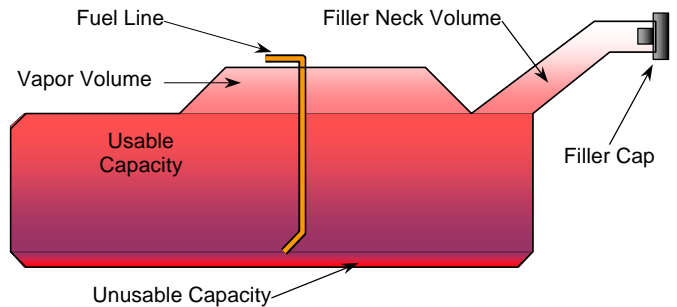

VEHICLE FUEL TANK ASSEMBLY

STEERING COLUMN ADJUSTMENT

Steering wheel and column adjustments are made so that the steering wheel hub is at the geometric center of the locus it describes, when it is moved through its full range of motion. An aluminum plate is placed across the rim of the steering wheel, an inclinometer is placed onto the plate and the angle is measured. The tested vehicle has an adjustable steering column with 5 detents. The column is set to the middle position as indicated in the drawing at right and the angle below.

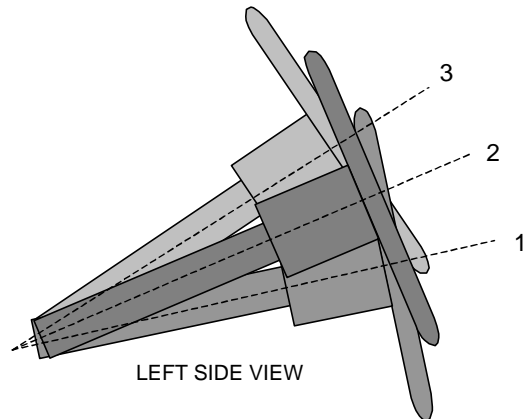

LEFT SIDE VIEW

STEERING COLUMN ASSEMBLY

Lowermost, position 1: 77°

Geometric center, position 2: 69°

Uppermost, position 3: 61°

DATA SHEET NO. 5

DUMMY POSITIONING IN VEHICLE

Test Vehicle: 2000 Ford Expedition 4WD 4 door SUV

NHTSA No.: FORD01

Test Program: 2000 NHTSA 40% Offset

Test Date: 8/15/00

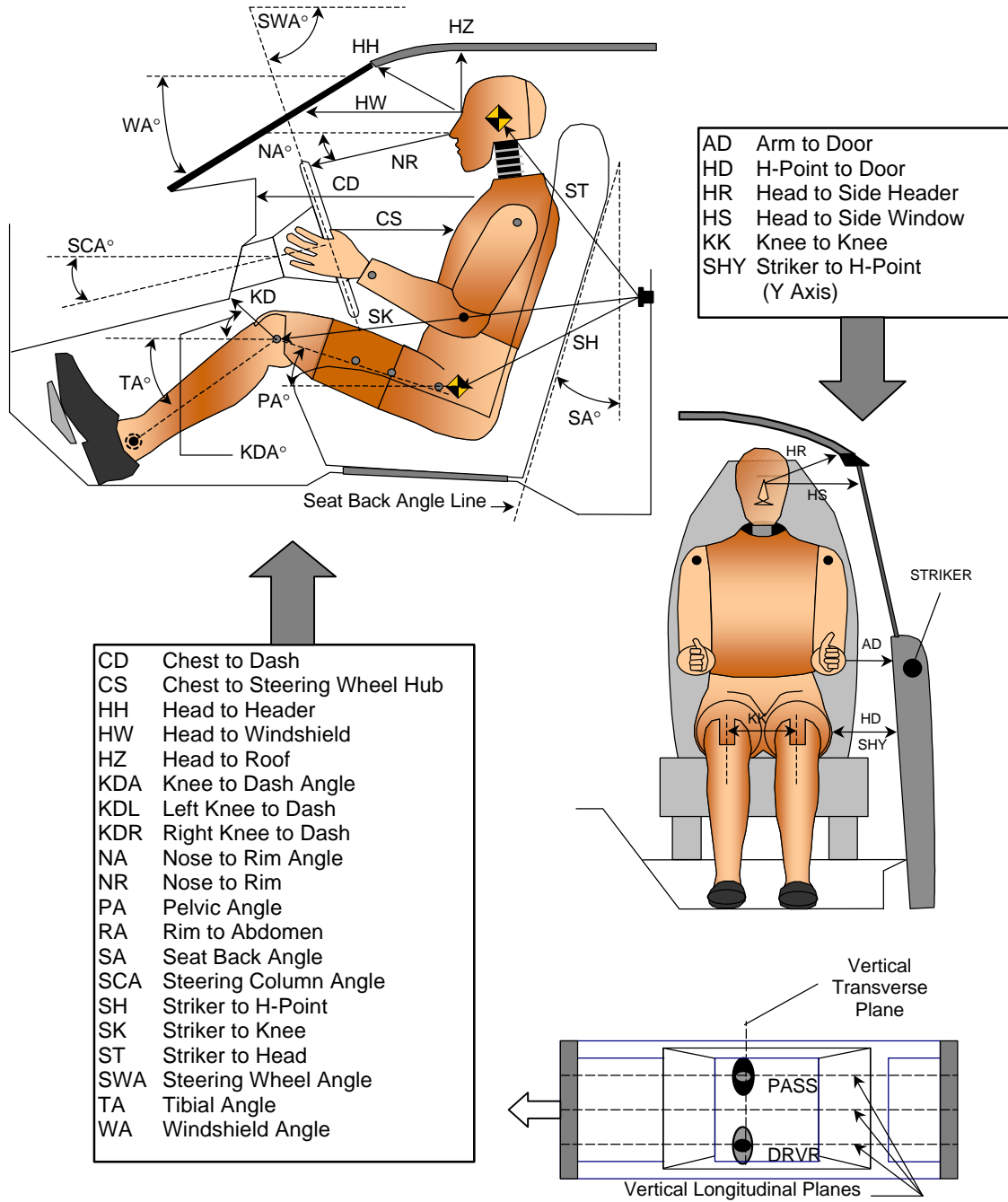

DUMMY MEASUREMENTS FOR FRONT SEAT OCCUPANTS

DATA SHEET NO. 5...(continued)
DUMMY POSITIONING IN VEHICLE

Test Vehicle: 2000 Ford Expedition 4WD 4 door SUV
 Test Program: 2000 NHTSA 40% Offset

NHTSA No.: FORD01
 Test Date: 8/15/00

TEST DUMMY POSITION MEASUREMENTS

Code	Measurement Description	Driver		Passenger	
		Length (mm)	Angle (°)	Length (mm)	Angle (°)
WA	Windshield Angle		32		
SWA	Steering Wheel Angle		69		
SCA	Steering Column Angle		19		
SA	Seat Back Angle		21		21
HZ	Head to Roof (Z)	235	90	220	90
HH	Head to Header	390	0	392	0
HW	Head to Windshield	620	0	612	0
HR	Head to Side Header (Y)	270		245	
NR	Nose to Rim	385	8		
CD	Chest to Dash	555		570	
CS	Chest to Steering Hub	300	0		
RA	Rim to Abdomen	200	0		
KDL	Left Knee to Dash	155	26	180	
KDR	Right Knee to Dash	165		180	35
TA	Tibia Angle		55		22
PA	Pelvic Angle		23		46
KK	Knee to Knee (Y)	290		210	
SK	Striker to Knee	615	5	630	3
ST	Striker to Head	680	81	684	10
SH	Striker to H-Point	220	5	220	4
SHY	Striker to H-Point (Y)	252	0	250	0
HS	Head to Side Window	352	0	295	0
HD	H-Point to Door (Y)	172	0	184	0
AD	Arm to Door (Y)	115	0	65	0

DATA SHEET NO. 6
SEAT BELT POSITIONING DATA

Test Vehicle: 2000 Ford Expedition 4WD 4 door SUV
 Test Program: 2000 NHTSA 40% Offset

NHTSA No.: FORD01
 Test Date: 8/15/00

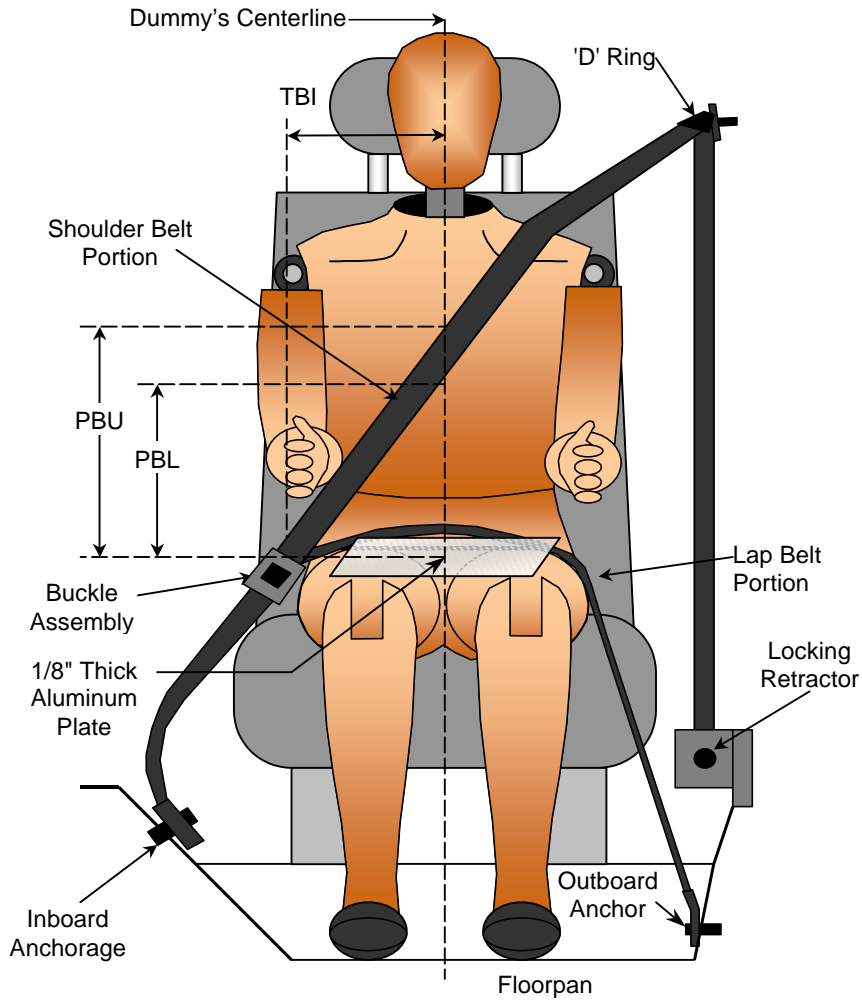

SEAT BELT POSITIONING MEASUREMENTS

Measurement Description	Units	Driver	Passenger
TBI - Dummy centerline to lap/shoulder belt intersect	mm	180	190
PBU - Top surface of reference to belt upper edge	mm	330	310
PBL - Top surface of reference to belt lower edge	mm	225	220
Lap Belt tension	Newtons	10	10
Shoulder Belt tension	N/A	Retractor	Retractor

DATA SHEET NO. 7 - VEHICLE ACCELEROMETER LOCATION AND DATA SUMMARY

Test Vehicle: 2000 Ford Expedition 4WD 4 Door SUV

NHTSA No.: FORD01

Test Program: 2000 NHTSA 40% Offset

Test Date: 8/15/00

VEHICLE X-AXIS ACCELEROMETER PEAK DATA AND PRE-TEST LOCATIONS

No.	Accelerometer Location	Measurements (mm)			Peak Values				
		X	Y	Z	Units	Max	Time	Min	Time
1	Left Sill X	1878	-695	685	G's	1.9	248.6	-25.9	110.6
2	Left Sill Y	1923	-695	685	G's	13.9	99.1	-5.2	148.1
3	Center Tunnel X	2351	25	690	G's	2.2	278.3	-24.8	111.4
4	Center Tunnel Y	2371	-40	690	G's	14.6	107.2	-7.5	146.5
5	Right Sill X	1981	695	680	G's	2.0	299.9	-21.9	108.1
6	Right Sill Y	1901	695	680	G's	12.8	107.8	-5.2	136.1
7	Trunk X	364	-35	895	G's	1.9	212.4	-25.0	110.6
8	Trunk Y	364	25	895	G's	10.2	144.2	-3.6	98.0

Reference Points X - From Vehicle Rear Surface Y - Vehicle Centerline Z - Ground Plane

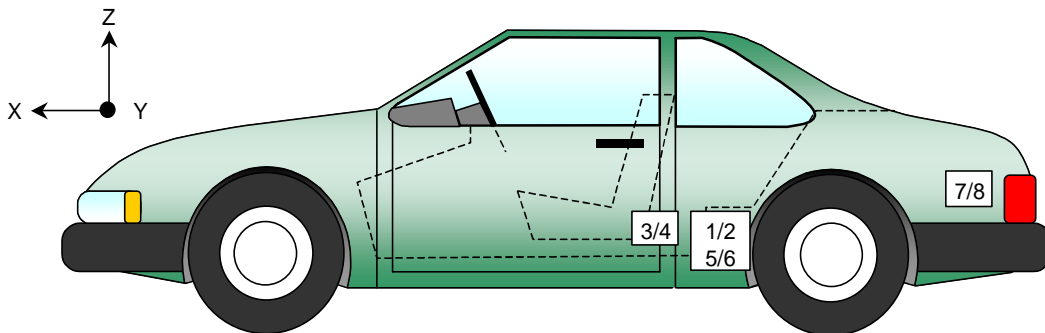
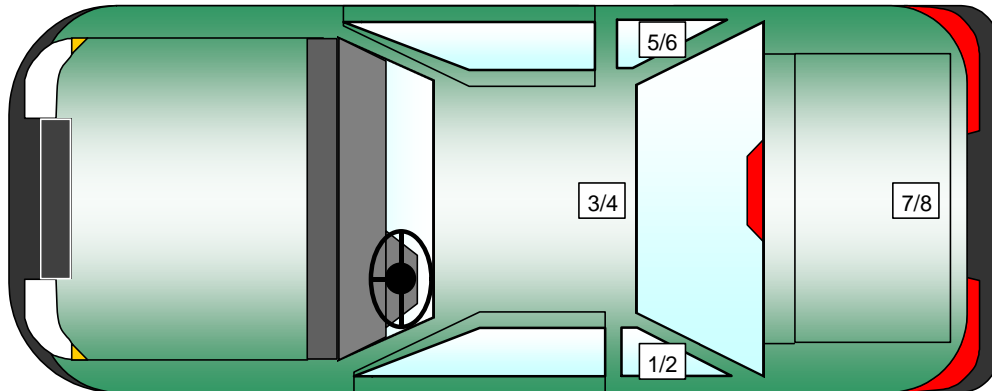

DATA SHEET NO. 8 - HYBRID III ATD INJURY CRITERIA AND SENSOR DATA

Test Vehicle: 2000 Ford Expedition 4WD 4 Door SUV

NHTSA No.: FORD01

Test Program: 2000 NHTSA 40% Offset

Test Date: 8/15/00

HEAD PRIMARY PEAK ACCELERATIONS

Location	Axis	Units	Driver				Passenger			
			Max	Time	Min	Time	Max	Time	Min	Time
Head CG	X	G's	3.4	299.3	-44.6	106.9	14.8	292.8	-38.4	118.3
Head CG	Y	G's	11.9	191.4	-14.4	115.1	32.5	128.1	-20.4	273.7
Head CG	Z	G's	17.4	92.6	-8.3	153.4	21.2	99.4	-4.1	85.1
Head CG Resultant	N/A	G's	47.2	106.9			48.9	127.6		

CHEST PRIMARY PEAK ACCELERATIONS

Location	Axis	Units	Driver				Passenger			
			Max	Time	Min	Time	Max	Time	Min	Time
Chest CG	X	G's	0.5	274.7	-28.4	95.5	1.8	212.6	-33.6	128.0
Chest CG	Y	G's	12.0	146.0	-3.0	77.9	15.3	125.1	-3.2	206.0
Chest CG	Z	G's	8.5	77.1	-8.9	160.6	6.1	115.5	-3.5	152.4
Chest CG Resultant	N/A	G's	29.2	95.5			36.7	127.6		

FEMUR PEAK FORCES

Location	Axis	Units	Driver				Passenger			
			Max	Time	Min	Time	Max	Time	Min	Time
Left Femur	Z	Newtons	999.3	155.0	-3956.3	88.9	633.6	124.1	-1410.8	102.8
Right Femur	Z	Newtons	1261.8	134.7	-1873.7	102.7	352.1	79.6	-937.8	95.3

SEAT BELT SENSOR PEAK VALUES

Location	Axis	Units	Driver				Passenger			
			Max	Time	Min	Time	Max	Time	Min	Time
Lap Belt Force	N/A	Newtons	2849.0	138.2	-9.8	0.0	3777.9	115.7	-7.3	3.5
Shoulder Belt Force	N/A	Newtons	4002.3	96.5	-0.7	288.3	5987.4	127.1	10.8	0.0
Shoulder Belt Pullout	N/A	MM	77.8	138.8	0.0	13.8	62.2	153.2	0.0	9.1
Shoulder Belt Stretch	N/A	MM/CM	0.000	0.0	0.000	0.0	0.117	138.2	-0.061	276.1

* Driver Channel Failed, No Data

HEAD INJURY CRITERIA (HIC)

Location	Driver				Passenger			
	HIC	Avg G	T ¹	T ²	HIC	Avg G	T ¹	T ²
Head CG Primary	293.5	36.7	88.8	124.7	396.3	41.4	103.5	139.4

CHEST CLIP (3MSEC)

Location	Driver			Passenger		
	CLIP	T ¹	T ²	CLIP	T ¹	T ²
Chest CG Primary	28.6	94.5	97.5	35.9	126.3	129.3

DATA SHEET NO. 8...(continued)

Test Vehicle: 2000 Ford Expedition 4WD 4 Door SUV

NHTSA No.: FORD01

Test Program: 2000 NHTSA 40% Offset

Test Date: 8/15/00

PELVIC PEAK ACCELERATIONS

Location	Axis	Units	Driver				Passenger			
			Max	Time	Min	Time	Max	Time	Min	Time
Pelvis	X	G's	3.3	178.8	-36.2	89.6	4.0	190.4	-27.0	99.3
Pelvis	Y	G's	15.2	133.0	-6.1	89.9	14.9	110.5	-6.3	174.0
Pelvis	Z	G's	3.9	74.7	-17.4	144.4	4.5	299.0	-11.4	125.4

UPPER NECK PEAK FORCES AND MOMENTS

Location	Axis	Units	Driver				Passenger			
			Max	Time	Min	Time	Max	Time	Min	Time
Neck Force	X	Newtons	299.7	109.0	-268.7	204.4	92.9	291.1	-383.6	106.3
Neck Force	Y	Newtons	450.8	190.6	-115.3	296.5	264.9	212.4	-434.4	273.2
Neck Force	Z	Newtons	1220.8	97.4	-271.3	156.2	1635.8	105.7	-131.3	294.9
Neck Moment	X	N•m	31.4	196.1	-31.0	113.9	23.1	111.4	-15.9	130.6
Neck Moment	Y	N•m	29.4	103.1	-20.8	143.0	7.3	219.1	-22.0	134.1
Neck Moment	Z	N•m	25.3	136.2	-10.2	190.7	16.7	218.6	-32.5	140.7

FOOT PEAK ACCELERATIONS

Location	Axis	Units	Driver				Passenger			
			Max	Time	Min	Time	Max	Time	Min	Time
Left Foot Aft	X	G's	62.4	90.5	-245.6	75.7	4.6	196.0	-38.1	89.9
Left Foot Aft	Z	G's	86.7	87.3	-89.1	82.6	6.6	119.1	-27.6	89.8
Left Foot Fore	Z	G's	118.2	97.1	-185.4	89.1	24.5	111.6	-47.7	89.9
Right Foot Aft	X	G's	19.4	93.0	-91.1	87.3	14.9	205.9	-57.5	95.3
Right Foot Aft	Z	G's	20.4	92.3	-134.3	85.4	1.0	272.0	-32.9	99.9
Right Foot Fore	Z	G's	115.5	91.8	-175.9	85.5	5.4	109.8	-45.1	91.7

UPPER AND LOWER TIBIA PEAK FORCES AND MOMENTS

Location	Axis	Units	Driver				Passenger			
			Max	Time	Min	Time	Max	Time	Min	Time
Left Lower Moment	X	N•m	18.9	83.5	-37.1	100.1	11.5	214.3	-39.0	111.0
Left Lower Moment	Y	N•m	413.0	90.4	-151.9	76.2	19.3	93.5	-16.3	123.6
Left Lower Force	Z	Newtons	111.0	272.7	-3235.7	75.4	105.1	150.9	-1172.7	72.5
Left Upper Moment	X	N•m	69.0	156.6	-34.1	93.6	7.7	188.0	-41.9	111.6
Left Upper Moment	Y	N•m	76.1	91.1	-218.0	145.7	45.7	89.5	-41.0	122.9
Right Lower Moment	X	N•m	16.4	85.4	-149.1	88.3	14.2	95.1	-17.6	151.3
Right Lower Moment	Y	N•m	280.9	102.5	-34.5	84.0	46.3	95.3	-5.2	258.6
Right Lower Force	Z	Newtons	79.3	291.7	-5158.7	88.9	223.1	148.3	-872.9	95.7
Right Upper Moment	X	N•m	37.7	85.1	-78.8	88.7	12.4	130.2	-42.3	152.7
Right Upper Moment	Y	N•m	5.8	56.4	-168.1	137.8	64.3	139.2	-17.1	81.2

DATA SHEET NO. 8...(continued)

Test Vehicle: 2000 Ford Expedition 4WD 4 Door SUV

NHTSA No.: FORD01

Test Program: 2000 NHTSA 40% Offset

Test Date: 8/15/00

CHEST PEAK DISPLACEMENTS

Location	Axis	Units	Driver				Passenger			
			Max	Time	Min	Time	Max	Time	Min	Time
Chest CG	X	MM	0.1	43.7	-21.3	102.6	0.5	0.4	-34.4	129.3

HEAD REDUNDANT PEAK ACCELERATIONS

Location	Axis	Units	Driver				Passenger			
			Max	Time	Min	Time	Max	Time	Min	Time
Head CG	X	G's	2.5	296.3	-44.1	106.5	14.6	292.7	-36.6	117.9
Head CG	Y	G's	12.5	192.0	-13.5	114.7	33.8	129.1	-21.3	273.6
Head CG	Z	G's	15.2	89.5	-11.0	148.5	19.1	117.3	-1.6	19.3
Head CG Resultant	N/A	G's	47.2	106.5			49.4	126.8		

CHEST REDUNDANT PEAK ACCELERATIONS

Location	Axis	Units	Driver				Passenger			
			Max	Time	Min	Time	Max	Time	Min	Time
Chest CG	X	G's	0.6	219.4	-28.1	95.4	1.5	213.1	-33.8	127.8
Chest CG	Y	G's	12.7	145.9	-3.7	78.1	15.5	126.8	-2.8	207.1
Chest CG	Z	G's	8.1	77.1	-9.4	160.7	7.1	115.5	-3.0	152.0
Chest CG Resultant	N/A	G's	28.7	95.5			37.0	127.4		

REDUNDANT HEAD INJURY CRITERA (HIC)

Location	Driver				Passenger			
	HIC	Avg G	T ¹	T ²	HIC	Avg G	T ¹	T ²
Head CG Redundant	294.1	36.7	88.4	124.3	396.7	41.4	103.3	139.2

REDUNDANT CHEST CLIP (3MSEC)

Location	Driver			Passenger		
	CLIP	T ¹	T ²	CLIP	T ¹	T ²
Chest CG Redundant	28.3	94.9	97.9	36.0	126.3	129.3

DATA SHEET NO. 9

SEAT BELT PERFORMANCE ASSESSMENT TEST DATA

Test Vehicle: 2000 Ford Expedition 4WD 4 door SUV

NHTSA No.: FORD01

Test Program: 2000 NHTSA 40% Offset

Test Date: 8/15/00

SEAT BELT PLACEMENT MEASUREMENTS

Measurement Description	Units	Driver	Passenger
TBI - Dummy centerline to lap/shoulder belt intersect	mm	180	190
PBU - Top surface of reference to belt upper edge	mm	330	310
PBL - Top surface of reference to belt lower edge	mm	225	220
Lap Belt tension	Newtons	10	10
Shoulder Belt tension	N/A	Retractor	Retractor

BELT LENGTH DATA

Measurement Description	Units	Driver	Passenger
Retractor reel to 'D' ring	mm	800	800
Shoulder belt length as measured on ATD	mm	810	840
Lap belt length as measured on ATD	mm	780	790
Remainder of belt on reel	mm	875	810
Total belt length for continuous webbing systems	mm	3265	3240

SHOULDER BELT SPOOL-OFF DATA

Measurement Description	Units	Driver	Passenger
As determined mechanically	mm	60.0	73.0
As determined electronically	mm	77.8	62.2

BELT STRETCH DATA

Measurement Description	Units	Driver	Passenger
Electronically from shoulder belt load cell and "D" ring	mm/cm	No Data	0.12
Mechanically	mm/cm	No Data	No Data

DATA SHEET NO. 10
SUMMARY OF FMVSS 212 DATA

Test Vehicle: 2000 Ford Expedition 4WD 4 door SUV

NHTSA No.: FORD01

Test Program: 2000 NHTSA 40% Offset

Test Date: 8/15/00

Windshield Mounting Details:

Windshield glass is secured to the vehicle frame with a rubber type adhesive. There is molding that covers the windshield periphery at the top and sides. A molding covers the bottom of the window but is not attached to the windshield.

The standard requires that the post-test retention measurement be a minimum of 75 percent of the pretest total periphery measurement for vehicles not equipped with occupant passive restraints and 50 percent for each side of the windshield for vehicles which are equipped with occupant passive restraints.

Temperature of windshield molding during test: 22.1 °C

WINDSHIELD PERIPHERY MEASUREMENTS

Measurement	Pre-Test (mm)	Post-Test (mm)	% of Retention
Left Side	2299	2299	100
Right Side	2299	2299	100
Total	4598	4598	100

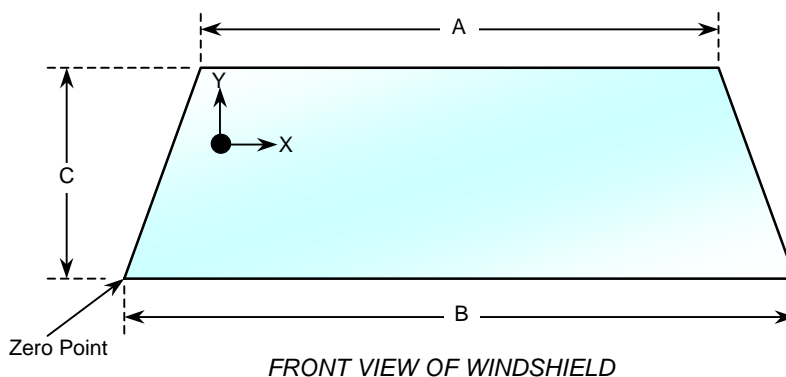

WINDSHIELD DIMENSIONS

Item	Units	Segment Length	Molding Width
A	mm	1368	30
B	mm	1759	14
C	mm	735	26

DATA SHEET NO. 11

WINDSHIELD ZONE INTRUSION FMVSS 219 (PARTIAL) DATA

Test Vehicle: 2000 Ford Expedition 4WD 4 door SUV

NHTSA No.: FORD01

Test Program: 2000 NHTSA 40% Offset

Test Date: 8/15/00

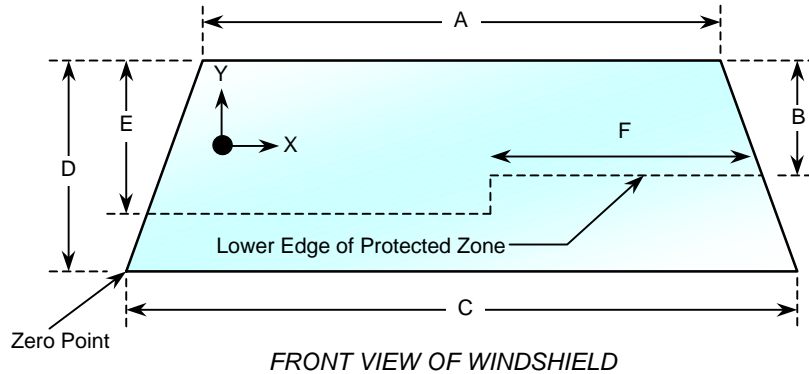

WINDSHIELD AND PROTECTED ZONE

Item	Units	Value
A	mm	1368
B	mm	406
C	mm	1759
D	mm	735
E	mm	524
F	mm	653

AREA OF PROTECTED ZONE FAILURES

- A. Provide coordinates of the area that the protected zone was penetrated more than 0.25 in. by a vehicle component other than one that is normally in contact with the windshield.

X	Y
N/A	N/A
N/A	N/A
N/A	N/A
N/A	N/A

- B. Provide coordinates of the area beneath the protected zone that the inner surface of the windshield was penetrated by a vehicle component.

X	Y
N/A	N/A
N/A	N/A
N/A	N/A
N/A	N/A

DATA SHEET NO. 12

FMVSS 301 FUEL SYSTEM INTEGRITY POST IMPACT DATA

Test Vehicle: 2000 Ford Expedition 4WD 4 door SUV

NHTSA No.: FORD01

Test Program: 2000 NHTSA 40% Offset

Test Date: 8/15/00

Temperature at Time of Impact: 40.6 °C

Test Time: 1:10 PM

STODDARD SOLVENT SPILLAGE MEASUREMENT

A. From impact until vehicle motion ceases: 0.0 oz.

(Maximum Allowable = 1 ounce)

B. For the 5-minute period after motion ceases: 640 oz.

(Maximum Allowable = 5 ounces)

C. For the following 25 minutes: 2560 oz.

(Maximum Allowable = 1 oz./minute)

C. Stoddard Solvent Spillage Details:

Driver side torsion bar moved rearward and ruptured the fuel tank on the forward most edge (see figure A-71 for close-up photograph).

DATA SHEET NO. 13
FMVSS 301 STATIC ROLLOVER DATA SHEET

Test Vehicle: 2000 Ford Expedition 4WD 4 door SUV

NHTSA No.: FORD01

Test Program: 2000 NHTSA 40% Offset

Test Date: 8/15/00

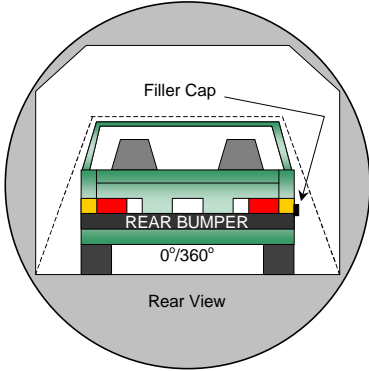

0° TO 90°

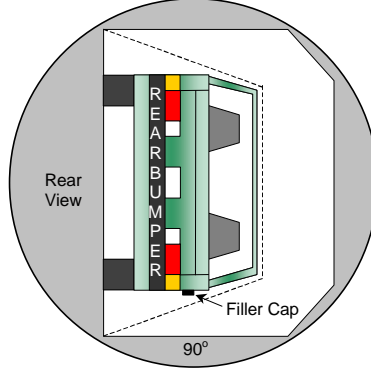

90° TO 180°

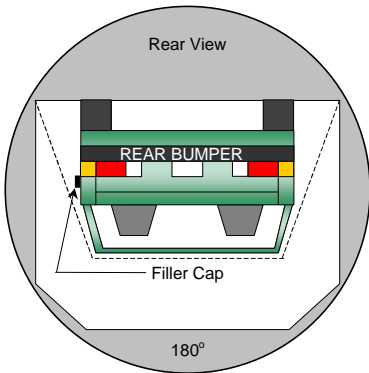
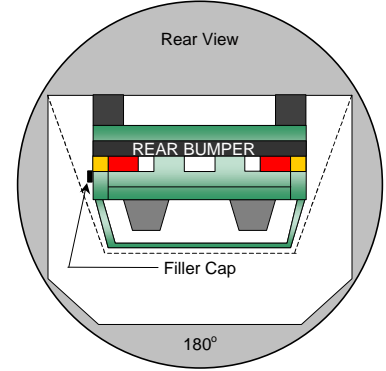

180° TO 270°

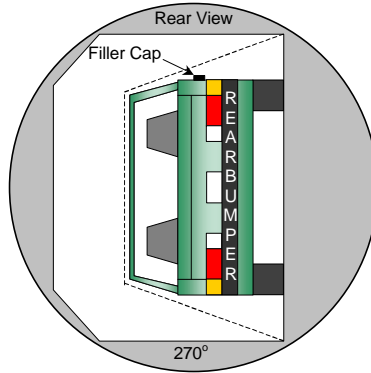

270° TO 360°

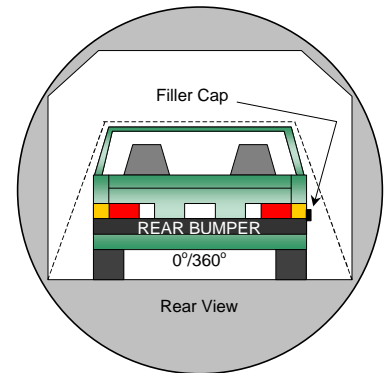

1. The specified fixture rollover rate for each 90° of rotation is 60 to 120 seconds.
2. The position hold time at each position is 300 seconds (minimum).
3. Details of Stoddard Solvent spillage location:

Spillage occurred from rupture at the front surface of fuel tank. Rupture caused by intrusion of driver side torsion bar and aft mounting bracket into fuel tank.

Rollover Test Phase	Rotation Time (sec.)	Hold Time (sec.)	Spillage (oz.)
0° TO 90°	82	300	0.0
90° TO 180°	80	300	56.0
180° TO 270°	80	300	0.1
270° TO 360°	80	300	0.6

DATA SHEET NO. 14
VEHICLE MEASUREMENTS

Test Vehicle: 2000 Ford Expedition 4WD 4 door SUV

NHTSA No.: FORD01

Test Program: 2000 NHTSA 40% Offset

Test Date: 8/15/00

No.	Measurement Description	Units	Pre-Test	Post-Test	Difference
1	Total length of vehicle at centerline	mm	5190	4505	-685
2	RSOV to front of engine	mm	4345	4270	-75
3	RSOV to firewall centerline	mm	3988	3985	-3
4	RSOV to upper leading edge of right door	mm	3603	3620	17
5	RSOV to upper leading edge of left door	mm	3605	3606	1
6	RSOV to lower leading edge of right door	mm	3522	3530	8
7	RSOV to lower leading edge of left door	mm	3523	3521	-2
8	RSOV to upper trailing edge of right door	mm	2471	2491	20
9	RSOV to upper trailing edge of left door	mm	2472	2467	-5
10	RSOV to lower trailing edge of right door	mm	2460	2480	20
11	RSOV to lower trailing edge of left door	mm	2460	2458	-2
12	RSOV to bottom of right 'A' pillar	mm	3600	3625	25
13	RSOV to bottom of left 'A' pillar	mm	3602	3515	-87
14	RSOV to firewall on right side	mm	3927	3965	38
15	RSOV to firewall of left side	mm	3969	3922	-47
16	RSOV to steering column	mm	3075	3130	55
17	Center of steering column to left 'A' pillar	mm	448	370	-78
18	Center of steering column to headlining	mm	480	400	-80
19	RSOV to right side of front bumper	mm	4910	5175	265
20	RSOV to left side of front bumper	mm	4910	3870	-1040
21	Length of engine block	mm	500	500	0
RD	RSOV to right side of dash panel	mm	3361	3380	19
CD	RSOV to center of dash panel	mm	3290	3300	10
LD	RSOV to left side of dash panel	mm	3211	3205	-6

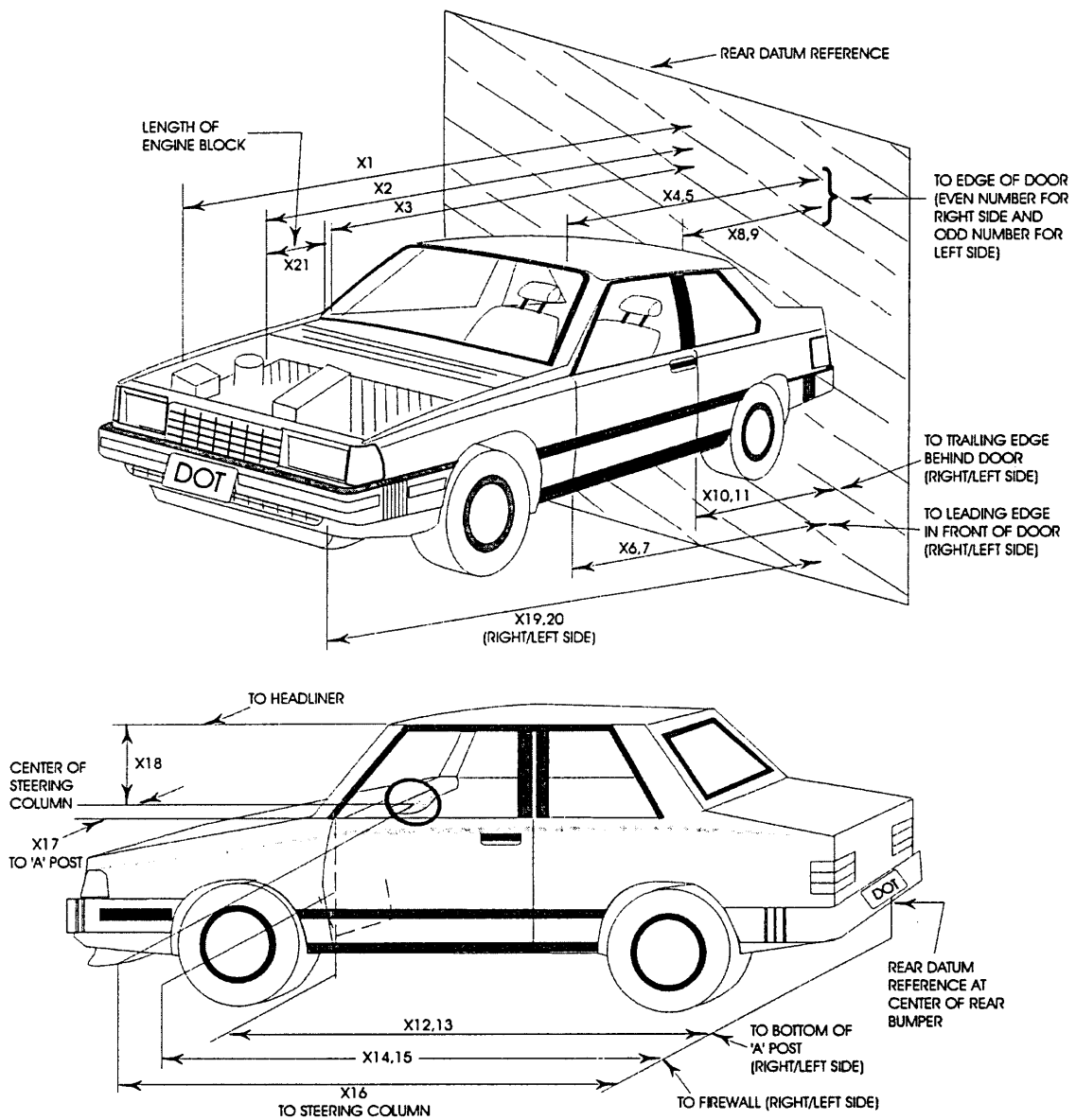

DATA SHEET NO. 15
CAMERA LOCATIONS

Test Vehicle: 2000 Ford Expedition 4WD 4 door SUV

NHTSA No.: FORD01

Test Program: 2000 NHTSA 40% Offset

Test Date: 8/15/00

No.	Camera View	Location (mm)			Angle (deg.)	Film Plane to Head	Lens (mm)	Speed (fr/sec)
		X	Y	Z				
1	Left Side, Real Time	7620	10290	956	1	12750	Zoom	24
2	Left Side, Overall	940	8250	1100	1	7750	12	*
3	Left Side, Close-Up	1140	8400	1570	3	8450	24	1020
4	Left Side, Above Vehicle	1025	8465	3190	16	8000	19	990
5	Left Side, Above Vehicle	1020	8450	2770	13	8020	19	1000
6	Right Side, Overall	1060	8300	975	3	7900	13	1000
7	Right Side, Close-up	600	0	5486	90	7950	24	970
8	Right Side, Over shoulder	7000	9200	2970	8	9980	40	960
9	Right Side, Close-up	5	11500	1800	1	N/A	25	1030
10	Overhead, Overall	1830	8500	1600	3	N/A	19	1000
11	Overhead, Close-Up	90	15	6300	90	N/A	85	1000
12	Front, Driver	1490	210	2700	29	N/A	19	1250
13	Front, Passenger	1490	460	2700	27	N/A	19	1250
14	Pit engine	60	200	-1500	90	N/A	13	960
15	Pit barrier	40	0	1410	15	N/A	25	970
16	Right side, tank view	4150	9900	10	1	N/A	63	640
17	Onboard, Driver	3800	260	1685	12	1300	13	440
18	Onboard, Passenger	3805	390	1685	12	1280	13	380
19	Right Side Close-up	10	8600	1060	2	N/A	13	*

X - Barrier Face Y - Monorail Centerline Z - Ground

* No timing marks

DATA SHEET NO. 16

PHOTOGRAPHIC REFERENCE TARGET LOCATIONS

Test Vehicle: 2000 Ford Expedition 4WD 4 door SUV

NHTSA No.: FORD01

Test Program: 2000 NHTSA 40% Offset

Test Date: 8/15/00

All Dimensions

in mm

Item	Value
A	432
B	1001
C	2303
D	610
E	2302
F	155
G	1875
H	1465
I	1556
J	960
K	965
L	1711
M	1465
N	1712
O	959
P	969
Q	1548

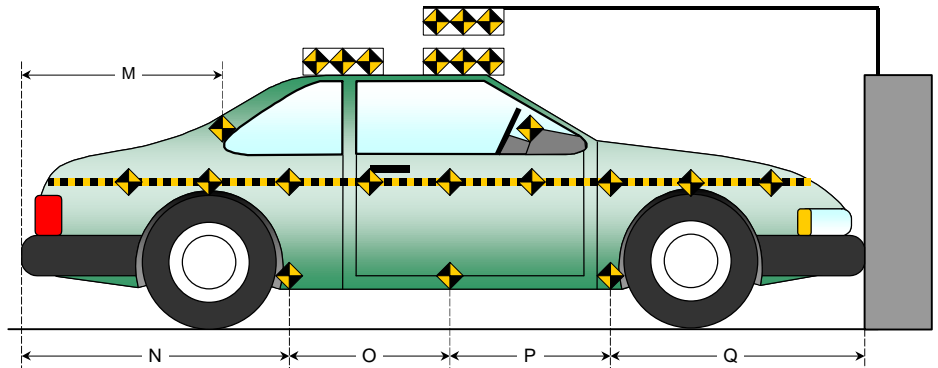
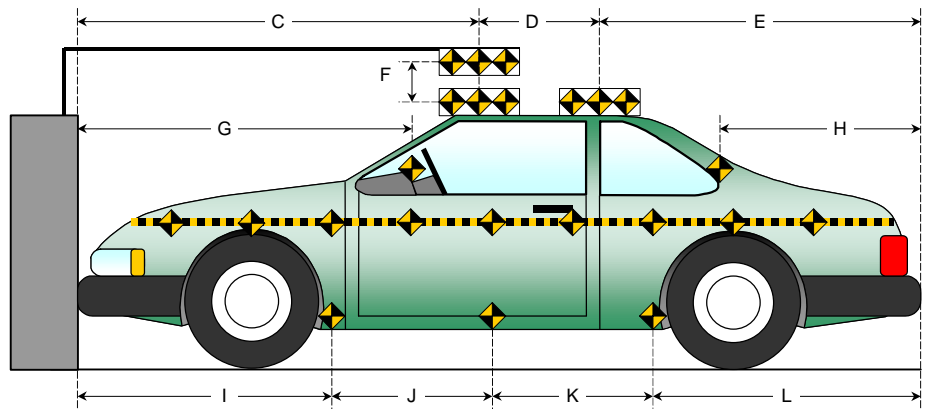
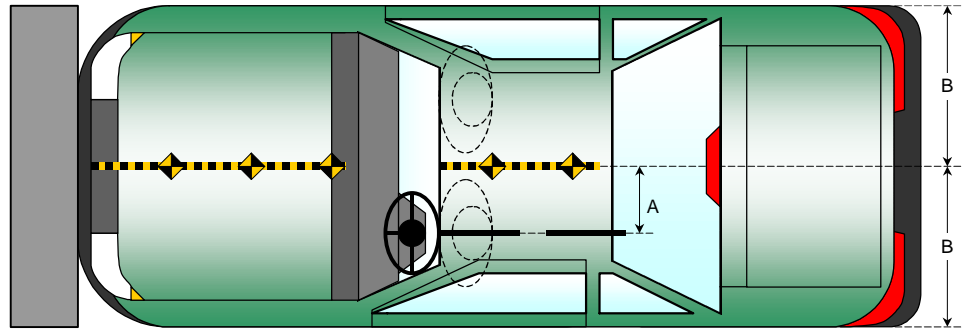

DATA SHEET NO. 17

VEHICLE INTRUSION MEASUREMENTS

Test Vehicle: 2000 Ford Expedition 4WD 4 door SUV

NHTSA No.: FORD01

Test Program: 2000 NHTSA 40% Offset

Test Date: 8/15/00

DOOR OPENING WIDTH

Item	Description	Units	Pre-Test	Post-Test	Difference
A	Left Side Upper	mm	1012	966	-46
B	Left Side Lower	mm	954	904	-50
D	Right Side Upper	mm	1009	1016	7
E	Right Side Lower	mm	954	961	7

WHEELBASE MEASUREMENTS

Item	Description	Units	Pre-Test	Post-Test	Difference
C	Left Side Wheel base	mm	3035	2545	-490
F	Right Side Wheel base	mm	3025	3110	85

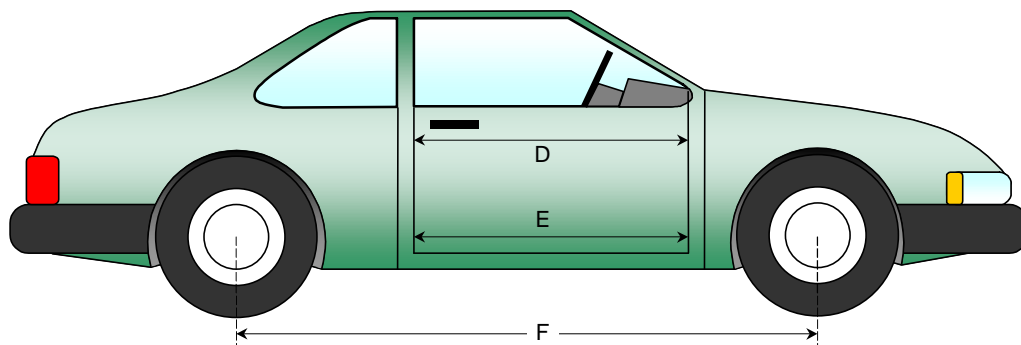
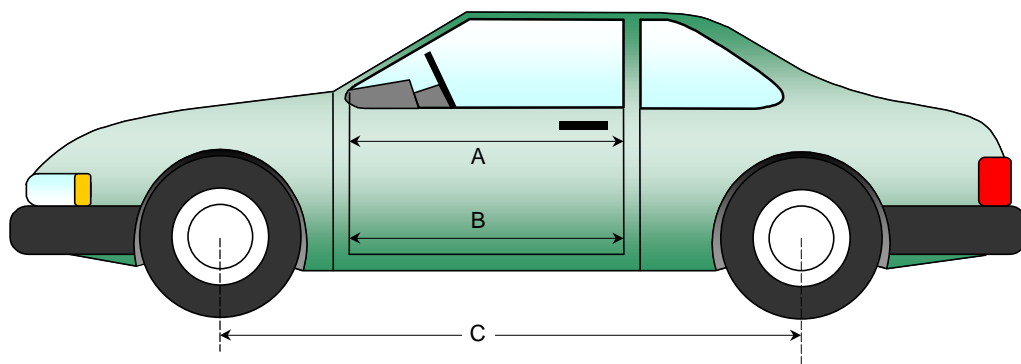

DATA SHEET NO. 17...(CONTINUED)
VEHICLE INTRUSION MEASUREMENTS

Test Vehicle: 2000 Ford Expedition 4WD 4 door SUV
 Test Program: 2000 NHTSA 40% Offset

NHTSA No.: FORD01
 Test Date: 8/15/00

DRIVER COMPARTMENT INTRUSION

Item	Description	Units	Pre-Test	Post-Test	Difference
AB	Door Opening (Inside window jam)	mm	1012	966	-46
CX	Left Knee Bolster to X	mm	300	310	10
DX	Right Knee Bolster to X	mm	306	290	-16
EX	Brake Pedal to X	mm	565	375	-190
FX	Foot Rest to X	mm	550	390	-160
GX	Center of Steering Wheel Hub to X	mm	86	135	49

X = Left Front Seat Outboard Anchor Bolt Head

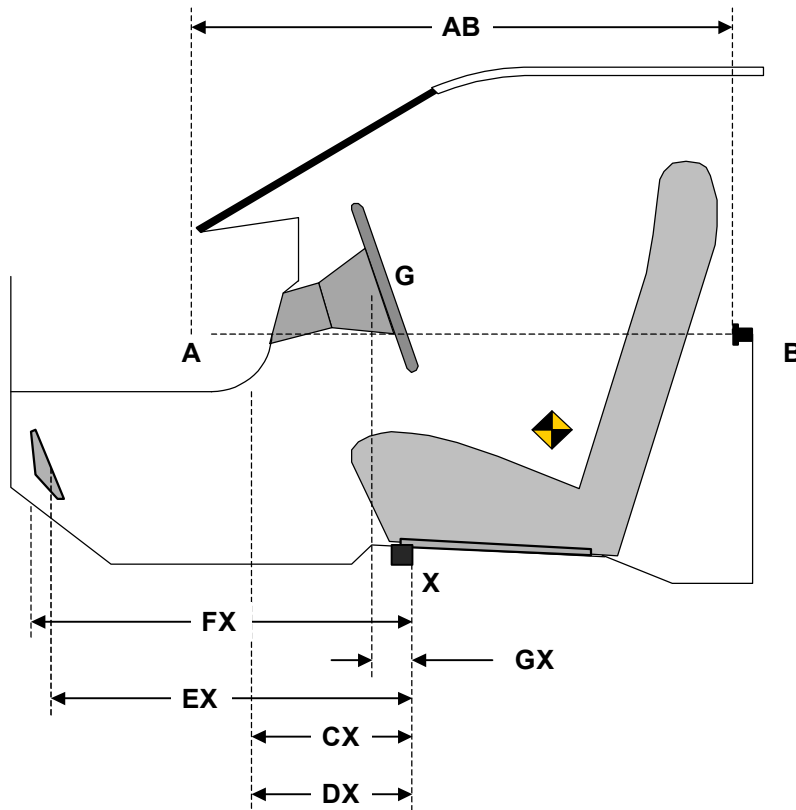

DRIVER COMPARTMENT

DATA SHEET NO. 17...(CONTINUED)
VEHICLE INTRUSION MEASUREMENTS

Test Vehicle: 2000 Ford Expedition 4WD 4 door SUV

NHTSA No.: FORD01

Test Program: 2000 NHTSA 40% Offset

Test Date: 8/15/00

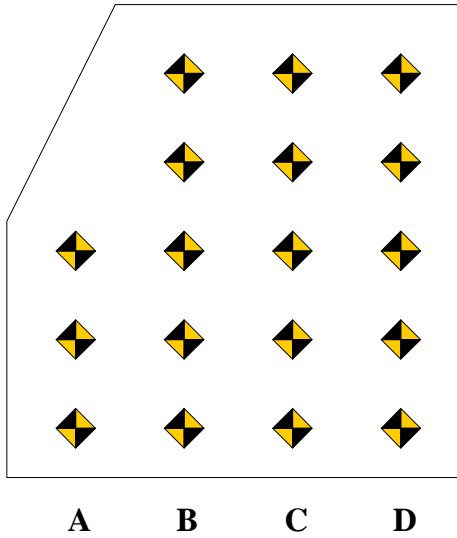

Measurement reference point for X and Z-axis is the forward outboard seat mounting bolt.

Columns A through D are evenly spaced.

Rows 1 and 2 are on the toe kick portion of the floor pan. Rows 3, 4, and 5 are located on the most level portion of the floor pan.

Row 3 will be at the intersection of the toe kick and the level sections of the floor pan.

DRIVER FLOOR PAN X-AXIS

	Pre-Test				Post-Test				Difference			
	A	B	C	D	A	B	C	D	A	B	C	D
1		701	693	696		391	391	394		-310	-302	-302
2		606	598	601		317	324	343		-289	-274	-258
3	503	503	498	501	289	304	332	346	-214	-199	-166	-155
4	401	405	398	401	224	264	268	276	-177	-141	-130	-125
5	301	303	299	301	169	178	181	191	-132	-125	-118	-110

DRIVER FLOOR PAN Z-AXIS

	Pre-Test				Post-Test				Difference			
	A	B	C	D	A	B	C	D	A	B	C	D
1		17	13	13		219	215	206		202	202	193
2		-23	-20	-27		153	138	121		176	158	148
3	-58	-58	-62	-62	81	67	55	54	139	125	117	116
4	-65	-65	-63	-63	10	6	-4	2	75	71	59	65
5	-64	-65	-65	-65	-75	-70	-50	-44	-11	-5	15	21

DATA SHEET NO. 17...(CONTINUED)
VEHICLE INTRUSION MEASUREMENTS

Test Vehicle: 2000 Ford Expedition 4WD 4 door SUV
 Test Program: 2000 NHTSA 40% Offset

NHTSA No.: FORD01
 Test Date: 8/15/00

Measurement reference point for X and Z-axis is the forward outboard seat mounting bolt.

Columns A through D are evenly spaced.

Rows 1 and 2 are on the toe kick portion of the floor pan. Rows 3, 4, and 5 are located on the most level portion of the floor pan.

Row 3 will be at the intersection of the toe kick and the level sections of the floor pan.

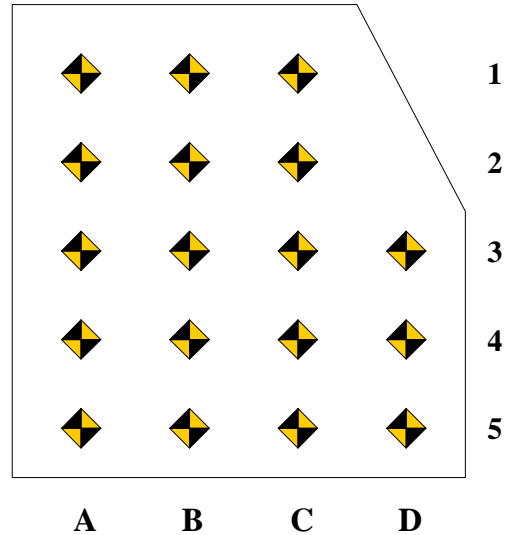

PASSENGER FLOOR PAN X-AXIS

	Pre-Test				Post-Test				Difference			
	A	B	C	D	A	B	C	D	A	B	C	D
1	677	663	681		498	517	644		-179	-146	-37	
2	581	566	583		403	438	547		-178	-128	-36	
3	477	466	483	479	323	335	447	458	-154	-131	-36	-21
4	379	367	383	381	325	337	347	360	-54	-30	-36	-21
5	281	265	281	281	230	235	245	260	-51	-30	-36	-21

PASSENGER FLOOR PAN Z-AXIS

	Pre-Test				Post-Test				Difference			
	A	B	C	D	A	B	C	D	A	B	C	D
1	15	8	2		-22	-65	-80		-37	-73	-82	
2	-32	-40	-38		-87	-130	-120		-55	-90	-82	
3	-62	-62	-62	-69	-128	-162	-148	-133	-66	-100	-86	-64
4	-65	-65	-65	-64	-155	-160	-140	-120	-90	-95	-75	-56
5	-63	-62	-60	-60	-152	-150	-130	-103	-89	-88	-70	-43

DATA SHEET NO. 18

DEFORMABLE BARRIER DIMENSIONS AND ORIENTATION

Test Vehicle: 2000 Ford Expedition 4WD 4 door SUV

NHTSA No.: FORD01

Test Program: 2000 NHTSA 40% Offset

Test Date: 8/15/00

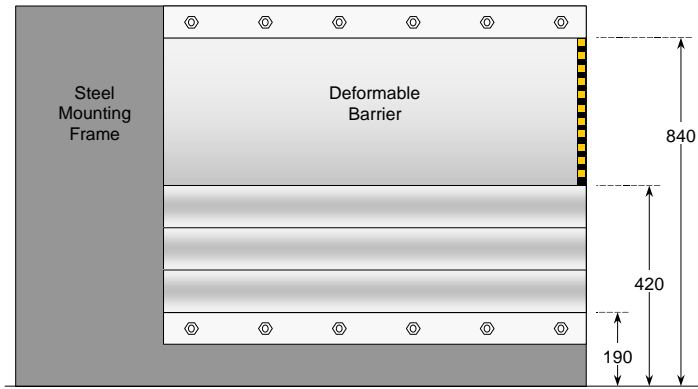

FRONT VIEW

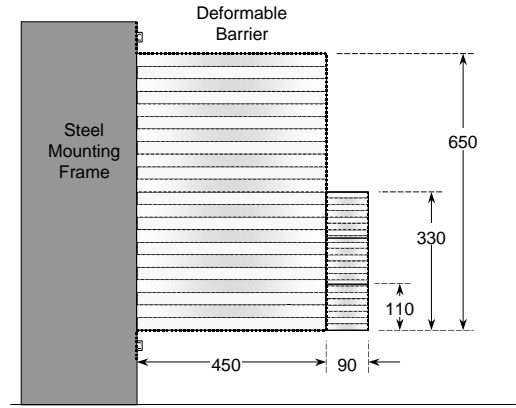

LEFT SIDE VIEW

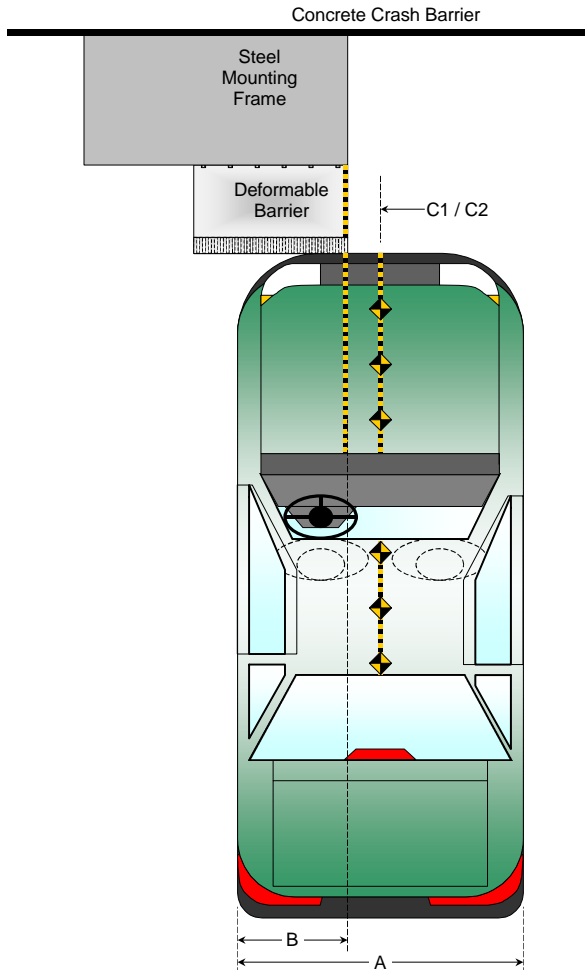

Item	Measured Parameter	Value
A	Vehicle Width at Widest Point	2002 *
B	40% Offset From Left Edge	801
C1	Impact Point Left of C_L	200
C2	Actual Impact Point Left of C_L	195

All Dimensions in mm

* Width does not include the vehicles bolt-on running boards.

**DATA SHEET NO. 19
ACCIDENT INVESTIGATION DATA**

Test Vehicle: 2000 Ford Expedition 4WD 4 door SUV
 Test Program: 2000 NHTSA 40% Offset

NHTSA No.: FORD01
 Test Date: 8/15/00

VEHICLE INFORMATION

VIN: 1FMRU1665YLA82245
 Vehicle Size Category: SUV

Wheel base (mm): 3035
 Test Weight (kg): 2874

ACCELEROMETER DATA

Accelerometer Location: Left Sill
 Cal. Procedure/Interval: 6 months / drop test
 Integration Algorithm: NHTSA Standard
 Impact Velocity (km/h): 59.82
 Velocity Change (km/h): 72.47

Linearity: Good

Time of Separation (msec): 142.6

CRUSH PROFILE

Collision Deformation Classification: 12FYEW8 Midpoint of Damage: Vehicle Driver Side
 Damage Region Length (mm): 1715 Impact Mode: 40% Offset

No.	Measurement Description	Units	Pre-Test	Post-Test	Difference
C1	Crush zone 1 at left side	mm	280	1320	-1040
C2	Crush zone 2 on left side	mm	66	920	-854
C3	Crush zone 3 on left side	mm	7	850	-843
C4	Crush zone 4 on right side	mm	7	535	-528
C5	Crush zone 5 on right side	mm	66	220	-154
C6	Crush zone 6 at right side	mm	280	-15	295

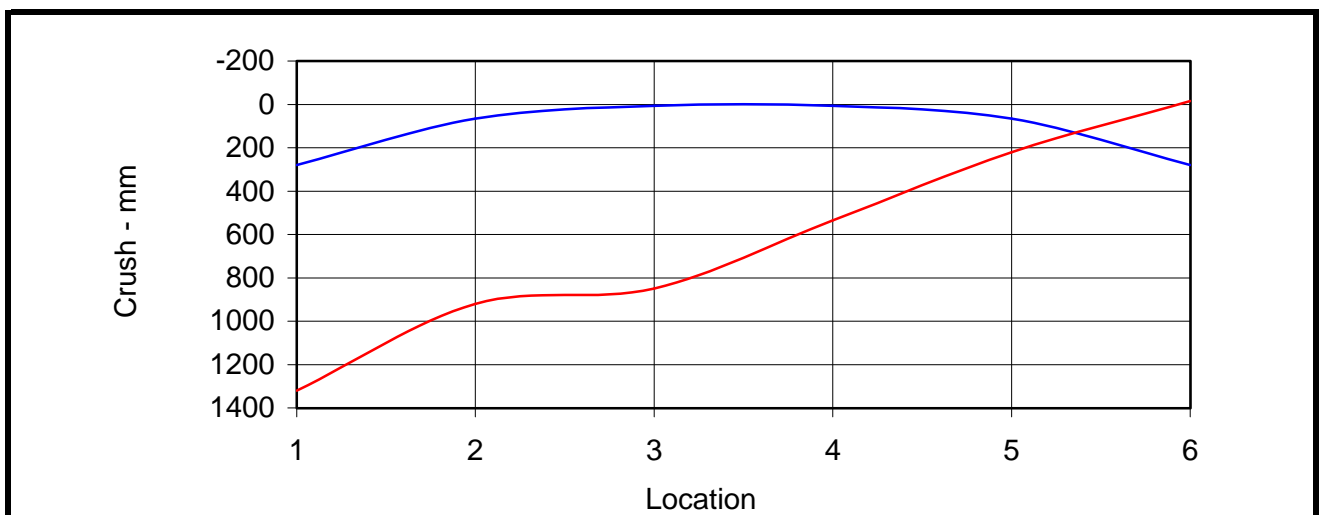

DATA SHEET NO. 20

DUMMY/ VEHICLE TEMPERATURE STABILIZATION

Test Vehicle: 2000 Ford Expedition 4WD 4 door SUV

NHTSA No.: FORD01

Test Program: 2000 NHTSA 40% Offset

Test Date: 8/15/00

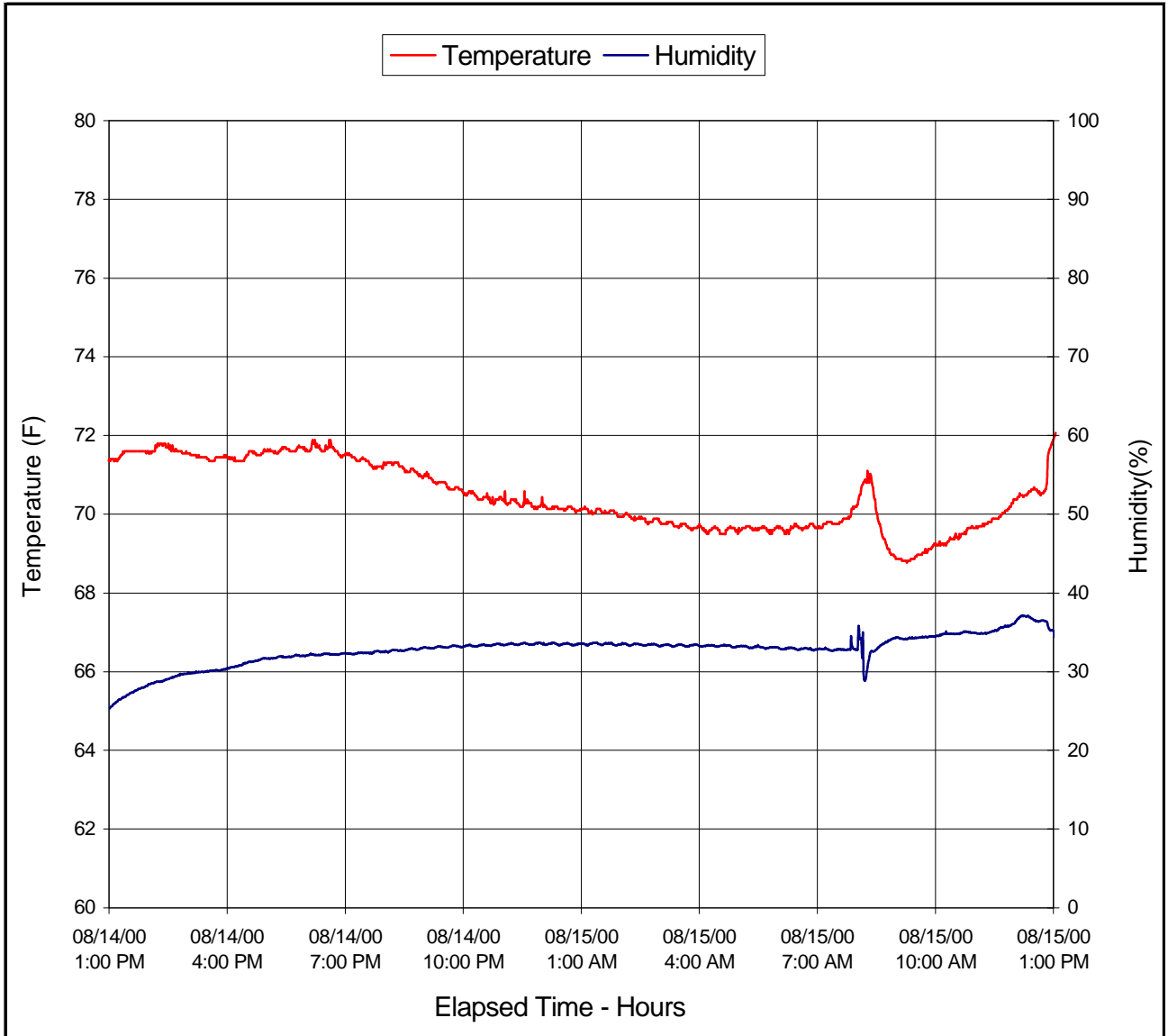

APPENDIX A
PHOTOGRAPHS

LIST OF PHOTOGRAPHS

Figure		Page
A-1	Left Front, as Received	A-1
A-2	Right Rear, as Received	A-2
A-3	Vehicle Certification Label	A-3
A-4	Vehicle Tire Placard	A-4
A-5	Front View, Pre-Test	A-5
A-6	Front View, Post-Test	A-6
A-7	Left Side View, Pre-Test	A-7
A-8	Left Side View, Post-Test	A-8
A-9	Right Side View, Pre-Test	A-9
A-10	Right Side View, Post-Test	A-10
A-11	Left Front View, Pre-Test	A-11
A-12	Left Front View, Post-Test	A-12
A-13	Right Rear View, Pre-Test	A-13
A-14	Right Rear View, Post-Test	A-14
A-15	Windshield, Pre-Test	A-15
A-16	Windshield, Post-Test	A-16
A-17	Engine Compartment, Pre-Test	A-17
A-18	Engine Compartment, Post-Test	A-18
A-19	Fuel Cap, Pre-Test	A-19
A-20	Fuel Cap, Post-Test	A-20
A-21	Front Underside, Pre-Test	A-21
A-22	Front Underside, Post-Test	A-22
A-23	Rear Underside, Pre-Test	A-23
A-24	Rear Underside, Post-Test	A-24
A-25	Overhead Overall, Pre-Test	A-25
A-26	Overhead Overall, Post-Test	A-26
A-27	Overhead Close-Up, Pre-Test	A-27
A-28	Overhead Close-Up, Post-Test	A-28
A-29	Driver Dummy Through Window, Pre-Test	A-29
A-30	Driver Dummy Through Window, Post-Test	A-30
A-31	Driver Dummy Door Open, Pre-Test	A-31
A-32	Driver Dummy Door Open, Post-Test	A-32
A-33	Driver Dummy 90° To Vehicle, Pre-Test	A-33
A-34	Driver Dummy 90° To Vehicle, Post-Test	A-34
A-35	Driver Dummy Lower Legs, Pre-Test	A-35
A-36	Driver Dummy Lower Legs, Post-Test	A-36

LIST OF PHOTOGRAPHS...(Continued)

Figure		Page
A-37	Driver Side Floor Pan, Pre-Test	A-37
A-38	Driver Side Floor Pan, Post-Test	A-38
A-39	Driver Side Knee Bolster, Pre-Test	A-39
A-40	Driver Side Knee Bolster, Post-Test	A-40
A-41	Driver Head, Post-Test	A-41
A-42	Driver Dummy Head Contact, Post-Test	A-42
A-43	Passenger Dummy Through Window, Pre-Test	A-43
A-44	Passenger Dummy Through Window, Post-Test	A-44
A-45	Passenger Dummy Door Open, Pre-Test	A-45
A-46	Passenger Dummy Door Open, Post-Test	A-46
A-47	Passenger Dummy 90° To Vehicle, Pre-Test	A-47
A-48	Passenger Dummy 90° To Vehicle, Post-Test	A-48
A-49	Passenger Dummy Lower Legs, Pre-Test	A-49
A-50	Passenger Dummy Lower Legs, Post-Test	A-50
A-51	Passenger Side Floor Pan, Pre-Test	A-51
A-52	Passenger Side Floor Pan, Post-Test	A-52
A-53	Passenger Side Knee Bolster, Pre-Test	A-53
A-54	Passenger Side Knee Bolster, Post-Test	A-54
A-55	Passenger Head, Post-Test	A-55
A-56	Passenger Dummy Head Contact, Post-Test	A-56
A-57	Vehicle During Rollover	A-57
A-58	Vehicle During Impact	A-58
A-59	Deformable Barrier Front, Pre-Test	A-59
A-60	Deformable Barrier Front, Post-Test	A-60
A-61	Deformable Barrier Left Side, Pre-Test	A-61
A-62	Deformable Barrier Left Side, Post-Test	A-62
A-63	Deformable Barrier Right Side, Pre-Test	A-63
A-64	Deformable Barrier Right Side, Post-Test	A-64
A-65	Deformable Barrier Top, Pre-Test	A-65
A-66	Deformable Barrier Top, Post-Test	A-66
A-67	Torsion Bar Mount Fuel Tank Clearance, Side View, Pre-Test	A-67
A-68	Torsion Bar Mount Fuel Tank Clearance, Side View, Post-Test	A-68
A-69	Torsion Bar and Mount Intrusion Into Fuel Tank, Oblique View, Post-Test	A-69
A-70	Torsion Bar and Mount Intrusion Into Fuel Tank, Underside View Post-Test	A-70
A-71	Fuel Tank Rupture Close-Up After Removal From Vehicle, Post-Test	A-71



Figure A-1: Left Front, as Received



Figure A-2: Right Rear, as Received

MFD. BY FORD MOTOR CO. IN U.S.A.

DATE: 12/99

GVWR: 6980LB/ 3166KG

FRONT GAWR: 3500LB

REAR GAWR: 3900LB

1587KG

WITH

1769KG

P255/70R16SL

TIRES

P255/70R16SL

16X7.0J

RIMS

16X7.0J

AT 207 kPa/30

PSI COLD

AT 241 kPa/35

WITH

TIRES

RIMS

PSI COLD

THIS VEHICLE CONFORMS TO ALL APPLICABLE FEDERAL MOTOR
VEHICLE SAFETY STANDARDS IN EFFECT ON THE DATE OF
MANUFACTURE SHOWN ABOVE.

VIN: 1FMRU1665YLA82245

F0274

T0730

TYPE: MPV



EXT PNT:

YN

RC: 71

DSO:

WB BRK

INT TR

TP/PS

R AXLE

TR

SPR

0B316

119 4

FT

8 H9

U

15

C05

UTC

▽ F85B-1520472-AB

Figure A-3: Vehicle Certification Label

MFD. BY FORD MOTOR CO. IN U.S.A.

DATE: 12/99

GVWR: 6980LB/ 3166KG

FRONT GAWR: 3500LB

REAR GAWR: 3900LB

1587KG

WITH

1769KG

P255/70R16SL

TIRES

P255/70R16SL

16X7.0J

RIMS

16X7.0J

AT 207 kPa/30

PSI COLD

AT 241 kPa/35

WITH

TIRES

RIMS

PSI COLD

THIS VEHICLE CONFORMS TO ALL APPLICABLE FEDERAL MOTOR
VEHICLE SAFETY STANDARDS IN EFFECT ON THE DATE OF
MANUFACTURE SHOWN ABOVE.

VIN: 1FMRU1665YLA82245

F0274

T0730

TYPE: MPV



EXT PNT:

YN

RC: 71

DSO:

WB BRK

INT TR

TP/PS

R AXLE

TR

SPR

0B316

119 4

FT

8 H9

U 15

C05

UTC

▽ F85B-1520472-AB

Figure A-4: Vehicle Tire Placard



Figure A-5: Front View, Pre-Test



Figure A-6: Front View, Post-Test



Figure A-7: Left Side View, Pre-Test



Figure A-8: Left Side View, Post-Test



Figure A-9: Right Side View, Pre-Test



Figure A-10: Right Side View, Post-Test



Figure A-11: Left Front View, Pre-Test



Figure A-12: Left Front View, Post-Test



Figure A-13: Right Rear View, Pre-Test



Figure A-14: Right Rear View, Post-Test

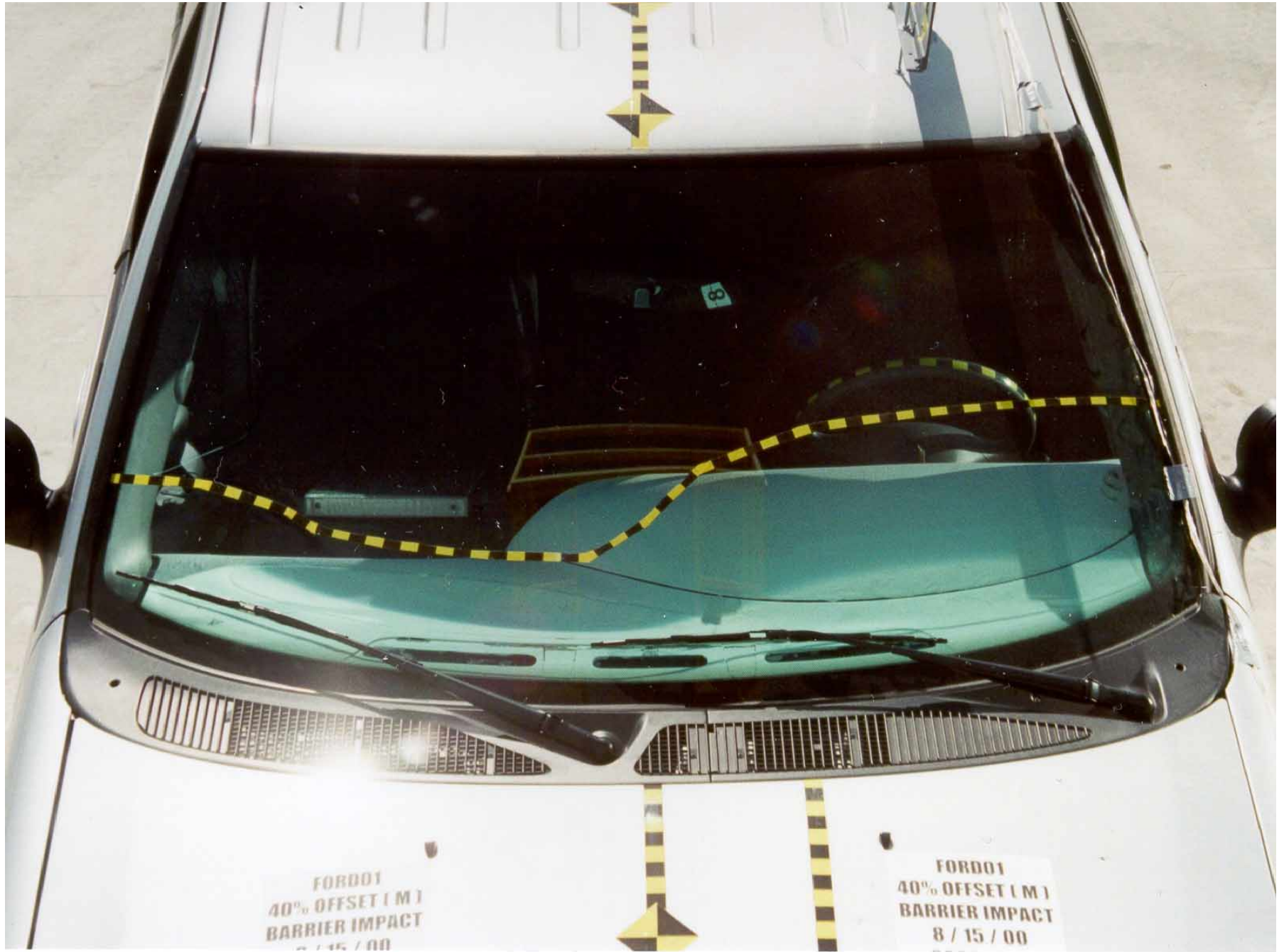

Figure A-15: Windshield, Pre-Test



Figure A-16: Windshield, Post-Test

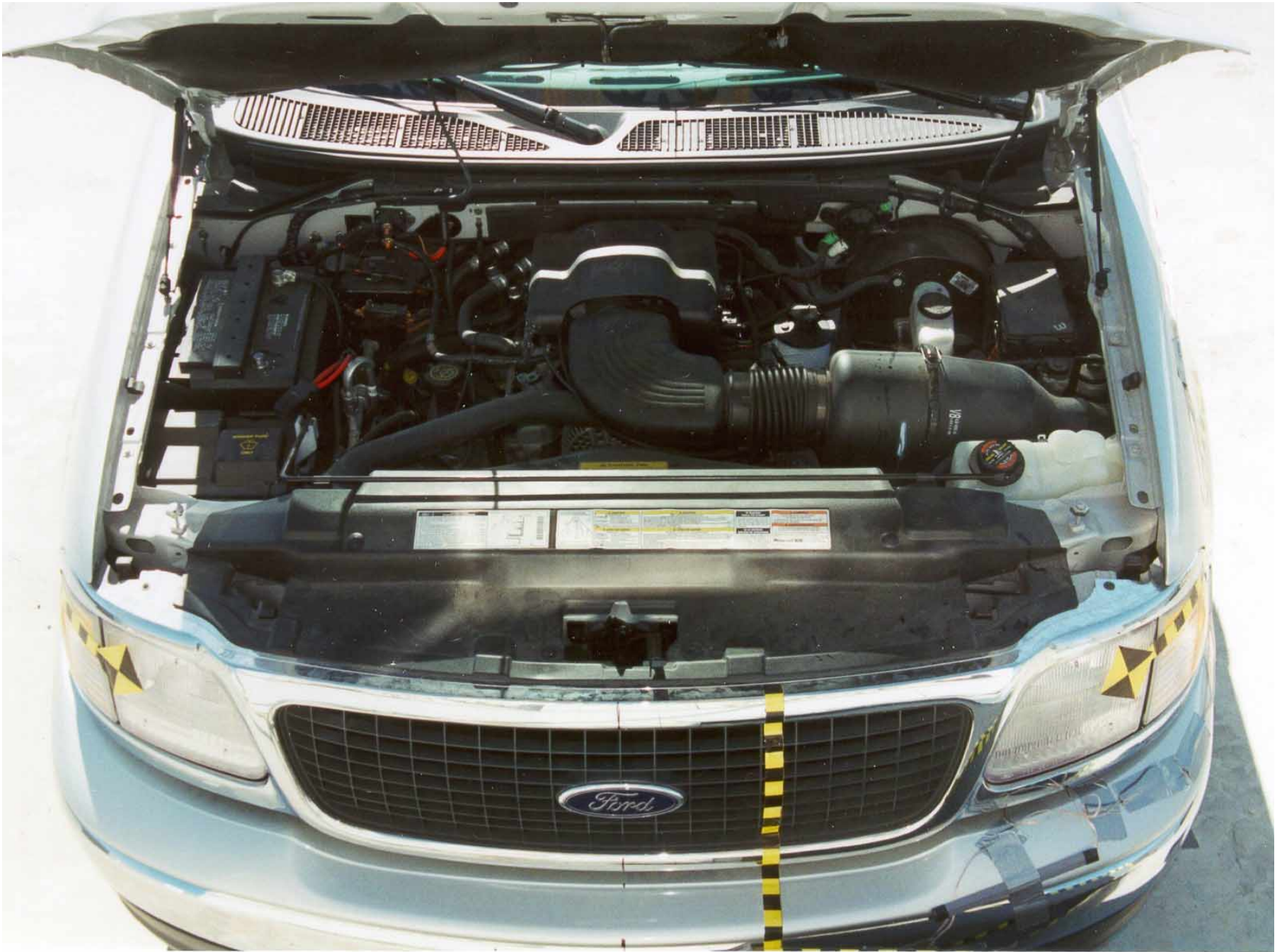

Figure A-17: Engine Compartment, Pre-Test



Figure A-18: Engine Compartment, Post-Test



Figure A-19: Fuel Cap, Pre-Test



Figure A-20: Fuel Cap, Post-Test

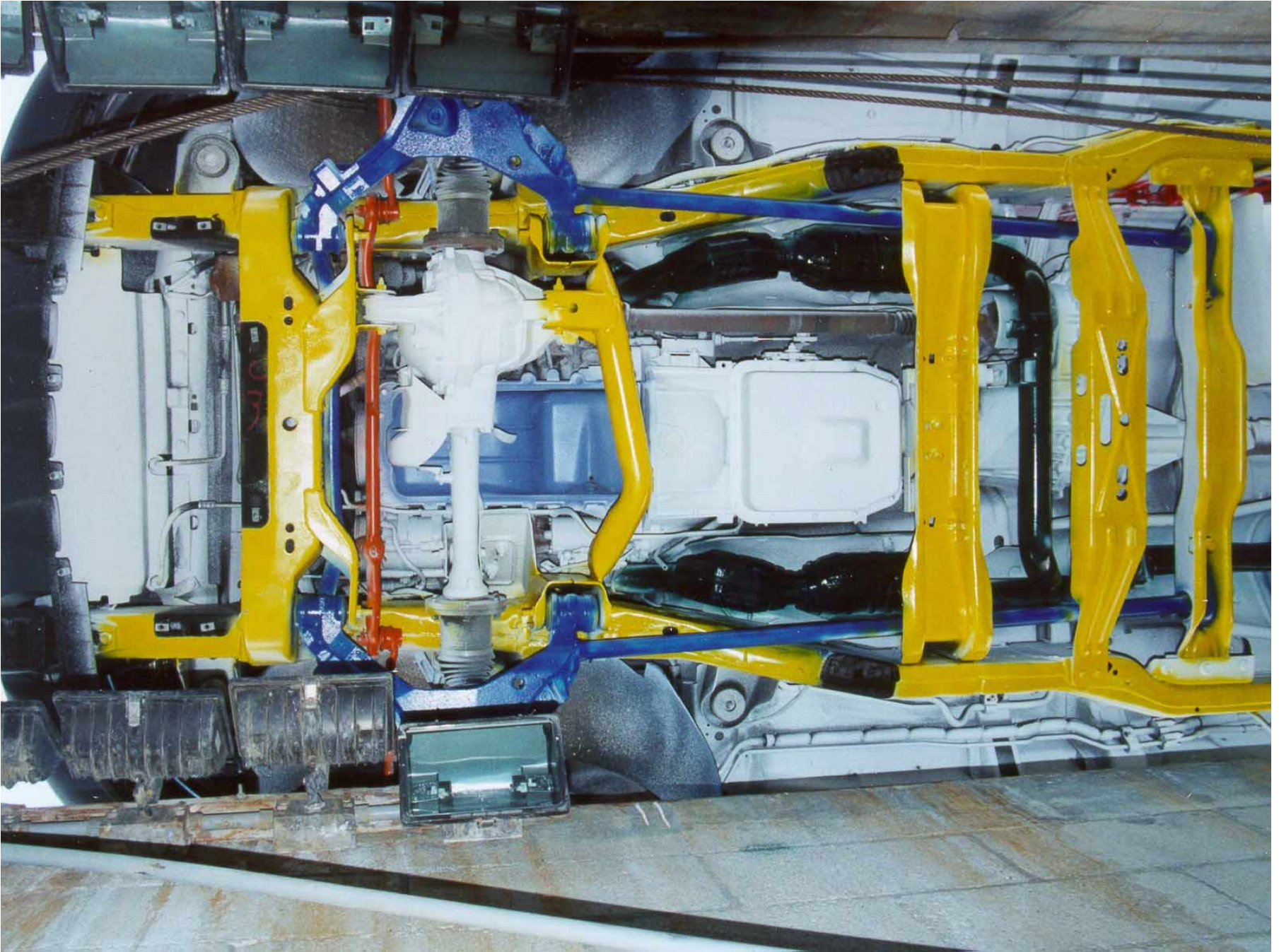

Figure A-21: Front Underside, Pre-Test

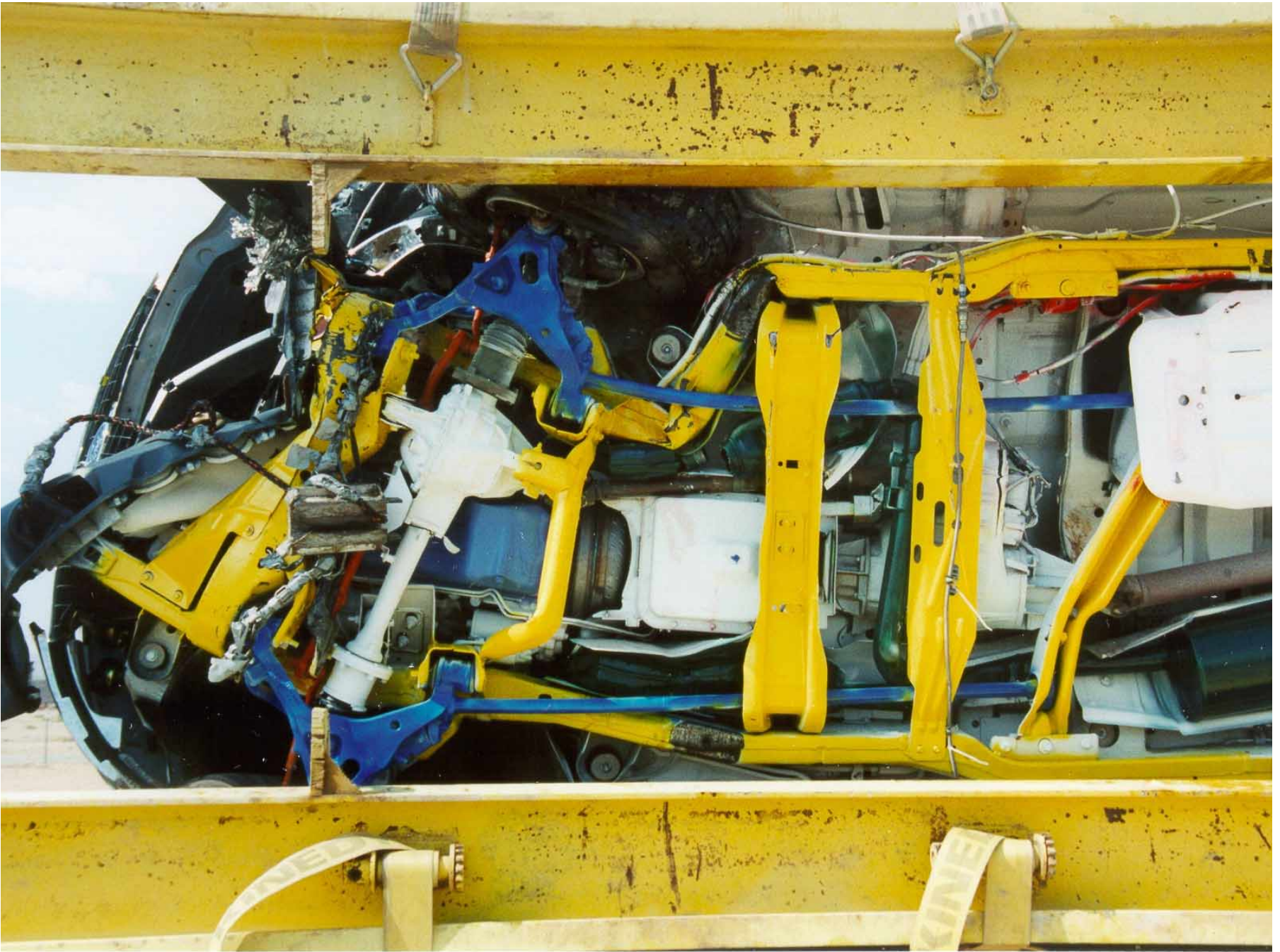

Figure A-22: Front Underside, Post-Test

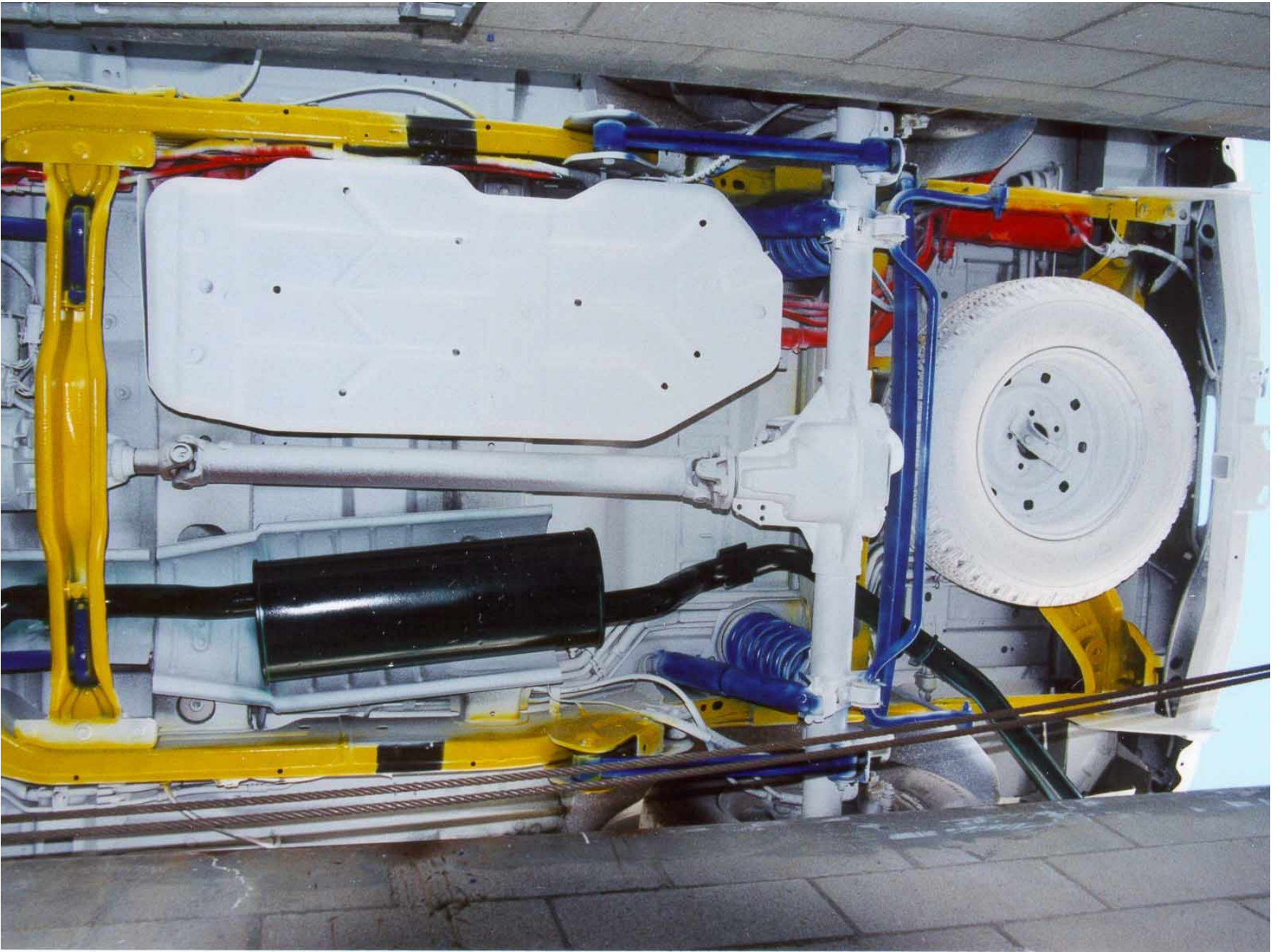

Figure A-23: Rear Underside, Pre-Test

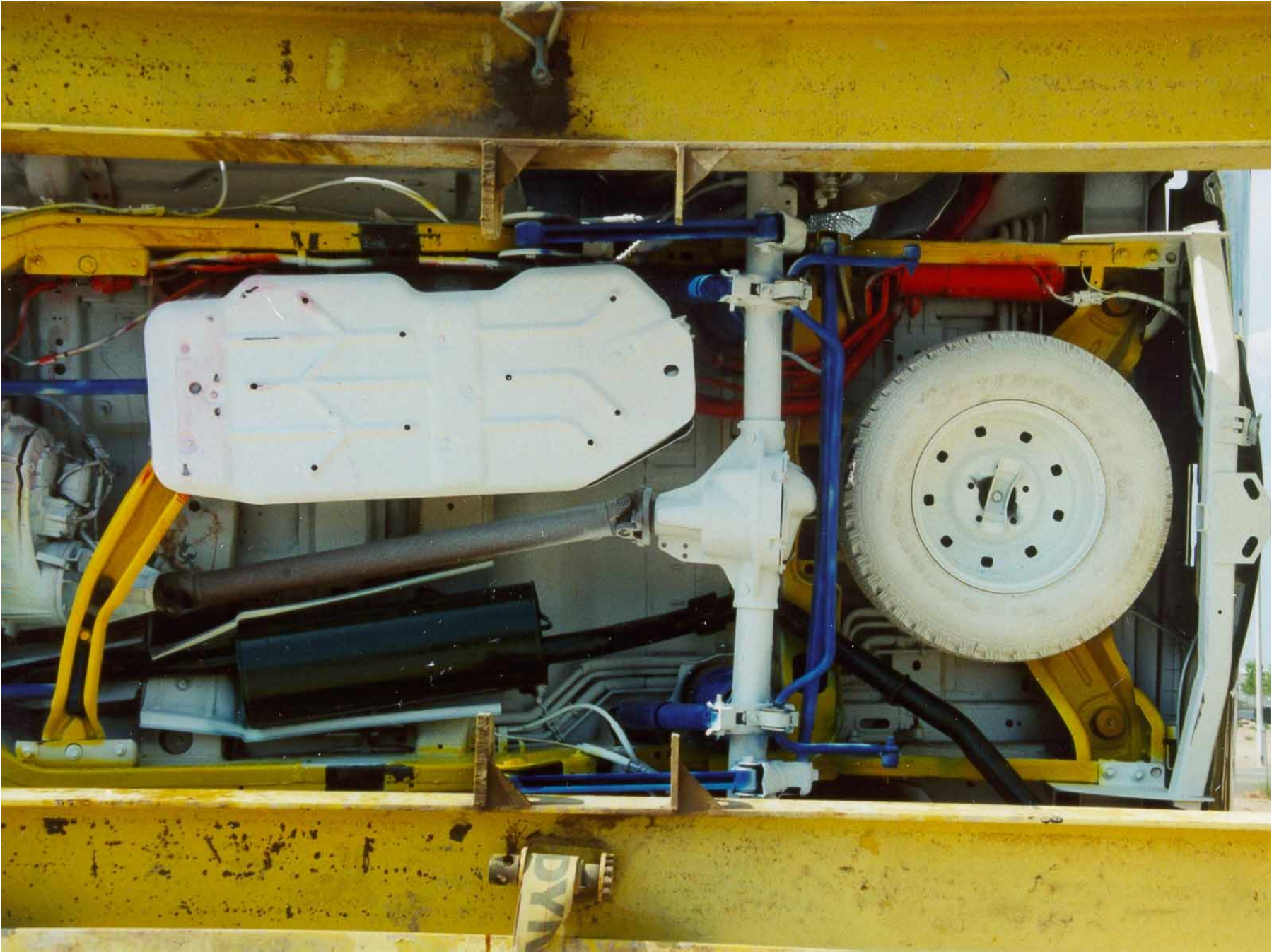

Figure A-24: Rear Underside, Post-Test

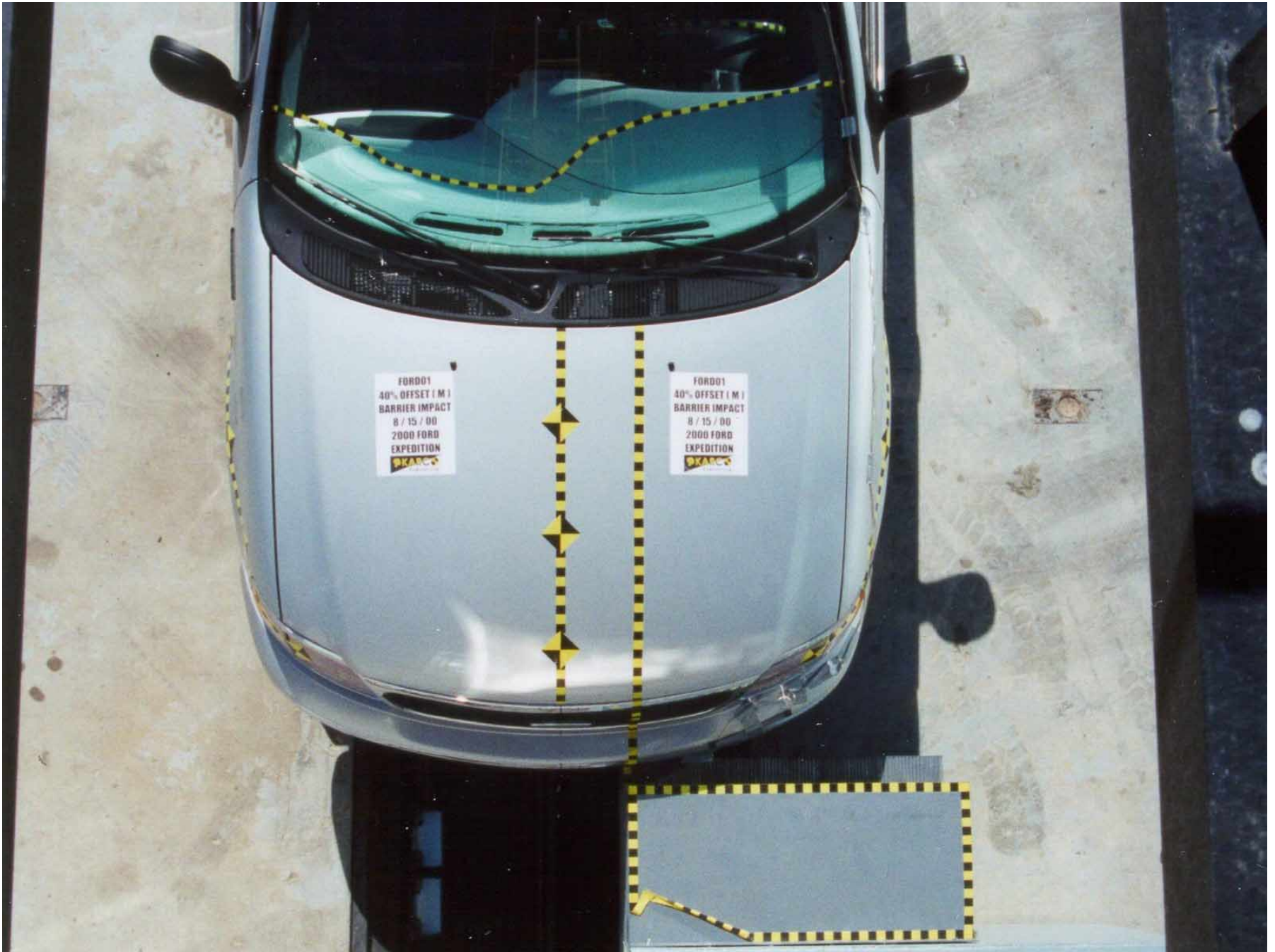

Figure A-25: Overhead Overall, Pre-Test



Figure A-26: Overhead Overall, Post-Test



Figure A-27: Overhead Overall Close-Up, Pre-Test



Figure A-28: Overhead Overall Close-Up, Post-Test



Figure A-29: Driver Dummy Through Window, Pre-Test



Figure A-30: Driver Dummy Through Window, Post-Test



Figure A-31: Driver Dummy Door Open, Pre-Test



Figure A-32: Driver Dummy Door Open, Post-Test



Figure A-33: Driver Dummy 90° To Vehicle, Pre-Test



Figure A-34: Driver Dummy 90° To Vehicle, Post-Test



Figure A-35: Driver Dummy Lower Legs, Pre-Test



Figure A-36: Driver Dummy Lower Legs, Post-Test



Figure A-37: Driver Side Floor Pan, Pre-Test



Figure A-38: Driver Side Floor Pan, Post-Test



Figure A-39: Driver Side Knee Bolster, Pre-Test

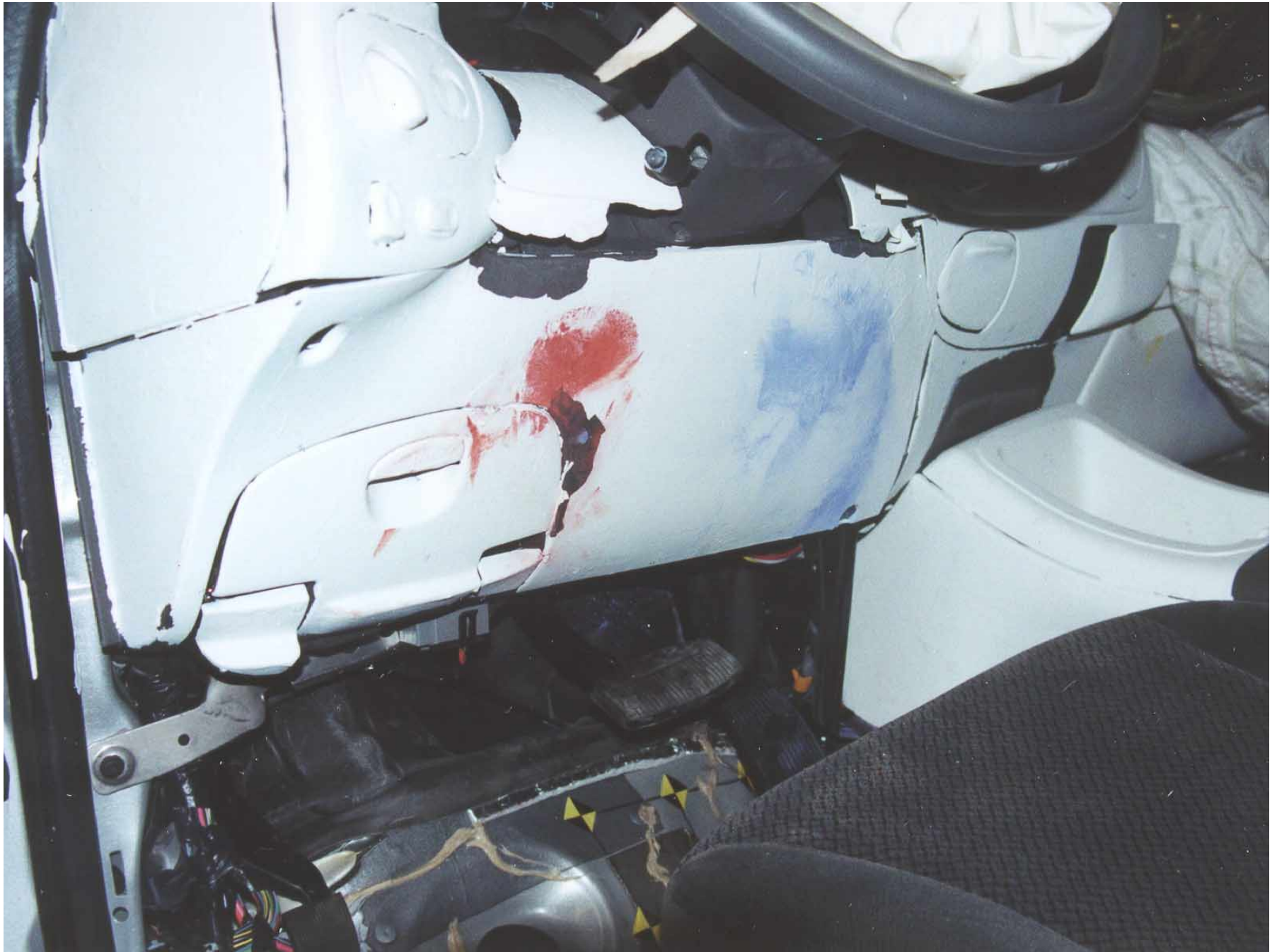

Figure A-40: Driver Side Knee Bolster, Post-Test



Figure A-41: Driver Dummy Head, Post-Test



Figure A-42: Driver Dummy Head Contact, Post-Test



Figure A-43: Passenger Dummy Through Window, Pre-Test



Figure A-44: Passenger Dummy Through Window, Post-Test



Figure A-45: Passenger Dummy Door Open, Pre-Test



Figure A-46: Passenger Dummy Door Open, Post-Test

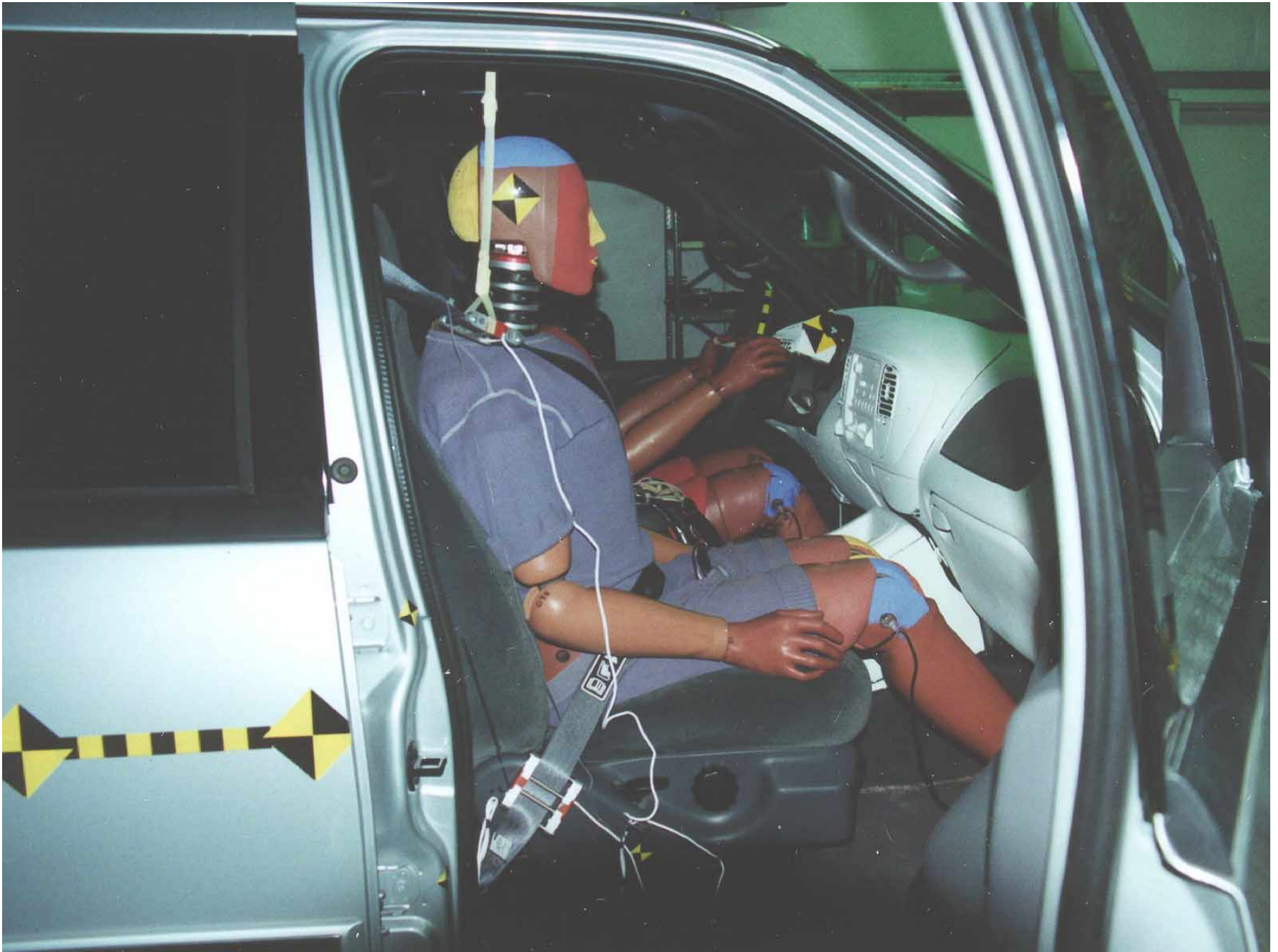

Figure A-47: Passenger Dummy 90° To Vehicle, Pre-Test



Figure A-48: Passenger Dummy 90° To Vehicle, Post-Test

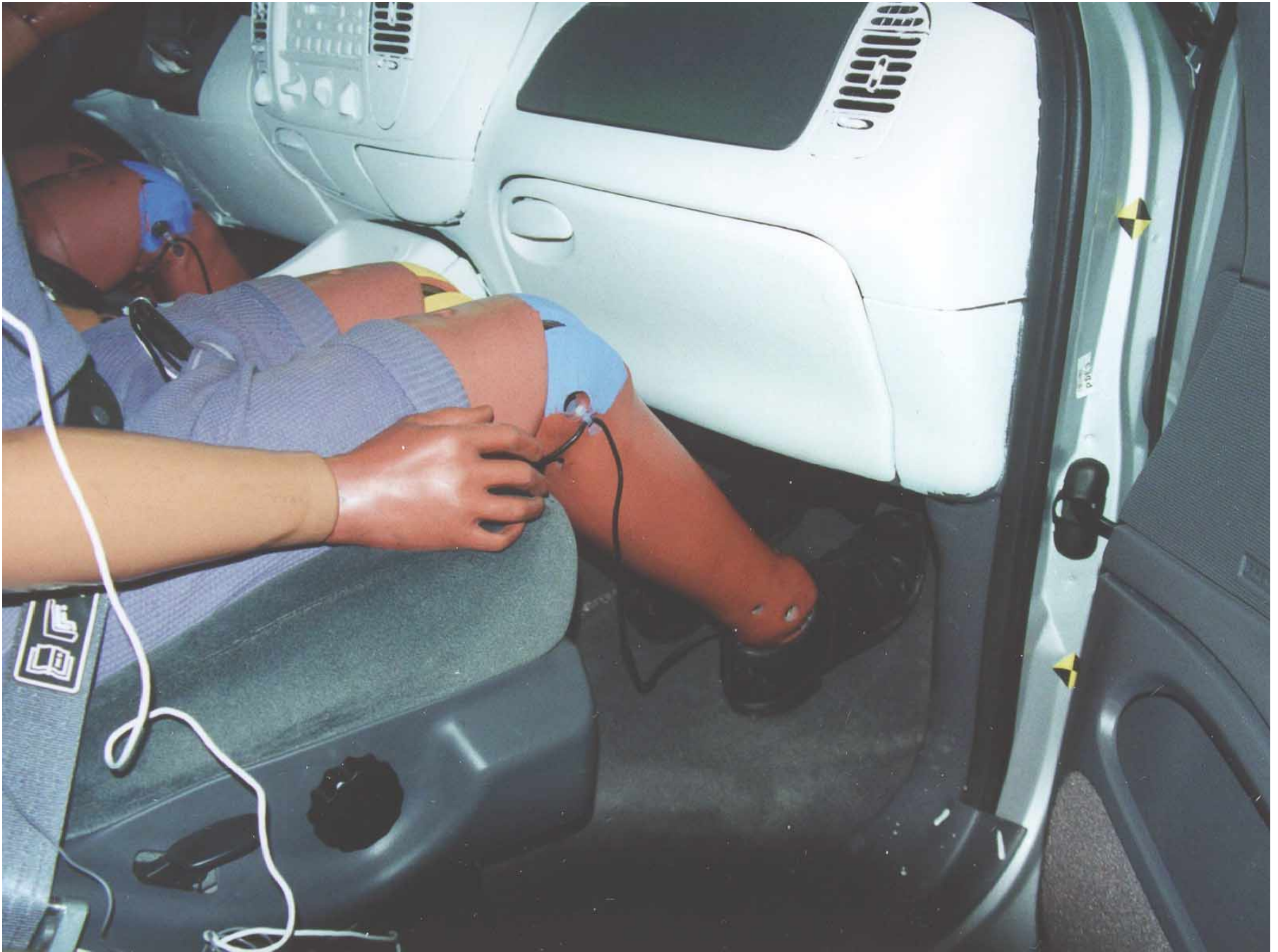

Figure A-49: Passenger Dummy Lower Legs, Pre-Test



Figure A-50: Passenger Dummy Lower Legs, Post-Test



Figure A-51: Passenger Side Floor Pan, Pre-Test



Figure A-52: Passenger Side Floor Pan, Post-Test

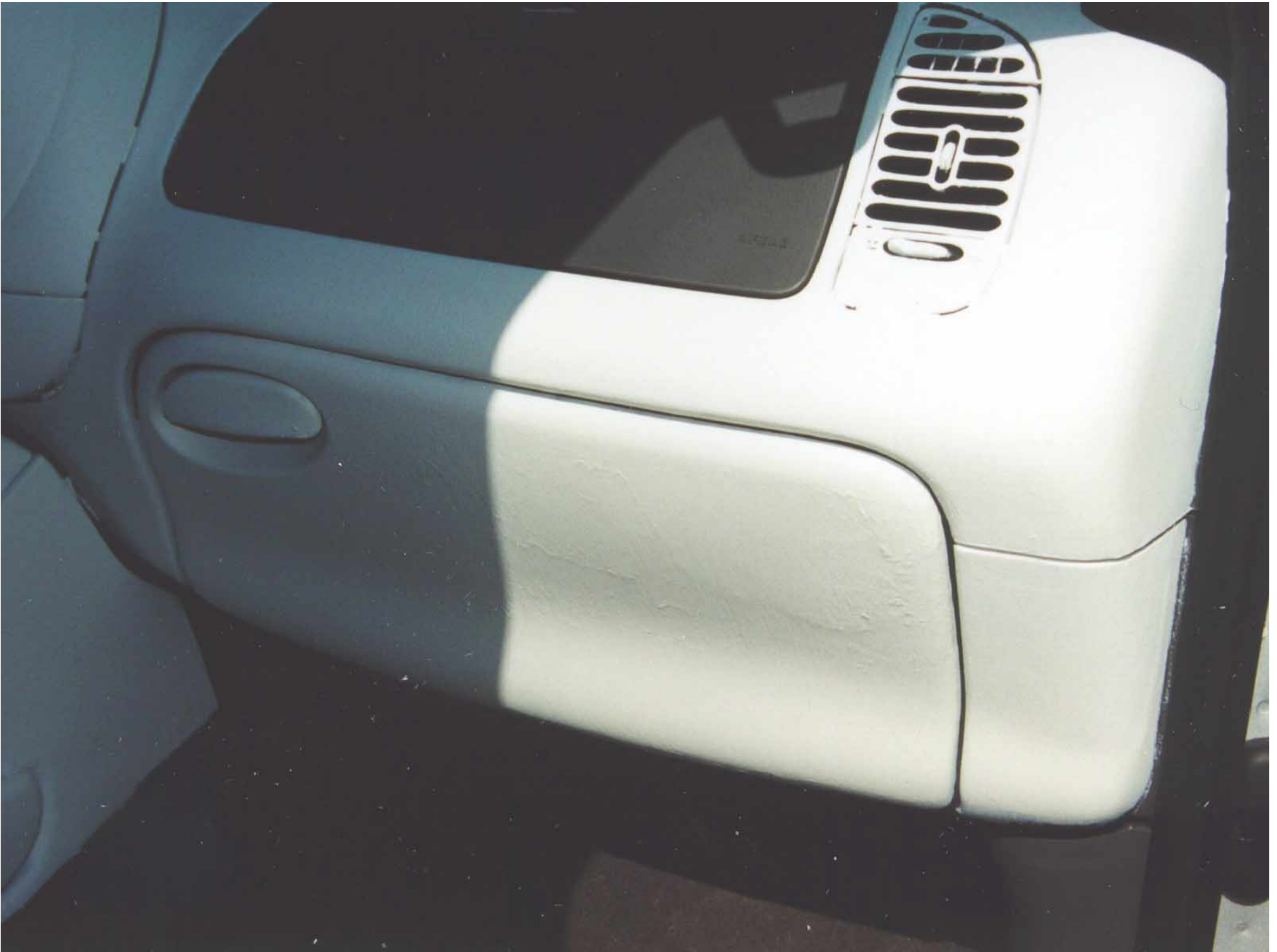

Figure A-53: Passenger Side Knee Bolster, Pre-Test



Figure A-54: Passenger Side Knee Bolster, Post-Test



Figure A-55: Passenger Head, Post-Test

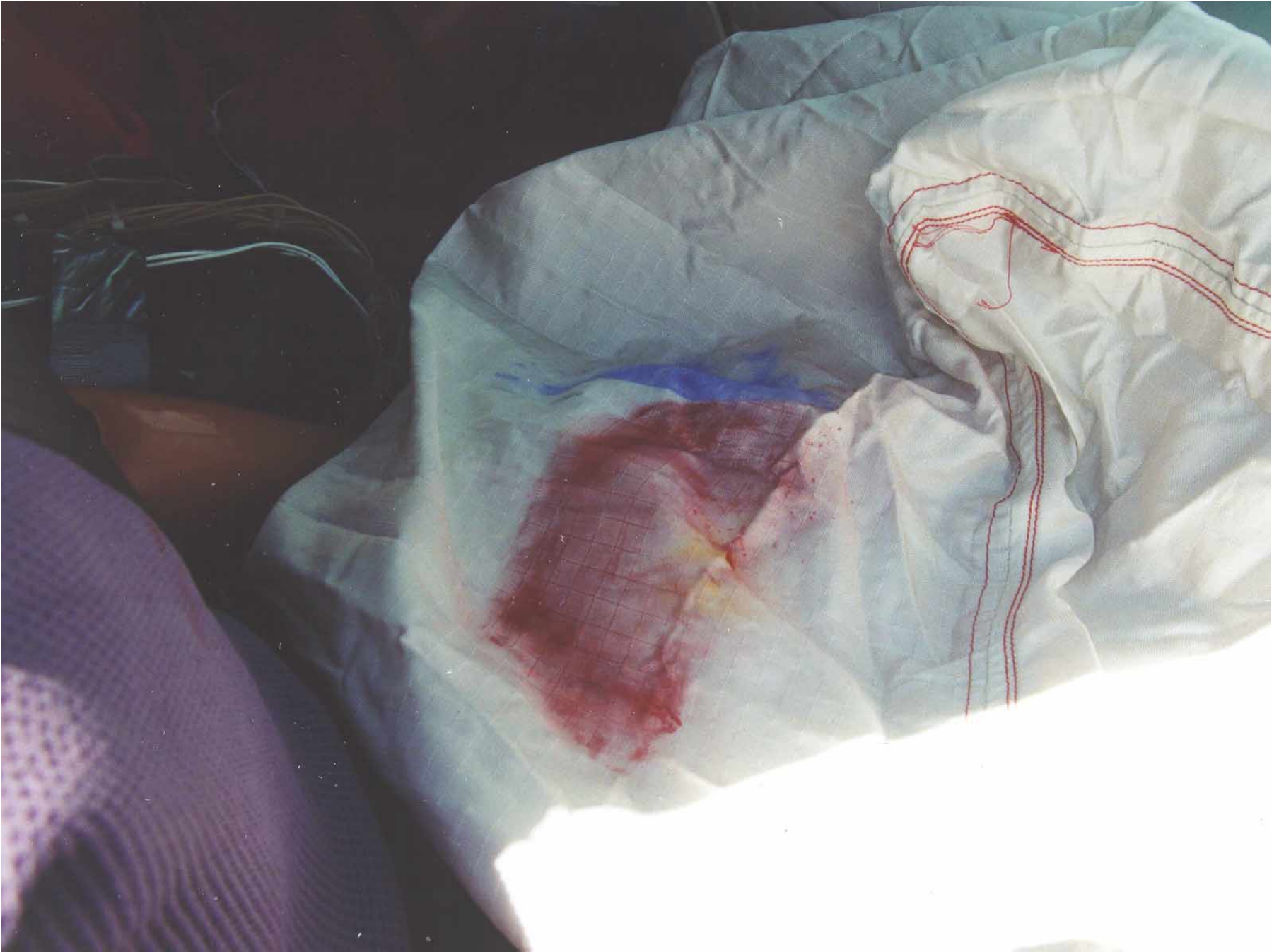

Figure A-56: Passenger Dummy Head Contact, Post-Test



Figure A-57: Vehicle During Rollover



Figure A-58: Vehicle During Impact



Figure A-59: Deformable Barrier Front, Pre-Test

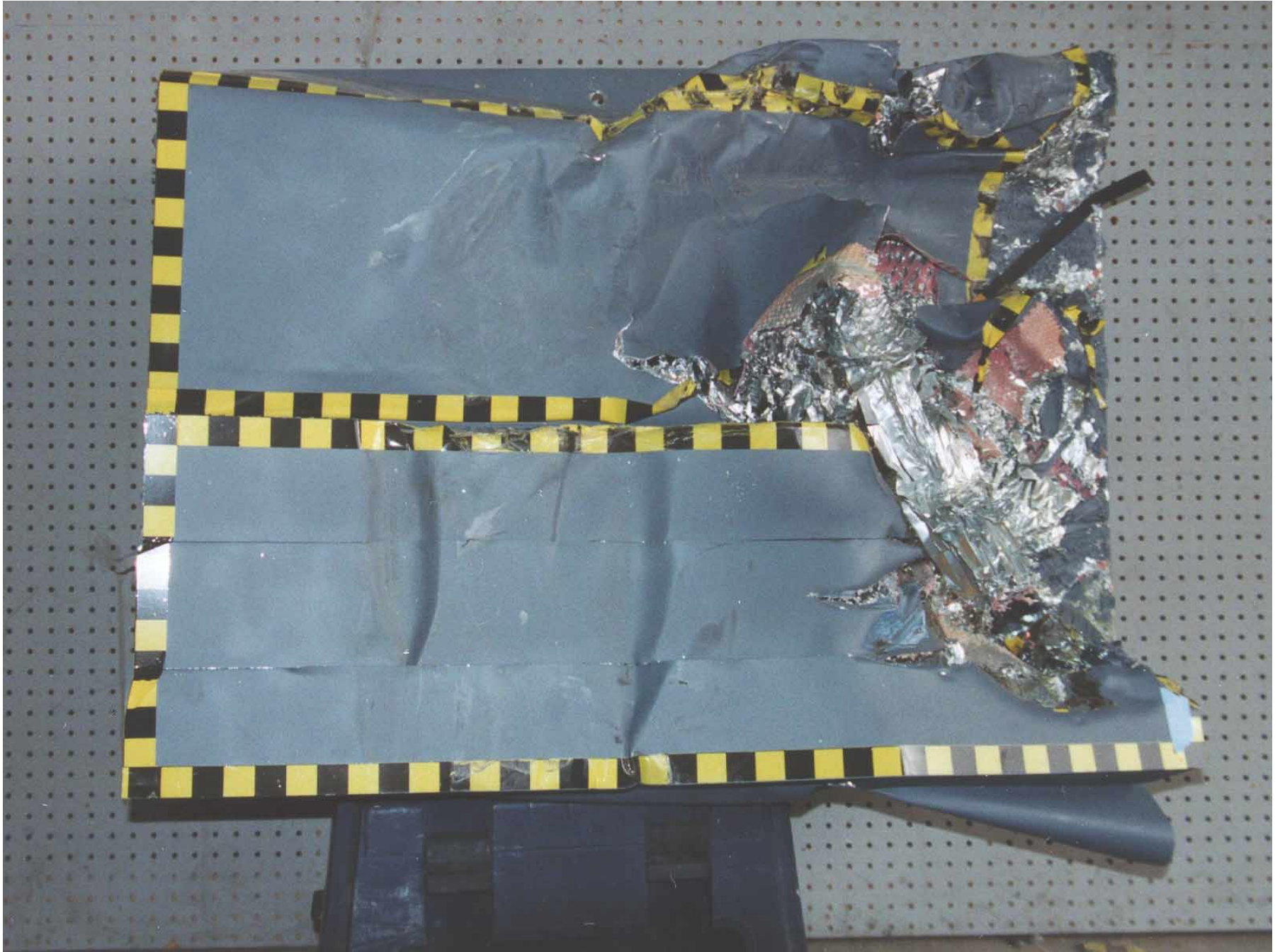

Figure A-60: Deformable Barrier Front, Post-Test

A-60

KAR20002-02

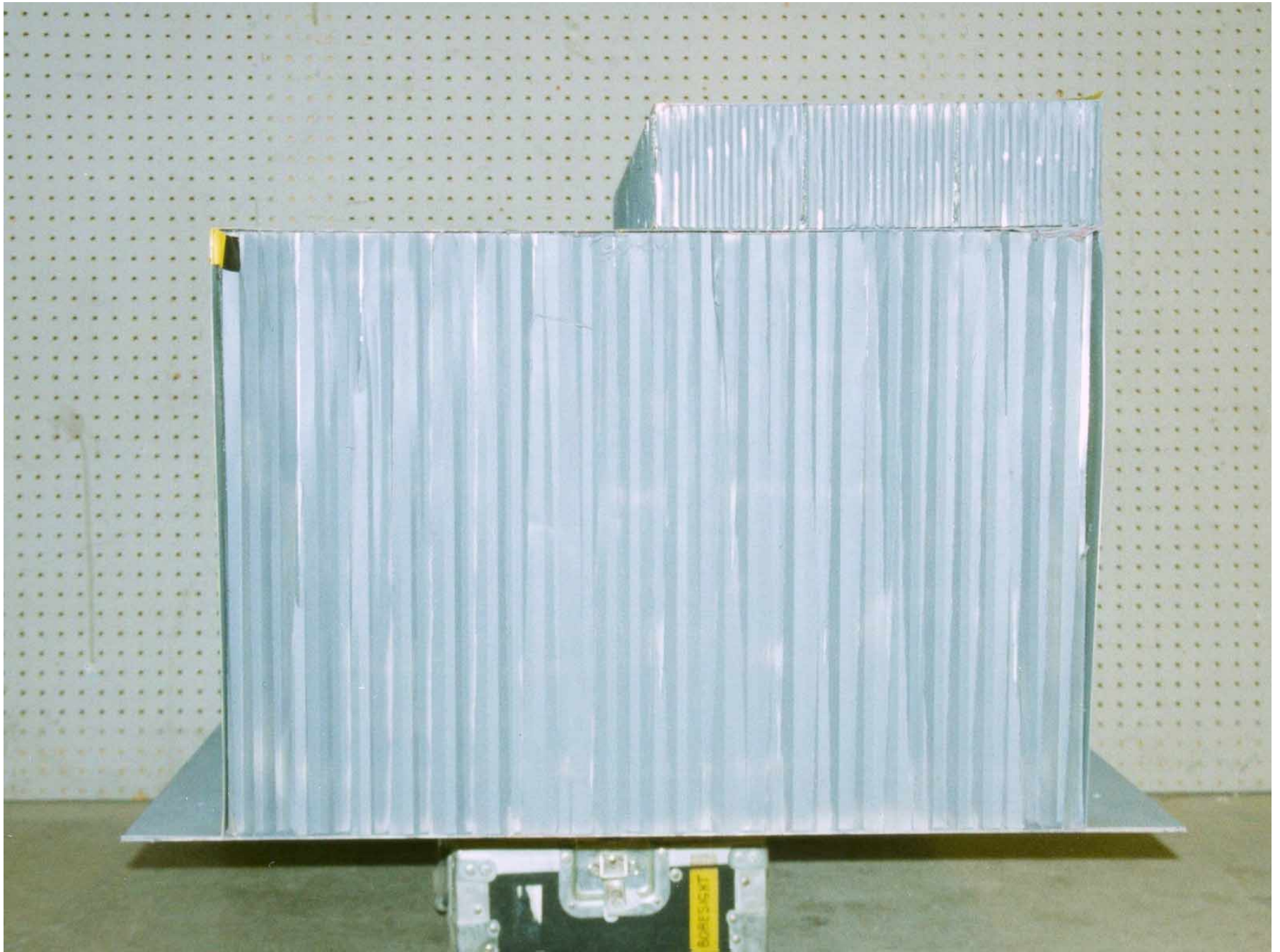

Figure A-61: Deformable Barrier Left Side, Pre-Test

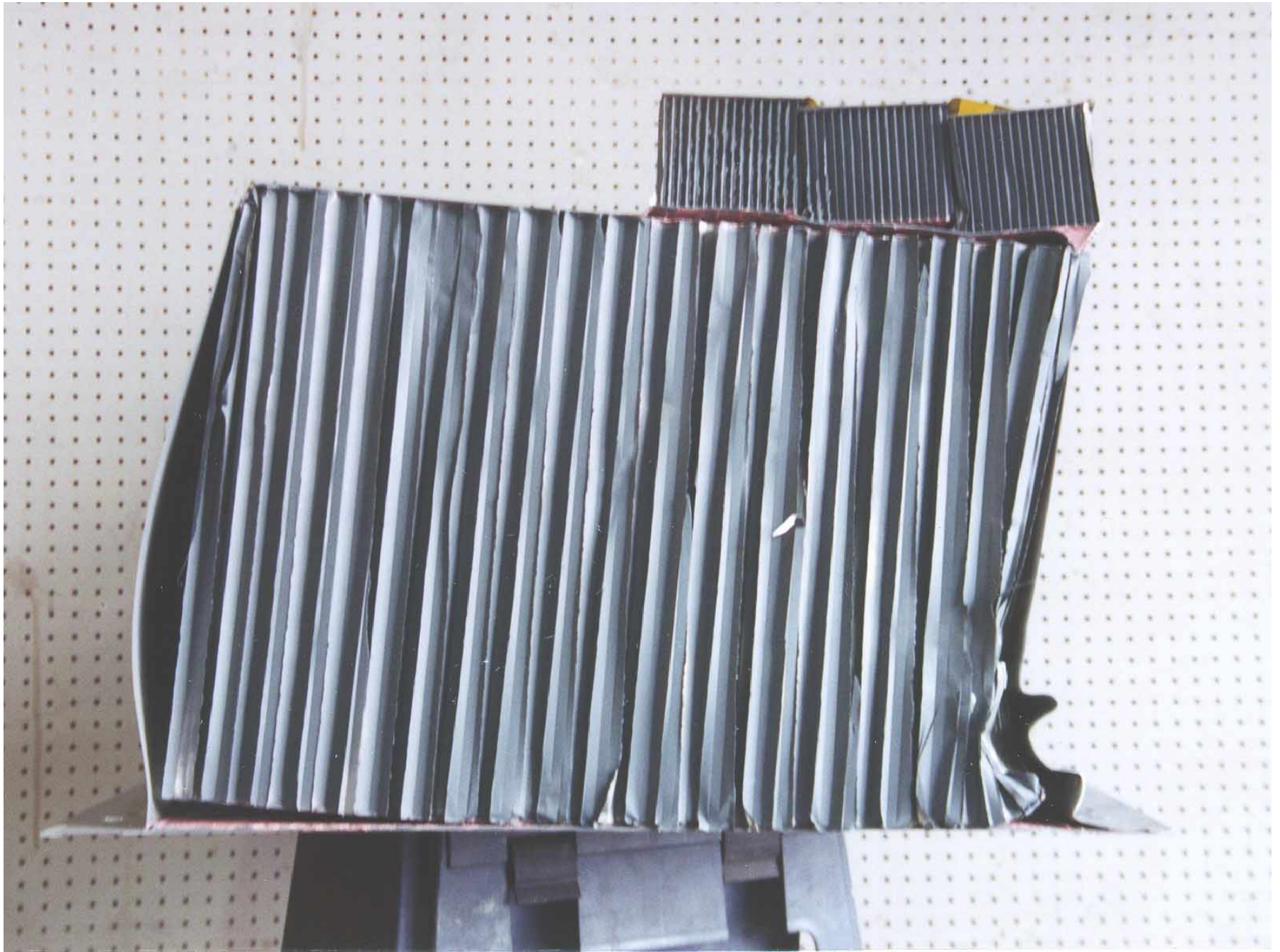

Figure A-62: Deformable Barrier Left Side, Post-Test

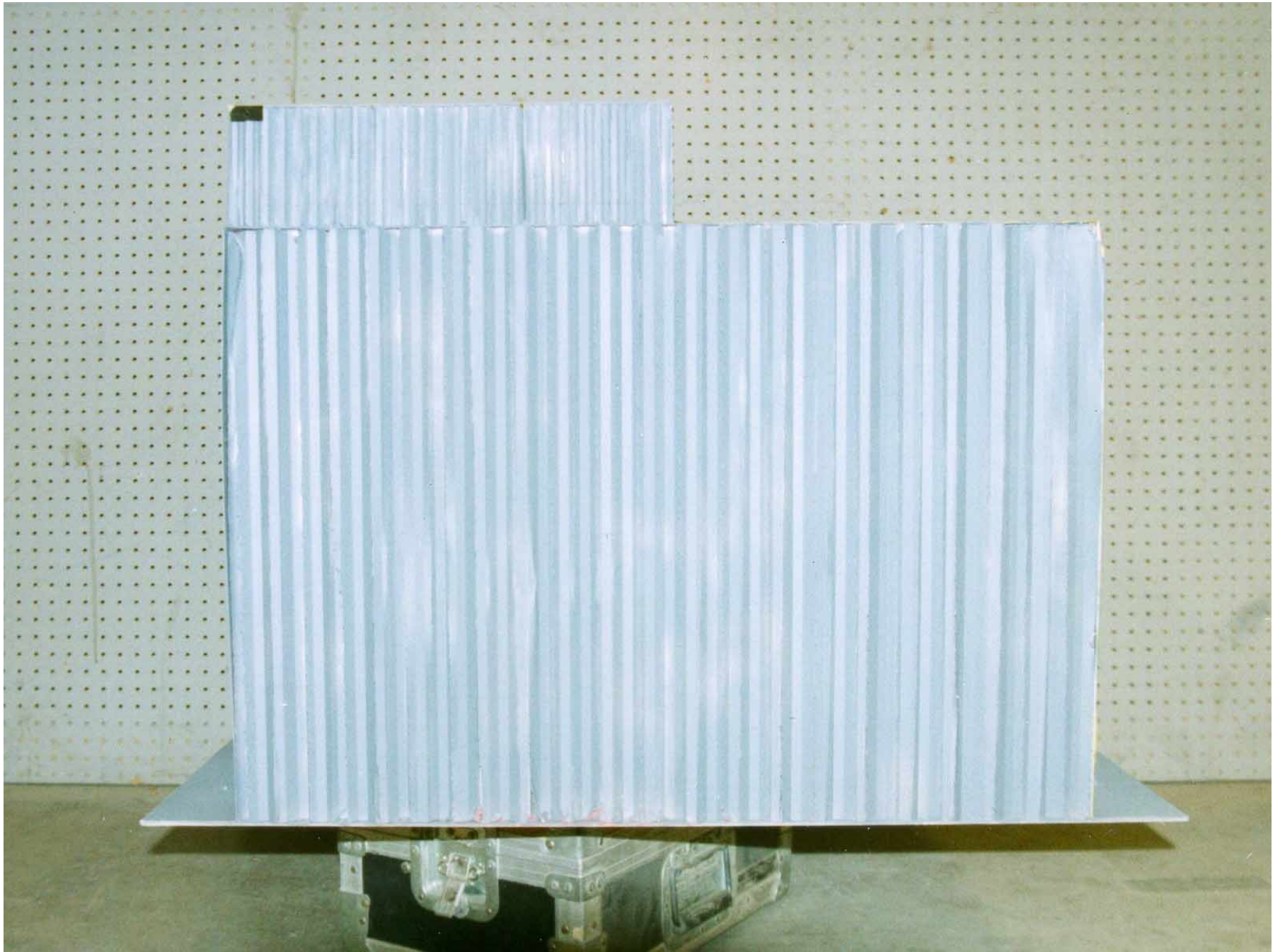

Figure A-63: Deformable Barrier Right Side, Pre-Test

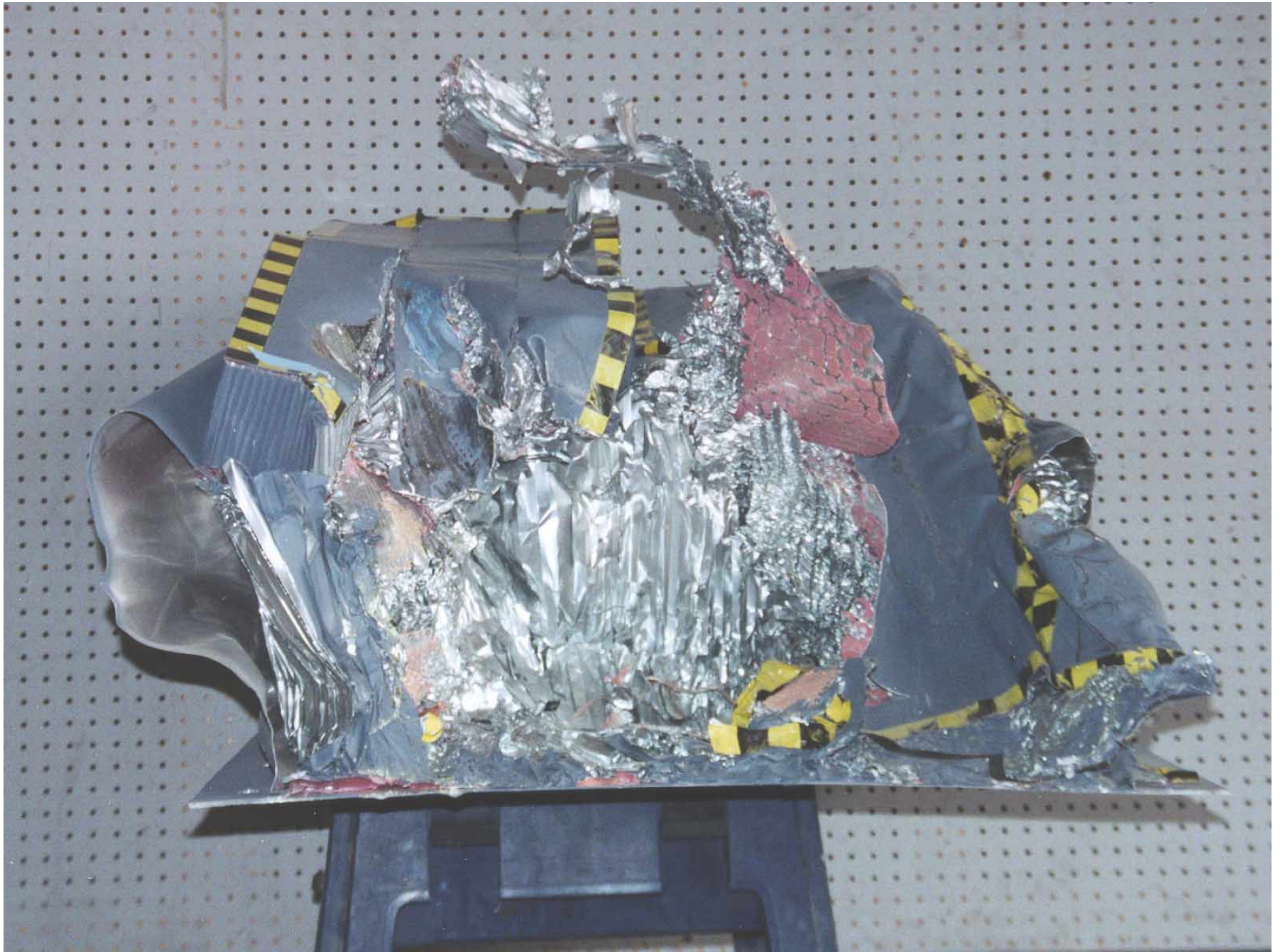

Figure A-64: Deformable Barrier Right Side, Post-Test



Figure A-65: Deformable Barrier Top, Pre-Test



Figure A-66: Deformable Barrier Top, Post-Test

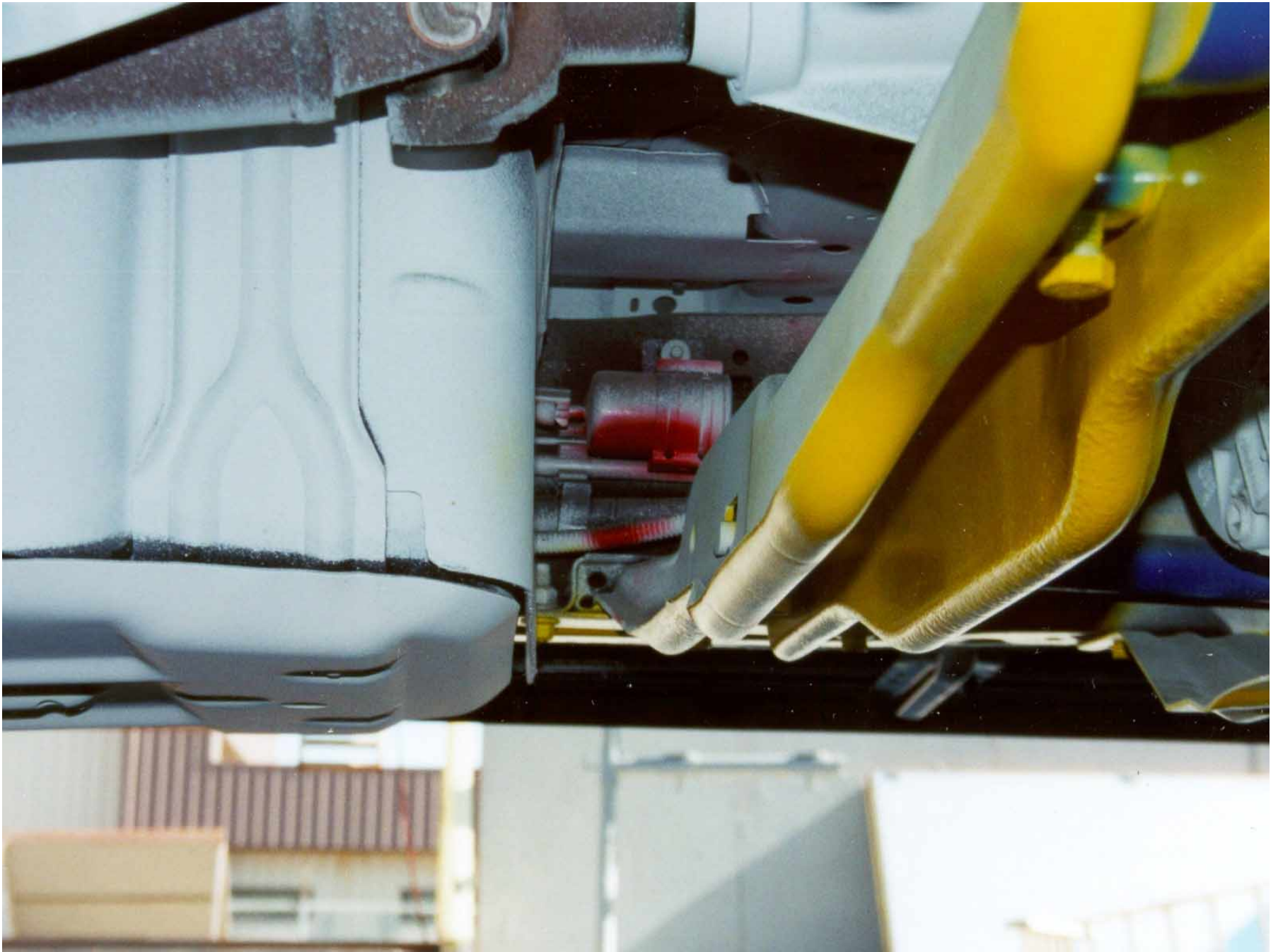

Figure A-67: Fuel Tank, Torsion Bar Mount to Fuel Tank Clearance, Side View, Pre-Test



Figure A-68: Fuel Tank, Torsion Bar Mount to Fuel Tank Clearance, Side View, Post-Test

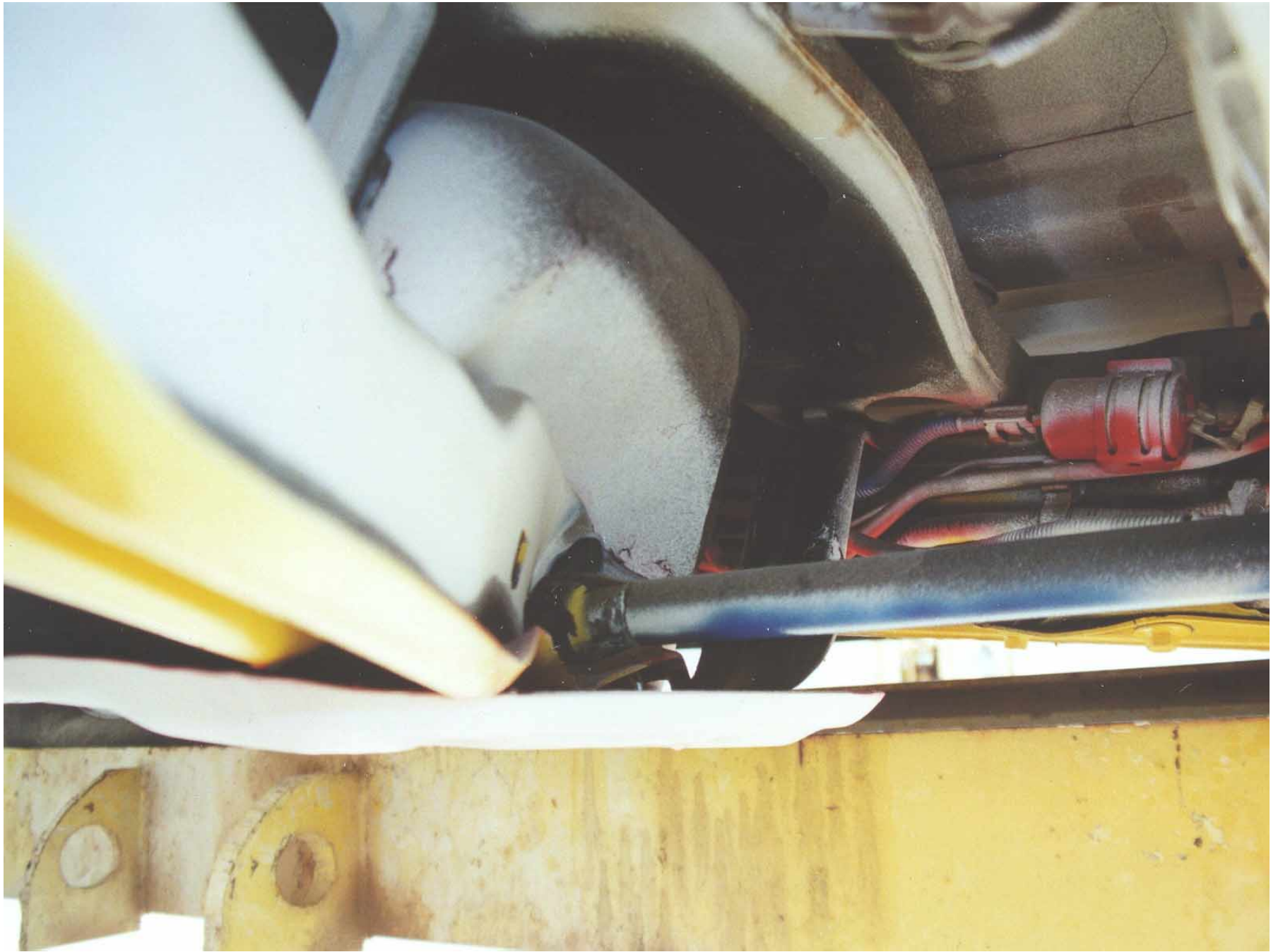

Figure A-69: Fuel Tank, Torsion Bar and Mount Intrusion Into Fuel Tank, Oblique View, Post-Test

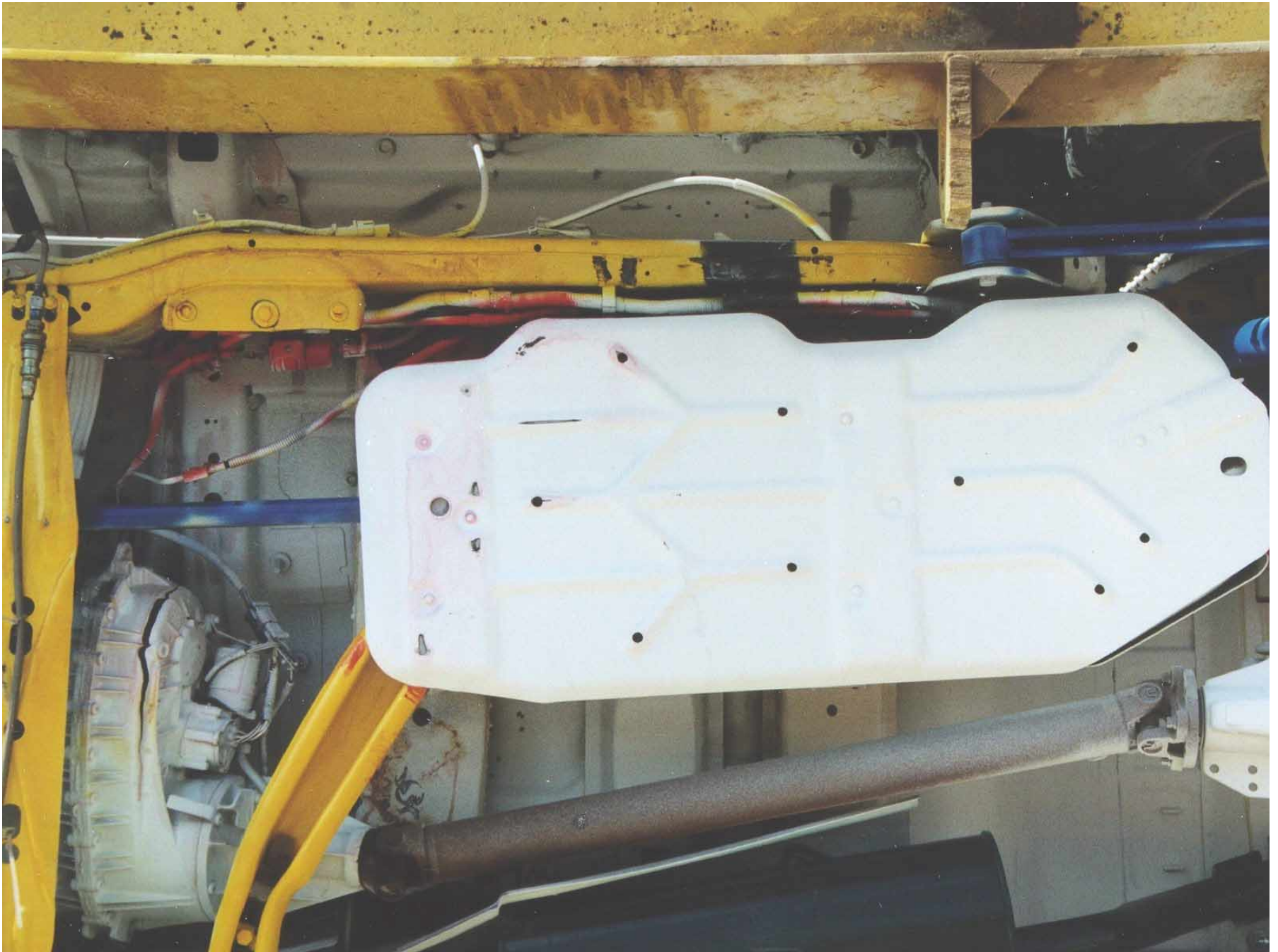

Figure A-70: Fuel Tank, Torsion Bar and Mount Intrusion Into Fuel Tank, Underside View, Post-Test



Figure A-71: Fuel Tank, Rupture Close-Up After Removal From Vehicle, Front View, Post-Test

APPENDIX B
DUMMY AND VEHICLE RESPONSE DATA TRACES

LIST OF DATA PLOTS, DRIVER DUMMY

Data Plot	Page
B-1 Driver Head Primary X	B-1
B-2 Driver Head Primary X Velocity	B-2
B-3 Driver Head Primary X Displacement	B-3
B-4 Driver Head Primary Y	B-4
B-5 Driver Head Primary Z	B-5
B-6 Driver Head Resultant Primary	B-6
B-7 Driver Head Redundant X	B-7
B-8 Driver Head Redundant X Velocity	B-8
B-9 Driver Head Redundant X Displacement	B-9
B-10 Driver Head Redundant Y	B-10
B-11 Driver Head Redundant Z	B-11
B-12 Driver Head Resultant Redundant	B-12
B-13 Driver Neck Force X	B-13
B-14 Driver Neck Force Y	B-14
B-15 Driver Neck Force Z	B-15
B-16 Driver Neck Force Resultant	B-16
B-17 Driver Neck Moment X	B-17
B-18 Driver Neck Moment Y	B-18
B-19 Driver Neck Moment Z	B-19
B-20 Driver Neck Moment Resultant	B-20
B-21 Driver Chest Primary X	B-21
B-22 Driver Chest Primary X Velocity	B-22
B-23 Driver Chest Primary X Displacement	B-23
B-24 Driver Chest Primary Y	B-24
B-25 Driver Chest Primary Z	B-25
B-26 Driver Chest Primary Resultant	B-26
B-27 Driver Chest Redundant X	B-27
B-28 Driver Chest Redundant X Velocity	B-28
B-29 Driver Chest Redundant X Displacement	B-29
B-30 Driver Chest Redundant Y	B-30
B-31 Driver Chest Redundant Z	B-31
B-32 Driver Chest Redundant Resultant	B-32
B-33 Driver Chest Displacement X	B-33

LIST OF DATA PLOTS, DRIVER DUMMY...(Continued)

Data Plot		Page
B-34	Driver Pelvis X	B-34
B-35	Driver Pelvis X Velocity	B-35
B-36	Driver Pelvis X Displacement	B-36
B-37	Driver Pelvis Y	B-37
B-38	Driver Pelvis Z	B-38
B-39	Driver Pelvis Resultant	B-39
B-40	Driver Left Femur Force	B-40
B-41	Driver Right Femur Force	B-41
B-42	Driver Left Upper Tibia Moment X	B-42
B-43	Driver Left Upper Tibia Moment Y	B-43
B-44	Driver Right Upper Tibia Moment X	B-44
B-45	Driver Right Upper Tibia Moment Y	B-45
B-46	Driver Left Lower Tibia Moment X	B-46
B-47	Driver Left Lower Tibia Moment Y	B-47
B-48	Driver Left Lower Tibia Force Z	B-48
B-49	Driver Right Lower Tibia Moment X	B-49
B-50	Driver Right Lower Tibia Moment Y	B-50
B-51	Driver Right Lower Tibia Force Z	B-51
B-52	Driver Left Foot Aft X	B-52
B-53	Driver Left Foot Aft Z	B-53
B-54	Driver Left Foot Fore Z	B-54
B-55	Driver Right Foot Aft X	B-55
B-56	Driver Right Foot Aft Z	B-56
B-57	Driver Right Foot Fore Z	B-57
B-58	Driver Lap Belt Force	B-58
B-59	Driver Shoulder Belt Force	B-59
B-60	Driver Shoulder Belt Pullout	B-60
B-61	Driver Shoulder Belt Elongation	B-61

LIST OF DATA PLOTS, PASSENGER DUMMY

Data Plot	Page	
B-62	Passenger Head Primary X	B-62
B-63	Passenger Head Primary X Velocity	B-63
B-64	Passenger Head Primary X Displacement	B-64
B-65	Passenger Head Primary Y	B-65
B-66	Passenger Head Primary Z	B-66
B-67	Passenger Head Resultant Primary	B-67
B-68	Passenger Head Redundant X	B-68
B-69	Passenger Head Redundant X Velocity	B-69
B-70	Passenger Head Redundant X Displacement	B-70
B-71	Passenger Head Redundant Y	B-71
B-72	Passenger Head Redundant Z	B-72
B-73	Passenger Head Resultant Redundant	B-73
B-74	Passenger Neck Force X	B-74
B-75	Passenger Neck Force Y	B-75
B-76	Passenger Neck Force Z	B-76
B-77	Passenger Neck Force Resultant	B-77
B-78	Passenger Neck Moment X	B-78
B-79	Passenger Neck Moment Y	B-79
B-80	Passenger Neck Moment Z	B-80
B-81	Passenger Neck Moment Resultant	B-81
B-82	Passenger Chest Primary X	B-82
B-83	Passenger Chest Primary X Velocity	B-83
B-84	Passenger Chest Primary X Displacement	B-84
B-85	Passenger Chest Primary Y	B-85
B-86	Passenger Chest Primary Z	B-86
B-87	Passenger Chest Primary Resultant	B-87
B-88	Passenger Chest Redundant X	B-88
B-89	Passenger Chest Redundant X Velocity	B-89
B-90	Passenger Chest Redundant X Displacement	B-90
B-91	Passenger Chest Redundant Y	B-91
B-92	Passenger Chest Redundant Z	B-92
B-93	Passenger Chest Redundant Resultant	B-93
B-94	Passenger Chest Displacement X	B-94

LIST OF DATA PLOTS, PASSENGER DUMMY...(Continued)

Data Plot	Page	
B-95	Passenger Pelvis X	B-95
B-96	Passenger Pelvis X Velocity	B-96
B-97	Passenger Pelvis X Displacement	B-97
B-98	Passenger Pelvis Y	B-98
B-99	Passenger Pelvis Z	B-99
B-100	Passenger Pelvis Resultant	B-100
B-101	Passenger Left Femur Force	B-101
B-102	Passenger Right Femur Force	B-102
B-103	Passenger Left Upper Tibia Moment X	B-103
B-104	Passenger Left Upper Tibia Moment Y	B-104
B-105	Passenger Right Upper Tibia Moment X	B-105
B-106	Passenger Right Upper Tibia Moment Y	B-106
B-107	Passenger Left Lower Tibia Moment X	B-107
B-108	Passenger Left Lower Tibia Moment Y	B-108
B-109	Passenger Left Lower Tibia Force Z	B-109
B-110	Passenger Right Lower Tibia Moment X	B-110
B-111	Passenger Right Lower Tibia Moment Y	B-111
B-112	Passenger Right Lower Tibia Force Z	B-112
B-113	Passenger Left Foot Aft X	B-113
B-114	Passenger Left Foot Aft Z	B-114
B-115	Passenger Left Foot Fore Z	B-115
B-116	Passenger Right Foot Aft X	B-116
B-117	Passenger Right Foot Aft Z	B-117
B-118	Passenger Right Foot Fore Z	B-118
B-119	Passenger Lap Belt Force	B-119
B-120	Passenger Shoulder Belt Force	B-120
B-121	Passenger Shoulder Belt Pullout	B-121
B-122	Passenger Shoulder Belt Elongation	B-122

LIST OF DATA PLOTS, VEHICLE

Data Plot		Page
B-123	Vehicle Left Sill X	B-123
B-124	Vehicle Left Sill X Velocity	B-124
B-125	Vehicle Left Sill X Displacement	B-125
B-126	Vehicle Left Sill Y	B-126
B-127	Vehicle Left Sill Y Velocity	B-127
B-128	Vehicle Left Sill Y Displacement	B-128
B-129	Vehicle Center Tunnel X	B-129
B-130	Vehicle Center Tunnel X Velocity	B-130
B-131	Vehicle Center Tunnel X Displacement	B-131
B-132	Vehicle Center Tunnel Y	B-132
B-133	Vehicle Center Tunnel Y Velocity	B-133
B-134	Vehicle Center Tunnel Y Displacement	B-134
B-135	Vehicle Right Sill X	B-135
B-136	Vehicle Right Sill X Velocity	B-136
B-137	Vehicle Right Sill X Displacement	B-137
B-138	Vehicle Right Sill Y	B-138
B-139	Vehicle Right Sill Y Velocity	B-139
B-140	Vehicle Right Sill Y Displacement	B-140
B-141	Vehicle Trunk X	B-141
B-142	Vehicle Trunk X Velocity	B-142
B-143	Vehicle Trunk X Displacement	B-143
B-144	Vehicle Trunk Y	B-144
B-145	Vehicle Trunk Y Velocity	B-145
B-146	Vehicle Trunk Y Displacement	B-146

B-1

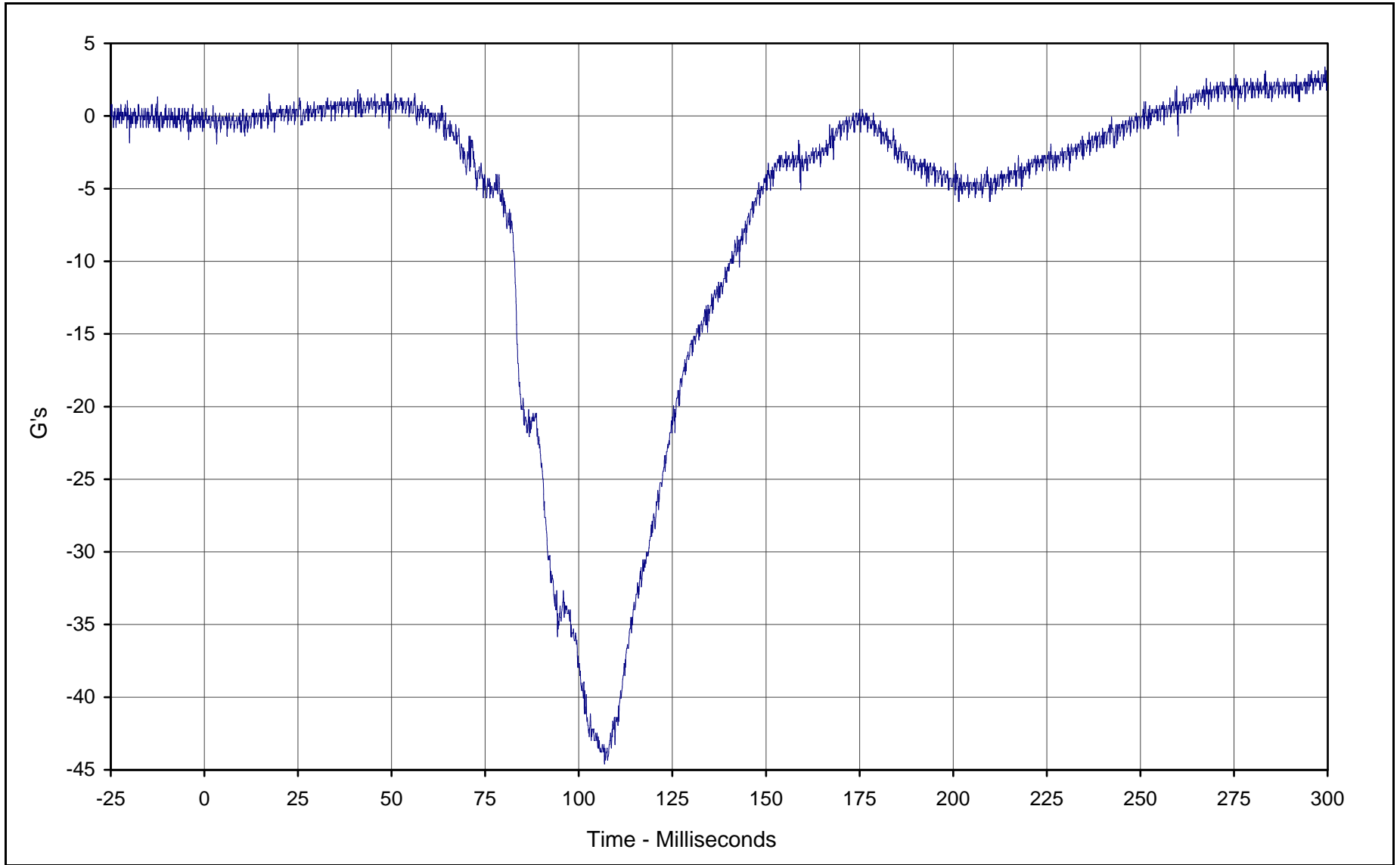

Curve Description: Driver Head Primary X
Maximum Value: 3.4 at 299.3 Milliseconds
Minimum Value: -44.6 at 106.9 Milliseconds
SAE Filter Class: 1000
Date of Test: 08/15/00
Curve Number: FIL-001

Test Program: 2000 NHTSA 40% Offset No.: FORD01
Test Vehicle: 2000 Ford Expedition 4WD 4 Door SUV



KARR20002-02

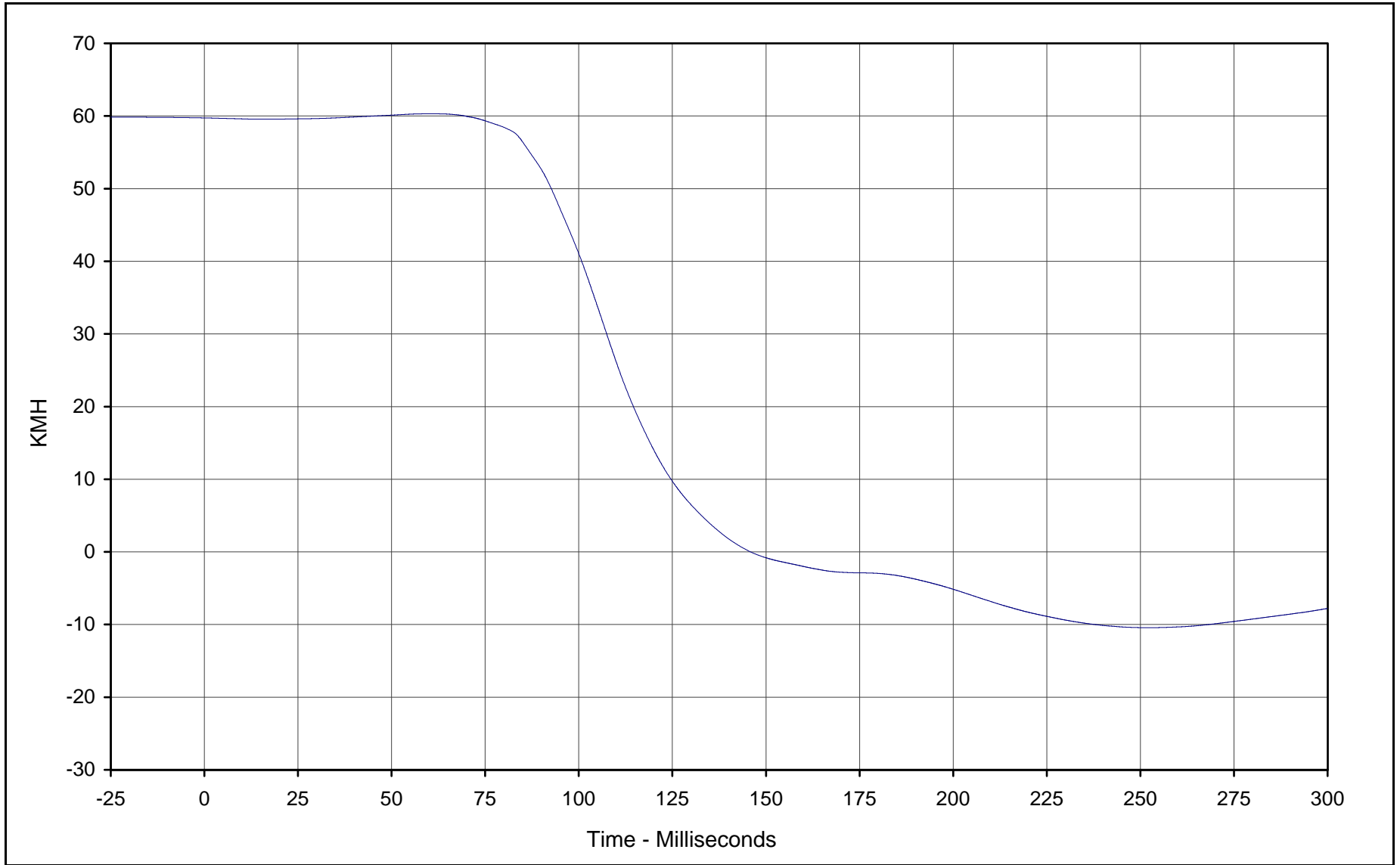

Curve Description: Driver Head Primary X Velocity
 Maximum Value: 60.3 at 60.2 Milliseconds
 Minimum Value: -10.4 at 252.8 Milliseconds
 SAE Filter Class: 180
 Date of Test: 08/15/00
 Curve Number: IN1-001

Test Program: 2000 NHTSA 40% Offset No.: FORD01
 Test Vehicle: 2000 Ford Expedition 4WD 4 Door SUV



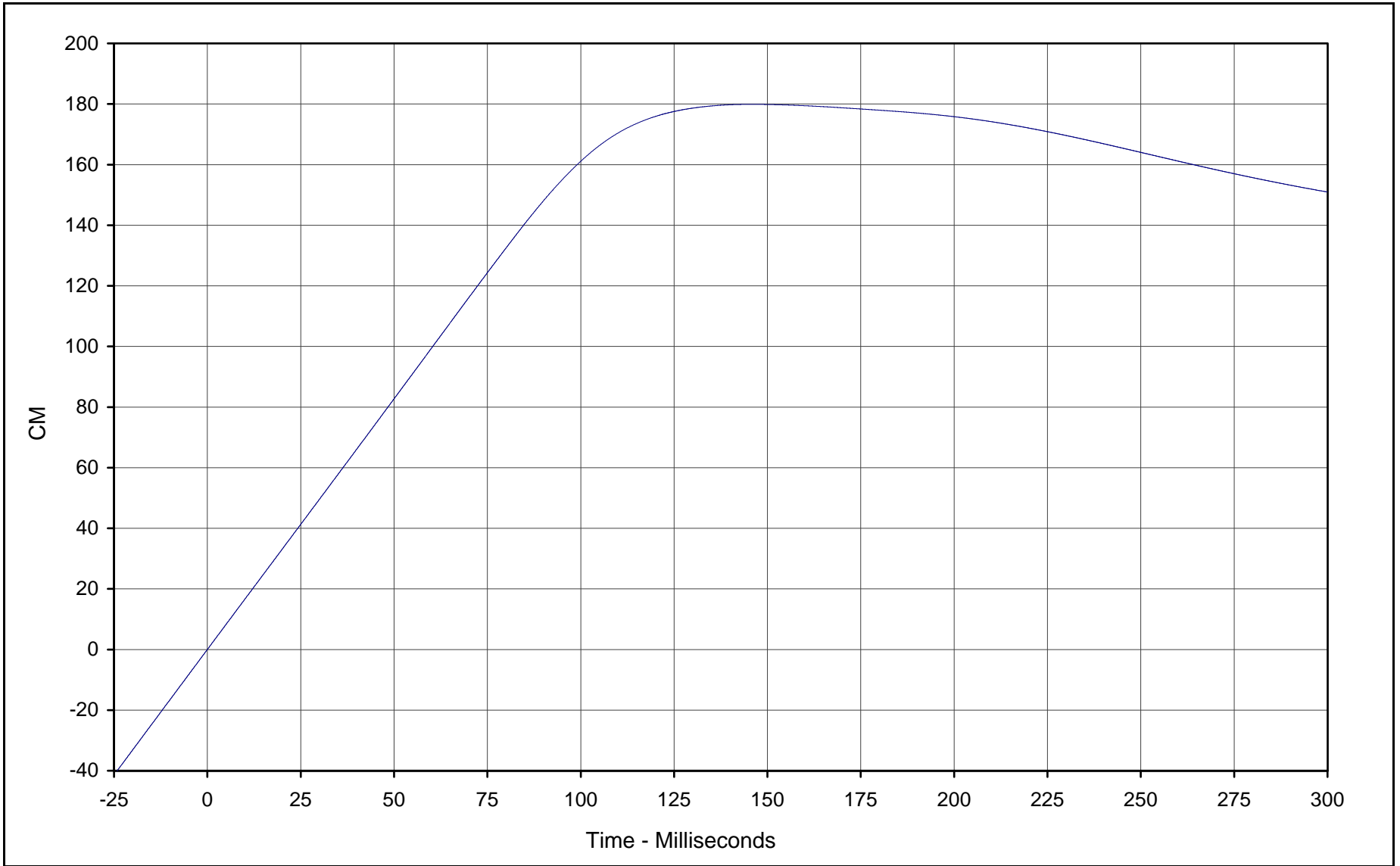

Curve Description: Driver Head Primary X Displ.
Maximum Value: 179.9 at 145.9 Milliseconds
Minimum Value: 0.0 at 0.0 Milliseconds
SAE Filter Class: 180
Date of Test: 08/15/00
Curve Number: IN2-001

Test Program: 2000 NHTSA 40% Offset No.: FORD01
Test Vehicle: 2000 Ford Expedition 4WD 4 Door SUV



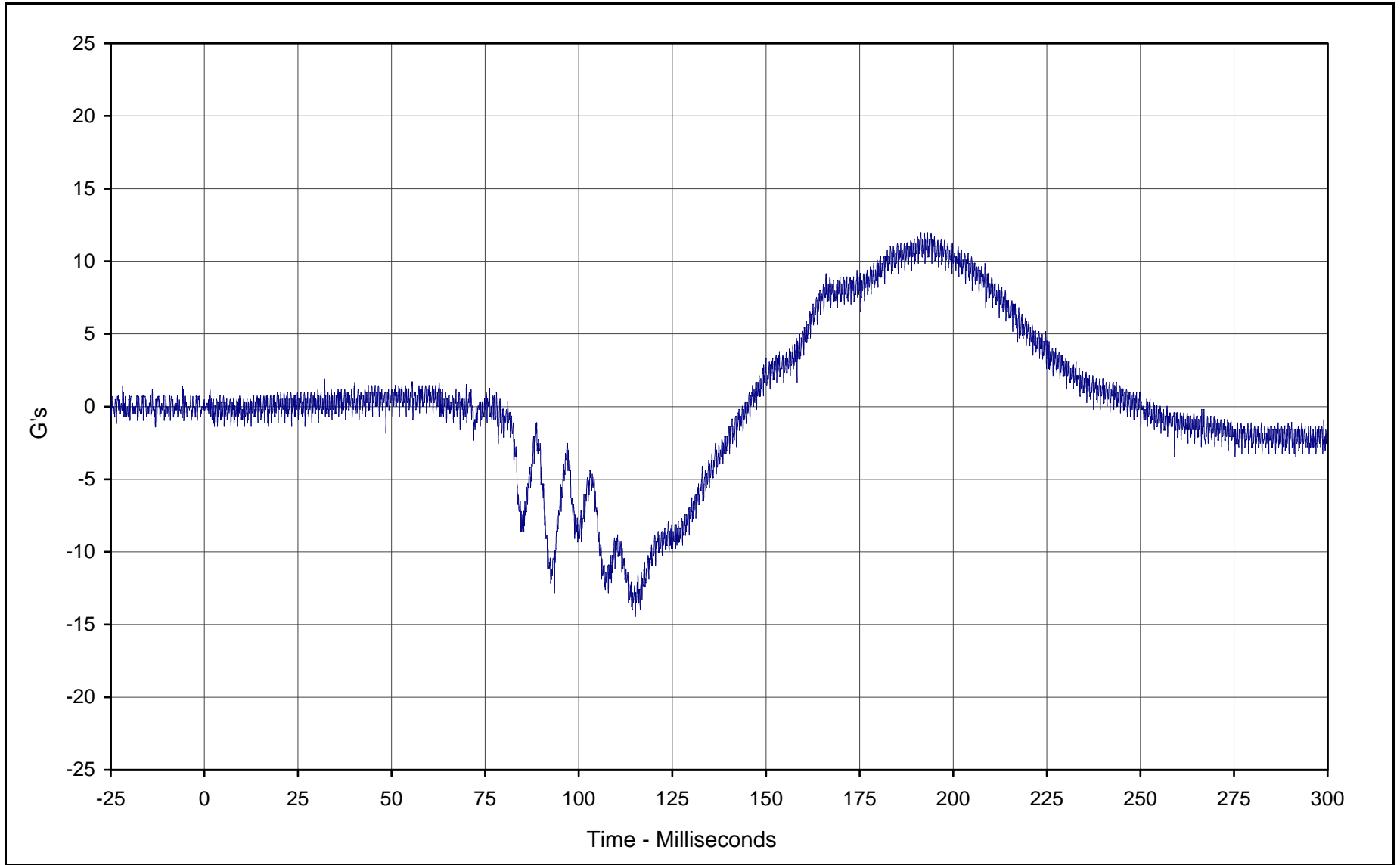

Curve Description: Driver Head Primary Y
Maximum Value: 11.9 at 191.4 Milliseconds
Minimum Value: -14.4 at 115.1 Milliseconds
SAE Filter Class: 1000
Date of Test: 08/15/00
Curve Number: FIL-002

Test Program: 2000 NHTSA 40% Offset No.: FORD01
Test Vehicle: 2000 Ford Expedition 4WD 4 Door SUV



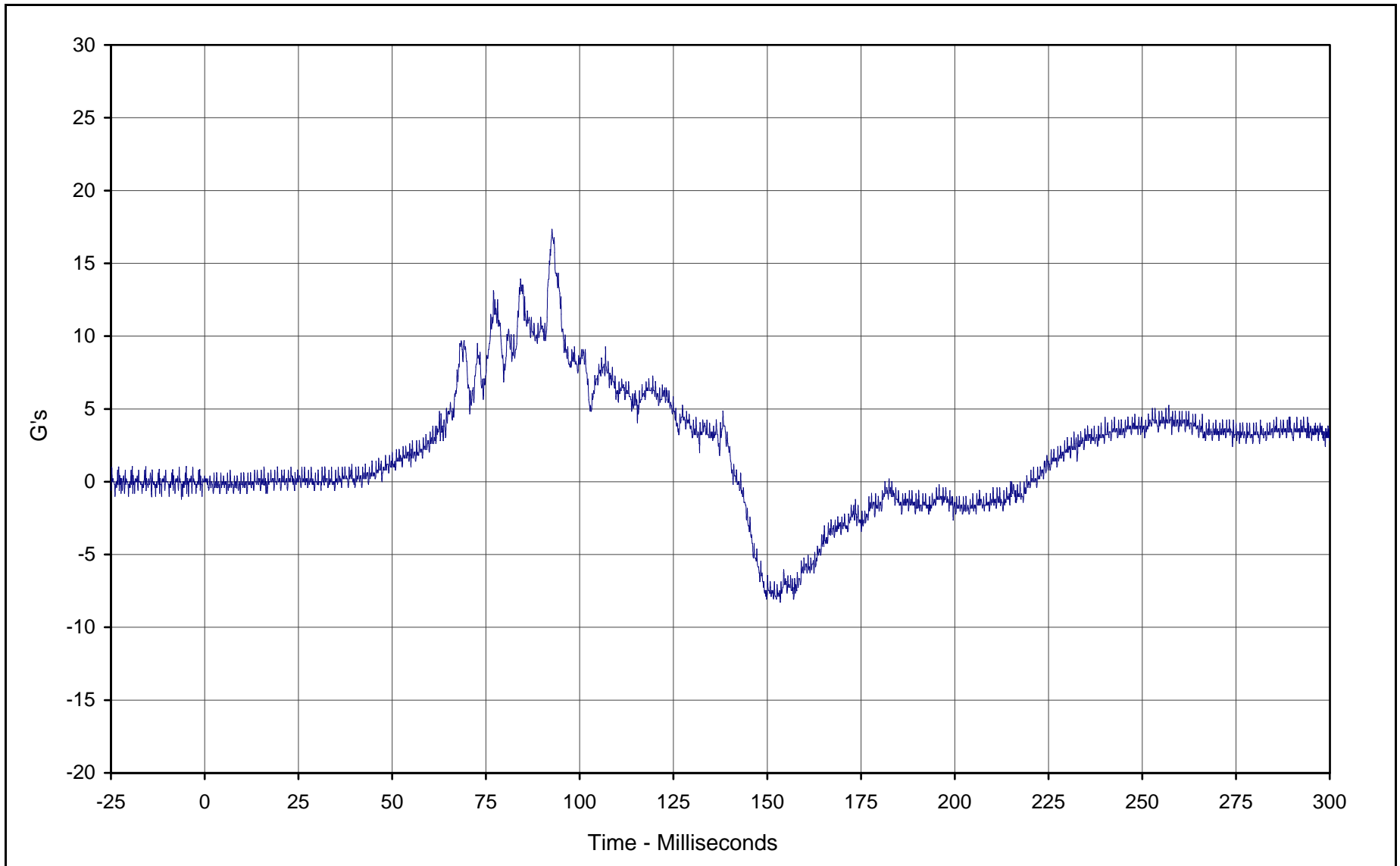

Curve Description: Driver Head Primary Z
 Maximum Value: 17.4 at 92.6 Milliseconds
 Minimum Value: -8.3 at 153.4 Milliseconds
 SAE Filter Class: 1000
 Date of Test: 08/15/00
 Curve Number: FIL-003

Test Program: 2000 NHTSA 40% Offset No.: FORD01
 Test Vehicle: 2000 Ford Expedition 4WD 4 Door SUV



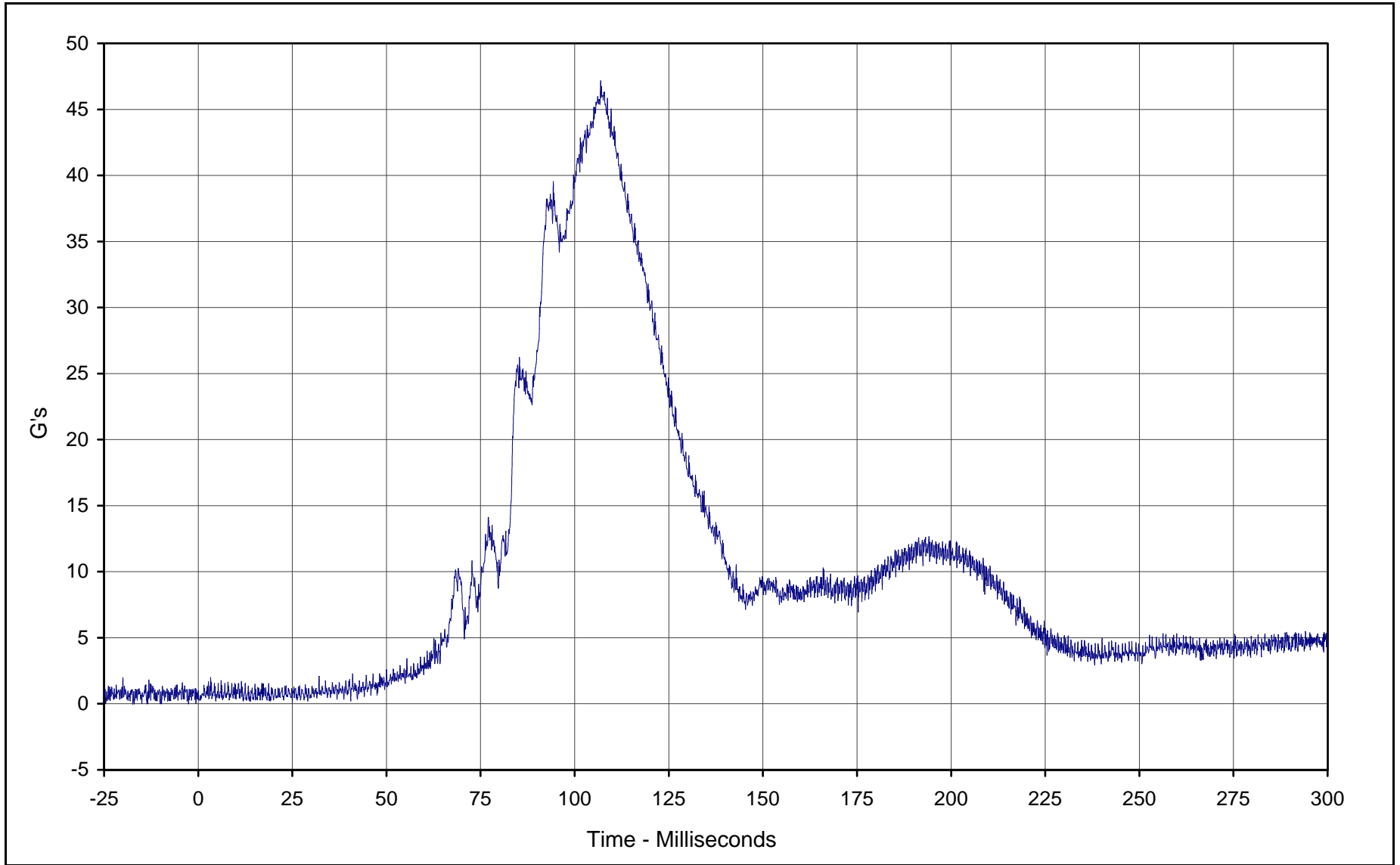

Curve Description: Driver Head Resultant Primary
 Maximum Value: 47.2 at 106.9 Milliseconds
 Minimum Value: 0.1 at 25.0 Milliseconds
 SAE Filter Class: 1000
 Date of Test: 08/15/00
 Curve Number: RES-001

Test Program: 2000 NHTSA 40% Offset No.: FORD01
 Test Vehicle: 2000 Ford Expedition 4WD 4 Door SUV



B-7

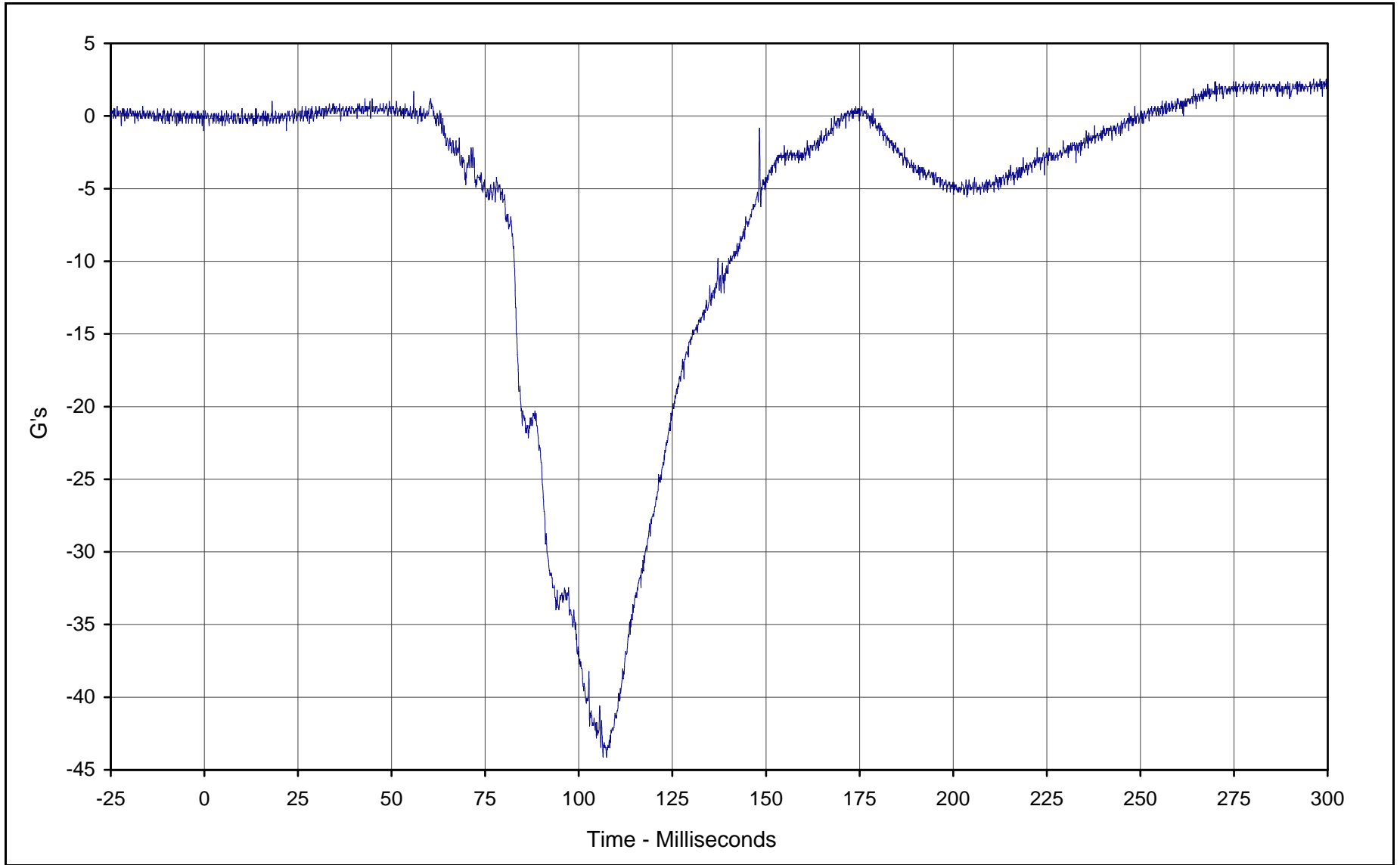

Curve Description: Driver Head Redundant X
Maximum Value: 2.5 at 296.3 Milliseconds
Minimum Value: -44.1 at 106.5 Milliseconds
SAE Filter Class: 1000
Date of Test: 08/15/00
Curve Number: FIL-004

Test Program: 2000 NHTSA 40% Offset No.: FORD01
Test Vehicle: 2000 Ford Expedition 4WD 4 Door SUV



KAR20002-02

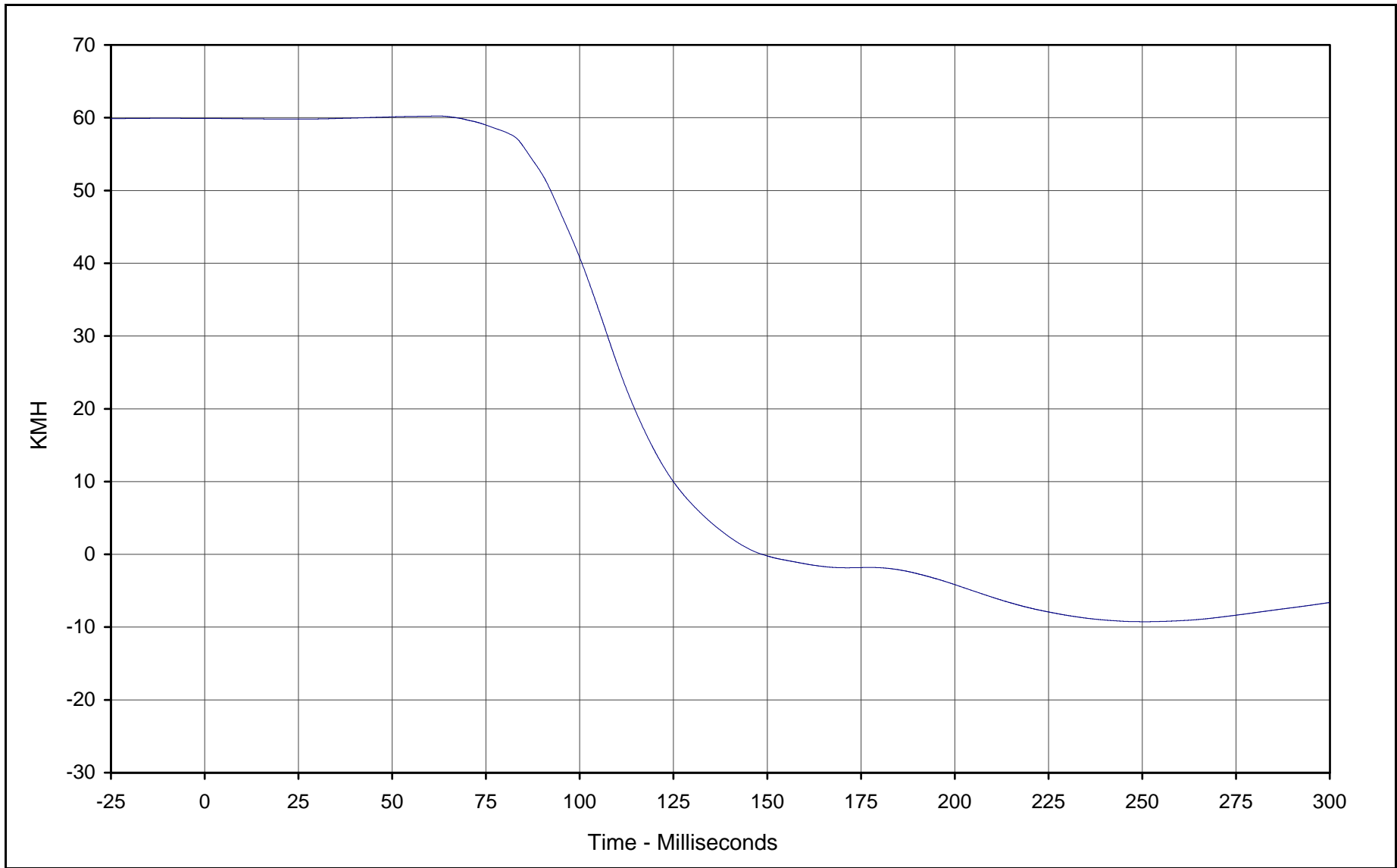

Curve Description: Driver Head Redundant X Velocity
Maximum Value: 60.2 at 61.6 Milliseconds
Minimum Value: -9.3 at 251.0 Milliseconds
SAE Filter Class: 180
Date of Test: 08/15/00
Curve Number: IN1-004

Test Program: 2000 NHTSA 40% Offset No.: FORD01
Test Vehicle: 2000 Ford Expedition 4WD 4 Door SUV



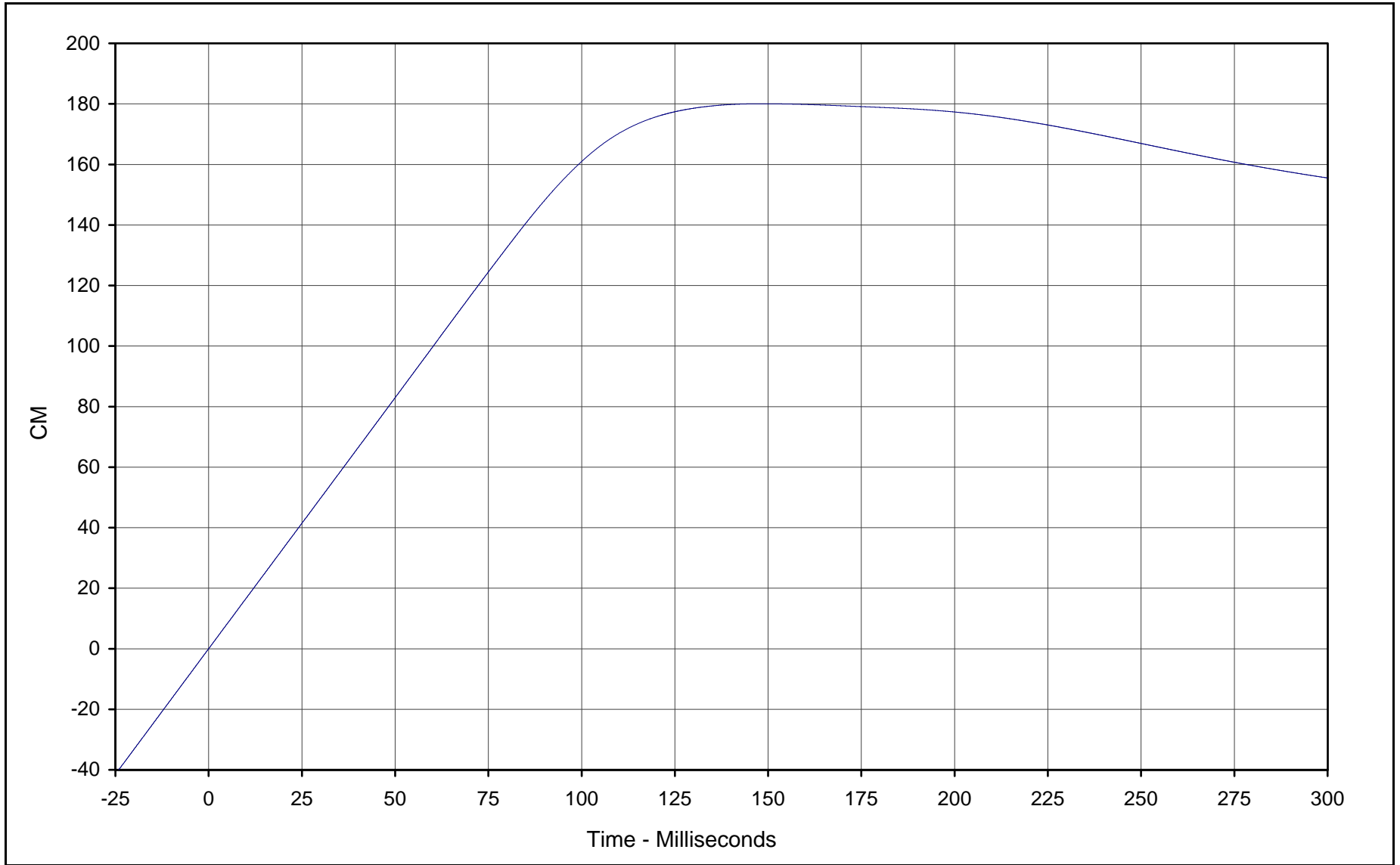

Curve Description: Driver Head Redundant X Displ.
 Maximum Value: 180.0 at 148.6 Milliseconds
 Minimum Value: 0.0 at 0.0 Milliseconds
 SAE Filter Class: 180
 Date of Test: 08/15/00
 Curve Number: IN2-004

Test Program: 2000 NHTSA 40% Offset No.: FORD01
 Test Vehicle: 2000 Ford Expedition 4WD 4 Door SUV



B-10

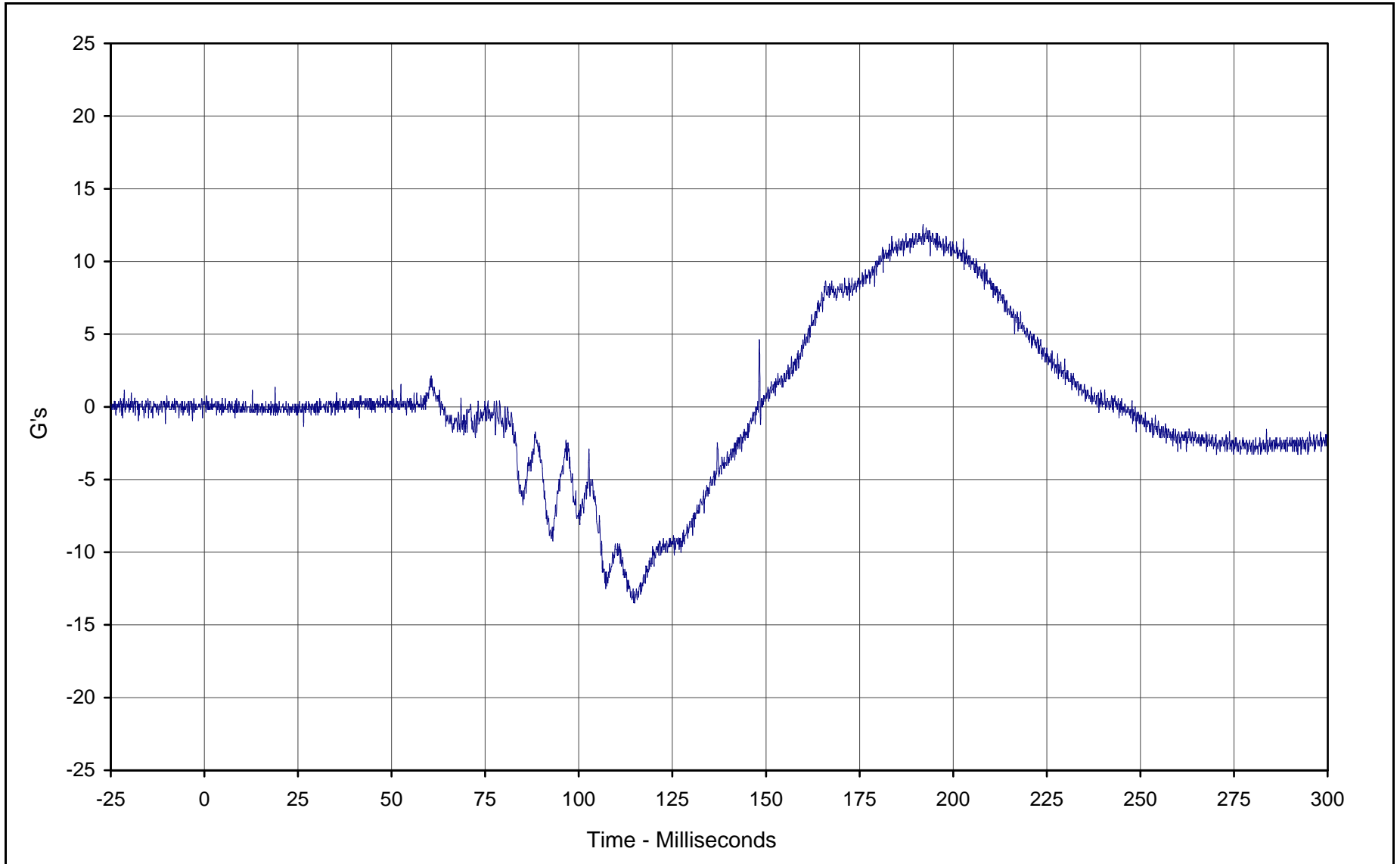

Curve Description: Driver Head Redundant Y
Maximum Value: 12.5 at 192.0 Milliseconds
Minimum Value: -13.5 at 114.7 Milliseconds
SAE Filter Class: 1000
Date of Test: 08/15/00
Curve Number: FIL-005

Test Program: 2000 NHTSA 40% Offset No.: FORD01
Test Vehicle: 2000 Ford Expedition 4WD 4 Door SUV



KARR20002-02

B-11

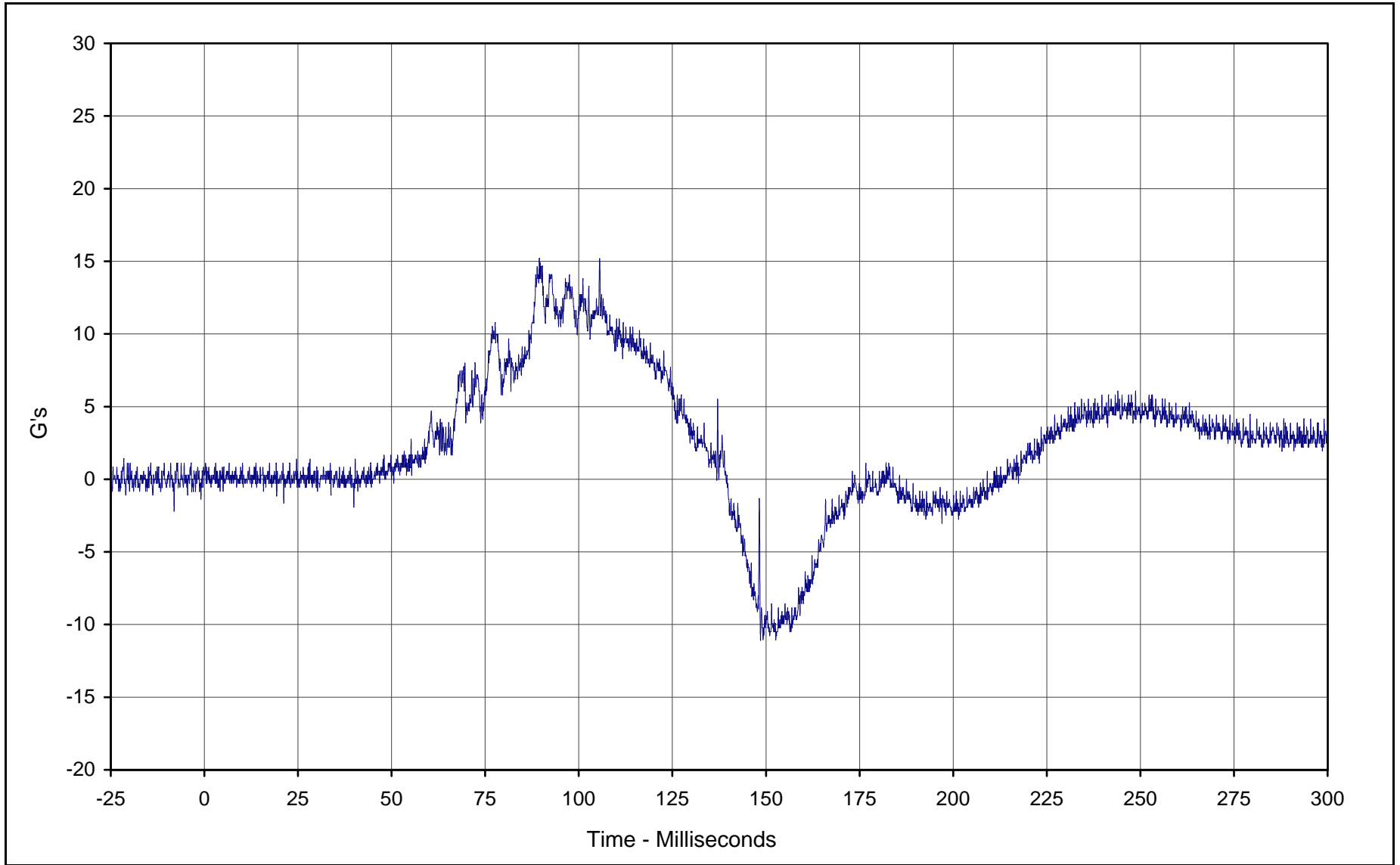

Curve Description: Driver Head Redundant Z
Maximum Value: 15.2 at 89.5 Milliseconds
Minimum Value: -11.0 at 148.5 Milliseconds
SAE Filter Class: 1000
Date of Test: 08/15/00
Curve Number: FIL-006

Test Program: 2000 NHTSA 40% Offset No.: FORD01
Test Vehicle: 2000 Ford Expedition 4WD 4 Door SUV



KARR20002-02

B-12

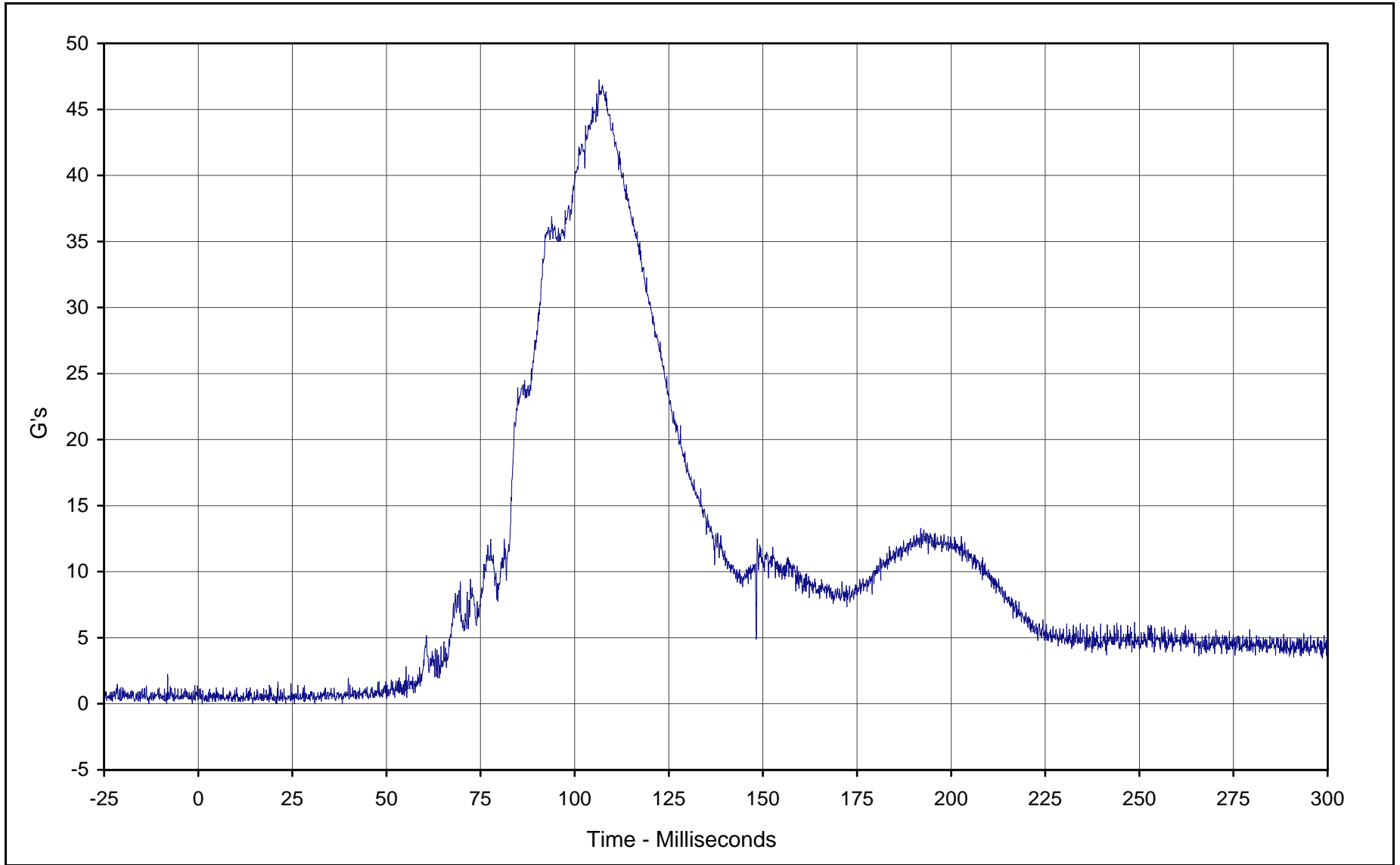

Curve Description: Driver Head Resultant Redundant
Maximum Value: 47.2 at 106.5 Milliseconds
Minimum Value: 0.0 at 1.1 Milliseconds
SAE Filter Class: 1000
Date of Test: 08/15/00
Curve Number: RES-004

Test Program: 2000 NHTSA 40% Offset No.: FORD01
Test Vehicle: 2000 Ford Expedition 4WD 4 Door SUV



KARR20002-02

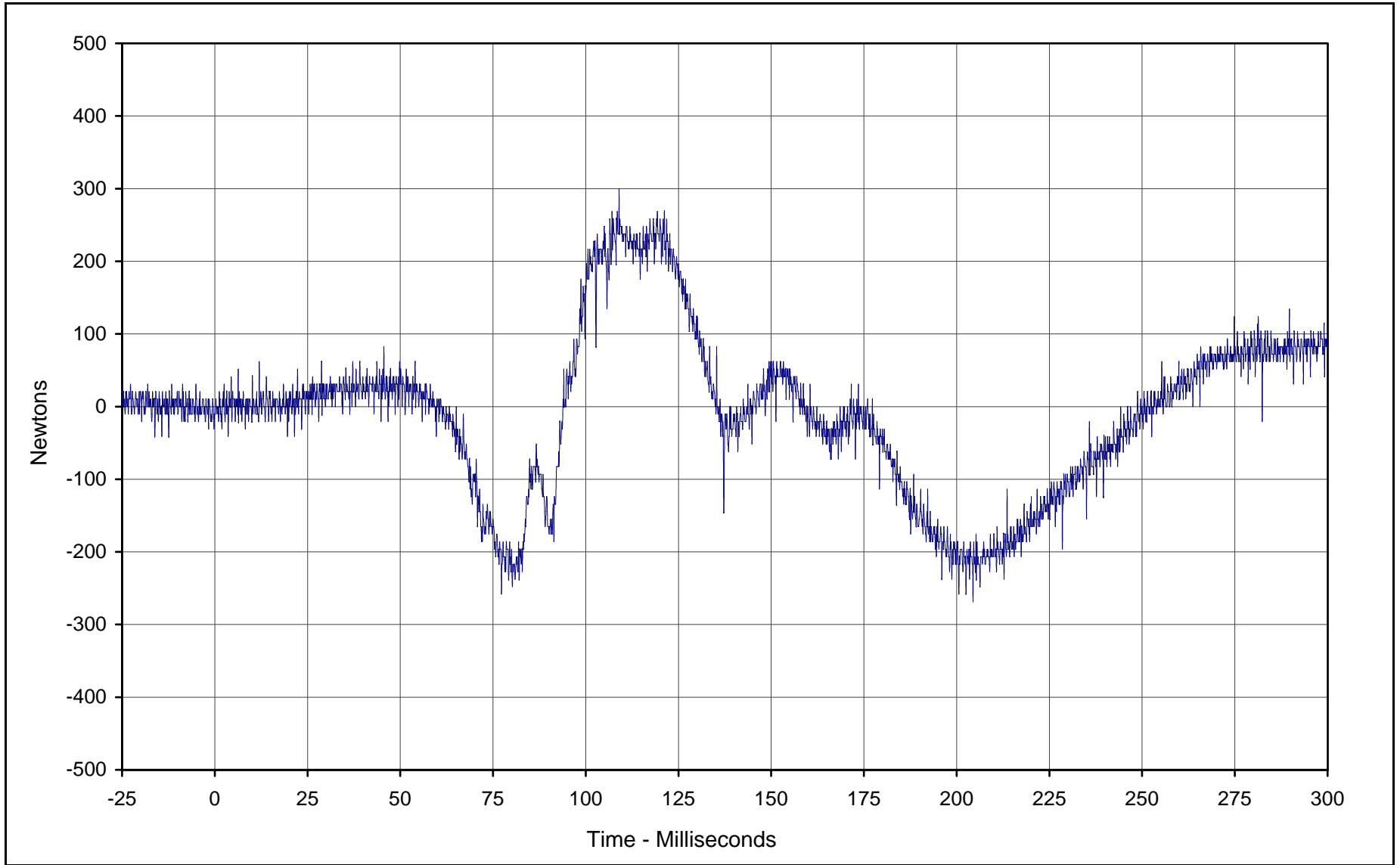

Curve Description: Driver Neck Force X
Maximum Value: 299.7 at 109.0 Milliseconds
Minimum Value: -268.7 at 204.4 Milliseconds
SAE Filter Class: 1000
Date of Test: 08/15/00
Curve Number: FIL-007

Test Program: 2000 NHTSA 40% Offset No.: FORD01
Test Vehicle: 2000 Ford Expedition 4WD 4 Door SUV



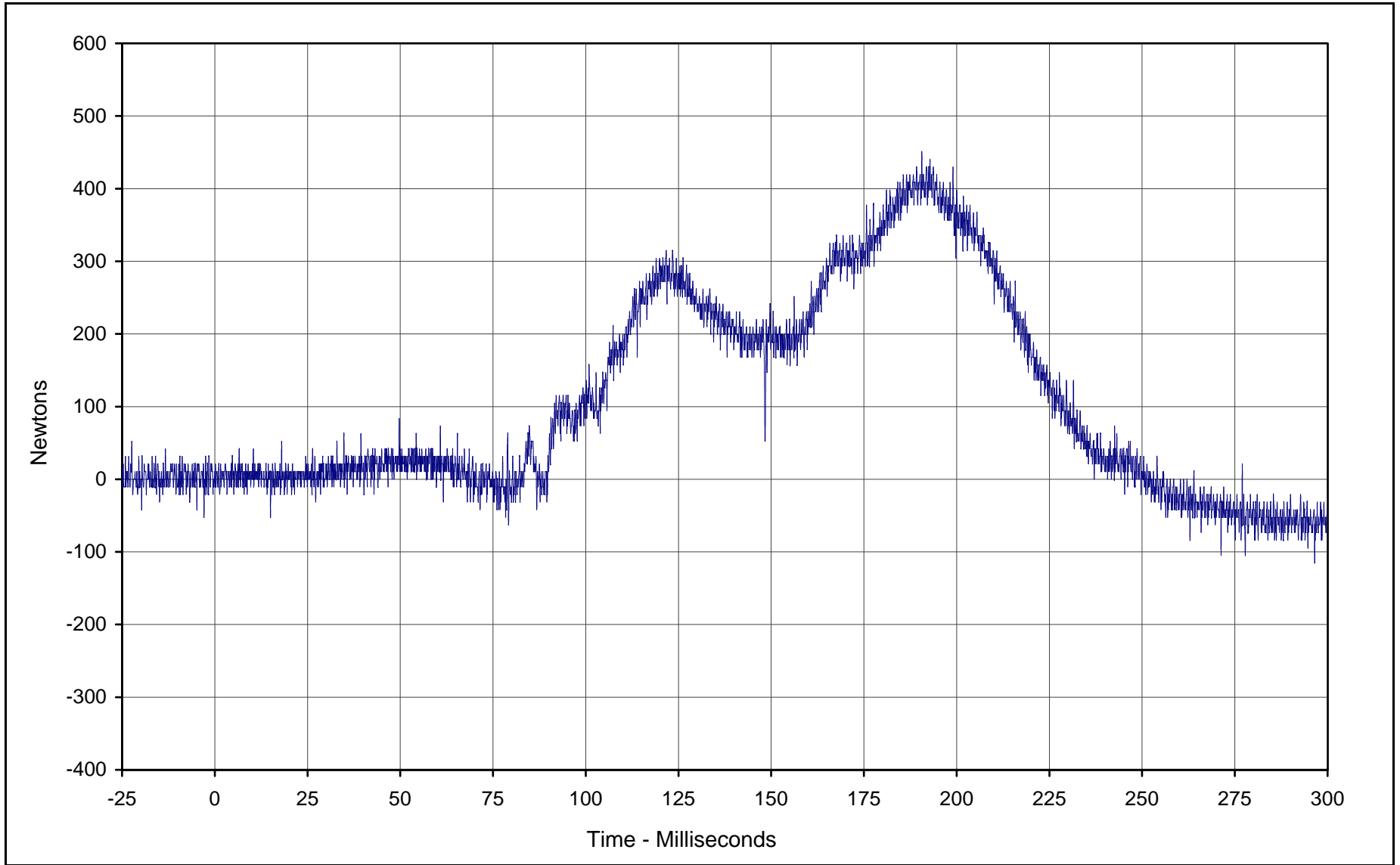

Curve Description: Driver Neck Force Y
 Maximum Value: 450.8 at 190.6 Milliseconds
 Minimum Value: -115.3 at 296.5 Milliseconds
 SAE Filter Class: 1000
 Date of Test: 08/15/00
 Curve Number: FIL-008

Test Program: 2000 NHTSA 40% Offset No.: FORD01
 Test Vehicle: 2000 Ford Expedition 4WD 4 Door SUV



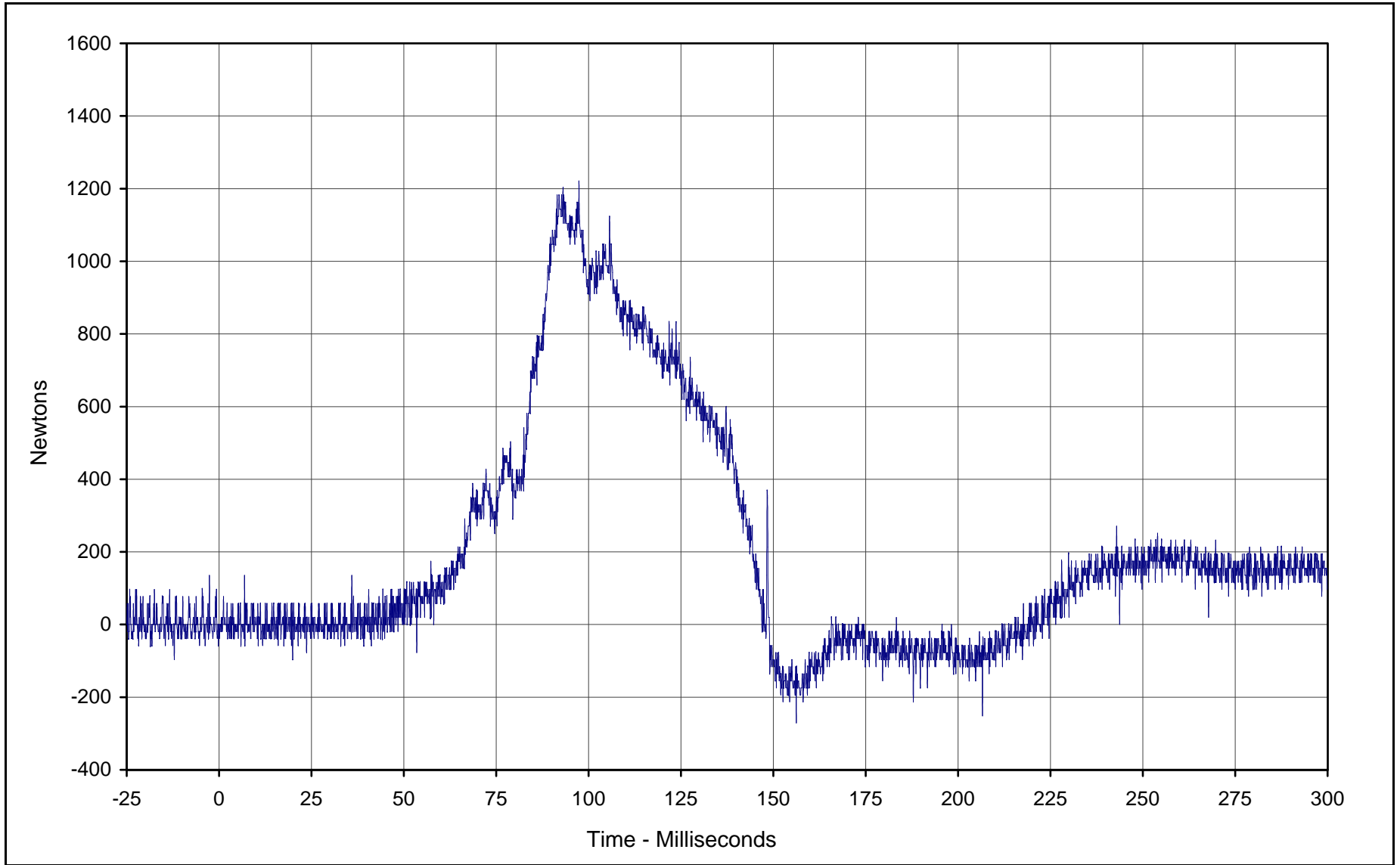

Curve Description: Driver Neck Force Z
Maximum Value: 1220.8 at 97.4 Milliseconds
Minimum Value: -271.3 at 156.2 Milliseconds
SAE Filter Class: 1000
Date of Test: 08/15/00
Curve Number: FIL-009

Test Program: 2000 NHTSA 40% Offset No.: FORD01
Test Vehicle: 2000 Ford Expedition 4WD 4 Door SUV



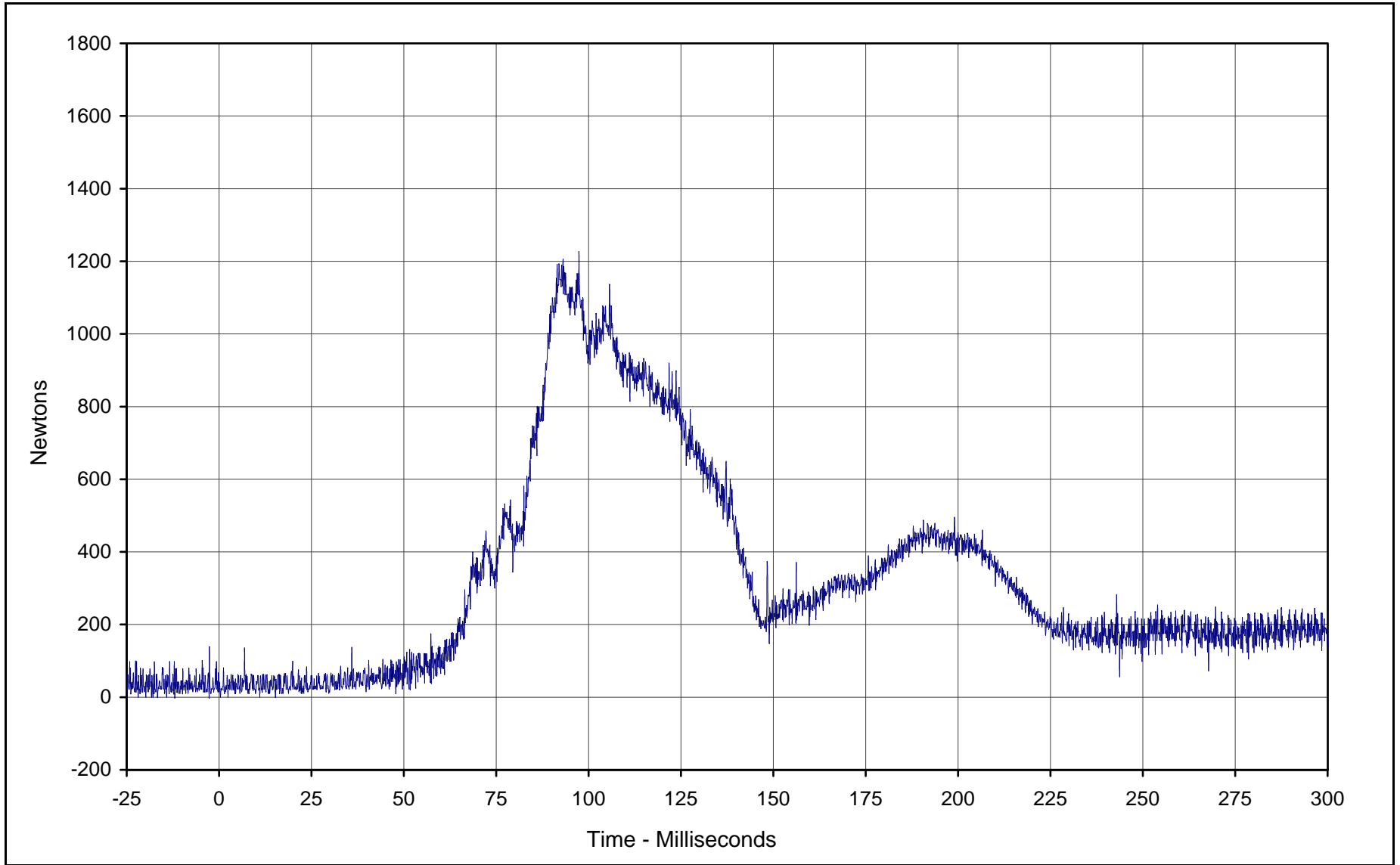

Curve Description: Driver Neck Force Resultant
Maximum Value: 1226.4 at 97.4 Milliseconds
Minimum Value: 0.0 at 0.4 Milliseconds
SAE Filter Class: 1000
Date of Test: 08/15/00
Curve Number: RES-007

Test Program: 2000 NHTSA 40% Offset No.: FORD01
Test Vehicle: 2000 Ford Expedition 4WD 4 Door SUV



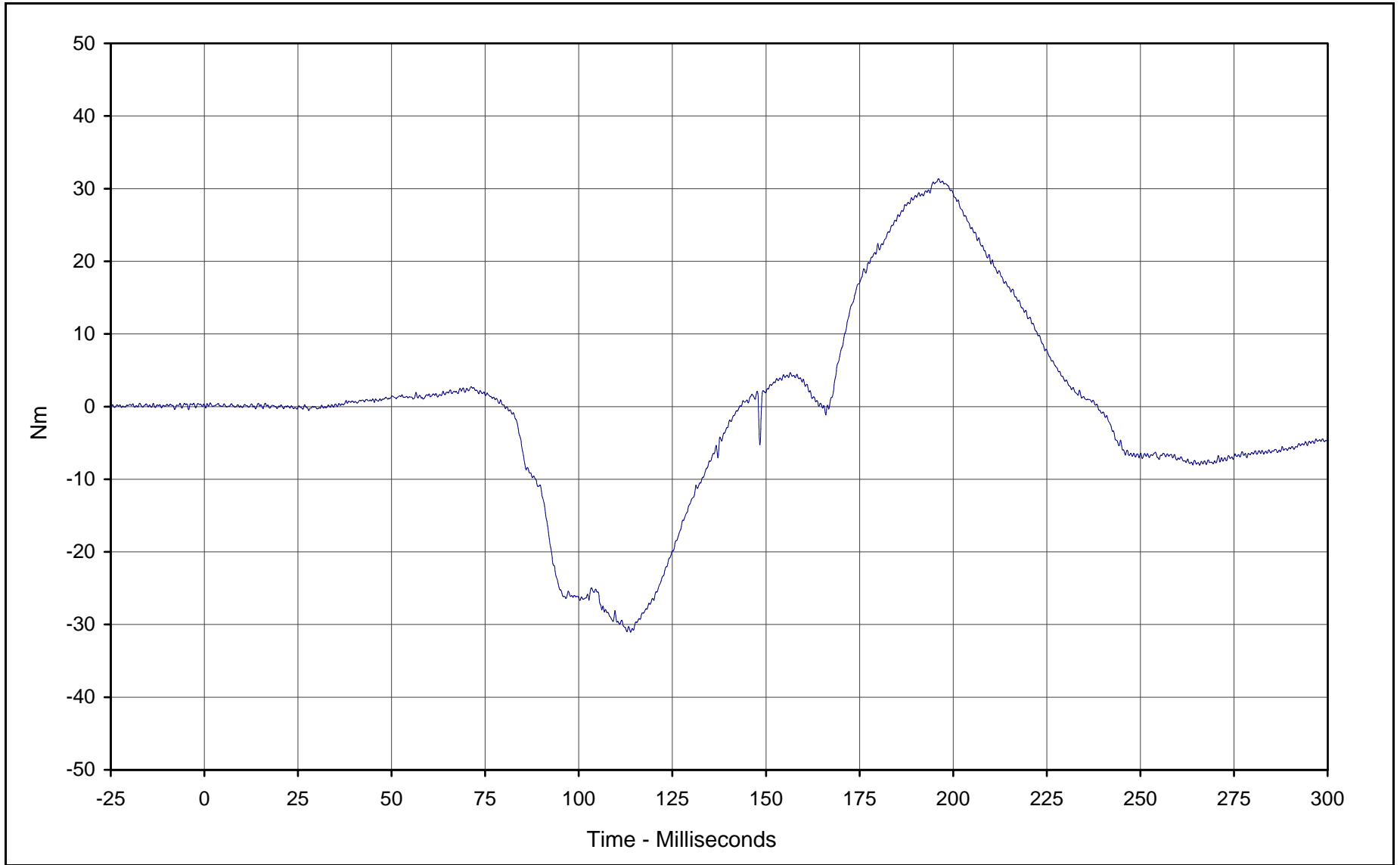

Curve Description: Driver Neck Moment X
 Maximum Value: 31.4 at 196.1 Milliseconds
 Minimum Value: -31.0 at 113.9 Milliseconds
 SAE Filter Class: 600
 Date of Test: 08/15/00
 Curve Number: FIL-010

Test Program: 2000 NHTSA 40% Offset No.: FORD01
 Test Vehicle: 2000 Ford Expedition 4WD 4 Door SUV



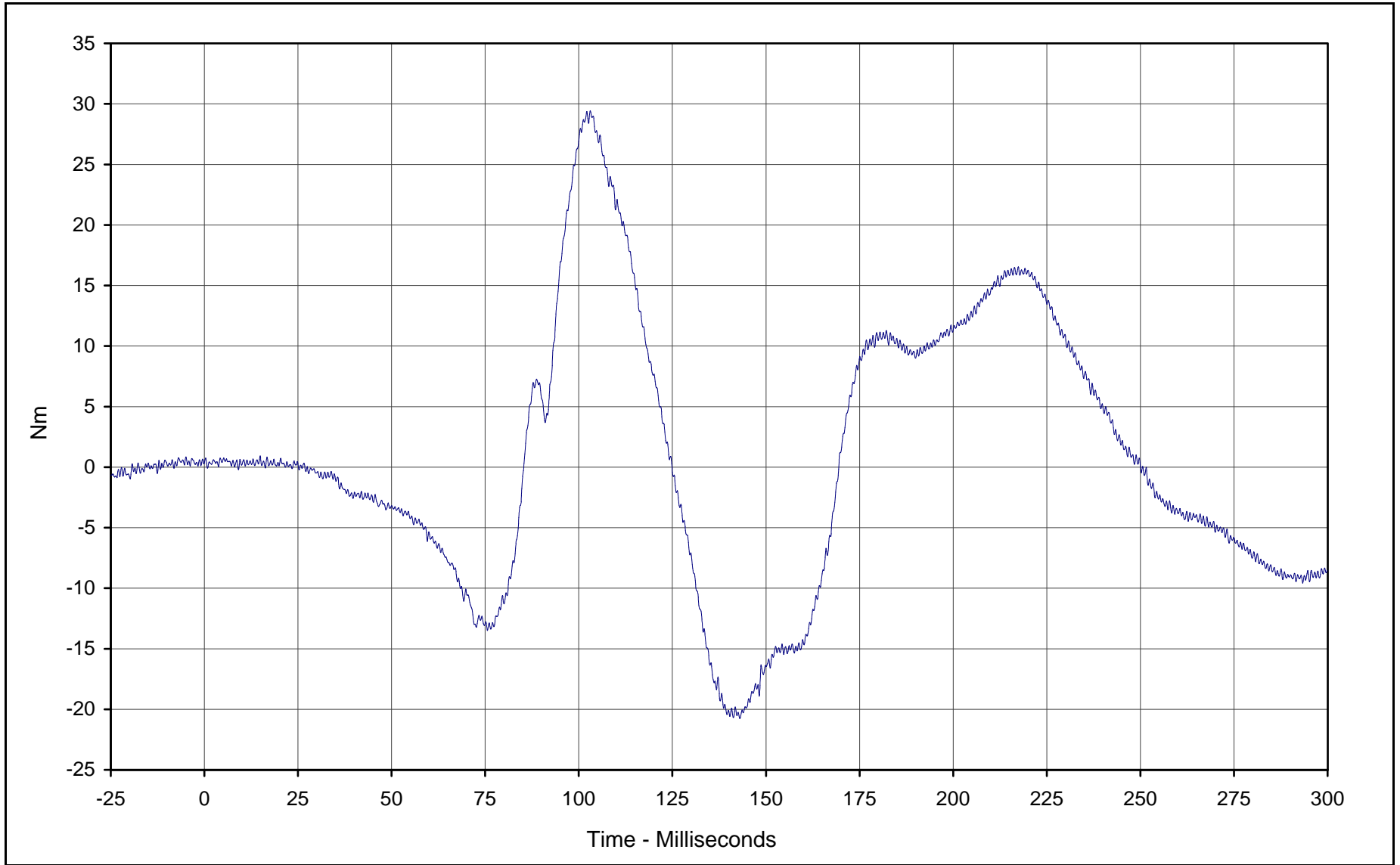

Curve Description: Driver Neck Moment Y
 Maximum Value: 29.4 at 103.1 Milliseconds
 Minimum Value: -20.8 at 143.0 Milliseconds
 SAE Filter Class: 600
 Date of Test: 08/15/00
 Curve Number: FIL-011

Test Program: 2000 NHTSA 40% Offset No.: FORD01
 Test Vehicle: 2000 Ford Expedition 4WD 4 Door SUV



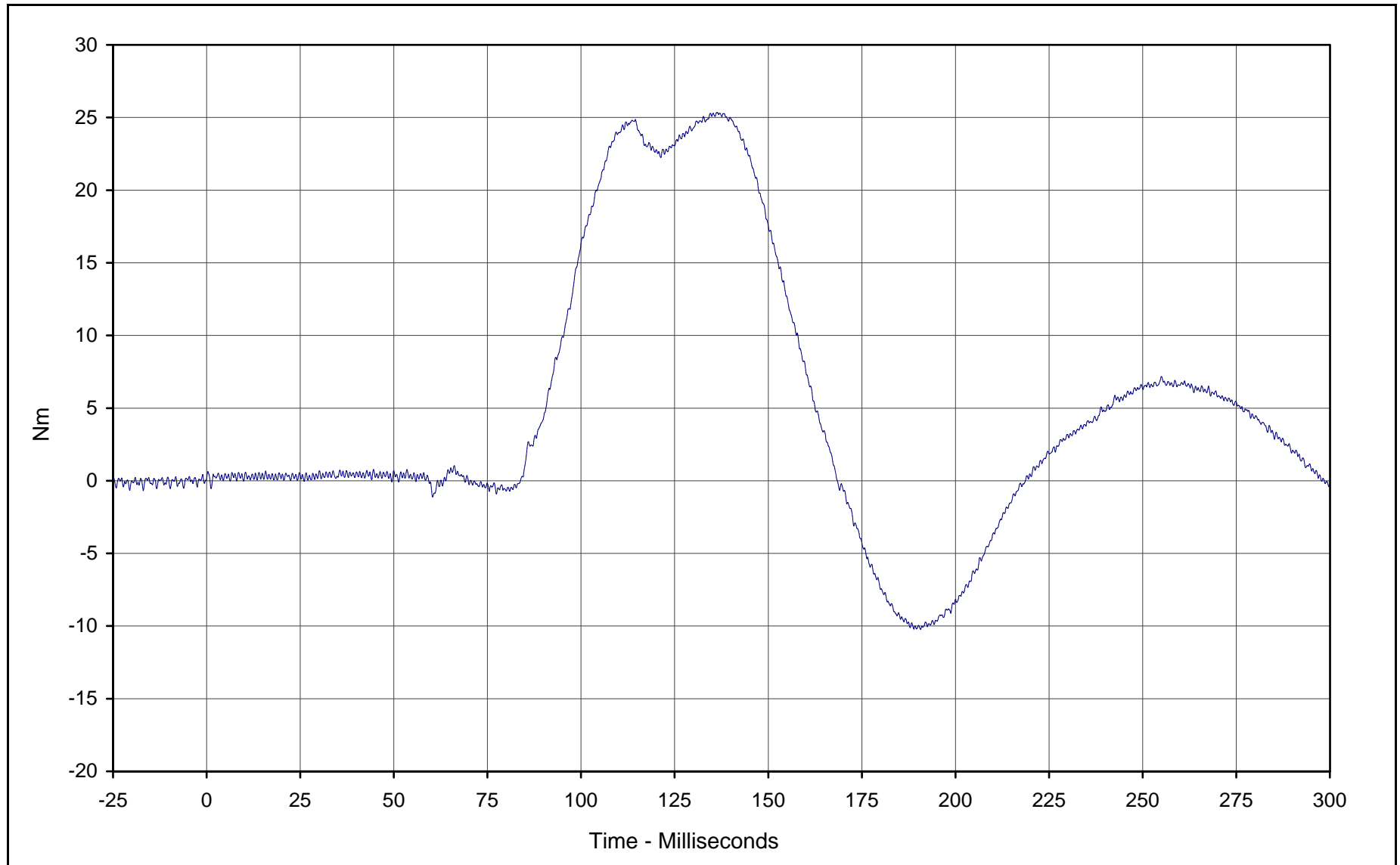

Curve Description: Driver Neck Moment Z
Maximum Value: 25.3 at 136.2 Milliseconds
Minimum Value: -10.2 at 190.7 Milliseconds
SAE Filter Class: 600
Date of Test: 08/15/00
Curve Number: FIL-012

Test Program: 2000 NHTSA 40% Offset No.: FORD01
Test Vehicle: 2000 Ford Expedition 4WD 4 Door SUV



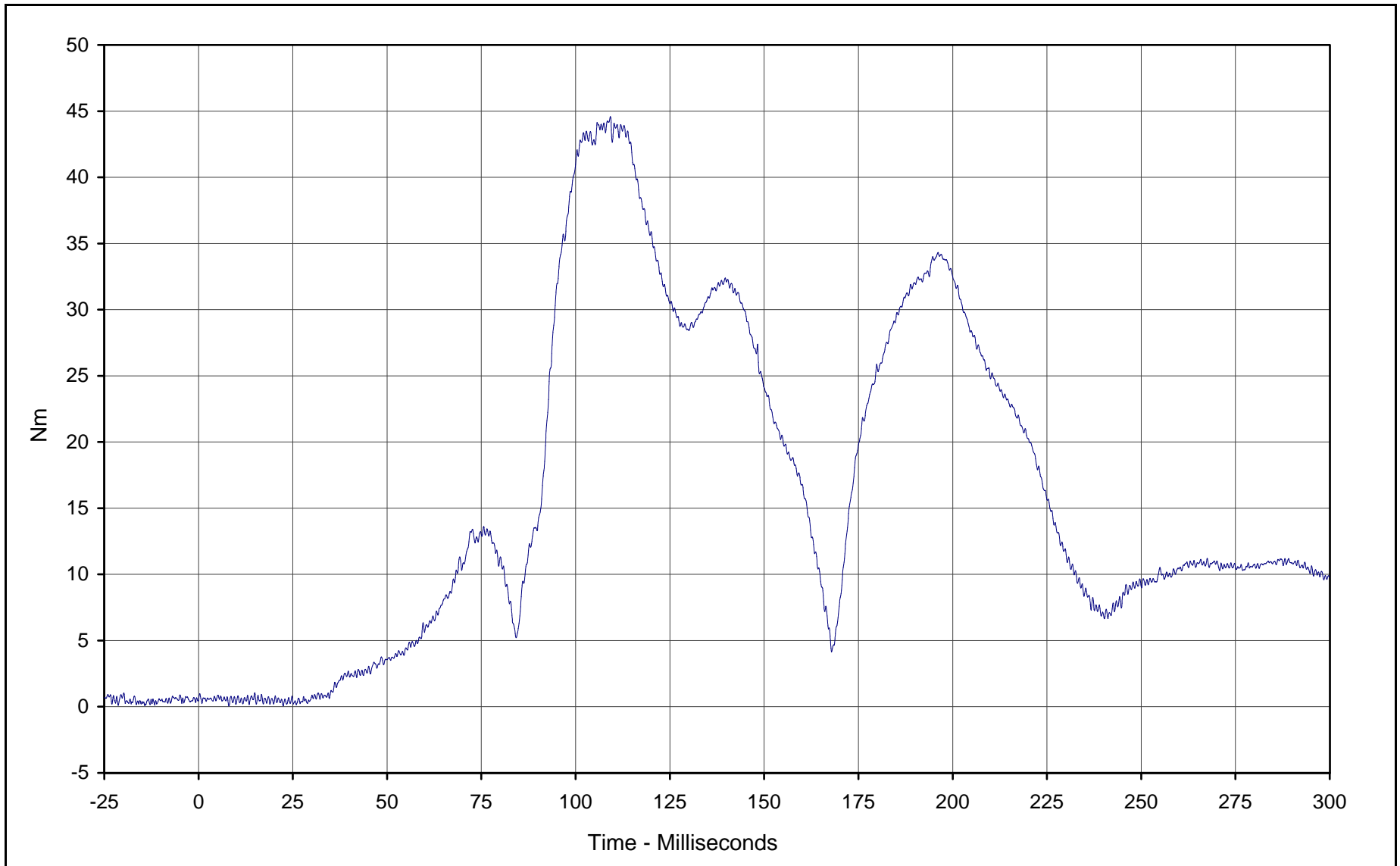

Curve Description: Driver Neck Moment Resultant
Maximum Value: 44.6 at 109.2 Milliseconds
Minimum Value: 0.0 at 8.0 Milliseconds
SAE Filter Class: 600
Date of Test: 08/15/00
Curve Number: RES-010

Test Program: 2000 NHTSA 40% Offset No.: FORD01
Test Vehicle: 2000 Ford Expedition 4WD 4 Door SUV



B-21

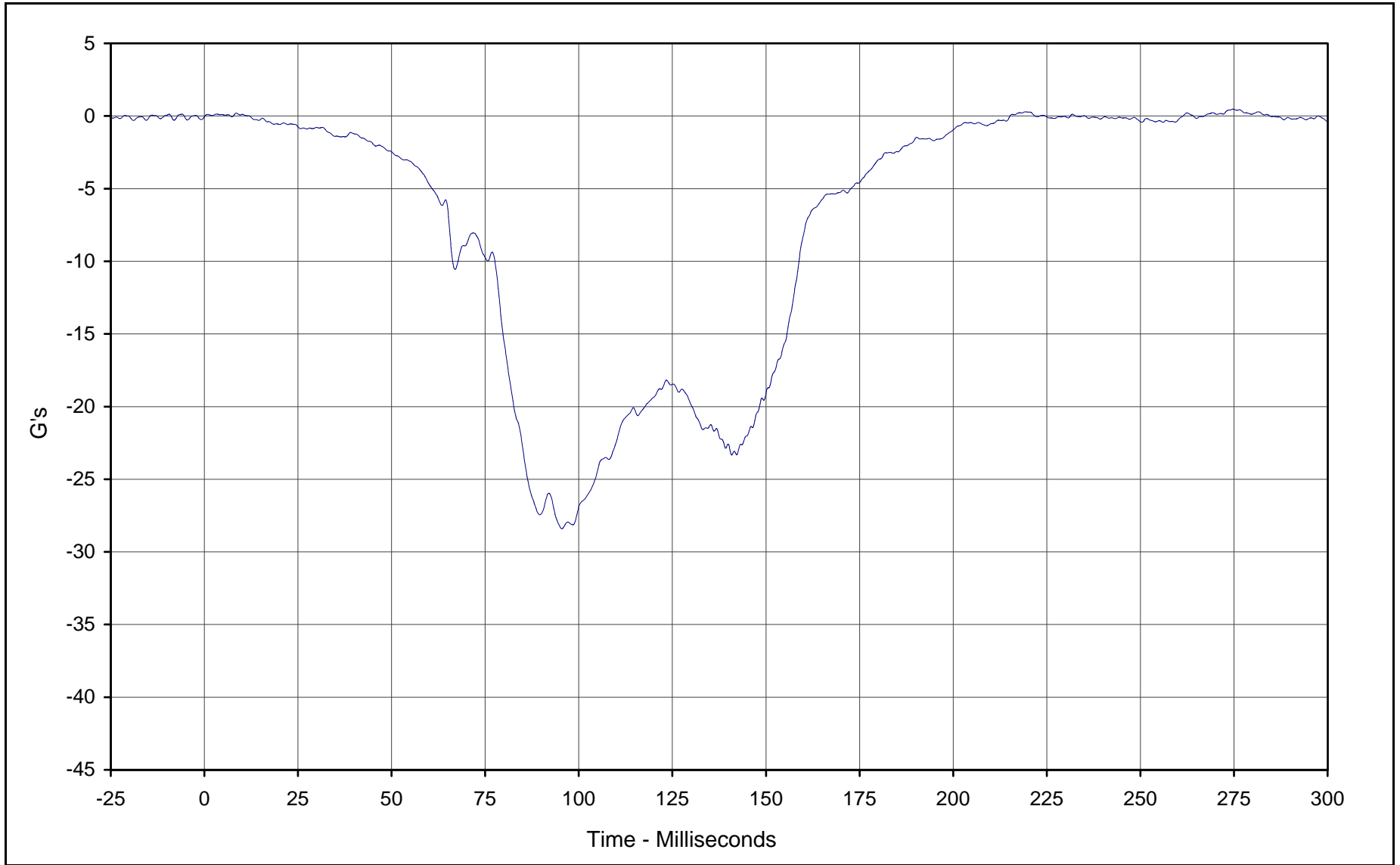

Curve Description: Driver Chest Primary X
Maximum Value: 0.5 at 274.7 Milliseconds
Minimum Value: -28.4 at 95.5 Milliseconds
SAE Filter Class: 180
Date of Test: 08/15/00
Curve Number: FIL-013

Test Program: 2000 NHTSA 40% Offset No.: FORD01
Test Vehicle: 2000 Ford Expedition 4WD 4 Door SUV



KARR20002-02

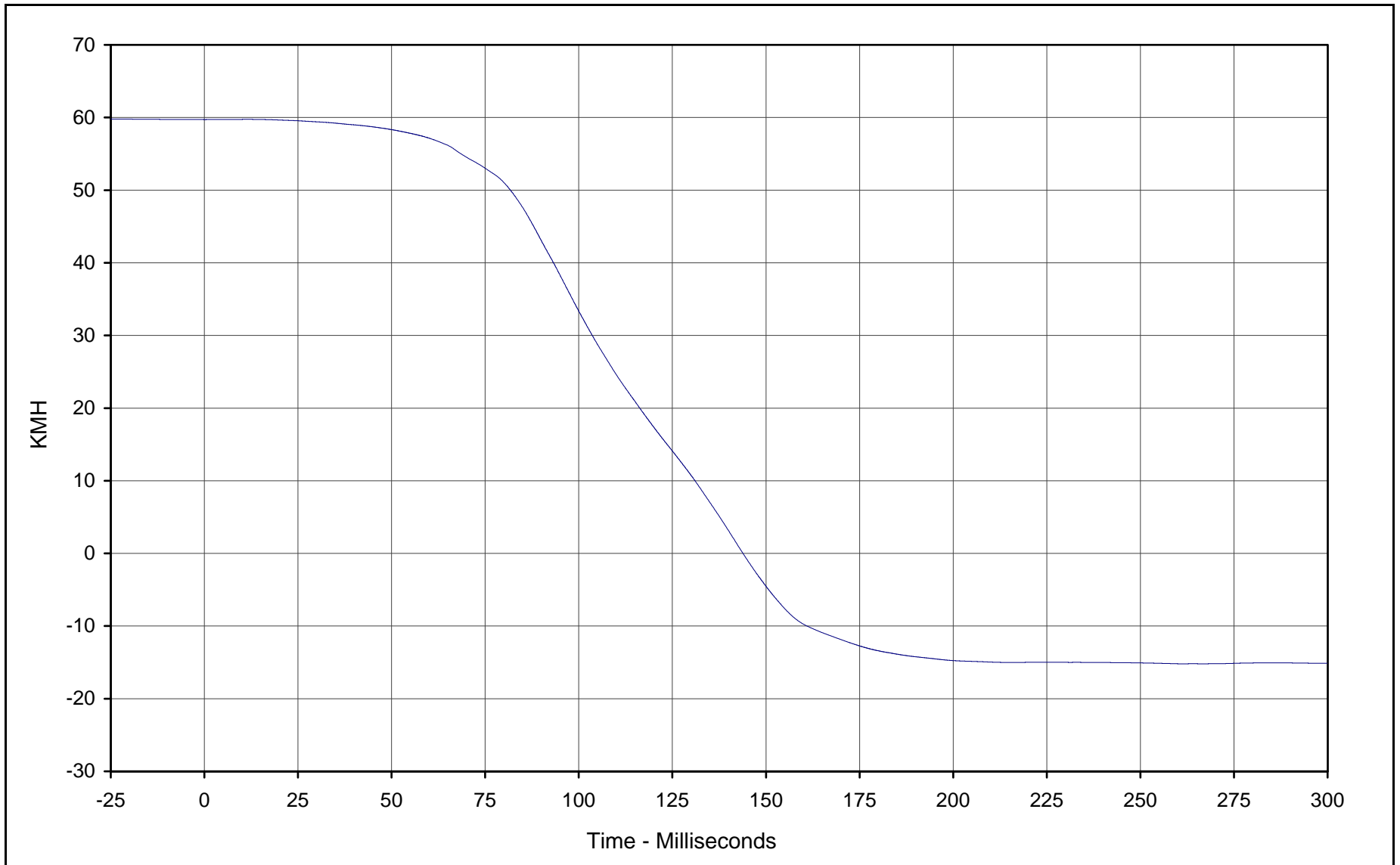

Curve Description: Driver Chest Primary X Velocity
Maximum Value: 59.7 at 12.1 Milliseconds
Minimum Value: -15.2 at 261.4 Milliseconds
SAE Filter Class: 180
Date of Test: 08/15/00
Curve Number: IN1-013

Test Program: 2000 NHTSA 40% Offset No.: FORD01
Test Vehicle: 2000 Ford Expedition 4WD 4 Door SUV



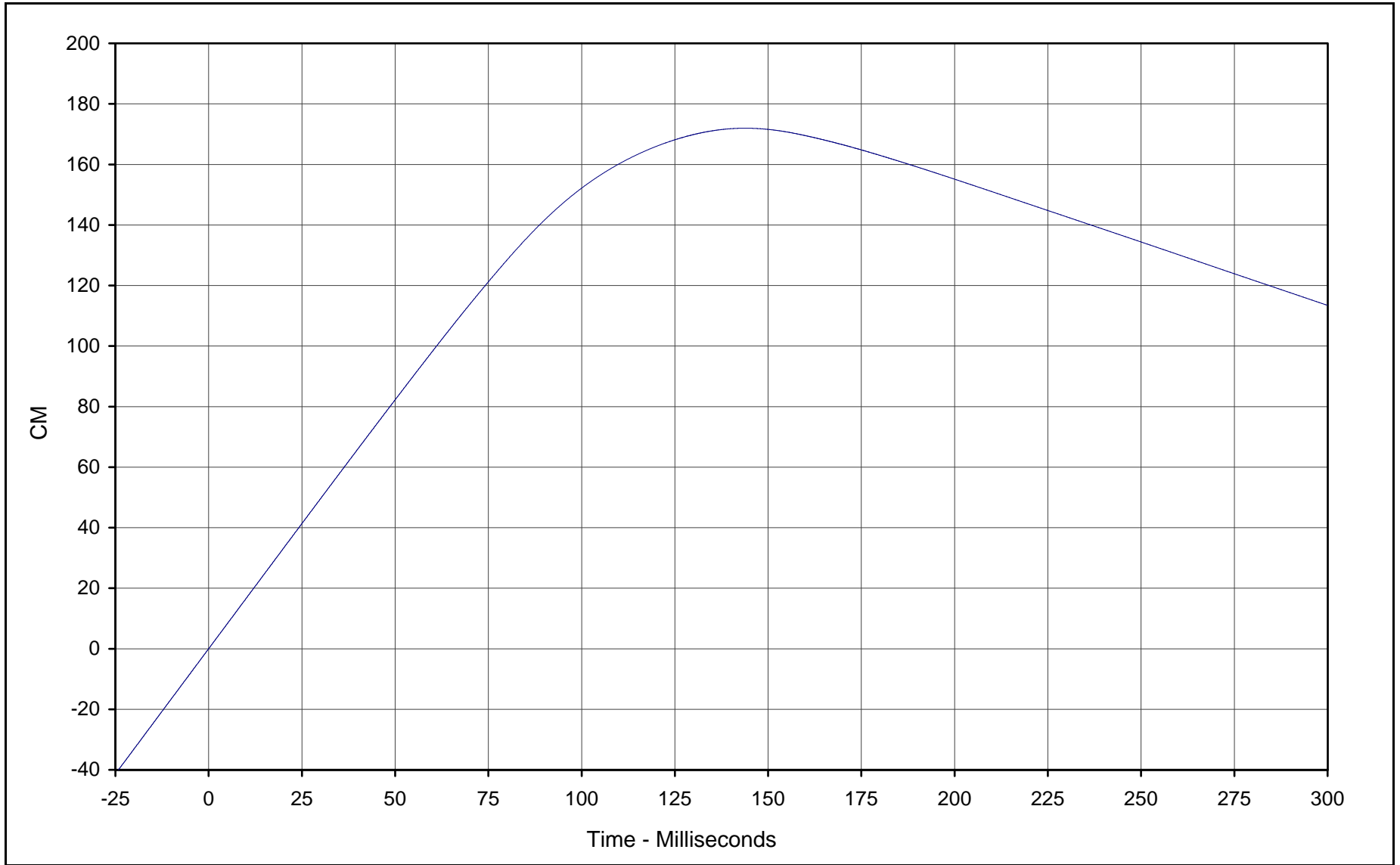

Curve Description: Driver Chest Primary X Displ.
Maximum Value: 172.0 at 143.9 Milliseconds
Minimum Value: 0.0 at 0.0 Milliseconds
SAE Filter Class: 180
Date of Test: 08/15/00
Curve Number: IN2-013

Test Program: 2000 NHTSA 40% Offset No.: FORD01
Test Vehicle: 2000 Ford Expedition 4WD 4 Door SUV



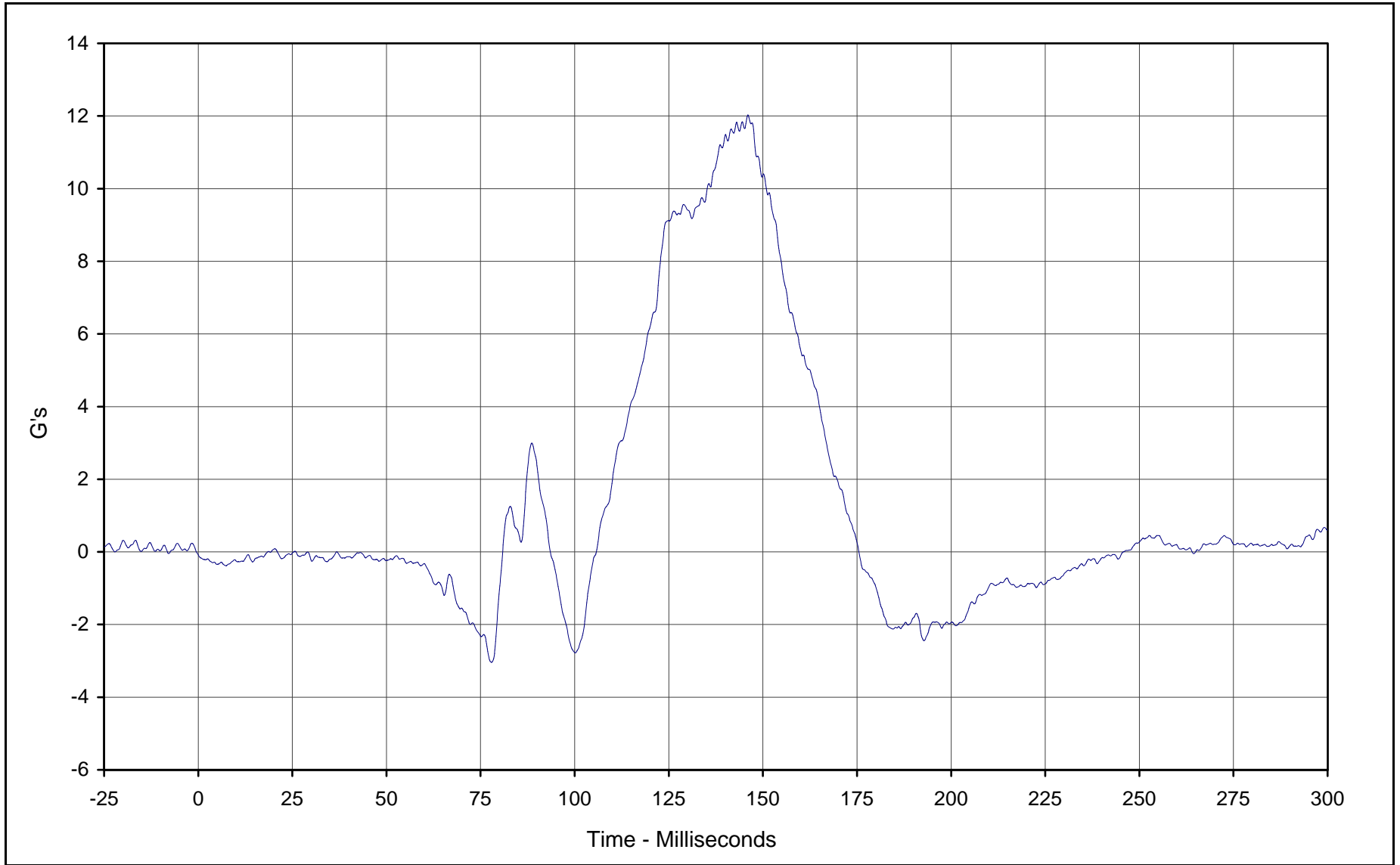

Curve Description: Driver Chest Primary Y
Maximum Value: 12.0 at 146.0 Milliseconds
Minimum Value: -3.0 at 77.9 Milliseconds
SAE Filter Class: 180
Date of Test: 08/15/00
Curve Number: FIL-014

Test Program: 2000 NHTSA 40% Offset No.: FORD01
Test Vehicle: 2000 Ford Expedition 4WD 4 Door SUV



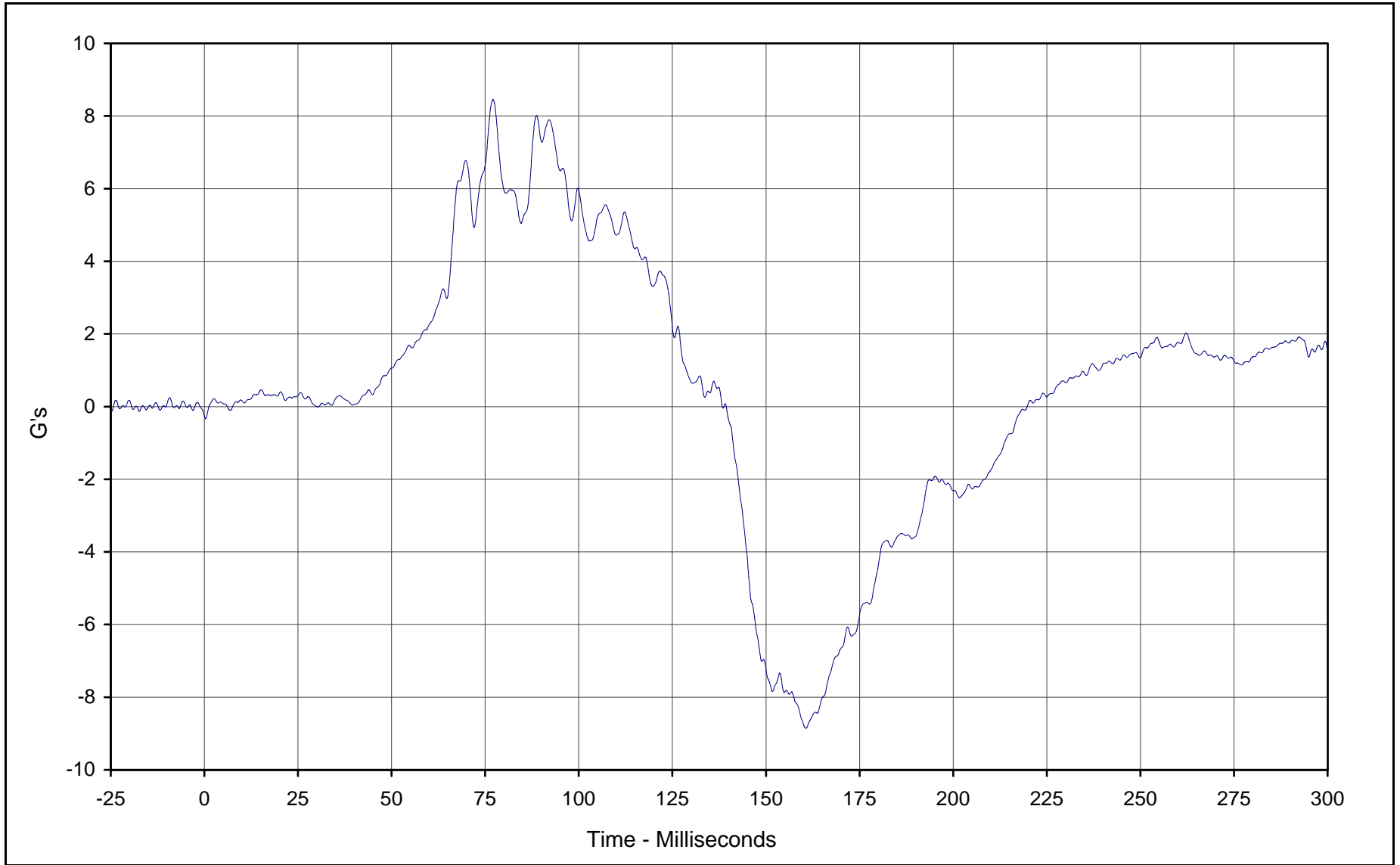

Curve Description: Driver Chest Primary Z
 Maximum Value: 8.5 at 77.1 Milliseconds
 Minimum Value: -8.9 at 160.6 Milliseconds
 SAE Filter Class: 180
 Date of Test: 08/15/00
 Curve Number: FIL-015

Test Program: 2000 NHTSA 40% Offset No.: FORD01
 Test Vehicle: 2000 Ford Expedition 4WD 4 Door SUV



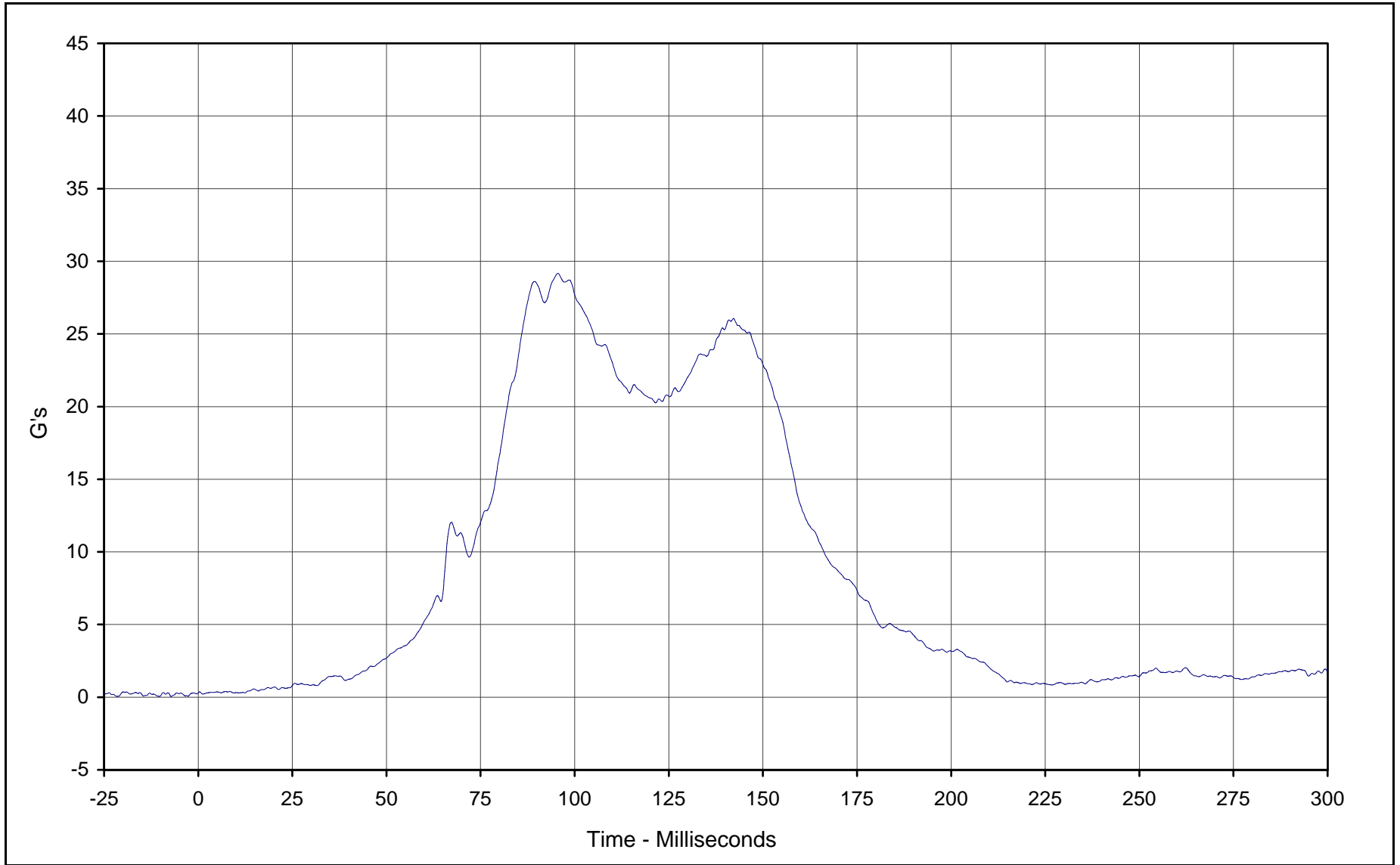

Curve Description: Driver Chest Resultant Primary
 Maximum Value: 29.2 at 95.5 Milliseconds
 Minimum Value: 0.2 at 1.2 Milliseconds
 SAE Filter Class: 180
 Date of Test: 08/15/00
 Curve Number: RES-013

Test Program: 2000 NHTSA 40% Offset No.: FORD01
 Test Vehicle: 2000 Ford Expedition 4WD 4 Door SUV



B-27

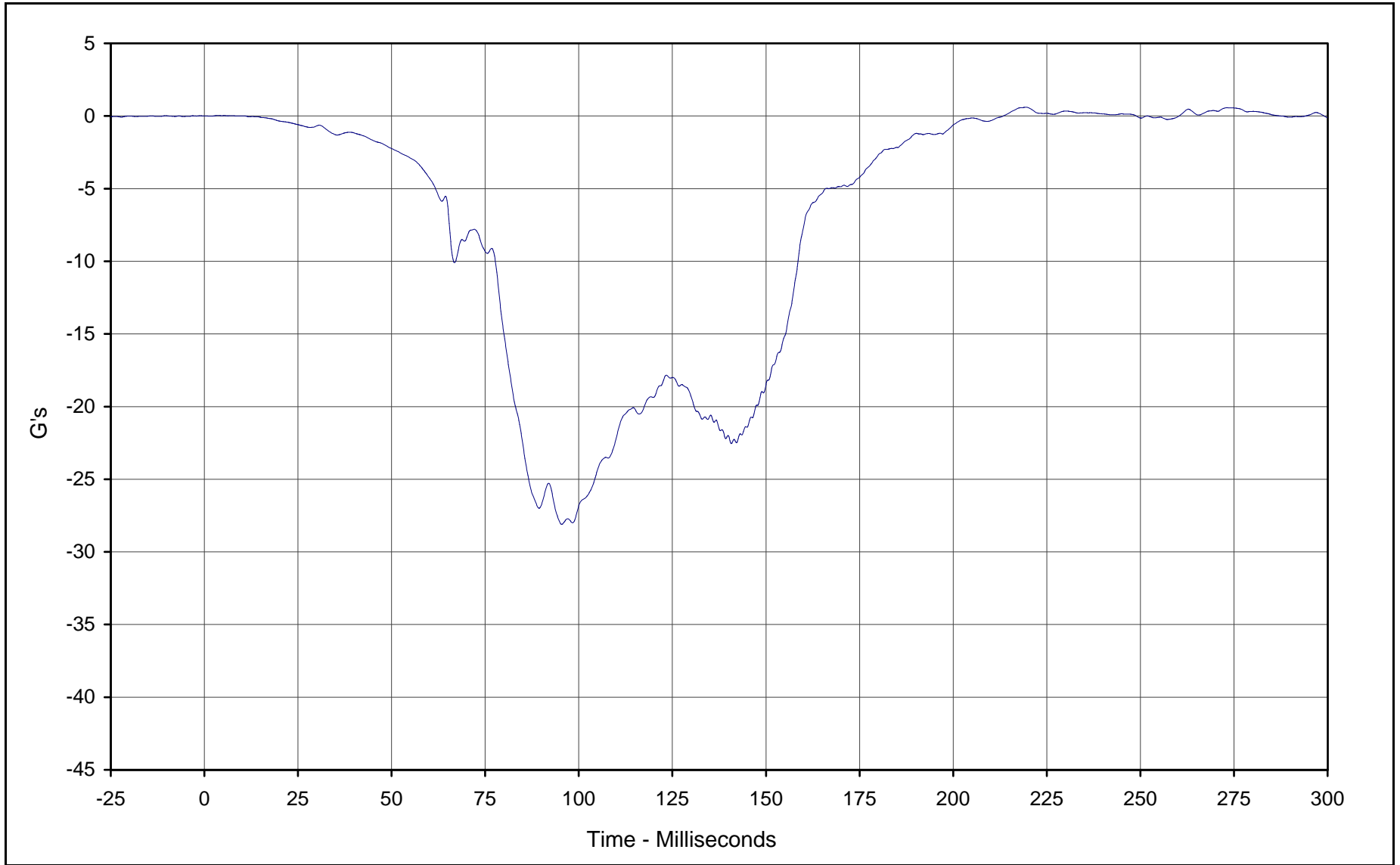

Curve Description: Driver Chest Redundant X
Maximum Value: 0.6 at 219.4 Milliseconds
Minimum Value: -28.1 at 95.4 Milliseconds
SAE Filter Class: 180
Date of Test: 08/15/00
Curve Number: FIL-016

Test Program: 2000 NHTSA 40% Offset No.: FORD01
Test Vehicle: 2000 Ford Expedition 4WD 4 Door SUV



KARR20002-02

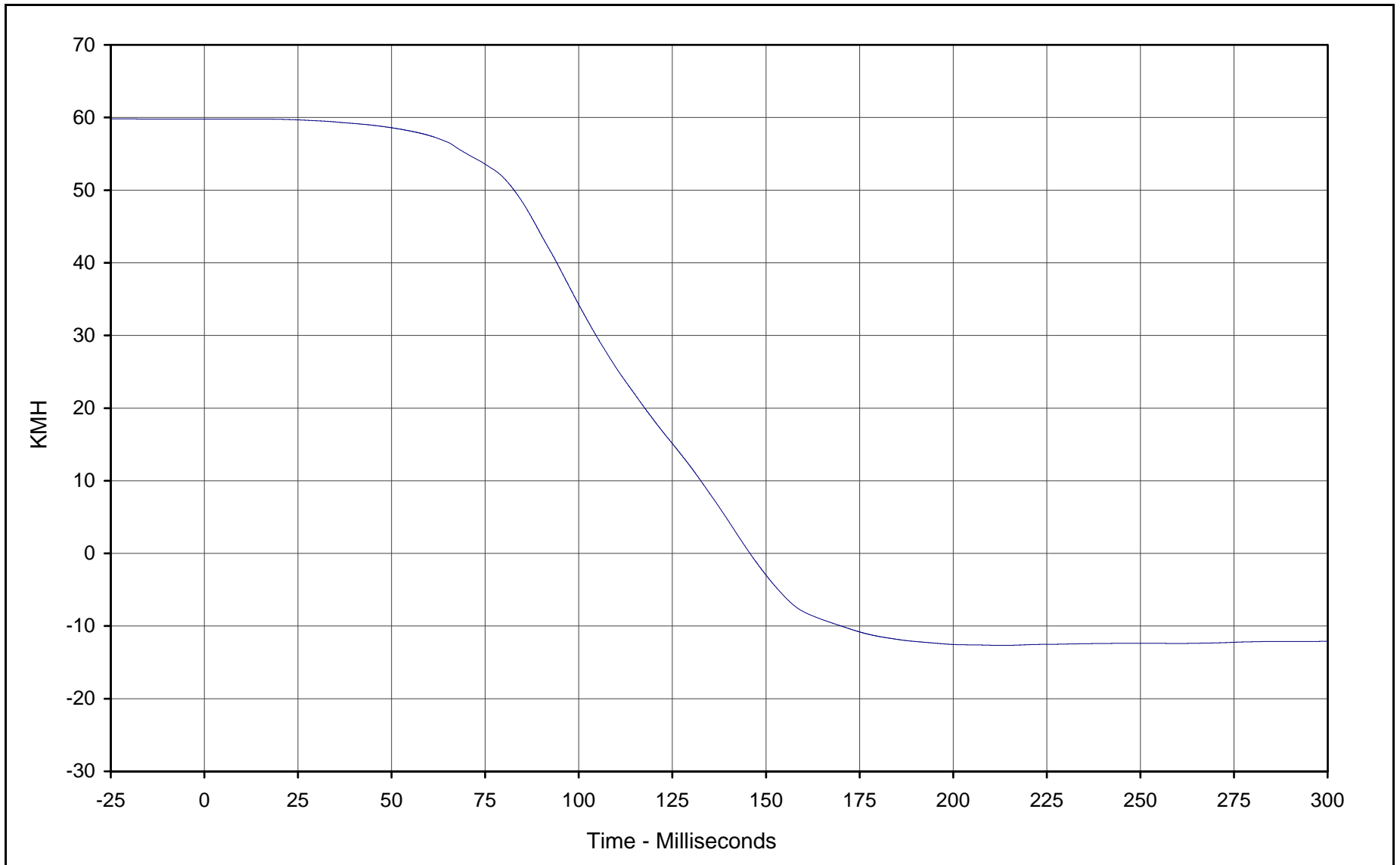

Curve Description: Driver Chest Redundant X Velocity
Maximum Value: 59.8 at 10.9 Milliseconds
Minimum Value: -12.7 at 213.3 Milliseconds
SAE Filter Class: 180
Date of Test: 08/15/00
Curve Number: IN1-016

Test Program: 2000 NHTSA 40% Offset No.: FORD01
Test Vehicle: 2000 Ford Expedition 4WD 4 Door SUV



B-29

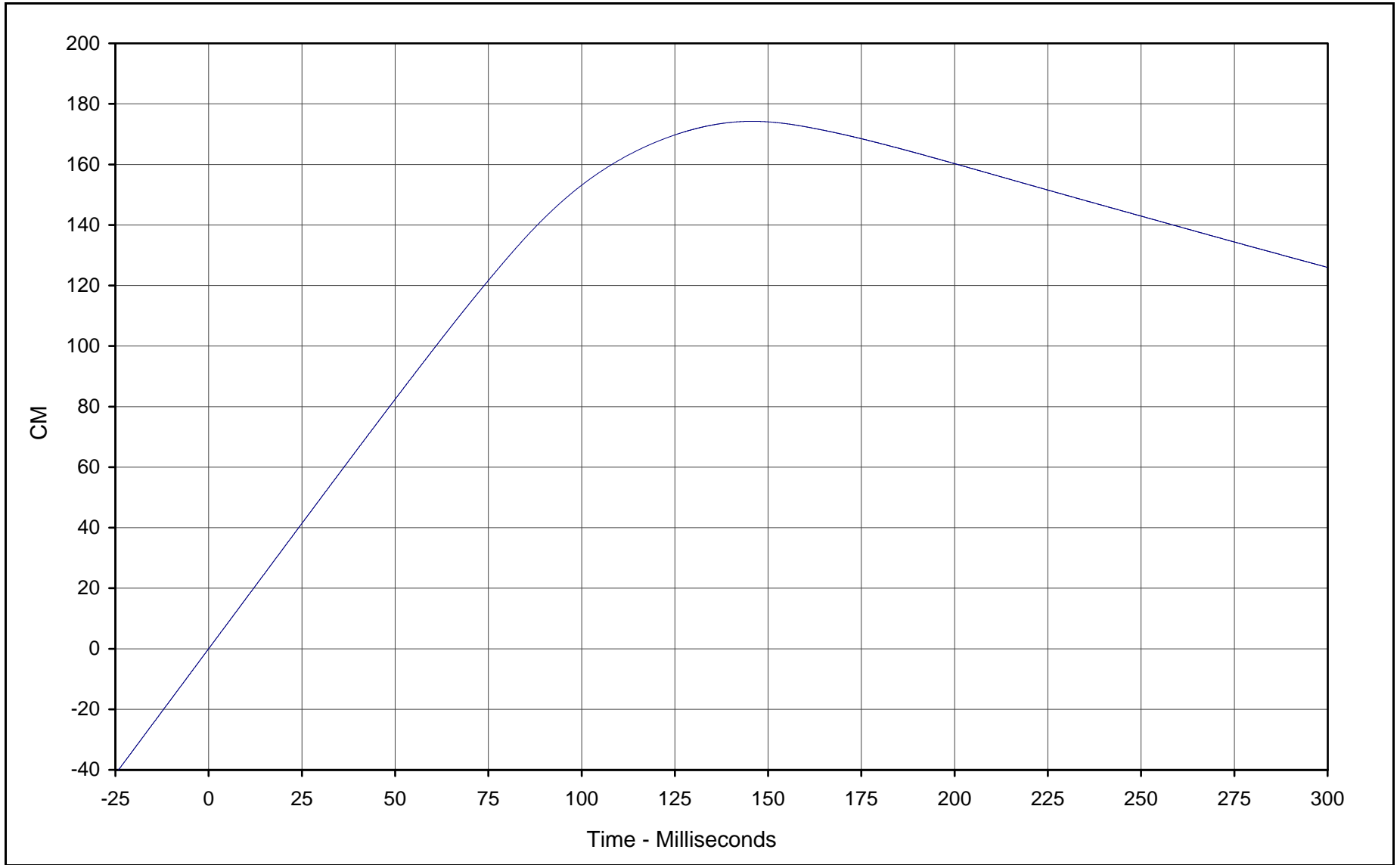

Curve Description: Driver Chest Redundant X Displ.
Maximum Value: 174.2 at 145.7 Milliseconds
Minimum Value: 0.0 at 0.0 Milliseconds
SAE Filter Class: 180
Date of Test: 08/15/00
Curve Number: IN2-016

Test Program: 2000 NHTSA 40% Offset No.: FORD01
Test Vehicle: 2000 Ford Expedition 4WD 4 Door SUV



KARR20002-02

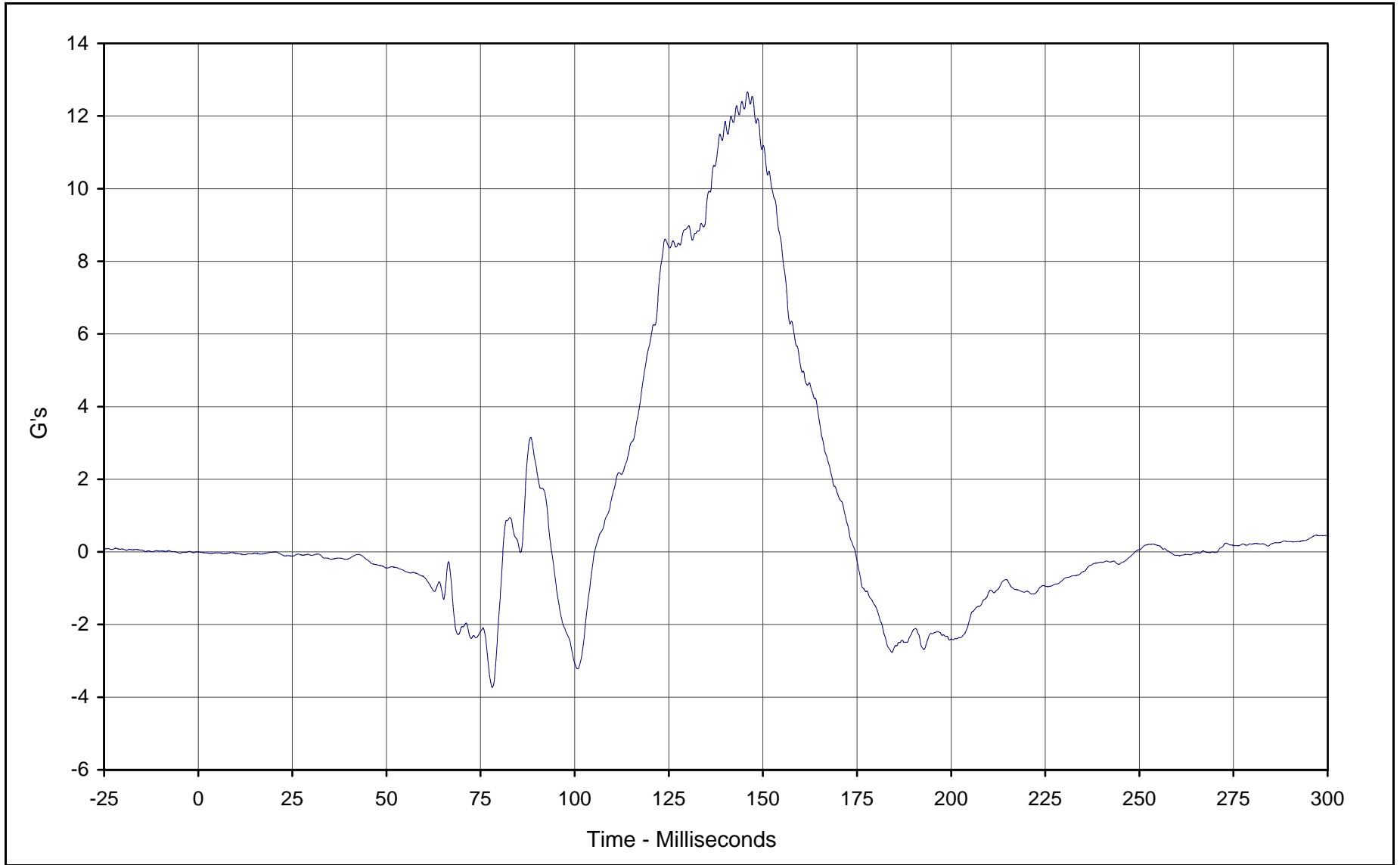

Curve Description: Driver Chest Redundant Y
Maximum Value: 12.7 at 145.9 Milliseconds
Minimum Value: -3.7 at 78.1 Milliseconds
SAE Filter Class: 180
Date of Test: 08/15/00
Curve Number: FIL-017

Test Program: 2000 NHTSA 40% Offset No.: FORD01
Test Vehicle: 2000 Ford Expedition 4WD 4 Door SUV



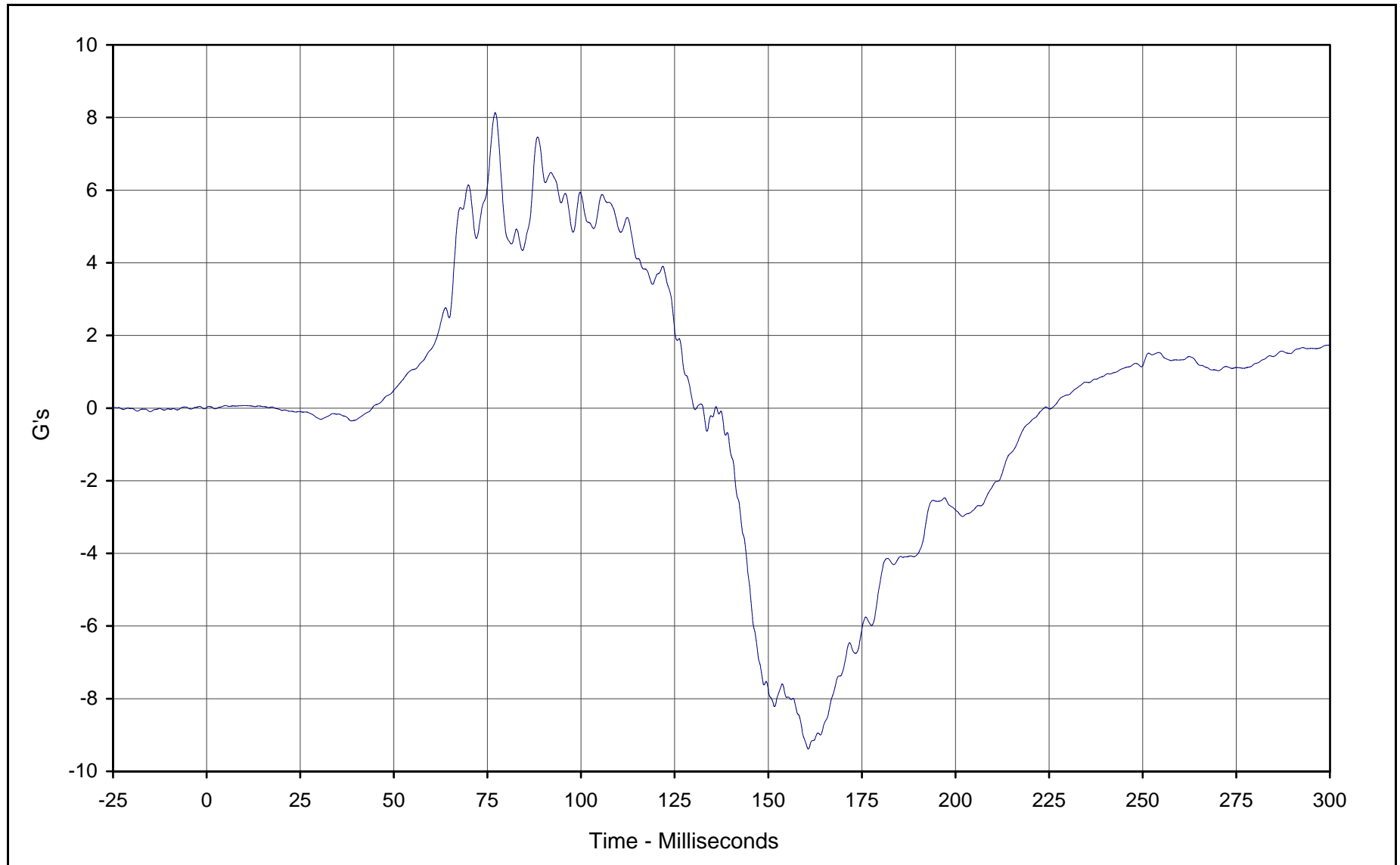

Curve Description: Driver Chest Redundant Z
 Maximum Value: 8.1 at 77.1 Milliseconds
 Minimum Value: -9.4 at 160.7 Milliseconds
 SAE Filter Class: 180
 Date of Test: 08/15/00
 Curve Number: FIL-018

Test Program: 2000 NHTSA 40% Offset No.: FORD01

Test Vehicle: 2000 Ford Expedition 4WD 4 Door SUV



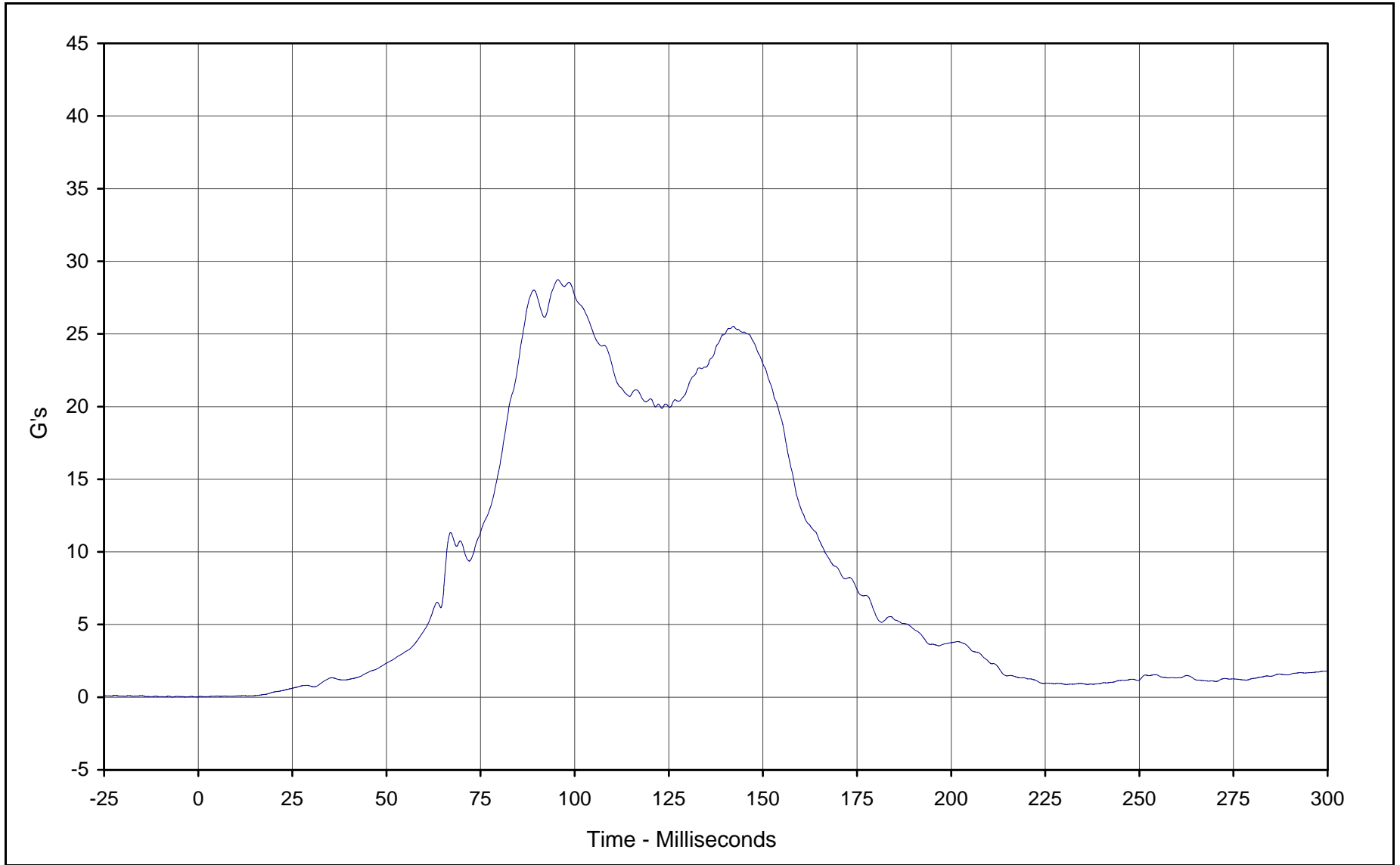

Curve Description: Driver Chest Resultant Redundant
 Maximum Value: 28.7 at 95.5 Milliseconds
 Minimum Value: 0.0 at 0.0 Milliseconds
 SAE Filter Class: 180
 Date of Test: 08/15/00
 Curve Number: RES-016

Test Program: 2000 NHTSA 40% Offset No.: FORD01
 Test Vehicle: 2000 Ford Expedition 4WD 4 Door SUV



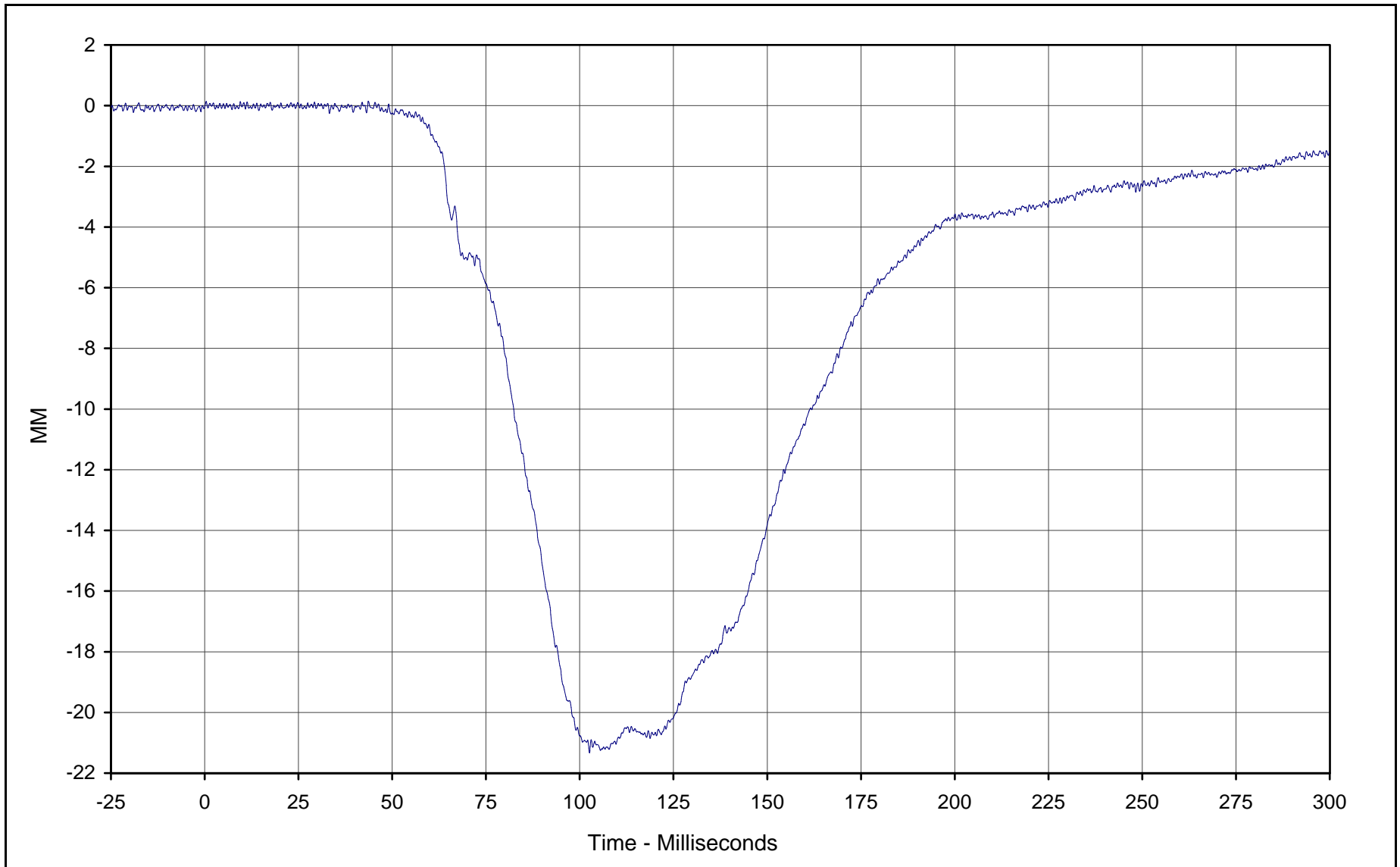

Curve Description: Driver Chest Displacement X
 Maximum Value: 0.1 at 43.7 Milliseconds
 Minimum Value: -21.3 at 102.6 Milliseconds
 SAE Filter Class: 600
 Date of Test: 08/15/00
 Curve Number: FIL-019

Test Program: 2000 NHTSA 40% Offset No.: FORD01

Test Vehicle: 2000 Ford Expedition 4WD 4 Door SUV



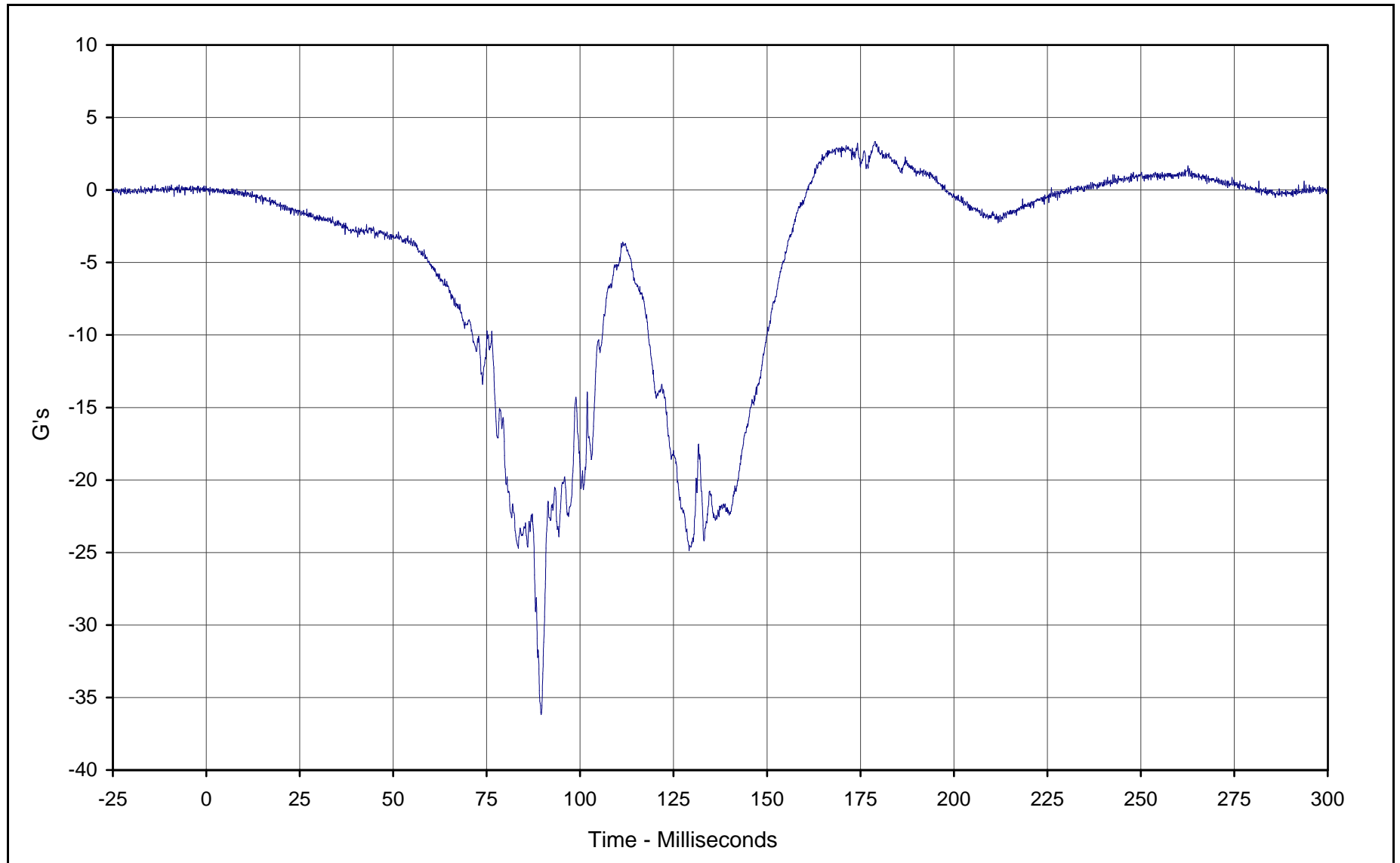

Curve Description: Driver Pelvis X
 Maximum Value: 3.3 at 178.8 Milliseconds
 Minimum Value: -36.2 at 89.6 Milliseconds
 SAE Filter Class: 1000
 Date of Test: 08/15/00
 Curve Number: FIL-020

Test Program: 2000 NHTSA 40% Offset No.: FORD01

Test Vehicle: 2000 Ford Expedition 4WD 4 Door SUV



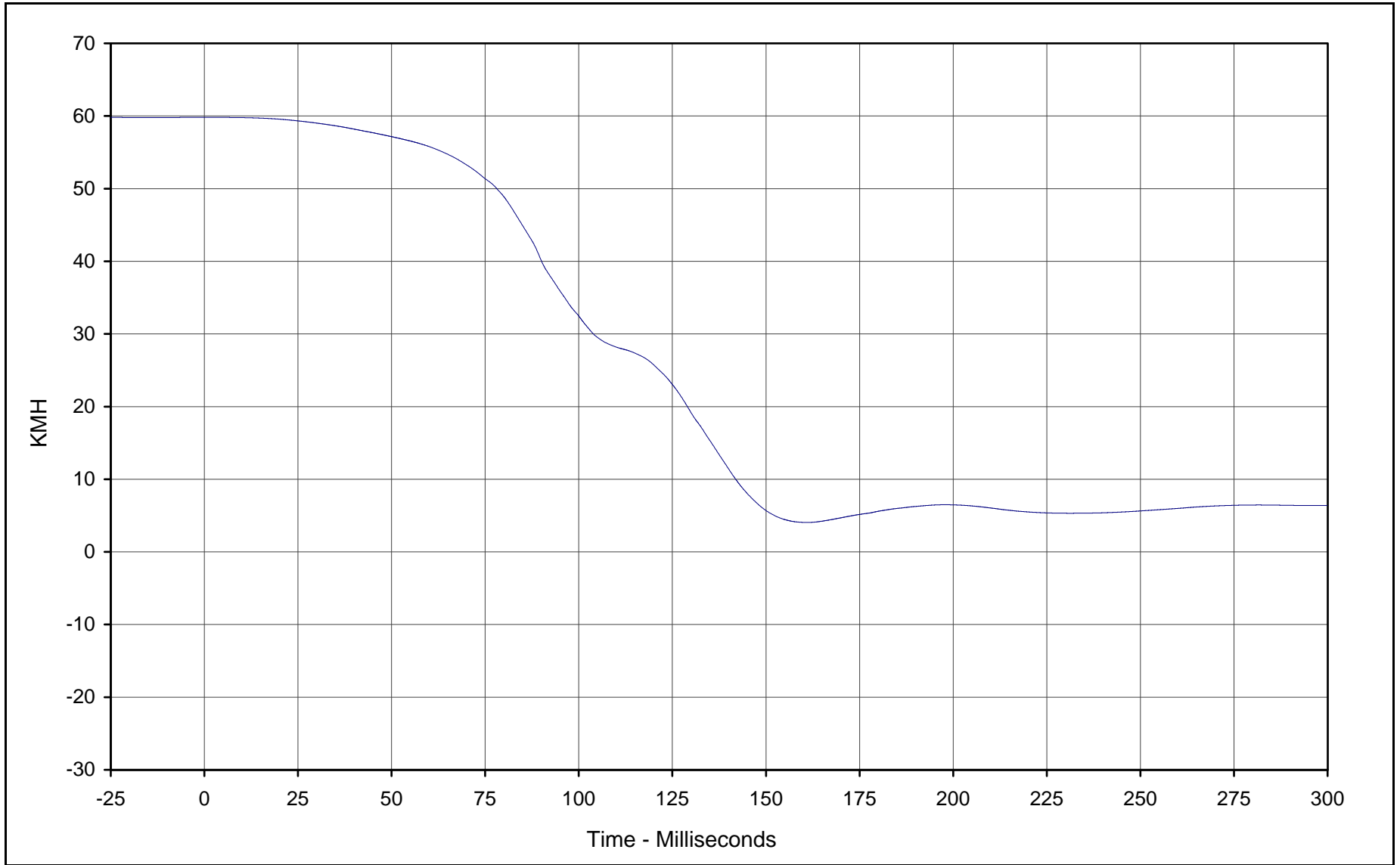

Curve Description: Driver Pelvis X Velocity
 Maximum Value: 59.8 at 0.7 Milliseconds
 Minimum Value: 4.0 at 160.8 Milliseconds
 SAE Filter Class: 180
 Date of Test: 08/15/00
 Curve Number: IN1-020

Test Program: 2000 NHTSA 40% Offset No.: FORD01
 Test Vehicle: 2000 Ford Expedition 4WD 4 Door SUV



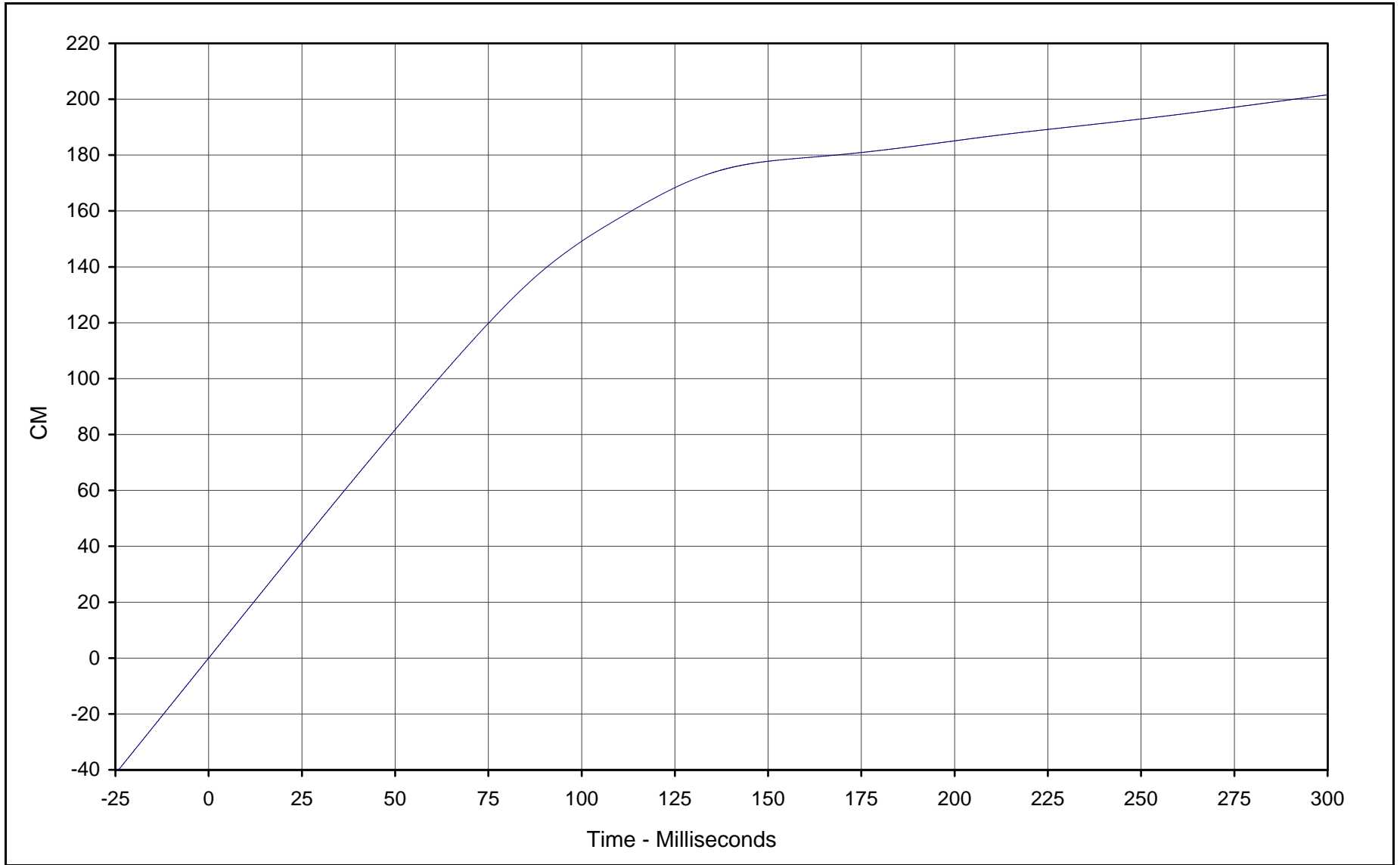

Curve Description: Driver Pelvis X Displ.
Maximum Value: 201.6 at 299.9 Milliseconds
Minimum Value: 0.0 at 0.0 Milliseconds
SAE Filter Class: 180
Date of Test: 08/15/00
Curve Number: IN2-020

Test Program: 2000 NHTSA 40% Offset No.: FORD01
Test Vehicle: 2000 Ford Expedition 4WD 4 Door SUV



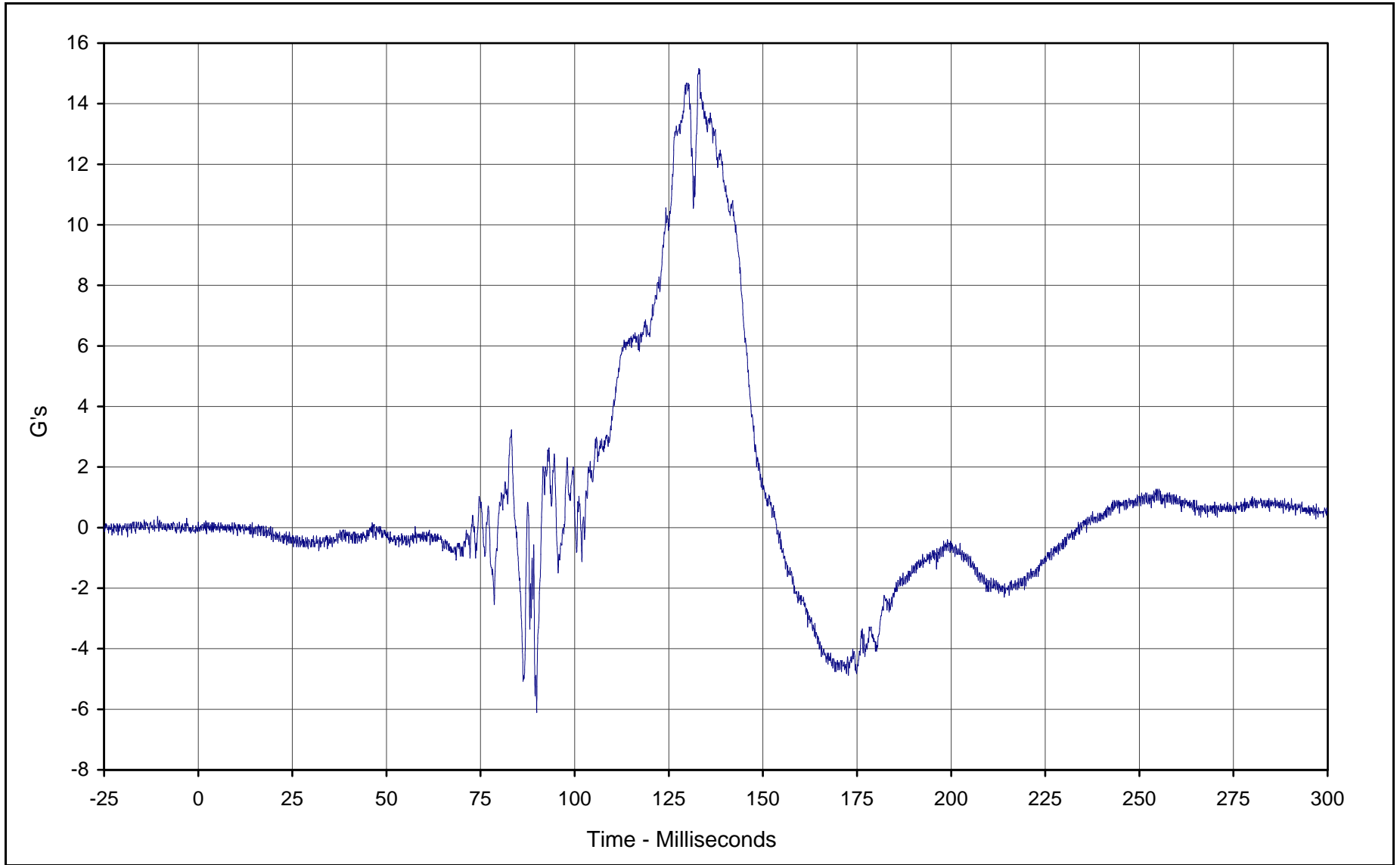

Curve Description: Driver Pelvis Y
 Maximum Value: 15.2 at 133.0 Milliseconds
 Minimum Value: -6.1 at 89.9 Milliseconds
 SAE Filter Class: 1000
 Date of Test: 08/15/00
 Curve Number: FIL-021

Test Program: 2000 NHTSA 40% Offset No.: FORD01
 Test Vehicle: 2000 Ford Expedition 4WD 4 Door SUV



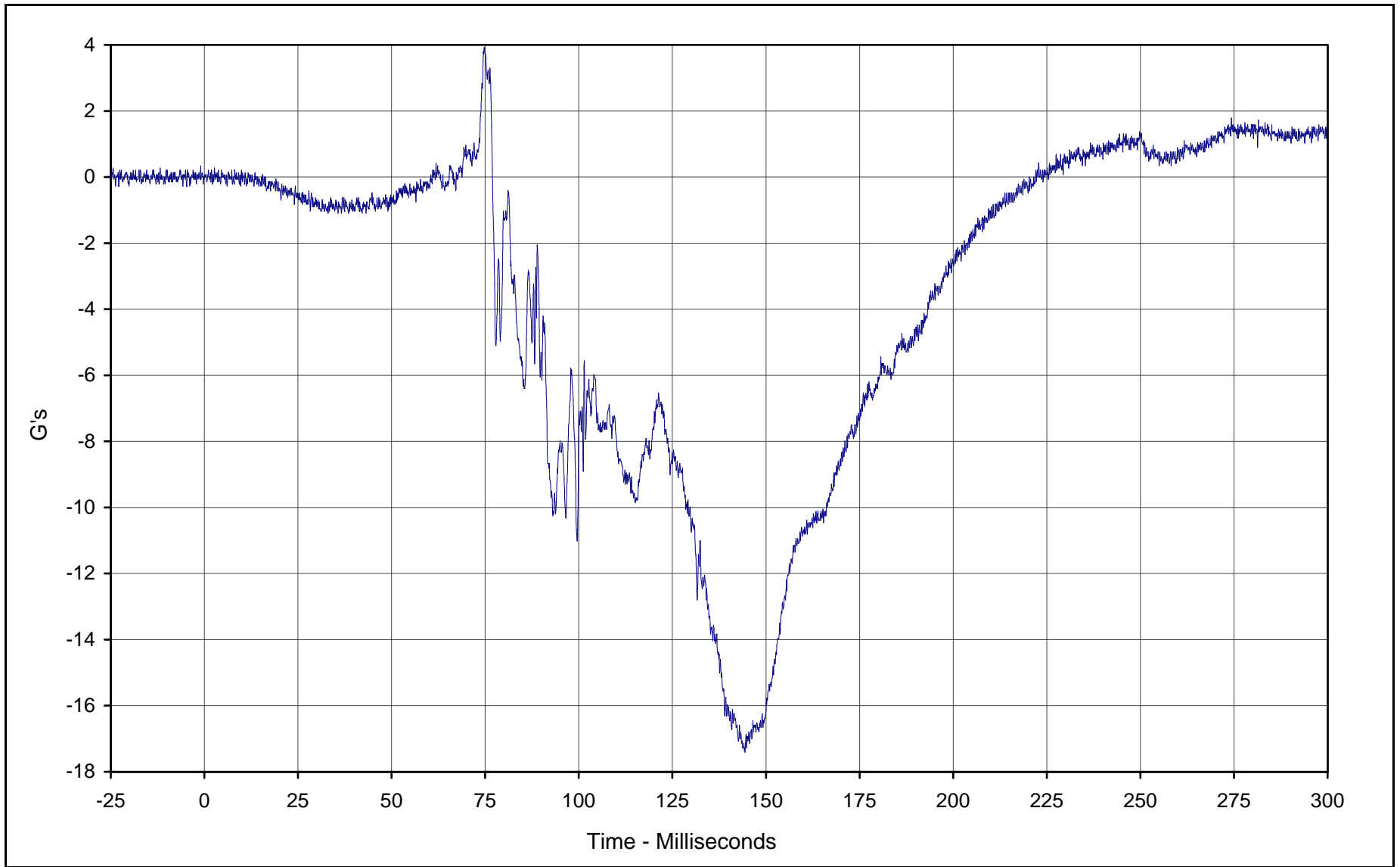

Curve Description: Driver Pelvis Z
 Maximum Value: 3.9 at 74.7 Milliseconds
 Minimum Value: -17.4 at 144.4 Milliseconds
 SAE Filter Class: 1000
 Date of Test: 08/15/00
 Curve Number: FIL-022

Test Program: 2000 NHTSA 40% Offset No.: FORD01
 Test Vehicle: 2000 Ford Expedition 4WD 4 Door SUV



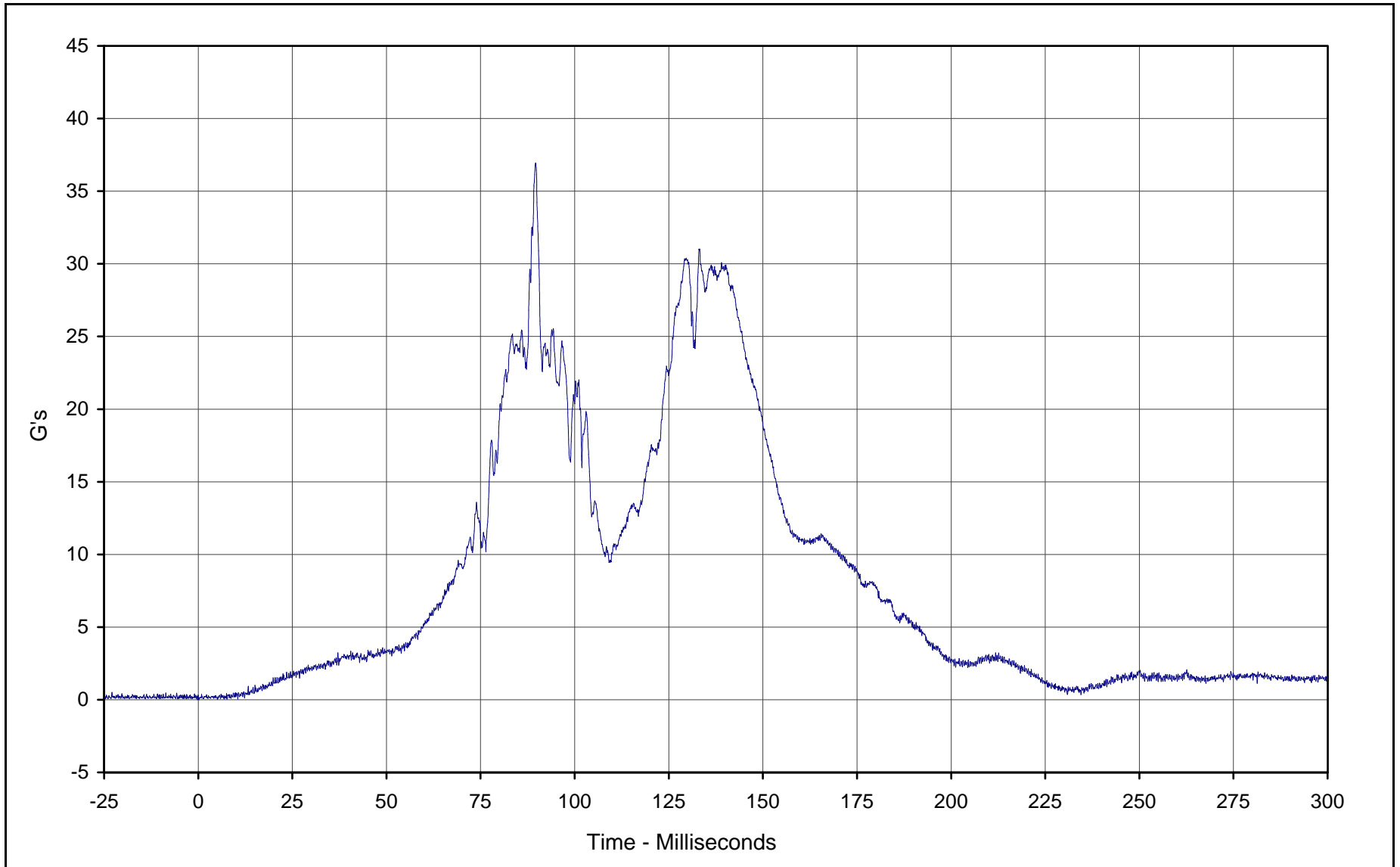

Curve Description: Driver Pelvis Resultant
Maximum Value: 36.9 at 89.6 Milliseconds
Minimum Value: 0.0 at 0.2 Milliseconds
SAE Filter Class: 1000
Date of Test: 08/15/00
Curve Number: RES-020

Test Program: 2000 NHTSA 40% Offset No.: FORD01
Test Vehicle: 2000 Ford Expedition 4WD 4 Door SUV



B-40

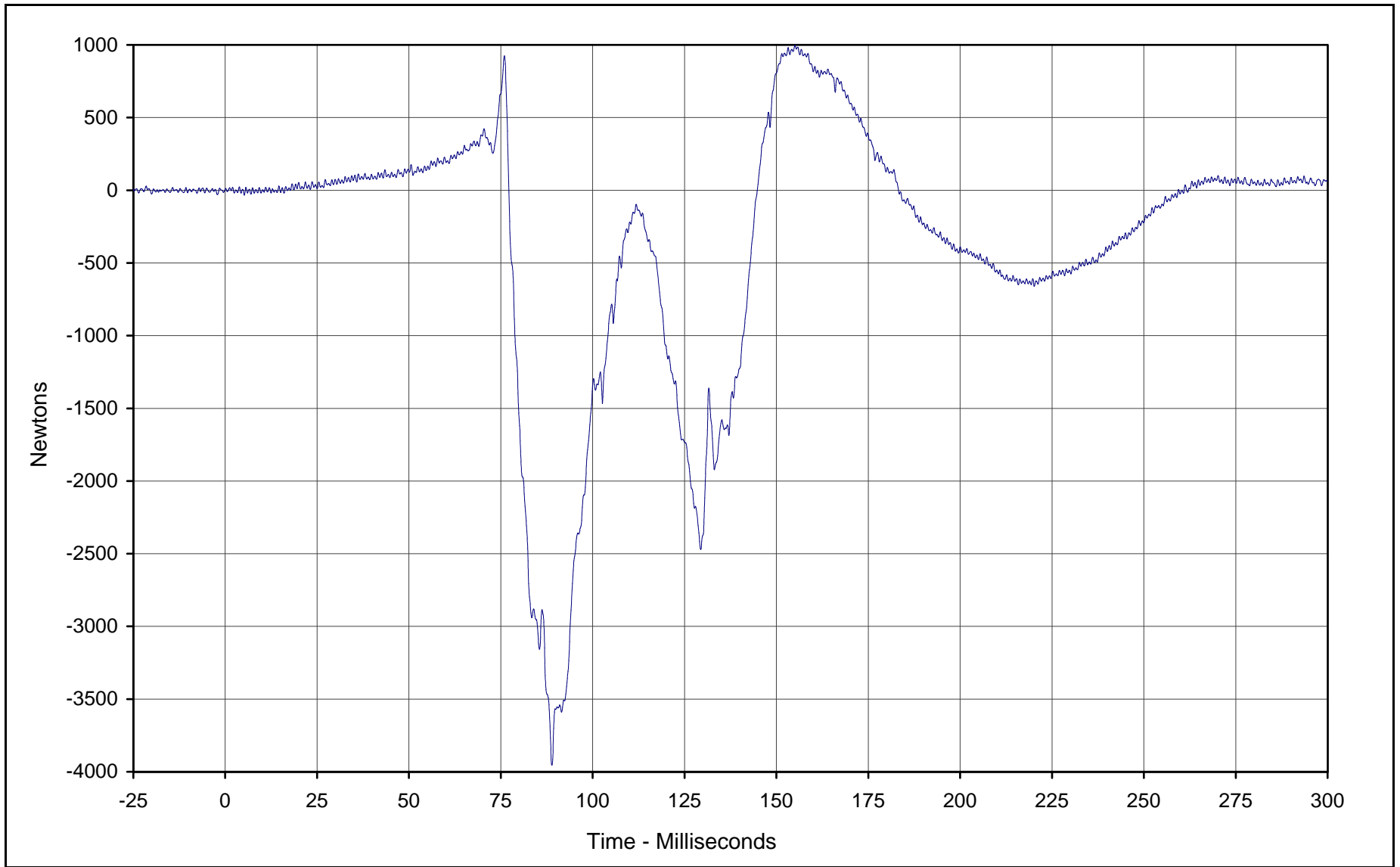

Curve Description: Driver Left Femur Force
Maximum Value: 999.3 at 155.0 Milliseconds
Minimum Value: -3956.3 at 88.9 Milliseconds
SAE Filter Class: 600
Date of Test: 08/15/00
Curve Number: FIL-023

Test Program: 2000 NHTSA 40% Offset No.: FORD01
Test Vehicle: 2000 Ford Expedition 4WD 4 Door SUV



KARR20002-02

B-41

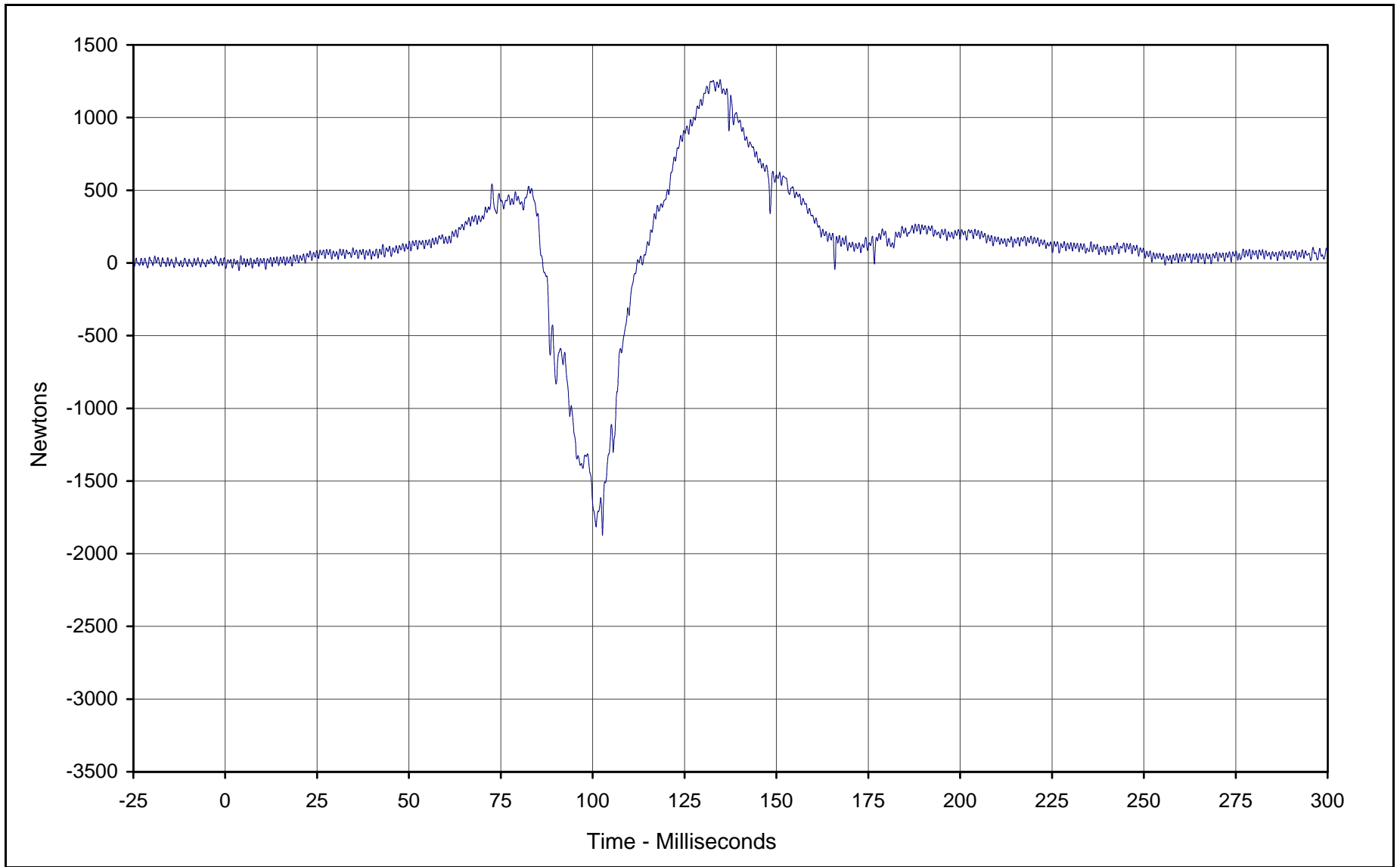

Curve Description: Driver Right Femur Force
Maximum Value: 1261.8 at 134.7 Milliseconds
Minimum Value: -1873.7 at 102.7 Milliseconds
SAE Filter Class: 600
Date of Test: 08/15/00
Curve Number: FIL-024

Test Program: 2000 NHTSA 40% Offset No.: FORD01
Test Vehicle: 2000 Ford Expedition 4WD 4 Door SUV



KARR20002-02

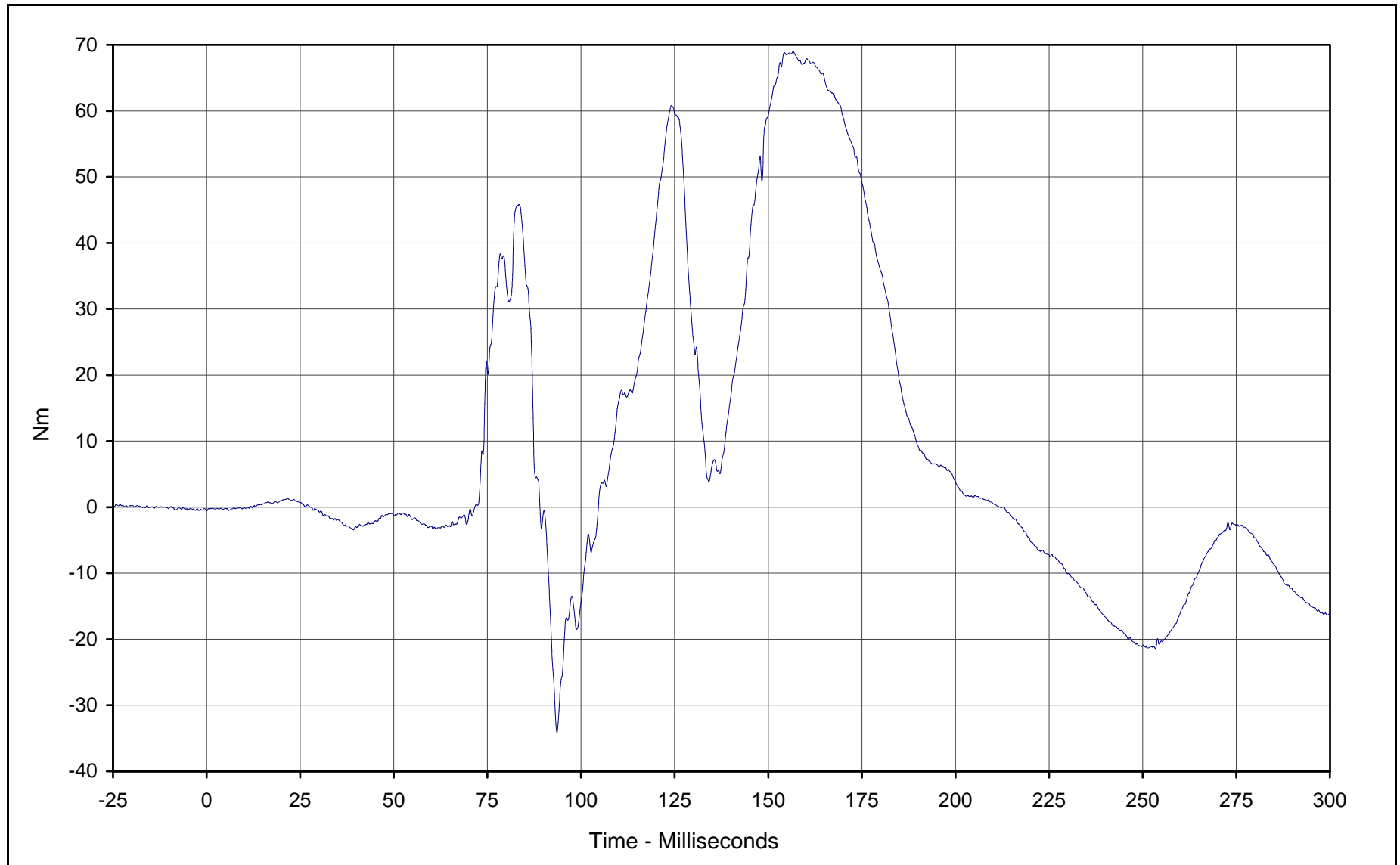

Curve Description: Driver Left Upper Tibia Moment X
Maximum Value: 69.0 at 156.6 Milliseconds
Minimum Value: -34.1 at 93.6 Milliseconds
SAE Filter Class: 600
Date of Test: 08/15/00
Curve Number: FIL-025

Test Program: 2000 NHTSA 40% Offset No.: FORD01
Test Vehicle: 2000 Ford Expedition 4WD 4 Door SUV



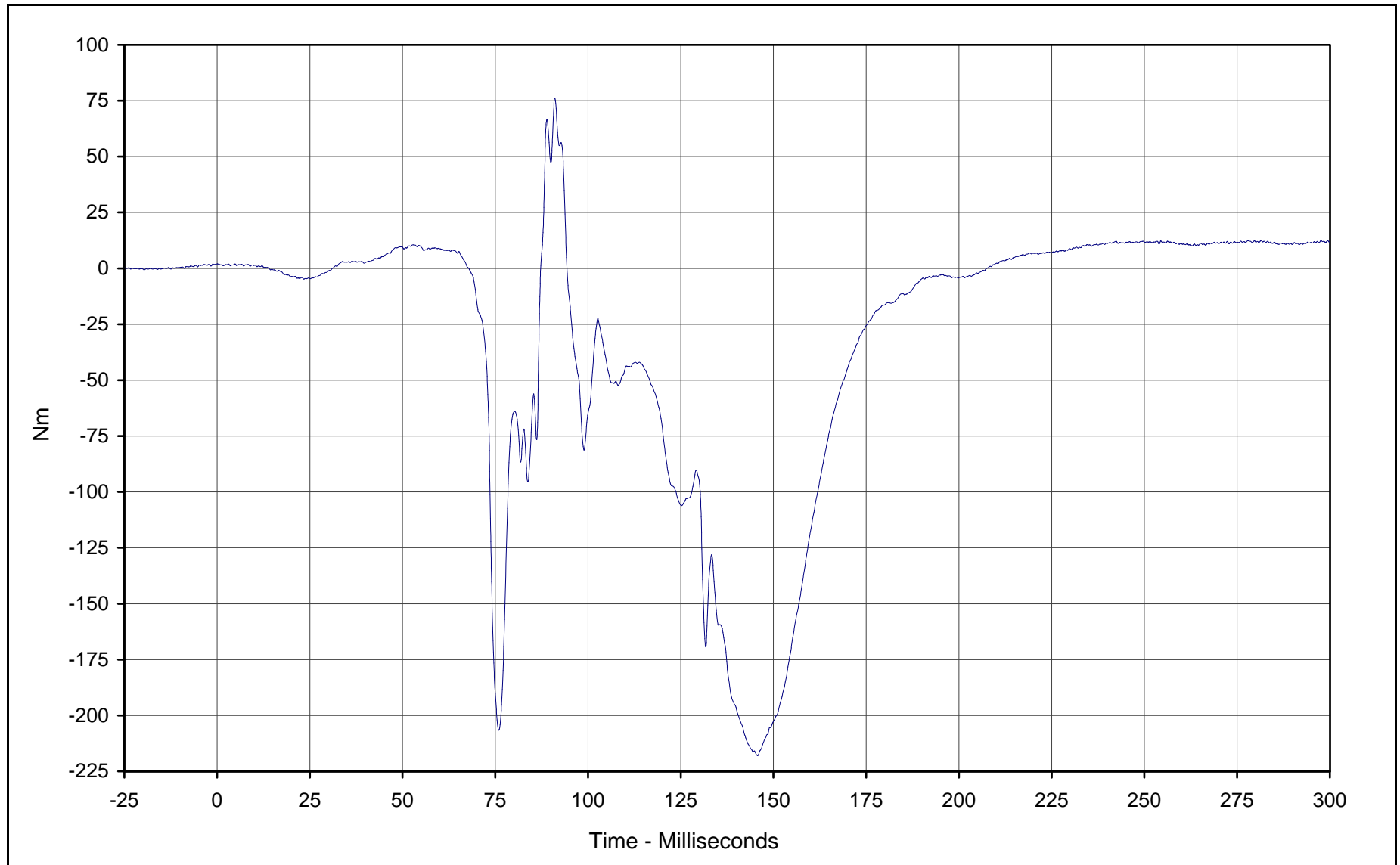

Curve Description: Driver Left Upper Tibia Moment Y
Maximum Value: 76.1 at 91.1 Milliseconds
Minimum Value: -218.0 at 145.7 Milliseconds
SAE Filter Class: 600
Date of Test: 08/15/00
Curve Number: FIL-026

Test Program: 2000 NHTSA 40% Offset No.: FORD01
Test Vehicle: 2000 Ford Expedition 4WD 4 Door SUV



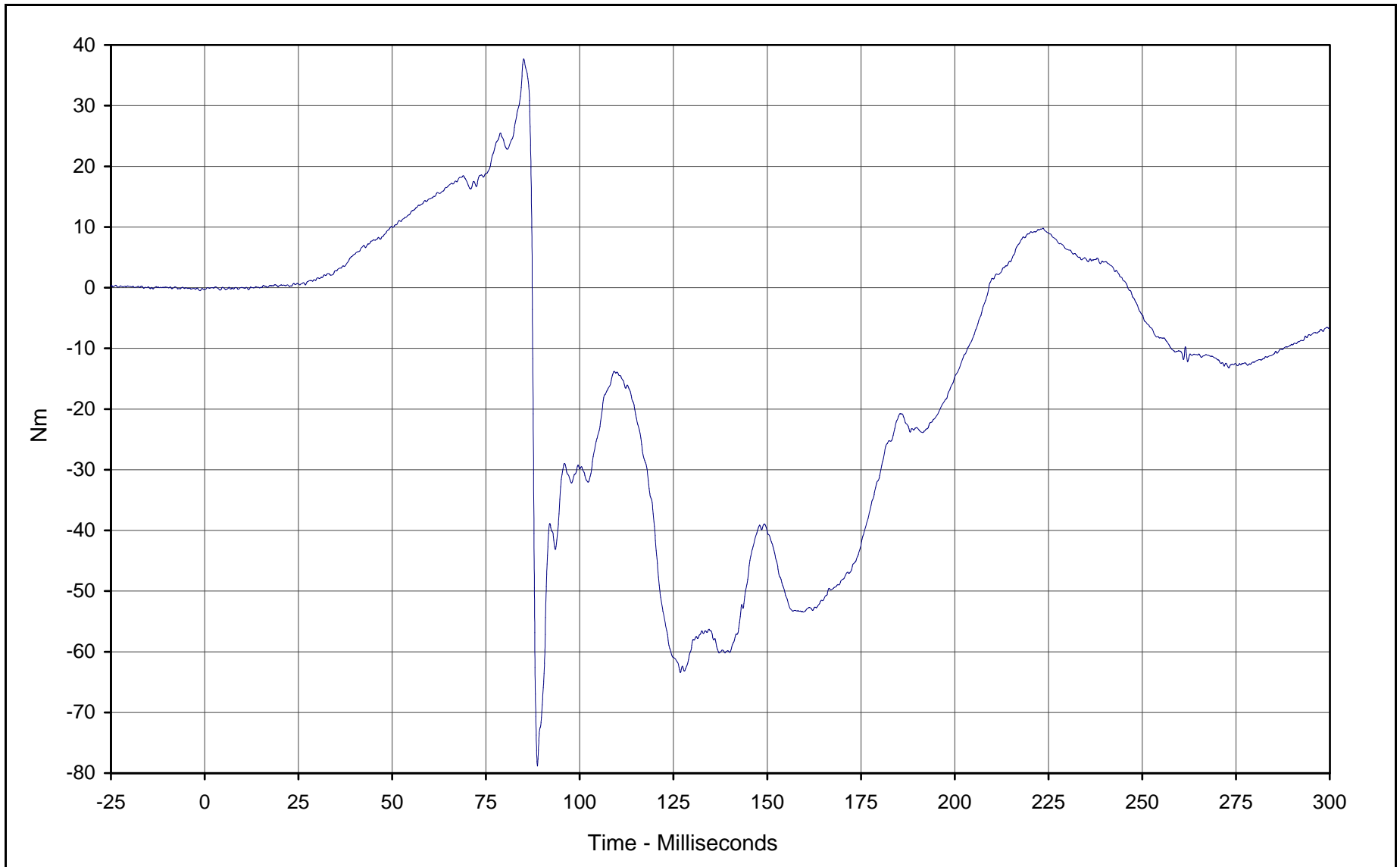

Curve Description: Driver Right Upper Tibia Moment X
 Maximum Value: 37.7 at 85.1 Milliseconds
 Minimum Value: -78.8 at 88.7 Milliseconds
 SAE Filter Class: 600
 Date of Test: 08/15/00
 Curve Number: FIL-027

Test Program: 2000 NHTSA 40% Offset No.: FORD01
 Test Vehicle: 2000 Ford Expedition 4WD 4 Door SUV



B-45

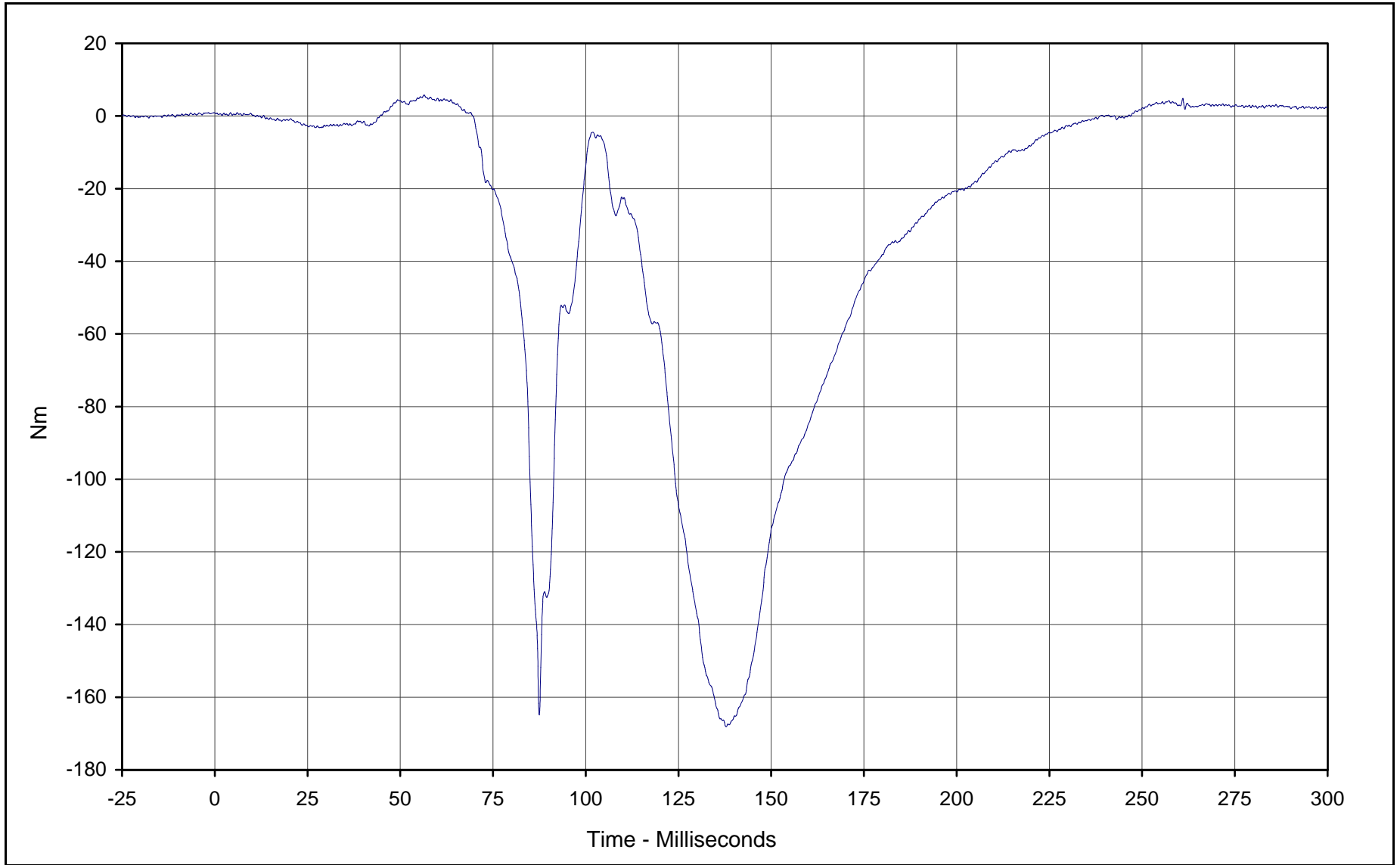

Curve Description: Driver Right Upper Tibia Moment Y
Maximum Value: 5.8 at 56.4 Milliseconds
Minimum Value: -168.1 at 137.8 Milliseconds
SAE Filter Class: 600
Date of Test: 08/15/00
Curve Number: FIL-028

Test Program: 2000 NHTSA 40% Offset No.: FORD01
Test Vehicle: 2000 Ford Expedition 4WD 4 Door SUV



KARR20002-02

B-46

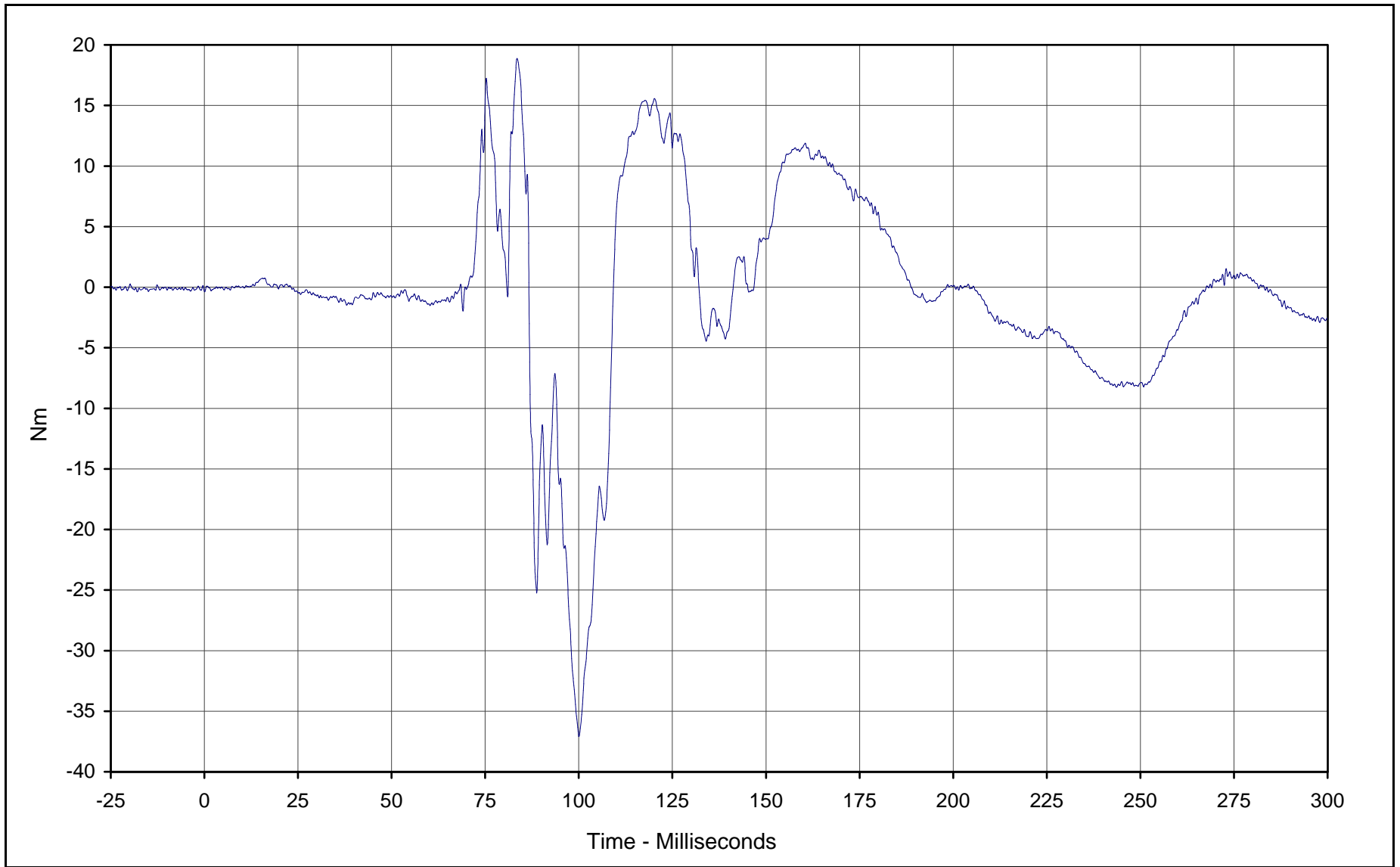

Curve Description: Driver Left Lower Tibia Moment X
Maximum Value: 18.9 at 83.5 Milliseconds
Minimum Value: -37.1 at 100.1 Milliseconds
SAE Filter Class: 600
Date of Test: 08/15/00
Curve Number: FIL-029

Test Program: 2000 NHTSA 40% Offset No.: FORD01
Test Vehicle: 2000 Ford Expedition 4WD 4 Door SUV



KARR20002-02

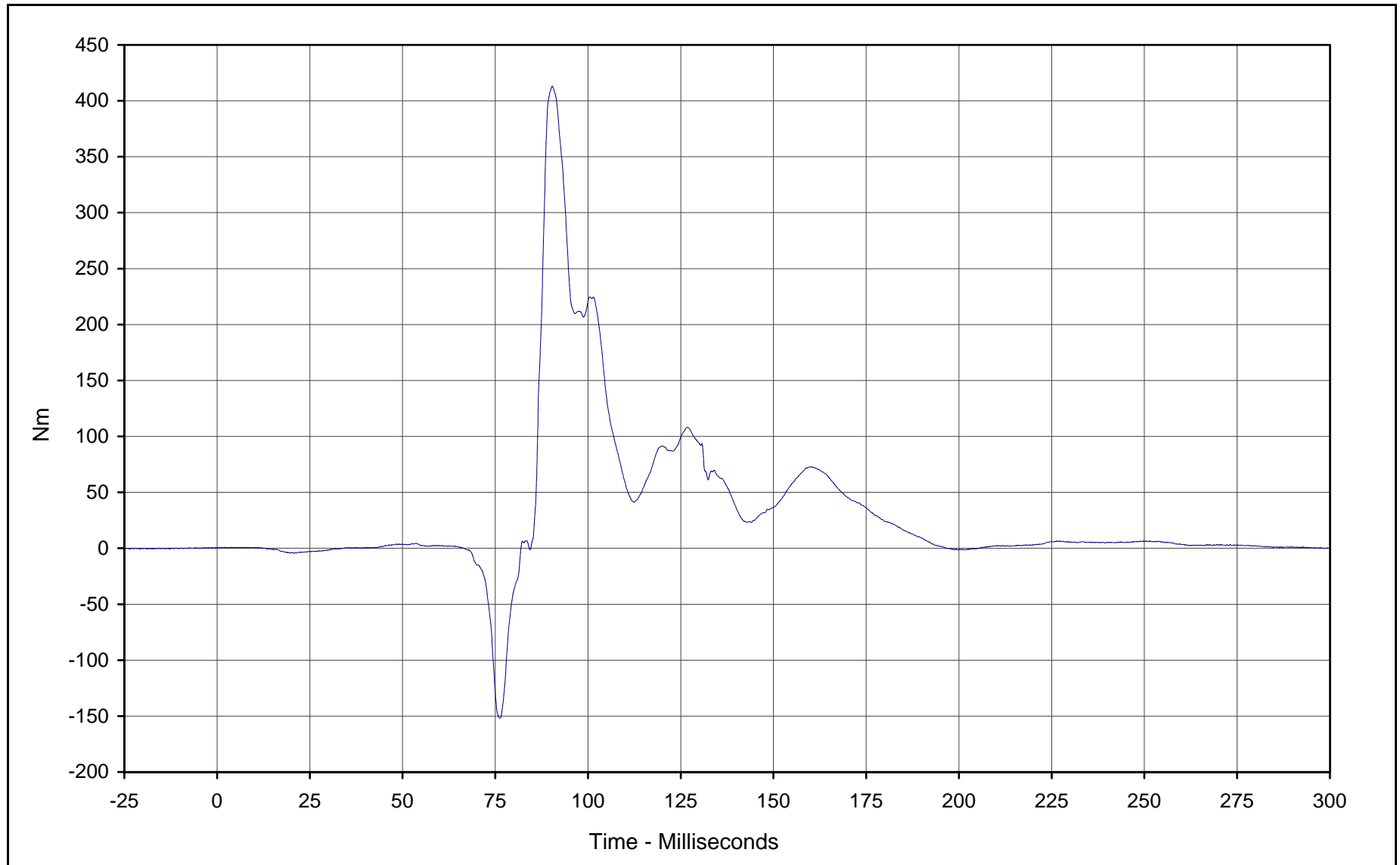

Curve Description: Driver Left Lower Tibia Moment Y
Maximum Value: 413.0 at 90.4 Milliseconds
Minimum Value: -151.9 at 76.2 Milliseconds
SAE Filter Class: 600
Date of Test: 08/15/00
Curve Number: FIL-030

Test Program: 2000 NHTSA 40% Offset No.: FORD01

Test Vehicle: 2000 Ford Expedition 4WD 4 Door SUV



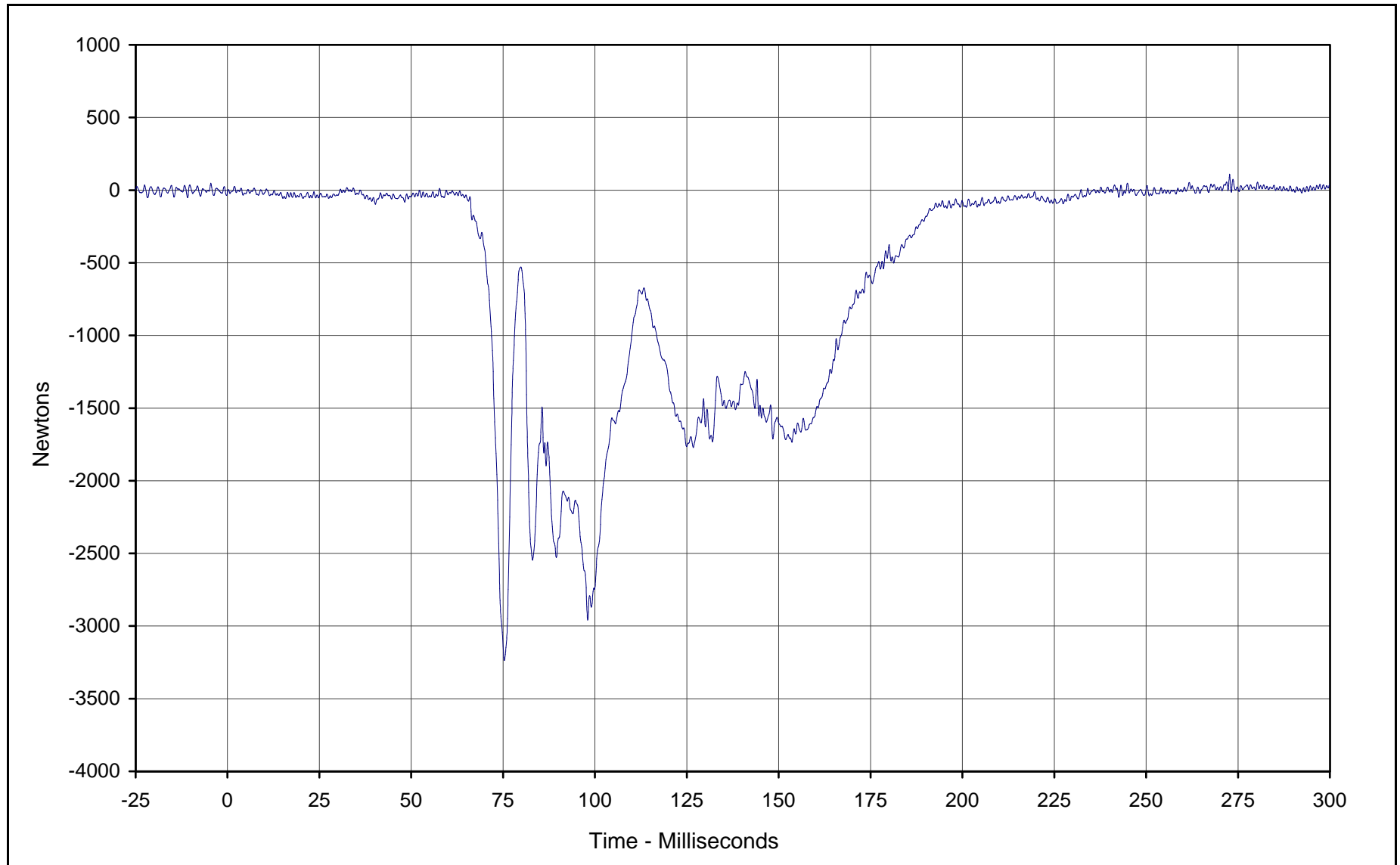

Curve Description: Driver Left Lower Tibia Force Z
 Maximum Value: 111.0 at 272.7 Milliseconds
 Minimum Value: -3235.7 at 75.4 Milliseconds
 SAE Filter Class: 600
 Date of Test: 08/15/00
 Curve Number: FIL-031

Test Program: 2000 NHTSA 40% Offset No.: FORD01

Test Vehicle: 2000 Ford Expedition 4WD 4 Door SUV



B-49

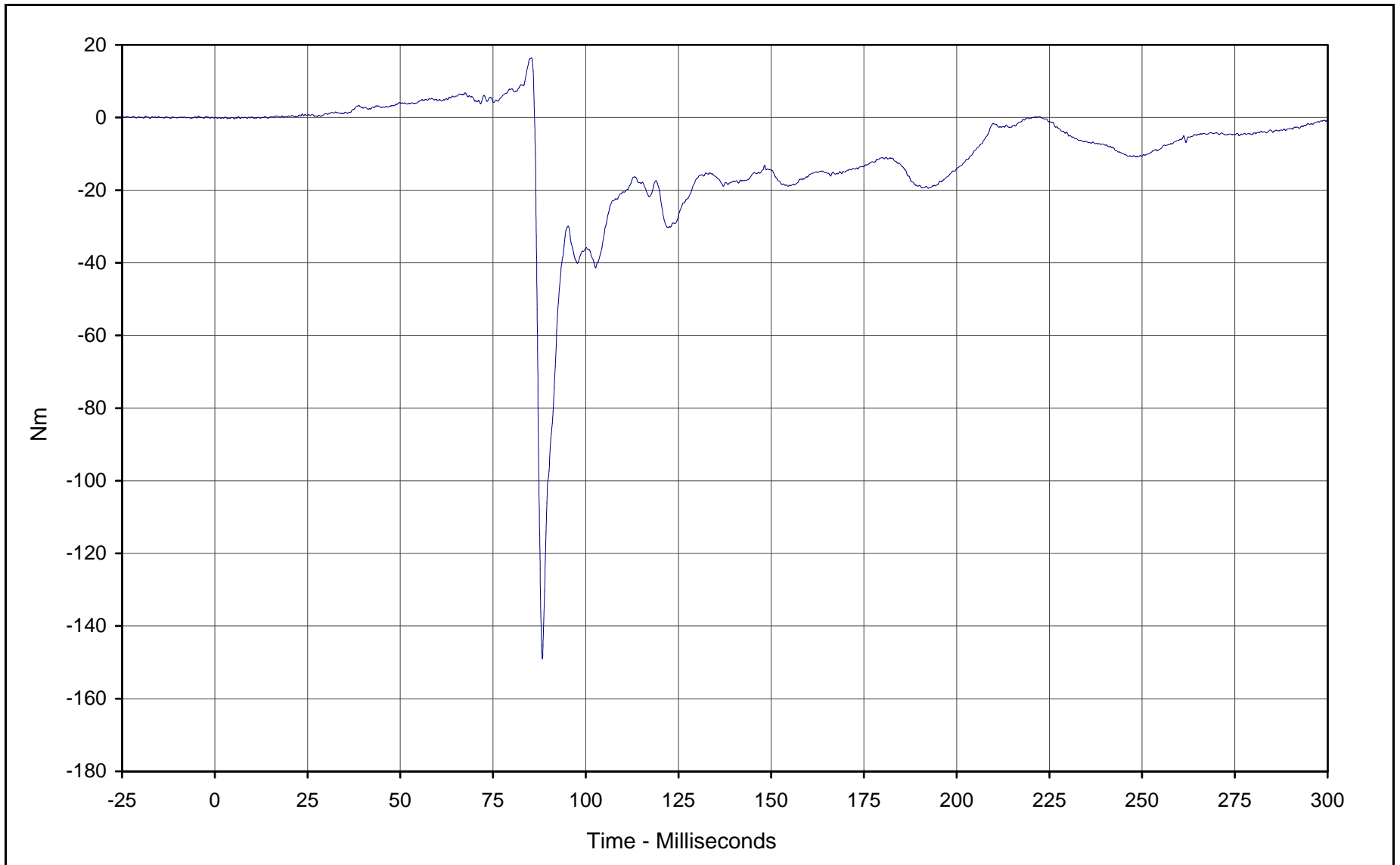

Curve Description: Driver Right Lower Tibia Moment X
Maximum Value: 16.4 at 85.4 Milliseconds
Minimum Value: -149.1 at 88.3 Milliseconds
SAE Filter Class: 600
Date of Test: 08/15/00
Curve Number: FIL-032

Test Program: 2000 NHTSA 40% Offset No.: FORD01
Test Vehicle: 2000 Ford Expedition 4WD 4 Door SUV



KARR20002-02

B-50

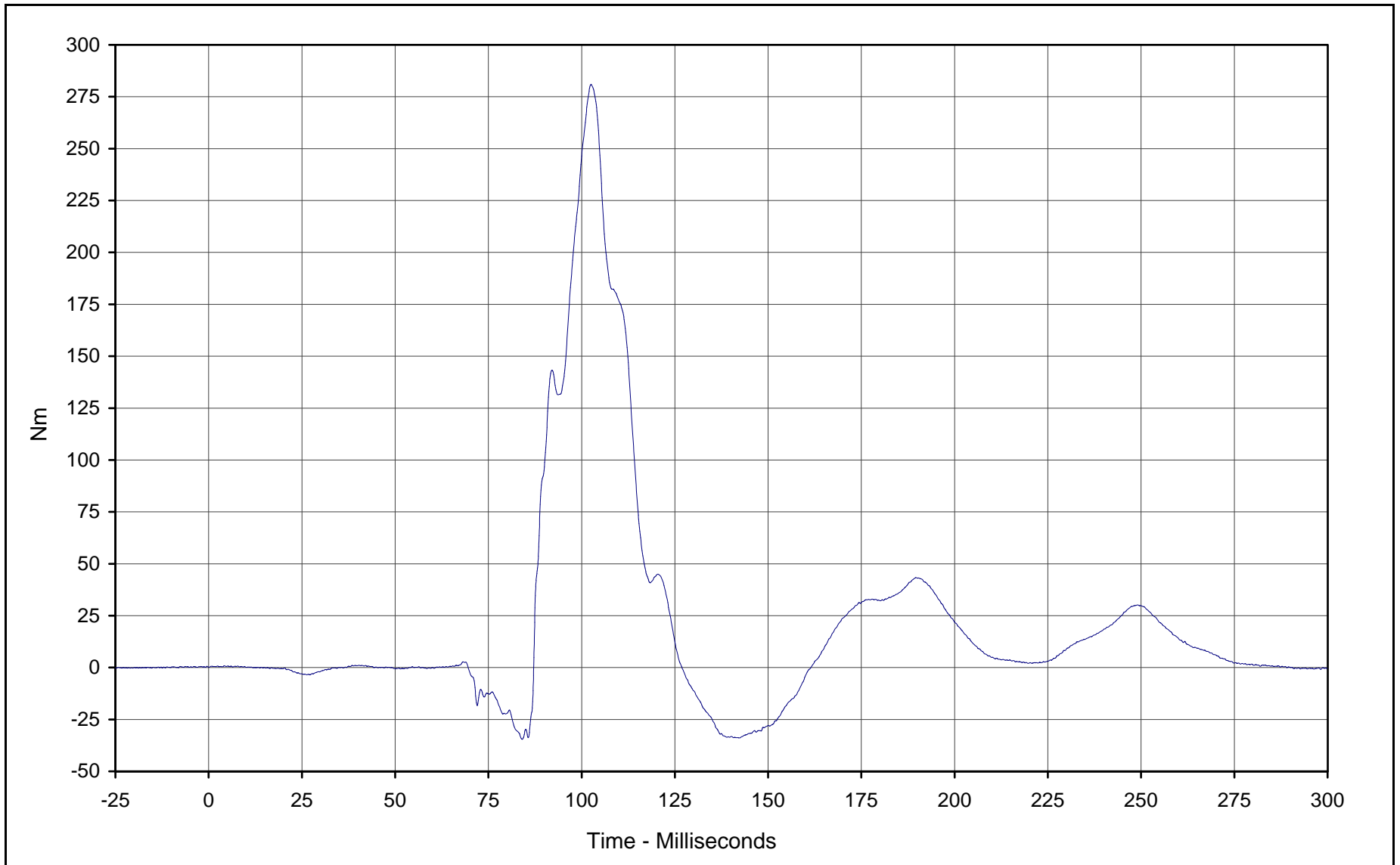

Curve Description: Driver Right Lower Tibia Moment Y
Maximum Value: 280.9 at 102.5 Milliseconds
Minimum Value: -34.5 at 84.0 Milliseconds
SAE Filter Class: 600
Date of Test: 08/15/00
Curve Number: FIL-033

Test Program: 2000 NHTSA 40% Offset No.: FORD01
Test Vehicle: 2000 Ford Expedition 4WD 4 Door SUV



KARR20002-02

B-51

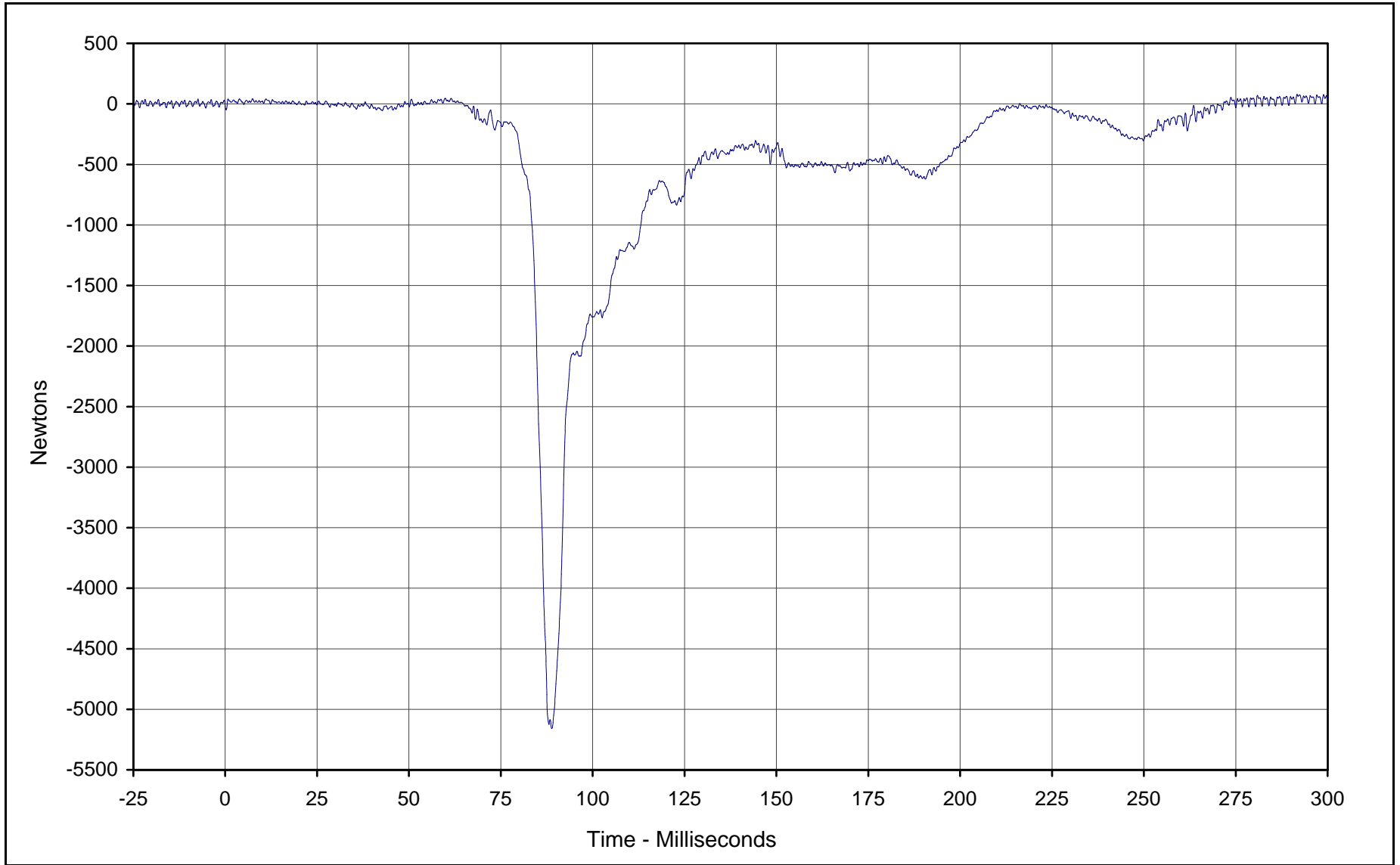

Curve Description: Driver Right Lower Tibia Force Z
Maximum Value: 79.3 at 291.7 Milliseconds
Minimum Value: -5158.7 at 88.9 Milliseconds
SAE Filter Class: 600
Date of Test: 08/15/00
Curve Number: FIL-034

Test Program: 2000 NHTSA 40% Offset No.: FORD01
Test Vehicle: 2000 Ford Expedition 4WD 4 Door SUV



KARR20002-02

B-52

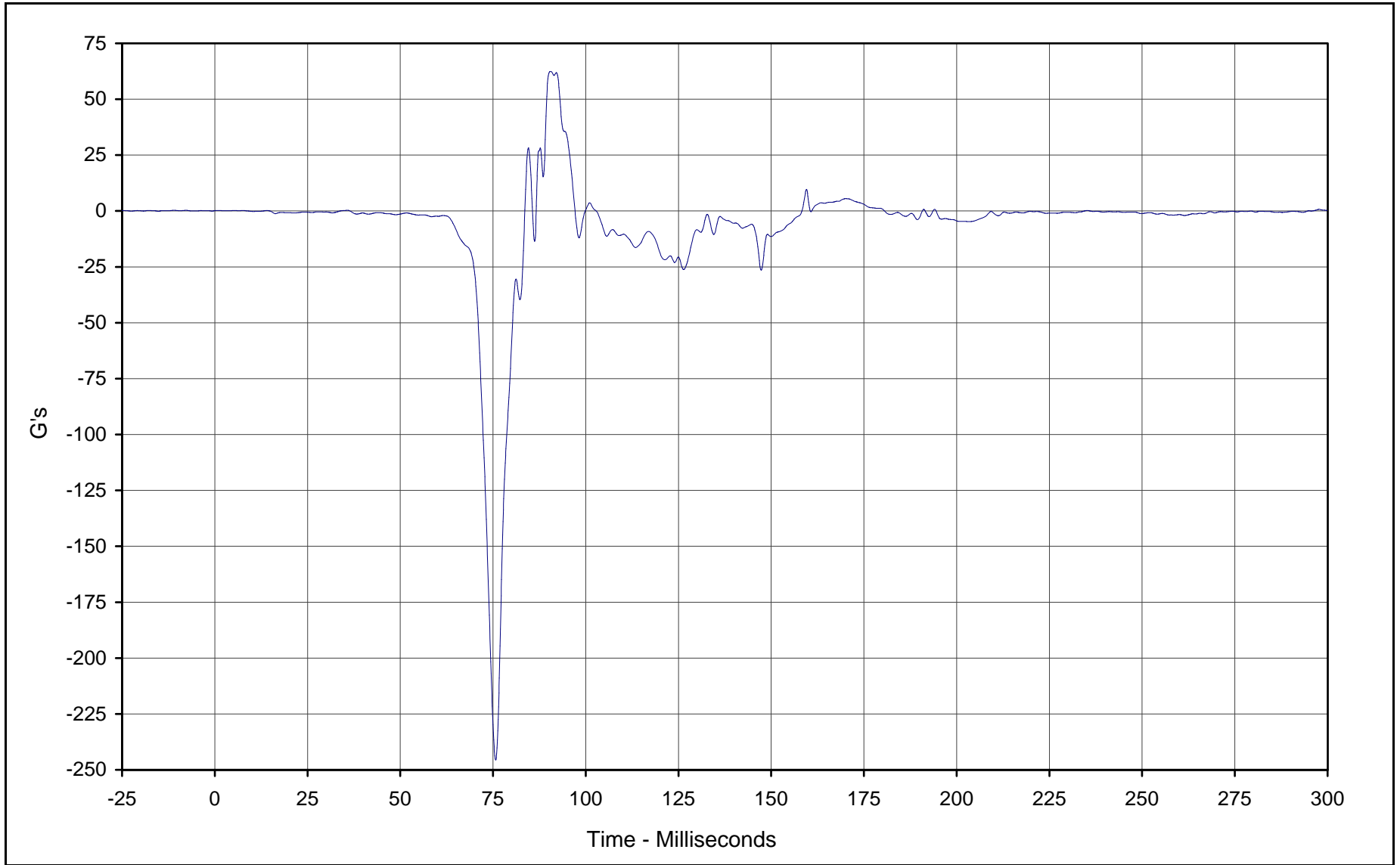

Curve Description: Driver Left Foot Aft X
Maximum Value: 62.4 at 90.5 Milliseconds
Minimum Value: -245.6 at 75.7 Milliseconds
SAE Filter Class: 180
Date of Test: 08/15/00
Curve Number: FIL-035

Test Program: 2000 NHTSA 40% Offset No.: FORD01
Test Vehicle: 2000 Ford Expedition 4WD 4 Door SUV



KARR20002-02

B-53

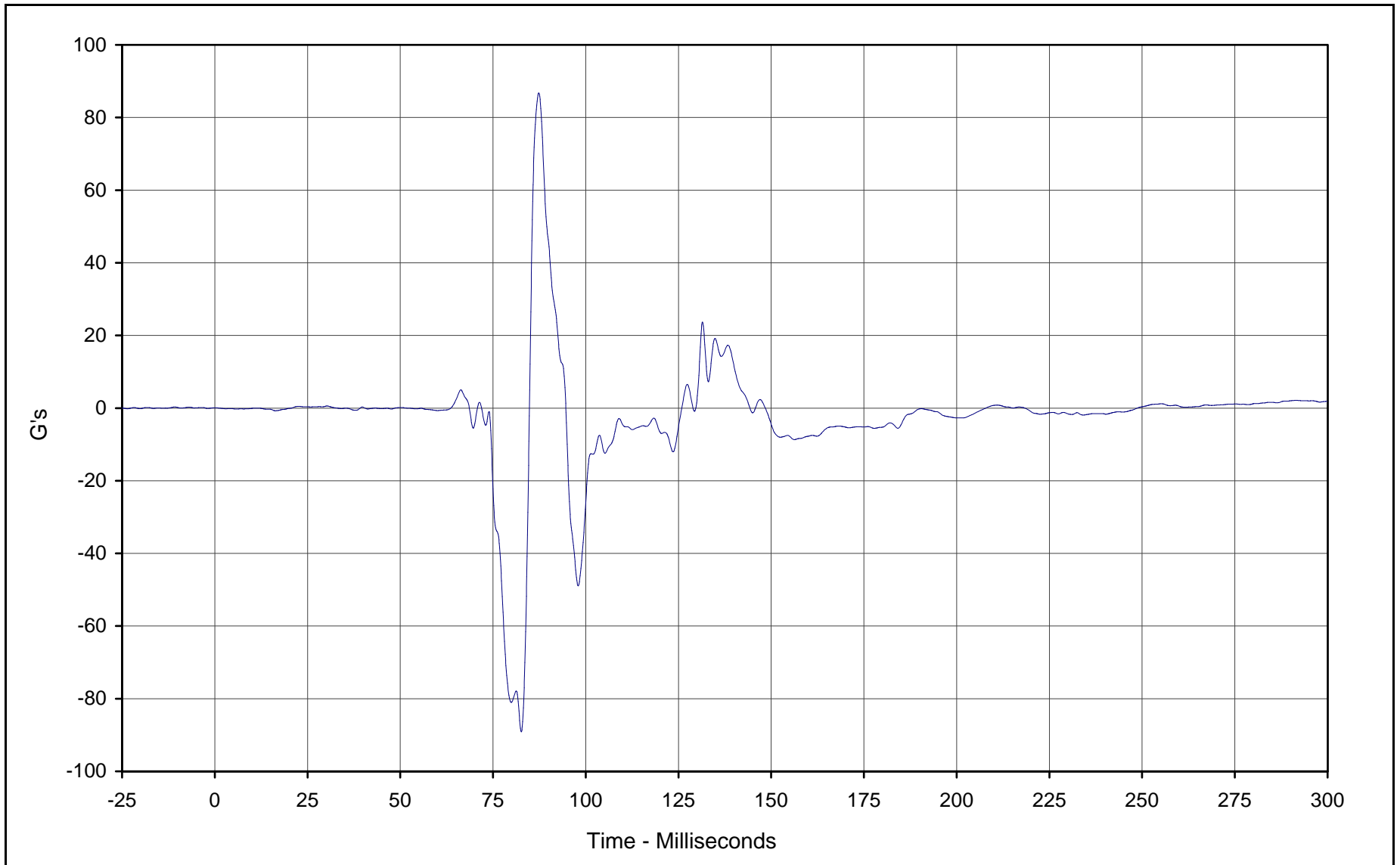

Curve Description: Driver Left Foot Aft Z
Maximum Value: 86.7 at 87.3 Milliseconds
Minimum Value: -89.1 at 82.6 Milliseconds
SAE Filter Class: 180
Date of Test: 08/15/00
Curve Number: FIL-036

Test Program: 2000 NHTSA 40% Offset No.: FORD01
Test Vehicle: 2000 Ford Expedition 4WD 4 Door SUV



KARR20002-02

B-54

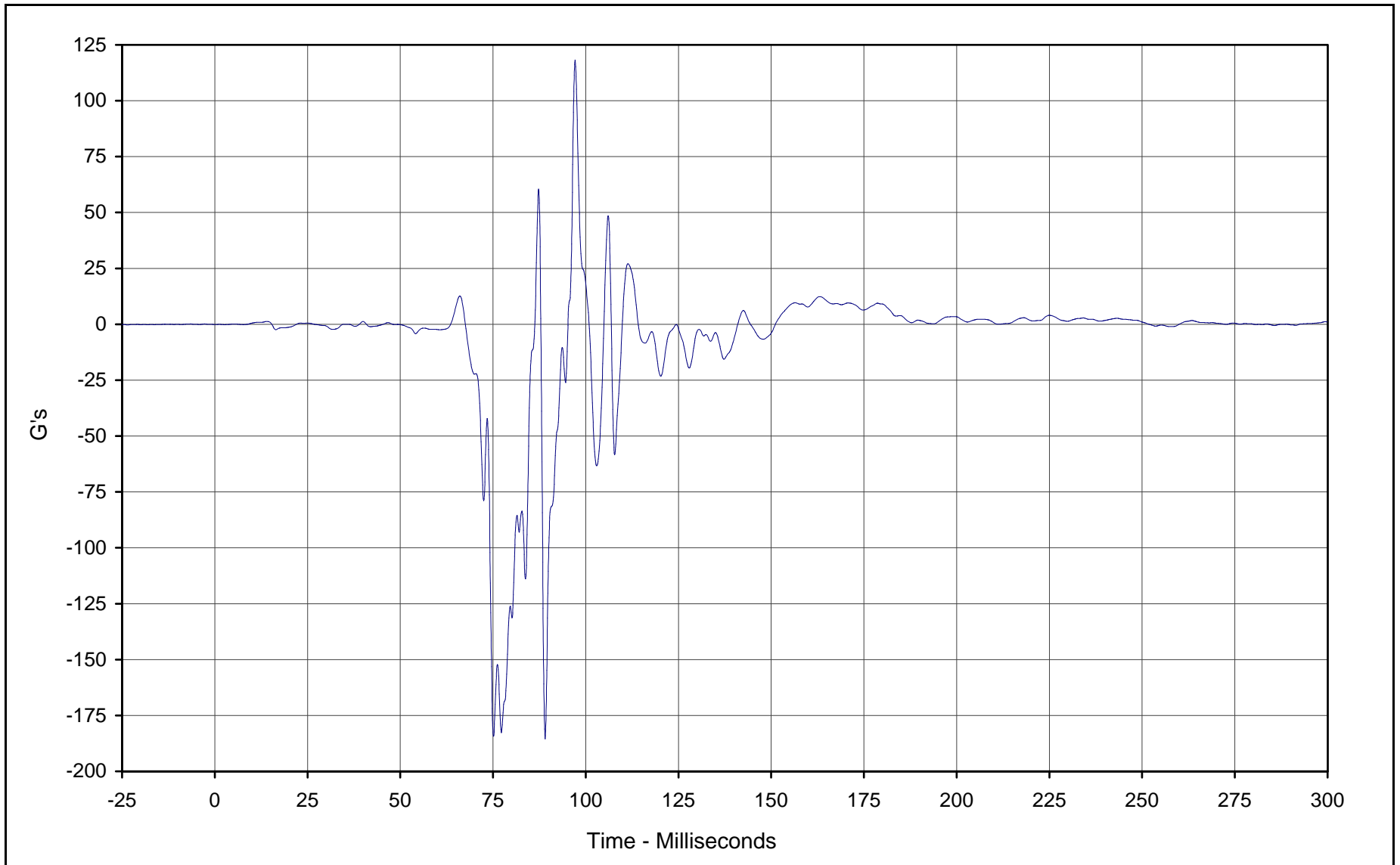

Curve Description: Driver Left Foot Fore Z
Maximum Value: 118.2 at 97.1 Milliseconds
Minimum Value: -185.4 at 89.1 Milliseconds
SAE Filter Class: 180
Date of Test: 08/15/00
Curve Number: FIL-037

Test Program: 2000 NHTSA 40% Offset No.: FORD01
Test Vehicle: 2000 Ford Expedition 4WD 4 Door SUV



KARR20002-02

B-55

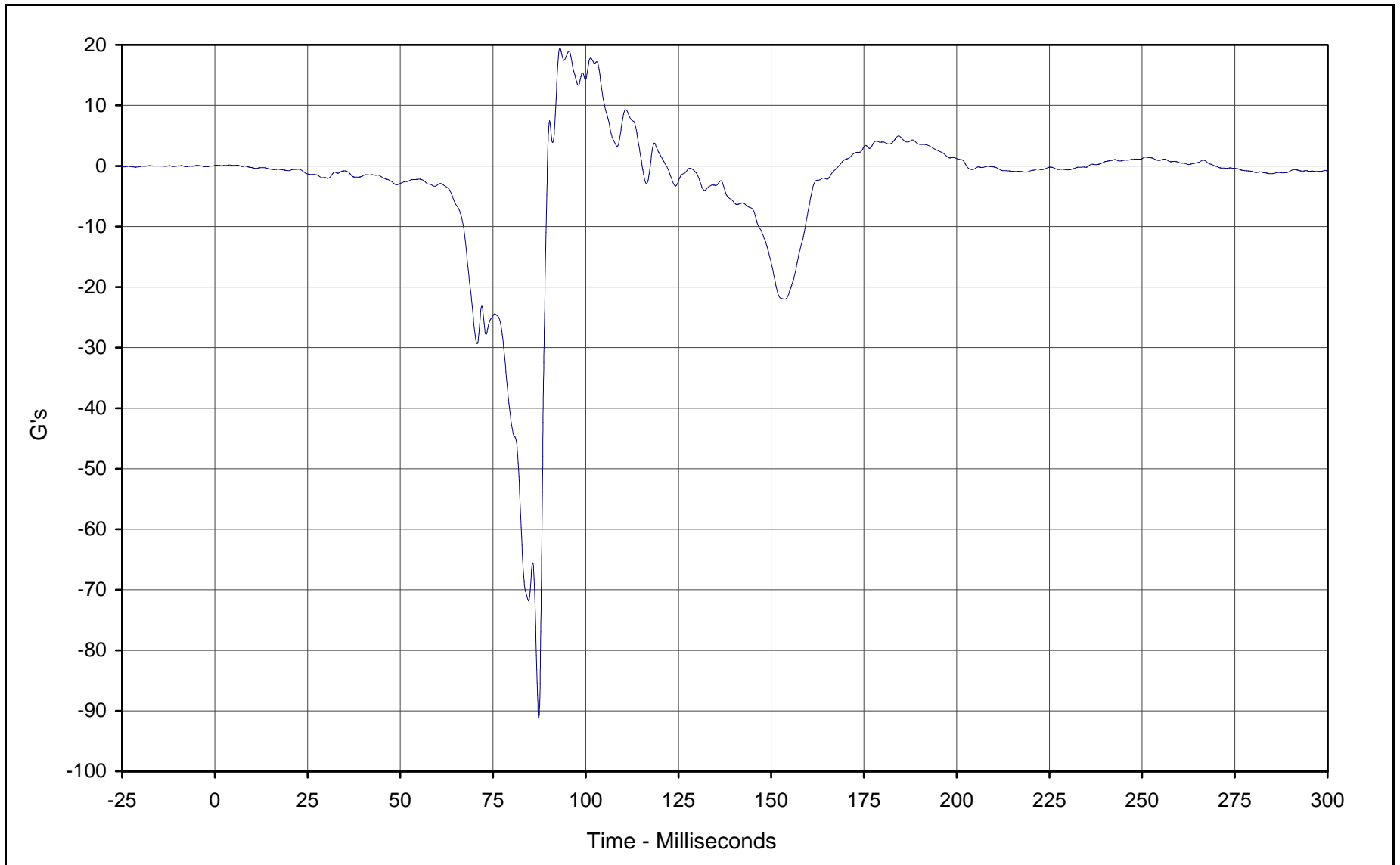

Curve Description: Driver Right Foot Aft X
Maximum Value: 19.4 at 93.0 Milliseconds
Minimum Value: -91.1 at 87.3 Milliseconds
SAE Filter Class: 180
Date of Test: 08/15/00
Curve Number: FIL-038

Test Program: 2000 NHTSA 40% Offset No.: FORD01
Test Vehicle: 2000 Ford Expedition 4WD 4 Door SUV



KARR20002-02

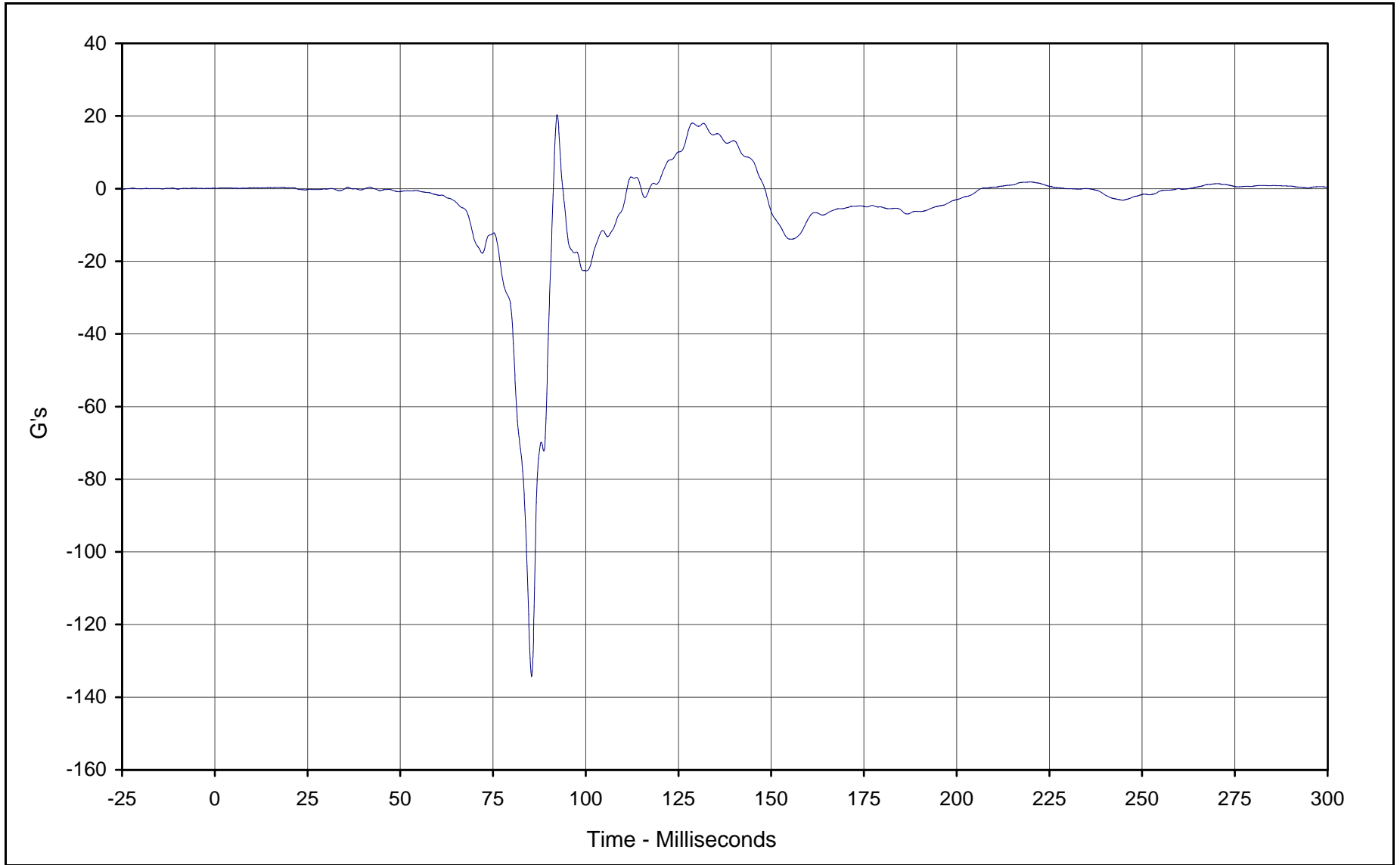

Curve Description: Driver Right Foot Aft Z
 Maximum Value: 20.4 at 92.3 Milliseconds
 Minimum Value: -134.3 at 85.4 Milliseconds
 SAE Filter Class: 180
 Date of Test: 08/15/00
 Curve Number: FIL-039

Test Program: 2000 NHTSA 40% Offset No.: FORD01
 Test Vehicle: 2000 Ford Expedition 4WD 4 Door SUV



B-57

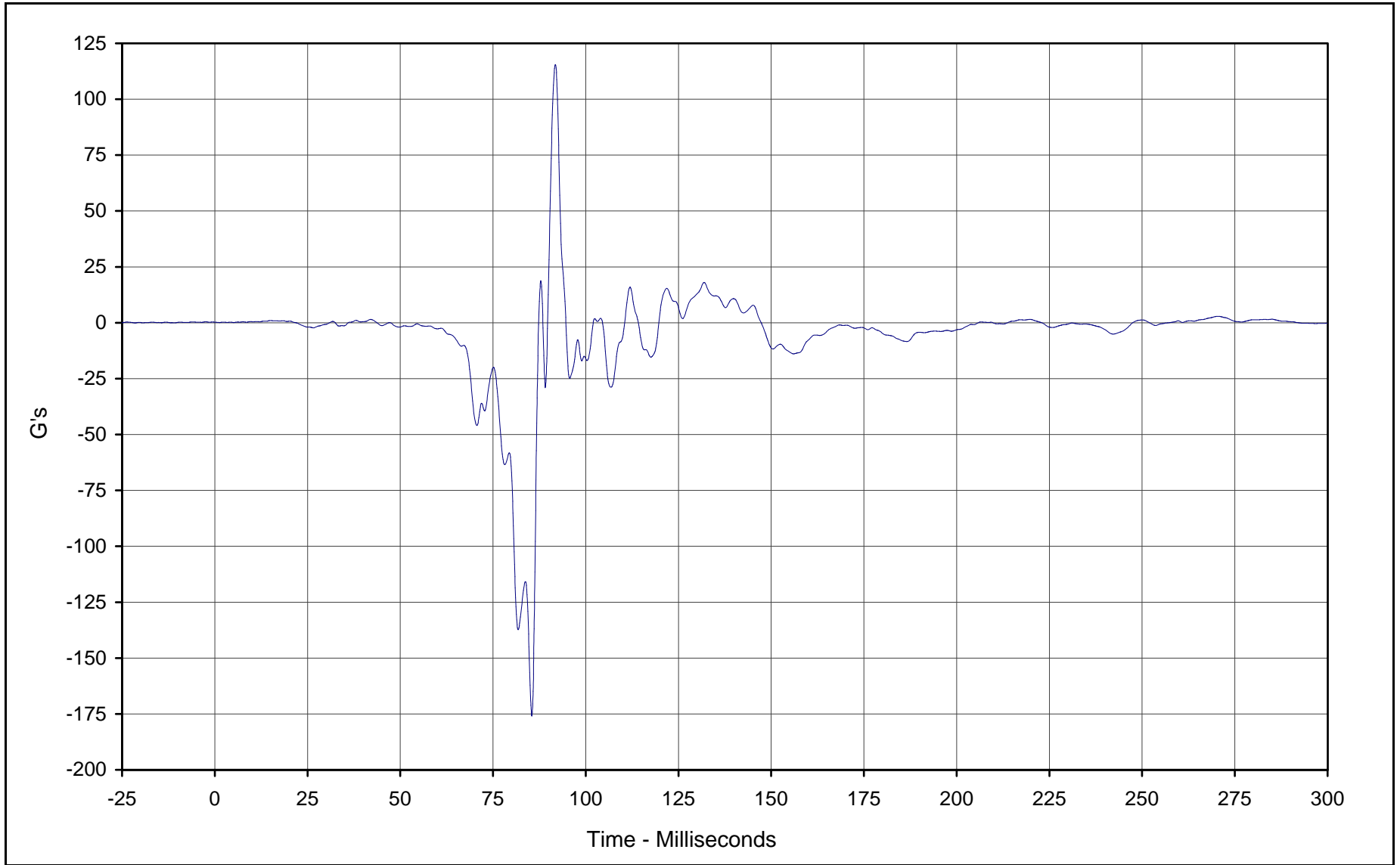

Curve Description: Driver Right Foot Fore Z
Maximum Value: 115.5 at 91.8 Milliseconds
Minimum Value: -175.9 at 85.5 Milliseconds
SAE Filter Class: 180
Date of Test: 08/15/00
Curve Number: FIL-040

Test Program: 2000 NHTSA 40% Offset No.: FORD01
Test Vehicle: 2000 Ford Expedition 4WD 4 Door SUV



KARR20002-02

B-58

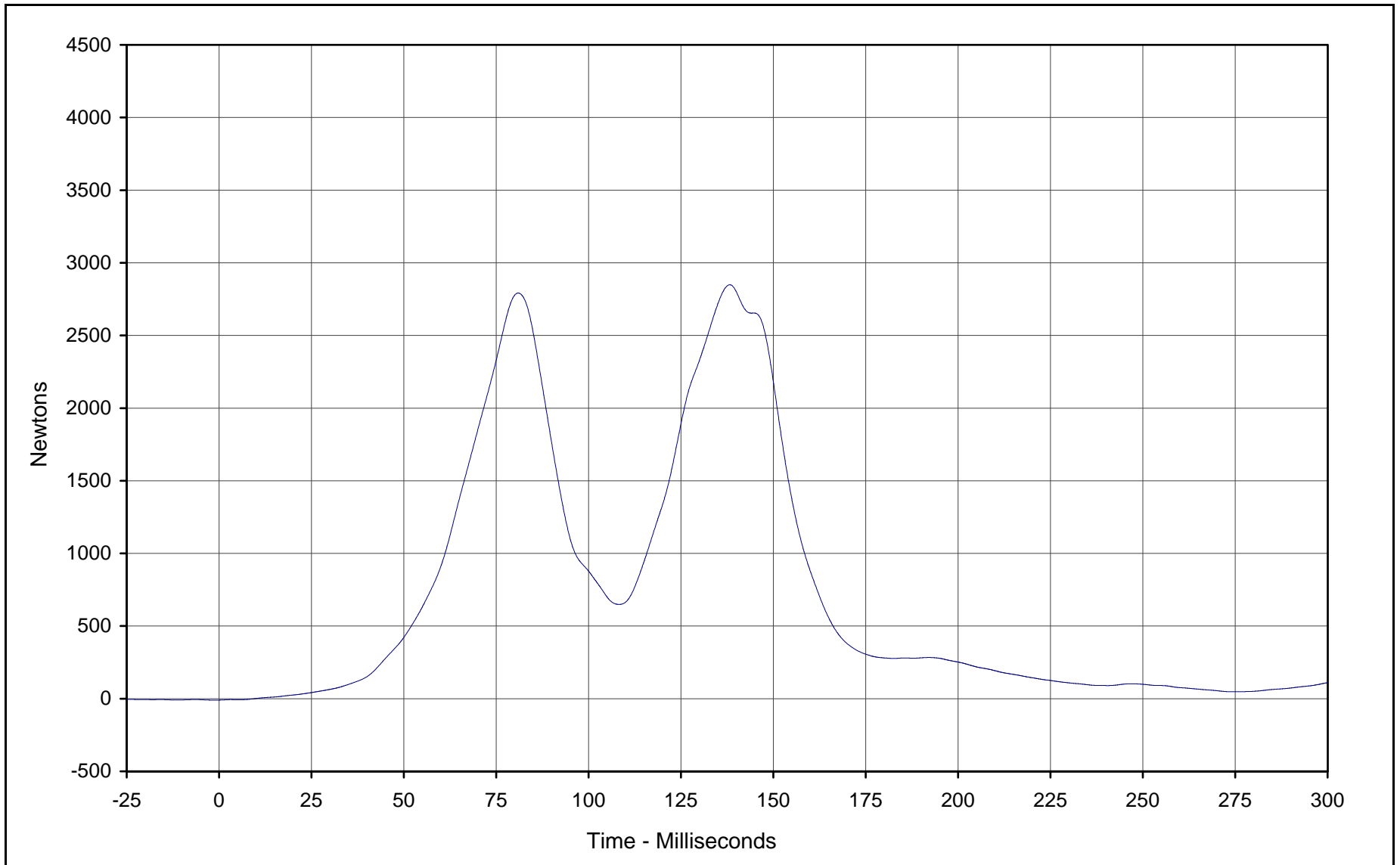

Curve Description: Driver Lap Belt Force
Maximum Value: 2849.0 at 138.2 Milliseconds
Minimum Value: -9.8 at 0.0 Milliseconds
SAE Filter Class: 60
Date of Test: 08/15/00
Curve Number: FIL-041

Test Program: 2000 NHTSA 40% Offset No.: FORD01
Test Vehicle: 2000 Ford Expedition 4WD 4 Door SUV



KARR20002-02

B-59

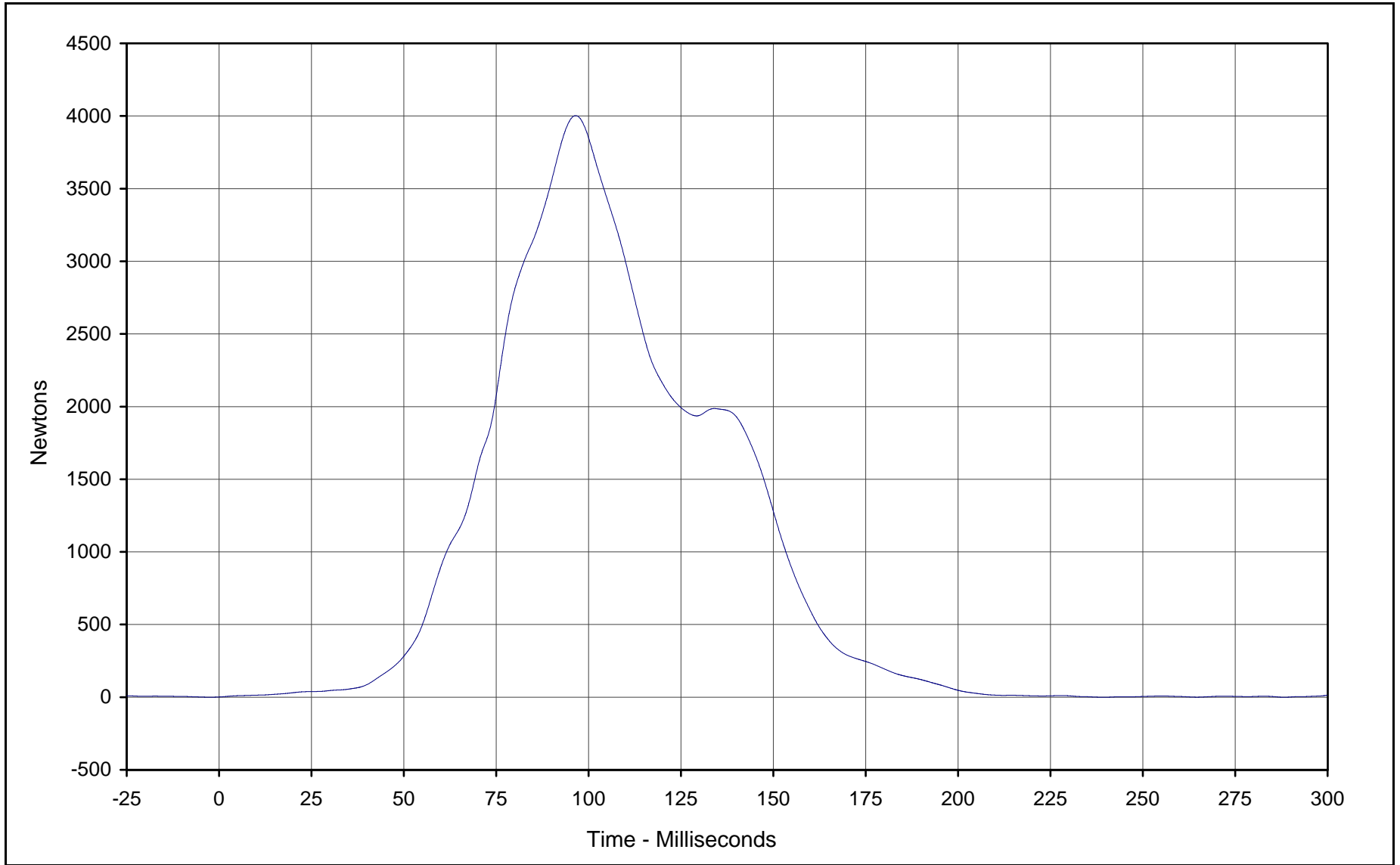

Curve Description: Driver Shoulder Belt Force
Maximum Value: 4002.3 at 96.5 Milliseconds
Minimum Value: -0.7 at 288.3 Milliseconds
SAE Filter Class: 60
Date of Test: 08/15/00
Curve Number: FIL-042

Test Program: 2000 NHTSA 40% Offset No.: FORD01
Test Vehicle: 2000 Ford Expedition 4WD 4 Door SUV



KARR20002-02

B-60

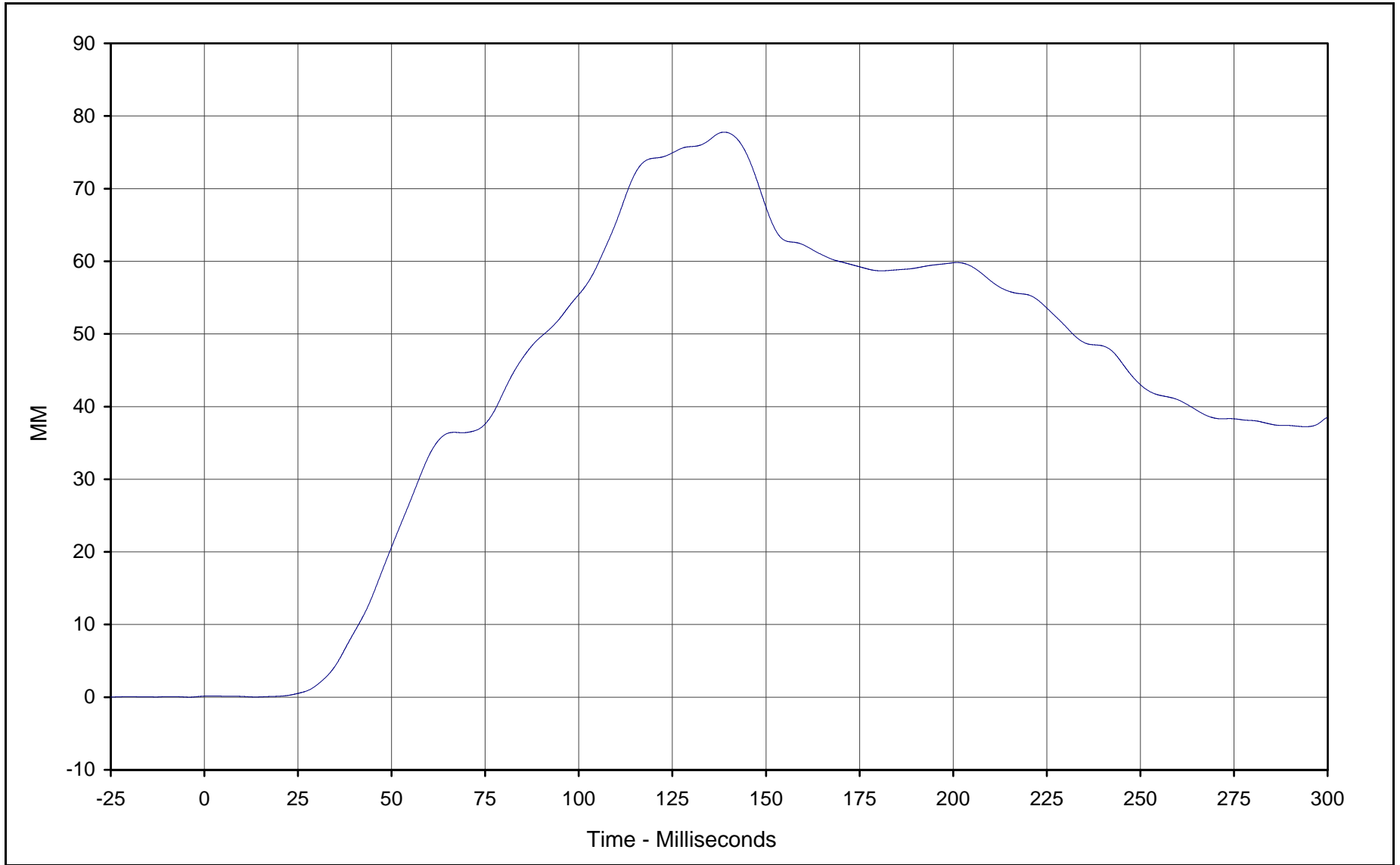

Curve Description: Driver Shoulder Belt Pullout
Maximum Value: 77.8 at 138.8 Milliseconds
Minimum Value: 0.0 at 13.8 Milliseconds
SAE Filter Class: 60
Date of Test: 08/15/00
Curve Number: FIL-043

Test Program: 2000 NHTSA 40% Offset No.: FORD01
Test Vehicle: 2000 Ford Expedition 4WD 4 Door SUV



KARR20002-02

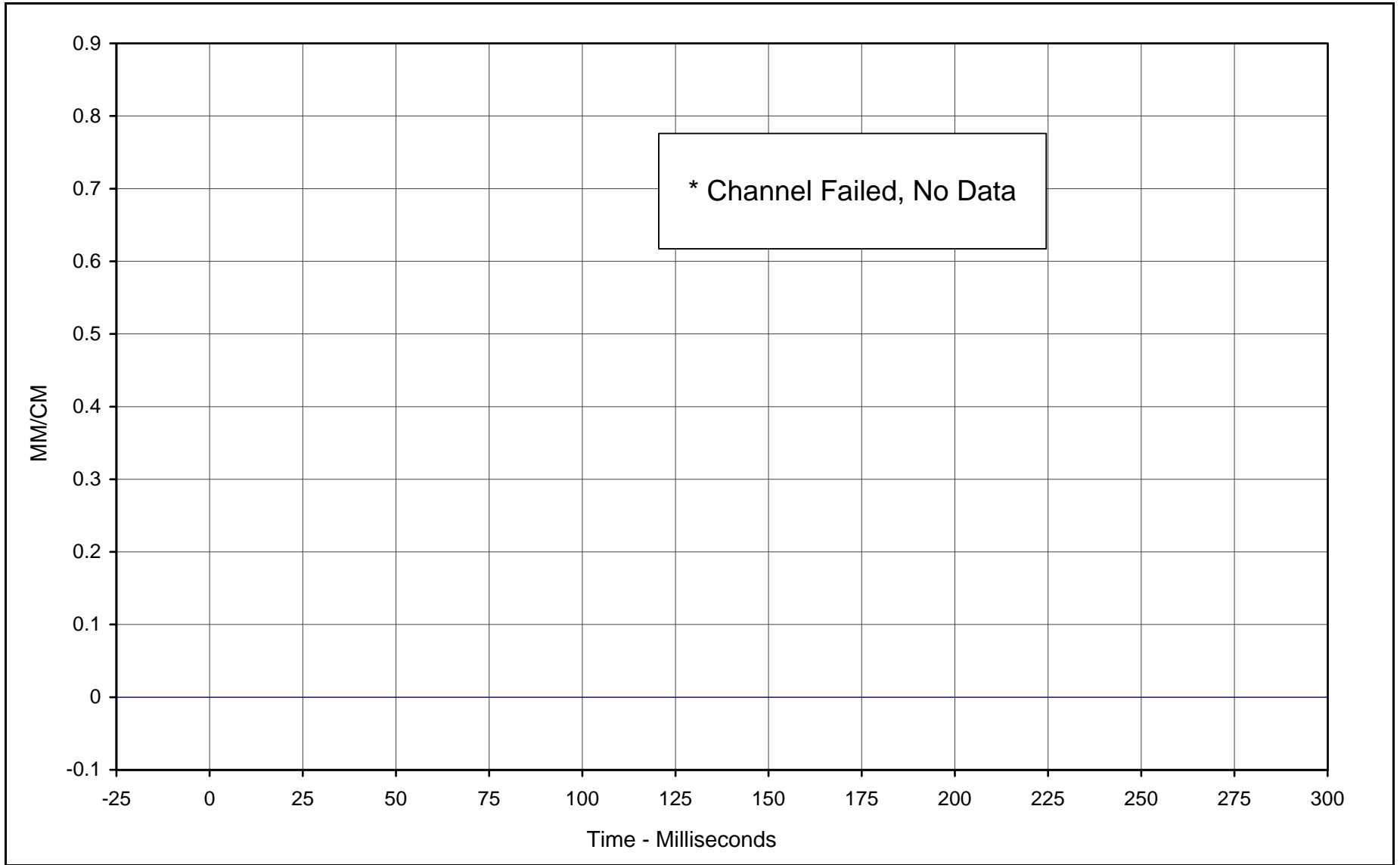

Curve Description: Driver Shoulder Belt Elongation *
Maximum Value: 0.00 at 0.0 Milliseconds
Minimum Value: 0.00 at 0.0 Milliseconds
SAE Filter Class: 60
Date of Test: 08/15/00
Curve Number: FIL-044

Test Program: 2000 NHTSA 40% Offset No.: FORD01
Test Vehicle: 2000 Ford Expedition 4WD 4 Door SUV

* Channel Failed, No Data



B-62

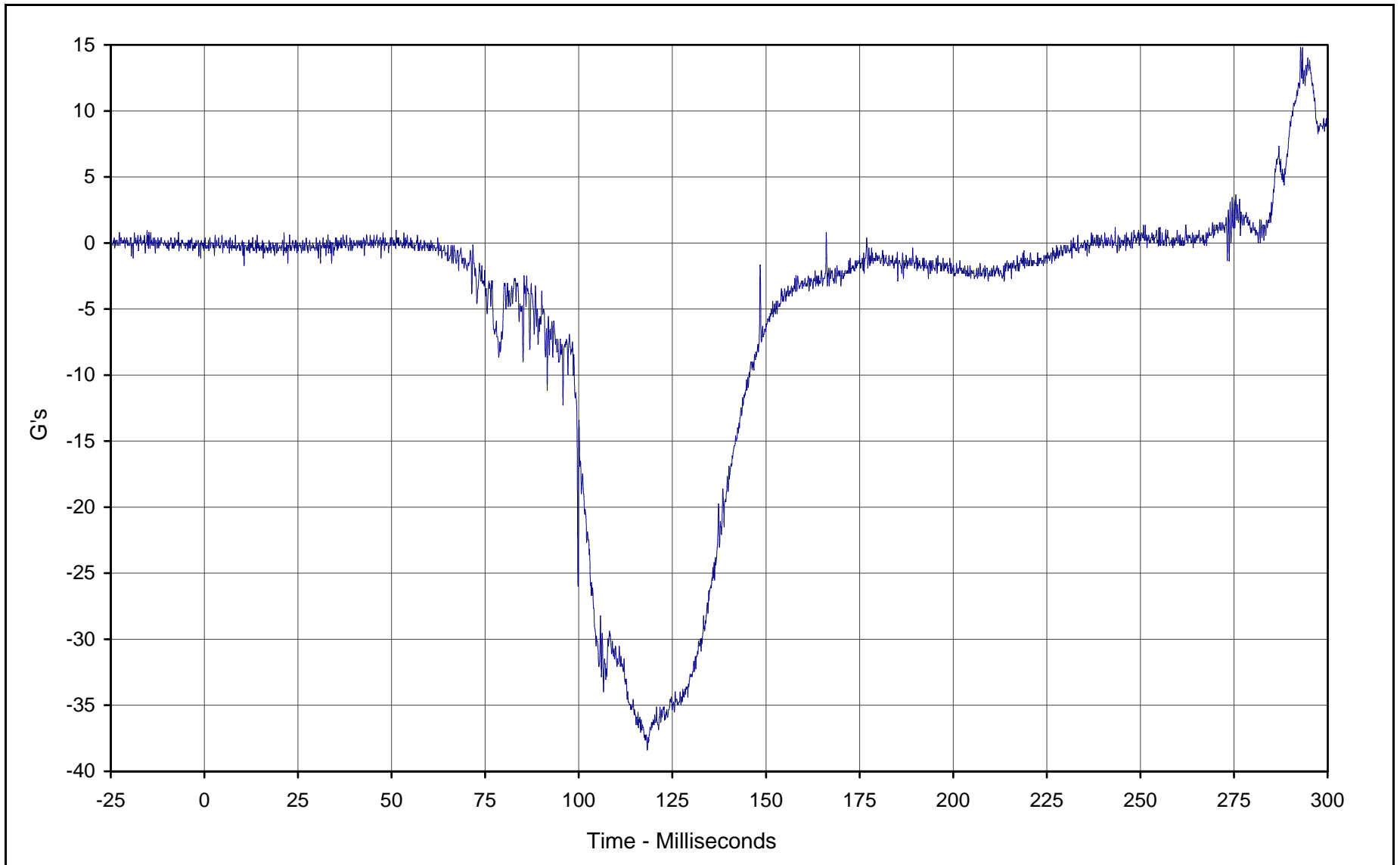

Curve Description: Passenger Head Primary X
Maximum Value: 14.8 at 292.8 Milliseconds
Minimum Value: -38.4 at 118.3 Milliseconds
SAE Filter Class: 1000
Date of Test: 08/15/00
Curve Number: FIL-045

Test Program: 2000 NHTSA 40% Offset No.: FORD01
Test Vehicle: 2000 Ford Expedition 4WD 4 Door SUV



KARR20002-02

B-63

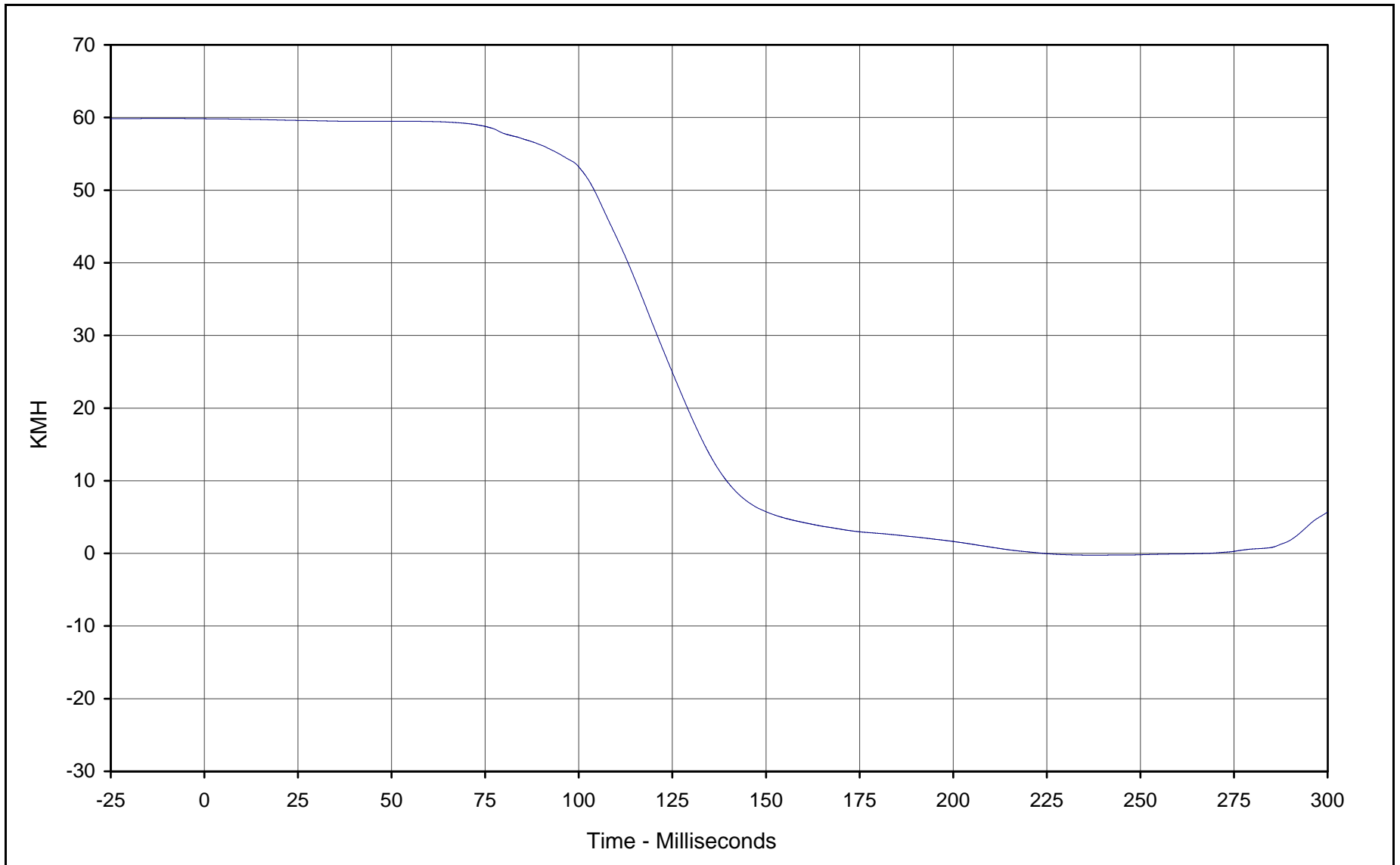

Curve Description: Passenger Head Primary X Velocity
Maximum Value: 59.8 at 0.0 Milliseconds
Minimum Value: -0.2 at 236.8 Milliseconds
SAE Filter Class: 180
Date of Test: 08/15/00
Curve Number: IN1-045

Test Program: 2000 NHTSA 40% Offset No.: FORD01
Test Vehicle: 2000 Ford Expedition 4WD 4 Door SUV



KARR20002-02

B-64

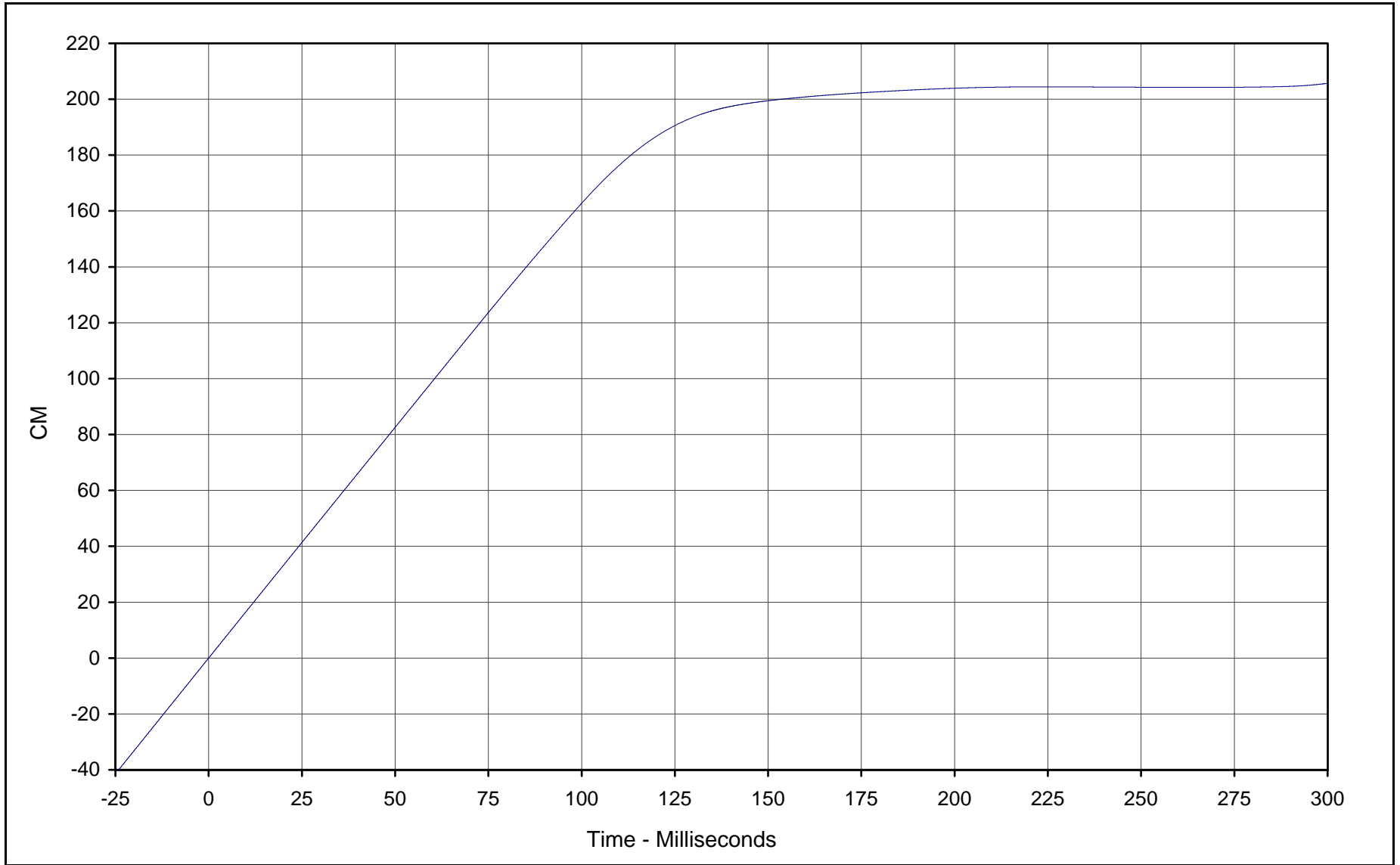

Curve Description: Passenger Head Primary X Displ.
Maximum Value: 205.7 at 299.9 Milliseconds
Minimum Value: 0.0 at 0.0 Milliseconds
SAE Filter Class: 180
Date of Test: 08/15/00
Curve Number: IN2-045

Test Program: 2000 NHTSA 40% Offset No.: FORD01
Test Vehicle: 2000 Ford Expedition 4WD 4 Door SUV



KARR20002-02

B-65

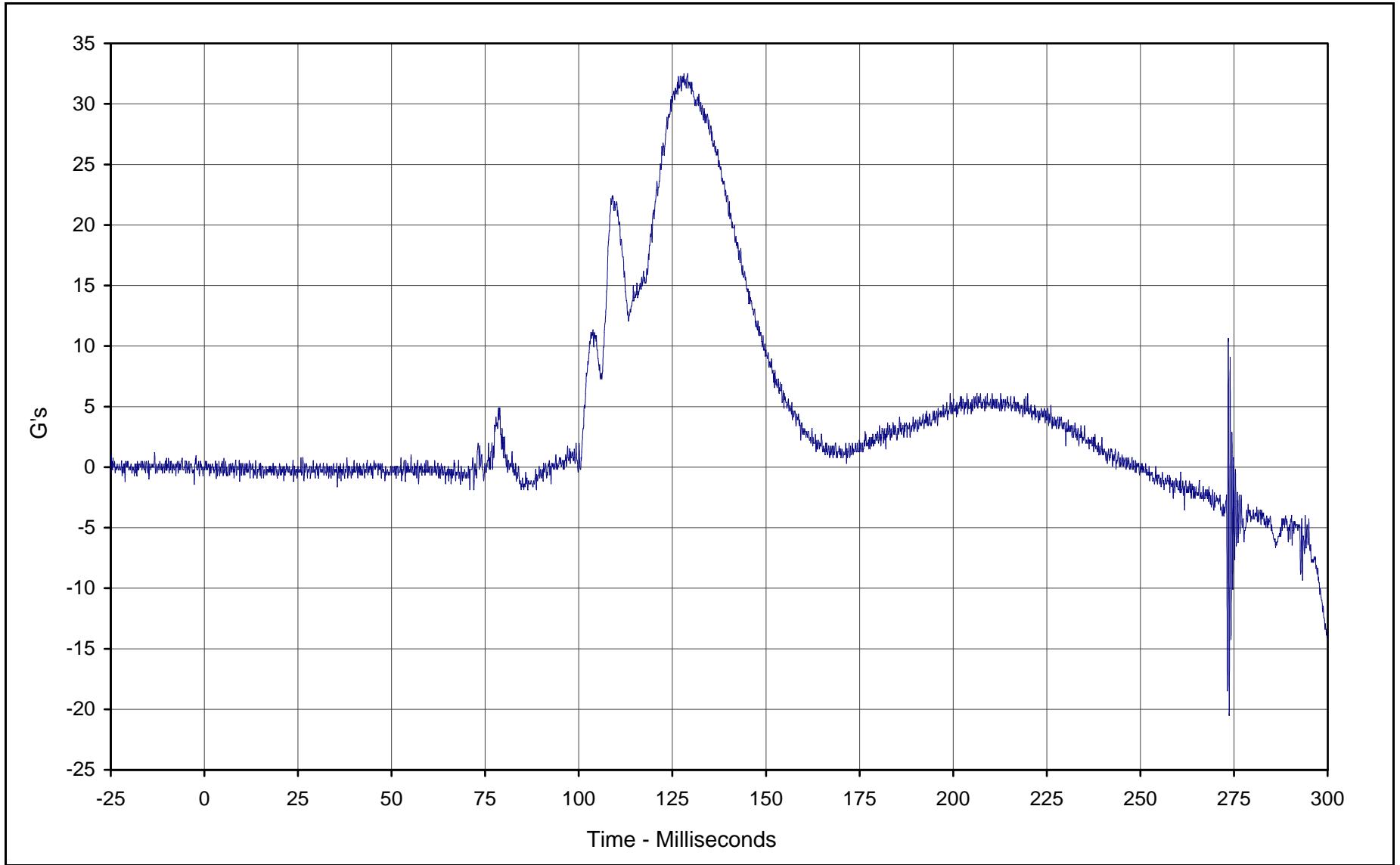

Curve Description: Passenger Head Primary Y
Maximum Value: 32.5 at 128.1 Milliseconds
Minimum Value: -20.4 at 273.7 Milliseconds
SAE Filter Class: 1000
Date of Test: 08/15/00
Curve Number: FIL-046

Test Program: 2000 NHTSA 40% Offset No.: FORD01
Test Vehicle: 2000 Ford Expedition 4WD 4 Door SUV



KARR20002-02

B-66

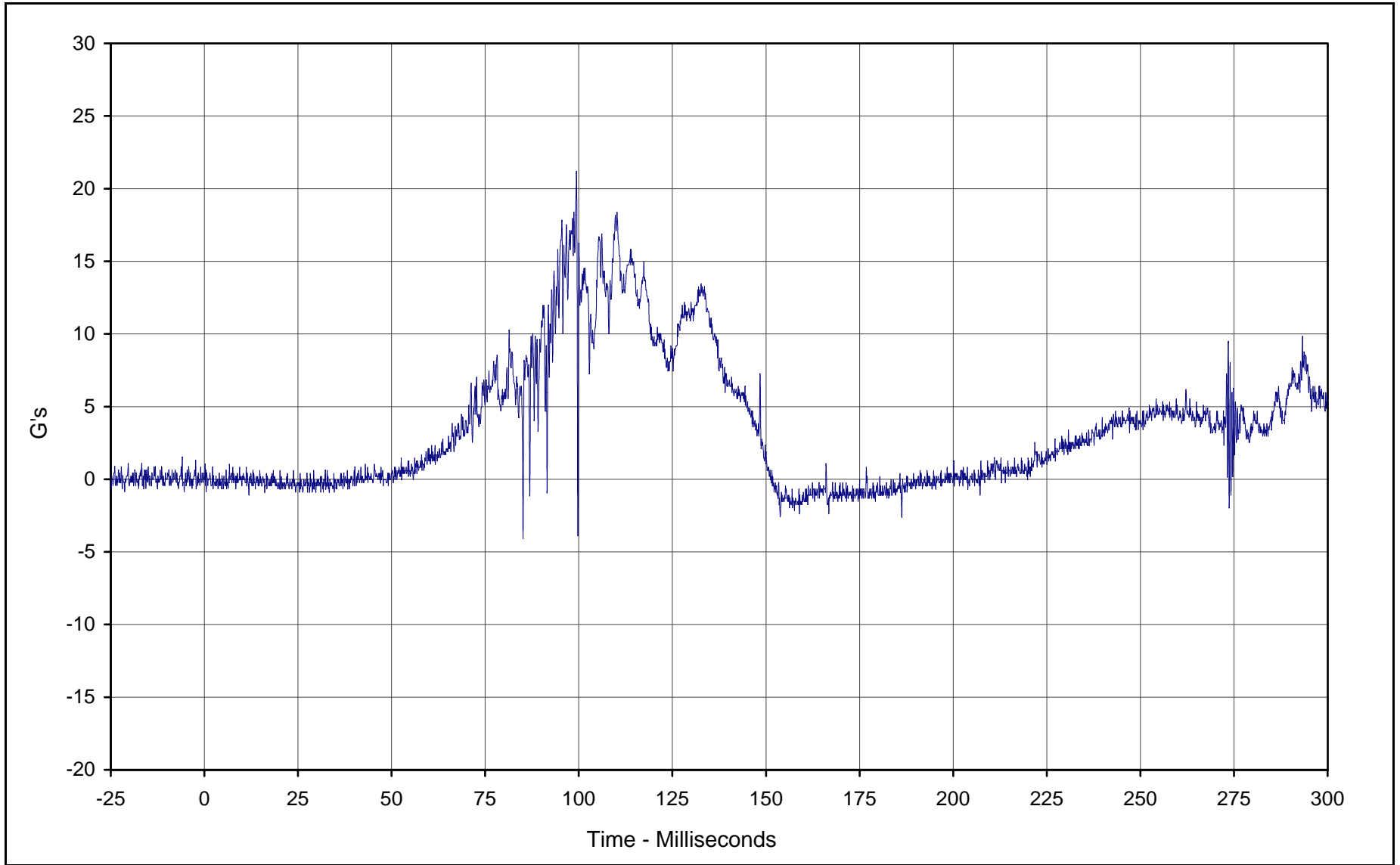

Curve Description: Passenger Head Primary Z
Maximum Value: 21.2 at 99.4 Milliseconds
Minimum Value: -4.1 at 85.1 Milliseconds
SAE Filter Class: 1000
Date of Test: 08/15/00
Curve Number: FIL-047

Test Program: 2000 NHTSA 40% Offset No.: FORD01
Test Vehicle: 2000 Ford Expedition 4WD 4 Door SUV



KARR20002-02

B-67

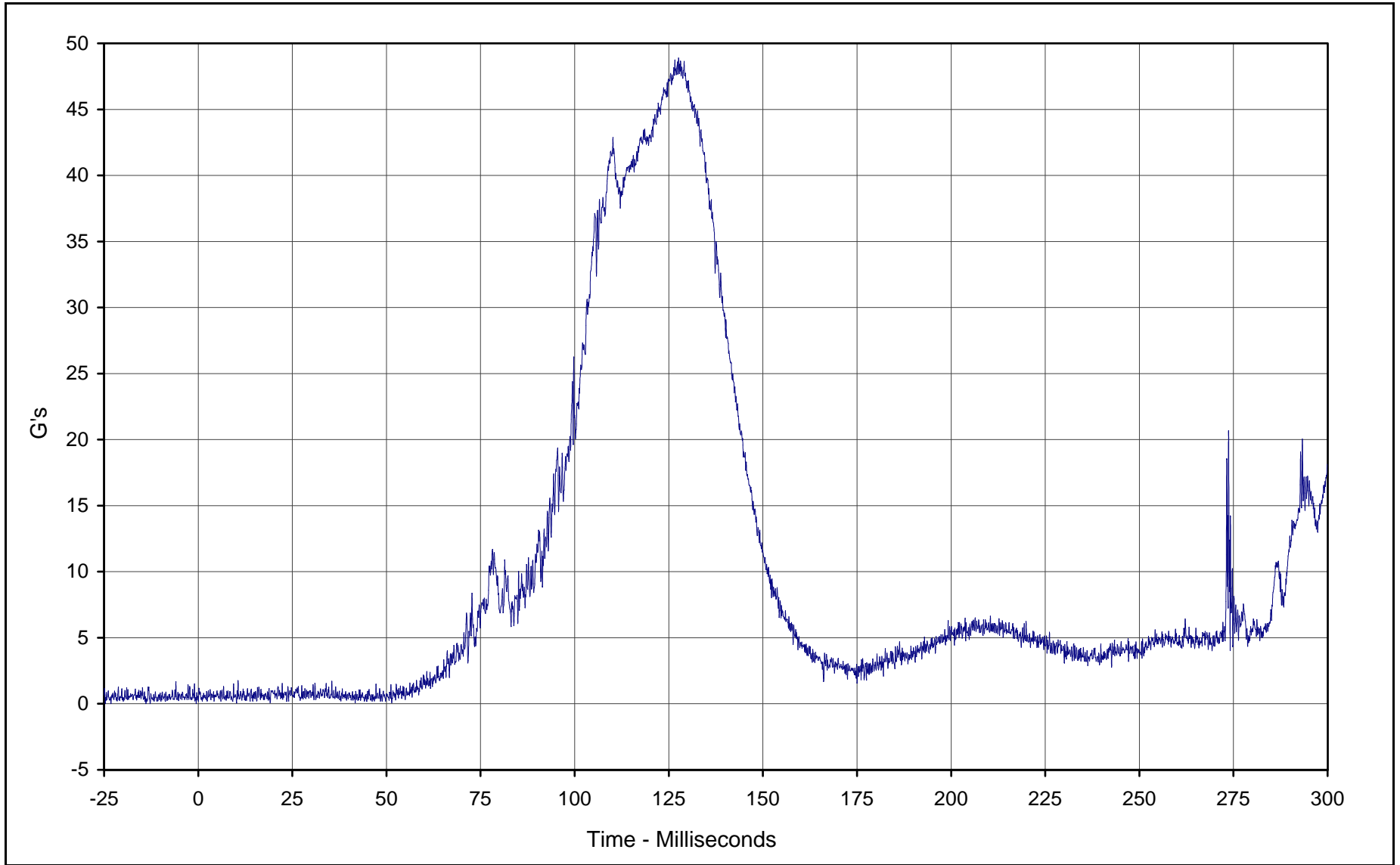

Curve Description: Passenger Head Resultant Primary
Maximum Value: 48.9 at 127.6 Milliseconds
Minimum Value: 0.1 at 10.2 Milliseconds
SAE Filter Class: 1000
Date of Test: 08/15/00
Curve Number: RES-045

Test Program: 2000 NHTSA 40% Offset No.: FORD01
Test Vehicle: 2000 Ford Expedition 4WD 4 Door SUV



KARR20002-02

B-68

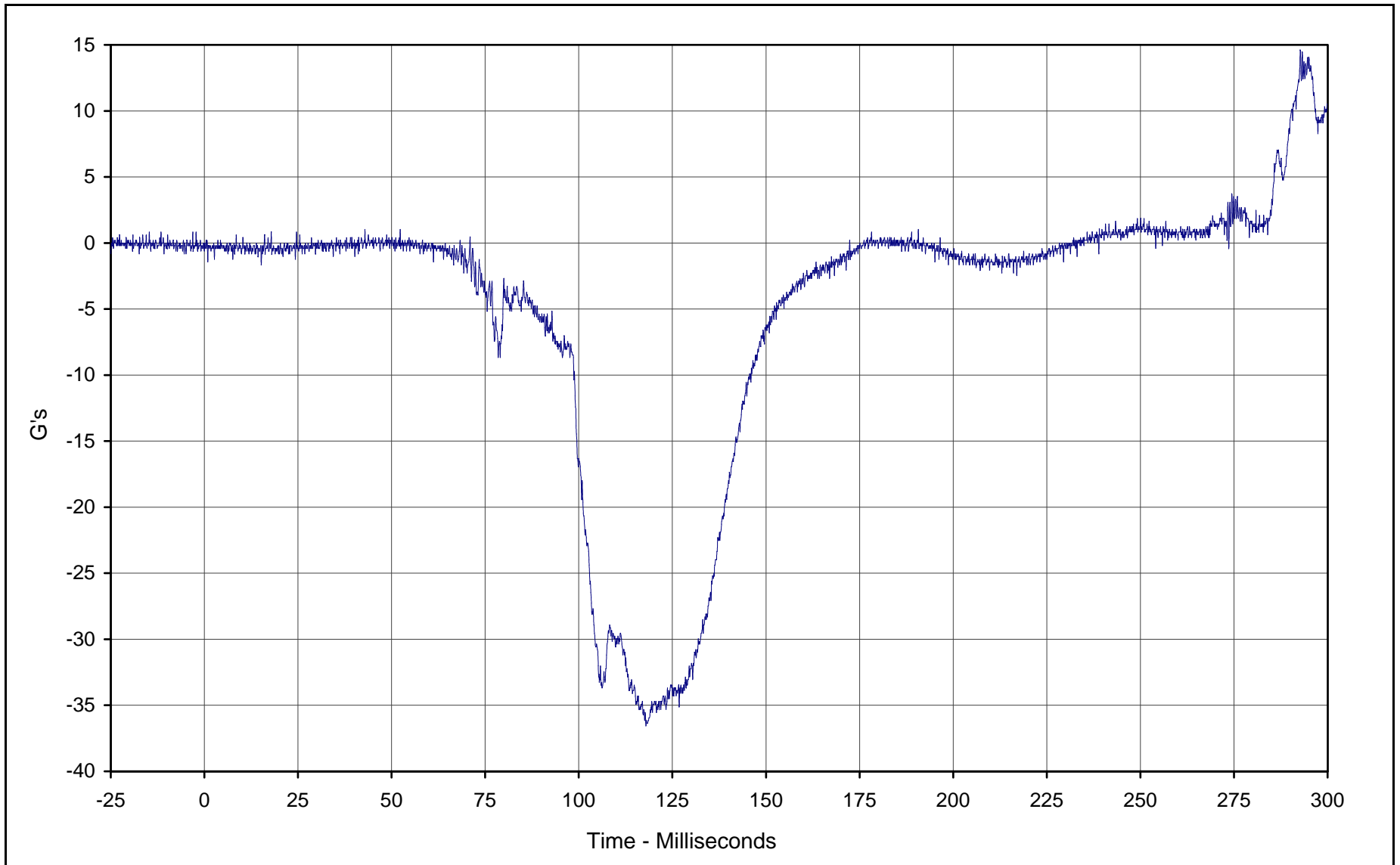

Curve Description: Passenger Head Redundant X
Maximum Value: 14.6 at 292.7 Milliseconds
Minimum Value: -36.6 at 117.9 Milliseconds
SAE Filter Class: 1000
Date of Test: 08/15/00
Curve Number: FIL-048

Test Program: 2000 NHTSA 40% Offset No.: FORD01
Test Vehicle: 2000 Ford Expedition 4WD 4 Door SUV



KARR20002-02

B-69

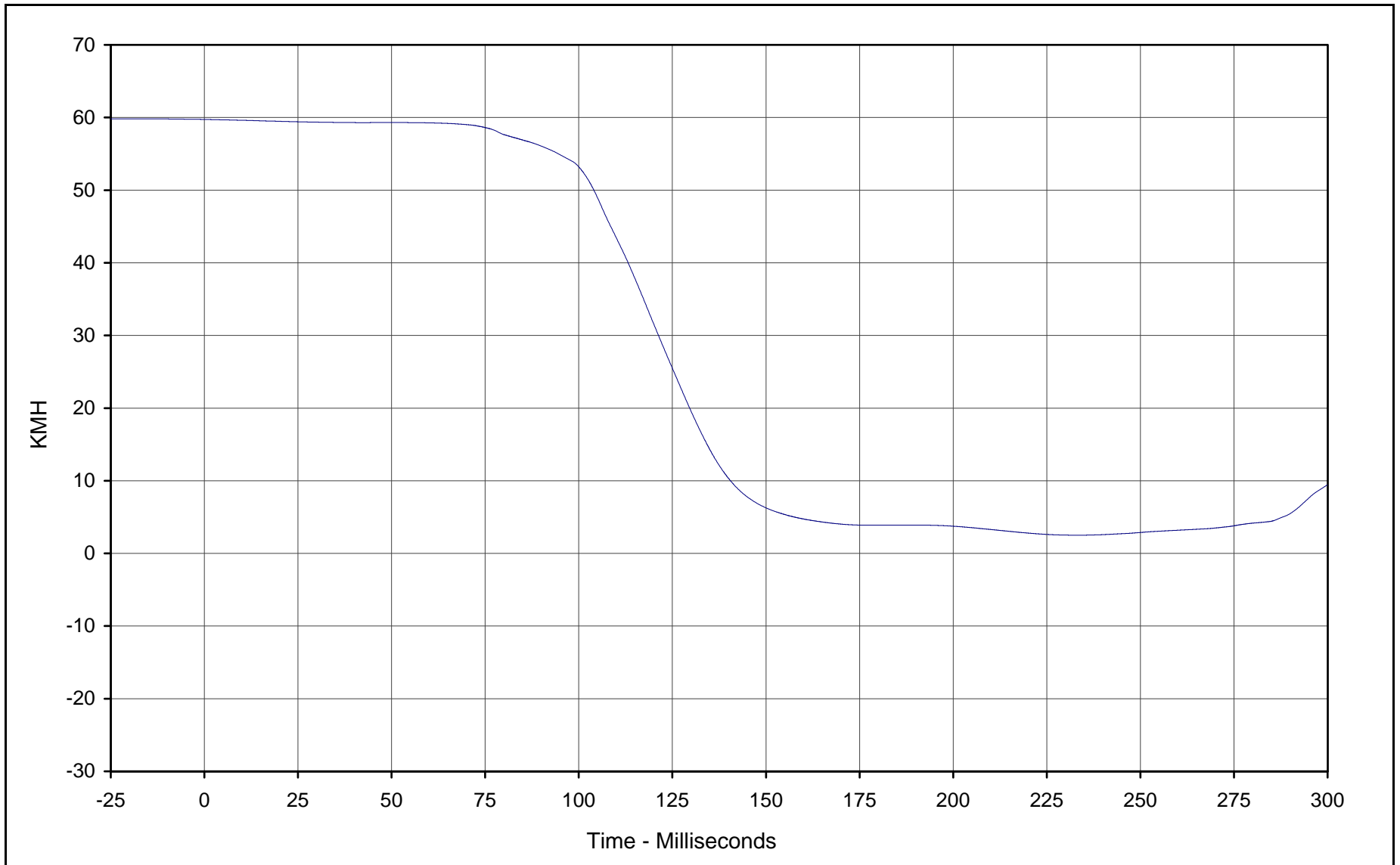

Curve Description: Passenger Head Redundant X Velocity

Maximum Value: 59.7 at 0.0 Milliseconds

Minimum Value: 2.5 at 233.5 Milliseconds

SAE Filter Class: 180

Date of Test: 08/15/00

Curve Number: IN1-048

Test Program: 2000 NHTSA 40% Offset No.: FORD01

Test Vehicle: 2000 Ford Expedition 4WD 4 Door SUV



KARR20002-02

B-70

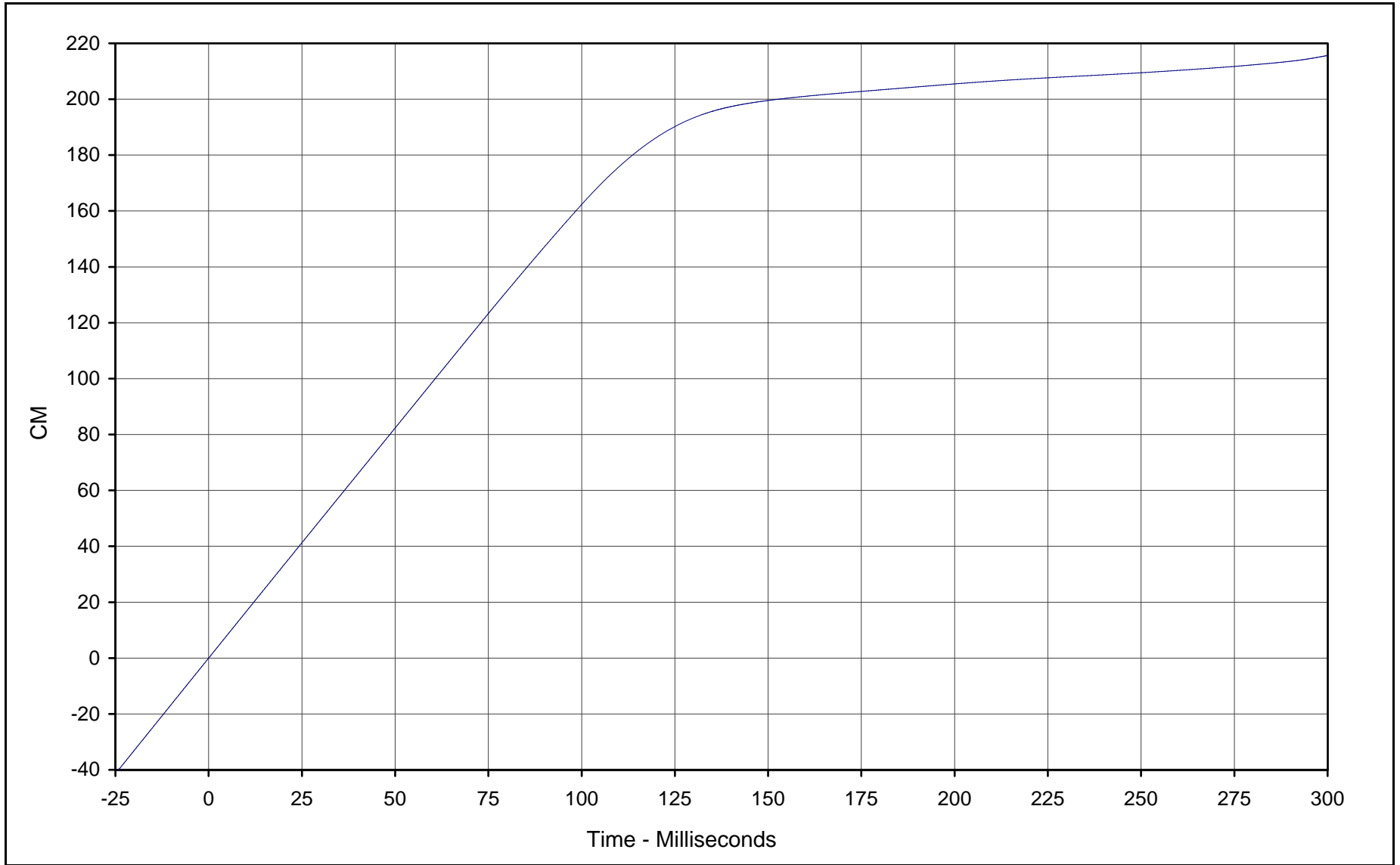

Curve Description: Passenger Head Redundant X Displ.
Maximum Value: 215.6 at 299.9 Milliseconds
Minimum Value: 0.0 at 0.0 Milliseconds
SAE Filter Class: 180
Date of Test: 08/15/00
Curve Number: IN2-048

Test Program: 2000 NHTSA 40% Offset No.: FORD01
Test Vehicle: 2000 Ford Expedition 4WD 4 Door SUV



KARR20002-02

B-71

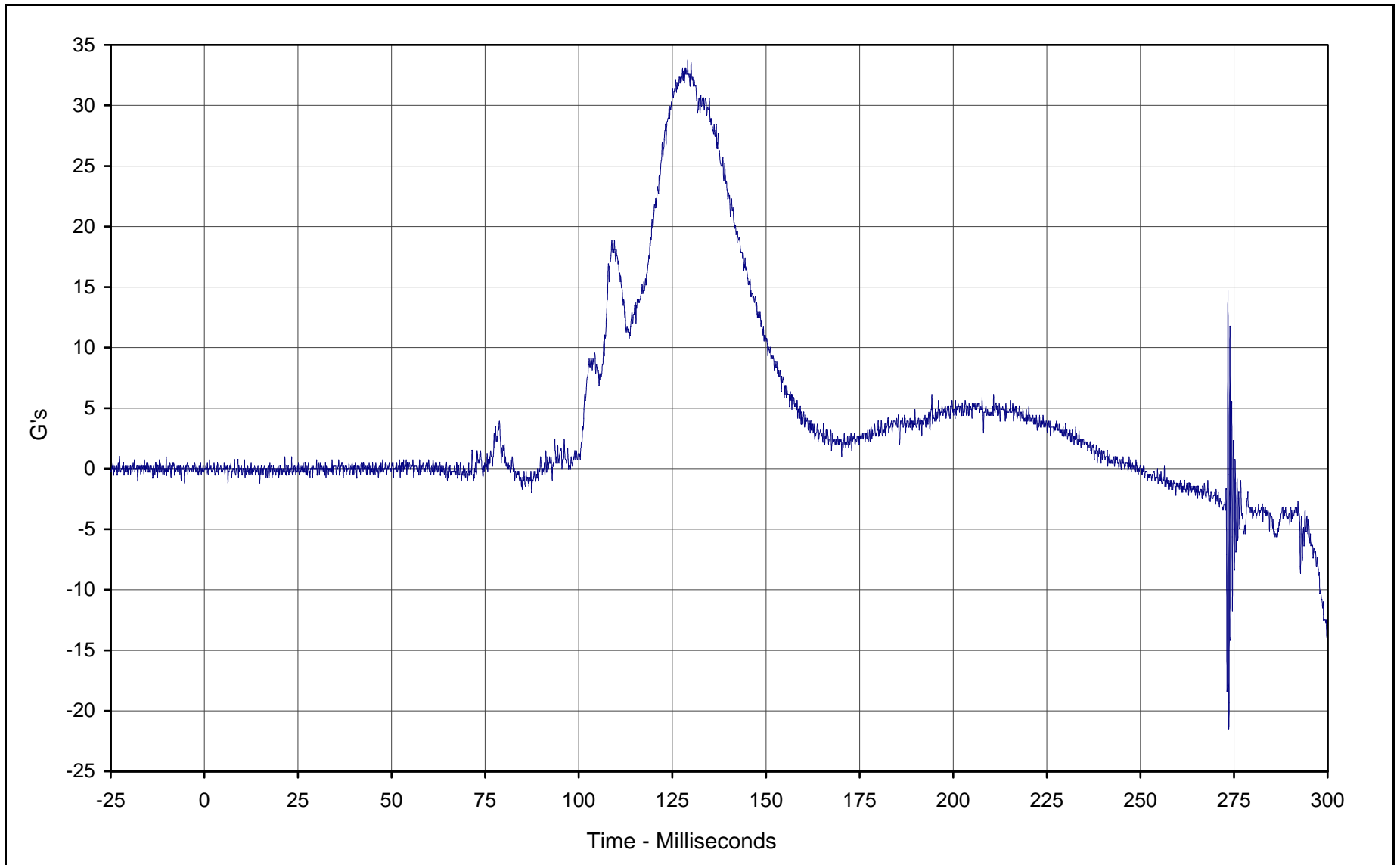

Curve Description: Passenger Head Redundant Y
Maximum Value: 33.8 at 129.1 Milliseconds
Minimum Value: -21.3 at 273.6 Milliseconds
SAE Filter Class: 1000
Date of Test: 08/15/00
Curve Number: FIL-049

Test Program: 2000 NHTSA 40% Offset No.: FORD01
Test Vehicle: 2000 Ford Expedition 4WD 4 Door SUV



KARR20002-02

B-72

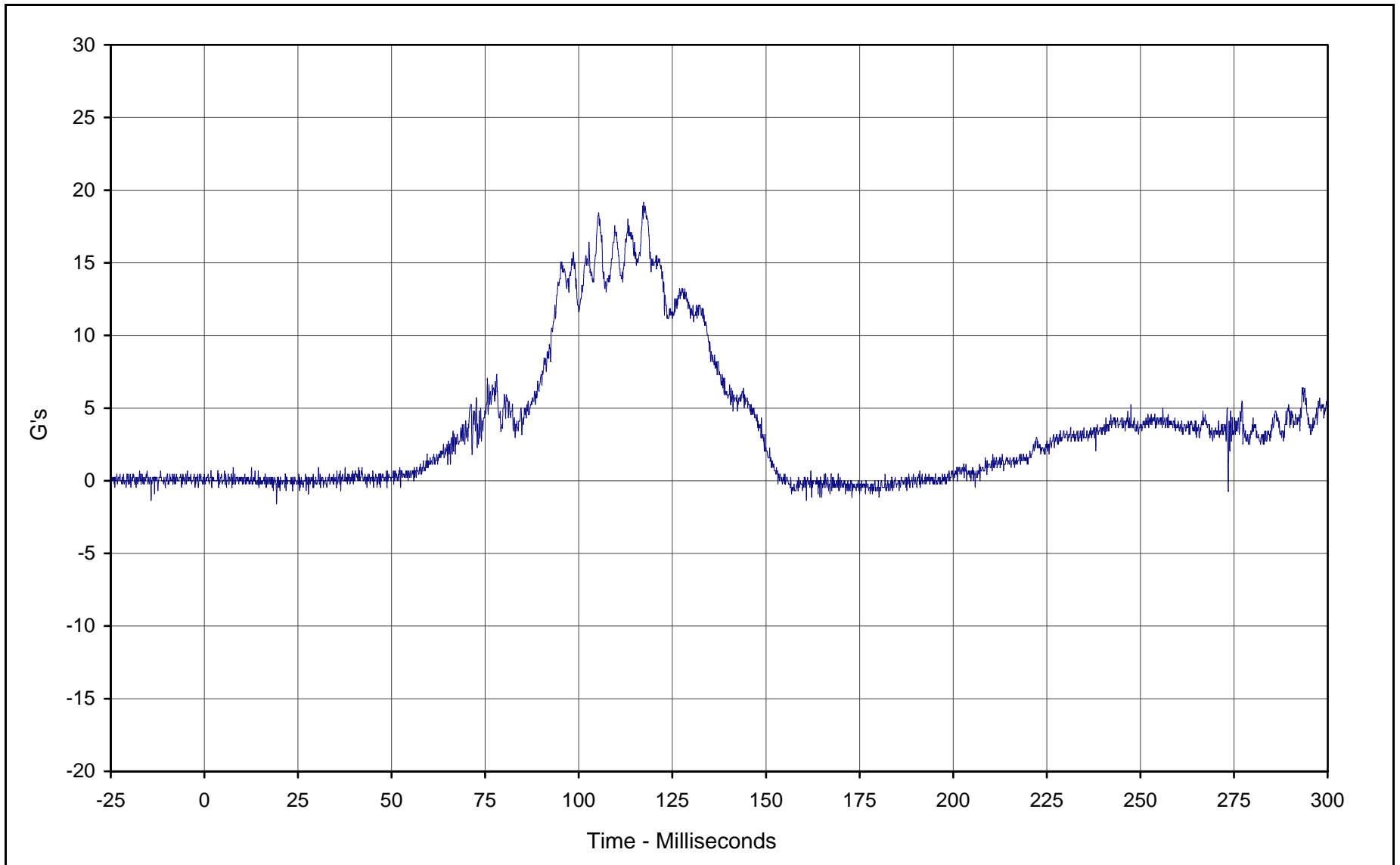

Curve Description: Passenger Head Redundant Z
Maximum Value: 19.1 at 117.3 Milliseconds
Minimum Value: -1.6 at 19.3 Milliseconds
SAE Filter Class: 1000
Date of Test: 08/15/00
Curve Number: FIL-050

Test Program: 2000 NHTSA 40% Offset No.: FORD01
Test Vehicle: 2000 Ford Expedition 4WD 4 Door SUV



KARR20002-02

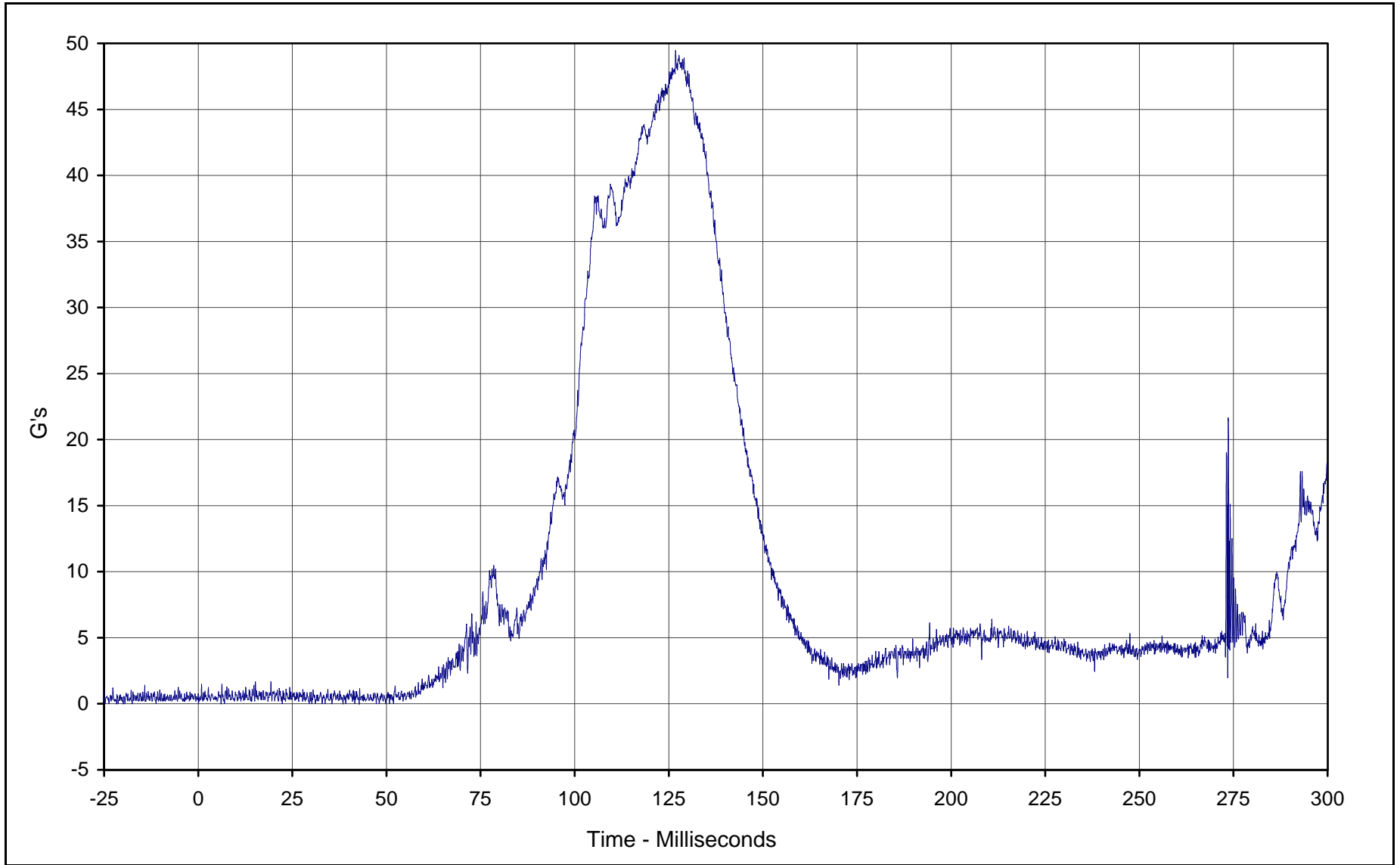

Curve Description: Passenger Head Resultant Redundant

Maximum Value: 49.4 at 126.8 Milliseconds

Minimum Value: 0.0 at 0.1 Milliseconds

SAE Filter Class: 1000

Date of Test: 08/15/00

Curve Number: RES-048

Test Program: 2000 NHTSA 40% Offset No.: FORD01

Test Vehicle: 2000 Ford Expedition 4WD 4 Door SUV



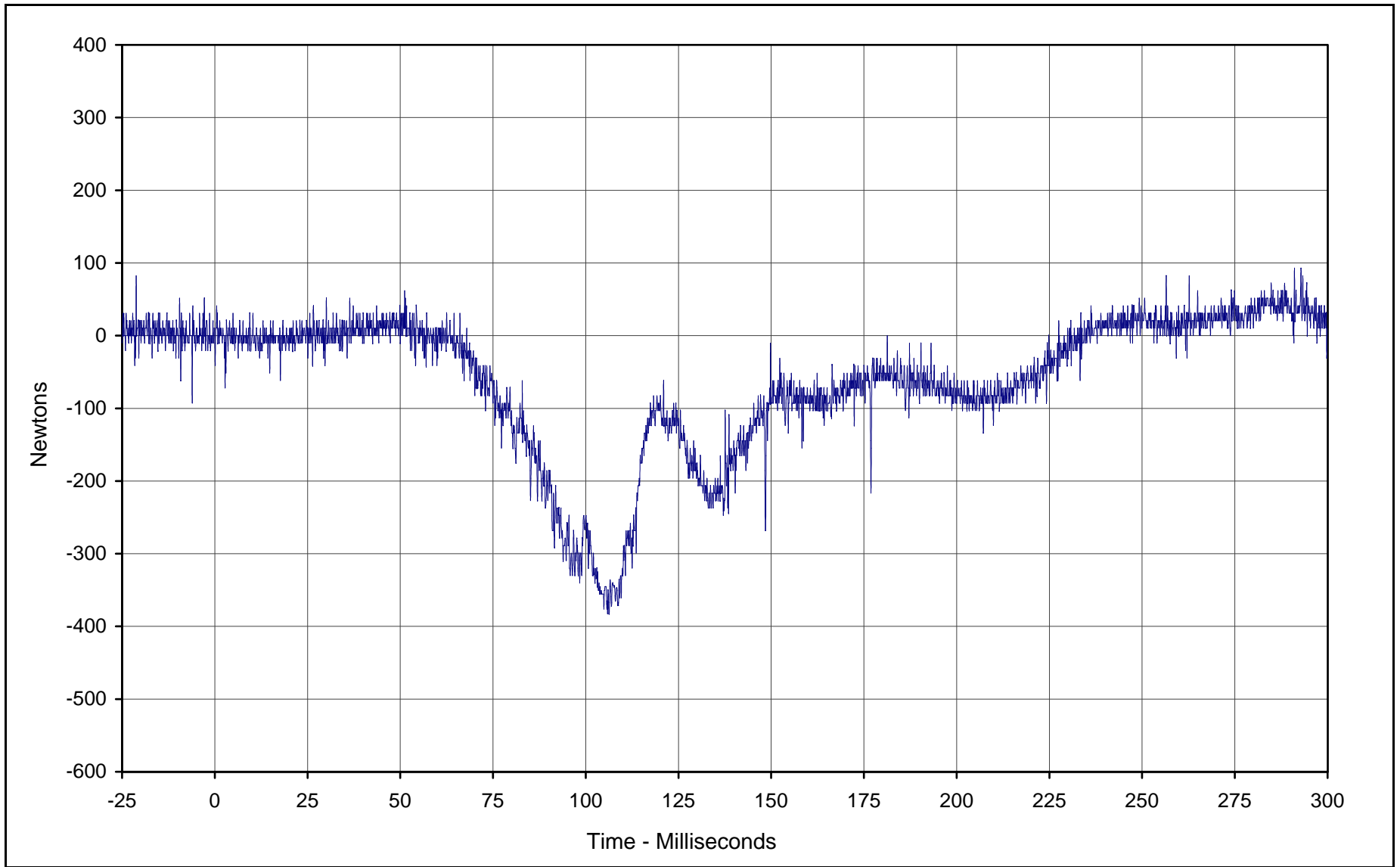

Curve Description: Passenger Neck Force X
 Maximum Value: 92.9 at 291.1 Milliseconds
 Minimum Value: -383.6 at 106.3 Milliseconds
 SAE Filter Class: 1000
 Date of Test: 08/15/00
 Curve Number: FIL-051

Test Program: 2000 NHTSA 40% Offset No.: FORD01
 Test Vehicle: 2000 Ford Expedition 4WD 4 Door SUV



B-75

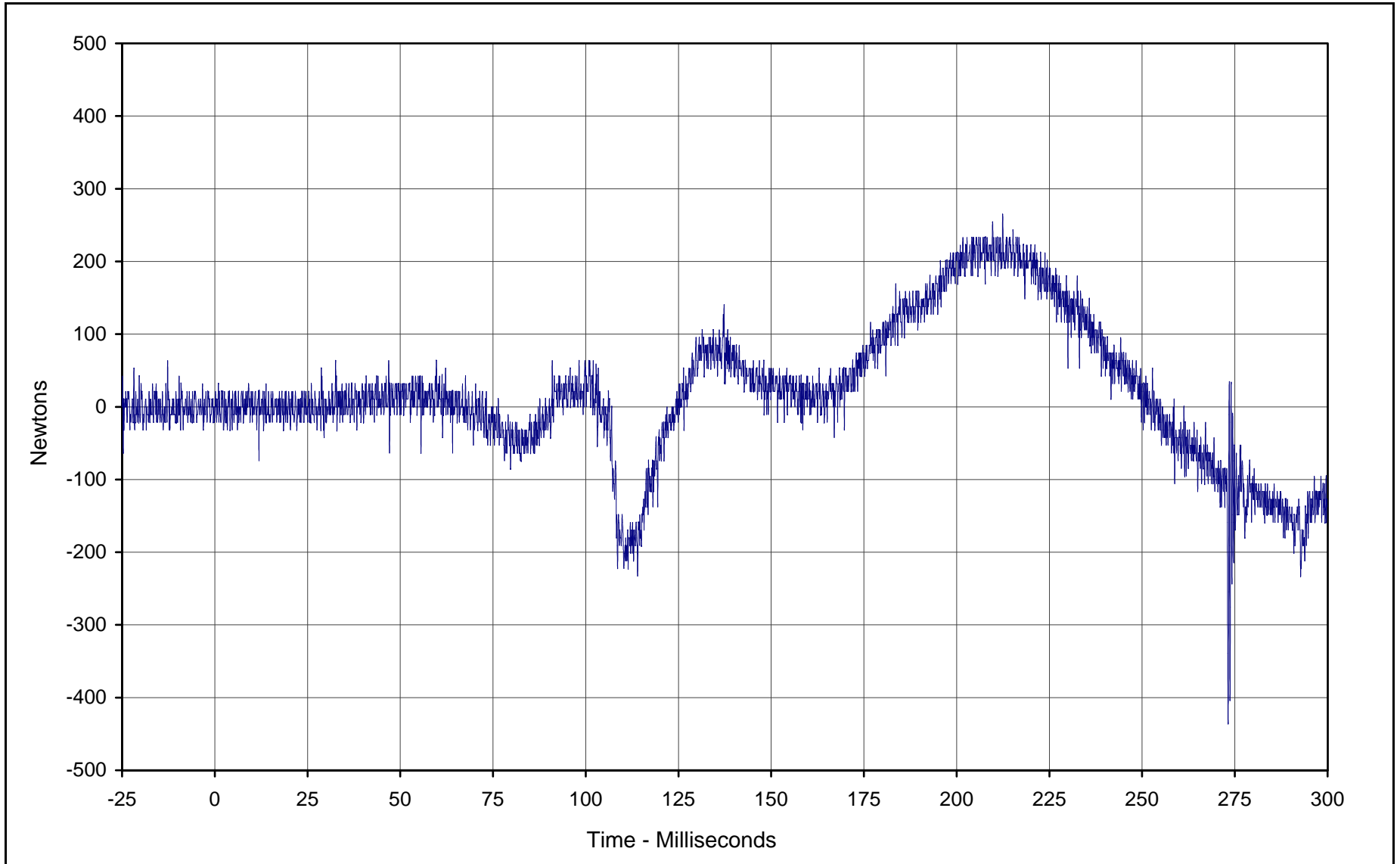

Curve Description: Passenger Neck Force Y
Maximum Value: 264.9 at 212.4 Milliseconds
Minimum Value: -434.4 at 273.2 Milliseconds
SAE Filter Class: 1000
Date of Test: 08/15/00
Curve Number: FIL-052

Test Program: 2000 NHTSA 40% Offset No.: FORD01
Test Vehicle: 2000 Ford Expedition 4WD 4 Door SUV



KARR20002-02

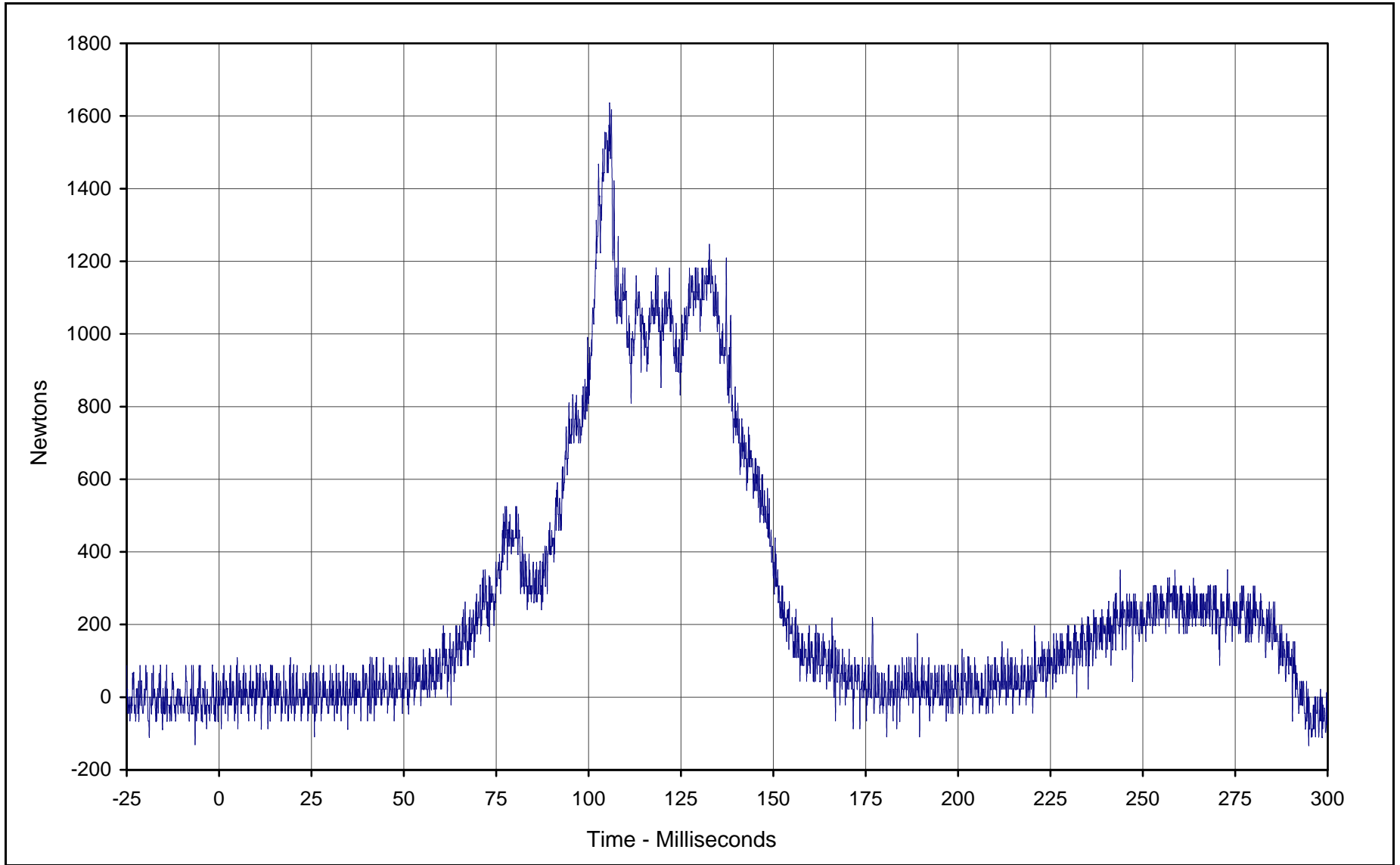

Curve Description: Passenger Neck Force Z
Maximum Value: 1635.8 at 105.7 Milliseconds
Minimum Value: -131.3 at 294.9 Milliseconds
SAE Filter Class: 1000
Date of Test: 08/15/00
Curve Number: FIL-053

Test Program: 2000 NHTSA 40% Offset No.: FORD01
Test Vehicle: 2000 Ford Expedition 4WD 4 Door SUV



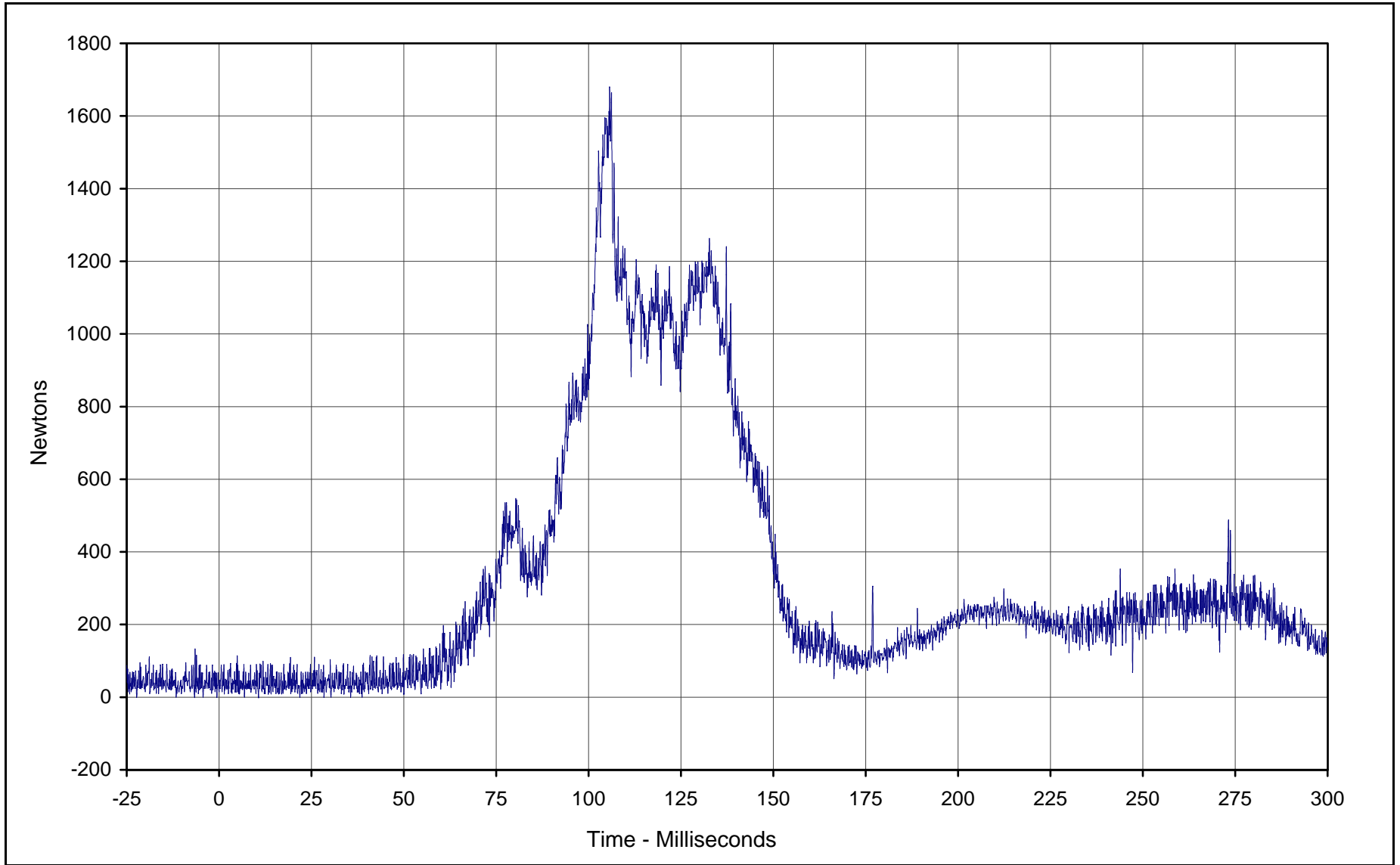

Curve Description: Passenger Neck Force Resultant
Maximum Value: 1679.5 at 105.7 Milliseconds
Minimum Value: 0.0 at 6.9 Milliseconds
SAE Filter Class: 1000
Date of Test: 08/15/00
Curve Number: RES-051

Test Program: 2000 NHTSA 40% Offset No.: FORD01
Test Vehicle: 2000 Ford Expedition 4WD 4 Door SUV



B-78

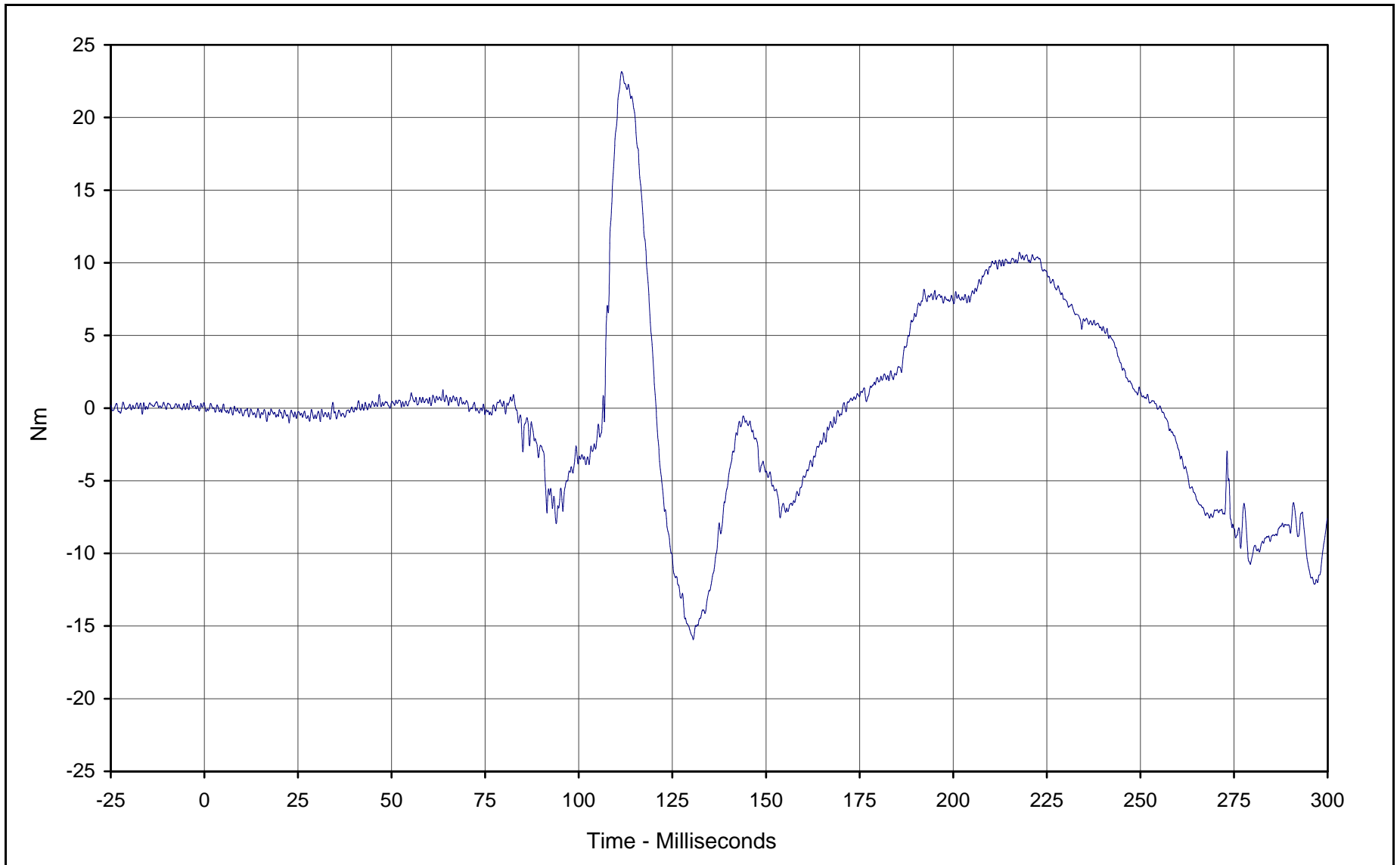

Curve Description: Passenger Neck Moment X
Maximum Value: 23.1 at 111.4 Milliseconds
Minimum Value: -15.9 at 130.6 Milliseconds
SAE Filter Class: 600
Date of Test: 08/15/00
Curve Number: FIL-054

Test Program: 2000 NHTSA 40% Offset No.: FORD01
Test Vehicle: 2000 Ford Expedition 4WD 4 Door SUV



KAR20002-02

B-79

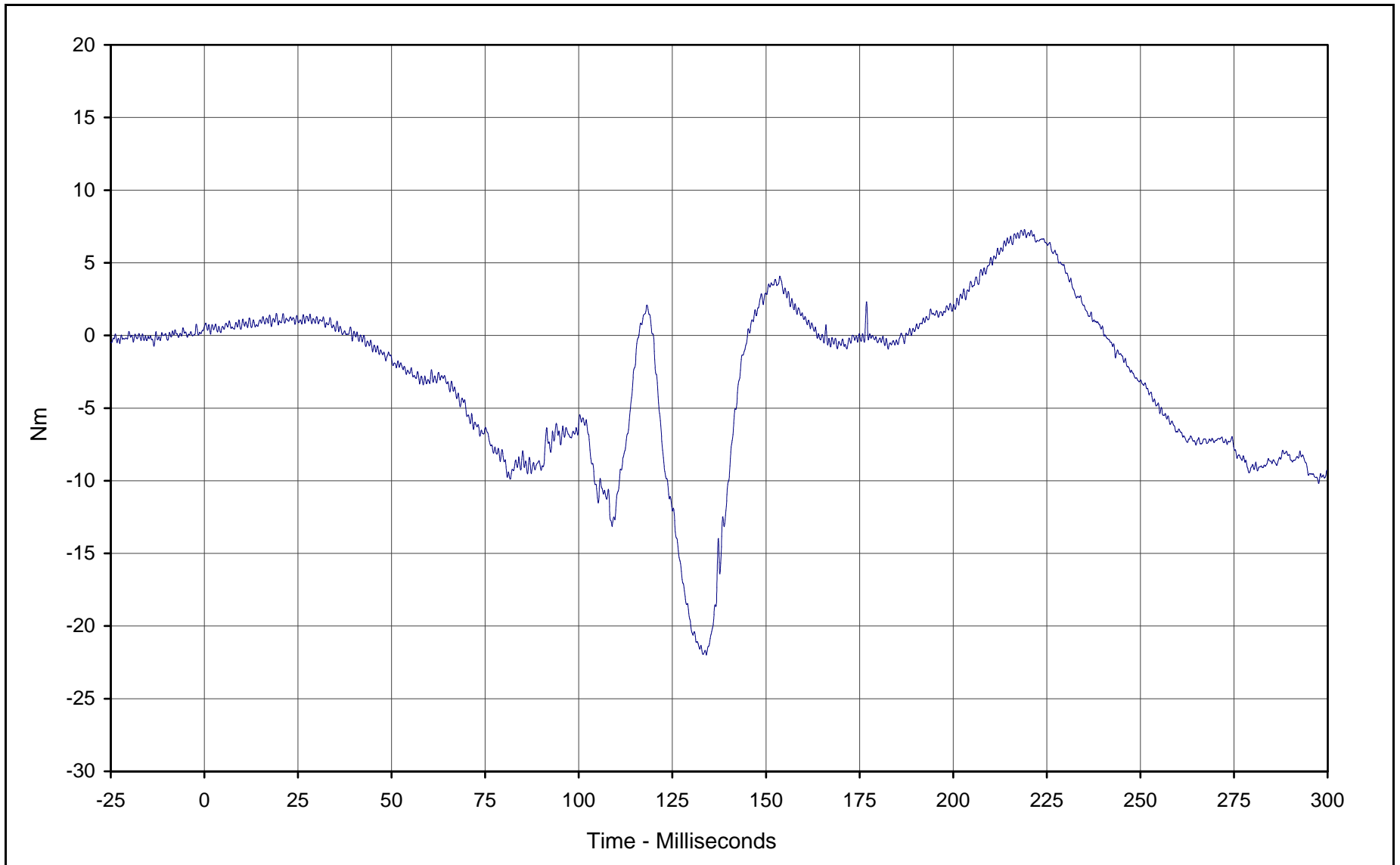

Curve Description: Passenger Neck Moment Y
Maximum Value: 7.3 at 219.1 Milliseconds
Minimum Value: -22.0 at 134.1 Milliseconds
SAE Filter Class: 600
Date of Test: 08/15/00
Curve Number: FIL-055

Test Program: 2000 NHTSA 40% Offset No.: FORD01
Test Vehicle: 2000 Ford Expedition 4WD 4 Door SUV



KARR20002-02

B-80

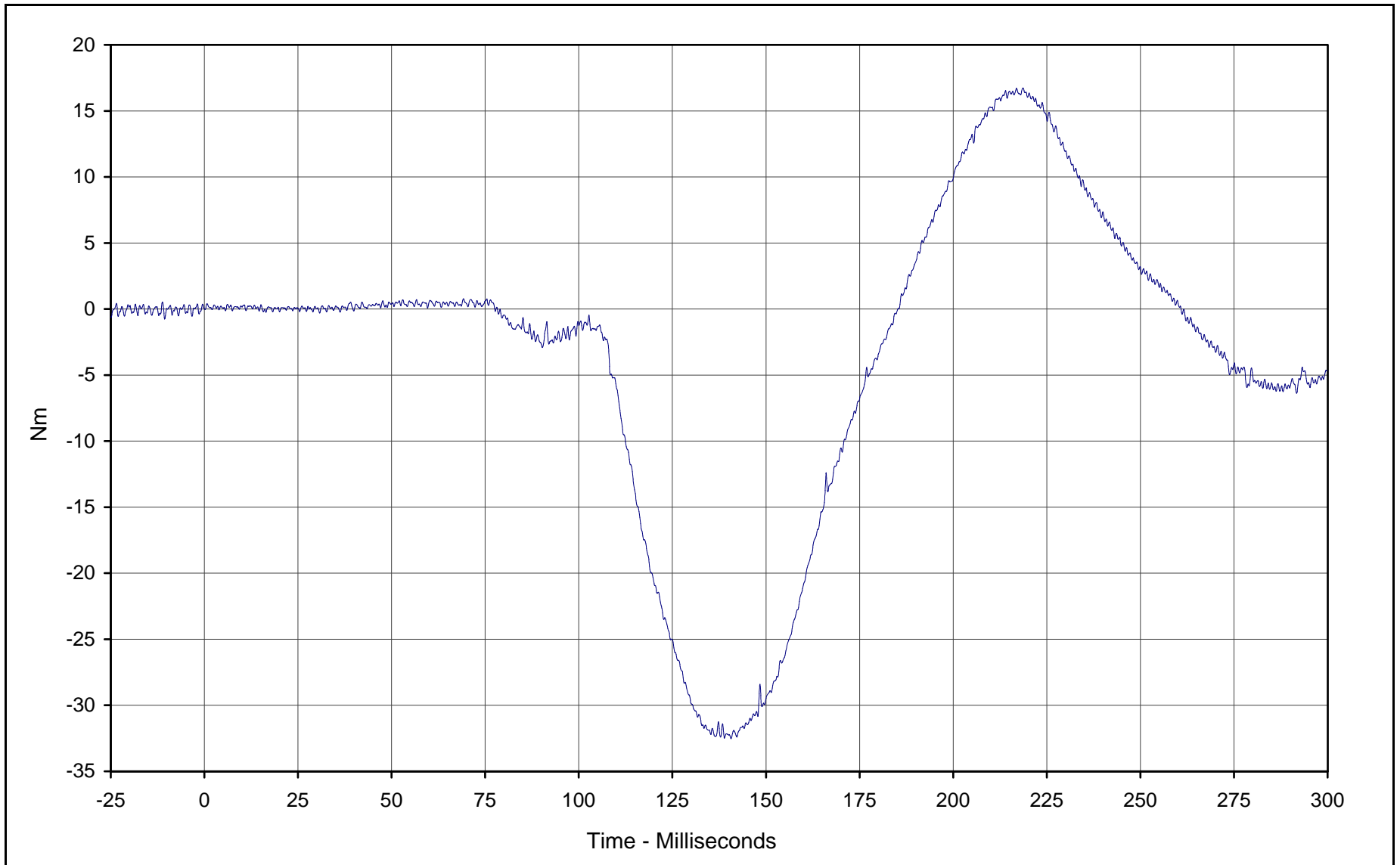

Curve Description: Passenger Neck Moment Z
Maximum Value: 16.7 at 218.6 Milliseconds
Minimum Value: -32.5 at 140.7 Milliseconds
SAE Filter Class: 600
Date of Test: 08/15/00
Curve Number: FIL-056

Test Program: 2000 NHTSA 40% Offset No.: FORD01
Test Vehicle: 2000 Ford Expedition 4WD 4 Door SUV



KARR20002-02

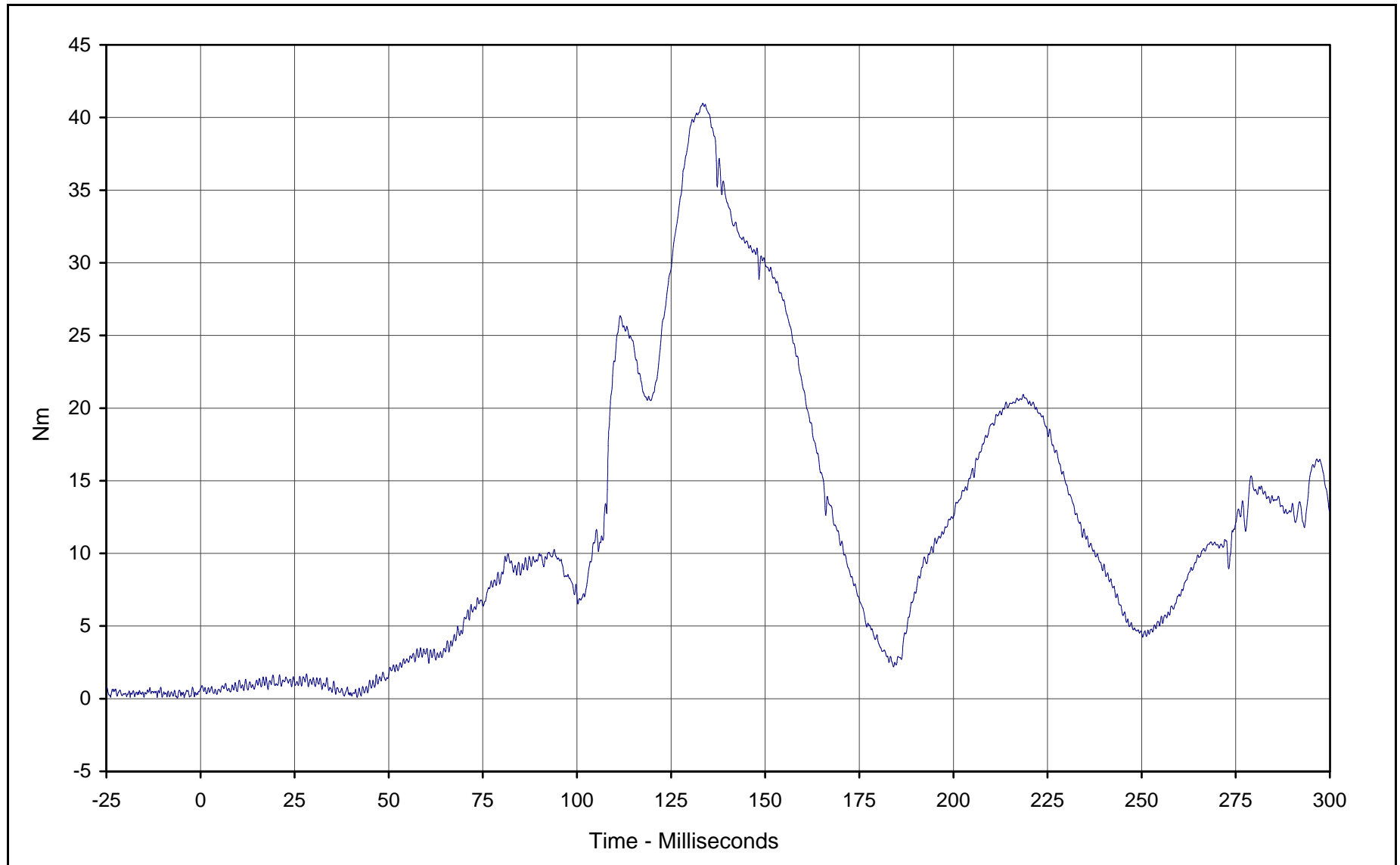

Curve Description: Passenger Neck Moment Resultant

Maximum Value: 41.0 at 133.4 Milliseconds

Minimum Value: 0.1 at 41.6 Milliseconds

SAE Filter Class: 600

Date of Test: 08/15/00

Curve Number: RES-054

Test Program: 2000 NHTSA 40% Offset No.: FORD01

Test Vehicle: 2000 Ford Expedition 4WD 4 Door SUV



B-82

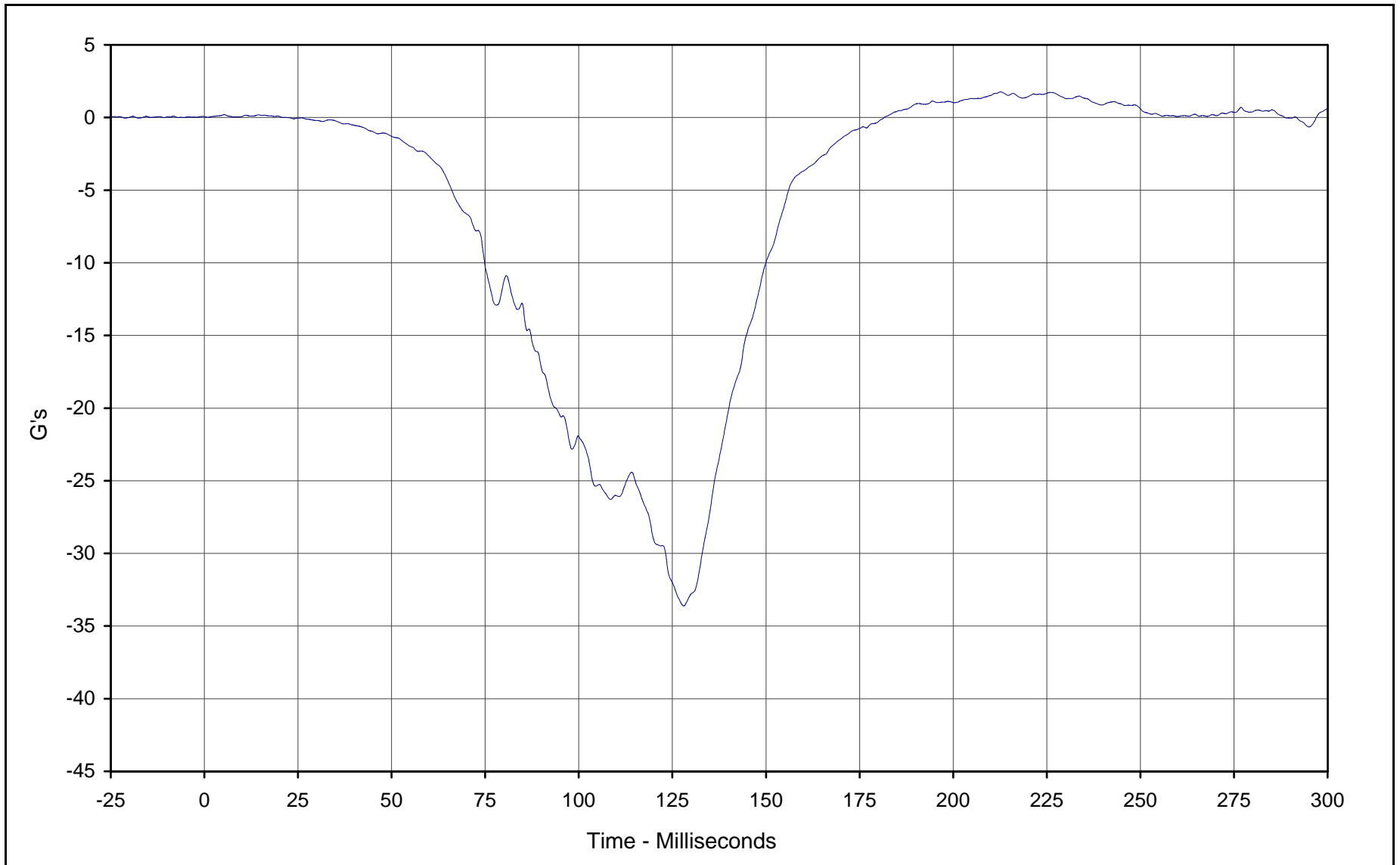

Curve Description: Passenger Chest Primary X
Maximum Value: 1.8 at 212.6 Milliseconds
Minimum Value: -33.6 at 128.0 Milliseconds
SAE Filter Class: 180
Date of Test: 08/15/00
Curve Number: FIL-057

Test Program: 2000 NHTSA 40% Offset No.: FORD01
Test Vehicle: 2000 Ford Expedition 4WD 4 Door SUV



KARR20002-02

B-83

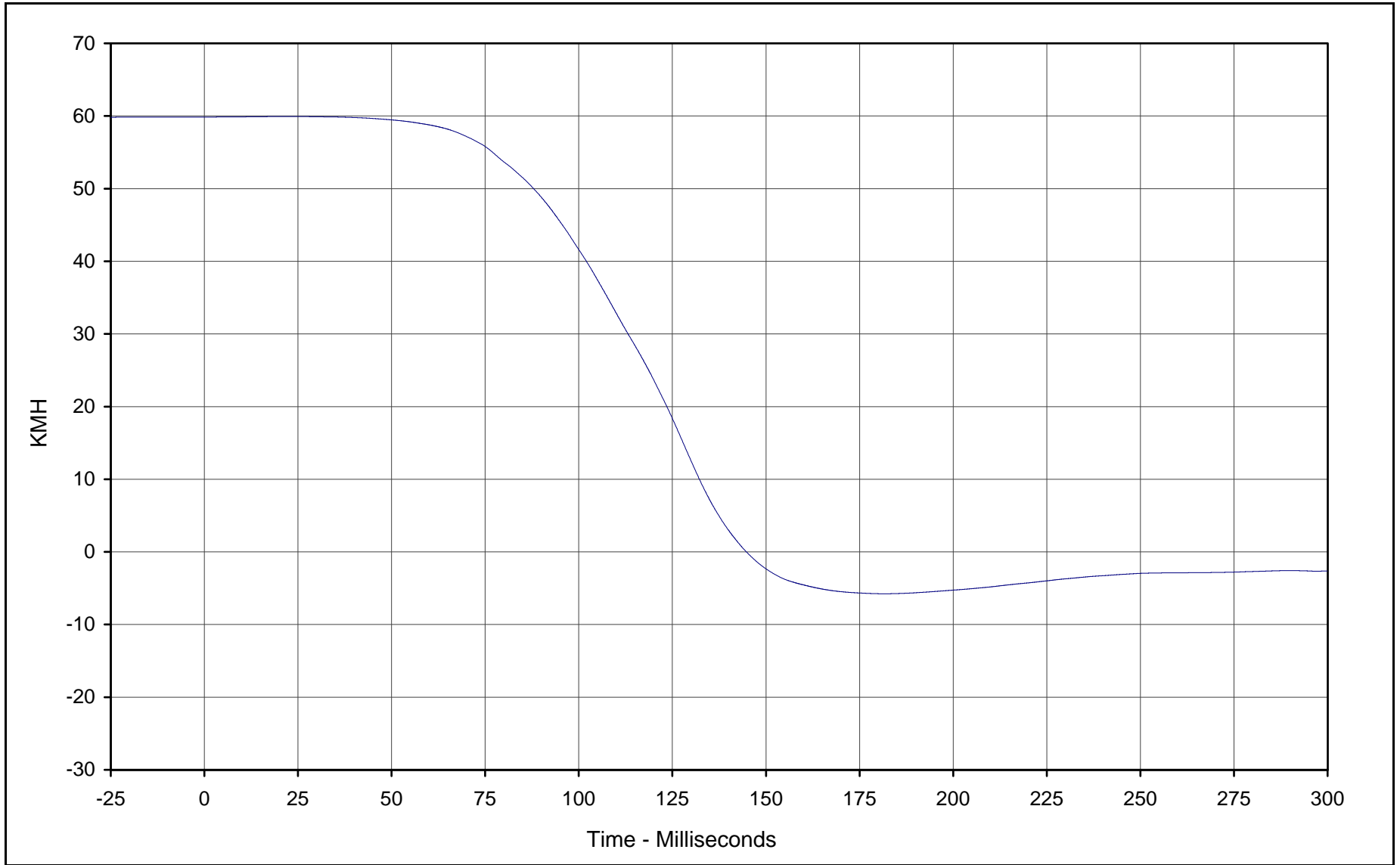

Curve Description: Passenger Chest Primary X Velocity
Maximum Value: 59.9 at 21.8 Milliseconds
Minimum Value: -5.8 at 181.6 Milliseconds
SAE Filter Class: 180
Date of Test: 08/15/00
Curve Number: IN1-057

Test Program: 2000 NHTSA 40% Offset No.: FORD01
Test Vehicle: 2000 Ford Expedition 4WD 4 Door SUV



KARR20002-02

B-84

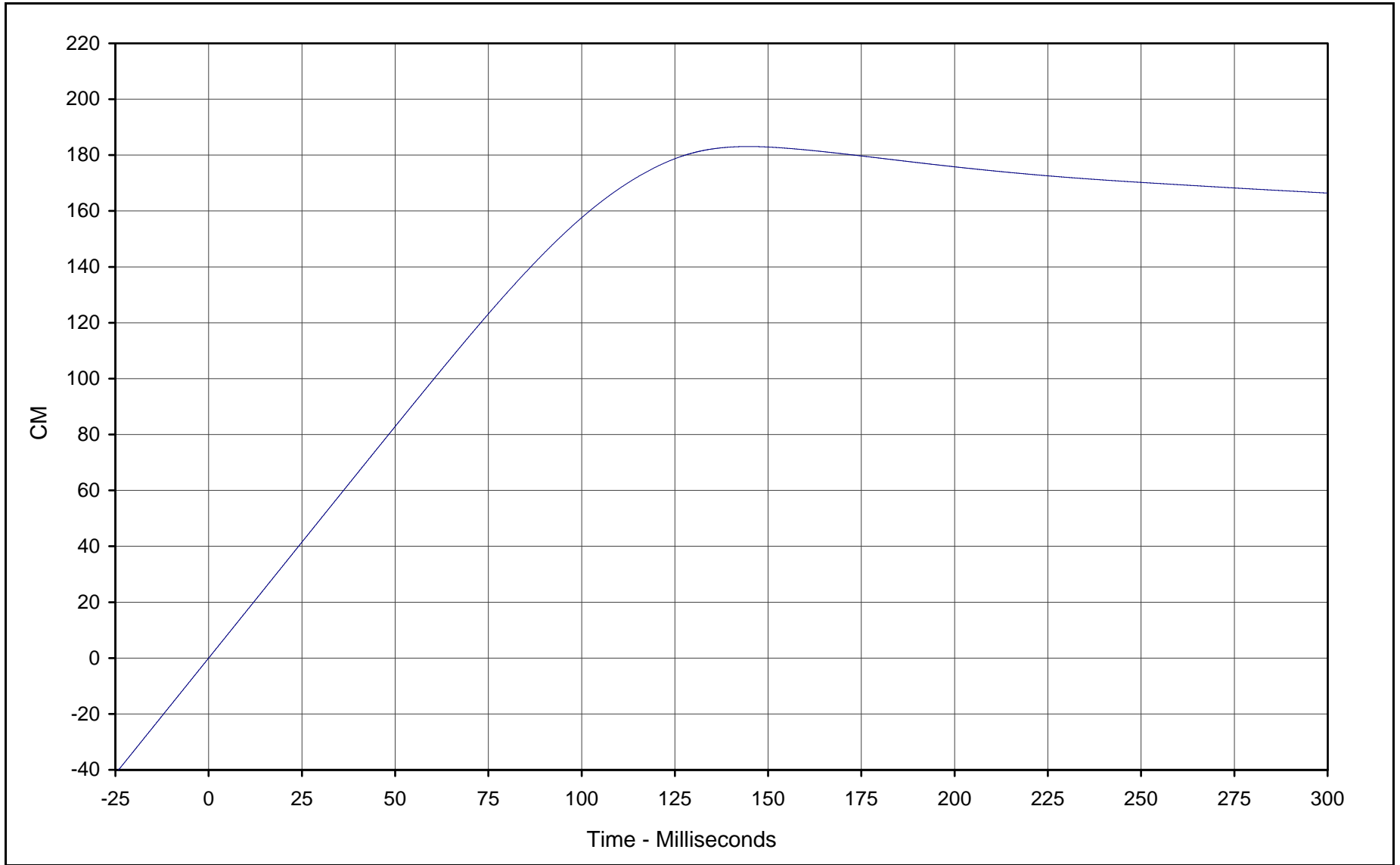

Curve Description: Passenger Chest Primary X Displ.
Maximum Value: 183.1 at 144.8 Milliseconds
Minimum Value: 0.0 at 0.0 Milliseconds
SAE Filter Class: 180
Date of Test: 08/15/00
Curve Number: IN2-057

Test Program: 2000 NHTSA 40% Offset No.: FORD01
Test Vehicle: 2000 Ford Expedition 4WD 4 Door SUV



KARR20002-02

B-85

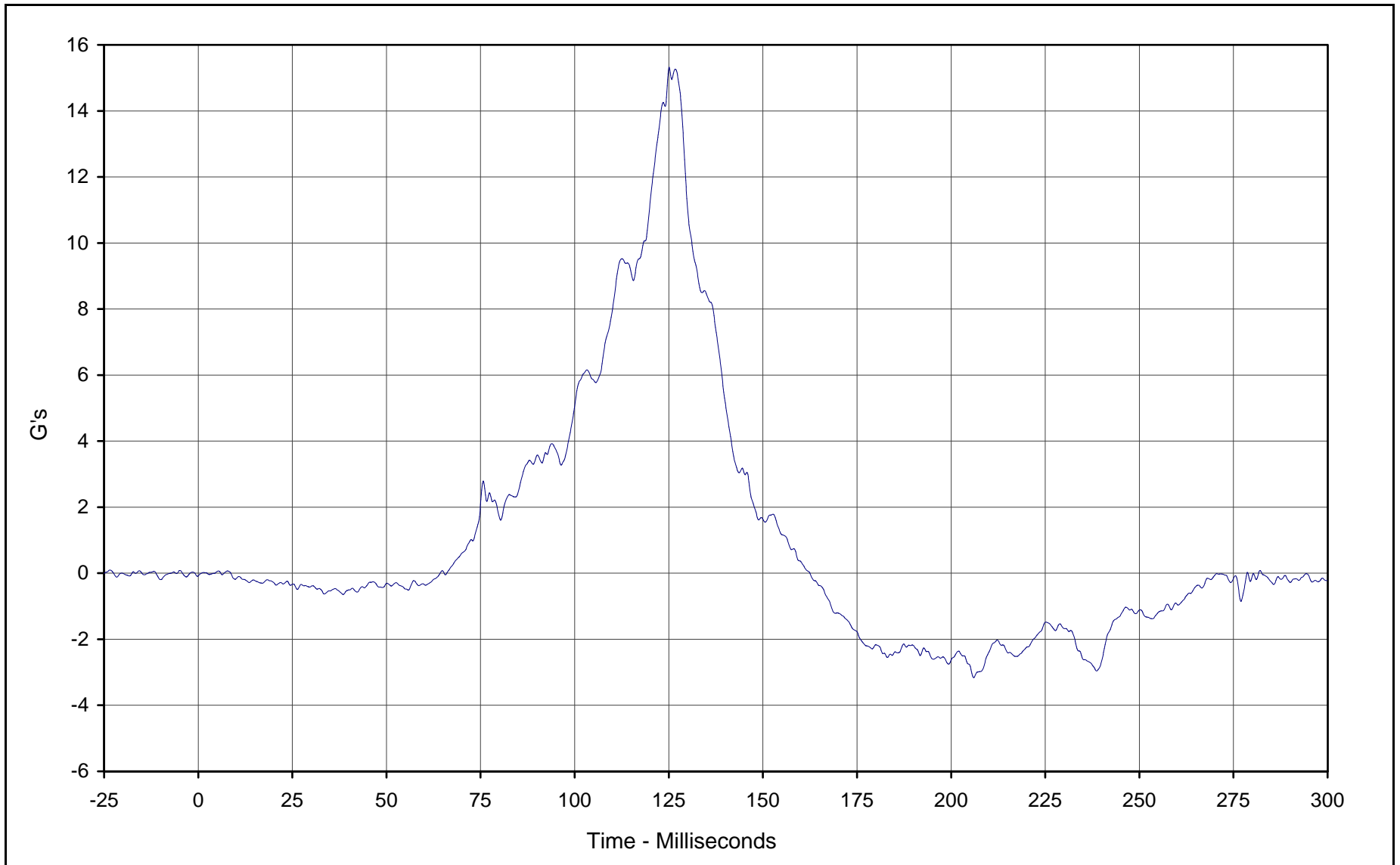

Curve Description: Passenger Chest Primary Y
Maximum Value: 15.3 at 125.1 Milliseconds
Minimum Value: -3.2 at 206.0 Milliseconds
SAE Filter Class: 180
Date of Test: 08/15/00
Curve Number: FIL-058

Test Program: 2000 NHTSA 40% Offset No.: FORD01
Test Vehicle: 2000 Ford Expedition 4WD 4 Door SUV



KARR20002-02

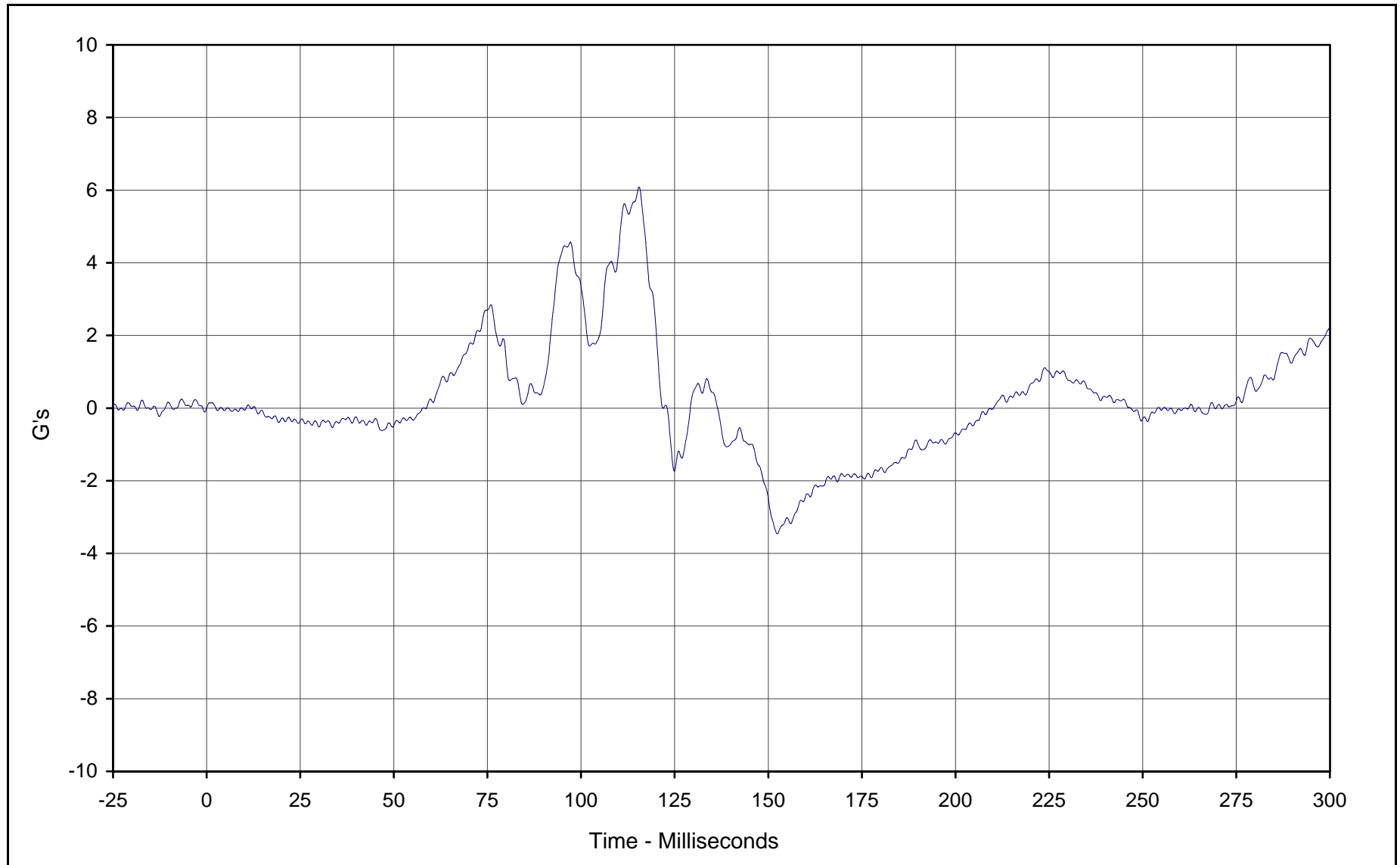

Curve Description: Passenger Chest Primary Z
Maximum Value: 6.1 at 115.5 Milliseconds
Minimum Value: -3.5 at 152.4 Milliseconds
SAE Filter Class: 180
Date of Test: 08/15/00
Curve Number: FIL-059

Test Program: 2000 NHTSA 40% Offset No.: FORD01
Test Vehicle: 2000 Ford Expedition 4WD 4 Door SUV



B-87

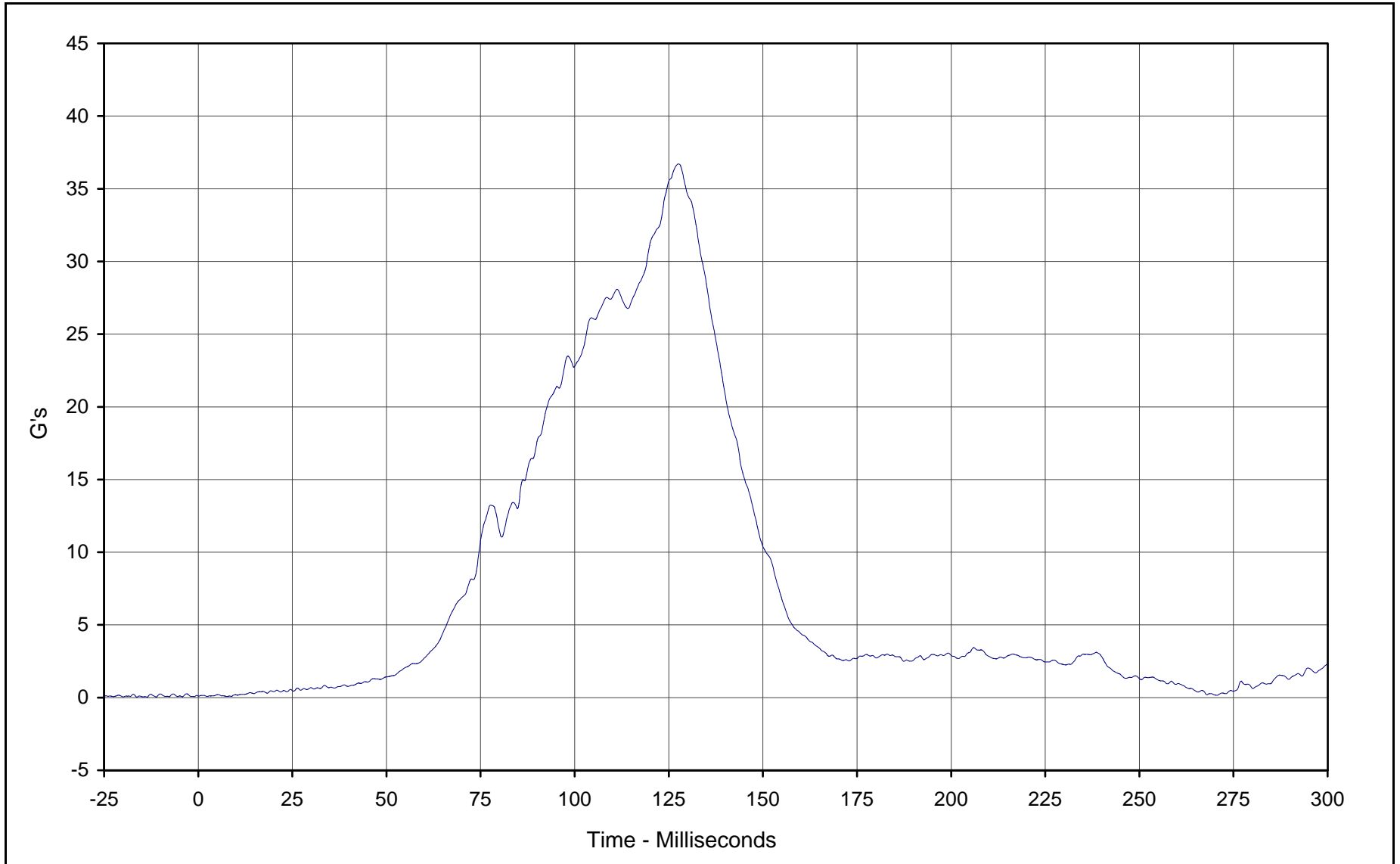

Curve Description: Passenger Chest Resultant Primary
Maximum Value: 36.7 at 127.6 Milliseconds
Minimum Value: 0.1 at 2.4 Milliseconds
SAE Filter Class: 180
Date of Test: 08/15/00
Curve Number: RES-057

Test Program: 2000 NHTSA 40% Offset No.: FORD01
Test Vehicle: 2000 Ford Expedition 4WD 4 Door SUV



KARR20002-02

B-88

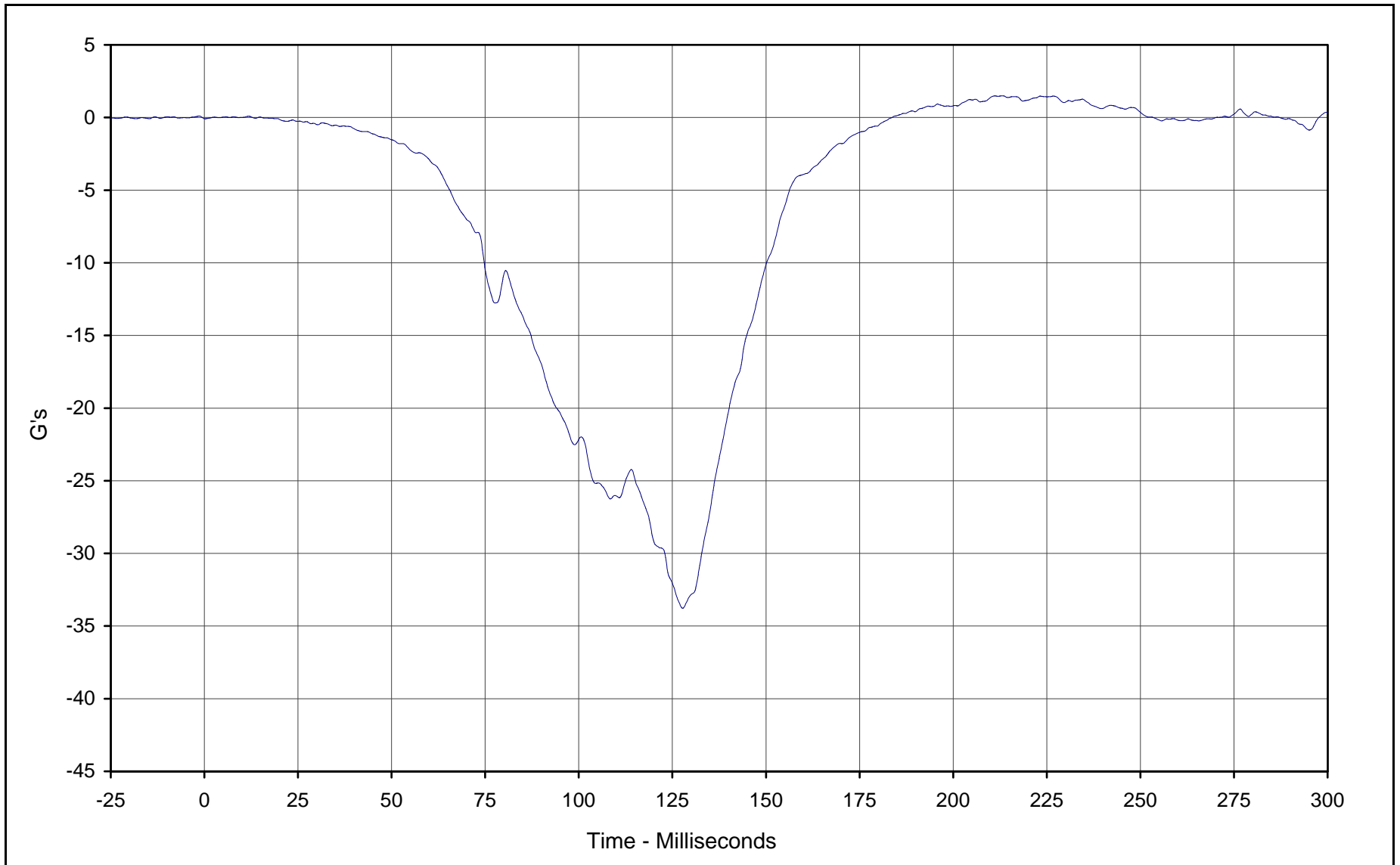

Curve Description: Passenger Chest Redundant X
Maximum Value: 1.5 at 213.1 Milliseconds
Minimum Value: -33.8 at 127.8 Milliseconds
SAE Filter Class: 180
Date of Test: 08/15/00
Curve Number: FIL-060

Test Program: 2000 NHTSA 40% Offset No.: FORD01
Test Vehicle: 2000 Ford Expedition 4WD 4 Door SUV



KARR20002-02

B-89

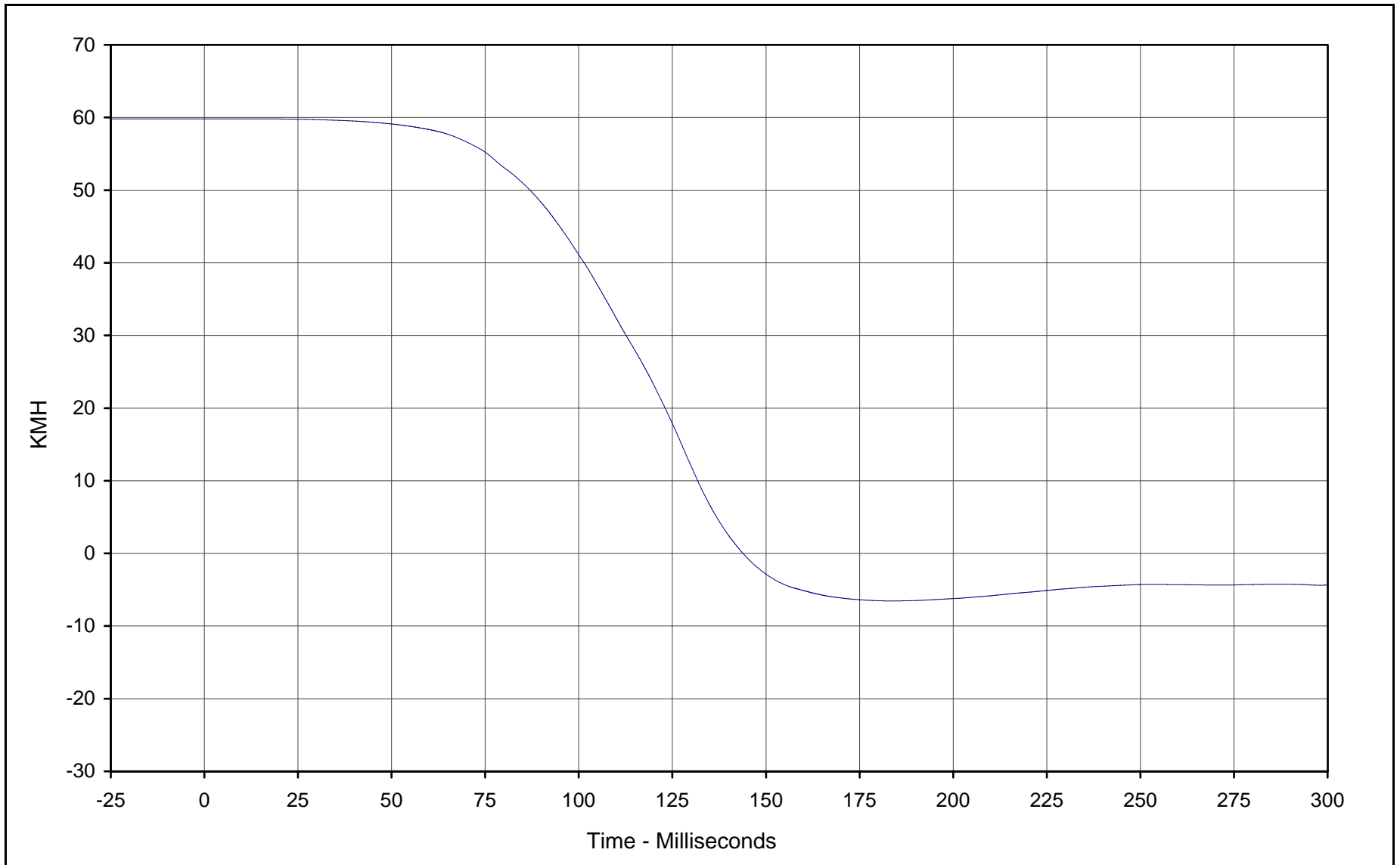

Curve Description: Passenger Chest Redundant X Velocity

Maximum Value: 59.8 at 12.9 Milliseconds

Minimum Value: -6.5 at 183.7 Milliseconds

SAE Filter Class: 180

Date of Test: 08/15/00

Curve Number: IN1-060

Test Program: 2000 NHTSA 40% Offset No.: FORD01

Test Vehicle: 2000 Ford Expedition 4WD 4 Door SUV



KARR20002-02

B-90

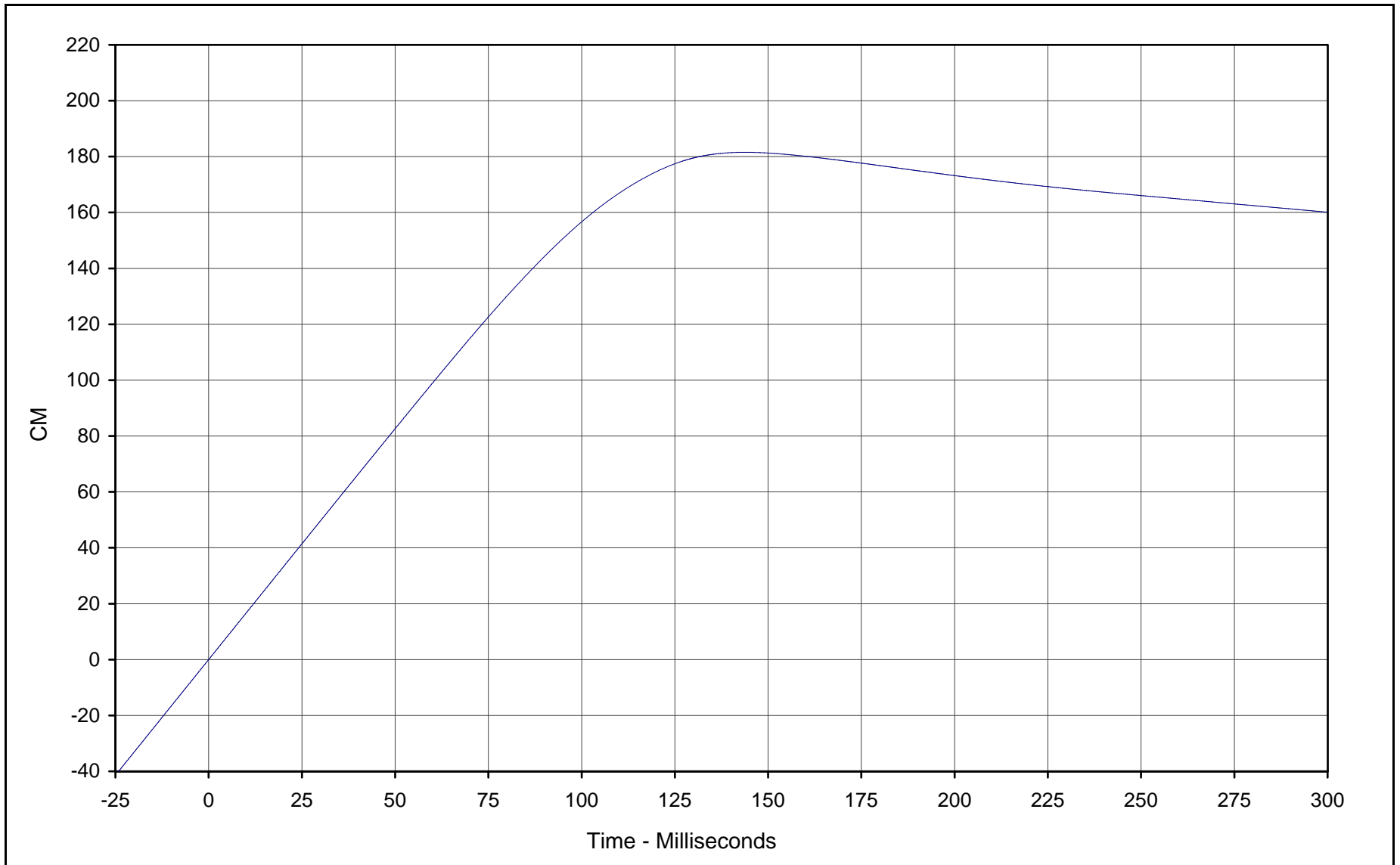

Curve Description: Passenger Chest Redundant X Displ.

Maximum Value: 181.5 at 143.9 Milliseconds

Minimum Value: 0.0 at 0.0 Milliseconds

SAE Filter Class: 180

Date of Test: 08/15/00

Curve Number: IN2-060

Test Program: 2000 NHTSA 40% Offset No.: FORD01

Test Vehicle: 2000 Ford Expedition 4WD 4 Door SUV

KARR20002-02



B-91

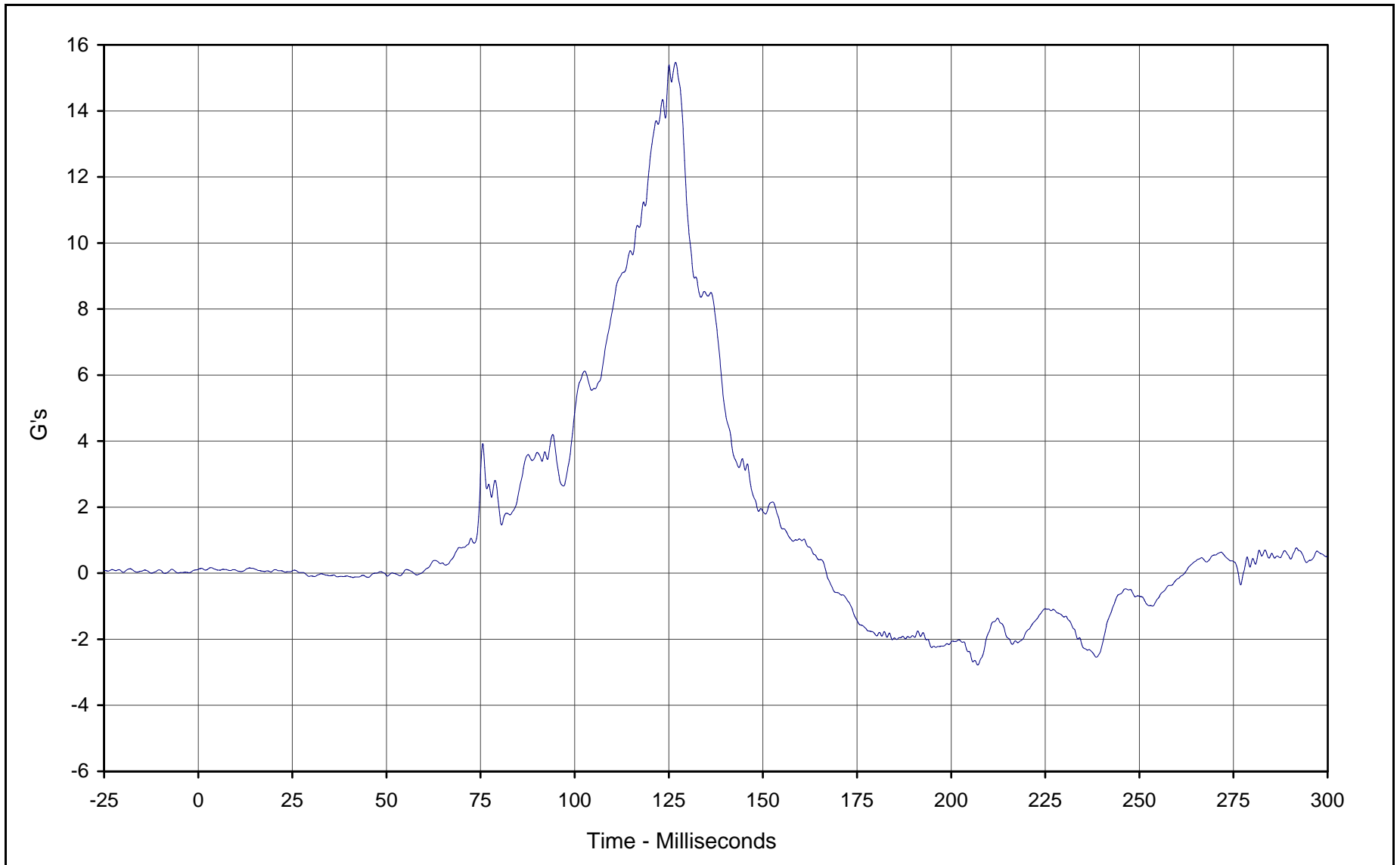

Curve Description: Passenger Chest Redundant Y
Maximum Value: 15.5 at 126.8 Milliseconds
Minimum Value: -2.8 at 207.1 Milliseconds
SAE Filter Class: 180
Date of Test: 08/15/00
Curve Number: FIL-061

Test Program: 2000 NHTSA 40% Offset No.: FORD01
Test Vehicle: 2000 Ford Expedition 4WD 4 Door SUV



KARR20002-02

B-92

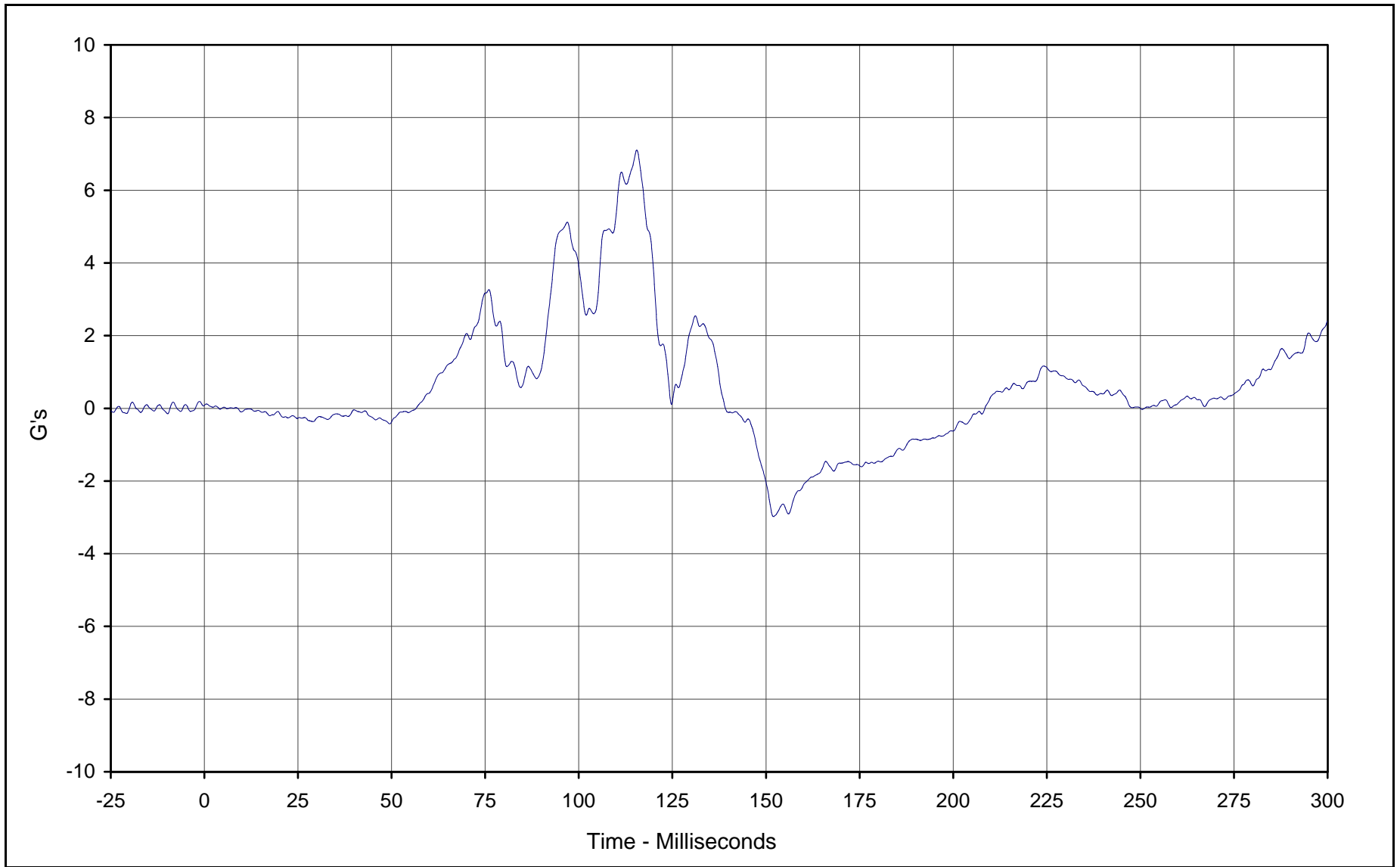

Curve Description: Passenger Chest Redundant Z
Maximum Value: 7.1 at 115.5 Milliseconds
Minimum Value: -3.0 at 152.0 Milliseconds
SAE Filter Class: 180
Date of Test: 08/15/00
Curve Number: FIL-062

Test Program: 2000 NHTSA 40% Offset No.: FORD01
Test Vehicle: 2000 Ford Expedition 4WD 4 Door SUV



KARR20002-02

B-93

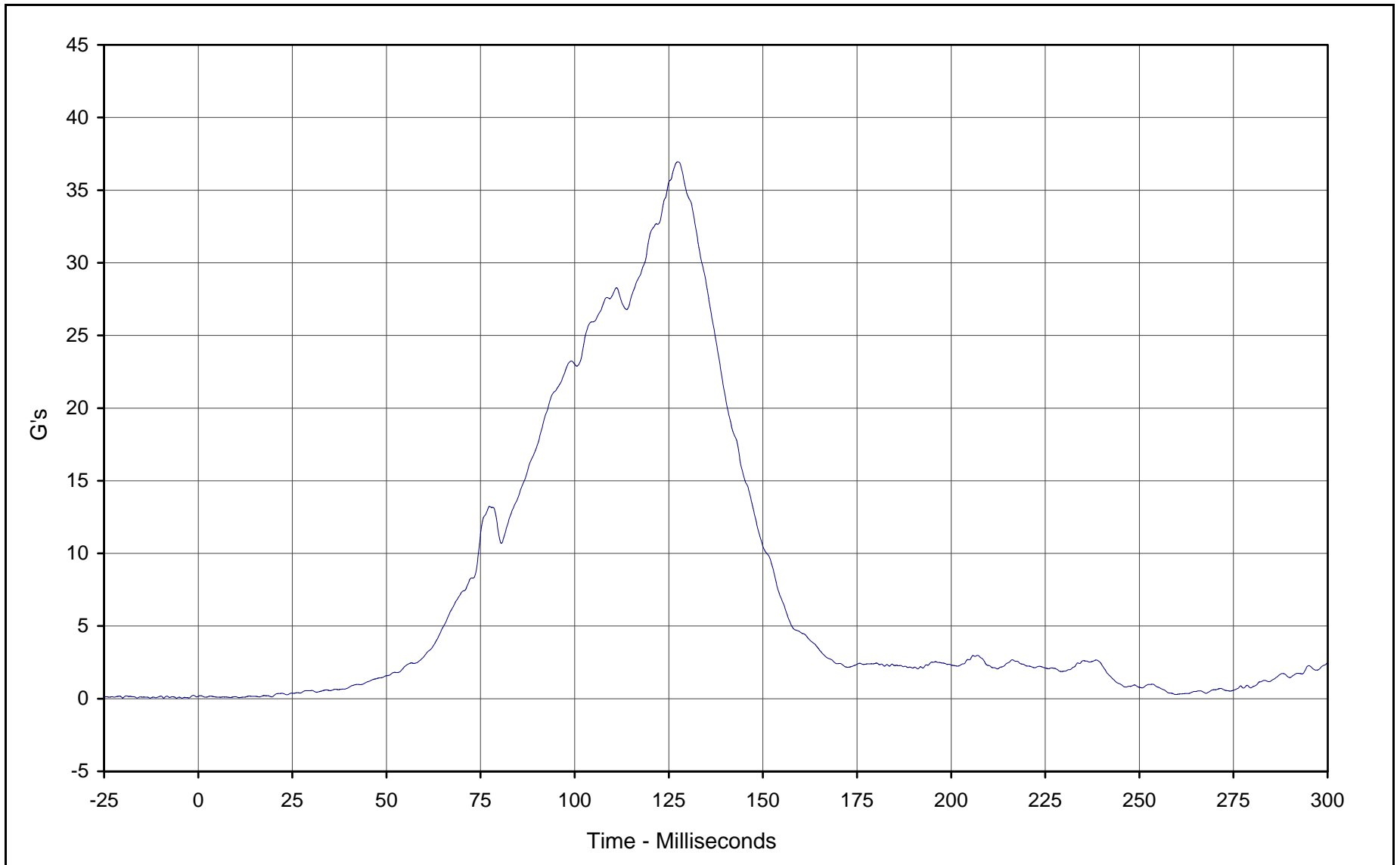

Curve Description: Passenger Chest Resultant Redundant

Maximum Value: 37.0 at 127.4 Milliseconds

Minimum Value: 0.1 at 10.9 Milliseconds

SAE Filter Class: 180

Date of Test: 08/15/00

Curve Number: RES-060

Test Program: 2000 NHTSA 40% Offset No.: FORD01

Test Vehicle: 2000 Ford Expedition 4WD 4 Door SUV

KARR20002-02



B-94

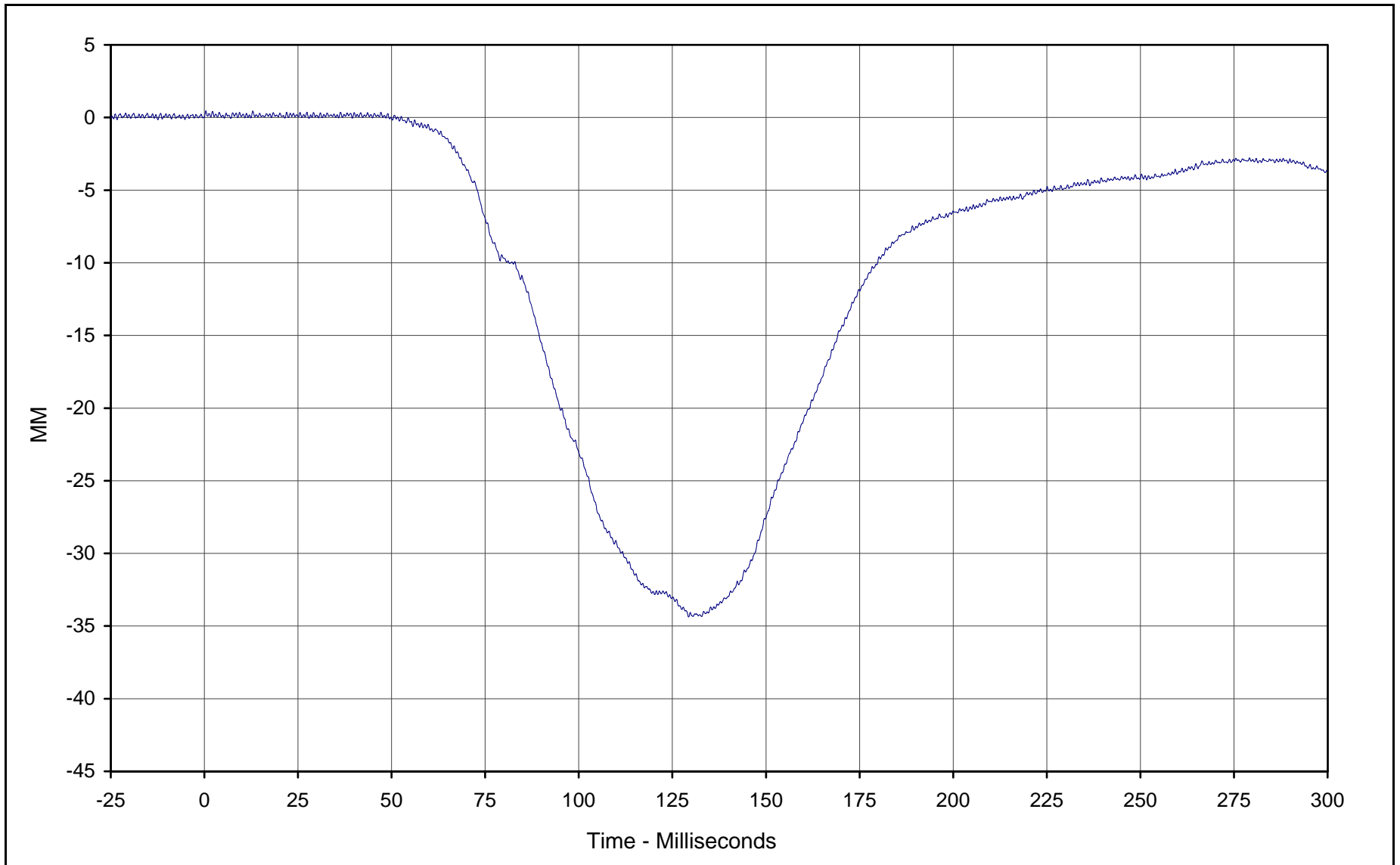

Curve Description: Passenger Chest Displacement X
Maximum Value: 0.5 at 0.4 Milliseconds
Minimum Value: -34.4 at 129.3 Milliseconds
SAE Filter Class: 600
Date of Test: 08/15/00
Curve Number: FIL-063

Test Program: 2000 NHTSA 40% Offset No.: FORD01
Test Vehicle: 2000 Ford Expedition 4WD 4 Door SUV



KARR20002-02

B-95

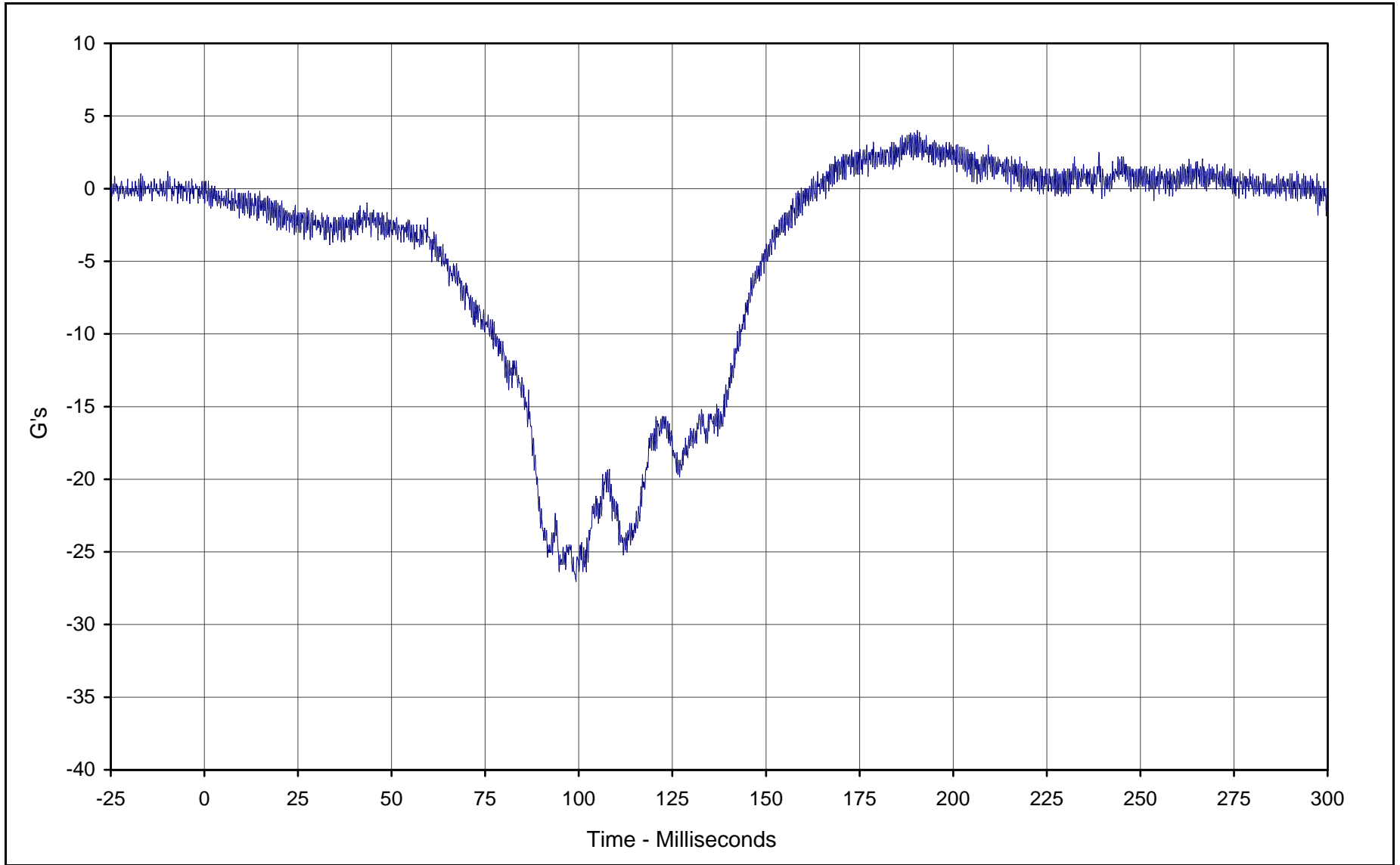

Curve Description: Passenger Pelvis X
Maximum Value: 4.0 at 190.4 Milliseconds
Minimum Value: -27.0 at 99.3 Milliseconds
SAE Filter Class: 1000
Date of Test: 08/15/00
Curve Number: FIL-064

Test Program: 2000 NHTSA 40% Offset No.: FORD01
Test Vehicle: 2000 Ford Expedition 4WD 4 Door SUV



KARR20002-02

B-96

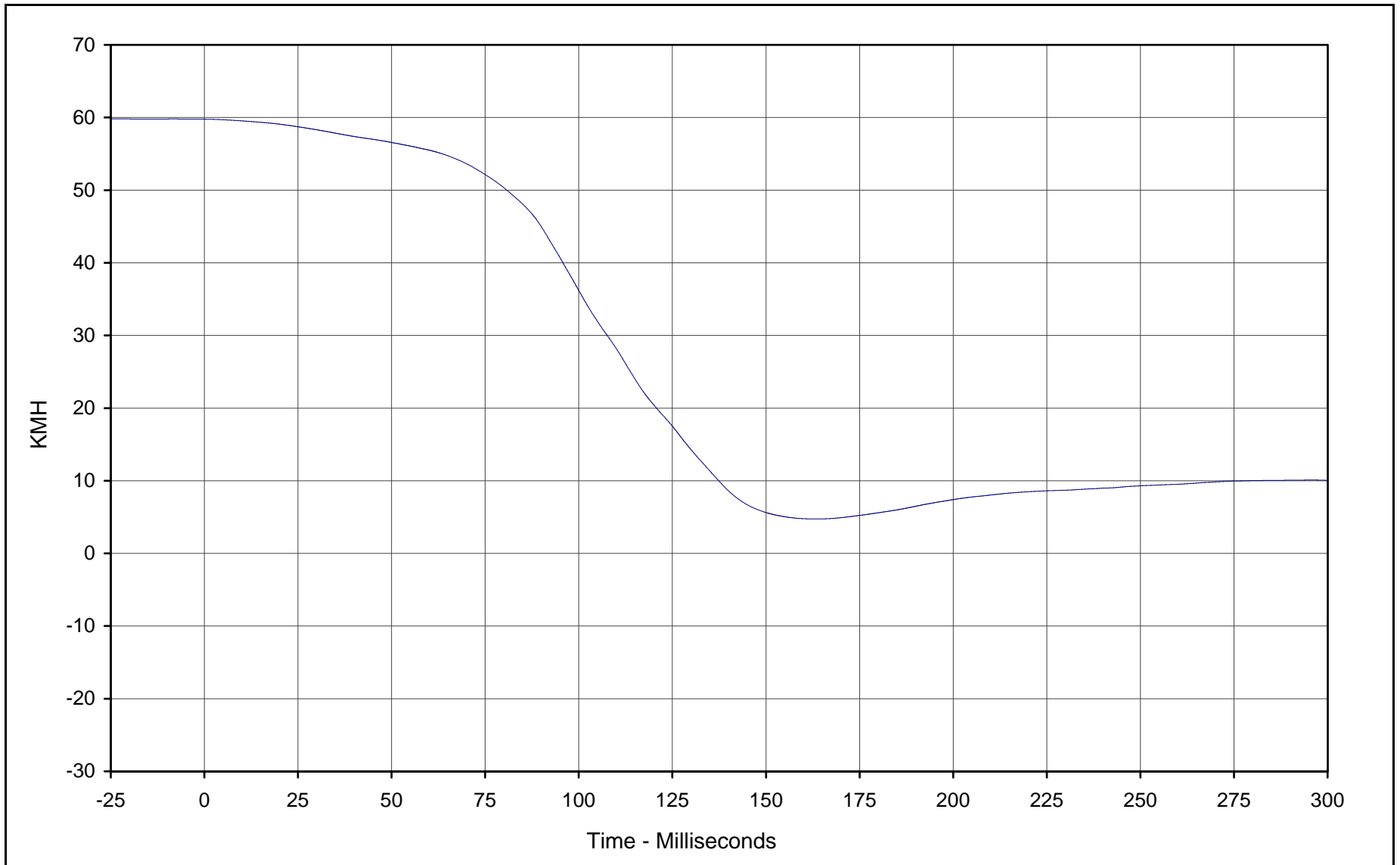

Curve Description: Passenger Pelvis X Velocity
Maximum Value: 59.8 at 0.0 Milliseconds
Minimum Value: 4.7 at 163.5 Milliseconds
SAE Filter Class: 180
Date of Test: 08/15/00
Curve Number: IN1-064

Test Program: 2000 NHTSA 40% Offset No.: FORD01
Test Vehicle: 2000 Ford Expedition 4WD 4 Door SUV



KAR20002-02

B-97

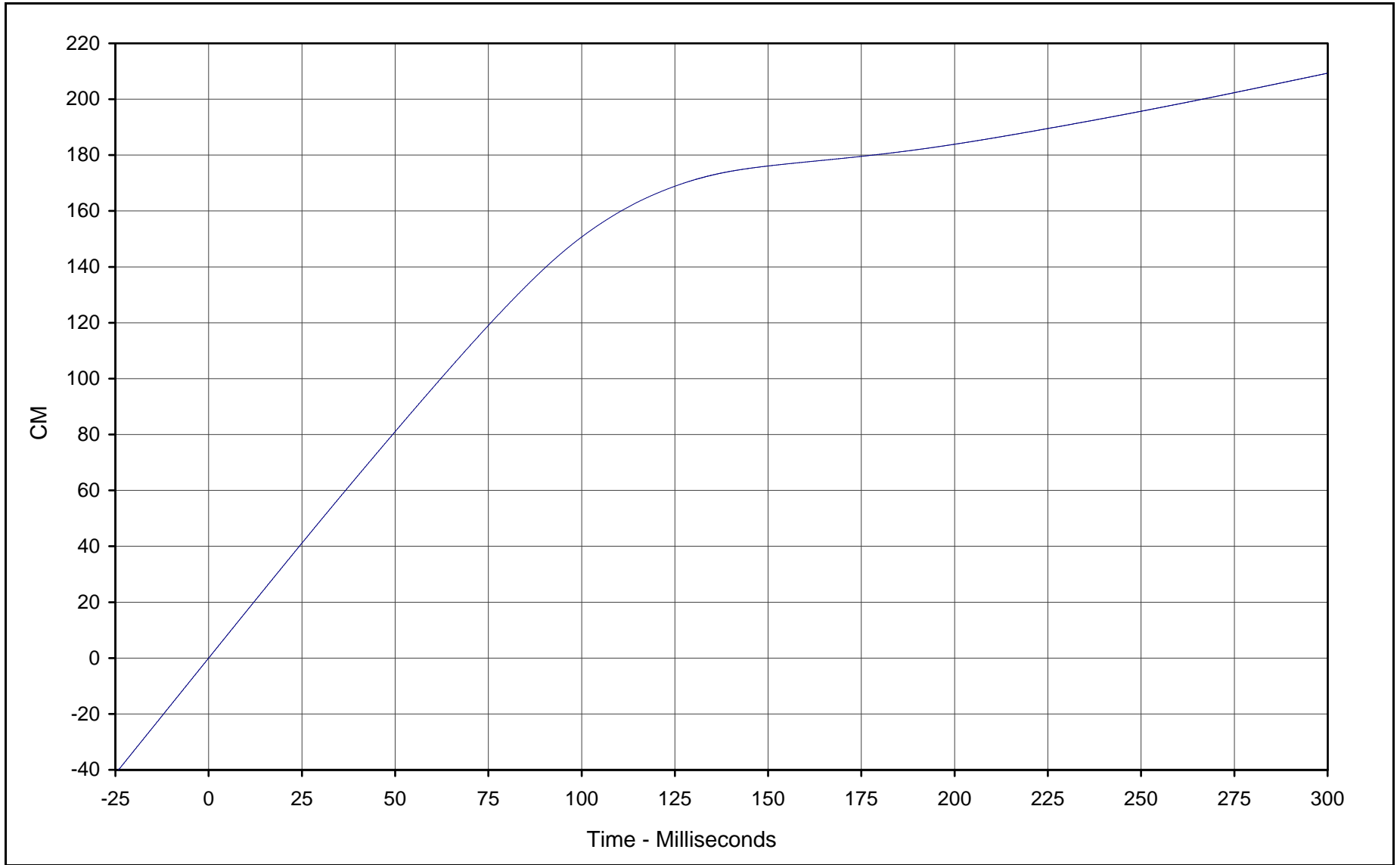

Curve Description: Passenger Pelvis X Displ.
Maximum Value: 209.3 at 299.9 Milliseconds
Minimum Value: 0.0 at 0.0 Milliseconds
SAE Filter Class: 180
Date of Test: 08/15/00
Curve Number: IN2-064

Test Program: 2000 NHTSA 40% Offset No.: FORD01
Test Vehicle: 2000 Ford Expedition 4WD 4 Door SUV



KARR20002-02

B-98

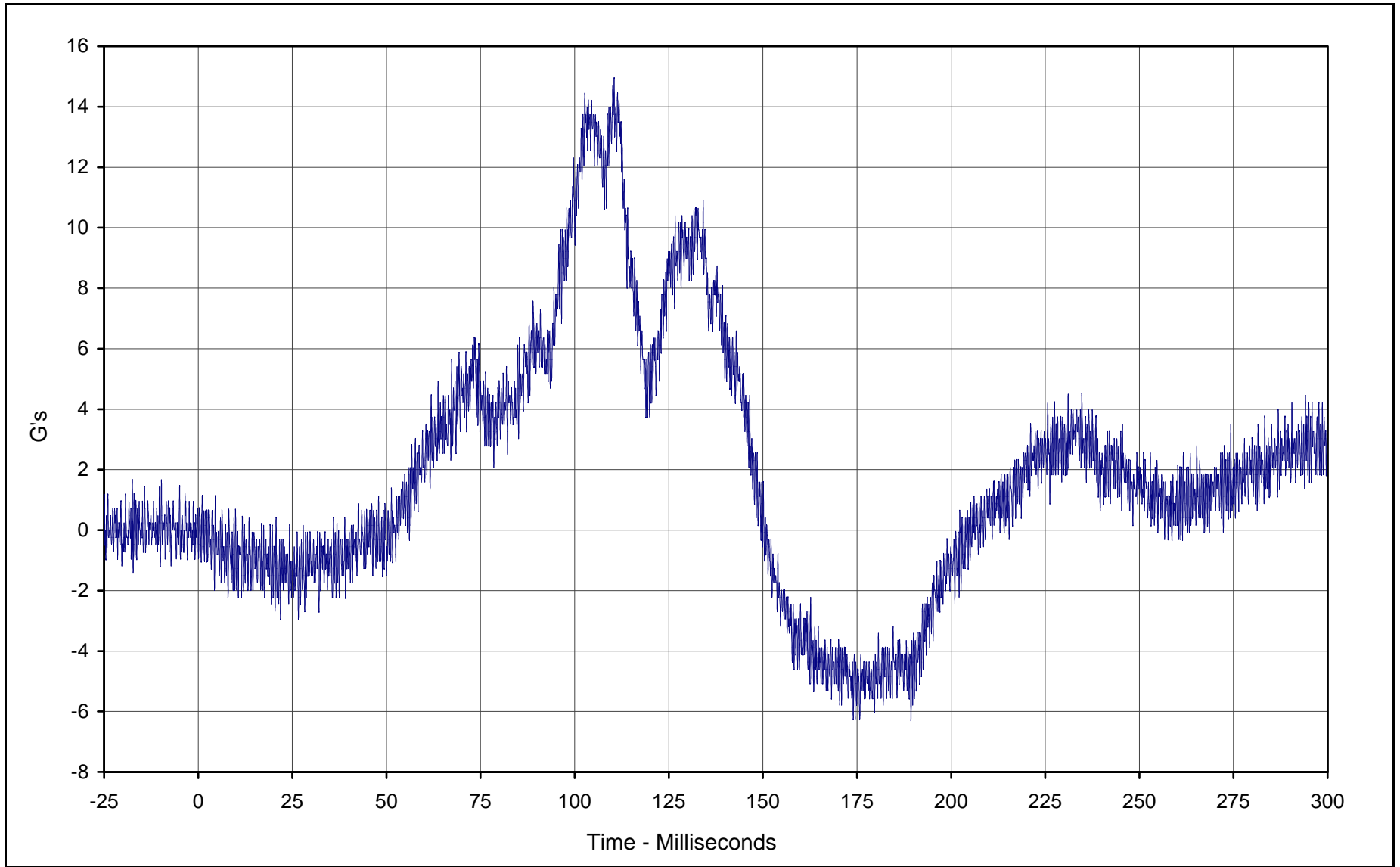

Curve Description: Passenger Pelvis Y
Maximum Value: 14.9 at 110.5 Milliseconds
Minimum Value: -6.3 at 174.0 Milliseconds
SAE Filter Class: 1000
Date of Test: 08/15/00
Curve Number: FIL-065

Test Program: 2000 NHTSA 40% Offset No.: FORD01
Test Vehicle: 2000 Ford Expedition 4WD 4 Door SUV



KARR20002-02

B-99

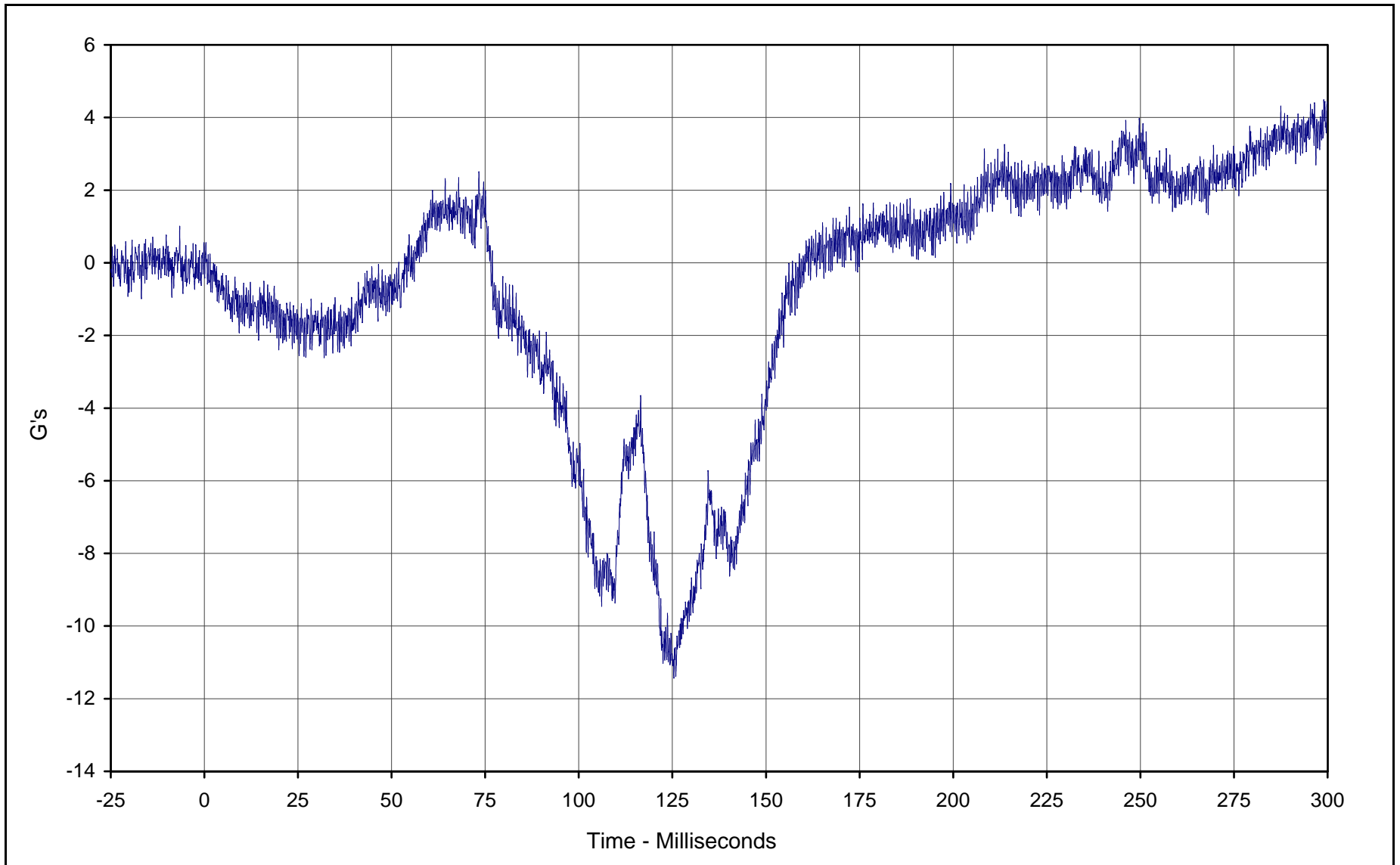

Curve Description: Passenger Pelvis Z
Maximum Value: 4.5 at 299.0 Milliseconds
Minimum Value: -11.4 at 125.4 Milliseconds
SAE Filter Class: 1000
Date of Test: 08/15/00
Curve Number: FIL-066

Test Program: 2000 NHTSA 40% Offset No.: FORD01
Test Vehicle: 2000 Ford Expedition 4WD 4 Door SUV



KARR20002-02

B-100

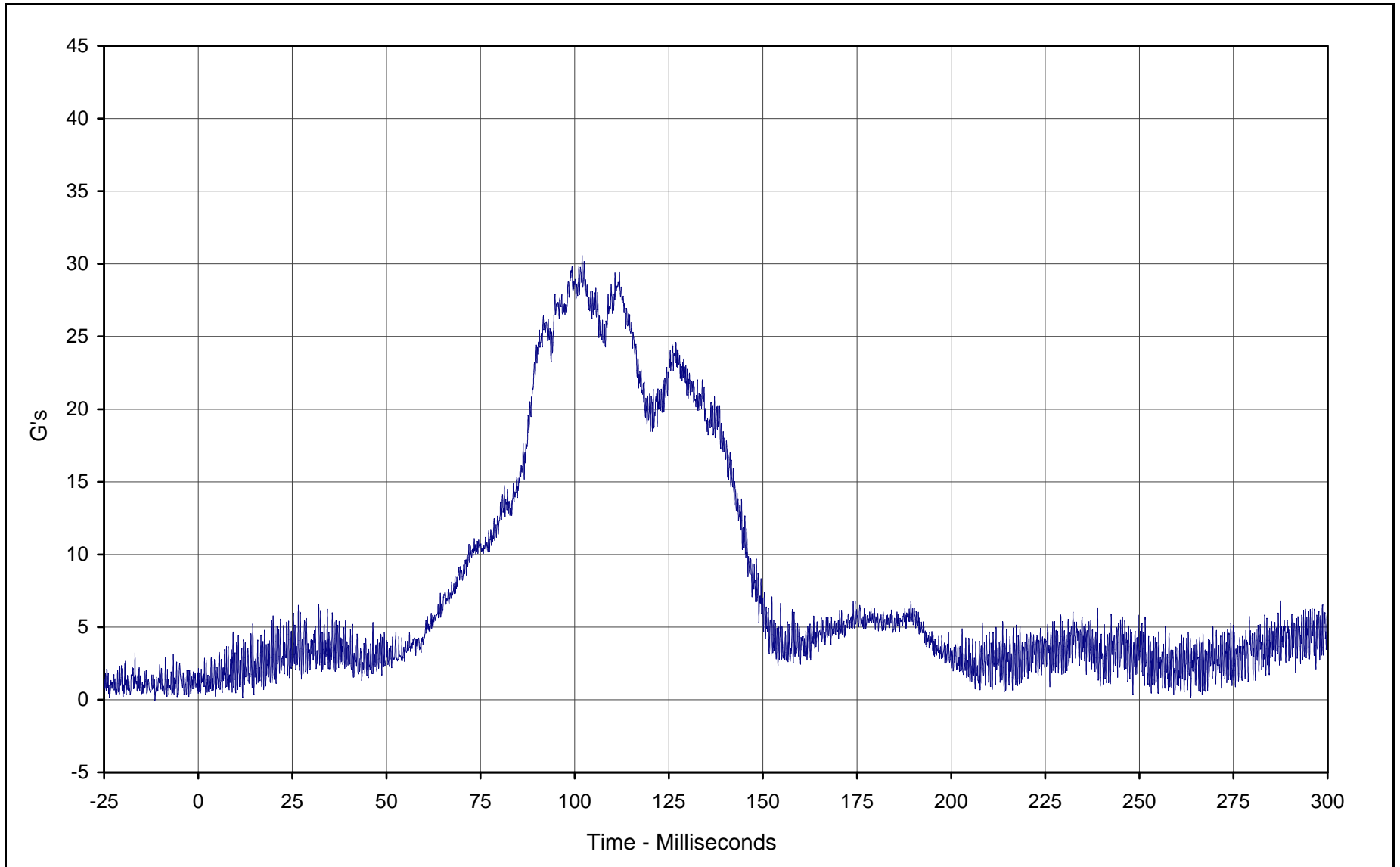

Curve Description: Passenger Pelvis Resultant
Maximum Value: 30.6 at 102.0 Milliseconds
Minimum Value: 0.2 at 263.7 Milliseconds
SAE Filter Class: 1000
Date of Test: 08/15/00
Curve Number: RES-064

Test Program: 2000 NHTSA 40% Offset No.: FORD01
Test Vehicle: 2000 Ford Expedition 4WD 4 Door SUV



KARR20002-02

B-101

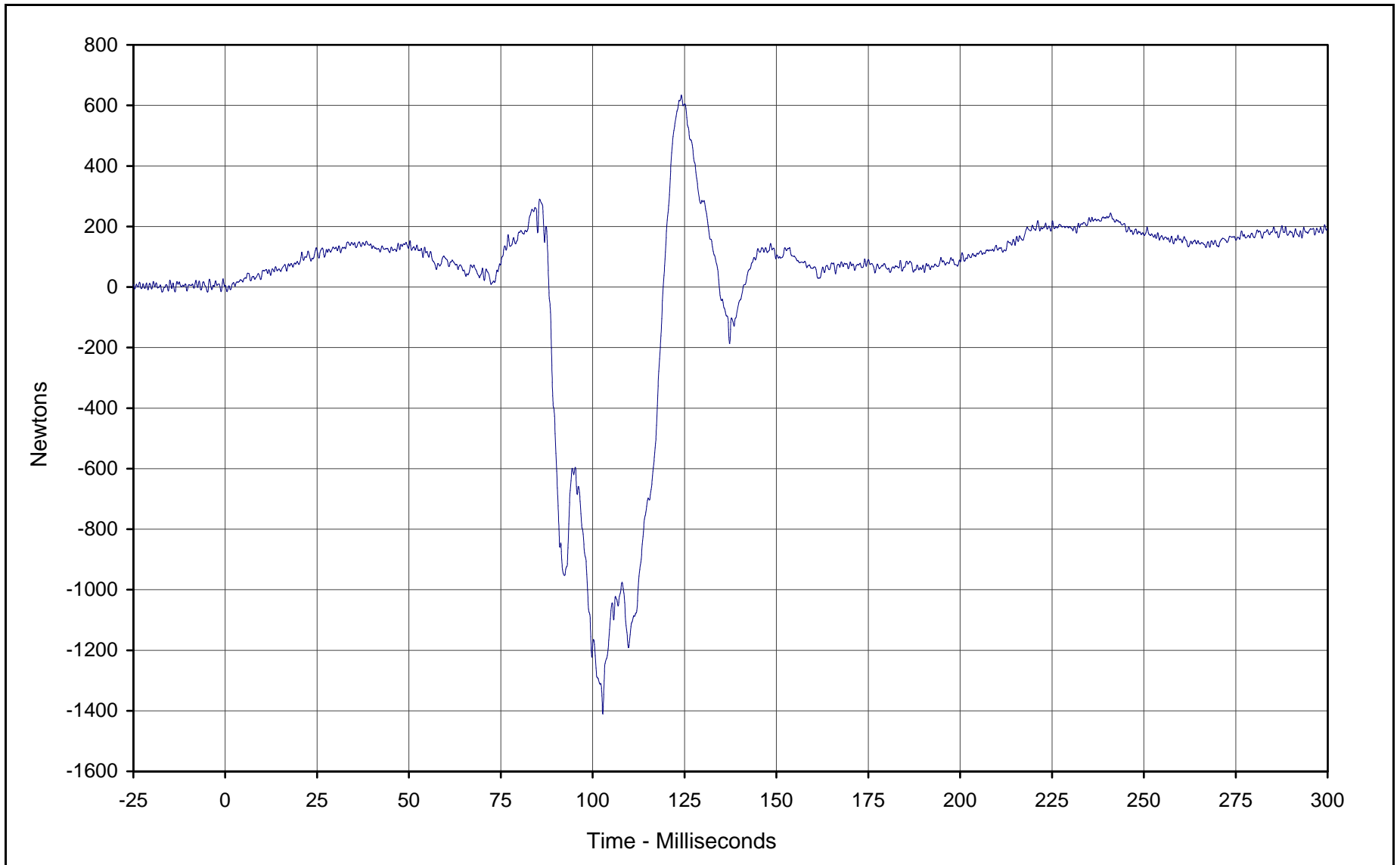

Curve Description: Passenger Left Femur Force
Maximum Value: 633.6 at 124.1 Milliseconds
Minimum Value: -1410.8 at 102.8 Milliseconds
SAE Filter Class: 600
Date of Test: 08/15/00
Curve Number: FIL-067

Test Program: 2000 NHTSA 40% Offset No.: FORD01
Test Vehicle: 2000 Ford Expedition 4WD 4 Door SUV



KARR20002-02

B-102

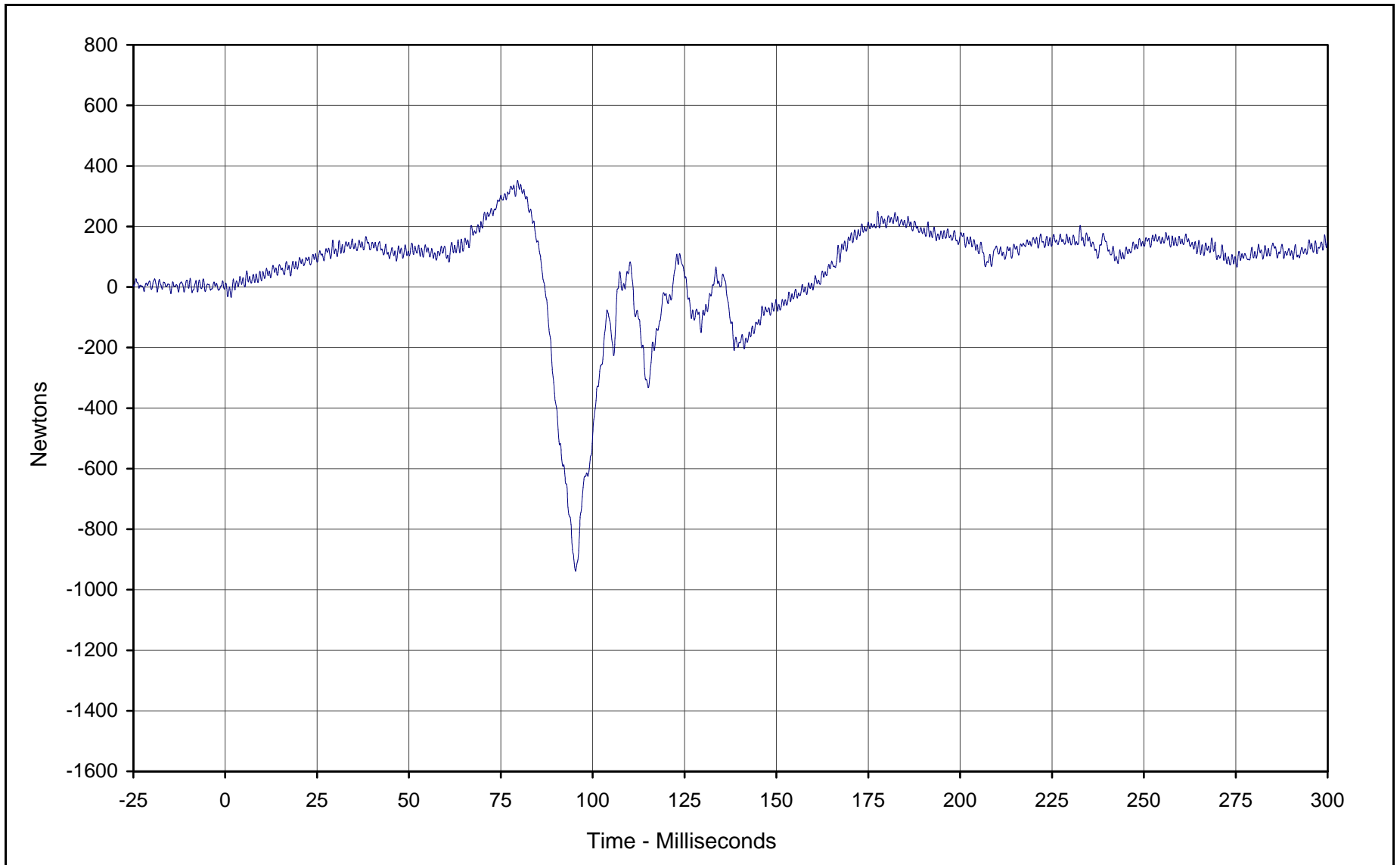

Curve Description: Passenger Right Femur Force
Maximum Value: 352.1 at 79.6 Milliseconds
Minimum Value: -937.8 at 95.3 Milliseconds
SAE Filter Class: 600
Date of Test: 08/15/00
Curve Number: FIL-068

Test Program: 2000 NHTSA 40% Offset No.: FORD01
Test Vehicle: 2000 Ford Expedition 4WD 4 Door SUV



KARR20002-02

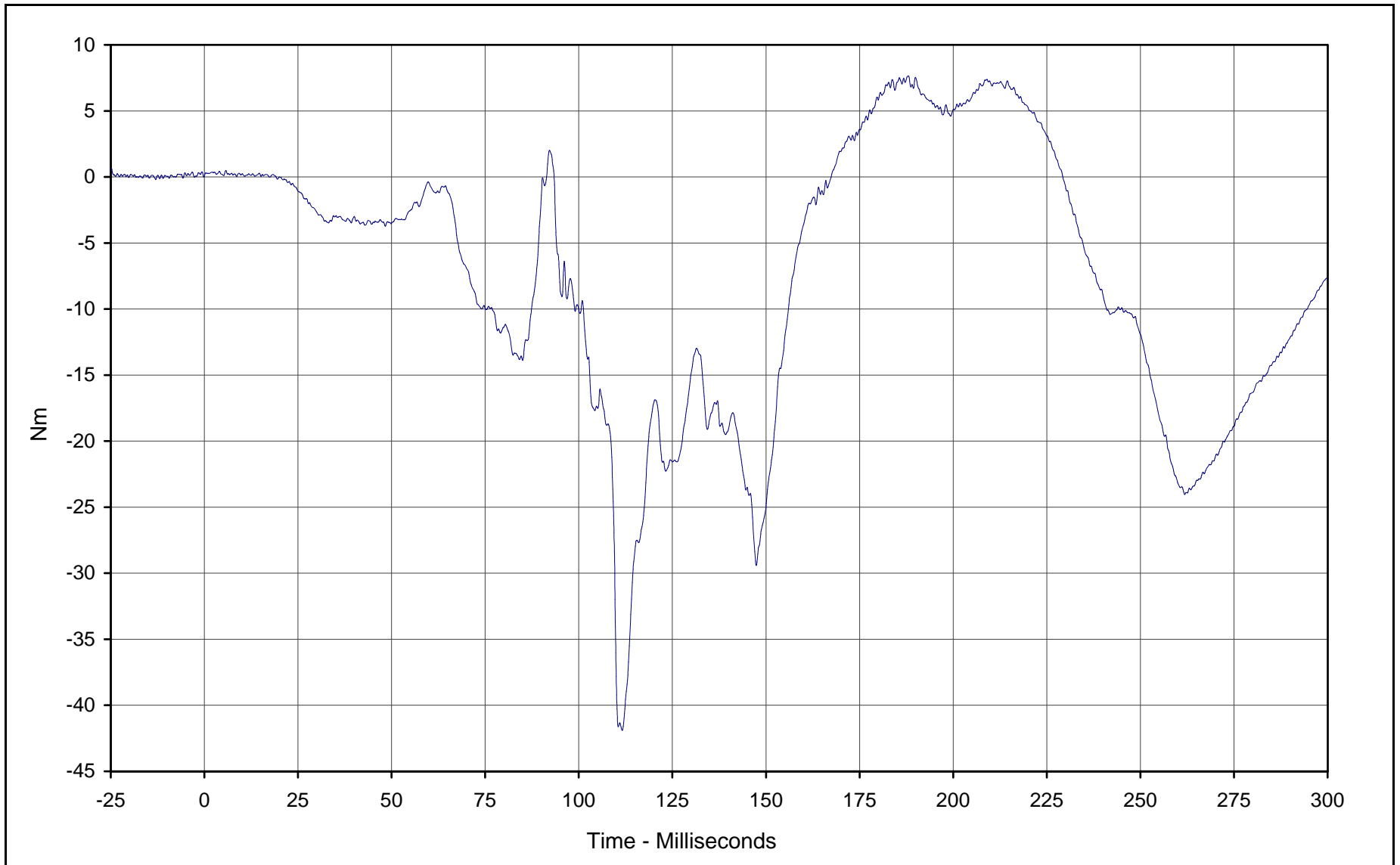

Curve Description: Passenger Left Upper Tibia Moment X

Maximum Value: 7.7 at 188.0 Milliseconds

Minimum Value: -41.9 at 111.6 Milliseconds

SAE Filter Class: 600

Date of Test: 08/15/00

Curve Number: FIL-069

Test Program: 2000 NHTSA 40% Offset No.: FORD01

Test Vehicle: 2000 Ford Expedition 4WD 4 Door SUV



B-104

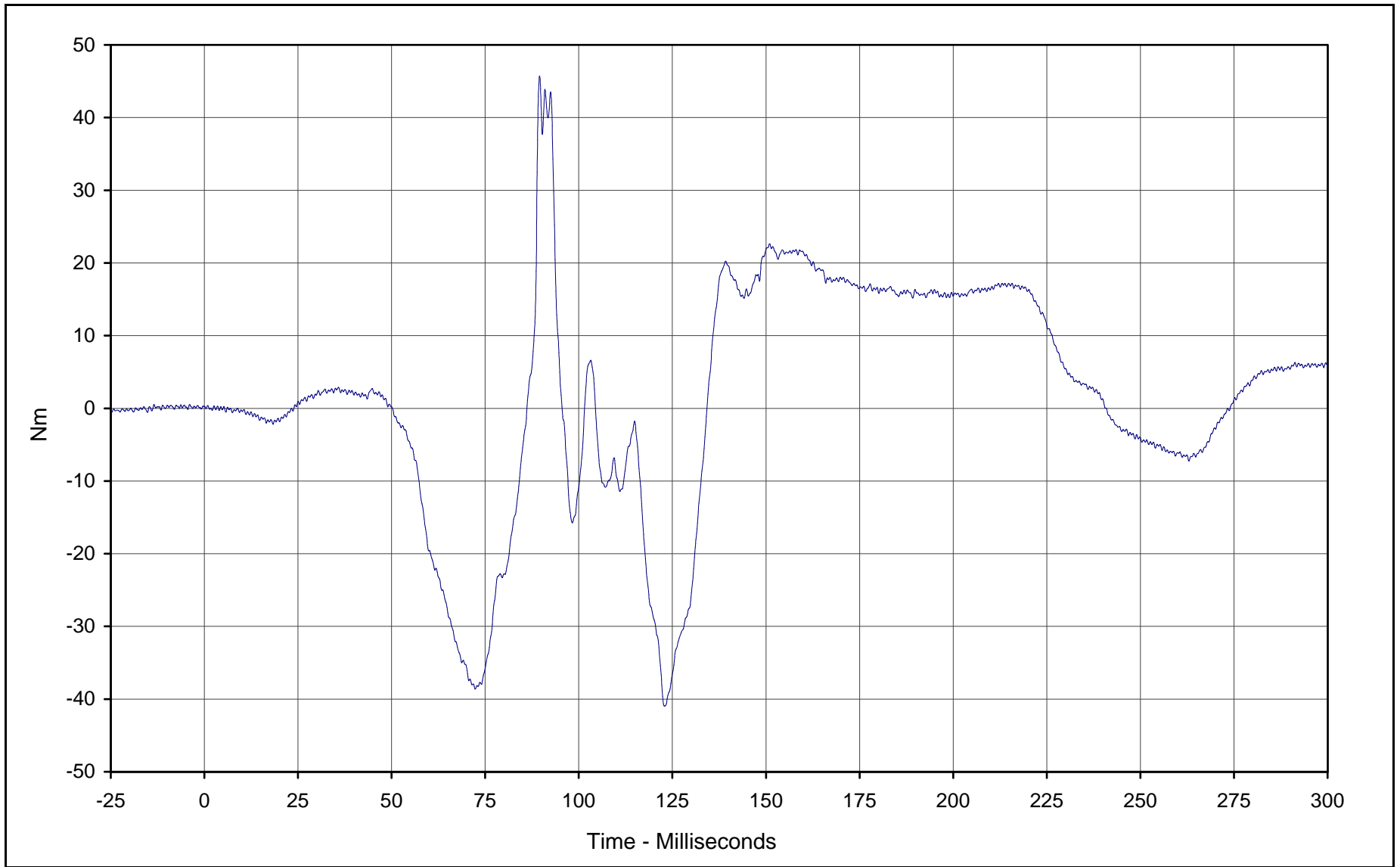

Curve Description: Passenger Left Upper Tibia Moment Y

Maximum Value: 45.7 at 89.5 Milliseconds

Minimum Value: -41.0 at 122.9 Milliseconds

SAE Filter Class: 600

Date of Test: 08/15/00

Curve Number: FIL-070

Test Program: 2000 NHTSA 40% Offset No.: FORD01

Test Vehicle: 2000 Ford Expedition 4WD 4 Door SUV

KARR20002-02



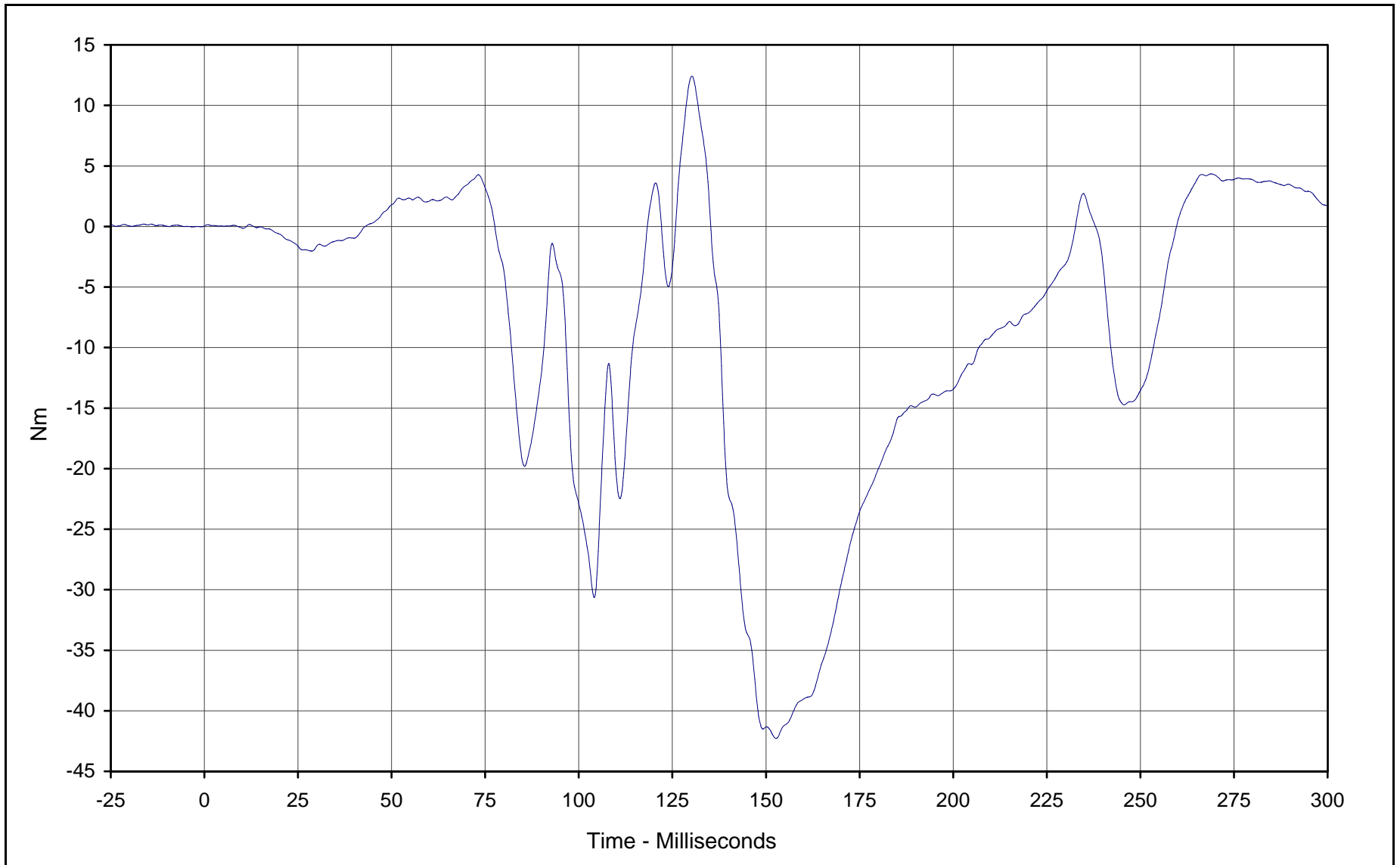

Curve Description: Passenger Right Upper Tibia Moment X

Maximum Value: 12.4 at 130.2 Milliseconds

Minimum Value: -42.3 at 152.7 Milliseconds

SAE Filter Class: 180

Date of Test: 08/15/00

Curve Number: FIL-071

Test Program: 2000 NHTSA 40% Offset No.: FORD01

Test Vehicle: 2000 Ford Expedition 4WD 4 Door SUV



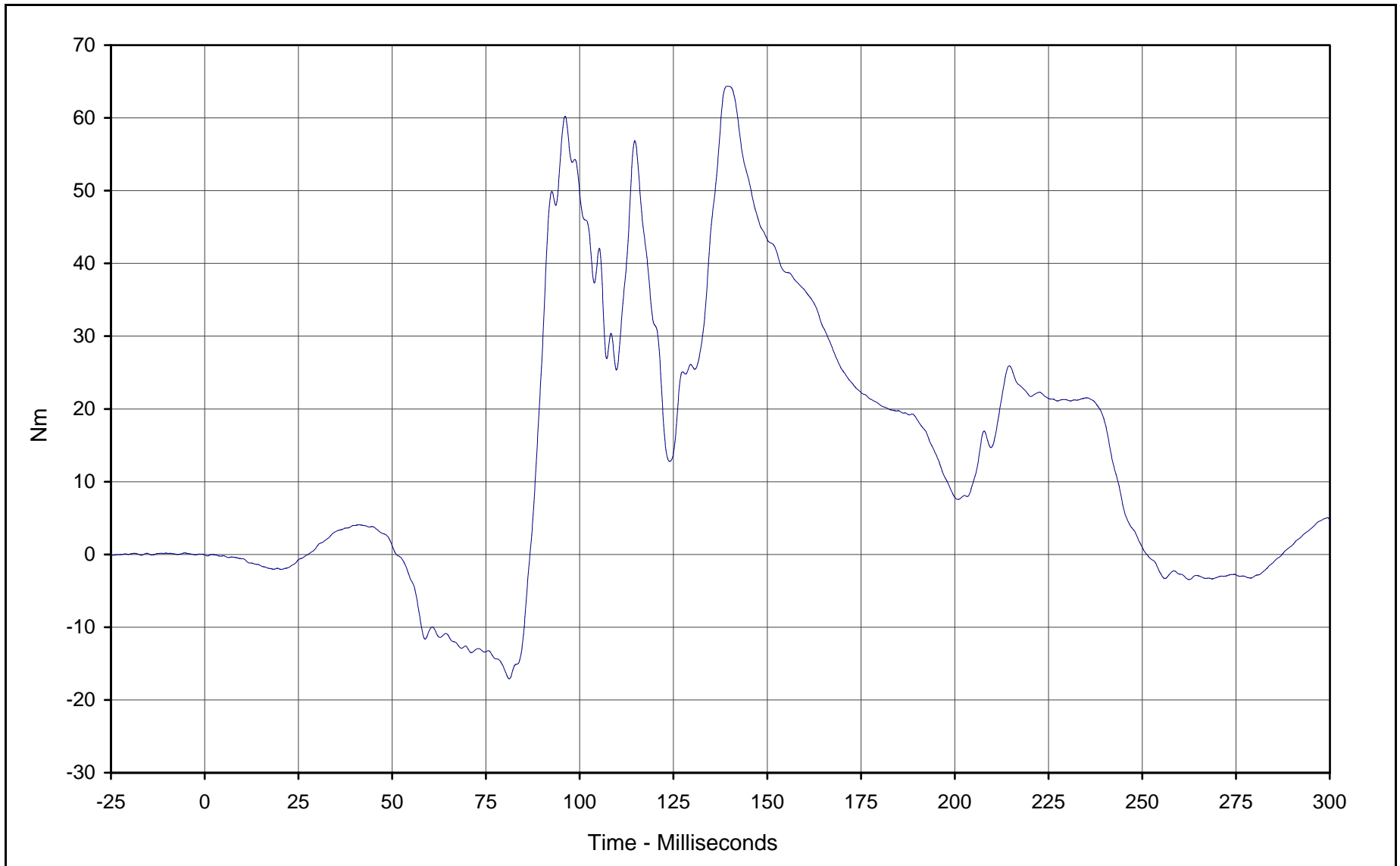

Curve Description: Passenger Right Upper Tibia Moment Y

Maximum Value: 64.3 at 139.2 Milliseconds

Minimum Value: -17.1 at 81.2 Milliseconds

SAE Filter Class: 180

Date of Test: 08/15/00

Curve Number: FIL-072

Test Program: 2000 NHTSA 40% Offset No.: FORD01

Test Vehicle: 2000 Ford Expedition 4WD 4 Door SUV



B-107

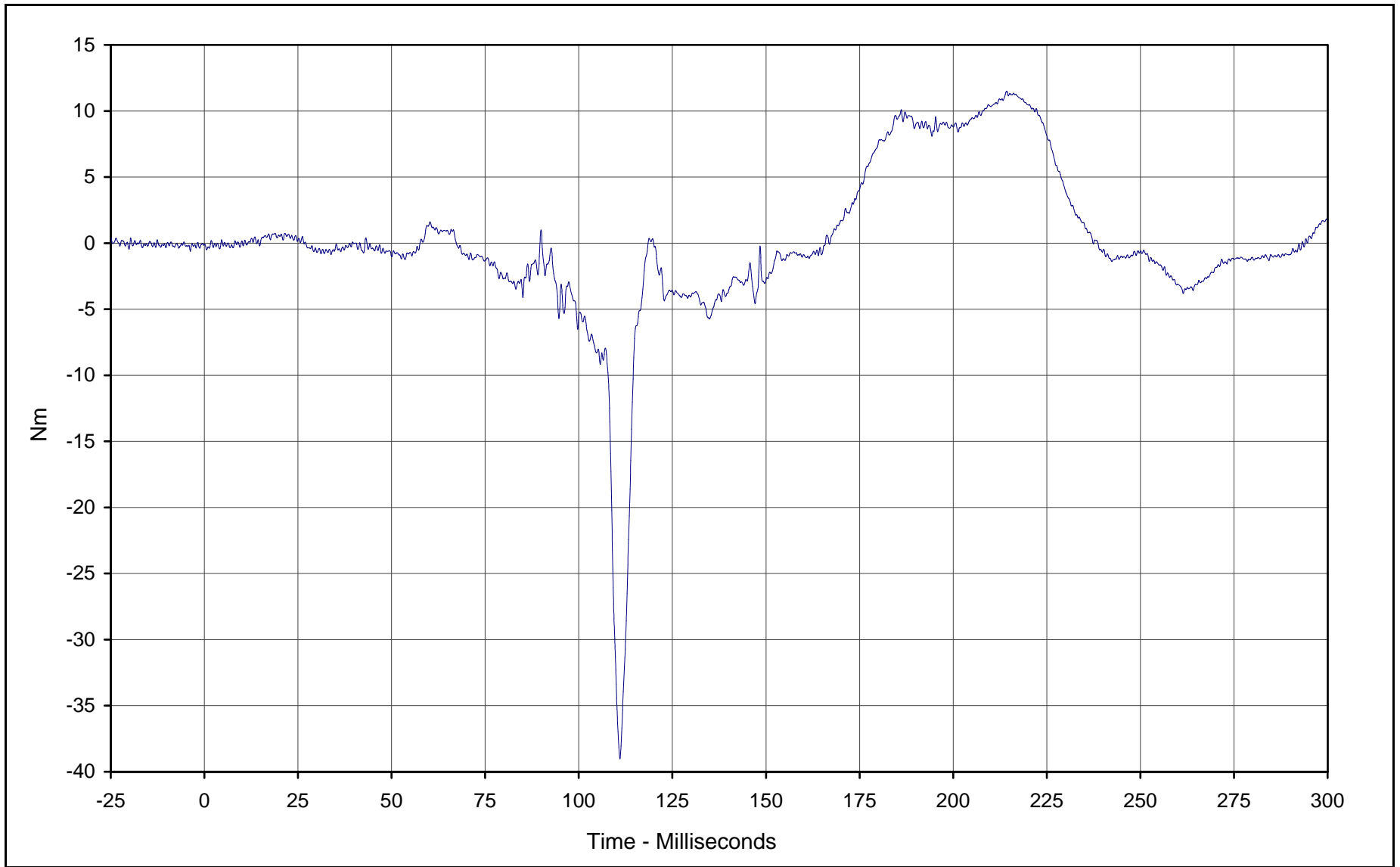

Curve Description: Passenger Left Lower Tibia Moment X

Maximum Value: 11.5 at 214.3 Milliseconds

Minimum Value: -39.0 at 111.0 Milliseconds

SAE Filter Class: 600

Date of Test: 08/15/00

Curve Number: FIL-073

Test Program: 2000 NHTSA 40% Offset No.: FORD01

Test Vehicle: 2000 Ford Expedition 4WD 4 Door SUV

KARR20002-02



B-108

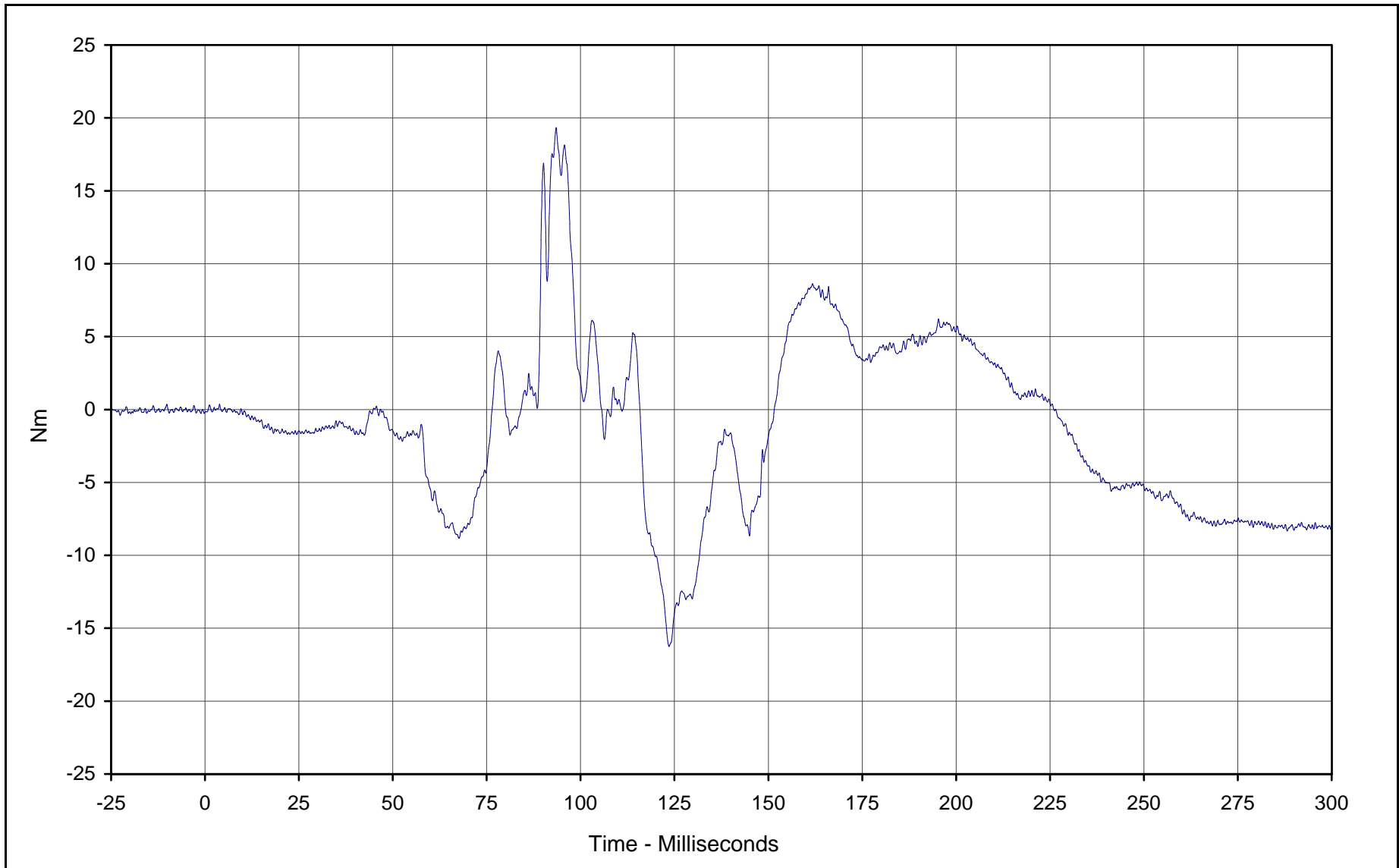

Curve Description: Passenger Left Lower Tibia Moment Y

Maximum Value: 19.3 at 93.5 Milliseconds

Minimum Value: -16.3 at 123.6 Milliseconds

SAE Filter Class: 600

Date of Test: 08/15/00

Curve Number: FIL-074

Test Program: 2000 NHTSA 40% Offset No.: FORD01

Test Vehicle: 2000 Ford Expedition 4WD 4 Door SUV

KARR20002-02



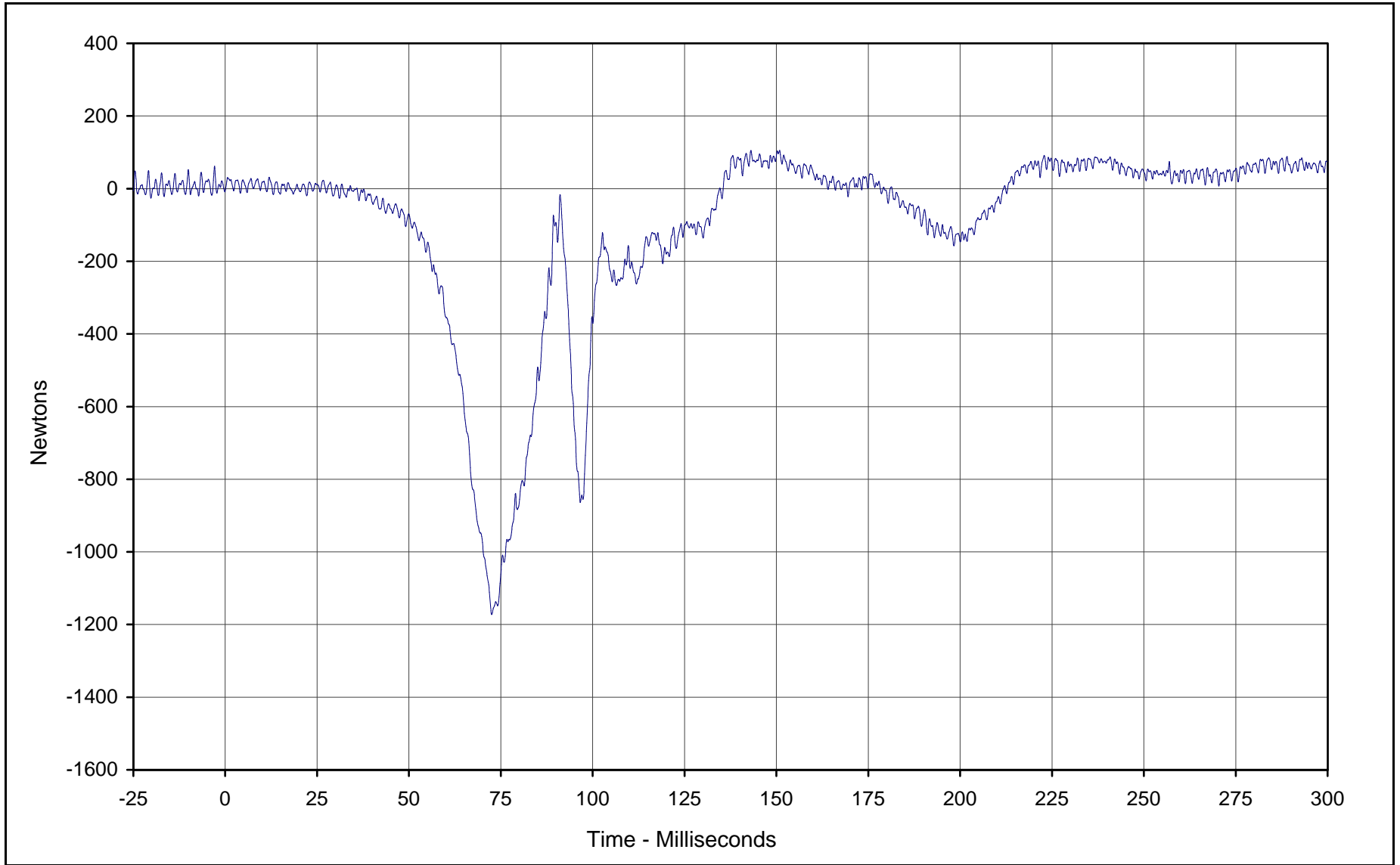

Curve Description: Passenger Left Lower Tibia Force Z
 Maximum Value: 105.1 at 150.9 Milliseconds
 Minimum Value: -1172.7 at 72.5 Milliseconds
 SAE Filter Class: 600
 Date of Test: 08/15/00
 Curve Number: FIL-075

Test Program: 2000 NHTSA 40% Offset No.: FORD01
 Test Vehicle: 2000 Ford Expedition 4WD 4 Door SUV



B-110

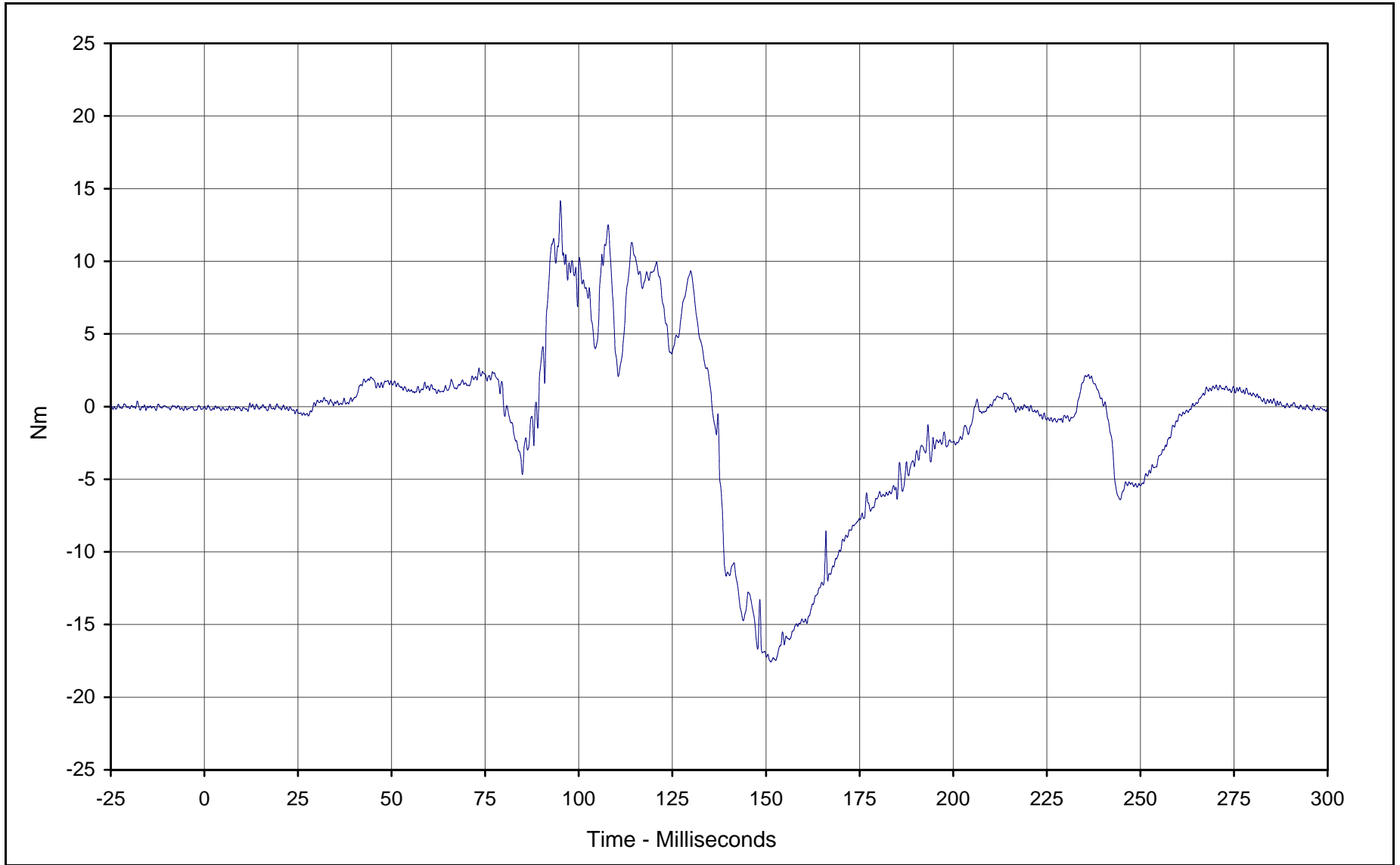

Curve Description: Passenger Right Lower Tibia Moment X

Maximum Value: 14.2 at 95.1 Milliseconds

Minimum Value: -17.6 at 151.3 Milliseconds

SAE Filter Class: 600

Date of Test: 08/15/00

Curve Number: FIL-076

Test Program: 2000 NHTSA 40% Offset No.: FORD01

Test Vehicle: 2000 Ford Expedition 4WD 4 Door SUV

KARR20002-02



B-111

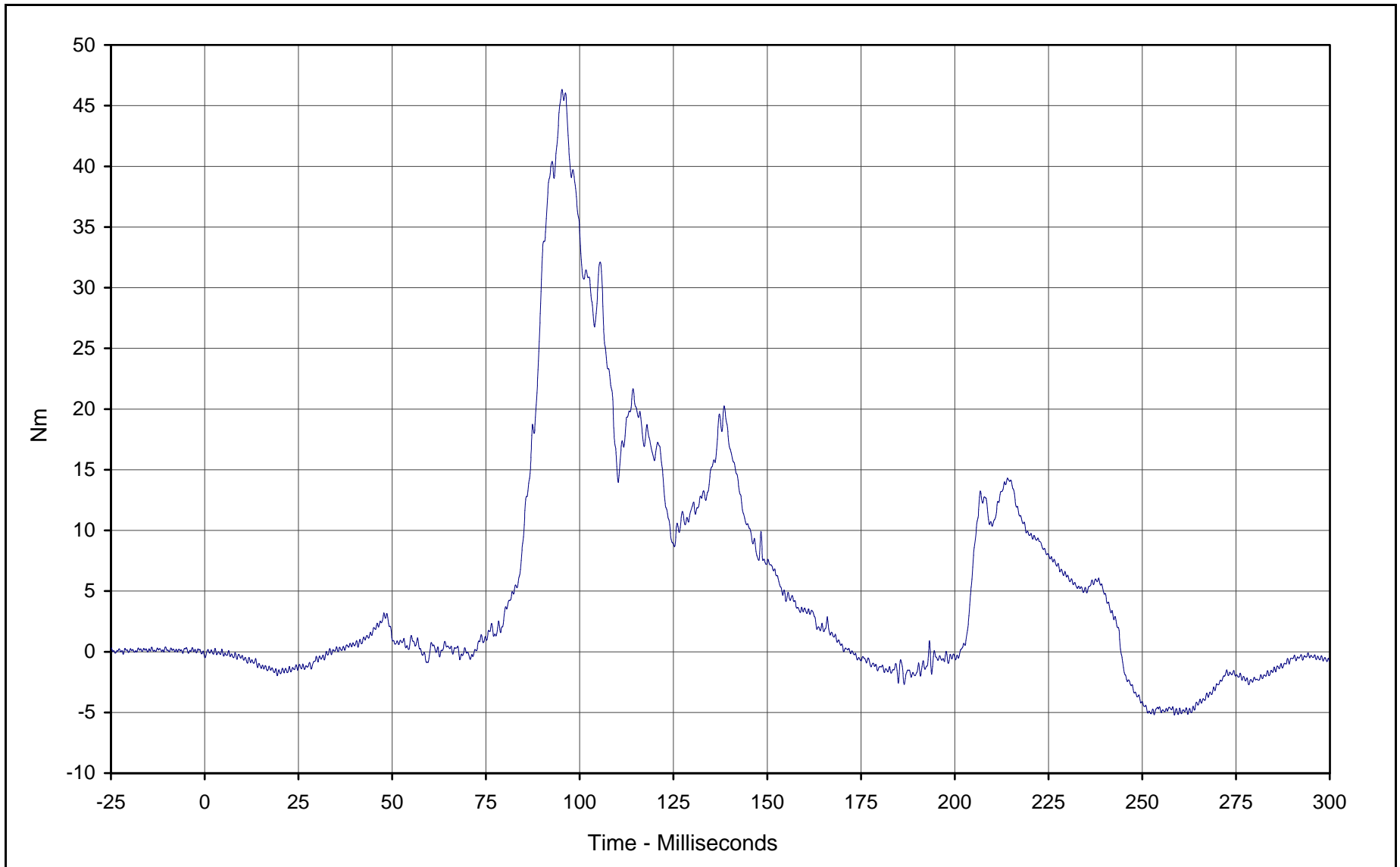

Curve Description: Passenger Right Lower Tibia Moment Y

Maximum Value: 46.3 at 95.3 Milliseconds

Minimum Value: -5.2 at 258.6 Milliseconds

SAE Filter Class: 600

Date of Test: 08/15/00

Curve Number: FIL-077

Test Program: 2000 NHTSA 40% Offset No.: FORD01

Test Vehicle: 2000 Ford Expedition 4WD 4 Door SUV

KARR20002-02



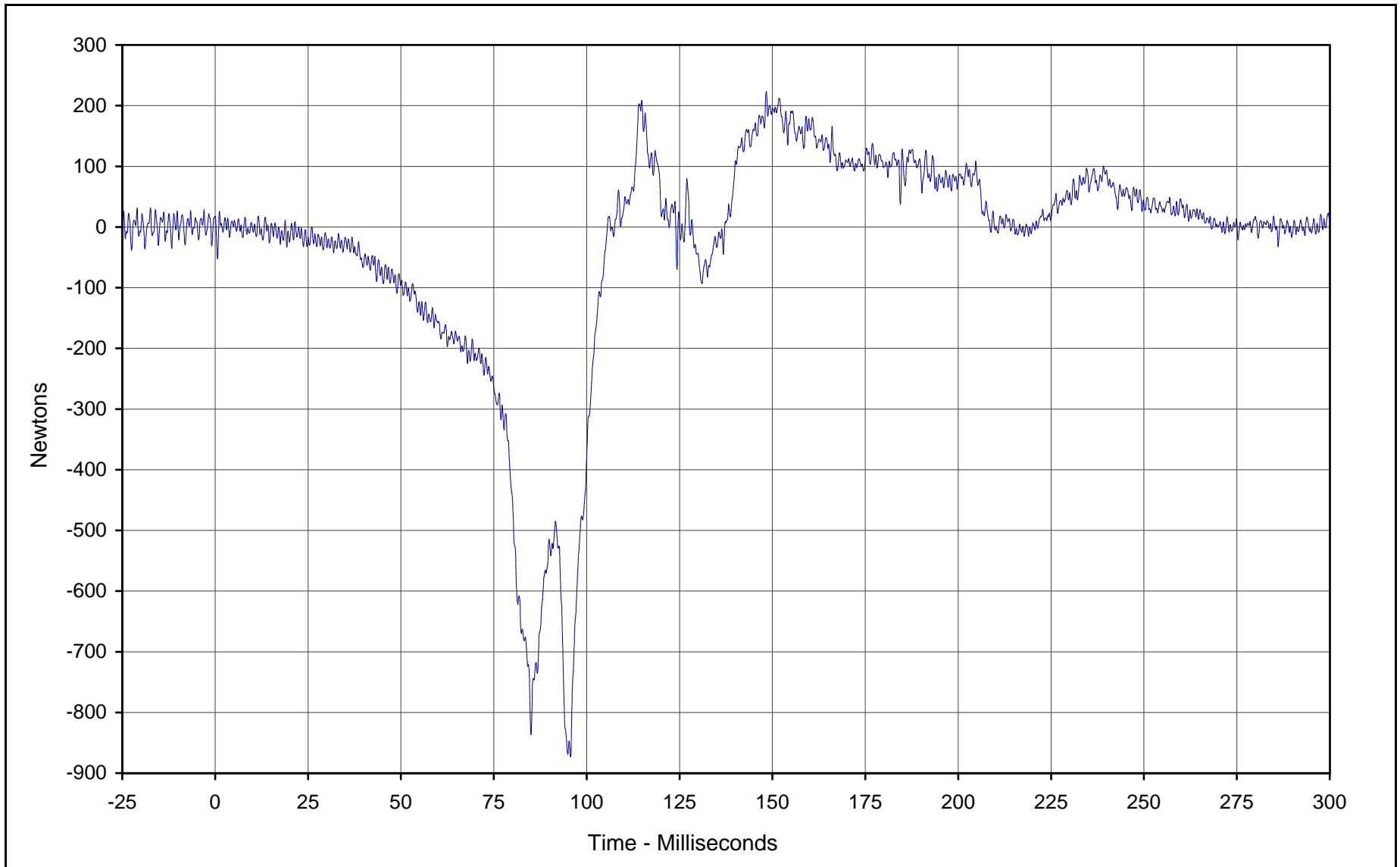

Curve Description: Passenger Right lower Tibia Force Z

Maximum Value: 223.1 at 148.3 Milliseconds

Minimum Value: -872.9 at 95.7 Milliseconds

SAE Filter Class: 600

Date of Test: 08/15/00

Curve Number: FIL-078

Test Program: 2000 NHTSA 40% Offset No.: FORD01

Test Vehicle: 2000 Ford Expedition 4WD 4 Door SUV



B-113

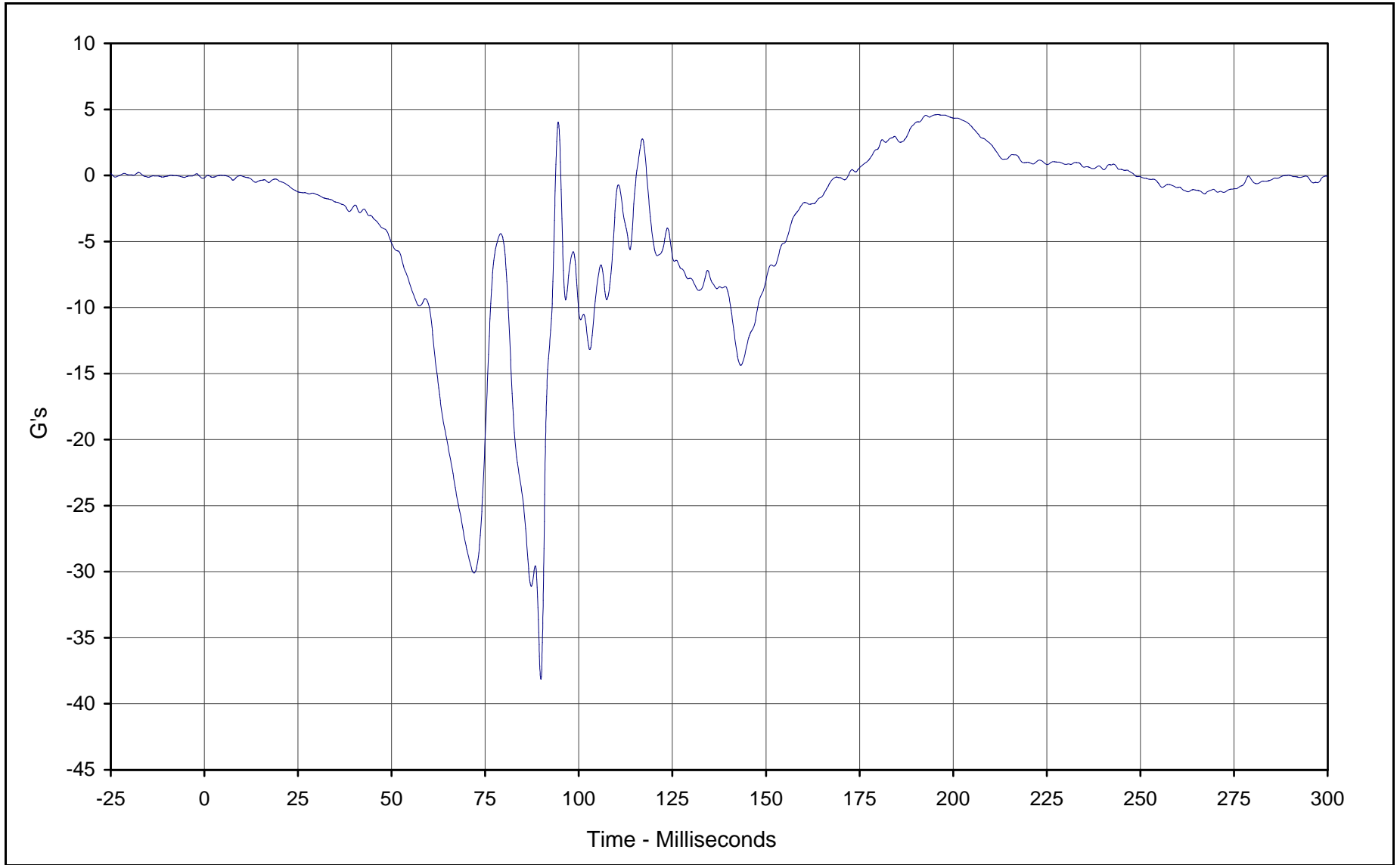

Curve Description: Passenger Left Foot Aft X
Maximum Value: 4.6 at 196.0 Milliseconds
Minimum Value: -38.1 at 89.9 Milliseconds
SAE Filter Class: 180
Date of Test: 08/15/00
Curve Number: FIL-079

Test Program: 2000 NHTSA 40% Offset No.: FORD01
Test Vehicle: 2000 Ford Expedition 4WD 4 Door SUV



KARR20002-02

B-114

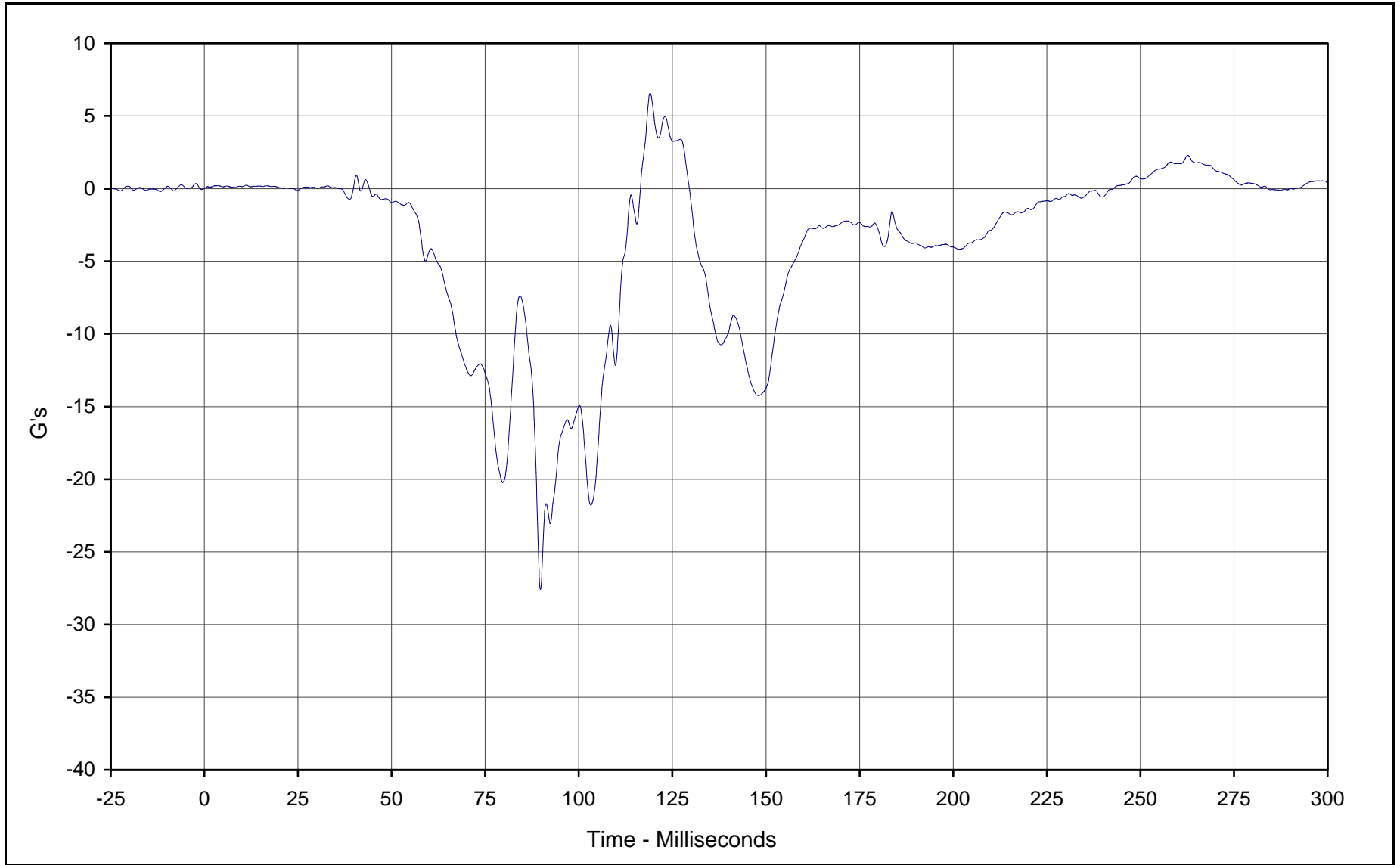

Curve Description: Passenger Left Foot Aft Z
Maximum Value: 6.6 at 119.1 Milliseconds
Minimum Value: -27.6 at 89.8 Milliseconds
SAE Filter Class: 180
Date of Test: 08/15/00
Curve Number: FIL-080

Test Program: 2000 NHTSA 40% Offset No.: FORD01
Test Vehicle: 2000 Ford Expedition 4WD 4 Door SUV



KARR20002-02

B-115

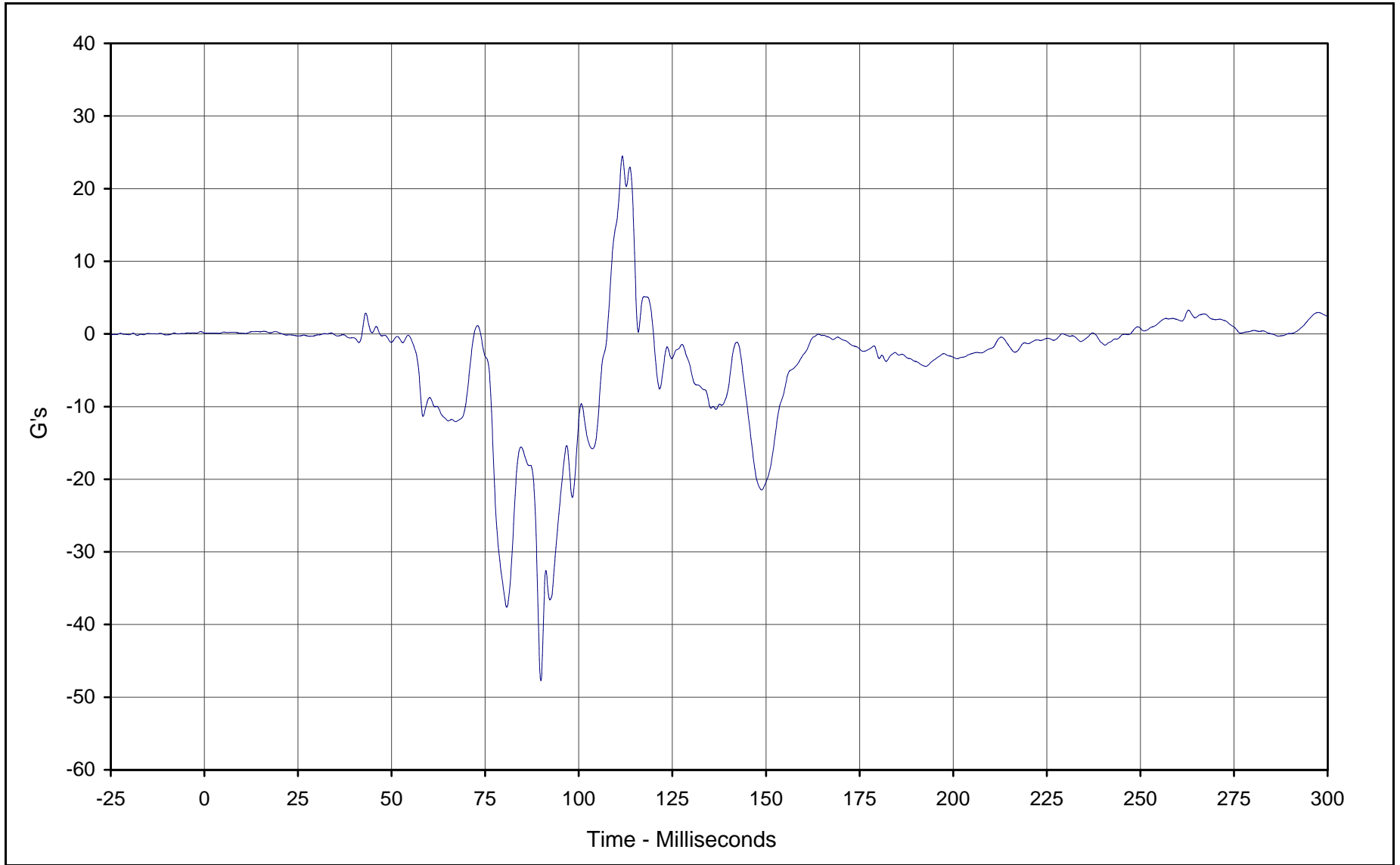

Curve Description: Passenger Left Foot Fore Z
Maximum Value: 24.5 at 111.6 Milliseconds
Minimum Value: -47.7 at 89.9 Milliseconds
SAE Filter Class: 180
Date of Test: 08/15/00
Curve Number: FIL-081

Test Program: 2000 NHTSA 40% Offset No.: FORD01
Test Vehicle: 2000 Ford Expedition 4WD 4 Door SUV



KARR20002-02

B-116

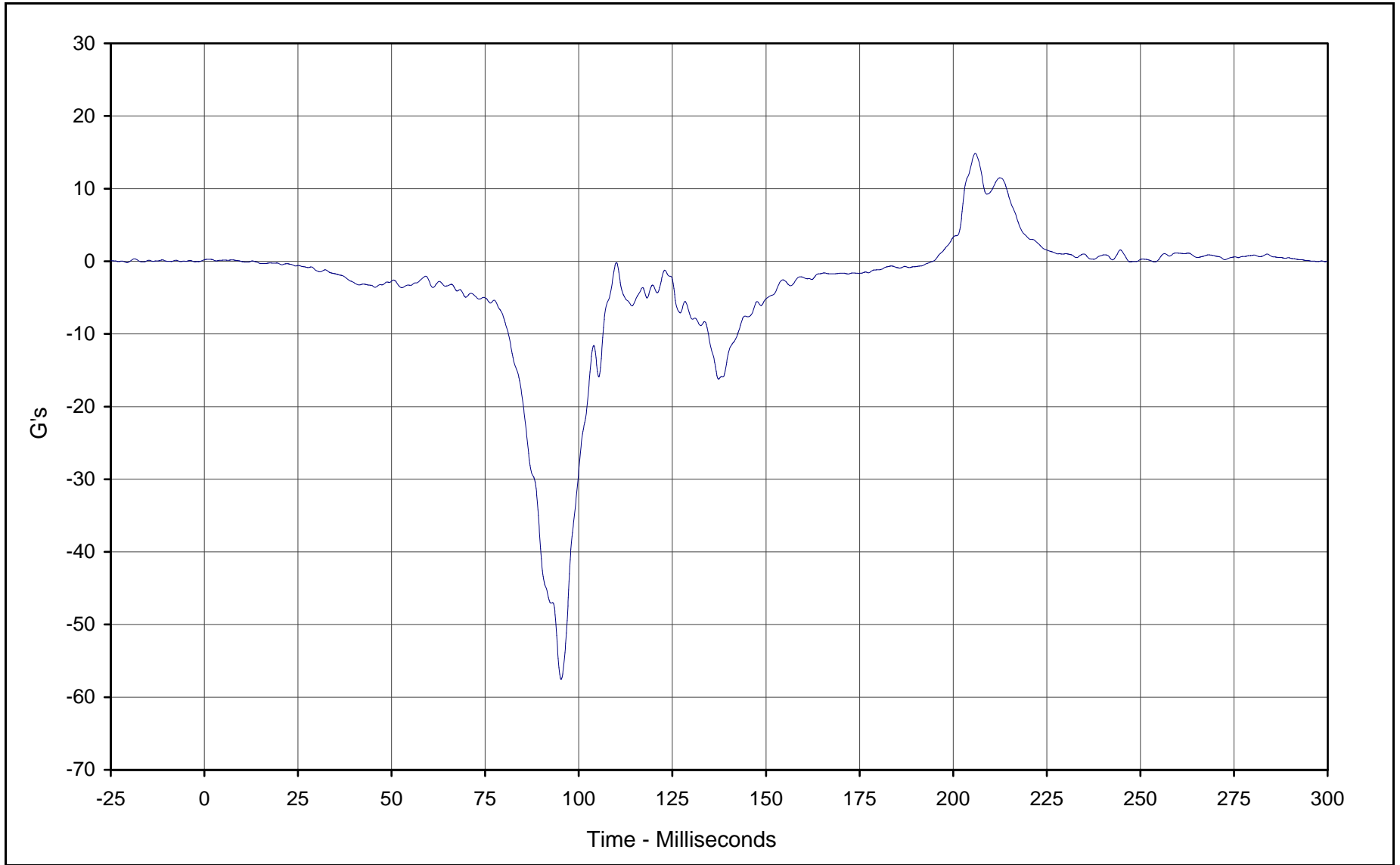

Curve Description: Passenger Right Foot Aft X
Maximum Value: 14.9 at 205.9 Milliseconds
Minimum Value: -57.5 at 95.3 Milliseconds
SAE Filter Class: 180
Date of Test: 08/15/00
Curve Number: FIL-082

Test Program: 2000 NHTSA 40% Offset No.: FORD01
Test Vehicle: 2000 Ford Expedition 4WD 4 Door SUV



KARR20002-02

B-117

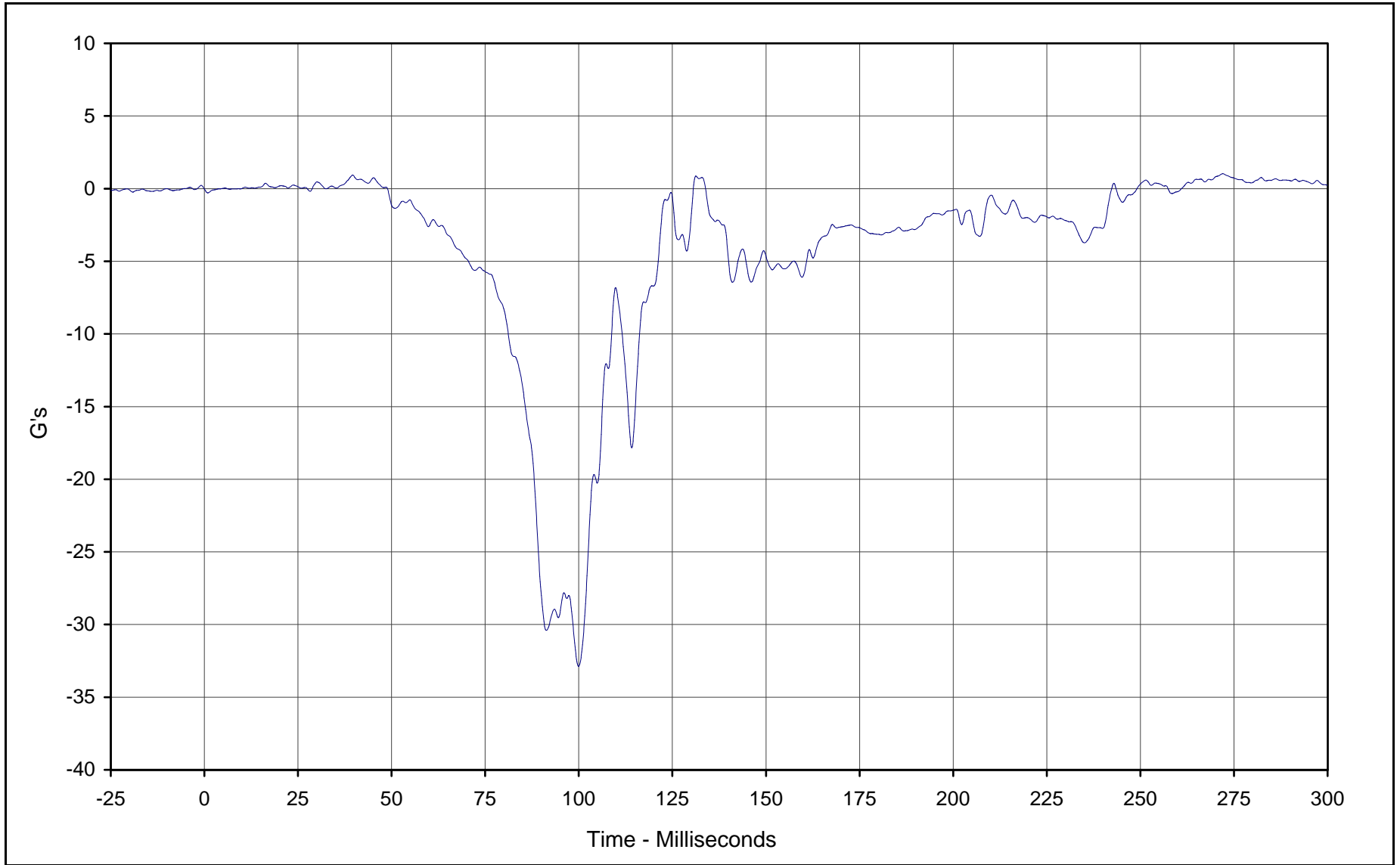

Curve Description: Passenger Right Foot Aft Z
Maximum Value: 1.0 at 272.0 Milliseconds
Minimum Value: -32.9 at 99.9 Milliseconds
SAE Filter Class: 180
Date of Test: 08/15/00
Curve Number: FIL-083

Test Program: 2000 NHTSA 40% Offset No.: FORD01
Test Vehicle: 2000 Ford Expedition 4WD 4 Door SUV



KARR20002-02

B-118

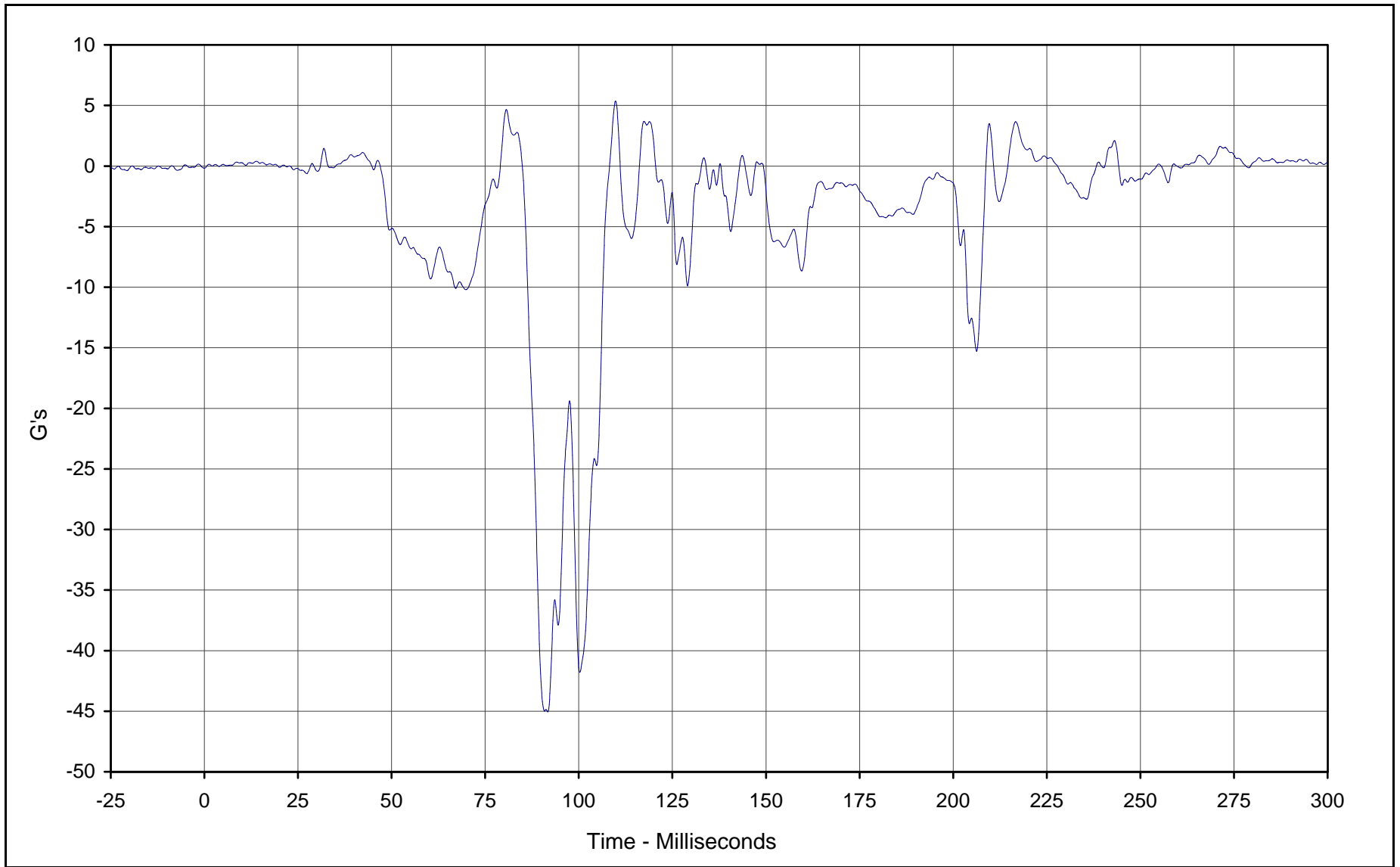

Curve Description: Passenger Right Foot Fore Z
Maximum Value: 5.4 at 109.8 Milliseconds
Minimum Value: -45.1 at 91.7 Milliseconds
SAE Filter Class: 180
Date of Test: 08/15/00
Curve Number: FIL-084

Test Program: 2000 NHTSA 40% Offset No.: FORD01
Test Vehicle: 2000 Ford Expedition 4WD 4 Door SUV



KARR20002-02

B-119

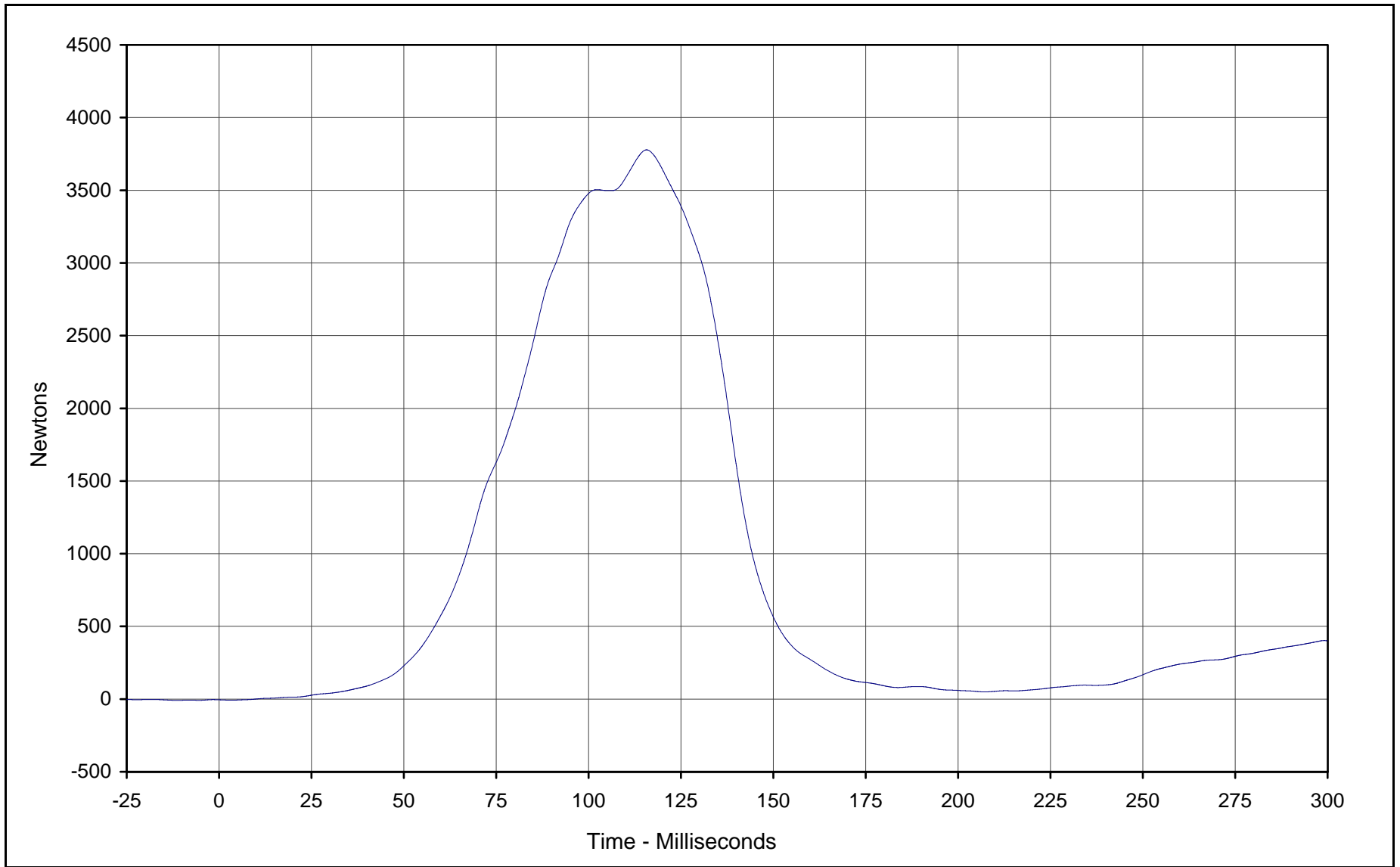

Curve Description: Passenger Lap Belt Force
Maximum Value: 3777.9 at 115.7 Milliseconds
Minimum Value: -7.3 at 3.5 Milliseconds
SAE Filter Class: 60
Date of Test: 08/15/00
Curve Number: FIL-085

Test Program: 2000 NHTSA 40% Offset No.: FORD01
Test Vehicle: 2000 Ford Expedition 4WD 4 Door SUV



KARR20002-02

B-120

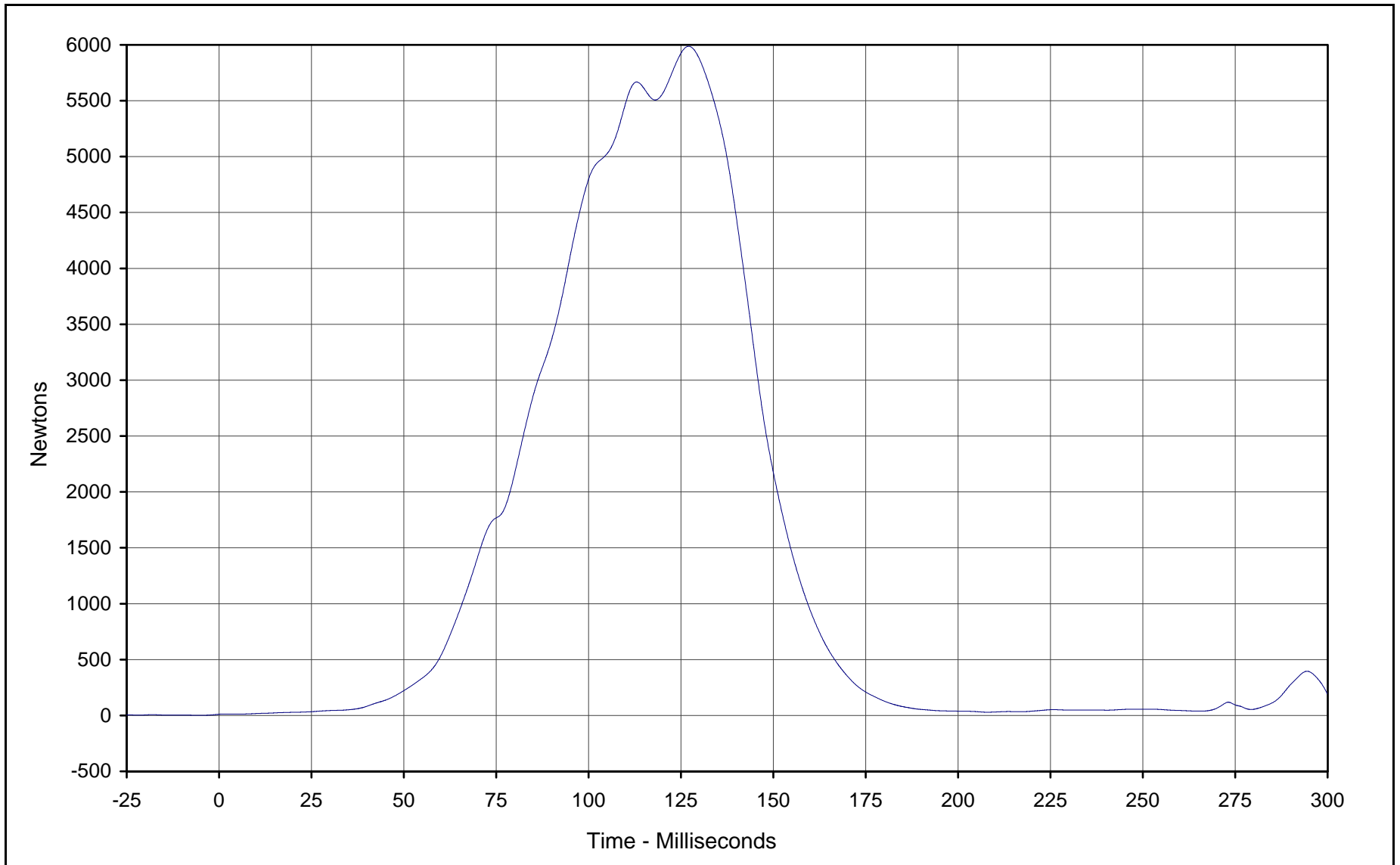

Curve Description: Passenger Shoulder Belt Force
Maximum Value: 5987.4 at 127.1 Milliseconds
Minimum Value: 10.8 at 0.0 Milliseconds
SAE Filter Class: 60
Date of Test: 08/15/00
Curve Number: FIL-086

Test Program: 2000 NHTSA 40% Offset No.: FORD01
Test Vehicle: 2000 Ford Expedition 4WD 4 Door SUV



KARR20002-02

B-121

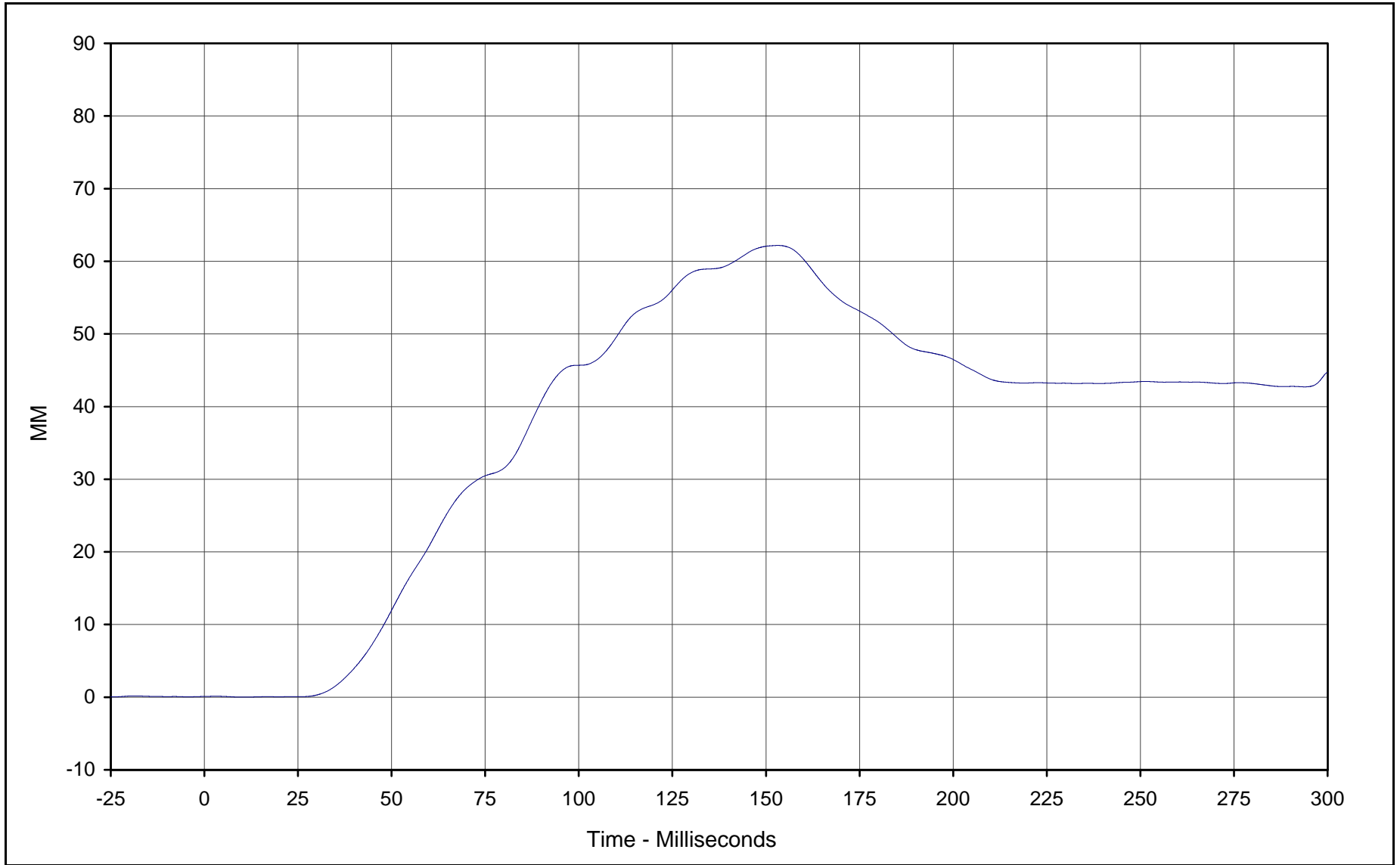

Curve Description: Passenger Shoulder Belt Pullout
Maximum Value: 62.2 at 153.2 Milliseconds
Minimum Value: 0.0 at 9.1 Milliseconds
SAE Filter Class: 60
Date of Test: 08/15/00
Curve Number: FIL-087

Test Program: 2000 NHTSA 40% Offset No.: FORD01
Test Vehicle: 2000 Ford Expedition 4WD 4 Door SUV



KARR20002-02

B-122

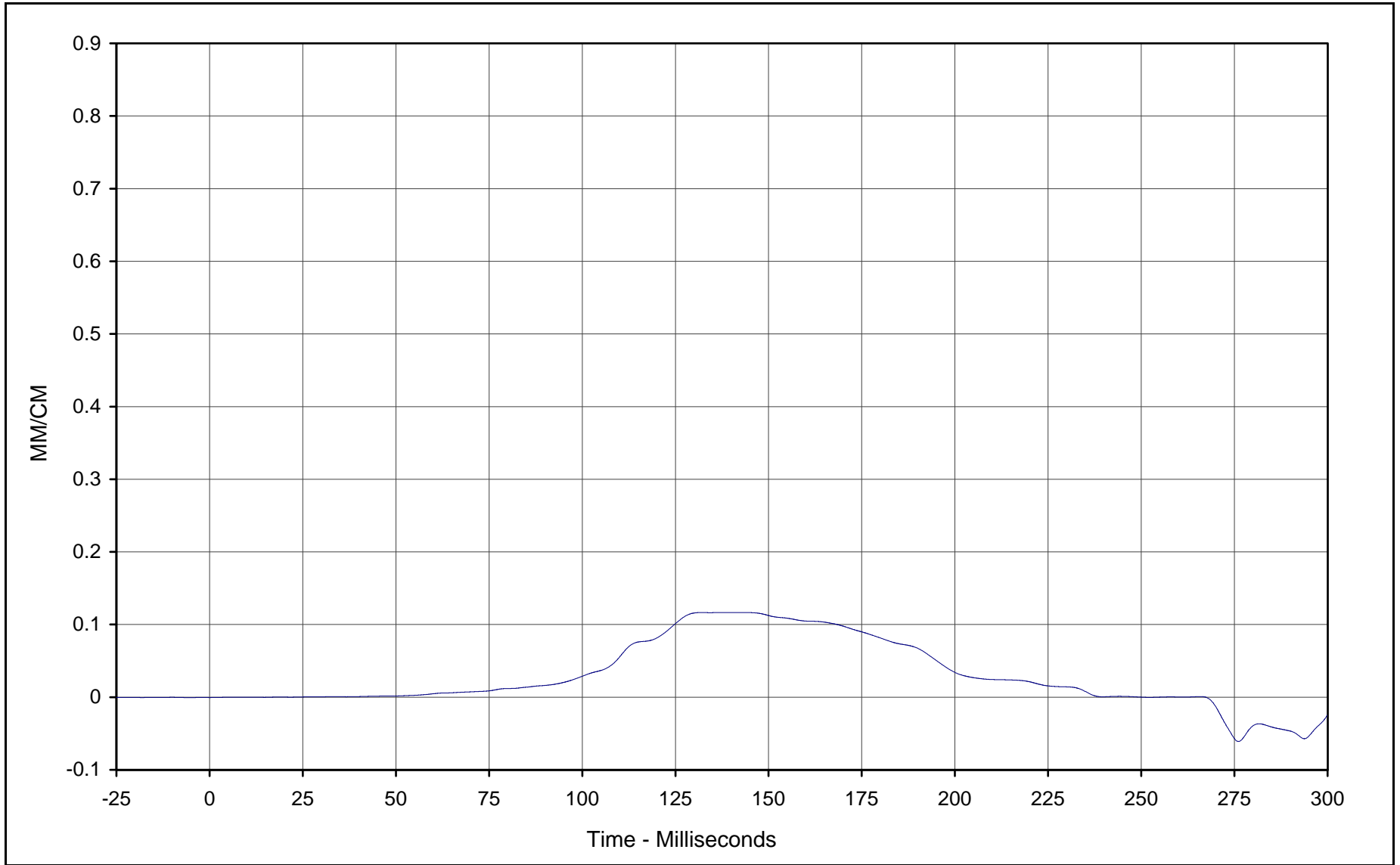

Curve Description: Passenger Shoulder Belt Elongation
Maximum Value: 0.12 at 138.2 Milliseconds
Minimum Value: -0.06 at 276.1 Milliseconds
SAE Filter Class: 60
Date of Test: 08/15/00
Curve Number: FIL-088

Test Program: 2000 NHTSA 40% Offset No.: FORD01
Test Vehicle: 2000 Ford Expedition 4WD 4 Door SUV



KARR20002-02

B-123

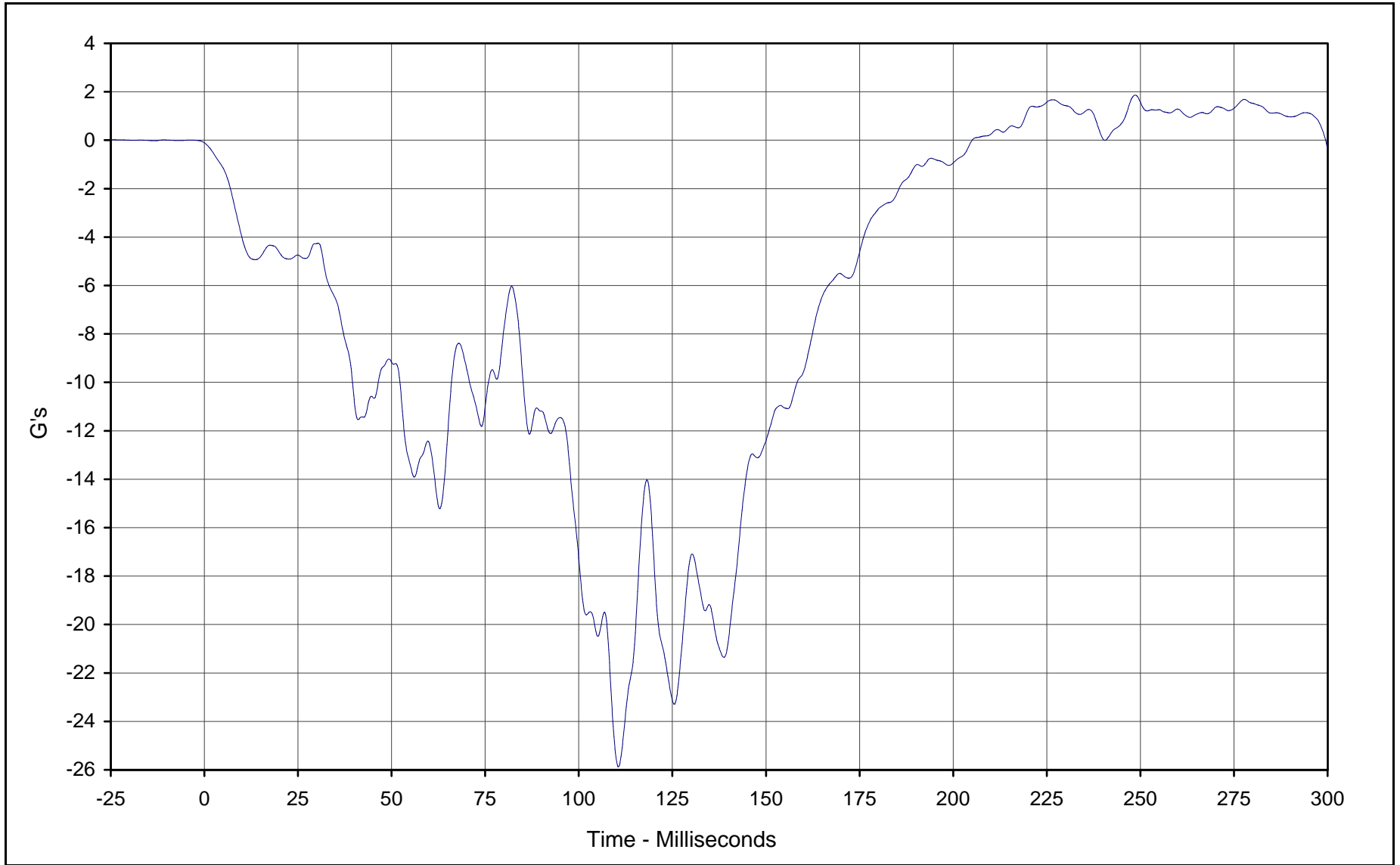

Curve Description: Vehicle Left Sill X
Maximum Value: 1.9 at 248.6 Milliseconds
Minimum Value: -25.9 at 110.6 Milliseconds
SAE Filter Class: 60
Date of Test: 08/15/00
Curve Number: FIL-089

Test Program: 2000 NHTSA 40% Offset No.: FORD01
Test Vehicle: 2000 Ford Expedition 4WD 4 Door SUV



KARR20002-02

B-124

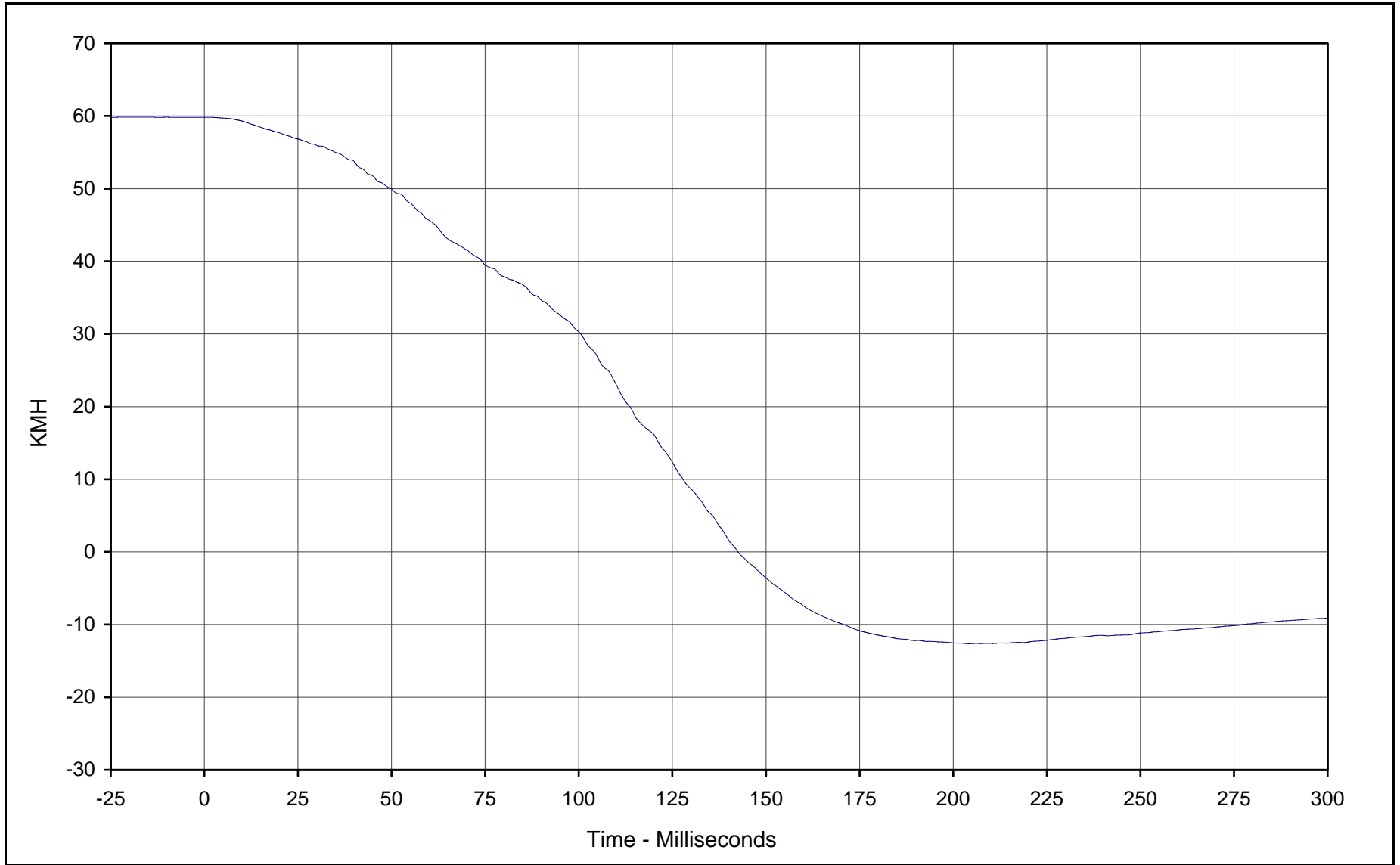

Curve Description: Vehicle Left Sill X Velocity
Maximum Value: 59.8 at 0.0 Milliseconds
Minimum Value: -12.6 at 204.3 Milliseconds
SAE Filter Class: 180
Date of Test: 08/15/00
Curve Number: IN1-089

Test Program: 2000 NHTSA 40% Offset No.: FORD01
Test Vehicle: 2000 Ford Expedition 4WD 4 Door SUV



KARR20002-02

B-125

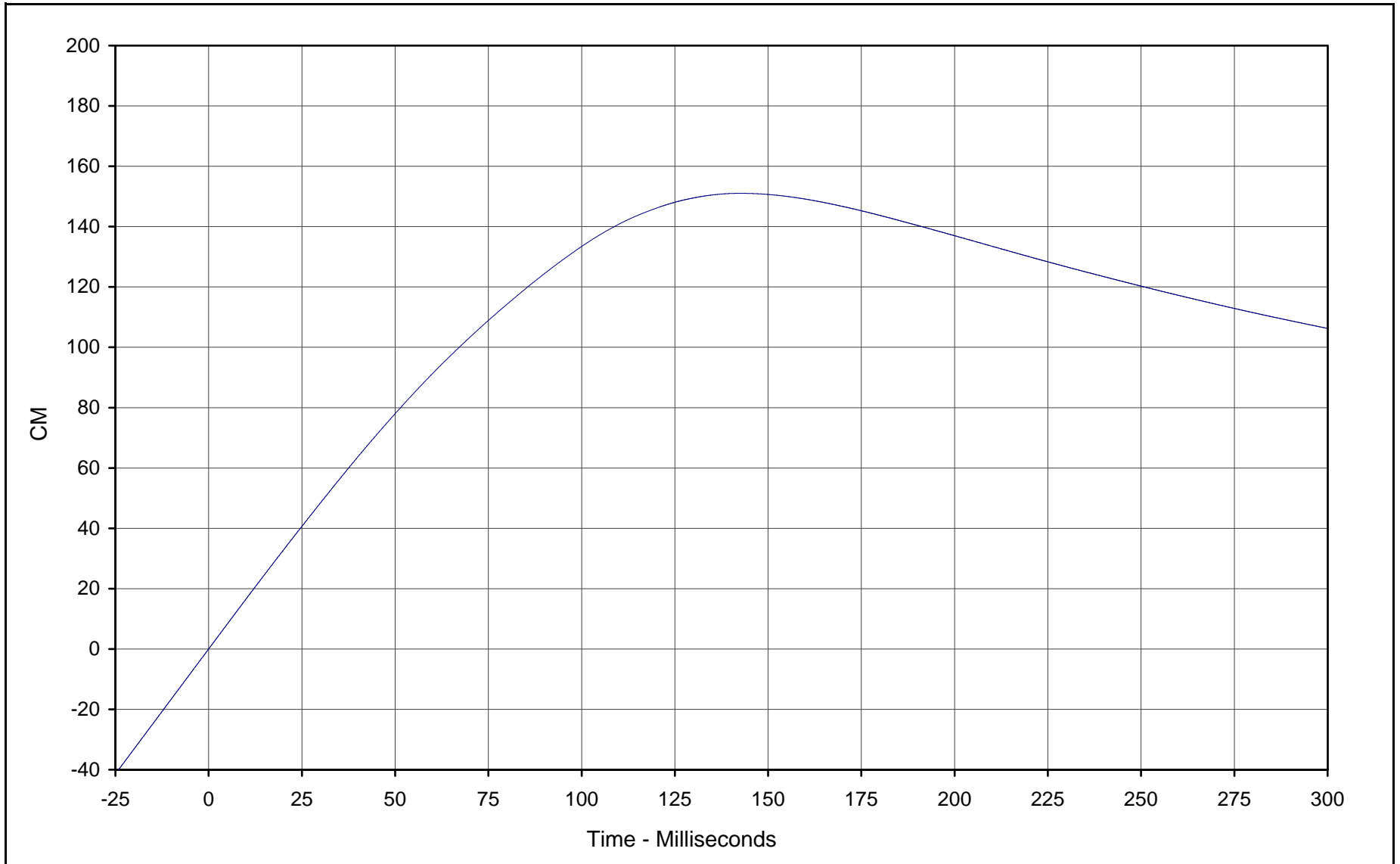

Curve Description: Vehicle Left Sill X Displacement
Maximum Value: 151.0 at 142.5 Milliseconds
Minimum Value: 0.0 at 0.0 Milliseconds
SAE Filter Class: 180
Date of Test: 08/15/00
Curve Number: IN2-089

Test Program: 2000 NHTSA 40% Offset No.: FORD01
Test Vehicle: 2000 Ford Expedition 4WD 4 Door SUV



KAR20002-02

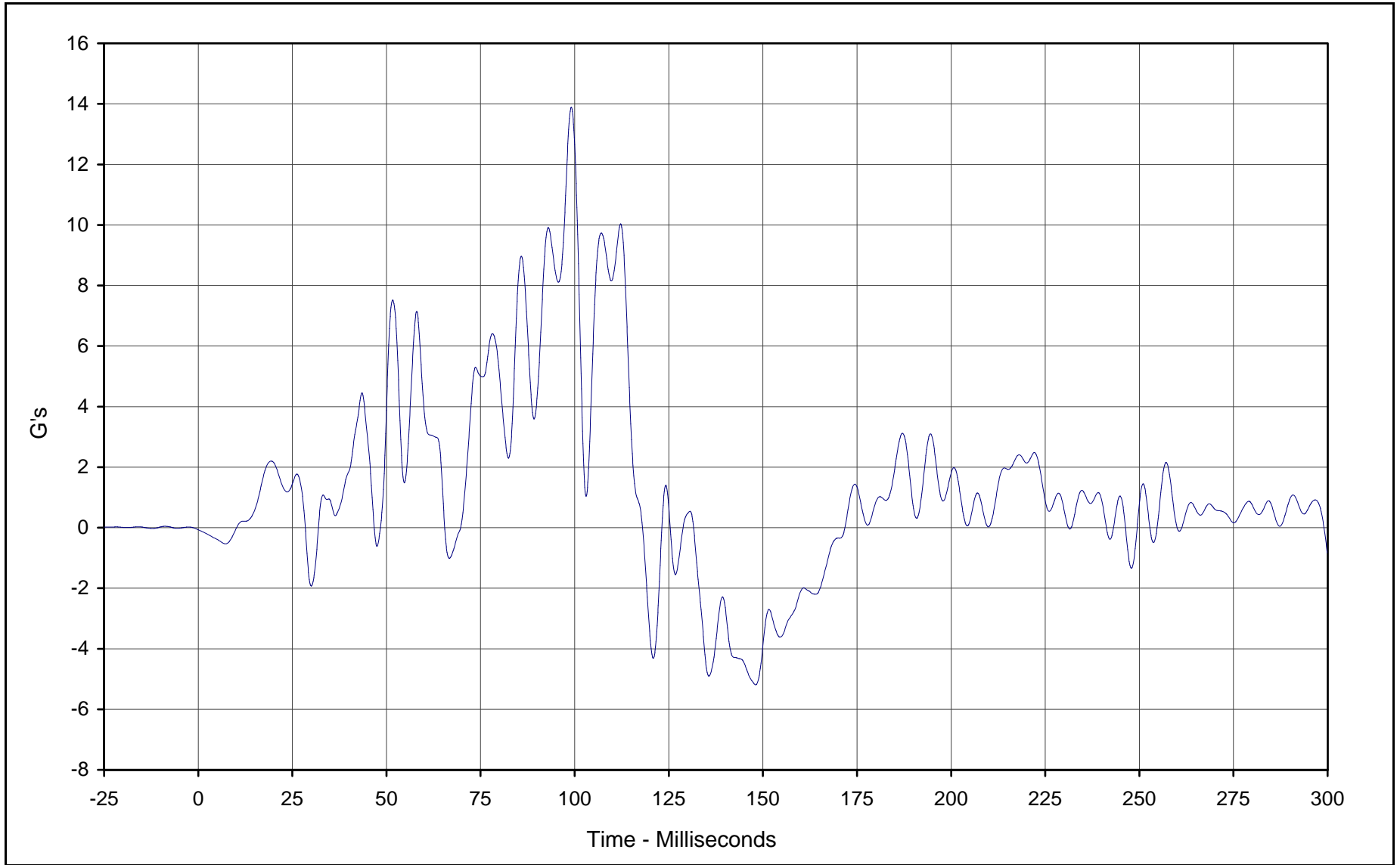

Curve Description: Vehicle Left Sill Y
 Maximum Value: 13.9 at 99.1 Milliseconds
 Minimum Value: -5.2 at 148.1 Milliseconds
 SAE Filter Class: 60
 Date of Test: 08/15/00
 Curve Number: FIL-090

Test Program: 2000 NHTSA 40% Offset No.: FORD01
 Test Vehicle: 2000 Ford Expedition 4WD 4 Door SUV



B-127

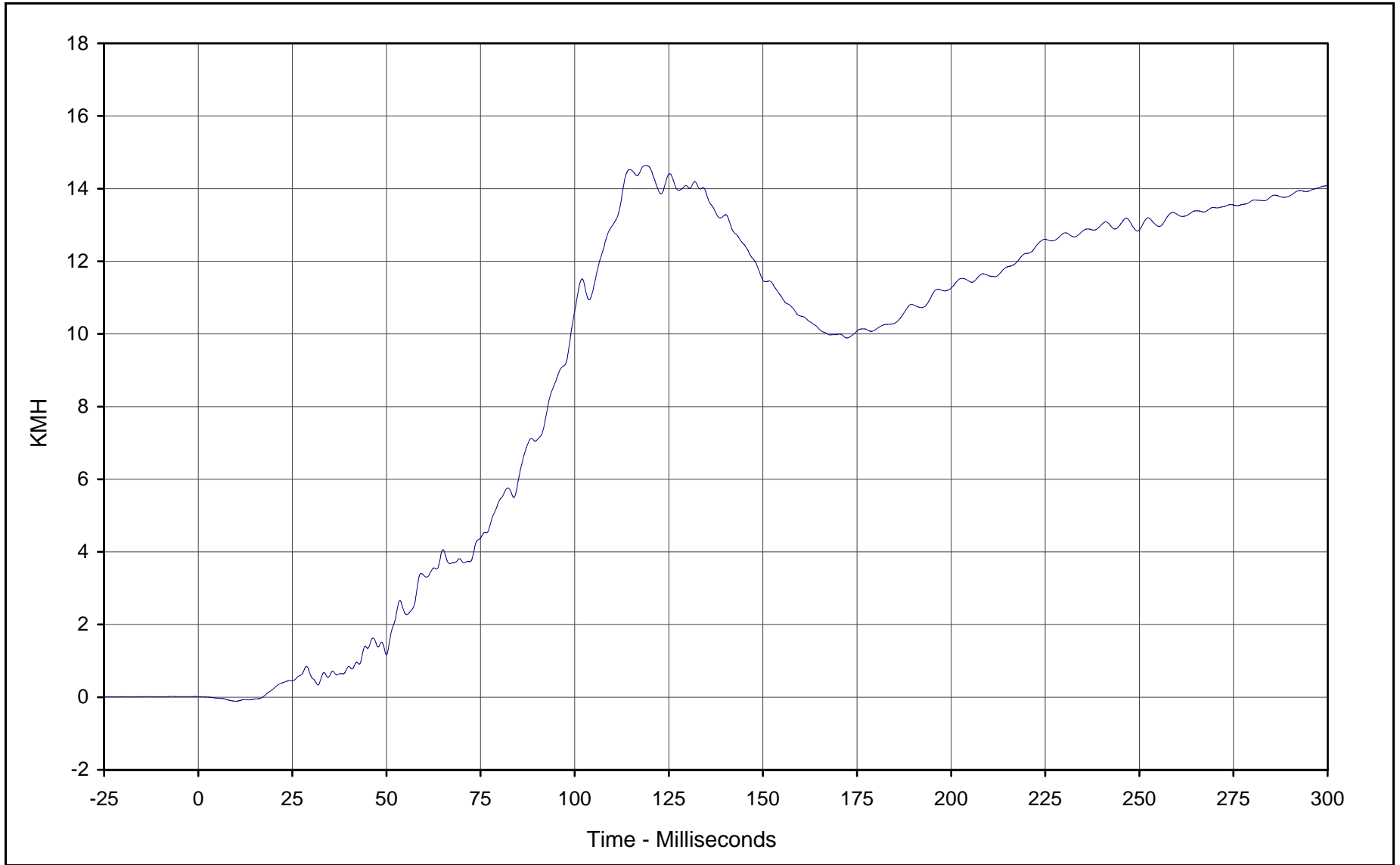

Curve Description: Vehicle Left Sill Y Velocity
Maximum Value: 14.6 at 118.8 Milliseconds
Minimum Value: -0.1 at 10.0 Milliseconds
SAE Filter Class: 180
Date of Test: 08/15/00
Curve Number: IN1-090

Test Program: 2000 NHTSA 40% Offset No.: FORD01
Test Vehicle: 2000 Ford Expedition 4WD 4 Door SUV



KARR20002-02

B-128

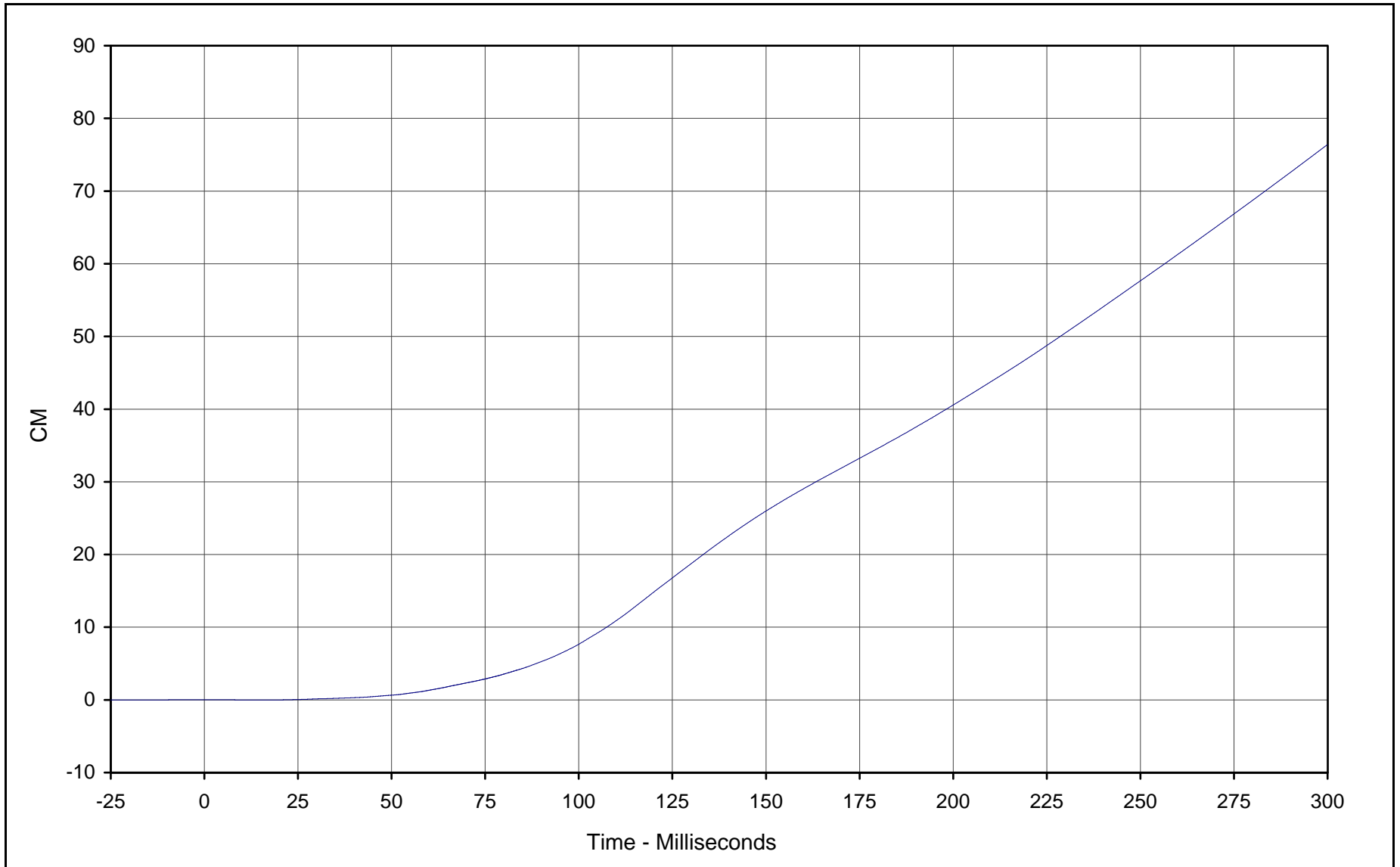

Curve Description: Vehicle Left Sill Y Displacement
Maximum Value: 76.4 at 299.9 Milliseconds
Minimum Value: 0.0 at 17.1 Milliseconds
SAE Filter Class: 180
Date of Test: 08/15/00
Curve Number: IN2-090

Test Program: 2000 NHTSA 40% Offset No.: FORD01
Test Vehicle: 2000 Ford Expedition 4WD 4 Door SUV



KARR20002-02

B-129

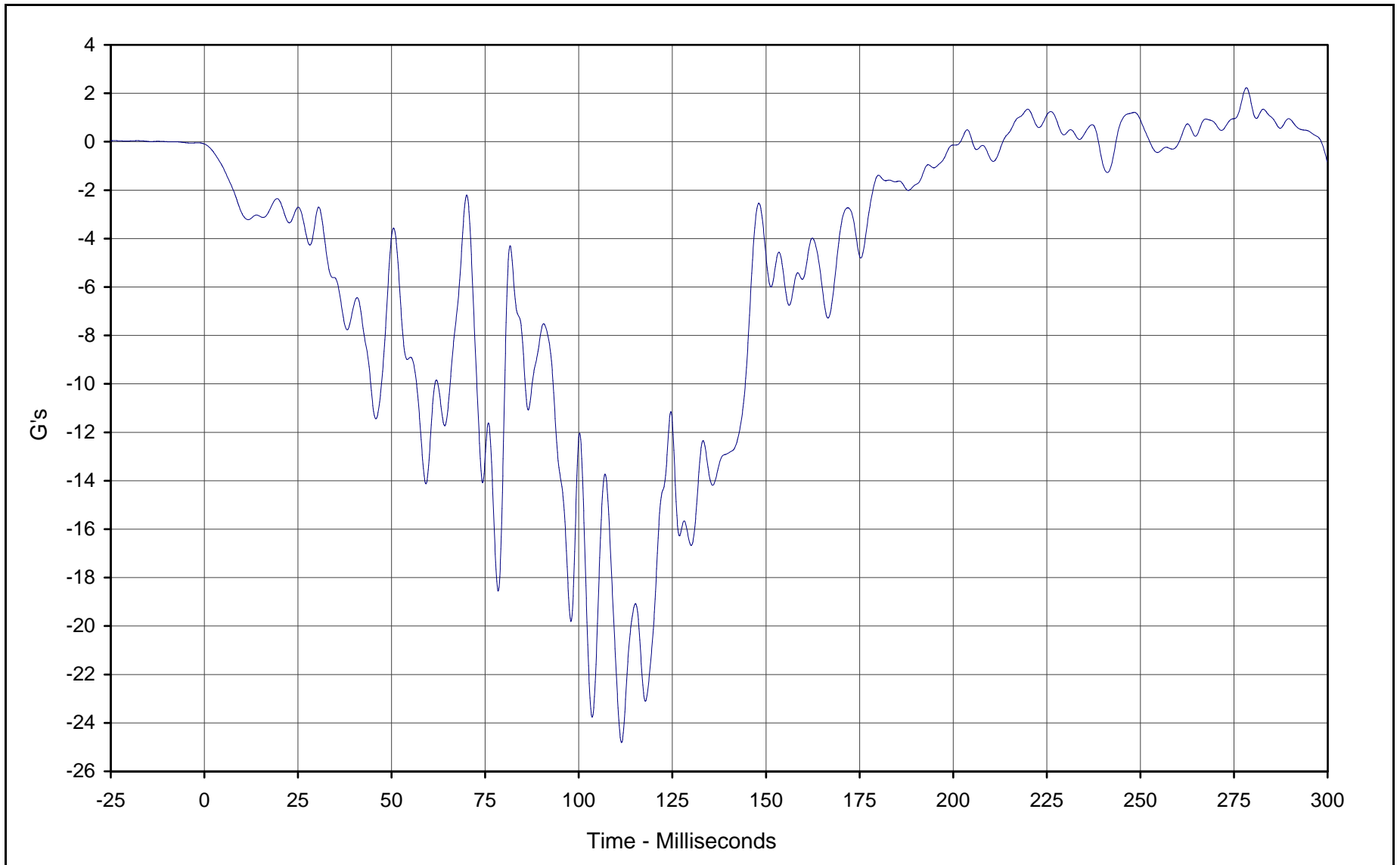

Curve Description: Vehicle Center Tunnel X
Maximum Value: 2.2 at 278.3 Milliseconds
Minimum Value: -24.8 at 111.4 Milliseconds
SAE Filter Class: 60
Date of Test: 08/15/00
Curve Number: FIL-091

Test Program: 2000 NHTSA 40% Offset No.: FORD01
Test Vehicle: 2000 Ford Expedition 4WD 4 Door SUV



KARR20002-02

B-130

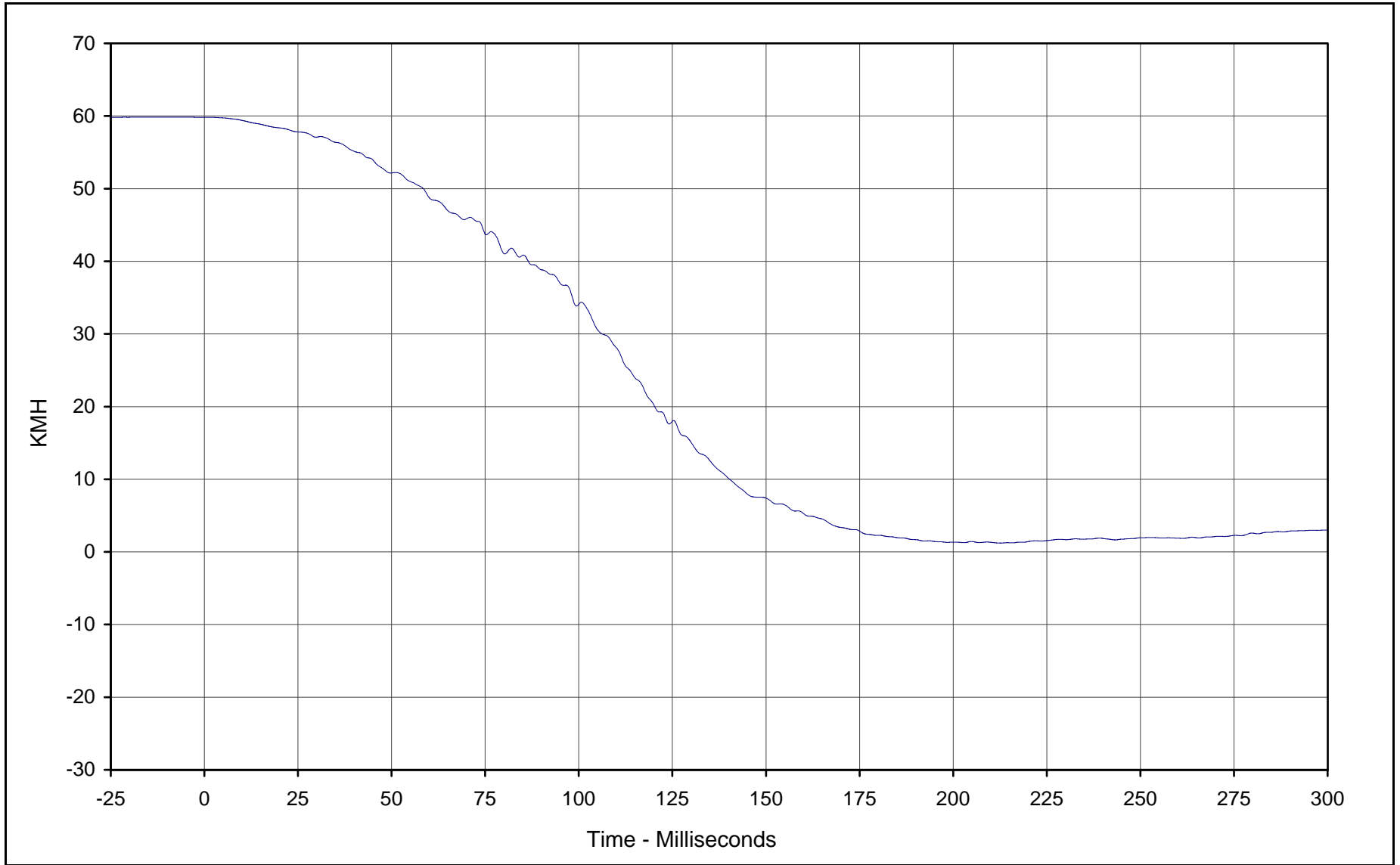

Curve Description: Vehicle Center Tunnel X Velocity
Maximum Value: 59.8 at 0.0 Milliseconds
Minimum Value: 1.2 at 212.6 Milliseconds
SAE Filter Class: 180
Date of Test: 08/15/00
Curve Number: IN1-091

Test Program: 2000 NHTSA 40% Offset No.: FORD01
Test Vehicle: 2000 Ford Expedition 4WD 4 Door SUV



KARR20002-02

B-131

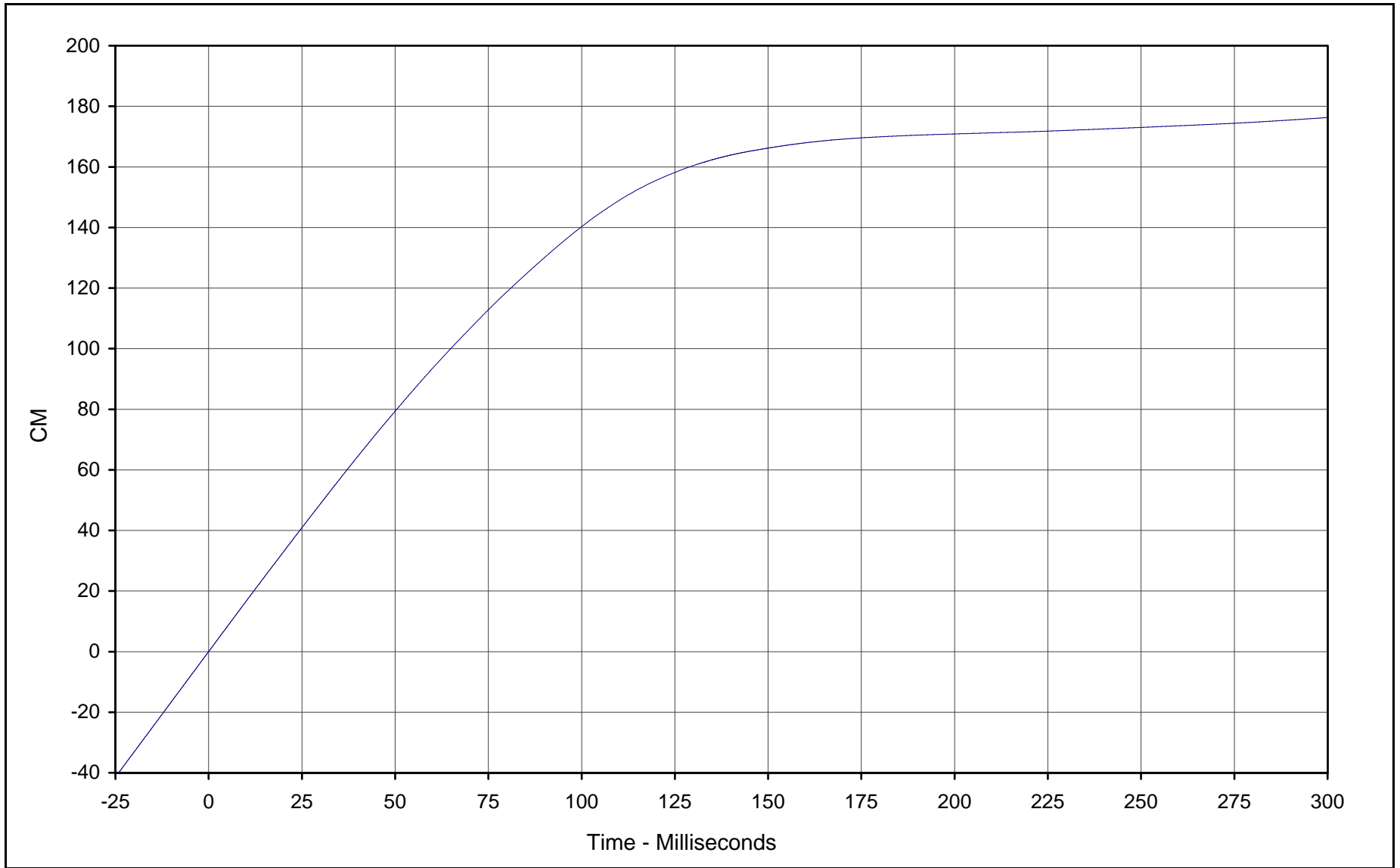

Curve Description: Vehicle Center Tunnel X Displacement

Maximum Value: 176.3 at 299.9 Milliseconds

Minimum Value: 0.0 at 0.0 Milliseconds

SAE Filter Class: 180

Date of Test: 08/15/00

Curve Number: IN2-091

Test Program: 2000 NHTSA 40% Offset No.: FORD01

Test Vehicle: 2000 Ford Expedition 4WD 4 Door SUV

KARR20002-02



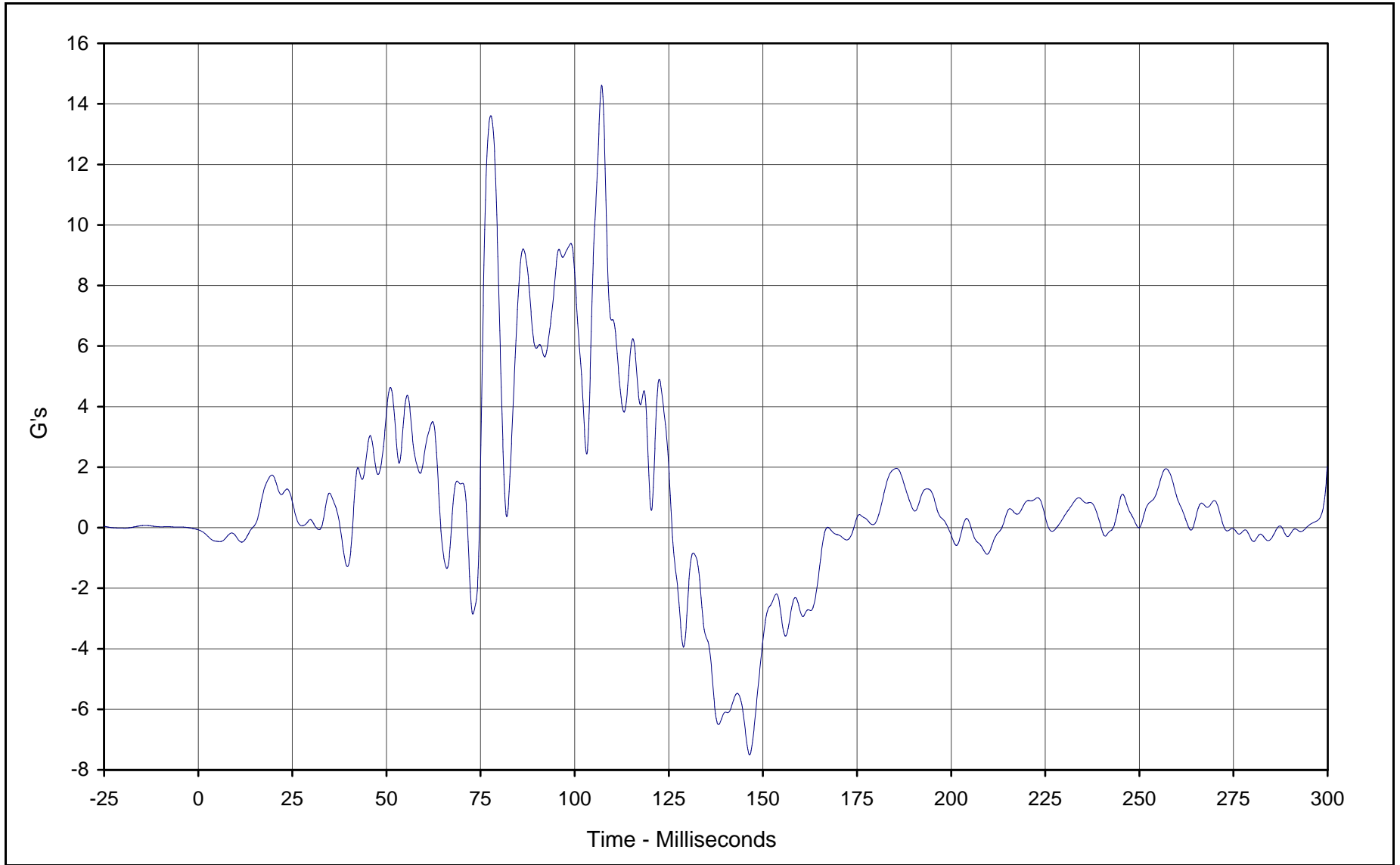

Curve Description: Vehicle Center Tunnel Y
 Maximum Value: 14.6 at 107.2 Milliseconds
 Minimum Value: -7.5 at 146.5 Milliseconds
 SAE Filter Class: 60
 Date of Test: 08/15/00
 Curve Number: FIL-092

Test Program: 2000 NHTSA 40% Offset No.: FORD01
 Test Vehicle: 2000 Ford Expedition 4WD 4 Door SUV



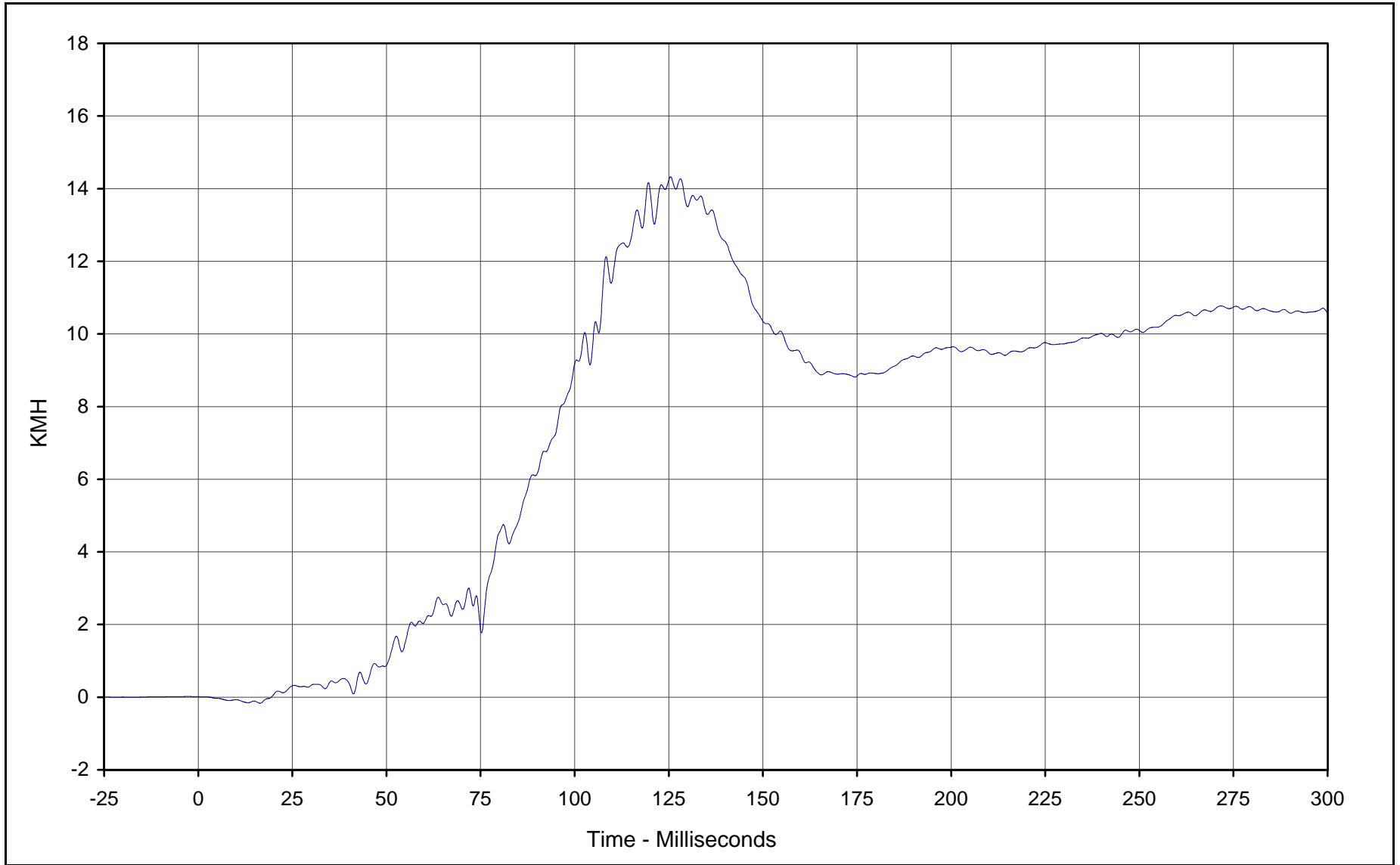

Curve Description: Vehicle Center Tunnel Y Velocity
 Maximum Value: 14.3 at 125.5 Milliseconds
 Minimum Value: -0.2 at 16.4 Milliseconds
 SAE Filter Class: 180
 Date of Test: 08/15/00
 Curve Number: IN1-092

Test Program: 2000 NHTSA 40% Offset No.: FORD01
 Test Vehicle: 2000 Ford Expedition 4WD 4 Door SUV



B-134

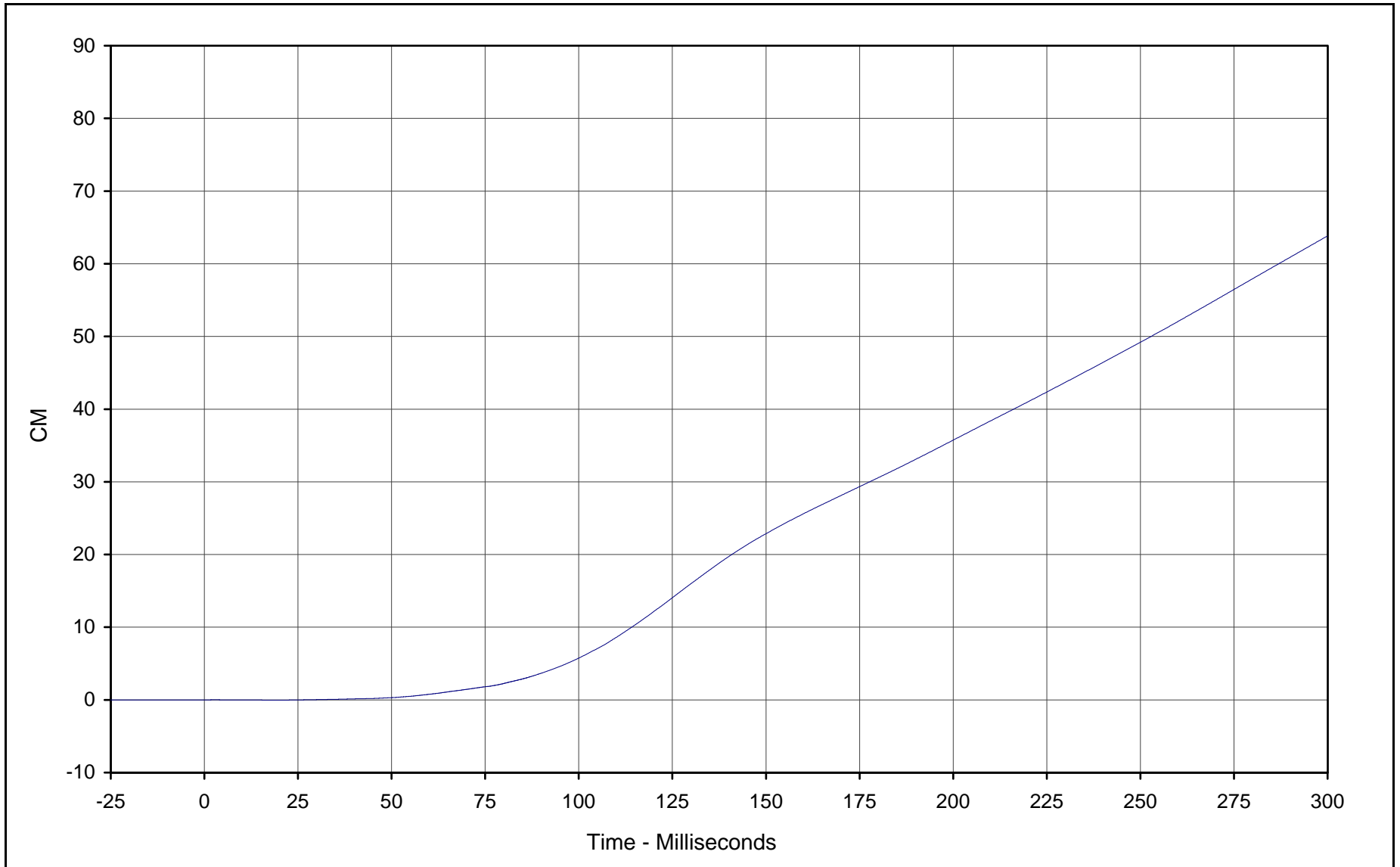

Curve Description: Vehicle Center Tunnel Y Displacement

Maximum Value: 63.8 at 299.9 Milliseconds

Minimum Value: 0.0 at 19.4 Milliseconds

SAE Filter Class: 180

Date of Test: 08/15/00

Curve Number: IN2-092

Test Program: 2000 NHTSA 40% Offset No.: FORD01

Test Vehicle: 2000 Ford Expedition 4WD 4 Door SUV



KARR20002-02

B-135

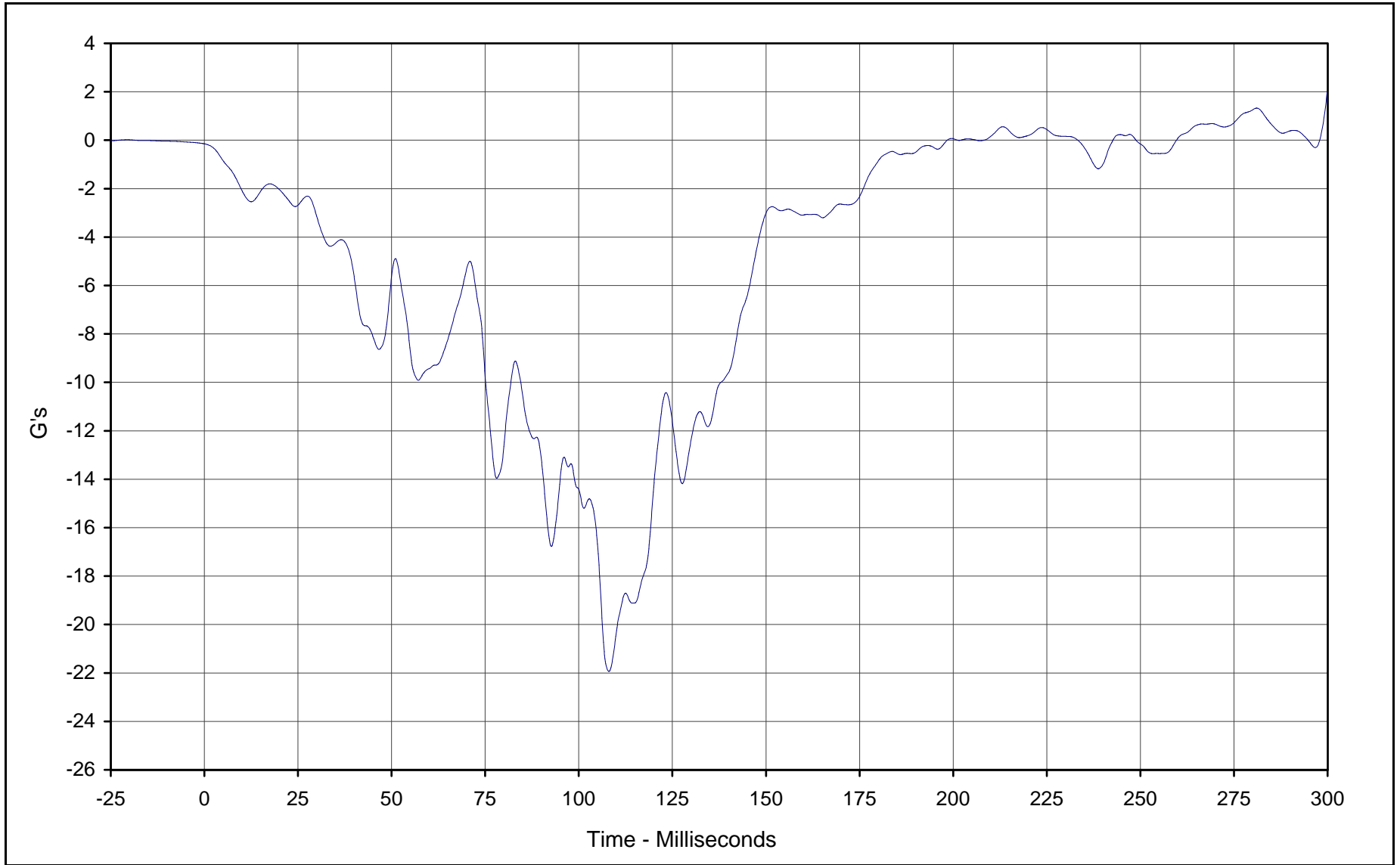

Curve Description: Vehicle Right Sill X
Maximum Value: 2.0 at 299.9 Milliseconds
Minimum Value: -21.9 at 108.1 Milliseconds
SAE Filter Class: 60
Date of Test: 08/15/00
Curve Number: FIL-093

Test Program: 2000 NHTSA 40% Offset No.: FORD01
Test Vehicle: 2000 Ford Expedition 4WD 4 Door SUV



KARR20002-02

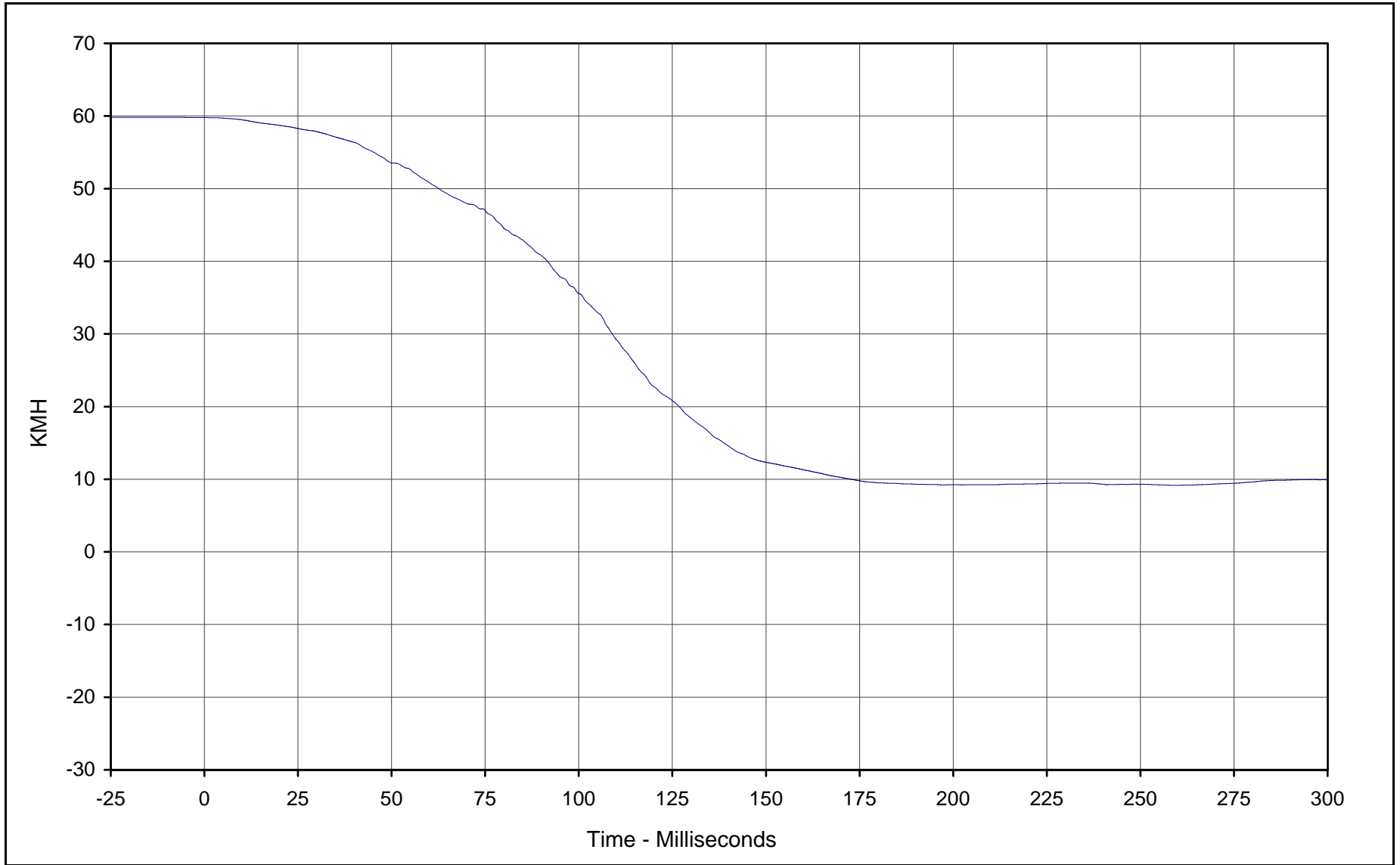

Curve Description: Vehicle Right Sill X Velocity
Maximum Value: 59.8 at 0.0 Milliseconds
Minimum Value: 9.2 at 258.8 Milliseconds
SAE Filter Class: 180
Date of Test: 08/15/00
Curve Number: IN1-093

Test Program: 2000 NHTSA 40% Offset No.: FORD01
Test Vehicle: 2000 Ford Expedition 4WD 4 Door SUV



B-137

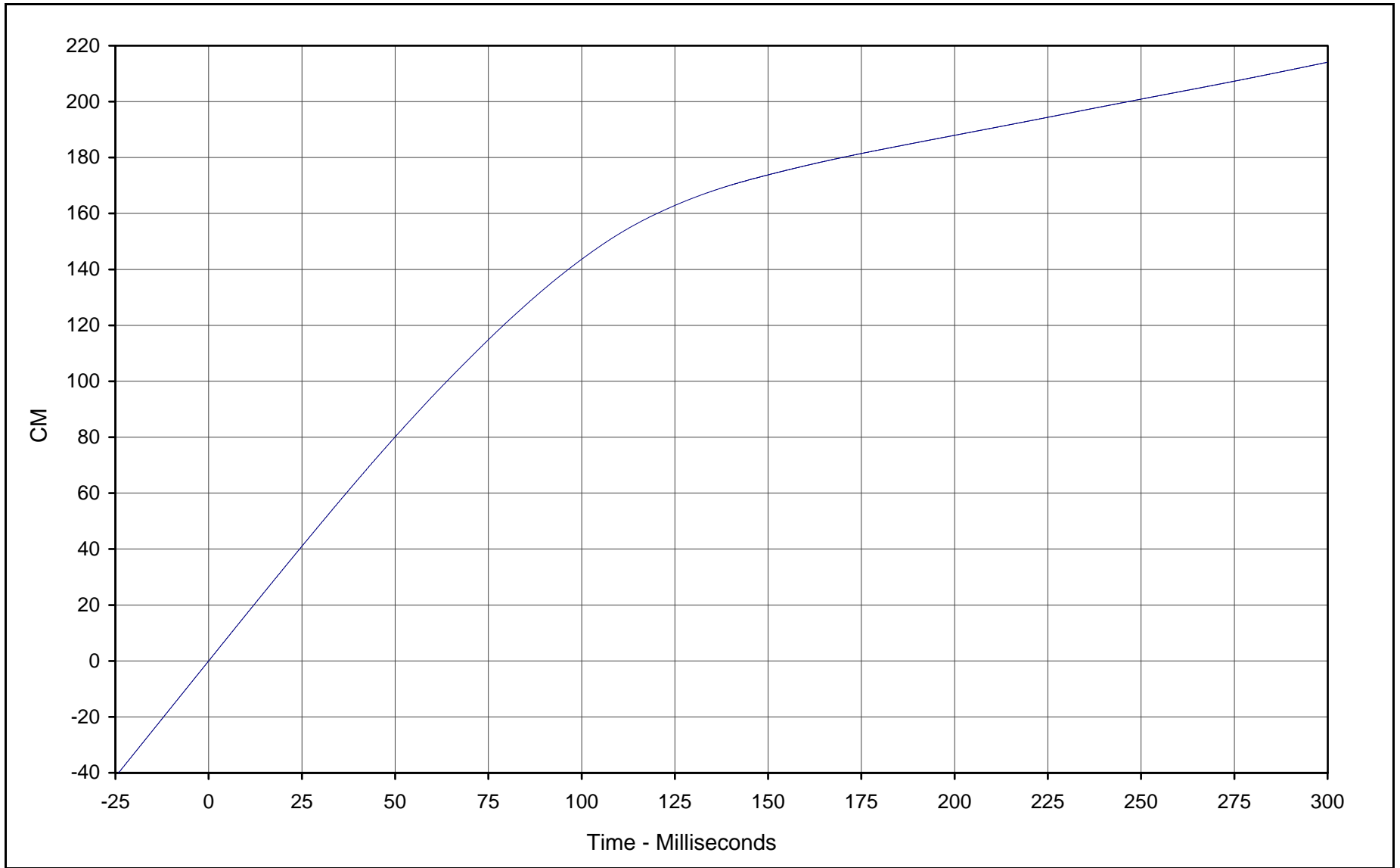

Curve Description: Vehicle Right Sill X Displacement
Maximum Value: 214.1 at 299.9 Milliseconds
Minimum Value: 0.0 at 0.0 Milliseconds
SAE Filter Class: 180
Date of Test: 08/15/00
Curve Number: IN2-093

Test Program: 2000 NHTSA 40% Offset No.: FORD01
Test Vehicle: 2000 Ford Expedition 4WD 4 Door SUV



KARR20002-02

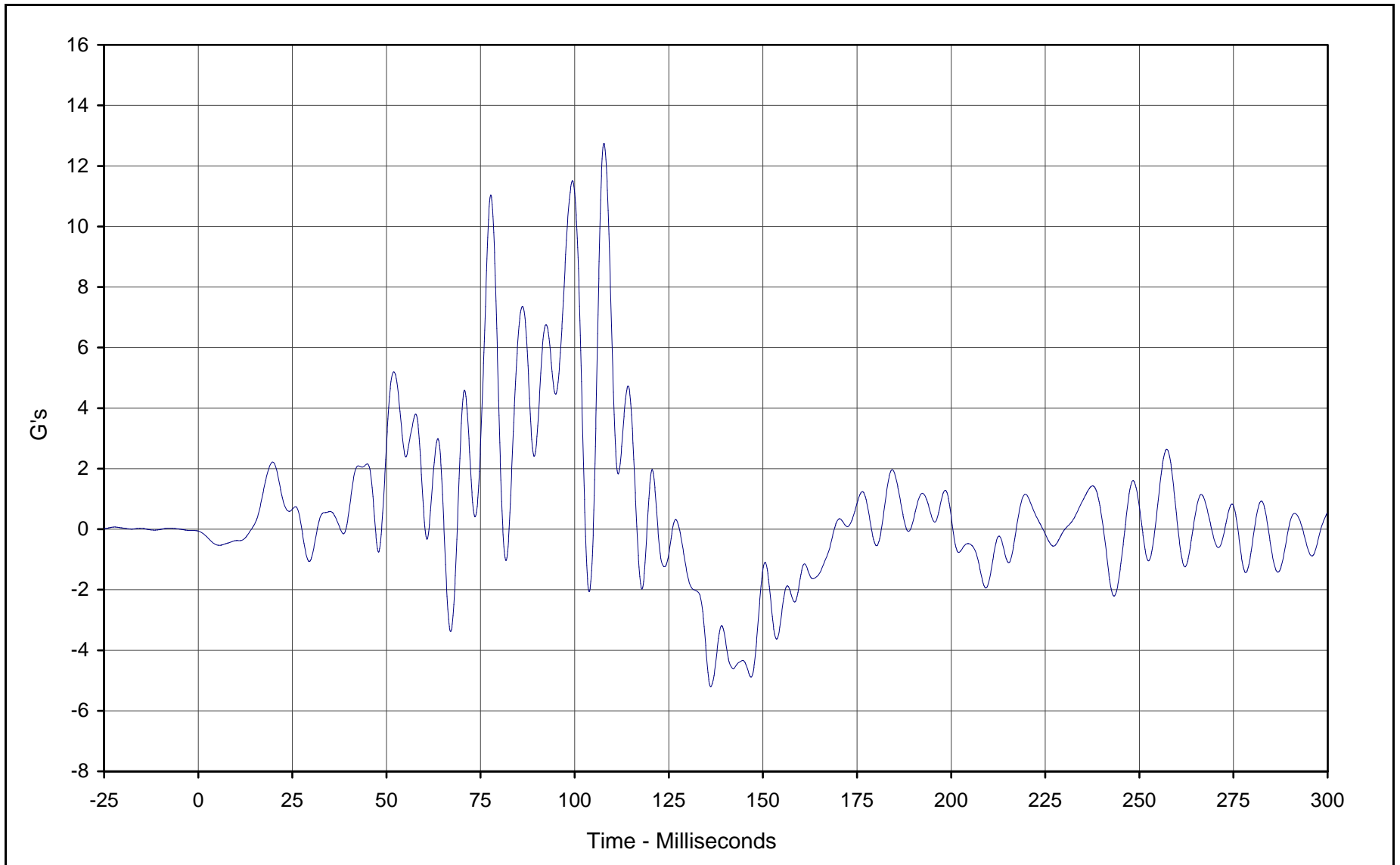

Curve Description: Vehicle Right Sill Y
 Maximum Value: 12.8 at 107.8 Milliseconds
 Minimum Value: -5.2 at 136.1 Milliseconds
 SAE Filter Class: 60
 Date of Test: 08/15/00
 Curve Number: FIL-094

Test Program: 2000 NHTSA 40% Offset No.: FORD01

Test Vehicle: 2000 Ford Expedition 4WD 4 Door SUV



B-139

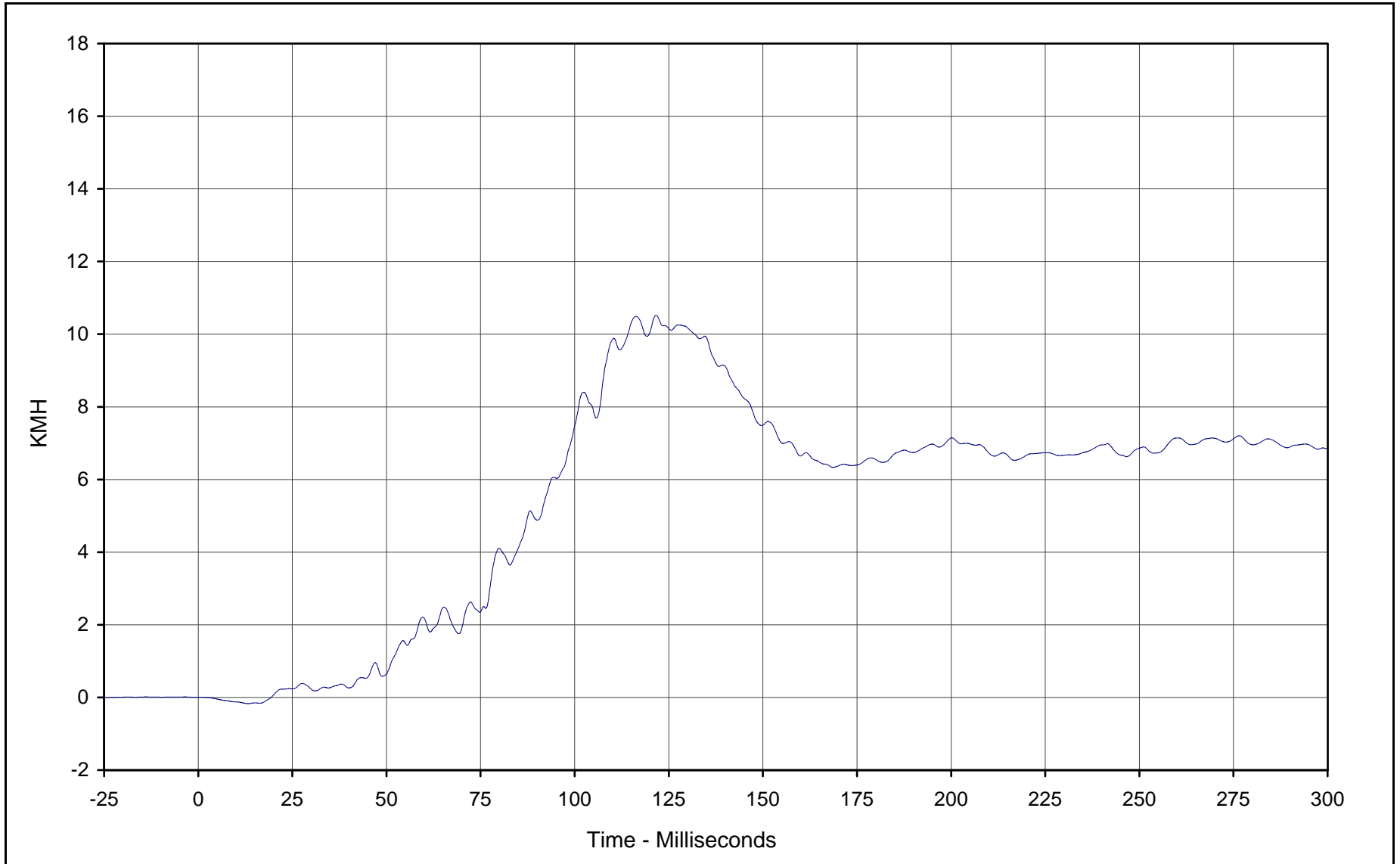

Curve Description: Vehicle Right Sill Y Velocity
Maximum Value: 10.5 at 121.6 Milliseconds
Minimum Value: -0.2 at 13.3 Milliseconds
SAE Filter Class: 180
Date of Test: 08/15/00
Curve Number: IN1-094

Test Program: 2000 NHTSA 40% Offset No.: FORD01
Test Vehicle: 2000 Ford Expedition 4WD 4 Door SUV



KARR20002-02

B-140

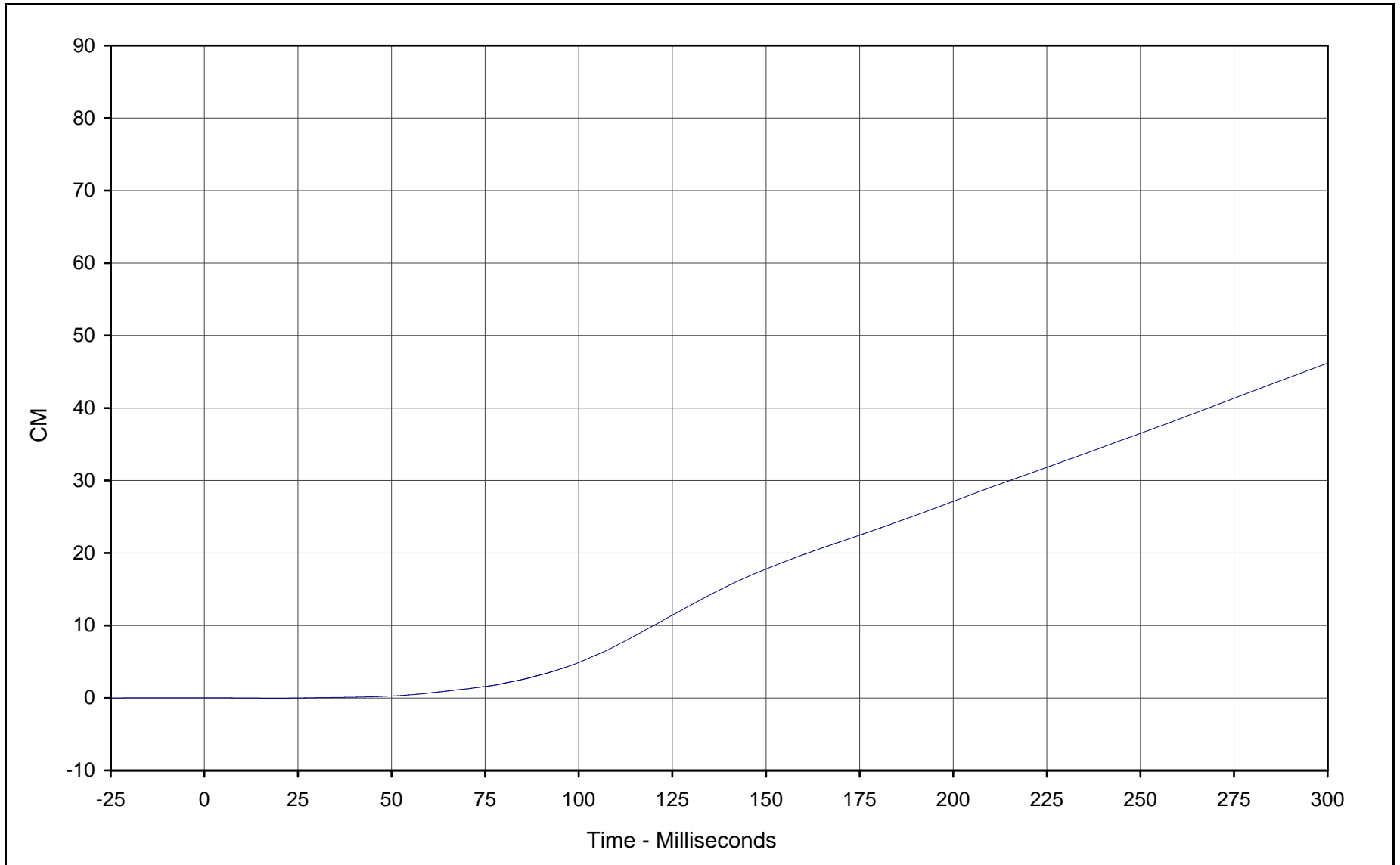

Curve Description: Vehicle Right Sill Y Displacement
Maximum Value: 46.2 at 299.9 Milliseconds
Minimum Value: 0.0 at 19.3 Milliseconds
SAE Filter Class: 180
Date of Test: 08/15/00
Curve Number: IN2-094

Test Program: 2000 NHTSA 40% Offset No.: FORD01
Test Vehicle: 2000 Ford Expedition 4WD 4 Door SUV



KAR20002-02

B-141

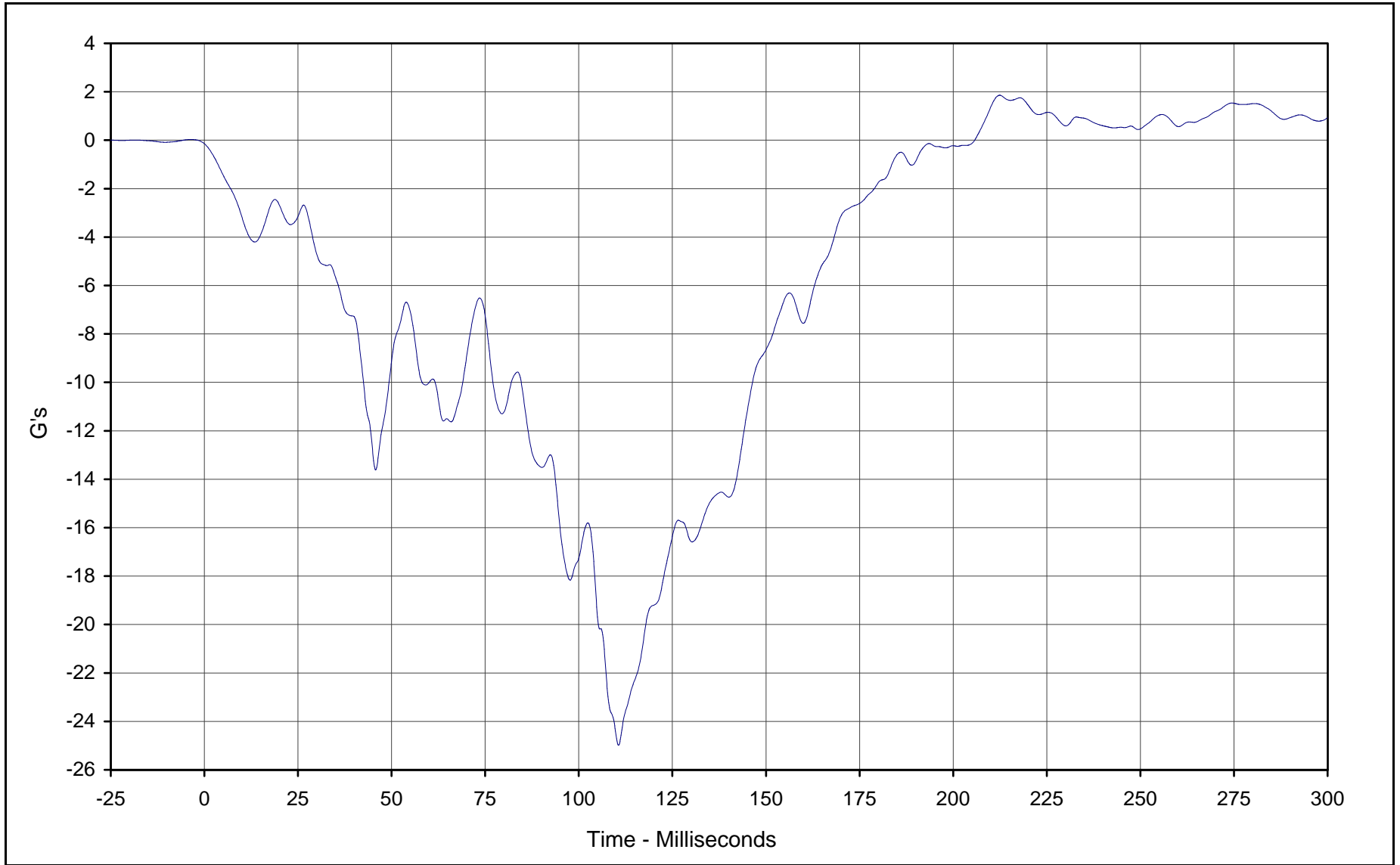

Curve Description: Vehicle Trunk X
Maximum Value: 1.9 at 212.4 Milliseconds
Minimum Value: -25.0 at 110.6 Milliseconds
SAE Filter Class: 60
Date of Test: 08/15/00
Curve Number: FIL-095

Test Program: 2000 NHTSA 40% Offset No.: FORD01
Test Vehicle: 2000 Ford Expedition 4WD 4 Door SUV



KARR20002-02

B-142

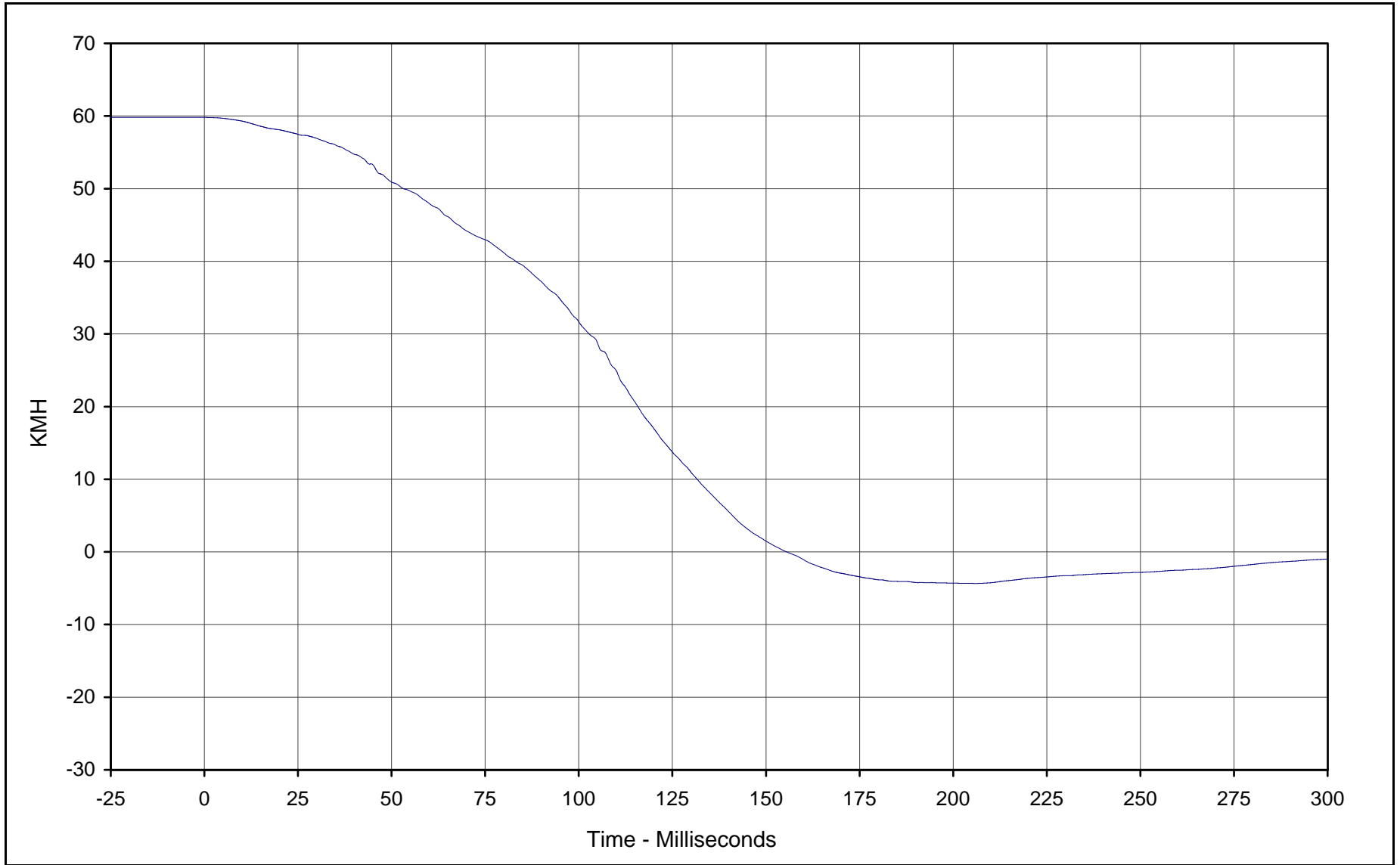

Curve Description: Vehicle Trunk X Velocity
Maximum Value: 59.8 at 0.0 Milliseconds
Minimum Value: -4.3 at 206.0 Milliseconds
SAE Filter Class: 180
Date of Test: 08/15/00
Curve Number: IN1-095

Test Program: 2000 NHTSA 40% Offset No.: FORD01
Test Vehicle: 2000 Ford Expedition 4WD 4 Door SUV



KARR20002-02

B-143

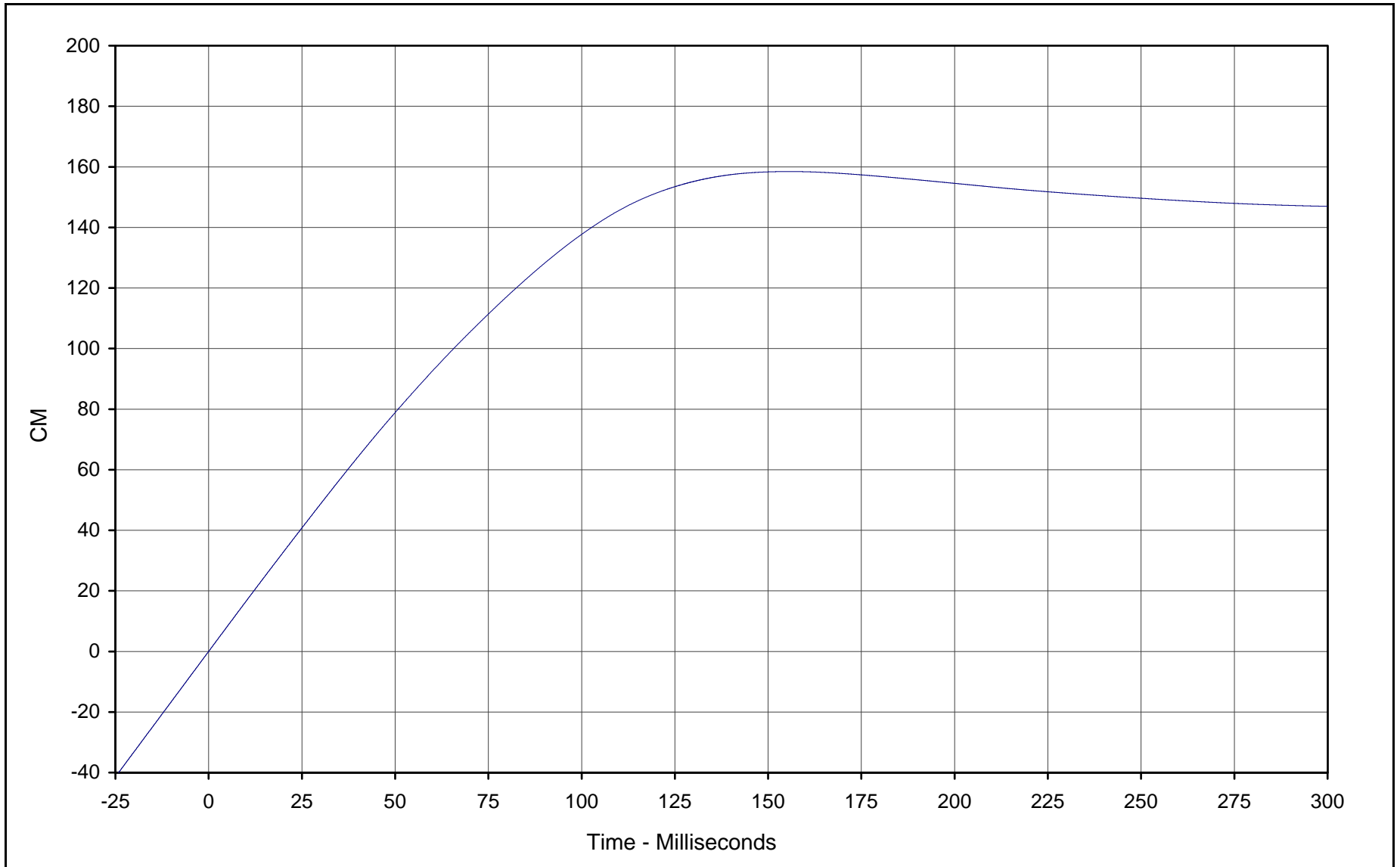

Curve Description: Vehicle Trunk X Displacement
Maximum Value: 158.4 at 155.5 Milliseconds
Minimum Value: 0.0 at 0.0 Milliseconds
SAE Filter Class: 180
Date of Test: 08/15/00
Curve Number: IN2-095

Test Program: 2000 NHTSA 40% Offset No.: FORD01
Test Vehicle: 2000 Ford Expedition 4WD 4 Door SUV



KARR20002-02

B-144

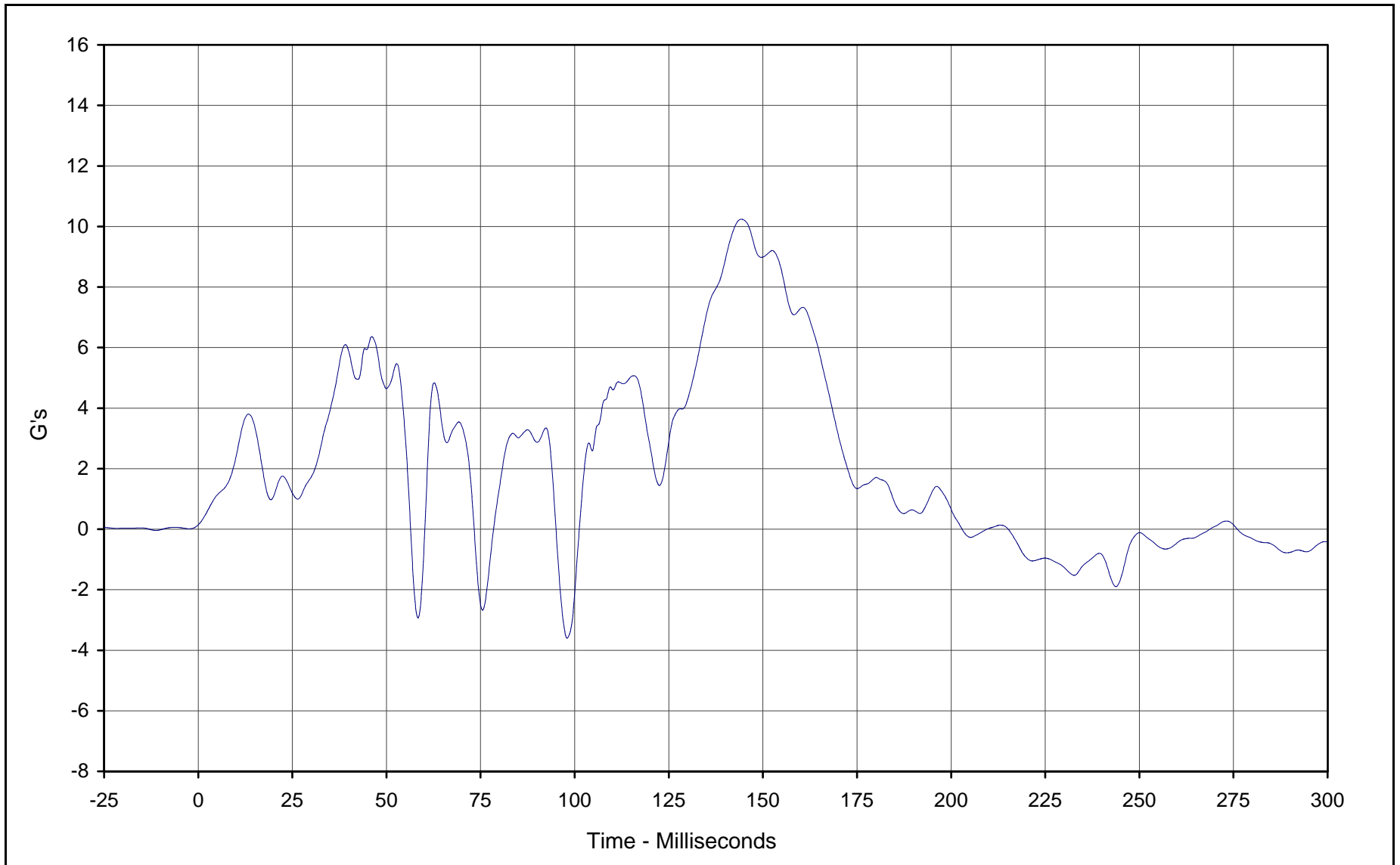

Curve Description: Vehicle Trunk Y
Maximum Value: 10.2 at 144.2 Milliseconds
Minimum Value: -3.6 at 98.0 Milliseconds
SAE Filter Class: 60
Date of Test: 08/15/00
Curve Number: FIL-096

Test Program: 2000 NHTSA 40% Offset No.: FORD01
Test Vehicle: 2000 Ford Expedition 4WD 4 Door SUV



KARR20002-02

B-145

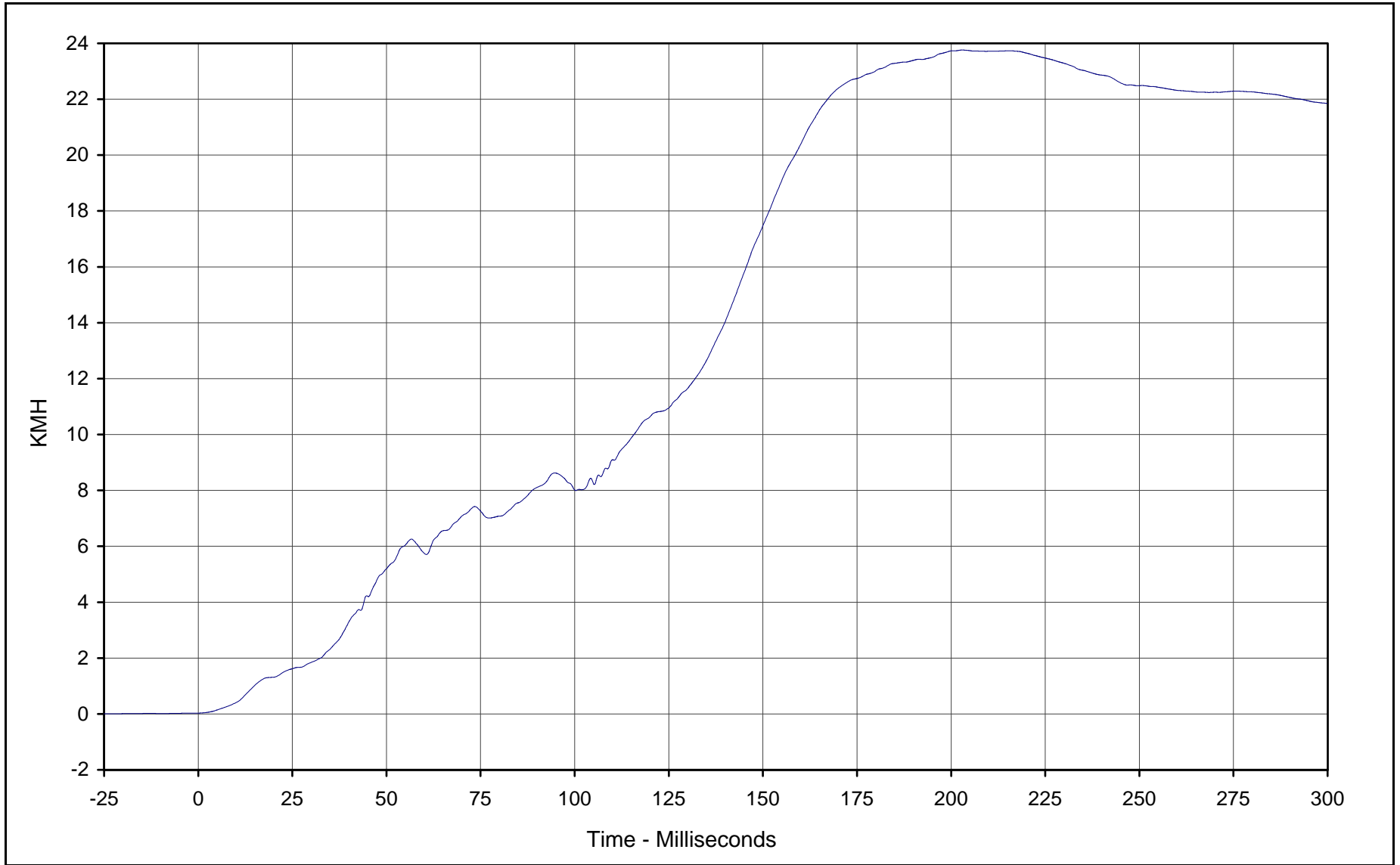

Curve Description: Vehicle Trunk Y Velocity
Maximum Value: 23.8 at 203.0 Milliseconds
Minimum Value: 0.0 at 0.0 Milliseconds
SAE Filter Class: 180
Date of Test: 08/15/00
Curve Number: IN1-096

Test Program: 2000 NHTSA 40% Offset No.: FORD01
Test Vehicle: 2000 Ford Expedition 4WD 4 Door SUV



KARR20002-02

B-146

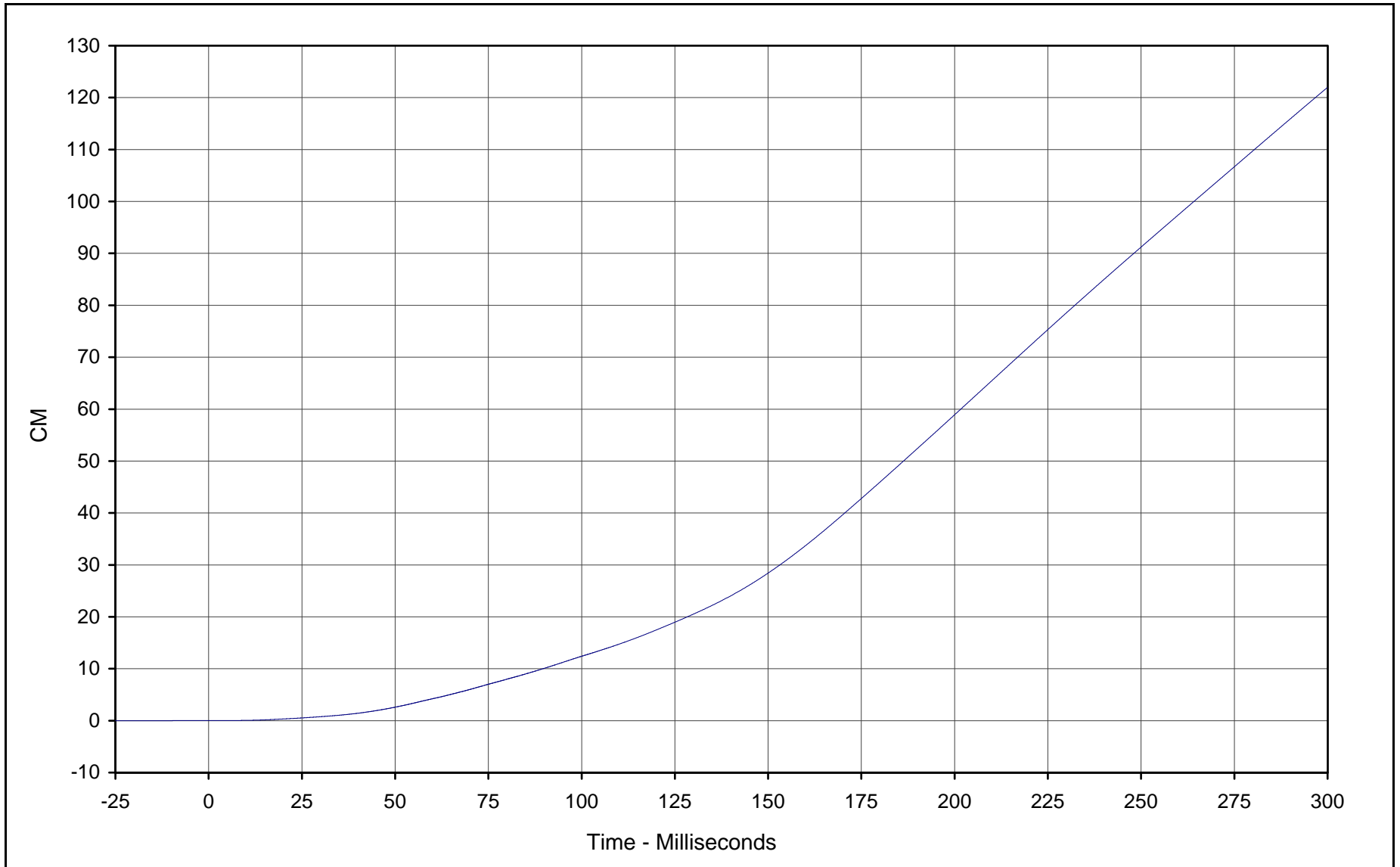

Curve Description: Vehicle Trunk Y Displacement
Maximum Value: 121.9 at 299.9 Milliseconds
Minimum Value: 0.0 at 0.0 Milliseconds
SAE Filter Class: 180
Date of Test: 08/15/00
Curve Number: IN2-096

Test Program: 2000 NHTSA 40% Offset No.: FORD01
Test Vehicle: 2000 Ford Expedition 4WD 4 Door SUV



KARR20002-02

APPENDIX C
DEFORMABLE BARRIER CRUSH PROFILE

DEFORMABLE BARRIER MEASUREMENTS, PRE-TEST

Test Vehicle: 2000 Ford Expedition 4WD 4 Door SUV

NHTSA No.: FORD01

Test Program: 2000 NHTSA 40% Offset

Test Date: 8/15/00

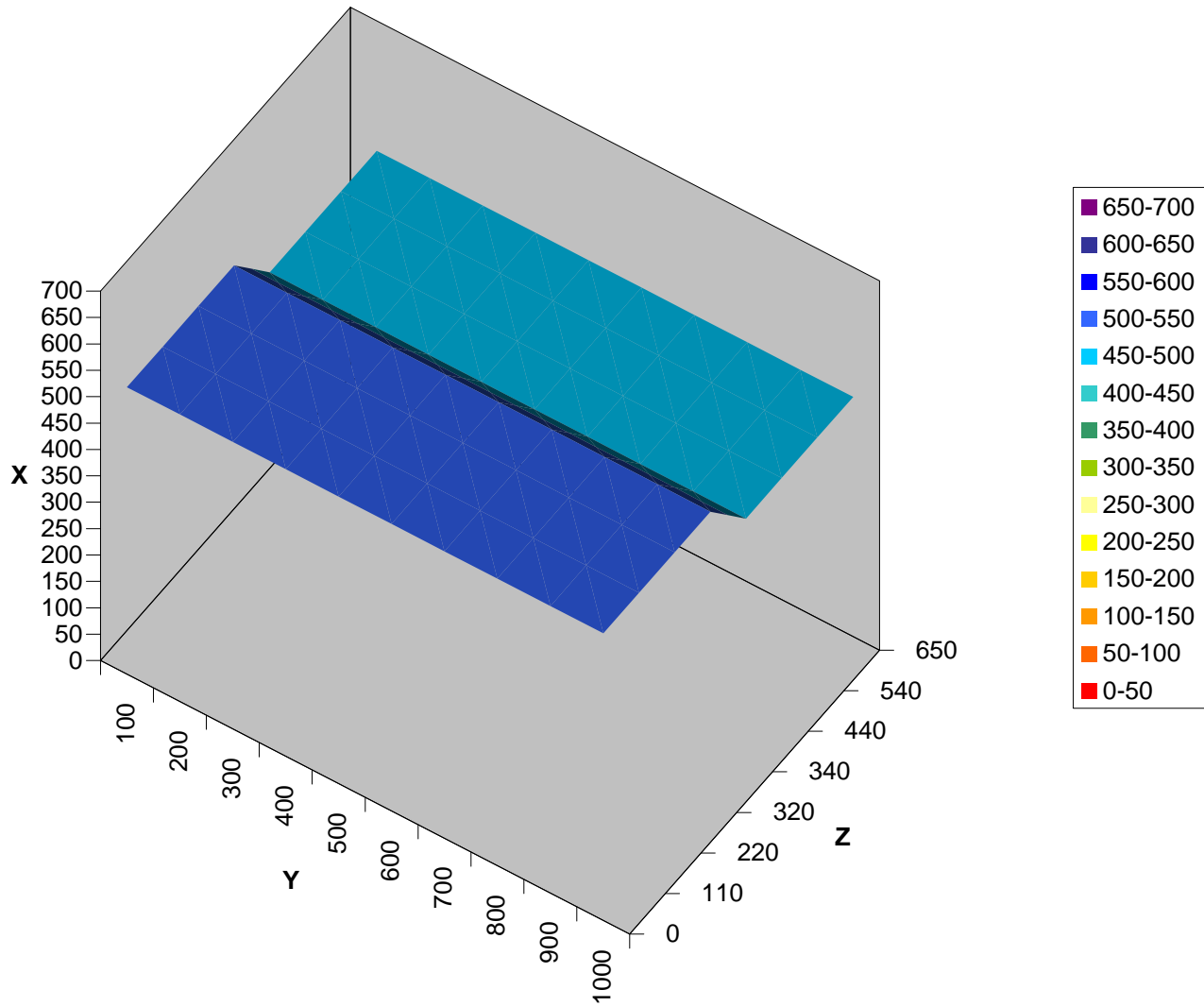

All Measurements are in Millimeters

	Z Axis	A	B	C	D	E	F	G	H	I	J
Y Axis		100	200	300	400	500	600	700	800	900	1000
Level 1	650	454	454	454	454	454	454	454	454	454	454
Level 2	540	454	454	454	454	454	454	454	454	454	454
Level 3	440	454	454	454	454	454	454	454	454	454	454
Level 4	340	454	454	454	454	454	454	454	454	454	454
Level 5	320	544	544	544	544	544	544	544	544	544	544
Level 6	220	544	544	544	544	544	544	544	544	544	544
Level 7	110	544	544	544	544	544	544	544	544	544	544
Level 8	0	544	544	544	544	544	544	544	544	544	544

DEFORMABLE BARRIER MEASUREMENTS, POST-TEST

Test Vehicle: 2000 Ford Expedition 4WD 4 Door SUV

NHTSA No.: FORD01

Test Program: 2000 NHTSA 40% Offset

Test Date: 8/15/00

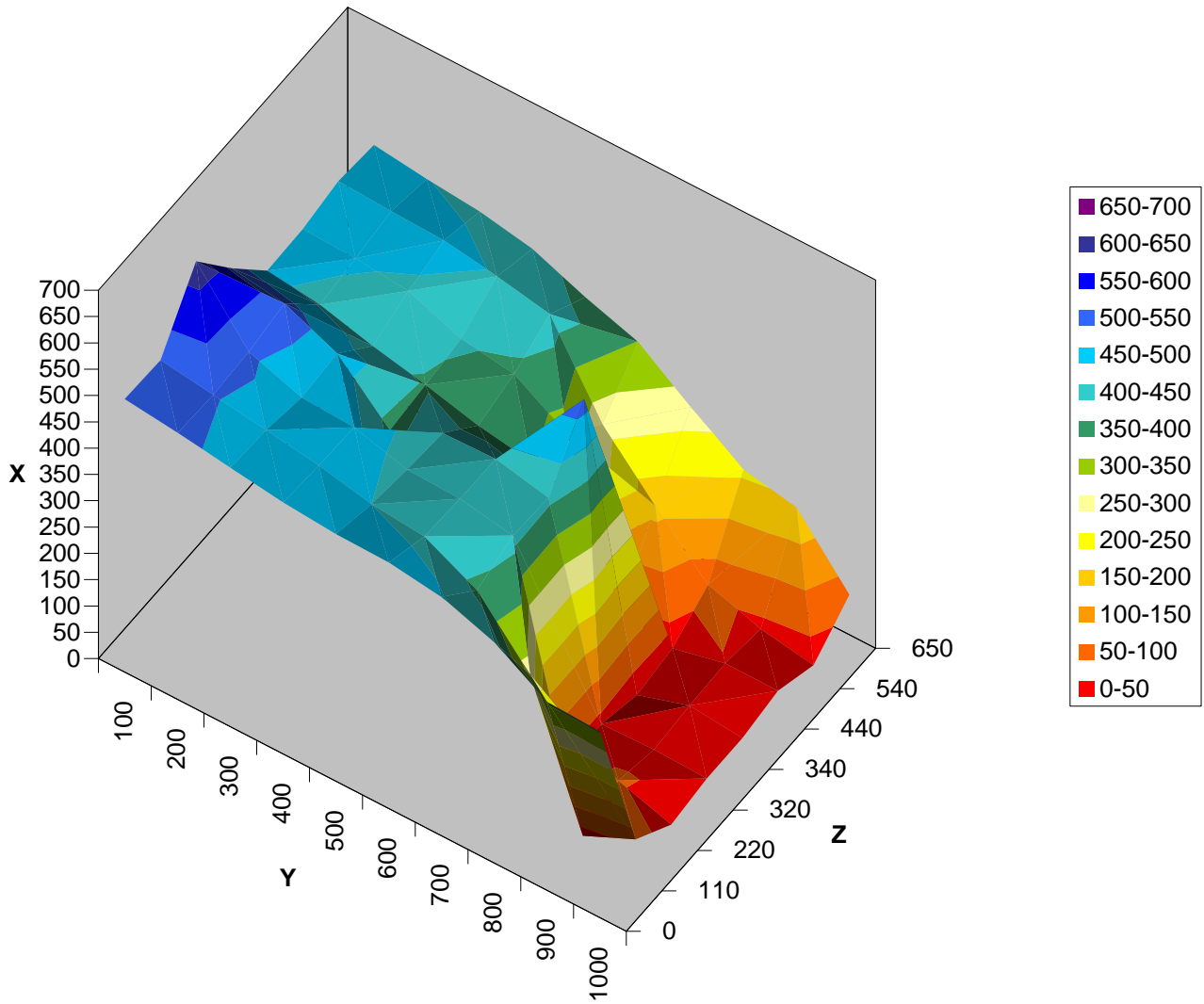

All Measurements are in Millimeters

	Z Axis	A	B	C	D	E	F	G	H	I	J
Y Axis		100	200	300	400	500	600	700	800	900	1000
Level 1	650	464	451	441	422	382	349	277	210	190	76
Level 2	540	472	467	463	447	427	269	166	68	36	19
Level 3	440	458	454	444	405	390	329	44	24	47	47
Level 4	340	456	443	416	394	369	352	522	12	44	34
Level 5	320	537	522	479	385	431	434	412	34	37	34
Level 6	220	627	507	472	467	439	435	417	32	55	23
Level 7	110	516	502	487	472	450	440	390	282	27	72
Level 8	0	519	507	492	478	470	468	454	420	358	354

APPENDIX D
INSTRUMENTATION DATA CHANNEL ASSIGNMENTS

**2000 NHTSA 40% Offset
Instrumentation Data Channel Assignments
Driver A.T.D Serial Number 34
7/15/00
2000 Ford Expedition 4WD 4 Door SUV**

CH.	LOCATION	AXIS	IDENT. NO.	DESCRIPTION	MFR	MODEL	UNITS
1	HEAD, PRIMARY	X	KEAC039	Accel., 1/2 bridge	Endevco	7264-2000	G
2	HEAD, PRIMARY	Y	KEAC038	Accel., 1/2 bridge	Endevco	7264-2000	G
3	HEAD, PRIMARY	Z	KEAC027	Accel., 1/2 bridge	Endevco	7264-2000	G
4	HEAD, REDUNDANT	X	KEAC031	Accel., 1/2 bridge	Endevco	7264-2000	G
5	HEAD, REDUNDANT	Y	KEAC032	Accel., 1/2 bridge	Endevco	7264-2000	G
6	HEAD, REDUNDANT	Z	KEAC026	Accel., 1/2 bridge	Endevco	7264-2000	G
7	NECK FORCE	X	GPUN02FX	Load cell, six axis neck	R. A. Denton	1716A	N
8	NECK FORCE	Y	GPUN02FY	Load cell, six axis neck	R. A. Denton	1716A	N
9	NECK FORCE	Z	GPUN02FZ	Load cell, six axis neck	R. A. Denton	1716A	N
10	NECK MOMENT	X	GPUN02MX	Load cell, six axis neck	R. A. Denton	1716A	Nm
11	NECK MOMENT	Y	GPUN02MY	Load cell, six axis neck	R. A. Denton	1716A	Nm
12	NECK MOMENT	Z	GPUN02MZ	Load cell, six axis neck	R. A. Denton	1716A	Nm
13	CHEST , PRIMARY	X	GPAC031	Accel., 1/2 bridge	Endevco	7264-2000	G
14	CHEST , PRIMARY	Y	GPAC024	Accel., 1/2 bridge	Endevco	7264-2000	G
15	CHEST , PRIMARY	Z	GPAC029	Accel., 1/2 bridge	Endevco	7264-2000	G
16	CHEST , REDUNDANT	X	KEAC023	Accel., 1/2 bridge	Endevco	7264-200	G
17	CHEST , REDUNDANT	Y	KEAC022	Accel., 1/2 bridge	Endevco	7264-200	G
18	CHEST , REDUNDANT	Z	KEAC024	Accel., 1/2 bridge	Endevco	7264-200	G
19	CHEST DISPLACEMENT	X	GPCP001	Rotary Pot Chest	Servo	14CBI	MM
20	PELVIS, PRIMARY	X	KEAC019	Accel., 1/2 bridge	Endevco	7264-200	G
21	PELVIS, PRIMARY	Y	KEAC020	Accel., 1/2 bridge	Endevco	7264-200	G
22	PELVIS, PRIMARY	Z	KEAC021	Accel., 1/2 bridge	Endevco	7264-200	G
23	LEFT FEMUR FORCE	Z	KEFF001	Load cell, Femur	R.A. Denton	2121	N
24	RIGHT FEMUR FORCE	Z	KEFF002	Load cell, Femur	R.A. Denton	2121	N

D-1

KAR20002-02

**2000 NHTSA 40% Offset
Instrumentation Data Channel Assignments
Driver A.T.D Serial Number 34
7/15/00
2000 Ford Expedition 4WD 4 Door SUV**

CH.	LOCATION	AXIS	IDENT. NO.	DESCRIPTION	MFR	MODEL	UNITS
25	UP. TIBIA LEFT MOM.	X	GPUT09MX	2 ch., Upper tibia gage	R. A. Denton	1583	Nm
26	UP. TIBIA LEFT MOM.	Y	GPUT09MY	2 ch., Upper tibia gage	R. A. Denton	1583	Nm
27	UP. TIBIA RIGHT MOM.	X	GPUT09MX	2 ch., Upper tibia gage	R. A. Denton	1583	Nm
28	UP. TIBIA RIGHT MOM.	Y	GPUT09MY	2 ch., Upper tibia gage	R. A. Denton	1583	Nm
29	LWR. TIBIA LEFT MOM.	X	GPLT09MX	3 ch., lower tibia gage	R. A. Denton	3093	Nm
30	LWR. TIBIA LEFT MOM.	Y	GPLT09MY	3 ch., lower tibia gage	R. A. Denton	3093	Nm
31	LWR. TIBIA LEFT FORCE	Z	GPLT09FZ	3 ch., lower tibia gage	R. A. Denton	3093	N
32	LWR. TIBIA RIGHT MOM.	X	GPLT09MX	3 ch., lower tibia gage	R. A. Denton	3093	Nm
33	LWR. TIBIA RIGHT MOM.	Y	GPLT09MY	3 ch., lower tibia gage	R. A. Denton	3093	Nm
34	LWR. TIBIA RIGHT FORCE	Z	GPLT09FZ	3 ch., lower tibia gage	R. A. Denton	3093	N
35	FOOT LEFT	X	KEIC003X	Accel., Foot Triax	I.C. Sensor	3031-500	G
36	FOOT LEFT	Y	KEIC003Y	Accel., Foot Triax	I.C. Sensor	3031-500	G
37	FOOT LEFT	Z	KEIC003Z	Accel., Foot Triax	I.C. Sensor	3031-500	G
38	FOOT RIGHT	X	KEIC004X	Accel., Foot Triax	I.C. Sensor	3031-500	G
39	FOOT RIGHT	Y	KEIC004Y	Accel., Foot Triax	I.C. Sensor	3031-500	G
40	FOOT RIGHT	Z	KEIC004Z	Accel., Foot Triax	I.C. Sensor	3031-500	G
41	LAP BELT FORCE	X	KELC001	Load cell, Seat belt	Lebow	3371	N
42	SHOULDER BELT FORCE	X	KELC002	Load cell, Seat belt	Lebow	3371	N
43	SHOULDER BELT SPOOL	X	KEPP001	Pullout pot	Celesco	PTX101-0030	MM
44	SHOULDER BELT ELONG.	X	KEEP001	Linear pot., belt stretch	E.T.I.	LCP8-10 10K	MM/CM

D-2

KAR20002-02

**2000 NHTSA 40% Offset
Instrumentation Data Channel Assignments
Driver A.T.D Serial Number 35
7/15/00
2000 Ford Expedition 4WD 4 Door SUV**

CH.	LOCATION	AXIS	IDENT. NO.	DESCRIPTION	MFR	MODEL	UNITS
45	HEAD, PRIMARY	X	GPAC027	Accel., 1/2 bridge	Endevco	7264-2000	G
46	HEAD, PRIMARY	Y	GPAC002	Accel., 1/2 bridge	Endevco	7264-2000	G
47	HEAD, PRIMARY	Z	GPAC003	Accel., 1/2 bridge	Endevco	7264-2000	G
48	HEAD, REDUNDANT	X	GPAC032	Accel., 1/2 bridge	Endevco	7264-2000	G
49	HEAD, REDUNDANT	Y	GPAC021	Accel., 1/2 bridge	Endevco	7264-2000	G
50	HEAD, REDUNDANT	Z	GPAC026	Accel., 1/2 bridge	Endevco	7264-2000	G
51	NECK FORCE	X	GPUN01FX	Load cell, six axis neck	R. A. Denton	1716A	N
52	NECK FORCE	Y	GPUN01FY	Load cell, six axis neck	R. A. Denton	1716A	N
53	NECK FORCE	Z	GPUN01FZ	Load cell, six axis neck	R. A. Denton	1716A	N
54	NECK MOMENT	X	GPUN01MX	Load cell, six axis neck	R. A. Denton	1716A	Nm
55	NECK MOMENT	Y	GPUN01MY	Load cell, six axis neck	R. A. Denton	1716A	Nm
56	NECK MOMENT	Z	GPUN01MZ	Load cell, six axis neck	R. A. Denton	1716A	Nm
57	CHEST , PRIMARY	X	GPAC005	Accel., 1/2 bridge	Endevco	7264-2000	G
58	CHEST , PRIMARY	Y	GPAC011	Accel., 1/2 bridge	Endevco	7264-2000	G
59	CHEST , PRIMARY	Z	GPAC010	Accel., 1/2 bridge	Endevco	7264-2000	G
60	CHEST , REDUNDANT	X	GPAC034	Accel., 1/2 bridge	Endevco	7264-2000	G
61	CHEST , REDUNDANT	Y	GPAC023	Accel., 1/2 bridge	Endevco	7264-2000	G
62	CHEST , REDUNDANT	Z	GPAC020	Accel., 1/2 bridge	Endevco	7264-2000	G
63	CHEST DISPLACEMENT	X	GPCP002	Rotary Pot Chest	Servo	14CBI	MM
64	PELVIS, PRIMARY	X	GPAC025	Accel., 1/2 bridge	Endevco	7264-2000	G
65	PELVIS, PRIMARY	Y	GPAC022	Accel., 1/2 bridge	Endevco	7264-2000	G
66	PELVIS, PRIMARY	Z	GPAC019	Accel., 1/2 bridge	Endevco	7264-2000	G
67	LEFT FEMUR FORCE	Z	KEFF003	Load cell, Femur	R.A. Denton	2121	N
68	RIGHT FEMUR FORCE	Z	KEFF004	Load cell, Femur	R.A. Denton	2121	N

D-3

KAR20002-02

**2000 NHTSA 40% Offset
Instrumentation Data Channel Assignments
Driver A.T.D Serial Number 35
7/15/00
2000 Ford Expedition 4WD 4 Door SUV**

CH.	LOCATION	AXIS	IDENT. NO.	DESCRIPTION	MFR	MODEL	UNITS
69	UP. TIBIA LEFT MOM.	X	GPUT09MX	2 ch., Upper tibia gage	R. A. Denton	1583	Nm
70	UP. TIBIA LEFT MOM.	Y	GPUT09MY	2 ch., Upper tibia gage	R. A. Denton	1583	Nm
71	UP. TIBIA RIGHT MOM.	X	GPUT09MX	2 ch., Upper tibia gage	R. A. Denton	1583	Nm
72	UP. TIBIA RIGHT MOM.	Y	GPUT09MY	2 ch., Upper tibia gage	R. A. Denton	1583	Nm
73	LWR. TIBIA LEFT MOM.	X	GPLT09MX	3 ch., lower tibia gage	R. A. Denton	3093	Nm
74	LWR. TIBIA LEFT MOM.	Y	GPLT09MY	3 ch., lower tibia gage	R. A. Denton	3093	Nm
75	LWR. TIBIA LEFT FORCE	Z	GPLT09FZ	3 ch., lower tibia gage	R. A. Denton	3093	N
76	LWR. TIBIA RIGHT MOM.	X	GPLT09MX	3 ch., lower tibia gage	R. A. Denton	3093	Nm
77	LWR. TIBIA RIGHT MOM.	Y	GPLT09MY	3 ch., lower tibia gage	R. A. Denton	3093	Nm
78	LWR. TIBIA RIGHT FORCE	Z	GPLT09FZ	3 ch., lower tibia gage	R. A. Denton	3093	N
79	FOOT LEFT	X	KEIC002X	Accel., Foot Triax	I.C. Sensor	3031-500	G
80	FOOT LEFT	Y	KEIC002Y	Accel., Foot Triax	I.C. Sensor	3031-500	G
81	FOOT LEFT	Z	KEIC002Z	Accel., Foot Triax	I.C. Sensor	3031-500	G
82	FOOT RIGHT	X	KEIC001X	Accel., Foot Triax	I.C. Sensor	3031-500	G
83	FOOT RIGHT	Y	KEIC001Y	Accel., Foot Triax	I.C. Sensor	3031-500	G
84	FOOT RIGHT	Z	KEIC001Z	Accel., Foot Triax	I.C. Sensor	3031-500	G
85	LAP BELT FORCE	X	KELC003	Load cell, Seat belt	Lebow	3371	N
86	SHOULDER BELT FORCE	X	KELC004	Load cell, Seat belt	Lebow	3371	N
87	SHOULDER BELT SPOOL	X	KEPP001	Pullout pot	Celesco	PTX101-0030	CM
88	SHOULDER BELT ELONG.	X	KEEP001	Linear pot., belt stretch	E.T.I.	LCP8-10 10K	MM/CM

D-4

KAR20002-02

**2000 NHTSA 40% Offset
Instrumentation Data Channel Assignments
Vehicle Accelerometers and Reference Channel
7/15/00
2000 Ford Expedition 4WD 4 Door SUV**

CH.	LOCATION	AXIS	IDENT. NO.	DESCRIPTION	MFR	MODEL	UNITS
89	Left Sill	X	KEVA002	Accel., Pre-Amp	I.C.S/Karco	3031-500	G
90	Left Sill	Y	KEVA006	Accel., Vehicle block	I.C. Sensor	3031-200	G
91	Center Tunnel	X	KEVA003	Accel., Vehicle block	I.C. Sensor	3031-500	G
92	Center Tunnel	Y	KEVA008	Accel., Vehicle block	I.C. Sensor	3031-500	G
93	Right Sill	X	KEVA011	Accel., Vehicle block	I.C. Sensor	3031-200	G
94	Right Sill	Y	KEVA010	Accel., Vehicle block	I.C. Sensor	3031-200	G
95	Trunk	X	KEVA007	Accel., Vehicle block	I.C. Sensor	3031-500	G
96	Trunk	Y	KEVA001	Accel., Vehicle block	I.C. Sensor	3031-500	G
97	ZERO REFERENCE	N/A	N/A	N/A	N/A	N/A	N/A

D-5

KAR20002-02

APPENDIX E
DUMMY CALIBRATION DATA



Hybrid III Calibration Data Sheet

50TH Percentile Male

Left Knee Impact Test

ATD Serial No.: 034

Part Serial No.: N/A

Test I.D.: LK06A

Tested Parameter	Units	Specification	Result	Pass/Fail
Laboratory Temperature	°C	18.9 to 25.5	21.1	Pass
Laboratory Relative Humidity	%	10 to 70	30	Pass
Probe Velocity	m/s	2.073 to 2.134	2.115	Pass
Peak Probe Force	Newtons	4715 to 5782	5343.1	Pass
Overall Test Results				Pass

Laboratory Technician

June 22, 2000

Test Date

Approved By

Date

E-2

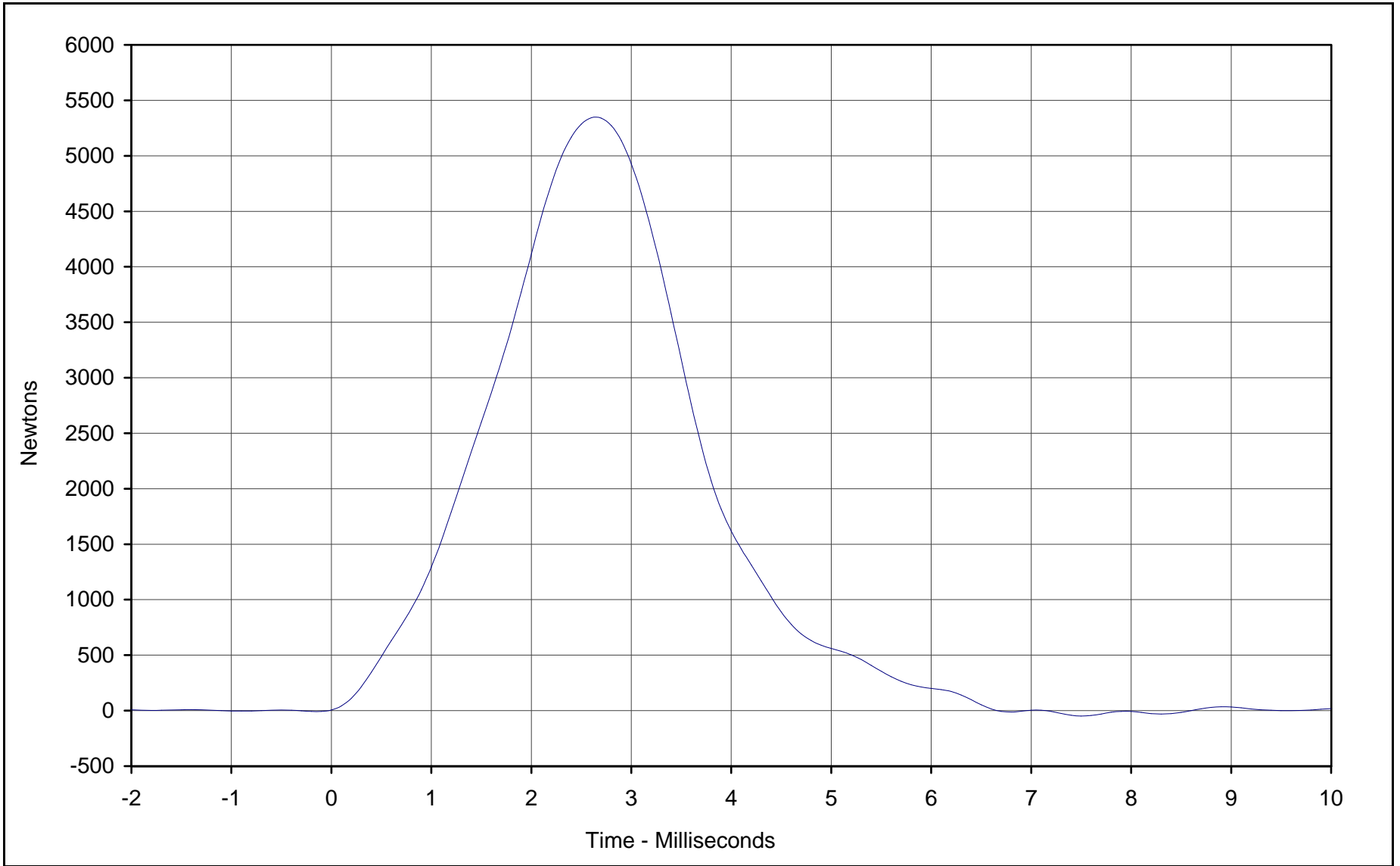

Curve Description: Probe Force
Maximum Value: 5343.1 at 2.6 Milliseconds
Minimum Value: -48.5 at 7.5 Milliseconds
SAE Filter Class: 600
Date of Test: 6/22/00
ATD Serial No.: 034

Testing Program: Hybrid III Left Knee Impact Test
Test Information: Part S/N: N/A Test I.D.: LK06A



KAR20002-02



Hybrid III Calibration Data Sheet

50TH Percentile Male

Right Knee Impact Test

ATD Serial No.: 034

Part Serial No.: N/A

Test I.D.: RK06A

Tested Parameter	Units	Specification	Result	Pass/Fail
Laboratory Temperature	°C	18.9 to 25.5	21.1	Pass
Laboratory Relative Humidity	%	10 to 70	30	Pass
Probe Velocity	m/s	2.073 to 2.134	2.113	Pass
Peak Probe Force	Newtons	4715 to 5782	5324.2	Pass
Overall Test Results				Pass

Laboratory Technician

June 22, 2000

Test Date

Approved By

Date

E-4

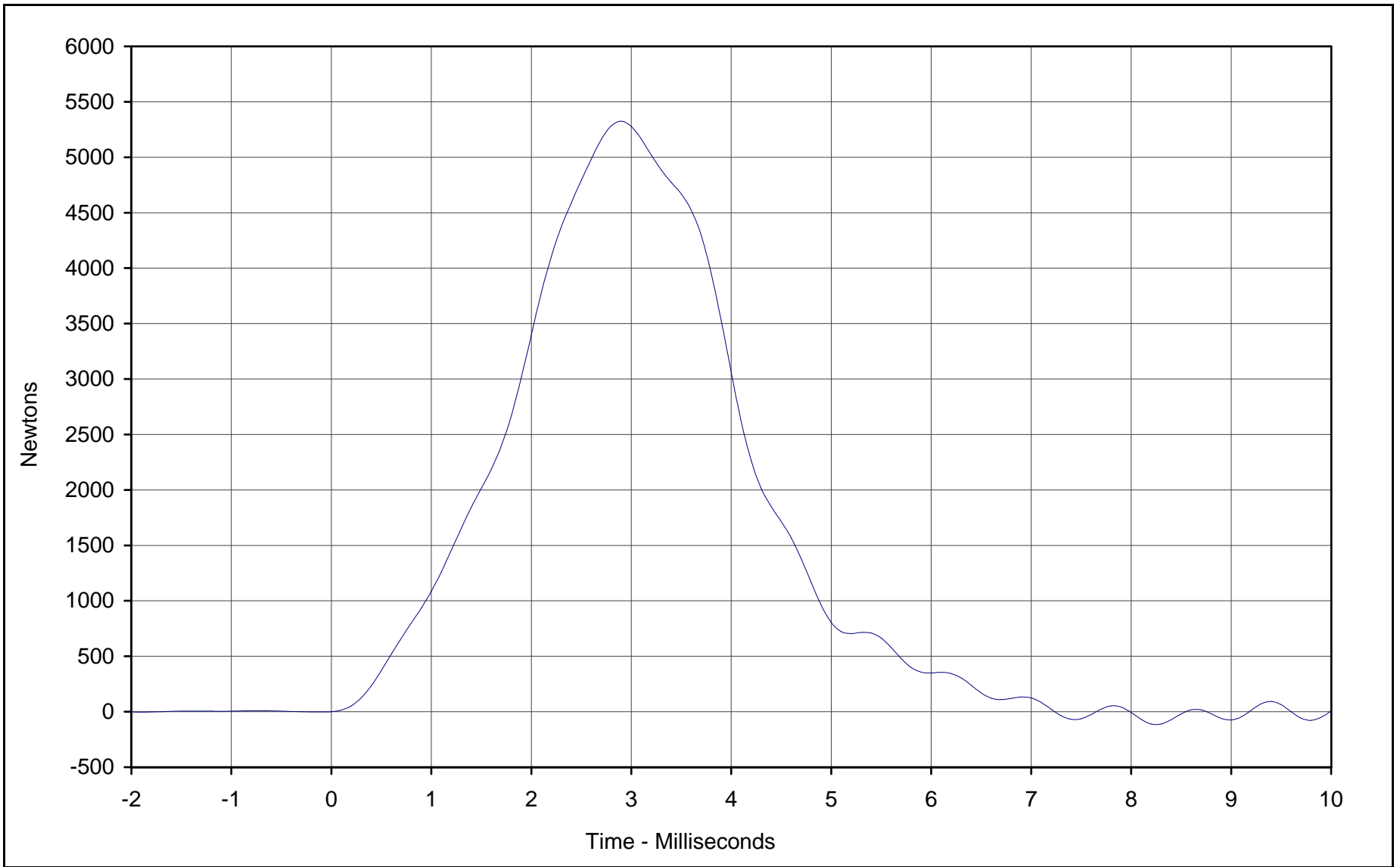

Curve Description: Probe Force
Maximum Value: 5324.2 at 2.9 Milliseconds
Minimum Value: -69.5 at 7.4 Milliseconds
SAE Filter Class: 600
Date of Test: 6/22/00
ATD Serial No.: 034

Testing Program: Hybrid III Right Knee Impact Test
Test Information: Part S/N: N/A Test I.D.: RK06A



KAR20002-02



Hybrid III Calibration Data Sheet

50TH Percentile Male

Head Drop Calibration

ATD Serial No.: 034

Part Serial No.: N/A

Test I.D.: HD06B

Tested Parameter	Units	Specification	Result	Pass/Fail
Laboratory Temperature	°C	18.9 to 25.6	21.1	Pass
Laboratory Relative Humidity	%	10 to 70	39	Pass
Peak Resultant Acceleration	G's	225.0 to 275.0	251.5	Pass
Peak Lateral Acceleration	G's	≤15.0	11.7	Pass
Is Acceleration Unimodal?	Yes/No	Yes	Yes	Pass
Overall Test Results				Pass

Laboratory Technician

June 23, 2000

Test Date

Approved By

Date

E-6

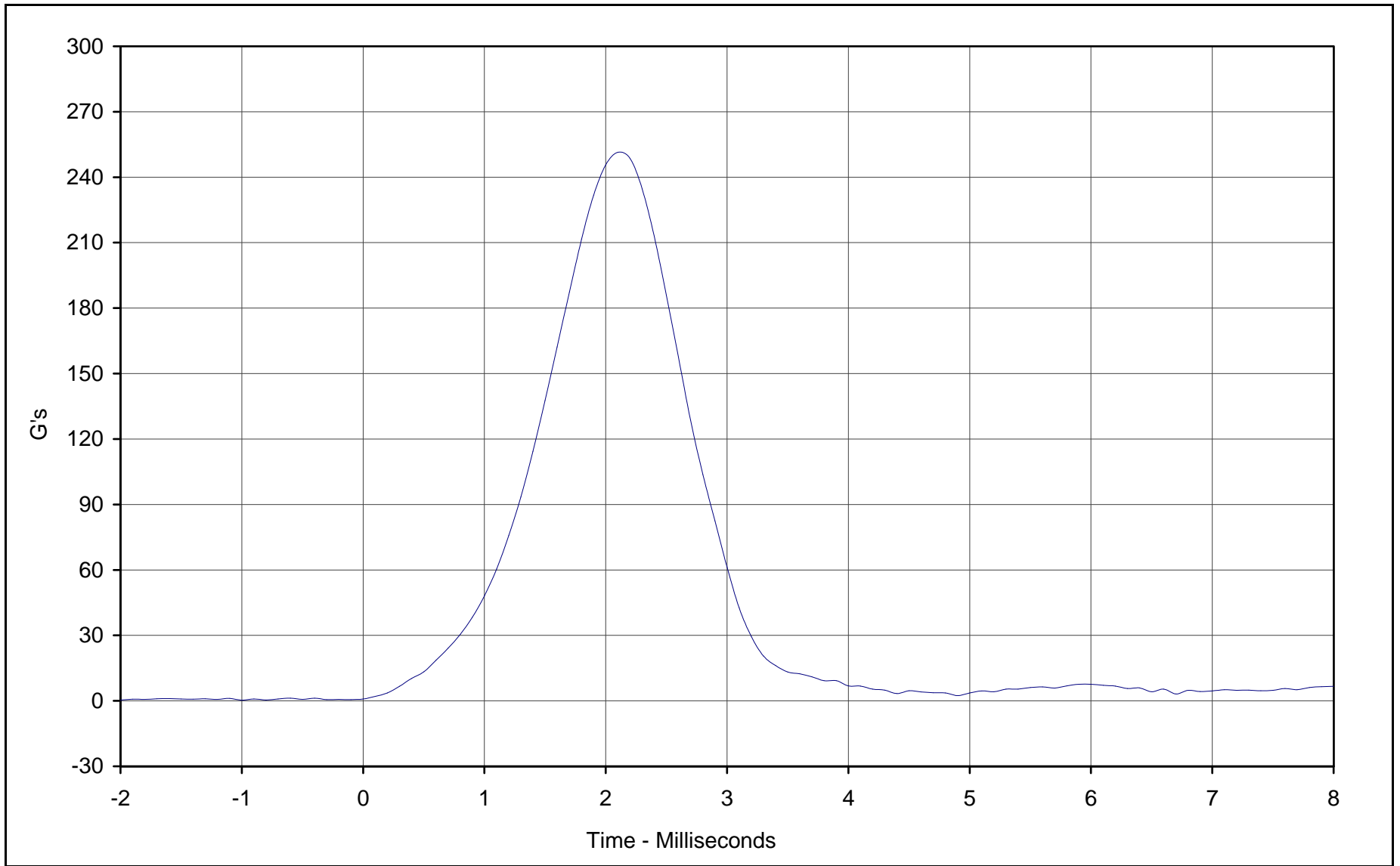

Curve Description: Head Resultant Acceleration

Maximum Value: 251.5 at 2.1 Milliseconds

Minimum Value: 0.3 at -1.0 Milliseconds

SAE Filter Class: 1000

Date of Test: 6/23/00

ATD Serial No.: 034

Testing Program: Hybrid III Head Drop Calibration (Male)

Test Information: S/N of Part: N/A Test I.D.: HD06B



KARR20002-02

E-7

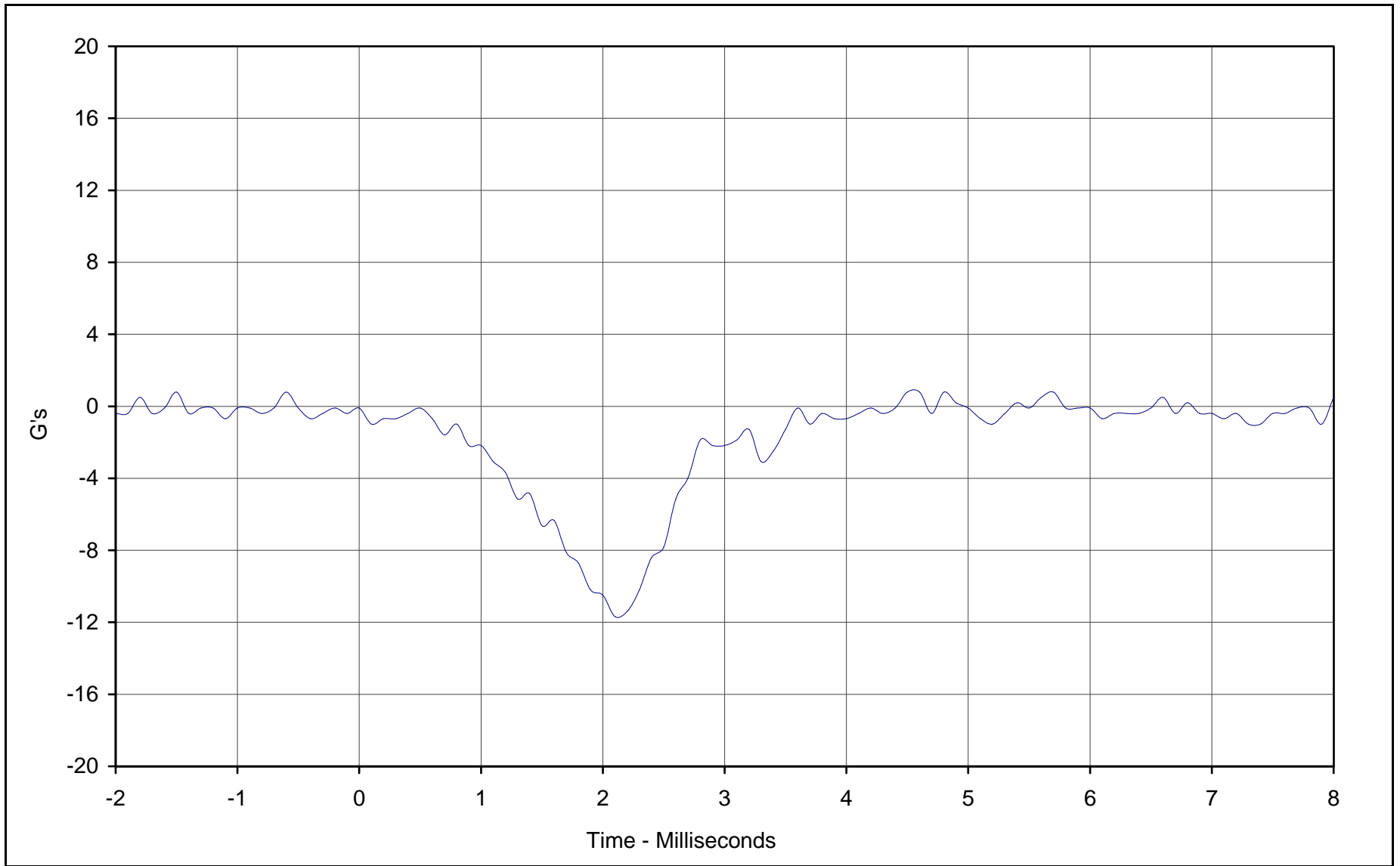

Curve Description: Head Acceleration Y Axis

Maximum Value: 0.8 at -1.5 Milliseconds

Minimum Value: -11.7 at 2.1 Milliseconds

SAE Filter Class: 1000

Date of Test: 6/23/00

ATD Serial No.: 034

Testing Program: Hybrid III Head Drop Calibration (Male)

Test Information: S/N of Part: N/A Test I.D.: HD06B



KAR20002-02



Hybrid III Calibration Data Sheet

50TH Percentile Male

Thorax Impact Test

ATD Serial No.: 034

Part Serial No.: N/A

Test I.D.: CH06C

Tested Parameter	Units	Specification	Result	Pass/Fail
Laboratory Temperature	°C	20.6 to 22.2	21.2	Pass
Laboratory Relative Humidity	%	10 to 70	39	Pass
Probe Velocity	m/s	6.58 to 6.82	6.61	Pass
Peak Probe Force	Newtons	5159 to 5893	5262	Pass
Peak Sternum Displacement	CM	6.35 to 7.26	7.08	Pass
Internal Hysteresis	%	69 to 85	73.3	Pass
Overall Test Results				Pass

Laboratory Technician

June 27, 2000

Test Date

Approved By

Date

E-9

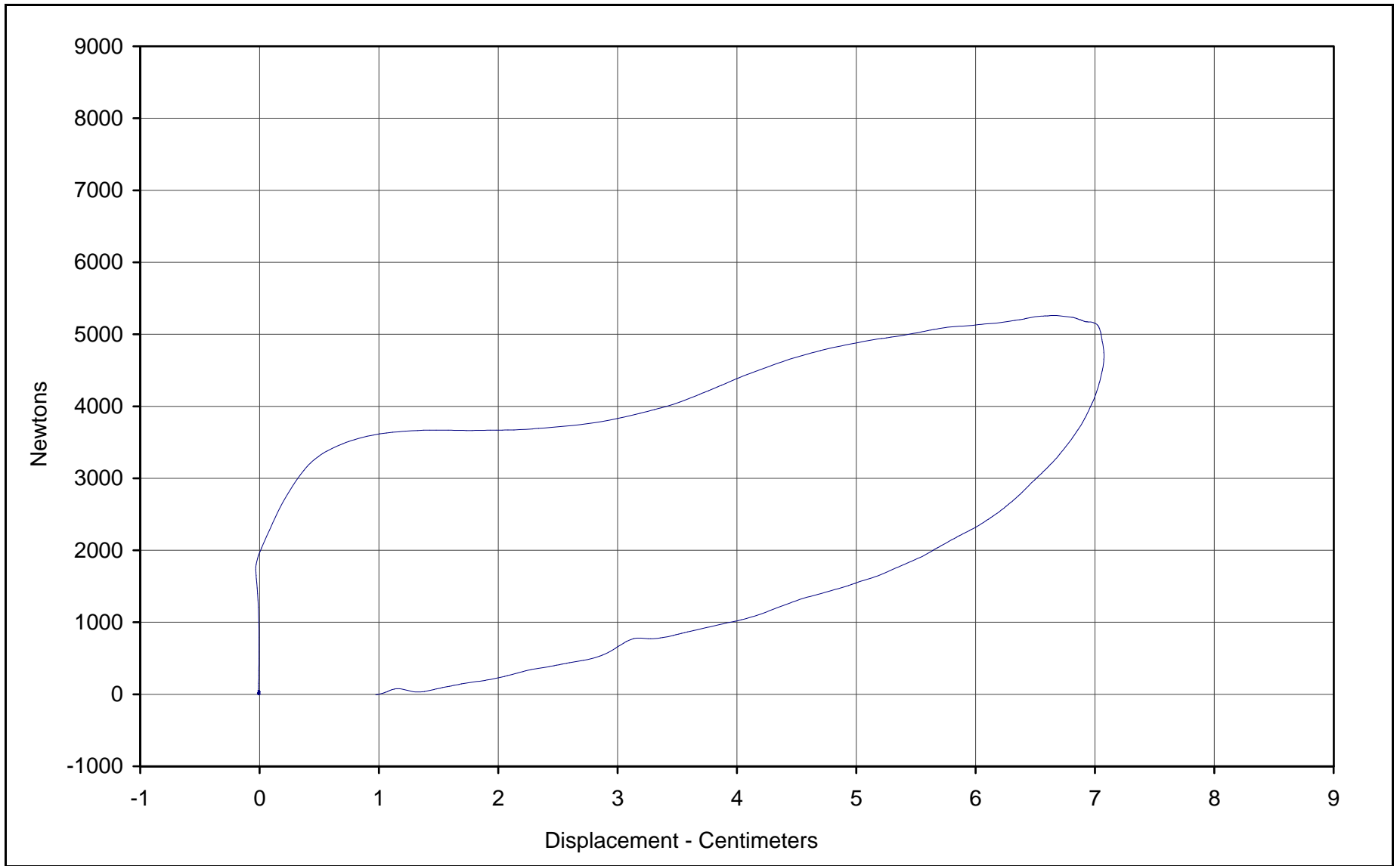

Curve Description: Probe Force vs. Chest Displacement

Testing Program: Hybrid III Thorax Impact Test

Probe Force: 5261.6 Newtons

Test Information: S/N of Part: N/A Test I.D.: CH06C

Chest Displ.: 7.08 Centimeters

SAE Filter Class: 180

Date of Test: 6/27/00

ATD Serial No.: 034



KAR20002-02



Hybrid III Calibration Data Sheet

50TH Percentile Male

Neck Flexion Test

ATD Serial No.: 034

Part Serial No.: N/A

Test I.D.: NF06C

Tested Parameter	Units	Specification	Result	Pass/Fail	
Laboratory Temperature	°C	20.6 to 22.2	21.7	Pass	
Laboratory Relative Humidity	%	10 to 70	31	Pass	
Pendulum Velocity	m/s	6.89 to 7.13	6.90	Pass	
Pendulum Deceleration	10 Msec.	G's	22.5 to 27.5	23.0	Pass
	20 Msec.	G's	17.6 to 22.6	20.0	Pass
	30 Msec.	G's	12.5 to 18.5	17.9	Pass
Peak Pendulum Decel. after 30 Msec.	G's	≤ 29.0	17.9	Pass	
Deceleration Decay, Time to Cross 5 G's	Msec.	34.0 to 42.0	36.9	Pass	
Maximum "D" Plane Rotation	Maximum	Degrees	64.0 to 78.0	64.9	Pass
	Time	Msec.	57.0 to 64.0	57.4	Pass
"D" Plane Rotation Decay, Time To Zero Crossing	Msec.	113.0 to 128.0	113.1	Pass	
Moment About Occipital Condyle	Maximum	N·m	84.1 to 108.5	88.7	Pass
	Time	Msec.	47.0 to 58.0	54.1	Pass
Positive Moment Decay, Time To Zero Crossing	Msec.	97.0 to 107.0	97.0	Pass	
Overall Test Results				Pass	

Laboratory Technician

June 23, 2000

Test Date

Approved By

Date

E-11

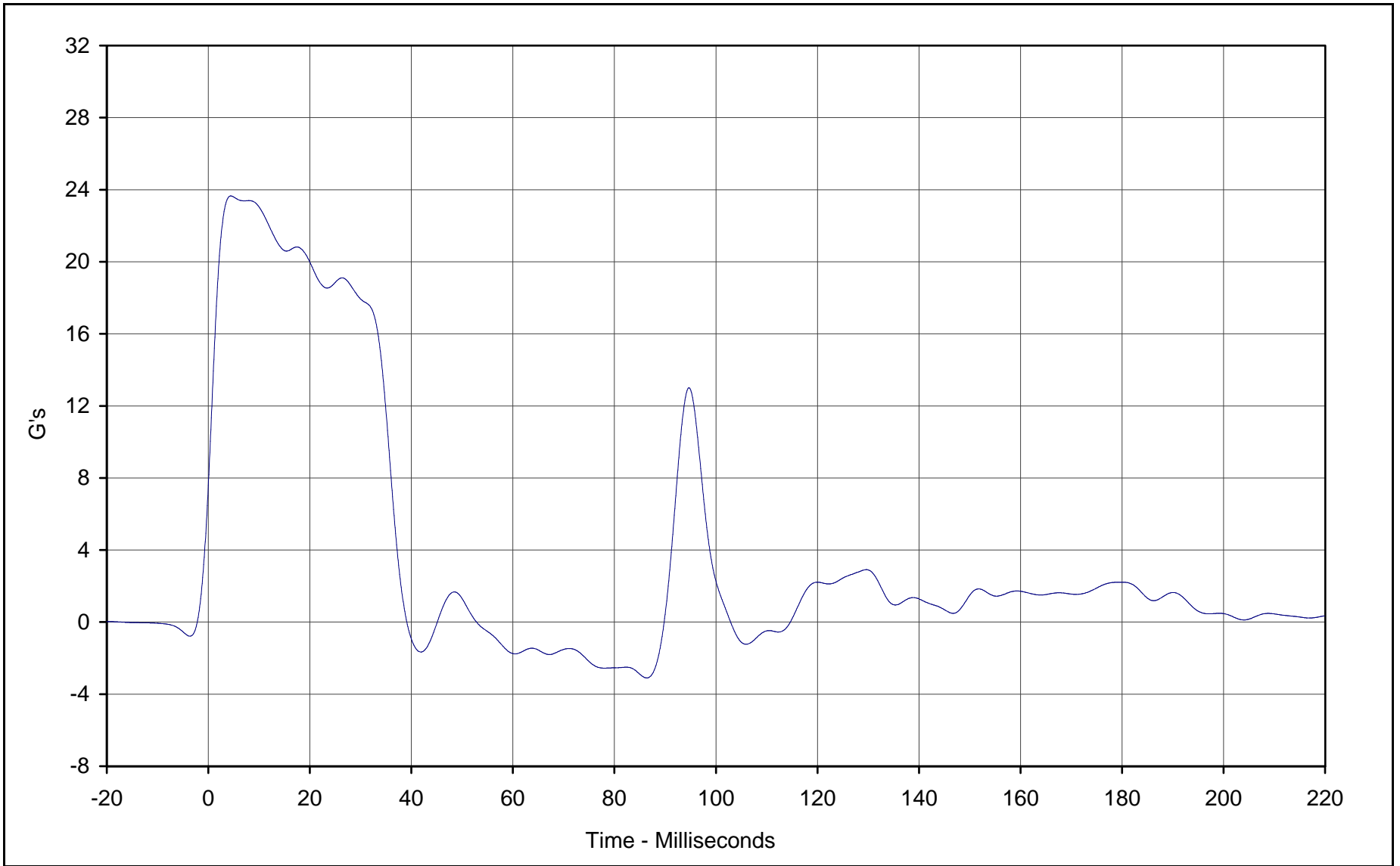

Curve Description: Pendulum Deceleration
Maximum Value: 23.7 at 4.4 Milliseconds
Minimum Value: -3.1 at 86.4 Milliseconds
SAE Filter Class: 60
Date of Test: 6/23/00
ATD Serial No.: 034

Testing Program: Hybrid III Neck Flexion Test (Male)
Test Information: S/N of Part: N/A Test I.D.: NF06C



KAR20002-02

E-12

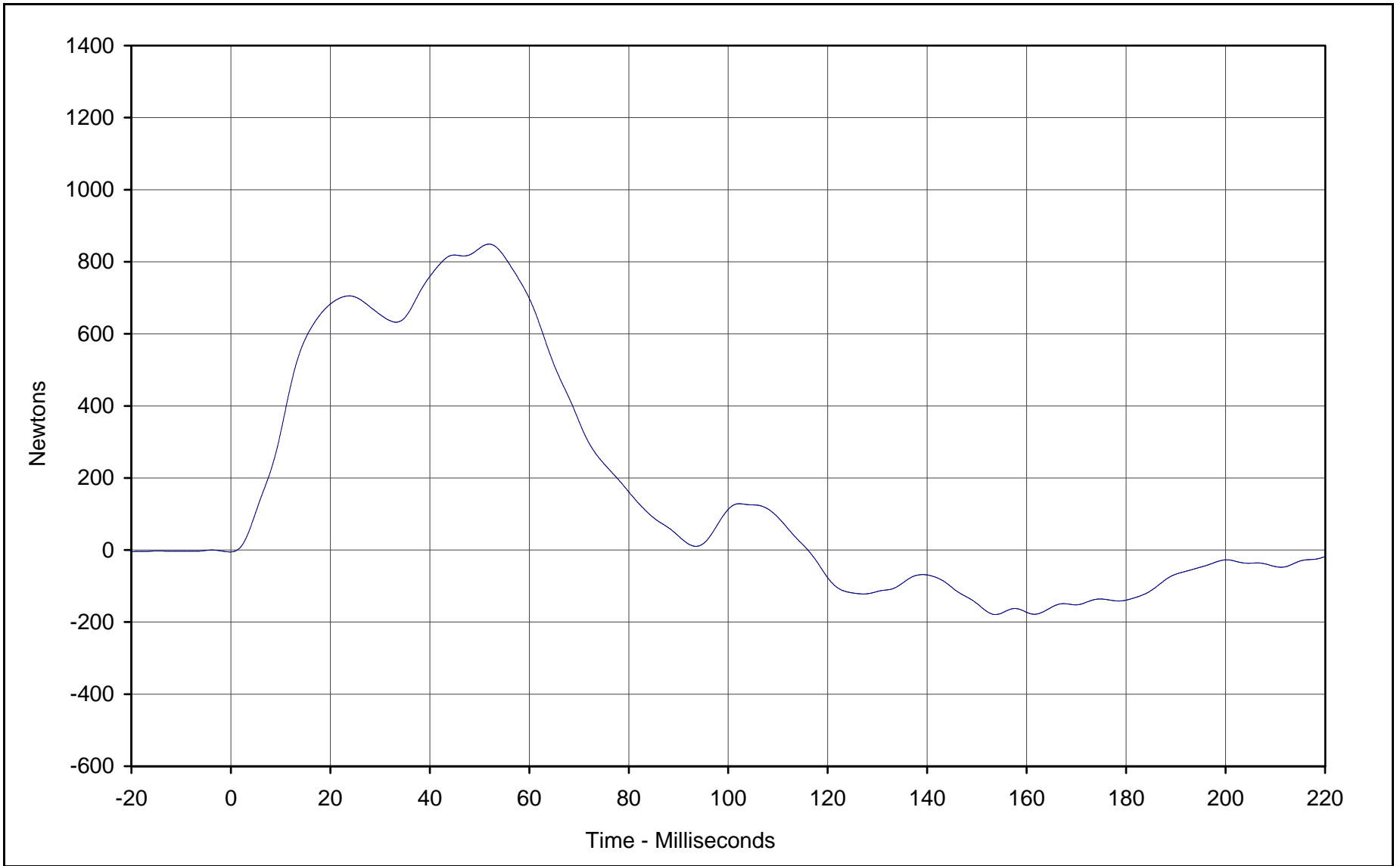

Curve Description: Neck Force X
Maximum Value: 848.9 at 51.9 Milliseconds
Minimum Value: -179.1 at 153.7 Milliseconds
SAE Filter Class: 60
Date of Test: 6/23/00
ATD Serial No.: 034

Testing Program: Hybrid III Neck Flexion Test (Male)
Test Information: S/N of Part: N/A Test I.D.: NF06C



KARR20002-02

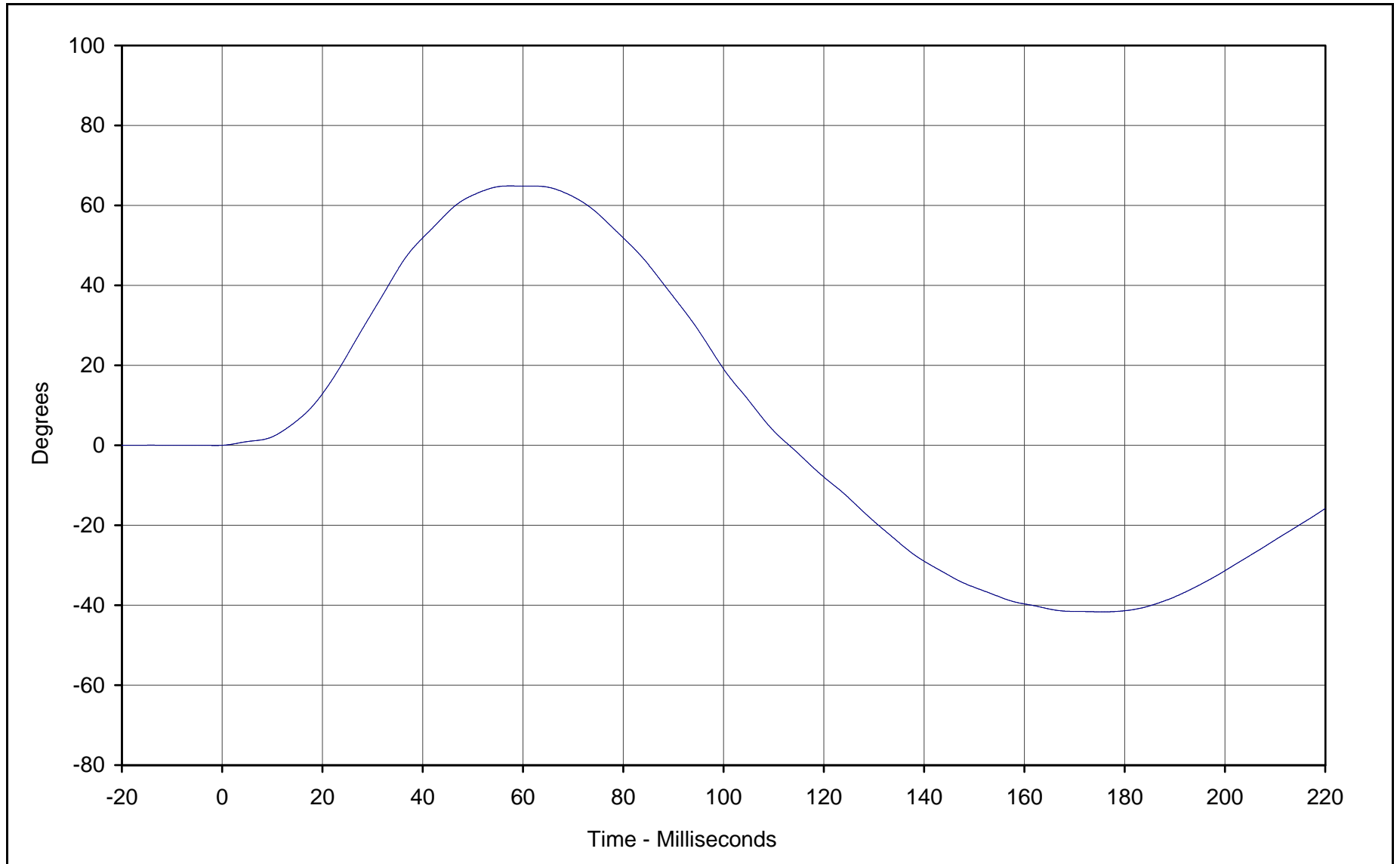

Curve Description: "D" Plane Rotation

Maximum Value: 64.9 at 57.4 Milliseconds

Minimum Value: -41.7 at 175.7 Milliseconds

SAE Filter Class: 60

Date of Test: 6/23/00

ATD Serial No.: 034

Testing Program: Hybrid III Neck Flexion Test (Male)

Test Information: S/N of Part: N/A Test I.D.: NF06C



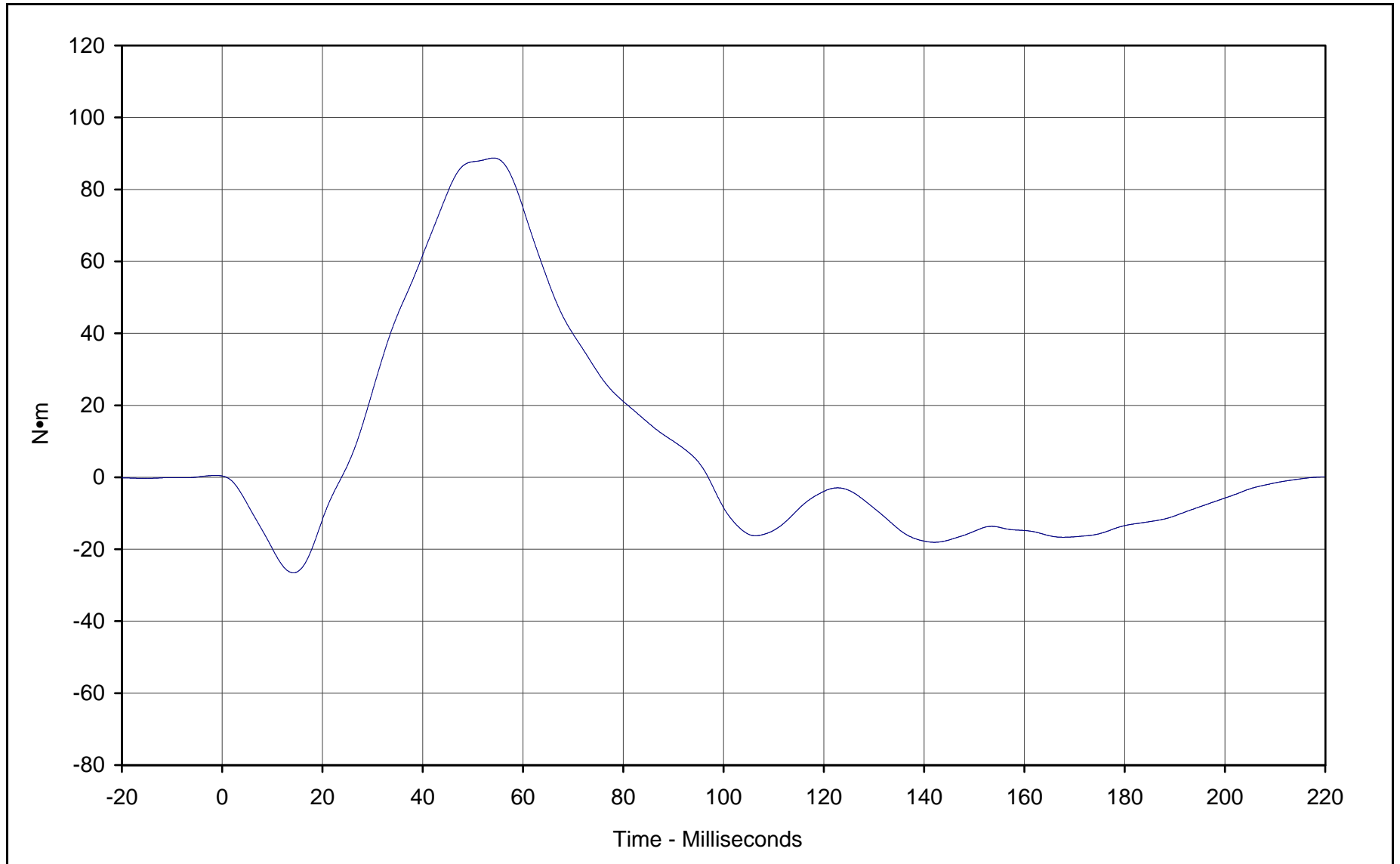

Curve Description: Moment About Occipital Condyles
 Maximum Value: 88.7 at 54.1 Milliseconds
 Minimum Value: -26.6 at 14.2 Milliseconds
 SAE Filter Class: 60
 Date of Test: 6/23/00
 ATD Serial No.: 034

Testing Program: Hybrid III Neck Flexion Test (Male)

Test Information: S/N of Part: N/A Test I.D.: NF06C





Hybrid III Calibration Data Sheet

50TH Percentile Male

Neck Extension Test

ATD Serial No.: 034

Part Serial No.: N/A

Test I.D.: NE06B

Tested Parameter	Units	Specification	Result	Pass/Fail	
Laboratory Temperature	°C	20.6 to 22.2	21.1	Pass	
Laboratory Relative Humidity	%	10 to 70	31	Pass	
Pendulum Velocity	m/s	5.95 to 6.19	6.01	Pass	
Pendulum Deceleration	10 Msec.	G's	17.2 to 21.2	17.8	Pass
	20 Msec.	G's	14.0 to 19.0	18.1	Pass
	30 Msec.	G's	11.0 to 16.0	15.4	Pass
Peak Pendulum Decel. after 30 Msec.	G's	≤ 22.0	15.4	Pass	
Deceleration Decay, Time to Cross 5 G's	Msec.	38.0 to 46.0	43.0	Pass	
Maximum "D" Plane Rotation	Maximum	Degrees	81.0 to 106.0	93.3	Pass
	Time	Msec.	72.0 to 82.0	81.8	Pass
"D" Plane Rotation Decay, Time To Zero Crossing	Msec.	147.0 to 174.0	162.4	Pass	
Moment About Occipital Condyle	Maximum	N·m	-52.9 to- 79.9	-67.5	Pass
	Time	Msec.	65.0 to 79.0	72.5	Pass
Negative Moment Decay, Time To Zero Crossing	Msec.	120.0 to 148.0	140.1	Pass	
Overall Test Results				Pass	

Laboratory Technician

June 23, 2000

Test Date

Approved By

Date

E-16

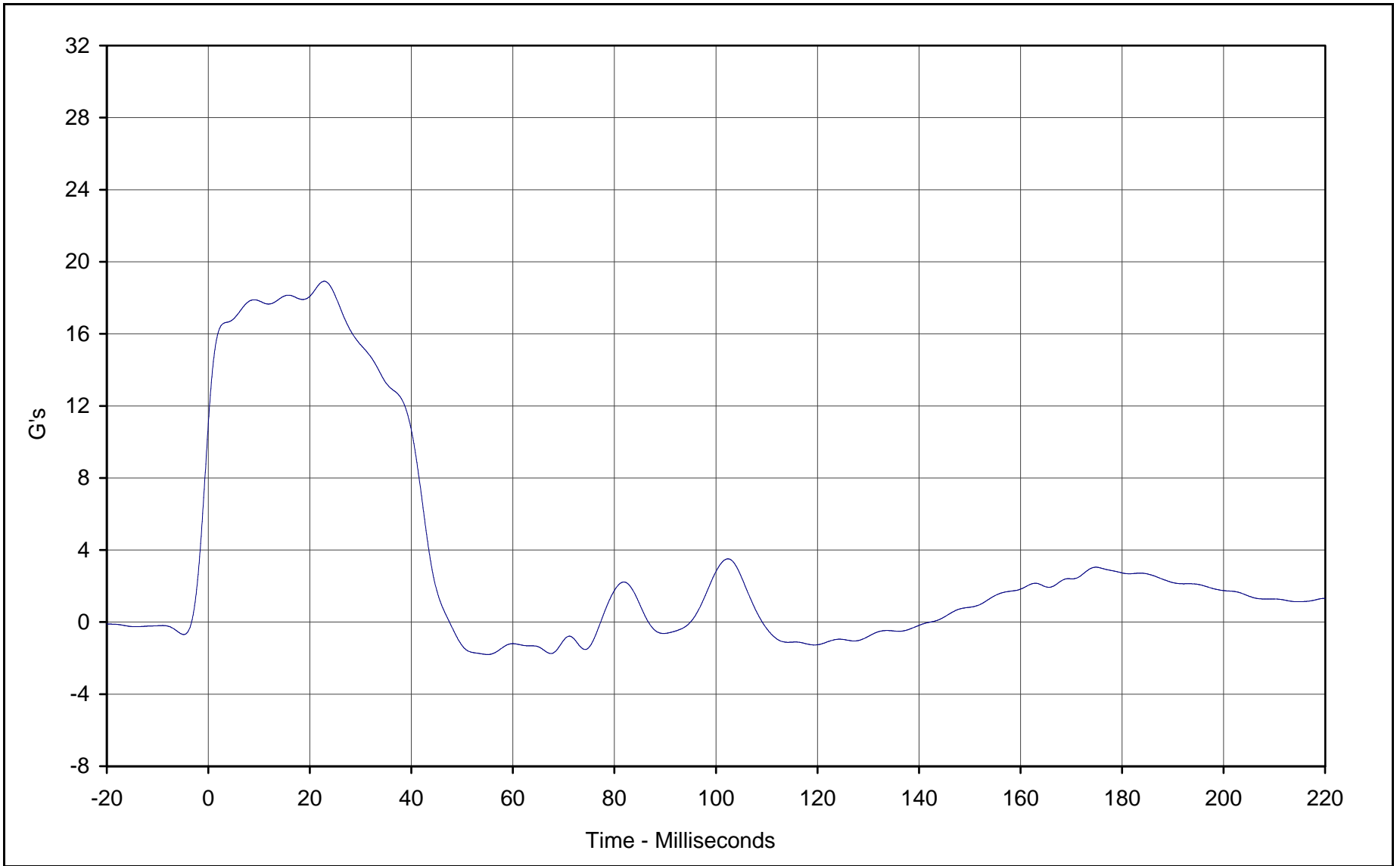

Curve Description: Pendulum Deceleration
Maximum Value: 18.9 at 22.9 Milliseconds
Minimum Value: -1.8 at 55.0 Milliseconds
SAE Filter Class: 60
Date of Test: 6/23/00
ATD Serial No.: 034

Testing Program: Hybrid III Neck Extension Test (Male)
Test Information: S/N of Part: N/A Test I.D.: NE06B



KAR20002-02

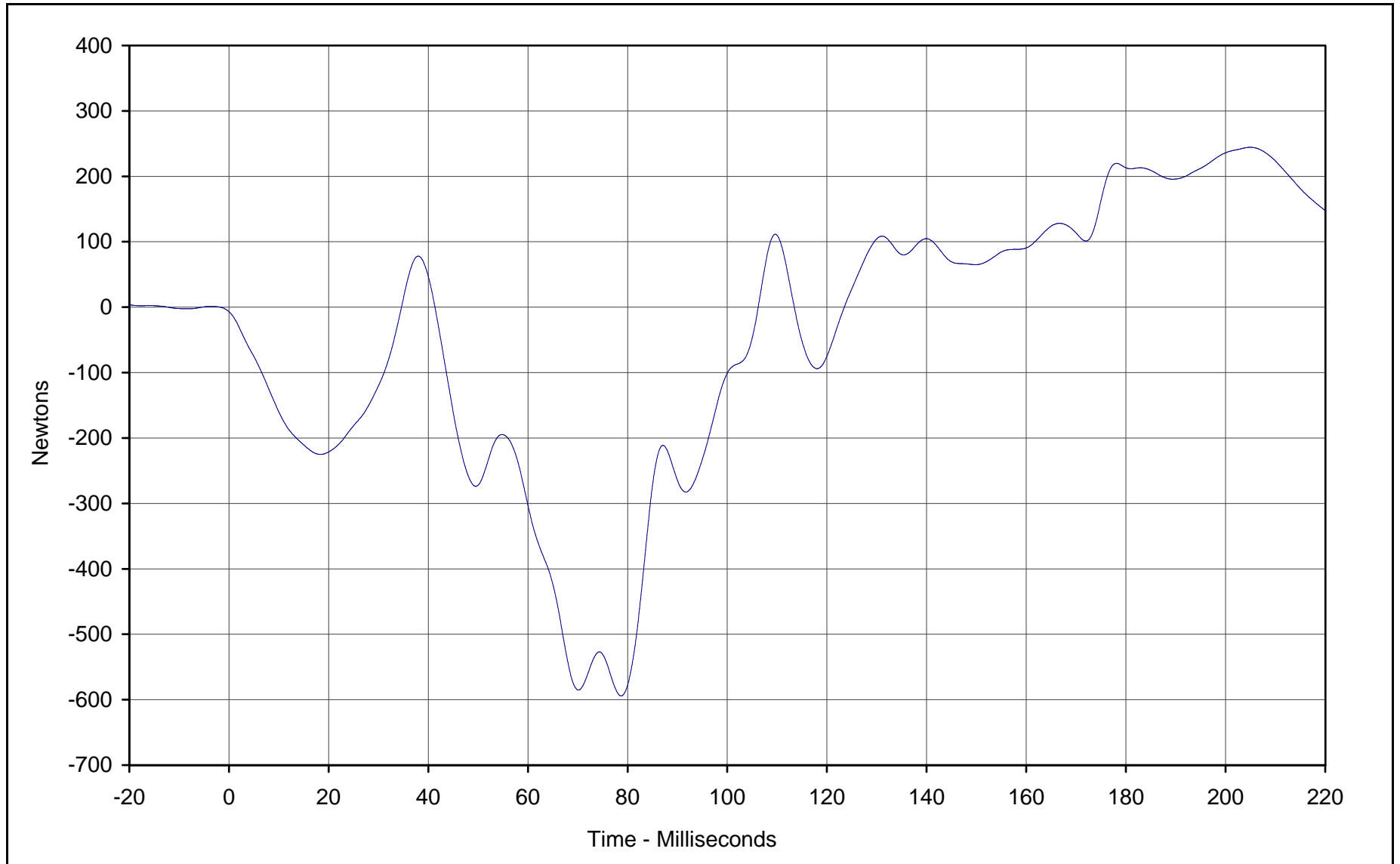

Curve Description: Neck Force X

Maximum Value: 244.4 at 205.0 Milliseconds

Minimum Value: -594.2 at 78.7 Milliseconds

SAE Filter Class: 60

Date of Test: 6/23/00

ATD Serial No.: 034

Testing Program: Hybrid III Neck Extension Test (Male)

Test Information: S/N of Part: N/A Test I.D.: NE06B



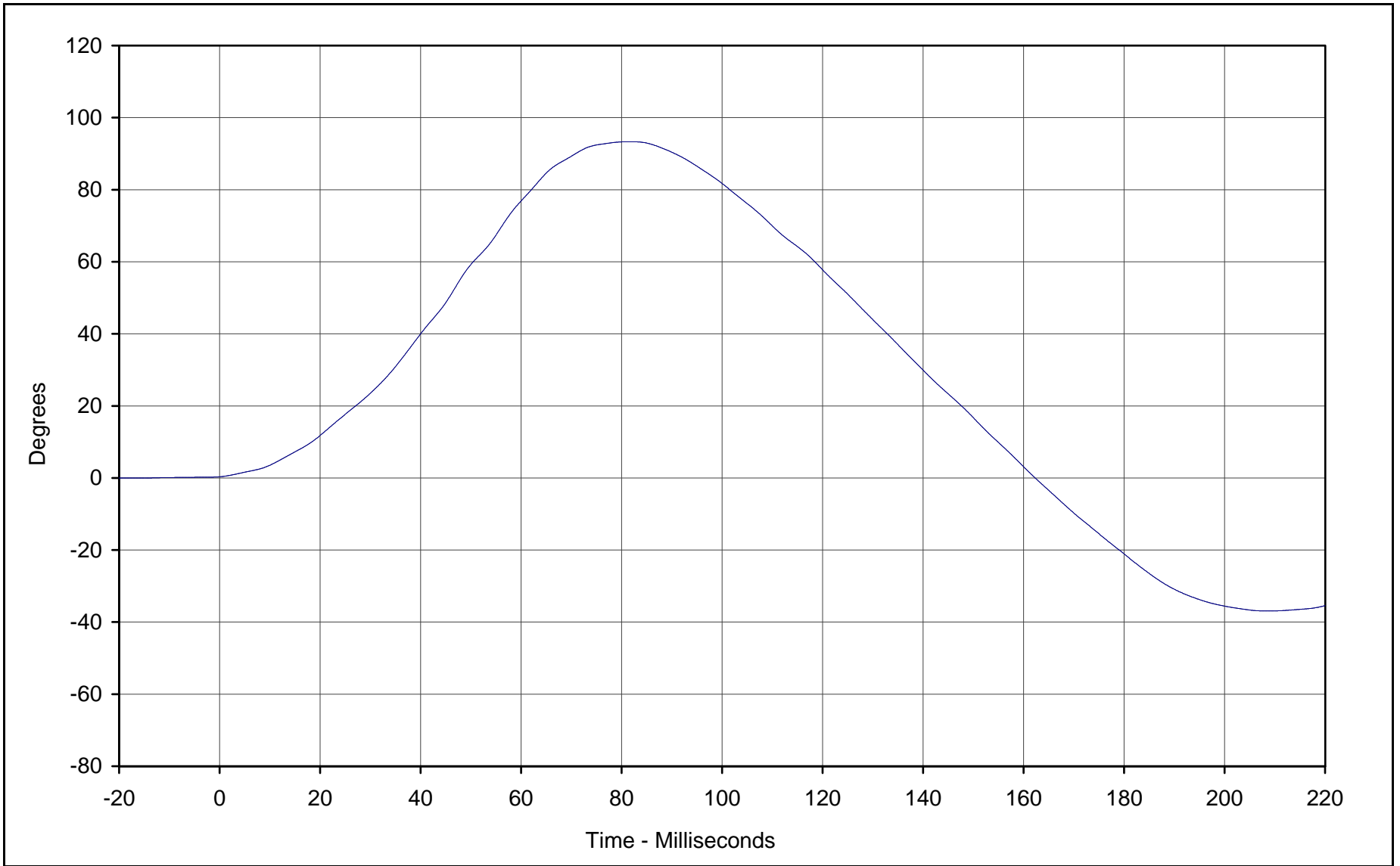

Curve Description: "D" Plane Rotation
Maximum Value: 93.3 at 81.8 Milliseconds
Minimum Value: -36.9 at 208.6 Milliseconds
SAE Filter Class: 60
Date of Test: 6/23/00
ATD Serial No.: 034

Testing Program: Hybrid III Neck Extension Test (Male)
Test Information: S/N of Part: N/A Test I.D.: NE06B



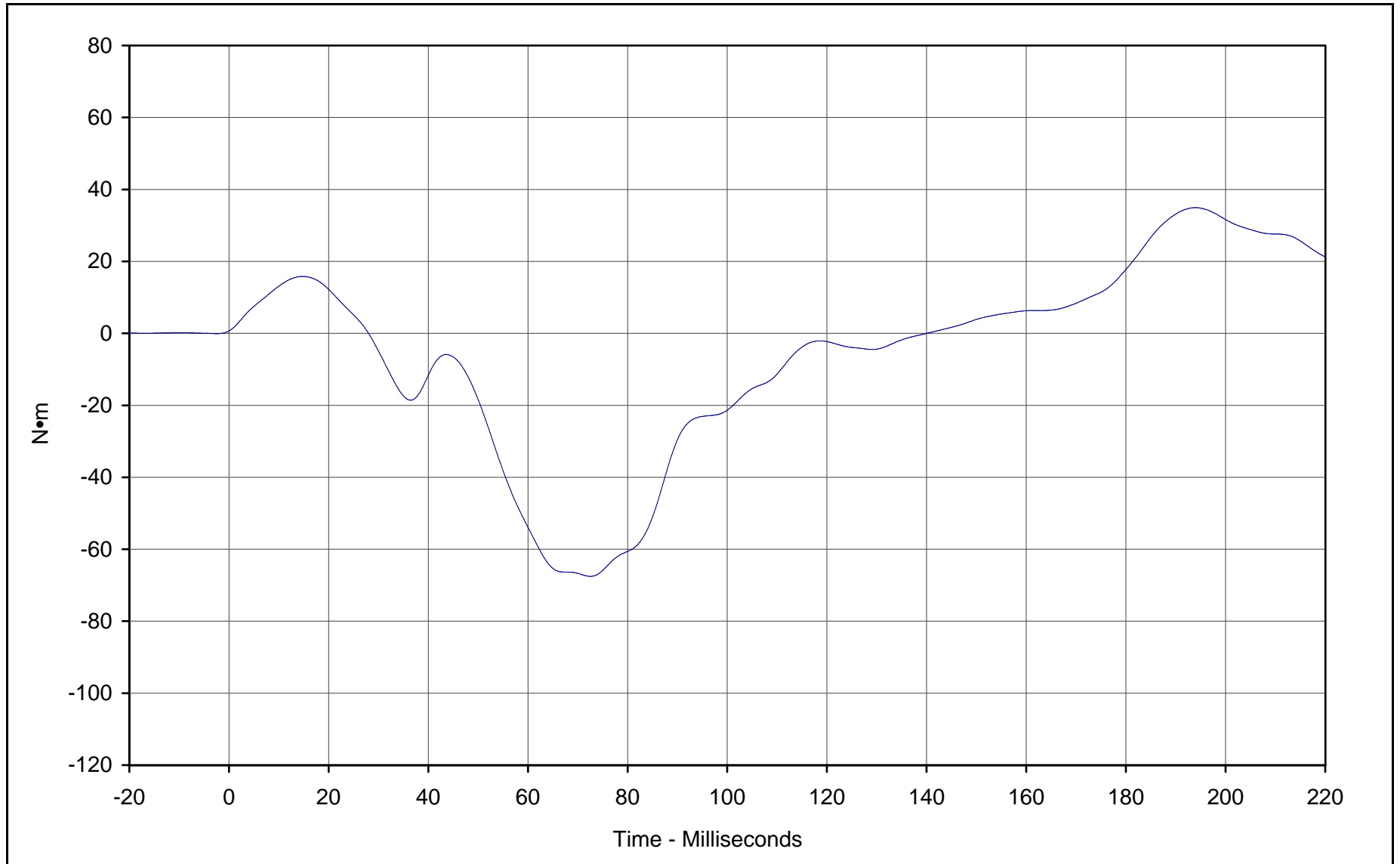

Curve Description: Moment About Occipital Condyles
 Maximum Value: 34.9 at 193.9 Milliseconds
 Minimum Value: -67.5 at 72.5 Milliseconds
 SAE Filter Class: 60
 Date of Test: 6/23/00
 ATD Serial No.: 034

Testing Program: Hybrid III Neck Extension Test (Male)

Test Information: S/N of Part: N/A Test I.D.: NE06B





Hybrid III Calibration Data Sheet

50TH Percentile Male

External Measurements

ATD Serial No.: 034

Part Serial No.: N/A

Test I.D.: N/A

External Measurement Data				
Tested Parameter	Units	Specification	Result	Pass/Fail
Laboratory temperature	°C	20.4 to 22.1	20.9	Pass
Laboratory relative humidity	%	10 to 70	43	Pass
A - Total sitting height	mm	879 to 889	885	Pass
B - Shoulder pivot height	mm	505 to 521	510	Pass
C - "H" point height	mm	84 to 89	85	Pass
D - "H" point from seat back	mm	135 to 140	135	Pass
E - Shoulder pivot from back	mm	84 to 94	92	Pass
F - Thigh clearance	mm	140 to 155	150	Pass
G - Elbow back to wrist pivot	mm	290 to 305	295	Pass
H - Skull cap to back line	mm	41 to 46	45	Pass
I - Shoulder to elbow length	mm	330 to 345	340	Pass
J - Elbow rest height	mm	190 to 211	200	Pass
K - Buttock to knee length	mm	579 to 604	590	Pass
L - Popliteal length	mm	429 to 455	435	Pass
M - Knee pivot height	mm	485 to 500	495	Pass
N - Buttock popliteal length	mm	452 to 477	475	Pass
O - Chest depth	mm	213 to 229	220	Pass
P - Foot length	mm	251 to 267	255	Pass
V - Shoulder breadth	mm	422 to 437	435	Pass
W - Foot breadth	mm	91 to 107	100	Pass
Y - Chest circumference	mm	970 to 1001	985	Pass
Z - Waist circumference	mm	836 to 866	855	Pass
AA - Location for chest circumference	mm	429 to 434	430	Pass
BB - Location for waist circumference	mm	226 to 231	229	Pass
Overall Test Results				Pass

Laboratory Technician

June 27, 2000

Test Date

Approved By

Date



Hybrid III Calibration Data Sheet

50TH Percentile Male

Left Knee Impact Test

ATD Serial No.: 035

Part Serial No.: N/A

Test I.D.: LK06C

Tested Parameter	Units	Specification	Result	Pass/Fail
Laboratory Temperature	°C	18.9 to 25.5	21.1	Pass
Laboratory Relative Humidity	%	10 to 70	30	Pass
Probe Velocity	m/s	2.073 to 2.134	2.118	Pass
Peak Probe Force	Newtons	4715 to 5782	5350.5	Pass
Overall Test Results				Pass

Laboratory Technician

June 22, 2000

Test Date

Approved By

Date

E-22

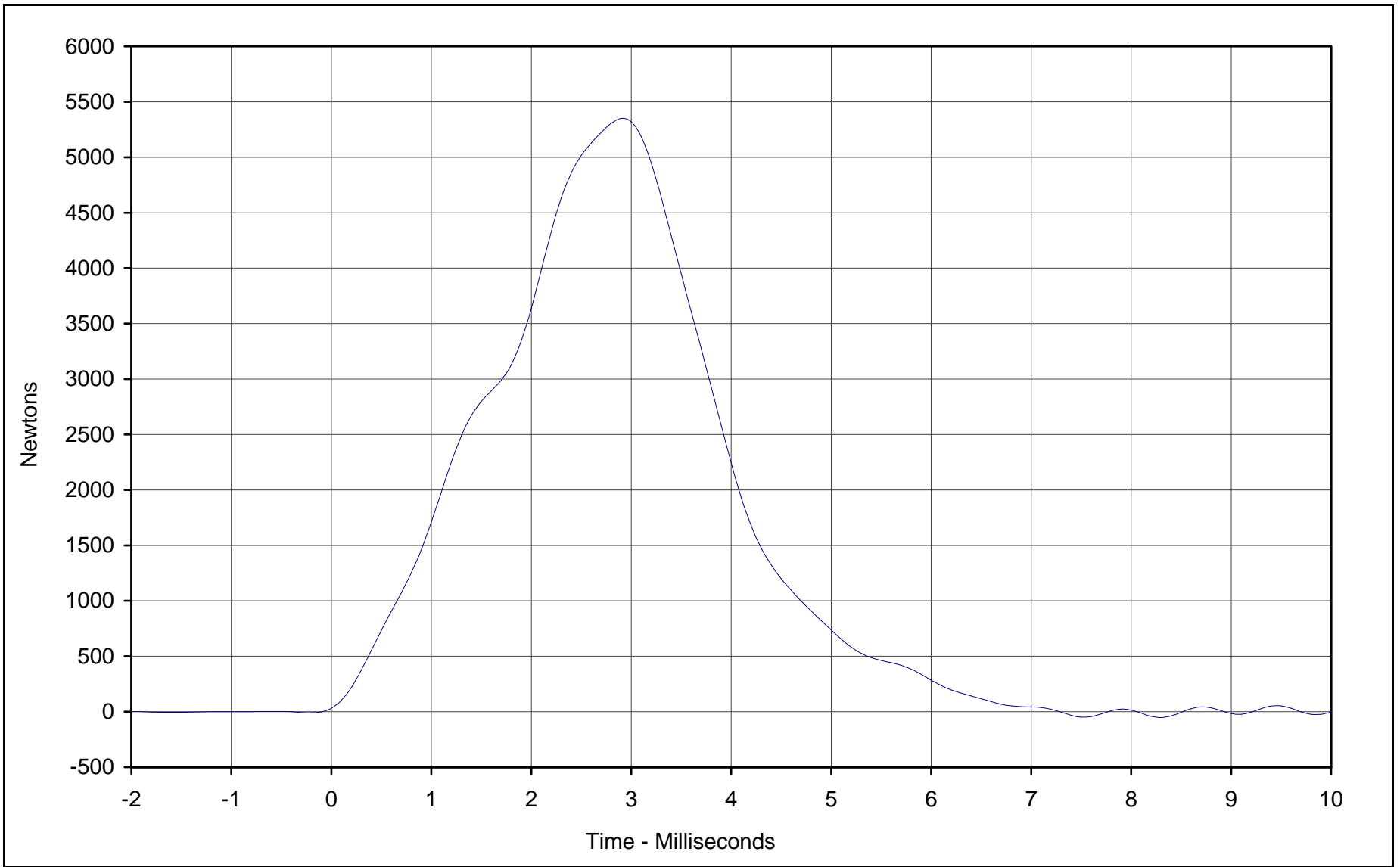

Curve Description: Probe Force
Maximum Value: 5350.5 at 2.9 Milliseconds
Minimum Value: -48.4 at 7.5 Milliseconds
SAE Filter Class: 600
Date of Test: 6/22/00
ATD Serial No.: 035

Testing Program: Hybrid III Left Knee Impact Test
Test Information: Part S/N: N/A Test I.D.: LK06C



KARR20002-02



Hybrid III Calibration Data Sheet

50TH Percentile Male

Right Knee Impact Test

ATD Serial No.: 035

Part Serial No.: N/A

Test I.D.: RK06D

Tested Parameter	Units	Specification	Result	Pass/Fail
Laboratory Temperature	°C	18.9 to 25.5	21.1	Pass
Laboratory Relative Humidity	%	10 to 70	30	Pass
Probe Velocity	m/s	2.073 to 2.134	2.124	Pass
Peak Probe Force	Newtons	4715 to 5782	5315.0	Pass
Overall Test Results				Pass

Laboratory Technician

June 22, 2000
Test Date

Approved By

Date

E-24

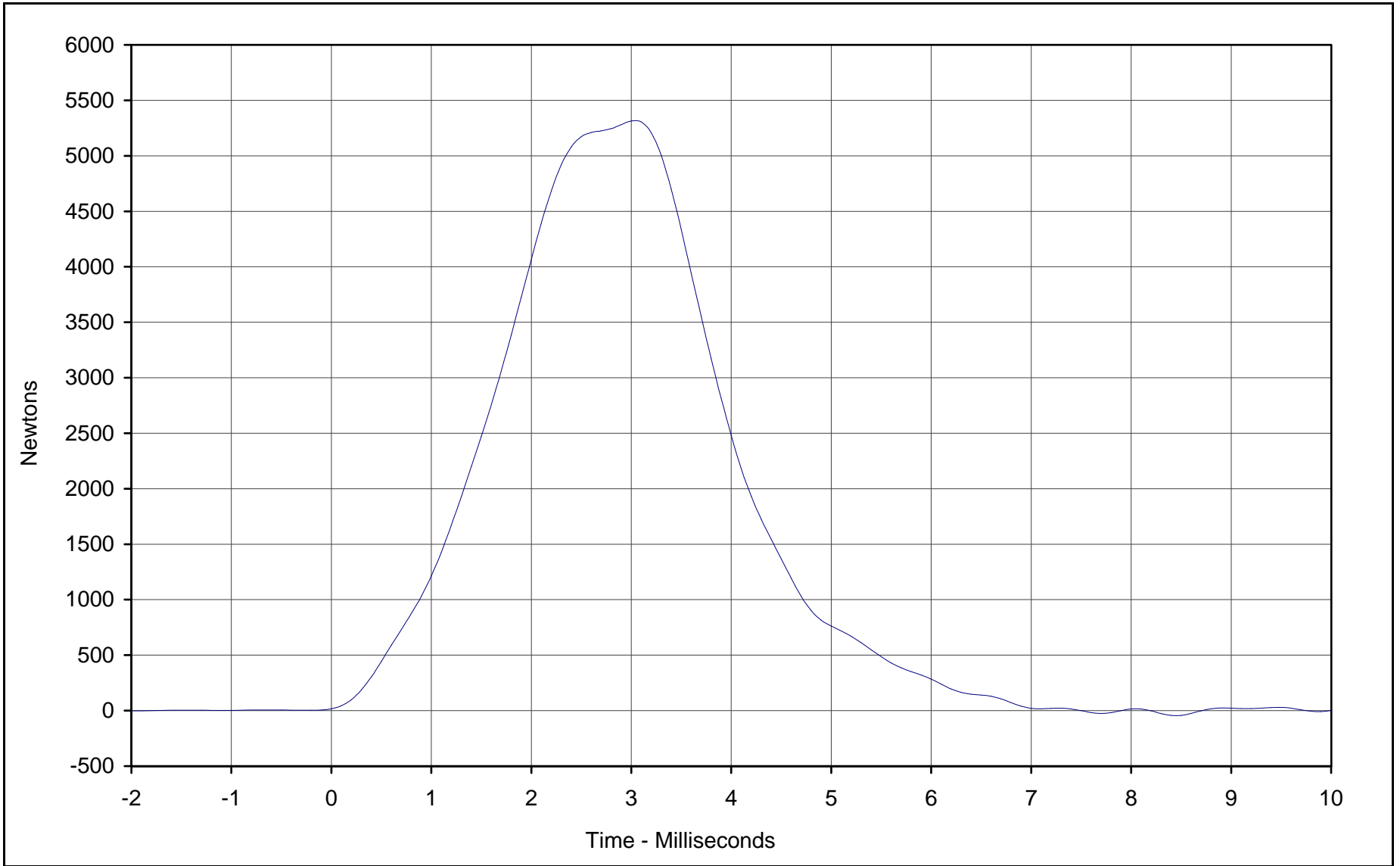

Curve Description: Probe Force
Maximum Value: 5315.0 at 3.0 Milliseconds
Minimum Value: -25.2 at 7.7 Milliseconds
SAE Filter Class: 600
Date of Test: 6/22/00
ATD Serial No.: 035

Testing Program: Hybrid III Right Knee Impact Test
Test Information: Part S/N: N/A Test I.D.: RK06D



KARR20002-02



Hybrid III Calibration Data Sheet

50TH Percentile Male

Head Drop Calibration

ATD Serial No.: 035

Part Serial No.: N/A

Test I.D.: HD06A

Tested Parameter	Units	Specification	Result	Pass/Fail
Laboratory Temperature	°C	18.9 to 25.6	21.1	Pass
Laboratory Relative Humidity	%	10 to 70	39	Pass
Peak Resultant Acceleration	G's	225.0 to 275.0	229.8	Pass
Peak Lateral Acceleration	G's	≤15.0	8.3	Pass
Is Acceleration Unimodal?	Yes/No	Yes	Yes	Pass
Overall Test Results				Pass

Laboratory Technician

June 22, 2000

Test Date

Approved By

Date

E-26

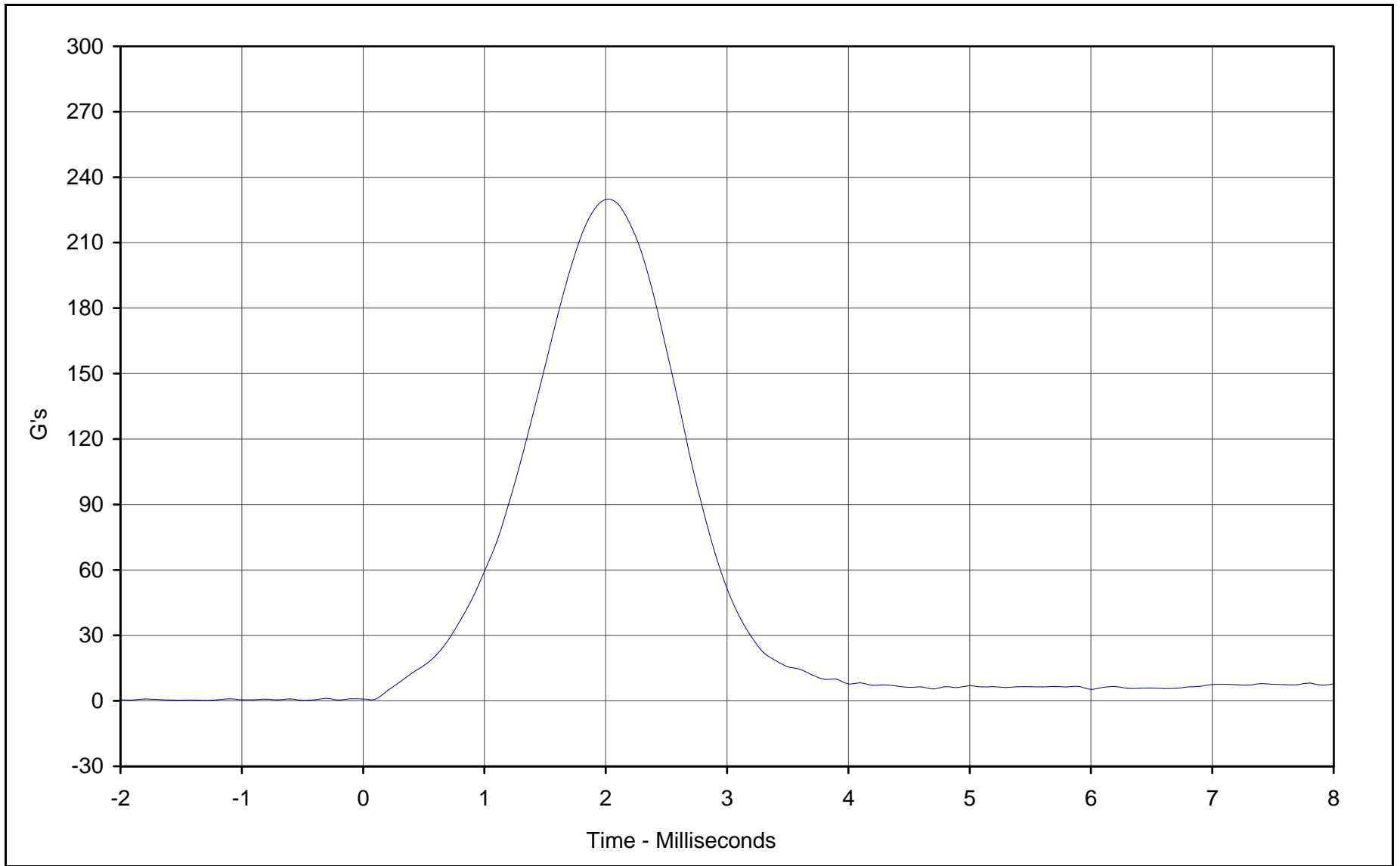

Curve Description: Head Resultant Acceleration

Maximum Value: 229.8 at 2.0 Milliseconds

Minimum Value: 0.2 at -0.5 Milliseconds

SAE Filter Class: 1000

Date of Test: 6/22/00

ATD Serial No.: 035

Testing Program: Hybrid III Head Drop Calibration (Male)

Test Information: S/N of Part: N/A Test I.D.: HD06A



KAR20002-02

E-27

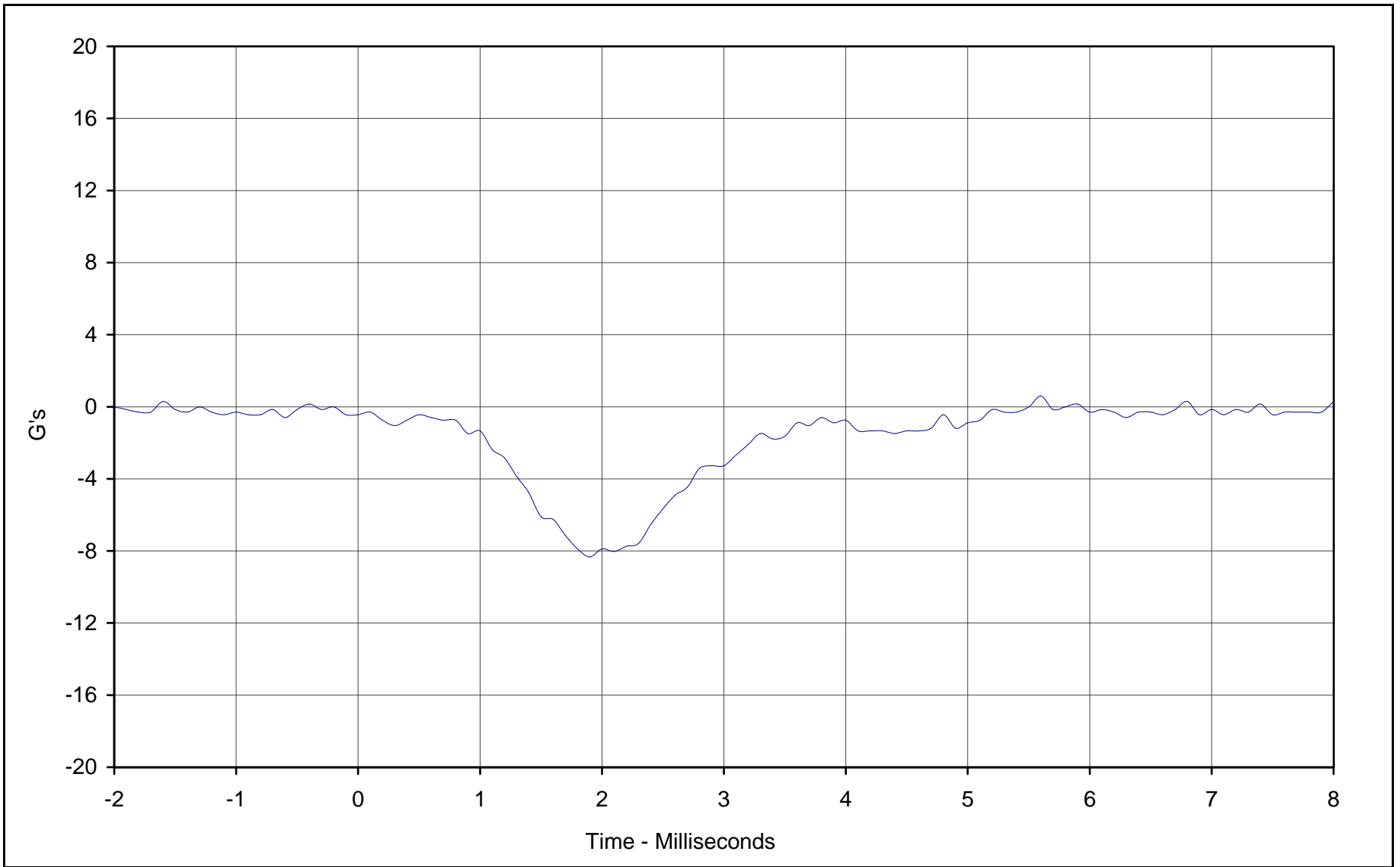

Curve Description: Head Acceleration Y Axis

Maximum Value: 0.6 at 5.6 Milliseconds

Minimum Value: -8.3 at 1.9 Milliseconds

SAE Filter Class: 1000

Date of Test: 6/22/00

ATD Serial No.: 035

Testing Program: Hybrid III Head Drop Calibration (Male)

Test Information: S/N of Part: N/A Test I.D.: HD06A



KAR20002-02



Hybrid III Calibration Data Sheet

50TH Percentile Male

Thorax Impact Test

ATD Serial No.: 035

Part Serial No.: N/A

Test I.D.: CH06B

Tested Parameter	Units	Specification	Result	Pass/Fail
Laboratory Temperature	°C	20.6 to 22.2	21.2	Pass
Laboratory Relative Humidity	%	10 to 70	39	Pass
Probe Velocity	m/s	6.58 to 6.82	6.59	Pass
Peak Probe Force	Newtons	5159 to 5893	5325	Pass
Peak Sternum Displacement	CM	6.35 to 7.26	7.13	Pass
Internal Hysteresis	%	69 to 85	74.0	Pass
Overall Test Results				Pass

Laboratory Technician

June 27, 2000

Test Date

Approved By

Date

E-29

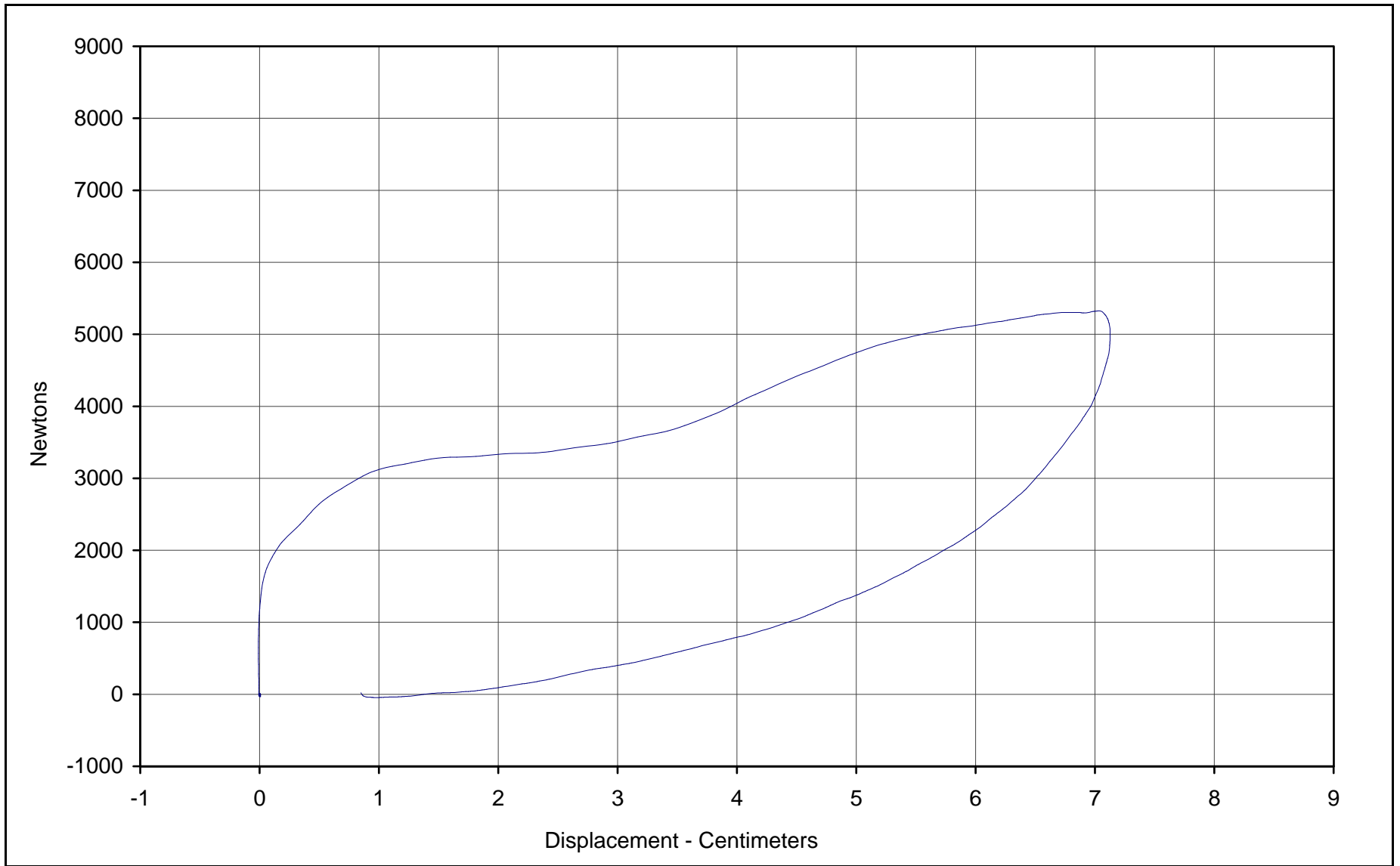

Curve Description: Probe Force vs. Chest Displacement

Testing Program: Hybrid III Thorax Impact Test

Probe Force: 5324.9 Newtons

Test Information: S/N of Part: N/A Test I.D.: CH06B

Chest Displ.: 7.13 Centimeters

SAE Filter Class: 180

Date of Test: 6/27/00

ATD Serial No.: 035



KAR20002-02



Hybrid III Calibration Data Sheet

50TH Percentile Male

Neck Flexion Test

ATD Serial No.: 035

Part Serial No.: N/A

Test I.D.: NF06B

Tested Parameter	Units	Specification	Result	Pass/Fail	
Laboratory Temperature	°C	20.6 to 22.2	21.7	Pass	
Laboratory Relative Humidity	%	10 to 70	31	Pass	
Pendulum Velocity	m/s	6.89 to 7.13	6.90	Pass	
Pendulum Deceleration	10 Msec.	G's	22.5 to 27.5	22.8	Pass
	20 Msec.	G's	17.6 to 22.6	20.6	Pass
	30 Msec.	G's	12.5 to 18.5	16.9	Pass
Peak Pendulum Decel. after 30 Msec.	G's	≤ 29.0	16.9	Pass	
Deceleration Decay, Time to Cross 5 G's	Msec.	34.0 to 42.0	37.1	Pass	
Maximum "D" Plane Rotation	Maximum	Degrees	64.0 to 78.0	73.8	Pass
	Time	Msec.	57.0 to 64.0	62.5	Pass
"D" Plane Rotation Decay, Time To Zero Crossing	Msec.	113.0 to 128.0	125.1	Pass	
Moment About Occipital Condyle	Maximum	N·m	84.1 to 108.5	91.9	Pass
	Time	Msec.	47.0 to 58.0	57.1	Pass
Positive Moment Decay, Time To Zero Crossing	Msec.	97.0 to 107.0	102.1	Pass	
Overall Test Results				Pass	

Laboratory Technician

June 23, 2000

Test Date

Approved By

Date

E-31

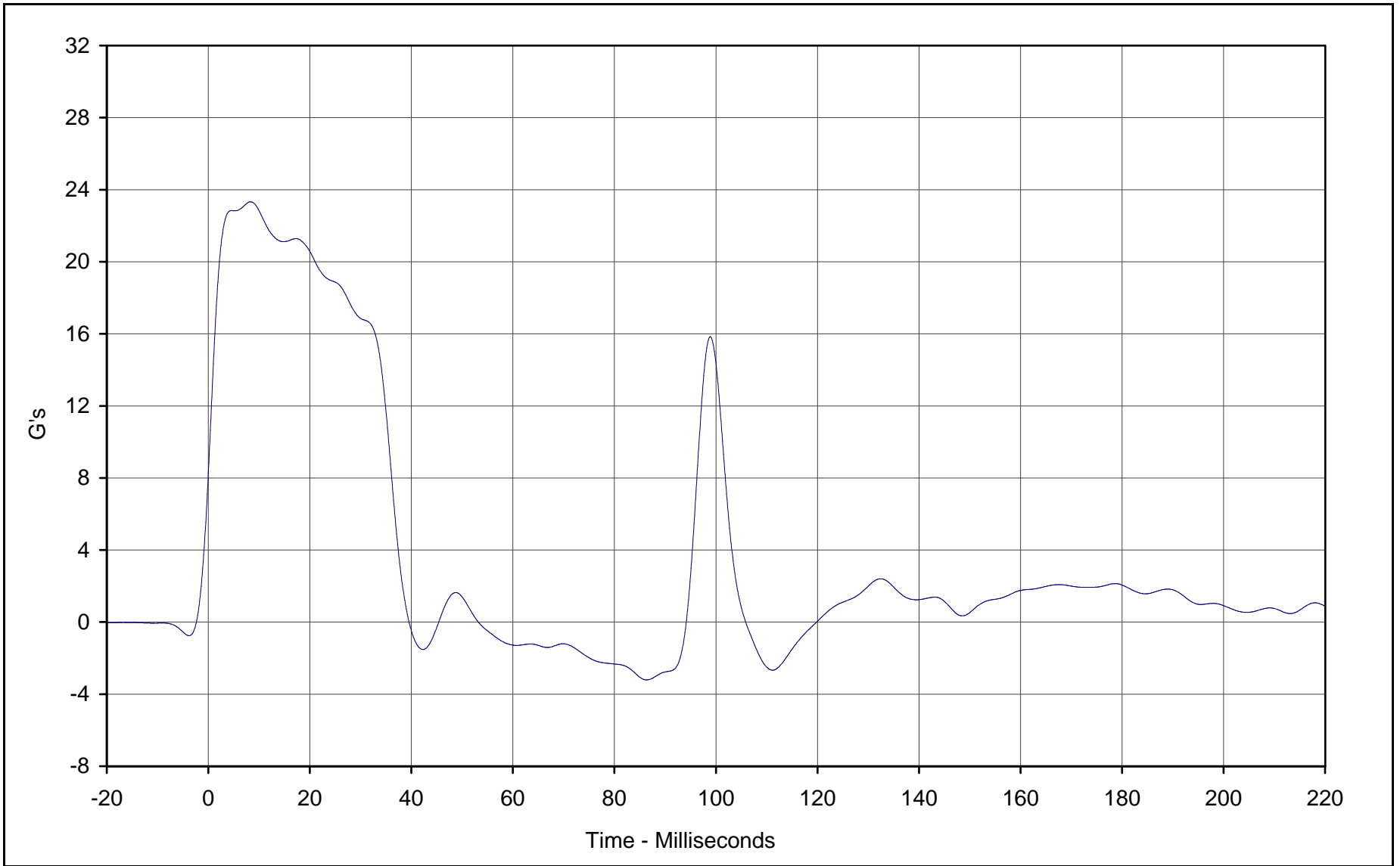

Curve Description: Pendulum Deceleration
Maximum Value: 23.3 at 8.3 Milliseconds
Minimum Value: -3.2 at 86.3 Milliseconds
SAE Filter Class: 60
Date of Test: 6/23/00
ATD Serial No.: 035

Testing Program: Hybrid III Neck Flexion Test (Male)
Test Information: S/N of Part: N/A Test I.D.: NF06B



KARR20002-02

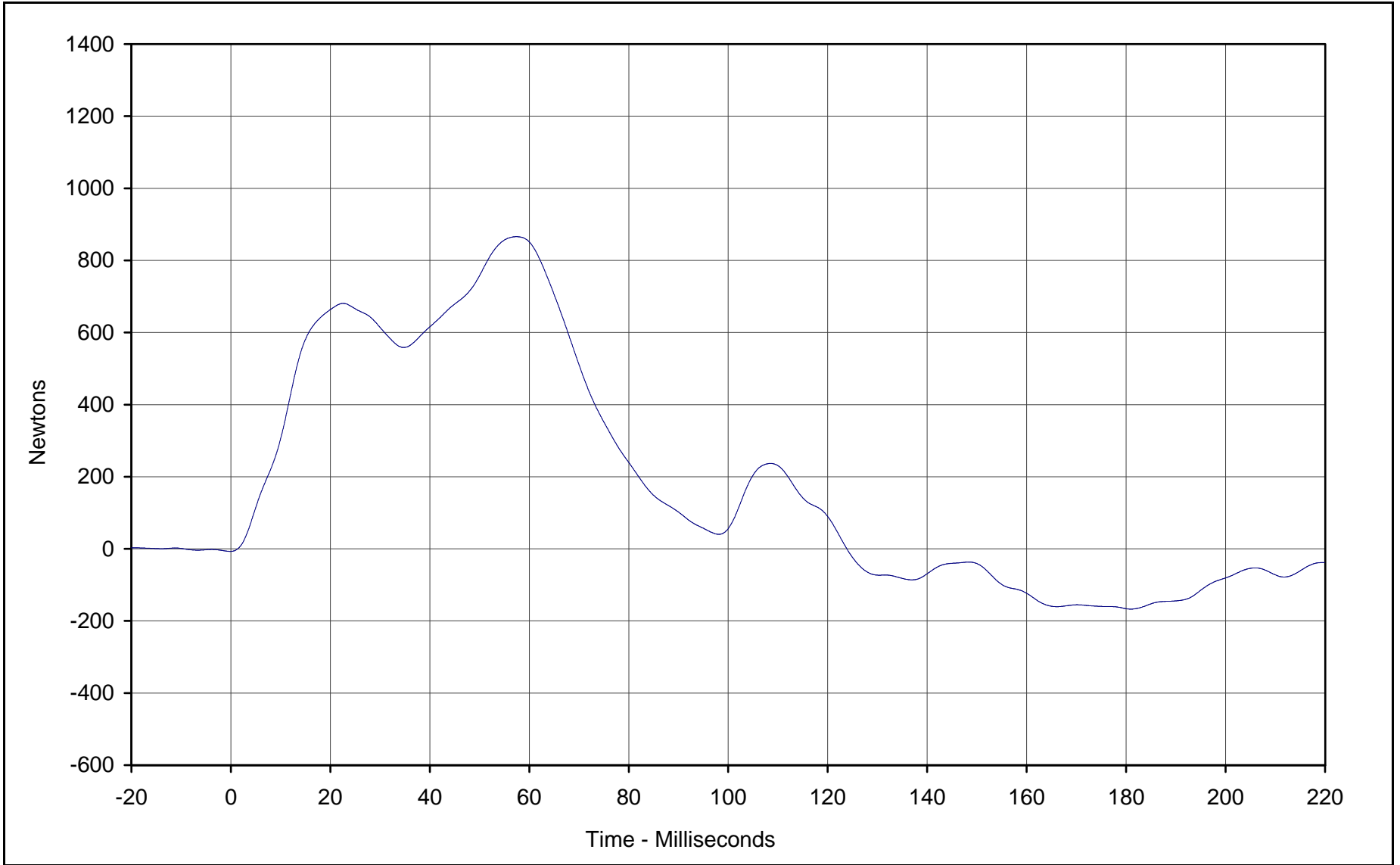

Curve Description: Neck Force X
Maximum Value: 865.8 at 57.4 Milliseconds
Minimum Value: -167.2 at 180.9 Milliseconds
SAE Filter Class: 60
Date of Test: 6/23/00
ATD Serial No.: 035

Testing Program: Hybrid III Neck Flexion Test (Male)
Test Information: S/N of Part: N/A Test I.D.: NF06B



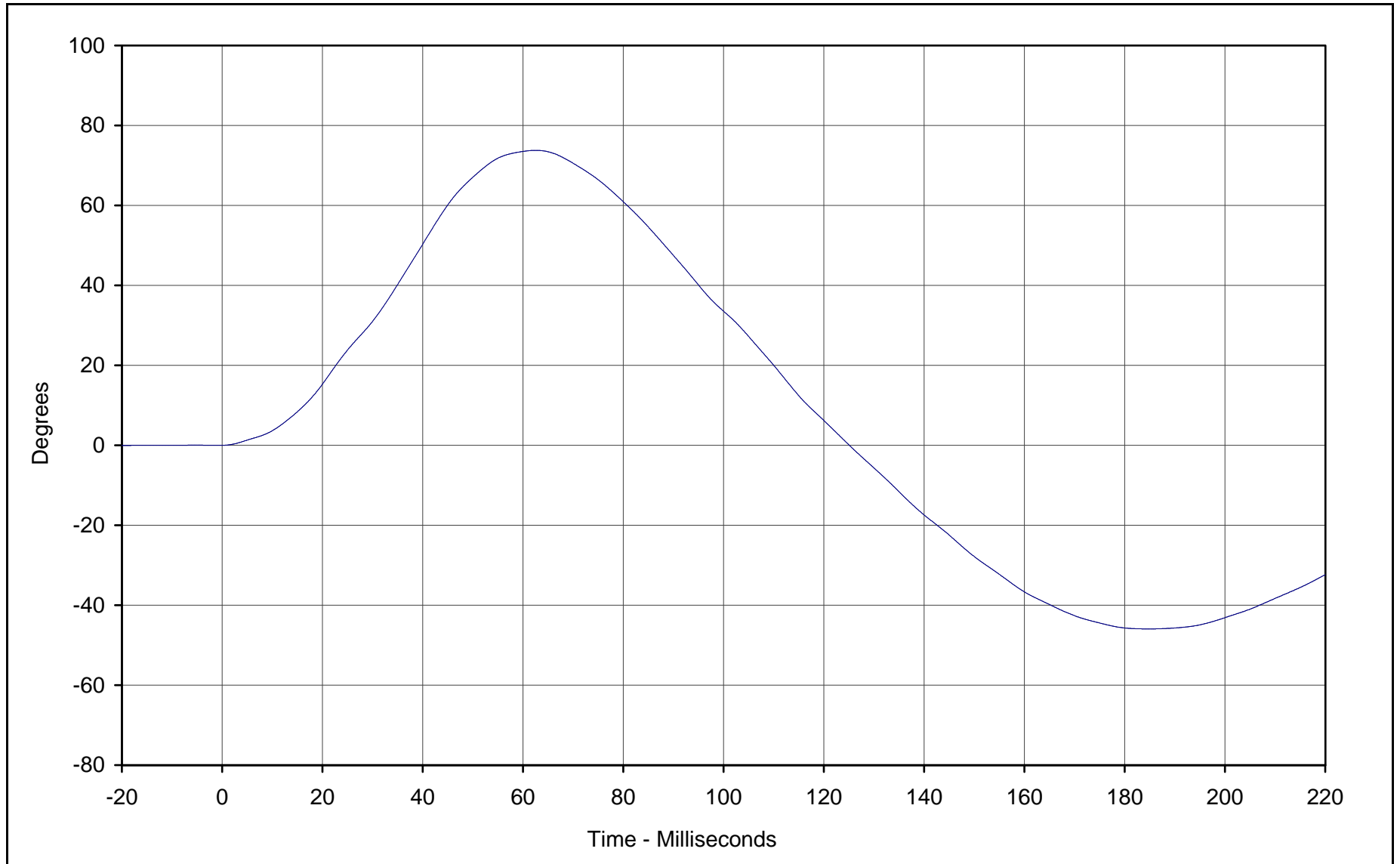

Curve Description: "D" Plane Rotation

Maximum Value: 73.8 at 62.5 Milliseconds

Minimum Value: -45.9 at 184.9 Milliseconds

SAE Filter Class: 60

Date of Test: 6/23/00

ATD Serial No.: 035

Testing Program: Hybrid III Neck Flexion Test (Male)

Test Information: S/N of Part: N/A Test I.D.: NF06B



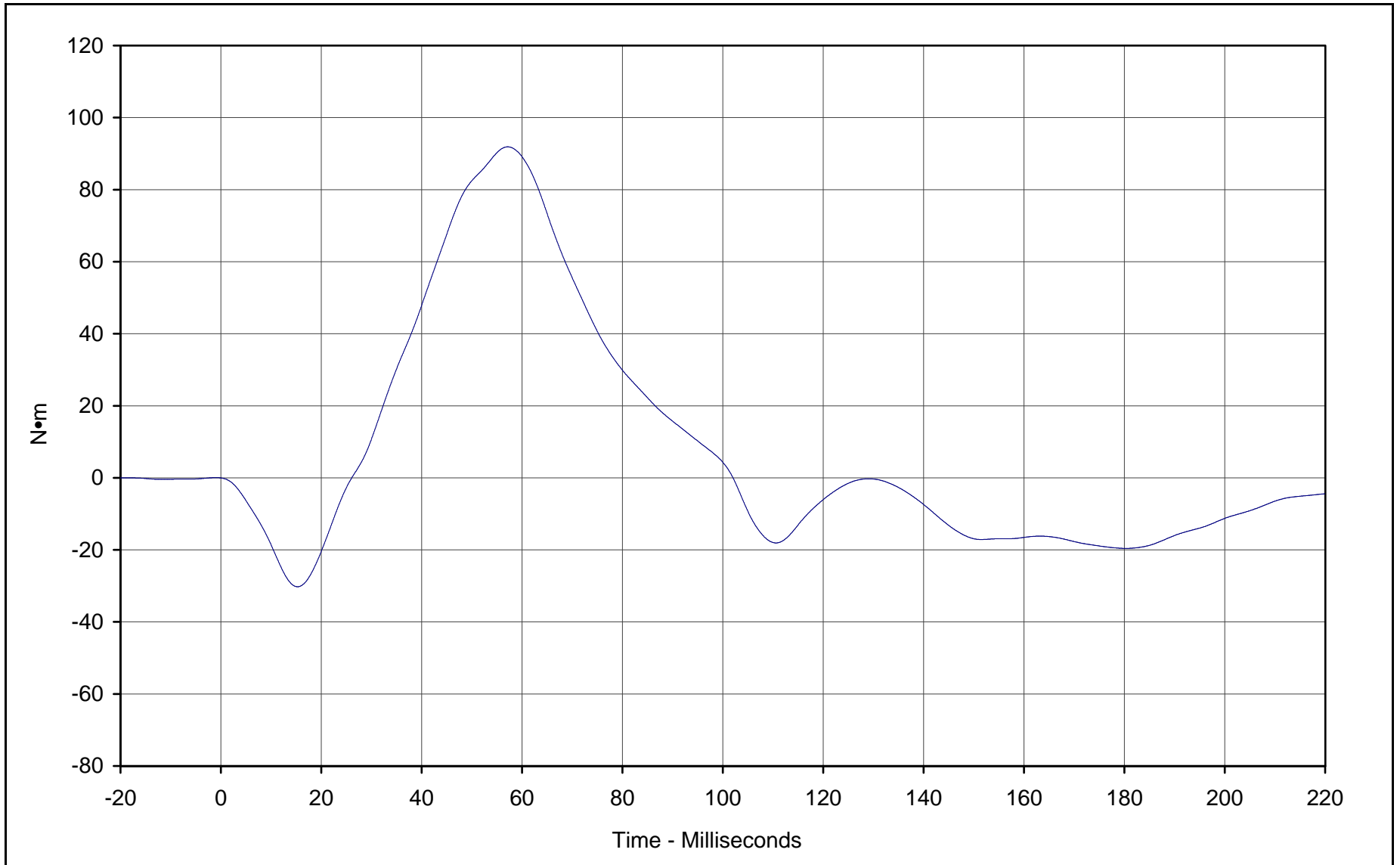

Curve Description: Moment About Occipital Condyles

Testing Program: Hybrid III Neck Flexion Test (Male)

Maximum Value: 91.9 at 57.1 Milliseconds

Test Information: S/N of Part: N/A Test I.D.: NF06B

Minimum Value: -30.2 at 15.3 Milliseconds

SAE Filter Class: 60

Date of Test: 6/23/00

ATD Serial No.: 035





Hybrid III Calibration Data Sheet

50TH Percentile Male

Neck Extension Test

ATD Serial No.: 035

Part Serial No.: N/A

Test I.D.: NE06B

Tested Parameter	Units	Specification	Result	Pass/Fail	
Laboratory Temperature	°C	20.6 to 22.2	21.1	Pass	
Laboratory Relative Humidity	%	10 to 70	31	Pass	
Pendulum Velocity	m/s	5.95 to 6.19	6.00	Pass	
Pendulum Deceleration	10 Msec.	G's	17.2 to 21.2	17.8	Pass
	20 Msec.	G's	14.0 to 19.0	18.1	Pass
	30 Msec.	G's	11.0 to 16.0	15.4	Pass
Peak Pendulum Decel. after 30 Msec.	G's	≤ 22.0	15.4	Pass	
Deceleration Decay, Time to Cross 5 G's	Msec.	38.0 to 46.0	43.0	Pass	
Maximum "D" Plane Rotation	Maximum	Degrees	81.0 to 106.0	93.3	Pass
	Time	Msec.	72.0 to 82.0	81.8	Pass
"D" Plane Rotation Decay, Time To Zero Crossing	Msec.	147.0 to 174.0	162.4	Pass	
Moment About Occipital Condyle	Maximum	N·m	-52.9 to- 79.9	-67.5	Pass
	Time	Msec.	65.0 to 79.0	72.5	Pass
Negative Moment Decay, Time To Zero Crossing	Msec.	120.0 to 148.0	140.1	Pass	
Overall Test Results				Pass	

Laboratory Technician

June 23, 2000
Test Date

Approved By

Date

E-36

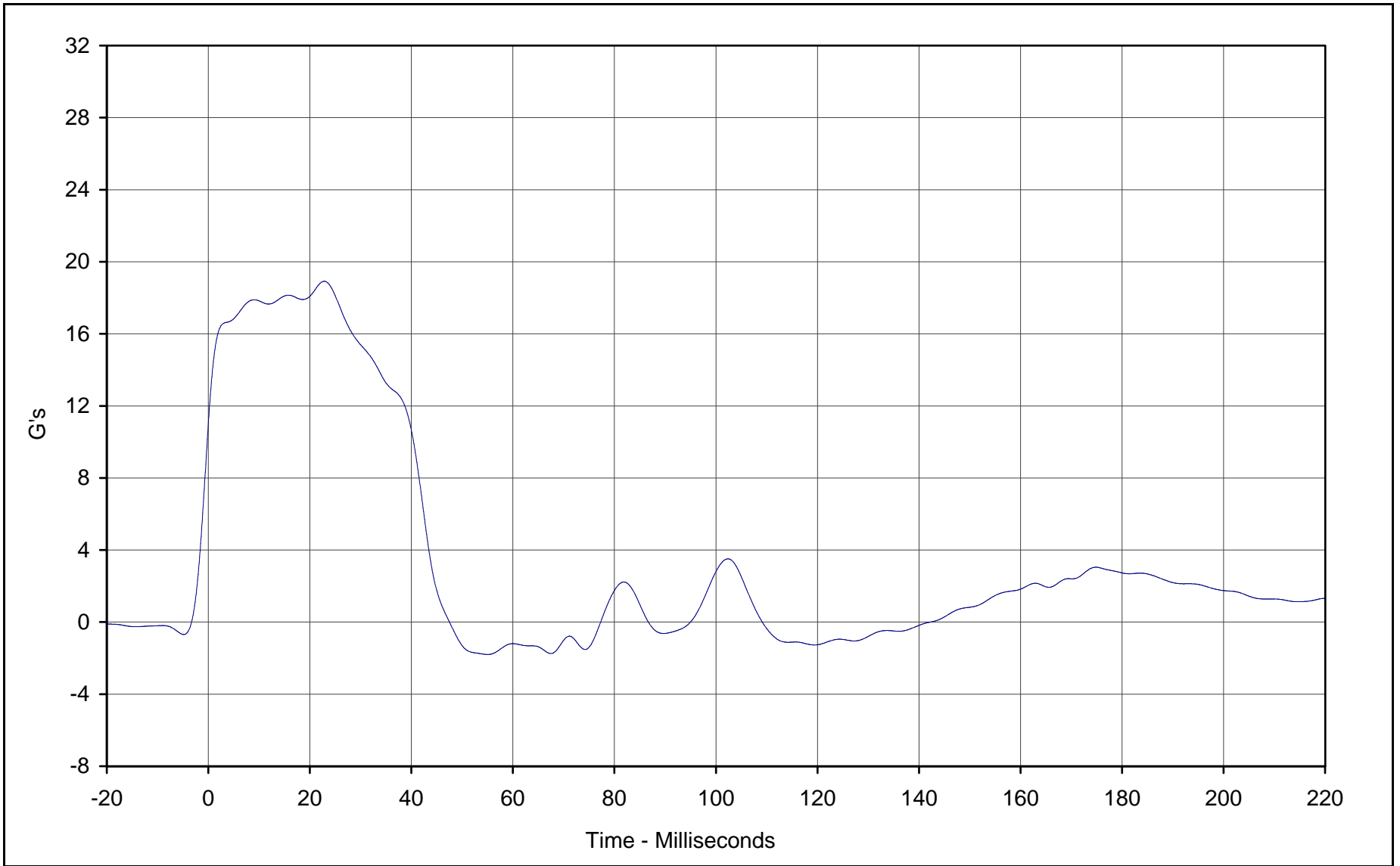

Curve Description: Pendulum Deceleration
Maximum Value: 18.9 at 22.9 Milliseconds
Minimum Value: -1.8 at 55.0 Milliseconds
SAE Filter Class: 60
Date of Test: 6/23/00
ATD Serial No.: 035

Testing Program: Hybrid III Neck Extension Test (Male)
Test Information: S/N of Part: N/A Test I.D.: NE06B



KAR20002-02

E-37

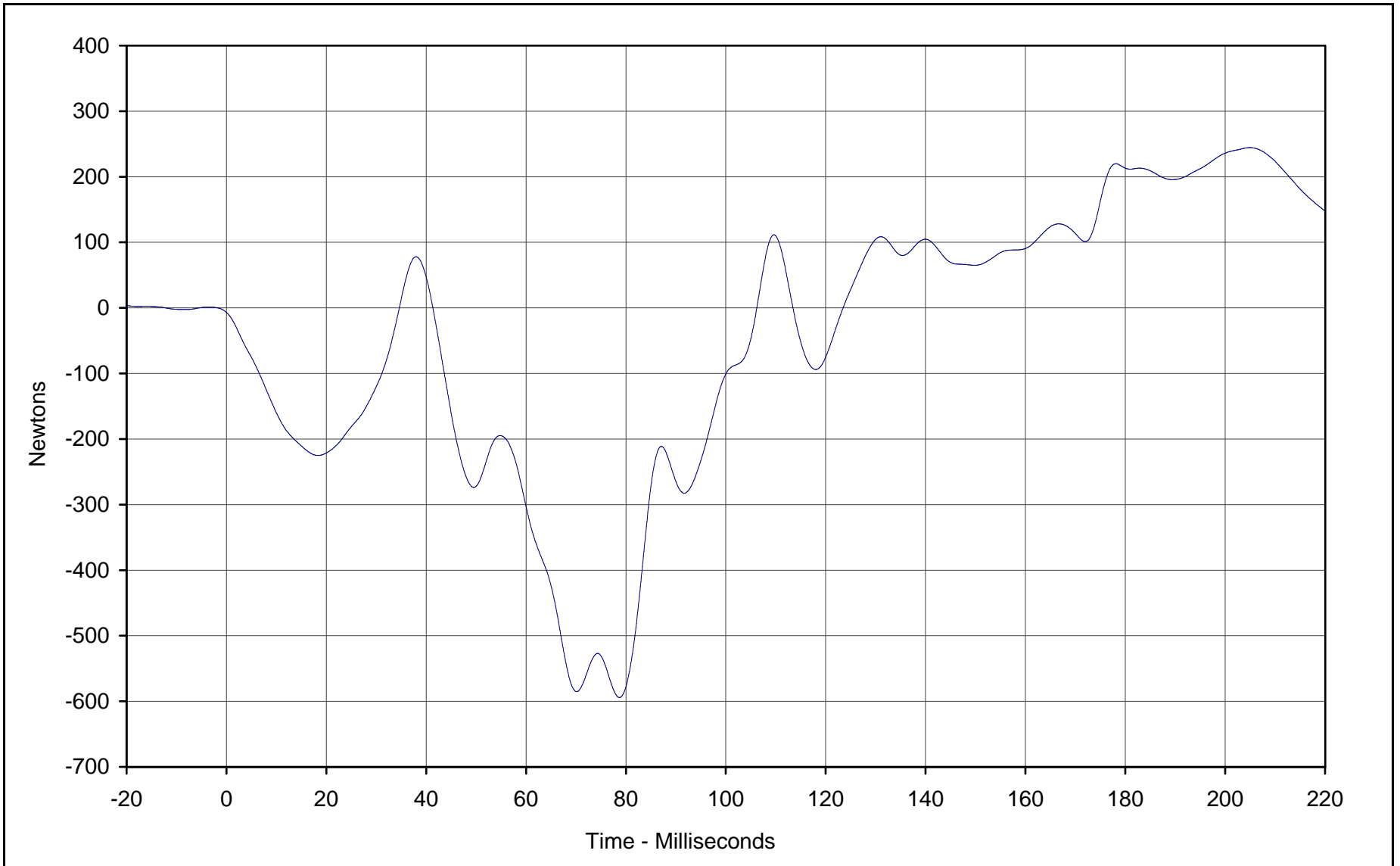

Curve Description: Neck Force X
Maximum Value: 244.4 at 205.0 Milliseconds
Minimum Value: -594.2 at 78.7 Milliseconds
SAE Filter Class: 60
Date of Test: 6/23/00
ATD Serial No.: 035

Testing Program: Hybrid III Neck Extension Test (Male)
Test Information: S/N of Part: N/A Test I.D.: NE06B



KARR20002-02

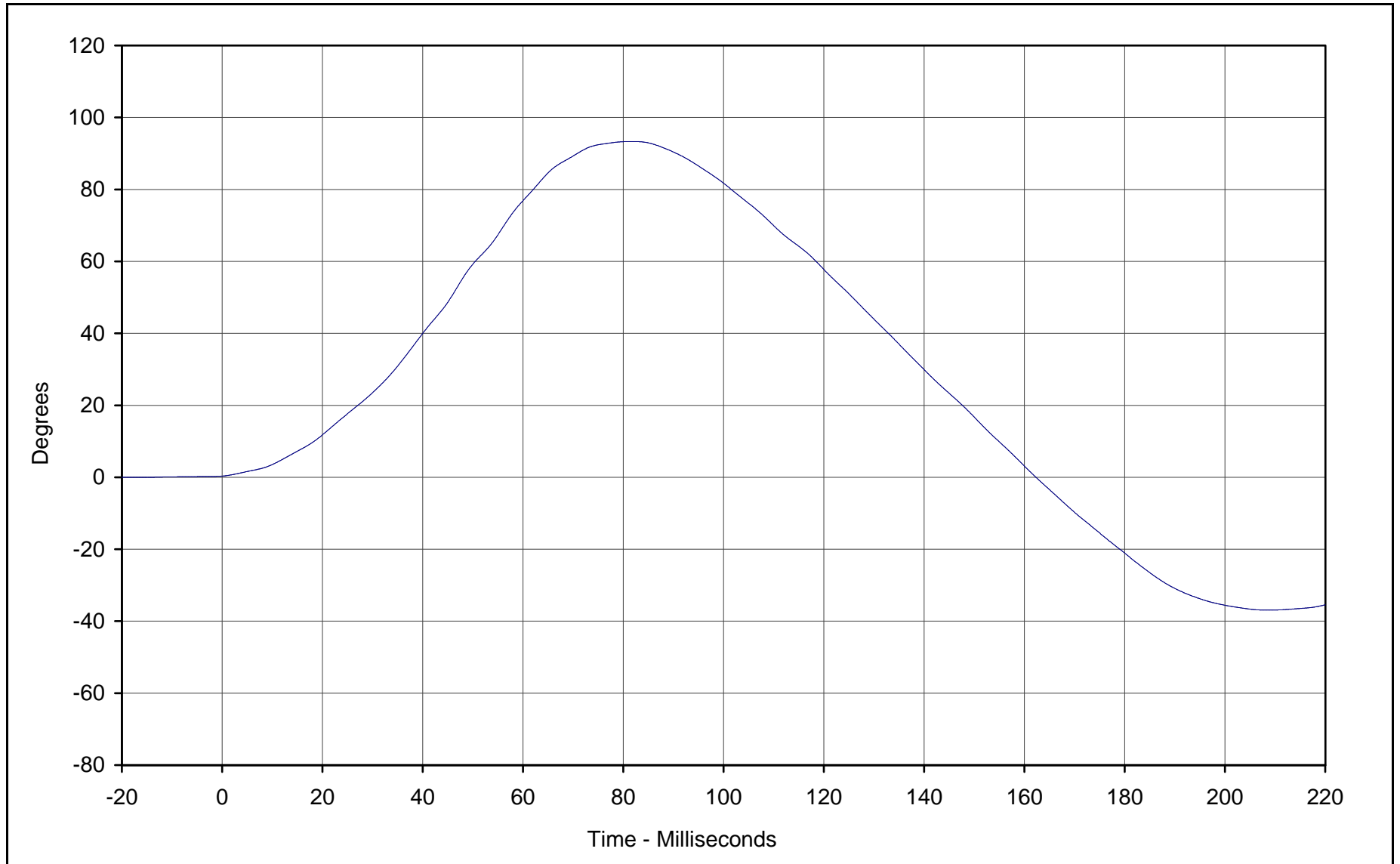

Curve Description: "D" Plane Rotation
 Maximum Value: 93.3 at 81.8 Milliseconds
 Minimum Value: -36.9 at 208.6 Milliseconds
 SAE Filter Class: 60
 Date of Test: 6/23/00
 ATD Serial No.: 035

Testing Program: Hybrid III Neck Extension Test (Male)
 Test Information: S/N of Part: N/A Test I.D.: NE06B



E-39

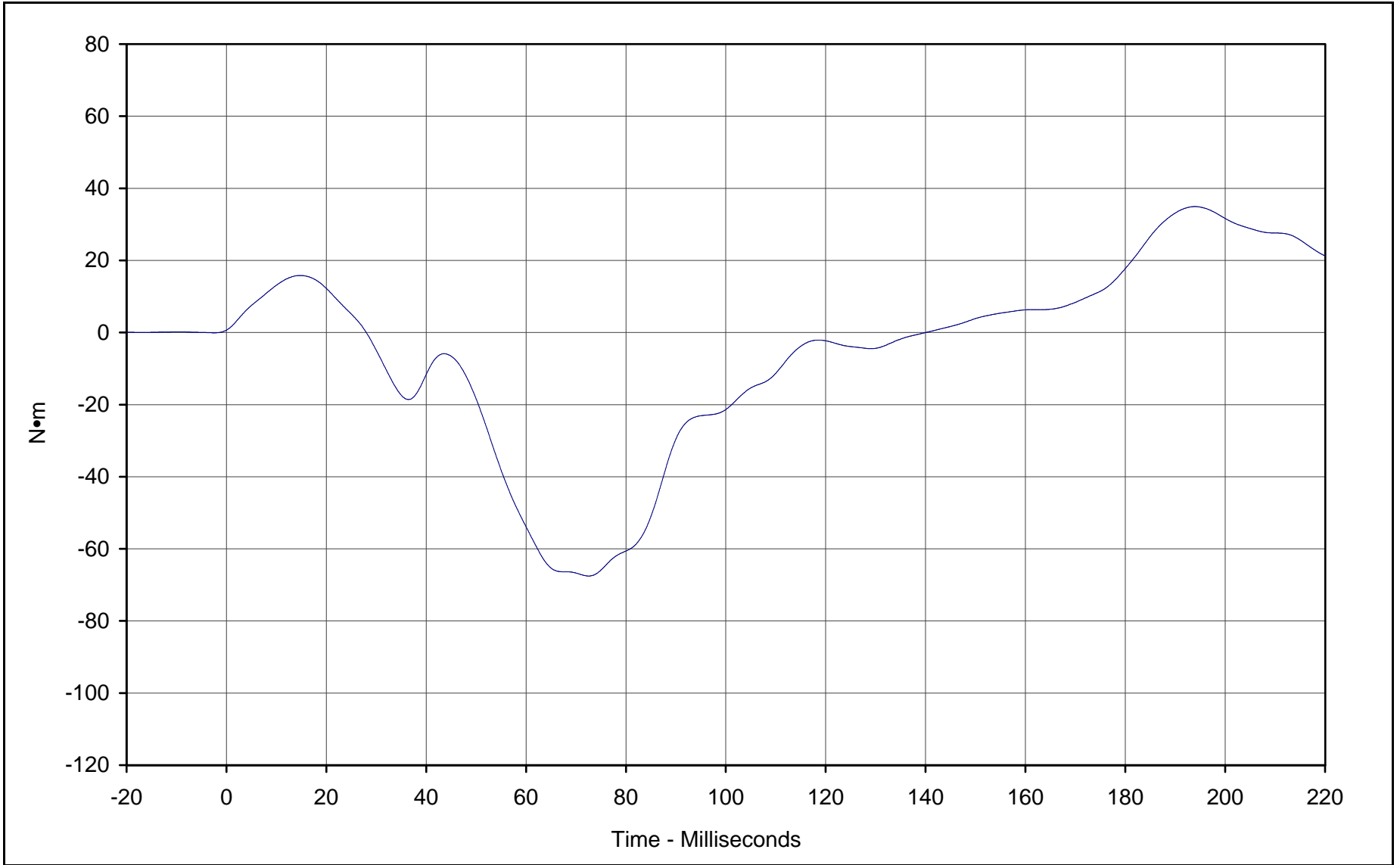

Curve Description: Moment About Occipital Condyles
Maximum Value: 34.9 at 193.9 Milliseconds
Minimum Value: -67.5 at 72.5 Milliseconds
SAE Filter Class: 60
Date of Test: 6/23/00
ATD Serial No.: 035

Testing Program: Hybrid III Neck Extension Test (Male)
Test Information: S/N of Part: N/A Test I.D.: NE06B

KARR20002-02





Hybrid III Calibration Data Sheet

50TH Percentile Male

External Measurements

ATD Serial No.: 035

Part Serial No.: N/A

Test I.D.: N/A

External Measurement Data				
Tested Parameter	Units	Specification	Result	Pass/Fail
Laboratory temperature	°C	20.4 to 22.1	20.9	Pass
Laboratory relative humidity	%	10 to 70	43	Pass
A - Total sitting height	mm	879 to 889	880	Pass
B - Shoulder pivot height	mm	505 to 521	515	Pass
C - "H" point height	mm	84 to 89	85	Pass
D - "H" point from seat back	mm	135 to 140	140	Pass
E - Shoulder pivot from back	mm	84 to 94	92	Pass
F - Thigh clearance	mm	140 to 155	145	Pass
G - Elbow back to wrist pivot	mm	290 to 305	300	Pass
H - Skull cap to back line	mm	41 to 46	45	Pass
I - Shoulder to elbow length	mm	330 to 345	335	Pass
J - Elbow rest height	mm	190 to 211	195	Pass
K - Buttock to knee length	mm	579 to 604	590	Pass
L - Popliteal length	mm	429 to 455	440	Pass
M - Knee pivot height	mm	485 to 500	495	Pass
N - Buttock popliteal length	mm	452 to 477	465	Pass
O - Chest depth	mm	213 to 229	220	Pass
P - Foot length	mm	251 to 267	255	Pass
V - Shoulder breadth	mm	422 to 437	430	Pass
W - Foot breadth	mm	91 to 107	100	Pass
Y - Chest circumference	mm	970 to 1001	990	Pass
Z - Waist circumference	mm	836 to 866	850	Pass
AA - Location for chest circumference	mm	429 to 434	430	Pass
BB - Location for waist circumference	mm	226 to 231	229	Pass
Overall Test Results				Pass

Laboratory Technician

June 27, 2000

Test Date

Approved By

Date

APPENDIX F
VEHICLE OWNER'S MANUAL
RESTRAINT AND SEATING INSTRUCTIONS

Controls and features

TILT STEERING

Pull the tilt steering control toward you to move the steering wheel up or down. Hold the control while adjusting the wheel to the desired position, then release the control.

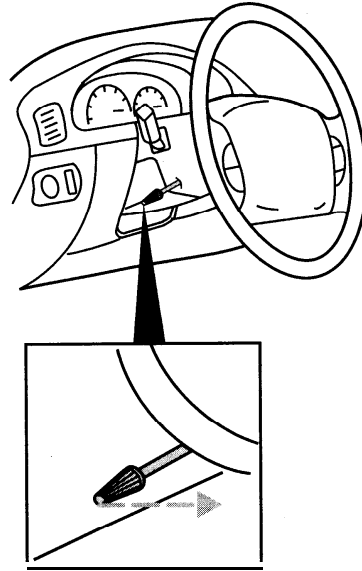

Never adjust the steering wheel when the vehicle is moving.

HAZARD FLASHER

For information on the hazard flasher control, refer to *Hazard flasher* in the *Roadside emergencies* chapter.

WINDSHIELD WIPER/WASHER CONTROLS

Rotate the windshield wiper control to the desired interval, low or high speed position.

The bars of varying length are for intermittent wipers. When in this position rotate the control upward for fast intervals and downward for slow intervals.

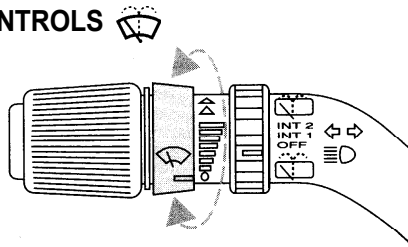

Seating and safety restraints

SEATING

Adjustable head restraints (if equipped)

Your vehicle's seats may be equipped with head restraints which are vertically adjustable. The purpose of these head restraints is to help limit head motion in the event of a rear collision. To properly adjust your head restraints, lift the head restraint so that it is located directly behind your head or as close to that position as possible. Refer to the following to raise and lower the head restraints.

The head restraints can be moved up and down.

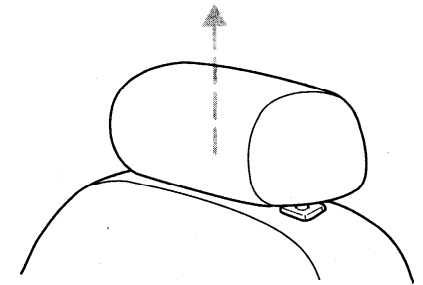

Using the manual lumbar support

Turn the lumbar support control toward the front of vehicle to increase

Turn the lumbar support control toward the rear of vehicle to increase softness.

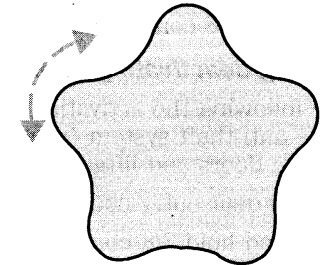

Adjusting the front manual seat





Never adjust the driver's seat or seatback when the vehicle is moving.



Do not pile cargo higher than the seatbacks to reduce the risk of injuring people in a collision or sudden stop.

Seating and safety restraints

 Always drive and ride with your seatback upright and the lap belt snug and low across the hips.

 Reclining the seatback can reduce the effectiveness of the seat's safety belt in the event of a collision.

Lift handle to move seat forward or backward.

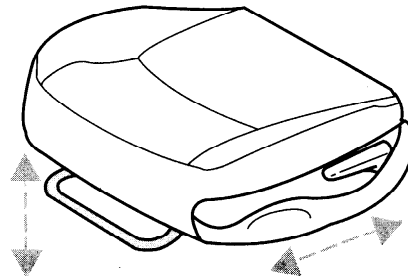

Pull lever up to adjust seatback.

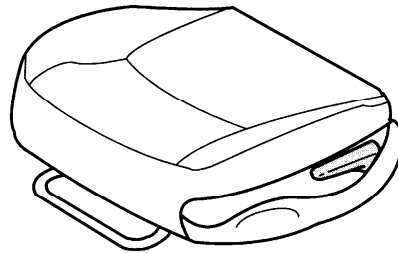

Seating and safety restraints

60/40 split bench seat (if equipped)

- Lift the release bar to move the seat forward or backward. Ensure the seat is latched into place.
- Pull the seatback handle up to recline the seat.

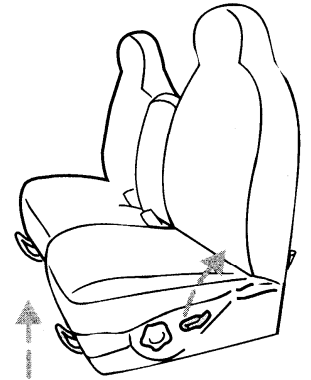

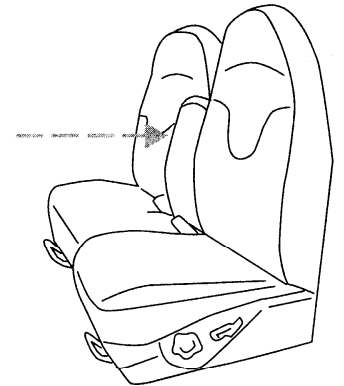

Using the armrest (if equipped)

Push the release control to move the armrest up or down.





Adjusting the front power seat (if equipped)

 Never adjust the driver's seat or seatback when the vehicle is moving.

 Do not pile cargo higher than the seatbacks to avoid injuring people in a collision or sudden stop.

Seating and safety restraints

 Always drive and ride with your seatback upright and the lap belt snug and low across the hips.

 Reclining the seatback can reduce the effectiveness of the seat's safety belt in the event of a collision.

The control is located on the outboard side of the seat cushion.

Press front to raise or lower the front portion of the seat cushion.

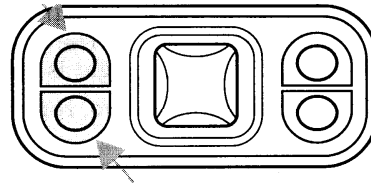

Press rear to raise or lower the rear portion of the seat cushion.

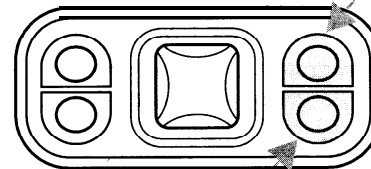

Press the control to move the seat forward, backward, up or down.

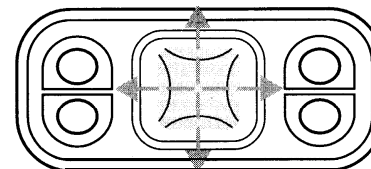



Seating and safety restraints

Front and second row safety belt height adjustment

Your vehicle has safety belt height adjustments for the driver, front passenger and second row passengers. Adjust the height of the shoulder belt so the belt rests across the middle of your shoulder.

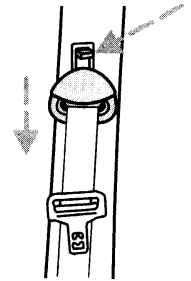
To lower the shoulder belt height, push the button down and slide the height adjuster down. To raise the height of the shoulder belt, slide the height adjuster up. Pull down on the height adjuster to make sure it is locked in place.



 Position the shoulder belt height adjuster so that the belt rests across the middle of your shoulder. Failure to adjust the safety belt properly could reduce the effectiveness of the safety belt and increase the risk of injury in a collision.

Safety belt extension assembly

If the safety belt assembly is too short, even when fully extended, 20 cm (8 inches) can be added to the safety belt assembly by adding a safety belt extension assembly (part number 611C22). Safety belt extension assemblies can be obtained from your dealer at no cost.

Use only extensions manufactured by the same supplier as the safety belt. Manufacturer identification is located at the end of the webbing on the label. Also, use the safety belt extension only if the safety belt is too short for you when fully extended. Do not use extensions to change the fit of the shoulder belt across the torso.

Safety belt warning light and indicator chime

The seat belt warning light illuminates in the instrument cluster and a chime sounds to remind the occupants to fasten their safety belts.