

5559
REPORT NUMBER: CAL-00-17

**NEW CAR ASSESSMENT PROGRAM (NCAP)
FRONTAL BARRIER IMPACT TEST**

**FORD MOTOR COMPANY
2000 FORD FOCUS
3-DOOR HATCHBACK**

NHTSA NUMBER: MY0204

VERIDIAN TEST NUMBER: 8413-55

VERIDIAN ENGINEERING
TRANSPORTATION SCIENCES CENTER
P.O. BOX 400
BUFFALO, NEW YORK 14225



April 5, 2000

FINAL REPORT

PREPARED FOR:

U. S. DEPARTMENT OF TRANSPORTATION
National Highway Traffic Safety Administration
Safety Performance Standards
Office of Crashworthiness Standards
Mail Code: NPS-10
400 Seventh Street, SW, Room No. 5313
Washington, DC 20590

This publication is distributed by the U. S. Department of Transportation, National Highway Traffic Safety Administration, in the interest of information exchange. The opinions, findings and conclusions expressed in this publication are those of the author(s) and not necessarily those of the Department of Transportation or the National Highway Traffic Safety Administration. The United States Government assumes no liability for its contents or use thereof. If trade or manufacturers' names or products are mentioned, it is only because they are considered essential to the object of the publication and should not be construed as an endorsement. The United States Government does not endorse products or manufacturers.

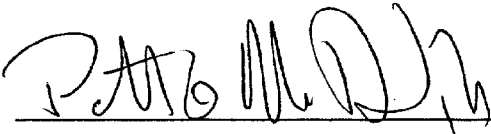
Prepared by: 
Patrick G. MacDiarmid, Jr., Project Engineer

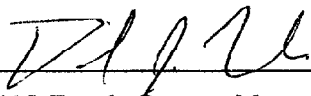
Approved by: 
David J. Travale, Program Manager
Transportation Science Center

Approval Date: April 12, 2000

FINAL REPORT ACCEPTANCE BY OCS:

Manager, New Car Assessment Program (NCAP)
NHTSA, Office of Crashworthiness Standards

Date of Report Acceptance

COTR, New Car Assessment Program (NCAP)
NHTSA, Office of Crashworthiness Standards

Date of Report Acceptance

TECHNICAL REPORT STANDARD TITLE PAGE

1. <i>Report No.</i> CAL-00-17		2. <i>Government Accession No.</i>		3. <i>Recipient's Catalog No.</i>	
4. <i>Title and Subtitle</i> Final Report of NEW CAR ASSESSMENT PROGRAM (NCAP) Testing of a 2000 Ford Focus 3-Door Hatchback NHTSA No. MY0204			5. <i>Report Date</i> April 5, 2000		
			6. <i>Performing Organization Code</i> CAL		
7. <i>Author(s)</i> David J. Travale, Program Manager Patrick G. MacDiarmid, Jr., Project Engineer			8. <i>Performing Organization Report No.</i> 8413-55		
9. <i>Performing Organization Name and Address</i> Veridian Engineering 4455 Genesee Street Buffalo, New York 14225			10. <i>Work Unit No.</i>		
			11. <i>Contract or Grant No.</i> DTNH22-96-D-02010		
12. <i>Sponsoring Agency Name and Address</i> U.S. Department of Transportation National Highway Traffic Safety Administration Office of Crashworthiness Standards Mail Code: NPS-10 400 Seventh, SW, Room 5313 Washington, D.C. 20590			13. <i>Type of Report and Period Covered</i> Final Report April 2000		
			14. <i>Sponsoring Agency Code</i> NPS-10		
15. <i>Supplementary Notes</i>					
16. <i>Abstract</i> A frontal load cell barrier test of a 2000 Ford Focus 3-Door Hatchback was performed at Veridian Engineering crash test facility in Buffalo, New York, on April 5, 2000. The impact velocity was 56.65 kph and the temperature at the barrier face was 21°C. The maximum post-test vehicle crush was 537mm. The test vehicle was equipped with 3-point restraint systems, knee bolsters, and airbags at both the driver and right outboard passenger seating positions. With respect to FMVSS 208 "Occupant Crash Protection - Injury Criteria" both the driver and passenger appeared to comply with head, chest, and femur requirements.					
ATD Position	HIC	Clip (g's)	Chest Disp (mm)	Left Femur (N)	Right Femur (N)
Driver (245)	366.2	39.3	31.0	4636.7	4407.1
Passenger (064)	329.1	41.6	24.3	4866.7	6822.3
17. <i>Key Words</i> 56 kph Frontal Barrier Impact test New Car Assessment Program (NCAP)			18. <i>Distribution Statement</i> <u>Copies of this report are available from:</u> NHTSA Technical Reference Division National Highway Traffic Safety Admin. 400 Seventh St., SW, Room 5108 Washington, DC 20590		
19. <i>Security Classif. (of this report)</i> UNCLASSIFIED		20. <i>Security Classif. (of this page)</i> UNCLASSIFIED		21. <i>No. of Pages</i> 272	22. <i>Price</i>

Form DOT F1700.7 (8-69)

SECTION 1

PURPOSE AND SUMMARY OF TEST MY0204

PURPOSE

This 56.65 kph frontal barrier impact test is part of the Vehicle Barrier Impact Testing Program sponsored by the National Highway Traffic Safety Administration (NHTSA) under Contract No. DTNH22-96-D-02010. The purpose of this test was to obtain vehicle crashworthiness and occupant restraint system performance data for an impact speed in excess of the current 48.3 kph requirements.

The 56.65 kph frontal barrier impact test was conducted in accordance with the Office of Crashworthiness Standards Laboratory Indicant Test procedure.

SUMMARY

A load cell barrier consisting of 36 load cells was impacted by a 2000 Ford Focus 3-Door Hatchback at a velocity of 56.65 kph. The test was performed at Veridian Engineering on April 5, 2000. Pre- and post-test photographs of the vehicle and dummies can be found in Appendix A.

The frontal barrier impact event was documented by 1 real-time camera and 16 high-speed cameras. Camera locations and other pertinent camera information can be found in this report.

Two Part 572E, 50th percentile male anthropomorphic test devices (ATDs), were placed in the driver and right-front passenger seating positions according to dummy placement instructions specified in the Laboratory Indicant Test Procedure.

Both ATDs were fully instrumented with head, chest, and pelvis triaxial accelerometers, chest displacement potentiometers, upper neck transducers, right/left femur load cells, and lower leg instrumentation. Seat belt load cells were also on the driver's and passenger's lap and shoulder belts to measure dummy torso and pelvic section loading. The driver (position 1) ATD (Serial No. 245) was used in one test (MY0206) previous to this test where it did not exceed FMVSS 208 head, chest and femur requirements. The right-front passenger (position 2) ATD (Serial No. 064) was used in two tests (MY0111 and MY0206) previous to this test where it did not exceed FMVSS 208 head, chest and femur requirements. Certification details, along with instrumentation calibration data, are found in Appendix C.

The 125 channels of data were recorded on an on-board data acquisition system. Appendix B contains the vehicle, load cell barrier and dummy response data traces.

The driver's HIC was 366.2. The maximum chest deceleration over 3 milliseconds was 39.3 g's and maximum chest deflection was 31.0 mm. Compressive femur load was 4407.1 Newtons on the right. The driver left femur suffered a cut wire at 106 ms. The maximum compressive left femur load was 4636.7 Newtons.

The right front passenger's HIC was 329.1. Maximum chest deceleration over 3 milliseconds was 41.6 g's and maximum chest deflection was 24.3 mm. Compressive femur loads were 4866.7 Newtons on the left and 6822.3 Newtons on the right.

The front outboard passenger seat belts were equipped with seat belt load limiters. The driver's seat is equipped with a torso belt pretensioner while the right front passenger seat is equipped with a lap belt pretensioner. At the request of Ford Motor Company representatives lap and torso seat belt load cells, seat belt displacement and stretch pots were not used in this test. In addition, the Ford representative requested that the steering column target be removed prior to the test to avoid interference with steering column stroke.

SECTION 2

GENERAL TEST AND VEHICLE PARAMETER DATA

DATA SHEET NO. 1 CRASH TEST SUMMARY

Vehicle NHTSA No. : MY0204 Test Mode : 56.3 kph Frontal Barrier
 Test Date : April 5, 2000 Time: 11:40 Temperature : 1 °C
 Vehicle Make/Model/Body Style : 2000 Ford Focus 3-Door Hatchback
 Vehicle Test Weight : 1407.0 kg
 Vehicle/Barrier Impact Angle : 0 °
 Impact Velocity : 56.65 kph
 Maximum Static Crush : 537 mm
 Vehicle Rebound : 637.3 mm

DUMMIES:

DRIVER

PASSENGER

Type :	<u>572E</u>	<u>572E</u>
Restraint System :	<u>Seatbelt, Airbag, Knee Bolster</u>	<u>Seatbelt, Airbag, Knee Bolster</u>

Number of Data Channels : 125
 Number of Cameras : 1 Real Time
16 High Speed

DOOR OPENING DATA : Closed/Operable - Left Front
Closed/Operable - Right Front

Front Seat(s) Data :

DRIVER

PASSENGER

Seat Track Failure :(mm of shift)	<u>0</u>	<u>0</u>
Seat Back Failure :	<u>None</u>	<u>None</u>

VISIBLE DUMMY CONTACT POINTS :

DRIVER

PASSENGER

Head :	<u>The face to the center of the airbag; The back of the head to the center of the headrest.</u>	<u>The face to the top center of the airbag; The back of the head to the left center of the headrest.</u>
Abdomen :	<u>-</u>	<u>-</u>
Chest	<u>Airbag</u>	<u>Airbag</u>
Knees	<u>Knee Bolster</u>	<u>Knee Bolster</u>

DATA SHEET NO. 2 GENERAL TEST AND VEHICLE PARAMETER DATA

TEST VEHICLE INFORMATION :

Year/Make/Model/Body Style : 2000 Ford Focus 3-Door Hatchback
NHTSA No. : MY0204 ; VIN: 3FAFP3132YR191423 ; Color : Silver
Engine Data: 4 cylinders; - CID; 2.0 Liters; - cc
Placement : - Longitudinal or In-Line; X Transverse or Lateral
Transmission Data : 4 speeds; - Manual; X Automatic; X Overdrive
Final Drive : - Rear Wheel Drive; X Front Wheel Drive; - Four Wheel Drive
Major Options : X A/C; X Pwr.Strg.; X Pwr. Brakes
- Pwr. Windows; X Pwr. Door Locks; - Tilt Wheel
Date Received : 3/29/2000 ; Odometer Reading 39 km
Selling Dealer : West Herr Ford
& Address: 5025 Camp Road Hamburg, New York 14075

DATA FROM TIRE VEHICLE'S CERTIFICATION LABEL:

Vehicle Manufactured by : Ford Motor Company
Date of Manufacture 3/2000
GVWR : 1610 kg; GAWR: 899 kg FRONT; 766 kg REAR

DATA FROM TIRE PLACARD:

Tire Pressure with Maximum Capacity Vehicle Load : 300 kpa FRONT
300 kpa REAR
Recommended Tire Size : P195/60R15
* Recommended Cold Tire Pressure : 221 kpa FRONT; 221 kpa REAR
Size of Tires on Test Vehicle: P195/60R15 ; Manufacturer: Goodyear
Vehicle Capacity Data :
Type of Front Seats: - Bench; X Bucket; - Split Bench
Number of Occupants: 2 Front; 3 Rear; 5 Total
Vehicle Capacity Weight (VCW) = 400.0 kg
No. of Occupants x 68 kg = 340.2 kg
Rated Cargo/Luggage Weight (RCLW) = 59.8 kg

*Tire pressure used for test

DATA SHEET NO. 2 GENERAL TEST AND VEHICLE PARAMETER DATA (cont.)

WEIGHT OF TEST VEHICLE AS RECEIVED FROM DEALER (with maximum fluids)= UDW:

Right Front	=	<u>371.5</u>	kg	Right Rear	=	<u>229.0</u>	kg
Left Front	=	<u>375.0</u>	kg	Left Rear	=	<u>224.5</u>	kg
TOTAL FRONT	=	<u>746.5</u>	kg	TOTAL REAR	=	<u>453.5</u>	kg
TOTAL DELIVERED WEIGHT	=	<u>1200.0</u>	kg				
% of Total Front of Vehicle Weight	=	<u>62.2</u>	%	% of Total Rear Weight	=	<u>37.8</u>	%

CALCULATION OF VEHICLE'S TARGET TEST WEIGHT :

Total Delivered Weight (UDW)	=	<u>1200.0</u>	kg
Rated Cargo/Luggage Weight (RCLW)	=	<u>59.8</u>	kg
Weight of 2 p.572 Dummies @ 76 each	=	<u>152.0</u>	kg
TARGET TEST WEIGHT	=	<u>1411.8</u>	kg

WEIGHT OF TEST VEHICLE WITH TWO DUMMIES AND 55 KG OF CARGO WEIGHT:

Right Front	=	<u>416.0</u>	kg	Right Rear	=	<u>291.5</u>	kg
Left Front	=	<u>406.5</u>	kg	Left Rear	=	<u>293.0</u>	kg
TOTAL FRONT	=	<u>822.5</u>	kg	TOTAL REAR	=	<u>584.5</u>	kg
TOTAL TEST WEIGHT	=	<u>1407.0</u>	kg				
% of Total Front Weight	=	<u>58.5</u>	%	% of Total Rear Weight	=	<u>41.5</u>	%
Weight of Ballast Secured in Vehicle Trunk Area	=	<u>0</u>	kg				
Vehicle Components Removed for Weight Reduction:				Rear interior trim; muffler; rear wiper and motor; tail lights, side view mirrors			

VEHICLE ATTITUDE (all dimension in millimeters):

AS DELIVERED :	RF	<u>680</u>	LF	<u>678</u>	RR	<u>701</u>	LR	<u>700</u>
FULLY LOADED :	RF	<u>663</u>	LF	<u>660</u>	RR	<u>673</u>	LR	<u>671</u>
AS TESTED :	RF	<u>670</u>	LF	<u>665</u>	RR	<u>677</u>	LR	<u>672</u>
Vehicle's Wheel Base :		<u>2613</u>	mm					
Location of Vehicle's C.G. :		<u>1085.5</u>	mm rearward of front wheel center.					

FUEL SYSTEM DATA :

Fuel System Capacity From Owner's Manual	=	<u>50.0</u>	liters
Usable Capacity Figure Furnished by COTR	=	<u>50.0</u>	liters
Test Volume Range (92 to 94% of Usable Capacity)	=	<u>46.0</u>	to <u>47.0</u> liters
ACTUAL TEST VOLUME	=	<u>46.0</u>	liters (with entire fuel system filled)
Test Fluid Type:	<u>Stoddard Solution</u> ;	Spec. Grav. =	<u>0.764</u>
	Kinematic Viscosity =	<u>0.96</u> centistokes;	Color = <u>Orange</u>
Type of Fuel Pump:	Electric- <u>X</u> ;	Mechanical-	<u>-</u>
Does Electric Pump operate with ignition switch "ON" & engine "OFF"		Yes- <u>X</u>	No- <u>-</u>
Details of Fuel System	<u>Filler Neck - Left side of the vehicle behind rear axle; Tank - Left of center, ahead of the rear axle; Lines - Inside right frame rail.</u>		

DATA SHEET NO. 3 POST IMPACT DATA

TYPE OF TEST:

Type of Test : Frontal Barrier Impact Angle : 0°
Test Date : April 5, 2000 Time: 11:40 Temperature: 1 °C
Vehicle NHTSA No. : MY0204
Required Impact Velocity Range : 55.5 to 57.1 kph

BARRIER IMPACT VELOCITY: (Speed traps within 5 feet of impact plane.)

Trap No. 1 = 56.65 kph; Trap No. 2 = 56.65 kph
Distance from vehicle to barrier : (1) entering trap = 813 mm
(2) exiting trap = 305 mm

VEHICLE STATIC CRUSH: (mm) (For frontal and rear impacts only.)

Vehicle Length:

Pre-Test Right = 4243 ; C/L = 4283 ; Left = 4253
Post-Test Right = 3725 ; C/L = 3746 ; Left = 3737
Crush Right = 518.0 ; C/L = 537.0 ; Left = 516.0
AVERAGE = 523.7 mm

VEHICLE REBOUND: (From rigid barrier only.)

Distance from front of test vehicle to impact point :
Right = 640 ; C/L = 555 ; Left = 717
AVERAGE = 637.3 mm

DATA SHEET NO. 4 TEST VEHICLE INFORMATION

VEHICLE IDENTIFICATION:

Model Year : 2000 Vehicle Model: Ford Focus Body Style : 3-Door Hatchback

1. Nominal Design Riding Position for adjustable driver and passenger seat backs. Please describe how to position the inclinometer to measure the seat back angle. Include description of the location of the adjustment latch detent, if applicable.

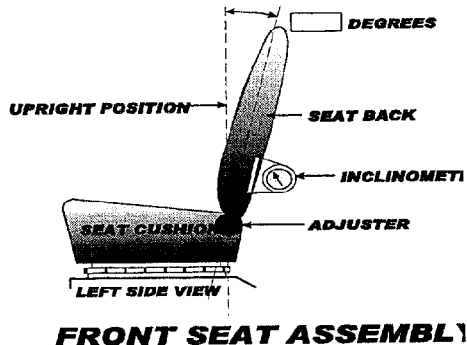

Seat back angle for driver's seat: 24°

Measurement instructions: Recline seatback to measure 24° on rear seat frame 330 mm above the seatback pivot

Seat back angle for passenger's seat: 24°

Measurement instructions: Same as the driver's seat

2. Seat Fore and Aft Positioning

Positioning of the driver's seat: Place seat in mid position; 8 detents forward of the rearmost position

Positioning of the passenger's seat: Same as the driver's seat

3. Fuel Tank Capacity Data

3.1 A. "Usable Capacity" of the standard equipment fuel tank is 50.0 liters

B. "Usable Capacity" of the optional equipment fuel tank is - liters

C. "Usable Capacity" of the vehicle(s) used for certification testing to requirements of FMVSS 301 = 50.0 liters

3.2 Amount of Stoddard solvent added to vehicle(s) used for certification test(s) = 46.0 liters

3.3 Is vehicle equipped with electric fuel pump? Yes- X ; No- -

If YES, explain the vehicle operating conditions under which the fuel pump will pump fuel.

With the ignition on, the fuel pump runs for a maximum of 3 seconds to build up fuel pressure. Fuel pump operates during engine operation.

DATA SHEET NO. 4 TEST VEHICLE INFORMATION (cont.)

4. STEERING COLUMN ADJUSTMENTS :

Steering wheel and column adjustments are made so that the steering wheel hub is at the geometric center of the locus it describes when it is moved through its full range of driving positions. If the tested vehicle has any of these adjustments, does your company use any specific procedures to determine the geometric center.

Operational Instructions: This vehicle was not equipped with an adjustable steering column

5. SEAT BELT UPPER ANCHORAGE

Nominal design riding position: Seat belt anchorage was placed one detent below uppermost position.

DUMMY MEASUREMENT FOR FRONT SEAT PASSENGER

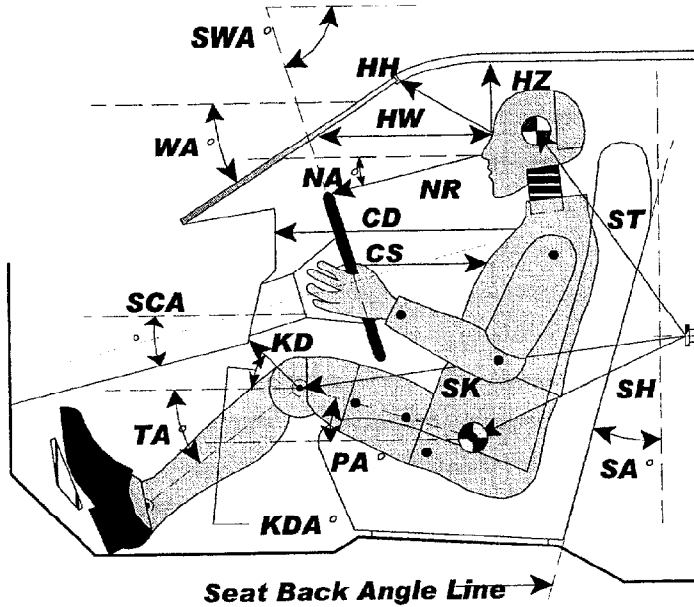

- AD - Arm to Door**
- HD - H-Point to Door**
- HR - Head to Side Header**
- HS - Head to Side Window**
- KK - Knee to Knee**
- SHY - Striker to H-Point (Y Dimension)**

- CD - Chest to Dash**
- CS - Steering Wheel to Chest**
- HH - Head to Header**
- HW - Head to Windshield**
- HZ - Head to Roof**
- KDA - Knee to Dash Angle**
- KDL - Left Knee to Dash**
- KDR - Right Knee to Dash**
- NA - Nose to Rim Angle**
- NR - Nose to Rim**
- PA - Pelvic Angle**
- RA - Rim to Abdomen**
- SA - Seat Back Angle**
- SCA - Steering Column Angle**
- SH - Striker to H-Point**
- SK - Striker to Knee**
- ST - Striker to Head**
- SWA - Steering Wheel Angle**
- TA - Tibial Angle**

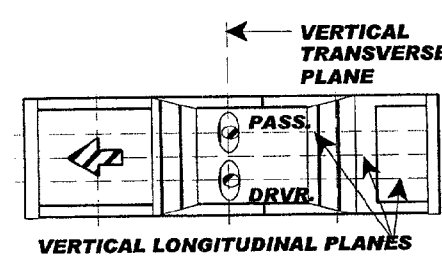
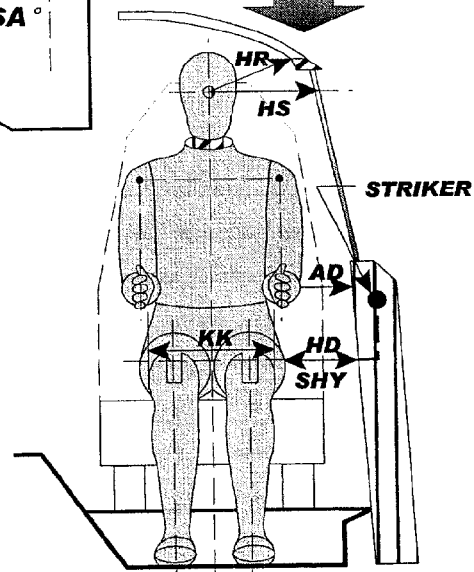

DATA SHEET NO. 5 FRONT SEAT DUMMY POSITIONING MEASUREMENTS IN VEHICLE (cont.)

	DRIVER (Serial #245)			PASS. (Serial # 064)		
WA°	28 deg.			N/A		
SWA°	23 deg.			N/A		
SCA°	67 deg.			N/A		
SA°	24 deg.			24 deg.		
HZ	189			184		
HH	344			350		
HW	614			598		
HR	185 (grab handle)			191 (grab handle)		
NR	412	Angle	-12 deg.	N/A		
CD	540			518		
CS	317			N/A		
RA	224			N/A		
KDL	146	Angle (KDA)	42 deg.	107 (dash console)		
KDR	127 (dash console)			152	Angle (KDA)	38 deg.
PA°	22 deg.			25 deg.		
TA°	-47 deg.			-44 deg.		
KK	310			280		
ST	608	Angle	33 deg.	645	Angle	33 deg.
SK	822	Angle	92 deg.	845	Angle	96 deg.
SH	470	Angle	108 deg.	463	Angle	110 deg.
SHY	230			221		
HS	312			318		
HD	100			100		
AD	94			93		

Dimensions in millimeters

SEAT BELT POSITIONING DATA

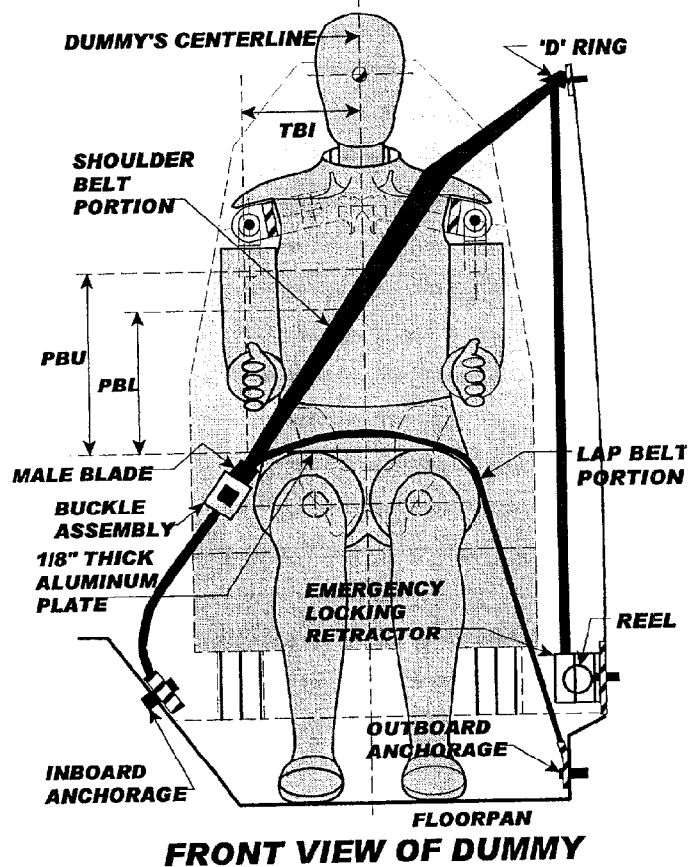

FRONT VIEW OF DUMMY

	DRIVER DUMMY (mm)	PASSENGER DUMMY (mm)
PBU -- Top surface of alum. plate to upper edge	370	372
PBL-- Top surface of alum. plate to belt lower edge	287	288
<u>LAP BELT TENSION</u>	10 N	10 N (Pretensioner)
<u>SHOULDER BELT TENSION</u>	Retractor (Pretensioner)	Retractor

VEHICLE ACCELEROMETER LOCATION AND DATA SUMMARY

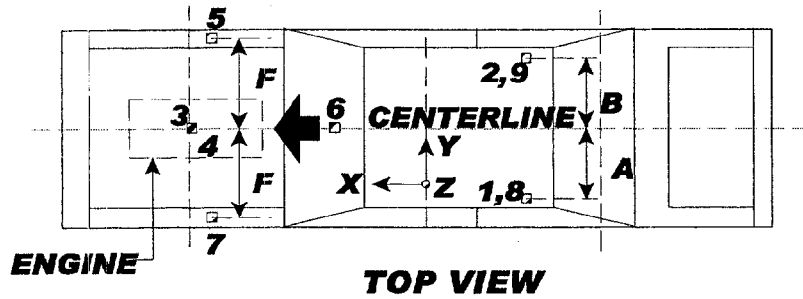

REAR SEAT CUSHION ASSY. FRONT ATTACHMENT BRACKET SUPPORT

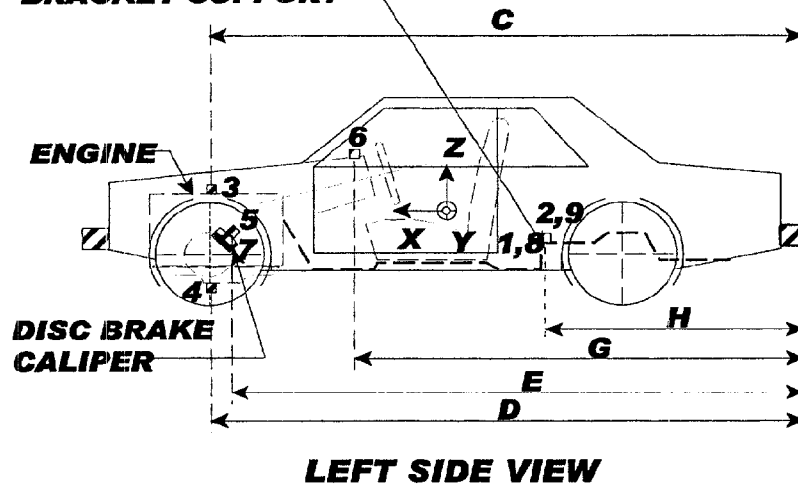

Note: Vehicle accelerometer location and data summary shown in DATA SHEET NO. 7

DATA SHEET NO. 7 VEHICLE ACCELEROMETER LOCATIONS AND DATA SUMMARY (cont.)

DIMENSION	LENGTH (mm)
	PRE-TEST VALUES
A Left Rear Seat Crossmember Y	-471
B Right Rear Seat Crossmember Y	473
C Top of Engine X	3615
D Bottom of Engine X	3232
E Disc Brake Calipers X	3376
F Disc Brake Calipers Y	573
G Instrument Panel X	2570
H Rear Seat Crossmembers X	1581

LOCATION NUMBER	DESCRIPTION	MAXIMUM VALUE (g's)			
		Pos.	msec.	Neg.	msec.
1	Rear Seat X-Member @ Left Side	2.5	175.1	-38.9	44.1
2	Rear Seat X-Member @ Right Side	2.6	154.5	-41.2	36.5
3	Top of Engine Block	29.4	47.0	-123.3	31.1
4	Bottom of Engine	21.9	41.5	-101.6	25.2
5	Disc Brake Caliper @ Right Side	*	*	*	*
6	Instrument Panel	9.2	29.3	-100.3	62.4
7	Disc Brake Caliper @Left Side	25.1	74.6	-118.1	45.0
8	Rear Seat X-Member @ Left-Redundant	3.5	133.9	-39.6	44.2
9	Rear Seat X-Member @ Right-Redundant	2.6	154.4	-41.0	36.5

*Not accurate after 40 ms

DATA SHEET NO. 8 DUMMY INJURY CRITERIA VALUES

Vehicle Year/Make/Model/Body Style: 2000 Ford Focus 3-Door Hatchback
 NHTSA Test No.: MY0204 Test Date: April 5, 2000

DESCRIPTION	Unit	MAXIMUM VALUE							
		Driver				Passenger			
		Pos	msec	Neg	msec	Pos	msec	Neg	msec
Head X	g	10.9	233.6	-54.0	80.0	3.6	280.9	-38.4	93.1
Head Y	g	15.7	87.3	-3.4	228.5	2.6	28.6	-15.0	101.3
Head Z	g	22.7	57.9	-9.9	96.9	25.4	65.8	-2.3	99.7
Head Resultant	g	56.0	80.0	0.0	-26.0	41.6	88.3	0.0	-23.8
Redundant Head X	g	11.0	233.6	-56.4	80.1	3.9	280.9	-45.2	102.9
Redundant Head Y	g	18.1	87.5	-2.0	228.4	2.3	28.6	-15.4	101.5
Redundant Head Z	g	26.5	45.2	-8.6	97.3	26.4	73.0	-4.7	122.9
Redundant Head Resultant	g	57.9	80.1	0.0	-26.6	47.8	102.9	0.0	-18.7
Upper Neck Fx	N	679.4	82.2	-413.3	114.2	226.7	81.7	-581.4	132.0
Upper Neck Fy	N	231.0	123.3	-155.9	79.5	84.1	62.1	-167.7	140.4
Upper Neck Fz	N	1111.9	54.6	-408.8	274.2	1380.1	72.9	-175.8	101.9
Upper Neck F Resultant	N	1122.2	54.5	0.7	-24.7	1384.9	72.9	0.8	-24.8
Upper Neck Mx	N-m	16.8	80.0	-4.5	256.7	21.3	100.2	-9.4	147.5
Upper Neck My	N-m	45.9	128.9	-27.9	282.8	47.9	123.3	-36.1	101.5
Upper Neck Mz	N-m	8.6	140.3	-21.3	97.2	13.5	98.4	-3.5	154.4
Upper Neck M Resultant	N-m	48.4	129.0	0.0	-28.8	48.0	123.3	0.0	-35.5
Chest X	g	2.4	270.1	-40.0	75.1	1.0	150.9	-43.1	68.5
Chest Y	g	3.8	81.3	-5.2	48.8	3.7	47.5	-10.8	80.2
Chest Z	g	18.2	96.0	-9.5	45.5	8.2	66.0	-10.4	101.2
Chest Resultant	g	40.2	75.1	0.0	-24.8	44.2	68.3	0.1	-23.1
Redundant Chest X	g	2.4	269.9	-40.4	56.6	1.2	151.6	-42.9	69.1
Redundant Chest Y	g	4.5	89.8	-3.8	48.9	4.5	47.5	-9.0	81.7
Redundant Chest Z	g	18.6	96.3	-9.9	46.0	8.1	85.1	-8.6	101.0
Redundant Chest Resultant	g	41.2	56.5	0.0	-24.7	43.6	69.0	0.1	-24.0
Chest Displacement	mm	0.0	-33.3	-31.0	64.7	0.0	9.1	-24.3	68.8

DATA SHEET NO. 8 DUMMY INJURY CRITERIA VALUES (cont.)

Vehicle Year/Make/Model/Body Style: 2000 Ford Focus 3-Door Hatchback
 NHTSA Test No.: MY0204 Test Date: April 5, 2000

DESCRIPTION	Unit	MAXIMUM VALUE							
		Driver				Passenger			
		Pos	msec	Neg	msec	Pos	msec	Neg	msec
Pelvic X	g	5.8	91.6	-84.3	50.1	2.7	120.2	-74.7	50.7
Pelvic Y	g	9.3	51.2	-8.0	49.1	6.6	82.8	-8.7	65.3
Pelvic Z	g	2.9	264.5	-26.2	69.2	1.5	278.3	-24.8	80.5
Pelvic Resultant	g	85.4	50.2	0.0	-27.2	75.7	50.7	0.1	-46.3
Left Femur*	N	993.9	46.2	-4636.7	50.5	357.0	39.6	-4866.7	46.8
Right Femur	N	772.1	43.4	-4407.1	50.7	294.7	42.4	-6822.3	50.9
Left Upper Tibia Mx	N-m	10.6	77.7	-44.1	61.2	41.4	66.7	-14.6	113.2
Left Upper Tibia My	N-m	13.7	108.1	-154.6	59.1	7.3	124.8	-167.5	62.5
Left Lower Tibia Fz	N	100.9	110.2	-2622.9	60.3	153.5	123.5	-3730.1	46.8
Left Lower Tibia Mx	N-m	142.7	59.7	-4.3	33.4	23.4	47.2	-34.6	65.0
Left Lower Tibia My	N-m	62.9	85.8	-37.5	52.0	38.0	76.2	-84.8	47.7
Right Upper Tibia Mx	N-m	31.6	52.2	-23.7	60.8	28.3	48.7	-22.4	43.1
Right Upper Tibia My	N-m	11.3	106.6	-94.2	56.1	8.2	299.9	-207.6	60.2
Right Lower Tibia Fz	N	100.4	113.4	-3608.8	54.7	66.4	299.0	-3456.4	60.5
Right Lower Tibia Mx	N-m	8.8	44.3	-99.2	56.4	64.5	47.9	-10.5	36.5
Right Lower Tibia My	N-m	100.9	59.4	-59.4	46.7	88.5	76.1	-35.8	44.3
Left Foot Aft Ax	g	19.6	89.5	-78.2	49.4	30.3	69.3	-155.7	46.8
Left Foot Aft Az	g	11.9	65.2	-45.6	49.6	8.8	58.7	-74.2	47.8
Left Foot Fore Az	g	14.9	51.1	-51.8	56.8	**	**	**	**
Right Foot Aft Ax	g	22.2	61.2	-182.9	47.9	40.6	70.0	-84.8	55.0
Right Foot Aft Az	g	23.1	66.3	-92.3	46.3	13.3	68.7	-48.7	58.8
Right Foot Fore Az	g	37.7	56.5	-191.5	44.7	46.0	70.1	-96.0	58.5
Lap Belt Load	N	***	***	***	***	***	***	***	***
Torso Belt	N	***	***	***	***	***	***	***	***

* Not accurate after 106 ms

** Not accurate after 130 ms

*** Due to the driver torso belt and passenger lap belt seat belt pretensioner systems, seat belt load cells were not used at the request of Ford Motor Company representatives.

DATA SHEET NO. 8 DUMMY INJURY CRITERIA VALUES (cont.)

Vehicle Year/Make/Model/Body Style: 2000 Ford Focus 3-Door Hatchback
 NHTSA Test No.: MY0204 Test Date: April 5, 2000

HEAD INJURY CRITERIA (HIC)				
	HIC**	t ₁ (msec)	t ₂ (msec)	Average Acceleration t ₁ to t ₂
Position #1 - Driver	366.2	62.7	96.1	41.3
Position #2 - Passenger	329.1	72.6	108.6	38.4

** HIC is as defined in FMVSS 208. The maximum time interval from t₁ to t₂ is 36 milliseconds.

CLIP SUMMARY*				
	CLIP (g's)	t ₁ (msec)	t ₂ (msec)	CSI
Position #1 - Driver	39.3	73.5	76.5	403.8
Position #2 - Passenger	41.6	67.1	70.1	358.7

* The maximum chest resultant acceleration is defined as the maximum acceleration which exceeds 0.003 seconds in duration.

**DATA SHEET NO. 8 DUMMY INJURY CRITERIA VALUES (cont.)
REDUNDANT DATA**

Vehicle Year/Make/Model/Body Style: 2000 Ford Focus 3-Door Hatchback
 NHTSA Test No.: MY0204 Test Date: April 5, 2000

HEAD INJURY CRITERIA (HIC) REDUNDANT				
	HIC**	t₁ (msec)	t₂ (msec)	Average Acceleration t₁ to t₂
Position #1 - Driver	400.4	63.8	95.0	44.0
Position #2 - Passenger	447.0	75.4	111.3	43.4

** HIC is as defined in FMVSS 208. The maximum time interval from t₁ to t₂ is 36 milliseconds.

CLIP SUMMARY* REDUNDANT				
	CLIP (g's)	t₁ (msec)	t₂ (msec)	CSI
Position #1 - Driver	39.3	55.2	58.2	425.6
Position #2 - Passenger	40.5	67.2	70.2	319.8

* The maximum chest resultant acceleration is defined as the maximum acceleration which exceeds 0.003 seconds in duration.

DATA SHEET NO. 9 SEAT BELT PERFORMANCE ASSESSMENT TEST DATA

BELT LENGTH DATA:

	<u>Driver</u>	<u>Passenger</u>
Belt length from trim panel exit to bolt hole anchor point for continuous webbing systems.	<u>1960</u>	<u>1965</u>
Shoulder belt length as measured on Part 572 Dummy.	<u>1035</u>	<u>1005</u>
Lap belt length as measured on Part 572 Dummy.	<u>925</u>	<u>960</u>

SHOULDER BELT SPOOL-OFF DATA:

As determined by film analysis.	<u>165</u>	<u>254</u>
As determined mechanically.	<u>*</u>	<u>*</u>
As determined electronically.	<u>*</u>	<u>*</u>

BELT STRETCH DATA:

Measured electronically between shoulder belt load cell and the "D" ring.	<u>*</u>	<u>*</u>
Measured mechanically.	<u>*</u>	<u>*</u>

_____ Dimensions in millimeters

* This vehicle was equipped with electronic seat belt pretensioners and load limiters. At the request of Ford Motor Company representatives seat belt instrumentation was not used.

DATA SHEET NO.10 SUMMARY OF FMVSS 212 DATA

FMVSS NO. 212 - "WINDSHIELD MOUNTING" DATA

DETAILS OF WINDSHIELD MOUNTING SUCH AS RETENTION METHOD, TRIM TYPE, ETC.:

Windshield is bonded in place and covered with a 15 mm molding.

FMVSS 212 REQUIREMENTS:

The Post-Test periphery retention amount must be at least 75% of the Pre-Test periphery measurement for vehicles NOT equipped with automatic restraints, and 50% for each side of the windshield for vehicles equipped with automatic restraint systems for front occupants,

FMVSS 212 TEST DATA

	WINDSHIELD PERIPHERY		% OF RETENTION
	PRE-TEST (mm)	POST-TEST(mm)	
RIGHT SIDE	2120	2120	100
LEFT SIDE	2120	2120	100
TOTAL	4240	4240	100

AREA OF RETENTION FAILURE: None

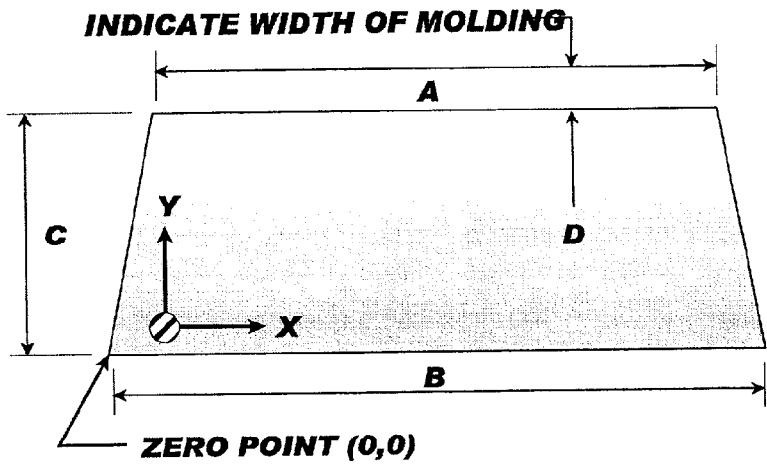

DIMENSIONS (mm)	
A	1130
B	1510
C	800
D	15

FRONT VIEW OF WINDSHIELD

FAILURE DETAILS: None

DATA SHEET NO. 11 FMVSS NO. 219 (PARTIAL) - "WINDSHIELD ZONE INTRUSION" DATA

PROTECTED ZONE LOWER EDGE REQUIREMENT:

The lower edge of the protected zone is determined by placing a 165 mm diameter rigid sphere weighing 6.8 kg in a position such that it simultaneously contacts the inner surface of the windshield and the top surface of the instrument panel including padding. The locus of points is drawn on the inner surface of the windshield contacted by the sphere across the width of the instrument panel. From the outermost contactable points extend the locus line horizontally to the edges of the windshield, then draw a line on the inner surface of the windshield below and 13 mm distant from the locus line. The LOWER EDGE OF THE PROTECTED ZONE is the longitudinal projection of this line onto the outer surface of the windshield.

FMVSS 219 TEST DATA:

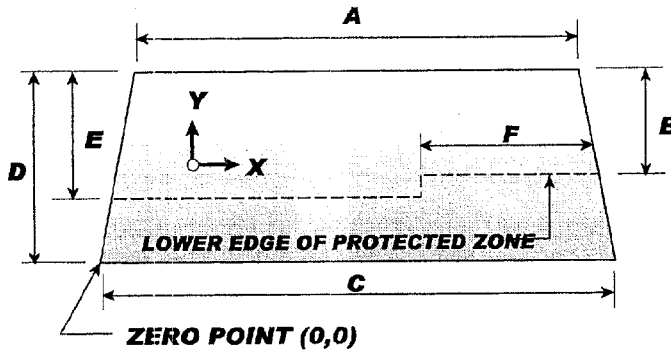

DIMENSIONS (mm)	
A	1130
B	480
C	1510
D	800
E	522
F	711

FRONT VIEW OF WINDSHIELD

DETAILS OF WINDSHIELD GLASS PENETRATION GREATER THAN 6 mm: None

(Show location of penetration on the above sketch)

	COORDINATES	
	X	Y
1.	-	-
2.	-	-
3.	-	-
4.	-	-

DATA SHEET NO. 12 FMVSS NO. 301-75 "FUEL SYSTEM INTEGRITY" POST IMPACT TEST DATA

NHTSA TEST No.: MY0204 TEST DATE: April 5, 2000
VEHICLE MAKE/MODEL: 2000 Ford Focus

The test vehicle was filled from 92% to 94% of the manufacturer's "usable" capacity. The electric fuel pump was operating if it will operate without engine operation. Two Part 572 anthropomorphic test devices were located at each of the front designated seating positions.

=====

TEST VEHICLE IMPACT TYPE: X Frontal (56 kph)
- Oblique (48 kph) with _____ deg. barrier face first contacting _____ (driver/passenger) side
- Rear Moving Barrier (48 kph)
- Lateral Moving Barrier (32 kph)

FUEL SPILLAGE MEASUREMENT:

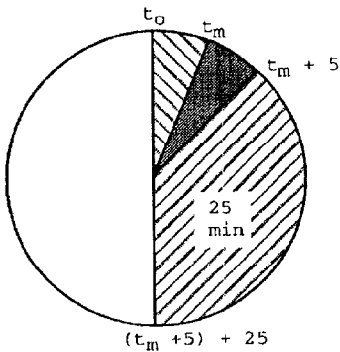

1. From impact until vehicle motion ceases
2. For 5 minute period after vehicle motion ceases
3. For next 25 minutes

ACTUAL	MAX ALLOWED
0	28 g
0	141 g
0	28 g/min.

SOLVENT SPILLAGE DETAILS: None

DATA SHEET 13

FMVSS NO. 301 STATIC ROLLOVER DATA SHEET

Vehicle: 2000 Ford Focus

NHTSA No. MY0204

0 - 90 Degrees

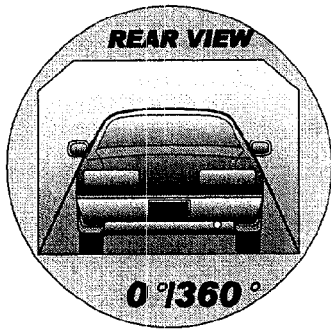

I. DETERMINATION OF SOLVENT COLLECTION TIME PERIOD :

Rollover Fixture 90° Rotation Time (Spec. Range = 1 to 3 minutes)	<u>1</u> minutes	<u>17</u> seconds
FMVSS 301 Position Hold Time +	<u>5</u> minutes	<u>0</u> seconds
TOTAL	<u>6</u> minutes	<u>17</u> seconds
Next whole minute interval	<u>7</u> minutes	

II. FMVSS 301 REQUIREMENTS :

(1) Time Period

First 5 minutes FROM onset of rotation	6th min.	7th min.	8th min. (if required)
--	----------	----------	------------------------

(2) Maximum Allowable Solvent Spillage

142 g	28 g	28 g	28 g
-------	------	------	------

III. ACTUAL TEST VEHICLE SOLVENT SPILLAGE:

0 g	0 g	0 g	N/A
-----	-----	-----	-----

Note: Record spillage for whole minute intervals only as determined above.

IV. SOLVENT SPILLAGE LOCATION(S) :

None

DATA SHEET 13

FMVSS NO. 301 STATIC ROLLOVER DATA SHEET (CONTINUED)

Vehicle: 2000 Ford Focus

NHTSA No. MY0204

90 - 180 Degrees

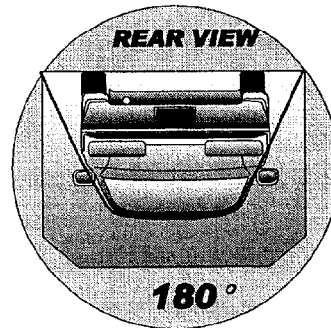
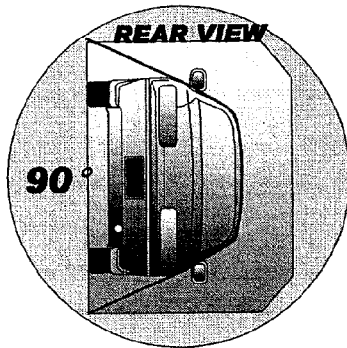

I. DETERMINATION OF SOLVENT COLLECTION TIME PERIOD :

Rollover Fixture 90° Rotation Time	<u>1</u>	minutes	<u>08</u>	seconds
(Spec. Range = 1 to 3 minutes)				
FMVSS 301 Position Hold Time +	<u>5</u>	minutes	<u>0</u>	seconds
TOTAL	<u>6</u>	minutes	<u>8</u>	seconds
Next whole minute interval	<u>7</u>	minutes		

II. FMVSS 301 REQUIREMENTS :

(1) Time Period

First 5 minutes FROM onset of rotation	6th min.	7th min.	8th min. (if required)
--	----------	----------	------------------------

(2) Maximum Allowable Solvent Spillage

142 g	28 g	28 g	28 g
-------	------	------	------

III. ACTUAL TEST VEHICLE SOLVENT SPILLAGE:

0 g	0 g	0 g	N/A
-----	-----	-----	-----

Note: Record spillage for whole minute intervals only as determined above.

IV. SOLVENT SPILLAGE LOCATION(S) :

None

DATA SHEET 13

FMVSS NO. 301 STATIC ROLLOVER DATA SHEET (CONTINUED)

Vehicle: 2000 Ford Focus

NHTSA No. MY0204

180 - 270 Degrees

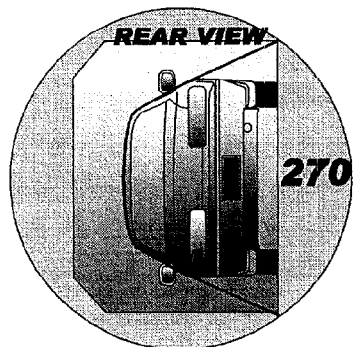
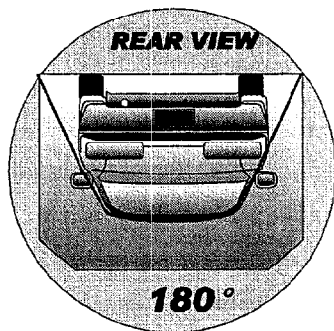

I. DETERMINATION OF SOLVENT COLLECTION TIME PERIOD :

Rollover Fixture 90° Rotation Time	<u>1</u> minutes	<u>03</u> seconds
(Spec. Range = 1 to 3 minutes)		
FMVSS 301 Position Hold Time +	<u>5</u> minutes	<u>0</u> seconds
TOTAL	<u>6</u> minutes	<u>3</u> seconds
Next whole minute interval	<u>7</u> minutes	

II. FMVSS 301 REQUIREMENTS :

(1) Time Period

First 5 minutes FROM onset of rotation	6th min.	7th min.	8th min. (if required)
--	----------	----------	------------------------

(2) Maximum Allowable Solvent Spillage

142 g	28 g	28 g	28 g
-------	------	------	------

III. ACTUAL TEST VEHICLE SOLVENT SPILLAGE:

0 g	0 g	0 g	N/A
-----	-----	-----	-----

Note: Record spillage for whole minute intervals only as determined above.

IV. SOLVENT SPILLAGE LOCATION(S) :

None

DATA SHEET 13

FMVSS NO. 301 STATIC ROLLOVER DATA SHEET (CONTINUED)

Vehicle: 2000 Ford Focus

NHTSA No. MY0204

270 - 360 Degrees

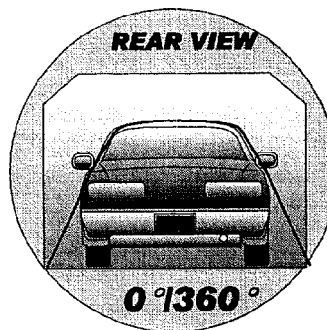
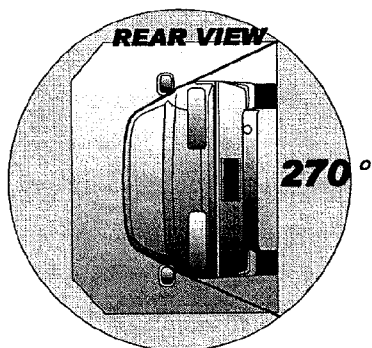

I. DETERMINATION OF SOLVENT COLLECTION TIME PERIOD :

Rollover Fixture 90° Rotation Time	<u>1</u> minutes	<u>14</u> seconds
(Spec. Range = 1 to 3 minutes)		
FMVSS 301 Position Hold Time +	<u>5</u> minutes	<u>0</u> seconds
TOTAL	<u>6</u> minutes	<u>14</u> seconds
Next whole minute interval	<u>7</u> minutes	

II. FMVSS 301 REQUIREMENTS :

(1) Time Period

First 5 minutes FROM onset of rotation	6th min.	7th min.	8th min. (if required)
--	----------	----------	------------------------

(2) Maximum Allowable Solvent Spillage

142 g	28 g	28 g	28 g
-------	------	------	------

III. ACTUAL TEST VEHICLE SOLVENT SPILLAGE:

0 g	0 g	0 g	N/A
-----	-----	-----	-----

Note: Record spillage for whole minute intervals only as determined above.

IV. SOLVENT SPILLAGE LOCATION(S) :

None

DATA SHEET NO. 14 TEST VEHICLE MEASUREMENTS

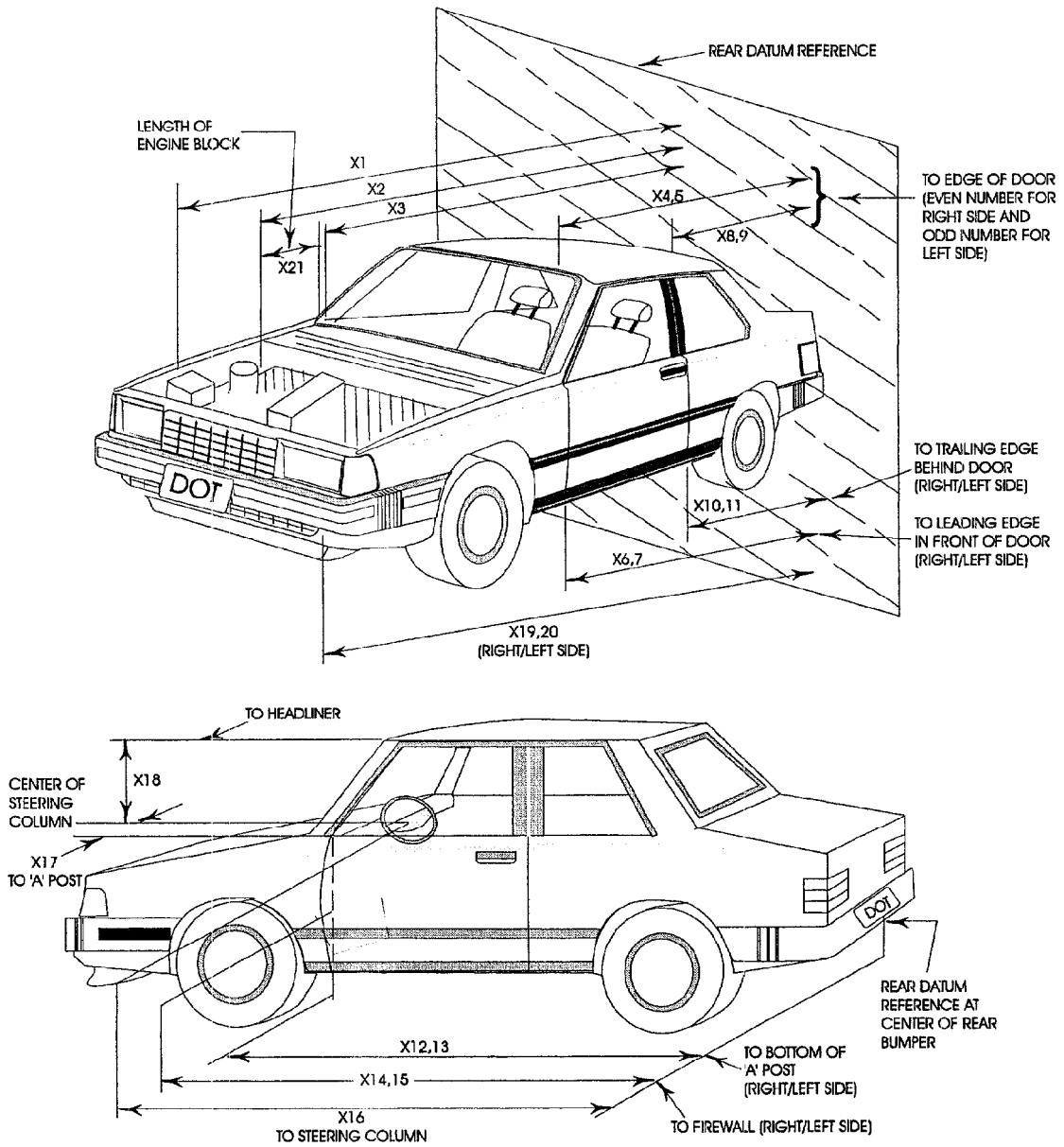

DATA SHEET NO.14 VEHICLE MEASUREMENTS (cont.)

No.		Pre-Test	Post-Test	Differences
X1	Total Length of Vehicle at Centerline	4283	3746	537
X2	Rear Surface of Vehicle to Front of Engine	3855	3505	350
X3	Rear Surface of Vehicle to Firewall	3377	3260	117
X4	Rear Surface of Vehicle to Upper Leading Edge of Right Door	2900	2901	-1
X5	Rear Surface of Vehicle to Upper Leading Edge of Left Door	2909	2904	5
X6	Rear Surface of Vehicle to Lower Leading Edge of Right Door	2865	2872	-7
X7	Rear Surface of Vehicle to Lower Leading Edge of Left Door	2871	2870	1
X8	Rear Surface of Vehicle to Upper Trailing Edge of Right Door	1632	1635	-3
X9	Rear Surface of Vehicle to Upper Trailing Edge of Left Door	1648	1638	10
X10	Rear Surface of Vehicle to Lower Trailing Edge of Right Door	1674	1677	-3
X11	Rear Surface of Vehicle to Lower Trailing Edge of Left Door	1697	1717	-20
X12	Rear Surface of Vehicle to Bottom of "A" Post of Right Side	3000	2996	4
X13	Rear Surface of Vehicle to Bottom of "A" Post of Left Side	3003	2975	28
X14	Rear Surface of Vehicle to Firewall, Right Side	3366	3231	135
X15	Rear Surface of Vehicle to Firewall, Left Side	3375	3213	162
X16	Rear Surface of Vehicle to Steering Column	2450	2468	-18
X17	Center of Steering Column to "A" Post	292	306	-14
X18	Center of Steering Column to Headliner	413	453	-40
X19	Rear Surface of Vehicle to Right Side of Front Bumper	4243	3725	518
X20	Rear Surface of Vehicle to Left Side of Front Bumper	4253	3737	516
X21	Length of Engine Block	318	318	0
RD	Rear Surface of Vehicle to Right Side of Dash Panel	2586	2582	4
CD	Rear Surface of Vehicle to Center of Dash Panel	2677	2695	-18
LD	Rear Surface of Vehicle to Left Side of Dash Panel	2602	2585	17

All Dimensions in mm

DATA SHEET NO.14 VEHICLE MEASUREMENTS (cont.)
VEHICLE INTRUSION MEASUREMENTS
DOOR OPENING WIDTH

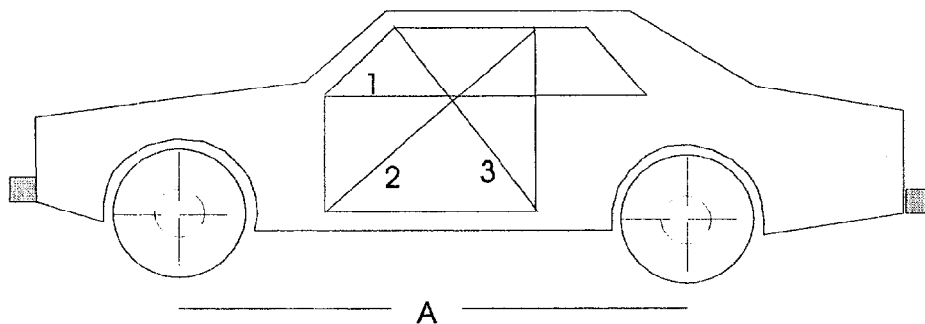

UNITS (mm)	LEFT			RIGHT		
MEASUREMENT	1	2	3	1	2	3
BEFORE TEST	1254	1554	1164	1248	1552	1161
AFTER TEST	1249	1554	1176	1233	1557	1172
DIFFERENCE	5	0	-12	15	-5	-11

UNITS (mm)	A = WHEELBASE LEFT	A = WHEELBASE RIGHT
BEFORE TEST	2616	2613
AFTER TEST	2560	2518
DIFFERENCE	56	95

DATA SHEET NO.14 VEHICLE MEASUREMENTS (cont.)
VEHICLE INTRUSION MEASUREMENTS
STATIC FOOTWELL DEFORMATION

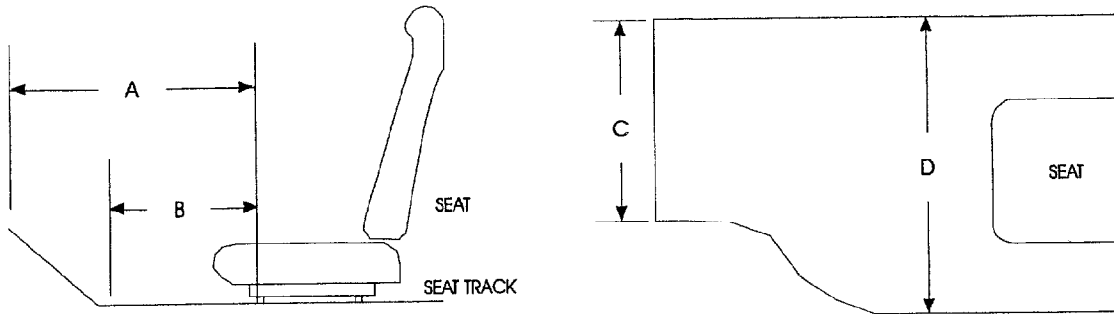

DRIVER

Measurement	Pre-Test	Post-Test	Difference
A	677	614	63
B	519	501	18
C	511	434	77
D	461	455	6

PASSENGER

Measurement	Pre-Test	Post-Test	Difference
A	688	575	113
B	557	487	70
C	496	475	21
D	462	463	-1

Units = mm

DATA SHEET NO.14 VEHICLE MEASUREMENTS (cont.)
VEHICLE INTRUSION MEASUREMENTS
STATIC PASSENGER COMPARTMENT INTRUSION

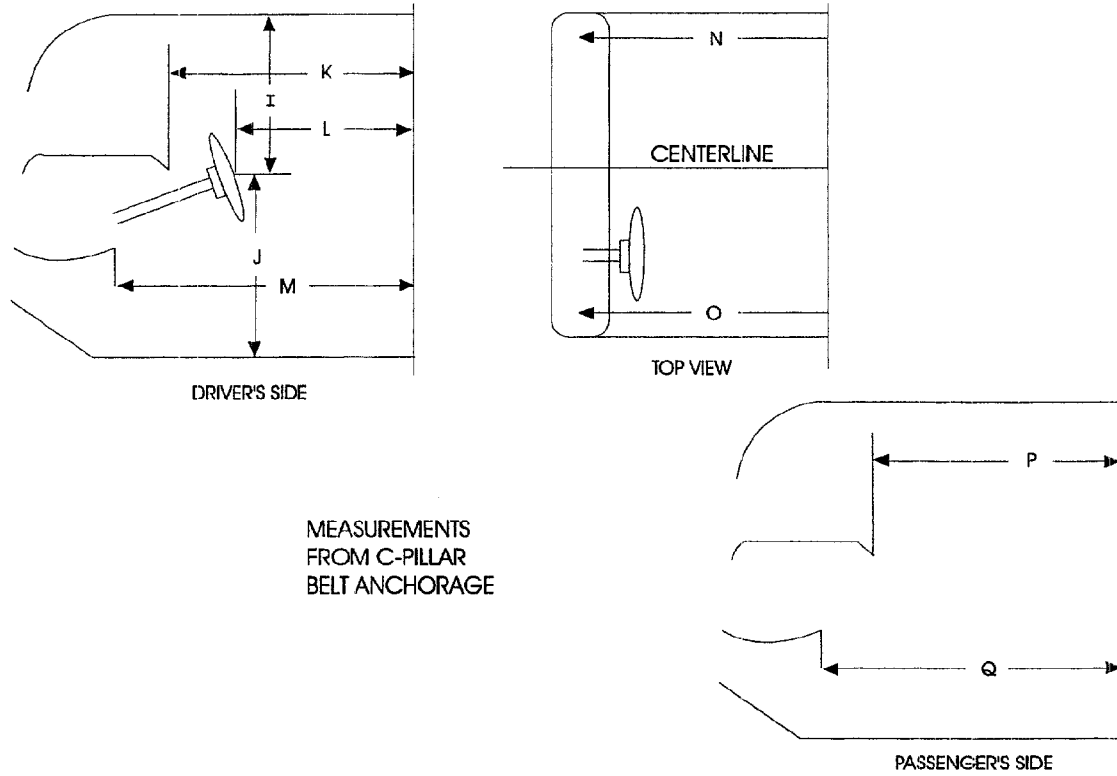

Measurement	Pre-Test	Post-Test	Difference
I	413	453	-40
J	647	607	40
K	1000	997	3
L	802	829	-27
M	996	1003	-7
N	949	946	3
O	954	946	8
P = K (PASS.)	1107	1114	-7
Q = M (PASS.)	1000	1000	0

Units = mm

DATA SHEET NO.14 VEHICLE MEASUREMENTS (cont.)
FLOORBOARD DEFORMATION

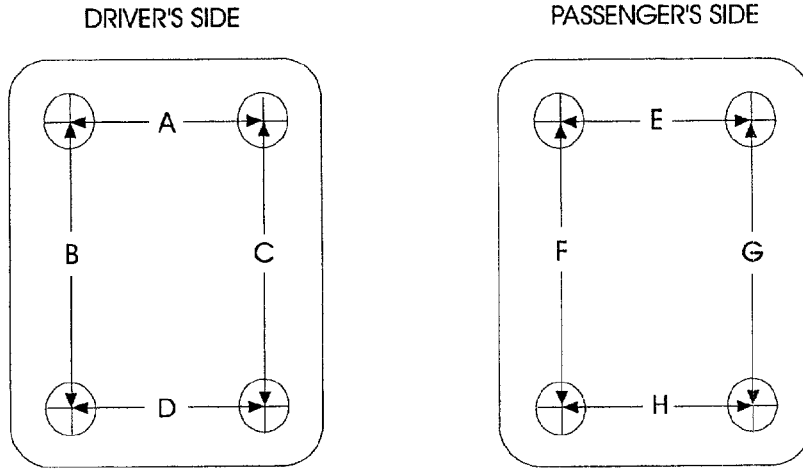

TOP VIEW THROUGH FLOOR PAN

Measurement	Pre-Test	Post-Test	Difference
A	165	171	-6
B	355	349	6
C	348	329	19
D	182	183	-1
E	200	199	1
F	400	397	3
G	357	345	12
H	195	188	7

Units = mm

DATA SHEET NO.14 VEHICLE MEASUREMENTS (cont.)
TOE-PAN INTRUSION

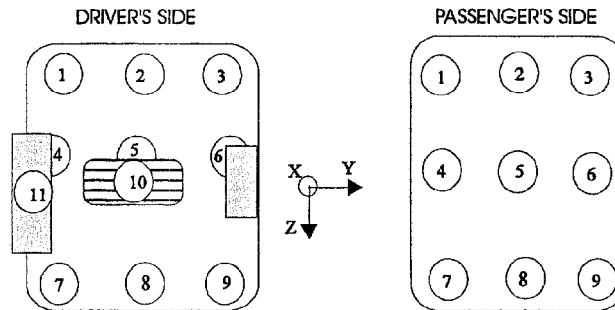

Driver Side Floorpan Measurements

Reference: X = Rear Bumper; Z = Ground

Floorpan Location	X Deformation			Z Deformation		
	Pre-Test	Post-Test	Difference	Pre-Test	Post-Test	Difference
1	3075	2995	80	-420	-452	32
2	3056	2979	77	-398	-430	32
3	3043	2955	88	-352	-431	79
4	2986	2938	48	-365	-383	18
5	2993	2951	42	-324	-349	25
6	2949	2927	22	-298	-320	22
7	2905	2860	45	-294	-315	21
8	2897	2866	31	-299	-315	16
9	2914	2884	30	-304	-283	-21
10	2916	2784	132	-455	-492	37
11	2949	2890	59	-412	-418	6

Passenger Side Floorpan Measurements

Reference: X = Rear Bumper; Z = Ground

Floorpan Location	X Deformation			Z Deformation		
	Pre-Test	Post-Test	Difference	Pre-Test	Post-Test	Difference
1	3036	2947	89	-365	-358	-7
2	3052	2942	110	-413	-368	-45
3	3047	2942	105	-406	-367	-39
4	2977	2851	126	-362	-322	-40
5	2992	2853	139	-366	-320	-46
6	3004	2875	129	-367	-323	-44
7	2905	2777	128	-287	-270	-17
8	2922	2854	68	-295	-314	19
9	2935	2854	81	-324	-299	-25

Units in mm

DATA SHEET NO.15 HIGH-SPEED CAMERA LOCATIONS

NOTE: Camera information shown in DATA SHEET NO. 15.

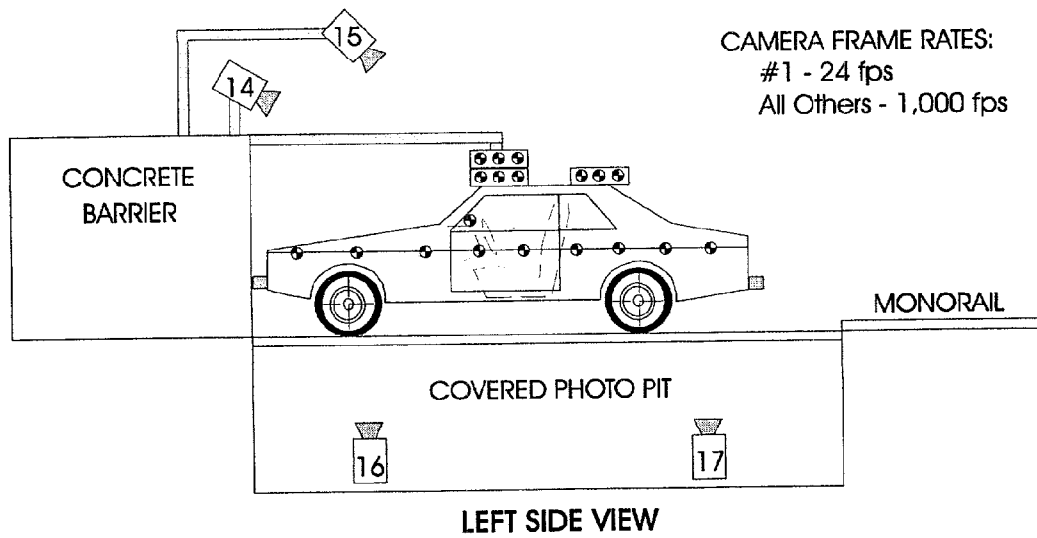
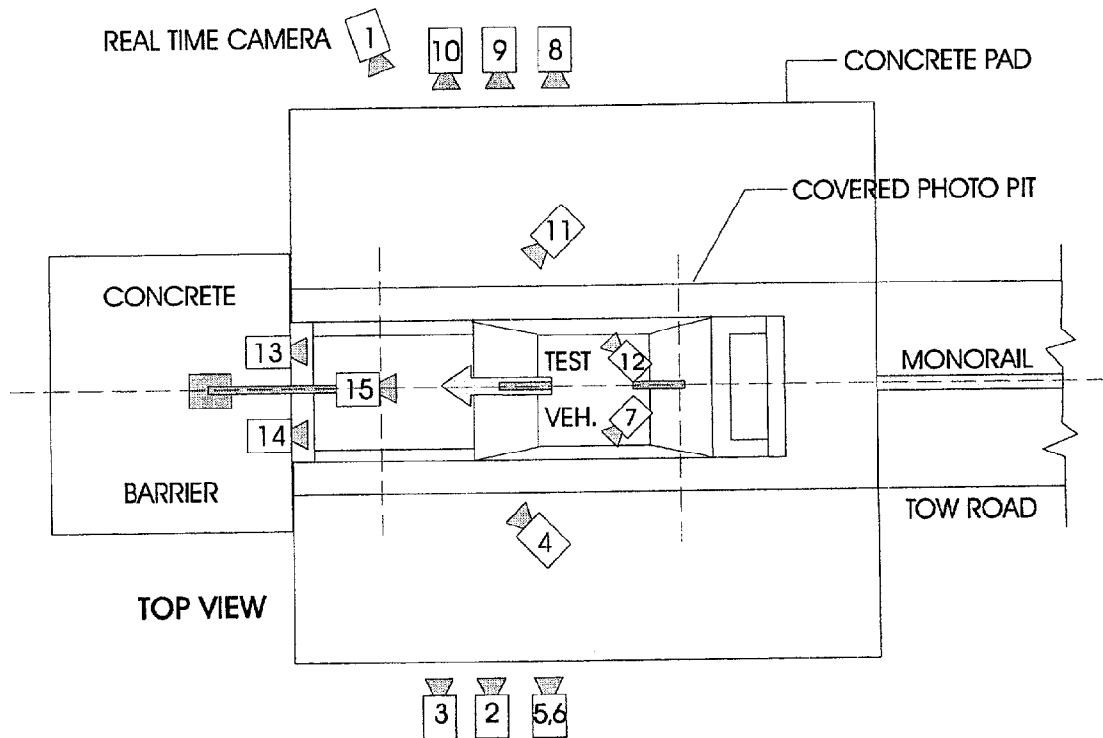

CAMERA FRAME RATES:
 #1 - 24 fps
 All Others - 1,000 fps

DATA SHEET NO.15 HIGH-SPEED CAMERA LOCATIONS (cont.)

NHTSA Test No.: MY0204 Vehicle: 2000 Ford Focus 3-Door Hatchback

CAMERA NO.	VIEW	CAMERA POSITIONS (mm)*			ANGLE (deg)**	FILM PLANE TO HEAD TARGET	LENS (mm)	SPEED (fps)
		X	Y	Z				
1	Real-Time Camera	-	-	-	-	-	-	24
2	Overall Left Side	6367	1542	1035	-4	5965	12.5	1005
3	Left Side View	7646	1002	1090	-3	7244	25	1010
4	Driver and Interior View	7113	2514	1918	-8	-	25	1055
5	Steering Column (Bottom)	7386	1853	1172	-4	6984	25	1010
6	Steering Column (Top)	7386	1853	1776	-9	6984	25	1015
7	Left Belt	-	-	-	-	-	13	1025
8	Overall Right Side	6381	1729	1022	-1	5979	12.5	1005
9	Right Side View	7947	1234	1045	-1	7545	25	1000
10	Right Passenger View	7288	1678	1400	-2	6886	35	1015
11	Passenger and Interior View	6993	2521	1970	-8	-	25	1005
12	Right Belt	-	-	-	-	-	13	1030
13	Passenger Front View	614	-104	1964	-40	-	13	1005
14	Driver Front View	614	-104	1967	-40	-	13	1005
15	Windshield View	0	-534	3374	-63	-	13	1005
16	Pit View of Engine	0	903	-3048	90	-	13	1050
17	Pit View of Fuel Tank	0	2563	-3048	90	-	13	1000

*X = film plane to monorail centerline

** = referenced to horizontal plane

Y = film plane to impact location

N.T. indicates No Timing

Z = film plane to ground

DATA SHEET NO. 16 VEHICLE REFERENCE PHOTO TARGET LOCATIONS

(Dimensions in millimeters)

A	326
B	504
C	1219
D	2063
E	273
F	1553
G	885
H	897
I	93
J	1423
K	990
L	1086
M	288
N	94
O	884
P	905
Q	1072
R	978
S	1429

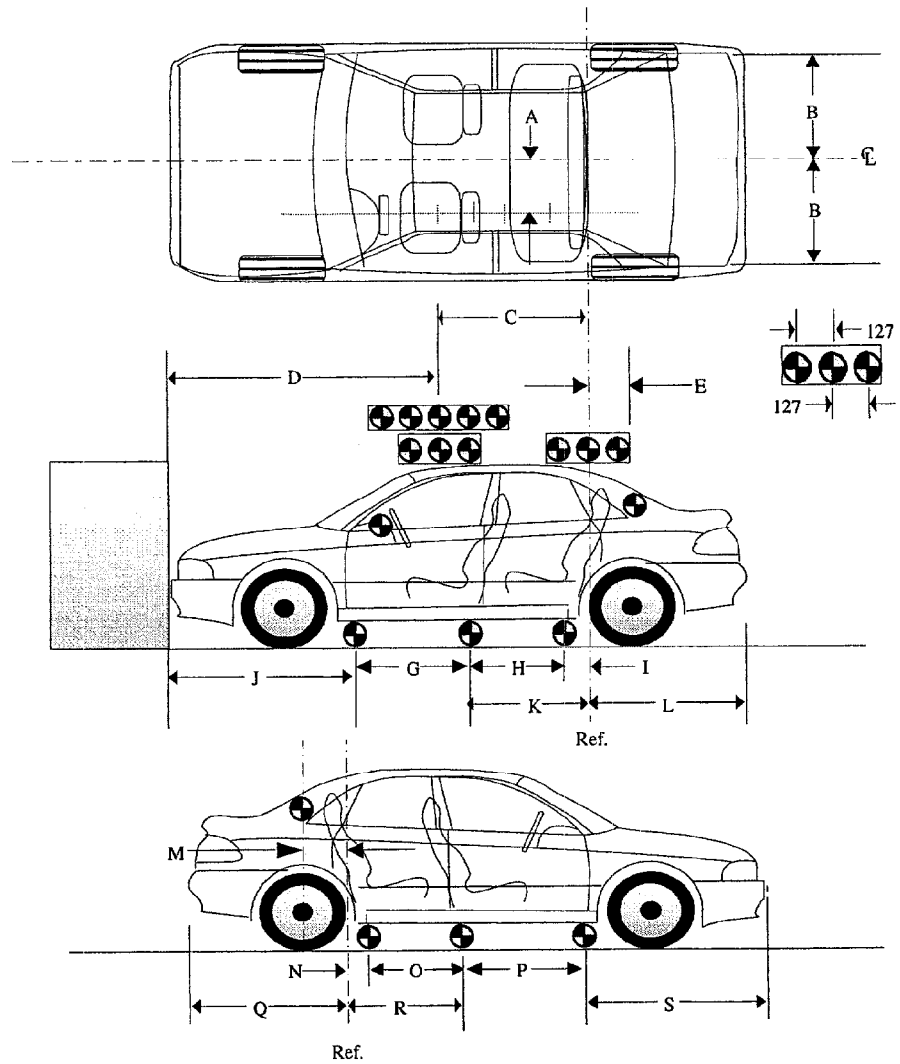

DATA SHEET NO. 17 LOAD CELL LOCATIONS ON FIXED BARRIER

- 36 Load Cells
- 4 Rows
- 9 Columns
- 6 Groupings (6 cells/group)

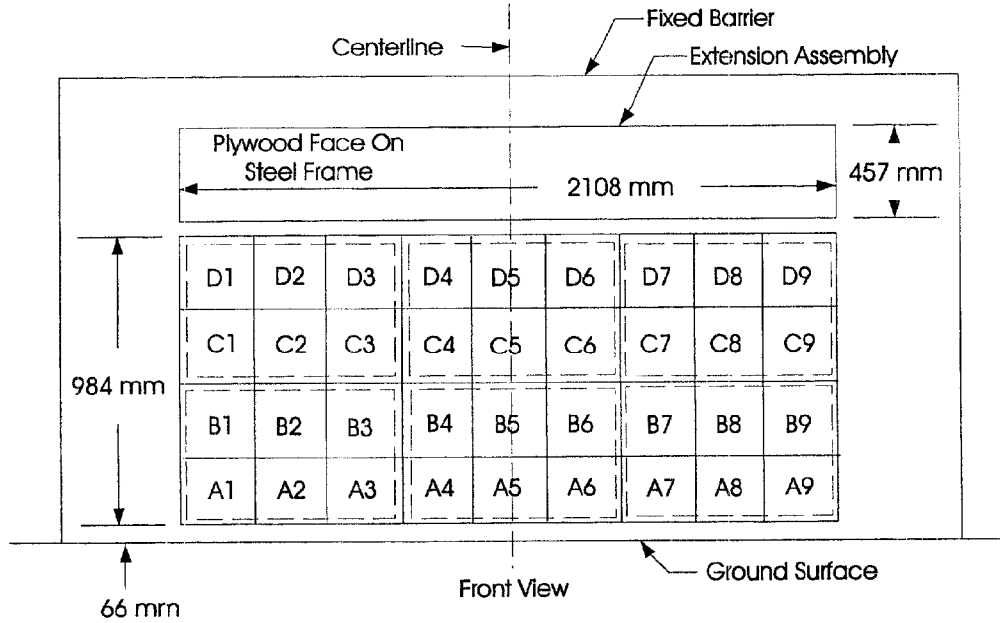

6 GROUPS OF 6 LOAD CELLS EACH

Group 4 C1 thru D3	Group 5 C4 thru D6	Group 6 C7 thru D9
Group 1 A1 thru B3	Group 2 A4 thru B6	Group 3 A7 thru B9

The following data is presented in Appendix B:

- (1) Data from 36 individual load cells
- (2) Total or Sum of 36 individual load cells
- (3) Data from 6 Groupings shown above (6 cells/group)

DATA SHEET NO. 18 POST TEST AIR BAG DATA

NHTSA No. : MY0204; Test Date: April 5, 2000; Technician: Patrick MacDiarmid

Vehicle Model Year/Make/Model: 2000 Ford Focus

- A. No. of vent holes: 9 ** -Driver 2 -Passenger
- B. Size of vent holes: (mm²) 88.35 -Driver 706.9 -Passenger
- C. Total vent area: (mm²) 397.6 -Driver 1413.7 -Passenger
- D. Deflated air bag length and width dimensions or, if round, diameter. (mm)
- Driver: 560 -Height; 500 -Width; 540 -Depth
- Passenger: 600 -Height; 560 -Width; 800 -Depth
- E. Is the air bag tethered?
- Driver: - -Yes; X -No; If yes, record length of tether- -
- Passenger: - -Yes; X -No; If yes, record length of tether- -

Sketch the air bag showing the location of the vent holes, how the bag is tethered, and where the bag is tethered. Also describe how the tethers are attached to the bag and the steering wheel.
(Note: Not to scale; V_n = Vent hole_n, T_n = Tether_n).

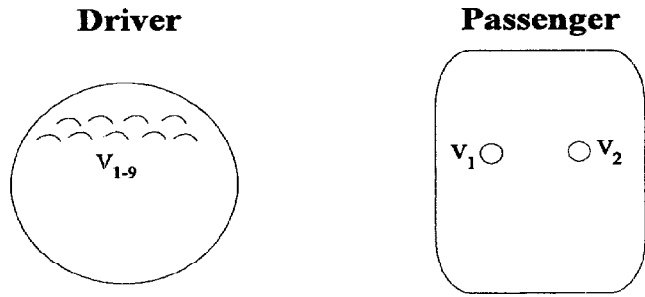

- F. Record part numbers and manufacturer name of the air bag and gas generator.
- Driver: Air bag: 990802-06
- Generator: FDBLCKKKT0ZNI42 FBM L22 54BGF
- Passenger: Air bag:
- Generator: YS41 A14B425 AD DP 6A0412061 YS41 A045G78 AD2UN2
- 5A03H274G Herstellingsjahr: 2000 Ford

** Driver Bag had an array of 9 semi-circular vents.

DATA SHEET NO. 19 ACCIDENT INVESTIGATION DIVISION DATA

FOR 56.3 KPH FRONTAL BARRIER IMPACT

Vehicle Make/Model/Body Style: Ford Focus 3-Door Hatchback

NHTSA Test No.: MY0204 VIN: 3FAFP3132YR191423

Model Year: 2000 Build Date: 3/2000 Test Date: April 5, 2000

Vehicle Size Category: Compact Test Weight: 1407.0 kg

Vehicle Wheelbase: 2613 mm; Front Overhang: 906 mm; Overall Width: 1998 mm

Collision Deformation Classification (CDC) Code: 12FDEW3

Crush Depth Dimensions:

	PRE	POST	DIFF	
C1 =	4230	3727	-503.0	mm
C2 =	4279	3754	-525.0	mm
C3 =	4280	3750	-530.0	mm
C4 =	4281	3749	-532.0	mm
C5 =	4270	3750	-520.0	mm
C6 =	4218	3725	-493.0	mm

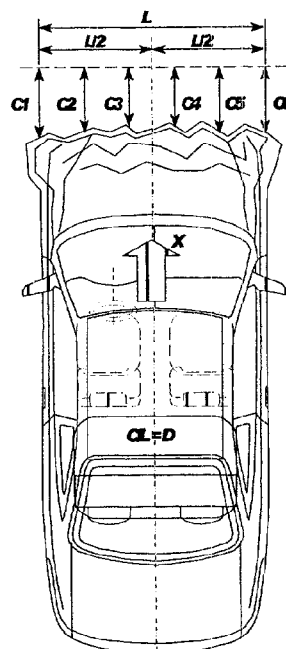

Midpoint of Damage: D = Vehicle Centerline
(Longitudinal)

Length of Damaged Region:

L1= 1200.0 mm
 L2= 600.0 mm
 L3= 400.0 mm

APPENDIX A
PHOTOGRAPHS

TABLE OF PHOTOGRAPHS

<u>Figure</u>	<u>Title</u>	<u>Page</u>
A-1	LOAD CELL LOCATIONS.	A-3
A-2	PRE-TEST FRONT VIEW	A-4
A-3	POST-TEST FRONT VIEW.	A-5
A-4	PRE-TEST LEFT SIDE VIEW	A-6
A-5	POST-TEST LEFT SIDE VIEW	A-7
A-6	PRE-TEST RIGHT SIDE VIEW	A-8
A-7	POST-TEST RIGHT SIDE VIEW	A-9
A-8	PRE-TEST RIGHT FRONT THREE-QUARTER VIEW	A-10
A-9	POST-TEST RIGHT FRONT THREE-QUARTER VIEW	A-11
A-10	PRE-TEST LEFT REAR THREE-QUARTER VIEW	A-12
A-11	POST-TEST LEFT REAR THREE-QUARTER VIEW	A-13
A-12	PRE-TEST WINDSHIELD VIEW	A-14
A-13	POST-TEST WINDSHIELD VIEW	A-15
A-14	PRE-TEST ENGINE COMPARTMENT VIEW	A-16
A-15	FUEL CAP VIEW	A-17
A-16	PRE-TEST FRONT UNDERBODY VIEW	A-18
A-17	POST-TEST FRONT UNDERBODY VIEW	A-19
A-18	PRE-TEST FRONT SIDE UNDERBODY VIEW	A-20
A-19	POST-TEST FRONT SIDE UNDERBODY VIEW	A-21
A-20	PRE-TEST REAR UNDERBODY VIEW	A-22
A-21	POST-TEST REAR UNDERBODY VIEW	A-23
A-22	PRE-TEST DRIVER POSITION VIEW	A-24
A-23	POST-TEST DRIVER POSITION VIEW	A-25
A-24	PRE-TEST PASSENGER POSITION VIEW	A-26
A-25	POST-TEST PASSENGER POSITION VIEW	A-27
A-26	PRE-TEST DRIVER AND INTERIOR VIEW	A-28
A-27	POST-TEST DRIVER AND INTERIOR VIEW	A-29
A-28	PRE-TEST PASSENGER AND INTERIOR VIEW	A-30
A-29	POST-TEST PASSENGER AND INTERIOR VIEW	A-31
A-30	PRE-TEST DRIVER HEAD LOCATION	A-32
A-31	POST-TEST DRIVER HEAD LOCATION	A-33
A-32	PRE-TEST PASSENGER HEAD LOCATION	A-34
A-33	POST-TEST PASSENGER HEAD LOCATION	A-35
A-34	PRE-TEST DRIVER FLOOR PAN VIEW	A-36
A-35	POST-TEST DRIVER FLOOR PAN VIEW	A-37
A-36	PRE-TEST PASSENGER FLOOR PAN VIEW	A-38
A-37	POST-TEST PASSENGER FLOOR PAN VIEW	A-39
A-38	ROLLOVER VIEW	A-40
A-39	IMPACT VIEW	A-41

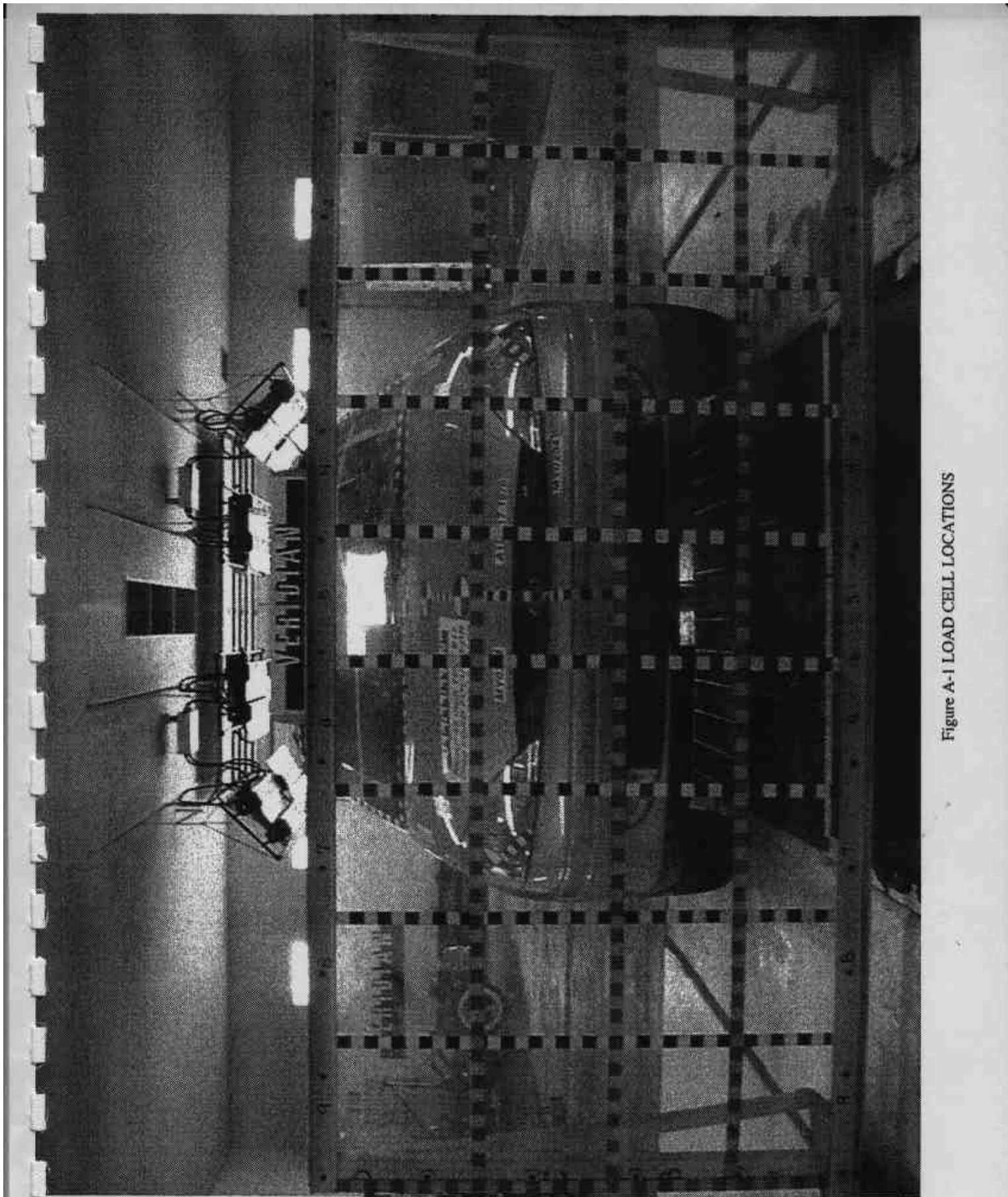

Figure A-1 LOAD CELL LOCATIONS



Figure A-2 PRE-TEST FRONT VIEW

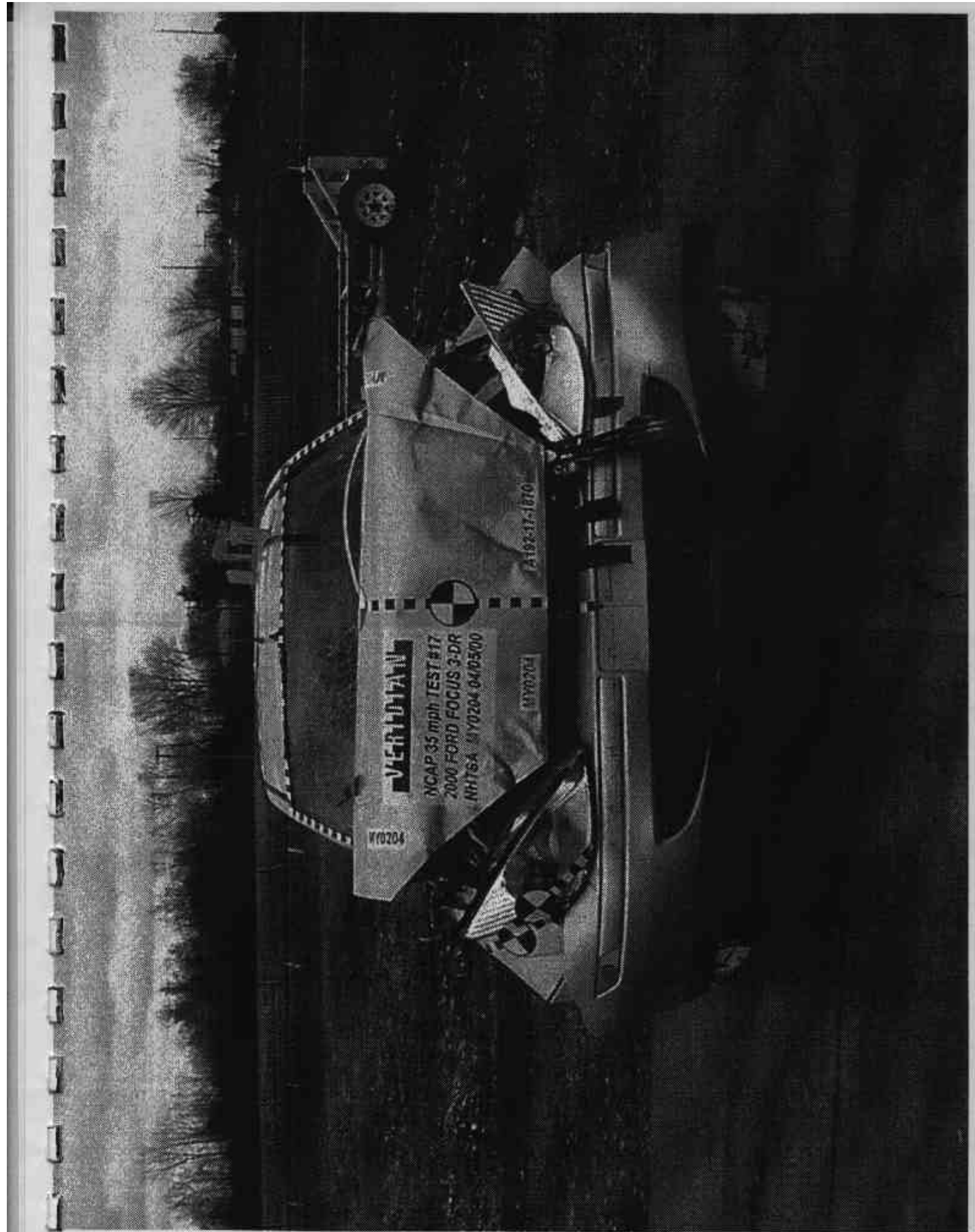

Figure A-3 POST-TEST FRONT VIEW

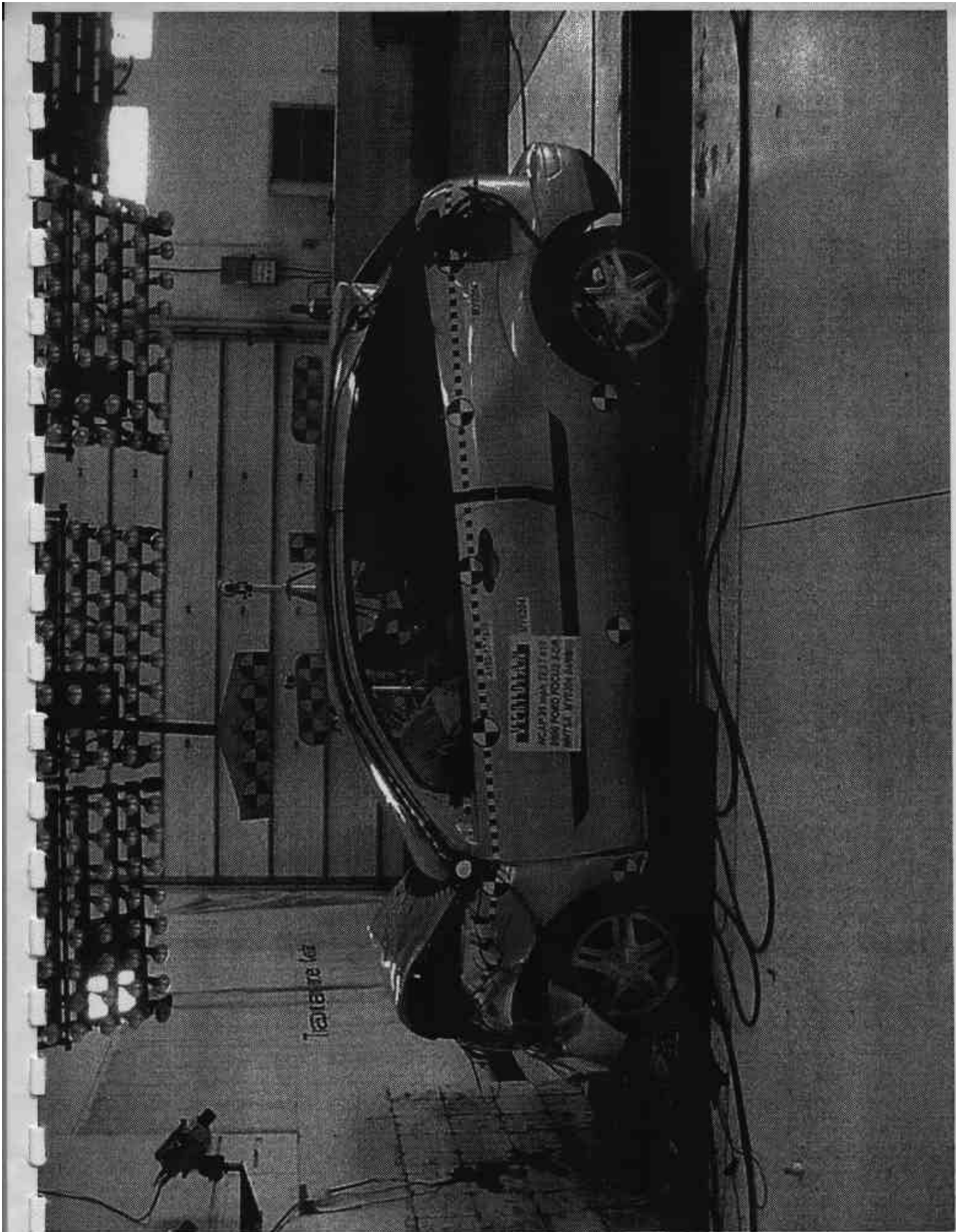

Figure A-5 POST-TEST LEFT SIDE VIEW

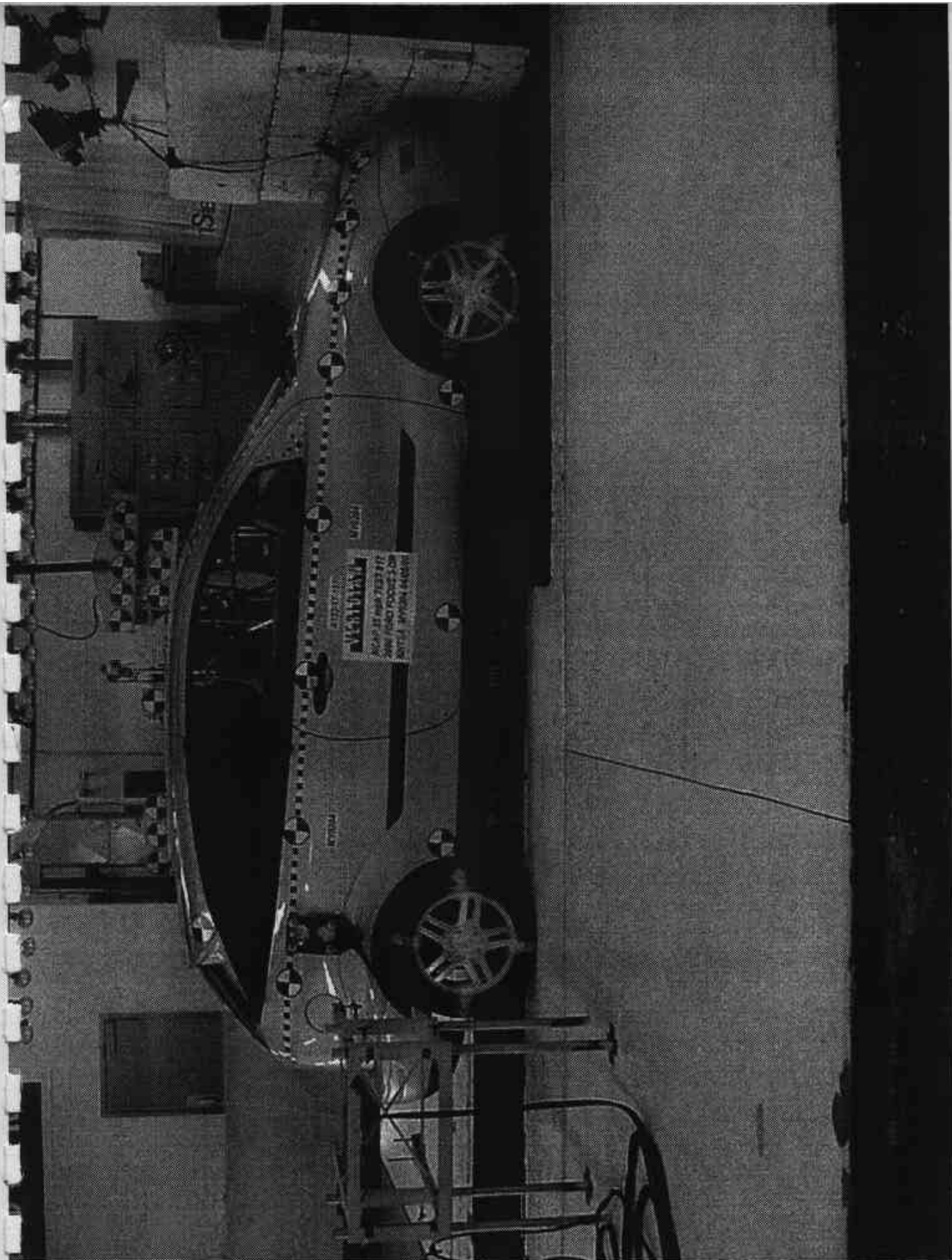

Figure A-6 PRE-TEST RIGHT SIDE VIEW

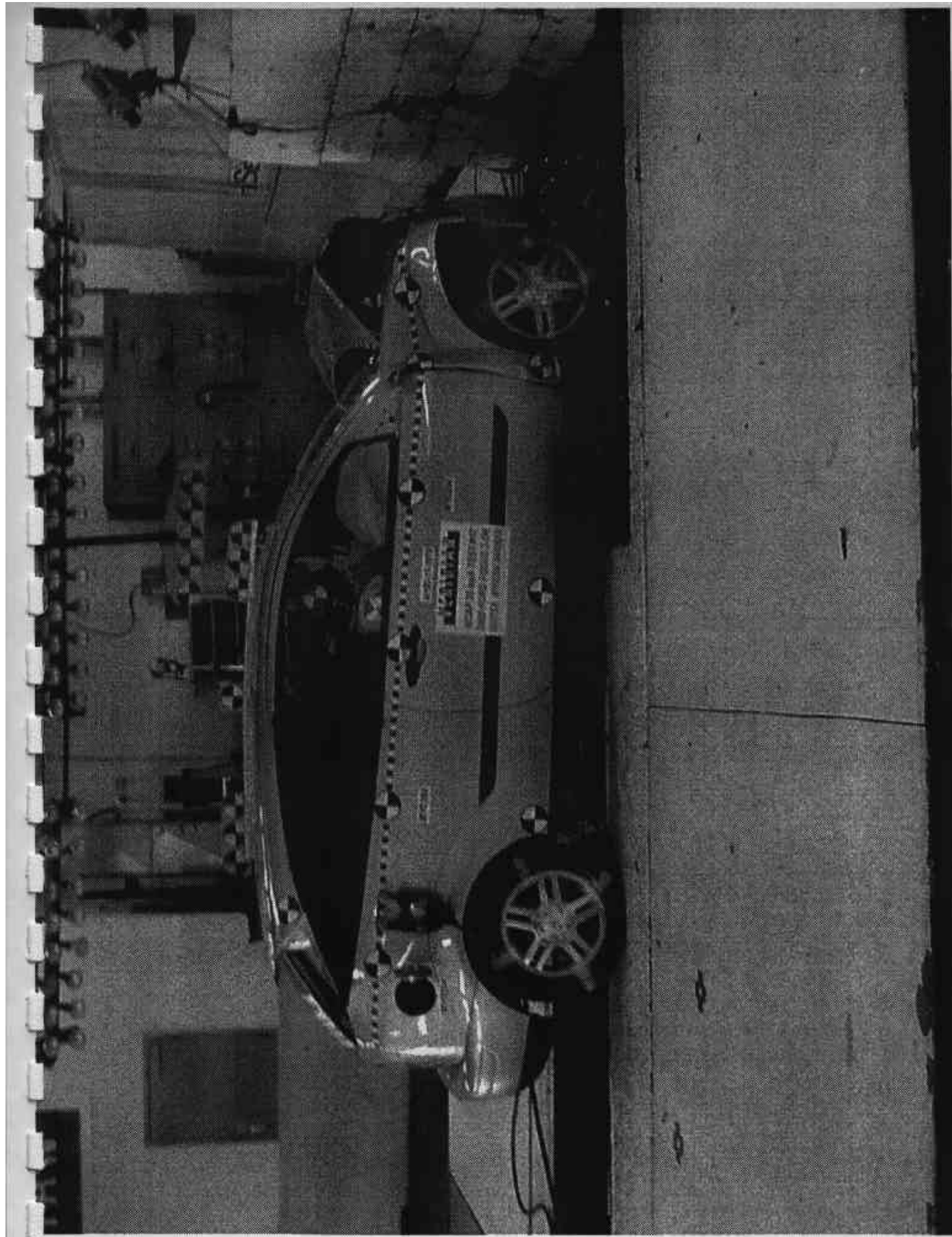

Figure A-7 POST-TEST RIGHT SIDE VIEW

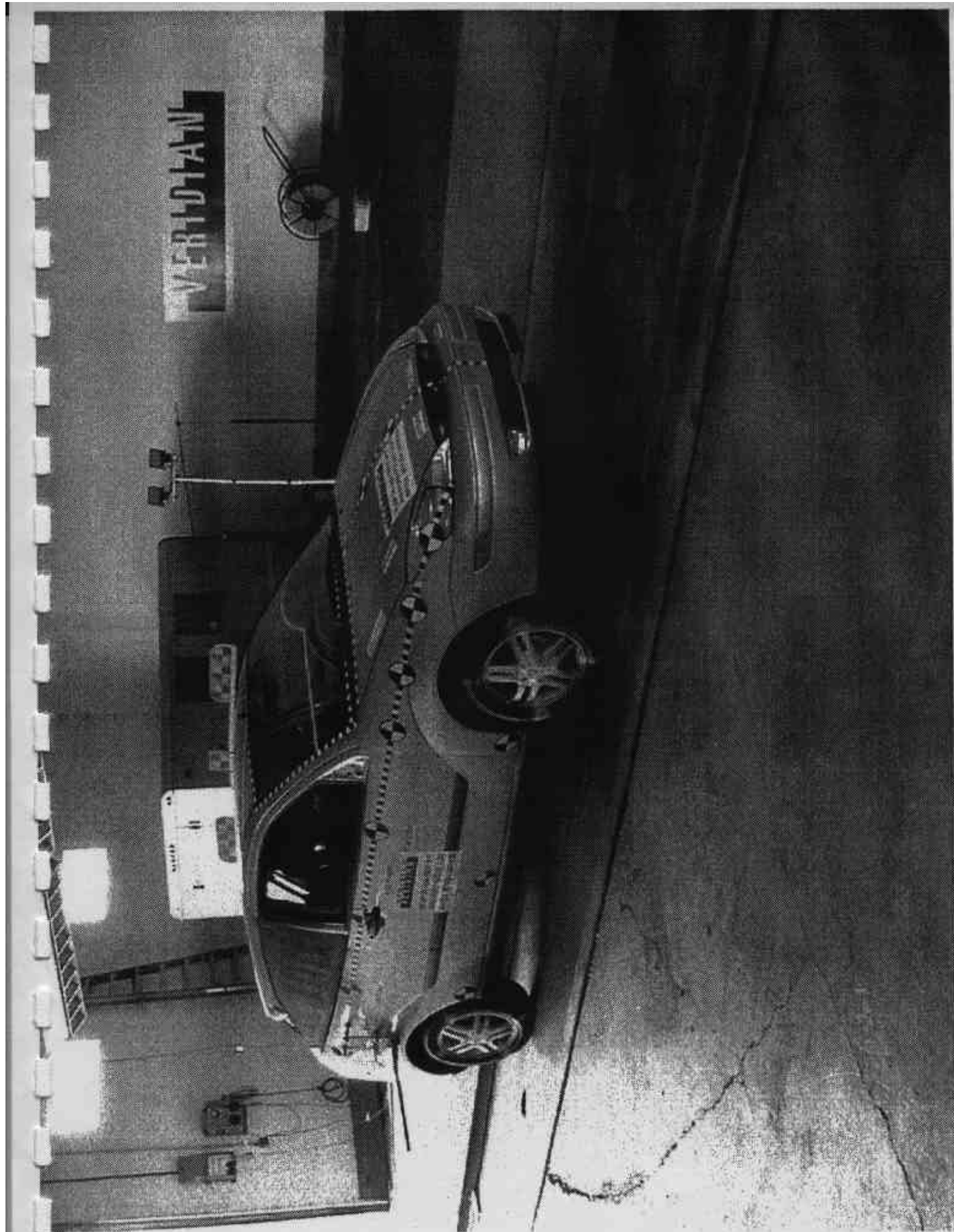

Figure A-8 PRE-TEST RIGHT FRONT THREE-QUARTER VIEW

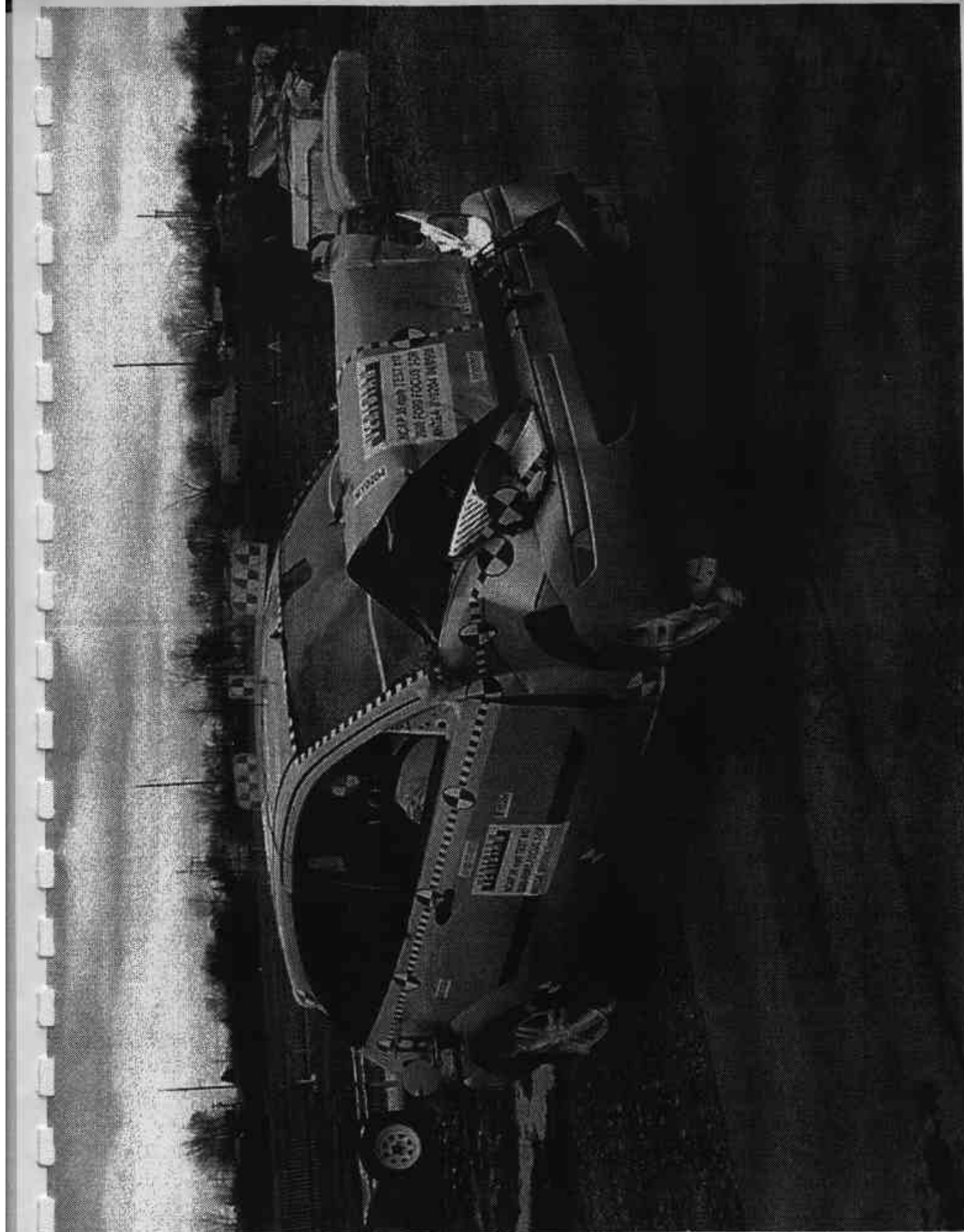

Figure A-9 POST-TEST RIGHT FRONT THREE-QUARTER VIEW

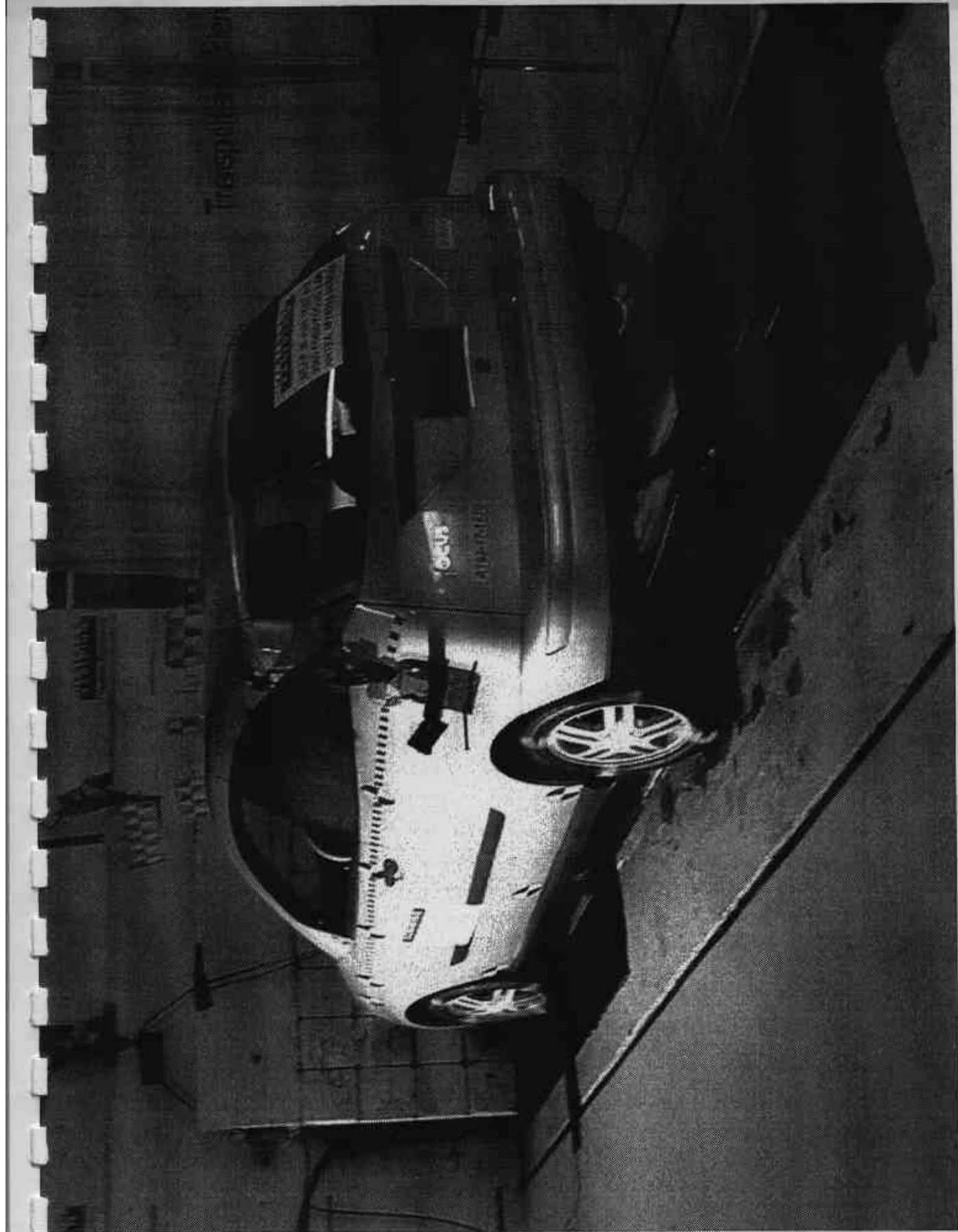

Figure A-10 PRE-TEST LEFT REAR THREE-QUARTER VIEW



Figure A-11 POST-TEST LEFT REAR THREE-QUARTER VIEW

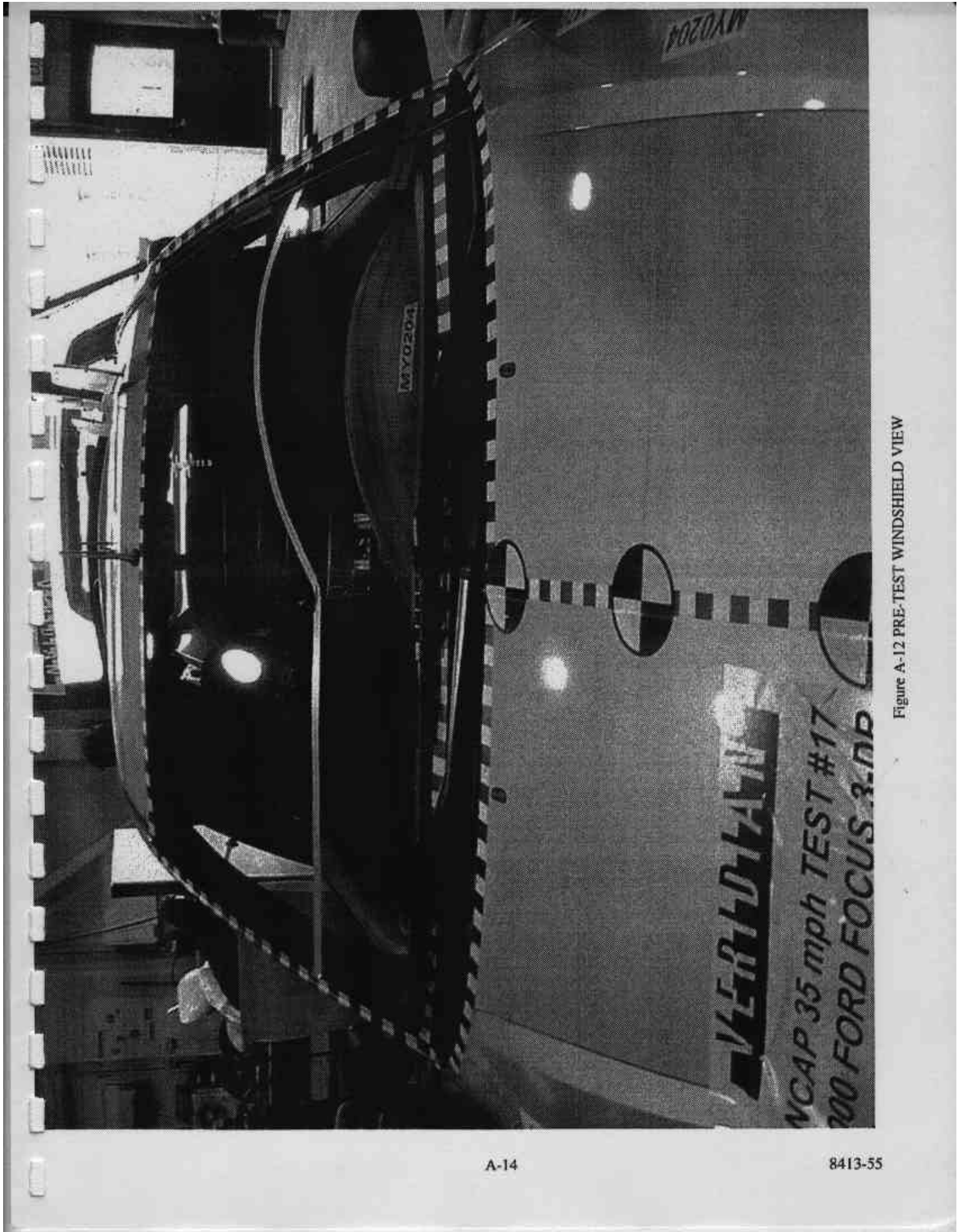

Figure A-12 PRE-TEST WINDSHIELD VIEW

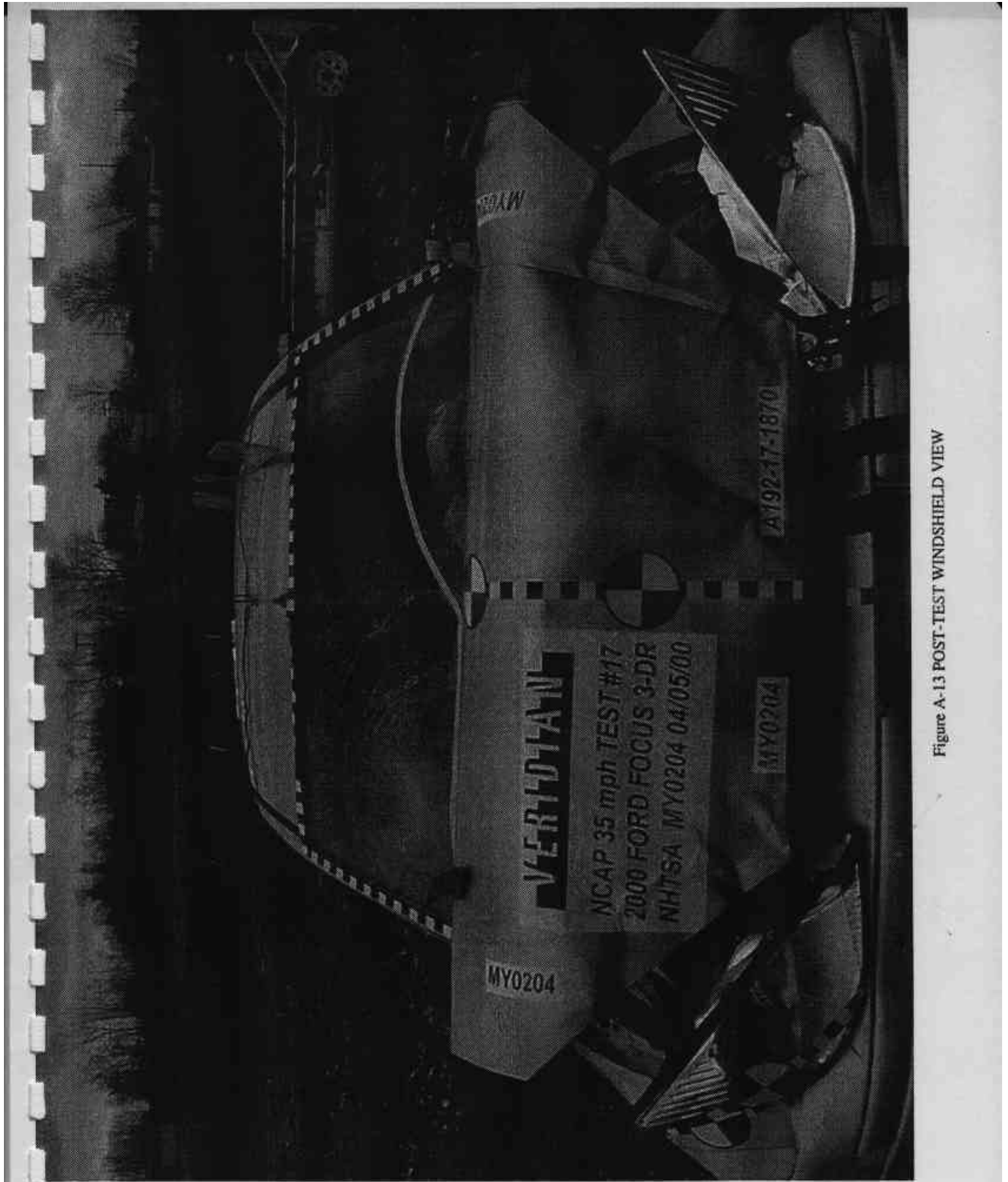

Figure A-13 POST-TEST WINDSHIELD VIEW

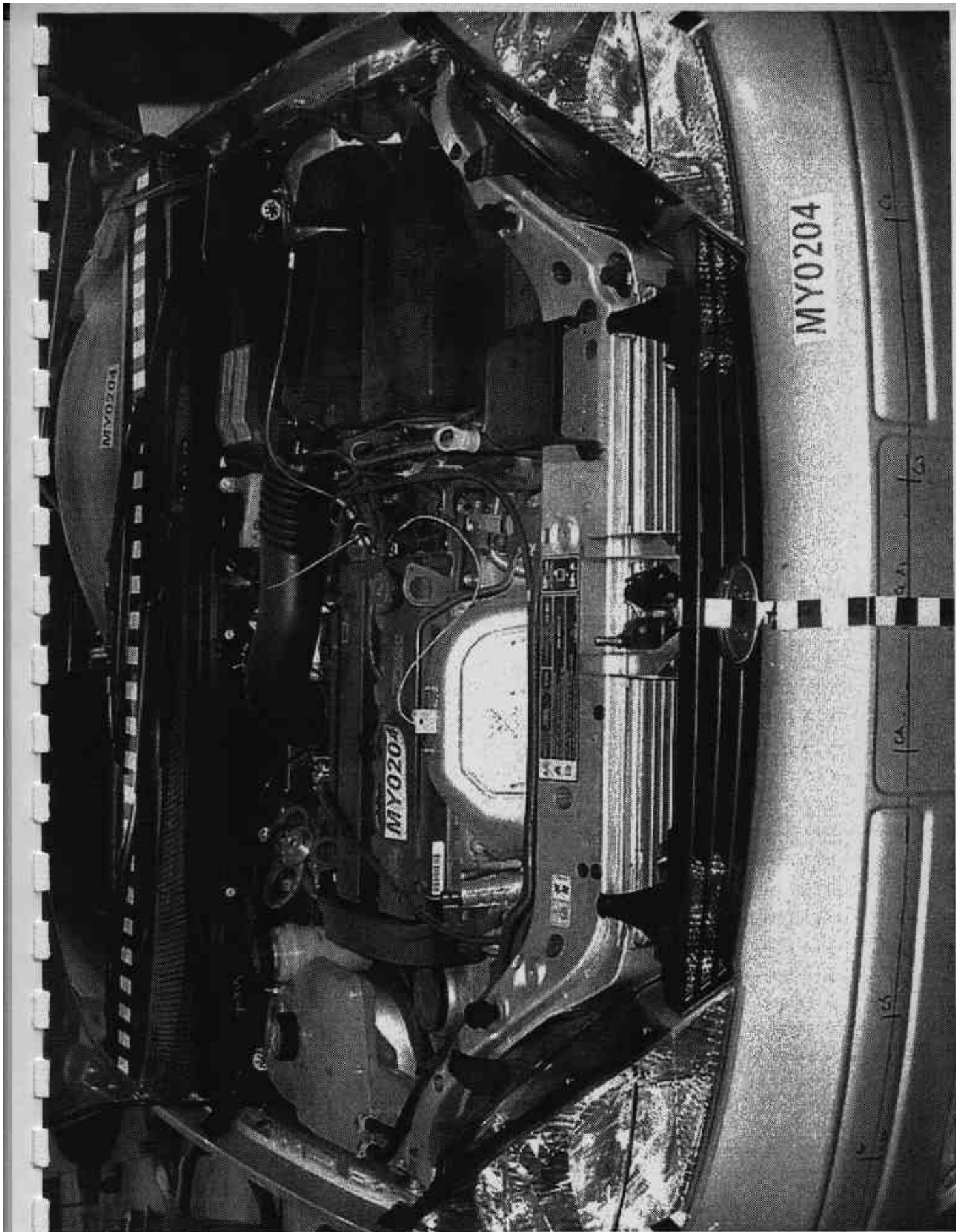

Figure A-14 PRE-TEST ENGINE COMPARTMENT VIEW

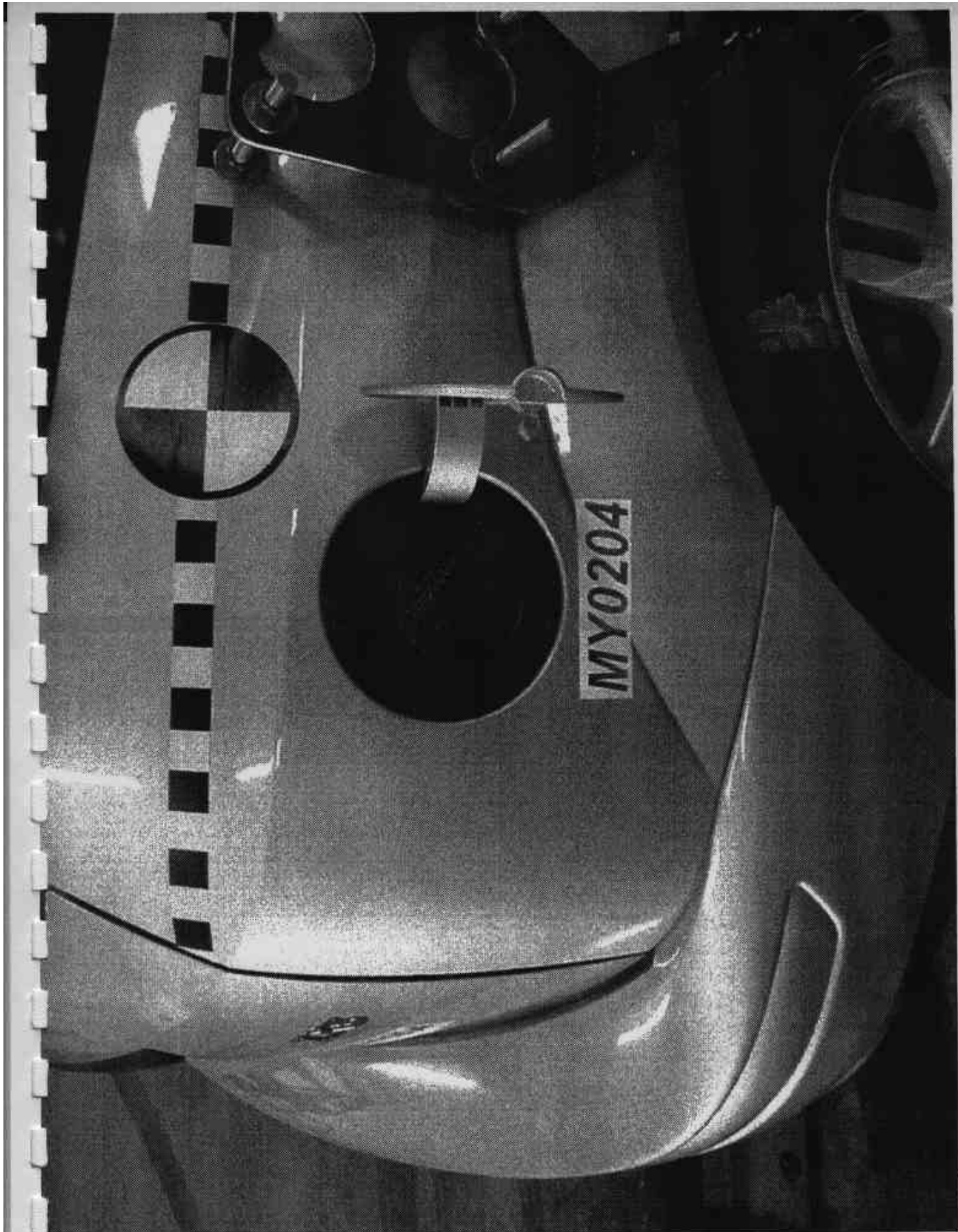

Figure A-15 FUEL CAP VIEW



Figure A-16 PRE-TEST FRONT UNDERBODY VIEW



Figure A-17 POST-TEST FRONT UNDERBODY VIEW

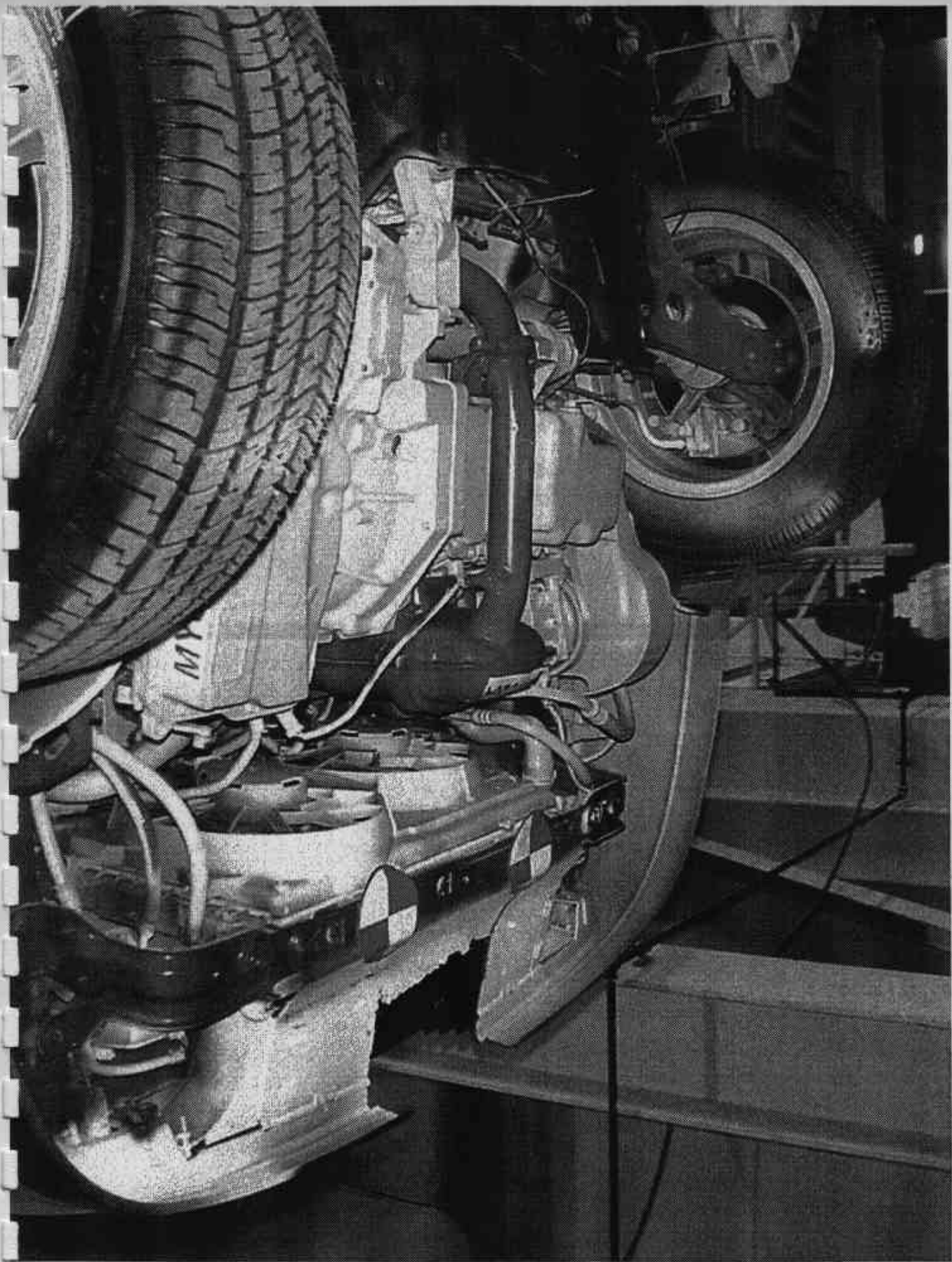

Figure A-18 PRE-TEST FRONT SIDE UNDERBODY VIEW

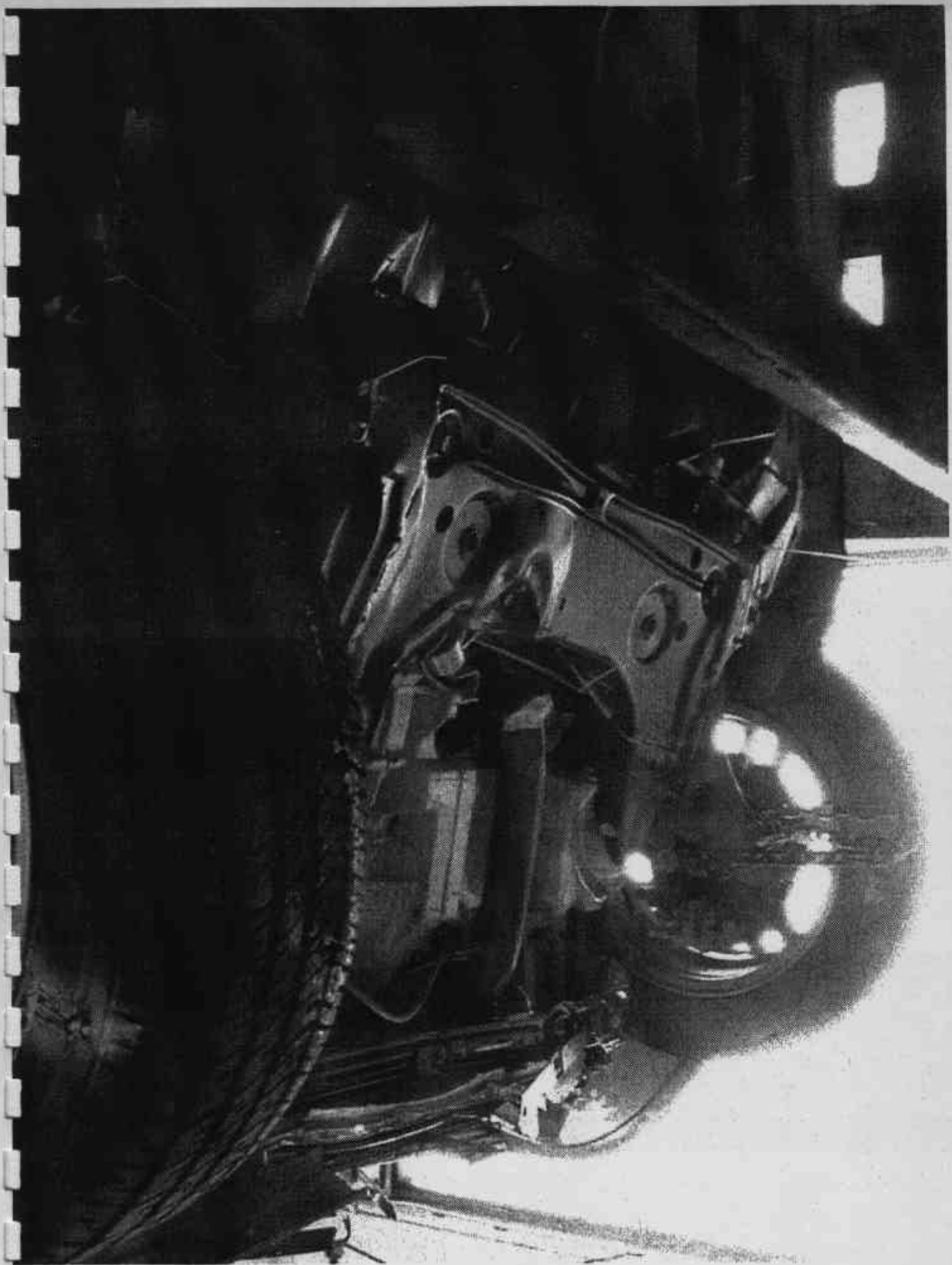

Figure A-19 POST-TEST FRONT SIDE UNDERBODY VIEW

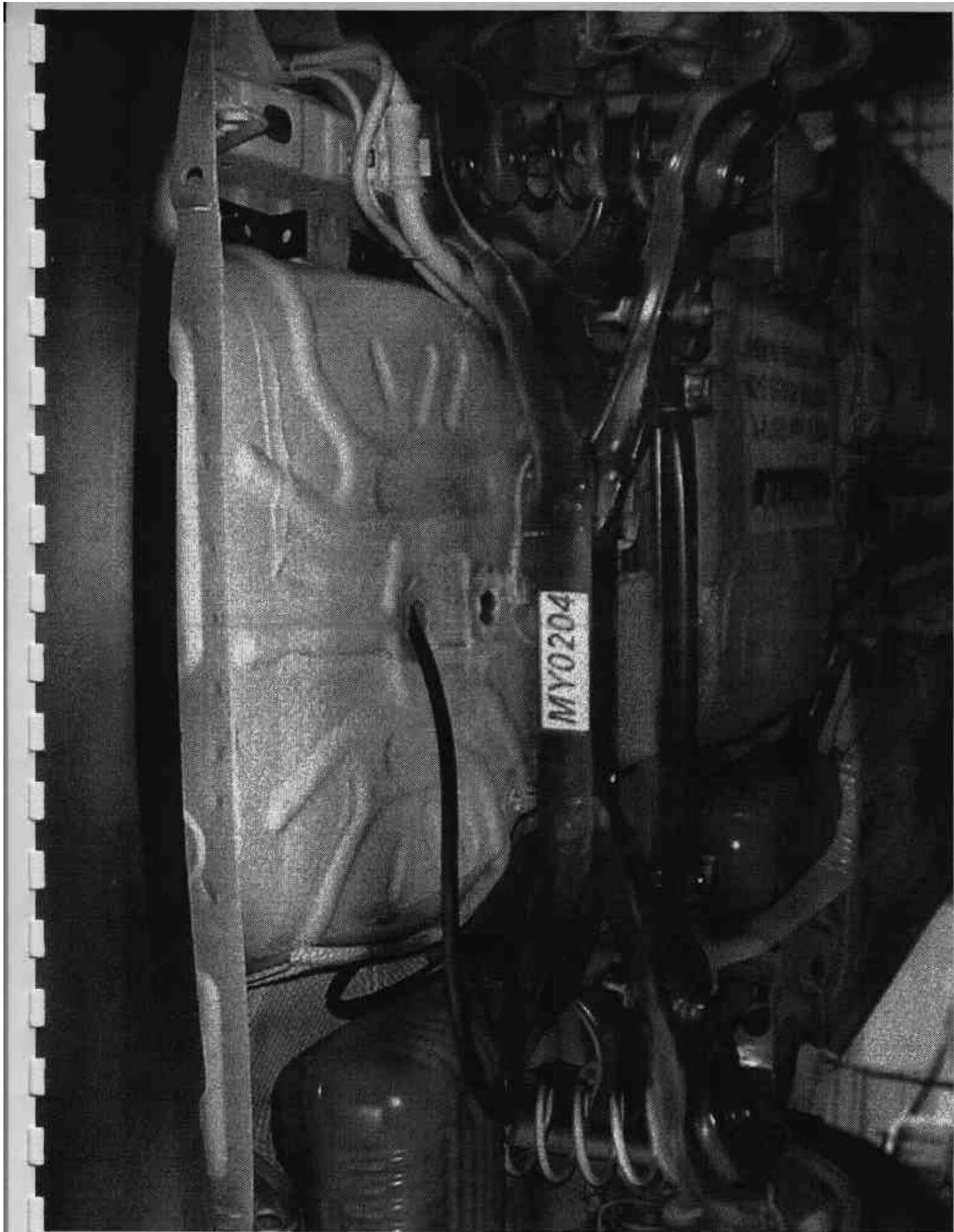

Figure A-20 PRE-TEST REAR UNDERBODY VIEW

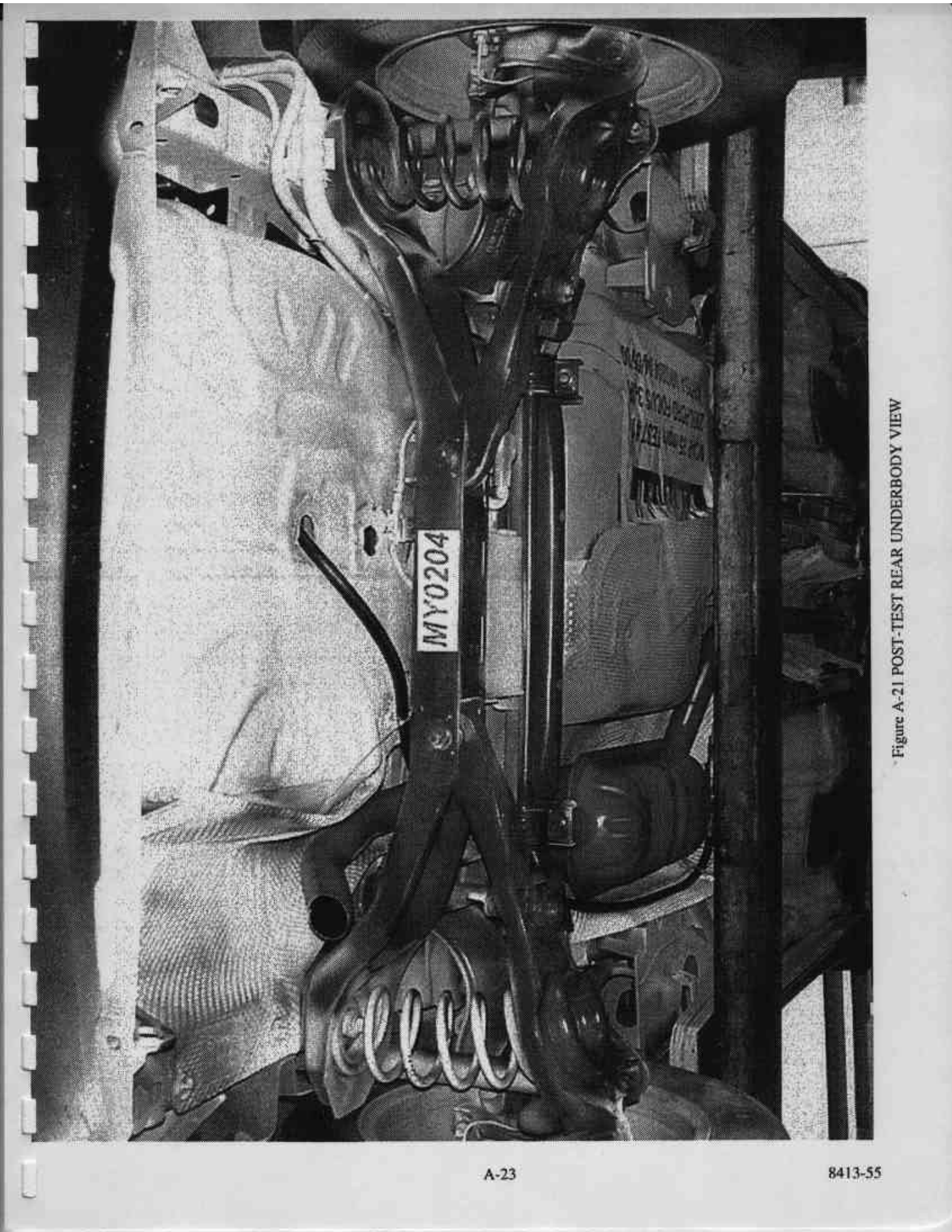

Figure A-21 POST-TEST REAR UNDERBODY VIEW



Figure A-22 PRE-TEST DRIVER POSITION VIEW



Figure A-23 POST-TEST DRIVER POSITION VIEW



Figure A-24 PRE-TEST PASSENGER POSITION VIEW

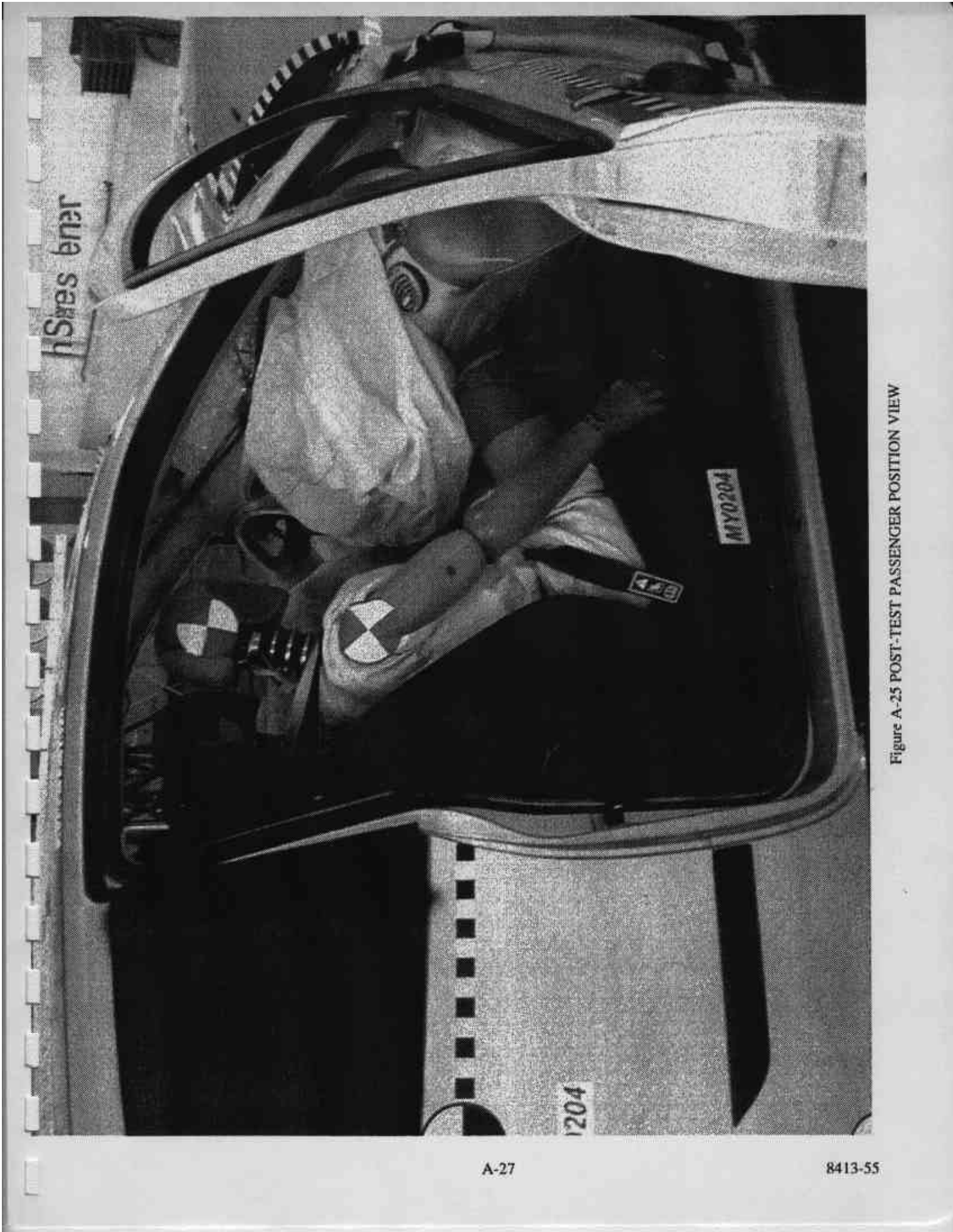

Figure A-25 POST-TEST PASSENGER POSITION VIEW

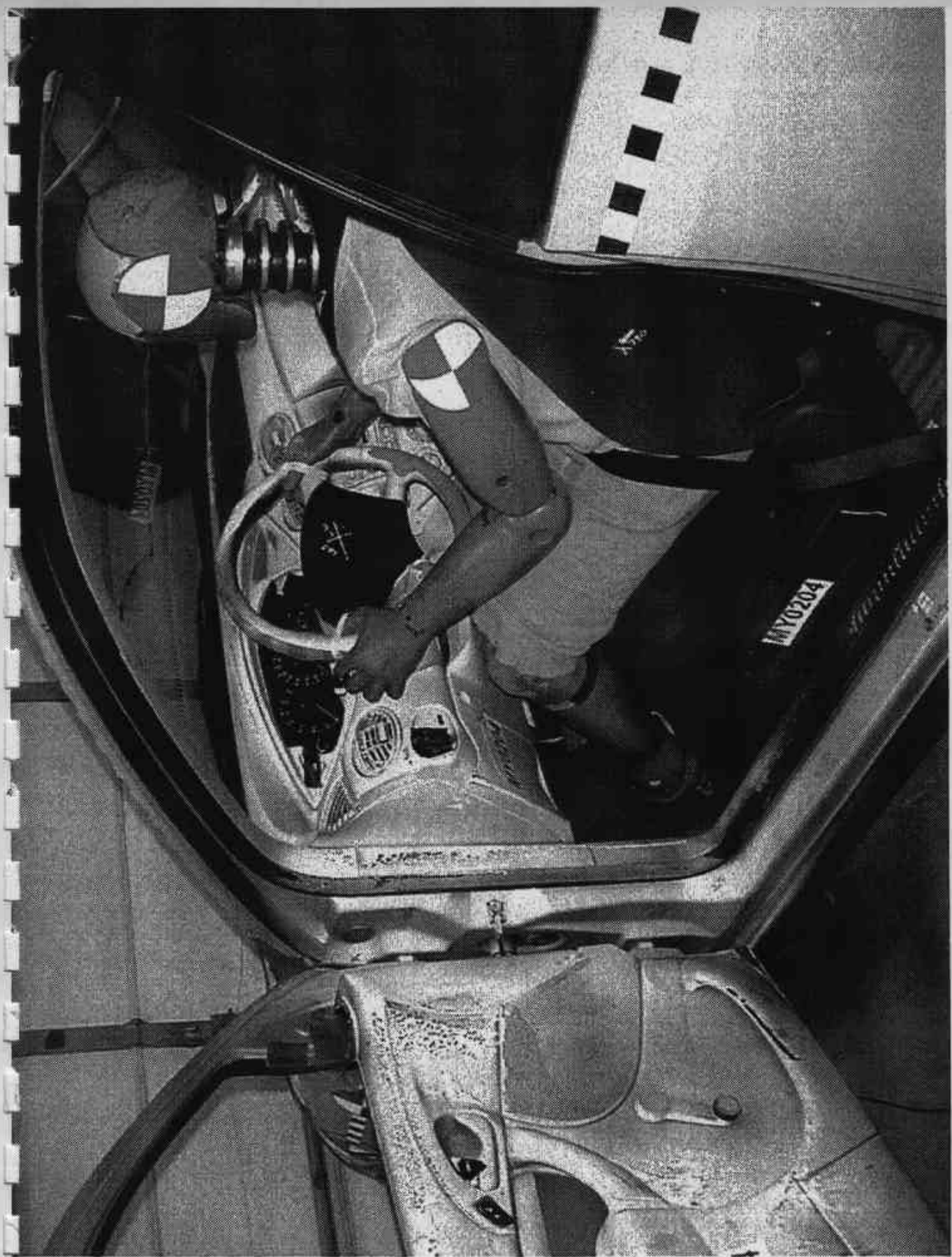

Figure A-26 PRE-TEST DRIVER AND INTERIOR VIEW



Figure A-27 POST-TEST DRIVER AND INTERIOR VIEW

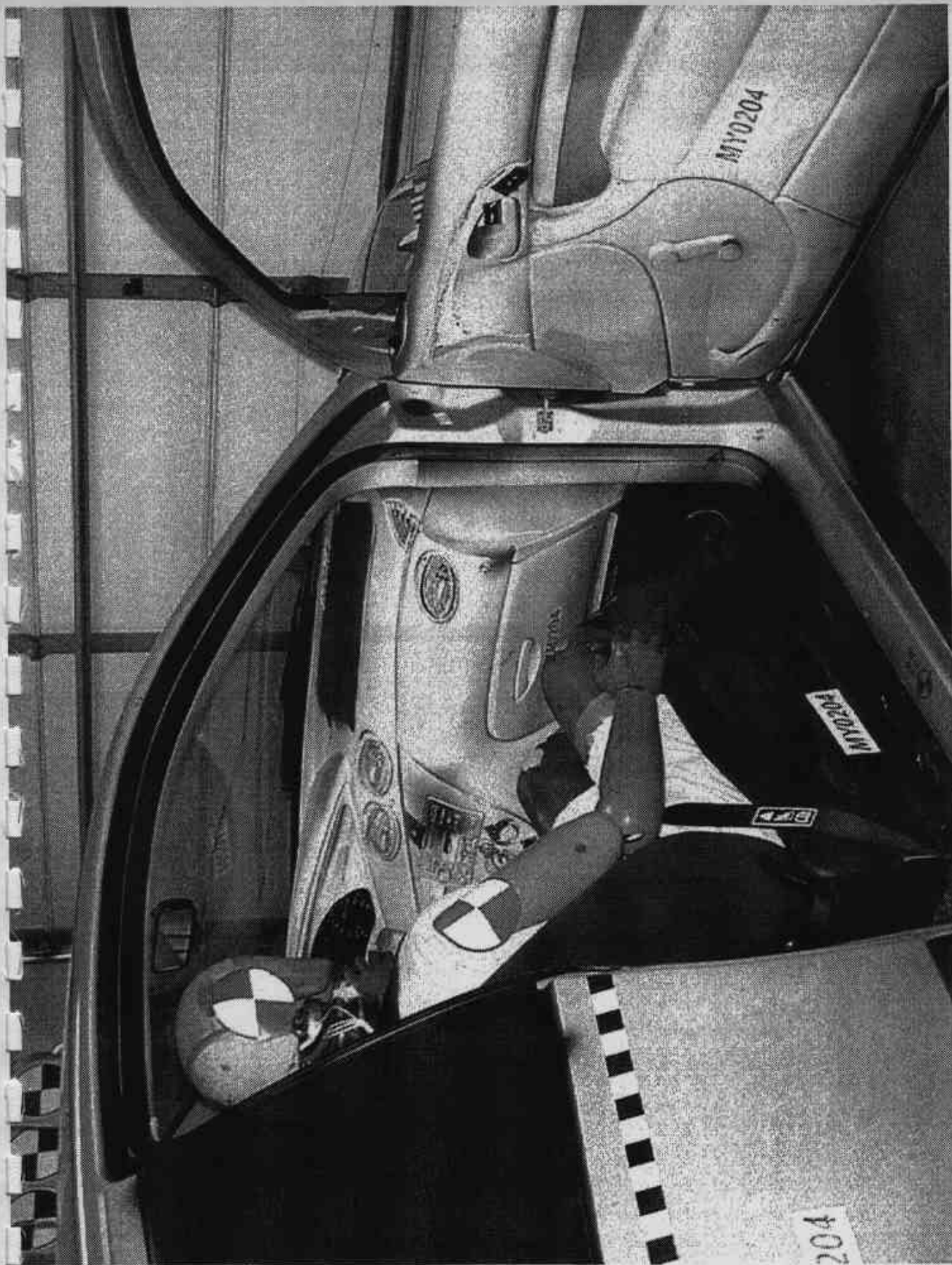

Figure A-28 PRE-TEST PASSENGER AND INTERIOR VIEW

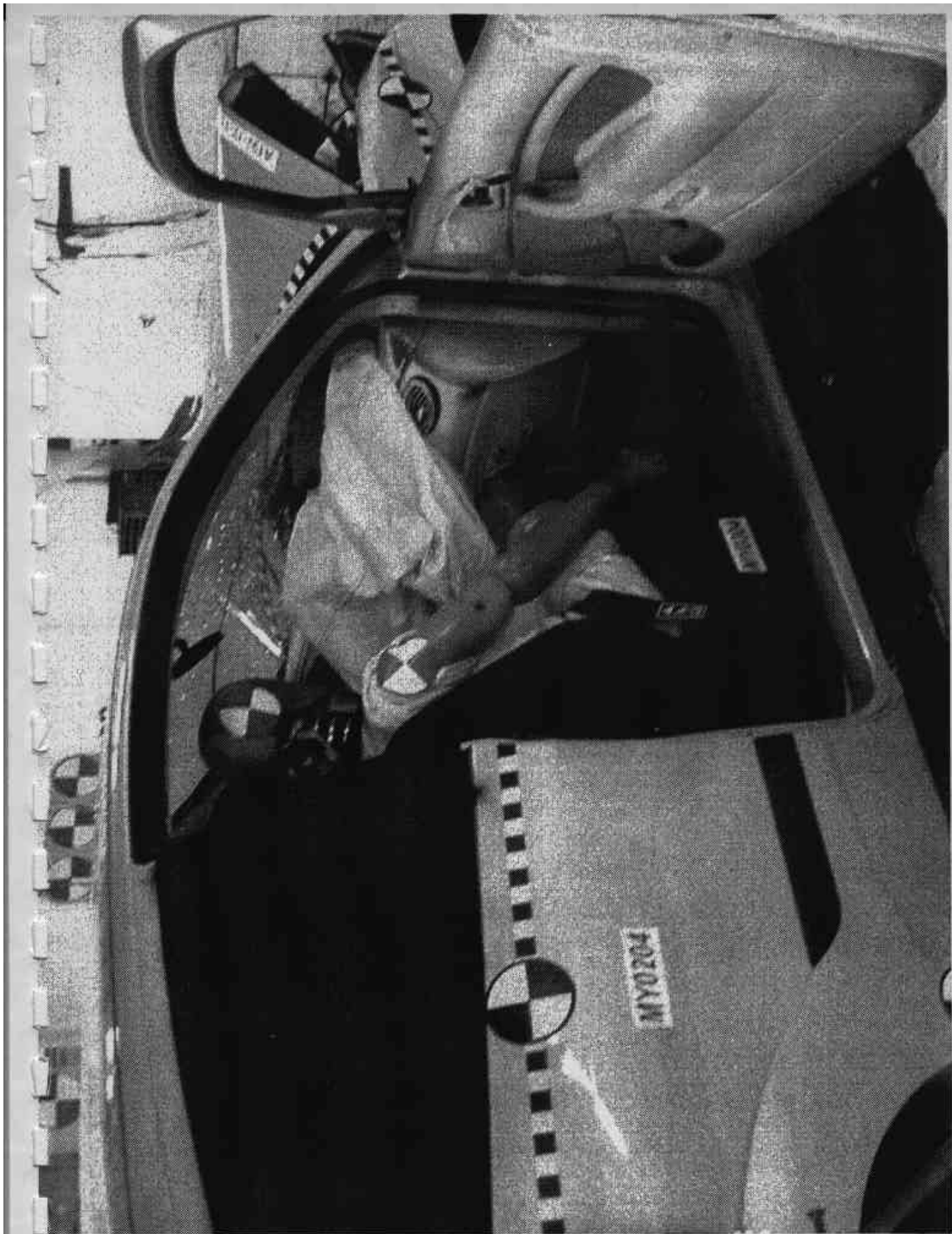

Figure A-29 POST-TEST PASSENGER AND INTERIOR VIEW

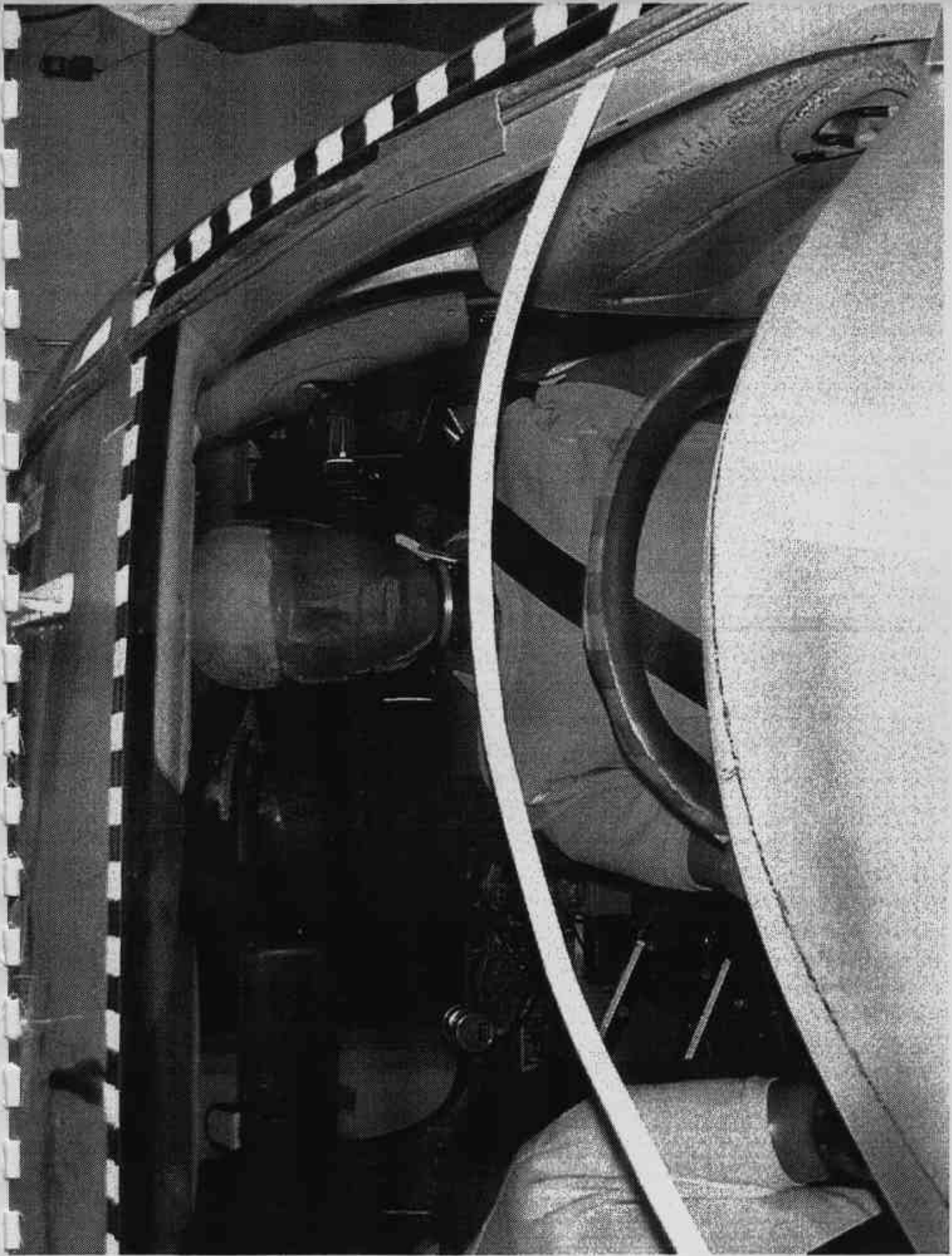

Figure A-30 PRE-TEST DRIVER HEAD LOCATION

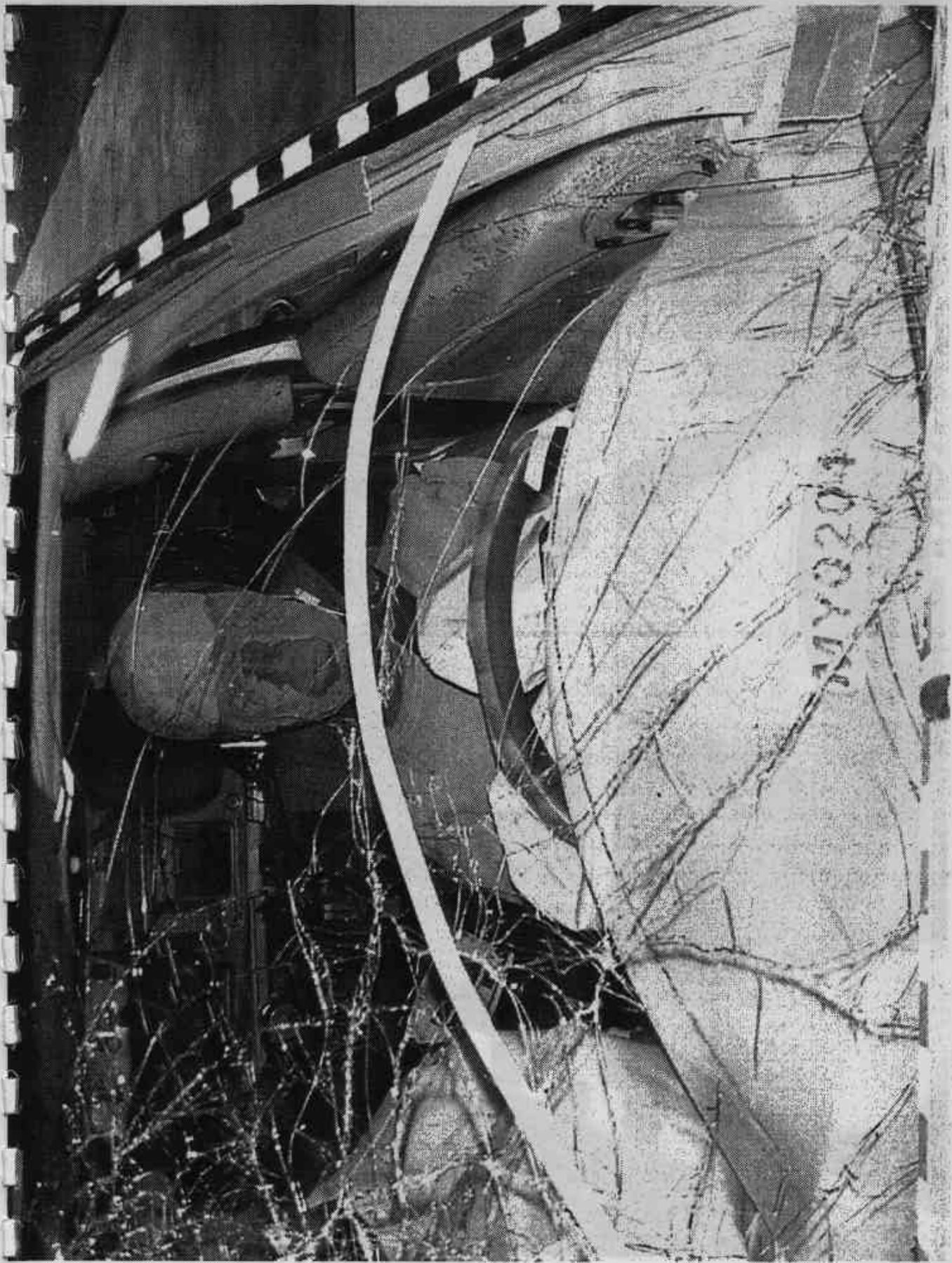

Figure A-31 POST-TEST DRIVER HEAD LOCATION

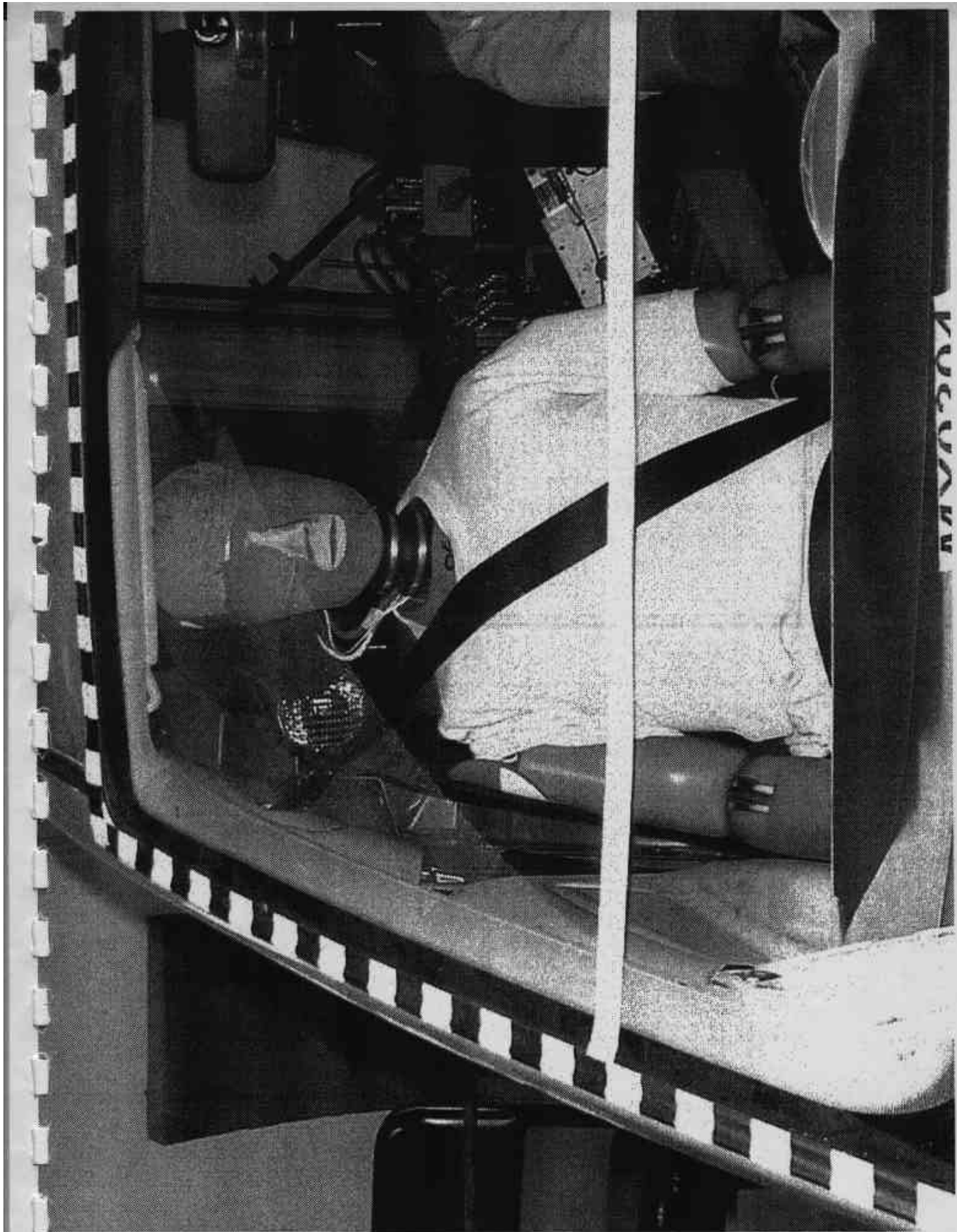

Figure A-32 PRE-TEST PASSENGER HEAD LOCATION



Figure A-33 POST-TEST PASSENGER HEAD LOCATION

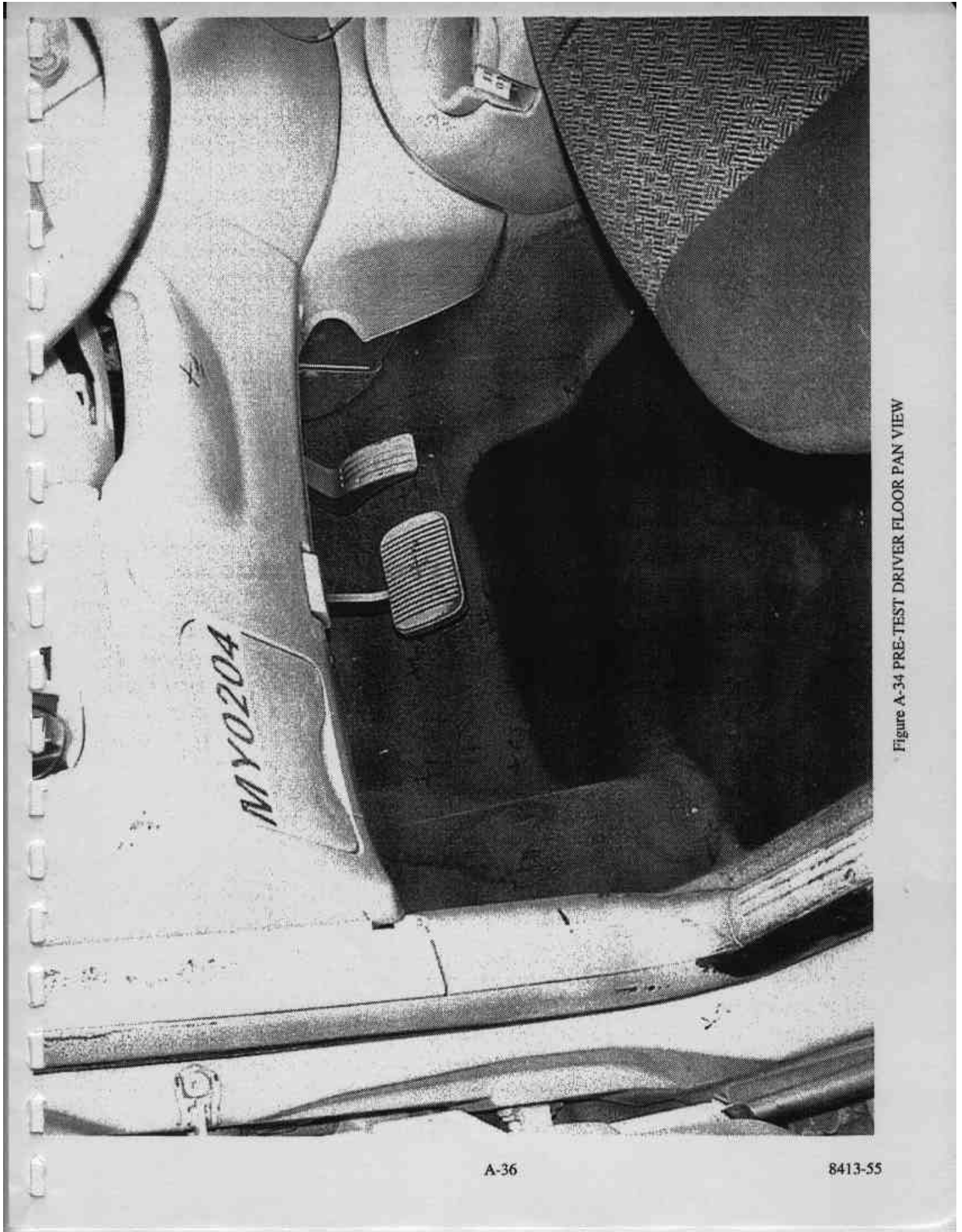

Figure A-34 PRE-TEST DRIVER FLOOR PAN VIEW

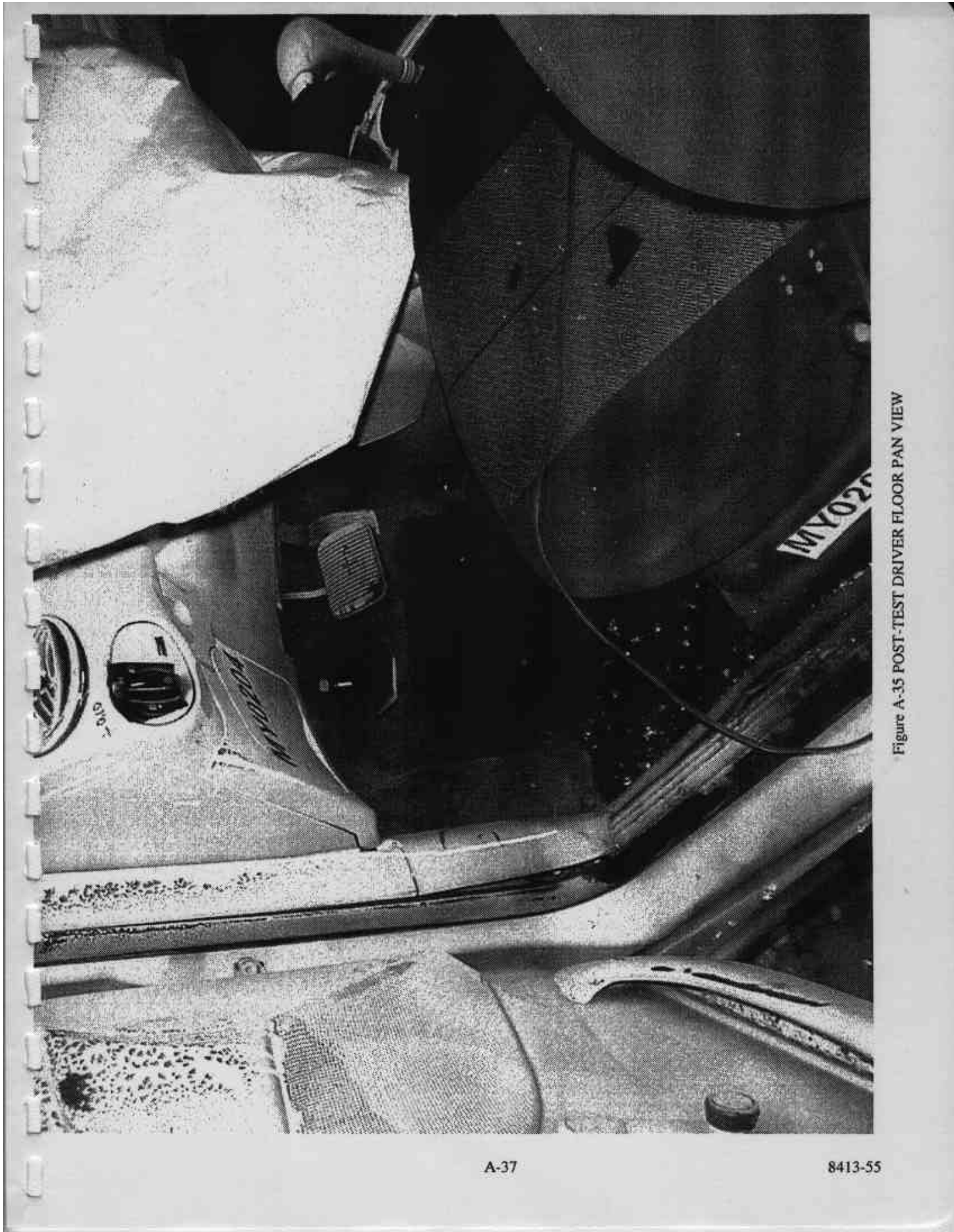

Figure A-35 POST-TEST DRIVER FLOOR PAN VIEW

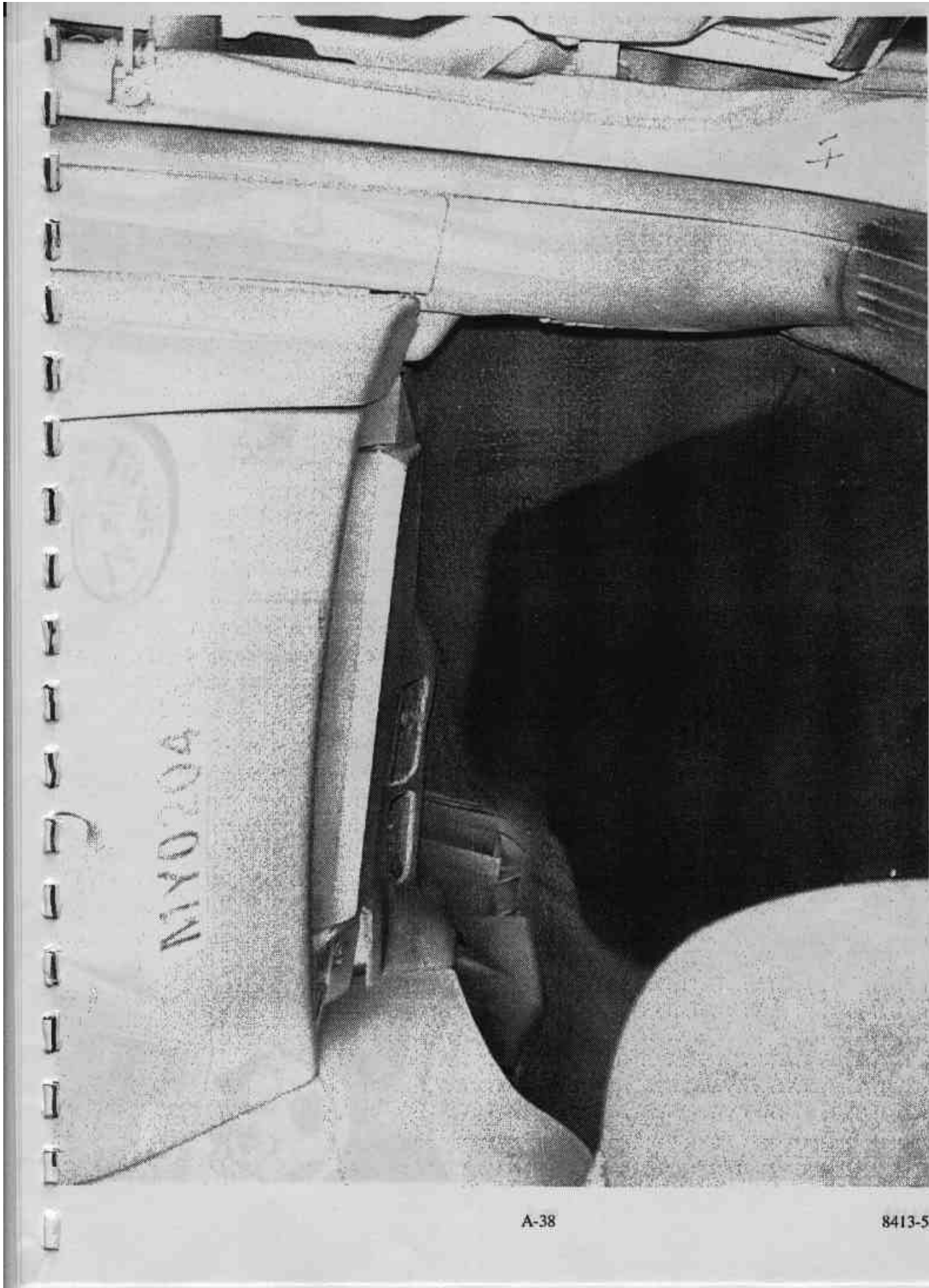

Figure A-36 PRE-TEST PASSENGER FLOOR PAN VIEW

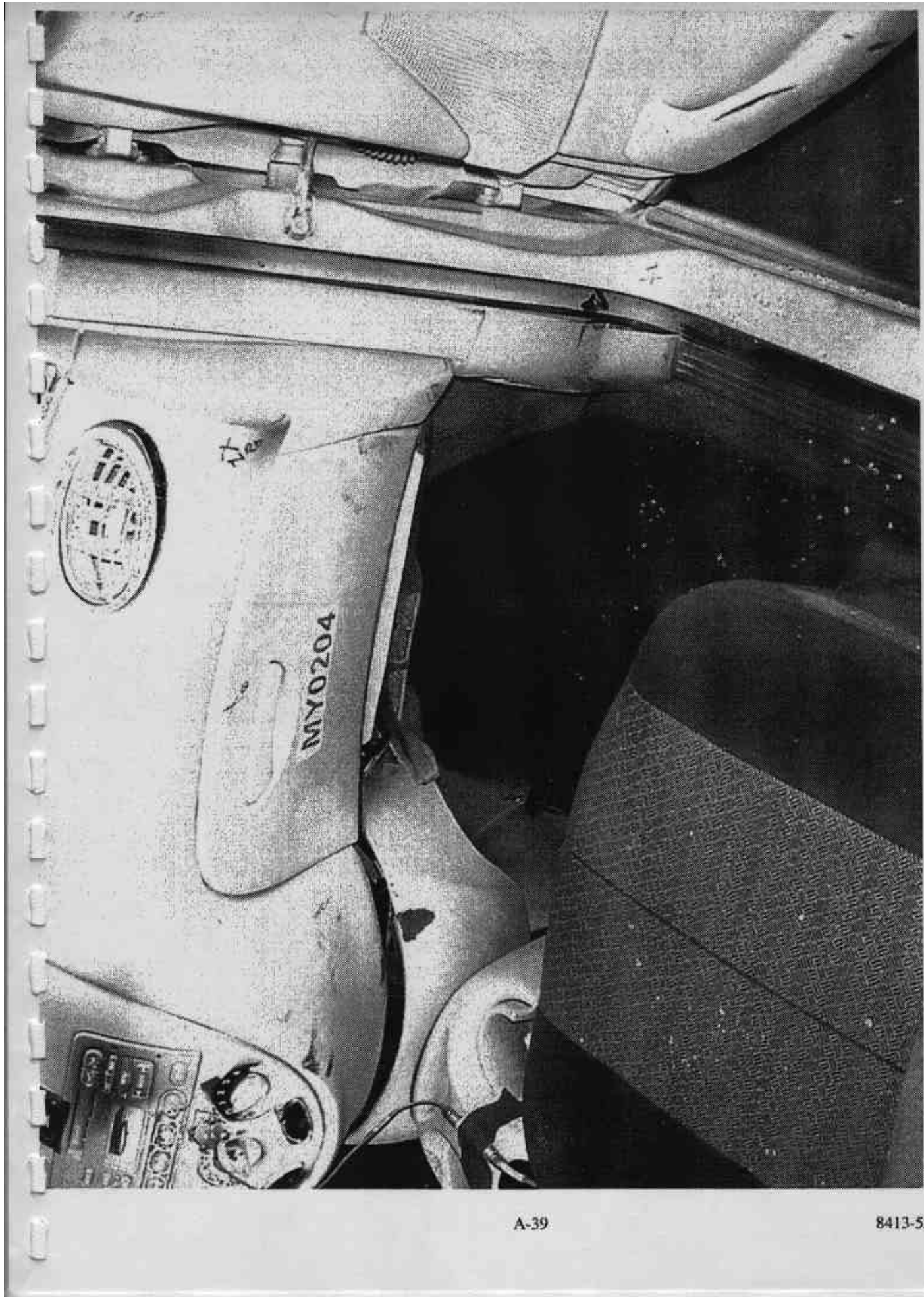

Figure A-37 POST-TEST PASSENGER FLOOR PAN VIEW

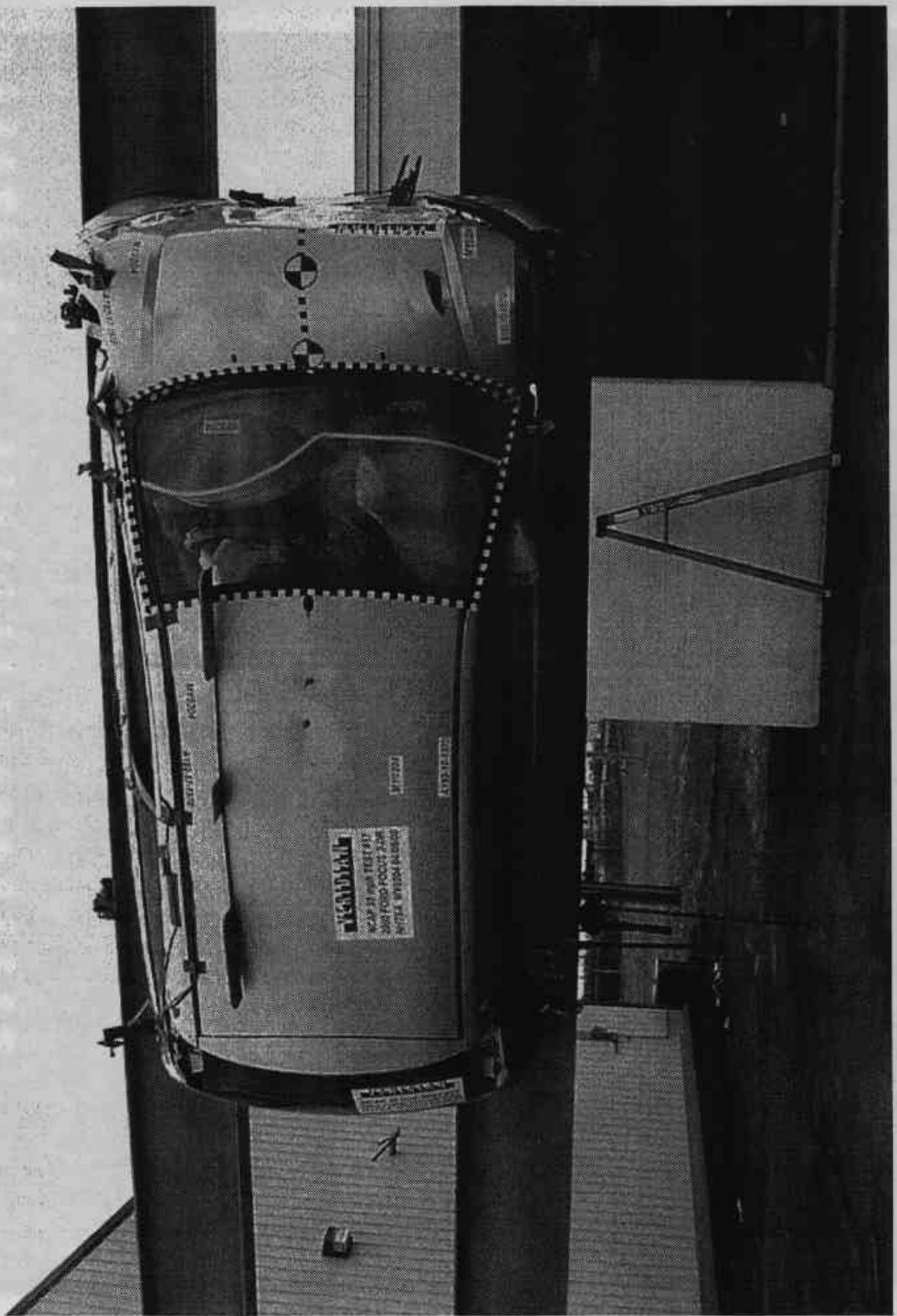

Figure A-38 ROLLOVER VIEW

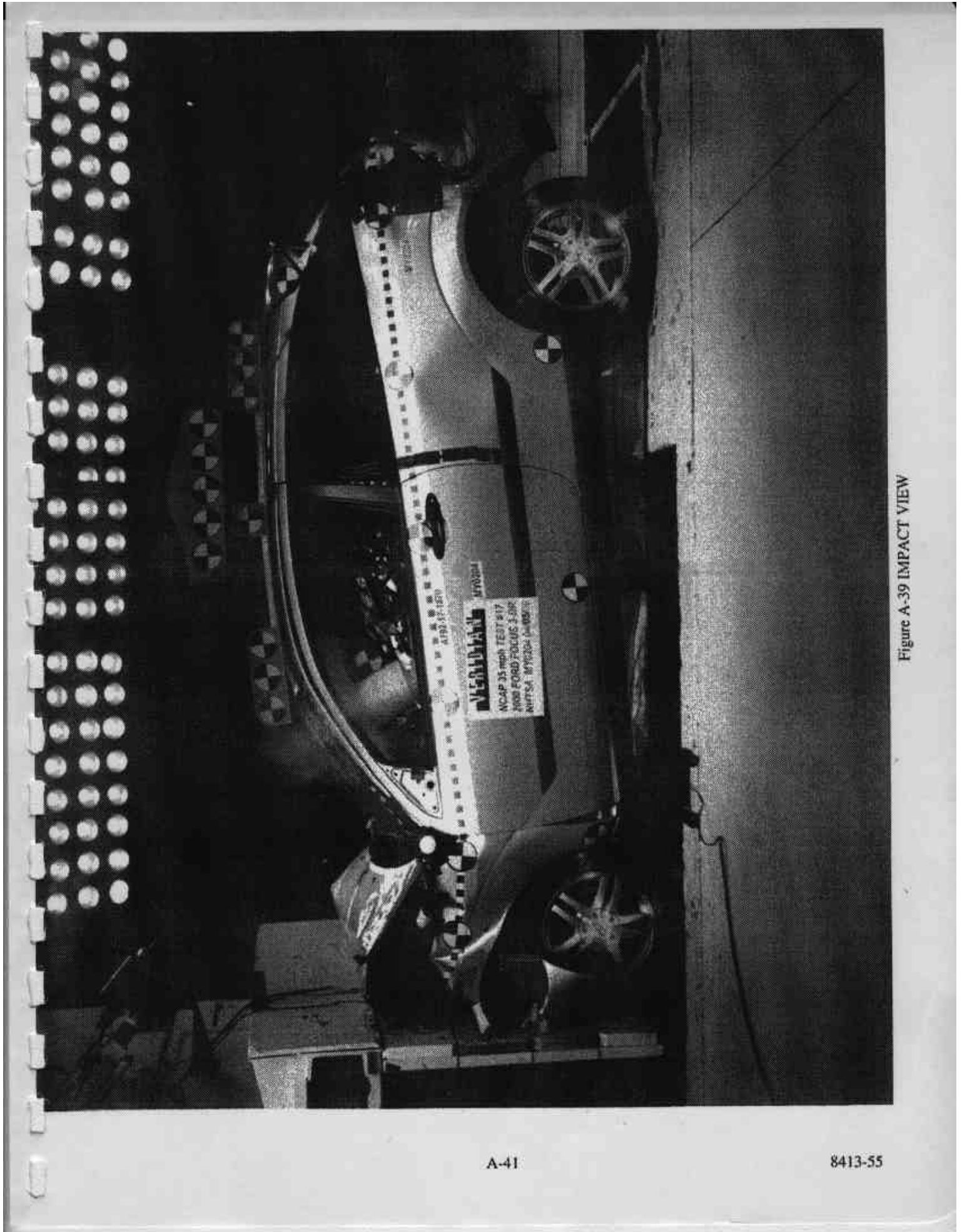

Figure A-39 IMPACT VIEW

APPENDIX B

DUMMY, VEHICLE AND LOAD CELL BARRIER RESPONSE DATA

**Hybrid III Dummy Sign Conventions
Load Cells and Special Transducers**

Transducer	SAE Sign Convention (positive unless noted)
Upper Neck Load Cell	Fx Head rearward Fy Head left Fz Neck in tension Mx Left ear to left shoulder My Chin to chest (flexion) Mz Chin to left shoulder (look left)
Chest Displacement Potentiometer	Compression is negative
Pelvic Load Cell (Lower Lumbar)	Fx Chest rearward Fy Chest left Fz Spine in tension
Femur Load Cell	Compression is negative
Upper Tibia Load Cell (right and left leg)	Mx Support tibia at ends, load left side center My Support tibia at ends, load front (shin) center
Lower Tibia Load Cell (right and left leg)	Fz Tibia in tension Mx Support tibia at ends, load left side center My Support tibia at ends, load front (shin) center

DATA CHANNEL FILTER CLASS SUMMARY

NHTSA TEST NO. MY0204

DATA TYPE	SAE FILTER CLASS (Hz)
Dummy Head Accelerations	1000
Dummy Chest Accelerations	180
Dummy Chest Displacements	60
Dummy Femur Forces	600
Dummy Belt Loads	60
Dummy Belt Displacements	180
Dummy Neck Forces	1000
Dummy Neck Moments	600
Vehicle Accelerations	60
Vehicle Velocity Integrations	180
Vehicle Displacement Integrations	180
Load Cell Barrier Forces	60

NCAP 2000 Test#17 - 2000 Ford Focus 3-Door

Max: 10.9 [g] at 0.234 [s]
Min: -54.0 [g] at 0.080 [s]

P1 Head x

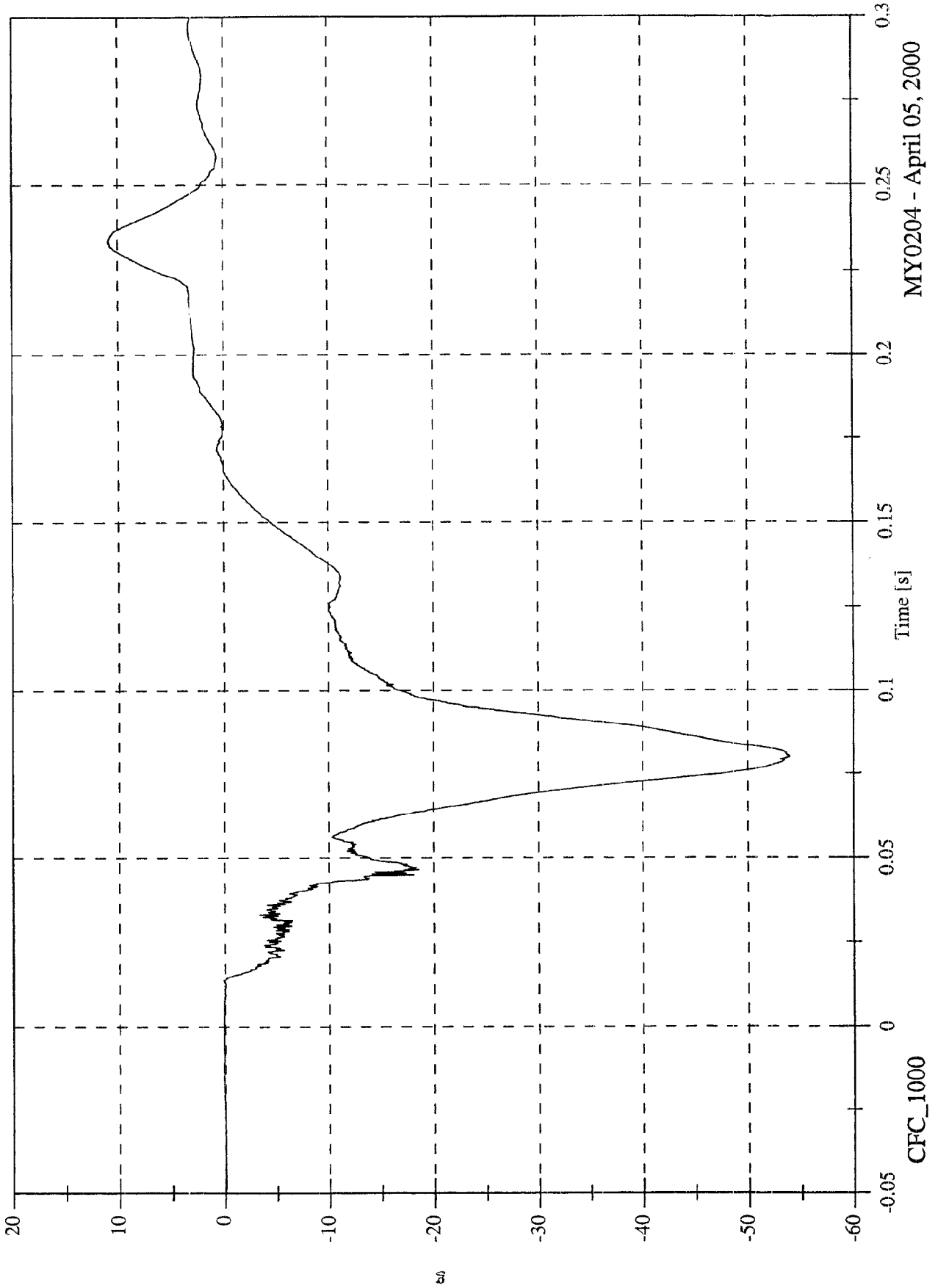

MY0204 - April 05, 2000

NCAP 2000 Test#17 - 2000 Ford Focus 3-Door

Max: 15.7 [g] at 0.087 [s]
Min: -3.4 [g] at 0.229 [s]

P1 Head y

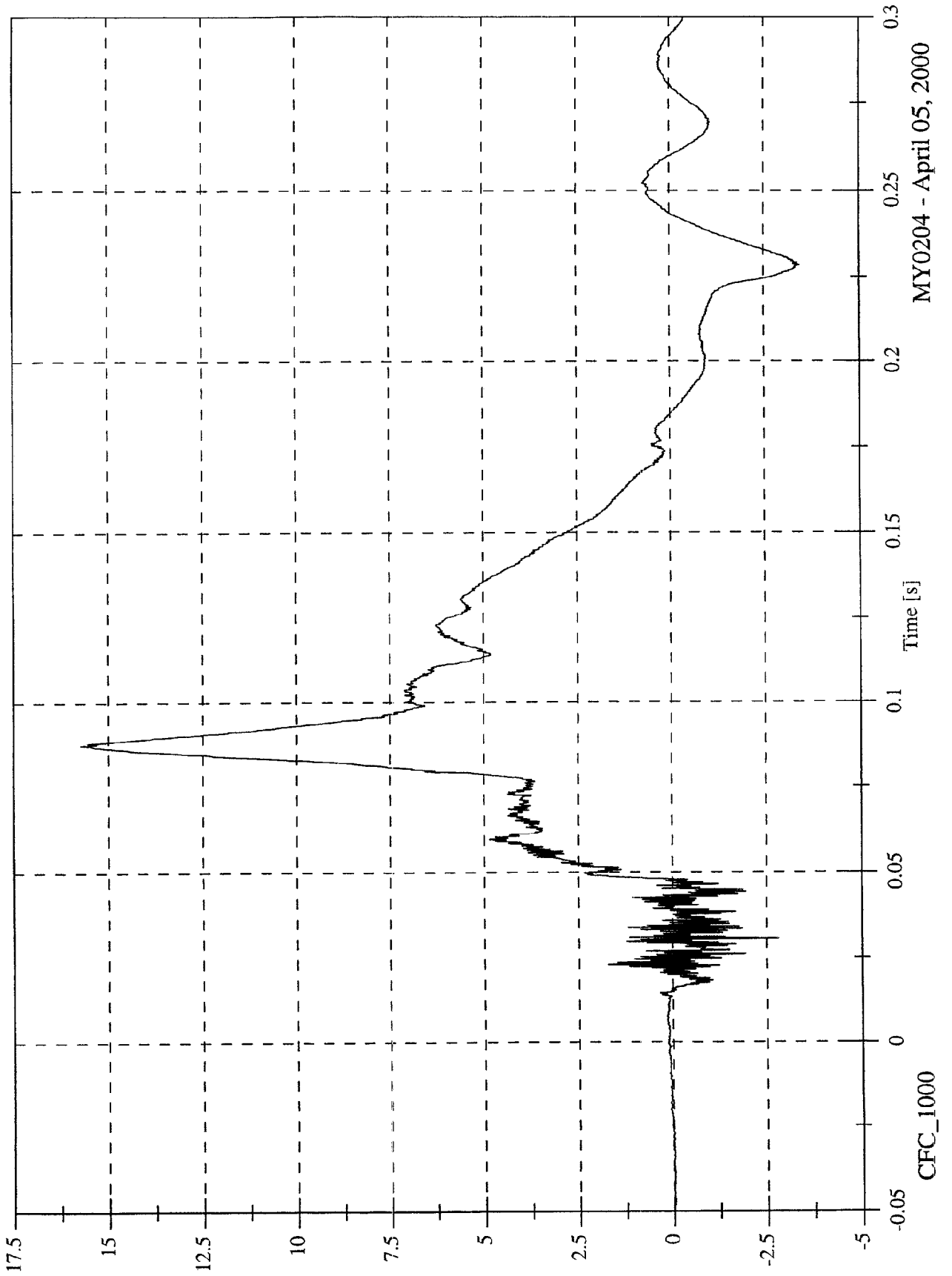

MY0204 - April 05, 2000

NCAP 2000 Test#17 - 2000 Ford Focus 3-Door

Max: 22.7 [g] at 0.058 [s]
Min: -9.9 [g] at 0.097 [s]

P1 Head z

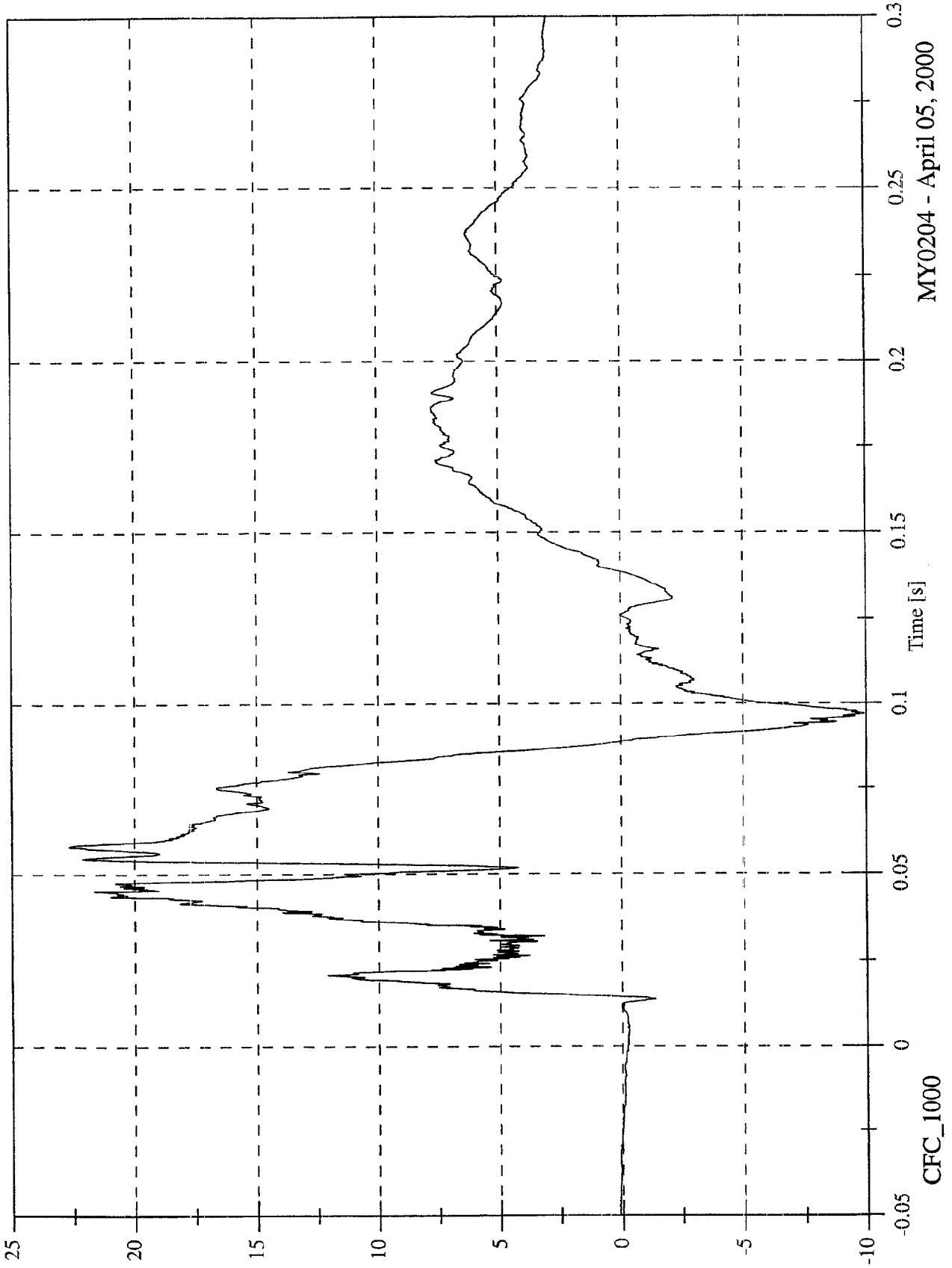

MY0204 - April 05, 2000

NCAP 2000 Test#17 - 2000 Ford Focus 3-Door

P1 Head Resultant

Max: 56.0 [g] at 0.080 [s]
Min: 0.0 [g] at -0.026 [s]

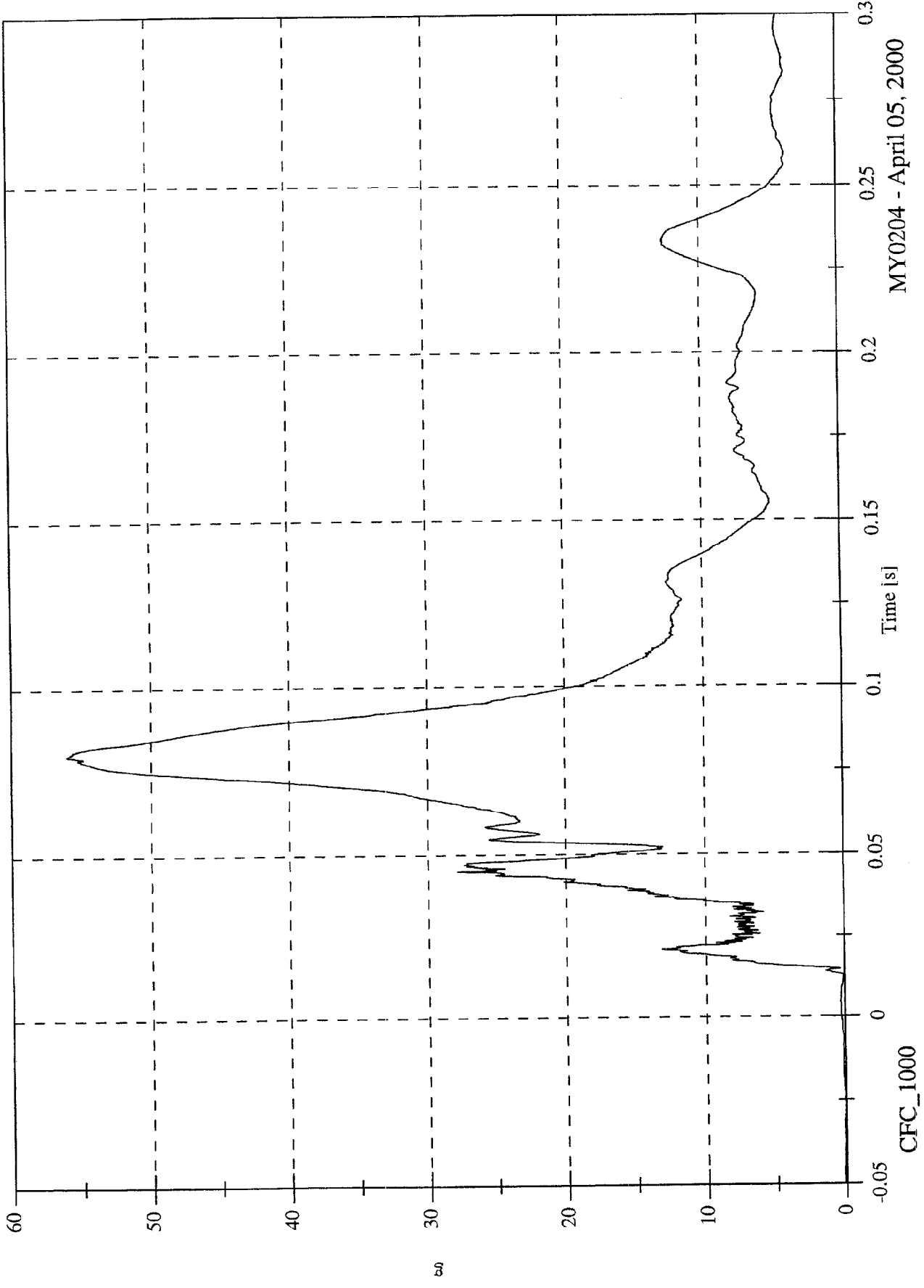

MY0204 - April 05, 2000

CFC_1000

NCAP 2000 Test#17 - 2000 Ford Focus 3-Door

Max: 11.0 [g] at 0.234 [s]
Min: -56.4 [g] at 0.080 [s]

P1 Head Red x

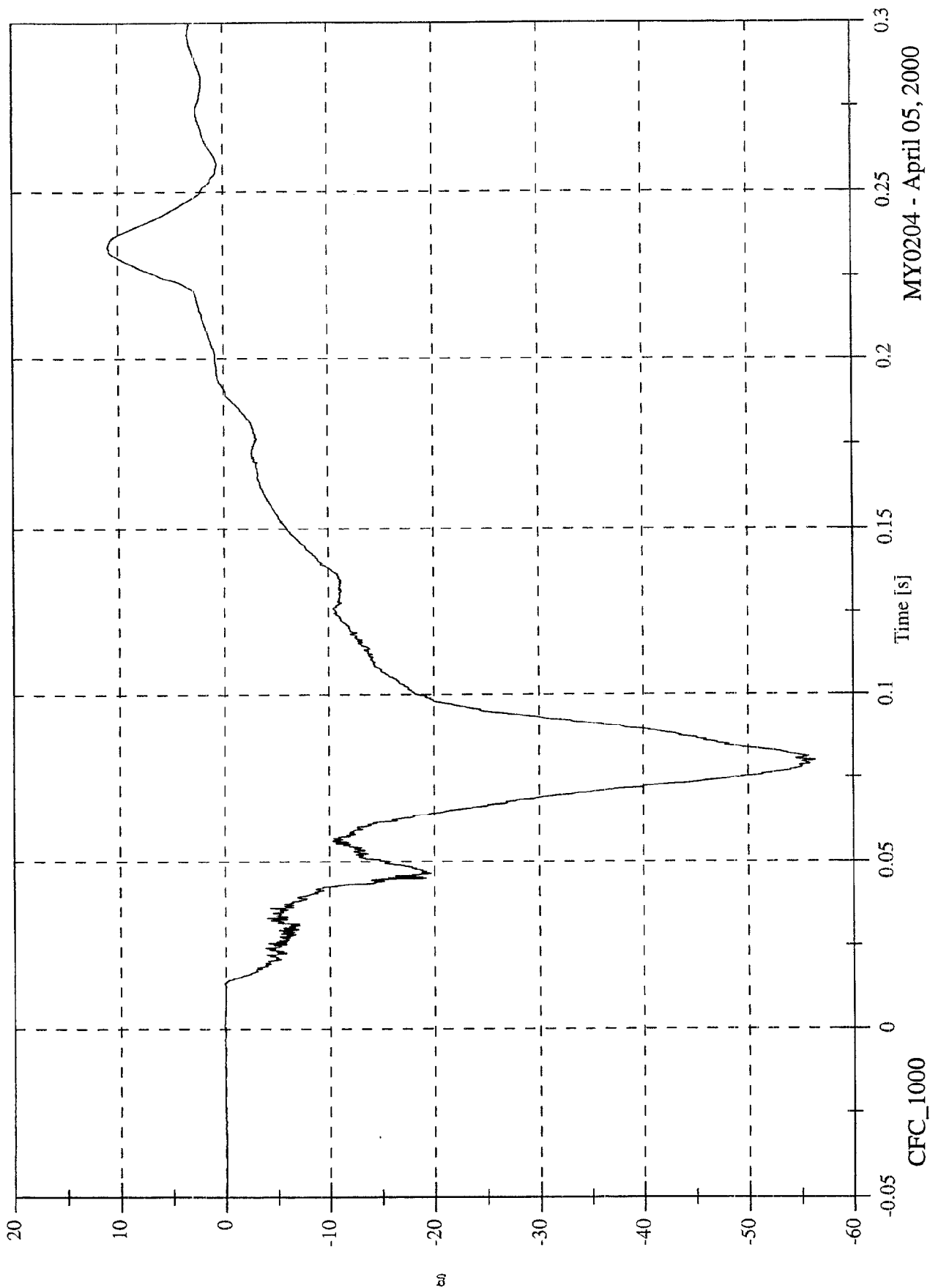

MY0204 - April 05, 2000

CFC_1000

NCAP 2000 Test#17 - 2000 Ford Focus 3-Door

Max: 18.1 [g] at 0.087 [s]
Min: -2.0 [g] at 0.228 [s]

P1 Head Red y

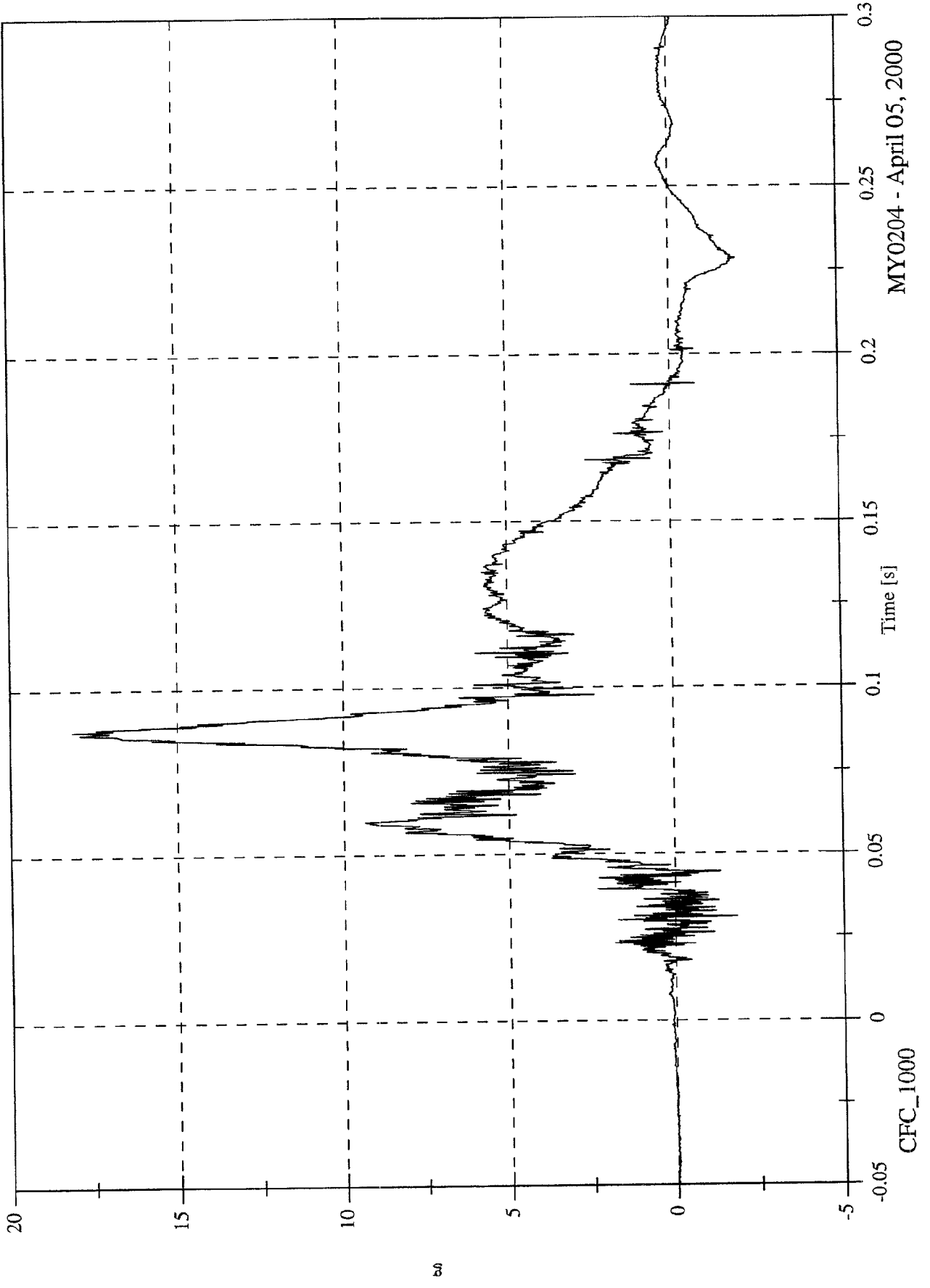

MY0204 - April 05, 2000

NCAP 2000 Test#17 - 2000 Ford Focus 3-Door

Max: 26.5 [g] at 0.045 [s]
Min: -8.6 [g] at 0.097 [s]

P1 Head Red z

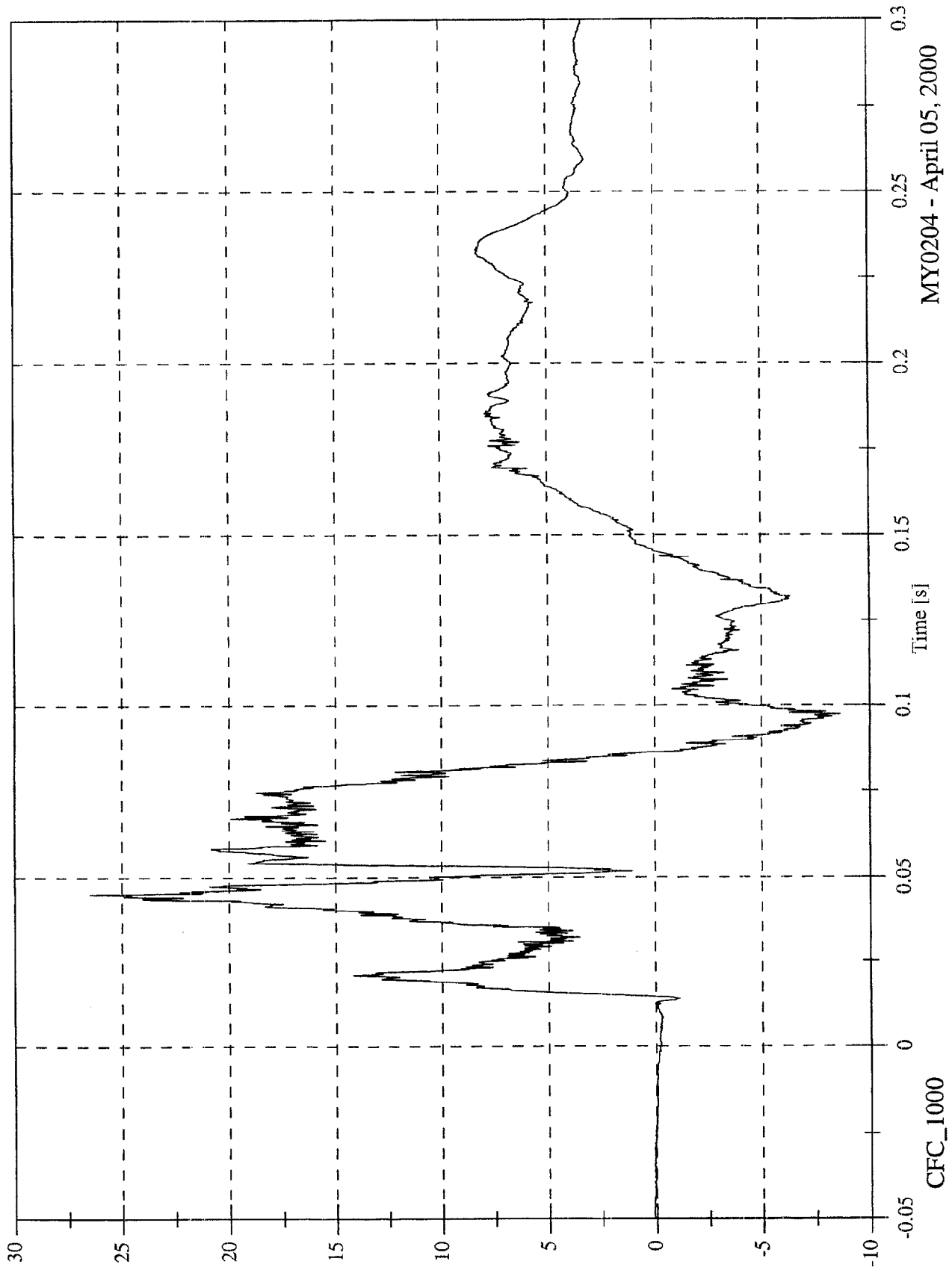

MY0204 - April 05, 2000

CFC_1000

NCAP 2000 Test#17 - 2000 Ford Focus 3-Door

P1 Head Red Resultant

Max: 57.9 [g] at 0.080 [s]
Min: 0.0 [g] at -0.027 [s]

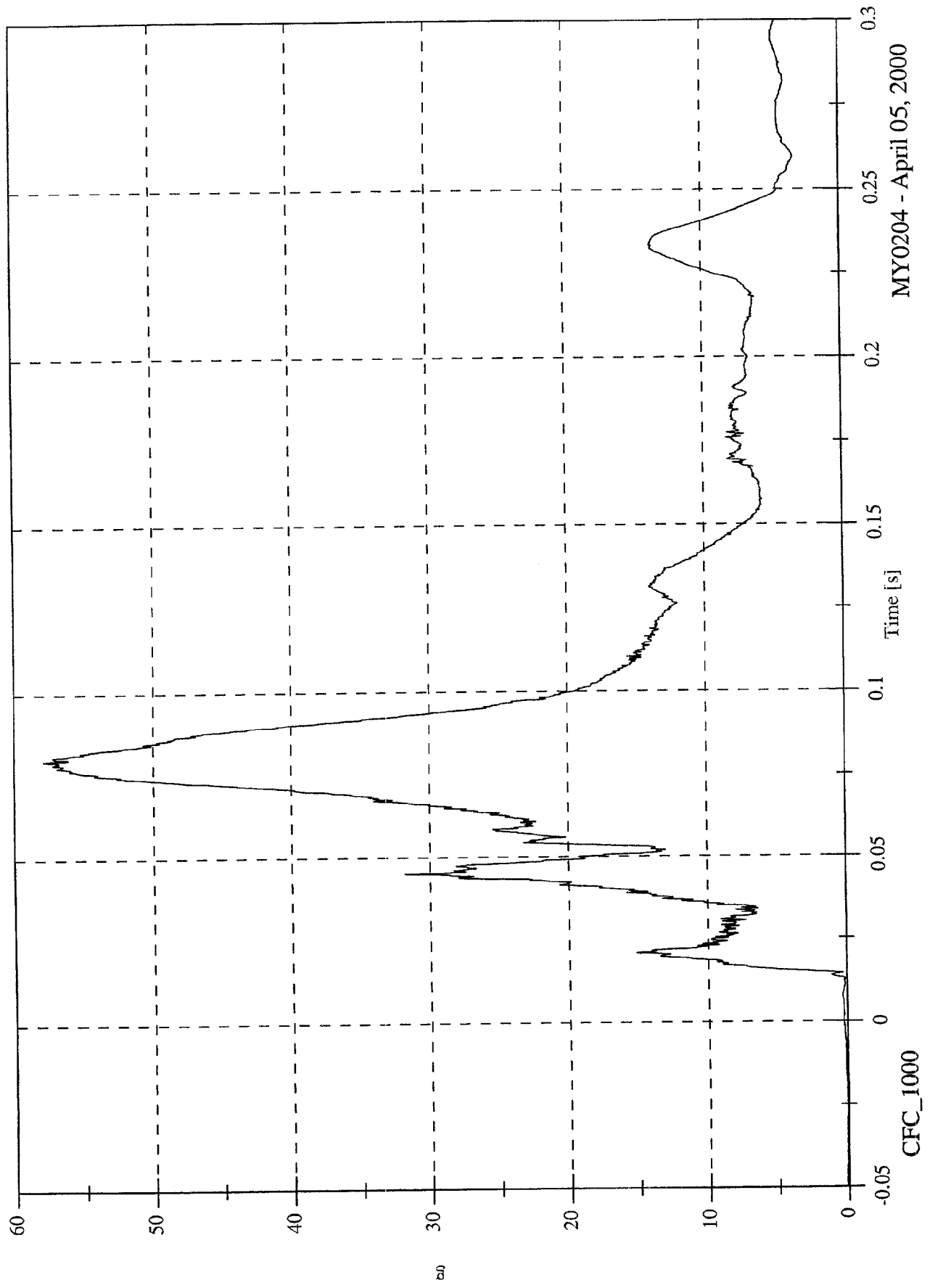

MY0204 - April 05, 2000

CFC_1000

NCAP 2000 Test#17 - 2000 Ford Focus 3-Door

Max: 679.4 [N] at 0.082 [s]
Min: -413.3 [N] at 0.114 [s]

P1 Upper Neck Fx

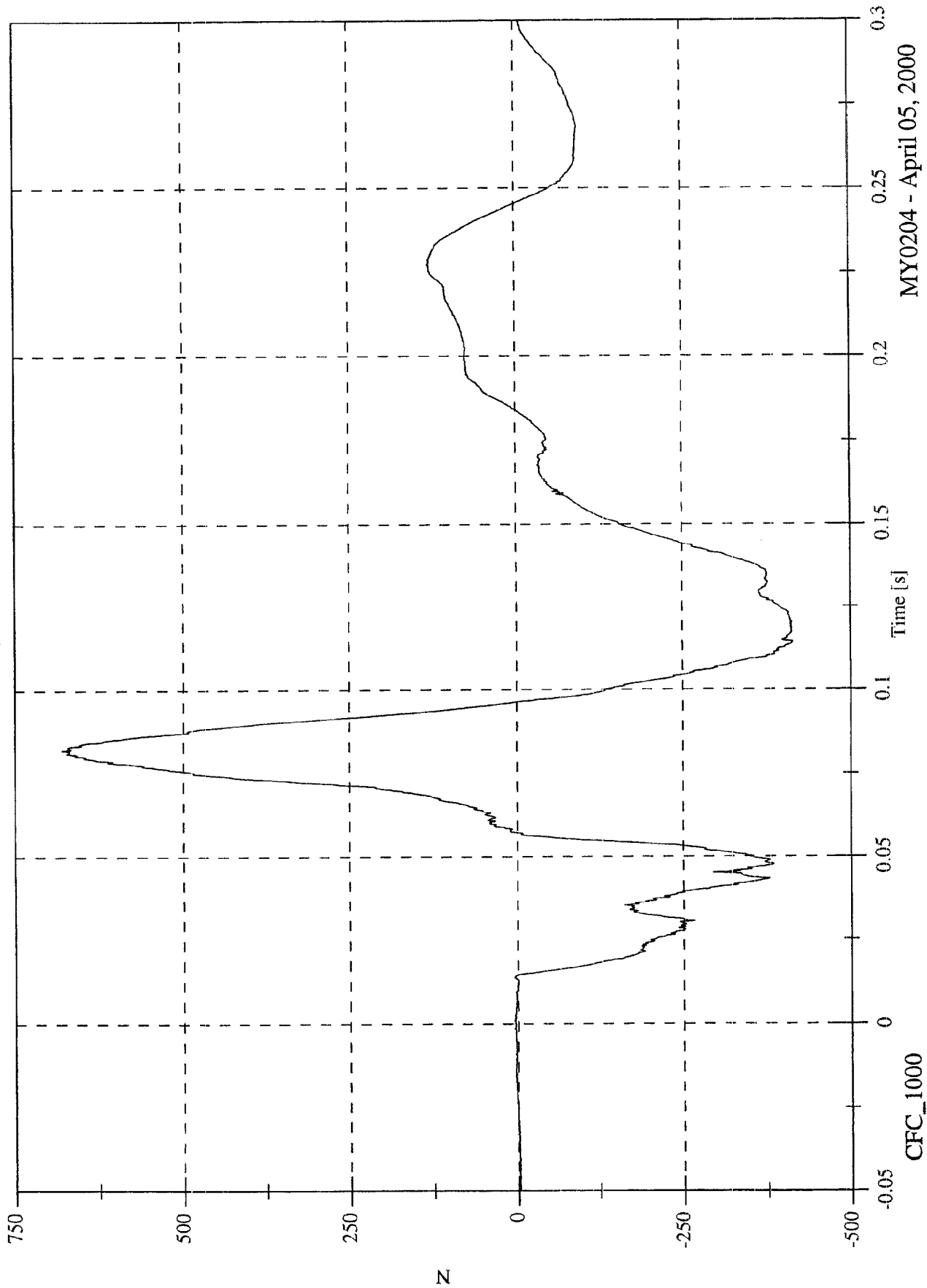

MY0204 - April 05, 2000

CFC_1000

NCAP 2000 Test#17 - 2000 Ford Focus 3-Door

Max: 231.0 [N] at 0.123 [s]
Min: -155.9 [N] at 0.079 [s]

P1 Upper Neck Fy

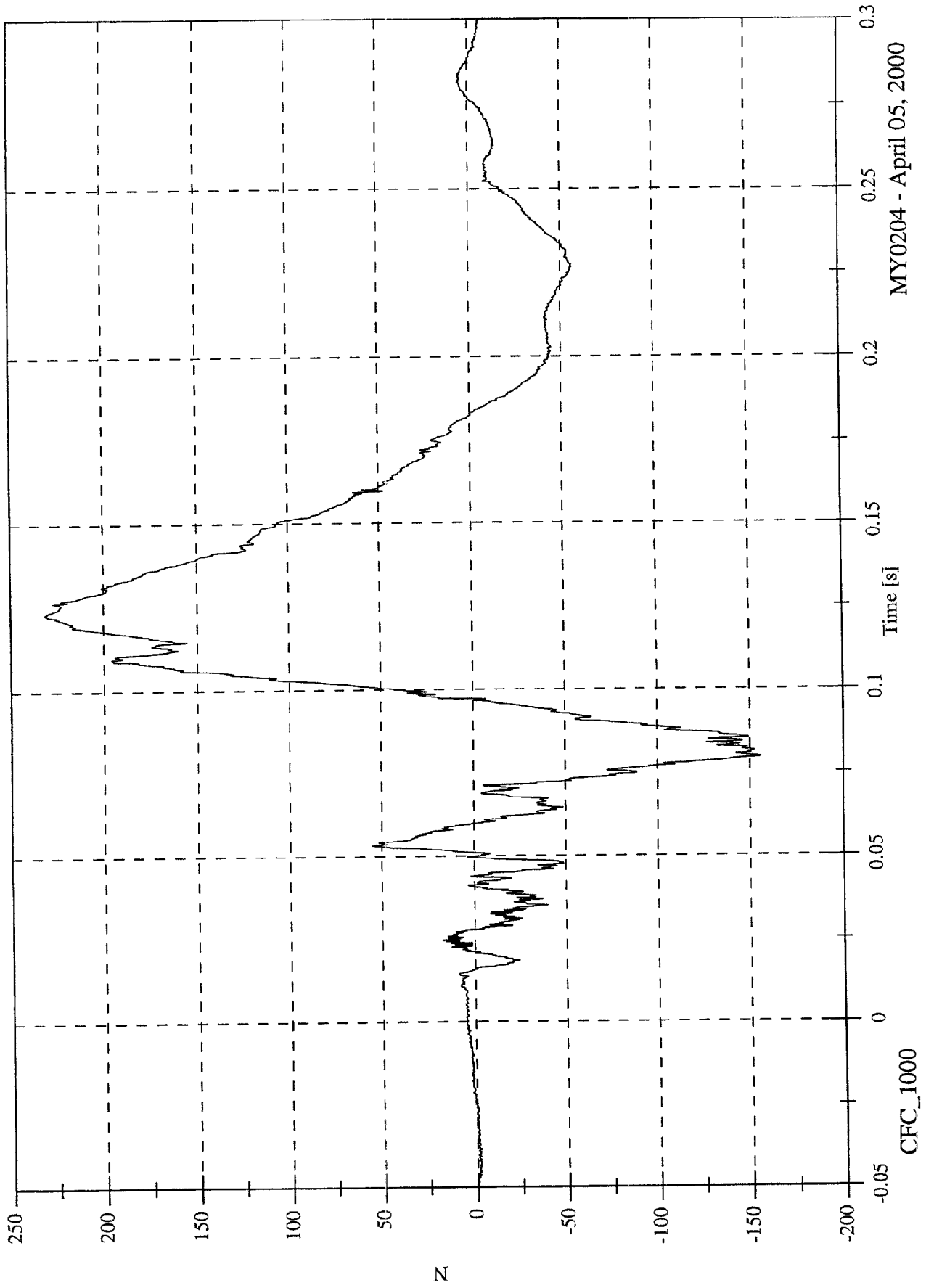

MY0204 - April 05, 2000

NCAP 2000 Test#17 - 2000 Ford Focus 3-Door

Max: 1111.9 [N] at 0.055 [s]
Min: -408.8 [N] at 0.274 [s]

P1 Upper Neck Fz

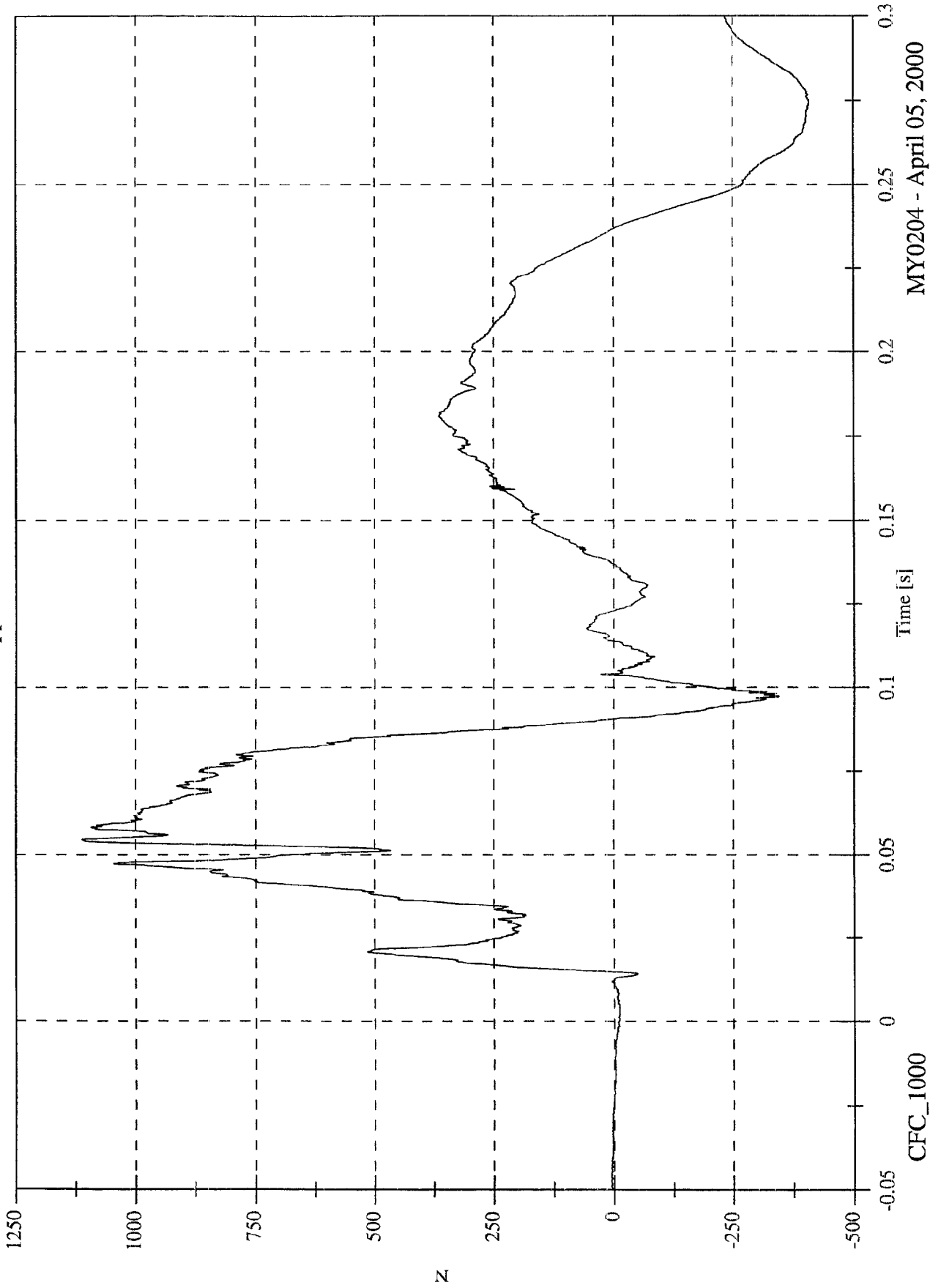

MY0204 - April 05, 2000

NCAP 2000 Test#17 - 2000 Ford Focus 3-Door

Max: 1122.2 [N] at 0.055 [s]
Min: 0.7 [N] at -0.025 [s]

P1 Upper Neck F Resultant

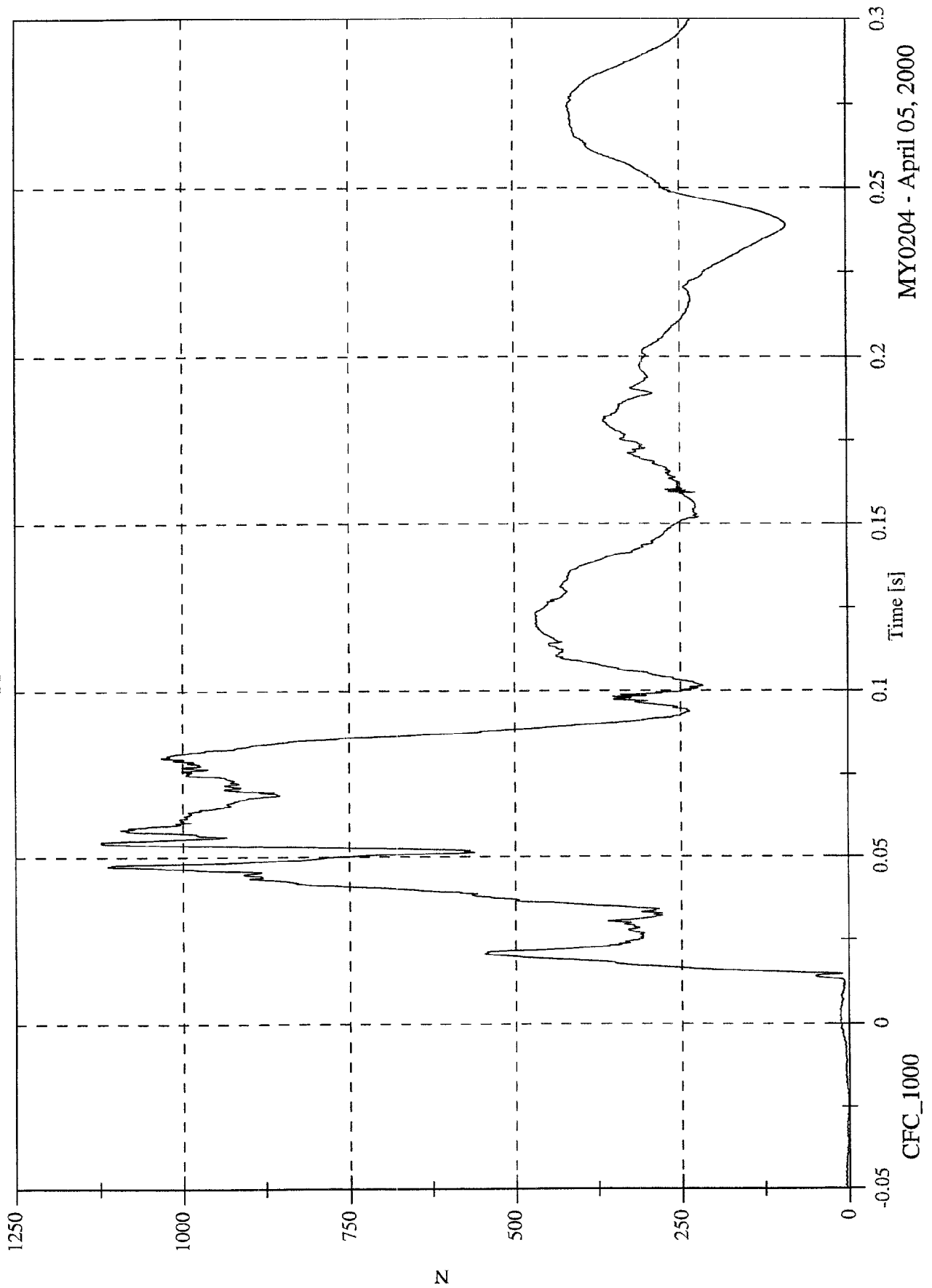

MY0204 - April 05, 2000

NCAP 2000 Test#17 - 2000 Ford Focus 3-Door

Max: 16.8 [N-m] at 0.080 [s]
Min: -4.5 [N-m] at 0.257 [s]

P1 Upper Neck Mx

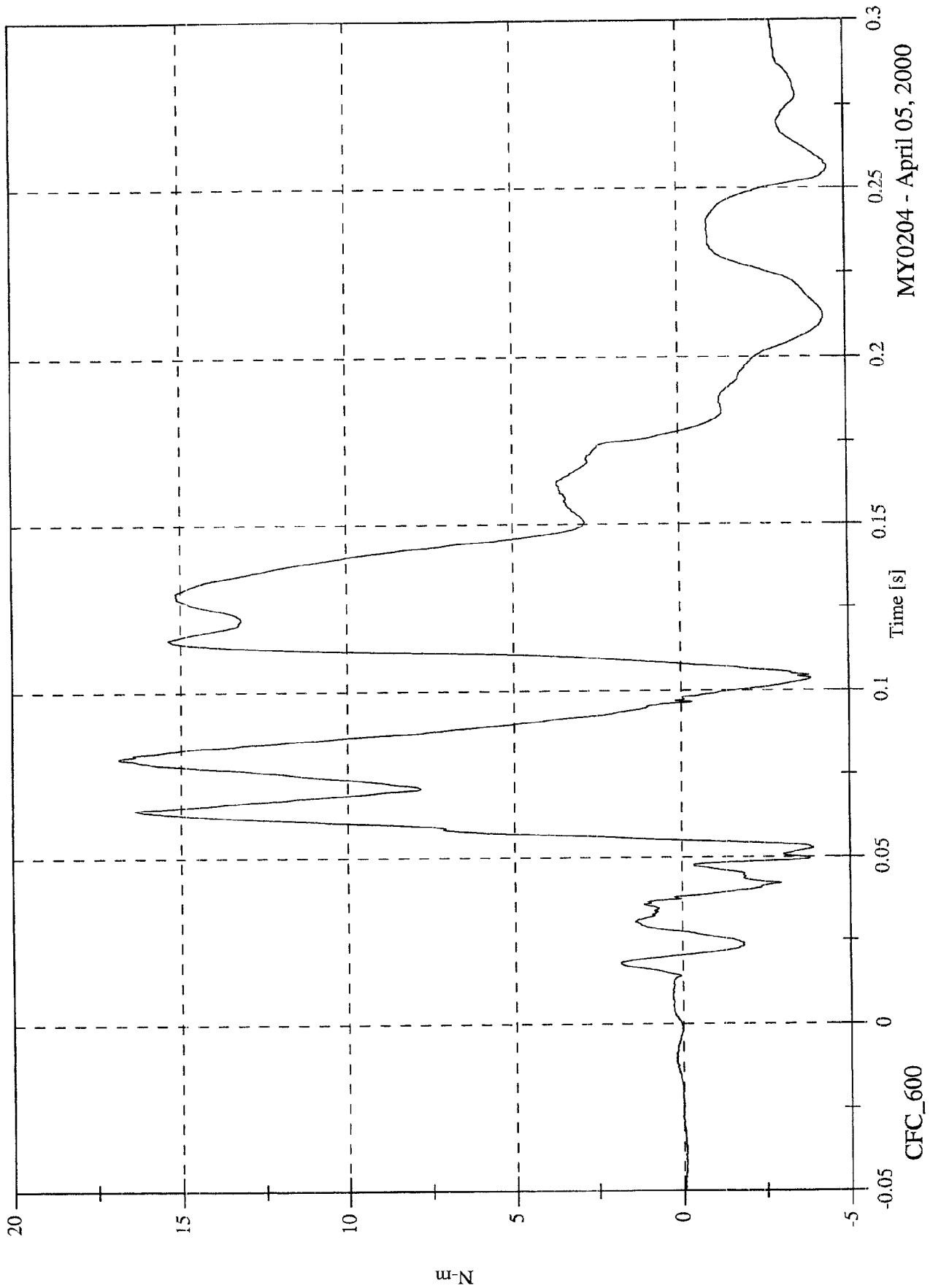

MY0204 - April 05, 2000

NCAP 2000 Test#17 - 2000 Ford Focus 3-Door

Max: 45.9 [N-m] at 0.129 [s]
Min: -27.9 [N-m] at 0.283 [s]

P1 Upper Neck My

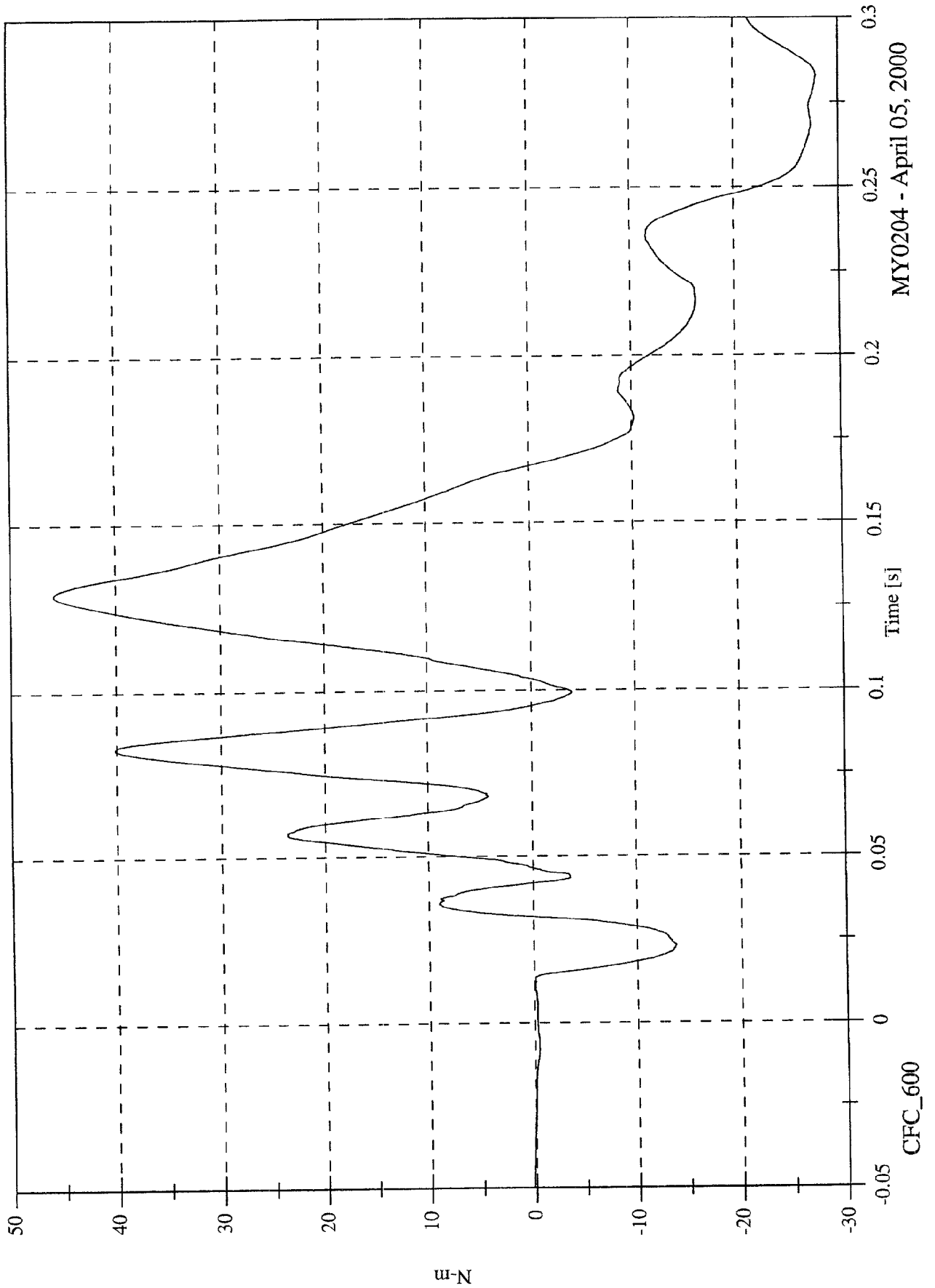

MY0204 - April 05, 2000

NCAP 2000 Test#17 - 2000 Ford Focus 3-Door

Max: 8.6 [N-m] at 0.140 [s]
Min: -21.3 [N-m] at 0.097 [s]

P1 Upper Neck Mz

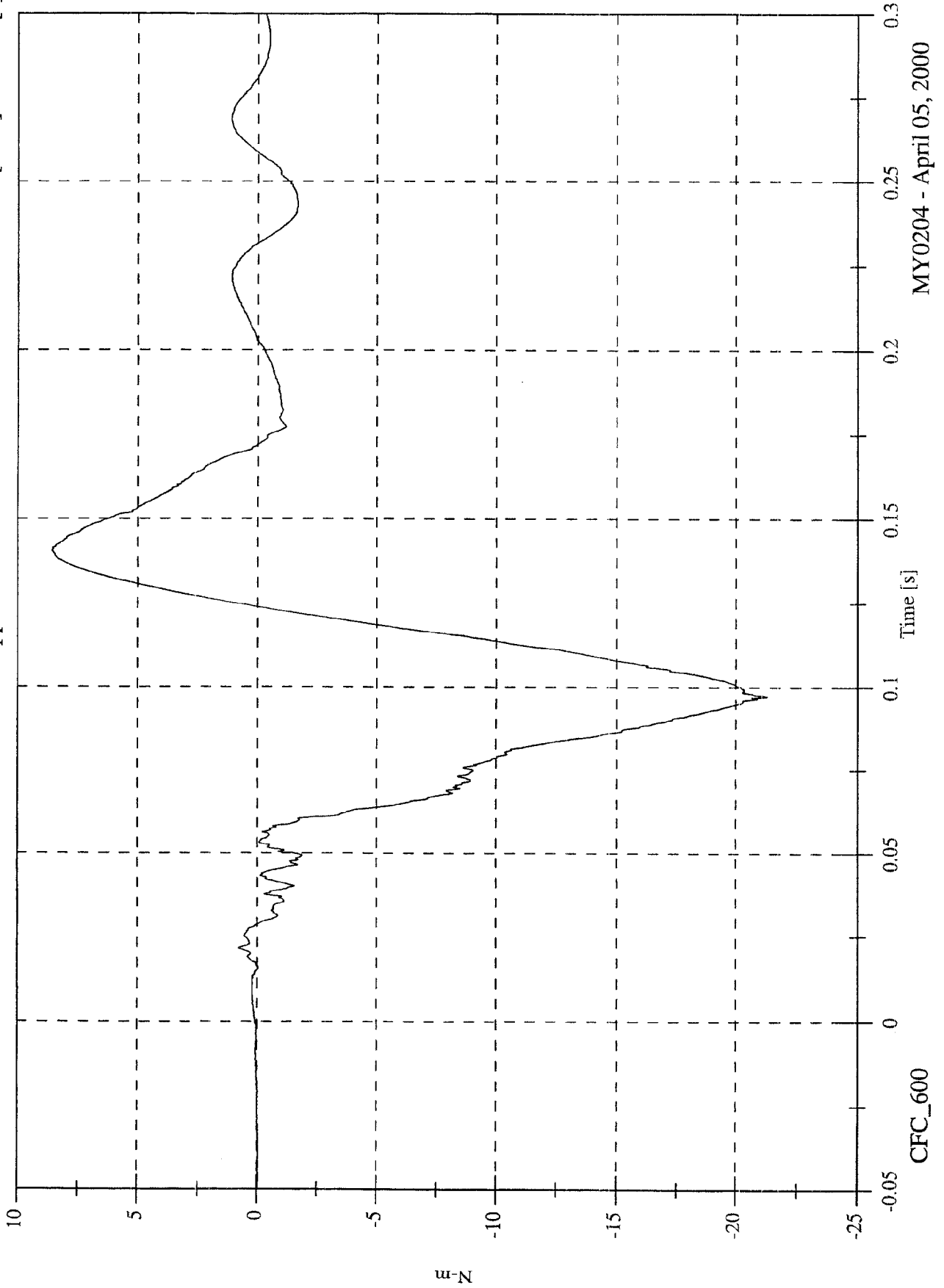

MY0204 - April 05, 2000

NCAP 2000 Test#17 - 2000 Ford Focus 3-Door

Max: 48.4 [N-m] at 0.129 [s]
Min: 0.0 [N-m] at -0.029 [s]

P1 Upper Neck M Resultant

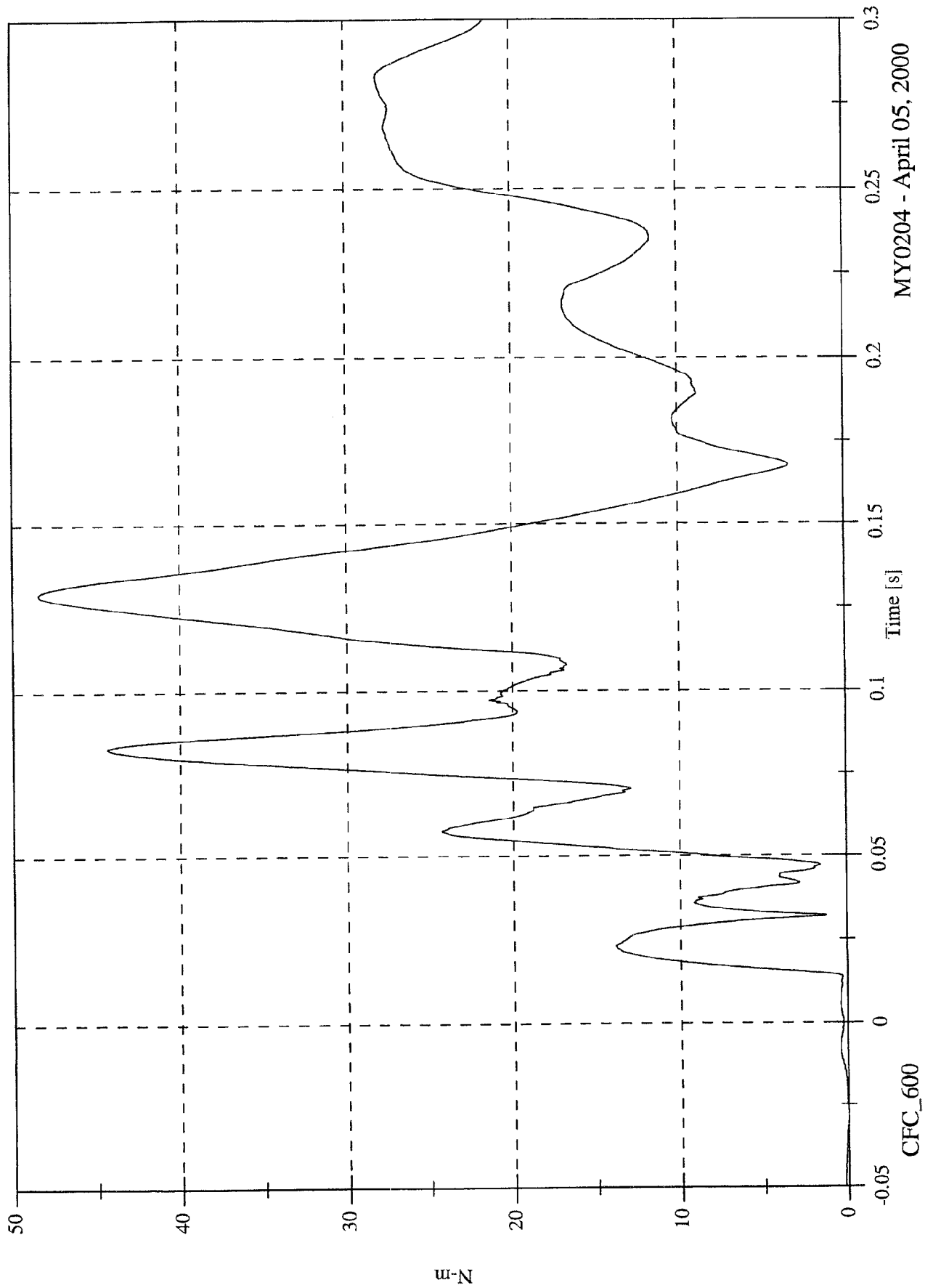

MY0204 - April 05, 2000

NCAP 2000 Test#17 - 2000 Ford Focus 3-Door

Max: 2.4 [g] at 0.270 [s]
Min: -40.0 [g] at 0.075 [s]

P1 Chest x

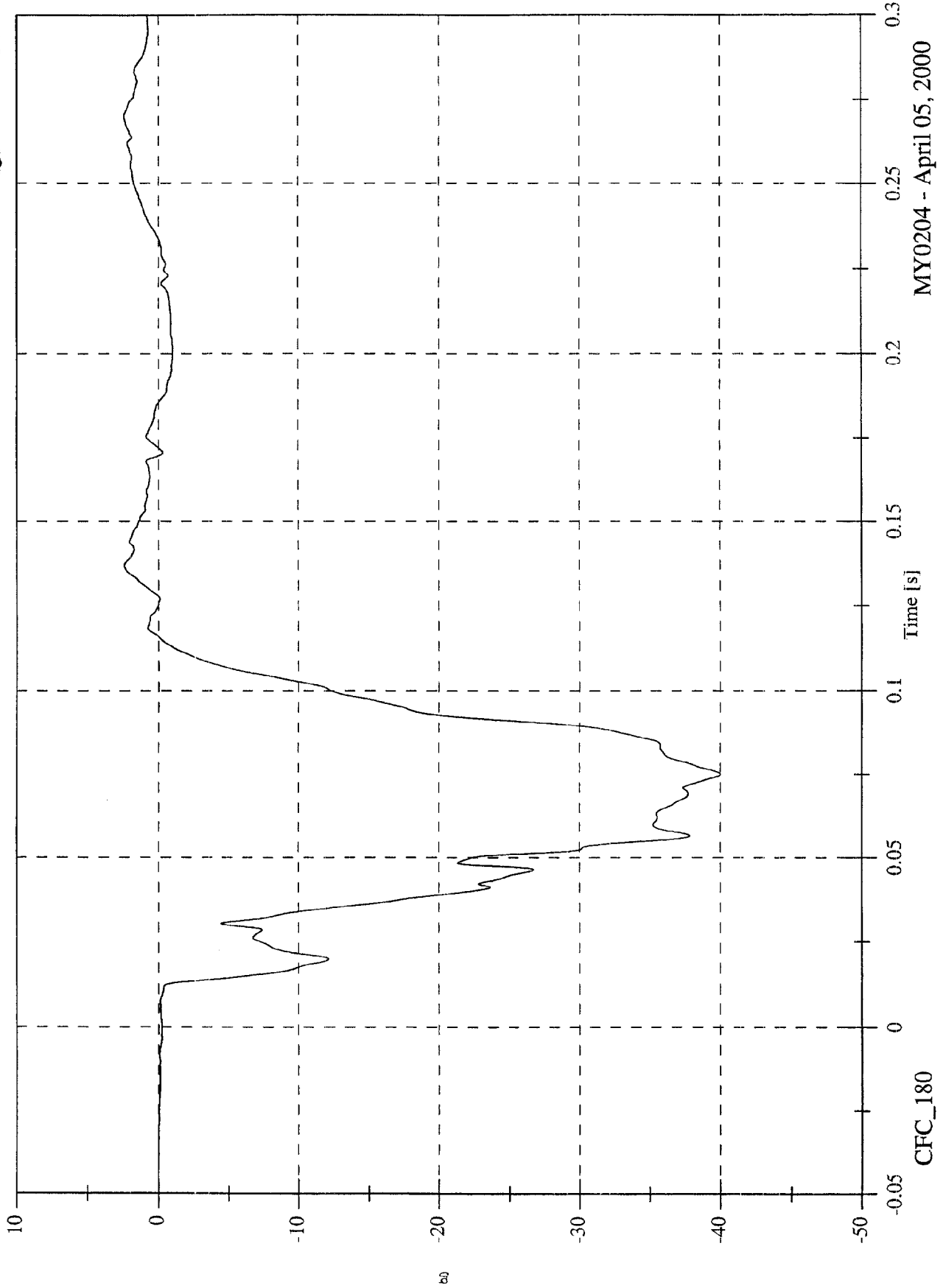

MY0204 - April 05, 2000

NCAP 2000 Test#17 - 2000 Ford Focus 3-Door

Max: 3.8 [g] at 0.081 [s]
Min: -5.2 [g] at 0.049 [s]

P1 Chest y

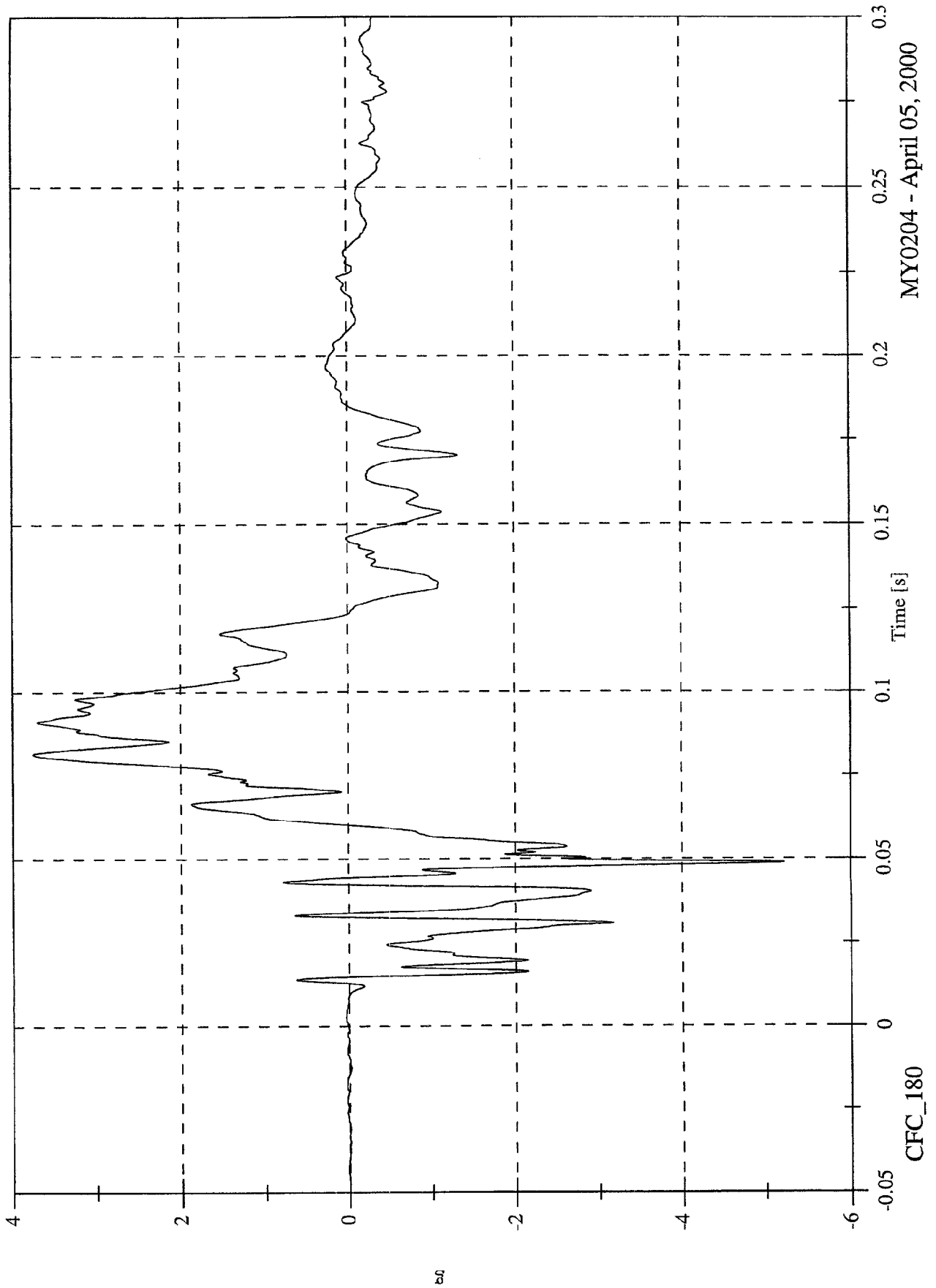

MY0204 - April 05, 2000

NCAP 2000 Test#17 - 2000 Ford Focus 3-Door

Max: 18.2 [g] at 0.096 [s]
Min: -9.5 [g] at 0.045 [s]

P1 Chest z

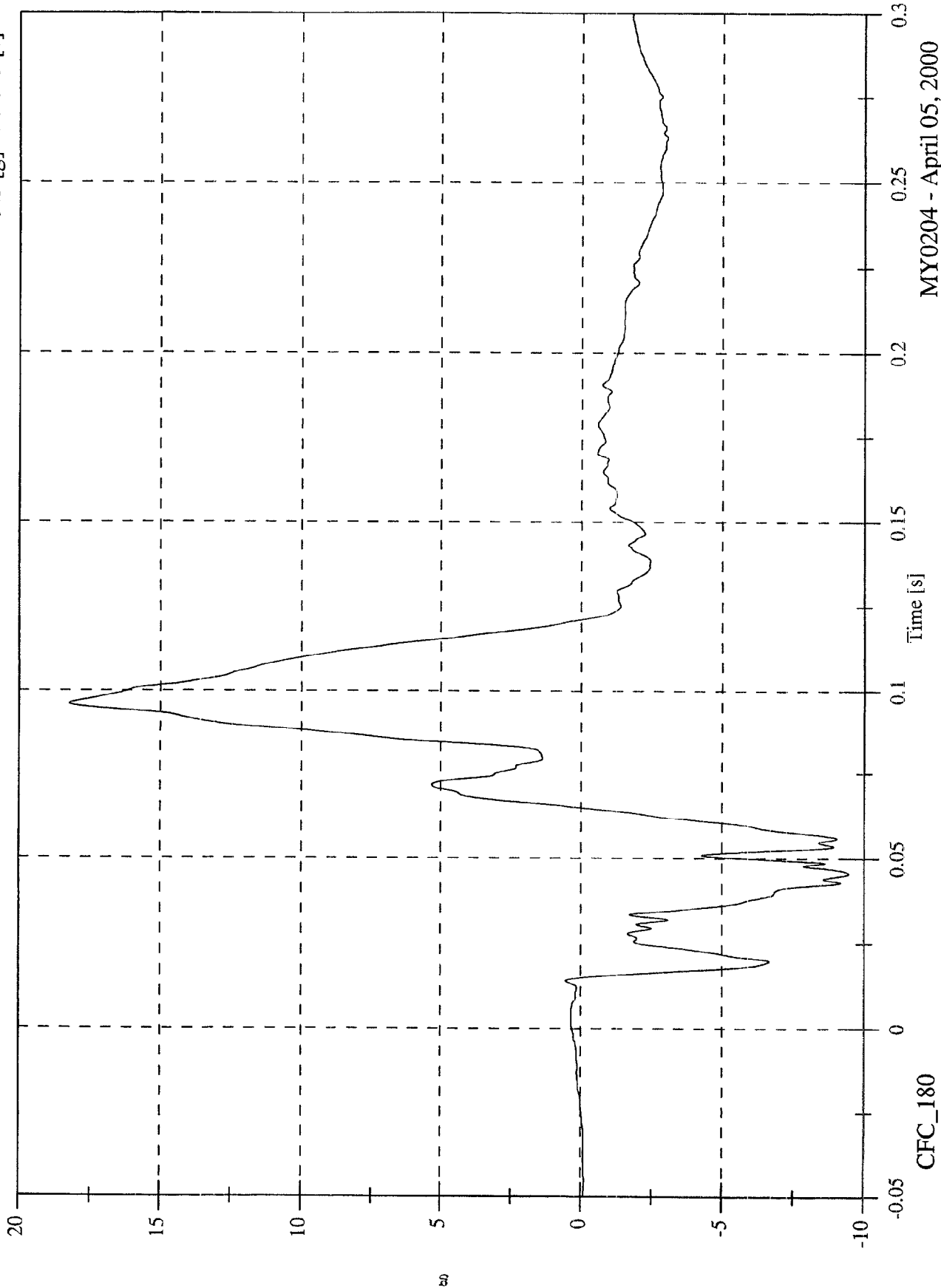

MY0204 - April 05, 2000

NCAP 2000 Test#17 - 2000 Ford Focus 3-Door

Max: 40.2 [g] at 0.075 [s]
Min: 0.0 [g] at -0.025 [s]

P1 Chest Resultant

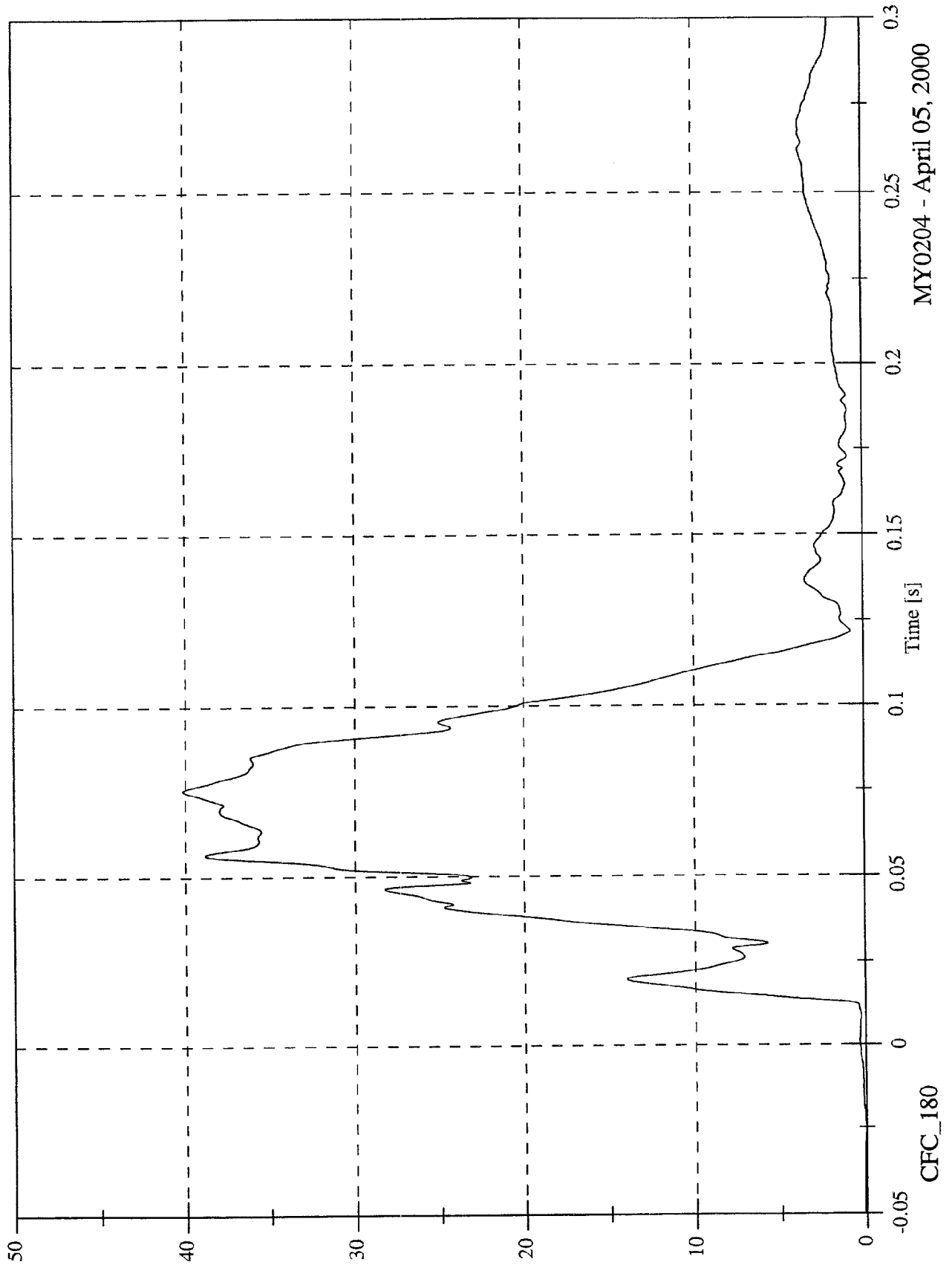

MY0204 - April 05, 2000

NCAP 2000 Test#17 - 2000 Ford Focus 3-Door

Max: 2.4 [g] at 0.270 [s]
Min: -40.4 [g] at 0.057 [s]

PI Chest Red x

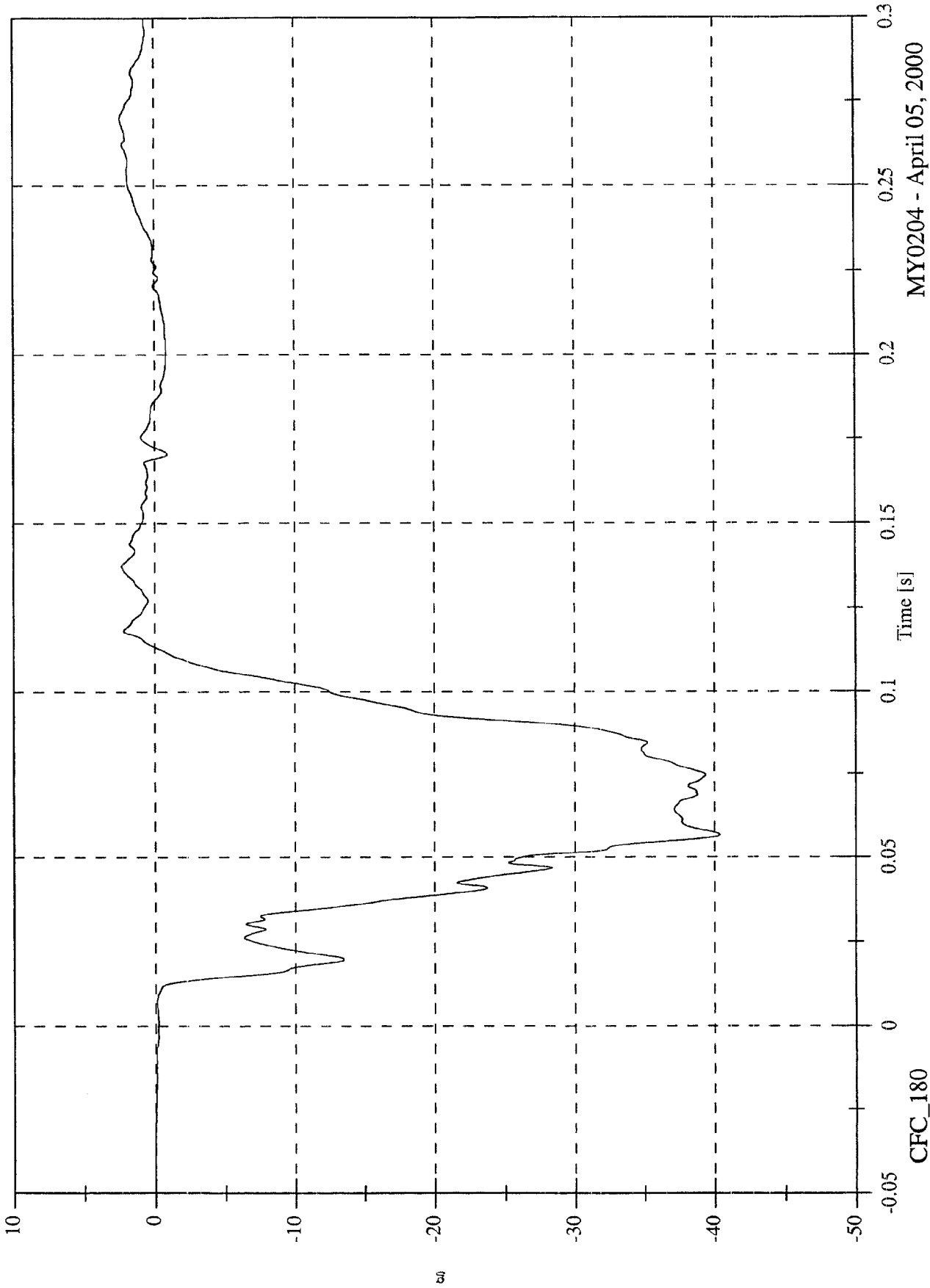

MY0204 - April 05, 2000

CFC_180

NCAP 2000 Test#17 - 2000 Ford Focus 3-Door

Max: 4.5 [g] at 0.090 [s]
Min: -3.8 [g] at 0.049 [s]

P1 Chest Red y

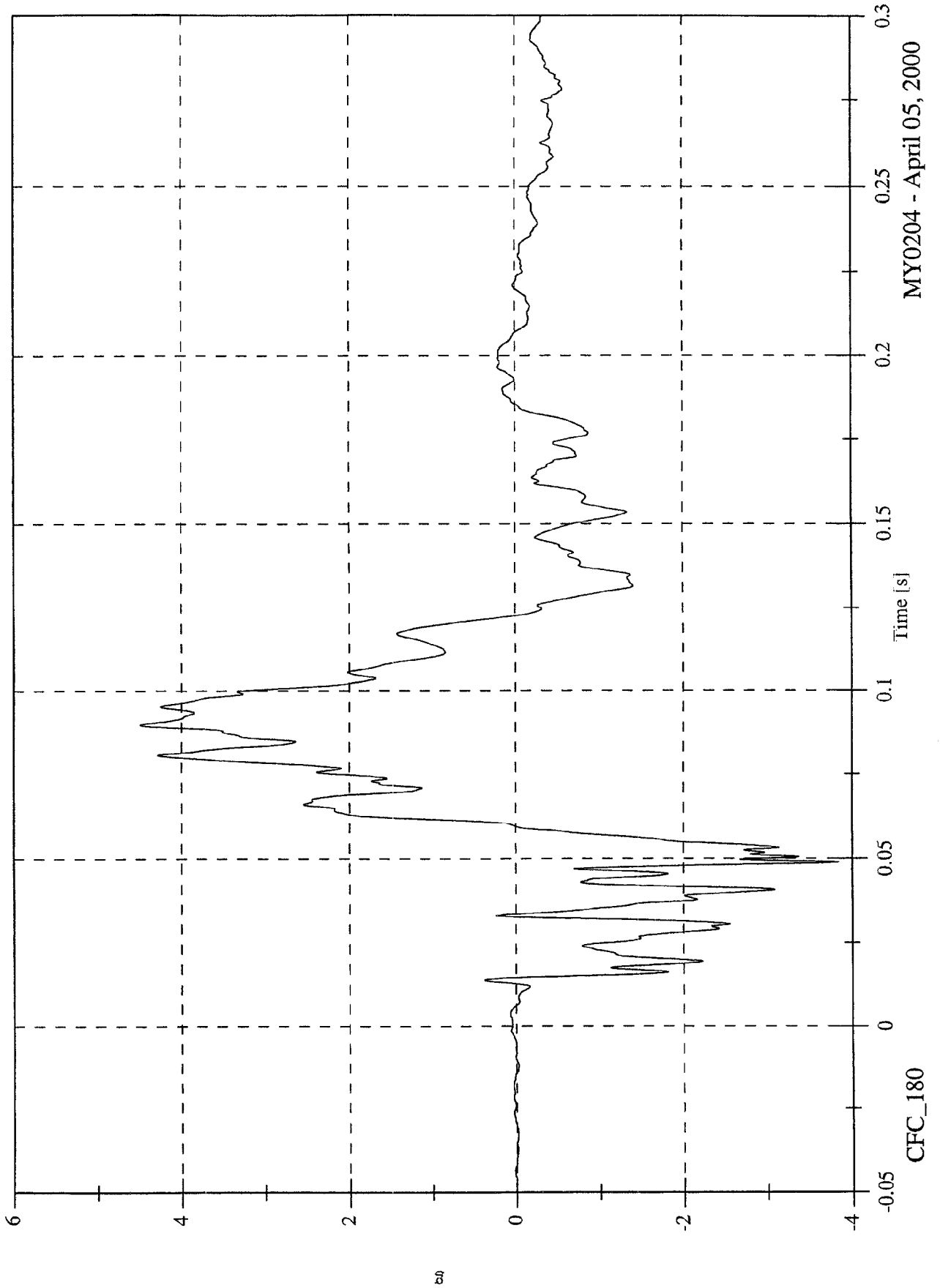

MY0204 - April 05, 2000

NCAP 2000 Test#17 - 2000 Ford Focus 3-Door

Max: 18.6 [g] at 0.096 [s]
Min: -9.9 [g] at 0.046 [s]

P1 Chest Red z

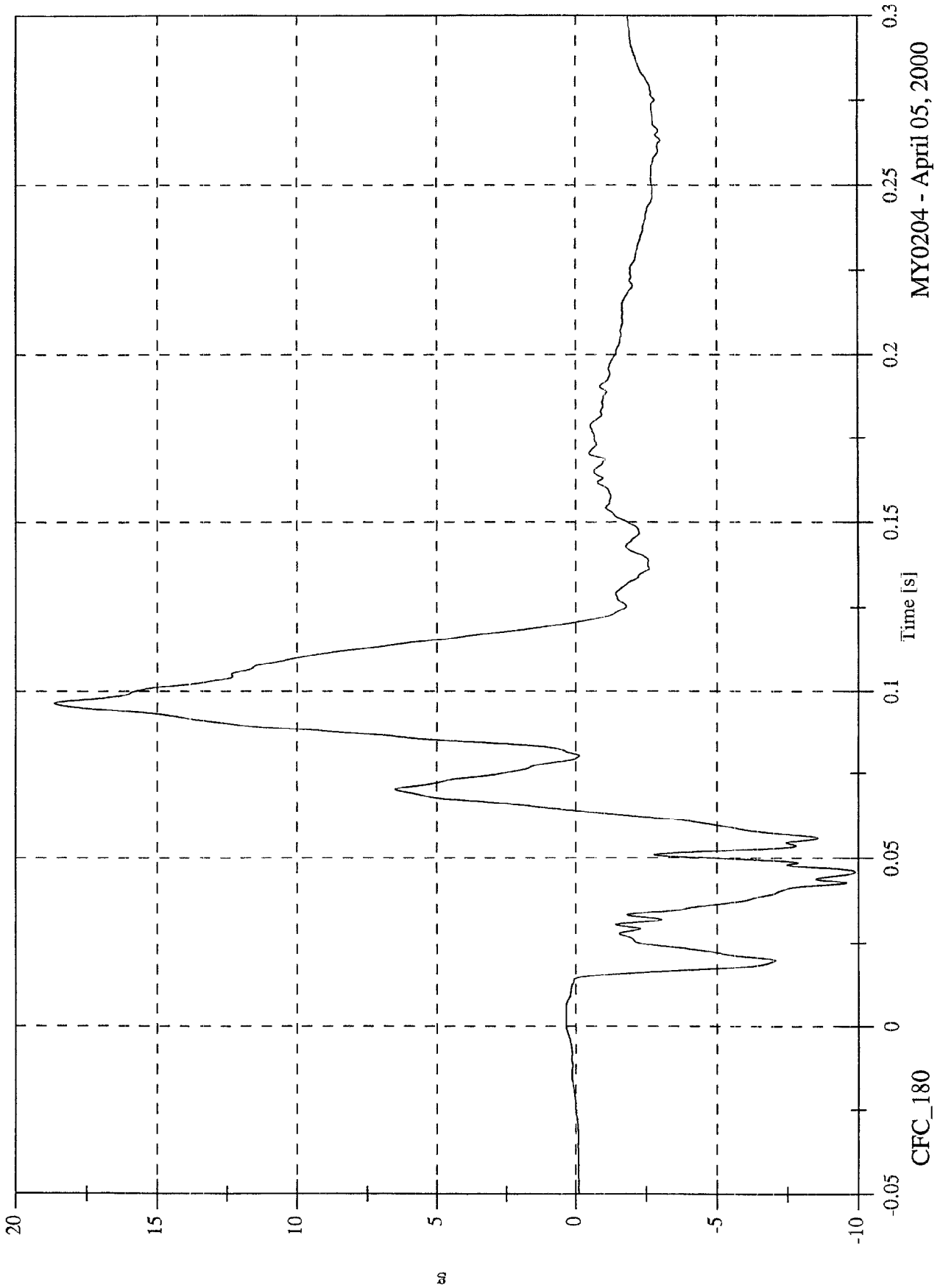

MY0204 - April 05, 2000

CFC_180

NCAP 2000 Test#17 - 2000 Ford Focus 3-Door

P1 Chest Red Resultant

Max: 41.2 [g] at 0.056 [s]
Min: 0.0 [g] at -0.025 [s]

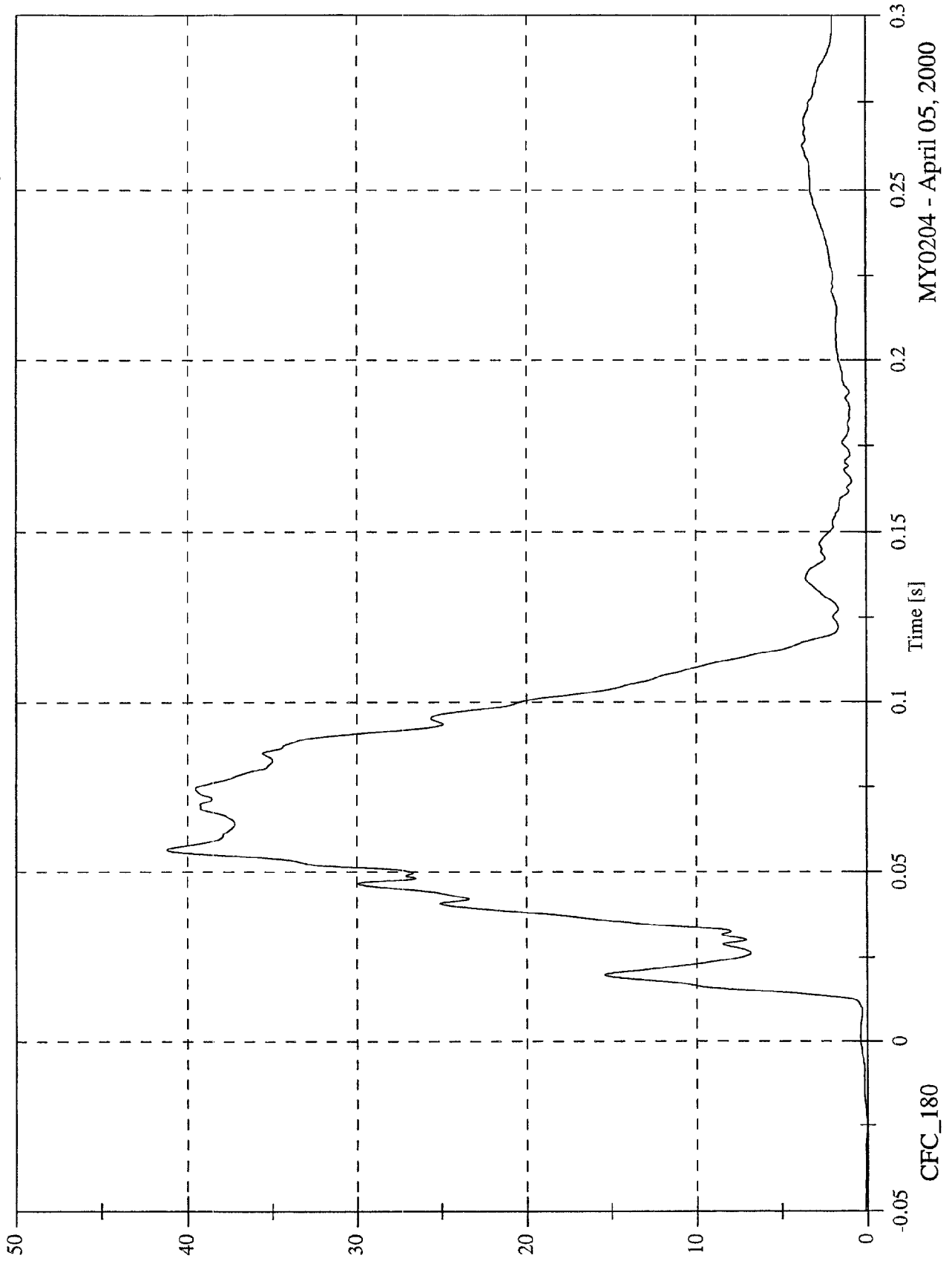

MY0204 - April 05, 2000

NCAP 2000 Test#17 - 2000 Ford Focus 3-Door

Max: 0.0 [mm] at -0.033 [s]
Min: -31.0 [mm] at 0.065 [s]

P1 Chest Compression

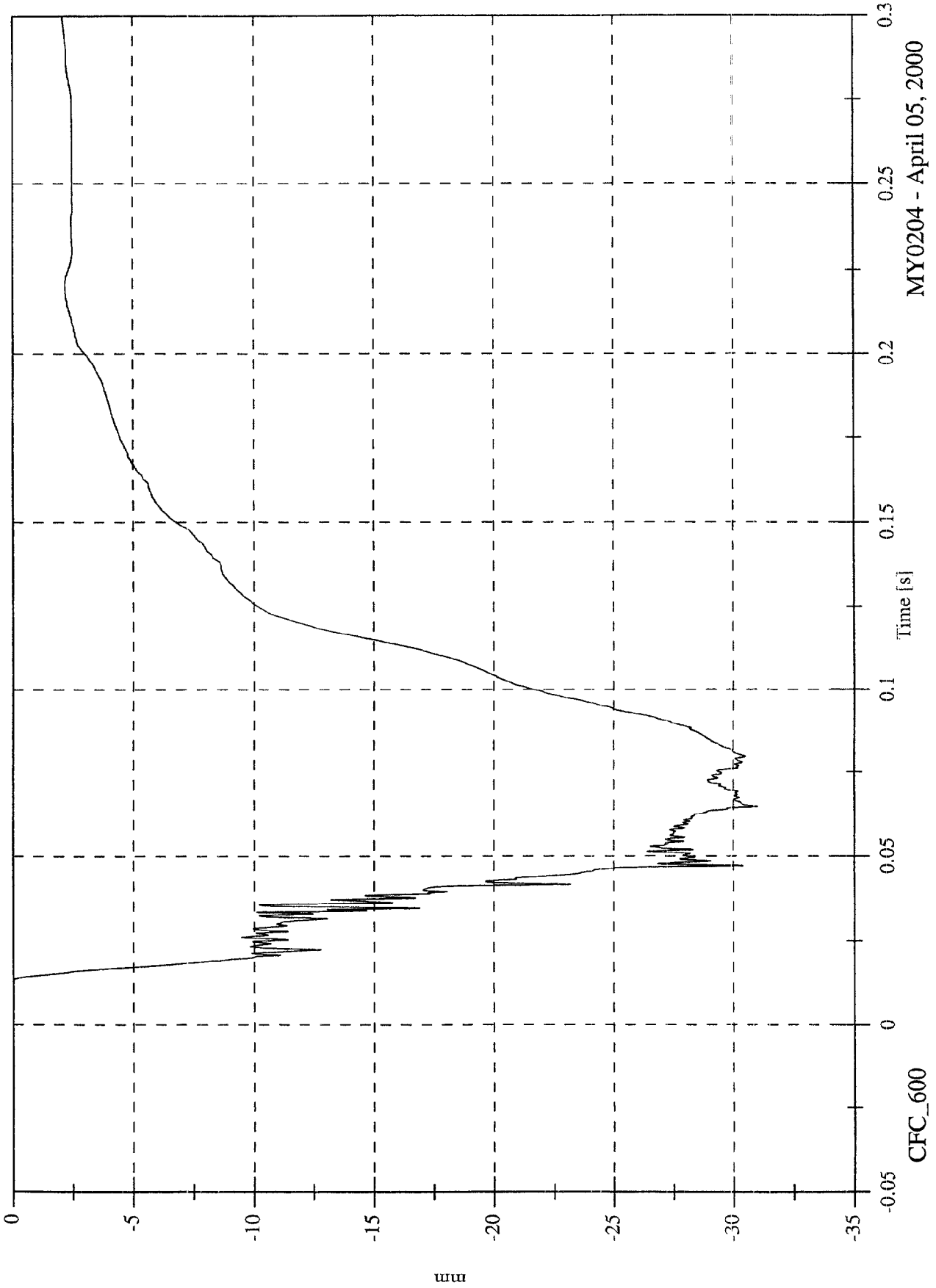

MY0204 - April 05, 2000

CFC_600

NCAP 2000 Test#17 - 2000 Ford Focus 3-Door

Max: 5.8 [g] at 0.092 [s]
Min: -84.3 [g] at 0.050 [s]

P1 Pelvic x

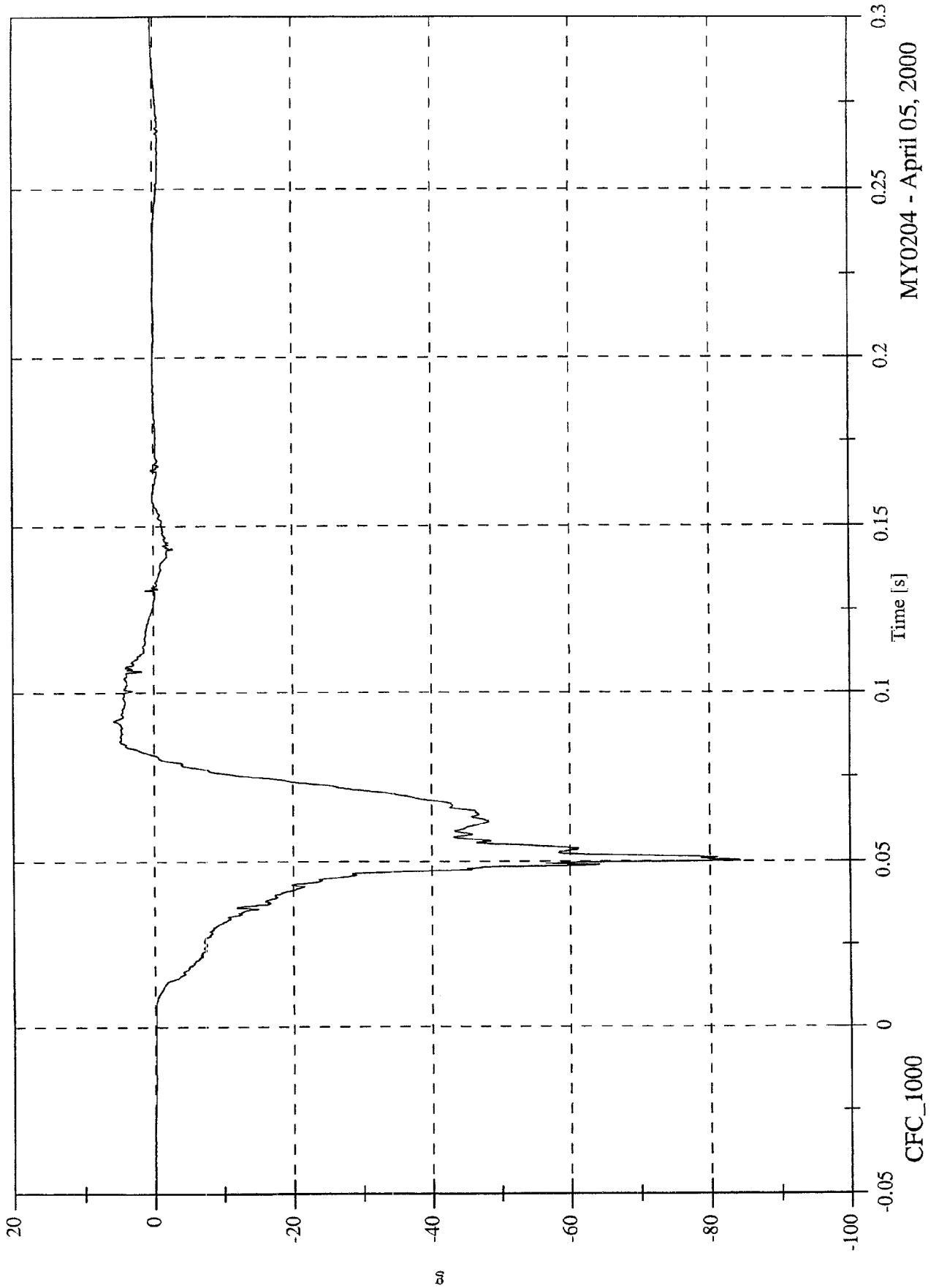

MY0204 - April 05, 2000

NCAP 2000 Test#17 - 2000 Ford Focus 3-Door

Max: 9.3 [g] at 0.051 [s]
Min: -8.0 [g] at 0.049 [s]

P1 Pelvic y

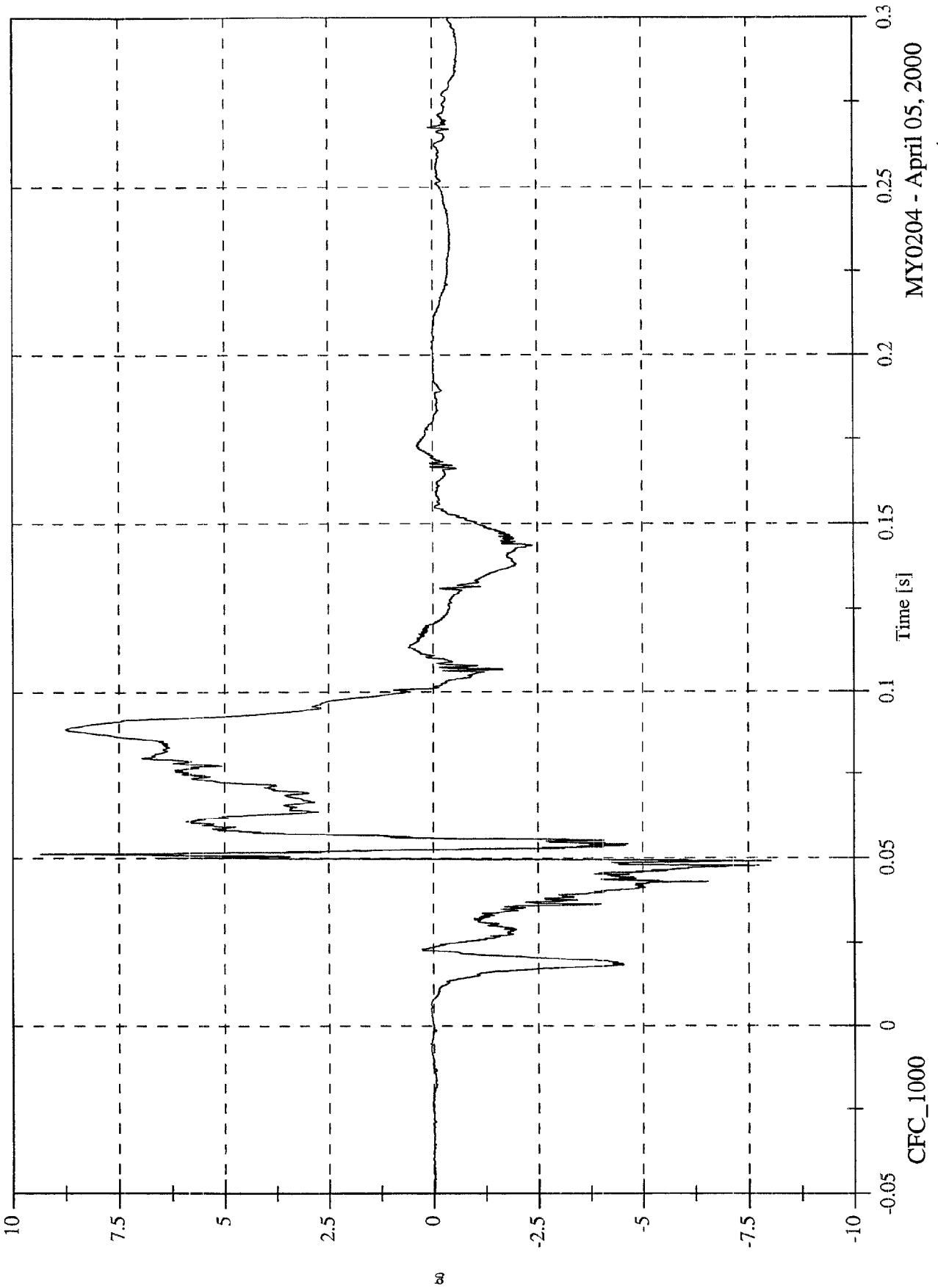

MY0204 - April 05, 2000

NCAP 2000 Test#17 - 2000 Ford Focus 3-Door

Max: 2.9 [g] at 0.264 [s]
Min: -26.2 [g] at 0.069 [s]

P1 Pelvic z

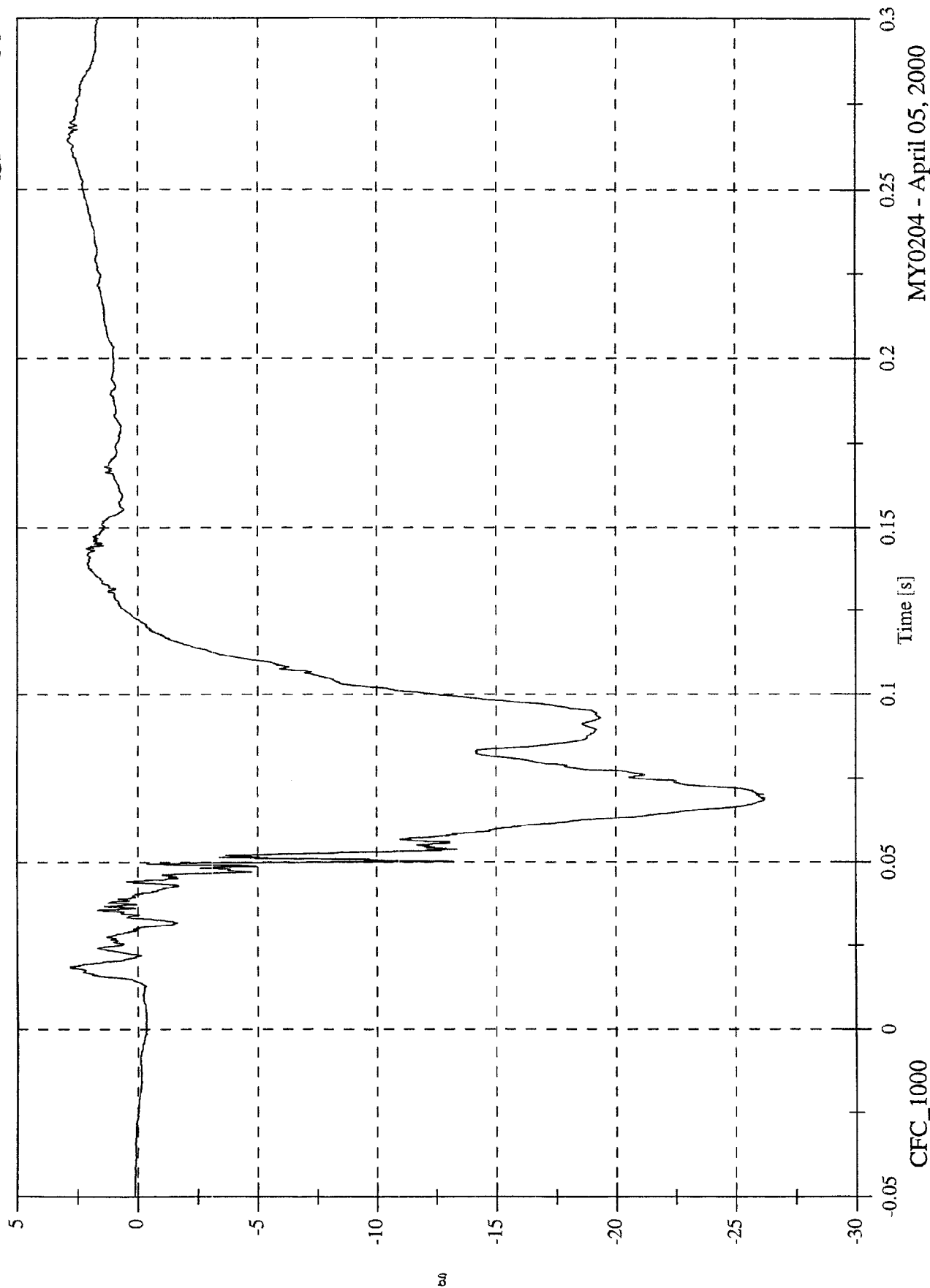

MY0204 - April 05, 2000

NCAP 2000 Test#17 - 2000 Ford Focus 3-Door

Max: 85.4 [g] at 0.050 [s]
Min: 0.0 [g] at -0.027 [s]

P1 Pelvic Resultant

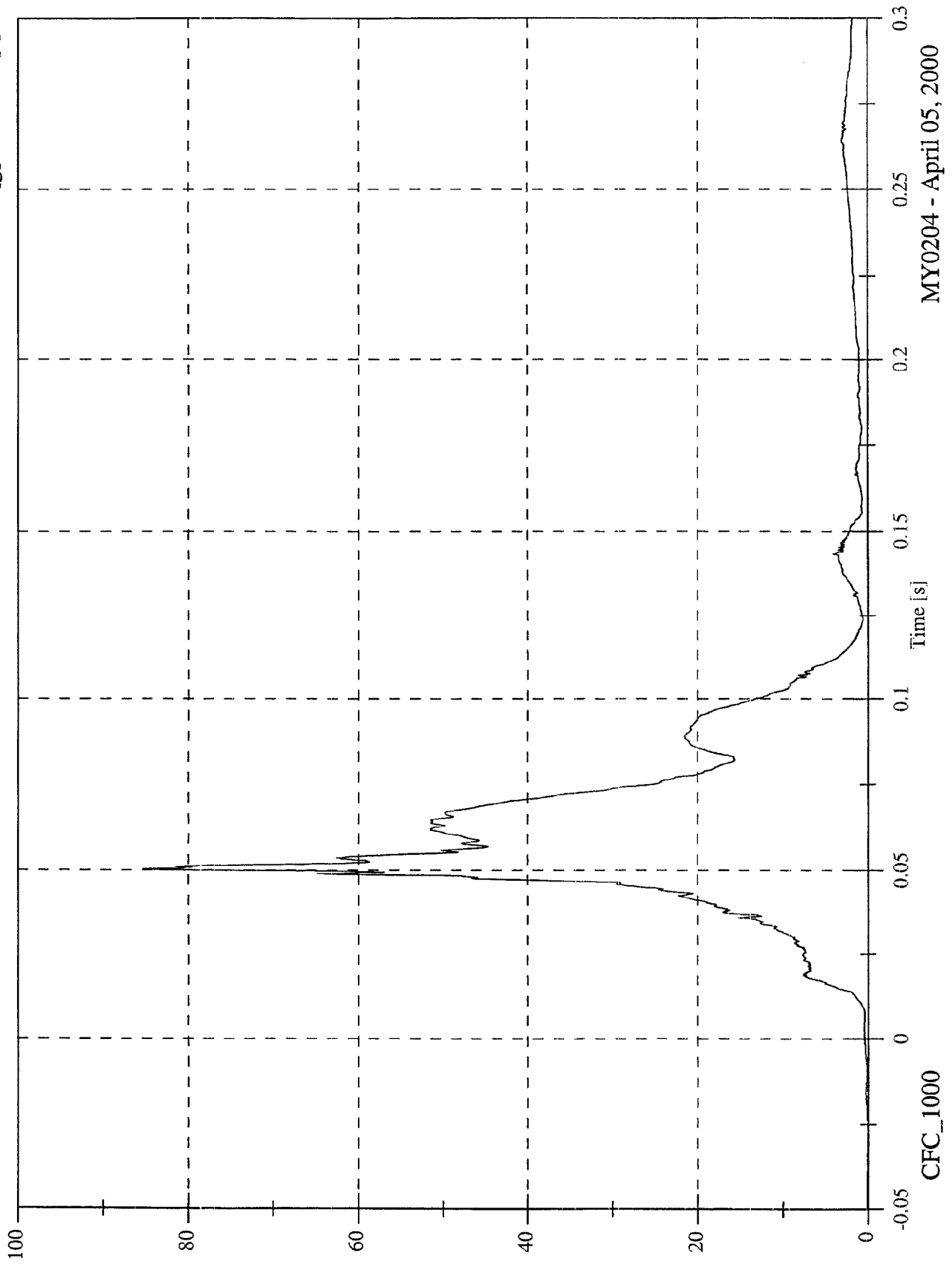

MY0204 - April 05, 2000

NCAP 2000 Test#17 - 2000 Ford Focus 3-Door

Max: 993.9 [N] at 0.046 [s]
Min: -7693.2 [N] at 0.297 [s]

P1 Left Femur

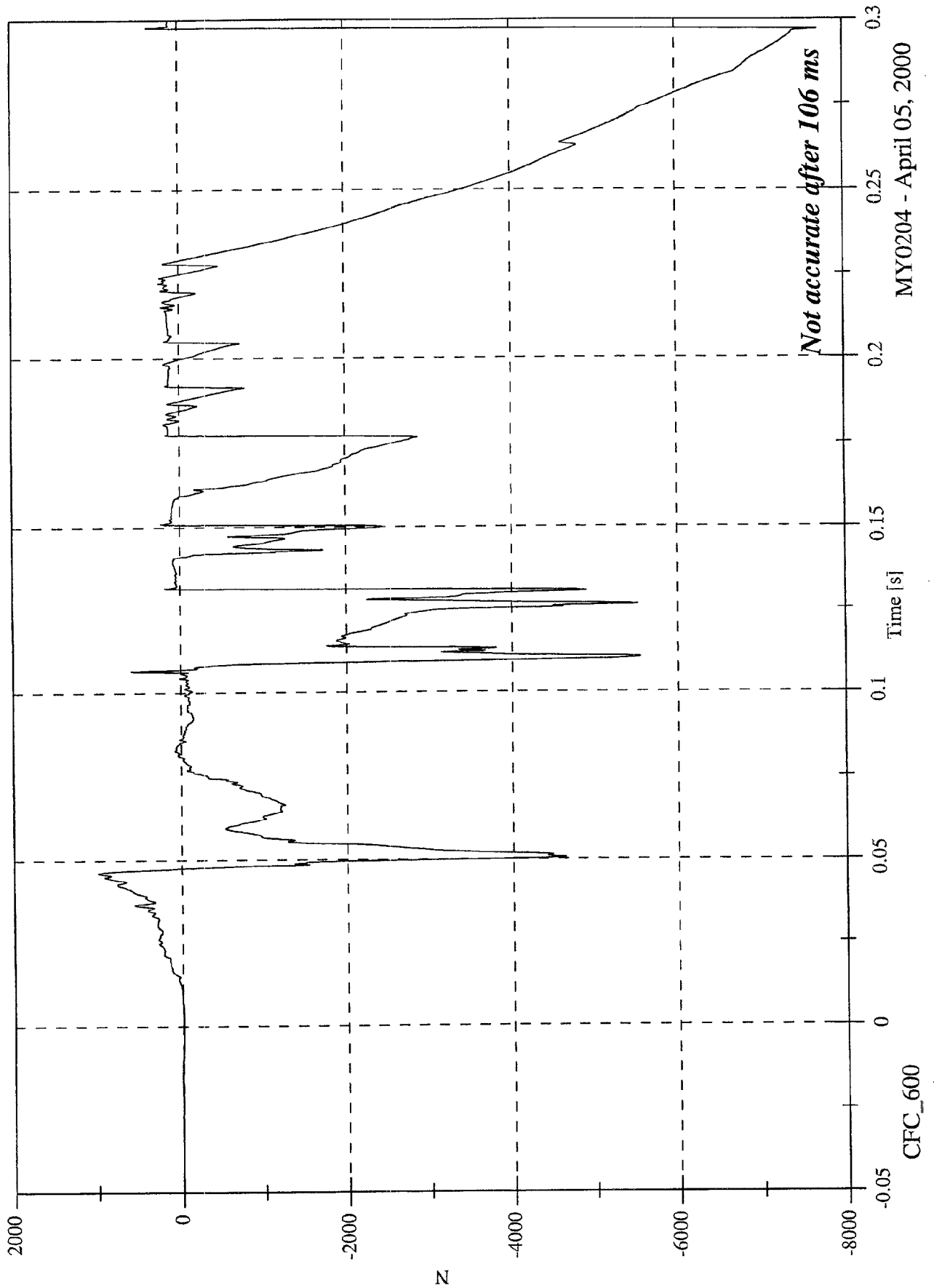

MY0204 - April 05, 2000

NCAP 2000 Test#17 - 2000 Ford Focus 3-Door

Max: 772.1 [N] at 0.043 [s]
Min: -4407.1 [N] at 0.051 [s]

P1 Right Femur

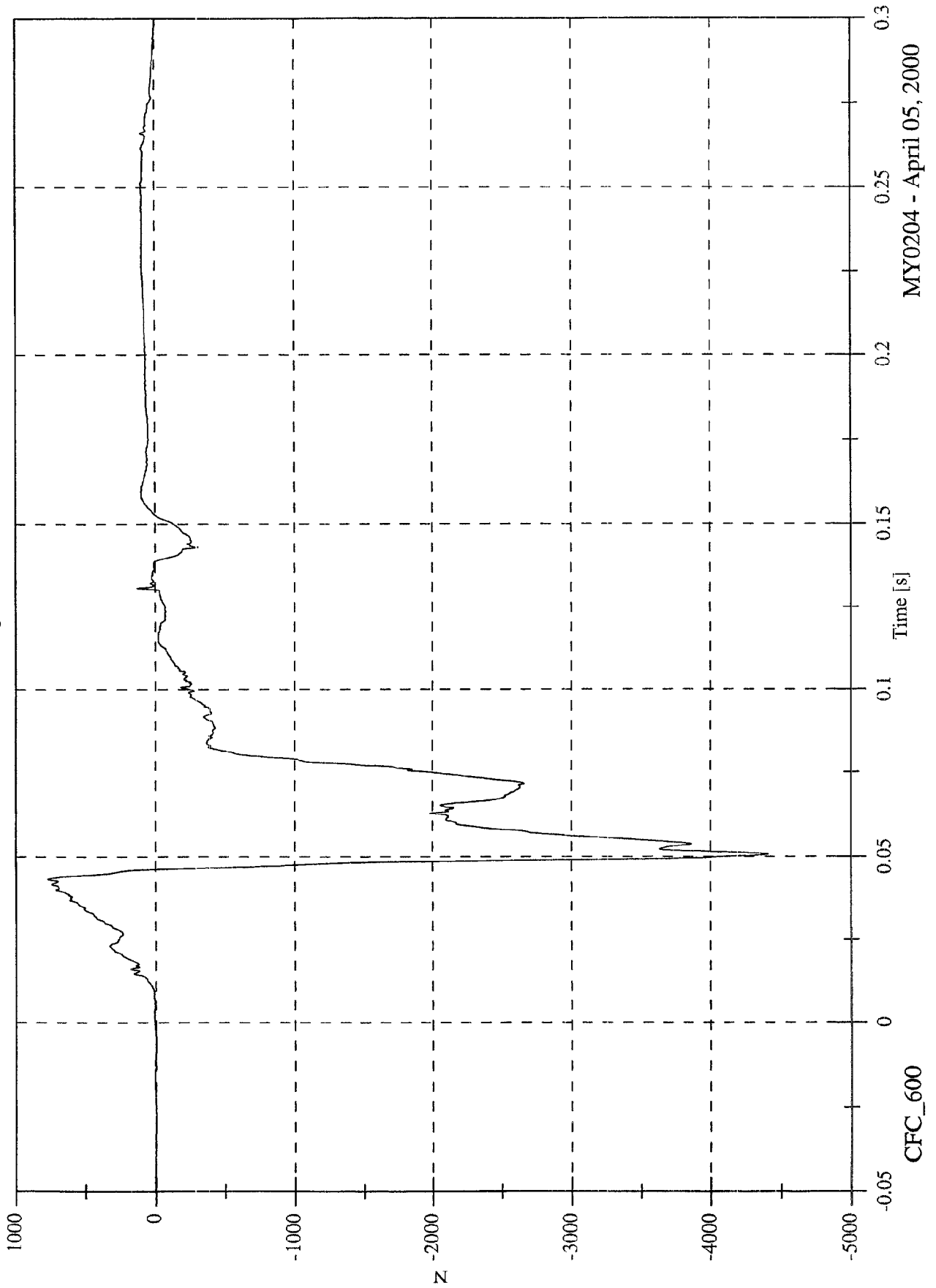

MY0204 - April 05, 2000

CFC_600

NCAP 2000 Test#17 - 2000 Ford Focus 3-Door
P1 Left Upper Tibia Mx

Max: 10.6 [N-m] at 0.078 [s]
Min: -44.1 [N-m] at 0.061 [s]

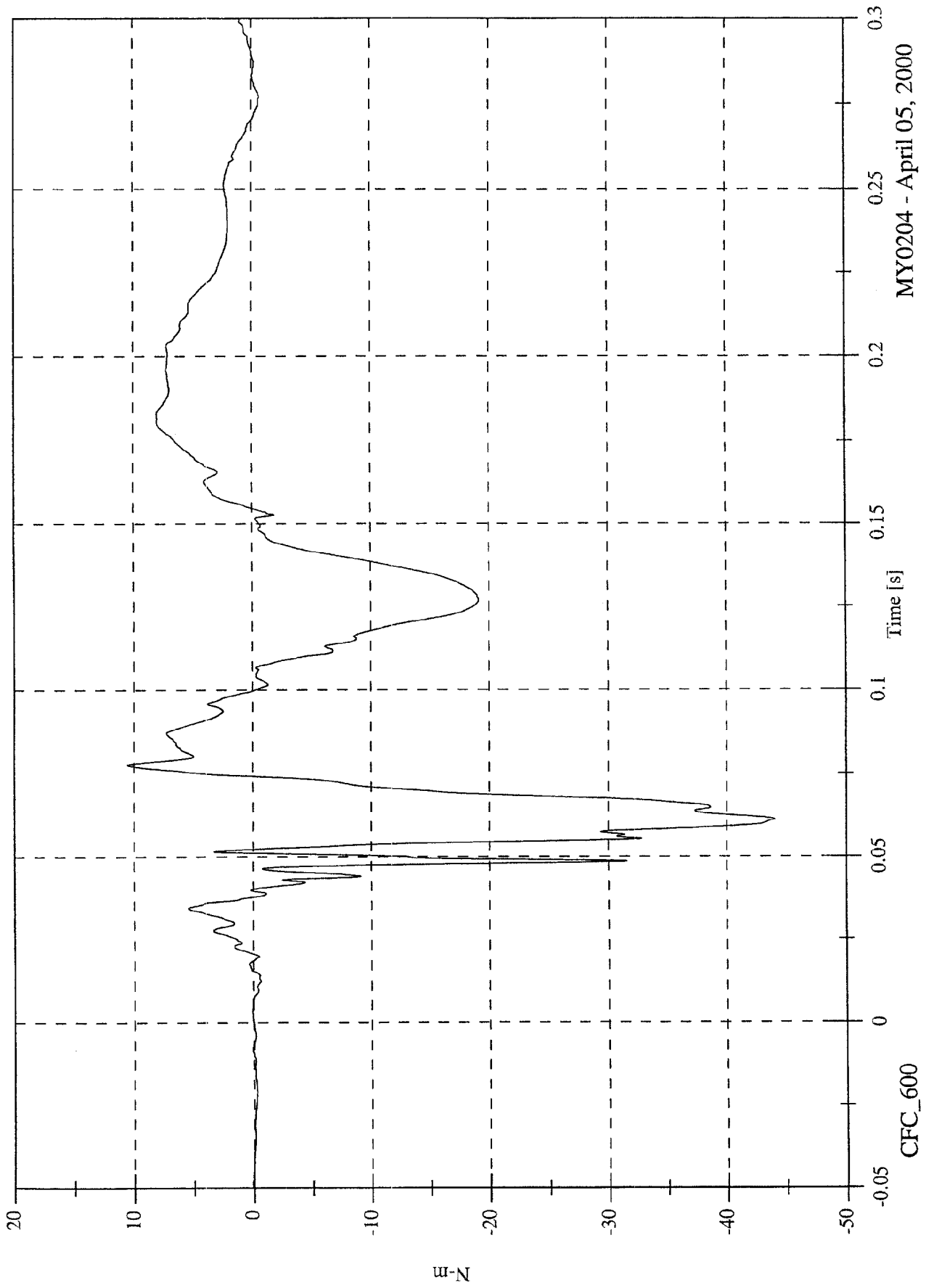

MY0204 - April 05, 2000

NCAP 2000 Test#17 - 2000 Ford Focus 3-Door

Max: 13.7 [N-m] at 0.108 [s]

Min: -154.6 [N-m] at 0.059 [s]

P1 Left Upper Tibia My

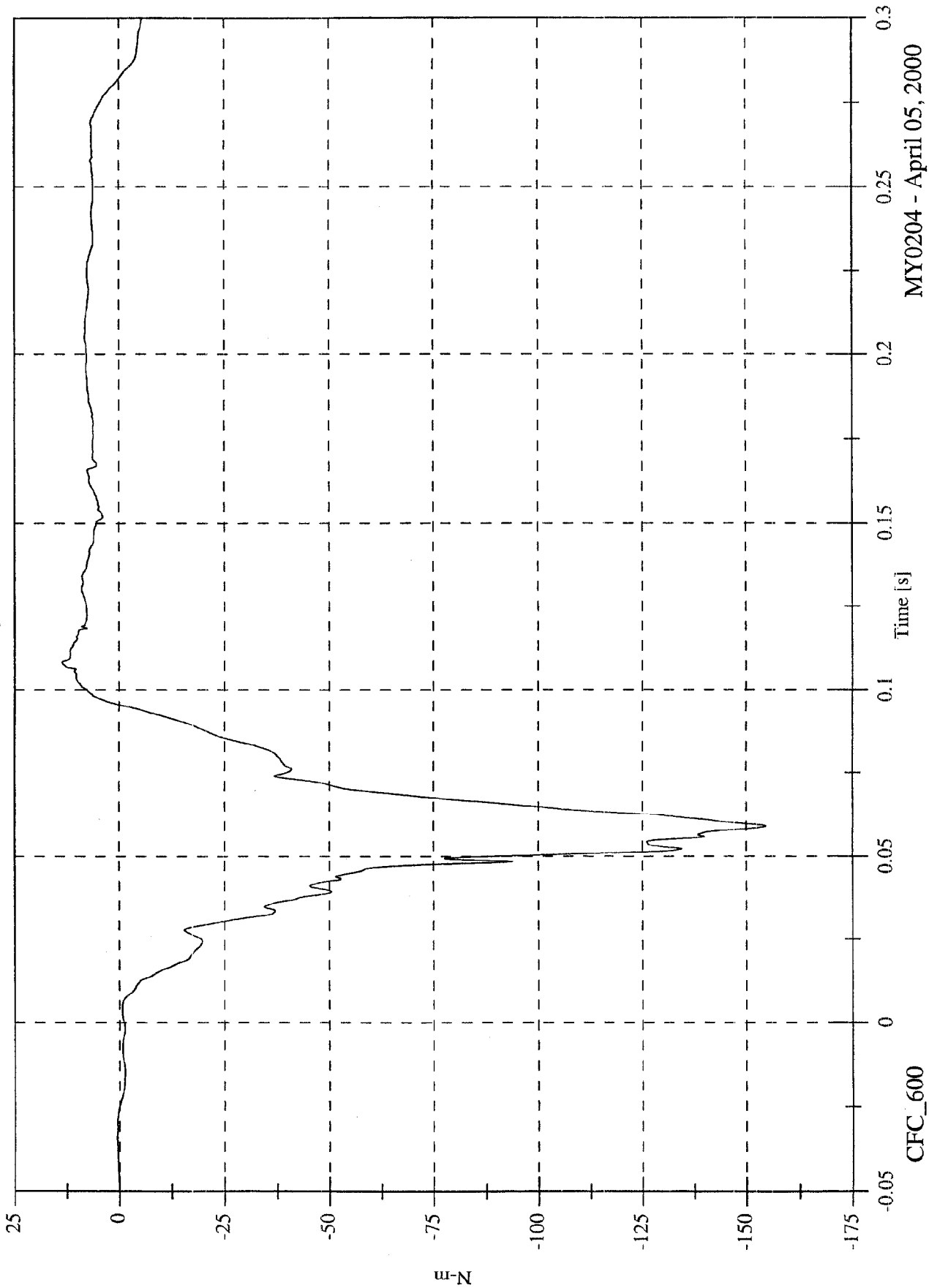

MY0204 - April 05, 2000

NCAP 2000 Test#17 - 2000 Ford Focus 3-Door

Max: 100.9 [N] at 0.110 [s]
Min: -2622.9 [N] at 0.060 [s]

P1 Left Lower Tibia Fz

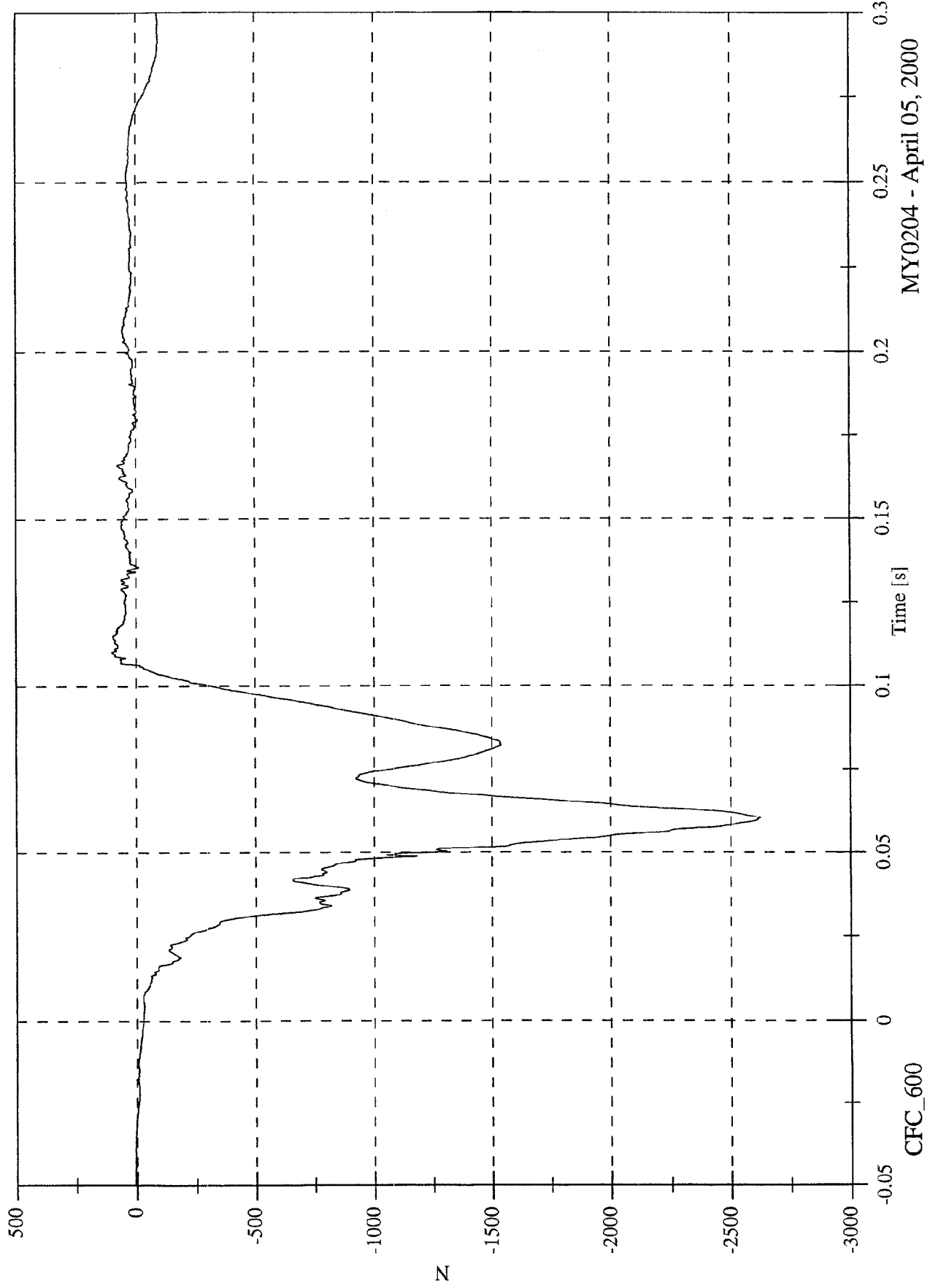

MY0204 - April 05, 2000

NCAP 2000 Test#17 - 2000 Ford Focus 3-Door

P1 Left Lower Tibia Mx

Max: 142.7 [N-m] at 0.060 [s]
Min: -4.3 [N-m] at 0.033 [s]

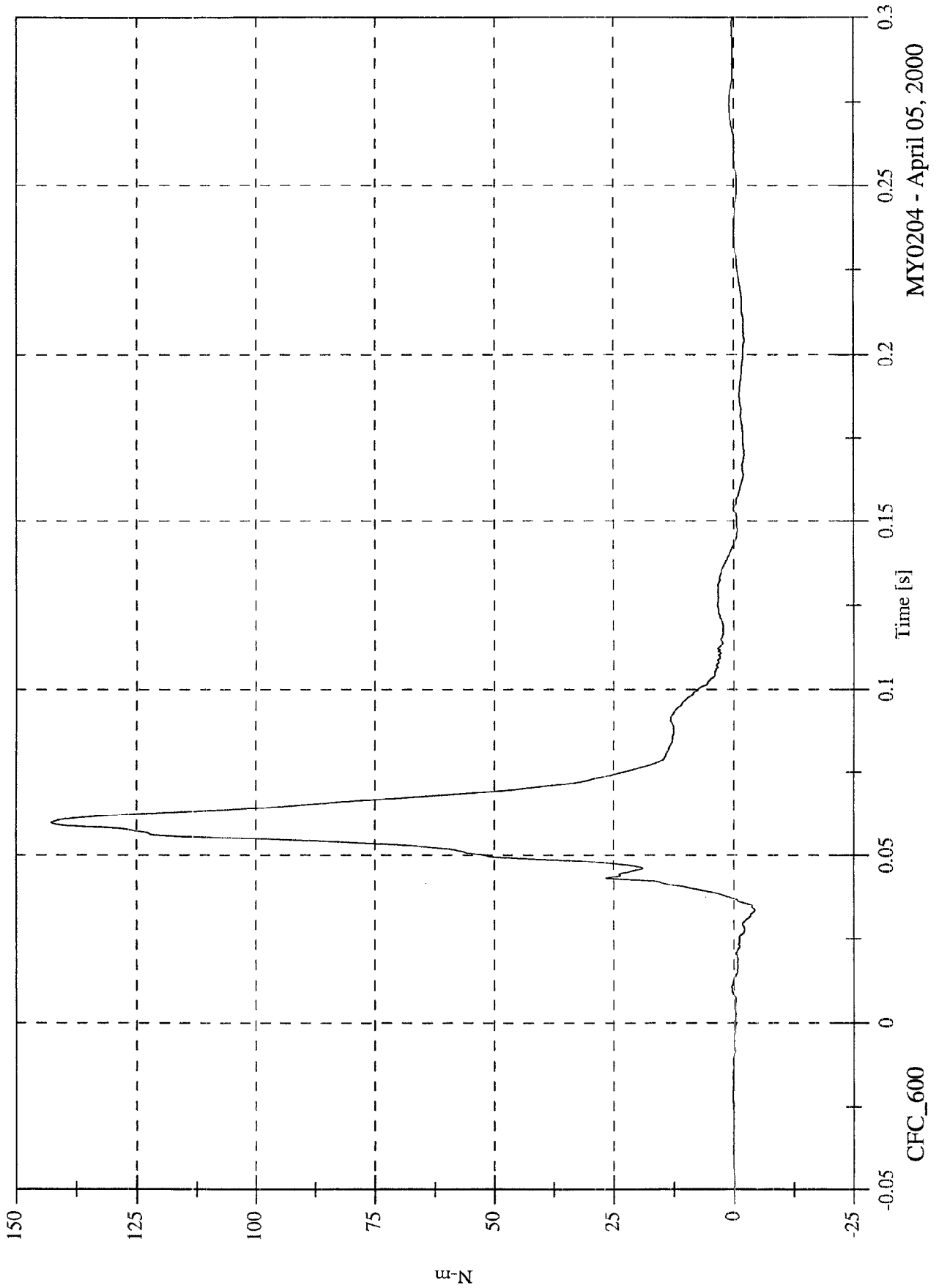

MY0204 - April 05, 2000

NCAP 2000 Test#17 - 2000 Ford Focus 3-Door

P1 Left Lower Tibia My

Max: 62.9 [N-m] at 0.086 [s]
Min: -37.5 [N-m] at 0.052 [s]

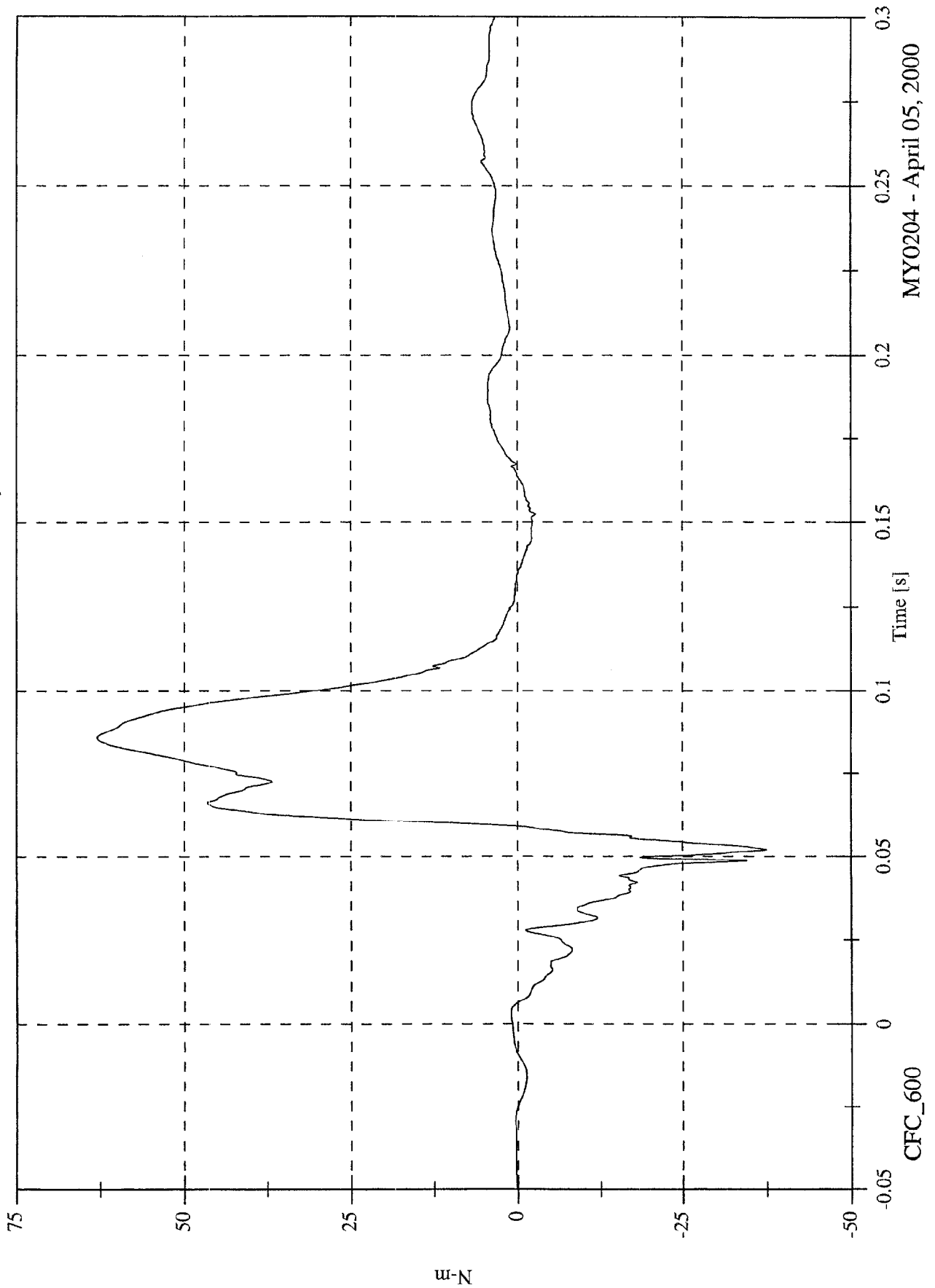

MY0204 - April 05, 2000

NCAP 2000 Test#17 - 2000 Ford Focus 3-Door

Max: 31.6 [N-m] at 0.052 [s]
Min: -23.7 [N-m] at 0.061 [s]

P1 Right Upper Tibia Mx

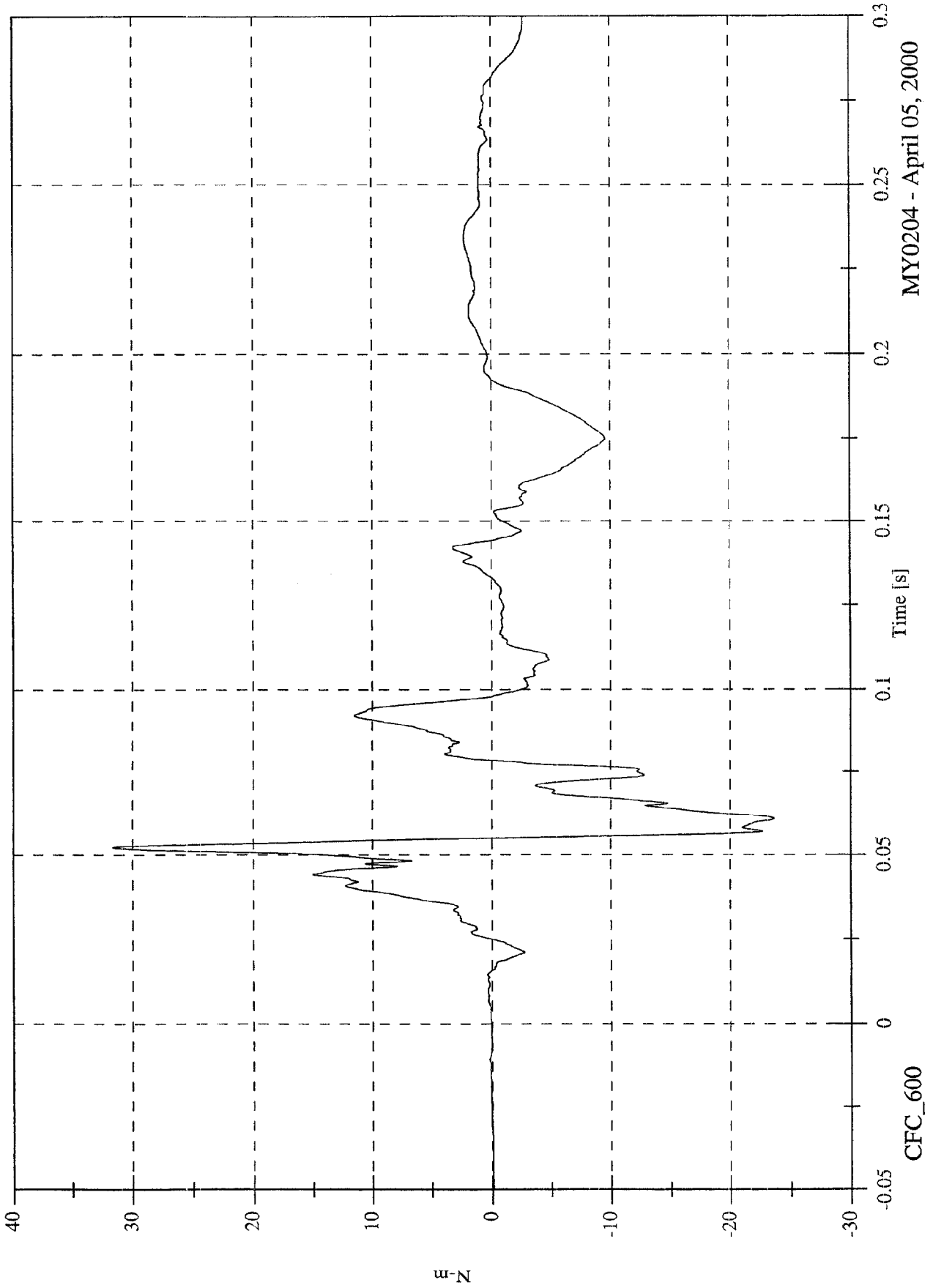

MY0204 - April 05, 2000

NCAP 2000 Test#17 - 2000 Ford Focus 3-Door
P1 Right Upper Tibia My

Max: 11.3 [N-m] at 0.107 [s]
Min: -94.2 [N-m] at 0.056 [s]

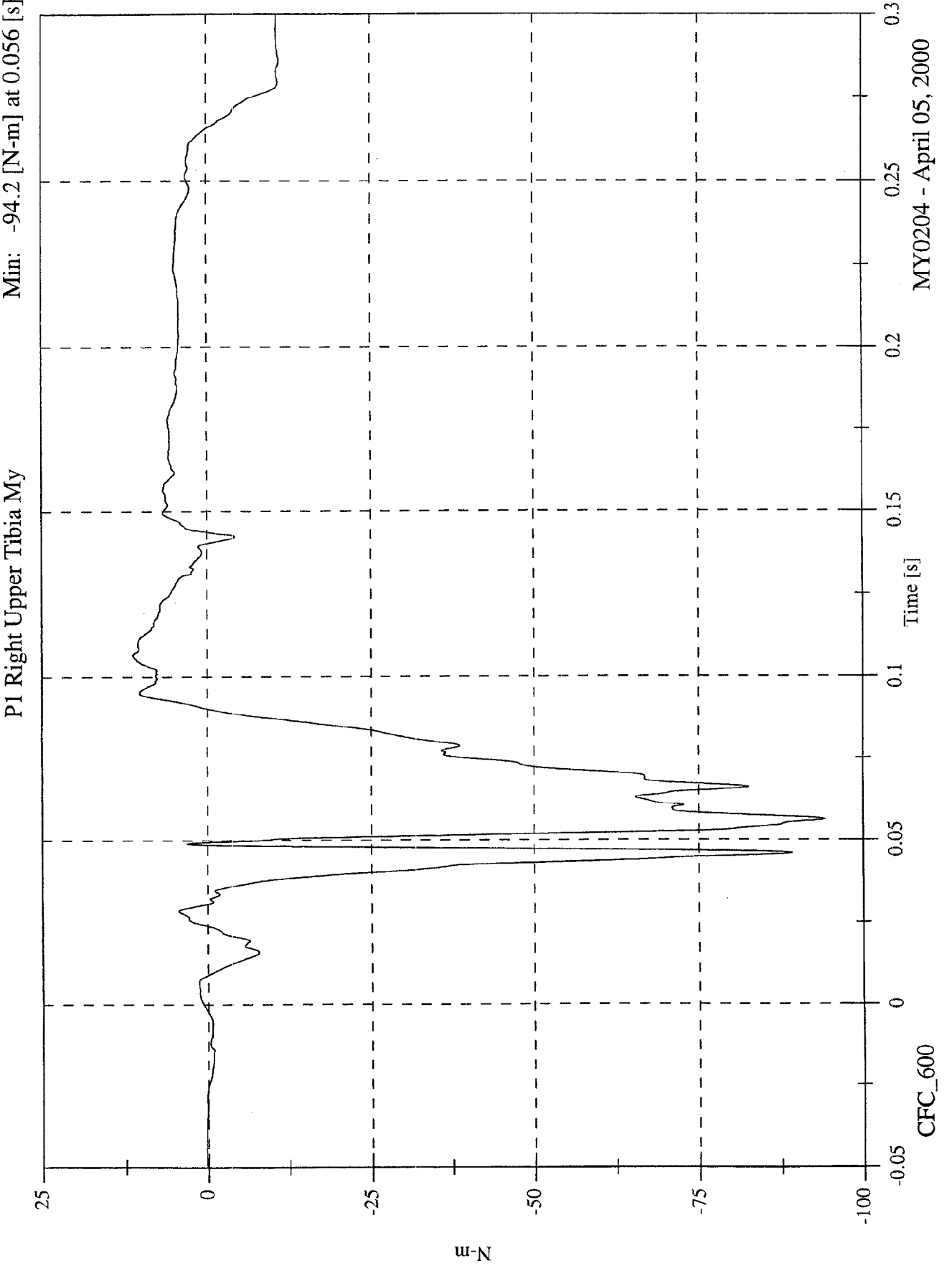

MY0204 - April 05, 2000

NCAP 2000 Test#17 - 2000 Ford Focus 3-Door

Max: 100.4 [N] at 0.113 [s]
Min: -3608.8 [N] at 0.055 [s]

P1 Right Lower Tibia Fz

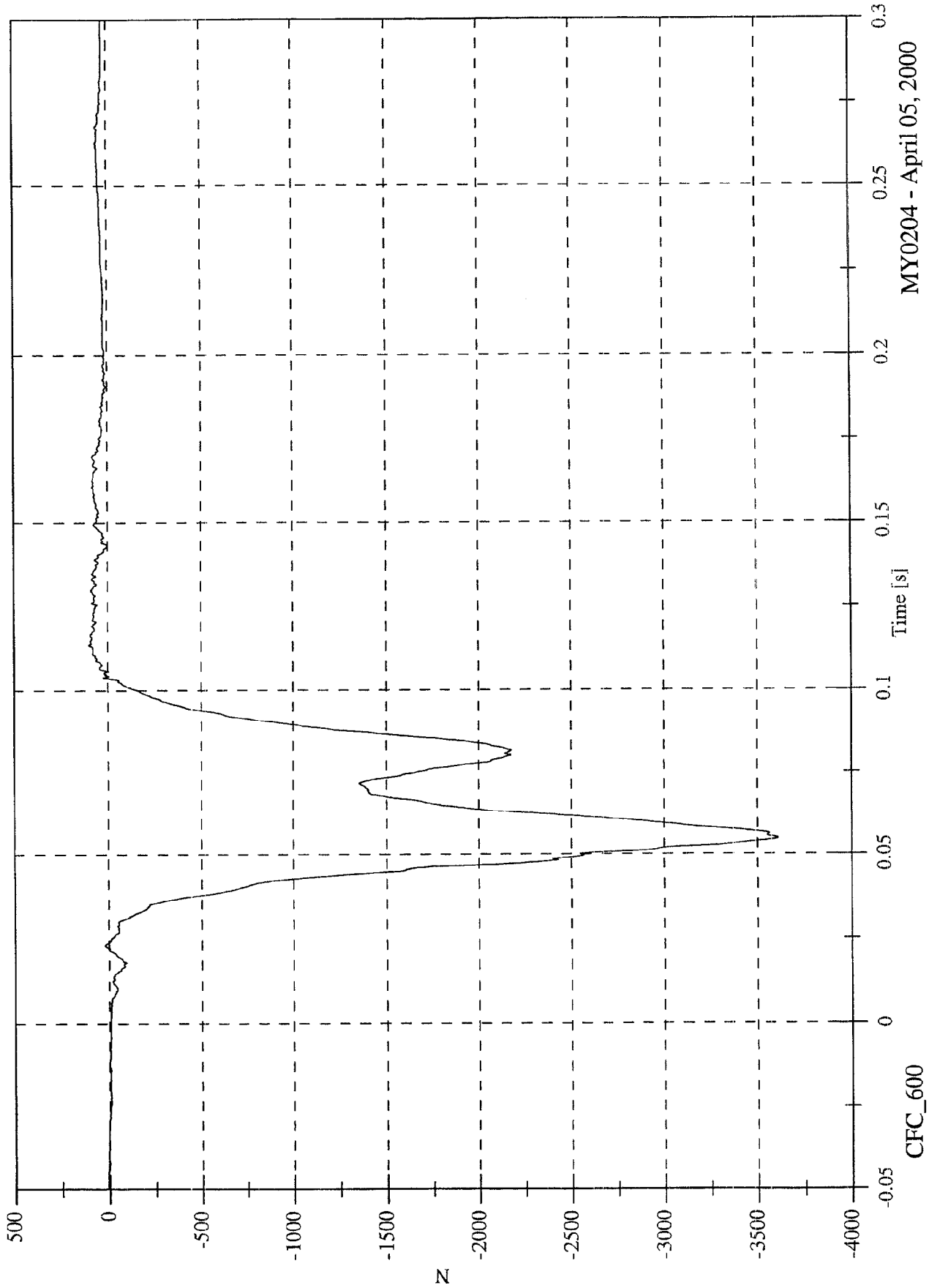

MY0204 - April 05, 2000

NCAP 2000 Test#17 - 2000 Ford Focus 3-Door

Max: 8.8 [N-m] at 0.044 [s]
Min: -99.2 [N-m] at 0.056 [s]

P1 Right Lower Tibia Mx

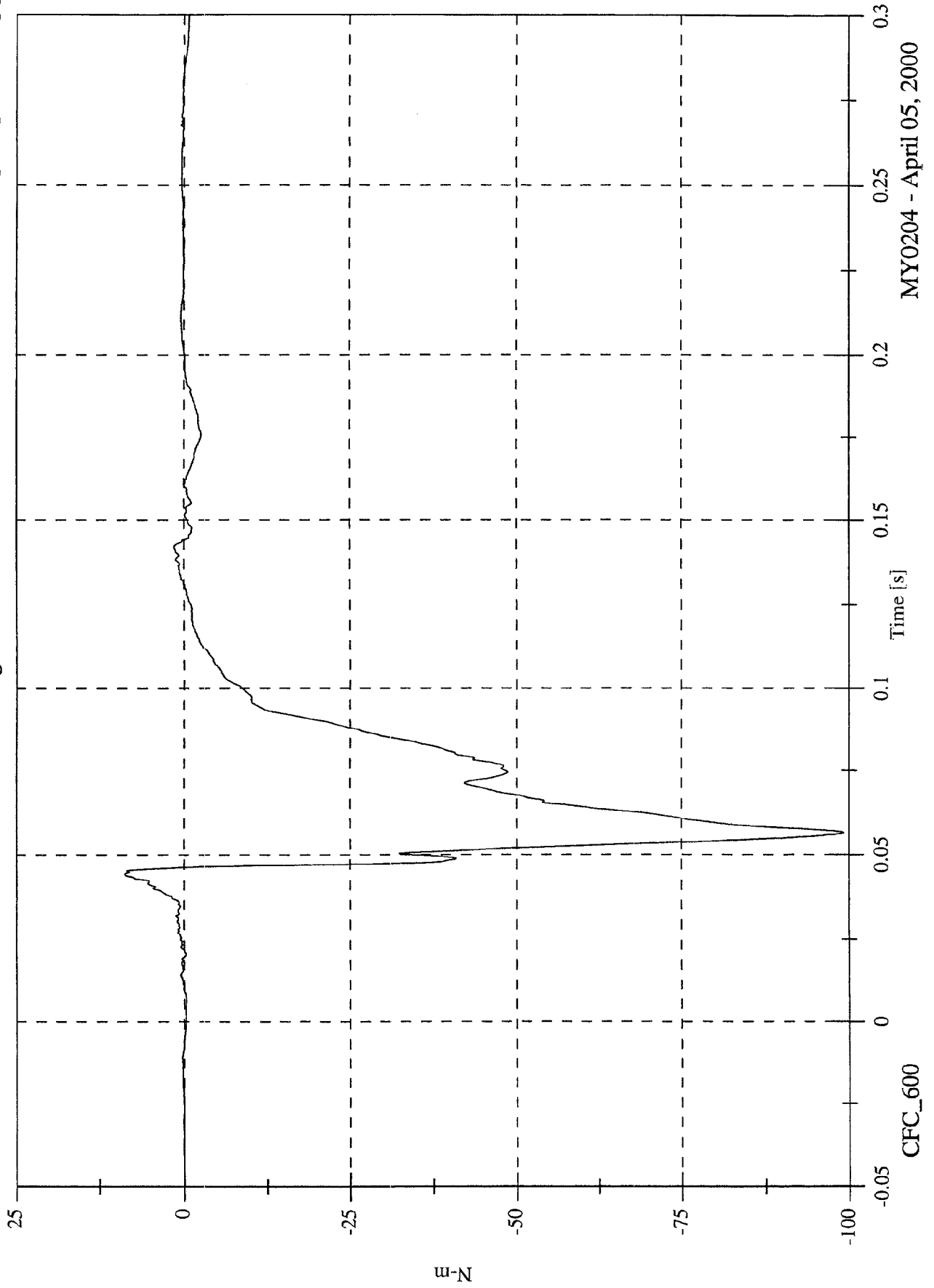

MY0204 - April 05, 2000

Max: 100.9 [N-m] at 0.059 [s]
Min: -59.4 [N-m] at 0.047 [s]

NCAP 2000 Test#17 - 2000 Ford Focus 3-Door
P1 Right Lower Tibia My

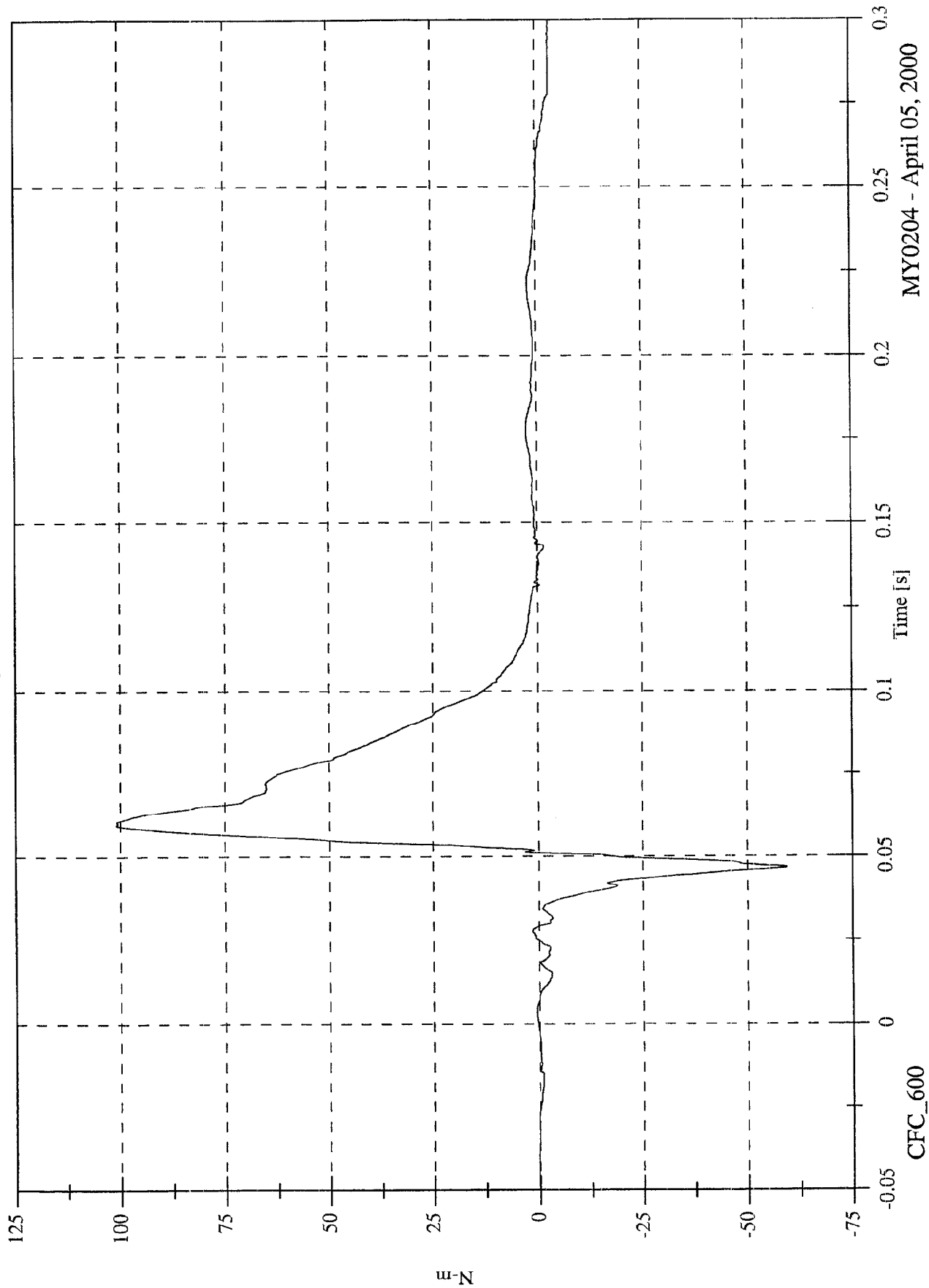

MY0204 - April 05, 2000

NCAP 2000 Test#17 - 2000 Ford Focus 3-Door

Max: 19.6 [g] at 0.090 [s]
Min: -78.2 [g] at 0.049 [s]

P1 Left Foot Aft x

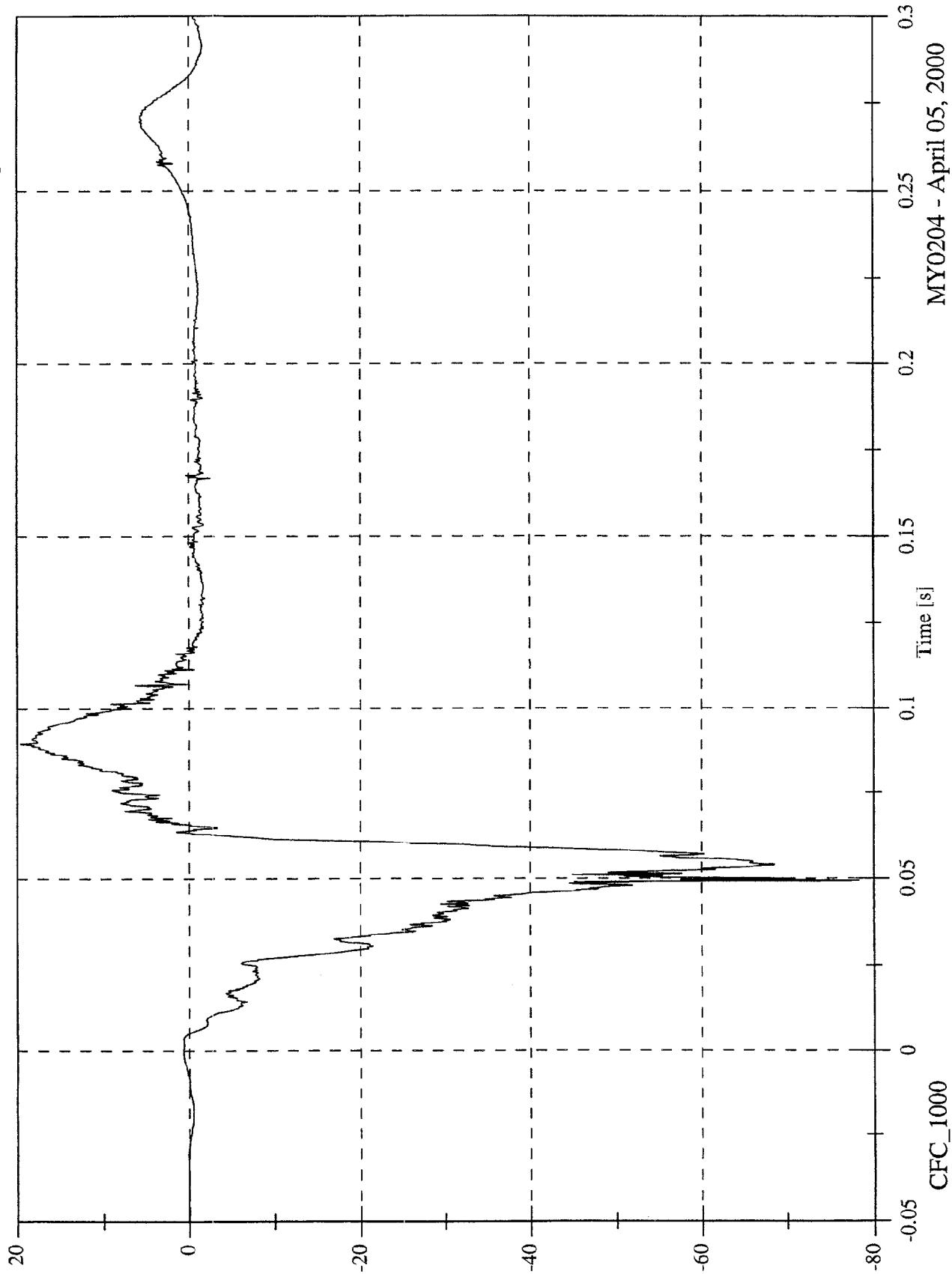

MY0204 - April 05, 2000

NCAP 2000 Test#17 - 2000 Ford Focus 3-Door

Max: 11.9 [g] at 0.065 [s]
Min: -45.6 [g] at 0.050 [s]

P1 Left Foot Aft z

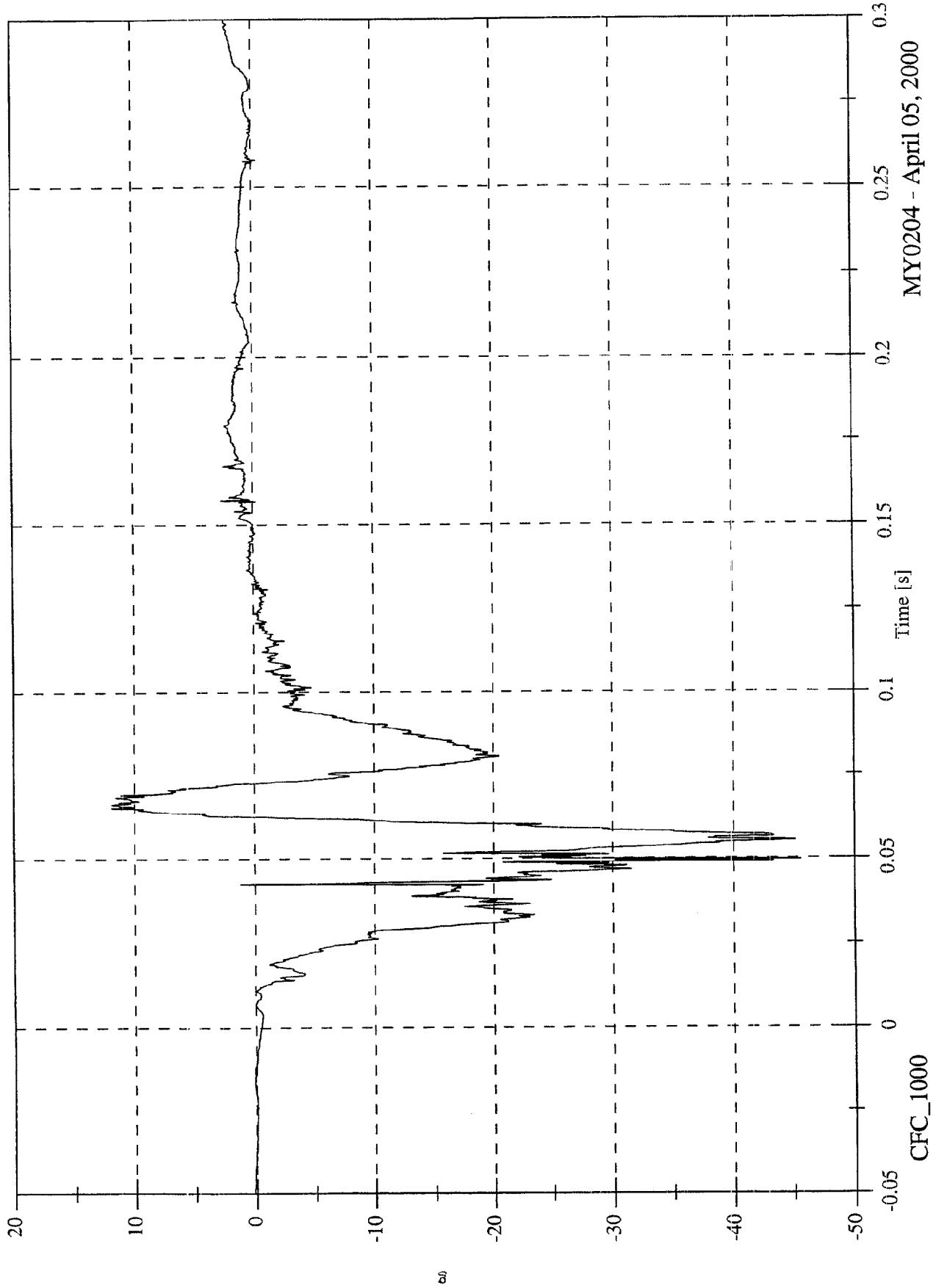

MY0204 - April 05, 2000

NCAP 2000 Test#17 - 2000 Ford Focus 3-Door

Max: 14.9 [g] at 0.051 [s]
Min: -51.8 [g] at 0.057 [s]

P1 Left Foot Fore z

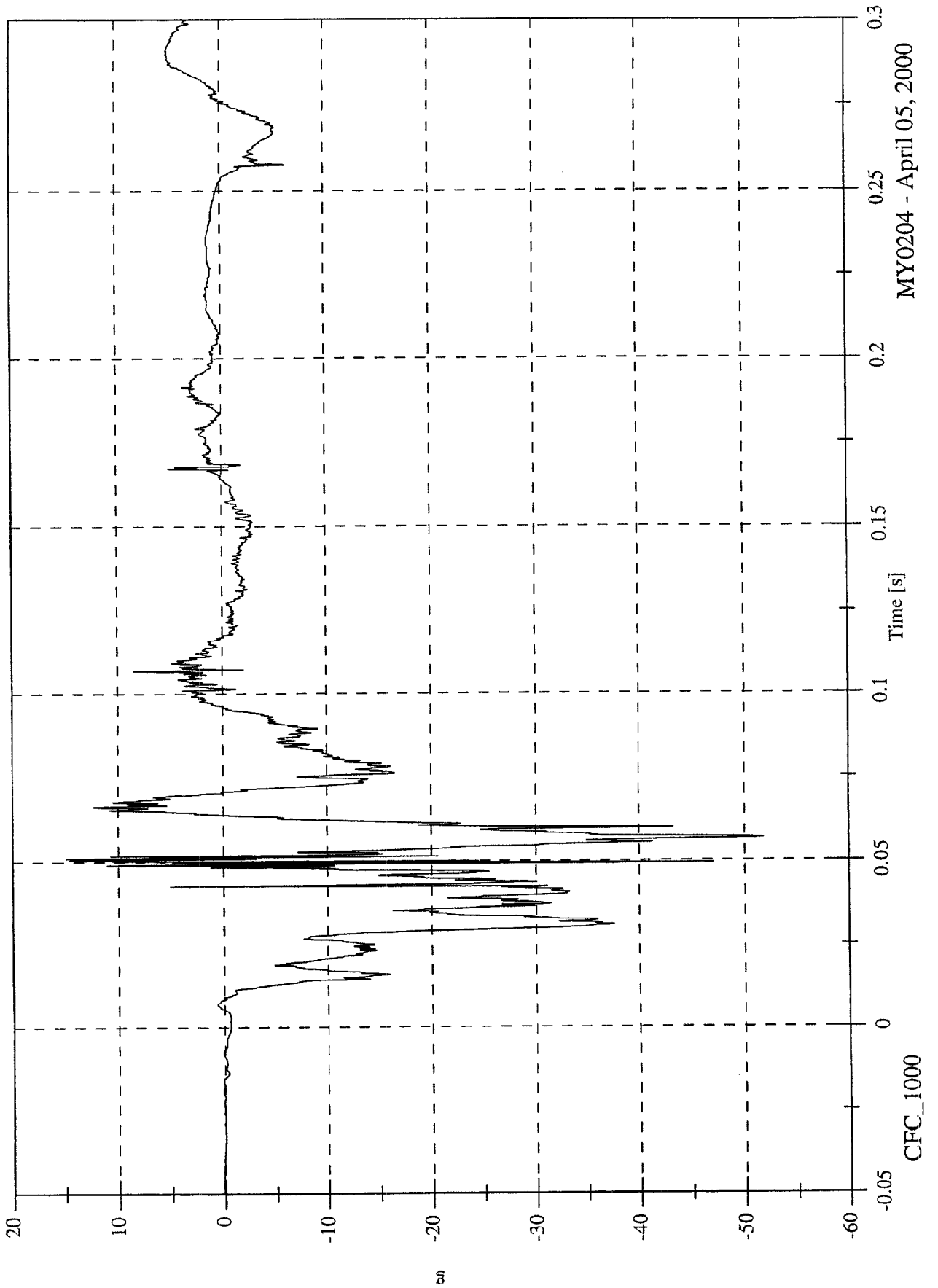

MY0204 - April 05, 2000

NCAP 2000 Test#17 - 2000 Ford Focus 3-Door

Max: 22.2 [g] at 0.061 [s]
Min: -182.9 [g] at 0.048 [s]

P1 Right Foot Aft x

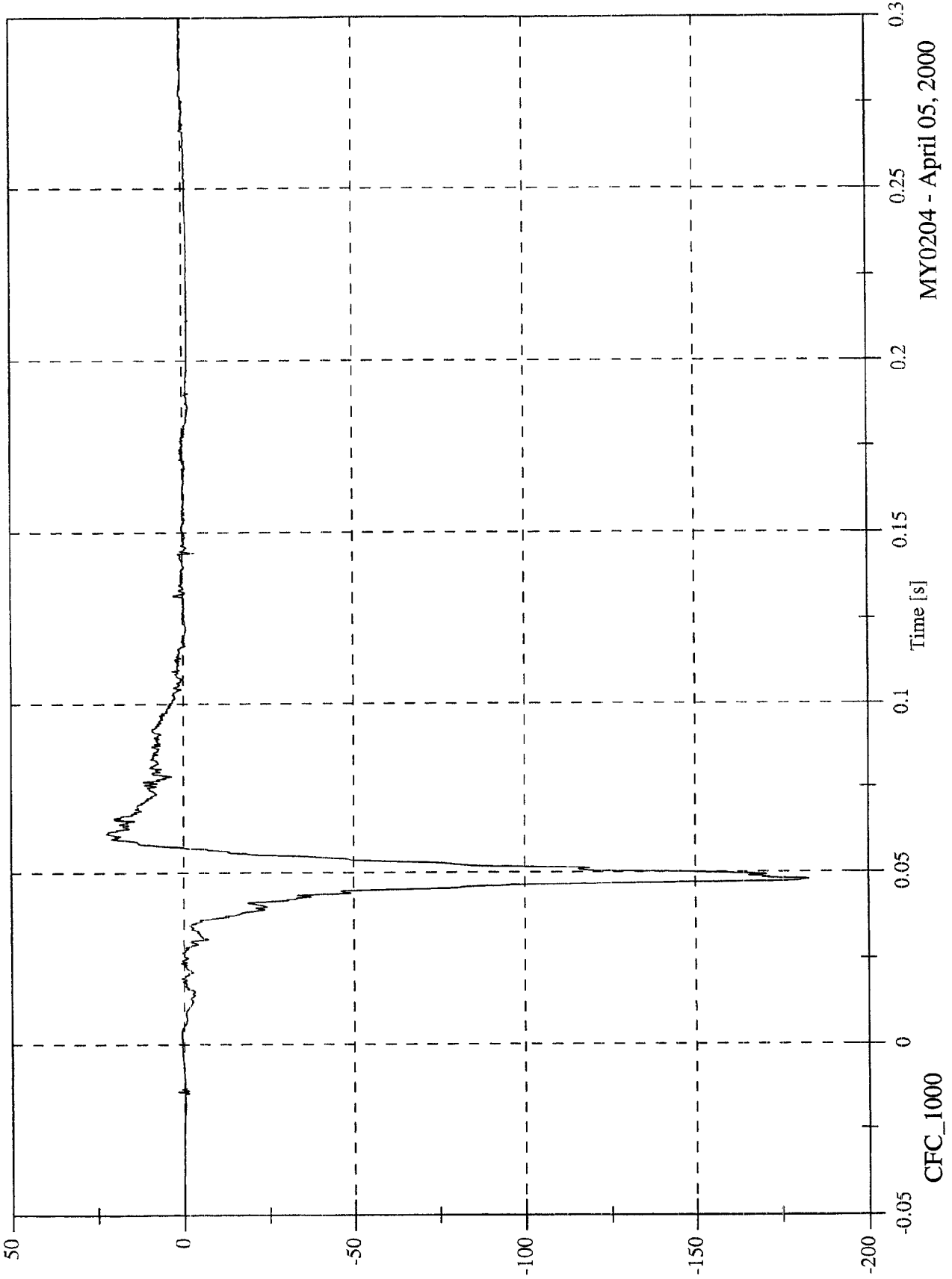

MY0204 - April 05, 2000

CFC_1000

NCAP 2000 Test#17 - 2000 Ford Focus 3-Door

Max: 23.1 [g] at 0.066 [s]
Min: -92.3 [g] at 0.046 [s]

P1 Right Foot Aft z

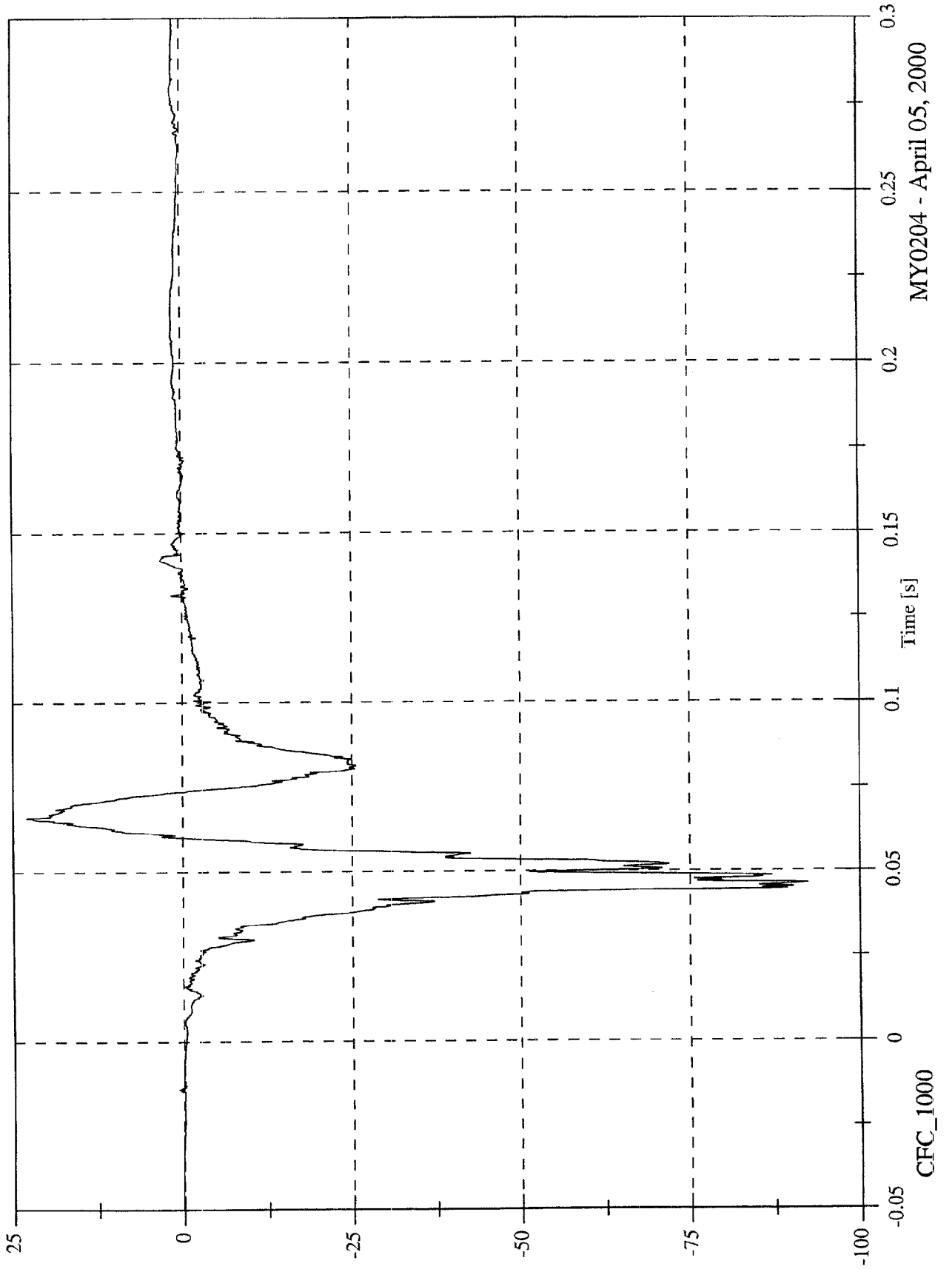

MY0204 - April 05, 2000

NCAP 2000 Test#17 - 2000 Ford Focus 3-Door

Max: 37.7 [g] at 0.056 [s]
Min: -191.5 [g] at 0.045 [s]

P1 Right Foot Fore z

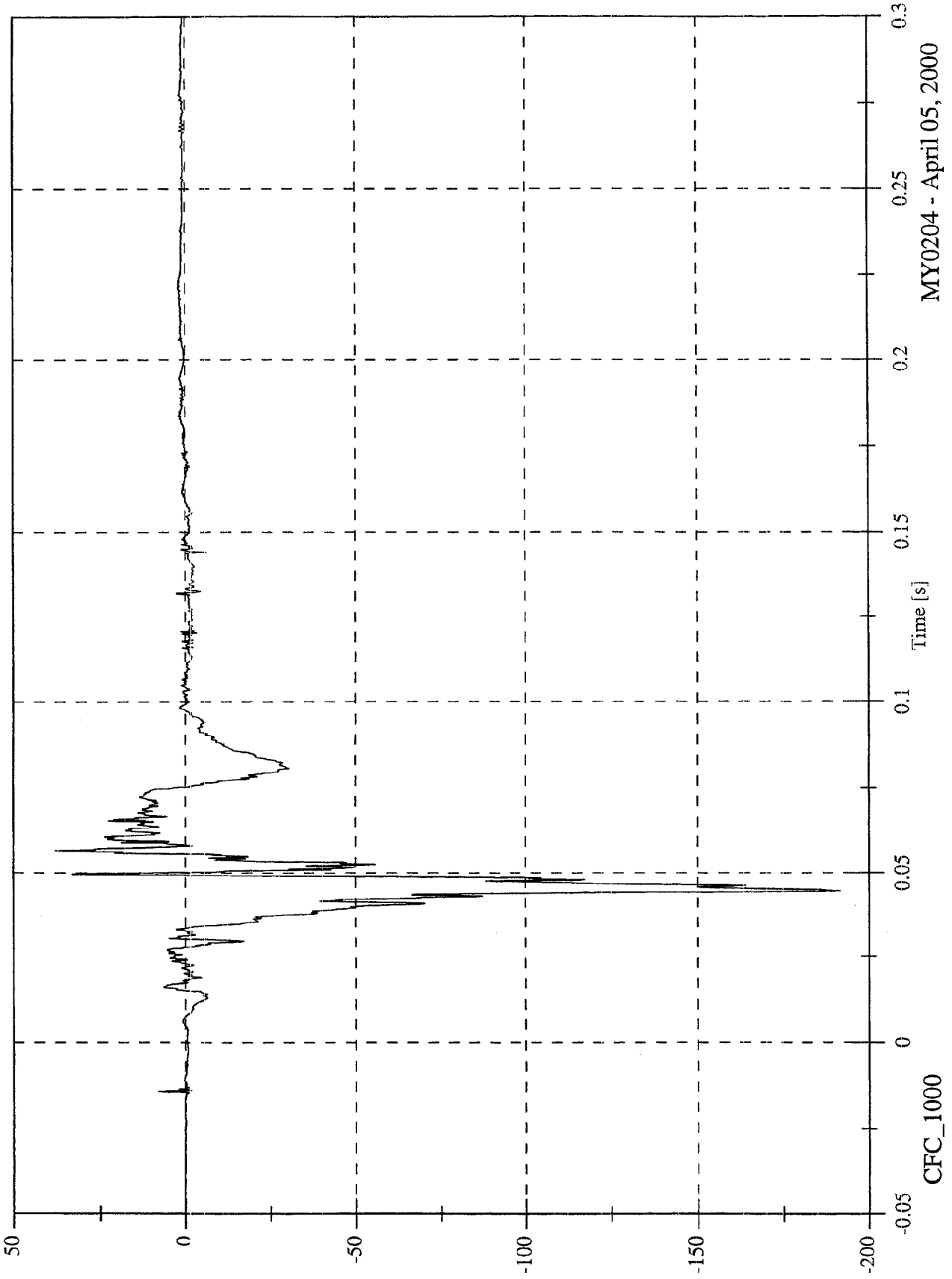

MY0204 - April 05, 2000

CFC_1000

NCAP 2000 Test#17 - 2000 Ford Focus 3-Door

Max: 3.6 [g] at 0.281 [s]
Min: -38.4 [g] at 0.093 [s]

P2 Head x

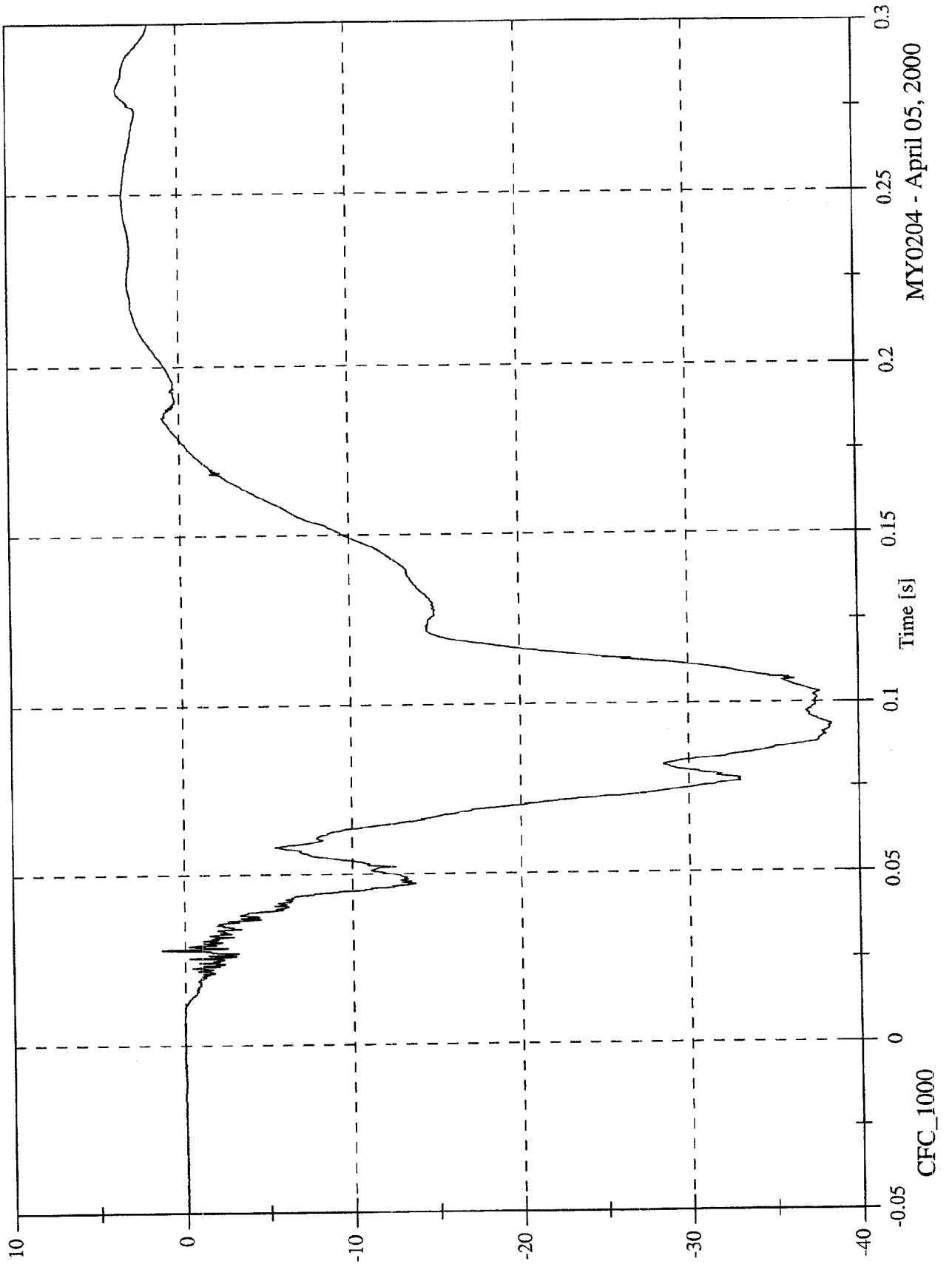

MY0204 - April 05, 2000

CFC_1000

NCAP 2000 Test#17 - 2000 Ford Focus 3-Door

Max: 2.6 [g] at 0.029 [s]
Min: -15.0 [g] at 0.101 [s]

P2 Head y

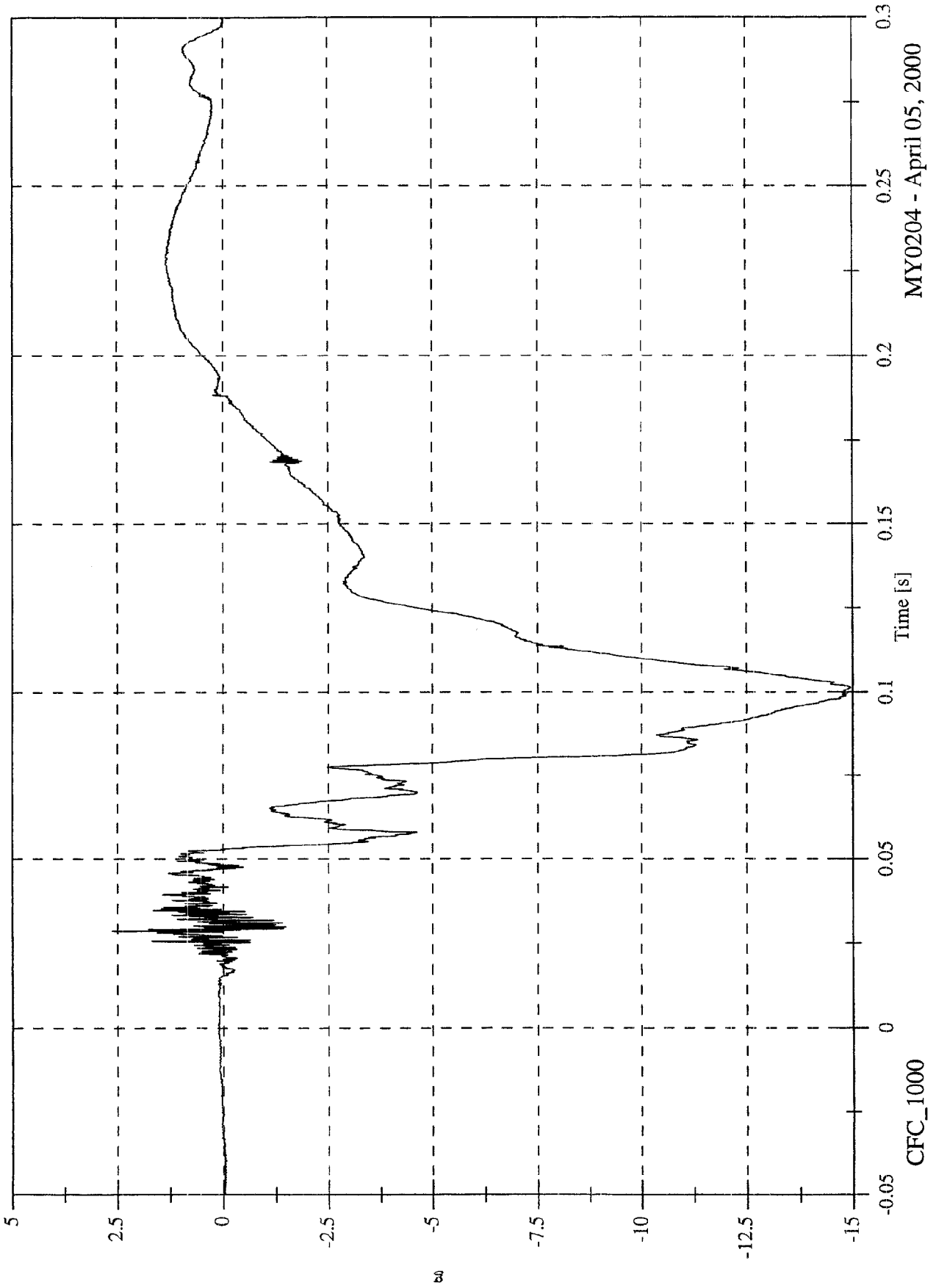

MY0204 - April 05, 2000

Max: 25.4 [g] at 0.066 [s]
Min: -2.3 [g] at 0.100 [s]

NCAP 2000 Test#17 - 2000 Ford Focus 3-Door

P2 Head z

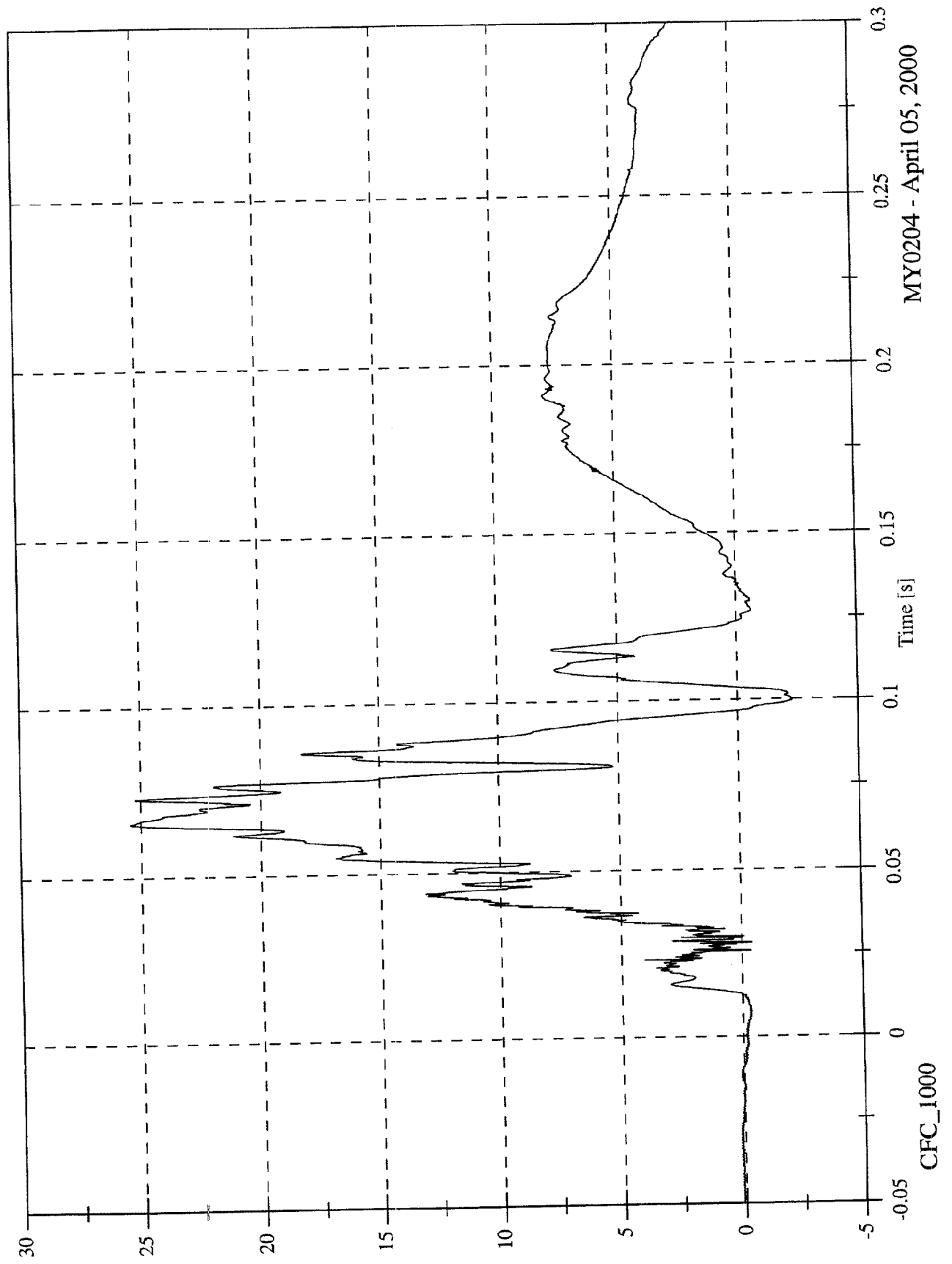

MY0204 - April 05, 2000

NCAP 2000 Test#17 - 2000 Ford Focus 3-Door

Max: 41.6 [g] at 0.088 [s]
Min: 0.0 [g] at -0.024 [s]

P2 Head Resultant

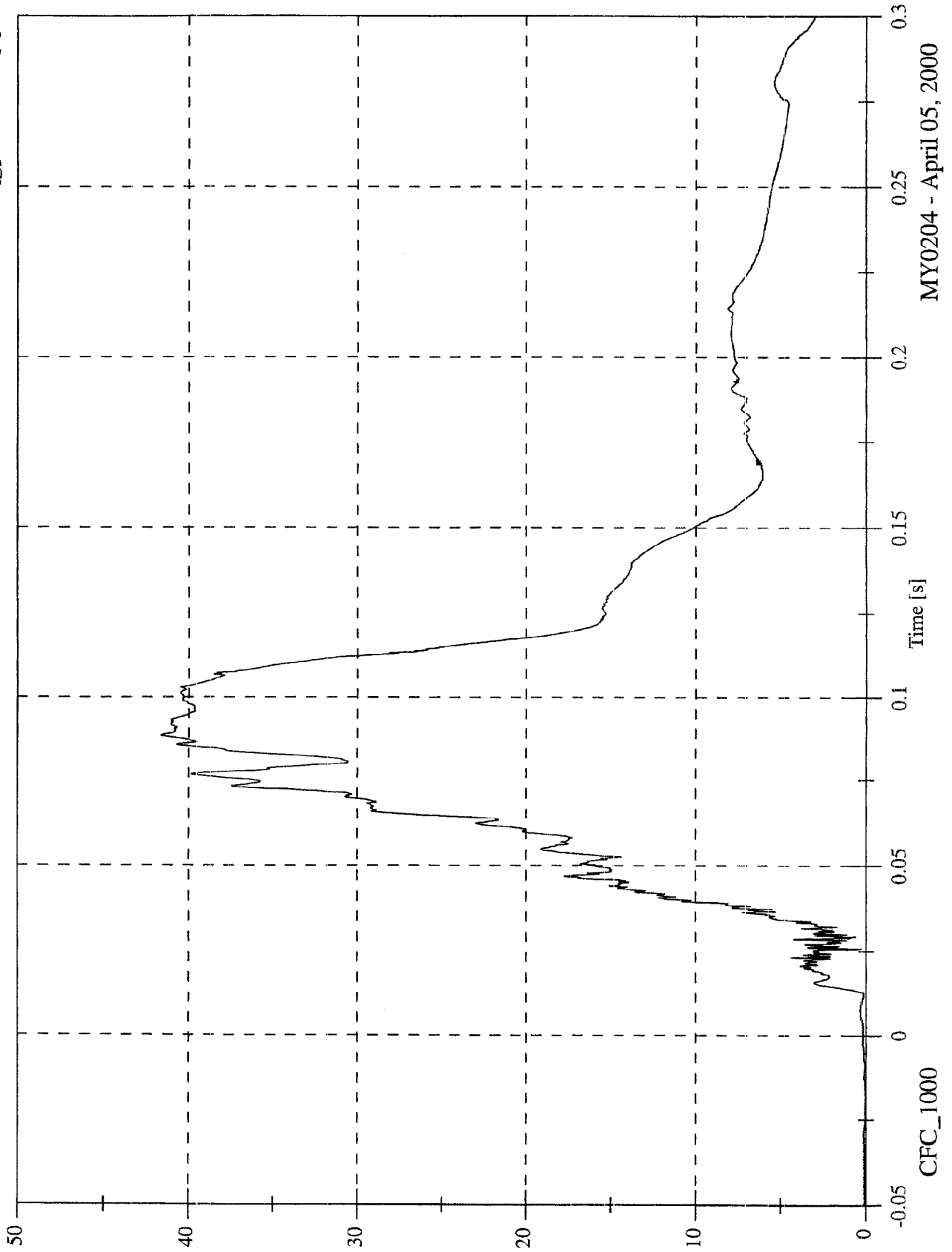

MY0204 - April 05, 2000

NCAP 2000 Test#17 - 2000 Ford Focus 3-Door

Max: 3.9 [g] at 0.281 [s]
Min: -45.2 [g] at 0.103 [s]

P2 Head Red x

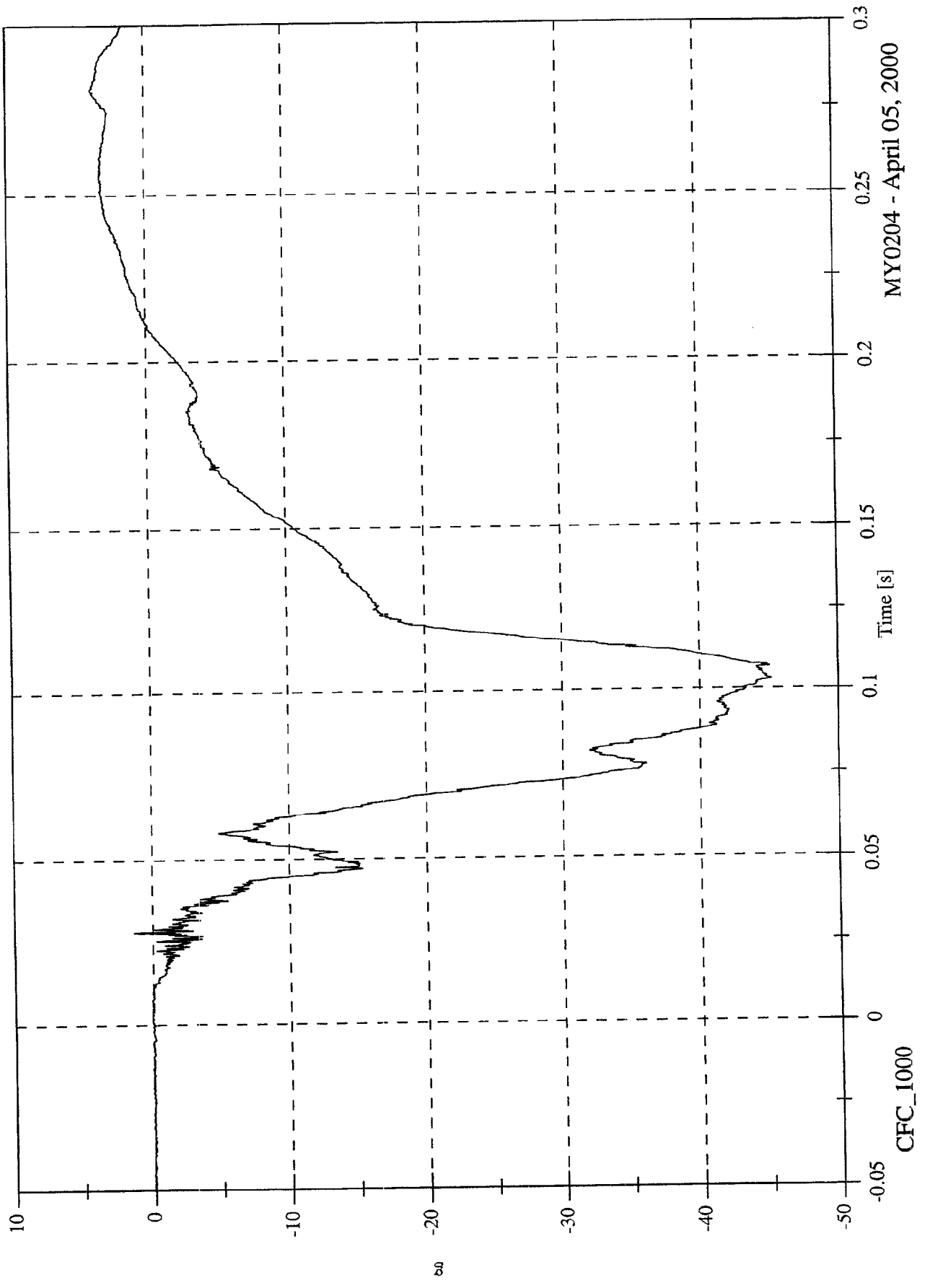

MY0204 - April 05, 2000

NCAP 2000 Test#17 - 2000 Ford Focus 3-Door

Max: 2.3 [g] at 0.029 [s]
Min: -15.4 [g] at 0.102 [s]

P2 Head Red y

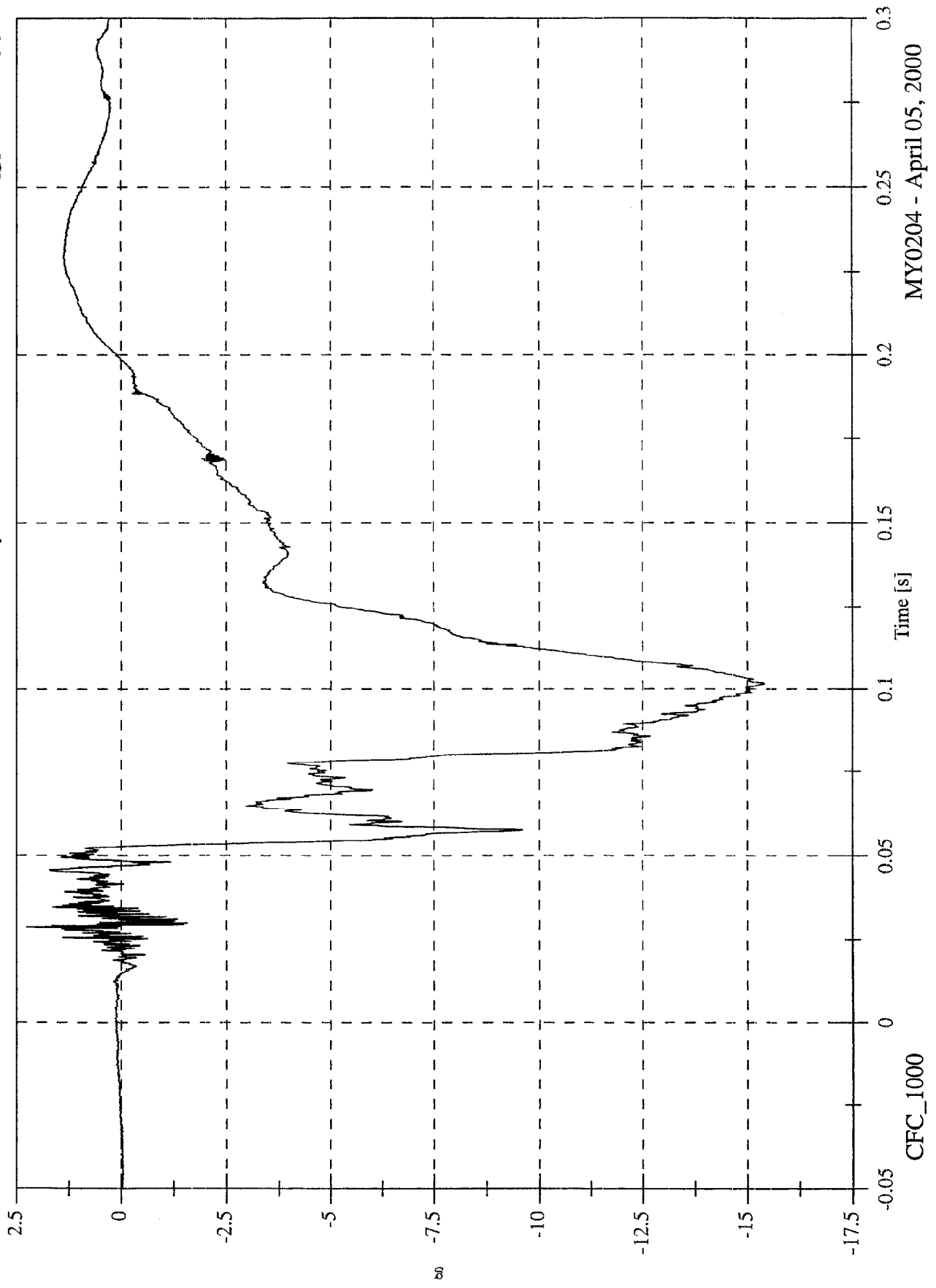

MY0204 - April 05, 2000

NCAP 2000 Test#17 - 2000 Ford Focus 3-Door

Max: 26.4 [g] at 0.073 [s]
Min: -4.7 [g] at 0.123 [s]

P2 Head Red z

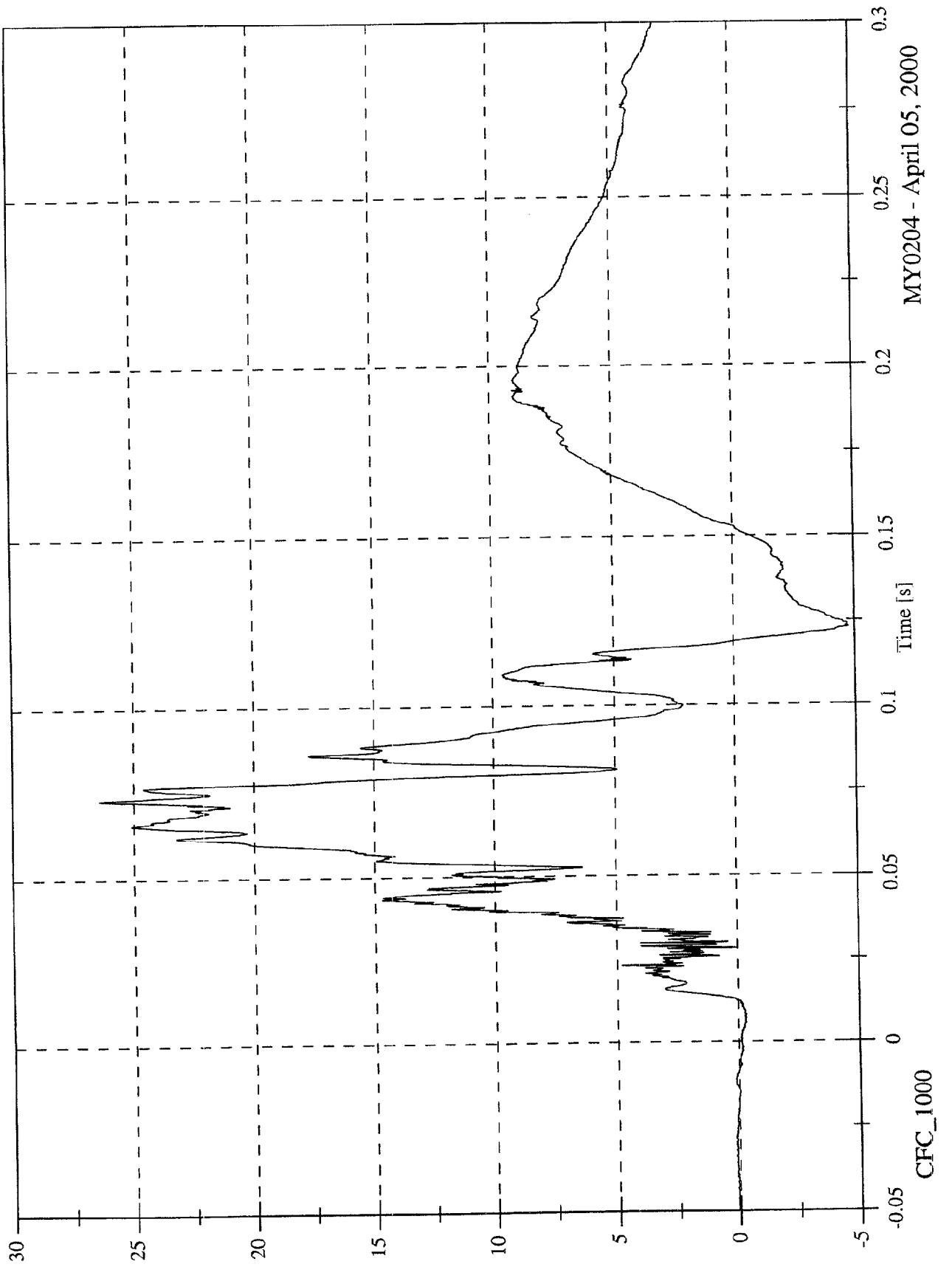

NCAP 2000 Test#17 - 2000 Ford Focus 3-Door

Max: 47.8 [g] at 0.103 [s]
Min: 0.0 [g] at -0.019 [s]

P2 Head Red Resultant

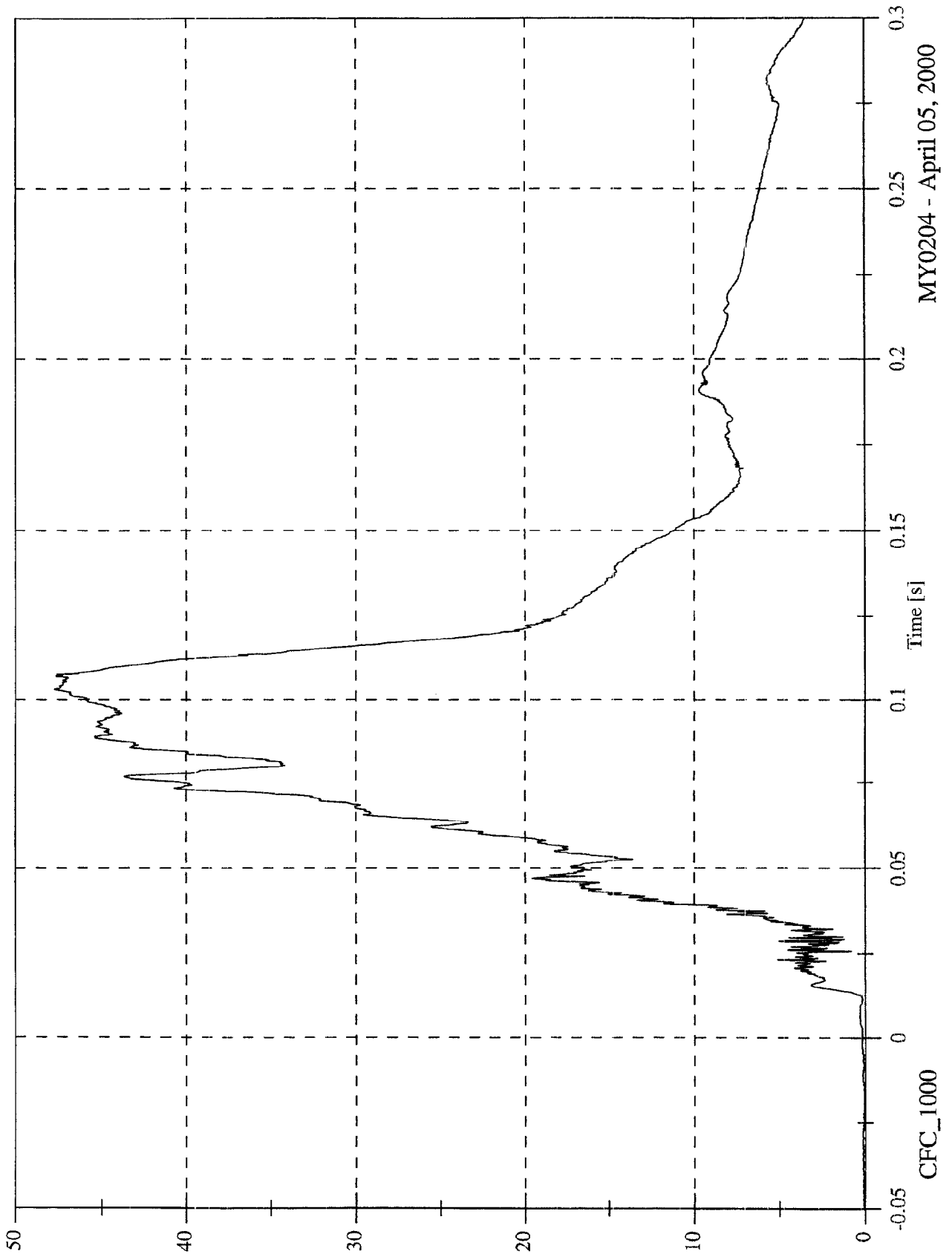

MY0204 - April 05, 2000

NCAP 2000 Test#17 - 2000 Ford Focus 3-Door

P2 Upper Neck Fx

Max: 226.7 [N] at 0.082 [s]
Min: -581.4 [N] at 0.132 [s]

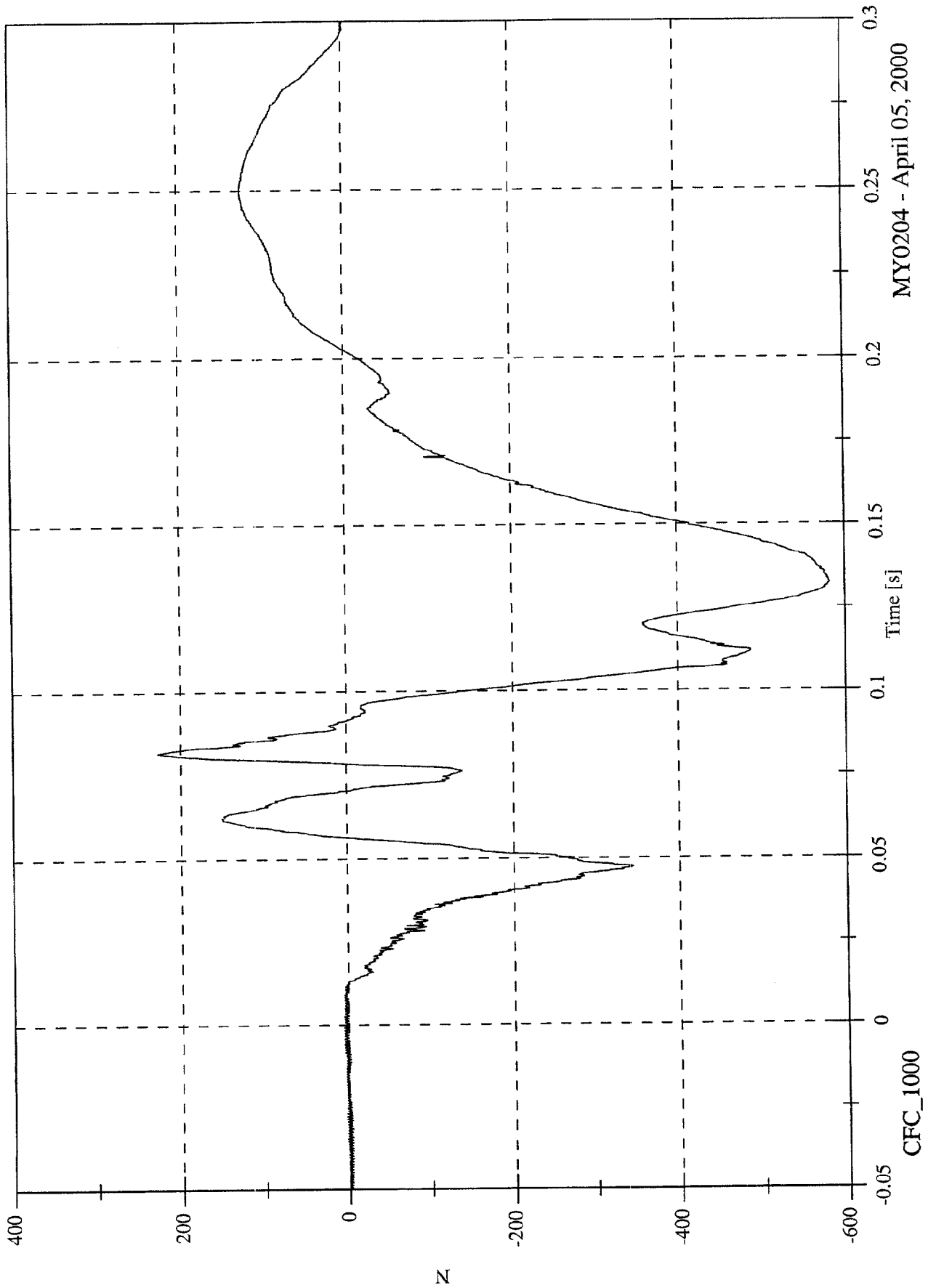

MY0204 - April 05, 2000

NCAP 2000 Test#17 - 2000 Ford Focus 3-Door

Max: 84.1 [N] at 0.062 [s]
Min: -167.7 [N] at 0.140 [s]

P2 Upper Neck Fy

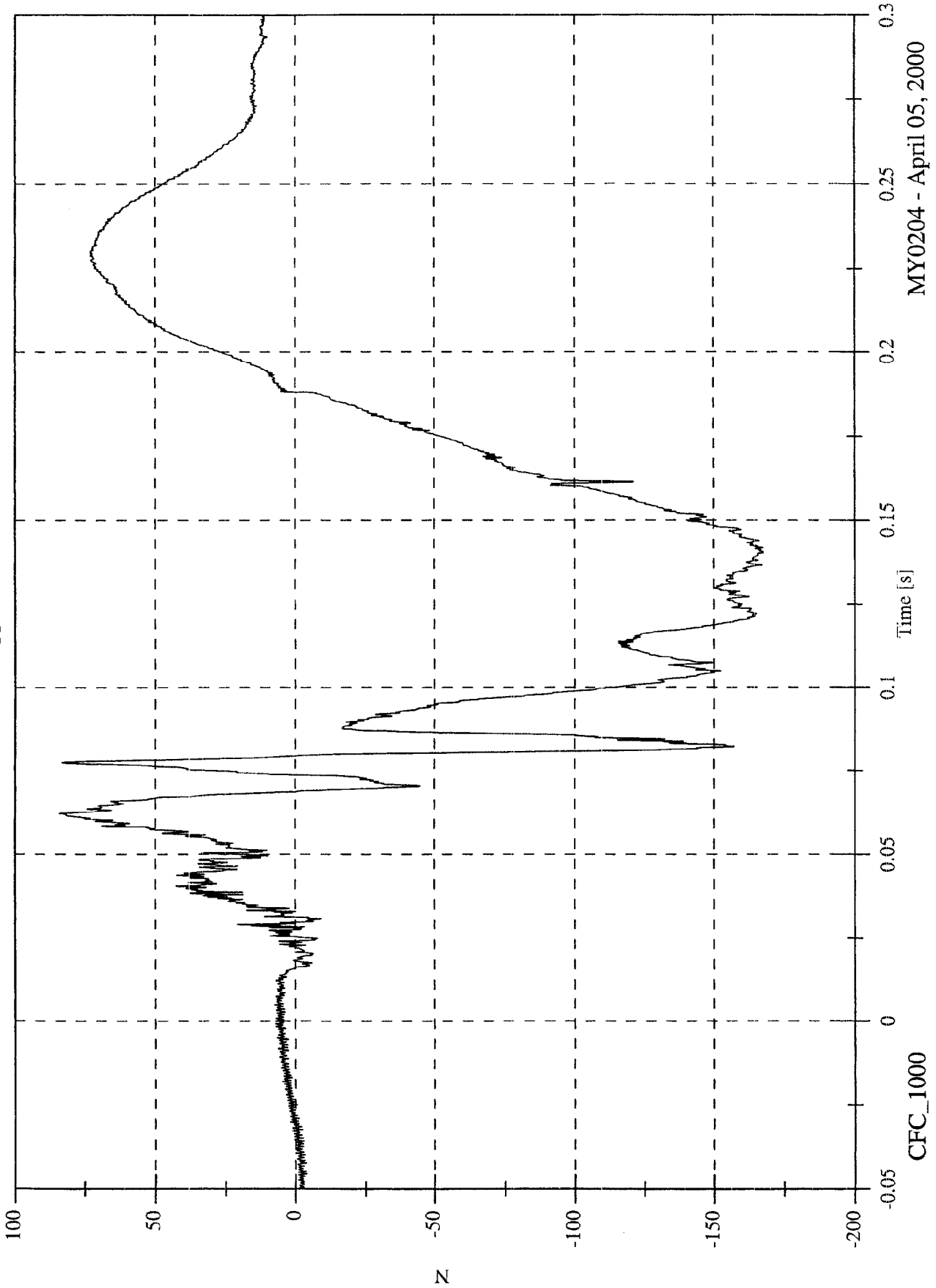

MY0204 - April 05, 2000

NCAP 2000 Test#17 - 2000 Ford Focus 3-Door

Max: 1380.1 [N] at 0.073 [s]
Min: -175.8 [N] at 0.102 [s]

P2 Upper Neck Fz

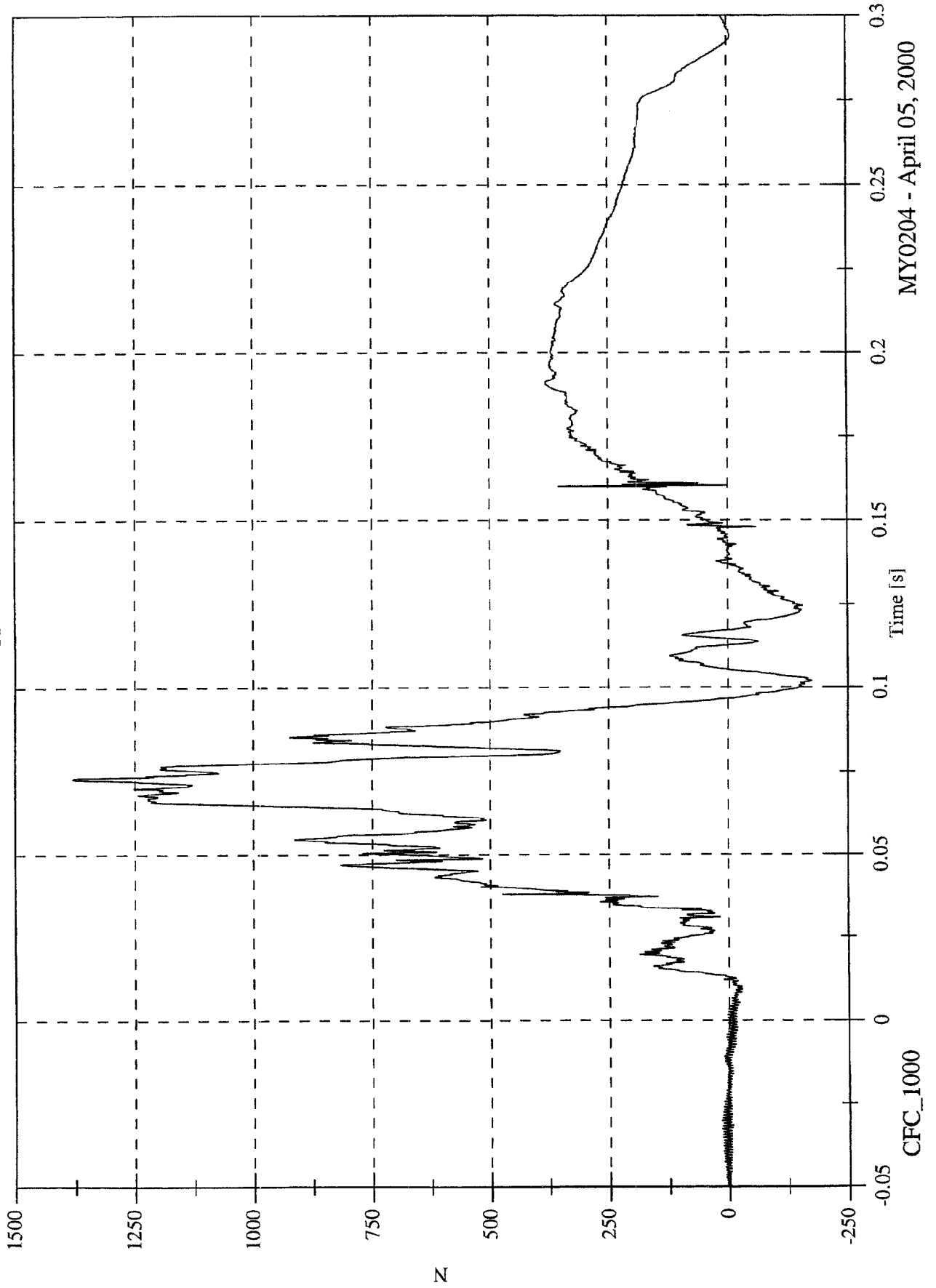

MY0204 - April 05, 2000

NCAP 2000 Test#17 - 2000 Ford Focus 3-Door
P2 Upper Neck F Resultant

Max: 1384.9 [N] at 0.073 [s]
Min: 0.8 [N] at -0.025 [s]

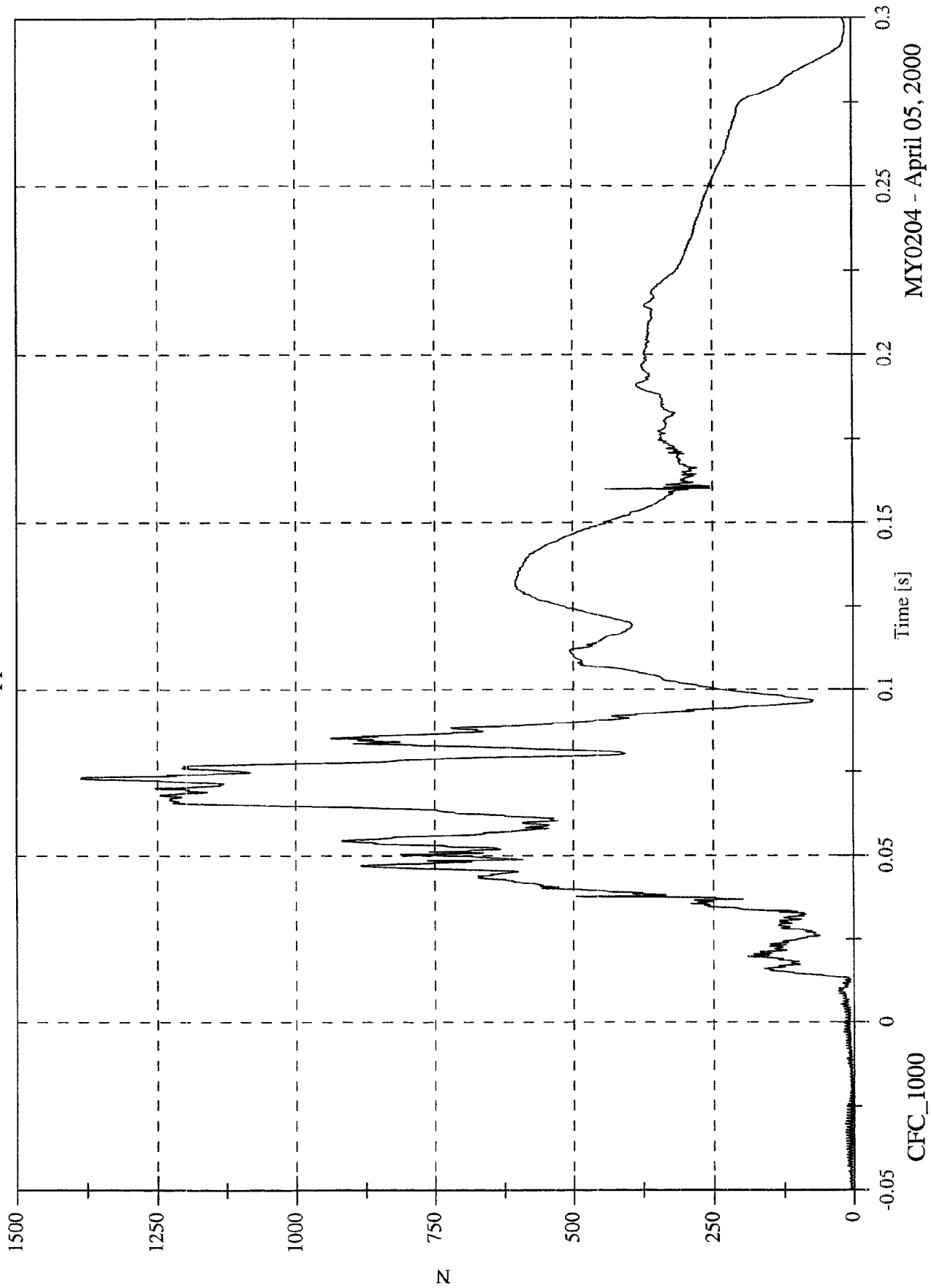

MY0204 - April 05, 2000

NCAP 2000 Test#17 - 2000 Ford Focus 3-Door

Max: 21.3 [N-m] at 0.100 [s]
Min: -9.4 [N-m] at 0.147 [s]

P2 Upper Neck Mx

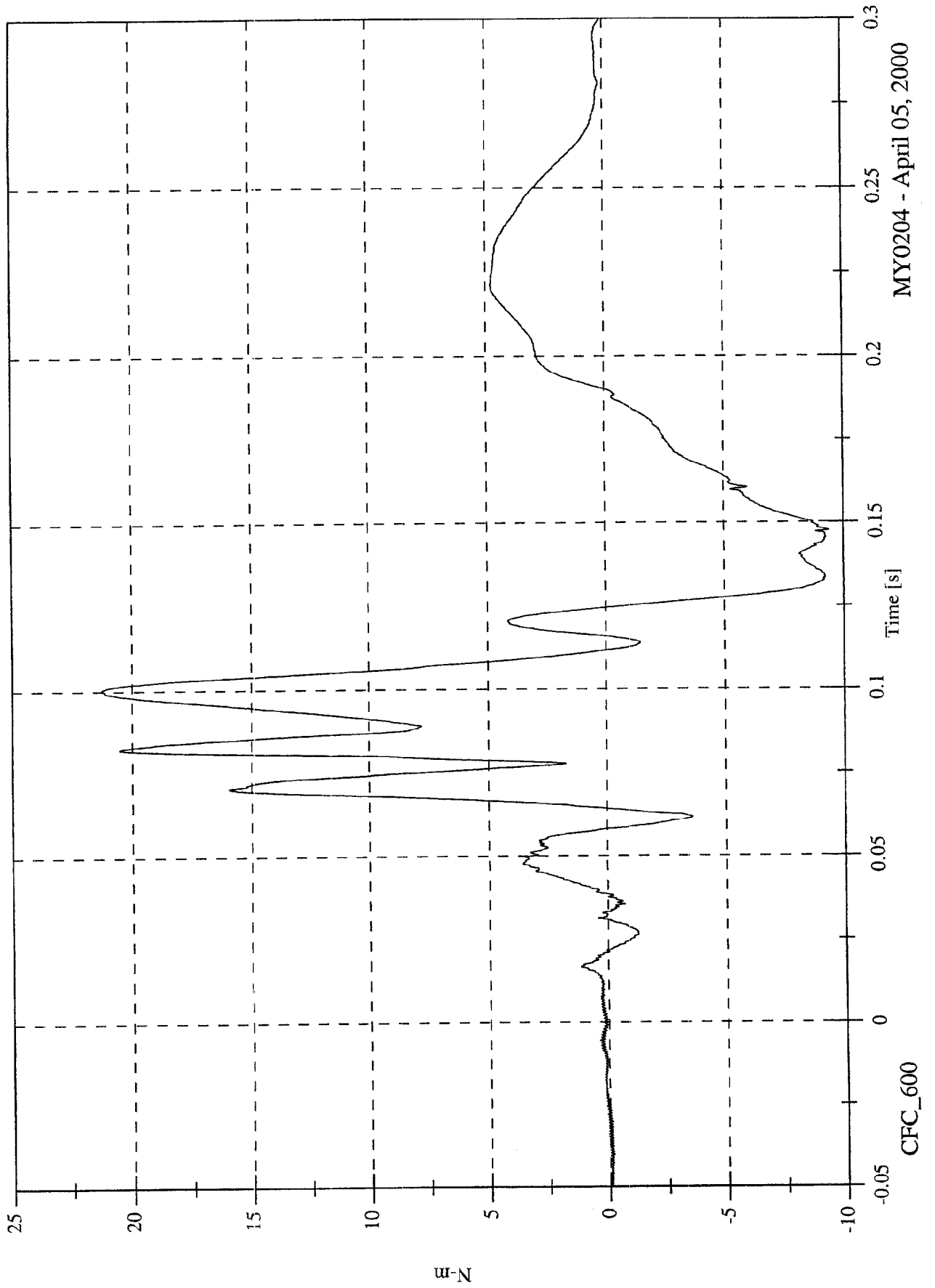

MY0204 - April 05, 2000

NCAP 2000 Test#17 - 2000 Ford Focus 3-Door

Max: 47.9 [N-m] at 0.123 [s]
Min: -36.1 [N-m] at 0.102 [s]

P2 Upper Neck My

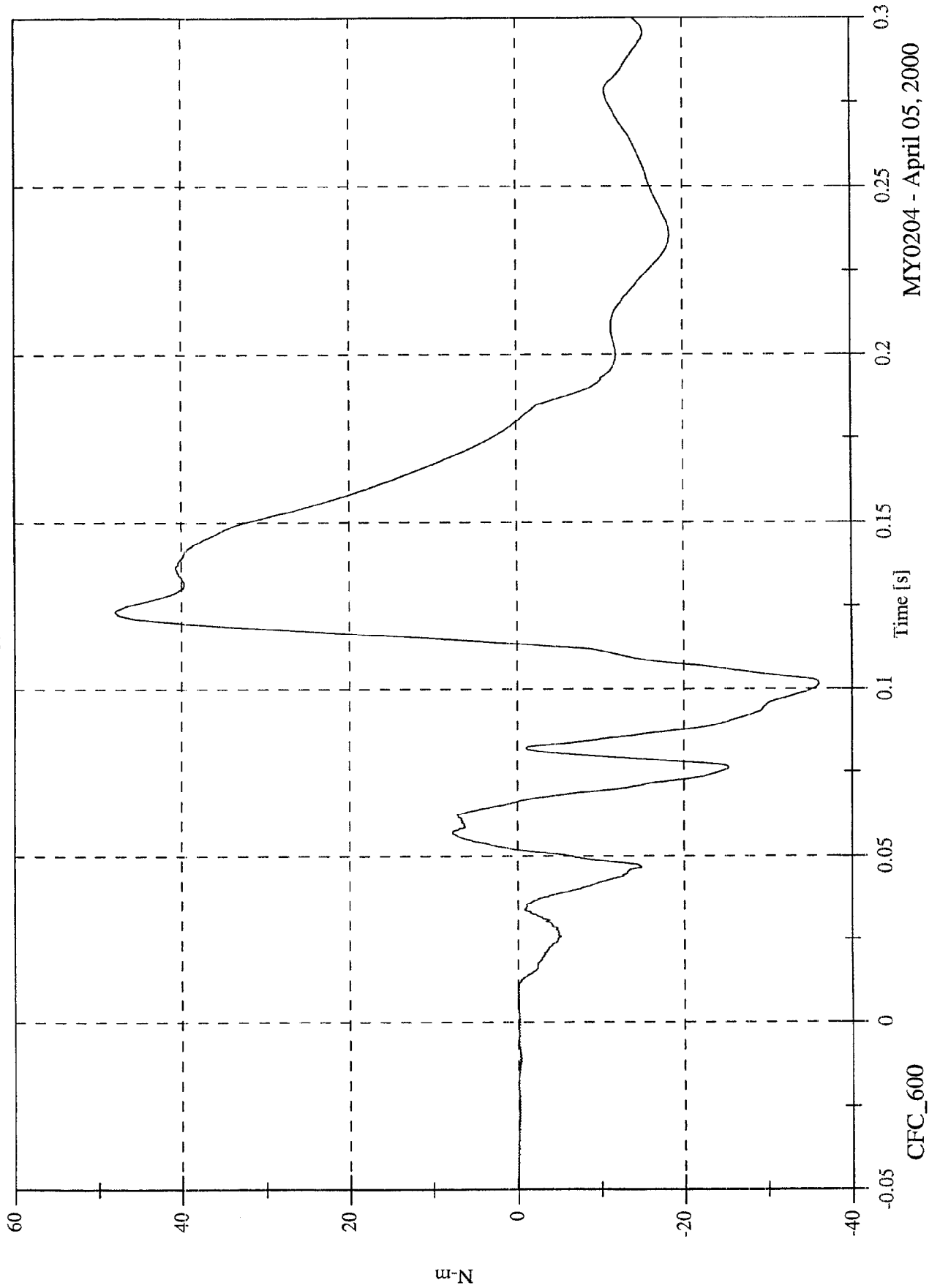

MY0204 - April 05, 2000

NCAP 2000 Test#17 - 2000 Ford Focus 3-Door

Max: 13.5 [N-m] at 0.098 [s]
Min: -3.5 [N-m] at 0.154 [s]

P2 Upper Neck Mz

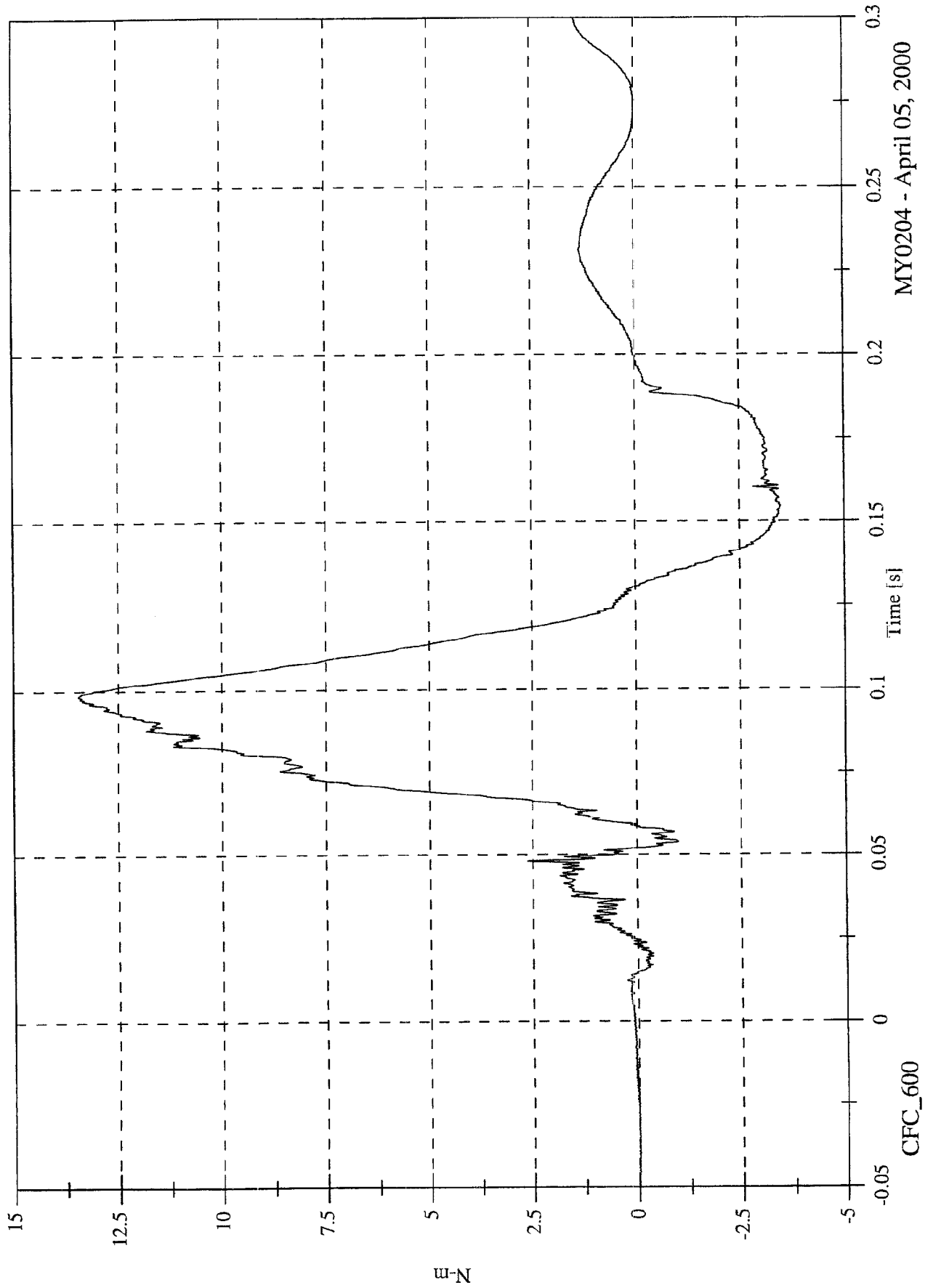

MY0204 - April 05, 2000

NCAP 2000 Test#17 - 2000 Ford Focus 3-Door
P2 Upper Neck M Resultant

Max: 48.0 [N-m] at 0.123 [s]
Min: 0.0 [N-m] at -0.036 [s]

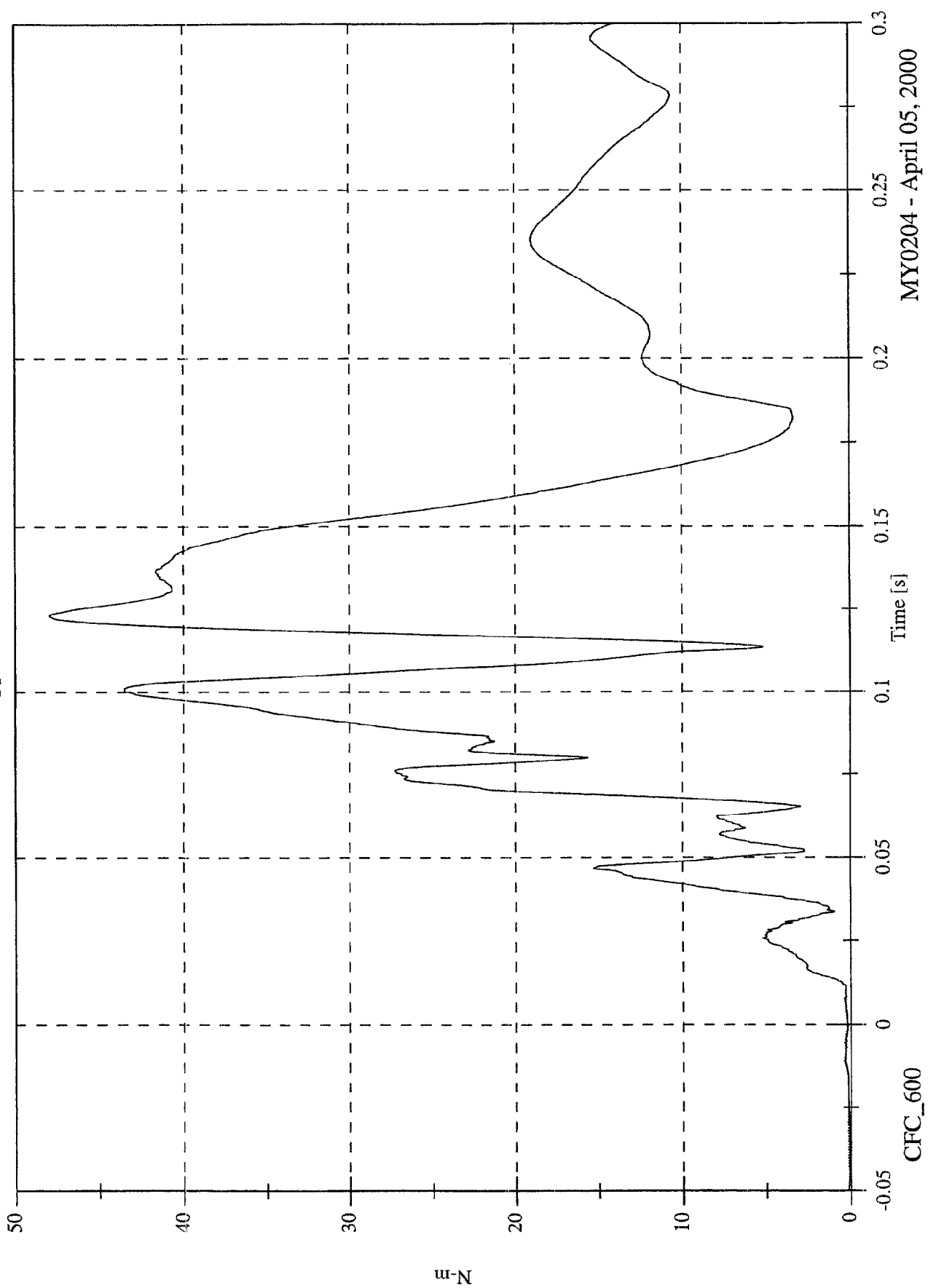

MY0204 - April 05, 2000

NCAP 2000 Test#17 - 2000 Ford Focus 3-Door

Max: 1.0 [g] at 0.151 [s]
Min: -43.1 [g] at 0.069 [s]

P2 Chest x

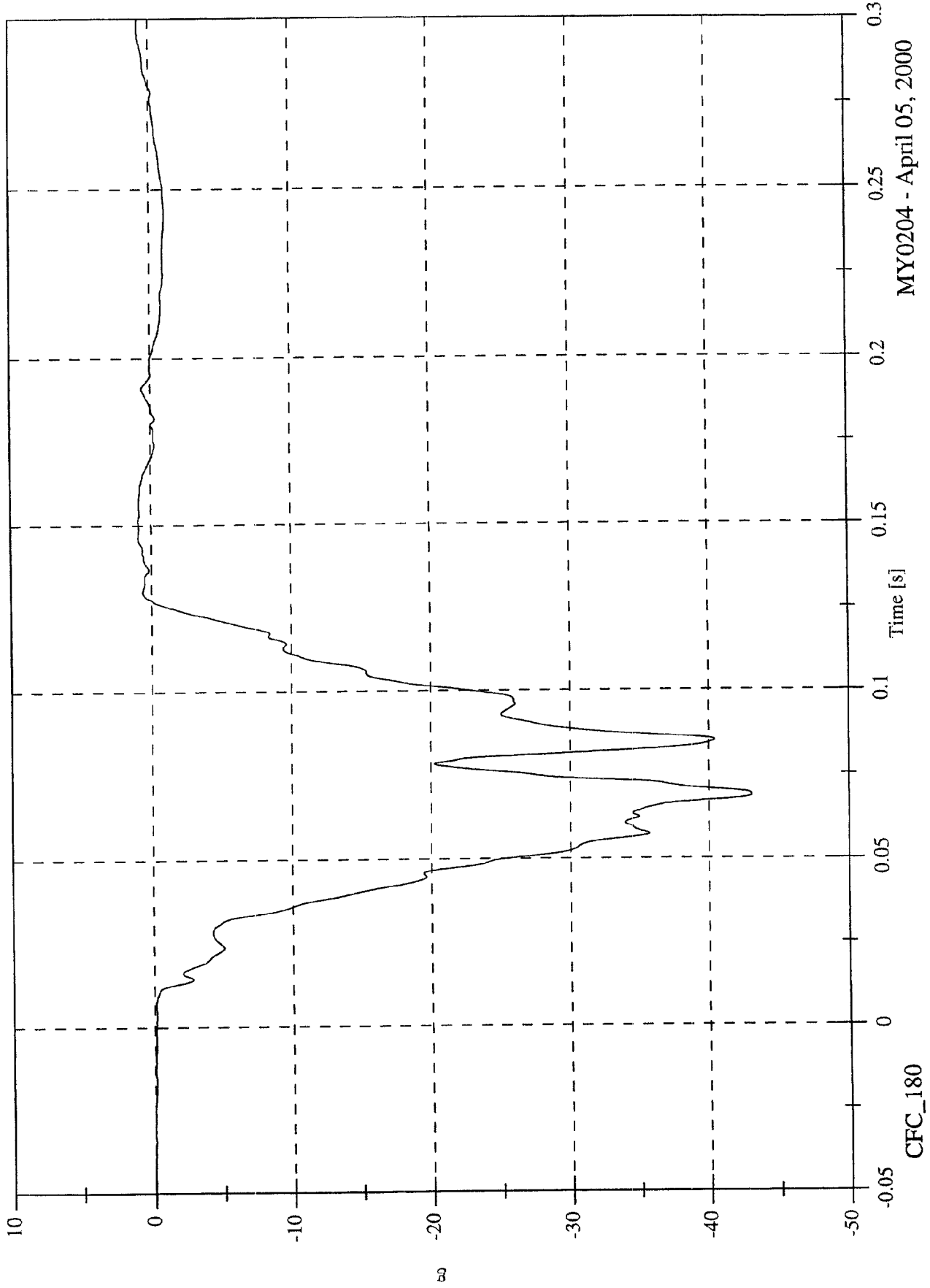

MY0204 - April 05, 2000

CFC_180

NCAP 2000 Test#17 - 2000 Ford Focus 3-Door

Max: 3.7 [g] at 0.047 [s]
Min: -10.8 [g] at 0.080 [s]

P2 Chest y

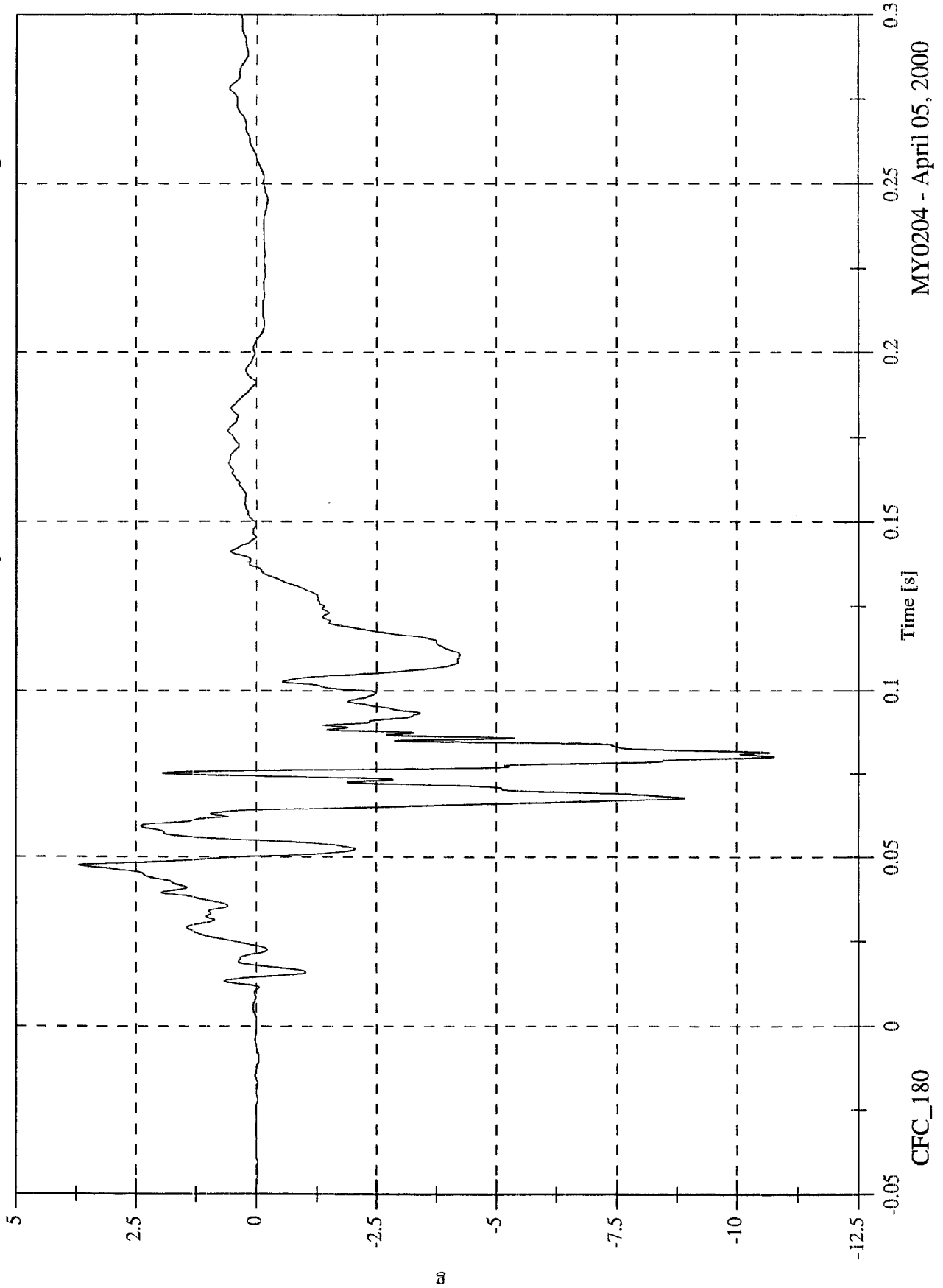

MY0204 - April 05, 2000

NCAP 2000 Test#17 - 2000 Ford Focus 3-Door

Max: 8.2 [g] at 0.066 [s]
Min: -10.4 [g] at 0.101 [s]

P2 Chest z

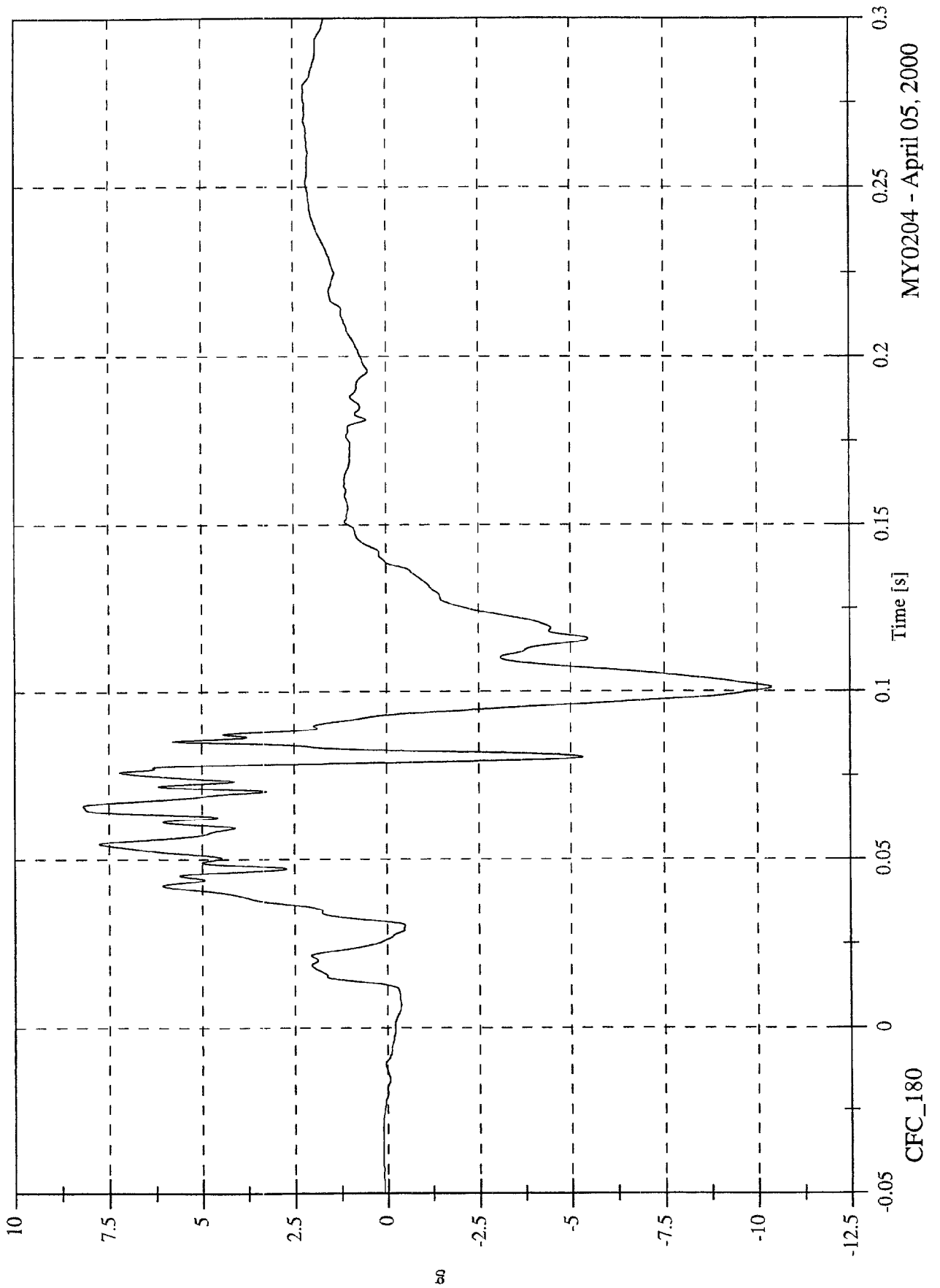

MY0204 - April 05, 2000

NCAP 2000 Test#17 - 2000 Ford Focus 3-Door

Max: 44.2 [g] at 0.068 [s]
Min: 0.1 [g] at -0.023 [s]

P2 Chest Resultant

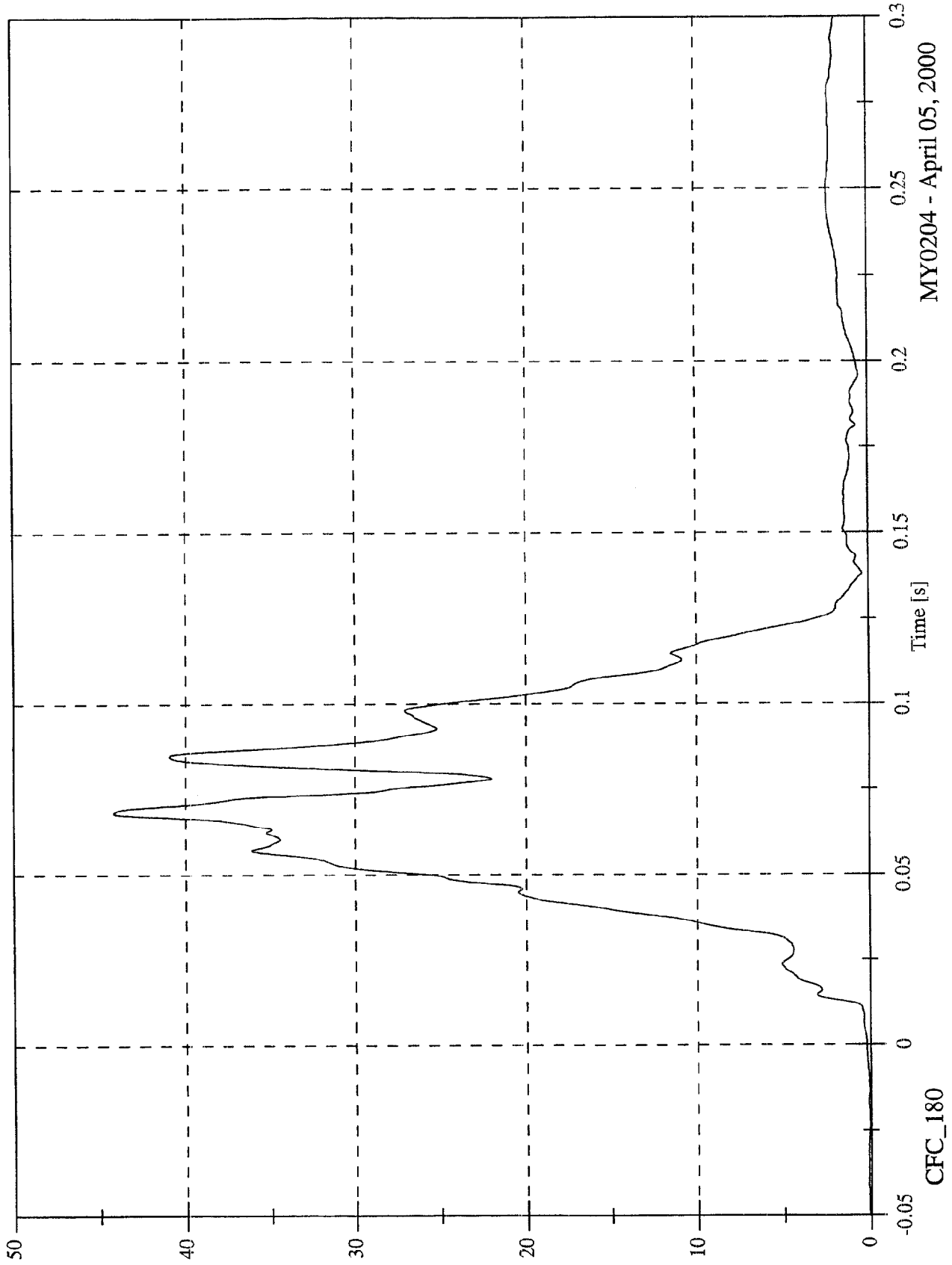

MY0204 - April 05, 2000

CFC_180

NCAP 2000 Test#17 - 2000 Ford Focus 3-Door

Max: 1.2 [g] at 0.152 [s]
Min: -42.9 [g] at 0.069 [s]

P2 Chest Red x

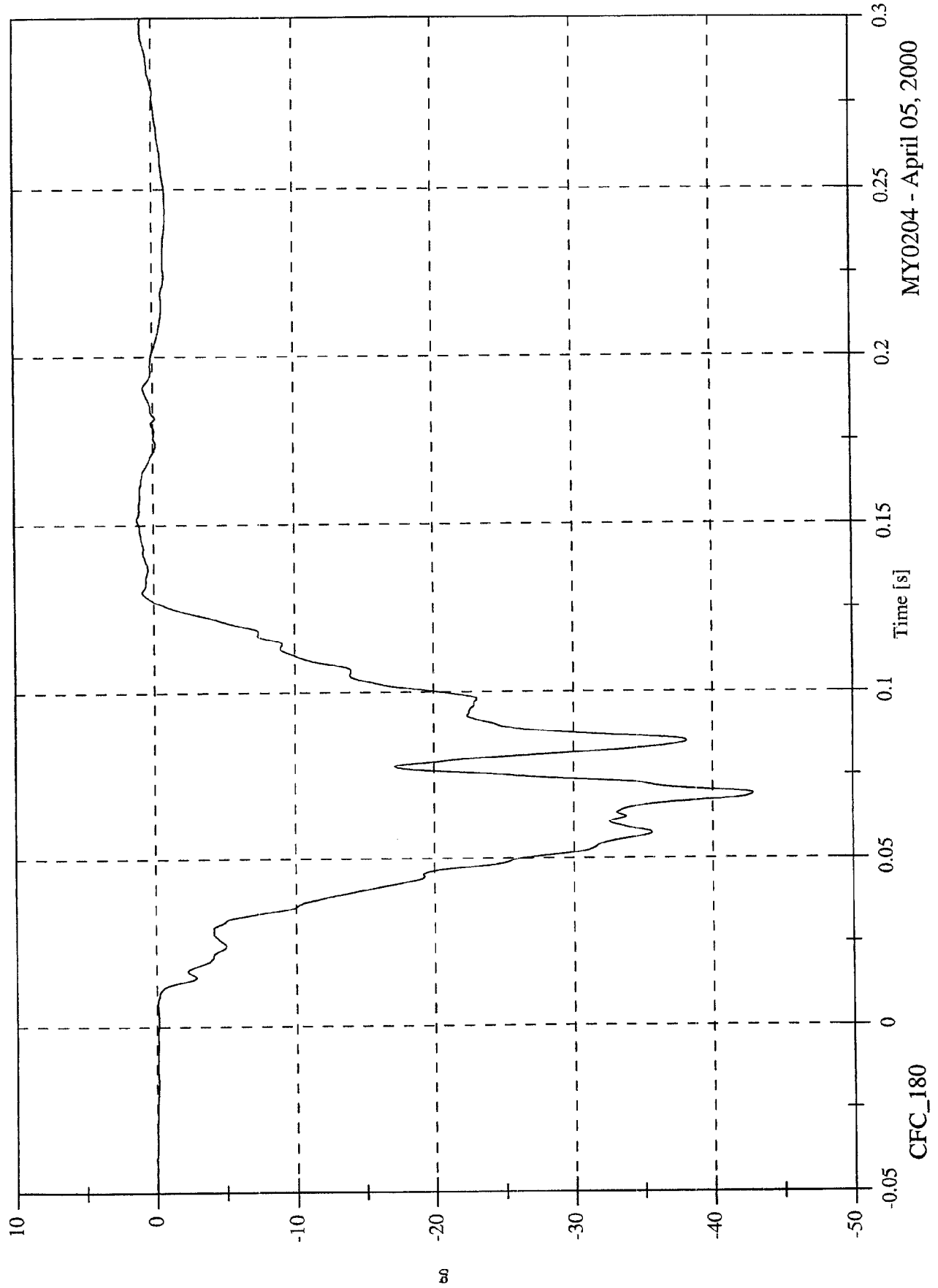

MY0204 - April 05, 2000

CFC_180

NCAP 2000 Test#17 - 2000 Ford Focus 3-Door

Max: 4.5 [g] at 0.047 [s]
Min: -9.0 [g] at 0.082 [s]

P2 Chest Red y

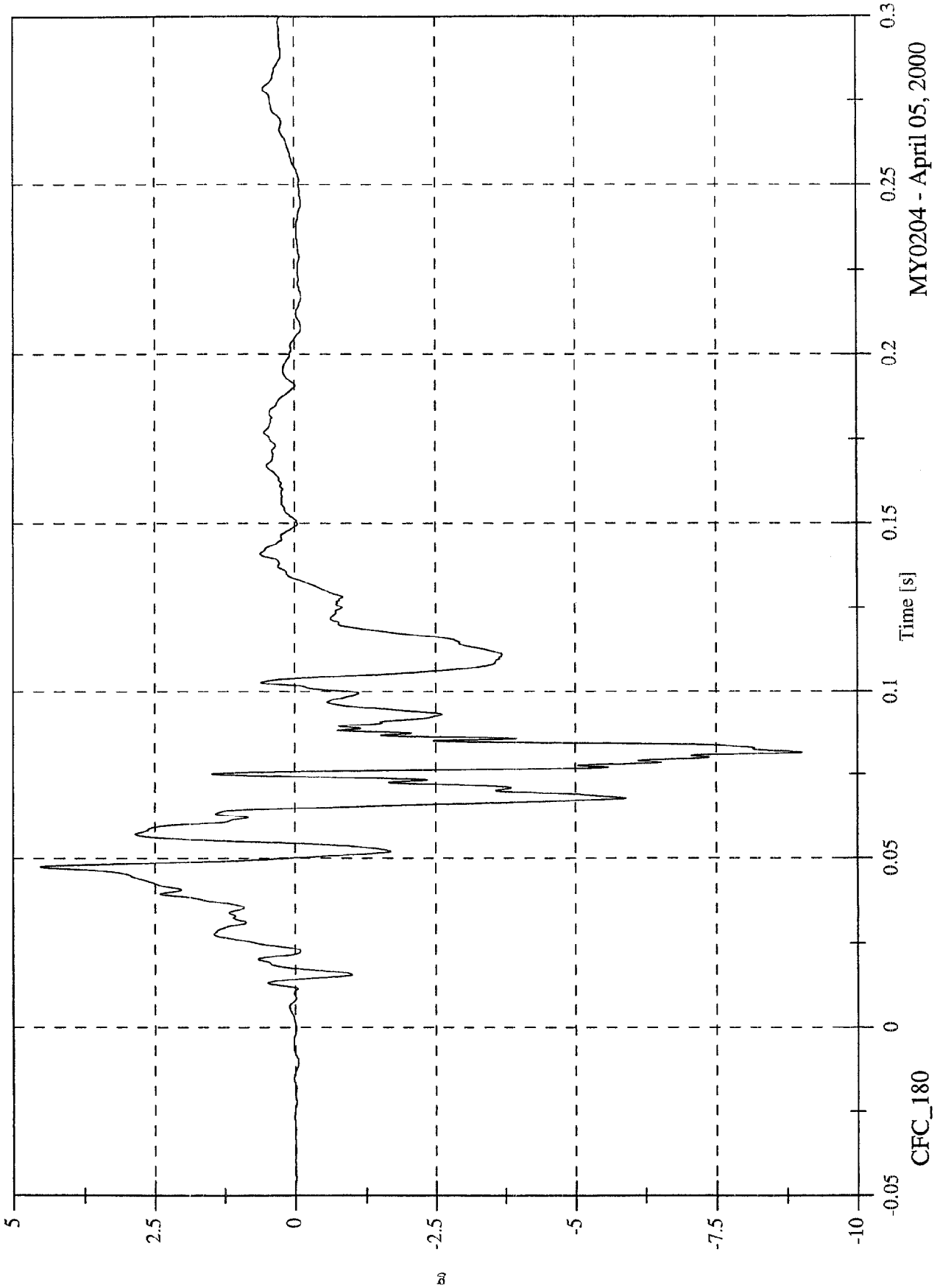

MY0204 - April 05, 2000

NCAP 2000 Test#17 - 2000 Ford Focus 3-Door

Max: 8.1 [g] at 0.085 [s]
Min: -8.6 [g] at 0.101 [s]

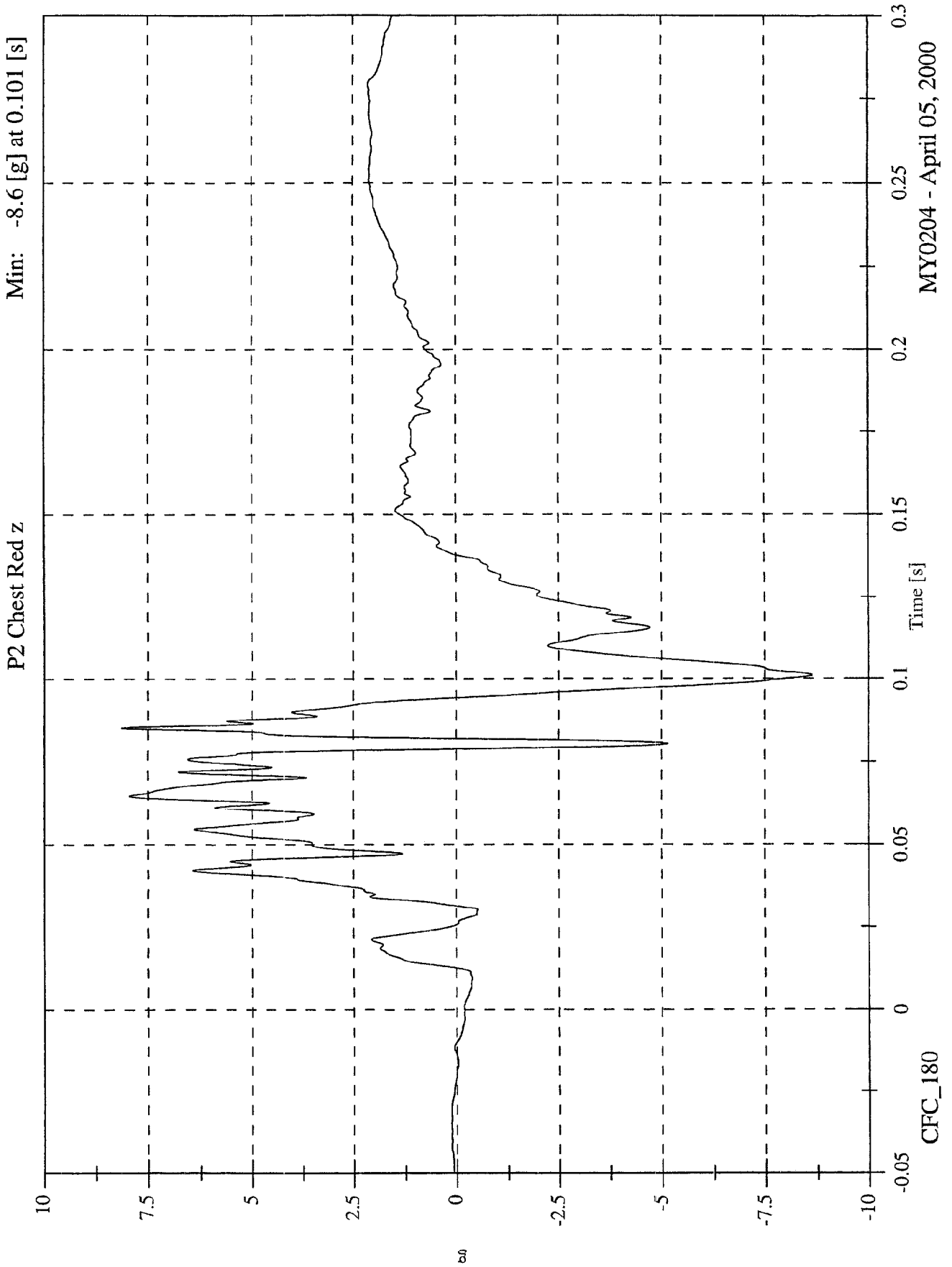

MY0204 - April 05, 2000

NCAP 2000 Test#17 - 2000 Ford Focus 3-Door

Max: 43.6 [g] at 0.069 [s]
Min: 0.1 [g] at -0.024 [s]

P2 Chest Red Resultant

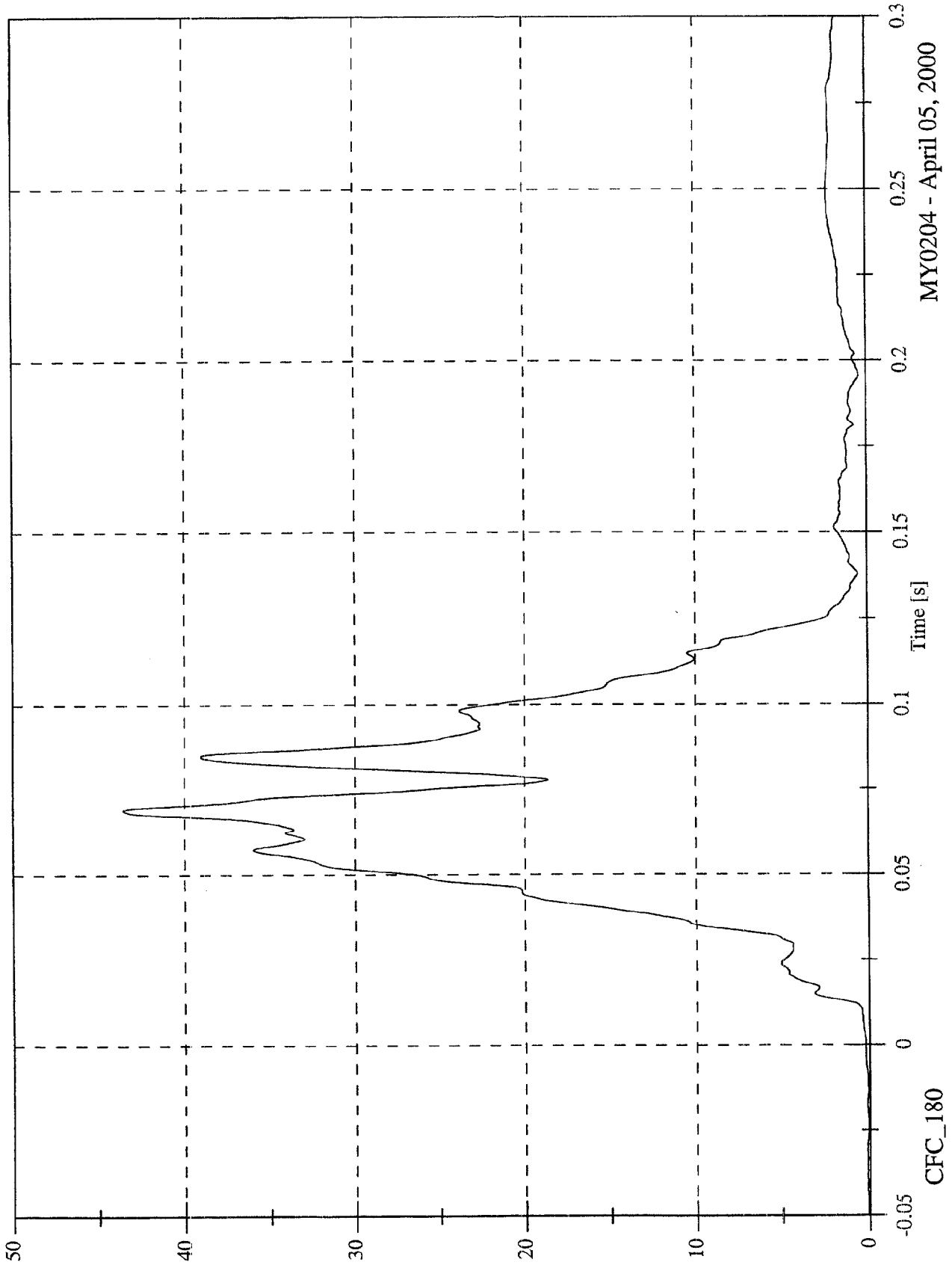

MY0204 - April 05, 2000

CFC_180

NCAP 2000 Test#17 - 2000 Ford Focus 3-Door

P2 Chest Compression x

Max: 0.0 [mm] at 0.009 [s]
Min: -24.3 [mm] at 0.069 [s]

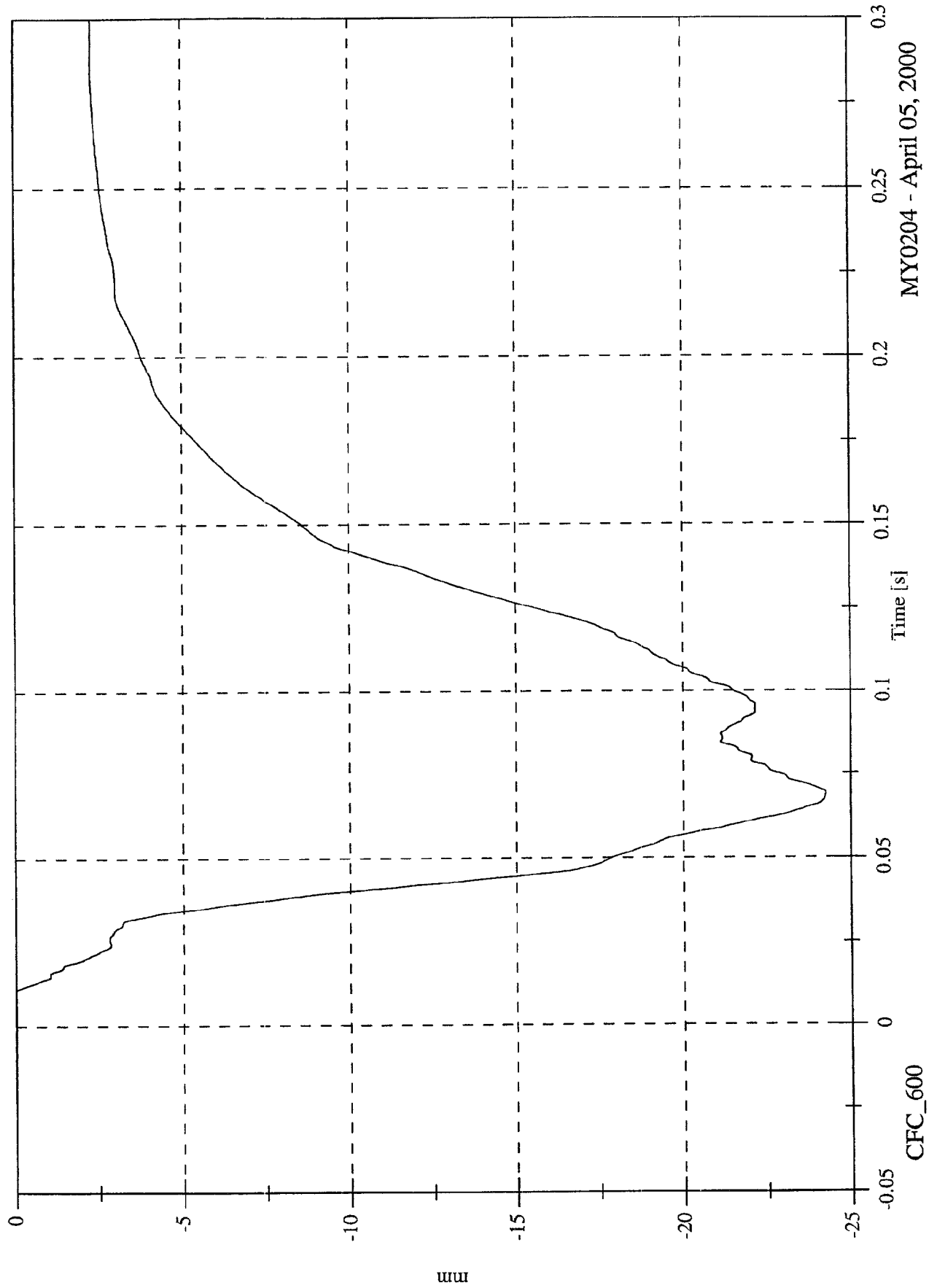

MY0204 - April 05, 2000

NCAP 2000 Test#17 - 2000 Ford Focus 3-Door

Max: 2.7 [g] at 0.120 [s]
Min: -74.7 [g] at 0.051 [s]

P2 Pelvic x

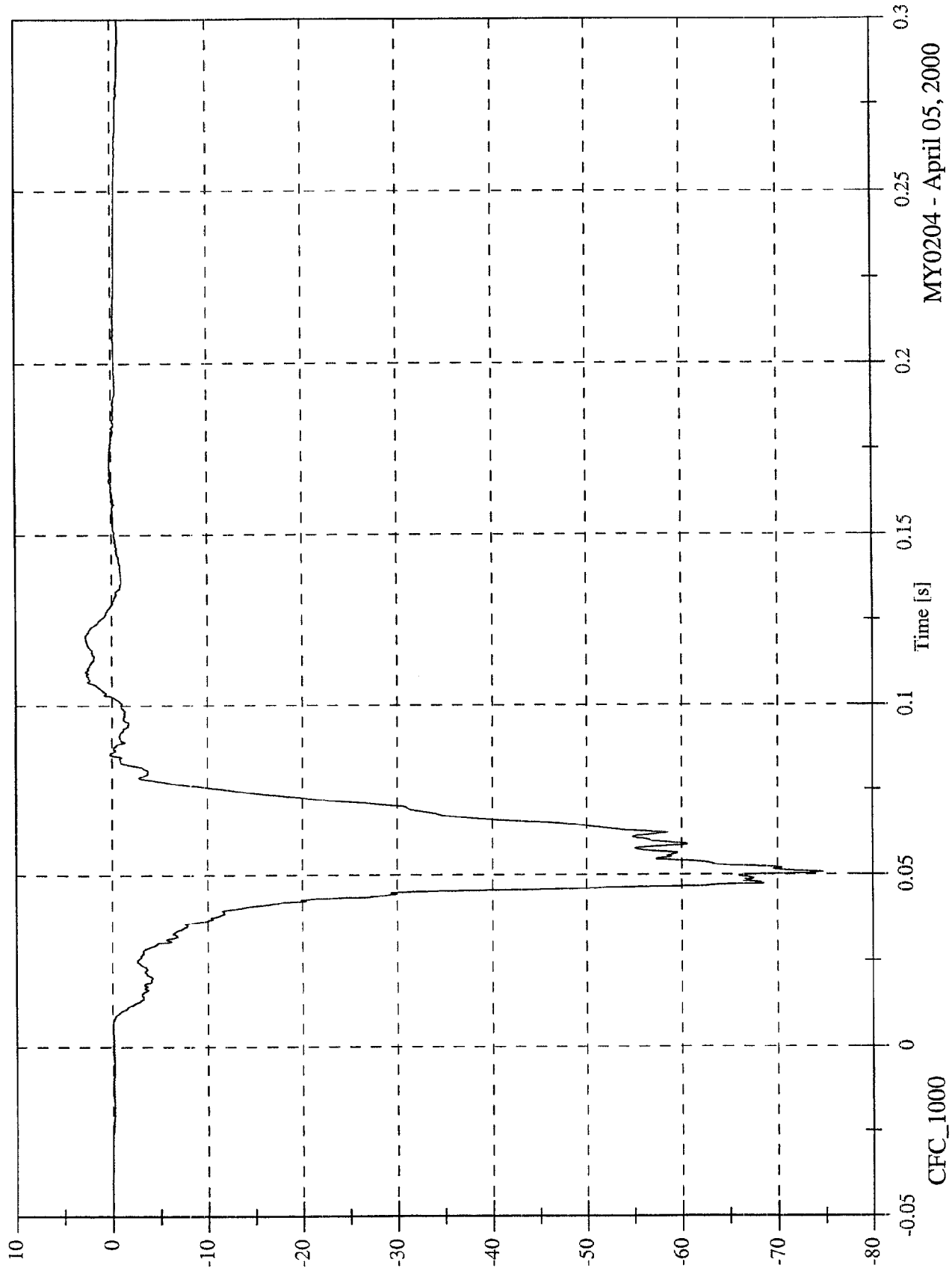

MY0204 - April 05, 2000

NCAP 2000 Test#17 - 2000 Ford Focus 3-Door

Max: 6.6 [g] at 0.083 [s]
Min: -8.7 [g] at 0.065 [s]

P2 Pelvic y

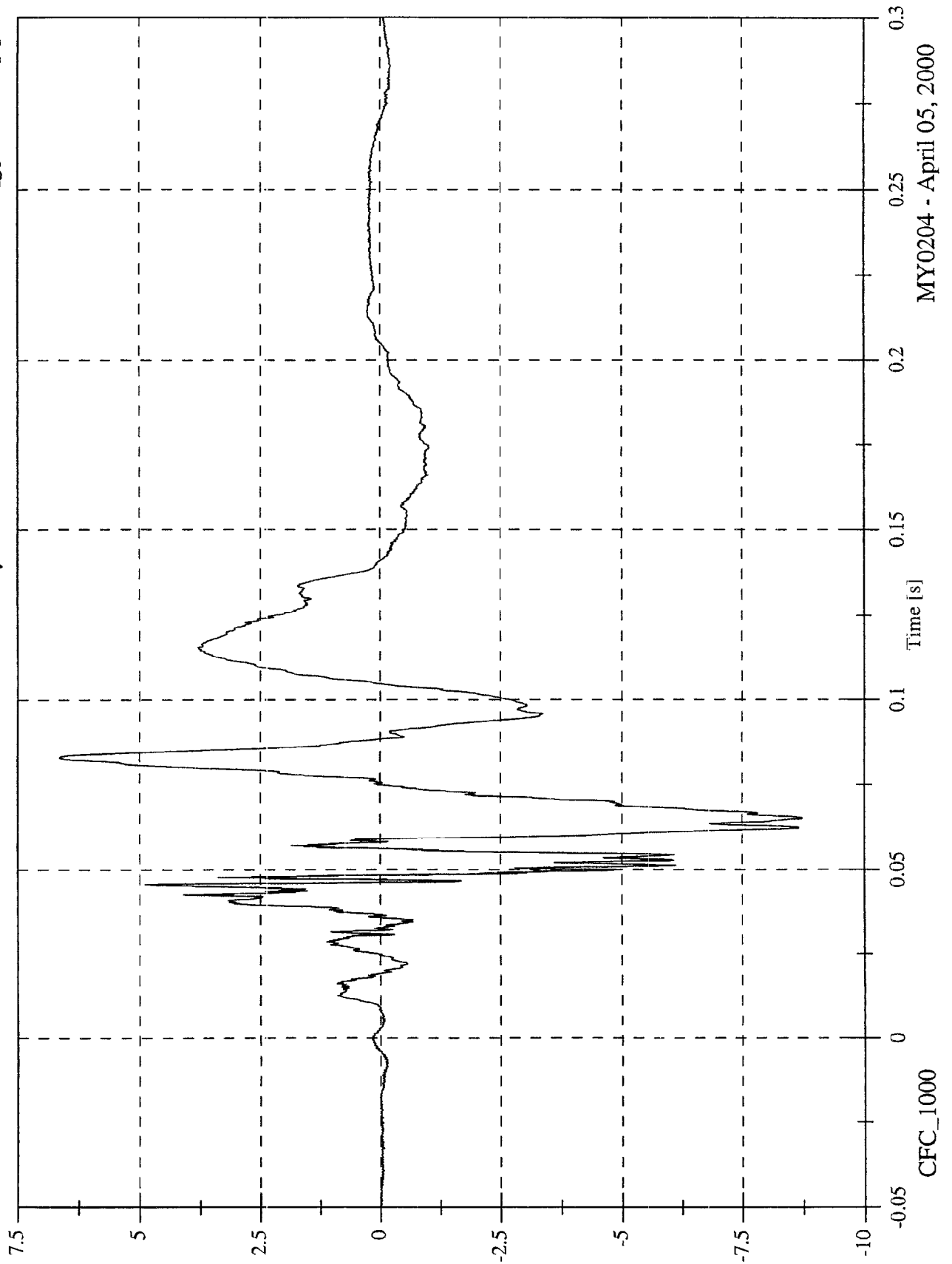

MY0204 - April 05, 2000

NCAP 2000 Test#17 - 2000 Ford Focus 3-Door

Max: 1.5 [g] at 0.278 [s]
Min: -24.8 [g] at 0.081 [s]

P2 Pelvic z

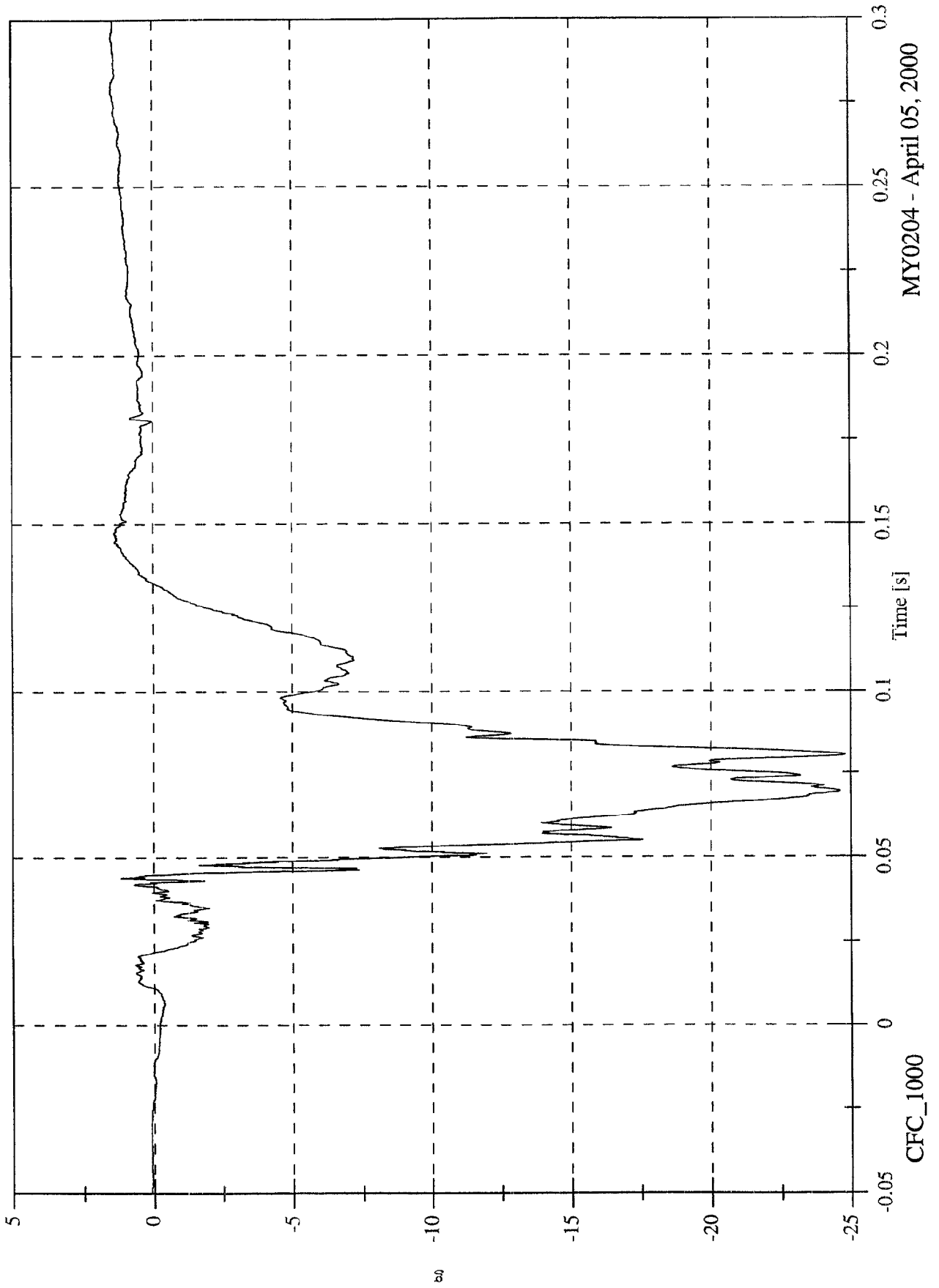

MY0204 - April 05, 2000

NCAP 2000 Test#17 - 2000 Ford Focus 3-Door

Max: 75.7 [g] at 0.051 [s]
Min: 0.1 [g] at -0.046 [s]

P2 Pelvic Resultant

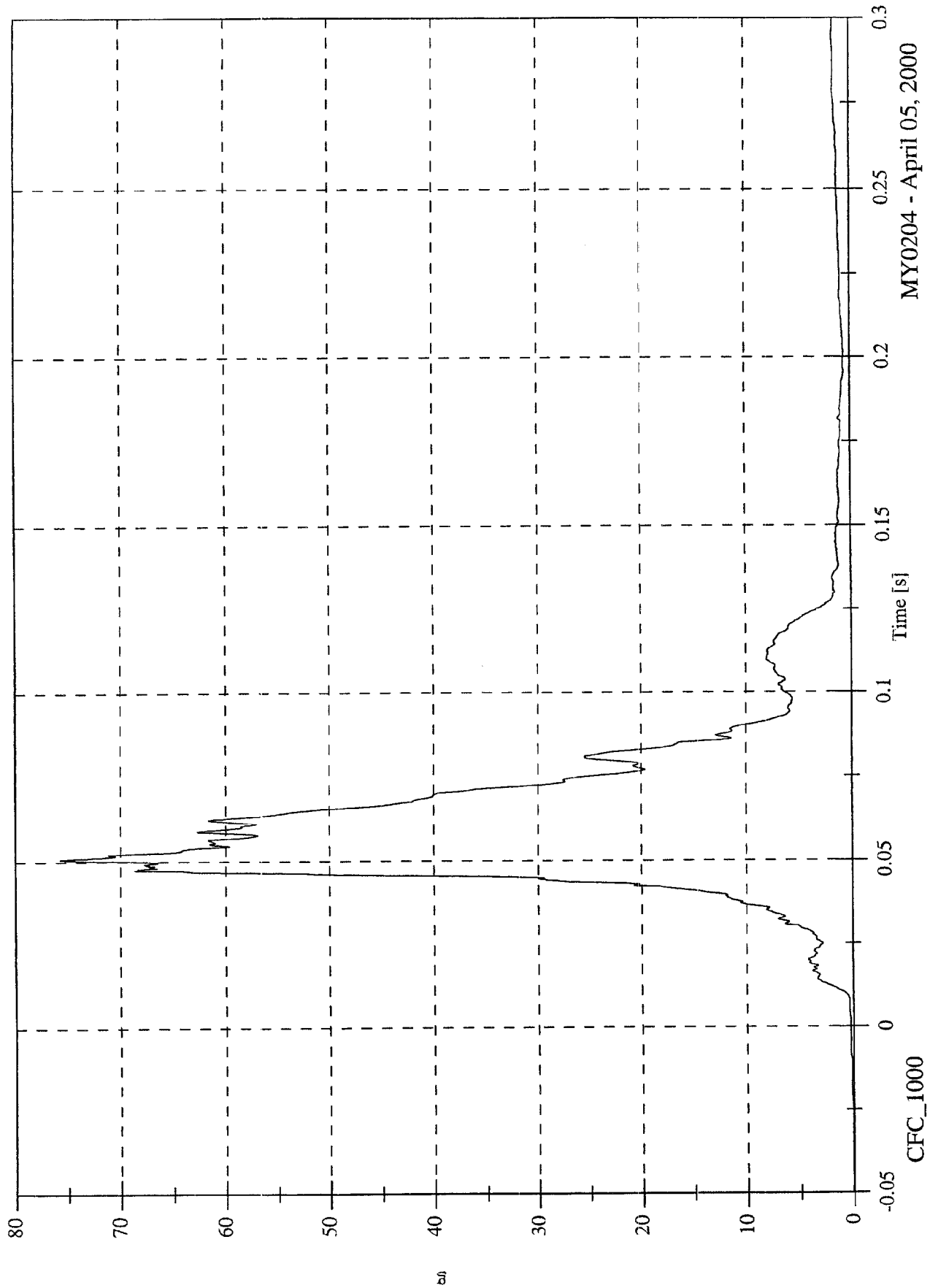

MY0204 - April 05, 2000

NCAP 2000 Test#17 - 2000 Ford Focus 3-Door

Max: 357.0 [N] at 0.040 [s]
Min: -4866.7 [N] at 0.047 [s]

P2 Left Femur z

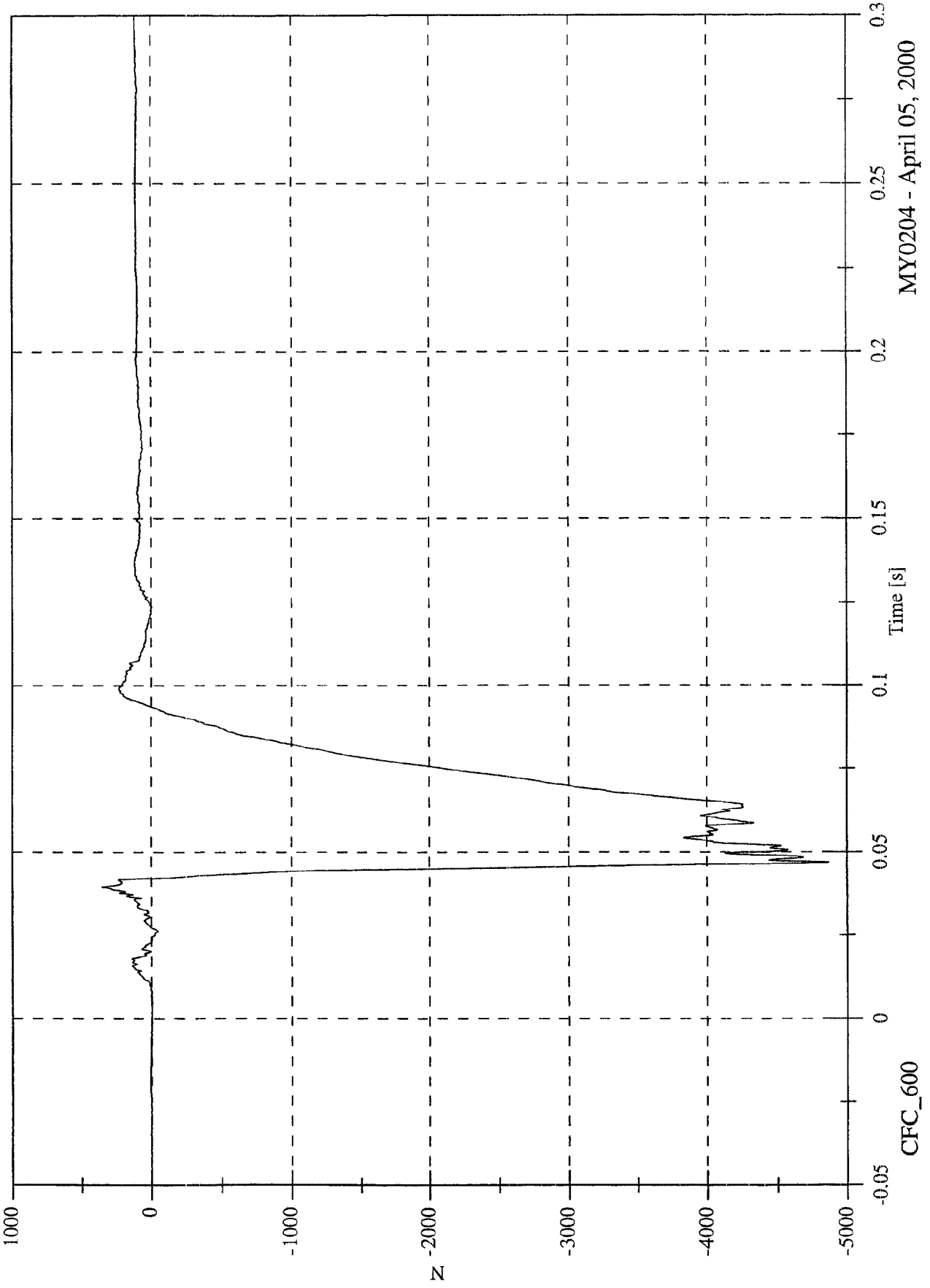

MY0204 - April 05, 2000

CFC_600

NCAP 2000 Test#17 - 2000 Ford Focus 3-Door

Max: 294.7 [N] at 0.042 [s]
Min: -6822.3 [N] at 0.051 [s]

P2 Right Femur z

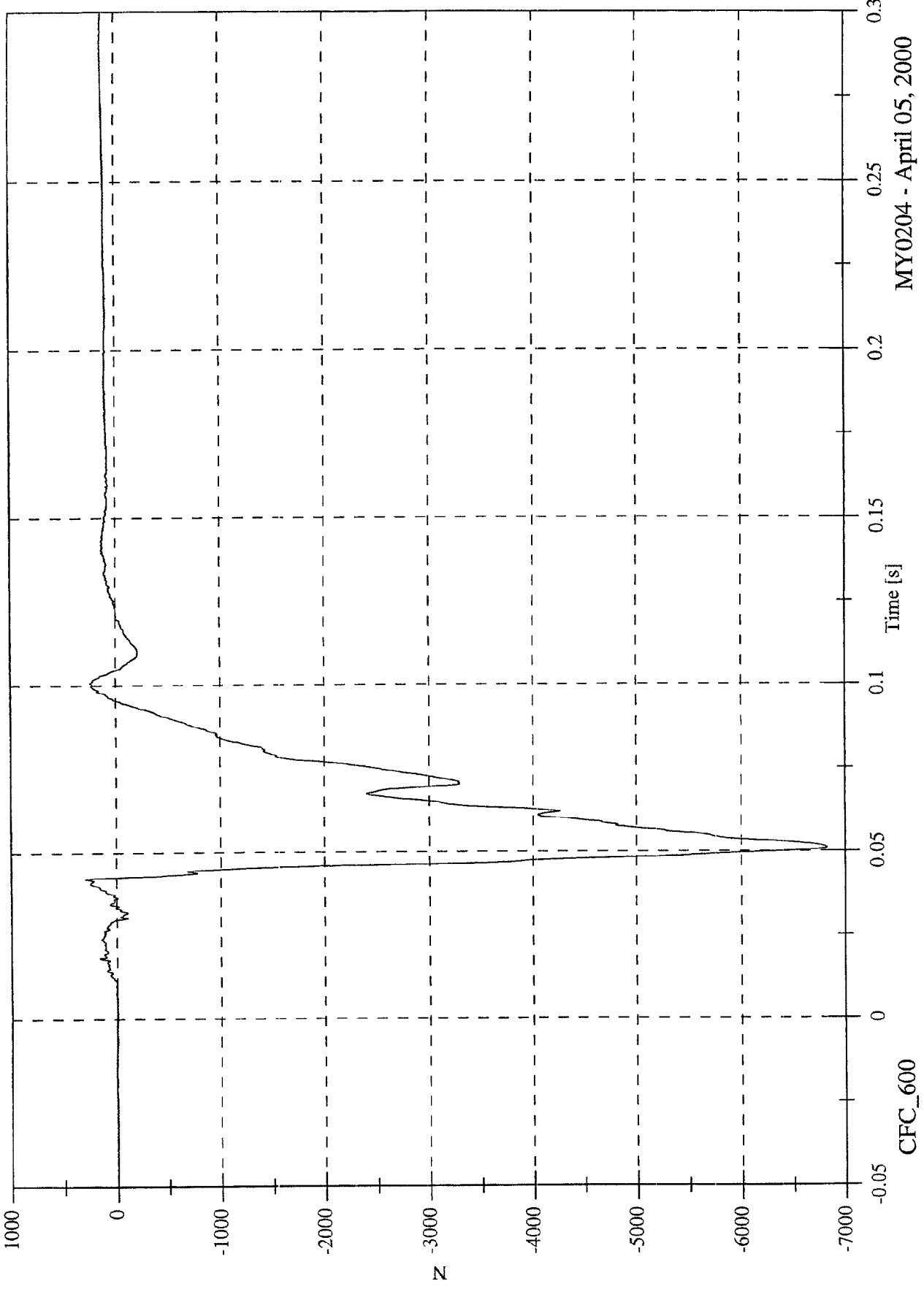

MY0204 - April 05, 2000

Max: 41.4 [N-m] at 0.067 [s]
Min: -14.6 [N-m] at 0.113 [s]

NCAP 2000 Test#17 - 2000 Ford Focus 3-Door
P2 Left Upper Tibia Mx

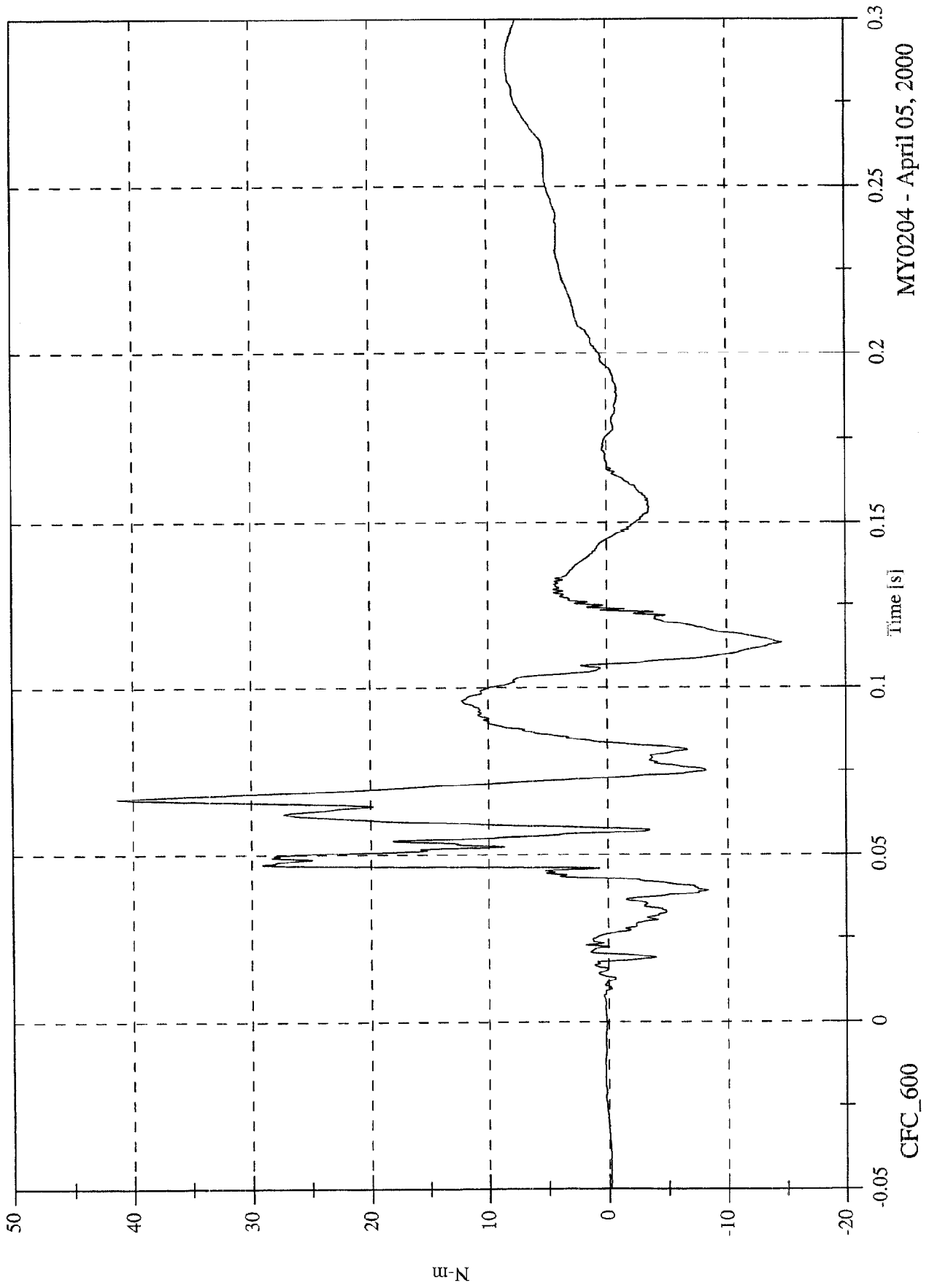

MY0204 - April 05, 2000

NCAP 2000 Test#17 - 2000 Ford Focus 3-Door
P2 Left Upper Tibia My

Max: 7.3 [N-m] at 0.125 [s]
Min: -167.5 [N-m] at 0.063 [s]

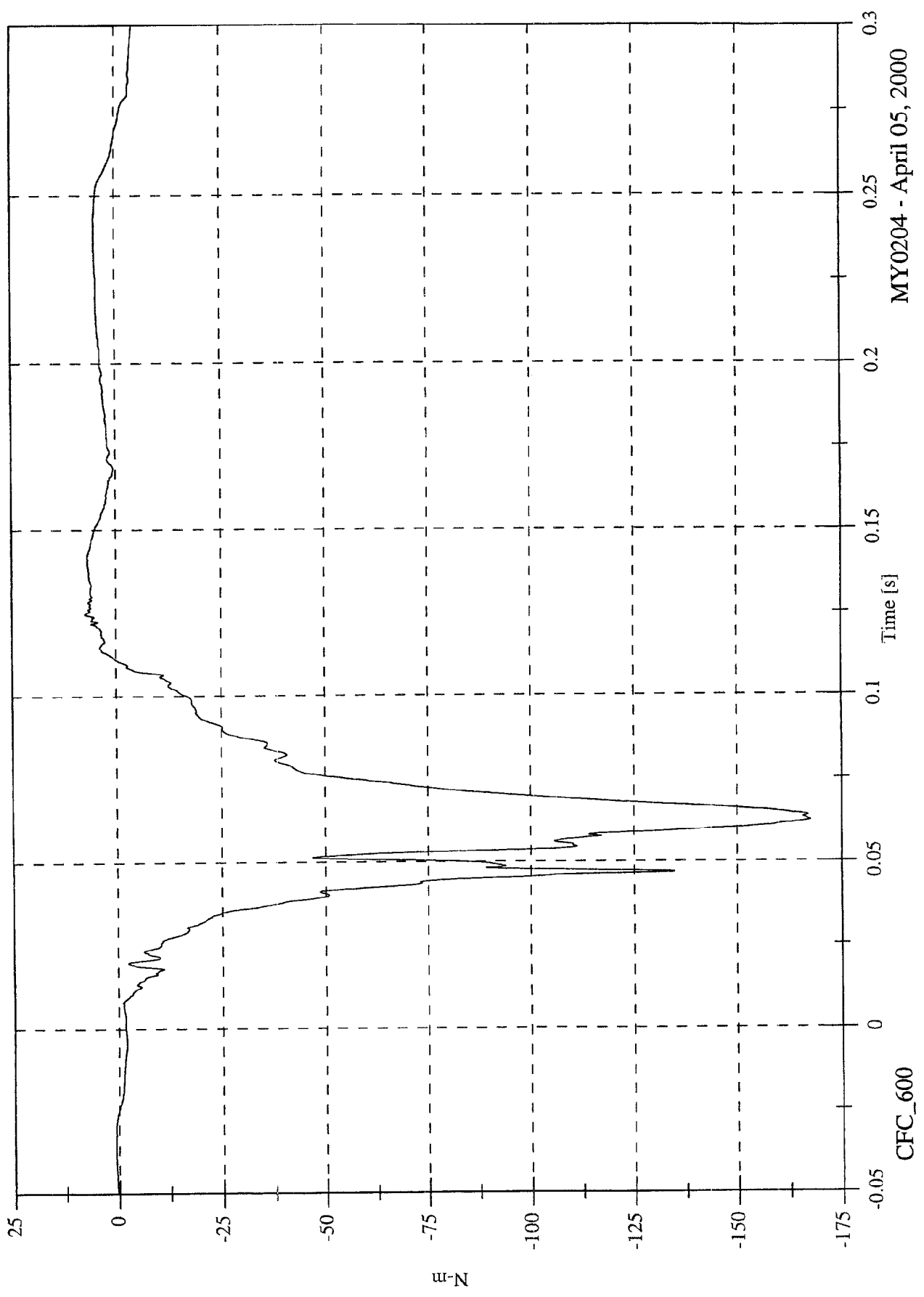

MY0204 - April 05, 2000

NCAP 2000 Test#17 - 2000 Ford Focus 3-Door

Max: 153.5 [N] at 0.123 [s]
Min: -3730.1 [N] at 0.047 [s]

P2 Left Lower Tibia Fz

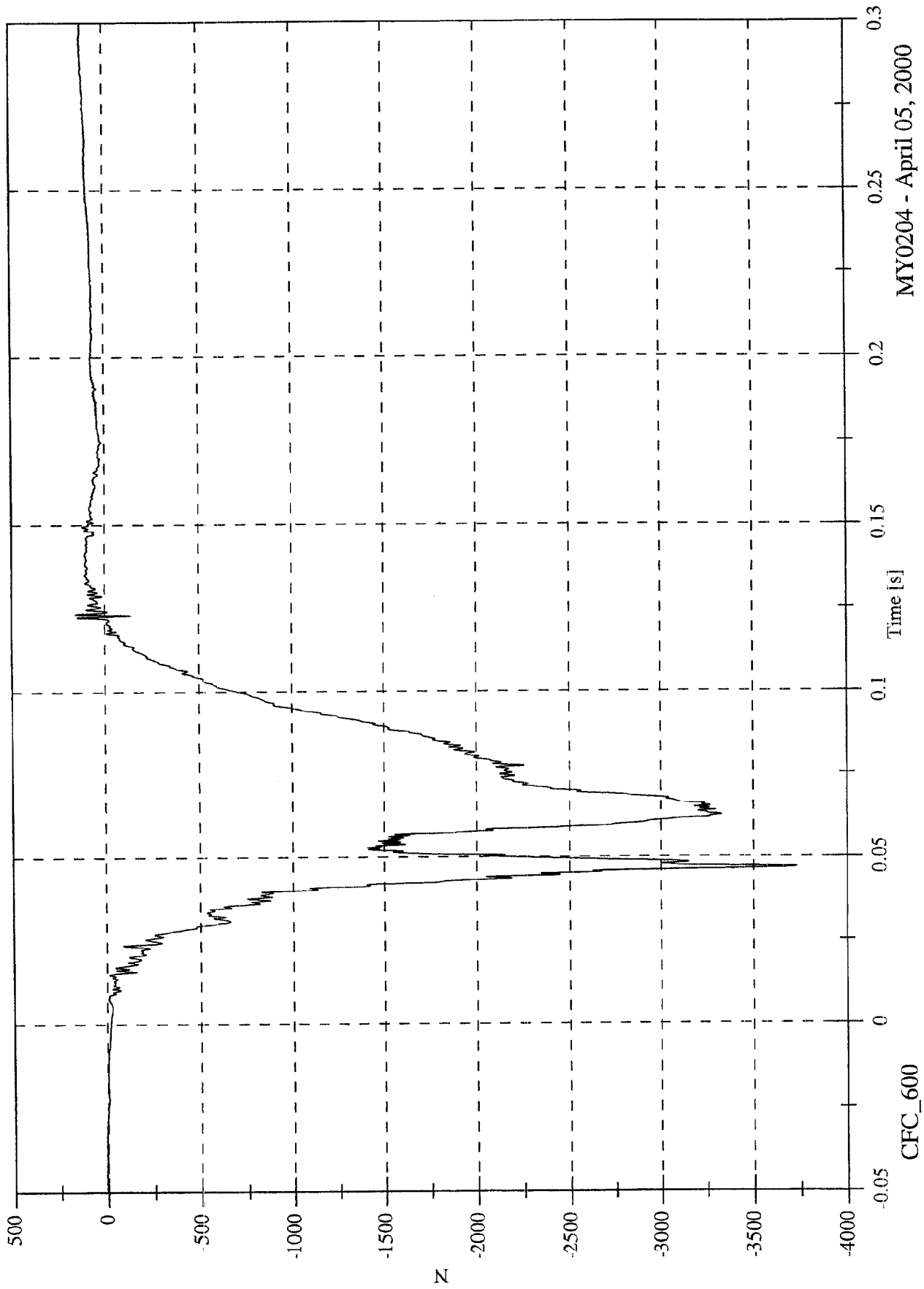

MY0204 - April 05, 2000

Max: 23.4 [N-m] at 0.047 [s]
Min: -34.6 [N-m] at 0.065 [s]

P2 Left Lower Tibia Mx

NCAP 2000 Test#17 - 2000 Ford Focus 3-Door

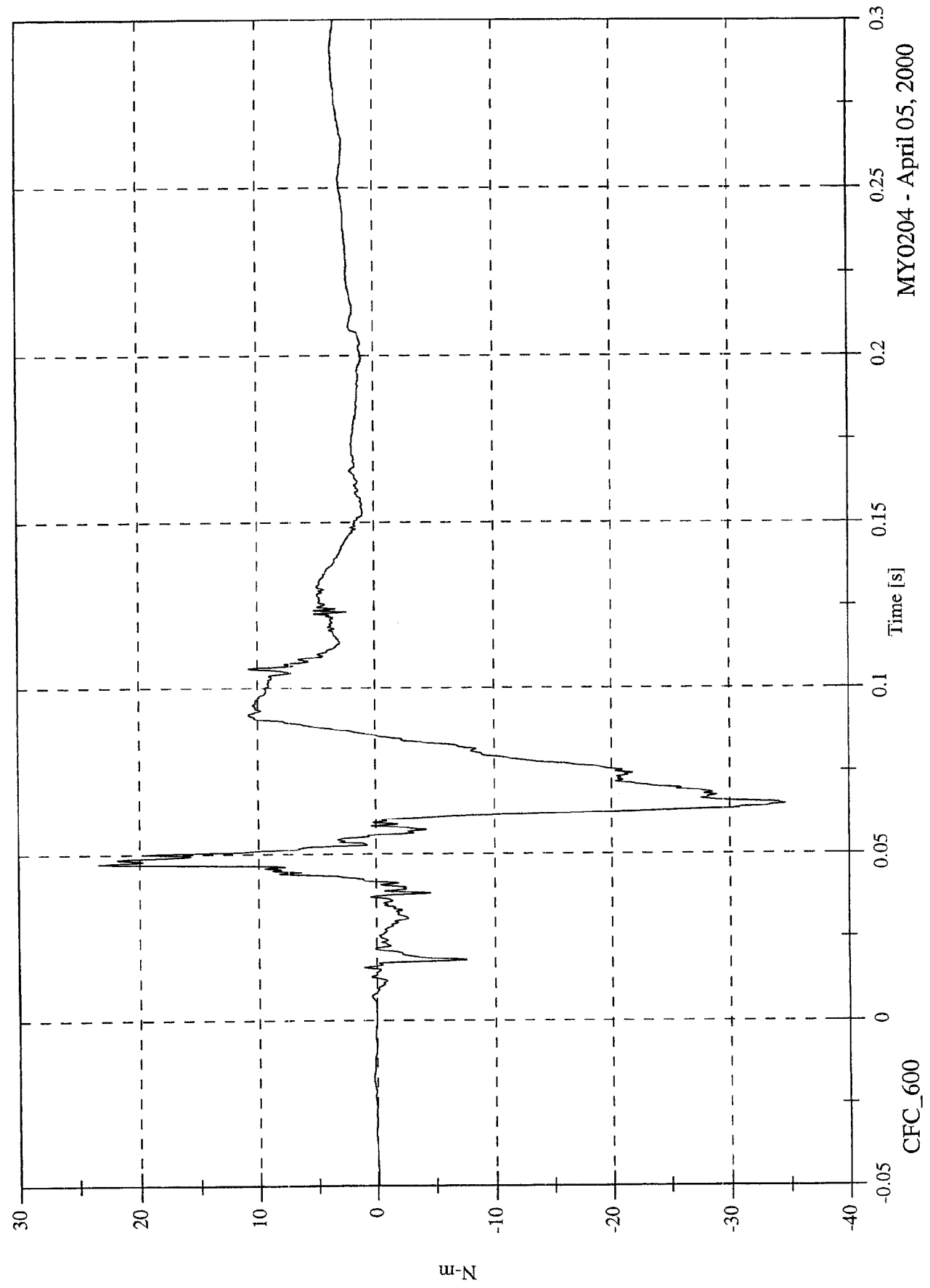

Max: 38.0 [N-m] at 0.076 [s]
Min: -84.8 [N-m] at 0.048 [s]

NCAP 2000 Test#17 - 2000 Ford Focus 3-Door

P2 Left Lower Tibia My

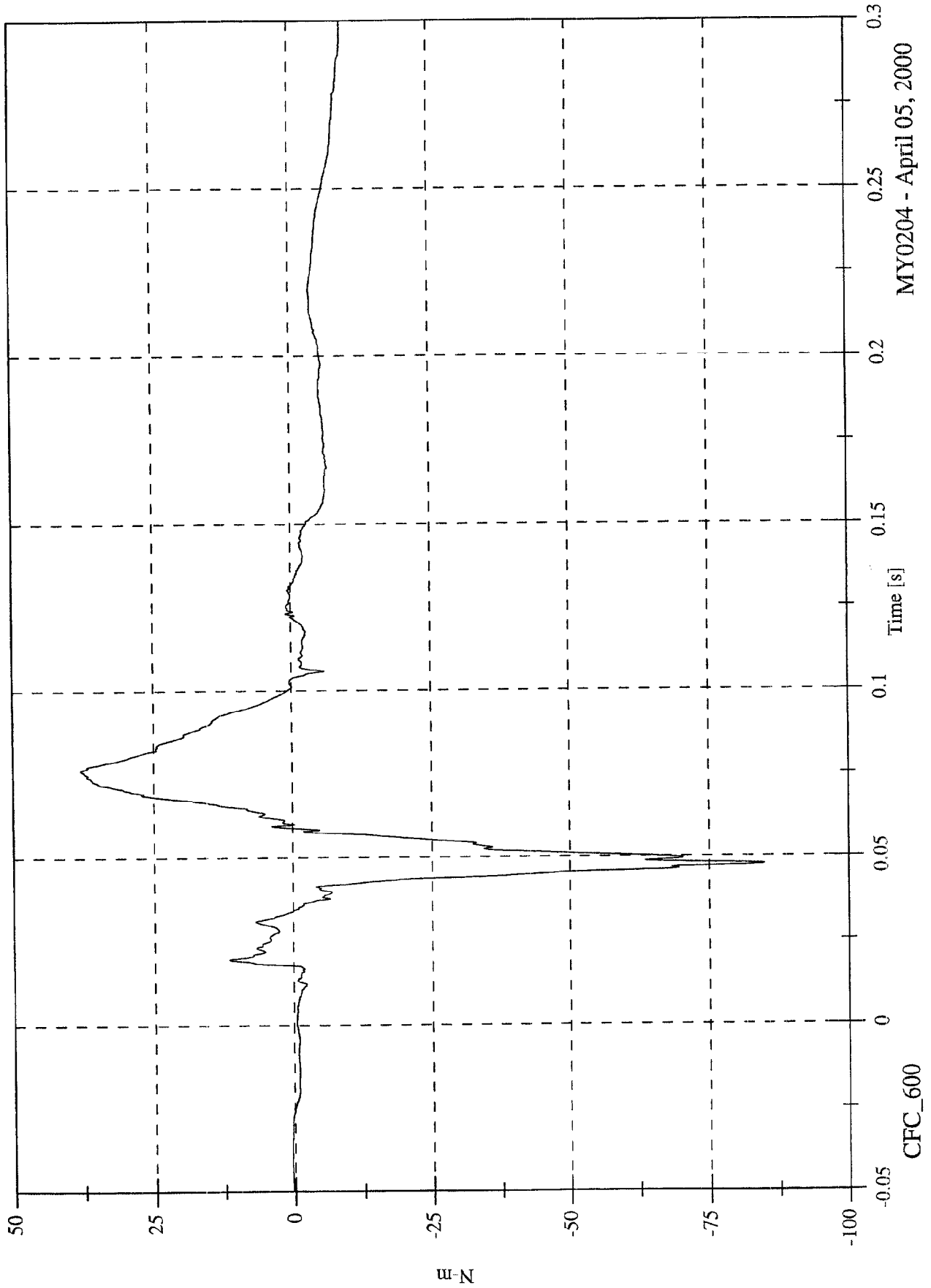

MY0204 - April 05, 2000

CFC_600

Max: 28.3 [N-m] at 0.049 [s]
Min: -22.4 [N-m] at 0.043 [s]

P2 Right Upper Tibia Mx

NCAP 2000 Test#17 - 2000 Ford Focus 3-Door

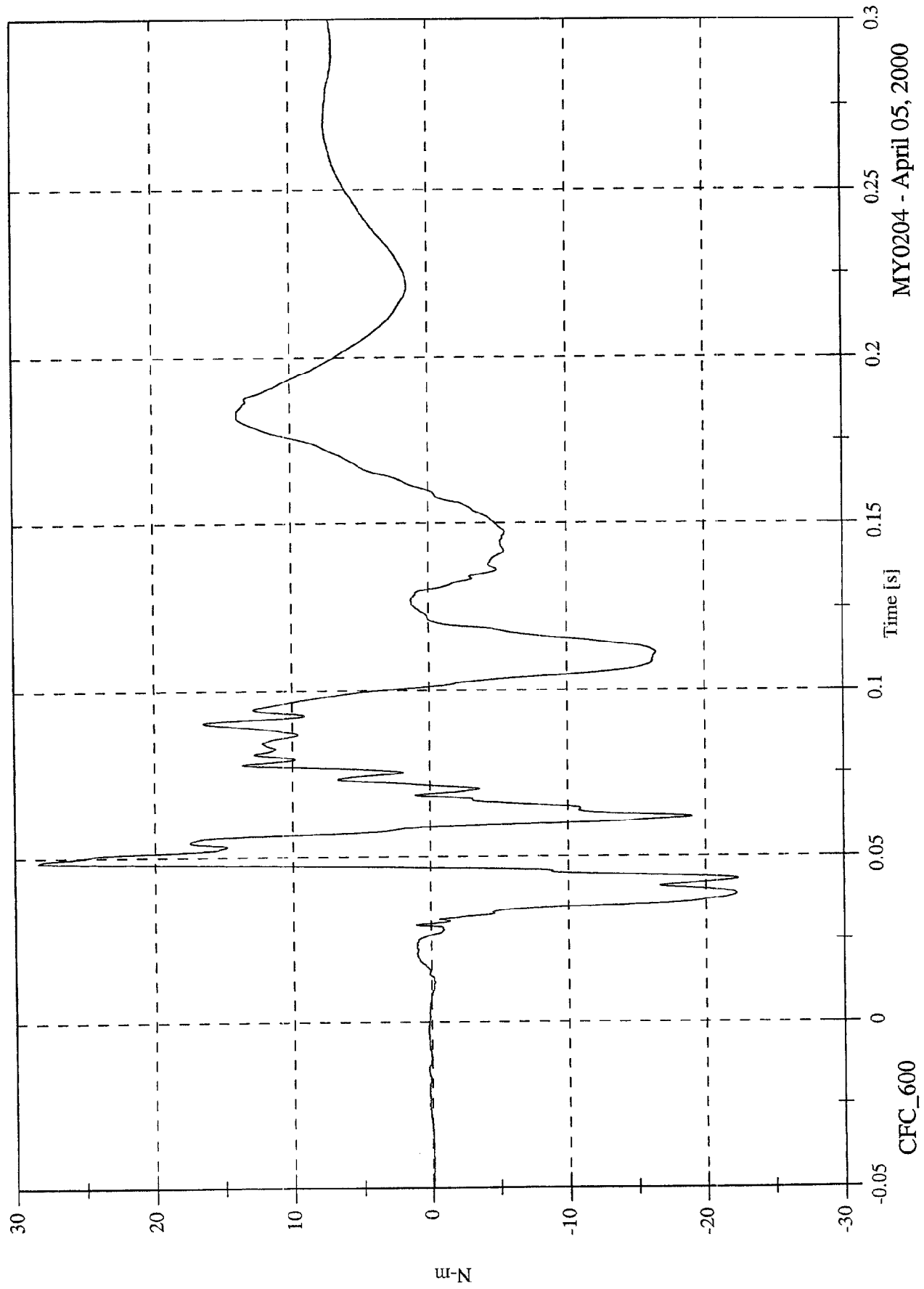

MY0204 - April 05, 2000

NCAP 2000 Test#17 - 2000 Ford Focus 3-Door

Max: 8.2 [N-m] at 0.300 [s]
Min: -207.6 [N-m] at 0.060 [s]

P2 Right Upper Tibia My

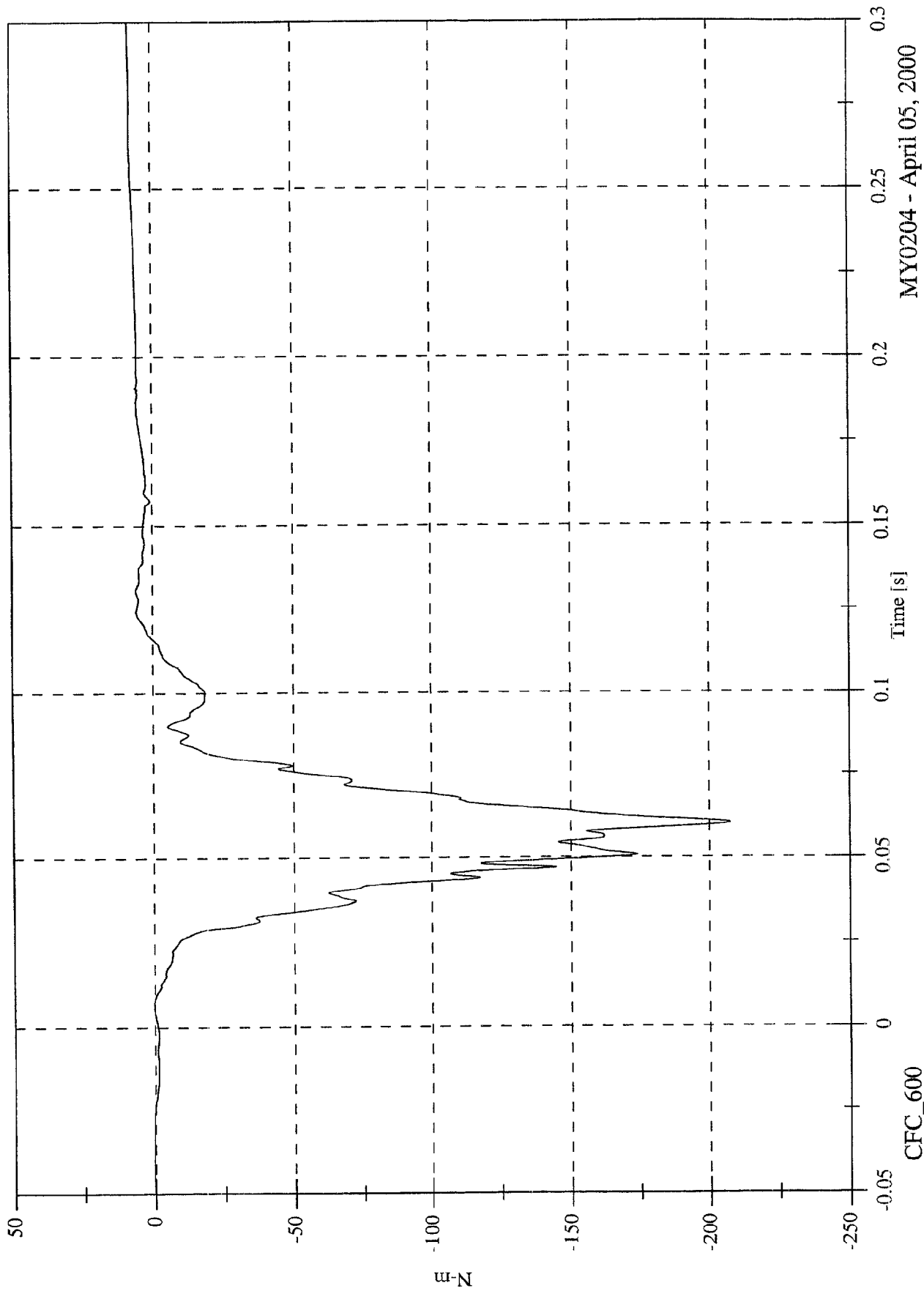

MY0204 - April 05, 2000

NCAP 2000 Test#17 - 2000 Ford Focus 3-Door
P2 Right Lower Tibia Fz

Max: 66.4 [N] at 0.299 [s]
Min: -3456.4 [N] at 0.060 [s]

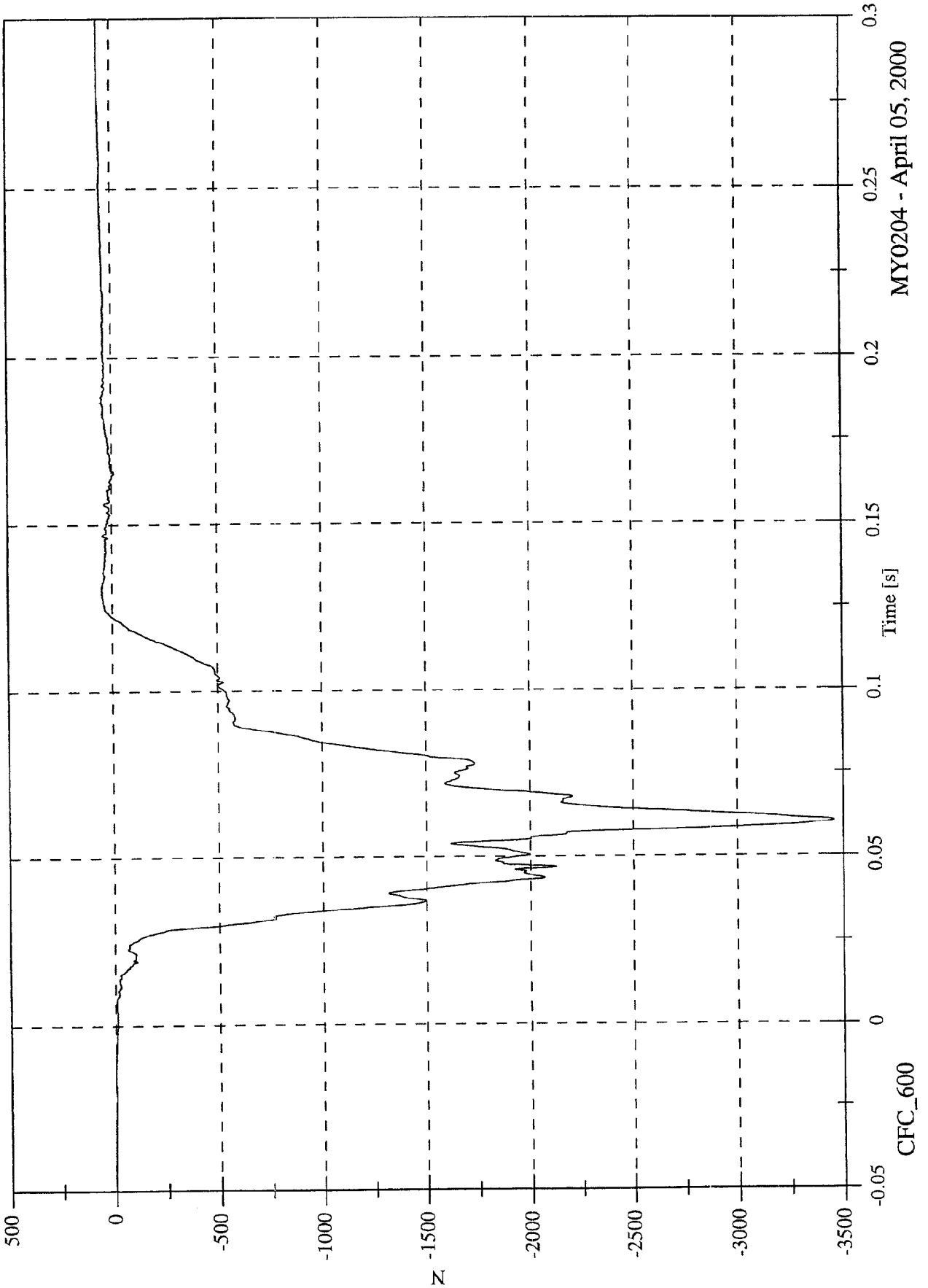

MY0204 - April 05, 2000

Max: 64.5 [N-m] at 0.048 [s]
Min: -10.5 [N-m] at 0.037 [s]

P2 Right Lower Tibia Mx

NCAP 2000 Test#17 - 2000 Ford Focus 3-Door

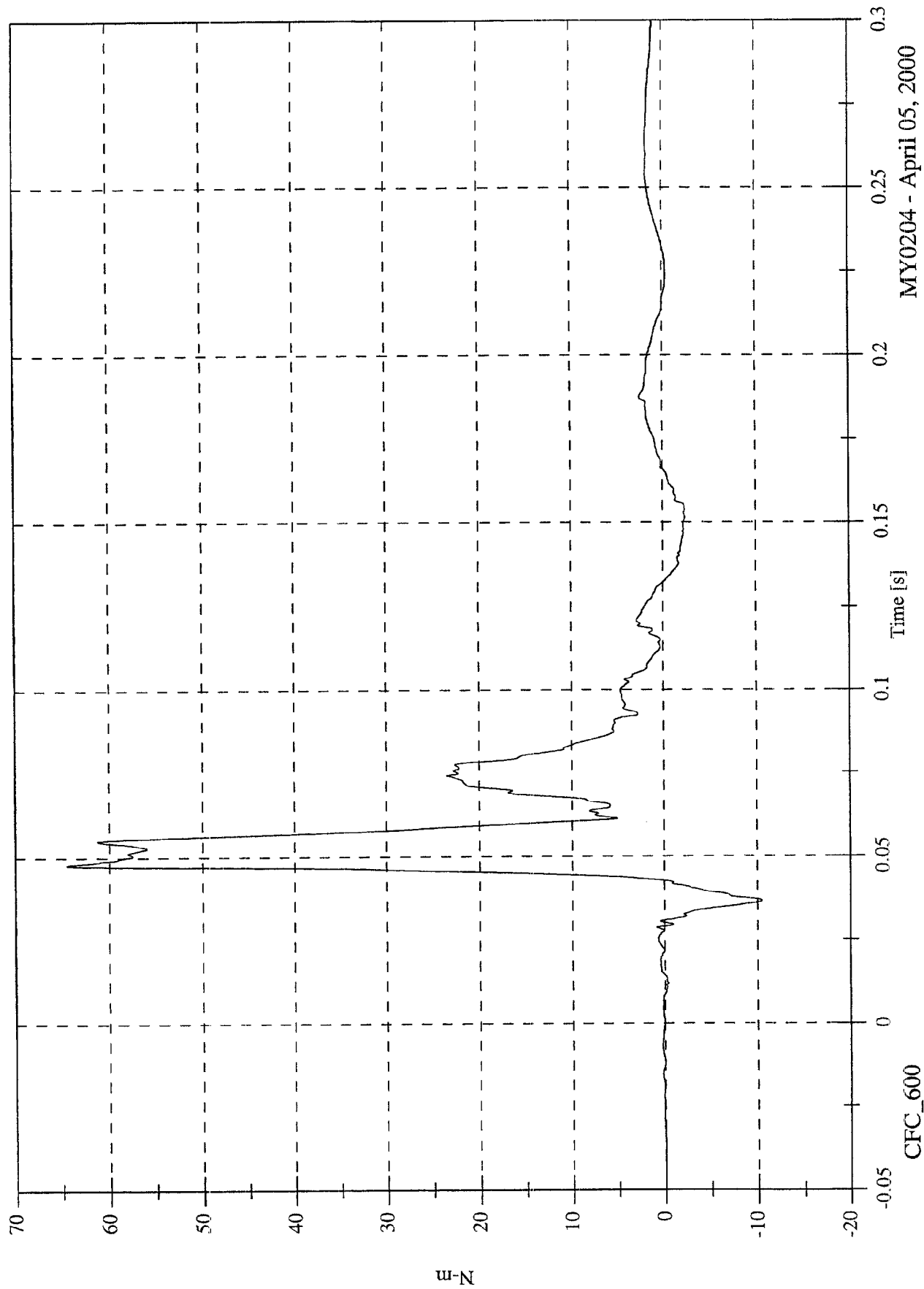

MY0204 - April 05, 2000

Max: 88.5 [N-m] at 0.076 [s]
Min: -35.8 [N-m] at 0.044 [s]

P2 Right Lower Tibia My

NCAP 2000 Test#17 - 2000 Ford Focus 3-Door

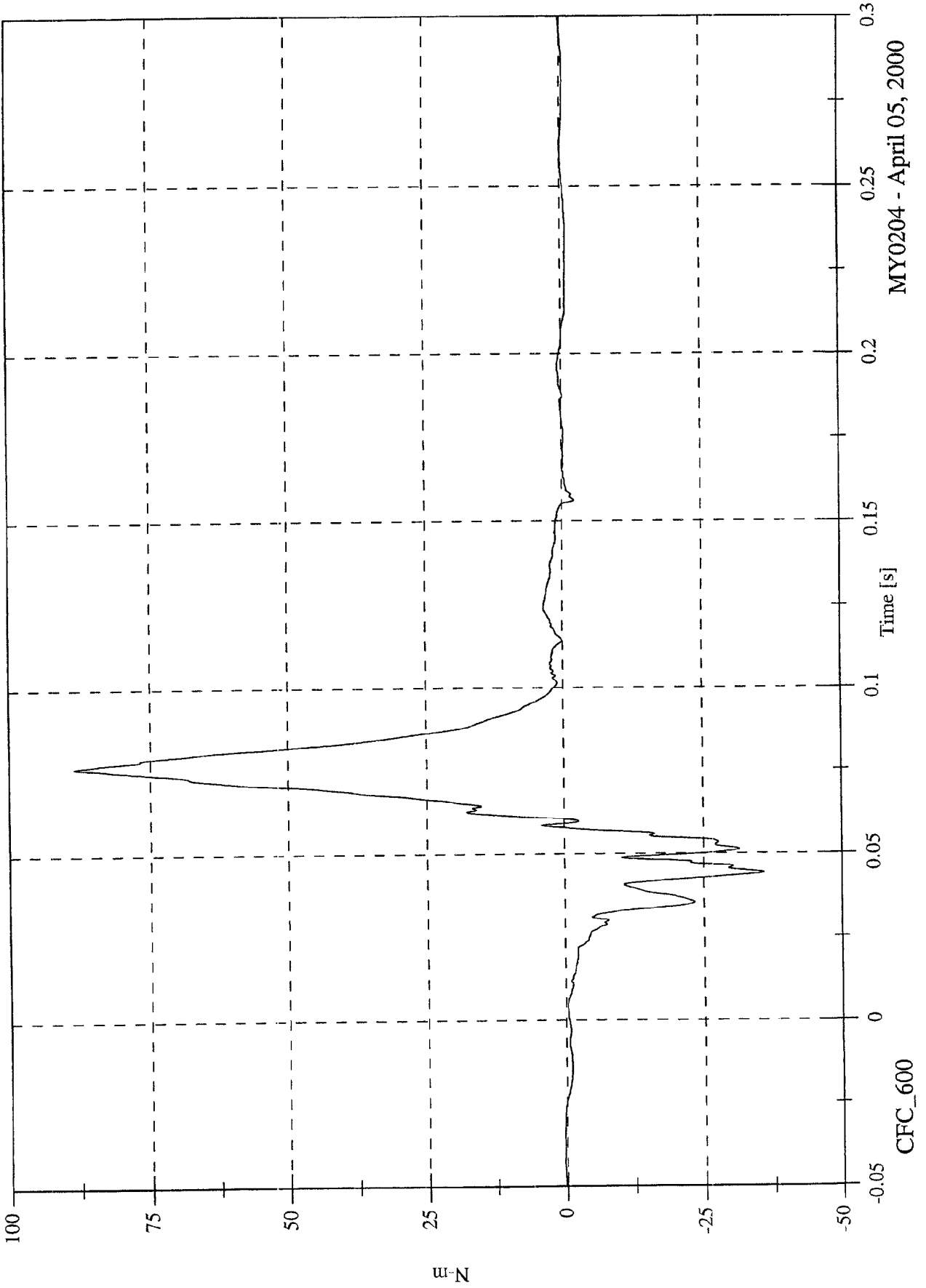

MY0204 - April 05, 2000

NCAP 2000 Test#17 - 2000 Ford Focus 3-Door

Max: 30.3 [g] at 0.069 [s]
Min: -155.7 [g] at 0.047 [s]

P2 Left Foot Aft x

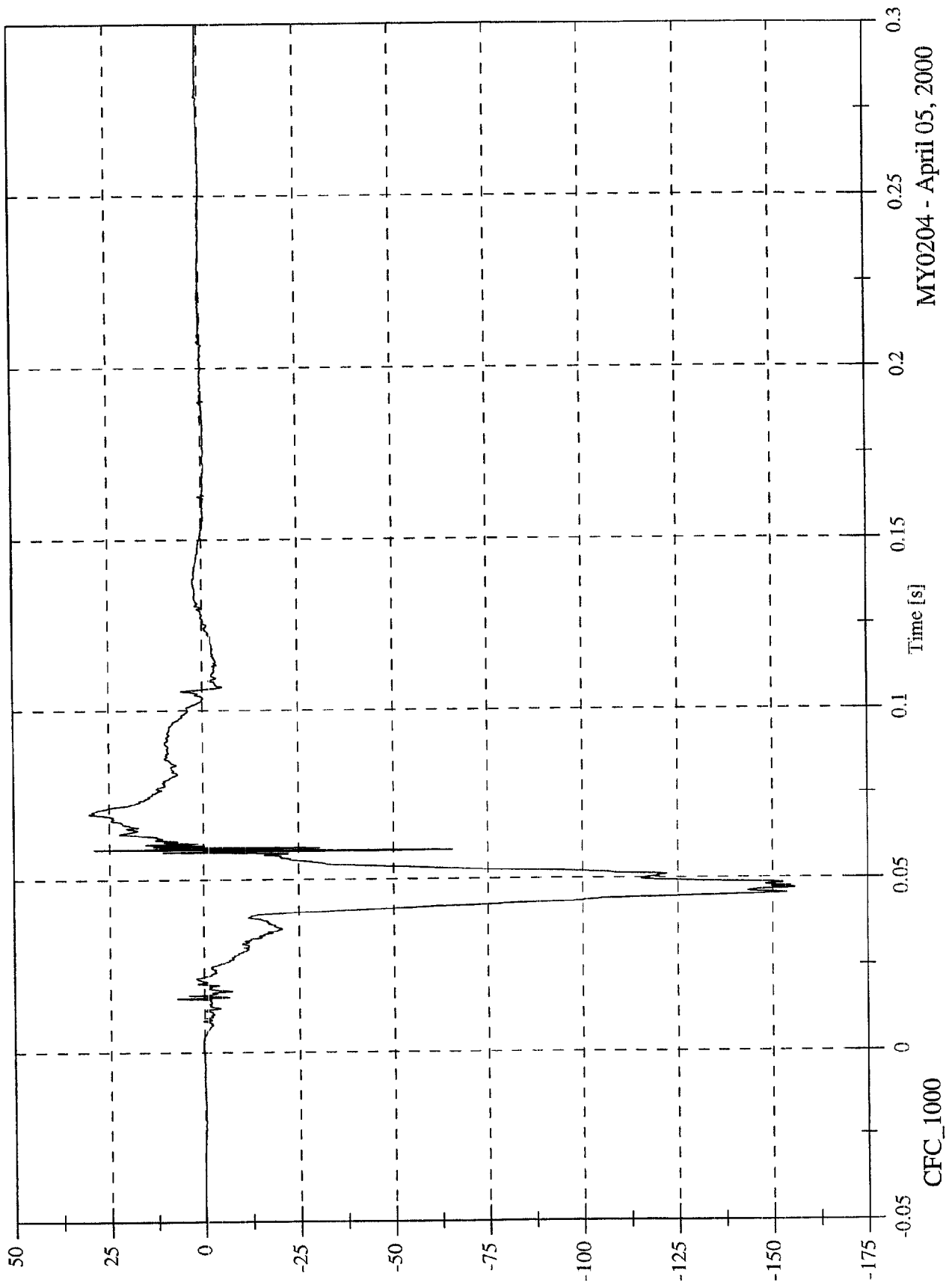

MY0204 - April 05, 2000

NCAP 2000 Test#17 - 2000 Ford Focus 3-Door

Max: 8.8 [g] at 0.059 [s]
Min: -74.2 [g] at 0.048 [s]

P2 Left Foot Aft z

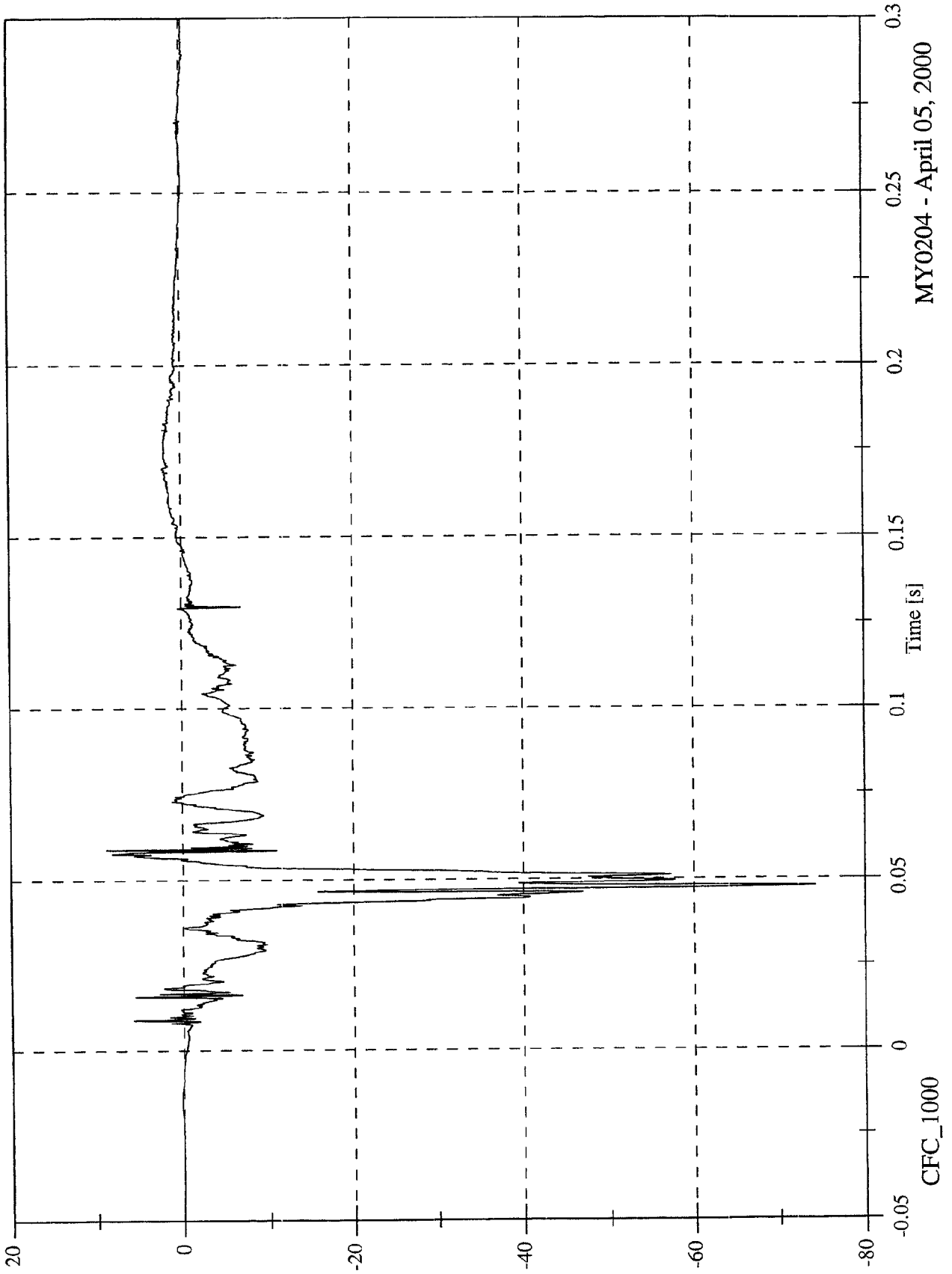

NCAP 2000 Test#17 - 2000 Ford Focus 3-Door

Max: 113.6 [g] at 0.059 [s]
Min: -528.1 [g] at 0.166 [s]

P2 Left Foot Fore z

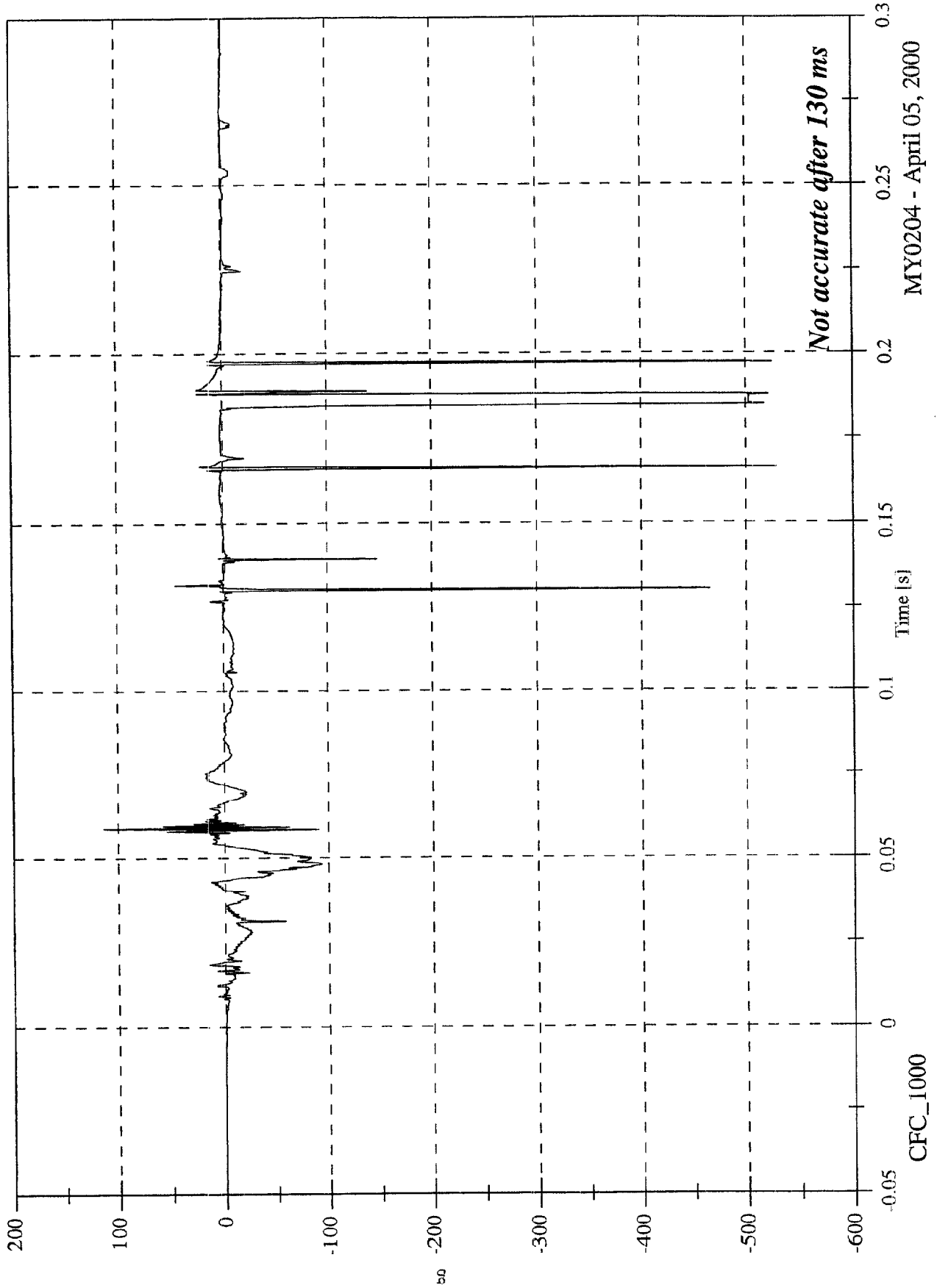

NCAP 2000 Test#17 - 2000 Ford Focus 3-Door

Max: 40.6 [g] at 0.070 [s]
Min: -84.8 [g] at 0.055 [s]

P2 Right Foot Aft x

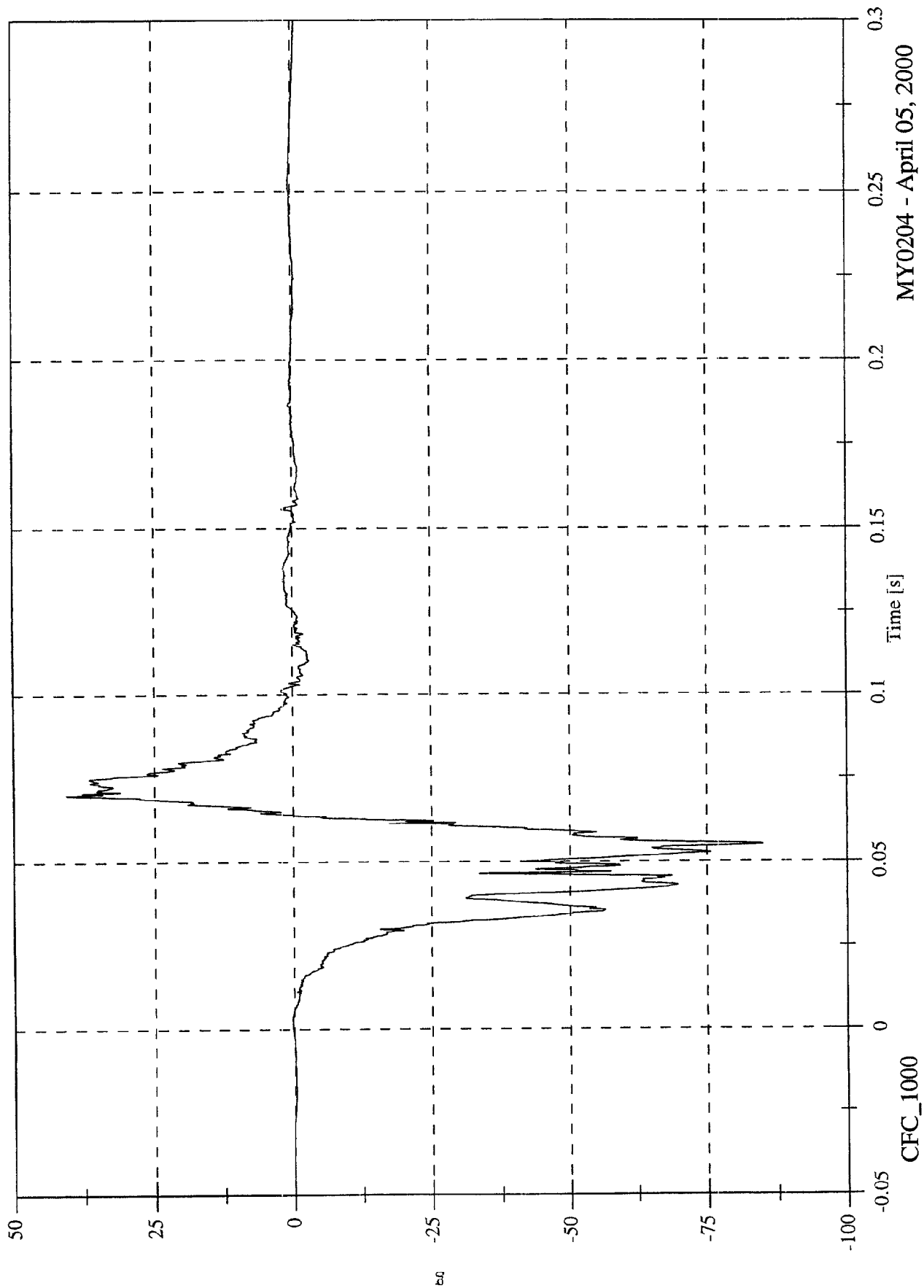

MY0204 - April 05, 2000

NCAP 2000 Test#17 - 2000 Ford Focus 3-Door

Max: 13.3 [g] at 0.069 [s]
Min: -48.7 [g] at 0.059 [s]

P2 Right Foot Aft z

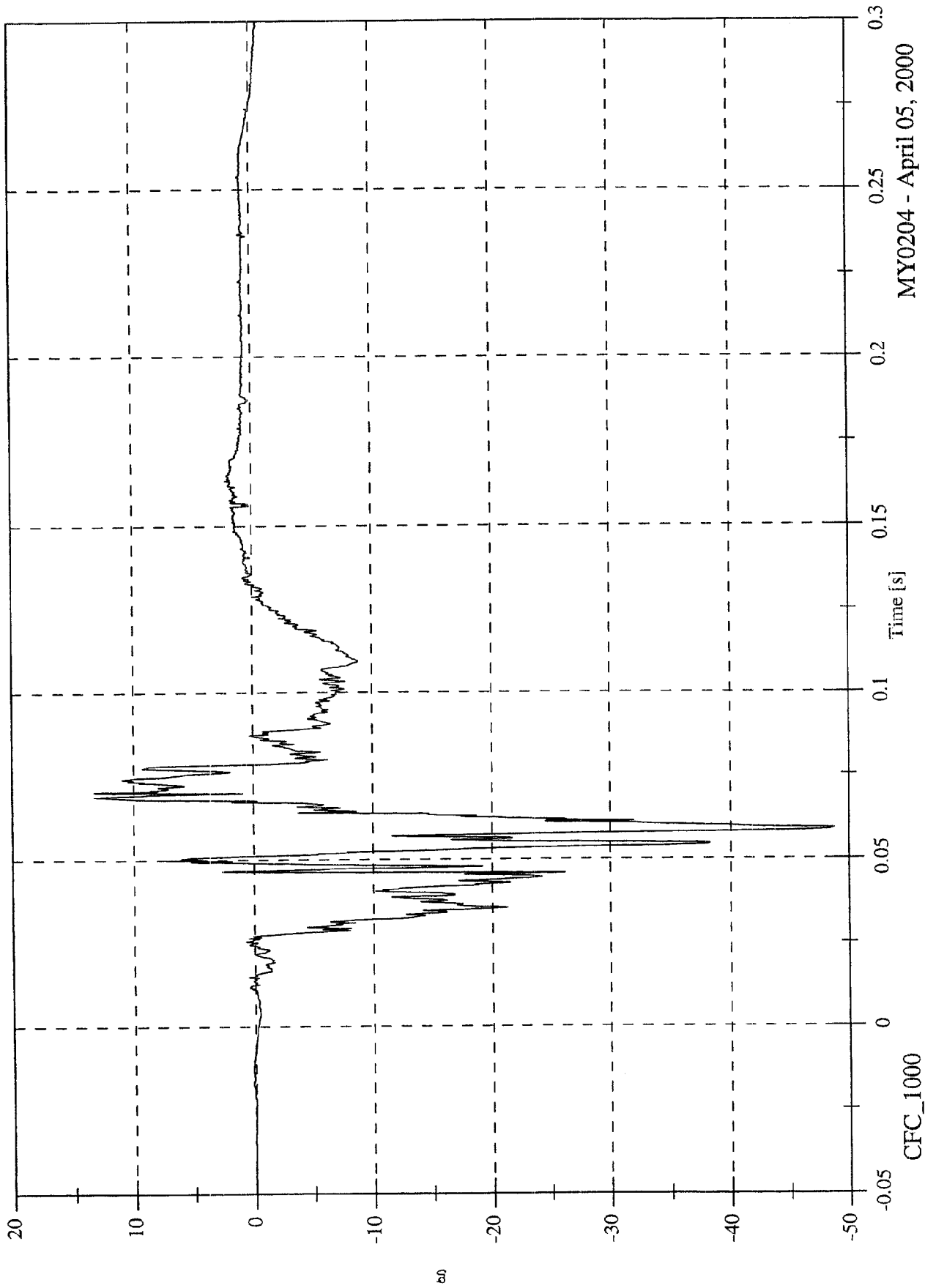

MY0204 - April 05, 2000

NCAP 2000 Test#17 - 2000 Ford Focus 3-Door

Max: 46.0 [g] at 0.070 [s]
Min: -96.0 [g] at 0.058 [s]

P2 Right Foot Fore x

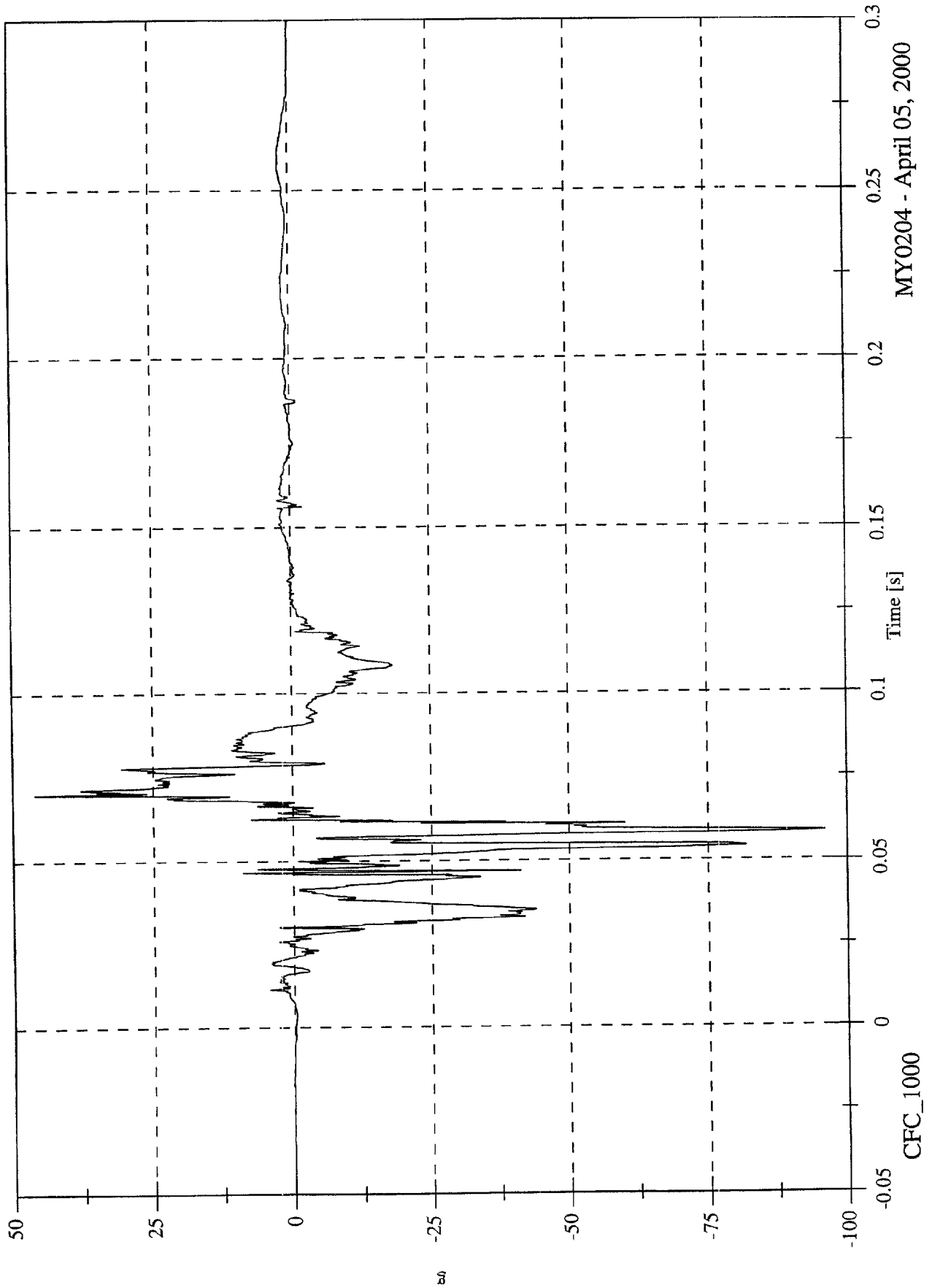

MY0204 - April 05, 2000

NCAP 2000 Test#17 - 2000 Ford Focus 3-Door

Max: 2.5 [g] at 0.175 [s]
Min: -38.9 [g] at 0.044 [s]

Left Rear #1x

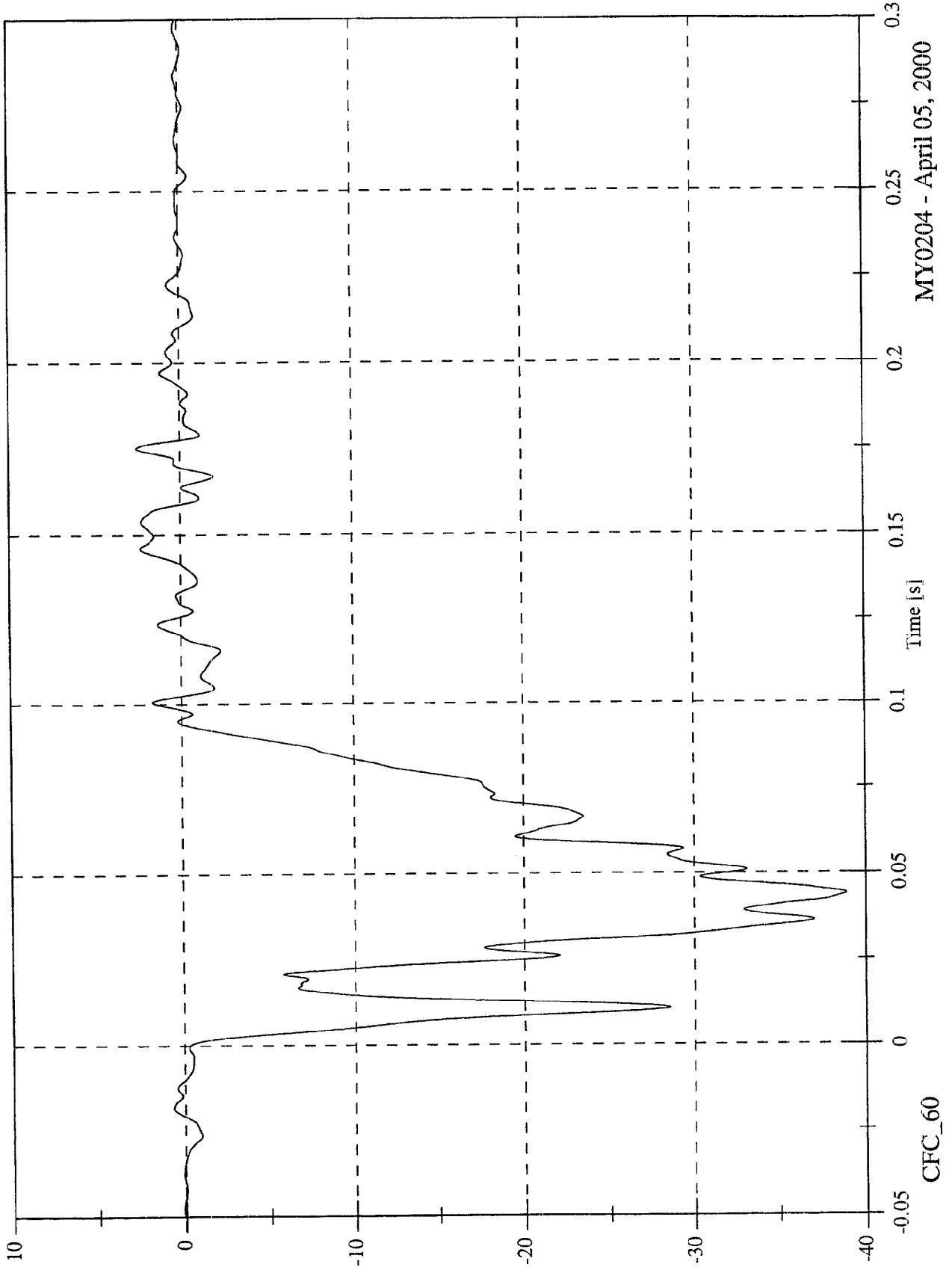

MY0204 - April 05, 2000

NCAP 2000 Test#17 - 2000 Ford Focus 3-Door
Left Rear #1x Velocity

Max: 56.8 [kph] at -0.045 [s]
Min: -9.3 [kph] at 0.142 [s]

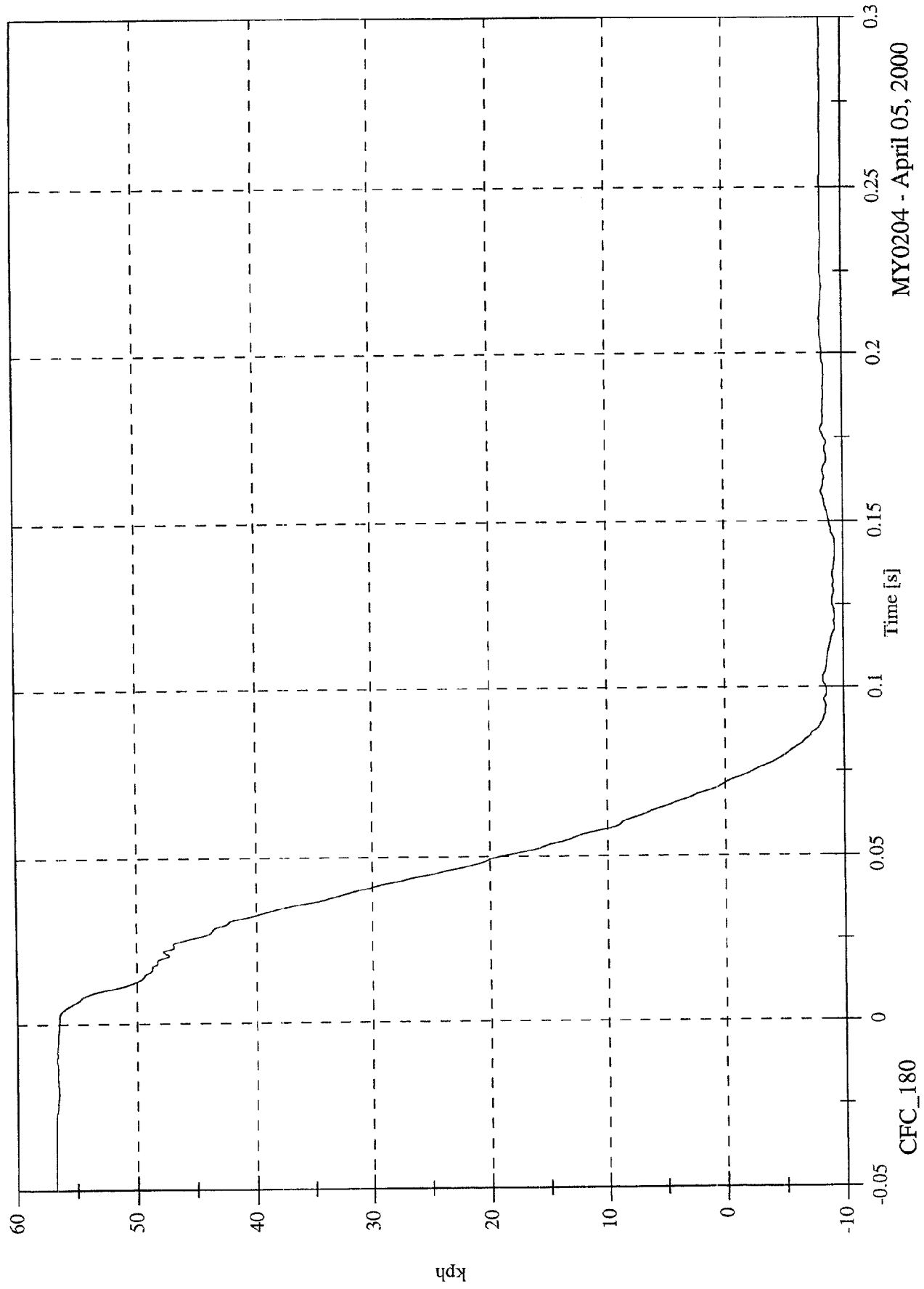

MY0204 - April 05, 2000

NCAP 2000 Test#17 - 2000 Ford Focus 3-Door

Max: 641.7 [mm] at 0.071 [s]
Min: -786.9 [mm] at -0.050 [s]

Left Rear #1x Displacement

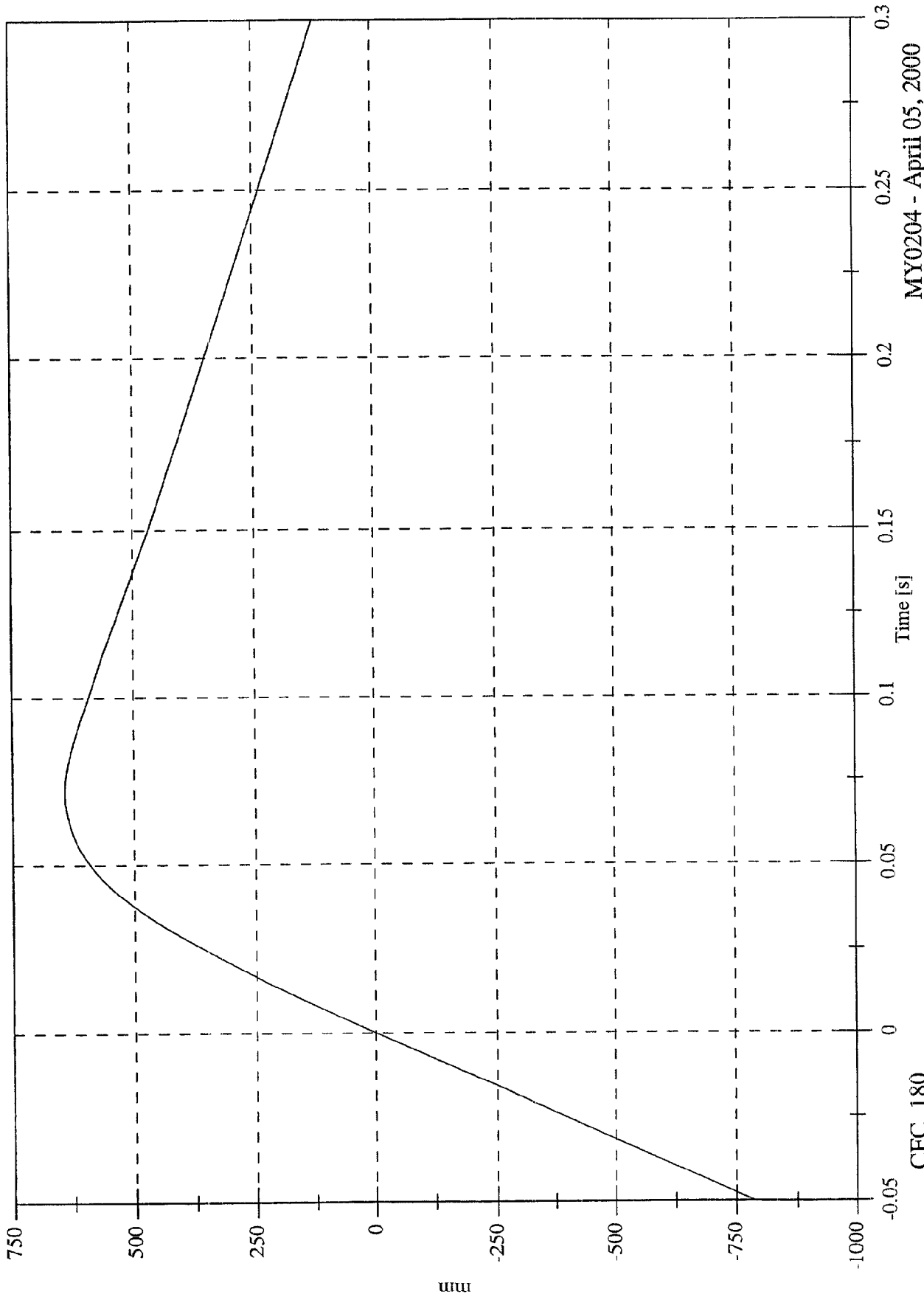

MY0204 - April 05, 2000

CFC_180

NCAP 2000 Test#17 - 2000 Ford Focus 3-Door

Max: 2.6 [g] at 0.154 [s]
Min: -41.2 [g] at 0.037 [s]

Right Rear #2x

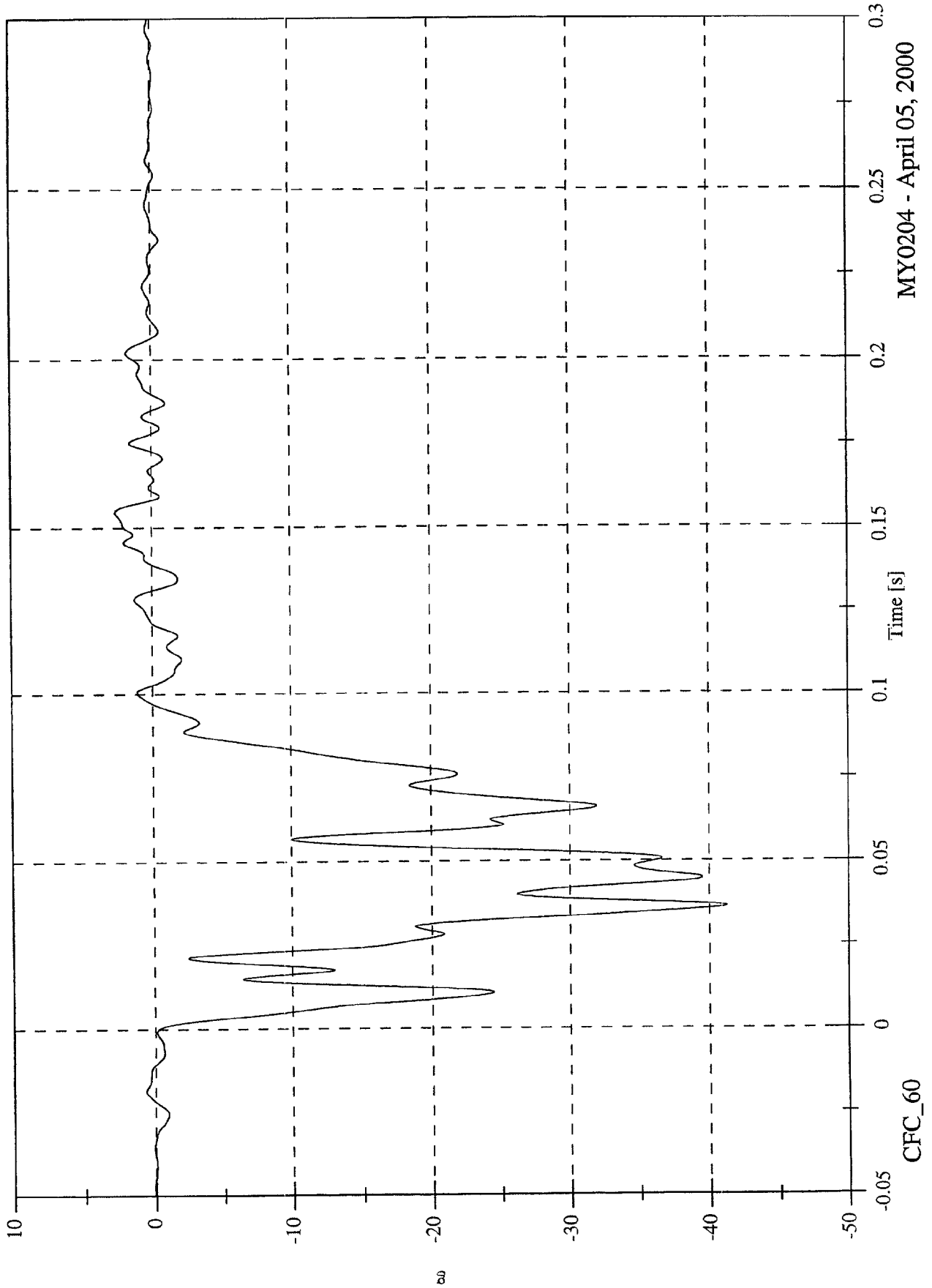

MY0204 - April 05, 2000

Max: 56.7 [kph] at -0.045 [s]
Min: -7.6 [kph] at 0.138 [s]

NCAP 2000 Test#17 - 2000 Ford Focus 3-Door
Right Rear #2x Velocity

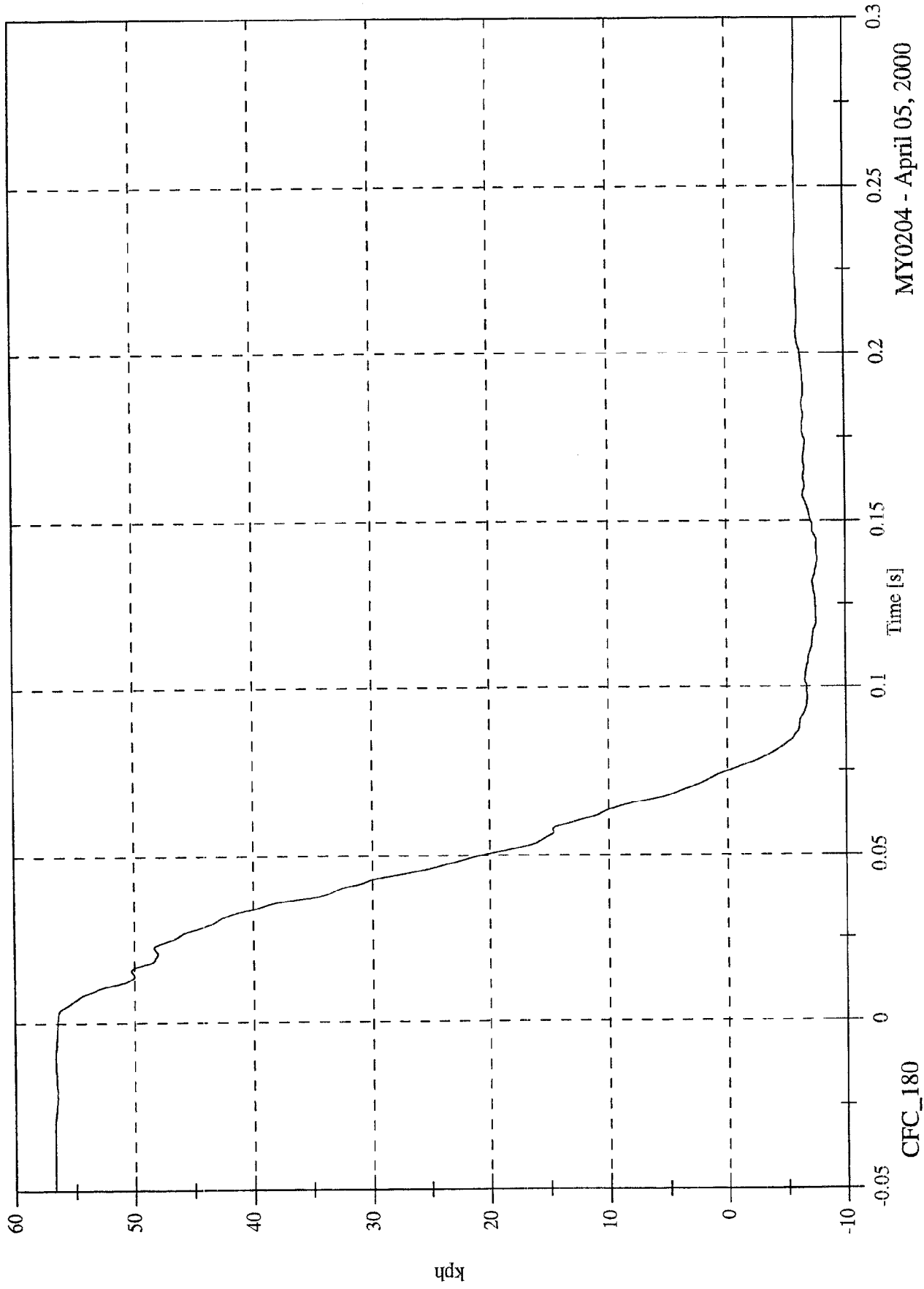

MY0204 - April 05, 2000

CFC_180

NCAP 2000 Test#17 - 2000 Ford Focus 3-Door
Right Rear #2x Displacement

Max: 672.5 [mm] at 0.075 [s]
Min: -786.5 [mm] at -0.050 [s]

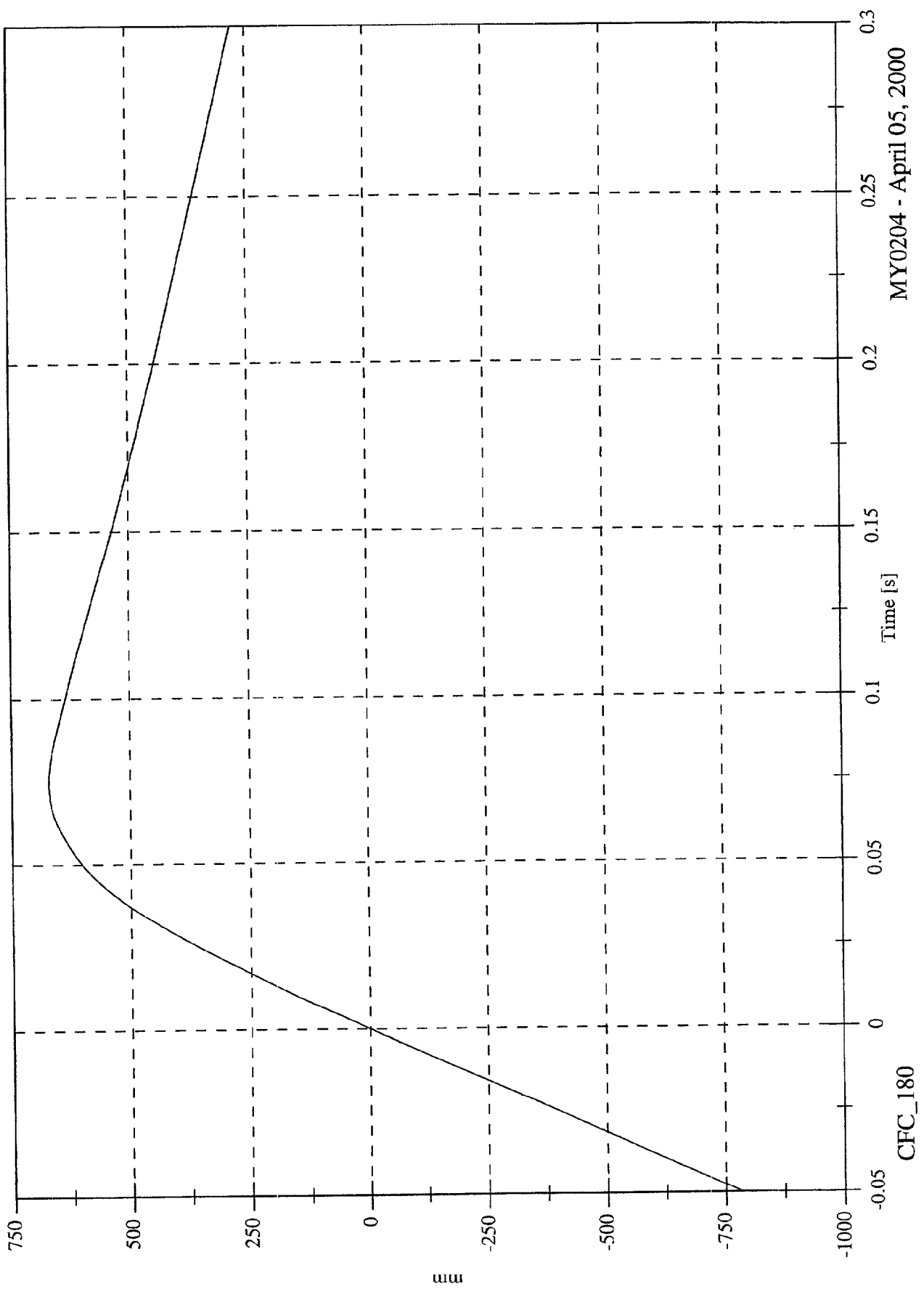

MY0204 - April 05, 2000

NCAP 2000 Test#17 - 2000 Ford Focus 3-Door

Max: 29.4 [g] at 0.047 [s]
Min: -123.3 [g] at 0.031 [s]

Engine Top #3x

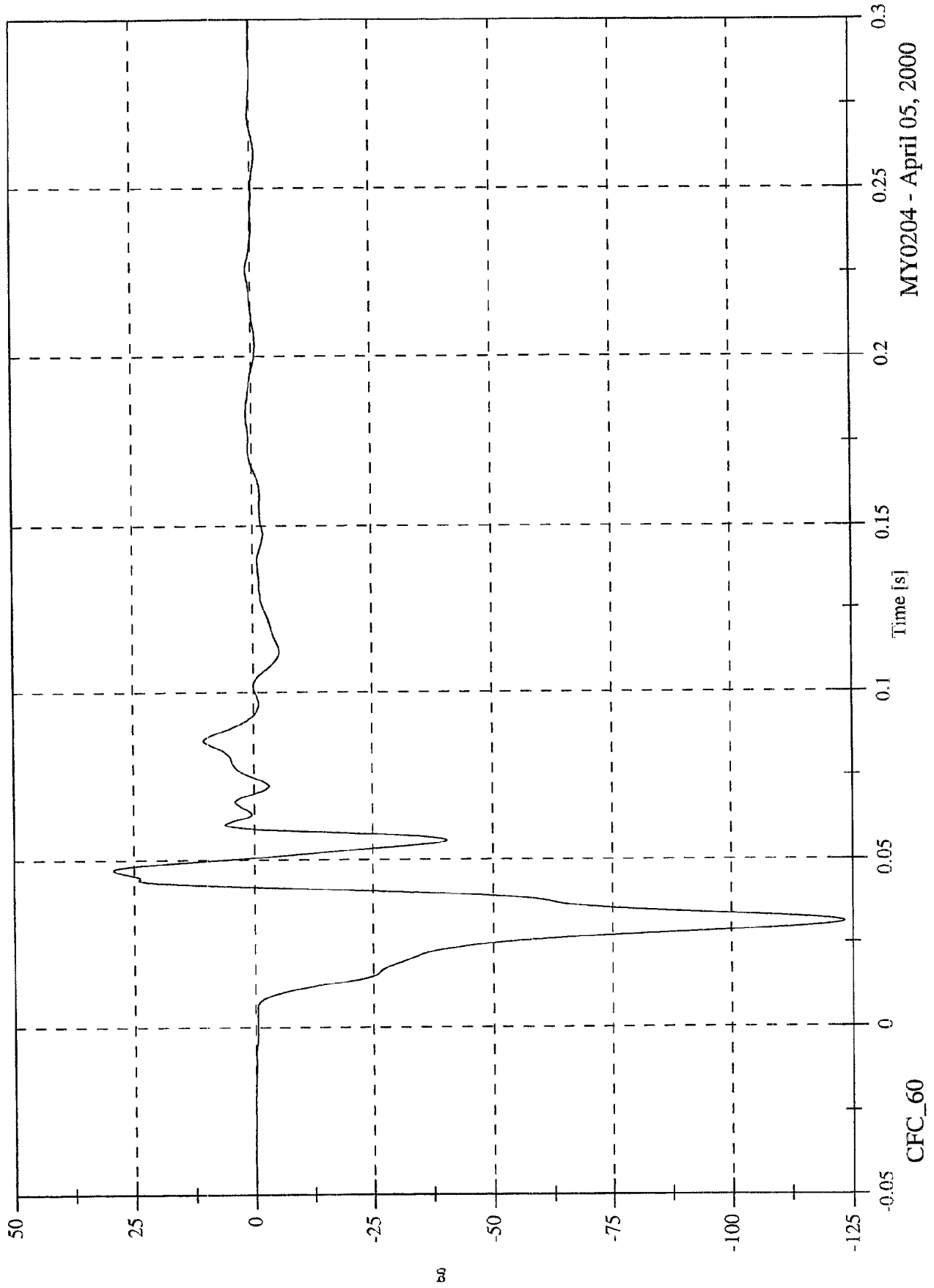

MY0204 - April 05, 2000

Max: 56.7 [kph] at -0.017 [s]
Min: -6.0 [kph] at 0.058 [s]

NCAP 2000 Test#17 - 2000 Ford Focus 3-Door
Engine Top #3x Velocity

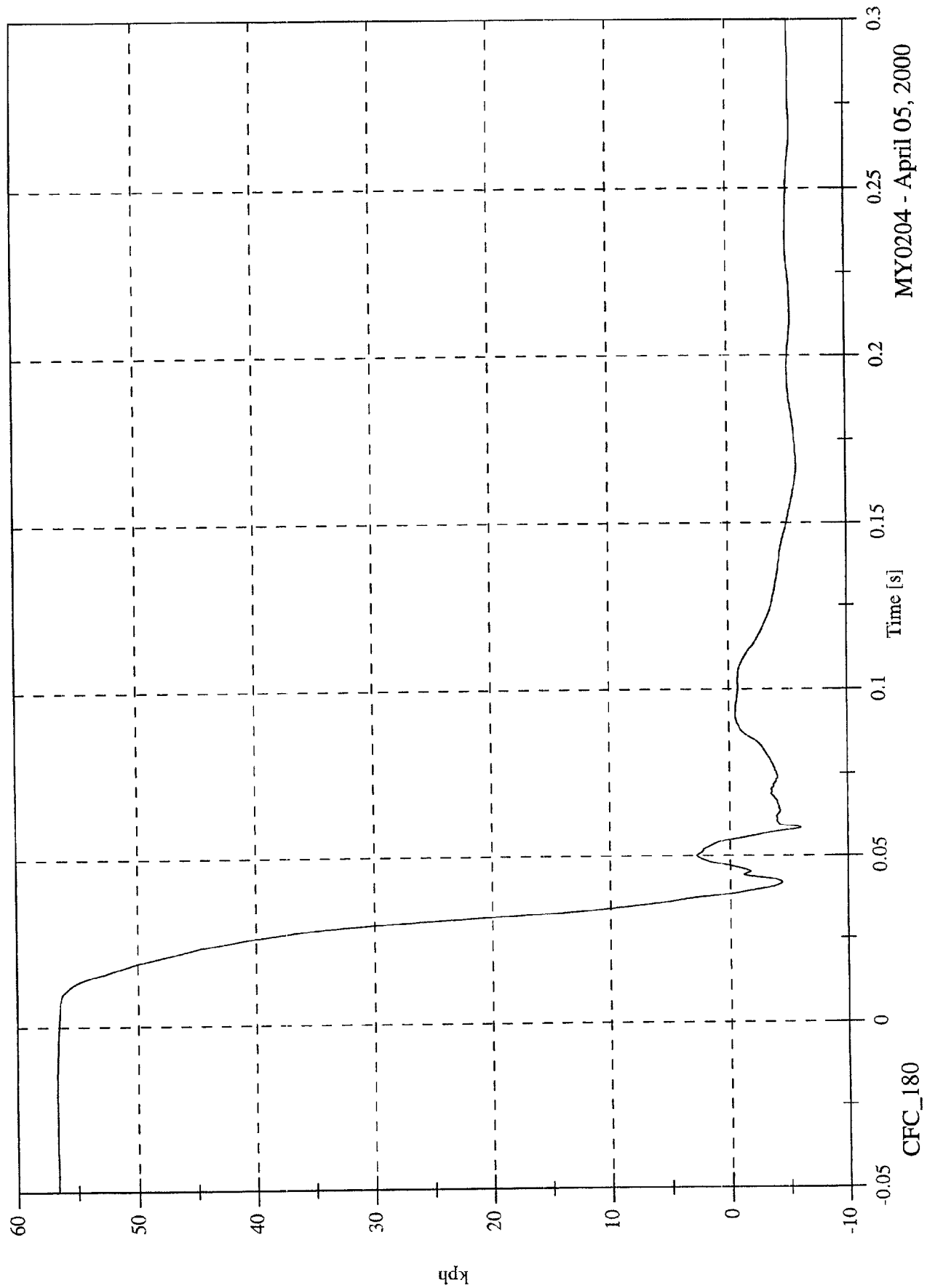

MY0204 - April 05, 2000

Max: 443.7 [mm] at 0.038 [s]
Min: -786.7 [mm] at -0.050 [s]

Engine Top #3x Displacement

NCAP 2000 Test#17 - 2000 Ford Focus 3-Door

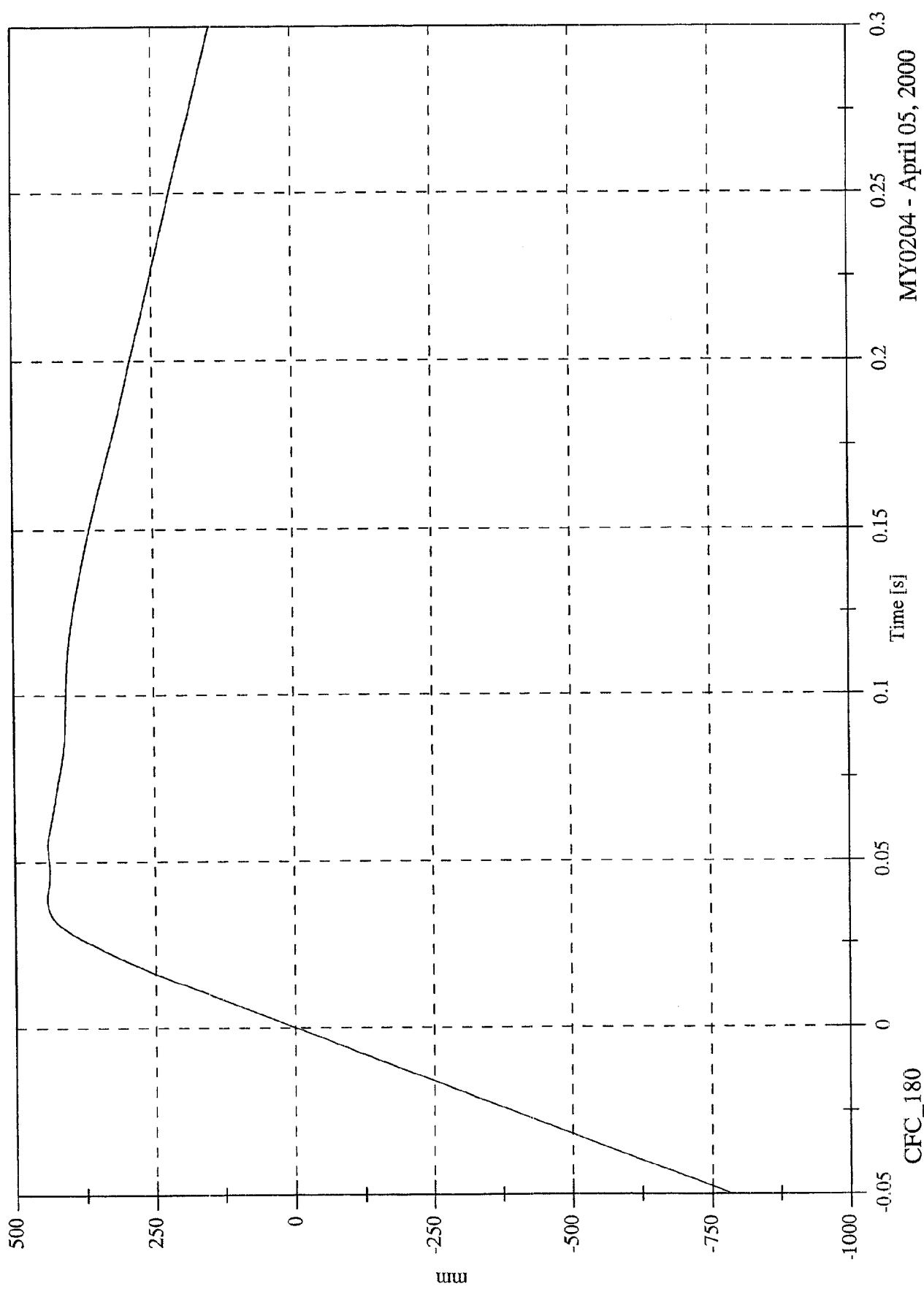

CFC_180
MY0204 - April 05, 2000

NCAP 2000 Test#17 - 2000 Ford Focus 3-Door

Engine Bottom #4x

Max: 21.9 [g] at 0.042 [s]
Min: -101.6 [g] at 0.025 [s]

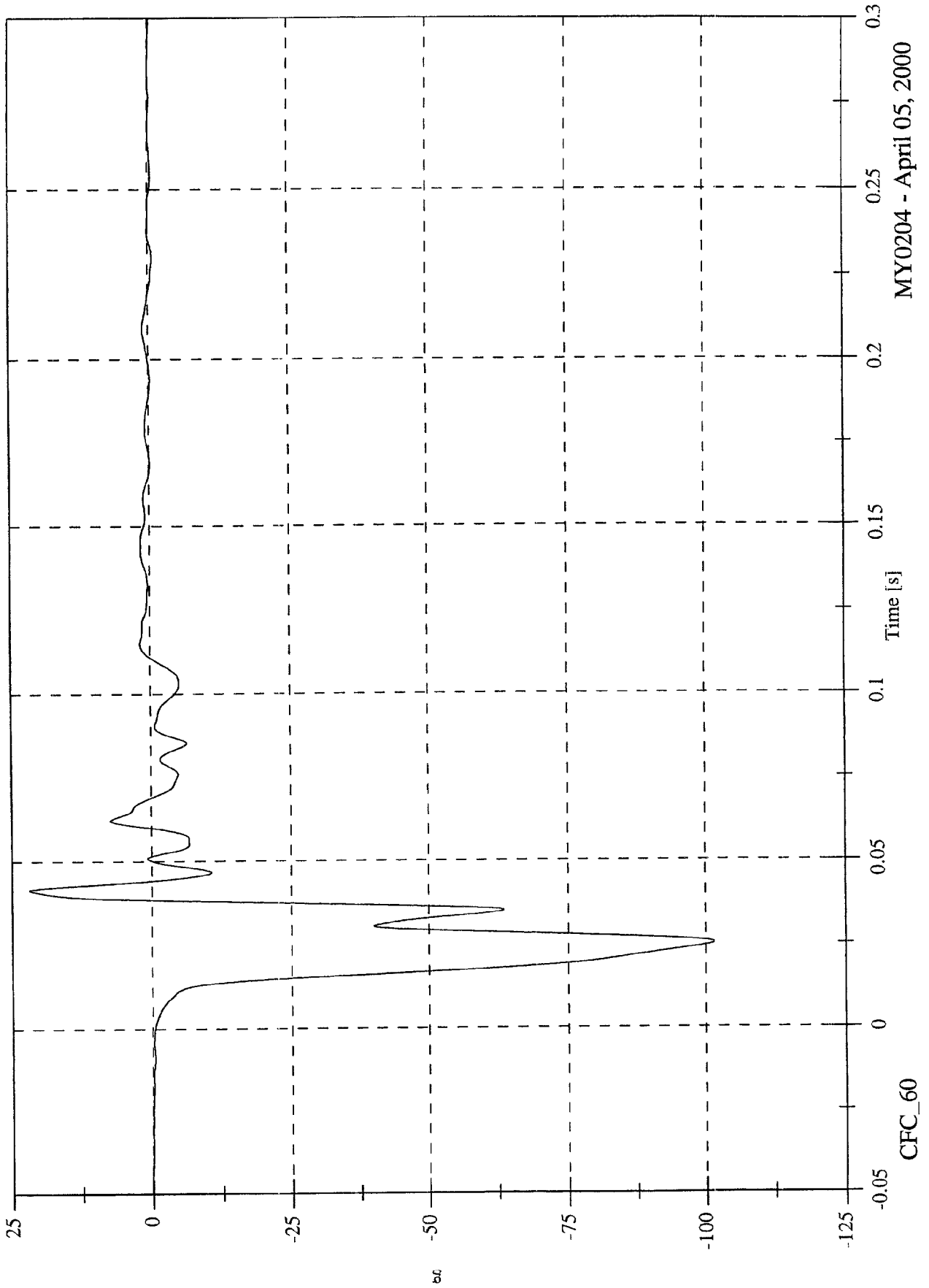

MY0204 - April 05, 2000

Max: 56.8 [kph] at -0.042 [s]
Min: -1.7 [kph] at 0.110 [s]

NCAP 2000 Test#17 - 2000 Ford Focus 3-Door
Engine Bottom #4x Velocity

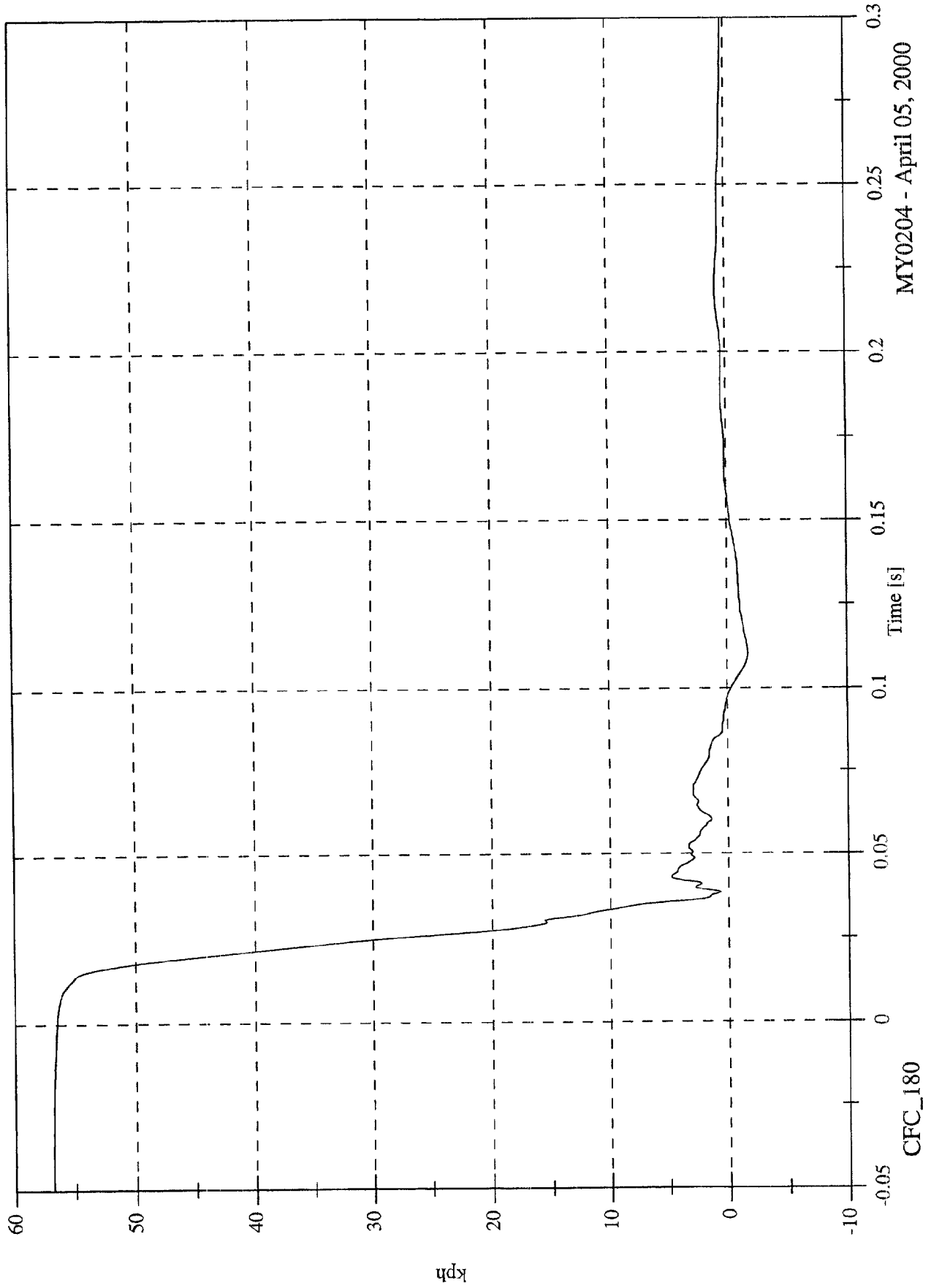

MY0204 - April 05, 2000

CFC_180

NCAP 2000 Test#17 - 2000 Ford Focus 3-Door

Max: 437.3 [mm] at 0.300 [s]

Engine Bottom #4x Displacement

Min: -788.1 [mm] at -0.050 [s]

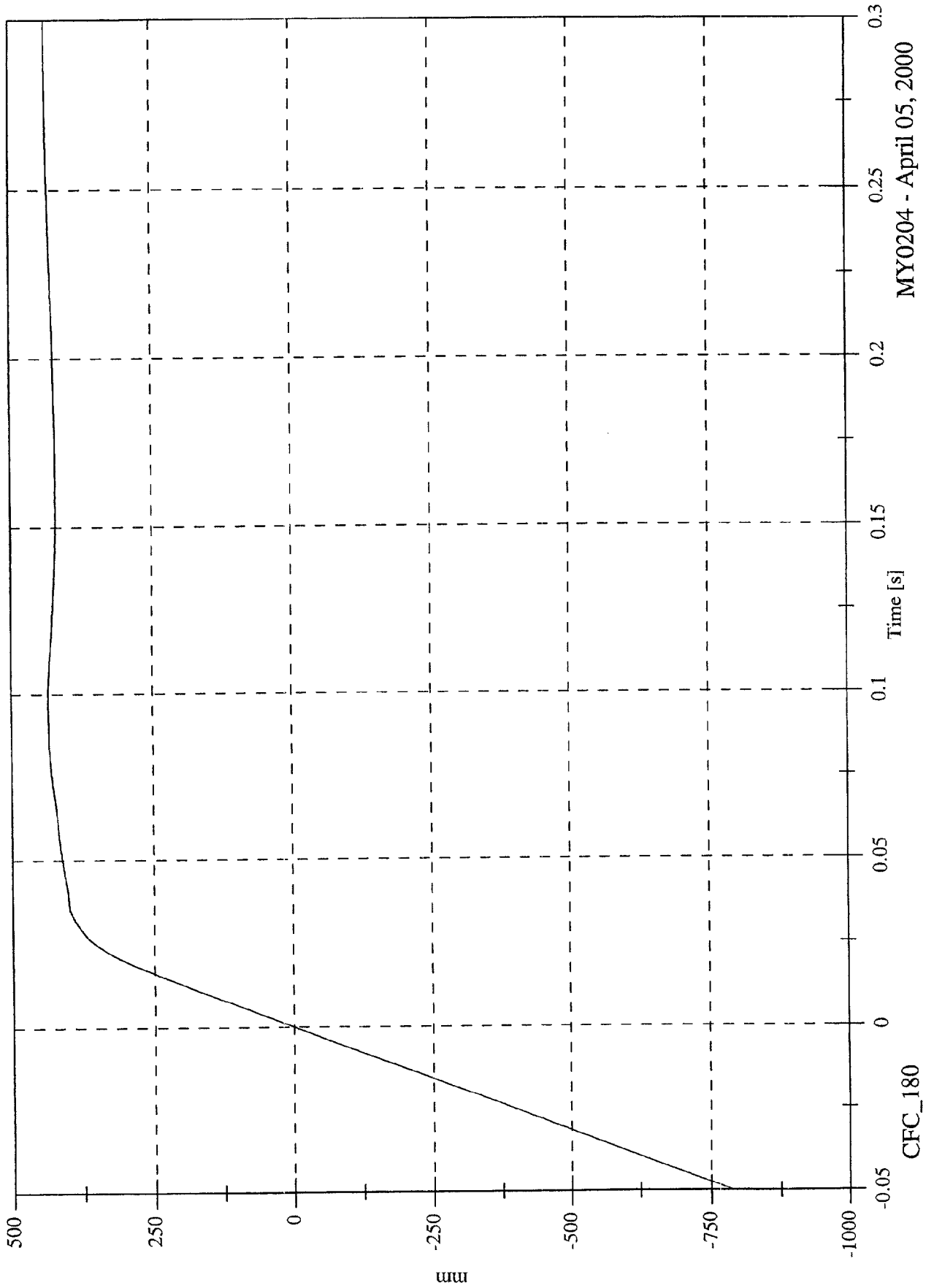

CFC_180

MY0204 - April 05, 2000

NCAP 2000 Test#17 - 2000 Ford Focus 3-Door

Max: 1.2 [g] at -0.005 [s]
Min: -99.6 [g] at 0.045 [s]

Right Caliper #5x

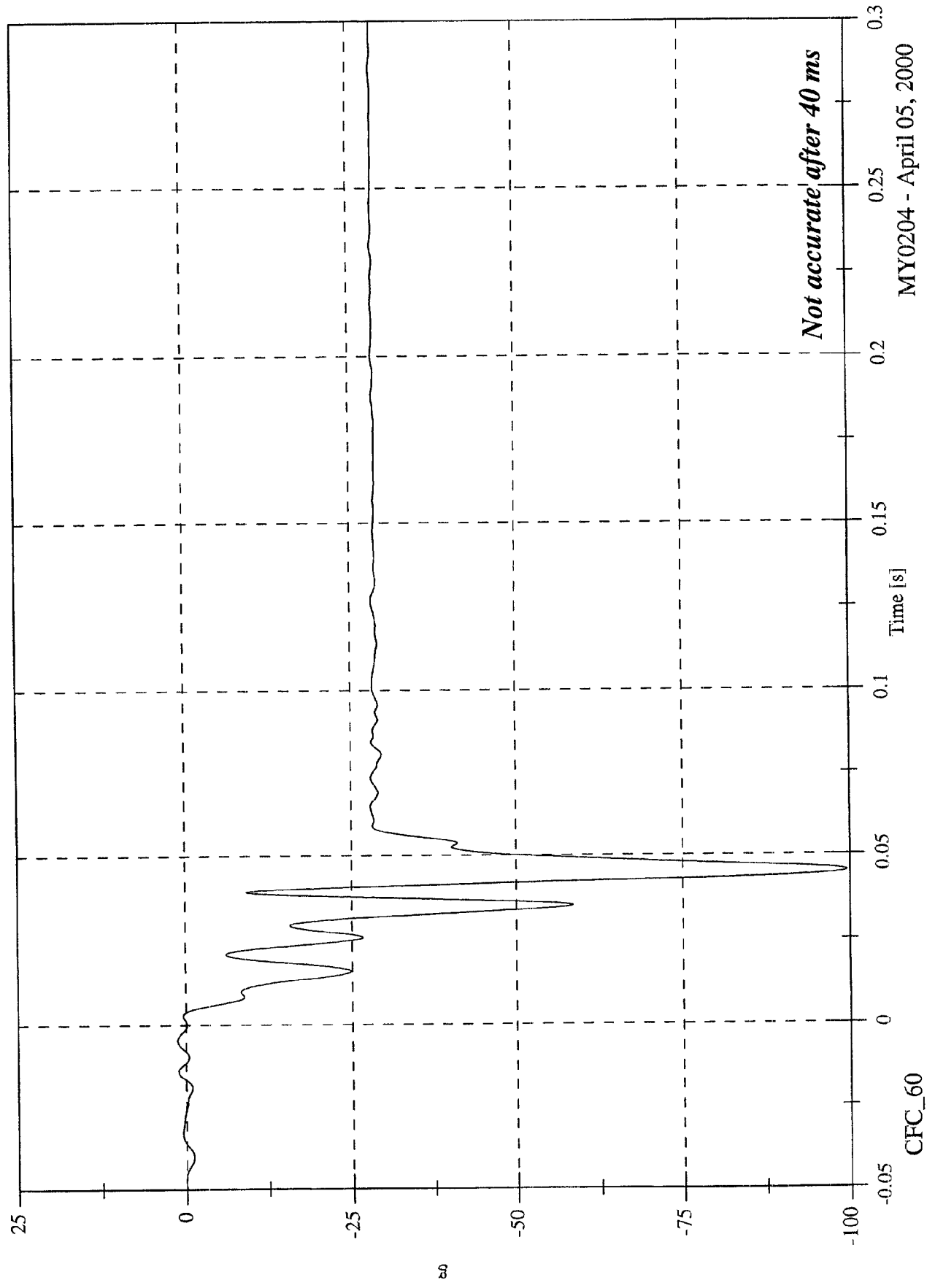

MY0204 - April 05, 2000

NCAP 2000 Test#17 - 2000 Ford Focus 3-Door

Right Caliper #5x Velocity

Max: 56.8 [kph] at 0.005 [s]
Min: -248.6 [kph] at 0.300 [s]

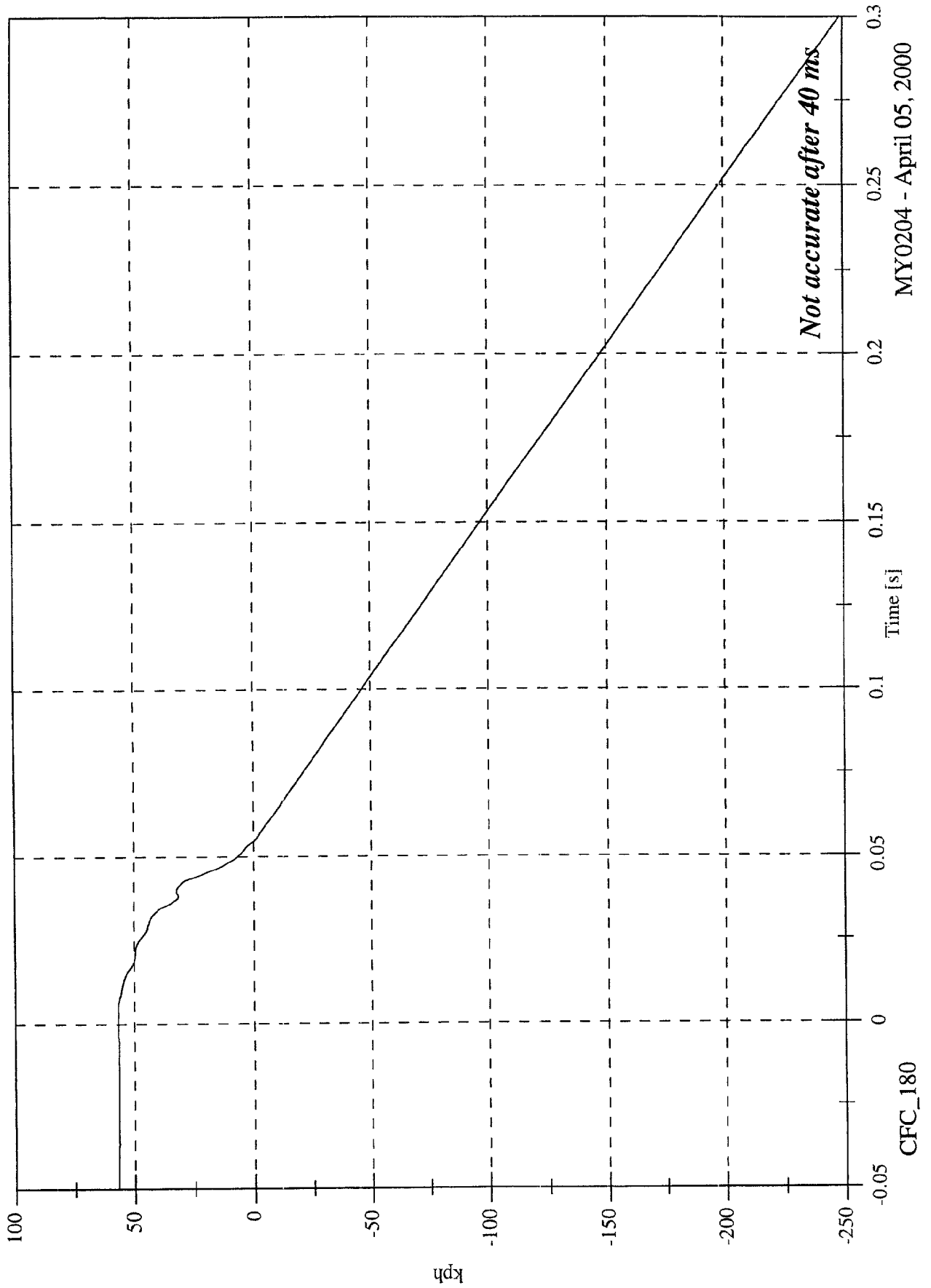

Not accurate after 40 ms

MY0204 - April 05, 2000

Max: 599.3 [mm] at 0.054 [s]
Min: -7885.6 [mm] at 0.300 [s]

NCAP 2000 Test#17 - 2000 Ford Focus 3-Door
Right Caliper #5x Displacement

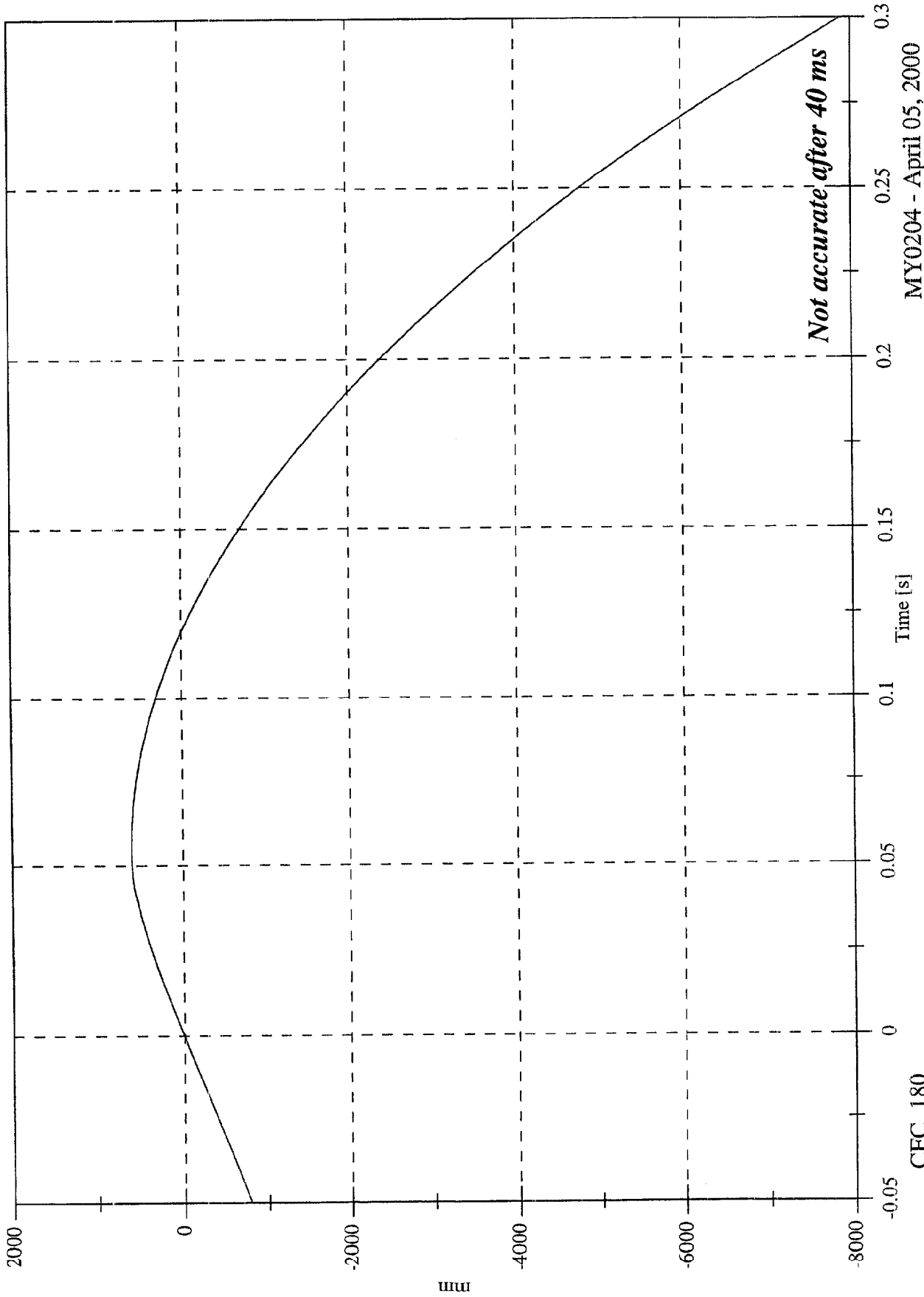

NCAP 2000 Test#17 - 2000 Ford Focus 3-Door

Max: 9.2 [g] at 0.029 [s]
Min: -100.3 [g] at 0.062 [s]

Instrument Panel #6x

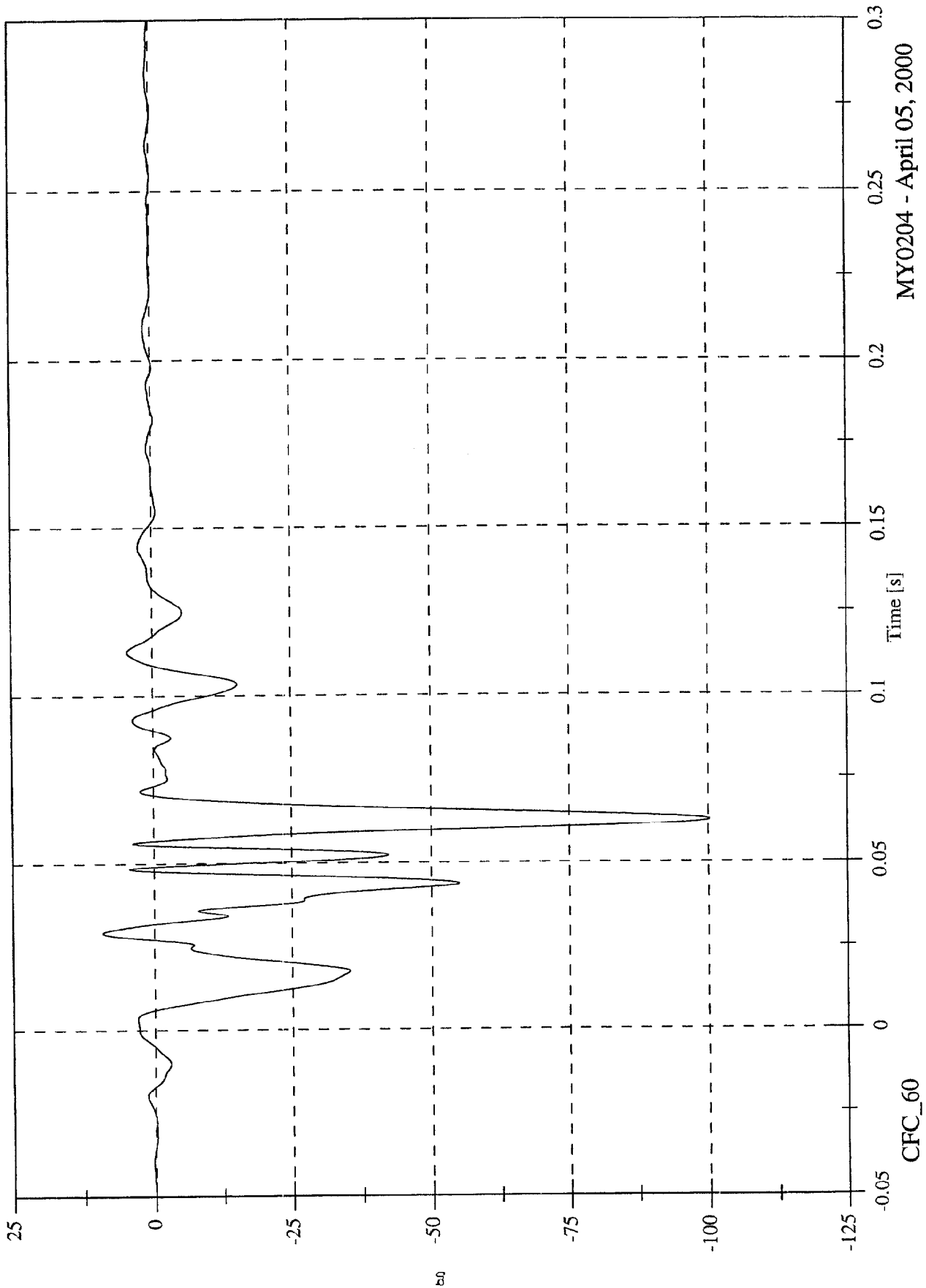

MY0204 - April 05, 2000

NCAP 2000 Test#17 - 2000 Ford Focus 3-Door

Instrument Panel #6x Velocity

Max: 57.2 [kph] at 0.007 [s]
Min: -3.9 [kph] at 0.132 [s]

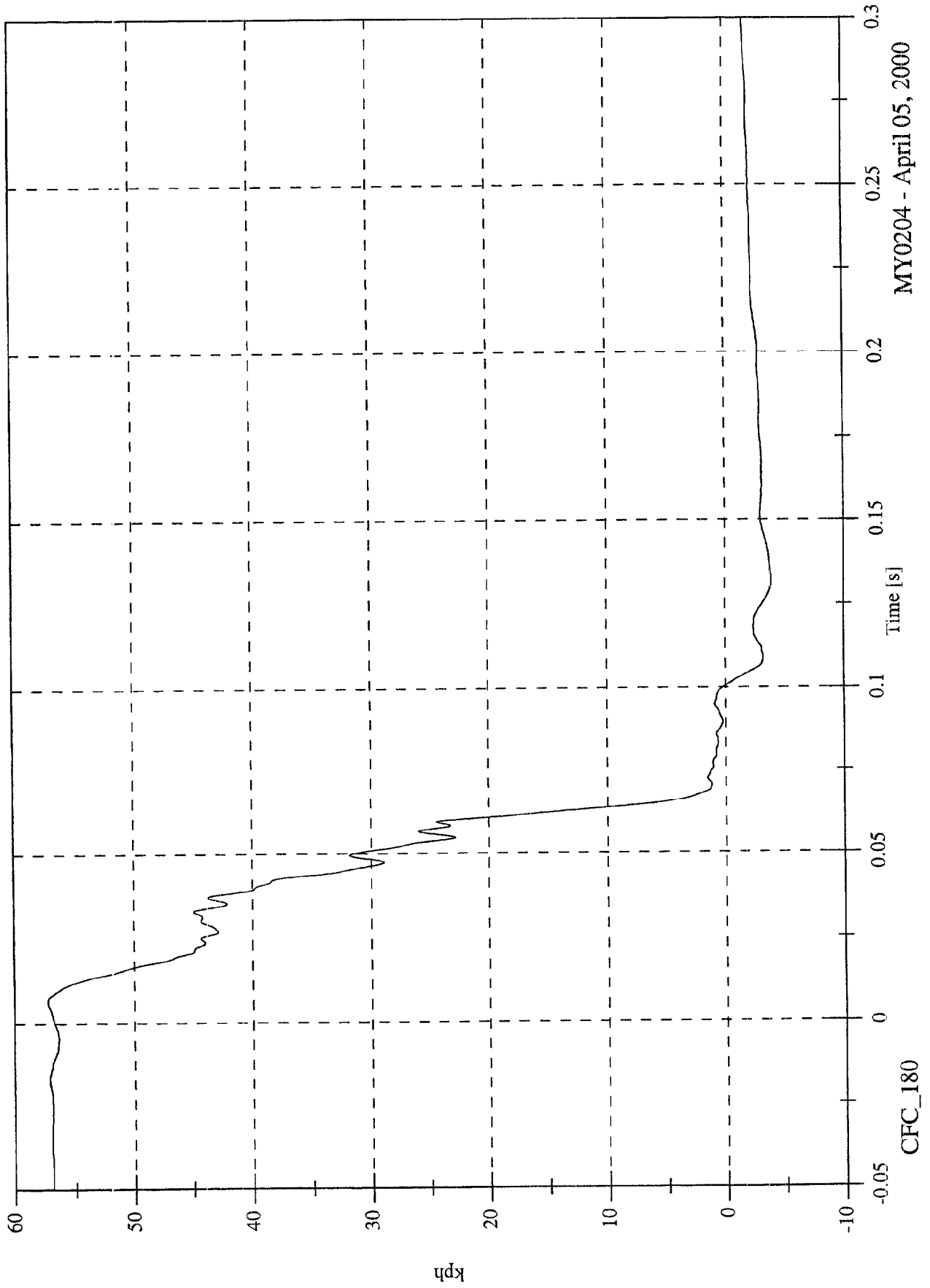

MY0204 - April 05, 2000

NCAP 2000 Test#17 - 2000 Ford Focus 3-Door

Max: 737.3 [mm] at 0.100 [s]

Min: -789.3 [mm] at -0.050 [s]

Instrument Panel #6x Displacement

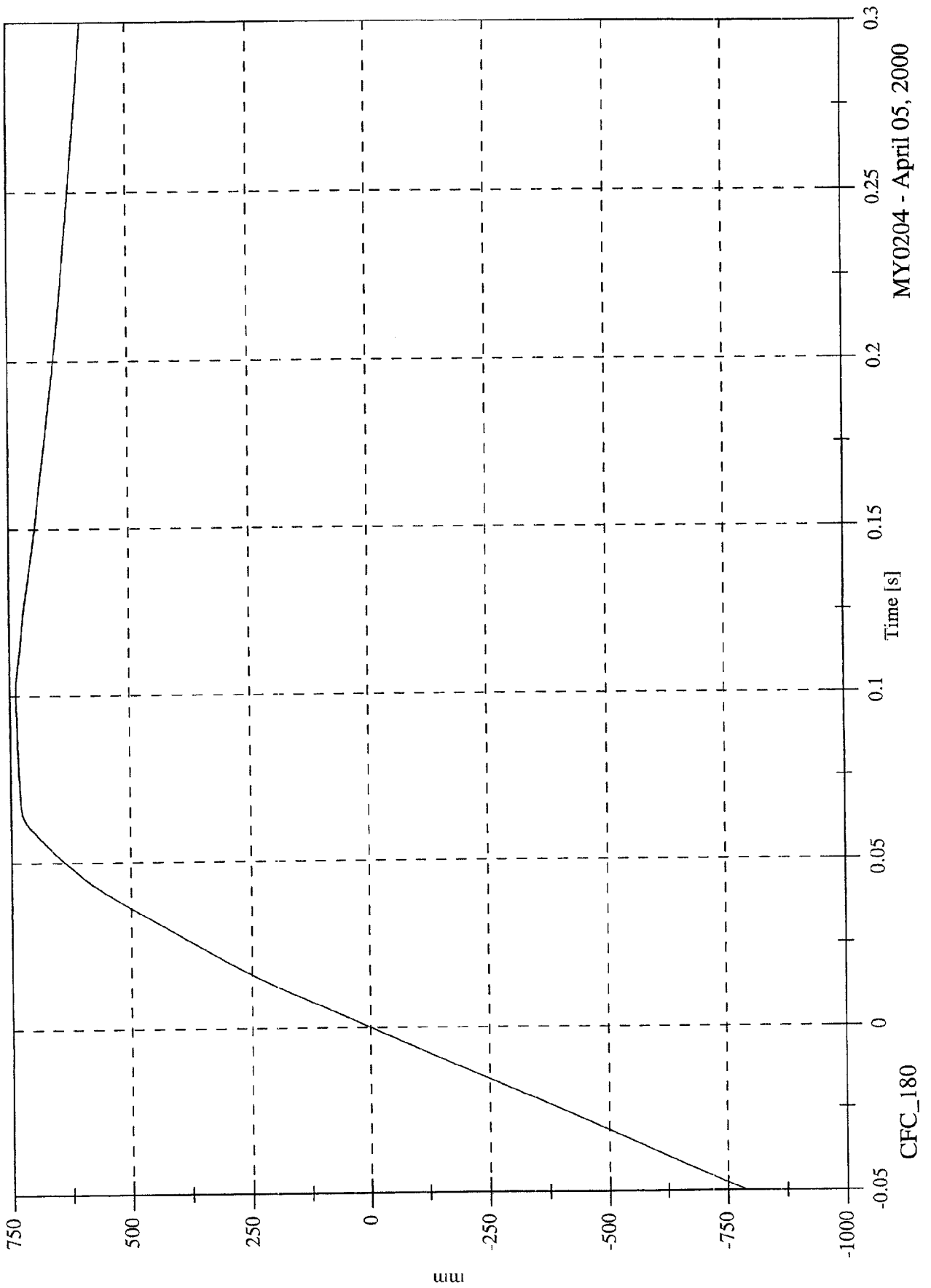

MY0204 - April 05, 2000

CFC_180

NCAP 2000 Test#17 - 2000 Ford Focus 3-Door

Max: 25.1 [g] at 0.075 [s]
Min: -118.1 [g] at 0.045 [s]

Left Caliper #7x

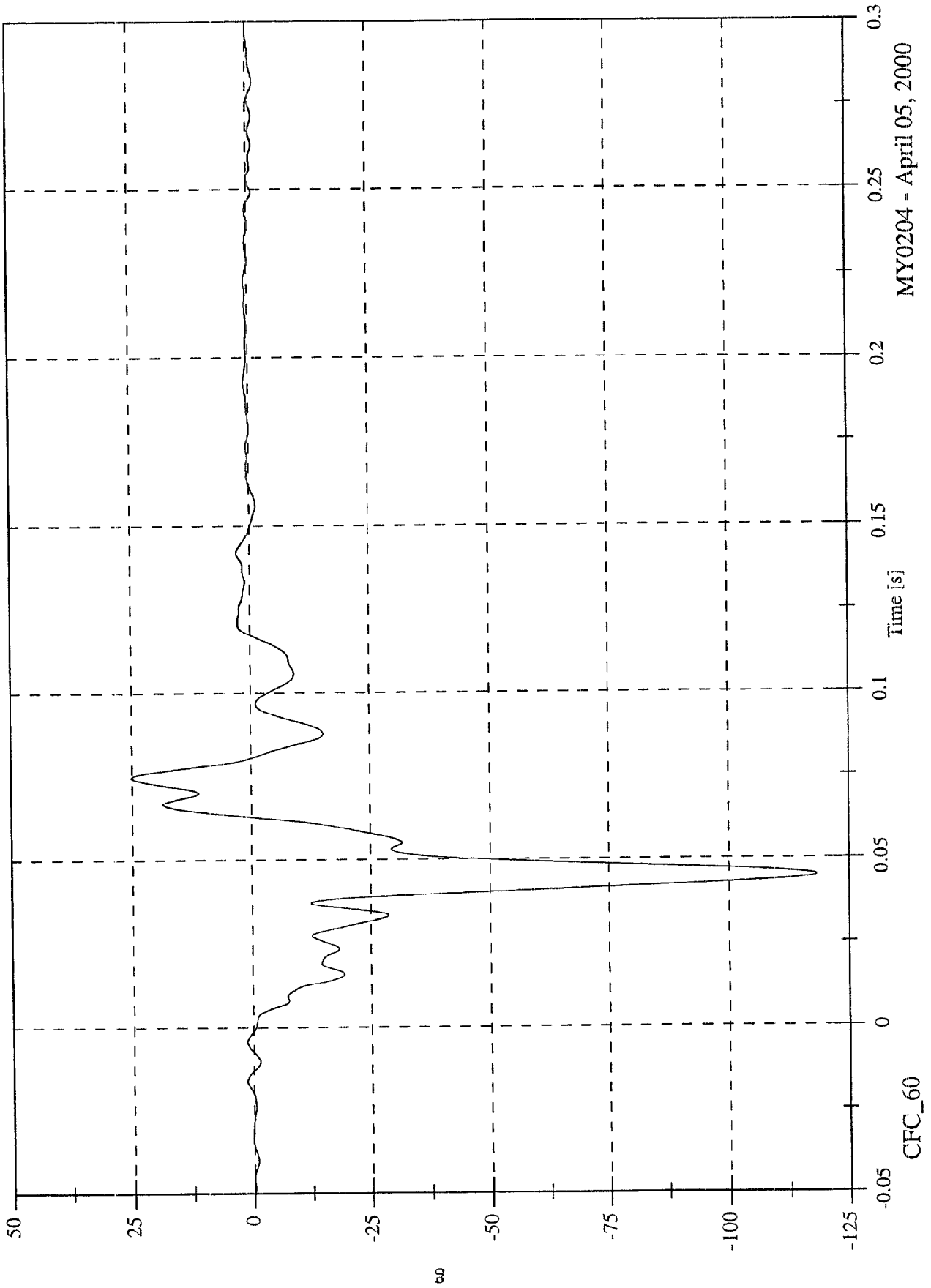

MY0204 - April 05, 2000

NCAP 2000 Test#17 - 2000 Ford Focus 3-Door
Left Caliper #7x Velocity

Max: 56.8 [kph] at -0.013 [s]
Min: -6.2 [kph] at 0.063 [s]

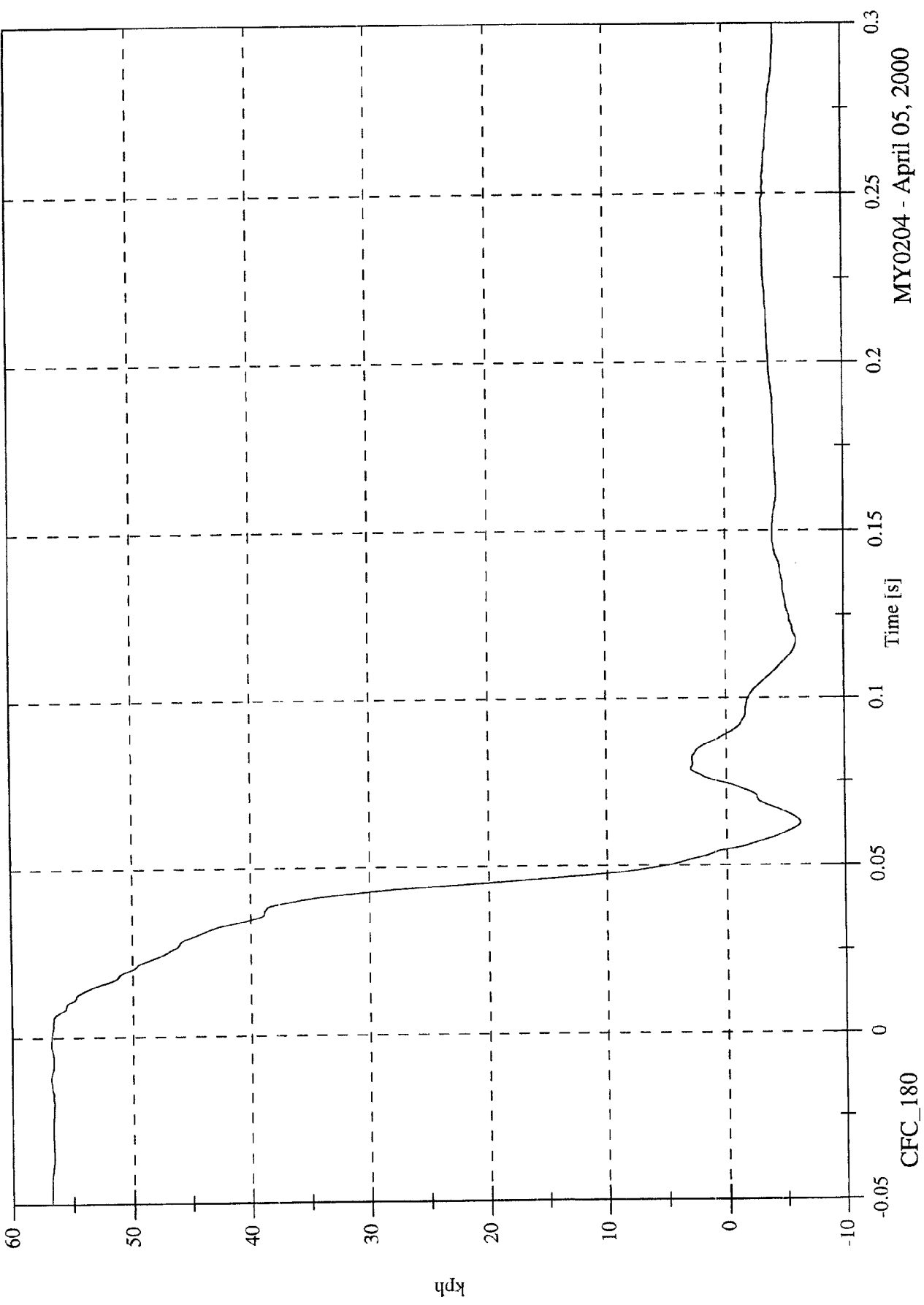

MY0204 - April 05, 2000

CFC_180

NCAP 2000 Test#17 - 2000 Ford Focus 3-Door

Max: 608.9 [mm] at 0.055 [s]
Min: -786.9 [mm] at -0.050 [s]

Left Caliper #7x Displacement

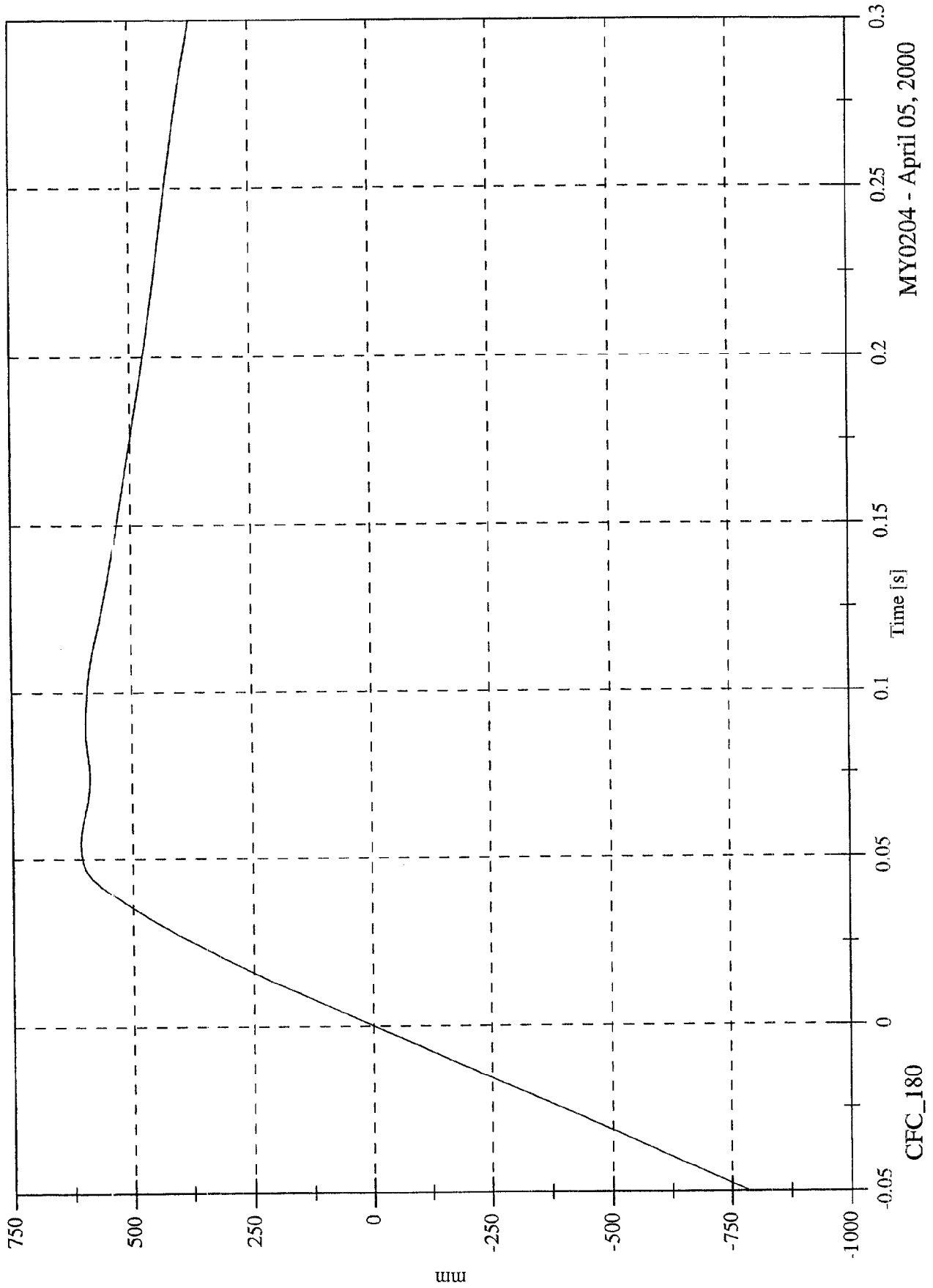

MY0204 - April 05, 2000

CFC_180

NCAP 2000 Test#17 - 2000 Ford Focus 3-Door

Max: 3.5 [g] at 0.134 [s]
Min: -39.6 [g] at 0.044 [s]

Left Rear Red #8x

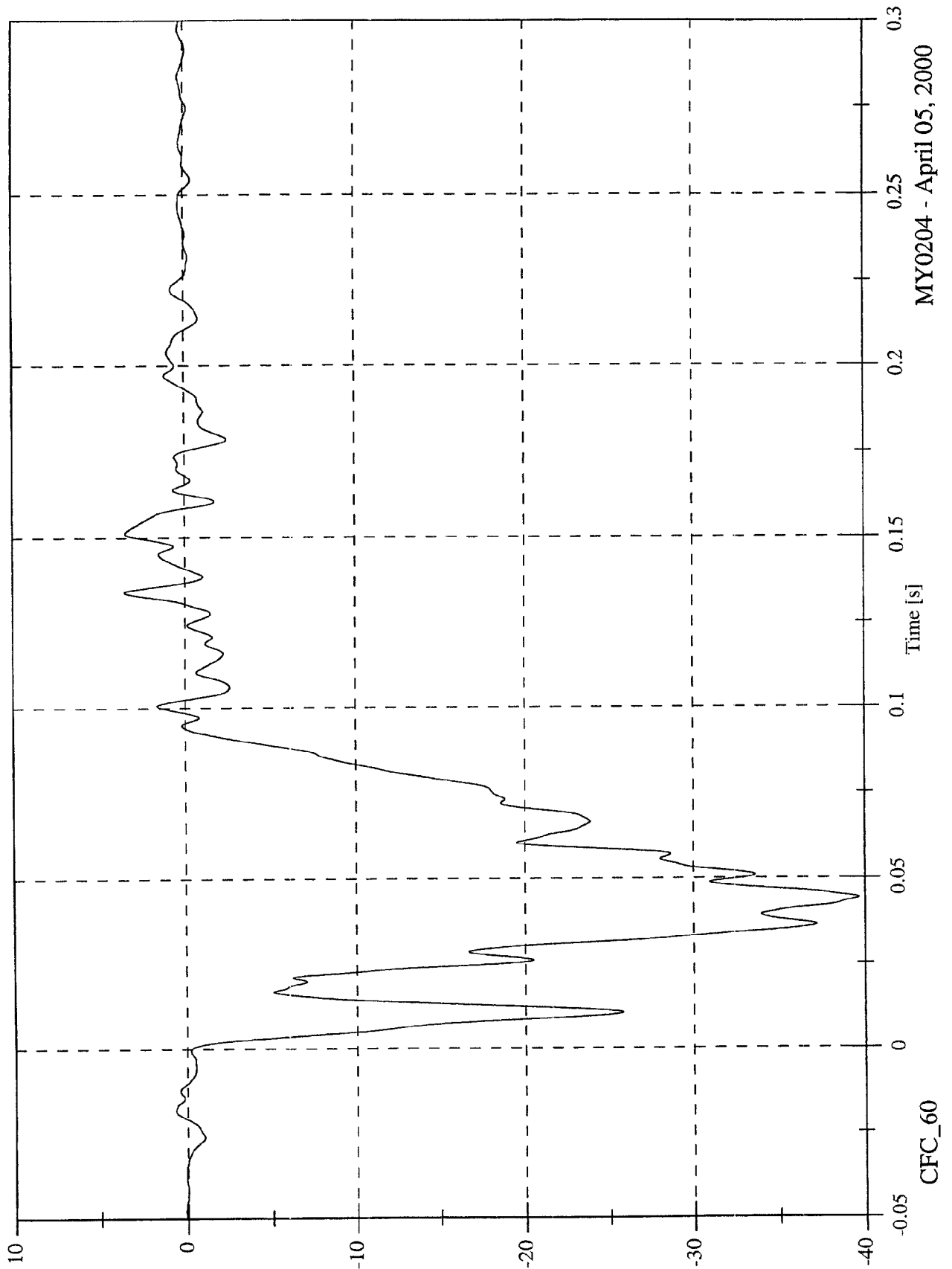

MY0204 - April 05, 2000

Max: 56.7 [kph] at -0.035 [s]
Min: -9.2 [kph] at 0.132 [s]

NCAP 2000 Test#17 - 2000 Ford Focus 3-Door
Left Rear Red #8x Velocity

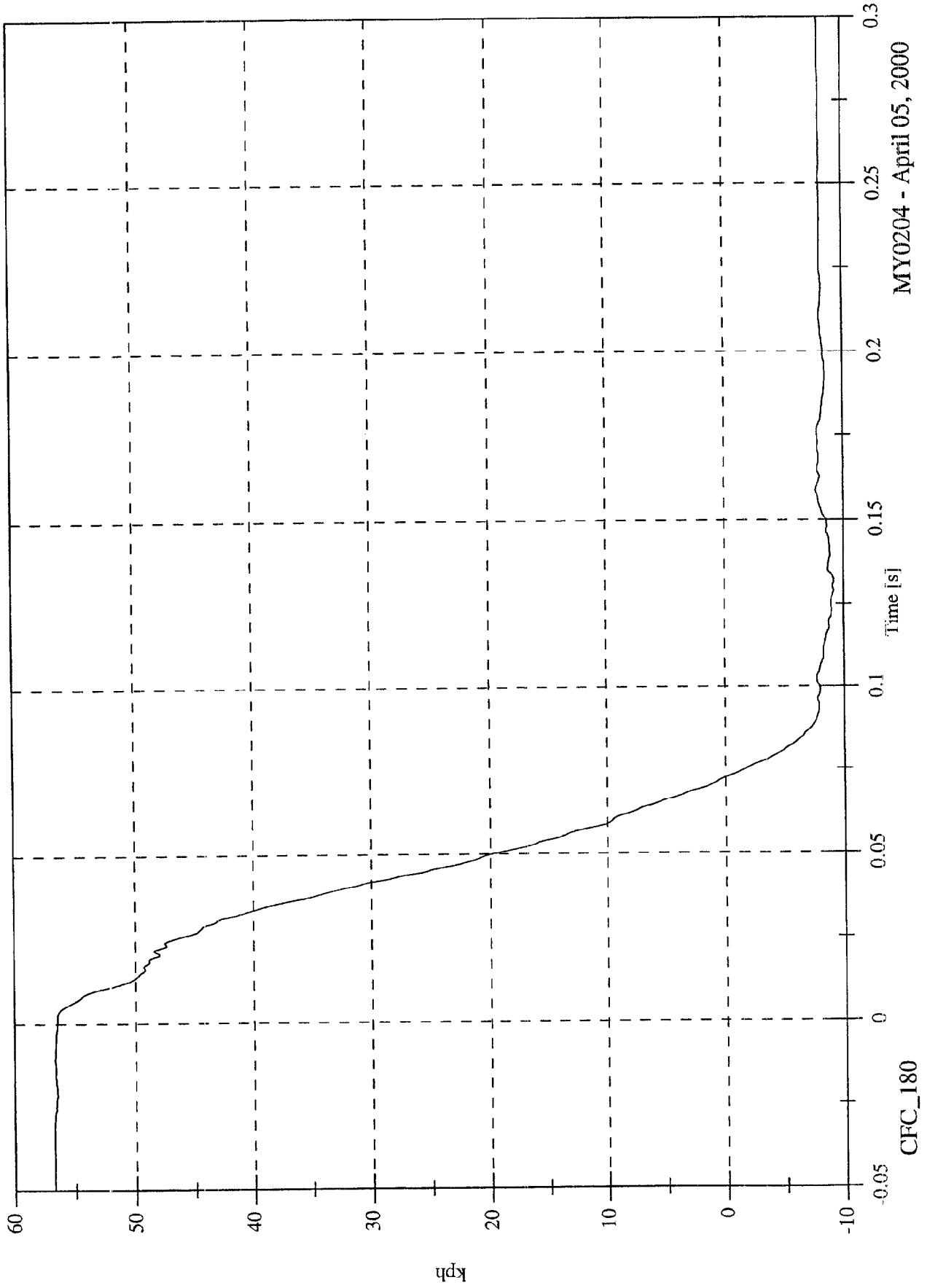

NCAP 2000 Test#17 - 2000 Ford Focus 3-Door

Max: 654.0 [mm] at 0.073 [s]

Min: -786.8 [mm] at -0.050 [s]

Left Rear Red #8x Displacement

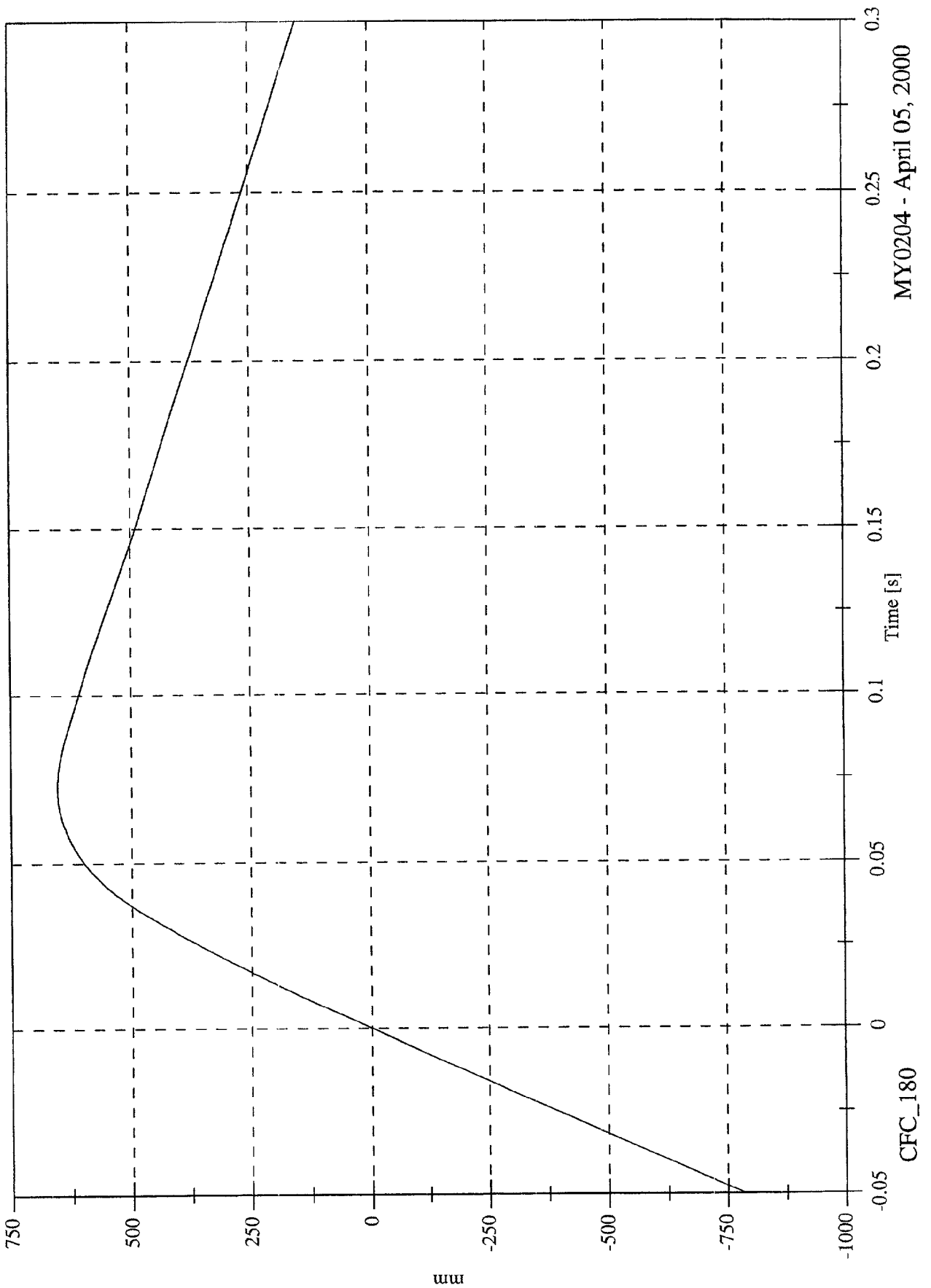

MY0204 - April 05, 2000

CFC_180

NCAP 2000 Test#17 - 2000 Ford Focus 3-Door

Max: 2.6 [g] at 0.154 [s]
Min: -41.0 [g] at 0.037 [s]

Right Rear Red #9x

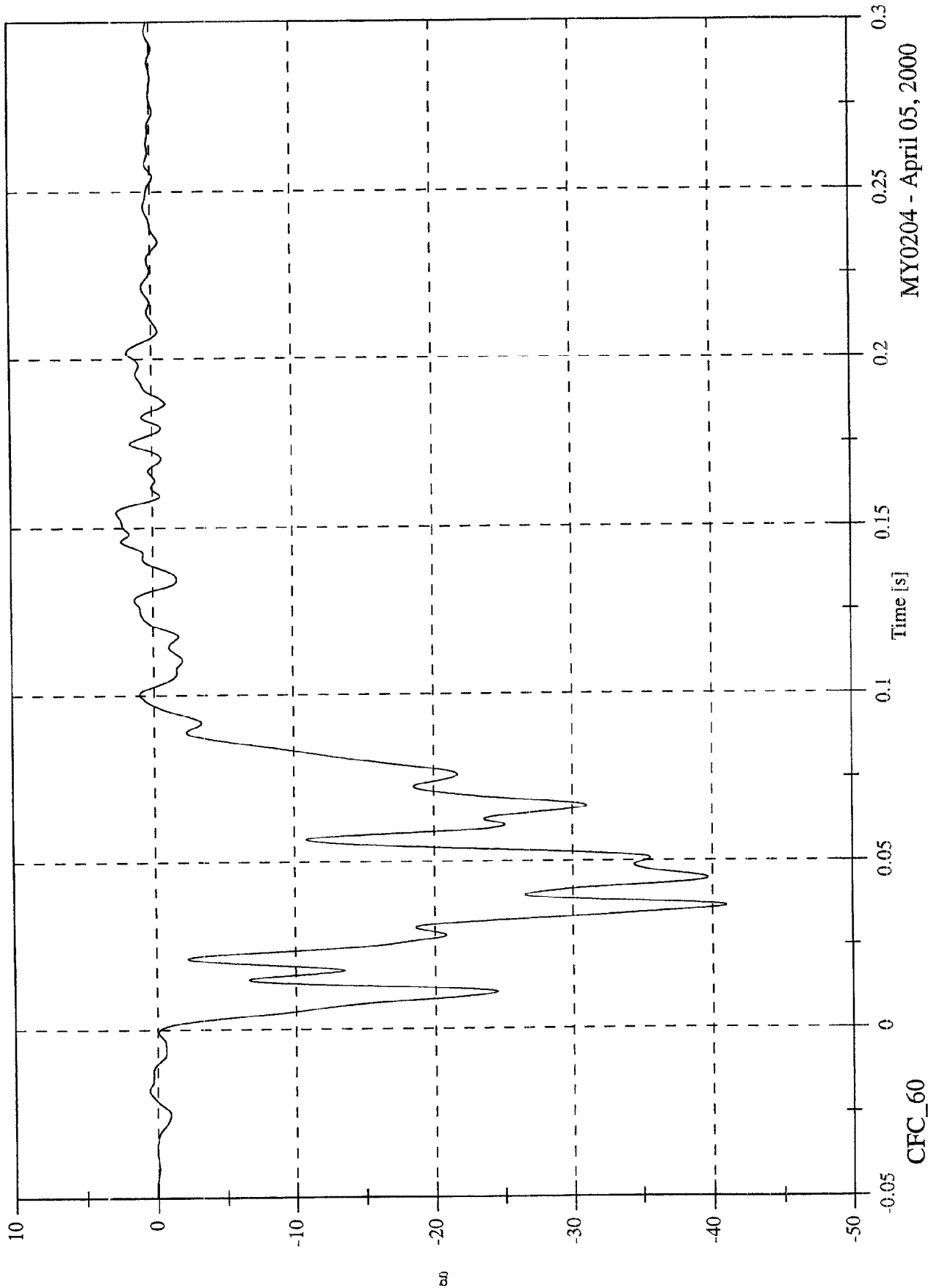

MY0204 - April 05, 2000

NCAP 2000 Test#17 - 2000 Ford Focus 3-Door

Max: 56.7 [kph] at -0.045 [s]

Min: -7.3 [kph] at 0.120 [s]

Right Rear Red #9x Velocity

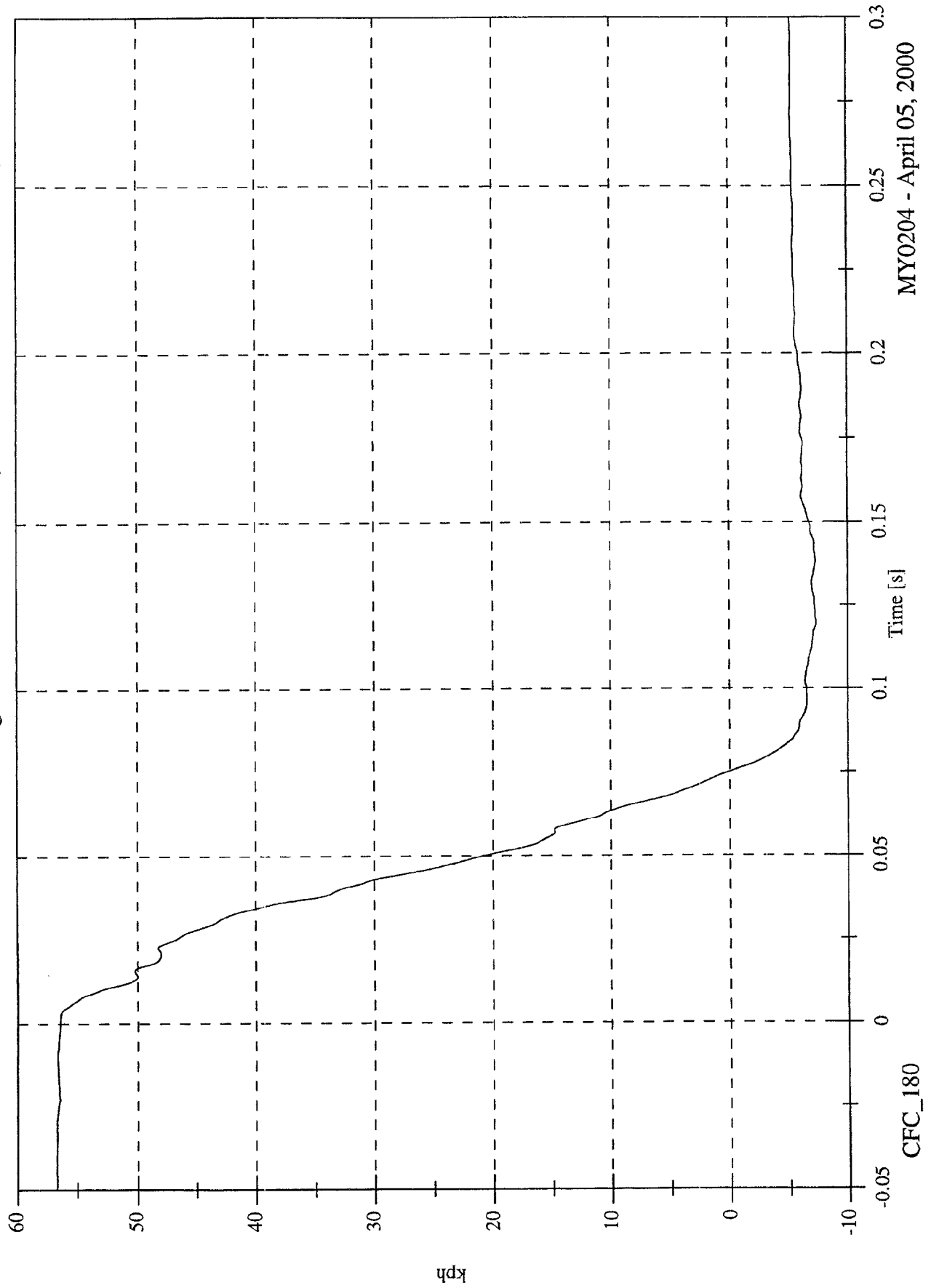

MY0204 - April 05, 2000

Max: 674.2 [mm] at 0.075 [s]
Min: -786.5 [mm] at -0.050 [s]

Right Rear Red #9x Displacement

NCAP 2000 Test#17 - 2000 Ford Focus 3-Door

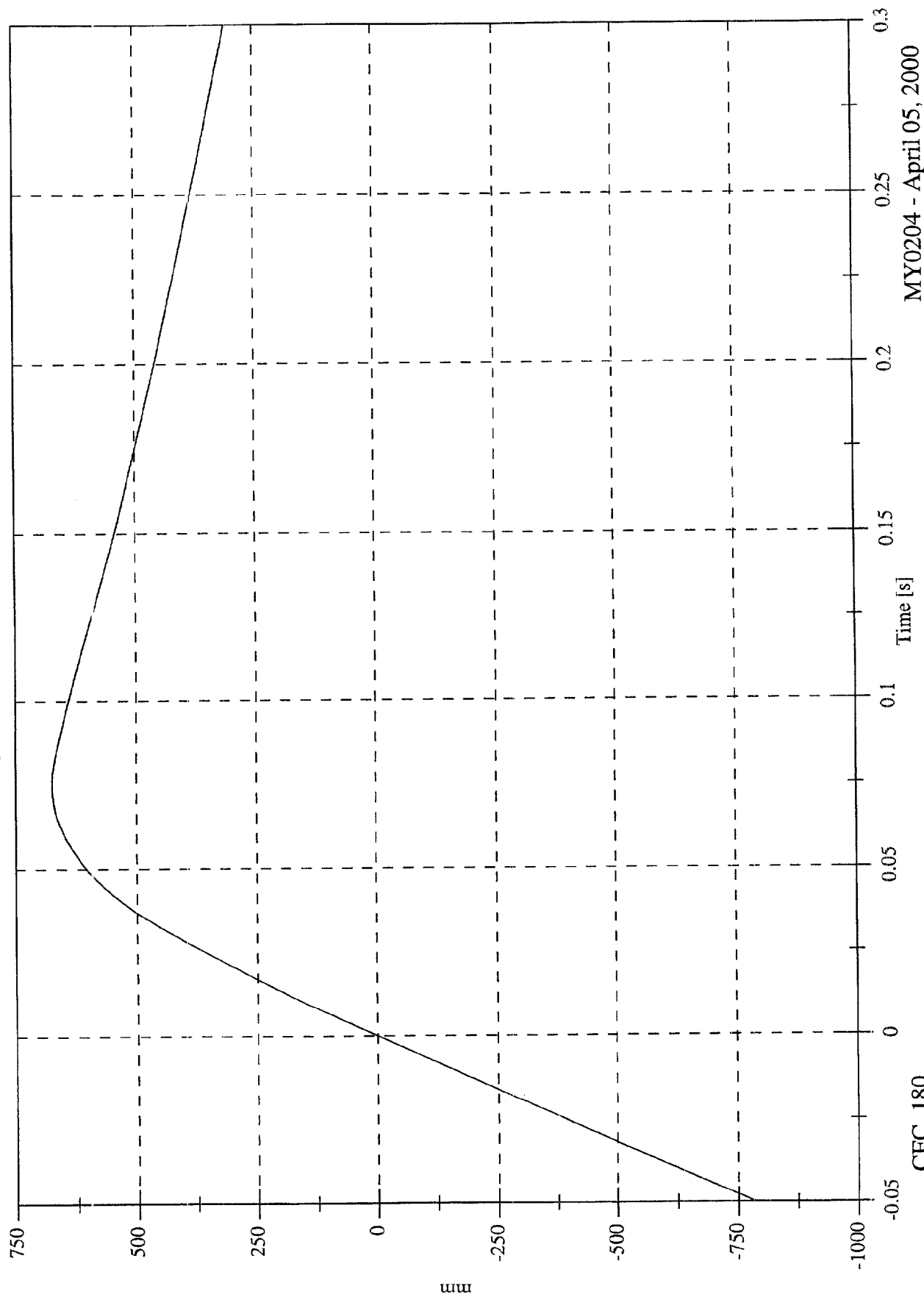

MY0204 - April 05, 2000

CFC_180

NCAP Test#17 - 2000 Ford Focus 3-Door

Max: 971.3 [N] at 0.037 [S]
Min: -900.3 [N] at 0.033 [S]

Barrier Load Cell A1 Fx

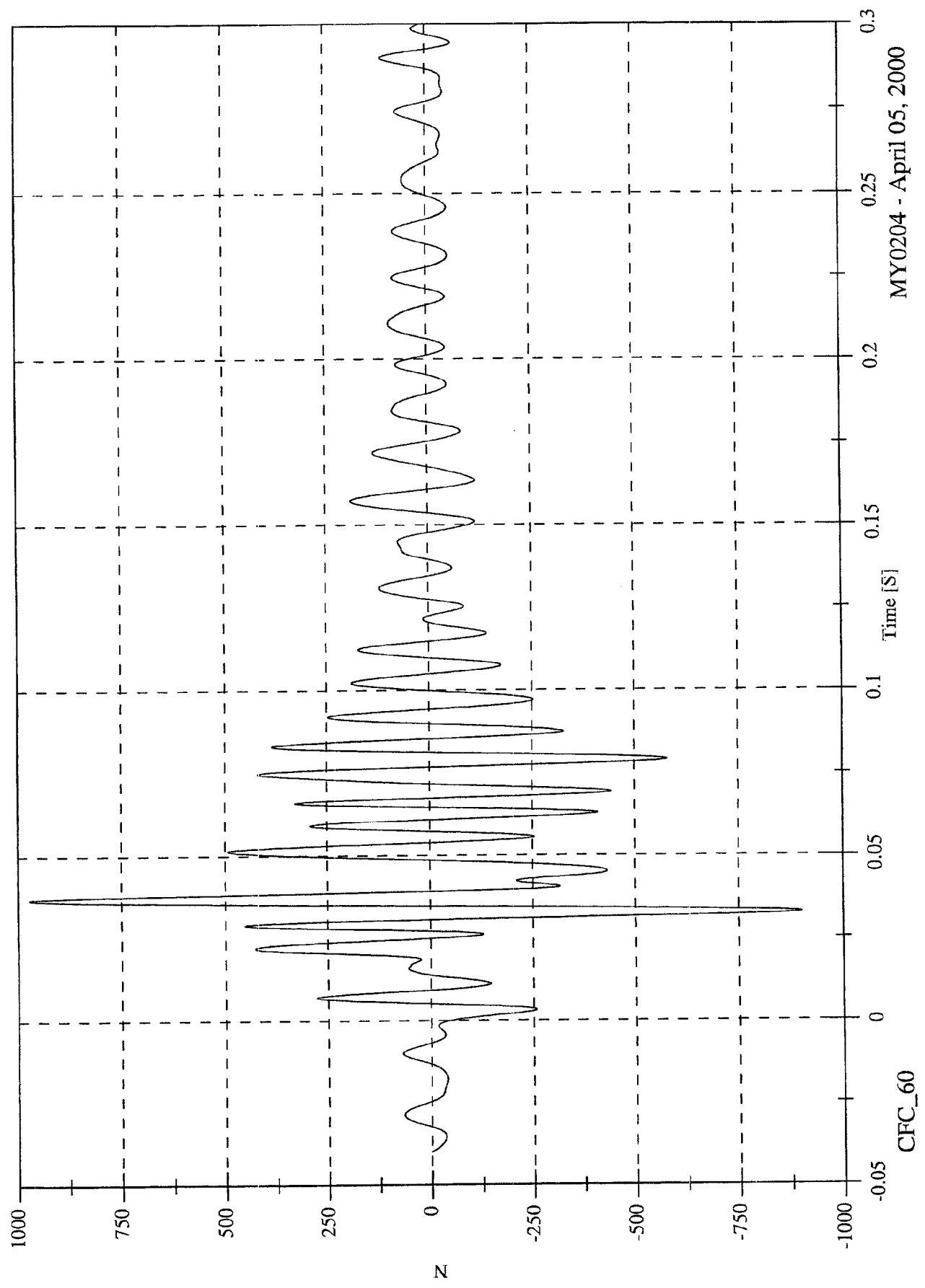

MY0204 - April 05, 2000

CFC_60

Max: 4154.7 [N] at 0.051 [S]
Min: -300.2 [N] at 0.025 [S]

NCAP Test#17 - 2000 Ford Focus 3-Door

Barrier Load Cell A2 Fx

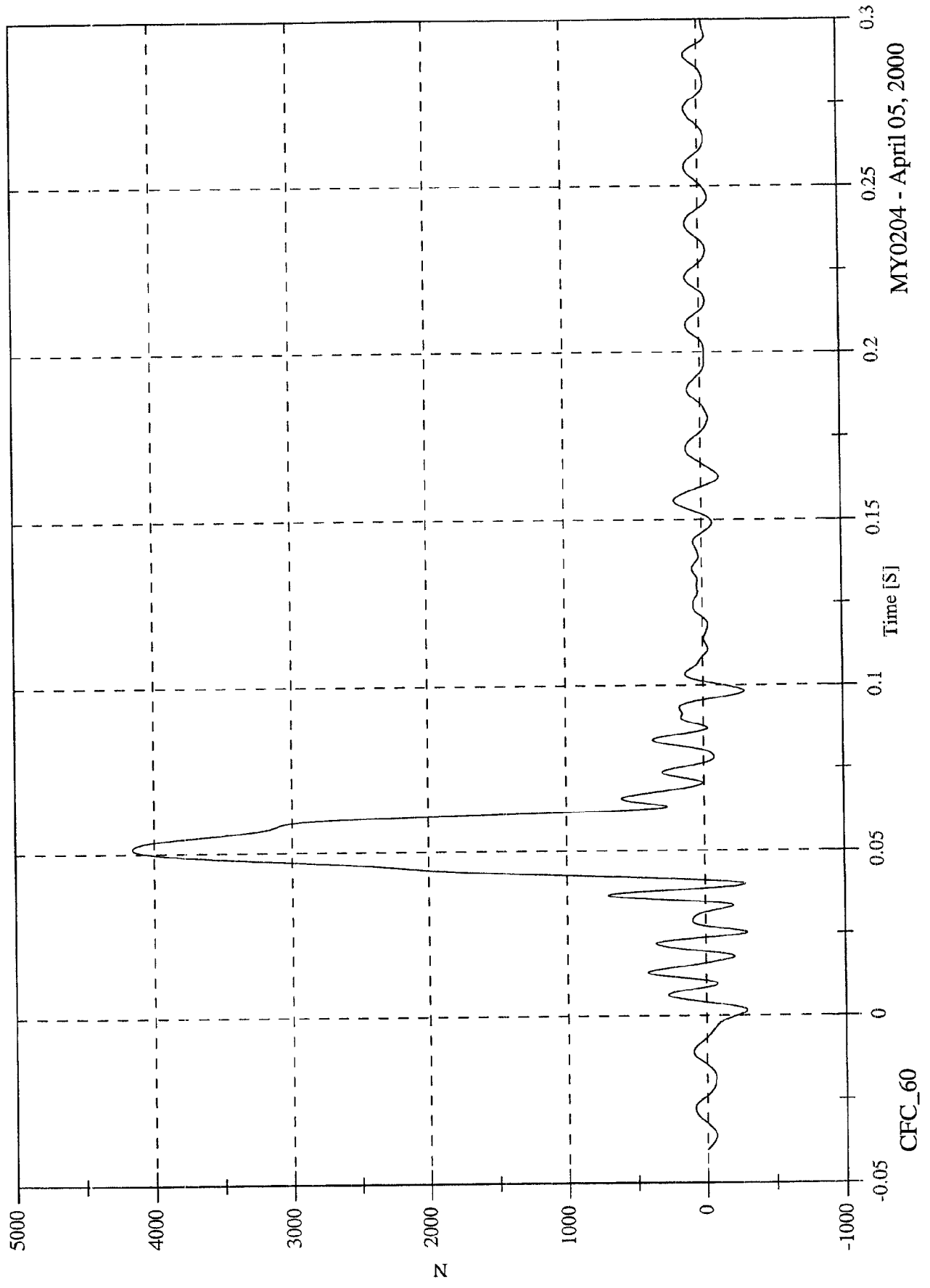

MY0204 - April 05, 2000

NCAP Test#17 - 2000 Ford Focus 3-Door

Max: 8200.5 [N] at 0.067 [S]
Min: -276.9 [N] at 0.000 [S]

Barrier Load Cell A3 Fx

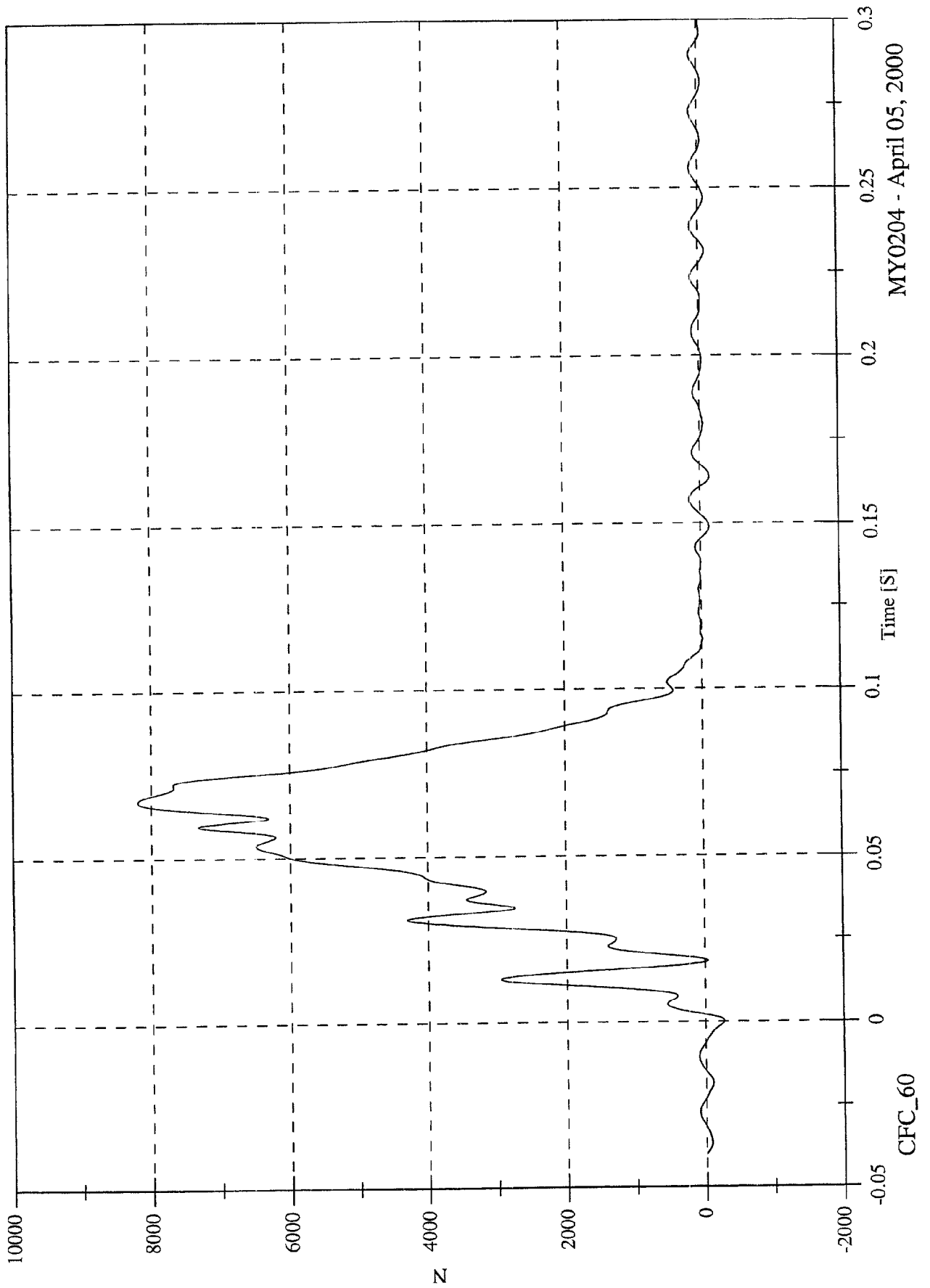

MY0204 - April 05, 2000

NCAP Test#17 - 2000 Ford Focus 3-Door

Barrier Load Cell A4 Fx

Max: 31517.6 [N] at 0.058 [S]
Min: -866.2 [N] at 0.017 [S]

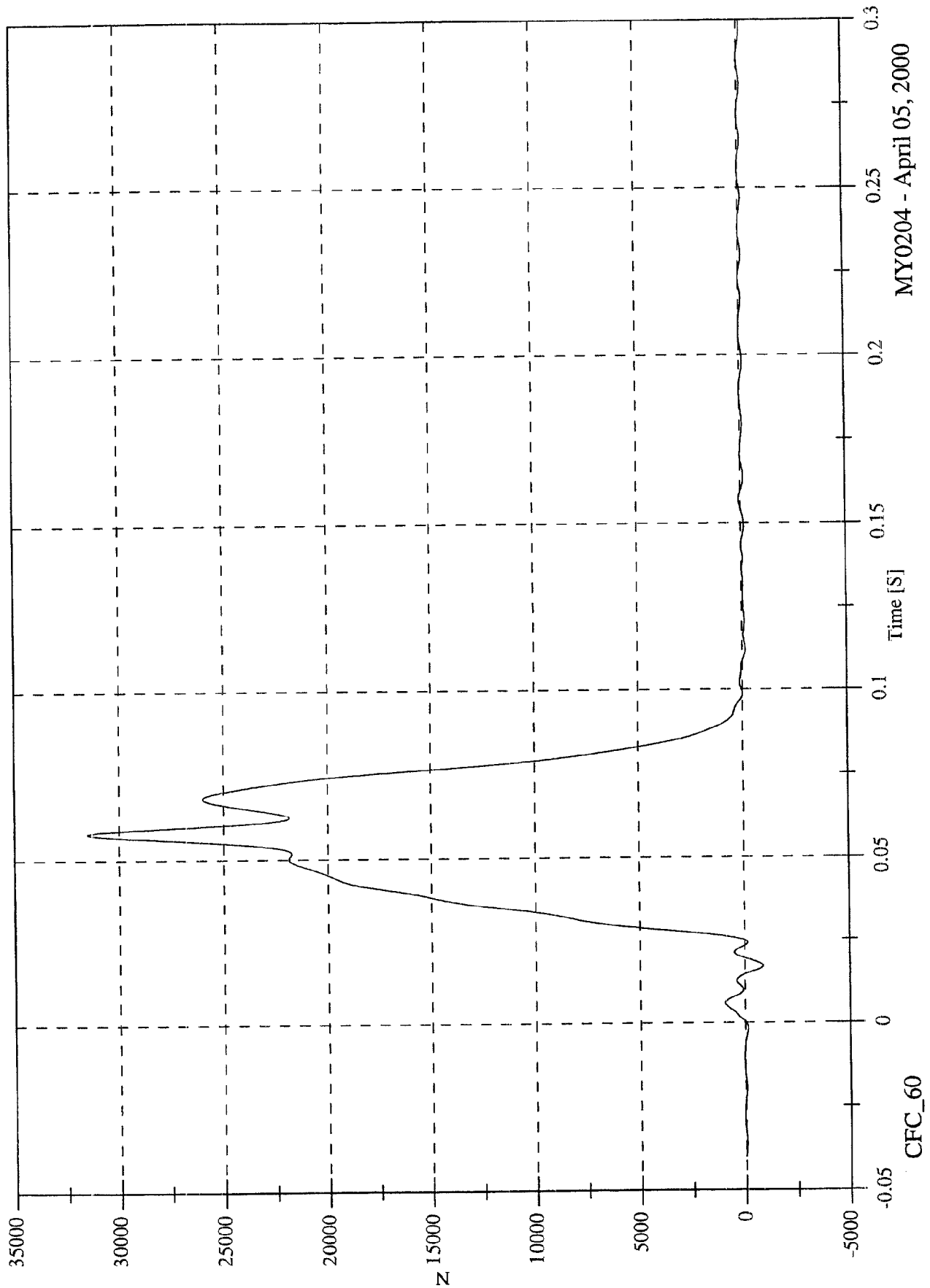

MY0204 - April 05, 2000

CFC_60

Max: 16474.1 [N] at 0.058 [S]
Min: -1359.0 [N] at 0.063 [S]

Barrier Load Cell A5 Fx

NCAP Test#17 - 2000 Ford Focus 3-Door

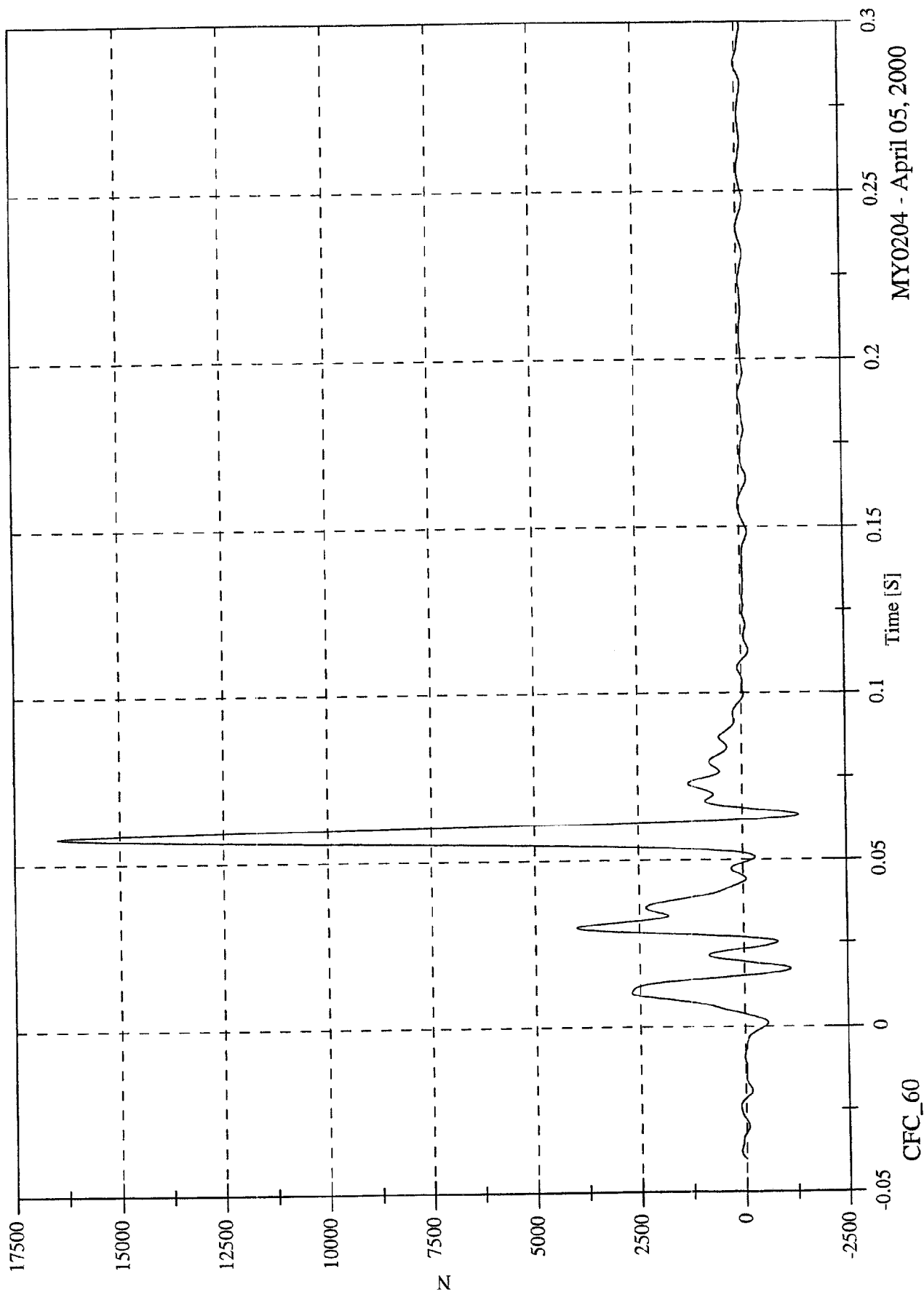

MY0204 - April 05, 2000

NCAP Test#17 - 2000 Ford Focus 3-Door

Max: 16423.5 [N] at 0.032 [S]
Min: -1007.6 [N] at 0.017 [S]

Barrier Load Cell A6 Fx

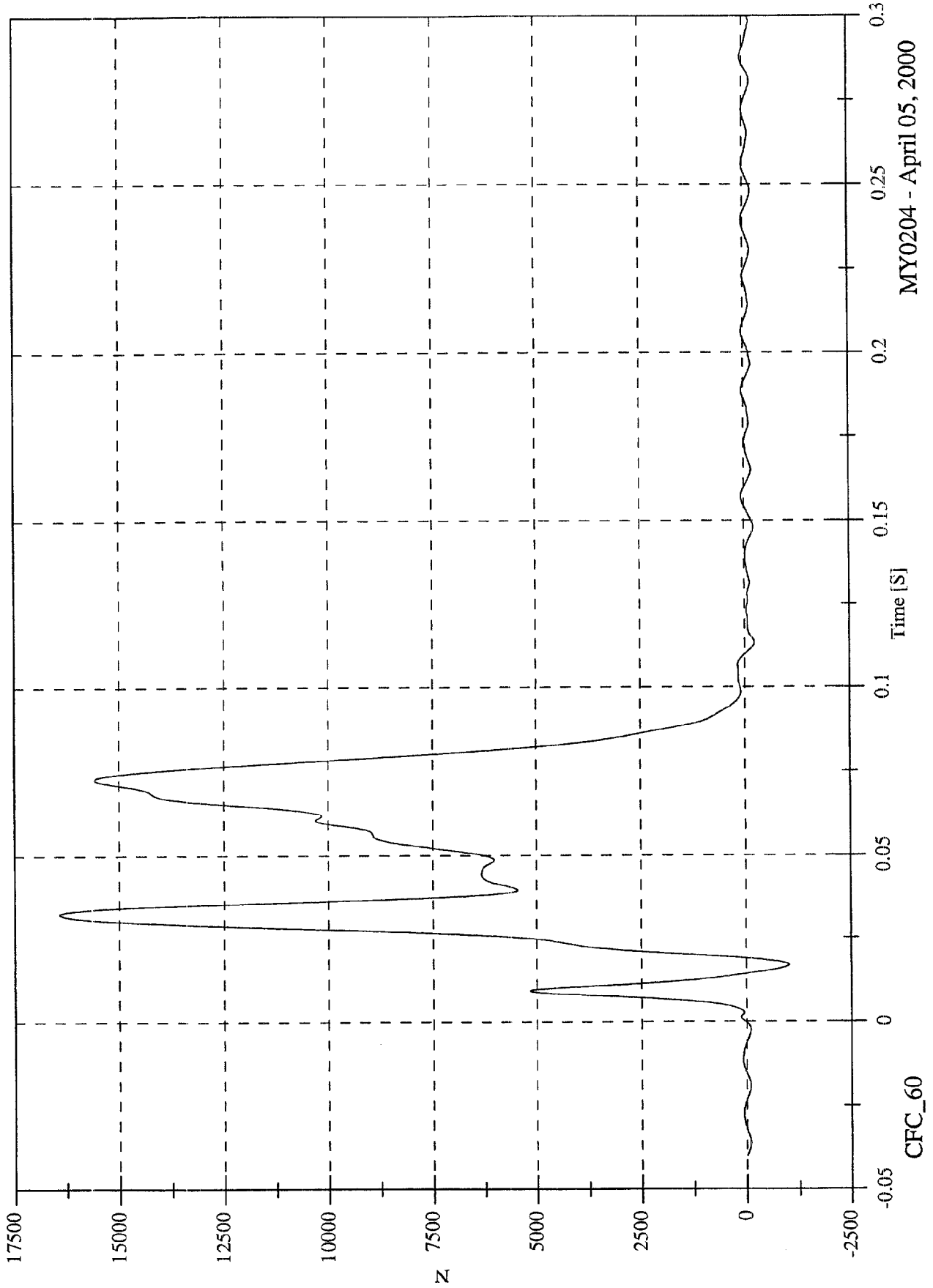

MY0204 - April 05, 2000

NCAP Test#17 - 2000 Ford Focus 3-Door

Barrier Load Cell A7 Fx

Max: 977.4 [N] at 0.021 [S]

Min: -748.6 [N] at 0.063 [S]

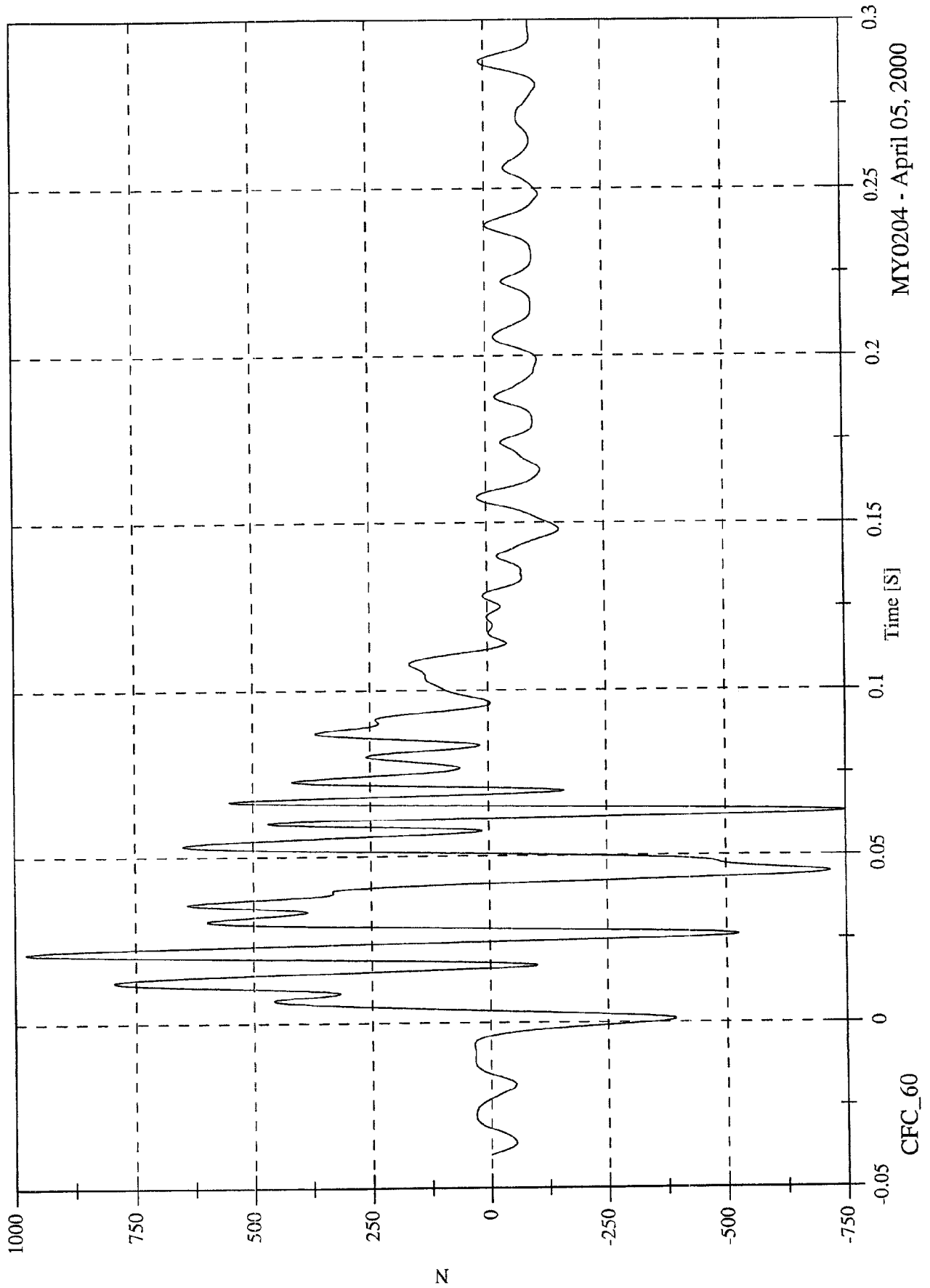

MY0204 - April 05, 2000

Max: 2927.7 [N] at 0.053 [S]
Min: -464.4 [N] at 0.002 [S]

Barrier Load Cell A8 Fx

NCAP Test#17 - 2000 Ford Focus 3-Door

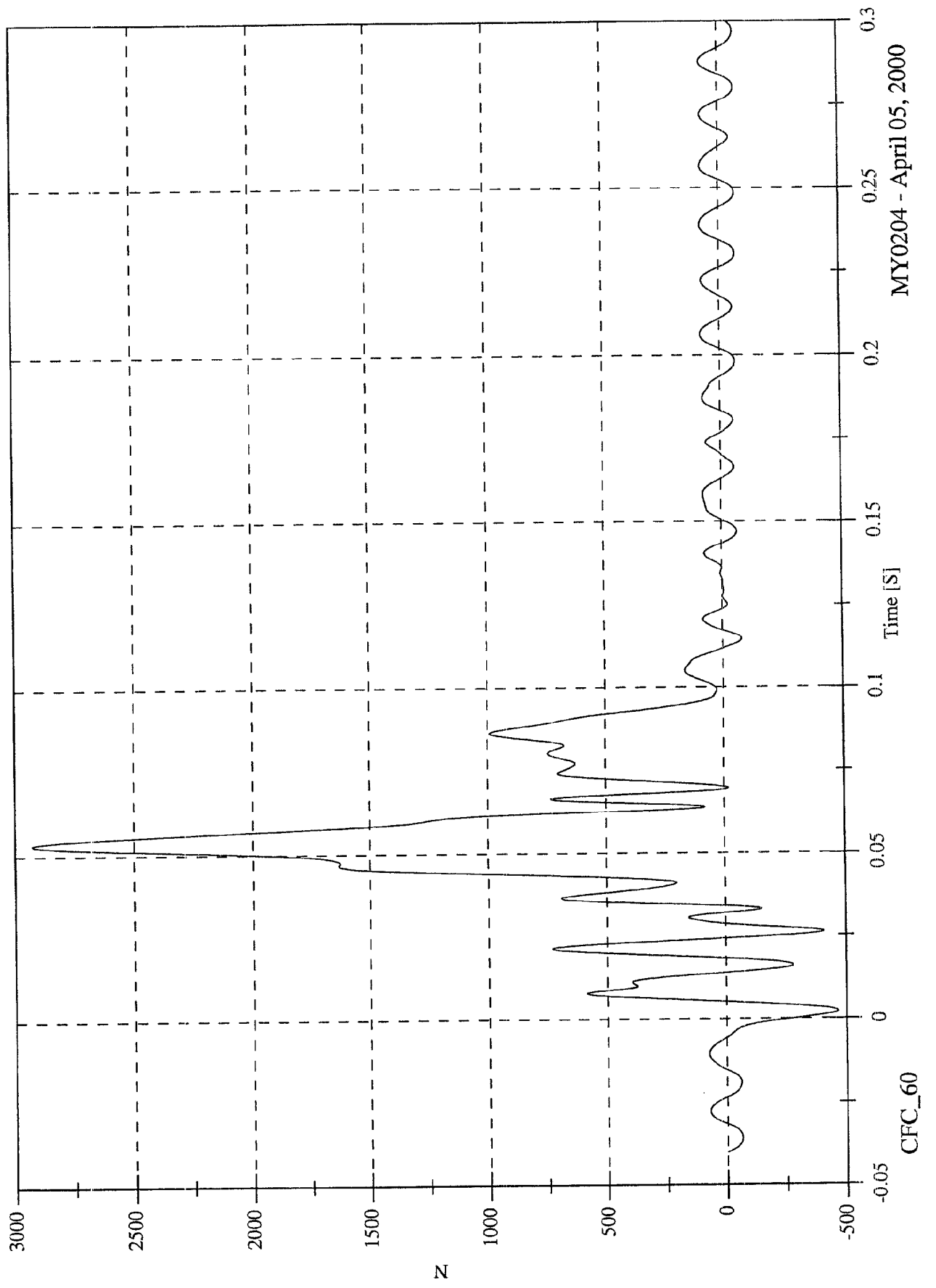

MY0204 - April 05, 2000

NCAP Test#17 - 2000 Ford Focus 3-Door

Barrier Load Cell A9 Fx

Max: 1402.7 [N] at 0.054 [S]
Min: -953.0 [N] at 0.060 [S]

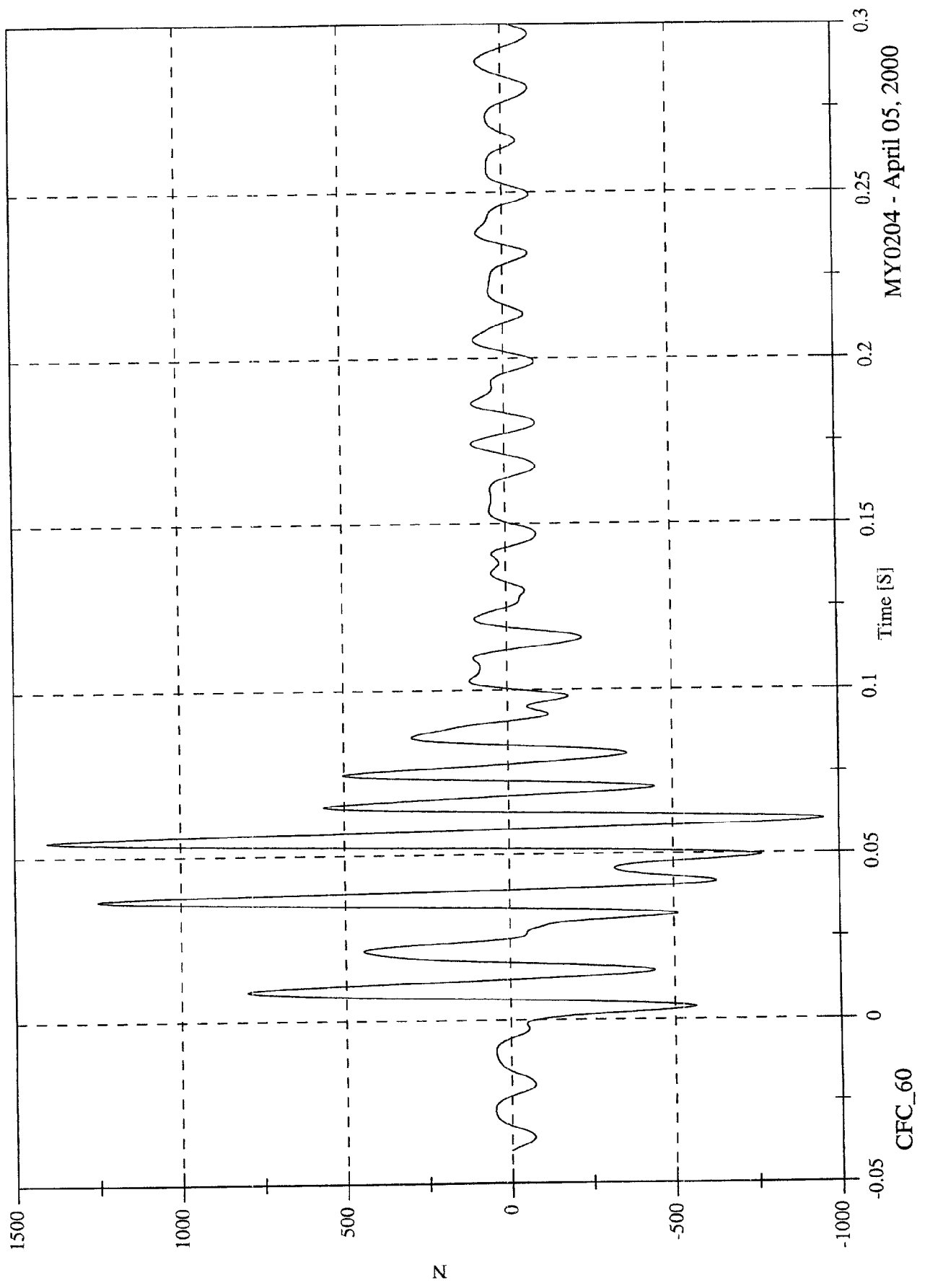

MY0204 - April 05, 2000

NCAP Test#17 - 2000 Ford Focus 3-Door

Max: 748.6 [N] at 0.029 [S]

Min: -324.3 [N] at 0.077 [S]

Barrier Load Cell B1 Fx

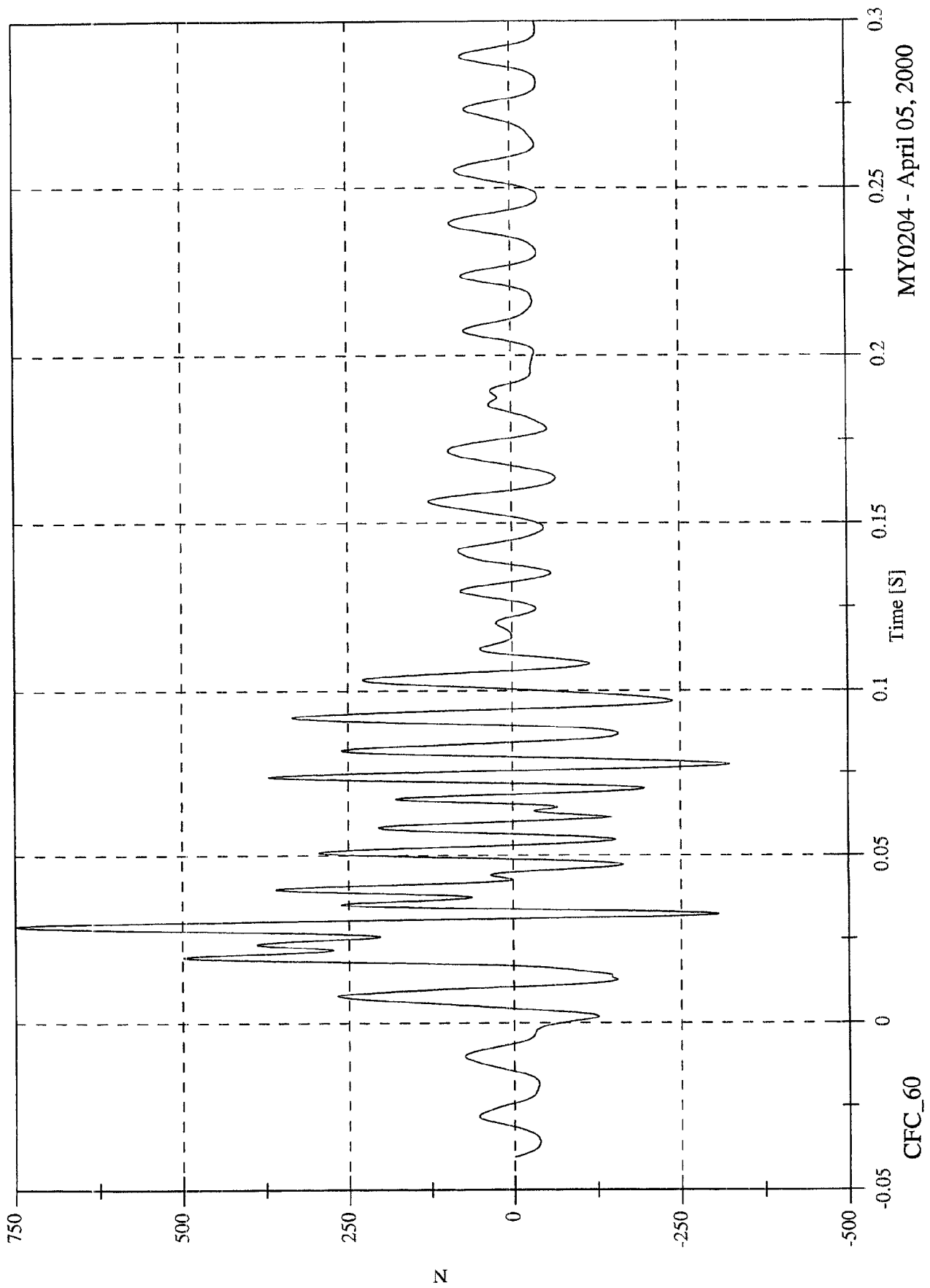

MY0204 - April 05, 2000

NCAP Test#17 - 2000 Ford Focus 3-Door

Barrier Load Cell B2 Fx

Max: 12279.9 [N] at 0.044 [S]
Min: -407.0 [N] at 0.001 [S]

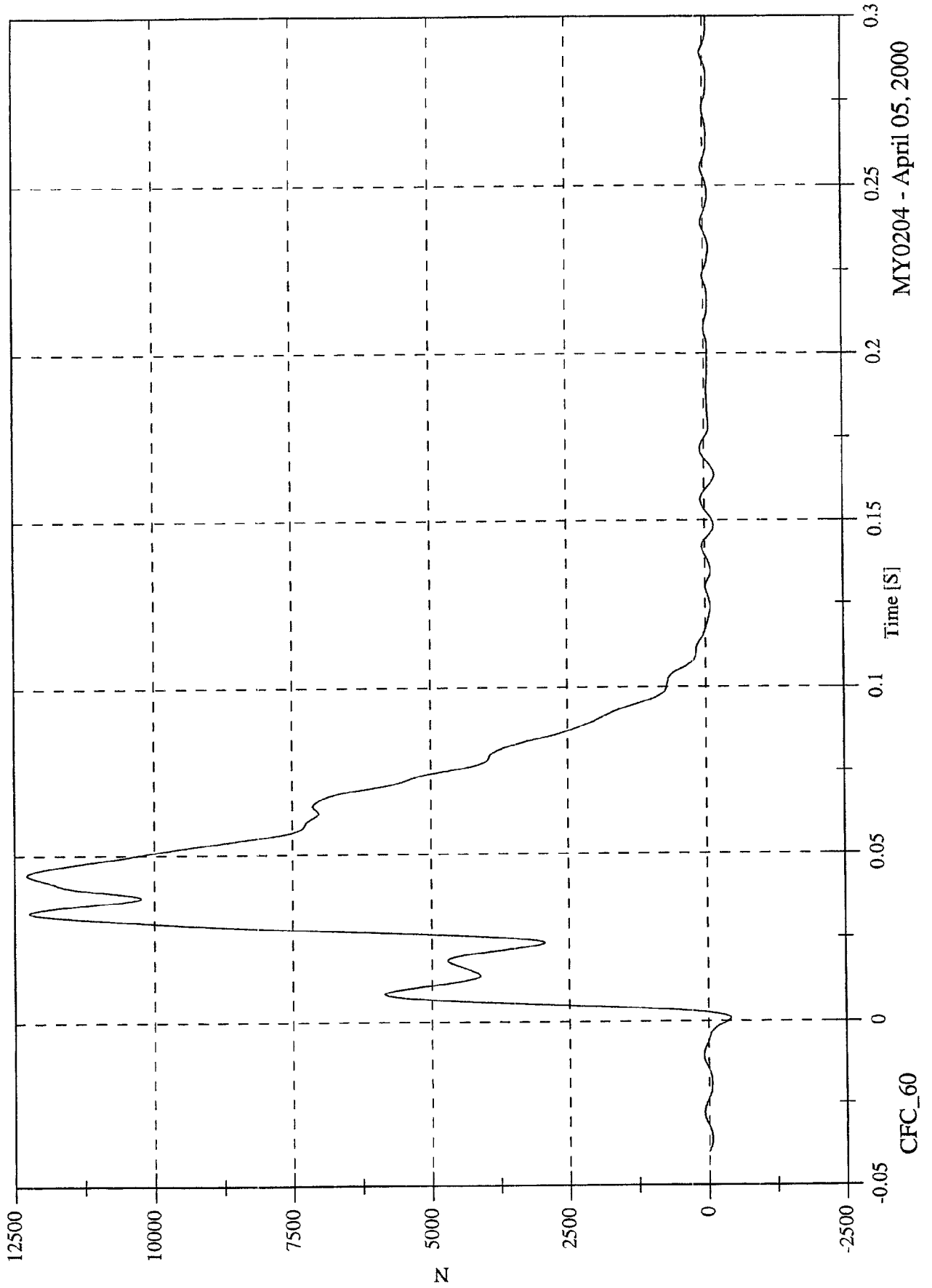

MY0204 - April 05, 2000

NCAP Test#17 - 2000 Ford Focus 3-Door

Barrier Load Cell B3 Fx

Max: 83327.2 [N] at 0.028 [S]
Min: -942.9 [N] at -0.002 [S]

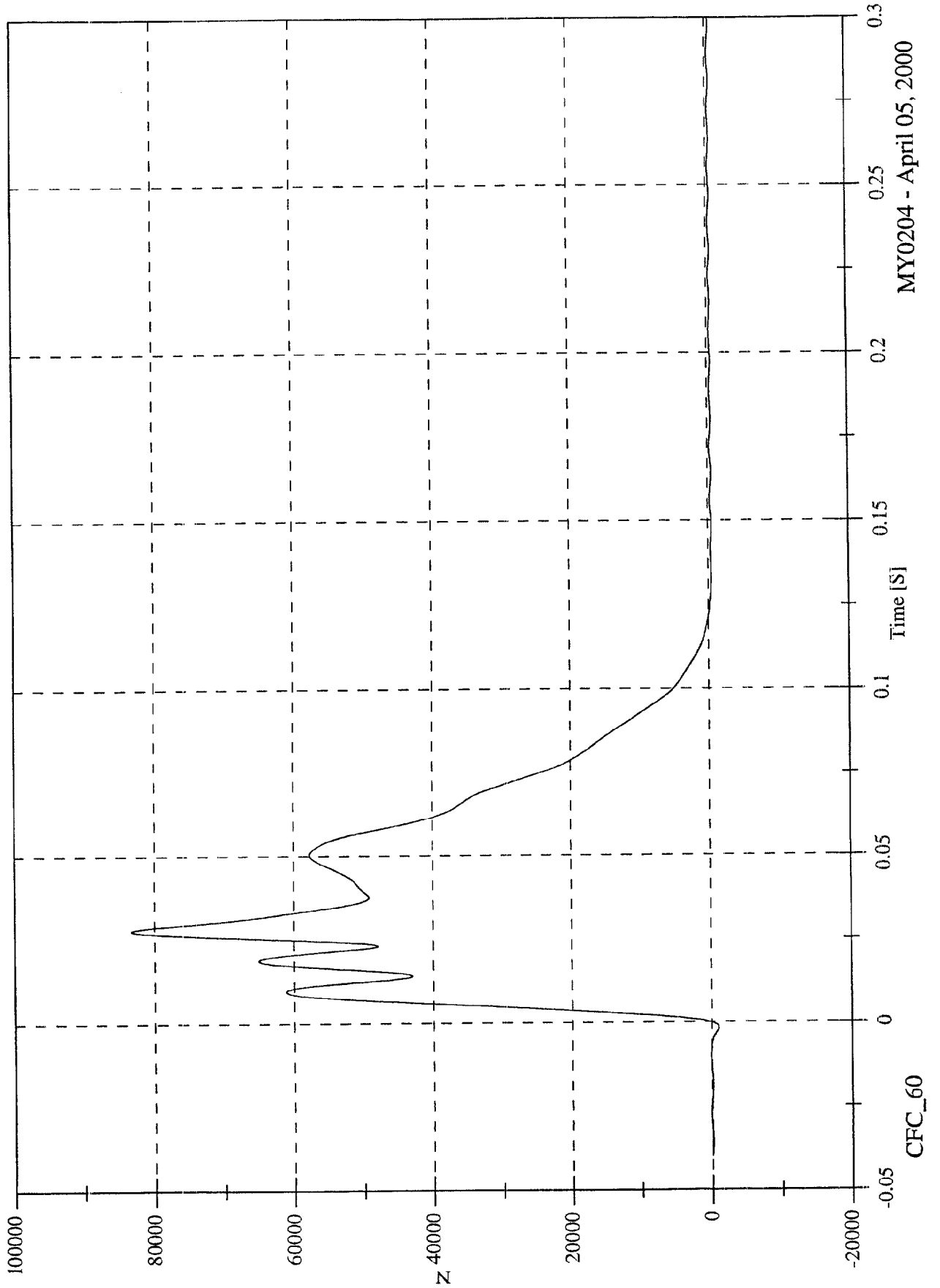

MY0204 - April 05, 2000

NCAP Test#17 - 2000 Ford Focus 3-Door

Max: 54917.5 [N] at 0.051 [S]
Min: -663.6 [N] at -0.005 [S]

Barrier Load Cell B4 Fx

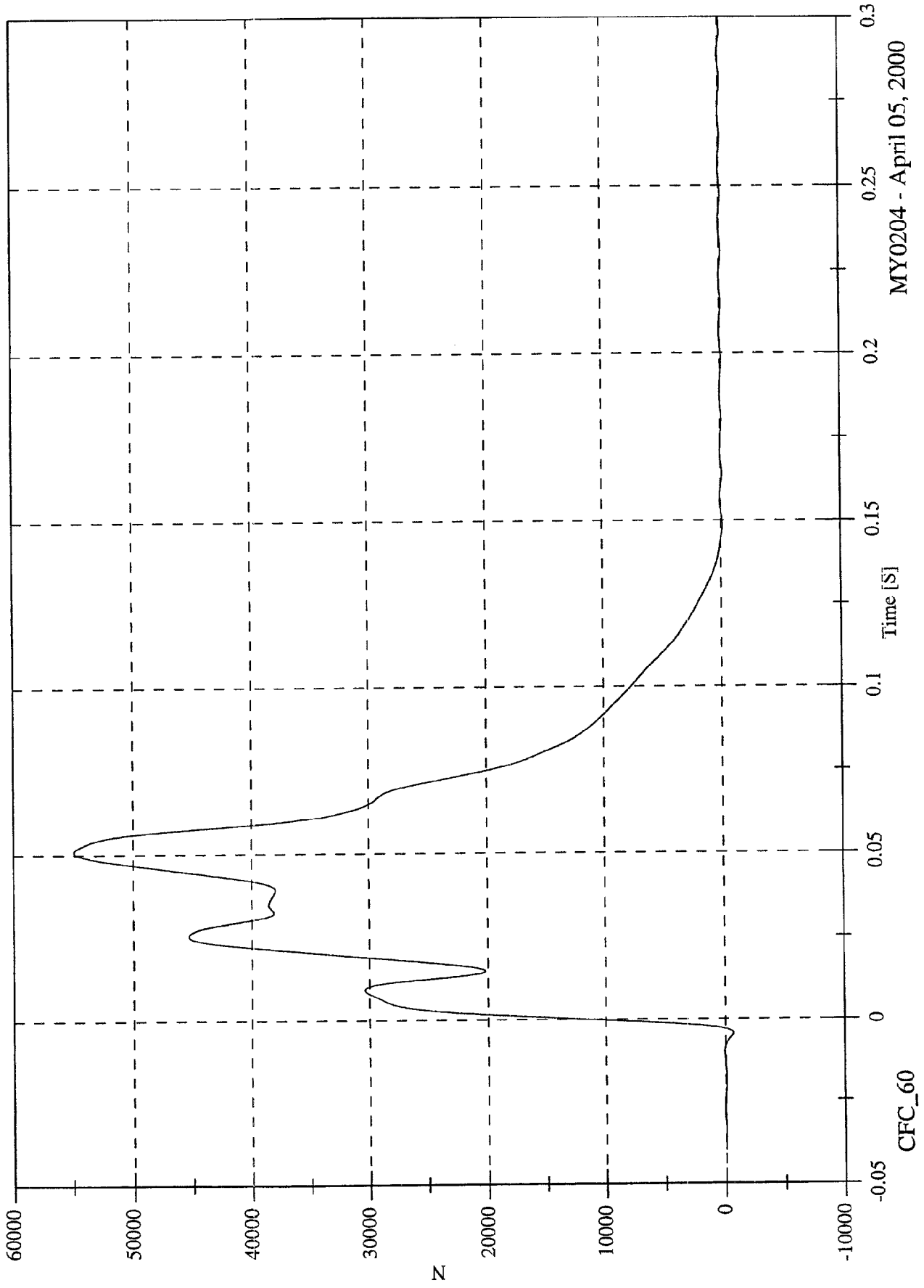

MY0204 - April 05, 2000

NCAP Test#17 - 2000 Ford Focus 3-Door

Max: 60673.0 [N] at 0.033 [S]
Min: -602.9 [N] at -0.005 [S]

Barrier Load Cell B5 Fx

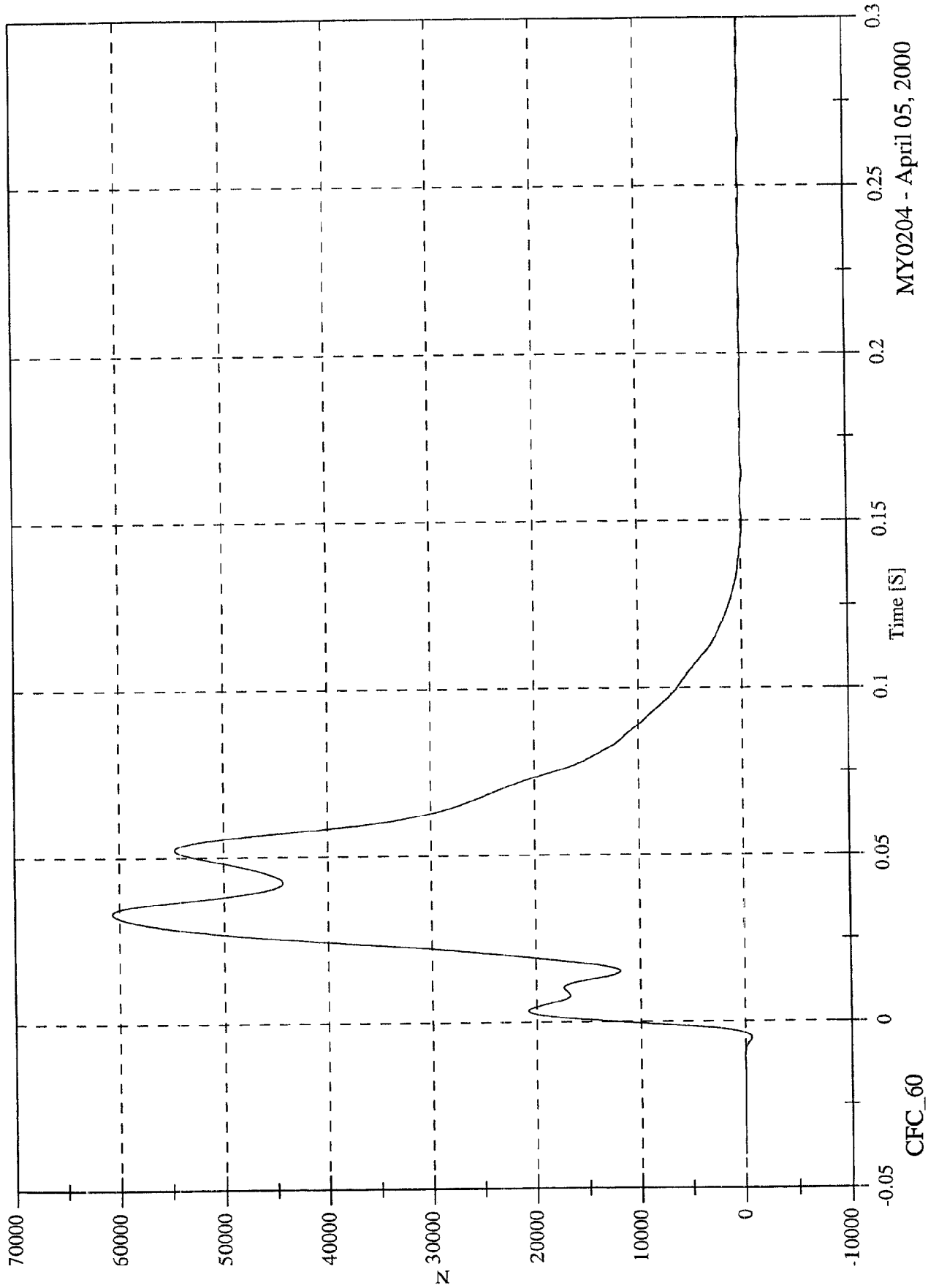

MY0204 - April 05, 2000

Max: 99863.7 [N] at 0.032 [S]
Min: -607.2 [N] at -0.004 [S]

Barrier Load Cell B6 Fx

NCAP Test#17 - 2000 Ford Focus 3-Door

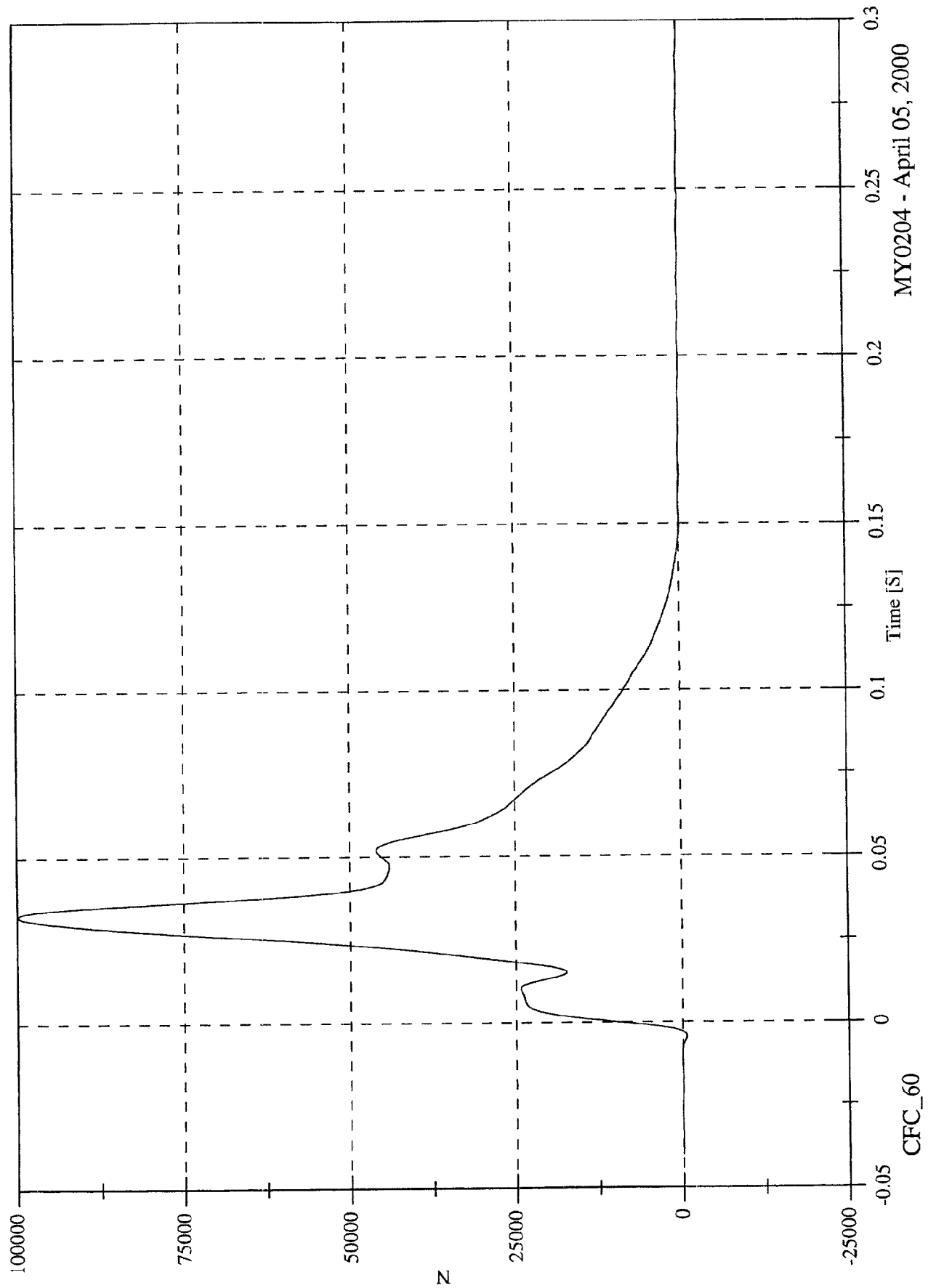

MY0204 - April 05, 2000

Max: 102076.9 [N] at 0.028 [S]
Min: -816.4 [N] at -0.002 [S]

Barrier Load Cell B7 Fx

NCAP Test#17 - 2000 Ford Focus 3-Door

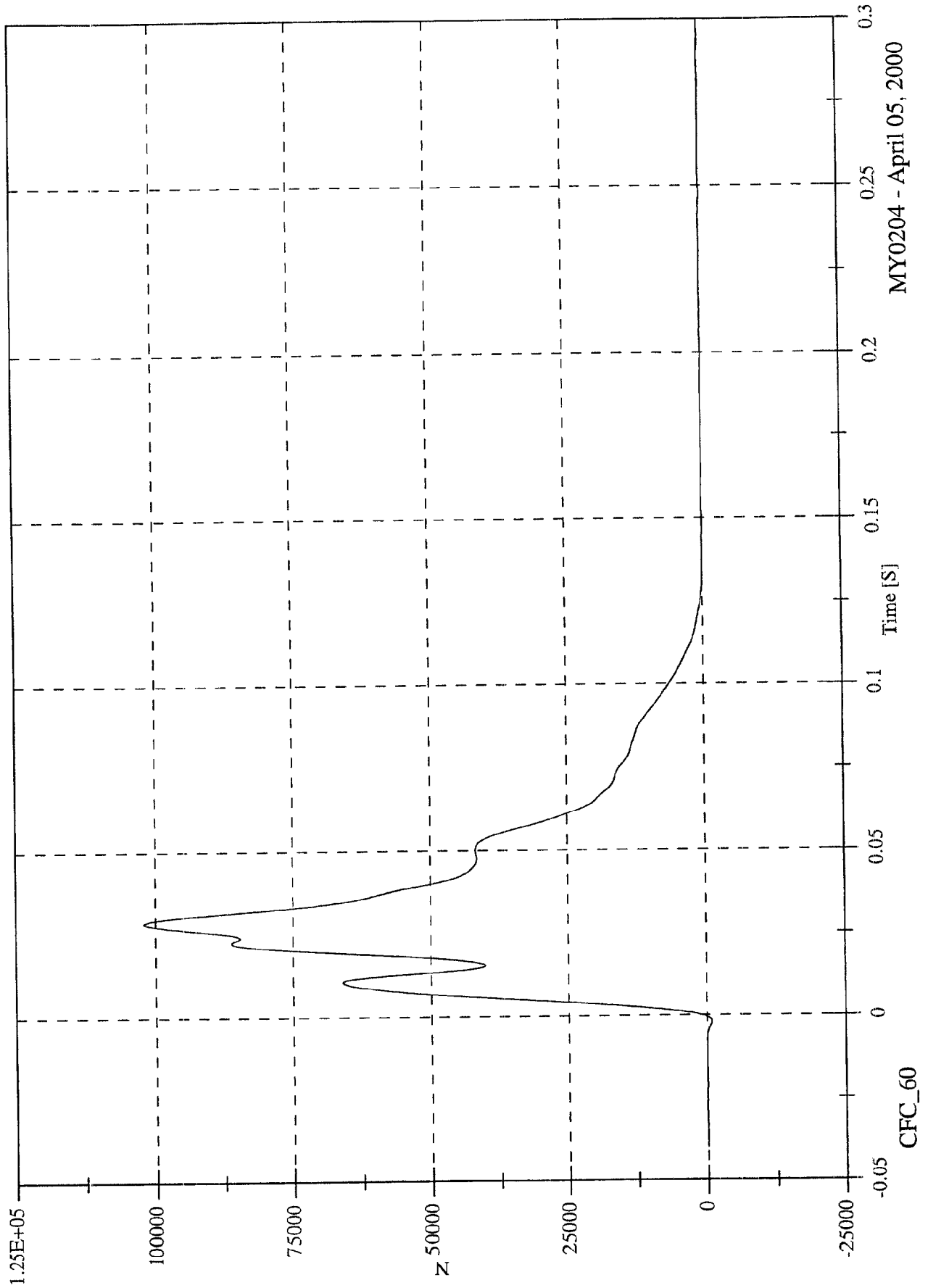

MY0204 - April 05, 2000

CFC_60

NCAP Test#17 - 2000 Ford Focus 3-Door

Max: 12097.8 [N] at 0.028 [S]
Min: -646.5 [N] at 0.166 [S]

Barrier Load Cell B8 Fx

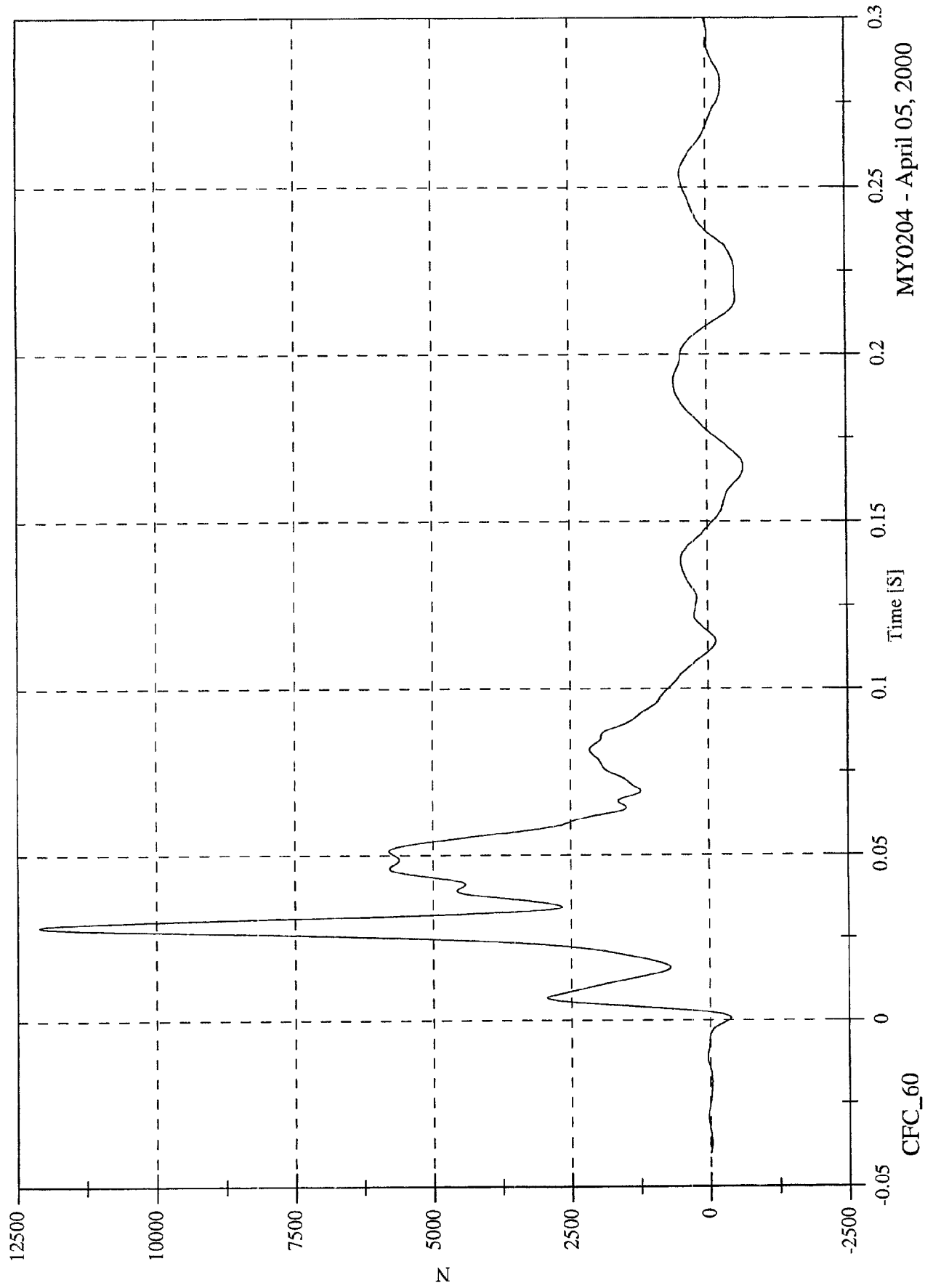

MY0204 - April 05, 2000

NCAP Test#17 - 2000 Ford Focus 3-Door

Max: 896.6 [N] at 0.055 [S]
Min: -568.5 [N] at 0.165 [S]

Barrier Load Cell B9 Fx

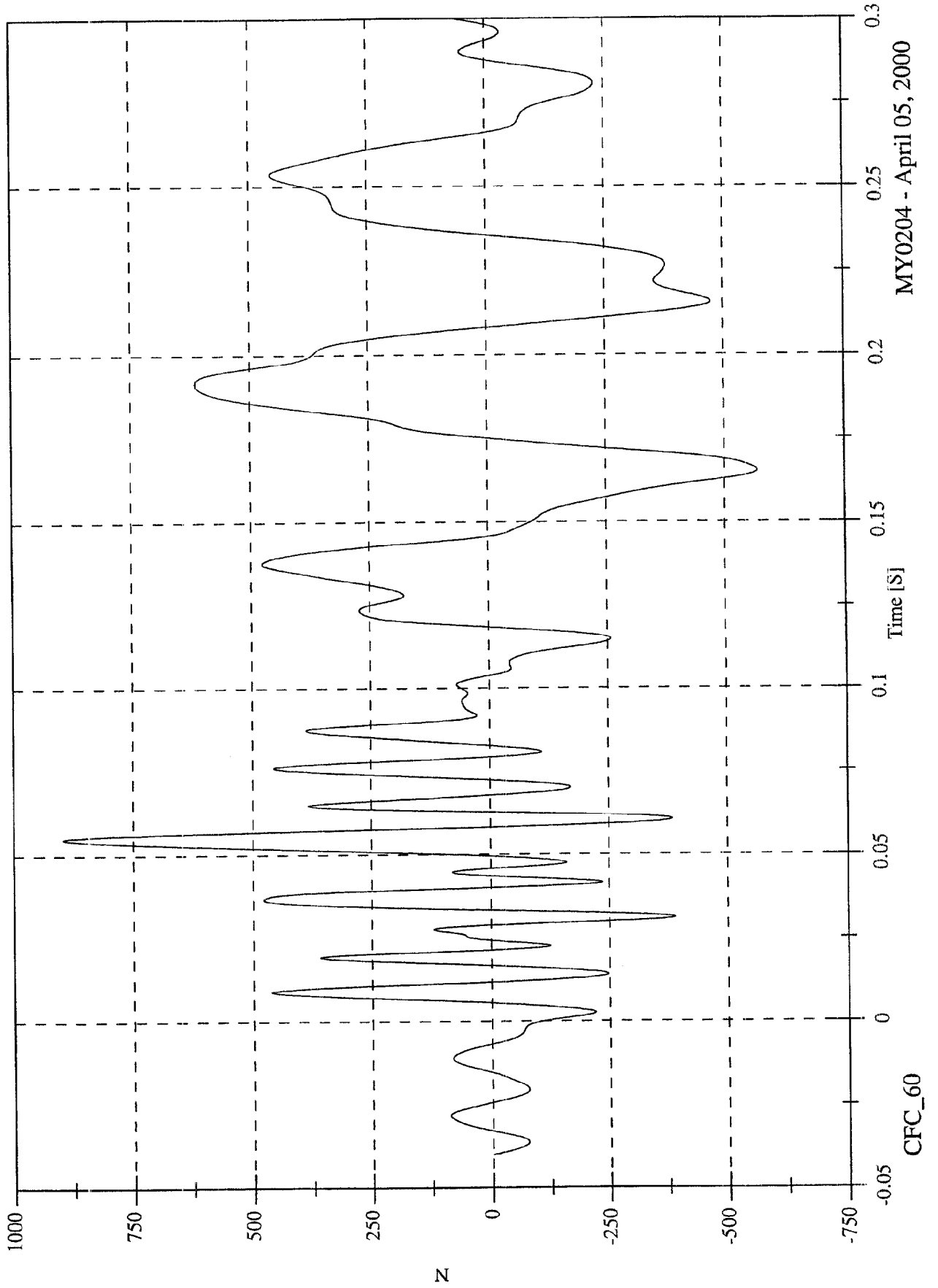

MY0204 - April 05, 2000

NCAP Test#17 - 2000 Ford Focus 3-Door

Max: 1013.0 [N] at 0.041 [S]
Min: -658.3 [N] at 0.164 [S]

Barrier Load Cell C1 Fx

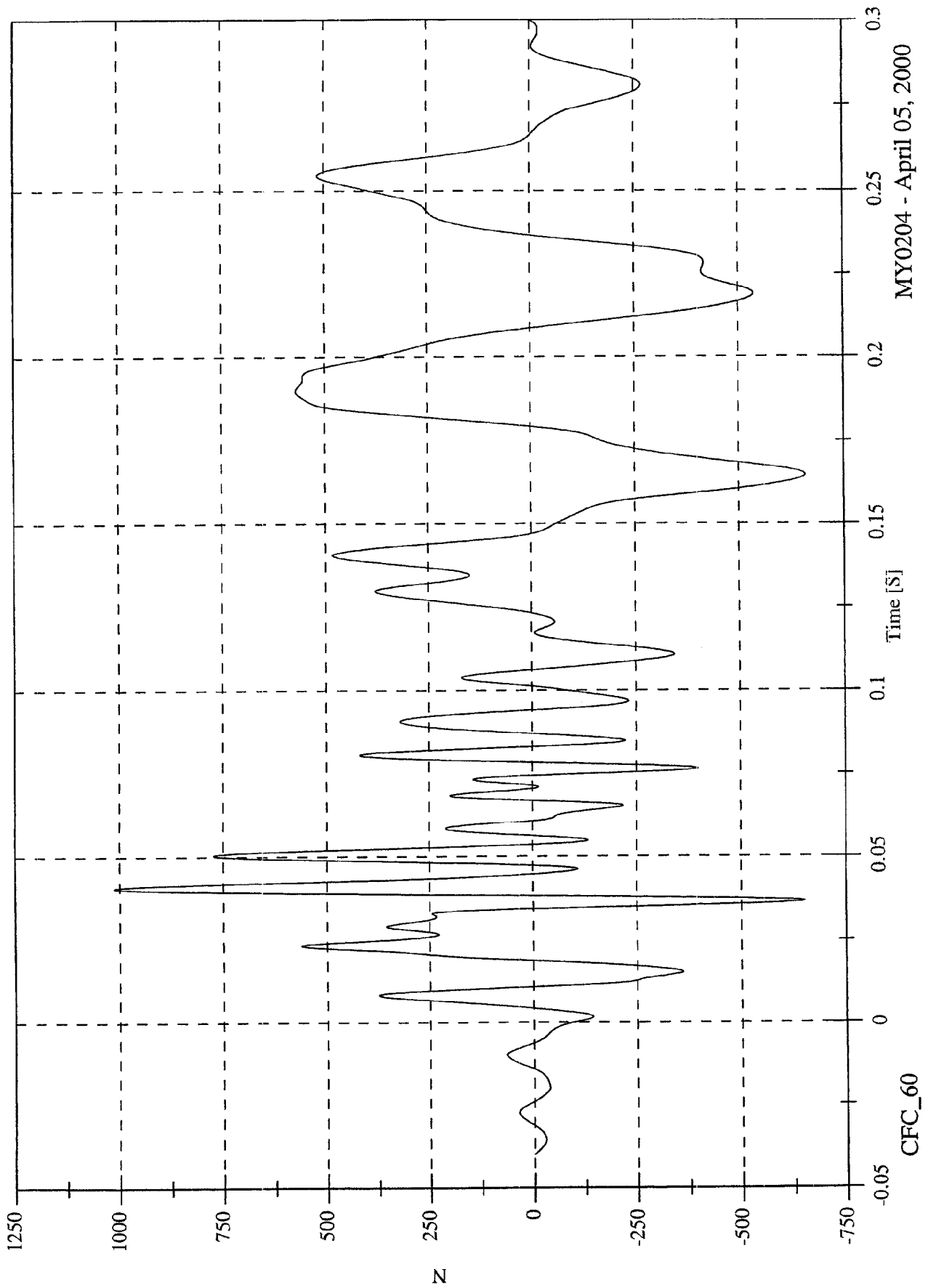

MY0204 - April 05, 2000

Max: 41357.2 [N] at 0.039 [S]
Min: -818.1 [N] at 0.164 [S]

NCAP Test#17 - 2000 Ford Focus 3-Door

Barrier Load Cell C2 Fx

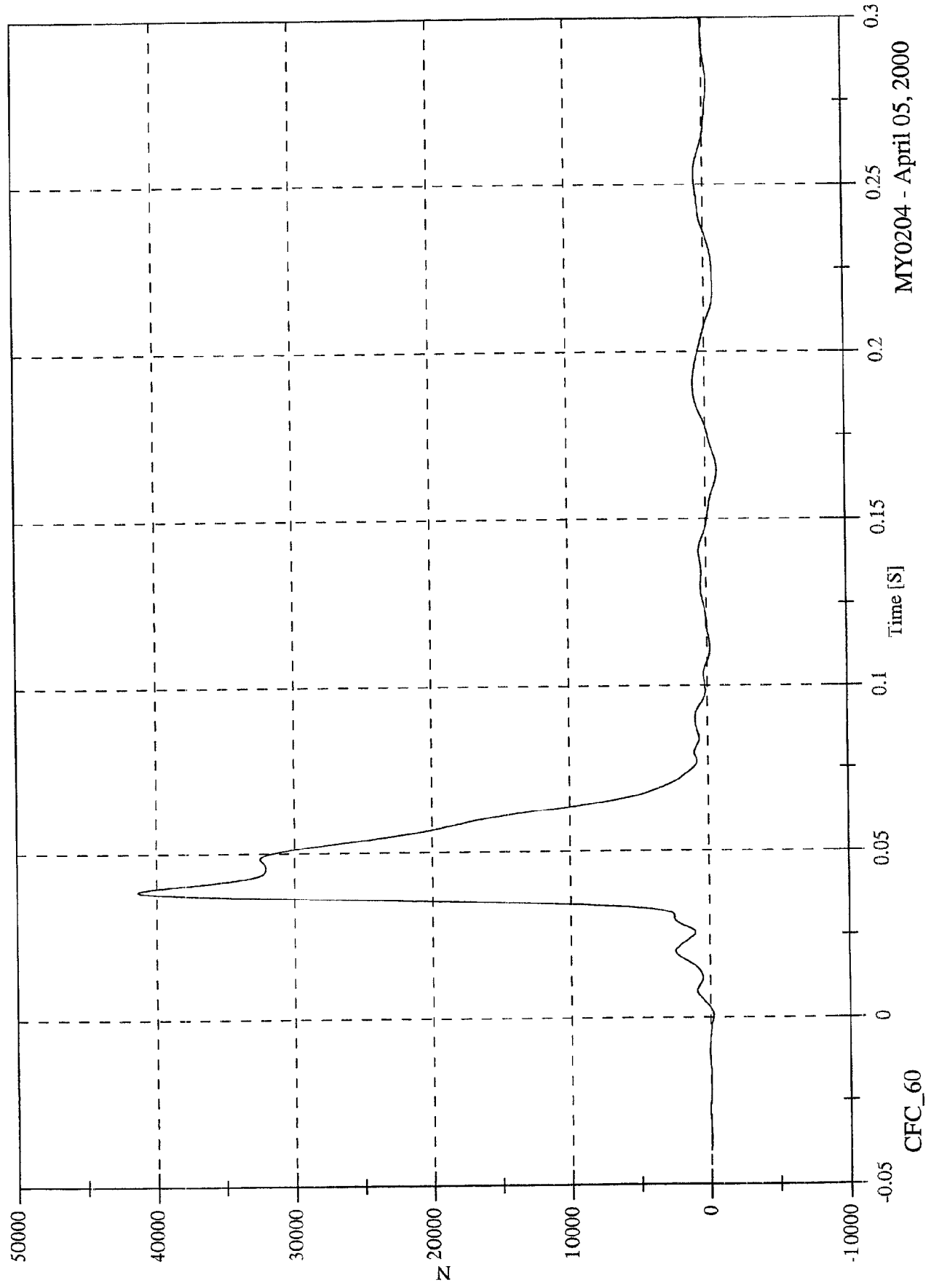

MY0204 - April 05, 2000

NCAP Test#17 - 2000 Ford Focus 3-Door

Barrier Load Cell C3 Fx

Max: 20606.9 [N] at 0.039 [S]
Min: -631.7 [N] at 0.161 [S]

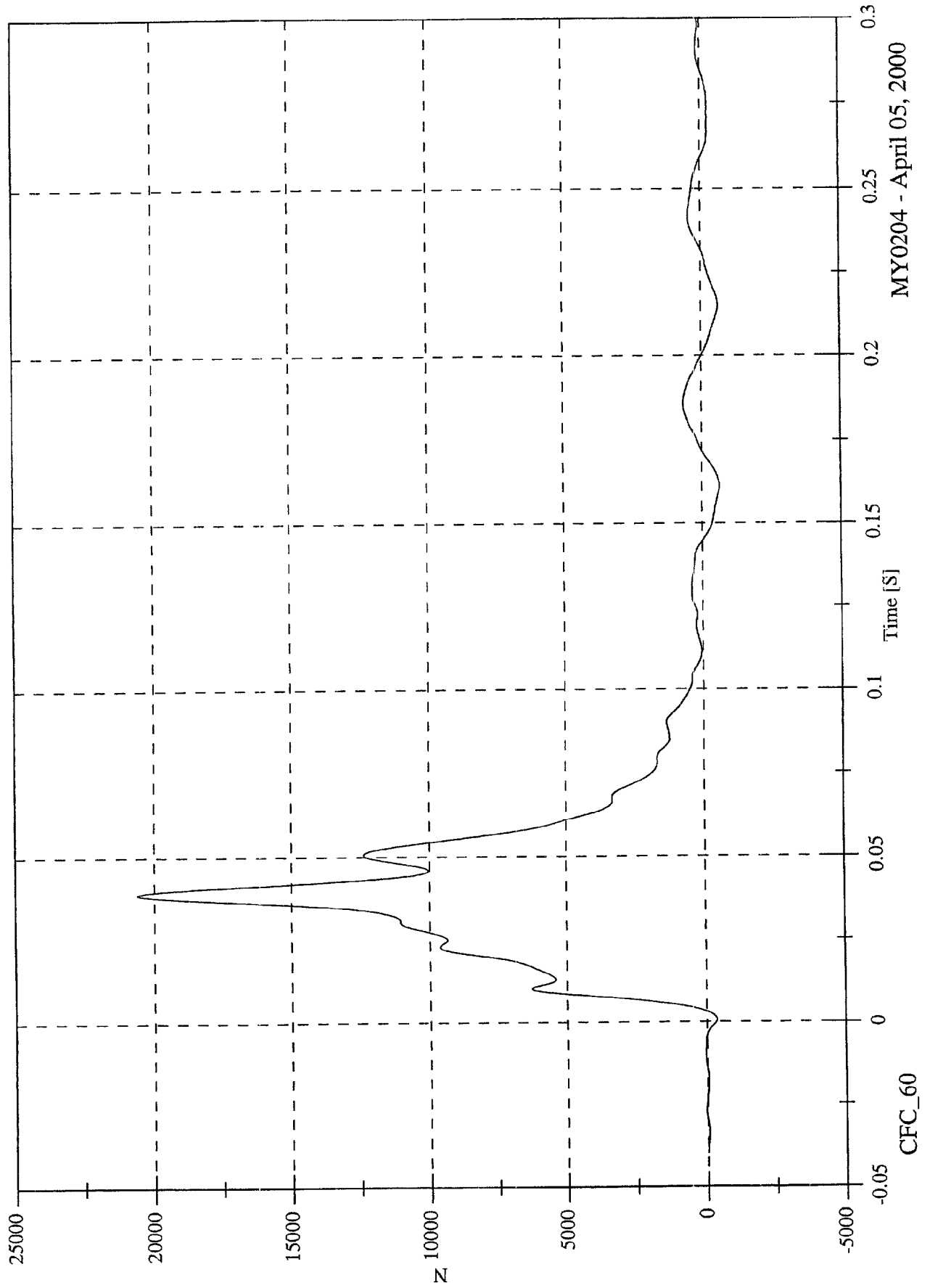

MY0204 - April 05, 2000

Max: 9505.4 [N] at 0.039 [S]
Min: -716.1 [N] at 0.161 [S]

NCAP Test#17 - 2000 Ford Focus 3-Door

Barrier Load Cell C4 Fx

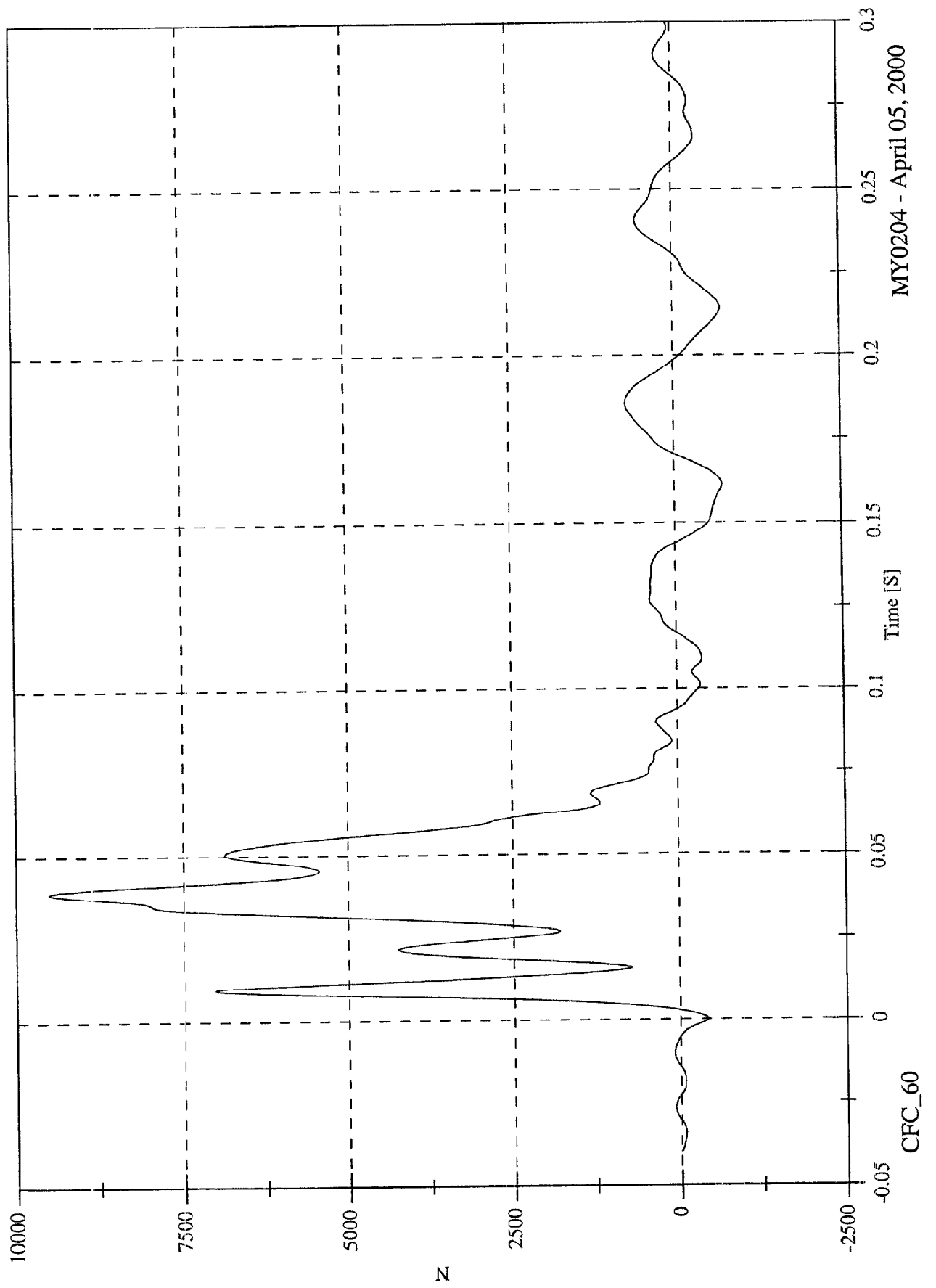

MY0204 - April 05, 2000

NCAP Test#17 - 2000 Ford Focus 3-Door

Barrier Load Cell C5 Fx

Max: 22116.8 [N] at 0.034 [S]

Min: -712.0 [N] at 0.161 [S]

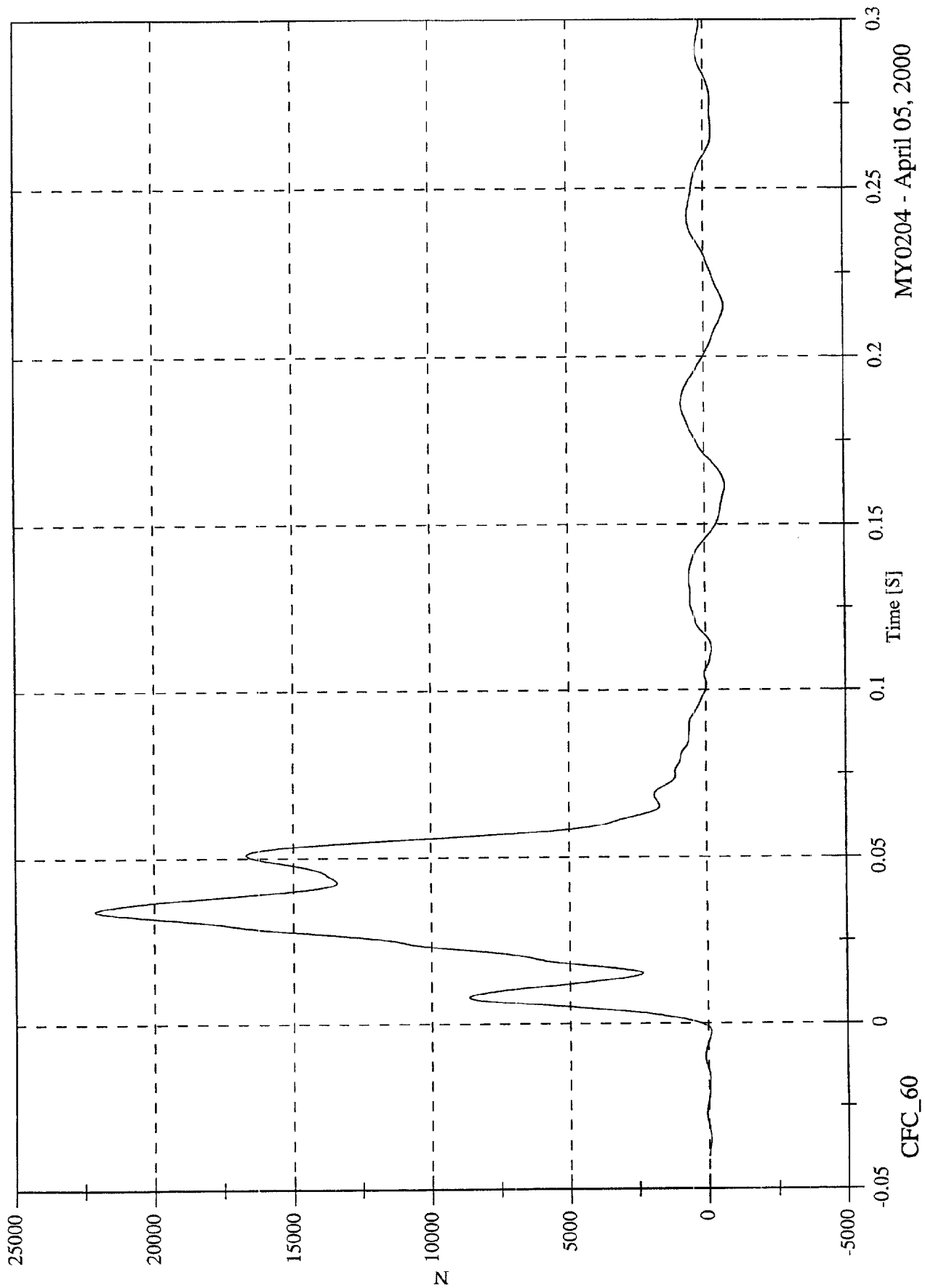

MY0204 - April 05, 2000

NCAP Test#17 - 2000 Ford Focus 3-Door

Max: 16105.6 [N] at 0.034 [S]
Min: -803.3 [N] at 0.214 [S]

Barrier Load Cell C6 Fx

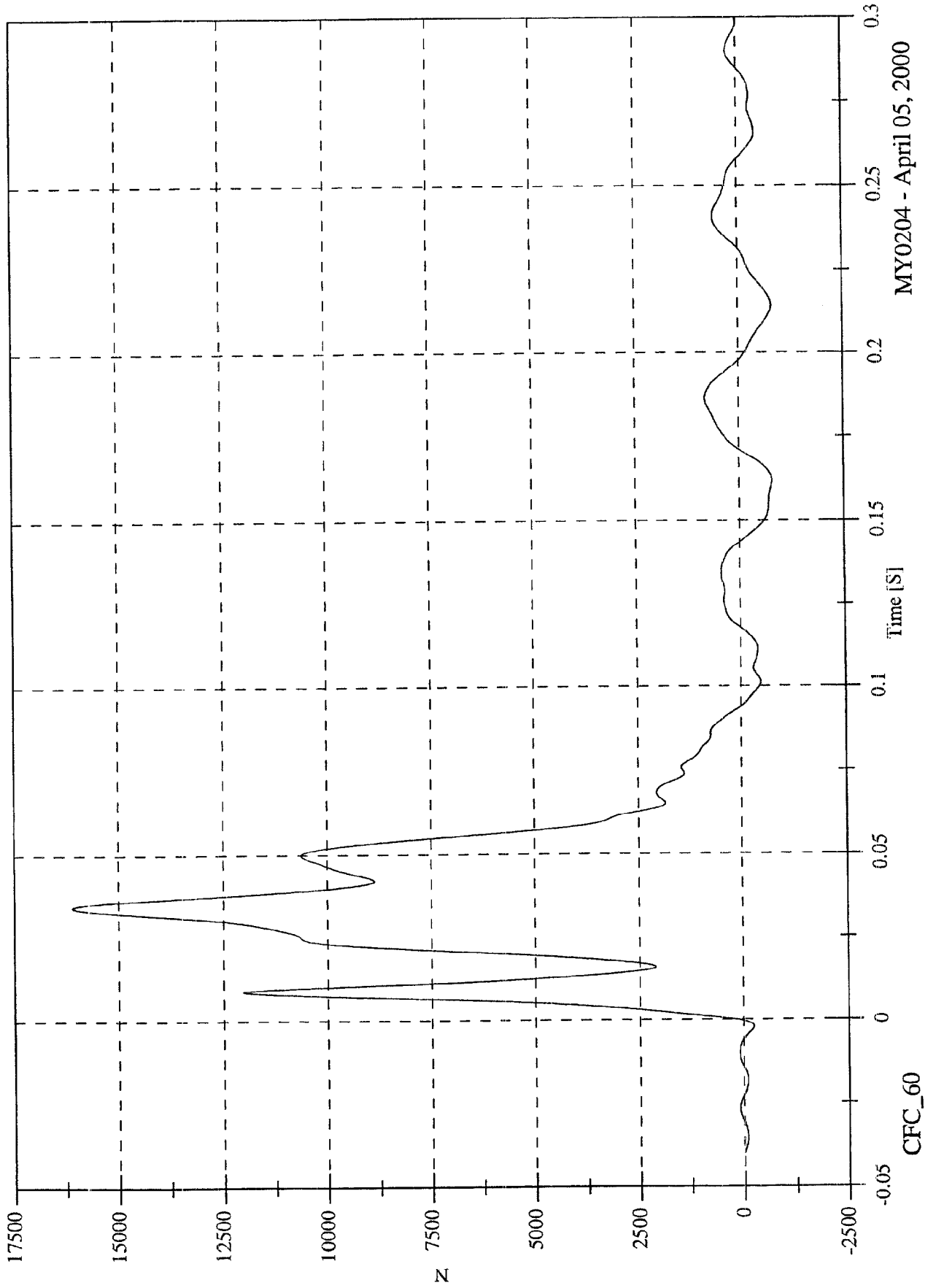

MY0204 - April 05, 2000

NCAP Test#17 - 2000 Ford Focus 3-Door

Max: 17263.7 [N] at 0.047 [S]

Min: -1374.2 [N] at 0.166 [S]

Barrier Load Cell C7 Fx

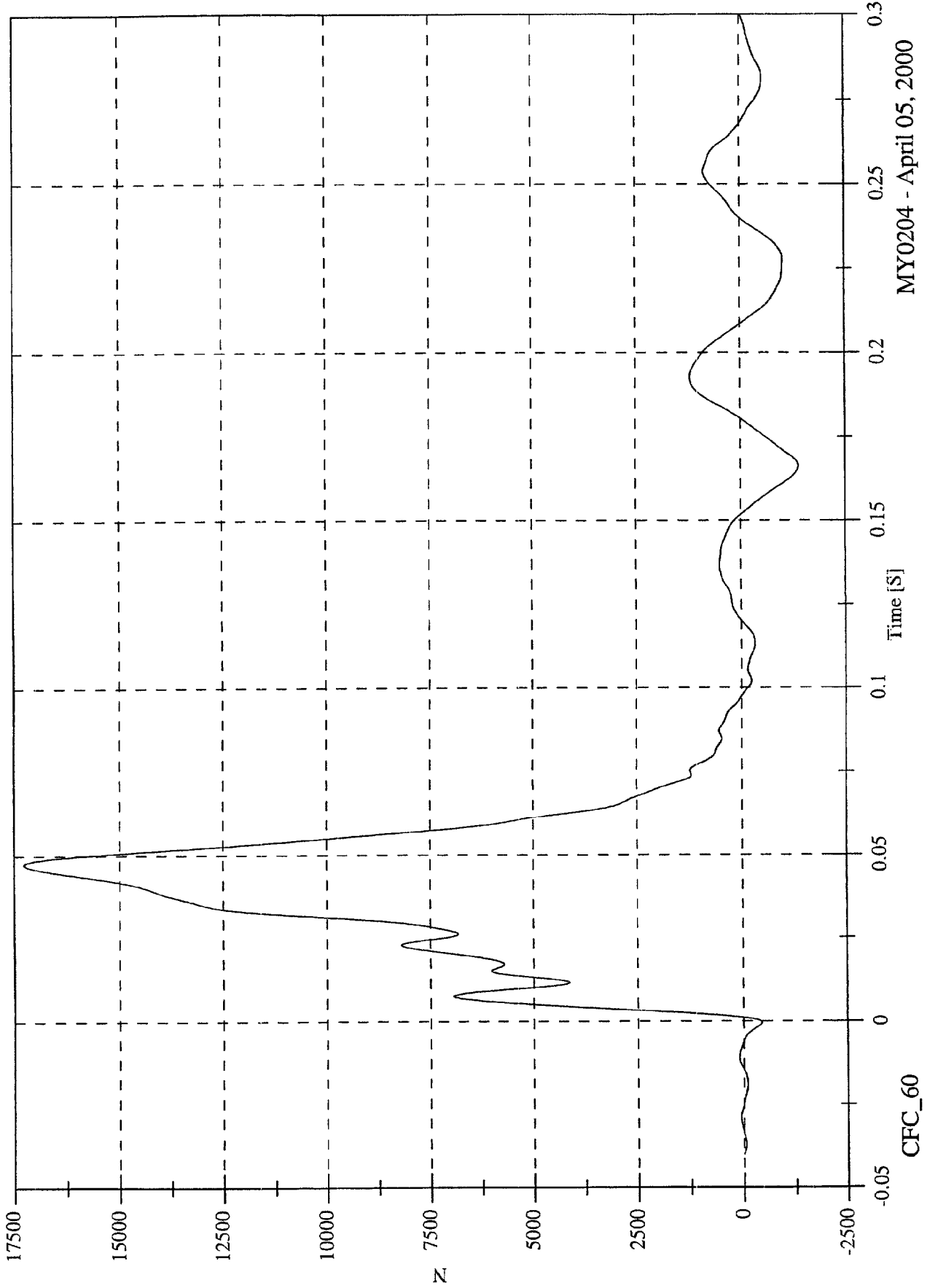

MY0204 - April 05, 2000

NCAP Test#17 - 2000 Ford Focus 3-Door

Barrier Load Cell C8 Fx

Max: 34361.2 [N] at 0.038 [S]
Min: -1454.0 [N] at 0.165 [S]

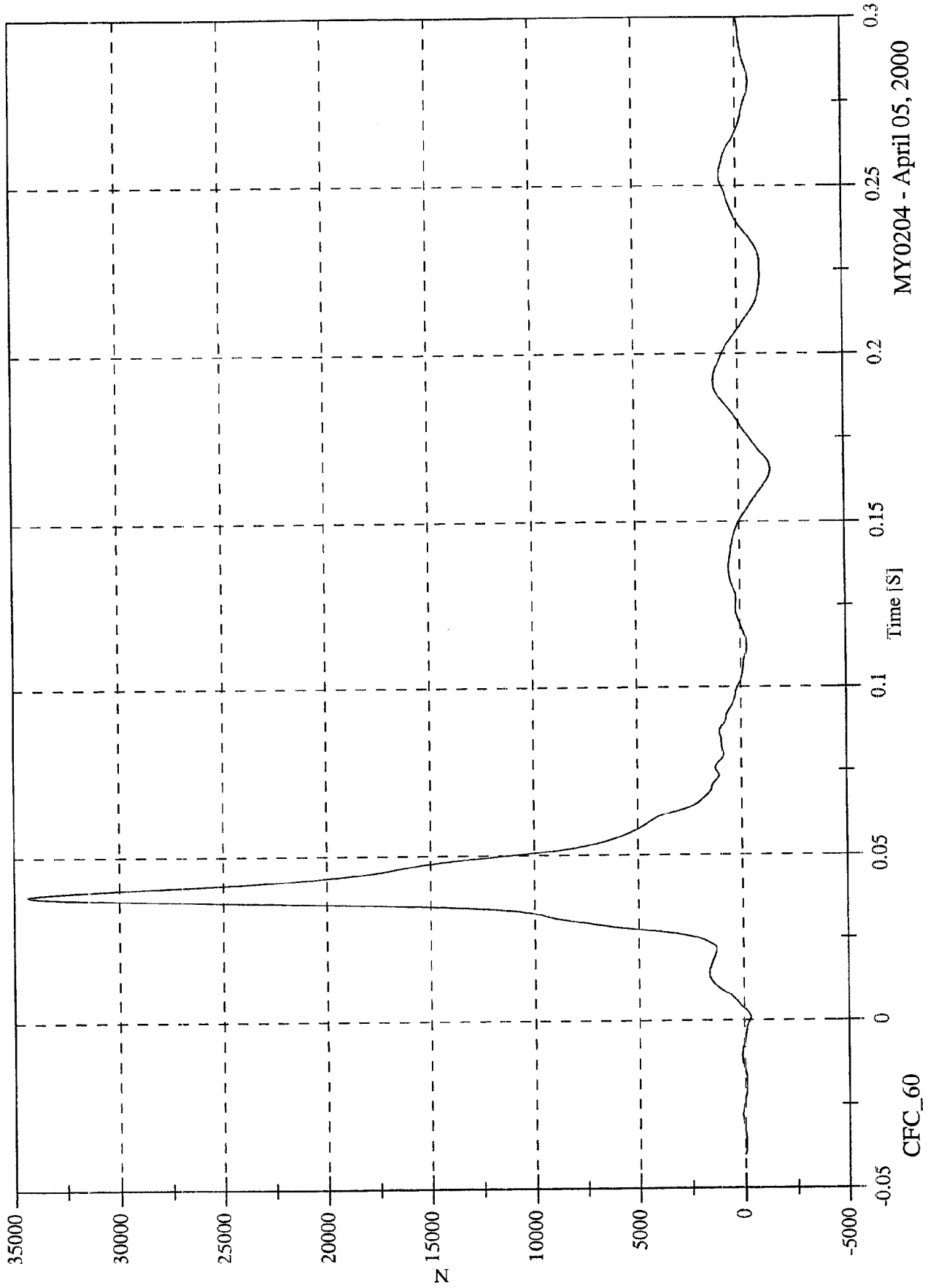

MY0204 - April 05, 2000

NCAP Test#17 - 2000 Ford Focus 3-Door

Max: 1243.5 [N] at 0.192 [S]
Min: -1391.5 [N] at 0.166 [S]

Barrier Load Cell C9 Fx

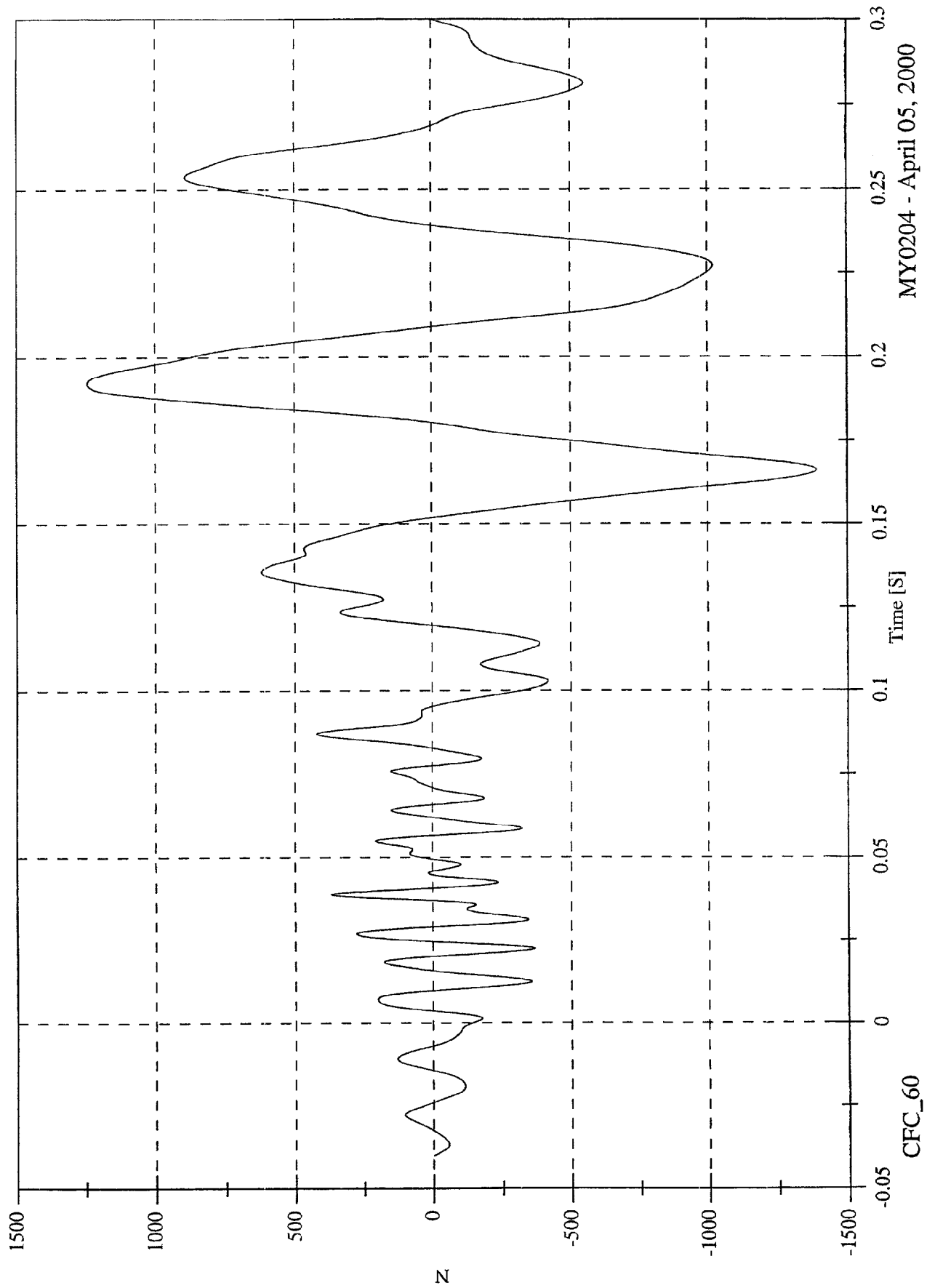

MY0204 - April 05, 2000

NCAP Test#17 - 2000 Ford Focus 3-Door

Barrier Load Cell D1 Fx

Max: 1259.4 [N] at 0.194 [S]
Min: -1891.8 [N] at 0.036 [S]

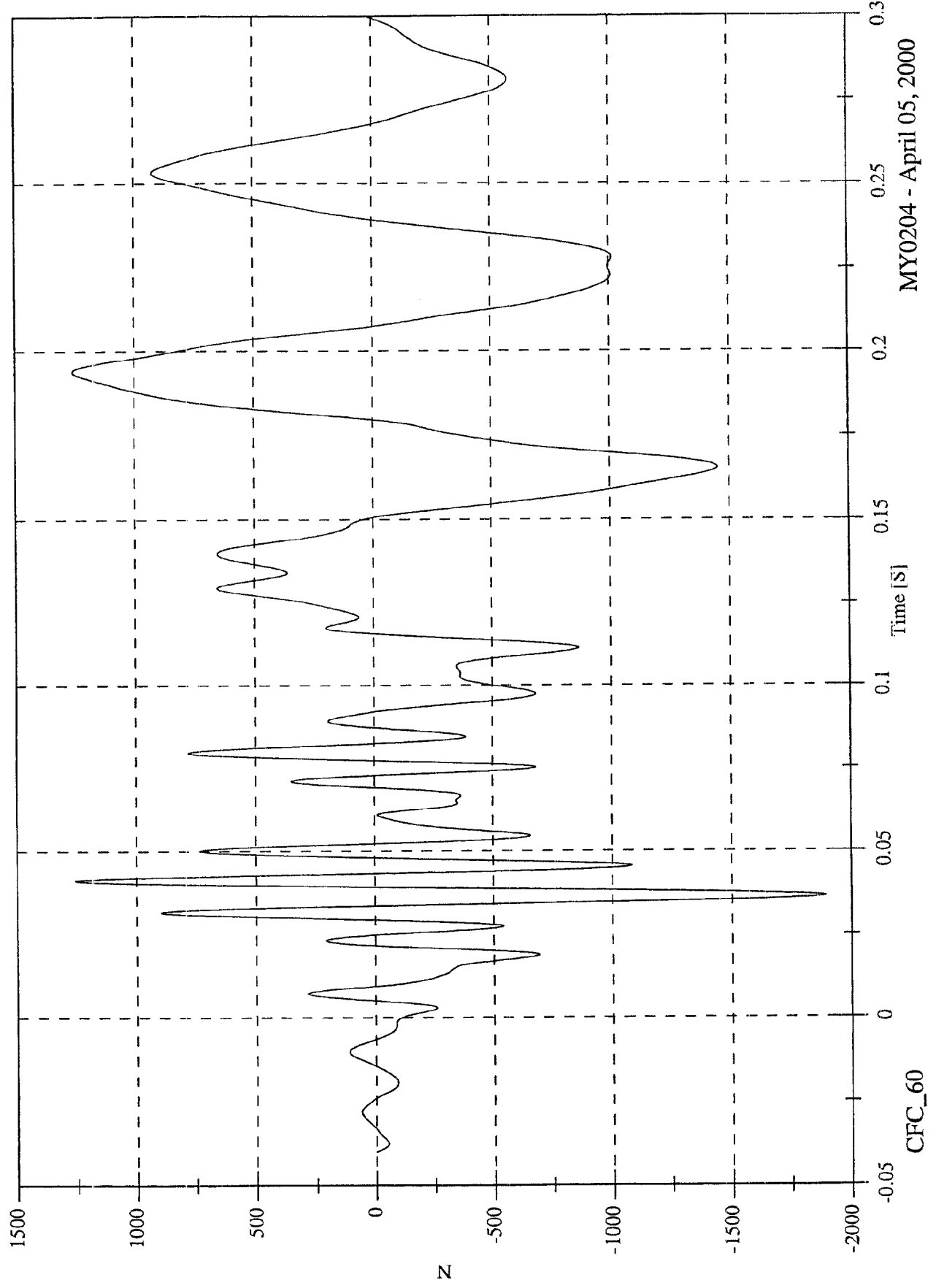

MY0204 - April 05, 2000

NCAP Test#17 - 2000 Ford Focus 3-Door

Max: 3994.9 [N] at 0.030 [S]
Min: -1474.6 [N] at 0.160 [S]

Barrier Load Cell D2 Fx

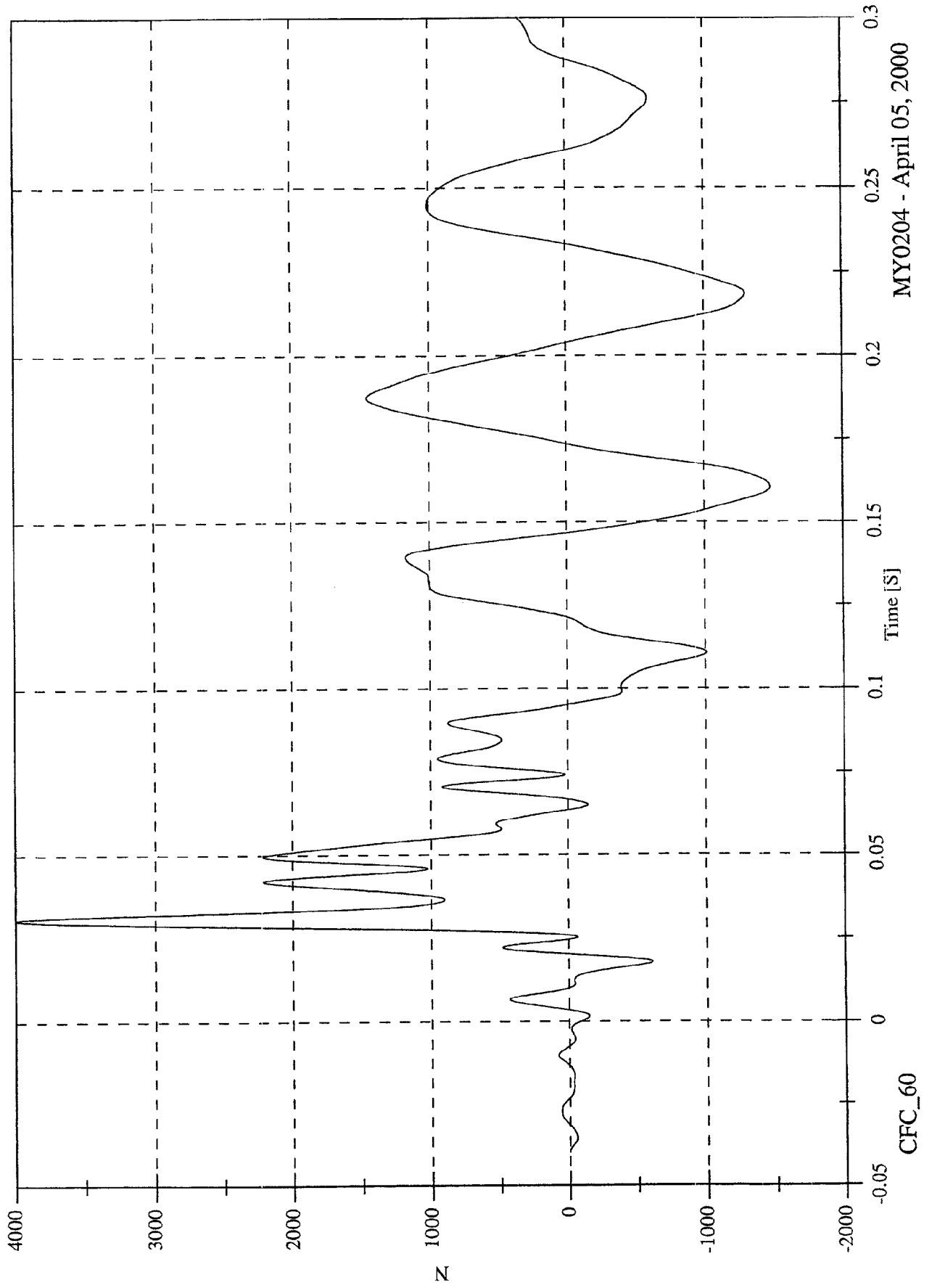

MY0204 - April 05, 2000

NCAP Test#17 - 2000 Ford Focus 3-Door

Max: 7519.5 [N] at 0.030 [S]
Min: -1335.5 [N] at 0.160 [S]

Barrier Load Cell D3 Fx

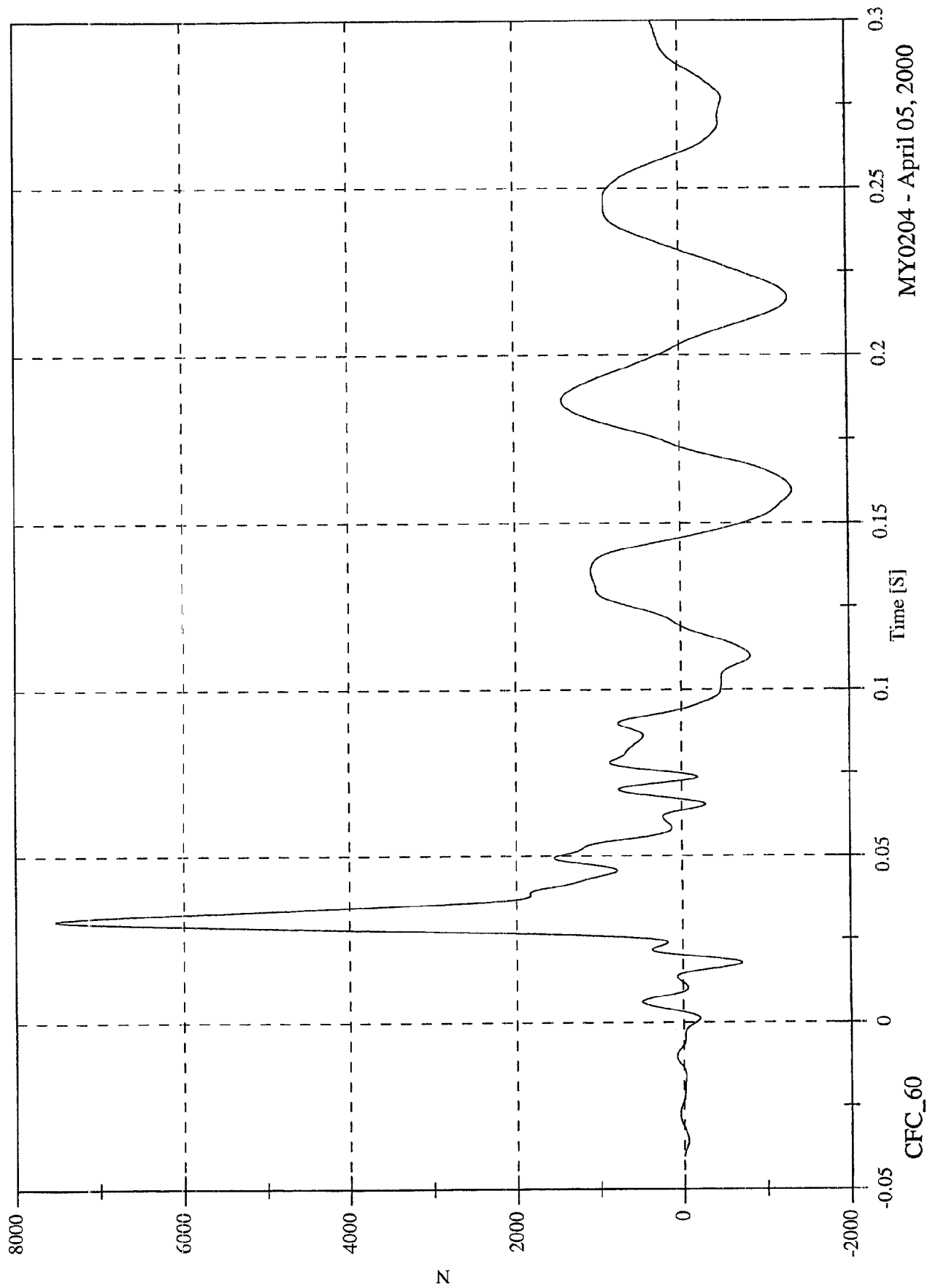

MY0204 - April 05, 2000

NCAP Test#17 - 2000 Ford Focus 3-Door

Max: 3382.6 [N] at 0.030 [S]
Min: -1380.4 [N] at 0.161 [S]

Barrier Load Cell D4 Fx

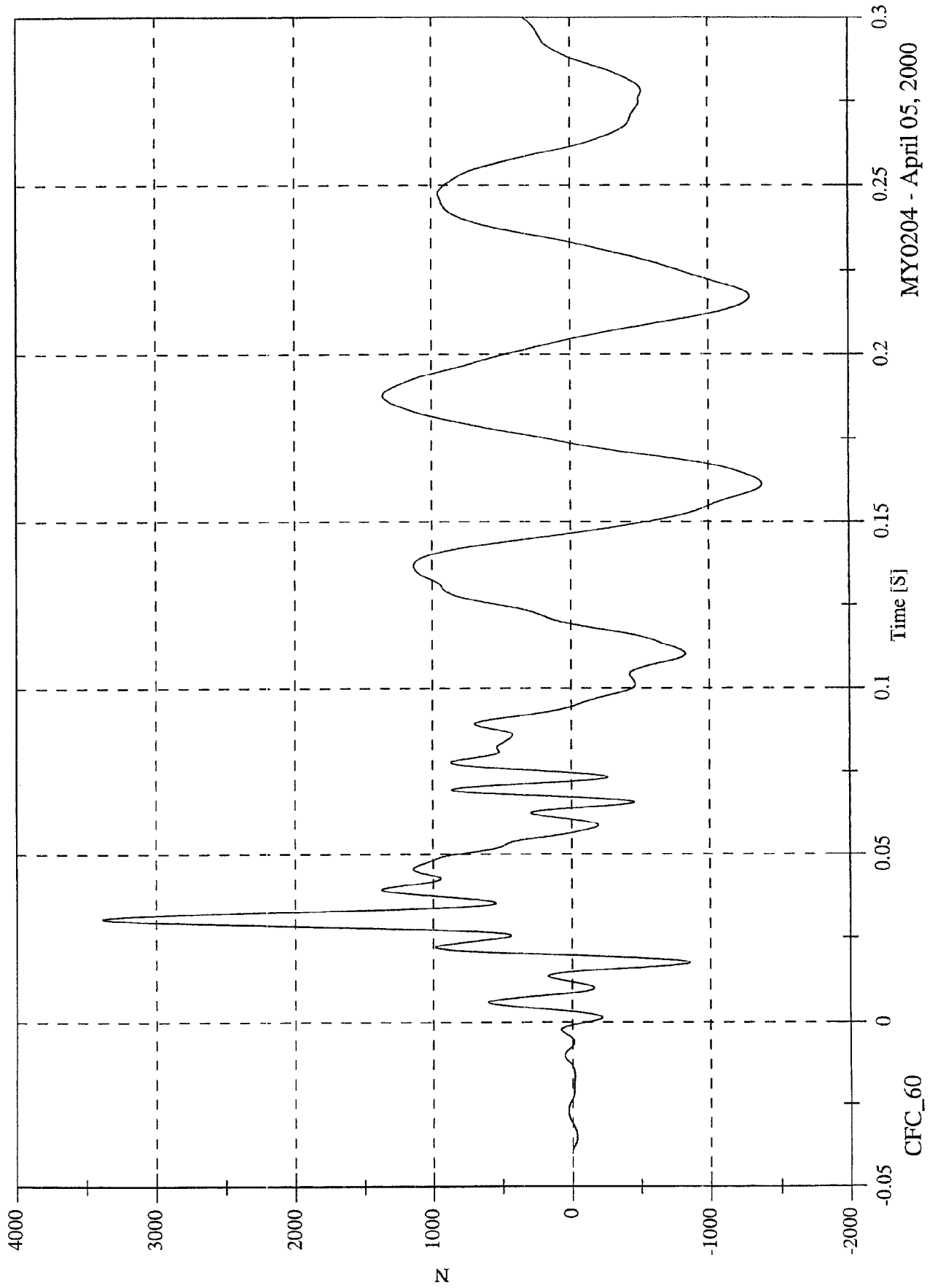

MY0204 - April 05, 2000

NCAP Test#17 - 2000 Ford Focus 3-Door

Max: 2208.0 [N] at 0.030 [S]
Min: -1354.9 [N] at 0.216 [S]

Barrier Load Cell D5 Fx

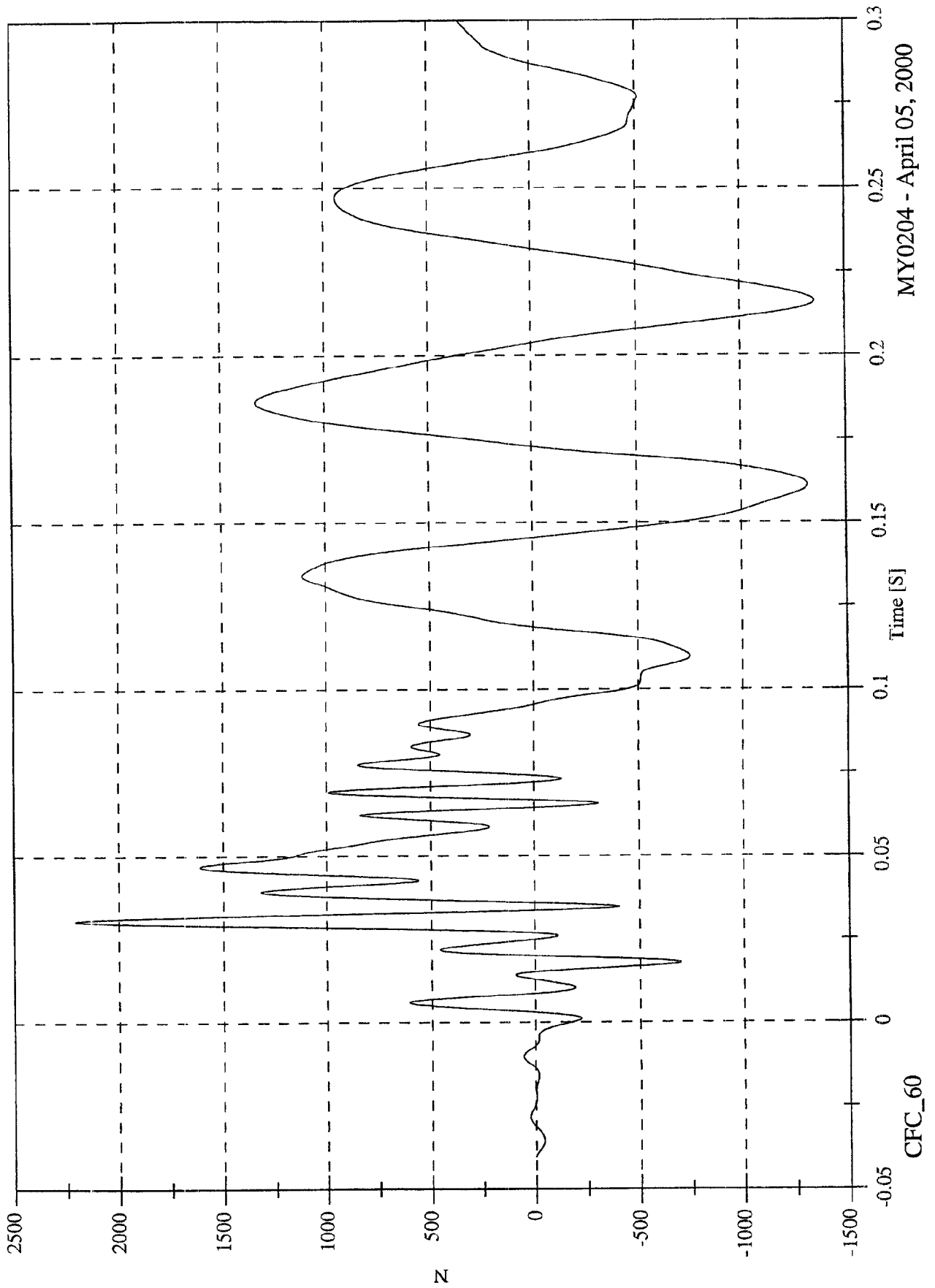

MY0204 - April 05, 2000

NCAP Test#17 - 2000 Ford Focus 3-Door

Barrier Load Cell D6 Fx

Max: 4499.2 [N] at 0.030 [S]
Min: -659.9 [N] at 0.018 [S]

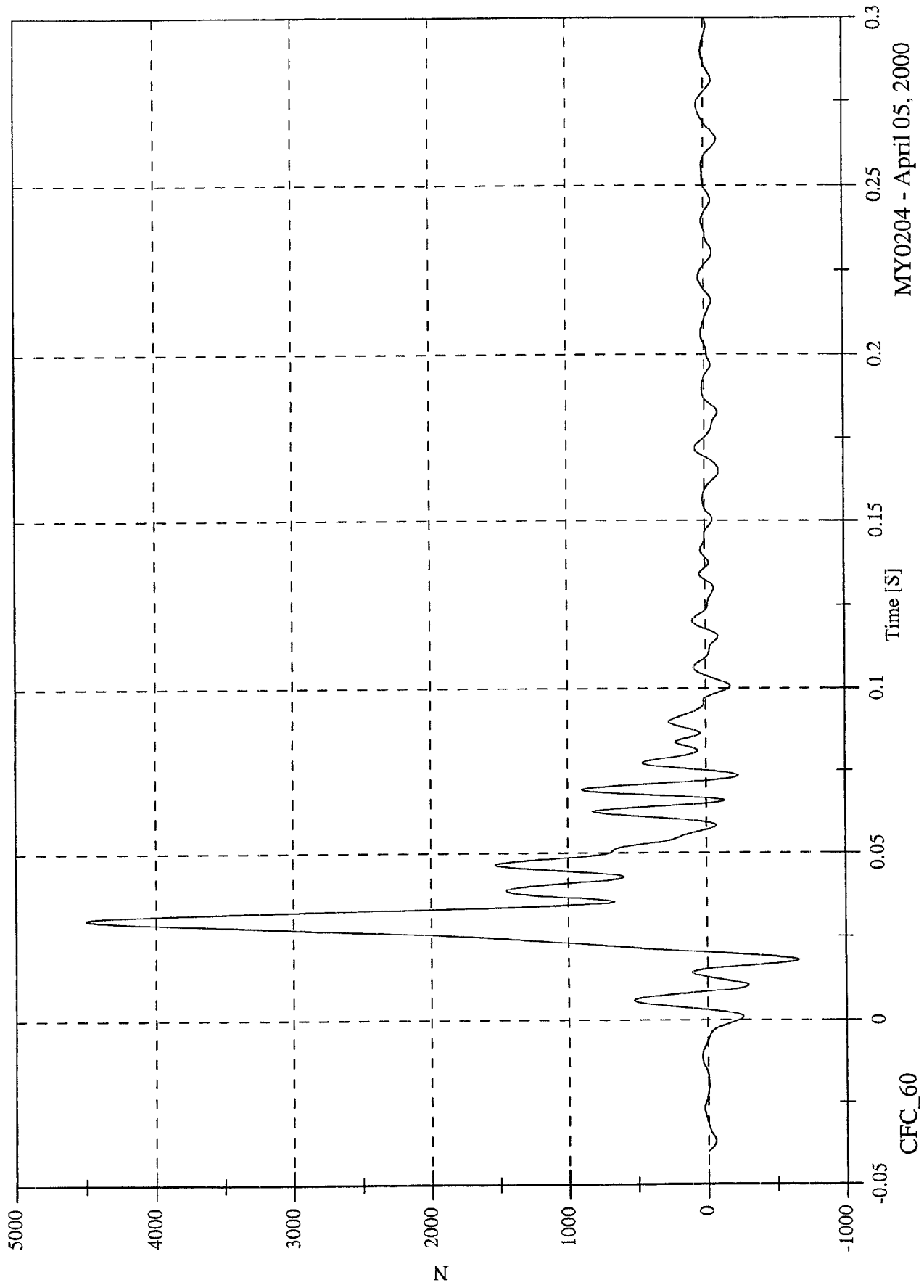

MY0204 - April 05, 2000

NCAP Test#17 - 2000 Ford Focus 3-Door

Barrier Load Cell D7 Fx

Max: 7449.7 [N] at 0.029 [S]
Min: -309.7 [N] at 0.018 [S]

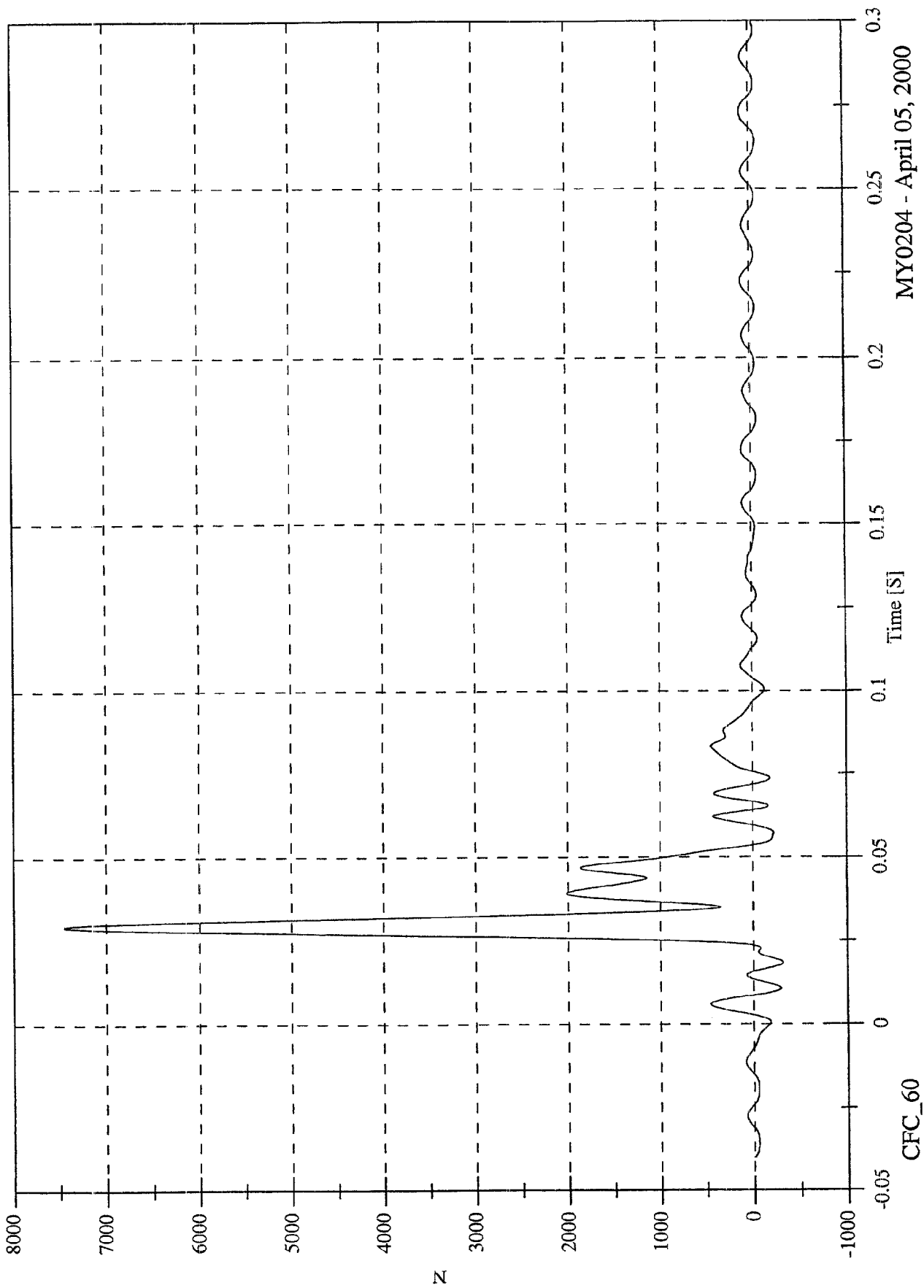

MY0204 - April 05, 2000

CFC_60

NCAP Test#17 - 2000 Ford Focus 3-Door

Max: 841.2 [N] at 0.030 [S]

Min: -1084.1 [N] at 0.035 [S]

Barrier Load Cell D8 Fx

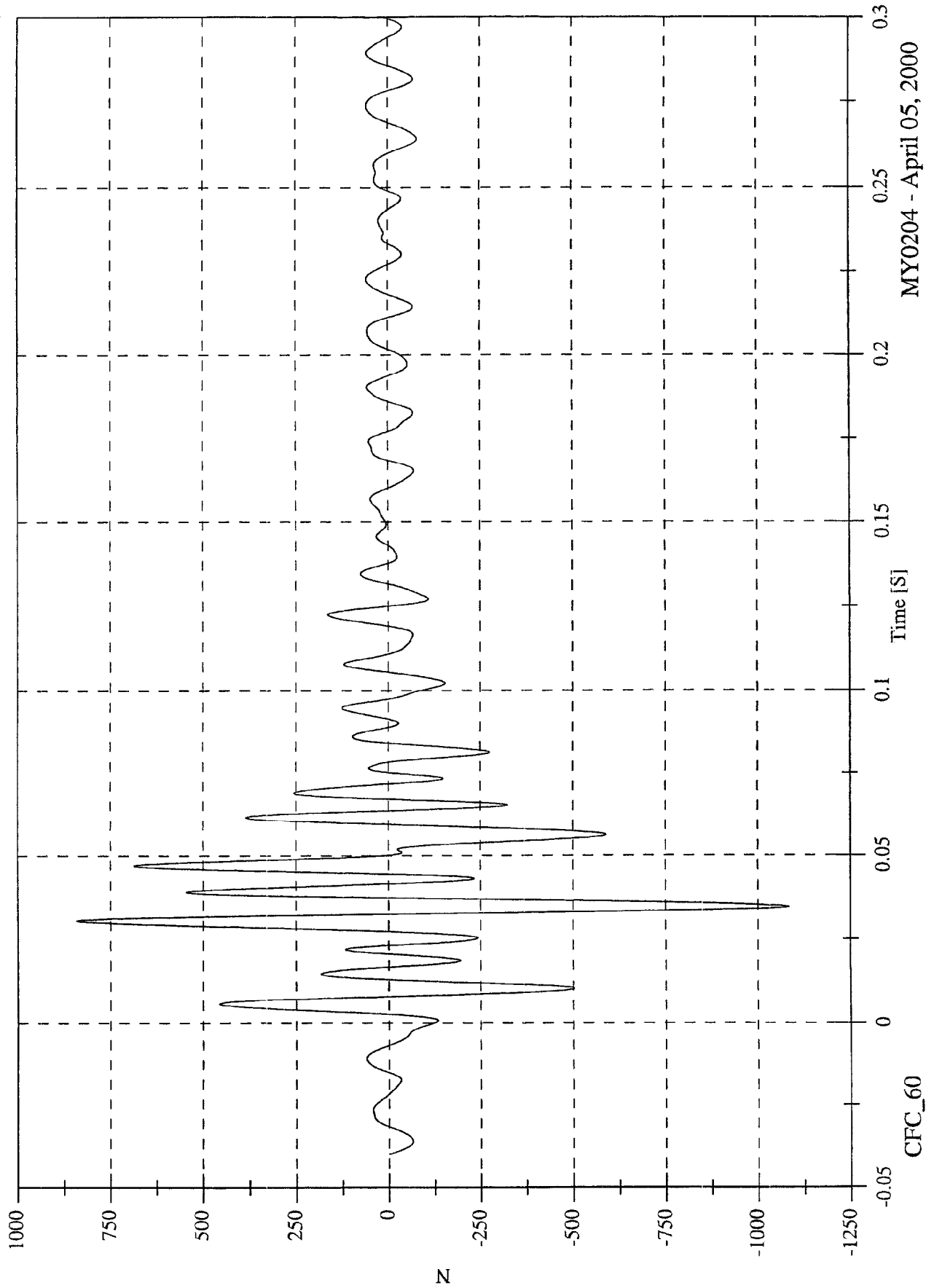

MY0204 - April 05, 2000

NCAP Test#17 - 2000 Ford Focus 3-Door

Max: 634.2 [N] at 0.040 [S]
Min: -989.4 [N] at 0.035 [S]

Barrier Load Cell D9 Fx

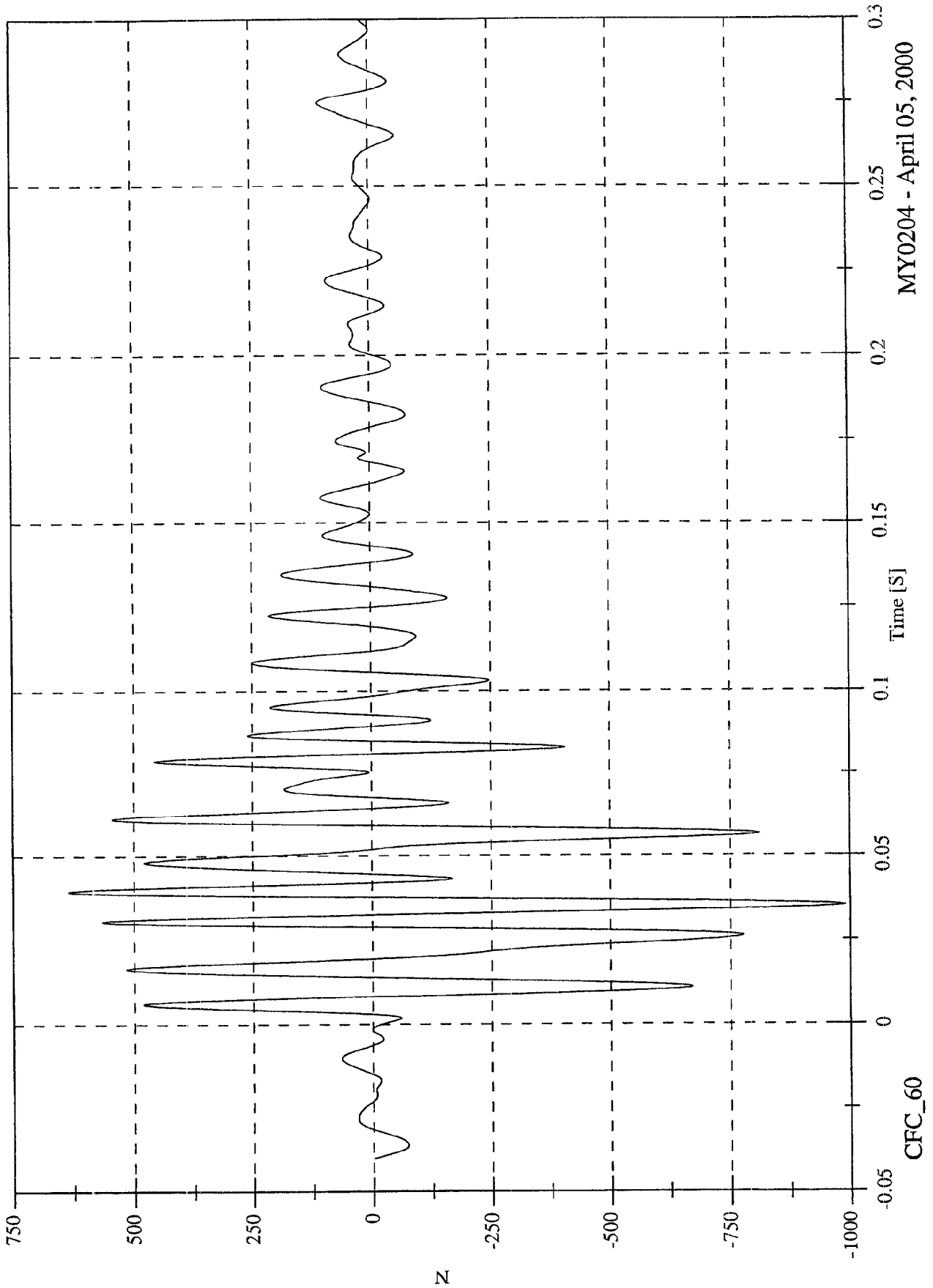

MY0204 - April 05, 2000

NCAP Test#17 - 2000 Ford Focus 3-Door

Max: 94784.8 [N] at 0.028 [S]
Min: -1513.6 [N] at -0.001 [S]

Group 1 Load Cell Sum (A1,A2,A3,B1,B2,B3)

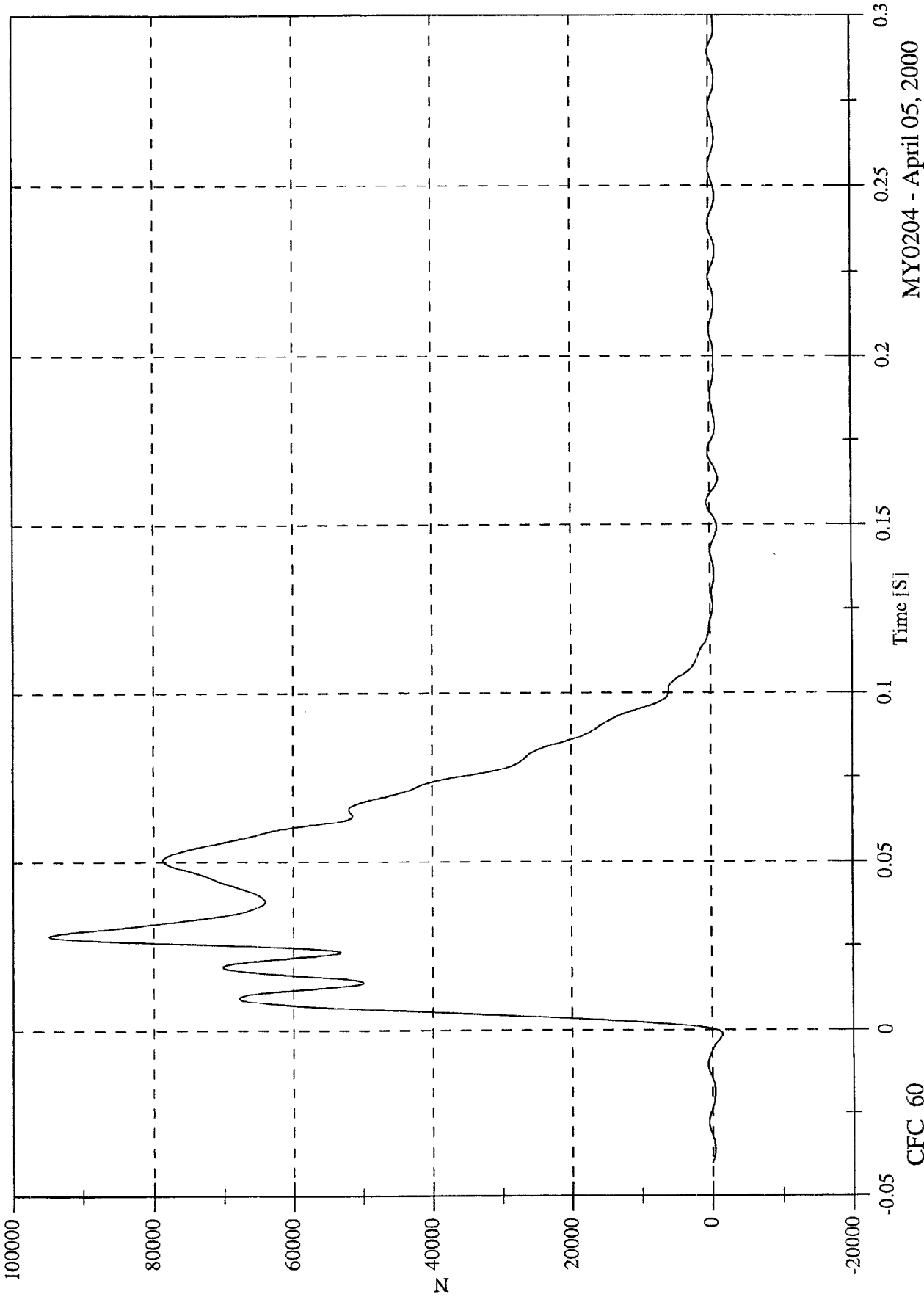

MY0204 - April 05, 2000

NCAP Test#17 - 2000 Ford Focus 3-Door
Group 2 Load Cell Sum (A4,A5,A6,B4,B5,B6)

Max: 225863.8 [N] at 0.033 [S]
Min: -2000.2 [N] at -0.005 [S]

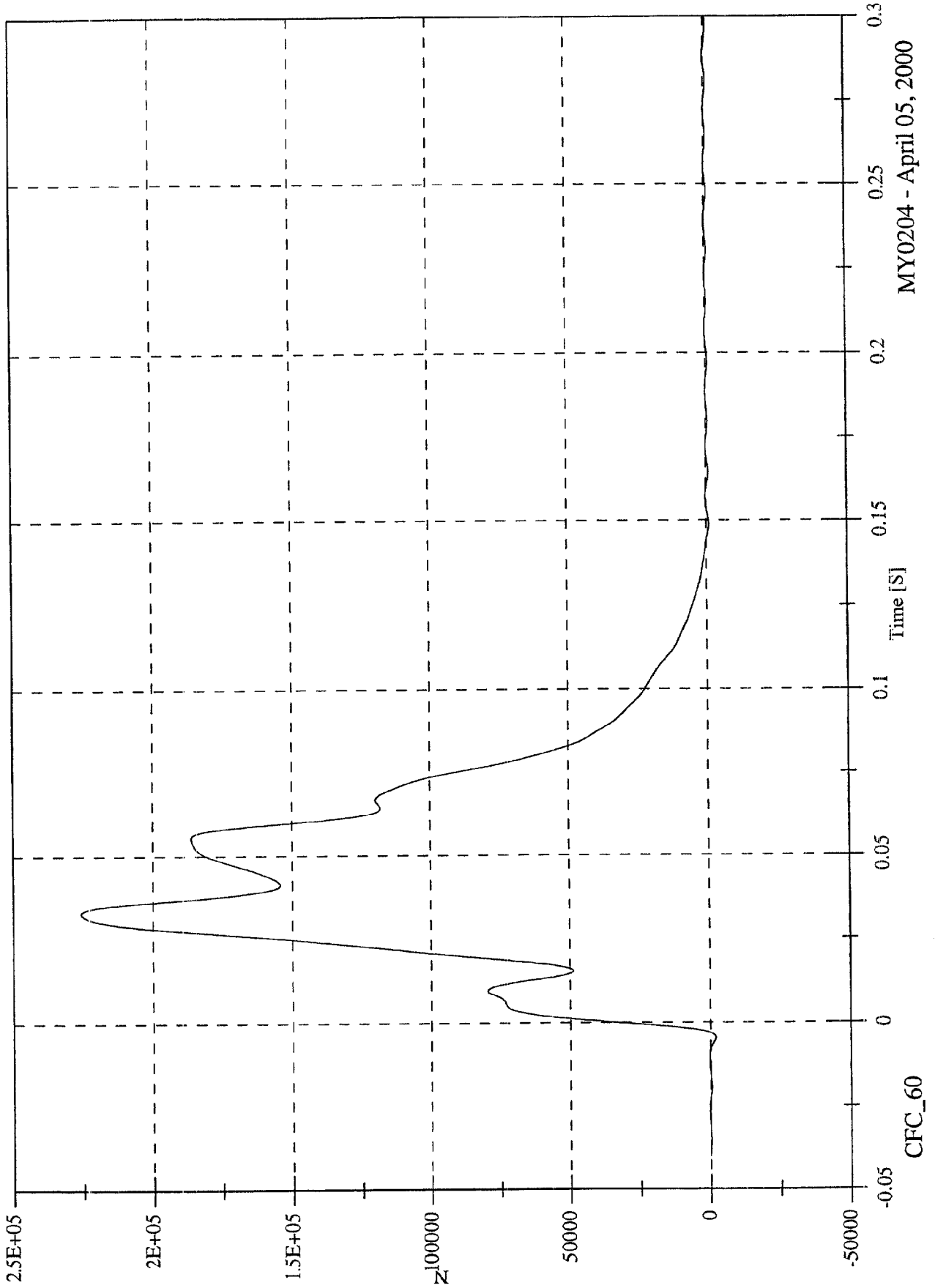

MY0204 - April 05, 2000

NCAP Test#17 - 2000 Ford Focus 3-Door

Max: 114280.7 [N] at 0.028 [S]
Min: -1502.3 [N] at 0.166 [S]

Group 3 Load Cell Sum (A7,A8,A9,B7,B8,B9)

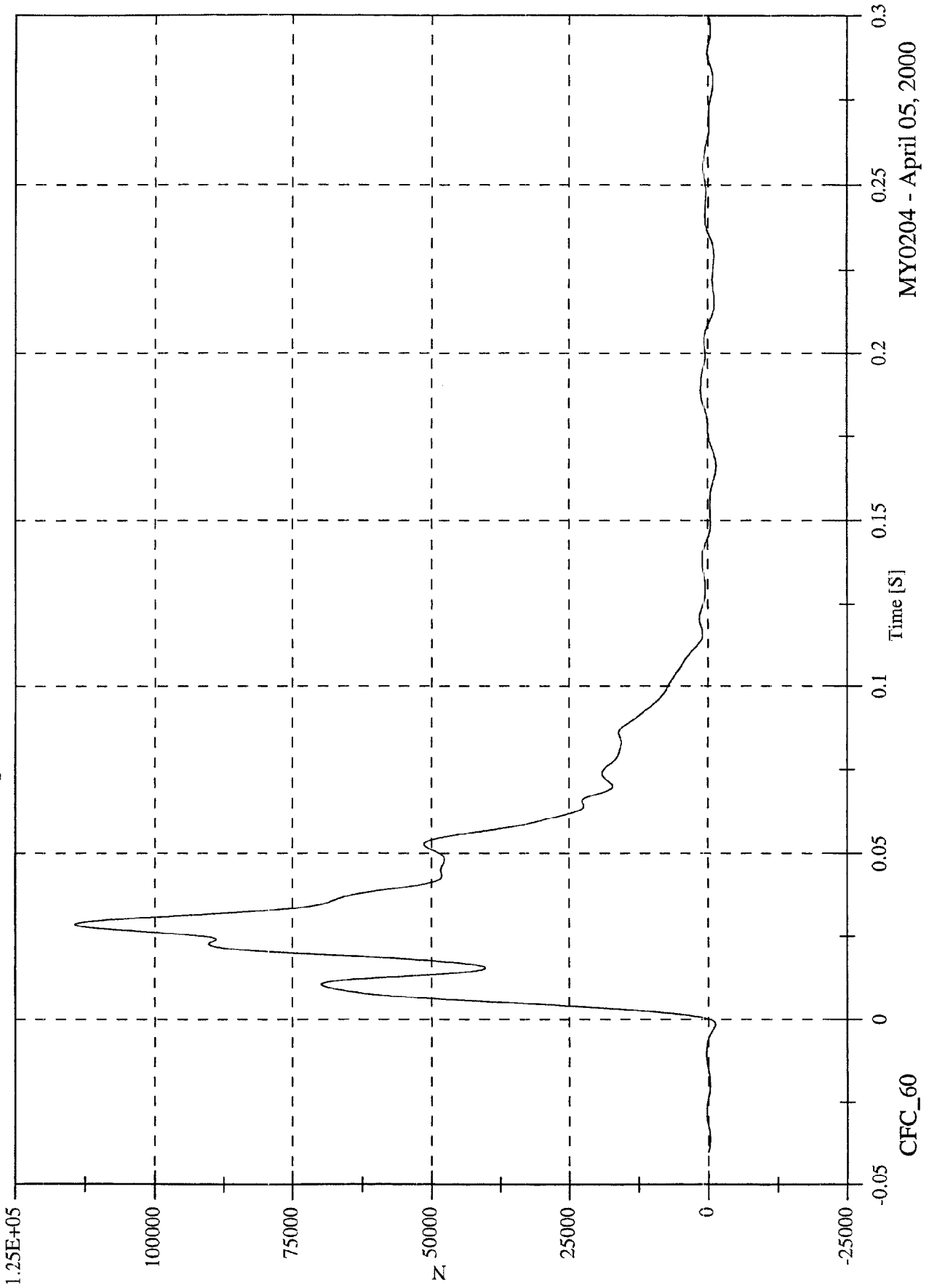

MY0204 - April 05, 2000

NCAP Test#17 - 2000 Ford Focus 3-Door

Group 4 Load Cell Sum (C1,C2,C3,D1,D2,D3)

Max: 65158.2 [N] at 0.039 [S]
Min: -6030.7 [N] at 0.163 [S]

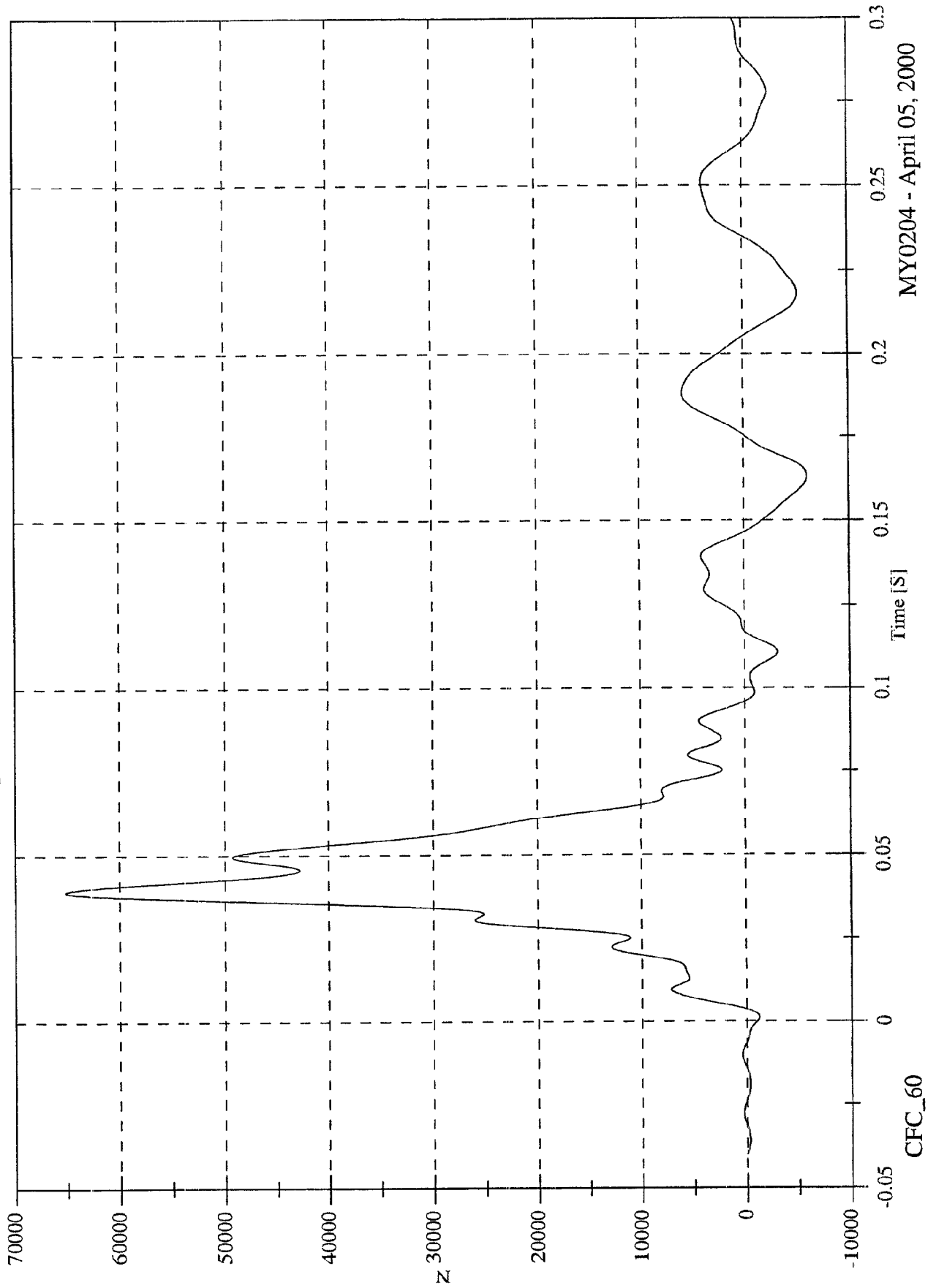

MY0204 - April 05, 2000

NCAP Test#17 - 2000 Ford Focus 3-Door

Max: 48362.4 [N] at 0.033 [S]

Group 5 Load Cell Sum (C4,C5,C6,D4,D5,D6)

Min: -4961.8 [N] at 0.161 [S]

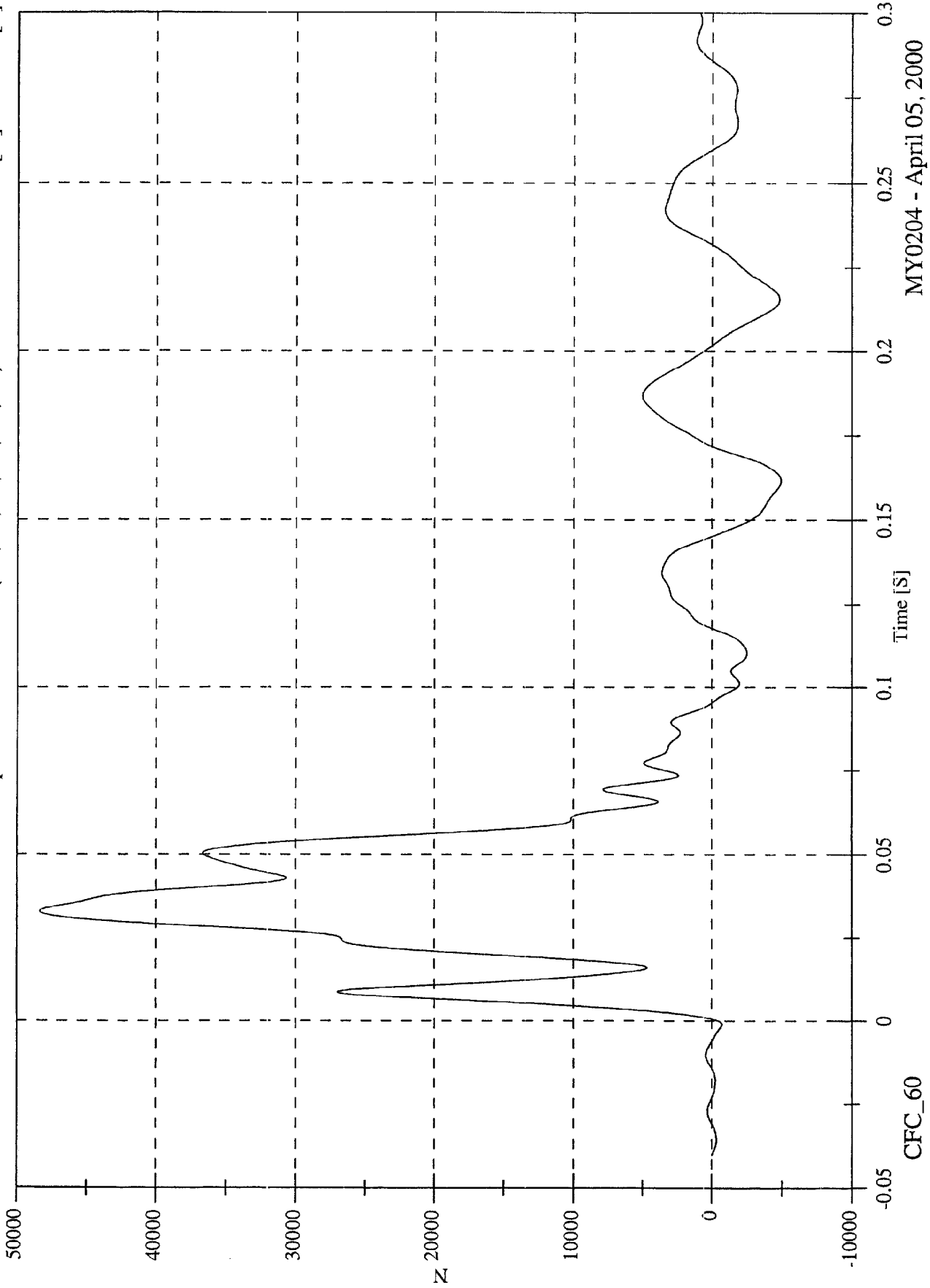

MY0204 - April 05, 2000

NCAP Test#17 - 2000 Ford Focus 3-Door
Group 6 Load Cell Sum (C7,C8,C9,D7,D8,D9)

Max: 51463.9 [N] at 0.039 [S]
Min: -4402.1 [N] at 0.166 [S]

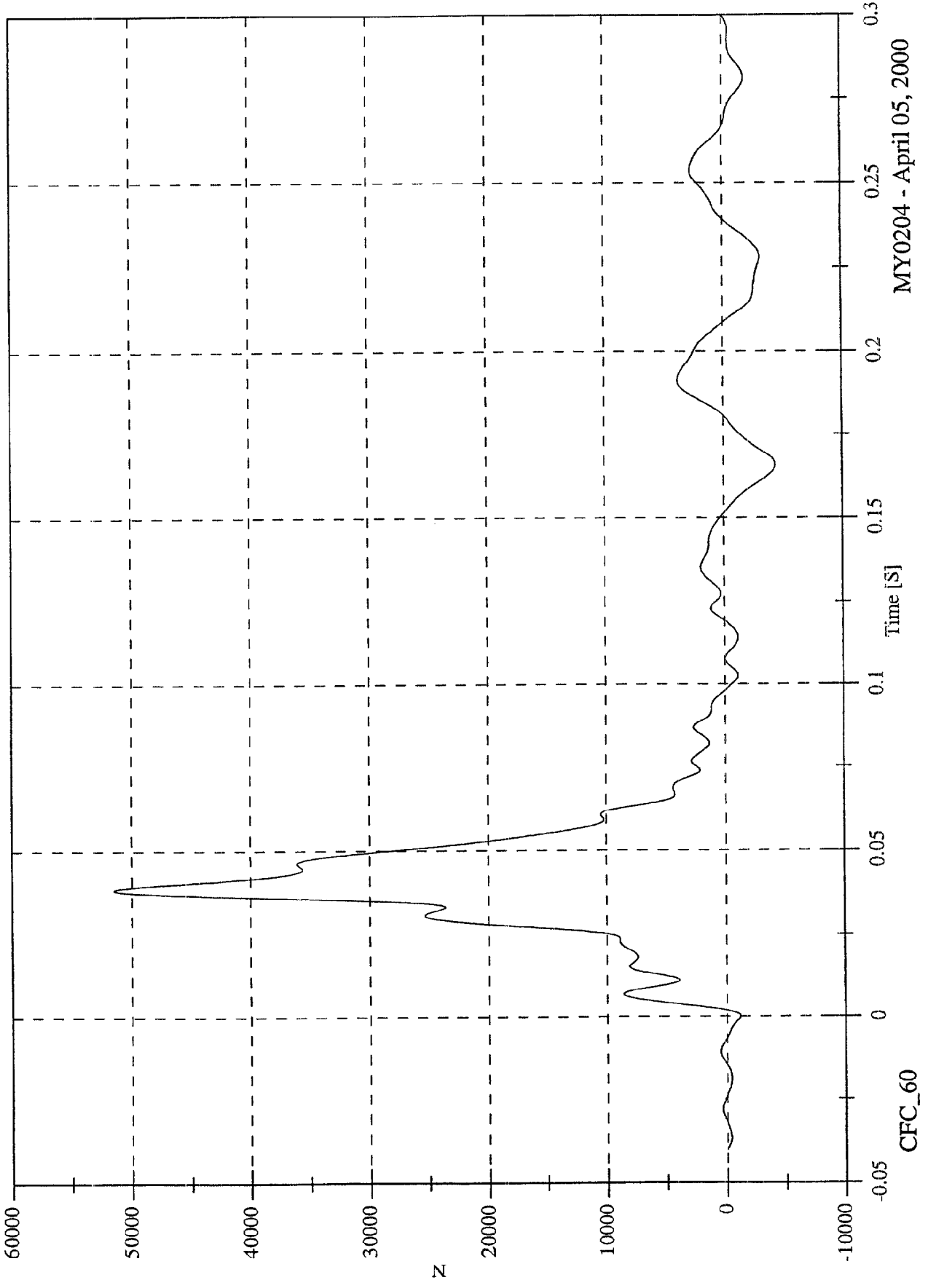

MY0204 - April 05, 2000

NCAP Test#17 - 2000 Ford Focus 3-Door

Max: 507845.9 [N] at 0.030 [S]
Min: -18101.4 [N] at 0.164 [S]

Total Load Cell Sum (All 6 Groups)

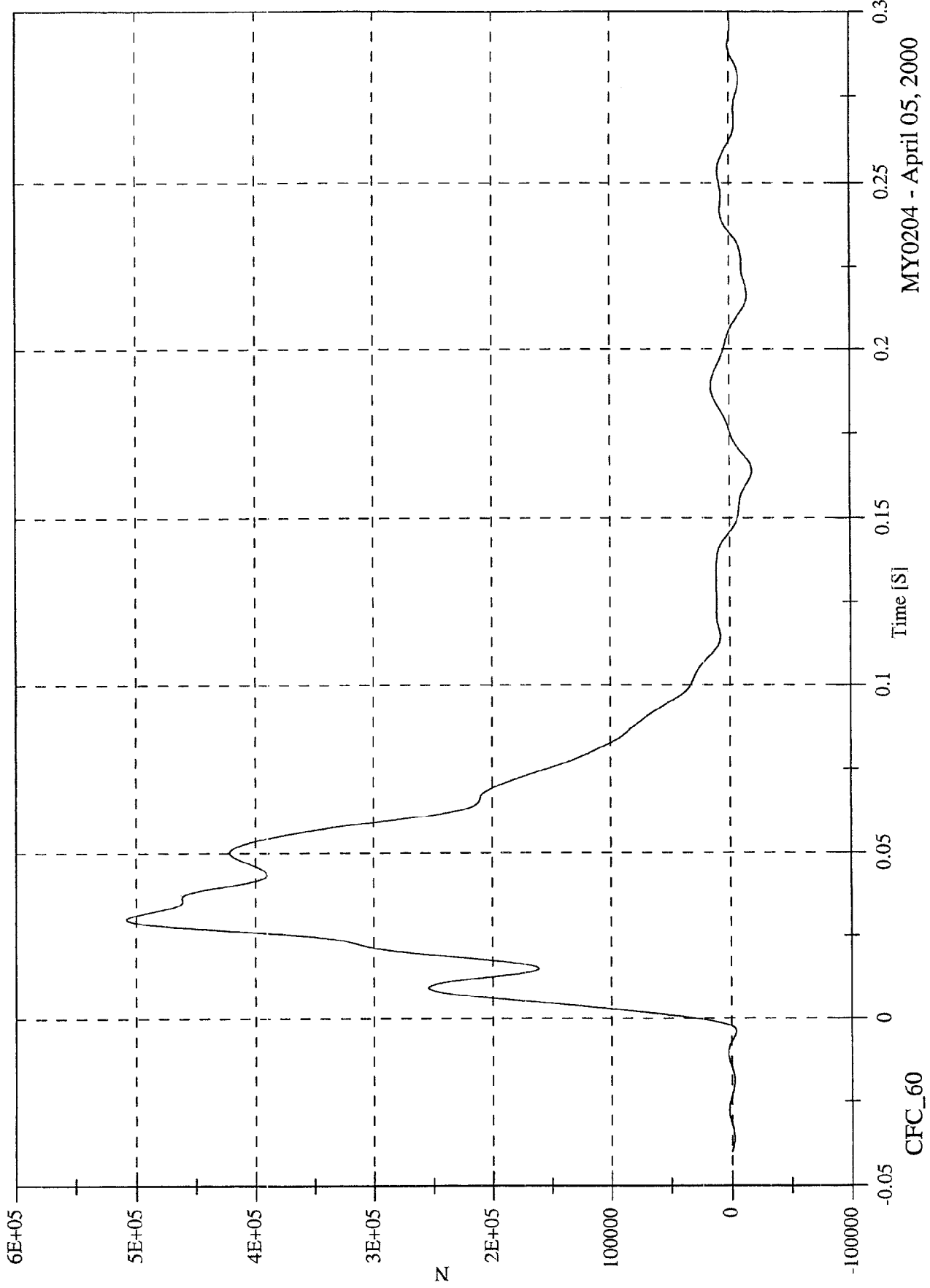

MY0204 - April 05, 2000

NCAP 2000 Test#17 - 2000 Ford Focus 3-Door

Max: 1.0 [] at 0.000 [s]
Min: 0.0 [] at -0.050 [s]

Contact Time

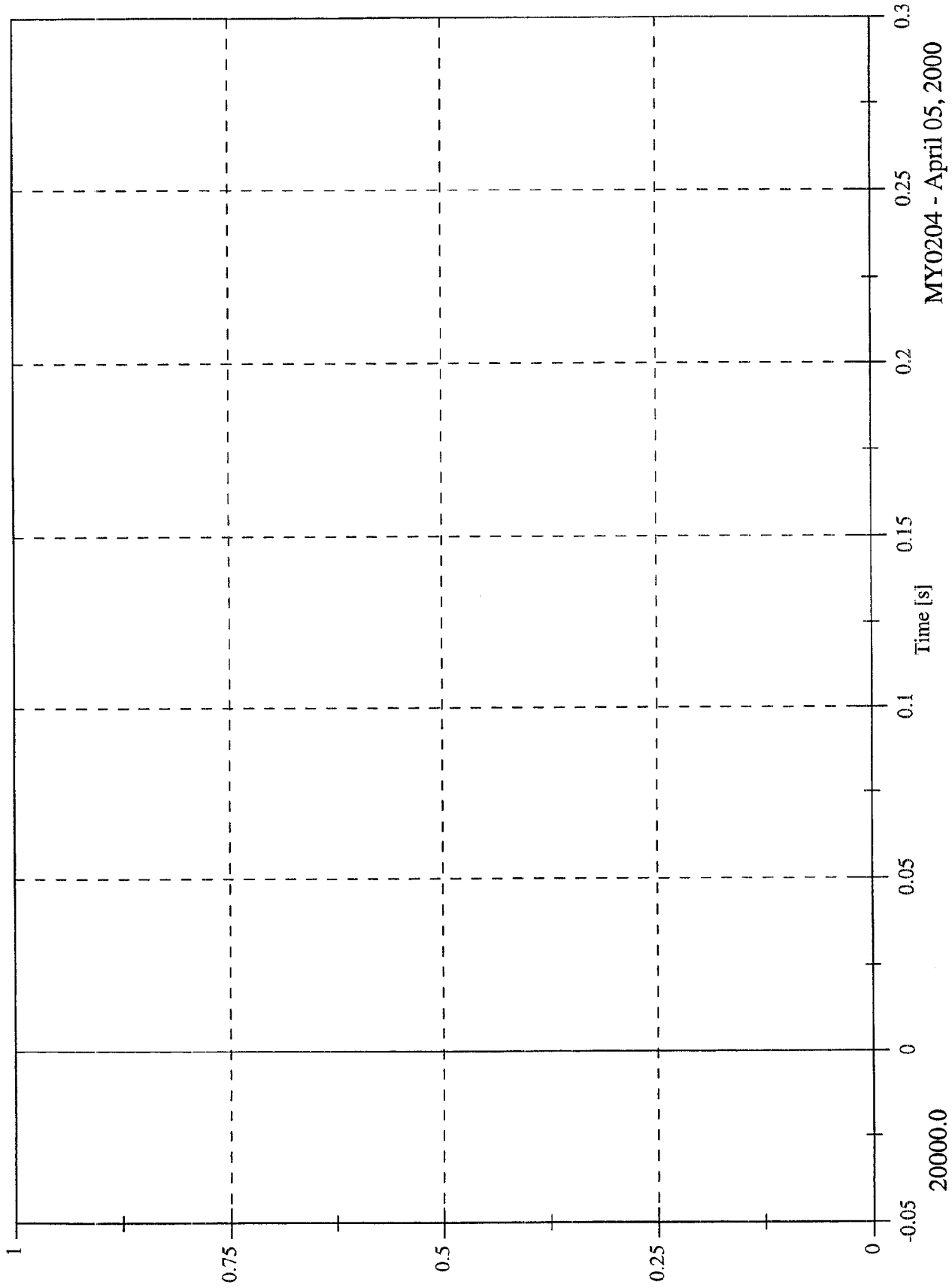

MY0204 - April 05, 2000

APPENDIX C

**PART 572B/E DUMMY CONFIGURATION
AND PERFORMANCE VERIFICATION DATA SHEETS**

Appendix C contains the results from certification tests performed on the 50th percentile male anthropomorphic test devices utilized for this crash test. The results indicate that the dummies meet all of the performance requirements of the six standard tests as specified in 49 CFR Part 572, Federal Register, Volume 42, No. 25, dated February 7, 1977.

The tests were conducted at the Dummy Certification Test Facility of Veridian Engineering. A summary of the test results, and Part 572 specifications are included in this Appendix.

Dummy serial numbers and certification dates are:

<u>Position No./Location</u>	<u>Serial No.</u>	<u>Completion Date</u>
#1/Driver	245	2-22-2000
#2/Right Front Passenger	064	2-22-2000

Electronic Test Equipment

The complement of signal conditioning, recording and display equipment, in conjunction with dummy certification testing, can be found in New Car Assessment and Standards Indicant Testing Final Report No. 6525-V-1.

DUMMY CONFIGURATION DIMENSIONS

**EXTERNAL DIMENSIONS
SPECIFICATIONS**

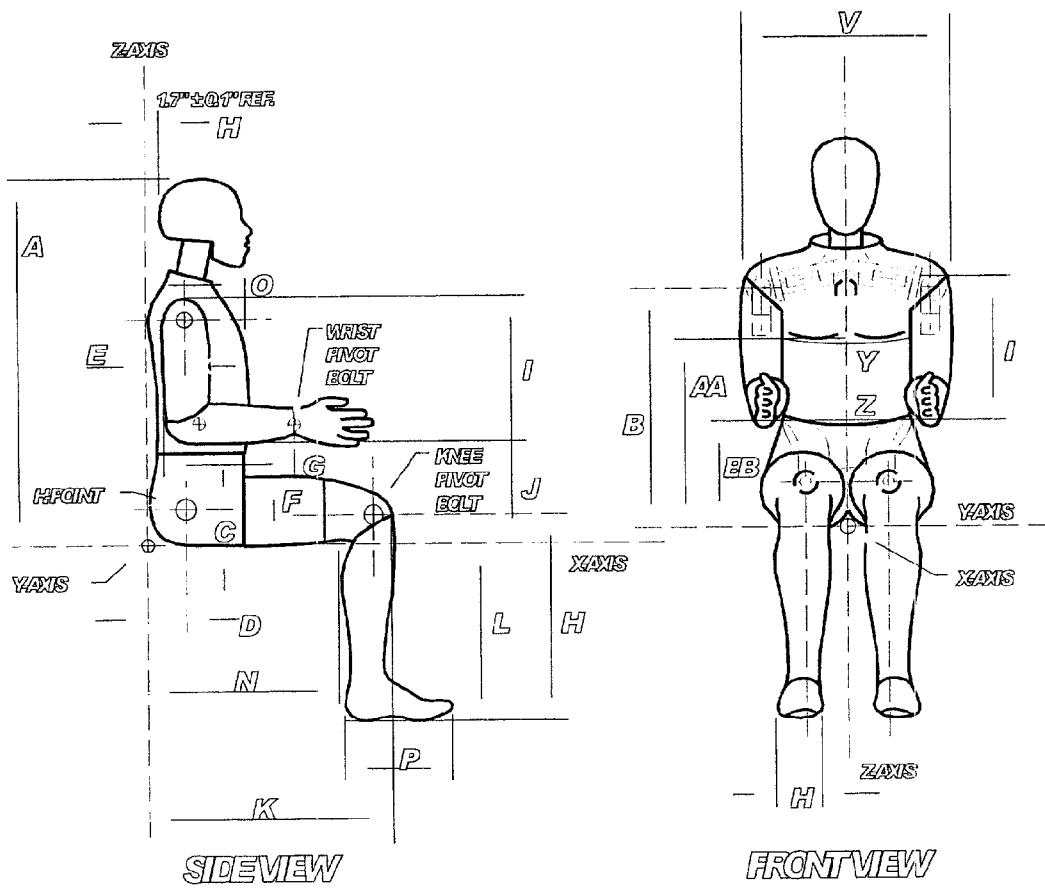

NOTE: Figure is referenced to the erect seated position. The curved lumbar does not allow the Hybrid III to be positioned in a perfect erect attitude. (REF: S572.31(A)(6))

PART 572E
HEAD DROP TEST

Dummy Serial Number 245
Sequential Test Number 2
Date 2/14/200
Workfile 245200.hdp

TEST PARAMETER	SPECIFICATION	TEST RESULTS
Temperature	66-78 Deg F	71
Relative Humidity	10% - 70%	31
Peak Resultant Acceleration	225-275 G's	246.3
Peak Lateral Acceleration	15 G's Max	14.9
Is Acceleration Curve Unimodal?	YES	YES

Remarks:

Laboratory Technician: B. Swiecicki

PART 572E
NECK FLEXION TEST

Dummy Serial Number 245
 Sequential Test Number 2
 Date 2/18/2000
 Workfile 245200.nfl

6 Axis Neck Transducer

TEST PARAMETER		SPECIFICATION	TEST RESULTS
Temperature		69-72 Deg F	70
Relative Humidity		10% - 70%	31
Impact Velocity		22.60 - 23.40 Ft/s	22.83
Pendulum Deceleration	10 ms	22.50 - 27.50 G's	22.71
	20 ms	17.60 - 22.60 G's	19.67
	30 ms	12.50 - 18.50 G's	15.65
Max Pendulum G's Above 30 ms		29 G's Max	15.65
Deceleration - Time Curve Decay Time to 5 G's		34 - 42 ms	40.50
D Plane Rotation	Max	64 - 78 Deg	71.41
	Time	57 - 64 ms	59.13
Moment About Occipital Condyle	Max	65 - 80 Ft-Lbs	71.02
	Time	47 - 58 ms	54.25
Rotation Angle - Time Curve Decay Time to Zero		113 - 128 ms	127.88
Positive Moment - Time Curve Decay Time to Zero		97 - 107 ms	99.00

Remarks:

Laboratory Technician: B. Swiecicki

PART 572E
NECK EXTENSION TEST

Dummy Serial Number 245
 Sequential Test Number 2
 Date 2/18/2000
 Workfile 245200.nex

6 Axis Neck Transducer

TEST PARAMETER		SPECIFICATION	TEST RESULTS
Temperature		69-72 Deg F	70
Relative Humidity		10% - 70%	31
Impact Velocity		19.50 - 20.30 Ft/s	19.86
Pendulum Deceleration	10 ms	17.20 - 21.20 G's	19.50
	20 ms	14.00 - 19.00 G's	17.66
	30 ms	11.00 - 16.00 G's	14.60
Max Pendulum G's Above 30 ms		22 G's Max	14.60
Deceleration - Time Curve Decay Time to 5 G's		38 - 46 ms	38.75
D Plane Rotation	Max	81 - 106 Deg	99.43
	Time	72 - 82 ms	72.38
Moment About Occipital Condyle	Max	-59.0 - -39.0 Ft-Lbs	-56.87
	Time	65 - 79 ms	68.75
Rotation Angle - Time Curve Decay Time to Zero		147 - 174 ms	148.13
Positive Moment - Time Curve Decay Time to Zero		120 - 148 ms	128.00

Remarks:

Laboratory Technician: B. Swiecicki

PART 572E
THORAX IMPACT TEST

Dummy Serial Number 245
Sequential Test Number 2
Date 2/22/2000
Workfile 245200.th3

TEST PARAMETER	SPECIFICATION	TEST RESULTS
Temperature	69-72 Deg F	71
Relative Humidity	10% - 70%	30
Pendulum Velocity	21.6 - 22.4 Ft/s	21.76
Maximum Deflection	2.50 - 2.86 in	2.83
Maximum Resistive Force	1160 - 1325 Lbs	1240.24
Internal Hysteresis	69 - 85 %	70.78

Remarks:

Laboratory Technician: B. Swiecicki

PART 572E
KNEE IMPACT TEST

Dummy Serial Number 245
 Sequential Test Number 2
 Date 2/22/2000
 Workfile 245200.lf/245200.rf

TEST PARAMETER	SPECIFICATION	TEST RESULTS
LEFT KNEE		
Temperature	66 - 78 Deg F	70
Relative Humidity	10% - 70%	29
Probe Velocity	6.8 - 7.0 Ft/s	7.00
Peak Knee Impact Force	1060 - 1300 Lbs	1299.0
RIGHT KNEE		
Temperature	66 - 78 Deg F	70
Relative Humidity	10% - 70%	30
Probe Velocity	6.8 - 7.0 Ft/s	7.00
Peak Knee Impact Force	1060 - 1300 Lbs	1243.0

Remarks:

Laboratory Technician: B. Swiecicki

PART 572E
EXTERNAL DIMENSIONS

Dummy Serial Number 245
Sequential Test Number 2
Date 2/22/2000

TEST PARAMETER		SPECIFICATION	TEST RESULTS
Temperature			70
Relative Humidity			30
Location for Chest Circumference	AA	16.9 - 17.1 in	17.0
Location for Waist Circumference	BB	8.9 - 9.1 in	9.0
Chest Circumference (With Jacket)	Y	38.2 - 39.4 in	39.0
Waist Circumference	Z	32.9 - 34.1 in	33.7
Chest Depth	O	8.4 - 9.0 in	8.4
H-Point Height	C	3.3 - 3.5 in	3.4
H-Point from Backline	D	5.3 - 5.5 in	5.4
Skull Cap to Backline	H	1.6 - 1.8 in	1.7
Total Sitting Height	A	34.6 - 35.0 in	34.9
Thigh Clearance	F	5.5 - 6.1 in	6.0
Buttock Knee Length	K	22.8 - 23.8 in	23.4
Buttock Popliteal Length	N	17.8 - 18.8 in	18.3
Popliteal Height	L	16.9 - 17.9 in	17.5
Knee Pivot Height	M	19.1 - 19.7 in	19.2
Foot Length	P	9.9 - 10.5 in	10.2
Foot Breadth	W	3.6 - 4.2 in	3.8
Shoulder Pivot from Backline	E	3.3 - 3.7 in	3.6
Shoulder Breadth	V	16.6 - 17.2 in	16.8
Shoulder Pivot Height	B	19.9 - 20.5 in	20.2
Elbow Rest Height	J	7.5 - 8.3 in	8.0
Shoulder - Elbow Length	I	13.0 - 13.6 in	13.2
Back of Elbow to Wrist Pivot	G	11.4 - 12.0 in	11.6

Remarks:

Laboratory Technician: B. Swiecicki

PART 572E
HEAD DROP TEST

Dummy Serial Number 064
Sequential Test Number 2
Date 2/14/200
Workfile 064200.hdp

TEST PARAMETER	SPECIFICATION	TEST RESULTS
Temperature	66-78 Deg F	71.0
Relative Humidity	10% - 70%	31.0
Peak Resultant Acceleration	225-275 G's	241.39
Peak Lateral Acceleration	15 G's Max	2.98
Is Acceleration Curve Unimodal?	YES	YES

Remarks:

Laboratory Technician: B. Swiecicki

PART 572E
NECK FLEXION TEST

Dummy Serial Number 064
 Sequential Test Number 2
 Date 2/18/2000 6 Axis Neck Transducer
 Workfile 064200.nfl

TEST PARAMETER		SPECIFICATION	TEST RESULTS
Temperature		69-72 Deg F	70.0
Relative Humidity		10% - 70%	32.0
Impact Velocity		22.60 - 23.40 Ft/s	22.77
Pendulum Deceleration	10 ms	22.50 - 27.50 G's	22.61
	20 ms	17.60 - 22.60 G's	18.40
	30 ms	12.50 - 18.50 G's	14.94
Max Pendulum G's Above 30 ms		29 G's Max	14.94
Deceleration - Time Curve Decay Time to 5 G's		34 - 42 ms	41.75
D Plane Rotation	Max	64 - 78 Deg	69.74
	Time	57 - 64 ms	57.00
Moment About Occipital Condyle	Max	65 - 80 Ft-Lbs	76.38
	Time	47 - 58 ms	54.38
Rotation Angle - Time Curve Decay Time to Zero		113 - 128 ms	121.62
Positive Moment - Time Curve Decay Time to Zero		97 - 107 ms	103.00

Remarks:

Laboratory Technician: B. Swiecicki

PART 572E
NECK EXTENSION TEST

Dummy Serial Number 064
 Sequential Test Number 2
 Date 2/18/2000
 Workfile 064200.nex

6 Axis Neck Transducer

TEST PARAMETER		SPECIFICATION	TEST RESULTS
Temperature		69-72 Deg F	70
Relative Humidity		10% - 70%	29
Impact Velocity		19.50 - 20.30 Ft/s	19.86
Pendulum Deceleration	10 ms	17.20 - 21.20 G's	19.90
	20 ms	14.00 - 19.00 G's	17.71
	30 ms	11.00 - 16.00 G's	14.34
Max Pendulum G's Above 30 ms		22 G's Max	14.34
Deceleration - Time Curve Decay Time to 5 G's		38 - 46 ms	39.25
D Plane Rotation	Max	81 - 106 Deg	96.45
	Time	72 - 82 ms	72.12
Moment About Occipital Condyle	Max	-59.0 - -39.0 Ft-Lbs	-53.89
	Time	65 - 79 ms	66.38
Rotation Angle - Time Curve Decay Time to Zero		147 - 174 ms	147.38
Positive Moment - Time Curve Decay Time to Zero		120 - 148 ms	132.88

Remarks:

Laboratory Technician: B. Swiecicki

PART 572E
THORAX IMPACT TEST

Dummy Serial Number 064
Sequential Test Number 2
Date 2/22/2000
Workfile 064200.th3

TEST PARAMETER	SPECIFICATION	TEST RESULTS
Temperature	69-72 Deg F	70.0
Relative Humidity	10% - 70%	32.0
Pendulum Velocity	21.6 - 22.4 Ft/s	22.0
Maximum Deflection	2.50 - 2.86 in	2.58
Maximum Resistive Force	1160 - 1325 Lbs	1227.57
Internal Hysteresis	69 - 85 %	79.51

Remarks:

Laboratory Technician: B. Swiecicki

PART 572E
KNEE IMPACT TEST

Dummy Serial Number 064
 Sequential Test Number 2
 Date 2/22/2000
 Workfile 064200.lf/064200.rf

TEST PARAMETER	SPECIFICATION	TEST RESULTS
LEFT KNEE		
Temperature	66 - 78 Deg F	70.0
Relative Humidity	10% - 70%	31.0
Probe Velocity	6.8 - 7.0 Ft/s	7.0
Peak Knee Impact Force	1060 - 1300 Lbs	1241.41
RIGHT KNEE		
Temperature	66 - 78 Deg F	70.0
Relative Humidity	10% - 70%	31.0
Probe Velocity	6.8 - 7.0 Ft/s	7.0
Peak Knee Impact Force	1060 - 1300 Lbs	1258.87

Remarks:

Laboratory Technician: B. Swiecicki

PART 572E
EXTERNAL DIMENSIONS

Dummy Serial Number 064
Sequential Test Number 2
Date 2/22/2000

TEST PARAMETER		SPECIFICATION	TEST RESULTS
Temperature			70
Relative Humidity			31
Location for Chest Circumference	AA	16.9 - 17.1 in	17.0
Location for Waist Circumference	BB	8.9 - 9.1 in	9.0
Chest Circumference (With Jacket)	Y	38.2 - 39.4 in	38.9
Waist Circumference	Z	32.9 - 34.1 in	33.4
Chest Depth	O	8.4 - 9.0 in	8.6
H-Point Height	C	3.3 - 3.5 in	3.4
H-Point from Backline	D	5.3 - 5.5 in	5.4
Skull Cap to Backline	H	1.6 - 1.8 in	1.7
Total Sitting Height	A	34.6 - 35.0 in	34.8
Thigh Clearance	F	5.5 - 6.1 in	6.0
Buttock Knee Length	K	22.8 - 23.8 in	23.6
Buttock Popliteal Length	N	17.8 - 18.8 in	18.4
Popliteal Height	L	16.9 - 17.9 in	17.3
Knee Pivot Height	M	19.1 - 19.7 in	19.4
Foot Length	P	9.9 - 10.5 in	10.1
Foot Breadth	W	3.6 - 4.2 in	3.8
Shoulder Pivot from Backline	E	3.3 - 3.7 in	3.6
Shoulder Breadth	V	16.6 - 17.2 in	16.8
Shoulder Pivot Height	B	19.9 - 20.5 in	20.4
Elbow Rest Height	J	7.5 - 8.3 in	8.0
Shoulder - Elbow Length	I	13.0 - 13.6 in	13.3
Back of Elbow to Wrist Pivot	G	11.4 - 12.0 in	11.6

Remarks:

Laboratory Technician: B. Swiecicki

APPENDIX D

DUMMY, VEHICLE AND LABORATORY INSTRUMENT CALIBRATION

INSTRUMENT CALIBRATION FOR DRIVER DUMMY

(6 Month Calibration Minimum)

DRIVER DUMMY (S/N 245)		Manufacturer	Serial #	Calibration	
				Last	Next
Head	X	ENDEVCO	AC-A57G	3/28/00	9/26/00
	Y	ENDEVCO	AC-AGHF5	3/28/00	9/26/00
	Z	ENDEVCO	AC-AL6K2	3/28/00	9/26/00
Head	X (R)	ENDEVCO	AC-J31058	10/7/99	4/6/00
	Y (R)	ENDEVCO	AC-J31010	10/7/99	4/6/00
	Z (R)	ENDEVCO	AC-J31034	10/7/99	4/6/00
Neck Load Cell	X	DENTON	LC-076Fx	2/14/00	8/14/00
	Y	DENTON	LC-076Fy	2/14/00	8/14/00
	Z	DENTON	LC-076Fz	2/14/00	8/14/00
Neck Moment	X	DENTON	LC-076Mx	2/14/00	8/14/00
	Y	DENTON	LC-076My	2/14/00	8/14/00
	Z	DENTON	LC-076Mz	2/14/00	8/14/00
Chest	X	ENDEVCO	AC-FB32L	3/28/00	9/26/00
	Y	ENDEVCO	AC-AE8W7	3/28/00	9/26/00
	Z	ENDEVCO	AC-AL508	3/28/00	9/26/00
Chest	X (R)	ENDEVCO	AC-P13331	10/5/99	4/4/00
	Y (R)	ENDEVCO	AC-P13356	10/5/99	4/4/00
	Z (R)	ENDEVCO	AC-P13323	10/5/99	4/4/00
Chest Deflection Gauge		SERVO	DS-245	11/23/99	5/23/00
Hybrid III Use Only					
Pelvic	X	ENDEVCO	AC-C14953	3/28/00	9/26/00
	Y	ENDEVCO	AC-C14966	3/28/00	9/26/00
	Z	ENDEVCO	AC-C14968	3/28/00	9/26/00

INSTRUMENT CALIBRATION FOR DRIVER DUMMY

(6 Month Calibration Minimum)

DRIVER DUMMY (S/N 245)	Manufacturer	Serial #	Calibration		
			Last	Next	
Left Femur Load Cell	GSE	LC-723	10/20/99	4/19/00	
Right Femur Load Cell	GSE	LC-419	10/20/99	4/19/00	
Left Upper Tibia	Mx	DENTON	LC-045Mx	4/3/00	10/2/00
	My	DENTON	LC-045My	4/3/00	10/2/00
Left Lower Tibia	Fz	DENTON	LC-125Fz	4/3/00	10/2/00
	Mx	DENTON	LC-125Mx	4/3/00	10/2/00
	My	DENTON	LC-125My	4/3/00	10/2/00
Right Upper Tibia	Mx	DENTON	LC-038Mx	4/3/00	10/2/00
	My	DENTON	LC-038My	4/3/00	10/2/00
Right Lower Tibia	Fz	DENTON	LC-124Fz	4/3/00	10/2/00
	Mx	DENTON	LC-124Mx	4/3/00	10/2/00
	My	DENTON	LC-124My	4/3/00	10/2/00
Left Foot Rear	X	ENDEVCO	AC-J32176	10/11/99	4/10/00
	Z	ENDEVCO	AC-J31042	10/11/99	4/10/00
Left Foot Front	Z	ENDEVCO	AC-J31009	10/11/99	4/10/00
Right Foot Rear	X	ENDEVCO	AC-J31050	10/11/99	4/10/00
	Z	ENDEVCO	AC-J31060	10/11/99	4/10/00
Right Foot Front	Z	ENDEVCO	AC-J32143	10/11/99	4/10/00
Lap Belt Load Cells	-	-	-	-	
Shoulder Belt Load Cells	-	-	-	-	
Spool-Out Potentiometer	-	-	-	-	
Belt Stretch Transducer	-	-	-	-	

INSTRUMENT CALIBRATION FOR PASSENGER DUMMY

(6 Month Calibration Minimum)

PASSENGER DUMMY (S/N 064)		Manufacturer	Serial #	Calibration	
				Last	Next
Head	X	ENDEVCO	AC-C15021	11/12/99	5/12/00
	Y	ENDEVCO	AC-C15007	11/12/99	5/12/00
	Z	ENDEVCO	AC-AH5N0	11/12/99	5/12/00
Head	X (R)	ENDEVCO	AC-P13329	10/5/99	4/4/00
	Y (R)	ENDEVCO	AC-P13355	10/5/99	4/4/00
	Z (R)	ENDEVCO	AC-J32774	1/28/00	7/28/00
Neck Load Cell	X	DENTON	LC-440Fx	2/8/00	8/8/00
	Y	DENTON	LC-440Fy	2/8/00	8/8/00
	Z	DENTON	LC-440Fz	2/8/00	8/8/00
Neck Moment	X	DENTON	LC-440Mx	2/8/00	8/8/00
	Y	DENTON	LC-440My	2/8/00	8/8/00
	Z	DENTON	LC-440Mz	2/8/00	8/8/00
Chest	X	ENDEVCO	AC-A08A	12/17/99	6/16/00
	Y	ENDEVCO	AC-ADL42	12/17/99	6/16/00
	Z	ENDEVCO	AC-A28F	12/17/99	6/16/00
Chest	X (R)	ENDEVCO	AC-A14077	12/17/99	6/16/00
	Y (R)	ENDEVCO	AC-A13882	12/17/99	6/16/00
	Z (R)	ENDEVCO	AC-ACCW0	12/17/99	6/16/00
Chest Deflection Gauge		SERVO	DS-064	2/9/00	8/9/00
Hybrid III Use Only					
Pelvic	X	ENDEVCO	AC-AF480	12/17/99	6/16/00
	Y	ENDEVCO	AC-AC2M6	12/17/99	6/16/00
	Z	ENDEVCO	AC-AF5C1	12/17/99	6/16/00

INSTRUMENT CALIBRATION FOR PASSENGER DUMMY

(6 Month Calibration Minimum)

PASSENGER DUMMY (S/N 064)	Manufacturer	Serial #	Calibration		
			Last	Next	
Left Femur Load Cell	GSE	LC-954	10/20/99	4/19/00	
Right Femur Load Cell	GSE	LC-955	10/19/99	4/18/00	
Left Upper Tibia	Mx	DENTON	LC-016Mx	4/3/00	10/2/00
	My	DENTON	LC-016My	4/3/00	10/2/00
Left Lower Tibia	Fz	DENTON	LC-123Fz	4/3/00	10/2/00
	Mx	DENTON	LC-123Mx	4/3/00	10/2/00
	My	DENTON	LC-123My	4/3/00	10/2/00
Right Upper Tibia	Mx	DENTON	LC-023Mx	4/3/00	10/2/00
	My	DENTON	LC-023My	4/3/00	10/2/00
Right Lower Tibia	Fz	DENTON	LC-111Fz	4/3/00	10/2/00
	Mx	DENTON	LC-111Mx	4/3/00	10/2/00
	My	DENTON	LC-111My	4/3/00	10/2/00
Left Foot Rear	X	ENDEVCO	AC-J32184	10/11/99	4/10/00
	Z	ENDEVCO	AC-J31011	10/11/99	4/10/00
Left Foot Front	Z	ENDEVCO	AC-J32185	10/11/99	4/10/00
Right Foot Rear	X	ENDEVCO	AC-J31101	10/11/99	4/10/00
	Z	ENDEVCO	AC-J31020	10/11/99	4/10/00
Right Foot Front	Z	ENDEVCO	AC-J31059	10/11/99	4/10/00
Lap Belt Load Cells	-	-	-	-	
Shoulder Belt Load Cells	-	-	-	-	
Spool-Out Potentiometer	-	-	-	-	
Belt Stretch Transducer	-	-	-	-	

INSTRUMENT CALIBRATION FOR VEHICLE ACCELEROMETERS

(6 Month Calibration Minimum)

	Manufacturer	Serial #	Calibration	
			Last	Next
Left Seat Rear Crossmember	ICS	AC-X93	12/7/99	6/6/00
Right Rear Seat Crossmember	ICS	AC-Y17	2/8/00	8/8/00
Top of Engine	ICS	AC-Y151	3/3/00	9/1/00
Bottom of Engine	ICS	AC-D75	2/28/00	8/28/00
Right Disc Brake Caliper	ICS	AC-D78	3/3/00	9/1/00
Instrument Panel	ICS	AC-D55	11/23/99	5/23/00
Left Disc Brake Caliper	ICS	AC-D37	12/13/99	6/12/00
Left Seat Rear Crossmember (R)	ICS	AC-D61	2/28/00	8/28/00
Right Seat Rear Crossmember (R)	ICS	AC-Y13	2/28/00	8/28/00