

3250

REPORT NUMBER: CAL-00-07

**NEW CAR ASSESSMENT PROGRAM (NCAP)  
FRONTAL BARRIER IMPACT TEST**

**SATURN CORPORATION  
2000 SATURN SL  
4 DOOR SEDAN**

NHTSA NUMBER: MY0113

VERIDIAN TEST NUMBER: 8413-46

VERIDIAN ENGINEERING  
TRANSPORTATION SCIENCES CENTER  
P.O. BOX 400  
BUFFALO, NEW YORK 14225



December 21, 1999

FINAL REPORT

PREPARED FOR:

U. S. DEPARTMENT OF TRANSPORTATION  
National Highway Traffic Safety Administration  
Safety Performance Standards  
Office of Crashworthiness Standards  
Mail Code: NPS-10  
400 Seventh Street, SW, Room No. 5313  
Washington, DC 20590

This publication is distributed by the U. S. Department of Transportation, National Highway Traffic Safety Administration, in the interest of information exchange. The opinions, findings and conclusions expressed in this publication are those of the author(s) and not necessarily those of the Department of Transportation or the National Highway Traffic Safety Administration. The United States Government assumes no liability for its contents or use thereof. If trade or manufacturers' names or products are mentioned, it is only because they are considered essential to the object of the publication and should not be construed as an endorsement. The United States Government does not endorse products or manufacturers.

Prepared by: James A. Czarniecki  
James A. Czarniecki, Project Engineer

Approved by: David J. Travale  
David J. Travale, Program Manager  
Transportation Science Center

Approval Date: January 23, 2000

FINAL REPORT ACCEPTANCE BY OCS:

\_\_\_\_\_  
Manager, New Car Assessment Program (NCAP)  
NHTSA, Office of Crashworthiness Standards

\_\_\_\_\_  
Date of Report Acceptance

\_\_\_\_\_  
COTR, New Car Assessment Program (NCAP)  
NHTSA, Office of Crashworthiness Standards

\_\_\_\_\_  
Date of Report Acceptance

**TECHNICAL REPORT STANDARD TITLE PAGE**

1. <i>Report No.</i> CAL-00-07		2. <i>Government Accession No.</i>		3. <i>Recipient's Catalog No.</i>	
4. <i>Title and Subtitle</i> Final Report of NEW CAR ASSESSMENT PROGRAM (NCAP) Testing of a 2000 Saturn SL 4 Door Sedan NHTSA No. MY0113			5. <i>Report Date</i> December 21, 1999		
			6. <i>Performing Organization Code</i> CAL		
7. <i>Author(s)</i> David J. Travale, Program Manager James A. Czarnecki, Project Engineer			8. <i>Performing Organization Report No.</i> 8413-46		
9. <i>Performing Organization Name and Address</i> Veridian Engineering 4455 Genesee Street Buffalo, New York 14225			10. <i>Work Unit No.</i>		
			11. <i>Contract or Grant No.</i> DTNH22-96-D-02010		
12. <i>Sponsoring Agency Name and Address</i> U.S. Department of Transportation National Highway Traffic Safety Administration Office of Crashworthiness Standards Mail Code: NPS-10 400 Seventh, SW, Room 5313 Washington, D.C. 20590			13. <i>Type of Report and Period Covered</i> Final Report December 1999 - January 2000		
			14. <i>Sponsoring Agency Code</i> NPS-10		
15. <i>Supplementary Notes</i>					
16. <i>Abstract</i> A frontal load cell barrier test of a 2000 Saturn SL 4 Door Sedan was performed at Veridian Engineering crash test facility in Buffalo, New York, on December 21, 1999. The impact velocity was 56.6 kph and the temperature at the barrier face was 21°C. The maximum post-test vehicle crush was 592 mm. The test vehicle was equipped with driver and passenger 3-point active safety belts and next generation reduced force frontal airbags. With respect to FMVSS 208 "Occupant Crash Protection - Injury Criteria" both the driver and front passenger appear to comply with the head, chest and femur requirement					
<b>ATD Position</b>	<b>HIC</b>	<b>Clip (g's)</b>	<b>Chest Disp (mm)</b>	<b>Left Femur (N)</b>	<b>Right Femur (N)</b>
<b>Driver (061)</b>	520.7	40.4	31.6	2156.5	1524.2
<b>Passenger (064)</b>	542.5	41.4	23.3	3966.6	2451.9
17. <i>Key Words</i> 56 kph Frontal Barrier Impact test New Car Assessment Program (NCAP)			18. <i>Distribution Statement</i> <u>Copies of this report are available from:</u> NHTSA Technical Reference Division National Highway Traffic Safety Admin. 400 Seventh St., SW, Room 5108 Washington, DC 20590		
19. <i>Security Classif. (of this report)</i> UNCLASSIFIED		20. <i>Security Classif. (of this page)</i> UNCLASSIFIED		21. <i>No. of Pages</i> 278	22. <i>Price</i>

Form DOT F1700.7 (8-69)

## TABLE OF CONTENTS

<u>Section</u>		<u>Page No.</u>
1	PURPOSE AND SUMMARY OF NCAP TEST	1-1
2	OCCUPANT AND VEHICLE INFORMATION	2-1
<u>Data Sheet</u>	<u>Description</u>	
1.	CRASH TEST SUMMARY	2-1
2.	GENERAL TEST AND VEHICLE PARAMETER DATA	2-2
3.	POST IMPACT DATA	2-4
4.	TEST VEHICLE INFORMATION	2-5
5.	DUMMY POSITIONING IN VEHICLE	2-7
6.	SEAT BELT POSITIONING DATA	2-9
7.	VEHICLE ACCELEROMETER LOCATION AND DATA SUMMARY	2-10
8.	DUMMY INJURY CRITERIA VALUES	2-12
9.	SEAT BELT PERFORMANCE DATA	2-16
10.	SUMMARY OF FMVSS 212 DATA	2-17
11.	WINDSHIELD ZONE INTRUSION FMVSS 219 DATA	2-18
12.	FMVSS 301 FUEL SYSTEM INTEGRITY DATA	2-19
13.	FMVSS 310 ROLLOVER DATA	2-20
14.	VEHICLE MEASUREMENTS	2-24
15.	CAMERA DATA	2-31
16.	REFERENCE PHOTO TARGETS	2-33
17.	LOAD CELL LOCATIONS ON FIXED BARRIER	2-34
18.	POST TEST AIR BAG DATA	2-35
19.	ACCIDENT INVESTIGATION DIVISION DATA	2-36
APPENDIX A	PHOTOGRAPHS	A-1
APPENDIX B	VEHICLE, LOAD CELL BARRIER AND DUMMY RESPONSE DATA	B-1
APPENDIX C	PART 572 B/E DUMMY CONFIGURATION AND PERFORMANCE VERIFICATION TESTS	C-1
APPENDIX D	DUMMY, VEHICLE AND LABORATORY INSTRUMENT CALIBRATION	D-1

## SECTION 1

### PURPOSE AND SUMMARY OF TEST MY0113

#### PURPOSE

This 56.6 kph frontal barrier impact test is part of the Vehicle Barrier Impact Testing Program sponsored by the National Highway Traffic Safety Administration (NHTSA) under Contract No. DTNH22-96-D-02010. The purpose of this test was to obtain vehicle crashworthiness and occupant restraint system performance data for an impact speed in excess of the current 48.3 kph requirements.

The 56.6 kph frontal barrier impact test was conducted in accordance with the Office of Crashworthiness Standards Laboratory Indicant Test procedure.

#### SUMMARY

A load cell barrier consisting of 36 load cells was impacted by a 2000 Saturn SL 4 Door Sedan at a velocity of 56.6 kph. The test was performed at Veridian Engineering on December 21, 1999. Pre- and post-test photographs of the vehicle and dummies can be found in Appendix A.

The frontal barrier impact event was documented by 1 real-time camera and 16 high-speed cameras. Camera locations and other pertinent camera information can be found in this report.

Two Part 572E, 50th percentile male anthropomorphic test devices (ATDs), were placed in the driver and right-front passenger seating positions according to dummy placement instructions specified in the Laboratory Indicant Test Procedure.

Both ATDs were fully instrumented with head, chest, and pelvis triaxial accelerometers, chest displacement potentiometers, upper neck transducers, right/left femur load cells, and lower leg instrumentation. Seat belt load cells were also on the driver's and passenger's lap and shoulder belts to measure dummy torso and pelvic section loading. The driver (position 1) ATD (Serial No. 061) and the right-front passenger (position 2) ATD (Serial No. 064) were used previous to this test. Injury criteria for ATD Serial No. 061 and No. 064 were not exceeded in previous test, MY5701. Certification details, along with instrumentation calibration data, are found in Appendix C.

The 132 channels of data were recorded on an on-board data acquisition system. Appendix B contains the vehicle, load cell barrier and dummy response data traces.

The driver's HIC was 520.7. The maximum chest deceleration over 3 milliseconds was 40.4 g's and maximum chest deflection was 31.6 mm. Compressive femur loads were 2156.5 Newtons on the left and 1524.2 Newtons on the right.

The right front passenger's HIC was 542.5. Maximum chest deceleration over 3 milliseconds was 41.4 g's and maximum chest deflection was 23.3 mm. Compressive femur loads were 3966.6 Newtons on the left and 2451.9 Newtons on the right.

The p1 right foot fore z accelerometer had its wire cut at 32 msec. The p2 shoulder belt elongation transducer is questionable after 89 msec. The right caliper 5 accelerometer had its wire cut 31 msec. The left rear redundant crossmember #8 accelerometer was a failed channel.

SECTION 2

GENERAL TEST AND VEHICLE PARAMETER DATA

DATA SHEET NO. 1 CRASH TEST SUMMARY

Vehicle NHTSA No. : MY0113 Test Mode : 56.3 kph Frontal Barrier

Test Date : December 21, 1999 Time: 11:30 Temperature : 11 °C

Vehicle Make/Model/Body Style : 2000 Saturn SL 4 Door Sedan

Vehicle Test Weight : 1250 kg

Vehicle/Barrier Impact Angle : 0 °

Impact Velocity : 56.6 kph

Maximum Static Crush : 592 mm

Vehicle Rebound : 944 mm

DUMMIES: DRIVER PASSENGER

Type : 572E 572E

Restraint System : 3-point belt system with airbag 3-point belt system with airbag

Number of Data Channels : 132

Number of Cameras : 1 Real Time

16 High Speed

DOOR OPENING DATA : Closed/Operable - Left Front

Closed/Operable - Right Front

Front Seat(s) Data : DRIVER PASSENGER

Seat Track Failure :(mm of shift) 0 0

Seat Back Failure : none none

VISIBLE DUMMY CONTACT POINTS : DRIVER PASSENGER

Head : Airbag / Back of head to headrest Airbag / Back of head to headrest

Abdomen : - -

Chest Airbag Airbag

Knees Knee Bolster Knee Bolster

DATA SHEET NO. 2 GENERAL TEST AND VEHICLE PARAMETER DATA

TEST VEHICLE INFORMATION :

Year/Make/Model/Body Style : 2000 Saturn SL 4 Door Sedan  
NHTSA No. : MY0113 ; VIN: 1G8ZF5280YZ177395 ; Color : Silver  
Engine Data: 4 cylinders; - CID; 1.9 Liters; - cc  
Placement : - Longitudinal or In-Line; x Transverse or Lateral  
Transmission Data : 5 speeds; x Manual; - Automatic; - Overdrive  
Final Drive : - Rear Wheel Drive; x Front Wheel Drive; - Four Wheel Drive  
Major Options : x A/C; x Pwr.Strg.; x Pwr. Brakes  
- Pwr. Windows; - Pwr. Door Locks; x Tilt Wheel  
Date Received : 12/10/99 ; Odometer Reading 22 km  
Selling Dealer : Saturn of Clarence  
& Address: 5535 Transit Rd. Williamsville, N.Y. 14221

DATA FROM TIRE VEHICLE'S CERTIFICATION LABEL:

Vehicle Manufactured by : Saturn Corporation  
Date of Manufacture 11/99  
GVWR : 1478 kg; GAWR: 748 kg FRONT; 730 kg REAR

DATA FROM TIRE PLACARD:

Tire Pressure with Maximum Capacity Vehicle Load : 210 kpa FRONT  
180 kpa REAR  
Recommended Tire Size : P185/65R14  
\* Recommended Cold Tire Pressure : 210 kpa FRONT; 180 kpa REAR  
Size of Tires on Test Vehicle: P185/65R14 ; Manufacturer: Firestone  
Vehicle Capacity Data :  
Type of Front Seats: - Bench; x Bucket; - Split Bench  
Number of Occupants: 2 Front; 3 Rear; 5 Total  
Vehicle Capacity Weight (VCW) = 385.0 kg  
No. of Occupants x 68 kg = 340.2 kg  
Rated Cargo/Luggage Weight (RCLW) = 44.8 kg

\*Tire pressure used for test

DATA SHEET NO. 2 GENERAL TEST AND VEHICLE PARAMETER DATA ( cont. )

WEIGHT OF TEST VEHICLE AS RECEIVED FROM DEALER (with maximum fluids)= UDW:

Right Front	=	<u>321</u>	kg	Right Rear	=	<u>210.5</u>	kg
Left Front	=	<u>320.5</u>	kg	Left Rear	=	<u>206.5</u>	kg
TOTAL FRONT	=	<u>641.5</u>	kg	TOTAL REAR	=	<u>417.0</u>	kg
TOTAL DELIVERED WEIGHT	=	<u>1058.5</u>	kg				
% of Total Front of Vehicle Weight	=	<u>60.6</u>	%	% of Total Rear Weight	=	<u>39.4</u>	%

CALCULATION OF VEHICLE'S TARGET TEST WEIGHT :

Total Delivered Weight (UDW)	=	<u>1058.5</u>	kg
Rated Cargo/Luggage Weight (RCLW)	=	<u>44.8</u>	kg
Weight of 2 p.572 Dummies @ 76 each	=	<u>152.0</u>	kg
TARGET TEST WEIGHT	=	<u>1255.3</u>	kg

WEIGHT OF TEST VEHICLE WITH TWO DUMMIES AND 40 KG OF CARGO WEIGHT:

Right Front	=	<u>358</u>	kg	Right Rear	=	<u>268</u>	kg
Left Front	=	<u>353</u>	kg	Left Rear	=	<u>271</u>	kg
TOTAL FRONT	=	<u>711.0</u>	kg	TOTAL REAR	=	<u>539.0</u>	kg
TOTAL TEST WEIGHT	=	<u>1250.0</u>	kg				
% of Total Front Weight	=	<u>56.9</u>	%	% of Total Rear Weight	=	<u>43.1</u>	%
Weight of Ballast Secured in Vehicle Trunk Area	=	<u>0</u>	kg				
Vehicle Components Removed for Weight Reduction:						<u>Tailights, trunk lid, rear view mirrors and muffler.</u>	

VEHICLE ATTITUDE (all dimension in millimeters):

AS DELIVERED :	RF	<u>667</u>	LF	<u>669</u>	RR	<u>680</u>	LR	<u>680</u>
FULLY LOADED :	RF	<u>648</u>	LF	<u>651</u>	RR	<u>649</u>	LR	<u>650</u>
AS TESTED :	RF	<u>650</u>	LF	<u>656</u>	RR	<u>653</u>	LR	<u>650</u>
Vehicle's Wheel Base :		<u>2603</u>	mm					
Location of Vehicle's C.G. :		<u>1122.4</u>	mm rearward of front wheel center.					

FUEL SYSTEM DATA :

Fuel System Capacity From Owner's Manual	=	<u>47.3</u>	liters
Usable Capacity Figure Furnished by COTR	=	<u>47.3</u>	liters
Test Volume Range (92 to 94% of Usable Capacity)	=	<u>43.5</u>	to <u>44.5</u> liters
ACTUAL TEST VOLUME	=	<u>43.5</u>	liters (with entire fuel system filled)
Test Fluid Type:	<u>Stoddard Solution</u>	;	Spec. Grav. = <u>0.764</u>
	Kinematic Viscosity = <u>0.96</u>	centistokes;	Color = <u>Orange</u>
Type of Fuel Pump:	Electric- <u>x</u>	;	Mechanical- <u>-</u>
Does Electric Pump operate with ignition switch "ON" & engine "OFF"			Yes- <u>x</u> No- <u>-</u>
Details of Fuel System	<u>Fuel filler aft or rear axle on left side, fuel tank is centered above rear axle with the fuel lines running along left frame rail.</u>		

DATA SHEET NO. 3 POST IMPACT DATA

TYPE OF TEST:

Type of Test : Frontal Barrier Impact Angle : 0°  
Test Date : December 21, 1999 Time: 11:30 Temperature: 11 °C  
Vehicle NHTSA No. : MY0113  
Required Impact Velocity Range : 55.5 to 57.1 kph

BARRIER IMPACT VELOCITY: (Speed traps within 5 feet of impact plane.)

Trap No. 1 = 56.6 kph; Trap No. 2 = 56.6 kph  
Distance from vehicle to barrier : (1) entering trap = 813 mm  
(2) exiting trap = 305 mm

VEHICLE STATIC CRUSH: (mm) (For frontal and rear impacts only.)

Vehicle Length:

Pre-Test	Right =	<u>4498</u>	; C/L =	<u>4545</u>	; Left =	<u>4495</u>
Post-Test	Right =	<u>3963</u>	; C/L =	<u>3953</u>	; Left =	<u>4022</u>
Crush	Right =	<u>535.0</u>	; C/L =	<u>592.0</u>	; Left =	<u>473.0</u>
AVERAGE	=	<u>533.3</u>	mm			

VEHICLE REBOUND: (From rigid barrier only.)

Distance from front of test vehicle to impact point :

	Right =	<u>957</u>	; C/L =	<u>961</u>	; Left =	<u>915</u>
AVERAGE	=	<u>944.3</u>	mm			

DATA SHEET NO. 4 TEST VEHICLE INFORMATION

VEHICLE IDENTIFICATION:

Model Year : 2000 Vehicle Model: Saturn SL Body Style : 4 Door Sedan

1. Nominal Design Riding Position for adjustable driver and passenger seat backs. Please describe how to position the inclinometer to measure the seat back angle. Include description of the location of the adjustment latch detent, if applicable.

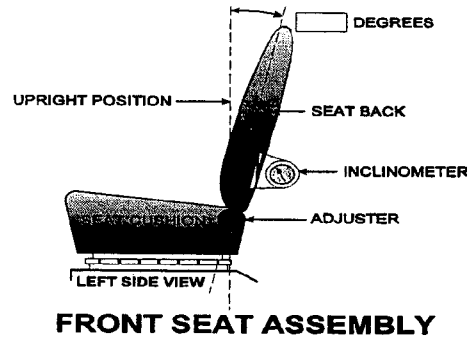

Seat back angle for driver's seat: 23

Measurement instructions: Found full upright position, moved two positions rearward to obtain angle

Seat back angle for passenger's seat: 23

Measurement instructions: Found full upright position, moved two positions rearward to obtain angle

2. Seat Fore and Aft Positioning

Positioning of the driver's seat: Located twenty mechanical notches, placed in 11<sup>th</sup> notch from front

Positioning of the passenger's seat: Located twenty mechanical notches, placed in 11<sup>th</sup> notch from front

3. Fuel Tank Capacity Data

3.1 A. "Usable Capacity" of the standard equipment fuel tank is 47.3 liters

B. "Usable Capacity" of the optional equipment fuel tank is - liters

C. "Usable Capacity" of the vehicle(s) used for certification testing to requirements of FMVSS 301 = 44.5 liters

3.2 Amount of Stoddard solvent added to vehicle(s) used for certification test(s) = 43.5 liters

3.3 Is vehicle equipped with electric fuel pump? Yes- x ; No-     

If YES, explain the vehicle operating conditions under which the fuel pump will pump fuel.

With ignition turned on.

DATA SHEET NO. 4 TEST VEHICLE INFORMATION (cont.)

4. STEERING COLUMN ADJUSTMENTS :

Steering wheel and column adjustments are made so that the steering wheel hub is at the geometric center of the locus it describes when it is moved through its full range of driving positions. If the tested vehicle has any of these adjustments, does your company use any specific procedures to determine the geometric center.

Operational Instructions: Measured highest and lowest point, bisected the difference and placed  
in its middle position.

5. SEAT BELT UPPER ANCHORAGE

Nominal design riding position: Found 5 positions, placed in third notch

**DUMMY MEASUREMENT FOR FRONT SEAT PASSENGER**

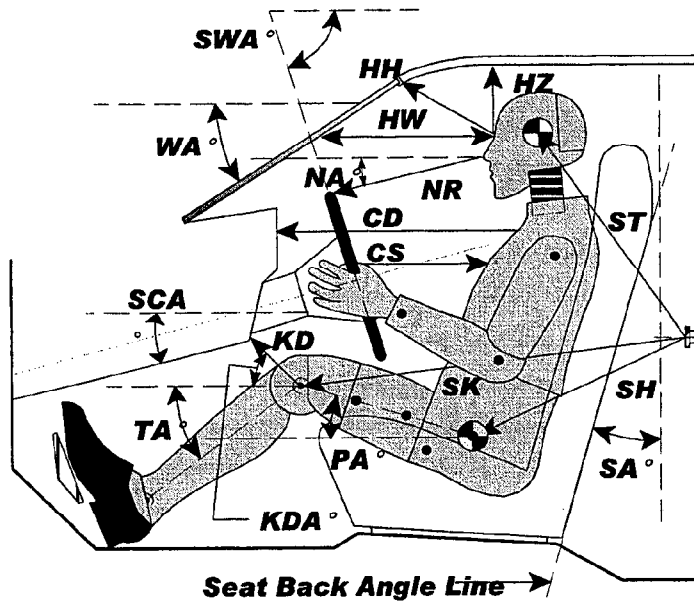

- AD - Arm to Door**
- HD - H-Point to Door**
- HR - Head to Side Header**
- HS - Head to Side Window**
- KK - Knee to Knee**
- SHY - Striker to H-Point (Y Direction)**

- CD - Chest to Dash**
- CS - Steering Wheel to Chest**
- HH - Head to Header**
- HW - Head to Windshield**
- HZ - Head to Roof**
- KDA - Knee to Dash Angle**
- KDL - Left Knee to Dash**
- KDR - Right Knee to Dash**
- NA - Nose to Rim Angle**
- NR - Nose to Rim**
- PA - Pelvic Angle**
- RA - Rim to Abdomen**
- SA - Seat Back Angle**
- SCA - Steering Column Angle**
- SH - Striker to H-Point**
- SK - Striker to Knee**
- ST - Striker to Head**
- SWA - Steering Wheel Angle**
- TA - Tibial Angle**

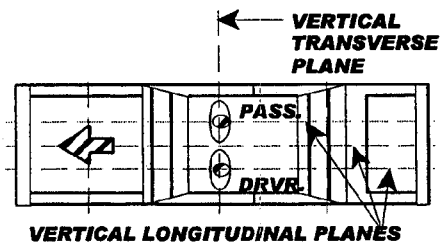
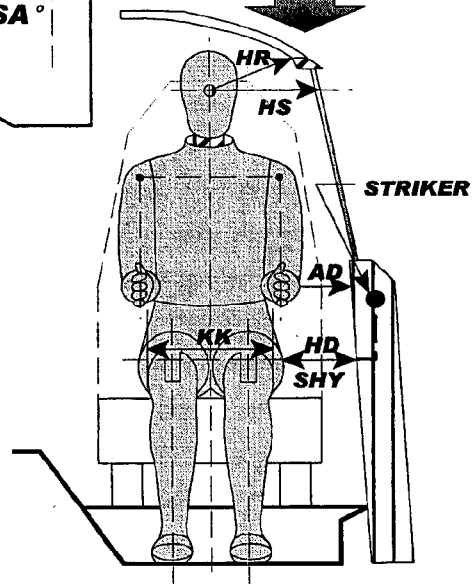

DATA SHEET NO. 5 FRONT SEAT DUMMY POSITIONING MEASUREMENTS IN VEHICLE (cont.)

	DRIVER (Serial #061)			PASS. (Serial # 064)		
WA°	26 deg.			N/A		
SWA°	70 deg.			N/A		
SCA°	20 deg.			N/A		
SA°	23 deg.			23 deg.		
HZ	165			165		
HH	325			304		
HW	627			611		
HR	227			227		
NR	375	Angle	11 deg.	N/A		
CD	505			473		
CS	337			N/A		
RA	191			N/A		
KDL	191	Angle (KDA)	35 deg.	179		
KDR	195			171	Angle (KDA)	15 deg.
PA°	22.5 deg.			22.5 deg.		
TA°	39 deg.			46 deg.		
KK	300			270		
ST	492	Angle	5 deg.	519	Angle	10 deg.
SK	561	Angle	90 deg.	566	Angle	90 deg.
SH	256	Angle	134 deg.	251	Angle	132 deg.
SHY	201			199		
HS	311			289		
HD	134			116		
AD	109			71		

Dimensions in millimeters

DATA SHEET NO. 6 SEAT BELT POSITIONING DATA

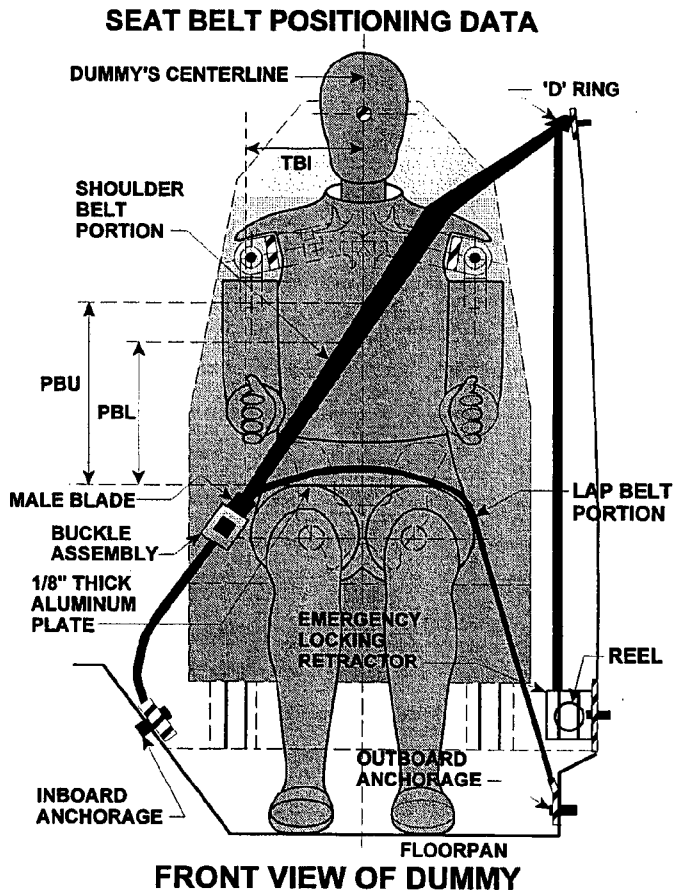

	DRIVER DUMMY (mm)	PASSENGER DUMMY (mm)
PBU -- Top surface of alum. plate to upper edge	310	310
PBL-- Top surface of alum. plate to belt lower edge	230	230
<u>LAP BELT TENSION</u>	10 nwt	10 nwt
<u>SHOULDER BELT TENSION</u>	Retractor	Retractor

### VEHICLE ACCELEROMETER LOCATION AND DATA SUMMARY

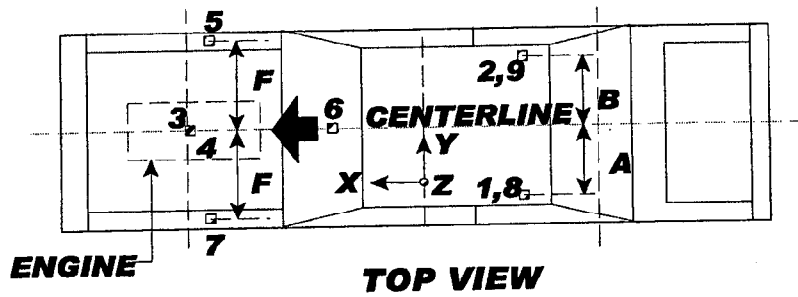

### REAR SEAT CUSHION ASSY. FRONT ATTACHMENT BRACKET SUPPORT

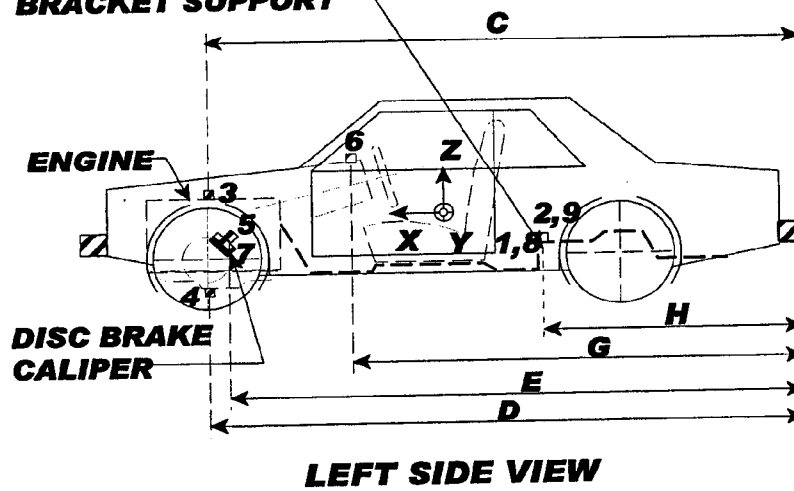

Note: Vehicle accelerometer location and data summary shown in DATA SHEET NO. 7

DATA SHEET NO. 7 VEHICLE ACCELEROMETER LOCATIONS AND DATA SUMMARY (cont).

DIMENSION	LENGTH (mm)
	PRE-TEST VALUES
A Left Rear Seat Crossmember Y	420
B Right Rear Seat Crossmember Y	410
C Top of Engine X	3620
D Bottom of Engine X	3588
E Disc Brake Calipers X	3585
F Disc Brake Calipers Y	590
G Instrument Panel X	2701
H Rear Seat Crossmembers X	1631

LOCATION NUMBER	DESCRIPTION	MAXIMUM VALUE (g's)			
		Pos.	msec.	Neg.	msec.
1	Rear Seat X-Member @ Left Side	1.8	162.5	-32.0	76.9
2	Rear Seat X-Member @ Right Side	1.2	164.3	-30.0	78.7
3	Top of Engine Block	46.1	55.6	-94.5	41.4
4	Bottom of Engine	29.2	56.2	-91.5	35.5
5	Disc Brake Caliper @ Right Side	*	*	*	*
6	Instrument Panel	31.4	76.3	-61.4	64.8
7	Disc Brake Caliper @Left Side	56.9	67.0	-80.0	50.0
8	Rear Seat X-Member @ Left-Redundant	**	**	**	**
9	Rear Seat X-Member @ Right-Redundant	1.3	140.3	-30.8	78.4

\* - Wire cut at 31 msec.

\*\* - Channel failed

DATA SHEET NO. 8 DUMMY INJURY CRITERIA VALUES

Vehicle Year/Make/Model/Body Style: 2000 Saturn SL 4 Door Sedan

NHTSA Test No.: MY0113 Test Date: December 21, 1999

DESCRIPTION	Unit	MAXIMUM VALE							
		Driver				Passenger			
		Pos	msec	Neg	msec	Pos	msec	Neg	msec
Head X	g	7.2	263.4	-51.8	87.4	4.0	255.9	-54.1	90.9
Head Y	g	0.9	249.1	-12.0	96.0	2.4	59.6	-5.0	96.4
Head Z	g	19.9	85.4	-1.0	468.6	17.1	73.7	-1.3	138.6
Head Resultant	g	56.4	85.8	0.0	-58.5	56.1	91.0	0.0	-7.4
Redundant Head X	g	7.3	262.3	-52.1	86.3	4.2	256.2	-58.4	86.7
Redundant Head Y	g	1.6	249.1	-14.0	81.9	2.8	59.6	-7.9	81.6
Redundant Head Z	g	21.0	59.7	-1.5	468.6	16.9	73.2	-26.0	135.3
Redundant Head Resultant	g	57.1	85.2	0.0	-56.2	59.0	86.7	0.0	-24.0
Upper Neck Fx	N	565.7	80.2	-372.0	58.2	456.2	92.6	-557.7	68.9
Upper Neck Fy	N	34.1	220.1	-123.5	130.1	109.3	63.0	-119.7	89.6
Upper Neck Fz	N	1150.3	72.9	-51.2	474.6	1836.1	80.6	-140.9	137.8
Upper Neck F Resultant	N	1210.8	73.4	0.1	-51.7	1837.2	80.6	0.2	-72.2
Upper Neck Mx	N-m	2.7	243.1	-10.7	121.8	11.1	74.6	-3.5	136.4
Upper Neck My	N-m	74.8	79.9	-23.3	57.7	35.1	92.4	-40.0	70.6
Upper Neck Mz	N-m	20.0	97.1	-8.0	146.6	11.4	112.0	-3.7	158.1
Upper Neck M Resultant	N-m	75.1	79.9	0.0	-65.6	40.7	70.6	0.0	-13.7
Chest X	g	3.1	292.5	-40.4	81.3	2.4	308.7	-40.2	90.4
Chest Y	g	0.9	117.3	-8.8	91.4	5.6	81.5	-6.3	105.1
Chest Z	g	3.6	38.0	-3.9	68.5	13.1	93.7	-2.7	66.3
Chest Resultant	g	41.2	81.4	0.0	-59.8	41.7	90.7	0.0	-71.2
Redundant Chest X	g	3.0	292.5	-41.3	81.5	2.3	308.9	-38.0	90.9
Redundant Chest Y	g	1.3	117.1	-7.9	83.8	7.0	82.1	-5.8	106.4
Redundant Chest Z	g	3.8	37.9	-3.5	65.2	15.1	93.4	-3.2	66.3
Redundant Chest Resultant	g	42.0	81.5	0.0	-58.6	40.2	91.7	0.0	-70.0
Chest Displacement	mm	0.0	-8.8	-31.6	76.7	0.0	-98.9	-23.3	95.5

DATA SHEET NO. 8      DUMMY INJURY CRITERIA VALUES (cont.)

Vehicle Year/Make/Model/Body Style: 2000 Saturn SL 4 Door Sedan  
 NHTSA Test No.: MY0113      Test Date: December 21, 1999

DESCRIPTION	Unit	MAXIMUM VALE							
		Driver				Passenger			
		Pos	msec	Neg	msec	Pos	msec	Neg	msec
Pelvic X	g	1.4	320.4	-36.6	71.1	1.8	252.4	-46.3	56.7
Pelvic Y	g	1.6	126.5	-11.7	71.3	9.1	57.8	-4.8	100.0
Pelvic Z	g	2.5	249.8	-21.0	83.5	2.3	259.2	-19.4	65.0
Pelvic Resultant	g	42.3	71.1	0.0	-60.7	48.8	56.7	0.0	-71.5
Left Femur	N	202.1	32.7	-2156.5	72.0	270.7	36.7	-3966.6	58.2
Right Femur	N	512.4	82.9	-1524.2	56.9	149.6	114.1	-2451.9	53.8
Left Upper Tibia Mx	N-m	46.1	53.1	-73.1	32.3	11.6	291.7	-58.1	107.3
Left Upper Tibia My	N-m	14.6	138.3	-69.8	66.3	24.2	130.0	-116.8	69.6
Left Lower Tibia Fz	N	157.6	201.3	-2758.6	34.0	505.8	154.1	-3923.7	46.6
Left Lower Tibia Mx	N-m	85.1	34.4	-36.0	31.3	11.4	90.1	-60.0	46.1
Left Lower Tibia My	N-m	44.9	34.1	-18.1	53.6	40.8	74.6	-39.4	41.6
Right Upper Tibia Mx	N-m	6.7	35.5	-56.6	72.9	26.0	42.1	-17.8	143.1
Right Upper Tibia My	N-m	11.0	247.3	-181.9	69.9	15.4	248.3	-89.9	77.0
Right Lower Tibia Fz	N	203.7	199.4	-4327.1	71.2	224.4	65.9	-2854.5	36.2
Right Lower Tibia Mx	N-m	1.2	35.3	-101.5	75.1	12.8	40.4	-14.1	109.1
Right Lower Tibia My	N-m	85.2	74.8	-15.2	47.8	97.9	83.6	-46.5	63.4
Left Foot Aft Ax	g	44.2	34.4	-34.4	65.1	34.7	57.0	-61.2	42.2
Left Foot Aft Az	g	47.9	33.8	-49.2	34.4	28.3	87.5	-42.3	41.7
Left Foot Fore Az	g	82.5	34.1	-60.5	34.6	37.2	87.7	-155.9	40.3
Right Foot Aft Ax	g	11.9	73.5	-52.7	46.9	15.0	81.2	-42.3	74.2
Right Foot Aft Az	g	8.7	91.2	-52.3	55.7	12.9	47.9	-44.1	37.0
Right Foot Fore Az	g	*	*	*	*	23.1	74.5	-55.5	27.2
Lap Belt Load	N	4154.9	72.1	-3.8	395.7	3639.7	91.8	-5.8	420.7
Torso Belt	N	3728.0	93.1	-28.7	361.5	3984.8	91.9	-46.5	452.2

\* - Wire cut at 32 msec.

DATA SHEET NO. 8 DUMMY INJURY CRITERIA VALUES (cont.)

Vehicle Year/Make/Model/Body Style: 2000 Saturn SL 4 Door Sedan

NHTSA Test No.: MY0113 Test Date: December 21, 1999

HEAD INJURY CRITERIA (HIC)				
	HIC**	t <sub>1</sub> (msec)	t <sub>2</sub> (msec)	Average Acceleration t <sub>1</sub> to t <sub>2</sub>
Position #1 - Driver	520.7	67.2	103.2	46.1
Position #2 - Passenger	542.5	70.3	106.3	46.9

\*\* HIC is as defined in FMVSS 208. The maximum time interval from t<sub>1</sub> to t<sub>2</sub> is 36 milliseconds.

CLIP SUMMARY*				
	CLIP (g's)	t <sub>1</sub> (msec)	t <sub>2</sub> (msec)	CSI
Position #1 - Driver	40.4	80.0	83.0	374.0
Position #2 - Passenger	41.4	89.2	92.2	356.4

\* The maximum chest resultant acceleration is defined as the maximum acceleration which exceeds 0.003 seconds in duration.

DATA SHEET NO. 8 DUMMY INJURY CRITERIA VALUES (cont.)  
REDUNDANT DATA

Vehicle Year/Make/Model/Body Style: 2000 Saturn SL 4 Door Sedan

NHTSA Test No.: MY0113 Test Date: December 21, 1999

HEAD INJURY CRITERIA (HIC) REDUNDANT				
	HIC**	t <sub>1</sub> (msec)	t <sub>2</sub> (msec)	Average Acceleration t <sub>1</sub> to t <sub>2</sub>
Position #1 - Driver	555.2	65.9	101.8	47.3
Position #2 - Passenger	611.0	70.5	106.4	49.2

\*\* HIC is as defined in FMVSS 208. The maximum time interval from t<sub>1</sub> to t<sub>2</sub> is 36 milliseconds.

CLIP SUMMARY* REDUNDANT				
	CLIP (g's)	t <sub>1</sub> (msec)	t <sub>2</sub> (msec)	CSI
Position #1 - Driver	41.2	80.2	83.2	384.3
Position #2 - Passenger	39.9	89.8	92.8	325.4

\* The maximum chest resultant acceleration is defined as the maximum acceleration which exceeds 0.003 seconds in duration.

DATA SHEET NO. 9 SEAT BELT PERFORMANCE ASSESSMENT TEST DATA

BELT LENGTH DATA:

	<u>Driver</u>	<u>Passenger</u>
Belt length from trim panel exit to bolt hole anchor point for continuous webbing systems.	1756	1750
Shoulder belt length as measured on Part 572 Dummy.	821	831
Lap belt length as measured on Part 572 Dummy.	785	779

SHOULDER BELT SPOOL-OFF DATA:

As determined by film analysis.	152	229
As determined mechanically.	141	214
As determined electronically.	-	-

BELT STRETCH DATA:

Measured electronically between shoulder belt load cell and the "D" ring.	.01 mm	*
Measured mechanically.	1 mm	1 mm

\* Data is questionable after 89 msec

Dimensions in millimeters

DATA SHEET NO.10 SUMMARY OF FMVSS 212 DATA

FMVSS NO. 212 - "WINDSHIELD MOUNTING" DATA

DETAILS OF WINDSHIELD MOUNTING SUCH AS RETENTION METHOD, TRIM TYPE, ETC.:

Windshield is bonded in place and covered with a 16 mm molding.

FMVSS 212 REQUIREMENTS:

The Post-Test periphery retention amount must be at least 75% of the Pre-Test periphery measurement for vehicles NOT equipped with automatic restraints, and 50% for each side of the windshield for vehicles equipped with automatic restraint systems for front occupants,

FMVSS 212 TEST DATA

	WINDSHIELD PERIPHERY		% OF RETENTION
	PRE-TEST (mm)	POST-TEST(mm)	
RIGHT SIDE	2142.5	2142.5	100
LEFT SIDE	2142.5	2142.5	100
TOTAL	4,285	4,285	100

AREA OF RETENTION FAILURE:

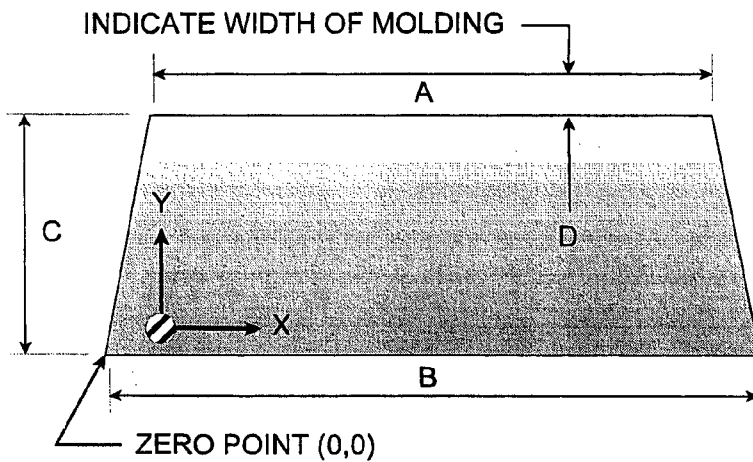

DIMENSIONS (mm)	
A	1140
B	1545
C	800
D	16

**FRONT VIEW OF WINDSHIELD**

FAILURE DETAILS:None

DATA SHEET NO. 11 FMVSS NO. 219 (PARTIAL) - "WINDSHIELD ZONE INTRUSION" DATA

PROTECTED ZONE LOWER EDGE REQUIREMENT:

The lower edge of the protected zone is determined by placing a 165 mm diameter rigid sphere weighing 6.8 kg in a position such that it simultaneously contacts the inner surface of the windshield and the top surface of the instrument panel including padding. The locus of points is drawn on the inner surface of the windshield contacted by the sphere across the width of the instrument panel. From the outermost contactable points extend the locus line horizontally to the edges of the windshield, then draw a line on the inner surface of the windshield below and 13 mm distant from the locus line. The LOWER EDGE OF THE PROTECTED ZONE is the longitudinal projection of this line onto the outer surface of the windshield.

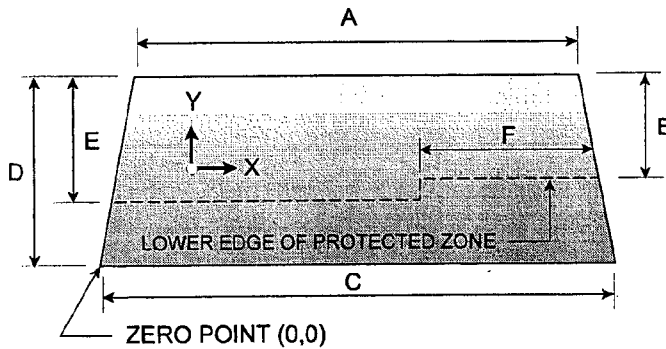

FRONT VIEW OF WINDSHIELD

FMVSS 219 TEST DATA:

DIMENSIONS (mm)	
A	1140
B	540
C	1545
D	800
E	585
F	645

DETAILS OF WINDSHIELD GLASS PENETRATION GREATER THAN 6 mm:

(Show location of penetration on the above sketch)

	COORDINATES	
	X	Y
1.		
2.		
3.		
4.		

DATA SHEET NO. 12 FMVSS NO. 301-75 "FUEL SYSTEM INTEGRITY" POST IMPACT TEST DATA

NHTSA TEST No.: MY0113 TEST DATE: December 21, 1999

VEHICLE MAKE/MODEL: 2000 Saturn SL

The test vehicle was filled from 92% to 94% of the manufacture's "usable" capacity. The electric fuel pump was operating if it will operate without engine operation. Two Part 572 anthropomorphic test devices were located at each of the front designated seating positions.

=====

TEST VEHICLE IMPACT TYPE: X Frontal (56 kph)  
- Oblique (48 kph) with \_\_\_\_\_ deg. barrier face first contacting \_\_\_\_\_  
 (driver/passenger) side  
- Rear Moving Barrier (48 kph)  
- Lateral Moving Barrier (32 kph)

FUEL SPILLAGE MEASUREMENT:

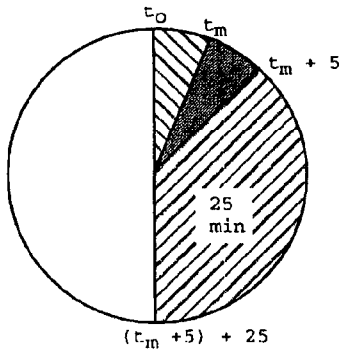

1. From impact until vehicle motion ceases
2. For 5 minute period after vehicle motion ceases
3. For next 25 minutes

ACTUAL	MAX ALLOWED
0	28 g
0	141 g
0	28 g/min.

SOLVENT SPILLAGE DETAILS: None

DATA SHEET 13

FMVSS NO. 301 STATIC ROLLOVER DATA SHEET

Vehicle: 2000 Saturn SL

NHTSA No. MY0113

0 - 90 Degrees

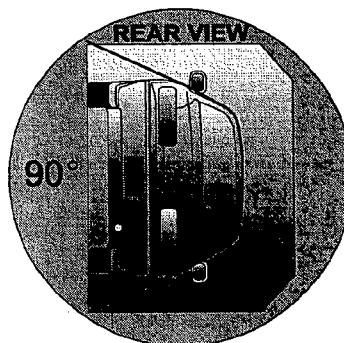
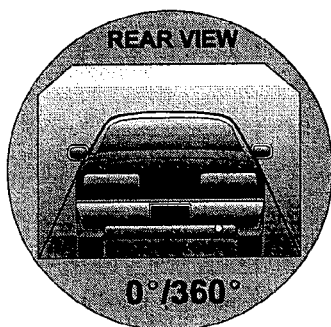

I. DETERMINATION OF SOLVENT COLLECTION TIME PERIOD :

Rollover Fixture 90° Rotation Time (Spec. Range = 1 to 3 minutes)	<u>1</u> minutes	<u>15</u> seconds
FMVSS 301 Position Hold Time +	<u>5</u> minutes	<u>0</u> seconds
TOTAL	<u>6</u> minutes	<u>15</u> seconds
Next whole minute interval	<u>7</u> minutes	

II. FMVSS 301 REQUIREMENTS :

(1) Time Period

First 5 minutes FROM onset of rotation	6th min.	7th min.	8th min. (if required)
--	----------	----------	------------------------

(2) Maximum Allowable Solvent Spillage

142 g	28 g	28 g	28 g
-------	------	------	------

III. ACTUAL TEST VEHICLE SOLVENT SPILLAGE:

0 g	0 g	0 g	N/A
-----	-----	-----	-----

Note: Record spillage for whole minute intervals only as determined above.

IV. SOLVENT SPILLAGE LOCATION(S) :

None

DATA SHEET 13

FMVSS NO. 301 STATIC ROLLOVER DATA SHEET (CONTINUED)

Vehicle: 2000 Saturn SL

NHTSA No. MY0113

90 - 180 Degrees

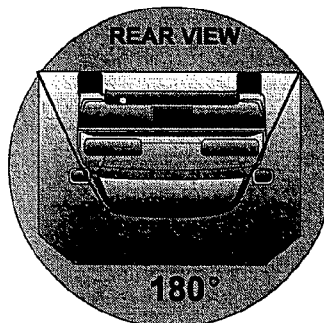
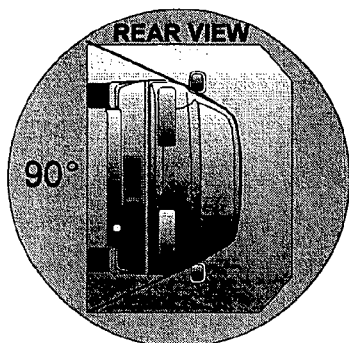

I. DETERMINATION OF SOLVENT COLLECTION TIME PERIOD :

Rollover Fixture 90° Rotation Time (Spec. Range = 1 to 3 minutes)	<u>1</u>	minutes	<u>11</u>	seconds
FMVSS 301 Position Hold Time +	<u>5</u>	minutes	<u>0</u>	seconds
TOTAL	<u>6</u>	minutes	<u>11</u>	seconds
Next whole minute interval	<u>7</u>	minutes		

II. FMVSS 301 REQUIREMENTS :

(1) Time Period

First 5 minutes FROM onset of rotation	6th min.	7th min.	8th min. (if required)
--	----------	----------	------------------------

(2) Maximum Allowable Solvent Spillage

142 g	28 g	28 g	28 g
-------	------	------	------

III. ACTUAL TEST VEHICLE SOLVENT SPILLAGE:

0 g	0 g	0 g	N/A
-----	-----	-----	-----

Note: Record spillage for whole minute intervals only as determined above.

IV. SOLVENT SPILLAGE LOCATION(S) :

None

---



---

DATA SHEET 13

FMVSS NO. 301 STATIC ROLLOVER DATA SHEET (CONTINUED)

Vehicle: 2000 Saturn SL

NHTSA No. MY0113

180 - 270 Degrees

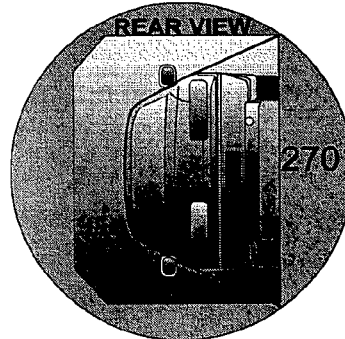
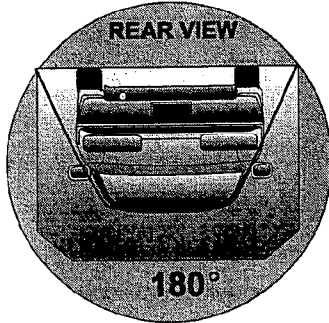

I. DETERMINATION OF SOLVENT COLLECTION TIME PERIOD :

Rollover Fixture 90° Rotation Time (Spec. Range = 1 to 3 minutes)	<u>1</u>	minutes	<u>13</u>	seconds
FMVSS 301 Position Hold Time +	<u>5</u>	minutes	<u>0</u>	seconds
TOTAL	<u>6</u>	minutes	<u>13</u>	seconds
Next whole minute interval	<u>7</u>	minutes		

II. FMVSS 301 REQUIREMENTS :

(1) Time Period

First 5 minutes FROM onset of rotation	6th min.	7th min.	8th min. (if required)
--	----------	----------	------------------------

(2) Maximum Allowable Solvent Spillage

142 g	28 g	28 g	28 g
-------	------	------	------

III. ACTUAL TEST VEHICLE SOLVENT SPILLAGE:

0 g	0 g	0 g	N/A
-----	-----	-----	-----

Note: Record spillage for whole minute intervals only as determined above.

IV. SOLVENT SPILLAGE LOCATION(S) :

None

DATA SHEET 13

FMVSS NO. 301 STATIC ROLLOVER DATA SHEET (CONTINUED)

Vehicle: 2000 Saturn SL

NHTSA No. MY0113

270 - 360 Degrees

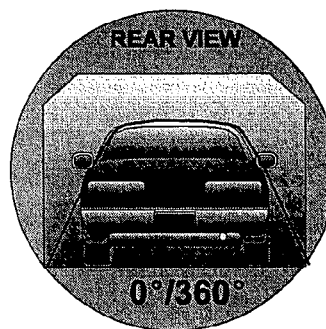
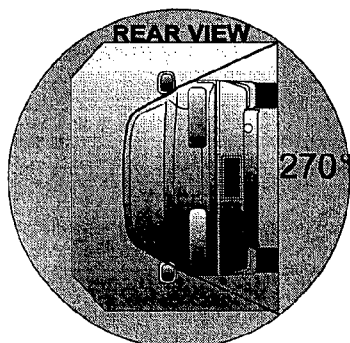

I. DETERMINATION OF SOLVENT COLLECTION TIME PERIOD :

Rollover Fixture 90° Rotation Time (Spec. Range = 1 to 3 minutes)	<u>1</u>	minutes	<u>16</u>	seconds
FMVSS 301 Position Hold Time +	<u>5</u>	minutes	<u>0</u>	seconds
TOTAL	<u>6</u>	minutes	<u>16</u>	seconds
Next whole minute interval	<u>7</u>	minutes		

II. FMVSS 301 REQUIREMENTS :

(1) Time Period

First 5 minutes FROM onset of rotation	6th min.	7th min.	8th min. (if required)
--	----------	----------	------------------------

(2) Maximum Allowable Solvent Spillage

142 g	28 g	28 g	28 g
-------	------	------	------

III. ACTUAL TEST VEHICLE SOLVENT SPILLAGE:

0 g	0 g	0 g	N/A
-----	-----	-----	-----

Note: Record spillage for whole minute intervals only as determined above.

IV. SOLVENT SPILLAGE LOCATION(S) :

None

**DATA SHEET NO.14 VEHICLE MEASUREMENTS**

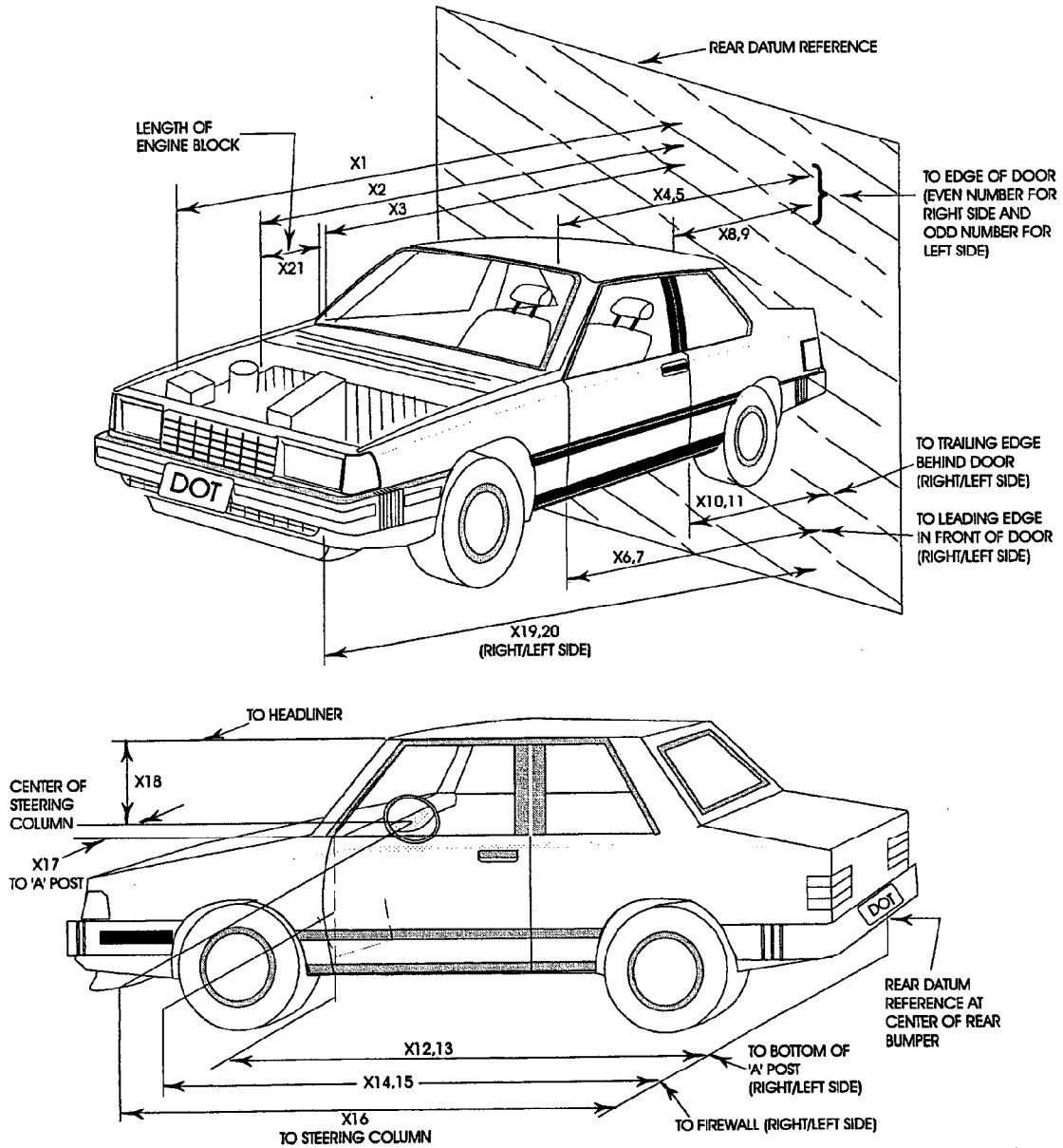

DATA SHEET NO.14      VEHICLE MEASUREMENTS (cont.)

No.		Pre-Test	Post-Test	Differences
X1	Total Length of Vehicle at Centerline	4544.6	3953.3	591
X2	Rear Surface of Vehicle to Front of Engine	3809.4	3517.7	292
X3	Rear Surface of Vehicle to Firewall	3407.6	3270.6	137
X4	Rear Surface of Vehicle to Upper Leading Edge of Right Door	3008.3	2992.7	16
X5	Rear Surface of Vehicle to Upper Leading Edge of Left Door	3014.6	3018.8	-4
X6	Rear Surface of Vehicle to Lower Leading Edge of Right Door	3002.6	2976.2	26
X7	Rear Surface of Vehicle to Lower Leading Edge of Left Door	3007.1	3010.9	-4
X8	Rear Surface of Vehicle to Upper Trailing Edge of Right Door	2009.0	1991.0	18
X9	Rear Surface of Vehicle to Upper Trailing Edge of Left Door	2012.6	2015.6	-3
X10	Rear Surface of Vehicle to Lower Trailing Edge of Right Door	2033.9	2016.0	18
X11	Rear Surface of Vehicle to Lower Trailing Edge of Left Door	2045.1	2037.3	8
X12	Rear Surface of Vehicle to Bottom of "A" Post of Right Side	3152.8	3142.4	10
X13	Rear Surface of Vehicle to Bottom of "A" Post of Left Side	3151.4	3156.7	-5
X14	Rear Surface of Vehicle to Firewall, Right Side	3365.0	3272.1	93
X15	Rear Surface of Vehicle to Firewall, Left Side	3399.6	3285.4	114
X16	Rear Surface of Vehicle to Steering Column	2590.1	2571.7	18
X17	Center of Steering Column to "A" Post	385.8	377.7	8
X18	Center of Steering Column to Headliner	435.6	430.0	6
X19	Rear Surface of Vehicle to Right Side of Front Bumper	4498.4	3962.8	536
X20	Rear Surface of Vehicle to Left Side of Front Bumper	4495.1	4022.1	473
X21	Length of Engine Block	19.4	19.4	0
RD	Rear Surface of Vehicle to Right Side of Dash Panel	2744.8	2710.5	34
CD	Rear Surface of Vehicle to Center of Dash Panel	2758.5	2747.7	11
LD	Rear Surface of Vehicle to Left Side of Dash Panel	2800.4	2784.2	16

All Dimensions in mm

DATA SHEET NO.14    VEHICLE MEASUREMENTS (cont.)  
 VEHICLE INTRUSION MEASUREMENTS  
 DOOR OPENING WIDTH

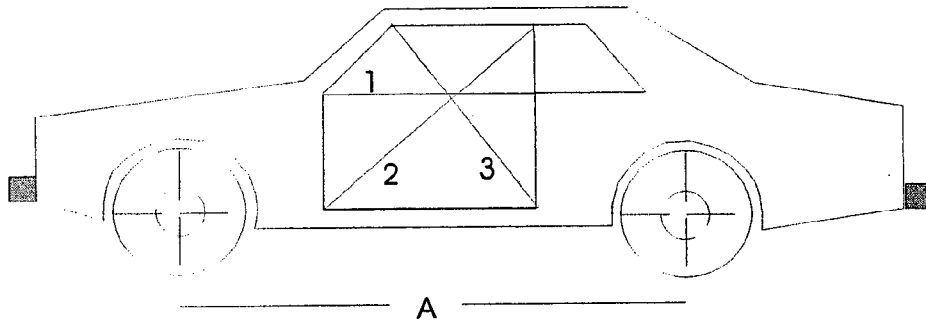

UNITS (mm)	LEFT			RIGHT		
MEASUREMENT	1	2	3	1	2	3
BEFORE TEST	911.8	1386.1	873.3	905.4	1377.5	866.3
AFTER TEST	913.0	1392.3	879.9	904.0	1393.3	892.6
DIFFERENCE	-1.2	-6.2	-6.6	1.4	-15.8	-26.3

UNITS (mm)	A = WHEELBASE LEFT	A = WHEELBASE RIGHT
BEFORE TEST	2603.3	2599.8
AFTER TEST	2485.8	2509.9
DIFFERENCE	117.5	89.9

DATA SHEET NO.14 VEHICLE MEASUREMENTS (cont.)  
VEHICLE INTRUSION MEASUREMENTS  
STATIC FOOTWELL DEFORMATION

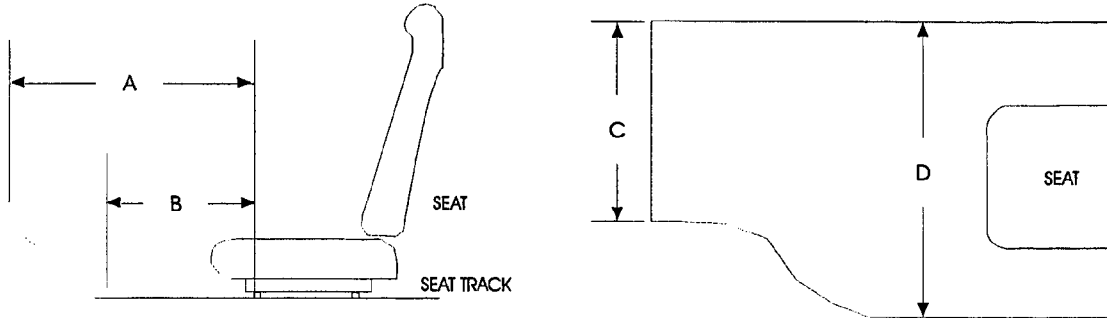

DRIVER

Measurement	Pre-Test	Post-Test	Difference
A	667.7	-2594.6	3,262
B	585.7	-2594.6	3,180
C	462.5	439.8	23
D	464.9	503.9	-39

PASSENGER

Measurement	Pre-Test	Post-Test	Difference
A	636.9	-2568.4	3,205
B	552.6	-2568.4	3,121
C	431.9	348.5	83
D	475.8	450.1	26

Units = mm

**DATA SHEET NO.14 VEHICLE MEASUREMENTS (cont.)**  
**VEHICLE INTRUSION MEASUREMENTS**  
**STATIC PASSENGER COMPARTMENT INTRUSION**

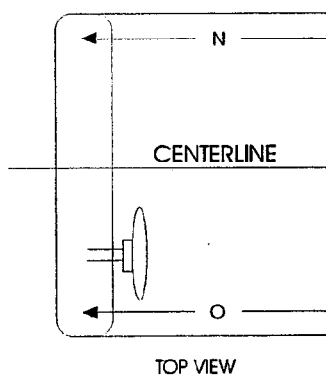
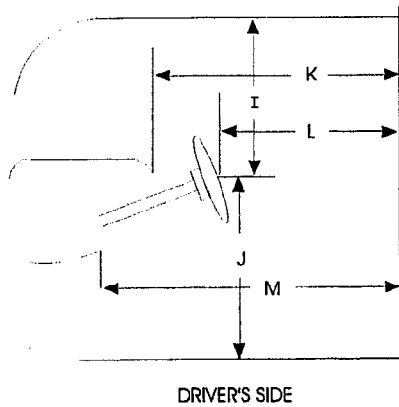

MEASUREMENTS  
FROM C-PILLAR  
BELT ANCHORAGE

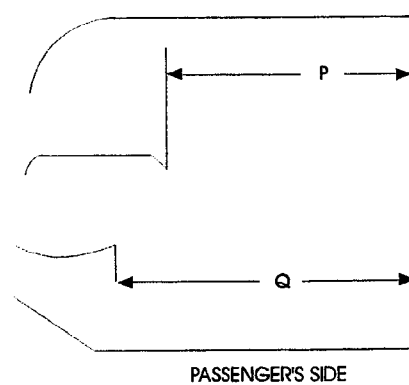

Measurement	Pre-Test	Post-Test	Difference
I	435.6	430.0	6
J	584.1	633.1	-49
K	1621.7	1601.7	20
L	1458.8	1439.7	19
M	1659.1	1640.2	19
N	1617.0	1615.8	1
O	1669.1	1652.3	17
P = K (PASS.)	1634.5	1618.4	16
Q = M (PASS.)	1728.5	1713.6	15

Units = mm

DATA SHEET NO.14 VEHICLE MEASUREMENTS (cont.)  
FLOORBOARD DEFORMATION

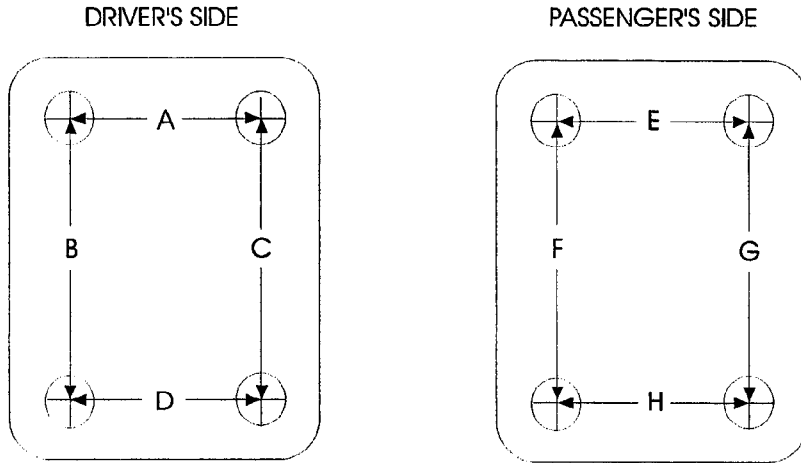

TOP VIEW THROUGH FLOOR PAN

Measurement	Pre-Test	Post-Test	Difference
A	390	395	-5
B	415	415	0
C	415	420	-5
D	415	415	0
E	360	355	5
F	420	410	10
G	425	425	0
H	410	410	0

Units = mm

**DATA SHEET NO.14 VEHICLE MEASUREMENTS (cont.)**  
**TOE-PAN INTRUSION**

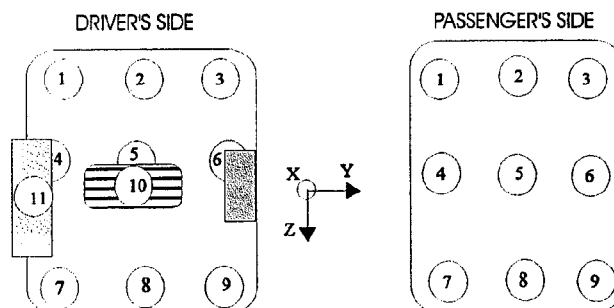

**Driver Side Floorpan Measurements**

Reference: X = Rear Bumper; Z = Ground

Floorpan Location	X Deformation			Z Deformation		
	Pre-Test	Post-Test	Difference	Pre-Test	Post-Test	Difference
1	3237.5	3150.1	87	-359.3	-371.5	12
2	3257.5	3167.9	90	-320.6	-345.9	25
3	3241.8	3156.8	85	-324.9	-348.4	24
4	3203.5	3148.5	55	-319.4	-322.6	3
5	3212.7	3124.0	89	-292.0	-292.9	1
6	3197.0	3126.0	71	-283.0	-277.9	-5
7	3157.6	3132.2	25	-270.3	-276.1	6
8	3175.6	3107.1	69	-269.1	-268.1	-1
9	3145.9	3142.5	3	-247.9	-232.8	-15
10	3118.6	3012.6	106	-383.4	-391.3	8
11	3140.6	3097.2	43	-360.7	-378.0	17

**Passenger Side Floorpan Measurements**

Reference: X = Rear Bumper; Z = Ground

Floorpan Location	X Deformation			Z Deformation		
	Pre-Test	Post-Test	Difference	Pre-Test	Post-Test	Difference
1	3204.5	3128.9	76	-327.2	-333.7	7
2	3223.1	3139.3	84	-326.4	-352.0	26
3	3193.5	3094.5	99	-359.4	-385.3	26
4	3170.0	3104.6	65	-277.7	-264.2	-14
5	3192.7	3130.8	62	-300.8	-309.8	9
6	3170.6	3092.1	79	-329.1	-338.0	9
7	3126.9	3096.5	30	-247.7	-199.8	-48
8	3138.7	3111.6	27	-268.5	-240.0	-29
9	3130.0	3083.9	46	-289.5	-277.3	-12

Units in mm

DATA SHEET NO.15 HIGH-SPEED CAMERA LOCATIONS

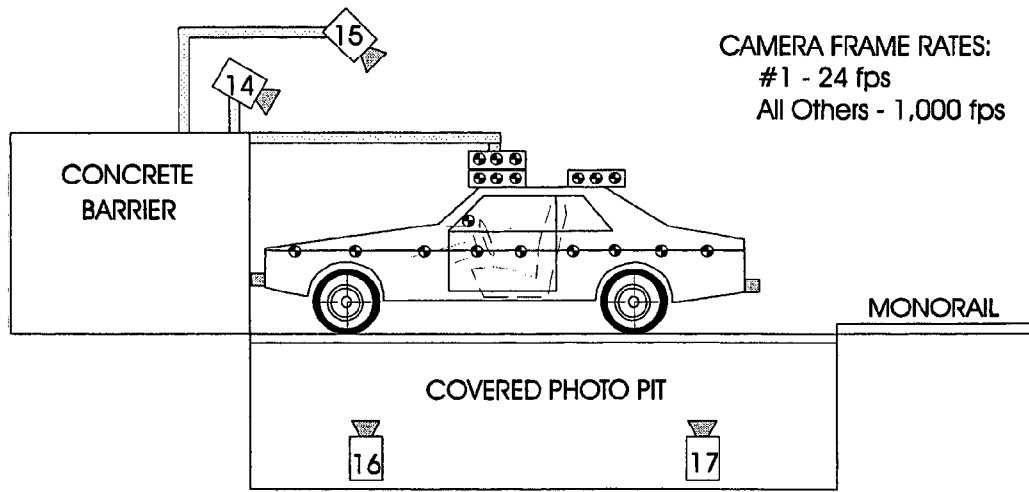
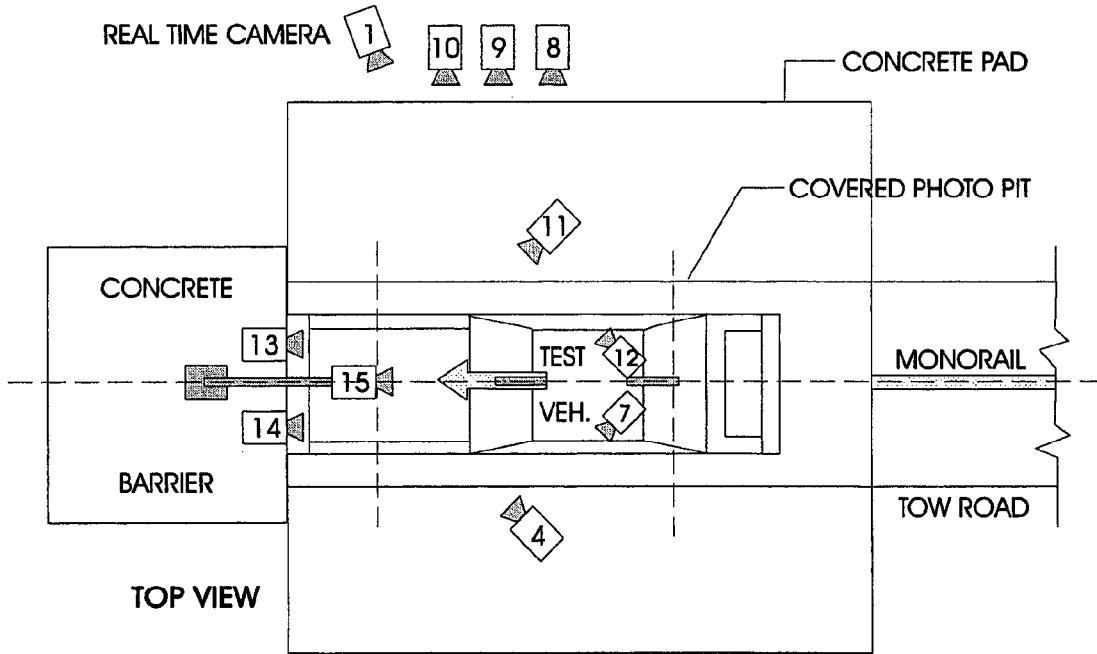

CAMERA FRAME RATES:  
 #1 - 24 fps  
 All Others - 1,000 fps

DATA SHEET NO.15 HIGH-SPEED CAMERA LOCATIONS (cont.)

NHTSA Test No.: MY0113 Vehicle: 2000 Saturn SL 4 Door Sedan

CAMERA NO.	VIEW	CAMERA POSITIONS (mm)*			ANGLE (deg)**	FILM PLANE TO HEAD TARGET	LENS (mm)	SPEED (fps)
		X	Y	Z				
1	Real-Time Camera	-	-	-	-	-	-	24
2	Overall Left Side	6610	1909	1110	-2	6278	12.5	1005
3	Left Side View	8153	1069	1036	-3	7821	25	1005
4	Driver and Interior View	4929	2889	1829	-12	-	35	1050
5	Steering Column (Bottom)	7287	1783	1171	-3	6955	25	1005
6	Steering Column (Top)	7287	1783	1774	-9	6955	25	1010
7	Left Belt	-	-	-	-	-	8	1020
8	Overall Right Side	6605	1843	1060	-5	6937	12.5	1015
9	Right Side View	7989	1317	1091	-4	8321	25	1000
10	Right Passenger View	7749	1734	1289	-3	8081	35	1010
11	Passenger and Interior View	5655	3264	1831	-10	-	35	1005
12	Right Belt	-	-	-	-	-	8	1015
13	Passenger Front View	-450	-65	1089	-50	-	13	1010
14	Driver Front View	-450	-65	1090	-50	-	13	1005
15	Windshield View	0	0	3365	-61	-	13	1000
16	Pit View of Engine	0	1075	-3048	90	-	13	1050
17	Pit View of Fuel Tank	0	2830	-3048	90	-	13	1005

\*X = film plane to monorail centerline

Y = film plane to impact location

Z = film plane to ground

\*\* = referenced to horizontal plane

N.T. indicates No Timing

DATA SHEET NO. 16 VEHICLE REFERENCE PHOTO TARGET LOCATIONS

(Dimensions in millimeters)

A	332.1
B	590.8
C	1216.9
D	2031.1
E	321.8
F	1452.2
G	827.3
H	842.2
I	172.8
J	1452.7
K	1015.0
L	1249.6
M	324.0
N	180.2
O	835.7
P	831.9
Q	1232.0
R	1015.8
S	1464.9

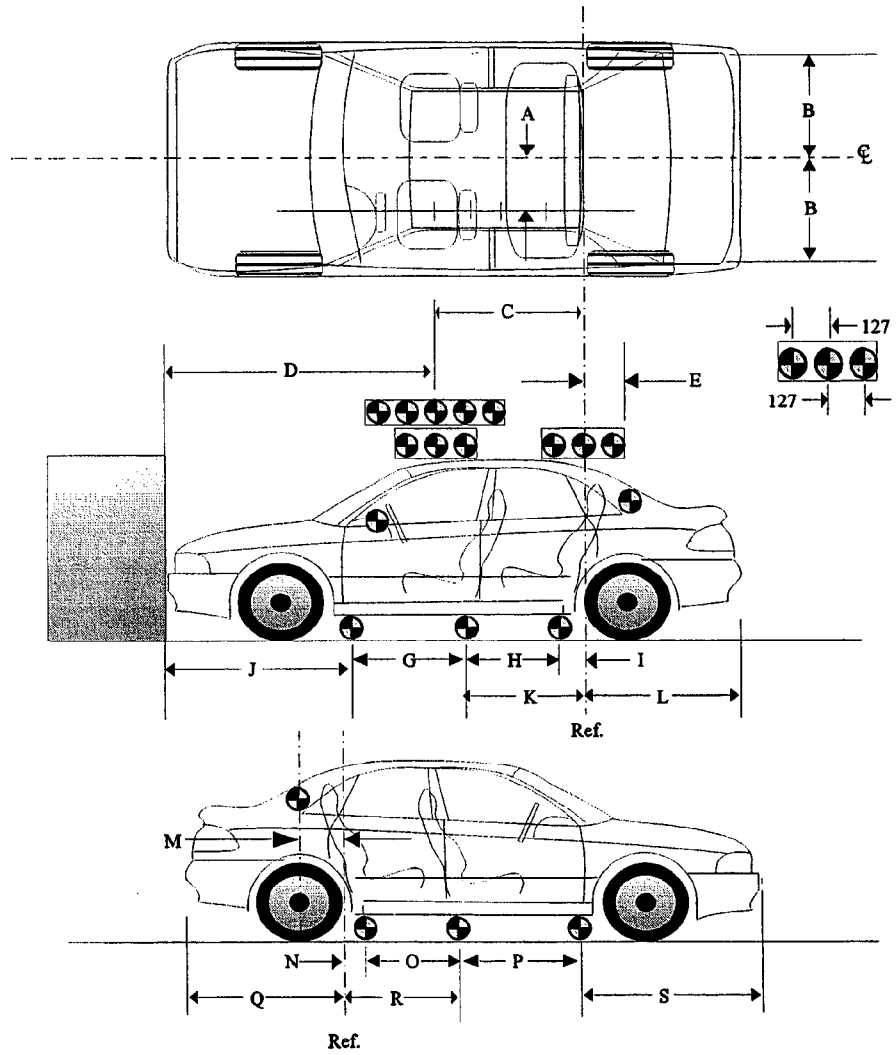

DATA SHEET NO. 17    LOAD CELL LOCATIONS ON FIXED BARRIER

- 36 Load Cells
- 4 Rows
- 9 Columns
- 6 Groupings (6 cells/group)

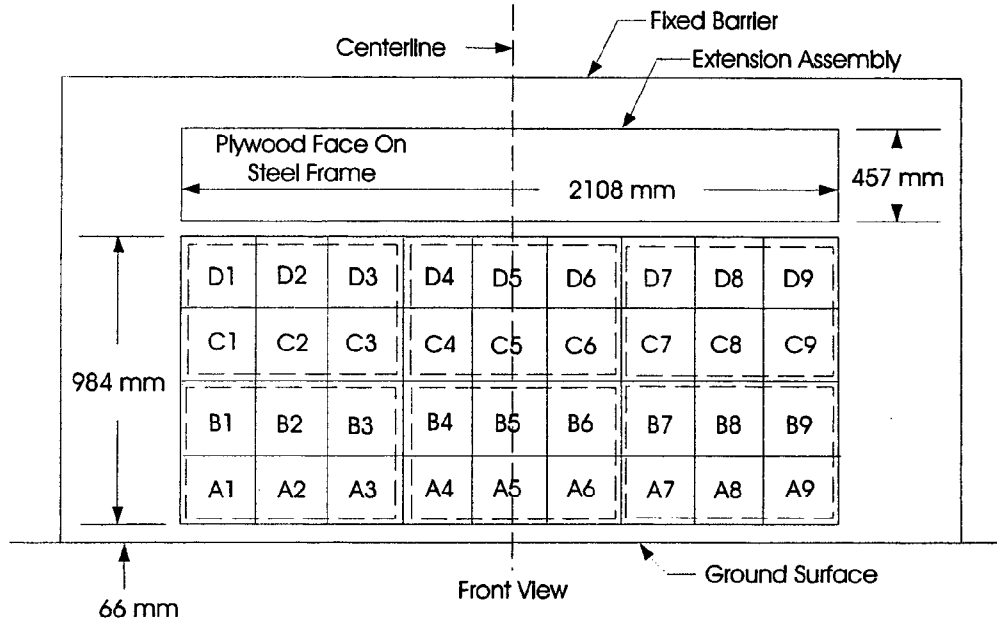

6 GROUPS OF 6 LOAD CELLS EACH

Group 4 C1 thru D3	Group 5 C4 thru D6	Group 6 C7 thru D9
Group 1 A1 thru B3	Group 2 A4 thru B6	Group 3 A7 thru B9

The following data is presented in Appendix B:

- (1) Data from 36 individual load cells
- (2) Total or Sum of 36 individual load cells
- (3) Data from 6 Groupings shown above (6 cells/group)

DATA SHEET NO. 18 POST TEST AIR BAG DATA

NHTSA No. : MY0113; Test Date: December 21, 1999; Technician: J. Czarnecki

Vehicle Model Year/Make/Model: 2000 Saturn SL

- A. No. of vent holes: 0 -Driver 0 -Passenger
- B. Size of vent holes: (mm<sup>2</sup>) 0 -Driver 0 -Passenger
- C. Total vent area: (mm<sup>2</sup>) 0 -Driver 0 -Passenger
- D. Deflated air bag length and width dimensions or, if round, diameter. (mm)
- Driver: - -Length; - -Width; 550 -Diameter
- Passenger: 560 -Height; 660 -Width; 300 -Depth
- E. Is the air bag tethered?
- Driver: x -Yes; - -No; If yes, record length of tether- 120
- Passenger: x -Yes; - -No; If yes, record length of tether- 190

Sketch the air bag showing the location of the vent holes, how the bag is tethered, and where the bag is tethered. Also describe how the tethers are attached to the bag and the steering wheel.

(Note: Not to scale; V<sub>n</sub> = Vent hole<sub>n</sub>, T<sub>n</sub> = Tether<sub>n</sub>).

**Driver**

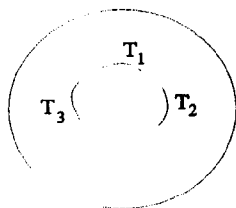

**Passenger**

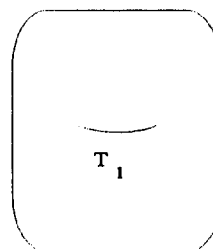

- F. Record part numbers and manufacturer name of the air bag and gas generator.

Driver: Air bag: Y165Y60M10154 30303447CWP

Generator: AB11941T309170

Passenger: Air bag: T1GH307M10482 30311677A

Generator: AL1113ICH2313567



APPENDIX A  
PHOTOGRAPHS

TABLE OF PHOTOGRAPHS

<u>Figure</u>	<u>Title</u>	<u>Page</u>
A-1	LOAD CELL LOCATIONS.	A-3
A-2	PRE-TEST FRONT VIEW	A-4
A-3	POST-TEST FRONT VIEW.	A-5
A-4	PRE-TEST LEFT SIDE VIEW	A-6
A-5	POST-TEST LEFT SIDE VIEW	A-7
A-6	PRE-TEST RIGHT SIDE VIEW	A-8
A-7	POST-TEST RIGHT SIDE VIEW	A-9
A-8	PRE-TEST RIGHT FRONT THREE-QUARTER VIEW	A-10
A-9	POST-TEST RIGHT FRONT THREE-QUARTER VIEW	A-11
A-10	PRE-TEST LEFT REAR THREE-QUARTER VIEW	A-12
A-11	POST-TEST LEFT REAR THREE-QUARTER VIEW	A-13
A-12	PRE-TEST WINDSHIELD VIEW	A-14
A-13	POST-TEST WINDSHIELD VIEW	A-15
A-14	PRE-TEST ENGINE COMPARTMENT VIEW	A-16
A-15	FUEL CAP VIEW	A-17
A-16	PRE-TEST FRONT UNDERBODY VIEW	A-18
A-17	POST-TEST FRONT UNDERBODY VIEW	A-19
A-18	PRE-TEST FRONT SIDE UNDERBODY VIEW	A-20
A-19	POST-TEST FRONT SIDE UNDERBODY VIEW	A-21
A-20	PRE-TEST REAR UNDERBODY VIEW	A-22
A-21	POST-TEST REAR UNDERBODY VIEW	A-23
A-22	PRE-TEST DRIVER POSITION VIEW	A-24
A-23	POST-TEST DRIVER POSITION VIEW	A-25
A-24	PRE-TEST PASSENGER POSITION VIEW	A-26
A-25	POST-TEST PASSENGER POSITION VIEW	A-27
A-26	PRE-TEST DRIVER AND INTERIOR VIEW	A-28
A-27	POST-TEST DRIVER AND INTERIOR VIEW	A-29
A-28	PRE-TEST PASSENGER AND INTERIOR VIEW	A-30
A-29	POST-TEST PASSENGER AND INTERIOR VIEW	A-31
A-30	PRE-TEST DRIVER HEAD LOCATION	A-32
A-31	POST-TEST DRIVER HEAD LOCATION	A-33
A-32	PRE-TEST PASSENGER HEAD LOCATION	A-34
A-33	POST-TEST PASSENGER HEAD LOCATION	A-35
A-34	PRE-TEST DRIVER FLOOR PAN VIEW	A-36
A-35	POST-TEST DRIVER FLOOR PAN VIEW	A-37
A-36	PRE-TEST PASSENGER FLOOR PAN VIEW	A-38
A-37	POST-TEST PASSENGER FLOOR PAN VIEW	A-39
A-38	ROLLOVER VIEW	A-40
A-39	IMPACT VIEW	A-41

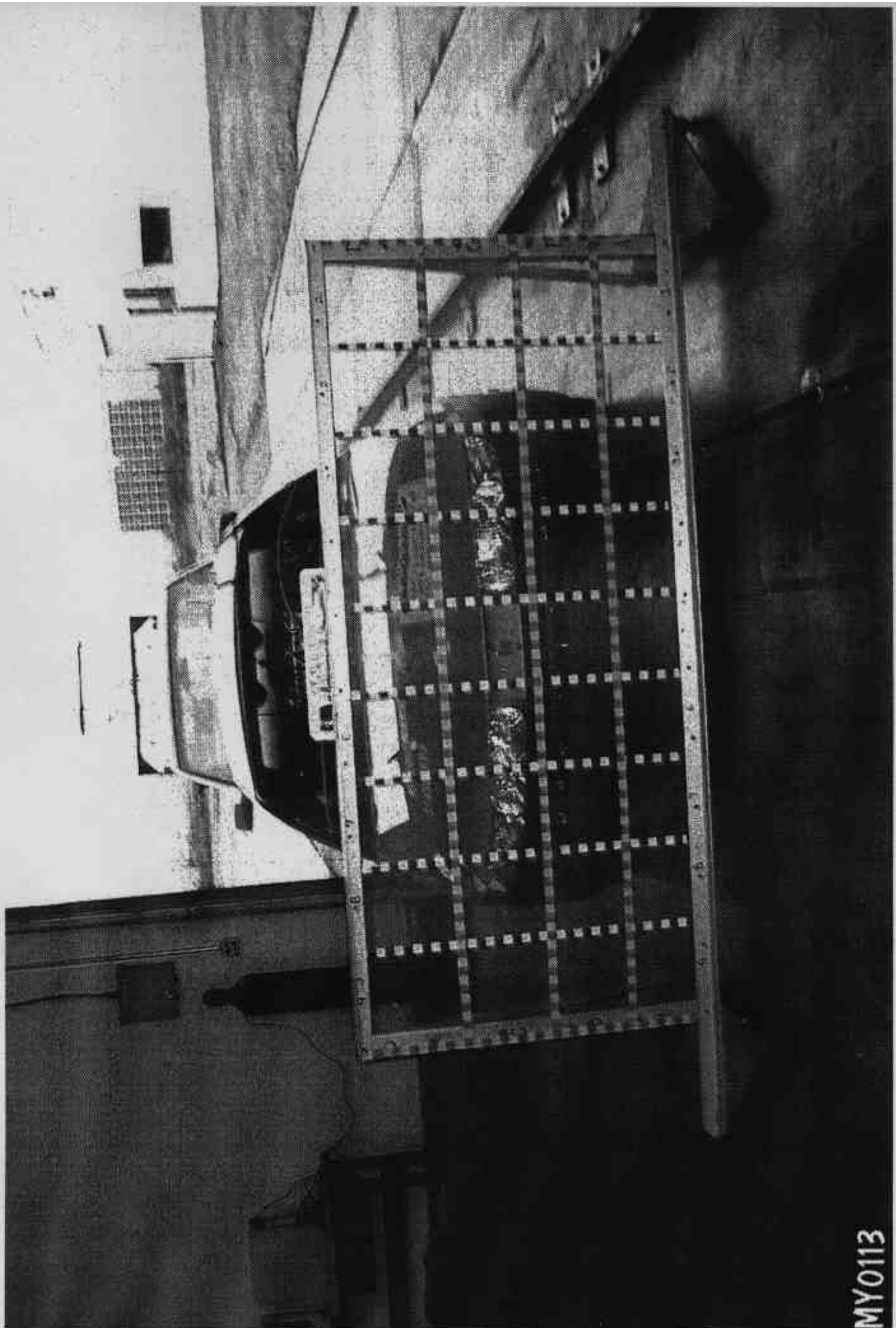

Figure A-1: LOAD CELL LOCATIONS.

MY0113



MY0113

Figure A-2: PRE-TEST FRONT VIEW

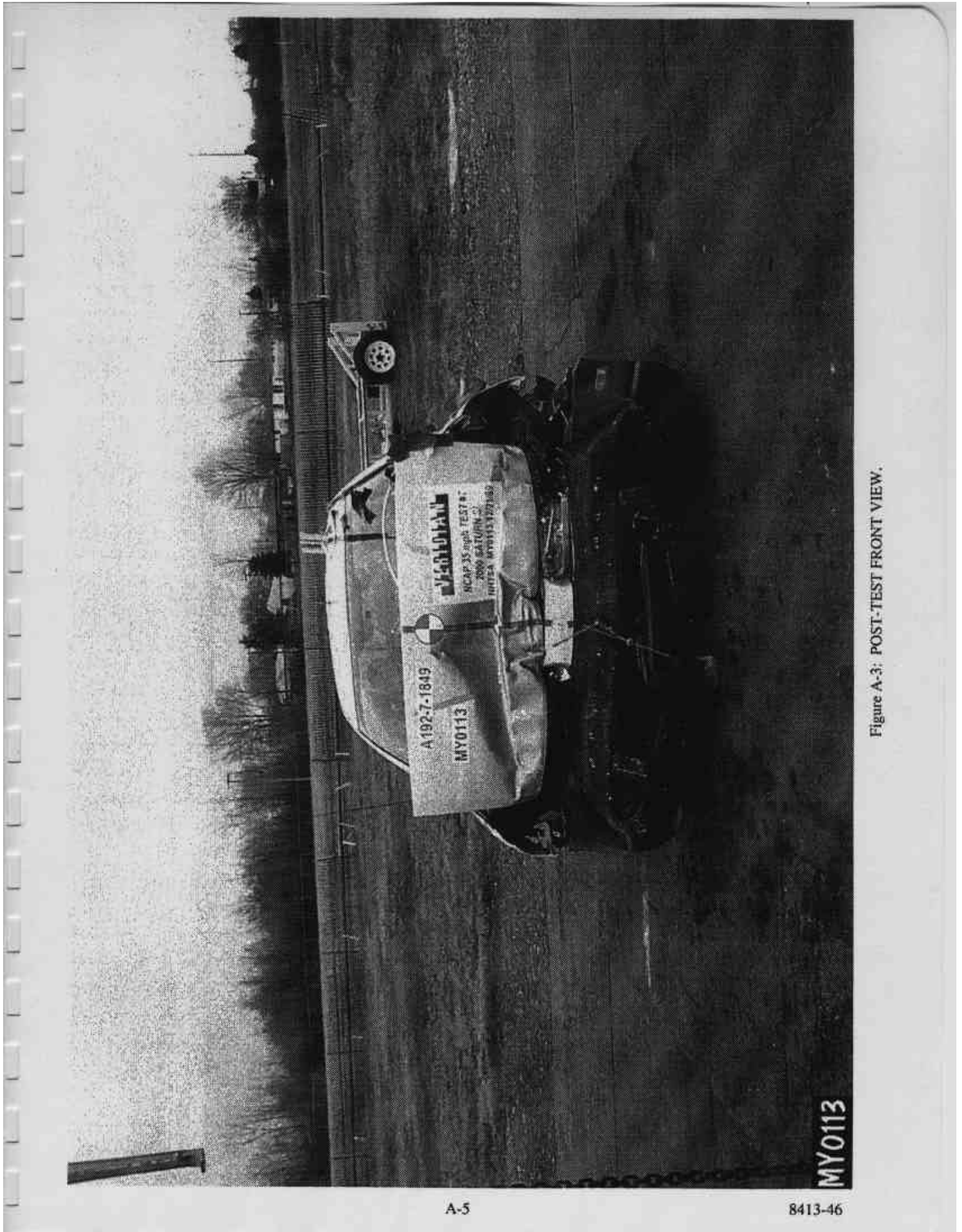
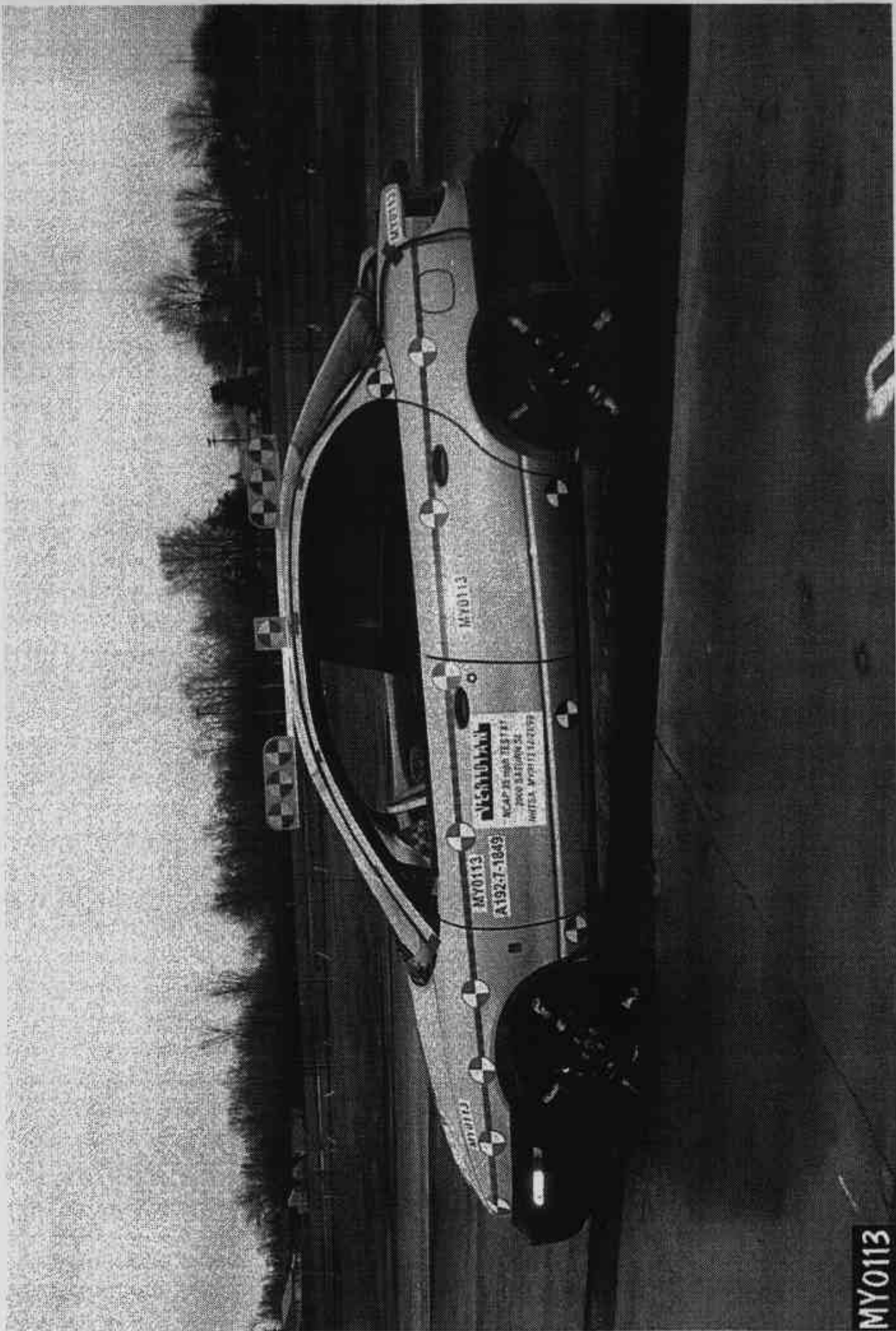

Figure A-3: POST-TEST FRONT VIEW.

MY0113



**MY0113**

Figure A-4: PRE-TEST LEFT SIDE VIEW

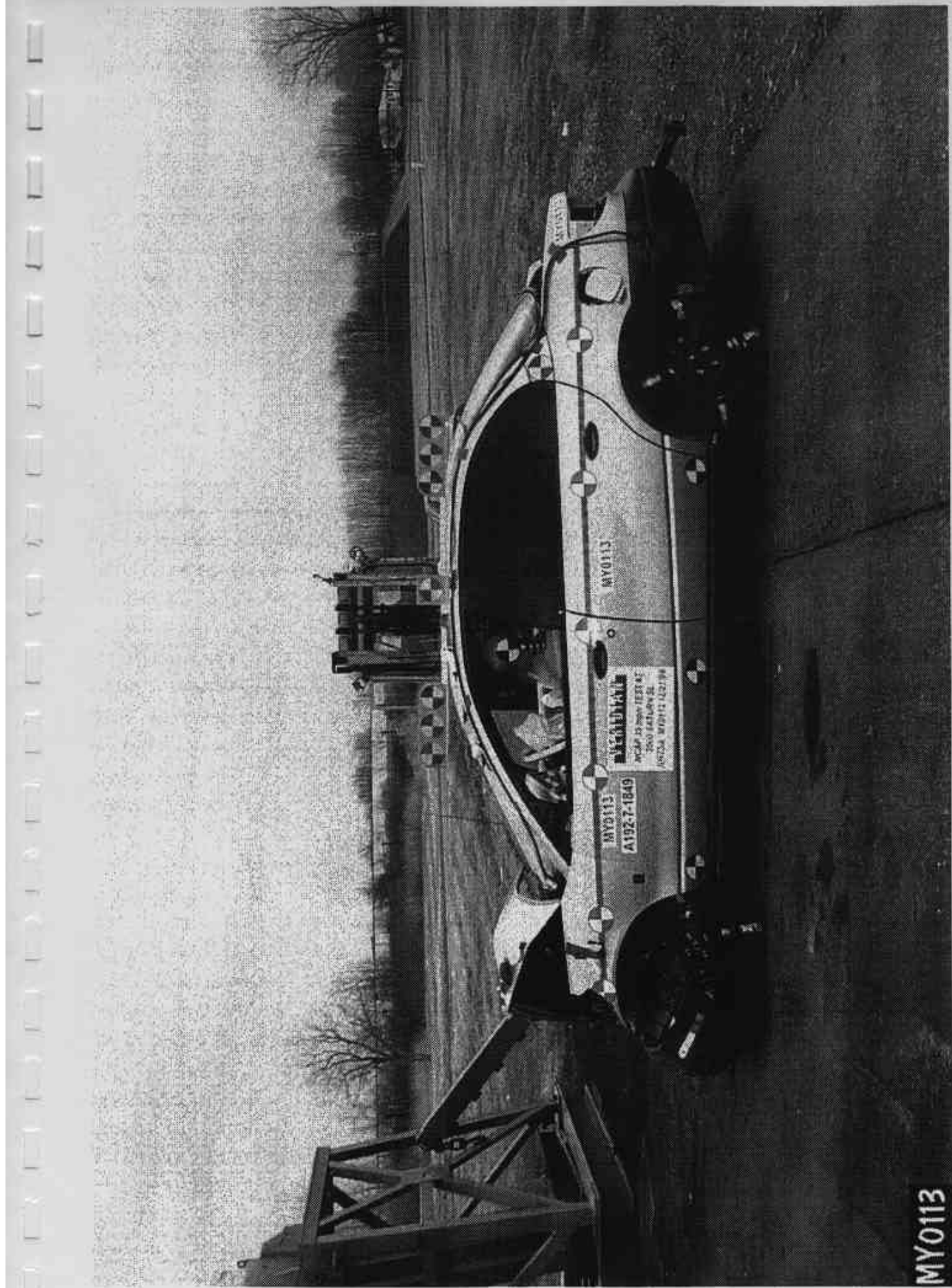

MY0113

Figure A-5: POST-TEST LEFT SIDE VIEW

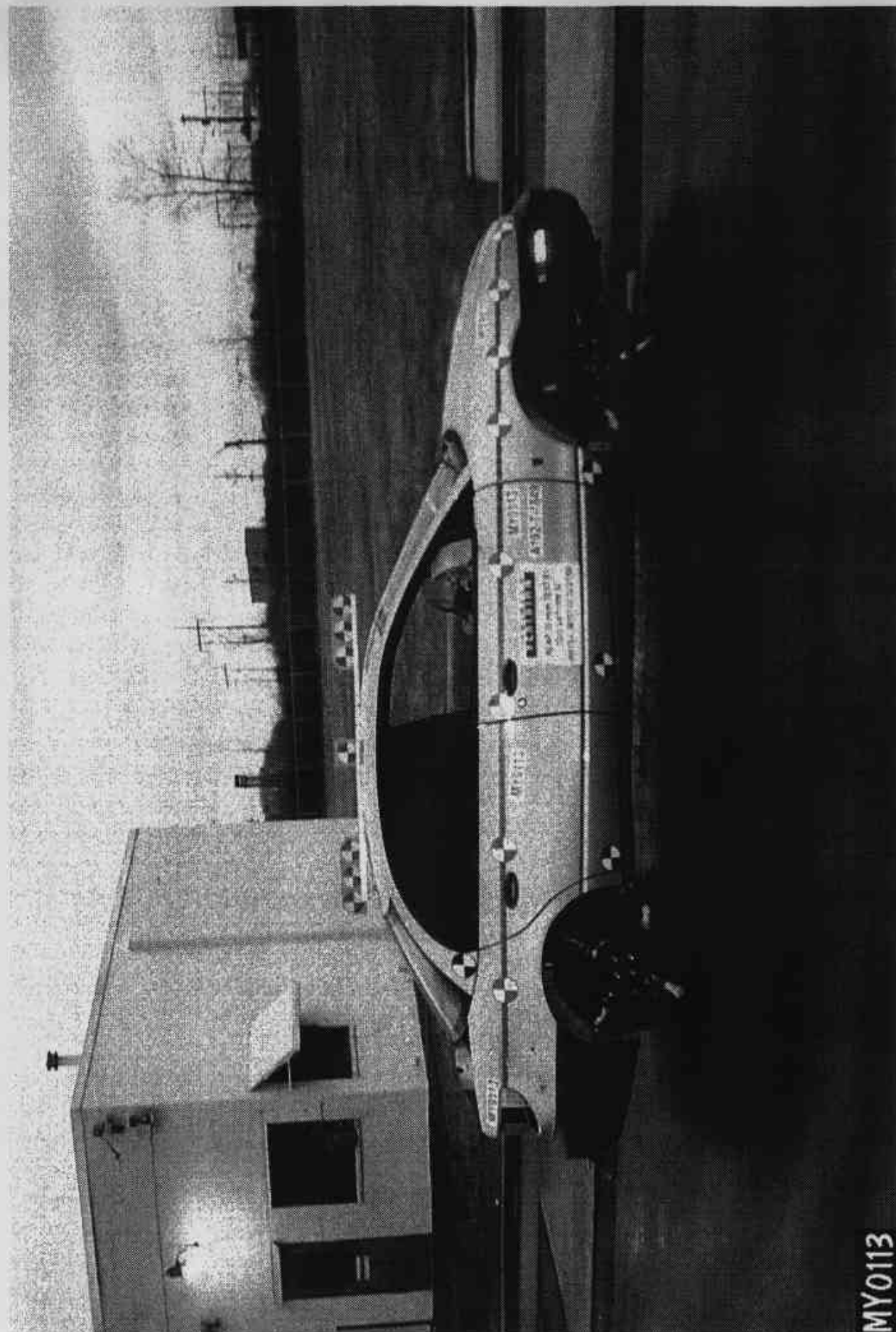

Figure A-6: PRE-TEST RIGHT SIDE VIEW

MY0113

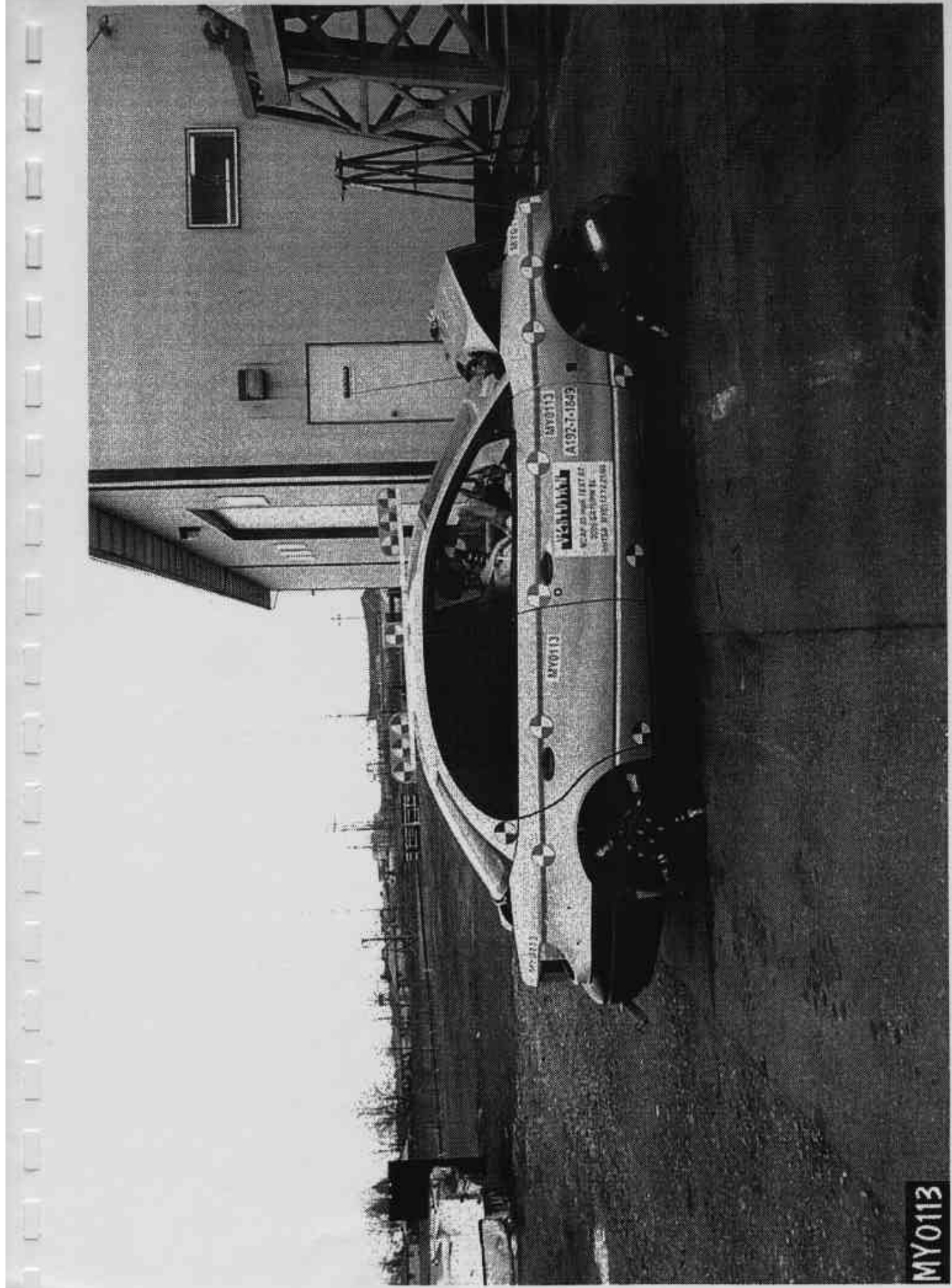

Figure A-7: POST-TEST RIGHT SIDE VIEW



Figure A-8: PRE-TEST RIGHT FRONT THREE-QUARTER VIEW

MY0113

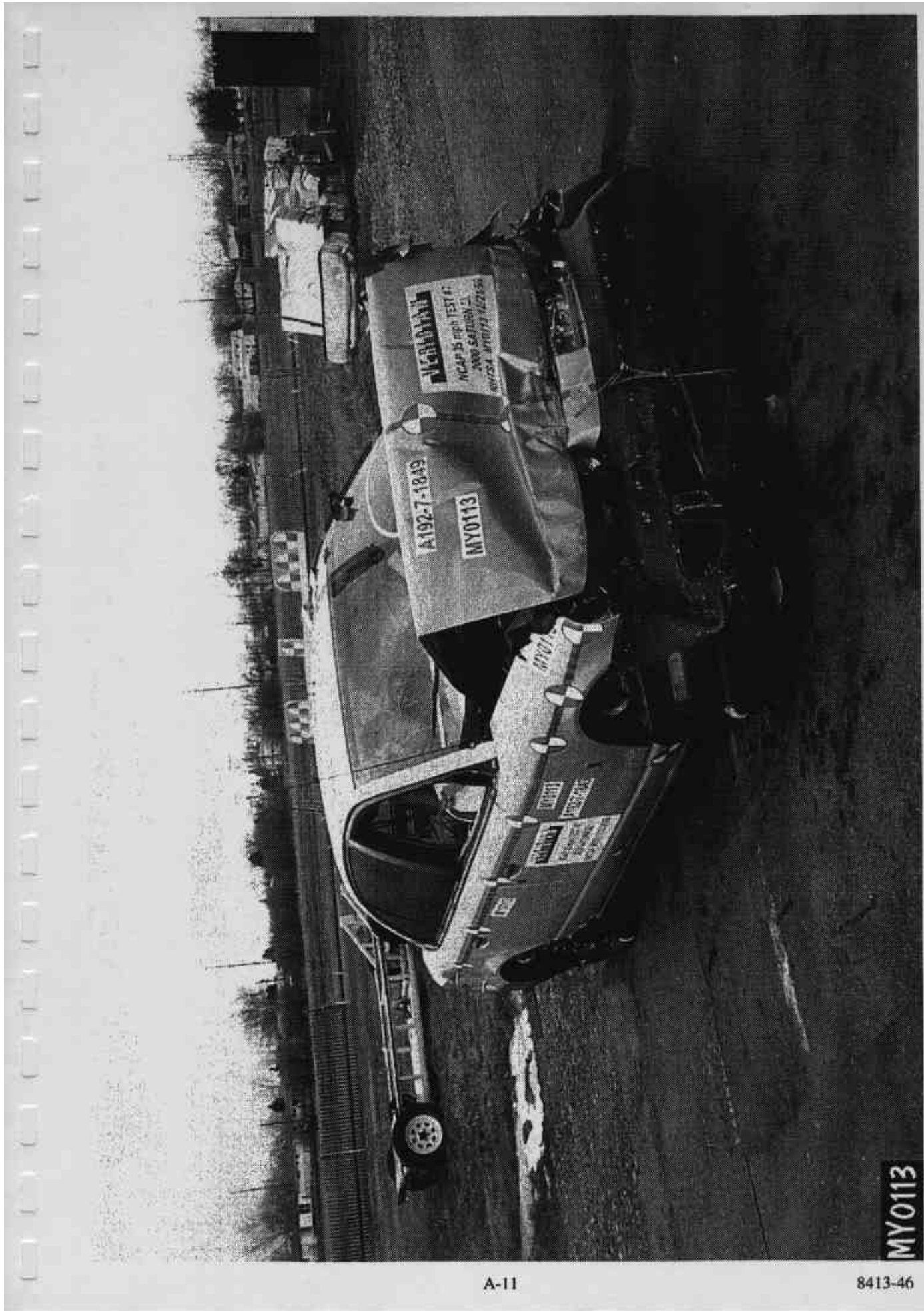

Figure A-9: POST-TEST RIGHT FRONT THREE-QUARTER VIEW

MY0113



Figure A-10: PRE-TEST LEFT REAR THREE-QUARTER VIEW

MY0113



Figure A-11: POST-TEST LEFT REAR THREE-QUARTER VIEW

MY0113

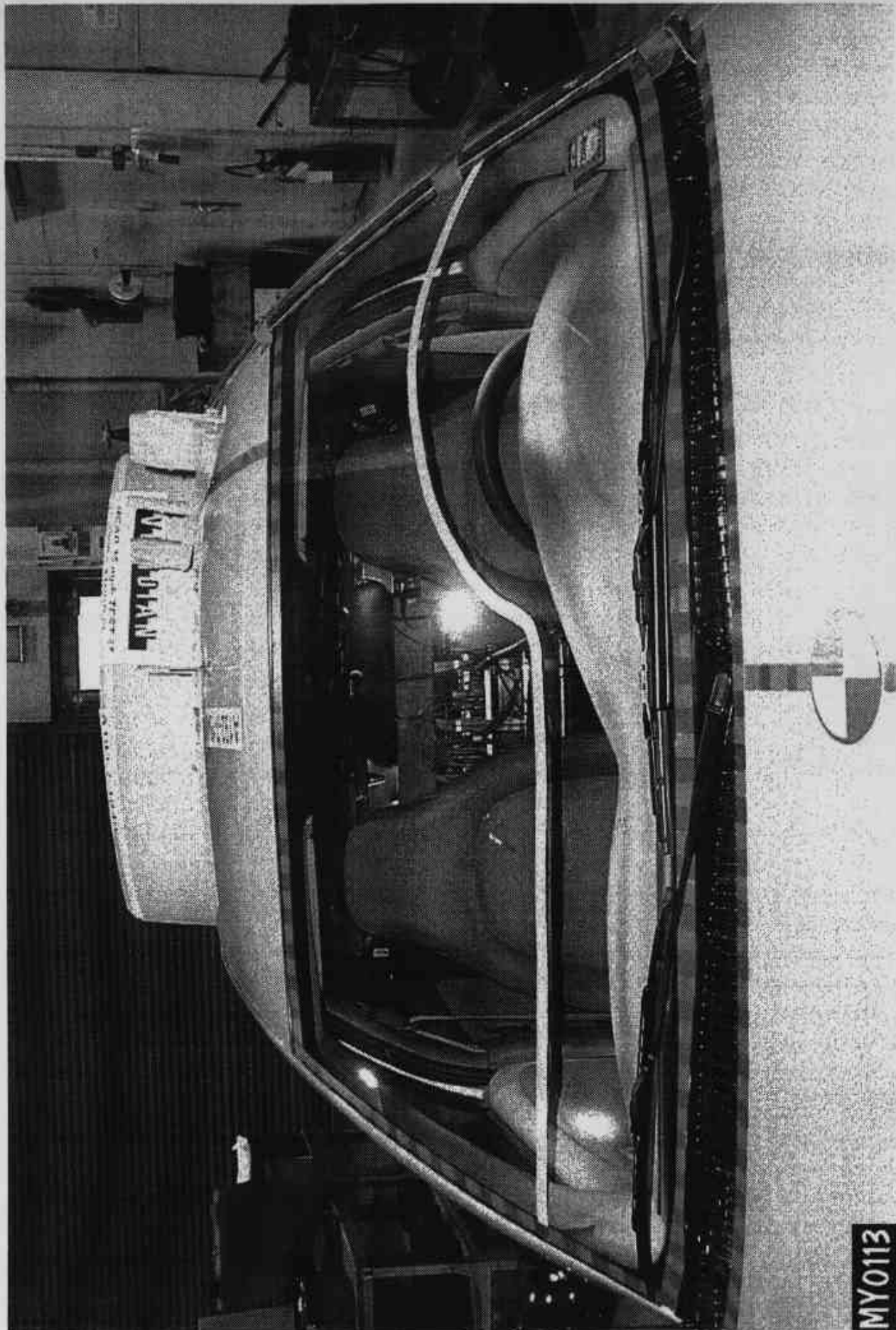

Figure A-12: PRE-TEST WINDSHIELD VIEW

MY0113



A192-7-1849

MY0113

VERBODEN

Figure A-13: POST-TEST WINDSHIELD VIEW

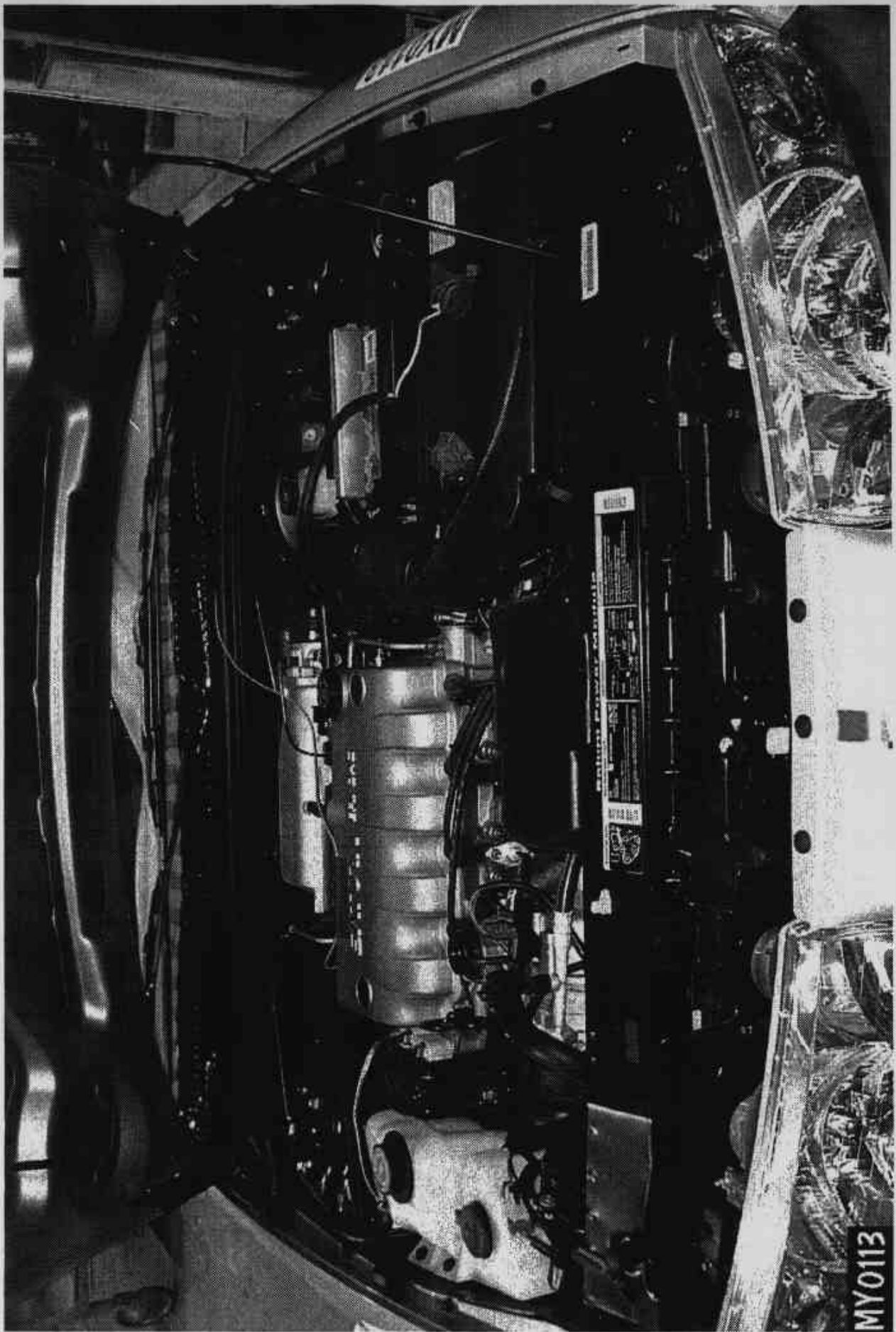

Figure A-14: PRE-TEST ENGINE COMPARTMENT VIEW

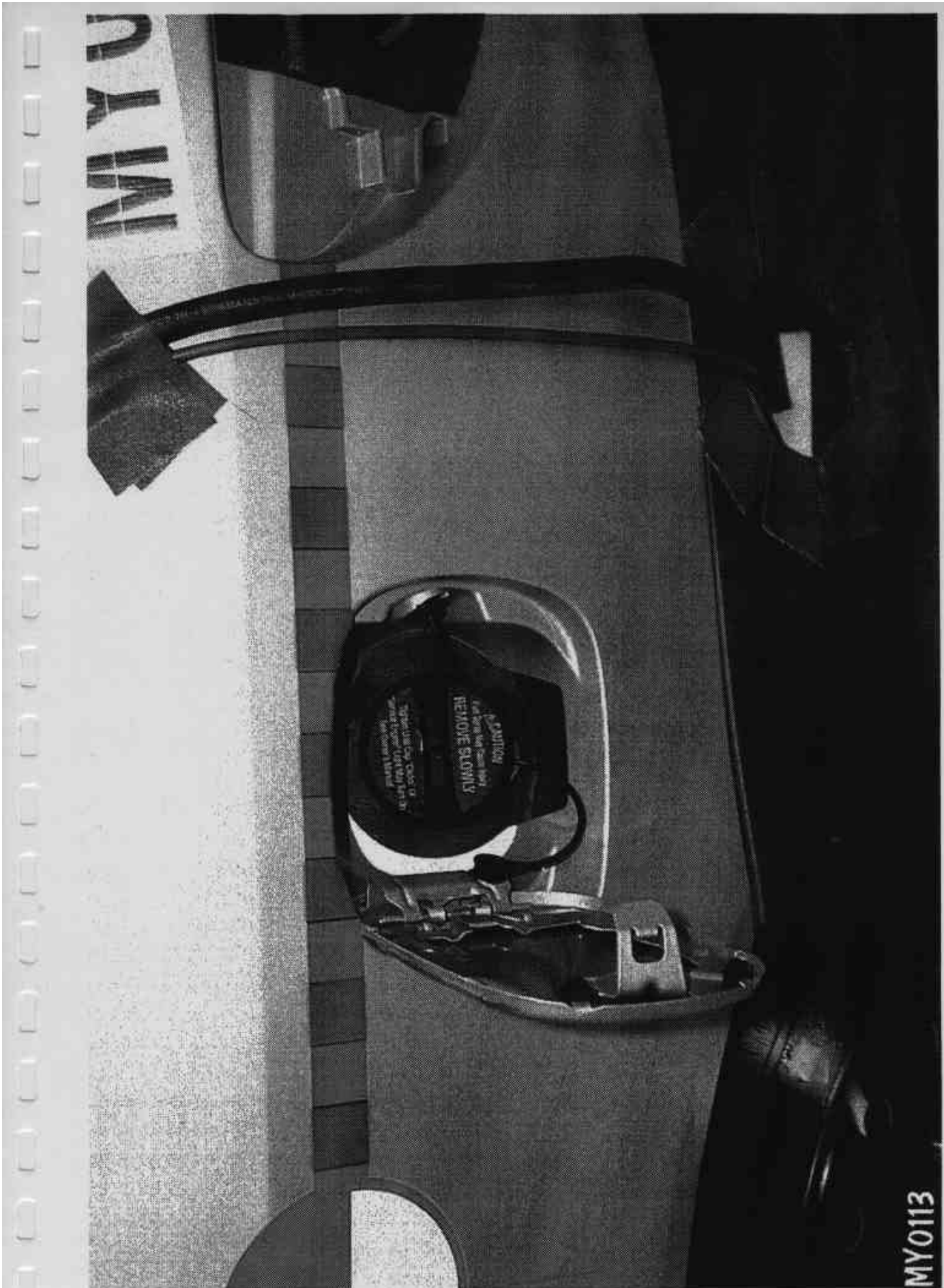

Figure A-15: FUEL CAP VIEW

MY0113

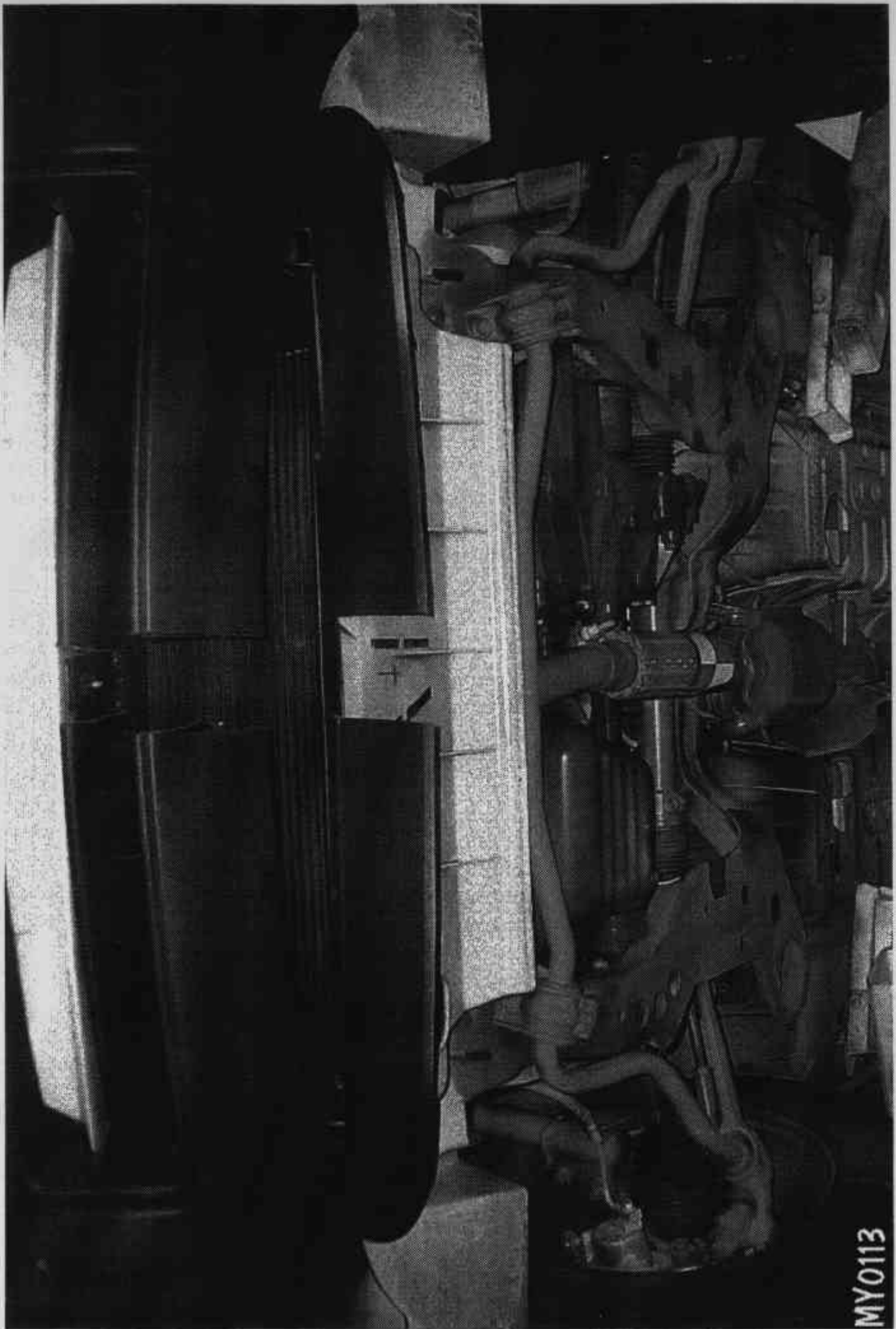

Figure A-16: PRE-TEST FRONT UNDERBODY VIEW

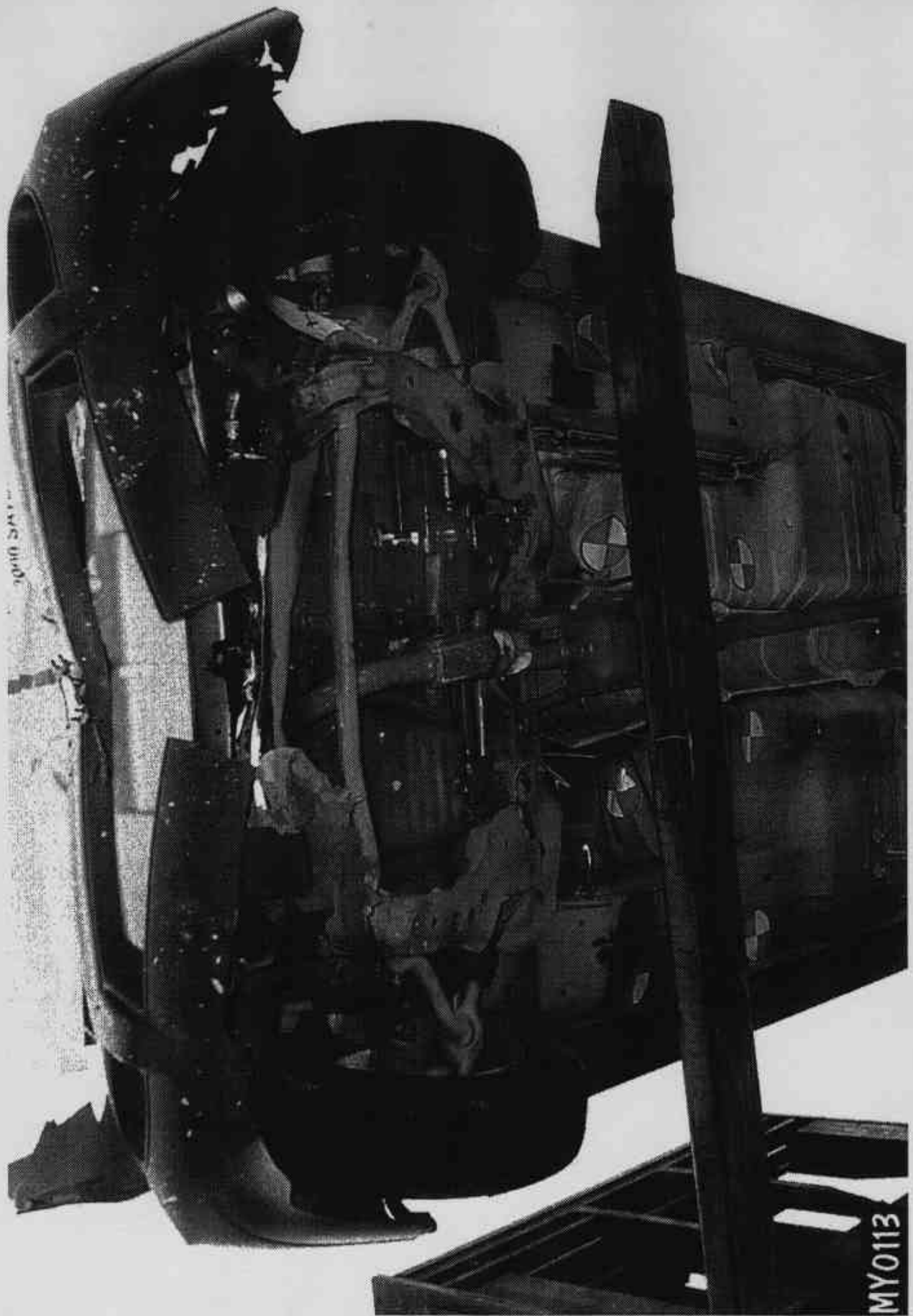

Figure A-17: POST-TEST FRONT UNDERBODY VIEW

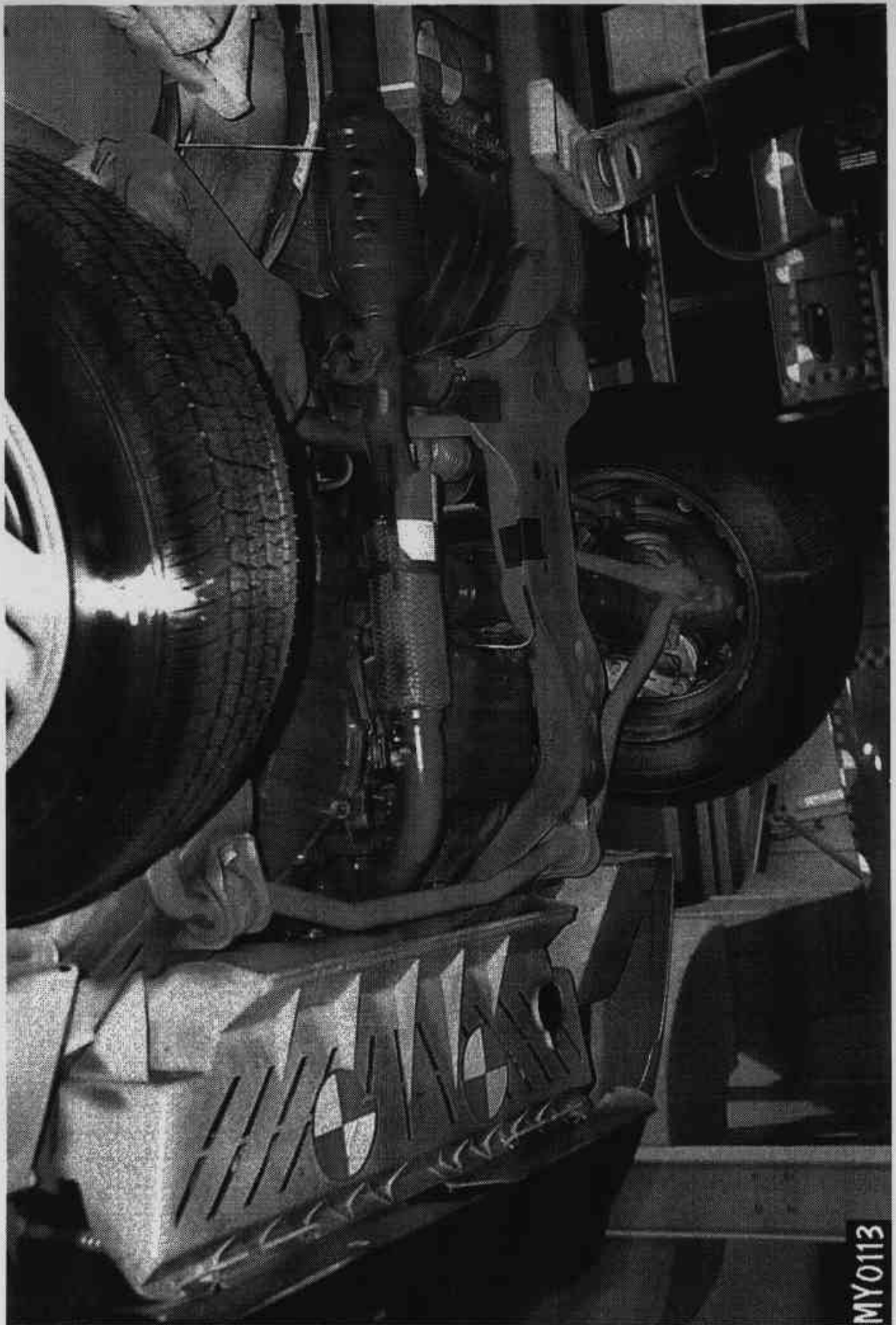

Figure A-18: PRE-TEST FRONT SIDE UNDERBODY VIEW

MY0113

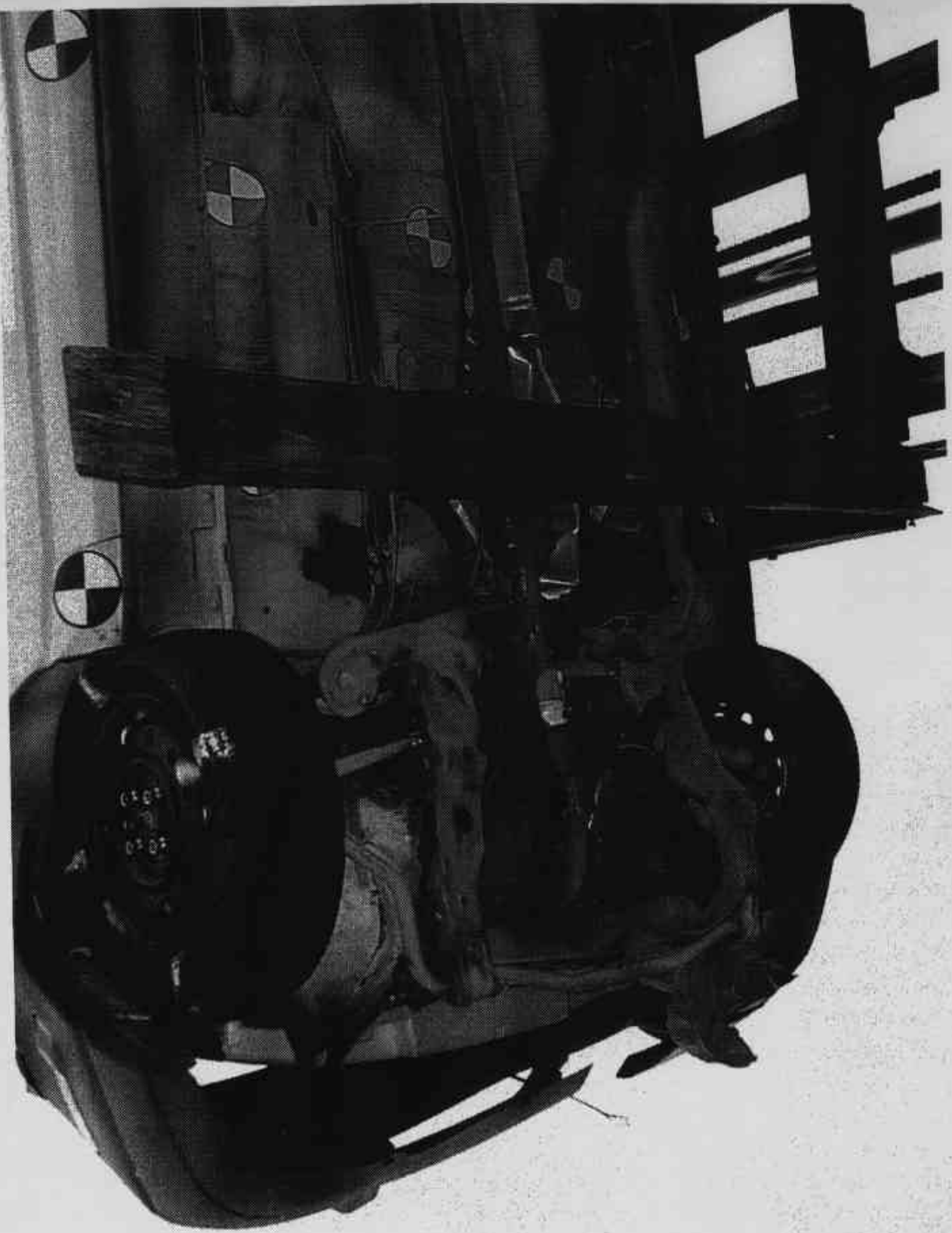

Figure A-19: POST-TEST FRONT SIDE UNDERBODY VIEW

**MY0113**

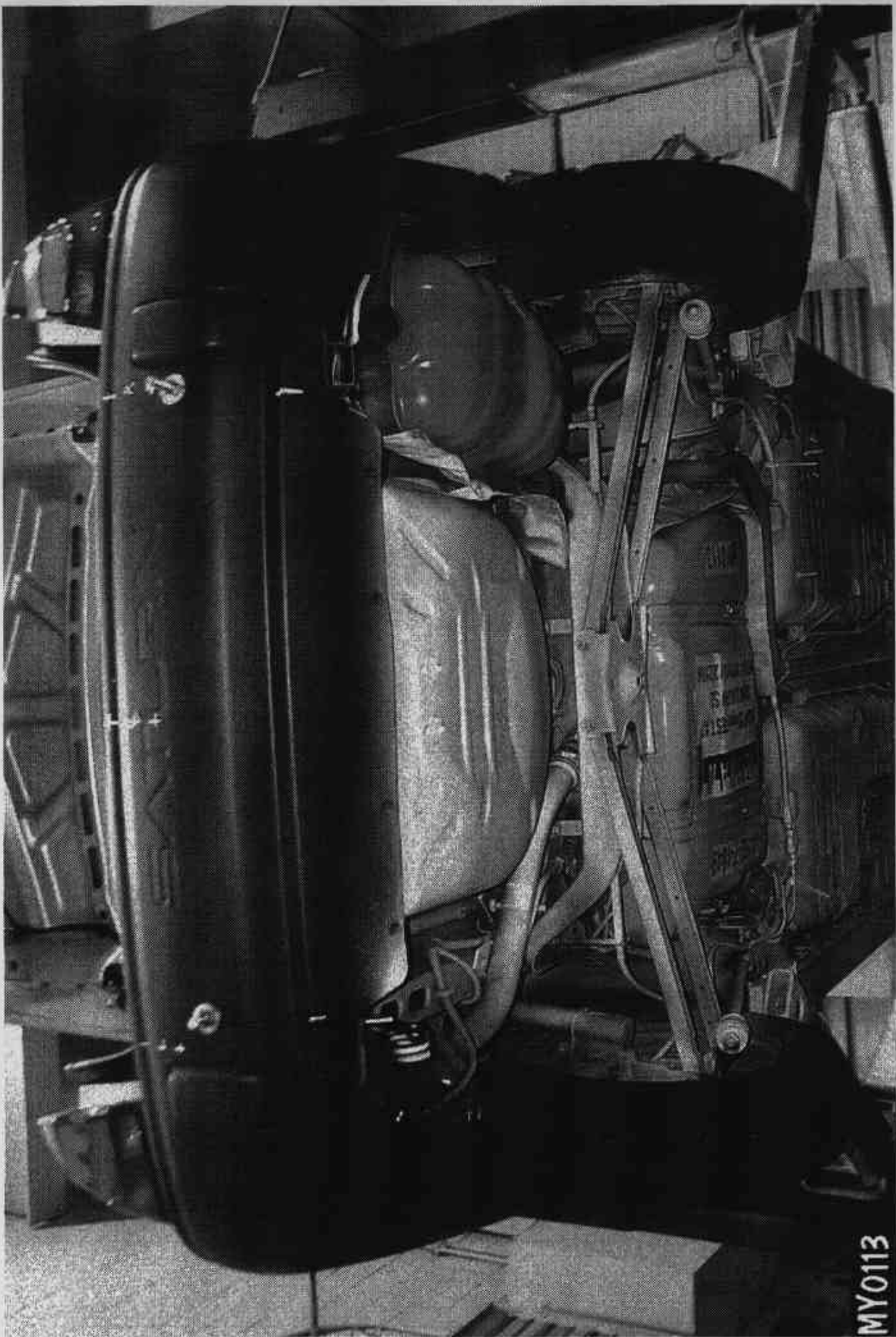

Figure A-20: PRE-TEST REAR UNDERBODY VIEW

MY0113



Figure A-21: POST-TEST REAR UNDERBODY VIEW



Figure A-22: PRE-TEST DRIVER POSITION VIEW

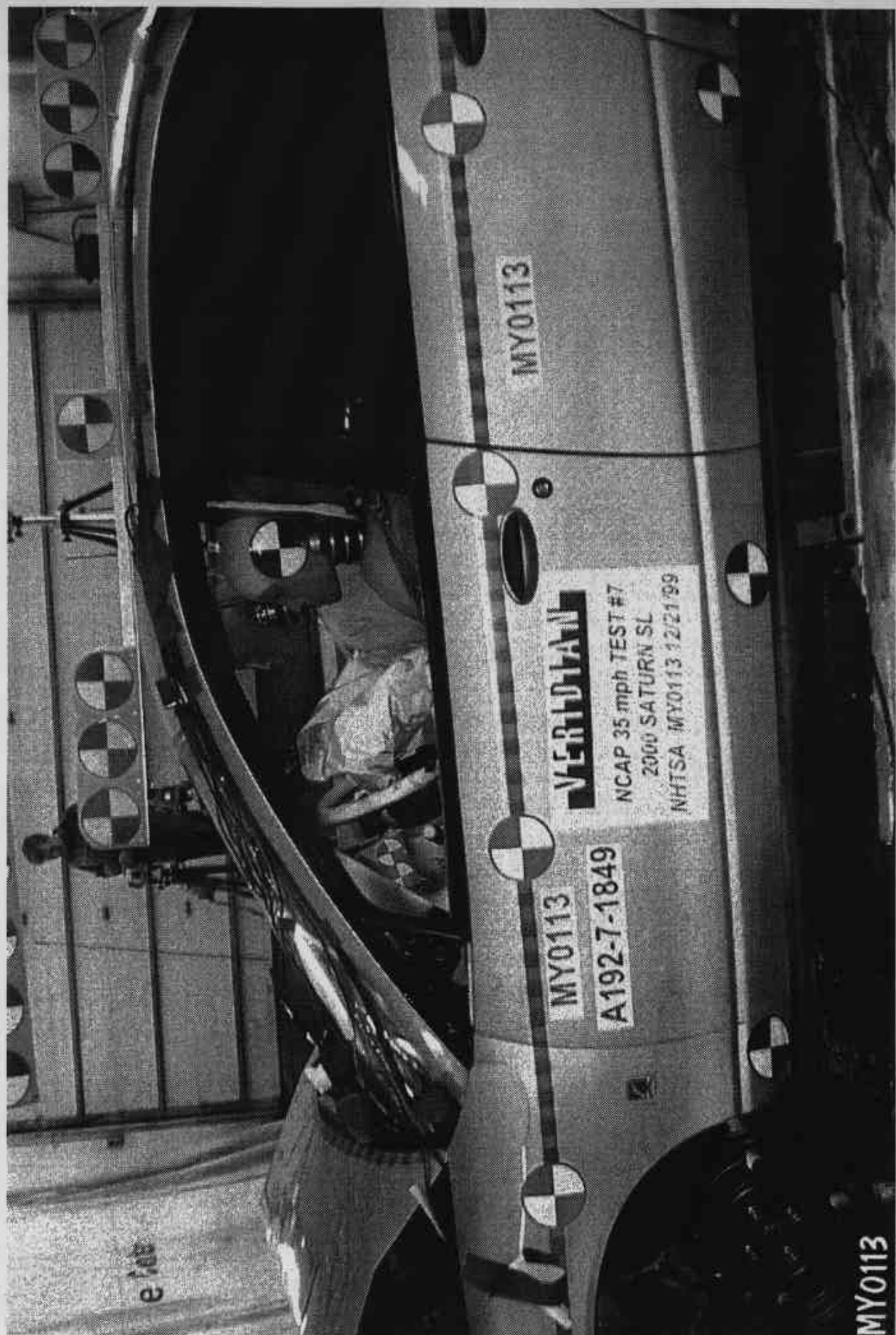

Figure A-23: POST-TEST DRIVER POSITION VIEW

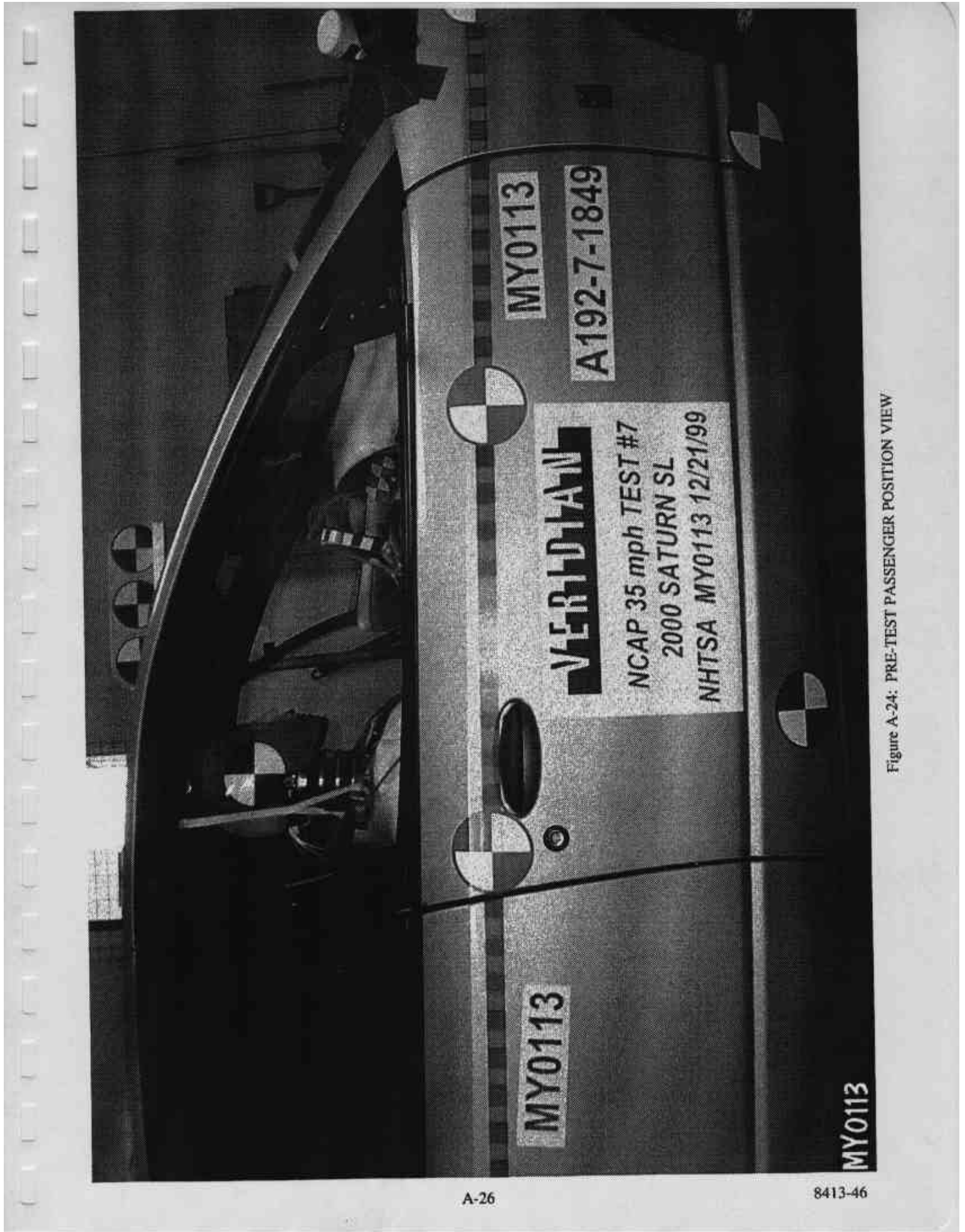

Figure A-24: PRE-TEST PASSENGER POSITION VIEW

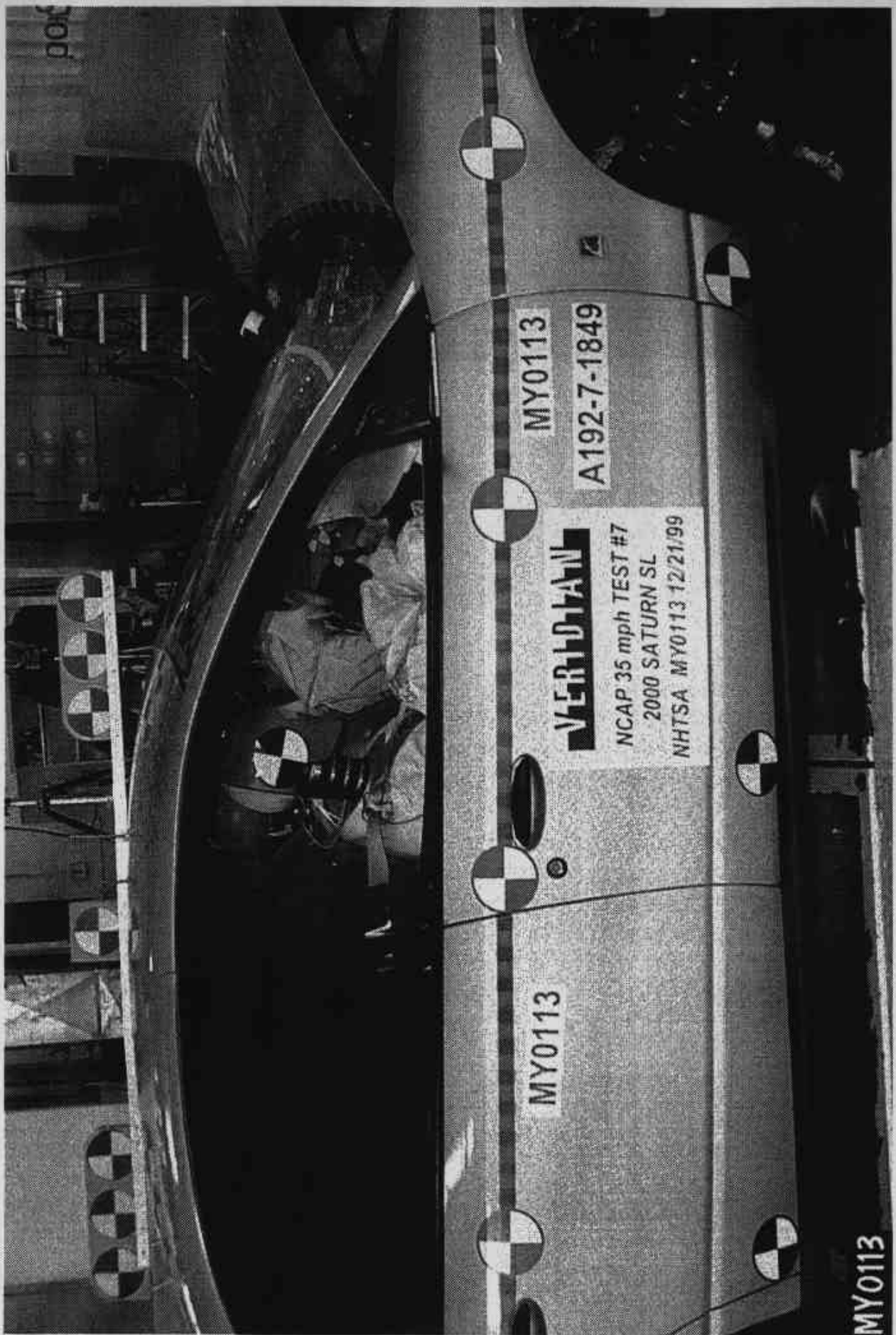

Figure A-25: POST-TEST PASSENGER POSITION VIEW

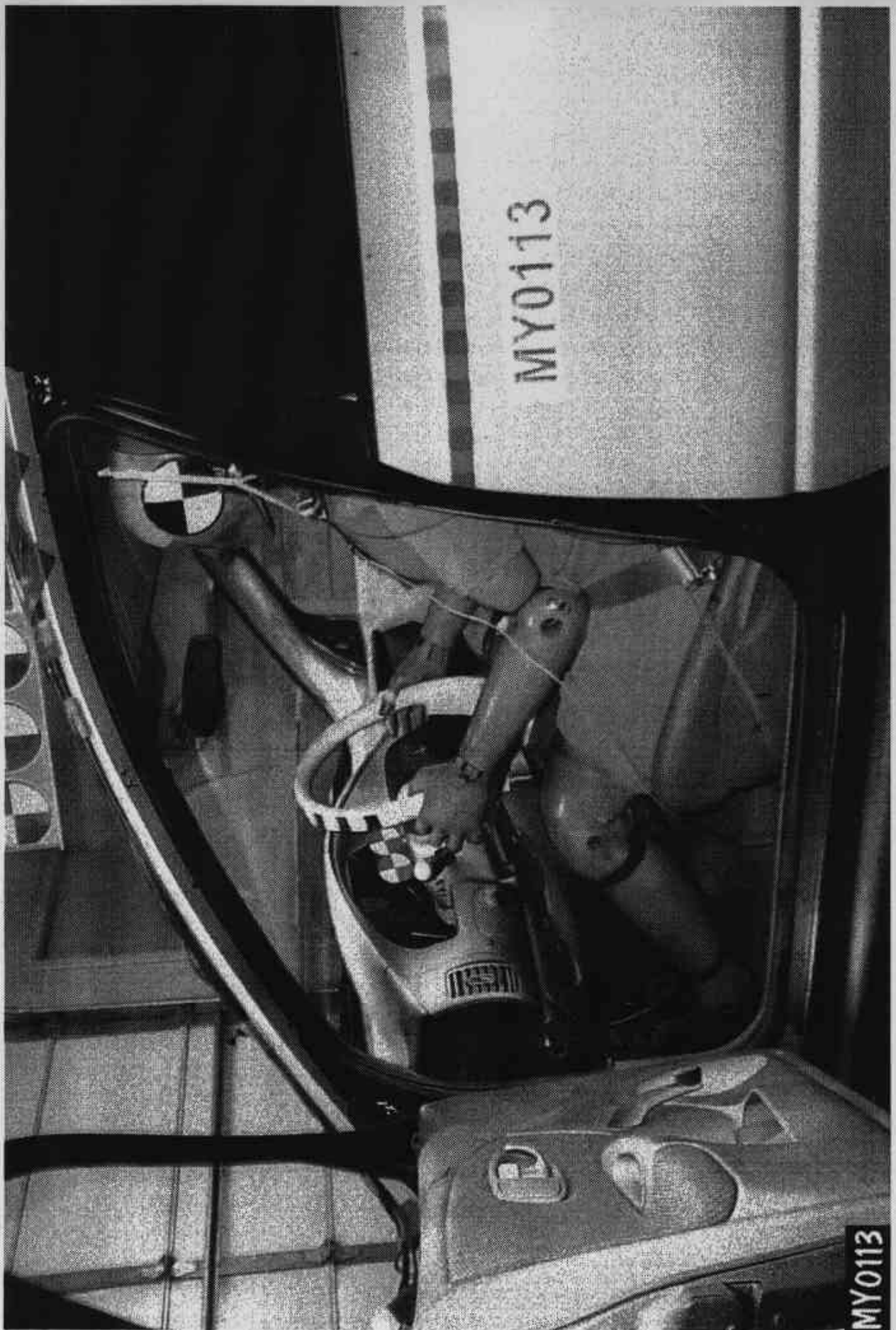

Figure A-26: PRE-TEST DRIVER AND INTERIOR VIEW



Figure A-27: POST-TEST DRIVER AND INTERIOR VIEW



Figure A-28: PRE-TEST PASSENGER AND INTERIOR VIEW



Figure A-29: POST-TEST PASSENGER AND INTERIOR VIEW

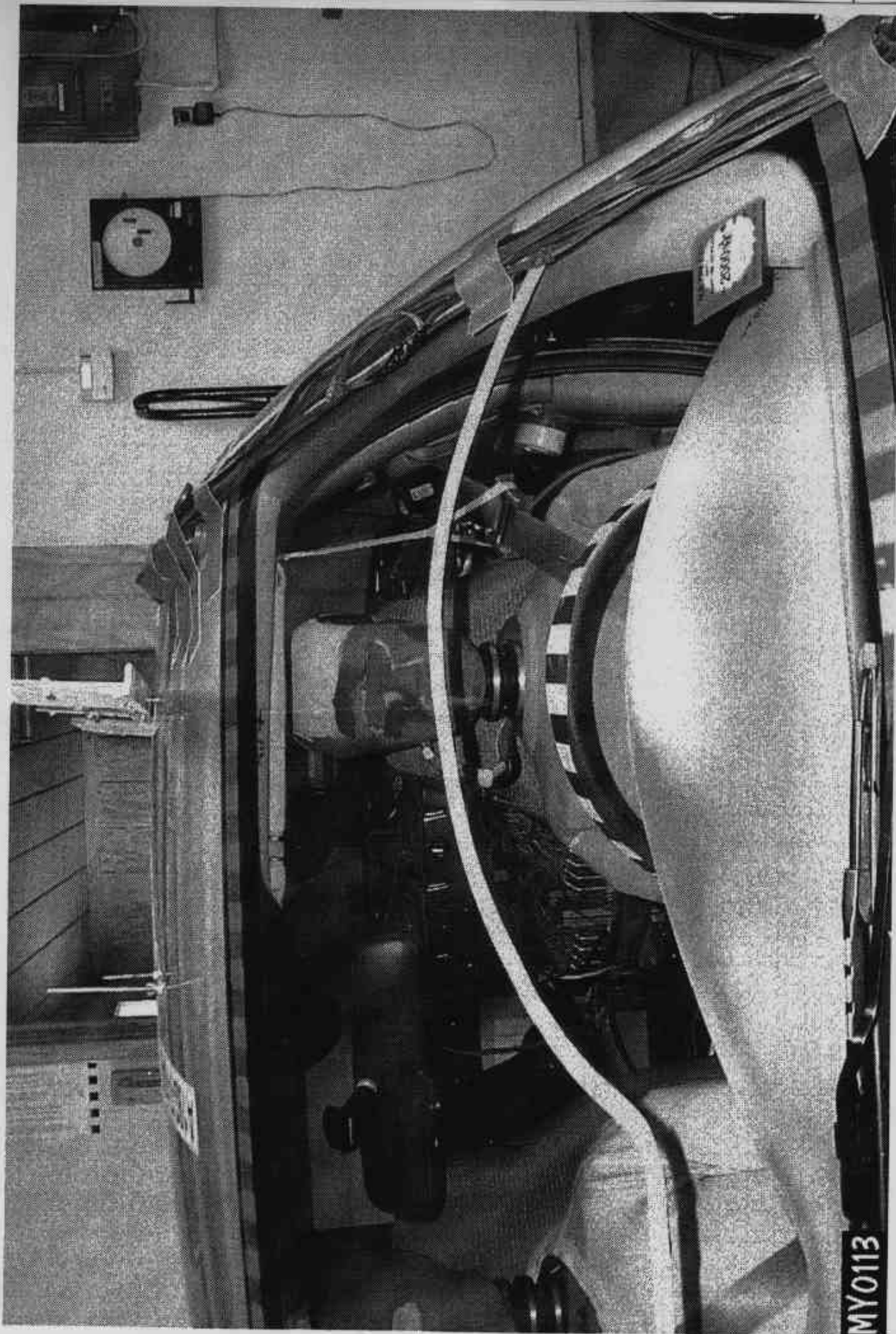

MY0113

Figure A-30: PRE-TEST DRIVER HEAD LOCATION



Figure A-33: POST-TEST PASSENGER HEAD LOCATION



Figure A-37: POST-TEST PASSENGER FLOOR PAN VIEW

MY0113

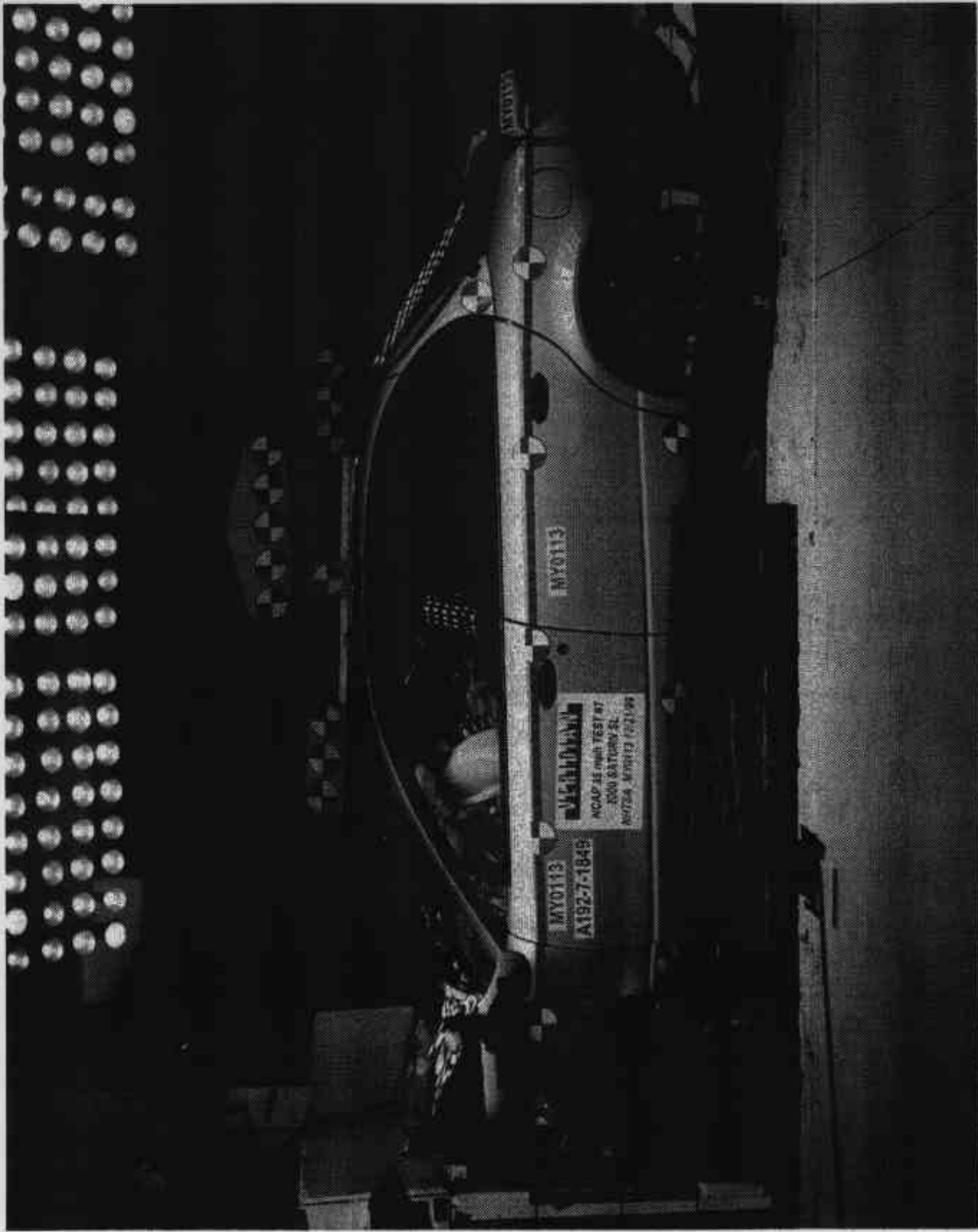

Figure A-39: IMPACT VIEW

**APPENDIX B**

**DUMMY, VEHICLE AND LOAD CELL BARRIER RESPONSE DATA**

**Hybrid III Dummy Sign Conventions  
Load Cells and Special Transducers**

Transducer	SAE Sign Convention (positive unless noted)
Upper Neck Load Cell	Fx Head rearward Fy Head left Fz Neck in tension Mx Left ear to left shoulder My Chin to chest (flexion) Mz Chin to left shoulder (look left)
Chest Displacement Potentiometer	Compression is negative
Pelvic Load Cell (Lower Lumbar)	Fx Chest rearward Fy Chest left Fz Spine in tension
Femur Load Cell	Compression is negative
Upper Tibia Load Cell (right and left leg)	Mx Support tibia at ends, load left side center My Support tibia at ends, load front (shin) center
Lower Tibia Load Cell (right and left leg)	Fz Tibia in tension Mx Support tibia at ends, load left side center My Support tibia at ends, load front (shin) center

DATA CHANNEL FILTER CLASS SUMMARY

NHTSA TEST NO. MY0113

<b>DATA TYPE</b>	<b>SAE FILTER CLASS (Hz)</b>
Dummy Head Accelerations	1000
Dummy Chest Accelerations	180
Dummy Chest Displacements	60
Dummy Femur Forces	600
Dummy Belt Loads	60
Dummy Belt Displacements	180
Dummy Neck Forces	1000
Dummy Neck Moments	600
Vehicle Accelerations	60
Vehicle Velocity Integrations	180
Vehicle Displacement Integrations	180
Load Cell Barrier Forces	60

NCAP Test 7 - 2000 Saturn SL

Max: 7.2 [g] at 0.263 [s]  
Min: -51.8 [g] at 0.087 [s]

P1 Head x

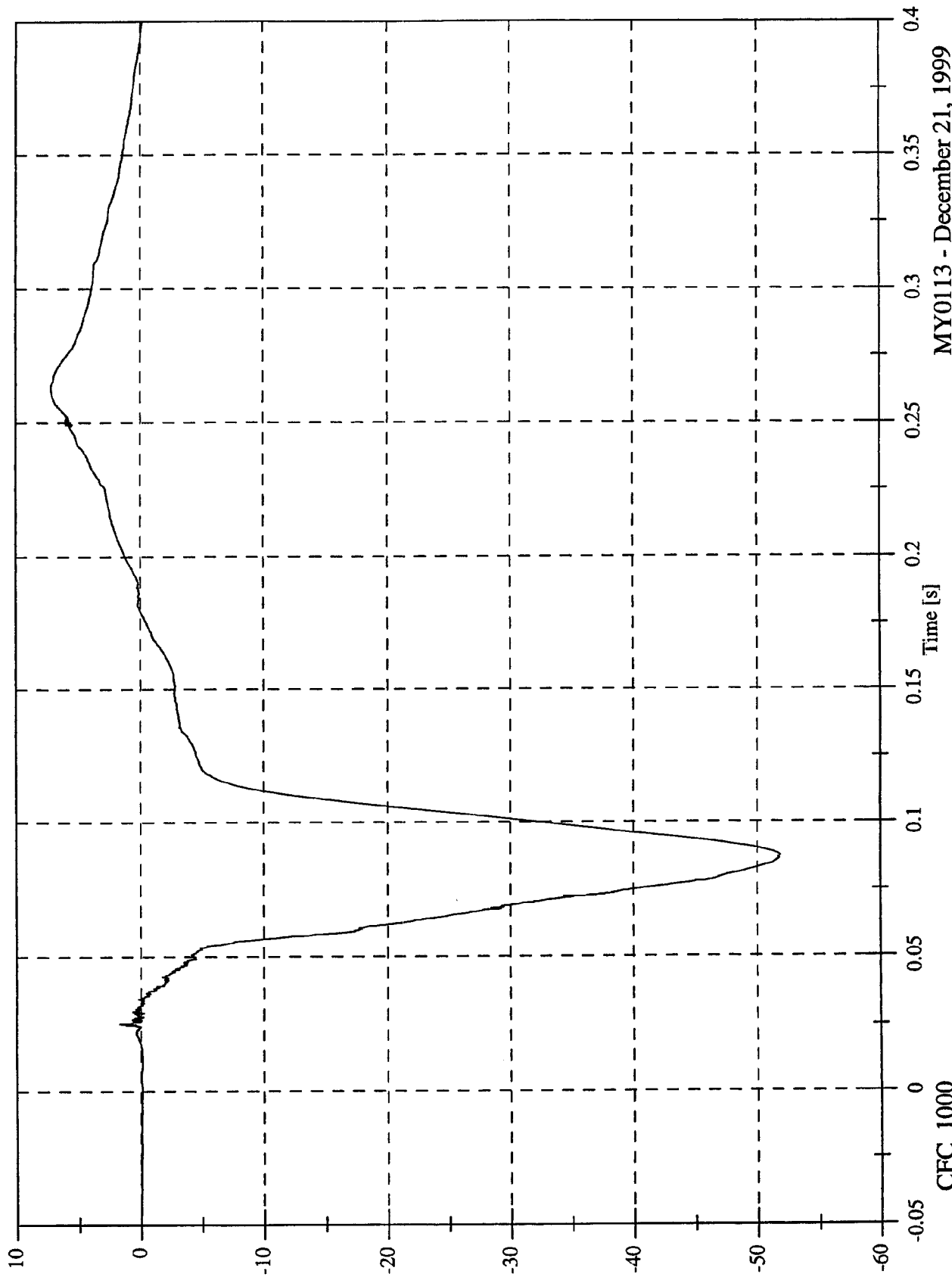

MY0113 - December 21, 1999

CFC\_1000

NCAP Test 7 - 2000 Saturn SL

Max: 0.9 [g] at 0.249 [s]  
Min: -12.0 [g] at 0.096 [s]

P1 Head y

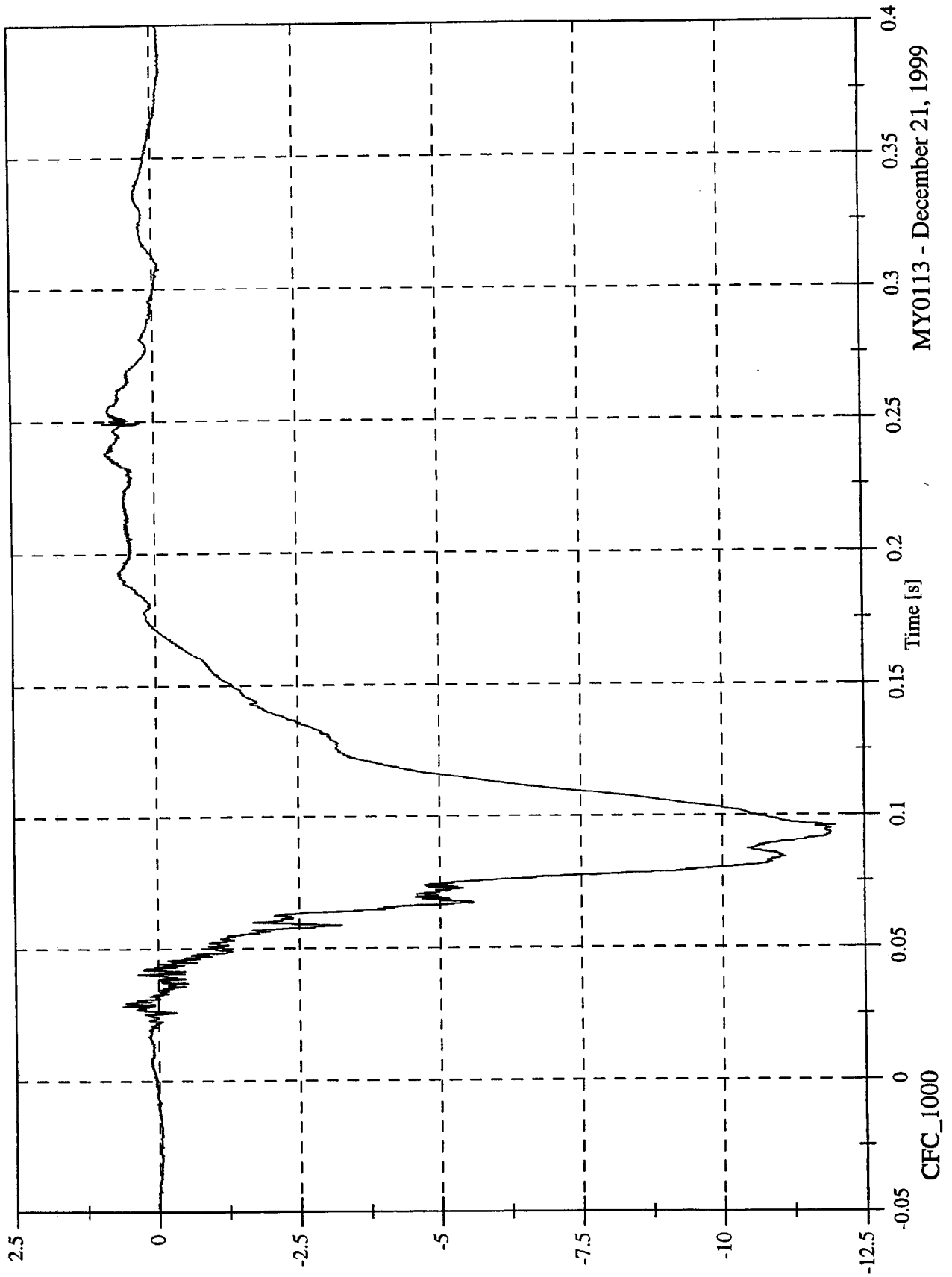

MY0113 - December 21, 1999

CFC\_1000

NCAP Test 7 - 2000 Saturn SL

Max: 19.9 [g] at 0.085 [s]  
Min: -0.4 [g] at 0.140 [s]

P1 Head z

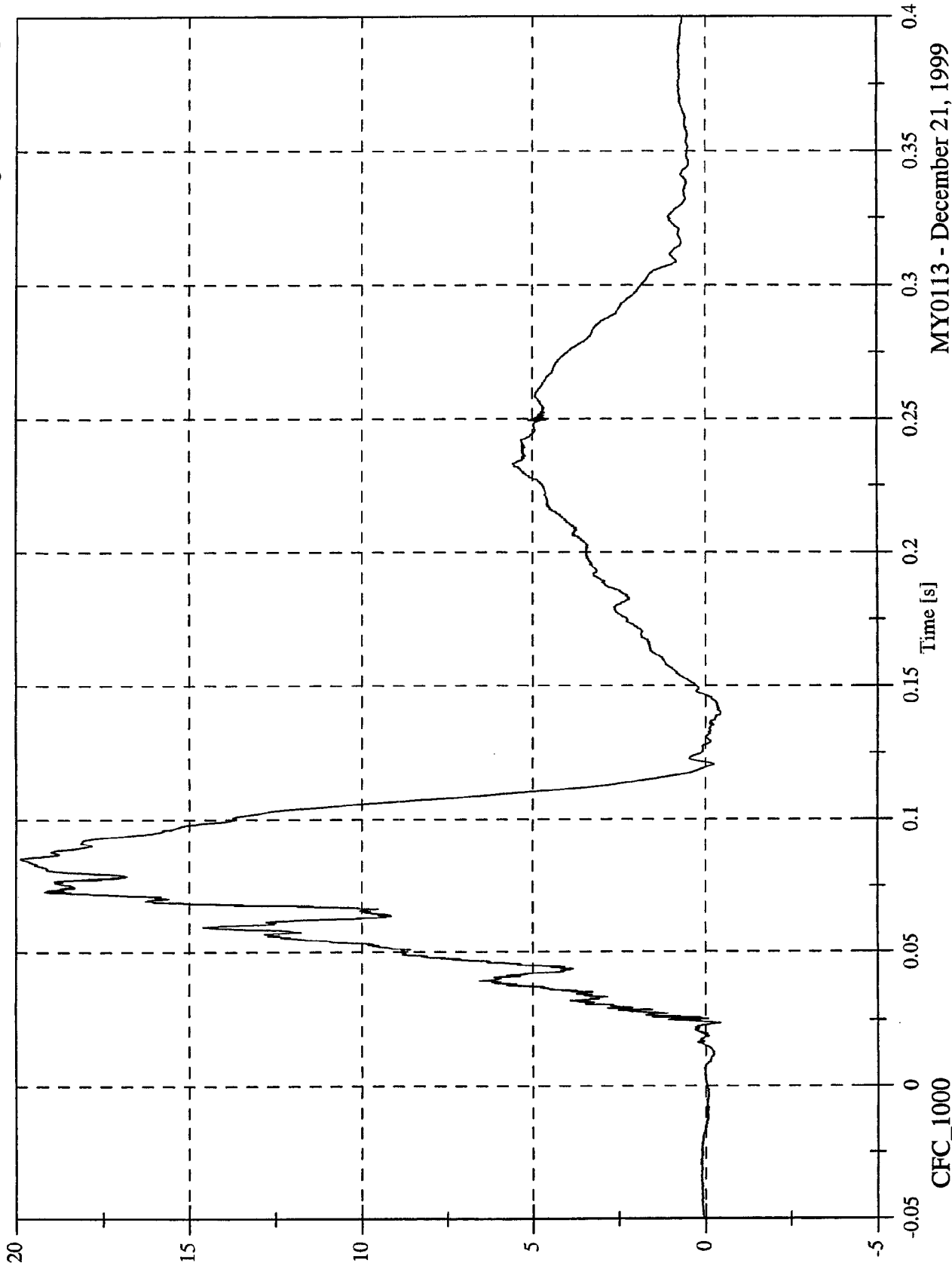

MY0113 - December 21, 1999

CFC\_1000

NCAP Test 7 - 2000 Saturn SL

P1 Head Resultant

Max: 56.4 [g] at 0.086 [s]  
Min: 0.0 [g] at -0.049 [s]

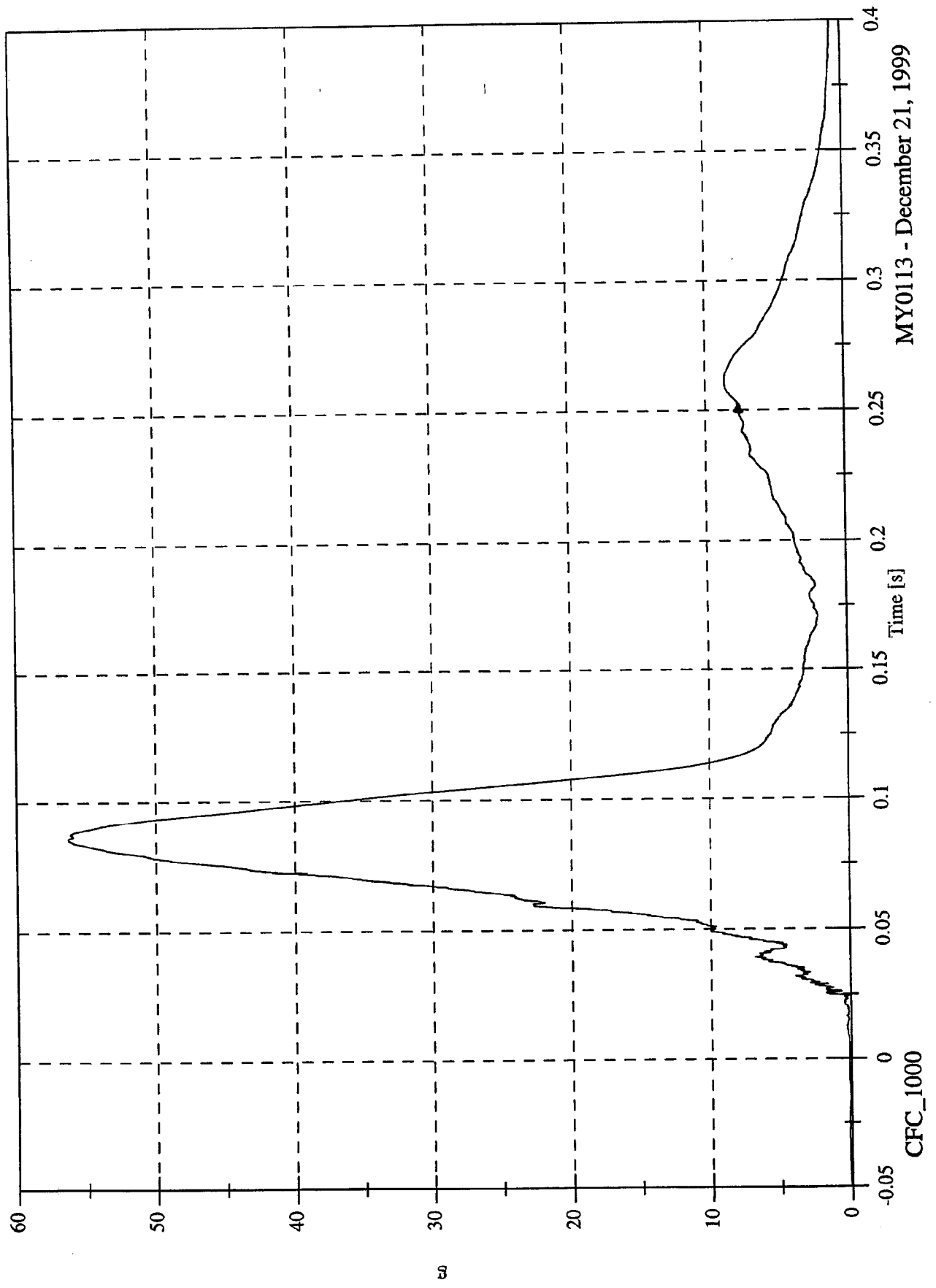

MY0113 - December 21, 1999

NCAP Test 7 - 2000 Saturn SL

Max: 7.3 [g] at 0.262 [s]  
Min: -52.1 [g] at 0.086 [s]

P1 Head Red x

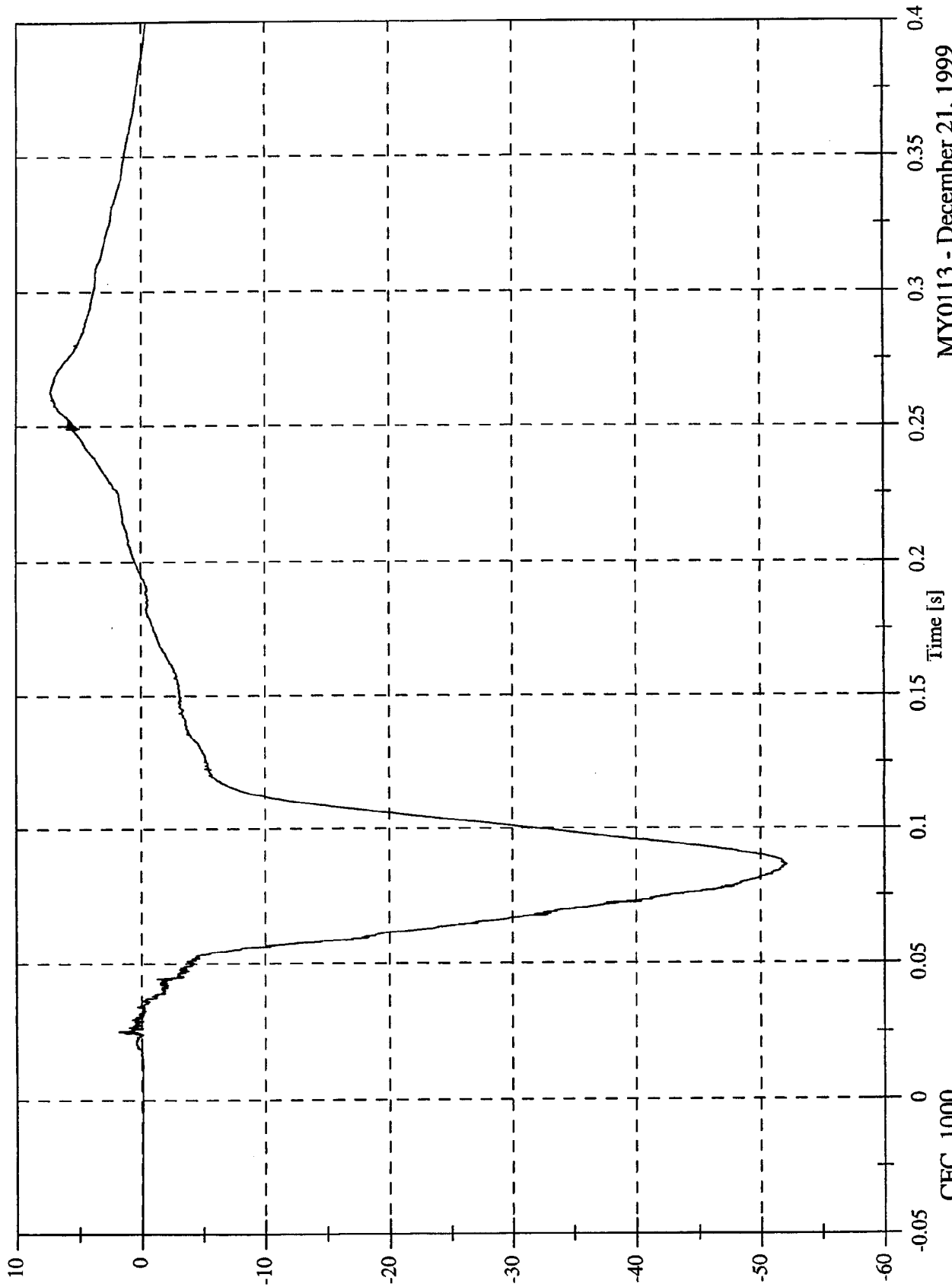

CFC\_1000

MY0113 - December 21, 1999

NCAP Test 7 - 2000 Saturn SL

Max: 1.6 [g] at 0.249 [s]  
Min: -14.0 [g] at 0.082 [s]

P1 Head Red y

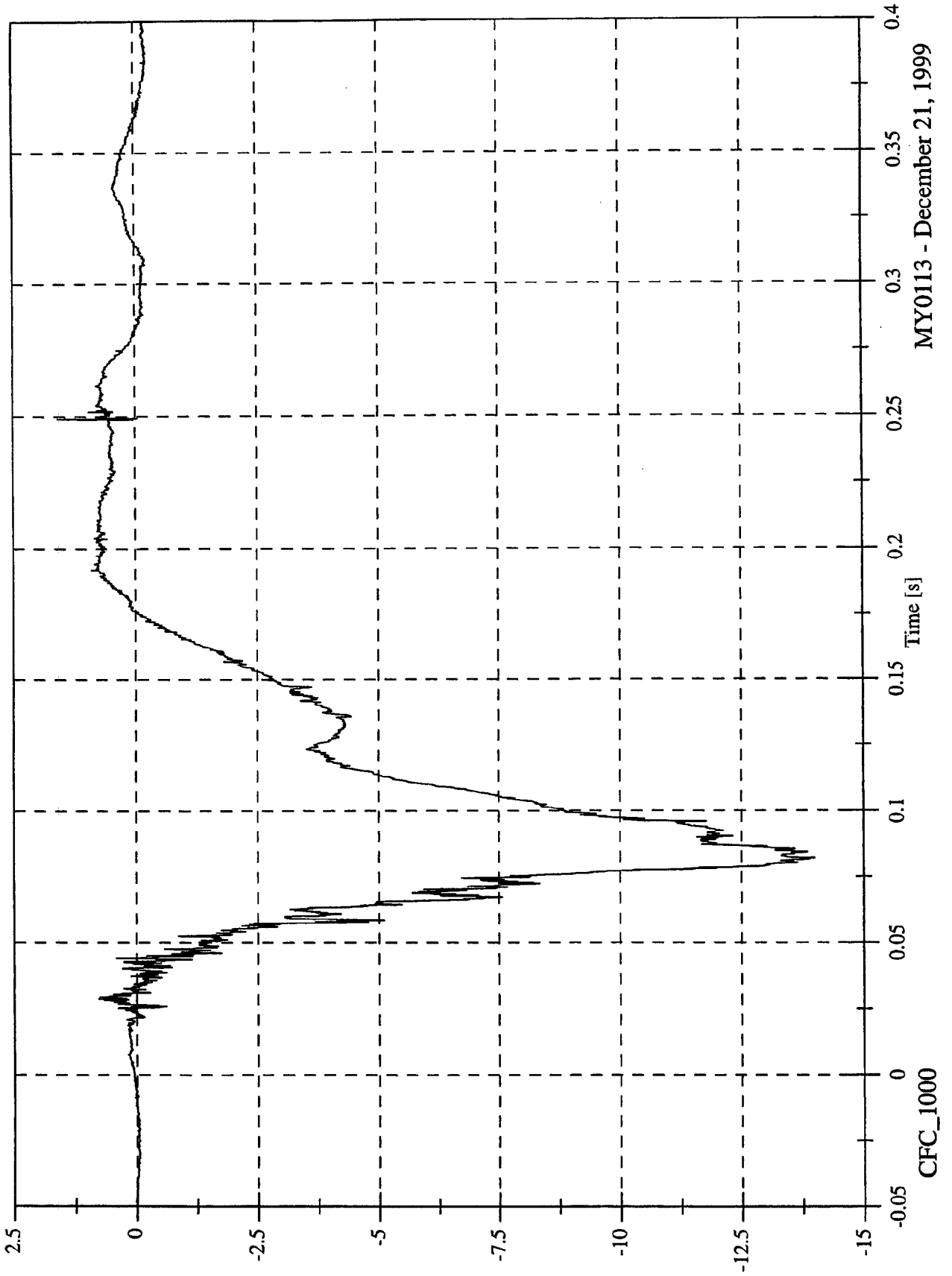

MY0113 - December 21, 1999

NCAP Test 7 - 2000 Saturn SL

Max: 21.0 [g] at 0.060 [s]  
Min: -1.4 [g] at 0.141 [s]

P1 Head Red z

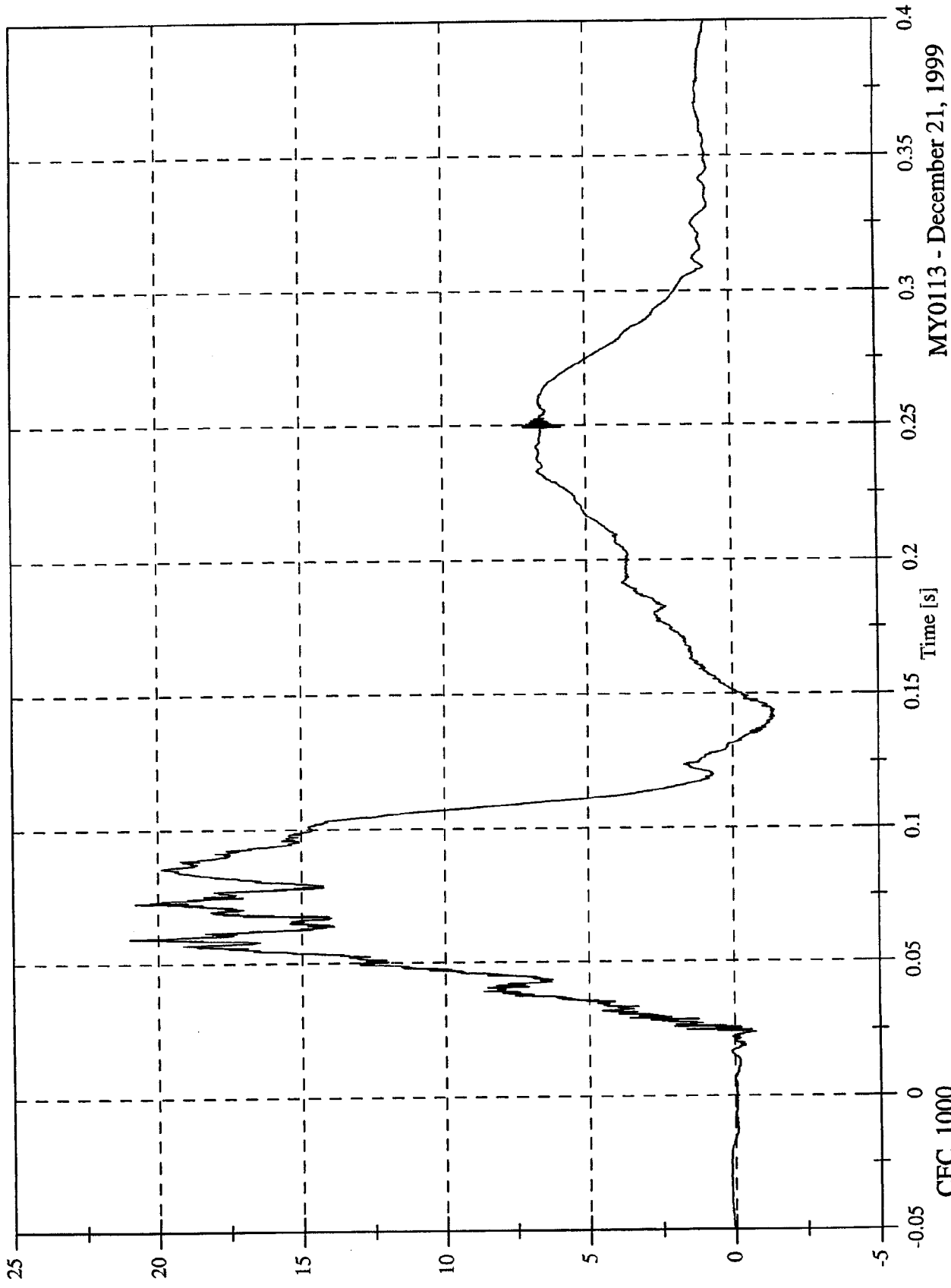

MY0113 - December 21, 1999

CFC\_1000

NCAP Test 7 - 2000 Saturn SL

Max: 57.1 [g] at 0.085 [s]  
Min: 0.0 [g] at -0.050 [s]

P1 Head Red Resultant

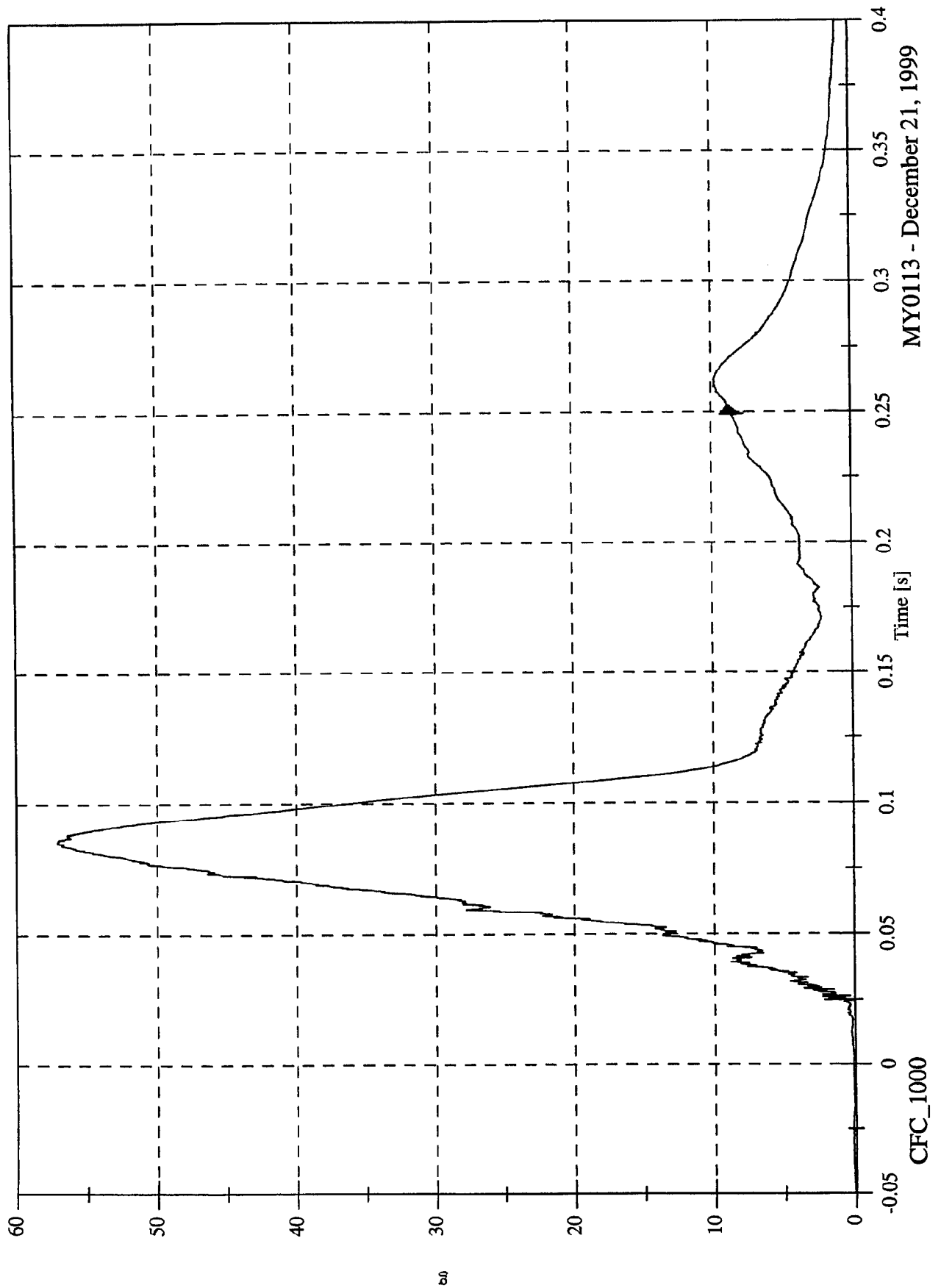

MY0113 - December 21, 1999

NCAP Test 7 - 2000 Saturn SL

P1 Upper Neck Fx

Max: 565.7 [N] at 0.080 [s]  
Min: -372.0 [N] at 0.058 [s]

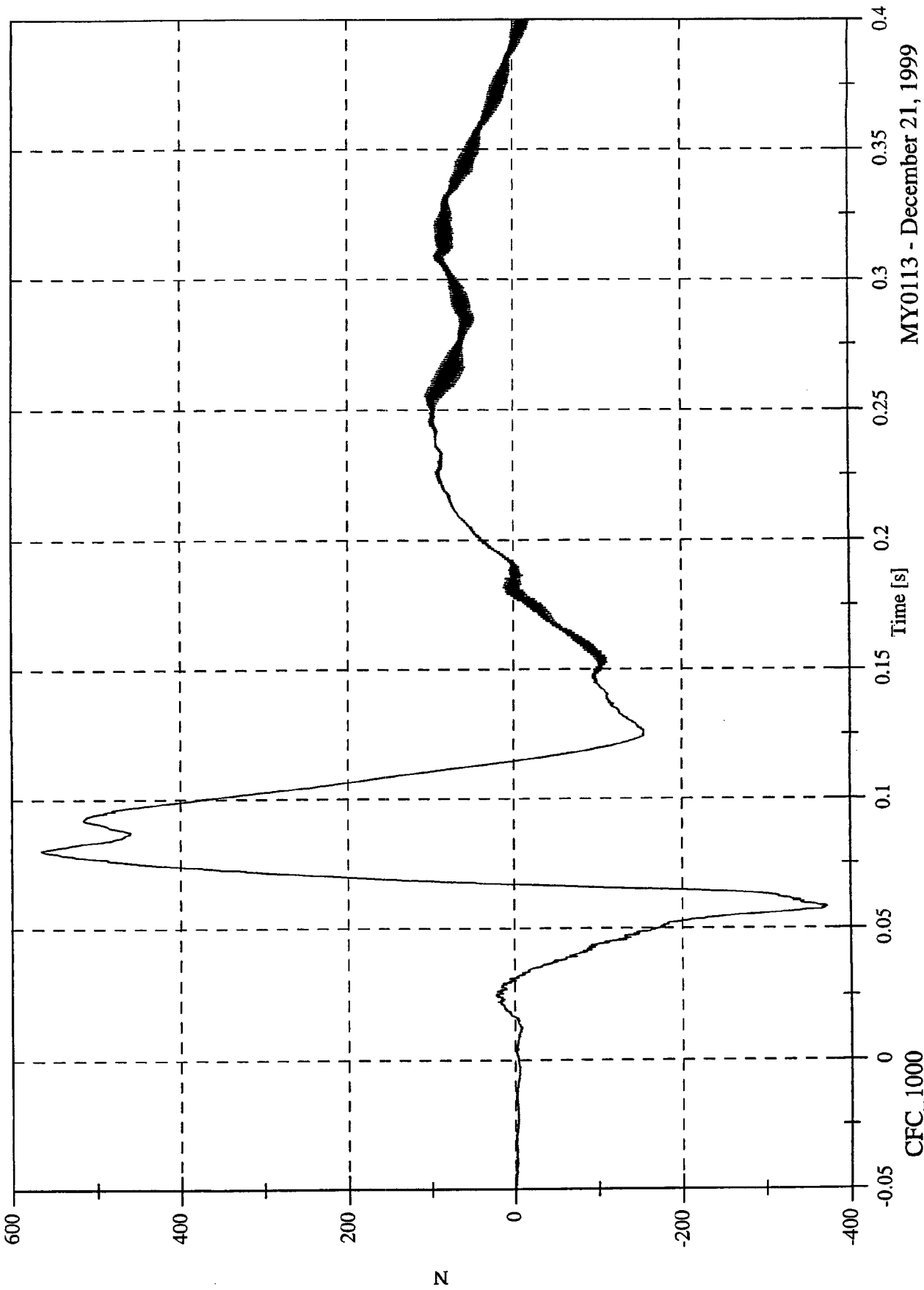

CFC\_1000

MY0113 - December 21, 1999

NCAP Test 7 - 2000 Saturn SL

Max: 34.1 [N] at 0.220 [s]  
Min: -123.5 [N] at 0.130 [s]

P1 Upper Neck Fy

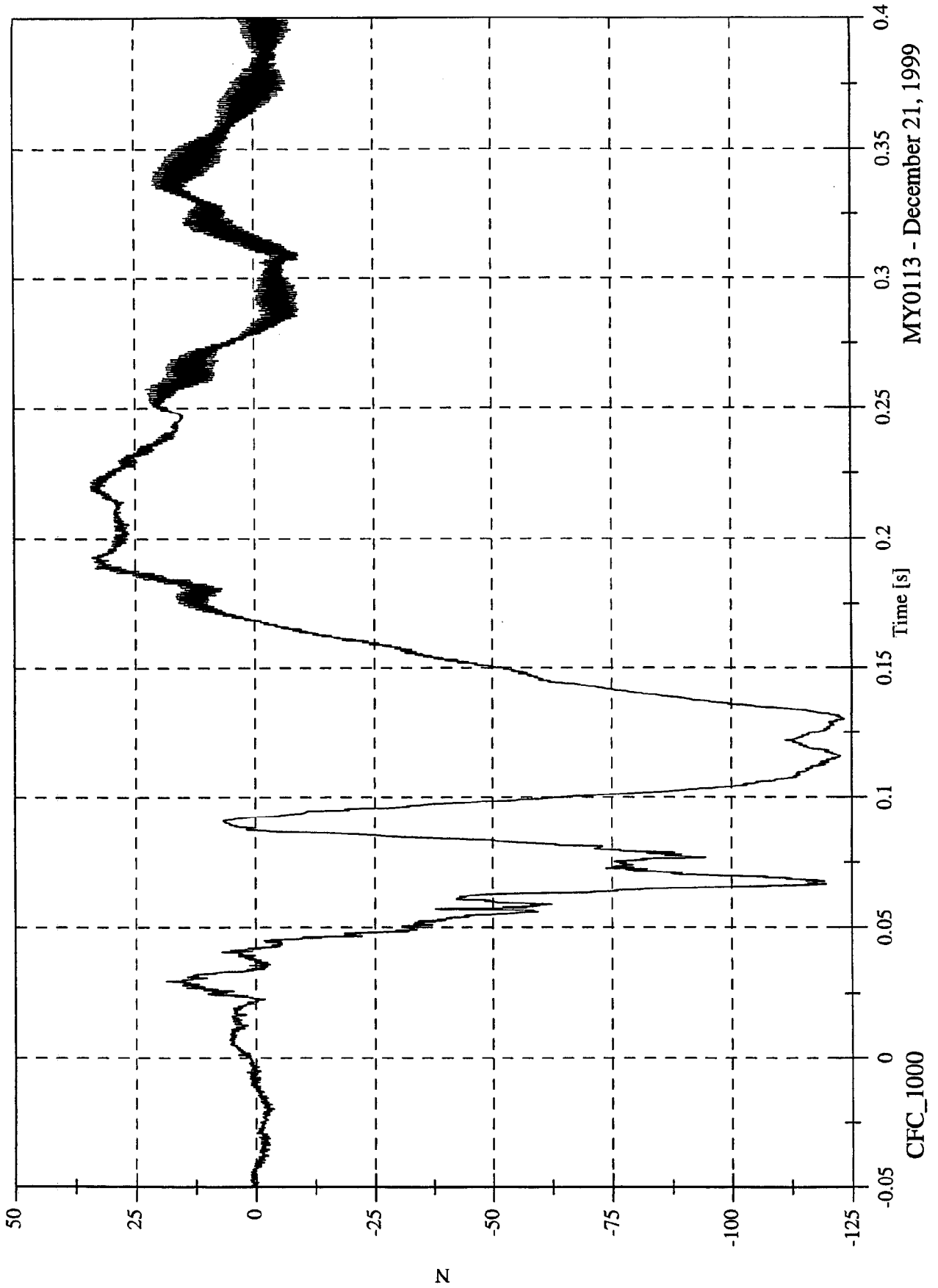

MY0113 - December 21, 1999

NCAP Test 7 - 2000 Saturn SL

Max: 1150.3 [N] at 0.073 [s]  
Min: -14.8 [N] at 0.140 [s]

P1 Upper Neck Fz

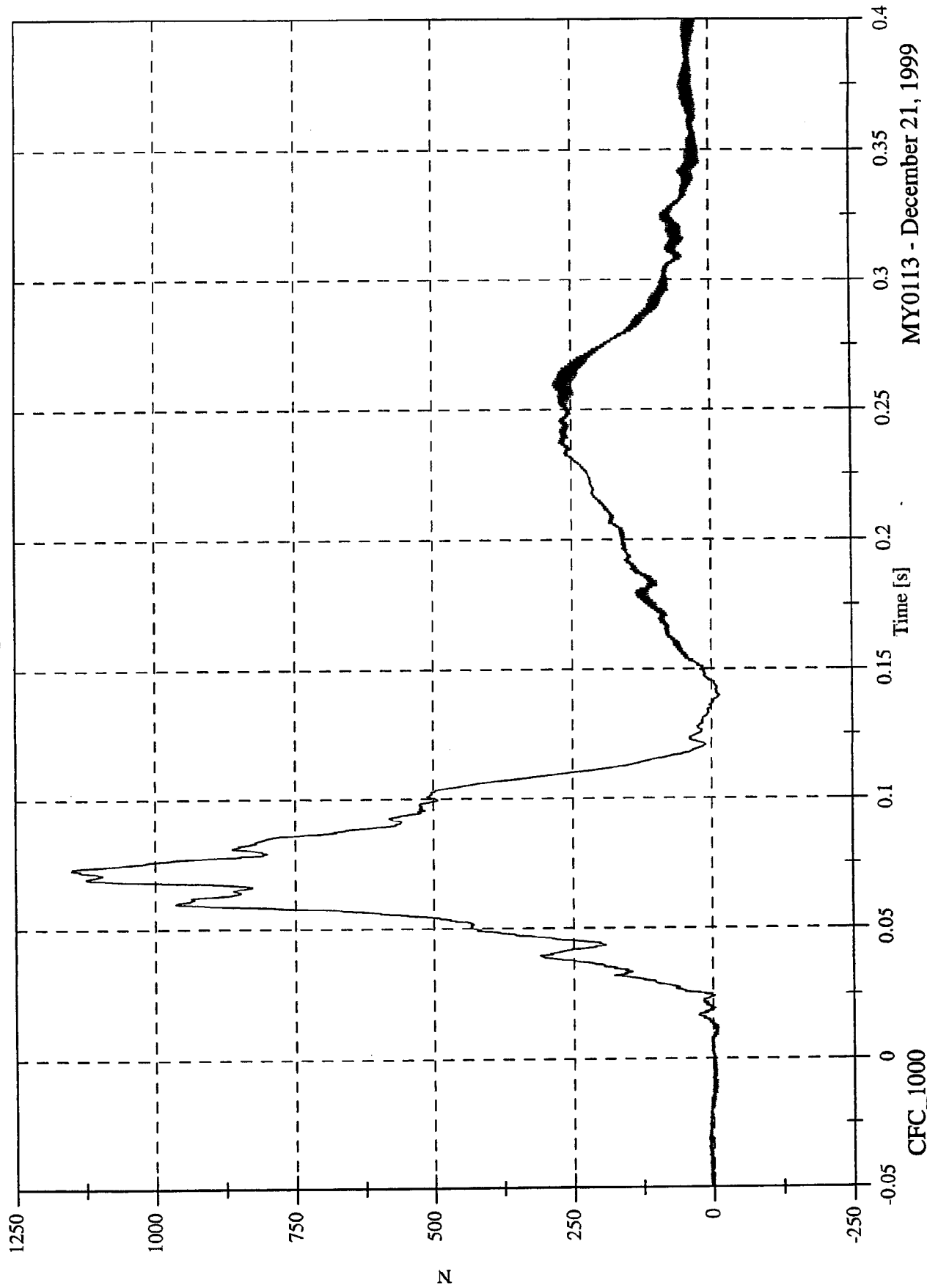

CFC\_1000

MY0113 - December 21, 1999

NCAP Test 7 - 2000 Saturn SL

Max: 1210.8 [N] at 0.073 [s]  
Min: 0.5 [N] at -0.050 [s]

P1 Upper Neck F Resultant

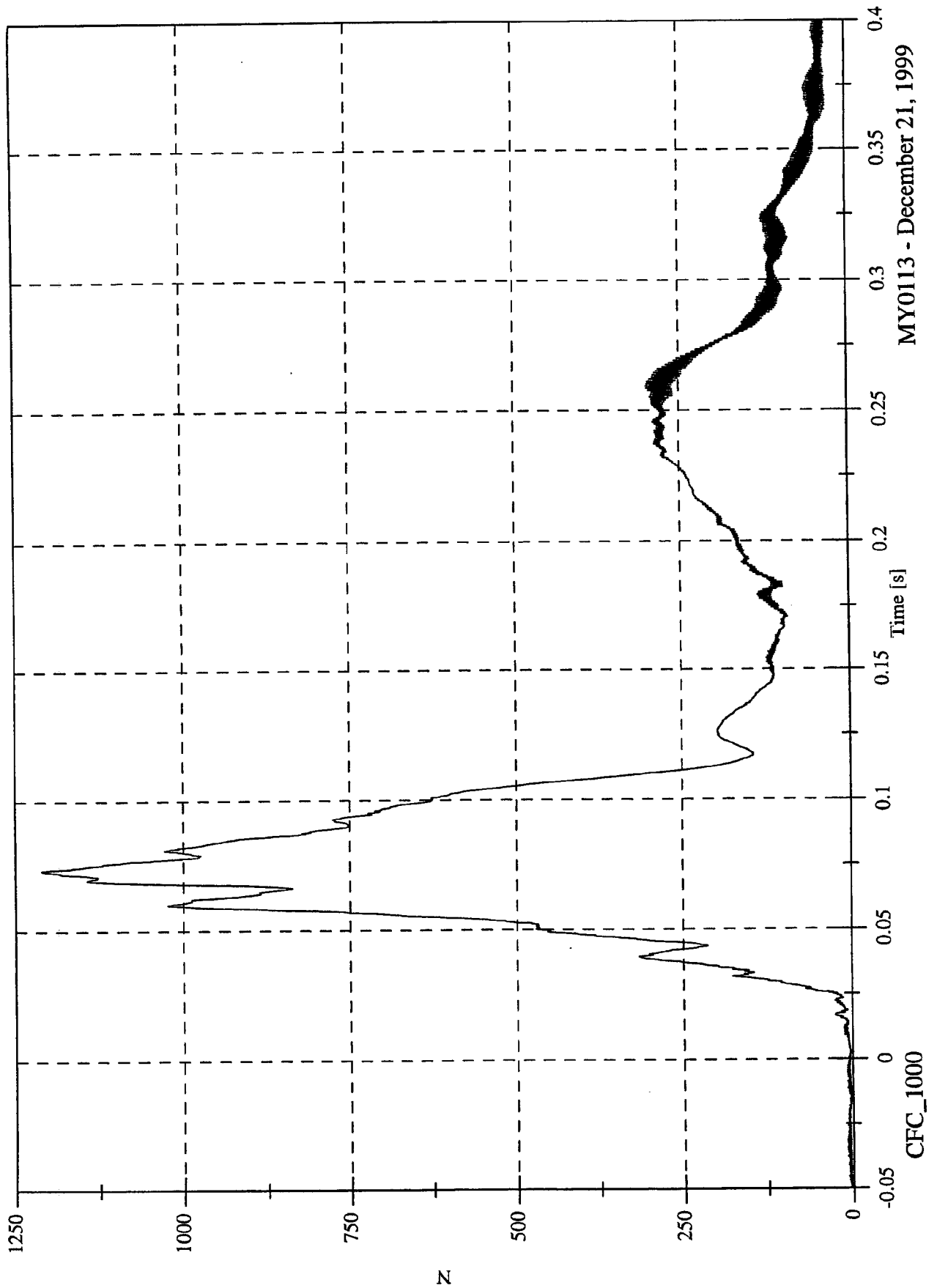

MY0113 - December 21, 1999

NCAP Test 7 - 2000 Saturn SL

Max: 2.7 [N-m] at 0.243 [s]  
Min: -10.7 [N-m] at 0.122 [s]

P1 Upper Neck Mx

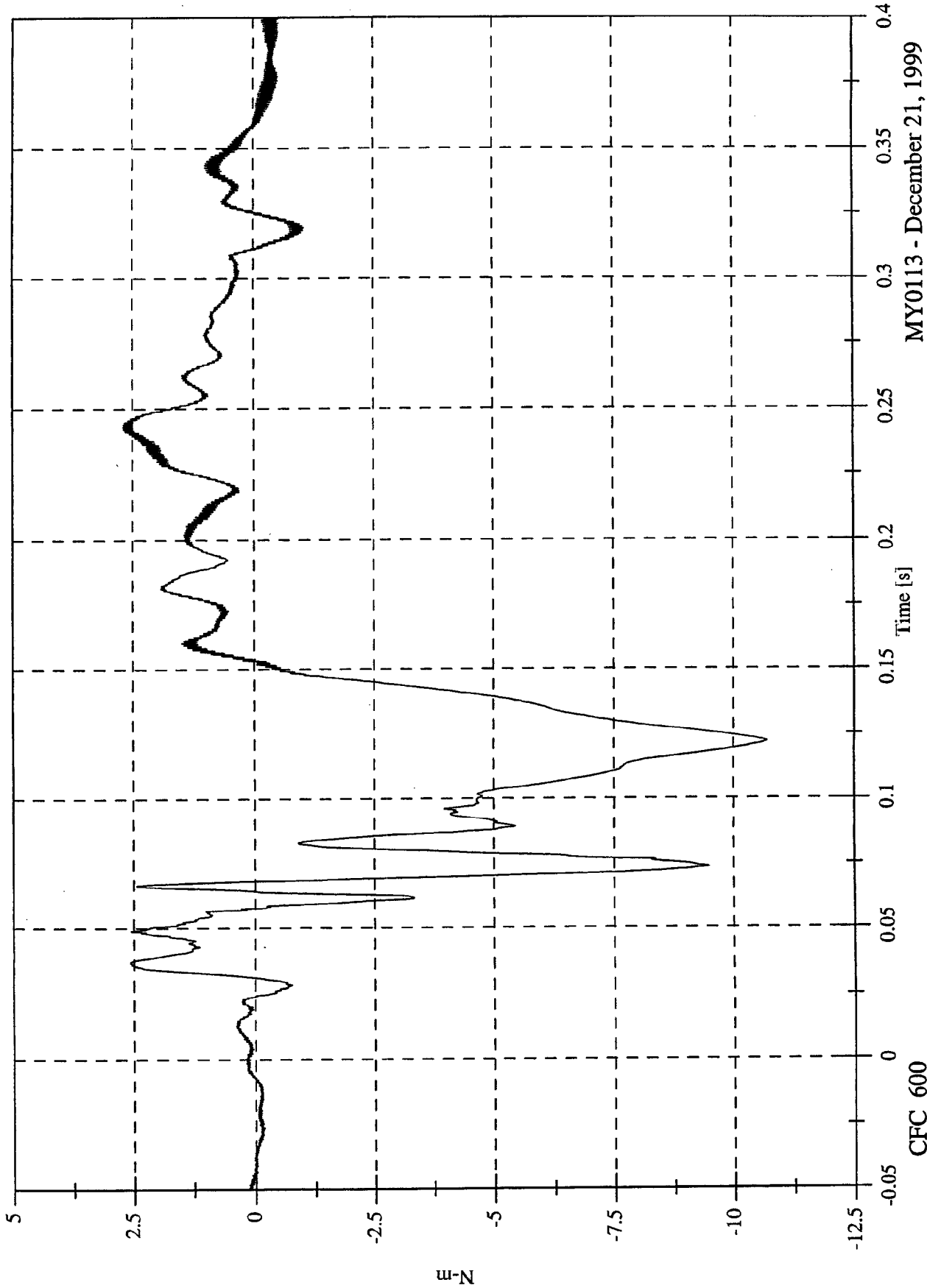

CFC\_600

MY0113 - December 21, 1999

NCAP Test 7 - 2000 Saturn SL

Max: 74.8 [N-m] at 0.080 [s]  
Min: -23.3 [N-m] at 0.058 [s]

P1 Upper Neck My

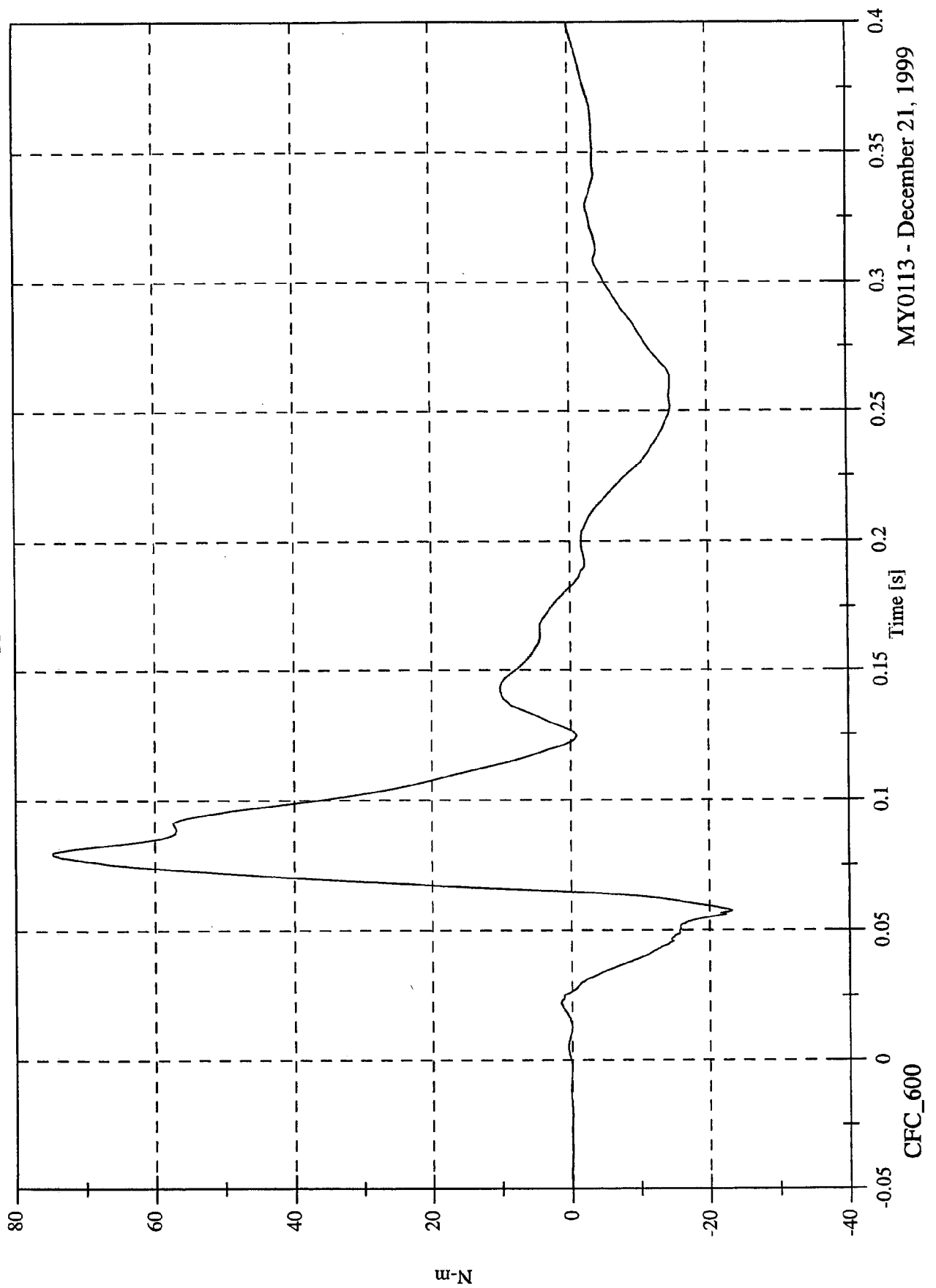

MY0113 - December 21, 1999

NCAP Test 7 - 2000 Saturn SL

Max: 20.0 [N-m] at 0.097 [s]  
Min: -8.0 [N-m] at 0.147 [s]

P1 Upper Neck Mz

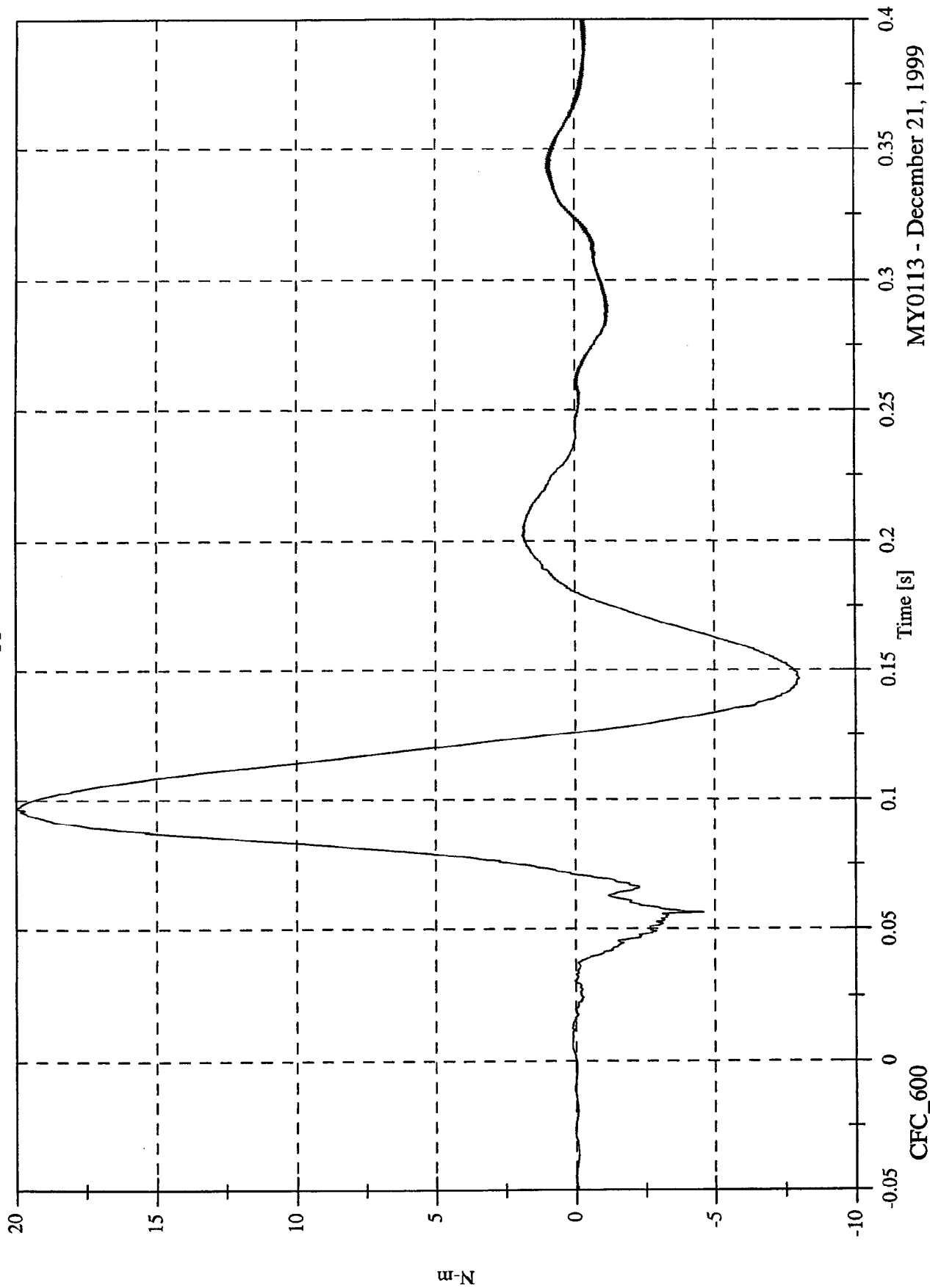

CFC\_600

MY0113 - December 21, 1999

NCAP Test 7 - 2000 Saturn SL

Max: 75.1 [N-m] at 0.080 [s]  
Min: 0.0 [N-m] at -0.043 [s]

P1 Upper Neck M Resultant

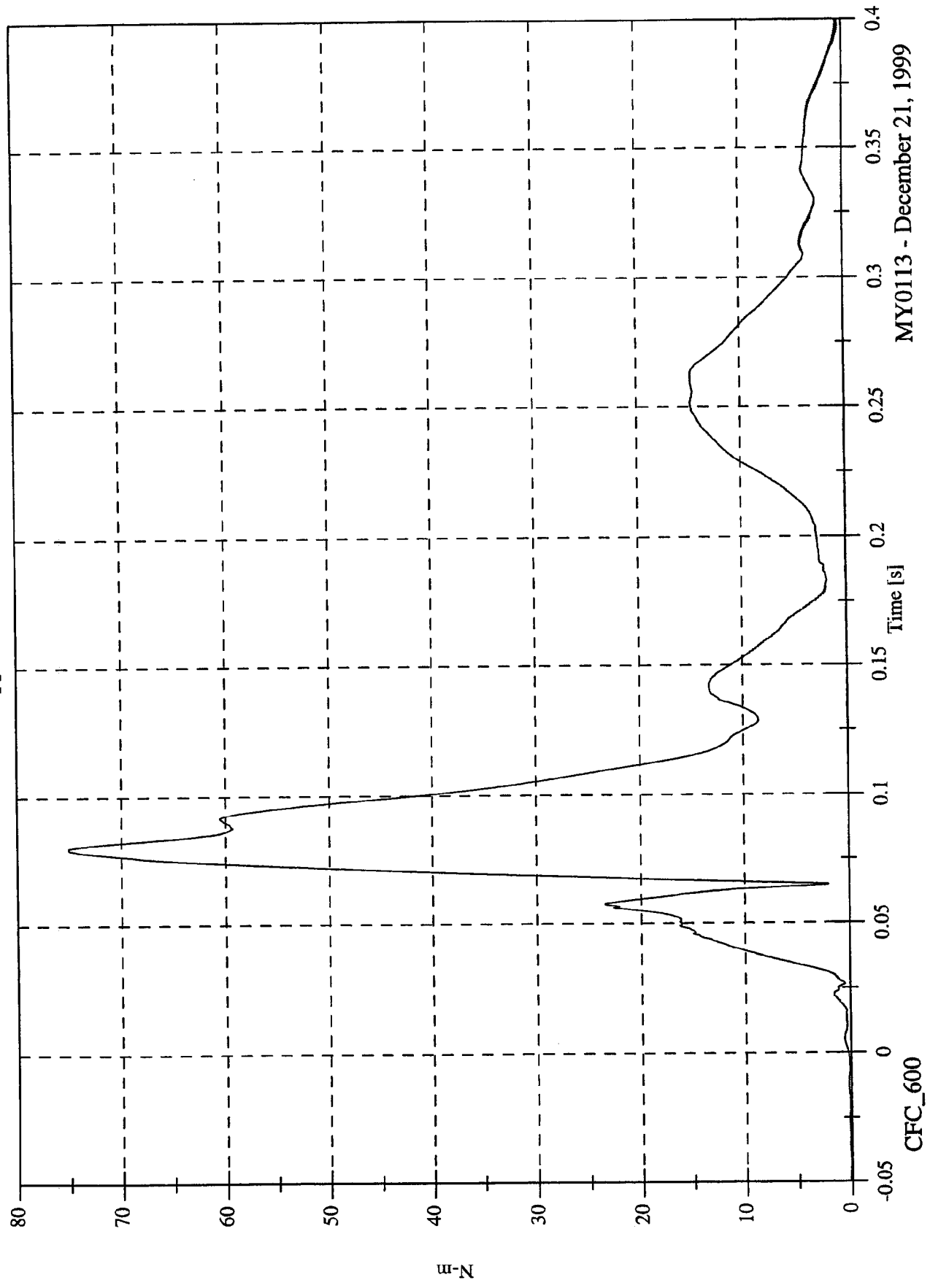

MY0113 - December 21, 1999

NCAP Test 7 - 2000 Saturn SL

Max: 3.1 [g] at 0.292 [s]  
Min: -40.4 [g] at 0.081 [s]

P1 Chest x

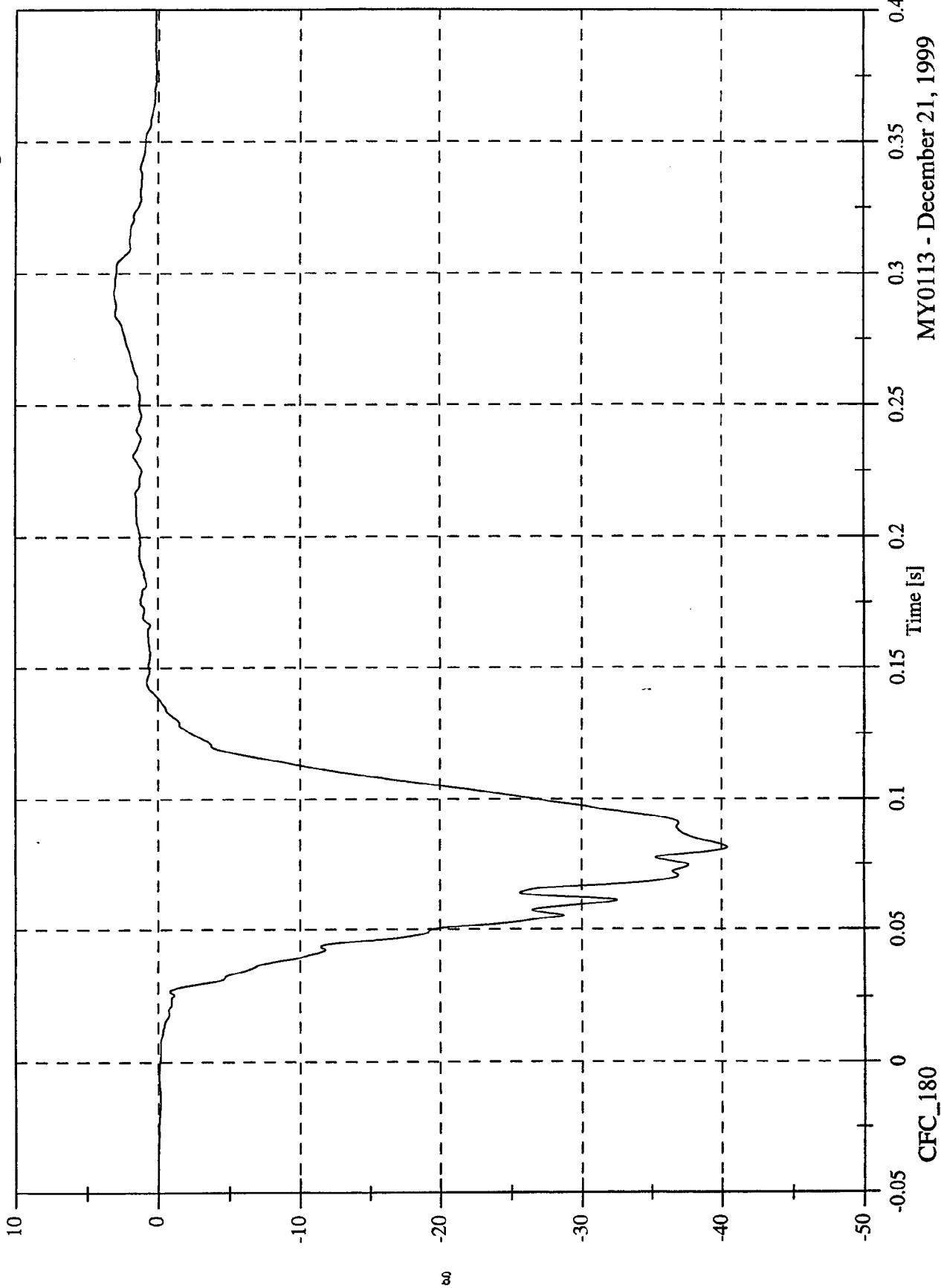

MY0113 - December 21, 1999

CFC\_180

NCAP Test 7 - 2000 Saturn SL

Max: 0.9 [g] at 0.117 [s]  
Min: -8.8 [g] at 0.091 [s]

PI Chest y

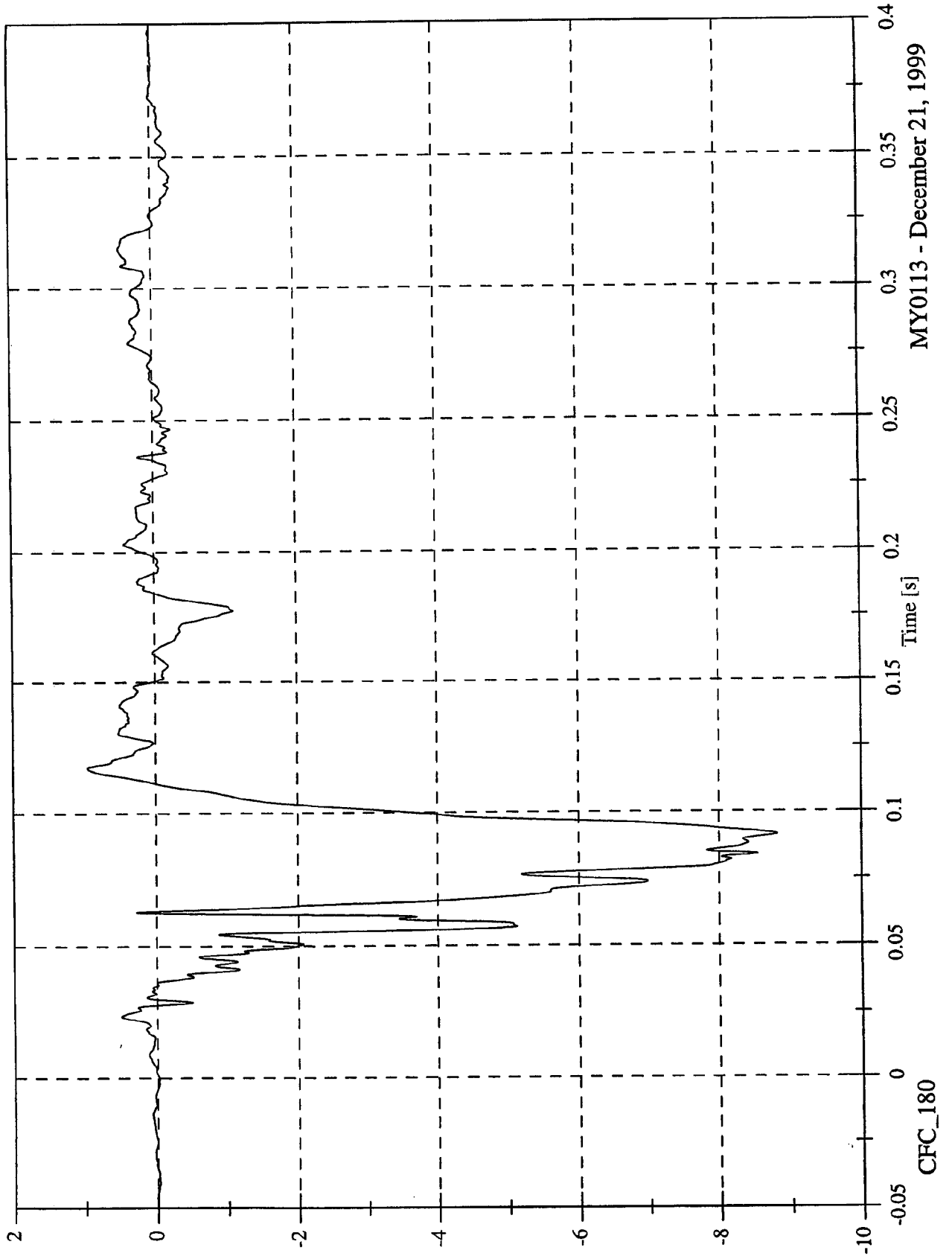

MY0113 - December 21, 1999

CFC\_180

NCAP Test 7 - 2000 Saturn SL

Max: 3.6 [g] at 0.038 [s]  
Min: -3.9 [g] at 0.069 [s]

P1 Chest z

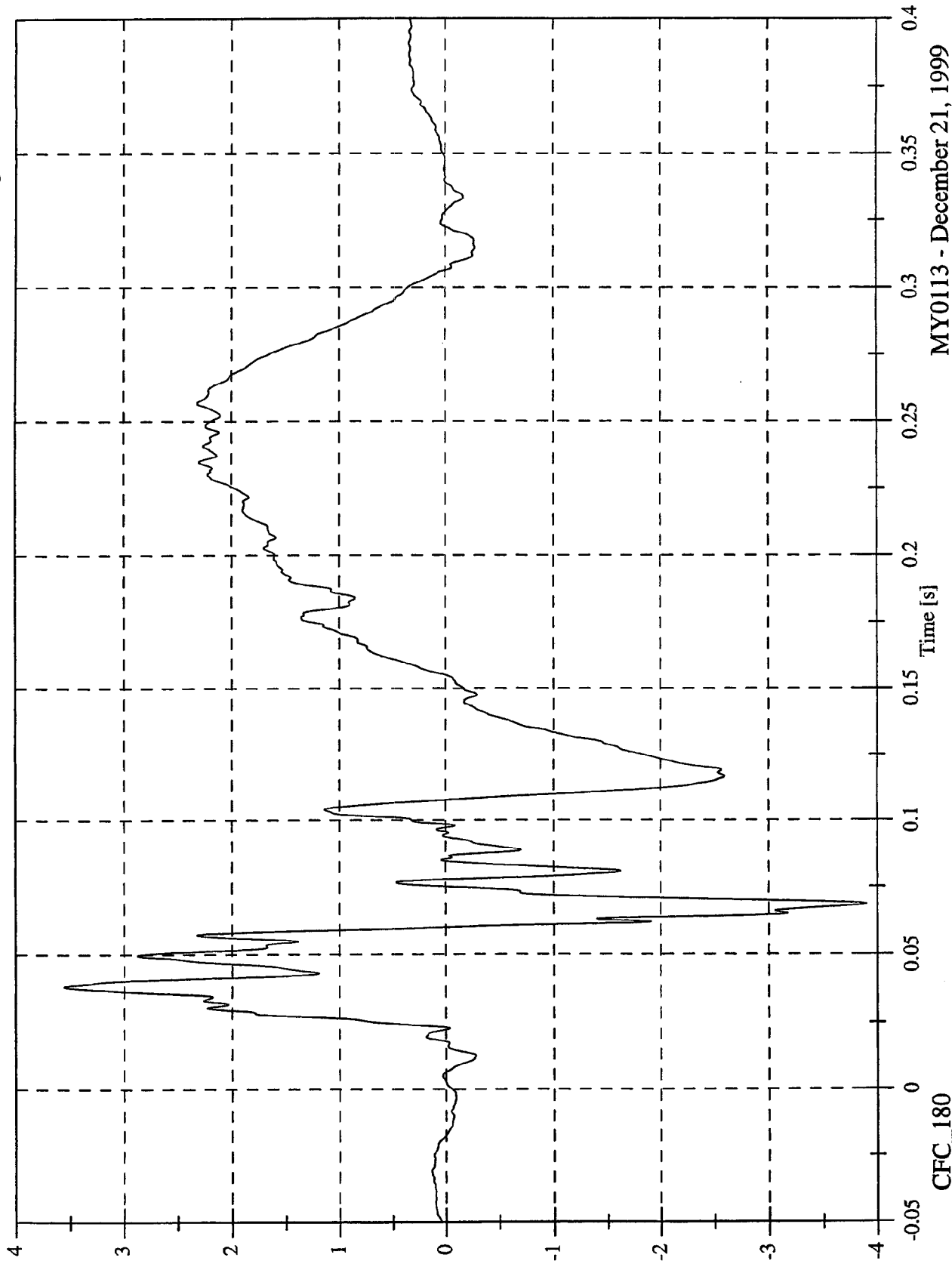

CFC\_180

MY0113 - December 21, 1999

NCAP Test 7 - 2000 Saturn SL

Max: 41.2 [g] at 0.081 [s]  
Min: 0.0 [g] at -0.050 [s]

P1 Chest Resultant

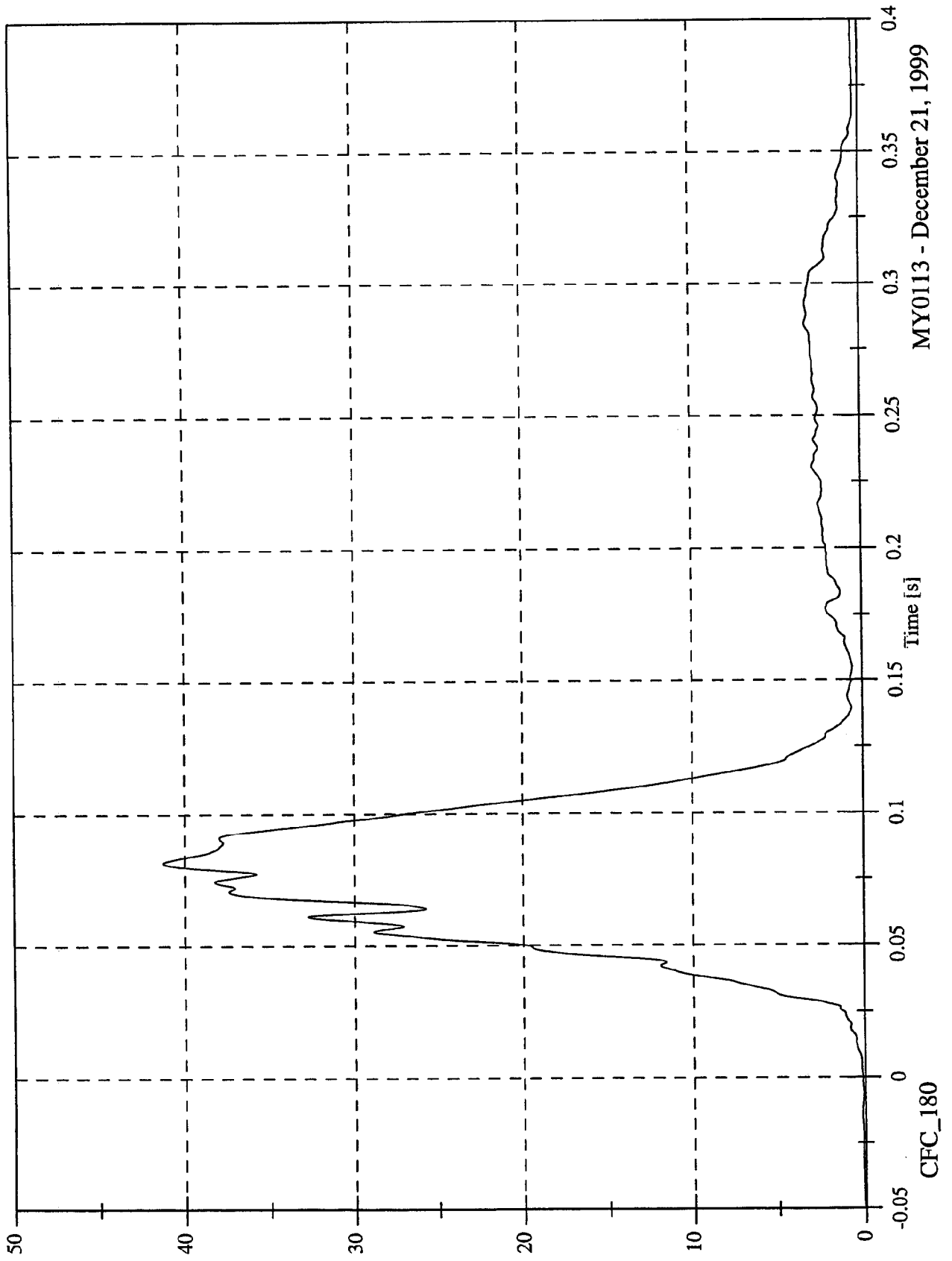

MY0113 - December 21, 1999

NCAP Test 7 - 2000 Saturn SL

Max: 3.0 [g] at 0.293 [s]

Min: -41.3 [g] at 0.082 [s]

P1 Chest Red x

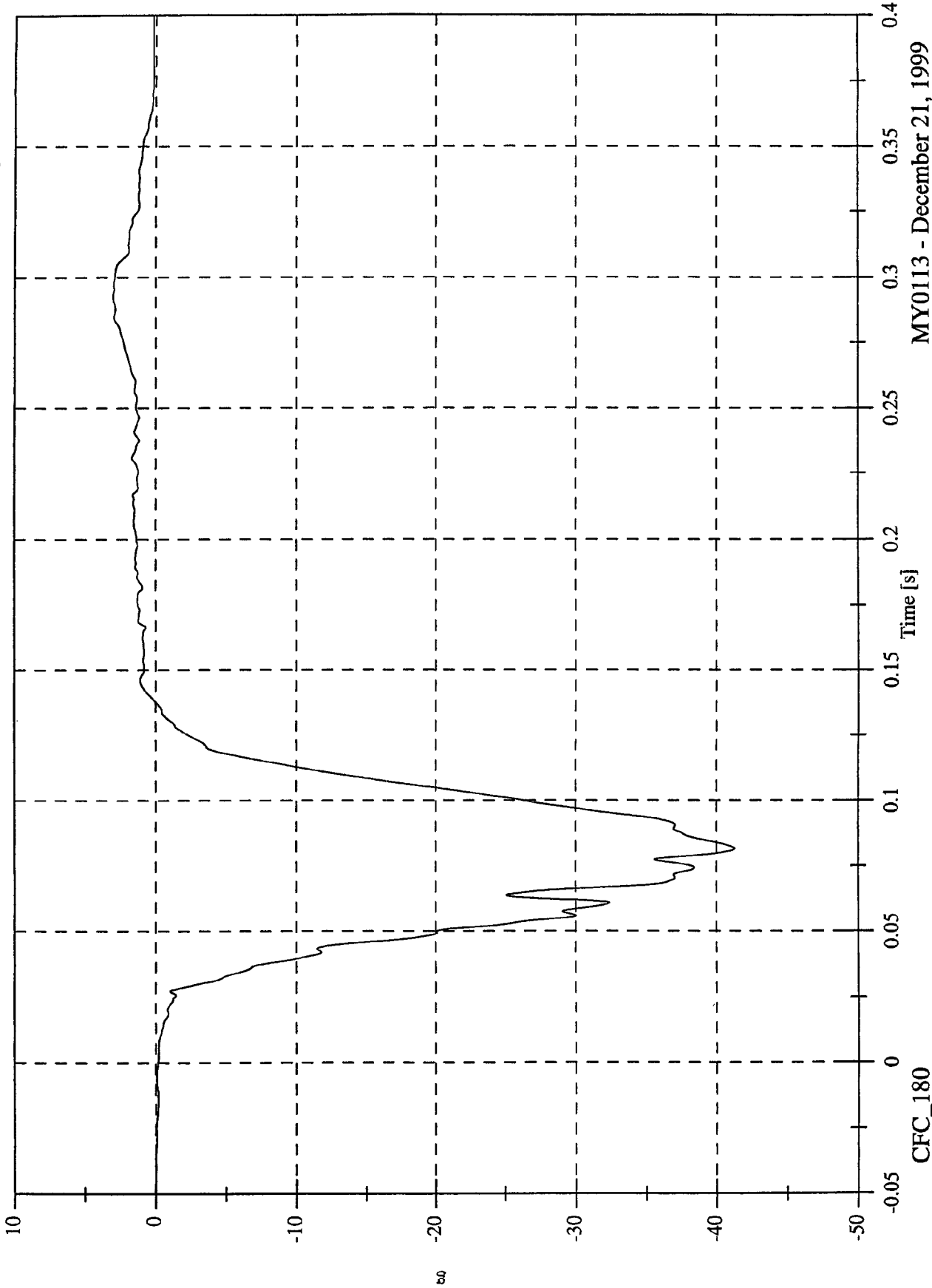

CFC\_180

MY0113 - December 21, 1999

NCAP Test 7 - 2000 Saturn SL

Max: 1.3 [g] at 0.117 [s]  
Min: -7.9 [g] at 0.084 [s]

P1 Chest Red y

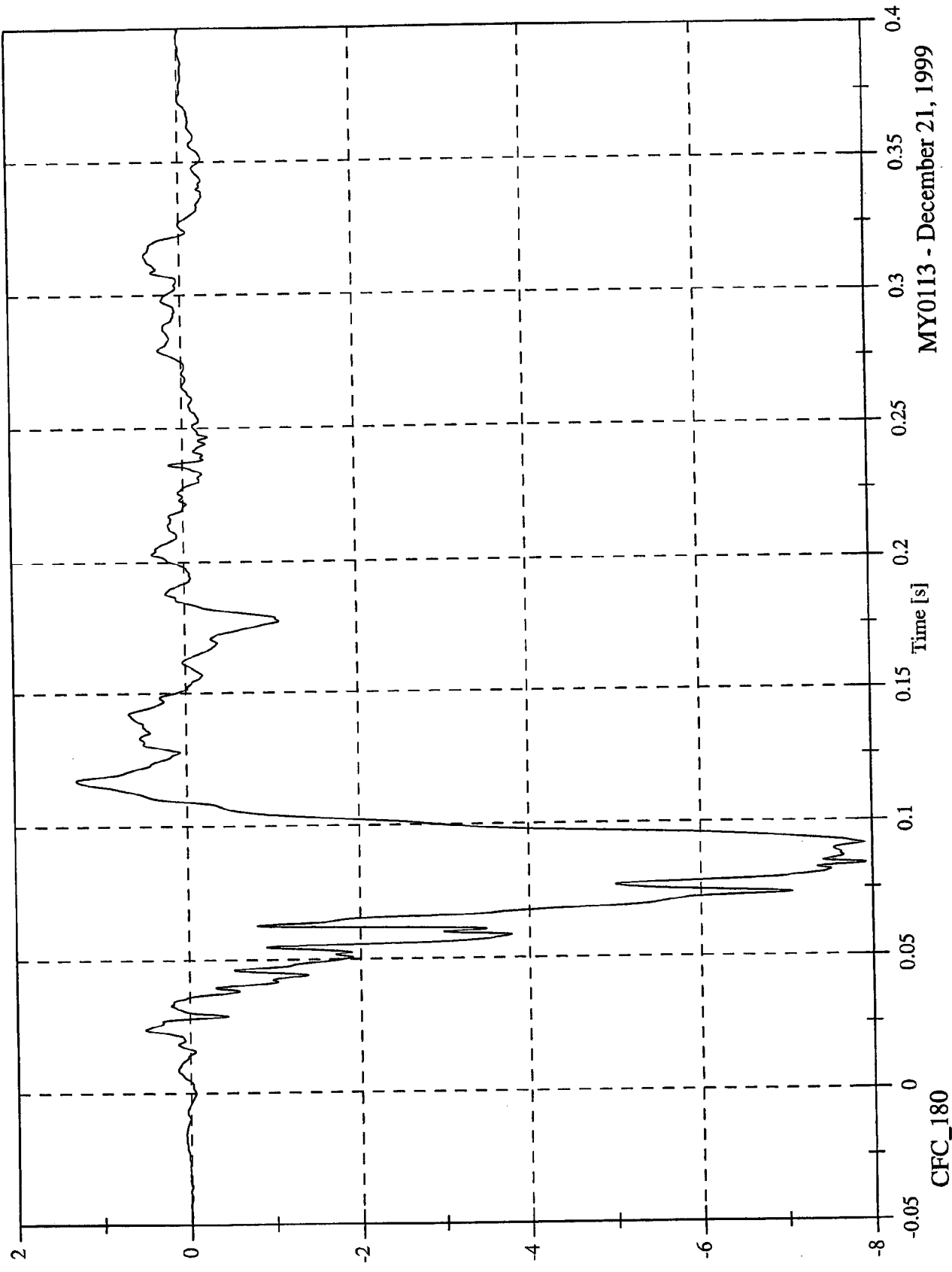

MY0113 - December 21, 1999

CFC\_180

NCAP Test 7 - 2000 Saturn SL

Max: 3.8 [g] at 0.038 [s]  
Min: -3.5 [g] at 0.065 [s]

P1 Chest Red z

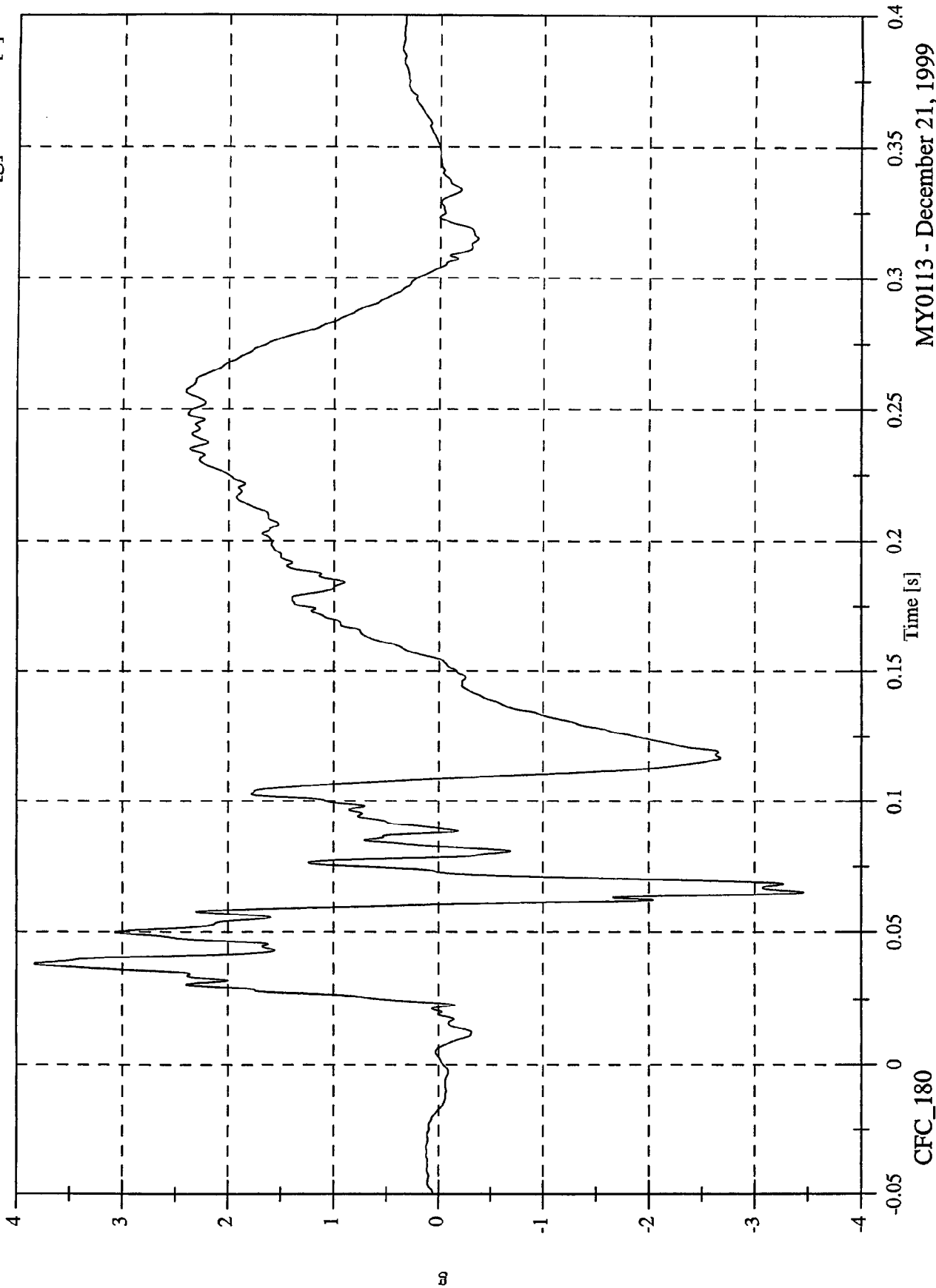

CFC\_180

MY0113 - December 21, 1999

NCAP Test 7 - 2000 Saturn SL

Max: 42.0 [g] at 0.082 [s]  
Min: 0.1 [g] at -0.050 [s]

P1 Chest Red Resultant

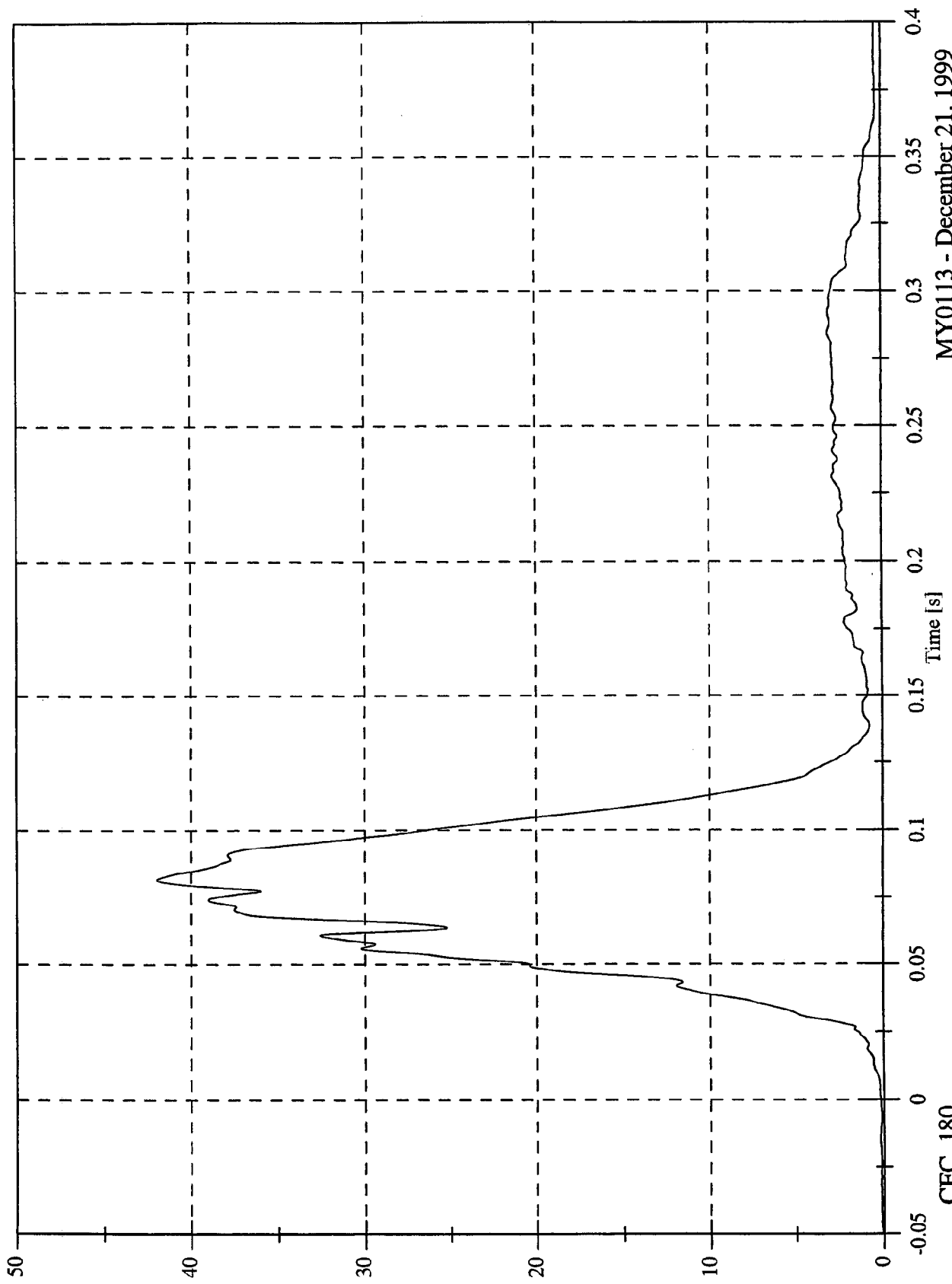

MY0113 - December 21, 1999

CFC\_180

NCAP Test 7 - 2000 Saturn SL

Max: 0.0 [mm] at -0.009 [s]  
Min: -31.6 [mm] at 0.077 [s]

P1 Chest Compression x

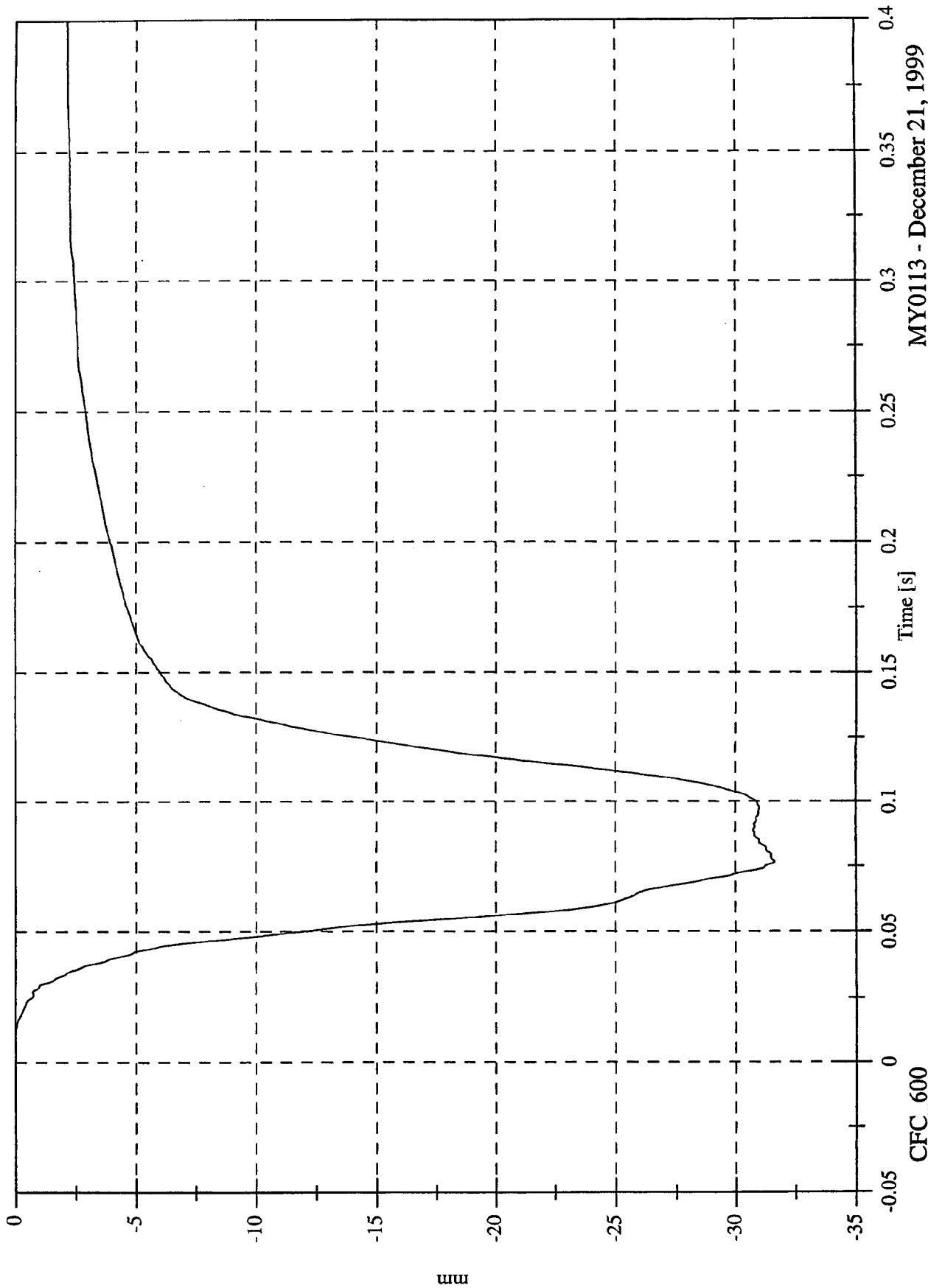

CFC\_600

MY0113 - December 21, 1999

NCAP Test 7 - 2000 Saturn SL

Max: 1.4 [g] at 0.320 [s]  
Min: -36.6 [g] at 0.071 [s]

P1 Pelvic x

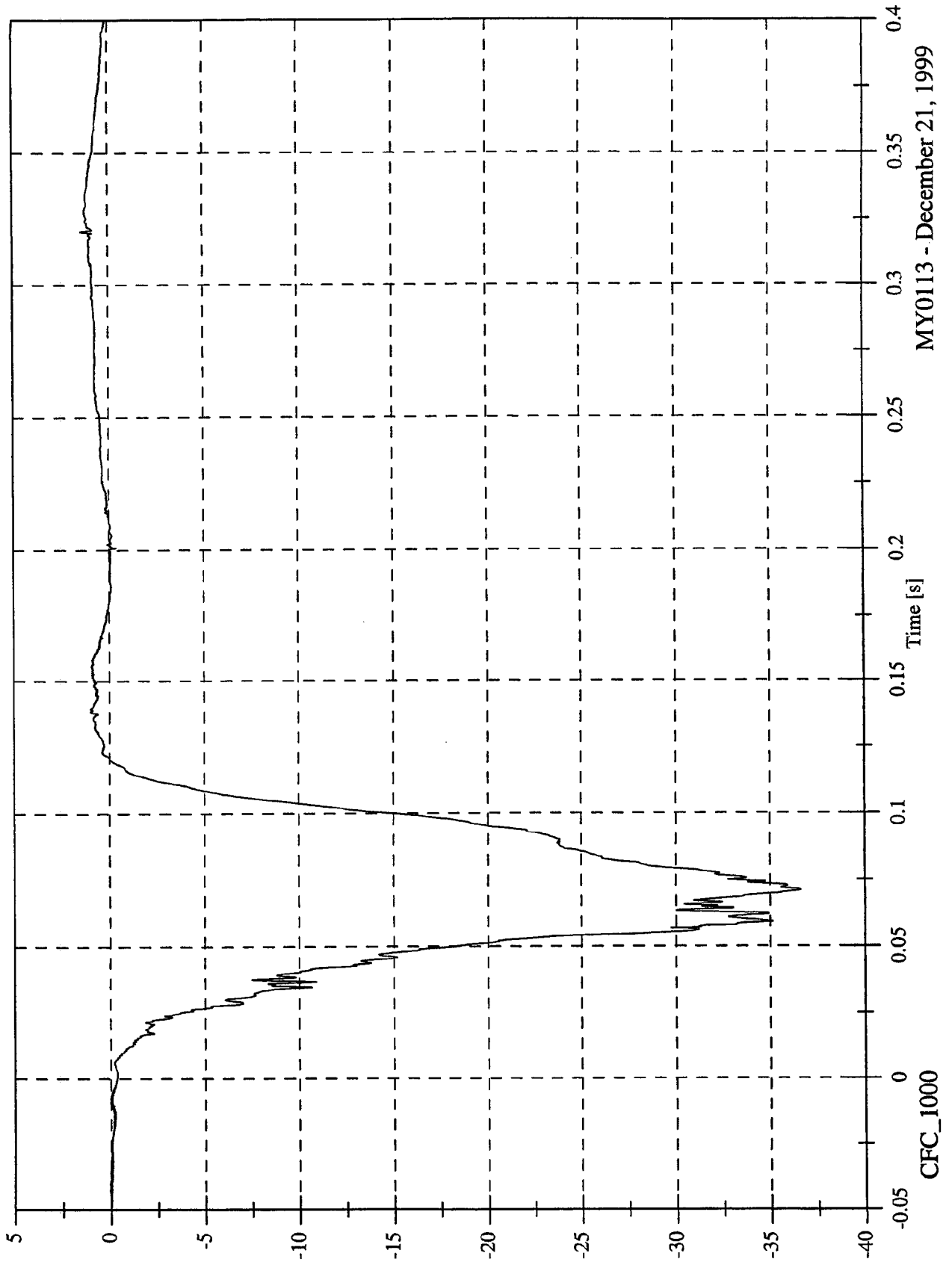

MY0113 - December 21, 1999

NCAP Test 7 - 2000 Saturn SL

Max: 1.6 [g] at 0.127 [s]  
Min: -11.7 [g] at 0.071 [s]

P1 Pelvic y

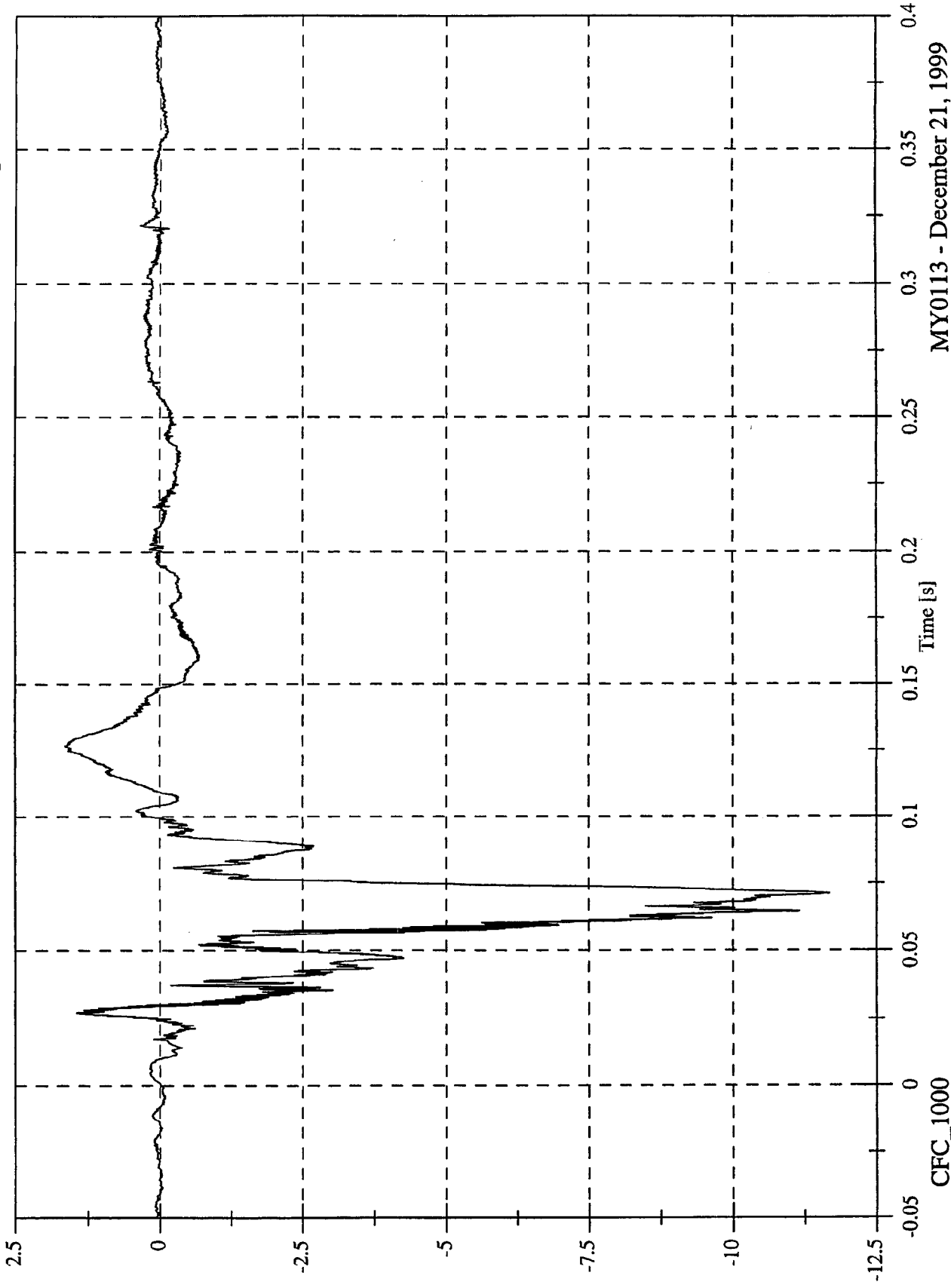

MY0113 - December 21, 1999

NCAP Test 7 - 2000 Saturn SL

Max: 2.5 [g] at 0.250 [s]  
Min: -21.0 [g] at 0.084 [s]

P1 Pelvic z

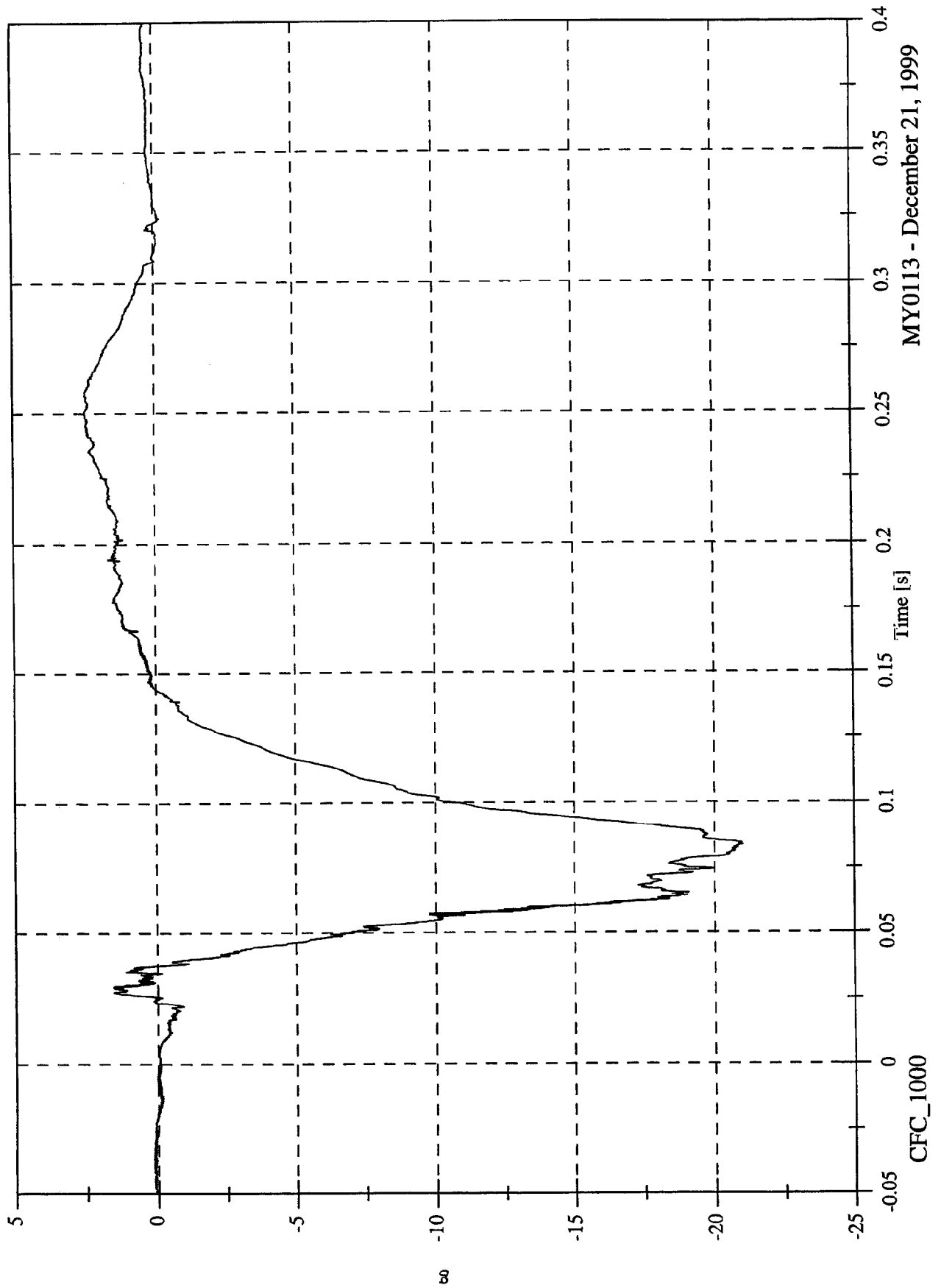

MY0113 - December 21, 1999

NCAP Test 7 - 2000 Saturn SL

Max: 42.3 [g] at 0.071 [s]  
Min: 0.0 [g] at -0.007 [s]

P1 Pelvic Resultant

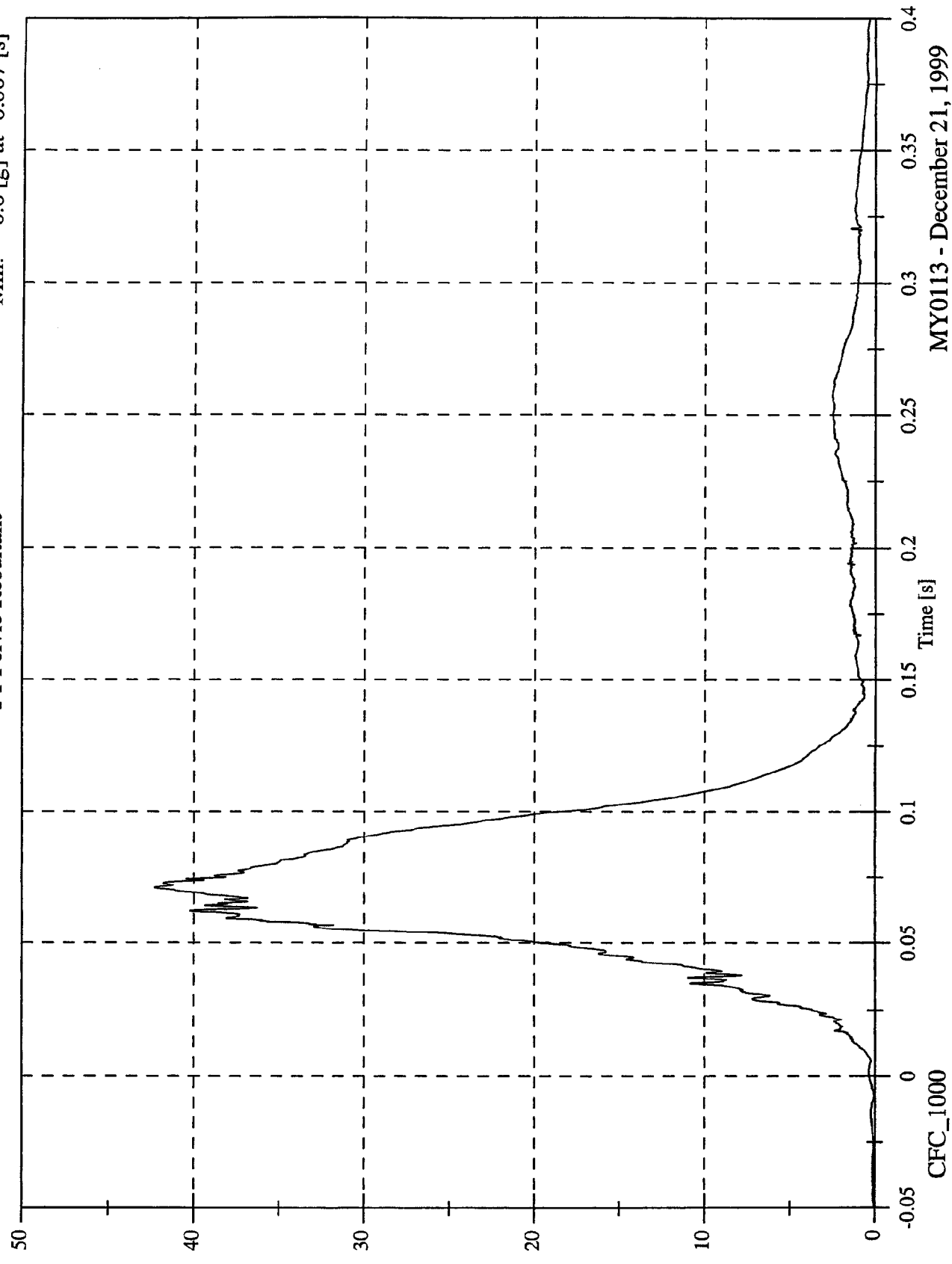

MY0113 - December 21, 1999

NCAP Test 7 - 2000 Saturn SL

Max: 202.1 [N] at 0.033 [s]  
Min: -2156.5 [N] at 0.072 [s]

P1 Left Femur z

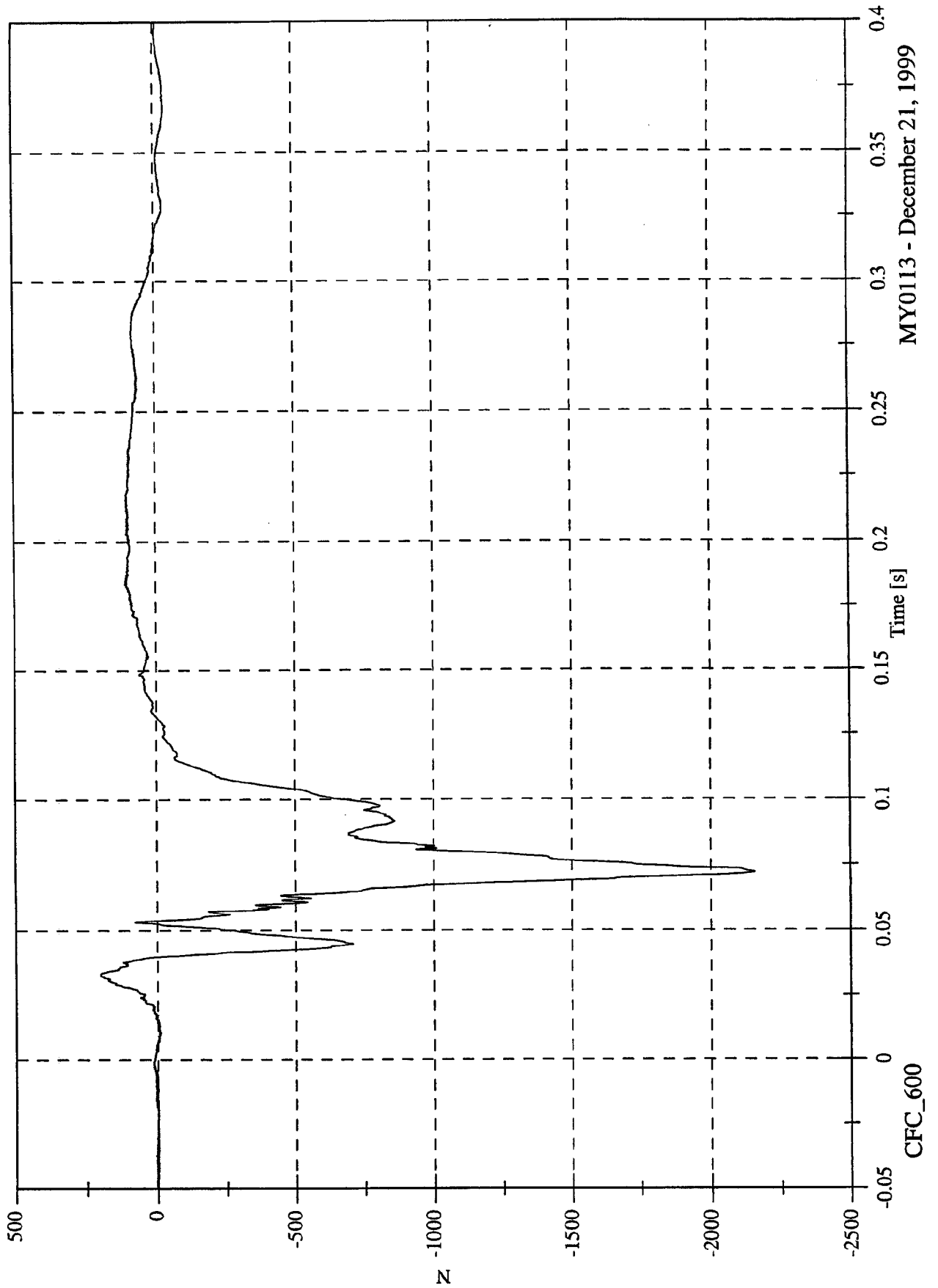

MY0113 - December 21, 1999

CFC\_600

NCAP Test 7 - 2000 Saturn SL

Max: 512.4 [N] at 0.083 [s]  
Min: -1524.2 [N] at 0.057 [s]

P1 Right Femur z

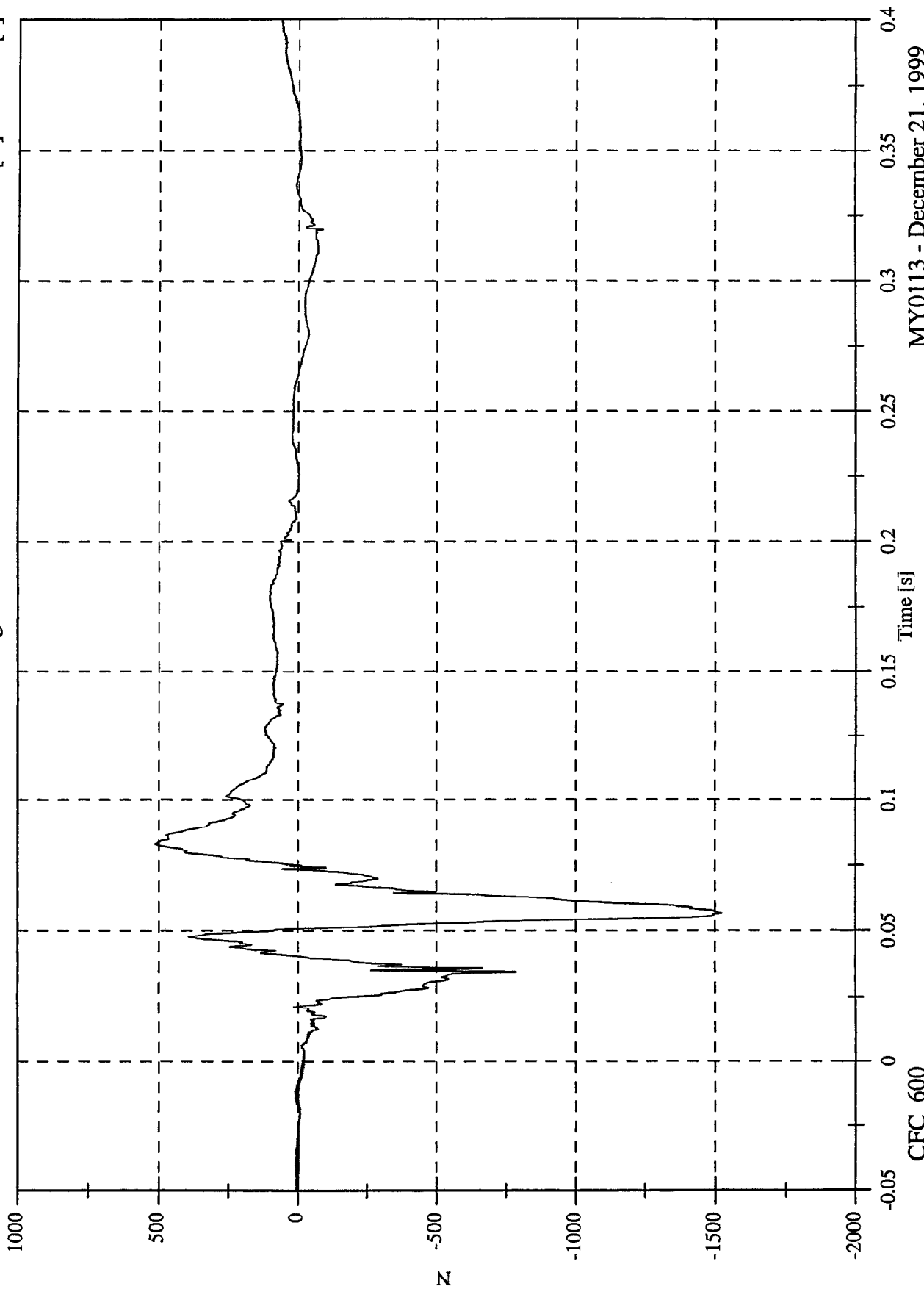

CFC\_600

MY0113 - December 21, 1999

NCAP Test 7 - 2000 Saturn SL

Max: 46.1 [N-m] at 0.053 [s]  
Min: -73.1 [N-m] at 0.032 [s]

P1 Left Upper Tibia Mx

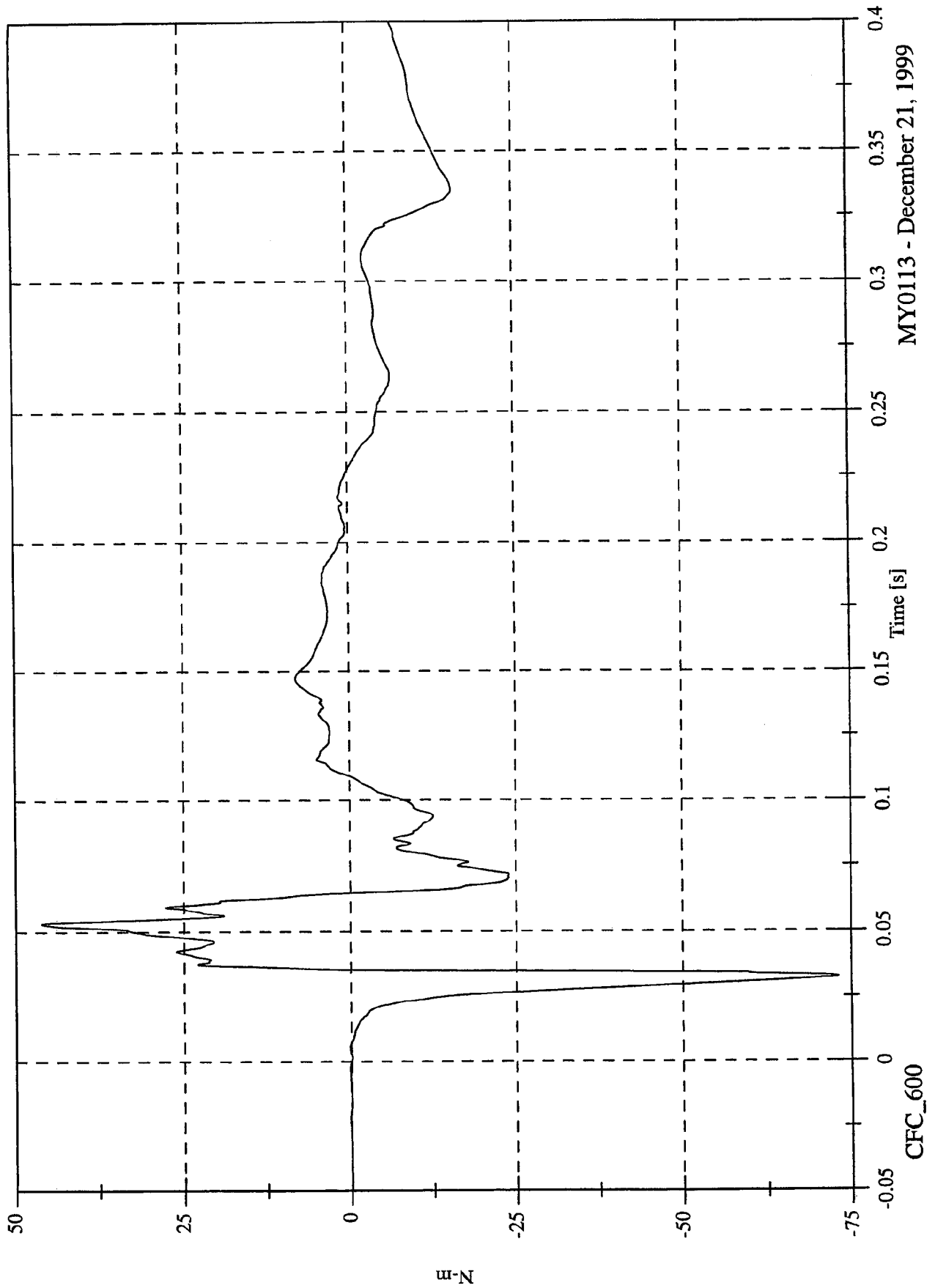

MY0113 - December 21, 1999

CFC\_600

NCAP Test 7 - 2000 Saturn SL

Max: 14.6 [N-m] at 0.138 [s]  
Min: -69.8 [N-m] at 0.066 [s]

P1 Left Upper Tibia My

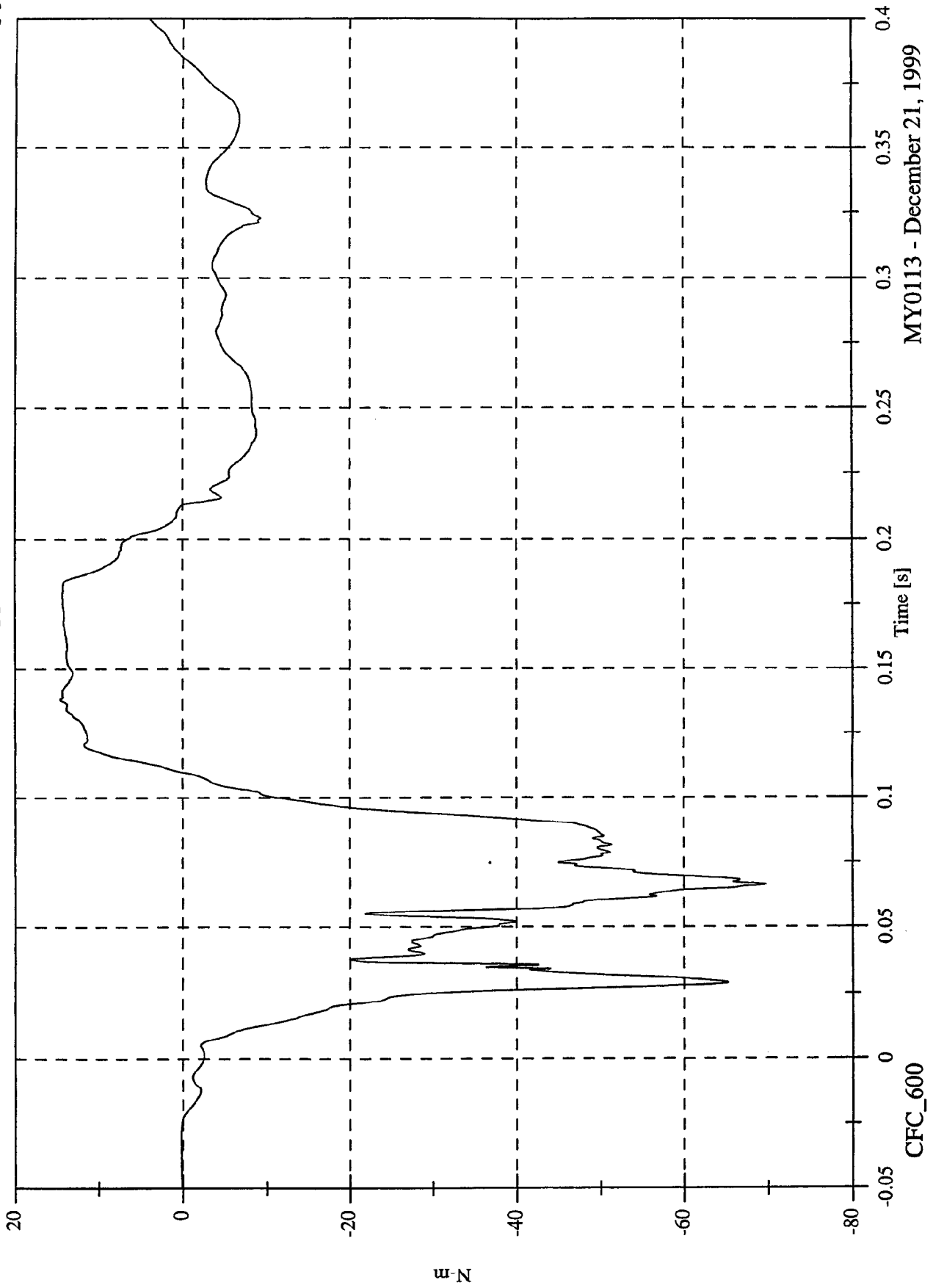

MY0113 - December 21, 1999

CFC\_600

NCAP Test 7 - 2000 Saturn SL

P1 Left Lower Tibia Fz

Max: 157.6 [N] at 0.201 [s]  
Min: -2758.6 [N] at 0.034 [s]

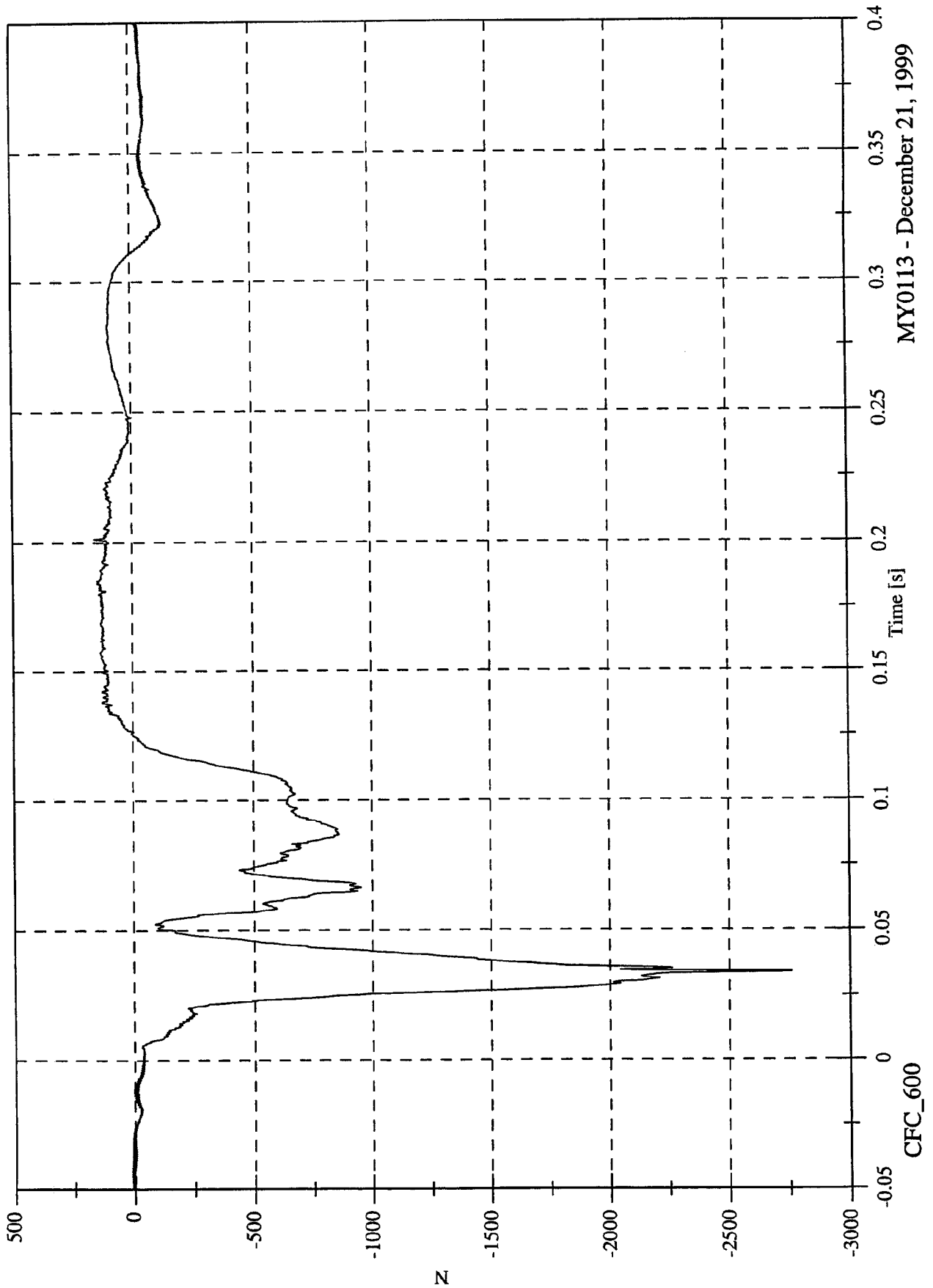

MY0113 - December 21, 1999

NCAP Test 7 - 2000 Saturn SL

Max: 85.1 [N-m] at 0.034 [s]  
Min: -36.0 [N-m] at 0.031 [s]

P1 Left Lower Tibia Mx

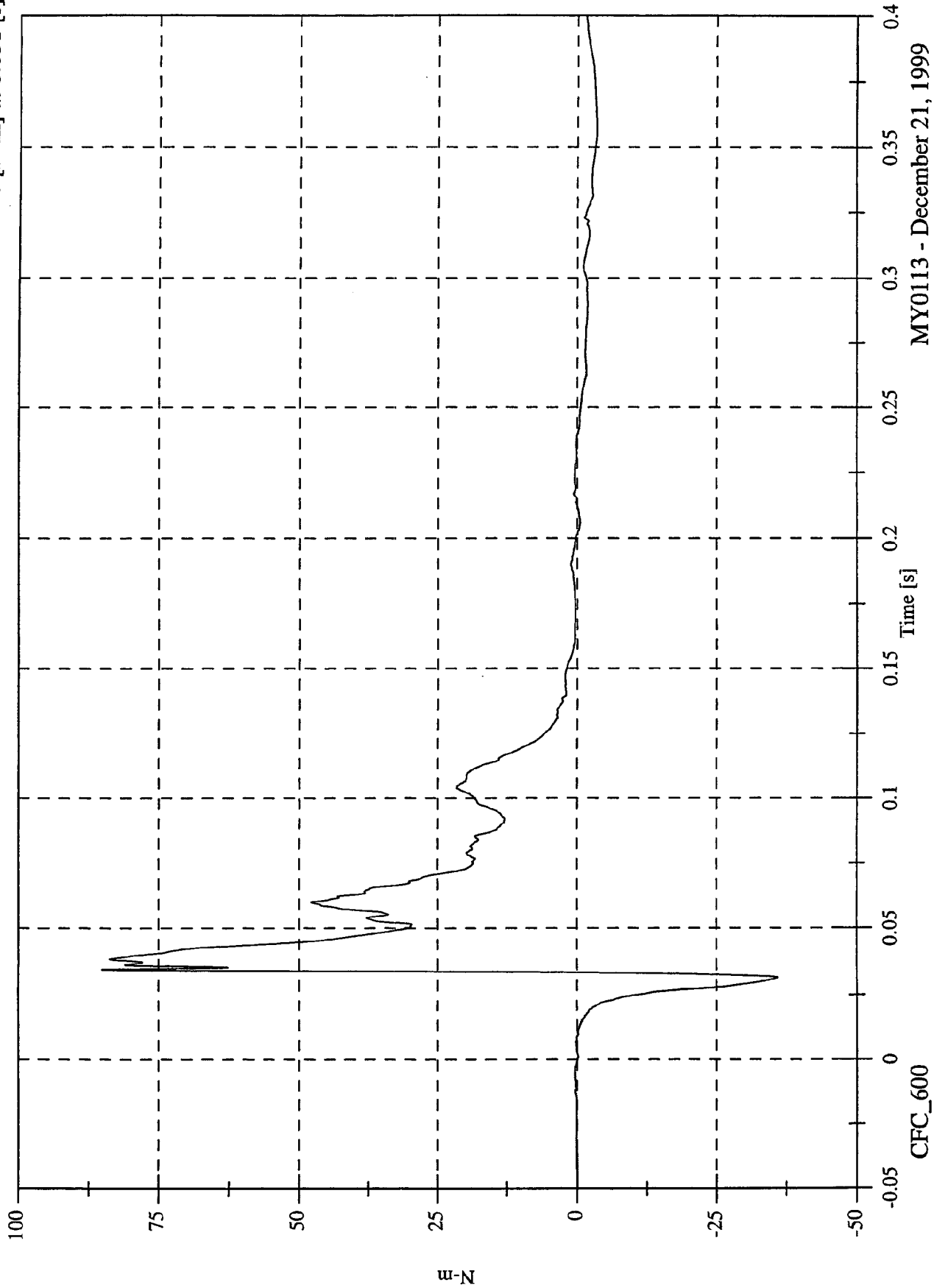

MY0113 - December 21, 1999

CFC\_600

NCAP Test 7 - 2000 Saturn SL

P1 Left Lower Tibia My

Max: 44.9 [N-m] at 0.034 [s]

Min: -18.1 [N-m] at 0.054 [s]

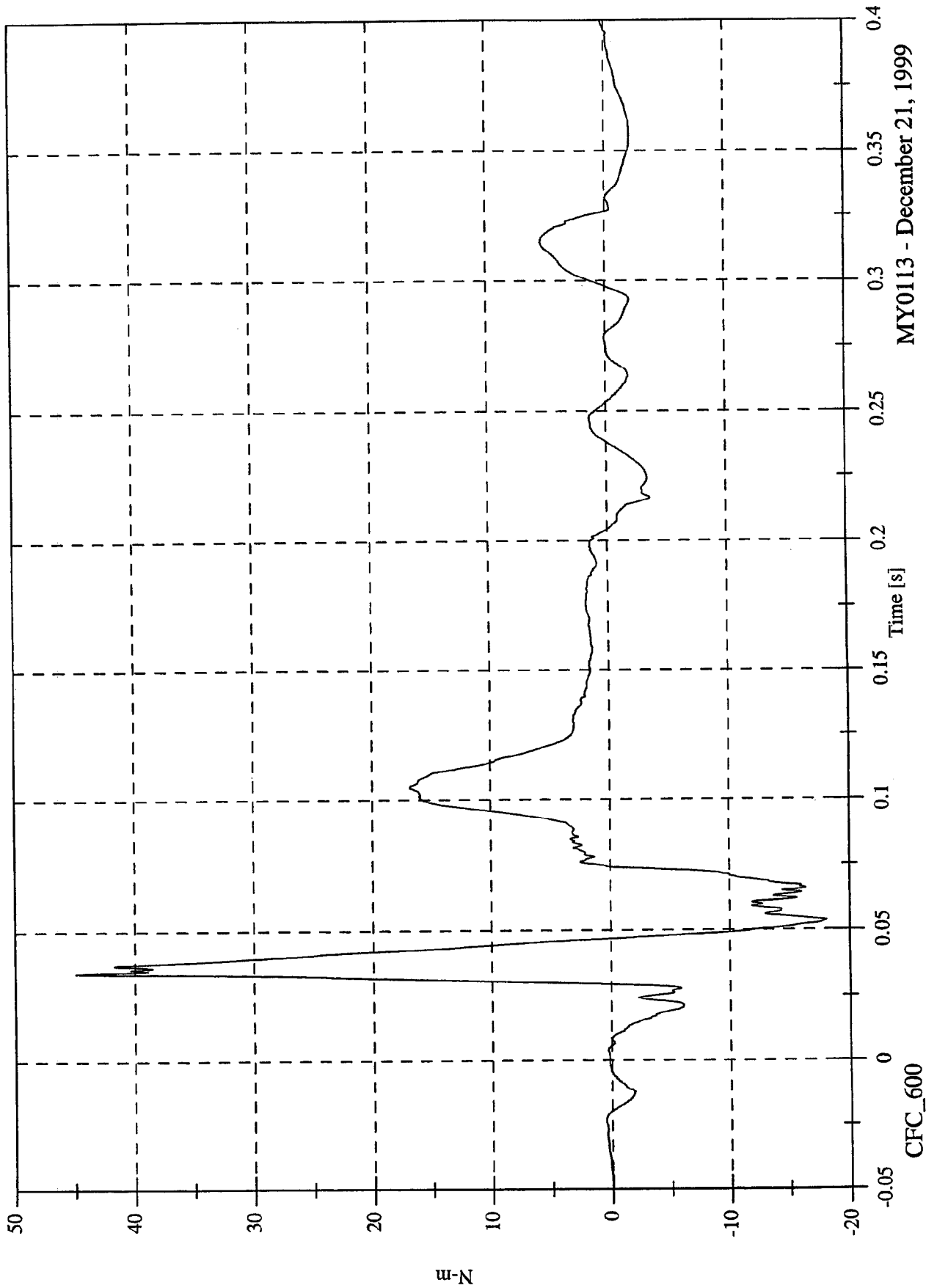

MY0113 - December 21, 1999

NCAP Test 7 - 2000 Saturn SL

Max: 6.7 [N-m] at 0.036 [s]  
Min: -56.6 [N-m] at 0.073 [s]

P1 Right Upper Tibia Mx

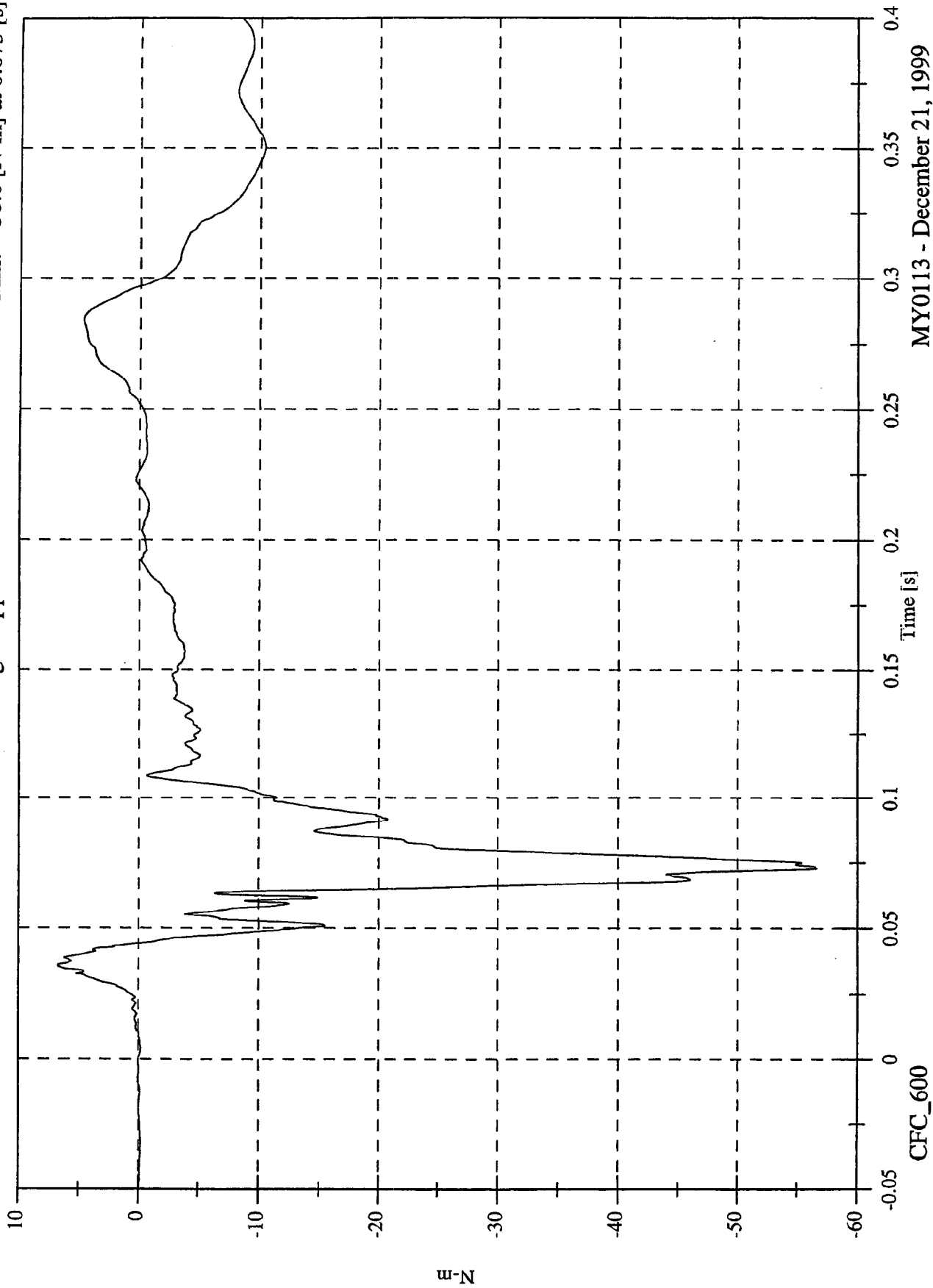

CFC\_600

NCAP Test 7 - 2000 Saturn SL

Max: 11.0 [N-m] at 0.247 [s]  
Min: -181.9 [N-m] at 0.070 [s]

P1 Right Upper Tibia My

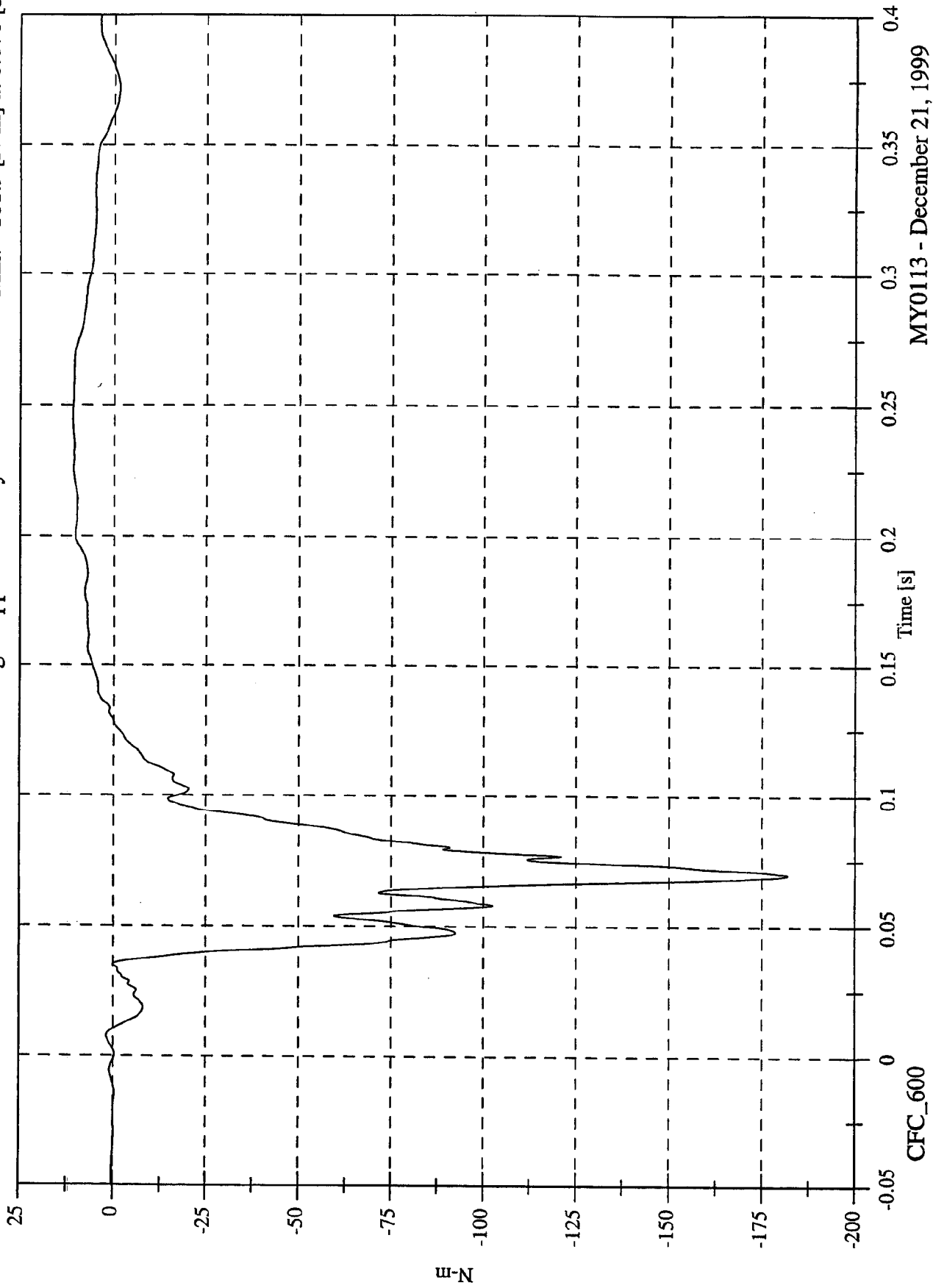

MY0113 - December 21, 1999

NCAP Test 7 - 2000 Saturn SL

Max: 203.7 [N] at 0.199 [s]  
Min: -4327.1 [N] at 0.071 [s]

P1 Right Lower Tibia Fz

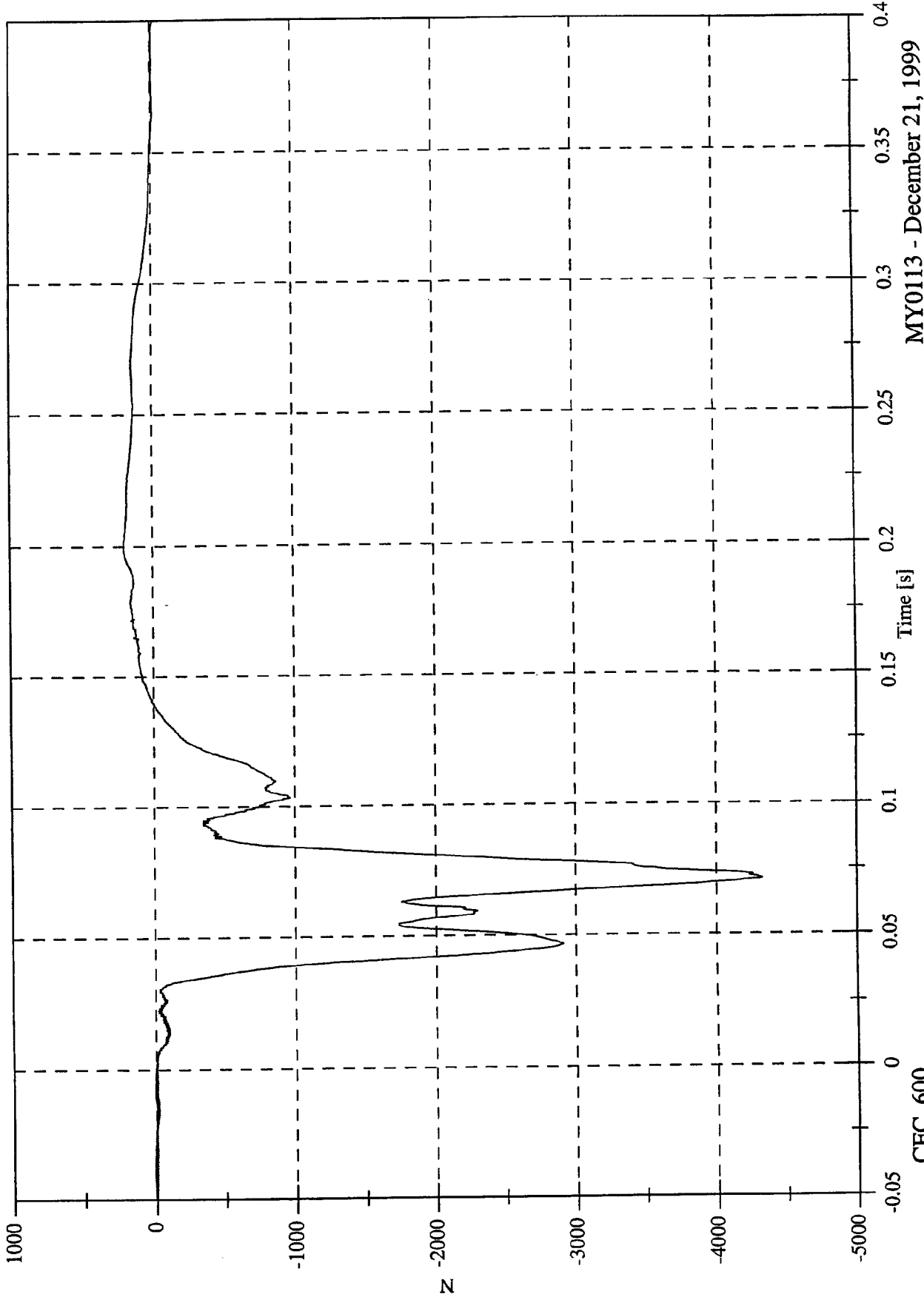

MY0113 - December 21, 1999

CFC\_600

NCAP Test 7 - 2000 Saturn SL

Max: 1.2 [N-m] at 0.035 [s]  
Min: -101.5 [N-m] at 0.075 [s]

P1 Right Lower Tibia Mx

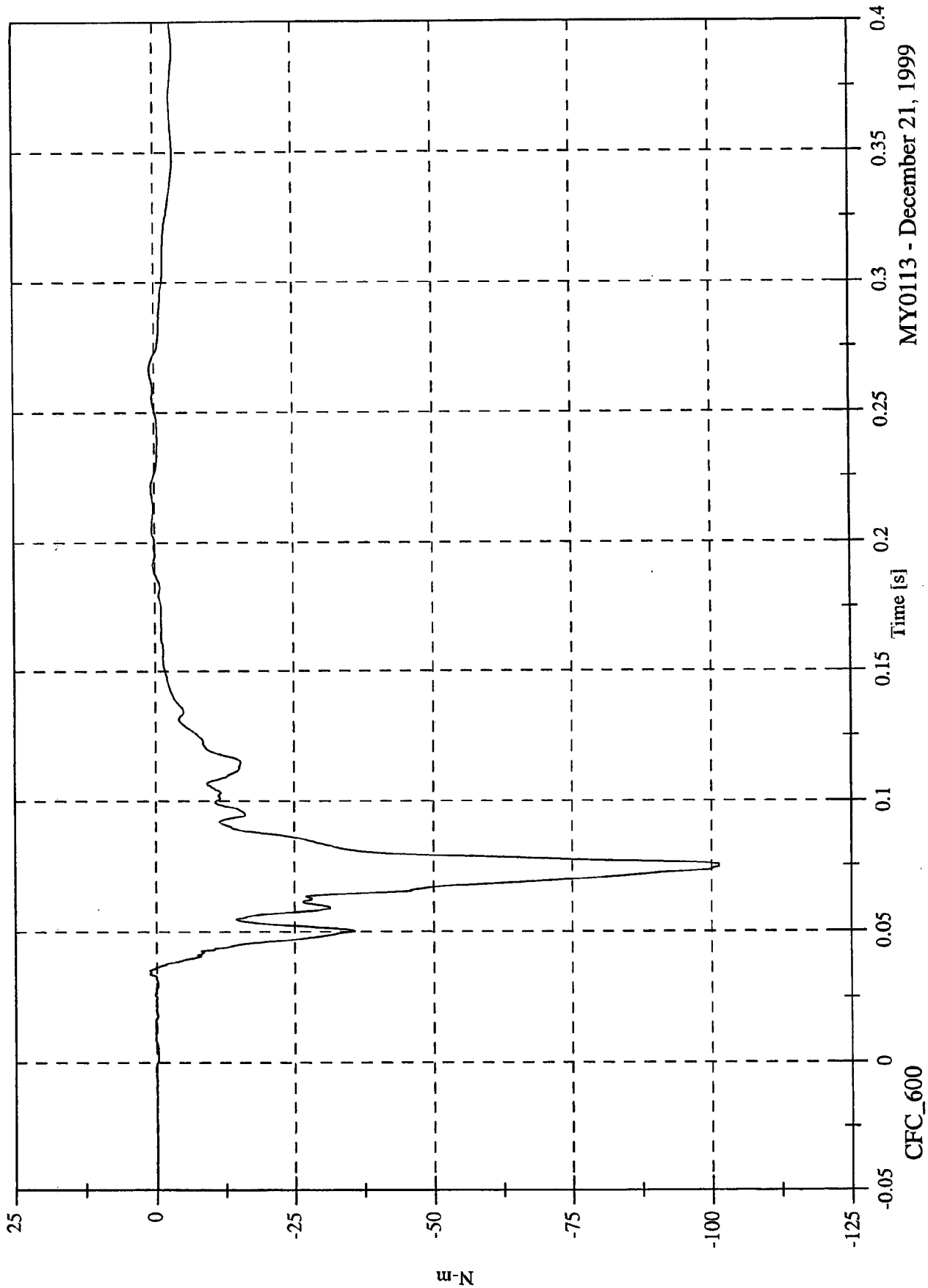

MY0113 - December 21, 1999

CFC\_600

NCAP Test 7 - 2000 Saturn SL

Max: 85.2 [N-m] at 0.075 [s]  
Min: -15.2 [N-m] at 0.048 [s]

P1 Right Lower Tibia My

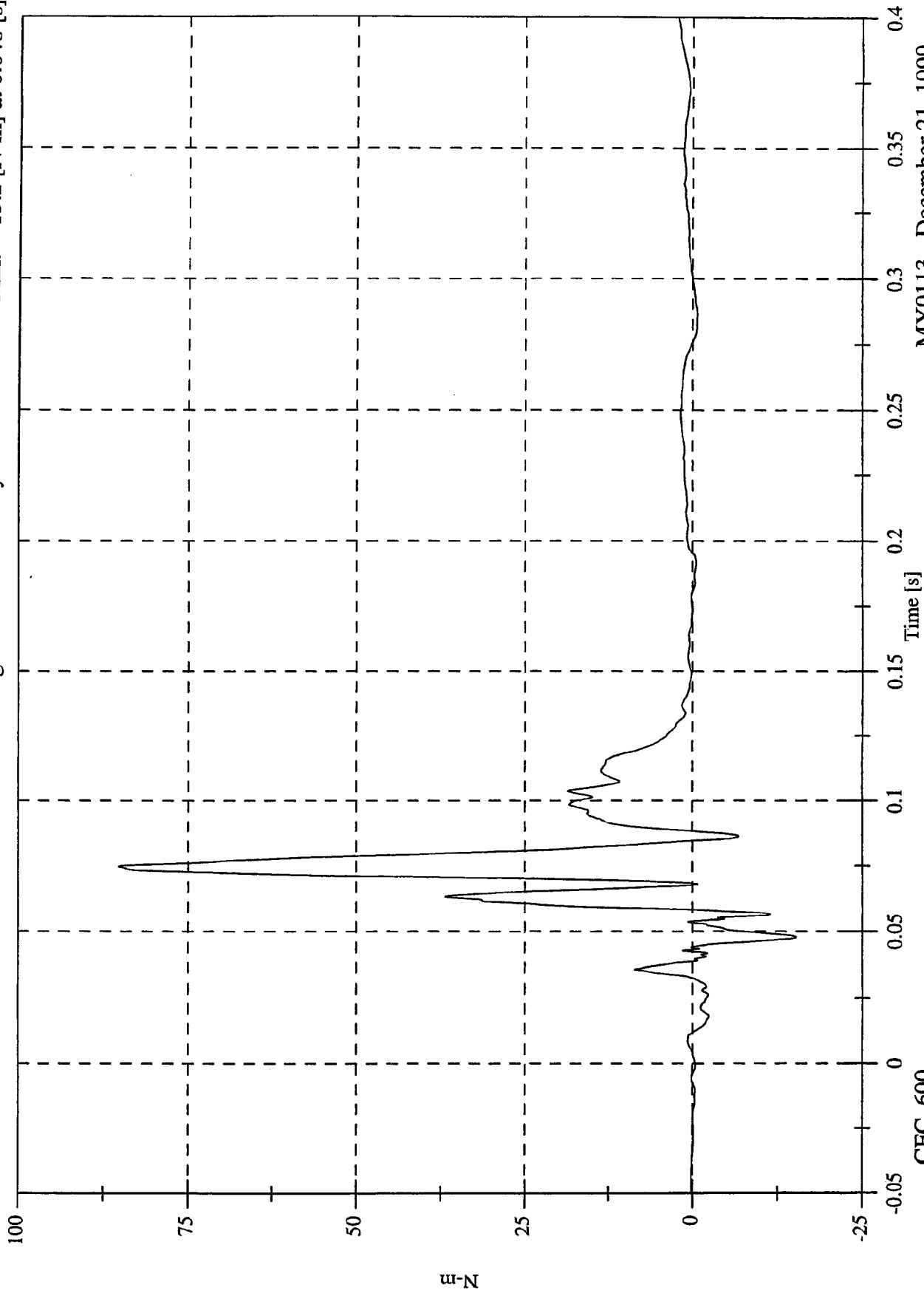

CFC\_600

MY0113 - December 21, 1999

NCAP Test 7 - 2000 Saturn SL

P1 Left Foot Aft x

Max: 44.2 [g] at 0.034 [s]

Min: -34.4 [g] at 0.065 [s]

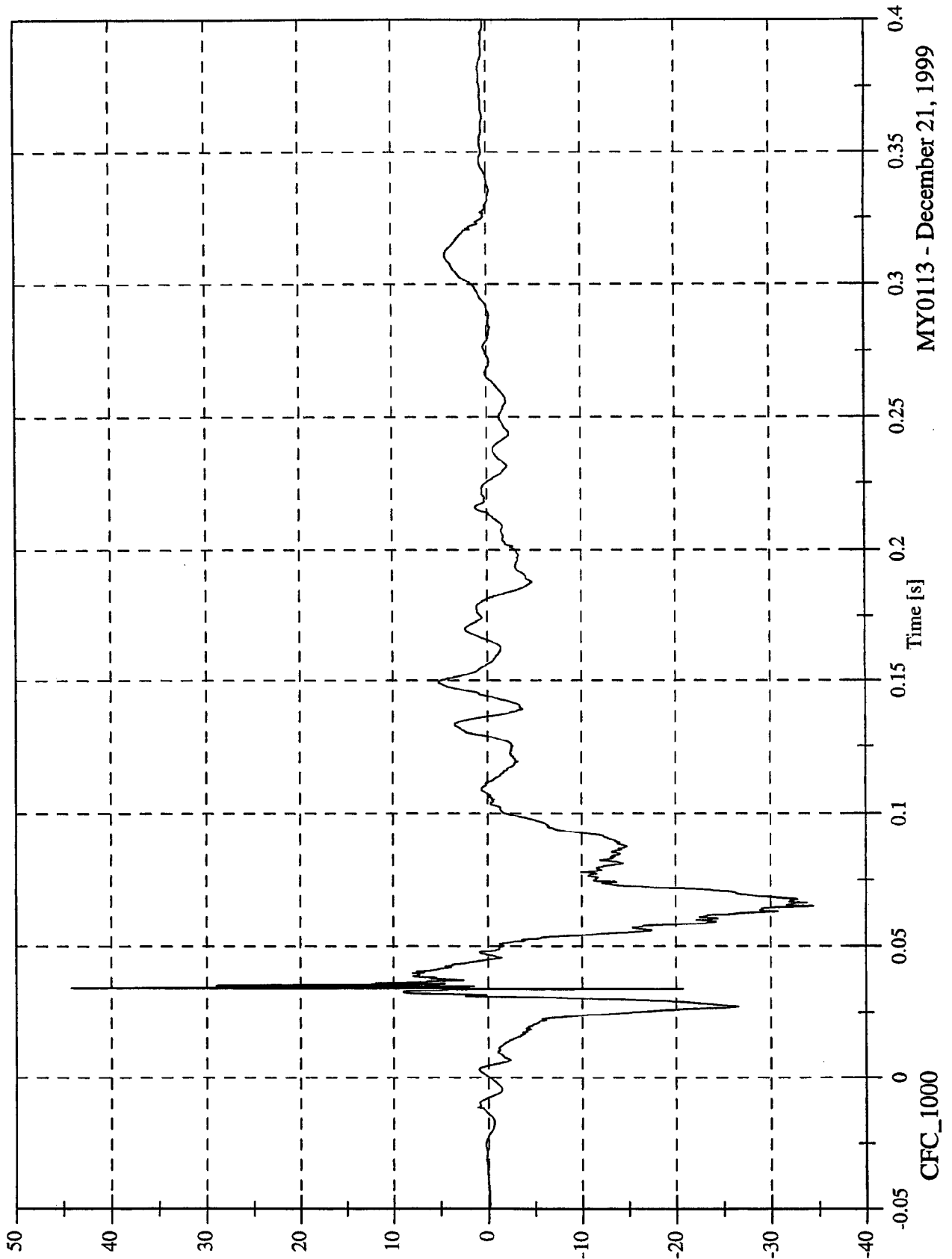

MY0113 - December 21, 1999

CFC\_1000

NCAP Test 7 - 2000 Saturn SL

Max: 47.9 [g] at 0.034 [s]  
Min: -49.2 [g] at 0.034 [s]

P1 Left Foot Aft z

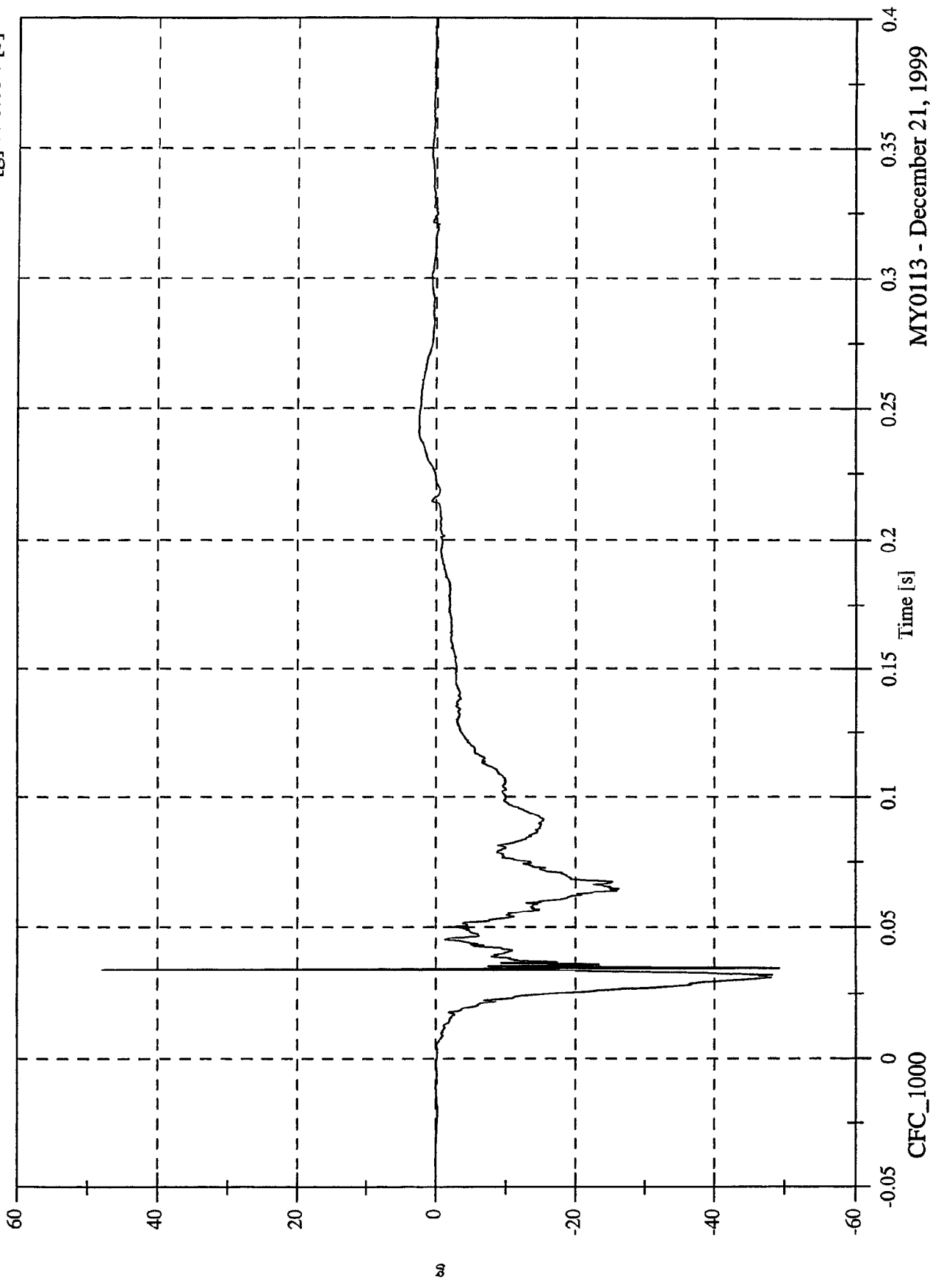

CFC\_1000

MY0113 - December 21, 1999

NCAP Test 7 - 2000 Saturn SL

Max: 82.5 [g] at 0.034 [s]  
Min: -60.5 [g] at 0.035 [s]

P1 Left Foot Fore z

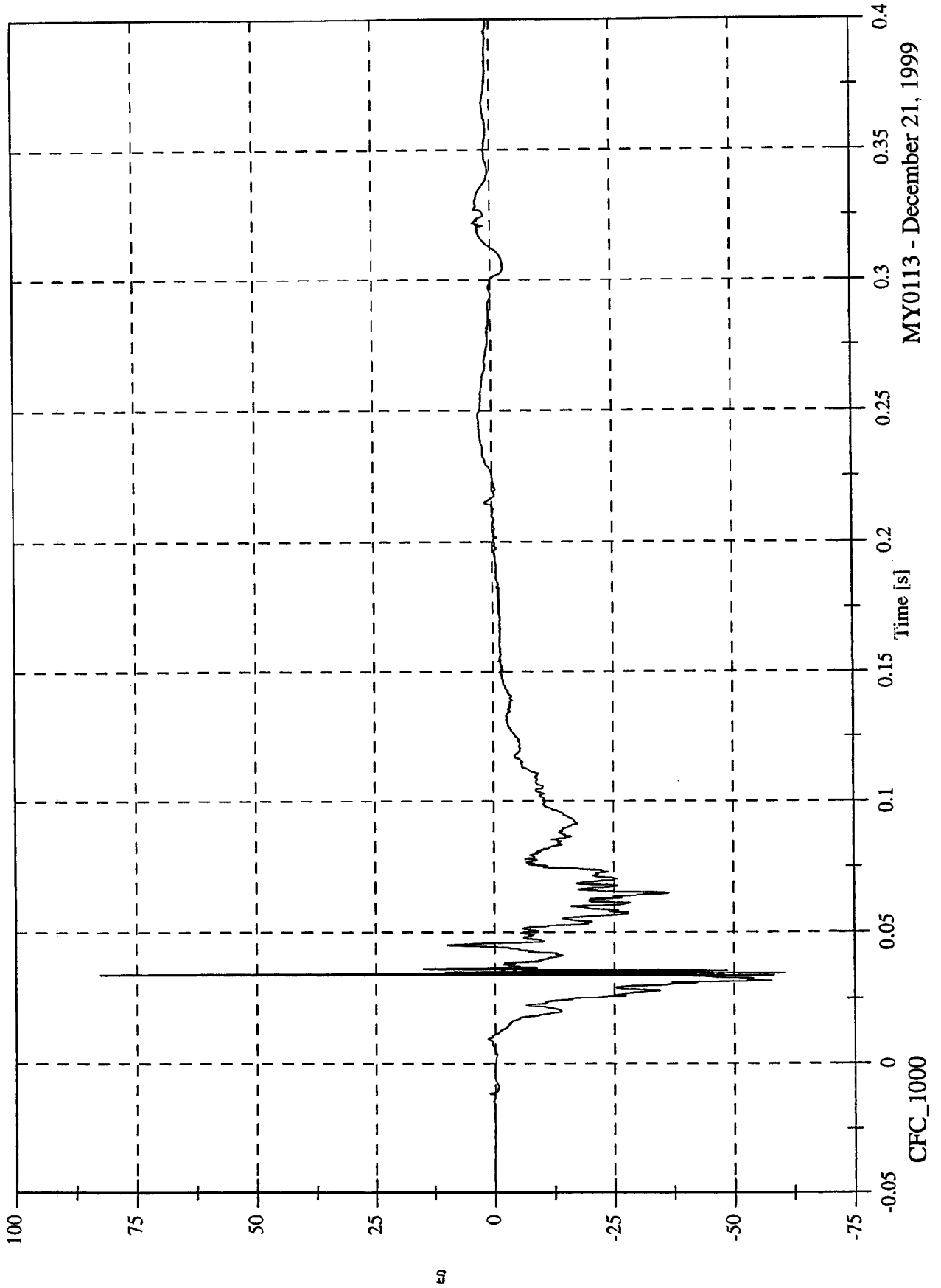

MY0113 - December 21, 1999

NCAP Test 7 - 2000 Saturn SL

P1 Right Foot Aft x

Max: 11.9 [g] at 0.073 [s]  
Min: -52.7 [g] at 0.047 [s]

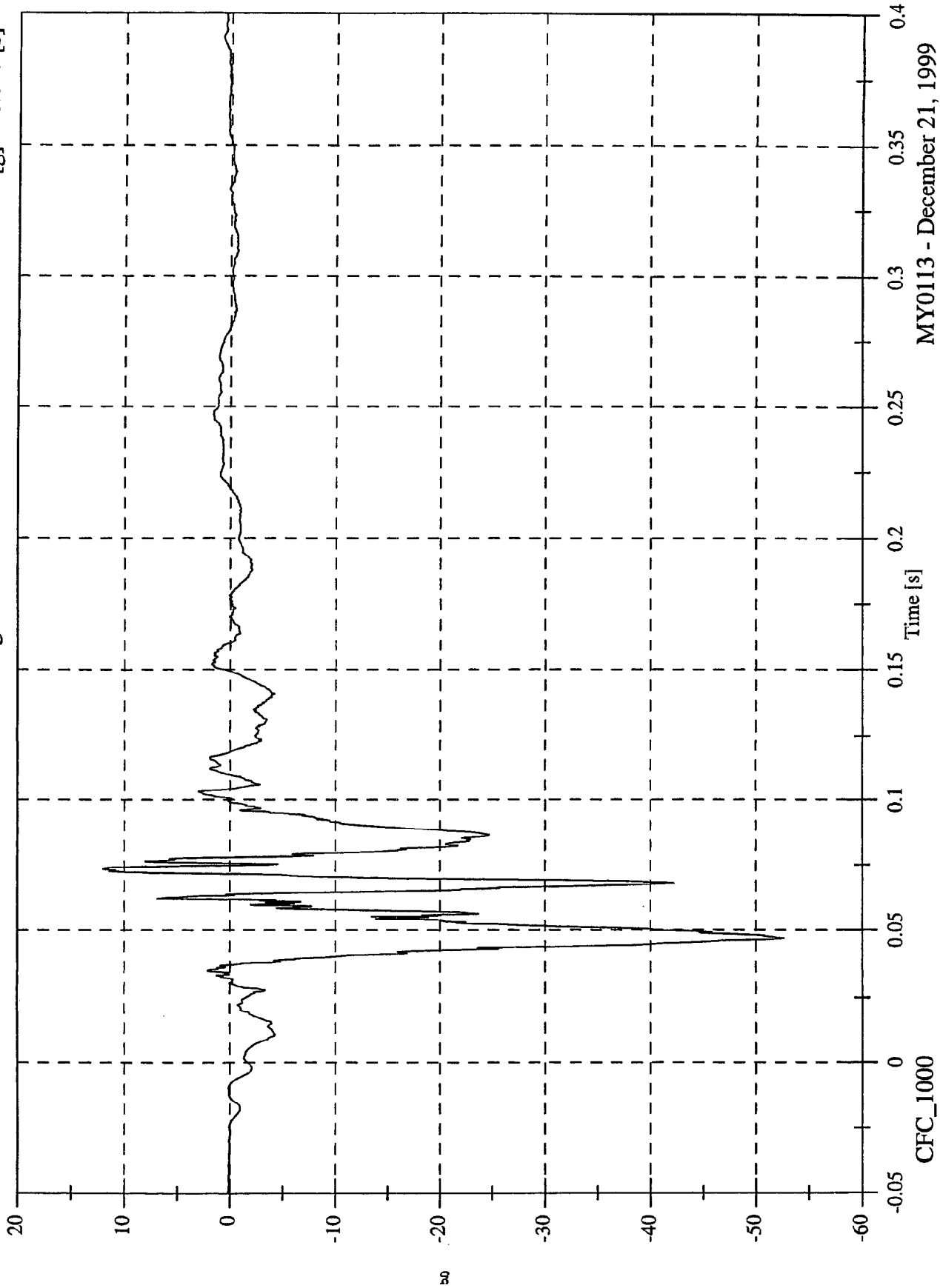

MY0113 - December 21, 1999

NCAP Test 7 - 2000 Saturn SL

Max: 8.7 [g] at 0.091 [s]  
Min: -52.3 [g] at 0.056 [s]

P1 Right Foot Aft z

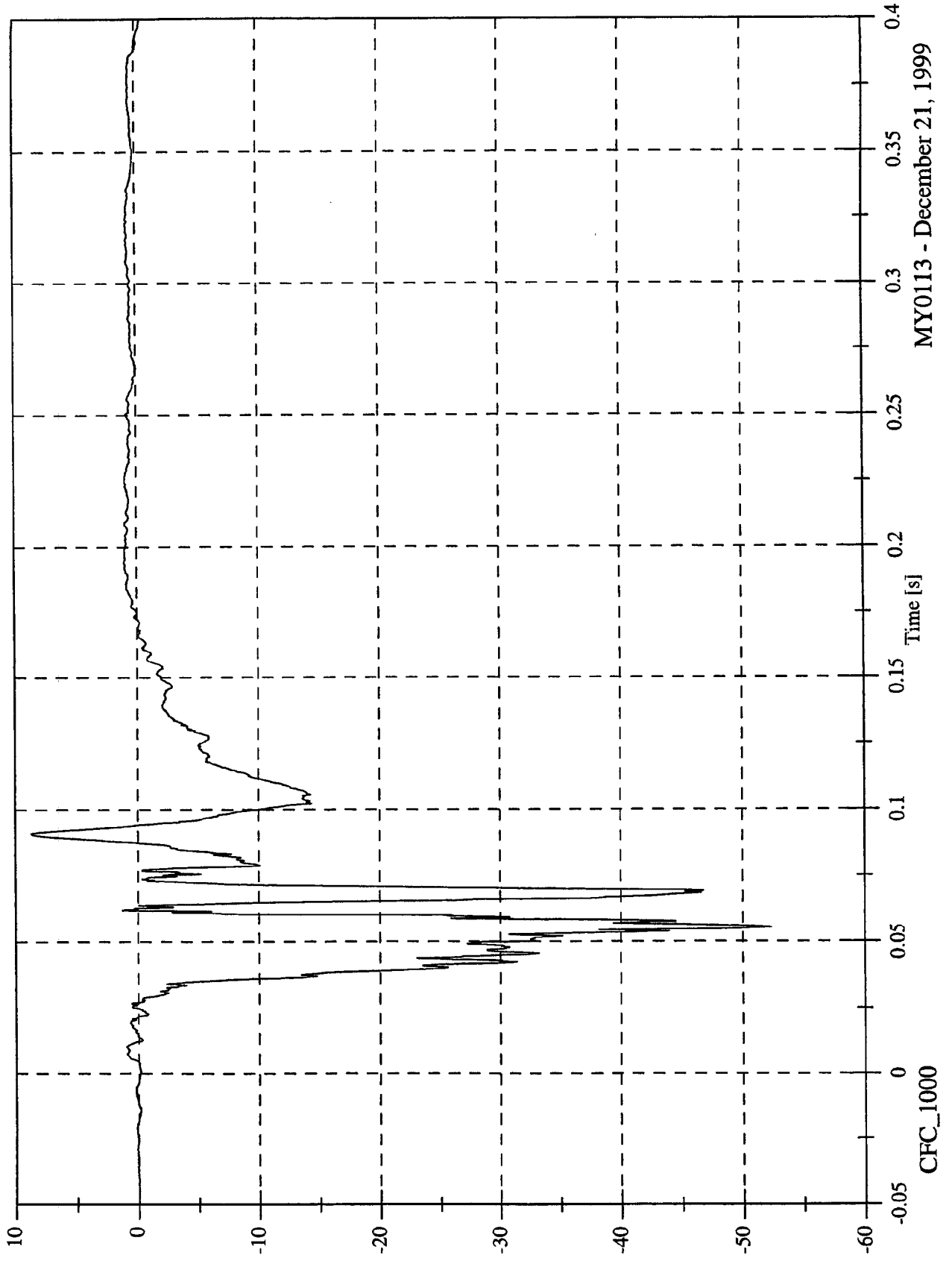

MY0113 - December 21, 1999

NCAP Test 7 - 2000 Saturn SL

Max: 3.3 [g] at 0.037 [s]

Min: -181.7 [g] at 0.054 [s]

P1 Right Foot Fore z

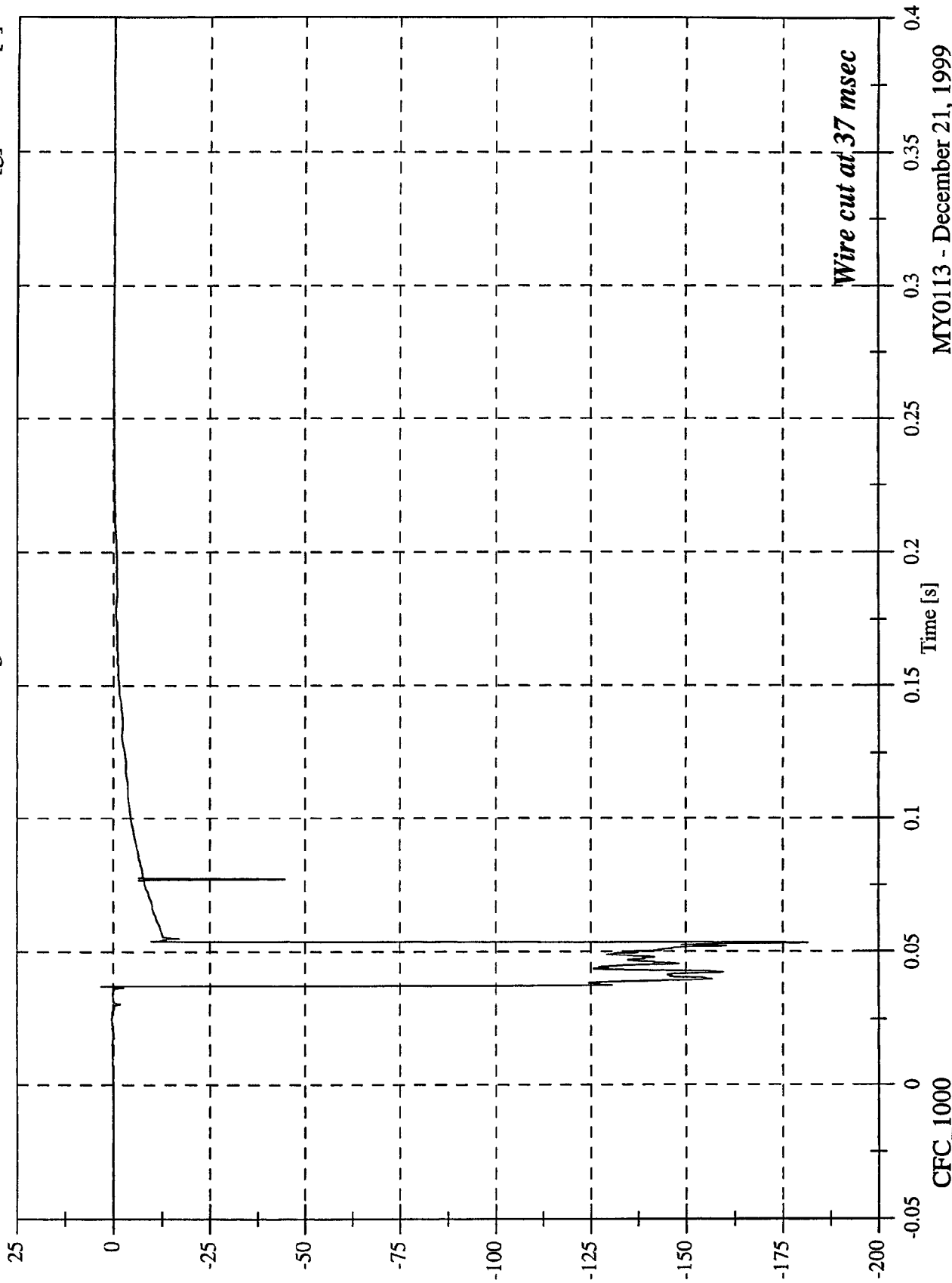

MY0113 - December 21, 1999

Wire cut at 37 msec

NCAP Test 7 - 2000 Saturn SL

Max: 4154.9 [N] at 0.072 [s]  
Min: -3.8 [N] at 0.396 [s]

P1 Lap Belt Force

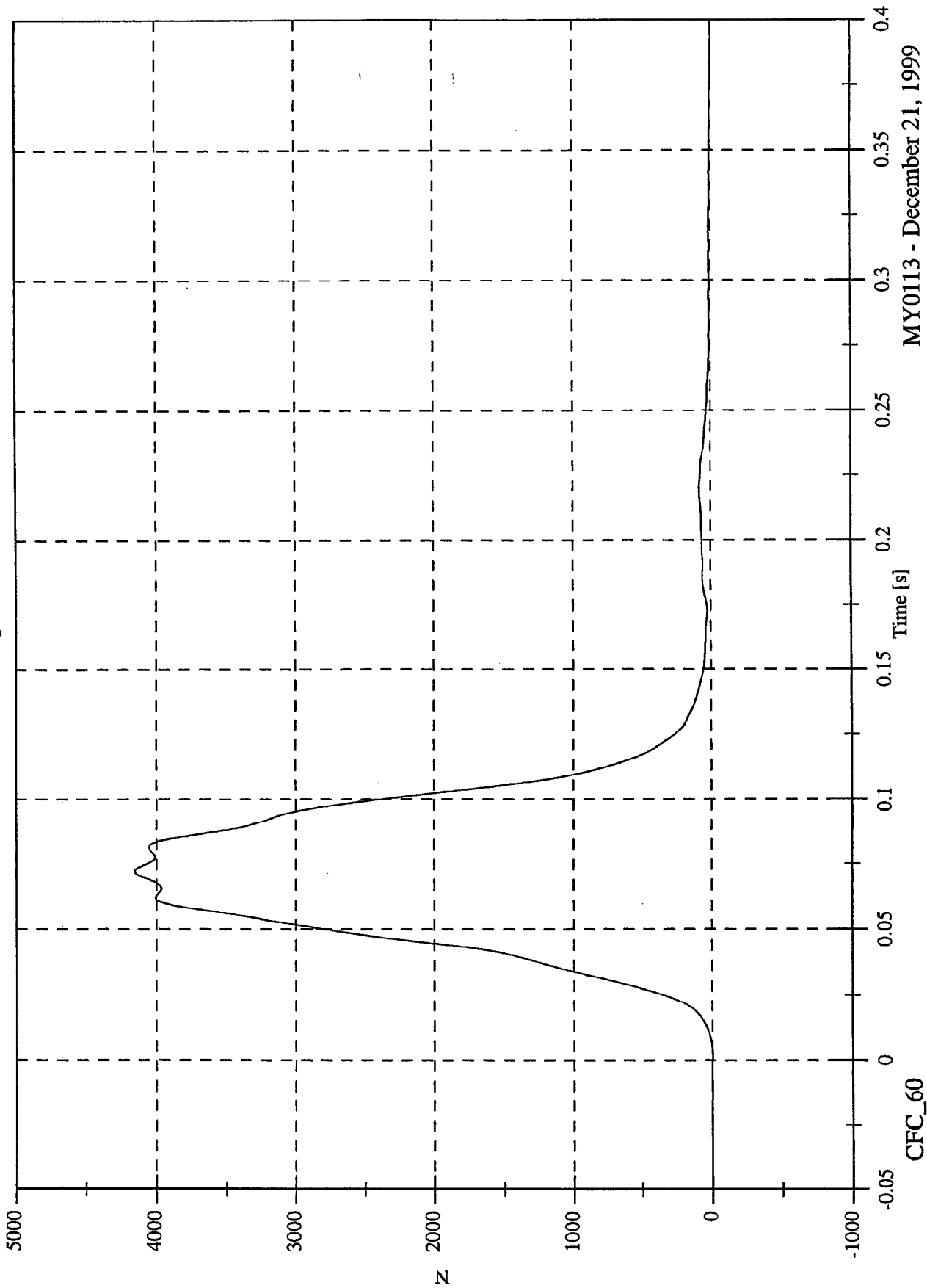

MY0113 - December 21, 1999

NCAP Test 7 - 2000 Saturn SL

Max: 3728.0 [N] at 0.093 [s]  
Min: -28.7 [N] at 0.361 [s]

P1 Shoulder Belt Force

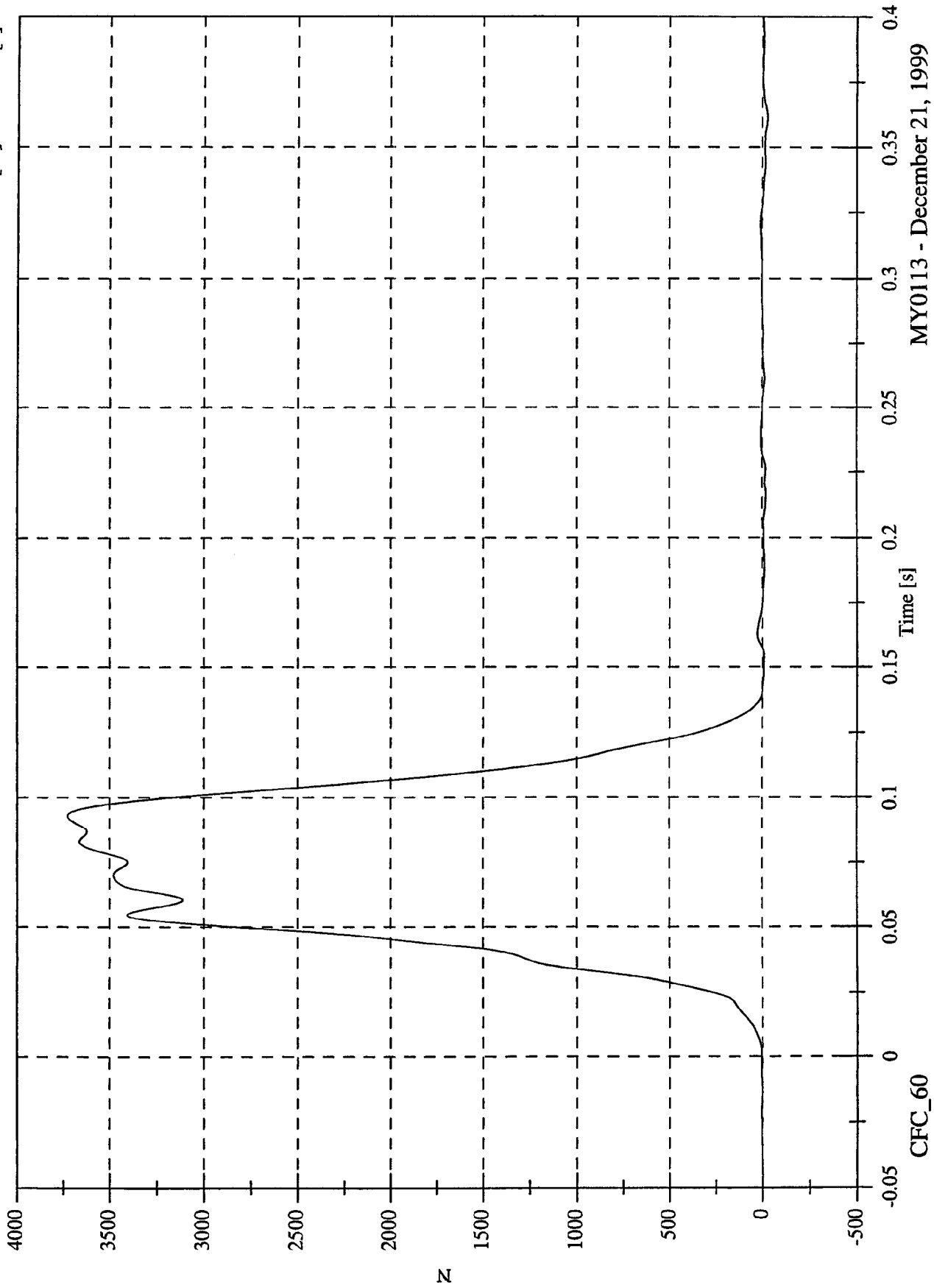

MY0113 - December 21, 1999

CFC\_60

NCAP Test 7 - 2000 Saturn SL

Max: 0.0 [mm] at 0.031 [s]  
Min: -0.0 [mm] at 0.023 [s]

P1 Shoulder Belt Elongation

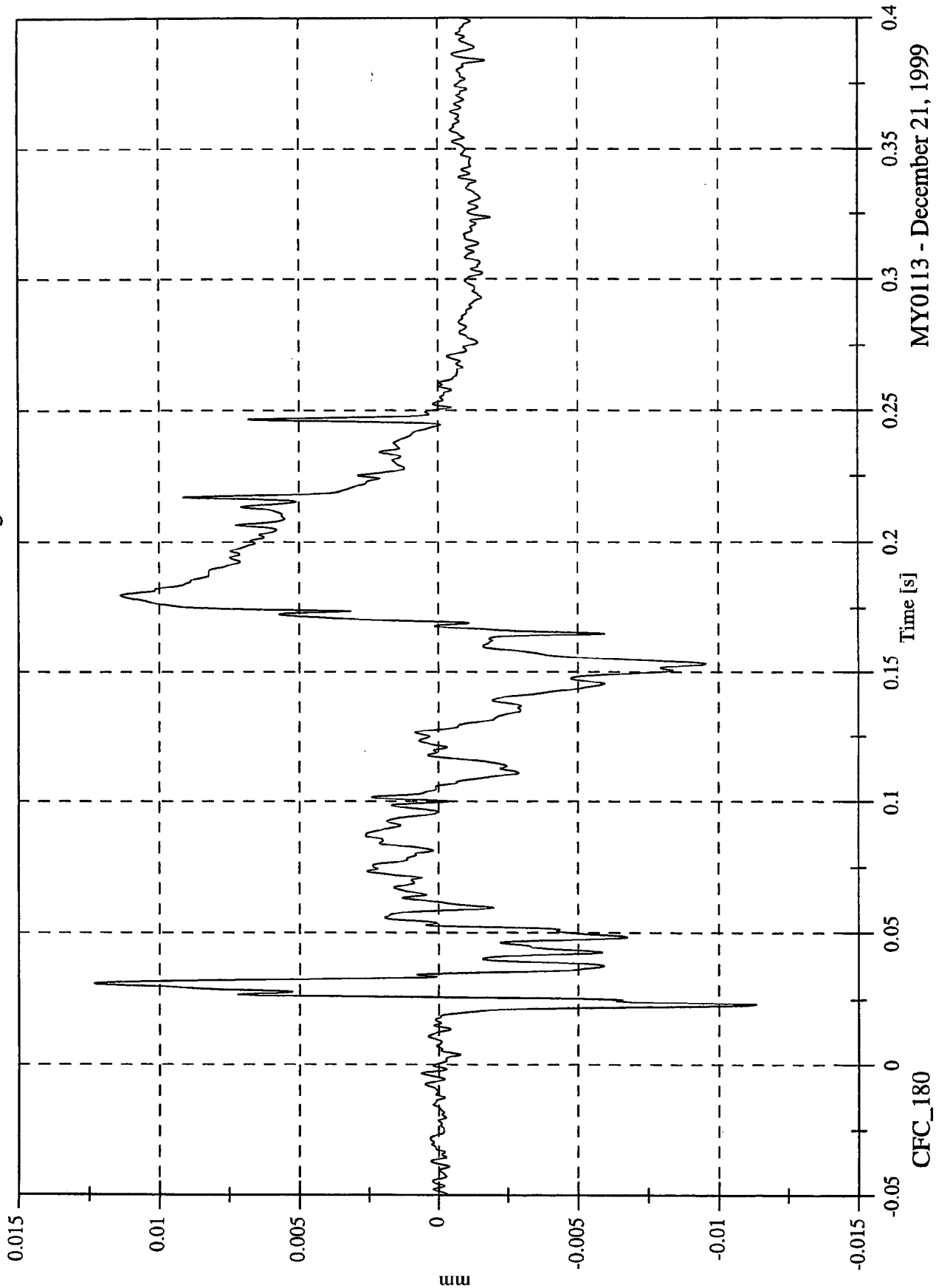

MY0113 - December 21, 1999

NCAP Test 7 - 2000 Saturn SL

Max: 4.0 [g] at 0.256 [s]  
Min: -54.1 [g] at 0.091 [s]

P2 Head x

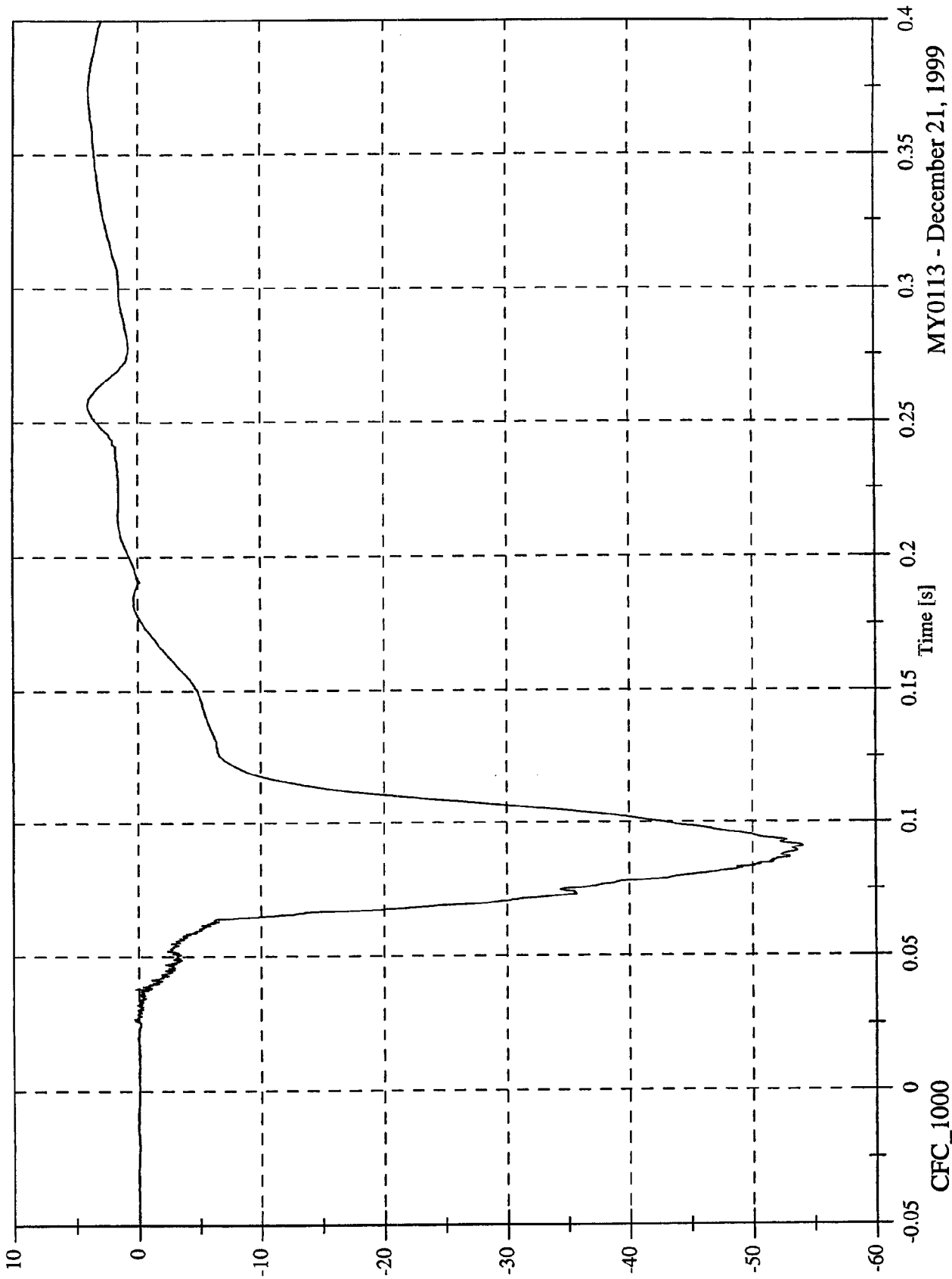

CFC\_1000

MY0113 - December 21, 1999

NCAP Test 7 - 2000 Saturn SL

Max: 2.4 [g] at 0.060 [s]  
Min: -5.0 [g] at 0.096 [s]

P2 Head y

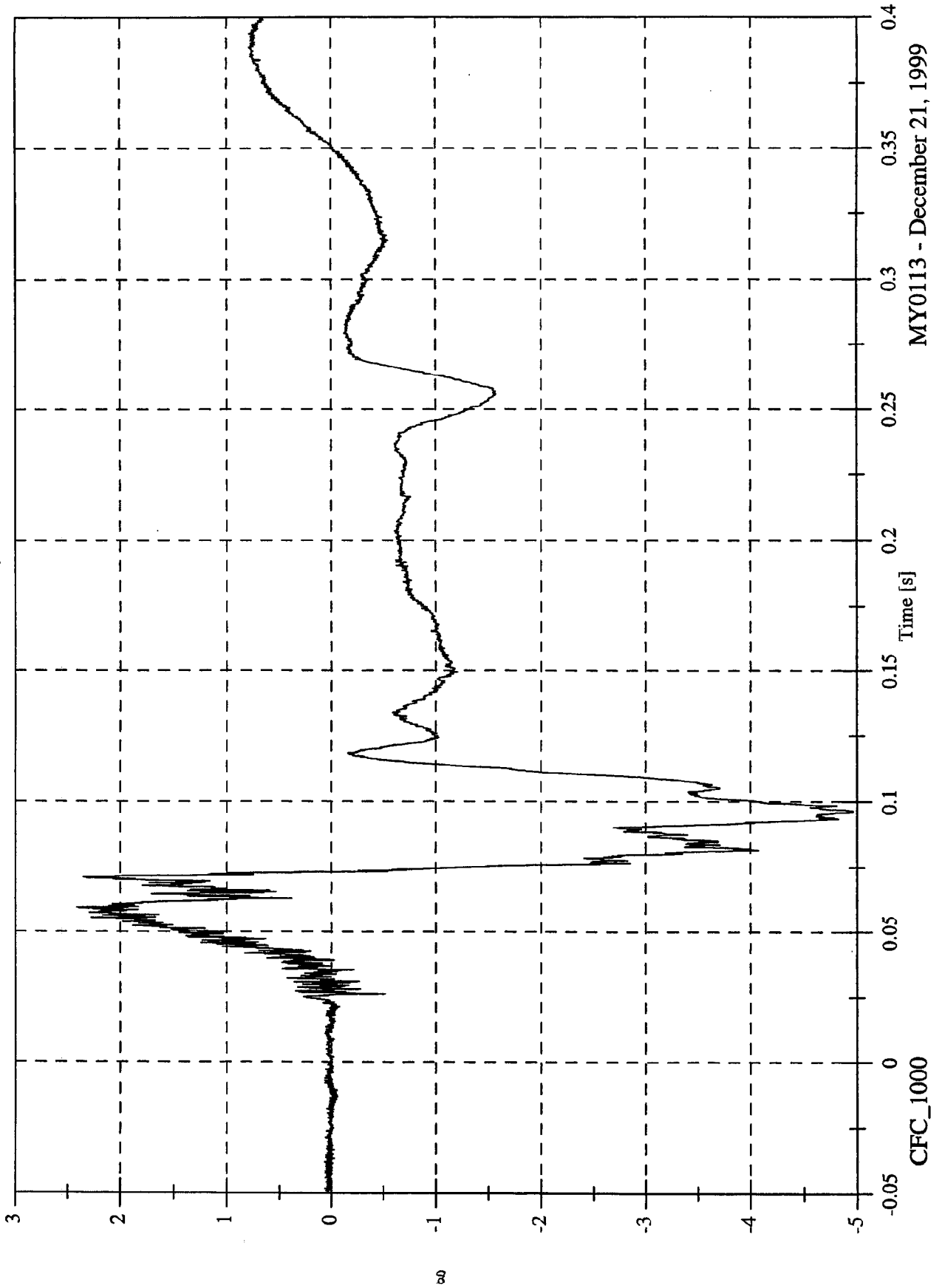

MY0113 - December 21, 1999

NCAP Test 7 - 2000 Saturn SL

Max: 17.1 [g] at 0.074 [s]  
Min: -1.3 [g] at 0.139 [s]

P2 Head z

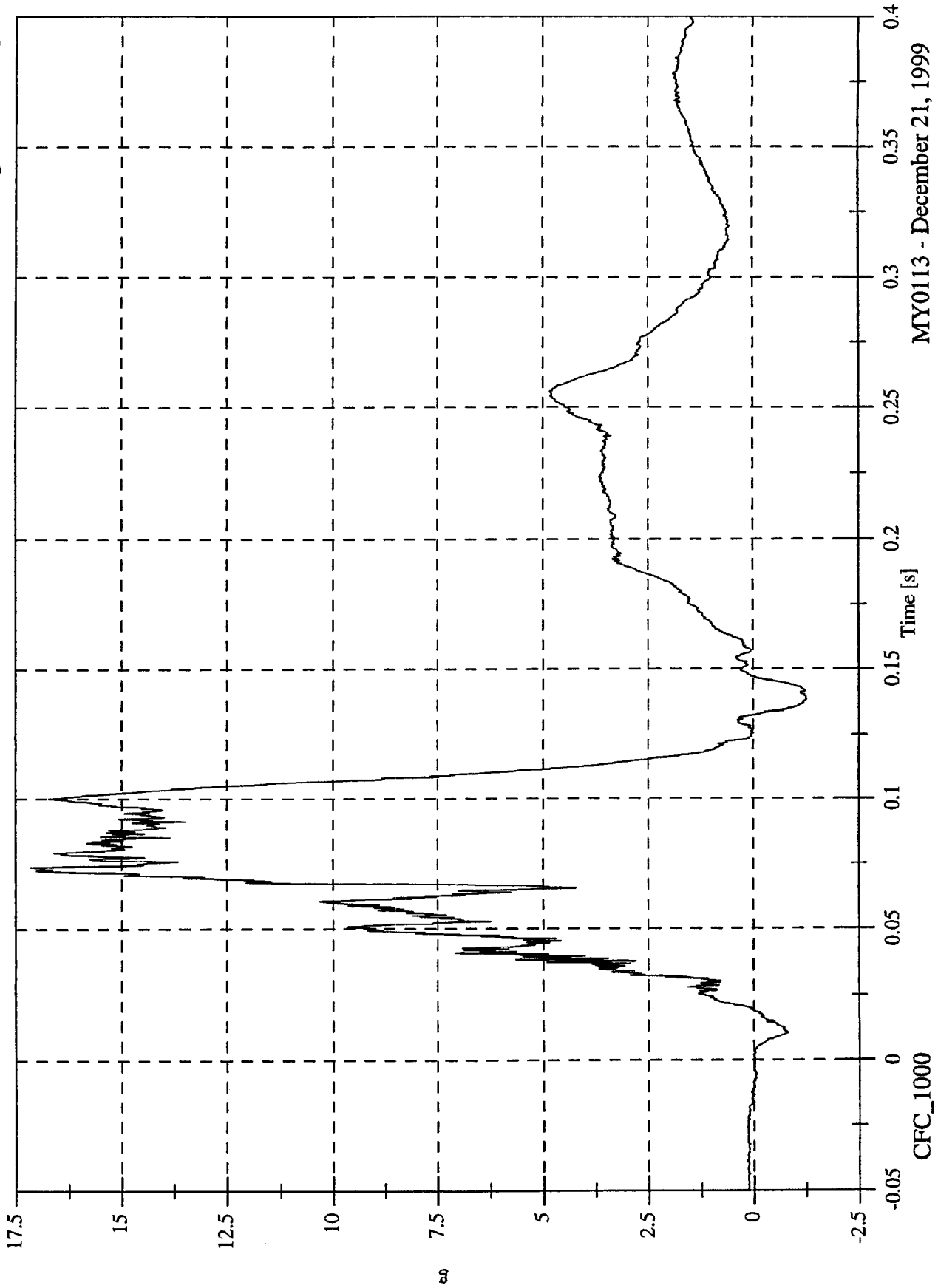

MY0113 - December 21, 1999

CFC\_1000

NCAP Test 7 - 2000 Saturn SL

Max: 56.1 [g] at 0.091 [s]  
Min: 0.0 [g] at -0.007 [s]

P2 Head Resultant

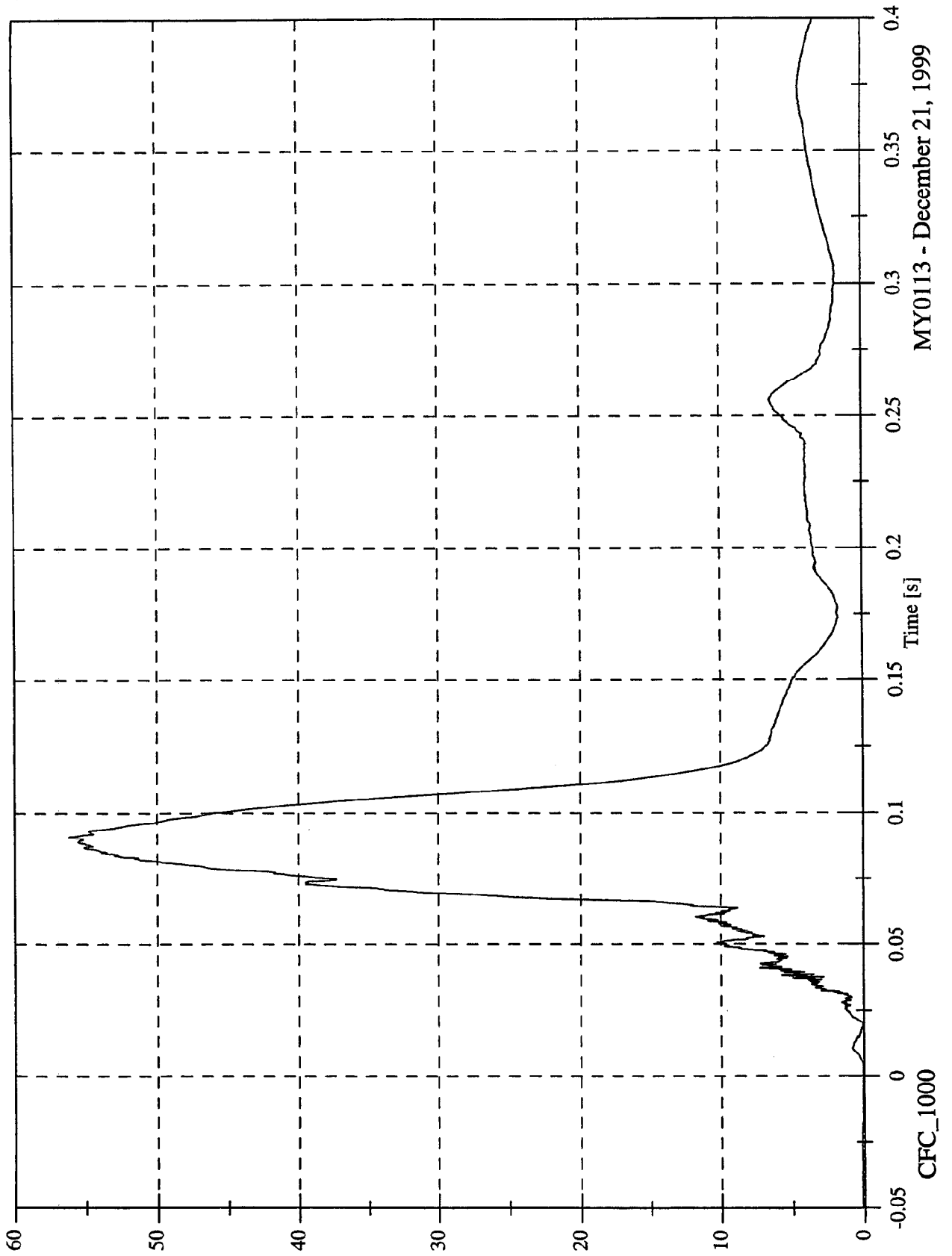

MY0113 - December 21, 1999

NCAP Test 7 - 2000 Saturn SL

Max: 4.2 [g] at 0.256 [s]  
Min: -58.4 [g] at 0.087 [s]

P2 Head Red x

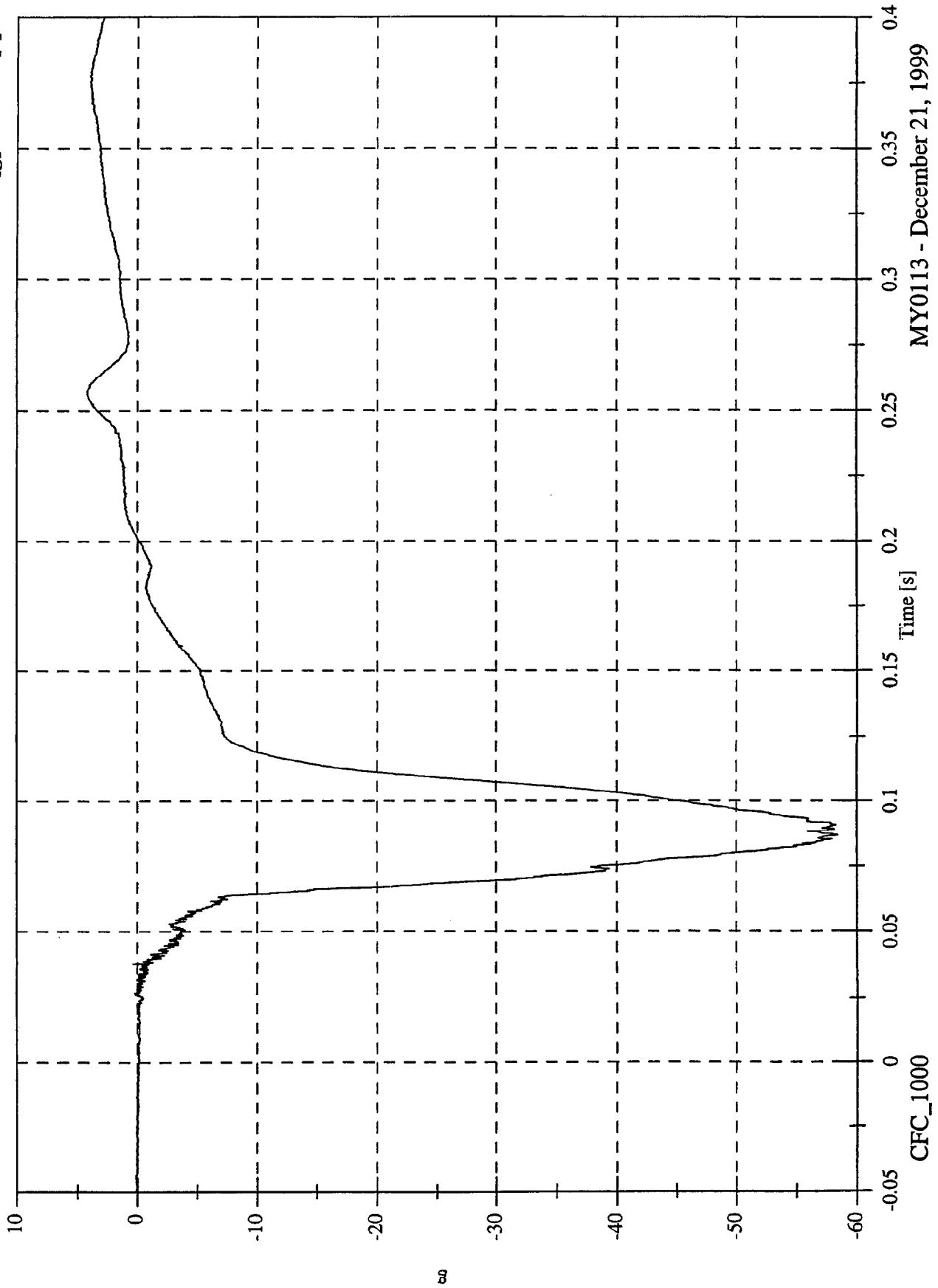

MY0113 - December 21, 1999

NCAP Test 7 - 2000 Saturn SL

Max: 2.8 [g] at 0.060 [s]  
Min: -7.9 [g] at 0.082 [s]

P2 Head Red y

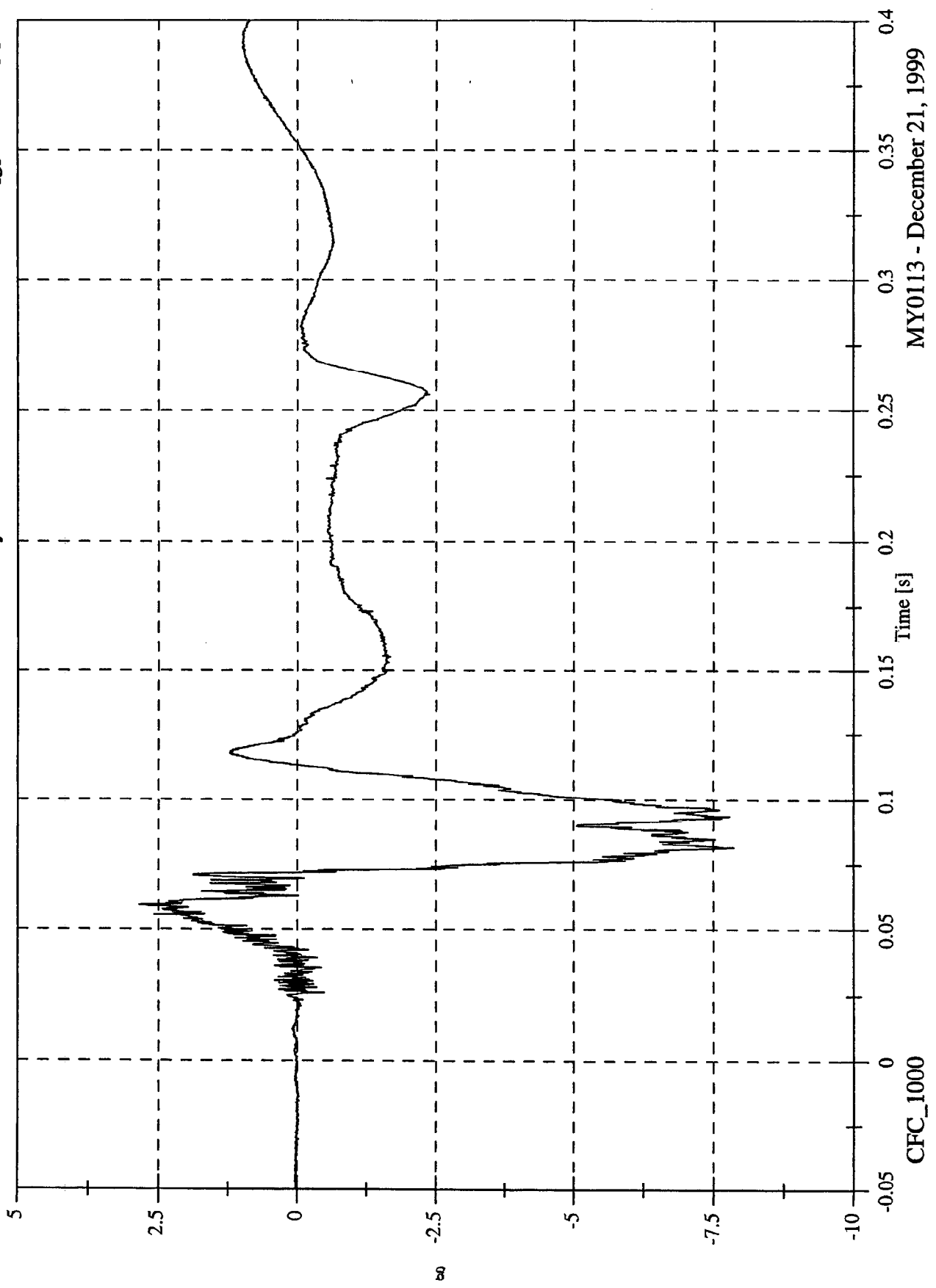

MY0113 - December 21, 1999

NCAP Test 7 - 2000 Saturn SL

Max: 16.9 [g] at 0.073 [s]

Min: -26.0 [g] at 0.135 [s]

P2 Head Red z

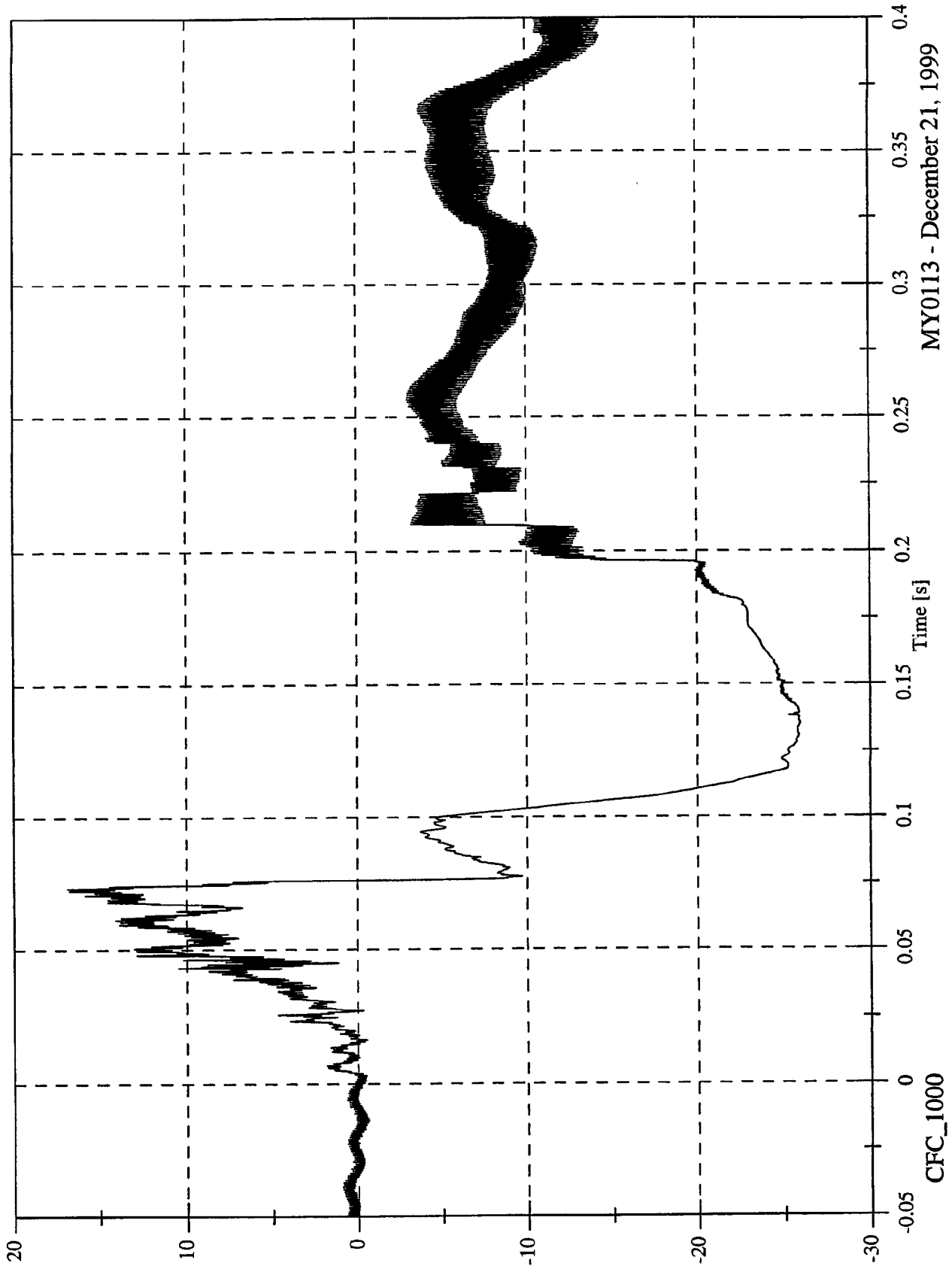

MY0113 - December 21, 1999

CFC\_1000

NCAP Test 7 - 2000 Saturn SL

Max: 59.0 [g] at 0.087 [s]  
Min: 0.0 [g] at -0.024 [s]

P2 Head Red Resultant

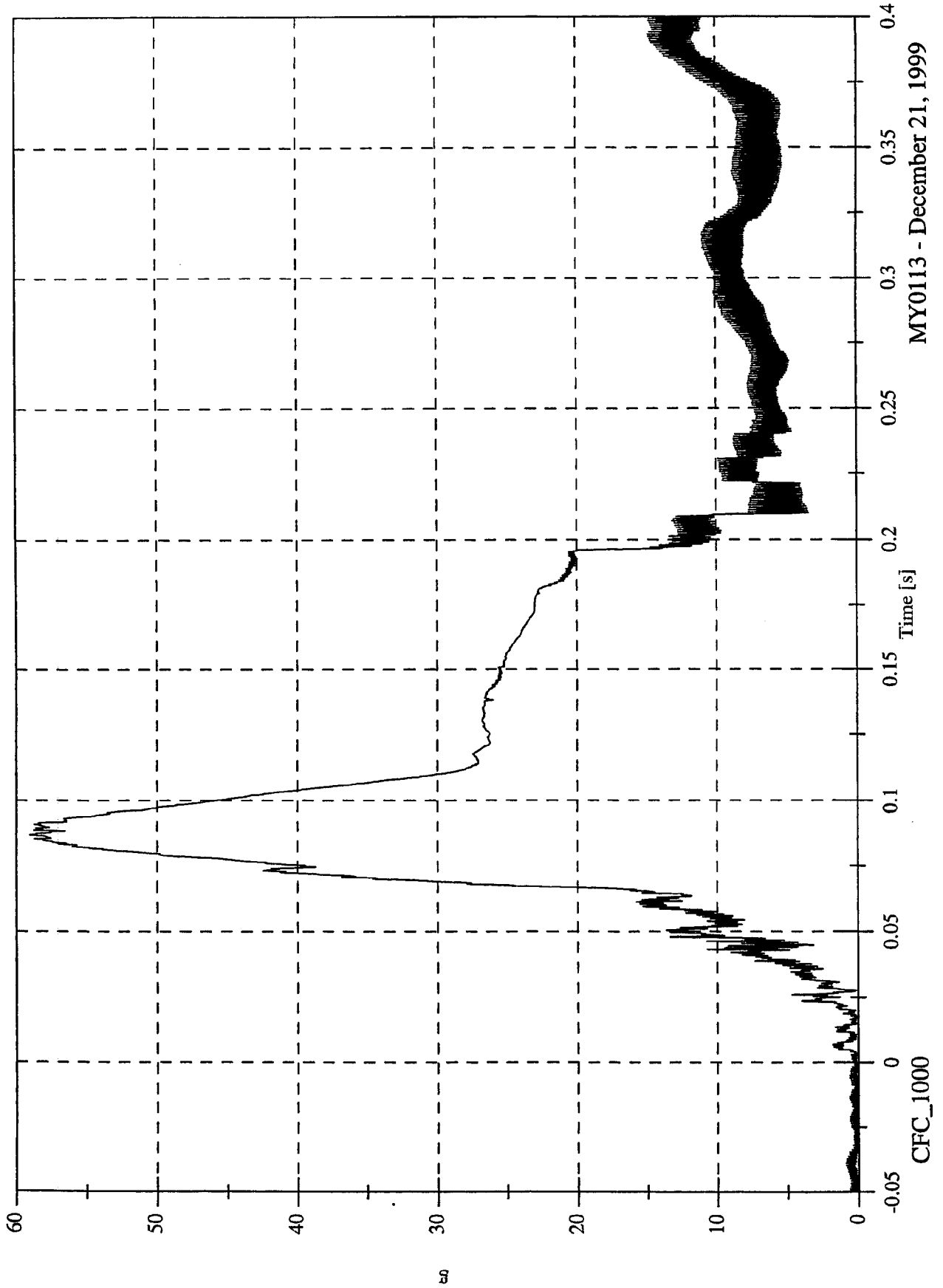

MY0113 - December 21, 1999

NCAP Test 7 - 2000 Saturn SL

Max: 456.2 [N] at 0.093 [s]  
Min: -557.7 [N] at 0.069 [s]

P2 Upper Neck Fx

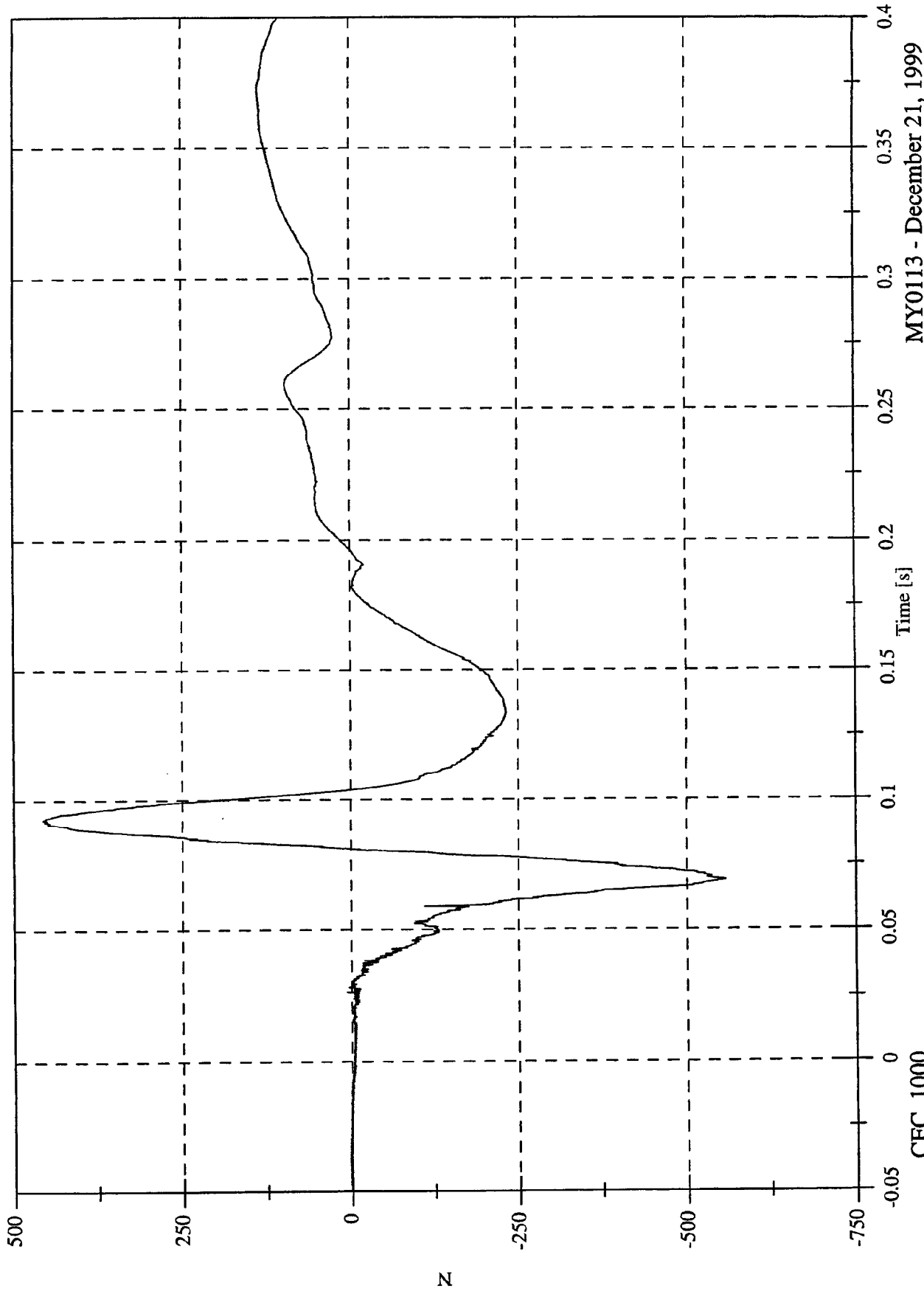

CFC\_1000

MY0113 - December 21, 1999

NCAP Test 7 - 2000 Saturn SL

Max: 109.3 [N] at 0.063 [s]  
Min: -119.7 [N] at 0.090 [s]

P2 Upper Neck Fy

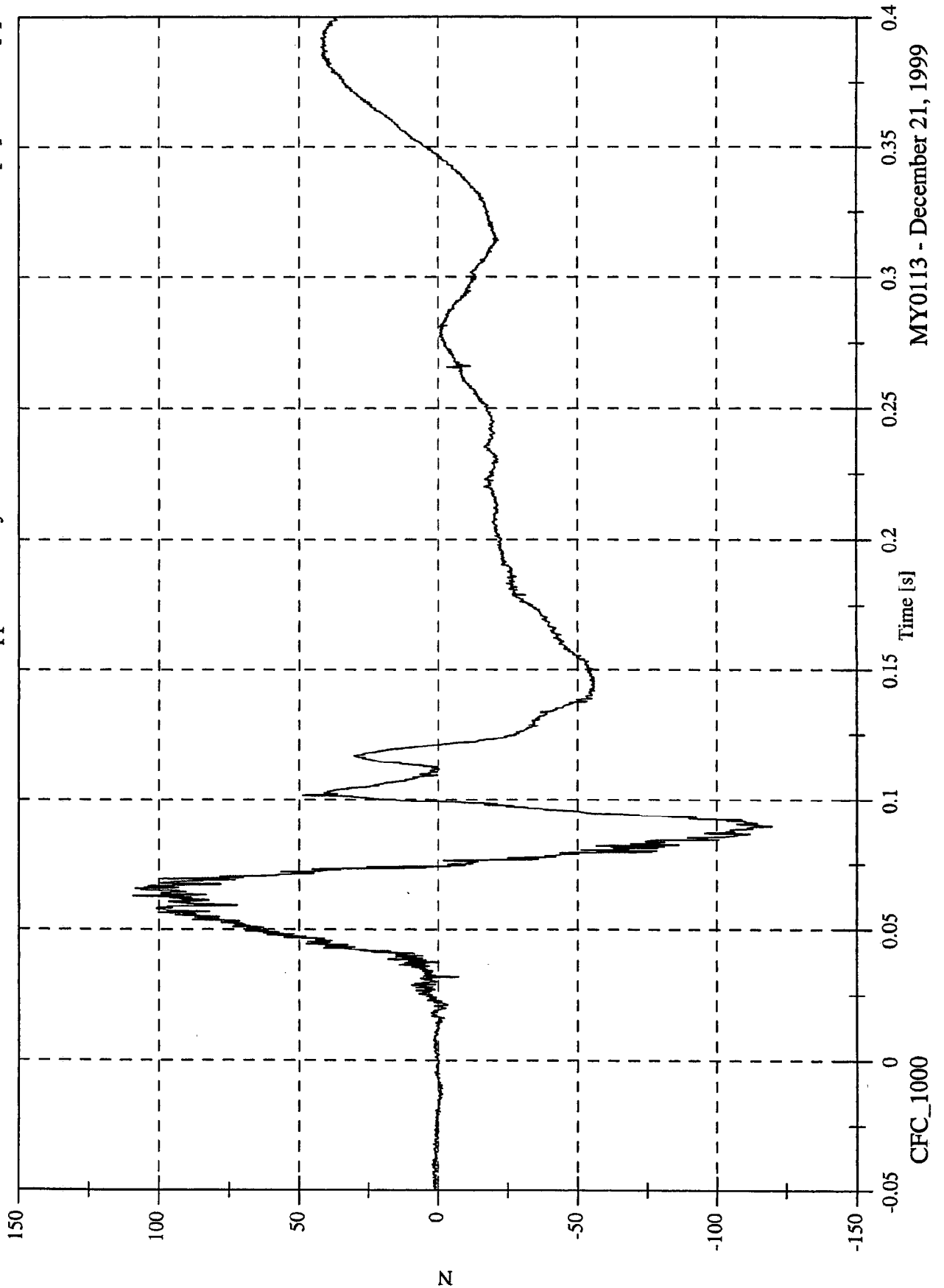

MY0113 - December 21, 1999

NCAP Test 7 - 2000 Saturn SL

Max: 1836.1 [N] at 0.081 [s]  
Min: -140.9 [N] at 0.138 [s]

P2 Upper Neck Fz

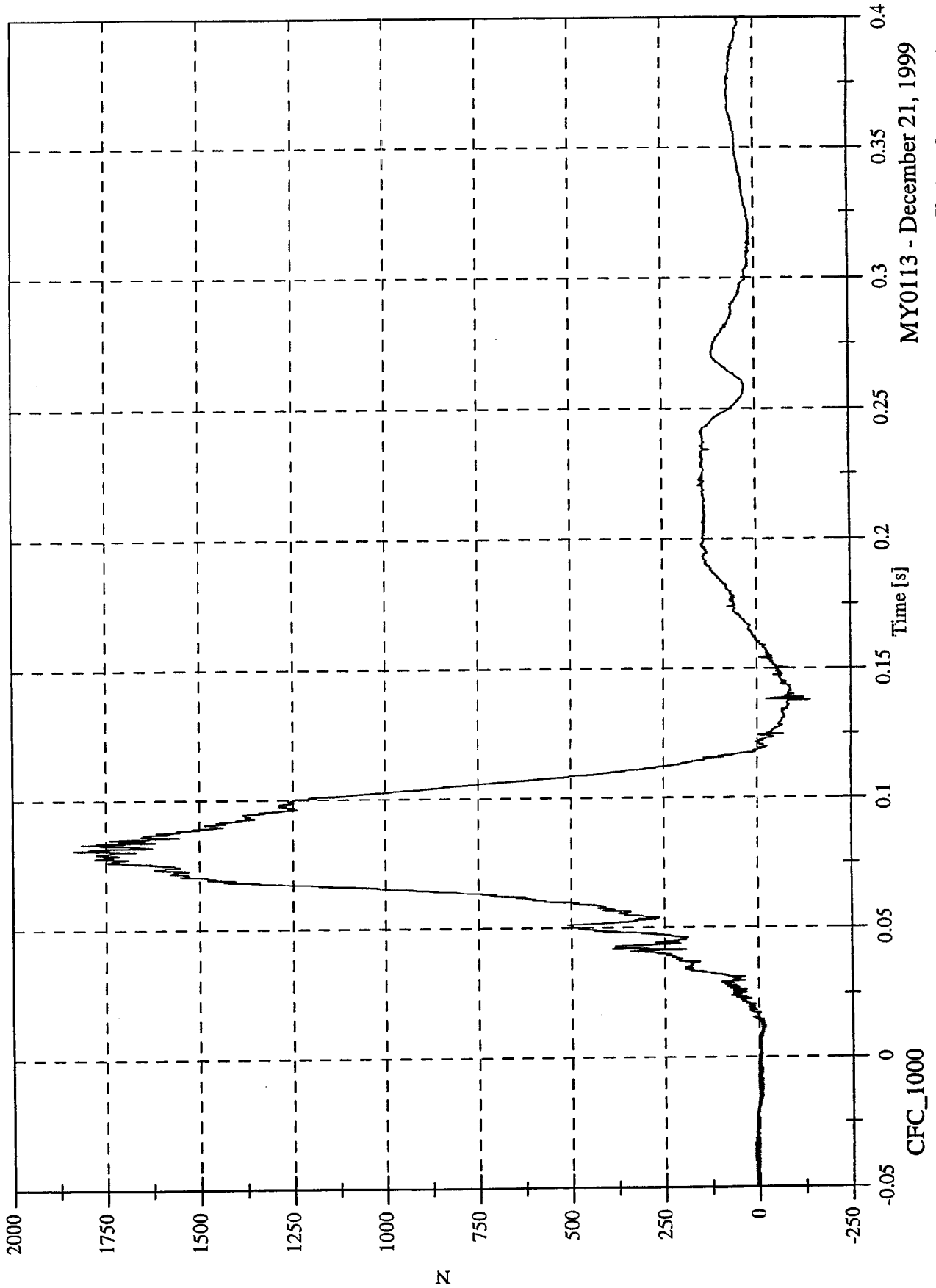

MY0113 - December 21, 1999

CFC\_1000

NCAP Test 7 - 2000 Saturn SL

P2 Upper Neck F Resultant

Max: 1837.2 [N] at 0.081 [s]

Min: 0.2 [N] at -0.014 [s]

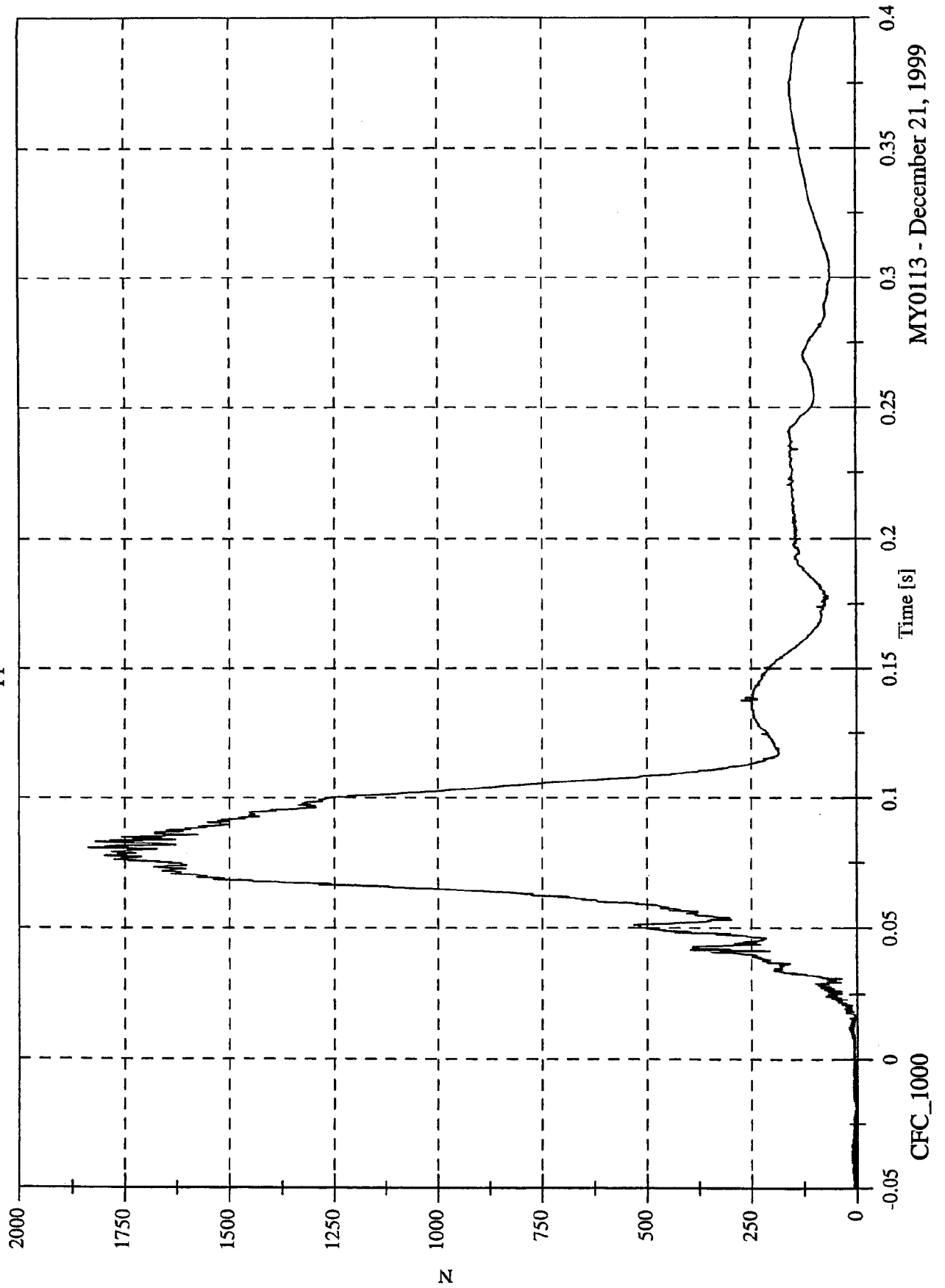

MY0113 - December 21, 1999

NCAP Test 7 - 2000 Saturn SL

Max: 11.1 [N-m] at 0.075 [s]  
Min: -3.5 [N-m] at 0.136 [s]

P2 Upper Neck Mx

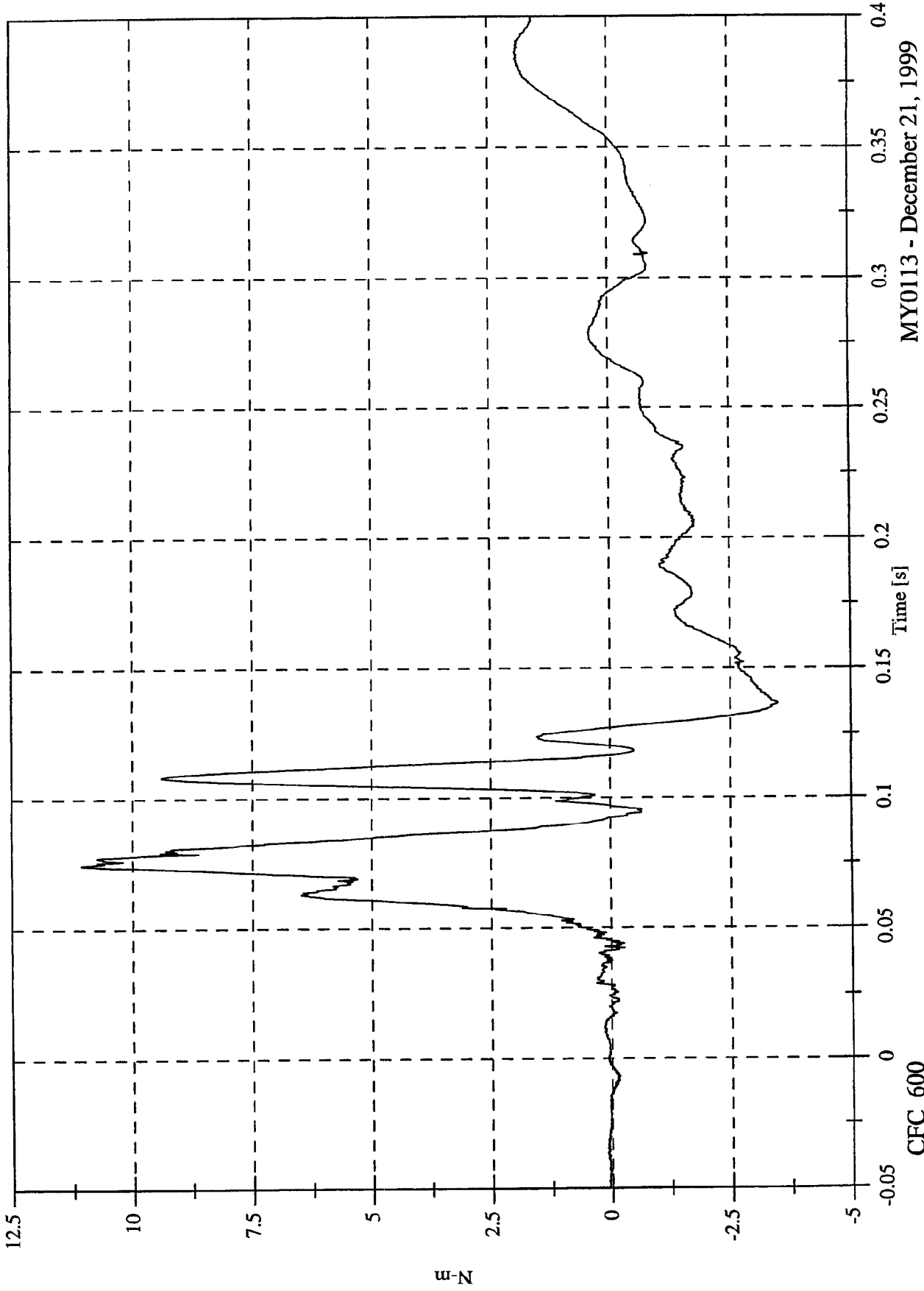

CFC\_600

MY0113 - December 21, 1999

NCAP Test 7 - 2000 Saturn SL

Max: 35.1 [N-m] at 0.092 [s]  
Min: -40.0 [N-m] at 0.071 [s]

P2 Upper Neck My

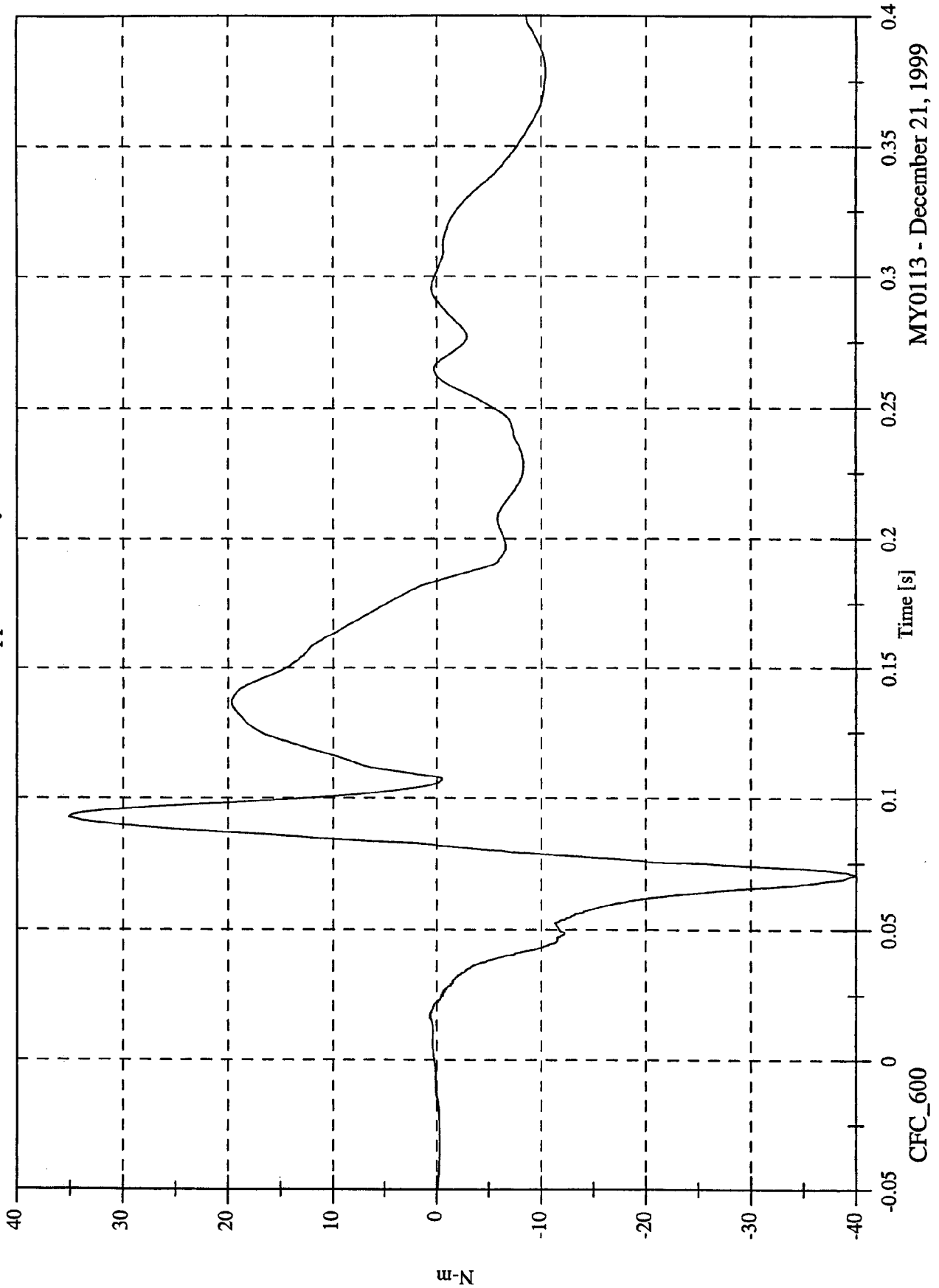

MY0113 - December 21, 1999

NCAP Test 7 - 2000 Saturn SL

Max: 11.4 [N-m] at 0.112 [s]  
Min: -3.7 [N-m] at 0.158 [s]

P2 Upper Neck Mz

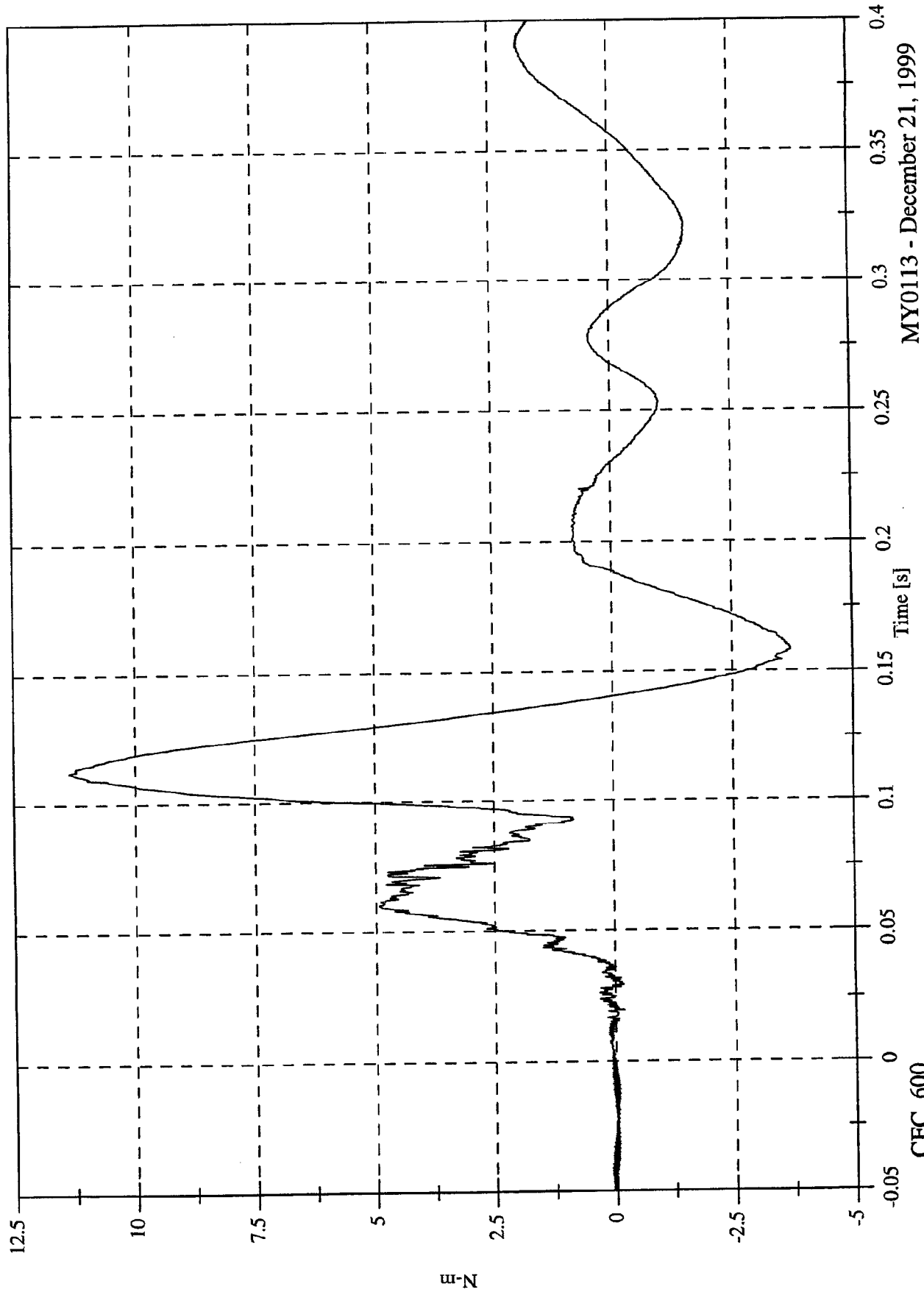

MY0113 - December 21, 1999

CFC\_600

NCAP Test 7 - 2000 Saturn SL

Max: 40.7 [N-m] at 0.071 [s]  
Min: 0.0 [N-m] at -0.014 [s]

P2 Upper Neck M Resultant

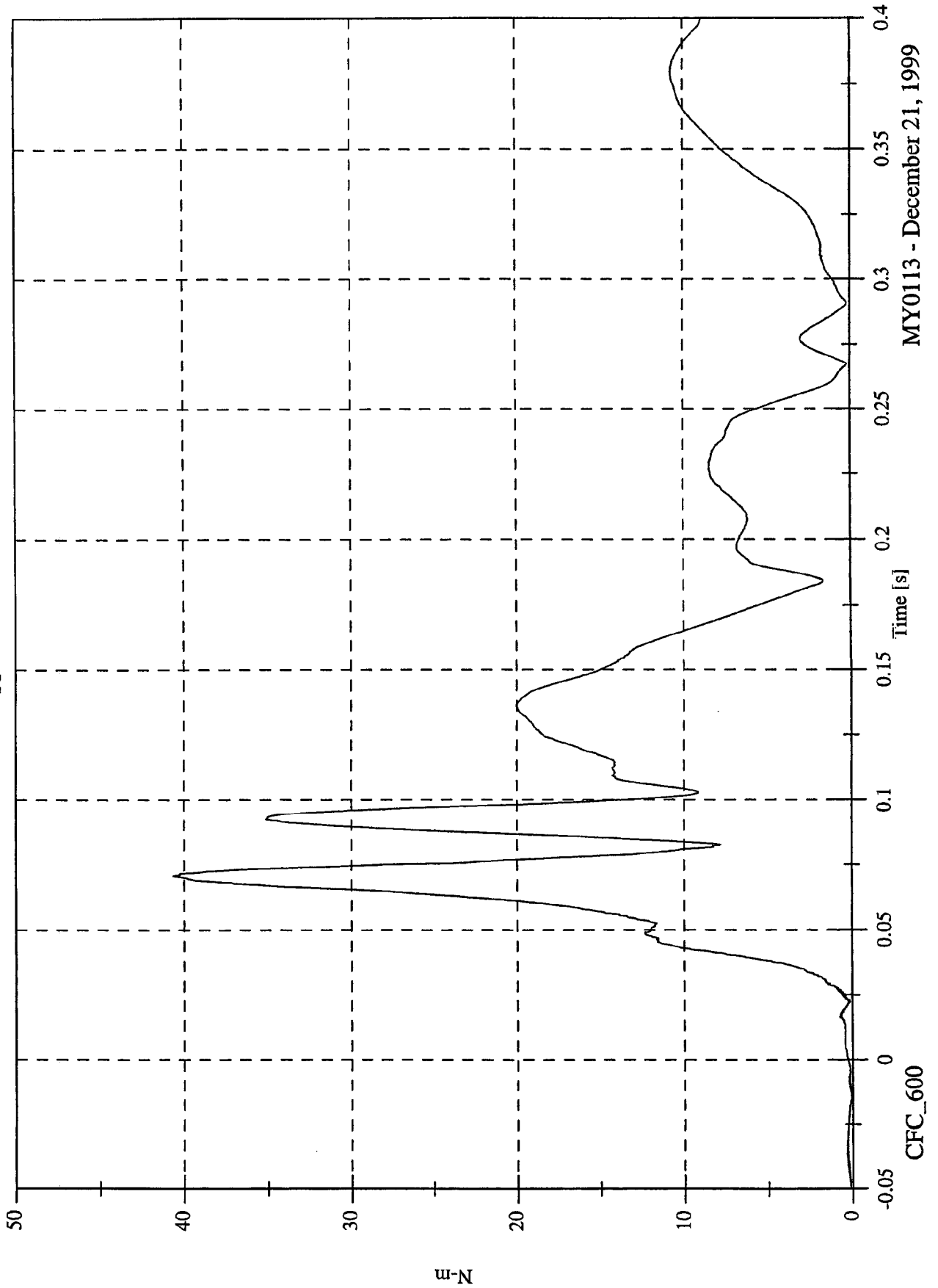

MY0113 - December 21, 1999

NCAP Test 7 - 2000 Saturn SL

Max: 2.4 [g] at 0.309 [s]  
Min: -40.2 [g] at 0.090 [s]

P2 Chest x

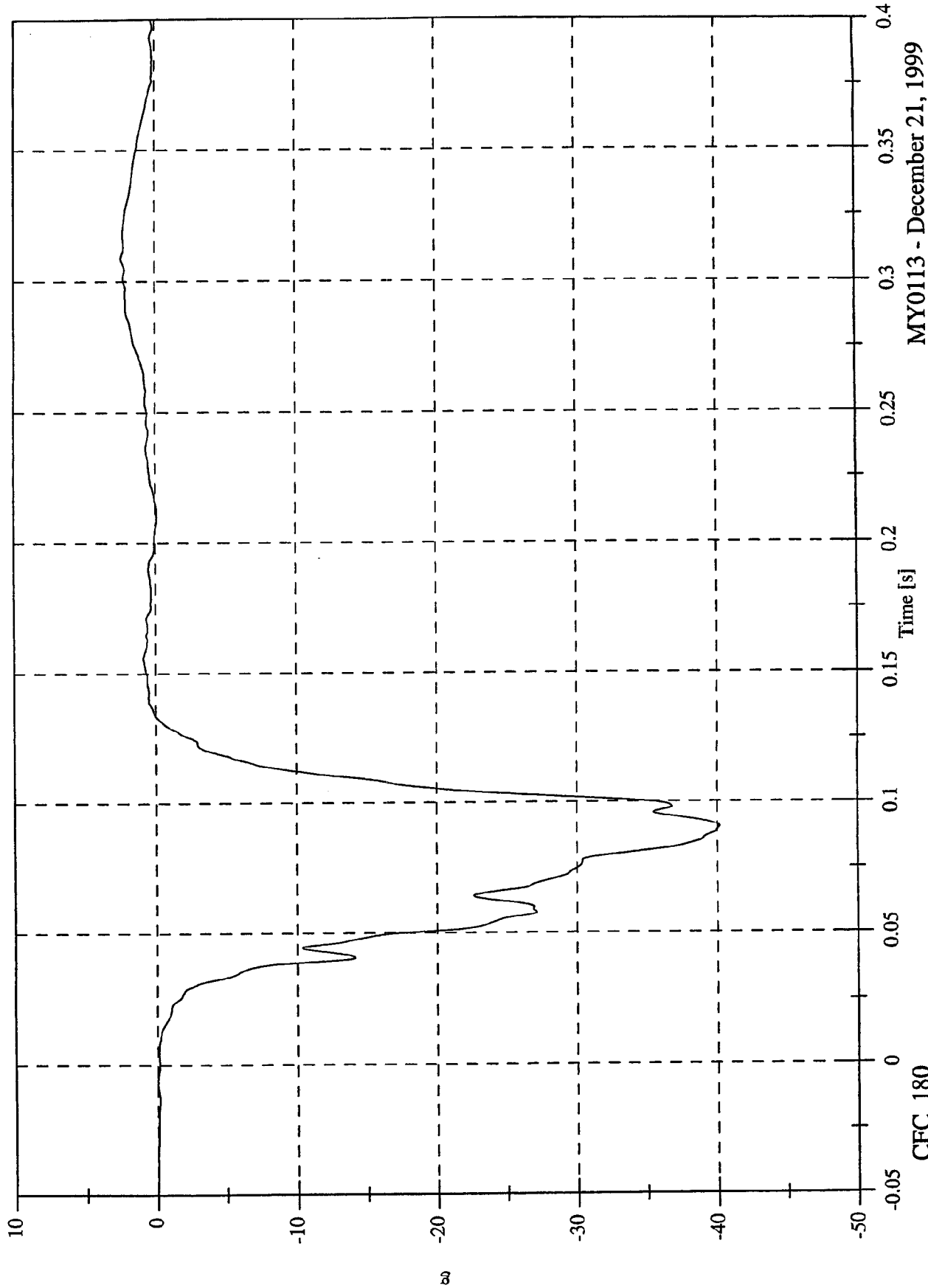

CFC\_180

MY0113 - December 21, 1999

NCAP Test 7 - 2000 Saturn SL

Max: 5.6 [g] at 0.082 [s]  
Min: -6.3 [g] at 0.105 [s]

P2 Chest y

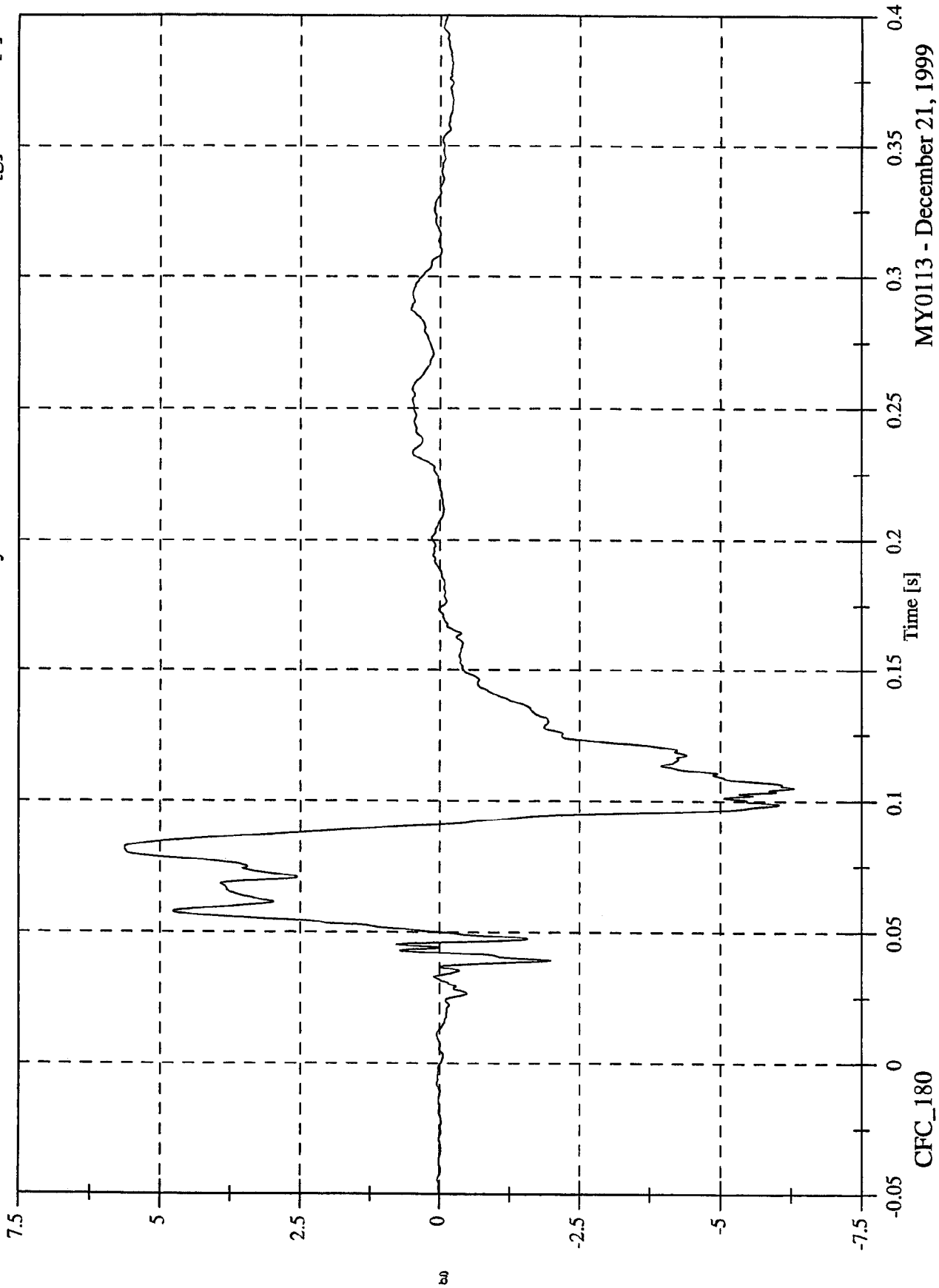

MY0113 - December 21, 1999

NCAP Test 7 - 2000 Saturn SL

Max: 13.1 [g] at 0.094 [s]  
Min: -2.7 [g] at 0.066 [s]

P2 Chest z

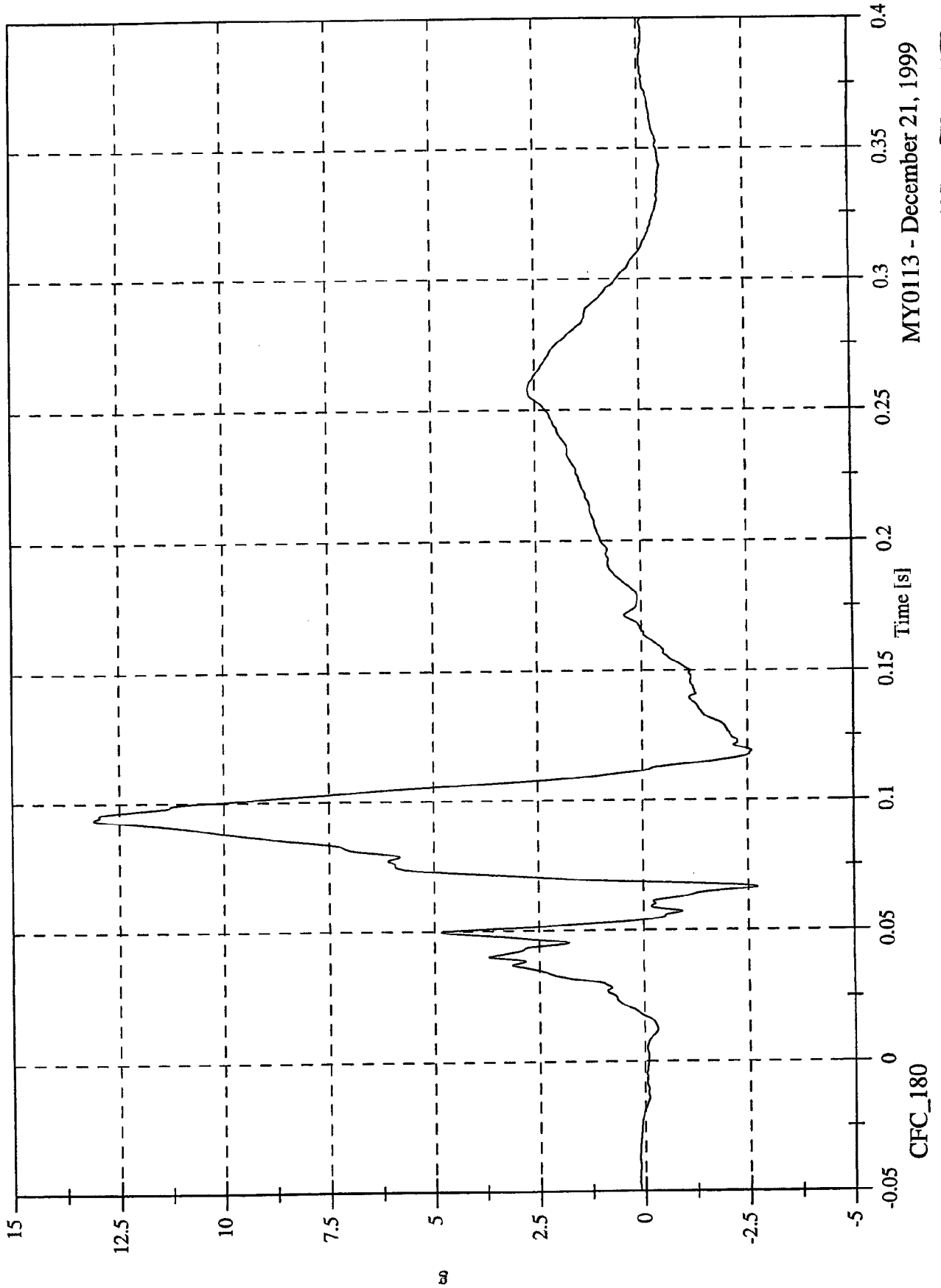

CFC\_180

MY0113 - December 21, 1999

NCAP Test 7 - 2000 Saturn SL

Max: 41.7 [g] at 0.091 [s]  
Min: 0.1 [g] at -0.005 [s]

P2 Chest Resultant

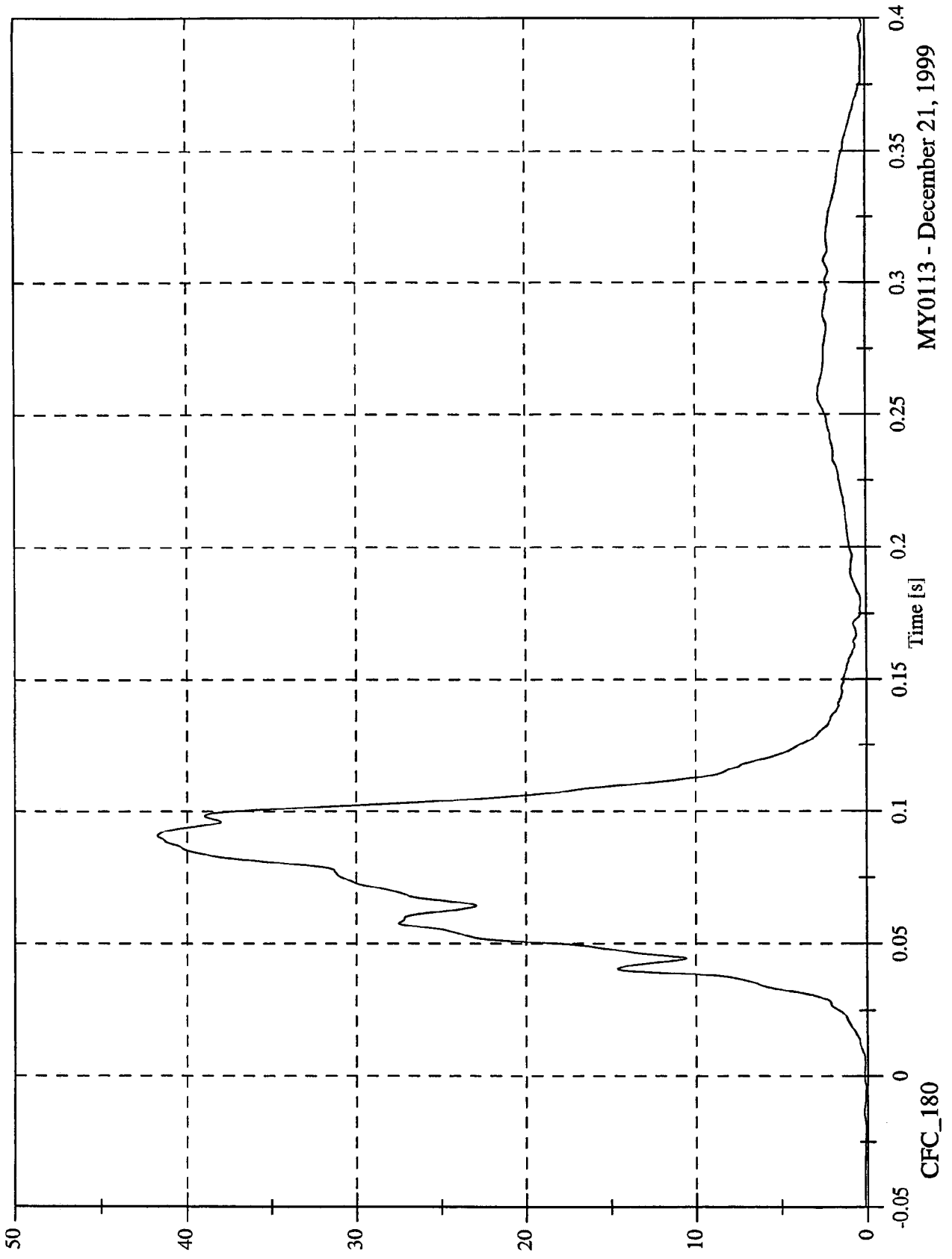

MY0113 - December 21, 1999

NCAP Test 7 - 2000 Saturn SL

Max: 2.3 [g] at 0.309 [s]  
Min: -38.0 [g] at 0.091 [s]

P2 Chest Red x

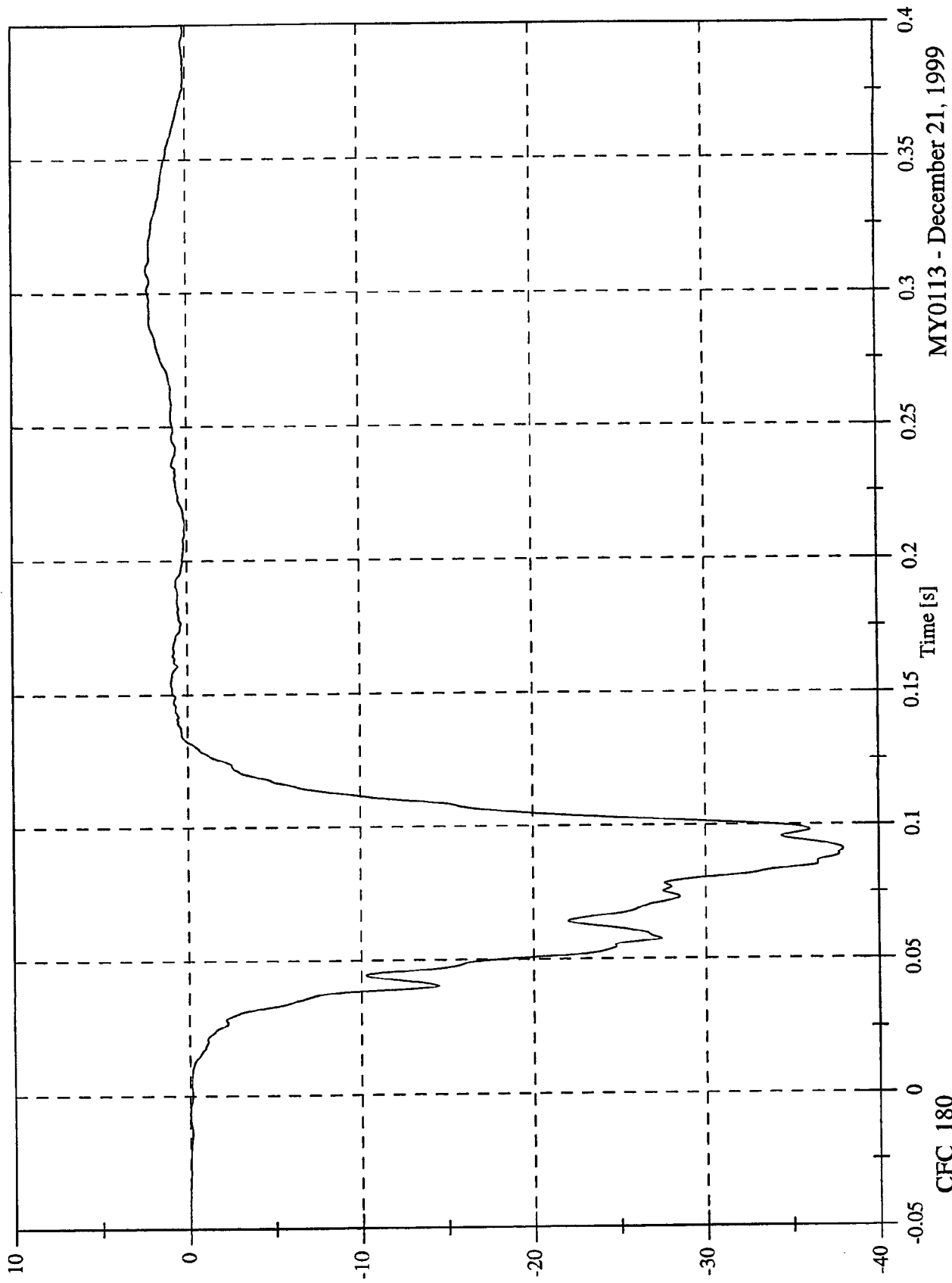

CFC\_180

MY0113 - December 21, 1999

NCAP Test 7 - 2000 Saturn SL

Max: 7.0 [g] at 0.082 [s]  
Min: -5.8 [g] at 0.106 [s]

P2 Chest Red y

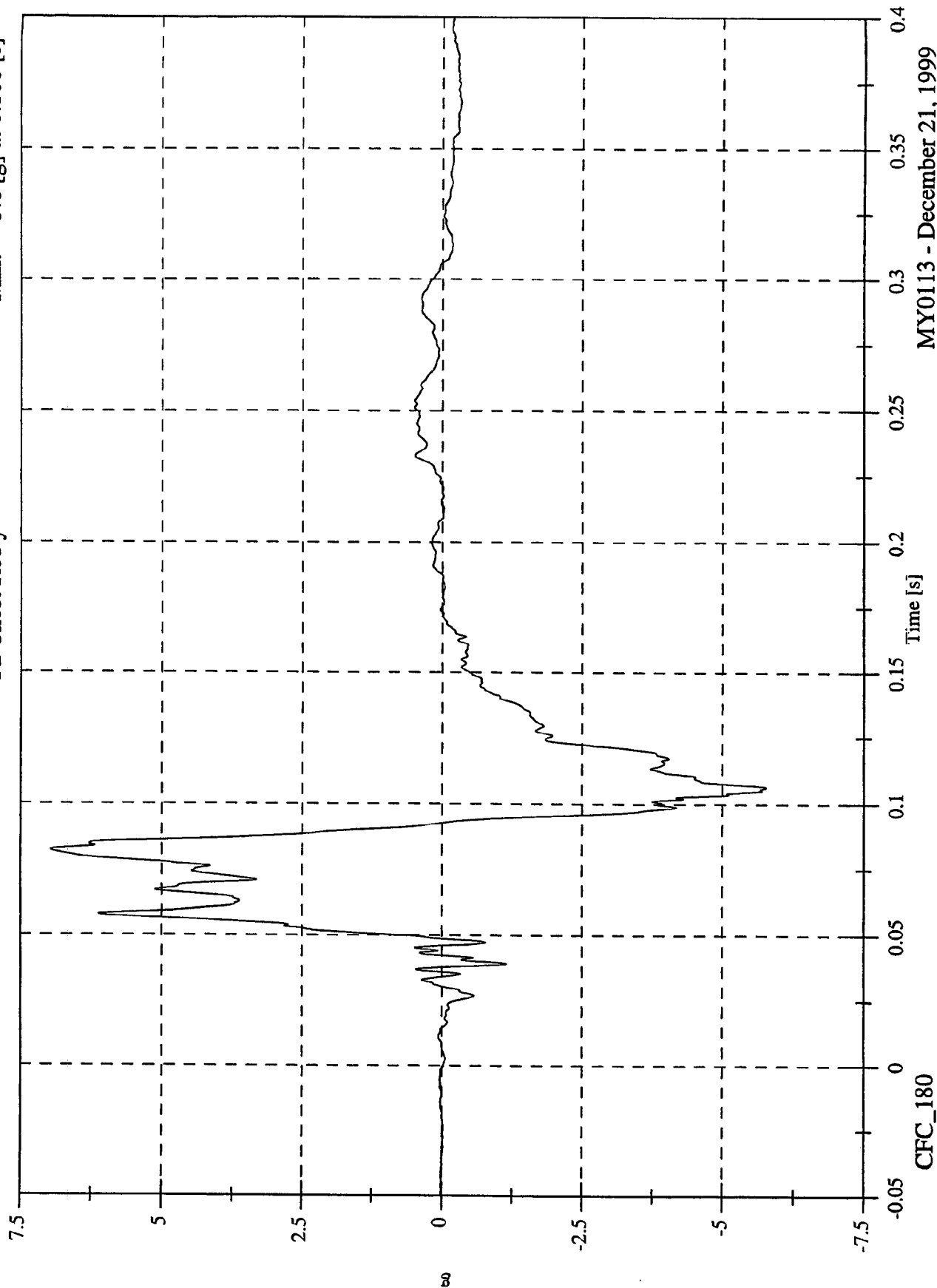

MY0113 - December 21, 1999

NCAP Test 7 - 2000 Saturn SL

Max: 15.1 [g] at 0.093 [s]  
Min: -3.2 [g] at 0.066 [s]

P2 Chest Red z

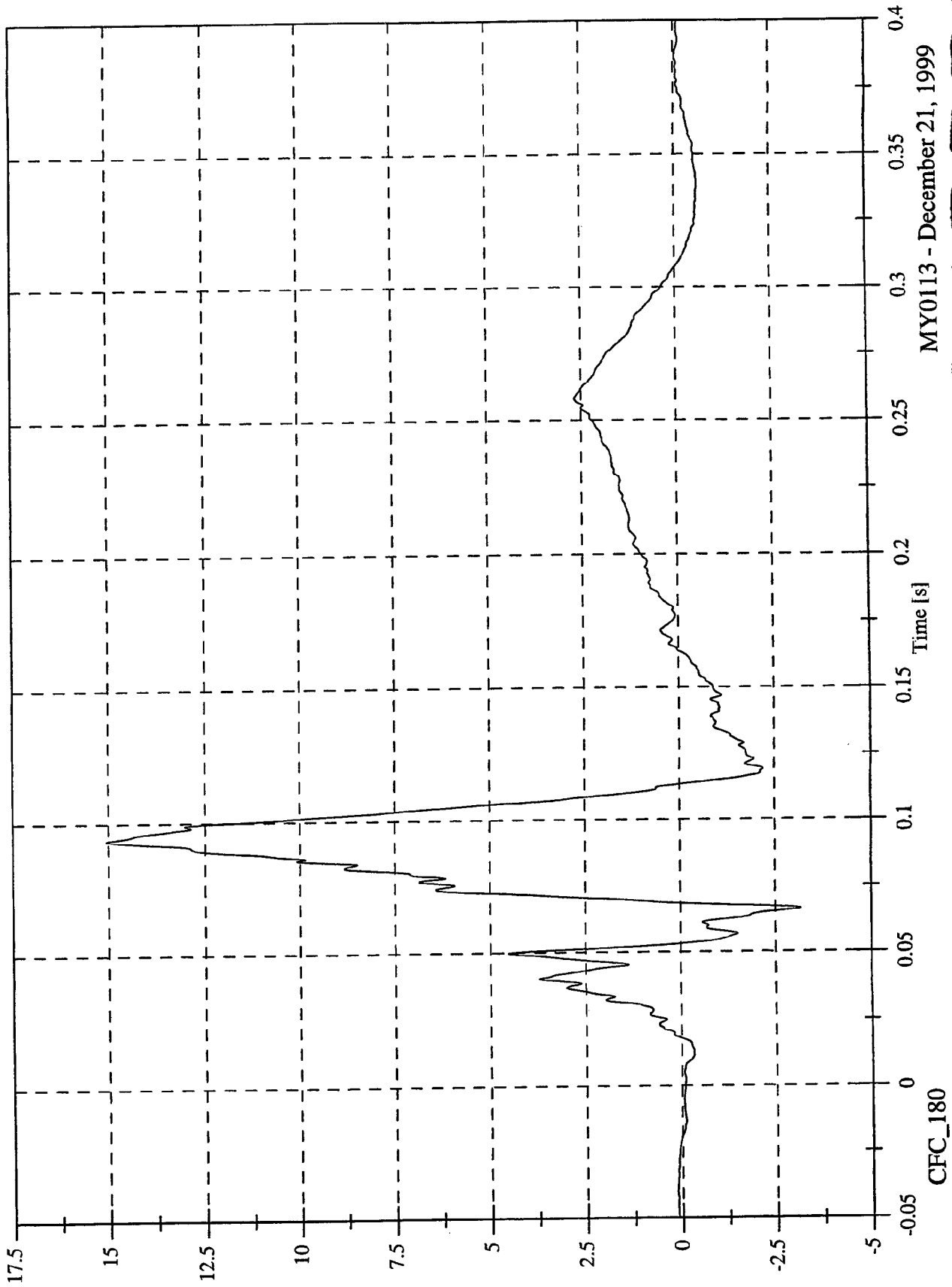

MY0113 - December 21, 1999

CFC\_180

NCAP Test 7 - 2000 Saturn SL

Max: 40.2 [g] at 0.092 [s]  
Min: 0.1 [g] at -0.020 [s]

P2 Chest Red Resultant

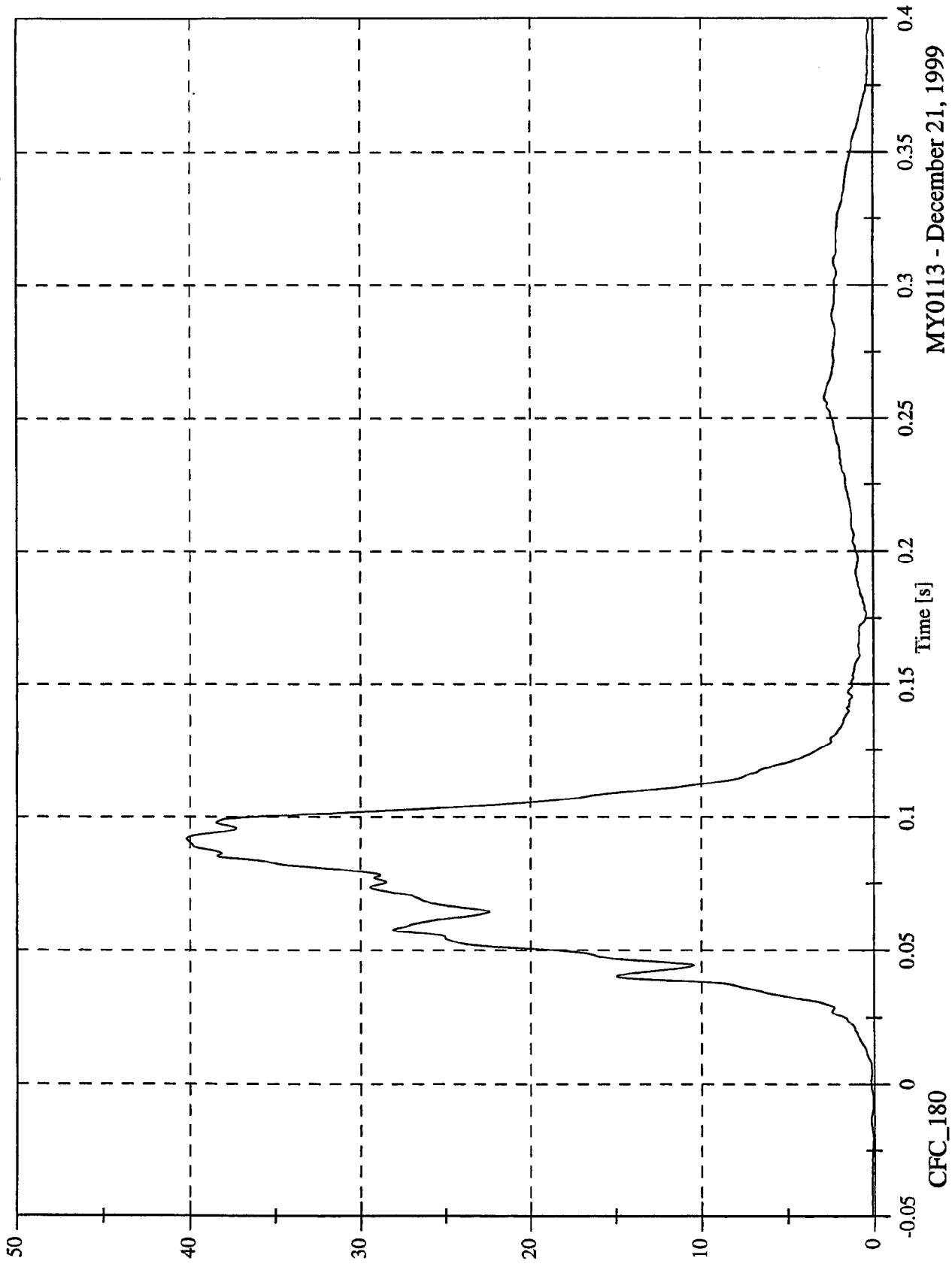

MY0113 - December 21, 1999

CFC\_180

NCAP Test 7 - 2000 Saturn SL

Max: 0.0 [mm] at -0.044 [s]  
Min: -23.3 [mm] at 0.096 [s]

P2 Chest Compression x

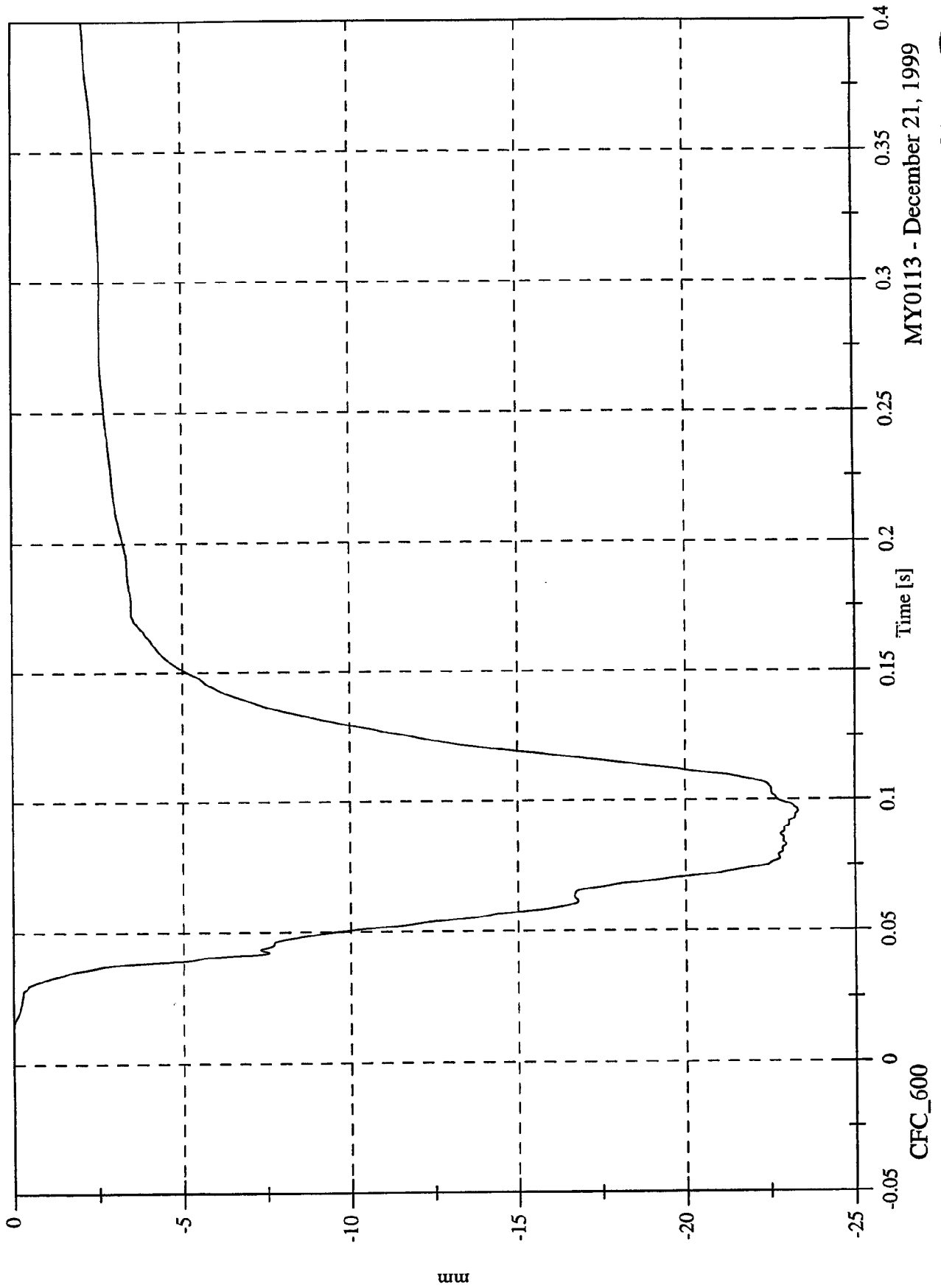

MY0113 - December 21, 1999

CFC\_600

NCAP Test 7 - 2000 Saturn SL

Max: 1.8 [g] at 0.252 [s]  
Min: -46.3 [g] at 0.057 [s]

P2 Pelvic x

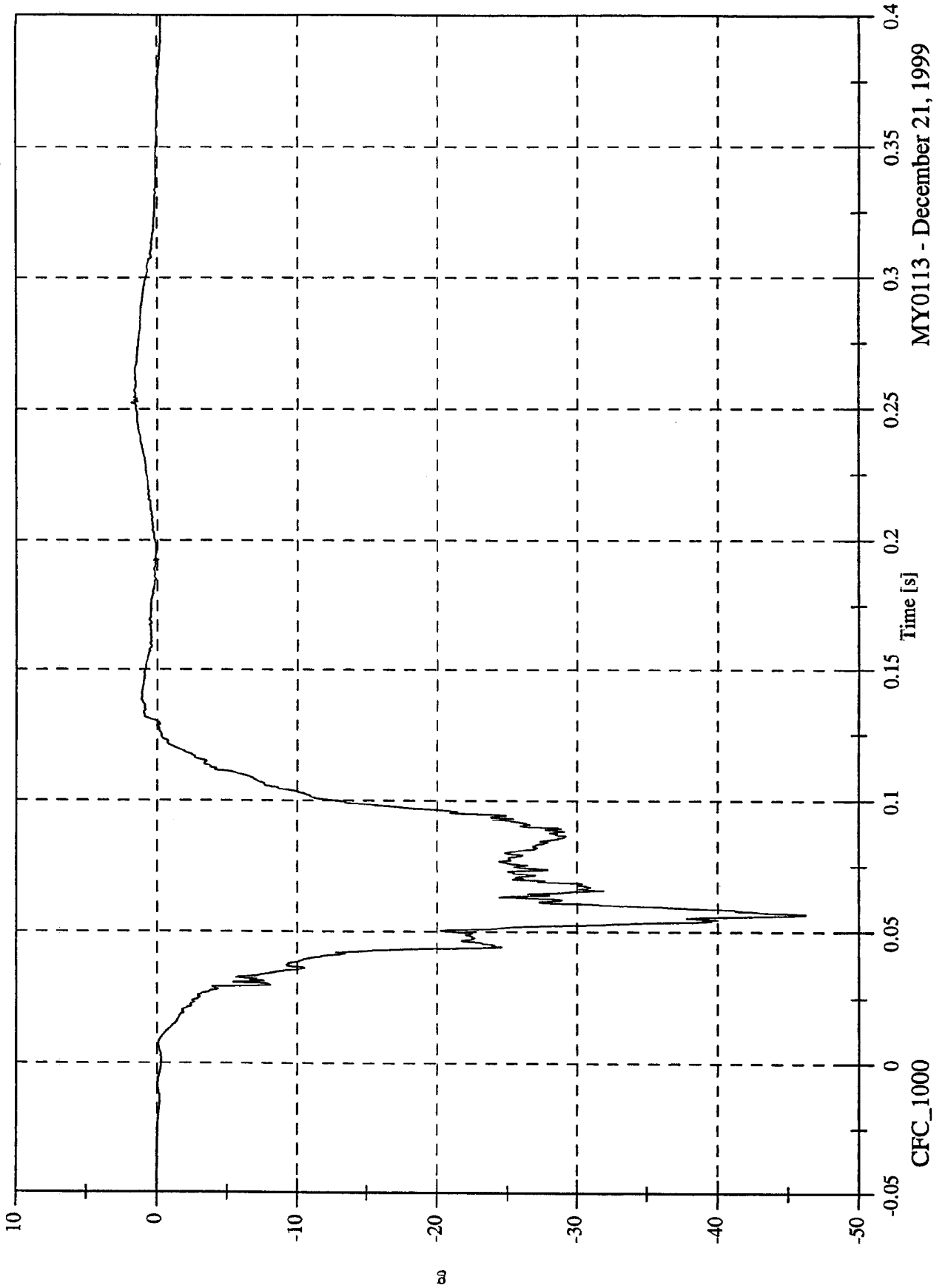

MY0113 - December 21, 1999

CFC\_1000

NCAP Test 7 - 2000 Saturn SL

Max: 9.1 [g] at 0.058 [s]  
Min: -4.8 [g] at 0.100 [s]

P2 Pelvic y

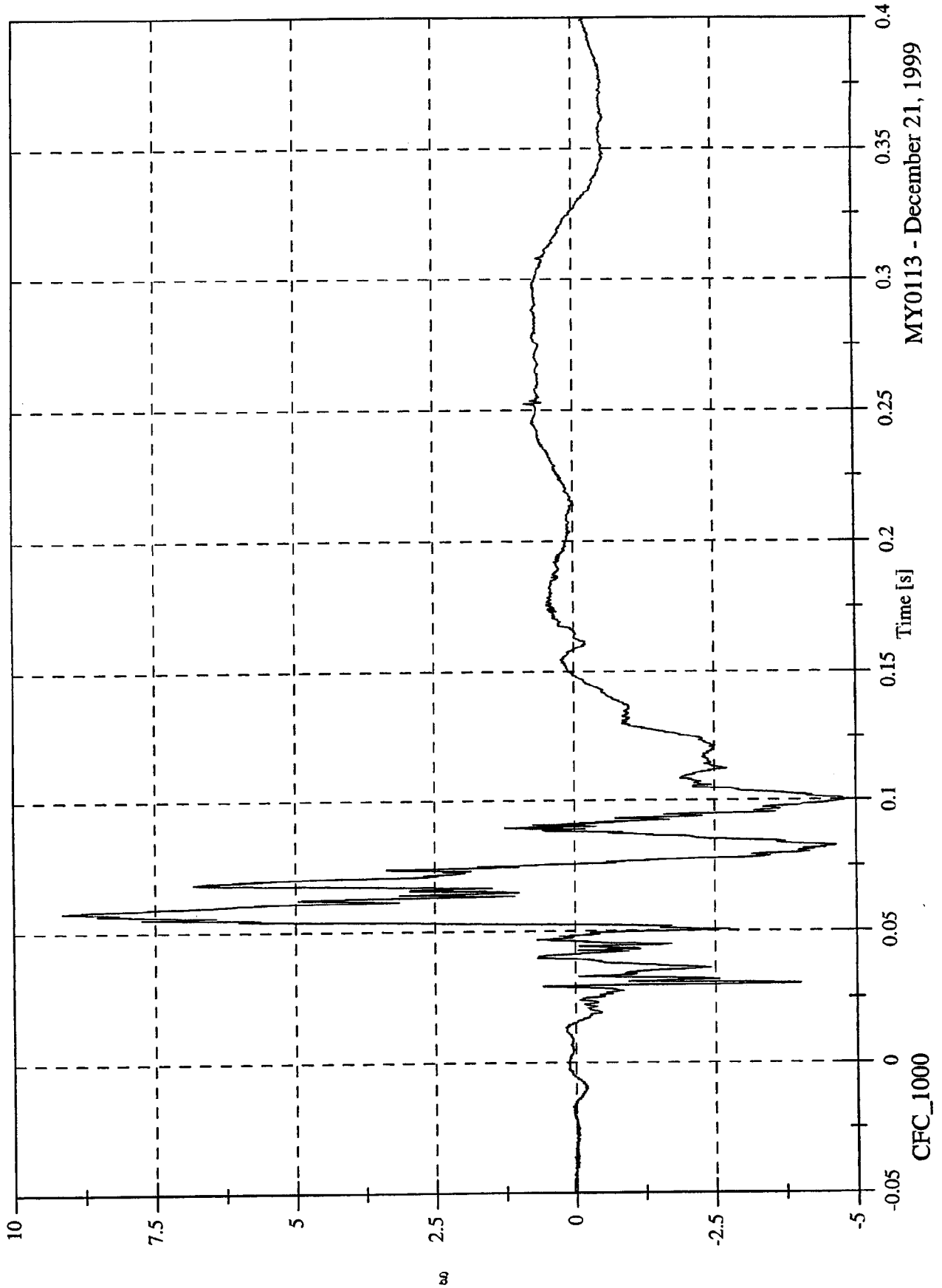

MY0113 - December 21, 1999

NCAP Test 7 - 2000 Saturn SL

Max: 2.3 [g] at 0.259 [s]  
Min: -19.4 [g] at 0.065 [s]

P2 Pelvic z

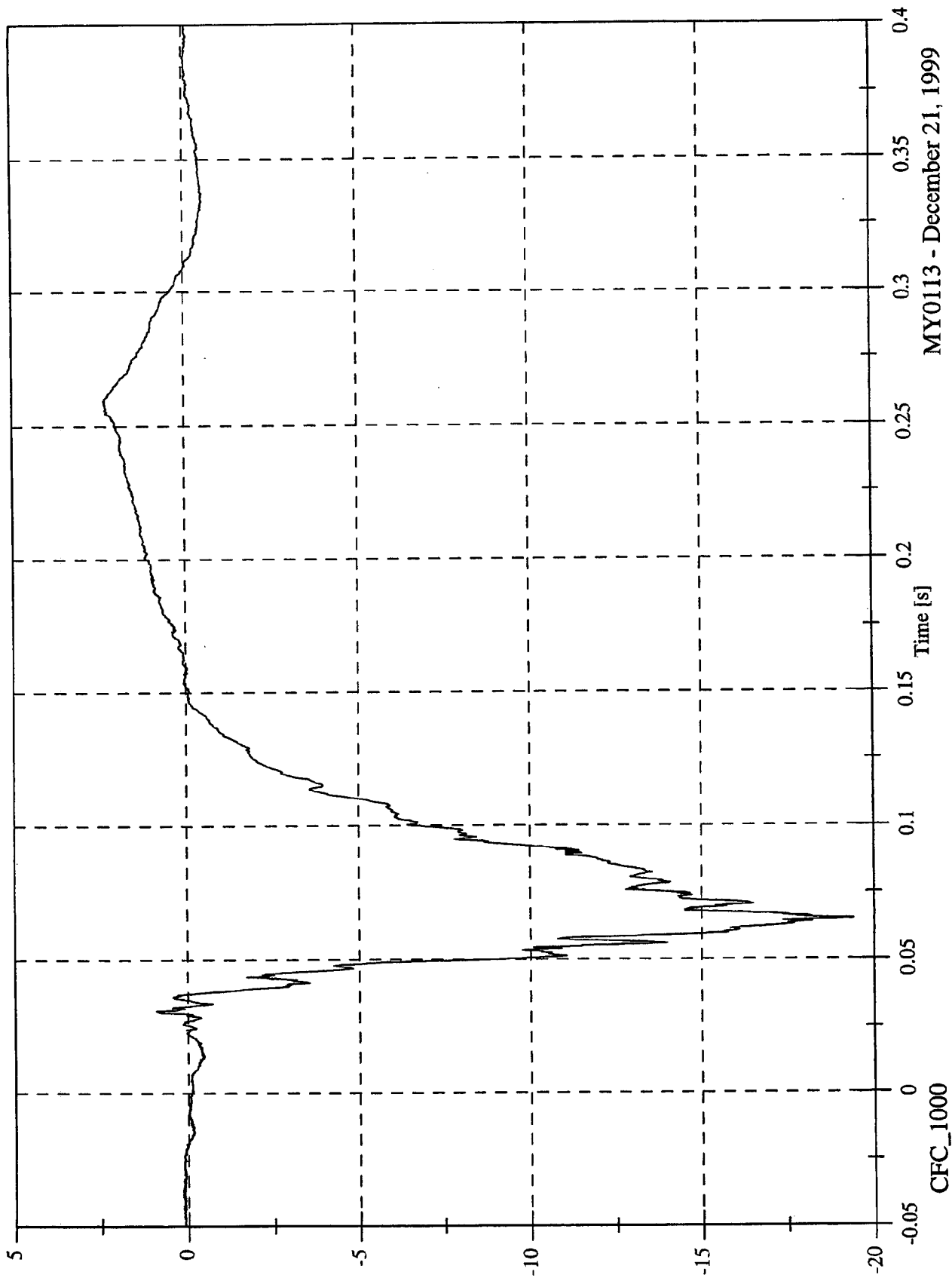

MY0113 - December 21, 1999

NCAP Test 7 - 2000 Saturn SL

Max: 48.8 [g] at 0.057 [s]  
Min: 0.1 [g] at -0.020 [s]

P2 Pelvic Resultant

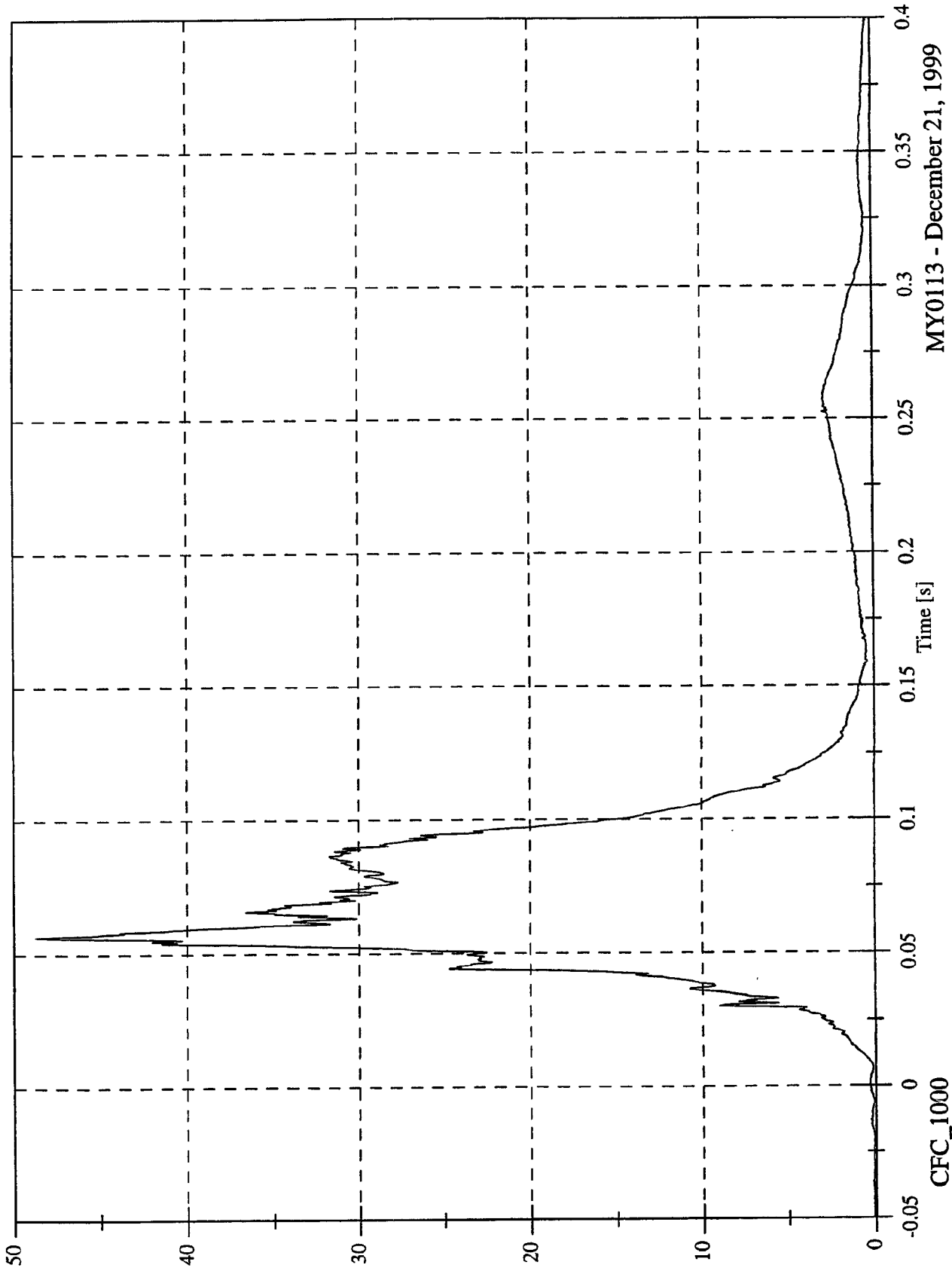

MY0113 - December 21, 1999

CFC\_1000

NCAP Test 7 - 2000 Saturn SL

Max: 270.7 [N] at 0.037 [s]  
Min: -3966.6 [N] at 0.058 [s]

P2 Left Femur z

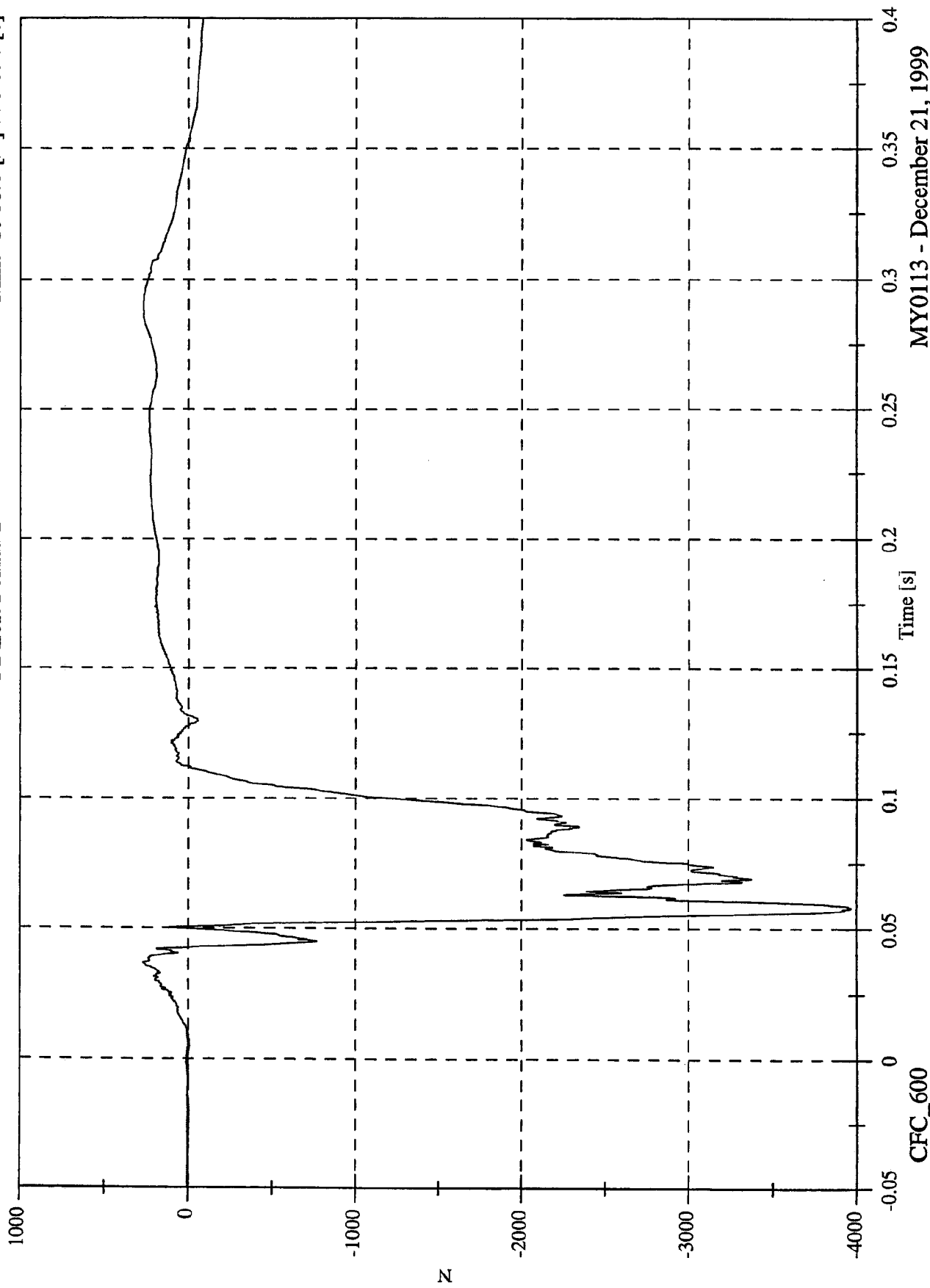

MY0113 - December 21, 1999

NCAP Test 7 - 2000 Saturn SL

Max: 149.6 [N] at 0.114 [s]  
Min: -2451.9 [N] at 0.054 [s]

P2 Right Femur z

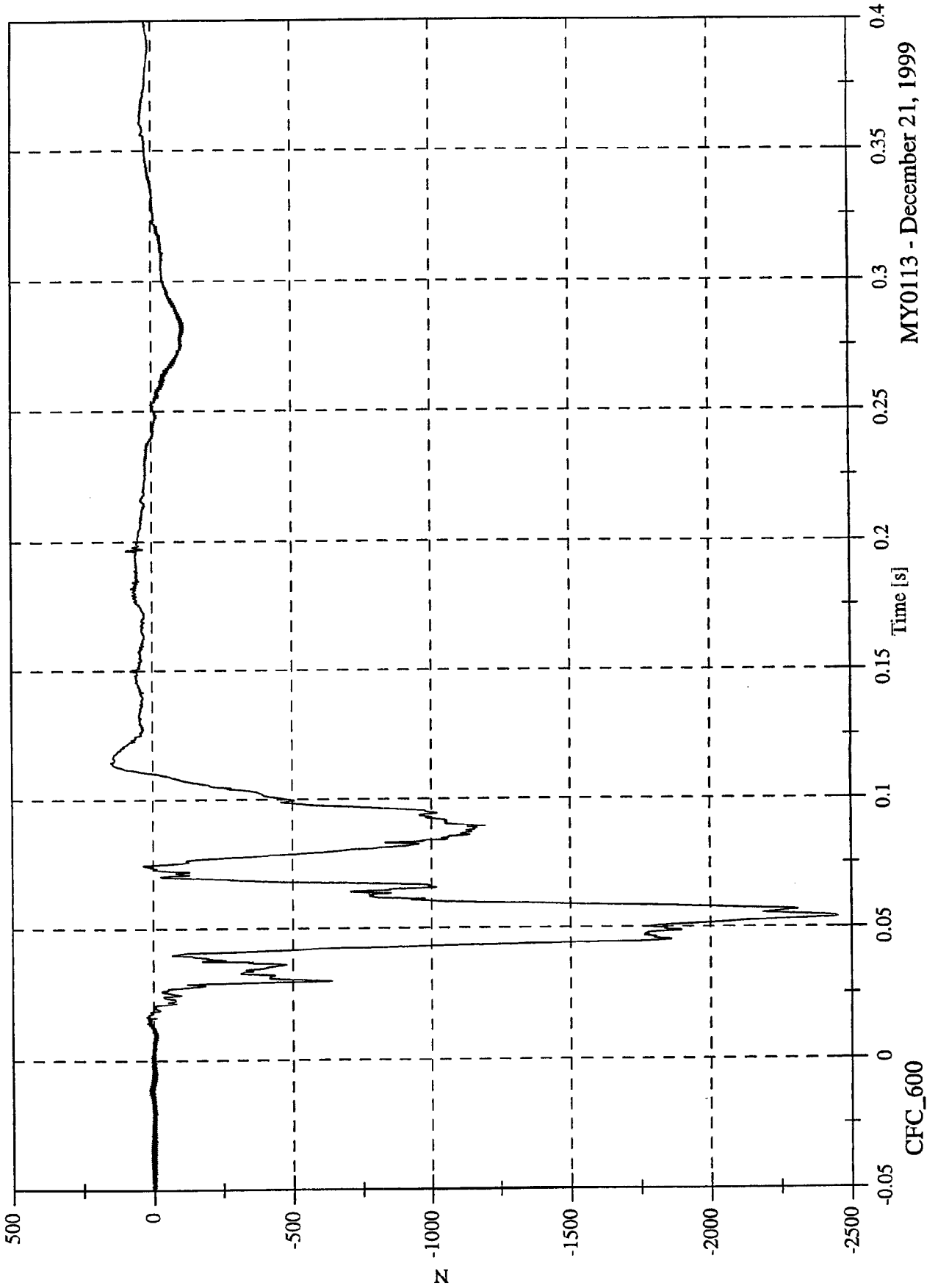

CFC\_600

MY0113 - December 21, 1999

NCAP Test 7 - 2000 Saturn SL

Max: 11.6 [N-m] at 0.292 [s]  
Min: -58.1 [N-m] at 0.107 [s]

P2 Left Upper Tibia Mx

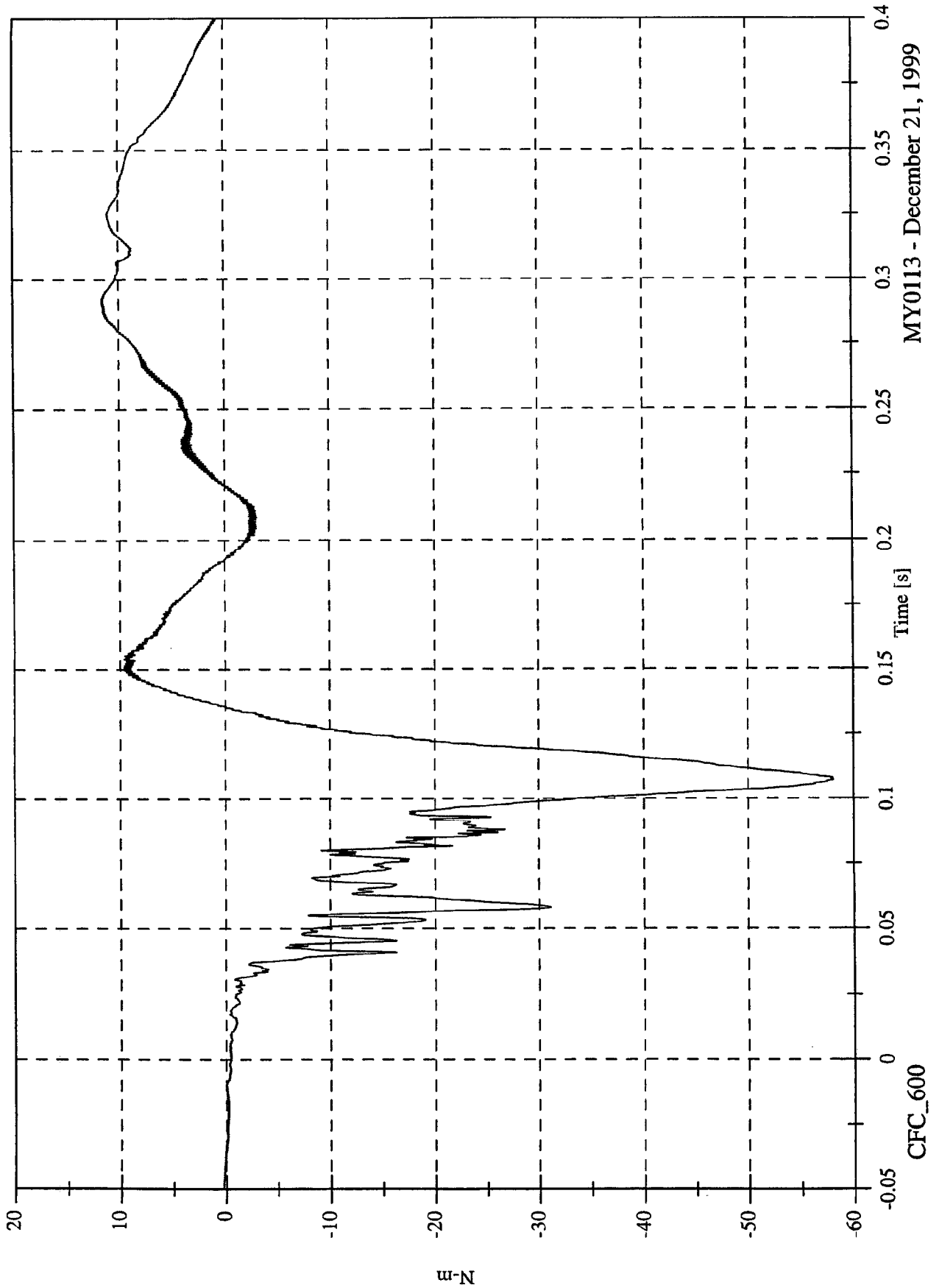

MY0113 - December 21, 1999

NCAP Test 7 - 2000 Saturn SL

Max: 24.2 [N-m] at 0.130 [s]  
Min: -116.8 [N-m] at 0.070 [s]

P2 Left Upper Tibia My

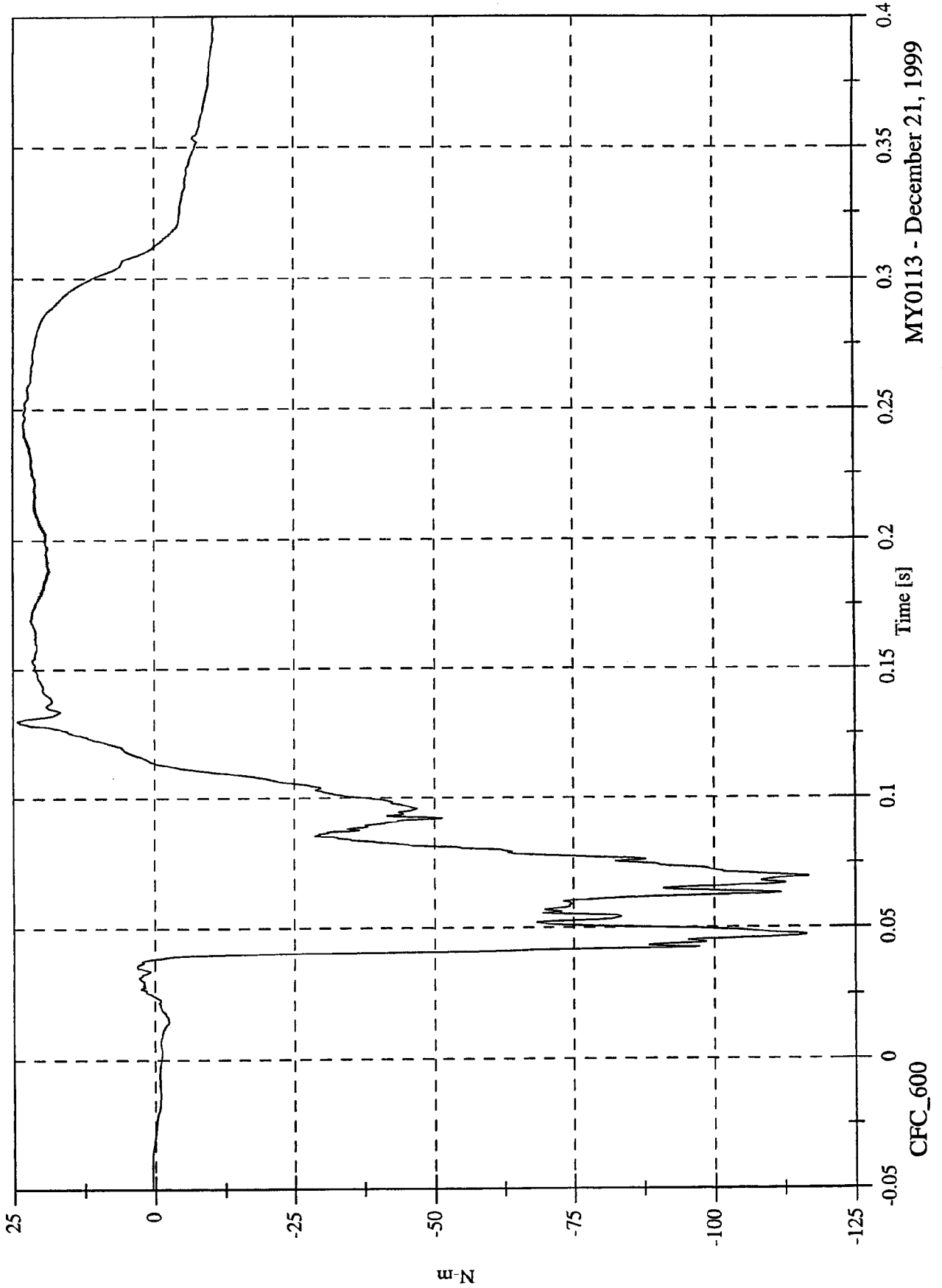

MY0113 - December 21, 1999

CFC\_600

NCAP Test 7 - 2000 Saturn SL

Max: 505.8 [N] at 0.154 [s]  
Min: -3923.7 [N] at 0.047 [s]

P2 Left Lower Tibia Fz

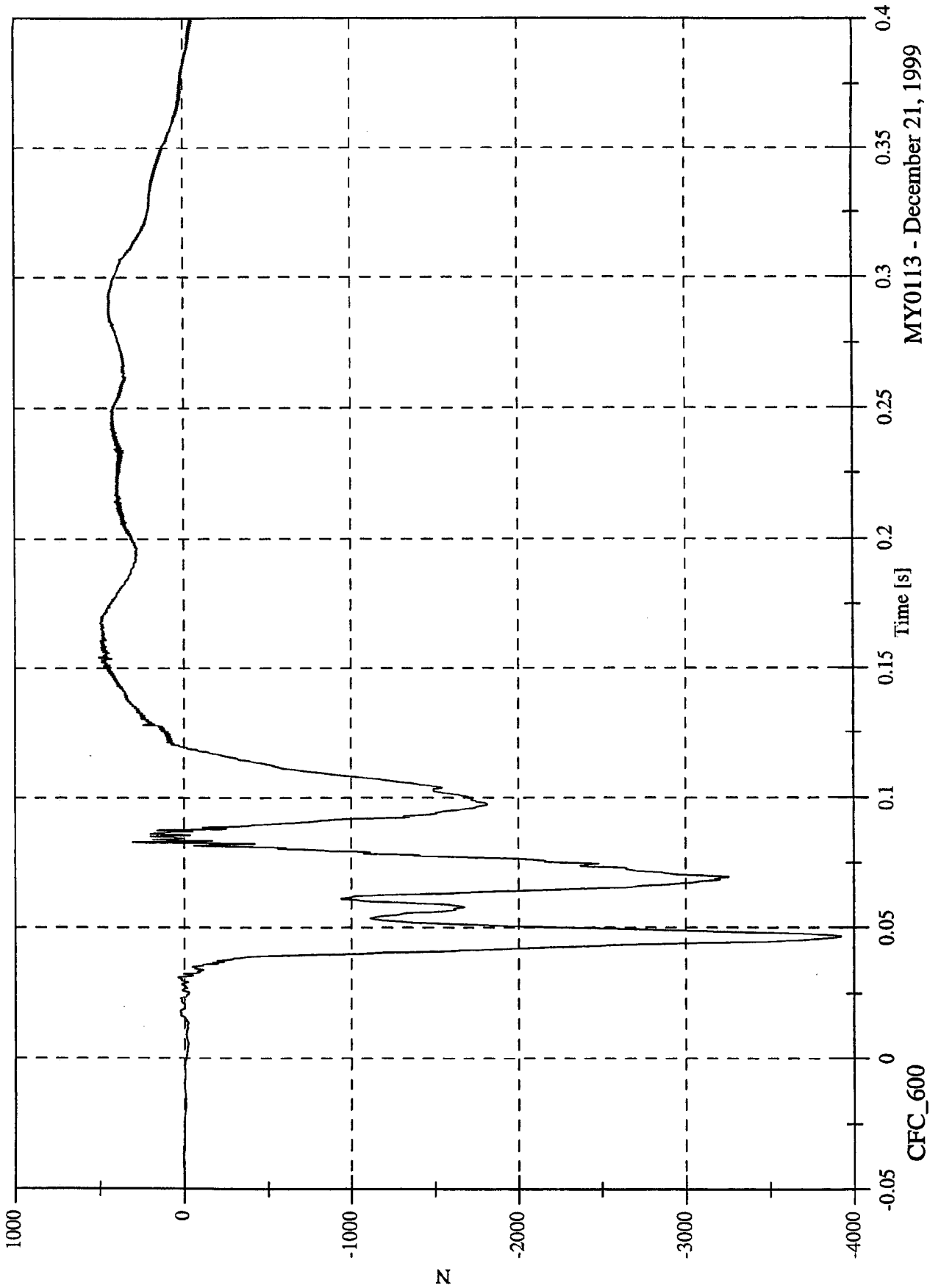

MY0113 - December 21, 1999

CFC\_600

NCAP Test 7 - 2000 Saturn SL

Max: 11.4 [N-m] at 0.090 [s]  
Min: -60.0 [N-m] at 0.046 [s]

P2 Left Lower Tibia Mx

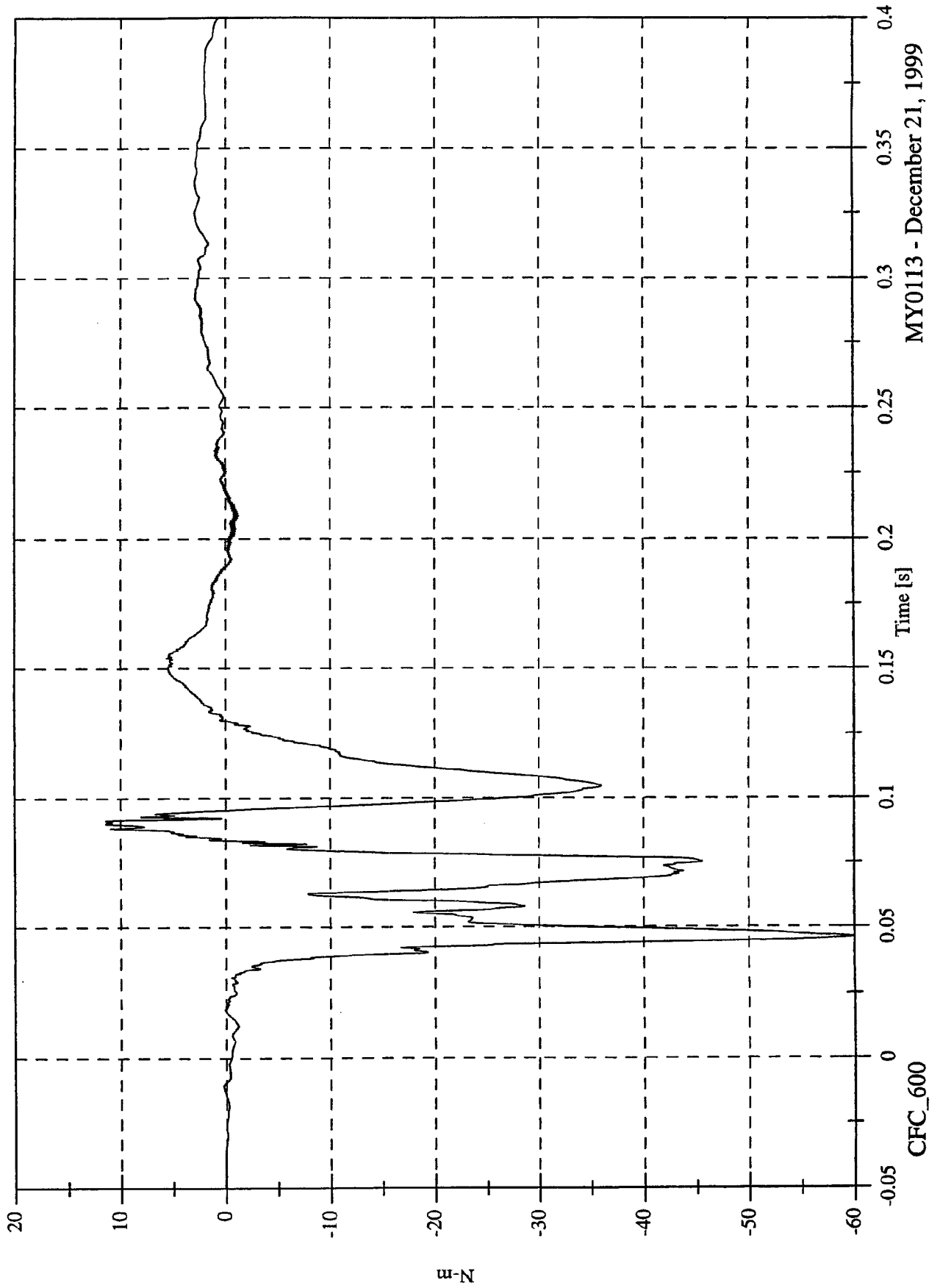

MY0113 - December 21, 1999

CFC\_600

NCAP Test 7 - 2000 Saturn SL

Max: 40.8 [N-m] at 0.075 [s]  
Min: -39.4 [N-m] at 0.042 [s]

P2 Left Lower Tibia My

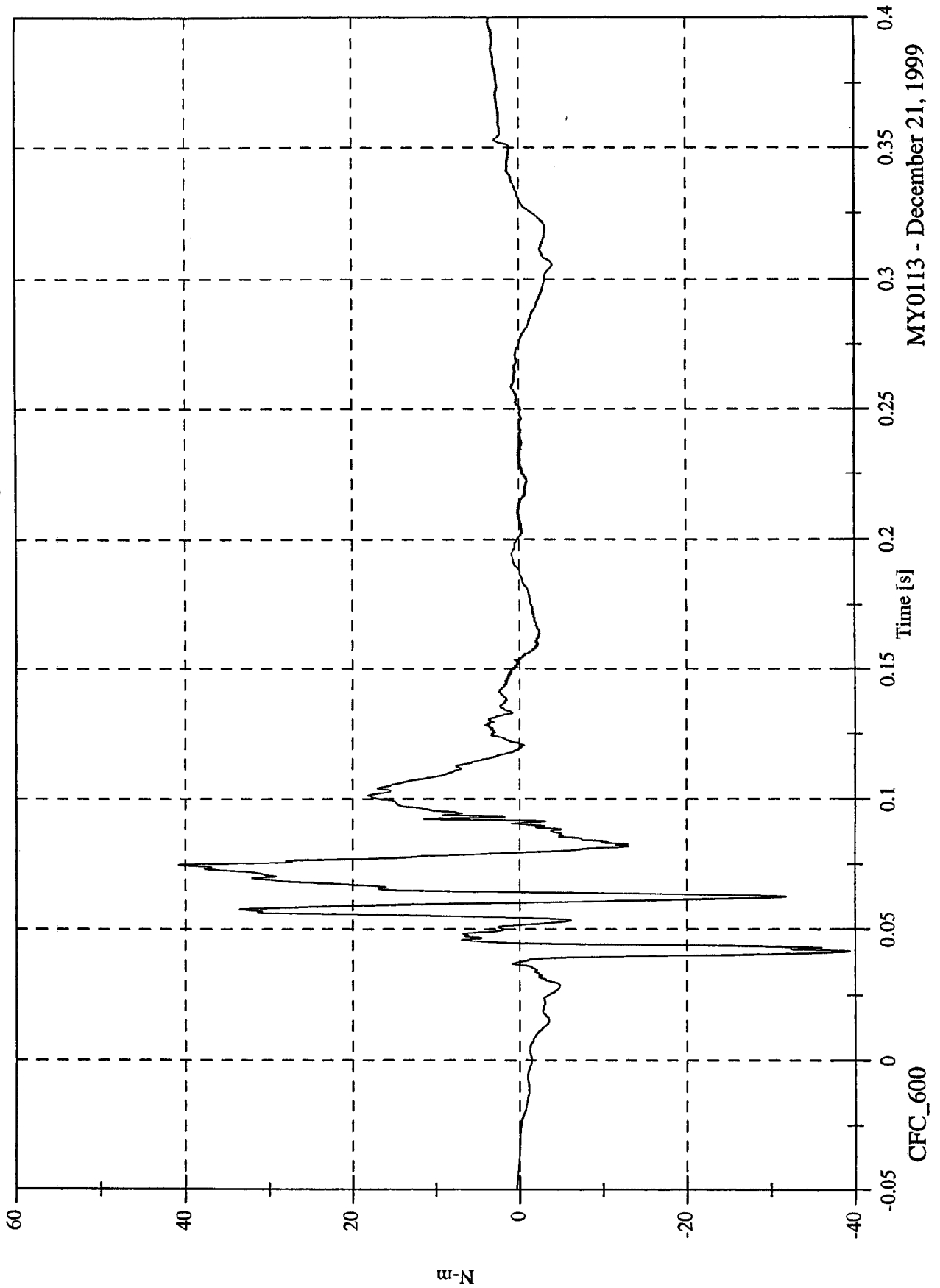

MY0113 - December 21, 1999

CFC\_600

NCAP Test 7 - 2000 Saturn SL

P2 Right Upper Tibia Mx

Max: 26.0 [N-m] at 0.042 [s]

Min: -17.8 [N-m] at 0.143 [s]

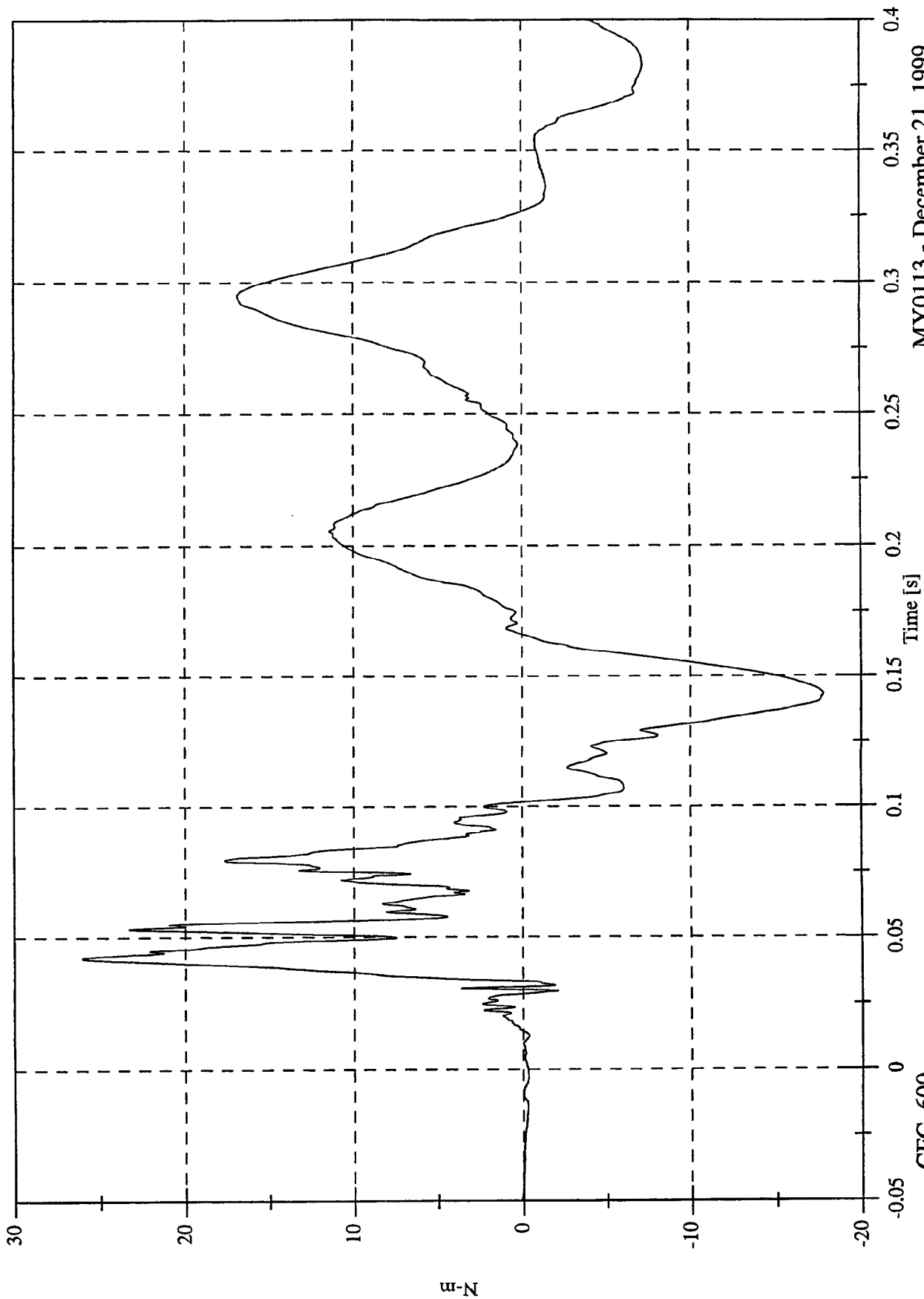

MY0113 - December 21, 1999

CFC\_600

NCAP Test 7 - 2000 Saturn SL

Max: 15.4 [N-m] at 0.248 [s]

Min: -89.9 [N-m] at 0.077 [s]

P2 Right Upper Tibia My

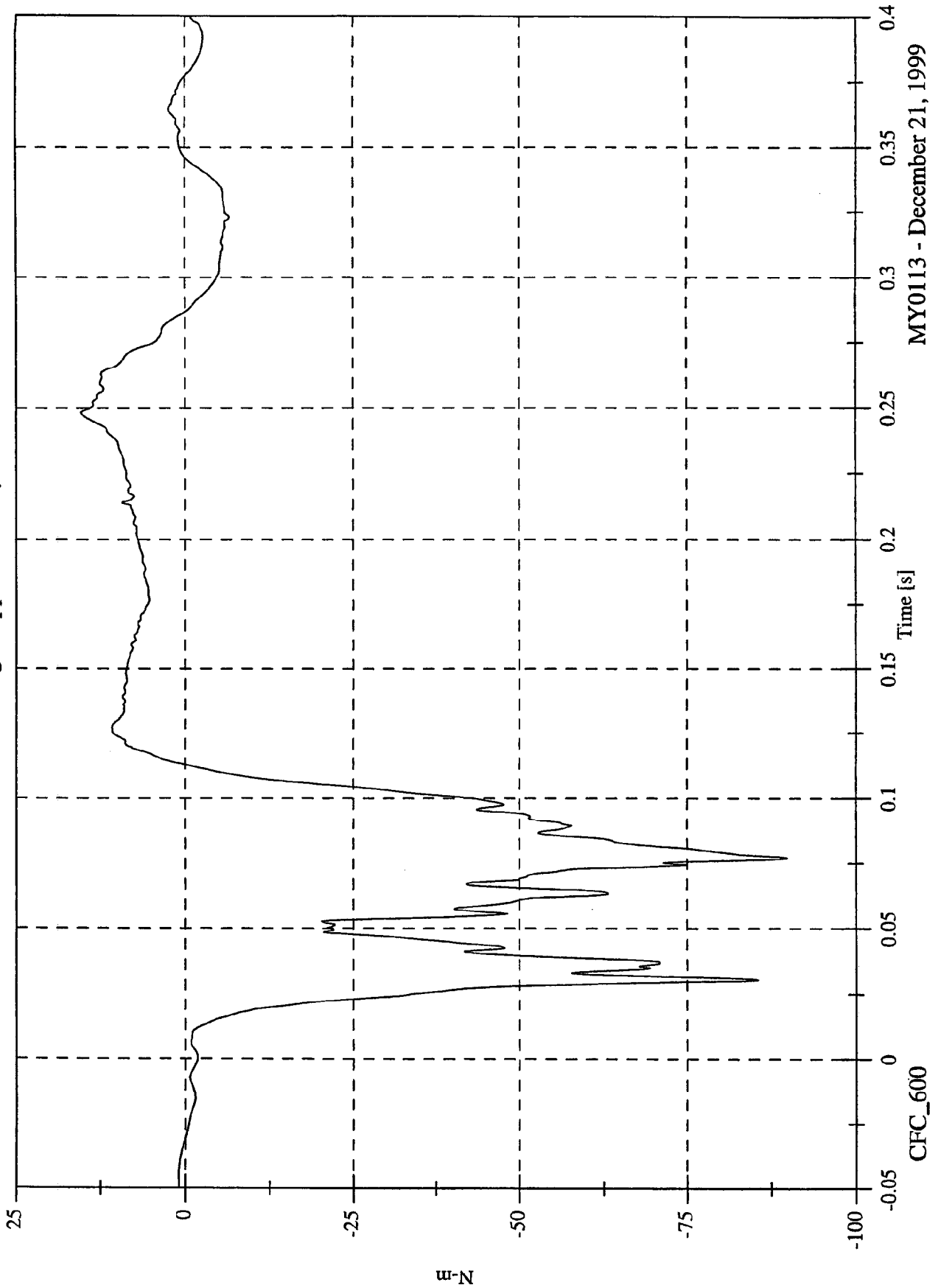

MY0113 - December 21, 1999

CFC\_600

NCAP Test 7 - 2000 Saturn SL

Max: 224.4 [N] at 0.066 [s]  
Min: -2854.5 [N] at 0.036 [s]

P2 Right Lower Tibia Fz

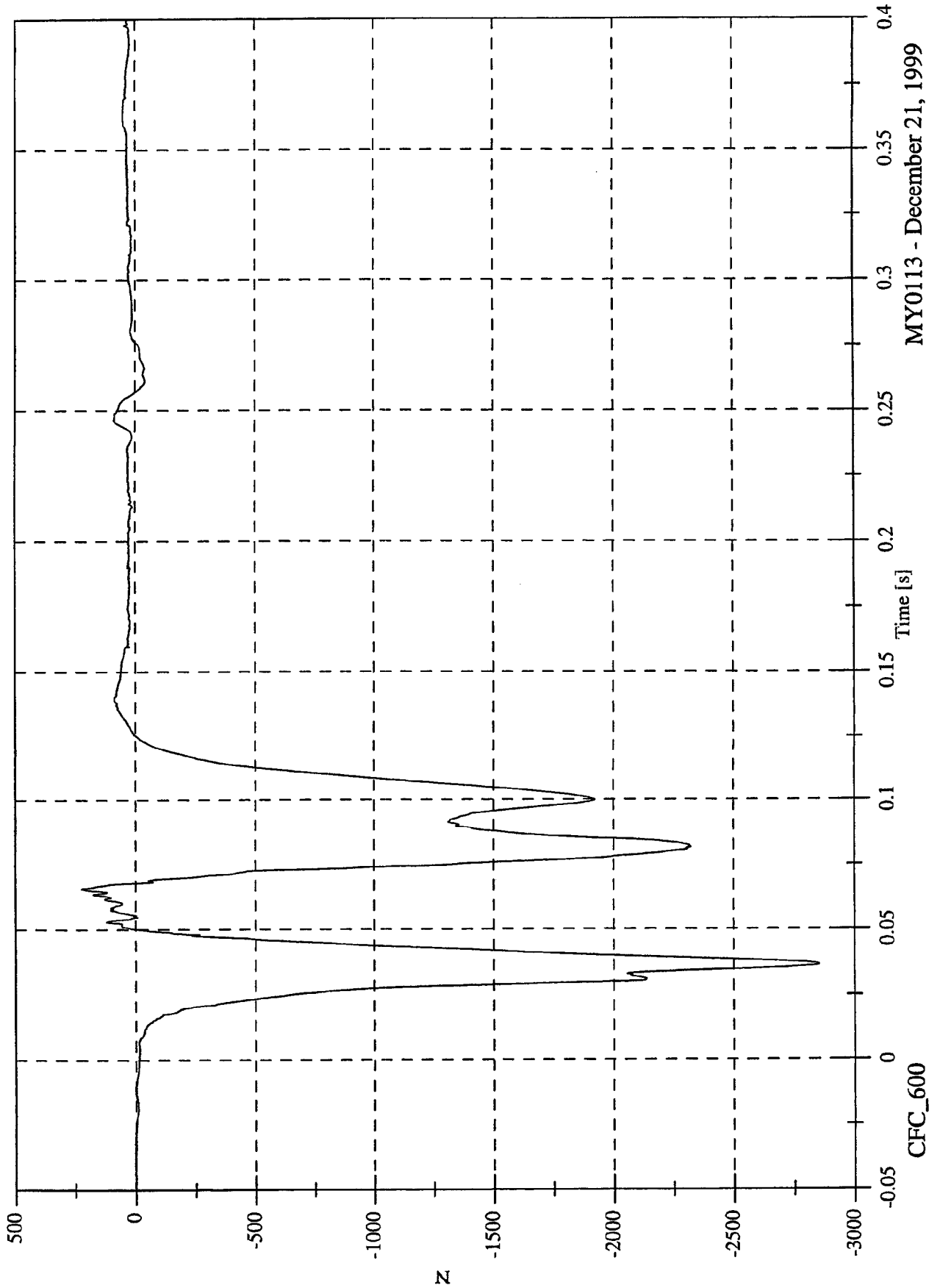

CFC\_600

MY0113 - December 21, 1999

NCAP Test 7 - 2000 Saturn SL

Max: 12.8 [N-m] at 0.040 [s]

P2 Right Lower Tibia Mx

Min: -14.1 [N-m] at 0.109 [s]

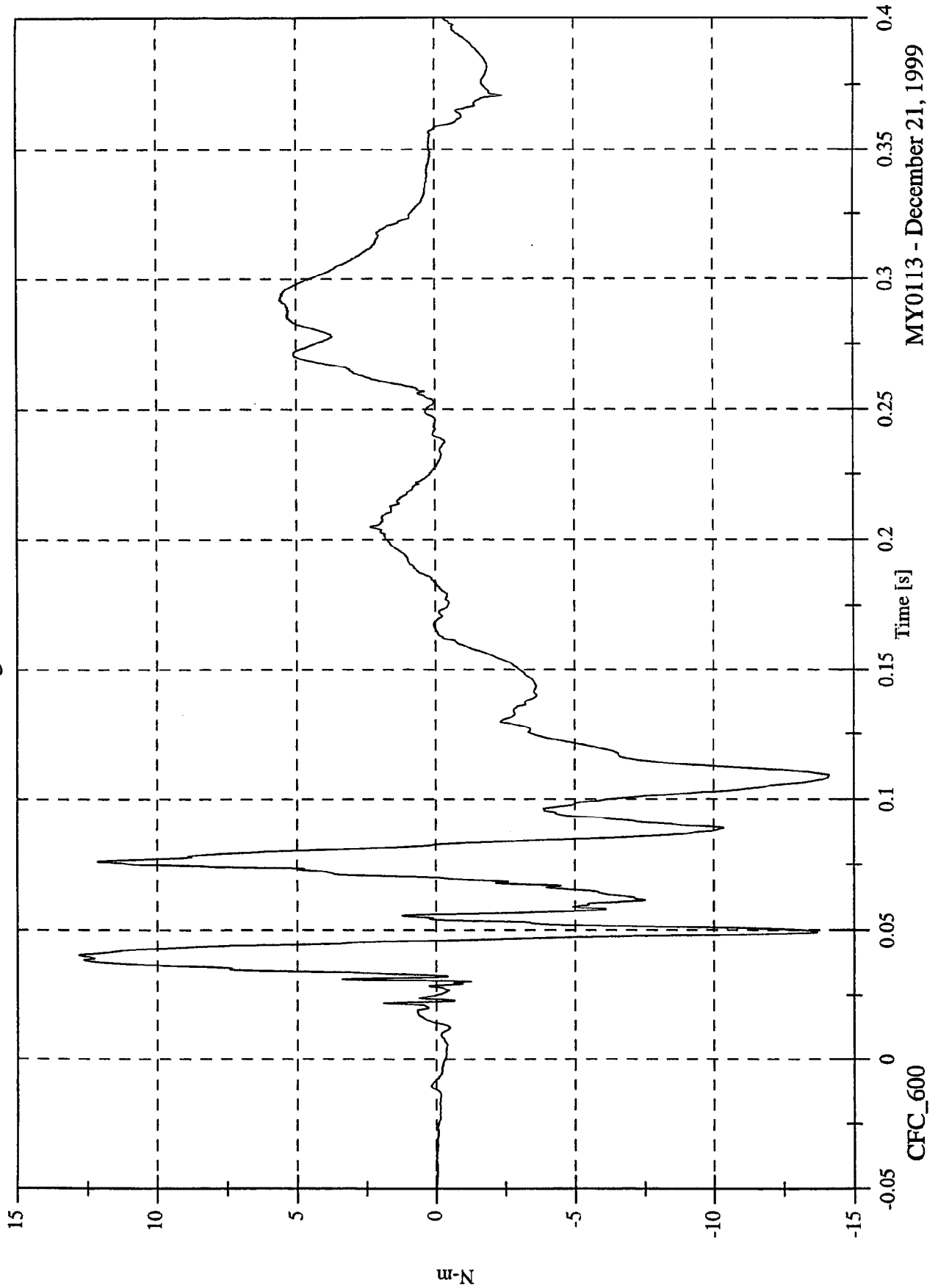

MY0113 - December 21, 1999

CFC\_600

NCAP Test 7 - 2000 Saturn SL

Max: 97.9 [N-m] at 0.084 [s]  
Min: -46.5 [N-m] at 0.063 [s]

P2 Right Lower Tibia My

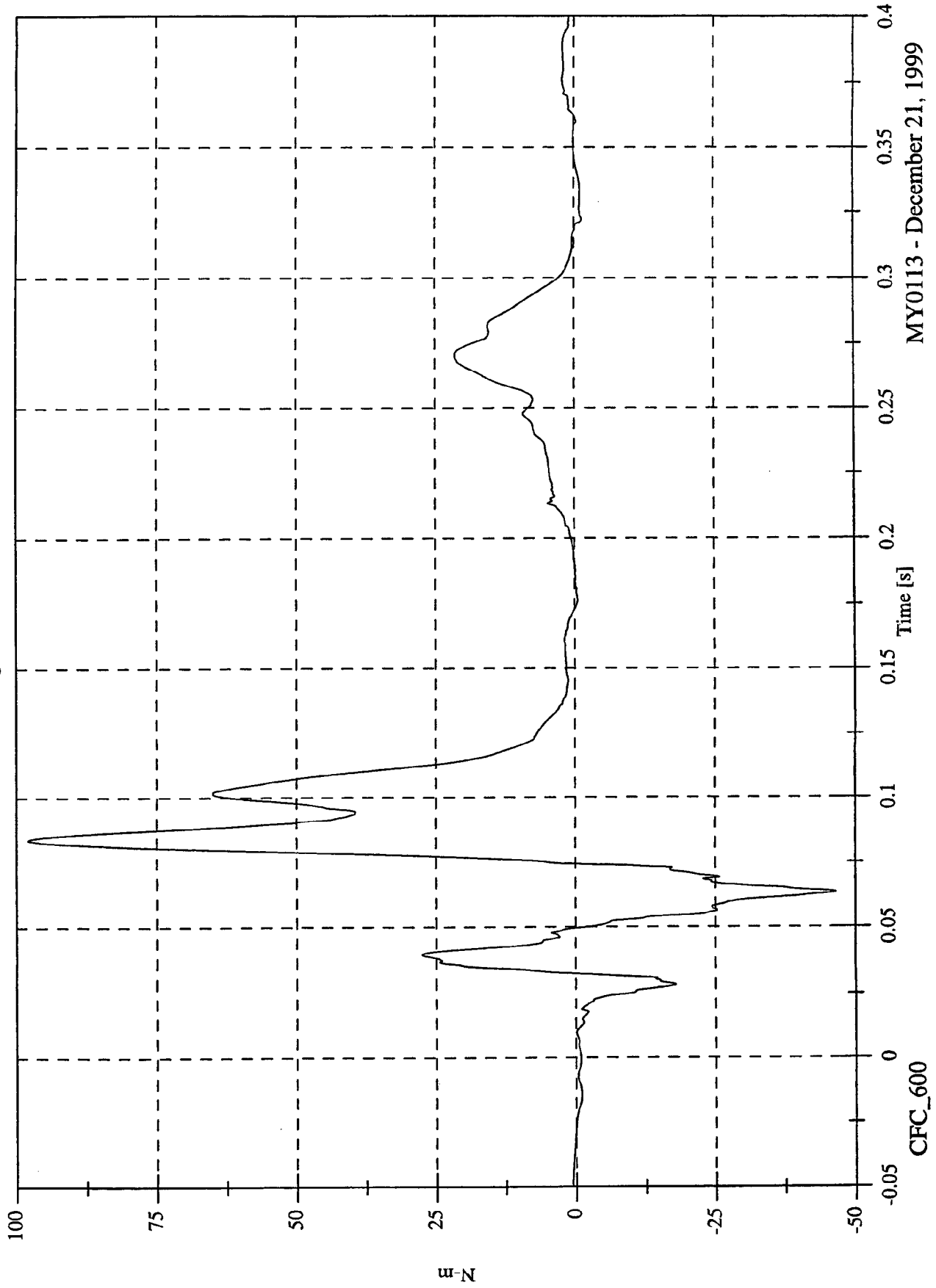

CFC\_600

MY0113 - December 21, 1999

NCAP Test 7 - 2000 Saturn SL

Max: 34.7 [g] at 0.057 [s]  
Min: -61.2 [g] at 0.042 [s]

P2 Left Foot Aft x

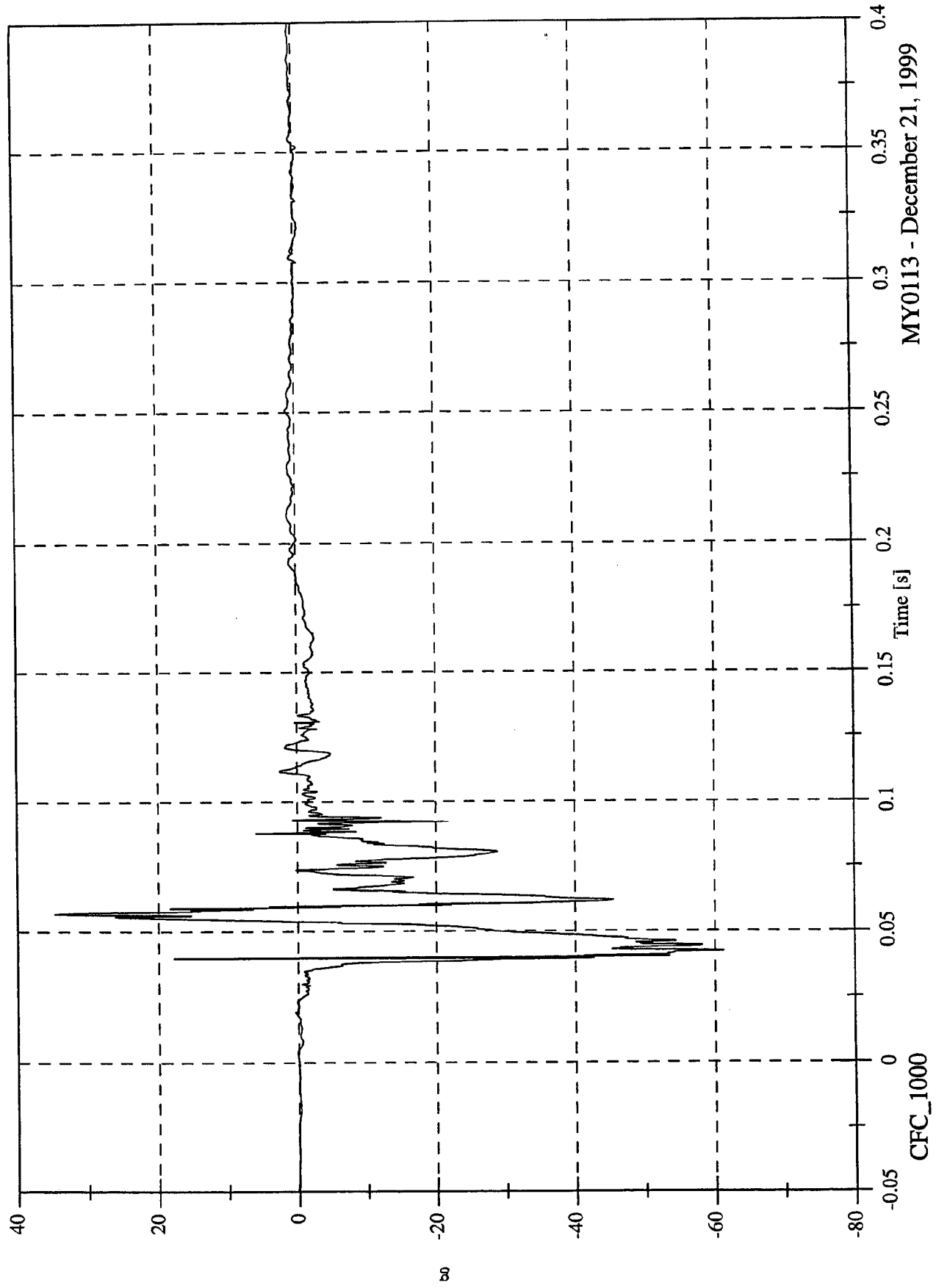

MY0113 - December 21, 1999

CFC\_1000

NCAP Test 7 - 2000 Saturn SL

Max: 28.3 [g] at 0.088 [s]  
Min: -42.3 [g] at 0.042 [s]

P2 Left Foot Aft z

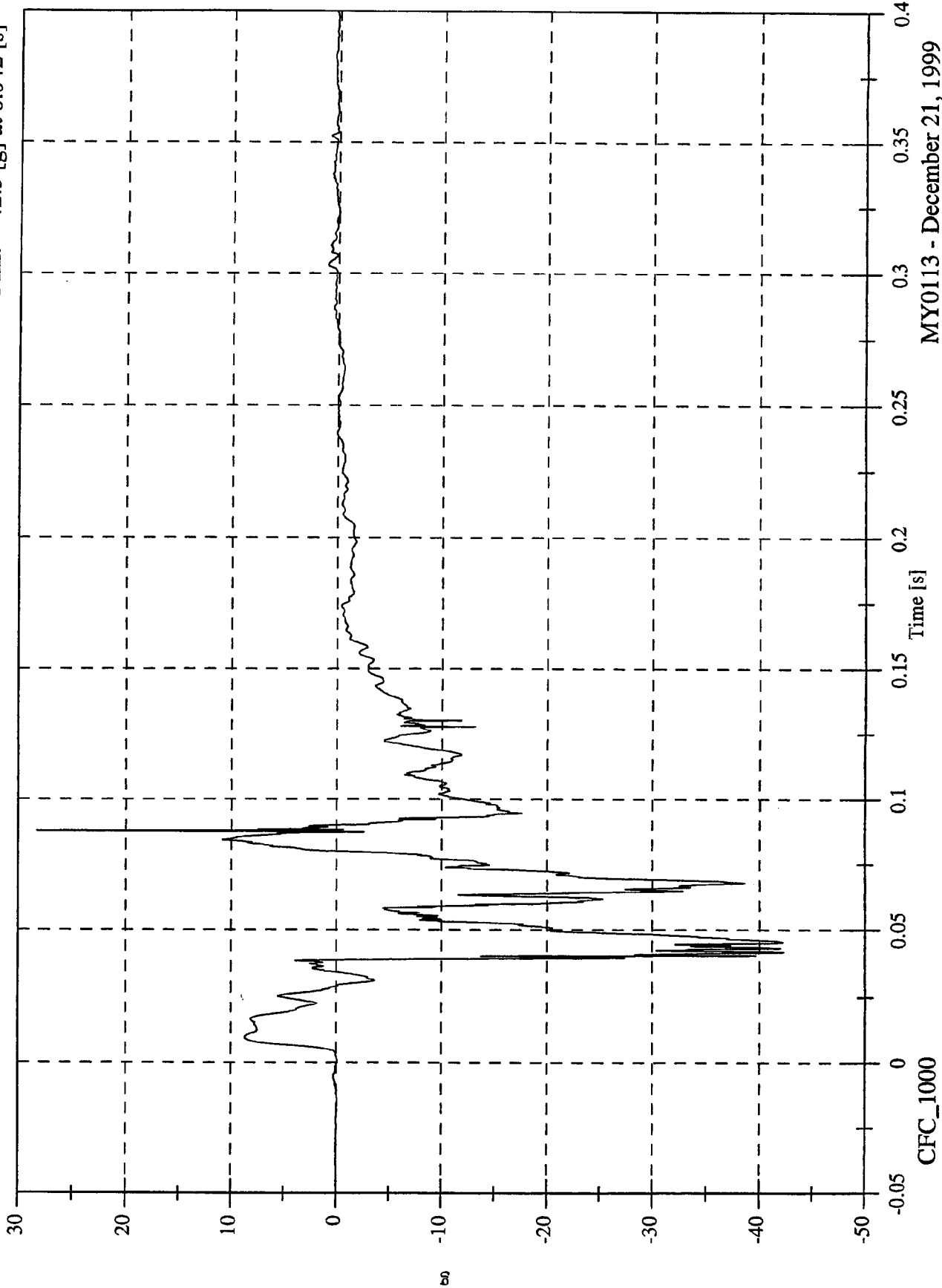

CFC\_1000

Time [s]

MY0113 - December 21, 1999

NCAP Test 7 - 2000 Saturn SL

P2 Left Foot Fore z

Max: 37.2 [g] at 0.088 [s]  
Min: -155.9 [g] at 0.040 [s]

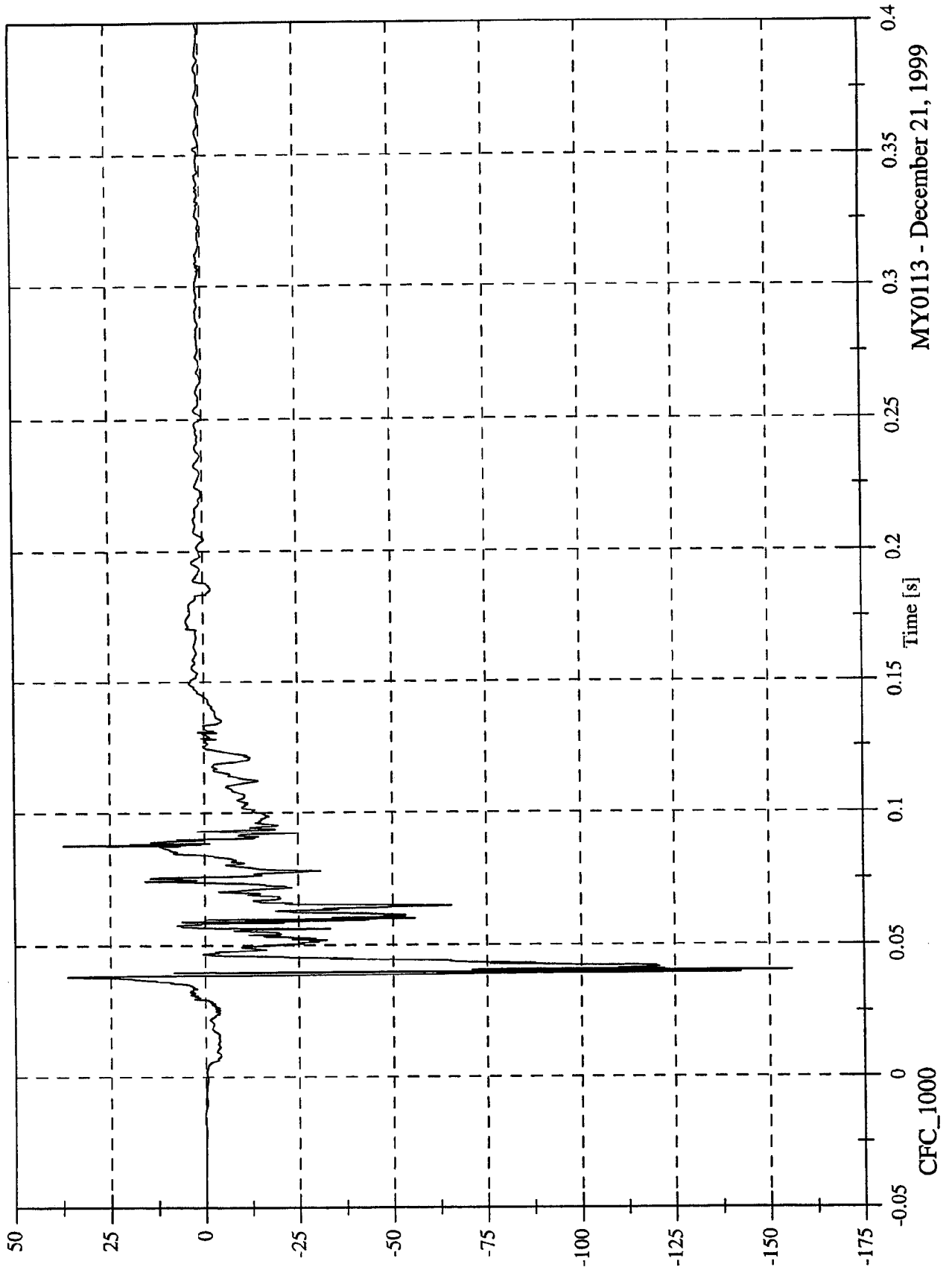

MY0113 - December 21, 1999

NCAP Test 7 - 2000 Saturn SL

Max: 15.0 [g] at 0.081 [s]  
Min: -42.3 [g] at 0.074 [s]

P2 Right Foot Aft x

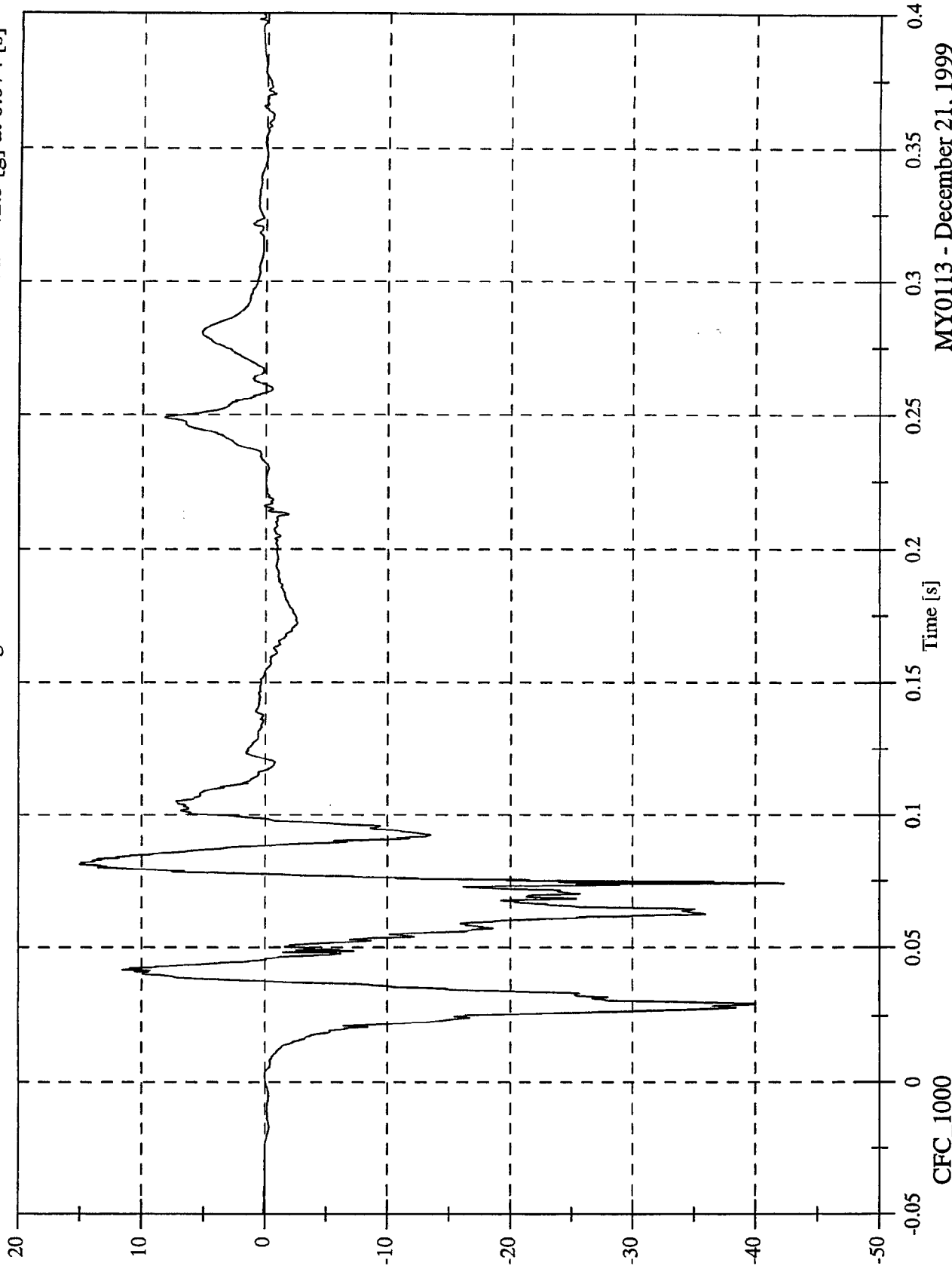

CFC\_1000

MY0113 - December 21, 1999

NCAP Test 7 - 2000 Saturn SL

P2 Right Foot Aft z

Max: 12.9 [g] at 0.048 [s]  
Min: -44.1 [g] at 0.037 [s]

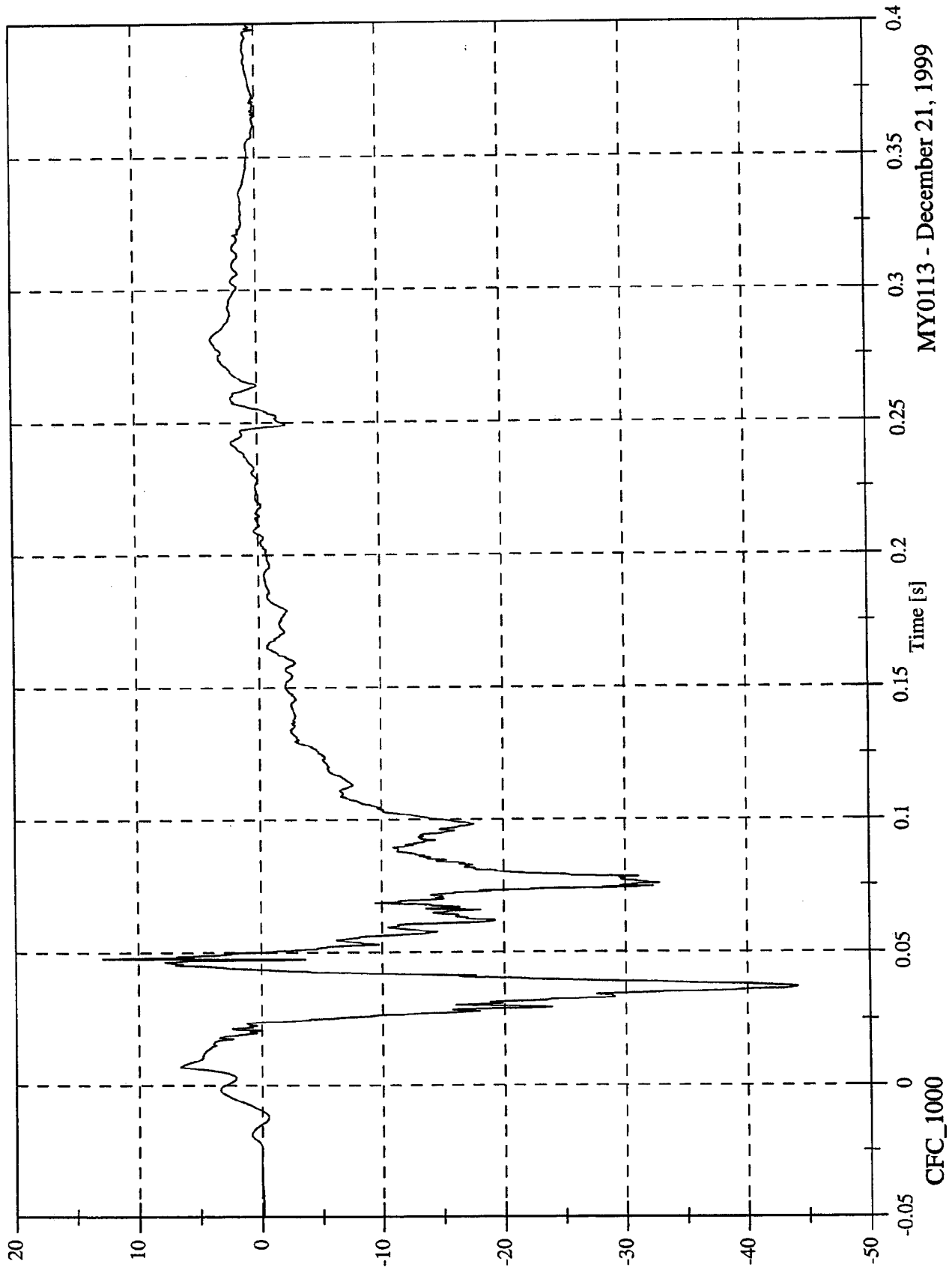

MY0113 - December 21, 1999

CFC\_1000

NCAP Test 7 - 2000 Saturn SL

Max: 23.1 [g] at 0.074 [s]  
Min: -55.5 [g] at 0.027 [s]

P2 Right Foot Fore z

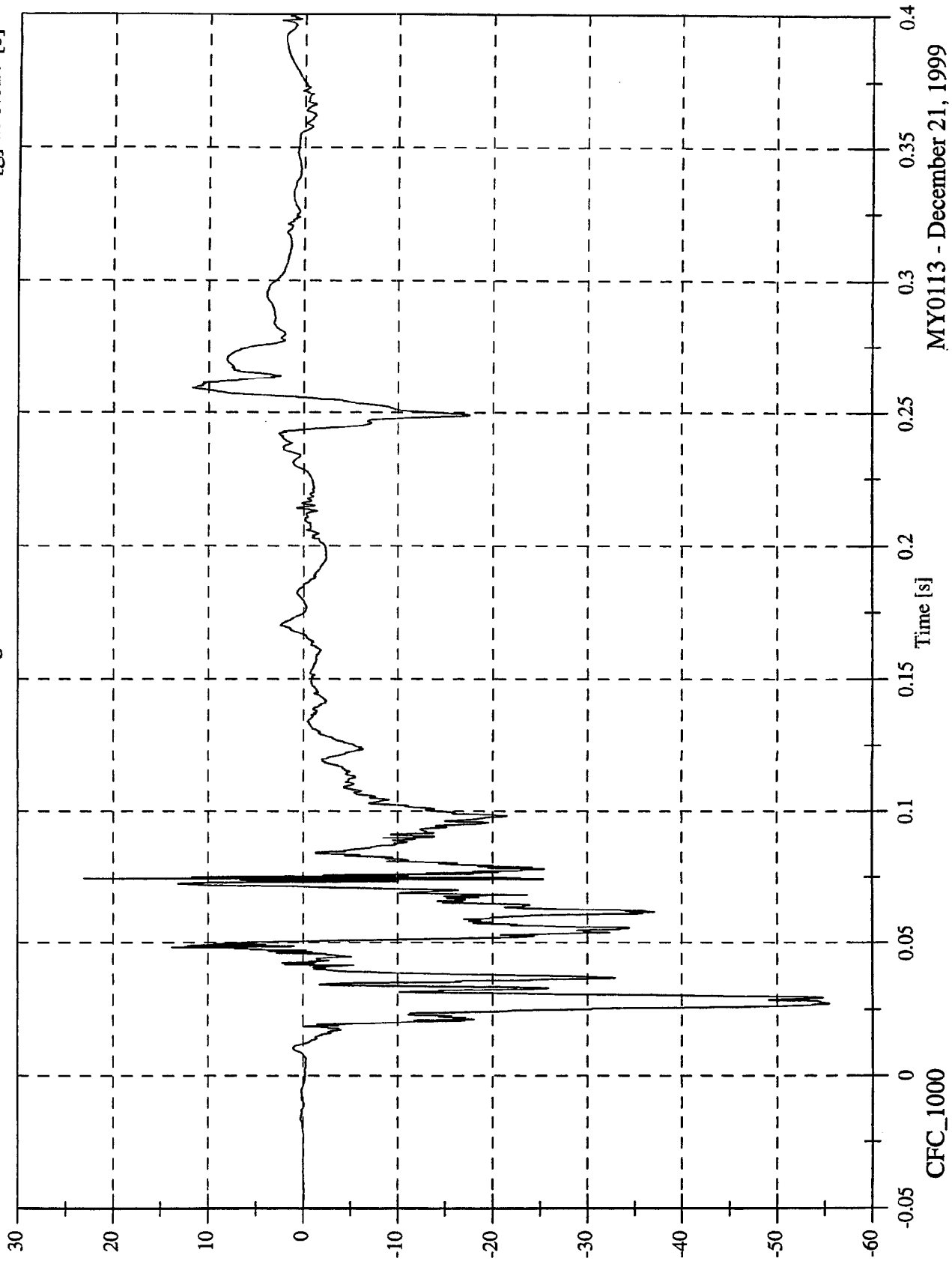

MY0113 - December 21, 1999

NCAP Test 7 - 2000 Saturn SL

Max: 3639.7 [N] at 0.092 [s]  
Min: -5.6 [N] at 0.400 [s]

P2 Lap Belt Force

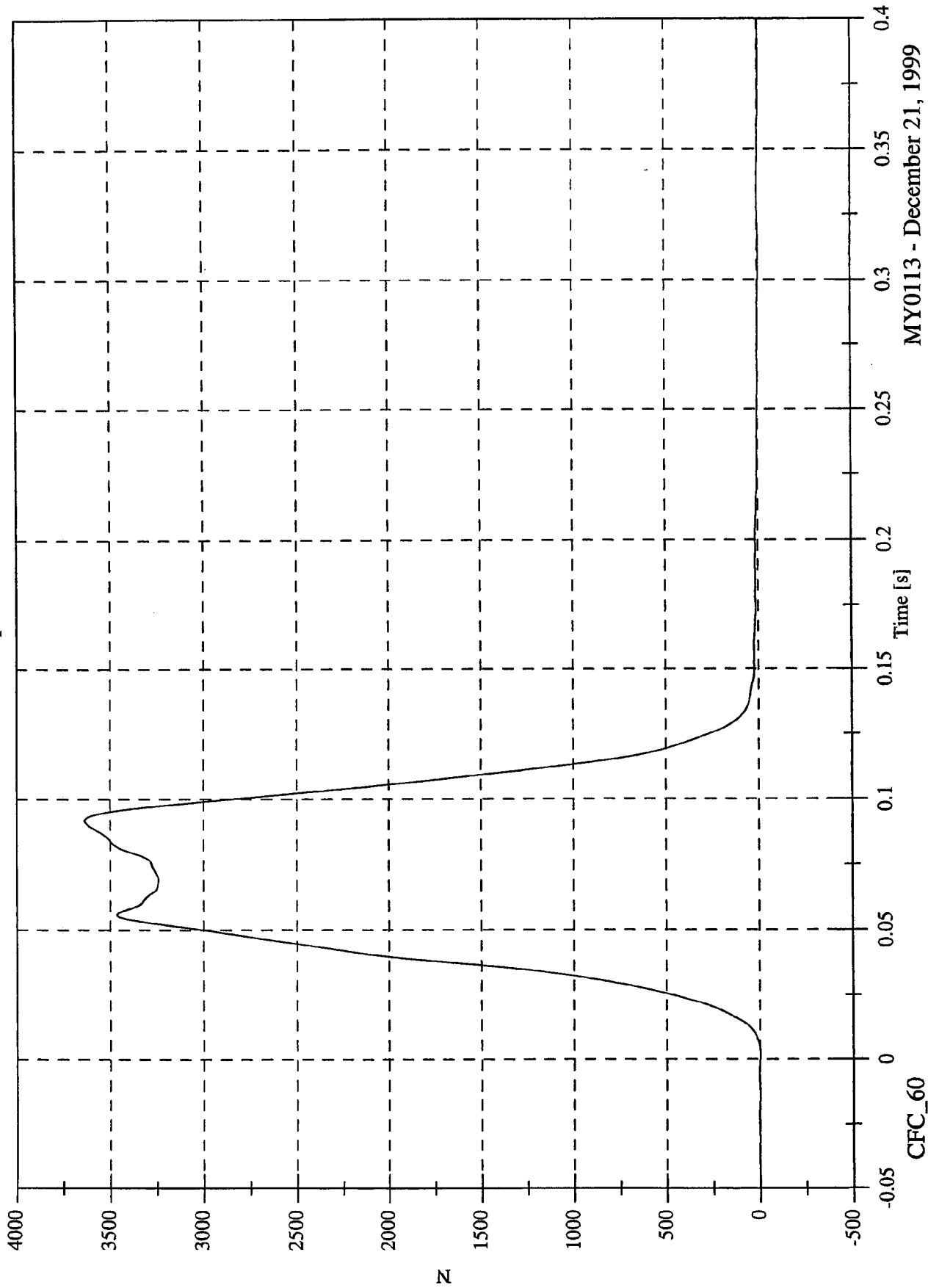

MY0113 - December 21, 1999

NCAP Test 7 - 2000 Saturn SL

Max: 3984.8 [N] at 0.092 [s]  
Min: -29.9 [N] at 0.375 [s]

P2 Shoulder Belt Force

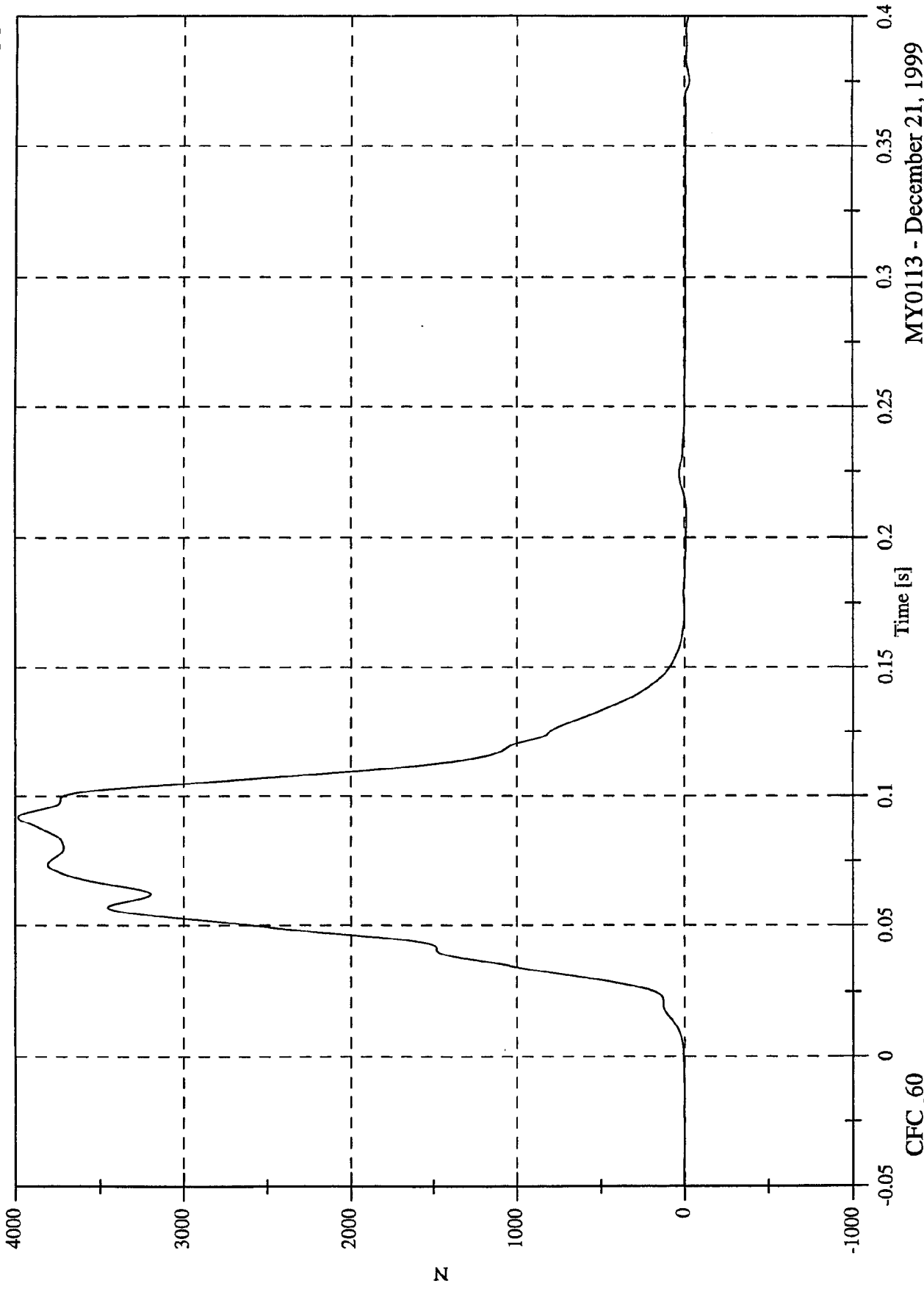

CFC\_60

MY0113 - December 21, 1999

NCAP Test 7 - 2000 Saturn SL

Max: 7.9 [mm] at 0.092 [s]  
Min: -0.1 [mm] at 0.194 [s]

P2 Shoulder Belt Elongation

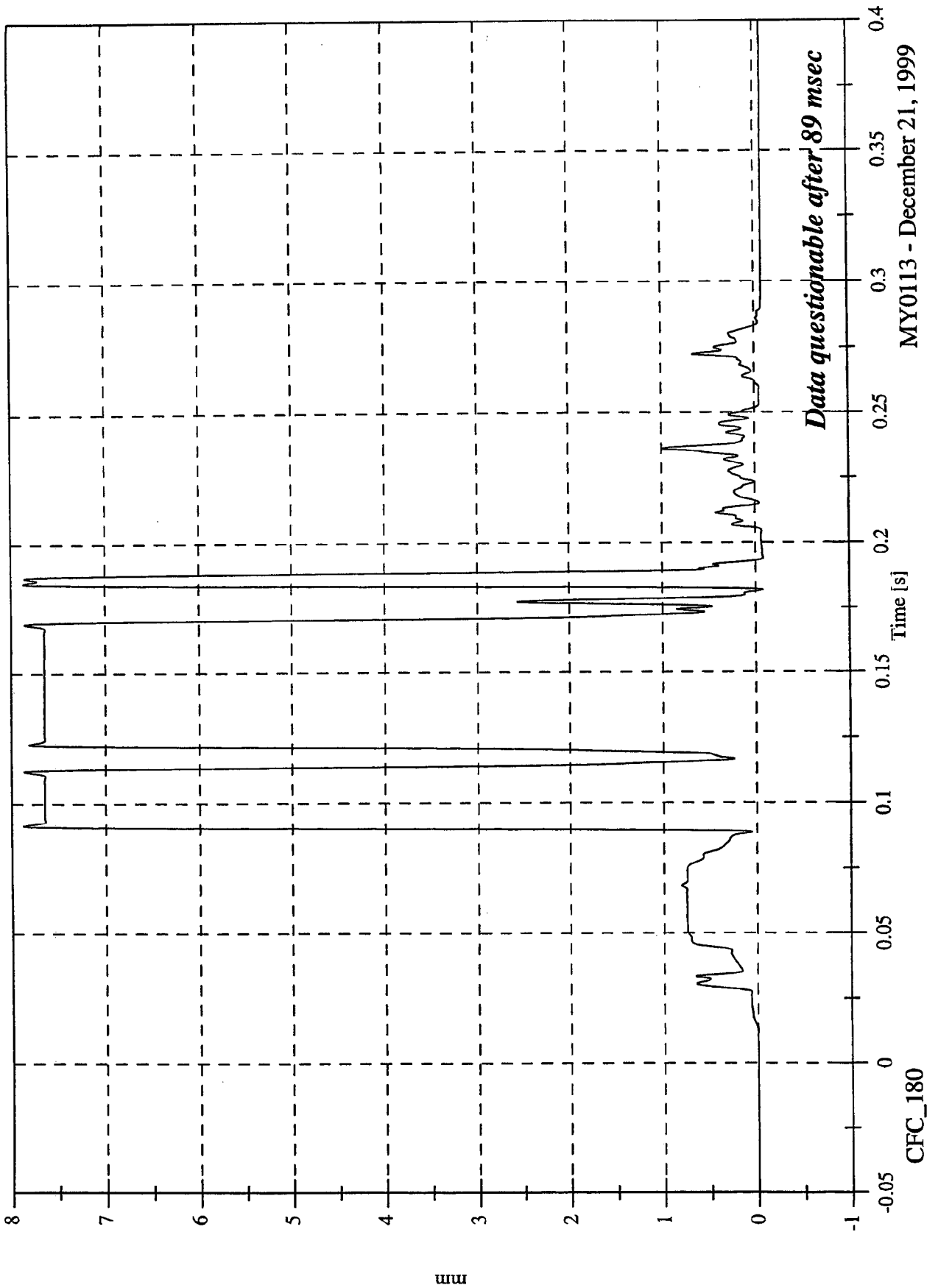

MY0113 - December 21, 1999

NCAP Test 7 - 2000 Saturn SL

Max: 1.8 [g] at 0.162 [s]  
Min: -32.0 [g] at 0.077 [s]

Left Rear #1x

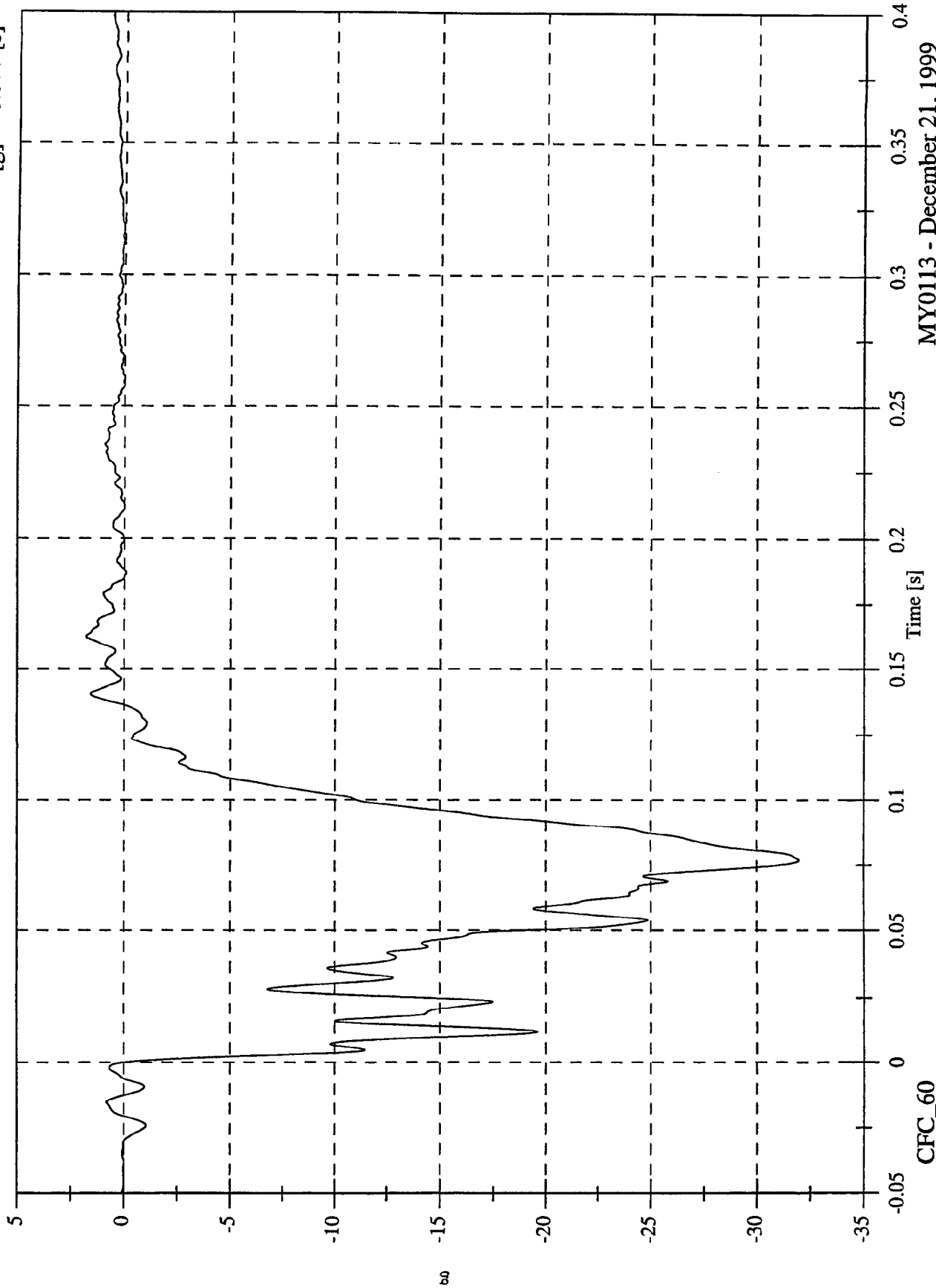

CFC\_60

MY0113 - December 21, 1999

Max: 56.7 [kph] at -0.029 [s]  
Min: -11.1 [kph] at 0.137 [s]

Left Rear #1x Velocity

NCAP Test 7 - 2000 Saturn SL

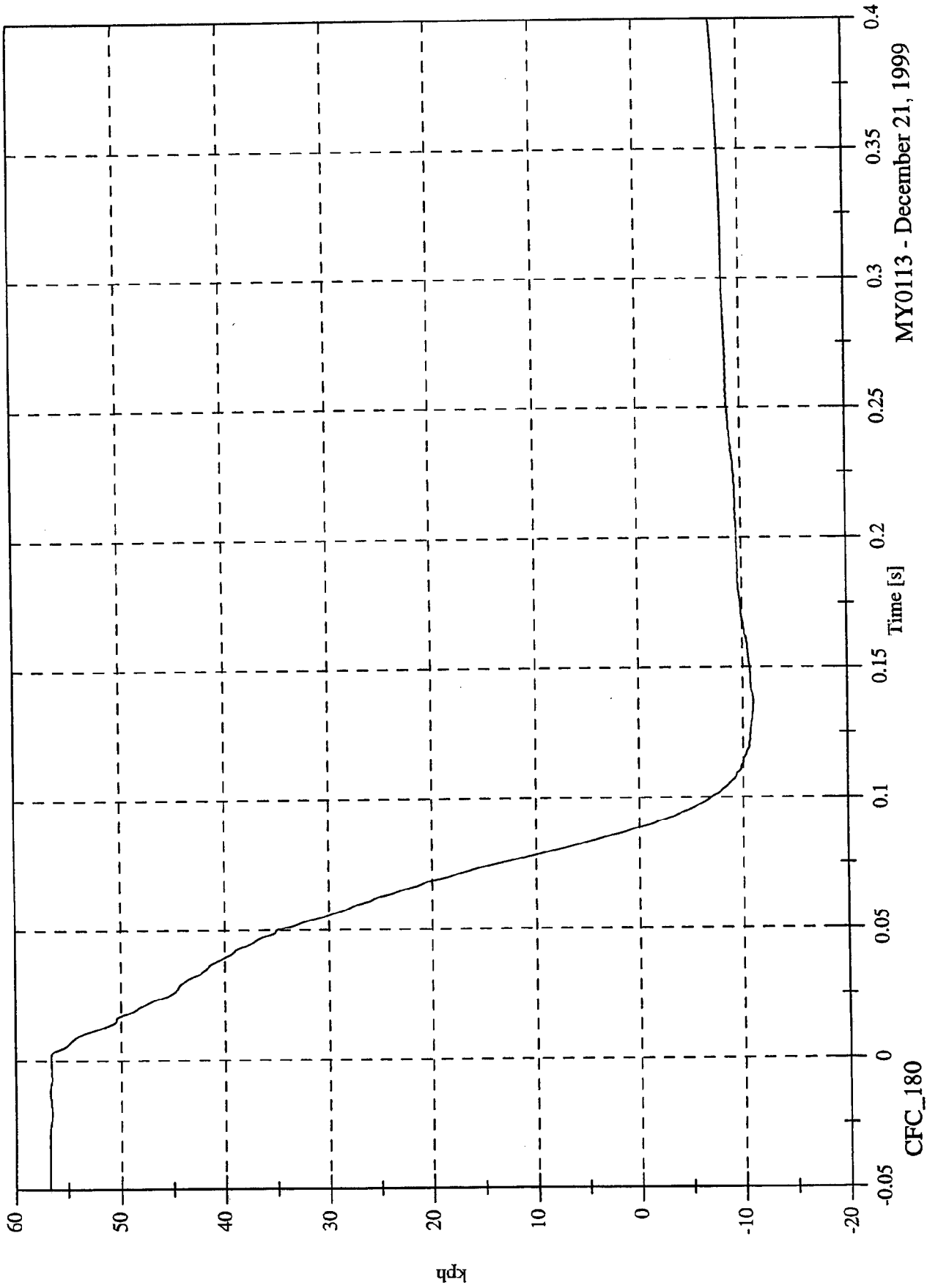

MY0113 - December 21, 1999

CFC\_180

NCAP Test 7 - 2000 Saturn SL

Max: 838.3 [mm] at 0.089 [s]  
Min: -787.0 [mm] at -0.050 [s]

Left Rear #1x Displacement

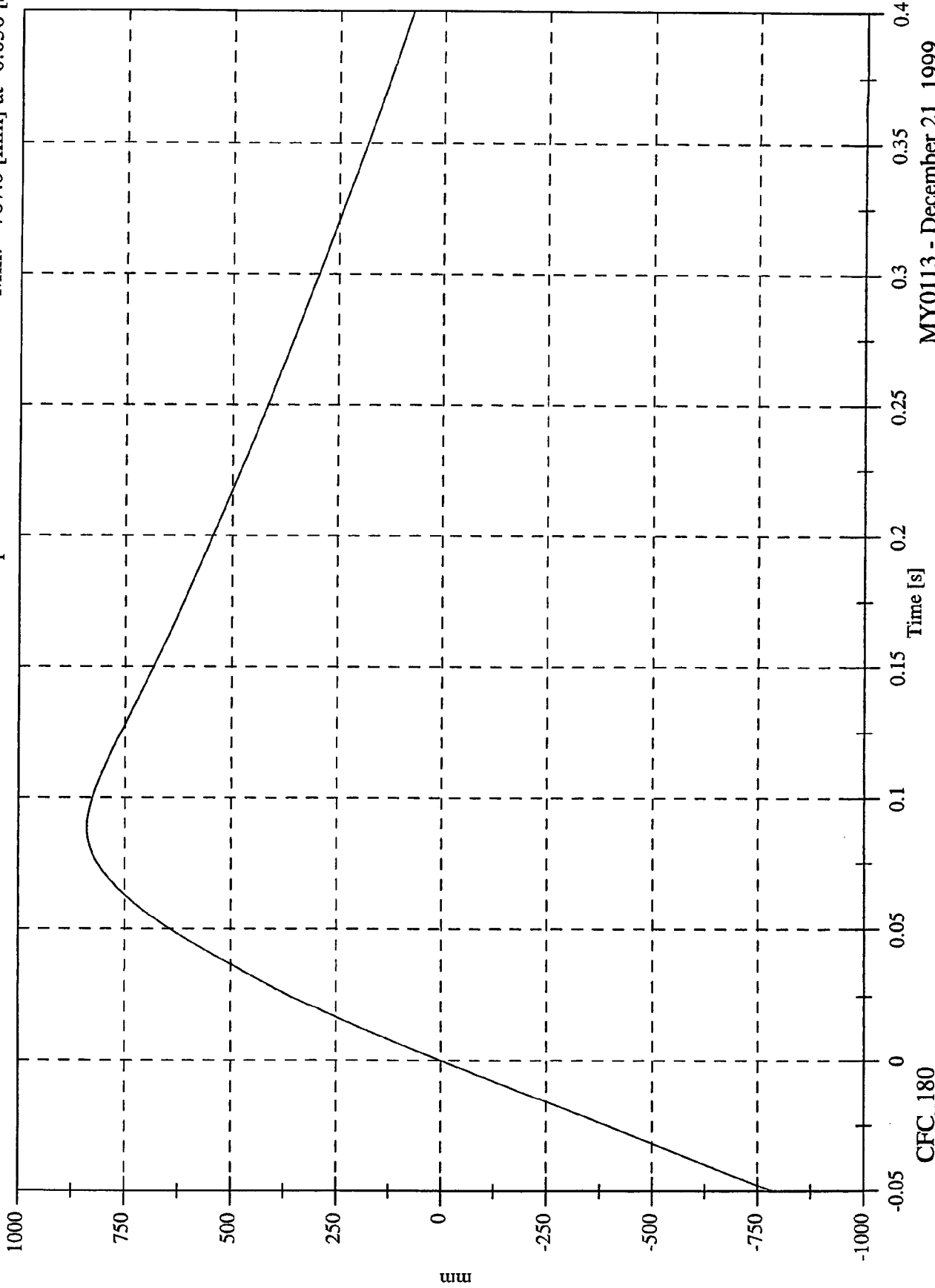

CFC\_180

MY0113 - December 21, 1999

NCAP Test 7 - 2000 Saturn SL

Max: 1.2 [g] at 0.164 [s]  
Min: -30.0 [g] at 0.079 [s]

Right Rear #2x

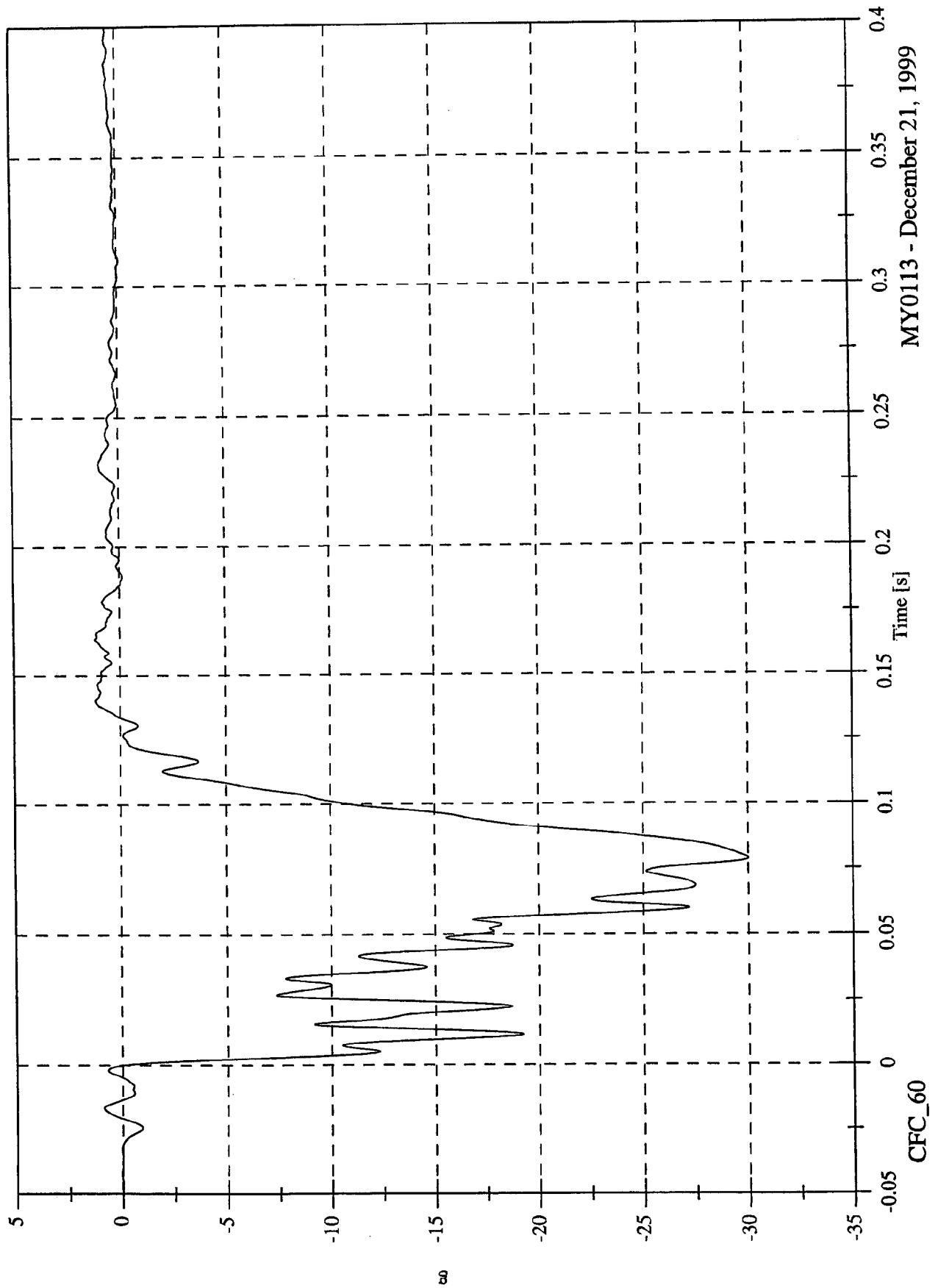

MY0113 - December 21, 1999

CFC\_60

NCAP Test 7 - 2000 Saturn SL

Max: 56.7 [kph] at -0.036 [s]  
Min: -9.7 [kph] at 0.133 [s]

Right Rear #2x Velocity

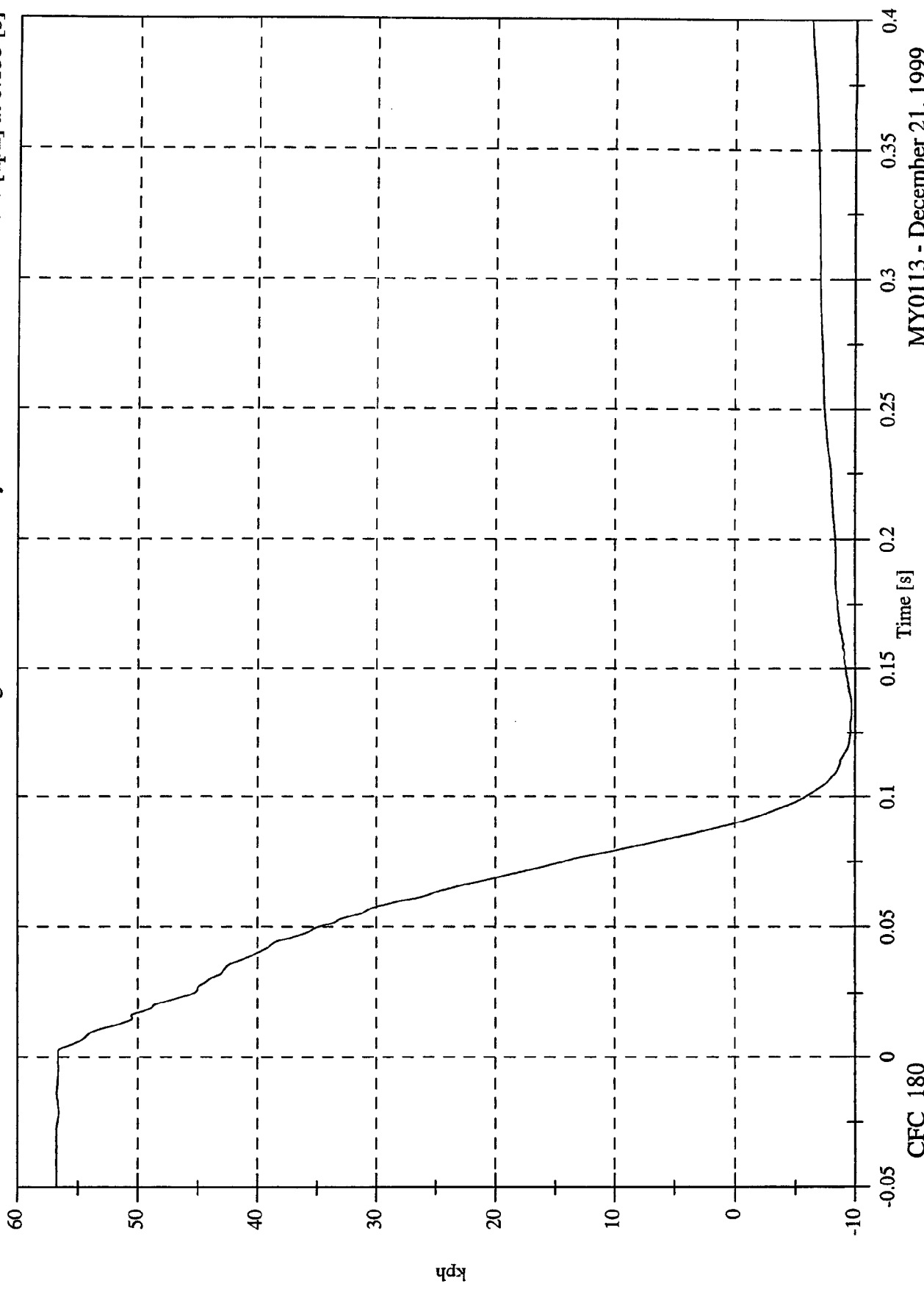

CFC\_180

MY0113 - December 21, 1999

NCAP Test 7 - 2000 Saturn SL

Max: 848.3 [mm] at 0.090 [s]  
Min: -787.3 [mm] at -0.050 [s]

Right Rear #2x Displacement

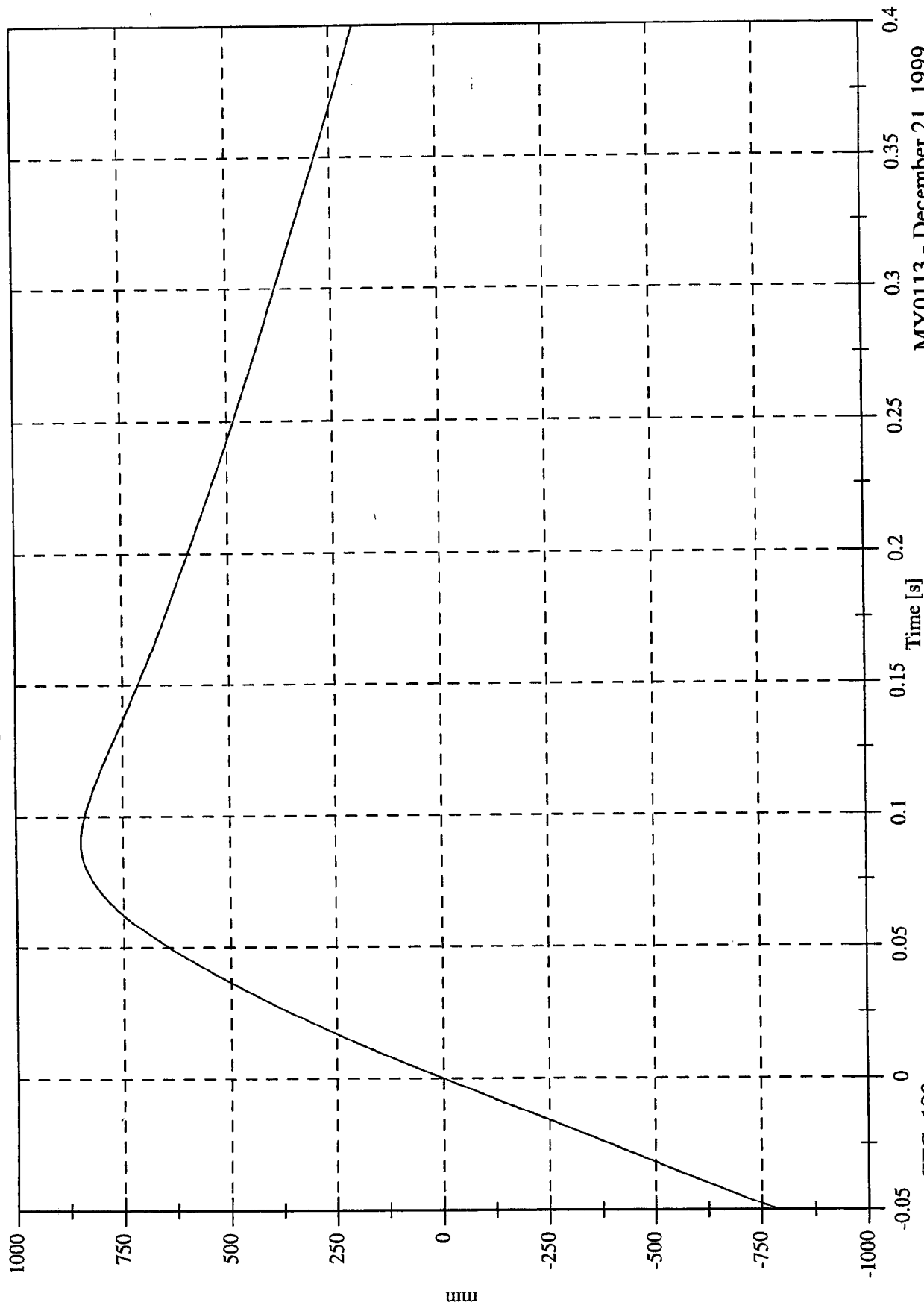

MY0113 - December 21, 1999

CFC\_180

NCAP Test 7 - 2000 Saturn SL

Max: 46.1 [g] at 0.056 [s]  
Min: -94.5 [g] at 0.041 [s]

Engine Top #3x

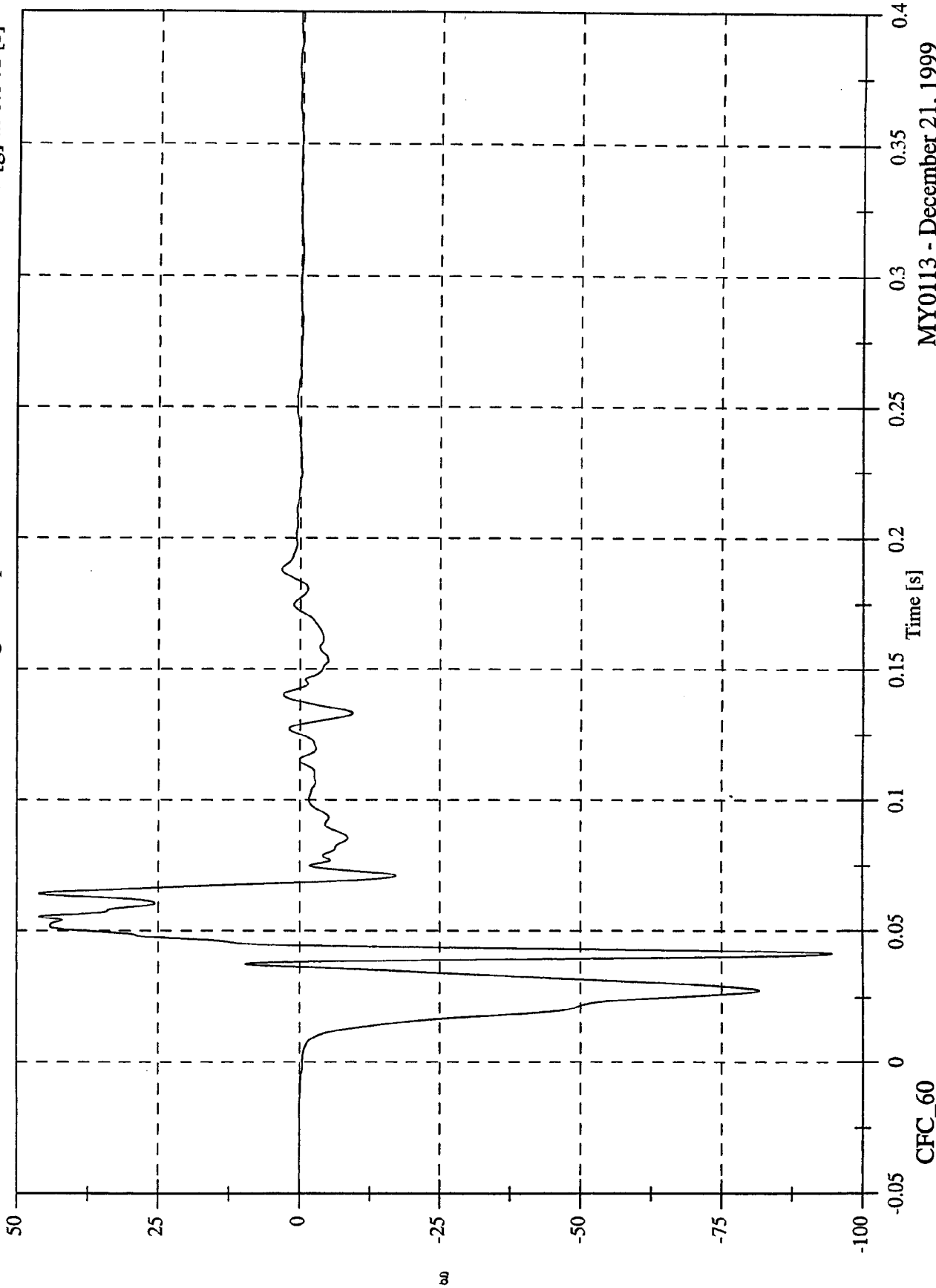

MY0113 - December 21, 1999

CFC\_60

NCAP Test 7 - 2000 Saturn SL

Engine Top #3x Velocity

Max: 56.7 [kph] at -0.013 [s]  
Min: 4.2 [kph] at 0.044 [s]

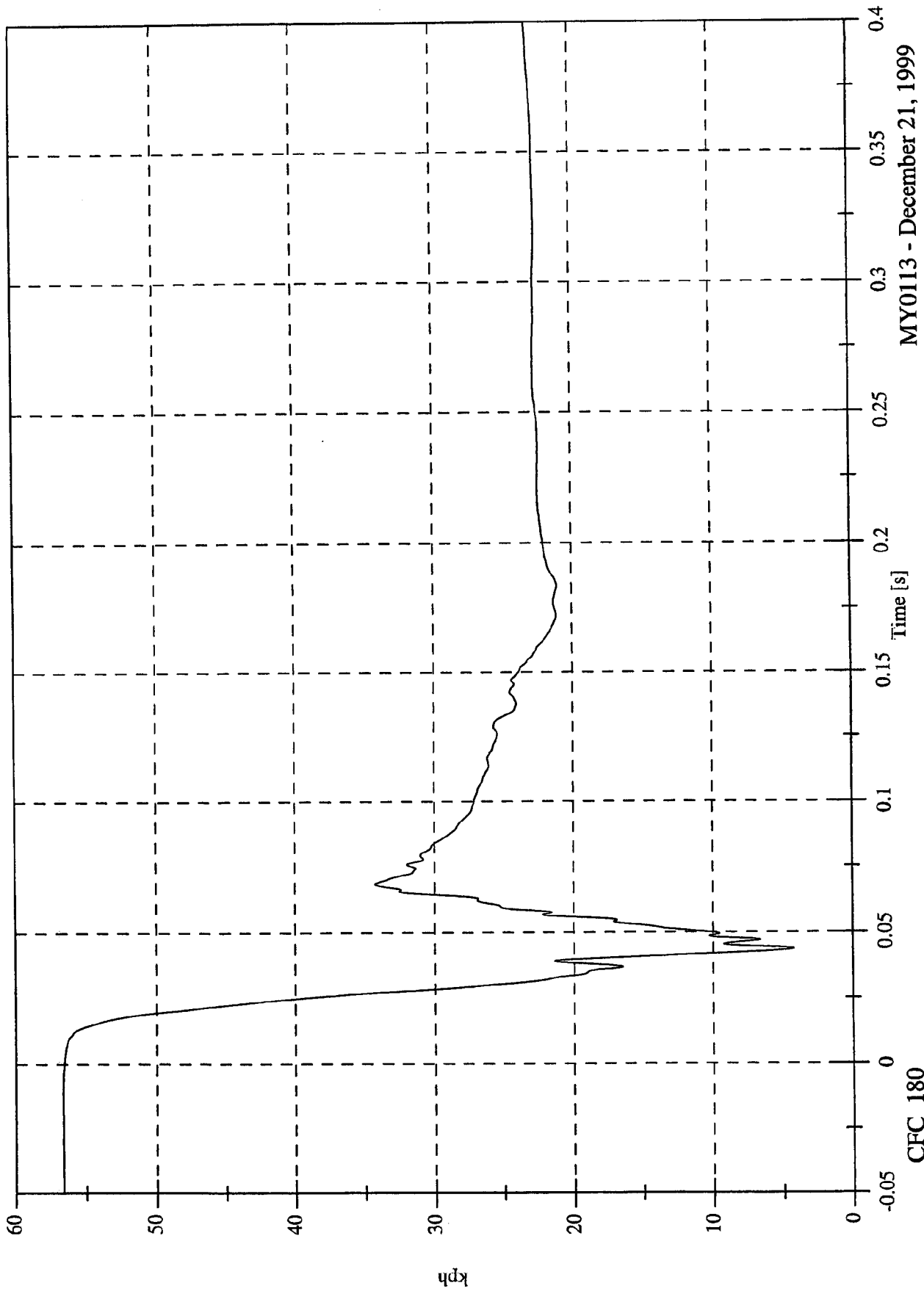

MY0113 - December 21, 1999

CFC\_180

NCAP Test 7 - 2000 Saturn SL

Engine Top #3x Displacement

Max: 2787.6 [mm] at 0.400 [s]

Min: -786.5 [mm] at -0.050 [s]

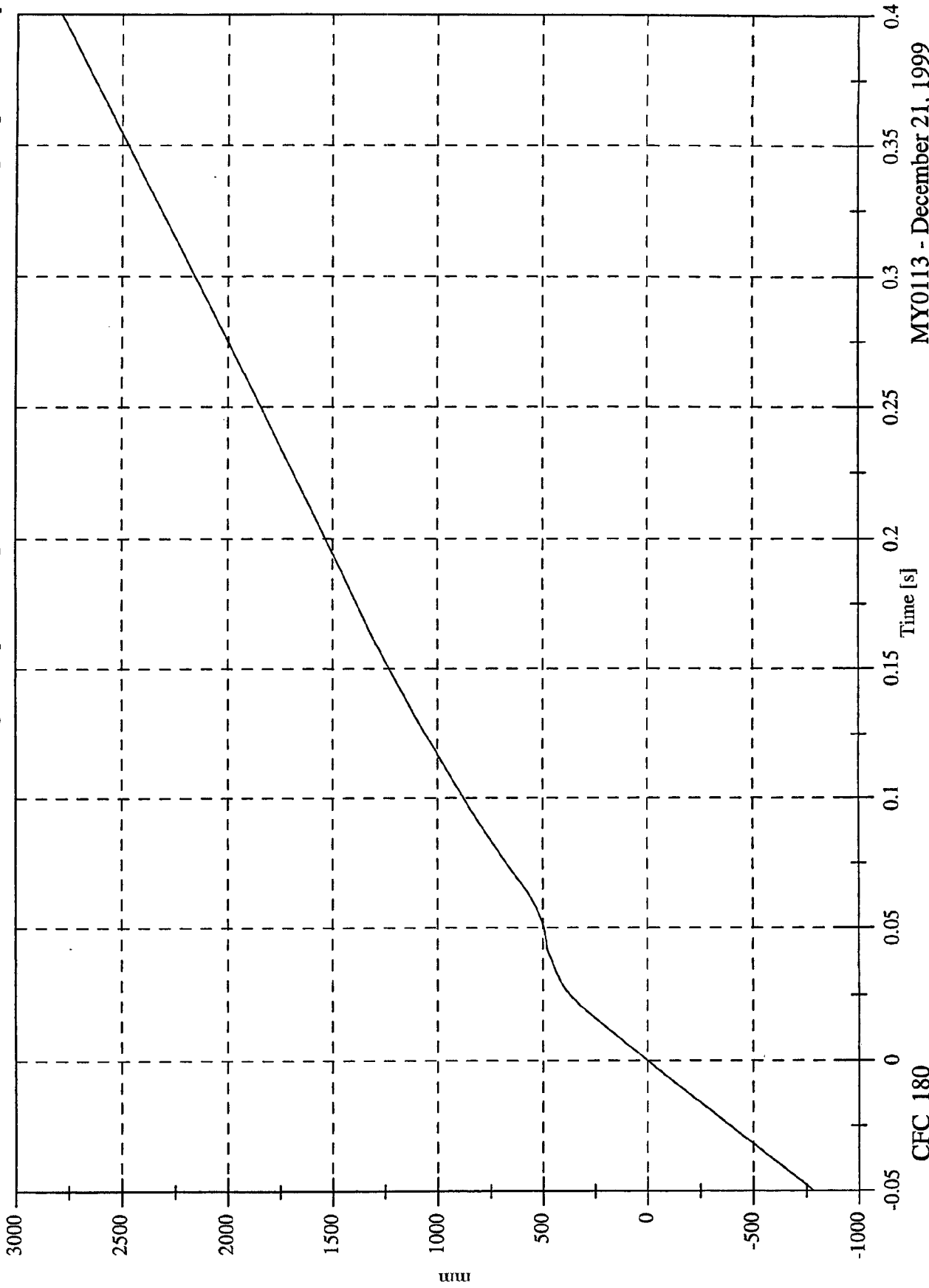

CFC\_180

MY0113 - December 21, 1999

NCAP Test 7 - 2000 Saturn SL

Max: 29.2 [g] at 0.056 [s]  
Min: -91.5 [g] at 0.036 [s]

Engine Bottom #4x

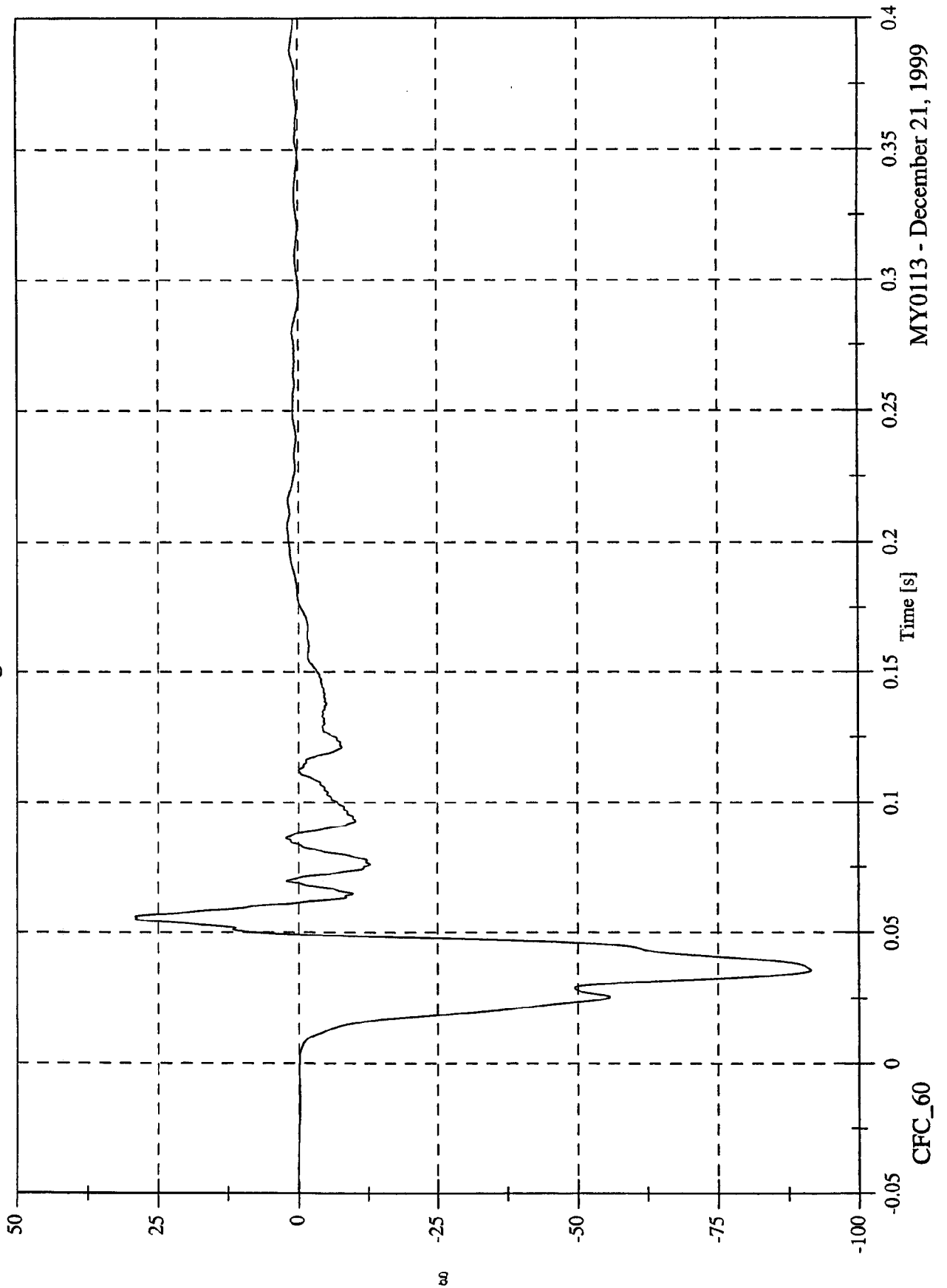

MY0113 - December 21, 1999

NCAP Test 7 - 2000 Saturn SL

Max: 56.8 [kph] at -0.035 [s]  
Min: -20.4 [kph] at 0.176 [s]

Engine Bottom #4x Velocity

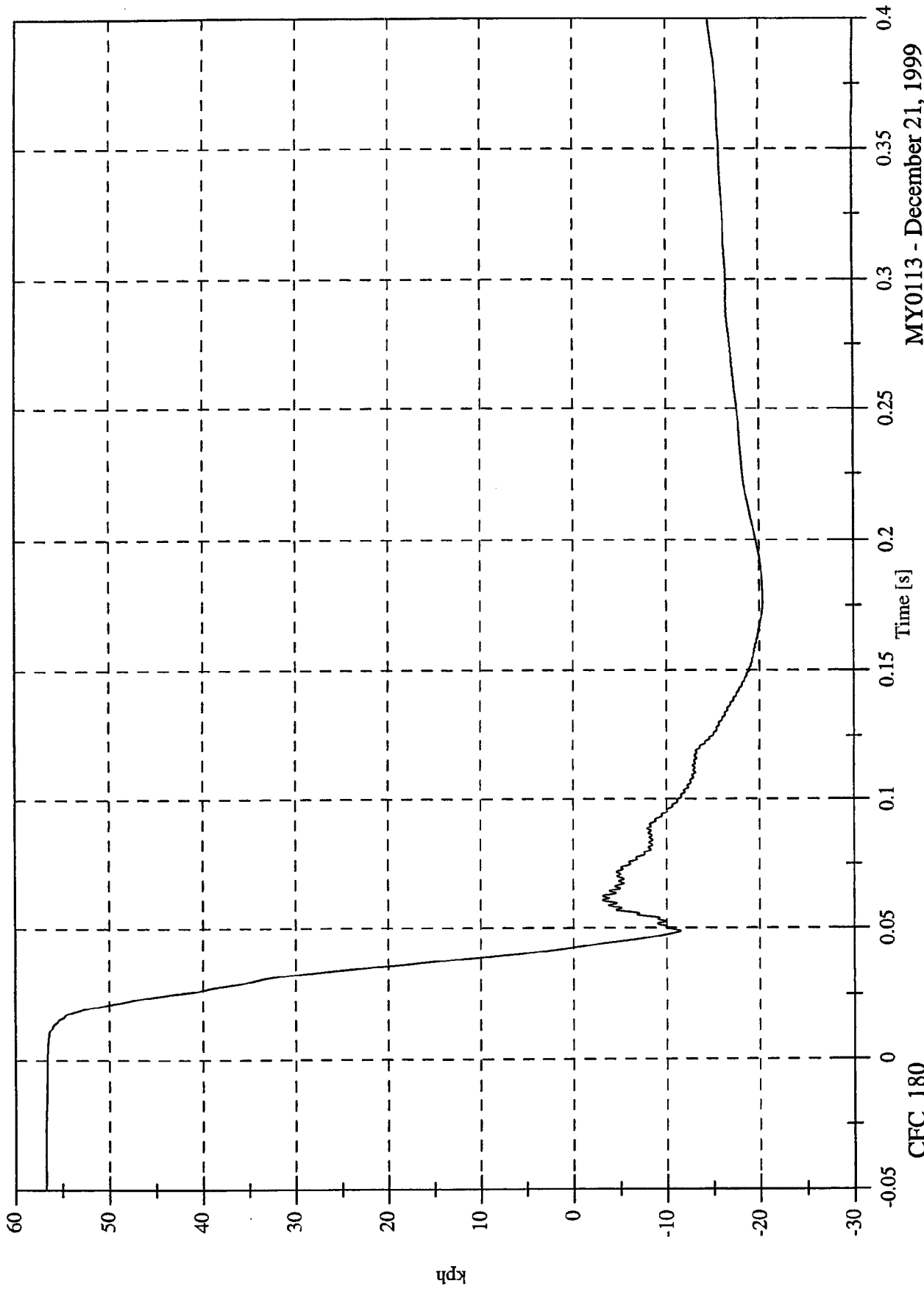

CFC\_180

MY0113 - December 21, 1999

NCAP Test 7 - 2000 Saturn SL

Engine Bottom #4x Displacement

Max: 492.7 [mm] at 0.042 [s]  
Min: -1032.9 [mm] at 0.400 [s]

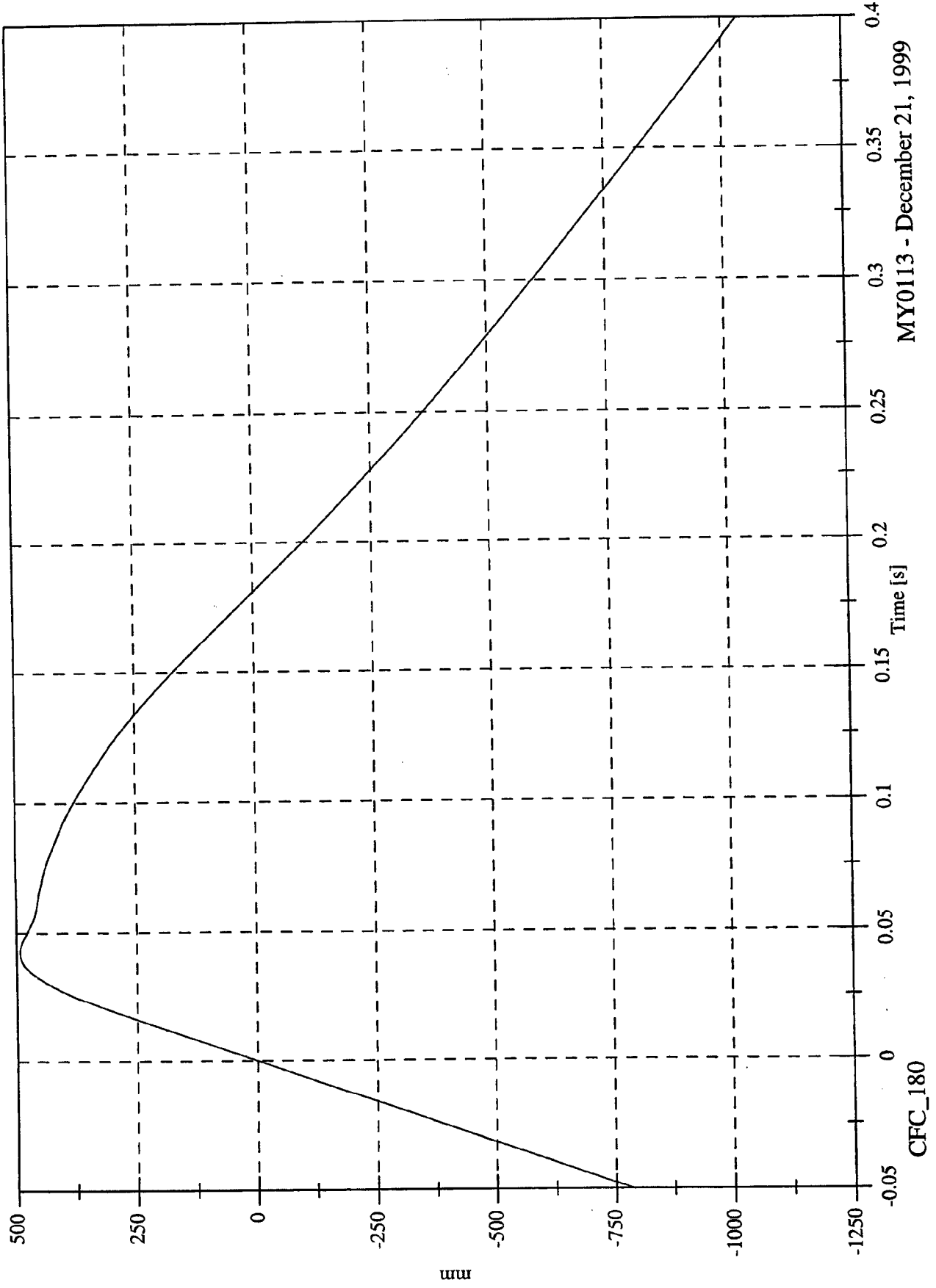

MY0113 - December 21, 1999

CFC\_180

NCAP Test 7 - 2000 Saturn SL

Max: 271.5 [g] at 0.108 [s]  
Min: -524.5 [g] at 0.040 [s]

Right Caliper #5x

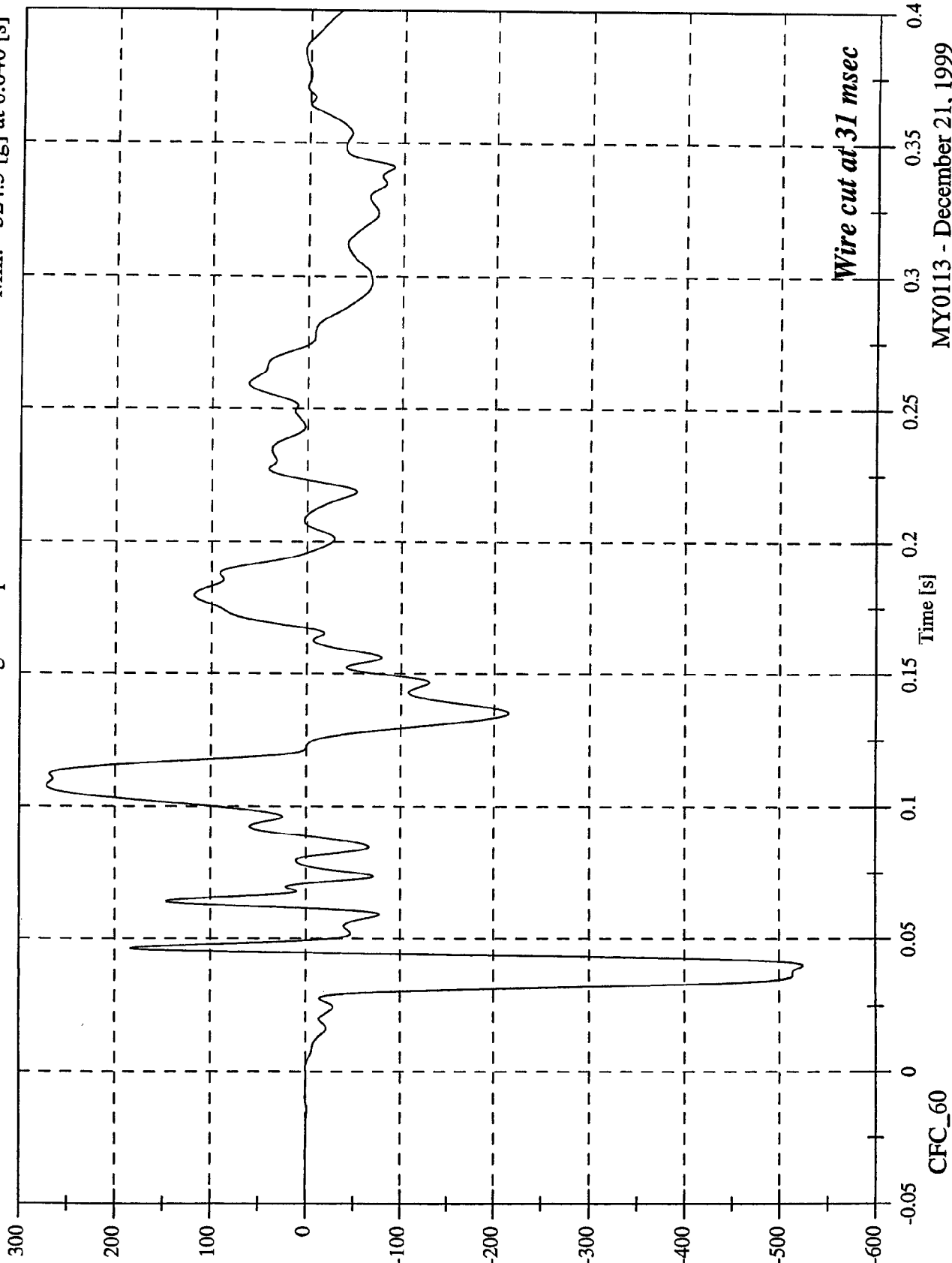

MY0113 - December 21, 1999

NCAP Test 7 - 2000 Saturn SL

Max: 56.8 [kph] at -0.025 [s]  
Min: -202.3 [kph] at 0.400 [s]

Right Caliper #5x Velocity

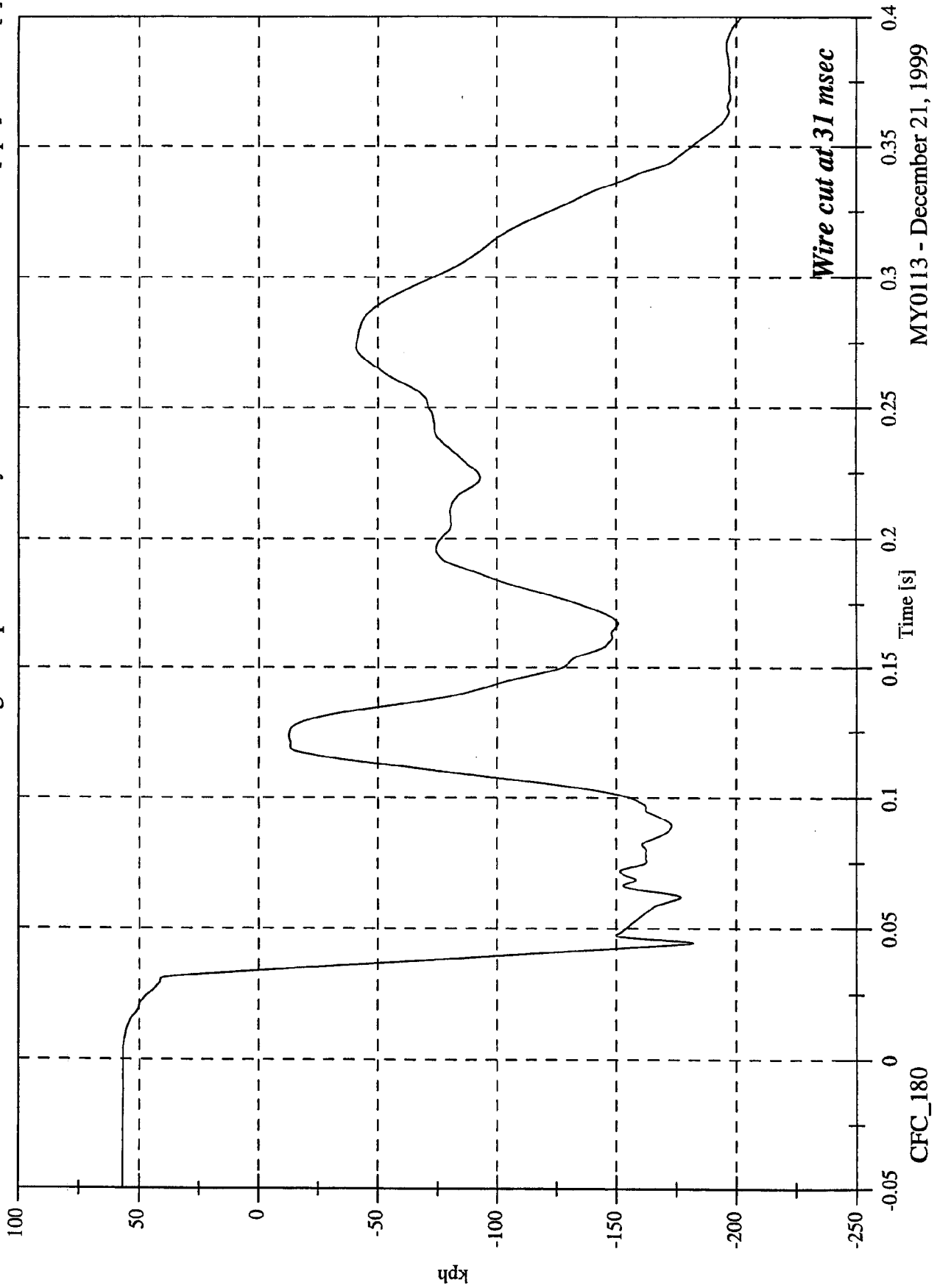

Wire cut at 31 msec

MY0113 - December 21, 1999

NCAP Test 7 - 2000 Saturn SL

Max: 462.7 [mm] at 0.034 [s]  
Min: -11209.1 [mm] at 0.400 [s]

Right Caliper #5x Displacement

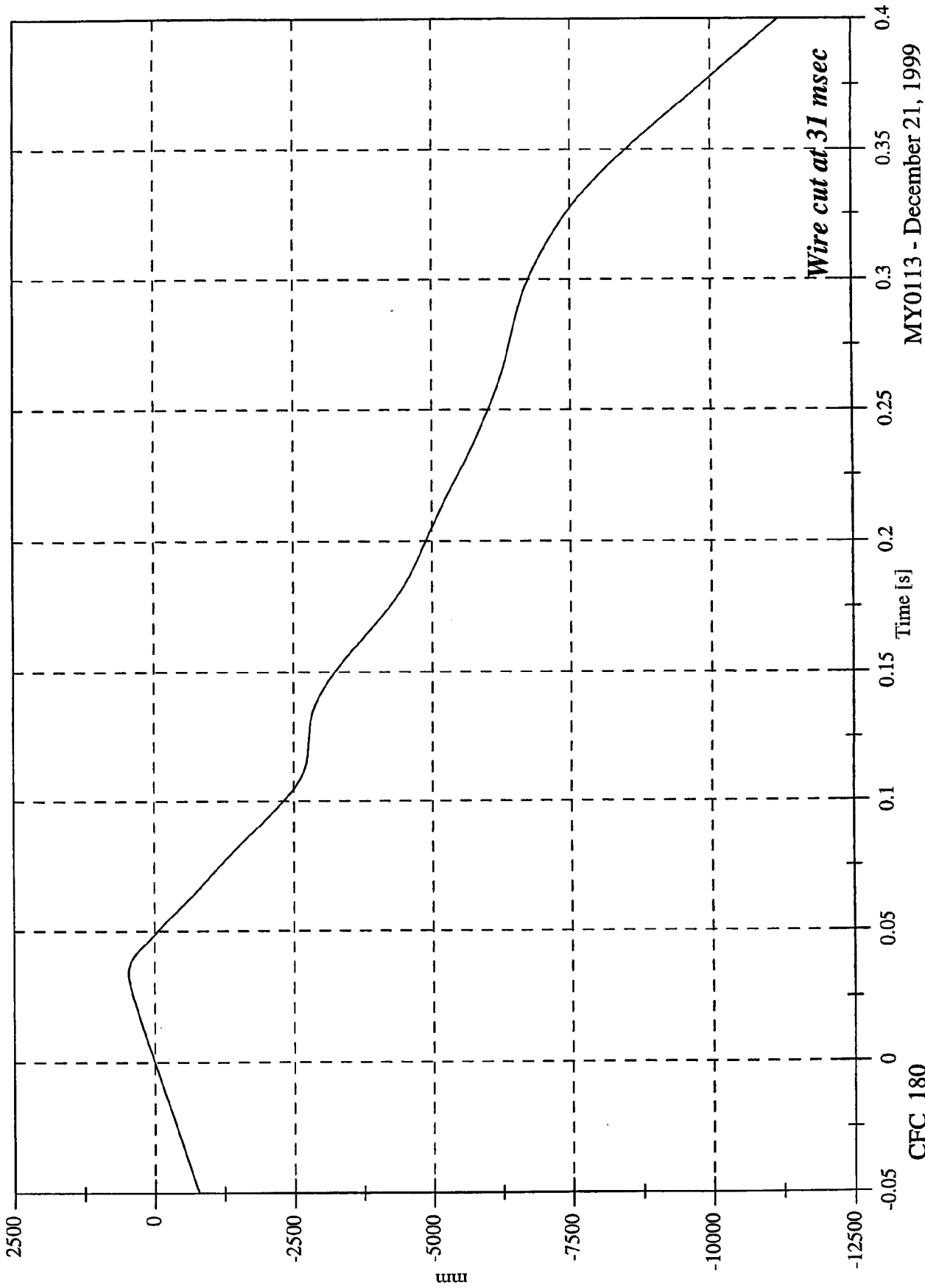

CFC\_180

MY0113 - December 21, 1999

NCAP Test 7 - 2000 Saturn SL

Max: 31.4 [g] at 0.076 [s]  
Min: -61.4 [g] at 0.065 [s]

Instrument Panel #6x

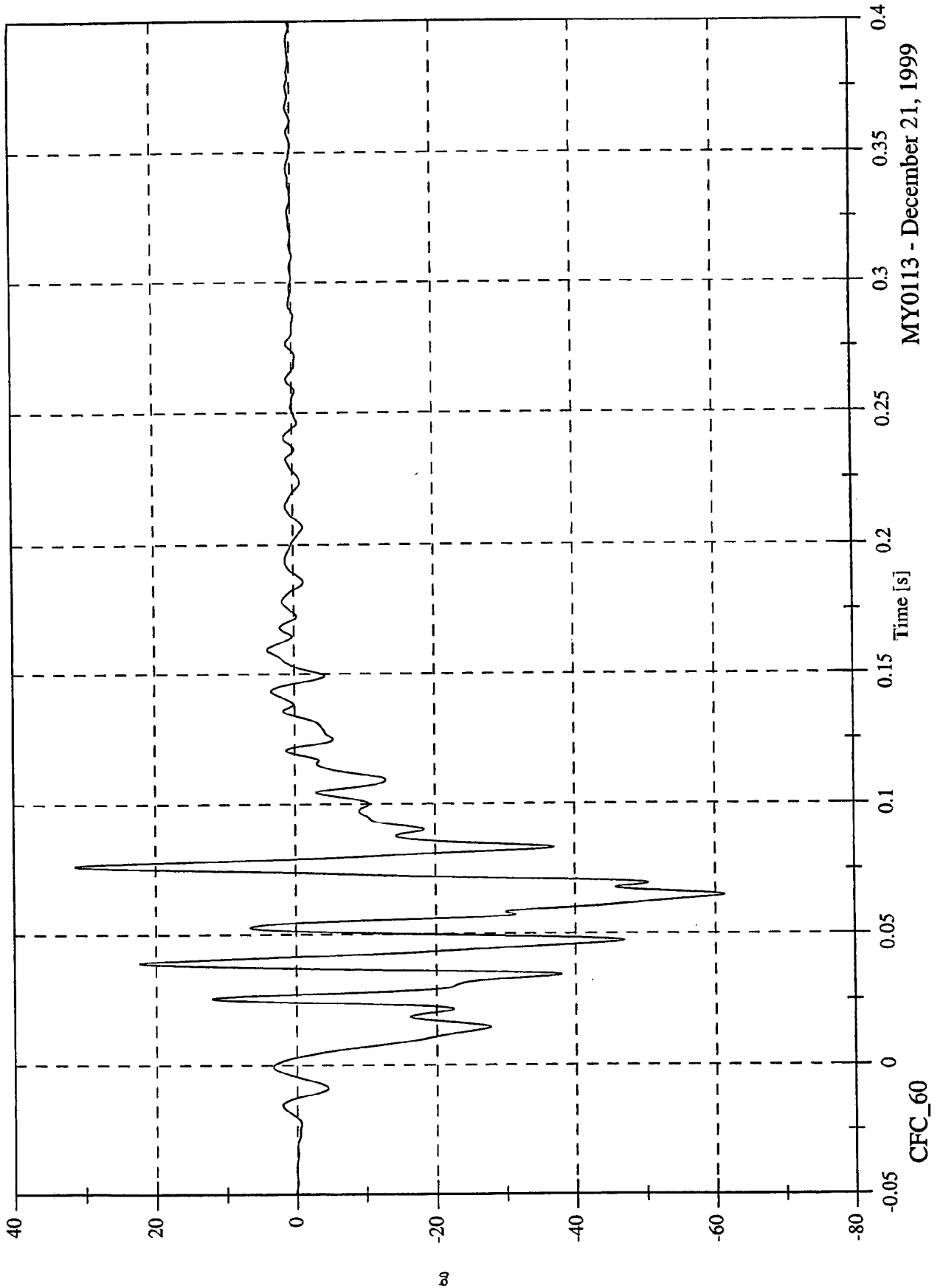

MY0113 - December 21, 1999

CFC\_60

NCAP Test 7 - 2000 Saturn SL

Max: 56.8 [kph] at -0.012 [s]  
Min: -11.0 [kph] at 0.134 [s]

Instrument Panel #6x Velocity

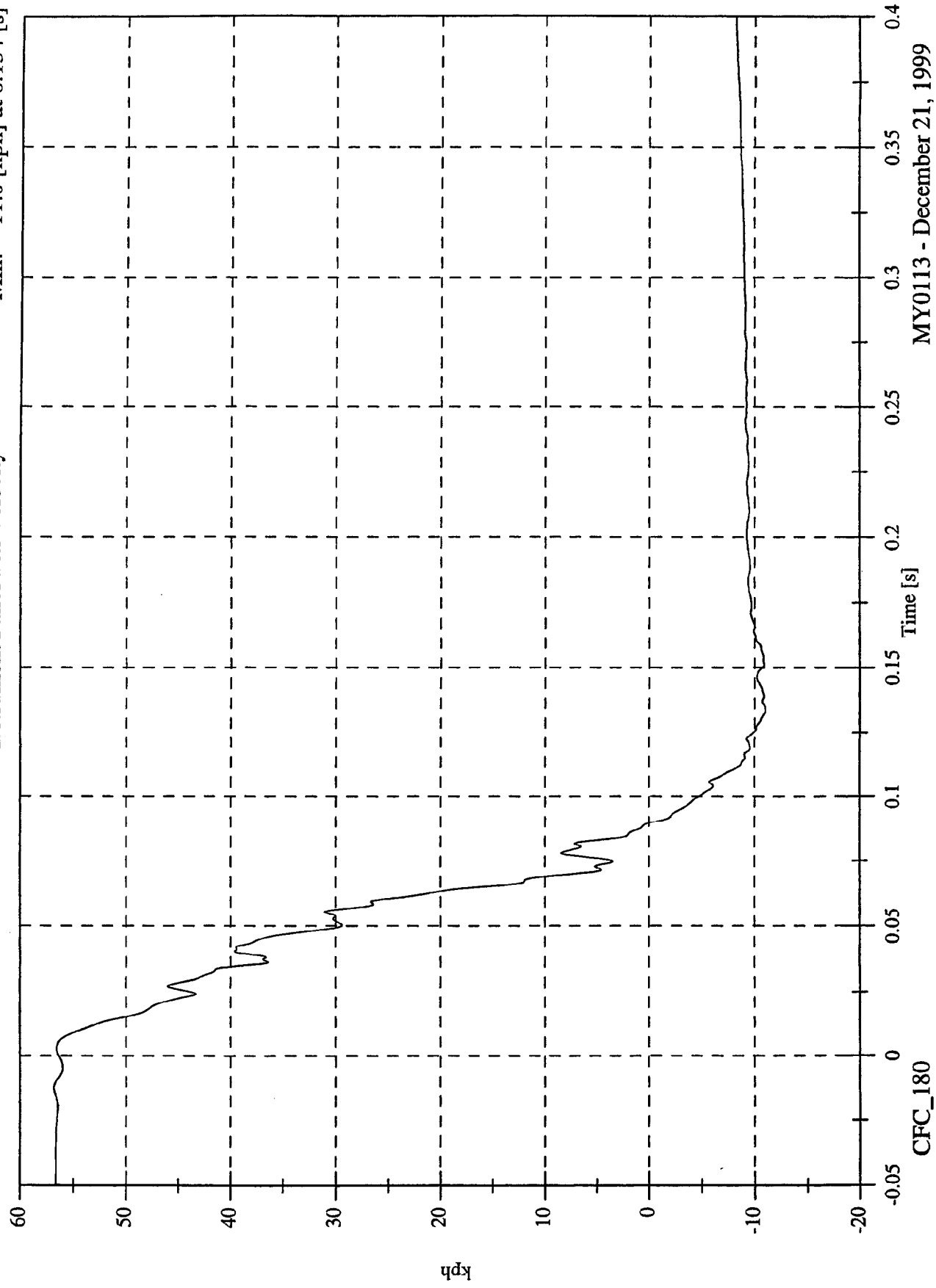

CFC\_180

MY0113 - December 21, 1999

NCAP Test 7 - 2000 Saturn SL

Max: 780.5 [mm] at 0.090 [s]  
Min: -785.0 [mm] at -0.050 [s]

Instrument Panel #6x Displacement

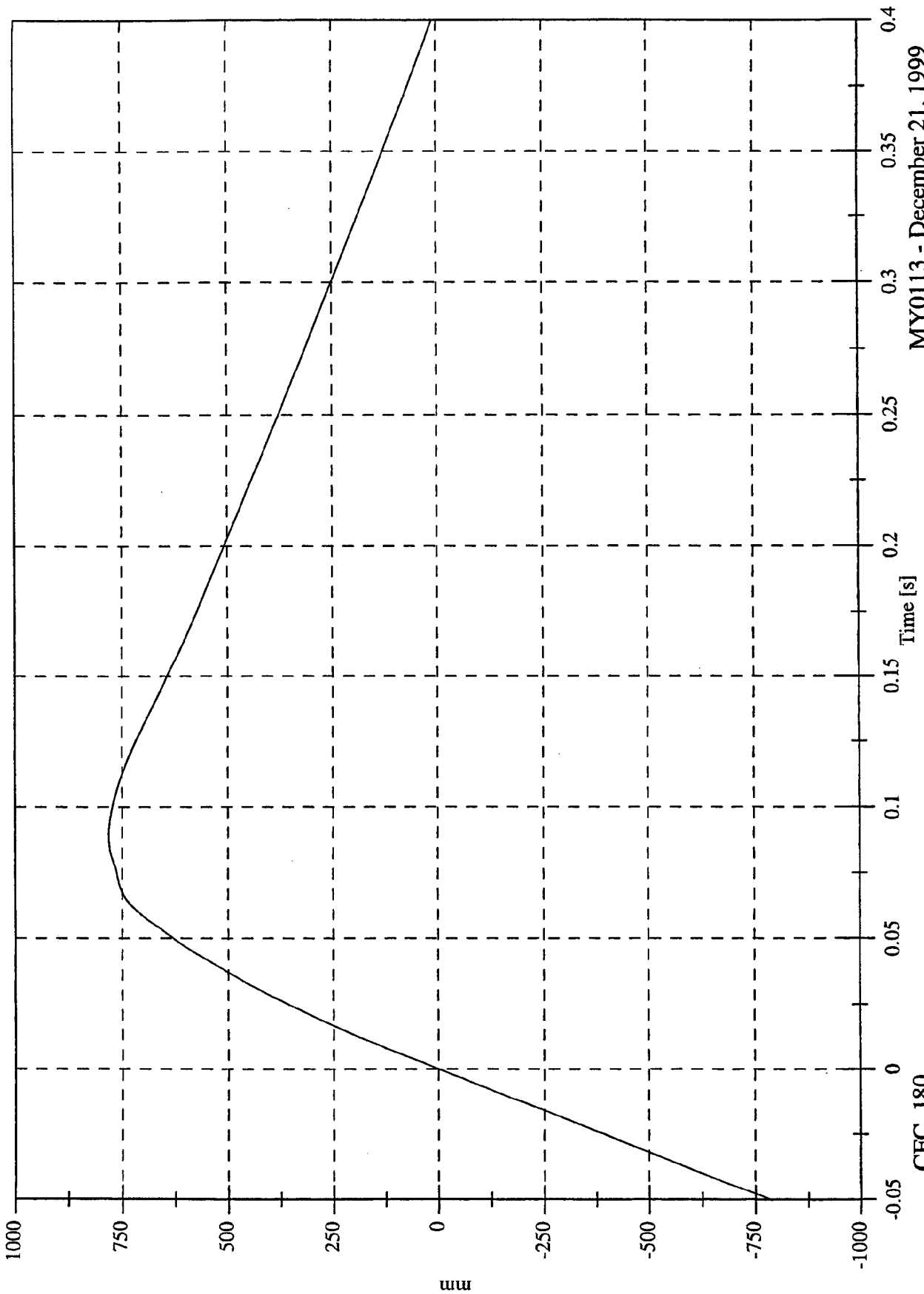

MY0113 - December 21, 1999

CFC\_180

NCAP Test 7 - 2000 Saturn SL

Max: 56.9 [g] at 0.067 [s]  
Min: -80.0 [g] at 0.050 [s]

Left Caliper #7x

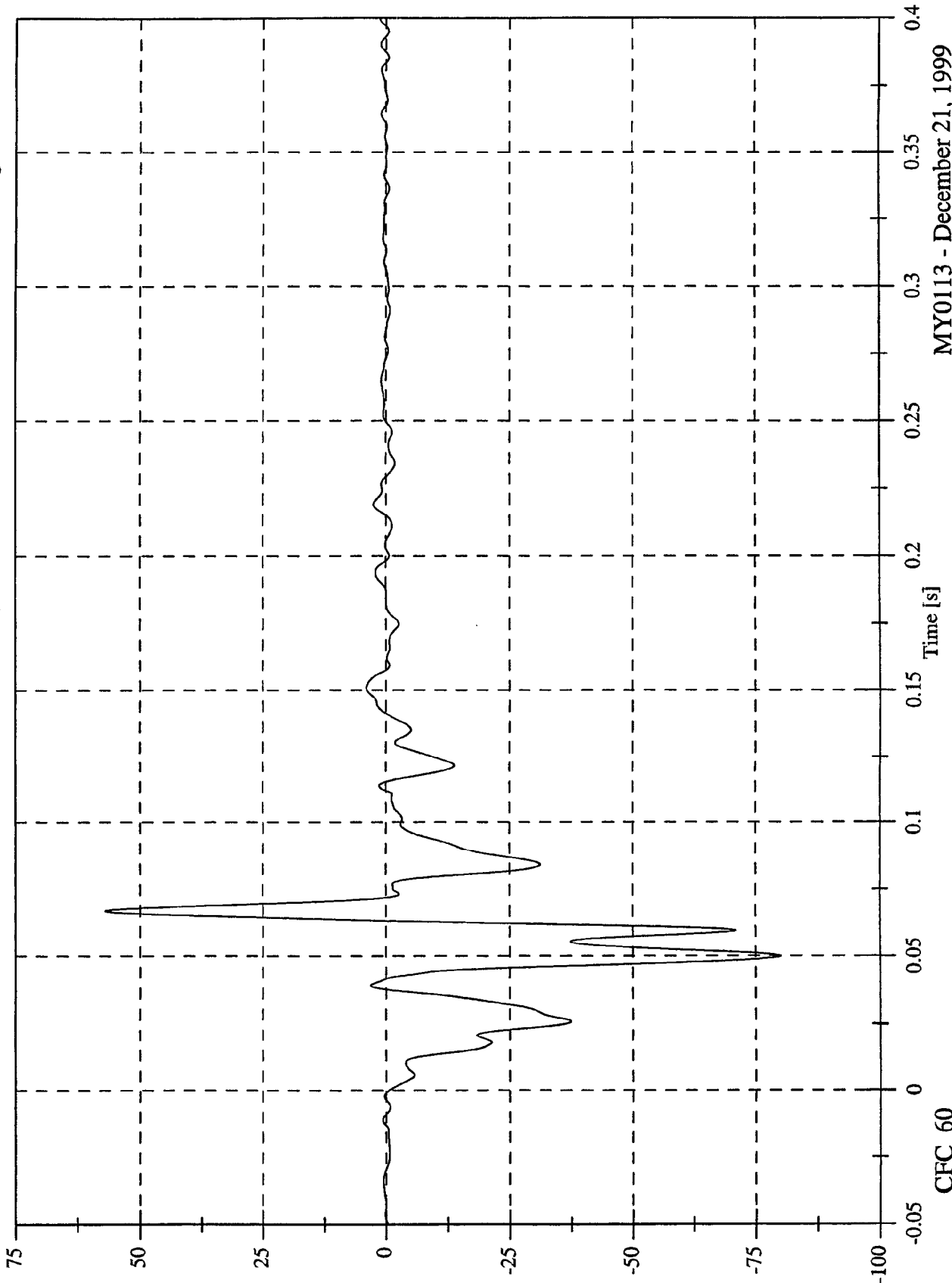

CFC\_60

MY0113 - December 21, 1999

NCAP Test 7 - 2000 Saturn SL

Max: 56.9 [kph] at -0.030 [s]  
Min: -8.4 [kph] at 0.141 [s]

Left Caliper #7x Velocity

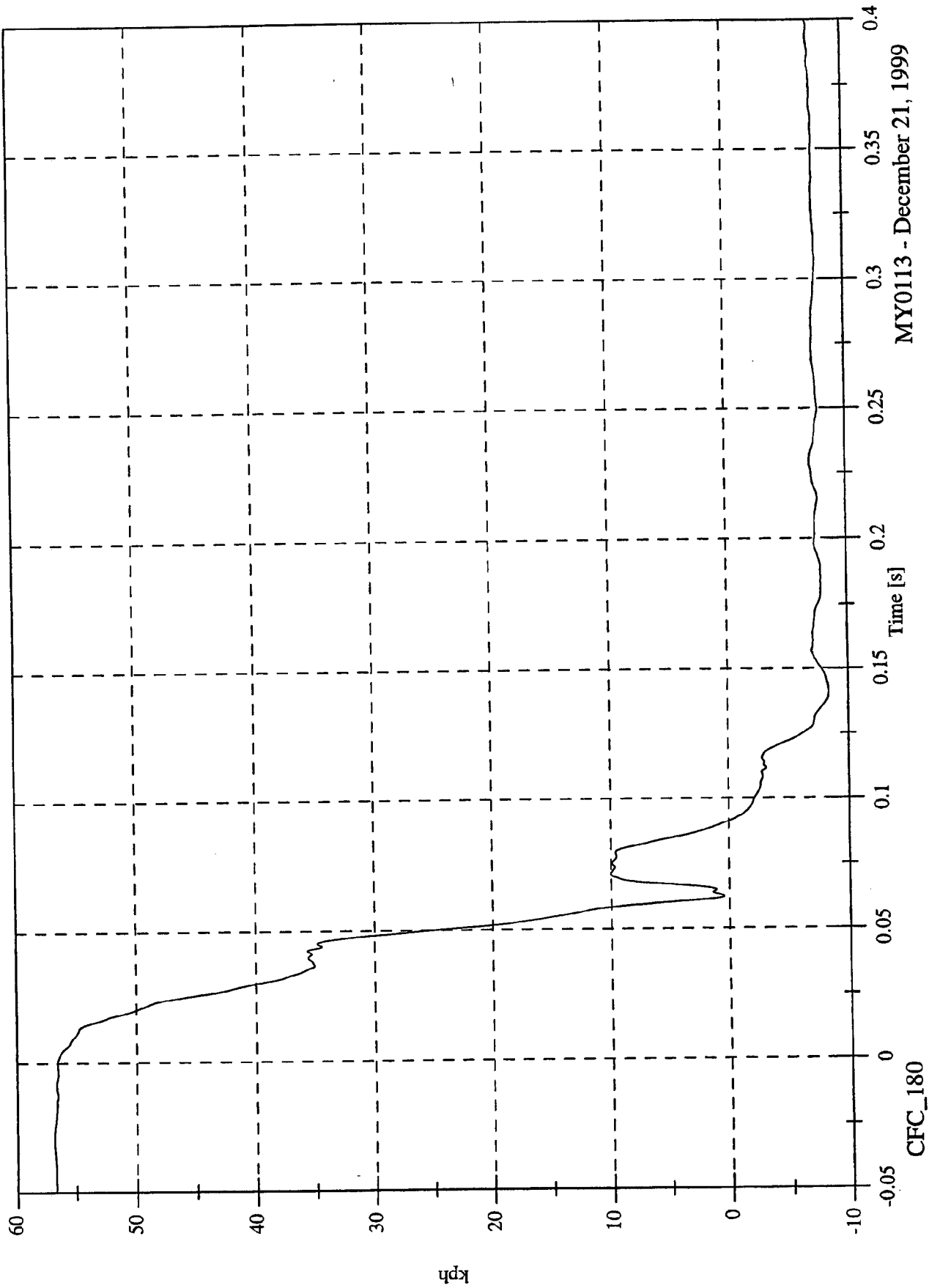

MY0113 - December 21, 1999

CFC\_180

NCAP Test 7 - 2000 Saturn SL

Max: 716.4 [mm] at 0.091 [s]  
Min: -787.5 [mm] at -0.050 [s]

Left Caliper #7x Displacement

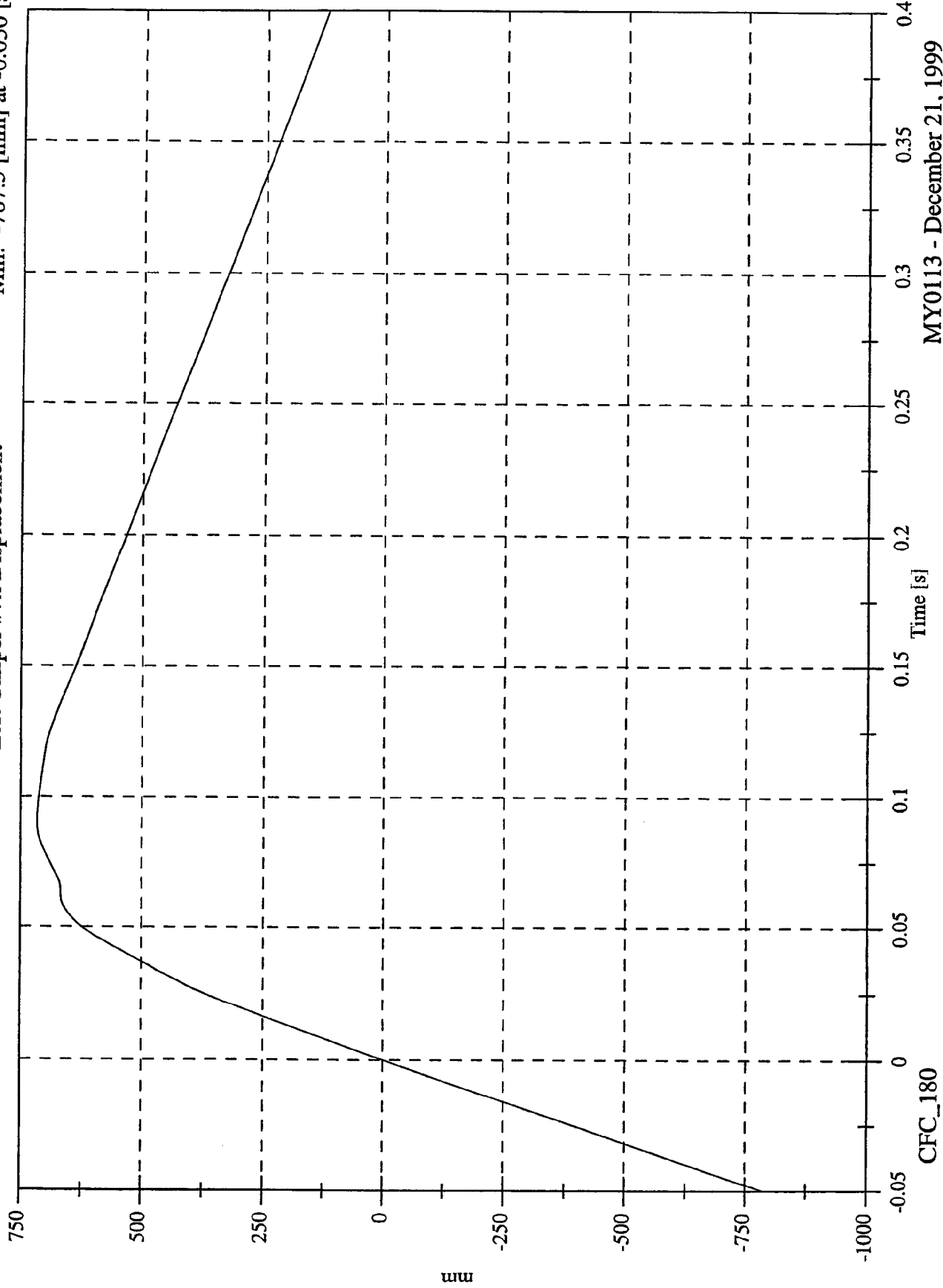

CFC\_180

NCAP Test 7 - 2000 Saturn SL

Left Rear Red #8x

Max: 2.7 [g] at 0.060 [s]  
Min: -24.2 [g] at 0.045 [s]

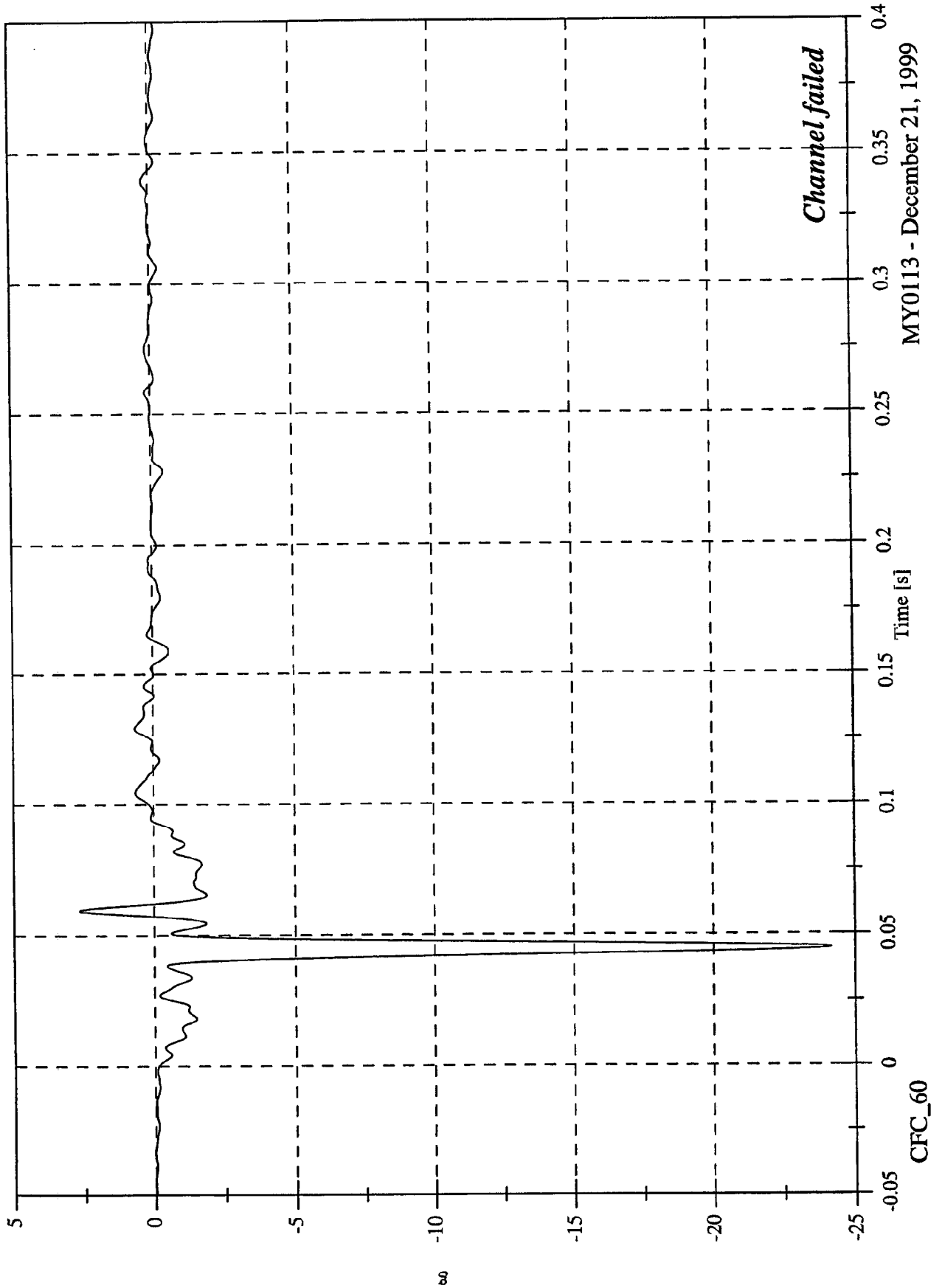

MY0113 - December 21, 1999

NCAP Test 7 - 2000 Saturn SL

Max: 56.7 [kph] at -0.050 [s]  
Min: 49.6 [kph] at 0.400 [s]

Left Rear Red #8x Velocity

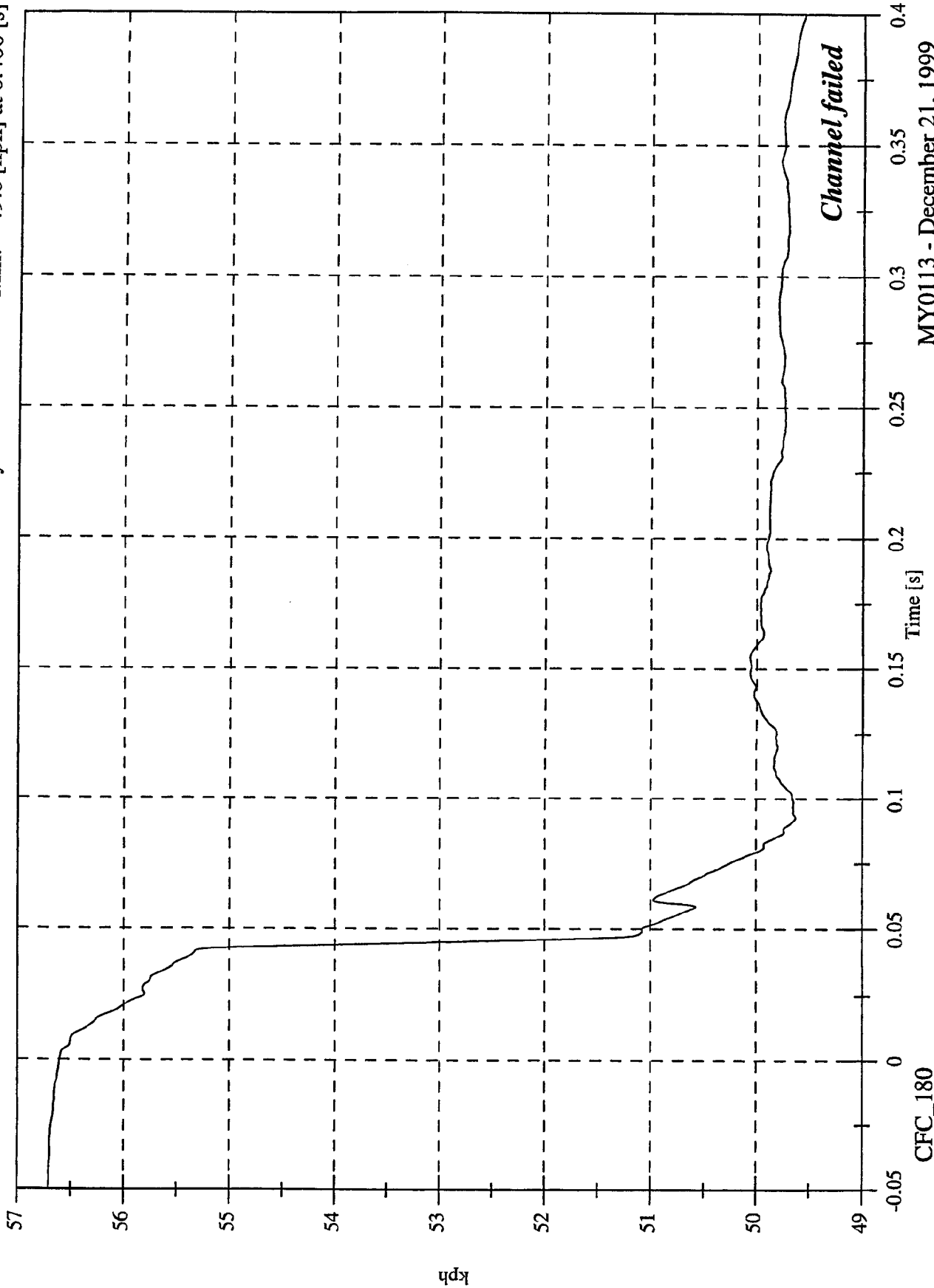

CFC\_180

MY0113 - December 21, 1999

NCAP Test 7 - 2000 Saturn SL

Left Rear Red #8x Displacement

Max: 5618.1 [mm] at 0.400 [s]  
Min: -787.1 [mm] at -0.050 [s]

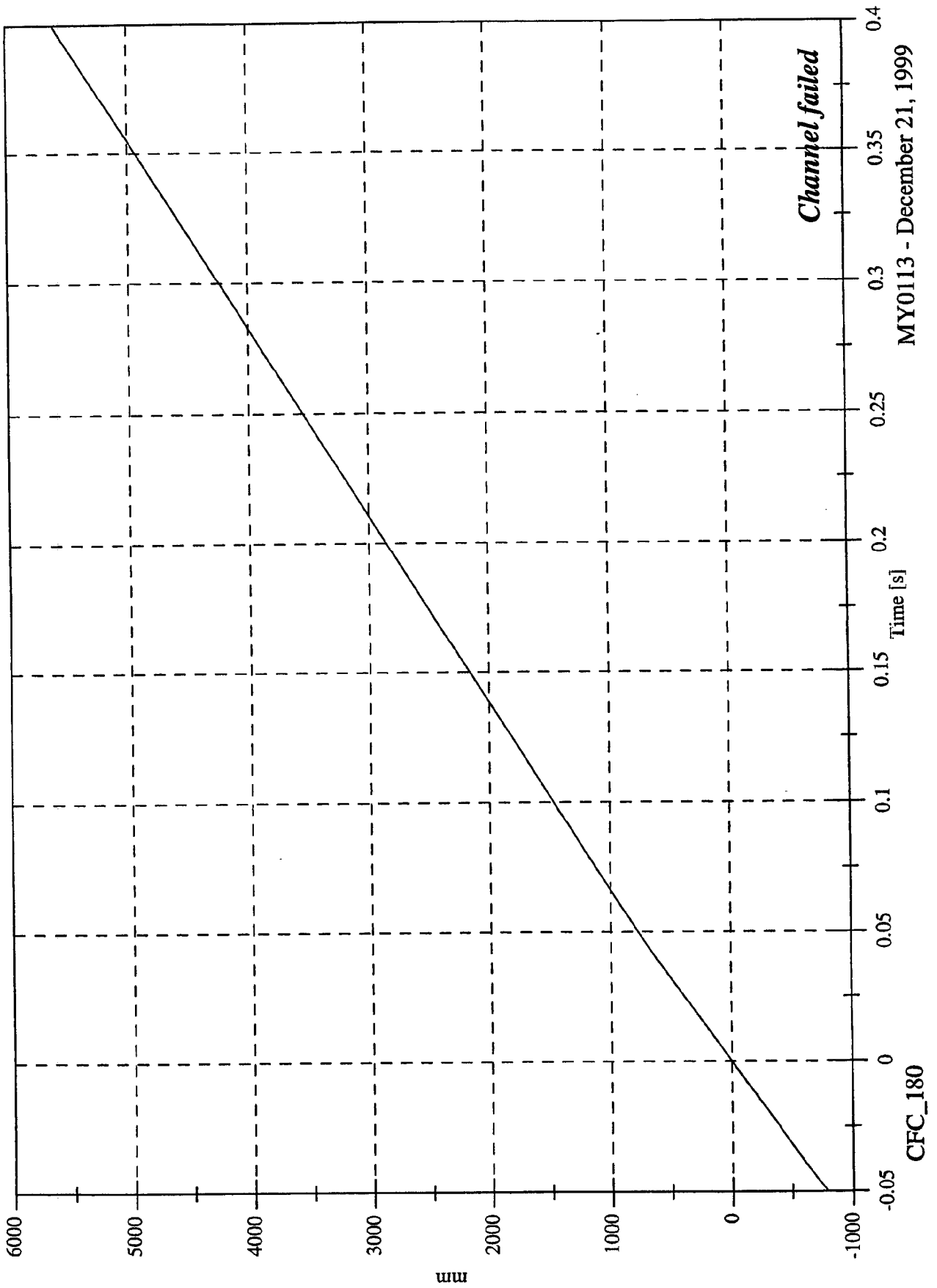

MY0113 - December 21, 1999

CFC\_180

NCAP Test 7 - 2000 Saturn SL

Max: 1.3 [g] at 0.140 [s]  
Min: -30.8 [g] at 0.078 [s]

Right Rear Red #9x

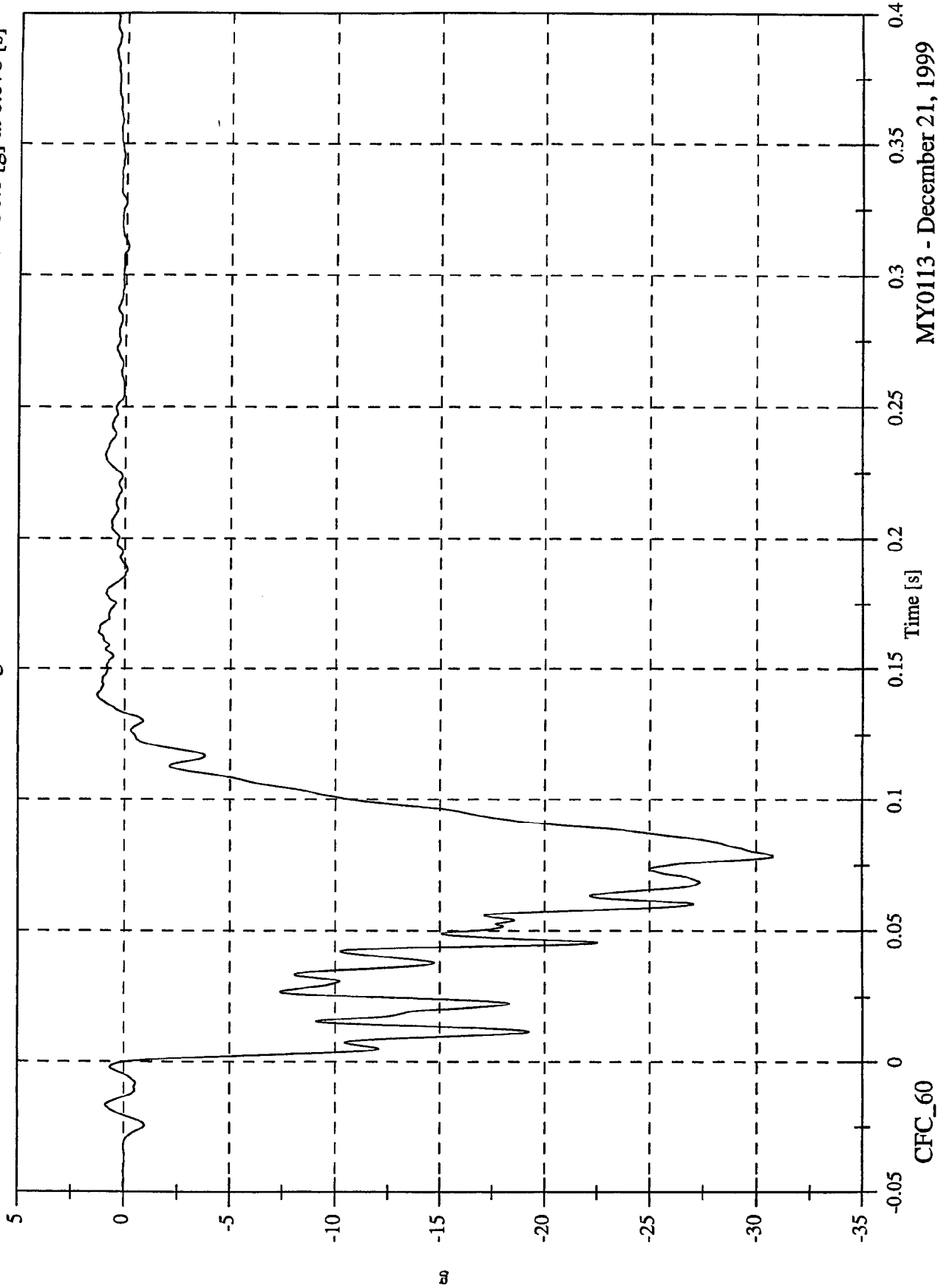

MY0113 - December 21, 1999

CFC\_60

NCAP Test 7 - 2000 Saturn SL

Max: 56.7 [kph] at -0.041 [s]  
Min: -9.8 [kph] at 0.132 [s]

Right Rear Red #9x Velocity

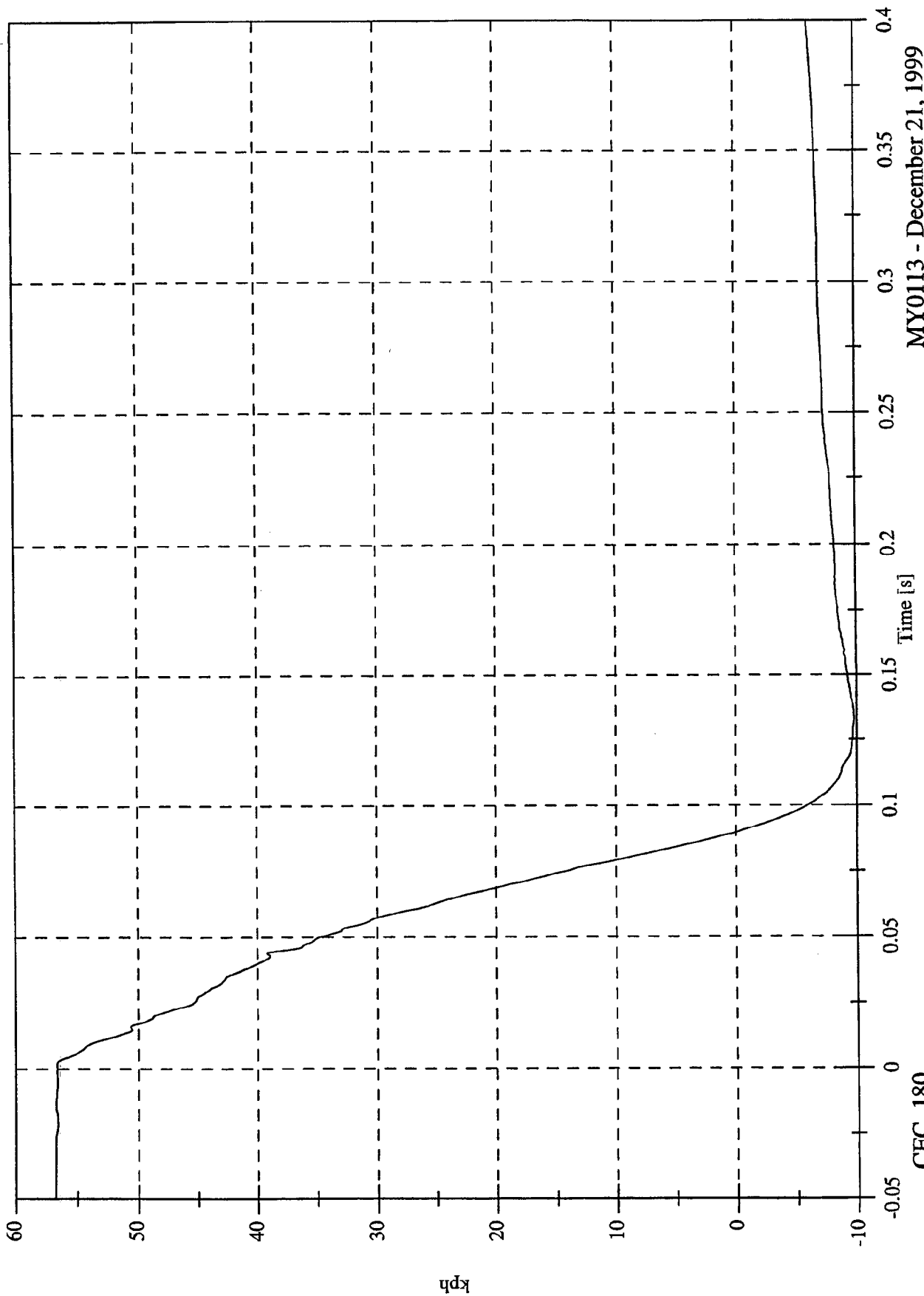

CFC\_180

Time [s]

MY0113 - December 21, 1999

NCAP Test 7 - 2000 Saturn SL

Max: 846.7 [mm] at 0.089 [s]  
Min: -787.2 [mm] at -0.050 [s]

Right Rear Red #9x Displacement

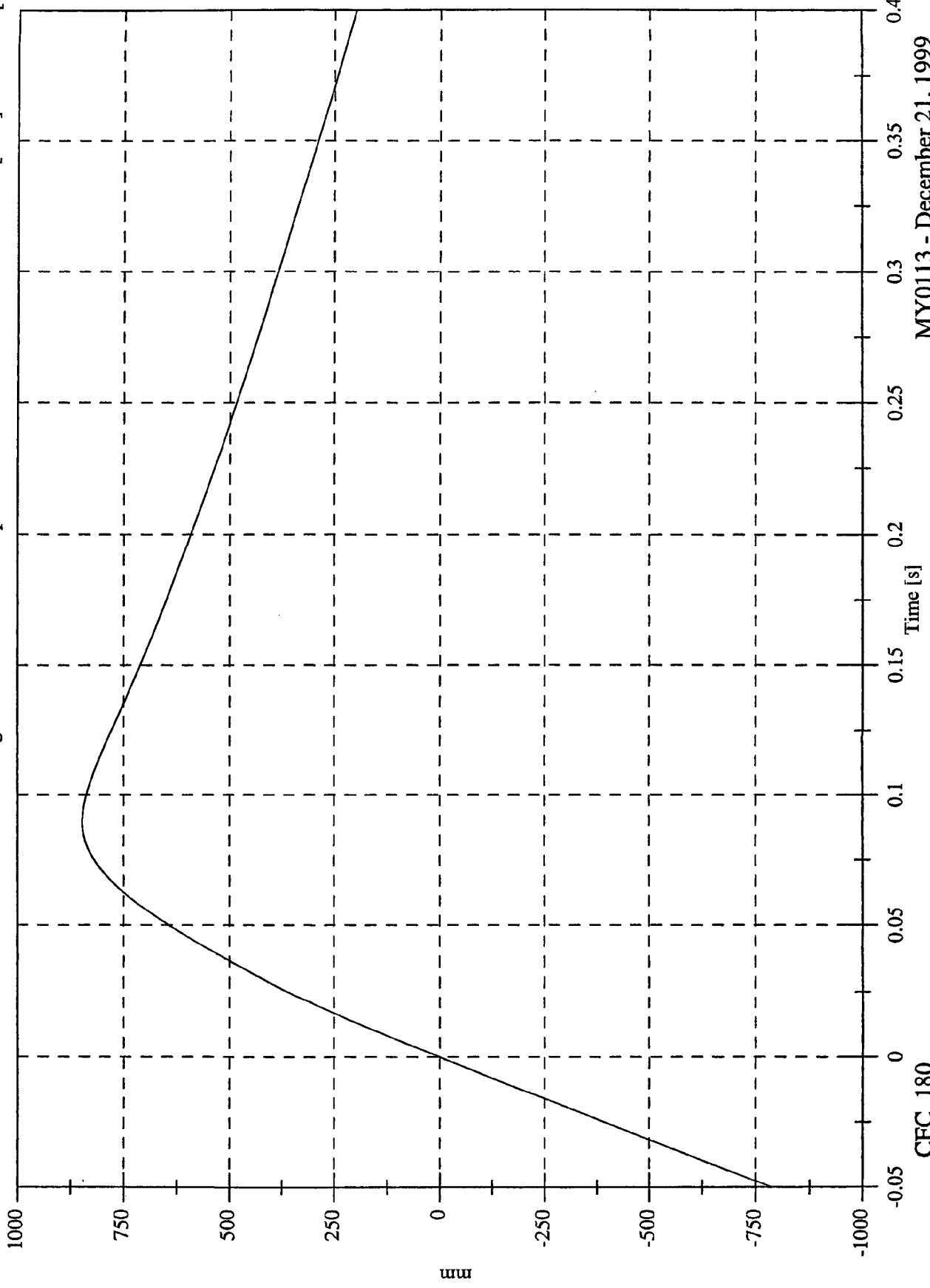

CFC\_180

MY0113 - December 21, 1999

NCAP Test 7 - 2000 Saturn SL

Max: 1.0 [ ] at 0.000 [s]  
Min: 0.0 [ ] at -0.050 [s]

Contact Time

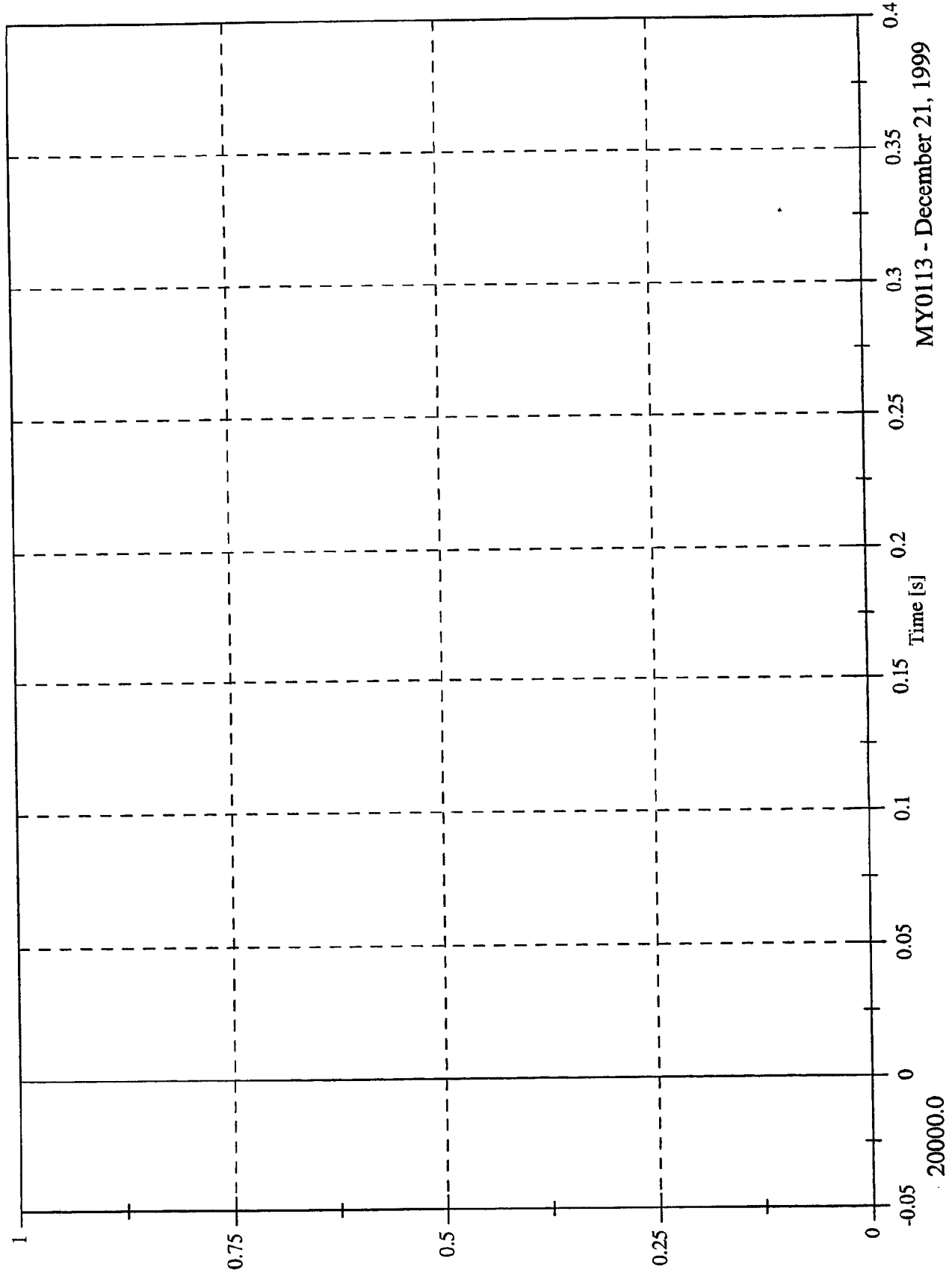

MY0113 - December 21, 1999

NCAP TEST #7 - 2000 Saturn SL

Max: 421.9 [Nwt] at 0.054 [S]  
Min: -637.0 [Nwt] at 0.029 [S]

BLC A1 Fx

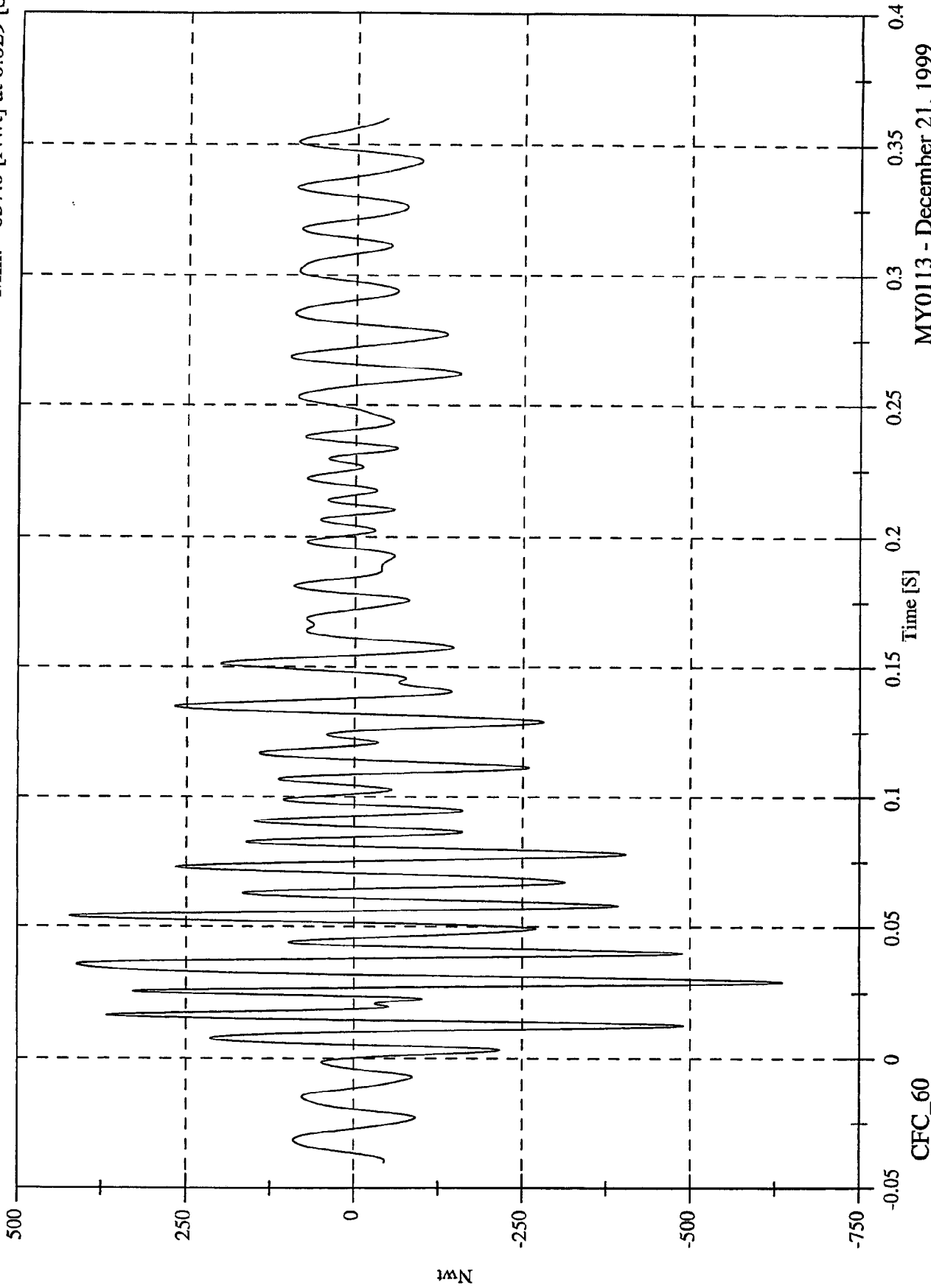

CFC\_60

MY0113 - December 21, 1999

NCAP TEST #7 - 2000 Saturn SL

Max: 1810.0 [Nwt] at 0.083 [S]  
Min: -455.0 [Nwt] at 0.029 [S]

BLC A2 Fx

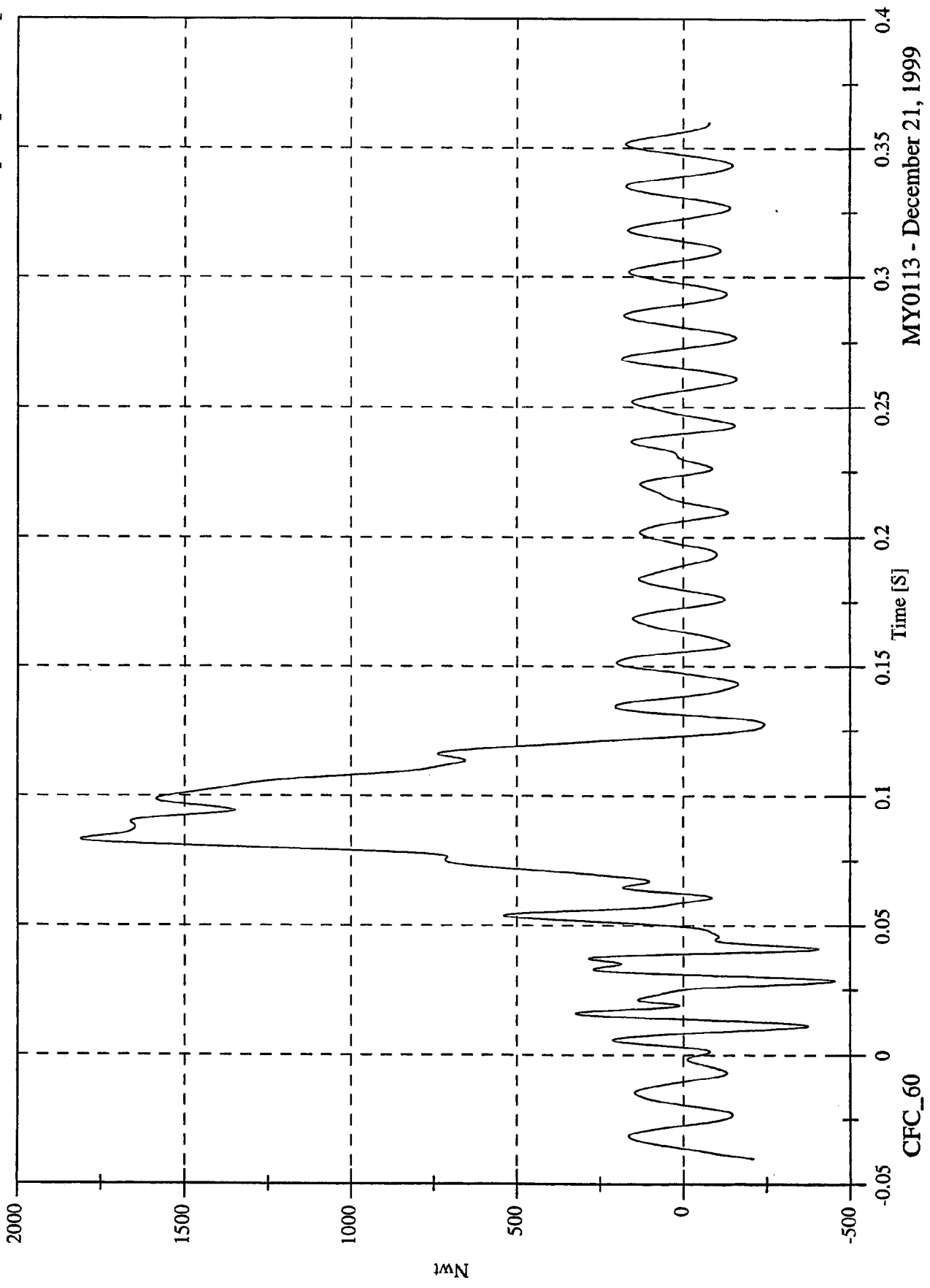

MY0113 - December 21, 1999

NCAP TEST #7 - 2000 Saturn SL

Max: 4666.8 [Nwt] at 0.087 [S]  
Min: -203.9 [Nwt] at 0.360 [S]

BLC A3 Fx

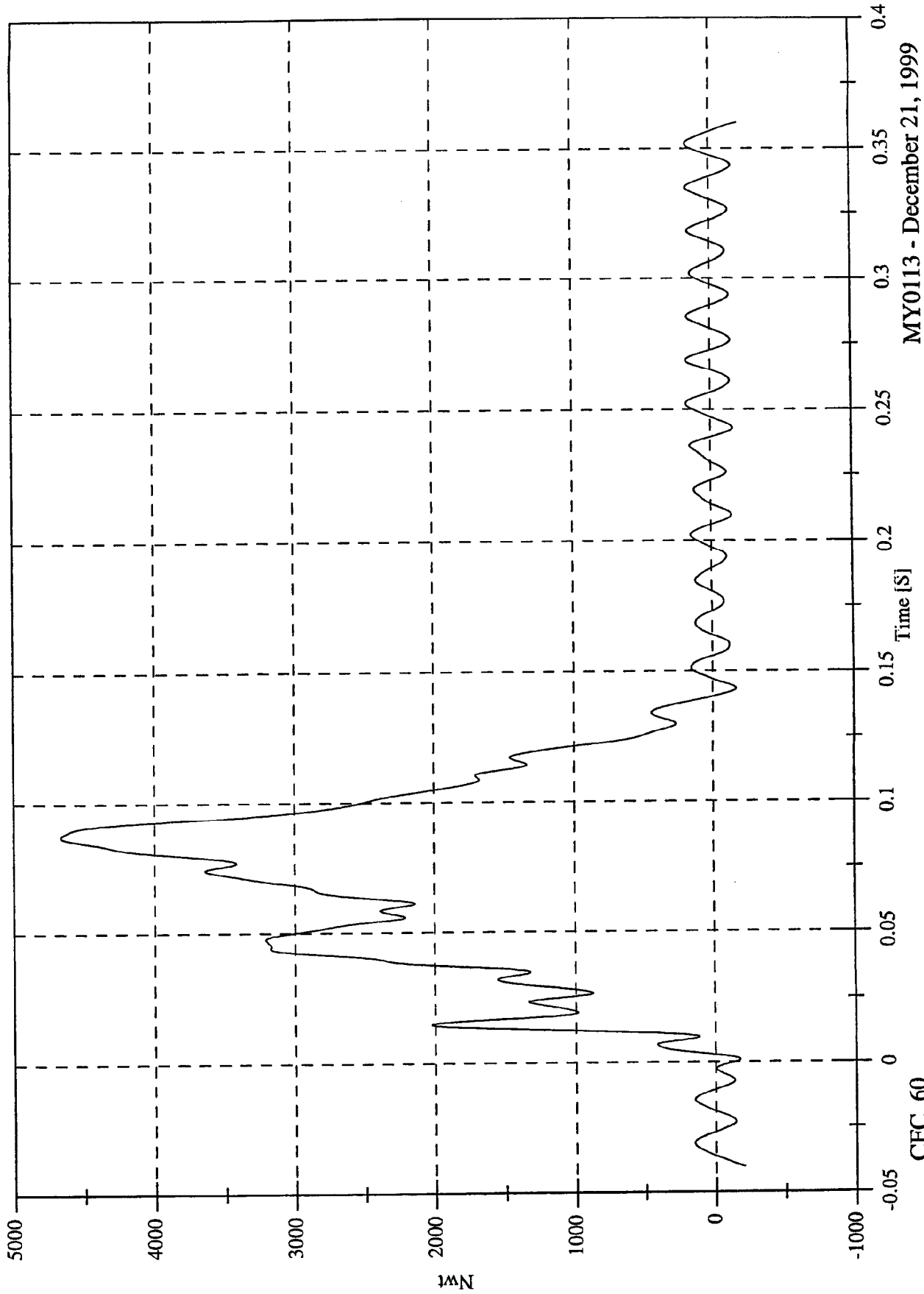

CFC\_60

MY0113 - December 21, 1999

NCAP TEST #7 - 2000 Saturn SL

Max: 2271.1 [Nwt] at 0.024 [S]  
Min: -421.2 [Nwt] at 0.011 [S]

BLC A4 Fx

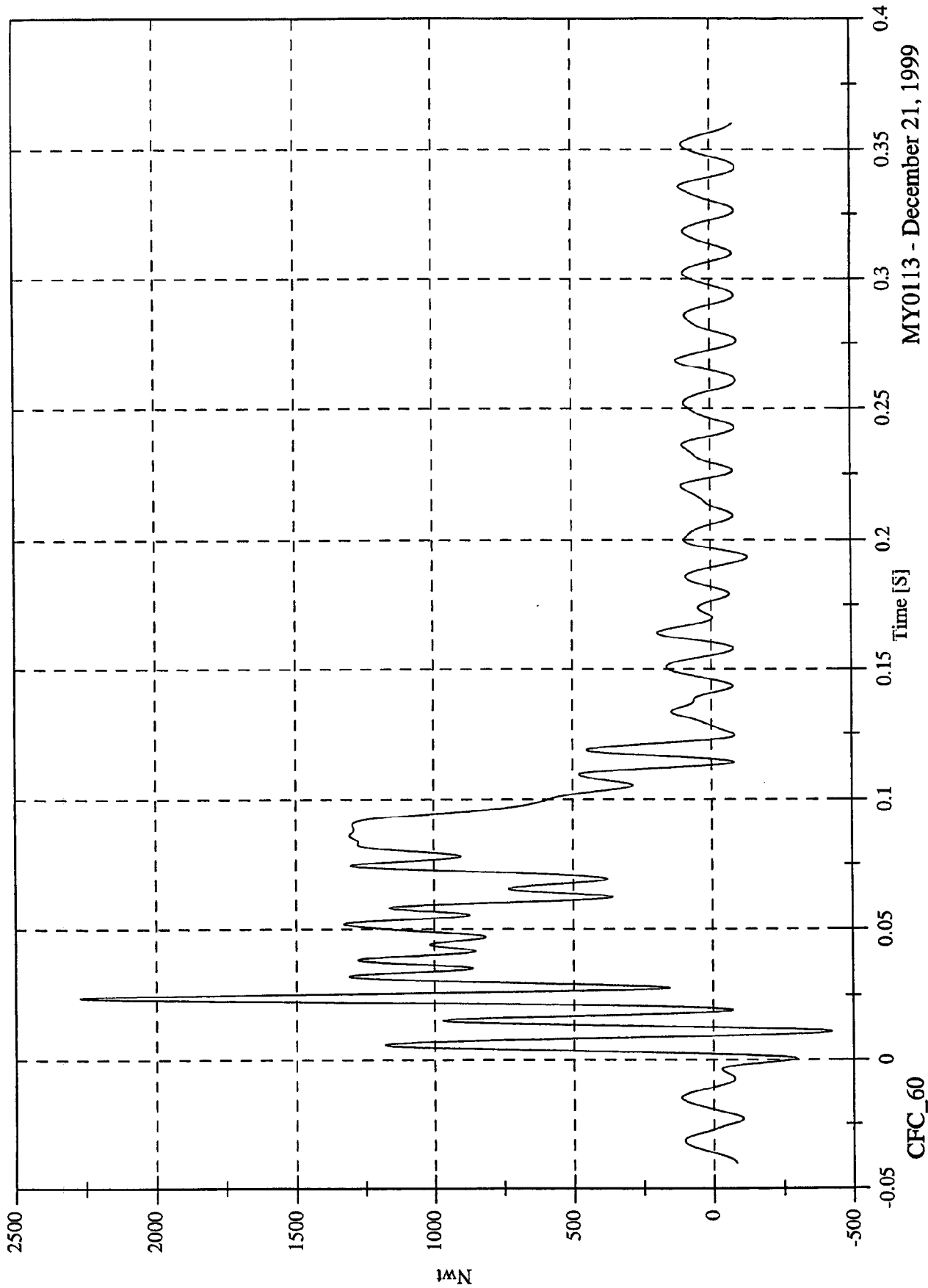

MY0113 - December 21, 1999

NCAP TEST #7 - 2000 Saturn SL

Max: 16071.0 [Nwt] at 0.055 [S]  
Min: -592.3 [Nwt] at 0.028 [S]

BLC A5 Fx

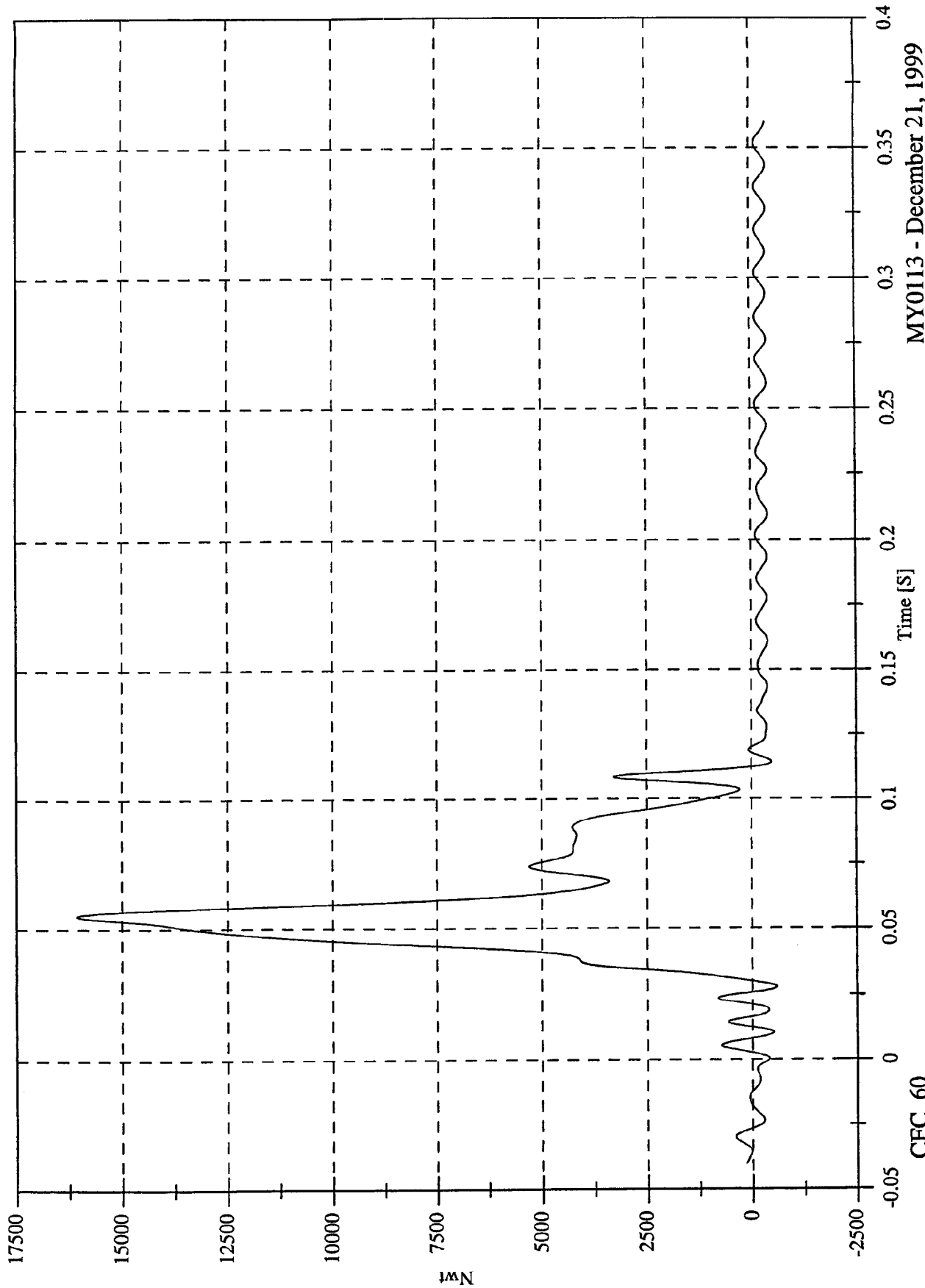

CFC\_60

MY0113 - December 21, 1999

NCAP TEST #7 - 2000 Saturn SL

Max: 7398.6 [Nwt] at 0.049 [S]  
Min: -352.8 [Nwt] at 0.011 [S]

BLC A6 Fx

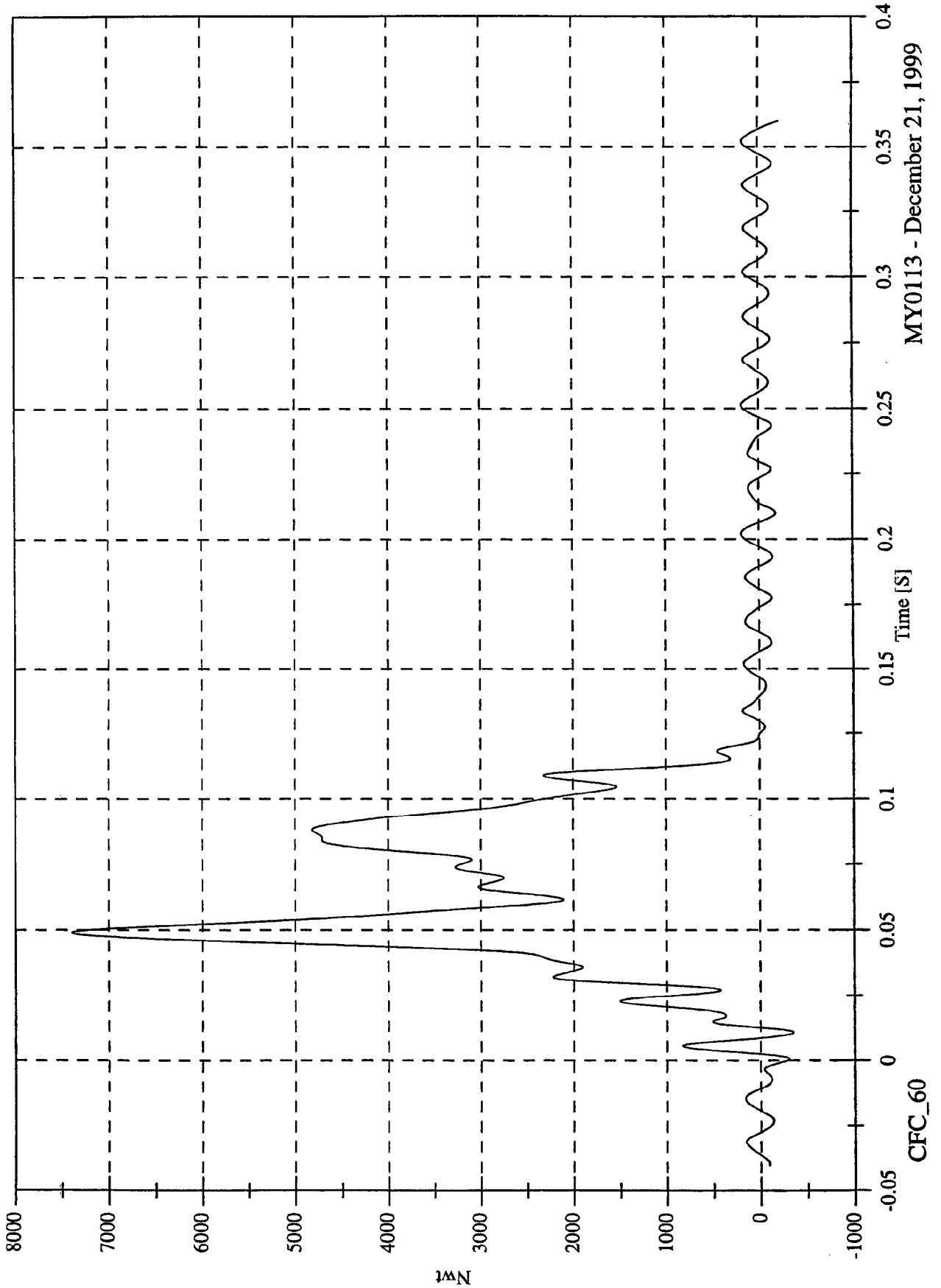

MY0113 - December 21, 1999

CFC\_60

NCAP TEST #7 - 2000 Saturn SL

Max: 13798.1 [Nwt] at 0.089 [S]  
Min: -334.3 [Nwt] at 0.001 [S]

BLC A7 Fx

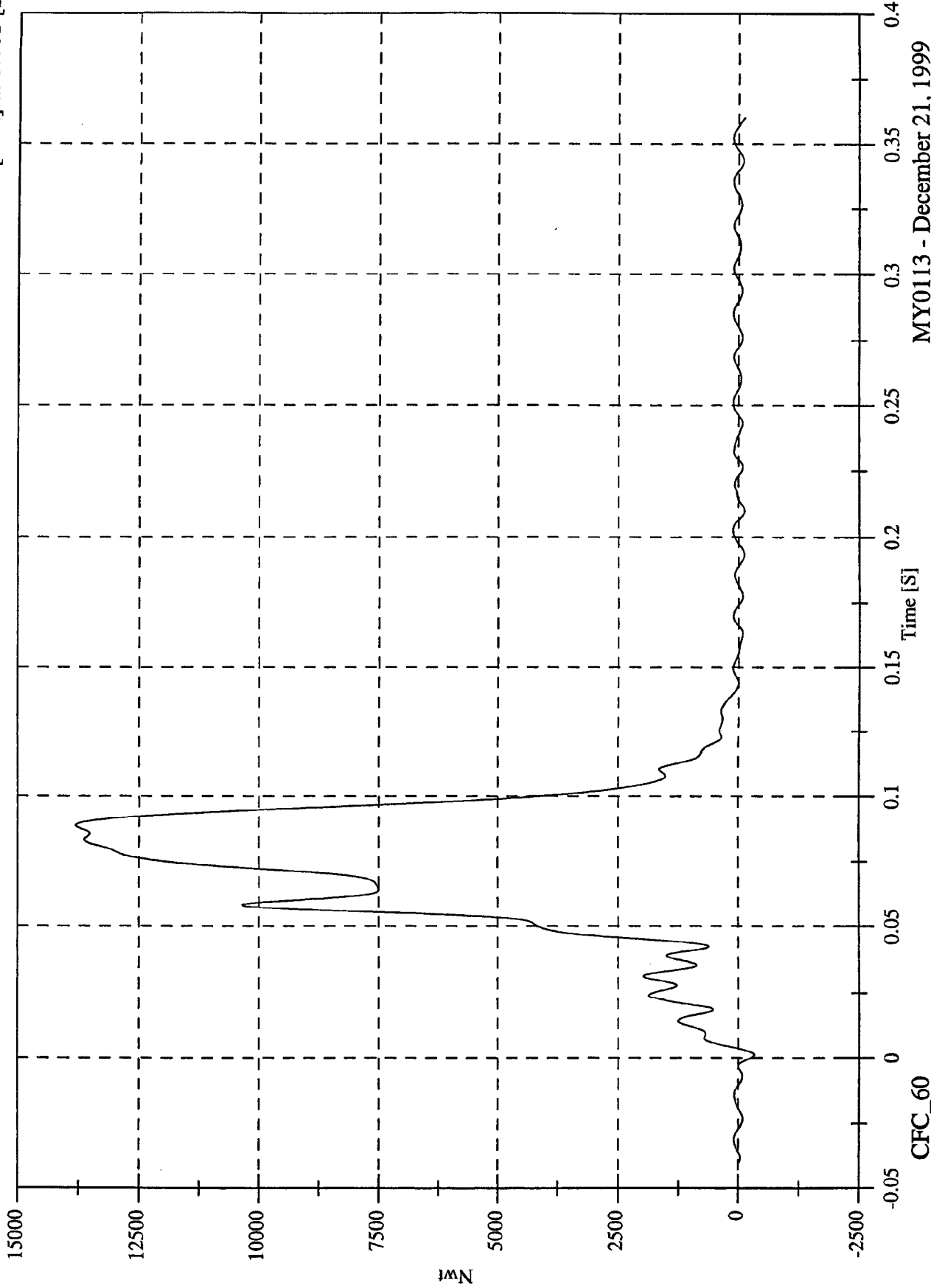

CFC\_60

MY0113 - December 21, 1999

NCAP TEST #7 - 2000 Saturn SL

Max: 2475.6 [Nwt] at 0.059 [S]  
Min: -721.6 [Nwt] at 0.044 [S]

BLC A8 Fx

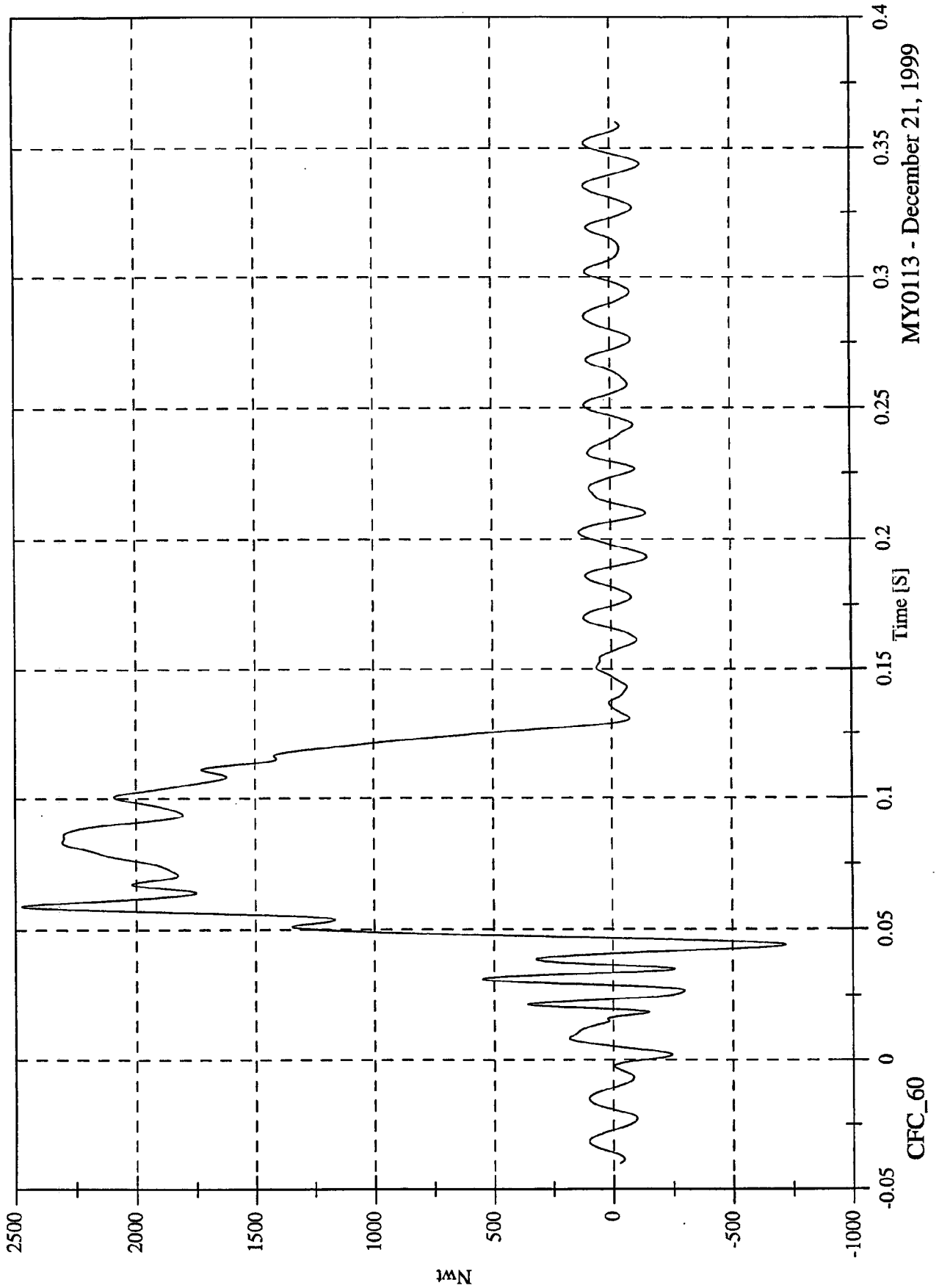

MY0113 - December 21, 1999

NCAP TEST #7 - 2000 Saturn SL

Max: 942.5 [Nwt] at 0.031 [S]  
Min: -1054.8 [Nwt] at 0.045 [S]

BLC A9 Fx

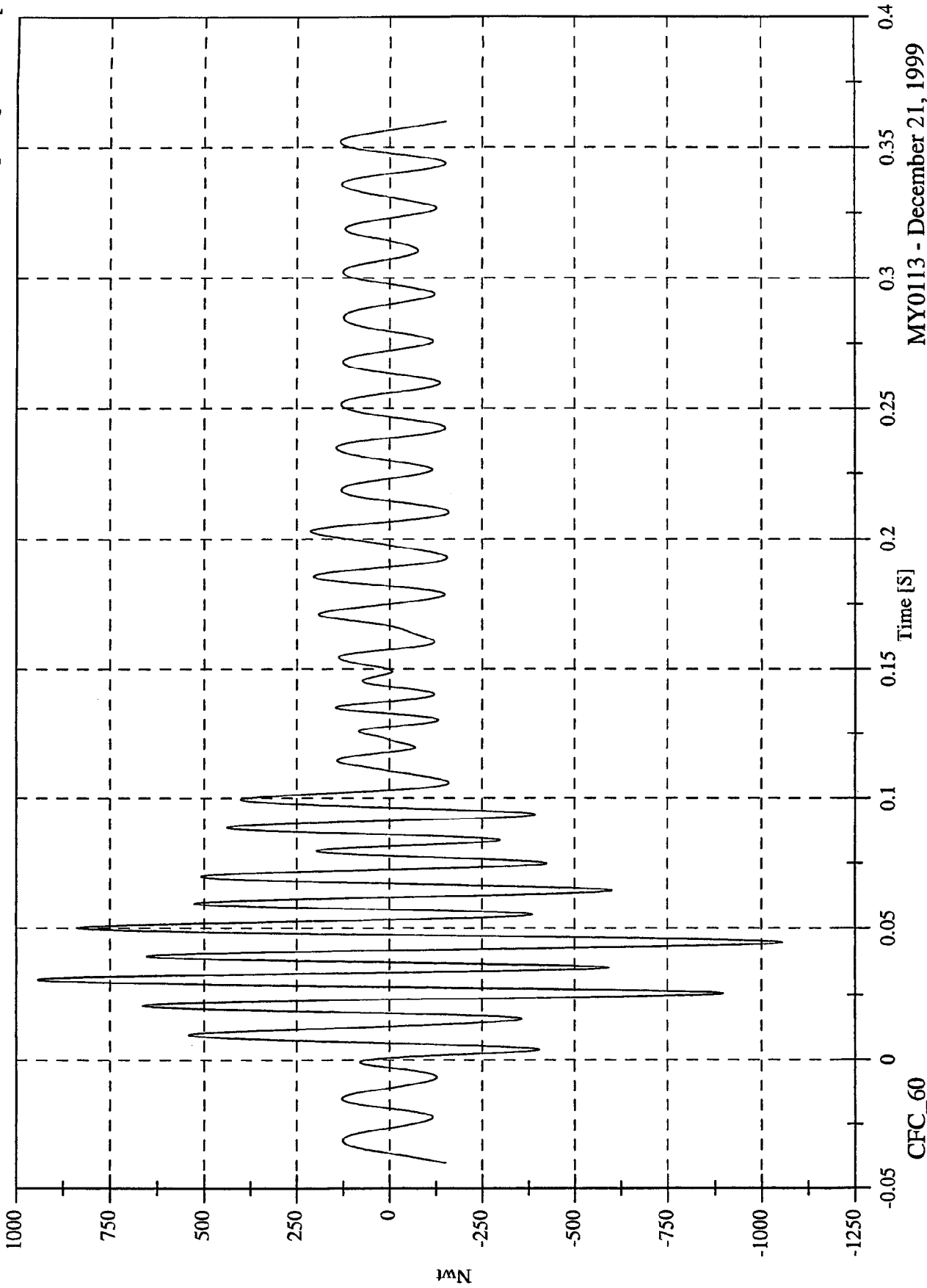

CFC\_60

MY0113 - December 21, 1999

NCAP TEST #7 - 2000 Saturn SL

Max: 628.7 [Nwt] at 0.035 [S]  
Min: -473.2 [Nwt] at 0.031 [S]

BLC B1 Fx

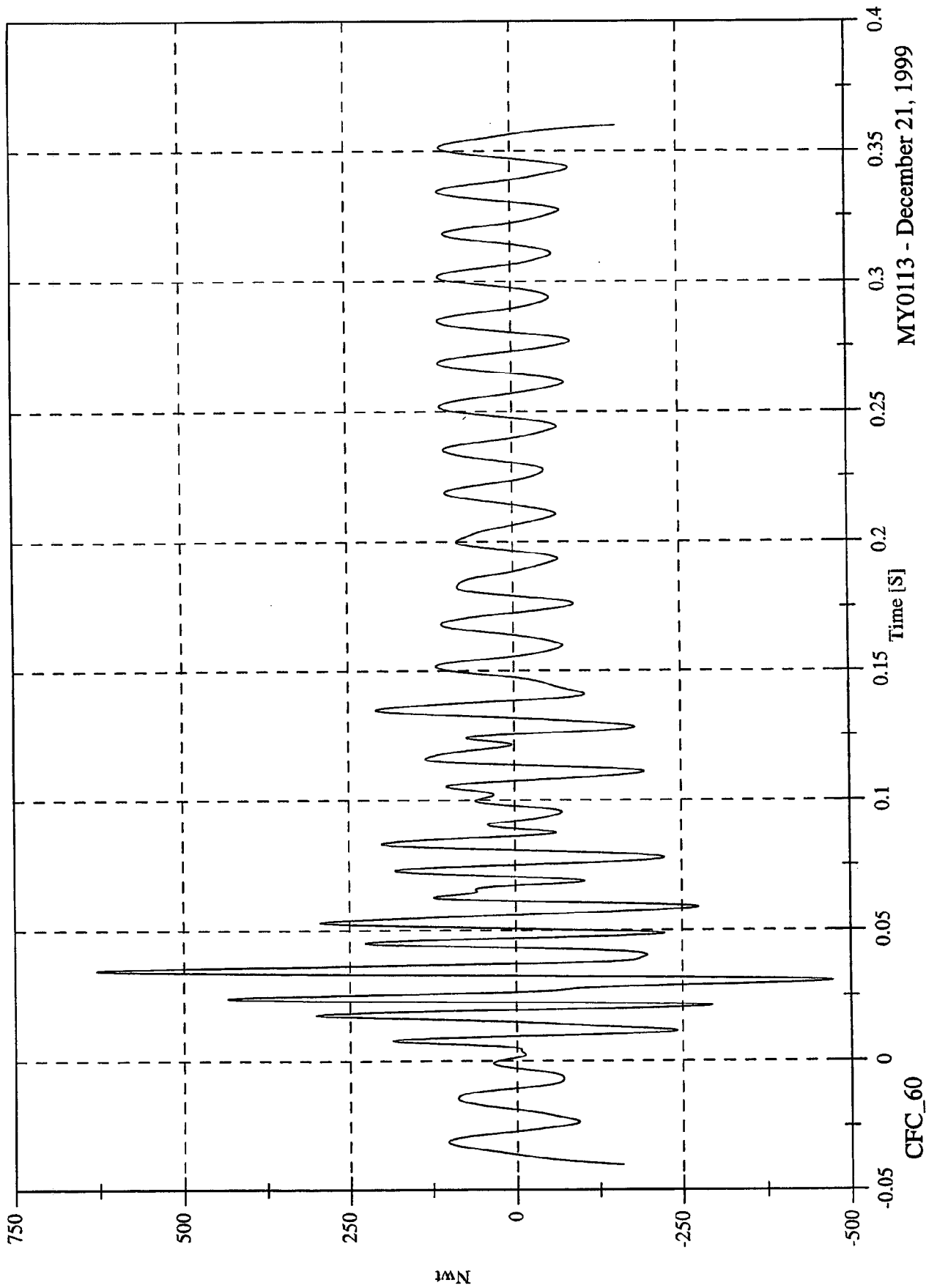

MY0113 - December 21, 1999

CFC\_60

NCAP TEST #7 - 2000 Saturn SL

Max: 4723.7 [Nwt] at 0.083 [S]  
Min: -109.5 [Nwt] at 0.176 [S]

BLC B2 Fx

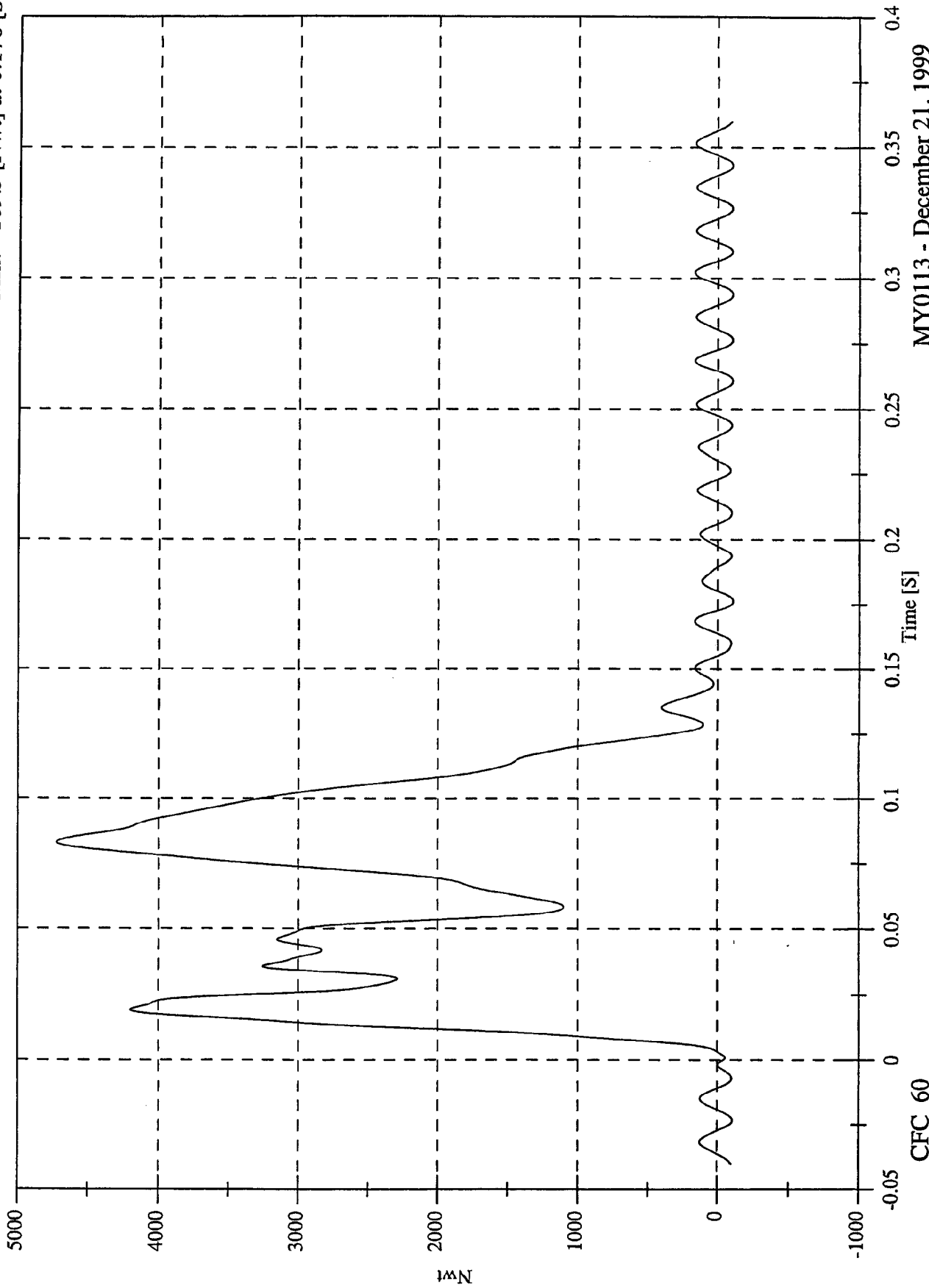

CFC\_60

MY0113 - December 21, 1999

NCAP TEST #7 - 2000 Saturn SL

Max: 92029.2 [Nwt] at 0.022 [S]  
Min: -618.3 [Nwt] at -0.000 [S]

BLC B3 Fx

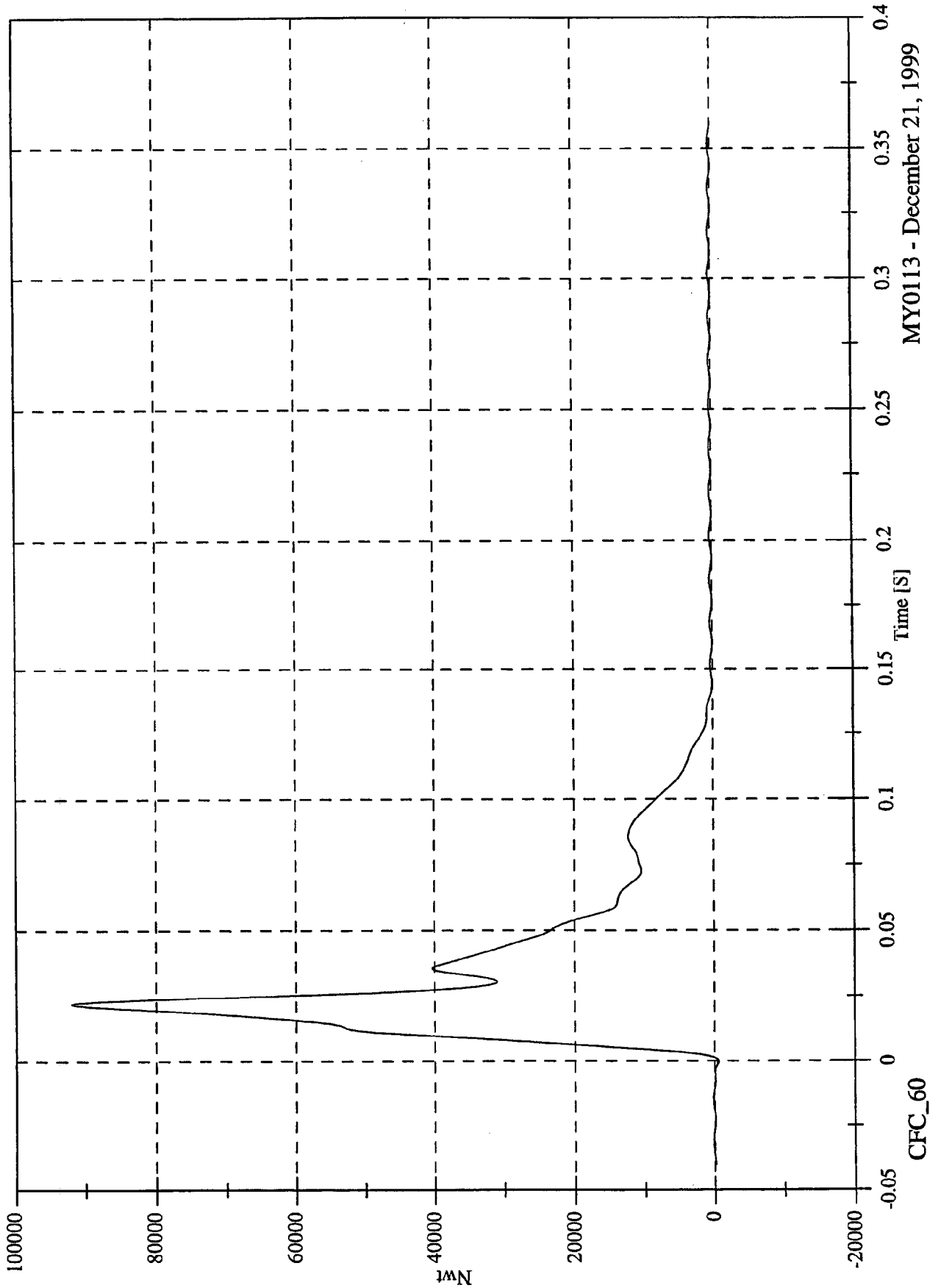

MY0113 - December 21, 1999

NCAP TEST #7 - 2000 Saturn SL

Max: 33207.8 [Nwt] at 0.039 [S]  
Min: -537.0 [Nwt] at -0.004 [S]

BLC B4 Fx

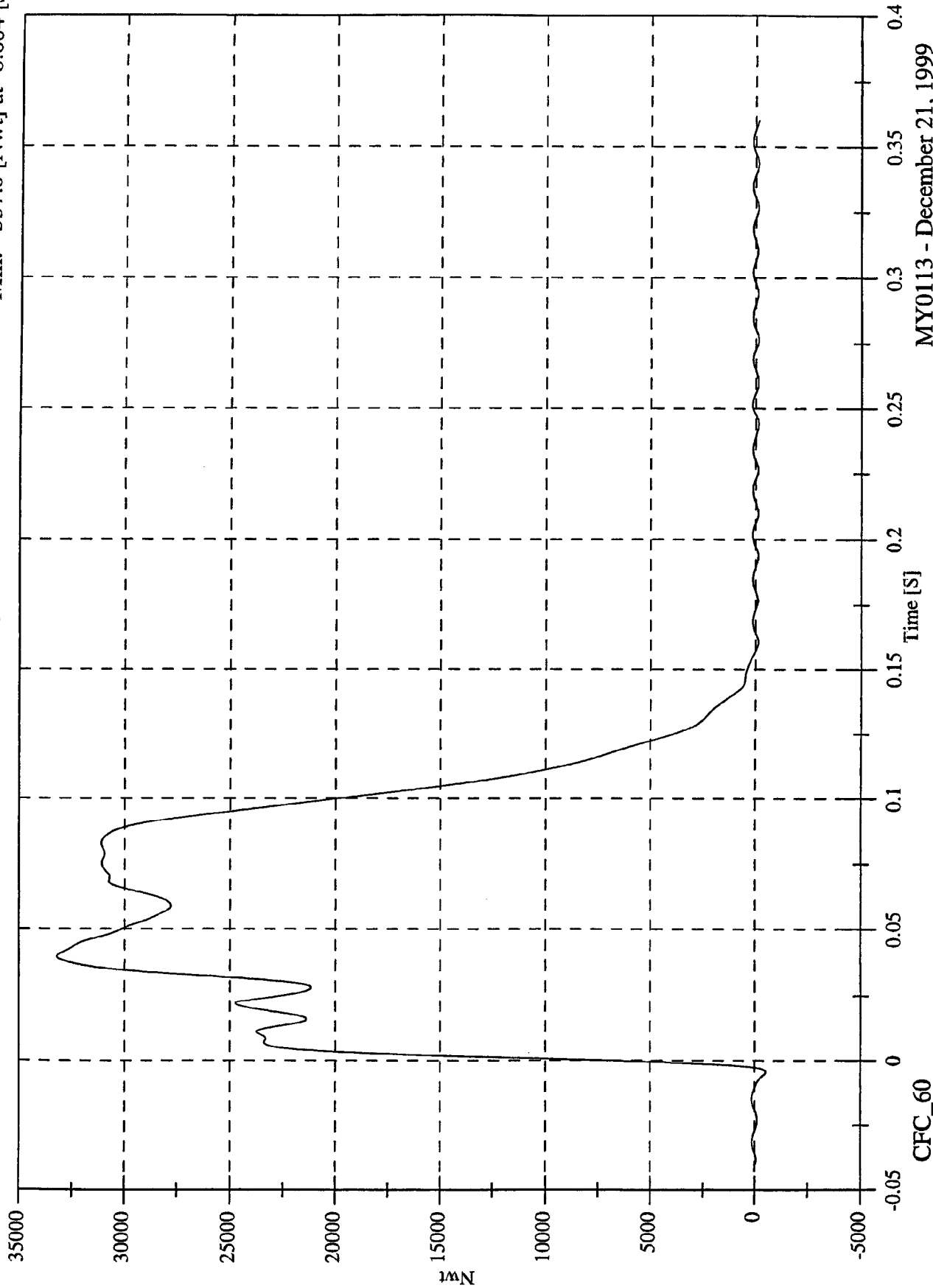

MY0113 - December 21, 1999

CFC\_60

NCAP TEST #7 - 2000 Saturn SL

Max: 40730.0 [Nwt] at 0.073 [S]  
Min: -843.9 [Nwt] at -0.005 [S]

BLC B5 Fx

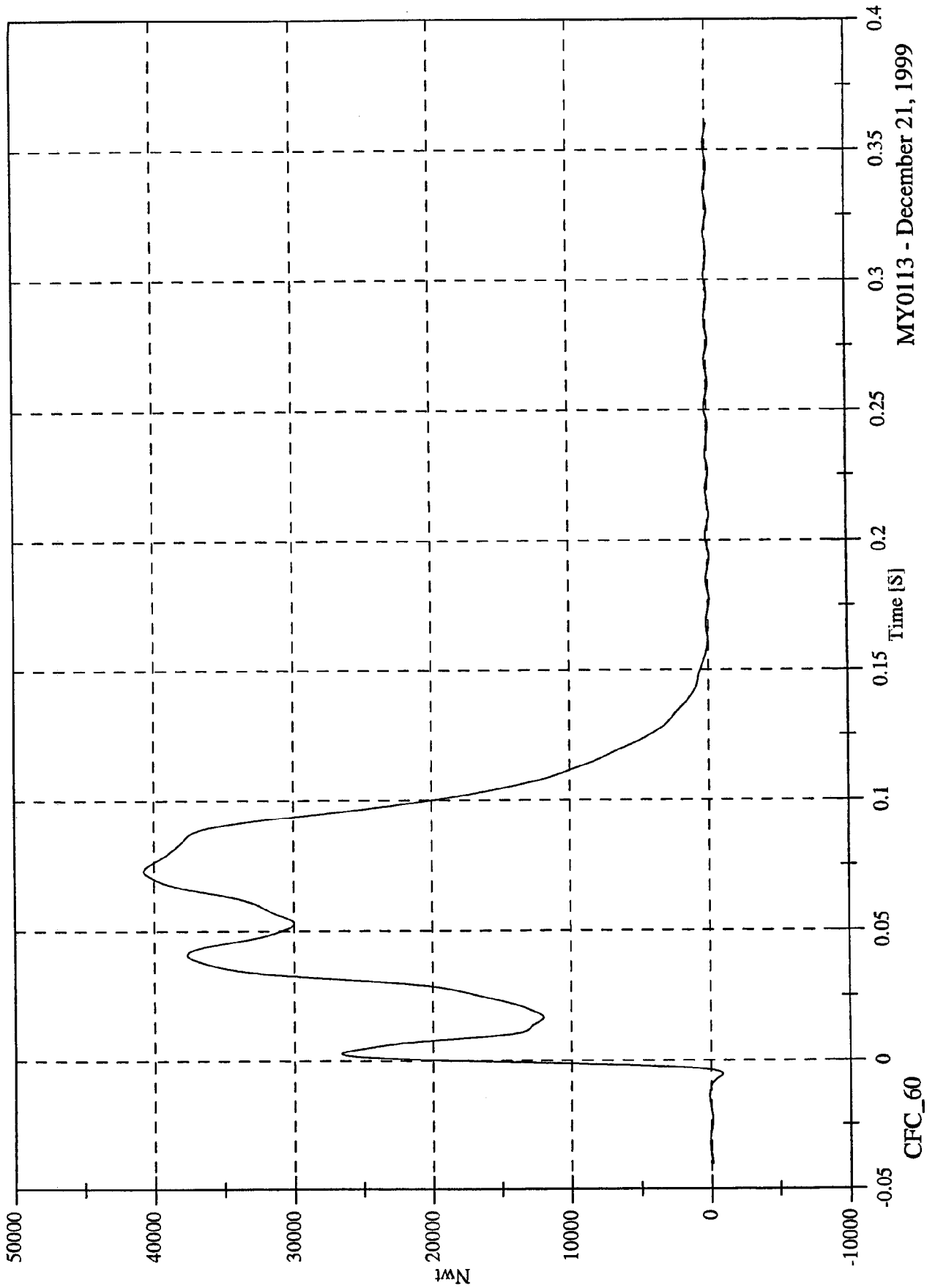

MY0113 - December 21, 1999

CFC\_60

NCAP TEST #7 - 2000 Saturn SL

Max: 37546.8 [Nwt] at 0.072 [S]  
Min: -627.2 [Nwt] at -0.004 [S]

BLC B6 Fx

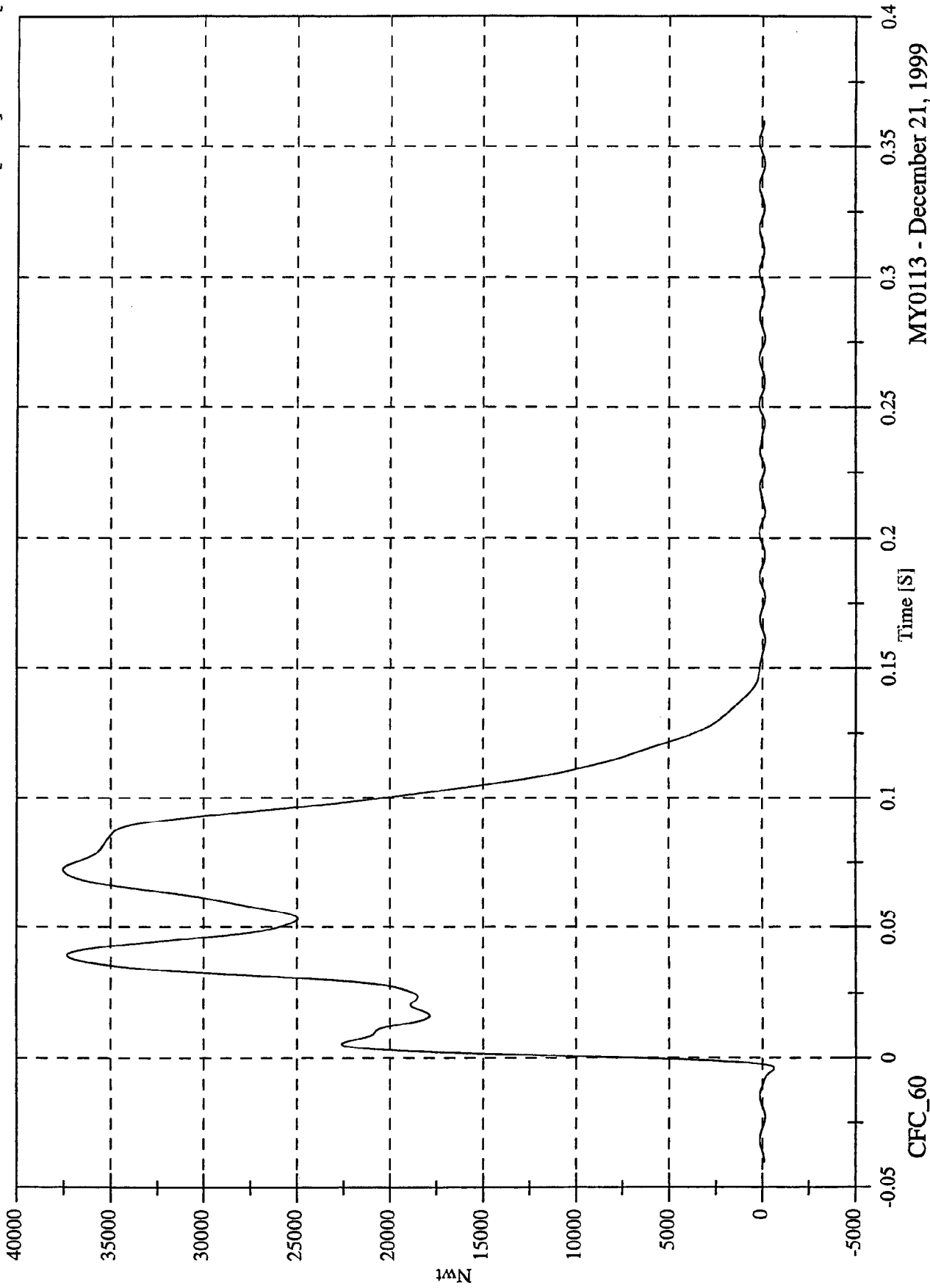

CFC\_60

MY0113 - December 21, 1999

NCAP TEST #7 - 2000 Saturn SL

Max: 87747.9 [Nwt] at 0.021 [S]  
Min: -851.5 [Nwt] at -0.000 [S]

BLC B7 Fx

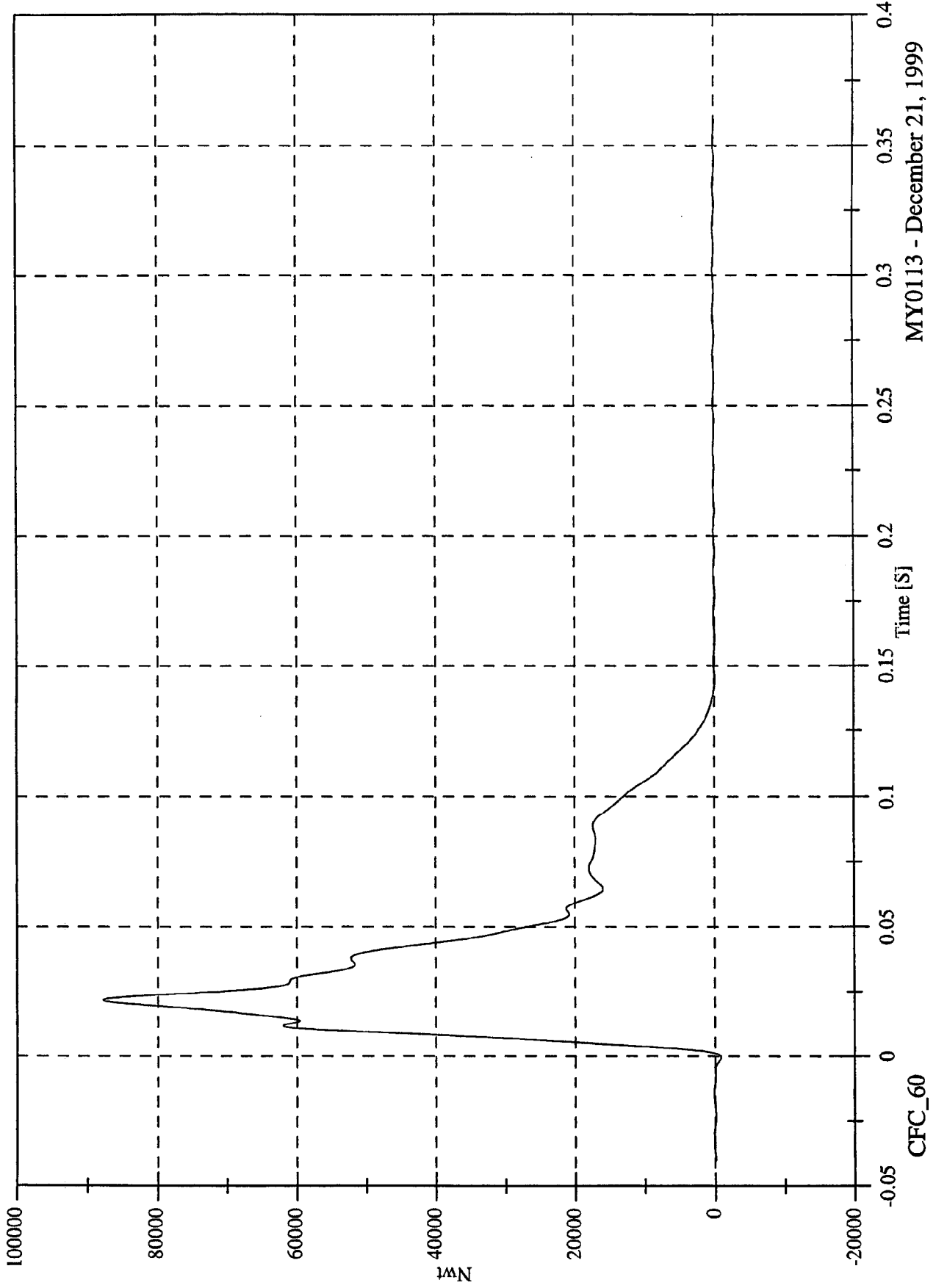

MY0113 - December 21, 1999

NCAP TEST #7 - 2000 Saturn SL

Max: 4959.2 [Nwt] at 0.085 [S]  
Min: -107.6 [Nwt] at 0.360 [S]

BLC B8 Fx

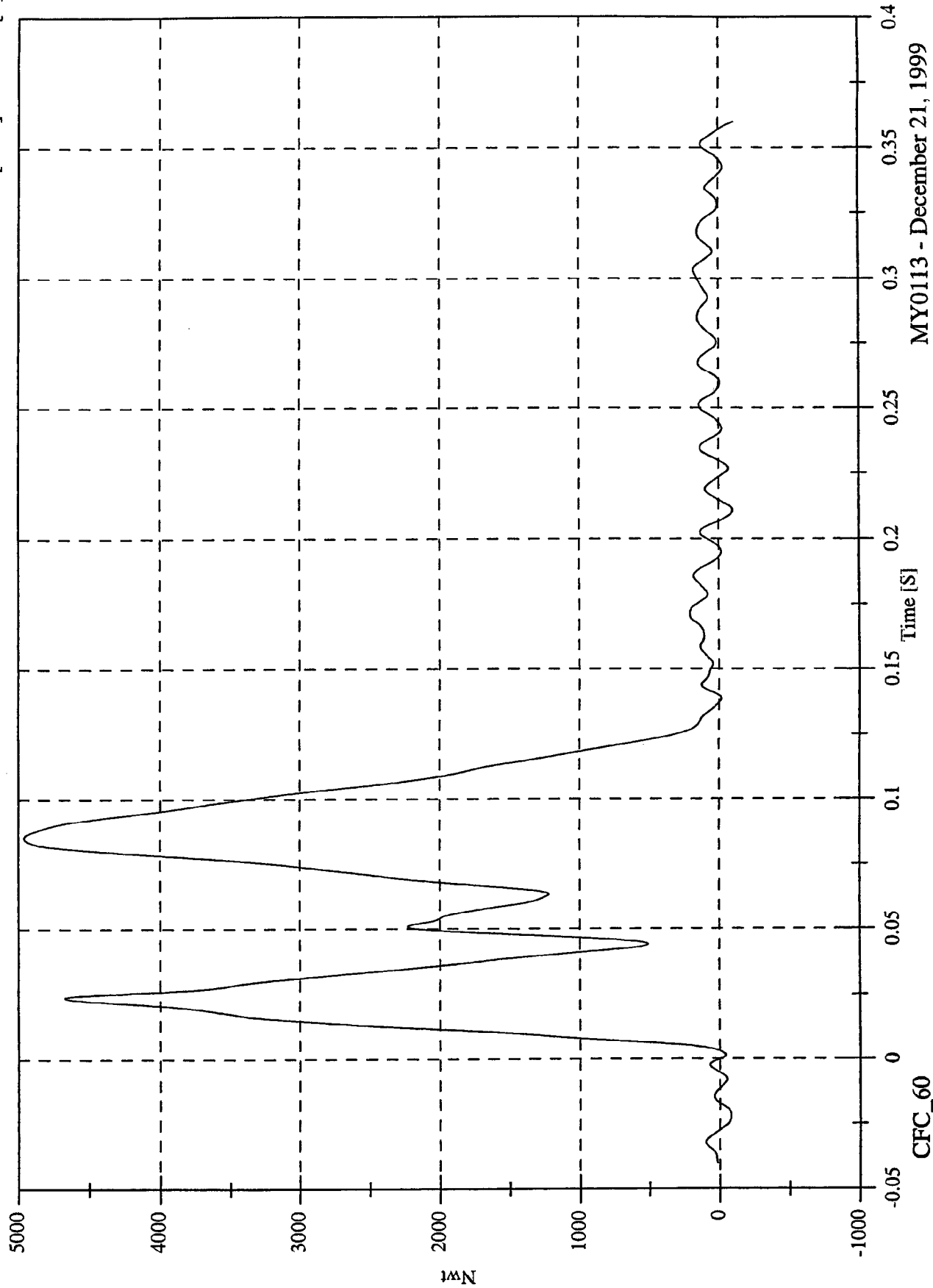

CFC\_60

MY0113 - December 21, 1999

NCAP TEST #7 - 2000 Saturn SL

Max: 931.0 [Nwt] at 0.029 [S]  
Min: -569.8 [Nwt] at 0.044 [S]

BLC B9 Fx

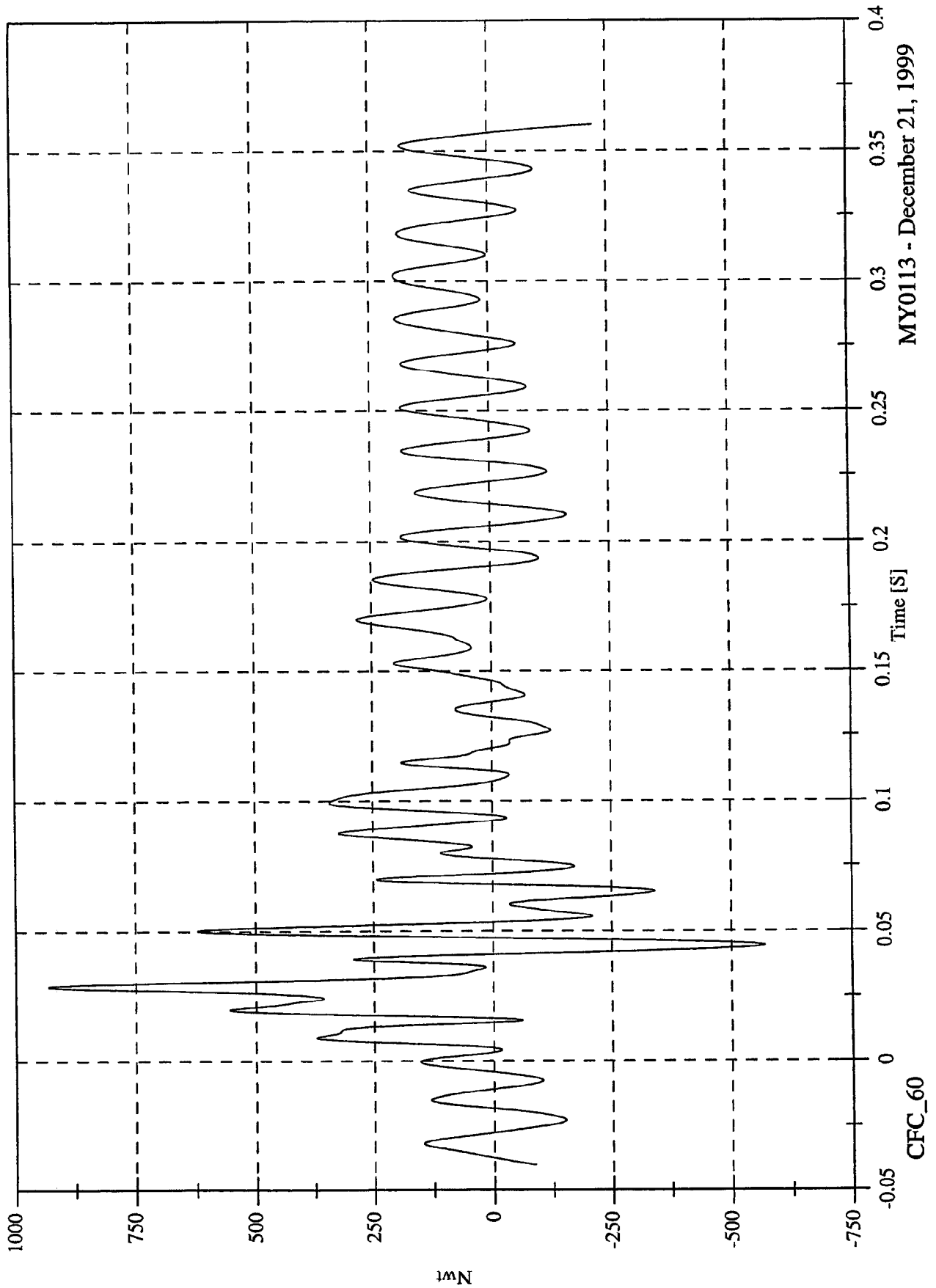

MY0113 - December 21, 1999

NCAP TEST #7 - 2000 Saturn SL

Max: 865.0 [Nwt] at 0.024 [S]  
Min: -597.0 [Nwt] at 0.031 [S]

BLC C1 Fx

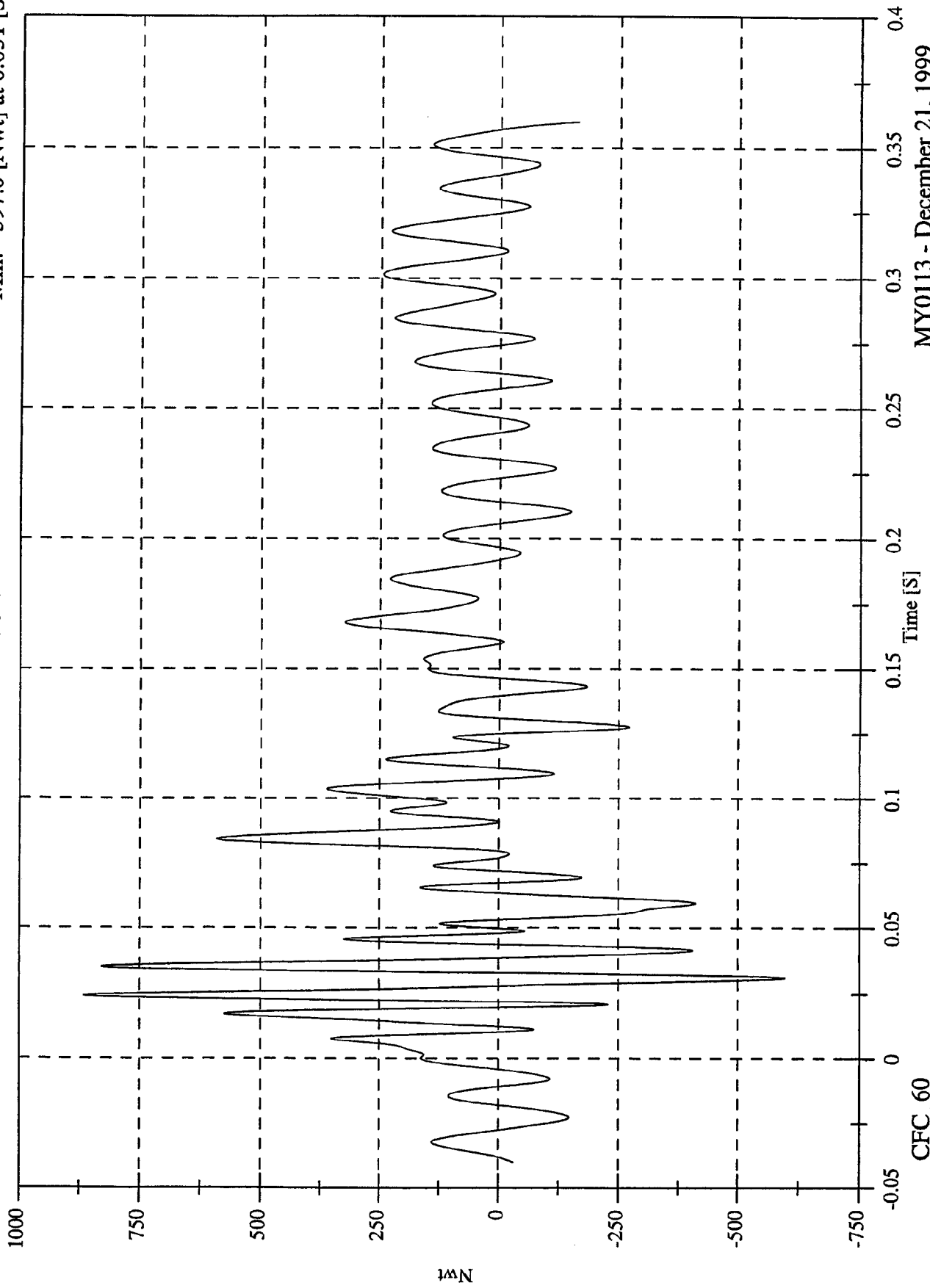

CFC\_60

MY0113 - December 21, 1999

NCAP TEST #7 - 2000 Saturn SL

Max: 13089.6 [Nwt] at 0.022 [S]  
Min: -170.3 [Nwt] at 0.127 [S]

BLC C2 Fx

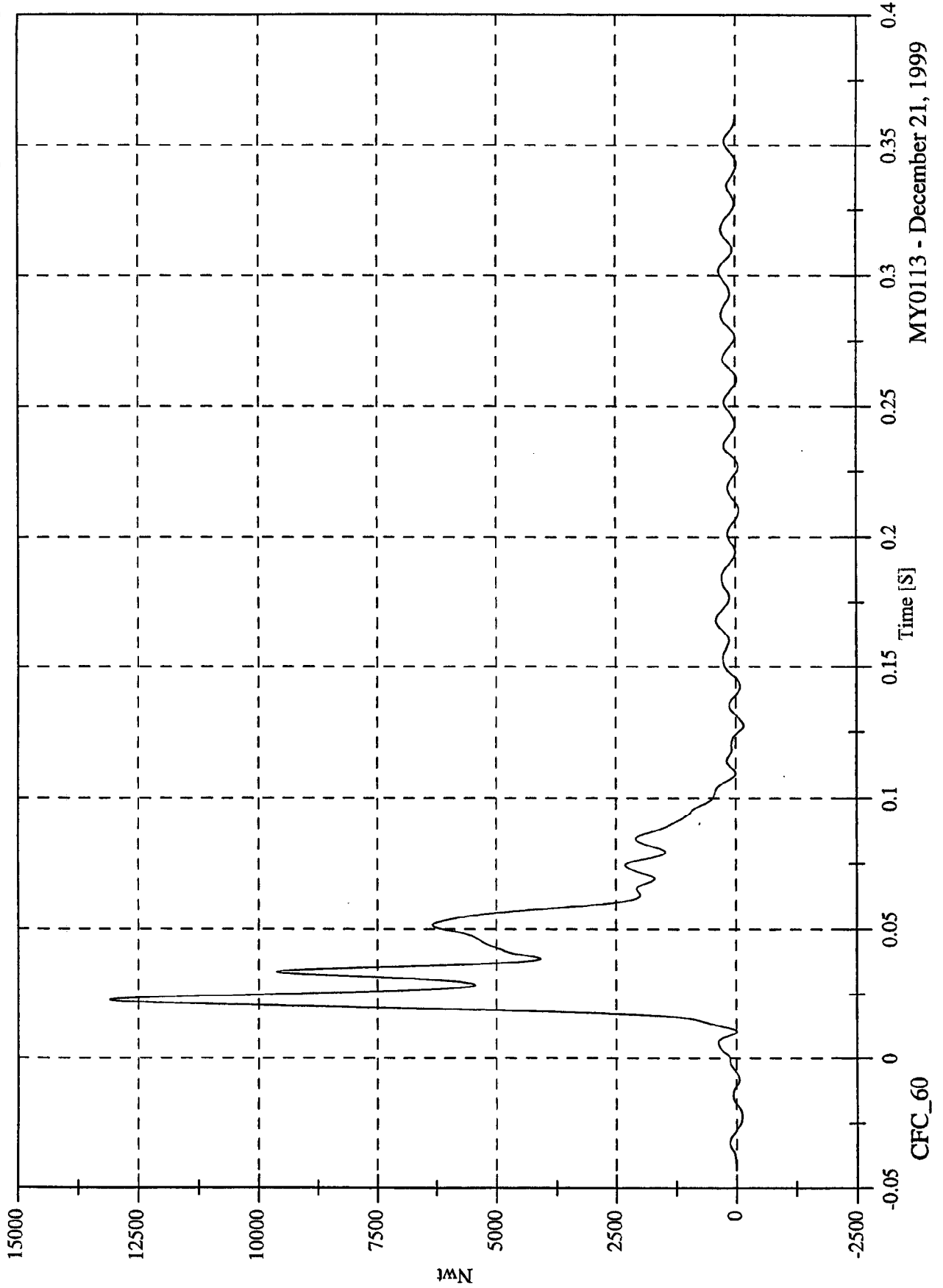

MY0113 - December 21, 1999

NCAP TEST #7 - 2000 Saturn SL

Max: 16135.1 [Nwt] at 0.065 [S]  
Min: -175.0 [Nwt] at 0.126 [S]

BLC C3 Fx

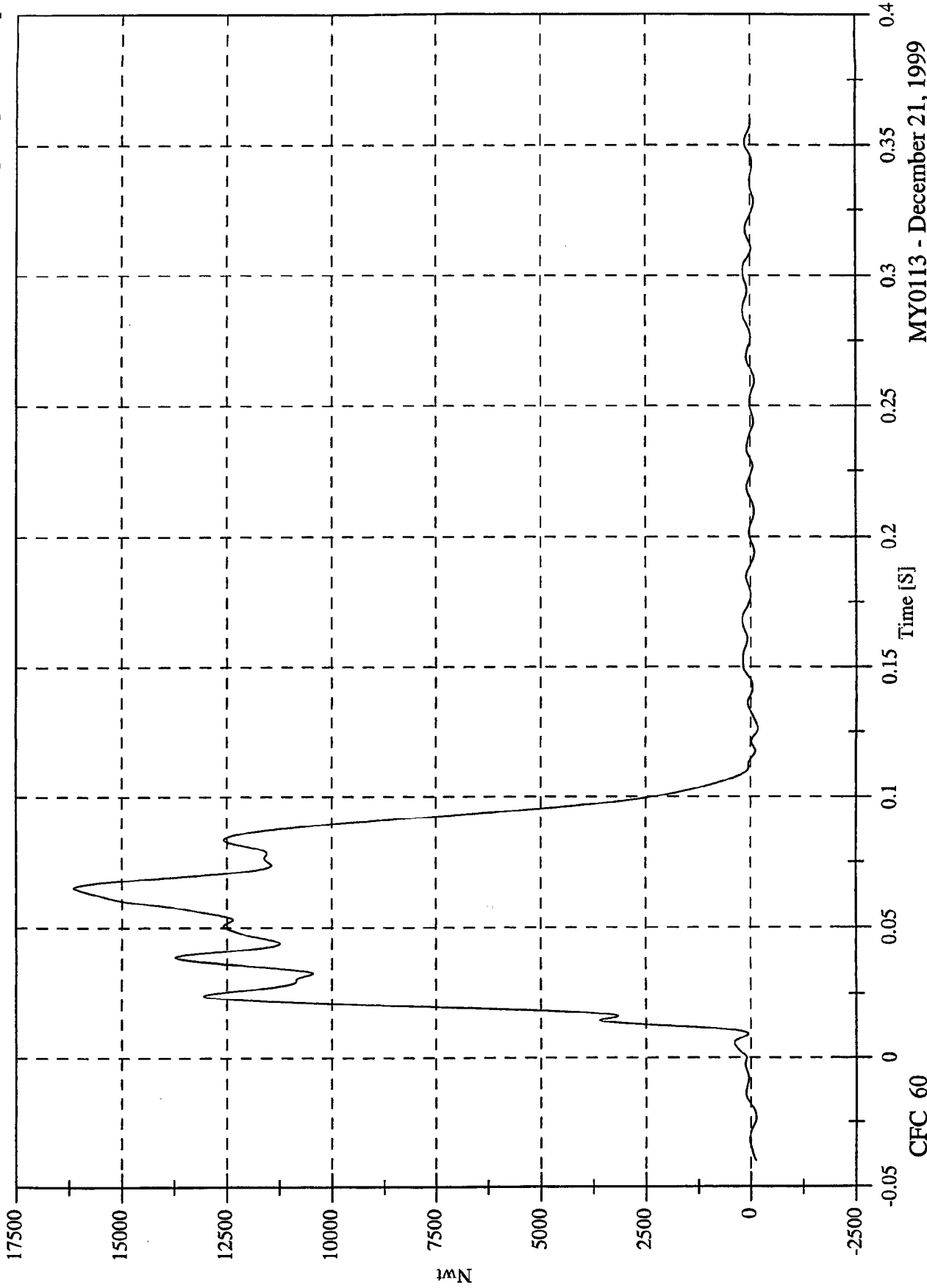

MY0113 - December 21, 1999

CFC\_60

NCAP TEST #7 - 2000 Saturn SL

Max: 11055.3 [Nwt] at 0.035 [S]  
Min: -339.4 [Nwt] at -0.040 [S]

BLC C4 Fx

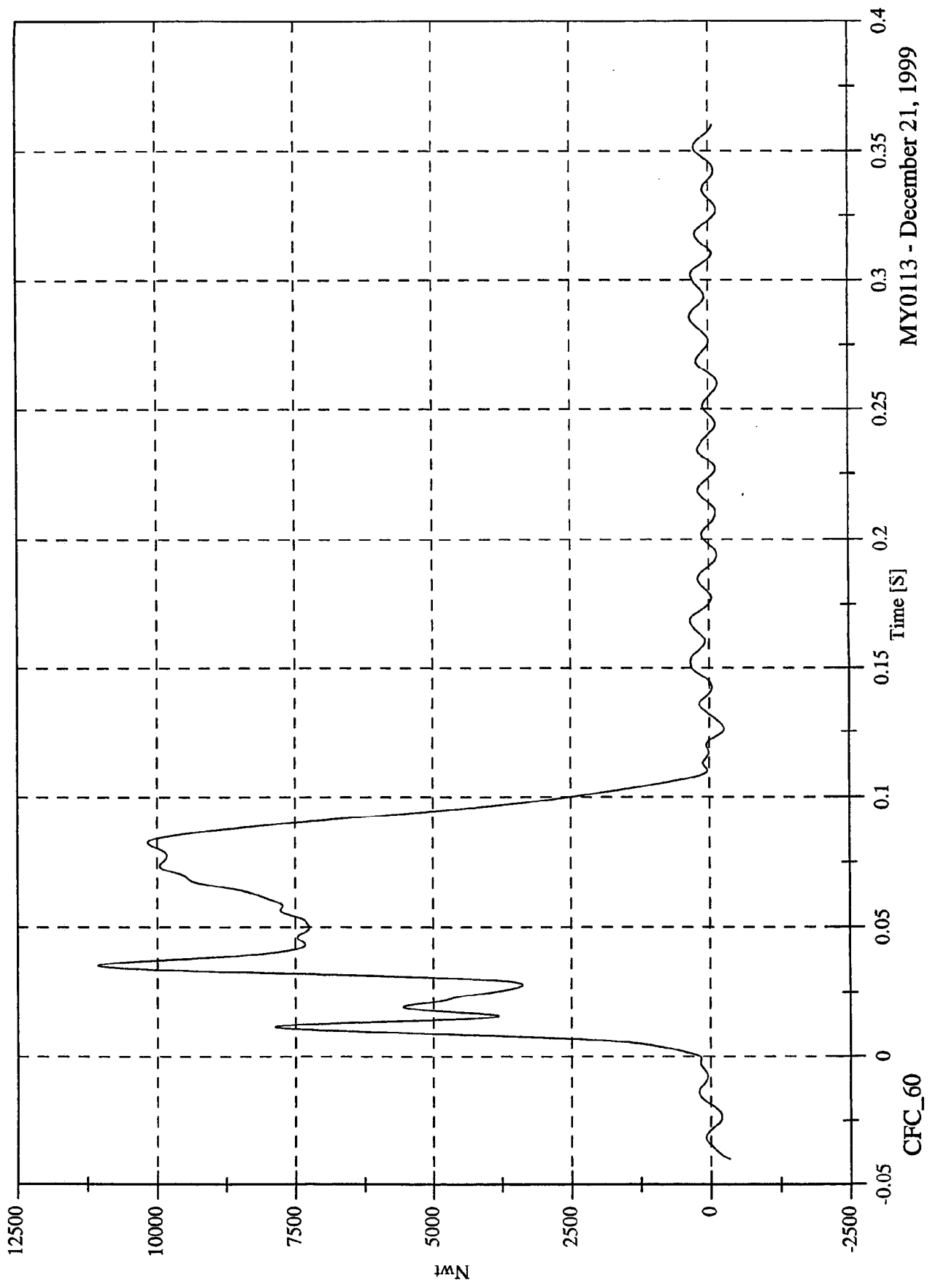

MY0113 - December 21, 1999

NCAP TEST #7 - 2000 Saturn SL

Max: 17410.3 [Nwt] at 0.011 [S]  
Min: -289.6 [Nwt] at 0.126 [S]

BLC C5 Fx

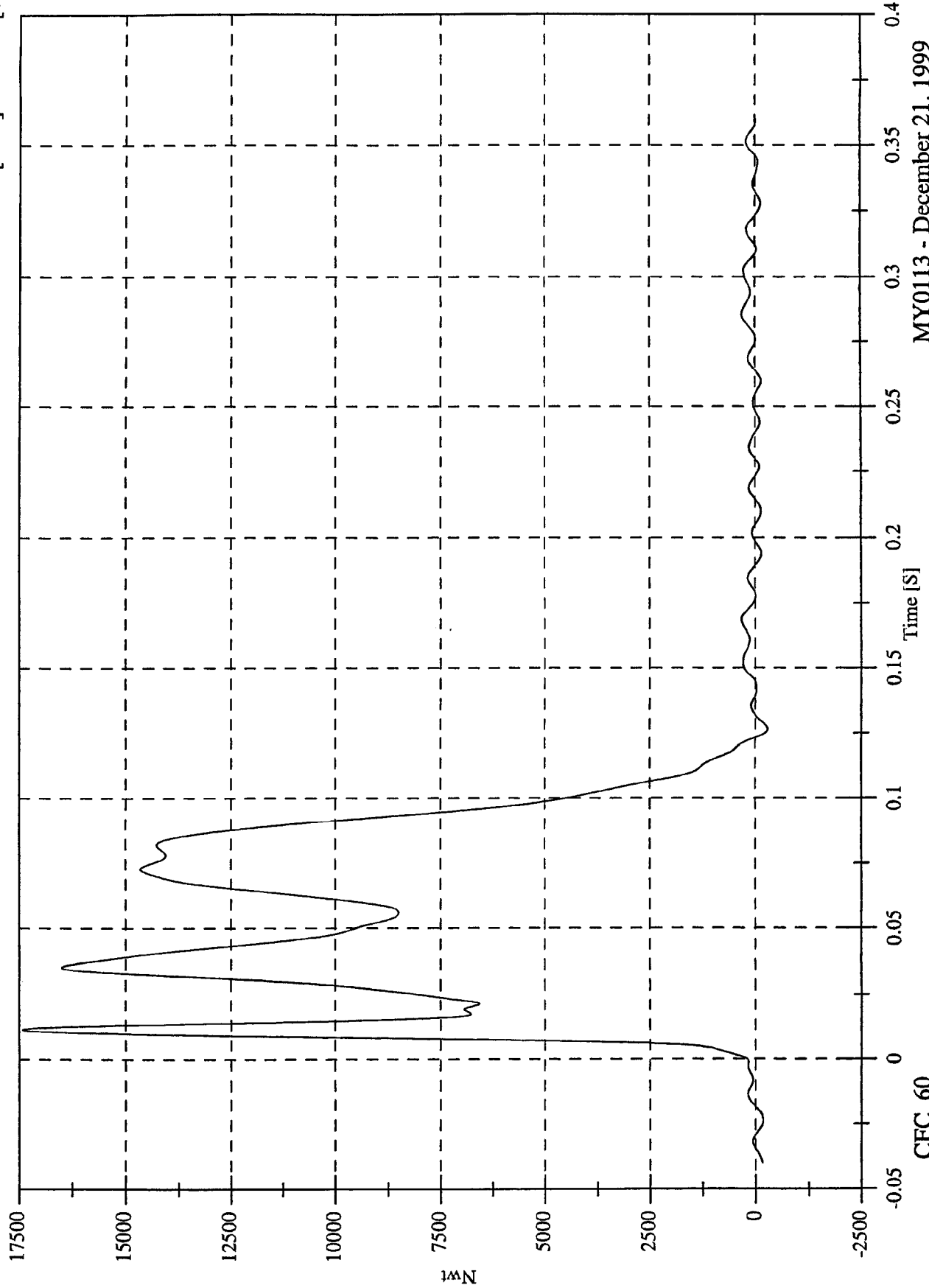

CFC\_60

MY0113 - December 21, 1999

NCAP TEST #7 - 2000 Saturn SL

Max: 17192.7 [Nwt] at 0.069 [S]  
Min: -255.8 [Nwt] at -0.040 [S]

BLC C6 Fx

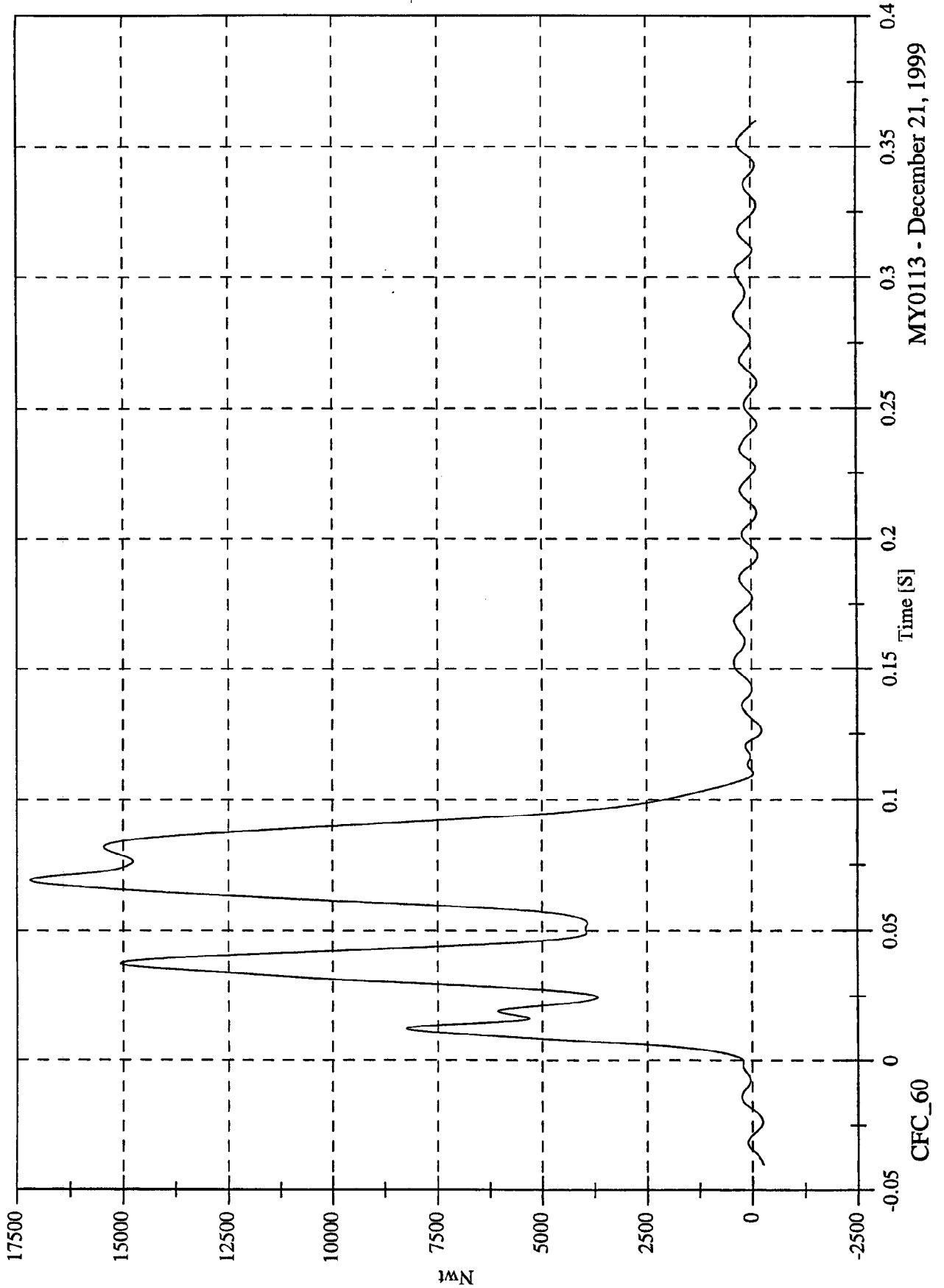

MY0113 - December 21, 1999

NCAP TEST #7 - 2000 Saturn SL

Max: 16930.2 [Nwt] at 0.070 [S]  
Min: -194.8 [Nwt] at 0.142 [S]

BLC C7 Fx

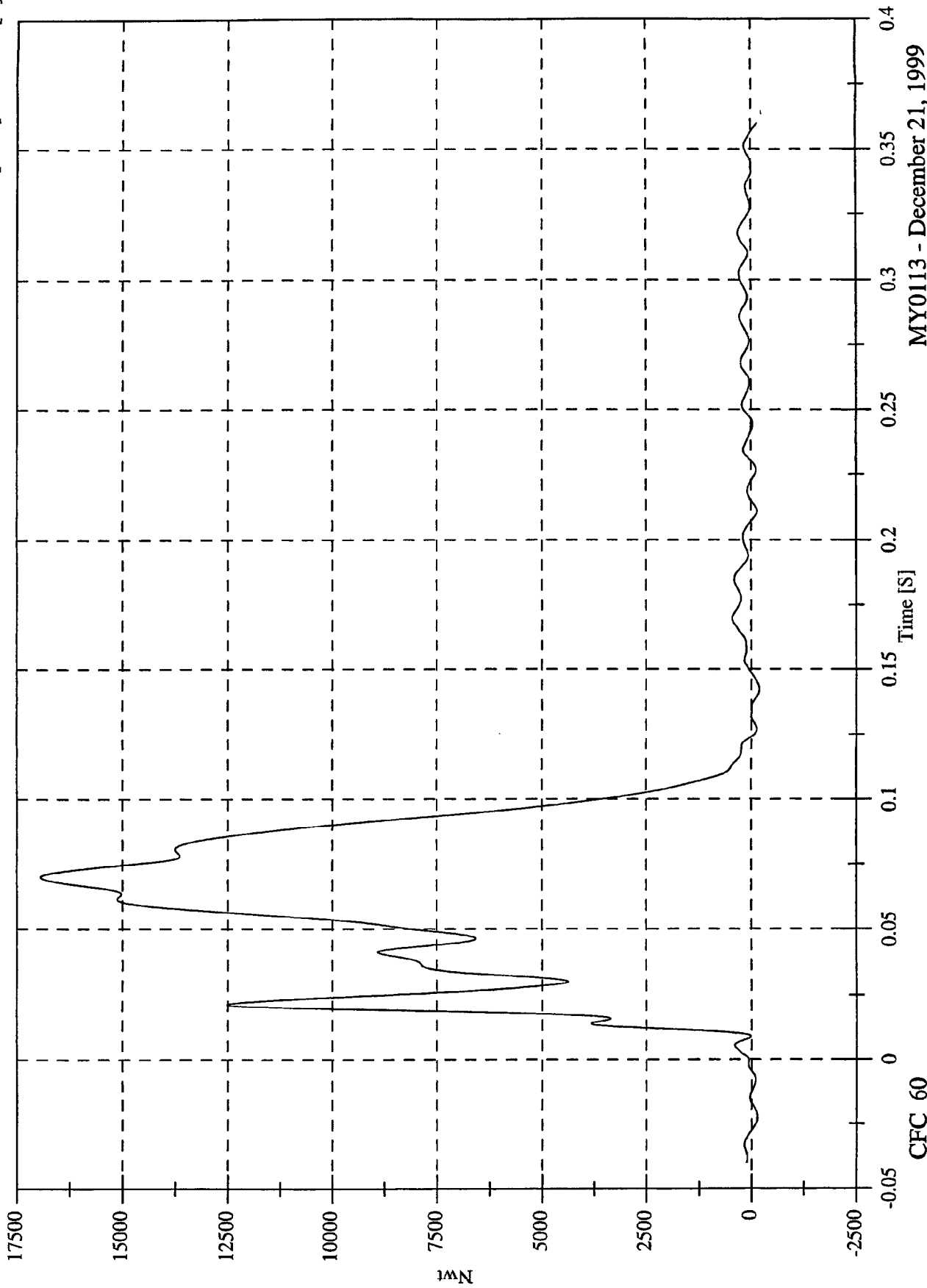

MY0113 - December 21, 1999

CFC\_60

NCAP TEST #7 - 2000 Saturn SL

Max: 12085.8 [Nwt] at 0.028 [S]  
Min: -244.3 [Nwt] at 0.360 [S]

BLC C8 Fx

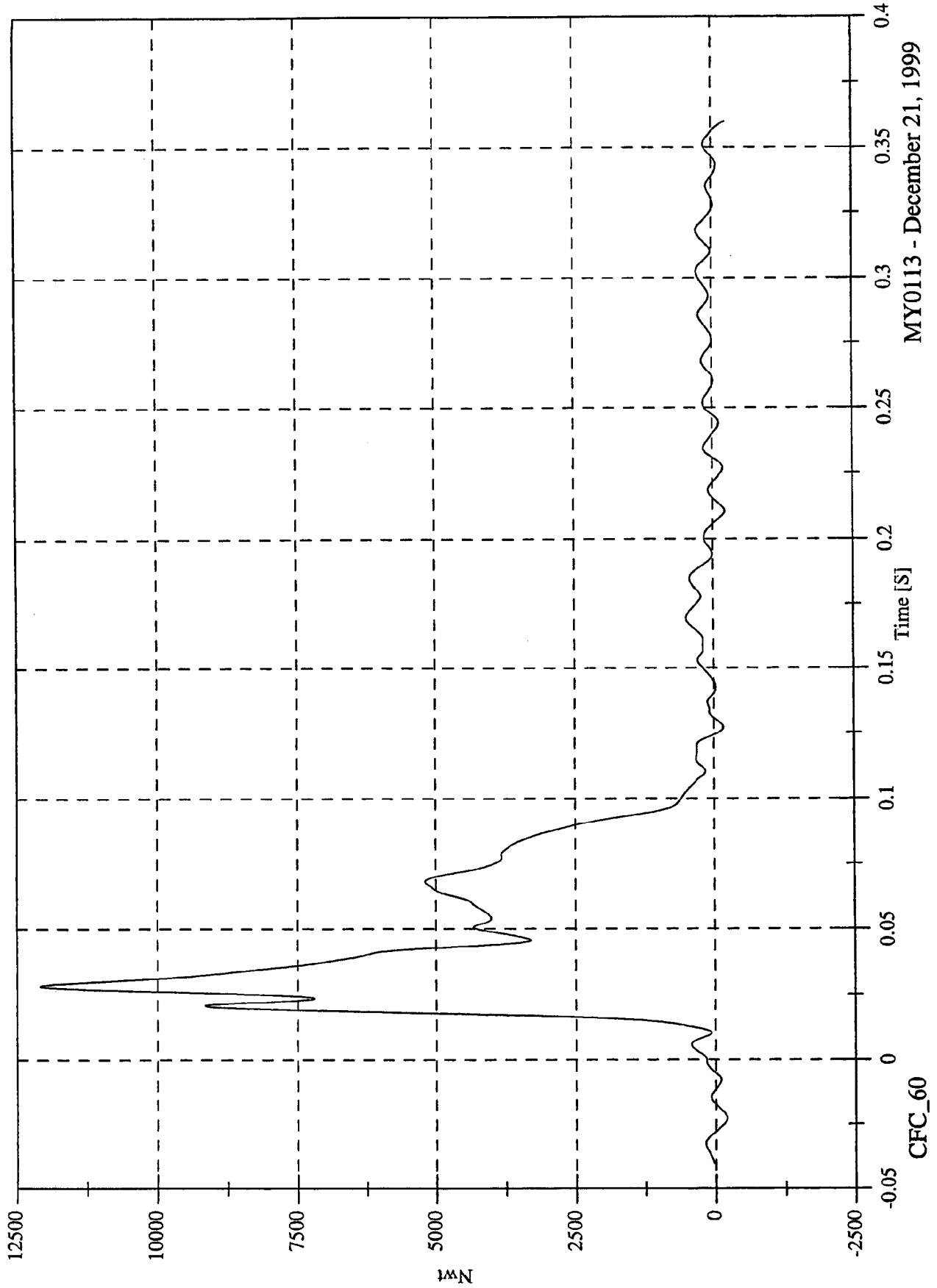

MY0113 - December 21, 1999

CFC\_60

NCAP TEST #7 - 2000 Saturn SL

Max: 1018.3 [Nwt] at 0.086 [S]  
Min: -364.8 [Nwt] at 0.066 [S]

BLC C9 Fx

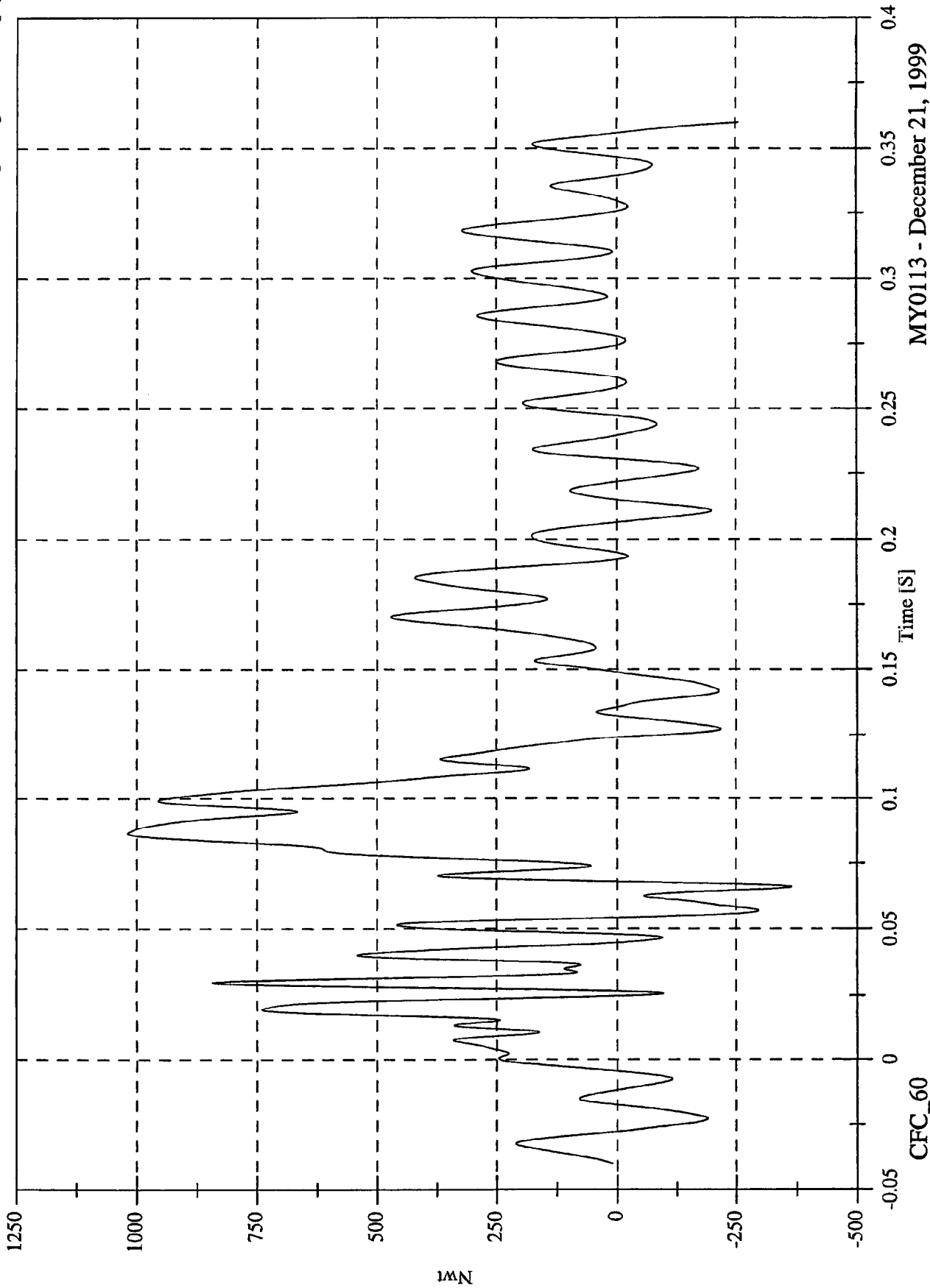

MY0113 - December 21, 1999

CFC\_60

NCAP TEST #7 - 2000 Saturn SL

Max: 1112.5 [Nwt] at 0.093 [S]  
Min: -732.2 [Nwt] at 0.030 [S]

BLC D1 Fx

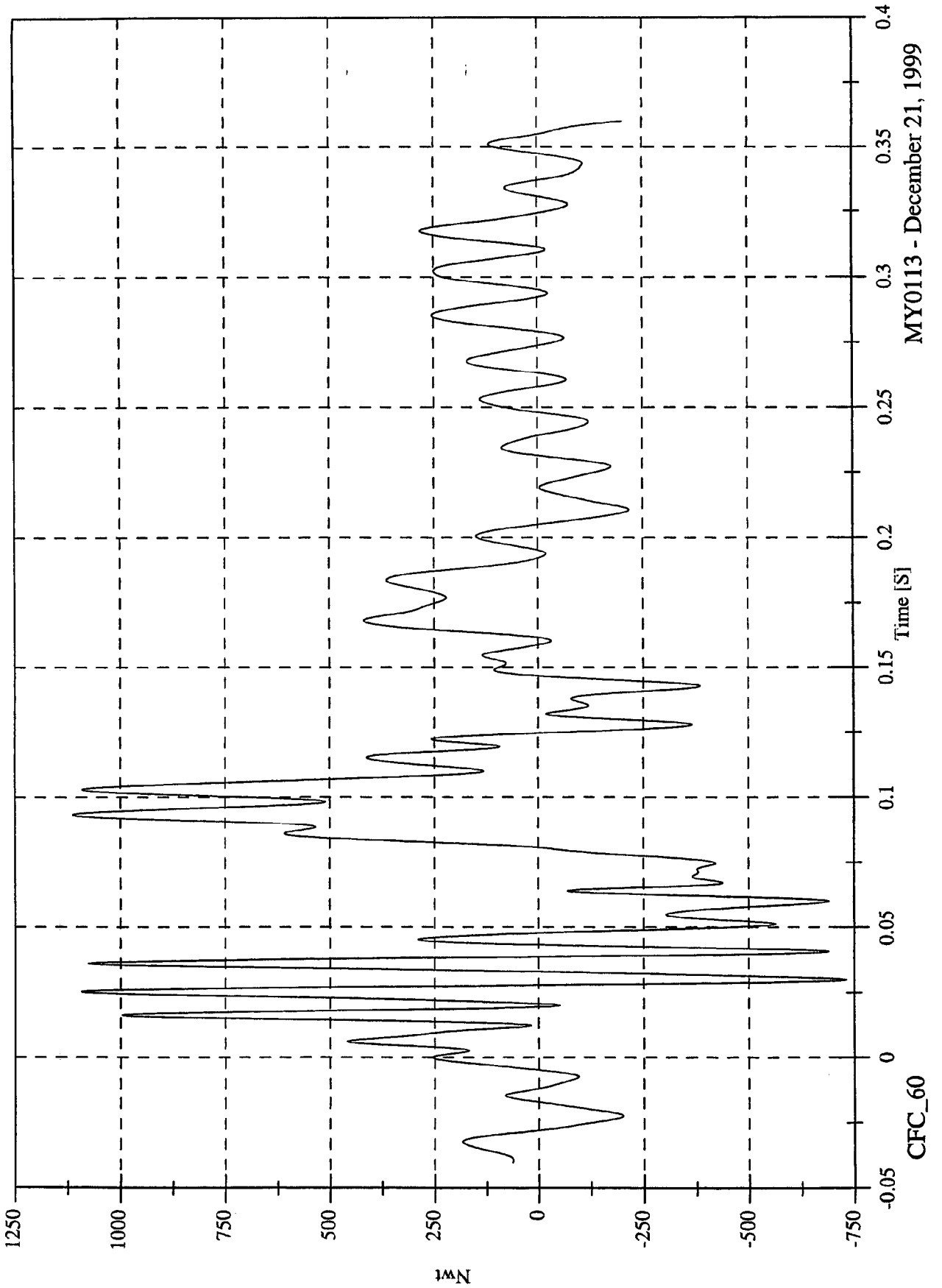

MY0113 - December 21, 1999

NCAP TEST #7 - 2000 Saturn SL

Max: 1519.1 [Nwt] at 0.065 [S]  
Min: -478.7 [Nwt] at 0.056 [S]

BLC D2 Fx

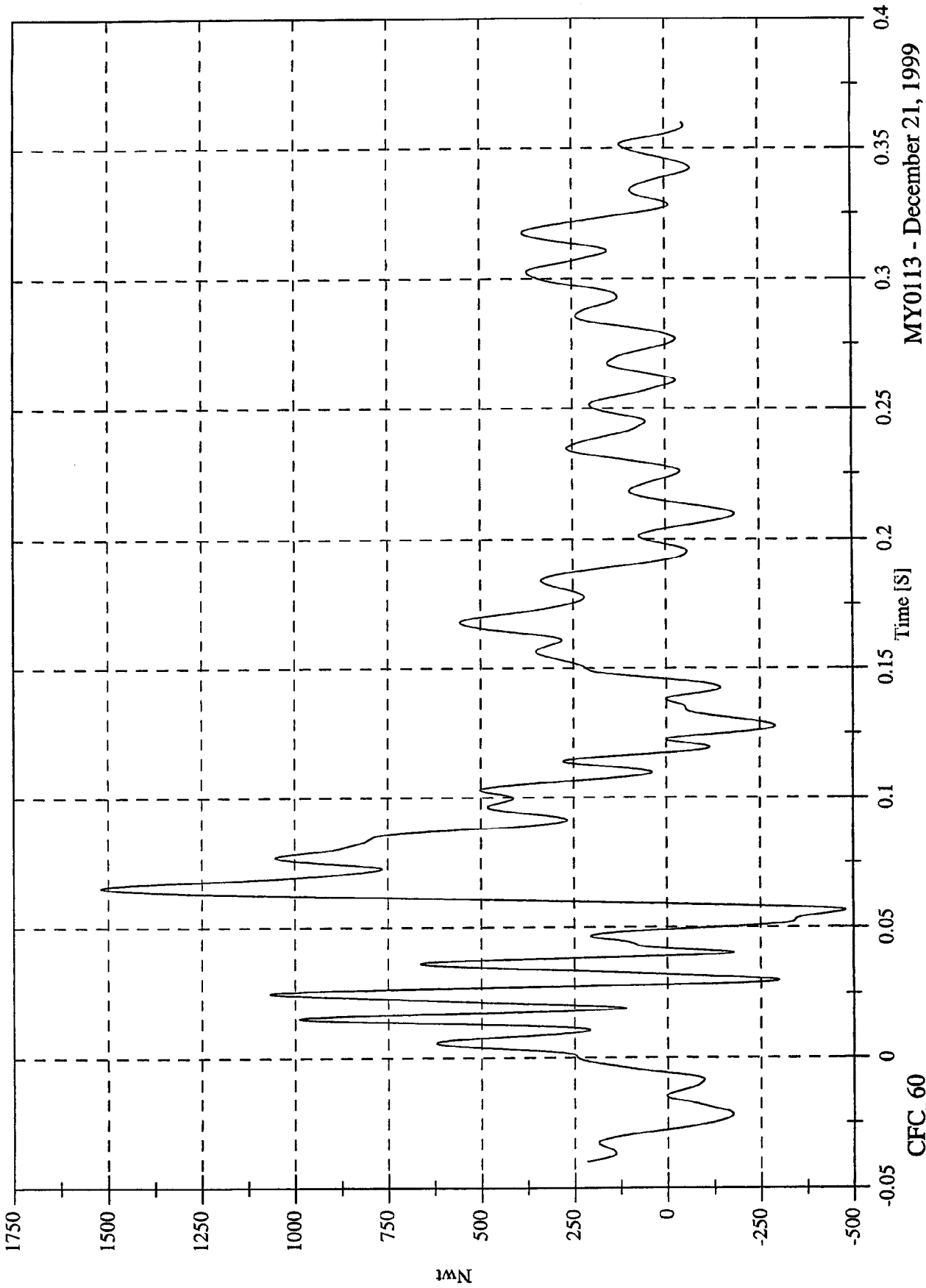

CFC\_60

MY0113 - December 21, 1999

NCAP TEST #7 - 2000 Saturn SL

Max: 12290.7 [Nwt] at 0.071 [S]  
Min: -572.4 [Nwt] at 0.053 [S]

BLC D3 Fx

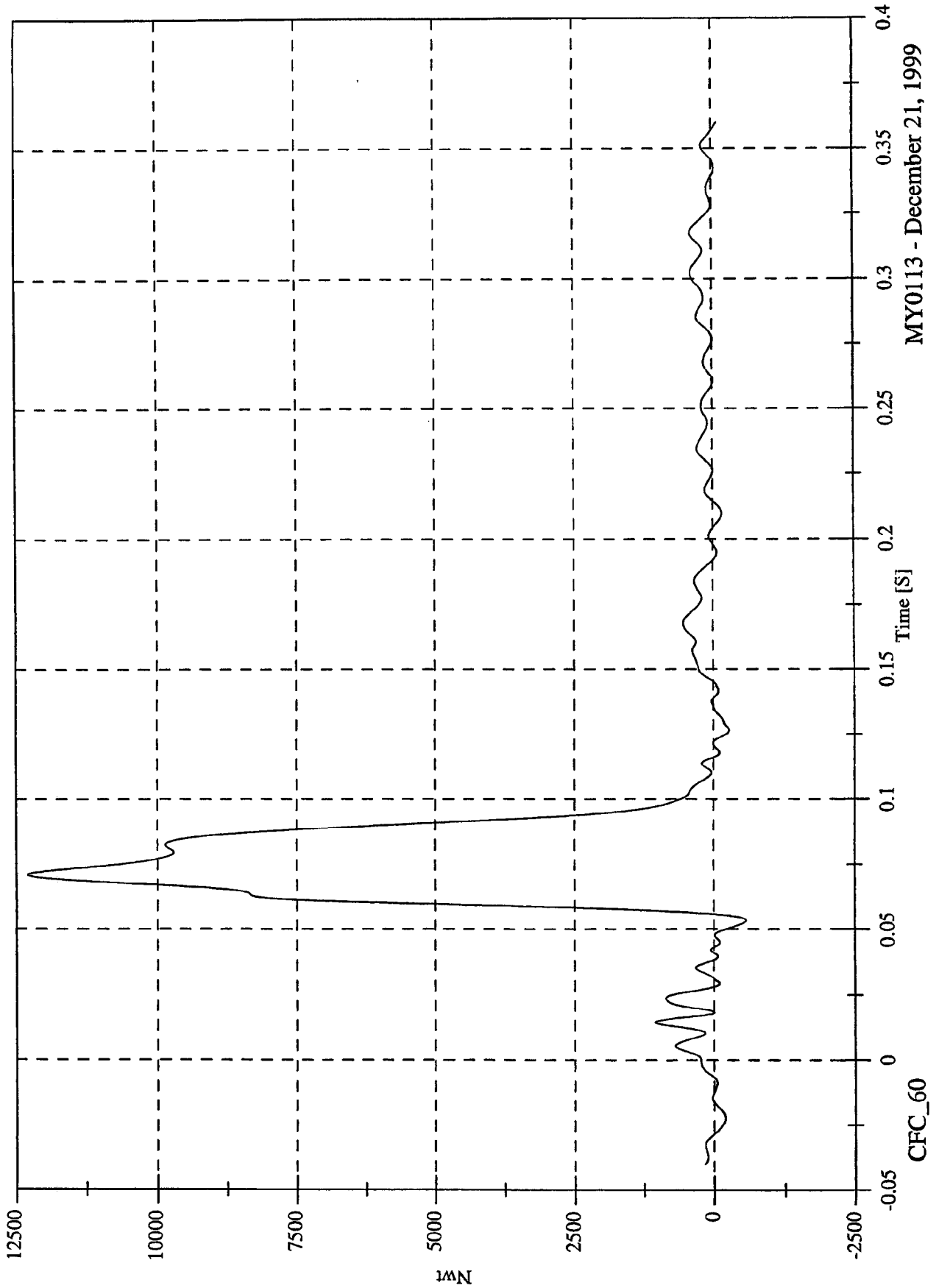

MY0113 - December 21, 1999

CFC\_60

NCAP TEST #7 - 2000 Saturn SL

Max: 6690.4 [Nwt] at 0.071 [S]  
Min: -996.0 [Nwt] at 0.063 [S]

BLC D4 Fx

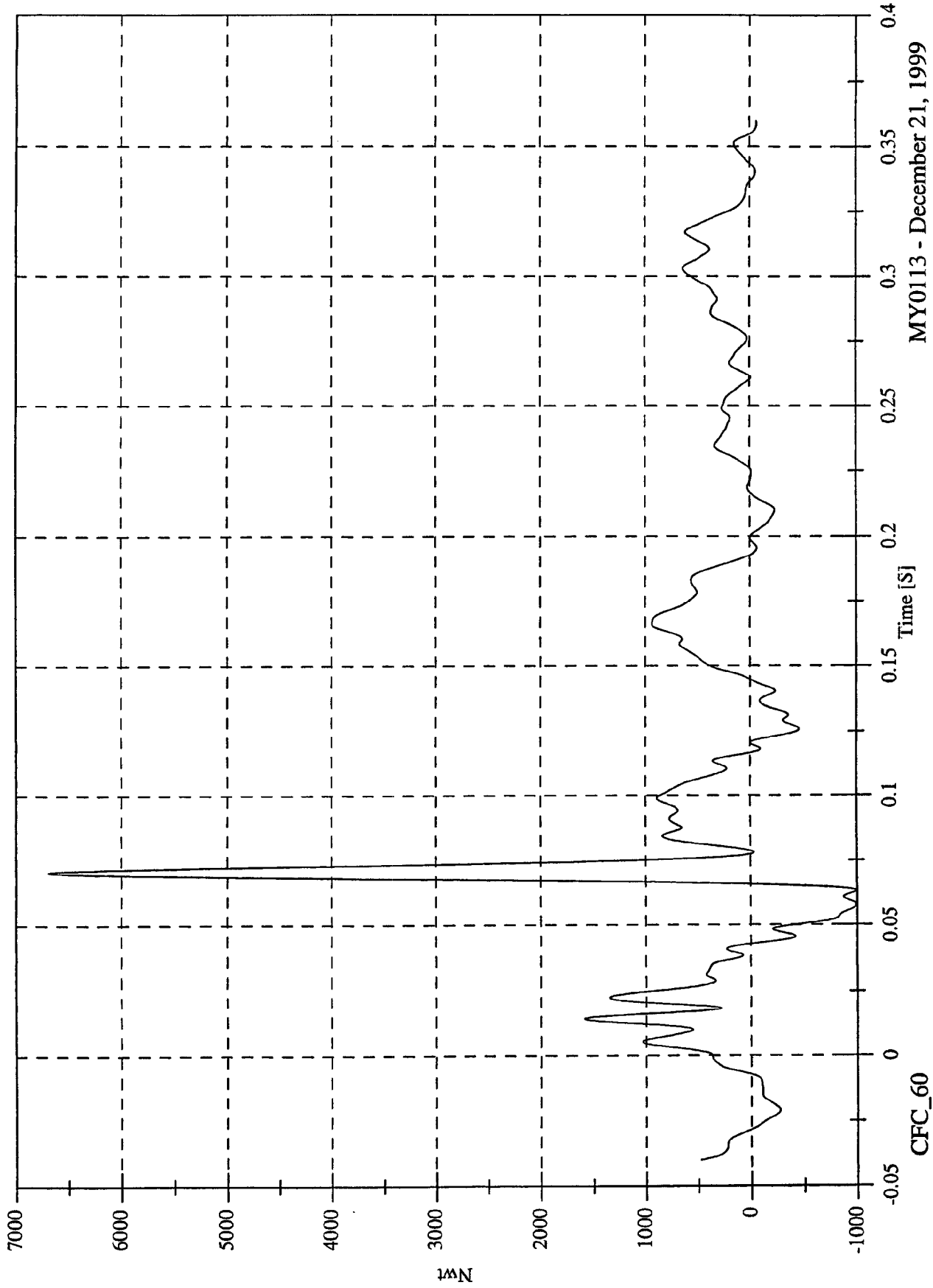

MY0113 - December 21, 1999

CFC\_60

NCAP TEST #7 - 2000 Saturn SL

Max: 1317.8 [Nwt] at 0.062 [S]  
Min: -693.8 [Nwt] at 0.056 [S]

BLC D5 Fx

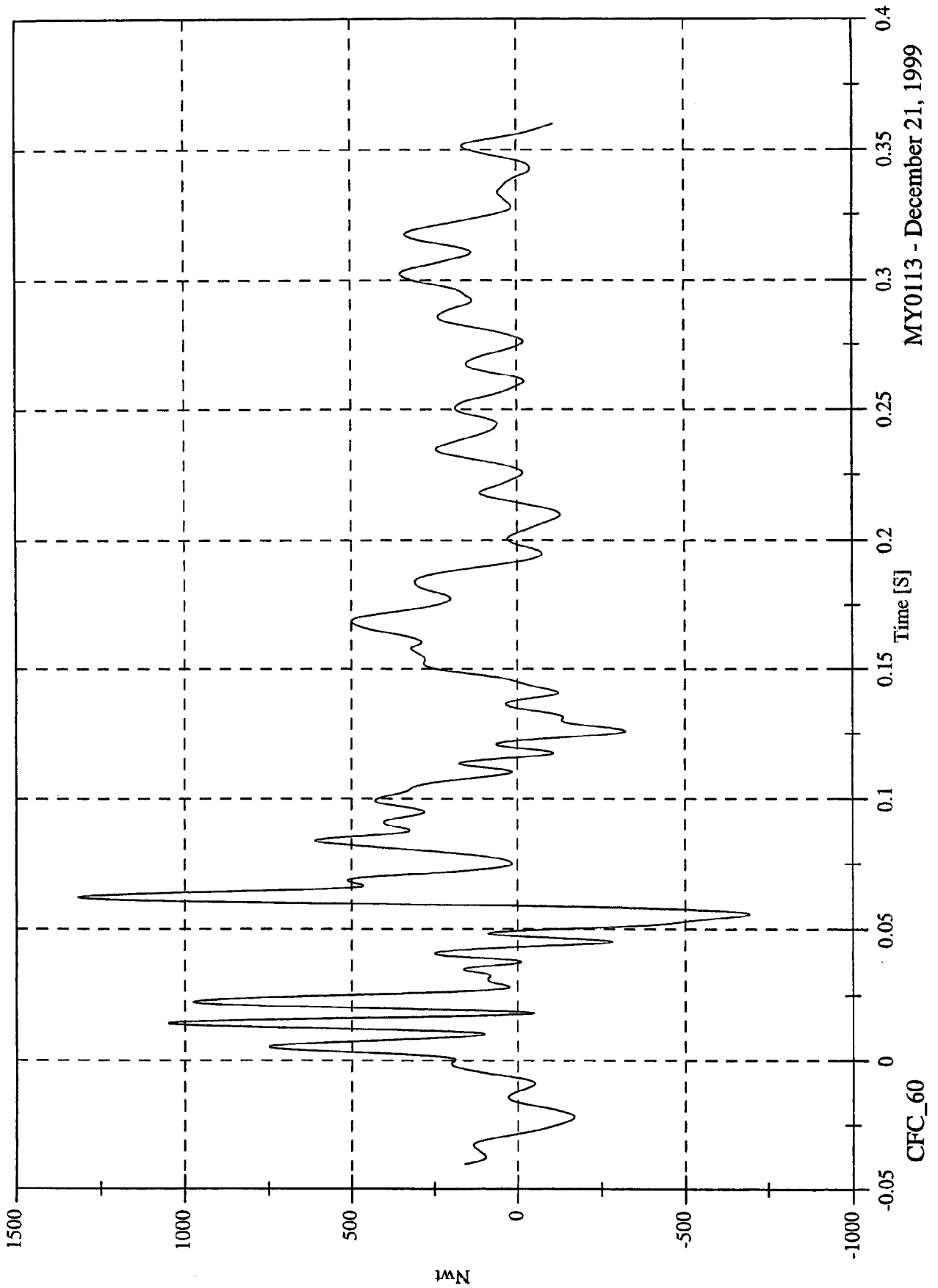

MY0113 - December 21, 1999

CFC\_60

NCAP TEST #7 - 2000 Saturn SL

Max: 754.0 [Nwt] at 0.022 [S]  
Min: -1131.2 [Nwt] at 0.360 [S]

BLC D6 Fx

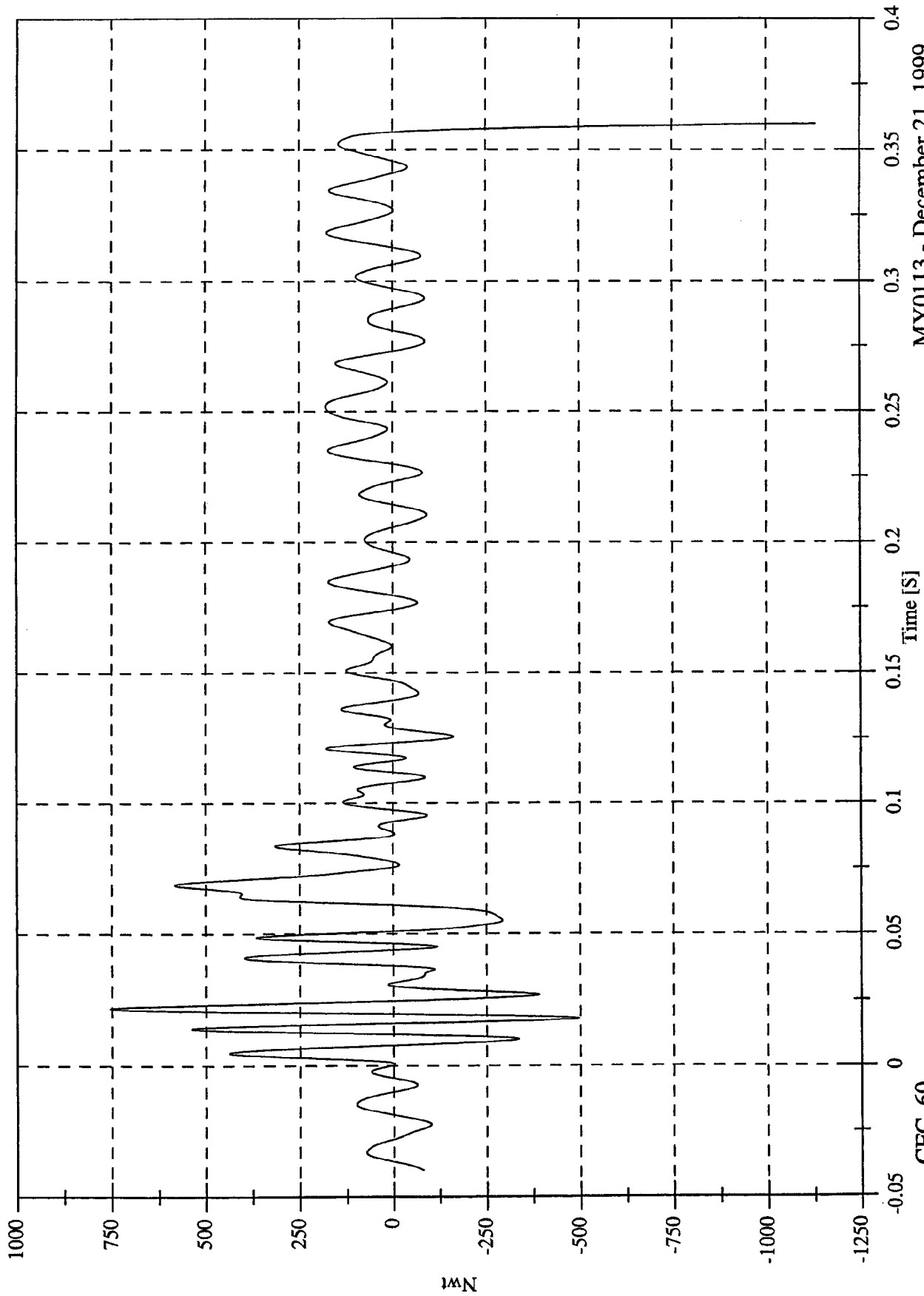

MY0113 - December 21, 1999

CFC\_60

NCAP TEST #7 - 2000 Saturn SL

Max: 2184.8 [Nwt] at 0.083 [S]  
Min: -1055.5 [Nwt] at 0.360 [S]

BLC D7 Fx

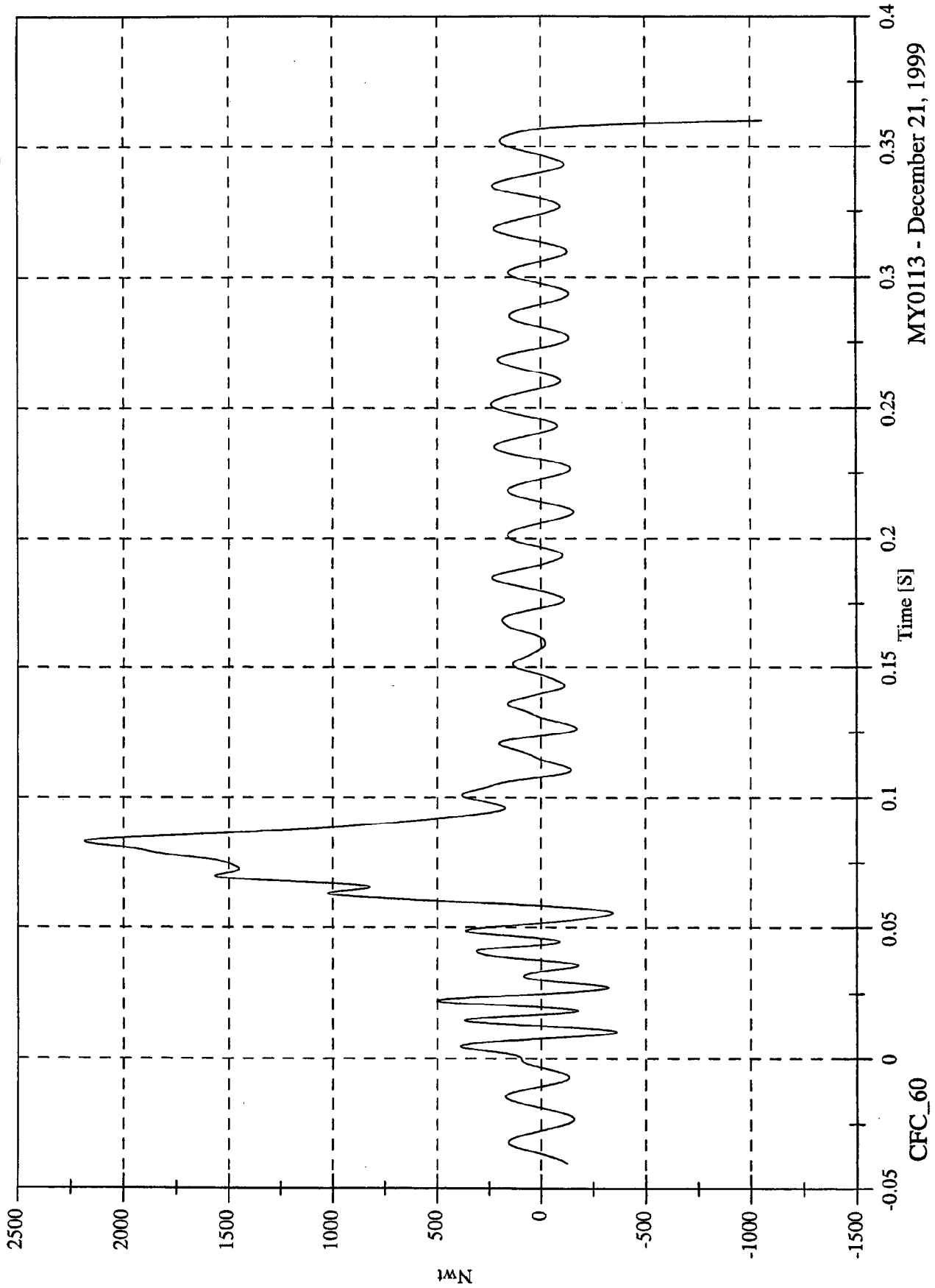

MY0113 - December 21, 1999

NCAP TEST #7 - 2000 Saturn SL

Max: 1325.6 [Nwt] at 0.070 [S]  
Min: -1589.4 [Nwt] at 0.360 [S]

BLC D8 Fx

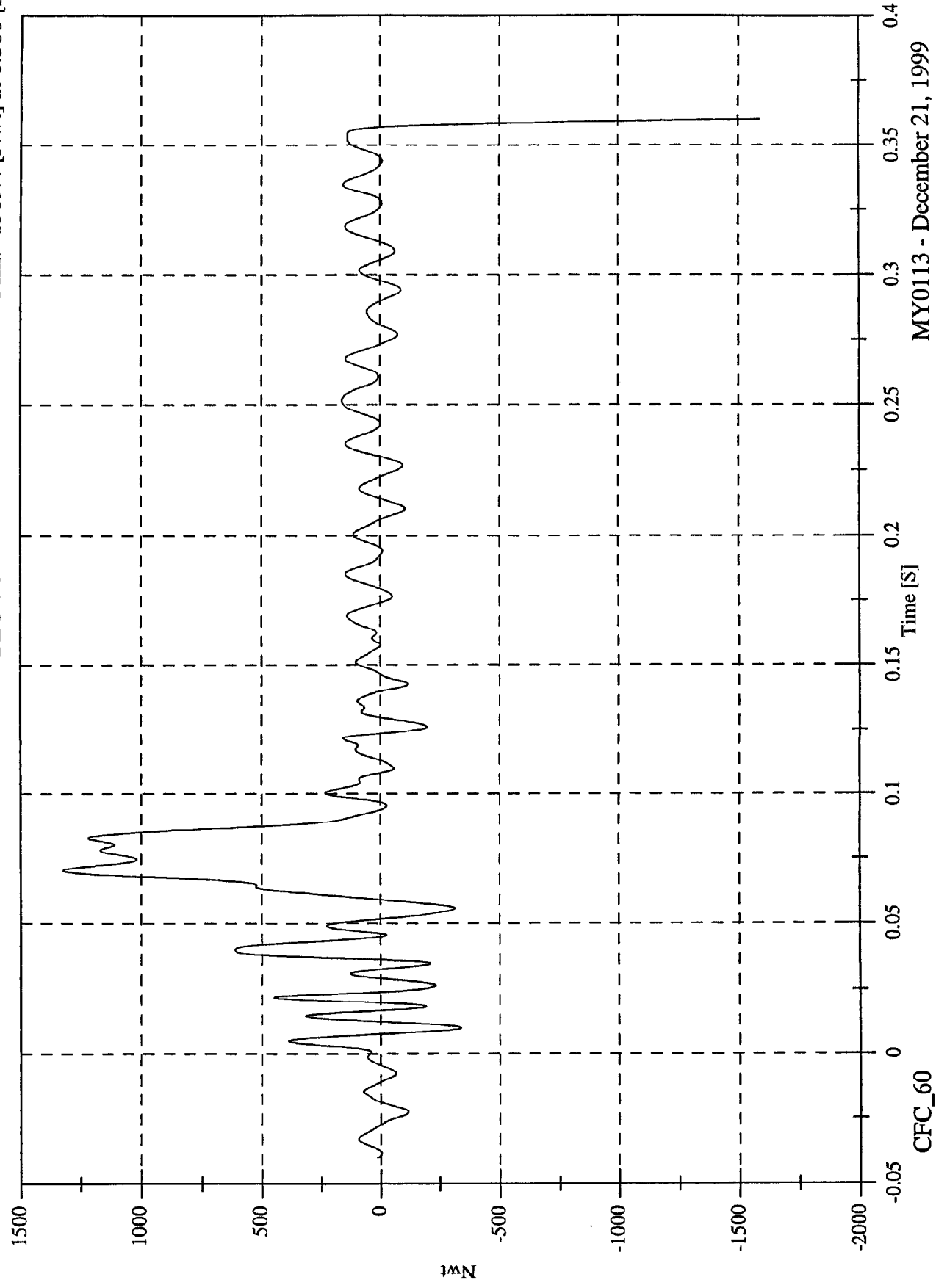

MY0113 - December 21, 1999

CFC\_60

NCAP TEST #7 - 2000 Saturn SL

Max: 593.0 [Nwt] at 0.040 [S]  
Min: -1529.3 [Nwt] at 0.360 [S]

BLC D9 Fx

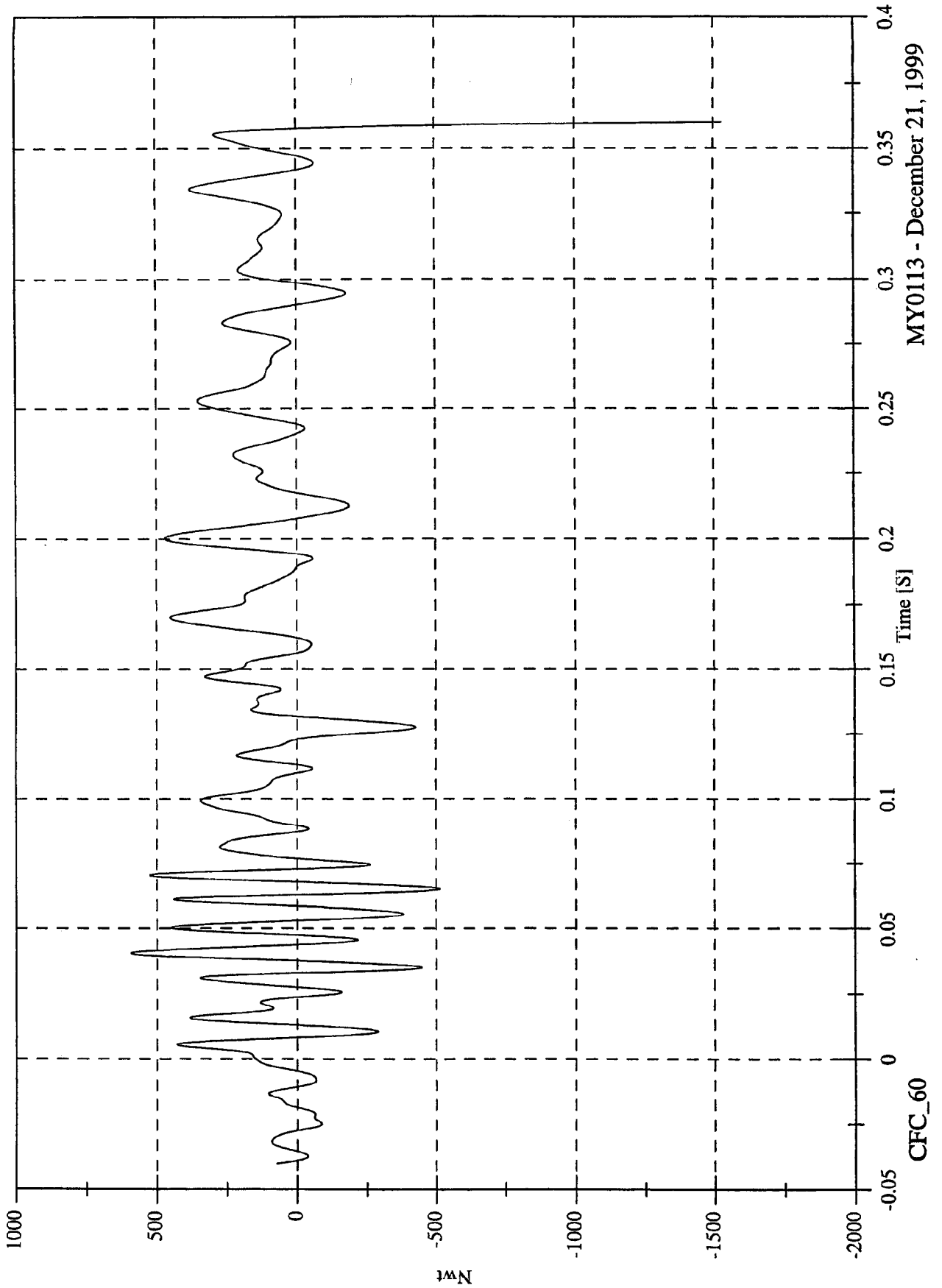

MY0113 - December 21, 1999

NCAP TEST #7 - 2000 Saturn SL

Max: 97154.3 [Nwt] at 0.022 [S]  
Min: -912.0 [Nwt] at -0.040 [S]

Group 1 Load Cell Sum (A1,A2,A3,B1,B2,B3)

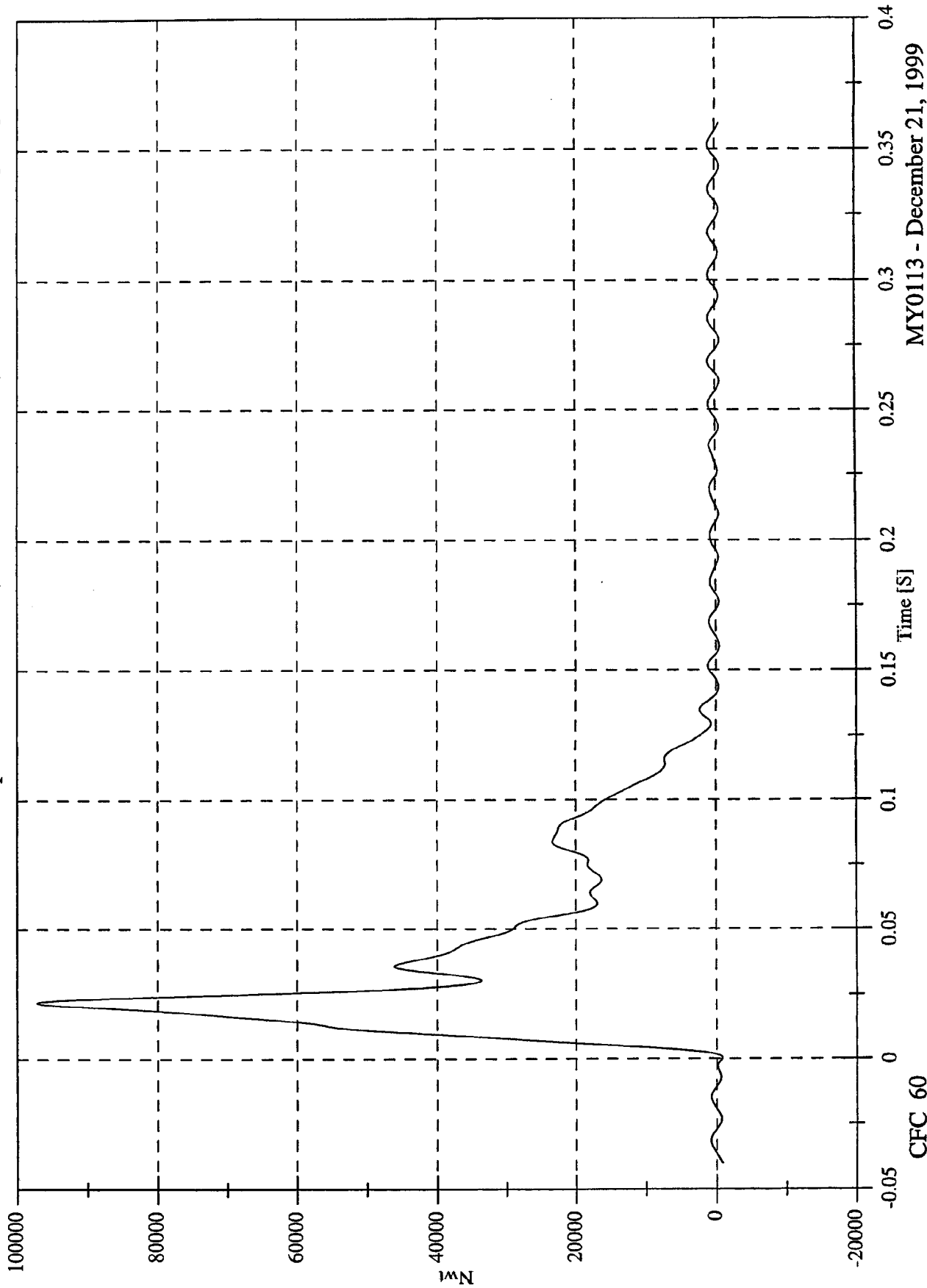

MY0113 - December 21, 1999

CFC\_60

NCAP TEST #7 - 2000 Saturn SL

Max: 118839.6 [Nwt] at 0.073 [S]  
Min: -2124.0 [Nwt] at -0.005 [S]

Group 2 Load Cell Sum (A4,A5,A6,B4,B5,B6)

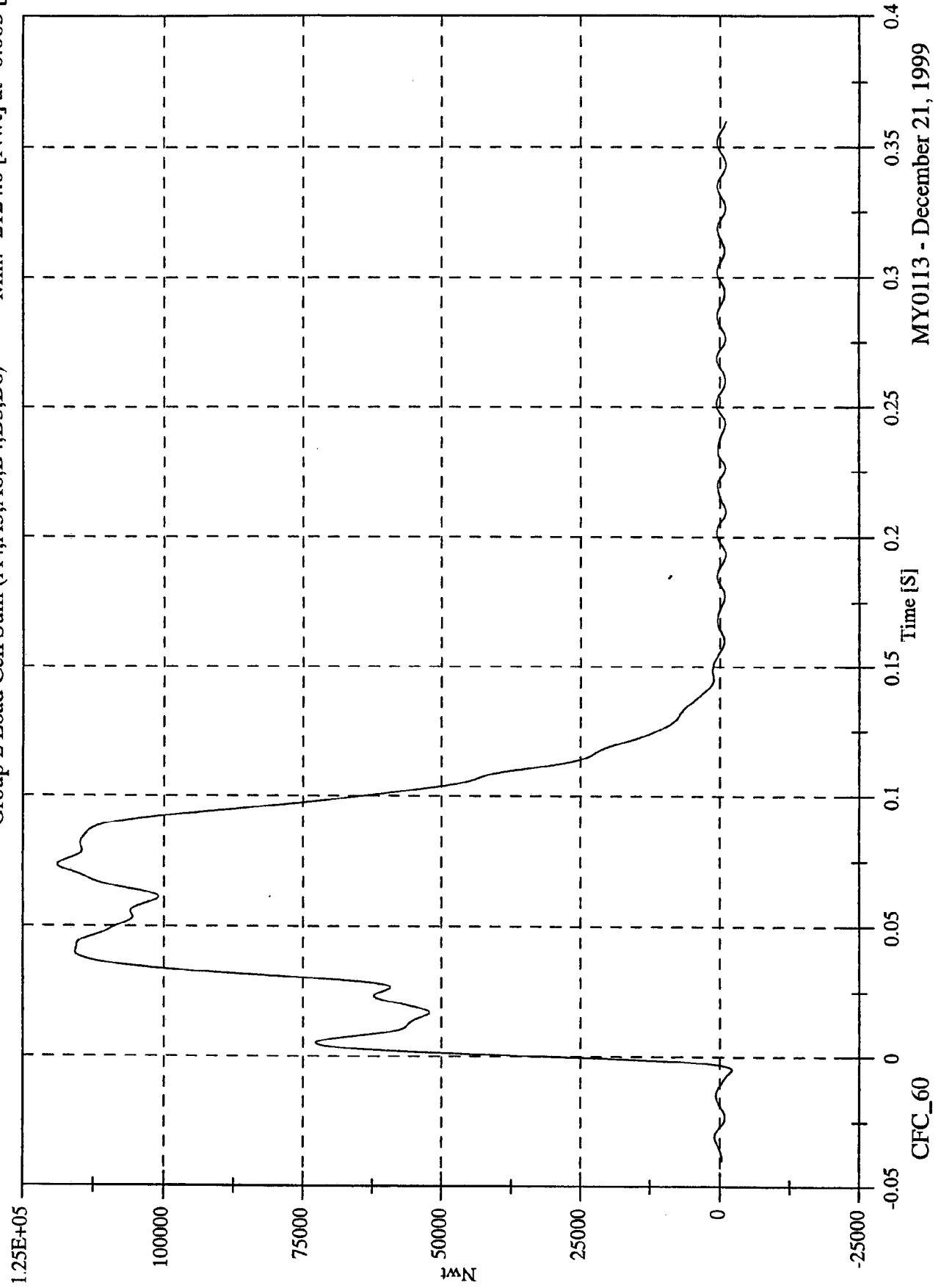

CFC\_60

NCAP TEST #7 - 2000 Saturn SL

Max: 94781.0 [Nwt] at 0.022 [S]  
Min: -1001.5 [Nwt] at 0.000 [S]

Group 3 Load Cell Sum (A7,A8,A9,B7,B8,B9)

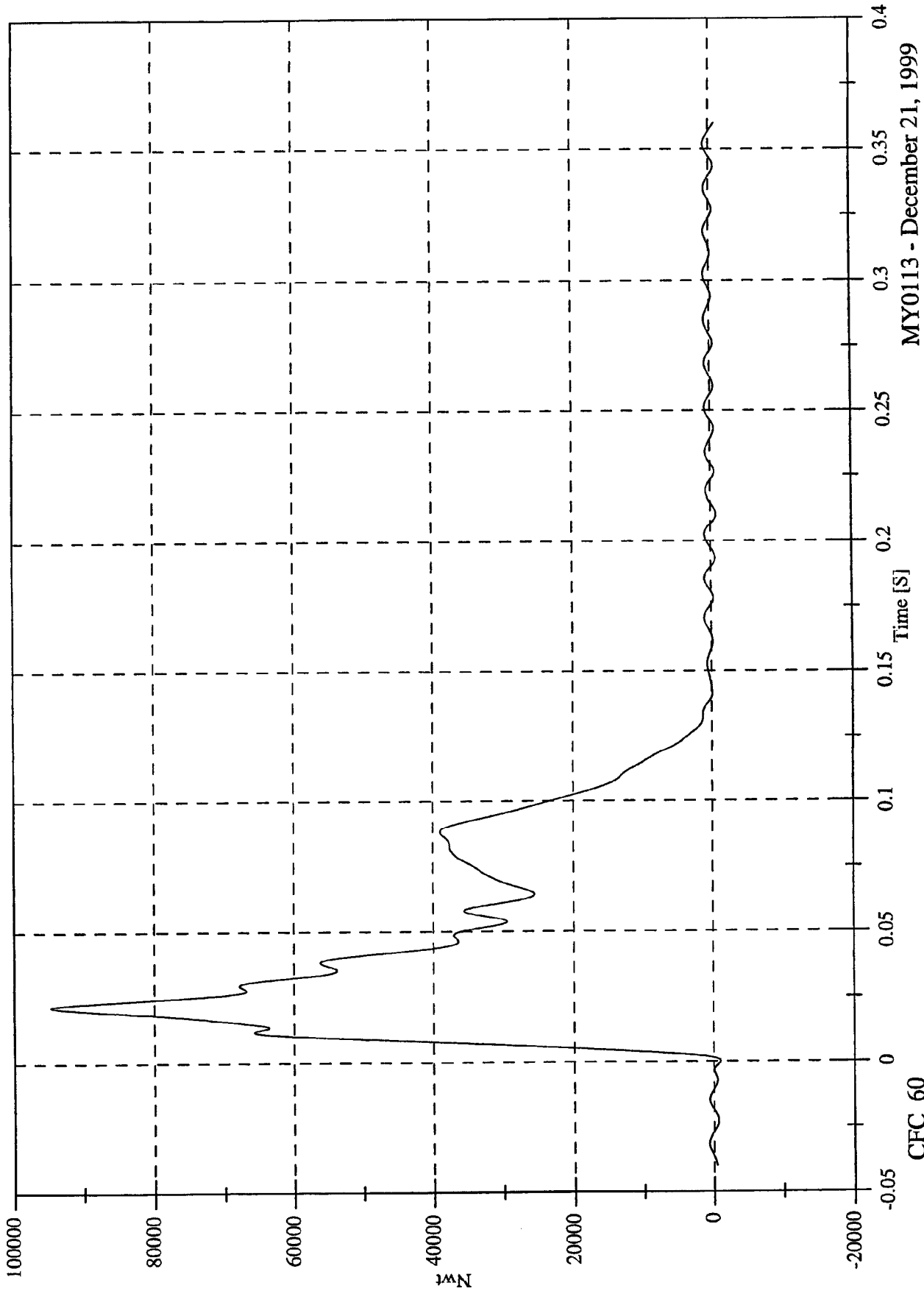

CFC\_60

MY0113 - December 21, 1999

NCAP TEST #7 - 2000 Saturn SL

Max: 28629.7 [Nwt] at 0.067 [S]  
Min: -1501.2 [Nwt] at 0.127 [S]

Group 4 Load Cell Sum (C1,C2,C3,D1,D2,D3)

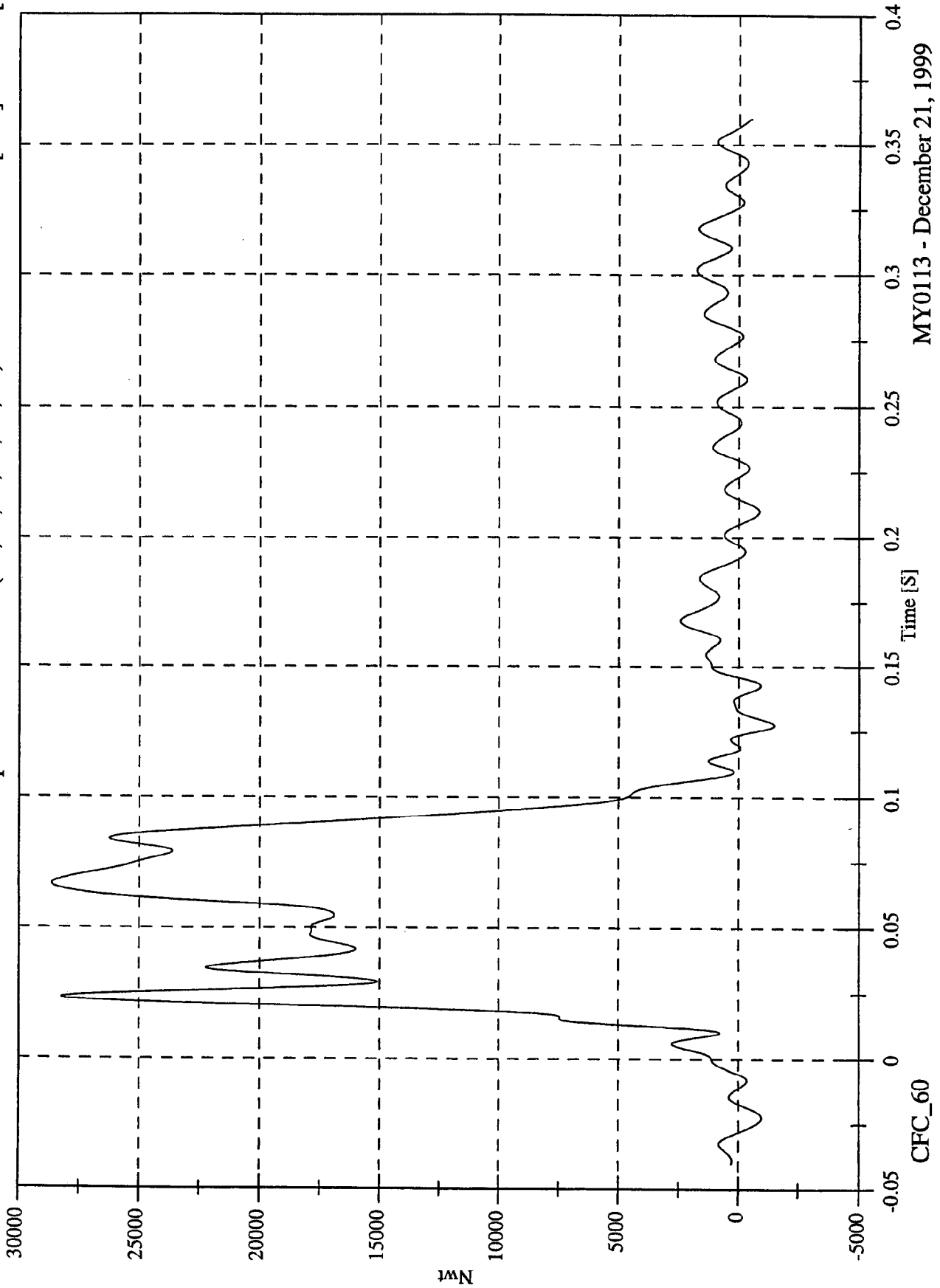

MY0113 - December 21, 1999

NCAP TEST #7 - 2000 Saturn SL

Max: 48203.8 [Nwt] at 0.070 [S]  
Min: -1714.9 [Nwt] at 0.126 [S]

Group 5 Load Cell Sum (C4,C5,C6,D4,D5,D6)

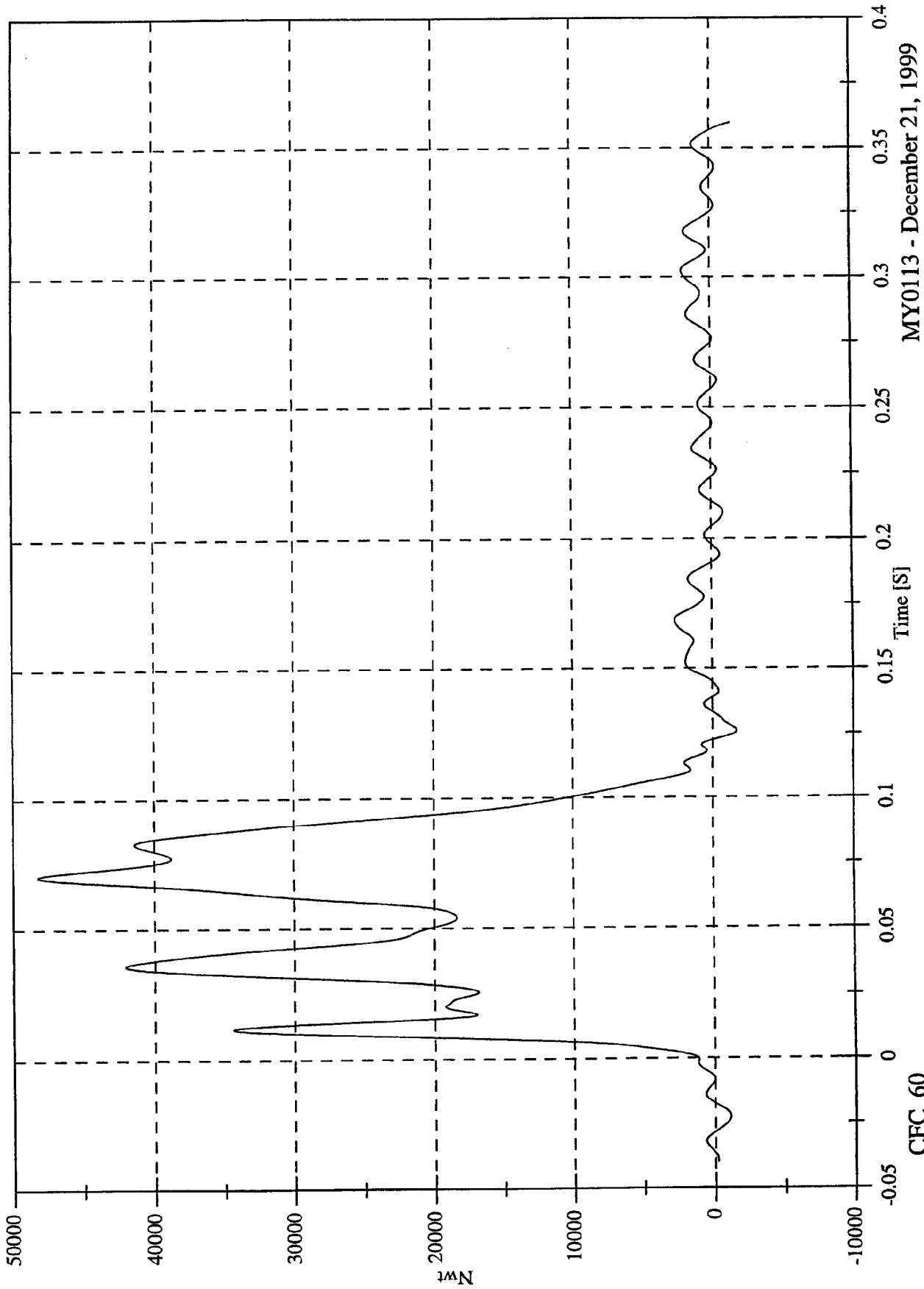

MY0113 - December 21, 1999

CFC\_60

NCAP TEST #7 - 2000 Saturn SL

Max: 25676.4 [Nwt] at 0.070 [S]  
Min: -4828.1 [Nwt] at 0.360 [S]

Group 6 Load Cell Sum (C7,C8,C9,D7,D8,D9)

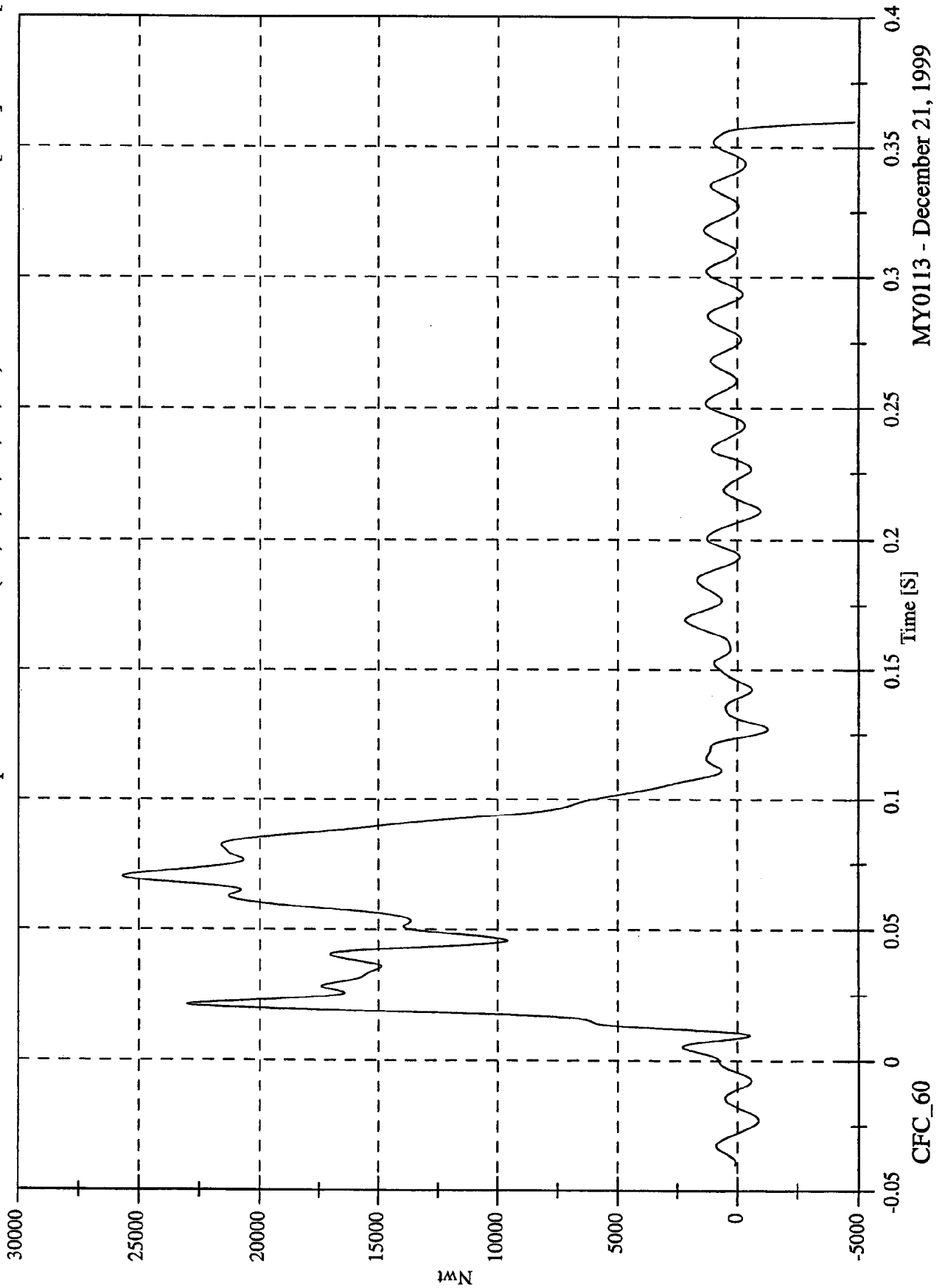

MY0113 - December 21, 1999

NCAP TEST #7 - 2000 Saturn SL

Max: 319415.8 [Nwt] at 0.022 [S]  
Min: -9377.6 [Nwt] at 0.360 [S]

Total Load Cell Sum (All 6 Groups)

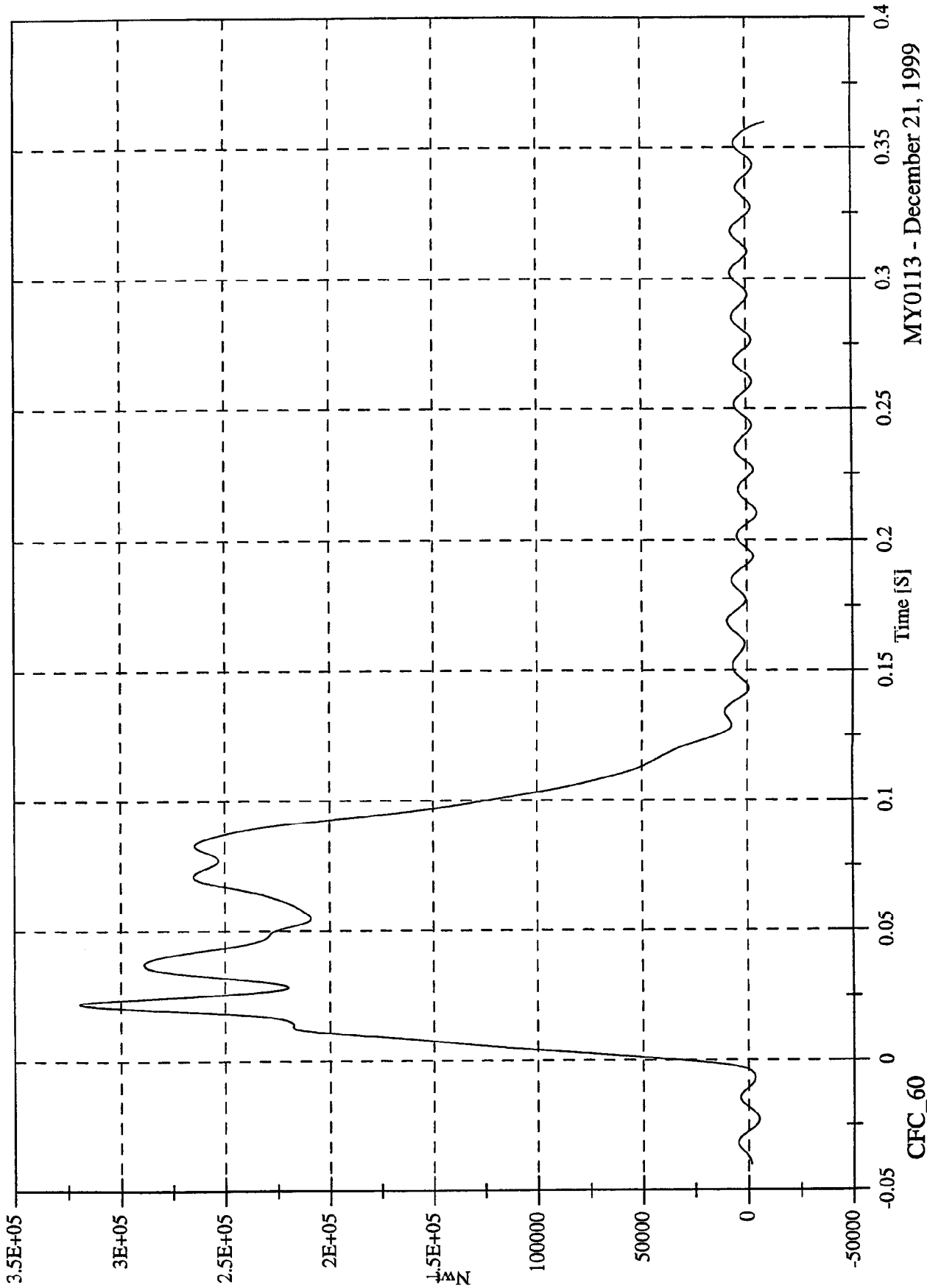

CFC\_60

MY0113 - December 21, 1999

**APPENDIX C**

**PART 572B/E DUMMY CONFIGURATION  
AND PERFORMANCE VERIFICATION DATA SHEETS**

Appendix C contains the results from certification tests performed on the 50th percentile male anthropomorphic test devices utilized for this crash test. The results indicate that the dummies meet all of the performance requirements of the six standard tests as specified in 49 CFR Part 572, Federal Register, Volume 42, No. 25, dated February 7, 1977.

The tests were conducted at the Dummy Certification Test Facility of Veridian Engineering. A summary of the test results, and Part 572 specifications are included in this Appendix.

Dummy serial numbers and certification dates are:

<u>Position No./Location</u>	<u>Serial No.</u>	<u>Completion Date</u>
#1/Driver	061	12/10/99
#2/Right Front Passenger	064	12/10/99

#### Electronic Test Equipment

The complement of signal conditioning, recording and display equipment, in conjunction with dummy certification testing, can be found in New Car Assessment and Standards Indicant Testing Final Report No. 6525-V-1.

DUMMY CONFIGURATION DIMENSIONS

EXTERNAL DIMENSIONS SPECIFICATIONS

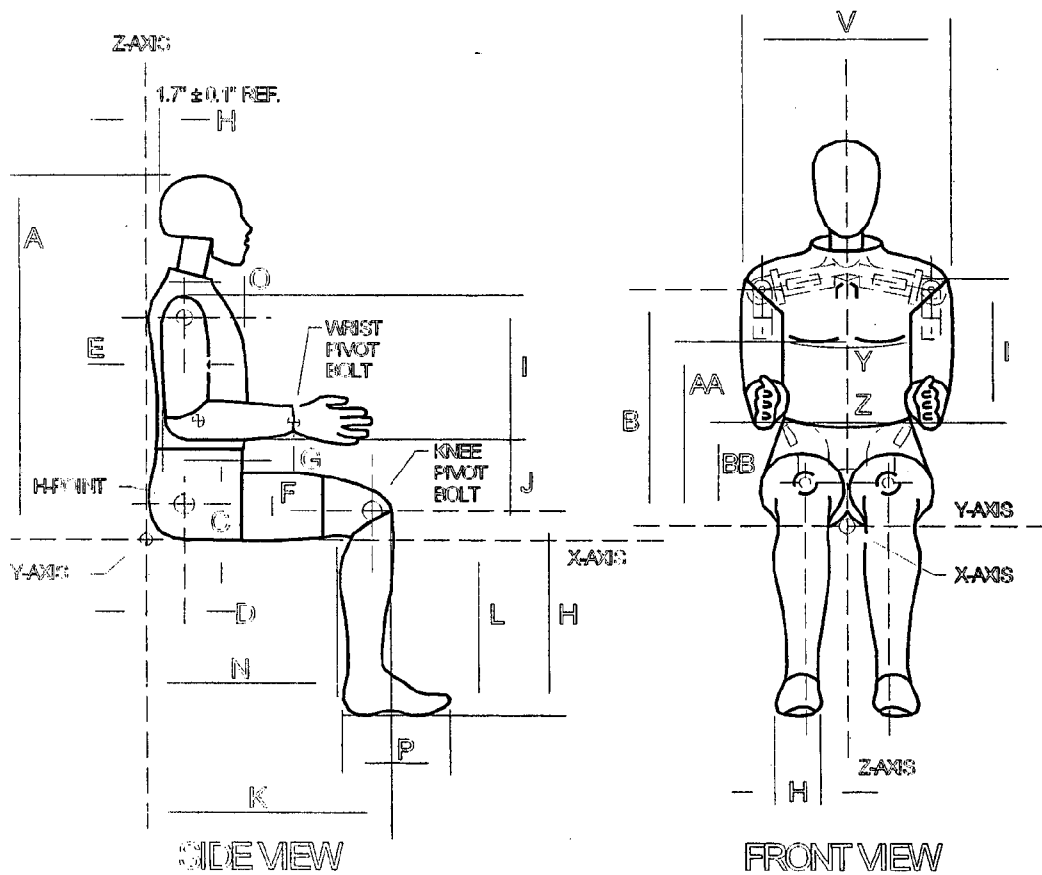

NOTE: Figure is referenced to the erect seated position. The curved lumbar does not allow the Hybrid III to be positioned in a perfect erect attitude. (REF: 37231(A)(3))

PART 572E  
HEAD DROP TEST

Dummy Serial Number 061  
Sequential Test Number 6  
Date December 6, 1999  
Workfile 061699.hdp

TEST PARAMETER	SPECIFICATION	TEST RESULTS
Temperature	66-78 Deg F	71
Relative Humidity	10% - 70%	32
Peak Resultant Acceleration	225-275 G's	237.2
Peak Lateral Acceleration	15 G's Max	10.0
Is Acceleration Curve Unimodal?	YES	YES

Remarks:

Laboratory Technician: B. Swiecicki

PART 572E  
NECK FLEXION TEST

Dummy Serial Number 061  
 Sequential Test Number 6  
 Date December 6, 1999  
 Workfile 061699.nfl  
 6 Axis Neck Transducer

TEST PARAMETER		SPECIFICATION	TEST RESULTS
Temperature		69-72 Deg F	71
Relative Humidity		10% - 70%	32
Impact Velocity		22.60 - 23.40 Ft/s	22.70
Pendulum Deceleration	10 ms	22.50 - 27.50 G's	24.58
	20 ms	17.60 - 22.60 G's	20.41
	30 ms	12.50 - 18.50 G's	14.35
Max Pendulum G's Above 30 ms		29 G's Max	14.35
Deceleration - Time Curve Decay Time to 5 G's		34 - 42 ms	40.63
D Plane Rotation	Max	64 - 78 Deg	76.03
	Time	57 - 64 ms	63.25
Moment About Occipital Condyle	Max	65 - 80 Ft-Lbs	76.29
	Time	47 - 58 ms	54.63
Rotation Angle - Time Curve Decay Time to Zero		113 - 128 ms	119.00
Positive Moment - Time Curve Decay Time to Zero		97 - 107 ms	100.88

Remarks:

Laboratory Technician: B. Swiecicki

PART 572E  
NECK EXTENSION TEST

Dummy Serial Number	061	
Sequential Test Number	6	
Date	December 6, 1999	6 Axis Neck Transducer
Workfile	061699.nex	

TEST PARAMETER		SPECIFICATION	TEST RESULTS
Temperature		69-72 Deg F	70
Relative Humidity		10% - 70%	31
Impact Velocity		19.50 - 20.30 Ft/s	19.77
Pendulum Deceleration	10 ms	17.20 - 21.20 G's	19.35
	20 ms	14.00 - 19.00 G's	18.69
	30 ms	11.00 - 16.00 G's	15.04
Max Pendulum G's Above 30 ms		22 G's Max	15.04
Deceleration - Time Curve Decay Time to 5 G's		38 - 46 ms	39.00
D Plane Rotation	Max	81 - 106 Deg	96.52
	Time	72 - 82 ms	74.25
Moment About Occipital Condyle	Max	-59.0 - -39.0 Ft-Lbs	-50.42
	Time	65 - 79 ms	70.00
Rotation Angle - Time Curve Decay Time to Zero		147 - 174 ms	155.25
Positive Moment - Time Curve Decay Time to Zero		120 - 148 ms	129.63

Remarks:

Laboratory Technician: B. Swiecicki

PART 572E  
THORAX IMPACT TEST

Dummy Serial Number      061  
Sequential Test Number     6  
Date                             December 6, 1999  
Workfile                        061699.th3

TEST PARAMETER	SPECIFICATION	TEST RESULTS
Temperature	69-72 Deg F	70
Relative Humidity	10% - 70%	31
Pendulum Velocity	21.6 - 22.4 Ft/s	22.65
Maximum Deflection	2.50 - 2.86 in	2.52
Maximum Resistive Force	1160 - 1325 Lbs	1243.47
Internal Hysteresis	69 - 85 %	74.03

Remarks:

Laboratory Technician: B. Swiecicki

PART 572E  
KNEE IMPACT TEST

Dummy Serial Number 061  
Sequential Test Number 6  
Date December 6, 1999  
Workfile 061699.lf/061699.rf

TEST PARAMETER	SPECIFICATION	TEST RESULTS
<b>LEFT KNEE</b>		
Temperature	66 - 78 Deg F	70
Relative Humidity	10% - 70%	30
Probe Velocity	6.8 - 7.0 Ft/s	7.00
Peak Knee Impact Force	1060 - 1300 Lbs	1265.0
<b>RIGHT KNEE</b>		
Temperature	66 - 78 Deg F	70
Relative Humidity	10% - 70%	30
Probe Velocity	6.8 - 7.0 Ft/s	7.00
Peak Knee Impact Force	1060 - 1300 Lbs	1246.0

Remarks:

Laboratory Technician: B. Swiecicki

PART 572E  
EXTERNAL DIMENSIONS

Dummy Serial Number           061  
 Sequential Test Number         6  
 Date                               December 10, 1999

TEST PARAMETER		SPECIFICATION	TEST RESULTS
Temperature			70
Relative Humidity			32
Location for Chest Circumference	AA	16.9 - 17.1 in	17.0
Location for Waist Circumference	BB	8.9 - 9.1 in	9.0
Chest Circumference (With Jacket)	Y	38.2 - 39.4 in	39.2
Waist Circumference	Z	32.9 - 34.1 in	33.5
Chest Depth	O	8.4 - 9.0 in	8.4
H-Point Height	C	3.3 - 3.5 in	3.4
H-Point from Backline	D	5.3 - 5.5 in	5.4
Skull Cap to Backline	H	1.6 - 1.8 in	1.7
Total Sitting Height	A	34.6 - 35.0 in	34.9
Thigh Clearance	F	5.5 - 6.1 in	6.1
Buttock Knee Length	K	22.8 - 23.8 in	23.6
Buttock Popliteal Length	N	17.8 - 18.8 in	18.4
Popliteal Height	L	16.9 - 17.9 in	17.7
Knee Pivot Height	M	19.1 - 19.7 in	19.4
Foot Length	P	9.9 - 10.5 in	10.1
Foot Breadth	W	3.6 - 4.2 in	3.8
Shoulder Pivot from Backline	E	3.3 - 3.7 in	3.5
Shoulder Breadth	V	16.6 - 17.2 in	16.8
Shoulder Pivot Height	B	19.9 - 20.5 in	20.1
Elbow Rest Height	J	7.5 - 8.3 in	7.7
Shoulder - Elbow Length	I	13.0 - 13.6 in	13.4
Back of Elbow to Wrist Pivot	G	11.4 - 12.0 in	11.6

Remarks:

Laboratory Technician:     B. Swiecicki

PART 572E  
HEAD DROP TEST

Dummy Serial Number      064  
Sequential Test Number    6  
Date                            December 6, 1999  
Workfile                      064699.hdp

TEST PARAMETER	SPECIFICATION	TEST RESULTS
Temperature	66-78 Deg F	71
Relative Humidity	10% - 70%	32
Peak Resultant Acceleration	225-275 G's	239.5
Peak Lateral Acceleration	15 G's Max	12.0
Is Acceleration Curve Unimodal?	YES	YES

Remarks:

Laboratory Technician: B. Swiecicki

PART 572E  
NECK FLEXION TEST

Dummy Serial Number	064	
Sequential Test Number	6	
Date	December 6, 1999	6 Axis Neck Transducer
Workfile	064699.nfl	

TEST PARAMETER		SPECIFICATION	TEST RESULTS
Temperature		69-72 Deg F	70
Relative Humidity		10% - 70%	31
Impact Velocity		22.60 - 23.40 Ft/s	22.64
Pendulum Deceleration	10 ms	22.50 - 27.50 G's	23.65
	20 ms	17.60 - 22.60 G's	19.38
	30 ms	12.50 - 18.50 G's	15.62
Max Pendulum G's Above 30 ms		29 G's Max	15.62
Deceleration - Time Curve Decay Time to 5 G's		34 - 42 ms	40.75
D Plane Rotation	Max	64 - 78 Deg	72.67
	Time	57 - 64 ms	58.13
Moment About Occipital Condyle	Max	65 - 80 Ft-Lbs	78.61
	Time	47 - 58 ms	53.88
Rotation Angle - Time Curve Decay Time to Zero		113 - 128 ms	121.00
Positive Moment - Time Curve Decay Time to Zero		97 - 107 ms	101.63

Remarks:

Laboratory Technician: B. Swiecicki

PART 572E  
NECK EXTENSION TEST

Dummy Serial Number	064	
Sequential Test Number	6	
Date	December 6, 1999	6 Axis Neck Transducer
Workfile	064699.nex	

TEST PARAMETER	SPECIFICATION	TEST RESULTS
Temperature	69-72 Deg F	70
Relative Humidity	10% - 70%	31
Impact Velocity	19.50 - 20.30 Ft/s	19.67
Pendulum Deceleration	10 ms	17.20 - 21.20 G's
	20 ms	14.00 - 19.00 G's
	30 ms	11.00 - 16.00 G's
Max Pendulum G's Above 30 ms	22 G's Max	15.32
Deceleration - Time Curve Decay Time to 5 G's	38 - 46 ms	39.13
D Plane Rotation	Max	81 - 106 Deg
	Time	72 - 82 ms
Moment About Occipital Condyle	Max	-59.0 - -39.0 Ft-Lbs
	Time	65 - 79 ms
Rotation Angle - Time Curve Decay Time to Zero	147 - 174 ms	147.75
Positive Moment - Time Curve Decay Time to Zero	120 - 148 ms	135.50

Remarks:

Laboratory Technician: B. Swiecicki

PART 572E  
THORAX IMPACT TEST

Dummy Serial Number 064  
Sequential Test Number 6  
Date December 6, 1999  
Workfile 064699.th3

TEST PARAMETER	SPECIFICATION	TEST RESULTS
Temperature	69-72 Deg F	70
Relative Humidity	10% - 70%	30
Pendulum Velocity	21.6 - 22.4 Ft/s	21.68
Maximum Deflection	2.50 - 2.86 in	2.50
Maximum Resistive Force	1160 - 1325 Lbs	1300.05
Internal Hysteresis	69 - 85 %	76.8

Remarks:

Laboratory Technician: B. Swiecicki

PART 572E  
KNEE IMPACT TEST

Dummy Serial Number 064  
Sequential Test Number 6  
Date December 6, 1999  
Workfile 064699.lf/064699.rf

TEST PARAMETER	SPECIFICATION	TEST RESULTS
<b>LEFT KNEE</b>		
Temperature	66 - 78 Deg F	70
Relative Humidity	10% - 70%	30
Probe Velocity	6.8 - 7.0 Ft/s	7.00
Peak Knee Impact Force	1060 - 1300 Lbs	1134.0
<b>RIGHT KNEE</b>		
Temperature	66 - 78 Deg F	70
Relative Humidity	10% - 70%	30
Probe Velocity	6.8 - 7.0 Ft/s	7.00
Peak Knee Impact Force	1060 - 1300 Lbs	1135.0

Remarks:

Laboratory Technician: B. Swiecicki

PART 572E  
EXTERNAL DIMENSIONS

Dummy Serial Number           064  
 Sequential Test Number         6  
 Date                               December 10, 1999

TEST PARAMETER		SPECIFICATION	TEST RESULTS
Temperature			70
Relative Humidity			30
Location for Chest Circumference	AA	16.9 - 17.1 in	17.0
Location for Waist Circumference	BB	8.9 - 9.1 in	9.0
Chest Circumference (With Jacket)	Y	38.2 - 39.4 in	38.8
Waist Circumference	Z	32.9 - 34.1 in	33.4
Chest Depth	O	8.4 - 9.0 in	8.6
H-Point Height	C	3.3 - 3.5 in	3.4
H-Point from Backline	D	5.3 - 5.5 in	5.4
Skull Cap to Backline	H	1.6 - 1.8 in	1.7
Total Sitting Height	A	34.6 - 35.0 in	34.8
Thigh Clearance	F	5.5 - 6.1 in	6.0
Buttock Knee Length	K	22.8 - 23.8 in	23.5
Buttock Popliteal Length	N	17.8 - 18.8 in	18.4
Popliteal Height	L	16.9 - 17.9 in	17.3
Knee Pivot Height	M	19.1 - 19.7 in	19.4
Foot Length	P	9.9 - 10.5 in	10.1
Foot Breadth	W	3.6 - 4.2 in	3.8
Shoulder Pivot from Backline	E	3.3 - 3.7 in	3.6
Shoulder Breadth	V	16.6 - 17.2 in	16.8
Shoulder Pivot Height	B	19.9 - 20.5 in	20.4
Elbow Rest Height	J	7.5 - 8.3 in	8.0
Shoulder - Elbow Length	I	13.0 - 13.6 in	13.3
Back of Elbow to Wrist Pivot	G	11.4 - 12.0 in	11.6

Remarks:

Laboratory Technician:           B. Swiecicki

**APPENDIX D**

**DUMMY, VEHICLE AND LABORATORY INSTRUMENT CALIBRATION**

INSTRUMENT CALIBRATION FOR DRIVER DUMMY

( 6 Month Calibration Minimum )

DRIVER DUMMY (S/N 061)	Manufacturer	Serial #	Calibration		
			Last	Next	
Head	X	ENDEVCO	AC-AL553	08-Nov-99	08-May-00
	Y	ENDEVCO	AC-A83G	08-Nov-99	08-May-00
	Z	ENDEVCO	AC-C14901	08-Nov-99	08-May-00
Head	X (R)	ENDEVCO	AC-A13939	08-Nov-99	08-May-00
	Y (R)	ENDEVCO	AC-A14181	08-Nov-99	08-May-00
	Z (R)	ENDEVCO	AC-A14124	08-Nov-99	08-May-00
Neck Load Cell	X	DENTON	LC-205Fx	06-Aug-99	06-Feb-00
	Y	DENTON	LC-205Fy	06-Aug-99	06-Feb-00
	Z	DENTON	LC-205Fz	06-Aug-99	06-Feb-00
Neck Moment	X	DENTON	LC-205Mx	06-Aug-99	06-Feb-00
	Y	DENTON	LC-205My	06-Aug-99	06-Feb-00
	Z	DENTON	LC-205Mz	06-Aug-99	06-Feb-00
Chest	X	ENDEVCO	AC-FP90	08-Nov-99	08-May-00
	Y	ENDEVCO	AC-A26A	08-Nov-99	08-May-00
	Z	ENDEVCO	AC-AL6H7	08-Nov-99	08-May-00
Chest	X (R)	ENDEVCO	AC-B11407	08-Nov-99	08-May-00
	Y (R)	ENDEVCO	AC-B11408	08-Nov-99	08-May-00
	Z (R)	ENDEVCO	AC-B10827	08-Nov-99	08-May-00
Chest Deflection Gauge Hybrid III Use Only	SERVO	DS-061	06-Aug-99	06-Feb-00	
Pelvic	X	ENDEVCO	AC-ADMB8	08-Nov-99	08-May-00
	Y	ENDEVCO	AC-ADL44	08-Nov-99	08-May-00
	Z	ENDEVCO	AC-ACT12	08-Nov-99	08-May-00

INSTRUMENT CALIBRATION FOR DRIVER DUMMY

( 6 Month Calibration Minimum )

DRIVER DUMMY (S/N 061)	Manufacturer	Serial #	Calibration		
			Last	Next	
Left Femur Load Cell	GSE	LC-418	20-Oct-99	20-Apr-00	
Right Femur Load Cell	GSE	LC-420	19-Oct-99	19-Apr-00	
Left Upper Tibia	Mx	DENTON	LC-045Mx	16-Sep-99	16-Mar-00
	My	DENTON	LC-045My	16-Sep-99	16-Mar-00
Left Lower Tibia	Fz	DENTON	LC-125Fz	16-Sep-99	16-Mar-00
	Mx	DENTON	LC-125Mx	16-Sep-99	16-Mar-00
	My	DENTON	LC-125My	16-Sep-99	16-Mar-00
Right Upper Tibia	Mx	DENTON	LC-038Mx	16-Sep-99	16-Mar-00
	My	DENTON	LC-038My	16-Sep-99	16-Mar-00
Right Lower Tibia	Fz	DENTON	LC-124Fz	16-Sep-99	16-Mar-00
	Mx	DENTON	LC-124Mx	16-Sep-99	16-Mar-00
	My	DENTON	LC-124My	16-Sep-99	16-Mar-00
Left Foot Rear	X	ENDEVCO	AC-J31009	11-Oct-99	11-Apr-00
	Z	ENDEVCO	AC-J32176	11-Oct-99	11-Apr-00
Left Foot Front	Z	ENDEVCO	AC-J31042	11-Oct-99	11-Apr-00
Right Foot Rear	X	ENDEVCO	AC-J32143	11-Oct-99	11-Apr-00
	Z	ENDEVCO	AC-J31050	11-Oct-99	11-Apr-00
Right Foot Front	Z	ENDEVCO	AC-J31060	11-Oct-99	11-Apr-00
Lap Belt Load Cells	LEBOW	LC-706	19-Oct-99	19-Apr-00	
Shoulder Belt Load Cells	LEBOW	LC-707	19-Oct-99	19-Apr-00	
Spool-Out Potentiometer	-	-	-	-	
Belt Stretch Transducer	CAL	DS-E5	24-Aug-99	24-Feb-00	

INSTRUMENT CALIBRATION FOR PASSENGER DUMMY

( 6 Month Calibration Minimum )

PASSENGER DUMMY (S/N 064)	Manufacturer	Serial #	Calibration		
			Last	Next	
Head	X	ENDEVCO	AC-AD4A9	01-Jul-99	01-Jan-00
	Y	ENDEVCO	AC-AE8T7	01-Jul-99	01-Jan-00
	Z	ENDEVCO	AC-AF5R1	01-Jul-99	01-Jan-00
Head	X (R)	ENDEVCO	AC-P13329	05-Oct-99	05-Apr-00
	Y (R)	ENDEVCO	AC-P13355	05-Oct-99	05-Apr-00
	Z (R)	ENDEVCO	AC-J31026	17-Nov-99	17-May-00
Neck Load Cell	X	DENTON	LC-440Fx	06-Aug-99	06-Feb-00
	Y	DENTON	LC-440Fy	06-Aug-99	06-Feb-00
	Z	DENTON	LC-440Fz	06-Aug-99	06-Feb-00
Neck Moment	X	DENTON	LC-440Mx	06-Aug-99	06-Feb-00
	Y	DENTON	LC-440My	06-Aug-99	06-Feb-00
	Z	DENTON	LC-440Mz	06-Aug-99	06-Feb-00
Chest	X	ENDEVCO	AC-A08A	01-Jul-99	01-Jan-00
	Y	ENDEVCO	AC-ADL42	01-Jul-99	01-Jan-00
	Z	ENDEVCO	AC-A28F	01-Jul-99	01-Jan-00
Chest	X (R)	ENDEVCO	AC-A14077	01-Jul-99	01-Jan-00
	Y (R)	ENDEVCO	AC-A13882	01-Jul-99	01-Jan-00
	Z (R)	ENDEVCO	AC-ACCW0	01-Jul-99	01-Jan-00
Chest Deflection Gauge	SERVO	DS-064	06-Aug-99	06-Feb-00	
Hybrid III Use Only					
Pelvic	X	ENDEVCO	AC-AF480	01-Jul-99	01-Jan-00
	Y	ENDEVCO	AC-AC2M6	01-Jul-99	01-Jan-00
	Z	ENDEVCO	AC-AF5C1	01-Jul-99	01-Jan-00

INSTRUMENT CALIBRATION FOR PASSENGER DUMMY

( 6 Month Calibration Minimum )

PASSENGER DUMMY (S/N 064)	Manufacturer	Serial #	Calibration		
			Last	Next	
Left Femur Load Cell	GSE	LC-954	20-Oct-99	20-Apr-00	
Right Femur Load Cell	GSE	LC-955	19-Oct-99	19-Apr-00	
Left Upper Tibia	Mx	DENTON	LC-016Mx	16-Sep-99	16-Mar-00
	My	DENTON	LC-016My	16-Sep-99	16-Mar-00
Left Lower Tibia	Fz	DENTON	LC-123Fz	16-Sep-99	16-Mar-00
	Mx	DENTON	LC-123Mx	16-Sep-99	16-Mar-00
	My	DENTON	LC-123My	16-Sep-99	16-Mar-00
Right Upper Tibia	Mx	DENTON	LC-023Mx	12-Oct-99	12-Apr-00
	My	DENTON	LC-023My	12-Oct-99	12-Apr-00
Right Lower Tibia	Fz	DENTON	LC-111Fz	12-Oct-99	12-Apr-00
	Mx	DENTON	LC-111Mx	12-Oct-99	12-Apr-00
	My	DENTON	LC-111My	12-Oct-99	12-Apr-00
Left Foot Rear	X	ENDEVCO	AC-J32185	11-Oct-99	11-Apr-00
	Z	ENDEVCO	AC-J32184	11-Oct-99	11-Apr-00
Left Foot Front	Z	ENDEVCO	AC-J31011	11-Oct-99	11-Apr-00
Right Foot Rear	X	ENDEVCO	AC-J31059	11-Oct-99	11-Apr-00
	Z	ENDEVCO	AC-J31101	11-Oct-99	11-Apr-00
Right Foot Front	Z	ENDEVCO	AC-J31020	11-Oct-99	11-Apr-00
Lap Belt Load Cells	LEBOW	LC-711	19-Oct-99	19-Apr-00	
Shoulder Belt Load Cells	LEBOW	LC-712	19-Oct-99	19-Apr-00	
Spool-Out Potentiometer	-	-	-	-	
Belt Stretch Transducer	CAL	DS-E6	24-Aug-99	24-Feb-00	

INSTRUMENT CALIBRATION FOR VEHICLE ACCELEROMETERS

( 6 Month Calibration Minimum )

	Manufacturer	Serial #	Calibration	
			Last	Next
Left Seat Rear Crossmember	ICS	AC-X26	01-Sep-99	01-Mar-00
Right Rear Seat Crossmember	ICS	AC-D85	08-Dec-99	08-Jun-00
Top of Engine	ICS	AC-D80	07-Dec-99	07-Jun-00
Bottom of Engine	ENDEVCO	AC-J18570	06-Dec-99	06-Jun-00
Right Disc Brake Caliper	ENDEVCO	AC-AC7W8	06-Dec-99	06-Jun-00
Instrument Panel	ICS	AC-D78	23-Nov-99	23-May-00
Left Disc Brake Caliper	ENTRAN	AC-D03	03-Sep-99	03-Mar-00
Left Seat Rear Crossmember (R)	ICS	AC-D69	01-Sep-99	01-Mar-00
Right Seat Rear Crossmember (R)	ICS	AC-D61	02-Sep-99	02-Mar-00

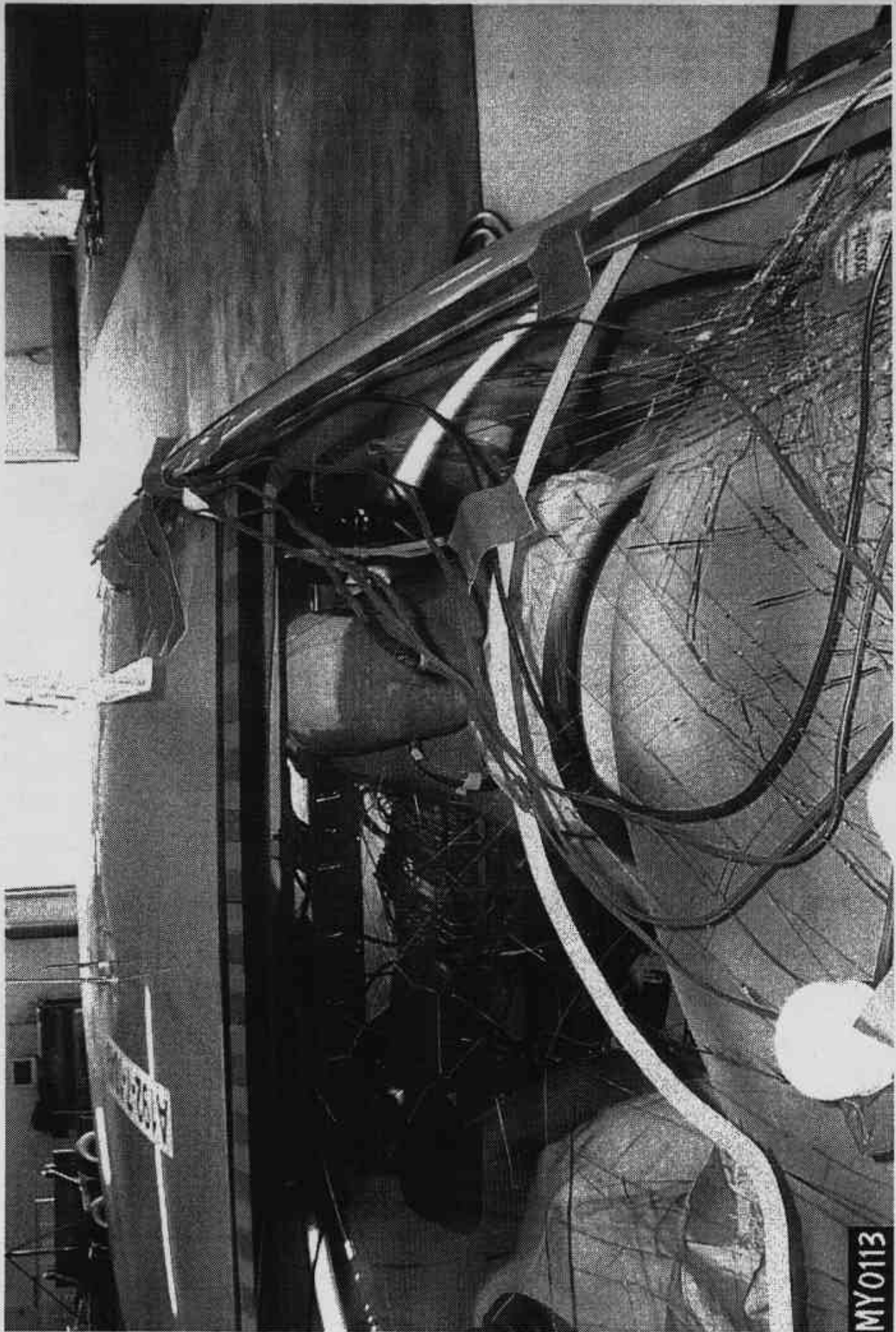

Figure A-31: POST-TEST DRIVER HEAD LOCATION

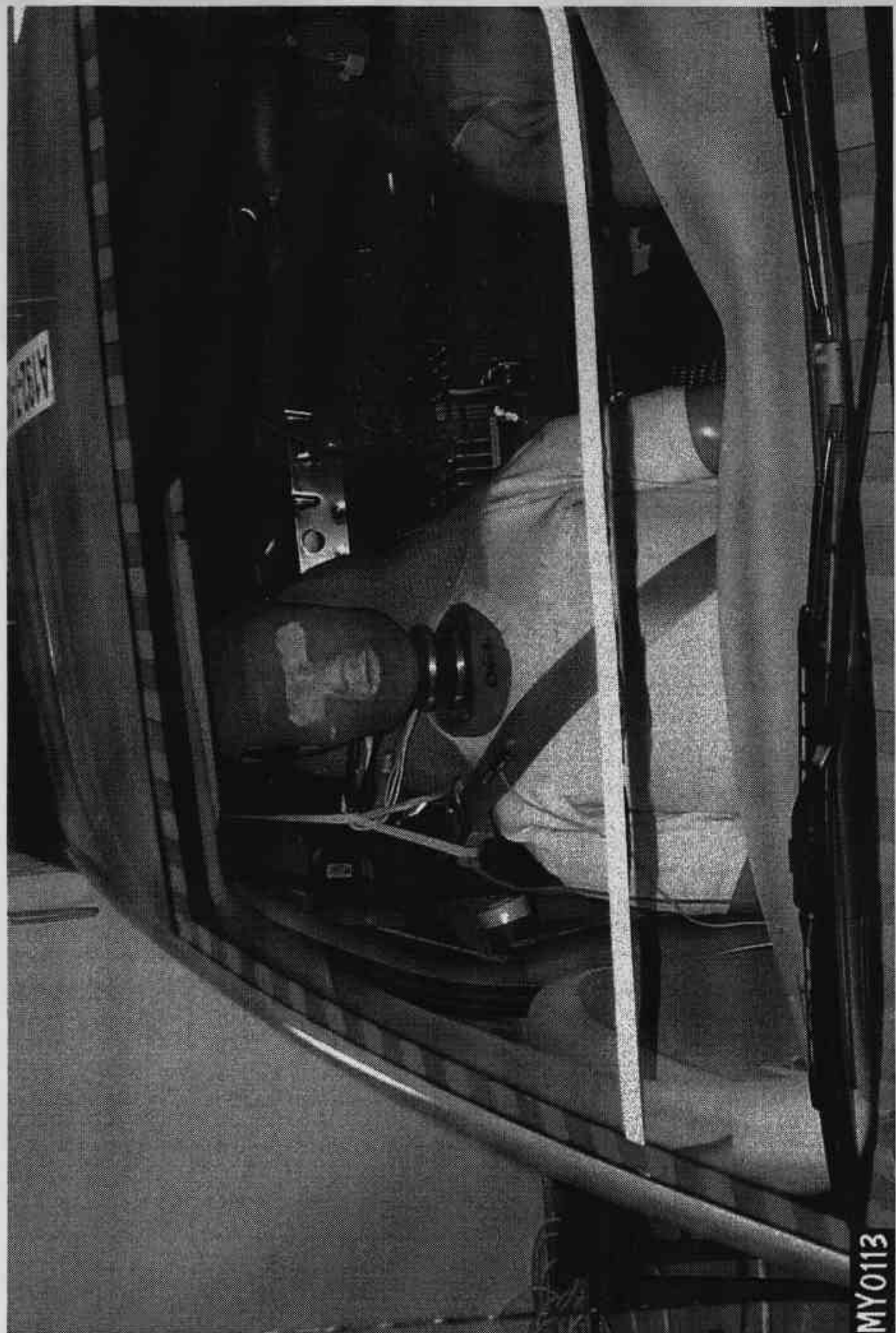

Figure A-32: PRE-TEST PASSENGER HEAD LOCATION

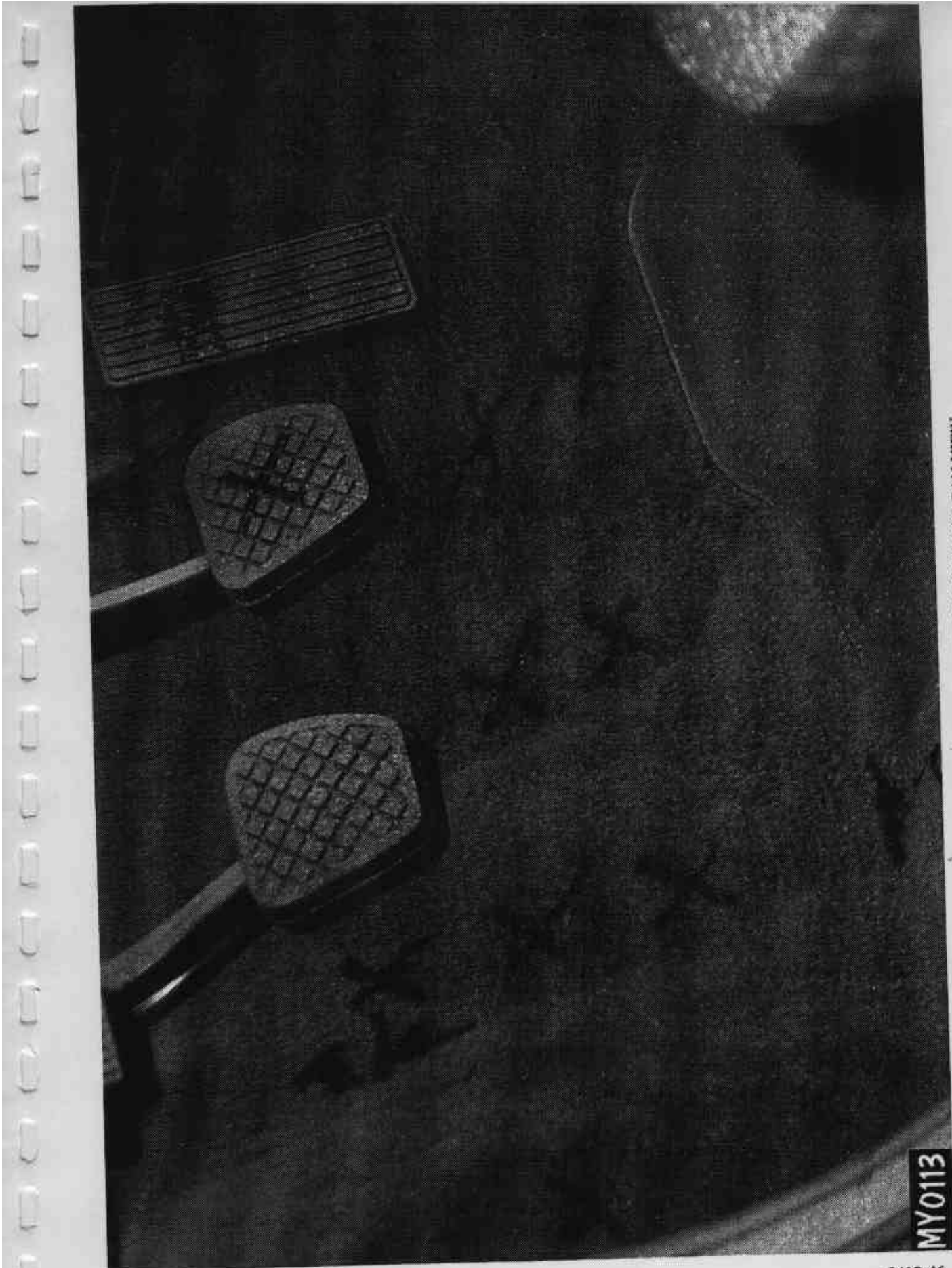

Figure A-34: PRE-TEST DRIVER FLOOR PAN VIEW

MY0113



Figure A-35: POST-TEST DRIVER FLOOR PAN VIEW

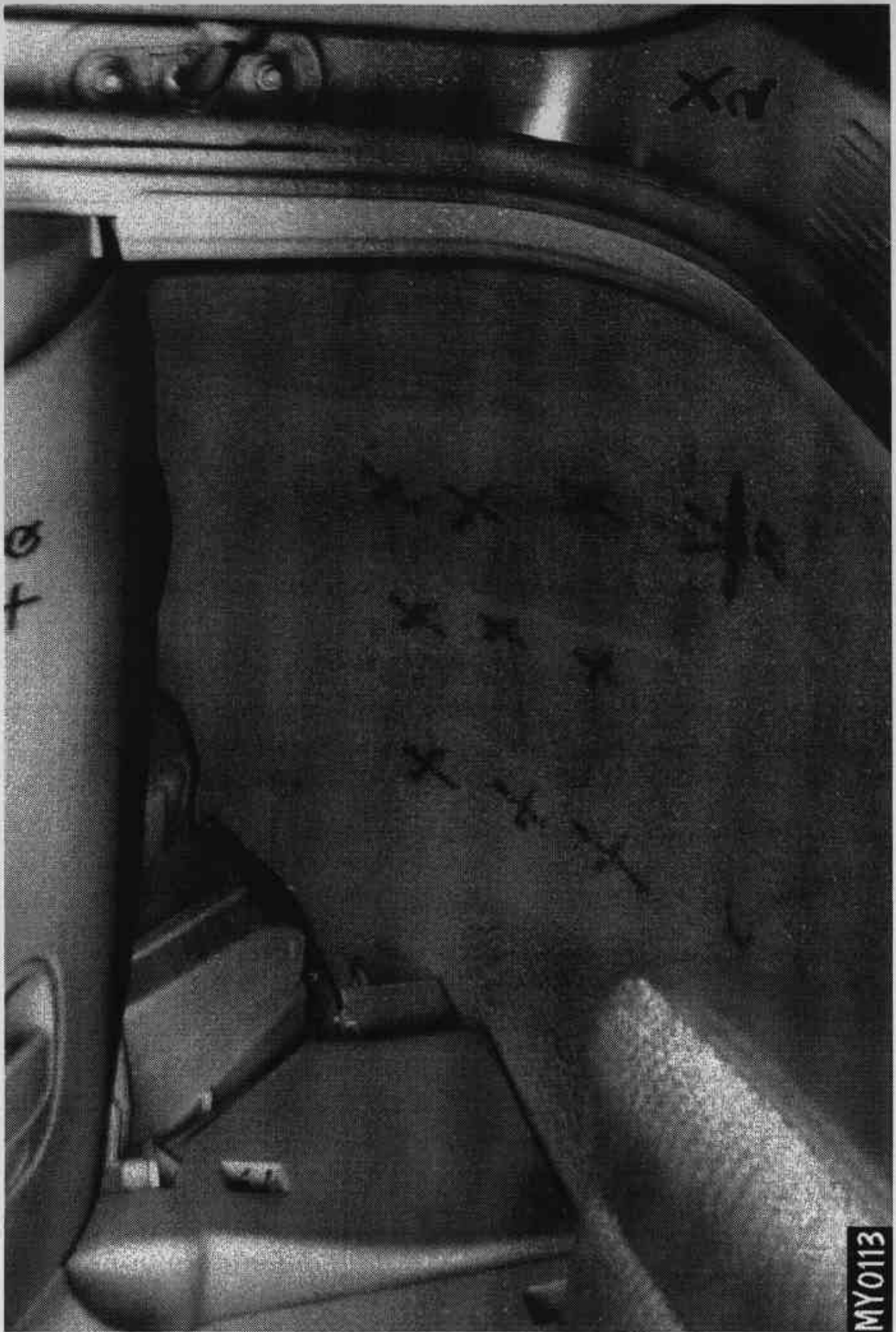

Figure A-36: PRE-TEST PASSENGER FLOOR PAN VIEW

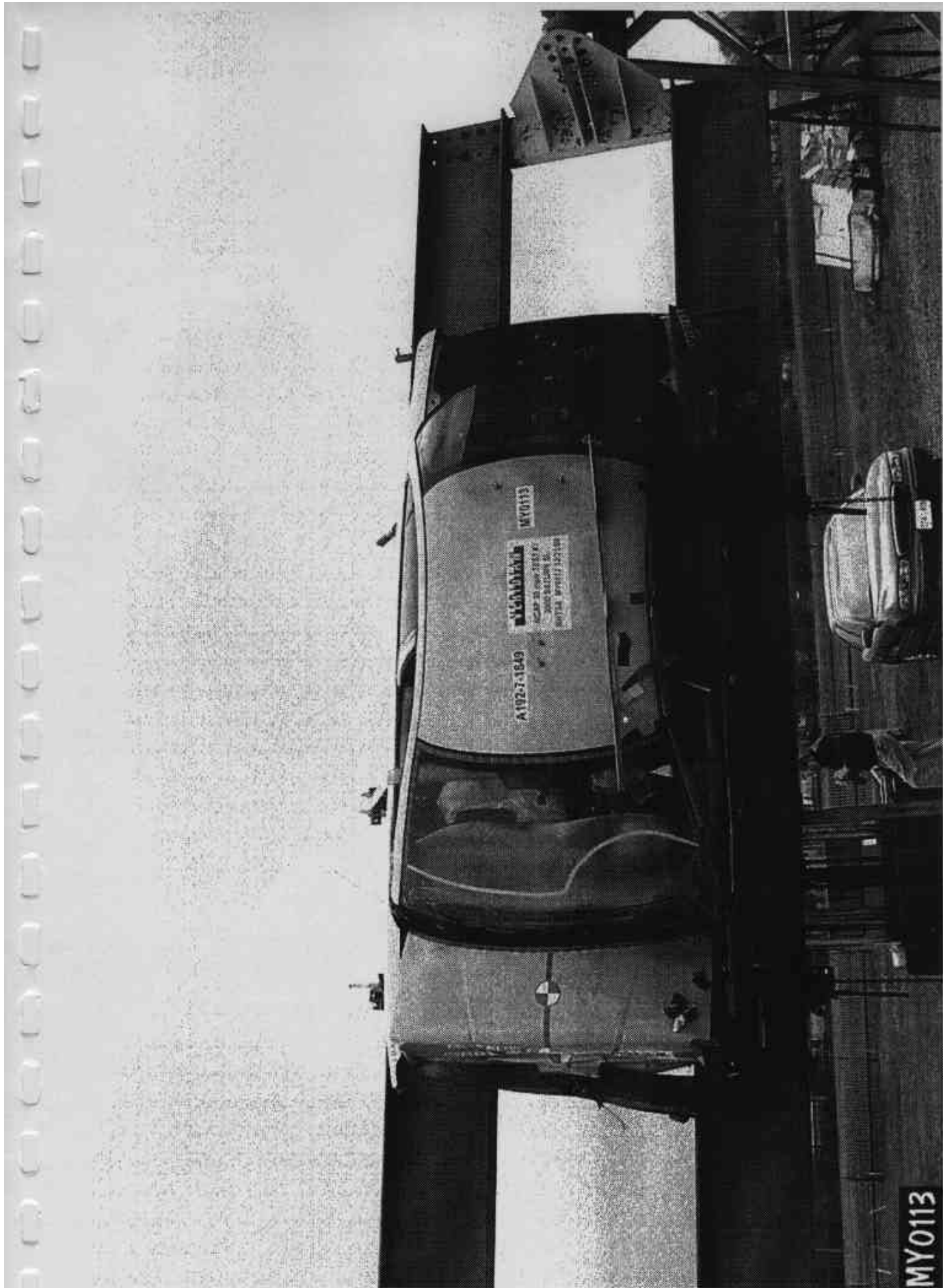

Figure A-38: ROLLOVER VIEW

MY0113