

V2787

Report Numbers: 208S-TRC-97-004

Vehicle Safety Compliance Testing
for Occupant Crash Protection

Ford Motor Company
1998 Ford F-150 Styleside Pickup Truck, 4x2 Regular Cab
NHTSA Number: CW0203
TRC Test Number: 971219S

Transportation Research Center Inc.
10820 State Route 347
East Liberty, OH 43319



January 16, 1998

Final Report

Prepared For:

U. S. Department of Transportation
National Highway Traffic Safety Administration
Safety Assurance
Office of Vehicle Safety Compliance (NSA-30)
400 Seventh Street, S.W., Room No. 6115
Washington, DC 20590

1. Report No. 208S-TRC-97-004	2. Government Accession No.	3. Recipient's Catalog No.	
4. Title and Subtitle Final Report of FMVSS No. 208 Compliance Testing of a 1998 Ford F-150 Pickup Truck NHTSA No. CW0203		5. Report Date January 16, 1998	
		6. Performing Organization Code TRC	
7. Author(s) Tim G. Macy, Engineering Technician Transportation Research Center Inc.		8. Performing Organization Report No. 208S-TRC-97-004	
9. Performing Organization Name and Address Transportation Research Center Inc. 10820 State Route 347 East Liberty, OH 43319		10. Work Unit No. (TRAIS)	
		11. Contract or Grant No. DTNH22-93-D-01089	
12. Sponsoring Agency Name and Address U.S. Department of Transportation National Highway Traffic Safety Administration Safety Assurance Office of Vehicle Safety Compliance (NSA-30) 400 Seventh Street, S.W., Room 6115 Washington, DC 20590		13. Type of Report and Period Covered Final Report January 1998	
		14. Sponsoring Agency Code NSA-30	
15. Supplemental Notes None			
16. Abstract <p>An FMVSS 208 compliance sled test was conducted on a 1998 Ford F-150 Pickup Truck, NHTSA No. CW0203, at Transportation Research Center Inc. on December 19, 1997. This test was conducted to determine compliance with Federal Motor Vehicle Safety Standards (FMVSS): 208, "Occupant Crash Protection". The Hybrid III dummies installed for this test were not restrained by seat belts. The ambient temperature was 70° F. The sled carriage was accelerated to 17.6 g with an integrated velocity change of 28.7 mph.</p> <p>The driver's Head Injury Criteria (HIC) was 222. The driver's chest maximum resultant acceleration with three (3) milliseconds minimum duration was 31.7 g. The driver's chest deflection was 0.7 inch. The driver's left and right femur maximum axial forces were 1394 pounds and 1607 pounds, respectively. The driver's maximum neck flexion about the occipital condyle was 33.6 Newton-meters. The driver's maximum neck extension about the occipital condyle was 10.1 Newton-meters. The driver's maximum axial neck tension was 1030 Newtons. The driver's maximum axial neck compression was 136 Newtons. The driver's maximum fore and aft neck shear was 703 Newtons.</p> <p>The passenger's HIC was 194. The passenger's chest maximum resultant acceleration with three (3) milliseconds minimum duration was 45.2 g. The passenger's chest deflection was 0.4 inch. The passenger's left and right femur maximum axial forces were 1281 pounds and 1296 pounds, respectively. The passenger's maximum neck flexion about the occipital condyle was 51.0 Newton-meters. The passenger's maximum neck extension about the occipital condyle was 3.0 Newton-meters. The passenger's maximum axial neck tension was 574 Newtons. The passenger's maximum axial neck compression was 534 Newtons. The passenger's maximum fore and aft neck shear was 1126 Newtons.</p>			
17. Key Words Safety Engineering Compliance Testing: FMVSS 208, "Occupant Crash Protection"		18. Distribution Statement Copies of this report are available from: NHTSA Technical Reference Division Room 5108 400 Seventh Street, S.W., NAD-52 Washington, DC 20590	
19. Security Classif. (of this report) Unclassified	20. Security Classif. (of this page) Unclassified	21. Number of Pages 146	22. Price

METRIC CONVERSION FACTORS

Approximate Conversions to Metric Measures

Symbol	When You Know	Multiply by	To Find	Symbol
LENGTH				
in	inches	2.5	centimeters	cm
ft	feet	30	centimeters	cm
yd	yards	0.9	meters	m
mi	miles	1.6	kilometers	km
AREA				
m ²	square inches	6.5	square centimeters	cm ²
ft ²	square feet	0.09	square meters	m ²
yd ²	square yards	0.8	square meters	m ²
mi ²	square miles	2.6	square kilometers	km ²
	acres	0.4	hectares	ha
MASS (weight)				
oz	ounces	28	grams	g
lb	pounds	0.45	kilograms	kg
	short tons (2000 lb)	0.9	tonnes	t
VOLUME				
tsp	teaspoons	5	milliliters	ml
Tbsp	tablespoons	15	milliliters	ml
fl oz	fluid ounces	30	milliliters	ml
c	cups	0.24	liters	l
pt	pints	0.47	liters	l
qt	quarts	0.95	liters	l
gal	gallons	3.8	liters	l
ft ³	cubic feet	0.03	cubic meters	m ³
yd ³	cubic yards	0.76	cubic meters	m ³

TEMPERATURE (exact)

°F	Fahrenheit temperature	5/9 (after subtracting 32)	Celsius temperature	°C
----	------------------------	----------------------------	---------------------	----

Approximate Conversions from Metric Measures

Symbol	When You Know	Multiply by	To Find	Symbol
LENGTH				
mm	millimeters	0.04	inches	in
cm	centimeters	0.4	inches	in
m	meters	3.3	feet	ft
m	meters	1.1	yards	yd
km	kilometers	0.6	miles	mi
AREA				
cm ²	square centimeters	0.15	square inches	in ²
m ²	square meters	1.2	square yards	yd ²
km ²	square kilometers	0.4	square miles	mi ²
ha	hectares (10,000 m ²)	2.5	acres	ac
MASS (weight)				
g	grams	0.035	ounces	oz
kg	kilograms	2.2	pounds	lb
t	tonnes (1000 kg)	1.1	short tons	
VOLUME				
ml	milliliters	0.03	fluid ounces	fl oz
l	liters	2.1	pints	pt
l	liters	1.06	quarts	qt
l	liters	0.26	gallons	gal
m ³	cubic meters	35	cubic feet	ft ³
m ³	cubic meters	1.3	cubic yards	yd ³

TEMPERATURE (exact)

°C	Celsius temperature	9/5 (then add 32)	Fahrenheit temperature	°F
----	---------------------	-------------------	------------------------	----

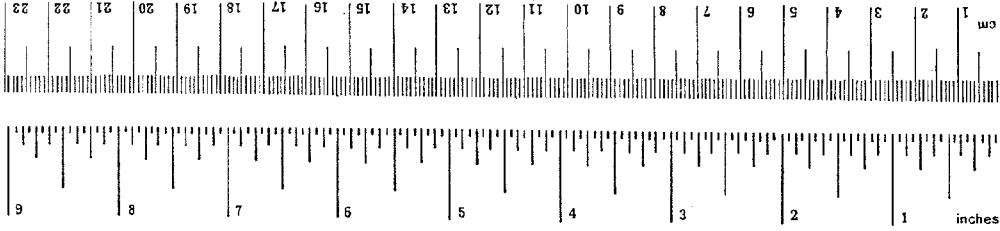

* 1 m = 2.54 (exactly). For other exact conversions and more detailed tables, see NIST Misc. Publ. 289, Units of Weights and Measures, Price \$2.25, SD Catalog No. C13,10298.

Table of Contents

<u>Section</u>	<u>Description</u>	<u>Page</u>
1.0	Purpose and Test Procedure	1-1
2.0	FMVSS 208 Compliance Sled Test Summary	2-1
3.0	FMVSS 208 Sled Test Data	3-1
4.0	Vehicle, Occupant, and Camera Measurements	4-1
Appendix A	Photographs	A-1
Appendix B	Data Plots	B-1
Appendix C	Manufacturer's Vehicle Information	C-1

List of Tables

<u>Number</u>	<u>Description</u>	<u>Page</u>
1	Sled Test Summary	2-4
2	Dummy Kinematics Summary	2-5
3	Test Vehicle Information	2-6
4	Post-Impact Data	2-10
5	Vehicle Accelerometer Locations and Data Summary	2-12
6	Dummy Injury Criteria	3-2
7	FMVSS 208 Seat Belt Warning System Test Summary	3-3
8	FMVSS 208 Labeling and Drivers Manual Information Summary	3-4
9	FMVSS 208 Readiness Indicator Test Summary	3-5
10	FMVSS 208 Rear Outboard Seating Position Seat Belts Summary	3-5
11	FMVSS 208 Lap Belt Lockability Test Summary	3-6
12	FMVSS 208 Air Bag Labels Data Summary	3-9
13	FMVSS 208 Seat Belt Comfort and Convenience Test Summary	3-17
14	Dummy Measurement Data for Front Seat Occupants	4-4
15	Motion Picture Camera Locations	4-6

List of Figures

<u>Number</u>	<u>Description</u>	<u>Page</u>
1	Vehicle Accelerometer Placement	2-11
2	Vehicle Target Locations	4-2
3	Dummy Measurement Locations for Front Seat Occupants	4-3
4	Camera Positions	4-5

List of Photographs

<u>Figure</u>	<u>Photograph Title</u>	<u>Page</u>
A-1.	Pre-Test Front View Of Test Vehicle Mounted To Sled	A-2
A-2.	Pre-Test Left Side View Of Test Vehicle Mounted To Sled	A-3
A-3.	Pre-Test Right Side View Of Test Vehicle Mounted To Sled	A-4
A-4.	Pre-Test Windshield View	A-5
A-5.	Post-Test Windshield View	A-6
A-6.	Pre-Test Driver Dummy Position View With Door Open	A-7
A-7.	Post-Test Driver Dummy Position View With Door Open	A-8
A-8.	Pre-Test Driver Seat Track Position View	A-9
A-9.	Post-Test Driver Seat Track Position View	A-10
A-10.	Pre-Test Driver Dummy Position View With Door Closed	A-11
A-11.	Post-Test Driver Dummy Position View With Door Closed	A-12
A-12.	Pre-Test Driver Knee Bolster View	A-13
A-13.	Post-Test Driver Knee Bolster View 1	A-14
A-14.	Post-Test Driver Knee Bolster View 2	A-15
A-15.	Pre-Test Driver Dummy Position Front View	A-16
A-16.	Post-Test Driver Dummy Position Front View	A-17
A-17.	Post-Test Driver Airbag View1	A-18
A-18.	Post-Test Driver Airbag View2	A-19
A-19.	Post-Test Driver Dummy Removed From Vehicle Overall View	A-20
A-20.	Pre-Test Passenger Dummy Position View With Door Open	A-21
A-21.	Post-Test Passenger Dummy Position View With Door Open	A-22
A-22.	Pre-Test Passenger Seat Track Position View	A-23
A-23.	Post-Test Passenger Seat Track Position View	A-24
A-24.	Pre-Test Passenger Dummy Position View With Door Closed	A-25
A-25.	Post-Test Passenger Dummy Position View With Door Closed	A-26
A-26.	Pre-Test Passenger Glove Box View	A-27
A-27.	Post-Test Passenger Knee Bolster View 1	A-28
A-28.	Post-Test Passenger Knee Bolster View 2	A-29
A-29.	Pre-Test Passenger Dummy Position Front View	A-30

List of Photographs

<u>Figure</u>	<u>Photograph Title</u>	<u>Page</u>
A-30.	Post-Test Passenger Dummy Position Front View	A-31
A-31.	Post-Test Passenger Airbag View	A-32
A-32.	Post-Test Passenger Dummy Overall View	A-33
A-33.	Pre-Test Steering Column Linkage In Engine Compartment View	A-34
A-34.	Post-Test Steering Column Linkage In Engine Compartment View	A-35
A-35.	Pre-Test Vehicle Certification Label View	A-36

Section 1.0

Purpose and Test Procedure

Purpose

This FMVSS 208 compliance sled test is part of the Federal Motor Vehicle Safety Standards (FMVSS) 208 compliance test program conducted for the National Highway Traffic Safety Administration (NHTSA) by the Transportation Research Center Inc. (TRC) under Contract No. DTNH22-93-D-01089. The purpose of this test was to determine if the subject vehicle, a 1998 Ford F-150 Pickup Truck, NHTSA No. CW0203, meets the performance requirements of FMVSS 208, "Occupant Crash Protection," in the impact simulation sled test mode. This test was conducted to determine if the front outboard dummies and restraint systems meets aforementioned performance requirements.

Test Procedure

This test was conducted in accordance with NHTSA's Office of Vehicle Safety Compliance (OVSC) Laboratory Test Procedure No. TP-208S-00, dated June 17, 1997. Data was obtained relative to FMVSS 208, "Occupant Crash Protection," performance.

The test vehicle was instrumented with six (6) accelerometers to measure longitudinal axis accelerations.

The test vehicle contained two (2) Part 572 E 50th percentile adult male anthropomorphic test devices (dummies). The dummies were positioned in the front outboard designated seating positions according to the dummy placement procedure specified in Appendix B of the Laboratory Test Procedure. The dummies were not restrained by seat belts.

Both dummies were instrumented with head and chest accelerometers to measure longitudinal, lateral, and vertical accelerations; chest deflection potentiometers; left and right femur load cells to measure axial forces; and upper neck load cells to measure longitudinal, lateral, and vertical forces and moments.

The forty (40) data channels were digitally sampled at 12,500 samples per second and processed per Sections 11.7 through 11.9 of the Laboratory Test Procedure.

The sled test event was recorded by one (1) real-time motion picture camera and six (6) high-speed motion picture cameras. The pre-test and post-test conditions were recorded by one (1) real-time motion picture camera.

The vehicle and occupant data are summarized in Section 2.0. The FMVSS 208 data are presented in Section 3.0. The vehicle, occupant, and camera measurements are presented in Section 4.0. Appendix A contains the still photographic prints. Appendix B contains the dummy and vehicle data plots. Appendix C contains the manufacturer's vehicle information.

Section 2.0

FMVSS 208 Compliance Sled Test Summary

Test Results Summary

This FMVSS 208 compliance sled test was conducted at TRC on December 19, 1997.

The test vehicle, a 1998 Ford F-150 Pickup Truck, NHTSA No. CW0203, appeared to comply with the performance requirements of FMVSS 208 in the impact simulation sled test mode. The Head Injury Criteria (HIC) calculations were less than 1000, the chest resultant accelerations did not exceed 60 g's, the chest deflections did not exceed 3.0 inches, and the compressive forces transmitted through the upper legs did not exceed 2,250 pounds as measured by the Part 572 E dummies. The neck flexion moments about the occipital condyles did not exceed 190 N·m, the neck extension moments about the occipitals condyle did not exceed 57 N·m, the neck tensions did not exceed 3300 N, the neck compressions did not exceed 4000 N, and the neck fore and aft shear forces did not exceed 3100 N as measured by the Part 572 E dummies.

The test vehicle was equipped with airbags at the driver and passenger seating positions. The Hybrid III dummies were not restrained by seat belts. The sled carriage was accelerated to 17.6 g with an integrated velocity change of 28.7 mph. The airbags were triggered at 20.2 milliseconds after 0.5 g acceleration was measured by the firing circuit. Following subsequent digital data processing and filtering the acceleration signal to Channel Class 60, the airbag event trigger signal was 20.6 ms after the 0.5 g acceleration level was indicated.

The driver's HIC was 222. The driver's chest maximum resultant acceleration with three (3) milliseconds minimum duration was 31.7 g. The driver's chest deflection was 0.7 inch. The driver's left and right femur maximum compressive forces were 1394 pounds and 1607 pounds, respectively. The driver's maximum neck moments were 10.1 N·m extension and 33.6 N·m flexion. The driver's maximum neck forces were 1030 N tension, 136 N compression and 703 N fore and aft shear.

Test Results Summary, Cont'd

The right front passenger's HIC was 194. The right front passenger's chest maximum resultant acceleration with three (3) milliseconds minimum duration was 45.2 g. The right front passenger's chest deflection was 0.4 inch. The right front passenger's left and right femur maximum compressive forces were 1281 pounds and 1296 pounds, respectively. The right front passenger's maximum neck moments about the occipital condyle were 3.0 N·m extension and 51.0 N·m flexion. The right front passenger's maximum neck forces were 574 N axial tension, 534 N axial compression and 1126 N fore and aft shear.

The vehicle's seat belt warning system met all of the applicable seat belt warning system requirements. Option (S7.3(a)(1)) was chosen by the manufacturer.

The vehicle's labeling and driver's manual information met all applicable requirements.

The vehicle's air bag readiness indicator met all applicable requirements.

The vehicle's rear outboard seating position applicable seat belt type requirements does not apply. The vehicle did not have a rear seat.

The vehicle's seat belts met the applicable lap belt lockability requirements.

The vehicle's permanently attached air bag labels met the applicable requirements.

The vehicle did NOT have a label on the dash or steering wheel hub (S4.5.1(e)). See page 3-15.

The seat belt comfort and convenience check for front outboard designated seating positions indicated the vehicle met all applicable requirements.

Table 1 Sled Test Summary

NHTSA number: CW0203
 Test type: FMVSS 208 Compliance Sled Test
 Test date: 12/19/97
 Test time: 3:04 pm
 Ambient temperature at impact area: 70° F
 Vehicle year/make/ model/body style: 1998/Ford /F-150/Styleside Pickup Truck, 4x2 Regular Cab
 Vehicle test weight: 4664 lb

Sled carriage:

Integrated velocity from the integration of the entire sled acceleration: 28.7 mph
 Measured velocity from the light trap device attached to the sled: 29.5 mph
 Acceleration: 17.6 g
 Time from T-0(-0.5 g) to 0.0 g: 124.0 msec
 Acceleration corridor achieved: Yes

Number of cameras:

Real-time: 1
 High-speed: 6

Dummies:

	<u>Driver #229</u>	<u>Passenger #230</u>
Type:	Part 572 E	Part 572 E
Location:	Left front	Right front
Restraint:	Airbag	Airbag
Number of data channels:	15	15

Front seat data:

Seat track failure:	No apparent failure	No apparent failure
Seat back failure:	No apparent failure	No apparent failure

Visible dummy contact points:

Head:	Airbag, sun visor, rear header	Airbag
Chest:	Airbag	Airbag
Abdomen:	Airbag	Airbag
Left knee:	Knee bolster	Glove box
Right knee:	Knee bolster	Glove box

Table 2 Dummy Kinematics Summary

Left Front Driver Dummy

Upon impact, the driver dummy translated forward on the seat impacting both knees into the instrument panel's knee bolster. The dummy's head and chest were restrained by the airbag. The top of the dummy's head contacted the sun visor. The dummy rebounded into the seatback. The dummy's head contacted the rear header, behind the seat back, upon rebound. The dummy came to rest seated upright in the driver's seat.

Right Front Passenger Dummy

Upon impact, the passenger dummy translated forward on the seat impacting both knees into the instrument panel's glove box. The dummy's head and chest were restrained by the airbag. The dummy rebounded into the seatback. The dummy came to rest seated upright in the passenger's seat.

Table 3 Test Vehicle Information

Vehicle year/make/
model/body style: 1998/Ford/F-150/Styleside Pickup Truck, 4 x2 Regular Cab

Color: Pacific Green Clearcoat

VIN: 1FTZF1727WNA77379

NHTSA number: CW0203

Engine data:

Placement: Longitudinal/V6

Cylinders: 6

Displacement: 4.2 liters

Transmission data: 5 speed, X manual, ___ automatic, ___ overdrive

Final drive: ___ fwd, X rwd, ___ 4wd

Date vehicle received: 12/2/97

Odometer reading: 32

Dealer's name
and address: Anderson Ford Sales Inc.
2348 US Route 68 S
Bellefontaine, OH 43311

Accessories:

Power steering	Yes	Automatic transmission	No
Power brakes	Yes	Automatic speed control	No
Power seats	No	Tilting steering wheel	No
Power windows	No	Telescoping steering wheel	No
Tinted glass	Yes	Air conditioning	No
Radio	Yes	Anti-lock brake	Rear only
Clock	Yes	Rear window defroster	No
Power door locks	No	Other:	None

Certification data from vehicle's label:

Vehicle manufactured by: Ford Motor Company, in U.S.A.

Date of manufacture: 11/97

VIN: 1FTZF1727WNA77379

GVWR: 5550 lb

GAWR: Front: 2800 lb

Rear: 2900 lb

Table 3 Test Vehicle Information, Cont'd.

Size of tires on vehicle: P235/70R16SL
Spare tire: P235/70R16SL
Type of front seats: 60/40 Split Back Bench

Tire & capacity data from vehicle's label:

Recommended tire size: P235/70R16SL
Recommended cold tire pressure:
Front: 32 psi
Rear: 35 psi

Designated Seating Capacity:

Front NA
Rear NA
Third Row NA
Total NA
Vehicle Capacity Weight: NA

Weight of test vehicle as received (with maximum fluids):

Right front	1183	lb	Right rear	807	lb
Left front	1145	lb	Left rear	899	lb
Total front weight	2328	lb	(57.7% of total vehicle weight)		
Total rear weight	1706	lb	(42.3% of total vehicle weight)		
Total delivered weight	4034	lb			

Table 3 Test Vehicle Information, Cont'd.

Calculation of test vehicle's target loaded test weight:

RCLW¹ = Rated Cargo and Luggage Weight

GVWR = Gross Vehicle Weight Rating (5550 lb)

UDW = Unloaded Delivered Weight (4034 lb)

VCW¹ = Vehicle Capacity Weight = 5550 - 4034 = 1516 lb

DSC² = Designated Seating Capacity (3)

RCLW¹ = GVWR - UDW - 150 (3) = 5550 - 4034 - (450) = 1066 lb

Target loaded test weight: = UDW + RCLW¹ +(No. of Hybrid III dummies x 167 lb per dummy)

Target loaded test weight: = 4034 + 300 + 334 = 4668 lb

Weight of test vehicle with required dummies and 300 lb of cargo weight:

Right front	1264 lb	Right rear	1055 lb
Left front	1254 lb	Left rear	1098 lb
Total front weight	2518 lb	(53.9% of total vehicle weight)	
Total rear weight	2153 lb	(46.1% of total vehicle weight)	
Total test weight	4671 lb	(3 lb. over target loaded test weight)	

Weight of ballast secured in vehicle: None

Components removed to meet target test weight: None

¹ Cargo weight for multi-purpose passenger vehicles, trucks, and buses is the vehicle's calculated cargo and luggage weight or 300 pounds, whichever is less.

² The designated seating capacity is determined by counting the number of seat belts installed in the vehicle.

Table 3 Test Vehicle Information, Cont'd.

Test Vehicle Attitude:

As delivered door sill angle: 1.3°
As tested door sill angle: 1.1°
Fully loaded door sill angle: 1.1°
Vehicle Wheelbase: 138.5 inches

Seat Data:

Front seats: Split back bench
Seat track settings: Mid. There were 19 available positions. Set seat in tenth position from full fwd. Full forward position is position number 1.
Seat back settings: Seat back angles are measured relative to rocker sill.
Driver: 23°. Measure up from seat back pivot 13 inches and place angle finder on seat back frame.
Passenger: 21°. Measure up from seat back pivot 13 inches and place angle finder on seat back frame.

Fuel System Data:

Fuel system capacity from owner's manual: 30.0 gallons
Useable capacity figure furnished by COTR: 28.5 gallons

Steering Column Adjustments

Non-tilt steering column

Table 4 Post-Impact Data

Test number:	971219S	
NHTSA number:	CW0203	
Test date:	12/19/97	
Test time:	3:04 pm	
Test type:	FMVSS 208 Compliance Sled Test	
Impact angle:	0°	
Ambient temperature at impact area:	70° F	
Temperature in occupant compartment:	71° F	
Sled carriage velocity:		
Integrated velocity from the integration of the entire sled acceleration:		28.7 mph
Measured velocity from the light trap device attached to the sled (backup):		29.5 mph
Sled carriage acceleration:		
Acceleration:	17.6 g	
Sled carriage acceleration duration:		
Time from T-0(-0.5 g) to 0.0 g:	124.0 msec	

The sled acceleration curve was within the specified corridor.

Figure 1 Vehicle Accelerometer Placement

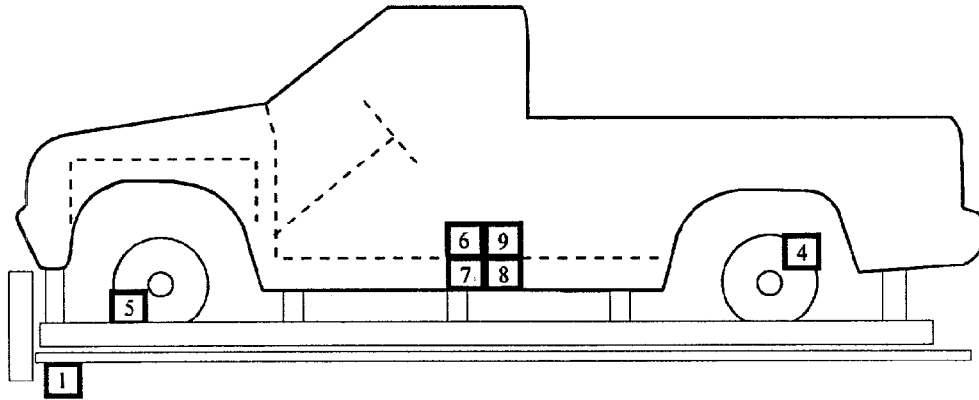

Side View

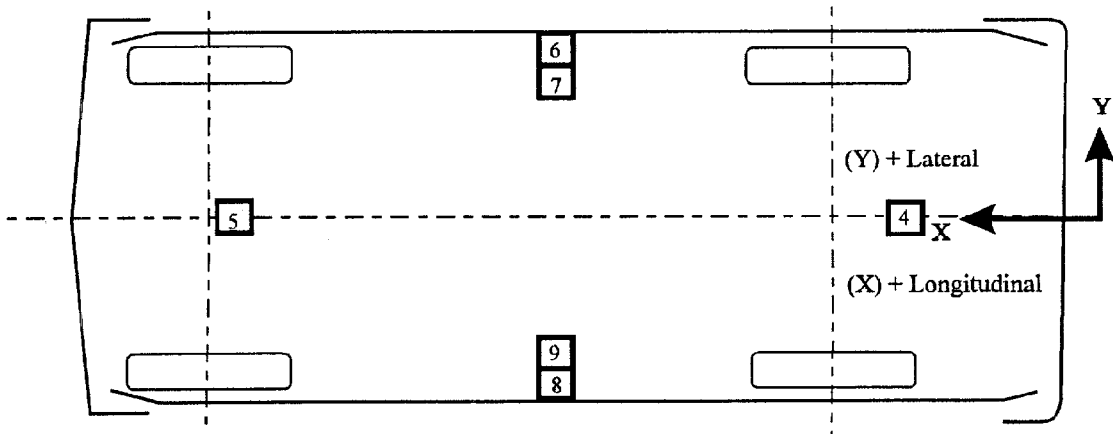

Bottom View

Table 5 Vehicle Accelerometer Locations and Data Summary

TEST NUMBER: 971219S No. LOCATION	X	Y	POSITIVE DIRECTION	NEGATIVE DIRECTION
1 SLED ACCELERATION PRIMARY	185.6 in	-1.0 in	0.9 g @ 127.8 ms	17.6 g @ 57.4 ms
2 SLED VELOCITY INTEGRATED			0.0 mph @ 127.8 ms	28.7 mph @ 124.2 ms
3 SLED VELOCITY MEASURED			0.0 mph @ 4.9 ms	29.5 mph @ 124.6 ms
4 REAR AXLE LONGITUDINAL	43.4 in	0.0 in	2.8 g @ 130.7 ms	18.6 g @ 61.0 ms
5 BOTTOM ENGINE LONGITUDINAL	182.0 in	-0.9 in	2.7 g @ 130.5 ms	18.7 g @ 62.9 ms
6 LEFT BODY LONGITUDINAL	111.3 in	-28.2 in	1.4 g @ 129.8 ms	19.6 g @ 54.7 ms
7 LEFT FRAME LONGITUDINAL	111.3 in	-21.9 in	1.8 g @ 129.7 ms	18.3 g @ 58.8 ms
8 RIGHT BODY LONGITUDINAL	111.3 in	28.2 in	1.6 g @ 129.3 ms	18.9 g @ 74.5 ms

Table 4 Vehicle Accelerometer Locations and Data Summary, Cont'd.

TEST NUMBER: 971219S No. LOCATION	X	Y	POSITIVE DIRECTION	NEGATIVE DIRECTION
9 RIGHT FRAME LONGITUDINAL	111.3 in	28.2 in	1.9 g @ 129.4 ms	18.1 g @ 59.0 ms
10 AIRBAG EVENT			7.0 volt @ 20.6 ms	---

REFERENCE: X: + FORWARD FROM VEHICLE REAR SURFACE
Y: + RIGHTWARD FROM SLED CARRIAGE CENTERLINE

Section 3.0

FMVSS 208 Sled Test Data

Table 6 Dummy Injury Criteria
Maximum Acceleration

	Head				Chest		
	X	Y	Z	R	X	Y	Z
Driver	-37.6 g	14.8 g	23.4 g	39.9 g	-31.6 g	6.6 g	8.7 g
Passenger	-34.4 g	-19.9 g	27.6 g	41.2 g	-44.2 g	3.3 g	20.9 g

Maximum Femur Compressive Force

	Left Femur	Right Femur
Driver	1394 lbf	1607 lbf
Passenger	1281 lbf	1296 lbf

Head Injury Criteria¹

	HIC	Time t ₁	Time t ₂
Driver	222	117.9 ms	153.9 ms
Passenger	194	98.1 ms	130.1 ms

Chest Maximum Resultant Acceleration²

	Acceleration	Time t ₁	Time t ₂
Driver	31.7 g	119.6 ms	122.6 ms
Passenger	45.2 g	107.1 ms	110.2 ms

Maximum Chest Deflection

Driver	0.7 in
Passenger	0.4 in

Neck Injury Criteria

	Flexion Moment	Extension Moment	Axial Tension Force	Axial Compression Force	Maximum Fore/Aft Shear Force
Driver	33.6 N·m	10.1 N·m	1030 N	136 N	703 N ³
Passenger	51.0 N·m	3.0 N·m	574 N	534 N	1126 N ³

¹ As defined in FMVSS No. 208

² Defined as equal to or exceeding 0.003 sec. duration

³ Maximum output of channel is positive (head rearward, chest forward)

Table 7
FMVSS 208 SEAT BELT WARNING SYSTEM CHECK

NHTSA NO.: CW0203

Technician: T. Macy

Date: 12/17/97

Complete the following to determine which seat belt warning system option (S7.3(a)(1)) or (S7.3(a)(2)) is used. (Manufacturers may use either option.)

A. With occupant in driver's position and lap belt in stowed position and ignition switch placed in "Start/On" position:

A.1 S7.3(a)(1)

Time duration of audible warning signal = 6 seconds
(4 to 8 seconds)

Time duration of reminder light operation = 60 seconds
(no less than 60 seconds)

A.2 S7.3(a)(2)

Time duration of audible warning signal = 6 seconds

Time duration of reminder light operation = 60 seconds
(4 to 8 seconds)

B. With occupant in driver's position and lap belt in use and the ignition switch placed in "Start/On" position:

B.1 S7.3(a)(1)

Time duration of audible warning signal = 0 seconds
(audible warning should not operate)

Time duration of reminder light operation = 0 (No Light) seconds
(reminder light does not operate)

B.2 S7.3(a)(2)

Time duration of audible warning signal = 0 seconds
(audible warning should not operate)

Time duration of reminder light operation = 0 (No Light) seconds
(4 to 8 seconds)

C. Note wording of visual warning:

Fasten Seat Belt _____

Fasten Belt _____

Symbol 101

Table 8
FMVSS 208 LABELING AND DRIVERS MANUAL INFORMATION

NHTSA NO.: CW0203

Technician: T. Macy

Date: 12/17/97

Locate label which describes manufacturer's maintenance or replacement schedule for crash deployed occupant protection system.

Describe location: _____

The manufacturer's recommended schedule is to replace or repair this system.

A. By _____ month, _____ year

B. By _____ miles

C. Or after a time interval of _____ months or _____ years.

Note: There was no label describing the manufacturer's maintenance or replacement schedule.

Were appropriate instructions concerning maintenance and/or replacement of this system provided?

Yes-; No-

Was a description of the functional operation of the system provided?

Yes-; No-

Is there a reference to the instructions and description of the system on the label?

Yes-; No-

Was an owner's manual provided?

Yes-; No-

Did the owner's manual contain appropriate information concerning maintenance and/or replacement and a description of the functional operation of the system?

Yes-; No-

Note: The manufacturer's owner's manual states that routine maintenance of the air bag is not required (Page 64).

Table 9
FMVSS 208 READINESS INDICATOR

NHTSA NO.: CW0203

Technician: T. Macy

Date: 12/17/97

An occupant restraint system that deploys in the event of a crash shall have a monitoring system with a readiness indicator. A totally mechanical system is exempt from this requirement. (11/8/94 legal interpretation)

Is the system totally mechanical?

Yes-; No-

Describe the location of the readiness of the readiness indicator: Lower left corner of the instrument cluster.

Is the readiness indicator clearly visible to the driver?

Yes-; No-

Is a list of the element in the occupant restraint system, being monitored by the readiness indicator, provided?

Yes-; No-

FMVSS 208 REAR OUTBOARD SEATING POSITION SEAT BELTS

Do all rear outboard seating positions have type 2 seat belts?

Yes-; No- N/A- No rear seat

If NO, describe the seat belt installed, the seat location, and any other information about the seat that would explain why a type 2 belt was not installed.

Table 11
FMVSS 208 Lap Belt Lockability

Passenger cars, trucks, buses, and multipurpose passenger
vehicles with a GVWR of 10,000 pounds or less. (S7.1.1.5)

Complete one of these forms for **each** designated seating position with forward-facing
seats or seats that can be adjusted to forward-facing **and** that has seat belt retractors that
are not automatic retractors. (S7.1.1.5(c))

NHTSA NO.: CW0203

Technician: R. Benavides

Date: 12/16/97

DESIGNATED SEATING POSITION: Right front passenger seat

1. Record test seat position. Mid
(S7.1.1.5(c)(1)) (Any position is acceptable.)
2. Buckle the seat belt. (S7.1.1.5(c)(1))
3. Complete any procedures recommended in the vehicle owner's manual to activate any
locking feature. (S7.1.1.5(c)(1))
4. Does the lap belt portion of the seat belt in the forward-facing seat or seat that can be
adjusted to forward-facing consist of a locking device that does NOT have to be attached
by the vehicle user to the seat belt webbing, retractor, or any other part to the vehicle?
(S7.1.1.5(a)) Yes-Pass No-Fail
5. Does the lap belt portion of the seat belt in the forward-facing seat or seat the can be
adjusted to forward-facing consist of a locking device that does NOT require inverting,
twisting or deforming of the belt webbing? (S7.1.1.5(a)) Yes-Pass No-Fail
6. Does the vehicle user need to take some action to activate the locking feature on the lap
belt portion of the seat belt in any forward-facing seat or seat that can be adjusted to
forward-facing? If yes, go to 6.1. If no, go to 7. Yes No
- 6.1 Does the vehicle owner's manual include a description in words and/or diagrams
describing how to activate the locking feature so that the seat belt assembly can
tightly secure a child restraint system and how to deactivate the locking feature to
remove the child restraint system. (S7.1.1.5(b)) Yes-Pass No-Fail

Table 11
FMVSS 208 Lap Belt Lockability, Cont'd.

NHTSA NO.: CW0203

Technician: R. Benavides

Date: 12/16/97

DESIGNATED SEATING POSITION: Right front passenger seat.

- 7. Locate a reference point a on the seat belt buckle. (S7.1.1.5(c)(2))
- 8. Locate a reference point B on the attachment hardware or retractor assembly at the other end of the lap belt or lap belt portion of the seat belt assembly. (S7.1.1.5(c)(2))
- 9. Adjust the lap belt or lap belt portion of the seat belt assembly according to any procedures recommended in the vehicle owner's manual to activate any locking feature so that the webbing between points A and B is at the maximum length allowed by the belt system. (S7.1.1.5(c)(2))
- 10. Measure and record the distance between points A and B along the longitudinal centerline of the webbing for the lap belt or lap belt portion of the seat belt assembly. (S7.1.1.5(c)(2)) Measured distance between A and B 66.5 inches.
- 11. Readjust the belt system so that the webbing between points A and B is at any length that is 5 inches or more shorter than the maximum length of the webbing and at least 3 inches more than in 10 above. (S7.1.1.5(c)(3) and S7.1.1.5(c)(7))
- 12. To the lap belt or lap belt portion of the seat belt assembly, apply a preload of 10 pounds using the webbing tension pull device in figure 5. Apply the load in a vertical plane parallel to the longitudinal axis of the vehicle and passing through the seating reference point of the designated seating position. Apply the preload in a horizontal direction toward the front of the vehicle with a force application angle of not less than 5 degrees nor more than 15 degrees above the horizontal. (S7.1.1.5(c)(4))
Measured force application angle 15 degrees. (Spec. 5~15 degrees)
- 13. Measure the length between points A and B along the longitudinal centerline of the webbing while the preload is being applied. (S7.1.1.5(c)(4))
Measured distance between A and B 33.7 inches.

Table 11
FMVSS 208 Lap Belt Lockability, Cont'd.

NHTSA NO.: CW0203

Technician: R. Benavides

Date: 12/16/97

DESIGNATED SEATING POSITION: Right front passenger seat.

14. Increase the load to 50 pounds at a rate of no more than 50 pounds per second. Attain the load in not more than 5 seconds. (If webbing sensitive emergency locking retractors are installed as part of the lap belt or lap belt portion of the seat belt assembly, apply the load at a rate less than the threshold value for lock-up specified by the manufacturer.) Maintain the load for at least 5 seconds. Measure and record the distance between points A and B along the longitudinal centerline of the webbing. (S7.1.1.5(c)(5))

Record onset rate 20 lb/sec (spec. 10 ~50 lb/sec)

The measured distance between A and B is 34.5 inches (7.1.1.5(c)(6))

15. Subtract the measurement in 13 from the measurement in 14. Is the difference 2 inches or less?

14-13=0.8 inches

Yes-Pass No-Fail

16. Subtract the measurement in 14 from the measurement in 10. Is the difference 3 inches or more? (7.1.1.5(c)(7))

10-14=32 inches.

Yes-Pass No-Fail

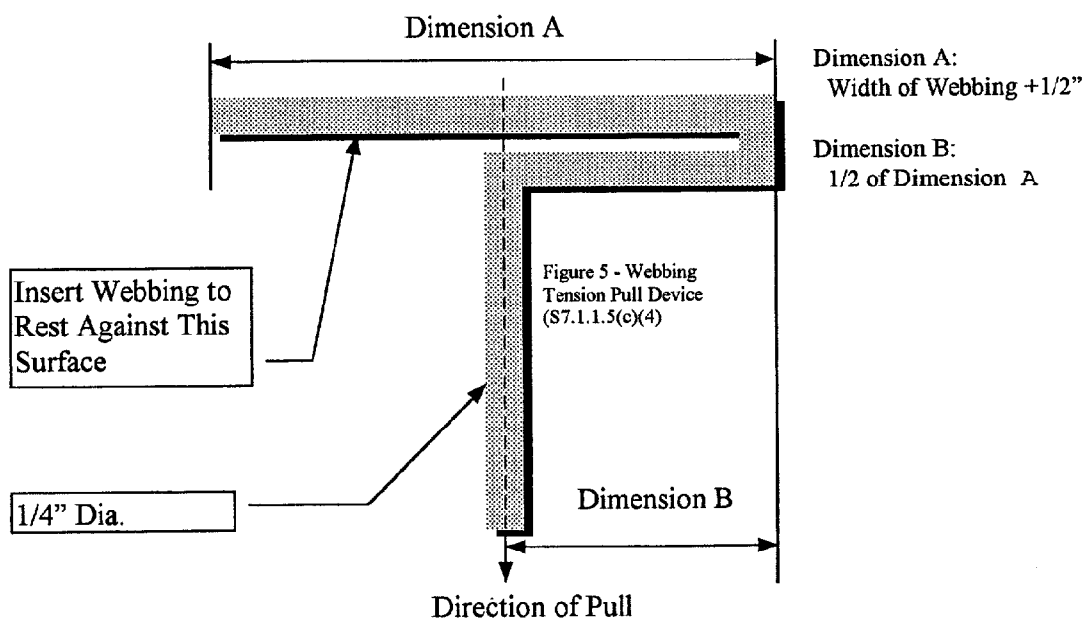

Table 12
FMVSS 208 Air Bag Labels

NHTSA NO.: CW0203

Technician: T. Macy

Date: 12/17/97

1. Air Bag Maintenance Label and Owner's Manual Instructions:
 - 1.1 Does the manufacturer recommend periodic maintenance or replacement of the air bag?
 Yes (Go to 1.2)
 No (Go to 2)
 - 1.2 Does the Vehicle have a maintenance or replacement label?
 Yes-Pass No-Fail
 - 1.3 Does the label contain one of the following? Yes-Pass No-Fail
 - Schedule on label specifies month and year
 - Schedule on label specifies vehicle mileage
 - Schedule on label specifies interval measured from date on certification label
 - 1.4 Is the label permanently affixed within the passenger compartment?
 Yes-Pass No-Fail
 - 1.5 Is the label lettered in English?
 Yes-Pass No-Fail
 - 1.6 Is the label in block capitals and numerals?
 Yes-Pass No-Fail
 - 1.7 Are the letters and numerals at 3/32 inch high?
 Yes-Pass No-Fail
 - 1.8 Does the owner's manual set forth the recommended schedule for maintenance or replacement?
 Yes-Pass No-Fail
2. Does the Vehicle:
 - 2.1 provide an automatic means to ensure that the air bag does not deploy when a child seat or child with a total mass of 30 kg or less is present on the front outboard seat?
 Yes No

Table 12
Air Bag Labels, Cont'd.

2.2 incorporate sensors, other than or in addition to weight sensors, which automatically prevent the passenger air bag from deploying in situations in which it might have an adverse effect on infants in rear-facing child seat, and unbelted or improperly belted children?

Yes No

2.3 have a passenger air bag designed to deploy in a manner that does not create a risk of serious injury to infants in rear-facing child seats, and unbelted or improperly belted children?

Yes No

If yes to 2.1, or 2.2, or 2.3, the vehicle is not required to have a Sun Visor Warning Label (S4.5.1(b)), an air bag alert label (S4.5.1(c)) or a label on the dash (S4.5.1(e)) and this check sheet is complete. (S4.5.1) If no to 2.1, 2.2, and 2.3, go to 3.

3. Sun Visor Warning Label

3.1 Is the label permanently affixed (may be permanent marking or molding) to either side of the sun visor at each front outboard seating position with an air bag?

Driver side Yes-Pass No-Fail

Passenger side N/A Yes-Pass No-Fail

3.2 Does the label conform in content (**vehicles without back seats may omit the statement: "The BACK SEAT is the SAFEST place for children."**)

(S4.5.1(b)(2)(v)) to the label shown in either Figure 6a or 6b as appropriate at each front outboard seating position with an air bag?

(S4.5.1(b)(2))

3.2.1 Dual air bags

N/A

Driver side Yes-Pass No-Fail

Passenger side Yes-Pass No-Fail

Table 12
Air Bag Labels, Cont'd.

3.2.1 Vehicles with driver air bag ONLY - either 3.2.1 or 3.2.2 is applicable, not both. (S4.5.1(b)(2)(iv))

3.2.1 Does the label conform on content to the label shown in either Figure 6a or 6b as appropriate?

N/A

Driver side Yes-Pass **No-Fail**

3.2.2 Does the label conform in content to the label shown in Figure 6a where the label can be modified to omit the pictogram and the message may read:

DEATH or SERIOUS INJURY can occur.

- Sit as far back as possible from the air bag.
- ALWAYS use SEAT BELTS and CHILD RESTRAINTS.
- The BACK SEAT is the SAFEST place for children.

N/A

Driver side Yes-Pass **No-Fail**

Table 12
Air Bag Labels, Cont'd.

SUN VISOR LABEL VISIBLE WHEN VISOR IS IN DOWN POSITION
LABEL OUTLINE, VERTICAL AND HORIZONTAL LINE BLACK

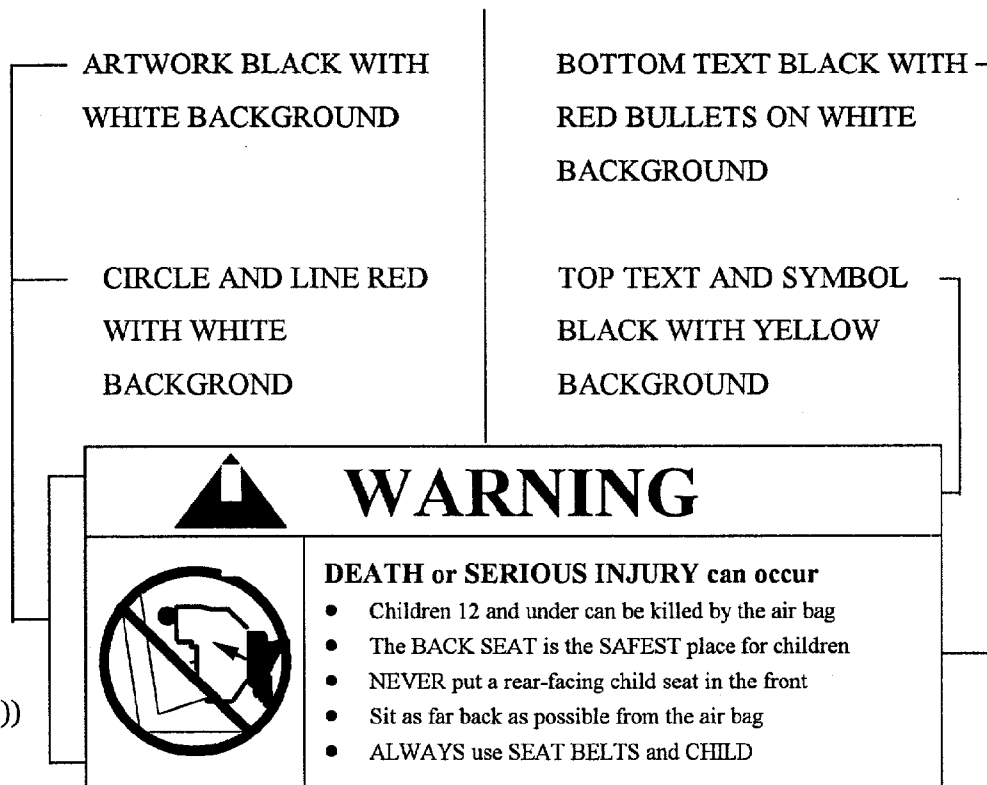

Figure 6a
(S4.5.1(b)(2))

Table 12
Air Bag Labels, Cont'd.

SUN VISOR LABEL VISIBLE WHEN VISOR IS IN DOWN POSITION
LABEL OUTLINE, VERTICAL AND HORIZONTAL LINE BLACK

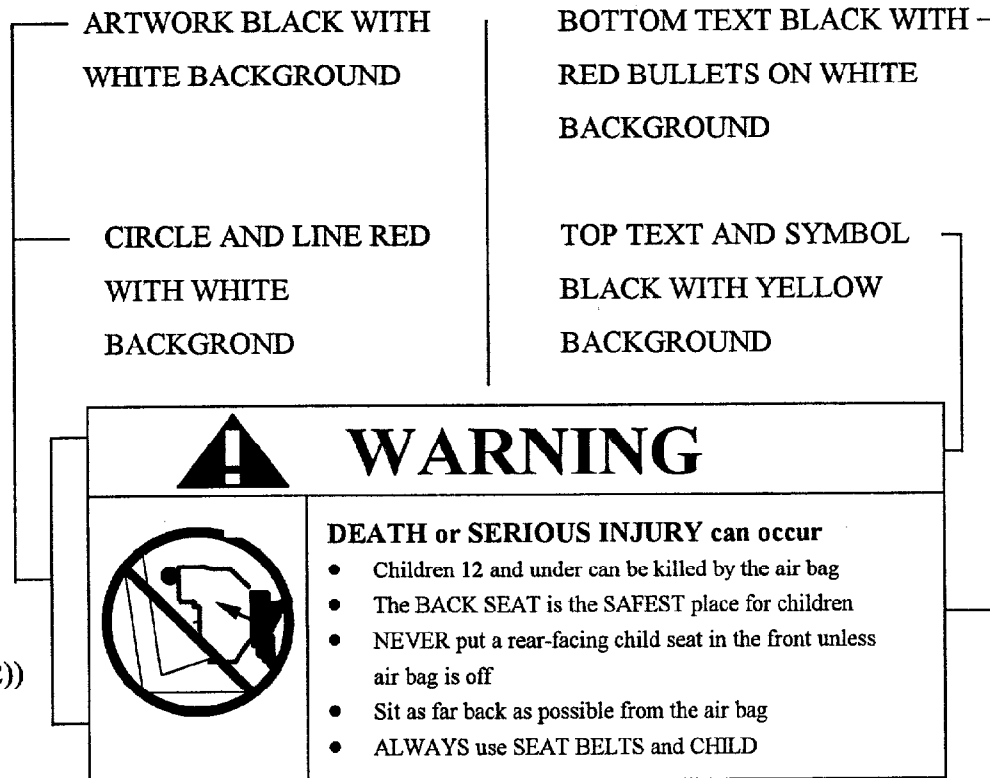

Figure 6b
(S4.5.1(b)(2))

3.3 Is the driver side label heading area yellow with the word "warning" and the alert symbol in black? (S4.5.1.(b)(2)(i))

Driver side Yes-Pass No-Fail

Passenger side Yes-Pass No-Fail

3.4 Is the message white with black text? (S4.5.1 (b)(2)(ii))

Driver side Yes-Pass No-Fail

Passenger side Yes-Pass No-Fail

3.5 Is the message area at least 30 cm²? (S4.5.1(b)(2)(ii))

Actual message area **34.4** cm²

Driver side Yes-Pass No-Fail

Passenger side Yes-Pass No-Fail

Table 12
Air Bag Labels, Cont'd.

- 3.6 Is the pictogram black with a red circle and slash on a white background?
(S4.5.1(b)(2)(iii)) & (S4.5.1(b)(2)(iv))
- For vehicles with driver side air bag ONLY N/A
- Driver side Yes-Pass No-Fail
- Passenger side Yes-Pass No-Fail
- 3.7 Is the pictogram at least 30 mm in diameter? (S4.5.1(b)(2)(iii))
Actual diameter **31.0** mm
- For vehicles with driver side air bag ONLY N/A
- Driver side Yes-Pass No-Fail
- Passenger side Yes-Pass No-Fail
- 3.8 Is the same side of the sun visor to which the sun visor label is affixed free of other information with the exception of an air bag maintenance label?
(S4.5.1(b)(3))
- Driver side Yes-Pass No-Fail
- Passenger side Yes-Pass No-Fail
- 3.9 Is the sun visor free of other information about air bags or the need to wear seat belts with the exception of the air bag alert label or the utility vehicle label?
- Driver side Yes-Pass No-Fail
- Passenger side Yes-Pass No-Fail

4. Air Bag Alert Label

4.1 Is the Sun Visor Warning Label visible when the sun visor is in the stowed position?

Yes No **If yes, go to 5**

4.2 does the label conform in content to the label shown in Figure 6c?
(S4.5.1(c)(2))

Yes-Pass No-Fail



Table 12
Air Bag Labels, Cont'd.

- 4.3 Is the message area black with yellow text? (S4.5.1(c)(2)(i))
 Yes-Pass No-Fail
- 4.4 Is the message area at least 20 cm²? (S4.5.1(c)(2)(i))
 Actual message area 20.1 cm² Yes-Pass No-Fail
- 4.5 Is the pictogram black with a red circle and slash on a white background?
 (S4.5.1(c)(2)(ii))
 For vehicles with driver side air bag ONLY N/A
 Yes-Pass No-Fail
- 4.6 Is the pictogram at least 20 mm in diameter? (S4.5.1(c)(2)(ii))
 Actual diameter is 24.5 mm
 For vehicles with driver side air bag ONLY N/A
 Yes-Pass No-Fail
5. Label On the Dash
- 5.1 Does the vehicle have a passenger air bag?
 Yes No
- If no, this check list is complete.**
- 5.2 Does the vehicle have a label on the dash or steering wheel hub? (S4.5.1(e))
 Yes-Pass No-Fail
- 5.3 Does the label conform in content (vehicles without back seats may omit the statement: "The back seat is the safest place for children 12 and under." (S4.5.1(e)(iii)) to the label shown in Figure 7? (S4.5.1(e))
 Yes-Pass No-Fail

Figure 7
(S4.5.1(e))

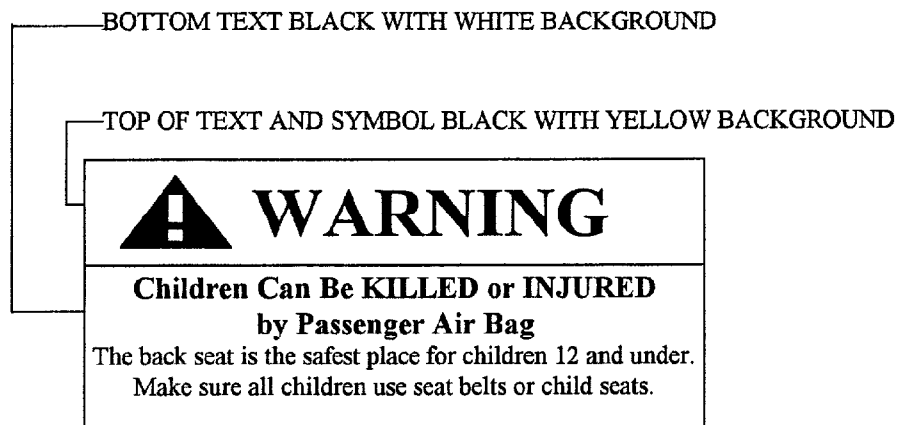

Table 12
Air Bag Labels, Cont'd.

- 5.4 Is the heading area yellow with the word “warning” and the alert symbol in black? (S4.5.1(e)(i)) Yes-Pass No-Fail
- 5.5 Is the message white with black text? (S4.5.1(e)(ii)) Yes-Pass No-Fail
- 5.6 Is the message area at least 30 cm²? (S4.5.1(e)(ii))
Actual message area: _____ cm² Yes-Pass No-Fail

Note: 5.3~5.6 can not be answered because there was no air bag label on dash or steering wheel hub.

Table 13
FMVSS 208 Seat Belt Comfort And Convenience Test Summary
Front Outboard Designated Seating Positions

Test Vehicle NHTSA No.: CW0203

Vehicle Model Year/Make/Model/Body Style: 1998/Ford/F-150/Styleside Pickup Truck,
4x2 Regular Cab

Date of Comfort and Convenience Check: 12/18/97

Technician Performing Check: T. Macy

GVWR: 5550 pounds

- Automatic seat belts installed in any vehicle other than walk-in van-type vehicles, which has a gross vehicle weight rating of 10,000 pounds or less, and is manufactured on or after September 1, 1986, shall meet the requirements for convenience hooks, webbing tension-relieving devices, and belt contact force.
- Manual seat belts installed for compliance with this standard in front outboard designated seating positions of any vehicle, other than walk-in van-type vehicles, which has a gross vehicle rating of 10,000 pounds or less, and is manufactured after September 1, 1989, shall meet the requirements for belt contact force, latch plate access, retraction and seat belt guides and hardware.

1. Was vehicle equipped with: (S7.4)

AUTOMATIC SEAT BELTS

Yes-; No-

If yes, go to requirements for Convenience Hooks (S7.4.1), Webbing Tension-Relieving Devices (S7.4.2), Belt Contact Force (S7.4.3)

**MANUAL SEAT BELTS IN OUTBOARD FRONT SEATS EXCLUDING TYPE 2
MANUAL BELTS IN PASSENGER CARS***

Yes-; No-

If yes, go to requirements for Belt Contact Force (S7.4.3), Latchplate Access (S7.4.4), Retraction (S7.4.5)

If any problems are encountered while checking the vehicle to ascertain that it meets the comfort and convenience requirements of FMVSS No. 208 contact the COTR immediately.

* If the seat belts are voluntarily installed by the manufacturer they do not have to comply.

Table 13
FMVSS 208 Seat Belt Comfort And Convenience Test Summary, Cont'd.
Belt Contact Force (S7.4.3)

FRONT OUTBOARD DRIVER

1. Do not measure the belt contact force if the manual or automatic seat belt assemblies in the vehicle incorporate a webbing tension-relieving device. Check

2. Seats are adjusted according to instructions in S8, "Test conditions" of FMVSS 208. Check

3. The test dummies are positioned according to dummy position placement instructions in Appendix B or C. Check

4. Fasten the seat belt latch. Close the vehicle's adjacent door, pull either 12 inches of belt webbing or the maximum available amount of belt webbing, whichever is less, from the retractor and then release it, allowing the belt webbing to return to the dummy's chest. Locate the point where the centerline of the upper torso belt webbing crosses the midsagittal line on the dummy's chest. At that point pull the belt webbing out 3 inches from the dummy's chest and release until it is within one inch from the dummy's chest. The contact force is 0.4 pounds. Contact the COTR if the contact force exceeds 0.7 pounds.

FRONT OUTBOARD PASSENGER

1. Do not measure the belt contact force if the manual or automatic seat belt assemblies in the vehicle incorporate a webbing tension-relieving device. Check

2. Seats are adjusted according to instructions in S8, "Test conditions" of FMVSS 208. Check

3. The test dummies are positioned according to dummy position placement instructions in Appendix B or C. Check

4. Fasten the seat belt latch. Close the vehicle's adjacent door, pull either 12 inches of belt webbing or the maximum available amount of belt webbing, whichever is less, from the retractor and then release it, allowing the belt webbing to return to the dummy's chest. Locate the point where the centerline of the upper torso belt webbing crosses the midsagittal line on the dummy's chest. At that point pull the belt webbing out 3 inches from the dummy's chest and release until it is within one inch from the dummy's chest. The contact force is 0.5 pounds. Contact the COTR if the contact force exceeds 0.7 pounds.

Table 13
FMVSS 208 Seat Belt Comfort And Convenience Test Summary, Cont'd.
Latchplate Access (S7.4.4)

FRONT OUTBOARD DRIVER

1. Position latch plate in its normal stowed position. Check
2. Position adjustable anchorages, if any, to manufactures nominal design position for a 50th percentile dummy. Check
3. Position the test dummy in the right front passenger seat in its forward most adjustment position and with its arms removed. Check
4. Attach the inboard and outboard reach string following the instructions on Figure 2C for Part 572E test device outlined in the test procedure. Check
5. Extend each line backward and outboard to generate arcs of the reach envelope of the test dummy's arms. With the latchplate in the normal stowed position check to assure that the latchplate is within the reach envelope. Check
6. Close the vehicle door. Using the clearance test block, specified in Figure 3C of the test procedure, determine if there is sufficient clearance between the vehicle seat and the side of vehicle to allow the test block to move unhindered to the latchplate or buckle. Check
7. Was the latch plate accessible? Yes- Pass; No- Fail

FRONT OUTBOARD PASSENGER

1. Position latch plate in its normal stowed position. Check
2. Position adjustable anchorages, if any, to manufactures nominal design position for a 50th percentile dummy. Check
3. Position the test dummy in the left front driver seat in its forward most adjustment position and with its arms removed. Check
4. Attach the inboard and outboard reach string following the instructions on Figure 2C for Part 572E test device outlined in the test procedure. Check
5. Extend each line backward and outboard to generate arcs of the reach envelope of the test dummy's arms. With the latchplate in the normal stowed position check to assure that the latchplate is within the reach envelope. Check
6. Close the vehicle door. Using the clearance test block, specified in Figure 3C of the test procedure, determine if there is sufficient clearance between the vehicle seat and the side of vehicle to allow the test block to move unhindered to the latchplate or buckle. Check
7. Was the latch plate accessible? Yes- Pass No- Fail

Table 13
FMVSS 208 Seat Belt Comfort And Convenience Test Summary, Cont'd.
Retraction (S7.4.5)

FRONT OUTBOARD DRIVER

1. Seat and seat back are adjusted according to instructions in S8.1.2 and S8.1.3 Check
2. Use anthropomorphic test dummies whose arms have been removed and position the dummies in the front outboard designated seating positions according to instructions in Appendix B (P572E) and restrain the dummies using the belt systems for the positions being tested. Check
3. Outboard armrests which are capable of being stowed on vehicle seats shall be placed in their stowed position. Check
4. Check the option which applies to this test vehicle:
 - (A) The torso and lap belt webbing of the seat belt system automatically retracts to a stowed position when the adjacent vehicle door is in an open position and the seat belt latch plate is released. Check
 - (B) The torso and lap belt webbing of the seat belt system automatically retracts when the seat belt latch plate is released. Check
5. With the webbing and hardware in the stowed position close the door to assure that the webbing and hardware are prevented from being pinched. Check
6. If this test vehicle has an open body (without doors) and has a belt system with a tension-relieving device, check to assure that the belt system fully retracts when the tension relieving device is manually deactivated. Check
7. Notes: No armrests installed on the test vehicle. Not an open body

Table 13
FMVSS 208 Seat Belt Comfort And Convenience Test Summary, Cont'd.
Retraction (S7.4.5)

FRONT OUTBOARD PASSENGER

1. Seat and seat back are adjusted according to instructions in S8.1.2 and S8.1.3 Check
2. Use anthropomorphic test dummies whose arms have been removed and position the dummies in the front outboard designated seating positions according to instructions in Appendix B (P572E) and restrain the dummies using the belt systems for the positions being tested. Check
3. Outboard armrests which are capable of being stowed on vehicle seats shall be placed in their stowed position. Check
4. Check the option which applies to this test vehicle:
 - (A) The torso and lap belt webbing of the seat belt system automatically retracts to a stowed position when the adjacent vehicle door is in an open position and the seat belt latch plate is released. Check
 - (B) The torso and lap belt webbing of the seat belt system automatically retracts when the seat belt latch plate is released. Check
5. With the webbing and hardware in the stowed position close the door to assure that the webbing and hardware are prevented from being pinched. Check
6. If this test vehicle has an open body (without doors) and has a belt system with a tension-relieving device, check to assure that the belt system fully retracts when the tension relieving device is manually deactivated. Check
7. Notes: No armrests installed on the test vehicle. Not an open body.

Table 13
FMVSS 208 Seat Belt Comfort And Convenience Test Summary, Cont'd.
Seat Belt Guides And Hardware (S7.4.6)

FRONT OUTBOARD DRIVER

The requirements for accessibility **DO NOT APPLY** to:

1. Seats whose seat cushions are movable so that the seat back serves a function other than seating (S7.4.6.1(b)).
2. Seat that are removable.
3. Seats that are movable so that the space formerly occupied by the seat can be used for a secondary function.

If the seats in this vehicle are different than the criteria above, determine if:

1. Each manual seat belt assembly in a front designated seating position whose webbing is designed to pass through the seat cushion or between the seat cushion and seat back has one of the following three parts (the seat belt latchplate, the buckle, or the seat belt webbing) on top of or above the seat cushion under normal conditions (i.e., conditions other than when belt hardware is intentionally pushed behind the seat by a vehicle occupant.) Check
2. The remaining two seat belt parts are accessible under normal conditions. Check
3. The buckle and latchplate do not pass through the guides or conduits provided and fall behind the seat when the following occur in order:
 - (A) The belt is completely retracted or, if the belt is non retractable, the belt is unlatched. Check
 - (B) The seat is moved to any position to which it is designed to be adjusted. Check
 - (C) The seat back, if foldable, is folded forward as far as possible and then moved backward into position. Check
4. Is the inboard receptacle end of the seat belt assembly, installed in the outboard designated seating position, accessible with the center arm rest in any position to which it can be adjusted (without moving the arm rest)? Yes-; No-, N/A-

Table 13
FMVSS 208 Seat Belt Comfort And Convenience Test Summary, Cont'd.
Seat Belt Guides And Hardware (S7.4.6)

FRONT OUTBOARD PASSENGER

The requirements for accessibility **DO NOT APPLY** to:

1. Seats whose seat cushions are movable so that the seat back serves a function other than seating (S7.4.6.1(b)).
2. Seat that are removable.
3. Seats that are movable so that the space formerly occupied by the seat can be used for a secondary function.

If the seats in this vehicle are different than the criteria above, determine if:

1. Each manual seat belt assembly in a front designated seating position whose webbing is designed to pass through the seat cushion or between the seat cushion and seat back has one of the following three parts (the seat belt latchplate, the buckle, or the seat belt webbing) on top of or above the seat cushion under normal conditions (i.e., conditions other than when belt hardware is intentionally pushed behind the seat by a vehicle occupant.). Check
2. The remaining two seat belt parts are accessible under normal conditions. Check
3. The buckle and latchplate do not pass through the guides or conduits provided and fall behind the seat when the following occur in order:
 - (A) The belt is completely retracted or, if the belt is non retractable, the belt is unlatched. Check
 - (B) The seat is moved to any position to which it is designed to be adjusted. Check
 - (C) The seat back, if foldable, is folded forward as far as possible and then moved backward into position. Check
4. Is the inboard receptacle end of the seat belt assembly, installed in the outboard designated seating position, accessible with the center arm rest in any position to which it can be adjusted (without moving the arm rest)? Yes-; No-, N/A-

Section 4.0

Vehicle, Occupant, and Camera Measurements

Figure 2 Vehicle Target Locations

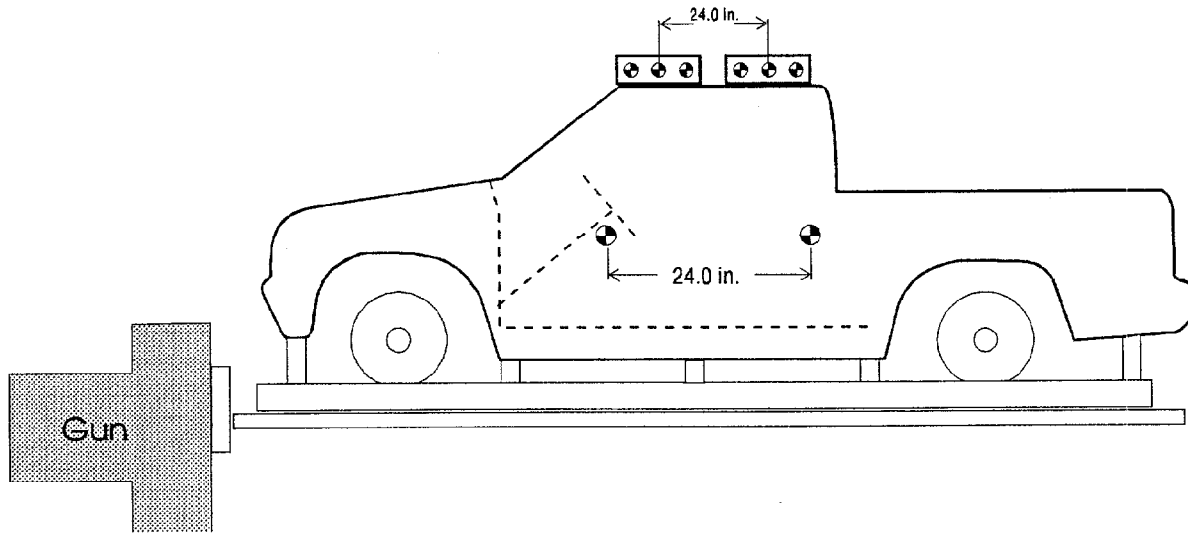

Figure 3 Dummy Measurement Locations for Front Seat Occupants

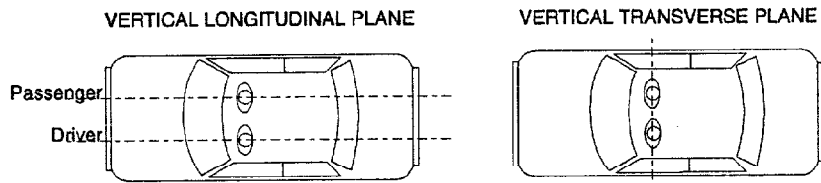
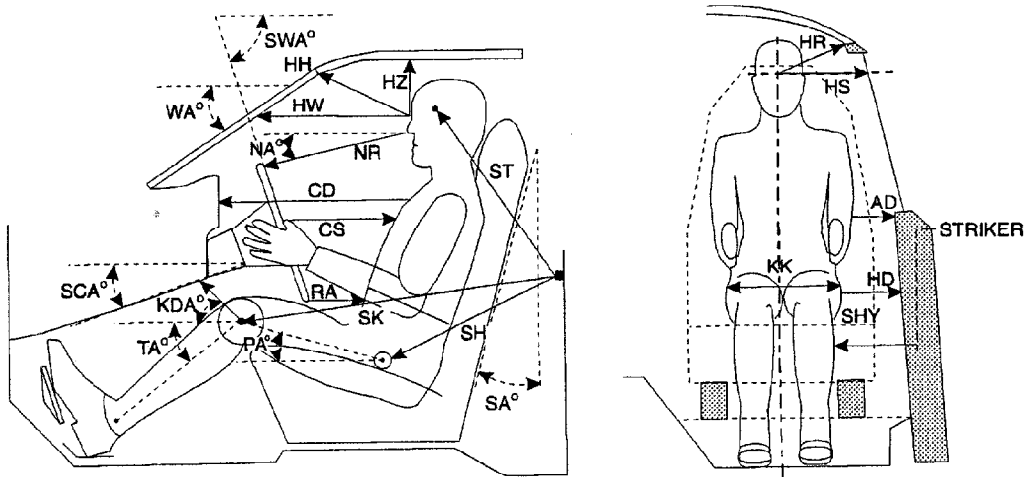

Table 14 Dummy Measurement Data for Front Seat Occupants

<u>Designation</u>	<u>Type of Measurement</u>	<u>Driver (Serial #229)</u>	<u>Passenger (Serial #230)</u>
WA	Windshield angle	34.0°	NA
SWA	Steering wheel angle	70.0°	NA
SCA	Steering column angle	20.0	NA
SA	Seat back angle	22.5°	21.2°
HZ	Head to roof	9.4 in	9.3 in
HH	Head to header	16.1 in	16.2 in
HW	Head to windshield	23.7 in	25.1 in
HR	Head to side header	9.8 in	9.6 in
NR	Nose to rim	16.9 in	NA
NA	Nose to rim angle	13.0°	NA
CD	Chest to dash	23.4 in	22.6 in
CS	Steering wheel to chest	13.0 in	NA
RA	Rim to abdomen	8.7 in	NA
KDL	Left knee to dash	6.9 in	7.2 in
KDR	Right knee to dash	6.8 in	7.1 in
KDA	Outboard knee to dash angle	-30.0°	-20.0°
PA	Pelvic angle	23.0°	23.0°
TA	Tibial angle	55.0°	54.0°
KK	Knee to knee	14.6 in	10.9 in
ST ¹	Striker to head	27.0 in	26.3 in
	Striker to head angle	-68.0°	-53.0°
SK ¹	Striker to knee	29.4 in	30.9 in
	Striker to knee angle	-3.0°	-1.0°
SH ¹	Striker to H-point	14.5 in	15.5 in
	Striker to H-point angle	8.0°	9.0°
SHY	Striker to H-point (Y dir.)	9.5 in	9.2 in
HS	Head to side window	13.8 in	16.6 in
HD	H-point to door	7.1 in	6.3 in
AD	Arm to door	4.9 in	5.3 in

The seat back angle (SA°) is measured relative to vertical, all other angles are measured relative to horizontal.

¹ A negative angle indicates the measurement point was located above the striker.

Figure 4 Camera Positions

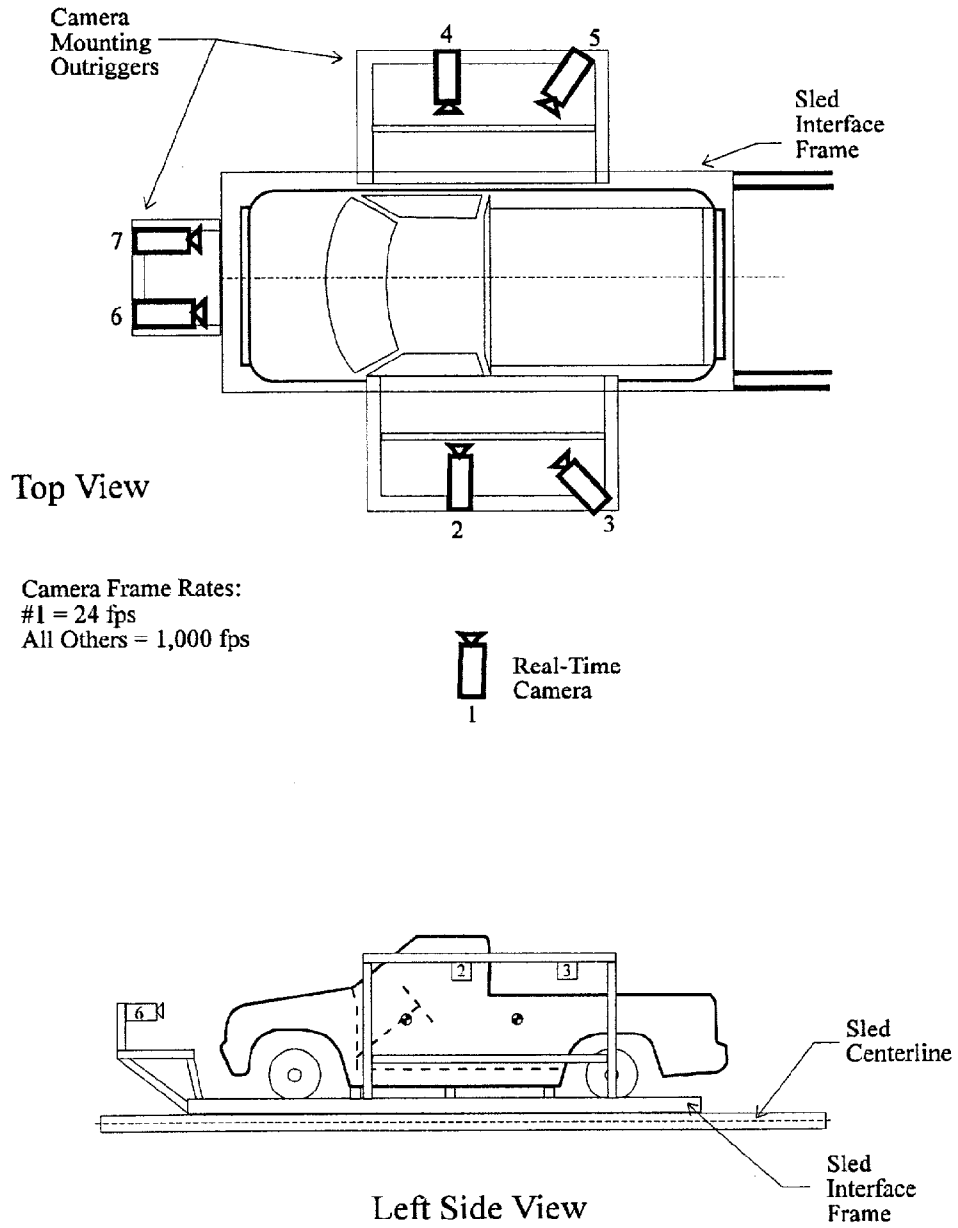

Table 15 Motion Picture Camera Locations

Vehicle year/make/model/body style: 1998/Ford/F-150/Styleside Pickup Truck, 4x2 Regular Cab
 Test number: 971219S

Camera Number	View	Camera Positions ¹			Camera Angle ²	Film Plane to Head Target	Camera Lens	Film Speed
		X	Y	Z				
1	Left side view offboard	94.0 in	229.0 in	56.0 in	-4.0°	284.0 in	NA	24 frames/s
2	Left side view wide	78.0 in	66.0 in	54.0 in	-4.0°	56.0 in	8 mm	1005 frames/s
3	Left side view over shoulder	101.0 in	51.0 in	56.0 in	-9.0°	35.0 in	8 mm	1008 frames/s
4	Right side view	75.0 in	88.0 in	48.0 in	0.0°	74.0 in	13 mm	998 frames/s
5	Right side view over shoulder	100.0 in	50.0 in	54.0 in	-10.0°	32.0 in	8.5 mm	1000 frames/s
6	Front view - driver	27.0 in	17.5 in	59.0 in	-8.0°	59.0 in	8 mm	1008 frames/s
7	Front view - passenger	27.0 in	17.0 in	59.0 in	-9.0°	59.0 in	8 mm	1005 frames/s

¹ +X: Film plane to front of sled
 +Y: Film plane to sled centerline
 +Z: Film plane to top of sled

² +Angle: Film plane of camera upward from horizontal plane

Appendix A

Photographs



Figure A-1 Pre-Test Front View Of Test Vehicle Mounted To Sled

A-2

971219

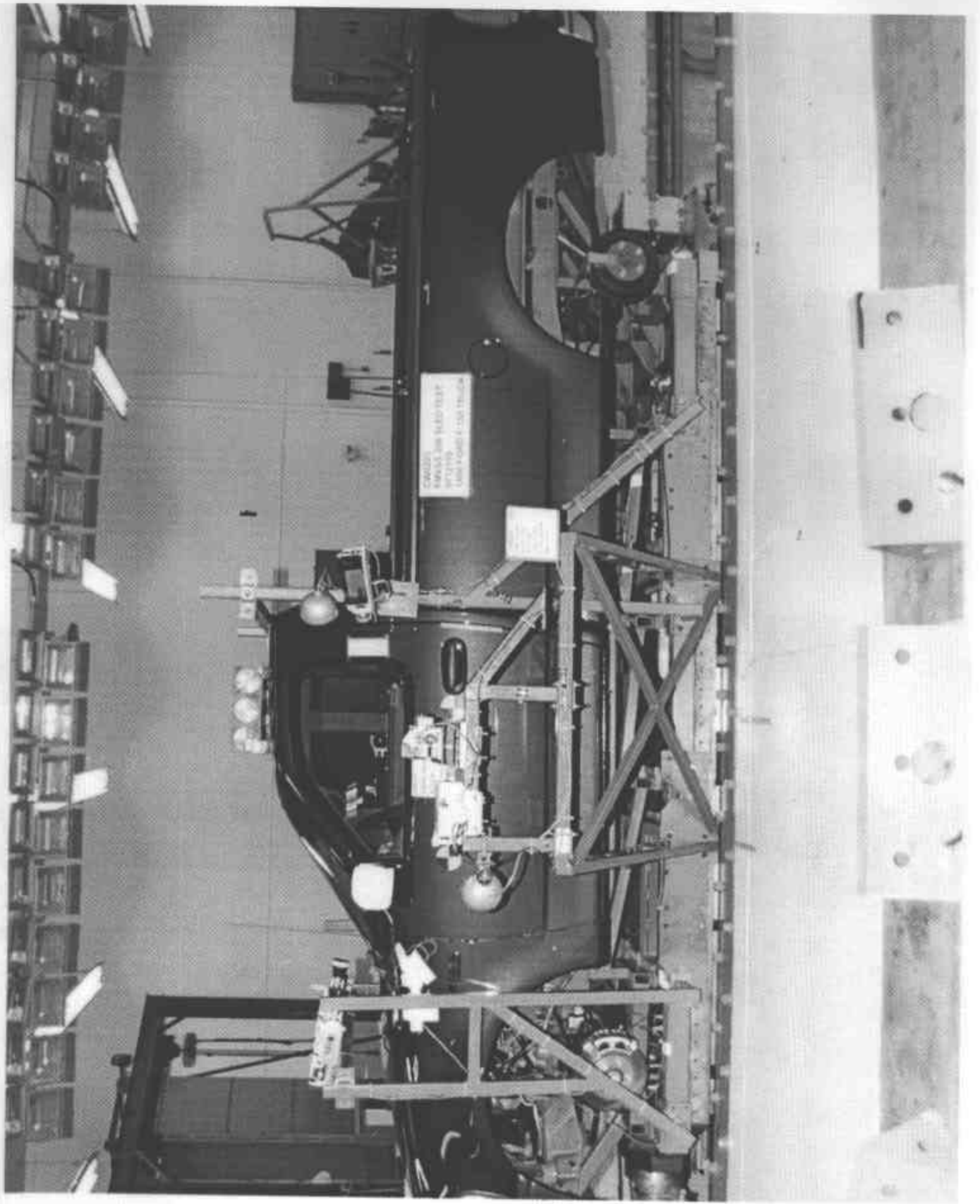

Figure A-2 Pre-Test Left Side View Of Test Vehicle Mounted To Sled

A-3

971219

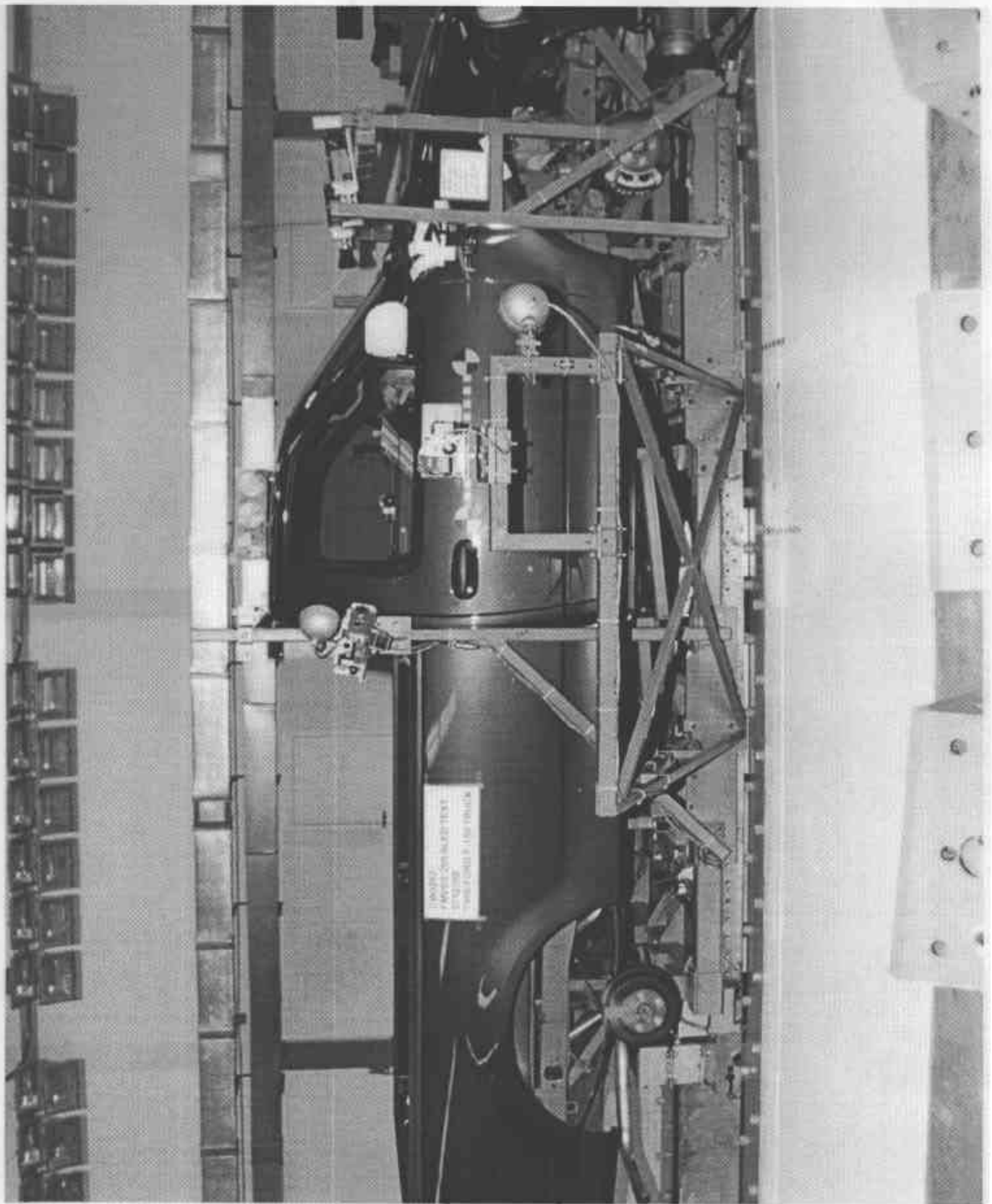

Figure A-3 Pre-Test Right Side View Of Test Vehicle Mounted To Sled

A-4

971219

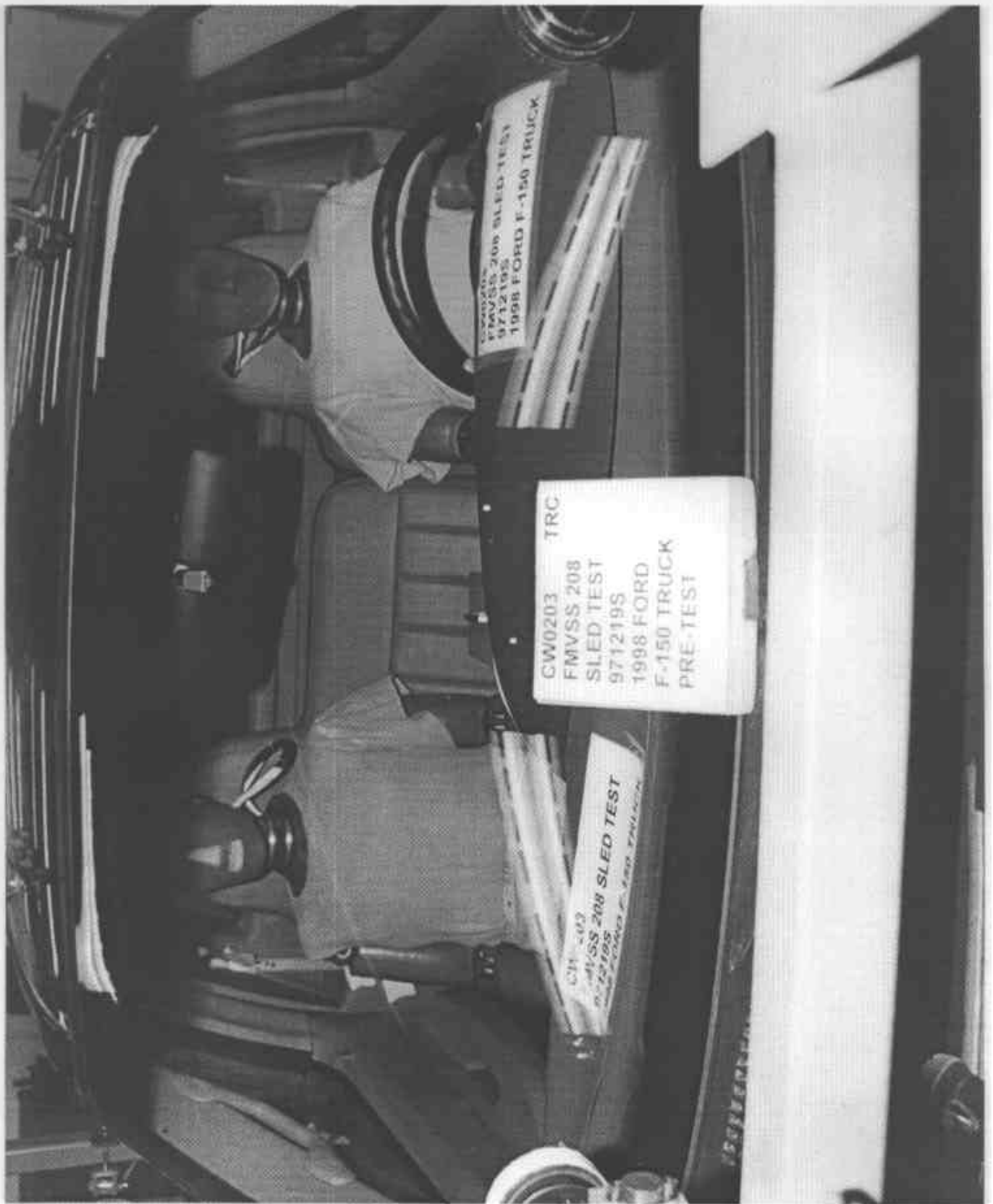

Figure A-4 Pre-Test Windshield View

A-5

971219

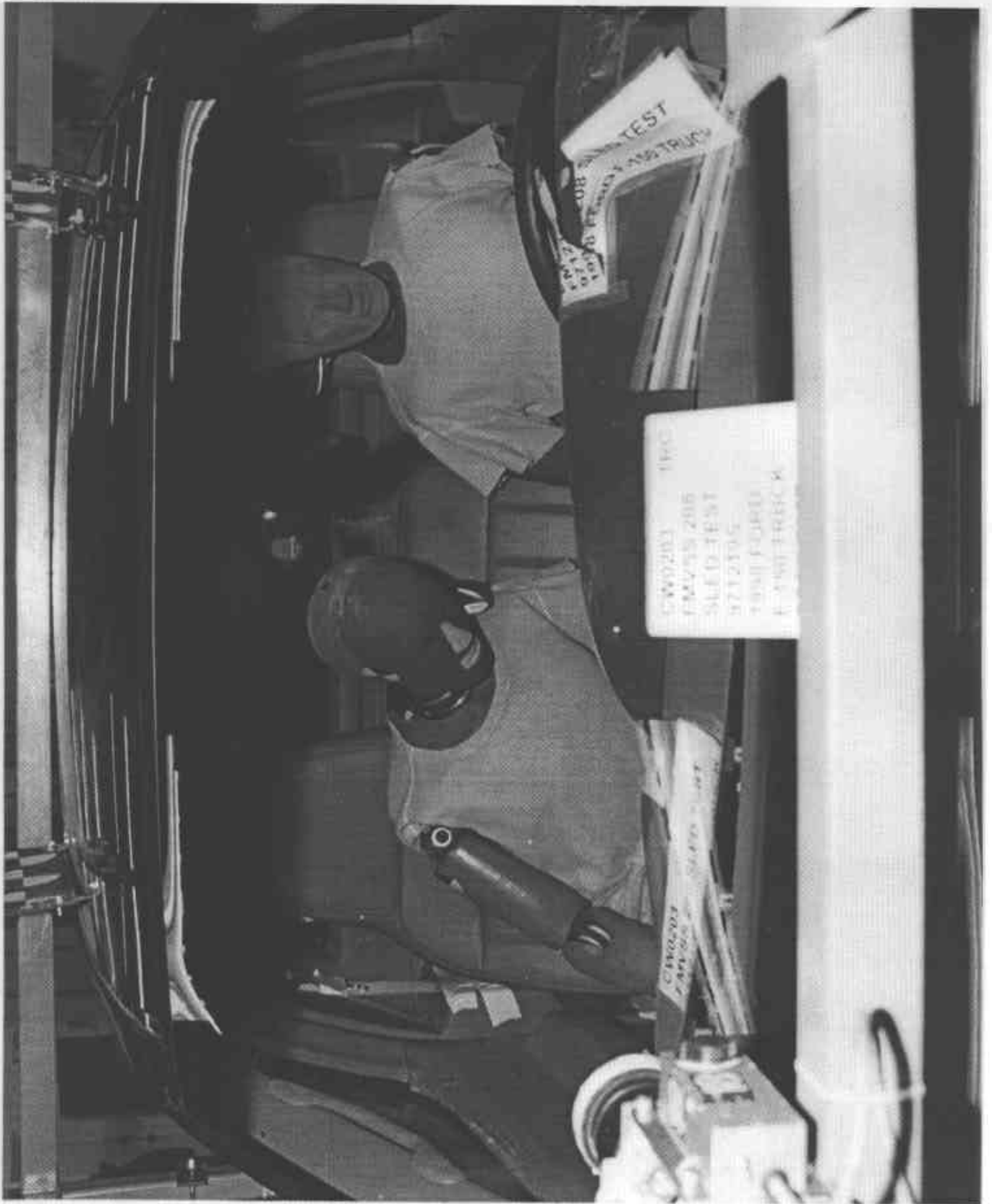

Figure A-5 Post-Test Windshield View

A-6

971219



Figure A-6 Pre-Test Driver Dummy Position View With Door Open

A-7

971219



Figure A-7 Post-Test Driver Dummy Position View With Door Open

A-8

971219

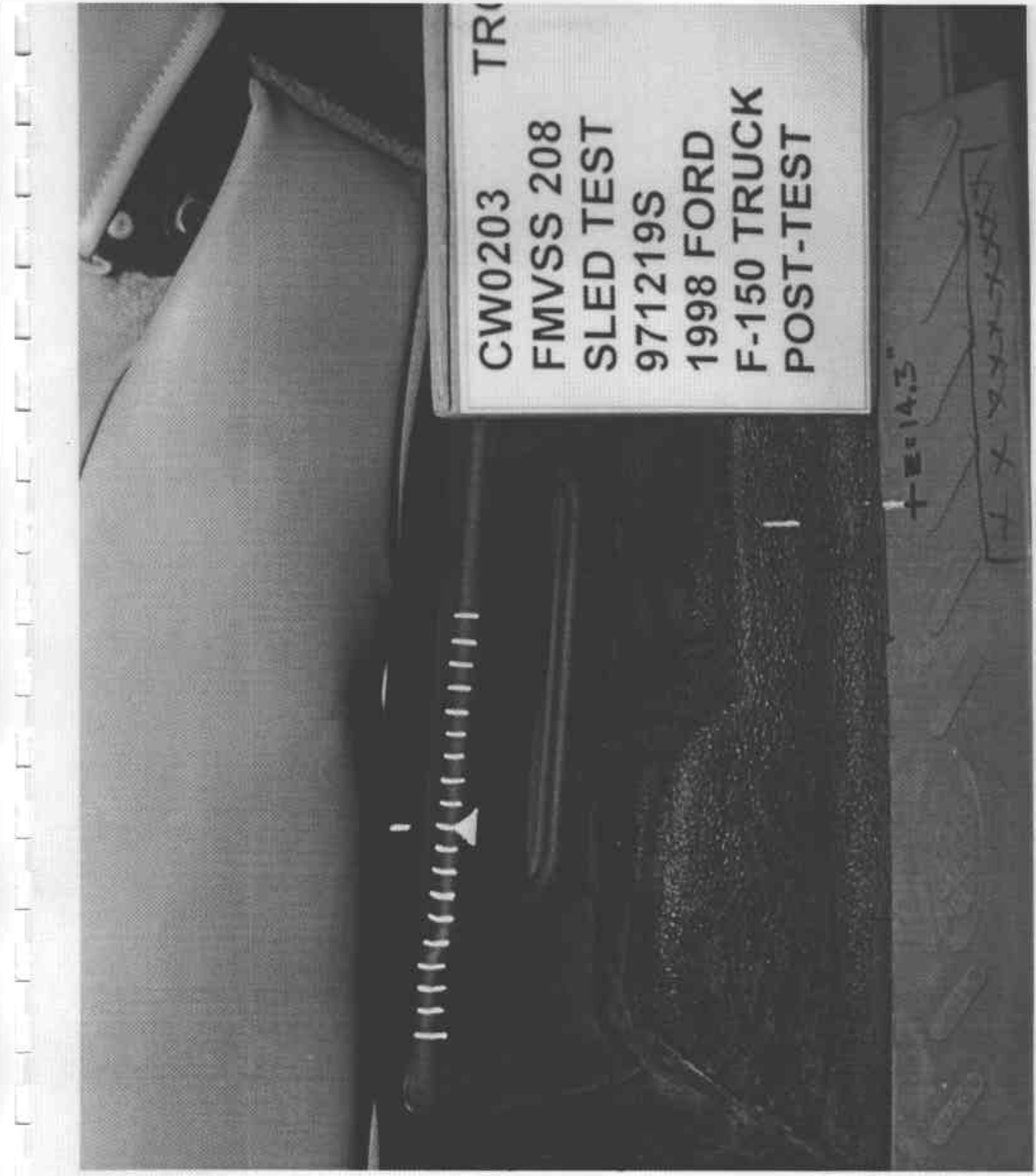

Figure A-9 Post-Test Driver Seat Track Position View

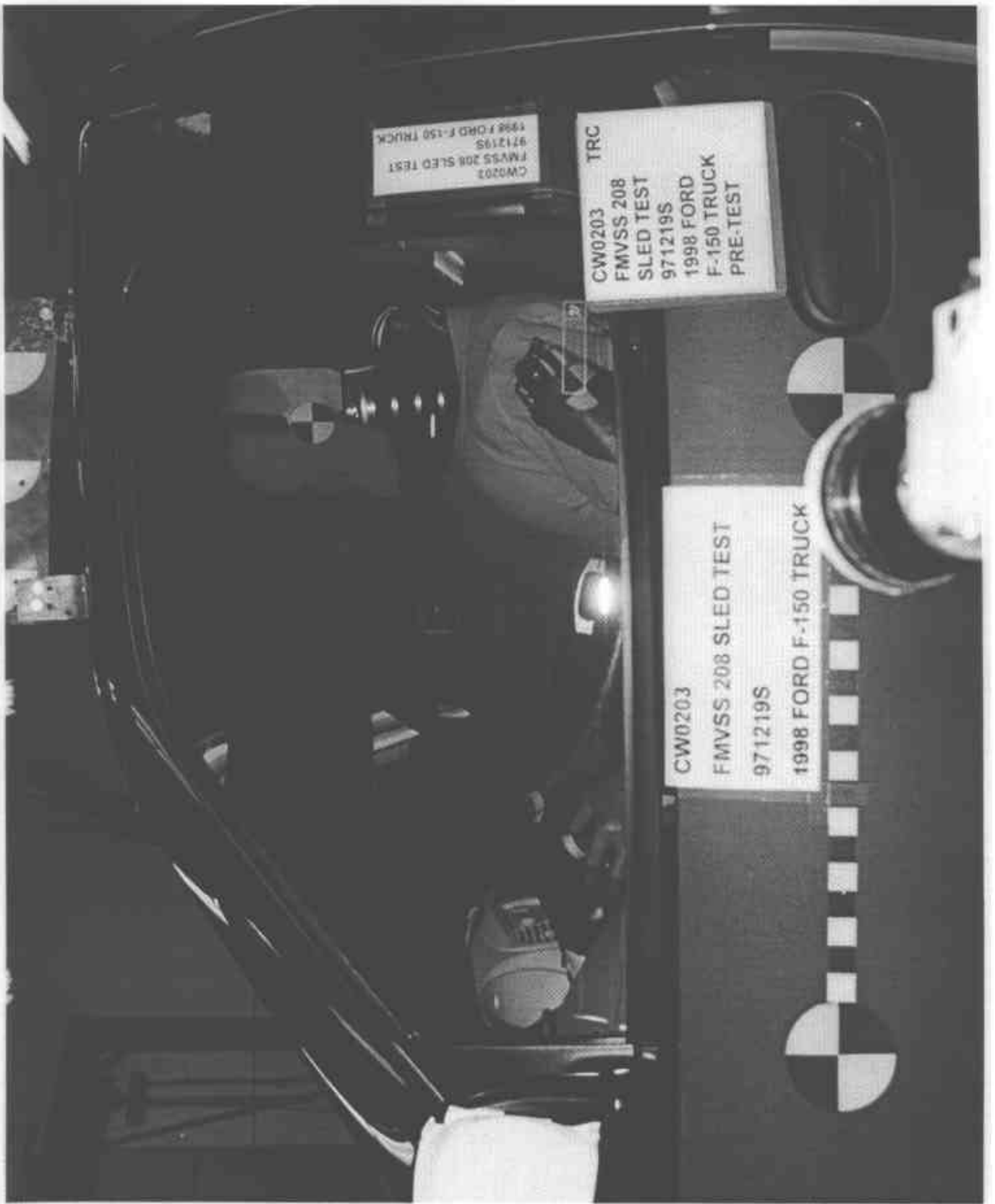

Figure A-10 Pre-Test Driver Dummy Position View With Door Closed

A-11

971219



Figure A-11 Post-Test Driver Dummy Position View With Door Closed

A-12

971219



Figure A-12 Pre-Test Driver Knee Bolster View
A-13

971219

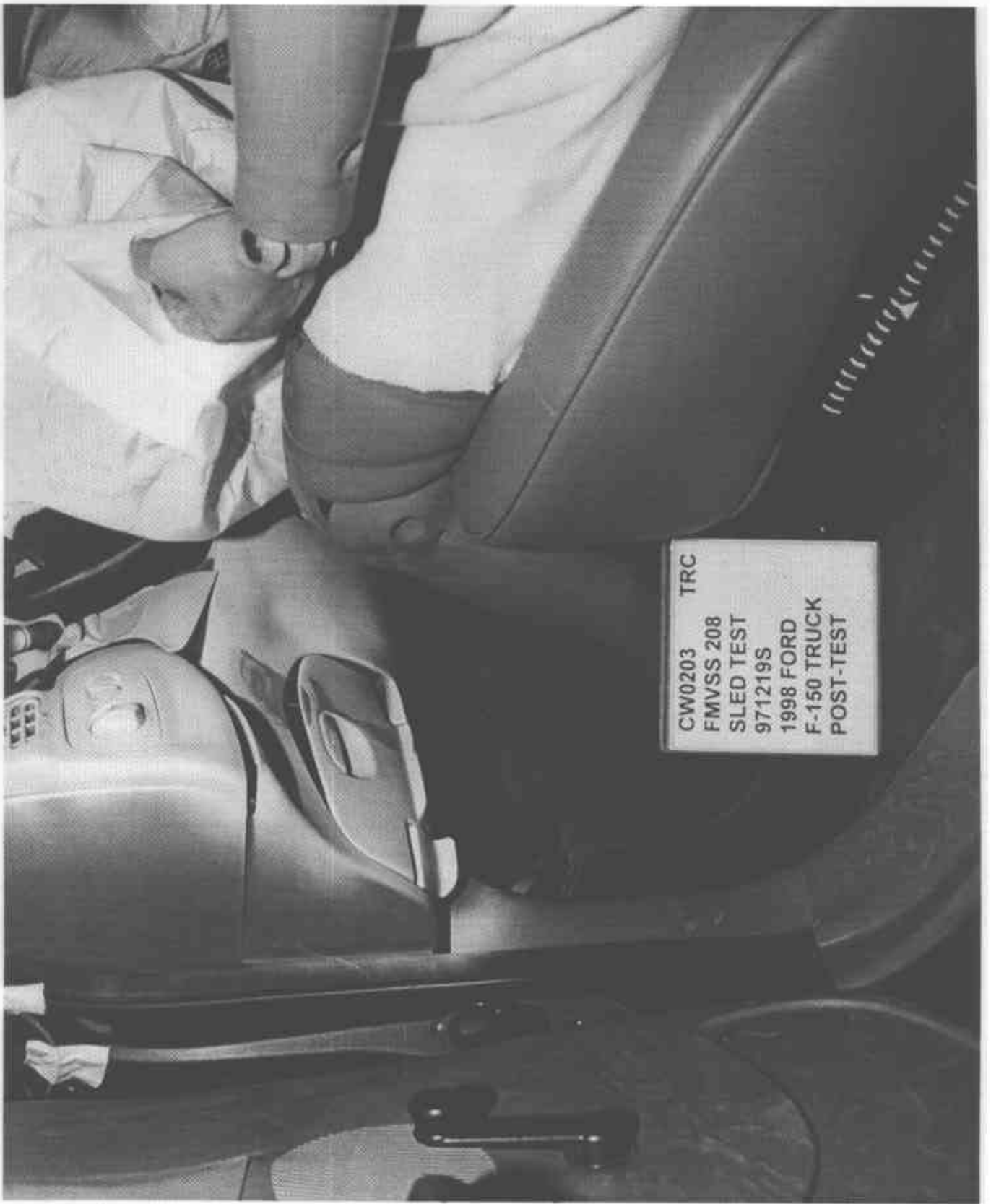

Figure A-13 Post-Test Driver Knee Bolster - View 1

A-14

971219

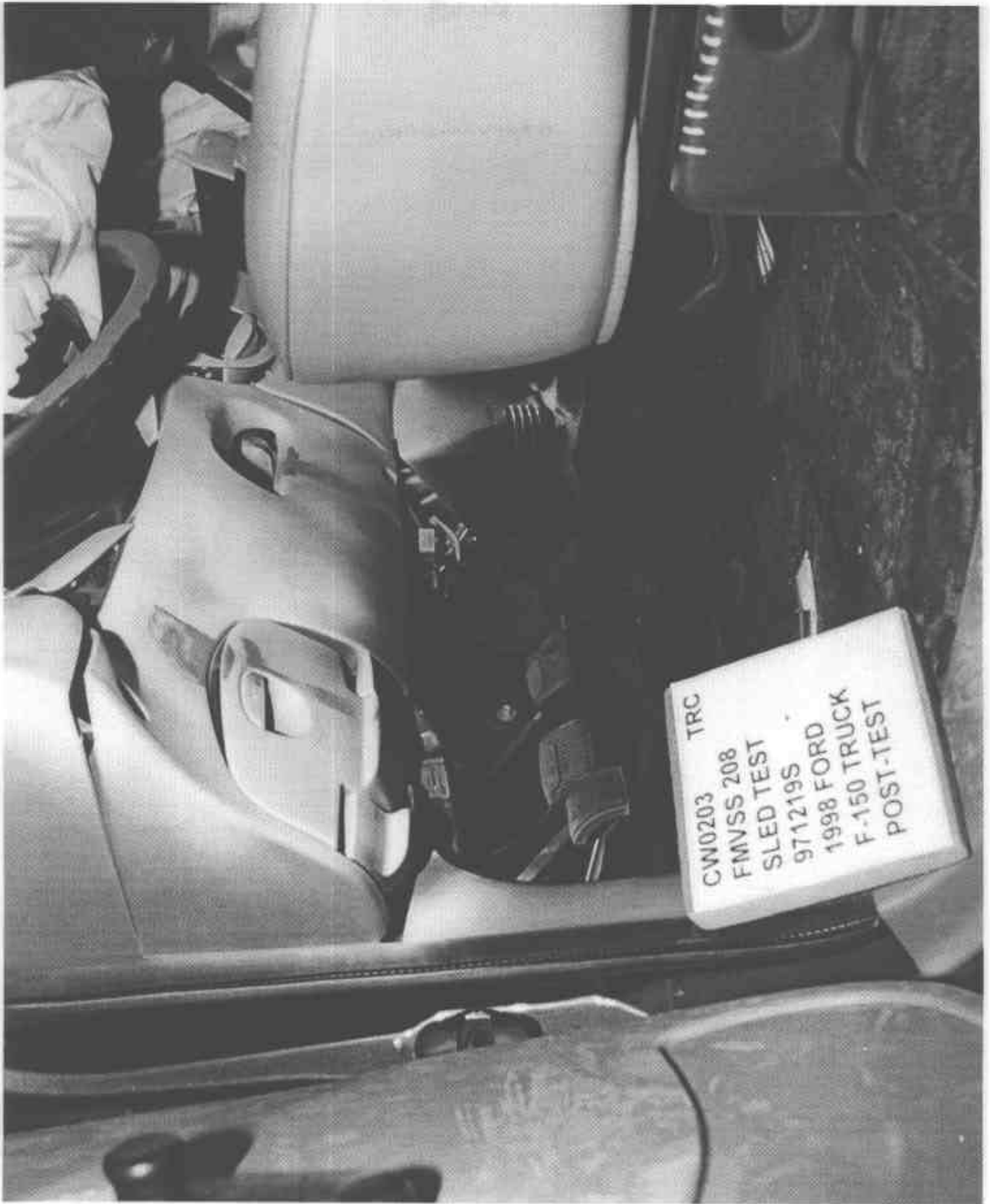
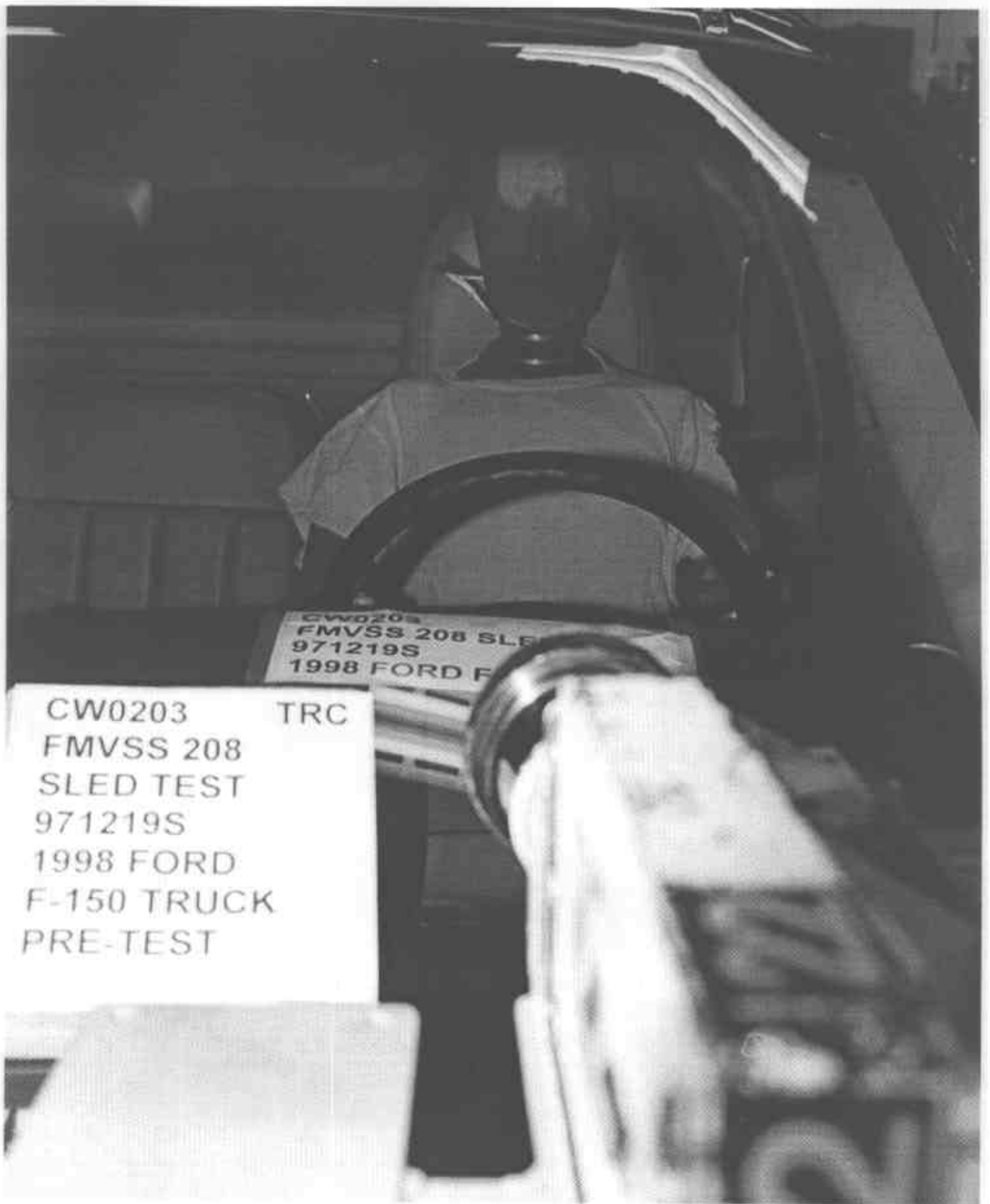

Figure A-14 Post-Test Driver Knee Bolster - View 2
A-15

971219



CW0203 TRC
FMVSS 208
SLED TEST
971219S
1998 FORD
F-150 TRUCK
PRE-TEST

Figure A-15 Pre-Test Driver Dummy Position Front View

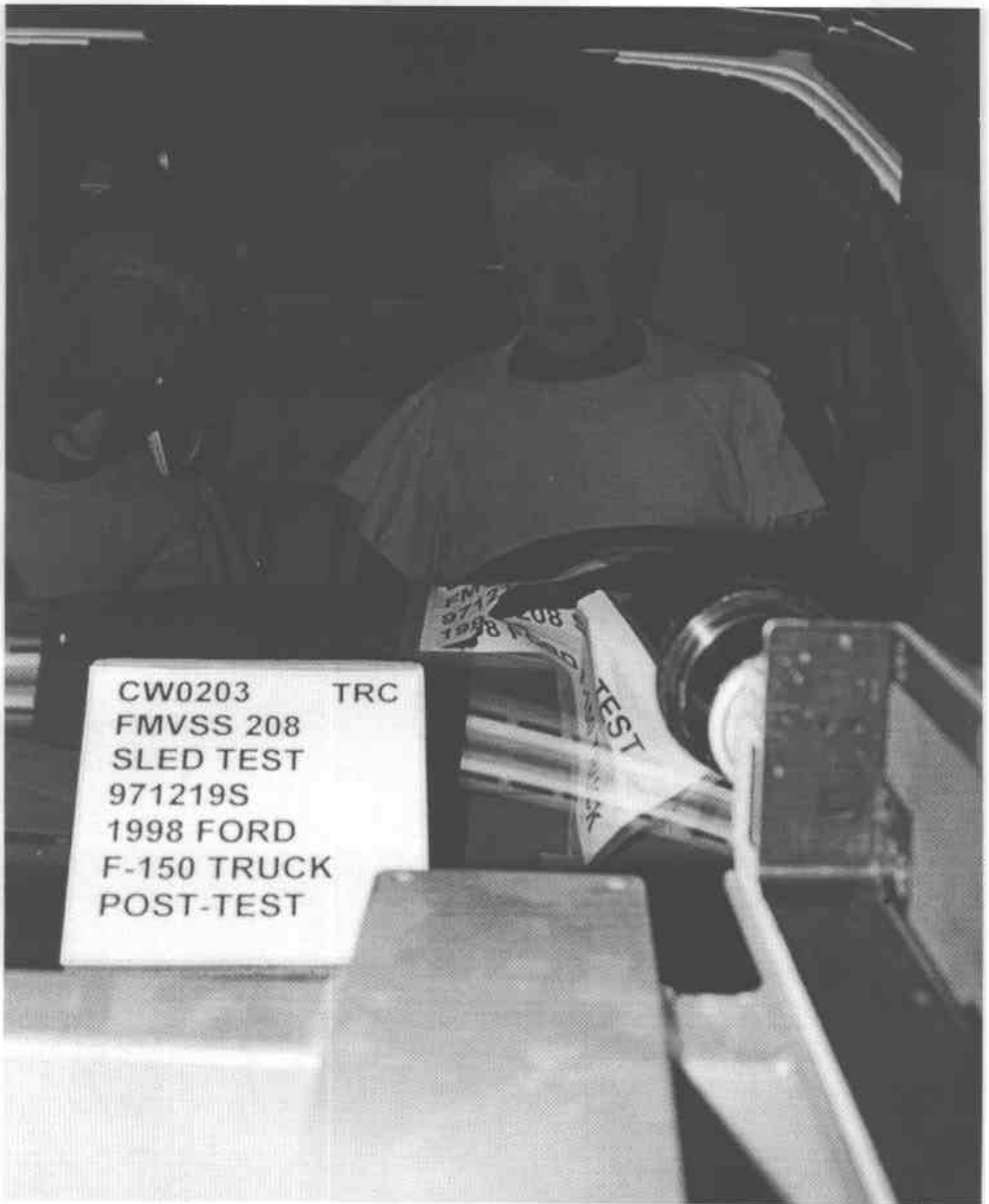

Figure A-16 Post-Test Driver Dummy Position Front View

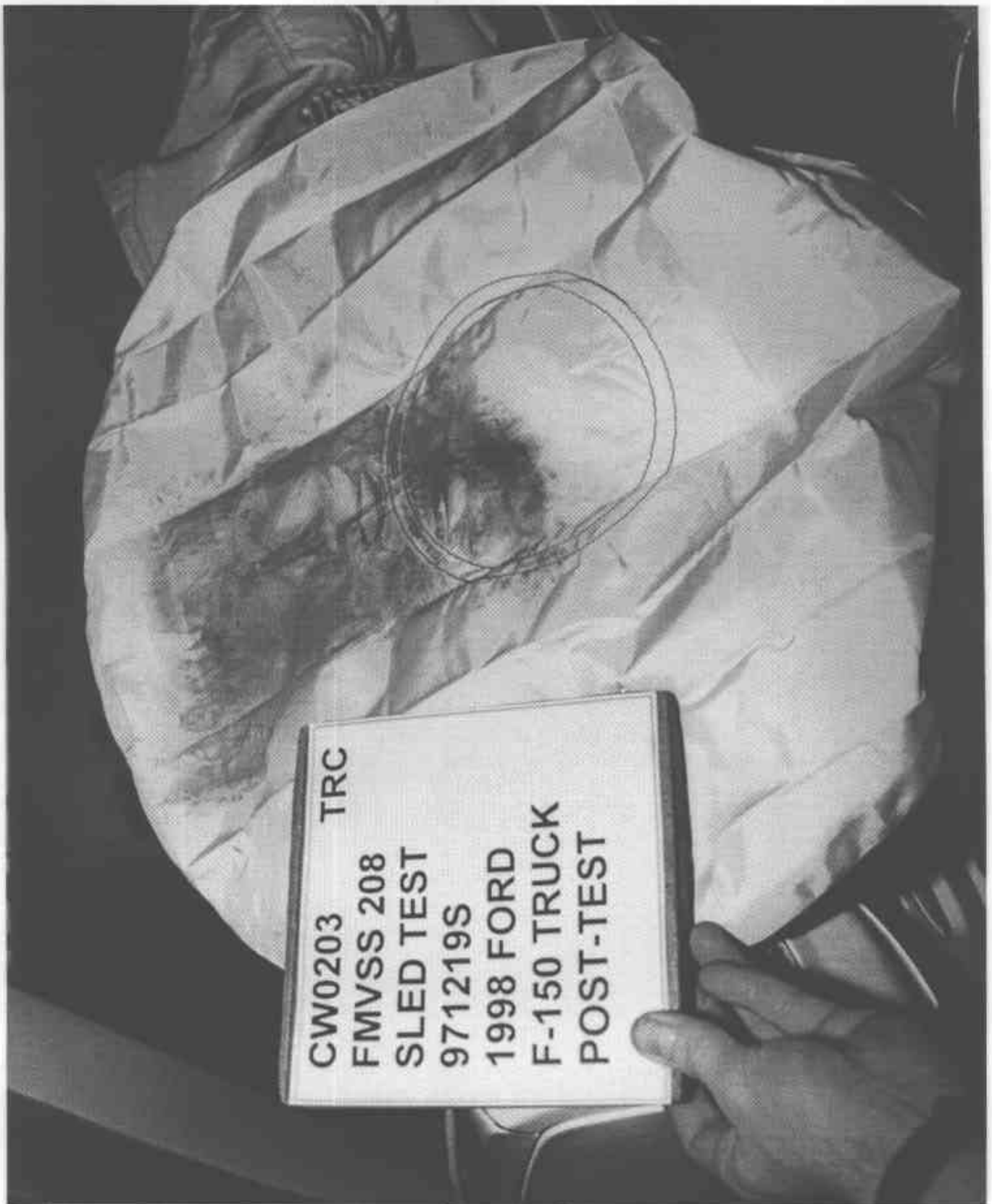

Figure A-17 Post-Test Driver Airbag - View 1

A-18

971219



Figure A-18 Post-Test Driver Airbag - View 2
A-19

971219

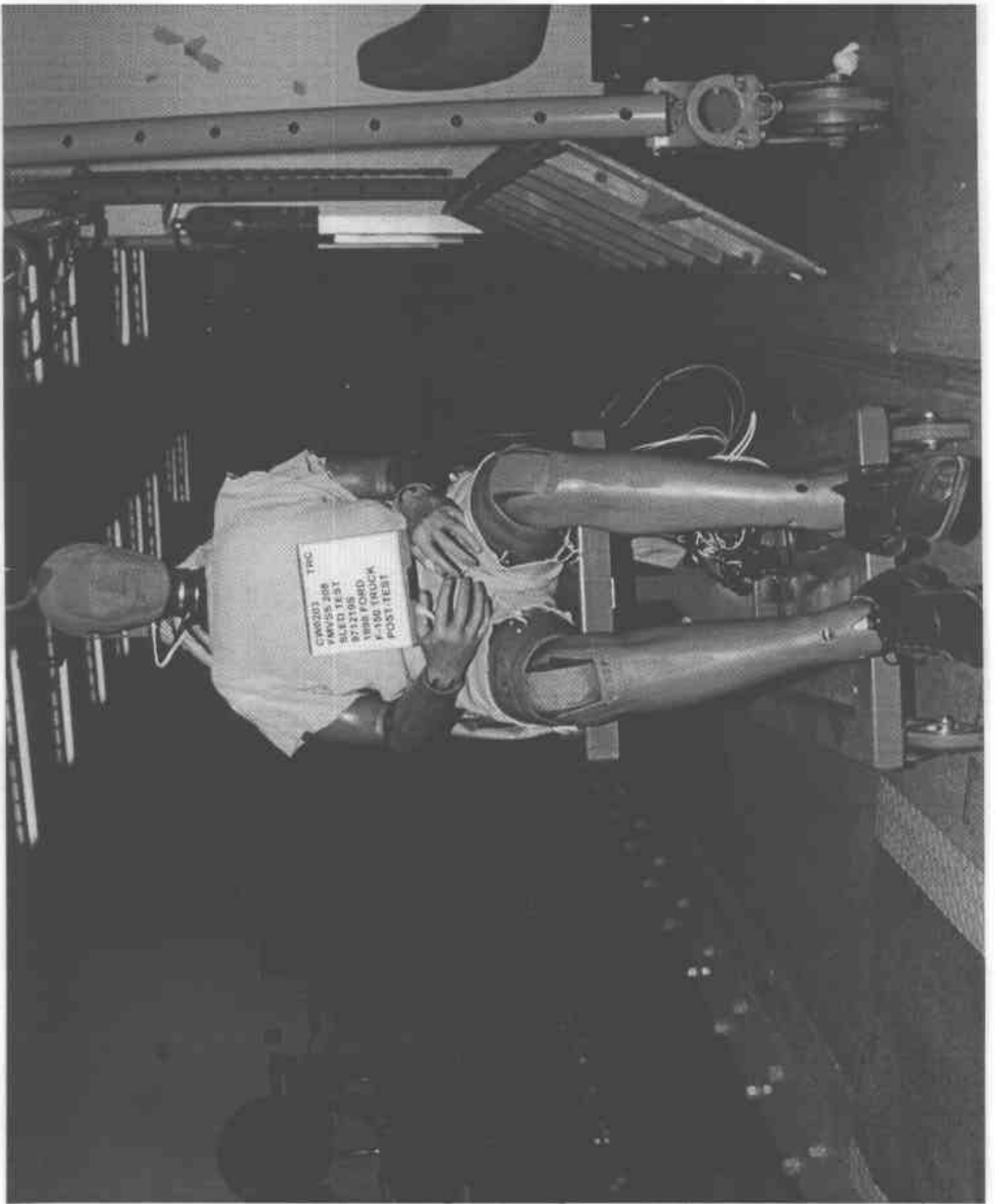

Figure A-19 Post-Test Driver Dummy Removed From Vehicle Overall View

A-20

971219



Figure A-20 Pre-Test Passenger Dummy Position View With Door Open

A-21

971219

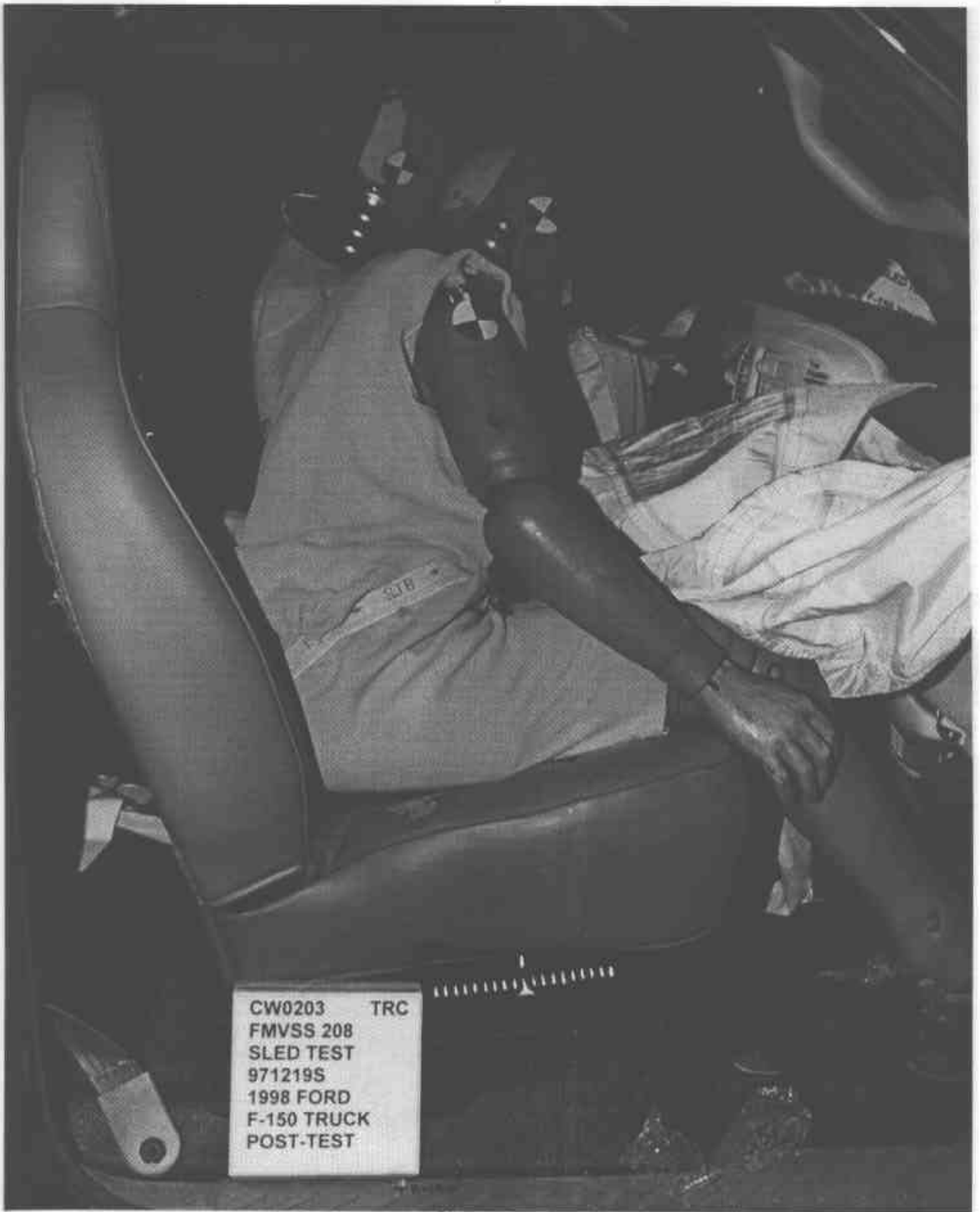

Figure A-21 Post-Test Passenger Dummy Position View With Door Open
A-22 971219

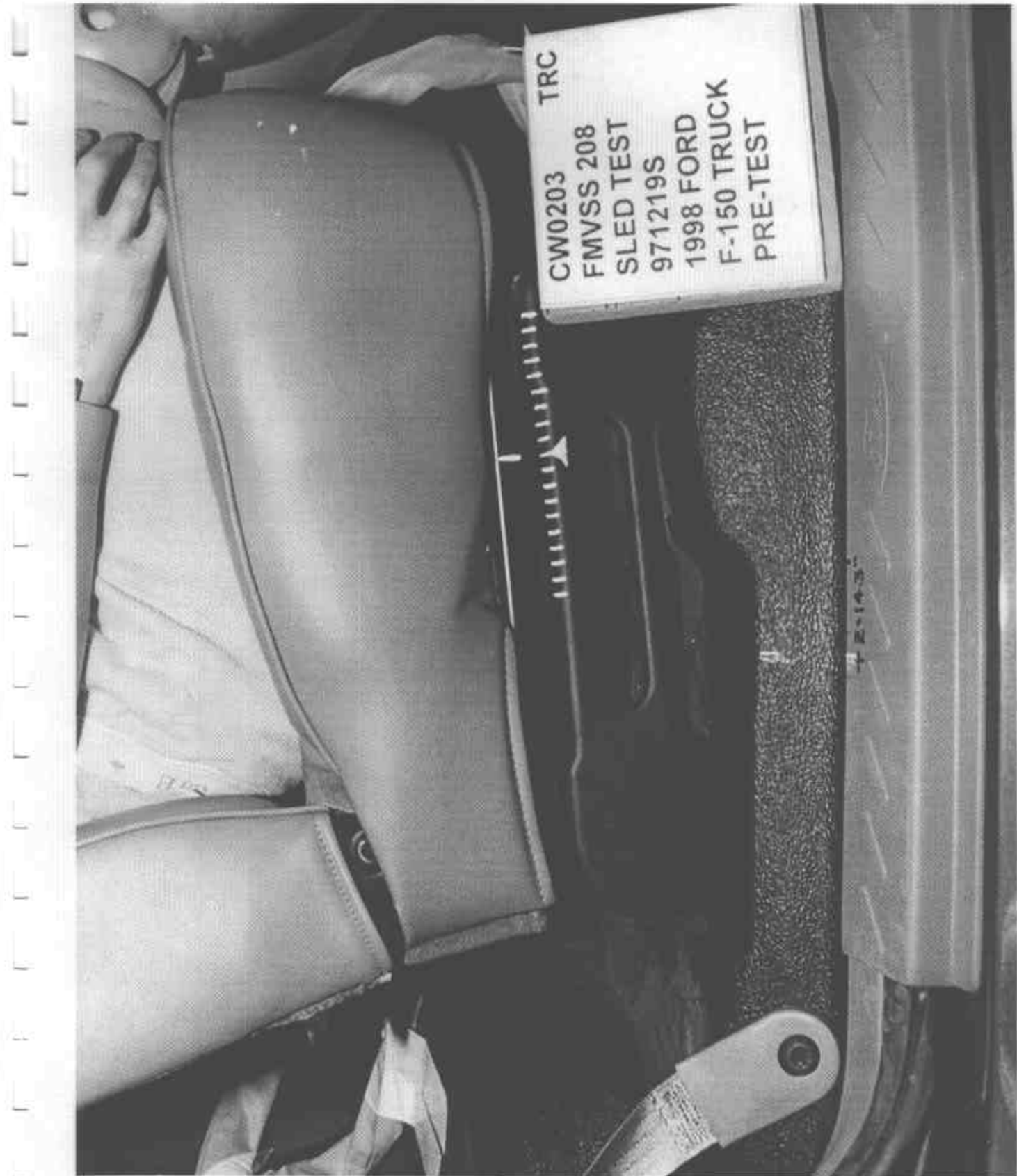

Figure A-22 Pre-Test Passenger Seat Track Position View



Figure A-23 Post-Test Passenger Seat Track Position View

A-24

971219

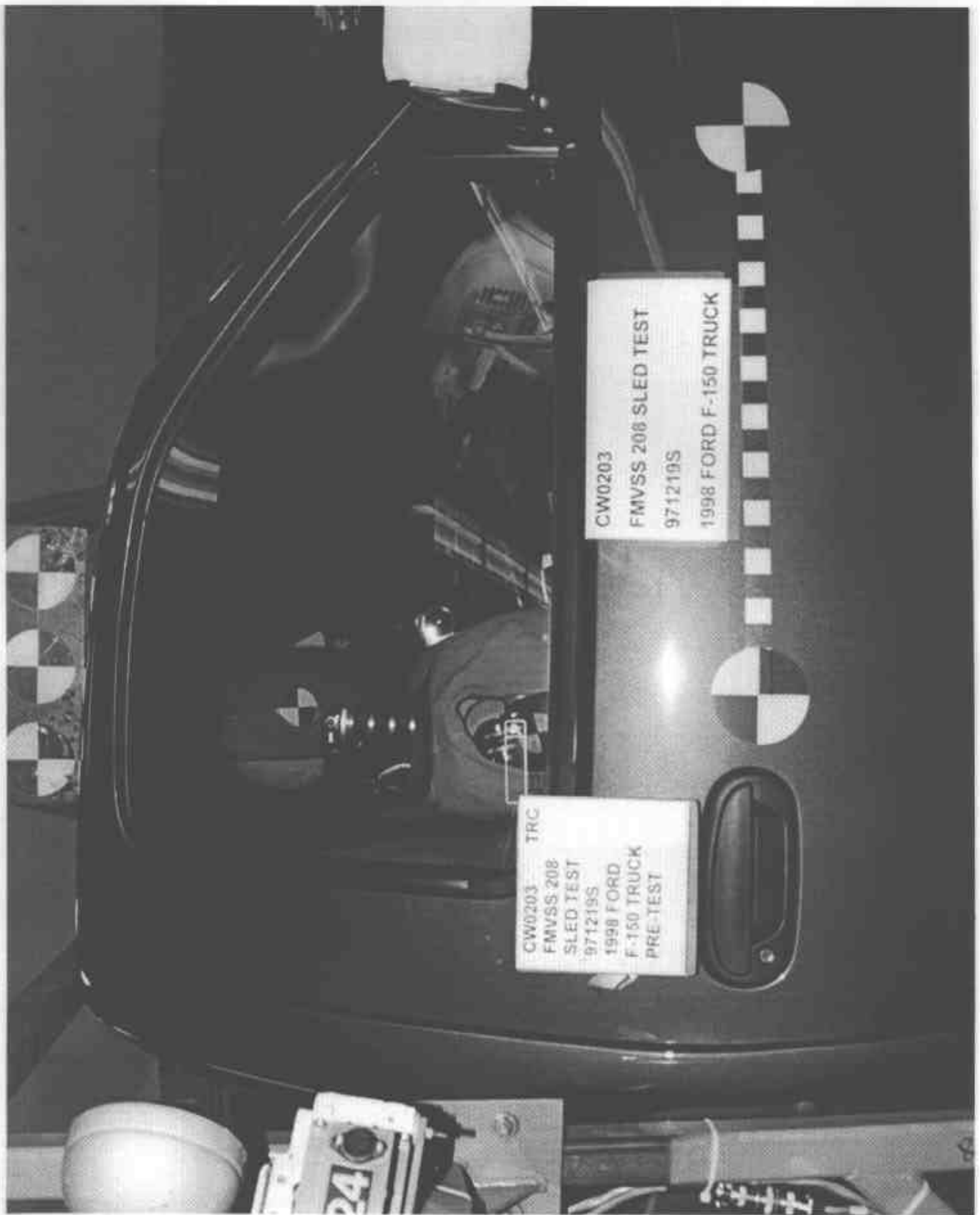

Figure A-24 Pre-Test Passenger Dummy Position View With Door Closed



Figure A-25 Post-Test Passenger Dummy Position View With Door Closed



Figure A-26 Pre-Test Passenger Glove Box View

A-27

971219



Figure A-27 Post-Test Passenger Knee Bolster - View 1
A-28

971219

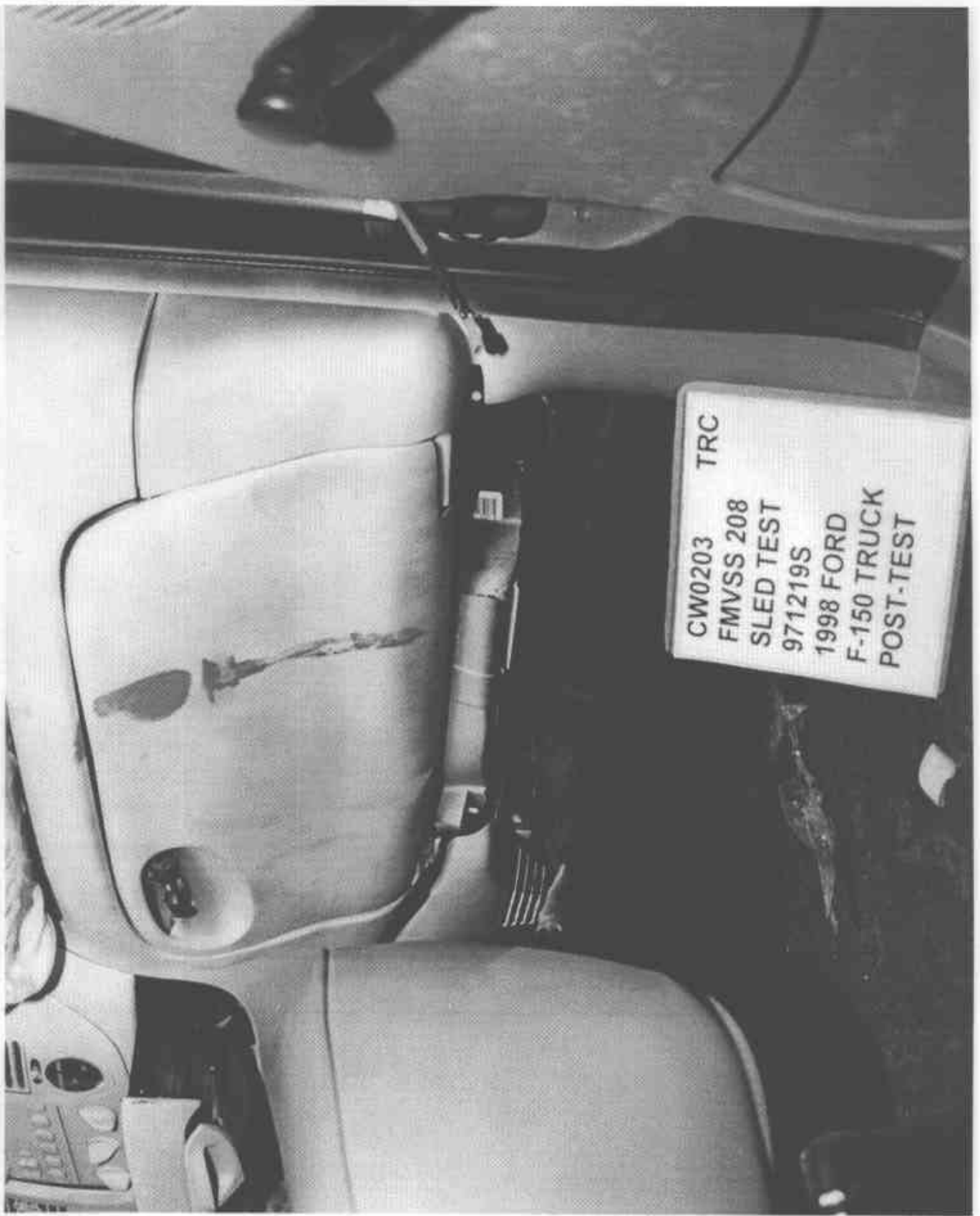

Figure A-28 Post-Test Passenger Knee Bolster - View 2

A-29

971219



Figure A-29 Pre-Test Passenger Dummy Position Front View



Figure A-30 Post-Test Passenger Dummy Position Front View

A-31

971219

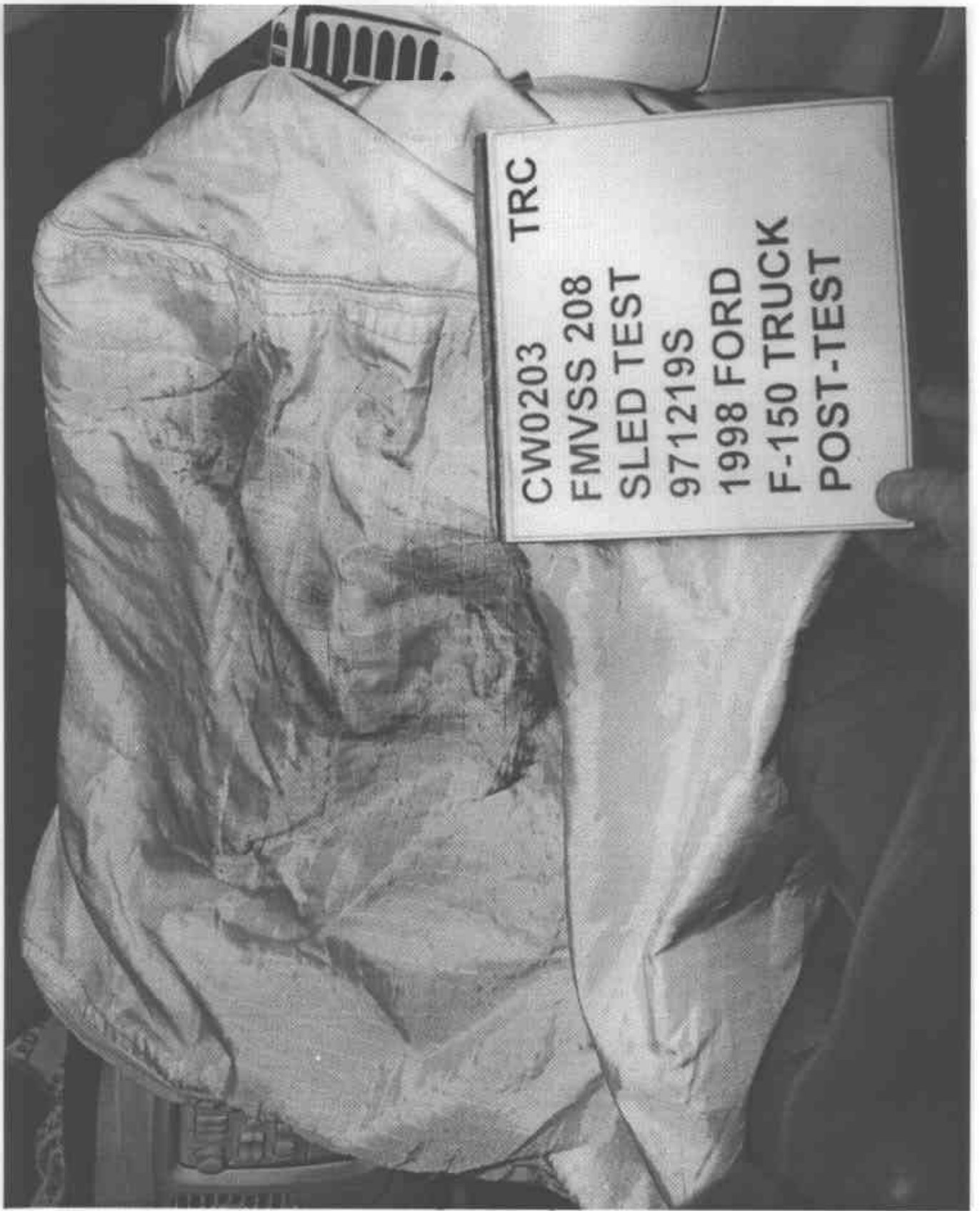

Figure A-31 Post-Test Passenger Airbag View

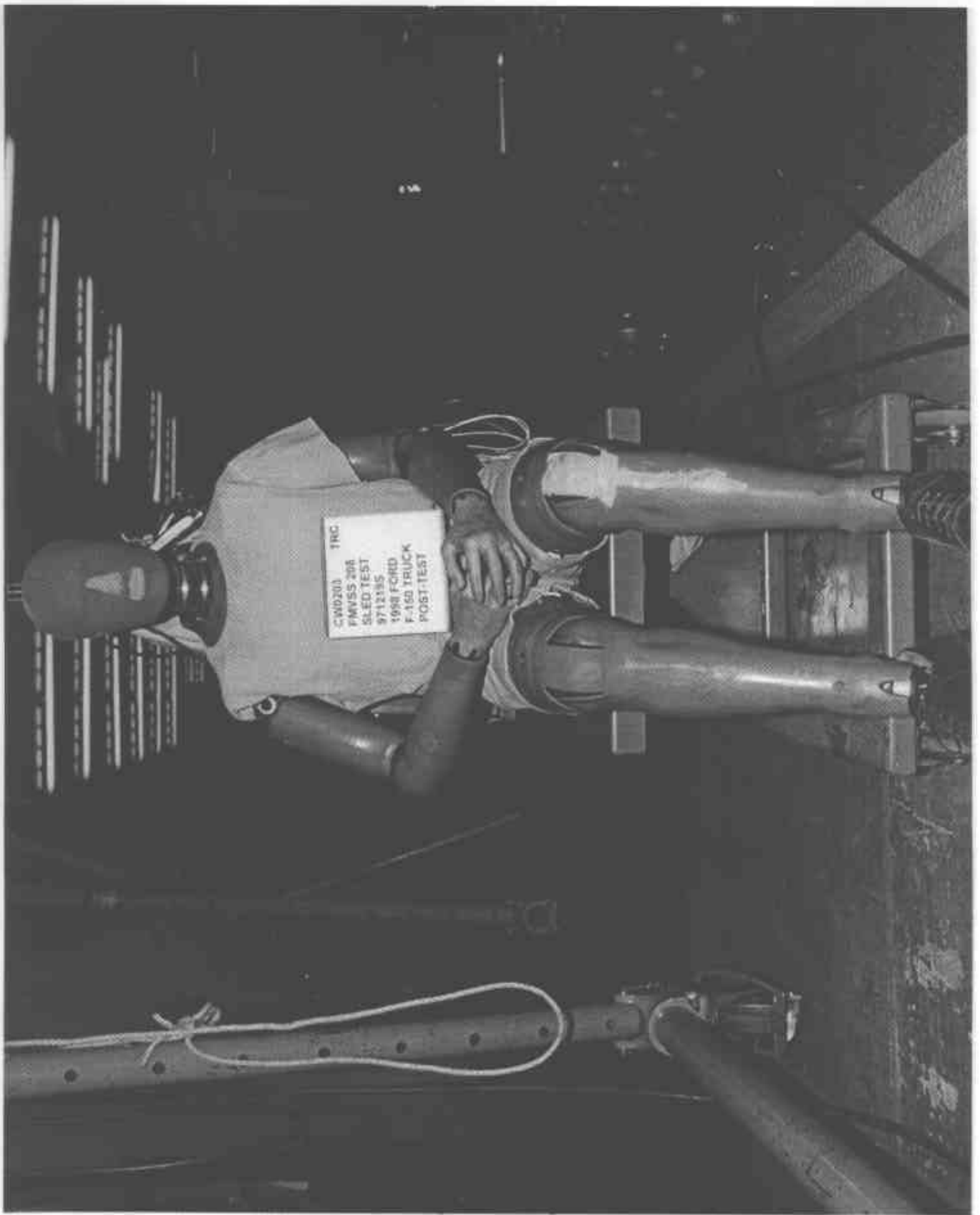

Figure A-32 Post-Test Passenger Dummy Overall View

A-33

971219

CW0203 TRC
FMVSS 208
SLED TEST
971219S
1998 FORD
F-150 TRUCK
PRE-TEST

Figure A-33 Pre-Test Steering Column Linkage In Engine Compartment View

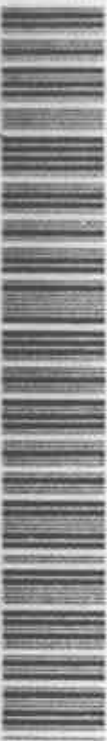

Figure A-34 Post-Test Steering Column Linkage In Engine Compartment View

MFD. BY FORD MOTOR CO. IN U.S.A.
 DATE: 11/97 GWR: 5550LB/ 2517KG
 FRONT GWR: 2800LB REAR GWR: 2900LB
 1270KG WITH 1315KG WITH
 P235/70R16SL TIRES P235/70R16SL TIRES
 16X7.0J RIMS 16X7.0J RIMS
 AT 221 kPa/ 32 PSI COLD AT 241 kPa/ 35 PSI COLD

THIS VEHICLE CONFORMS TO ALL APPLICABLE FEDERAL MOTOR
 VEHICLE SAFETY STANDARDS IN EFFECT ON THE DATE OF
 MANUFACTURE SHOWN ABOVE.

VIN: 1FTZF1727WNA77379 F0133
 TYPE: TRUCK T0946



EXT PNT: PS IRC: 47 | DSO:
 MB, IBRK | INT TR | TP/FC | R | AXLE | TR | SPR
 139 B A2 7 18 H MG
 UTC 97458-1528472-44

Figure A-35 Pre-Test Vehicle Certification Label View

Appendix B

Data Plots

CW0203 / 1998 FORD F-150 TRUCK
SLED ACCELERATION
FMVSS 208 SLED TEST

TRC INC. TEST NUMBER: 971219S

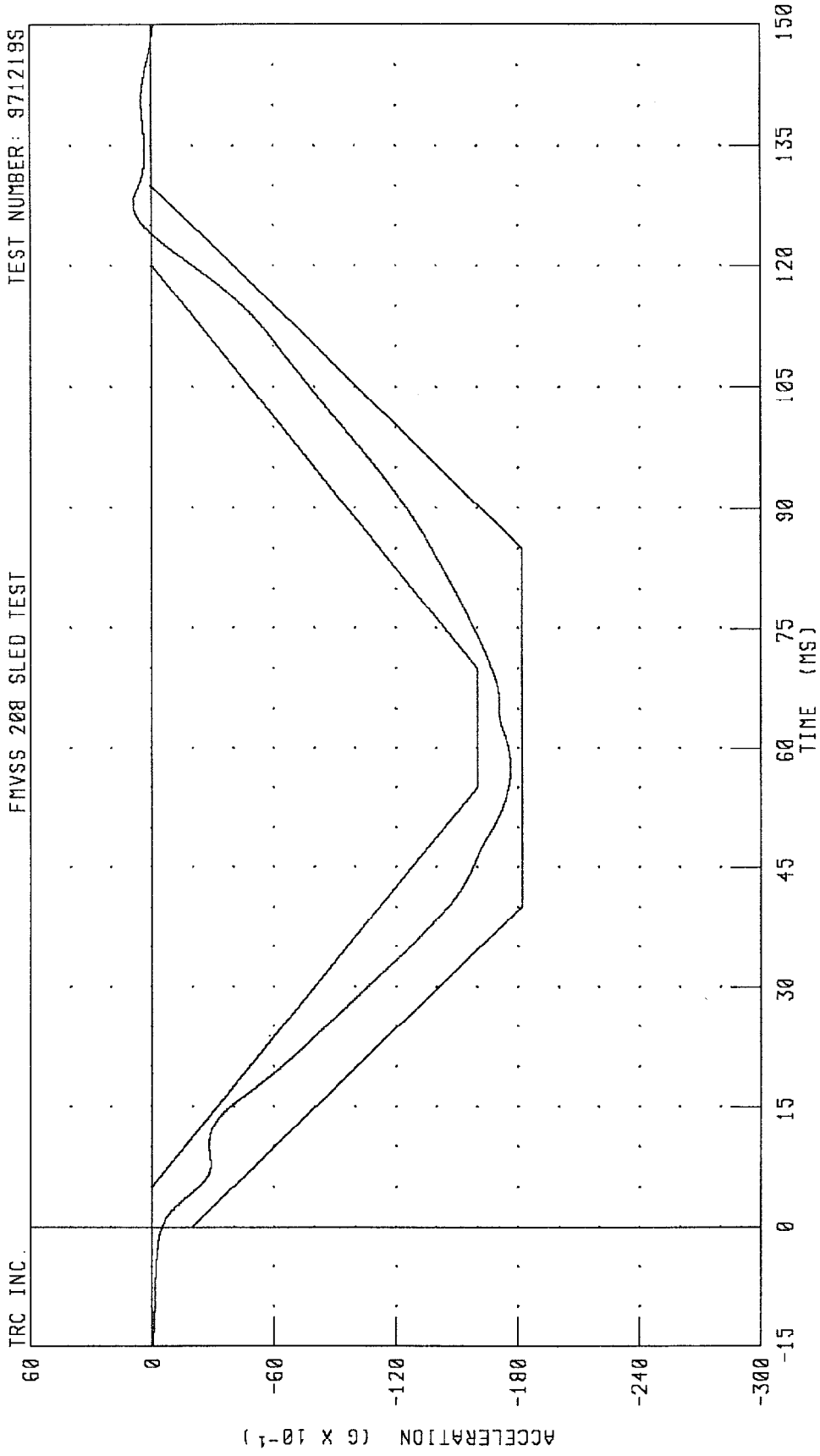

CHANNEL: SLDXG FILTER: CH. CLASS 60

PEAK DATA: 0.87 G @ 127.76 MS; -17.64 G @ 57.36 MS

CW0302 / 1998 FORD F-150 TRUCK
SLED ACCELERATION
FHYSS 208 SLED TEST

TEST NUMBER: 971219S

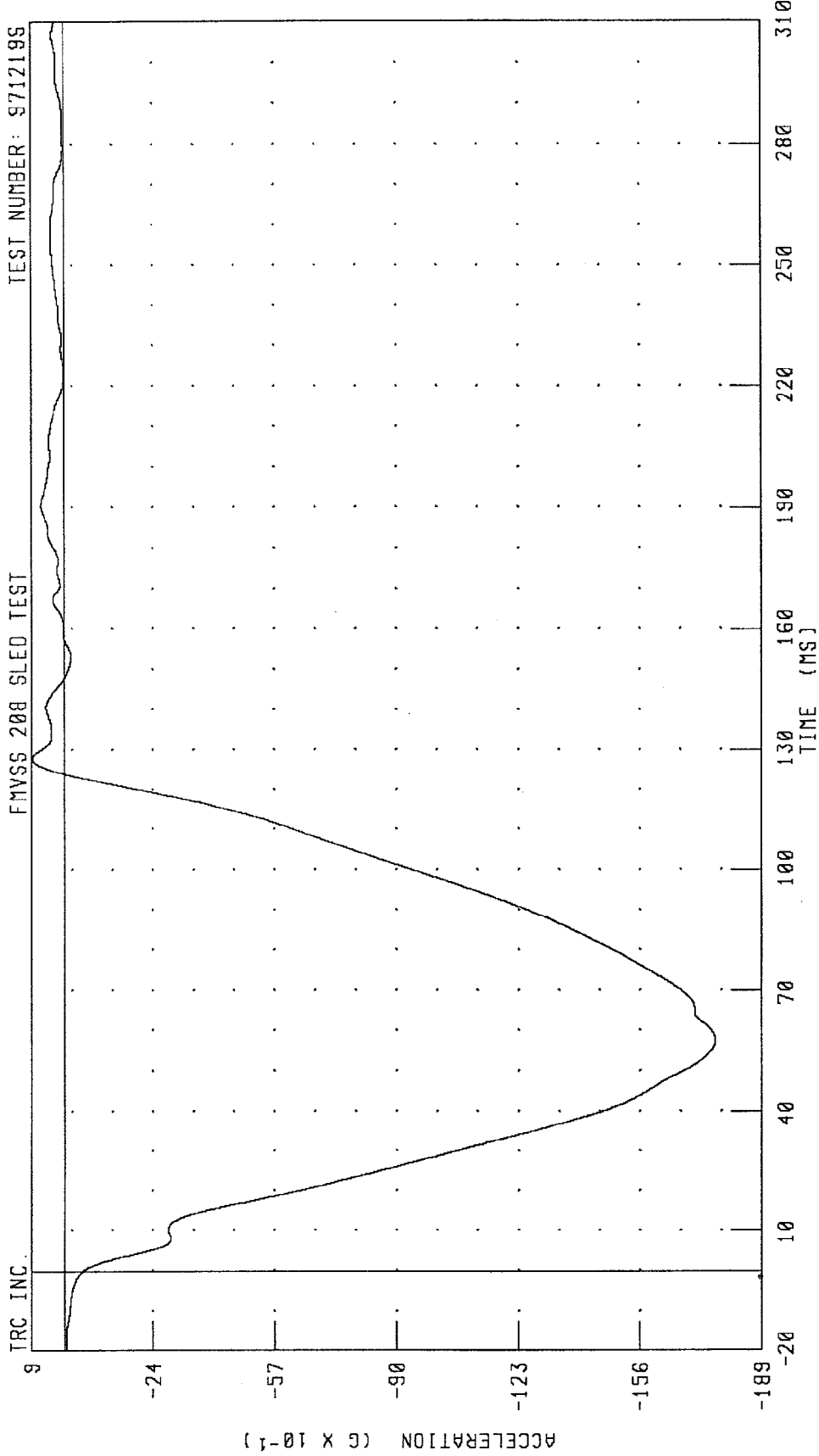

CHANNEL: SLDXG FILTER: CH. CLASS 60

PEAK DATA: 0.87 G @ 127.76 MS; -17.64 G @ 57.36 MS

CW0302 / 1998 FORD F-150 TRUCK
SLED ACCELERATION REDUNDANT
FMVSS 208 SLED TEST

TRC INC. TEST NUMBER: 971219S

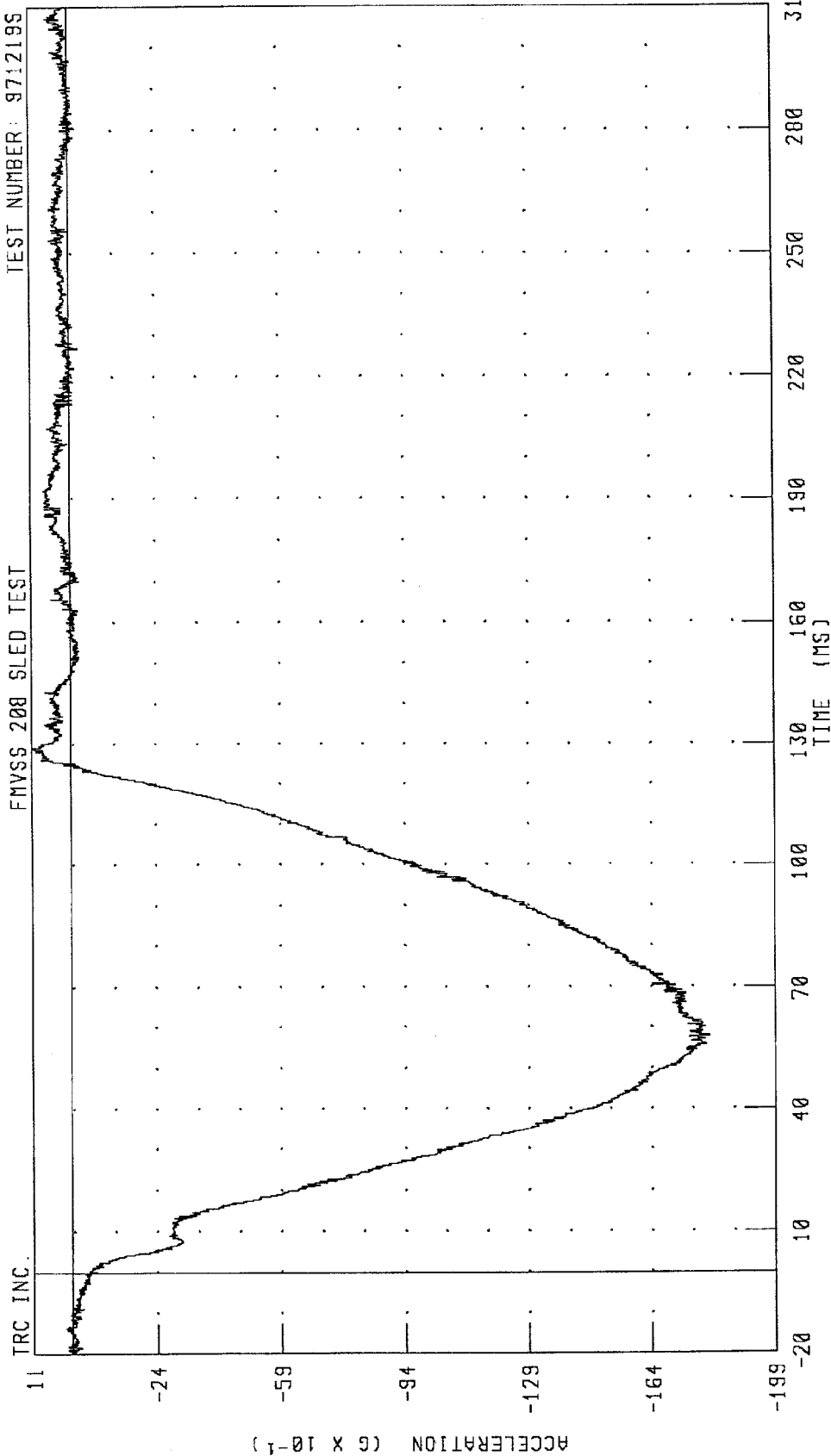

CHANNEL: SLDXGA FILTER: CH. CLASS 1000
PEAK DATA: 1.08 G @ 129.04 MS; -18.04 G @ 57.92 MS

CW0302 / 1988 FORD F-150 TRUCK
MEASURED VELOCITY TRAP
FMVSS 208 SLED TEST

TEST NUMBER: 971219S

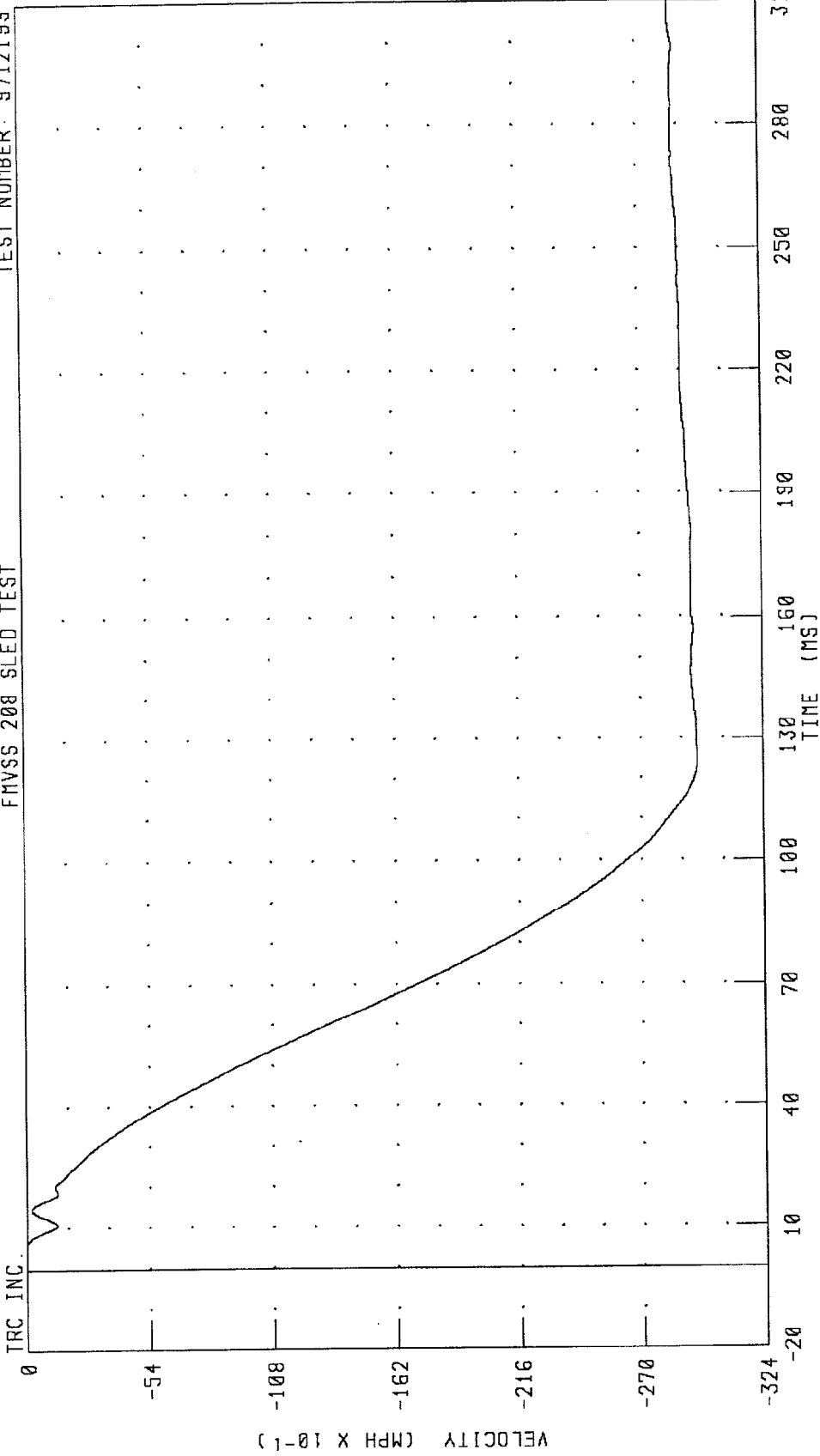

CHANNEL: SLDXV FILTER: CH. CLASS 60

PEAK DATA: 0.03 MPH @ 4.88 MS; -29.51 MPH @ 124.56 MS

CW0302 / 1998 FORD F-150 TRUCK
SLED VELOCITY (INTEGRATED)
FMVSS 208 SLED TEST

TRC INC TEST NUMBER: 971219S

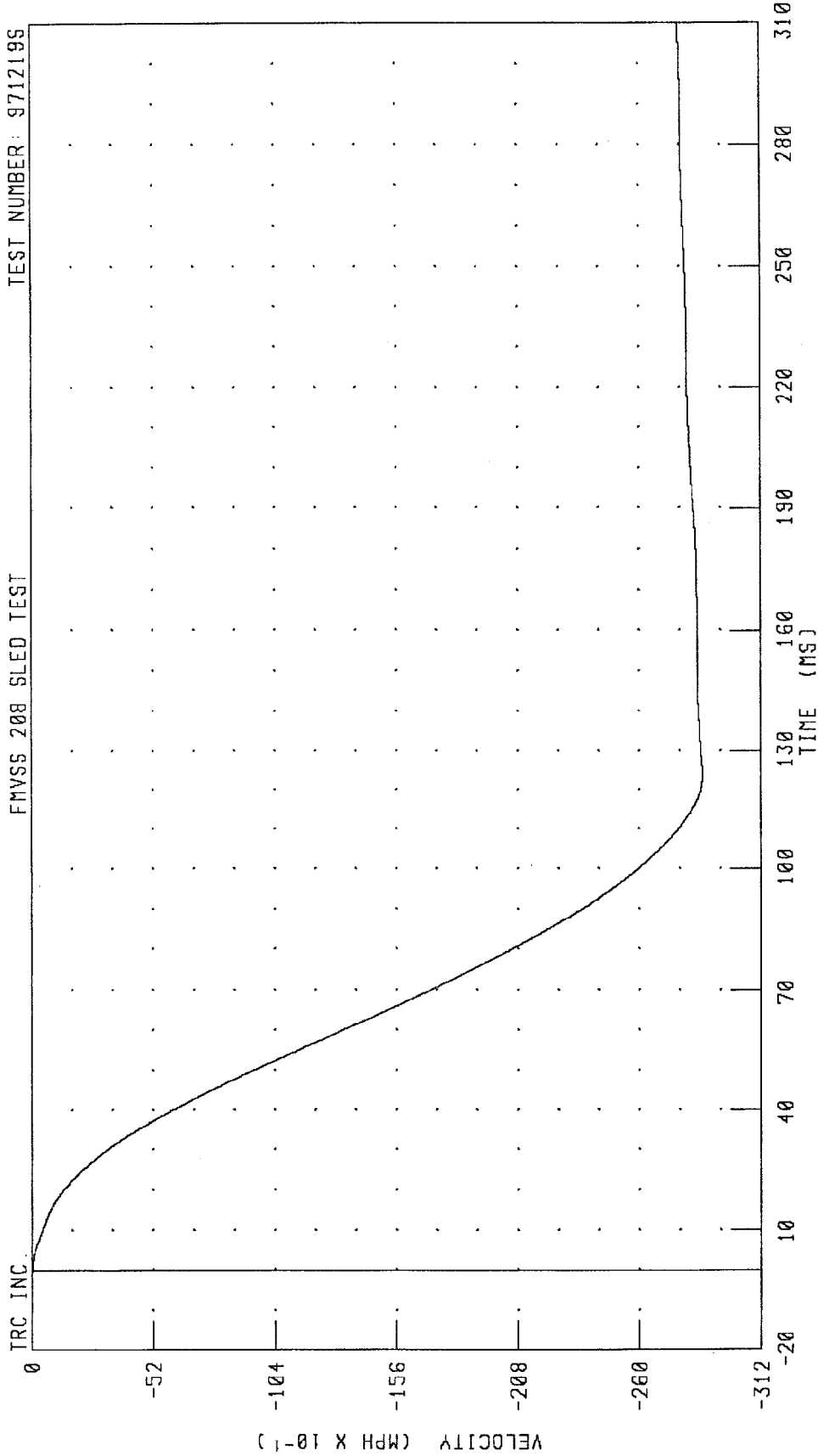

CHANNEL: SLDXVI FILTER: CH. CLASS 180

CW0302 / 1998 FORD F-150 TRUCK
AIRBAC EVENT
FMVSS 208 SLED TEST

TEST NUMBER: 971219S

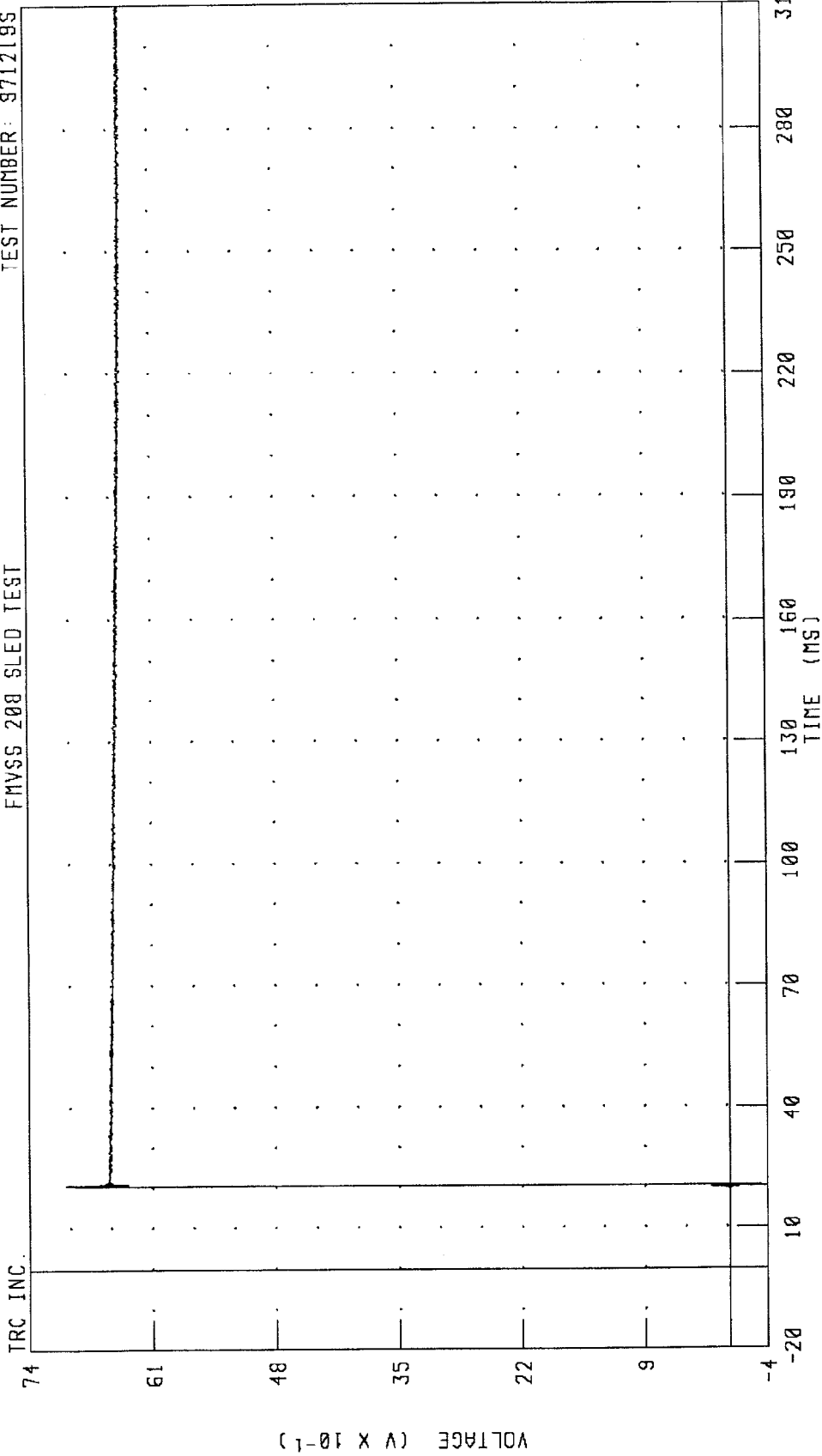

CHANNEL: ABEVT FILTER: CH. CLASS 1000

PEAK DATA: 7.01 V @ 20.64 MS; -0.45 V @ 20.24 MS

CW0302 / 1998 FORD F-150 TRUCK
REAR AXLE X-AXIS ACCELERATION
FMVSS 208 SLED TEST

TEST NUMBER: 971219S

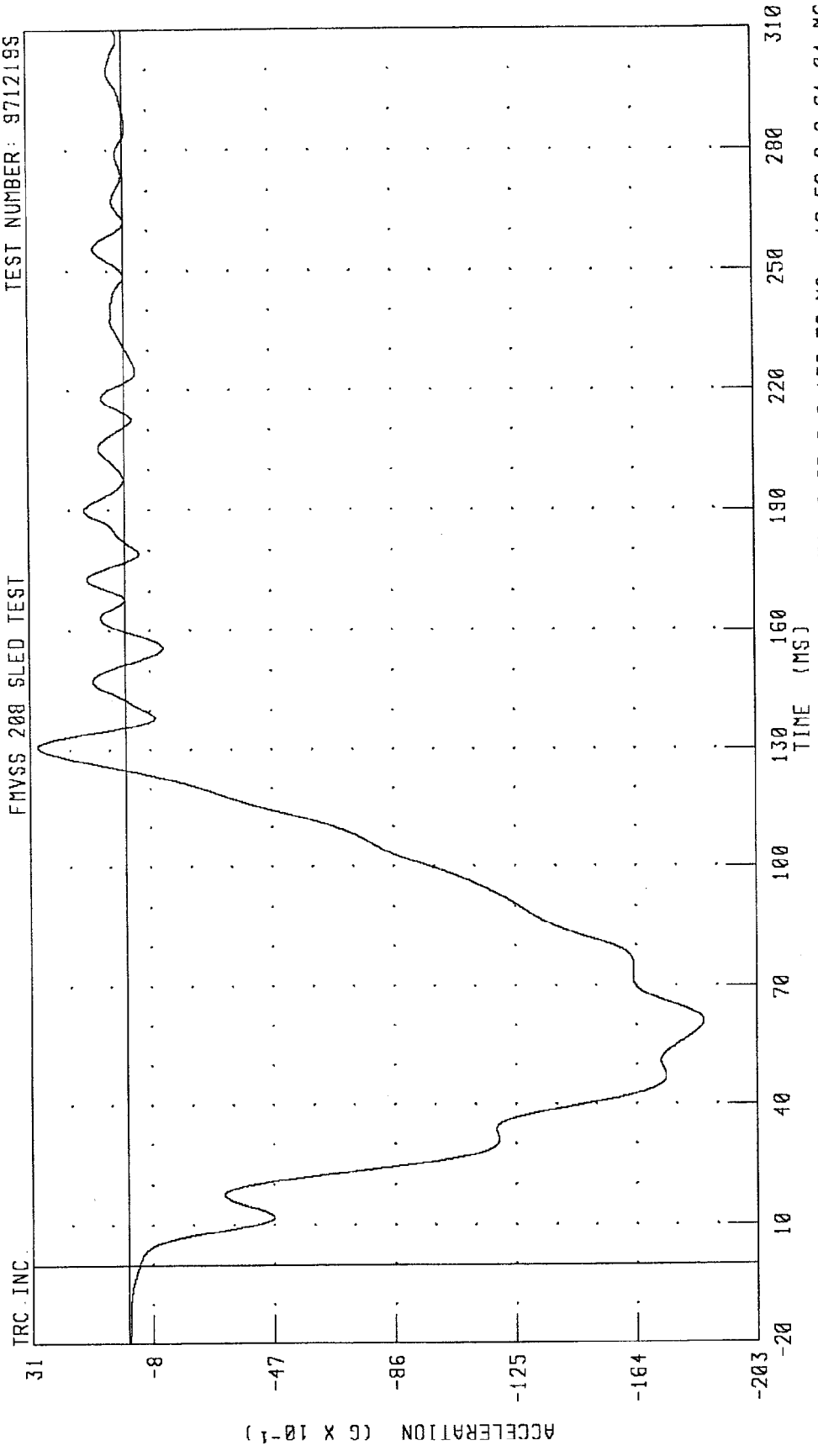

CHANNEL: RAXG FILTER: CH. CLASS 60 PEAK DATA: 2.83 G @ 130.72 MS; -18.58 G @ 61.04 MS

CW0302 / 1998 FORD F-150 TRUCK
LEFT BODY X-AXIS ACCELERATION
FNYS 208 SLED TEST

TEST NUMBER: 971219S

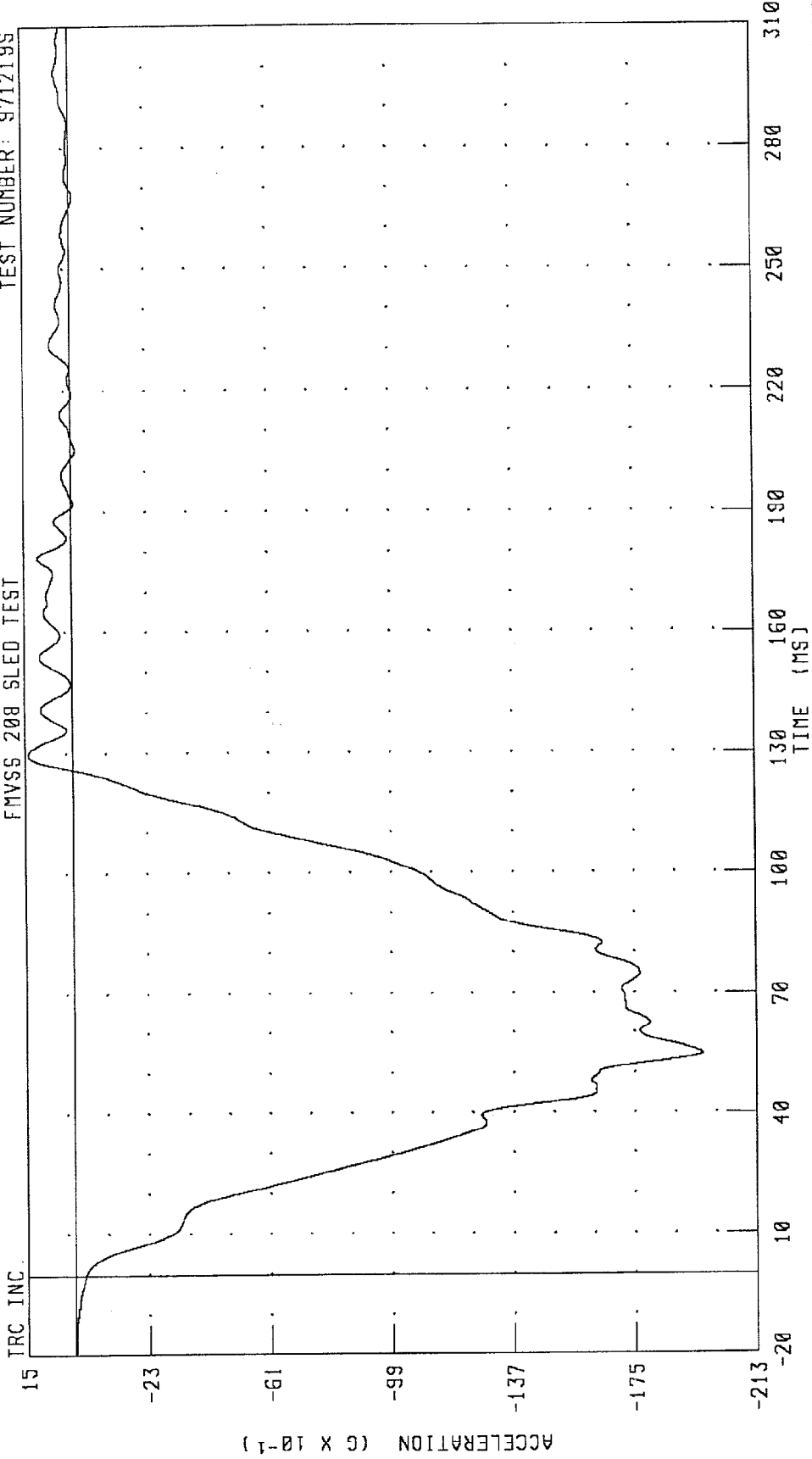

CHANNEL: LBXG FILTER: CH. CLASS 60

PEAK DATA: 1.40 G @ 129.76 MS; -19.60 G @ 54.72 MS

CW0302 / 1998 FORD F-150 TRUCK
RIGHT BODY X-AXIS ACCELERATION
FMVSS 208 SLED TEST

TRC INC. TEST NUMBER: 971219S

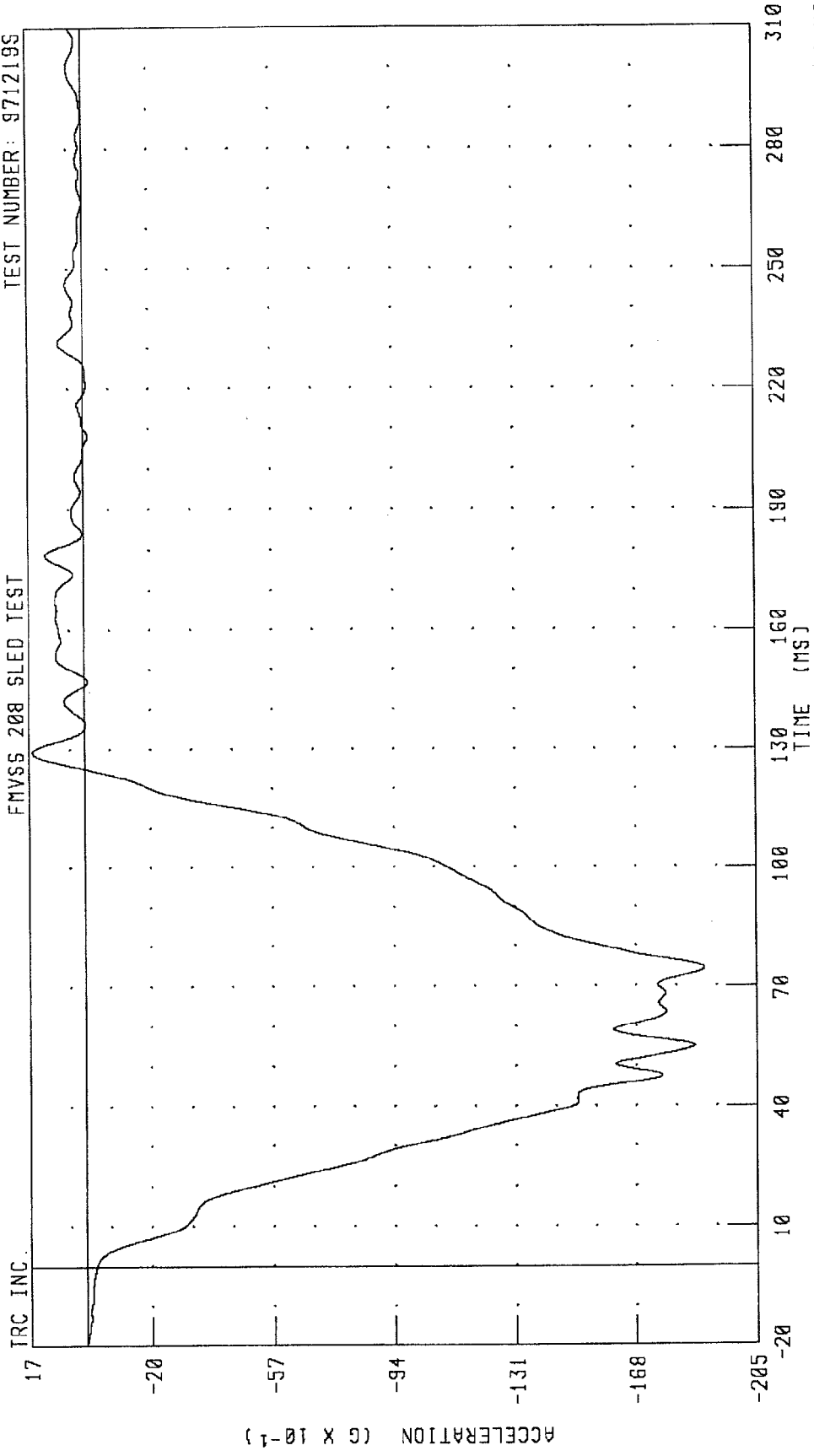

CHANNEL: RBXG FILTER: CH. CLASS 60 PEAK DATA: 1.59 G @ 129.28 MS; -18.90 G @ 74.48 MS

CW0302 / 1998 FORD F-150 TRUCK
LEFT FRAME X-AXIS ACCELERATION
FMVSS 208 SLED TEST

TRC INC. TEST NUMBER: 971219S

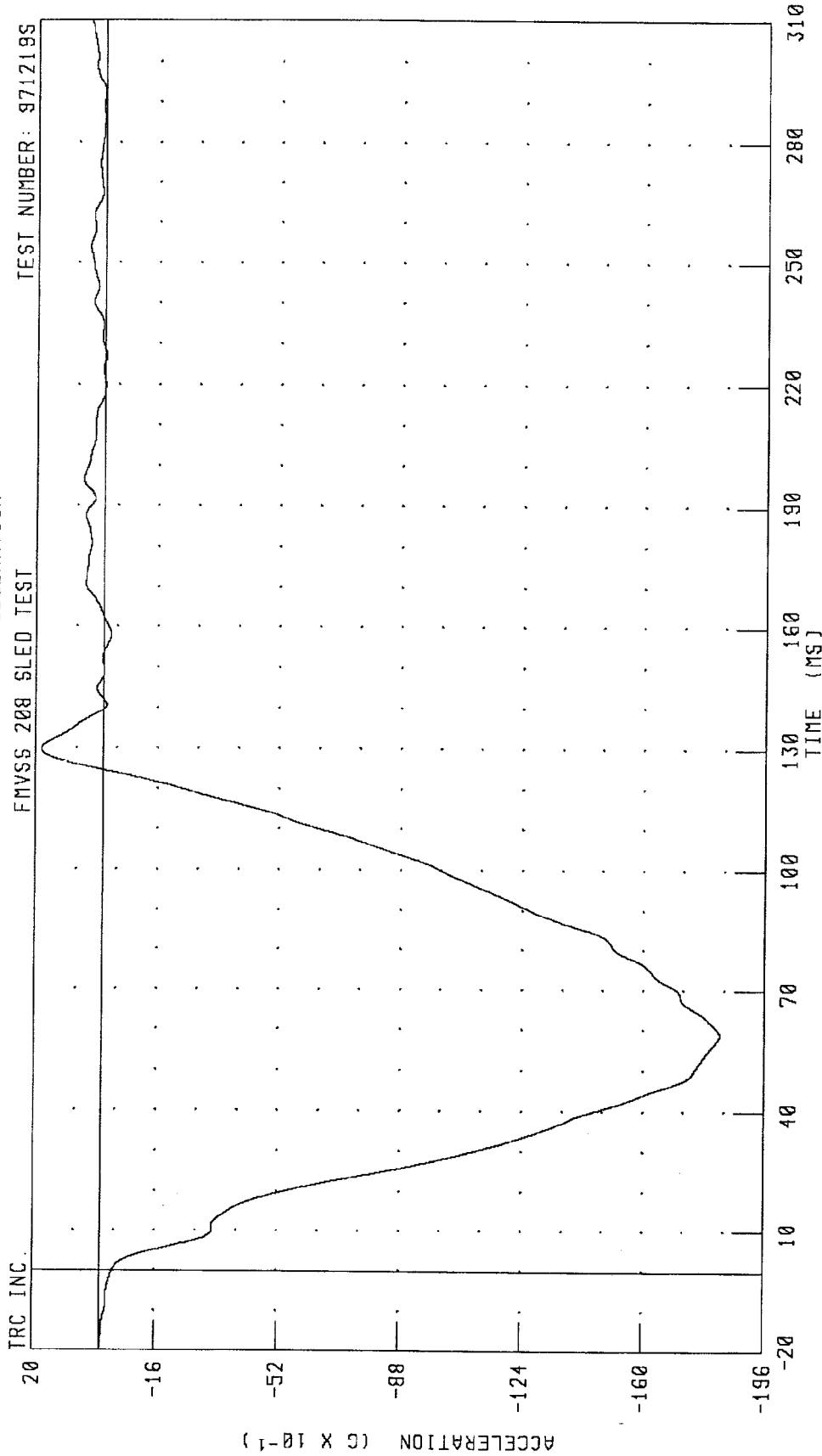

CHANNEL: LFXG FILTER: CH. CLASS 60 PEAK DATA: 1.82 G @ 129.68 MS, -18.28 G @ 58.80 MS

CW0302 / 1998 FORD F-150 TRUCK
RIGHT FRAME X-AXIS ACCELERATION
FMVSS 208 SLED TEST

TRC, INC.
TEST NUMBER: 971219S

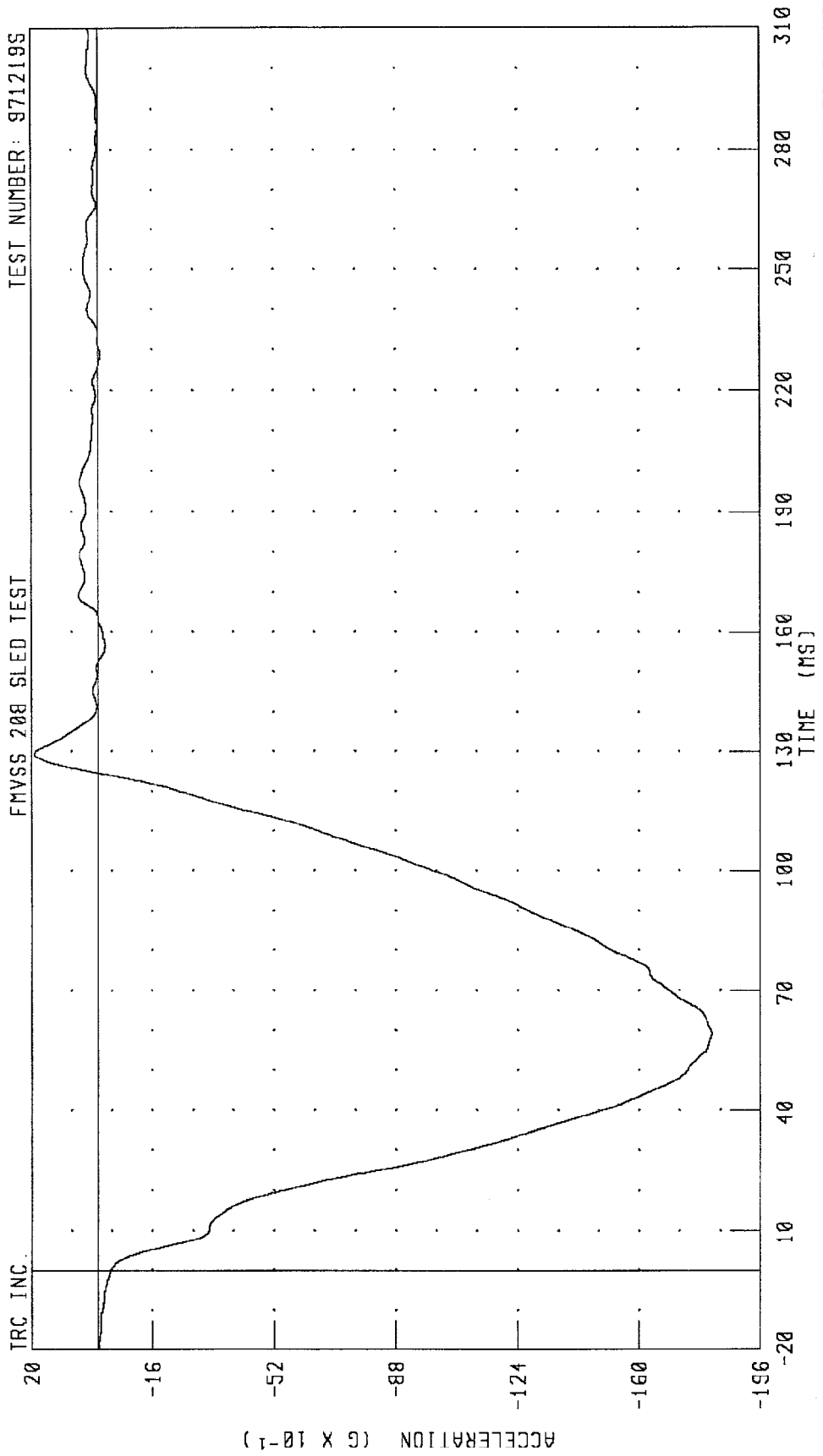

CHANNEL: RFXG FILTER: CH. CLASS 60 PEAK DATA: 1.90 G @ 129.36 MS; -18.15 G @ 59.04 MS

CW0302 / 1998 FORD F-150 TRUCK
BOTTOM ENGINE X-AXIS ACCELERATION
FMVSS 208 SLED TEST

TEST NUMBER: 971219S

TRC INC.

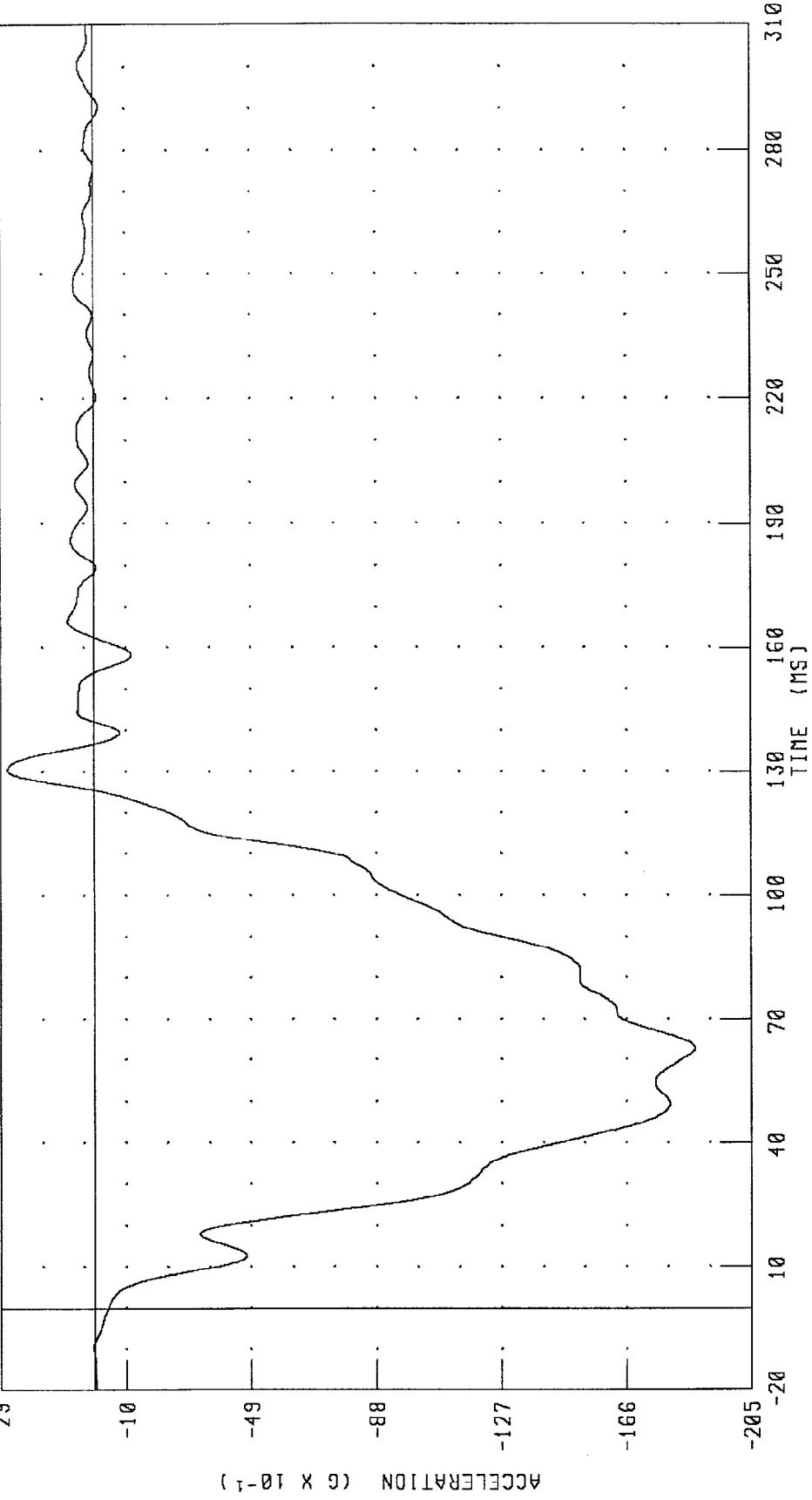

CHANNEL: BEXG FILTER: CH. CLASS 60

PEAK DATA: 2.68 G @ 130.48 MS; -18.74 G @ 62.88 MS

CW0302 / 1998 FORD F-150 TRUCK
DRIVER HEAD X-AXIS ACCELERATION
FMVSS 208 SLED TEST

TEST NUMBER: 971219S

TRC INC.

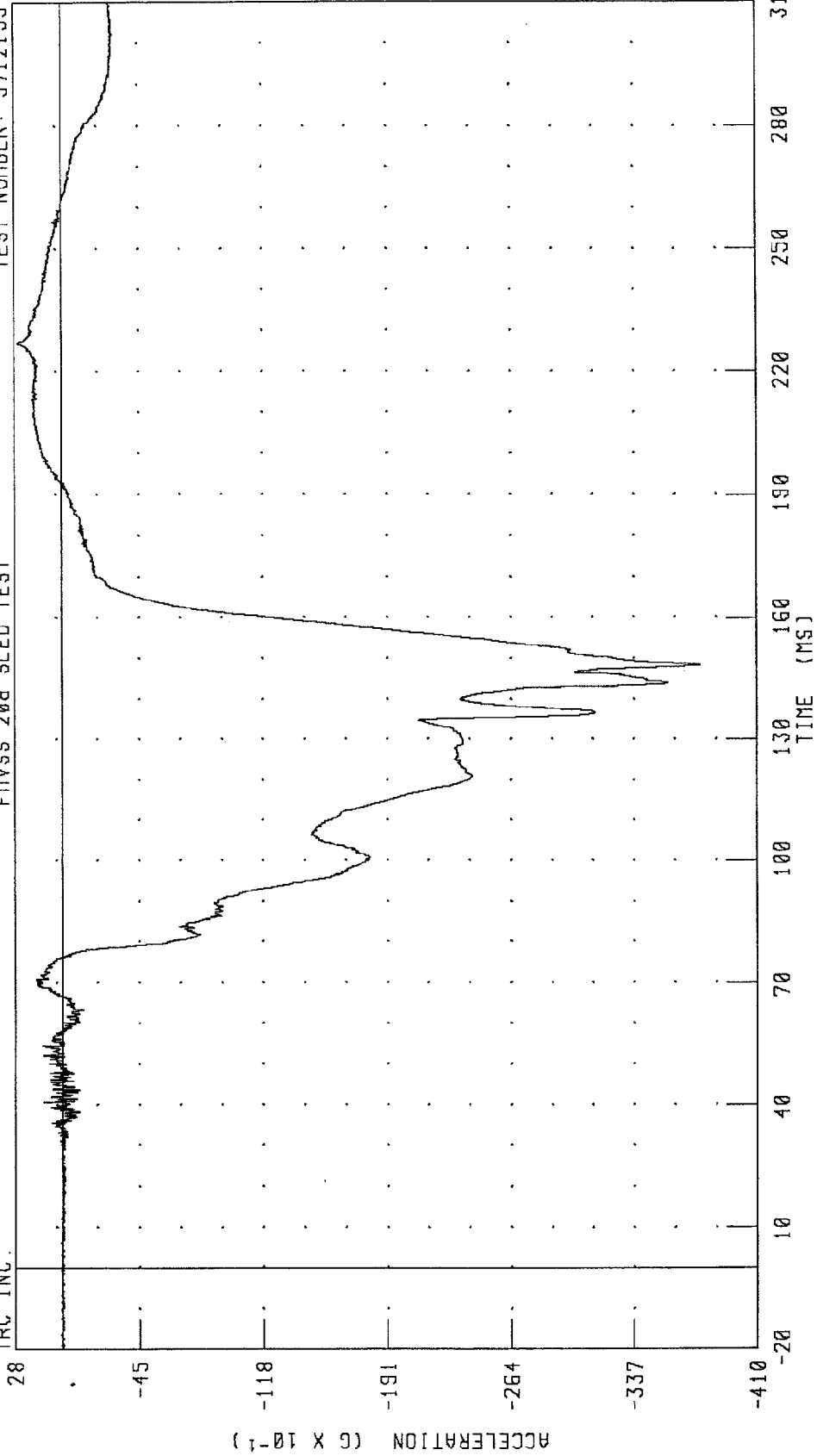

PEAK DATA: 2.59 G @ 226.96 MS; -37.64 G @ 148.32 MS

CHANNEL: HEDXG1 FILTER: CH. CLASS 1000

CW0302 / 1998 FORD F-150 TRUCK
DRIVER HEAD Y-AXIS ACCELERATION
FMVSS 208 SLED TEST

TEST NUMBER: 971219S

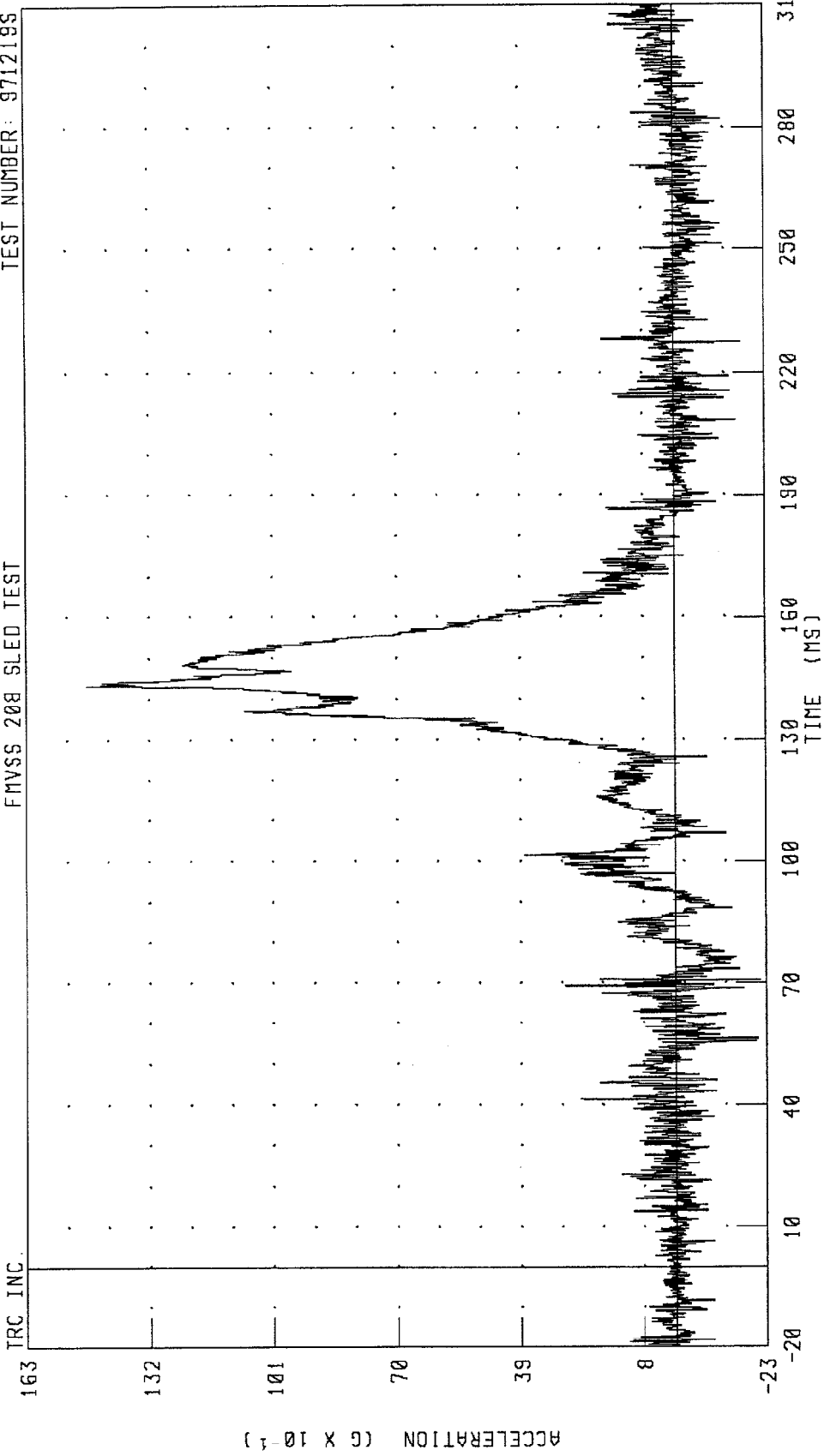

CHANNEL: HEDYG1 FILTER: CH. CLASS 1000 PEAK DATA: 14.78 G @ 143.44 MS; -2.13 G @ 70.72 MS

CW0302 / 1988 FORD F-150 TRUCK
DRIVER HEAD Z-AXIS ACCELERATION
FMVSS 208 SLED TEST

TEST NUMBER: 9712195

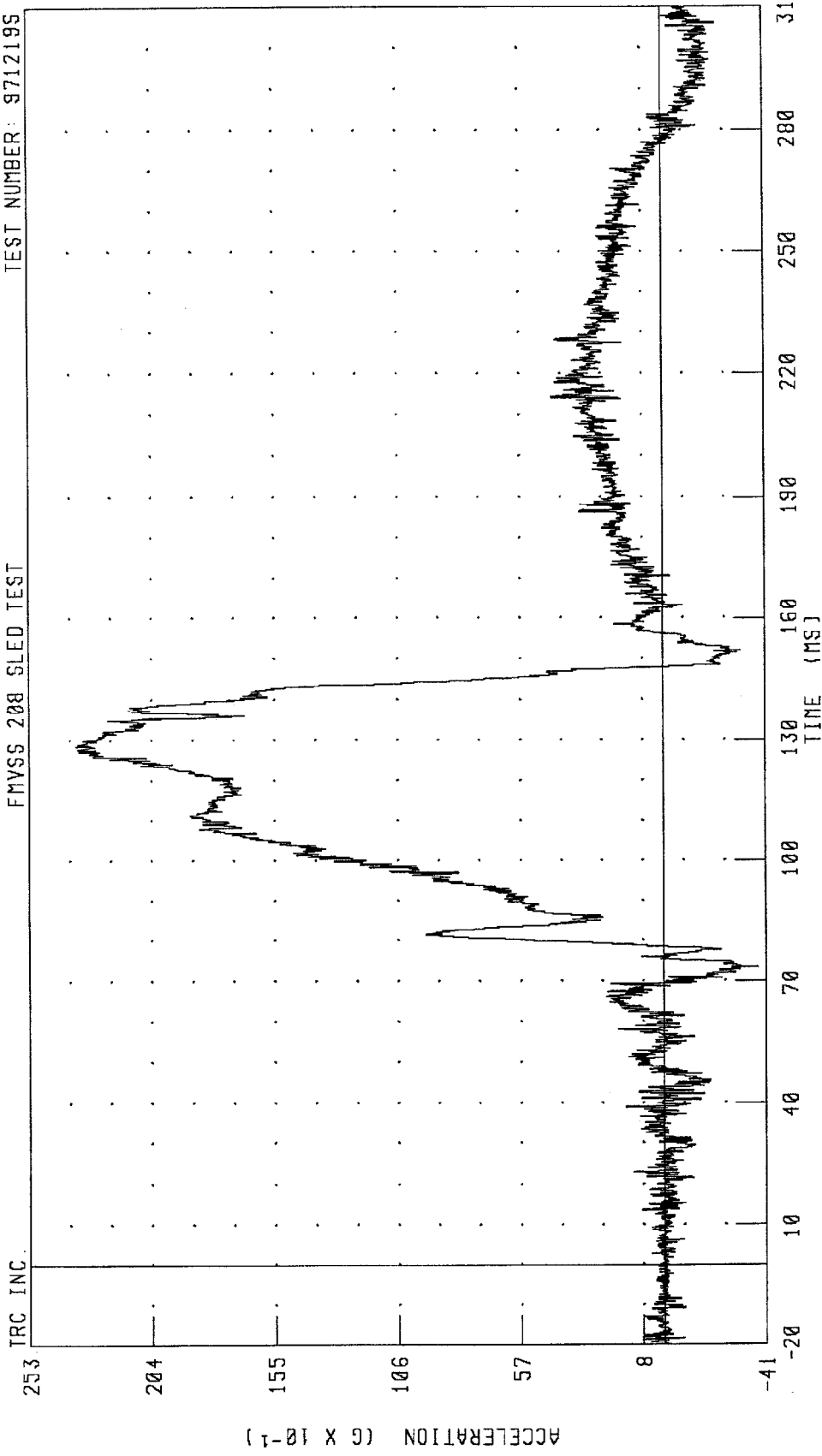

TRC INC.

PEAK DATA: 23.42 G @ 128.64 MS; -3.79 G @ 73.28 MS

CHANNEL: HEDZG1 FILTER: CH. CLASS 1000

CW0302 / 1998 FORD F-150 TRUCK
DRIVER HEAD RESULTANT ACCELERATION
FMVSS 208 SLED TEST

TEST NUMBER: 971219S

TRC INC.

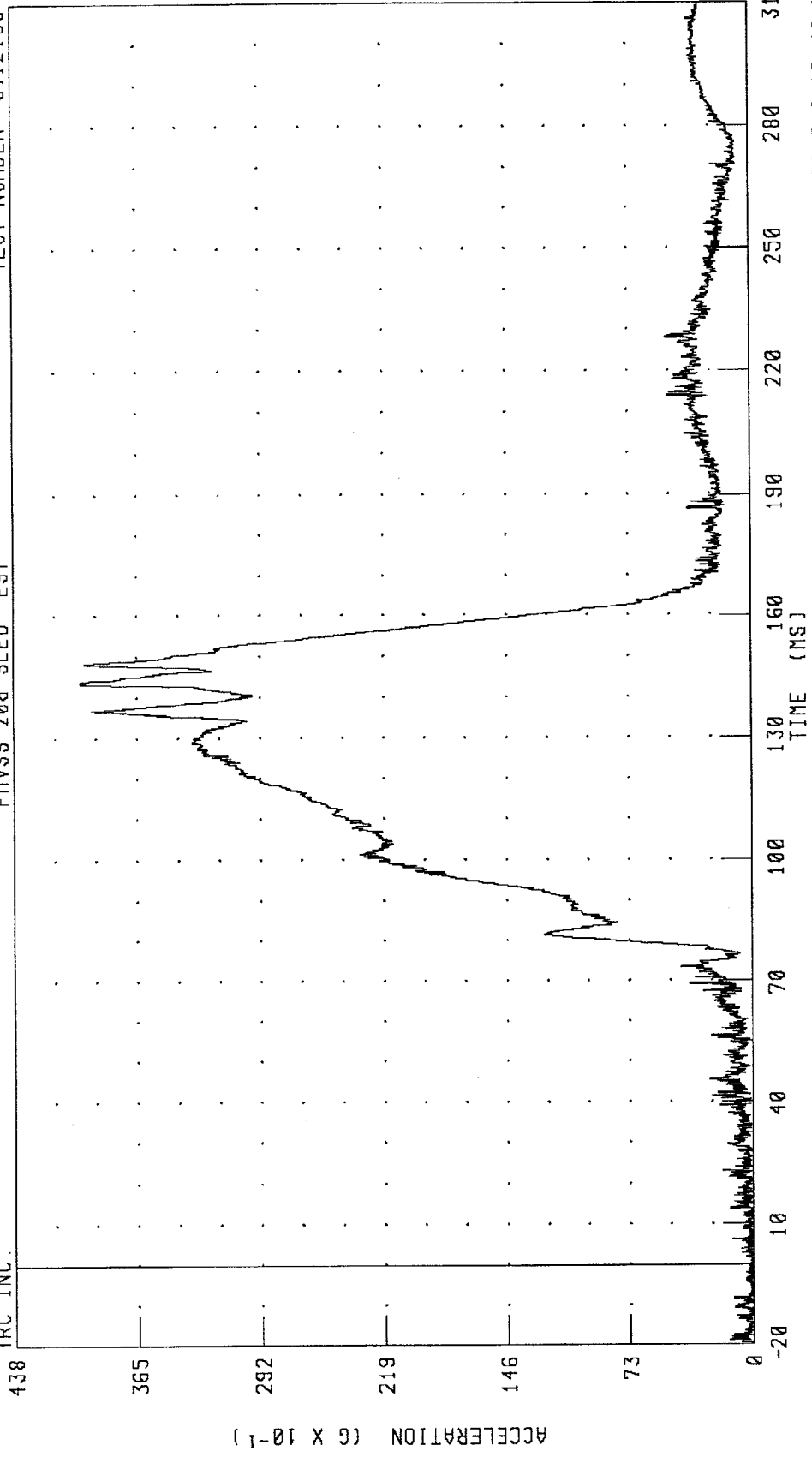

PEAK DATA: 39.91 G @ 143.84 MS; 0.02 G @ 12.40 MS

CHANNEL: HEDRG1 FILTER: CH. CLASS 1000

CW0302 / 1998 FORD F-150 TRUCK
DRIVER NECK X-AXIS SHEAR FORCE
FMVSS 208 SLED TEST

TEST NUMBER: 971219S

TRC, INC.

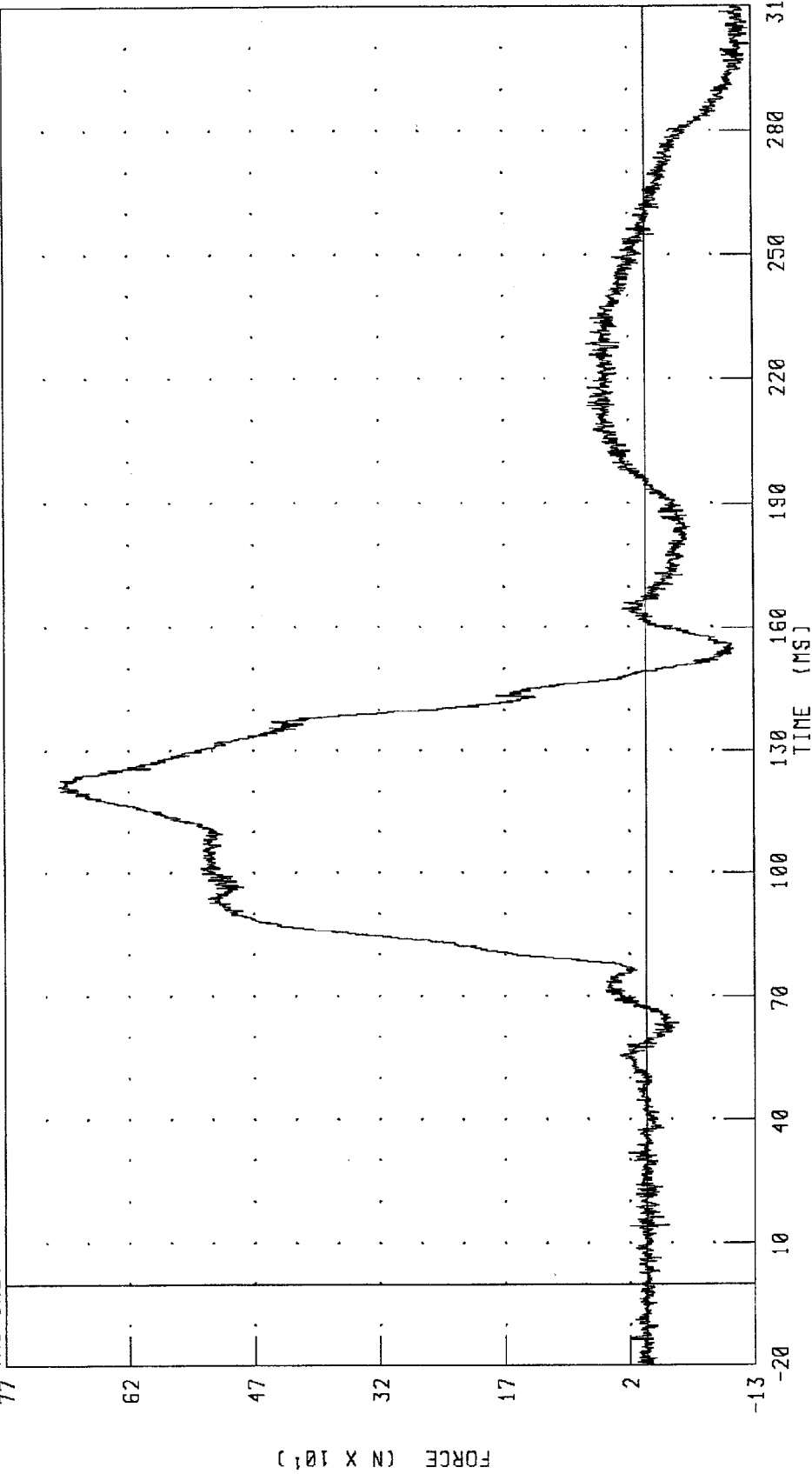

PEAK DATA: 703.07 N @ 121.20 MS; -126.32 N @ 300.96 MS

CHANNEL: NEKXF1 FILTER: CH. CLASS 1000

CW0302 / 1998 FORD F-150 TRUCK
DRIVER NECK Y-AXIS SHEAR FORCE
FMVSS 208 SLED TEST

TRC INC. TEST NUMBER: 971219S

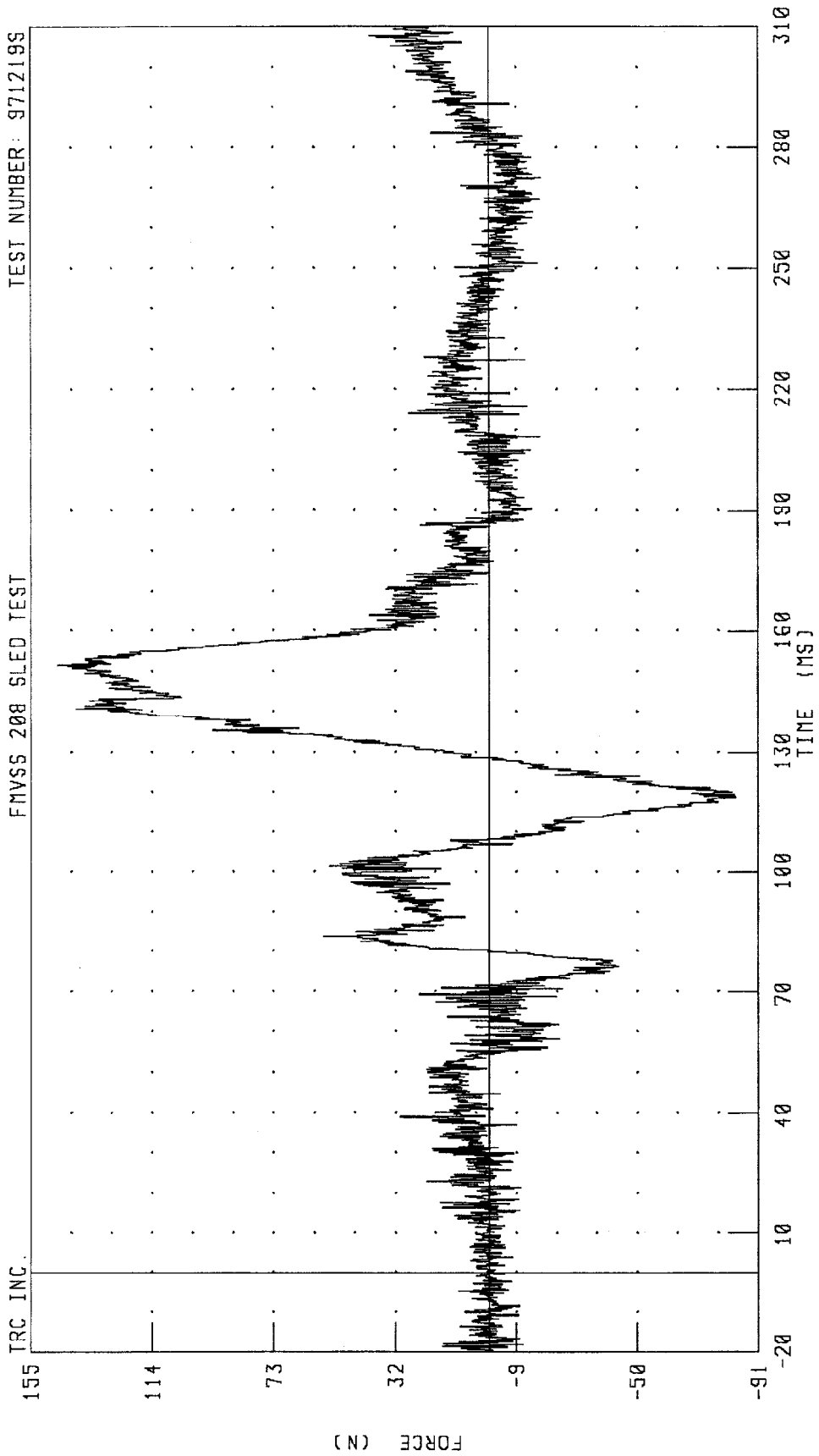

CHANNEL: NEKYF1 FILTER: CH. CLASS 1000

PEAK DATA: 145.85 N @ 151.60 MS; -83.10 N @ 118.88 MS

CW0302 / 1998 FORD F-150 TRUCK
DRIVER NECK Z-AXIS AXIAL FORCE
FMVSS 208 SLED TEST

TEST NUMBER: 971219S

TRC INC.

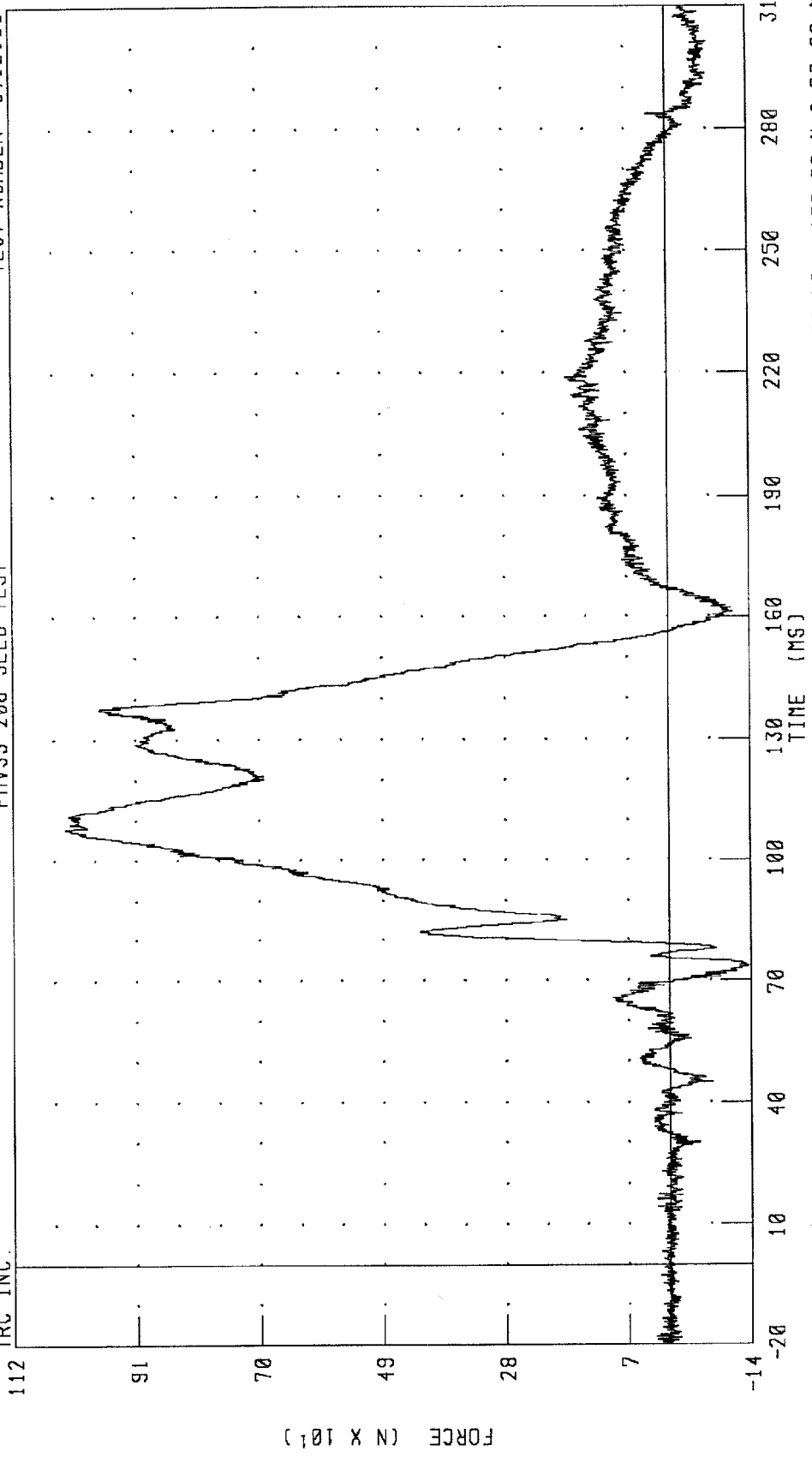

PEAK DATA: 1029.88 N @ 107.92 MS; -136.02 N @ 73.60 MS

CHANNEL: NEKZF1 FILTER: CH. CLASS 1000

CW0302 / 1998 FORD F-150 TRUCK
DRIVER NECK MOMENT ABOUT X AXIS

FMVSS_208_SLED_TEST TEST NUMBER: 971219S

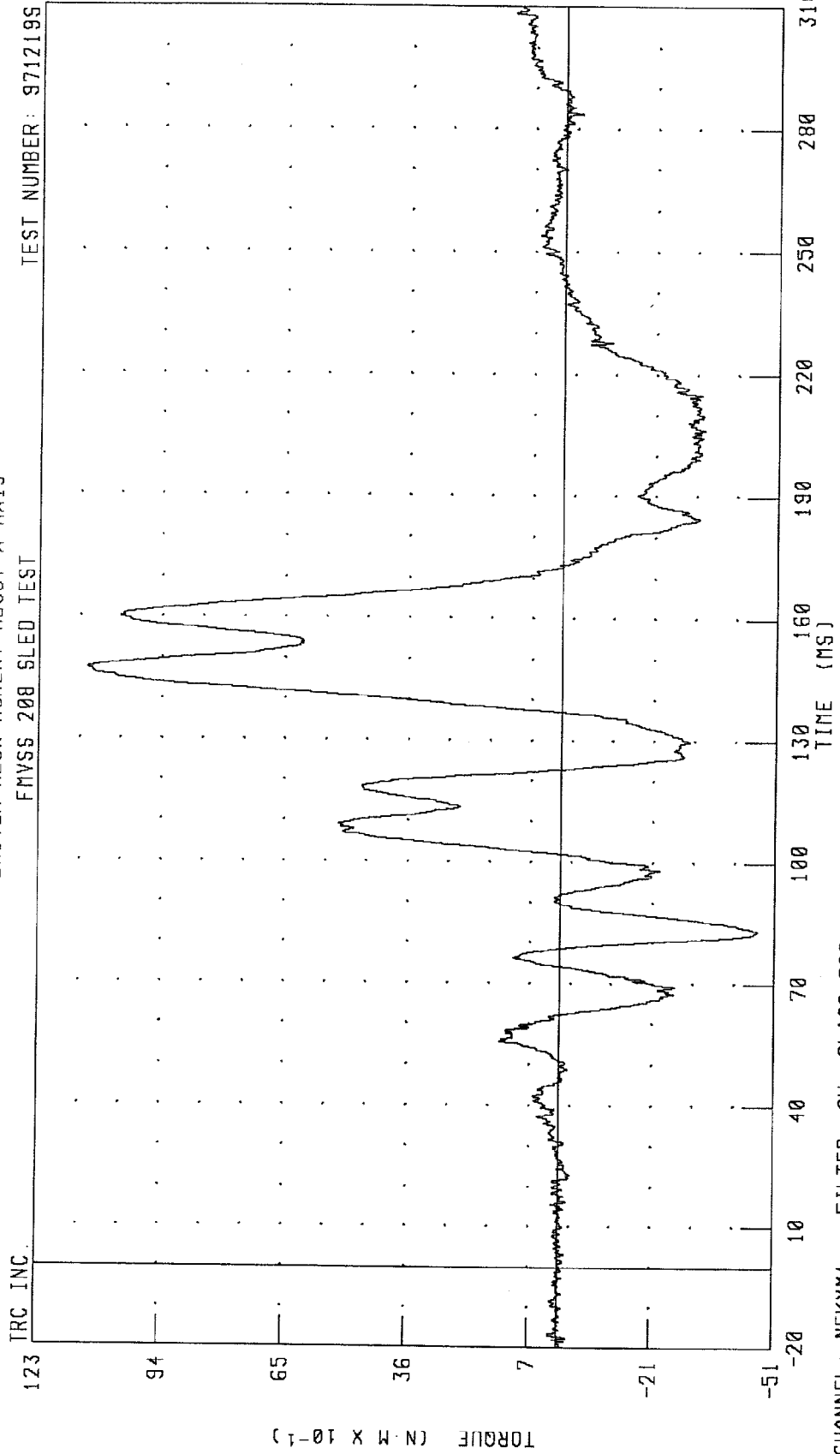

CHANNEL: NEXXM1 FILTER: CH. CLASS 600

PEAK DATA: 11.17 N·M @ 147.76 MS; -4.69 N·M @ 82.96 MS

CW0302 / 1998 FORD F-150 TRUCK
DRIVER NECK MOMENT ABOUT Y AXIS
FMVSS 208 SLED TEST

TEST NUMBER: 971219S

TRC INC.

458

365

TORQUE (N·M X 10⁻¹)

272

179

86

-6

-100

-20

10

40

70

100

130

160

190

220

250

280

310

TIME (MS)

CHANNEL: NEKYM1 FILTER: CH. CLASS 600

PEAK DATA: 41.85 N·M @ 105.28 MS; -9.20 N·M @ 237.20 MS

CW0302 / 1988 FORD F-150 TRUCK
DRIVER NECK MOMENT ABOUT Z AXIS
FMVSS 208 SLED TEST

TEST NUMBER: 971219S

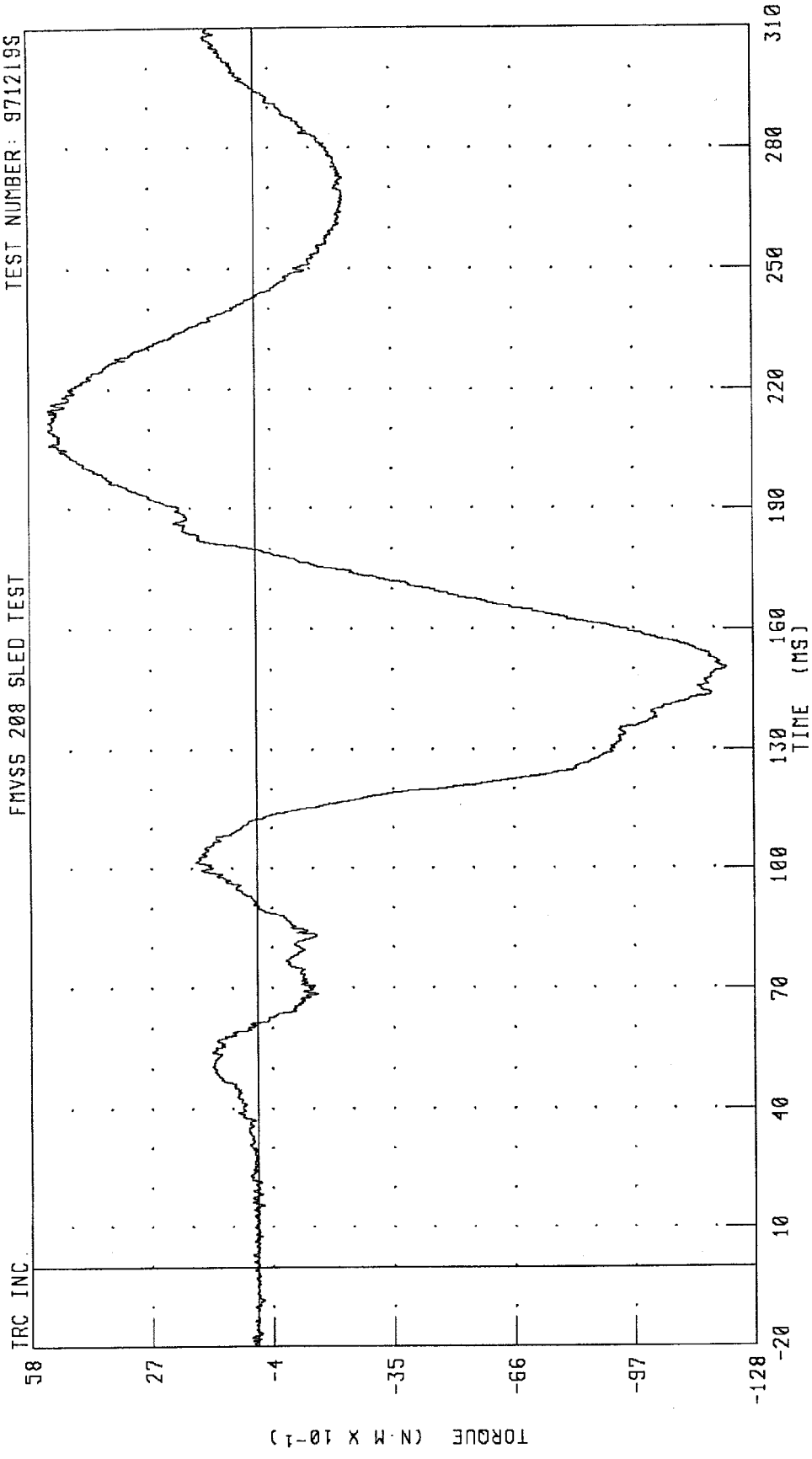

CHANNEL: NEKZMI FILTER: CH. CLASS 600
PEAK DATA: 5.30 N·M @ 214.88 MS; -12.11 N·M @ 150.48 MS

CH0302 / 1998 FORD F-150 TRUCK
DRIVER NECK OCCIPITAL CONDYLE ABOUT Y AXIS
FMVSS 208 SLED TEST

TEST NUMBER: 971219S

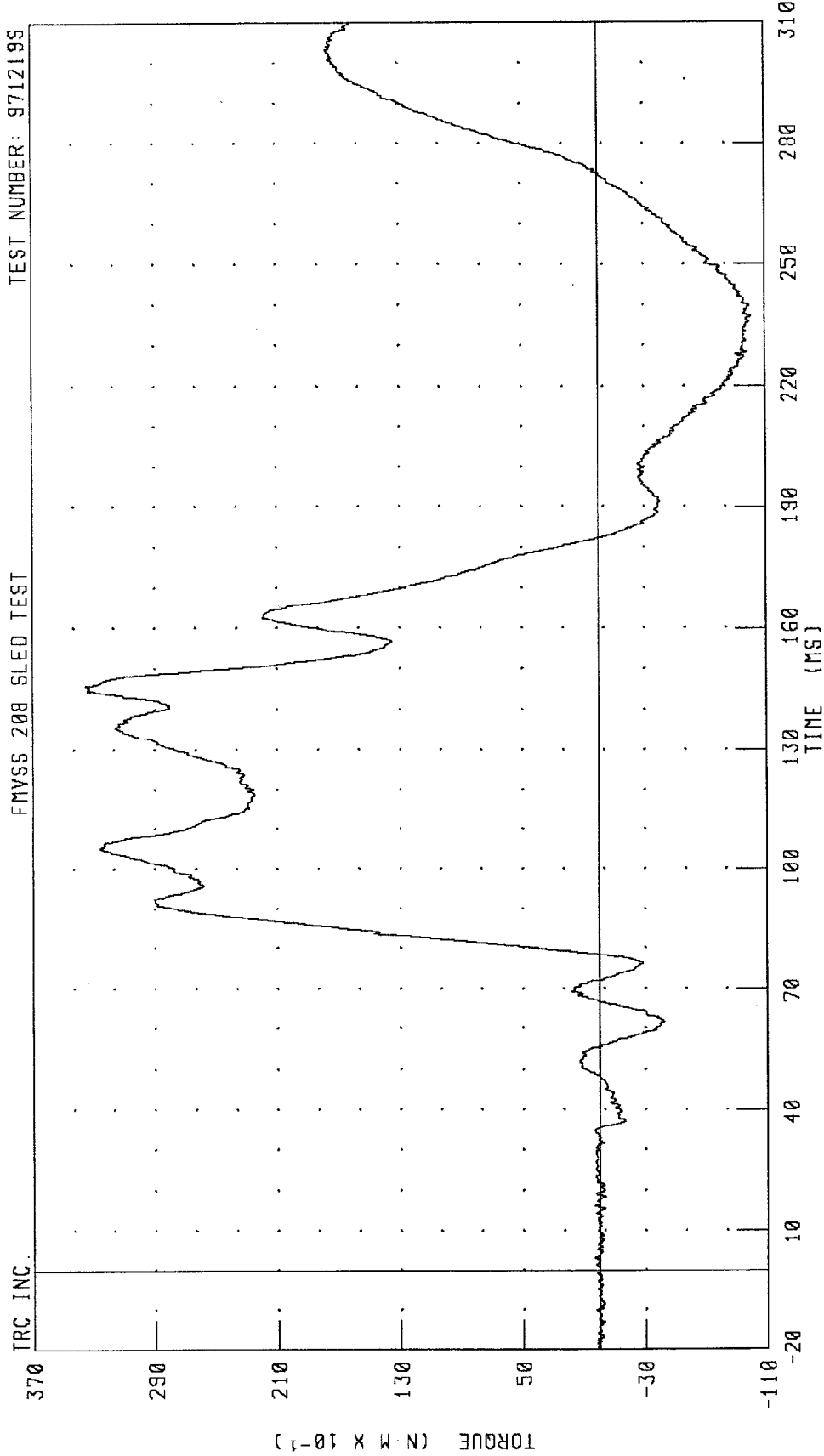

CHANNEL: NEKOM1 FILTER: CH. CLASS 600

CW0302 / 1998 FORD F-150 TRUCK
DRIVER CHEST X-AXIS ACCELERATION
FMVSS 208 SLED TEST

TEST NUMBER: 971219S

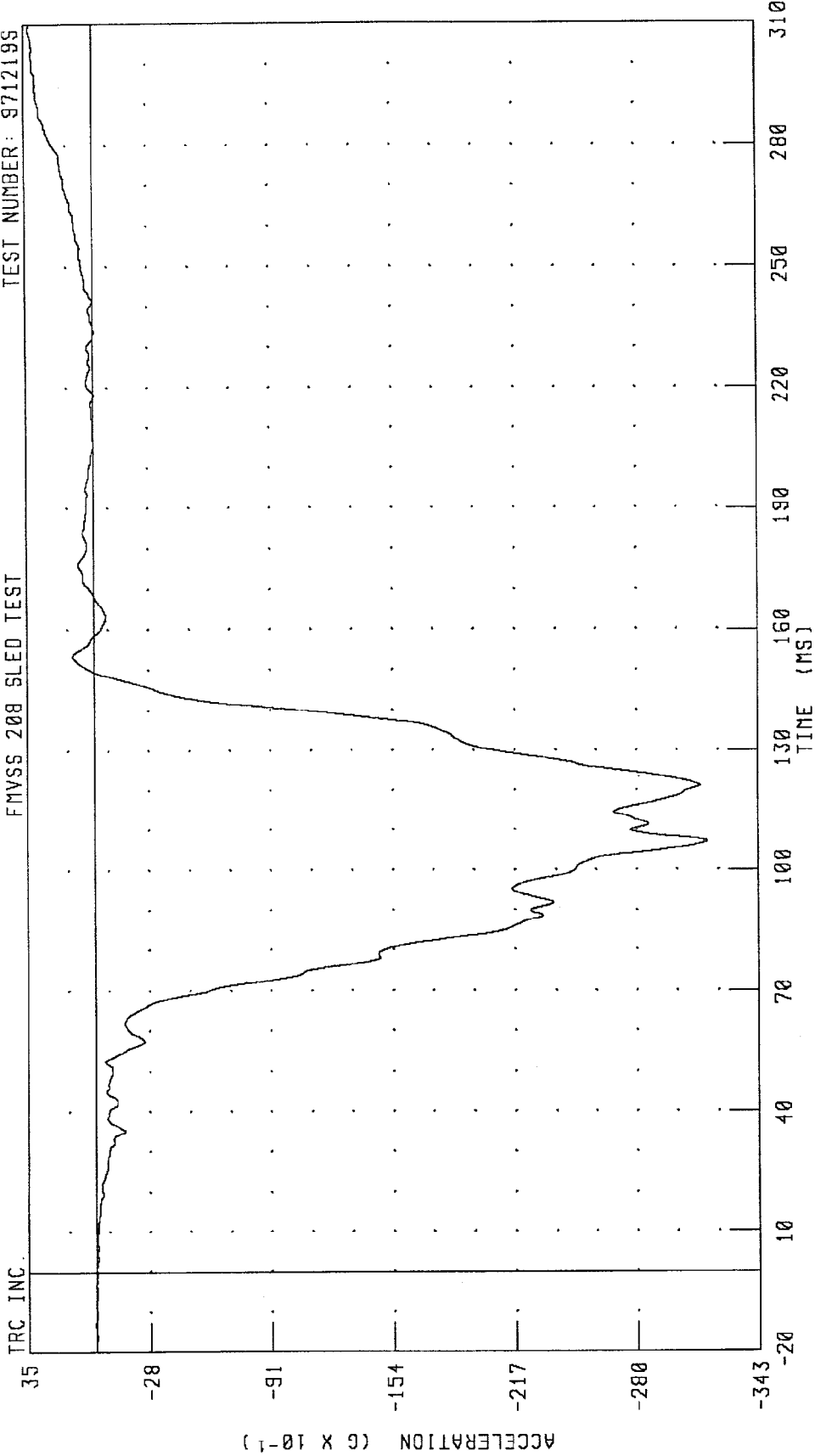

CHANNEL: CSTXG1 FILTER: CH. CLASS 180

PEAK DATA: 3.27 G @ 308.56 MS; -31.61 G @ 107.04 MS

CW0302 / 1998 FORD F-150 TRUCK
DRIVER CHEST Y-AXIS ACCELERATION
FMVSS 208 SLED TEST

TEST NUMBER: 971219S

TRC INC.

67

53

39

25

11

-3

-17

ACCELERATION (G X 10⁻¹)

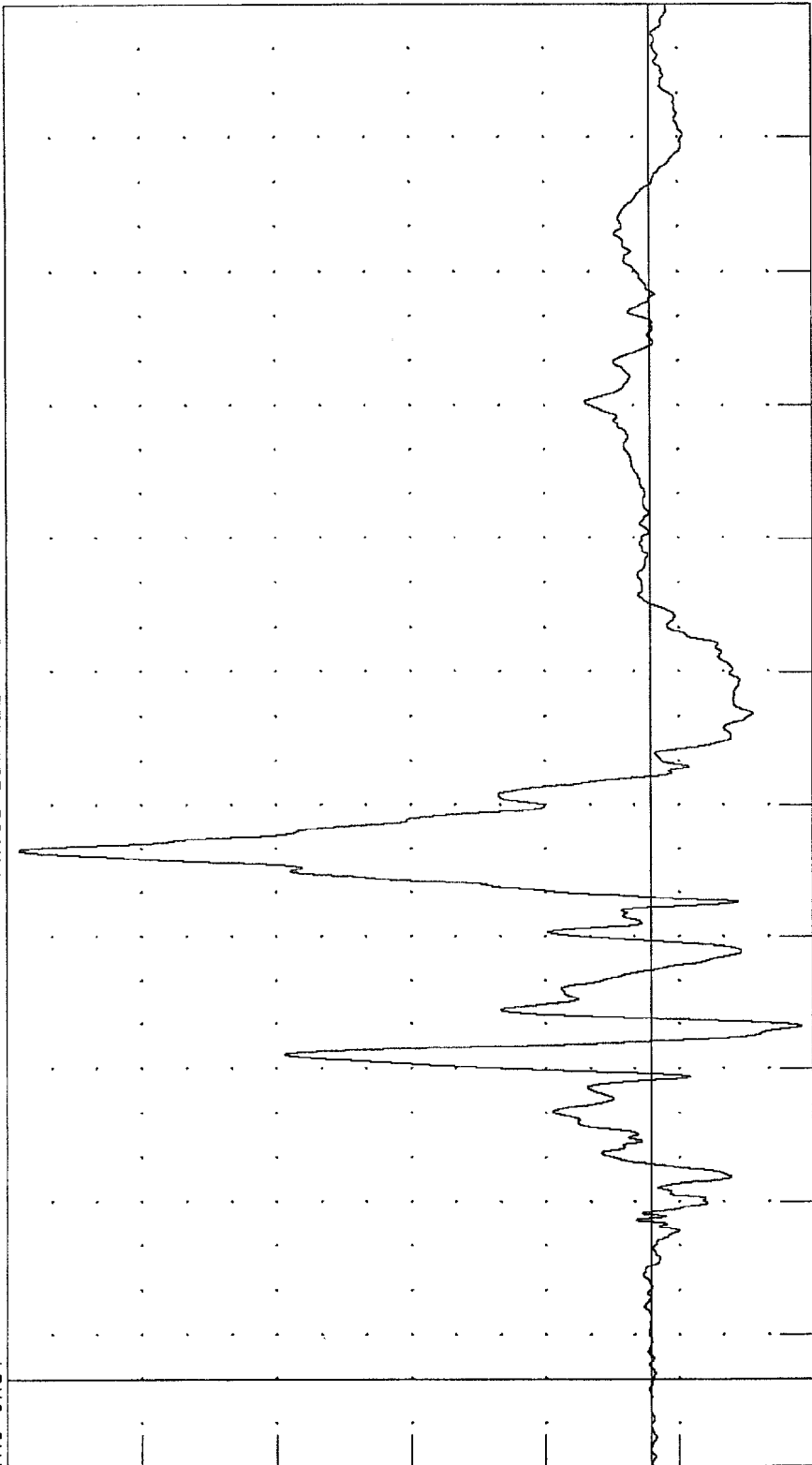

310
280
250
220
190
160
130
100
70
40
10

TIME (MS)

PEAK DATA: 6.57 G @ 119.68 MS; -1.58 G @ 79.52 MS

CHANNEL: CSTYG1 FILTER: CH. CLASS 180

CW0302 / 1998 FORD F-150 TRUCK
DRIVER CHEST Z-AXIS ACCELERATION
FMVSS 208 SLED TEST

TEST NUMBER: 971219S

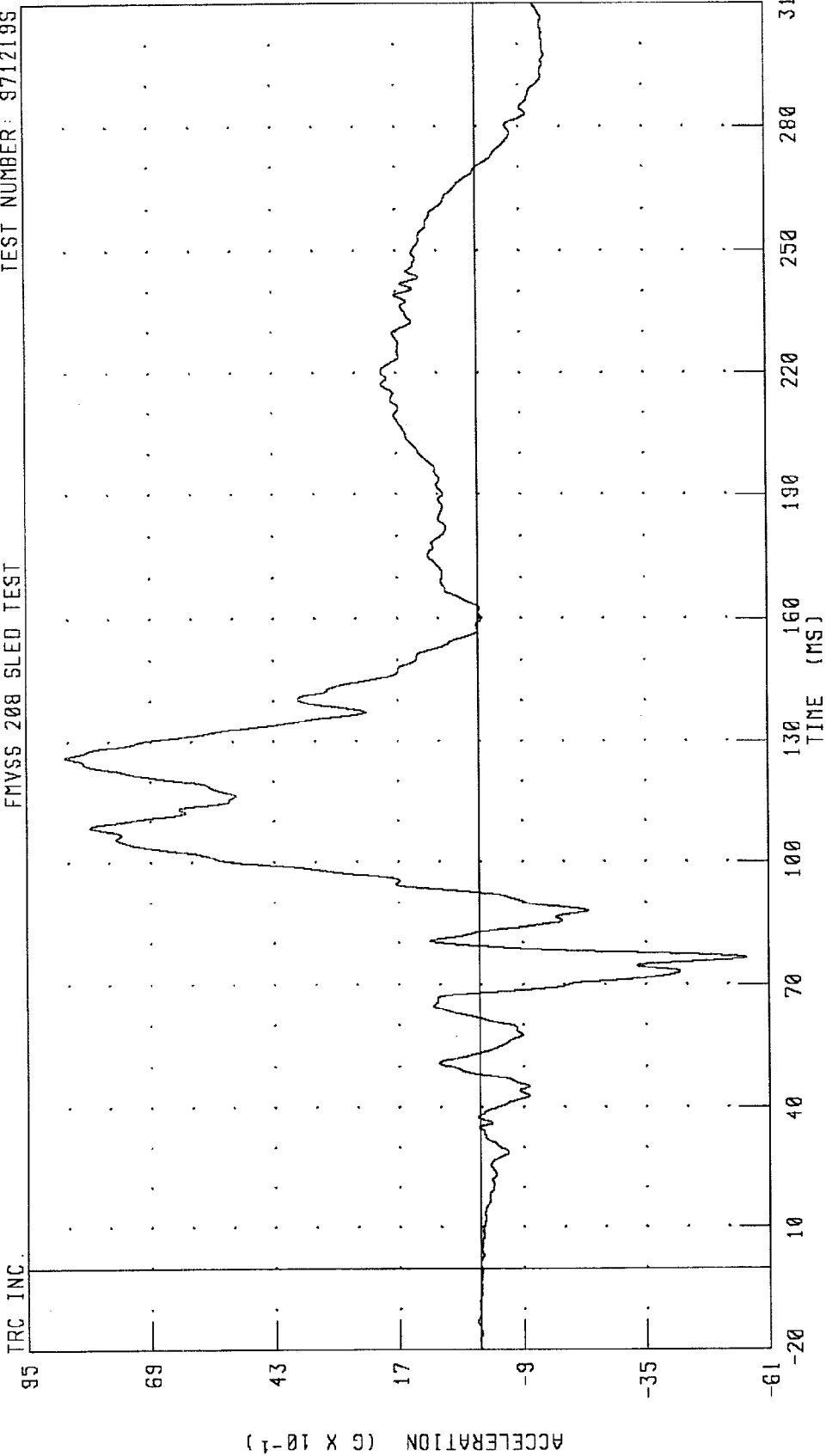

PEAK DATA: 8.69 G @ 126.08 MS; -5.63 G @ 76.40 MS

CHANNEL: CSTZG1 FILTER: CH. CLASS 180

CW0302 / 1998 FORD F-150 TRUCK
DRIVER CHEST RESULTANT ACCELERATION
FMVSS 208 SLED TEST

TEST NUMBER: 9712199

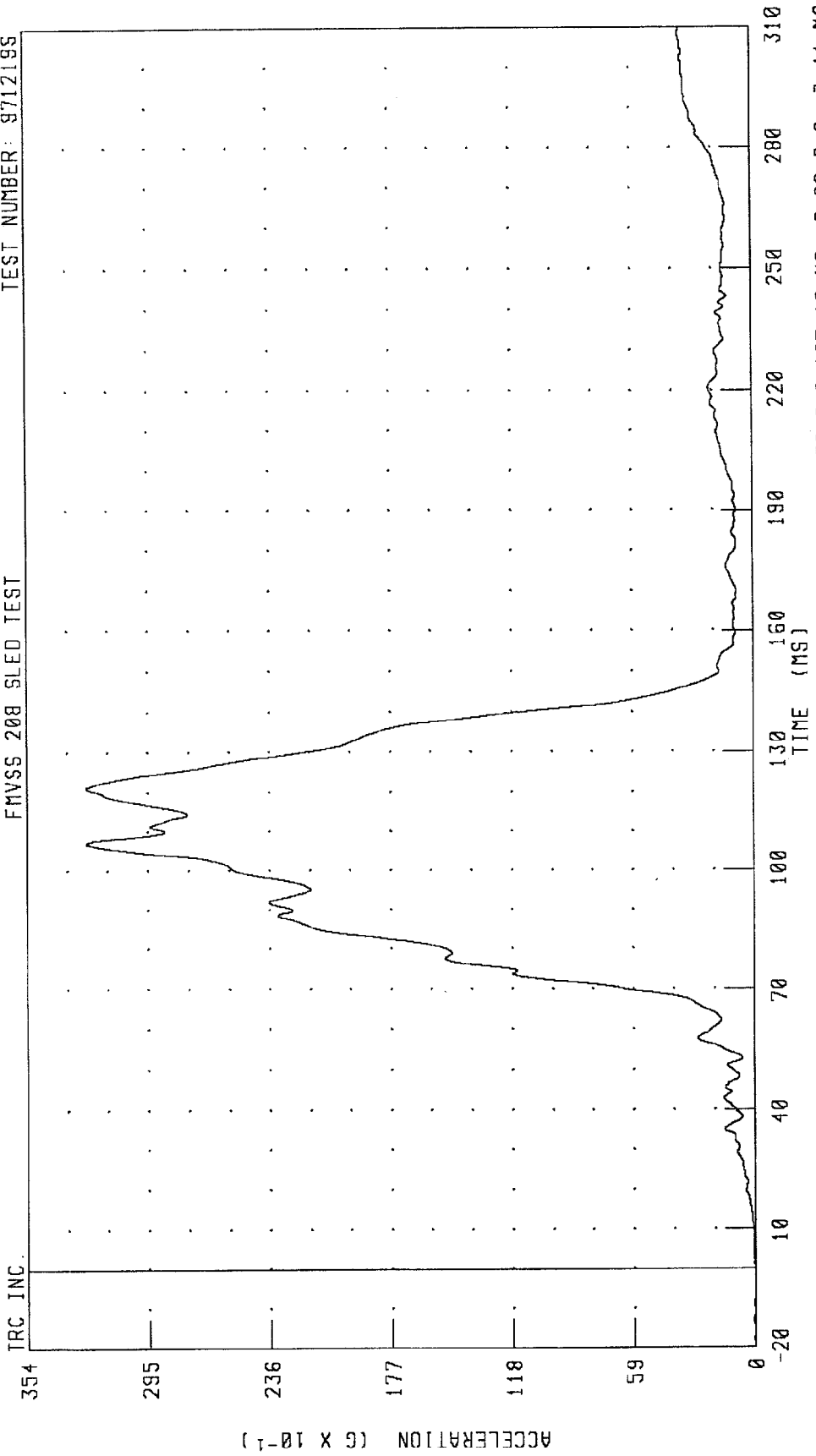

PEAK DATA: 32.50 G @ 107.12 MS; 0.00 G @ -3.44 MS

CHANNEL: CSTRG1 FILTER: CH. CLASS 180

CW0302 / 1988 FORD F-150 TRUCK
DRIVER CHEST DEFLECTION
FMVSS 208 SLED TEST

TRC NUMBER: TRC622P

TEST NUMBER: 971219S

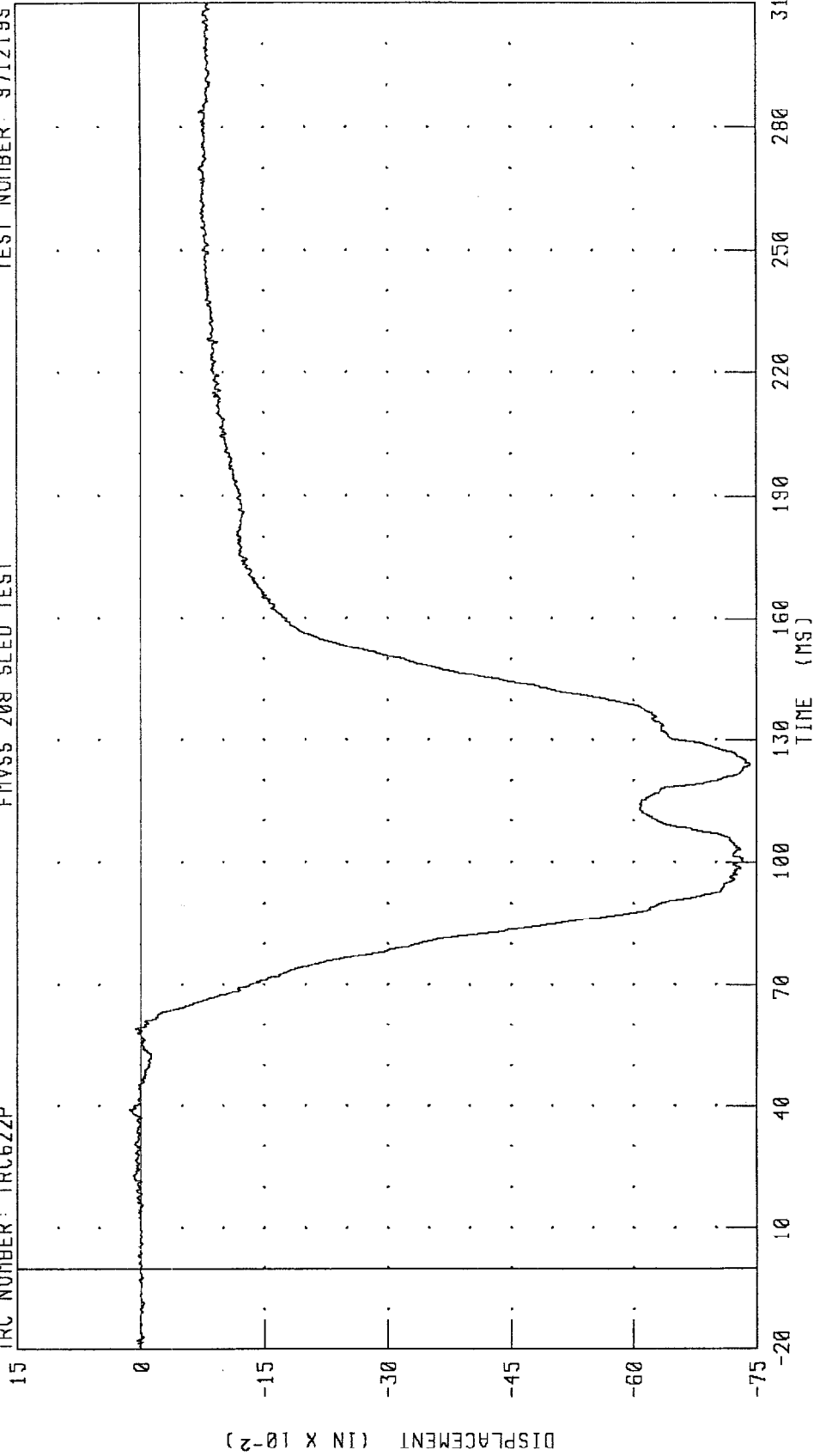

CHANNEL: CSTXD1 FILTER: CH. CLASS 600

PEAK DATA: 0.01 IN @ 39.04 MS, -0.74 IN @ 124.00 MS

CW0302 / 1998 FORD F-150 TRUCK
DRIVER LEFT FEMUR FORCE
FMVSS 208 SLED TEST

TEST NUMBER: 971219S

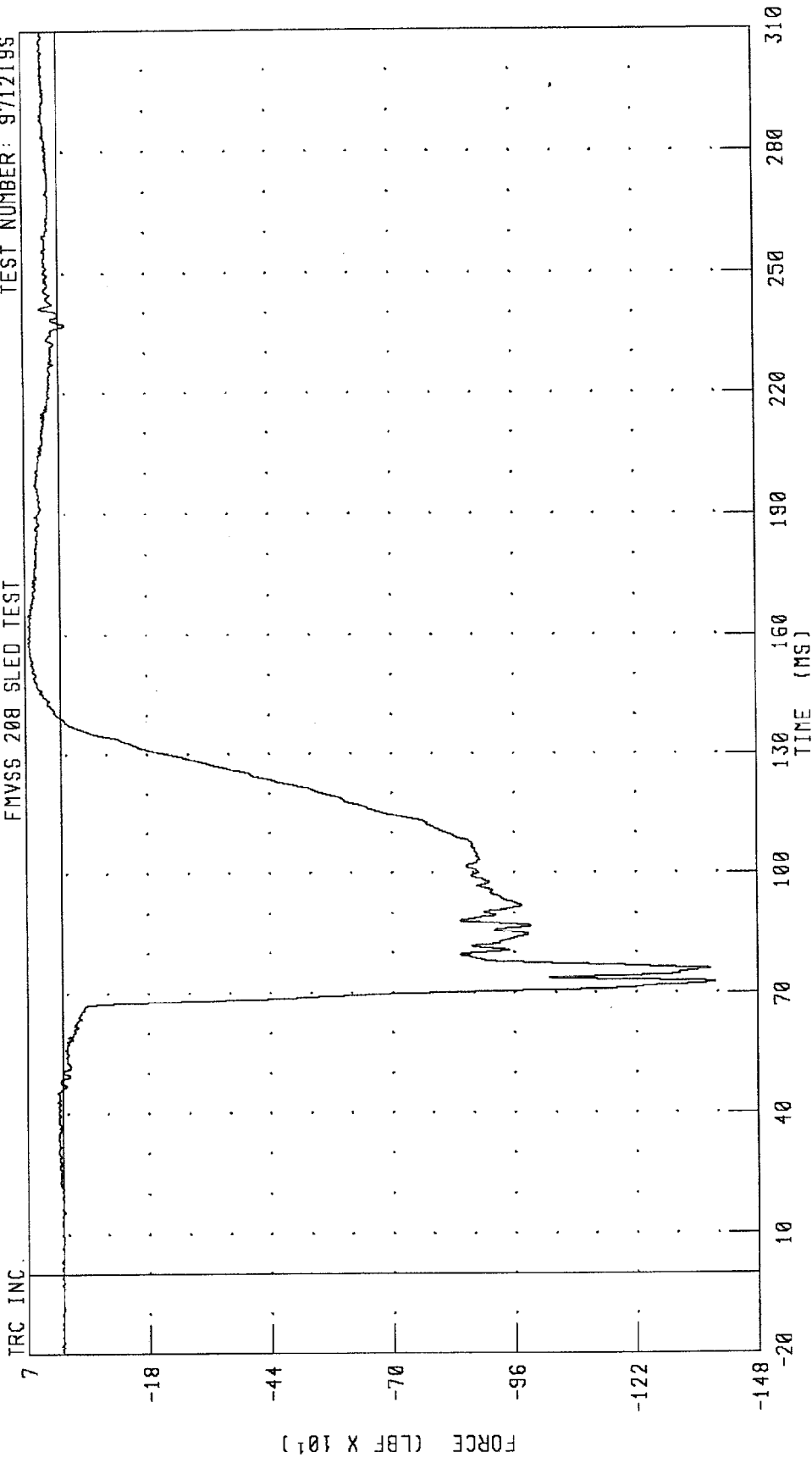

PEAK DATA: 68.47 LBF @ 162.56 MS; -1394.48 LBF @ 72.64 MS

CHANNEL: LFMF1 FILTER: CH. CLASS 600

CW0302 / 1998 FORD F-150 TRUCK
DRIVER RIGHT FEMUR FORCE
FMVSS 208 SLED TEST

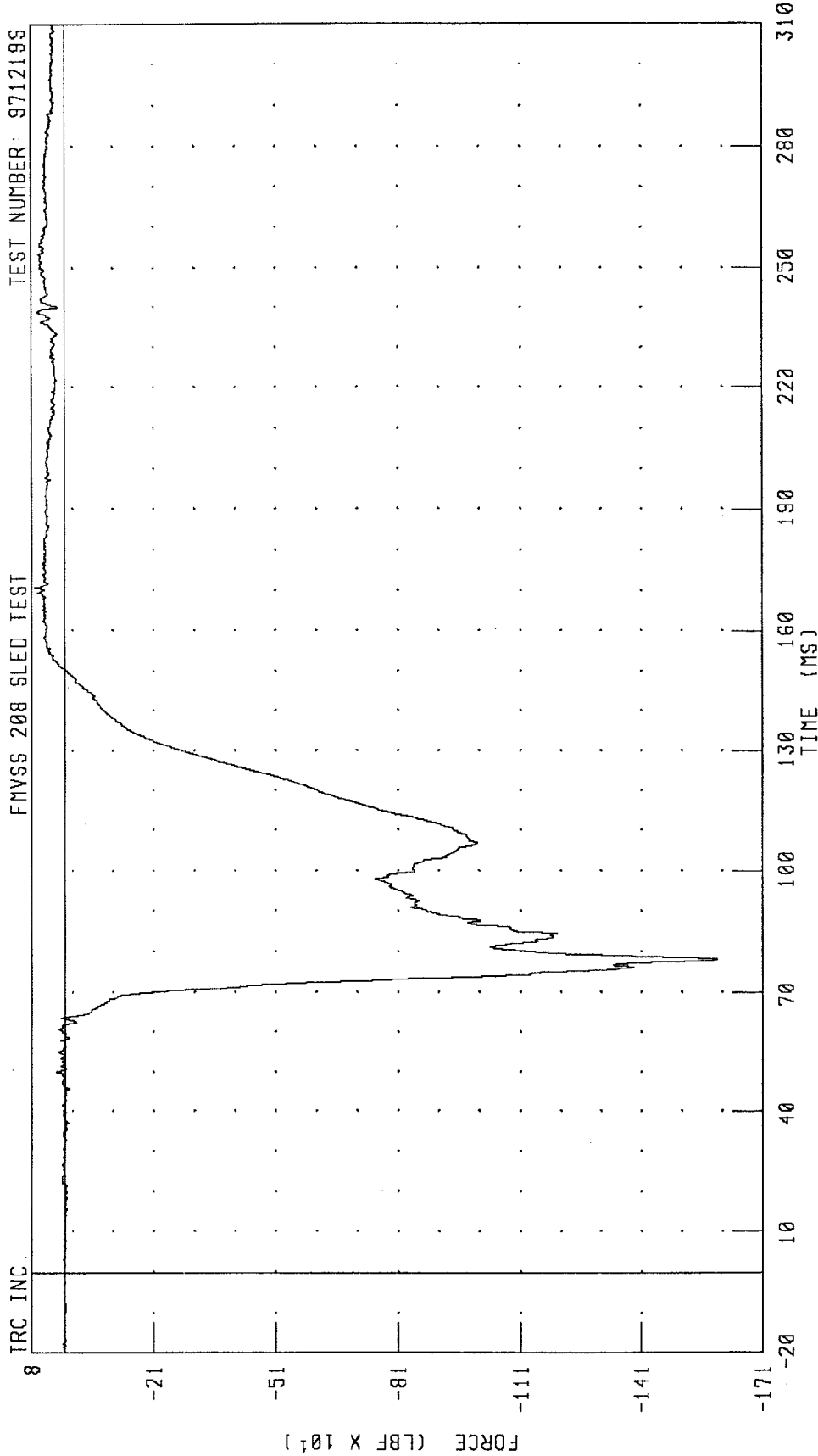

CHANNEL: RFMFI FILTER: CH. CLASS 600

CW0302 / 1988 FORD F-150 TRUCK
RIGHT FRONT PASSENGER HEAD X-AXIS ACCELERATION
FMVSS 208 SLED TEST

TEST NUMBER: 971219S

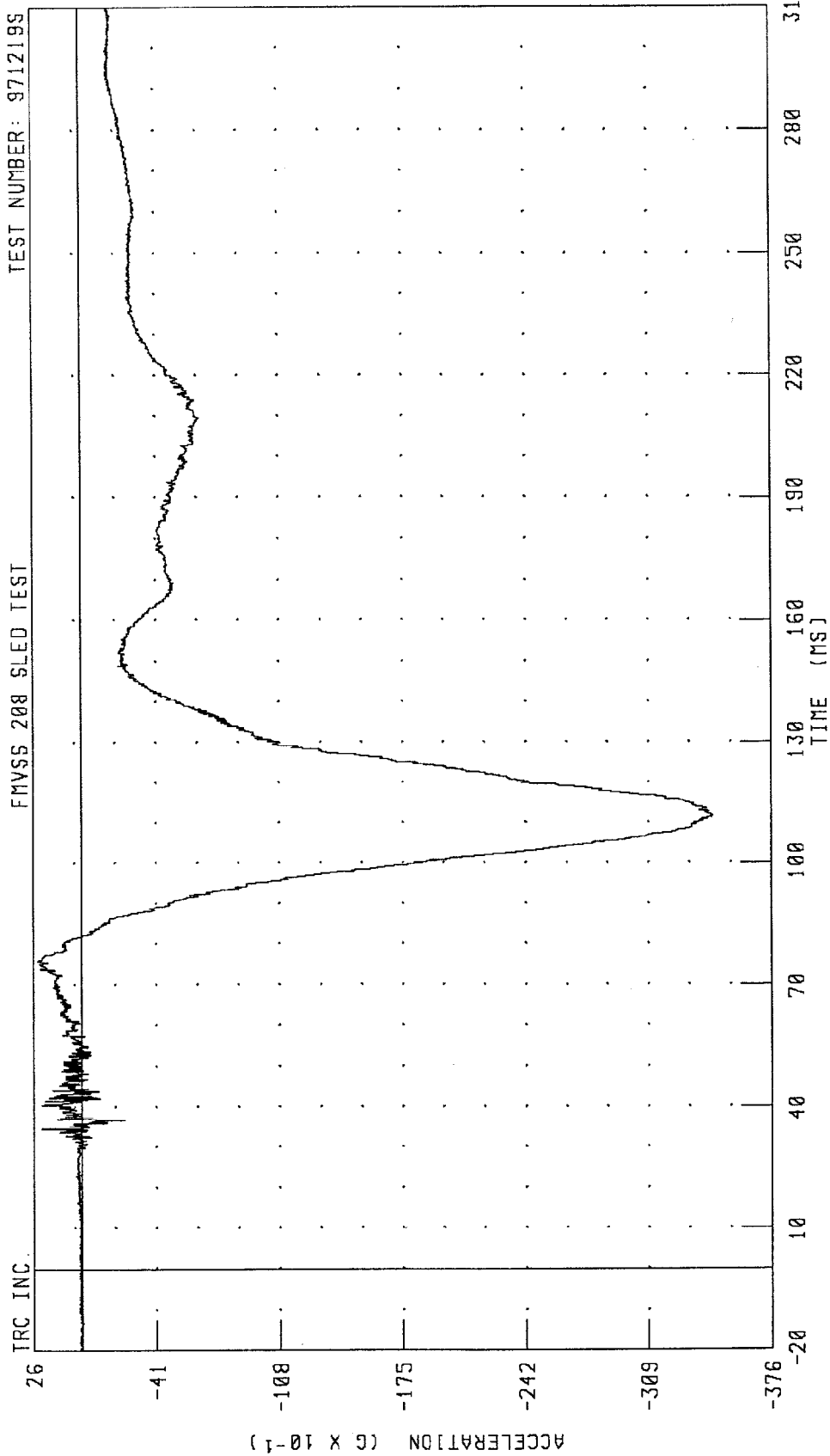

CHANNEL: HEDXG2 FILTER: CH. CLASS 1000

PEAK DATA: 2.37 G @ 75.84 MS; -34.39 G @ 111.76 MS

CW0302 / 1998 FORD F-150 TRUCK
RIGHT FRONT PASSENGER HEAD Y-AXIS ACCELERATION
FMVSS 208 SLED TEST

TEST NUMBER: 971219S

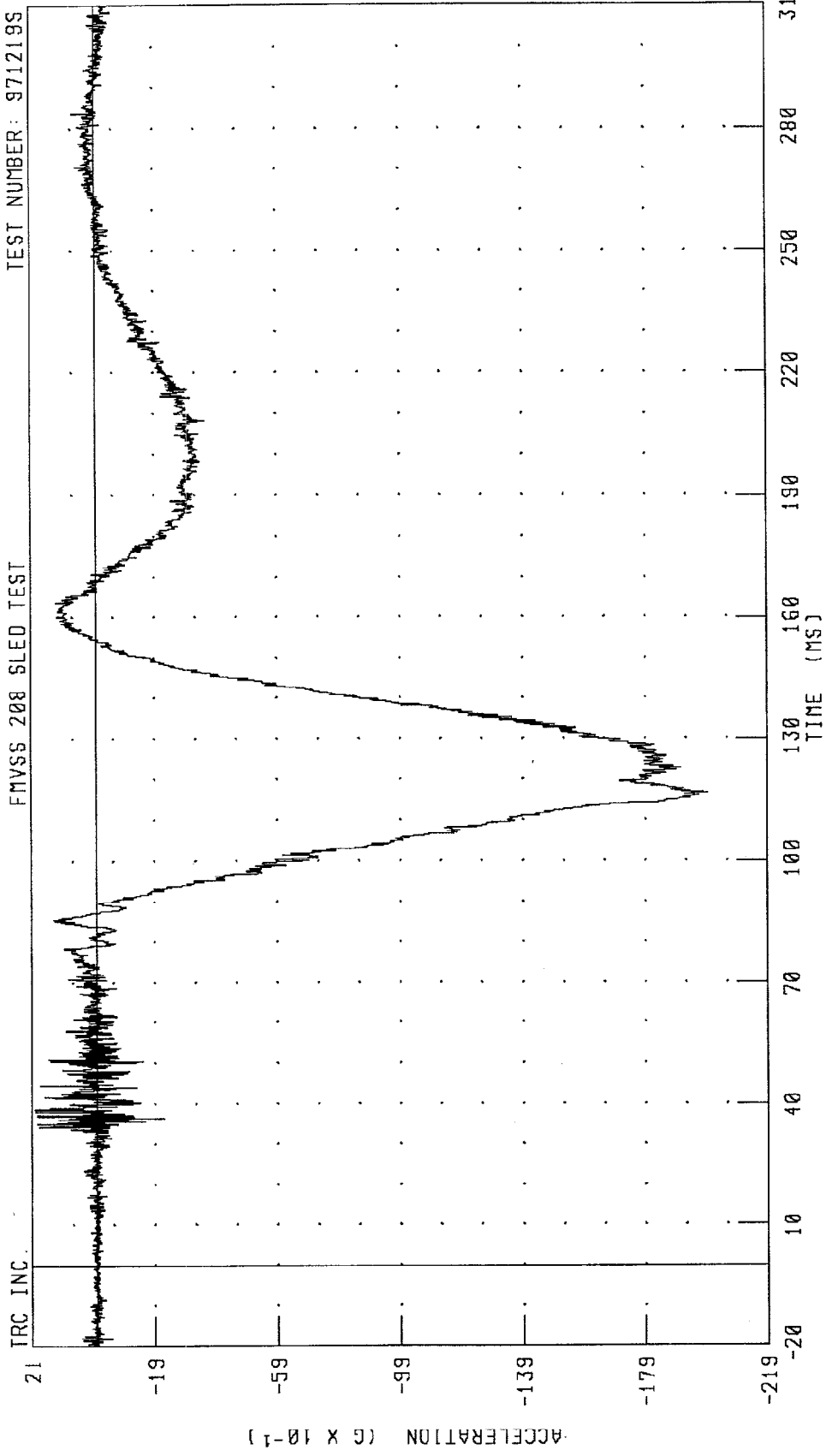

PEAK DATA: 1.99 G @ 38.16 MS; -19.91 G @ 116.72 MS

CHANNEL: HEDYG2 FILTER: CH. CLASS 1000

CW0302 / 1998 FORD F-150 TRUCK
RIGHT FRONT PASSENGER HEAD Z-AXIS ACCELERATION
FMYSS 208 SLED TEST

TEST NUMBER: 971219S

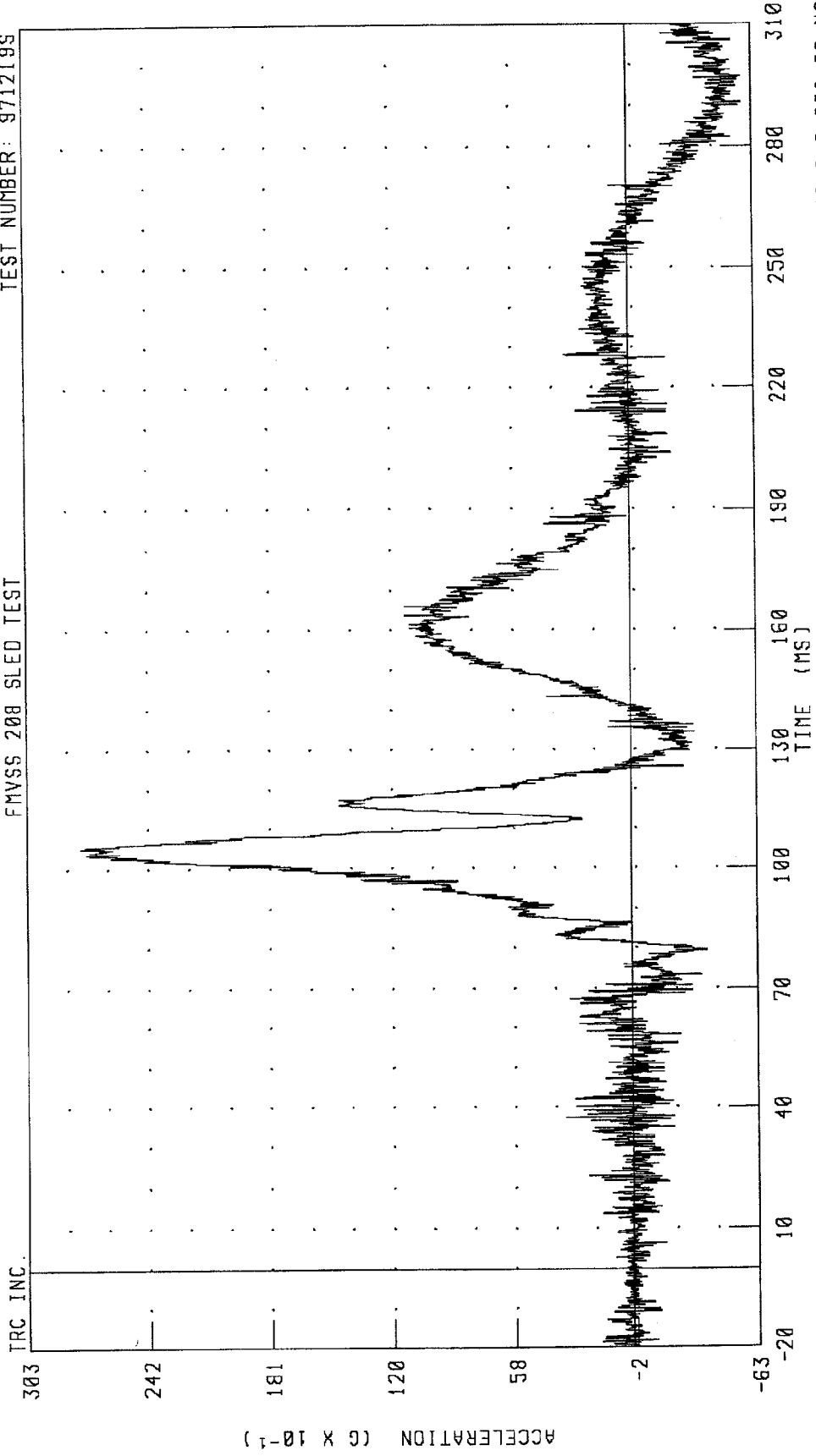

CHANNEL: HEDZG2 FILTER: CH. CLASS 1000 PEAK DATA: 27.59 G @ 105.28 MS; -5.78 G @ 290.88 MS

CW0302 / 1998 FORD F-150 TRUCK
RIGHT FRONT PASSENGER HEAD RESULTANT ACCELERATION
FMVSS 208 SLED TEST

TEST NUMBER: 971219S

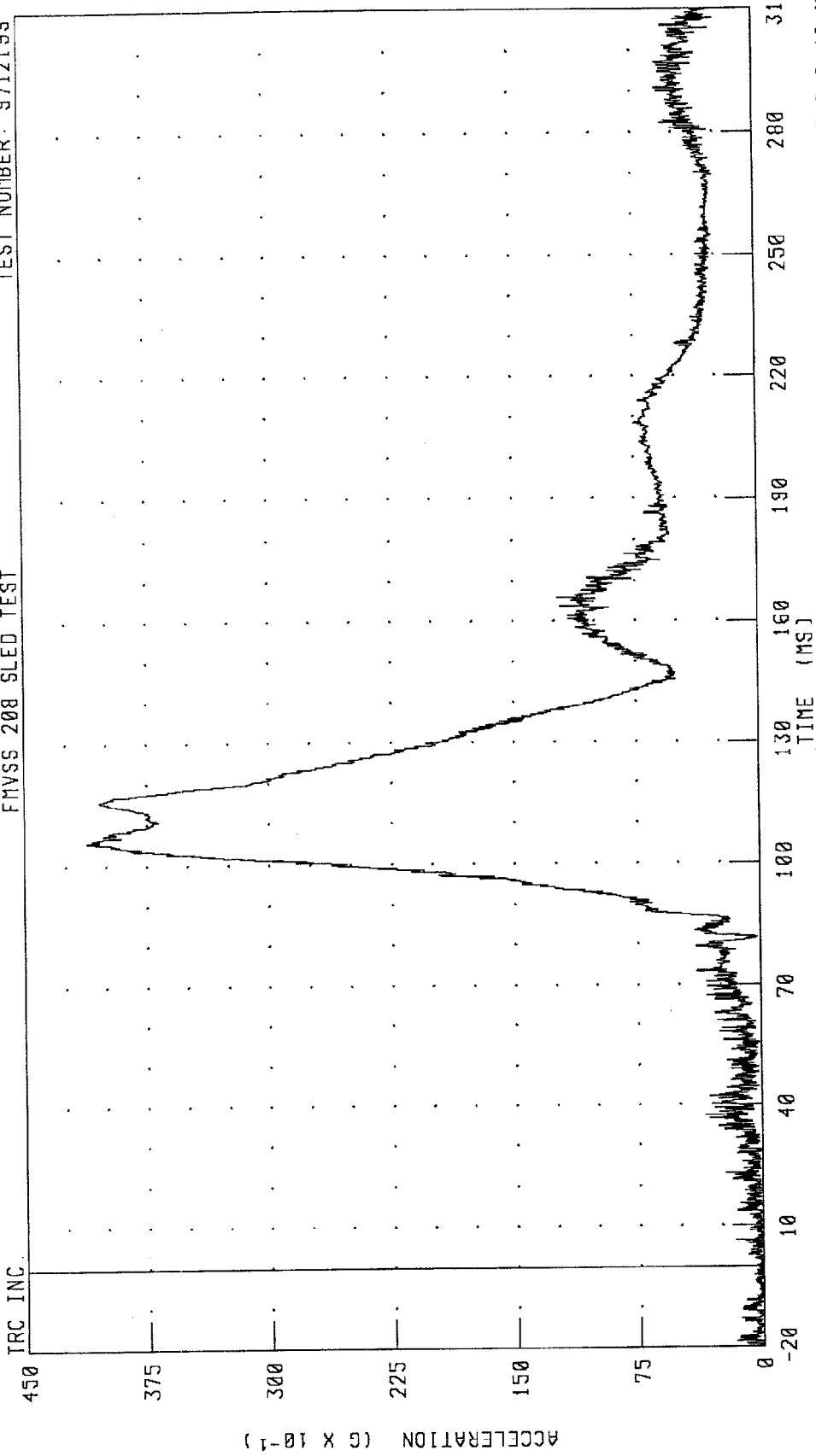

CHANNEL: HEDRG2 FILTER: CH. CLASS 1000

PEAK DATA: 41.20 G @ 105.68 MS; 0.01 G @ 6.48 MS

CW0302 / 1998 FORD F-150 TRUCK
RIGHT FRONT PASSENGER NECK X-AXIS SHEAR FORCE
FMVSS 208 SLED TEST

TEST NUMBER: 971219S

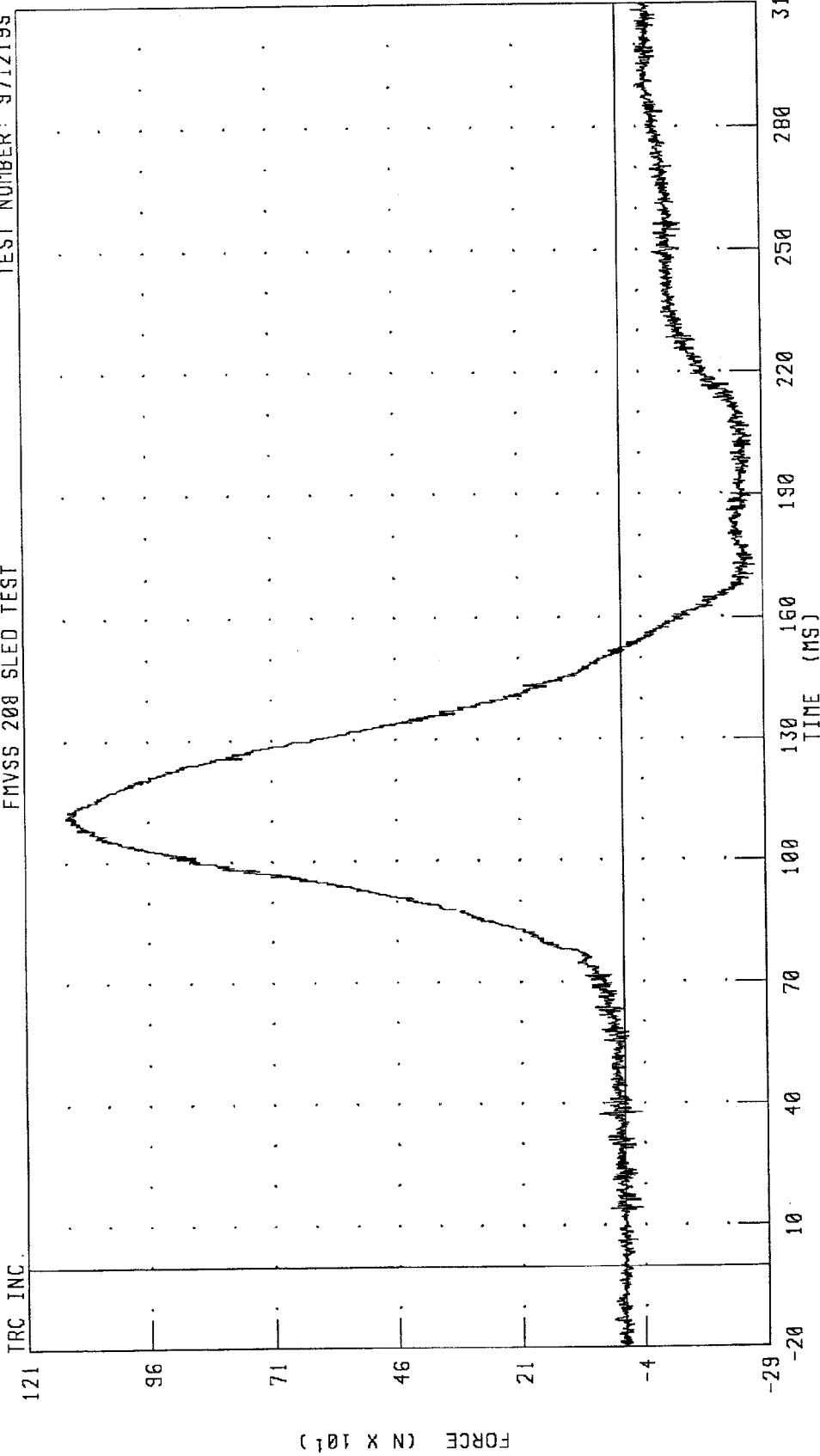

CHANNEL: NEKXF2 FILTER: CH. CLASS 1000

PEAK DATA: 1126.03 N @ 110.96 MS; -271.17 N @ 172.88 MS

TRC INC.

121

96

71

46

21

-4

-29

FORCE (N X 10⁴)

TIME (MS)

CW0302 / 1998 FORD F-150 TRUCK
RIGHT FRONT PASSENGER NECK Y-AXIS SHEAR FORCE
FMVSS 208 SLED TEST

TEST NUMBER: 971219S

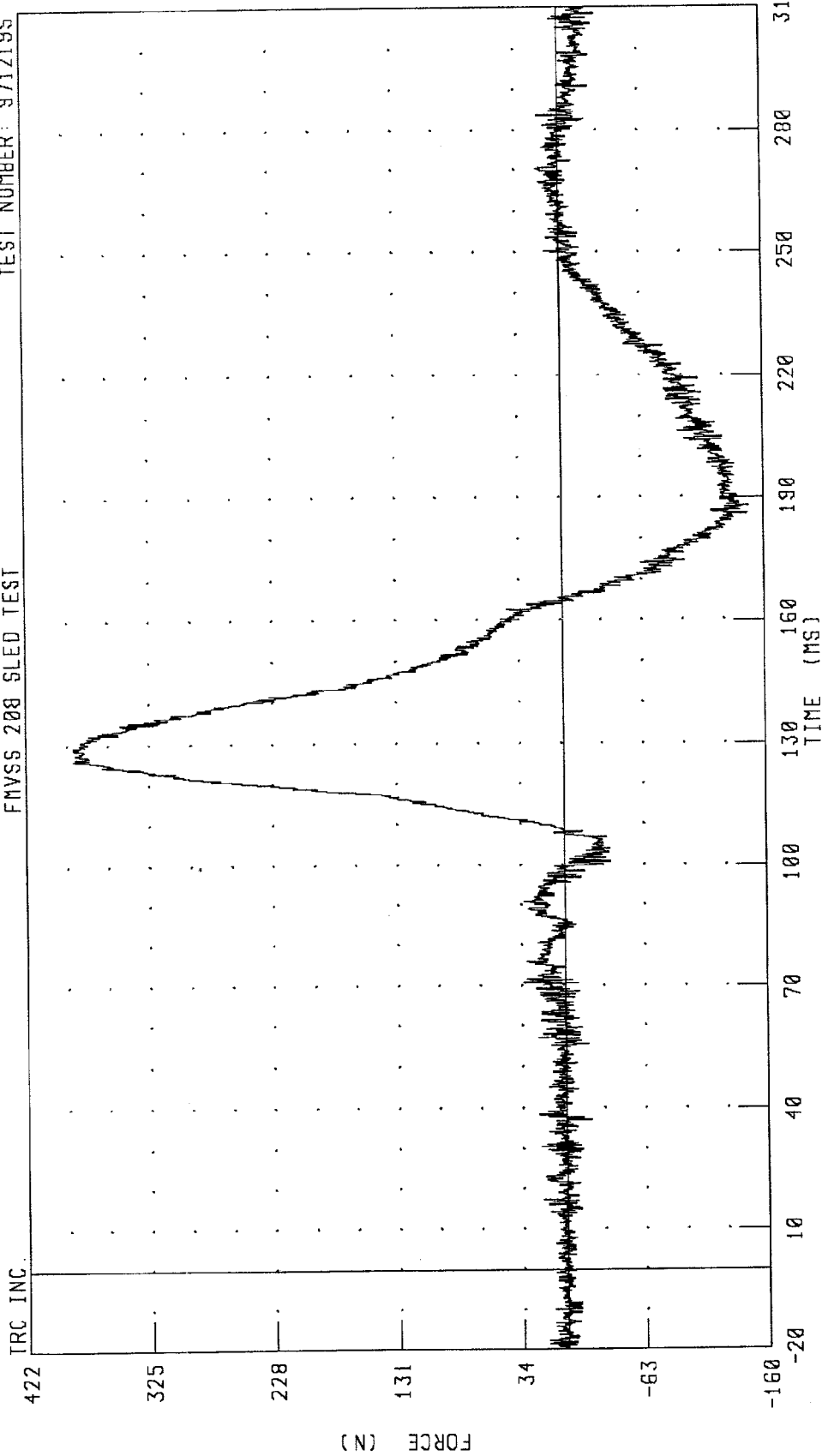

CHANNEL: NEKYF2 FILTER: CH. CLASS 1000

PEAK DATA: 384.77 N @ 126.08 MS; -148.29 N @ 187.76 MS

TRC INC.

FORCE (N)

TIME (MS)

CW0302 / 1998 FORD F-150 TRUCK
RIGHT FRONT PASSENGER NECK Z-AXIS AXIAL FORCE
FMVSS 208 SLED TEST

TEST NUMBER: 971219S

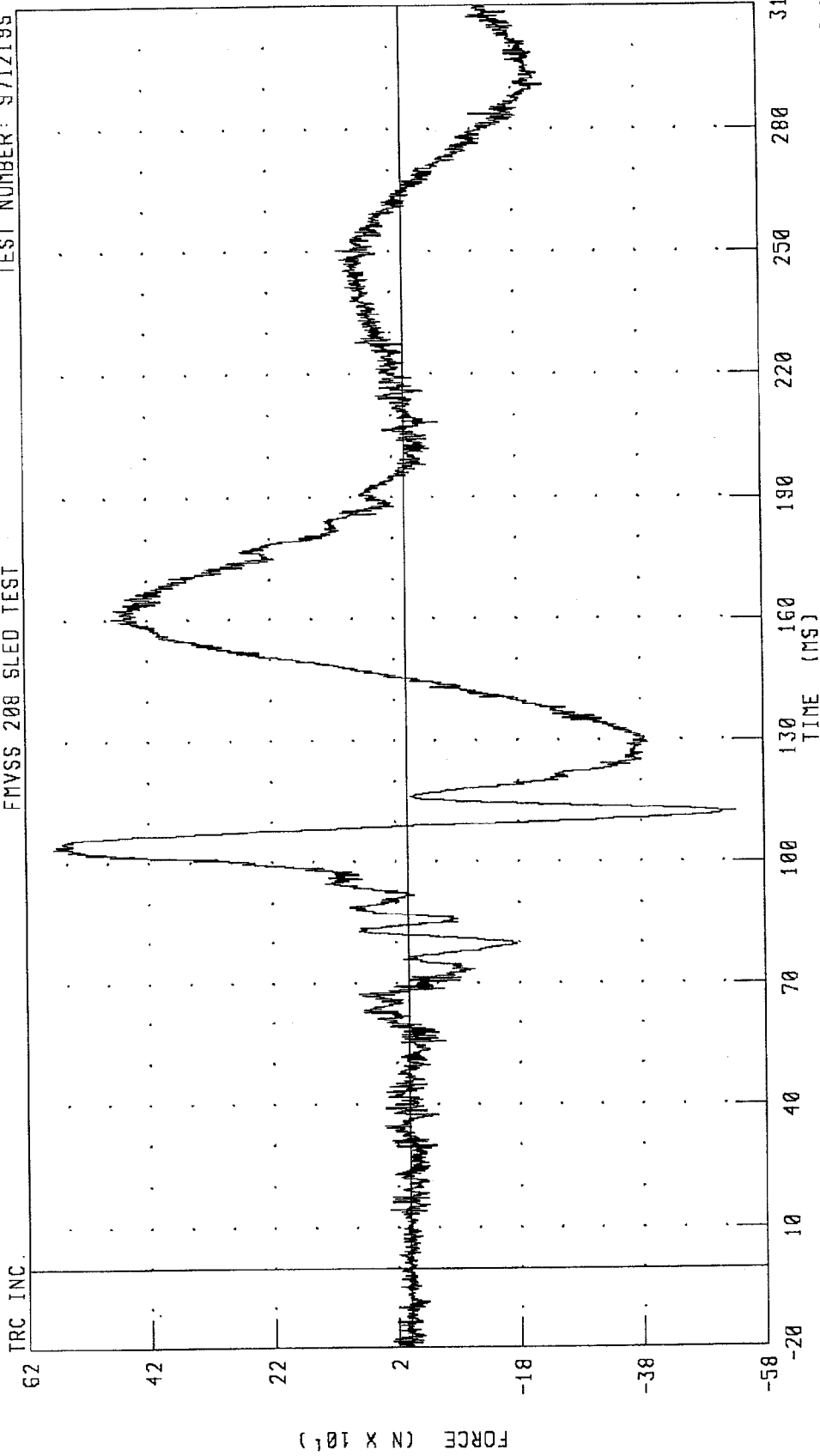

CHANNEL: NEKZF2 FILTER: CH. CLASS 1000

CW0302 / 1998 FORD F-150 TRUCK
RIGHT FRONT PASSENGER NECK MOMENT ABOUT X AXIS
FMVSS 208 SLED TEST

TEST NUMBER: 971219S

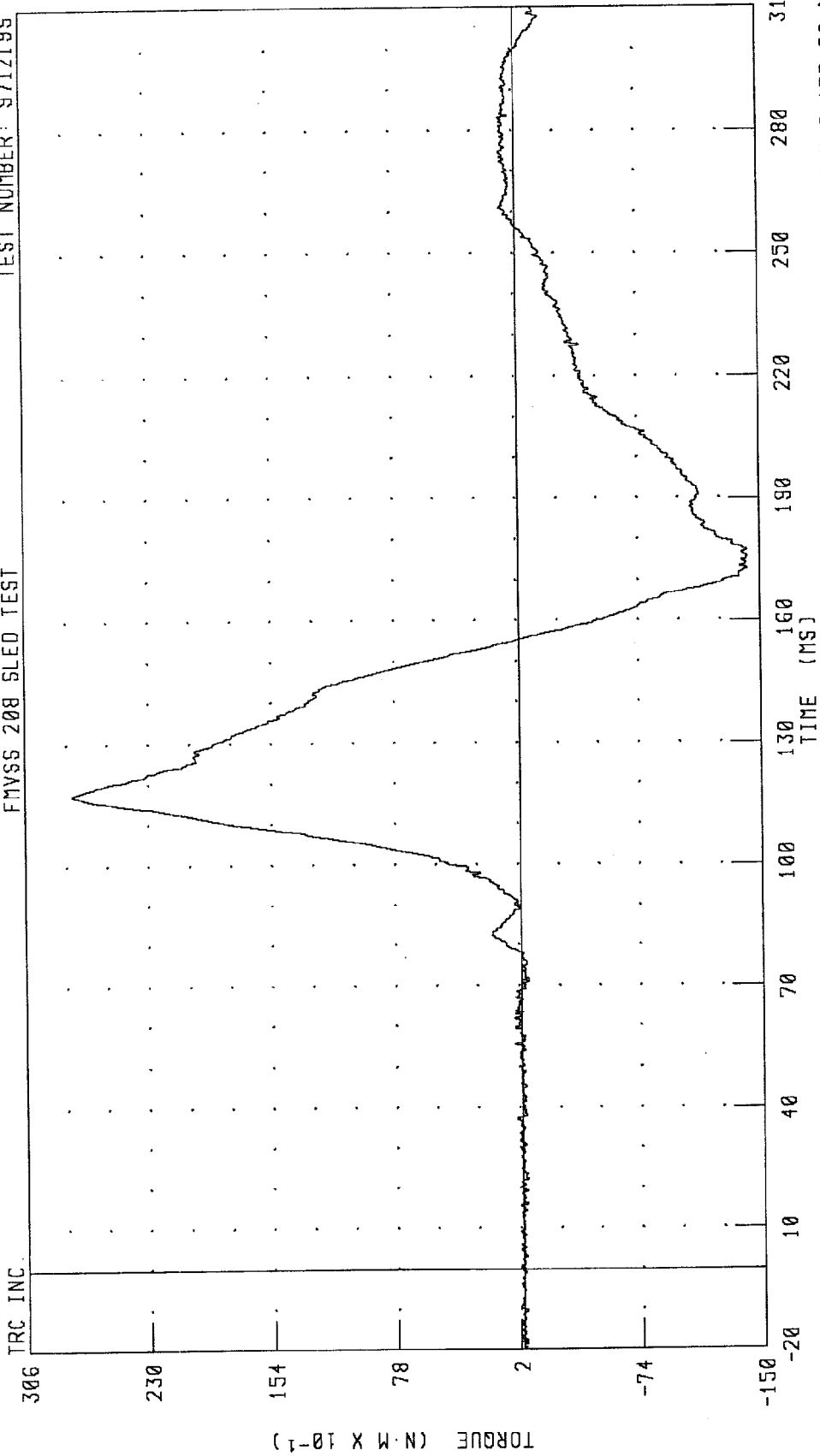

CHANNEL: NEKX12 FILTER: CH. CLASS 600

PEAK DATA: 27.72 N·M @ 117.36 MS; -14.18 N·M @ 177.20 MS

CW0302 / 1998 FORD F-150 TRUCK
RIGHT FRONT PASSENGER NECK MOMENT ABOUT Y AXIS
FMVSS 208 SLED TEST

TEST NUMBER: 971219S

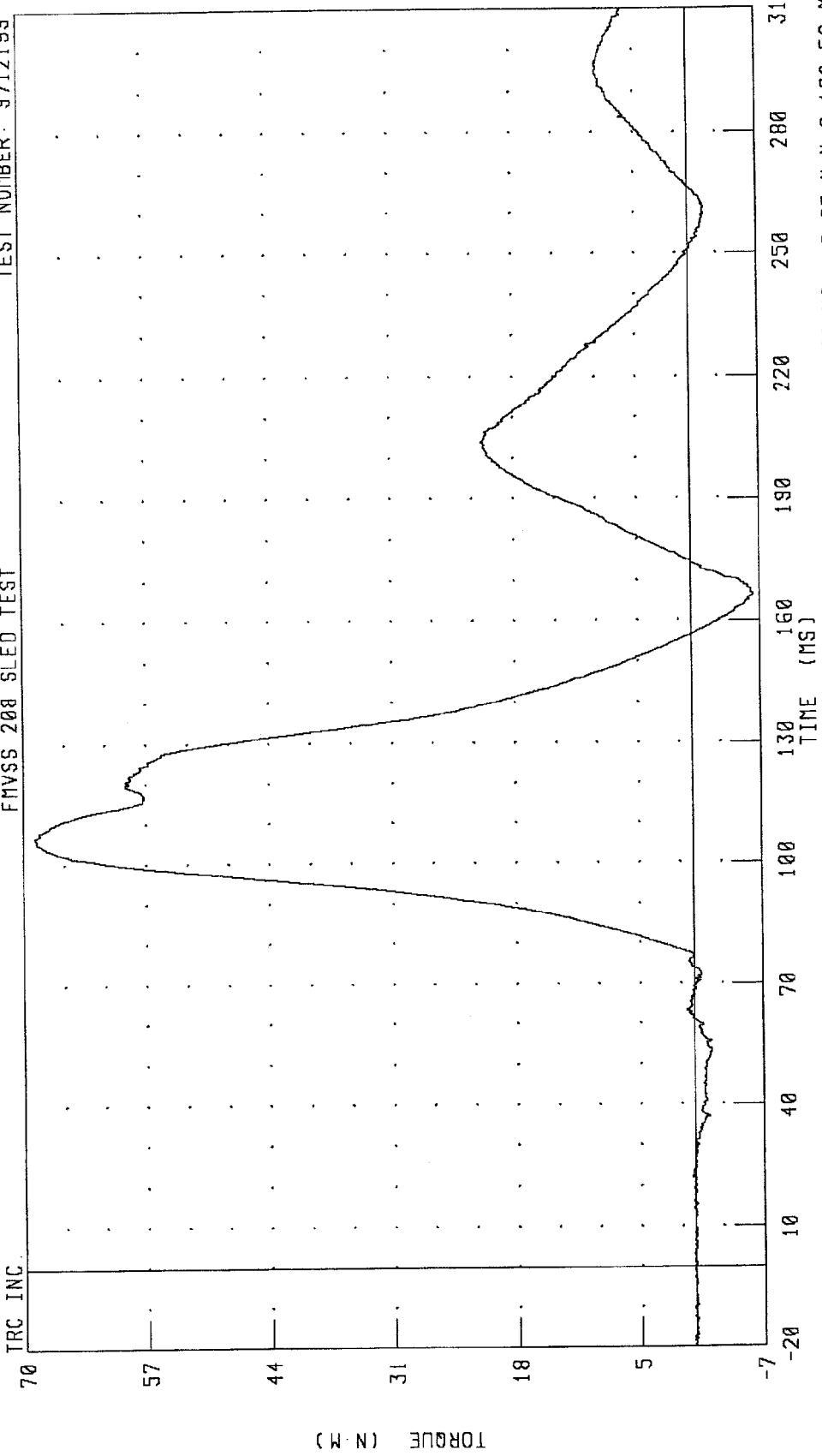

CHANNEL: NEKYM2 FILTER: CH. CLASS 600

PEAK DATA: 69.46 N.M @ 106.56 MS; -6.65 N.M @ 166.56 MS

CW0302 / 1998 FORD F-150 TRUCK
RIGHT FRONT PASSENGER NECK MOMENT ABOUT Z AXIS
FMVSS 208 SLED TEST

TEST NUMBER: 971219S

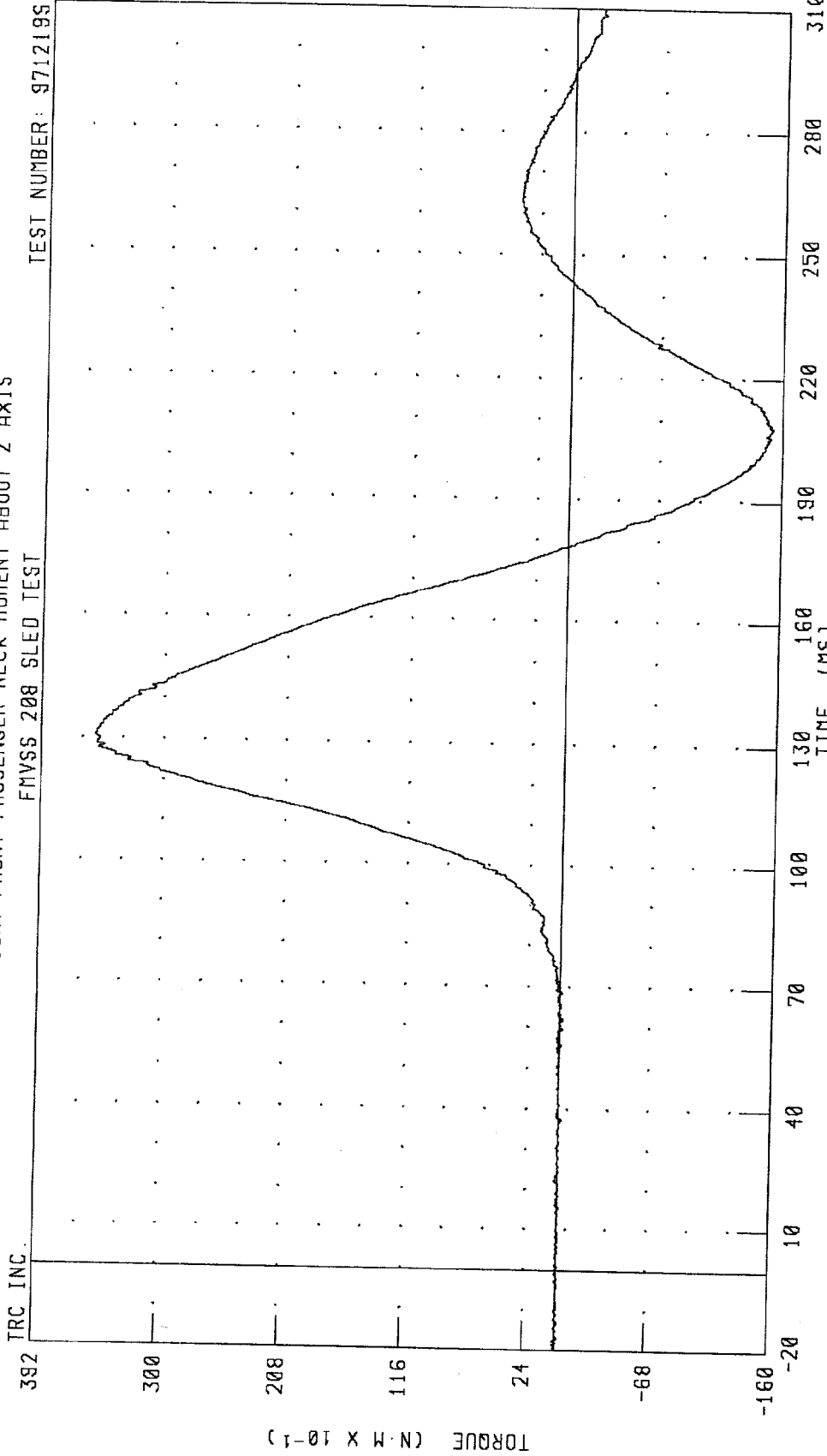

CHANNEL: NEKZM2 FILTER: CH. CLASS 600

PEAK DATA: 35.16 N·M @ 130.88 MS; -15.25 N·M @ 208.32 MS

CW0302 / 1998 FORD F-150 TRUCK
RIGHT FRONT PASSENGER NECK OCCIPITAL CONDYLE ABOUT Y AXIS
FMVSS 208 SLED TEST

TEST NUMBER: 971219S

TRC INC.

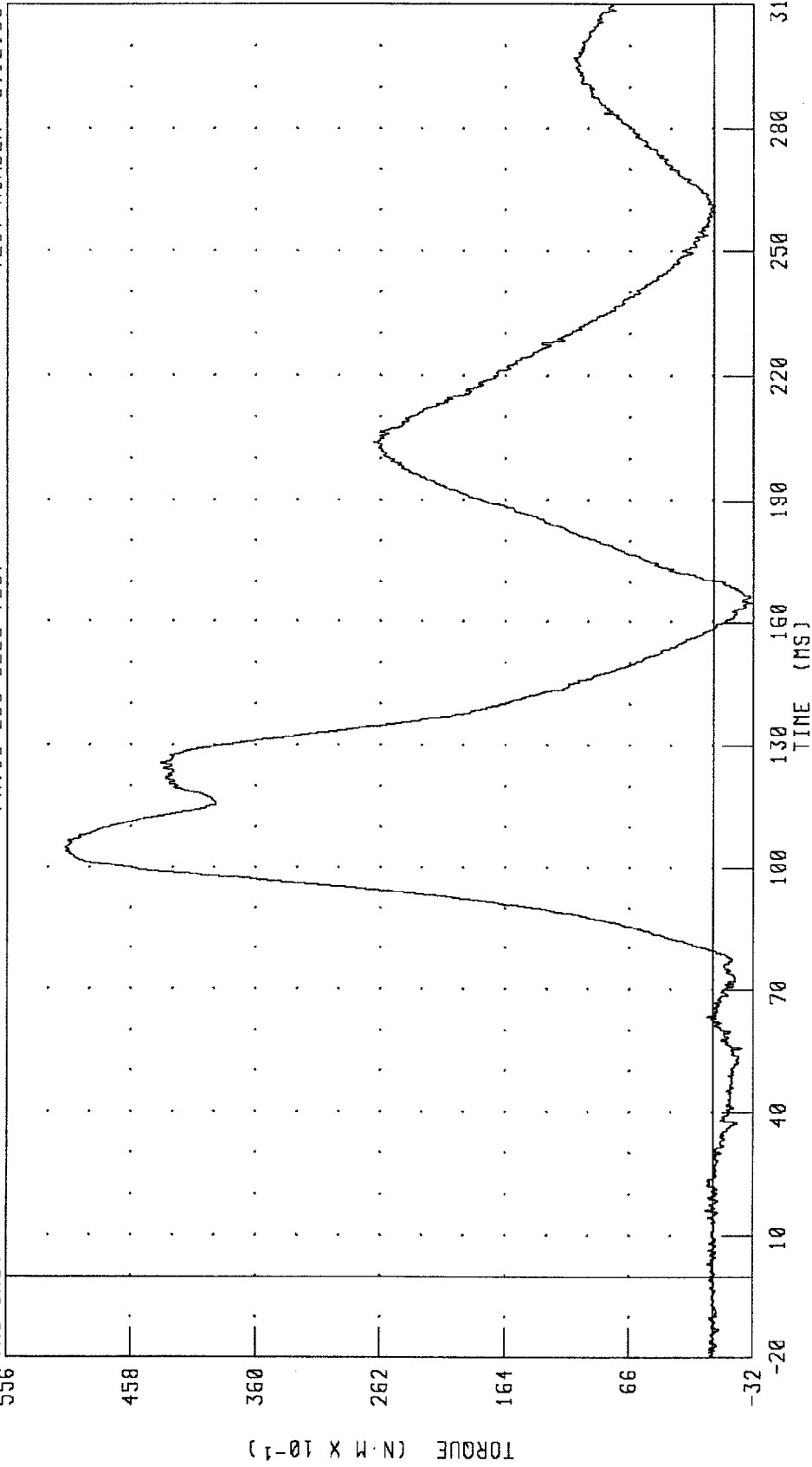

CHANNEL: NEKOM2 FILTER: CH. CLASS 600

PEAK DATA: 50.99 N·M @ 104.96 MS; -3.00 N·M @ 164.88 MS

CW0302 / 1998 FORD F-150 TRUCK
 RIGHT FRONT PASSENGER CHEST X-AXIS ACCELERATION
 FMVSS 208 SLED TEST TEST NUMBER: 971219S

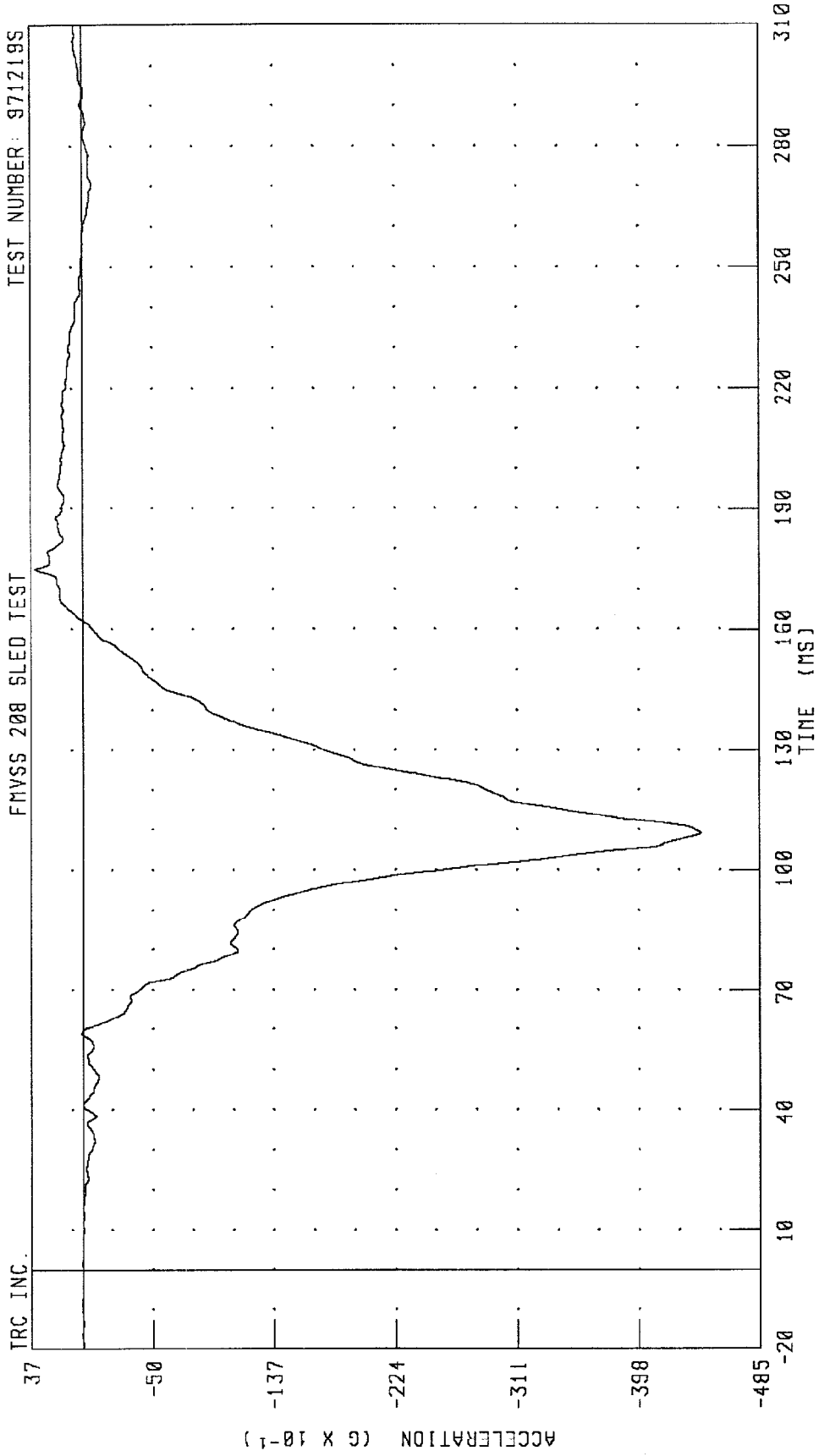

TRC INC.
 CHANNEL: CSTXG2 FILTER: CH. CLASS 180
 PEAK DATA: 3.39 G @ 174.96 MS; -44.25 G @ 109.20 MS

CW0302 / 1998 FORD F-150 TRUCK
RIGHT FRONT PASSENGER CHEST Y-AXIS ACCELERATION
FMVSS 208 SLED TEST TEST NUMBER: 971219S

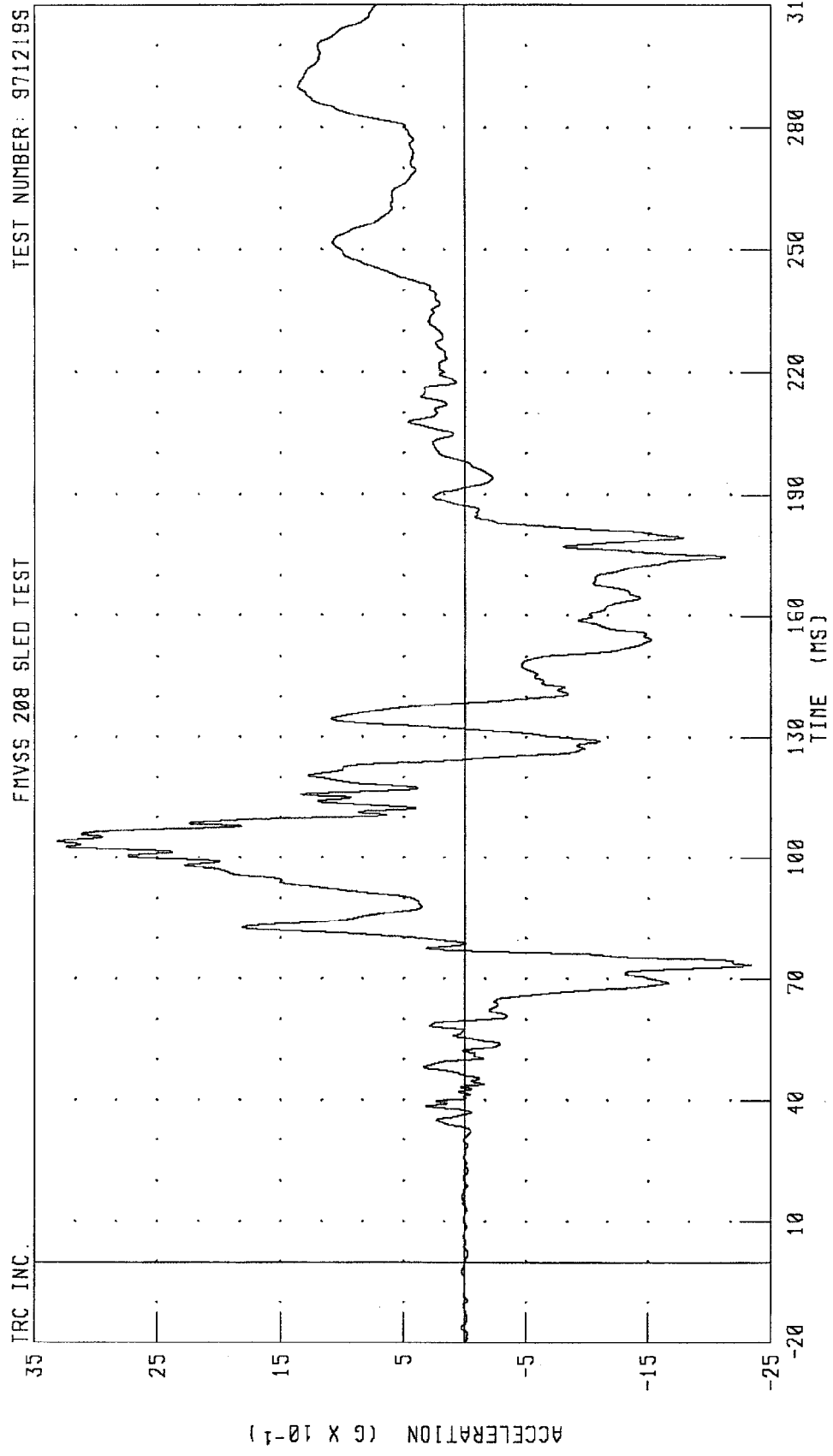

CHANNEL: CSTYG2 FILTER: CH. CLASS 180 PEAK DATA: 3.31 G @ 104.16 MS; -2.33 G @ 73.36 MS

CW0302 / 1998 FORD F-150 TRUCK
RIGHT FRONT PASSENGER CHEST Z-AXIS ACCELERATION
FMVSS 208 SLED TEST

TEST NUMBER: 971219S

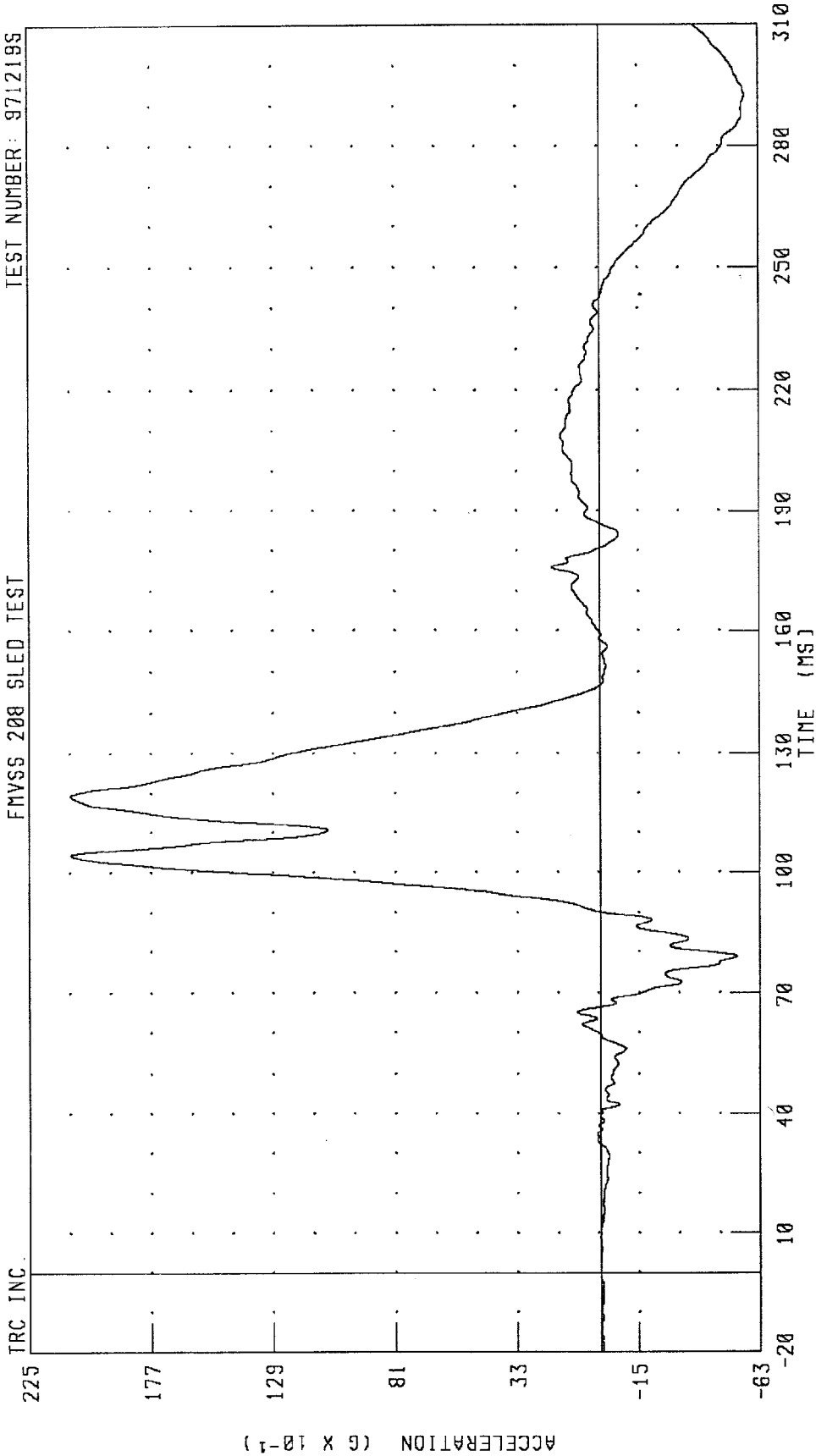

CHANNEL: CSTZG2 FILTER: CH. CLASS 180 PEAK DATA: 20.88 G @ 119.44 MS; -5.74 G @ 292.72 MS

CW0302 / 1998 FORD F-150 TRUCK
RIGHT FRONT PASSENGER CHEST RESULTANT ACCELERATION
FMVSS 208 SLED TEST

TEST NUMBER: 971219S

TRC INC.

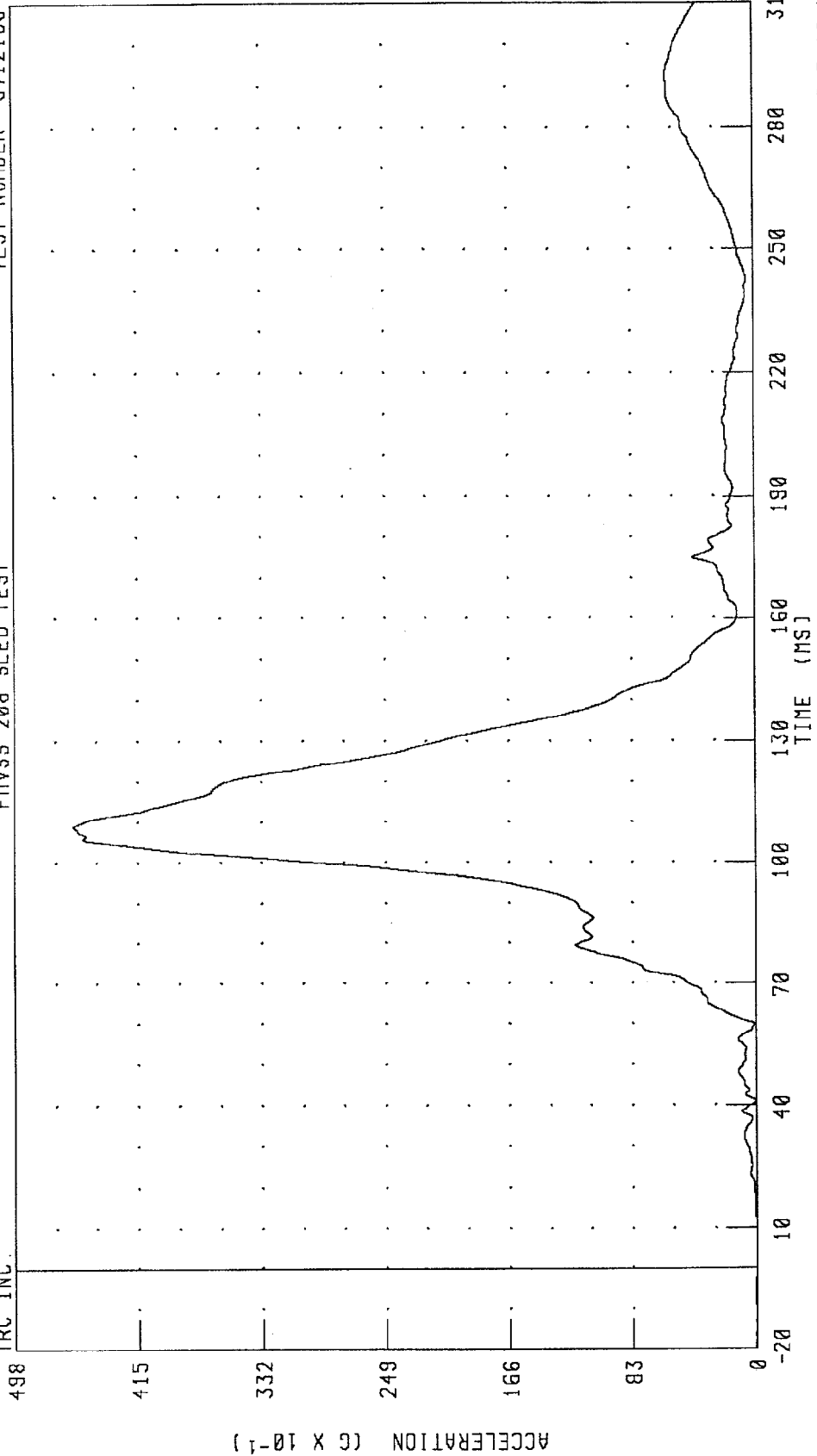

PEAK DATA: 45.82 G @ 108.96 MS; 0.01 G @ 5.12 MS

CHANNEL: CSTRG2 FILTER: CH. CLASS 180

ACCELERATION (G X 10⁻¹)

TIME (MS)

CW0302 / 1998 FORD F-150 TRUCK
RIGHT FRONT PASSENGER CHEST DEFLECTION
FMVSS 208 SLED TEST

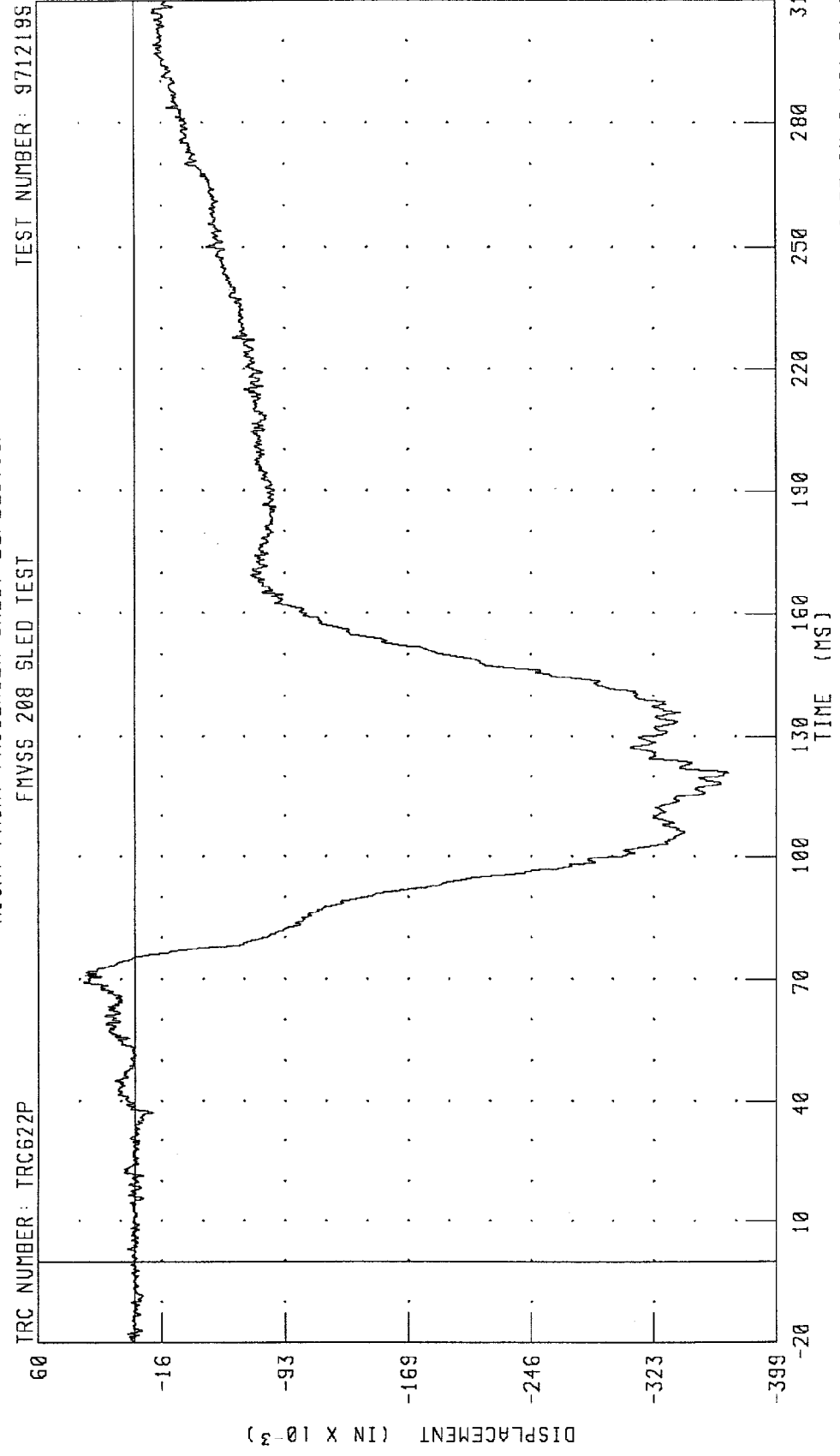

CHANNEL: CSTXD2 FILTER: CH. CLASS 600
PEAK DATA: 0.03 IN @ 69.36 MS; -0.37 IN @ 121.04 MS

CW0302 / 1988 FORD F-150 TRUCK
RIGHT FRONT PASSENGER LEFT FEMUR FORCE
FMVSS 208 SLED TEST

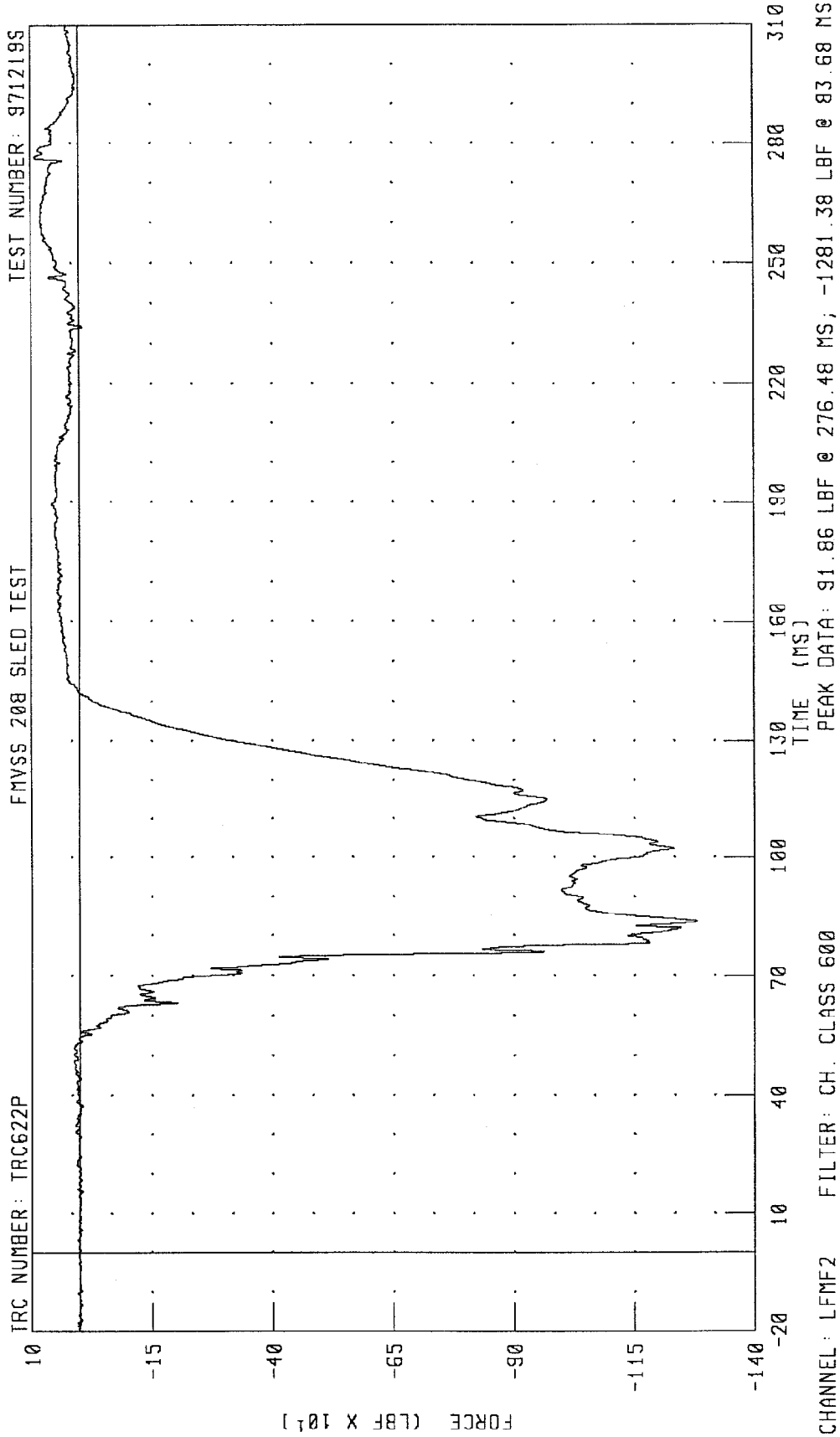

CW0302 / 1988 FORD F-150 TRUCK
RIGHT FRONT PASSENGER RIGHT FEMUR FORCE

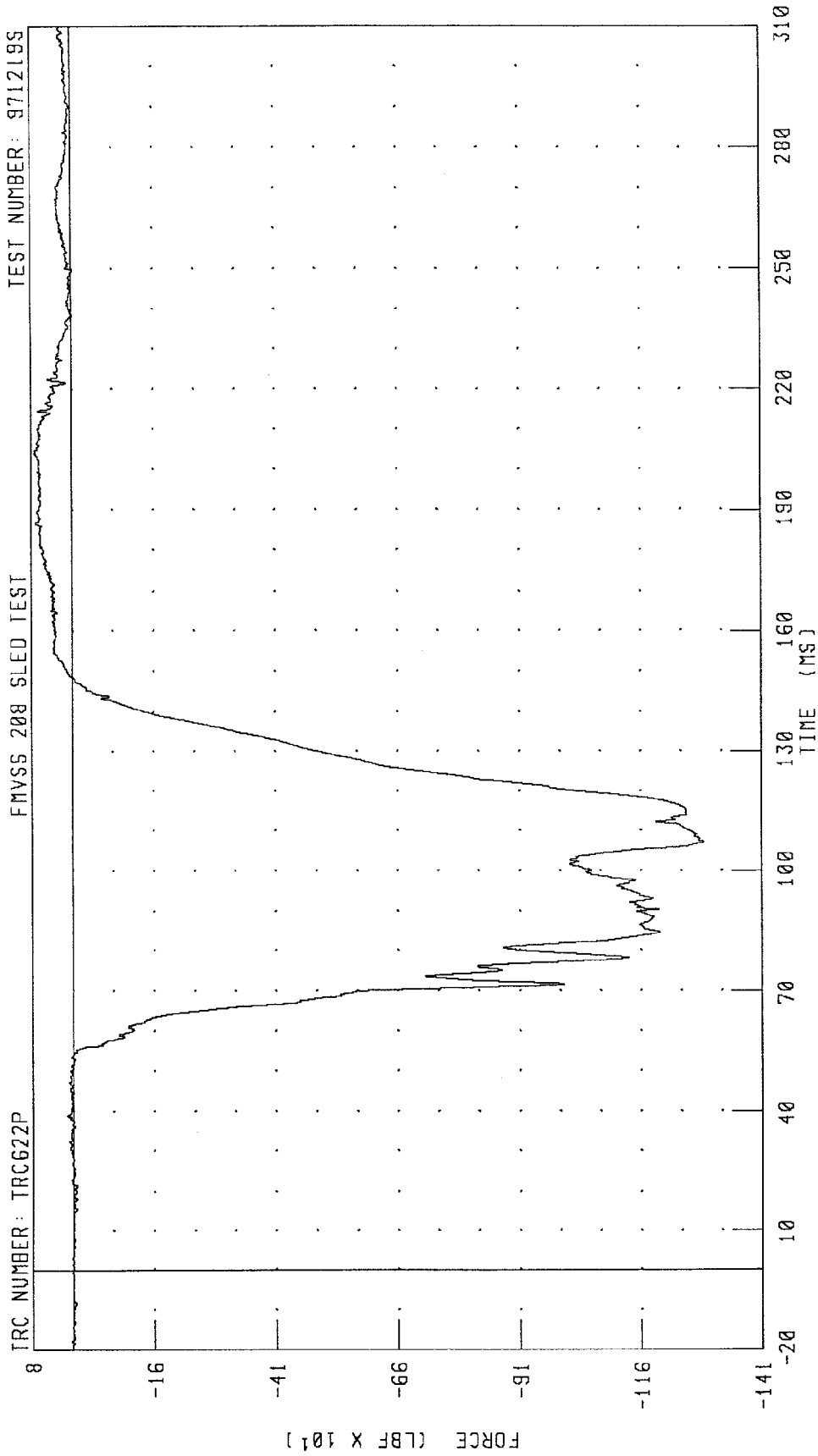

PEAK DATA: 76.86 LBF @ 204.00 MS; -1296.21 LBF @ 107.04 MS

CHANNEL: RFMF2 FILTER: CH. CLASS 600

Appendix C

Manufacturer's Vehicle Information



L. W. Camp
Director
Automotive Safety Office
Environmental And Safety Engineering

Ford Motor Company
330 Town Center Drive
Dearborn, Michigan 48126

October 3, 1997

Mr. Harry Thompson
Chief, Vehicle Division
Office of Vehicle Safety Compliance
National Highway Traffic Safety
Administration
400 Seventh Street, S. W.
Washington, D.C. 20590

07 OCT 6 P 1: 02

RECEIVED NSA-30

Dear Mr. Thompson:

Reference: NSA-31CCA/ OA:208970811J

This is in response to your letter of August 13, 1997, requesting information relative to possible FMVSS 208 testing by OVSC of the 1998 model year Ford F-Series (F150/F250) Pickup equipped with driver and passenger air bag restraint systems.

By means of this submittal Ford is responding in full to your request nos. 2-5 and 7-13, and in part to your request nos. 1 and 6. We currently estimate that we will be providing the remaining information by November 20, 1997. For your convenience, each request is listed followed by Ford's response.

Request No. 1

"Please inform OVSC if the air bag restraint system is certified to meet the requirements of S4.1.5.1(a)(1) or S13.

If the air bags were installed to meet the requirements of S4.1.5.1(a)(1), please provide a copy of the certification test reports for the frontal/angular barrier impact tests of the automatic restraint system with the manual safety belts unfastened and fastened.

If the air bags were installed to meet the requirements of S13, please provide a copy of the certification test reports for the frontal/angular barrier impact tests of the automatic restraint system with the manual safety belts fastened and the certification test reports for the sled test with only the automatic restraint system."



Response

Ford is installing Second Generation air bags in all 1998 MY vehicles subject to the FMVSS 208 passive restraint requirements. The air bag restraint systems for all 1998 Ford F-Series F150 and F250 vehicles incorporated Second Generation air bags and meet the requirements S13 of FMVSS 208.

Test reports demonstrating FMVSS 208 conformance for these Second Generation air bag equipped vehicles for the frontal barrier impact tests of the automatic restraint system with the manual safety belts fastened and test reports for the sled test with only the automatic restraint system will be finalized and provided to you by November 20, 1997. Angular requirements were addressed by means of engineering judgment based on the results of angular barrier tests of vehicles equipped with First Generation powered air bags with safety belts unfastened. A Test Report Data Summary of the frontal barrier and sled tests is provided as Attachment I.

Request No. 2

"If the air bags are or will be depowered or changed from the previous model year, explain the changes."

Response

The Second Generation driver air bag system has a revised inflator for a more shallow rise rate and revised air bag venting (vents were enlarged). The passenger air bag system has a revised inflator for a more shallow rise rate and lower maximum inflator pressure and reduced air bag volume.

Request No. 3

"If the air bag has been depowered or changed, explain how it can be determined, prior to purchase, that a particular vehicle has a depowered air bag."

Response

Attachment II contains a copy of the label affixed to the driver and front passenger side door windows indicating that the vehicle contains Second Generation air bags. Attachment 2 also contains a copy of that portion of the Ford Vehicle Identification Number (VIN) code information pertaining to restraint systems. For 1998 F-Series Pickups, the presence of a Second Generation air bag is indicated in position 4 of the VIN by an alternative code scheme which combines the brake system, the GVWR class and the type of restraint system. For instance, if the F-Series vehicle to be tested has hydraulic brakes and is in Class E, the position 4 VIN code will be "E" for vehicles equipped with first generation air bags or "R" for vehicles equipped with Second Generation air bags. Please note that a few early built vehicles have been equipped with the Second Generation air bags but may not contain this code. The presence of the label in the door windows should be relied on for establishing with certainty the presence of Second Generation air bags.

Request No. 4

"If the vehicle was certified with unrestrained dummies to meet the requirements of S13, describe how to disconnect the air bags from the vehicle sensors and connect them to the triggering mechanism used in the sled test. Describe the method used in certification to determine when to trigger the air bag and the system used to trigger the air bag."

Response

The air bag was disconnected by locating the squib wires going into the air bag and unhooking the connector between the vehicle wiring harness and the air bag. The squib wires are then connected to an extension cable which supplies the firing current from the Programmable Time Fire Unit located in the Hyge sled control room. This system has an arming circuit and variable time delay (adjustable to 0.1 msec) which starts counting once time zero (T=0) has been triggered. At 20 msec after T=0, the Programmable Time Fire Unit sends current through the extension cable and into the air bag squib.

The Programmable Time Fire Unit has the capability of supplying between 12.0 and 12.5 volts with a momentary peak current draw of 20 amps. In testing conducted by Ford, the typical current draw is 3 to 6 amps. The time delay between T=0 and air bag deployment has been determined to be 20 msec. (An accelerometer is used on the sled to actually trigger T=0 when an acceleration of 0.5g is attained on the sled.)

Request No.5

"State for any safety belt system in this vehicle whether or not it is equipped with a tension-relieving device. Provide a copy of the information furnished in accordance with S7.4.2, if the tension-relieving device is used."

Response

Tension-relieving devices are not used in 1998 F-Series Pickup safety belt systems.

Request No. 6

"FMVSS No. 208, S8.1.5, allows the manufacturer the option of having movable vehicle windows and vents placed in the closed position. State whether the vehicle's movable windows and vents were opened or closed for the certification tests."

Response

The positions of moveable windows in the crash tests that were relied upon as a basis for certification to FMVSS 208 of 1998 F-Series Pickup vehicles will be provided with the test report summaries which will be forwarded to you by November 20, 1997. Ford prefers that the windows be in the closed (up) position for testing.

Request No. 7

" Submit dummy placement measurements, including diagrams or photographs which show exactly where measurements were taken. Enclosed is a diagram of some of OVSC's dummy measurements. Where possible, use the dimension shown in the diagram to provide the individual dummy placement measurements.

State whether the vehicle has a foot rest for the driver."

Response

Attachment III contains dummy placement measurements applicable to the 1998 Ford F-Series Pickup.

The 1998 F-Series Pickup has a foot rest for the driver .

Request No. 8

"Provide the seat positioning, steering column positioning, and fuel tank data on the enclosed form. If more than one front seating configuration, steering column, or fuel tank are available on this vehicle, provide separate information for each."

Response

Attachment IV contains the NHTSA form enclosed with your letter completed with the requested seat positioning, steering column positioning, and fuel tank data applicable to FMVSS No. 208 testing of the 1998 F-Series Pickup.

Request No. 9

"If the vehicle is equipped with adjustable seat [belt] anchorages, provide the manufacturer's nominal design position for a 50th percentile adult male occupant."

Response

The 1998 F-Series Pickup vehicles are equipped with adjustable seat belt anchorages. The nominal design position of the D-ring for the 50th percentile adult male occupant is in the mid position.

Request No. 10

" For barrier tests provide the speed at impact, vehicle test weight, and resulting injury criteria (i.e., HIC, chest acceleration, chest compression and femur loads) recorded for all certification tests conducted to meet the requirements of S4.1.5.1(a)(1). For sled tests, provide the resulting injury criteria (i.e., HIC, chest acceleration, chest compression, femur loads, and neck moments and forces) recorded for all certification tests conducted to meet the requirements of S13."

Response

This information is included in a Test Report Summary found in Attachment 1.

Request No. 11

"When vehicle components must be removed to obtain the proper test weight for the barrier test, what components do you recommend for removal and in what priority order do you recommend removal?"

Response

The following is a suggested list of items which may be removed from the test vehicle for the barrier test. The list below is in order of removal priority:

- ◊ Liftgate
- ◊ Rear bumper
- ◊ Rear Seat (supercab)
- ◊ Spare tire

All onboard instrumentation should be included in the vehicle test weight.

Request No. 12

"If the vehicle uses a pressure vessel to inflate the air bag, provide a copy of the test reports or engineering analysis to demonstrate that it meets all the requirements of S9.1."

Response

The 1998 F-Series vehicles do not use pressure vessels to inflate the air bags.

Request No. 13

"If the vehicle uses an explosive device to inflate the air bag, provide a copy of the test report or engineering analysis to demonstrate that it meets all the requirements of S9.2."

Response

Attachment V contains the engineering analyses and the related TRW test reports demonstrating compliance to S9.2 of FMVSS No. 208 for the 1998 Ford F-Series 150/250 (PN96/PN102) driver and passenger air bag systems.

We believe the information and test reports contained herein are otherwise fully responsive to your request. If you have any questions, please call Mr. Roger Kolassa on (313) 337-6969.

Very truly yours,

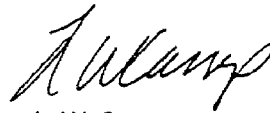

L. W. Camp

Attachments

TEST VEHICLE INFORMATION

Vehicle Model Year & Make: 1998 Ford F-Series Pickup
 Vehicle Model & Body Style: F150/F250

1. NOMINAL DESIGN RIDING POSITION –

For adjustable driver and passenger seat backs.

Please describe how to position the inclinometer to measure the seat back angle. Include description of the location of the adjustment latch detent if applicable.

Seat back angle for driver's seat = 21.4 degrees.

Measurement instructions:

Seat back angle is measured relative to the rocker sill. Remove back panel and position inclinometer as shown in drawing 13 inches above back pivot point on rear outboard seat frame. Avoid taking measurement on reinforced plate.

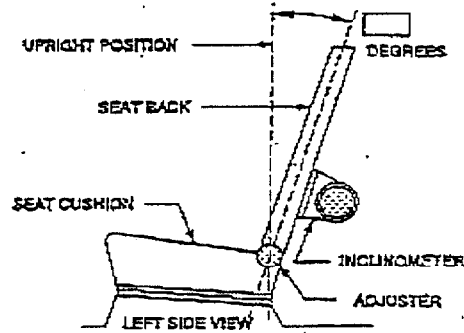

Seat back angle for passenger's seat = 21.4 degrees.

Measurement instructions:

Same as driver.

2. SEAT FORE & AFT POSITIONS –

Provide instructions for positioning the driver and front outboard passenger seat(s) in the center of fore and aft travel. For example, provide information to locate the detent in which the seat track is to be locked.

Positioning of the driver's seat:

A reference mark is made on the seat. The seat is moved to the full rear position, and a mark is placed on the pedestal or carpet. The procedure is repeated for the full forward position. The distance from full forward to full rear is taken, half the distance is measured and marked on the pedestal. The seat reference is located at the mid position mark or 1" notch rearward. There should be an equal number of notches forward and rearward when in mid position.

Positioning of the passenger's seat (if applicable):

Same as driver.

FUEL TANK CAPACITY DATA --

3.1 A. "Usable Capacity" of standard equipment fuel tank = gallons.

B. "Usable Capacity" of optional equipment fuel tank = N/A gallons.

C. Capacity used when certification testing to requirements of FMVSS 301 = gallons.

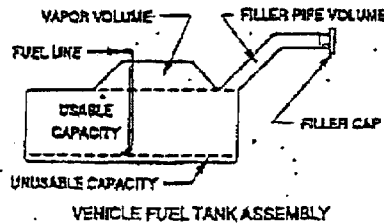

Operational Instructions:

* See bottom of page 2

3.2 Amount of Stoddard solvent added to vehicle for certification test = * gallons

3.3 Is vehicle equipped with electric fuel pump? YES NO

If YES, explain the vehicle operating conditions under which the fuel pump will pump fuel.

The electric fuel pump operates for 2 seconds to pressurize the fuel system following the actuation of the ignition. If no attempt has been made to start the engine within 2 seconds following ignition actuation, the fuel pump will shut off. The fuel pump operates continuously while the engine is running. If the engine stalls, the fuel pump is inactivated. Also, a fuel pump shut-off switch is provided, designed to stop fuel flow to the engine if the vehicle sustains an impact above a certain magnitude.

4. STEERING COLUMN ADJUSTMENTS --

Steering wheel and column adjustments are made so that the steering wheel hub is at the geometric center of the locus it describes when it is moved through its full range of driving positions.

If the tested vehicle has any of these adjustments, does your company use any specific procedures to determine the geometric center.

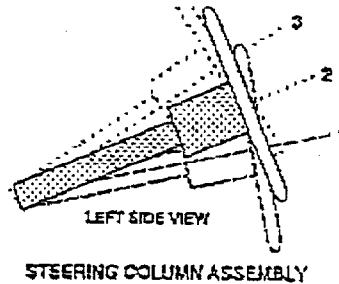

Operational Instructions:

Adjust column to center detent which is 3rd notch of the 5 positions.

* "Usable Capacity" of standard equipment fuel tank and of vehicles used for certification testing to the requirements of FMVSS 301/ amount of Stoddard solvent added to vehicles used for certification tests

Regular Cab/ Short 4X4	24.5 gallon capacity	23.3 gallons Stoddard solvent added
Regular Cab/ Short 4X2 & Super Cab/Short	25.0 gallon capacity	23.8 gallons Stoddard solvent added
Regular Cab/Long & Super Cab/Long	30.0 gallon capacity	28.5 gallons Stoddard solvent added