

V2748

REPORT NUMBER: CAL-98-11

**NEW CAR ASSESSMENT PROGRAM (NCAP)
FRONTAL BARRIER IMPACT TEST**

**FORD MOTOR CO. INC.
1998 FORD TAURUS
4-DOOR SEDAN**

NHTSA NUMBER: MW0209

CALSPAN TEST NUMBER: 8413-10

CALSPAN SRL CORPORATION
TRANSPORTATION SCIENCE CENTER
P.O. BOX 400
BUFFALO, NEW YORK 14225



December 2, 1997

FINAL REPORT

PREPARED FOR:

U. S. DEPARTMENT OF TRANSPORTATION
National Highway Traffic Safety Administration
Safety Performance Standards
Office of Crashworthiness Standards
Mail Code: NPS-10
400 Seventh Street, SW, Room No. 5313
Washington, DC 20590

This publication is distributed by the U. S. Department of Transportation, National Highway Traffic Safety Administration, in the interest of information exchange. The opinions, findings and conclusions expressed in this publication are those of the author(s) and not necessarily those of the Department of Transportation or the National Highway Traffic Safety Administration. The United States Government assumes no liability for its contents or use thereof. If trade or manufacturers' names or products are mentioned, it is only because they are considered essential to the object of the publication and should not be construed as an endorsement. The United States Government does not endorse products or manufacturers.

Prepared by: James A. Czarnetzki
James A. Czarnetzki, Project Engineer

Approved by: David J. Travale
David J. Travale, Program Manager
Transportation Research/
Physical Sciences Department

Approval Date: January 5, 1998

FINAL REPORT ACCEPTANCE BY OCS:

Manager, New Car Assessment Program (NCAP)
NHTSA, Office of Crashworthiness Standards

Date of Report Acceptance

COTR, New Car Assessment Program (NCAP)
NHTSA, Office of Crashworthiness Standards

Date of Report Acceptance

TECHNICAL REPORT STANDARD TITLE PAGE

1. <i>Report No.</i> CAL-98-11	2. <i>Government Accession No.</i>	3. <i>Recipient's Catalog No.</i>	
4. <i>Title and Subtitle</i> Final Report of NEW CAR ASSESSMENT PROGRAM (NCAP) Testing of a 1998 Ford Taurus 4-Door Sedan NHTSA No. MW0209		5. <i>Report Date</i> December 2, 1997	
		6. <i>Performing Organization Code</i> CAL	
7. <i>Author(s)</i> David J. Travale, Program Manager James A. Czarnecki, Project Engineer		8. <i>Performing Organization Report No.</i> 8413-10	
9. <i>Performing Organization Name and Address</i> Calspan SRL Corporation 4455 Genesee Street Buffalo, New York 14225		10. <i>Work Unit No.</i>	
		11. <i>Contract or Grant No.</i> DTNH22-96-D-02010	
12. <i>Sponsoring Agency Name and Address</i> U.S. Department of Transportation National Highway Traffic Safety Administration Office of Crashworthiness Standards Mail Code: NPS-10 400 Seventh, SW, Room 5313 Washington, D.C. 20590		13. <i>Type of Report and Period Covered</i> Final Report December 1997	
		14. <i>Sponsoring Agency Code</i> NPS-10	
15. <i>Supplementary Notes</i>			
16. <i>Abstract</i> A frontal barrier test of a 1998 Ford Taurus 4-Door Sedan was performed at Calspan SRL Corporation crash test facility in Buffalo, New York, on December 2, 1997. The impact velocity was 56.2 kph and the temperature at the barrier face was 20.5°C. The maximum post-test vehicle crush was 405 mm. The test vehicle was equipped with a 3-point belt system and supplemental second generation airbags at both front outboard seating positions. With respect to FMVSS 208 "Occupant Crash Protection - Injury Criteria" both the driver and passenger appear to comply with the head, chest and femur requirements.			
17. <i>Key Words</i> 56 kph Frontal Barrier Impact test New Car Assessment Program (NCAP)		18. <i>Distribution Statement</i> <u>Copies of this report are available from:</u> NHTSA Technical Reference Division National Highway Traffic Safety Admin. 400 Seventh St., SW, Room 5108 Washington, DC 20590	
19. <i>Security Classif. (of this report)</i> UNCLASSIFIED	20. <i>Security Classif. (of this page)</i> UNCLASSIFIED	21. <i>No. of Pages</i> 243	22. <i>Price</i>

Form DOT F1700.7 (8-69)

TABLE OF CONTENTS

<u>Section</u>		<u>Page No.</u>
1	PURPOSE AND SUMMARY OF NCAP TEST	1-1
2	OCCUPANT AND VEHICLE INFORMATION / DATA SHEETS	2-1
	DATA SHEET NO. DESCRIPTION	
	1. CRASH TEST SUMMARY	2-1
	2. GENERAL TEST AND VEHICLE PARAMETER DATA	2-2
	3. POST IMPACT DATA	2-4
	4. TEST VEHICLE INFORMATION	2-5
	5. DUMMY POSITIONING IN VEHICLE	2-8
	6. SEAT BELT POSITIONING DATA	2-9
	7. VEHICLE ACCELEROMETER LOCATION AND DATA SUMMARY	2-11
	8. DUMMY INJURY CRITERIA VALUES	2-12
	9. SEAT BELT PERFORMANCE DATA	2-19
	10. SUMMARY OF FMVSS 212 DATA	2-20
	11. WINDSHIELD ZONE INTRUSION FMVSS 219 DATA	2-21
	12. FMVSS 301 FUEL SYSTEM INTEGRITY DATA	2-22
	13. FMVSS 310 ROLLOVER DATA	2-23
	14. VEHICLE MEASUREMENTS	2-28
	15. CAMERA DATA	2-34
	16. REFERENCE PHOTO TARGETS	2-35
	17. LOAD CELL LOCATIONS ON FIXED BARRIER	2-36
	18. POST TEST AIR BAG DATA	2-37
	19. ACCIDENT INVESTIGATION DIVISION DATA	2-38
APPENDIX A	PHOTOGRAPHS	A-1
APPENDIX B	VEHICLE AND DUMMY RESPONSE DATA	B-1
APPENDIX C	PART 572 B&E DUMMY CONFIGURATION AND PERFORMANCE VERIFICATION TESTS	C-1
APPENDIX D	DUMMY, VEHICLE AND LABORATORY INSTRUMENT CALIBRATION	D-1

Section 1

PURPOSE AND SUMMARY OF TEST MW0209

PURPOSE

This 56.2 kph frontal barrier impact test is part of the Vehicle Barrier Impact Testing Program sponsored by the National Highway Traffic Safety Administration (NHTSA) under Contract No. DTNH22-96-D-02010. The purpose of this test was to obtain vehicle crashworthiness and occupant restraint system performance data for an impact speed in excess of the current 48.3 kph requirements.

The 56.2 kph frontal barrier impact test was conducted in accordance with the Office of Market Incentives (OMI) Laboratory Indicant Test procedure.

SUMMARY

A barrier was impacted by a 1998 Ford Taurus 4-Door Sedan at a velocity of 56.2 kph. The test was performed at the Calspan SRL Corporation on December 2, 1997. Pre- and post-test photographs of the vehicle and dummies can be found in Appendix A.

The frontal barrier impact event was documented by 1 real-time camera and 16 high-speed cameras. Camera locations and other pertinent camera information can be found in this report.

Two Part 572E, 50th percentile male anthropomorphic test devices (ATDs), were placed in the driver and right-front passenger seating positions according to dummy placement instructions specified in the Laboratory Indicant Test Procedure.

Both ATDs were fully instrumented with head, chest, and pelvis triaxial accelerometers, chest displacement potentiometers, upper neck transducers, right/left femur load cells, and lower leg instrumentation. Seat belt load cells were also on the driver's and passenger's lap and shoulder belts to measure dummy torso and pelvic section loading. The driver (position 1) ATD (Serial No. 064) was used for two previous tests (MW0102 and MW5102) and the right-front passenger (position 2) ATD (Serial No. 245) was used for one previous test (MW5102). FMVSS injury criteria for ATD's No. 064 and 245 were not exceeded in the previous tests. Certification details, along with instrumentation calibration data, are found in Appendix C.

The 97 channels of data were recorded on a P.C. based data acquisition system. Appendix B contains the vehicle and dummy response data traces. Load cell barrier data was not requested for this test.

The driver's HIC was 577.3. The maximum chest deceleration over 3 milliseconds was 48.8 g's and maximum chest deflection was 36.2 mm. Femur loads were -4368.7 Newtons on the left and -4351.4 Newtons on the right.

The right front passenger's HIC was 485.8. Maximum chest deceleration over 3 milliseconds was 51.0 g's and maximum chest deflection was 27.9 mm. Femur loads were -4623.4 Newtons on the left and -3808.6 Newtons on the right.

The position 1 neck Fx, and Fy and position 2 neck Fx, Fy, and Fz channels have noise superimposed after 125 ms. The position 2 belt elongation data is not accurate after 85 ms. The engine bottom X accelerometer (#4) data is questionable after 40 ms.

SECTION 2

GENERAL TEST AND VEHICLE PARAMETER DATA

DATA SHEET NO. 1 CRASH TEST SUMMARY

Vehicle NHTSA No. : MW0209 Test Mode : 56 kph Frontal Barrier

Test Date : December 2,1997 Time: 11:00 Temperature : 20.5 °C

Vehicle Make/Model/Body Style : 1998 Ford Taurus 4-Door Sedan

Vehicle Test Weight : 1738 kg

Vehicle/Barrier Impact Angle : 0 °

Impact Velocity : 56.2 kph

Maximum Static Crush : 405 mm

Vehicle Rebound : 408 mm

<u>DUMMIES:</u>	<u>DRIVER</u>	<u>PASSENGER</u>
Type :	<u> 572E </u>	<u> 572E </u>
Restraint System :	<u> Airbag with 3 point belt system </u>	<u> Airbag with 3 point belt system </u>

Number of Data Channels : 97

Number of Cameras : 1 Real Time
 16 High Speed

DOOR OPENING DATA : Closed/Operable - Left Front
 Closed/Operable - Right Front

Front Seat(s) Data :	<u>DRIVER</u>	<u>PASSENGER</u>
Seat Track Failure :(mm of shift)	<u> 0 </u>	<u> 0 </u>
Seat Back Failure :	<u> None </u>	<u> None </u>

<u>VISIBLE DUMMY CONTACT POINTS :</u>	<u>DRIVER</u>	<u>PASSENGER</u>
Head :	<u> Airbag/ Back of head to headrest </u>	<u> Airbag/ Back of head to headrest </u>
Abdomen :	<u> - </u>	<u> - </u>
Chest	<u> Airbag </u>	<u> Airbag </u>
Knees	<u> Knee Bolster </u>	<u> Knee Bolster </u>

DATA SHEET NO. 2 GENERAL TEST AND VEHICLE PARAMETER DATA

TEST VEHICLE INFORMATION :

Year/Make/Model/Body Style : 1998 Ford Taurus 4-Door Sedan
NHTSA No. : MW0209 ; VIN: 1FAFP52U6WG110835 ; Color : Blue
Engine Data: 6 cylinders; - CID; 3.0 Liters; - cc
Placement : x Longitudinal or In-Line; - Transverse or Lateral
Transmission Data : 3 speeds; - Manual; x Automatic; x Overdrive
Final Drive : - Rear Wheel Drive; x Front Wheel Drive; - Four Wheel Drive
Major Options : x A/C; x Pwr.Strg.; x Pwr. Brakes
x Pwr. Windows; - Pwr. Door Locks; x Tilt Wheel
Date Received : 11/25/97 ; Odometer Reading 51 km
Selling Dealer : West Herr Ford Inc.
& Address: S 5025 Camp Rd, Hamburg, N.Y. 14075

DATA FROM TIRE VEHICLE'S CERTIFICATION LABEL:

Vehicle Manufactured by : Ford Motor Co. Inc.
Date of Manufacture 9/97
GVWR : 2125 kg; GAWR: 1200 kg FRONT; 936 kg REAR

DATA FROM TIRE PLACARD:

Tire Pressure with Maximum Capacity Vehicle Load : 226 kpa FRONT
226 kpa REAR
Recommended Tire Size : P205/65R15
* Recommended Cold Tire Pressure : 226 kpa FRONT; 226 kpa REAR
Size of Tires on Test Vehicle: P205/65R15 ; Manufacturer: General
Vehicle Capacity Data :
Type of Front Seats: - Bench; x Bucket; - Split Bench
Number of Occupants: 3 Front; 3 Rear; 6 Total
Vehicle Capacity Weight (VCW) = 499 kg
No. of Occupants x 68 kg = 408 kg
Rated Cargo/Luggage Weight (RCLW) = 91 kg

*Tire pressure used for test

DATA SHEET NO. 2 GENERAL TEST AND VEHICLE PARAMETER DATA (cont.)

WEIGHT OF TEST VEHICLE AS RECEIVED FROM DEALER (with maximum fluids)= UDW:

Right Front	=	<u>495.5</u>	kg	Right Rear	=	<u>257.5</u>	kg
Left Front	=	<u>480.5</u>	kg	Left Rear	=	<u>266.5</u>	kg
TOTAL FRONT	=	<u>976.0</u>	kg	TOTAL REAR	=	<u>524.0</u>	kg
TOTAL DELIVERED WEIGHT	=	<u>1,500.0</u>	kg				
% of Total Front of Vehicle Weight	=	<u>65.1</u>	%	% of Total Rear Weight	=	<u>34.9</u>	%

CALCULATION OF VEHICLE'S TARGET TEST WEIGHT :

Total Delivered Weight (UDW)	=	<u>1,500.0</u>	kg
Rated Cargo/Luggage Weight (RCLW)	=	<u>91.0</u>	kg
Weight of 2 p.572 Dummies @ 76 each	=	<u>152</u>	kg
TARGET TEST WEIGHT	=	<u>1,743.0</u>	kg

WEIGHT OF TEST VEHICLE WITH TWO DUMMIES AND 86 KG OF CARGO WEIGHT:

Right Front	=	<u>524</u>	kg	Right Rear	=	<u>353</u>	kg
Left Front	=	<u>513</u>	kg	Left Rear	=	<u>348</u>	kg
TOTAL FRONT	=	<u>1,037.0</u>	kg	TOTAL REAR	=	<u>701.0</u>	kg
TOTAL TEST WEIGHT	=	<u>1,738.0</u>	kg				
% of Total Front Weight	=	<u>59.7</u>	%	% of Total Rear Weight	=	<u>40.3</u>	%
Weight of Ballast Secured in Vehicle Trunk Area	=	<u>0</u>	kg				
Vehicle Components Removed for Weight Reduction:		<u>None</u>					

VEHICLE ATTITUDE (all dimension in millimeters):

AS DELIVERED :	RF	<u>709</u>	LF	<u>713</u>	RR	<u>704</u>	LR	<u>701</u>
FULLY LOADED :	RF	<u>699</u>	LF	<u>705</u>	RR	<u>660</u>	LR	<u>658</u>
AS TESTED :	RF	<u>706</u>	LF	<u>706</u>	RR	<u>661</u>	LR	<u>659</u>
Vehicle's Wheel Base :		<u>2760</u>	mm					
Location of Vehicle's C.G. :		<u>1,113.2</u>	mm rearward of front wheel center.					

FUEL SYSTEM DATA :

Fuel System Capacity From Owner's Manual	=	<u>60.6</u>	liters
Usable Capacity Figure Furnished by COTR	=	<u>60.6</u>	liters
Test Volume Range (92 to 94% of Usable Capacity)	=	<u>55.7</u>	to <u>56.8</u> liters
ACTUAL TEST VOLUME	=	<u>56.0</u>	liters (with entire fuel system filled)
Test Fluid Type:	<u>Stoddard Solution</u> ;	Spec. Grav. =	<u>0.764</u>
	Kinematic Viscosity =	<u>0.96</u> centistokes;	Color = <u>Orange</u>
Type of Fuel Pump:	Electric- <u>x</u> ;	Mechanical- <u>-</u>	
Does Electric Pump operate with ignition switch "ON" & engine "OFF"		Yes- <u>X</u>	No- <u>-</u>
Details of Fuel System <u>Fuel filler located on right side aft of rear axle, fuel tank is centered fore of rear axle and fuel lines are running along right side of vehicle.</u>			

DATA SHEET NO. 3 POST IMPACT DATA

TYPE OF TEST:

Type of Test : Frontal Barrier Impact Angle : 0°
Test Date : December 2, 1997 Time: 11:00 Temperature: 20.5 °C
Vehicle NHTSA No. : MW0209
Required Impact Velocity Range : 55.7 to 57.1 kph

BARRIER IMPACT VELOCITY : (Speed traps within 5 feet of impact plane.)

Trap No. 1 = 56.2 kph; Trap No. 2 = 56.2 kph
Distance from vehicle to barrier : (1) entering trap = 813 mm
(2) exiting trap = 305 mm

VEHICLE STATIC CRUSH: (mm) (For frontal and rear impacts only.)

Vehicle Length:

Pre-Test Right = 4920 ; C/L = 5005 ; Left = 4925
Post-Test Right = 4515 ; C/L = 4605 ; Left = 4565
Crush Right = 405.0 ; C/L = 400.0 ; Left = 360.0
AVERAGE = 388.3 mm

VEHICLE REBOUND: (From rigid barrier only.)

Distance from front of test vehicle to impact point :

Right = 391 ; C/L = 395 ; Left = 437
AVERAGE = 407.7 mm

DATA SHEET NO. 4 TEST VEHICLE INFORMATION

VEHICLE IDENTIFICATION:

Model Year : 1998 Vehicle Model: Ford Taurus Body Style : 4-Door Sedan

1. Nominal Design Riding Position for adjustable driver and passenger seat backs. Please describe how to position the inclinometer to measure the seat back angle. Include description of the location of the adjustment latch detent, if applicable.

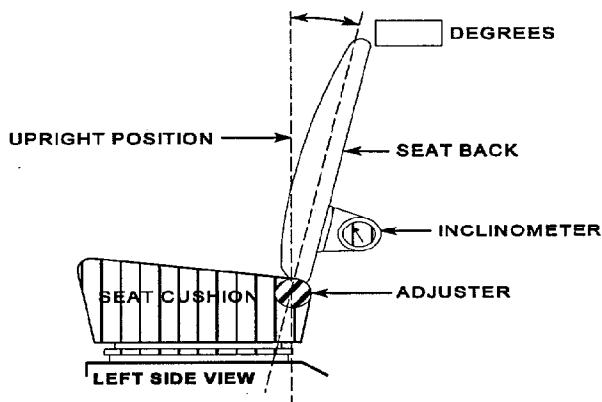

FRONT SEAT ASSEMBLY

Seat back angle for driver's seat : 27.8
 Measurement instructions : Position inclinometer 13" above pivot point on seat back frame, adjust to 27.8 degrees.

Seat back angle for passenger's seat : 27.8
 Measurement instructions : Position inclinometer 13" above pivot point on seat back frame, adjust to 27.8 degrees.

2. Seat Fore and Aft Positioning

Positioning of the driver's seat : Mechanical mid-position - 13 detents placed on 7th

Positioning of the passenger's seat (if applicable) : Mechanical mid-position - 13 detents placed on 7th

3. Fuel Tank Capacity Data

3.1

- A. "Usable Capacity" of the standard equipment fuel tank is 60.6 liters
 B. "Usable Capacity" of the optional equipment fuel tank is - liters
 C. "Usable Capacity" of the vehicle(s) used for certification testing to requirements of FMVSS 301 = 60.6 liters

3.2 Amount of Stoddard solvent added to vehicle(s) used for certification test(s) = 56.0 liters

3.3 Is vehicle equipped with electric fuel pump? Yes- x ; No- -

If YES, explain the vehicle operating conditions under which the fuel pump will pump fuel.

With ignition turned on.

DUMMY MEASUREMENT FOR FRONT SEAT PASSENGERS

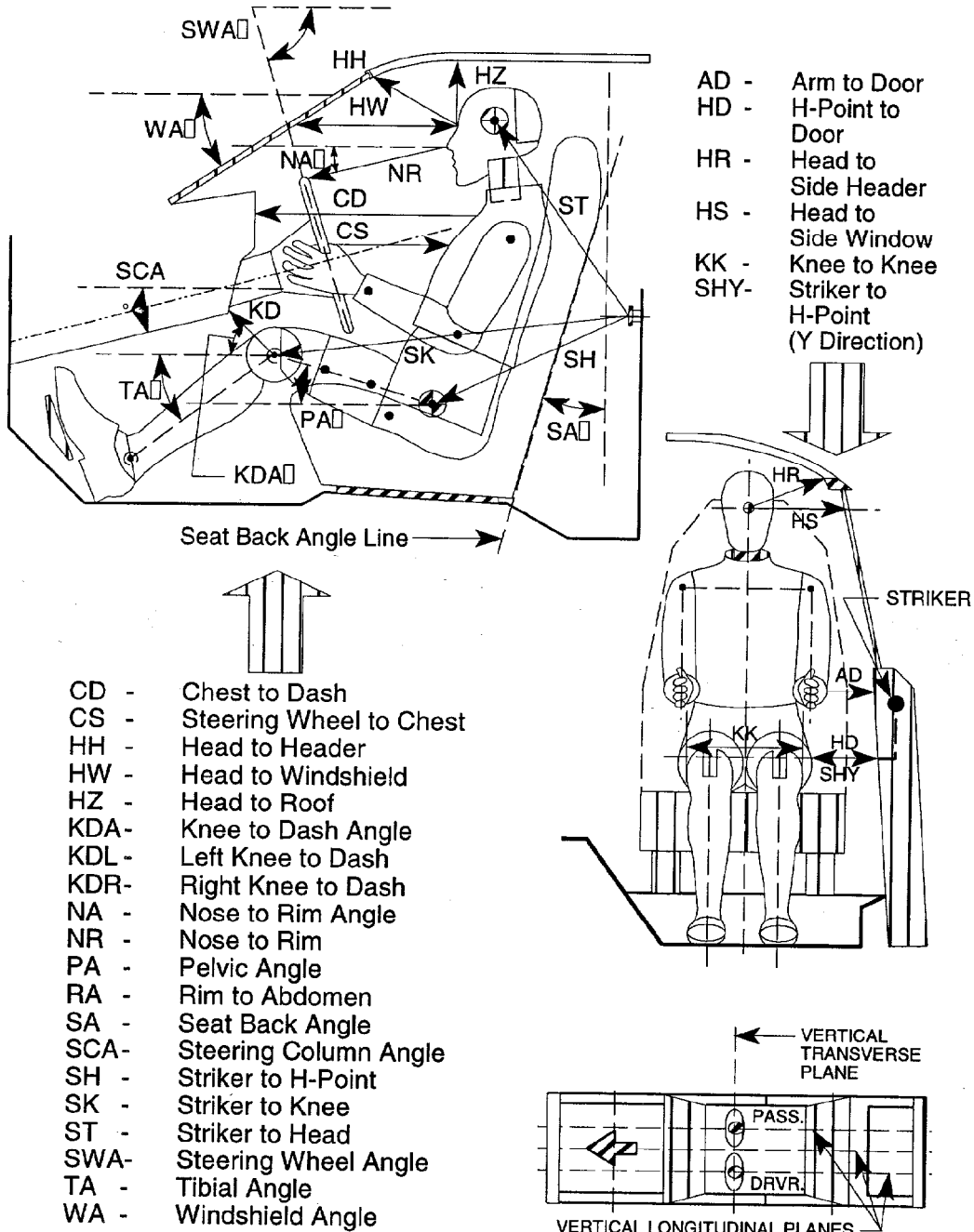

DATA SHEET NO. 5 FRONT SEAT DUMMY POSITIONING MEASUREMENTS IN VEHICLE

	DRIVER (Serial #064)			PASS. (Serial # 245)		
WA°	24 deg.			N/A		
SWA°	69 deg.			N/A		
SCA°	21 deg.			N/A		
SA°	27.8 deg.			27.8 deg.		
HZ	126			123		
HH	294			273		
HW	566			562		
HR	219			220		
NR	415	Angle	-12 deg.	N/A		
CD	542			473		
CS	341			N/A		
RA	197			N/A		
KDL	166	Angle (KDA)	36 deg.	116		
KDR	121			161	Angle (KDA)	45 deg.
PA°	22 deg.			24 deg.		
TA°	-55 deg.			-41 deg.		
KK	292			280		
ST	554	Angle	7 deg.	542	Angle	10 deg.
SK	601	Angle	90 deg.	596	Angle	93 deg.
SH	231	Angle	126 deg.	260	Angle	121 deg.
SHY	262			241		
HS	333			305		
HD	157			149		
AD	106			120		

Dimensions in millimeters

DATA SHEET NO. 6 SEAT BELT POSITIONING DATA

SEAT BELT POSITIONING DATA

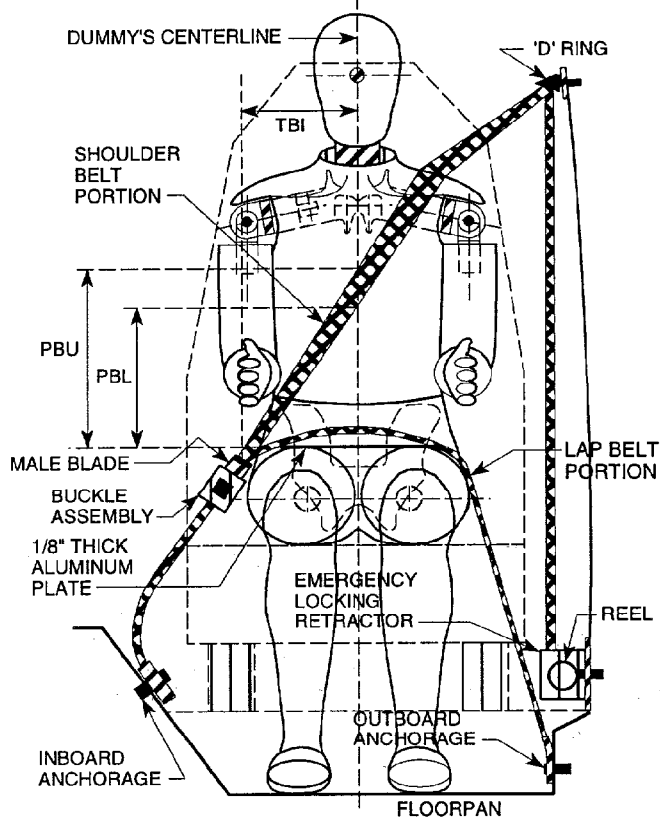

FRONT VIEW OF DUMMY

	DRIVER DUMMY (mm)	PASSENGER DUMMY (mm)
PBU -- Top surface of alum. plate to upper edge	304	292
PBL-- Top surface of alum. plate to belt lower edge	225	220
LAP BELT TENSION	10 N	10 N
SHOULDER BELT TENSION	Retractor	Retractor

VEHICLE ACCELEROMETER LOCATION AND DATA SUMMARY

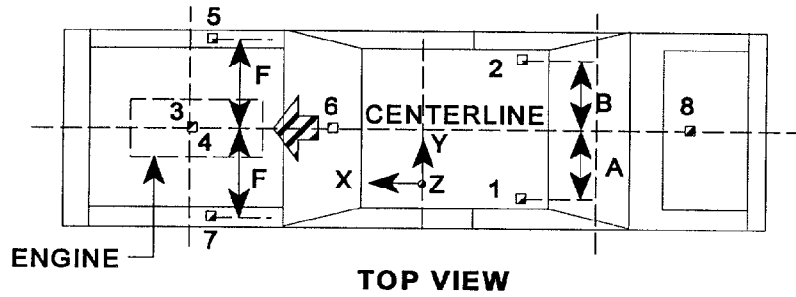

REAR SEAT CUSHION
ASSY. FRONT ATTACHMENT
BRACKET SUPPORT

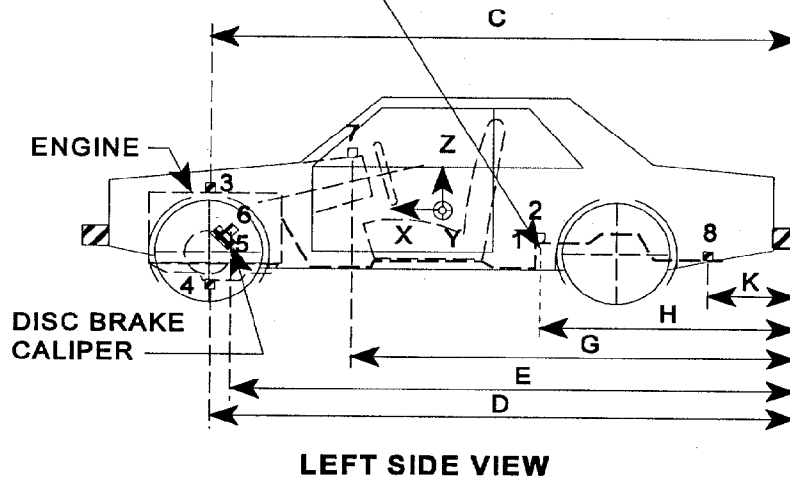

Note: Vehicle accelerometer location and data summary shown in DATA SHEET NO. 7

DATA SHEET NO. 8 DUMMY INJURY CRITERIA VALUES

NHTSA Test No.: MW0209 Vehicle: 1998 Ford Taurus 4-Door Sedan

DESCRIPTION	UNIT	MAXIMUM VALUE			
		Pos.	msec.	Neg.	msec.
Pos. 1 Head X	g's	8.5	243.6	-62.1	73.5
Pos. 1 Head Y	g's	1.1	231.1	-19.8	86
Pos. 1 Head Z	g's	24	67.7	-5.4	85.2
Pos. 1 Head Resultant	g's	65.8	73.5	0.1	-31.3
Pos. 2 Head X	g's	6.5	252	-49.7	74.1
Pos. 2 Head Y	g's	9.3	37	-15.3	48.7
Pos. 2 Head Z	g's	34.7	68.4	-3.2	126.1
Pos. 2 Head Resultant	g's	56.7	71.8	0.1	-30.7
Pos. 1 Chest X	g's	3.8	187.2	-48.2	72.2
Pos. 1 Chest Y	g's	1.1	148.2	-14.1	85.9
Pos. 1 Chest Z	g's	13.1	69.2	-7.7	86.6
Pos. 1 Chest Resultant	g's	49.8	72.2	0.0	10.2
Pos. 1 Chest Displacement	mm	0	23.2	-36.2	76.1
Pos. 2 Chest X	g's	4.1	290.9	-51.5	70.1
Pos. 2 Chest Y	g's	12.9	73.2	-10.1	92.2
Pos. 2 Chest Z	g's	14.7	56.4	-8.9	110.3
Pos. 2 Chest Resultant	g's	52.4	70.1	0.0	-33.4
Pos. 2 Chest Displacement	mm	0	20.3	-27.9	78.6
Pos. 1 Left Femur	N	462.6	42.0	-4368.7	49.7
Pos. 1 Right Femur	N	273.8	92.0	-4351.4	54.2
Pos. 2 Left Femur	N	578.4	91.2	-4623.4	52.8
Pos. 2 Right Femur	N	191.0	42.9	-3808.6	53.1
Pos. 1 Left Belt Load	N	5031.2	57.4	-34.1	278.8
Pos. 1 Torso Belt Load	N	8433.4	68.3	-38.2	235.7
Pos. 2 Right Belt Load	N	4685.1	59.3	-83	348.1
Pos. 2 Torso Belt Load	N	6609.1	67.9	-49.6	334.3

DATA SHEET NO. 7 VEHICLE ACCELEROMETER LOCATIONS AND DATA SUMMARY

DIMENSION	LENGTH (mm)	
	PRE-TEST VALUES	
A Left Rear Seat Crossmember Y	625	655 (redundant)
B Right Rear Seat Crossmember Y	615	645 (redundant)
C Top of Engine X	4054	
D Bottom of Engine X	3914	
E Disc Brake Calipers X	3849	
F Disc Brake Calipers Y	645 left	640 right
G Instrument Panel X	3053	
H Rear Seat Crossmembers X	1783	

LOCATION NUMBER	DESCRIPTION	MAXIMUM VALUE (g's)			
		Pos.	msec.	Neg.	msec.
1	Rear Seat X-Member @ Left Side	1.9	137.1	-32.9	35.2
2	Rear Seat X-Member @ Right Side	2.8	137.3	-32.7	33.7
3	Top of Engine Block	41.3	53.2	-100	35.9
4	Bottom of Engine	*	*	-136.5	36.7
5	Disc Brake Caliper @ Left Side	3.4	144.2	-53.7	33.9
6	Disc Brake Caliper @ Right Side	2.5	222.3	-67.8	36.2
7	Instrument Panel	14.9	67.8	-58.7	74
8	Rear Seat X-Member @ Left-Redundant	1.8	142.1	-33.2	35.5
9	Rear Seat X-Member @ Right-Redundant	2.1	143.9	-31.9	33.5

* Data questionable after 40 ms.

DATA SHEET NO. 8 DUMMY INJURY CRITERIA VALUES (cont.)
HYBRID III NECK AND PELVIC DATA SHEET

Vehicle Year/Make/Model/Body Style: 1998 Ford Taurus 4-Door Sedan
 NHTSA Test No.: MW0209 Test Date: December 2, 1997

DESCRIPTION	UNIT	MAXIMUM VALUE			
		Pos.	msec	Neg.	msec
Pos. 1 Upper Neck Fx	N	415.8	83.6	*	*
Pos. 1 Upper Neck Fy	N	*	*	*	*
Pos. 1 Upper Neck Fz	N	3148.4	67.8	-370.1	137.6
Pos. 1 Neck Force Result	N	3156.2	67.8	5.0	-21.7
Pos. 1 Upper Neck Mx	N-m	9.5	148.1	-31.2	79.1
Pos. 1 Upper Neck My	N-m	31.4	131.7	-28.0	248.1
Pos. 1 Upper Neck Mz	N-m	32.4	103.8	-17.0	160.3
Pos. 1 Neck Moment Result	N-m	36.9	101.8	0.1	-35.5
Pos. 2 Upper Neck Fx	N	*	*	*	*
Pos. 2 Upper Neck Fy	N	*	*	*	*
Pos. 2 Upper Neck Fz	N	1307.9	63.3	*	*
Pos. 2 Neck Force Result	N	1324.9	62.7	4.0	-4.4
Pos. 2 Upper Neck Mx	N-m	26.2	88.4	-18.7	121.2
Pos. 2 Upper Neck My	N-m	44.7	58.5	-19.3	253.9
Pos. 2 Upper Neck Mz	N-m	25.3	98.0	-14.6	150.2
Pos. 2 Neck Moment Result	N-m	46.9	57.1	0.1	-35.7
Pos. 1 Pelvic (X)	g's	3.2	142.8	-57.0	50.3
Pos. 1 Pelvic (Y)	g's	6.2	49.6	-12.3	65.2
Pos. 1 Pelvic (Z)	g's	4.2	41.5	-15.4	73.7
Pos. 1 Pelvic (R)	g's	57.4	50.3	0.1	-32.1
Pos. 2 Pelvic (X)	g's	4.9	118.6	-49.6	52.9
Pos. 2 Pelvic (Y)	g's	8.2	46.4	-10.3	75.2
Pos. 2 Pelvic (Z)	g's	6.5	38.7	-18.9	87.1
Pos. 2 Pelvic (R)	g's	49.9	52.9	0.1	9.4

*Data noise superimposed after 125 ms.

DATA SHEET NO. 8 DUMMY INJURY CRITERIA VALUES (cont.)
HYBRID III LOWER LEG DATA SHEET

Vehicle Year/Make/Model/Body Style: 1998 Ford Taurus 4-Door Sedan

NHTSA Test No.: MW0209 Test Date: December 2, 1997

DESCRIPTION	UNIT	MAXIMUM VALUE			
		Pos.	msec	Neg.	msec
P1 Lt Upper Tibia Mx	N-m	30.9	51.7	-20.5	79.7
P1 Lt Upper Tibia My	N-m	7.9	104.8	-115.0	55.4
P1 Lt Lower Tibia Fx	N	57.1	166.9	-1258.7	60.1
P1 Lt Lower Tibia Fz	N	143.8	140.9	-2108.9	59.2
P1 Lt Lower Tibia My	N-m	140.1	64.1	-12.9	23.9
P1 Rt Upper Tibia Mx	N-m	60.3	55.9	-36.7	44.7
P1 Rt Upper Tibia My	N-m	186.4	59.7	-10.3	155.4
P1 Rt Lower Tibia Fx	N	85.5	140.5	-1354.2	43.6
P1 Rt Lower Tibia Fz	N	122.8	160.8	-2244.5	43.0
P1 Rt Lower Tibia My	N-m	217.4	70.9	-39.4	47.9
Pos. 2 Lt Upper Tibia Mx	N-m	8.9	199.4	-60.1	79.1
Pos. 2 Lt Upper Tibia My	N-m	6.5	161.2	-164.1	40.2
Pos. 2 Lt Lower Tibia Fx	N	62.0	162.6	-1245.3	40.0
Pos. 2 Lt Lower Tibia Fz	N	189.7	280.4	-5745.4	40.0
Pos. 2 Lt Lower Tibia My	N-m	21.6	37.9	-24.2	57.0
Pos. 2 Rt Upper Tibia Mx	N-m	38.4	81.1	-15.9	72.5
Pos. 2 Rt Upper Tibia My	N-m	18.0	73.4	-119.0	39.5
Pos. 2 Rt Lower Tibia Fx	N	492.2	85.7	-1024.1	56.7
Pos. 2 Rt Lower Tibia Fz	N	225.5	150.3	-4414.8	38.1
Pos. 2 Rt Lower Tibia My	N-m	20.6	74.1	-24.2	57.0

DATA SHEET NO. 8 DUMMY INJURY CRITERIA VALUES (cont.)
HYBRID III ANKLE DATA SHEET

Vehicle Year/Make/Model/Body Style: 1998 Ford Taurus 4-Door Sedan
 NHTSA Test No.: MW0209 Test Date: December 2,1997

DESCRIPTION	UNIT	MAXIMUM VALUE			
		Pos.	msec	Neg.	msec
Pos. 1 Left Ankle X	g's	75.5	47.1	-78.9	48
Pos. 1 Left Ankle Z	g's	67.2	47.5	-56.7	58.7
Pos. 1 Left Toe Z	g's	179.1	47.1	-76.8	53.6
Pos. 1 Right Ankle X	g's	22.4	82.8	-129.1	44.9
Pos. 1 Right Ankle Z	g's	38.1	67.9	-159.1	42.4
Pos. 1 Right Toe Z	g's	99.9	68.1	-259.0	42.4
Pos. 2 Left Ankle X	g's	10.6	84.2	-111.0	40.4
Pos. 2 Left Ankle Z	g's	20.8	46.4	-75.7	39.6
Pos. 2 Left Toe Z	g's	29.5	76.1	-125.5	35.2
Pos. 2 Right Ankle X	g's	6.1	76.8	-45.9	54.0
Pos. 2 Right Ankle Z	g's	21.1	76.7	-86.9	39.3
Pos. 2 Right Toe Z	g's	19.8	83.9	-100.8	40.5

DATA SHEET NO. 8 DUMMY INJURY CRITERIA VALUES (cont.)
REDUNDANT DUMMY DATA

NHTSA Test No.: MW0209 Vehicle: 1998 Ford Taurus 4-Door Sedan

DESCRIPTION	UNIT	MAXIMUM VALUE			
		Pos.	msec	Neg.	msec
Pos. 1 Head X(R)	g's	8.5	243.3	-67.4	73.7
Pos. 1 Head Y(R)	g's	9.7	272.3	-25	86
Pos. 1 Head Z(R)	g's	26.3	54.4	-5.4	85
Pos. 1 Head Resultant(RR)	g's	71.8	73.7	0	-21.7
Pos. 2 Head X(R)	g's	53.2	74.4	-7	251.6
Pos. 2 Head Y(R)	g's	23.7	52.4	-12.4	37
Pos. 2 Head Z(R)	g's	35.5	65.1	-5.7	126
Pos. 2 Head Resultant(RR)	g's	49.8	72	0	-33.7
Pos. 1 Chest X(R)	g's	4	188.5	-48.2	72
Pos. 1 Chest Y(R)	g's	1.4	149.9	-12.4	86
Pos. 1 Chest Z(R)	g's	13.7	69.3	-6.1	86.6
Pos. 1 Chest Resultant(RR)	g's	59.4	71.7	0	-26.2
Pos. 2 Chest X(R)	g's	3.8	293.9	-50.6	69.9
Pos. 2 Chest Y(R)	g's	9.1	73.3	-10	92.3
Pos. 2 Chest Z(R)	g's	14.7	56.4	-10.3	119.4
Pos. 2 Chest Resultant(RR)	g's	51.7	69.9	0	-34.6

DATA SHEET NO. 9 SEAT BELT PERFORMANCE ASSESSMENT TEST DATA

BELT LENGTH DATA:

	<u>Driver</u>	<u>Passenger</u>
Belt length from trim panel exit to bolt hole anchor point for continuous webbing systems.	<u>1777</u>	<u>1798</u>
Shoulder belt length as measured on Part 572 Dummy.	<u>841</u>	<u>862</u>
Lap belt length as measured on Part 572 Dummy.	<u>741</u>	<u>751</u>

SHOULDER BELT SPOOL-OFF DATA:

As determined by film analysis.	<u>63.5</u>	<u>69.9</u>
As determined mechanically.	<u>61</u>	<u>69</u>
As determined electronically.	<u>-</u>	<u>-</u>

BELT STRETCH DATA:

Measured electronically between shoulder belt load cell and the "D" ring.	<u>40.7</u>	<u>*</u>
Measured mechanically.	<u>1</u>	<u>1</u>

Dimensions in millimeters

* Data inaccurate after 85 ms.

DATA SHEET NO.10 SUMMARY OF FMVSS 212 DATA

FMVSS NO. 212 - "WINDSHIELD MOUNTING" DATA

DETAILS OF WINDSHIELD MOUNTING SUCH AS RETENTION METHOD, TRIM TYPE, ETC.:

Windshield is bonded in place and covered with 22 mm molding.

FMVSS 212 REQUIREMENTS:

The Post-Test periphery retention amount must be at least 75% of the Pre-Test periphery measurement for vehicles NOT equipped with automatic restraints, and 50% for each side of the windshield for vehicles equipped with automatic restraint systems for front occupants,

FMVSS 212 TEST DATA

	WINDSHIELD PERIPHERY		% OF RETENTION
	PRE-TEST (mm)	POST-TEST(mm)	
RIGHT SIDE	2242.5	2242.5	100
LEFT SIDE	2242.5	2242.5	100
TOTAL	4,485	4,485	100

AREA OF RETENTION FAILURE:

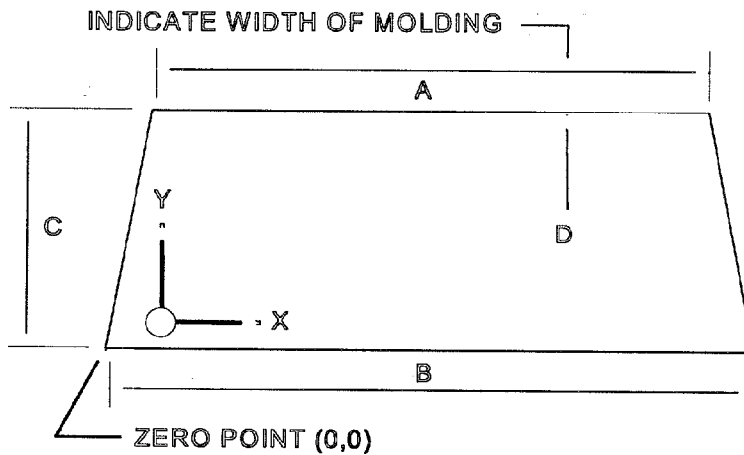

DIMENSIONS (mm)	
A	1171
B	1654
C	830
D	22

FRONT VIEW OF WINDSHIELD

FAILURE DETAILS: None

DATA SHEET NO. 11 FMVSS NO. 219 (PARTIAL) - "WINDSHIELD ZONE INTRUSION" DATA

PROTECTED ZONE LOWER EDGE REQUIREMENT:

The lower edge of the protected zone is determined by placing a 165 mm diameter rigid sphere weighing 6.8 kg in a position such that it simultaneously contacts the inner surface of the windshield and the top surface of the instrument panel including padding. The locus of points is drawn on the inner surface of the windshield contacted by the sphere across the width of the instrument panel. From the outermost contactable points extend the locus line horizontally to the edges of the windshield, then draw a line on the inner surface of the windshield below and 13 mm distant from the locus line. The **LOWER EDGE OF THE PROTECTED ZONE** is the longitudinal projection of this line onto the outer surface of the windshield.

FMVSS 219 TEST DATA:

(Dimensions in mm)

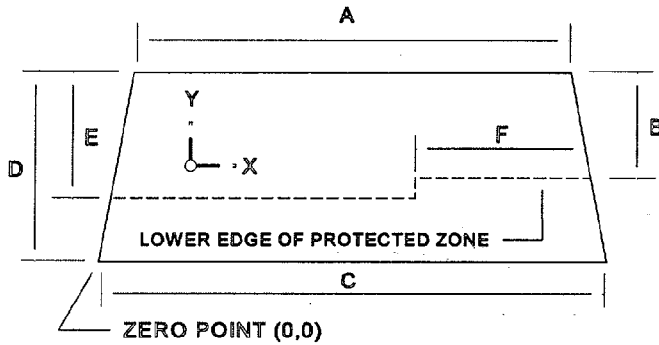

DIMENSIONS	
A	1171
B	343
C	1654
D	830
E	491
F	784

FRONT VIEW OF WINDSHIELD

DETAILS OF WINDSHIELD GLASS PENETRATION GREATER THAN 6 mm:

None

(Show location of penetration on the above sketch)

	COORDINATES	
	X	Y
1.		
2.		
3.		
4.		

DATA SHEET NO. 12 FMVSS NO. 301-75 "FUEL SYSTEM INTEGRITY" POST IMPACT TEST DATA

NHTSA TEST No.: MW0209 TEST DATE: December 2, 1997
VEHICLE MAKE/MODEL: 1998 Ford Taurus

The test vehicle was filled from 92% to 94% of the manufacture's "usable" capacity. The electric fuel pump was operating if it will operate without engine operation. Two Part 572 anthropomorphic test devices were located at each of the front designated seating positions.

=====

TEST VEHICLE IMPACT TYPE: X Frontal (56 kph)
 - Oblique (48 kph) with _____ deg. barrier face first contacting _____ (driver/passenger) side
 - Rear Moving Barrier (48 kph)
 - Lateral Moving Barrier (32 kph)

FUEL SPILLAGE MEASUREMENT:

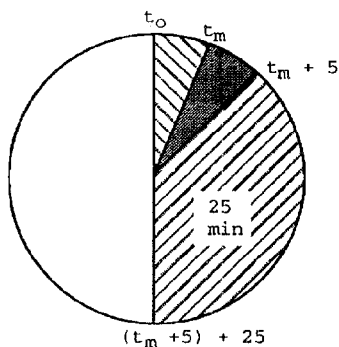

1. From impact until vehicle motion ceases
2. For 5 minute period after vehicle motion ceases
3. For next 25 minutes

ACTUAL	MAX ALLOWED
0	28 g
0	141 g
0	28 g/min.

SOLVENT SPILLAGE DETAILS:

None

DATA SHEET NO. 13 FMVSS NO. 301 STATIC ROLLOVER DATA SHEET

TEST PHASE:
0-90 deg.

NHTSA Test No.:
MW0209

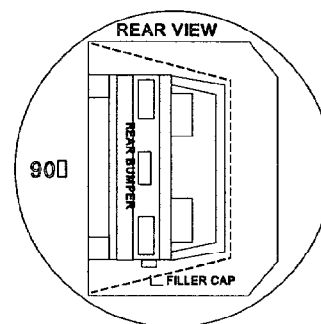
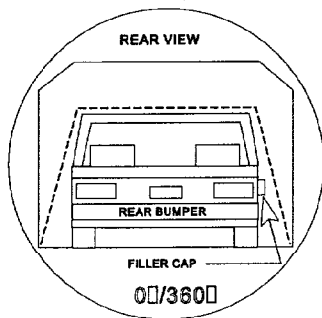

INDETERMINATION OF SOLVENT COLLECTION TIME PERIOD:

Rollover Fixture 90 deg. Rotation Time (Spec. Range = 1 to 3 minutes)	<u>1</u> minutes	<u>12</u> seconds
FMVSS 301 Position Hold Time +	<u>5</u> minutes	<u>00</u> seconds
TOTAL	<u>6</u> minutes	<u>12</u> seconds
Next whole minute interval	<u>7</u> minutes	<u>00</u> seconds

II. FMVSS 301 REQUIREMENTS:

(1) Time Period

First 5 min. from onset of rotation	6th min.	7th min.	8th min. if reqd.
-------------------------------------	----------	----------	-------------------

(2) Maximum Allowable Solvent Spillage

141 g	28 g	28 g	28 g
-------	------	------	------

III. ACTUAL TEST VEHICLE SOLVENT SPILLAGE:

0	0	0	n/a
---	---	---	-----

Note: Record spillage for whole minute intervals only as determined above.

IV. SOLVENT SPILLAGE LOCATION(S): None

TEST SHEET NO. 13 FMVSS NO. 301 STATIC ROLLOVER DATA SHEET (cont.)

TEST PHASE:
90-180 deg.

NHTSA Test No.:
MW0209

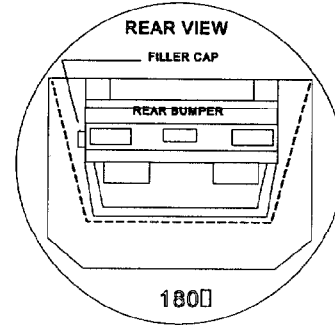
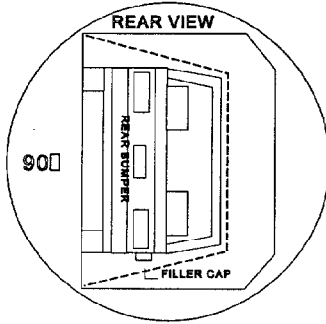

I. DETERMINATION OF SOLVENT COLLECTION TIME PERIOD:

Rollover Fixture 90 deg. Rotation Time (Spec. Range = 1 to 3 minutes)	<u>1</u>	minutes	<u>9</u>	seconds
FMVSS 301 Position Hold Time +	<u>5</u>	minutes	<u>00</u>	seconds
TOTAL	<u>6</u>	minutes	<u>9</u>	seconds
Next whole minute interval	<u>7</u>	minutes	<u>00</u>	seconds

II. FMVSS 301 REQUIREMENTS:

(1) Time Period

First 5 min. from onset of rotation	6th min.	7th min.	8th min. if reqd.
-------------------------------------	----------	----------	-------------------

(2) Maximum Allowable Solvent Spillage

141 g	28 g	28 g	28 g
-------	------	------	------

III. ACTUAL TEST VEHICLE SOLVENT SPILLAGE:

0	0	0	n/a
---	---	---	-----

Note: Record spillage for whole minute intervals only as determined above.

IV. SOLVENT SPILLAGE LOCATION(S): None

TEST SHEET NO. 13 FMVSS NO. 301 STATIC ROLLOVER DATA SHEET (cont.)

TEST PHASE:
180-270 deg.

NHTSA Test No.:
MW0209

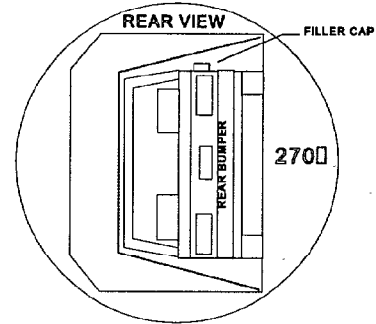
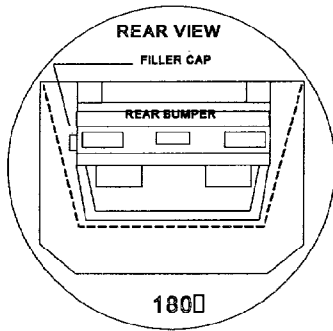

I. DETERMINATION OF SOLVENT COLLECTION TIME PERIOD:

Rollover Fixture 90 deg. Rotation Time (Spec. Range = 1 to 3 minutes)	<u>1</u> minutes	<u>4</u> seconds
FMVSS 301 Position Hold Time +	<u>5</u> minutes	<u>00</u> seconds
TOTAL	<u>6</u> minutes	<u>4</u> seconds
Next whole minute interval	<u>7</u> minutes	<u>00</u> seconds

II. FMVSS 301 REQUIREMENTS:

(1) Time Period

First 5 min. from onset of rotation	6th min.	7th min.	8th min. if reqd.
-------------------------------------	----------	----------	-------------------

(2) Maximum Allowable Solvent Spillage

141 g	28 g	28 g	28 g
-------	------	------	------

III. ACTUAL TEST VEHICLE SOLVENT SPILLAGE:

0	0	0	n/a
---	---	---	-----

Note: Record spillage for whole minute intervals only as determined above.

IV. SOLVENT SPILLAGE LOCATION(S): None

TEST SHEET NO. 13 FMVSS NO. 301 STATIC ROLLOVER DATA SHEET (cont.)

TEST PHASE:
270-360 deg.

NHTSA Test No.:
MW0209

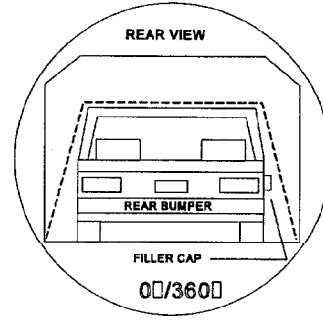
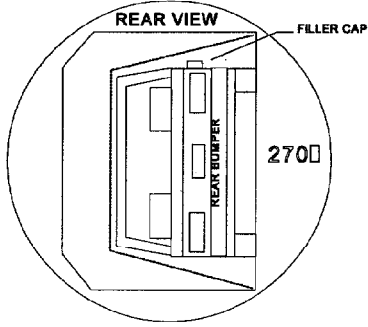

I. DETERMINATION OF SOLVENT COLLECTION TIME PERIOD:

Rollover Fixture 90 deg. Rotation Time (Spec. Range = 1 to 3 minutes)	<u>1</u> minutes	<u>3</u> seconds
FMVSS 301 Position Hold Time +	<u>5</u> minutes	<u>00</u> seconds
TOTAL	<u>6</u> minutes	<u>3</u> seconds
Next whole minute interval	<u>7</u> minutes	<u>00</u> seconds

II. FMVSS 301 REQUIREMENTS:

(1) Time Period

First 5 min. from onset of rotation	6th min.	7th min.	8th min. if reqd.
-------------------------------------	----------	----------	-------------------

(2) Maximum Allowable Solvent Spillage

141 g	28 g	28 g	28 g
-------	------	------	------

III. ACTUAL TEST VEHICLE SOLVENT SPILLAGE:

0	0	0	n/a
---	---	---	-----

Note: Record spillage for whole minute intervals only as determined above.

IV. SOLVENT SPILLAGE LOCATION(S): None

TEST VEHICLE MEASUREMENTS

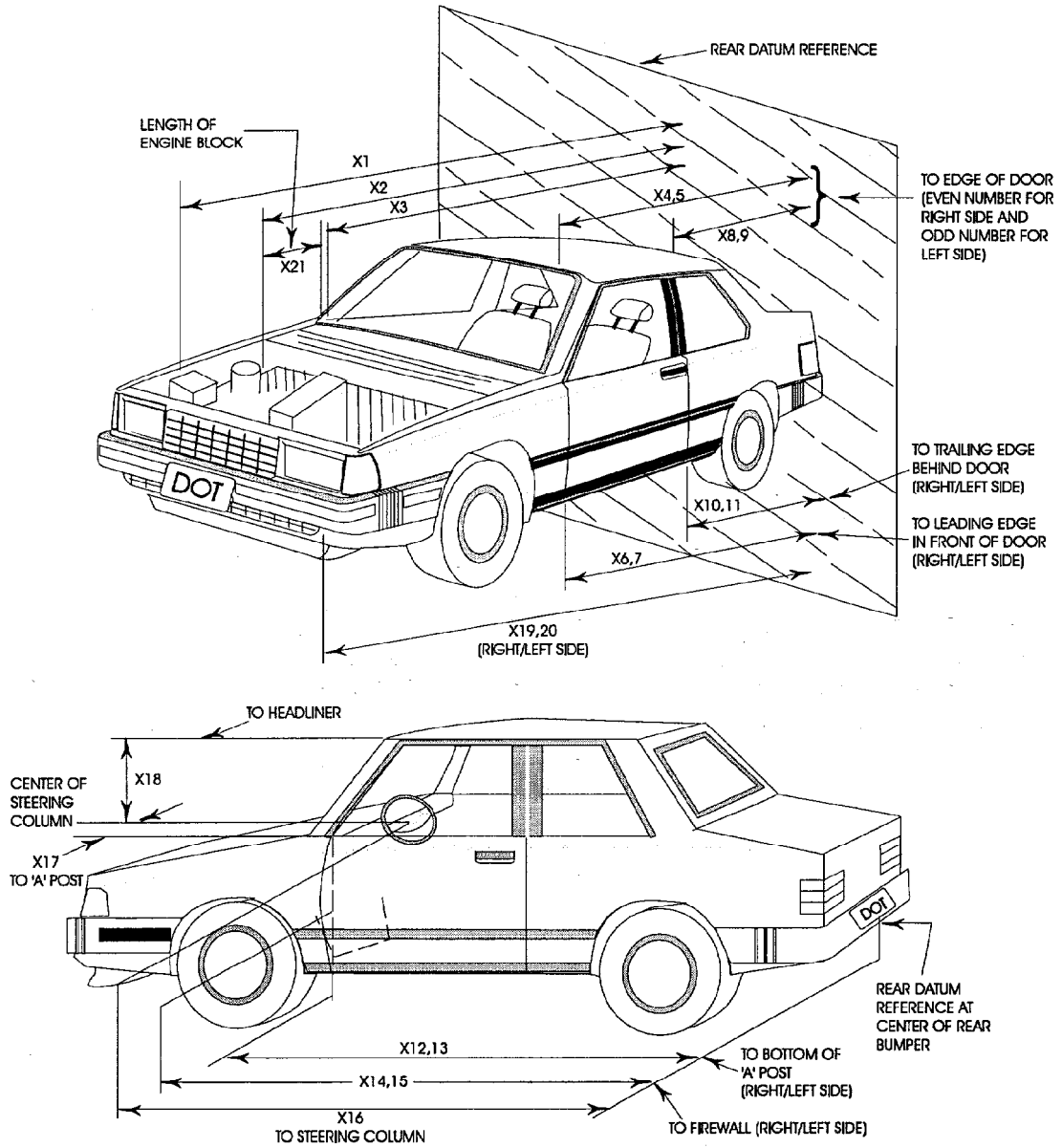

DATA SHEET NO.14 VEHICLE MEASUREMENTS

No.	All Dimensions in mm	All Dimensions in mm		
		Pre-Test	Post-Test	Differences
X1	Total Length of Vehicle at Centerline	5005	4605	400
X2	Rear Surface of Vehicle to Front of Engine	4170	3955	215
X3	Rear Surface of Vehicle to Firewall	3865	3360	505
X4	Rear Surface of Vehicle to Upper Leading Edge of Right Door	3475	3472	3
X5	Rear Surface of Vehicle to Upper Leading Edge of Left Door	3483	3477	6
X6	Rear Surface of Vehicle to Lower Leading Edge of Right Door	3405	3376	29
X7	Rear Surface of Vehicle to Lower Leading Edge of Left Door	3418	3385	33
X8	Rear Surface of Vehicle to Upper Trailing Edge of Right Door	2377	2377	0
X9	Rear Surface of Vehicle to Upper Trailing Edge of Left Door	2387	2383	4
X10	Rear Surface of Vehicle to Lower Trailing Edge of Right Door	2321	2310	11
X11	Rear Surface of Vehicle to Lower Trailing Edge of Left Door	2333	2320	13
X12	Rear Surface of Vehicle to Bottom of "A" Post of Right Side	3385	3373	12
X13	Rear Surface of Vehicle to Bottom of "A" Post of Left Side	3386	3374	12
X14	Rear Surface of Vehicle to Firewall, Right Side	3830	3600	230
X15	Rear Surface of Vehicle to Firewall, Left Side	3910	3600	310
X16	Rear Surface of Vehicle to Steering Column	2980	2990	-10
X17	Center of Steering Column to "A" Post	440	435	5
X18	Center of Steering Column to Headliner	410	380	30
X19	Rear Surface of Vehicle to Right Side of Front Bumper	4920	4515	405
X20	Rear Surface of Vehicle to Left Side of Front Bumper	4925	4565	360
X21	Length of Engine Block	500	500	0
RD	Rear Surface of Vehicle to Right Side of Dash Panel	3095	3100	-5
CD	Rear Surface of Vehicle to Center of Dash Panel	2980	3125	-145
LD	Rear Surface of Vehicle to Left Side of Dash Panel	3150	3145	5

DATA SHEET NO.14 VEHICLE MEASUREMENTS (cont.)
VEHICLE INTRUSION MEASUREMENTS
DOOR OPENING WIDTH

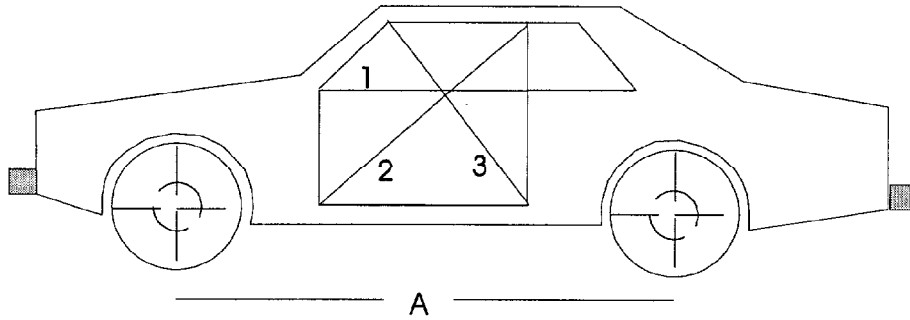

UNITS (mm)	LEFT			RIGHT		
	1	2	3	1	2	3
BEFORE TEST	955	1485	1020	960	1490	1015
AFTER TEST	955	1495	1010	955	1490	1020
DIFFERENCE	0	-10	10	5	0	-5

UNITS (mm)	A = WHEELBASE LEFT	A = WHEELBASE RIGHT
BEFORE TEST	2760	2760
AFTER TEST	2652	2652
DIFFERENCE	108	108

DATA SHEET NO.14 VEHICLE MEASUREMENTS (cont.)
VEHICLE INTRUSION MEASUREMENTS
STATIC FOOTWELL DEFORMATION

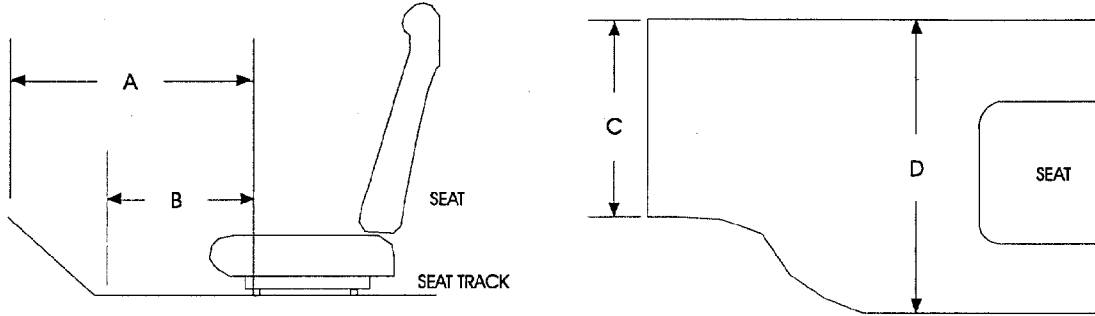

DRIVER

Measurement	Pre-Test	Post-Test	Difference
A	540	500	40
B	465	460	5
C	445	410	35
D	410	390	20

PASSENGER

Measurement	Pre-Test	Post-Test	Difference
A	535	500	35
B	490	480	10
C	400	400	0
D	415	405	10

Units = mm

DATA SHEET NO.14 VEHICLE MEASUREMENTS (cont.)
VEHICLE INTRUSION MEASUREMENTS
STATIC PASSENGER COMPARTMENT INTRUSION

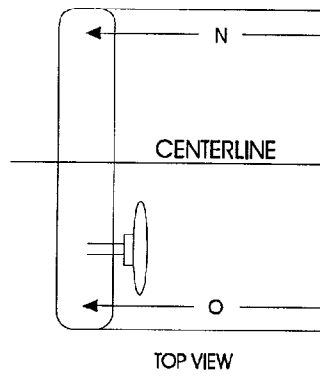
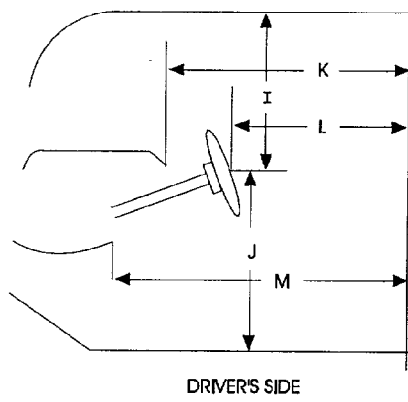

MEASUREMENTS
FROM C-PILLAR
BELT ANCHORAGE

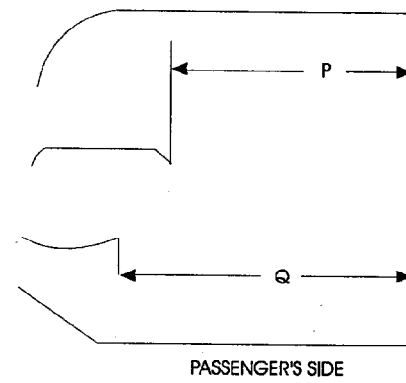

Measurement	Pre-Test	Post-Test	Difference
I	400	390	10
J	700	710	-10
K	755	750	5
L	560	570	-10
M	750	745	5
N	675	680	-5
O	730	725	5
P = K (PASS.)	720	720	0
Q = M (PASS.)	705	710	-5

Units = mm

DATA SHEET NO.14 VEHICLE MEASUREMENTS (cont.)
FLOORBOARD DEFORMATION

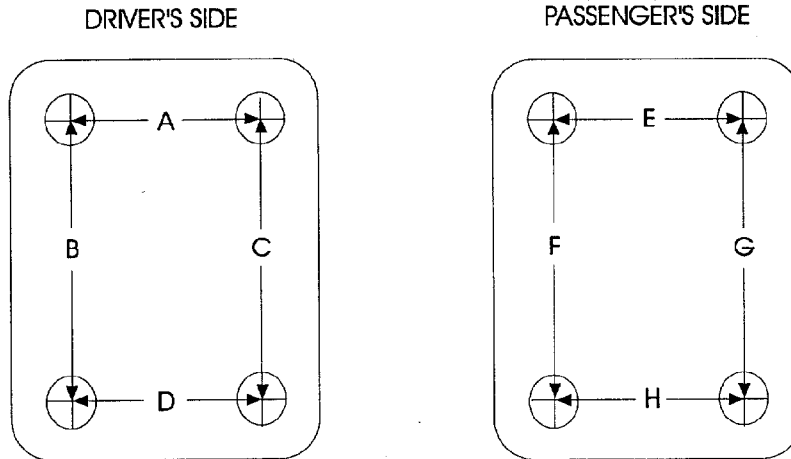

TOP VIEW THROUGH FLOOR PAN

Measurement	Pre-Test	Post-Test	Difference
A	330	345	-15
B	630	620	10
C	625	585	40
D	400	400	0
E	355	340	15
F	625	590	35
G	640	640	0
H	405	405	0

Units = mm

CAMERA POSITIONS FOR FRONTAL IMPACTS

NOTE: Camera information shown in DATA SHEET NO. 15.

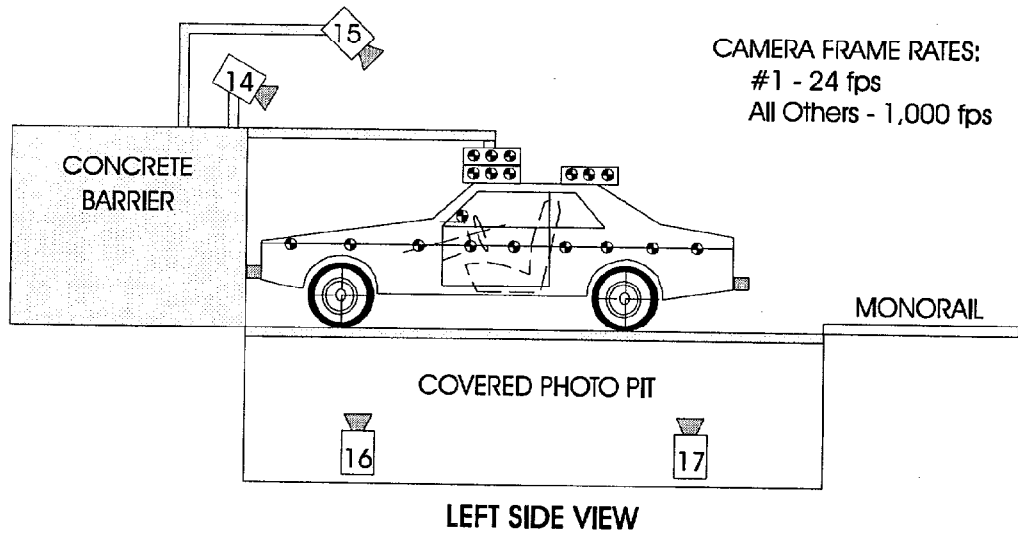
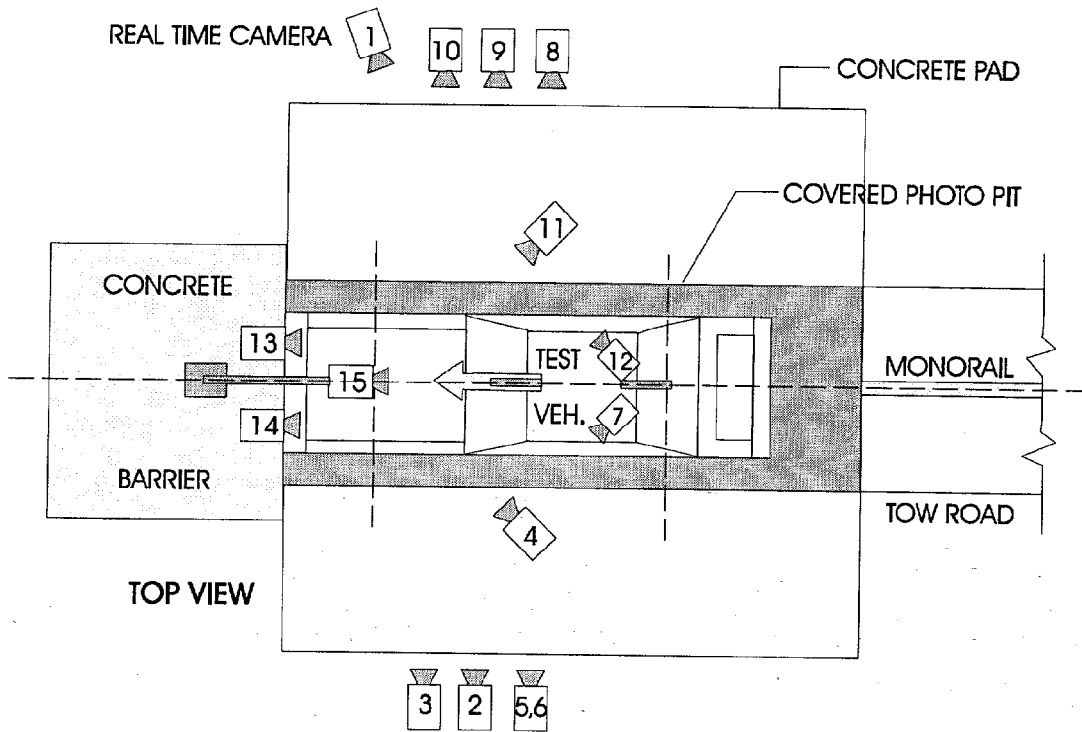

DATA SHEET NO.15 HIGH-SPEED CAMERA LOCATIONS

NHTSA Test No.: MW0209 Vehicle: 1998 Ford Taurus 4-Door Sedan

CAMERA NO.	VIEW	CAMERA POSITIONS (mm)*			ANGLE** (deg)	FILM PLANE TO HEAD TARGET	LENS (mm)	SPEED (fps)
		X	Y	Z				
1	Real-Time Camera	-	-	-	-	-	24	
2	Overall Left Side	6520	1597	1099	-3.5	6222	1000	
3	Left Side View	7964	745	1134	-4	7666	1000	
4	Driver and Interior View	4981	2791	1941	-14	-	1000	
5	Steering Column (Bottom)	7763	1864	1167	-5	7465	1010	
6	Steering Column (Top)	7763	1864	1769	-9	7465	1010	
7	Left Belt	-	-	-	-	-	690	
8	Overall Right Side	6596	2111	1126	-4.5	6298	970	
9	Right Side View	7941	1600	1257	-3.5	7643	990	
10	Right Passenger View	7287	2122	1408	-3.5	6989	1000	
11	Passenger and Interior View	5109	3109	2005	-9	-	990	
12	Right Belt	-	-	-	-	-	770	
13	Passenger Front View	580	0	2000	-52	-	1000	
14	Driver Front View	580	0	2000	-51	-	1000	
15	Windshield View	0	530	3048	-58	-	1000	
16	Pit View of Engine	0	950	-3048	90	-	1000	
17	Pit View of Fuel Tank	0	2864	-3048	90	-	1010	

*X = film plane to monorail centerline
 Y = film plane to impact location
 Z = film plane to ground
 ** = referenced to horizontal plane
 N.T. indicates No Timing

DATA SHEET NO. 16 VEHICLE REFERENCE PHOTO TARGET LOCATIONS

(Dimensions in millimeters)

A	374
B	1310
C	1219
D	2274
E	333
F	1636
G	958
H	958
I	64
J	1440
K	1022
L	1583
M	333
N	64
O	958
P	958
Q	1583
R	1022
S	1440

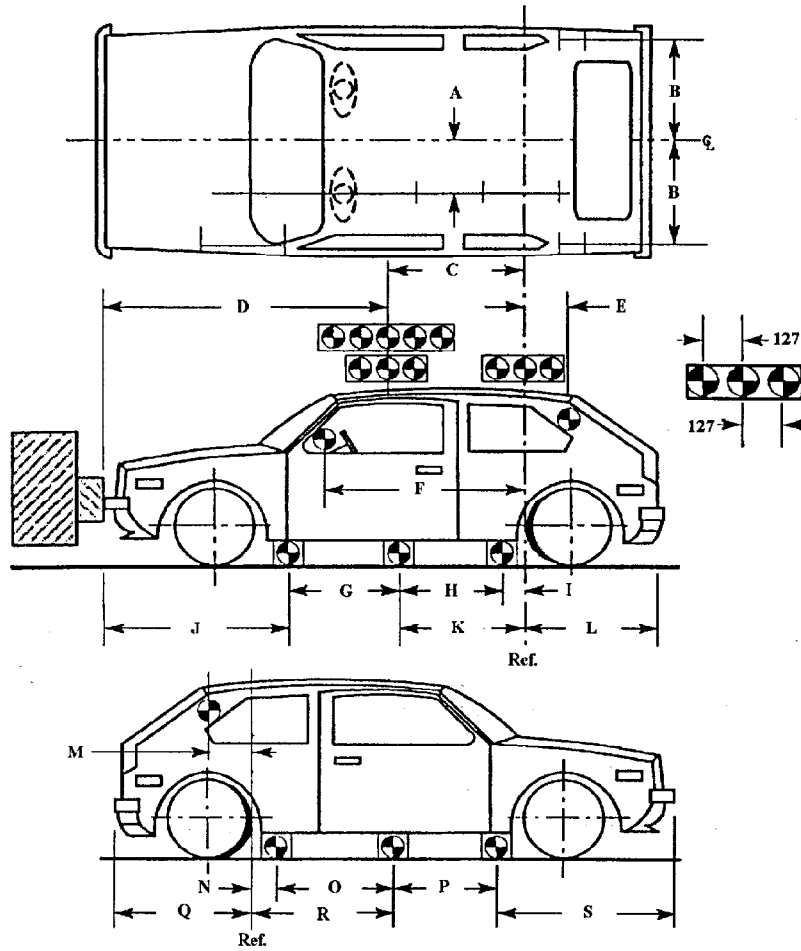

DATA SHEET NO. 17 LOAD CELL LOCATIONS ON FIXED BARRIER

LOAD CELL BARRIER NOT REQUESTED FOR THIS TEST

- 36 Load Cells
- 4 Rows
- 9 Columns
- 6 Groupings (6 cells/group)

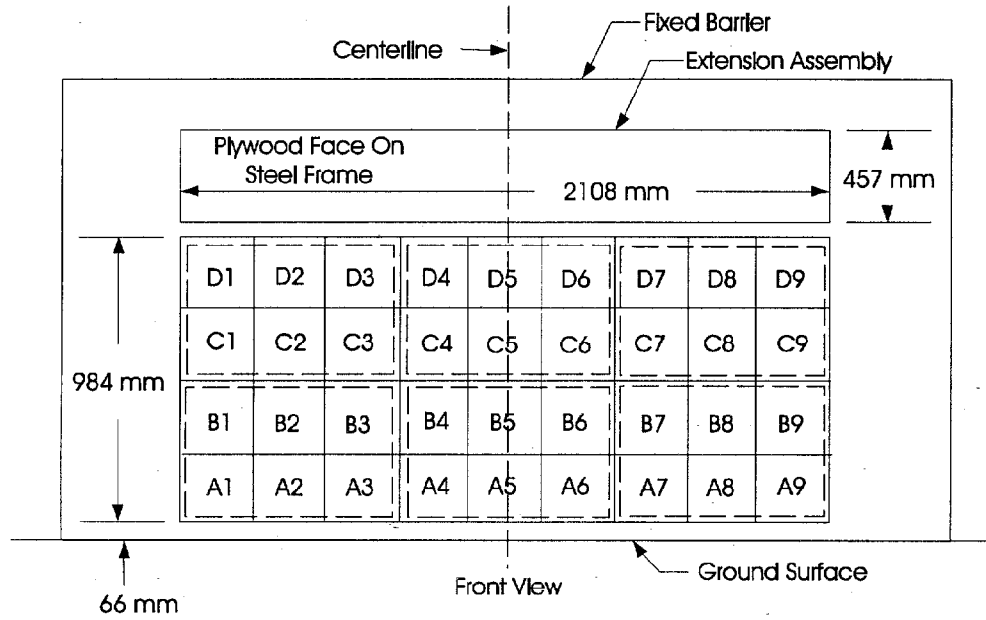

6 GROUPS OF 6 LOAD CELLS EACH

Group 4 C1 thru D3	Group 5 C4 thru D6	Group 6 C7 thru D9
Group 1 A1 thru B3	Group 2 A4 thru B6	Group 3 A7 thru B9

The following data is presented in Appendix B:

- (1) Data from 36 individual load cells
- (2) Total or Sum of 36 individual load cells
- (3) Data from 6 Groupings shown above (6 cells/group)

DATA SHEET NO. 18 POST TEST AIR BAG DATA

NHTSA No. : MW0209; Test Date: December 2,1997; Technician: J.Cz.

Vehicle Model Year/Make/Model: 1998 Ford Taurus

- A. No. of vent holes: 2 -Driver 0 -Passenger
- B. Size of vent holes: (mm²) 20 -Driver 0 -Passenger
- C. Total vent area: (mm²) 40 -Driver 0 -Passenger
- D. Deflated air bag length and width dimensions or, if round, diameter. (mm)
- Driver: - -Length; - -Width; 640 -Diameter
- Passenger: 530 -Height; 620 -Width; 620 -Depth
- E. Is the air bag tethered?
- Driver: x -Yes; -No; If yes, record length of tether- 250
- Passenger: x -Yes; -No; If yes, record length of tether- 400

Sketch the air bag showing the location of the vent holes, how the bag is tethered, and where the bag is tethered. Also describe how the tethers are attached to the bag and the steering wheel.

(Note: Not to scale; V_n = Vent hole_n, T_n = Tether_n).

DRIVER
vents underneath bag

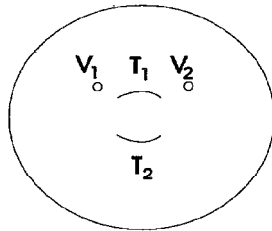

PASSENGER
vents underneath bag

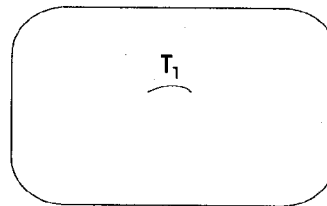

- F. Record part numbers and manufacturer name of the air bag and gas generator.

Driver: Air bag: P12165201C

Generator: FARH9H36AUH

Passenger: Air bag: TM11261800307

Generator: -

DATA SHEET NO.19 ACCIDENT INVESTIGATION DIVISION DATA

FOR 56.3 KPH FRONTAL BARRIER IMPACT

Vehicle Make/Model/Body Style: Ford Taurus 4-Door Sedan

NHTSA Test No.: MW0209 VIN: 1FAFP52U6WG110835

Model Year: 1998 Build Date: 9/97 Test Date: December 2,1997

Vehicle Size Category: Sedan Test Weight: 1738 kg

Vehicle Wheelbase: 2760 mm; Front Overhang: 1440 mm; Overall Width: 1852 mm

Collision Deformation Classification (CDC) Code: 12FDEW2

Crush Depth Dimensions:

	PRE	POST	DIFF	
C1 =	4710	4405	-305	mm
C2 =	4950	4575	-375	mm
C3 =	5005	4605	-400	mm
C4 =	5005	4600	-405	mm
C5 =	4945	4515	-430	mm
C6 =	4695	4385	-310	mm

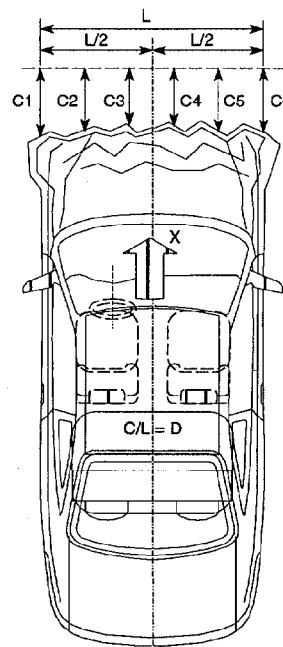

Midpoint of Damage: D = Vehicle Centerline (Longitudinal)

Length of Damaged Region:

L1= 1740 mm

L2= 870 mm

L3= 348 mm

PHOTOGRAPHS

<u>Figure</u>	<u>Title</u>	<u>Page</u>
A-1	LOAD CELL LOCATIONS.	A-4
A-2	PRE-TEST FRONT VIEW	A-5
A-3	POST-TEST FRONT VIEW.	A-6
A-4	PRE-TEST LEFT SIDE VIEW	A-7
A-5	POST-TEST LEFT SIDE VIEW	A-8
A-6	PRE-TEST RIGHT SIDE VIEW	A-9
A-7	POST-TEST RIGHT SIDE VIEW	A-10
A-8	PRE-TEST RIGHT FRONT THREE-QUARTER VIEW	A-11
A-9	POST-TEST RIGHT FRONT THREE-QUARTER VIEW	A-12
A-10	PRE-TEST LEFT REAR THREE-QUARTER VIEW	A-13
A-11	POST-TEST LEFT REAR THREE-QUARTER VIEW	A-14
A-12	PRE-TEST WINDSHIELD VIEW	A-15
A-13	POST-TEST WINDSHIELD VIEW	A-16
A-14	PRE-TEST ENGINE COMPARTMENT VIEW	A-17
A-15	FUEL CAP VIEW	A-18
A-16	PRE-TEST FRONT UNDERBODY VIEW	A-19
A-17	POST-TEST FRONT UNDERBODY VIEW	A-20
A-18	PRE-TEST FRONT SIDE UNDERBODY VIEW	A-21
A-19	POST-TEST FRONT SIDE UNDERBODY VIEW	A-22
A-20	PRE-TEST REAR UNDERBODY VIEW	A-23
A-21	POST-TEST REAR UNDERBODY VIEW	A-24
A-22	PRE-TEST DRIVER POSITION VIEW	A-25
A-23	POST-TEST DRIVER POSITION VIEW	A-26
A-24	PRE-TEST PASSENGER POSITION VIEW	A-27
A-25	POST-TEST PASSENGER POSITION VIEW.	A-28
A-26	PRE-TEST DRIVER AND INTERIOR VIEW	A-29
A-27	POST-TEST DRIVER AND INTERIOR VIEW	A-30
A-28	PRE-TEST PASSENGER AND INTERIOR VIEW	A-31
A-29	POST-TEST PASSENGER AND INTERIOR VIEW	A-32
A-30	PRE-TEST DRIVER HEAD LOCATION	A-33
A-31	POST-TEST DRIVER HEAD LOCATION	A-34

PHOTOGRAPHS (continued)

<u>Figure</u>	<u>Title</u>	<u>Page</u>
A-32	PRE-TEST PASSENGER HEAD LOCATION	A-35
A-33	POST-TEST PASSENGER HEAD LOCATION	A-36
A-34	PRE-TEST DRIVER FLOOR PAN VIEW	A-37
A-35	POST-TEST DRIVER FLOOR PAN VIEW	A-38
A-36	PRE-TEST PASSENGER FLOOR PAN VIEW	A-39
A-37	POST-TEST PASSENGER FLOOR PAN VIEW	A-40
A-38	ROLLOVER VIEW	A-41
A-39	IMPACT VIEW	A-42

PHOTOGRAPH NOT AVAILABLE



Figure A-2 PRE-TEST FRONT VIEW

A-5

8413-10

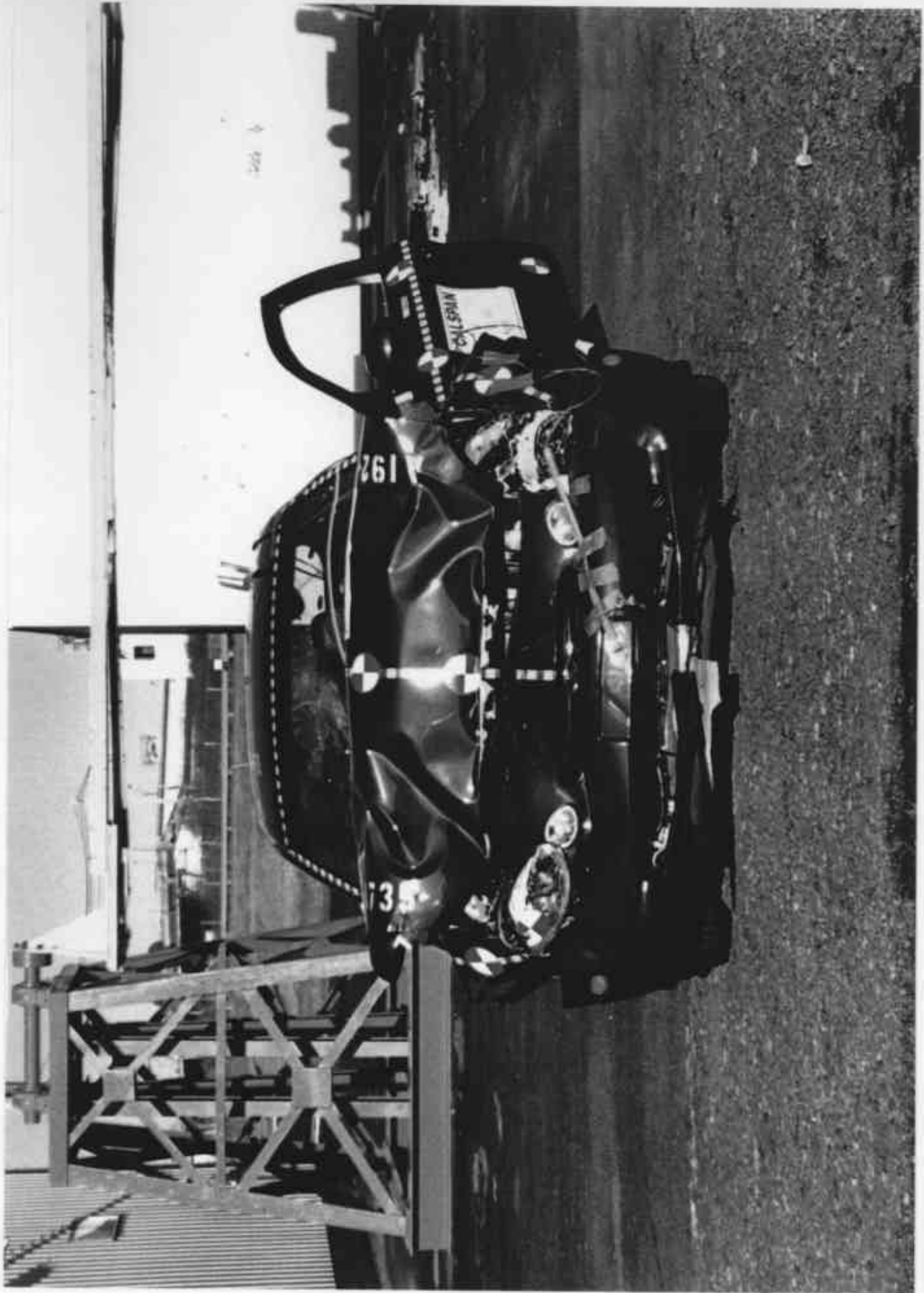

Figure A-3 POST-TEST FRONT VIEW



Figure A-4 PRE-TEST LEFT SIDE VIEW

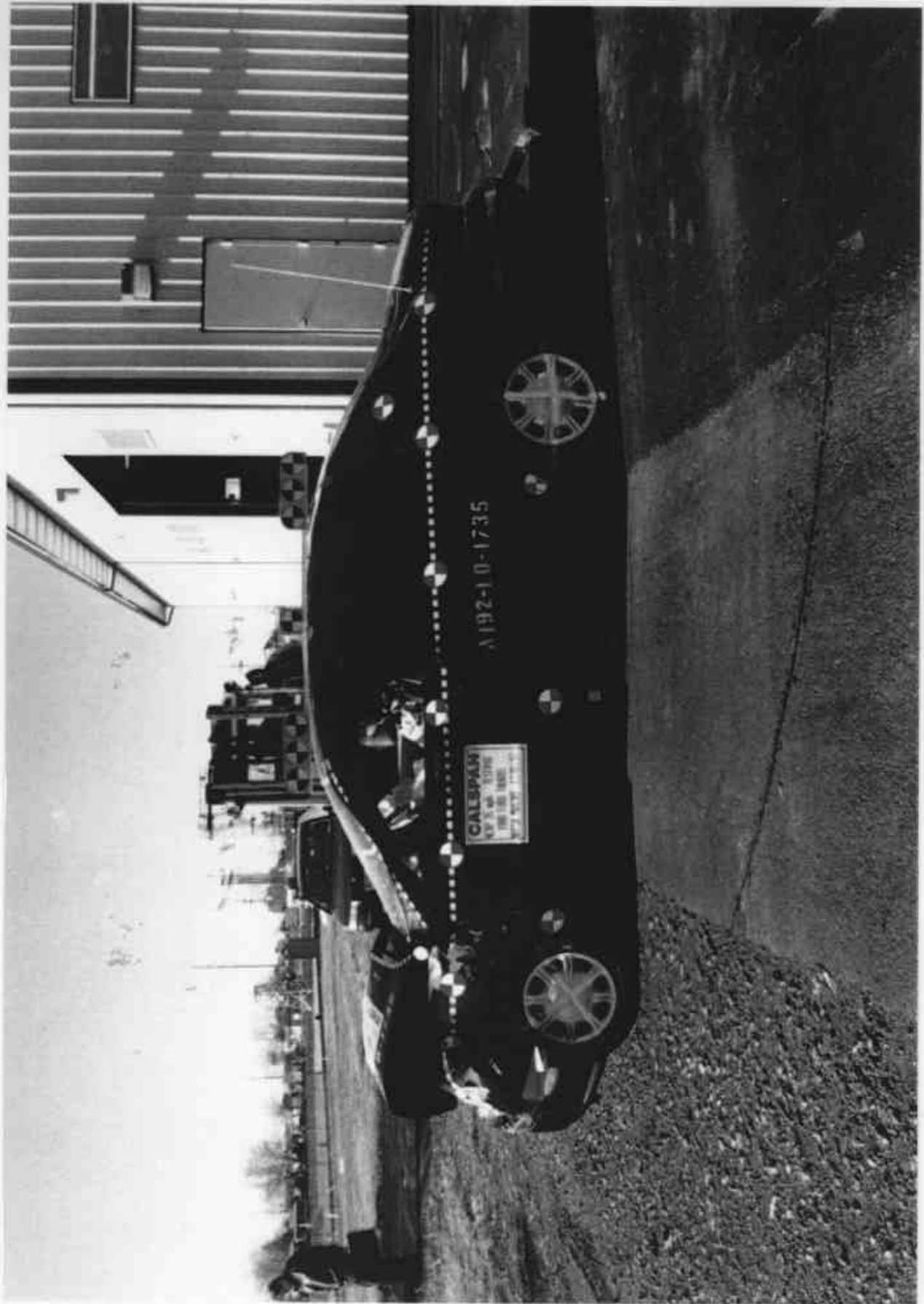

Figure A-5 POST-TEST LEFT SIDE VIEW



Figure A-6 PRE-TEST RIGHT SIDE VIEW

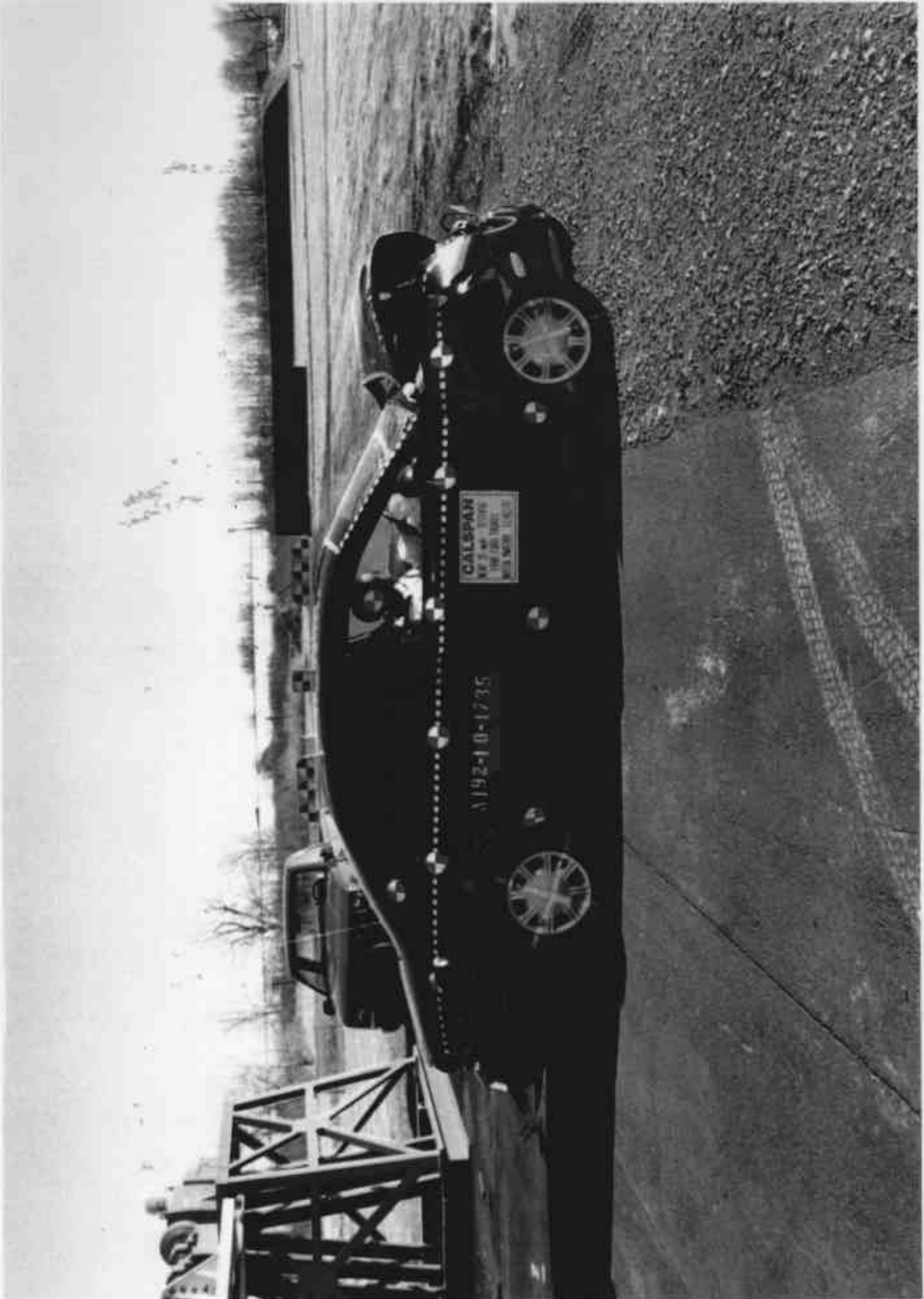

Figure A-7 POST-TEST RIGHT SIDE VIEW



Figure A-8 PRE-TEST RIGHT FRONT THREE-QUARTER VIEW

A-11

8413-10



Figure A-9 POST-TEST RIGHT FRONT THREE-QUARTER VIEW

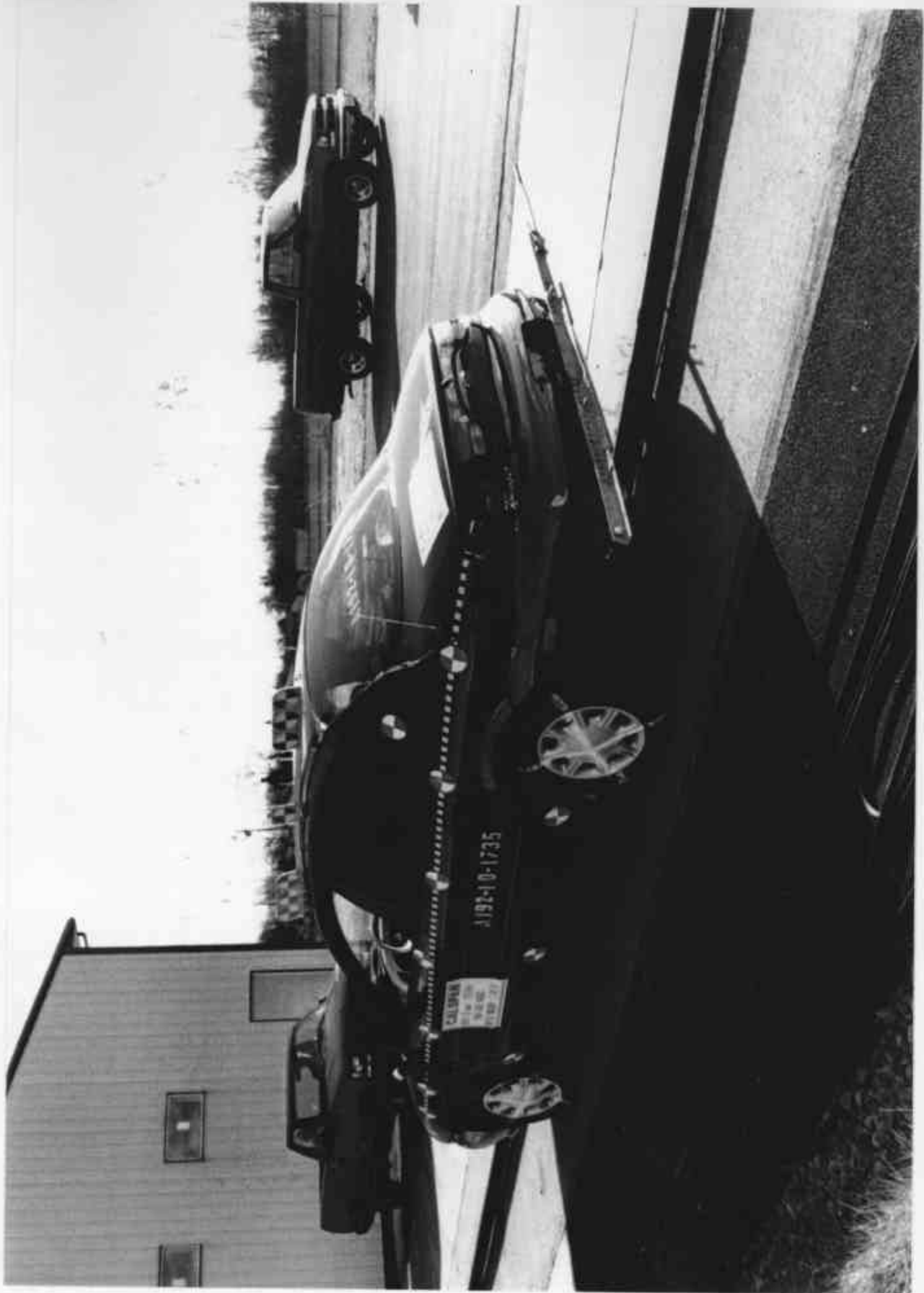

Figure A-10 PRE-TEST LEFT REAR THREE-QUARTER VIEW



Figure A-11 POST-TEST LEFT REAR THREE-QUARTER VIEW

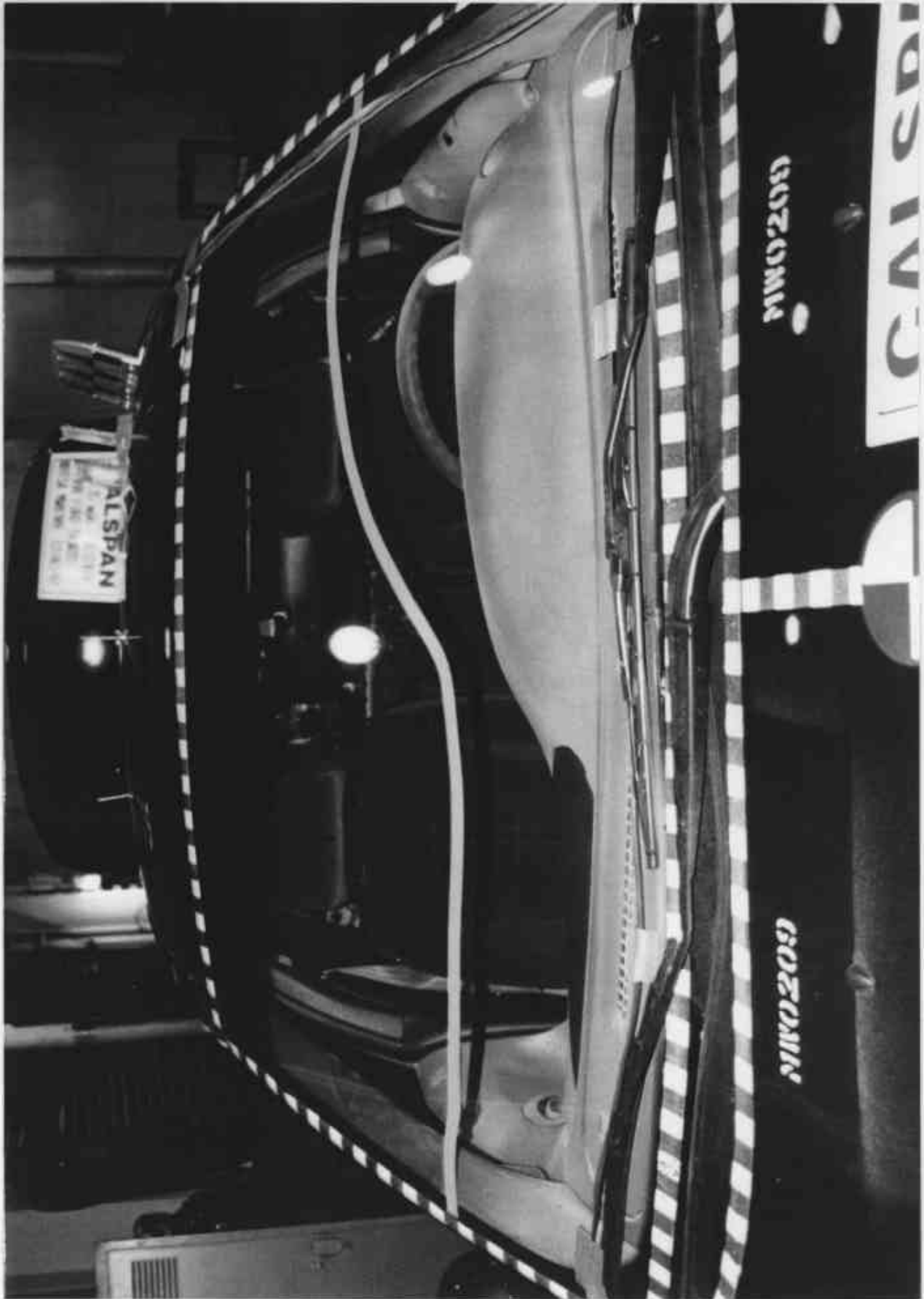

Figure A-12 PRE-TEST WINDSHIELD VIEW

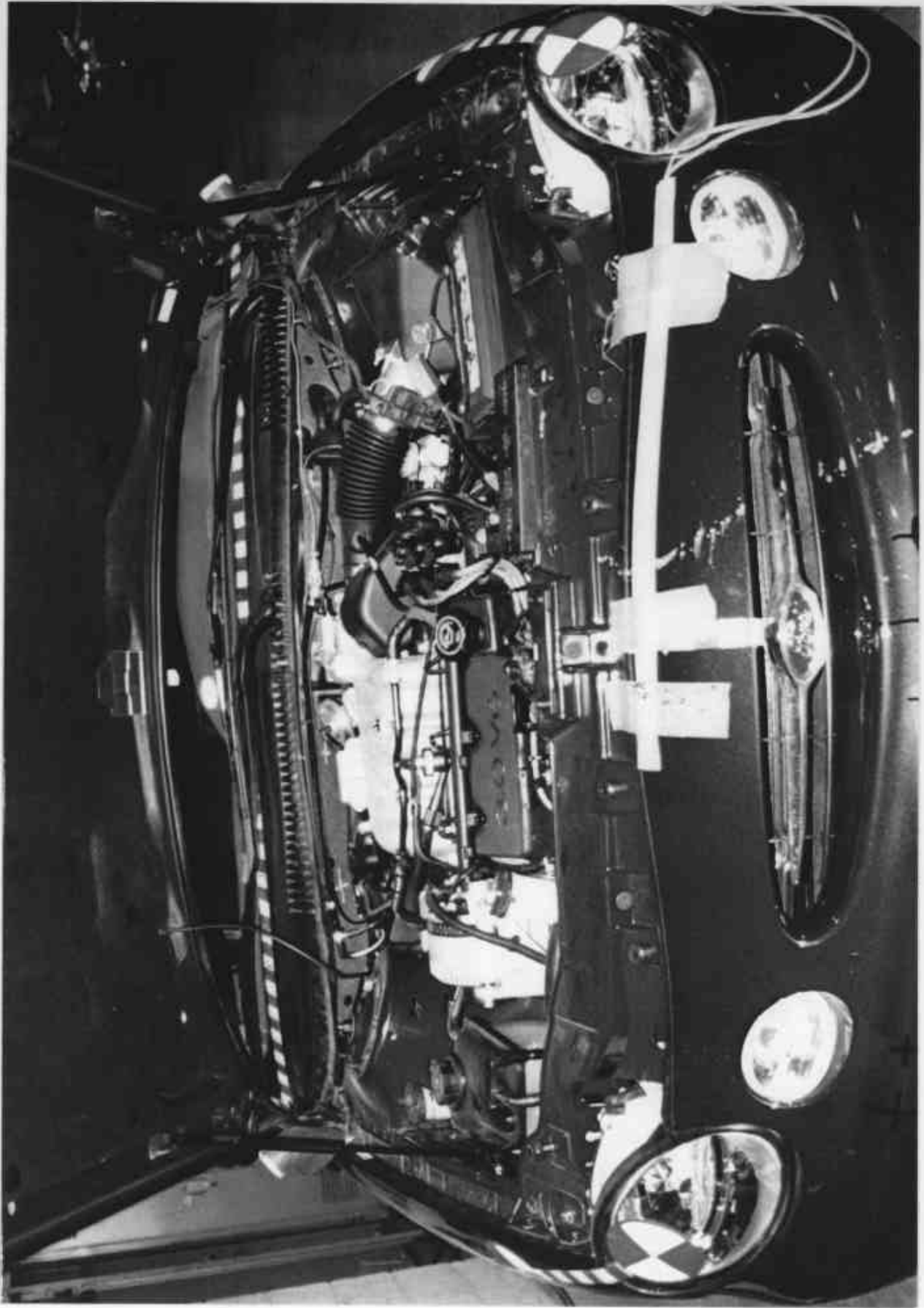

Figure A-14 PRE-TEST ENGINE COMPARTMENT VIEW



Figure A-15 FUEL CAP VIEW



Figure A-16 PRE-TEST FRONT UNDERBODY VIEW



Figure A-17 POST-TEST FRONT UNDERBODY VIEW



Figure A-18 PRE-TEST FRONT SIDE UNDERBODY VIEW

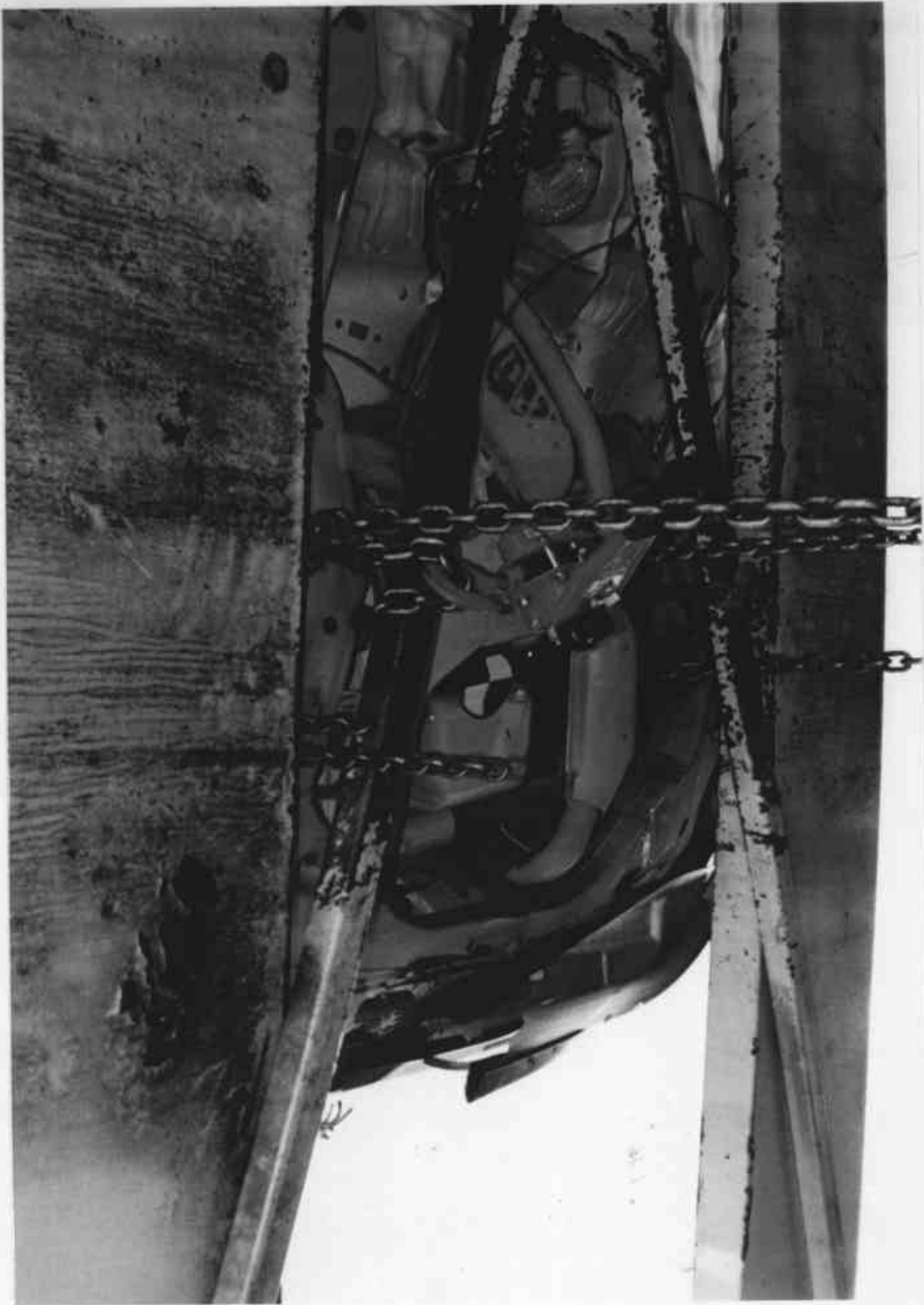

Figure A-19 POST-TEST FRONT SIDE UNDERBODY VIEW



Figure A-20 PRE-TEST REAR UNDERBODY VIEW

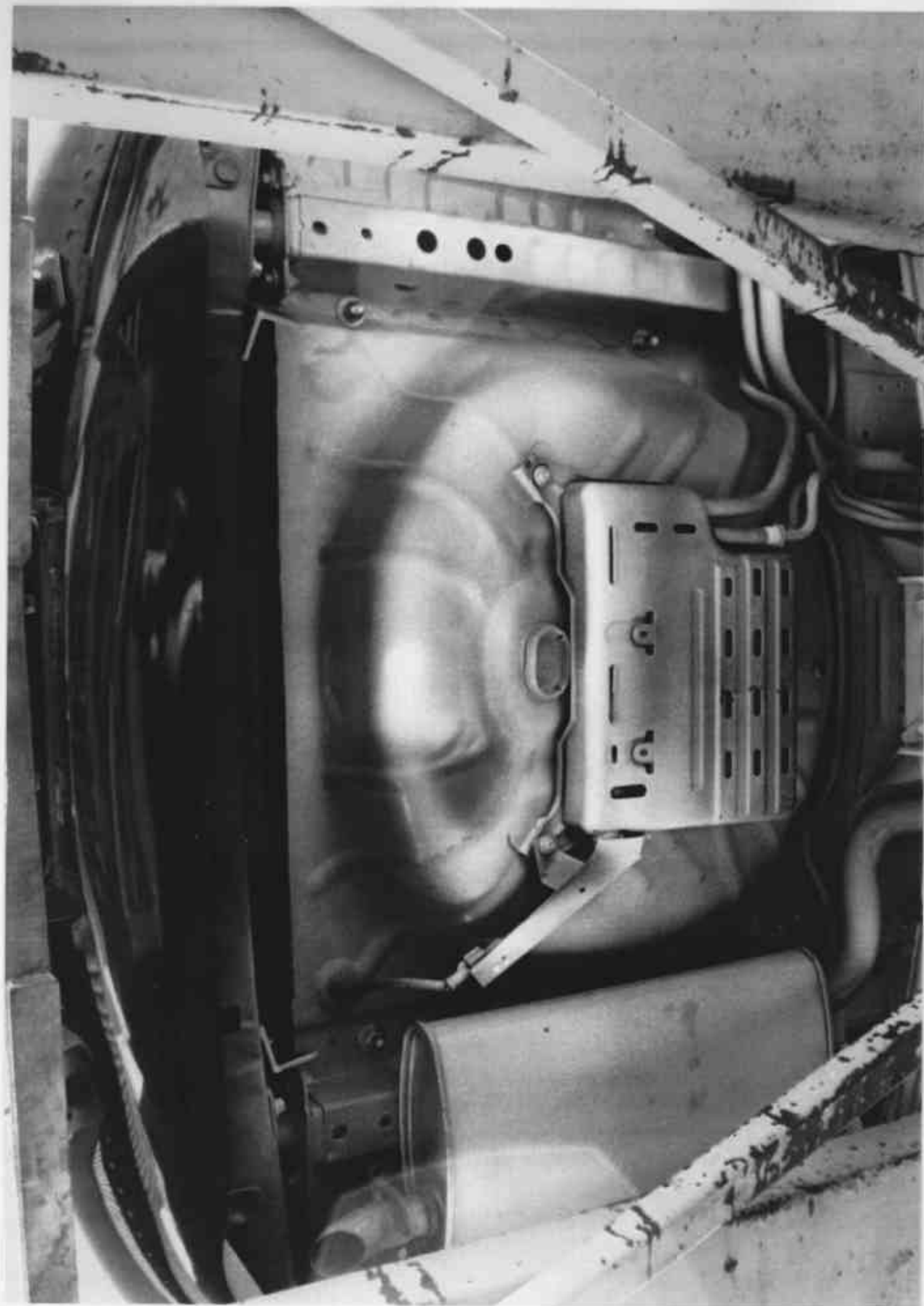

Figure A-21 POST-TEST REAR UNDERBODY VIEW

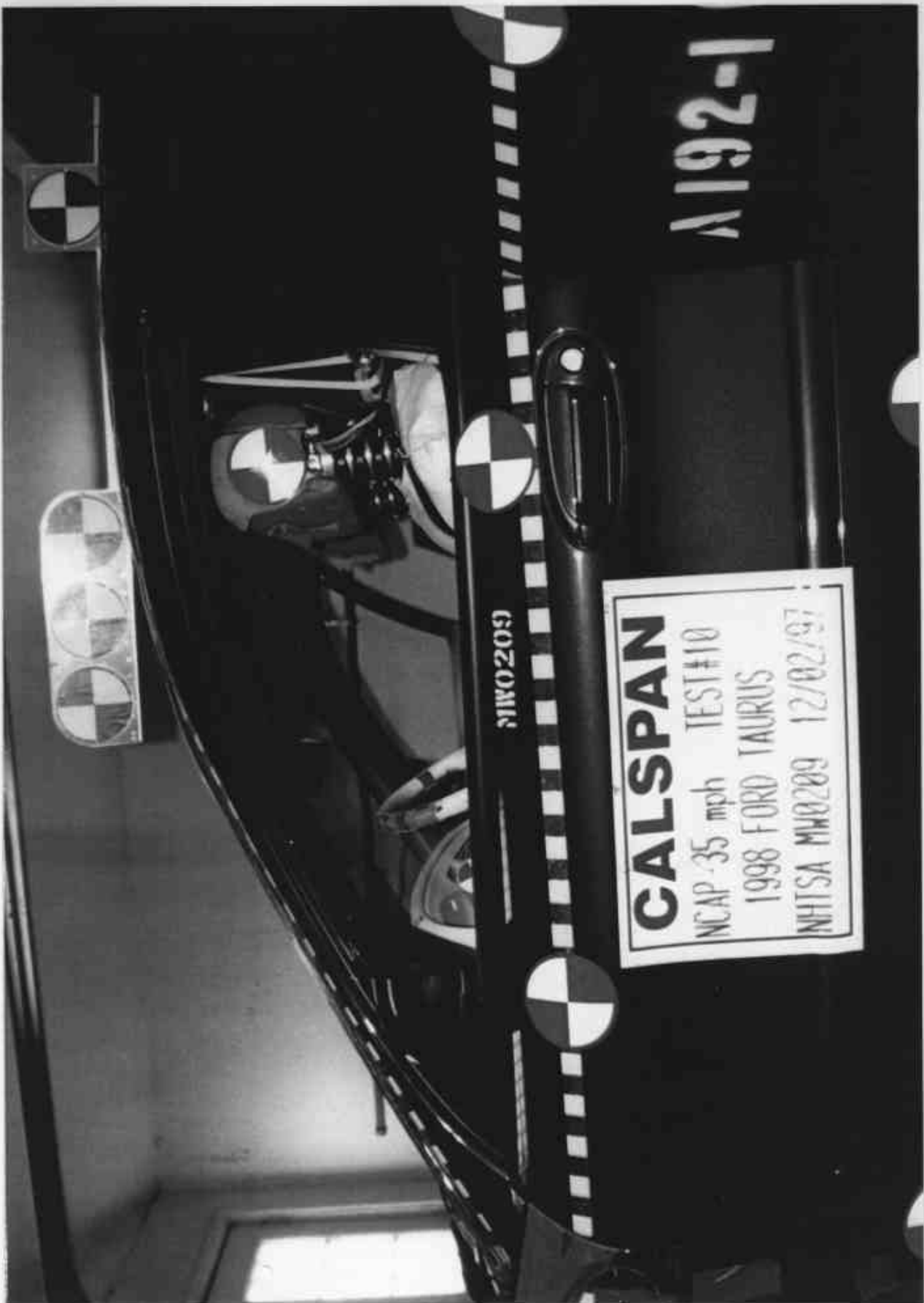

Figure A-22 PRE-TEST DRIVER POSITION VIEW



Figure A-23 POST-TEST DRIVER POSITION VIEW



Figure A-24 PRE-TEST PASSENGER POSITION VIEW



Figure A-25 POST-TEST PASSENGER POSITION VIEW



Figure A-26 PRE-TEST DRIVER AND INTERIOR VIEW



Figure A-27 POST-TEST DRIVER AND INTERIOR VIEW



Figure A-28 PRE-TEST PASSENGER AND INTERIOR VIEW



Figure A-29 POST-TEST PASSENGER AND INTERIOR VIEW

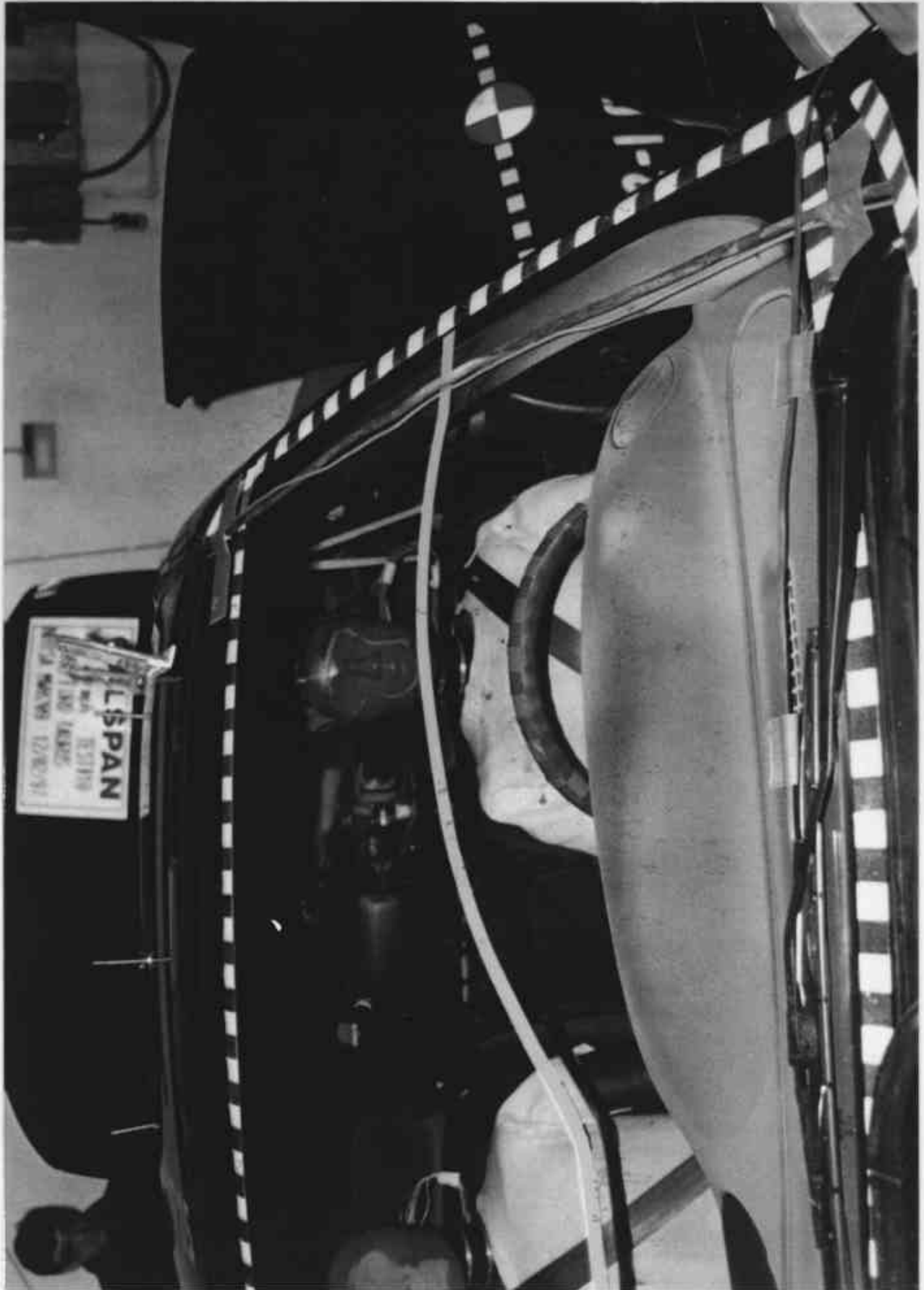

Figure A-30 PRE-TEST DRIVER HEAD LOCATION



Figure A-31 POST-TEST DRIVER HEAD LOCATION



Figure A-32 PRE-TEST PASSENGER HEAD LOCATION

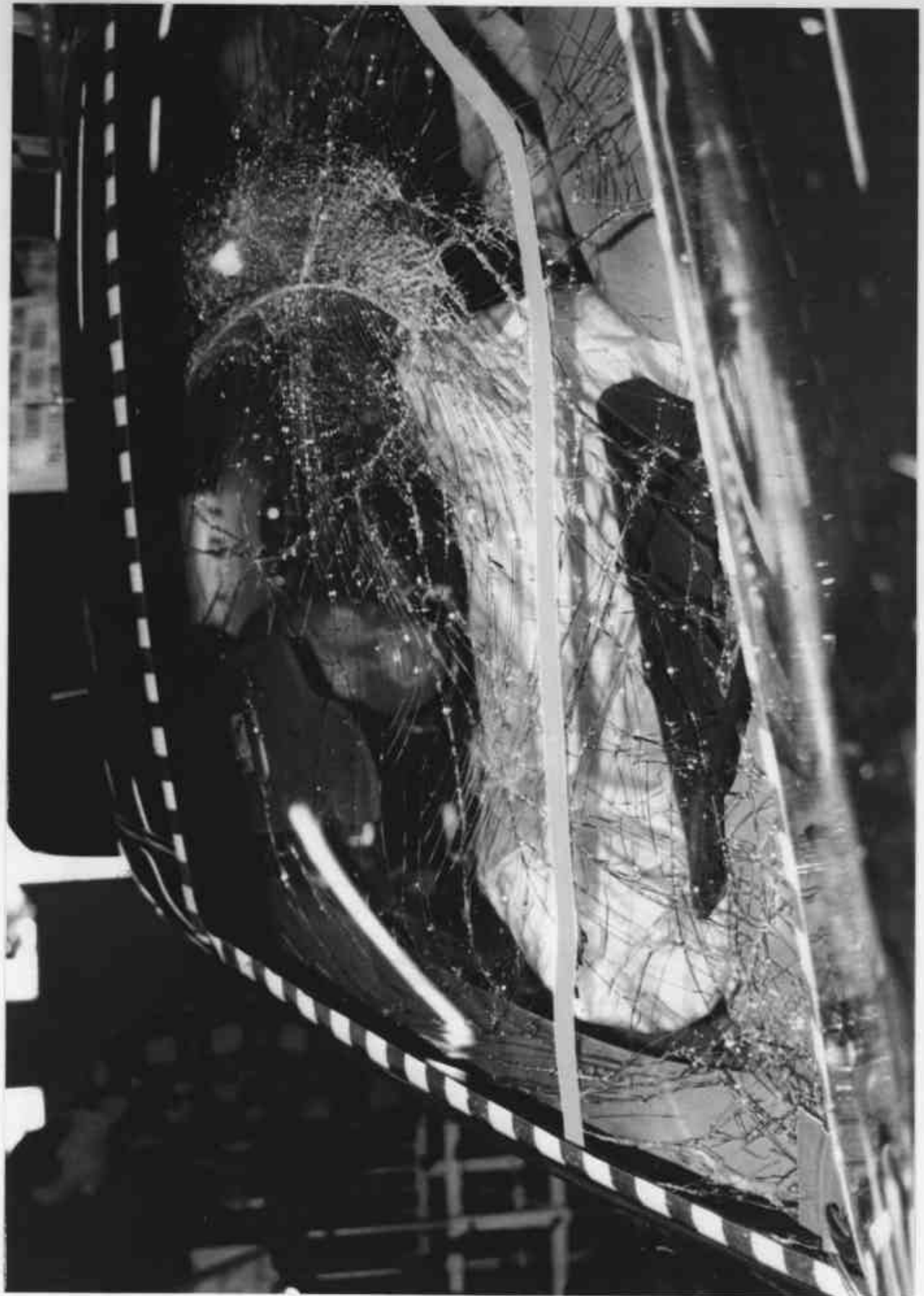

Figure A-33 POST-TEST PASSENGER HEAD LOCATION



Figure A-34 PRE-TEST DRIVER FLOOR PAN VIEW



Figure A-35 POST-TEST DRIVER FLOOR PAN VIEW



Figure A-36 PRE-TEST PASSENGER FLOOR PAN VIEW

A-39

8413-10



Figure A-37 POST-TEST PASSENGER FLOOR PAN VIEW

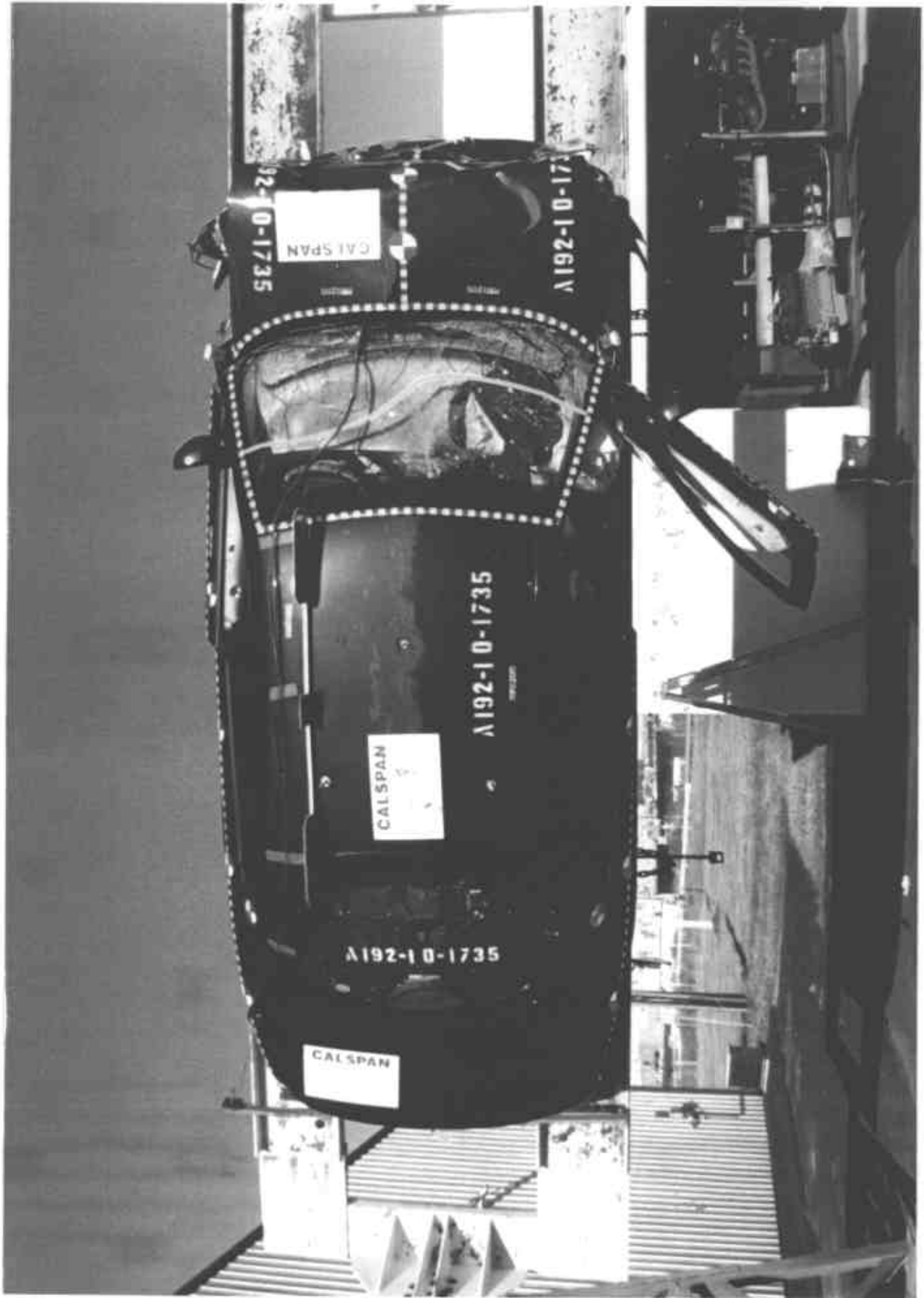

Figure A-38 ROLLOVER VIEW

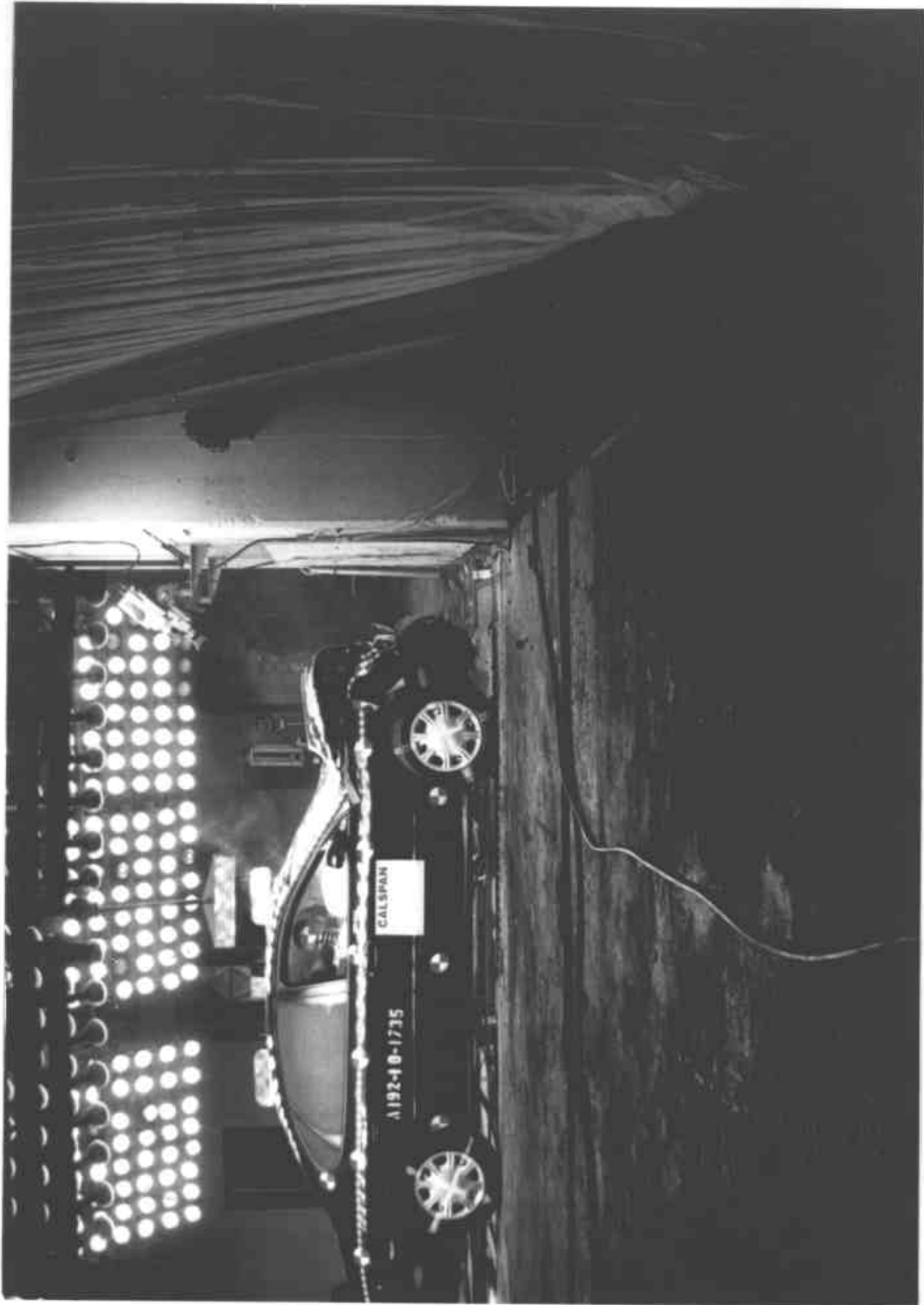

Figure A-39 IMPACT VIEW

Appendix B

DUMMY, VEHICLE AND LOAD CELL BARRIER RESPONSE DATA

**Hybrid III Dummy Sign Conventions
Load Cells and Special Transducers**

Transducer	DOT/NHTSA Sign Convention (positive unless noted)
Upper Neck Load Cell	Fx Head forward Fy Head left Fz Neck in tension Mx Right ear to right shoulder My Chin to chest (flexion) Mz Chin to left shoulder (look left)
Chest Displacement Potentiometer	Compression is negative
Pelvic Load Cell (Lower Lumbar)	Fx Chest forward Fy Chest left Fz Spine in tension
Femur Load Cell	Compression is negative
Upper Tibia Load Cell (right and left leg)	Mx Support tibia, load right side center My Support tibia, load front (shin) center
Lower Tibia Load Cell (right and left leg)	Fy Foot right w/r to left Fz Tibia in tension Mx Support tibia, press right side center

NHTSA TEST NO. MW0209

DUMMY DATA

CLASS	FILTER CHANNEL
Head Accelerations	1000
Chest Accelerations	180
Chest Displacements	60
Femur Forces	600
Belt Loads	60
Belt Displacements	180
Neck Forces	1000
Neck Moments	600

NCAP TEST #10 - 1998 FORD TAURUS

Max = 8.51 Gs @ 243.30 msec
Min = -62.1 Gs @ 73.60 msec

Pos. 1 Head X

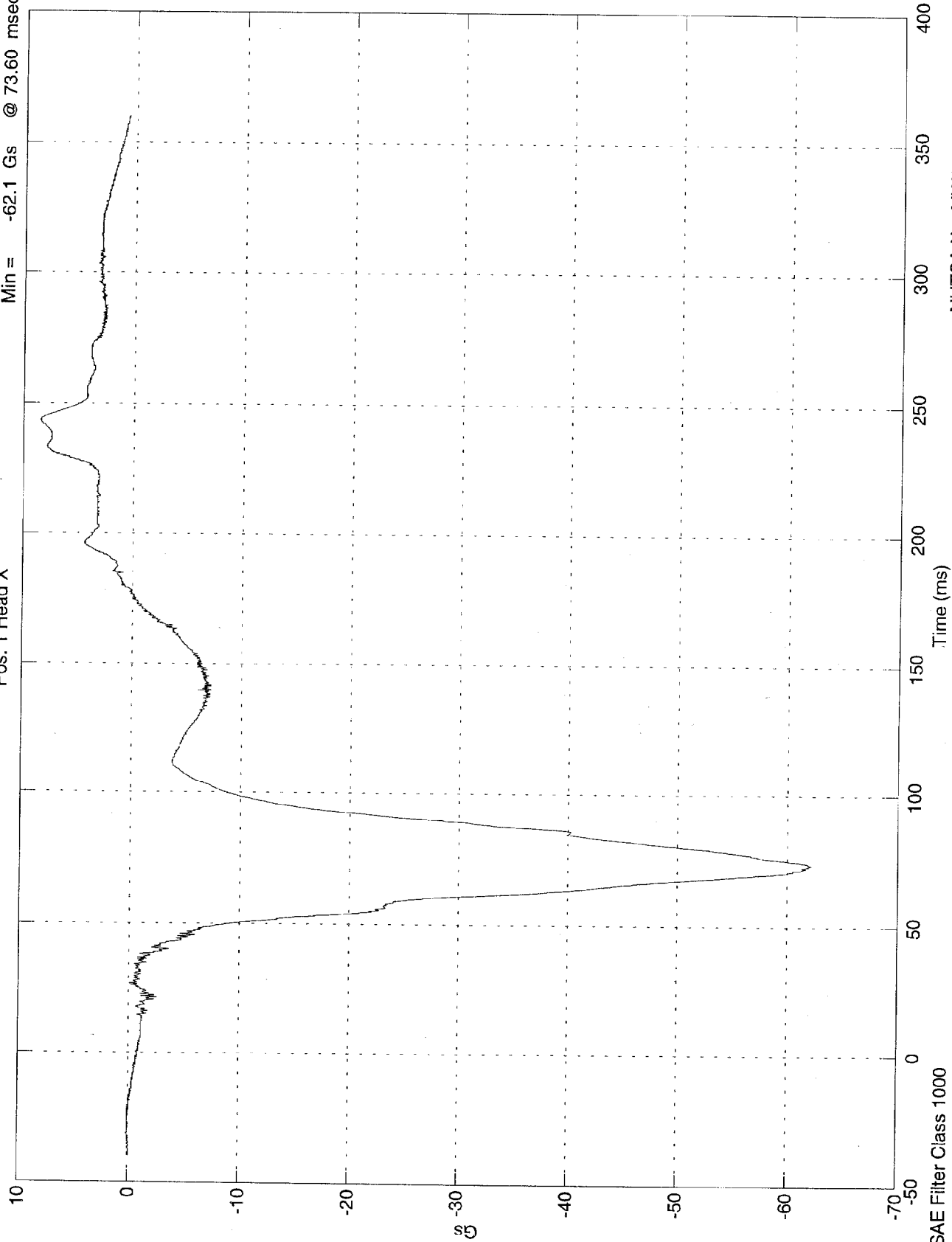

NHTSA No: MW0209
Date: 02 Dec 1997

NCAP TEST #10 - 1998 FORD TAURUS

Max = 1.08 Gs @ 231.20 msec
Min = -19.8 Gs @ 86.00 msec

Pos. 1 Head Y

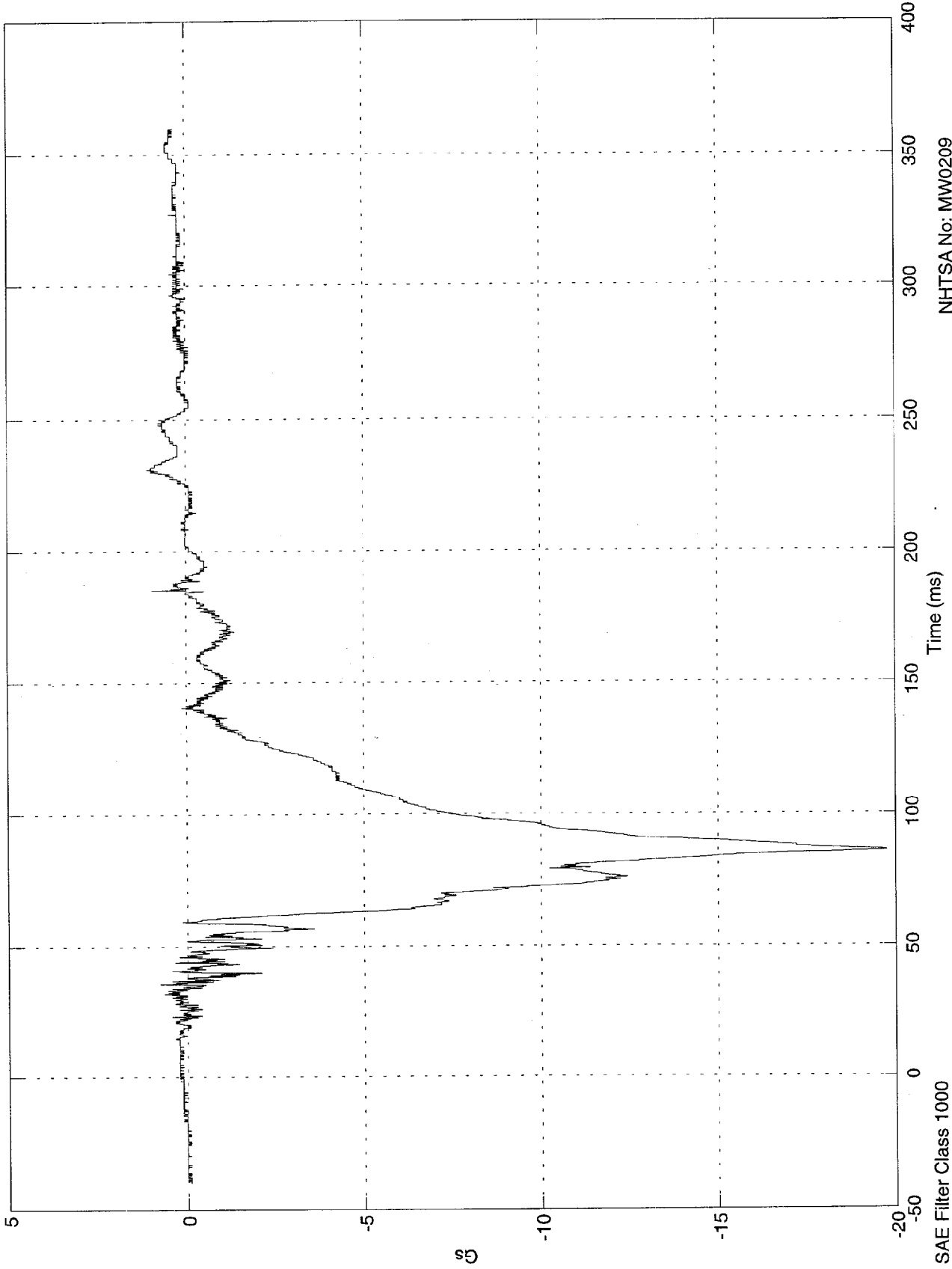

NHTSA No: MW0209
Date: 02 Dec 1997

SAE Filter Class 1000

NCAP TEST #10 - 1998 FORD TAURUS

Max = 24 Gs @ 67.80 msec
Min = -5.44 Gs @ 85.10 msec

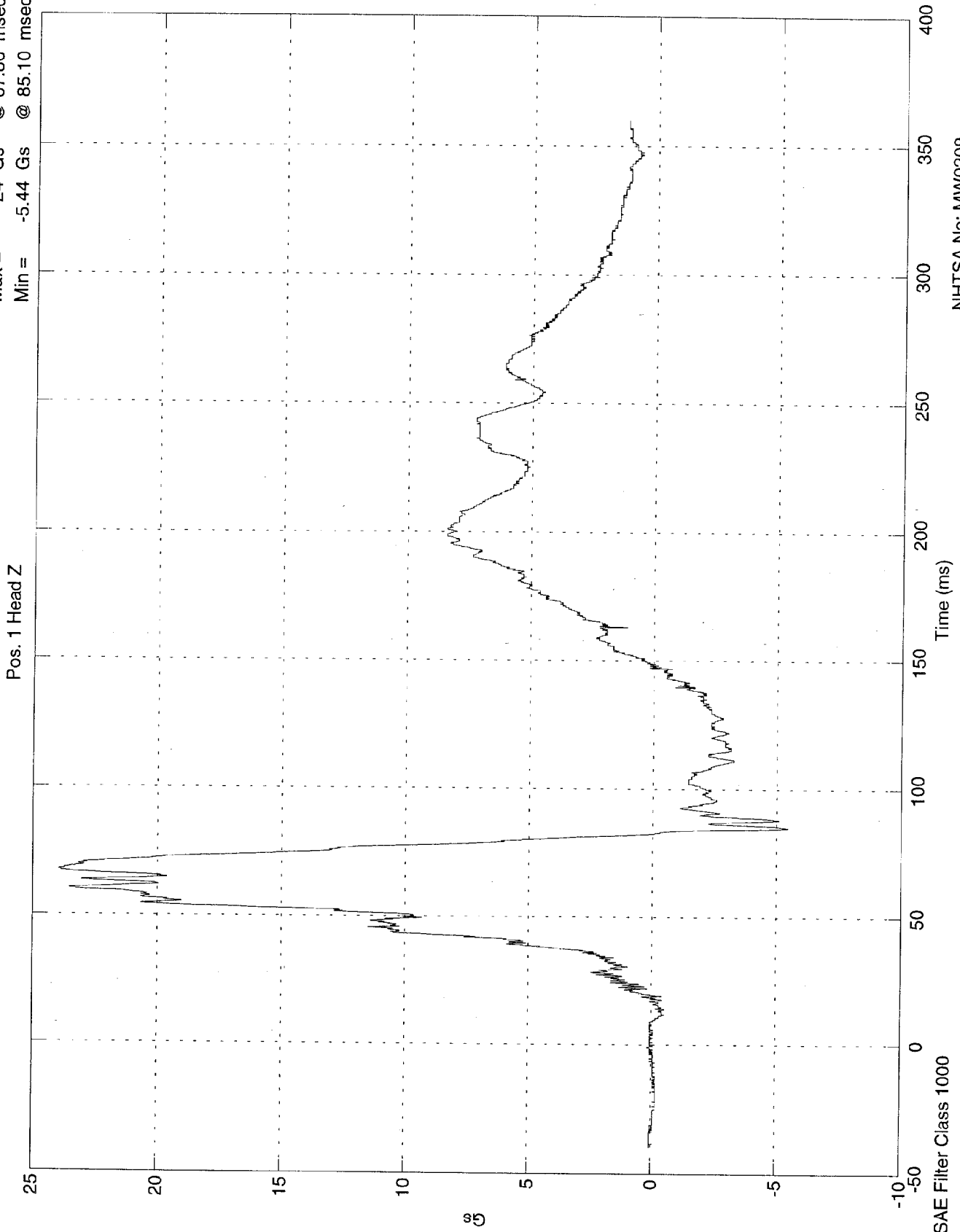

NHTSA No: MW0209
Date: 02 Dec 1997

NCAP TEST #10 - 1998 FORD TAURUS

Max = 65.8 Gs @ 73.60 msec
Min = 0.0749 Gs @ -39.30 msec

Pos. 1 Head Resultant

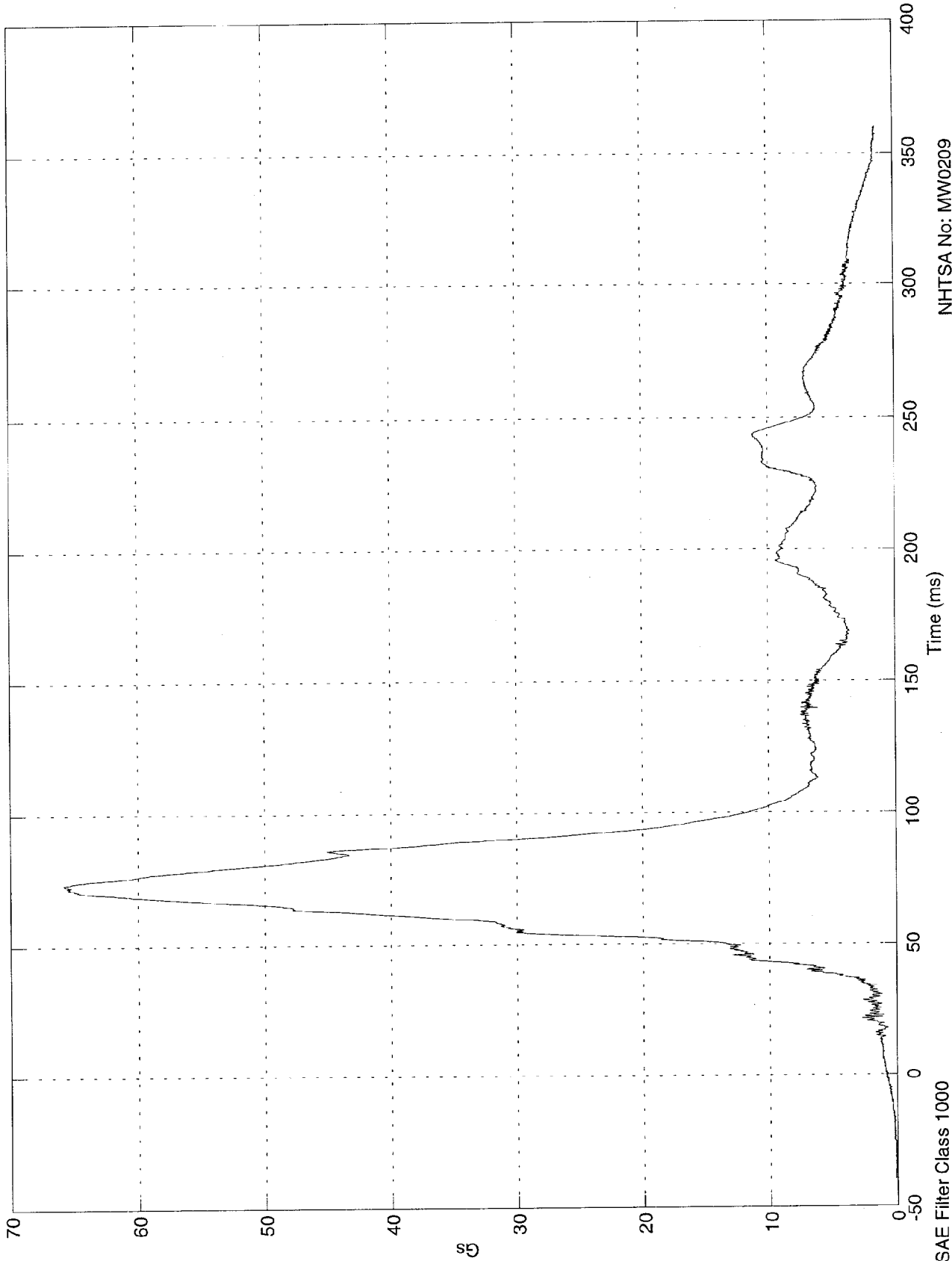

NHTSA No: MW0209
Date: 02 Dec 1997

SAE Filter Class 1000

NCAP TEST #10 - 1998 FORD TAURUS

Max = 8.48 Gs @ 243.40 msec
Min = -67.4 Gs @ 73.80 msec

Pos: 1 Head X(R)

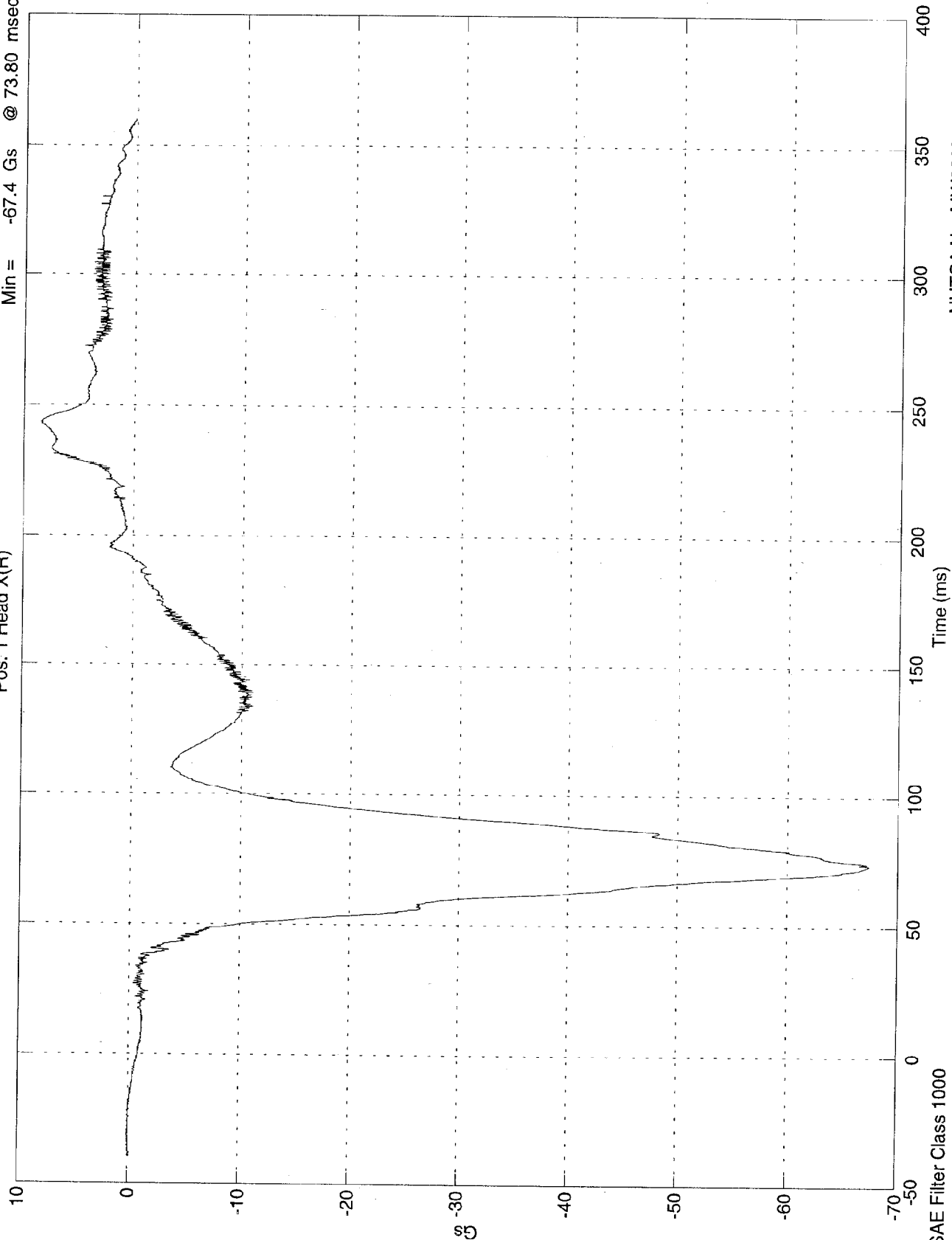

NHTSA No: MW0209
Date: 02 Dec 1997

NCAP TEST #10 - 1998 FORD TAURUS

Max = 9.75 Gs @ 272.40 msec
Min = -25 Gs @ 86.00 msec

Pos. 1 Head Y(R)

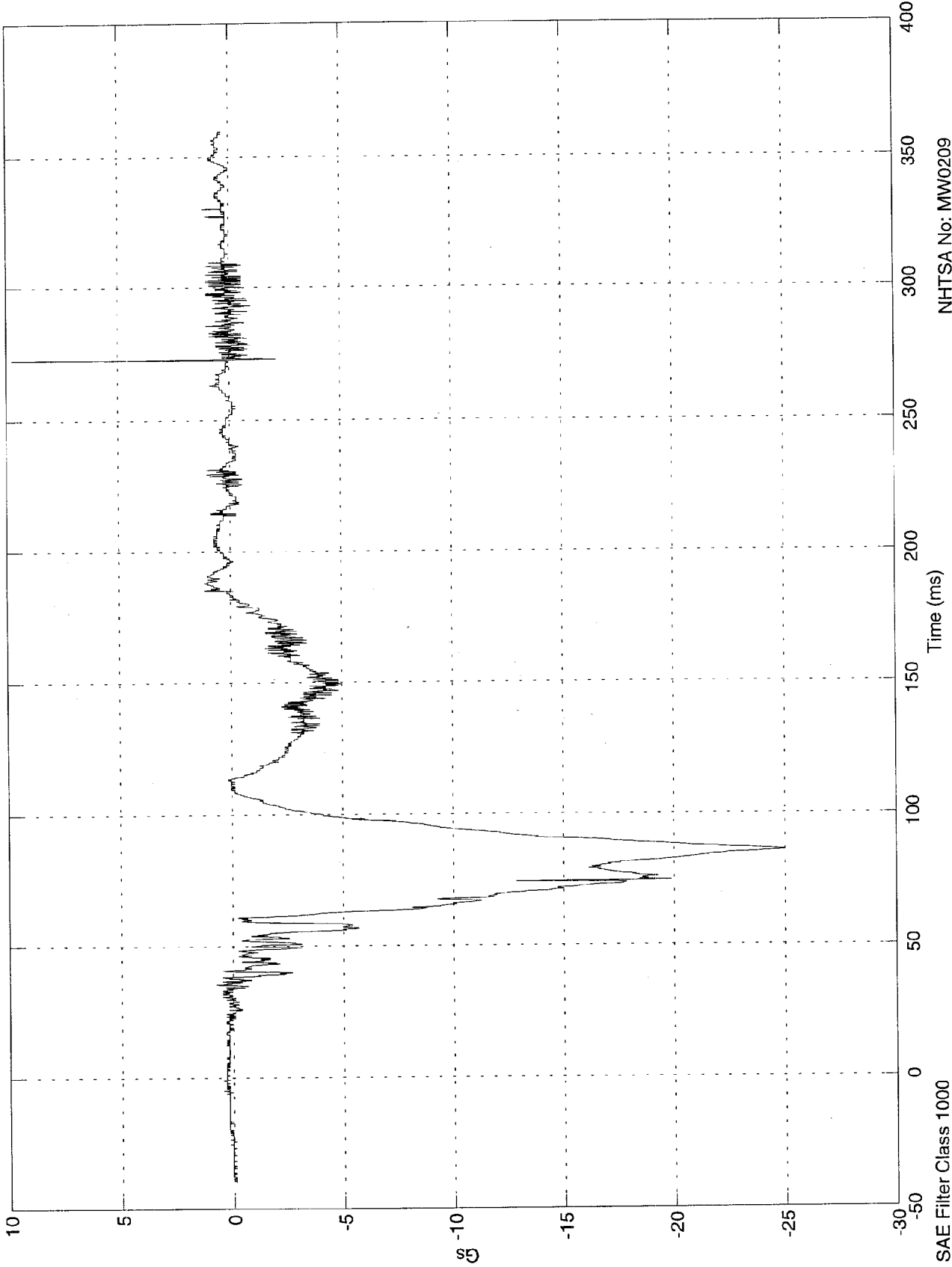

NIHTSA No: MW0209
Date: 02 Dec 1997

SAE Filter Class 1000

NCAP TEST #10 - 1998 FORD TAURUS

Max = 26.3 Gs @ 54.40 msec
Min = -5.43 Gs @ 85.10 msec

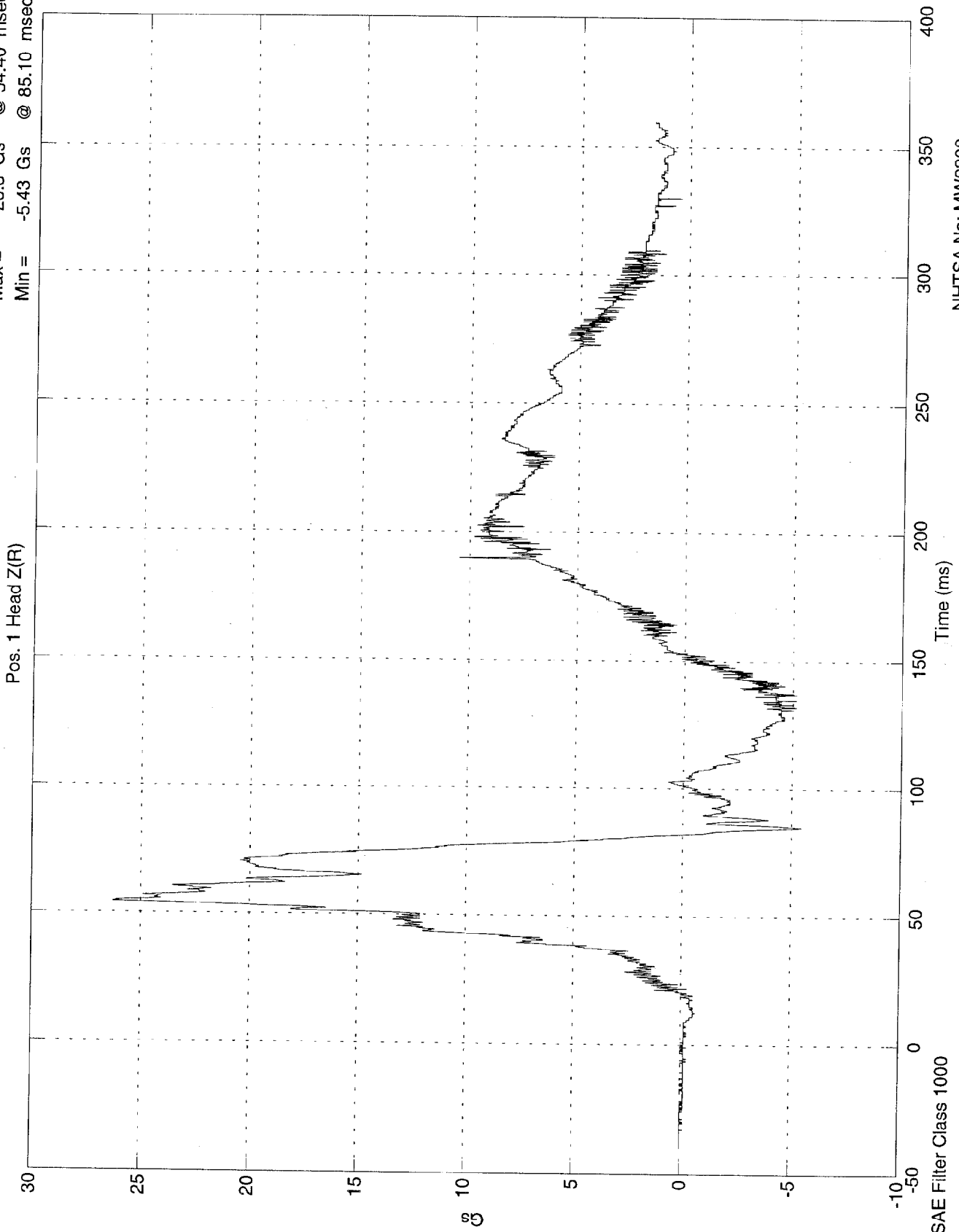

NHTSA No: MW0209
Date: 02 Dec 1997

NCAP TEST #10 - 1998 FORD TAURUS

Max = 71.8 Gs @ 73.80 msec
Min = 0.0284 Gs @ -39.40 msec

Pos. 1 Head Resultant(RR)

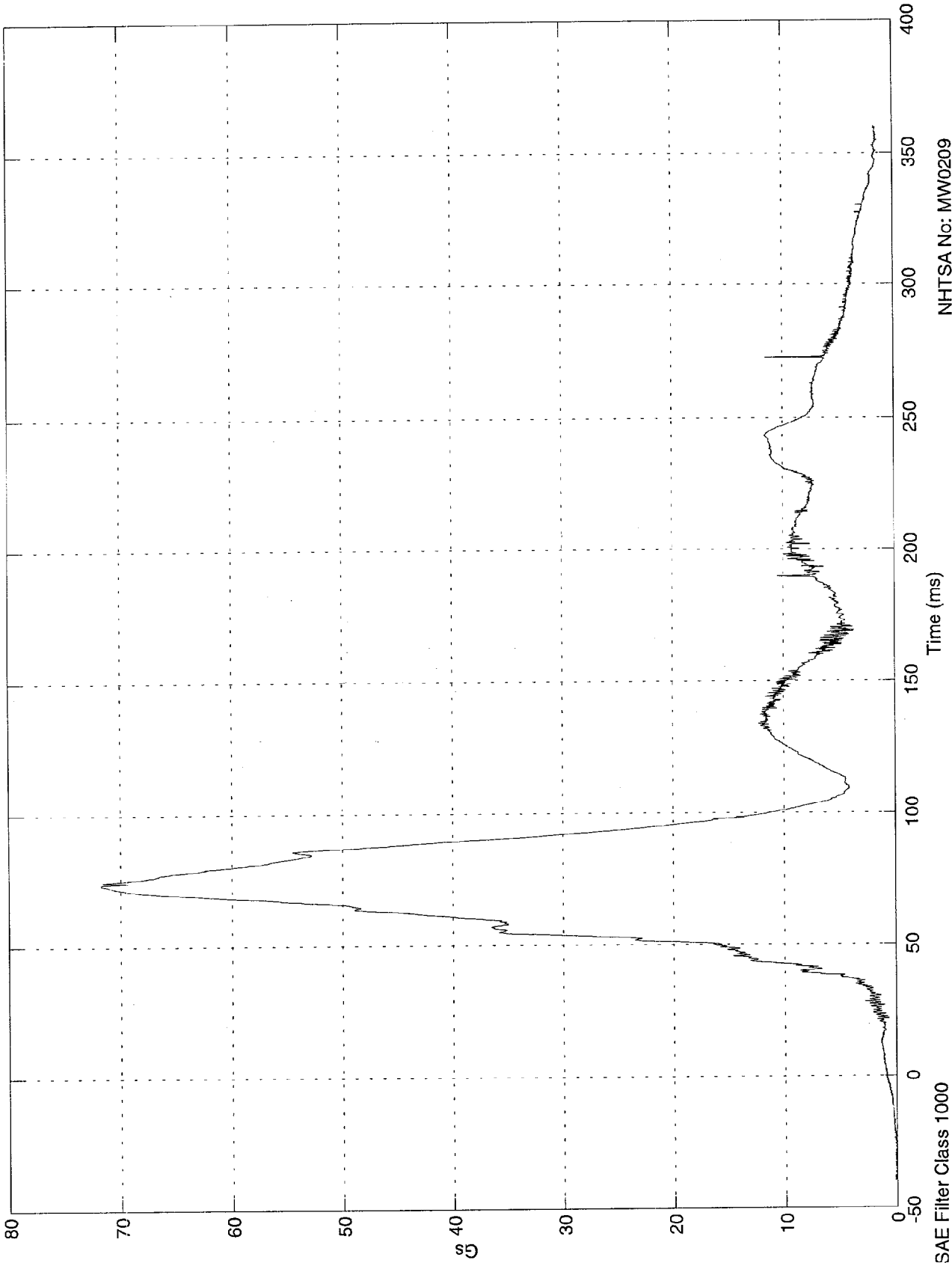

NHTSA No: MW0209
Date: 02 Dec 1997

SAE Filter Class 1000

NCAP TEST #10 - 1998 FORD TAURUS

Pos. 1 Upper Neck Fx

Max = 416 Nwt @ 81.60 msec
Min = -533 Nwt @ 135.30 msec

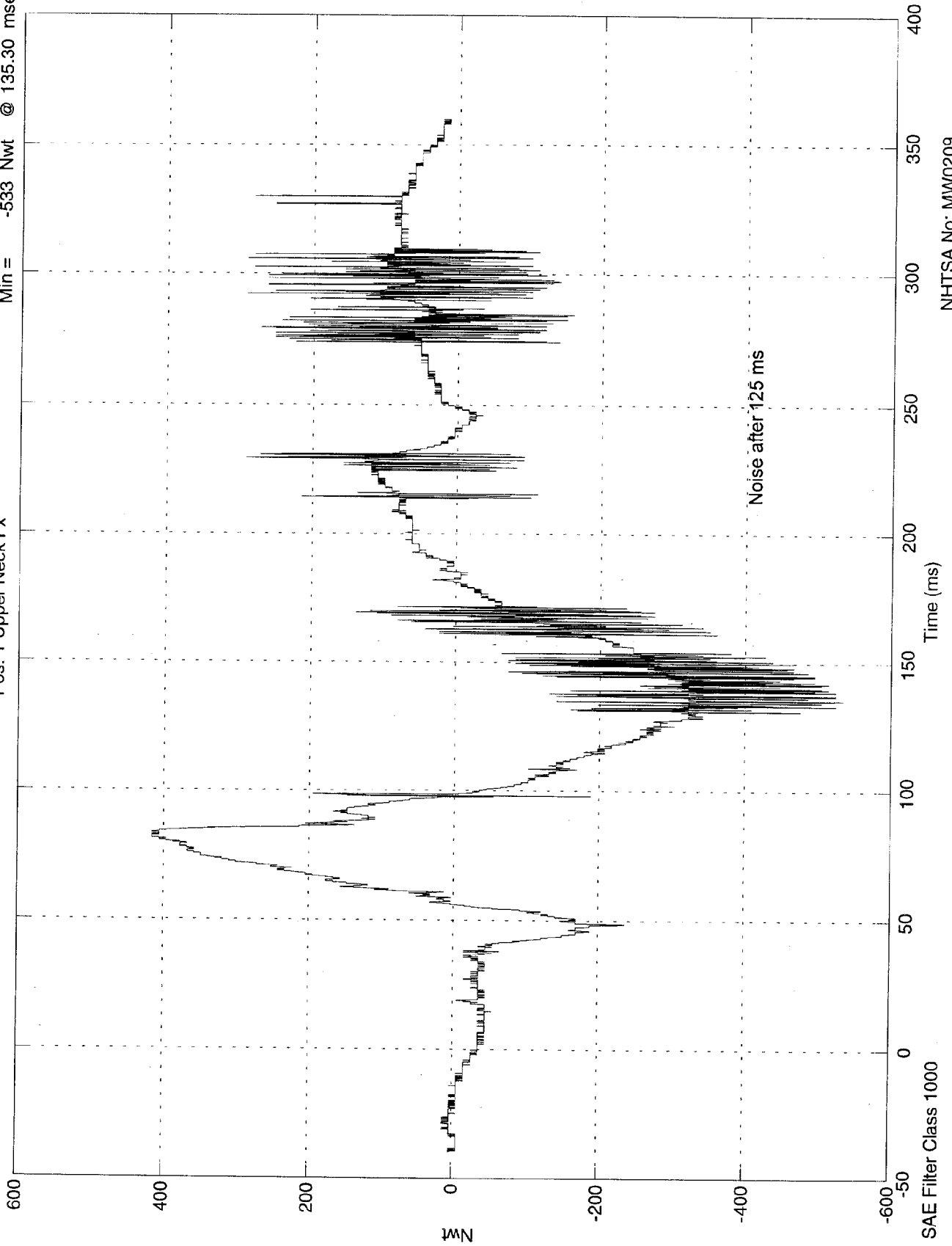

NHTSA No: MW0209
Date: 02 Dec 1997

NCAP TEST #10 - 1998 FORD TAURUS

Max = 205 Nwt @ 81.90 msec
Min = -324 Nwt @ 131.90 msec

Pos. 1 Upper Neck Fy

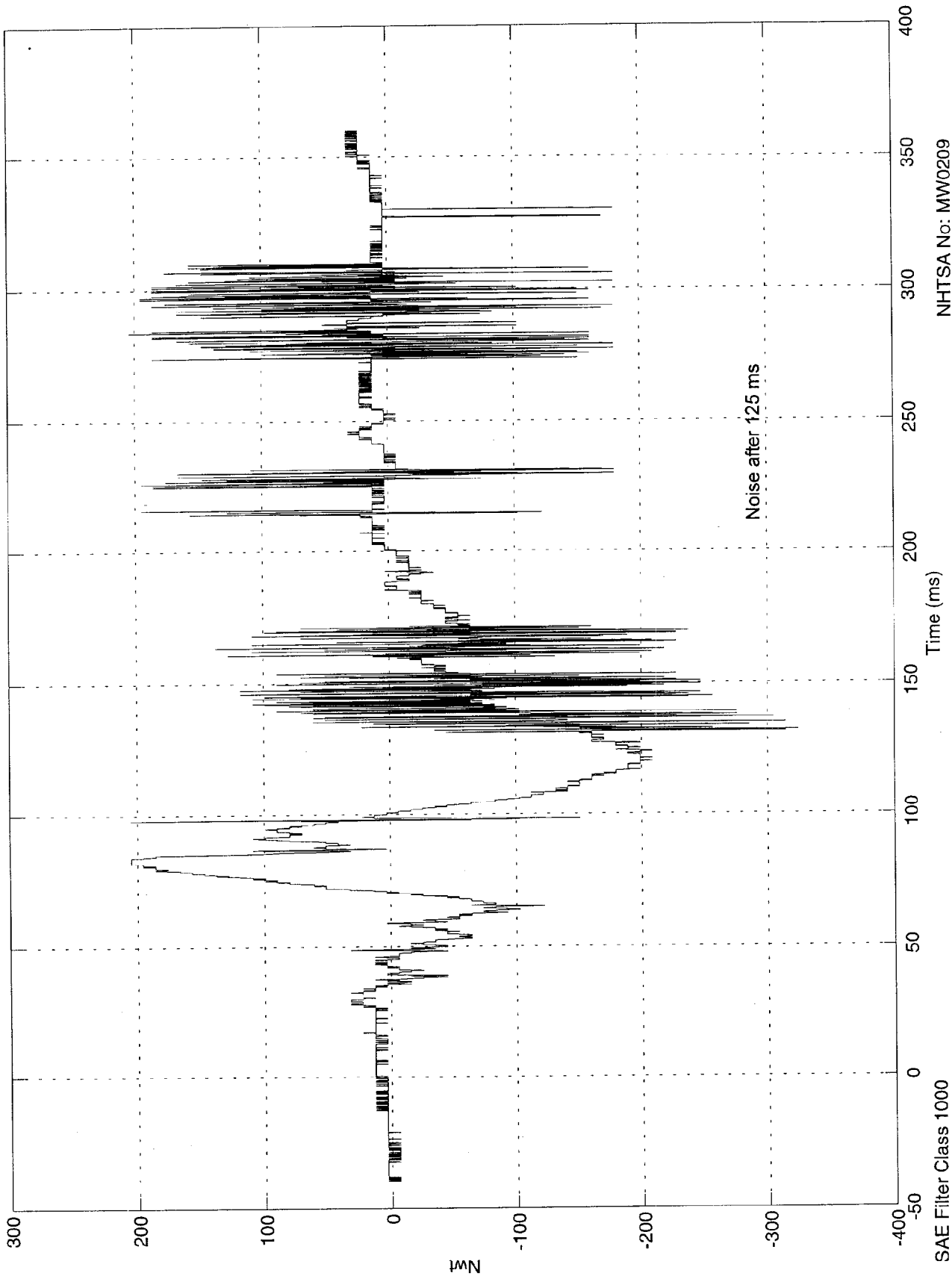

NHTSA No: MW0209
Date: 02 Dec 1997

SAE Filter Class 1000

NCAP TEST #10 - 1998 FORD TAURUS

Pos. 1 Upper Neck Fz

Max = 3.15e+003 Nwt @ 67.70 msec
Min = -370 Nwt @ 136.70 msec

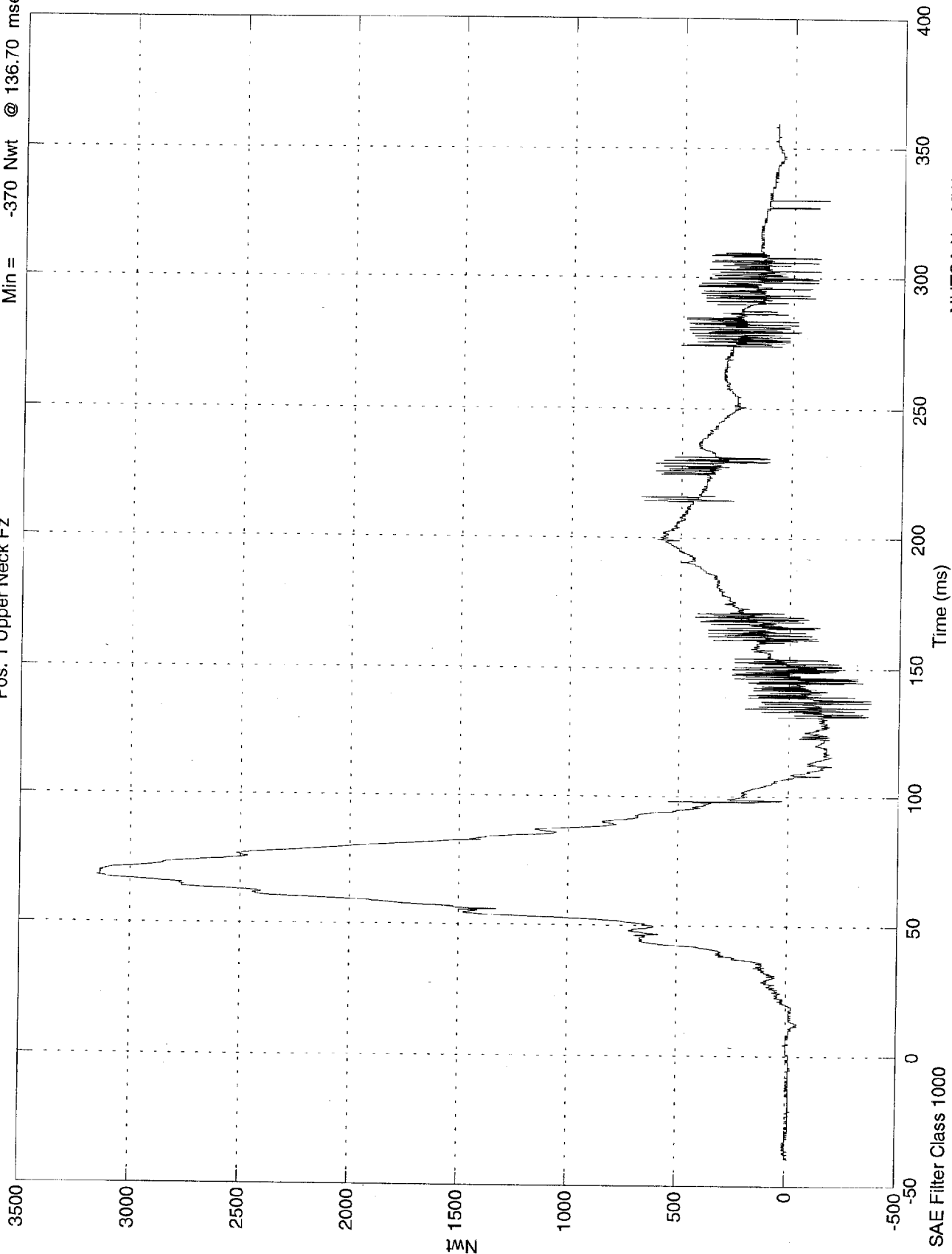

NHTSA No: MW0209
Date: 02 Dec 1997

NCAP TEST #10 - 1998 FORD TAURUS

Max = 3.16e+003 Nwt @ 67.90 msec
Min = 4.96 Nwt @ -39.30 msec

Pos. 1 Neck Force Res.

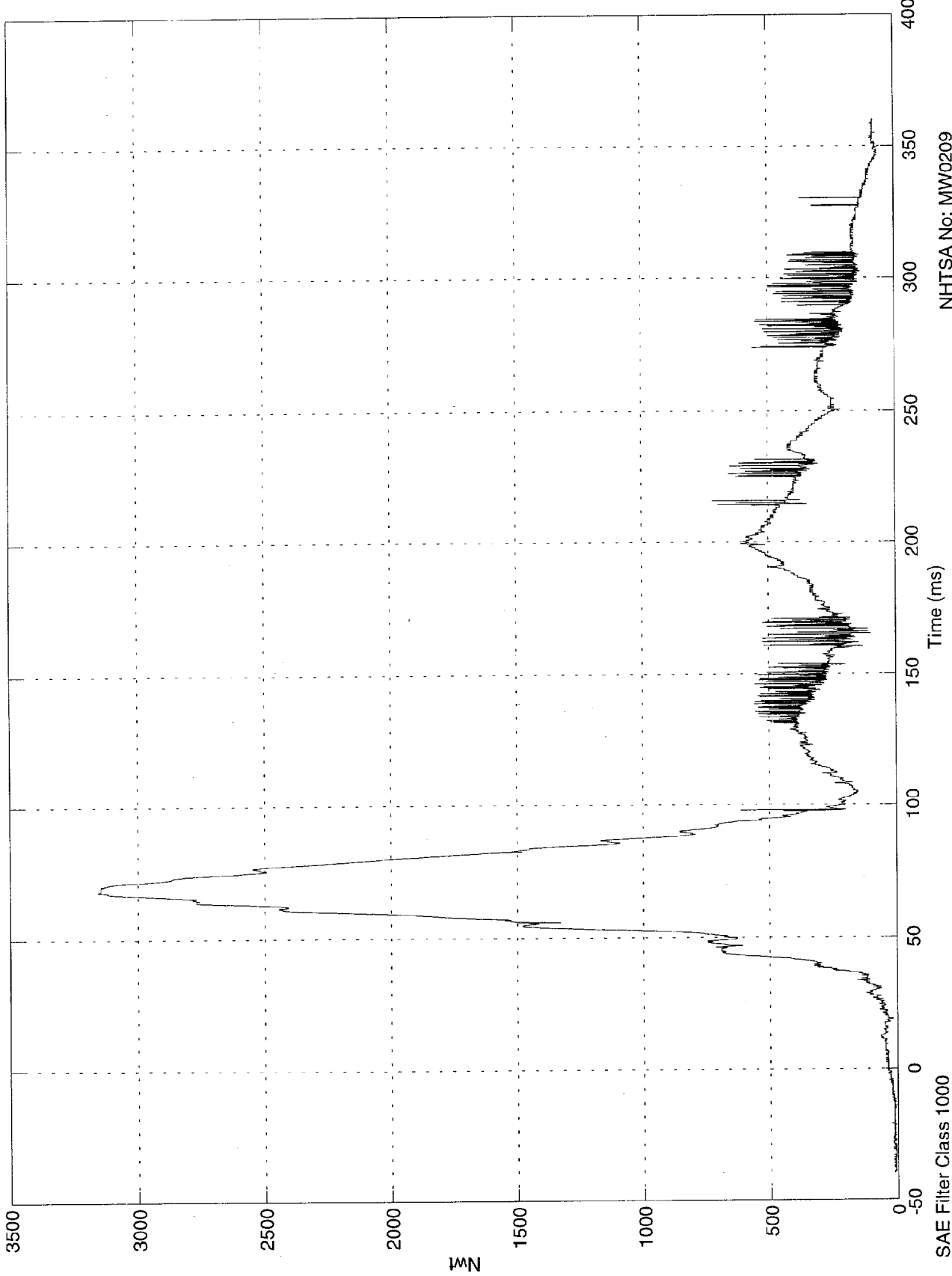

NHTSA No: MW0209
Date: 02 Dec 1997

SAE Filter Class 1000

NCAP TEST #10 - 1998 FORD TAURUS

Max = 9.49 Nwt-M @ 148.20 msec
Min = -31.2 Nwt-M @ 79.20 msec

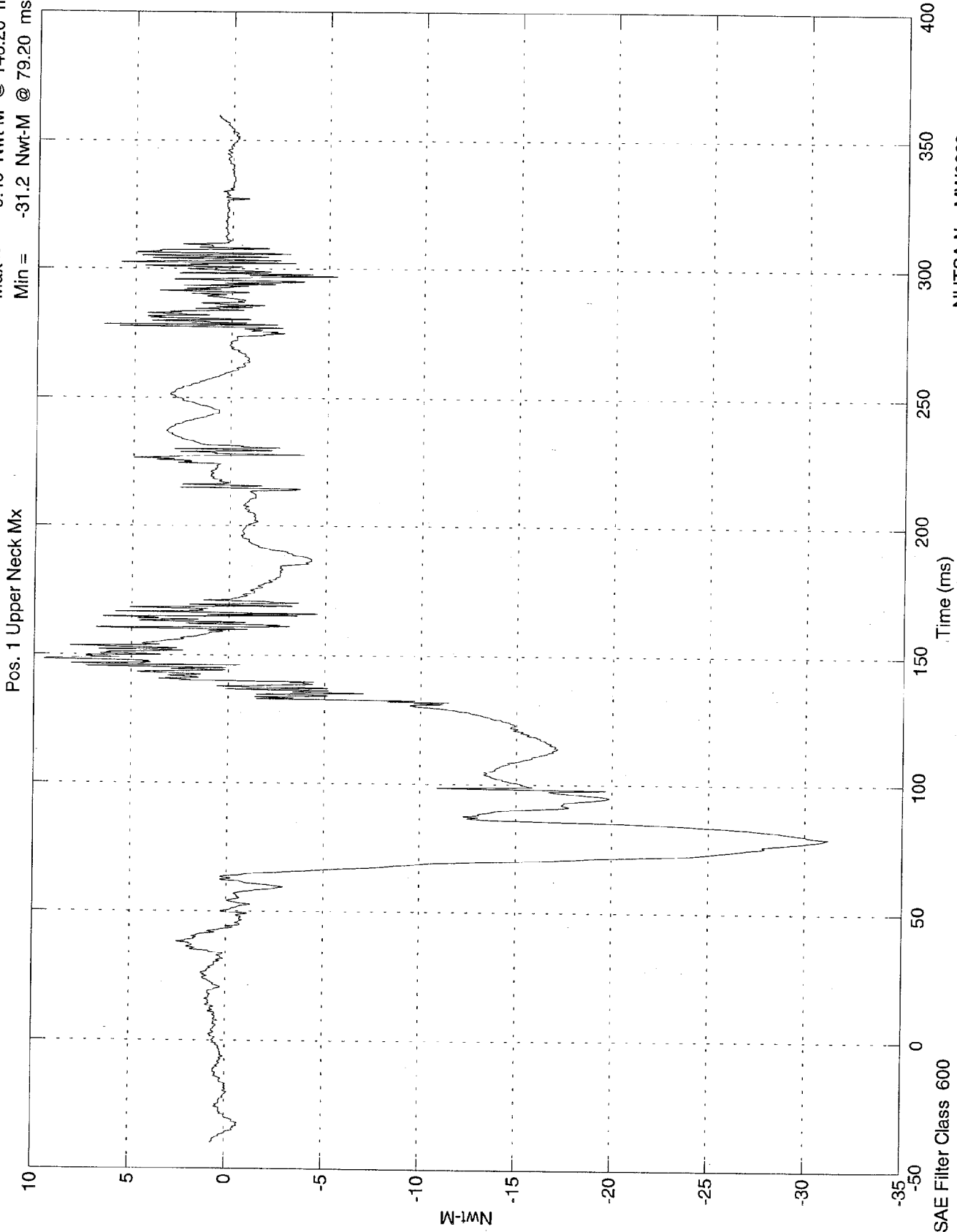

NHTSA No: MW0209
Date: 02 Dec 1997

NCAP TEST #10 - 1998 FORD TAURUS

Max = 31.4 Nwt-M @ 131.80 msec
Min = -28 Nwt-M @ 248.20 msec

Pos. 1 Upper Neck My

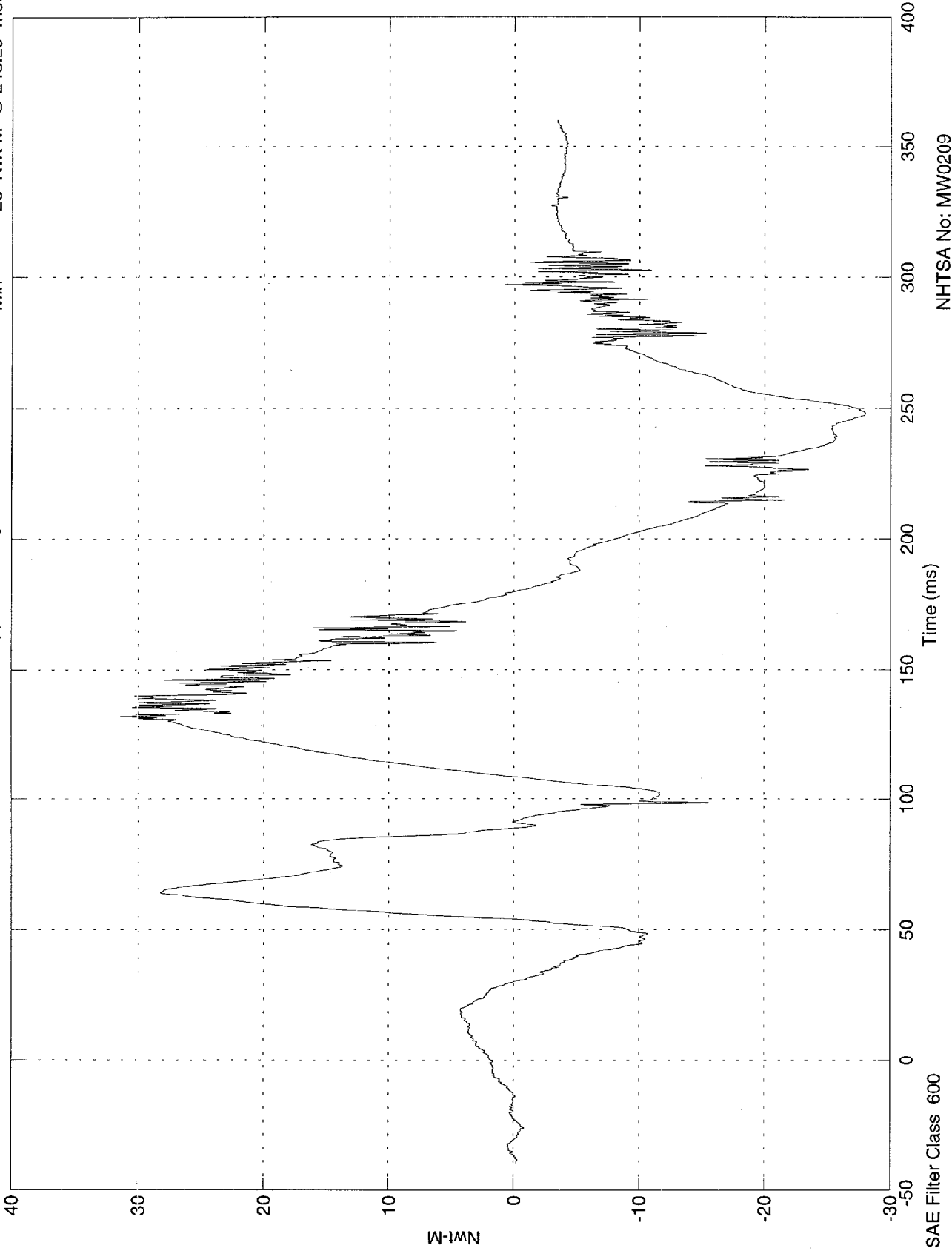

NHTSA No: MW0209
Date: 02 Dec 1997

NCAP TEST #10 - 1998 FORD TAURUS

Max = 32.4 Nwt-M @ 103.90 msec
Min = -17 Nwt-M @ 160.40 msec

Pos. 1 Upper Neck Mz

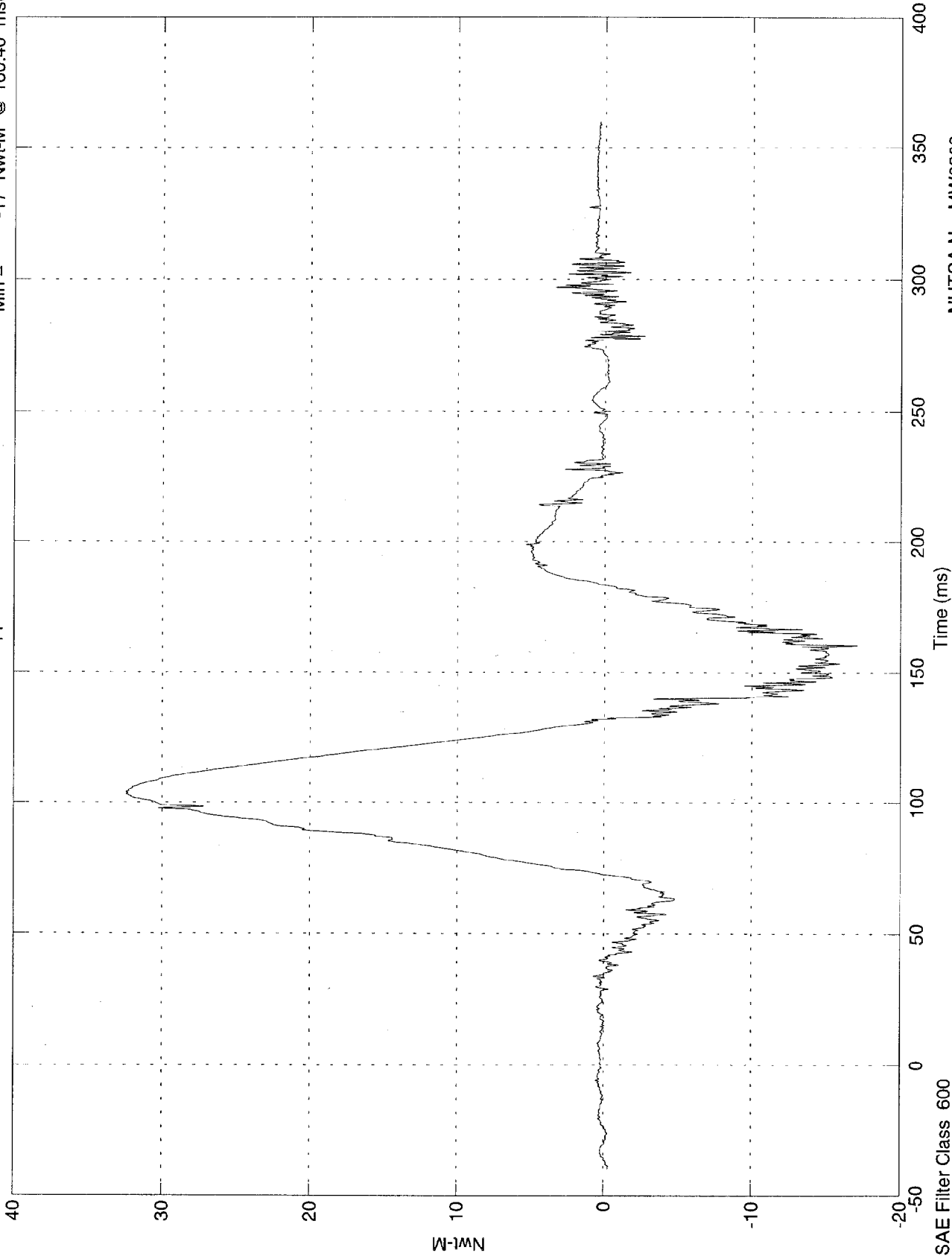

NHTSA No: MW0209
Date: 02 Dec 1997

SAE Filter Class 600

NCAP TEST #10 - 1998 FORD TAURUS

Max = 36.9 Nwt-M @ 101.90 msec
Min = 0.0916 Nwt-M @ -35.40 msec

Pos. 1 Neck Moment Res.

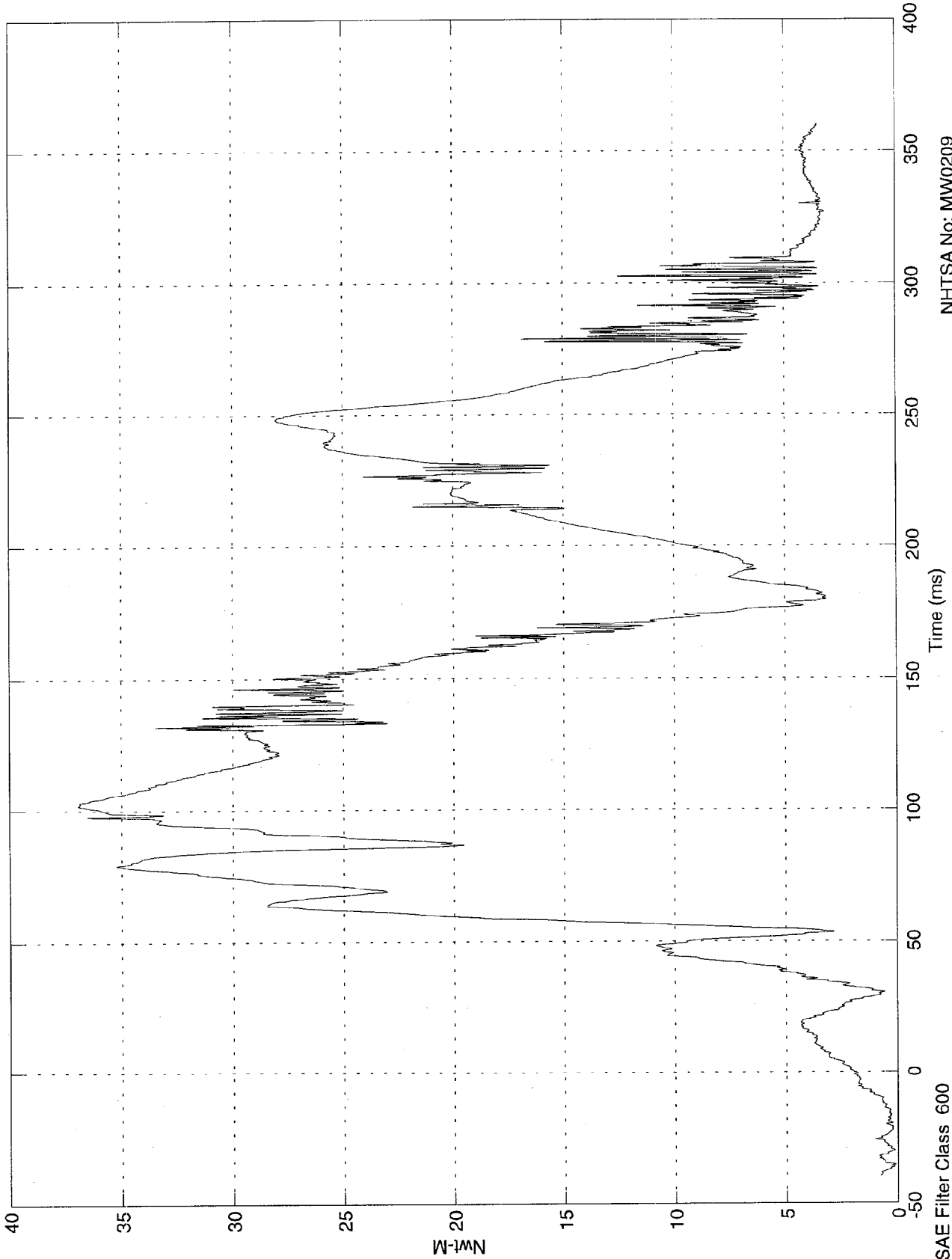

NHTSA No: MW0209
Date: 02 Dec 1997

SAE Filter Class 600

NCAP TEST #10 - 1998 FORD TAURUS

Max = 3.84 Gs @ 187.30 msec
Min = -48.2 Gs @ 72.30 msec

Pos. 1 Chest X

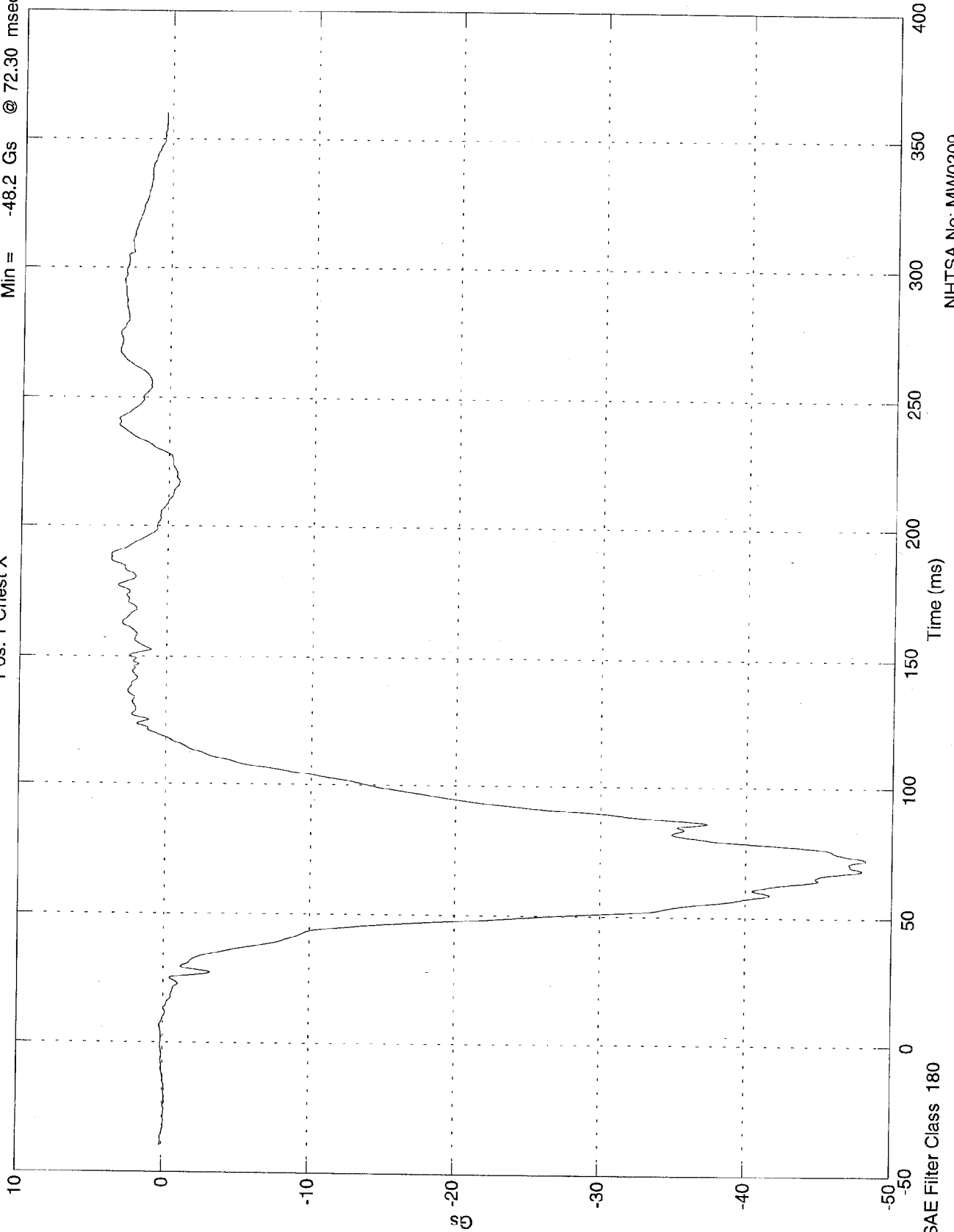

NHTSA No: MW0209
Date: 02 Dec 1997

NCAP TEST #10 - 1998 FORD TAURUS

Max = 1.09 Gs @ 148.30 msec
Min = -14.1 Gs @ 86.00 msec

Pos. 1 Chest Y

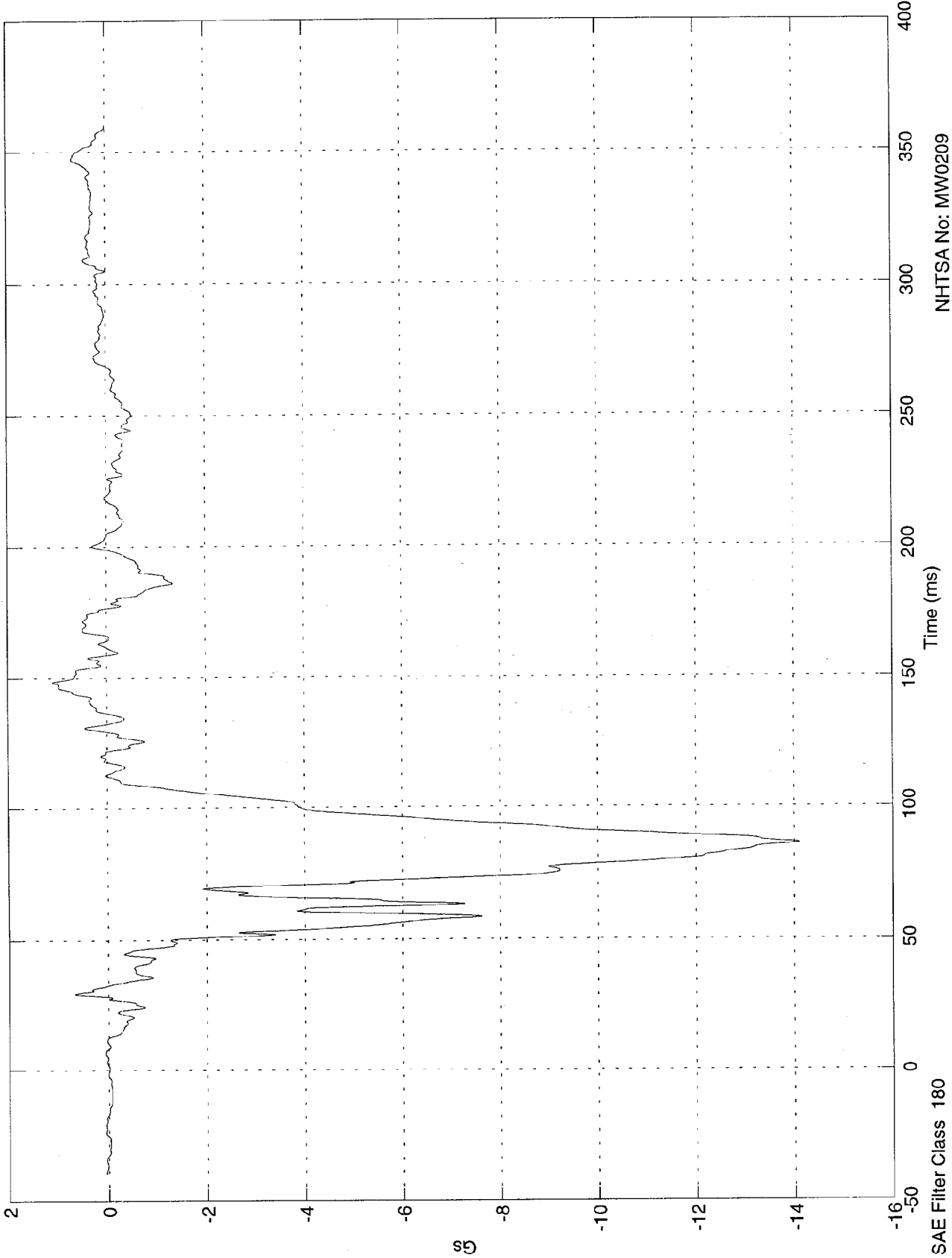

NHTSA No: MW0209
Date: 02 Dec 1997

SAE Filter Class 180

NCAP TEST #10 - 1998 FORD TAURUS

Max = 13.1 Gs @ 69.30 msec
Min = -7.68 Gs @ 86.70 msec

Pos. 1 Chest Z

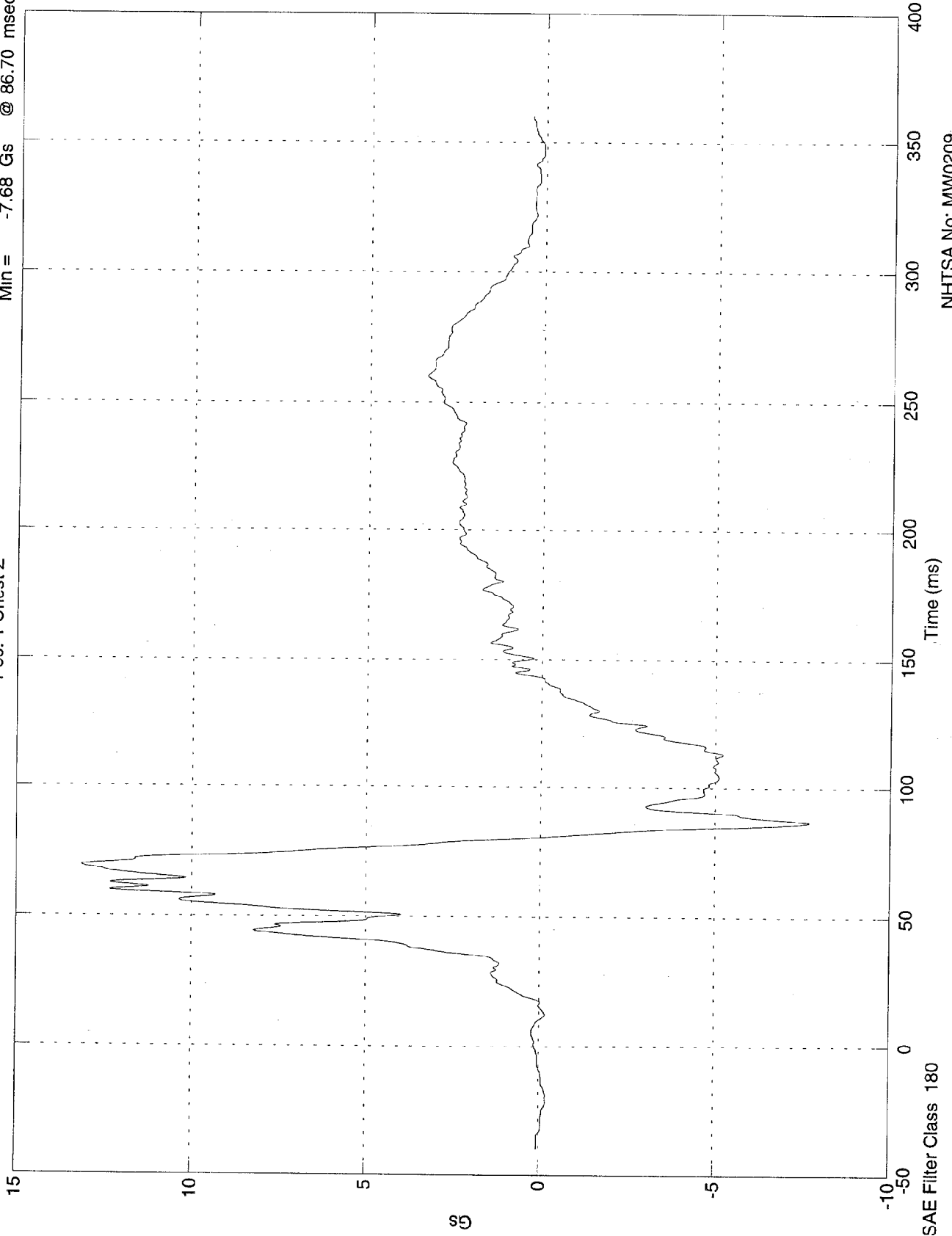

NHTSA No: MW0209
Date: 02 Dec 1997

SAE Filter Class 180

NCAP TEST #10 - 1998 FORD TAURUS

Max = 49.8 Gs @ 72.30 msec
Min = 0.0358 Gs @ 10.30 msec

Pos. 1 Chest Resultant

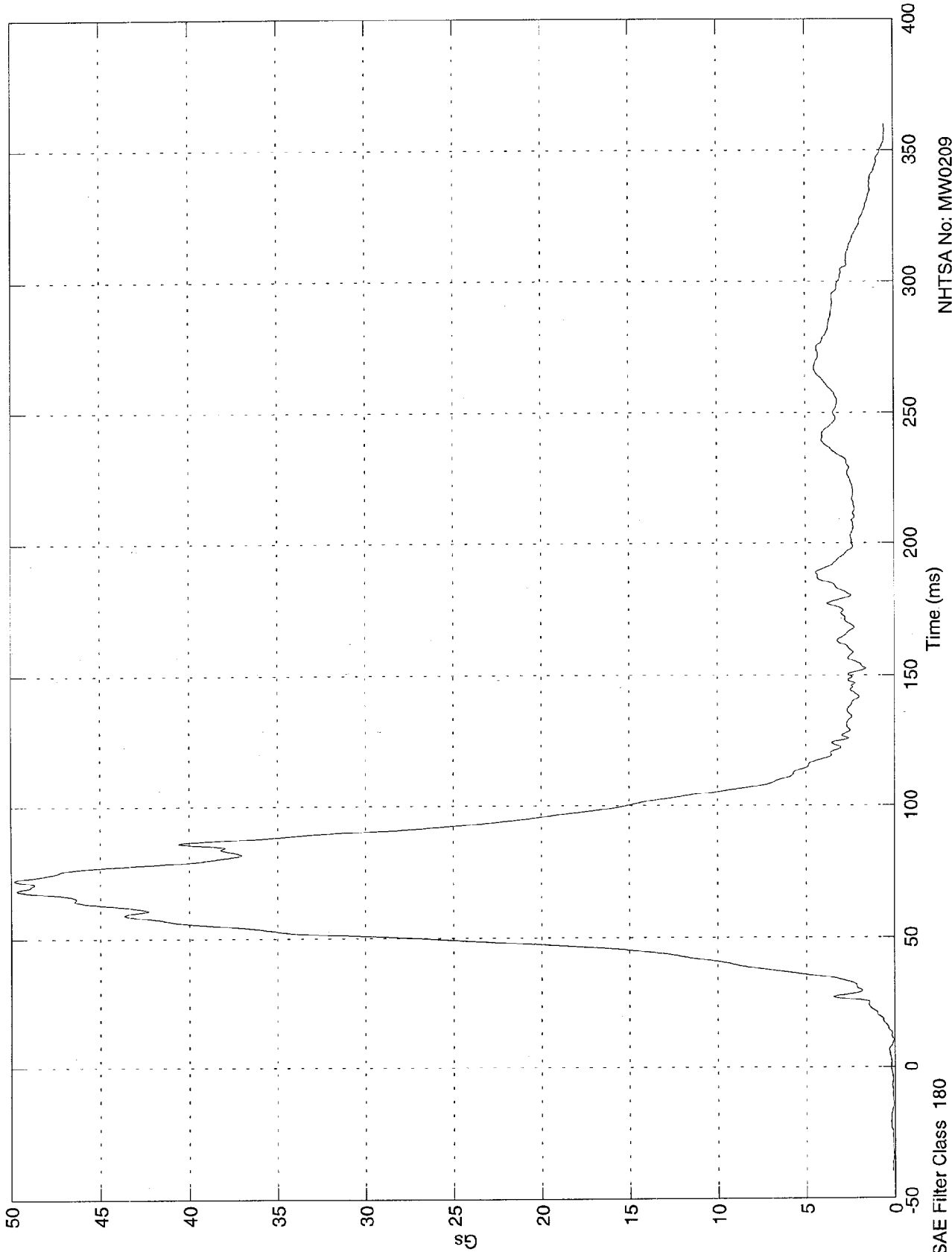

NHTSA No: MW0209
Date: 02 Dec 1997

SAE Filter Class 180

NCAP TEST #10 - 1998 FORD TAURUS

Max = 3.95 Gs @ 188.60 msec
Min = -48.2 Gs @ 72.10 msec

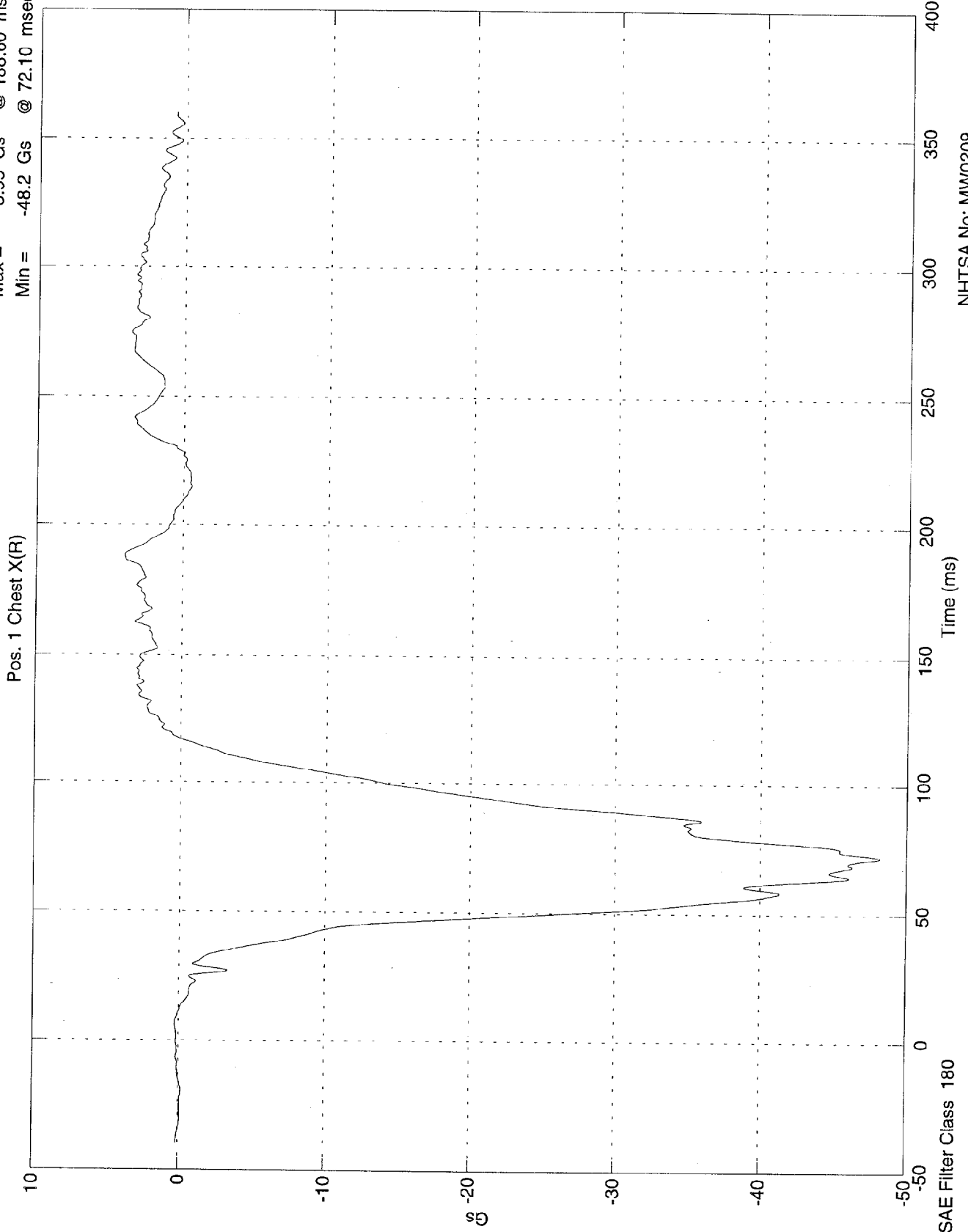

NHTSA No: MW0209
Date: 02 Dec 1997

NCAP TEST #10 - 1998 FORD TAURUS

Max = 1.41 Gs @ 150.00 msec
Min = -12.4 Gs @ 86.10 msec

Pos. 1 Chest Y(R)

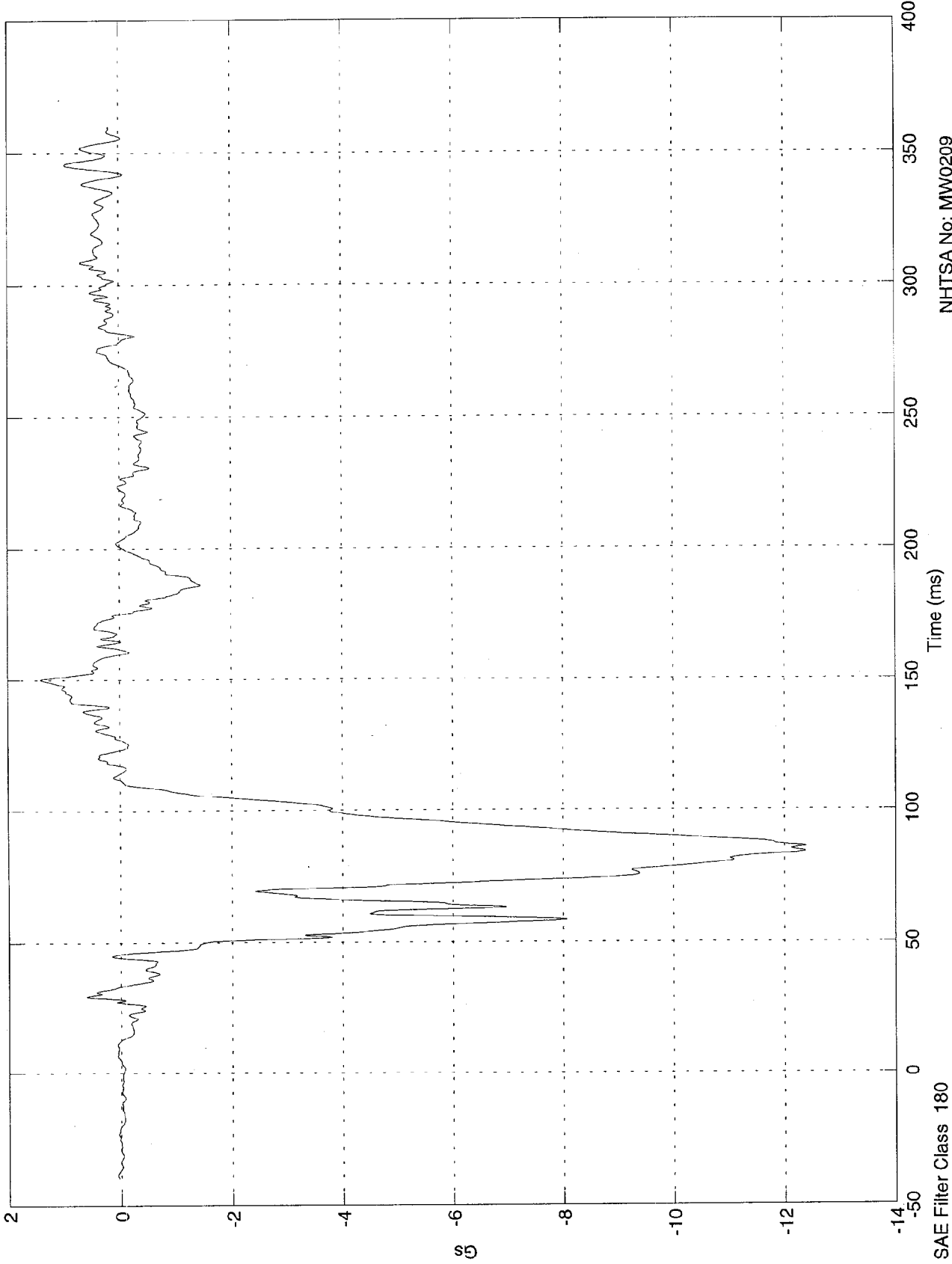

NHTSA No: MW0209
Date: 02 Dec 1997

SAE Filter Class 180

NCAP TEST #10 - 1998 FORD TAURUS

Max = 13.7 Gs @ 69.40 msec
Min = -6.06 Gs @ 86.70 msec

Pos. 1 Chest Z(R)

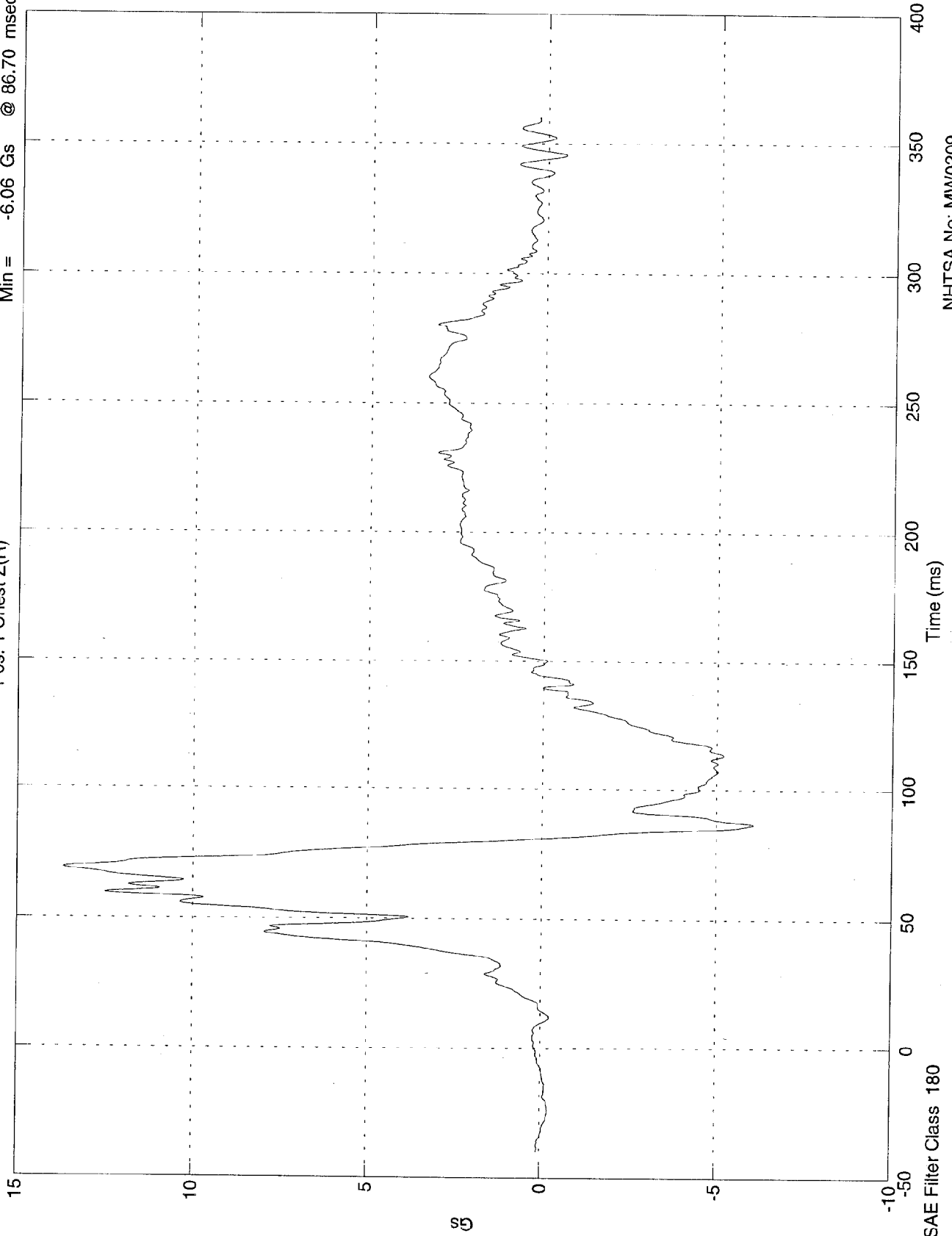

NHITSA No: MW0209
Date: 02 Dec 1997

SAE Filter Class 180

NCAP TEST #10 - 1998 FORD TAURUS

Max = 49.8 Gs @ 72.10 msec
Min = 0.0112 Gs @ -33.60 msec

Pos. 1 Chest Res(RR)

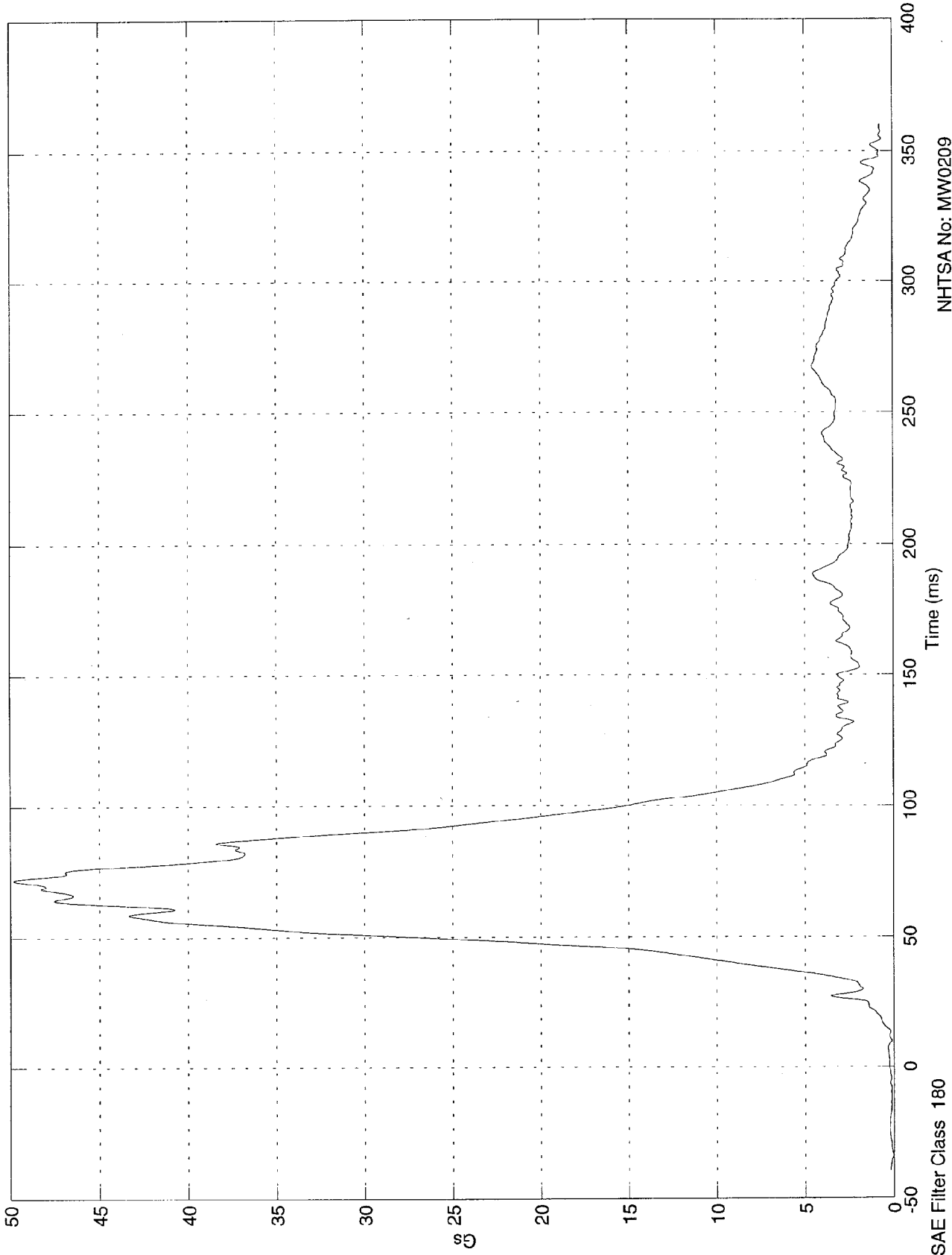

NHTSA No: MW0209
Date: 02 Dec 1997

SAE Filter Class 180

NCAP TEST #10 - 1998 FORD TAURUS

Max = 0.00705 mm @ 23.30 msec
Min = -36.2 mm @ 76.10 msec

Pos. 1 Chest Disp.

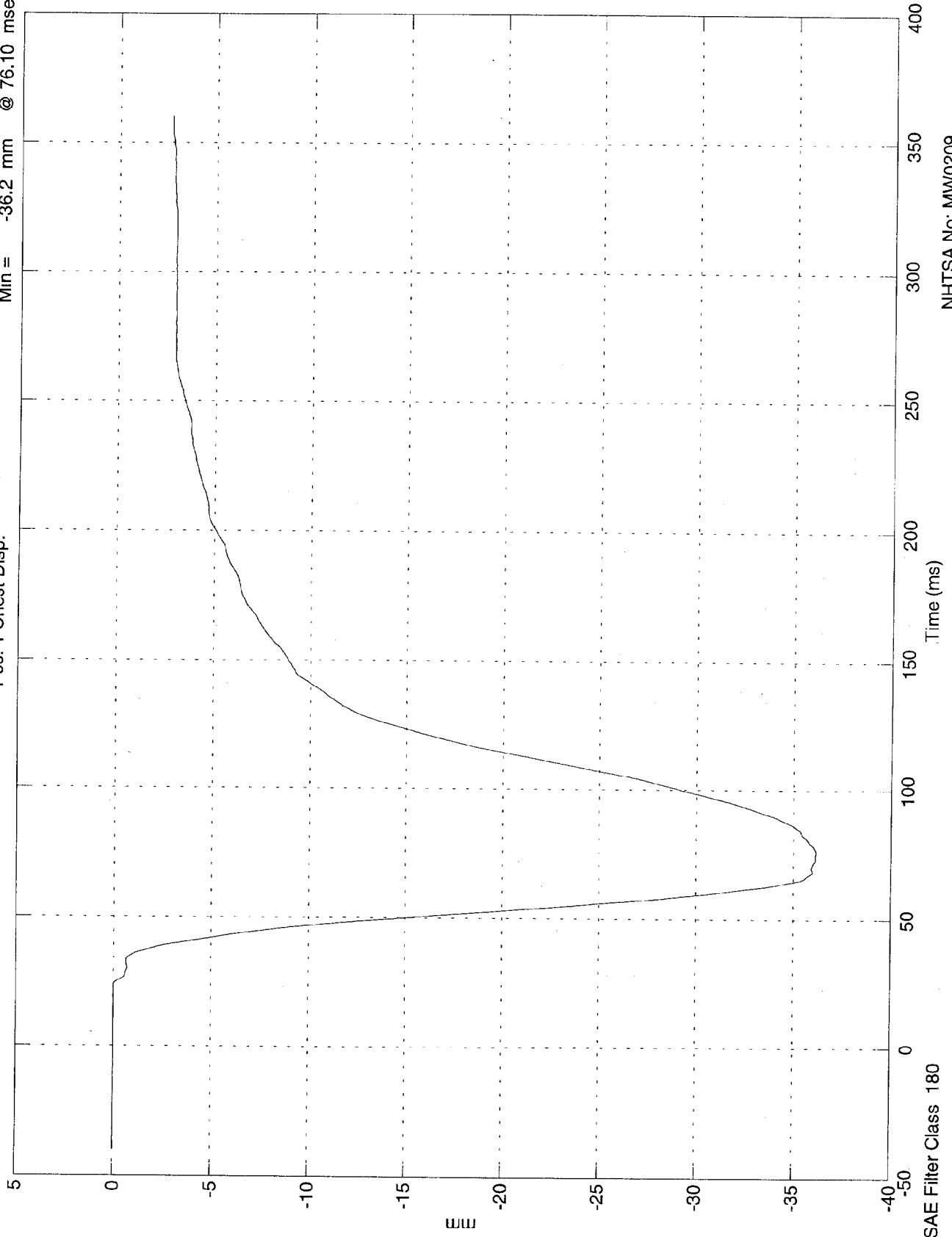

NHTSA No: MW0209
Date: 02 Dec 1997

NCAP TEST #10 - 1998 FORD TAURUS

Max = 3.2 Gs @ 142.90 msec
Min = -57 Gs @ 50.40 msec

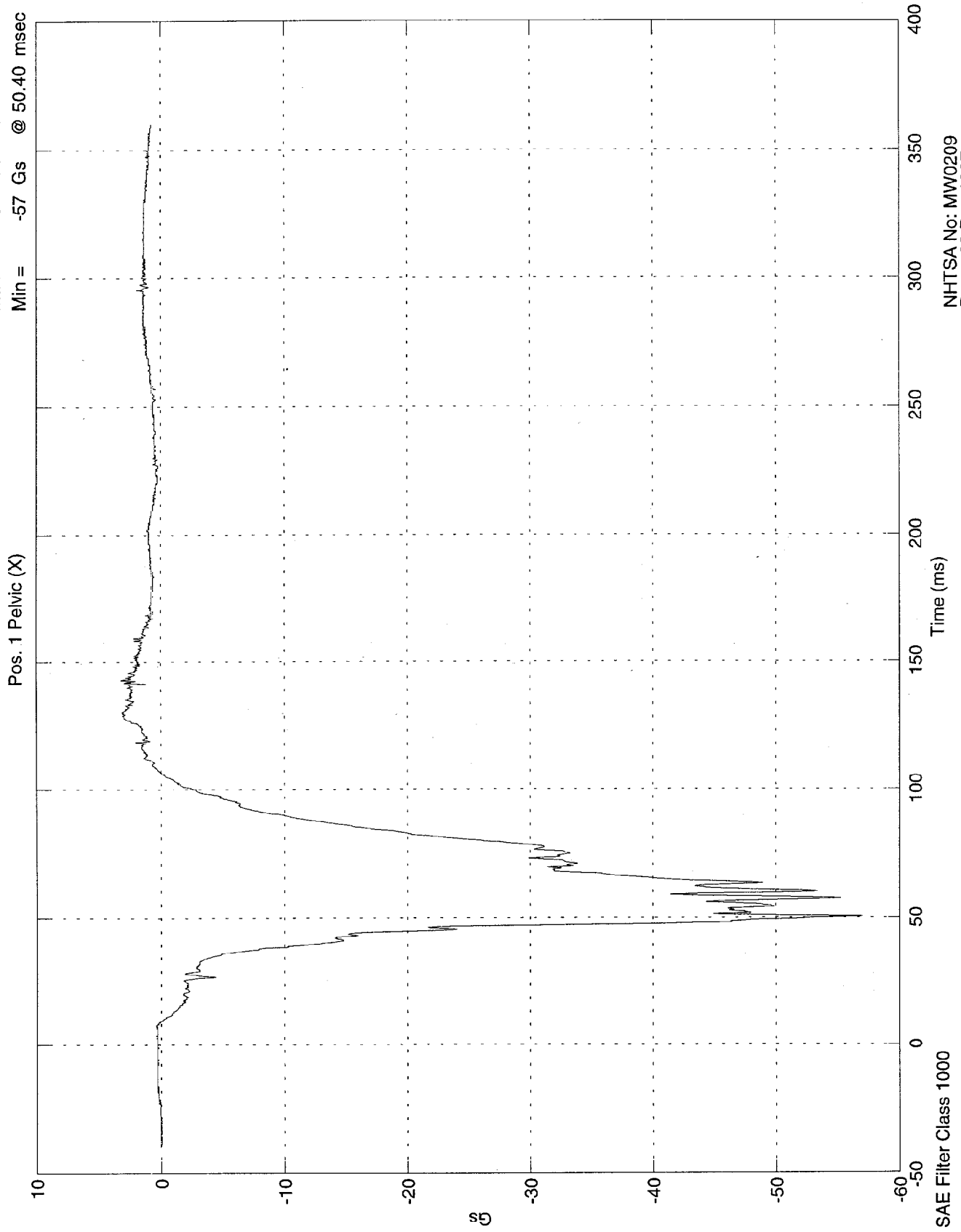

NHTSA No: MW0209
Date: 02 Dec 1997

NCAP TEST #10 - 1998 FORD TAURUS

Max = 6.23 Gs @ 49.70 msec
Min = -12.3 Gs @ 65.20 msec

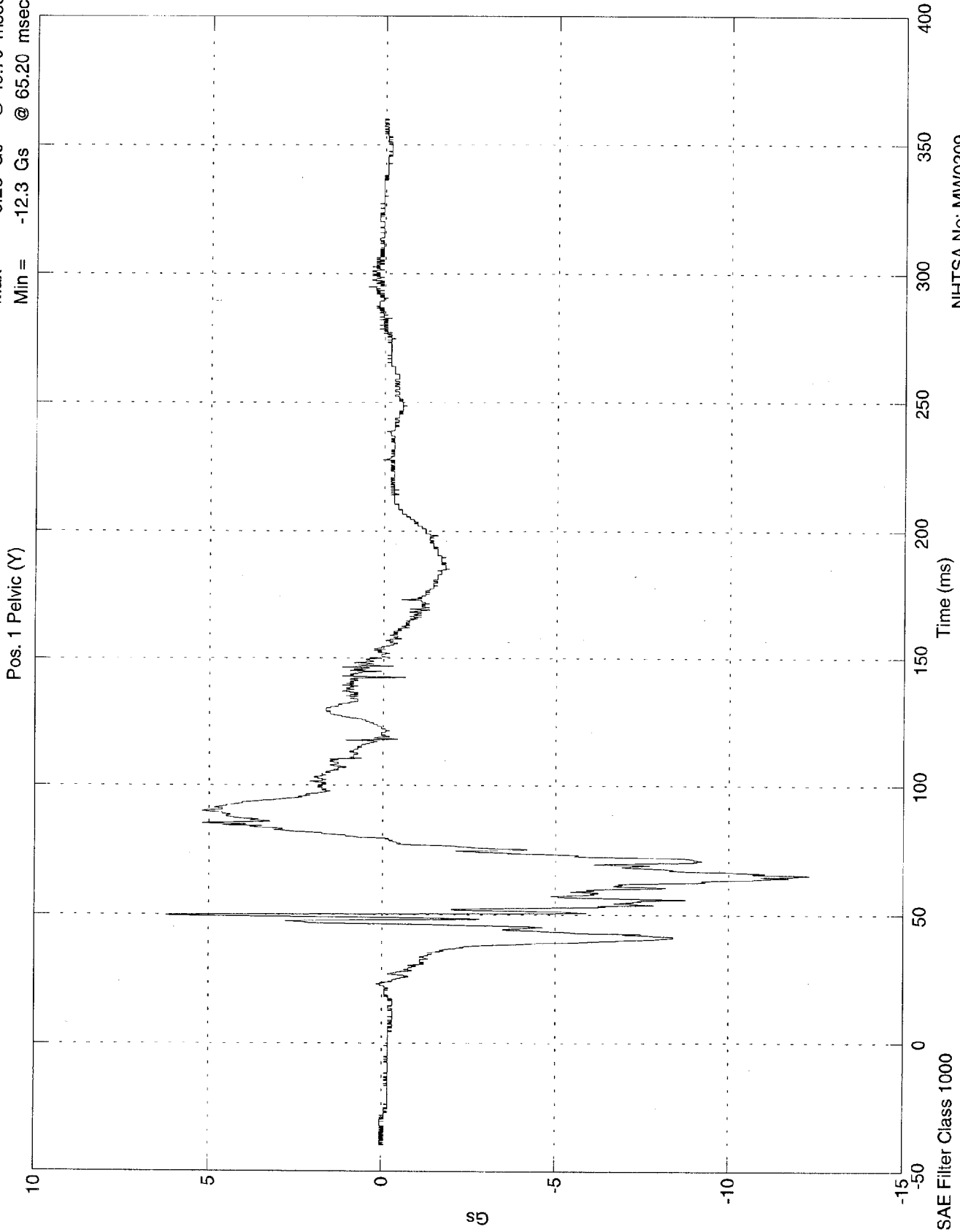

NHTSA No: MW0209
Date: 02 Dec 1997

NCAP TEST #10 - 1998 FORD TAURUS

Max = 4.24 Gs @ 41.60 msec
Min = -15.4 Gs @ 73.70 msec

Pos. 1 Pelvic (Z)

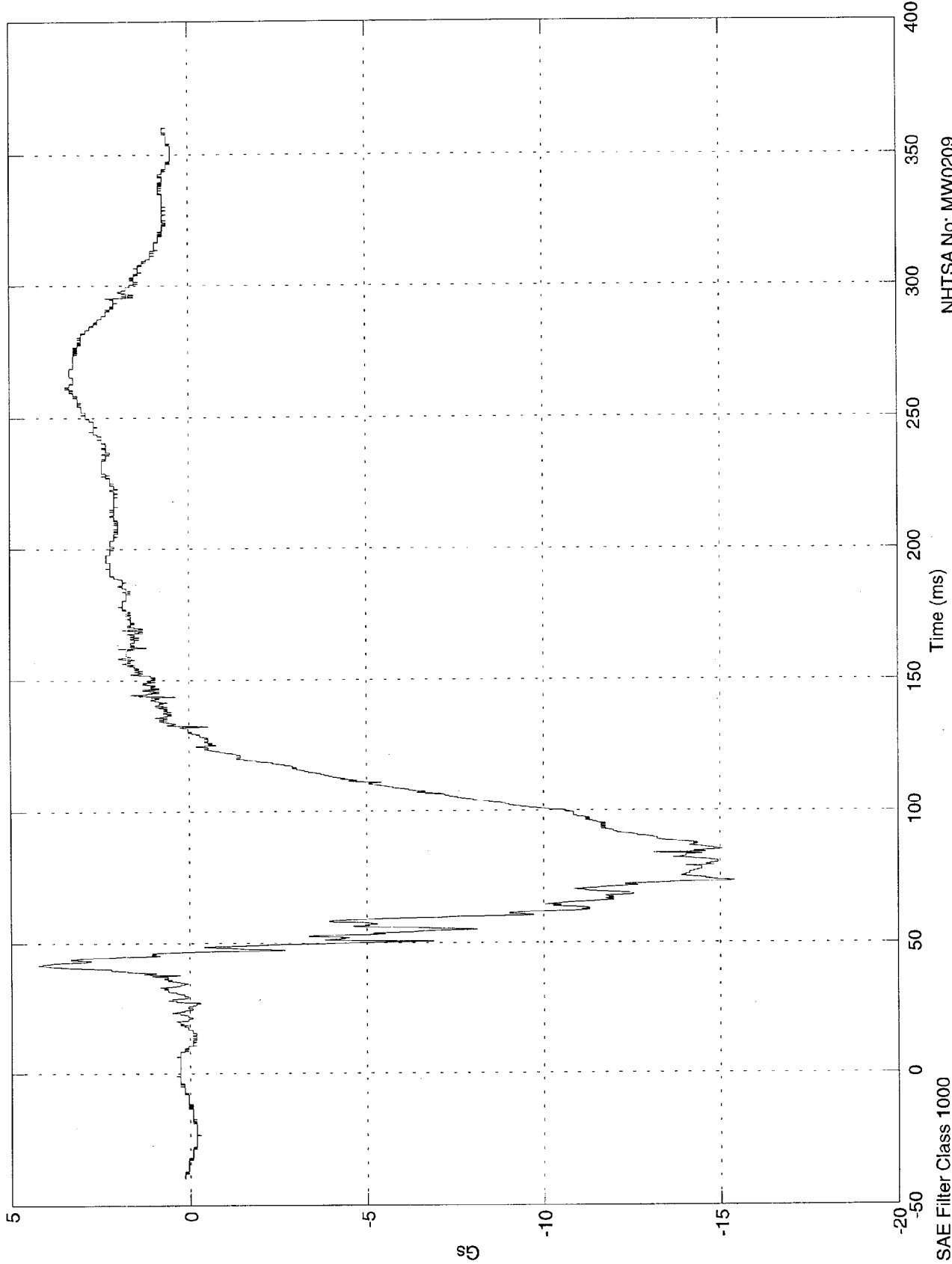

NHTSA No: MW0209
Date: 02 Dec 1997

SAE Filter Class 1000

NCAP TEST #10 - 1998 FORD TAURUS

Max = 57.4 Gs @ 50.40 msec
Min = 0.0822 Gs @ -36.80 msec

Pos. 1 Pelvic (R)

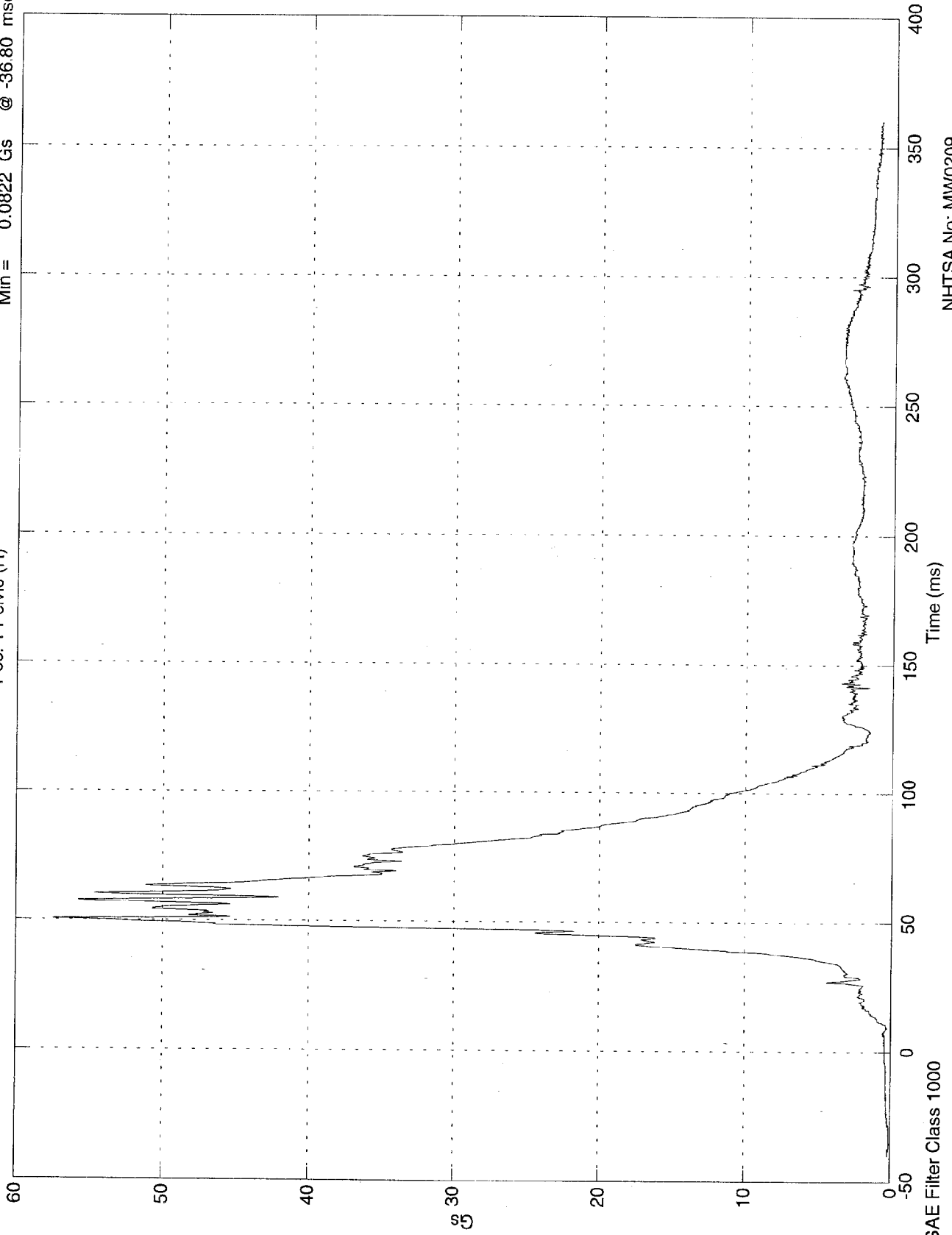

NHTSA No: MW0209
Date: 02 Dec 1997

NCAP TEST #10 - 1998 FORD TAURUS

Max = 463 Nwt @ 42.10 msec
Min = -4.37e+003 Nwt @ 49.80 msec

Pos. 1 Left Femur

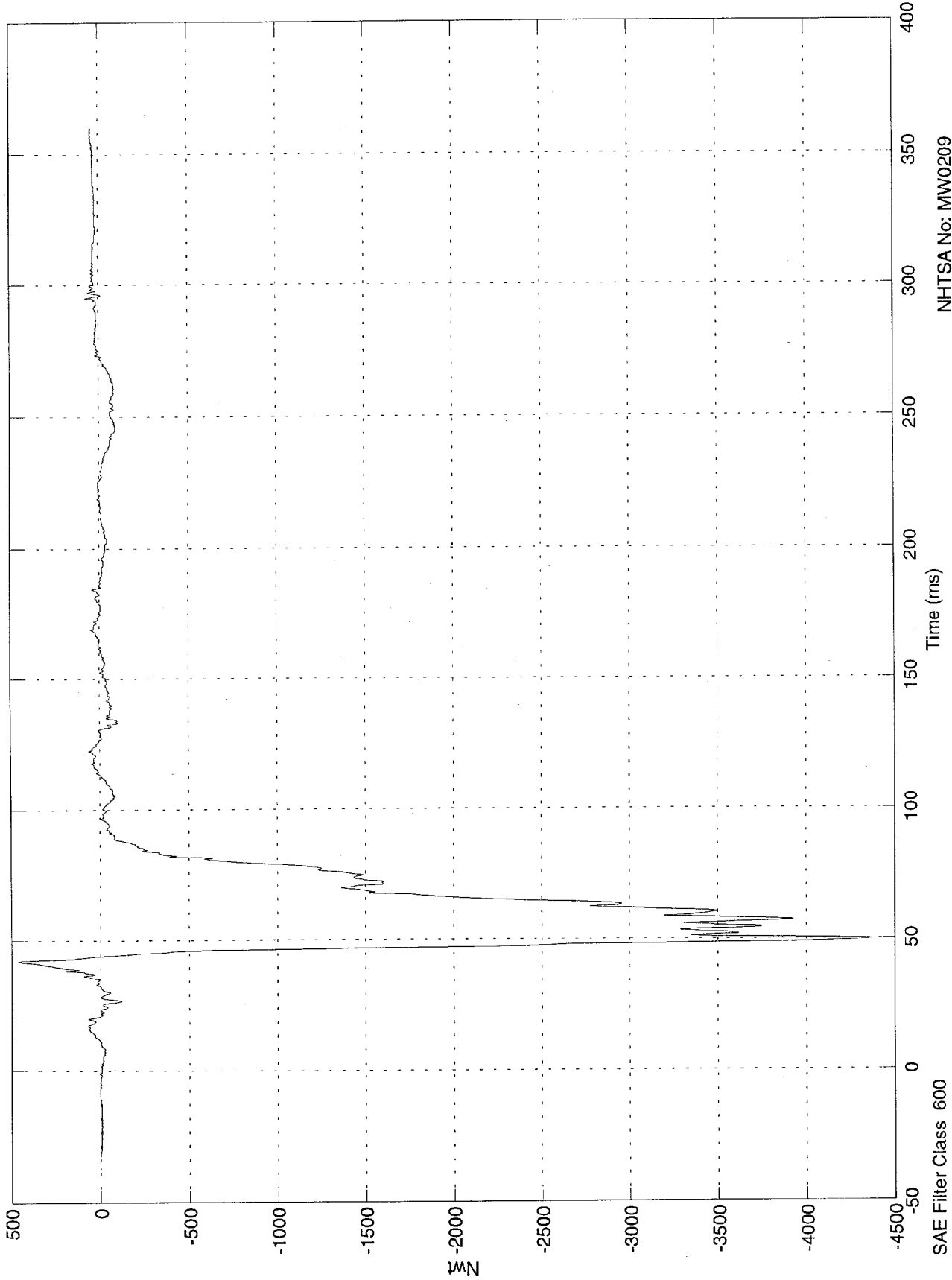

NHTSA No: MW0209
Date: 02 Dec 1997

NCAP TEST #10 - 1998 FORD TAURUS

Max = 274 Nwt @ 92.10 msec
Min = -4.35e+003 Nwt @ 54.30 msec

Pos. 1 Right Femur

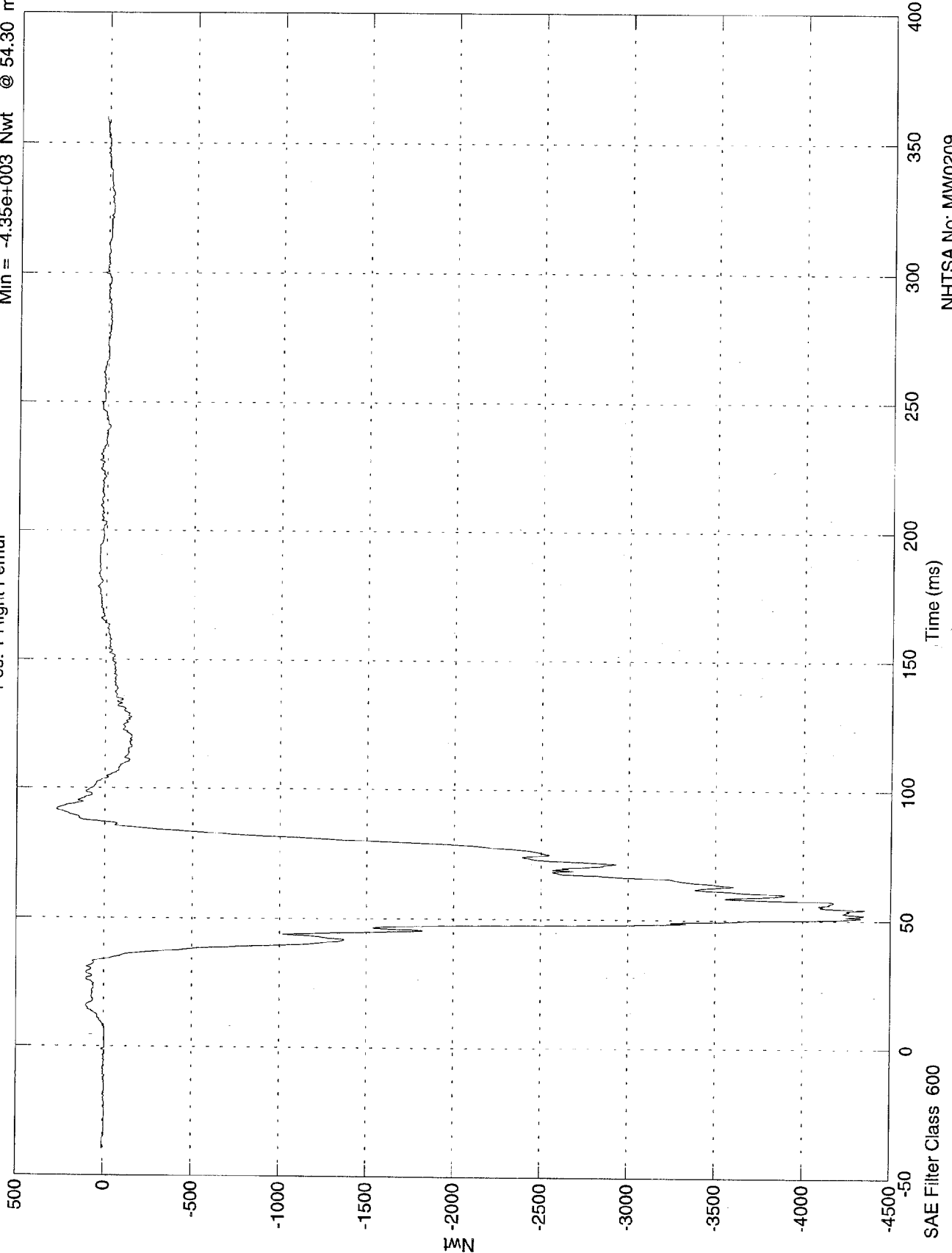

NHTSA No: MW0209
Date: 02 Dec 1997

NCAP TEST #10 - 1998 FORD TAURUS

Max = 30.9 Nwt-M @ 51.80 msec
Min = -20.5 Nwt-M @ 79.80 msec

P1 Lt Upper Tibia Mx

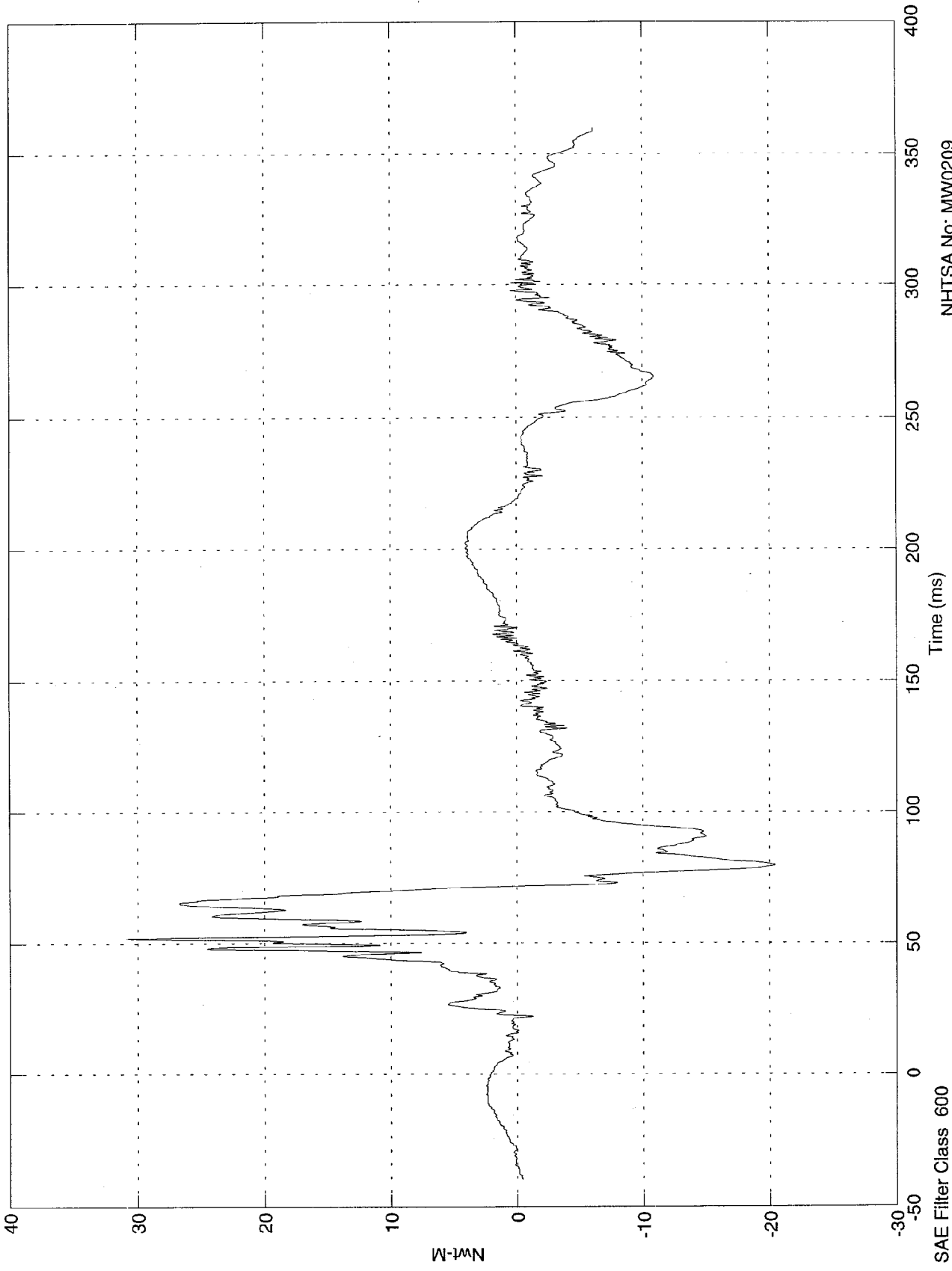

NHTSA No: MW0209
Date: 02 Dec 1997

SAE Filter Class 600

NCAP TEST #10 - 1998 FORD TAURUS

Max = 7.87 Nwt-M @ 104.90 msec
Min = -115 Nwt-M @ 55.50 msec

P1 Lt Upper Tibia My

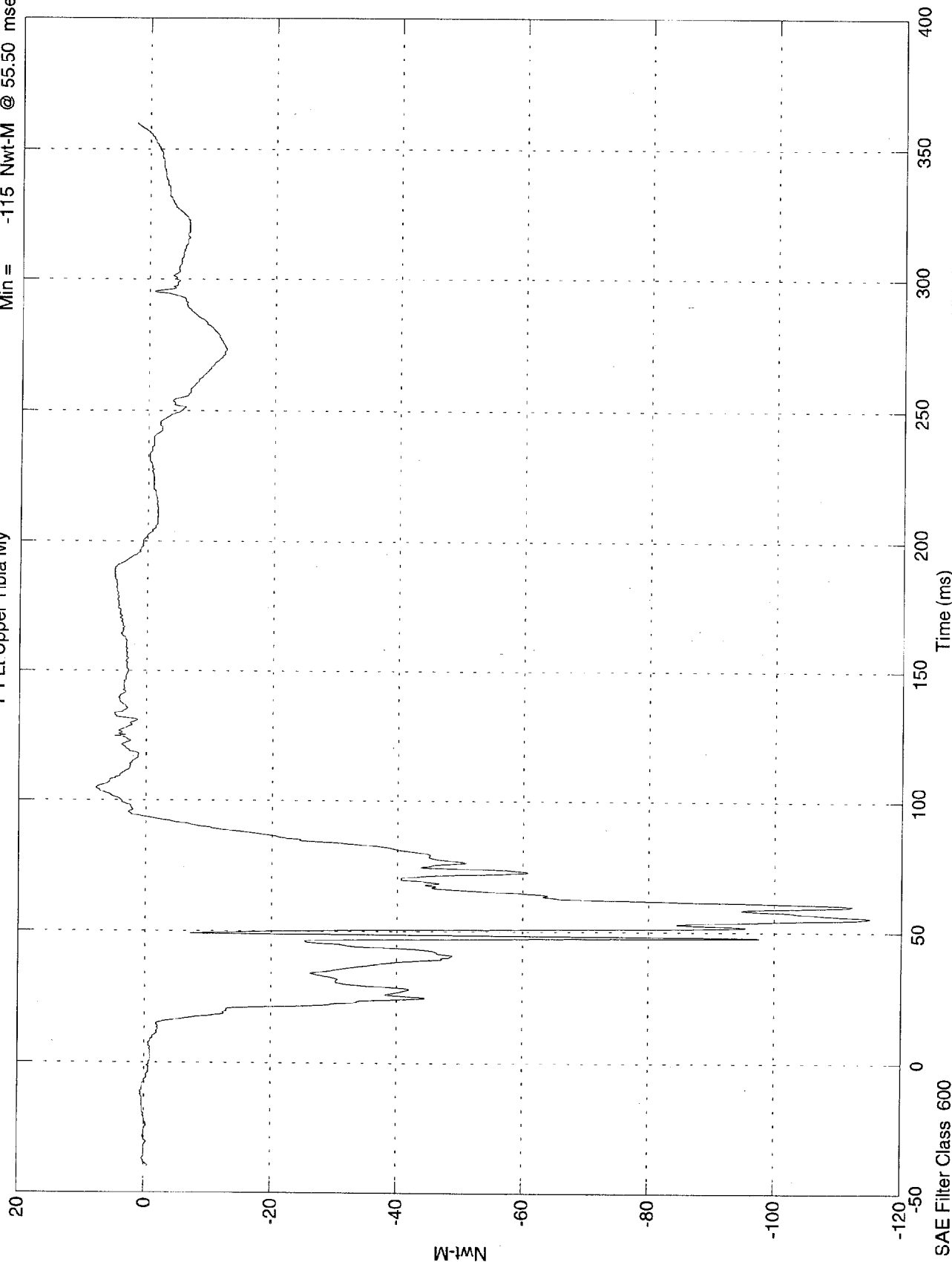

NHTSA No: MW0209
Date: 02 Dec 1997

W-MN

NCAP TEST #10 - 1998 FORD TAURUS

Max = 57.1 Nwt @ 167.00 msec
Min = -1.26e+003 Nwt @ 60.20 msec

P1 Lt Lower Tibia Fx

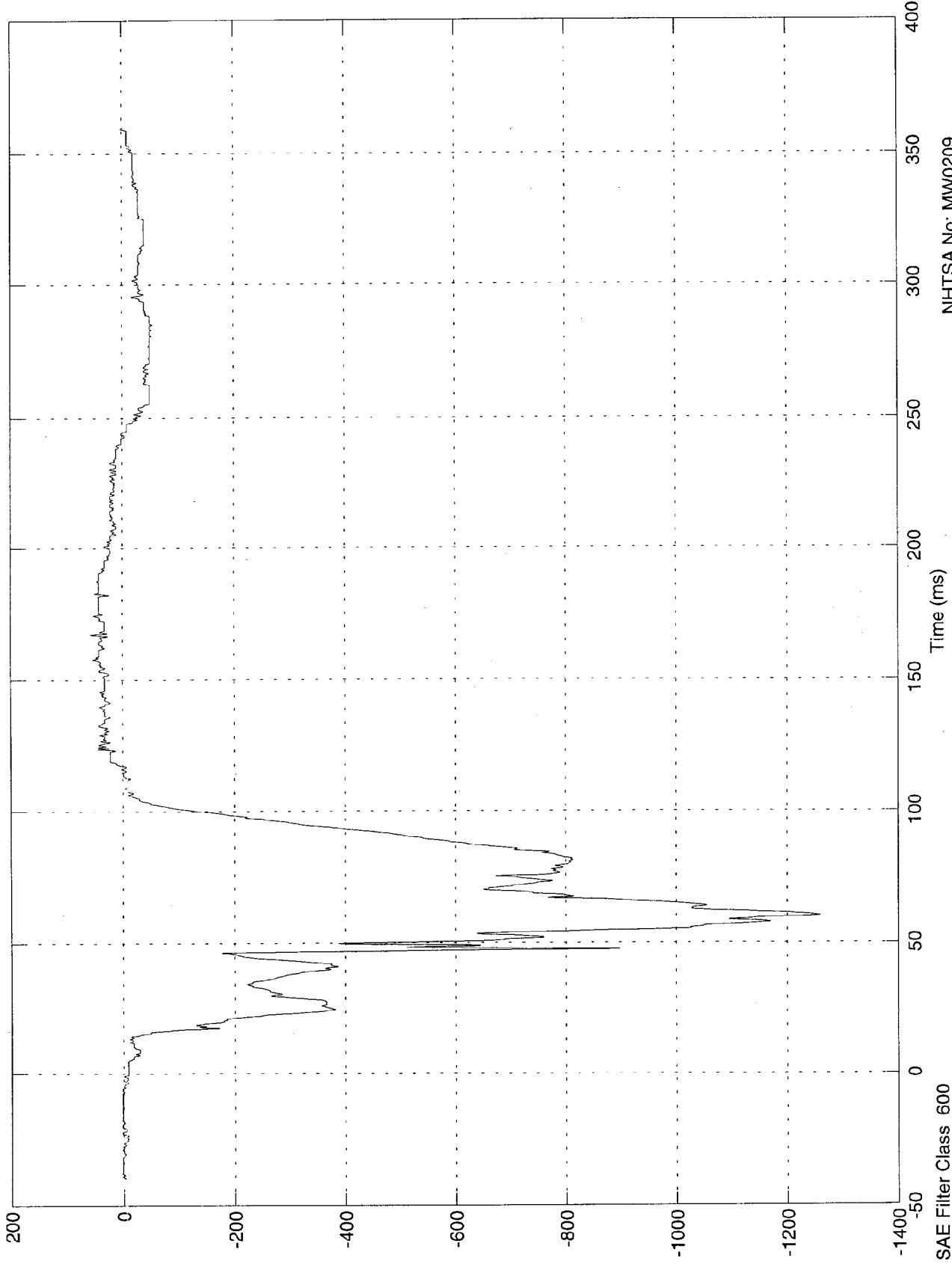

NHTSA No: MW0209
Date: 02 Dec 1997

NCAP TEST #10 - 1998 FORD TAURUS

Max = 144 Nwt @ 141.00 msec
Min = -2.11e+003 Nwt @ 59.30 msec

P1 Lt Lower Tibia Fz

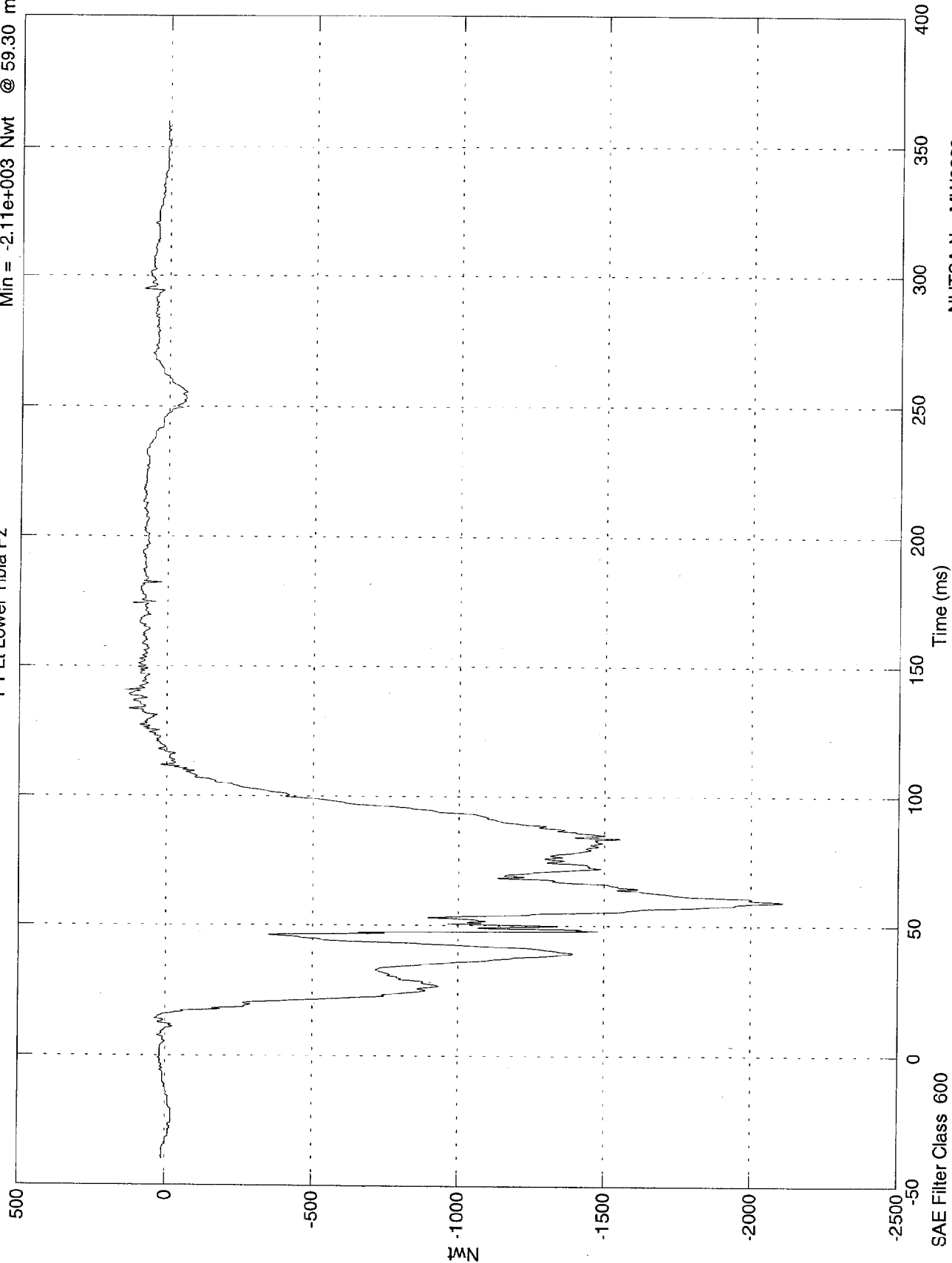

NHTSA No: MW0209
Date: 02 Dec 1997

NCAP TEST #10 - 1998 FORD TAURUS

Max = 140 Nwt-M @ 64.20 msec
Min = -12.9 Nwt-M @ 24.00 msec

P1 Lt Lower Tibia My

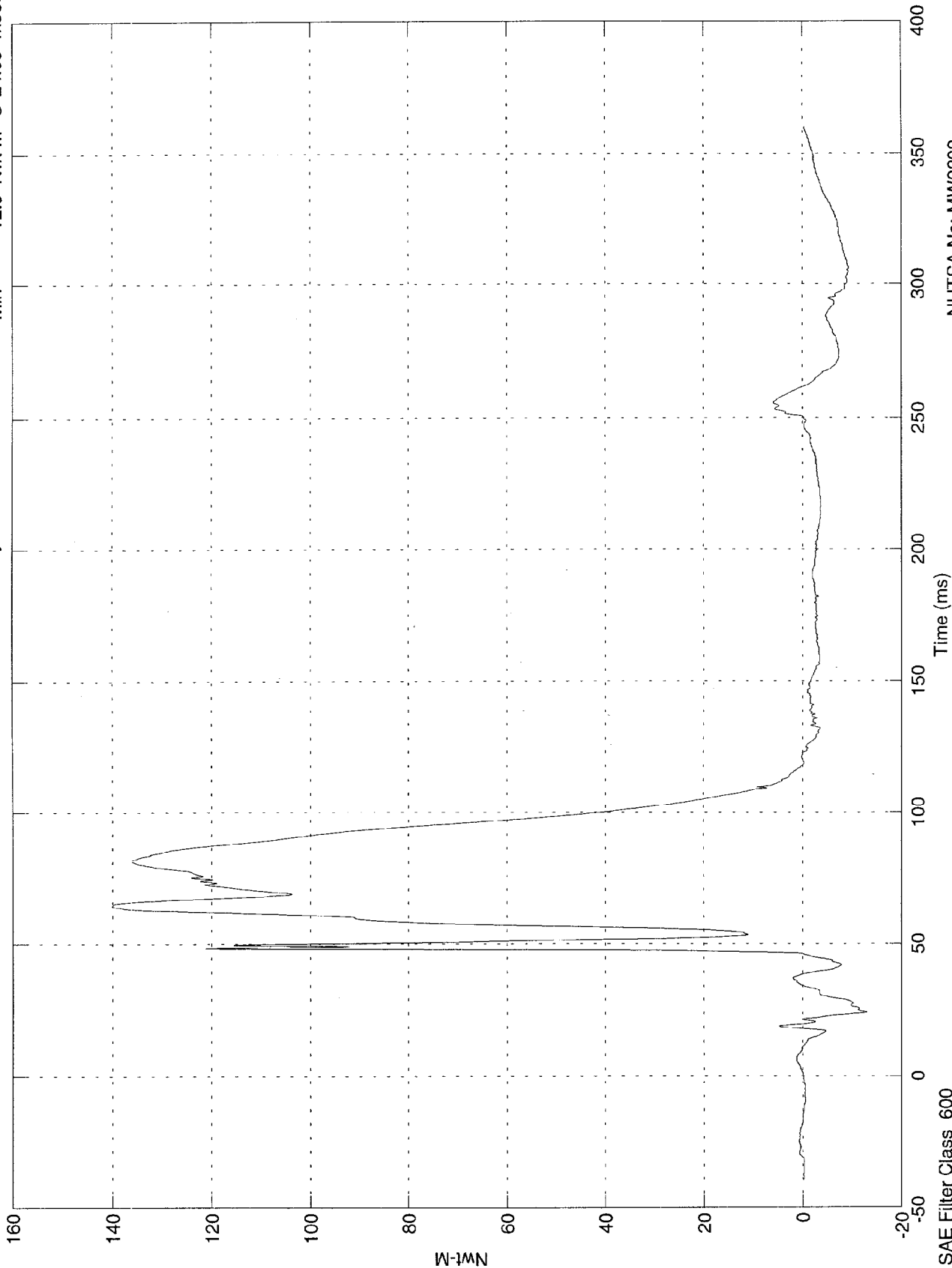

NHTSA No: MW0209
Date: 02 Dec 1997

SAE Filter Class 600

NCAP TEST #10 - 1998 FORD TAURUS

Max = 60.3 Nwt-M @ 56.00 msec
Min = -36.7 Nwt-M @ 44.80 msec

P1 Rt Upper Tibia Mx

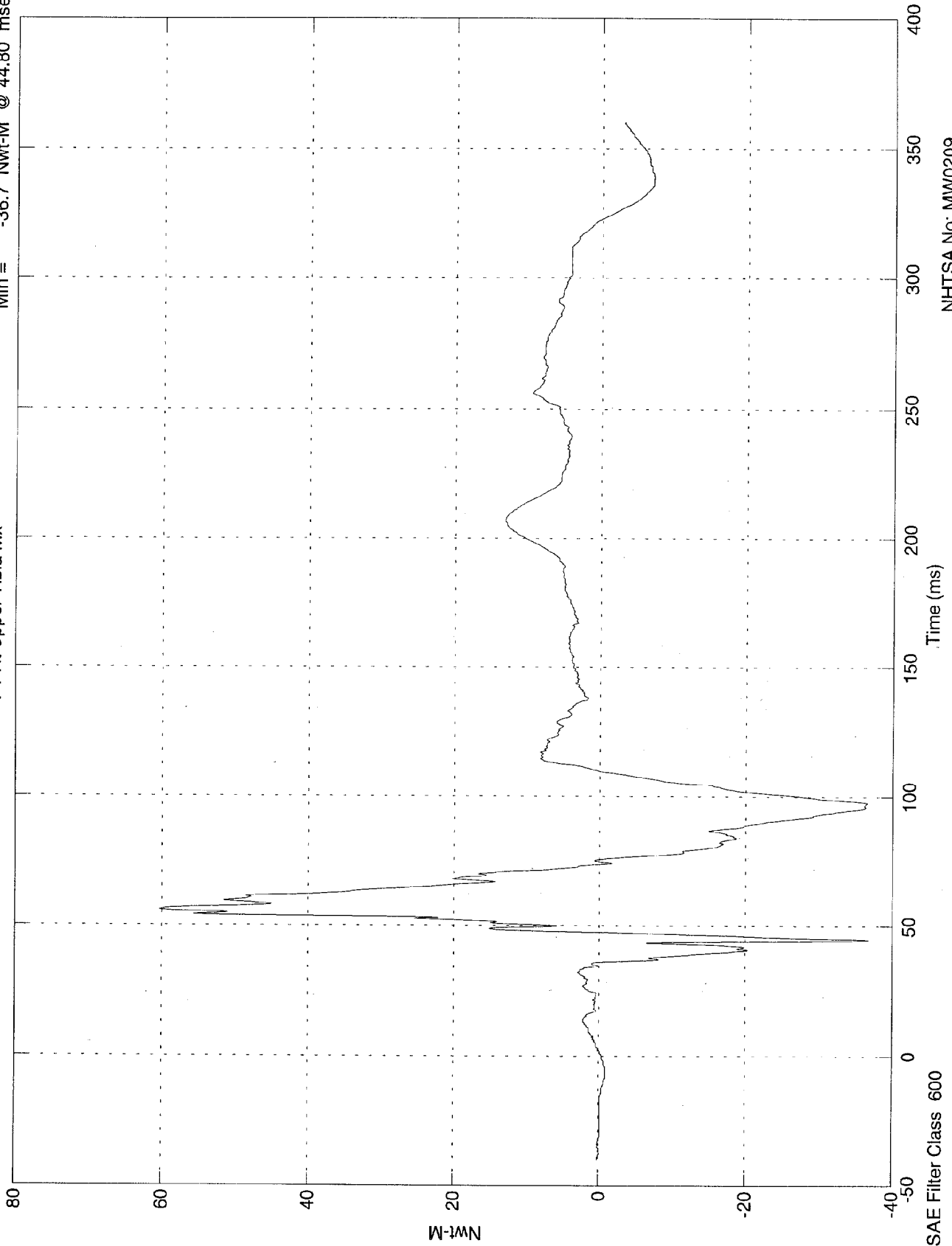

NHTSA No: MW0209
Date: 02 Dec 1997

NCAP TEST #10 - 1998 FORD TAURUS

Max = 186 Nwt-M @ 59.80 msec
Min = -10.3 Nwt-M @ 155.50 msec

P1 Rt Upper Tibia My

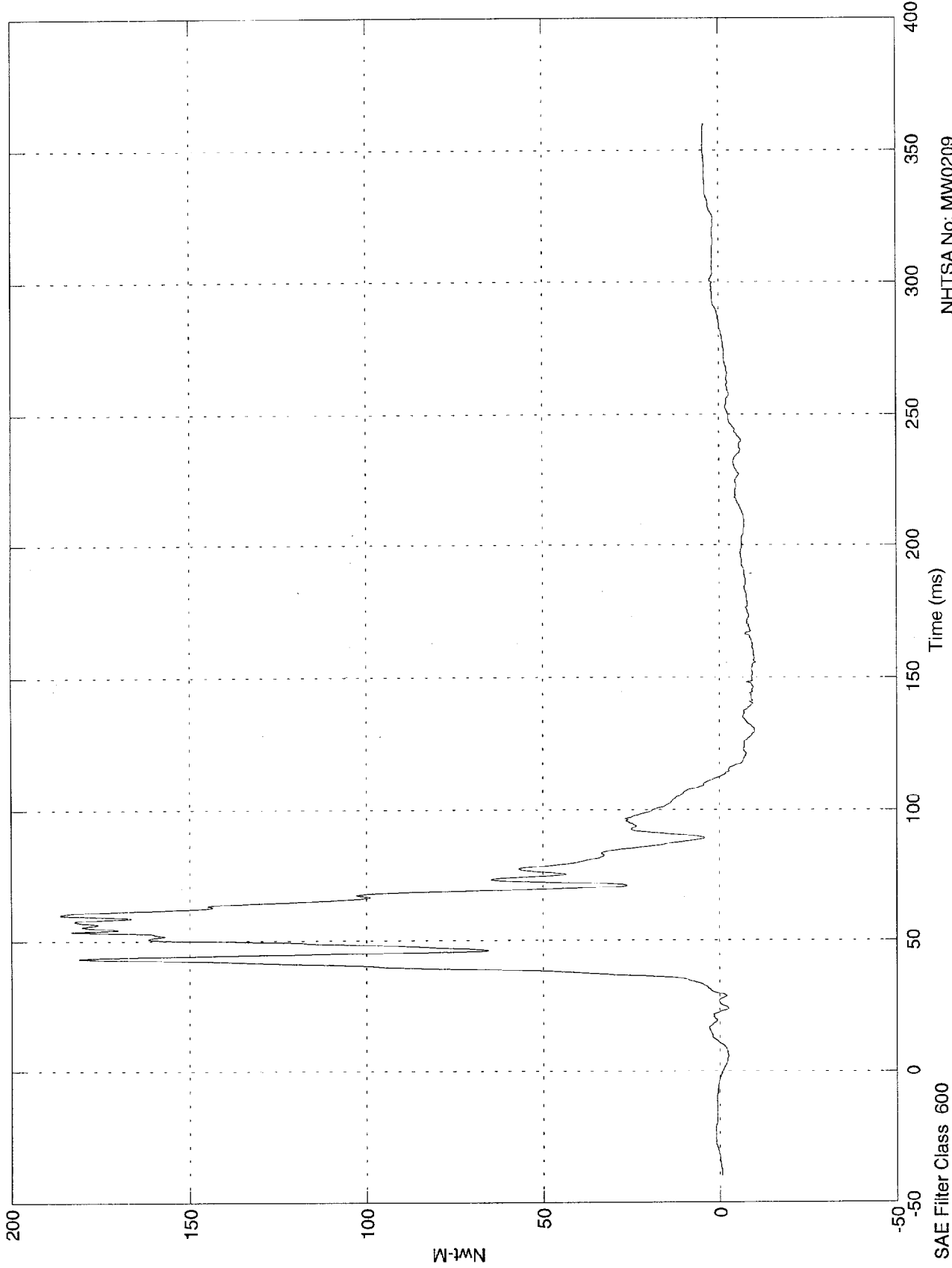

NHTSA No: MW0209
Date: 02 Dec 1997

Nwt-M

SAE Filter Class 600

NCAP TEST #10 - 1998 FORD TAURUS

Max = 85.5 Nwt @ 140.60 msec
Min = -1.35e+003 Nwt @ 43.70 msec

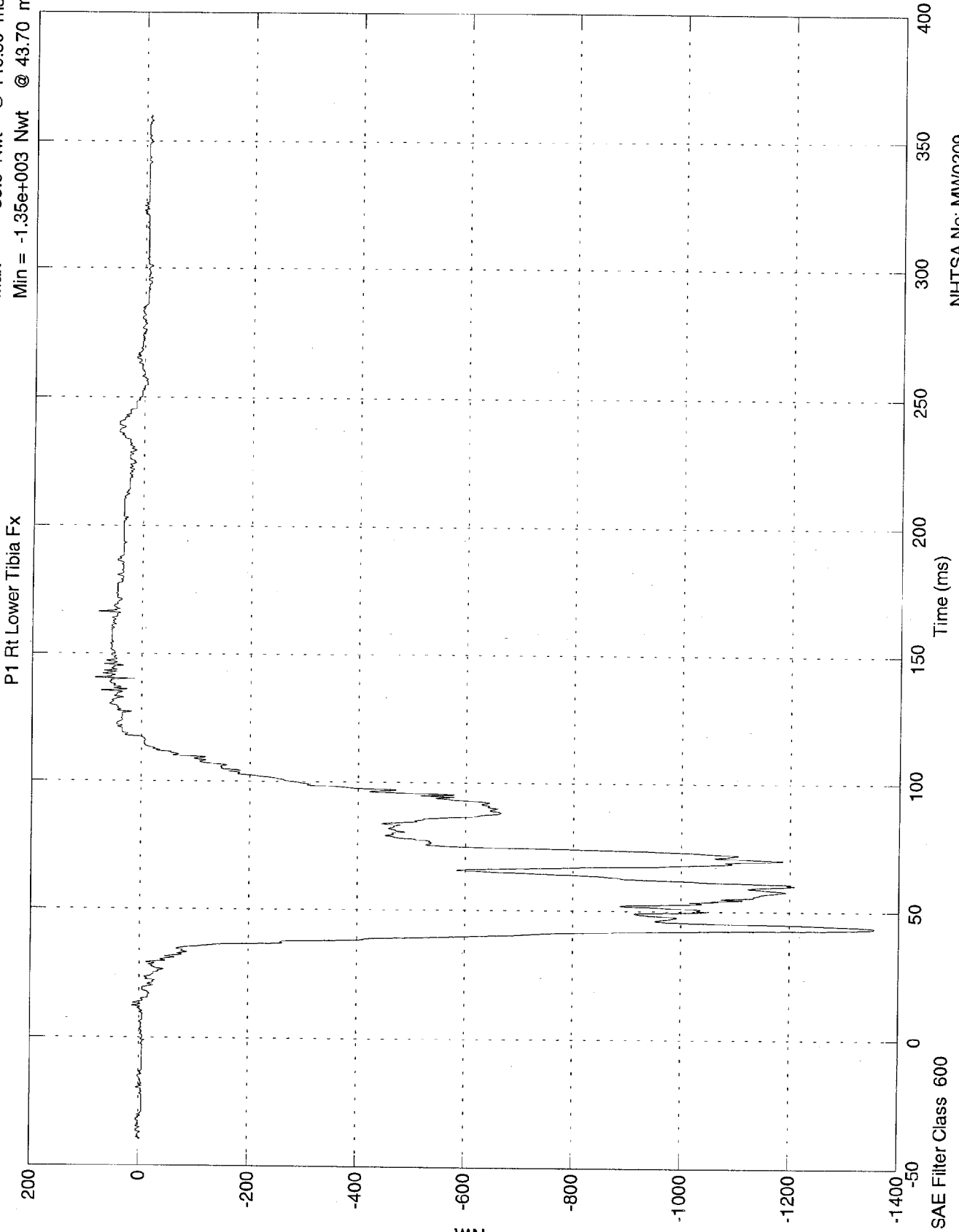

NHTSA No: MW0209
Date: 02 Dec 1997

NCAP TEST #10 - 1998 FORD TAURUS

Max = 123 Nwt @ 160.90 msec
Min = -2.24e+003 Nwt @ 43.10 msec

P1 Rt Lower Tibia Fz

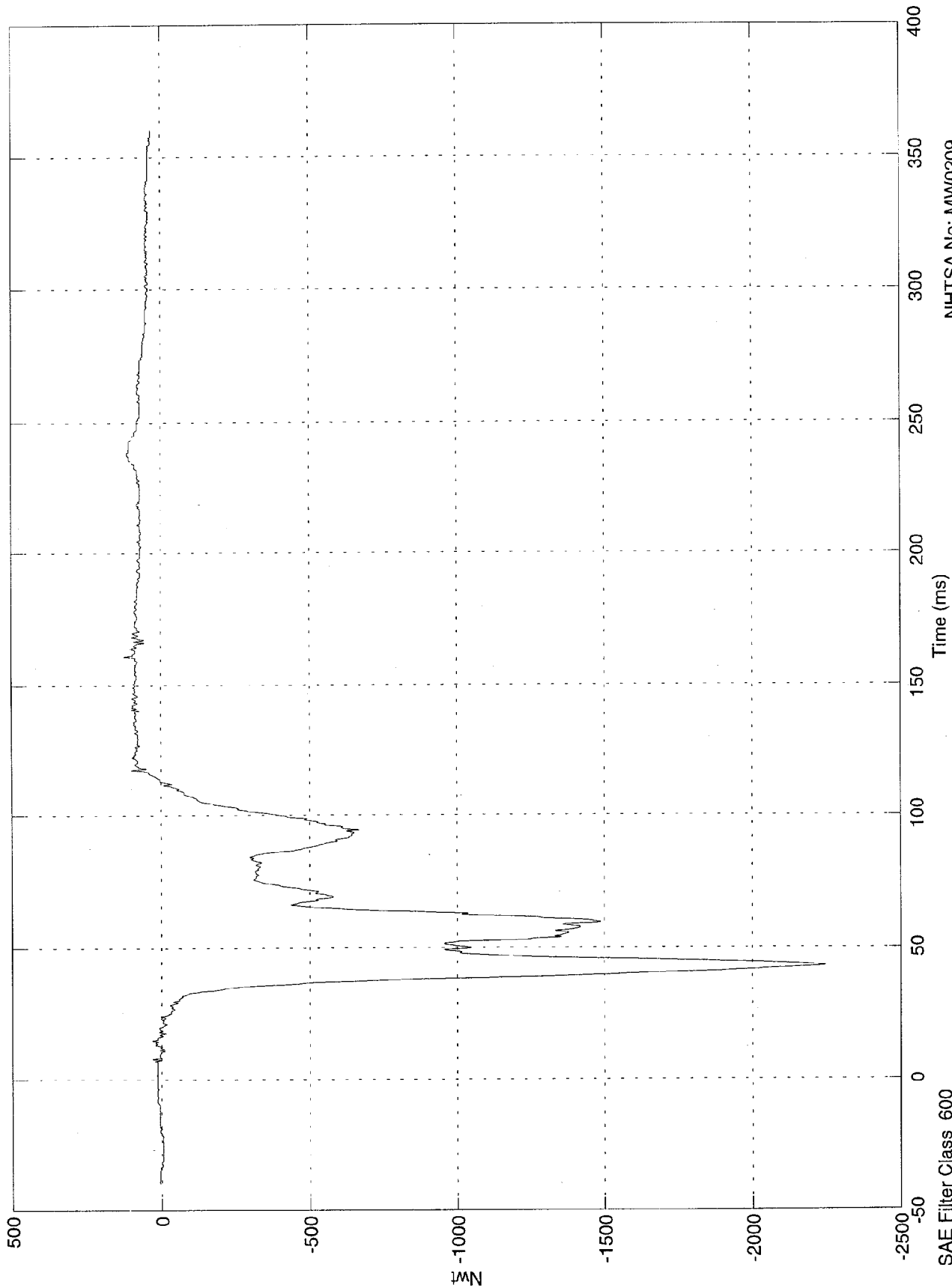

NHTSA No: MW0209
Date: 02 Dec 1997

SAE Filter Class 600

NCAP TEST #10 - 1998 FORD TAURUS

Max = 217 Nwt-M @ 71.00 msec
Min = -39.4 Nwt-M @ 48.00 msec

P1 Rt Lower Tibia My

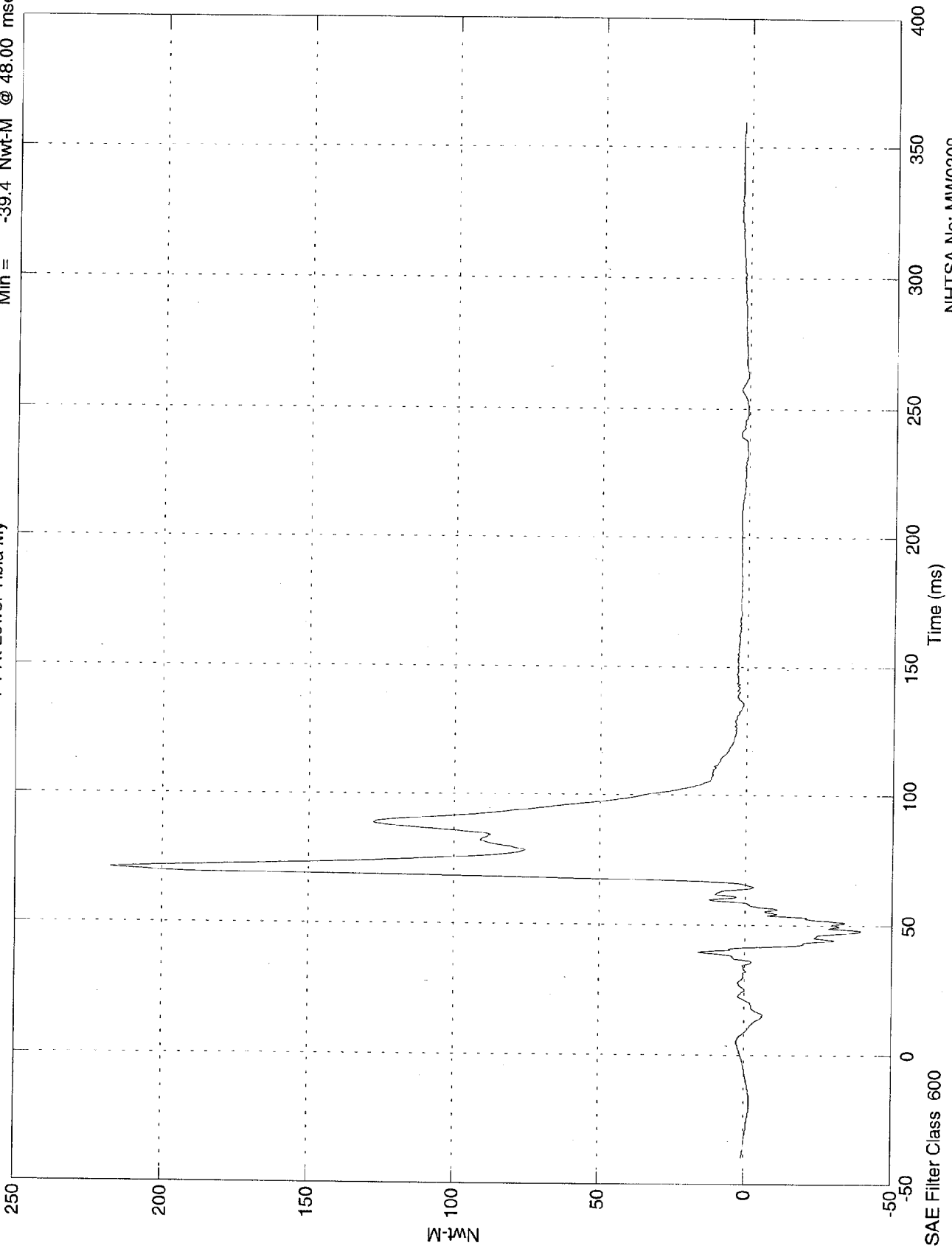

NHTSA No: MW0209
Date: 02 Dec 1997

NCAP TEST #10 - 1998 FORD TAURUS

Max = 75.5 Gs @ 47.20 msec
Min = -78.9 Gs @ 48.10 msec

Pos. 1 Left Ankle X

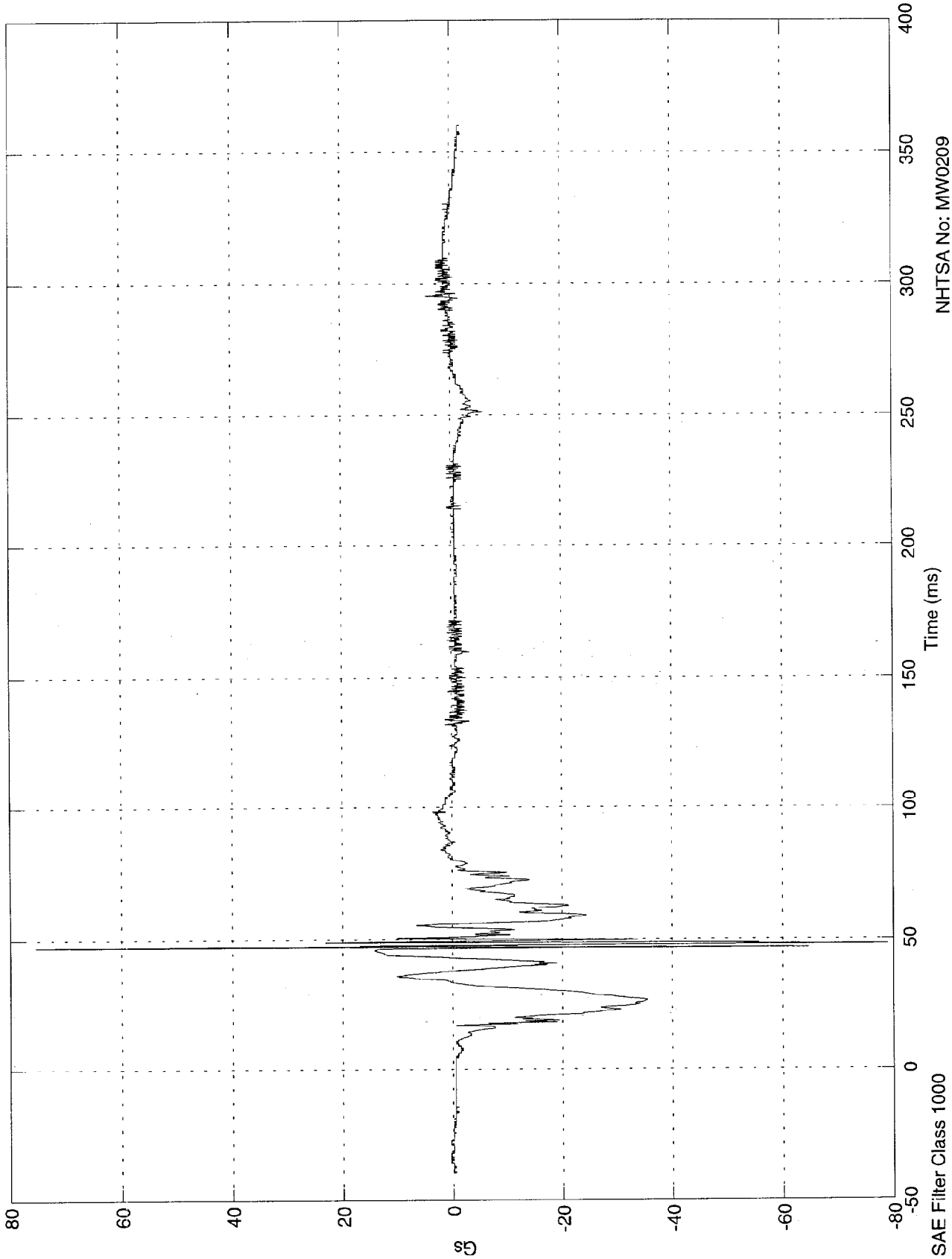

NHTSA No: MW0209
Date: 02 Dec 1997

SAE Filter Class 1000

NCAP TEST #10 - 1998 FORD TAURUS

Max = 67.2 Gs @ 47.60 msec
Min = -56.7 Gs @ 58.60 msec

Pos. 1 Left Ankle Z

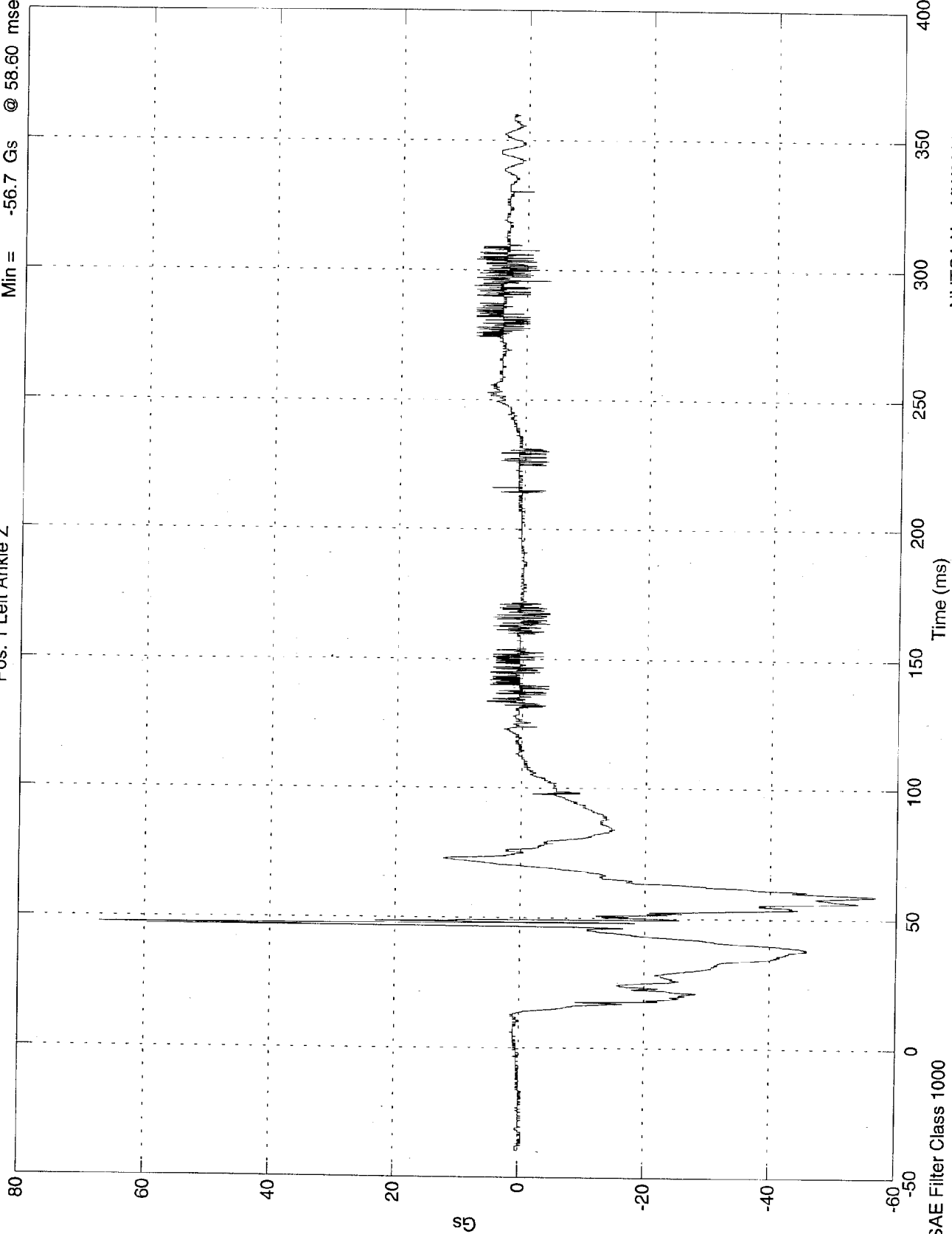

NHTSA No: MW0209
Date: 02 Dec 1997

NCAP TEST #10 - 1998 FORD TAURUS

Max = 179 Gs @ 47.20 msec
Min = -76.8 Gs @ 53.70 msec

Pos. 1 Left Toe Z

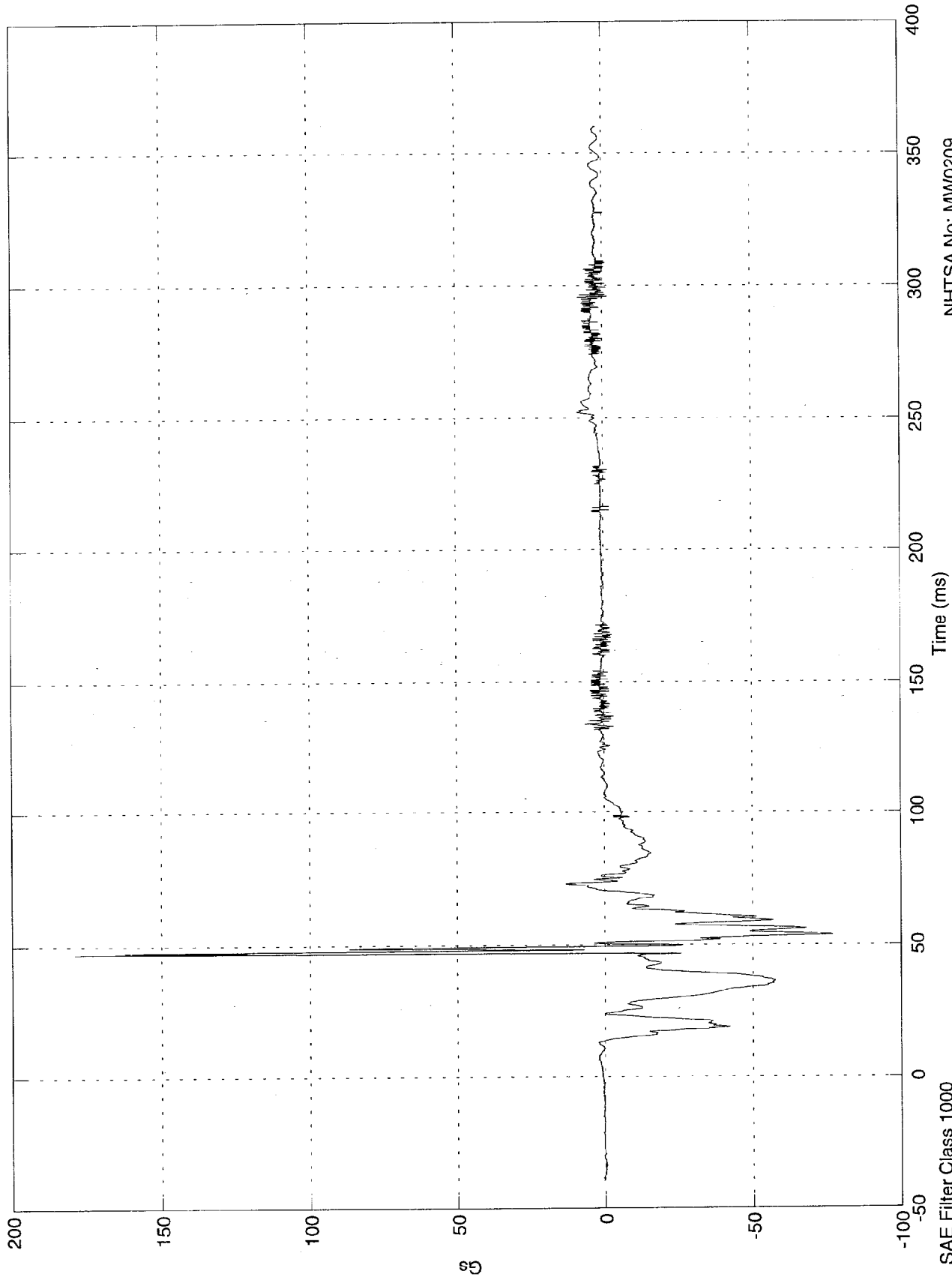

NHTSA No: MW0209
Date: 02 Dec 1997

SAE Filter Class 1000

NCAP TEST #10 - 1998 FORD TAURUS

Max = 22.4 Gs @ 82.10 msec
Min = -129 Gs @ 45.00 msec

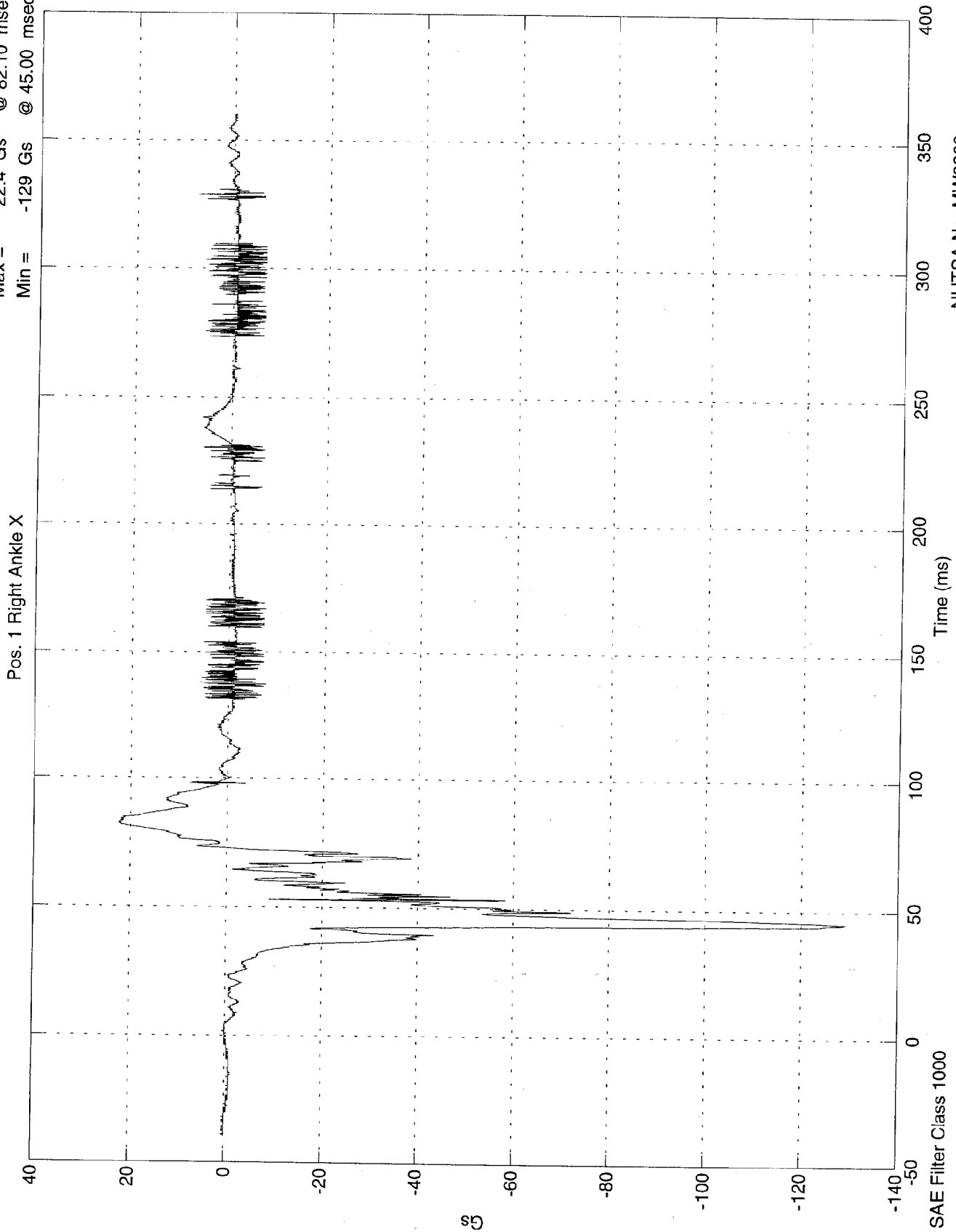

NHTSA No: MW0209
Date: 02 Dec 1997

NCAP TEST #10 - 1998 FORD TAURUS

Max = 38.1 Gs @ 68.00 msec
Min = -159 Gs @ 42.40 msec

Pos. 1 Right Ankle Z

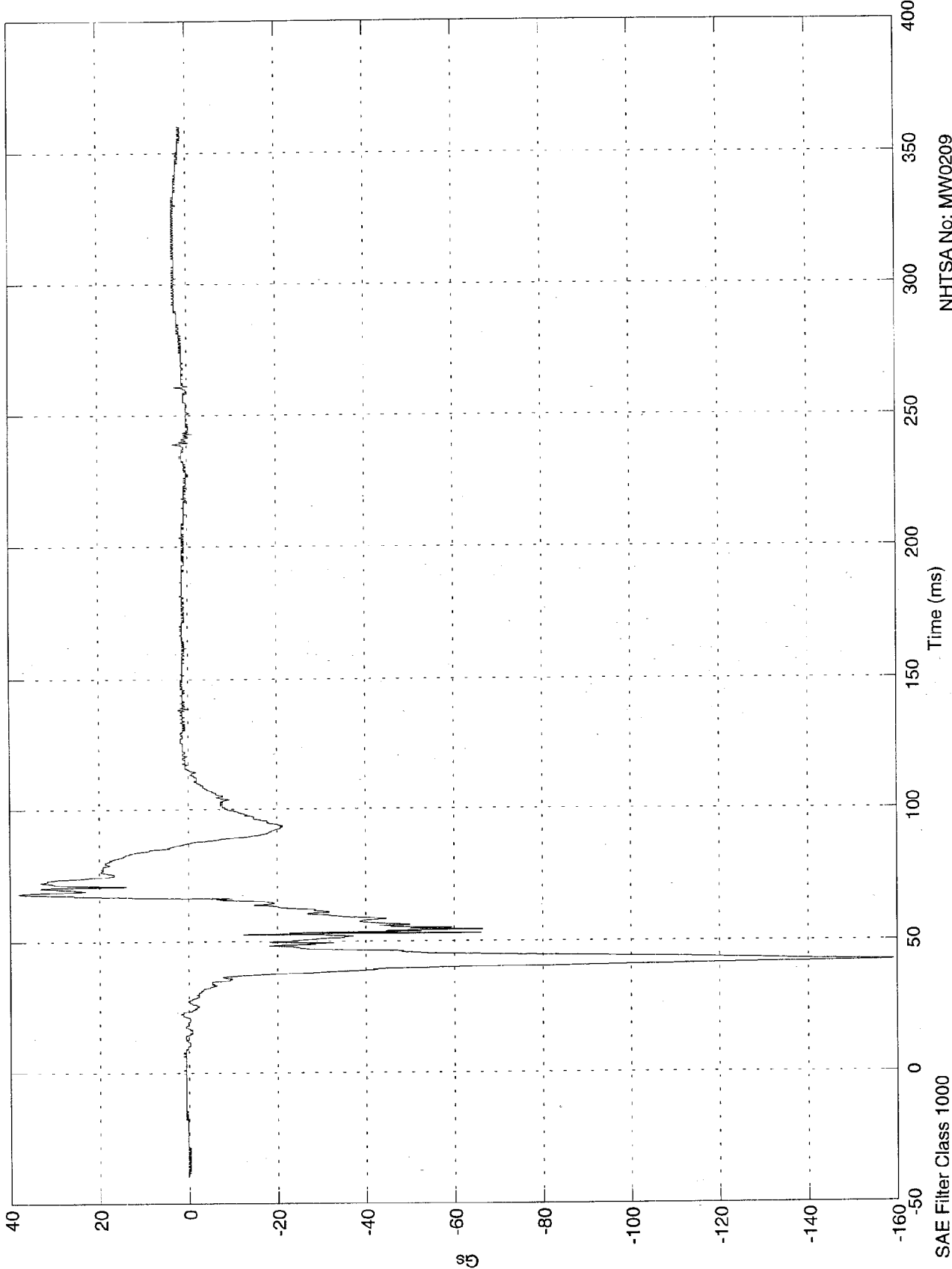

NHTSA No: MW0209
Date: 02 Dec 1997

NCAP TEST #10 - 1998 FORD TAURUS

Max = 99.9 Gs @ 68.20 msec
Min = -259 Gs @ 42.50 msec

Pos. 1 Right Toe Z

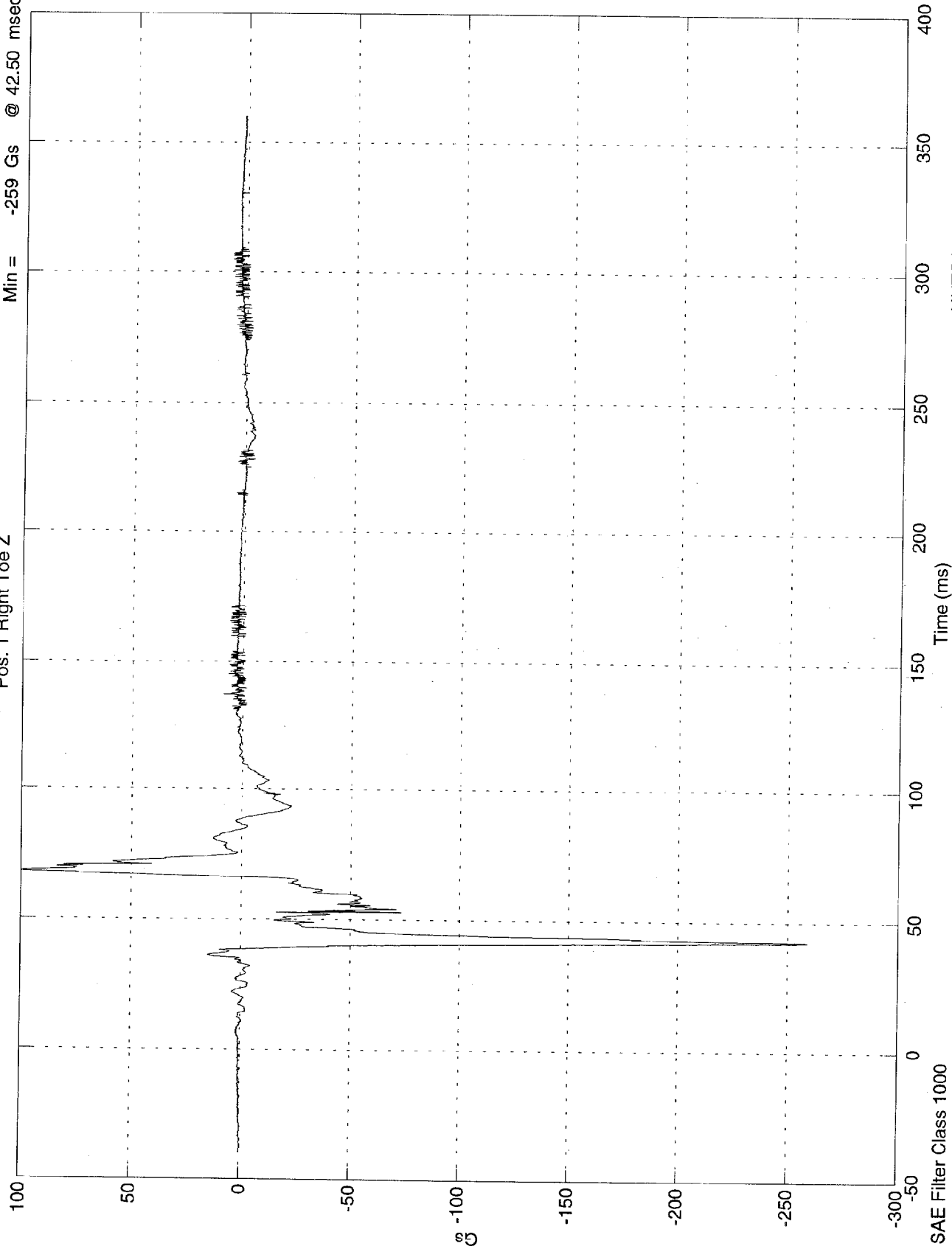

NHTSA No: MW0209
Date: 02 Dec 1997

NCAP TEST #10 - 1998 FORD TAURUS

Max = 5.03e+003 Nwt @ 57.50 msec
Min = -34.1 Nwt @ 278.90 msec

Pos. 1 Left Belt Load

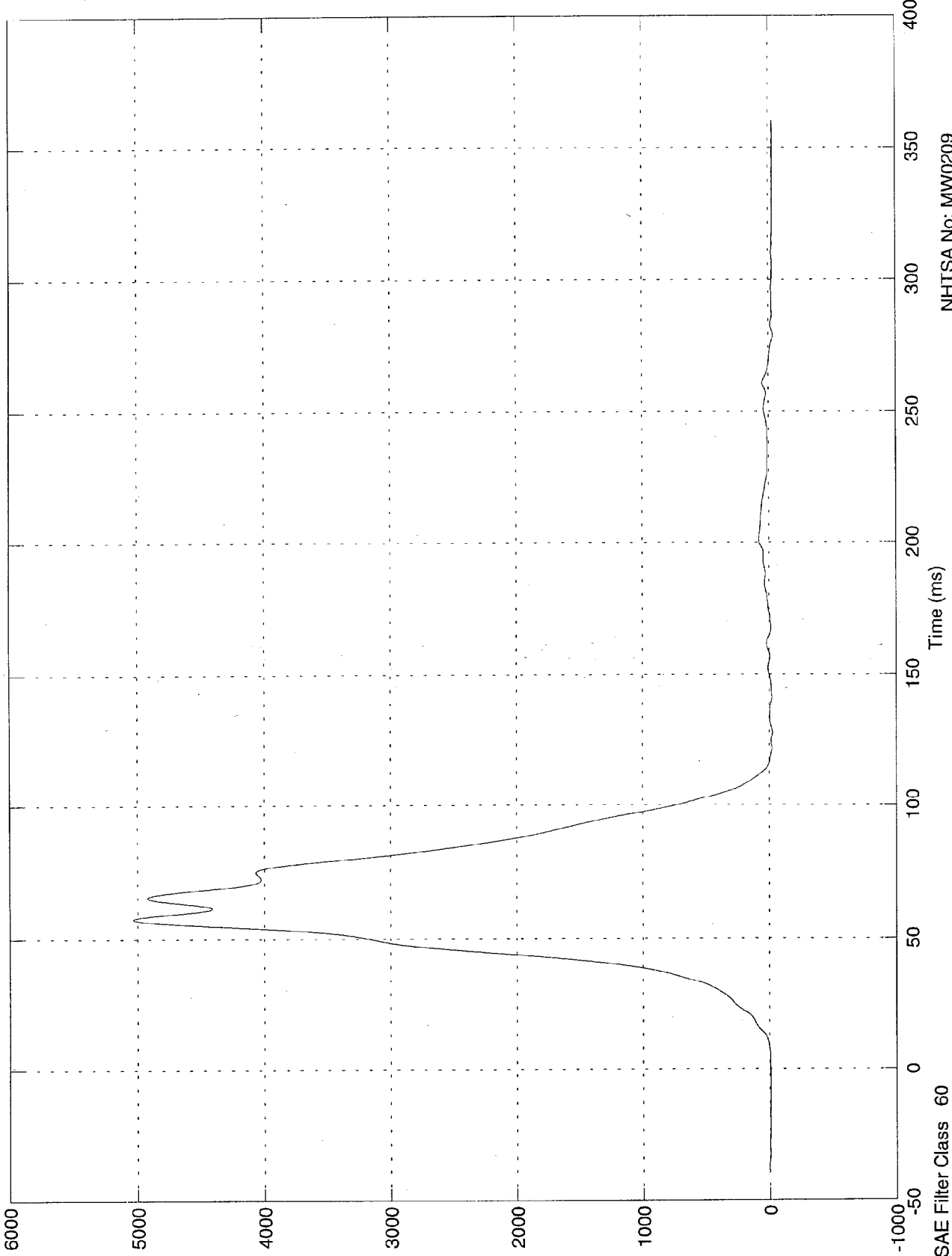

NHTSA No: MW0209
Date: 02 Dec 1997

NCAP TEST #10 - 1998 FORD TAURUS

Pos. 1 Torso Belt Load

Max = 8.43e+003 Nwt @ 68.40 msec
Min = -38.2 Nwt @ 235.80 msec

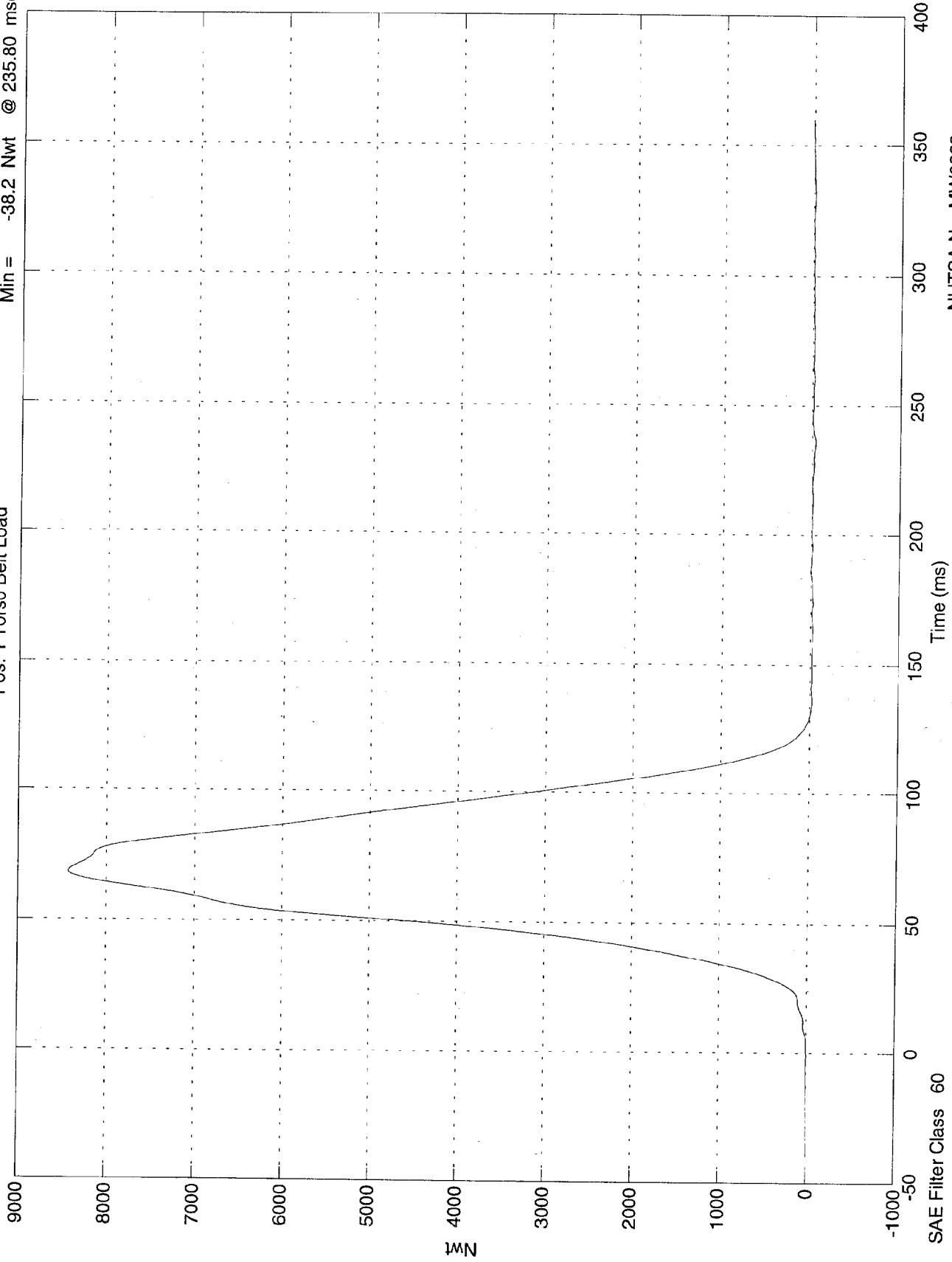

NHTSA No: MW0209
Date: 02 Dec 1997

NCAP TEST #10 - 1998 FORD TAURUS

Max = 0.214 mm/M @ -35.50 msec
Min = -40.7 mm/M @ 98.30 msec

Pos. 1 Belt Elongation

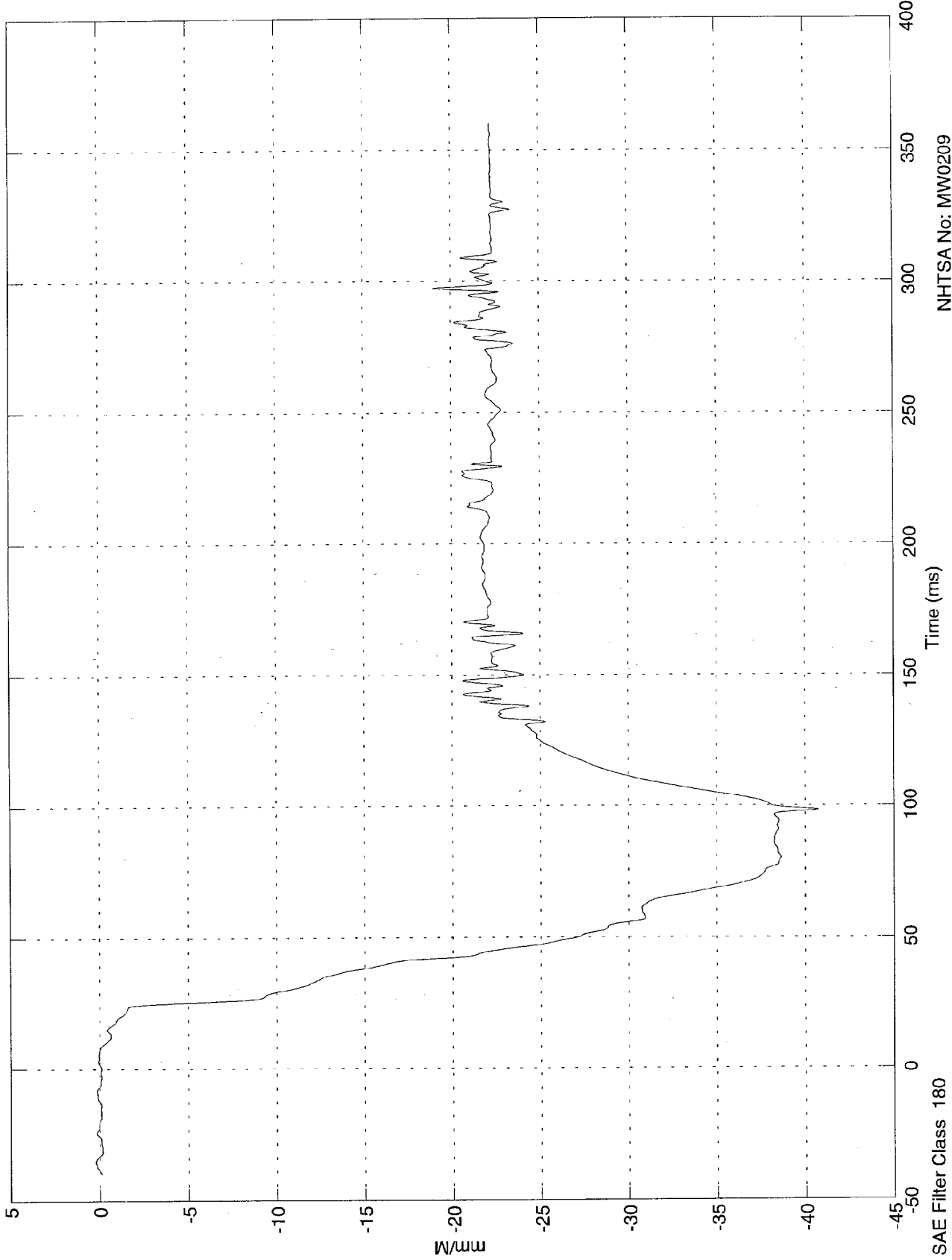

NHTSA No: MW0209
Date: 02 Dec 1997

SAE Filter Class 180

NCAP TEST #10 - 1998 FORD TAURUS

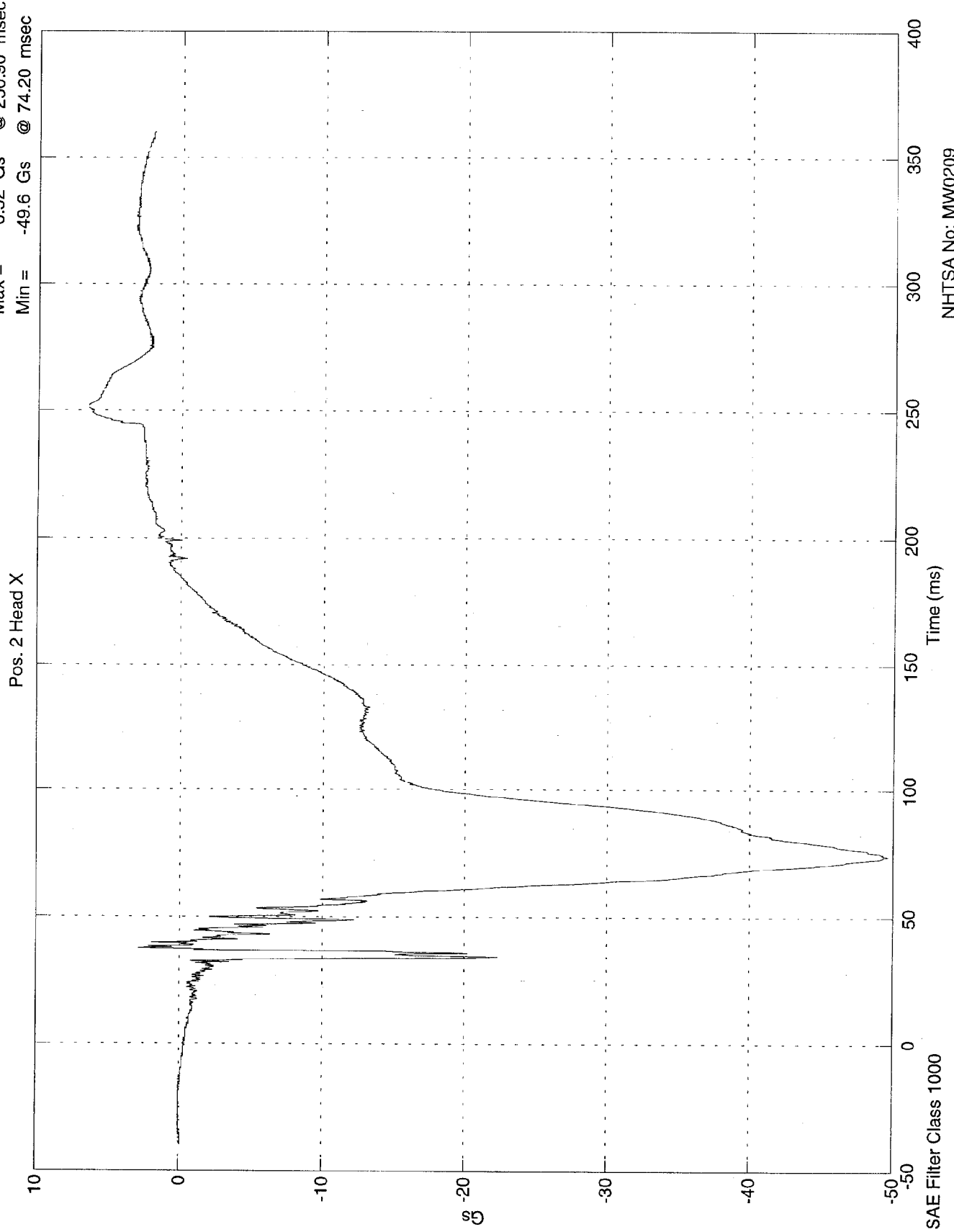

NHTSA No: MW0209
Date: 02 Dec 1997

NCAP TEST #10 - 1998 FORD TAURUS

Max = 9.31 Gs @ 37.10 msec
Min = -15.3 Gs @ 48.80 msec

Pos. 2 Head Y

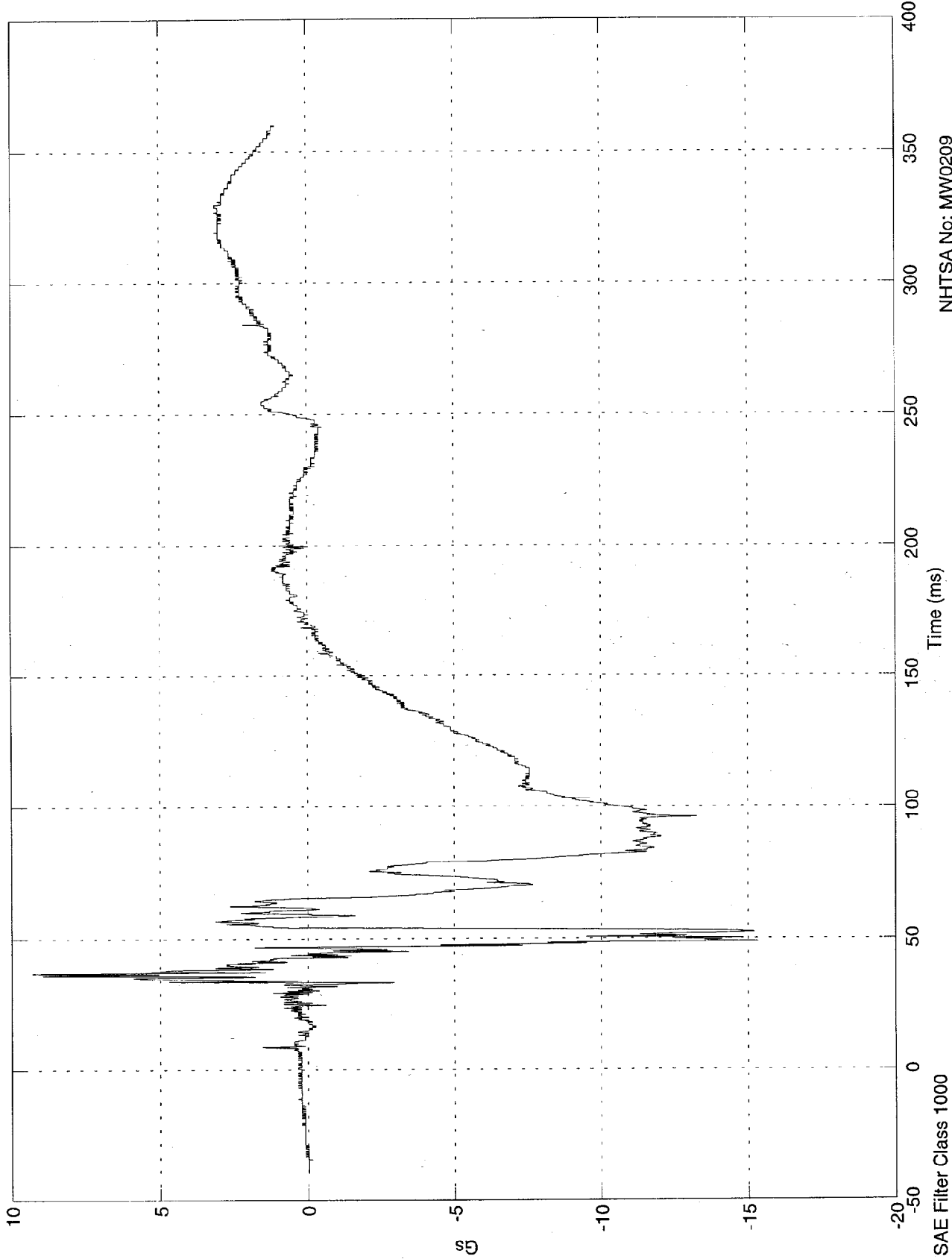

NHTSA No: MW0209
Date: 02 Dec 1997

SAE Filter Class 1000

NCAP TEST #10 - 1998 FORD TAURUS

Max = 34.7 Gs @ 68.50 msec
Min = -3.2 Gs @ 122.20 msec

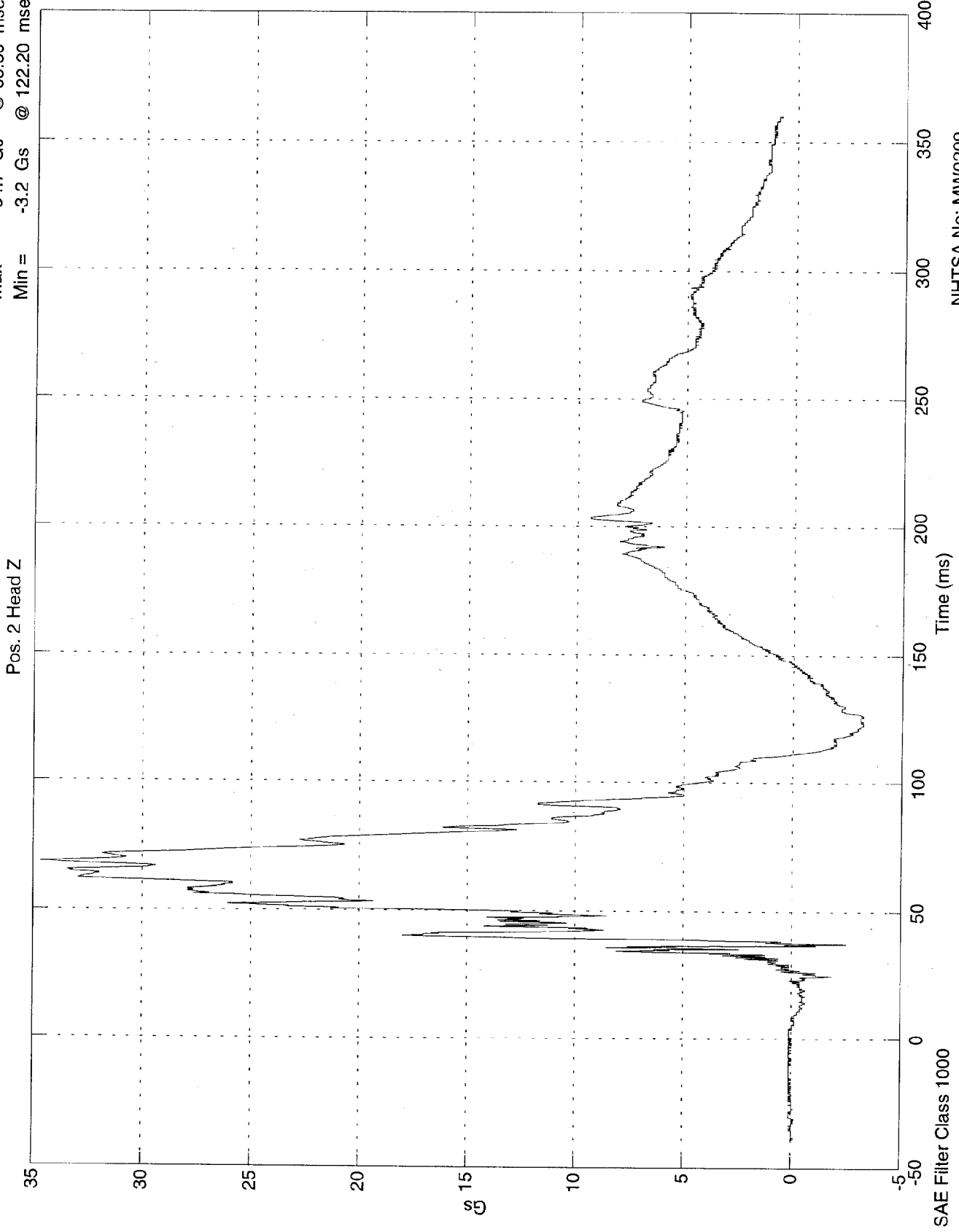

NHTSA No: MW0209
Date: 02 Dec 1997

NCAP TEST #10 - 1998 FORD TAURUS

Max = 56.7 Gs @ 71.90 msec
Min = 0.0567 Gs @ -38.80 msec

Pos. 2 Head Resultant

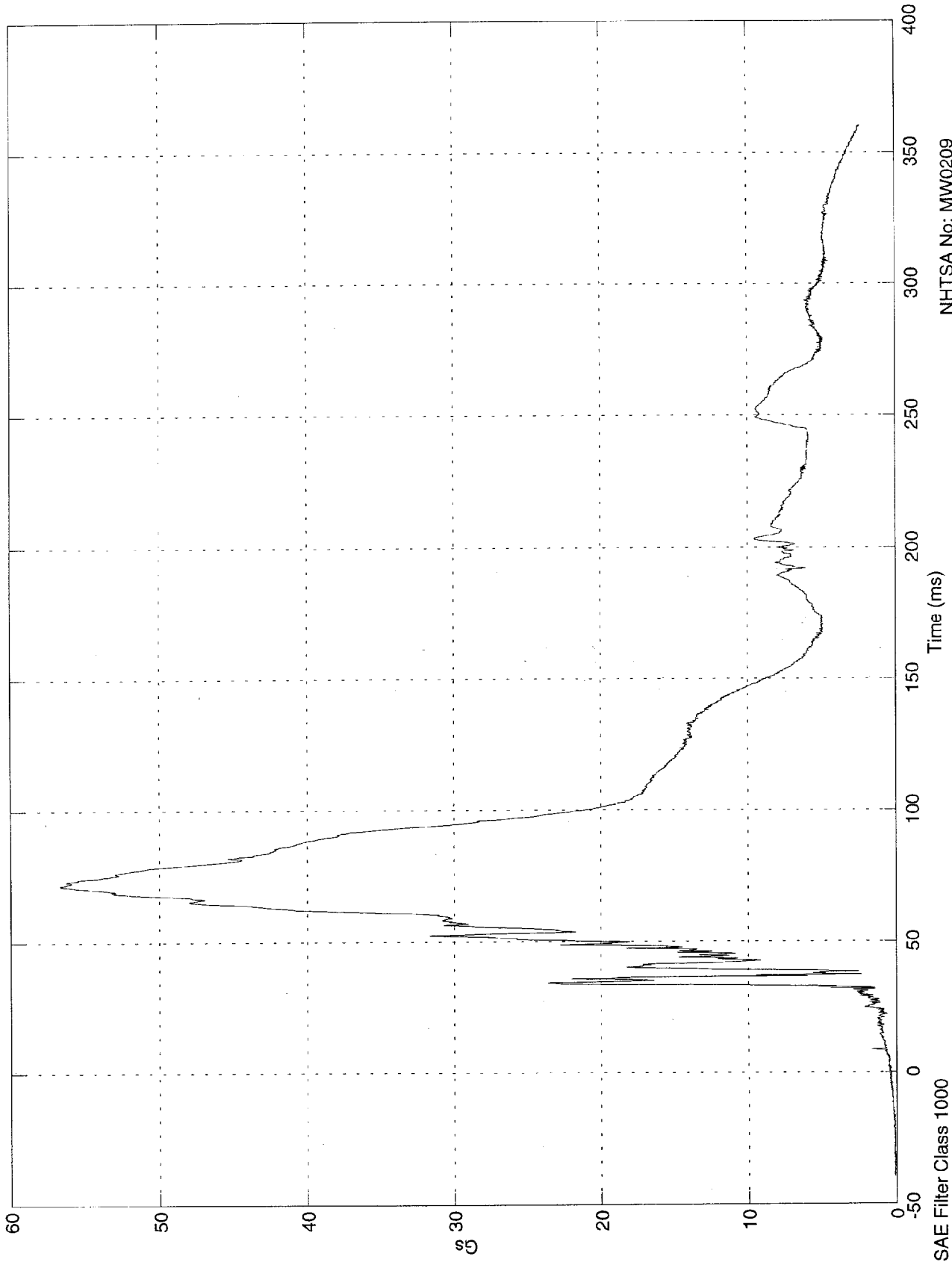

SAE Filter Class 1000
NHTSA No: MW0209
Date: 02 Dec 1997

NCAP TEST #10 - 1998 FORD TAURUS

Max = 53.2 Gs @ 74.50 msec
Min = -7.03 Gs @ 251.00 msec

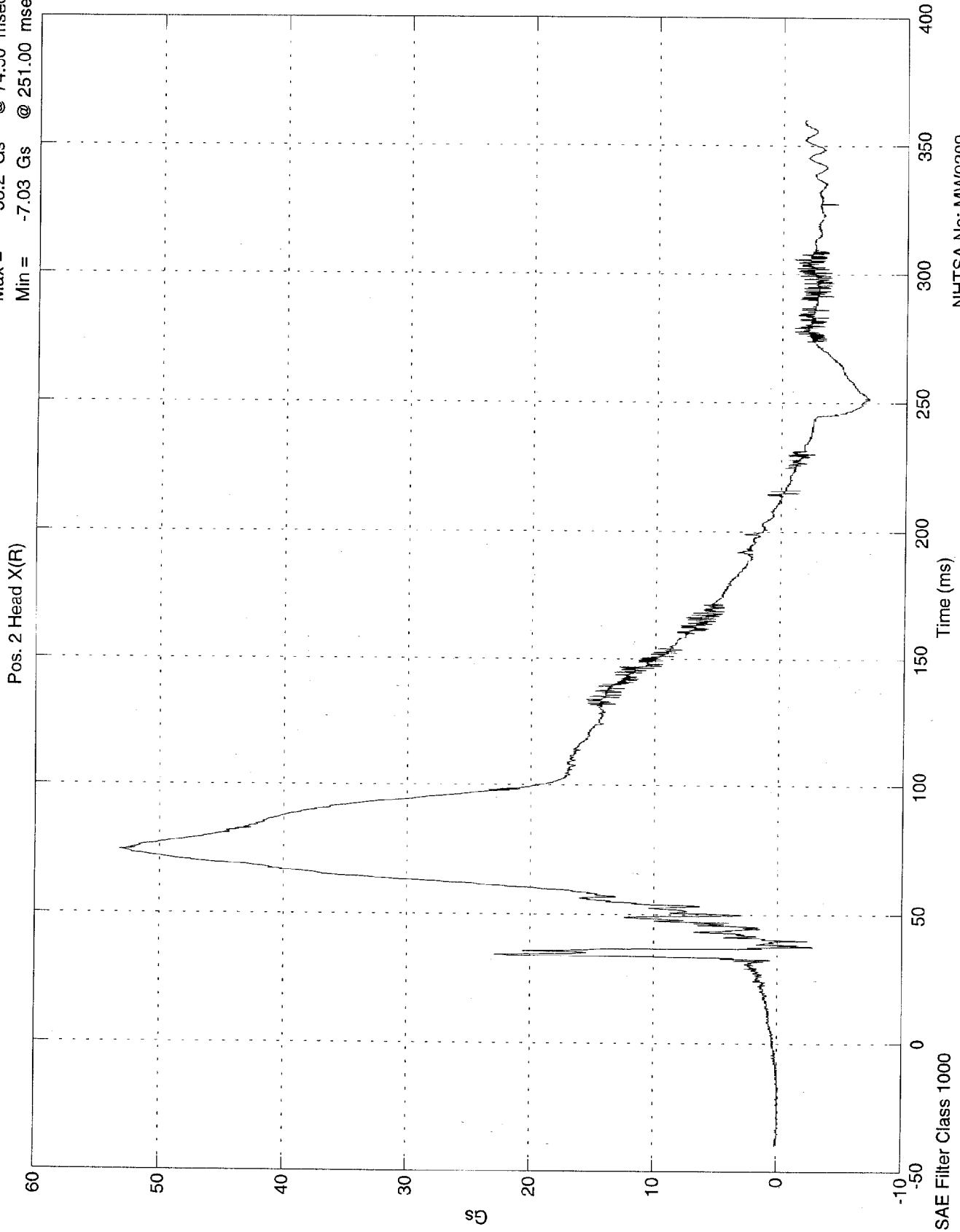

NHTSA No: MW0209
Date: 02 Dec 1997

NCAP TEST #10 - 1998 FORD TAURUS

Max = 23.7 Gs @ 52.40 msec
Min = -12.4 Gs @ 37.10 msec

Pos. 2 Head Y(R)

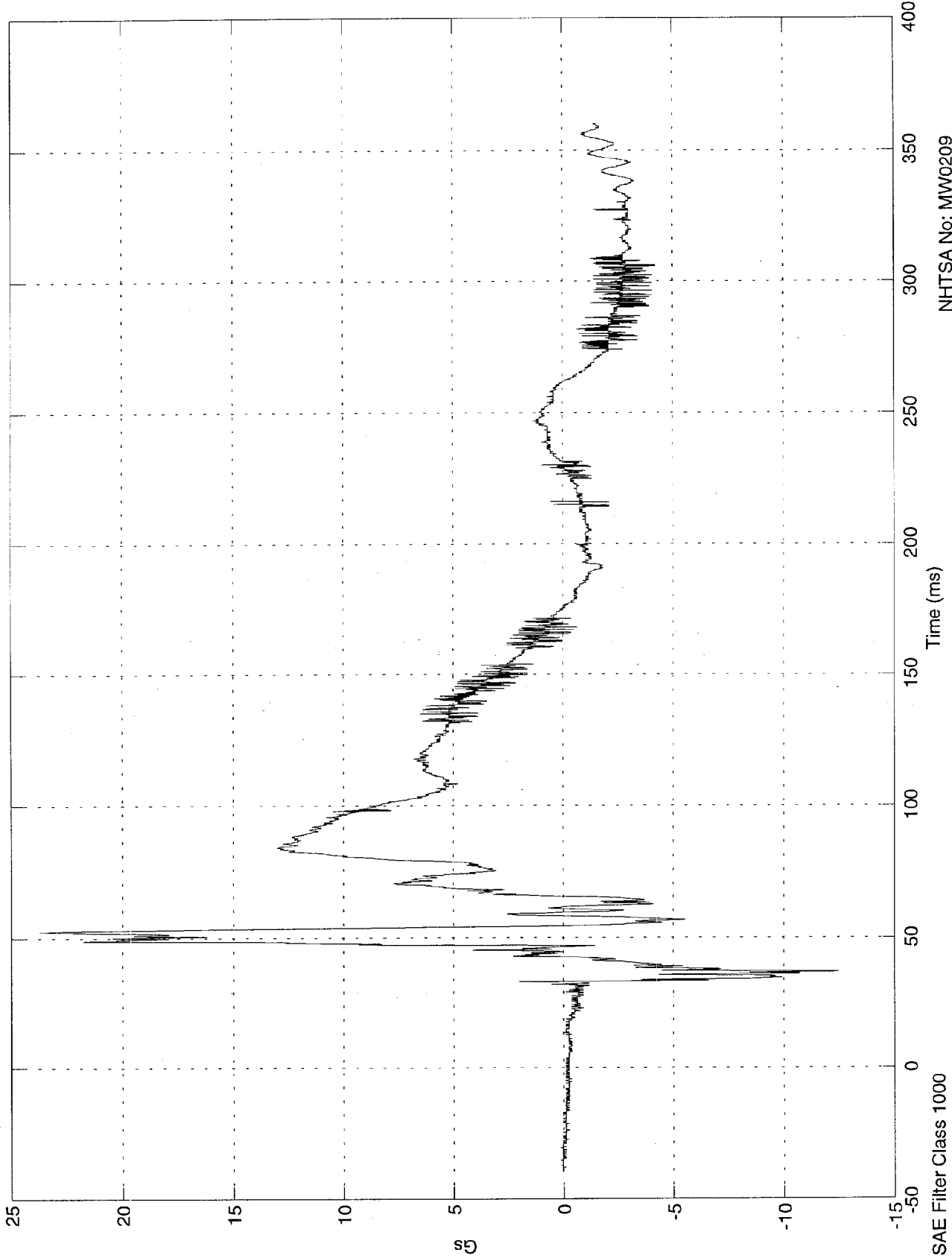

NHTSA No: MW0209
Date: 02 Dec 1997

SAE Filter Class 1000

NCAP TEST #10 - 1998 FORD TAURUS

Max = 35.5 Gs @ 65.20 msec
Min = -5.72 Gs @ 124.20 msec

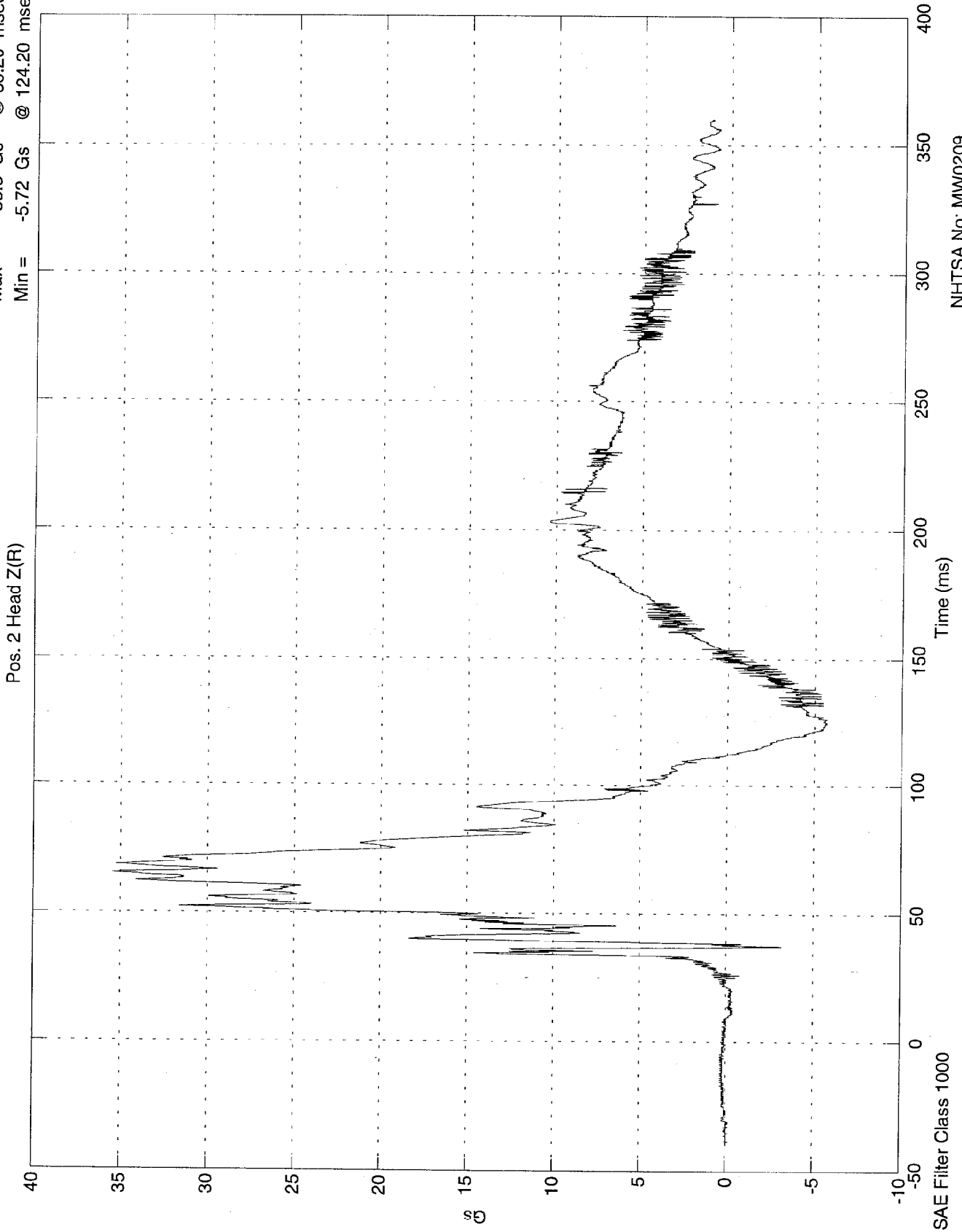

NHTSA No: MW0209
Date: 02 Dec 1997

NCAP TEST #10 - 1998 FORD TAURUS

Max = 59.4 Gs @ 71.80 msec
Min = 0.0494 Gs @ -39.40 msec

Pos. 2 Head Resultant(RR)

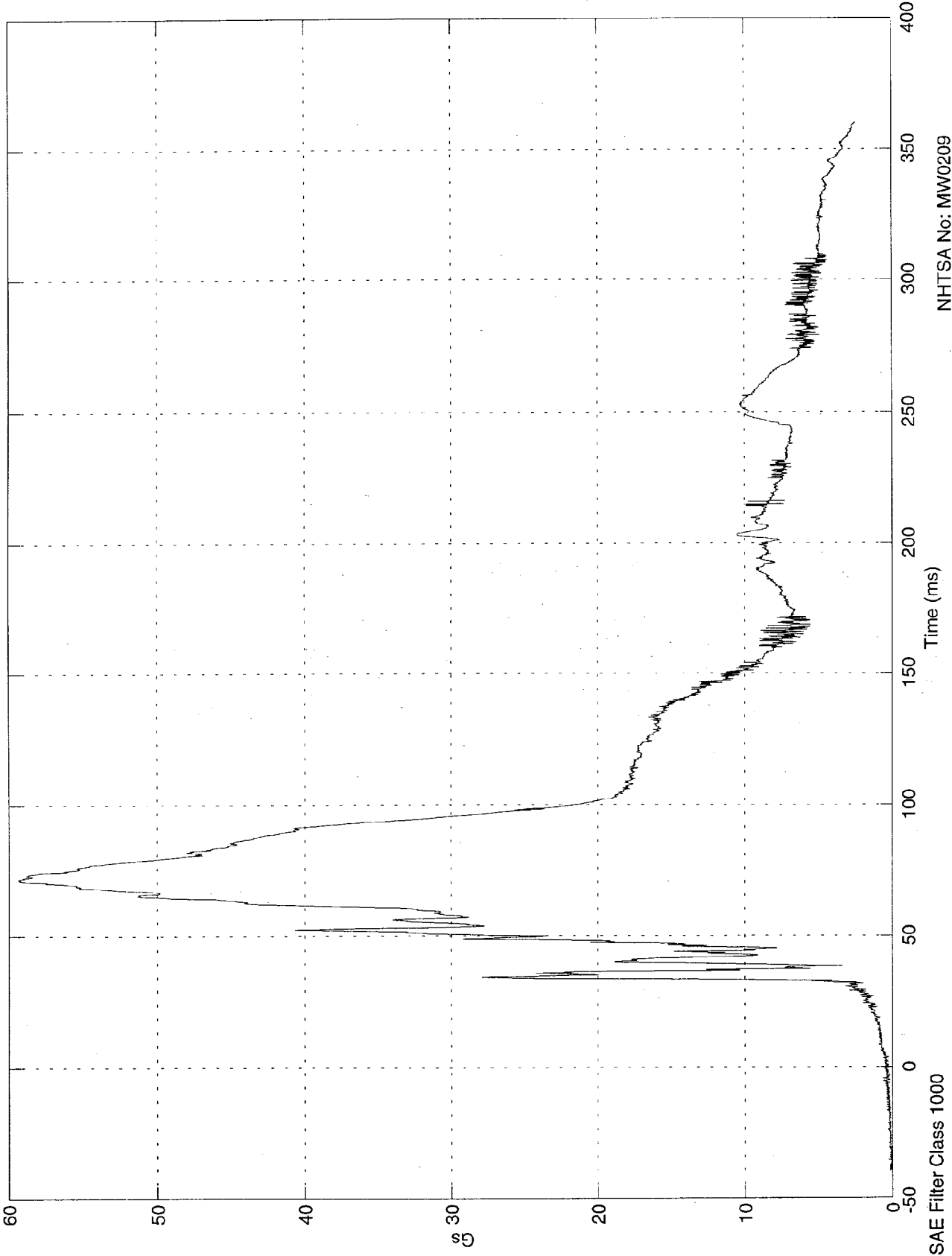

NHTSA No: MW0209
Date: 02 Dec 1997

NCAP TEST #10 - 1998 FORD TAURUS

Pos. 2 Upper Neck Fx

Max = 466 Nwt @ 326.80 msec
Min = -873 Nwt @ 134.20 msec

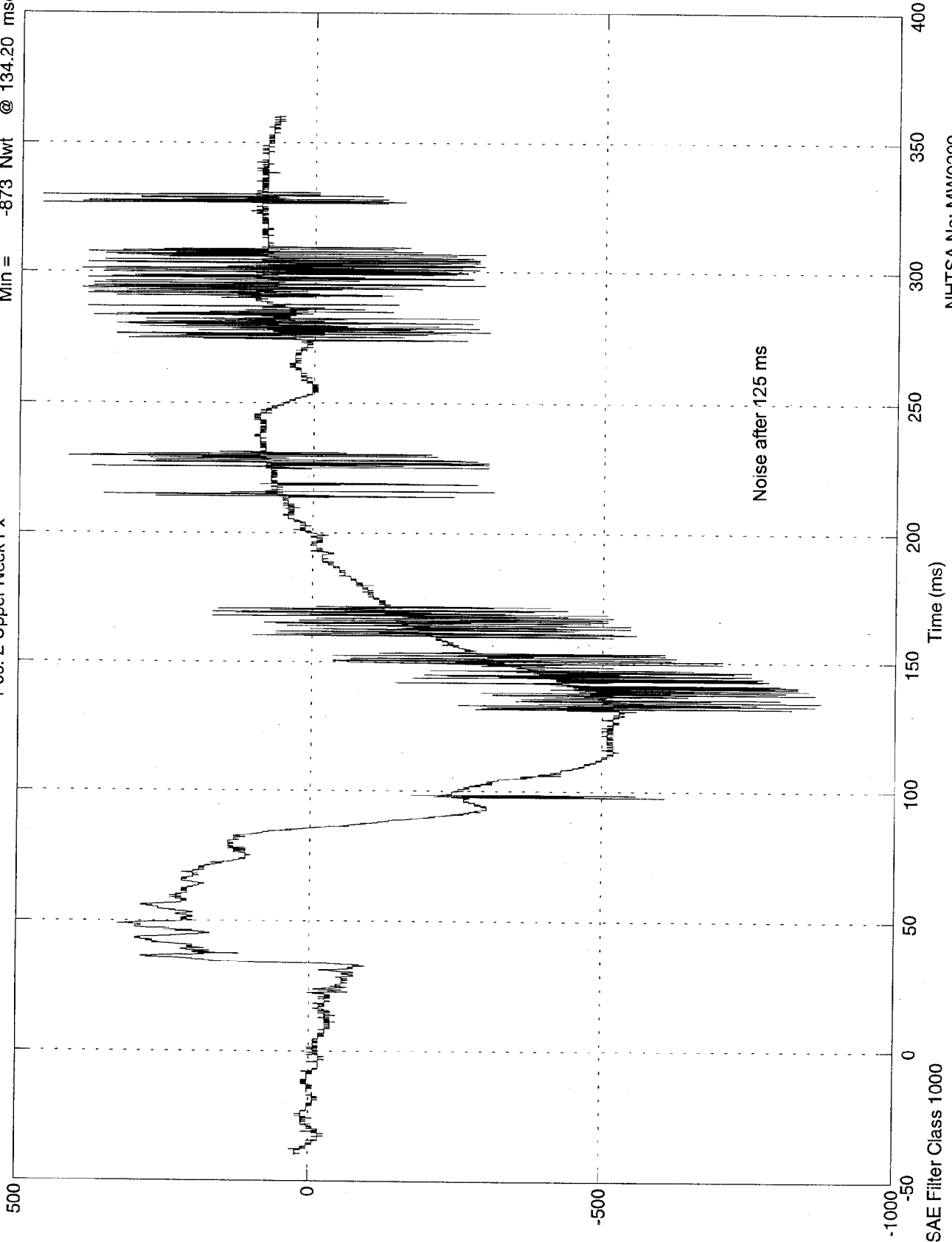

NHTSA No: MW0209
Date: 02 Dec 1997

NCAP TEST #10 - 1998 FORD TAURUS

Max = 545 Nwt @ 297.00 msec
Min = -568 Nwt @ 131.40 msec

Pos. 2 Upper Neck Fy

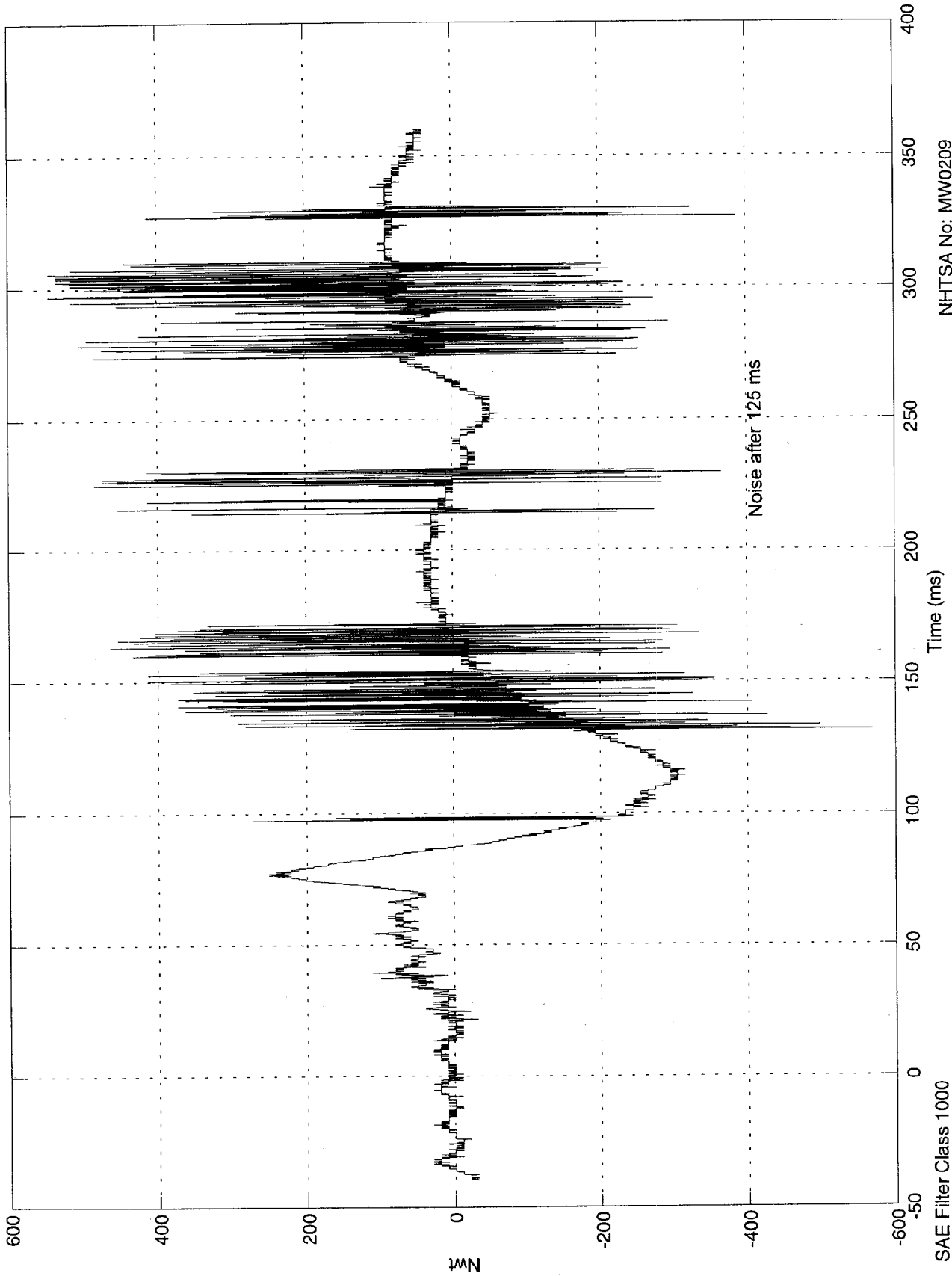

NHTSA No: MW0209
Date: 02 Dec 1997

SAE Filter Class 1000

NCAP TEST #10 - 1998 FORD TAURUS

Max = 1.31e+003 Nwt @ 62.80 msec
Min = -1.05e+003 Nwt @ 134.60 msec

Pos. 2 Upper Neck Fz

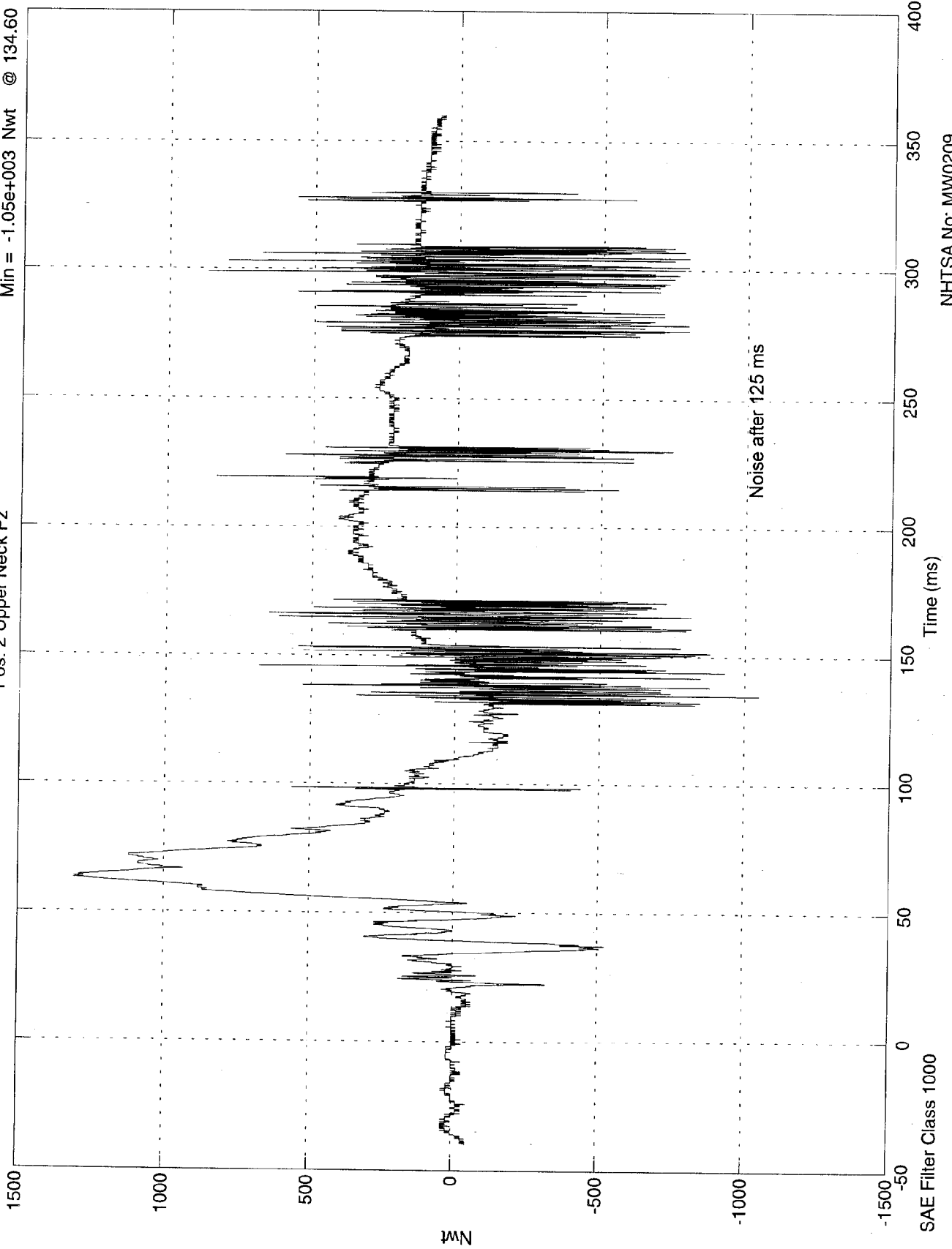

NHTSA No: MW0209
Date: 02 Dec 1997

NCAP TEST #10 - 1998 FORD TAURUS

Max = 1.32e+003 Nwt @ 62.80 msec
Min = 4.01 Nwt @ -36.20 msec

Pos. 2 Neck Force Res.

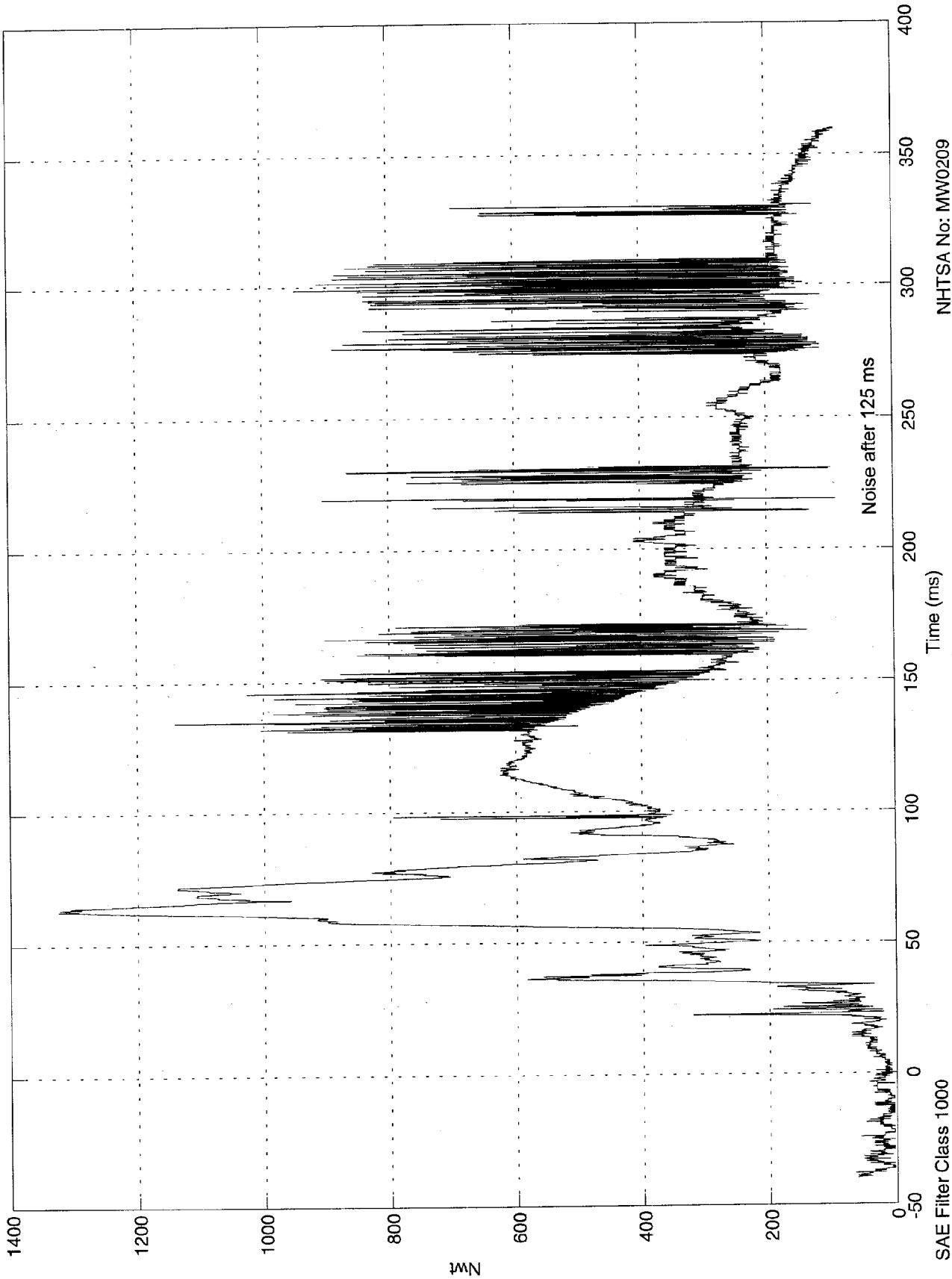

NHTSA No: MW0209
Date: 02 Dec 1997

SAE Filter Class 1000

NCAP TEST #10 - 1998 FORD TAURUS

Max = 26.2 Nwt-M @ 88.50 msec
Min = -18.7 Nwt-M @ 121.30 msec

Pos. 2 Upper Neck Mx

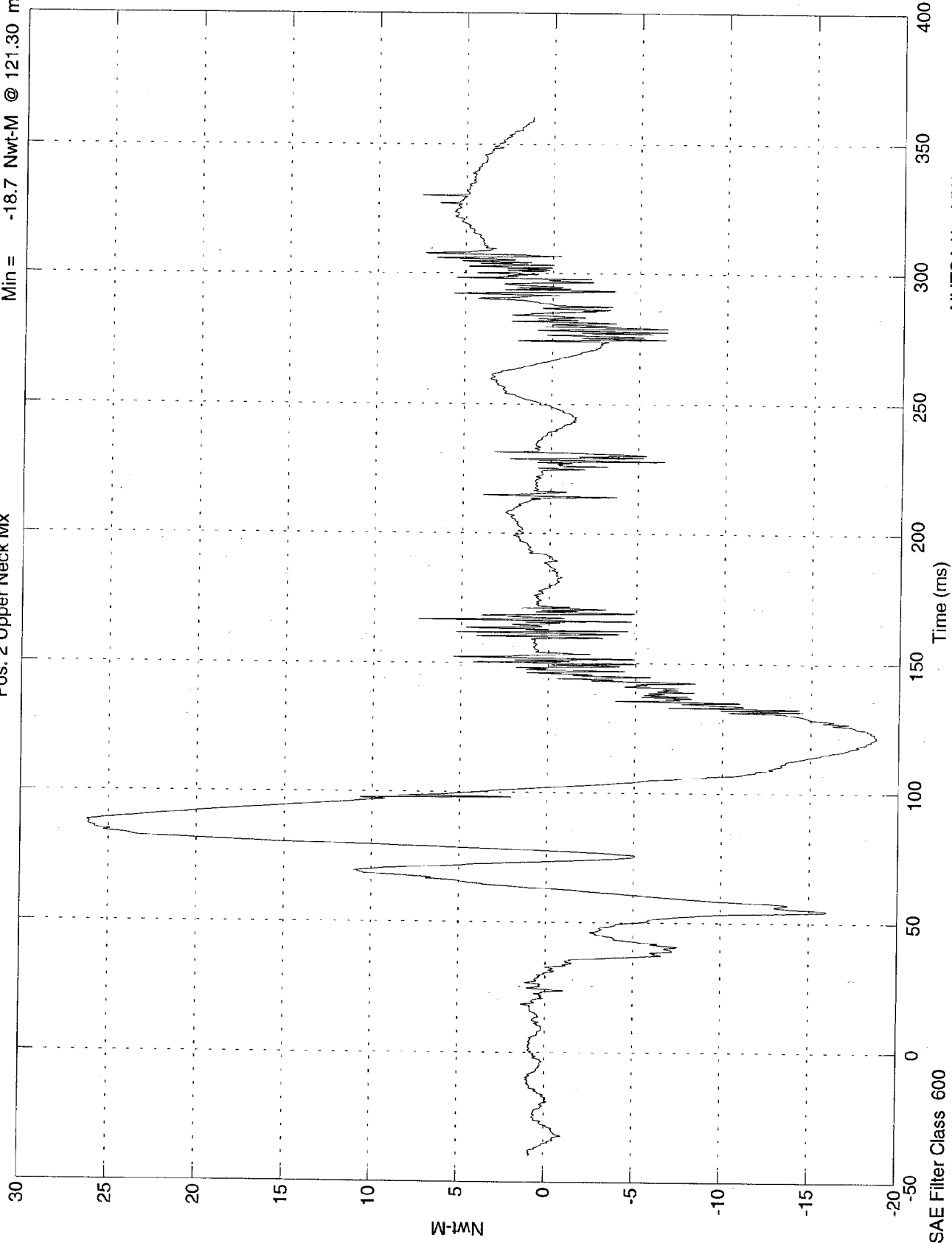

NHTSA No: MW0209
Date: 02 Dec 1997

NCAP TEST #10 - 1998 FORD TAURUS

Max = 44.7 Nwt-M @ 58.60 msec
Min = -19.3 Nwt-M @ 254.00 msec

Pos. 2 Upper Neck My

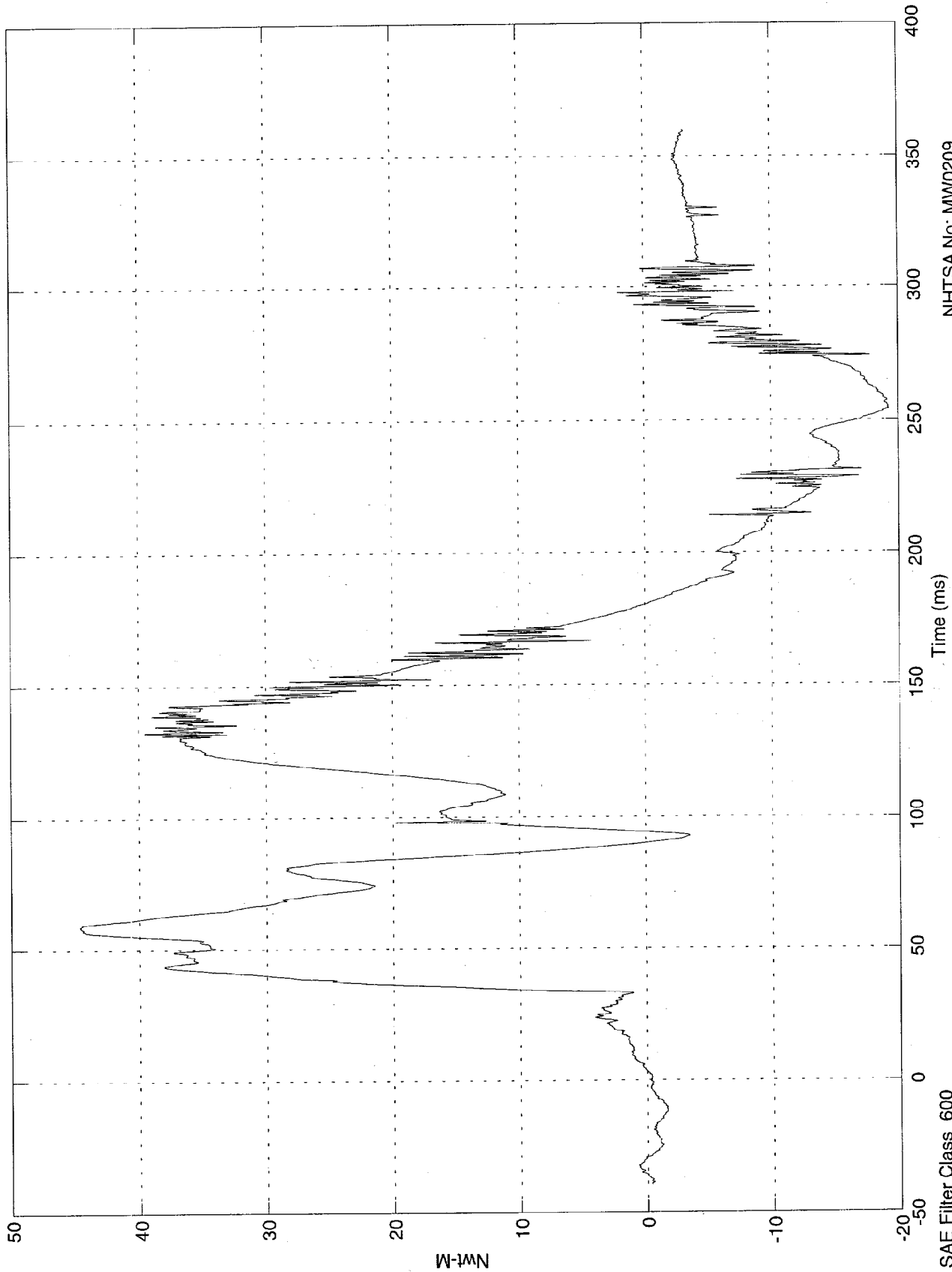

NHTSA No: MW0209
Date: 02 Dec 1997

SAE Filter Class 600

NCAP TEST #10 - 1998 FORD TAURUS

Max = 25.3 Nwt-M @ 98.10 msec
Min = -14.6 Nwt-M @ 150.30 msec

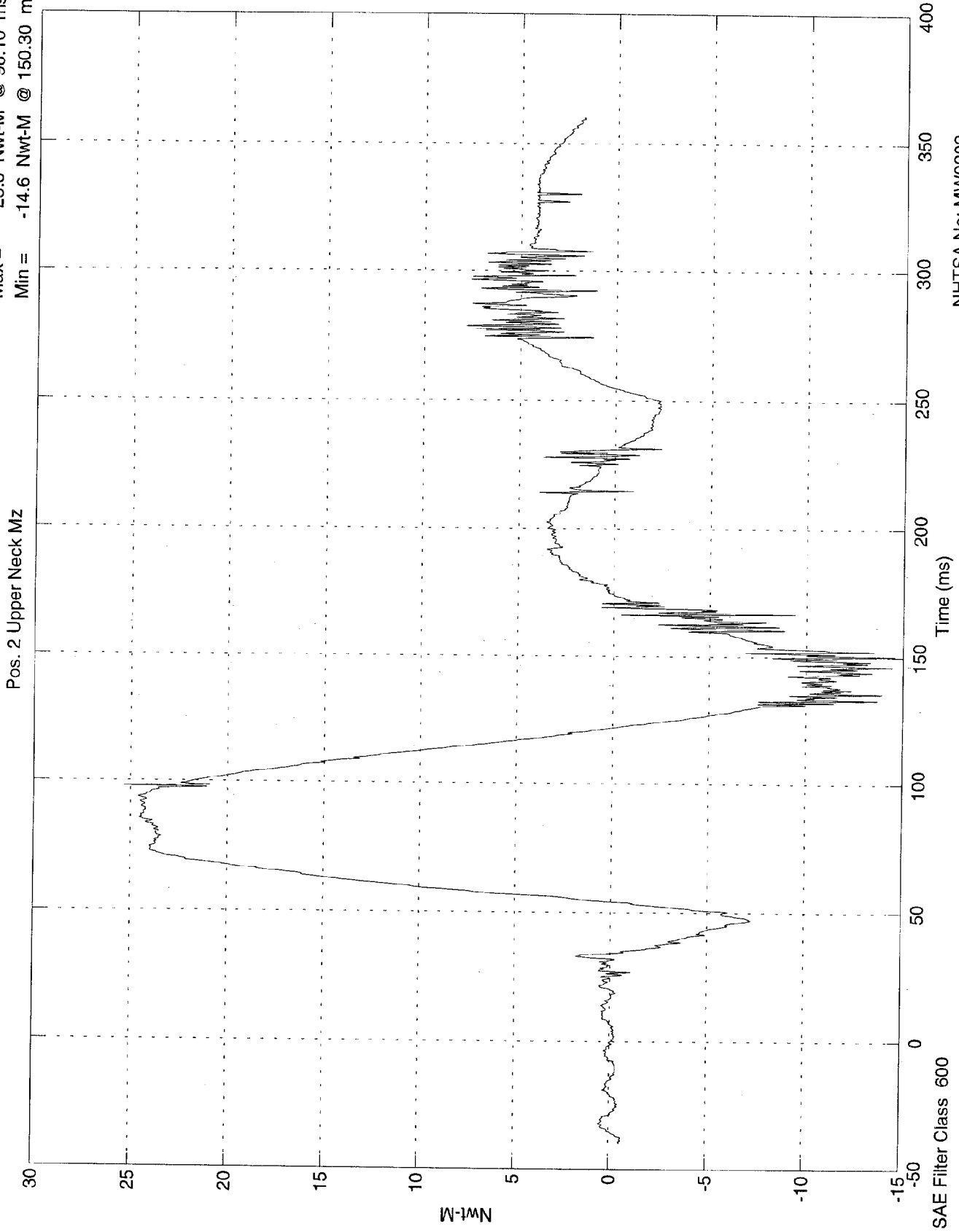

NHTSA No: MW0209
Date: 02 Dec 1997

NCAP TEST #10 - 1998 FORD TAURUS

Max = 46.9 Nwt-M @ 57.20 msec
Min = 0.147 Nwt-M @ -35.60 msec

Pos. 2 Neck Moment Res.

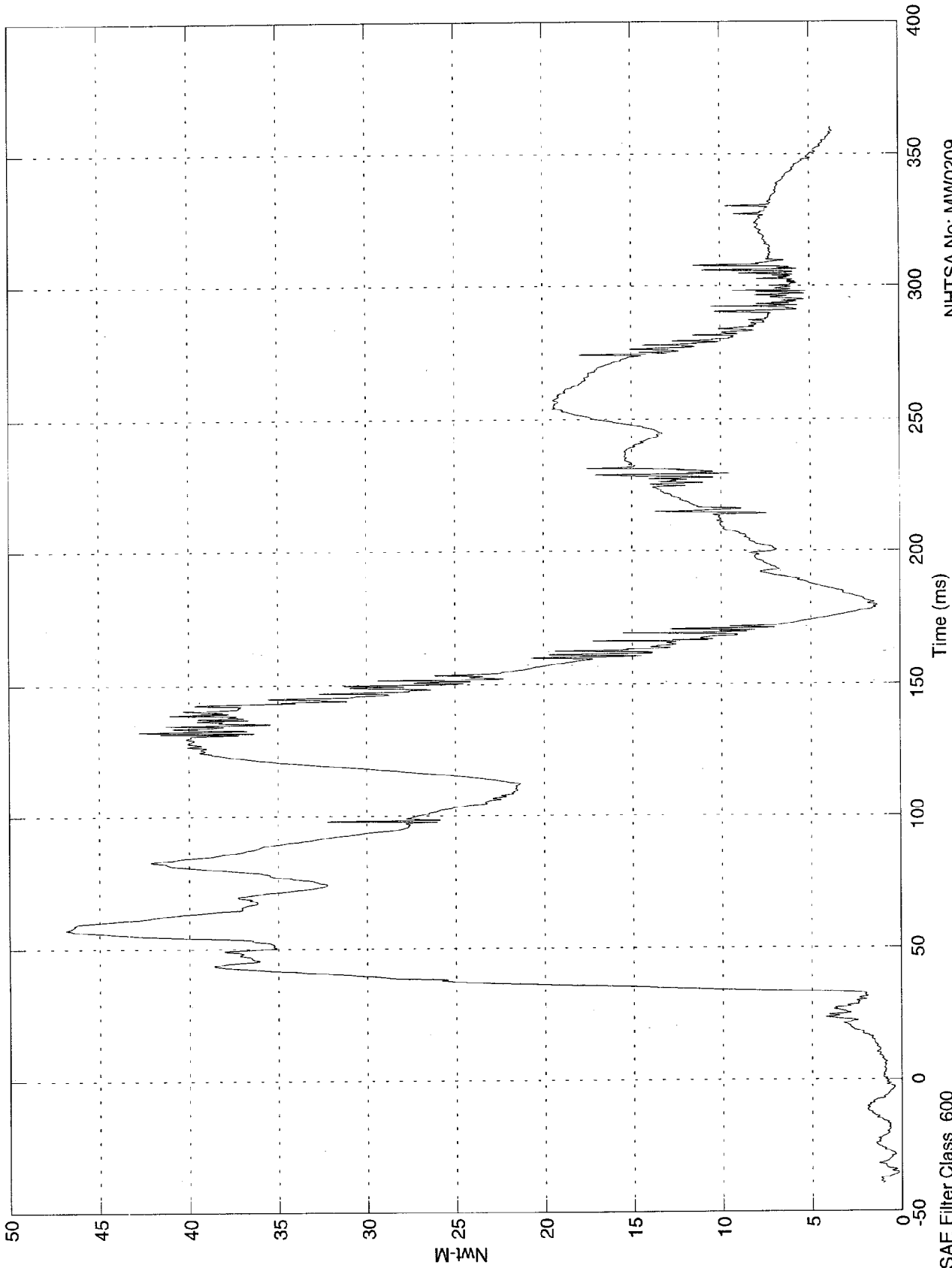

NHTSA No: MW0209
Date: 02 Dec 1997

SAE Filter Class 600

NCAP TEST #10 - 1998 FORD TAURUS

Max = 4.12 Gs @ 291.00 msec
Min = -51.5 Gs @ 70.20 msec

Pos. 2 Chest X

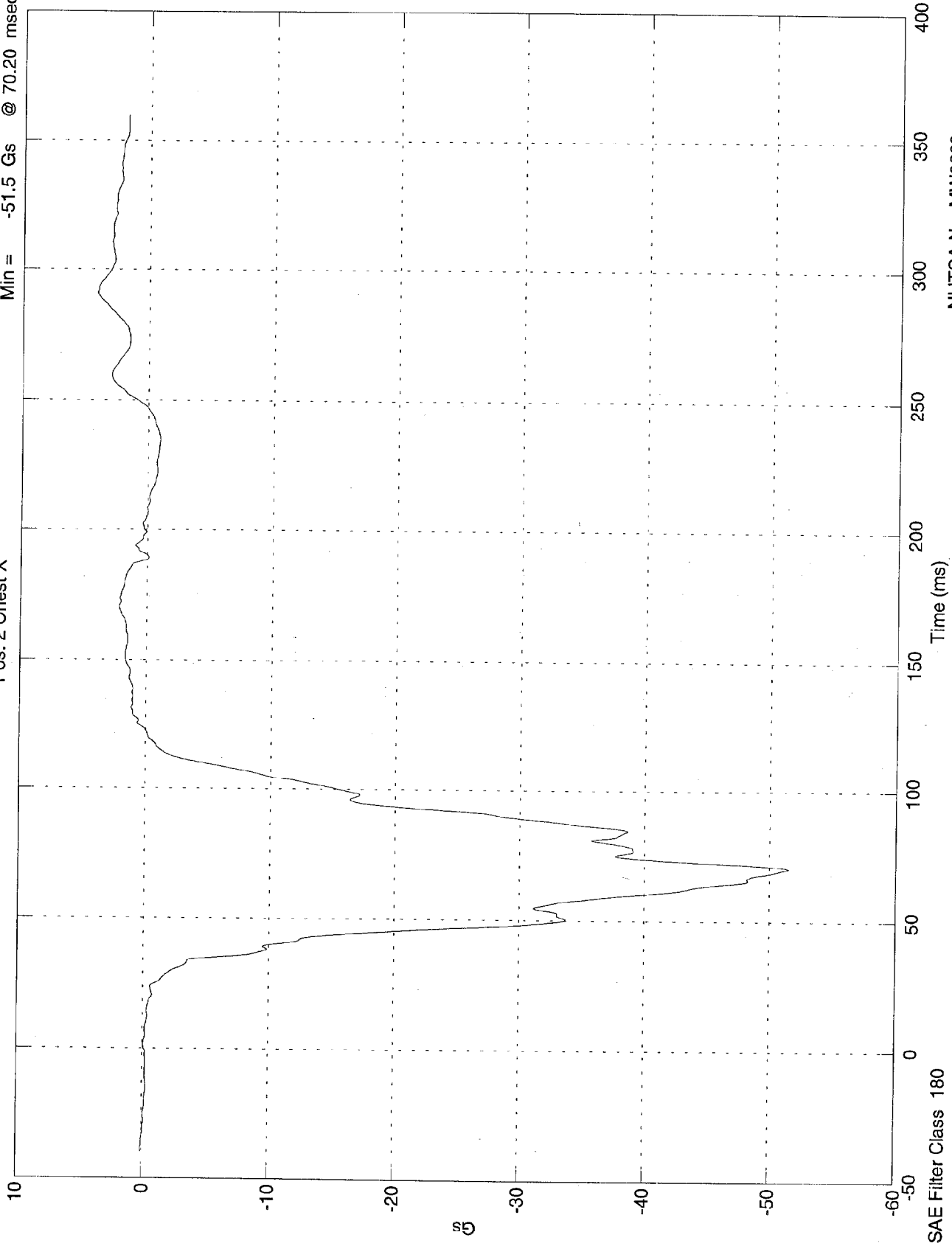

NHTSA No: MW0209
Date: 02 Dec 1997

NCAP TEST #10 - 1998 FORD TAURUS

Max = 12.9 Gs @ 73.30 msec
Min = -10.1 Gs @ 92.30 msec

Pos. 2 Chest Y

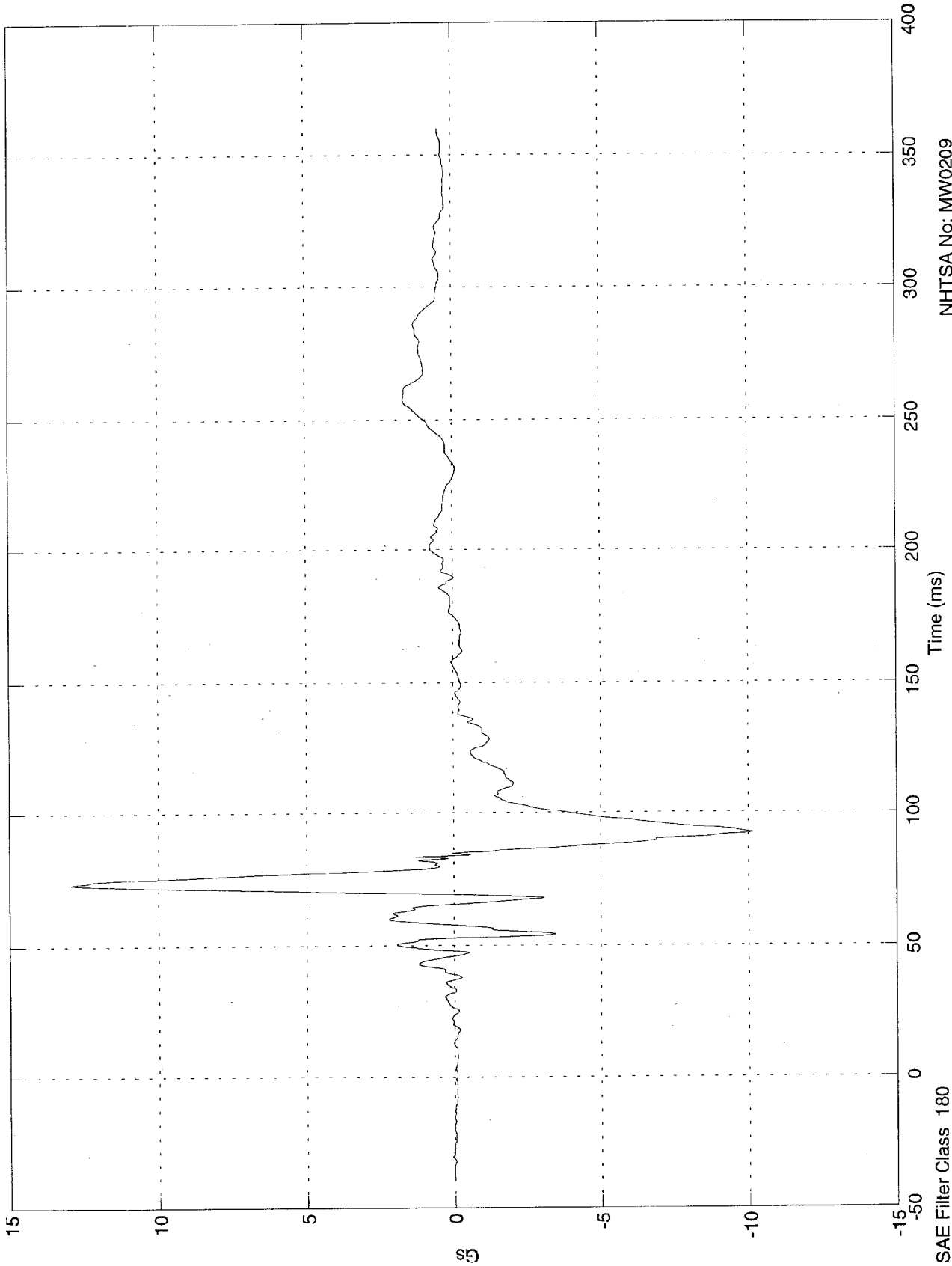

NHTSA No: MW0209
Date: 02 Dec 1997

SAE Filter Class 180

NCAP TEST #10 - 1998 FORD TAURUS

Max = 14.7 Gs @ 56.50 msec
Min = -8.95 Gs @ 110.40 msec

Pos. 2 Chest Z

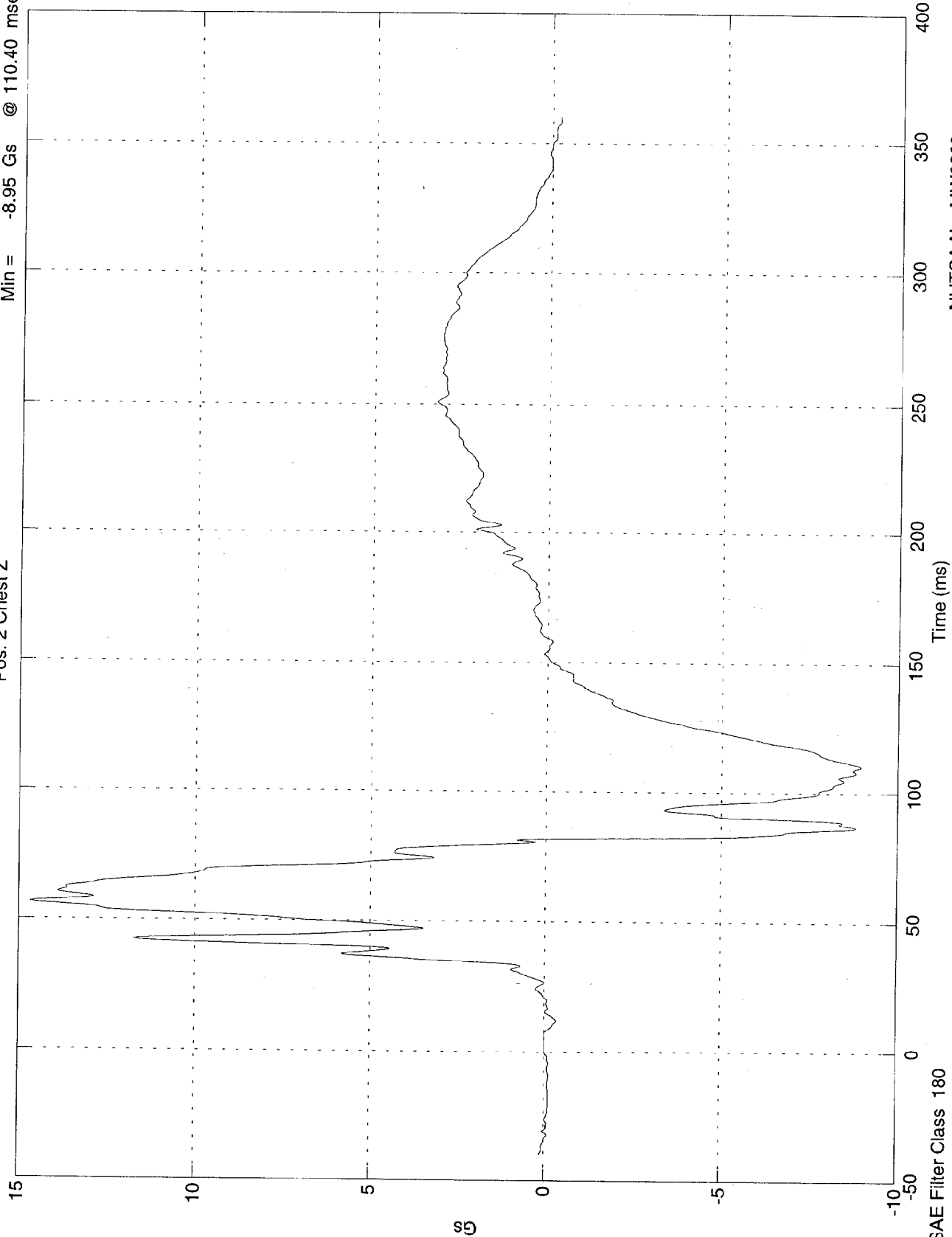

SAE Filter Class 180

NHTSA No: MW0209
Date: 02 Dec 1997

NCAP TEST #10 - 1998 FORD TAURUS

Max = 52.4 Gs @ 70.20 msec
Min = 0.0241 Gs @ -33.30 msec

Pos. 2 Chest Resultant

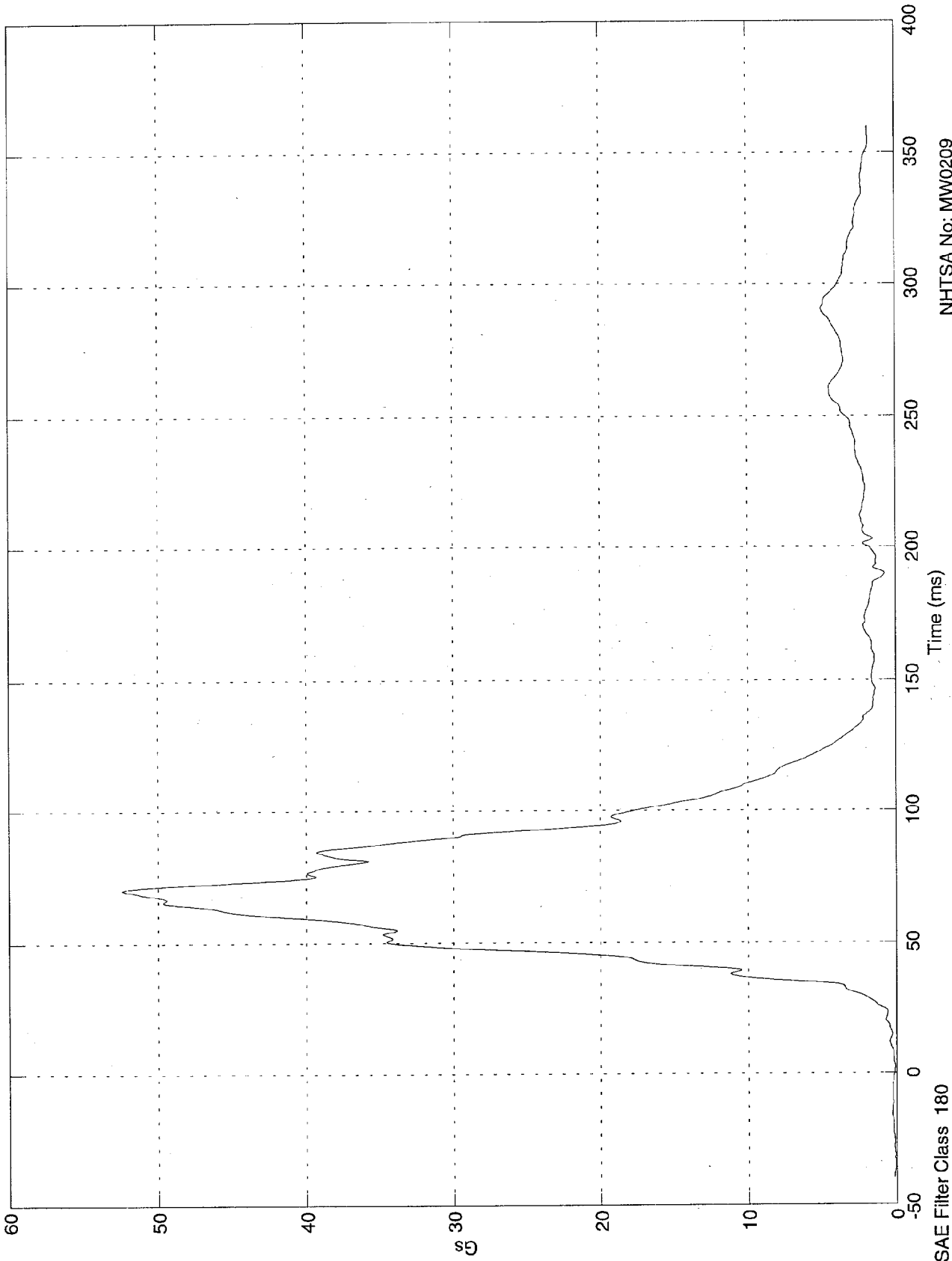

NHTSA No: MW0209
Date: 02 Dec 1997

SAE Filter Class 180

NCAP TEST #10 - 1998 FORD TAURUS

Max = 3.76 Gs @ 294.00 msec
Min = -50.6 Gs @ 70.00 msec

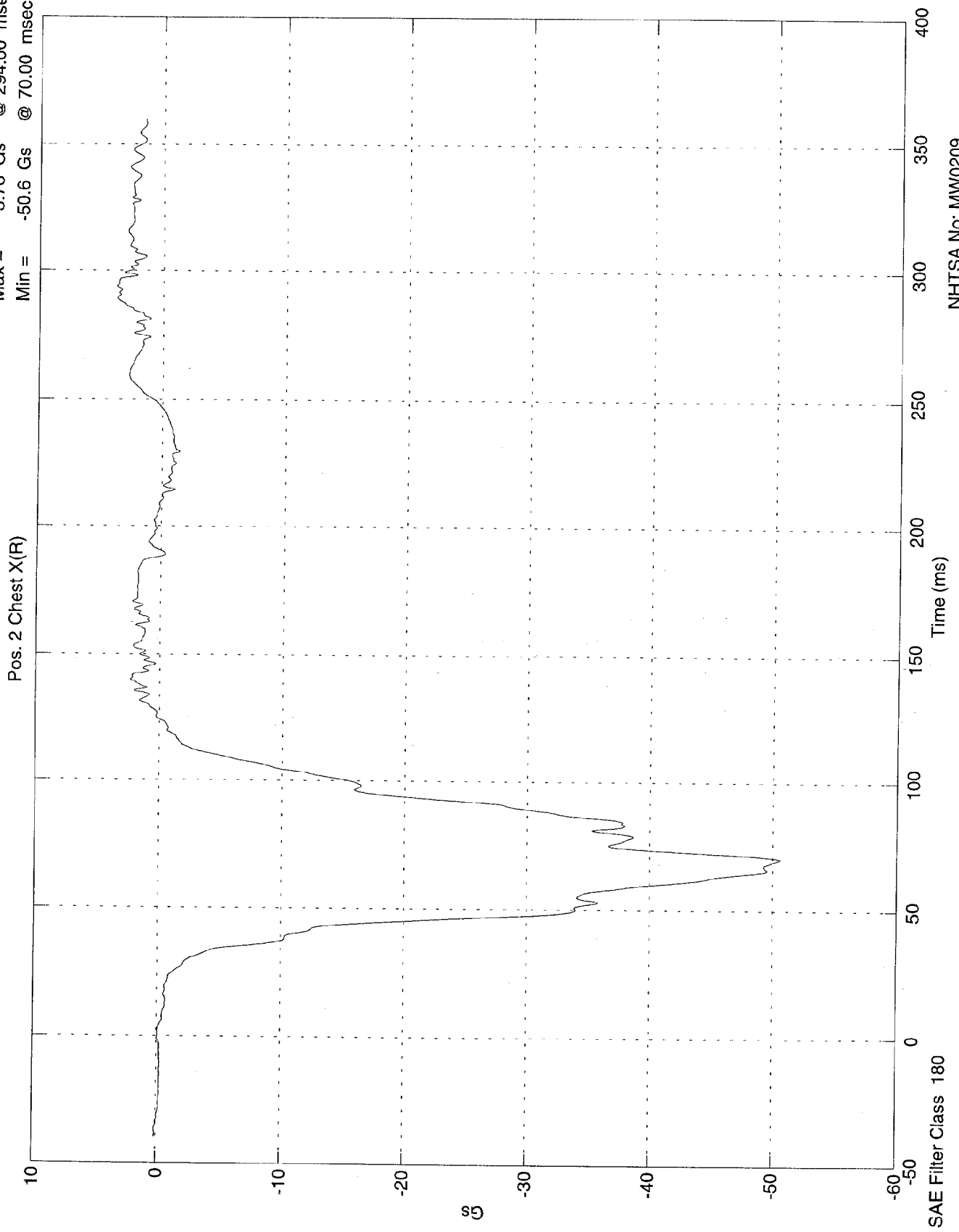

NHTSA No: MW0209
Date: 02 Dec 1997

NCAP TEST #10 - 1998 FORD TAURUS

Max = 9.1 Gs @ 73.40 msec
Min = -9.96 Gs @ 92.40 msec

Pos. 2 Chest Y(R)

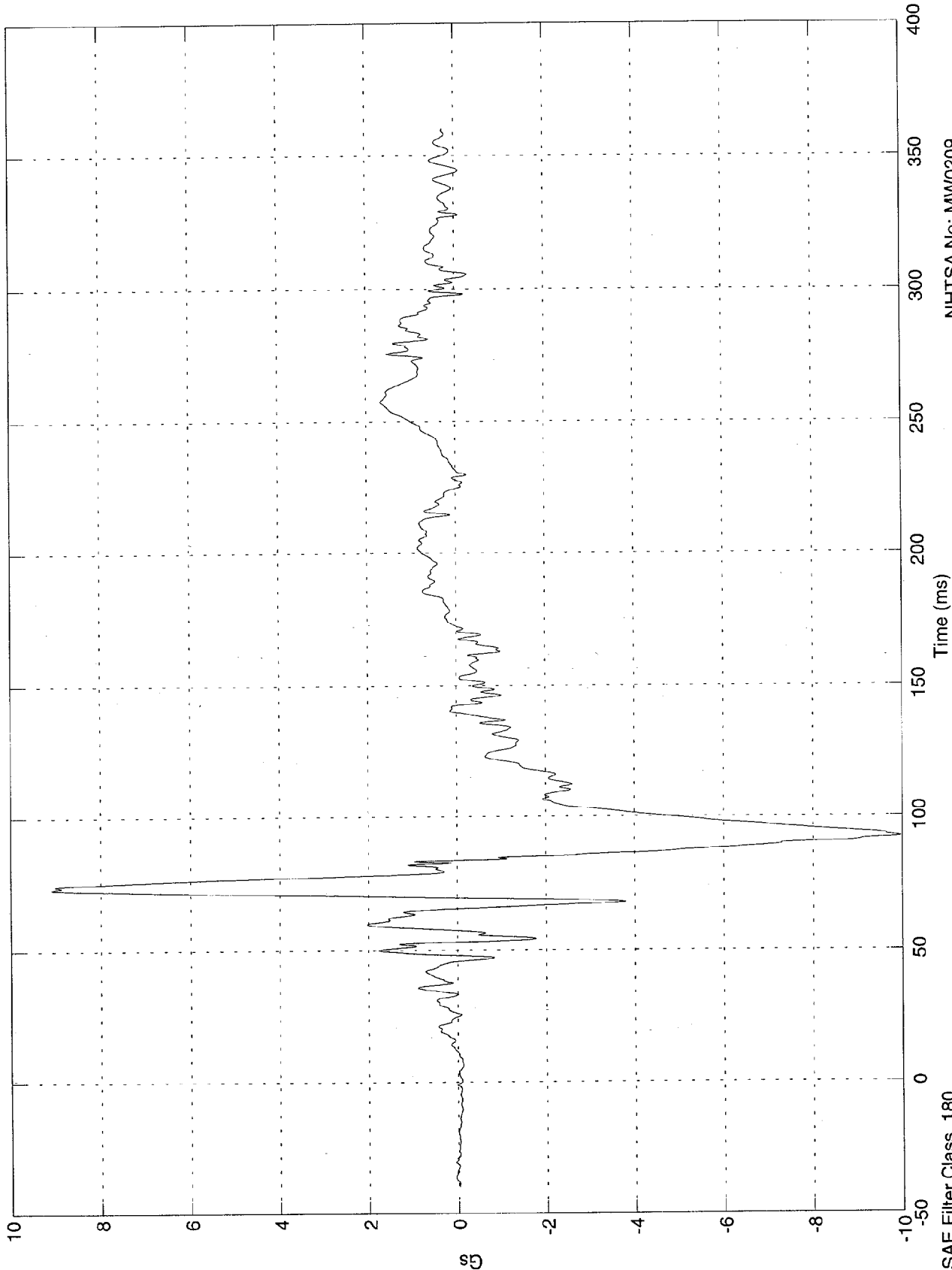

NHTSA No: MW0209
Date: 02 Dec 1997

SAE Filter Class 180

NCAP TEST #10 - 1998 FORD TAURUS

Max = 14.7 Gs @ 56.50 msec
Min = -10.3 Gs @ 119.50 msec

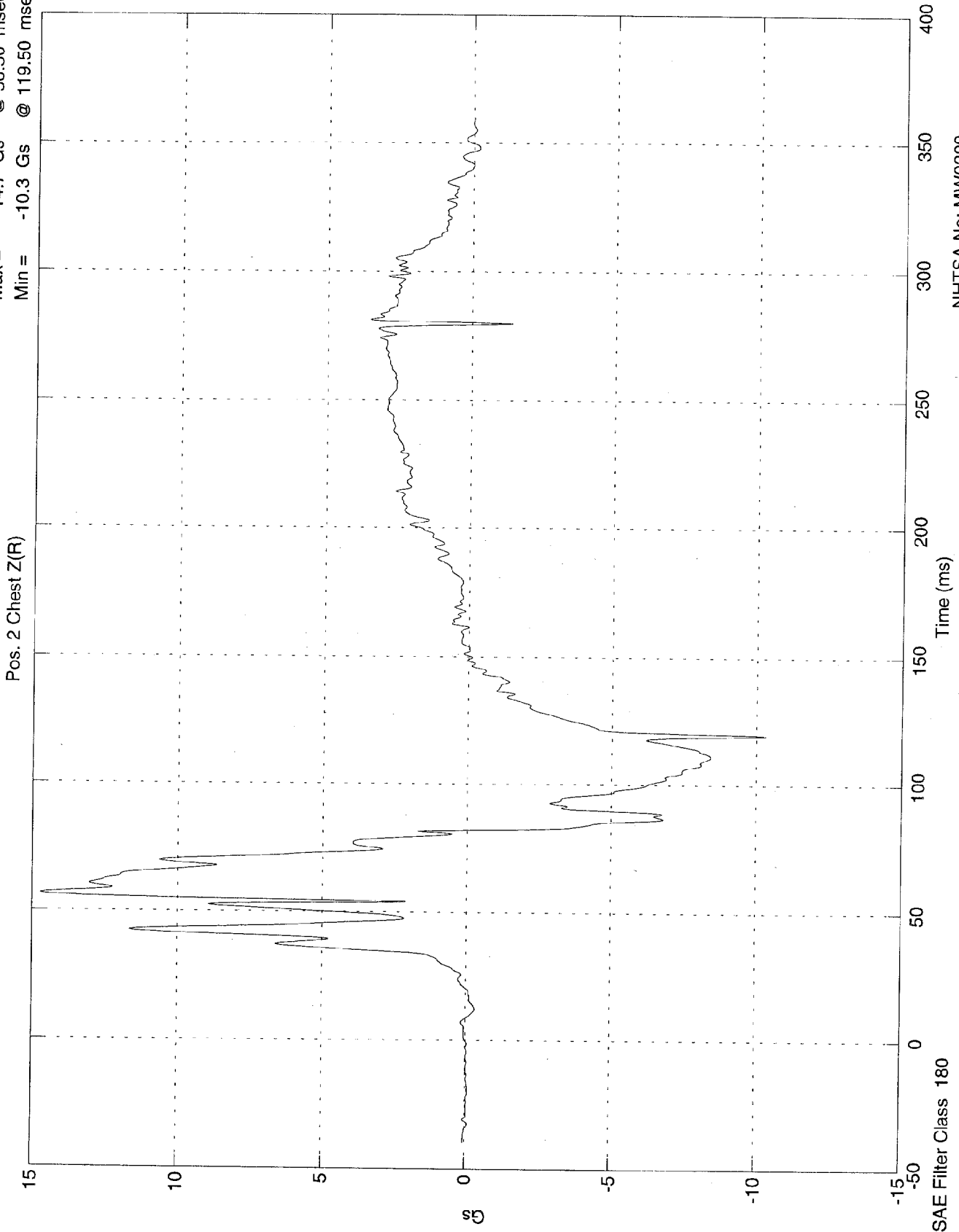

NHTSA No: MW0209
Date: 02 Dec 1997

NCAP TEST #10 - 1998 FORD TAURUS

Max = 51.7 Gs @ 70.00 msec
Min = 0.0358 Gs @ -34.50 msec

Pos. 2 Chest Res(RR)

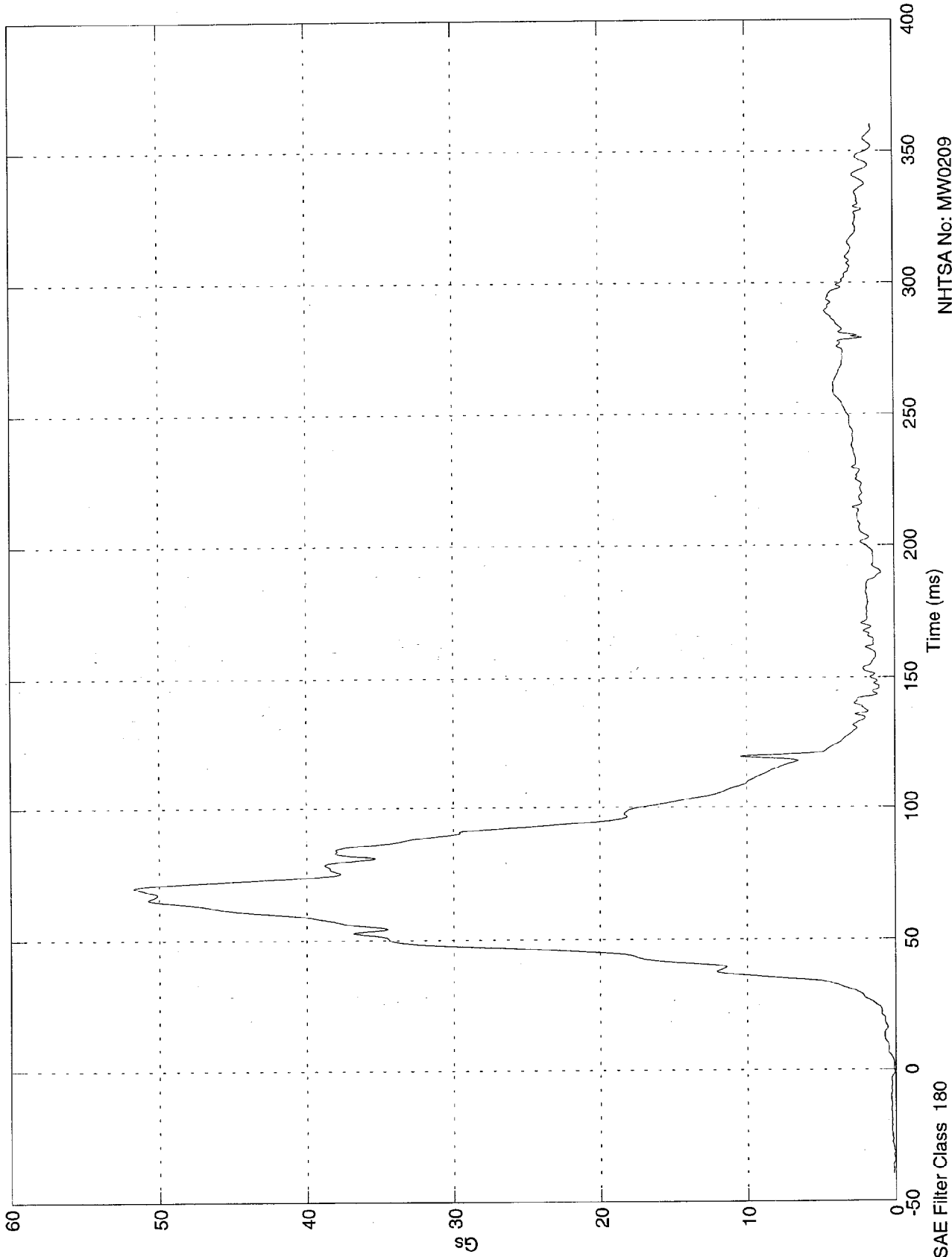

NHTSA No: MW0209
Date: 02 Dec 1997

SAE Filter Class 180

NCAP TEST #10 - 1998 FORD TAURUS

Max = 0.0113 mm @ 20.40 msec
Min = -27.9 mm @ 78.50 msec

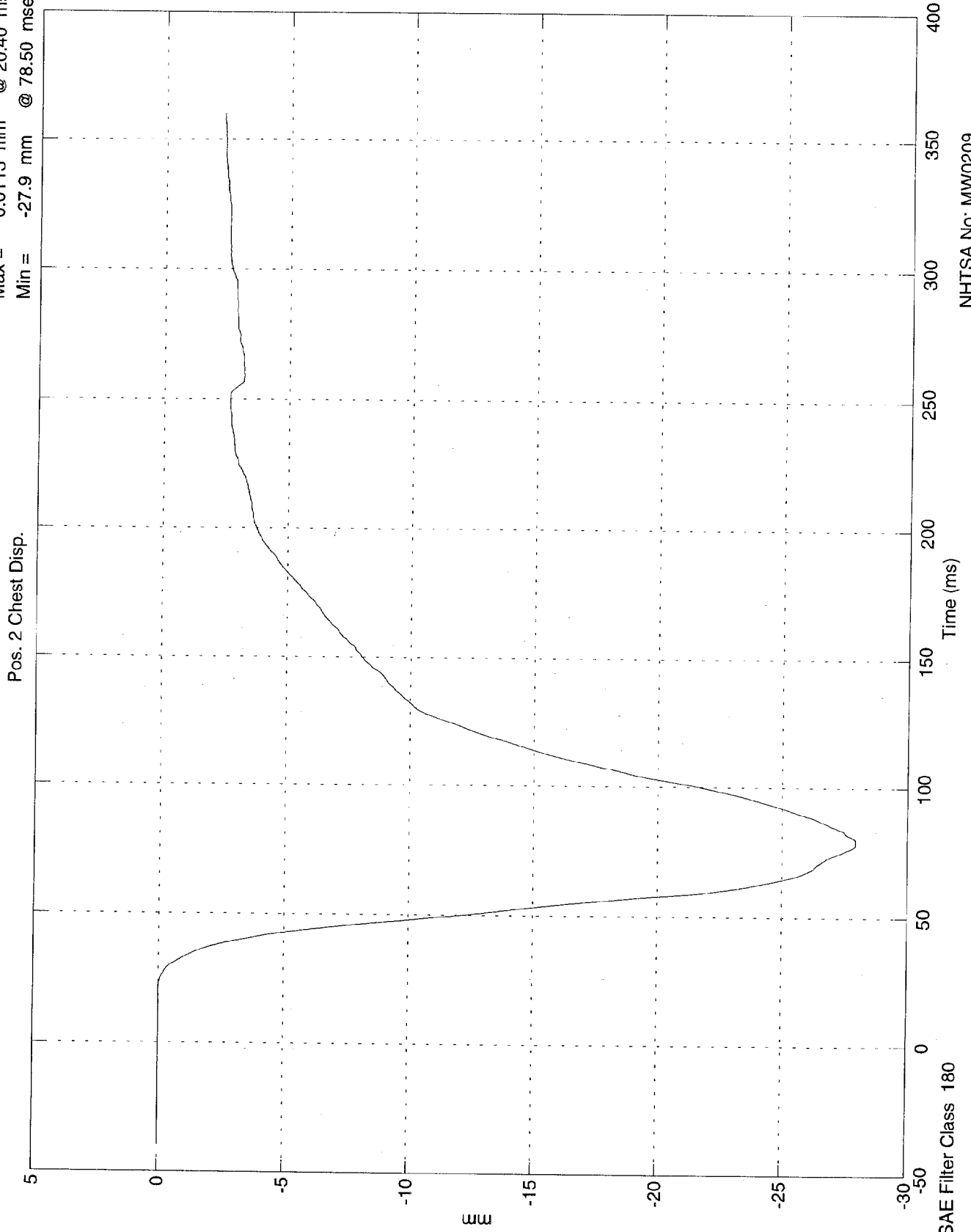

NHTSA No: MW0209
Date: 02 Dec 1997

NCAP TEST #10 - 1998 FORD TAURUS

Max = 4.88 Gs @ 118.70 msec
Min = -49.6 Gs @ 53.00 msec

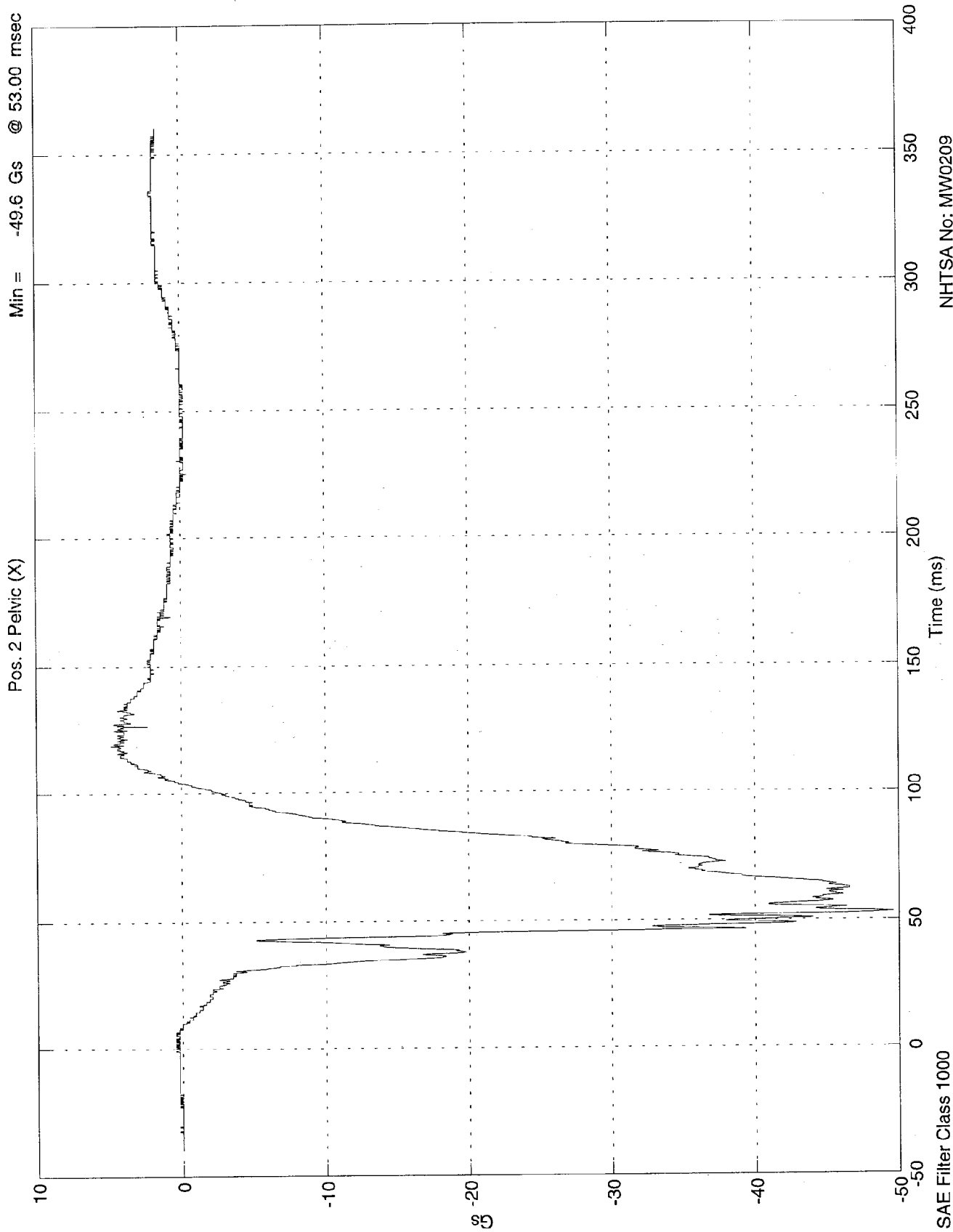

NHTSA No: MW0209
Date: 02 Dec 1997

SAE Filter Class 1000

NCAP TEST #10 - 1998 FORD TAURUS

Max = 8.21 Gs @ 46.40 msec
Min = -10.3 Gs @ 75.10 msec

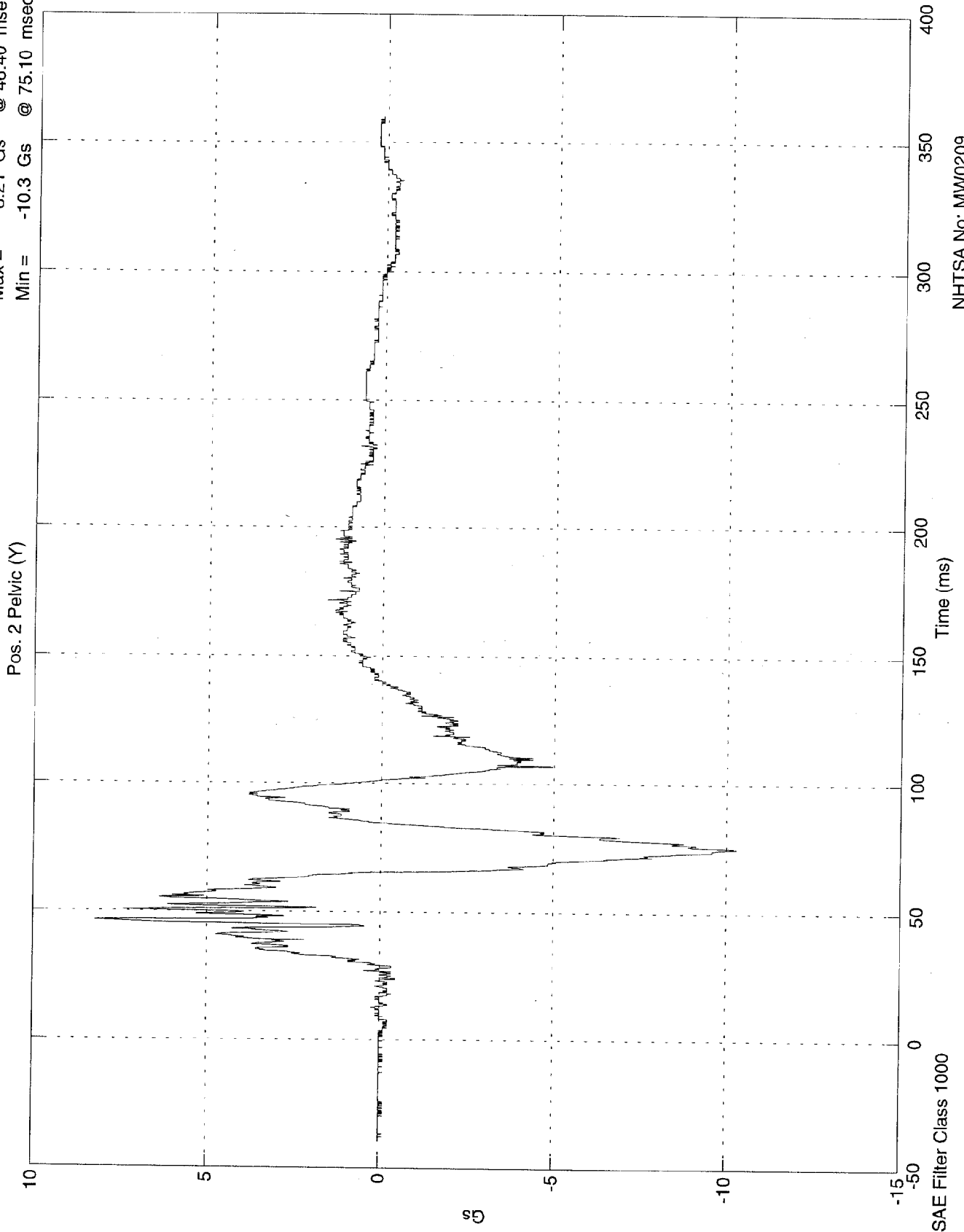

NHTSA No: MW0209
Date: 02 Dec 1997

NCAP TEST #10 - 1998 FORD TAURUS

Max = 6.51 Gs @ 38.70 msec
Min = -18.9 Gs @ 86.60 msec

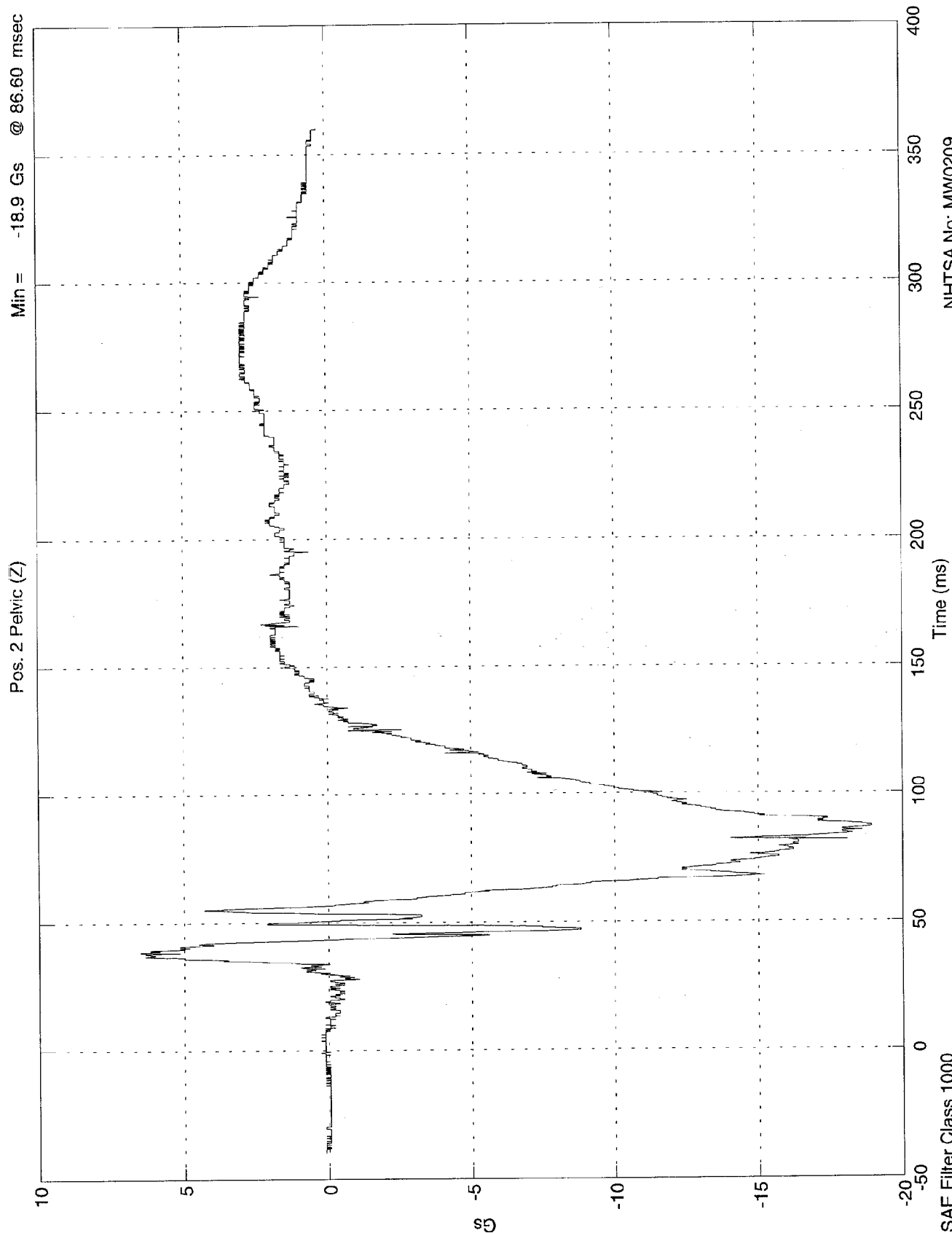

NHTSA No: MW0209
Date: 02 Dec 1997

NCAP TEST #10 - 1998 FORD TAURUS

Max = 49.9 Gs @ 53.00 msec
Min = 0.0606 Gs @ -38.30 msec

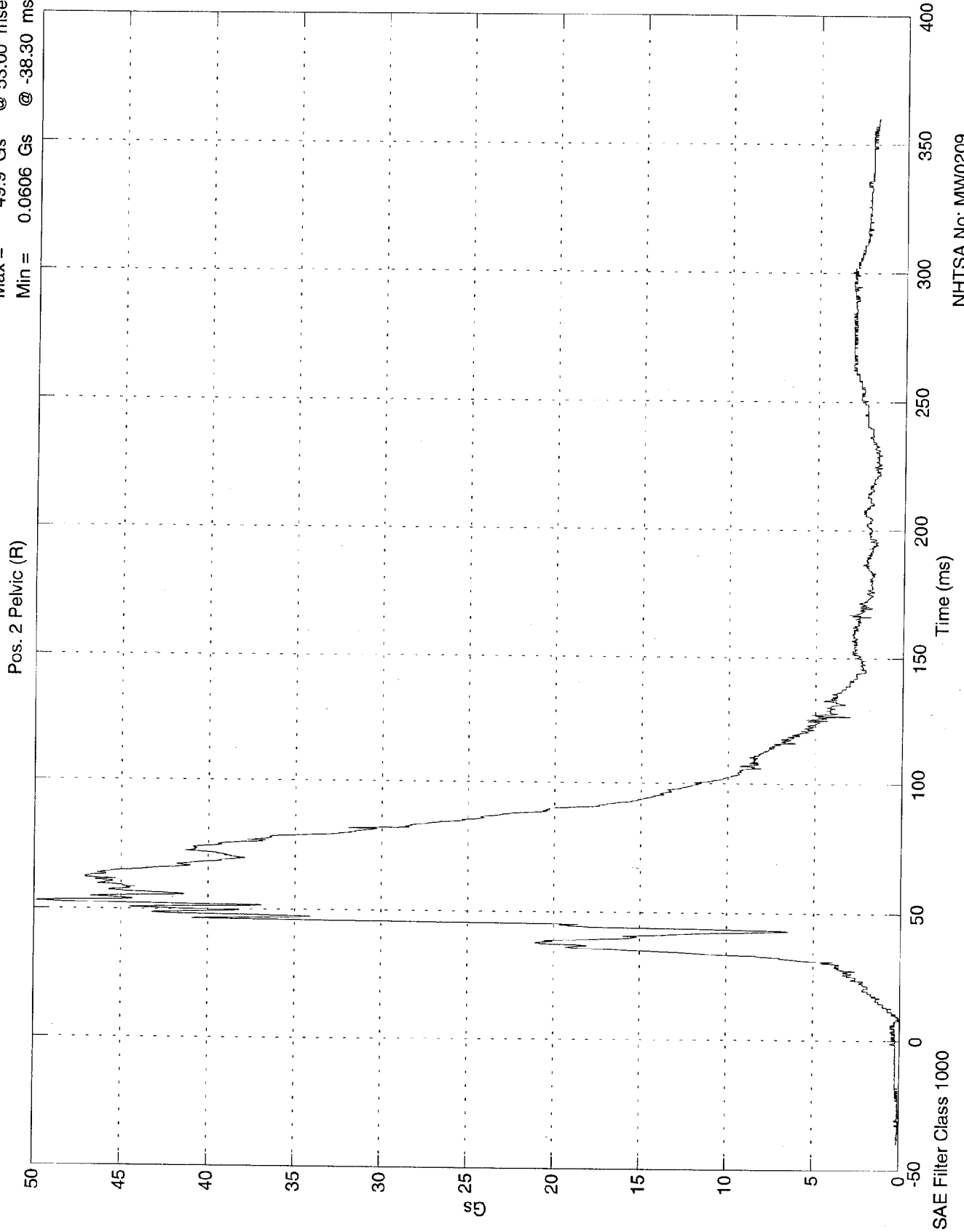

NHTSA No: MW0209
Date: 02 Dec 1997

NCAP TEST #10 - 1998 FORD TAURUS

Max = 578 Nwt @ 91.30 msec
Min = -4.62e+003 Nwt @ 52.90 msec

Pos. 2 Left Femur

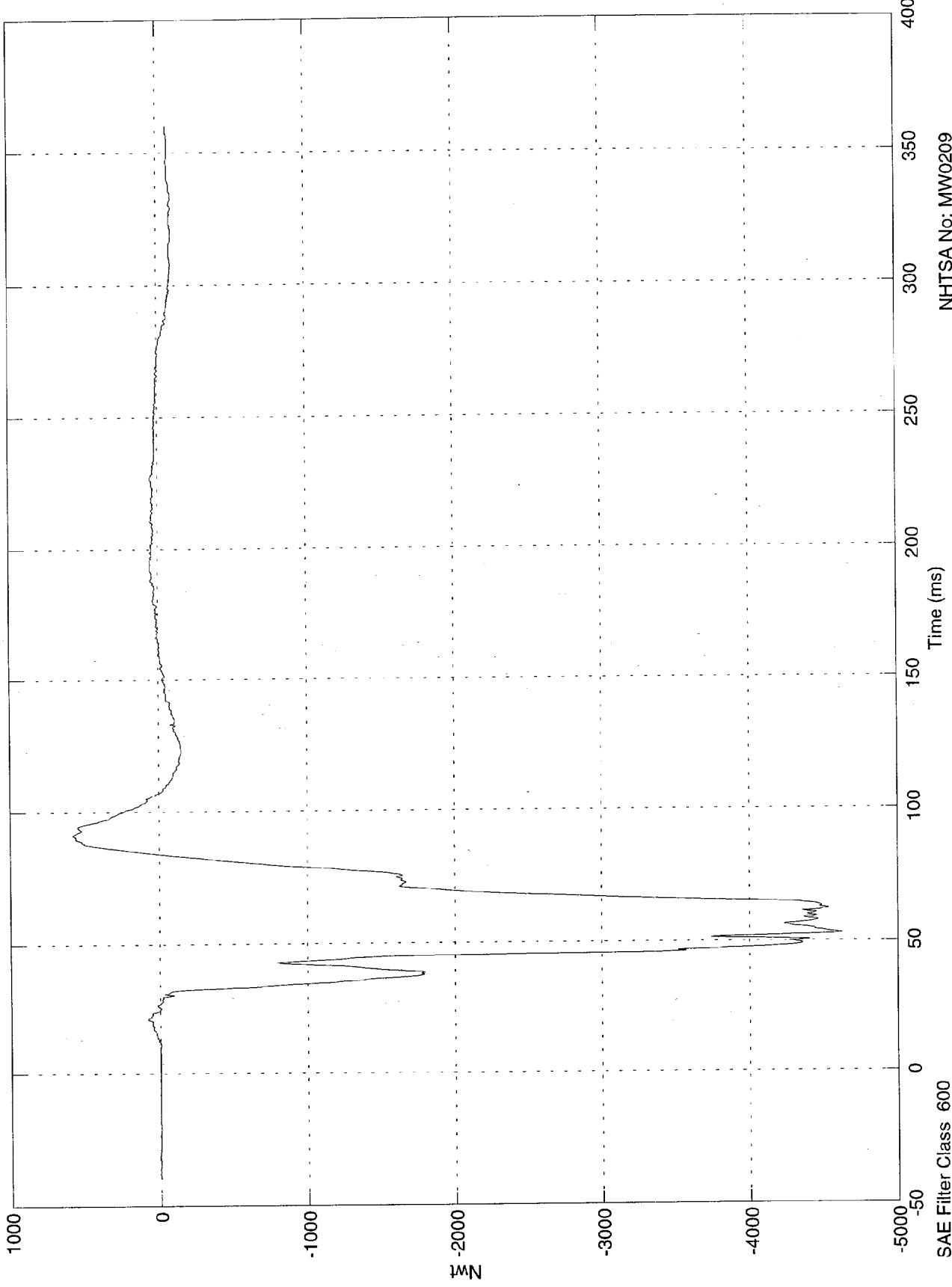

NHTSA No: MW0209
Date: 02 Dec 1997

NCAP TEST #10 - 1998 FORD TAURUS

Max = 191 Nwt @ 43.00 msec
Min = -3.81e+003 Nwt @ 53.20 msec

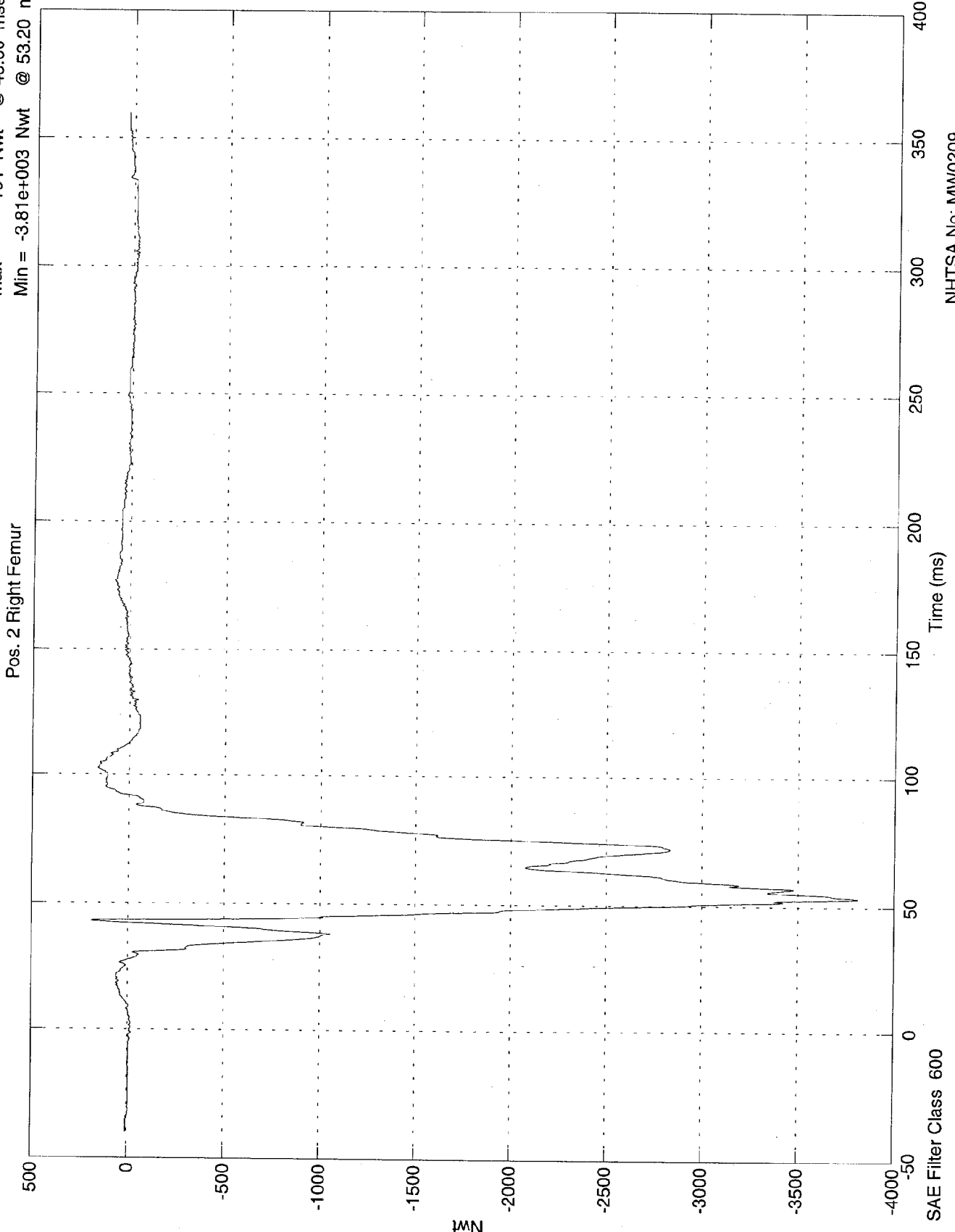

NHTSA No: MW0209
Date: 02 Dec 1997

NCAP TEST #10 - 1998 FORD TAURUS

Max = 8.93 Nwt-M @ 199.50 msec
Min = -60.1 Nwt-M @ 79.20 msec

Pos. 2 Lt Upper Tibia Mx

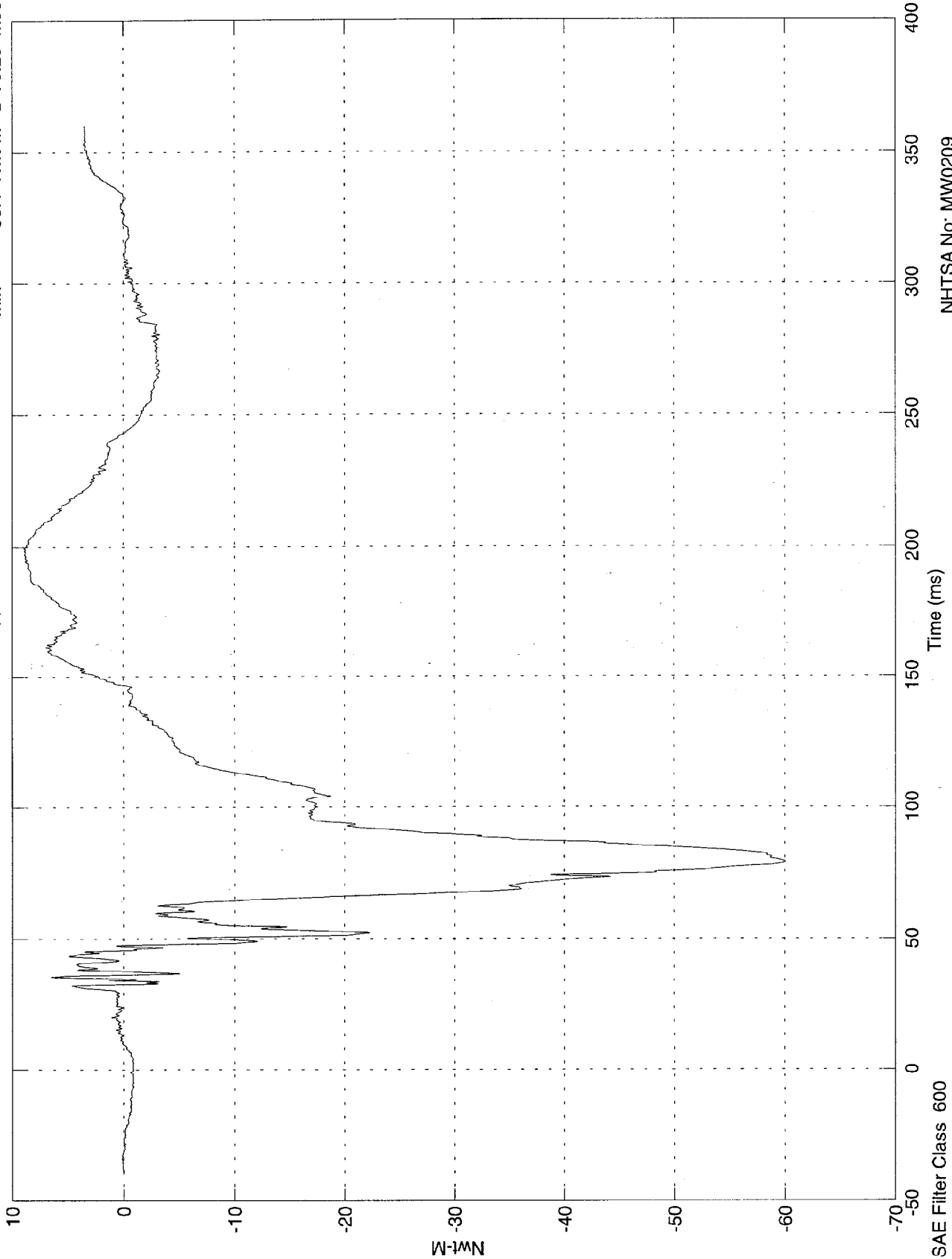

NHTSA No: MW0209
Date: 02 Dec 1997

NCAP TEST #10 - 1998 FORD TAURUS

Max = 6.45 Nwt-M @ 161.30 msec
Min = -164 Nwt-M @ 40.30 msec

Pos. 2 Lt Upper Tibia My

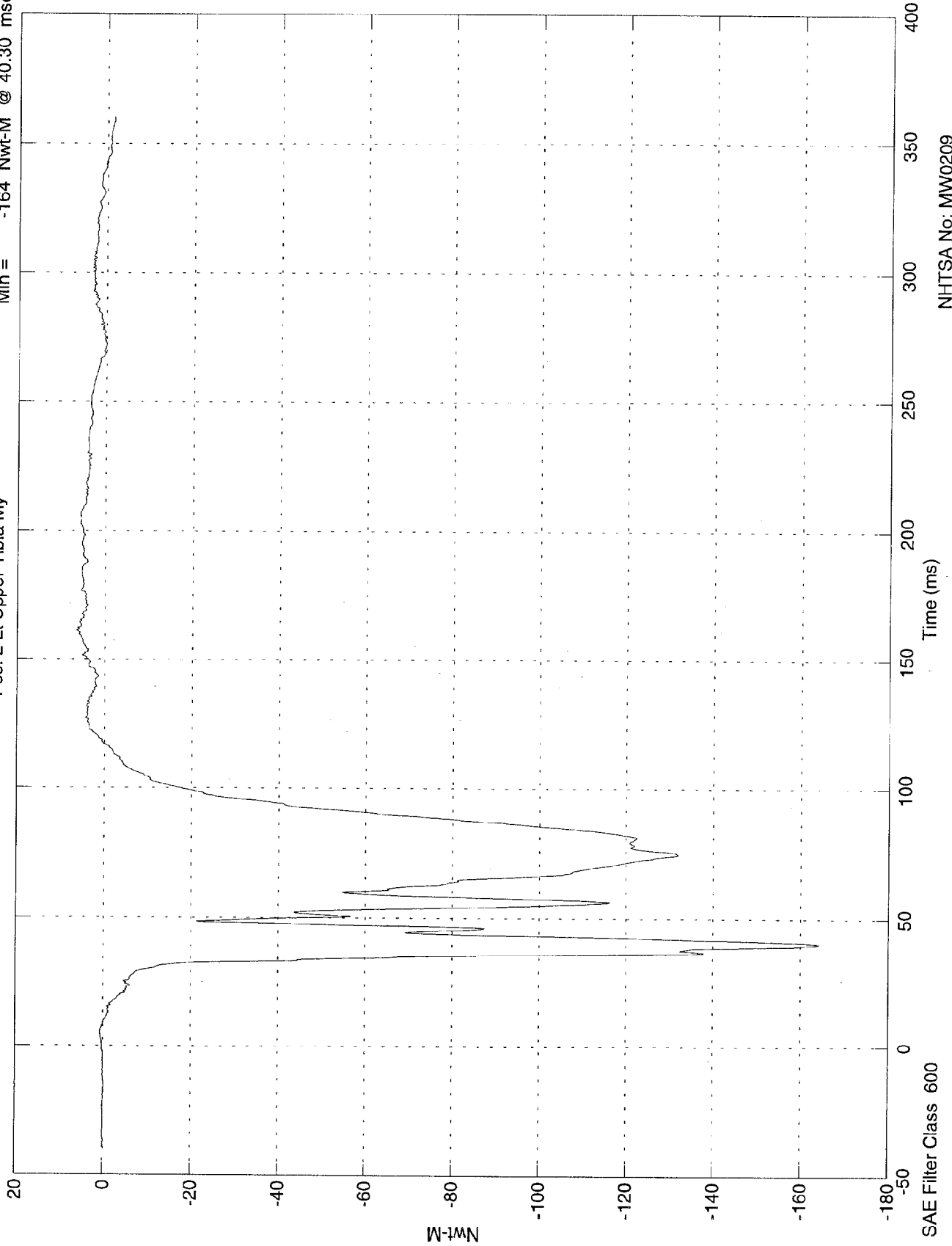

NHTSA No: MW0209
Date: 02 Dec 1997

W-MN

NCAP TEST #10 - 1998 FORD TAURUS

Max = 62 Nwt @ 162.70 msec
Min = -1.25e+003 Nwt @ 40.10 msec

Pos. 2 Lt Lower Tibia Fx

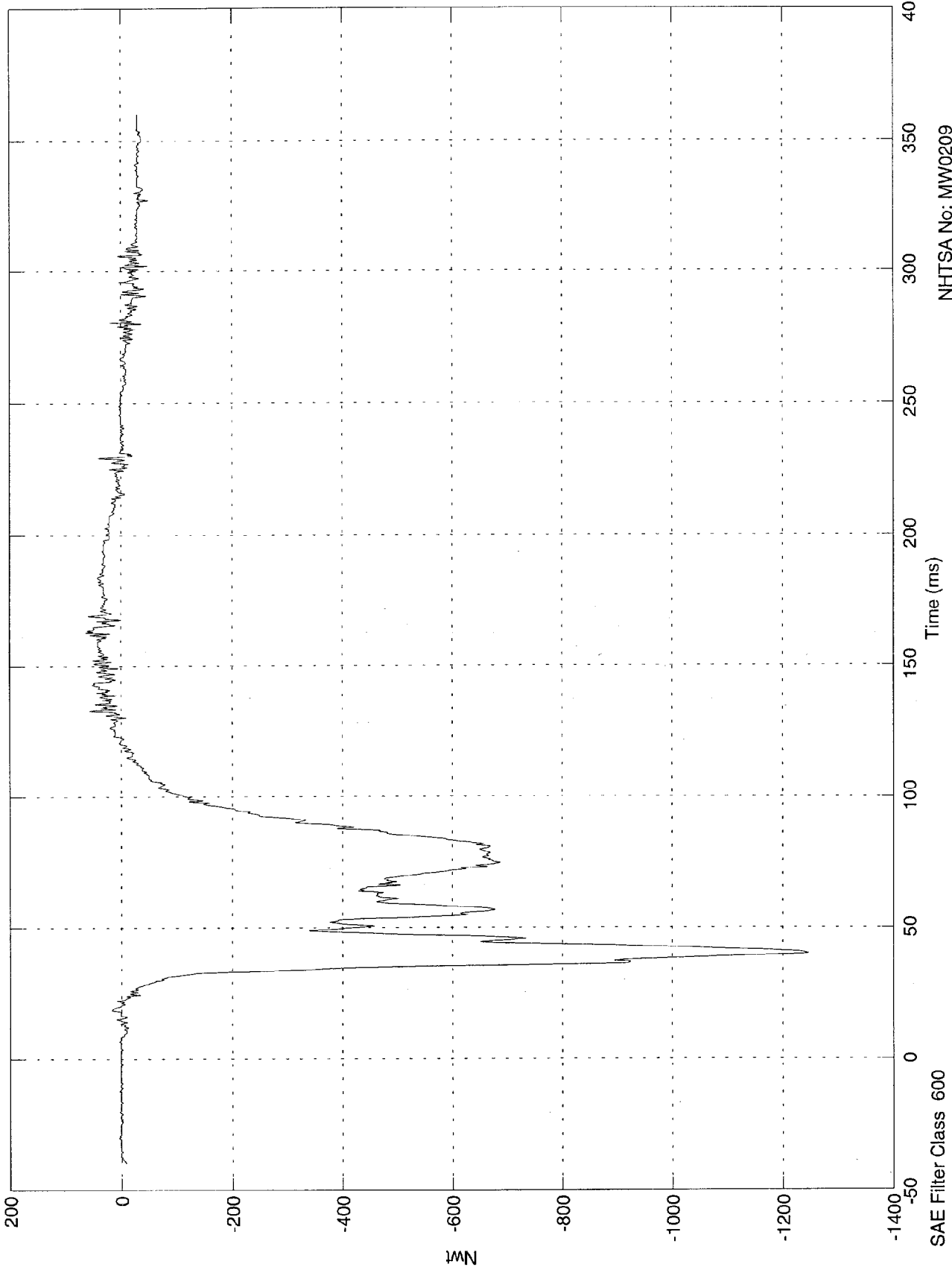

NHTSA No: MW0209
Date: 02 Dec 1997

NCAP TEST #10 - 1998 FORD TAURUS

Max = 190 Nwt @ 280.50 msec
Min = -5.75e+003 Nwt @ 40.10 msec

Pos. 2 Lt Lower Tibia Fz

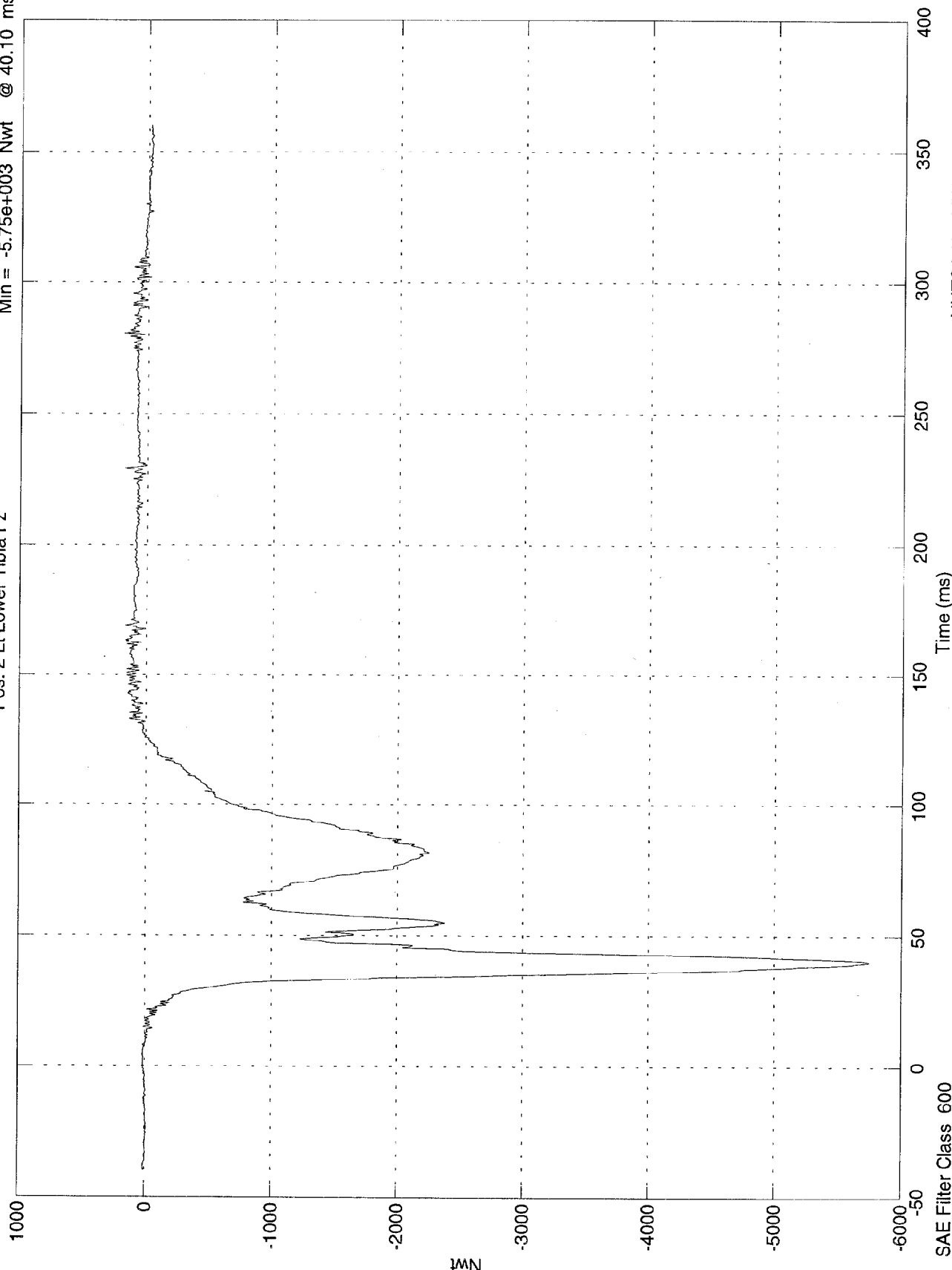

NHTSA No: MW0209
Date: 02 Dec 1997

NCAP TEST #10 - 1998 FORD TAURUS

Max = 21.6 Nwt-M @ 38.00 msec
Min = -24.2 Nwt-M @ 57.10 msec

Pos. 2 Lt Lower Tibia My

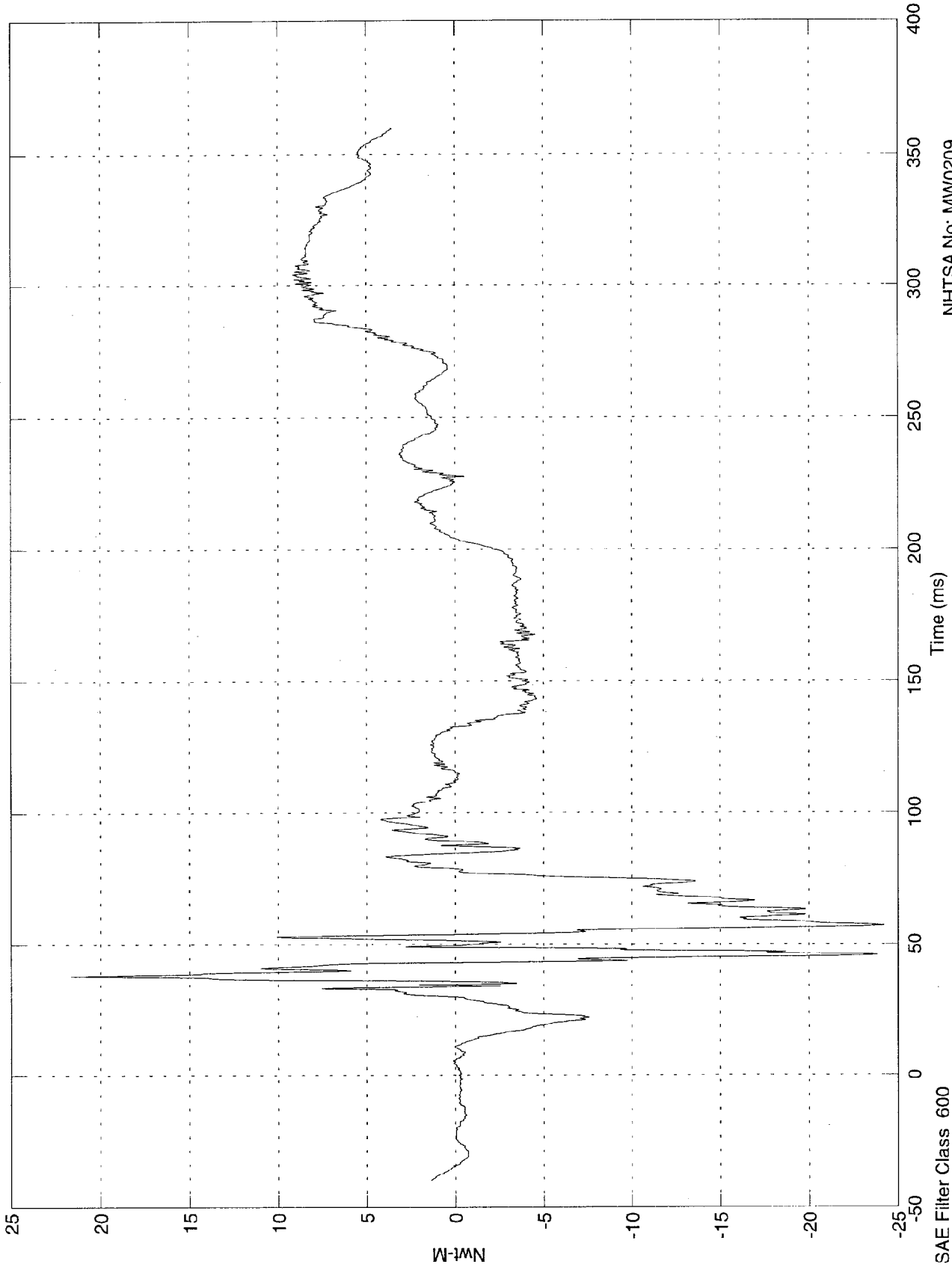

NHTSA No: MW0209
Date: 02 Dec 1997

SAE Filter Class 600

NCAP TEST #10 - 1998 FORD TAURUS

Max = 38.4 Nwt-M @ 81.20 msec
Min = -15.9 Nwt-M @ 72.60 msec

Pos. 2 Rt Upper Tibia Mx

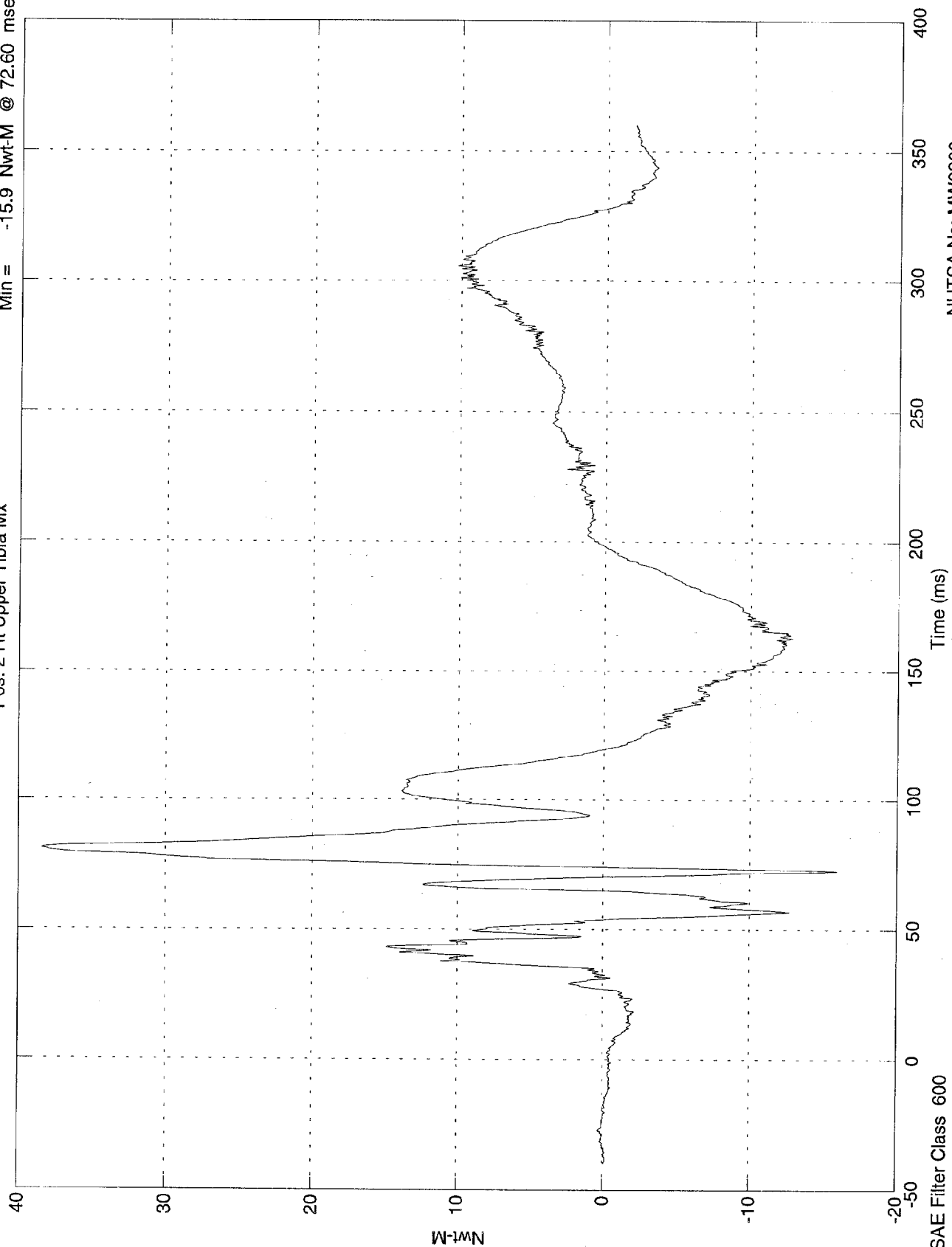

NHTSA No: MW0209
Date: 02 Dec 1997

NCAP TEST #10 - 1998 FORD TAURUS

Max = 18 Nwt-M @ 73.50 msec
Min = -119 Nwt-M @ 39.60 msec

Pos. 2 Rt Upper Tibia My

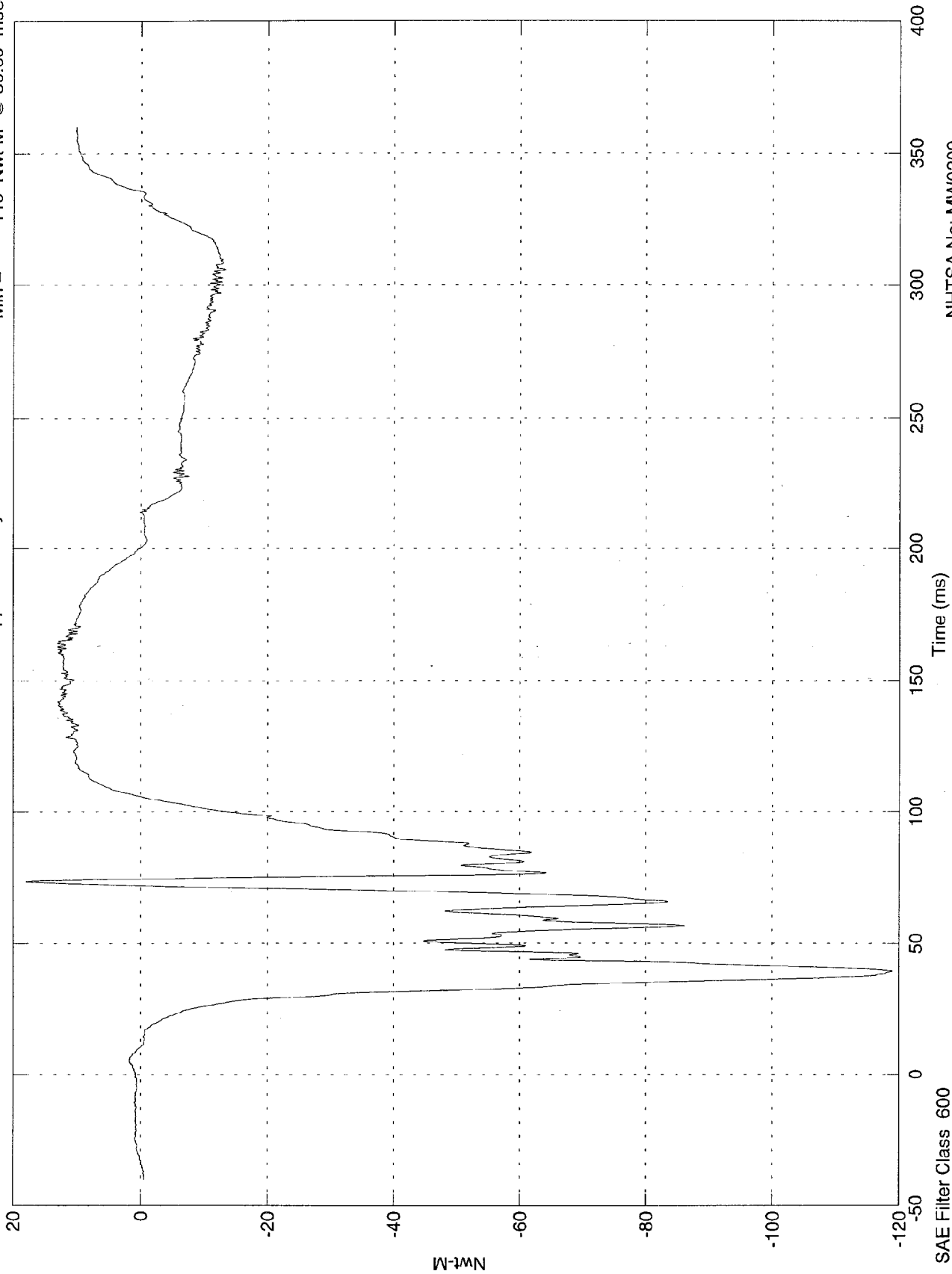

NHTSA No: MW0209
Date: 02 Dec 1997

Nwt-M

SAE Filter Class 600

NCAP TEST #10 - 1998 FORD TAURUS

Max = 492 Nwt @ 85.80 msec
Min = -1.02e+003 Nwt @ 56.80 msec

Pos. 2 Rt Lower Tibia Fx

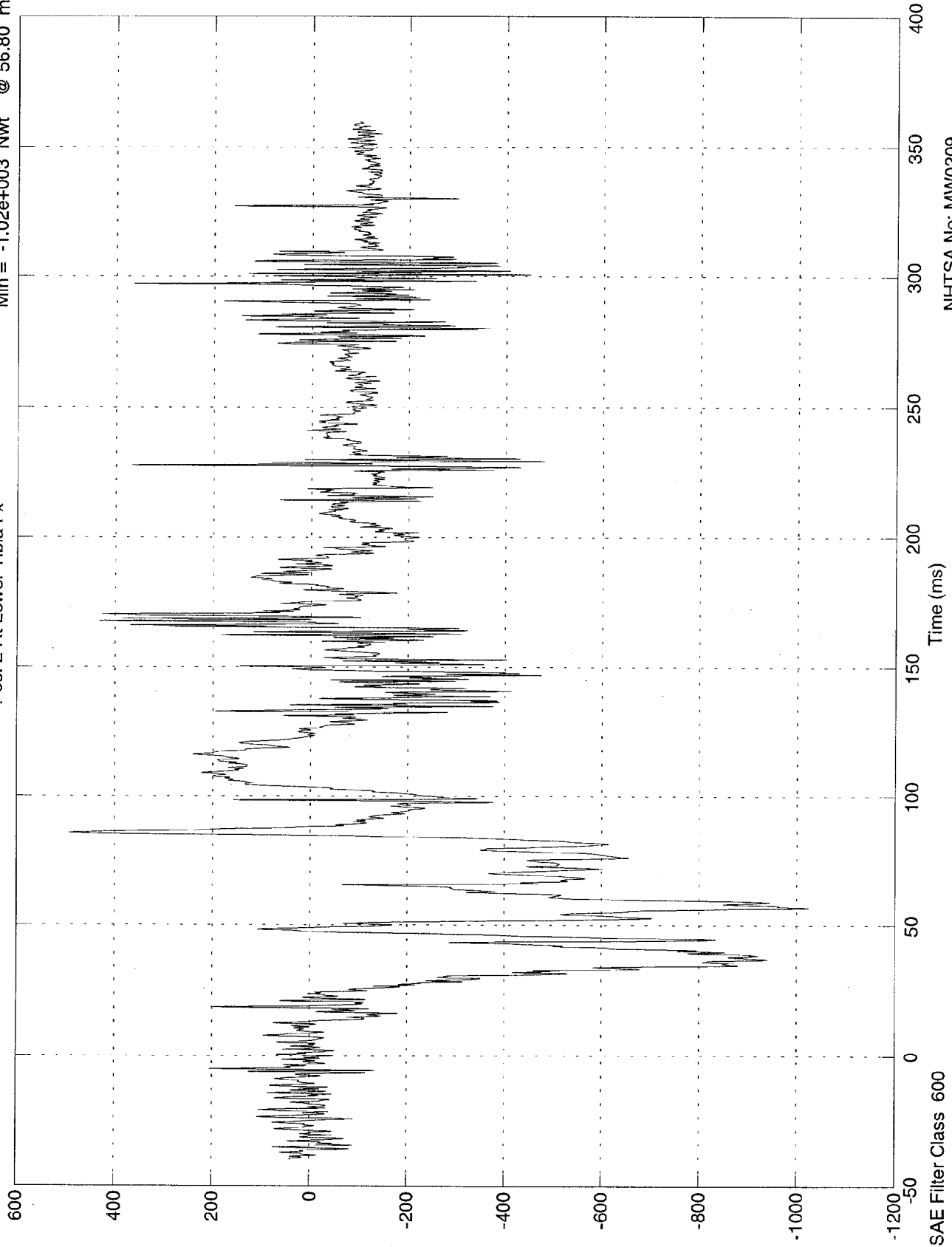

NHTSA No: MW0209
Date: 02 Dec 1997

NCAP TEST #10 - 1998 FORD TAURUS

Max = 225 Nwt @ 150.40 msec
Min = -4.41e+003 Nwt @ 38.20 msec

Pos. 2 Rt Lower Tibia Fz

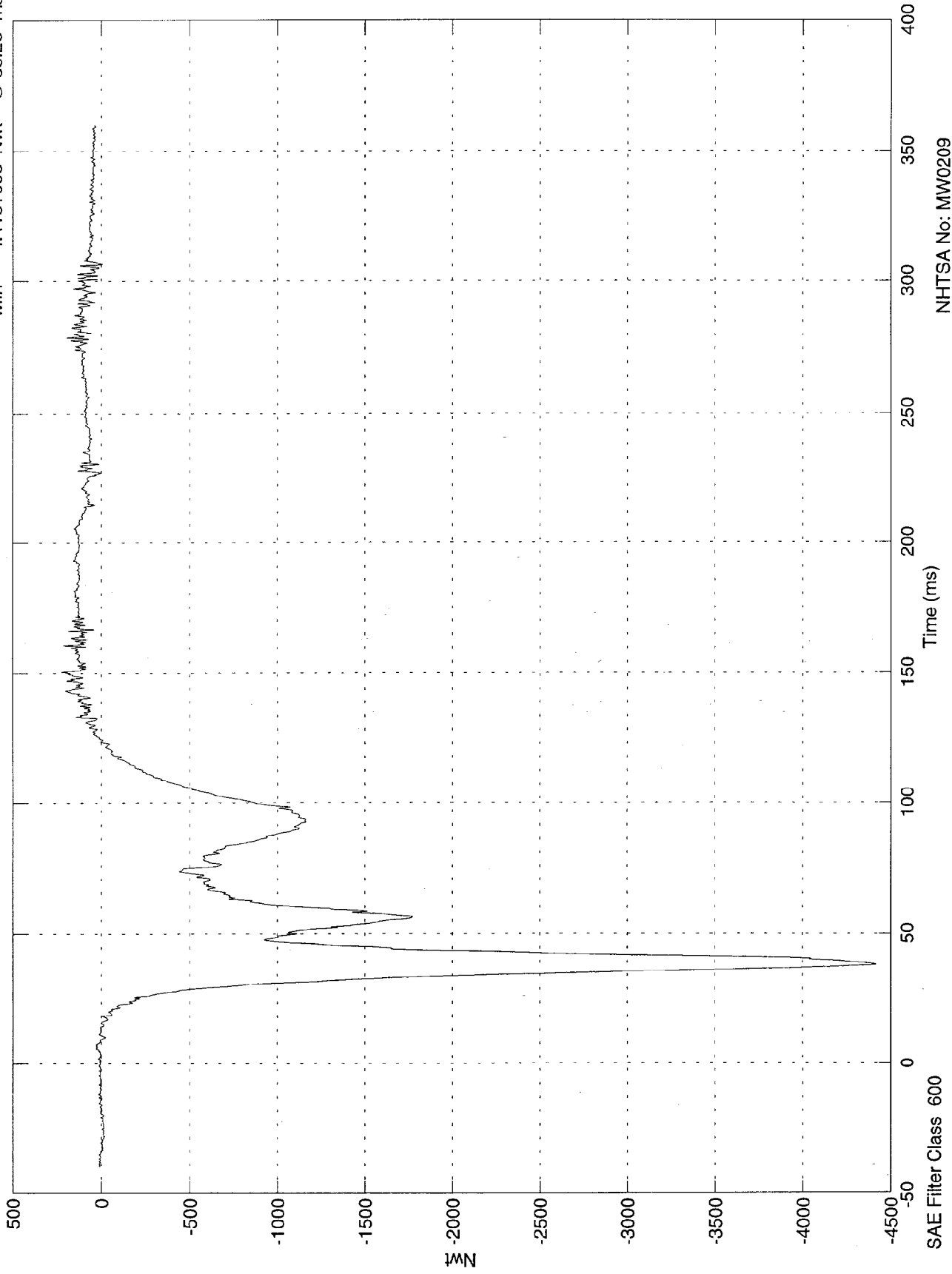

NHTSA No: MW0209
Date: 02 Dec 1997

SAE Filter Class 600

NCAP TEST #10 - 1998 FORD TAURUS

Max = 20.6 Nwt-M @ 74.20 msec
Min = -24.2 Nwt-M @ 57.10 msec

Pos. 2 Rt Lower Tibia My

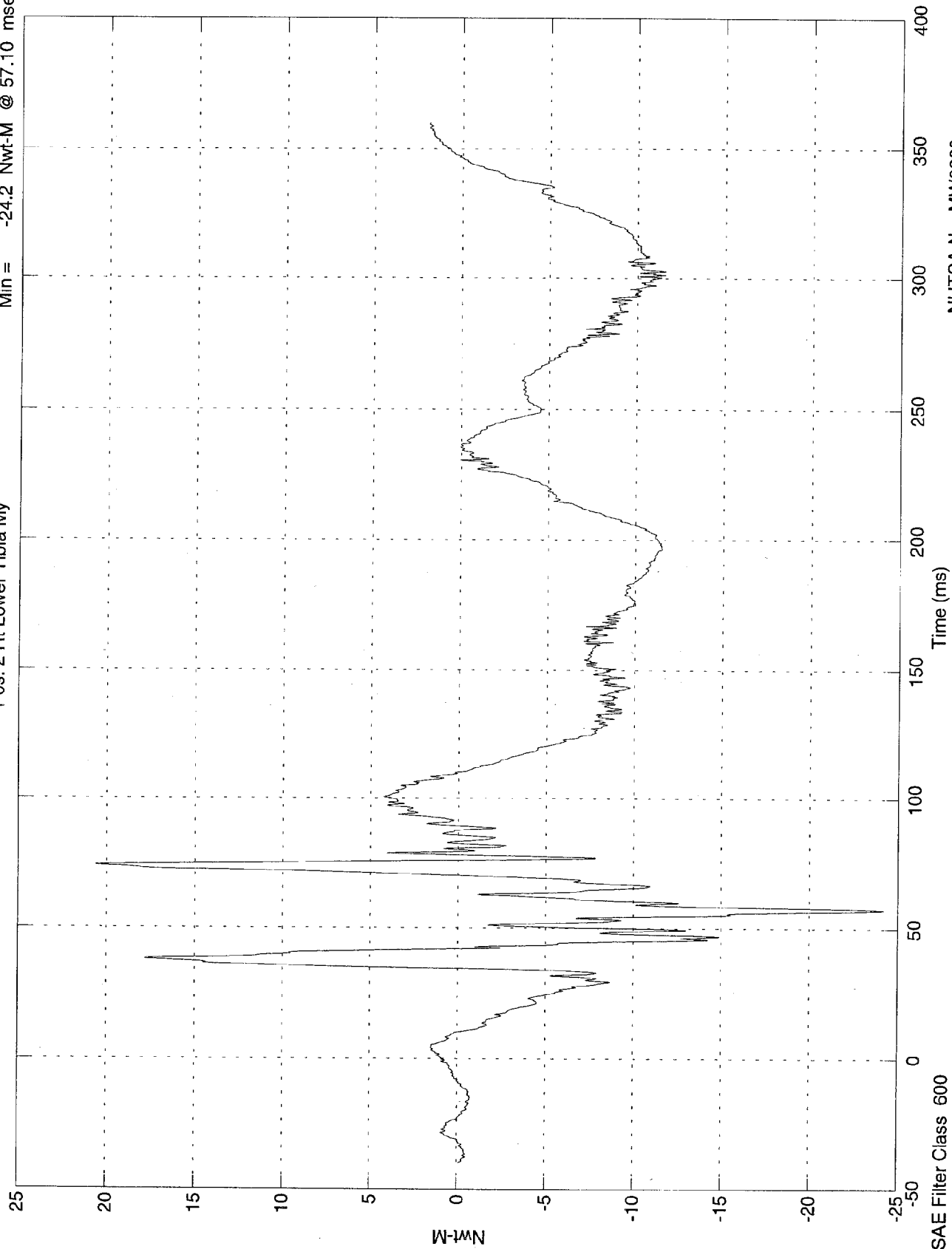

NHTSA No: MW0209
Date: 02 Dec 1997

NCAP TEST #10 - 1998 FORD TAURUS

Max = 10.6 Gs @ 84.30 msec
Min = -111 Gs @ 40.50 msec

Pos. 2 Left Ankle X

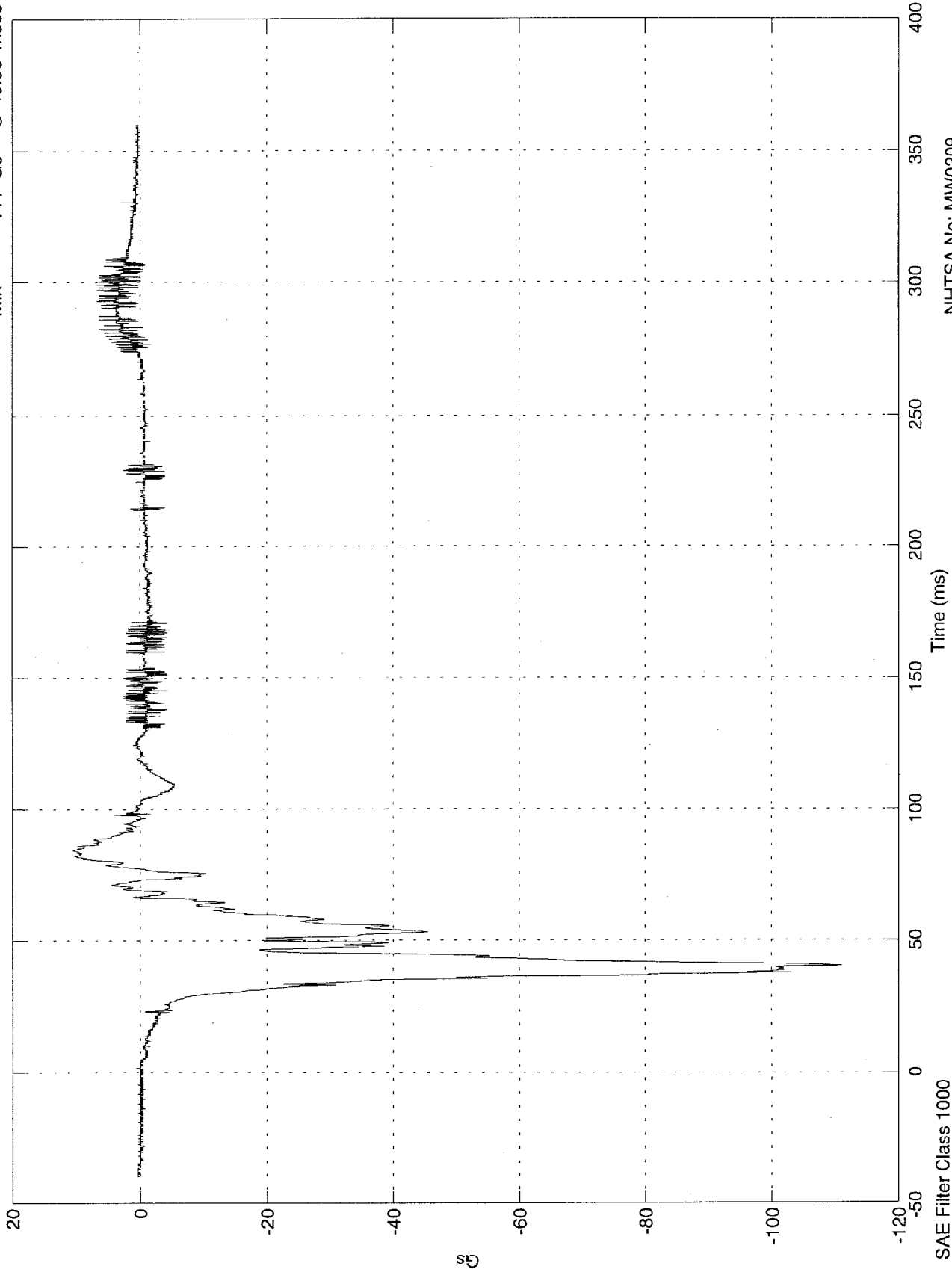

NHTSA No: MW0209
Date: 02 Dec 1997

NCAP TEST #10 - 1998 FORD TAURUS

Max = 20.8 Gs @ 46.50 msec
Min = -75.7 Gs @ 39.70 msec

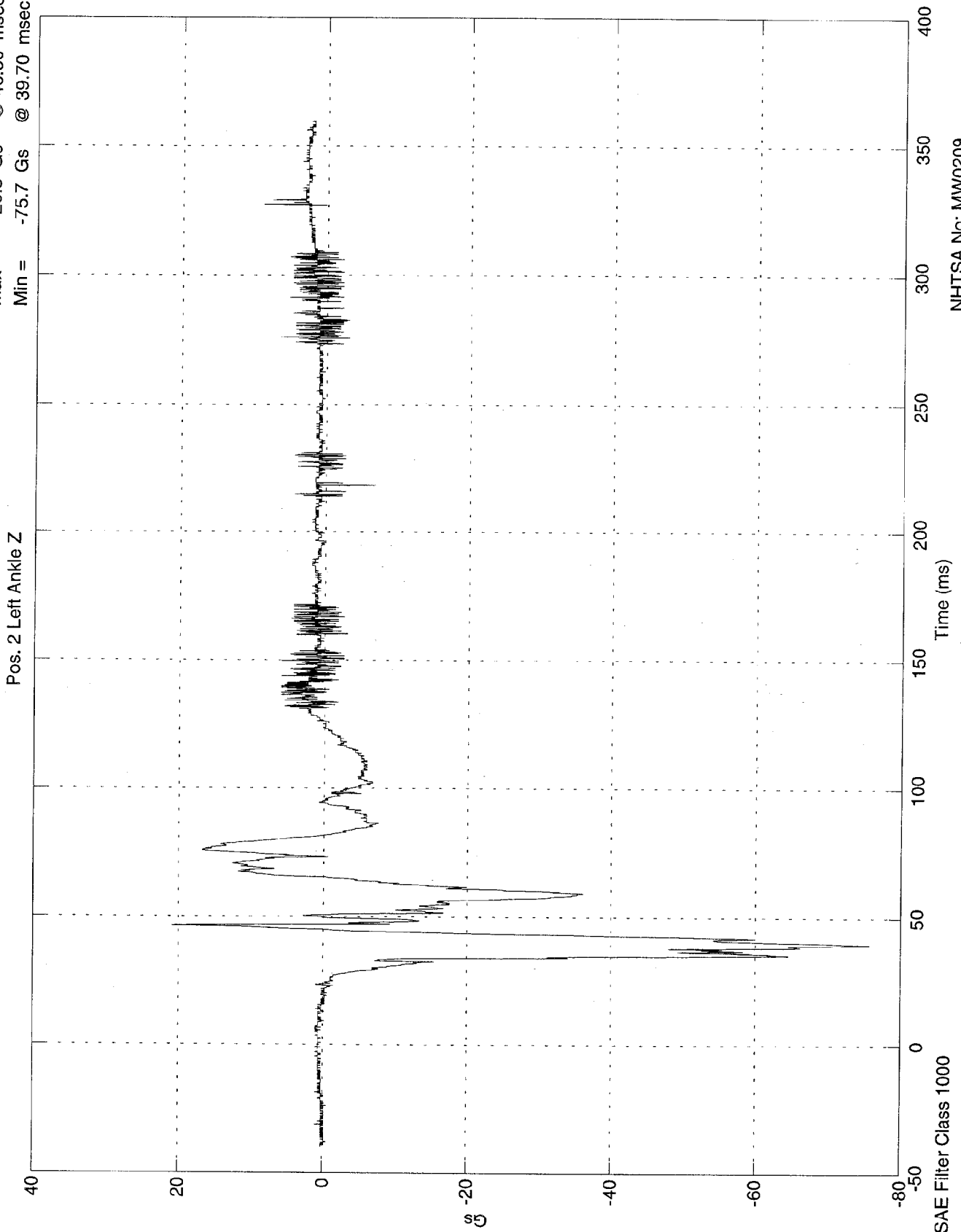

NHTSA No: MW0209
Date: 02 Dec 1997

NCAP TEST #10 - 1998 FORD TAURUS

Max = 29.5 Gs @ 76.10 msec
Min = -125 Gs @ 35.30 msec

Pos. 2 Left Toe Z

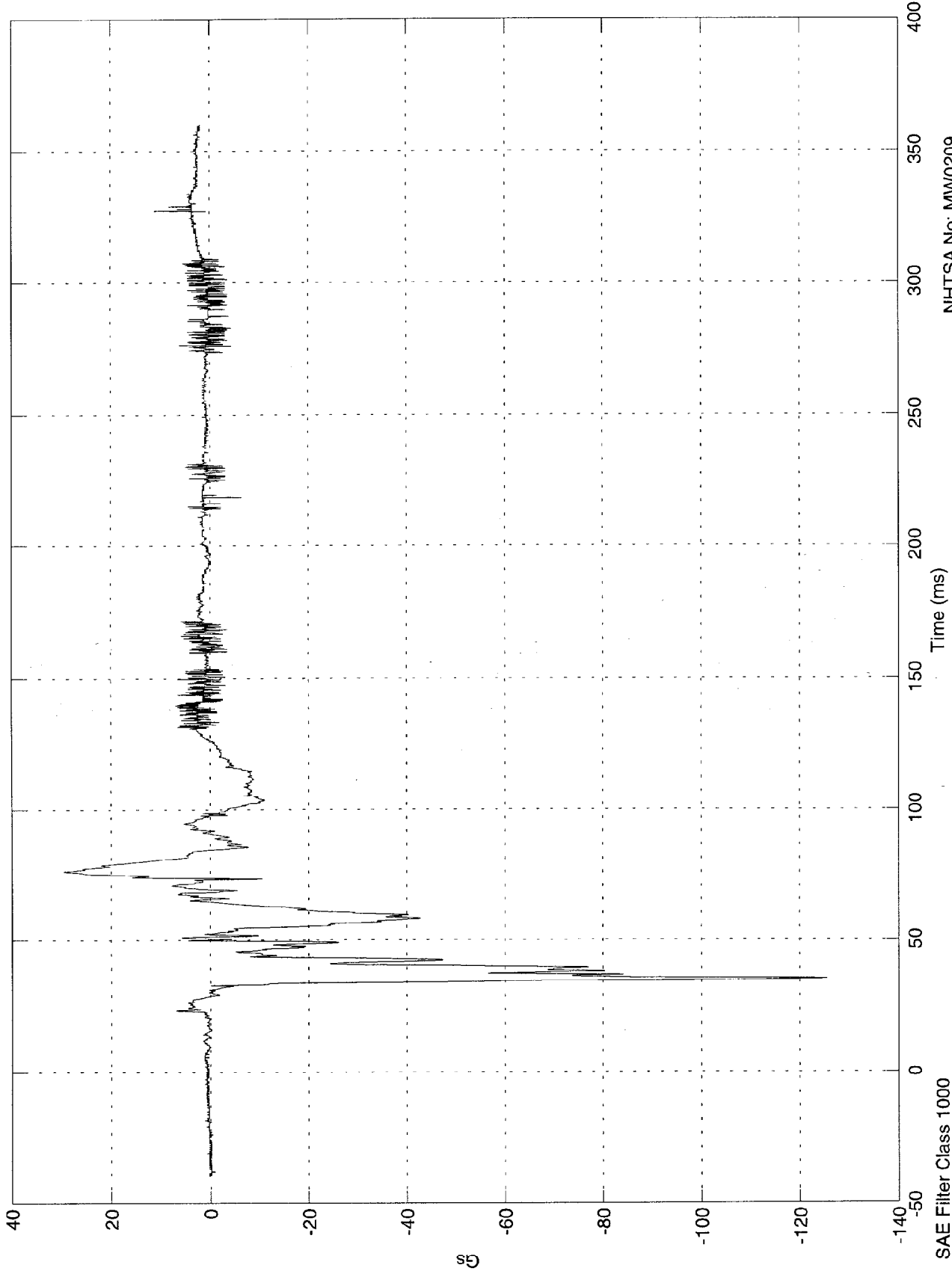

NHTSA No: MW0209
Date: 02 Dec 1997

NCAP TEST #10 - 1998 FORD TAURUS

Max = 6.11 Gs @ 76.90 msec
Min = -45.9 Gs @ 53.90 msec

Pos. 2 Right Ankle X

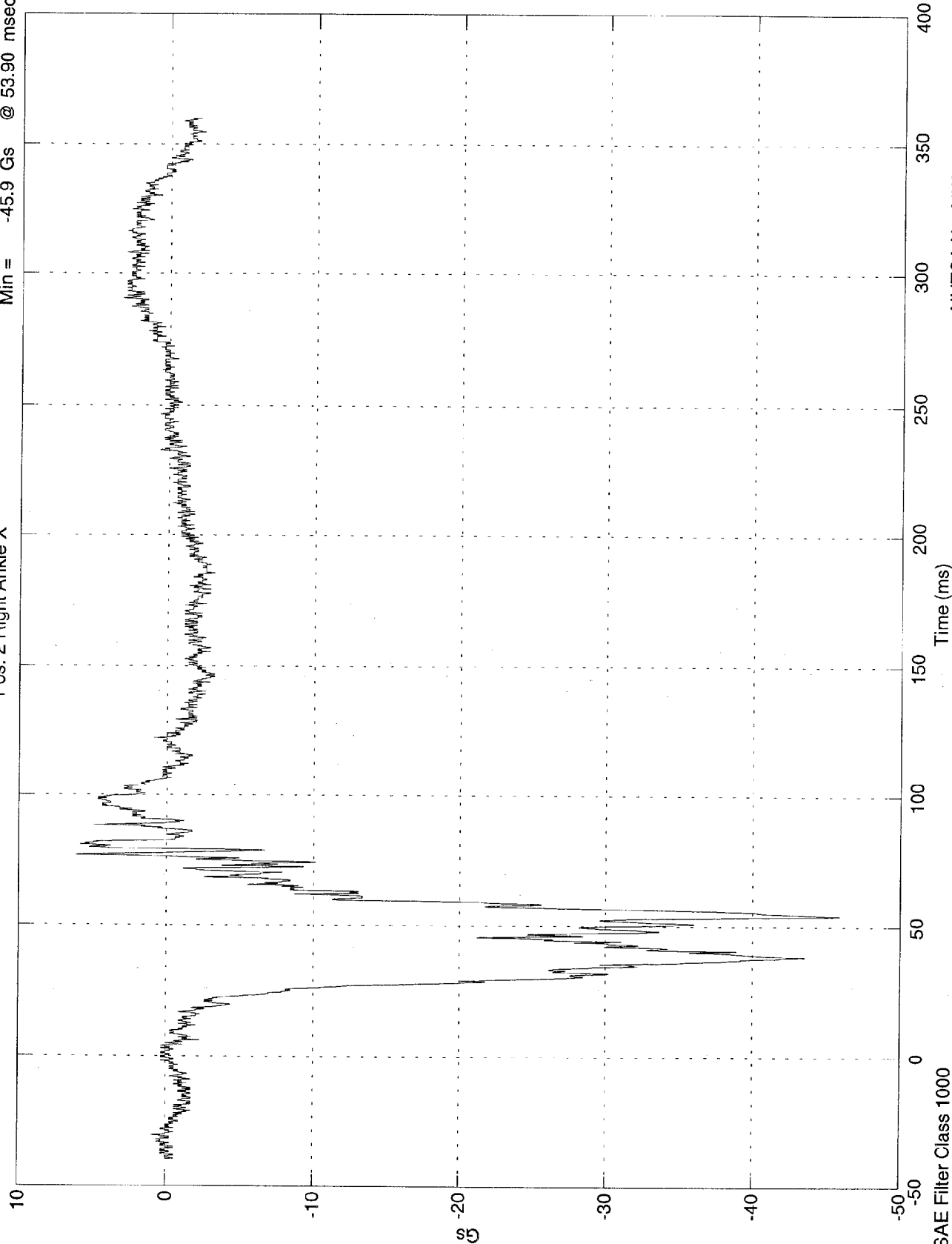

NHTSA No: MW0209
Date: 03 Dec 1997

NCAP TEST #10 - 1998 FORD TAURUS

Max = 21.1 Gs @ 76.80 msec
Min = -86.9 Gs @ 39.30 msec

Pos. 2 Right Ankle Z

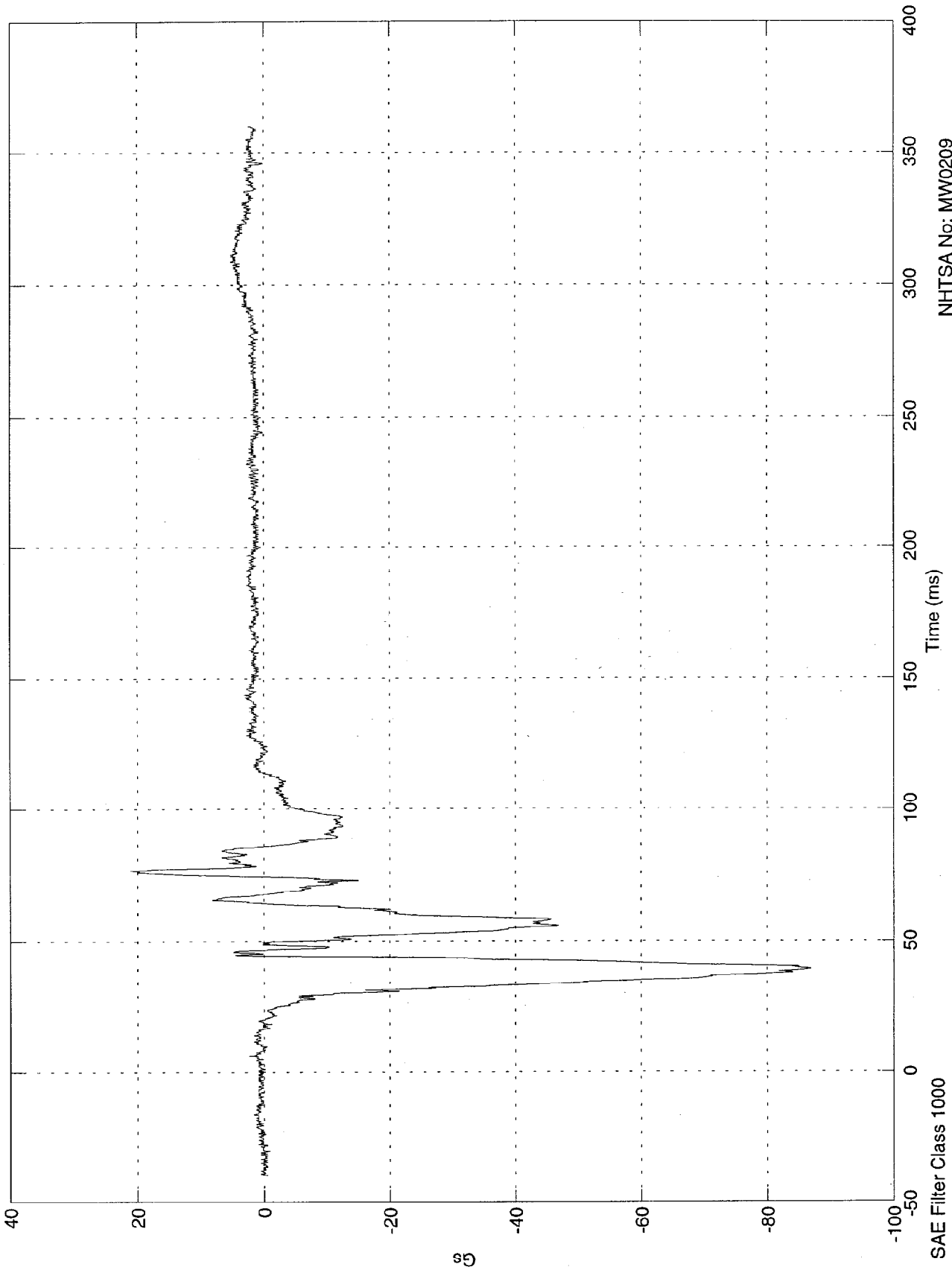

NHTSA No: MW0209
Date: 03 Dec 1997

NCAP TEST #10 - 1998 FORD TAURUS

Max = 19.8 Gs @ 83.60 msec
Min = -101 Gs @ 40.60 msec

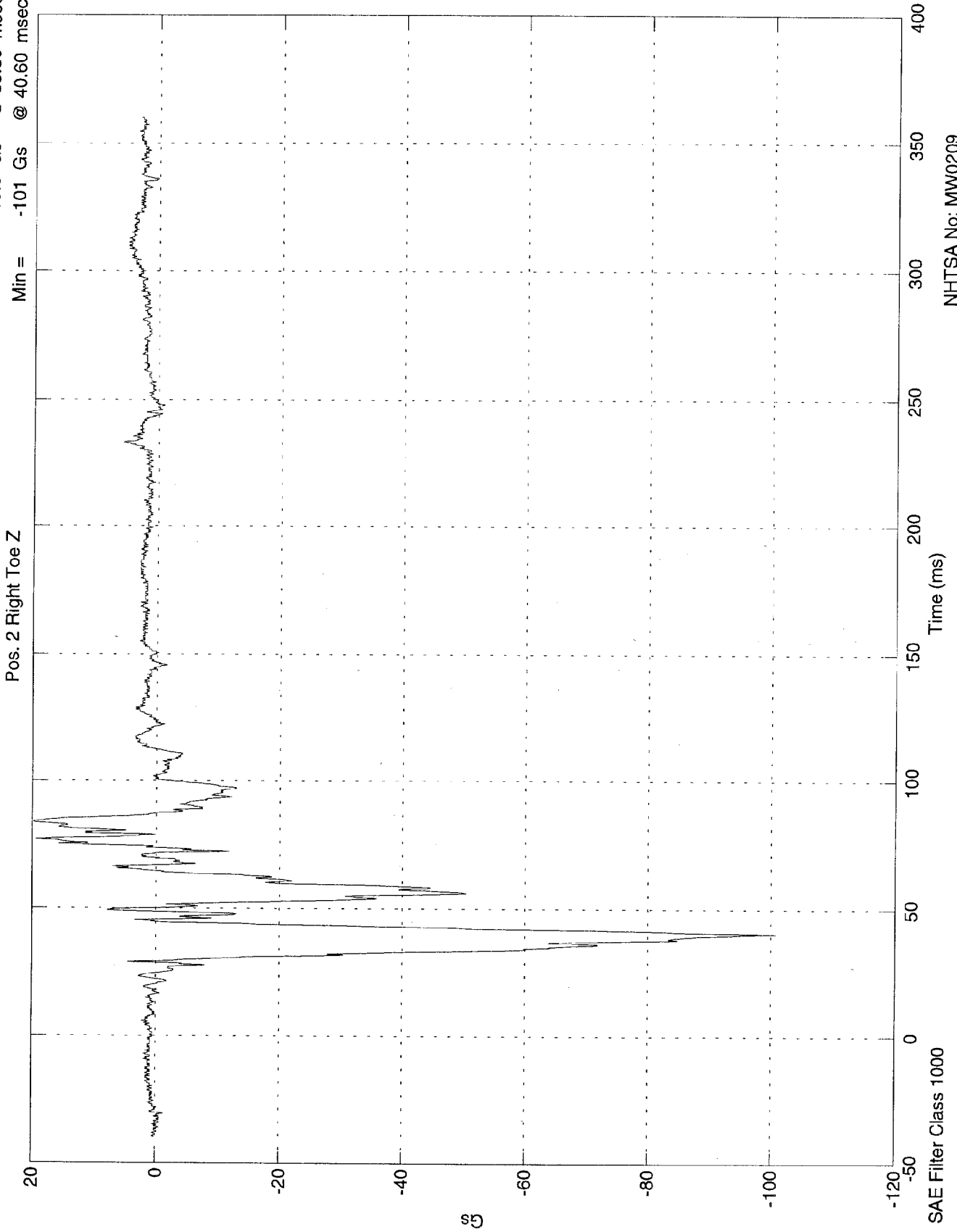

NHTSA No: MW0209
Date: 03 Dec 1997

NCAP TEST #10 - 1998 FORD TAURUS

Max = 4.69e+003 Nwt @ 59.30 msec
Min = -83 Nwt @ 348.00 msec

Pos. 2 Right Belt Load

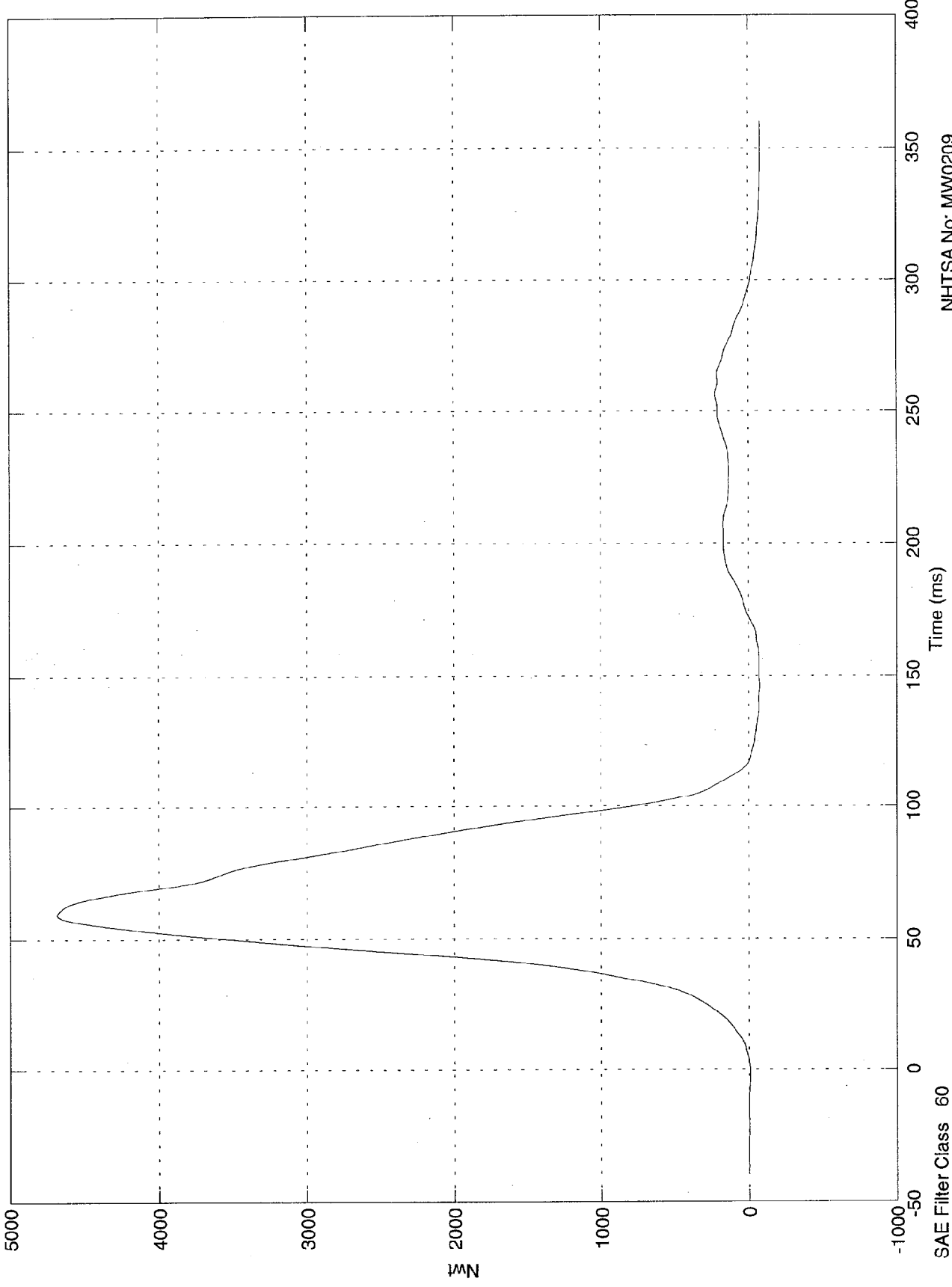

NHTSA No: MW0209
Date: 02 Dec 1997

NCAP TEST #10 - 1998 FORD TAURUS

Max = 6.61e+003 Nwt @ 68.00 msec
Min = -49.6 Nwt @ 334.40 msec

Pos. 2 Torso Belt Load

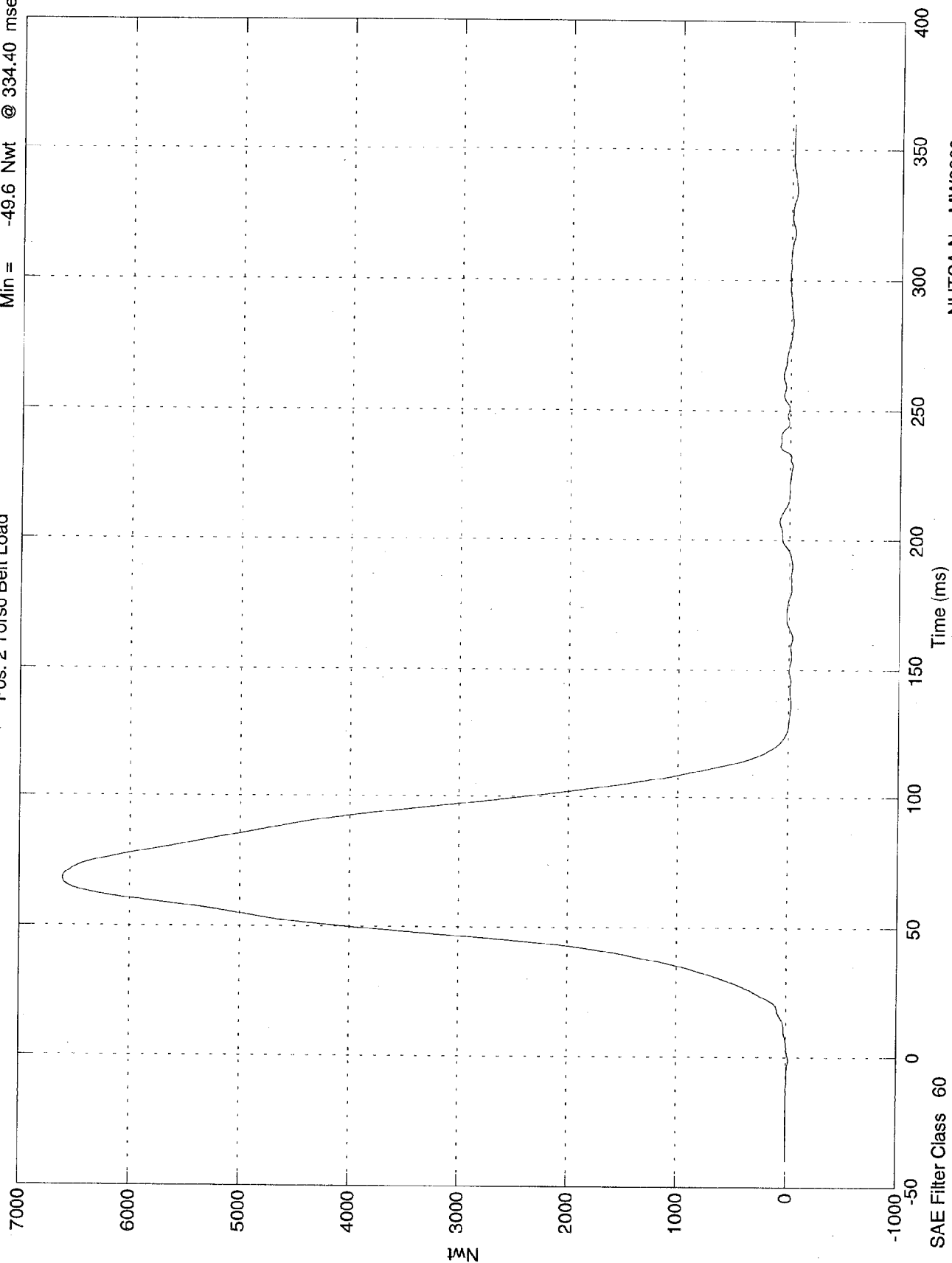

NHTSA No: MW0209
Date: 02 Dec 1997

NCAP TEST #10 - 1998 FORD TAURUS

Max = 0.968 mm/M @ -32.30 msec
Min = -966 mm/M @ 356.10 msec

Pos. 2 Belt Elongation

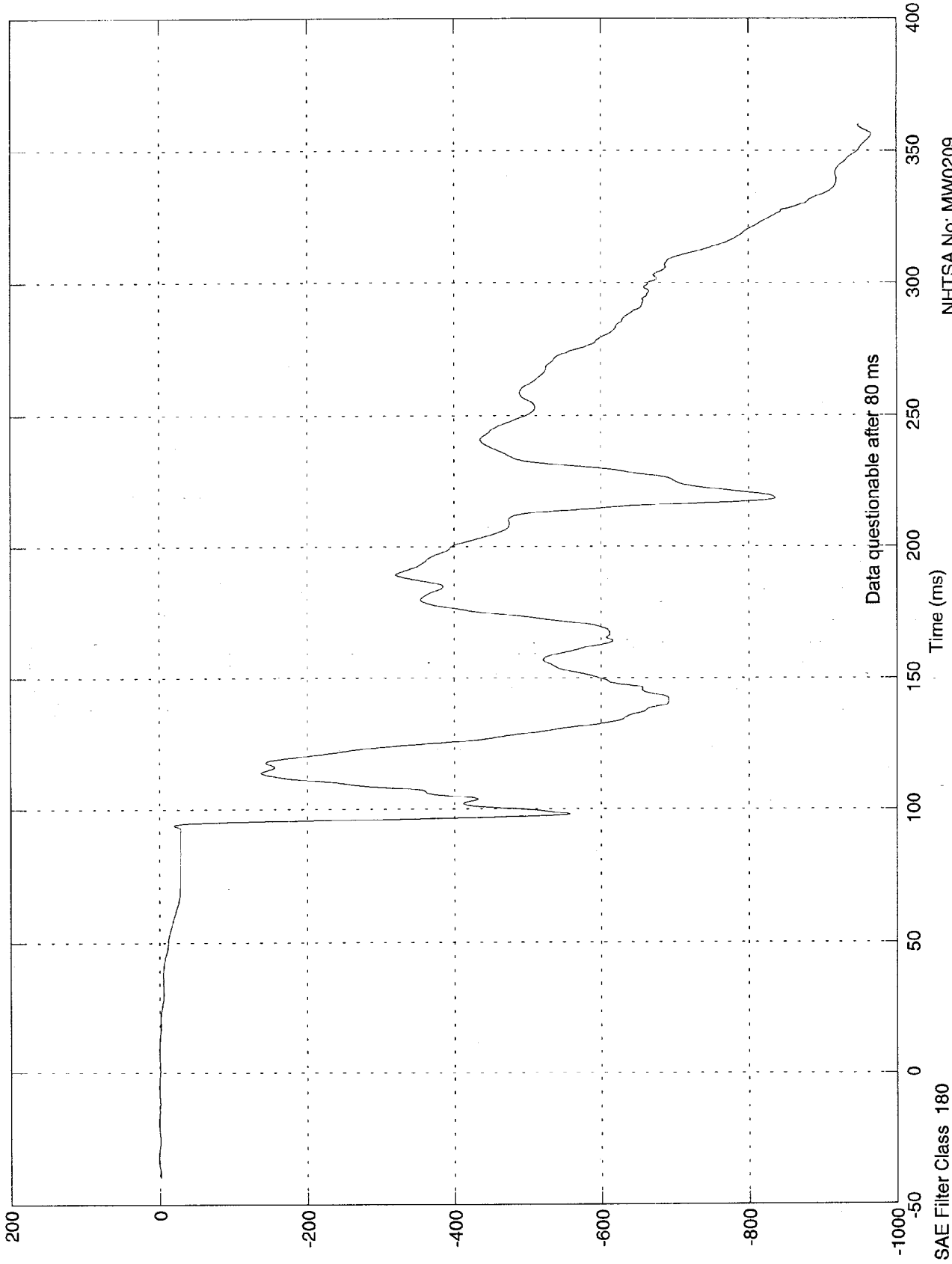

NHTSA No: MW0209
Date: 02 Dec 1997

SAE Filter Class 180

NHTSA TEST NO. MW0209

VEHICLE DATA

FILTER CHANNEL CLASS

Acceleration

60

Velocity

180

Displacement

180

NCAP TEST #10 - 1998 FORD TAURUS

Max = 1.89 Gs @ 137.20 msec
Min = -32.9 Gs @ 35.30 msec

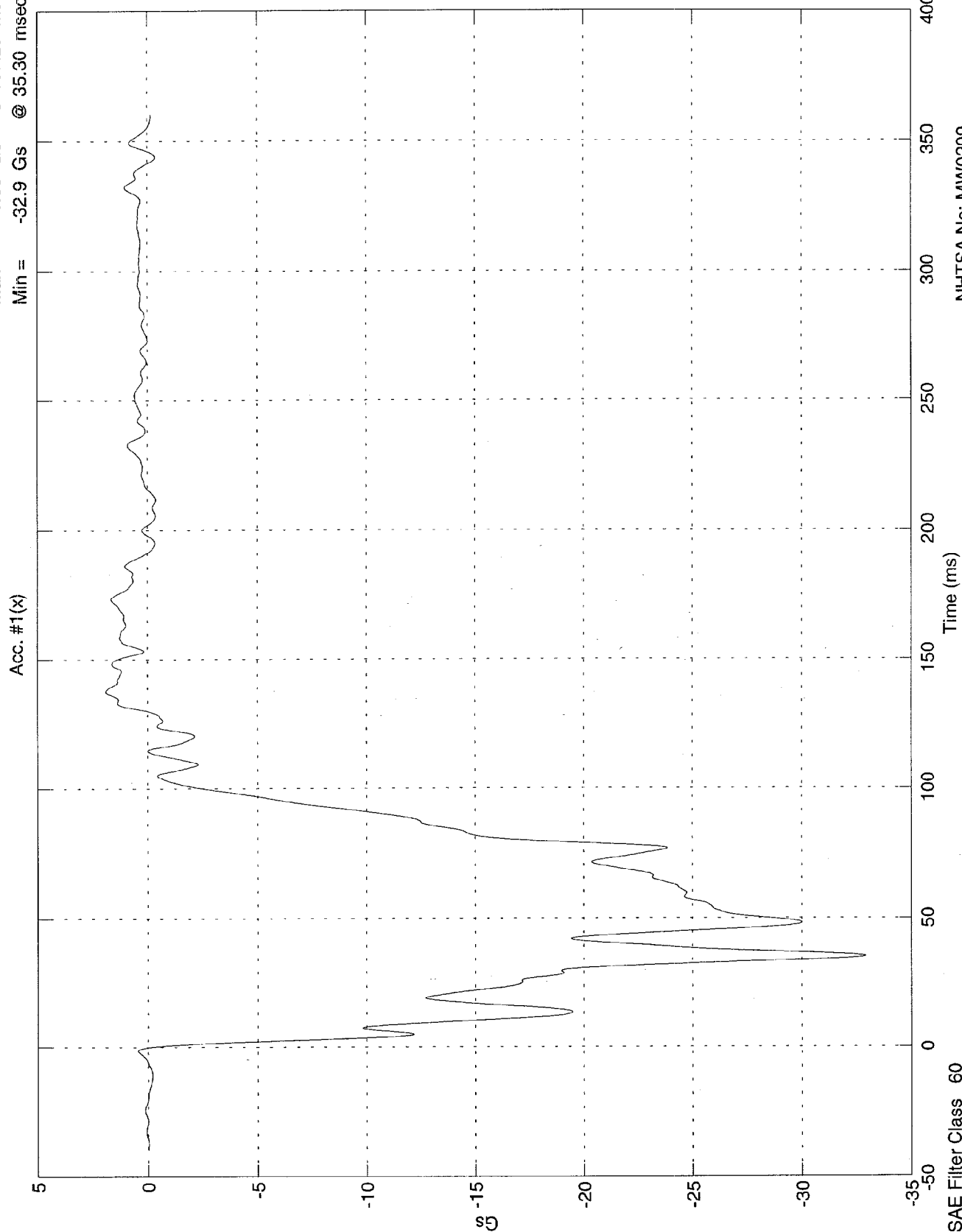

NHTSA No: MW0209
Date: 02 Dec 1997

SAE Filter Class 60

NCAP TEST #10 - 1998 FORD TAURUS

Max = 56.5 kph @ -22.30 msec
Min = -9.9 kph @ 130.60 msec

1st Integral Acc. #1(x)

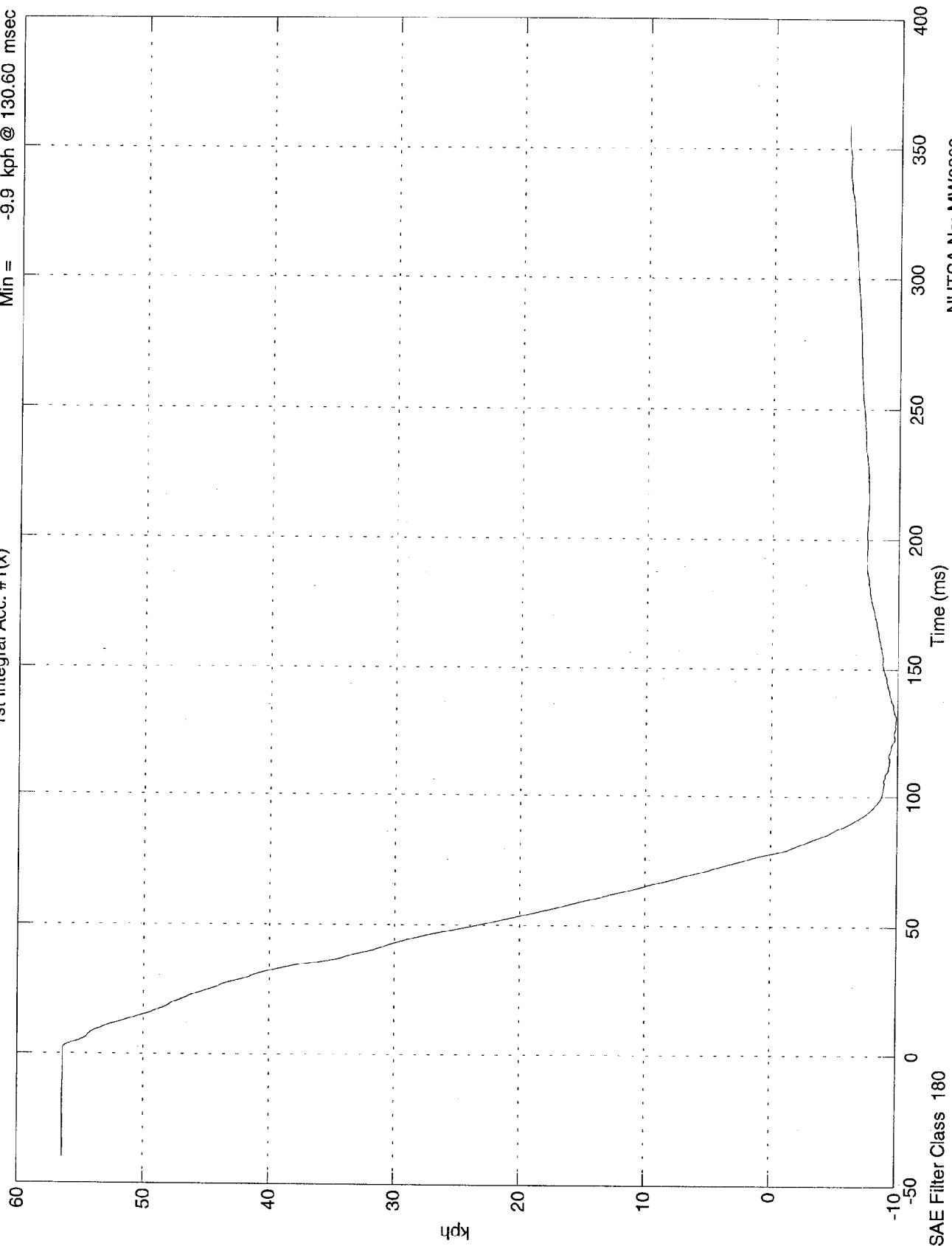

NHTSA No: MW0209
Date: 02 Dec 1997

NCAP TEST #10 - 1998 FORD TAURUS

Max = 686 mm @ 77.80 msec
Min = -625 mm @ -39.90 msec

2nd Integral Acc. #1(x)

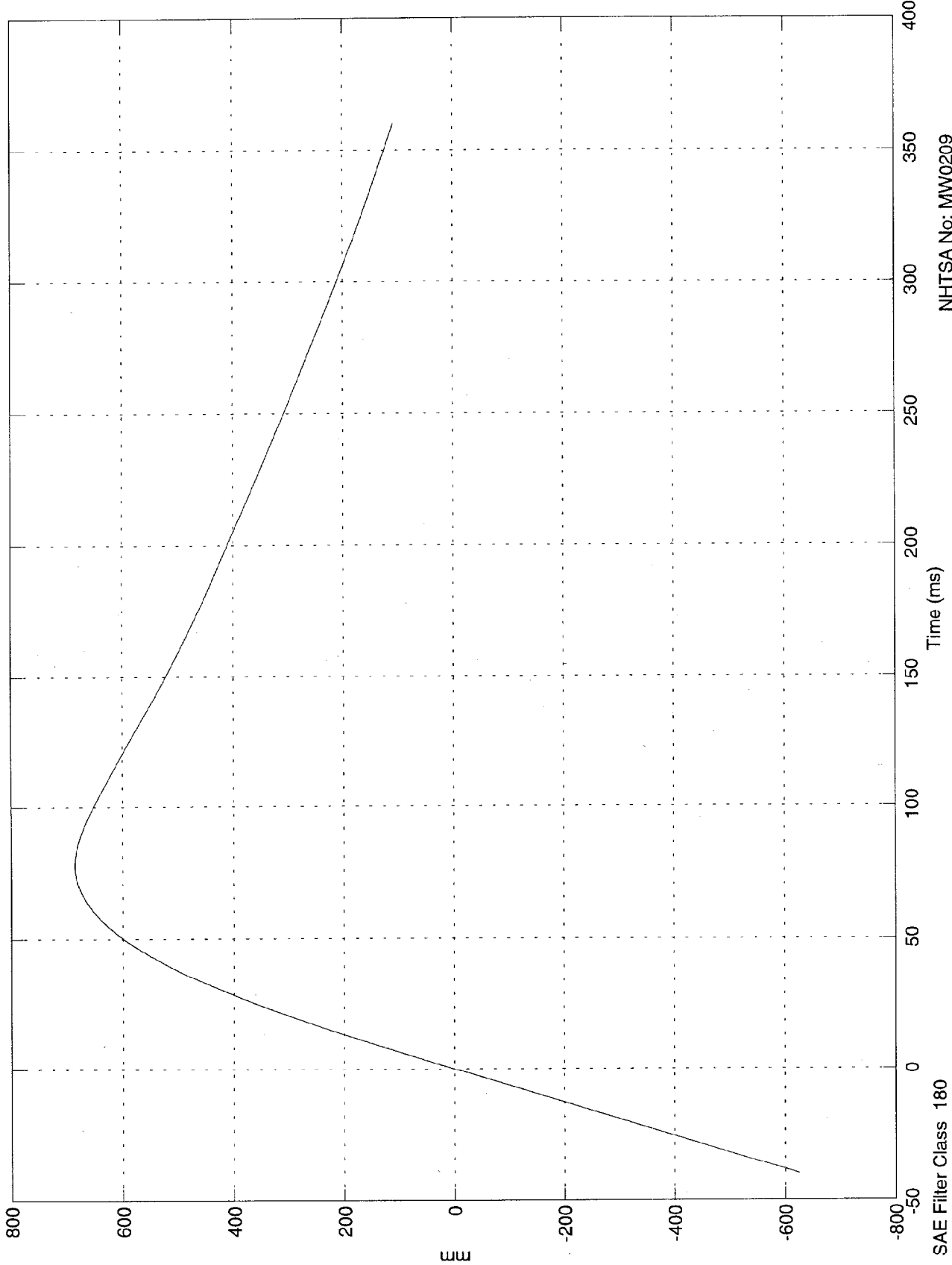

NHTSA No: MW0209
Date: 02 Dec 1997

NCAP TEST #10 - 1998 FORD TAURUS

Max = 2.76 Gs @ 137.40 msec
Min = -32.7 Gs @ 33.80 msec

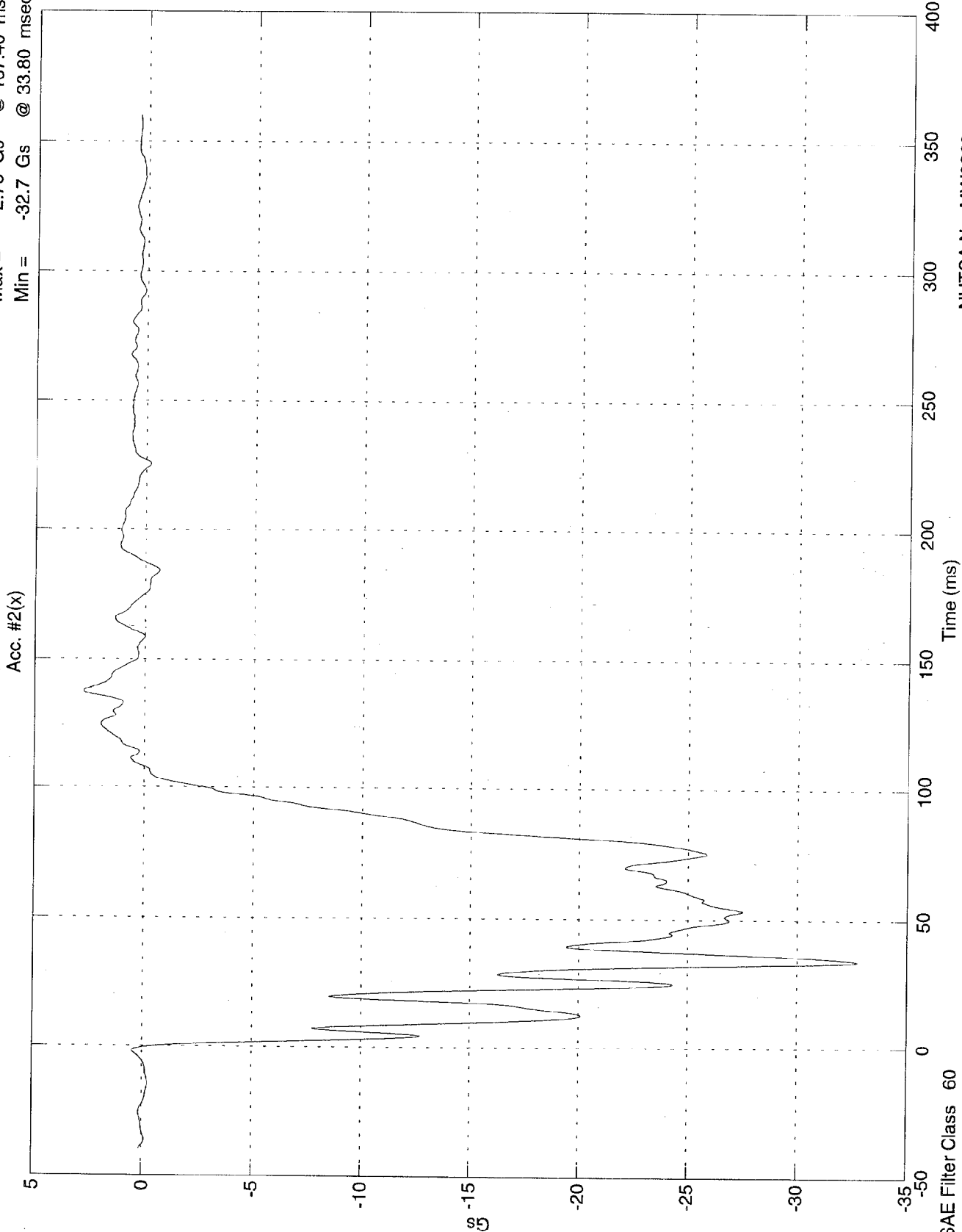

NHTSA No: MW0209
Date: 02 Dec 1997

NCAP TEST #10 - 1998 FORD TAURUS

Max = 56.5 kph @ -23.10 msec
Min = -10.3 kph @ 108.00 msec

1st Integral Acc. #2(x)

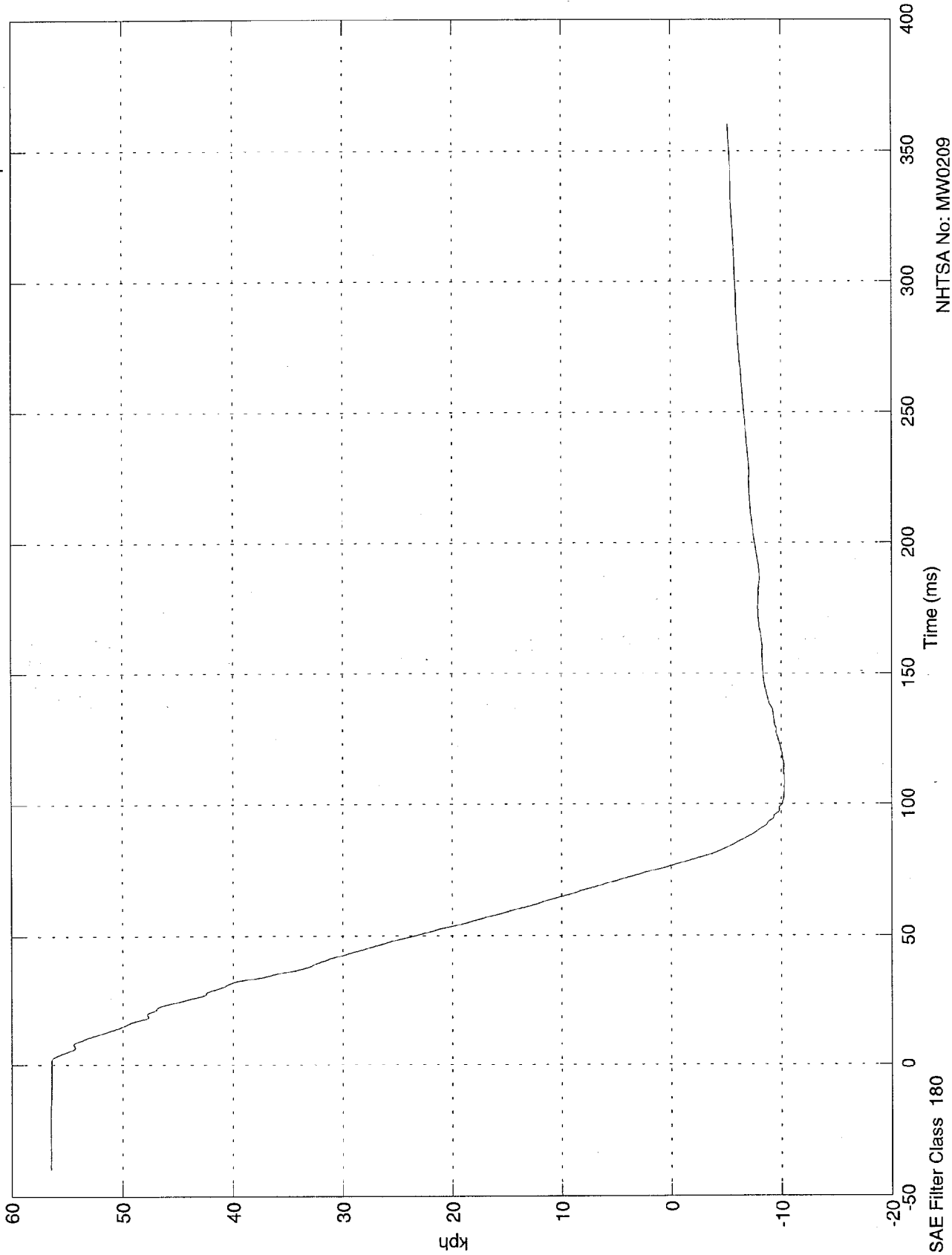

NHTSA No: MW0209
Date: 02 Dec 1997

SAE Filter Class 180

NCAP TEST #10 - 1998 FORD TAURUS

Max = 680 mm @ 76.80 msec
Min = -626 mm @ -39.90 msec

2nd Integral Acc. #2(x)

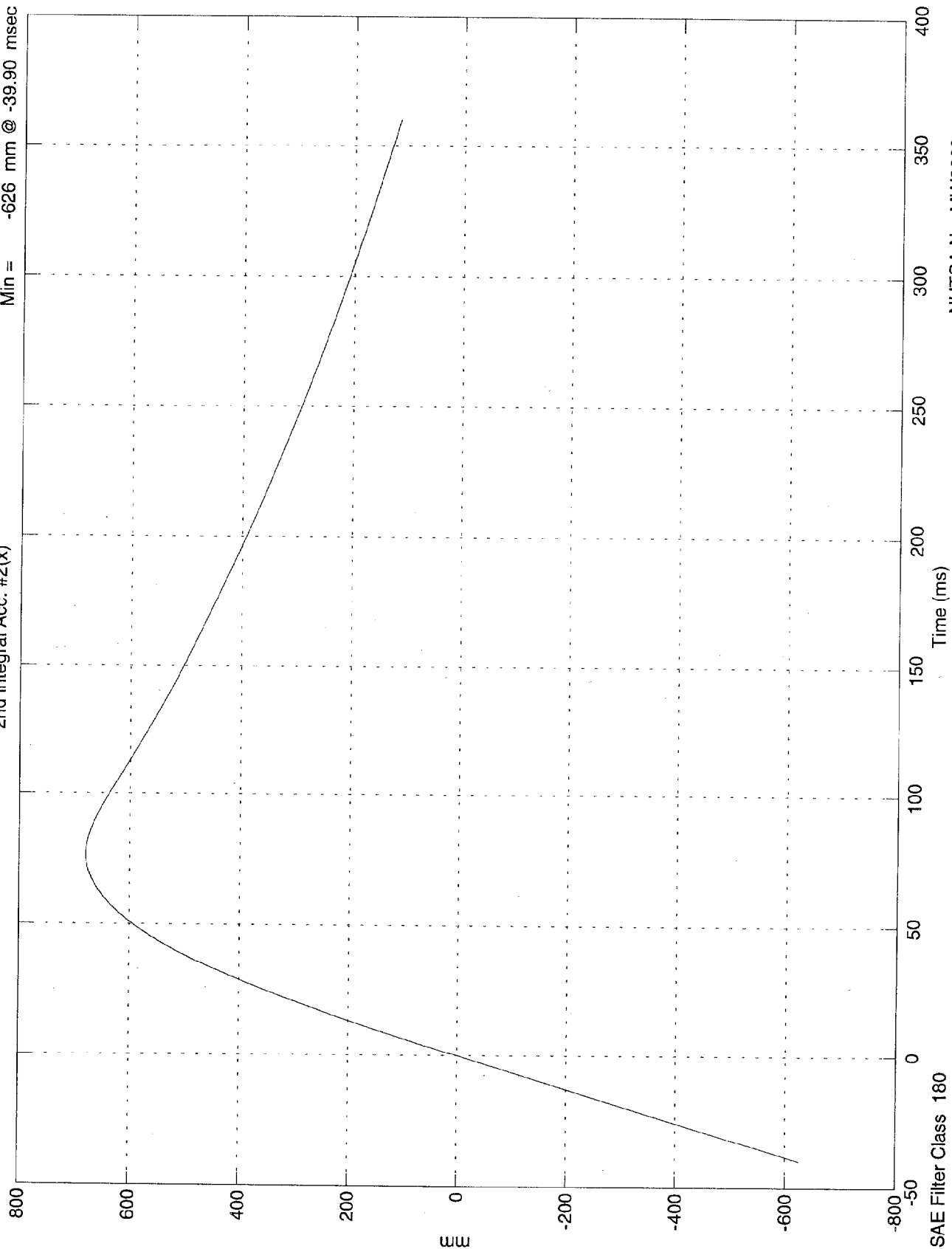

NHTSA No: MW0209
Date: 02 Dec 1997

NCAP TEST #10 - 1998 FORD TAURUS

Max = 41.3 Gs @ 53.30 msec
Min = -100 Gs @ 36.00 msec

Acc. #3(x)

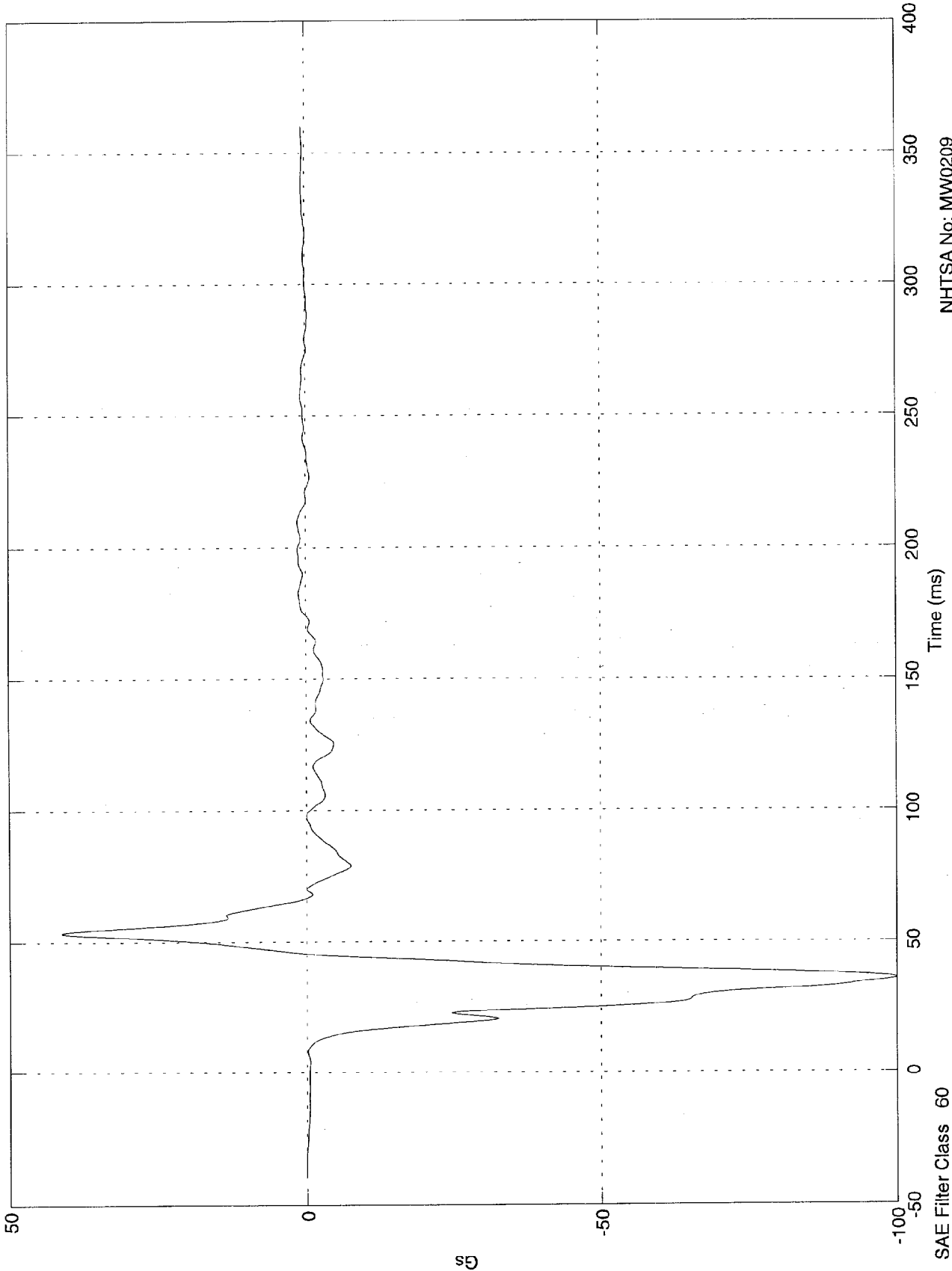

NHTSA No: MW0209
Date: 02 Dec 1997

SAE Filter Class 60

NCAP TEST #10 - 1998 FORD TAURUS

Max = 56.8 kph @ -31.60 msec
Min = 0.471 kph @ 43.90 msec

1st Integral Acc. #3(x)

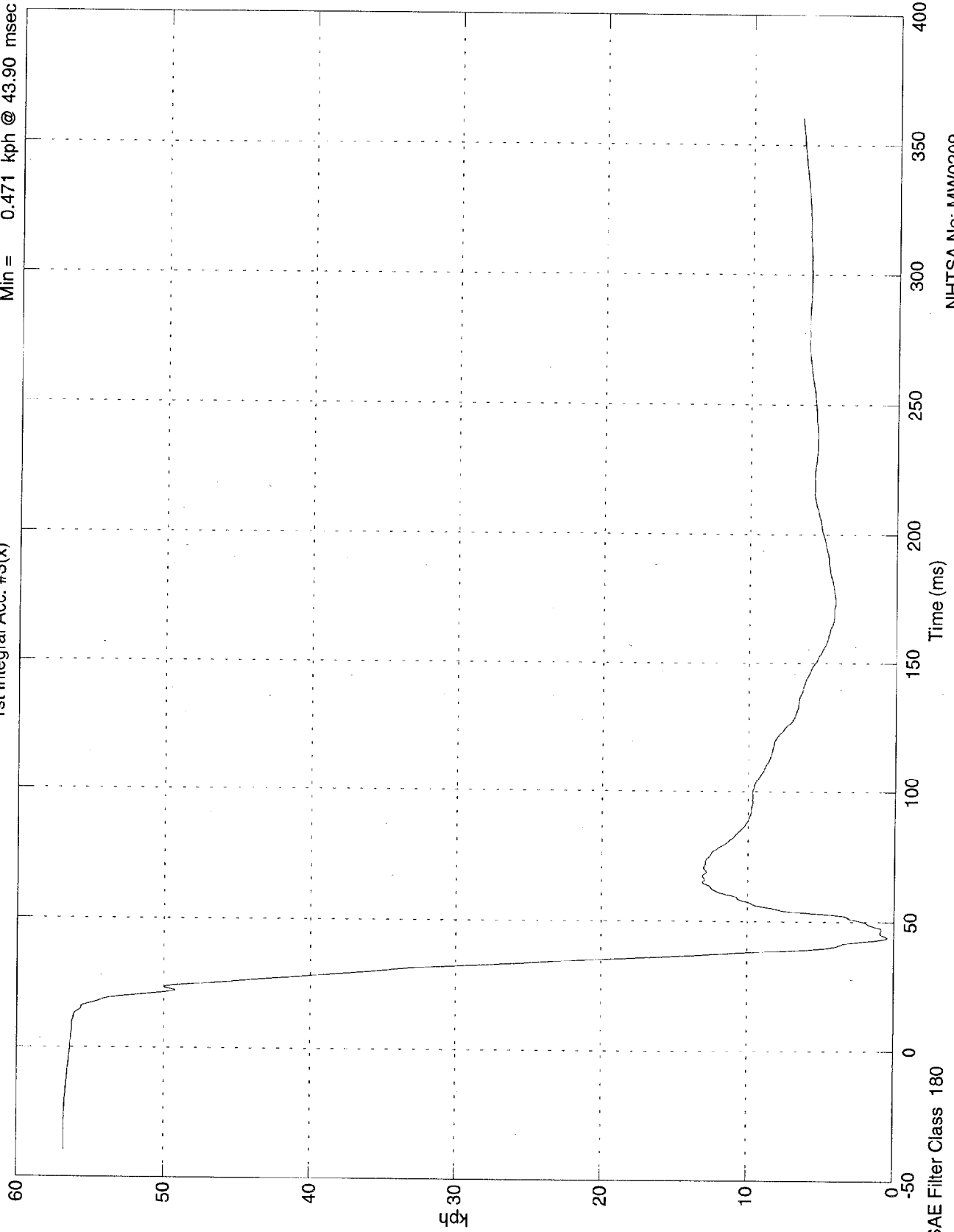

NHTSA No: MW0209
Date: 02 Dec 1997

NCAP TEST #10 - 1998 FORD TAURUS

Max = 1.08e+003 mm @ 360.00 msec
Min = -628 mm @ -39.90 msec

2nd Integral Acc. #3(x)

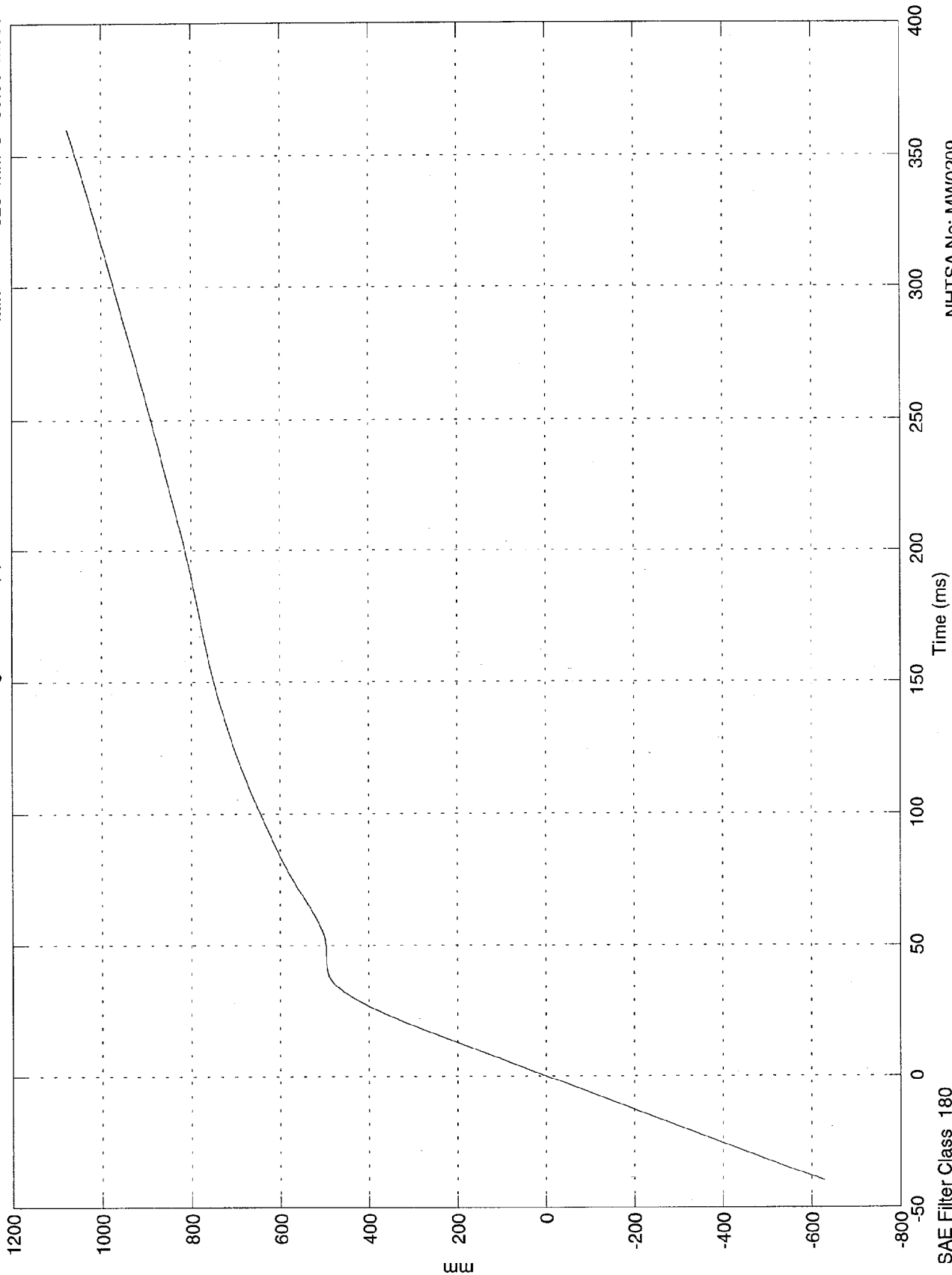

NHTSA No: MW0209
Date: 02 Dec 1997

SAE Filter Class 180

NCAP TEST #10 - 1998 FORD TAURUS

Max = 85.6 Gs @ 41.30 msec
Min = -136 Gs @ 36.80 msec

Acc. #4(x)

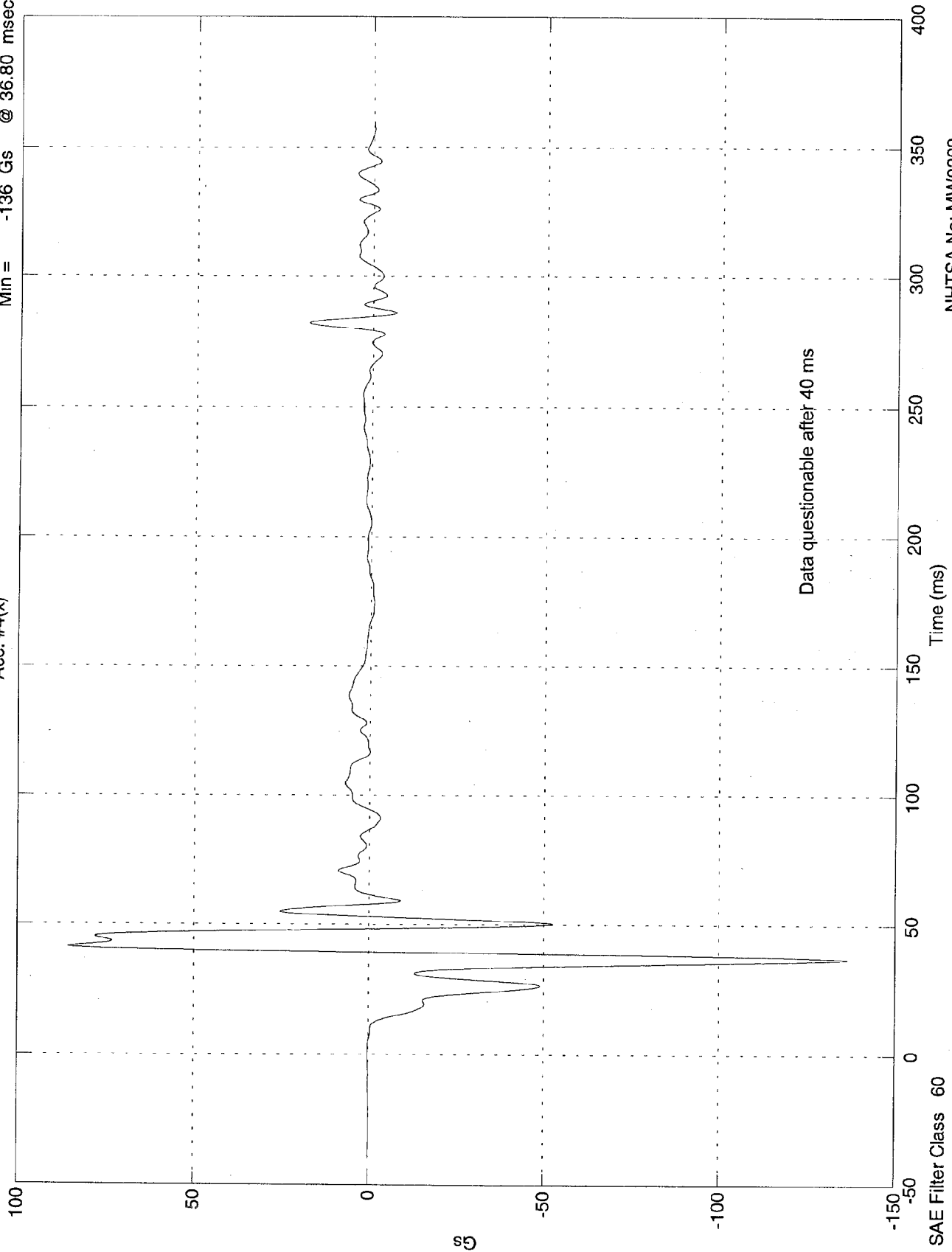

NHTSA No: MW0209
Date: 02 Dec 1997

NCAP TEST #10 - 1998 FORD TAURUS

Max = 56.5 kph @ 6.80 msec
Min = 15.3 kph @ 39.20 msec

1st Integral Acc. #4(x)

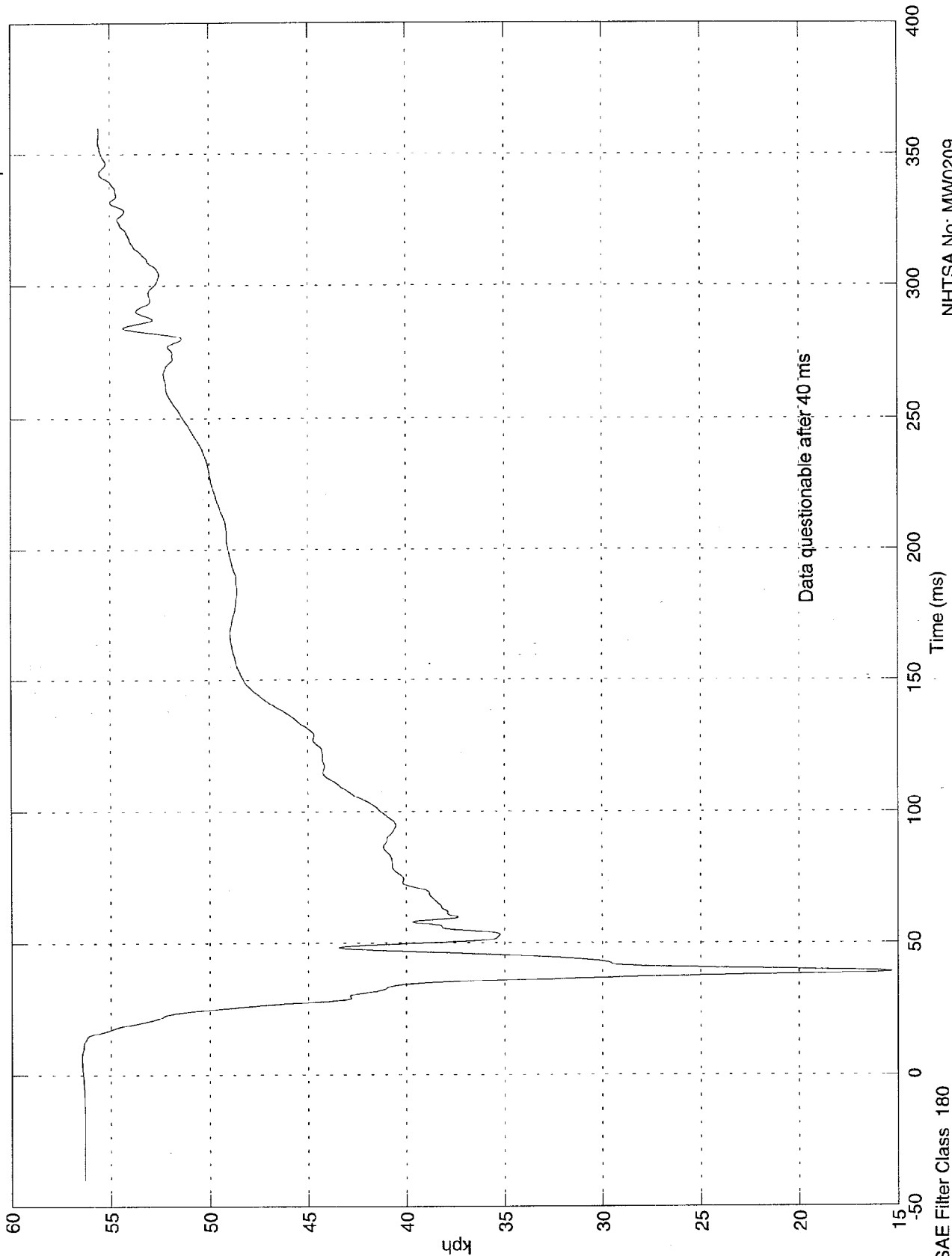

Data questionable after 40 ms

SAE Filter Class 180

NHTSA No: MW0209
Date: 02 Dec 1997

NCAP TEST #10 - 1998 FORD TAURUS

Max = 4.81e+003 mm @ 360.00 msec
Min = -624 mm @ -39.90 msec

2nd Integral Acc. #4(x)

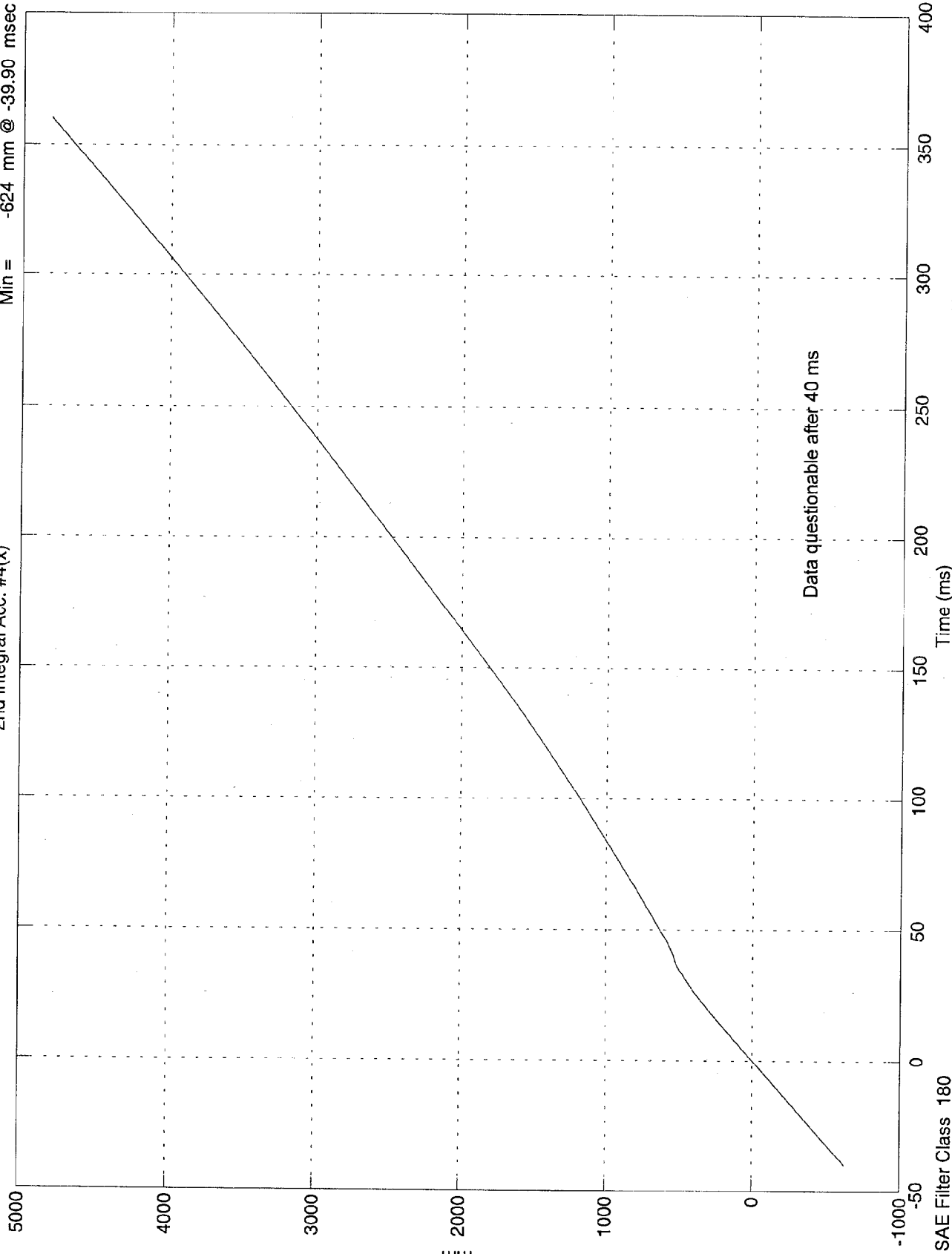

NHTSA No: MW0209
Date: 02 Dec 1997

NCAP TEST #10 - 1998 FORD TAURUS

Max = 3.42 Gs @ 144.30 msec
Min = -53.7 Gs @ 34.00 msec

Acc. #5(x)

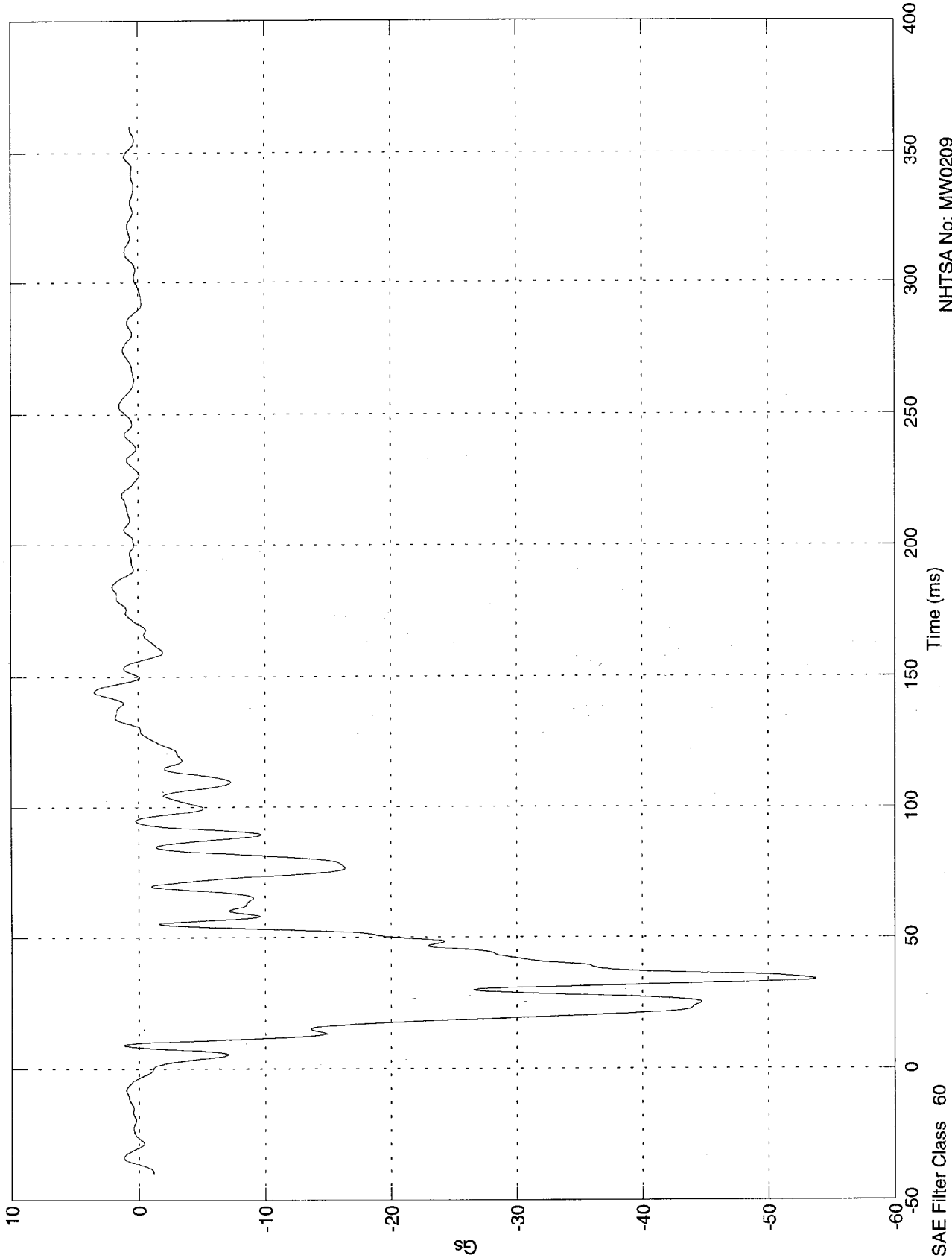

NHTSA No: MW0209
Date: 02 Dec 1997

SAE Filter Class 60

NCAP TEST #10 - 1998 FORD TAURUS

Max = 56.6 kph @ -3.30 msec
Min = -4.97 kph @ 131.70 msec

1st Integral Acc. #5(x)

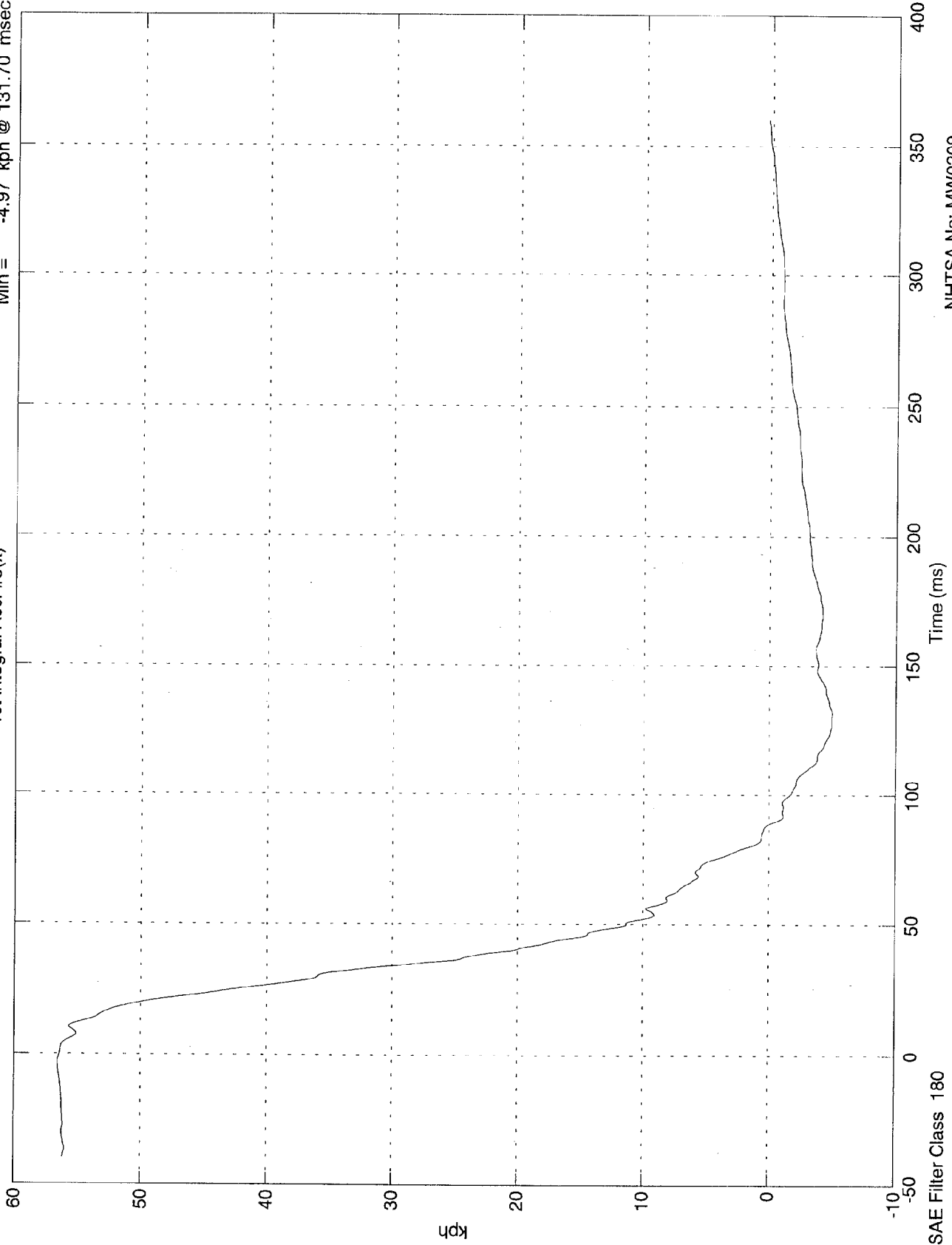

NHTSA No: MW0209
Date: 02 Dec 1997

NCAP TEST #10 - 1998 FORD TAURUS

Max = 600 mm @ 88.80 msec
Min = -624 mm @ -39.90 msec

2nd Integral Acc. #5(x)

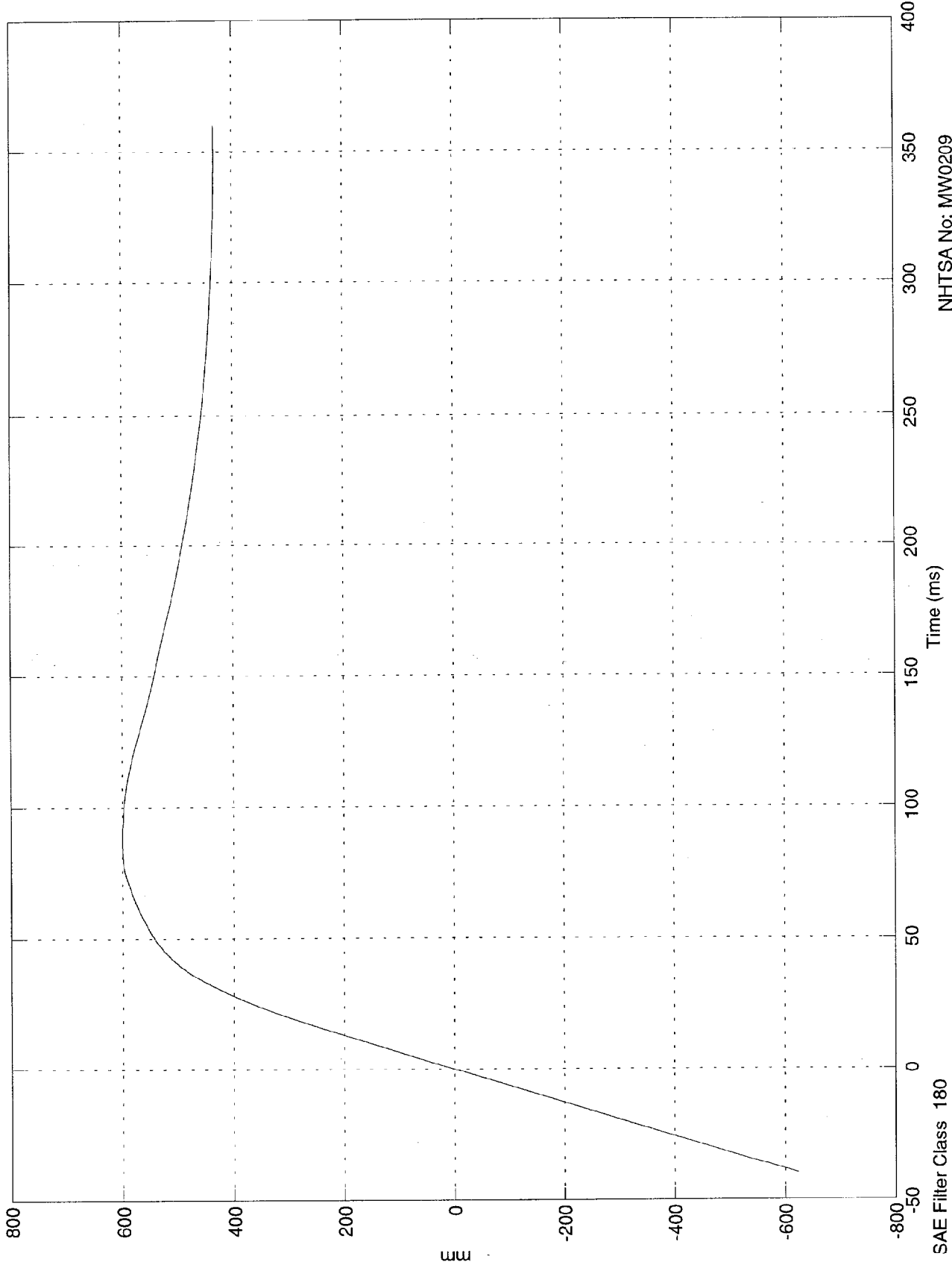

NHTSA No: MW0209
Date: 02 Dec 1997

SAE Filter Class 180

NCAP TEST #10 - 1998 FORD TAURUS

Max = 2.55 Gs @ 222.40 msec
Min = -67.8 Gs @ 36.30 msec

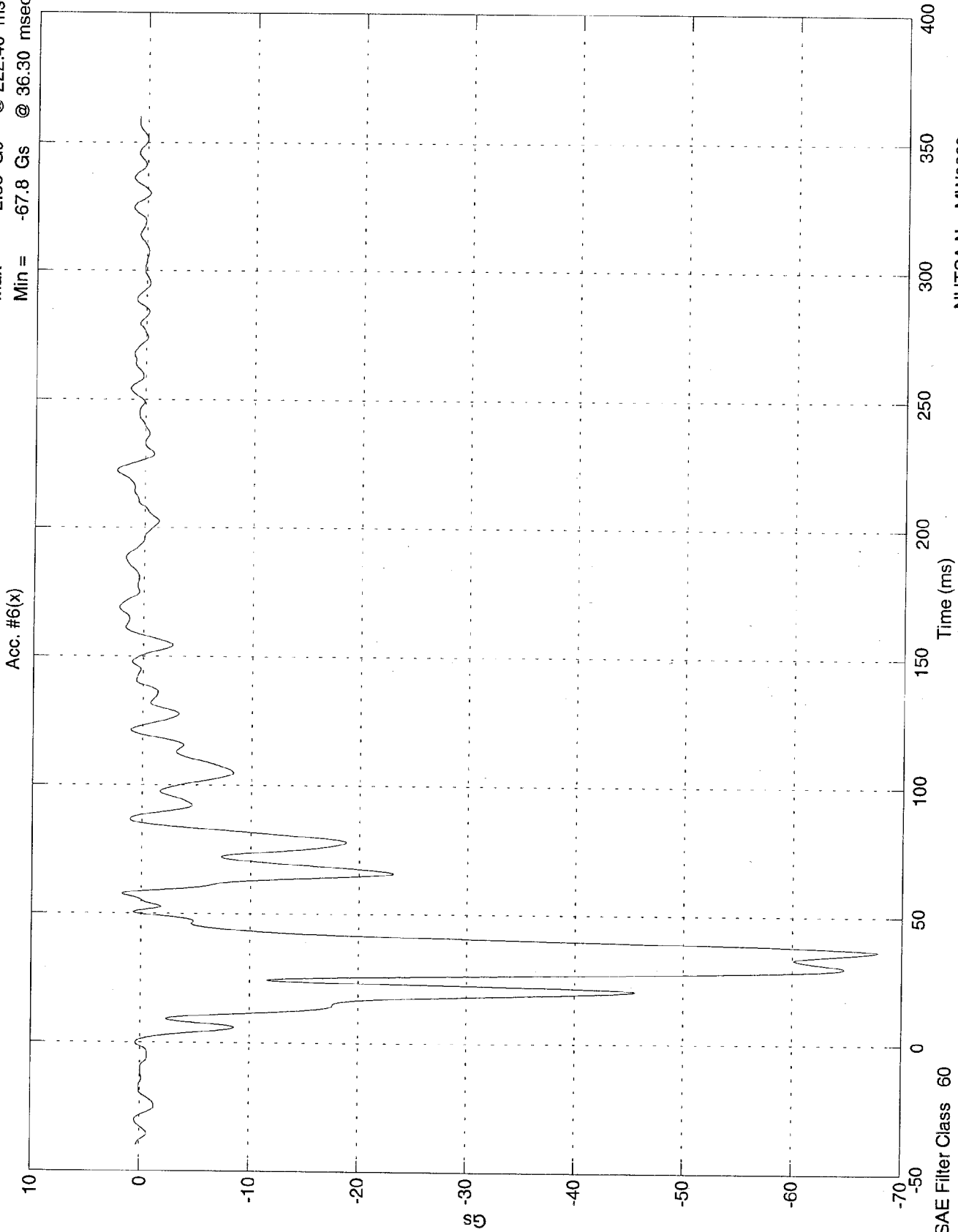

NHTSA No: MW0209
Date: 02 Dec 1997

NCAP TEST #10 - 1998 FORD TAURUS

Max = 56.8 kph @ -37.40 msec
Min = -7.56 kph @ 158.30 msec

1st Integral Acc. #6(x)

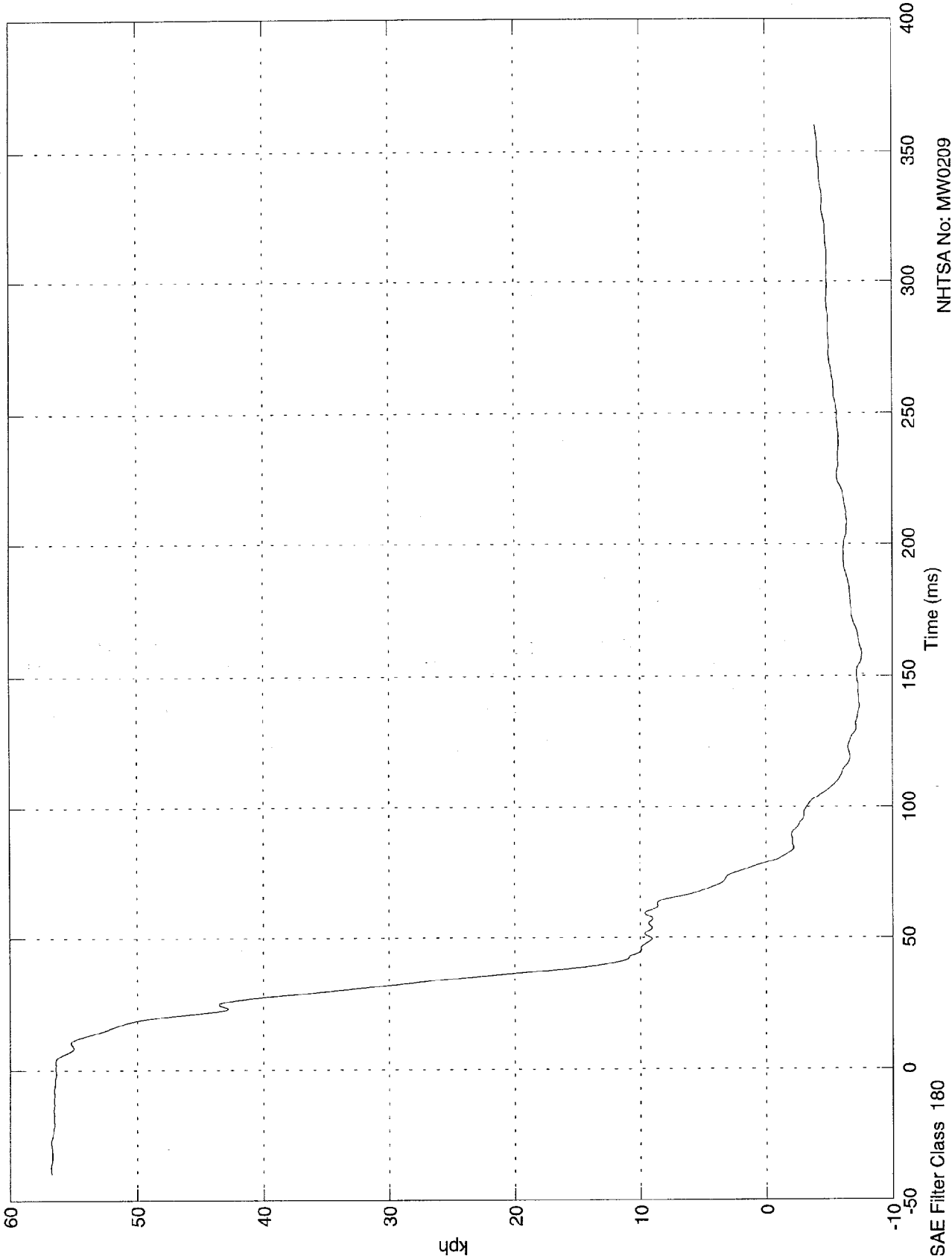

NHTSA No: MW0209
Date: 02 Dec 1997

SAE Filter Class 180

NCAP TEST #10 - 1998 FORD TAURUS

Max = 561 mm @ 78.80 msec
Min = -627 mm @ -39.90 msec

2nd Integral Acc. #5(x)

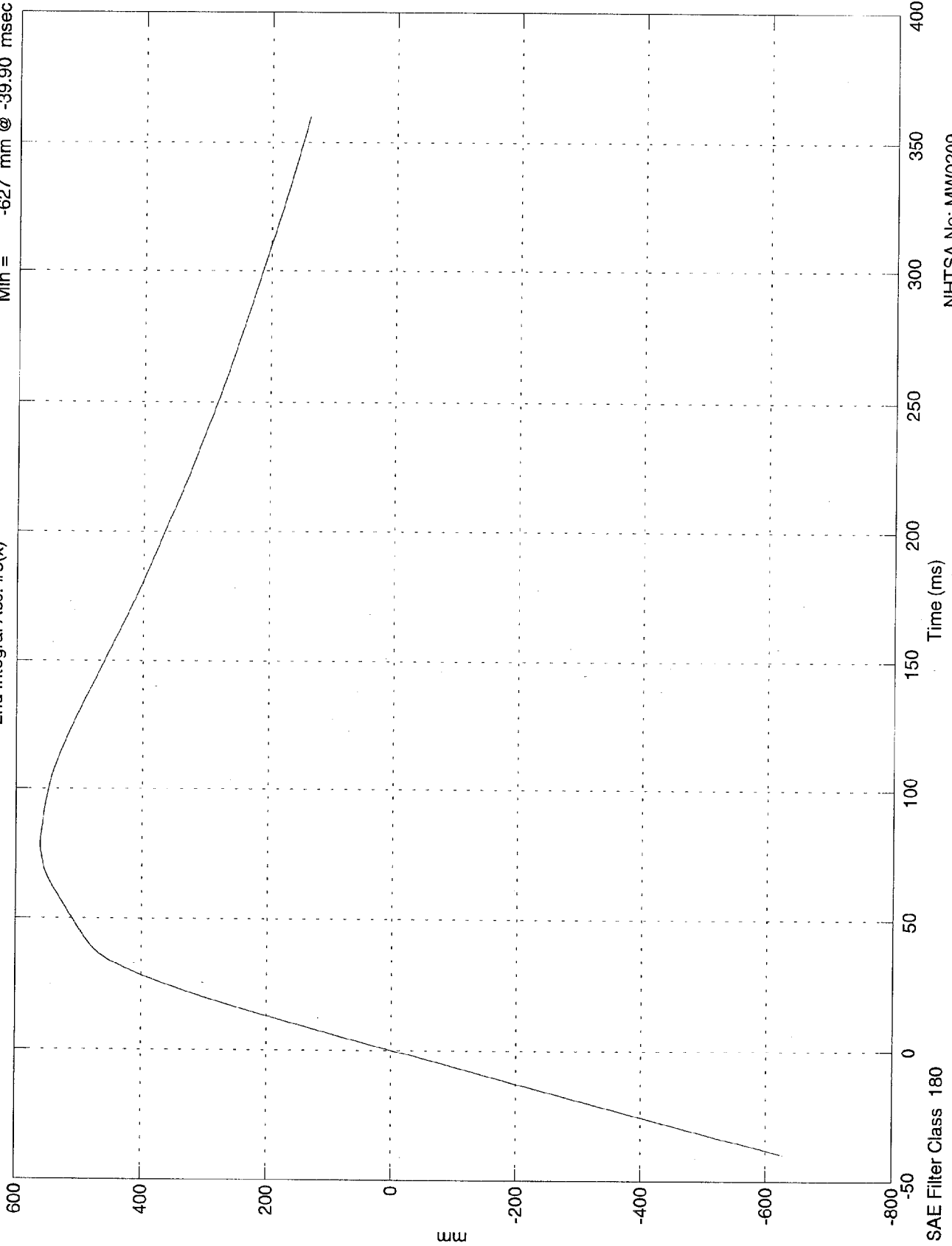

NHTSA No: MW0209
Date: 02 Dec 1997

NCAP TEST #10 - 1998 FORD TAURUS

Max = 14.9 Gs @ 67.90 msec
Min = -58.7 Gs @ 74.10 msec

Acc. #7(x)

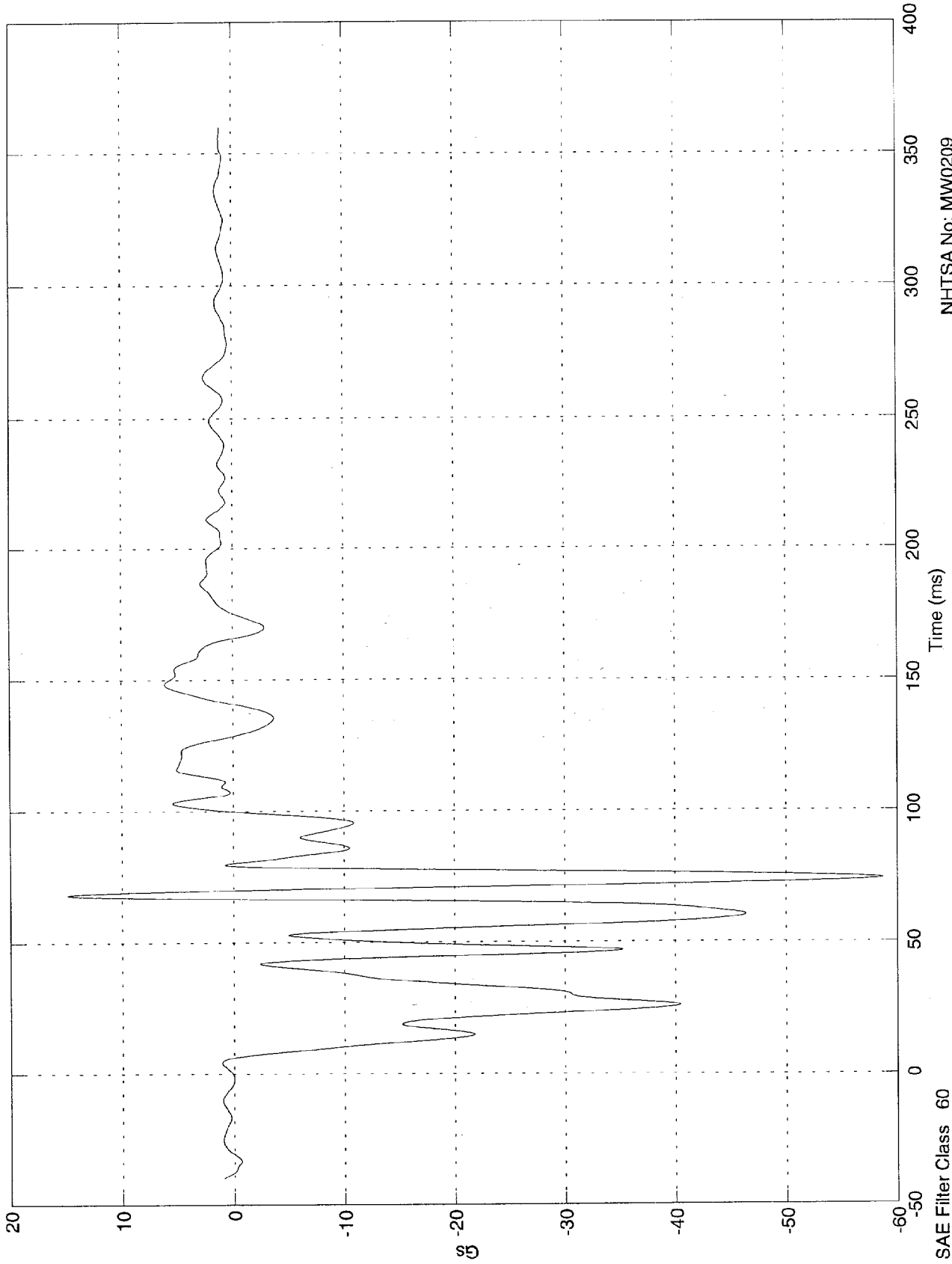

NHTSA No: MW0209
Date: 02 Dec 1997

SAE Filter Class 60

NCAP TEST #10 - 1998 FORD TAURUS

Max = 56.6 kph @ 7.40 msec
Min = -4.78 kph @ 99.10 msec

1st Integral Acc. #7(x)

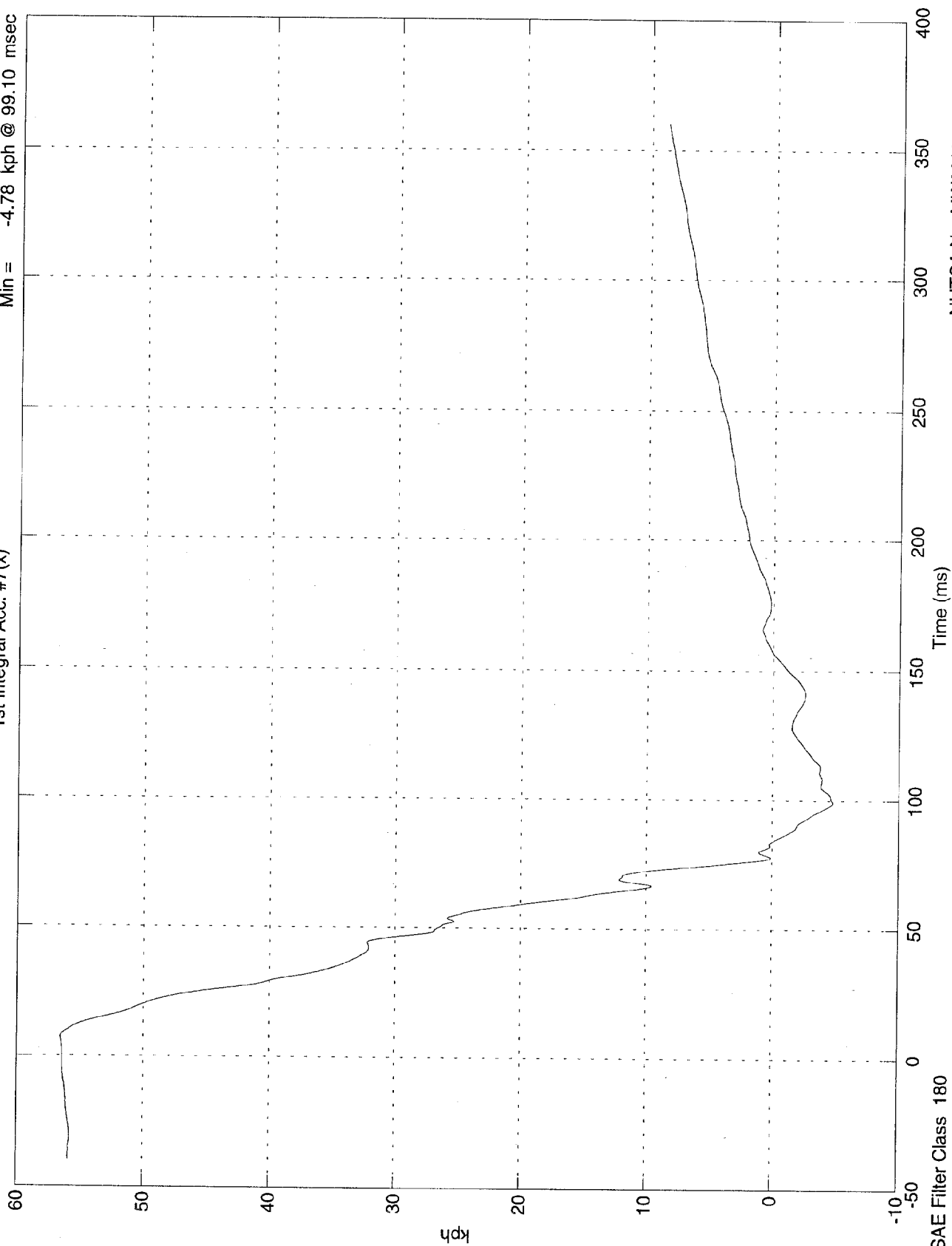

NHTSA No: MW0209
Date: 02 Dec 1997

SAE Filter Class 180

NCAP TEST #10 - 1998 FORD TAURUS

Max = 929 mm @ 360.00 msec
Min = -622 mm @ -39.90 msec

2nd Integral Acc. #7(x)

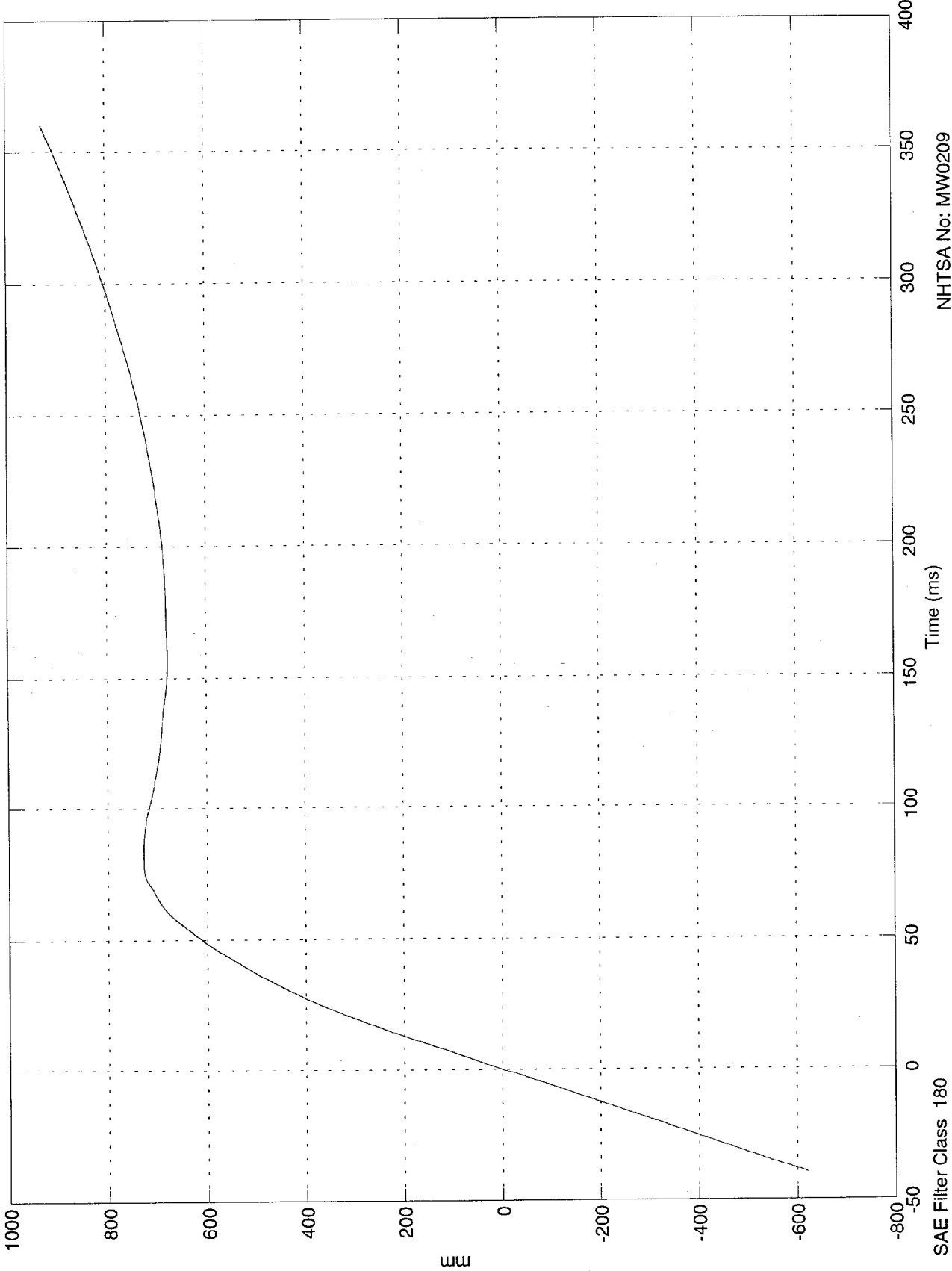

NHTSA No: MW0209
Date: 02 Dec 1997

SAE Filter Class 180

mm

B-125

8413-10

NCAP TEST #10 - 1998 FORD TAURUS

Max = 1.85 Gs @ 142.20 msec
Min = -33.2 Gs @ 35.60 msec

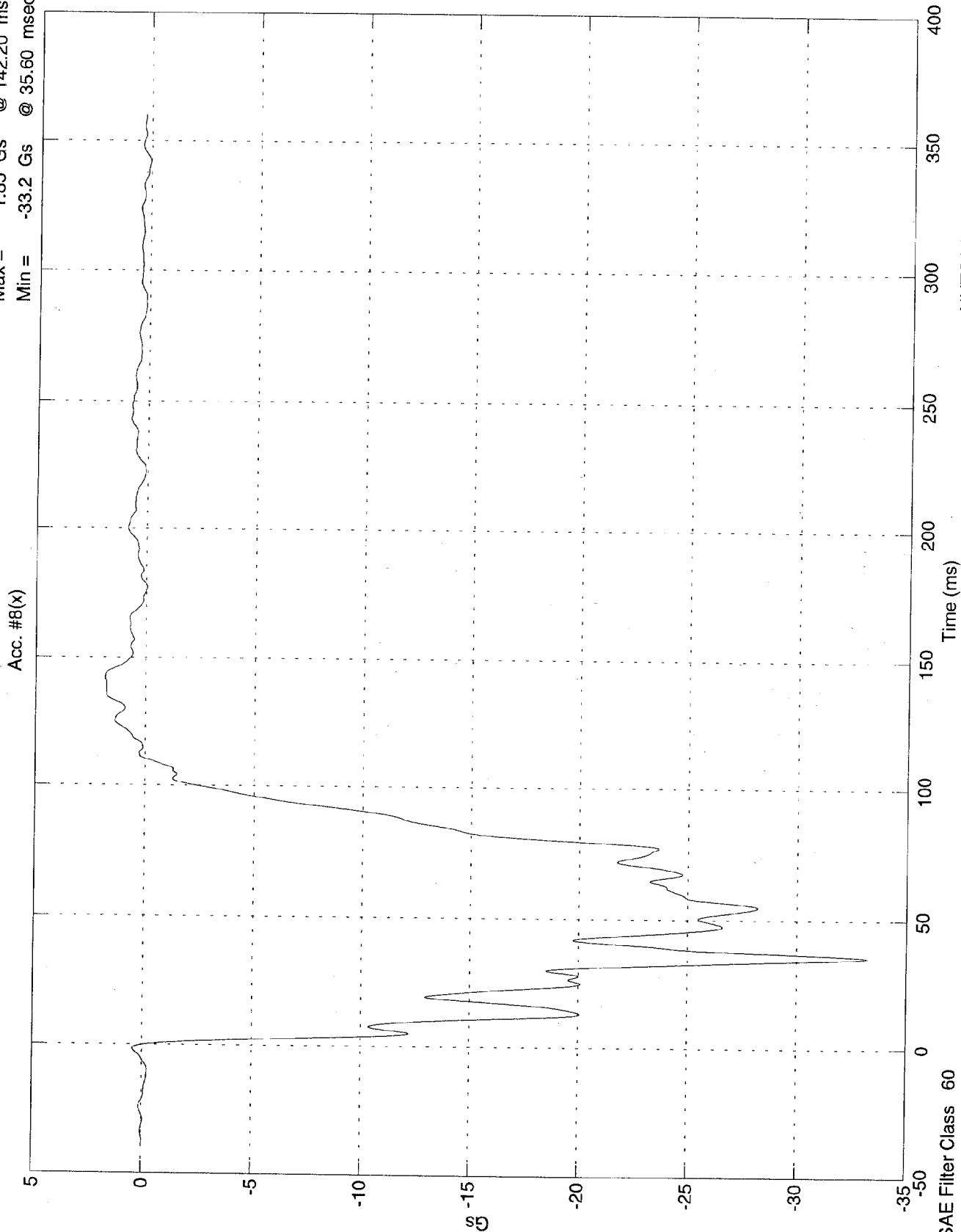

NHTSA No: MW0209
Date: 02 Dec 1997

NCAP TEST #10 - 1998 FORD TAURUS

Max = 56.5 kph @ -22.20 msec
Min = -9.93 kph @ 110.30 msec

1st Integral Acc. #8(x)

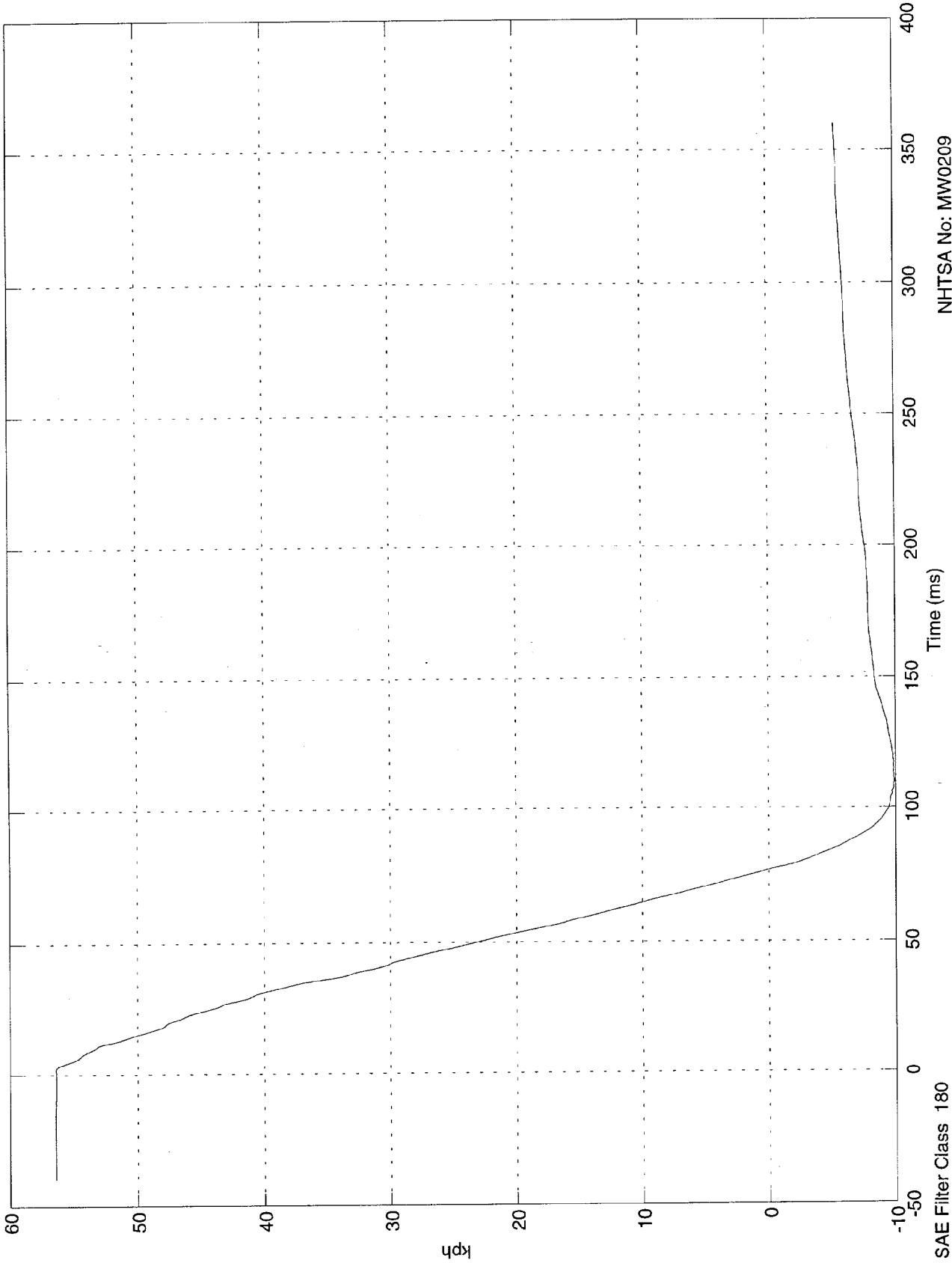

NHTSA No: MW0209
Date: 02 Dec 1997

SAE Filter Class 180

NCAP TEST #10 - 1998 FORD TAURUS

Max = 677 mm @ 76.90 msec
Min = -625 mm @ -39.90 msec

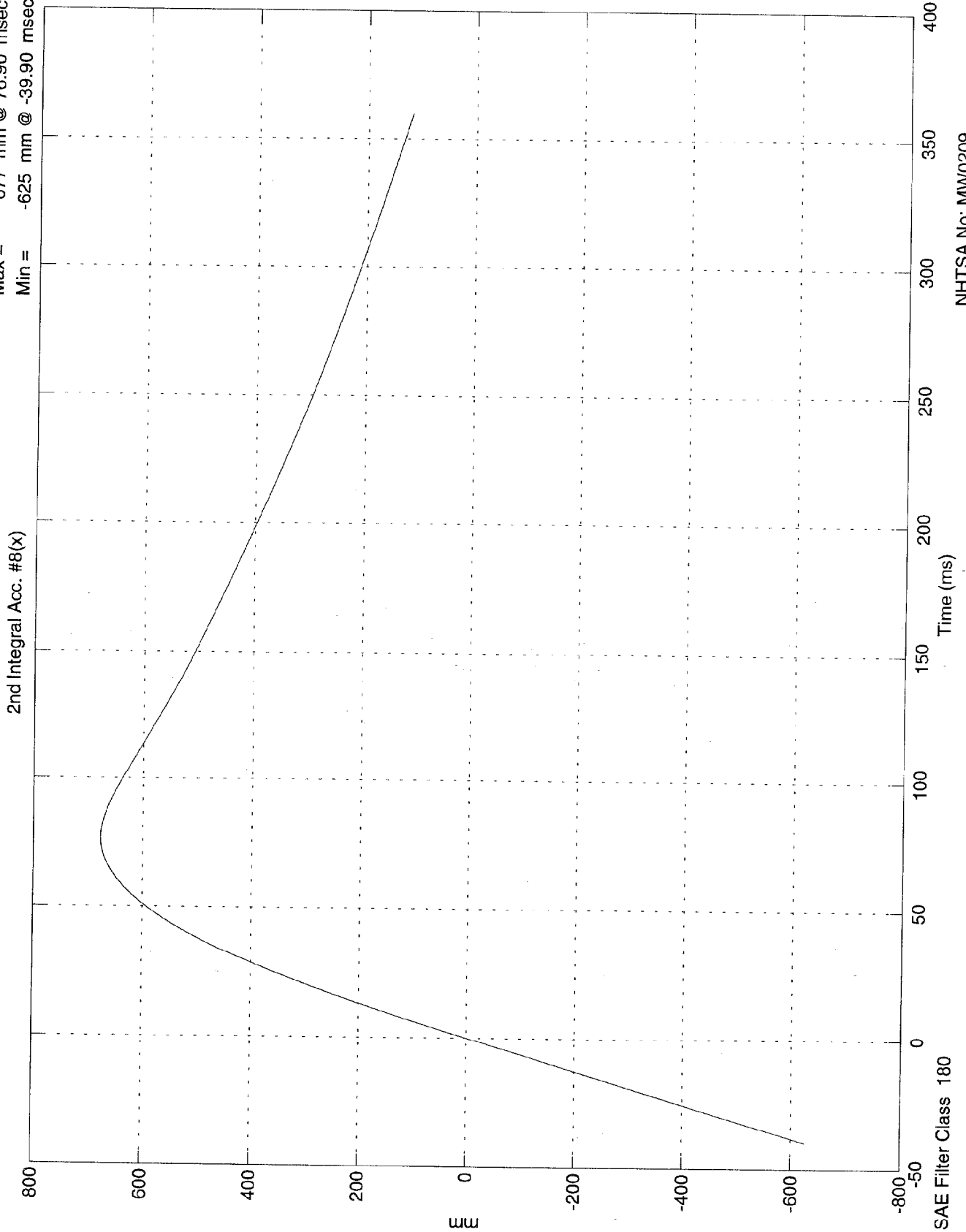

NHTSA No: MW0209
Date: 02 Dec 1997

NCAP TEST #10 - 1998 FORD TAURUS

Max = 2.07 Gs @ 143.90 msec
Min = -31.9 Gs @ 33.60 msec

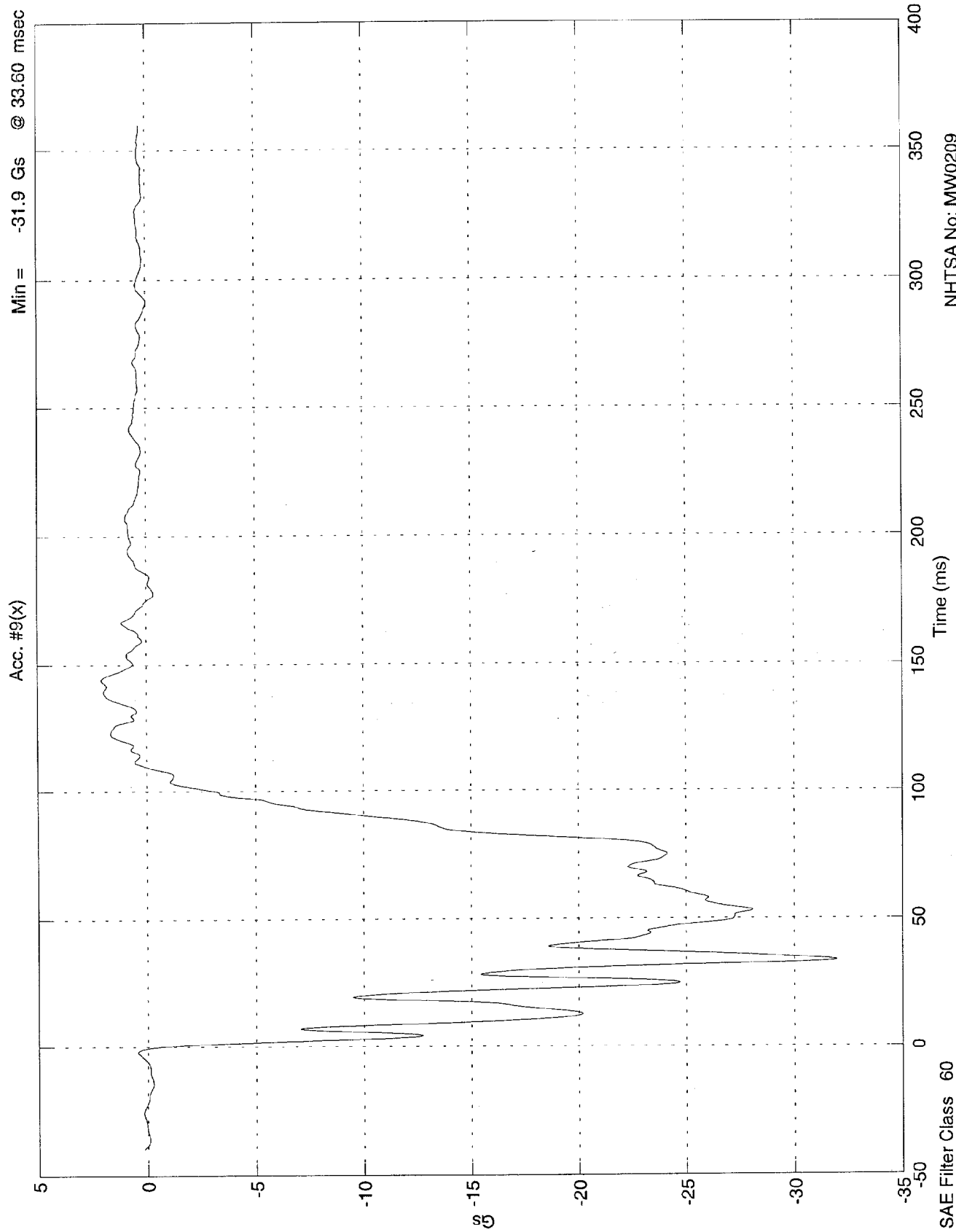

NHTSA No: MW0209
Date: 02 Dec 1997

SAE Filter Class 60

NCAP TEST #10 - 1998 FORD TAURUS

Max = 56.5 kph @ -22.70 msec
Min = -10.1 kph @ 108.20 msec

1st Integral Acc. #9(x)

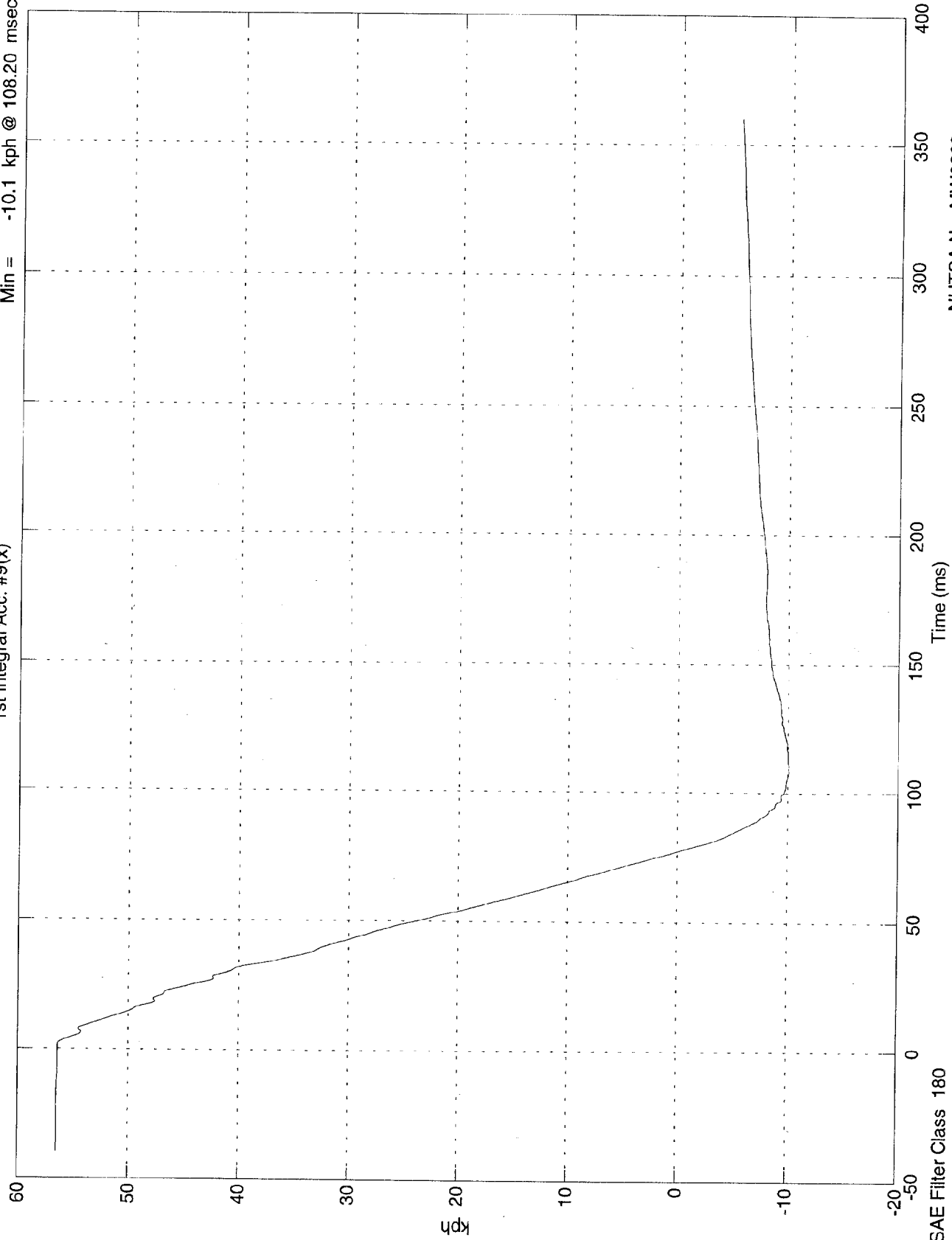

NHTSA No: MW0209
Date: 02 Dec 1997

SAE Filter Class 180

NCAP TEST #10 - 1998 FORD TAURUS

Max = 683 mm @ 77.40 msec
Min = -626 mm @ -39.90 msec

2nd Integral Acc. #9(x)

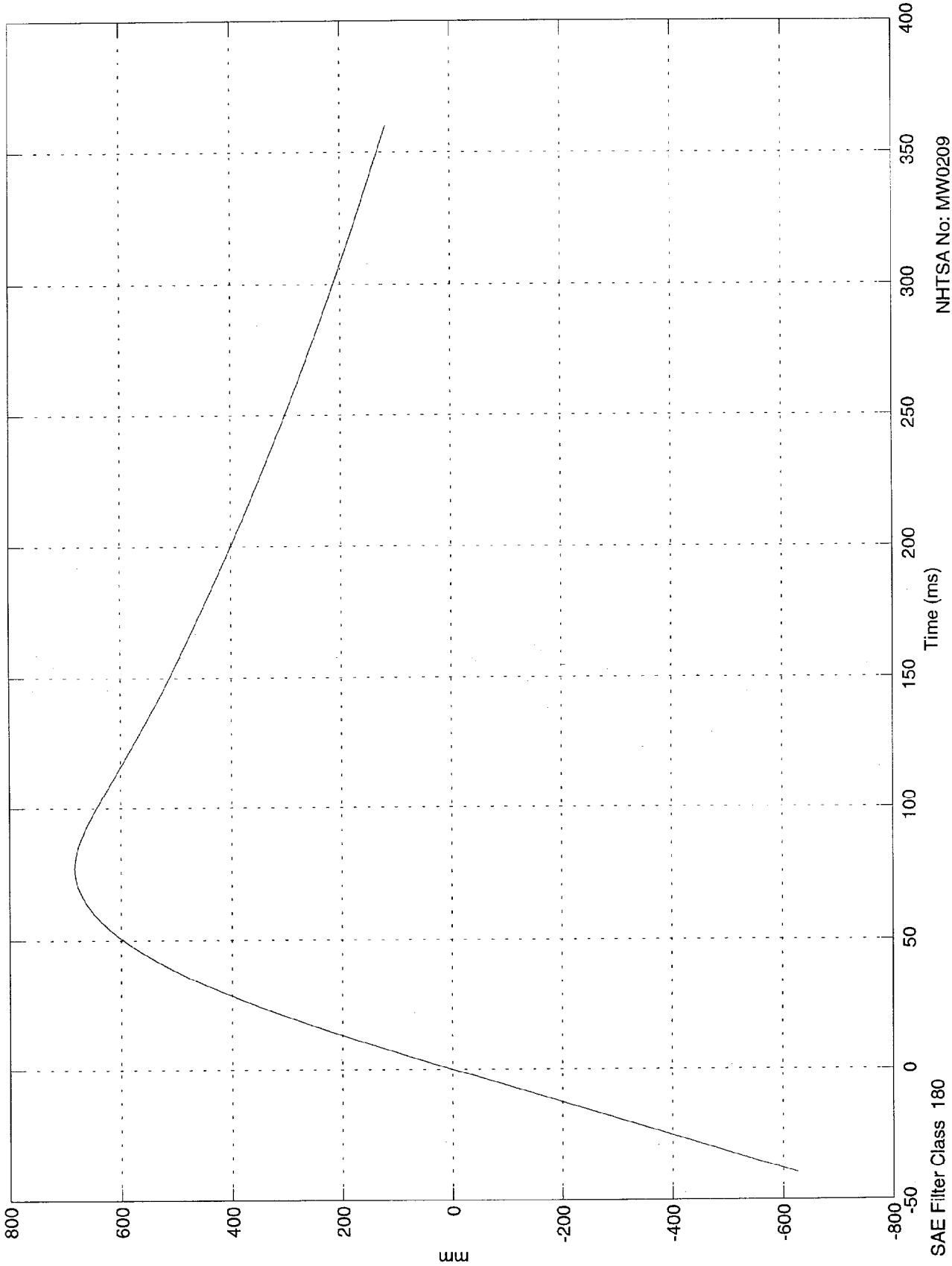

NHTSA No: MW0209
Date: 02 Dec 1997

SAE Filter Class 180

NCAP TEST #10 - 1998 FORD TAURUS

Max = 8.49e+003 non @ -5.20 msec
Min = -2.46e+005 non @ 0.80 msec

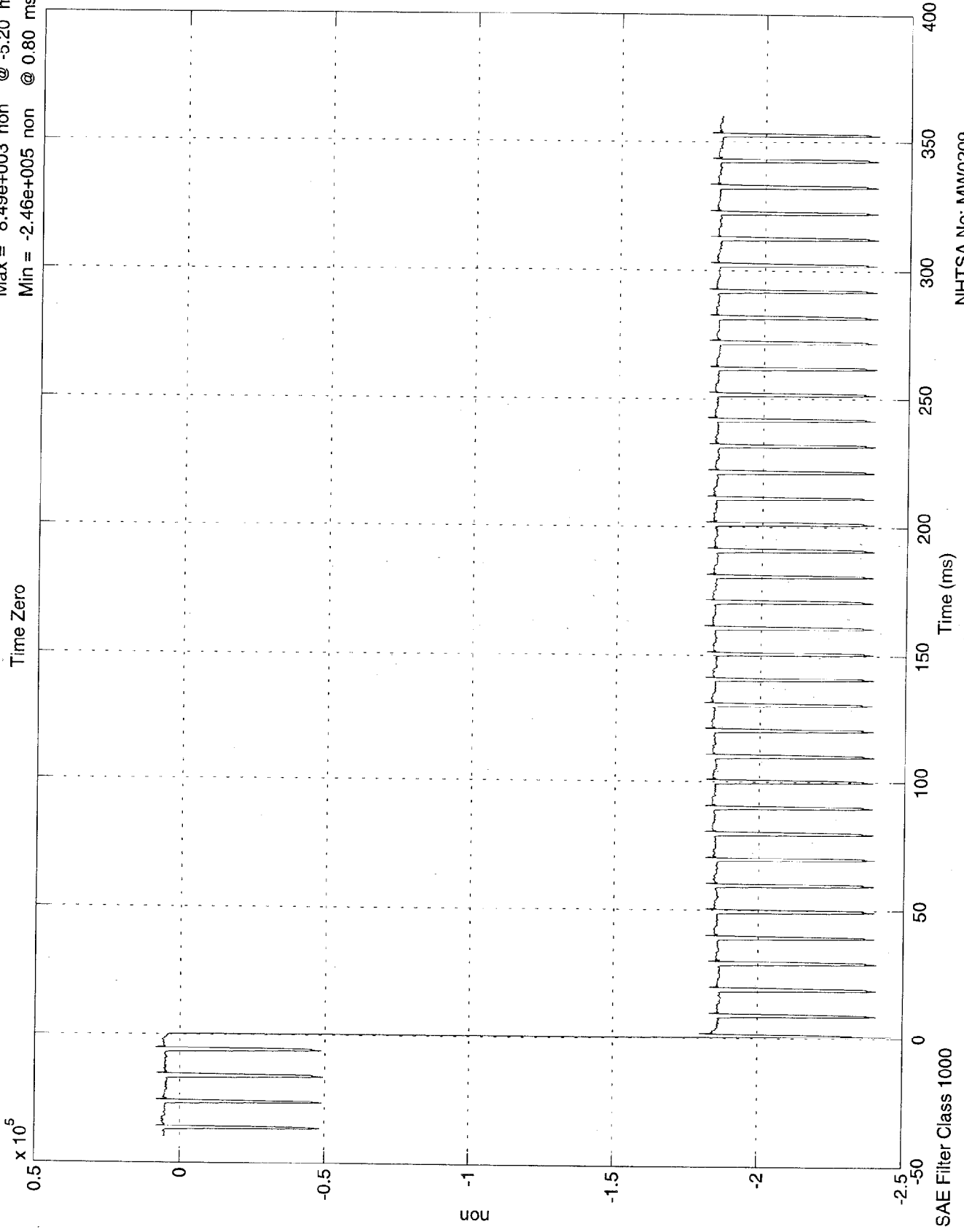

NHTSA No: MW0209
Date: 03 Dec 1997

Appendix C

PART 572B/E DUMMY CONFIGURATION
AND PERFORMANCE VERIFICATION DATA SHEETS

Appendix C contains the results from certification tests performed on the 50th percentile male anthropomorphic test devices utilized for this crash test. The results indicate that the dummies meet all of the performance requirements of the six standard tests as specified in 49 CFR Part 572, Federal Register, Volume 42, No. 25, dated February 7, 1977.

The tests were conducted at the Dummy Certification Test Facility of Calspan SRL Corporation. A summary of the test results, and Part 572 specifications are included in this Appendix.

Dummy serial numbers and certification dates are:

<u>Position No./Location</u>	<u>Serial No.</u>	<u>Completion Date</u>
#1/Driver	064	10/22/97
#2/Right Front Passenger	245	11/18/97

Electronic Test Equipment

The complement of signal conditioning, recording and display equipment, in conjunction with dummy certification testing, can be found in New Car Assessment and Standards Indicant Testing Final Report No. 6525-V-1.

DUMMY CONFIGURATION DIMENSIONS

EXTERNAL DIMENSIONS
SPECIFICATIONS

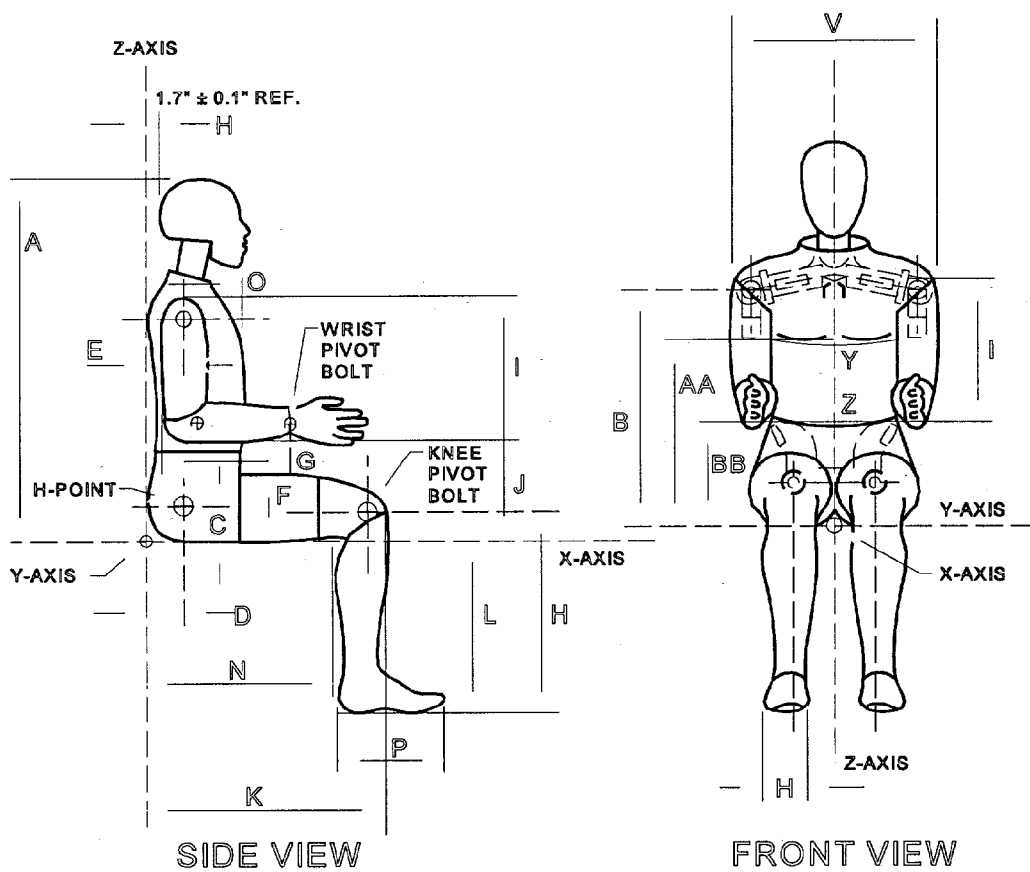

NOTE: Figure is referenced to the erect seated position. The curved lumbar does not allow the Hybrid III to be positioned in a perfect erect attitude. (REF: S572.31(A)(6))

PART 572E
HEAD DROP TEST

Dummy Serial Number 064
Calspan Sequential Test Number 4
Date 10/21/97
Workfile 164497.hpd

TEST PARAMETER	SPECIFICATION	TEST RESULTS
Temperature	66-78 Deg F	70
Relative Humidity	10% - 70%	32
Peak Resultant Acceleration	225-275 G's	268.5
Peak Lateral Acceleration	15 G's Max	3.1
Is Acceleration Curve Unimodal?	YES	Yes

Remarks:

Laboratory Technician: B. Swiecicki

PART 572E
NECK FLEXION TEST

Dummy Serial Number 064
 Calspan Sequential Test Number 4
 Date 10/21/97
 Workfile 064497.nfl

6 Axis Neck Transducer

TEST PARAMETER		SPECIFICATION	TEST RESULTS
Temperature		69-72 Deg F	70
Relative Humidity		10% - 70%	32
Impact Velocity		22.60 - 23.40 Ft/s	23.05
Pendulum Deceleration	10 ms	22.50 - 27.50 G's	24.25
	20 ms	17.60 - 22.60 G's	19.80
	30 ms	12.50 - 18.50 G's	13.78
Max Pendulum G's Above 30 ms		29 G's Max	13.78
Deceleration - Time Curve Decay Time to 5 G's		34 - 42 ms	41.13
D Plane Rotation	Max	64 - 78 Deg	68.17
	Time	57 - 64 ms	60.63
Moment About Occipital Condyle	Max	65 - 80 Ft-Lbs	78.17
	Time	47 - 58 ms	53.38
Rotation Angle - Time Curve Decay Time to Zero		113 - 128 ms	115.88
Positive Moment - Time Curve Decay Time to Zero		97 - 107 ms	101.63

Remarks:

Laboratory Technician: B. Swiecicki

PART 572E
NECK EXTENSION TEST

Dummy Serial Number 064
 Calspan Sequential Test Number 4
 Date 10/21/97
 Workfile 064497.nxt

6 Axis Neck Transducer

TEST PARAMETER		SPECIFICATION	TEST RESULTS
Temperature		69-72 Deg F	70
Relative Humidity		10% - 70%	32
Impact Velocity		19.50 - 20.30 Ft/s	19.56
Pendulum Deceleration	10 ms	17.20 - 21.20 G's	18.99
	20 ms	14.00 - 19.00 G's	17.07
	30 ms	11.00 - 16.00 G's	14.55
Max Pendulum G's Above 30 ms		22 G's Max	14.55
Deceleration - Time Curve Decay Time to 5 G's		38 - 46 ms	40.25
D Plane Rotation	Max	81 - 106 Deg	98.34
	Time	72 - 82 ms	74.75
Moment About Occipital Condyle	Max	-59.0 - -39.0 Ft-Lbs	-49.31
	Time	65 - 79 ms	70.13
Rotation Angle - Time Curve Decay Time to Zero		147 - 174 ms	153.50
Positive Moment - Time Curve Decay Time to Zero		120 - 148 ms	140.38

Remarks:

Laboratory Technician: B. Swiecicki

PART 572E
THORAX IMPACT TEST

Dummy Serial Number 064
Calspan Sequential Test Number 4
Date 10/22/97
Workfile 064497.th3

TEST PARAMETER	SPECIFICATION	TEST RESULTS
Temperature	69-72 Deg F	71
Relative Humidity	10% - 70%	33
Pendulum Velocity	21.6 - 22.4 Ft/s	21.62
Maximum Deflection	2.50 - 2.86 in	2.59
Maximum Resistive Force	1160 - 1325 Lbs	1296.7
Internal Hysteresis	69 - 85 %	72.5

Remarks:

Laboratory Technician: B. Swiecicki

PART 572E
KNEE IMPACT TEST

Dummy Serial Number 064
 Calspan Sequential Test Number 4
 Date 10/22/97
 Workfile 064497.

TEST PARAMETER	SPECIFICATION	TEST RESULTS
LEFT KNEE		
Temperature	66 - 78 Deg F	71
Relative Humidity	10% - 70%	33
Probe Velocity	6.8 - 7.0 Ft/s	6.90
Peak Knee Impact Force	1060 - 1300 Lbs	1187.0
RIGHT KNEE		
Temperature	66 - 78 Deg F	71
Relative Humidity	10% - 70%	33
Probe Velocity	6.8 - 7.0 Ft/s	6.91
Peak Knee Impact Force	1060 - 1300 Lbs	1203.0

Remarks:

Laboratory Technician: B. Swiecicki

PART 572E
EXTERNAL DIMENSIONS

Dummy Serial Number 064
 Calspan Sequential Test Number 4
 Date 10/22/97

TEST PARAMETER		SPECIFICATION	TEST RESULTS
Temperature			71
Relative Humidity			33
Location for Chest Circumference	AA	16.9 - 17.1 in	17.0
Location for Waist Circumference	BB	8.9 - 9.1 in	9.0
Chest Circumference (With Jacket)	Y	38.2 - 39.4 in	38.8
Waist Circumference	Z	32.9 - 34.1 in	33.3
Chest Depth	O	8.4 - 9.0 in	8.6
H-Point Height	C	3.3 - 3.5 in	3.4
H-Point from Backline	D	5.3 - 5.5 in	5.4
Skull Cap to Backline	H	1.6 - 1.8 in	1.7
Total Sitting Height	A	34.6 - 35.0 in	34.8
Thigh Clearance	F	5.5 - 6.1 in	6.0
Buttock Knee Length	K	22.8 - 23.8 in	23.6
Buttock Popliteal Length	N	17.8 - 18.8 in	18.4
Popliteal Height	L	16.9 - 17.9 in	17.3
Knee Pivot Height	M	19.1 - 19.7 in	19.4
Foot Length	P	9.9 - 10.5 in	10.1
Foot Breadth	W	3.6 - 4.2 in	3.8
Shoulder Pivot from Backline	E	3.3 - 3.7 in	3.6
Shoulder Breadth	V	16.6 - 17.2 in	16.8
Shoulder Pivot Height	B	19.9 - 20.5 in	20.4
Elbow Rest Height	J	7.5 - 8.3 in	8.0
Shoulder - Elbow Length	I	13.0 - 13.6 in	13.3
Back of Elbow to Wrist Pivot	G	11.4 - 12.0 in	11.6

Remarks:

Laboratory Technician: B. Swiecicki

PART 572E
HEAD DROP TEST

Dummy Serial Number 245
Calspan Sequential Test Number 5
Date 11/13/97
Workfile 245597.hdp

TEST PARAMETER	SPECIFICATION	TEST RESULTS
Temperature	66-78 Deg F	70
Relative Humidity	10% - 70%	30
Peak Resultant Acceleration	225-275 G's	268.0
Peak Lateral Acceleration	15 G's Max	12.6
Is Acceleration Curve Unimodal?	YES	Yes

Remarks:

Laboratory Technician: B. Swiecicki

PART 572E
NECK FLEXION TEST

Dummy Serial Number 245
 Calspan Sequential Test Number 5
 Date 11/17/97
 Workfile 245597.nfl

6 Axis Neck Transducer

TEST PARAMETER		SPECIFICATION	TEST RESULTS
Temperature		69-72 Deg F	70
Relative Humidity		10% - 70%	30
Impact Velocity		22.60 - 23.40 Ft/s	23.14
Pendulum Deceleration	10 ms	22.50 - 27.50 G's	24.01
	20 ms	17.60 - 22.60 G's	21.48
	30 ms	12.50 - 18.50 G's	17.20
Max Pendulum G's Above 30 ms		29 G's Max	17.20
Deceleration - Time Curve Decay Time to 5 G's		34 - 42 ms	38.63
D Plane Rotation	Max	64 - 78 Deg	74.91
	Time	57 - 64 ms	58.13
Moment About Occipital Condyle	Max	65 - 80 Ft-Lbs	75.84
	Time	47 - 58 ms	53.38
Rotation Angle - Time Curve Decay Time to Zero		113 - 128 ms	120.38
Positive Moment - Time Curve Decay Time to Zero		97 - 107 ms	97.75

Remarks:

Laboratory Technician: B. Swiecicki

PART 572E
NECK EXTENSION TEST

Dummy Serial Number 245
 Calspan Sequential Test Number 5
 Date 11/17/97
 Workfile 245597.nex

6 Axis Neck Transducer

TEST PARAMETER		SPECIFICATION	TEST RESULTS
Temperature		69-72 Deg F	71
Relative Humidity		10% - 70%	35
Impact Velocity		19.50 - 20.30 Ft/s	19.70
Pendulum Deceleration	10 ms	17.20 - 21.20 G's	19.42
	20 ms	14.00 - 19.00 G's	18.01
	30 ms	11.00 - 16.00 G's	14.72
Max Pendulum G's Above 30 ms		22 G's Max	14.72
Deceleration - Time Curve Decay Time to 5 G's		38 - 46 ms	39.25
D Plane Rotation	Max	81 - 106 Deg	89.97
	Time	72 - 82 ms	73.75
Moment About Occipital Condyle	Max	-59.0 - -39.0 Ft-Lbs	-52.45
	Time	65 - 79 ms	68.63
Rotation Angle - Time Curve Decay Time to Zero		147 - 174 ms	150.50
Positive Moment - Time Curve Decay Time to Zero		120 - 148 ms	134.63

Remarks:

Laboratory Technician: B. Swiecicki

PART 572E
THORAX IMPACT TEST

Dummy Serial Number 245
Calspan Sequential Test Number 5
Date 11/18/97
Workfile 245597.th3

TEST PARAMETER	SPECIFICATION	TEST RESULTS
Temperature	69-72 Deg F	70
Relative Humidity	10% - 70%	30
Pendulum Velocity	21.6 - 22.4 Ft/s	22.00
Maximum Deflection	2.50 - 2.86 in	2.67
Maximum Resistive Force	1160 - 1325 Lbs	1302.28
Internal Hysteresis	69 - 85 %	73.47

Remarks:

Laboratory Technician: B. Swiecicki

PART 572E
KNEE IMPACT TEST

Dummy Serial Number 245
Calspan Sequential Test Number 5
Date 11/18/97
Workfile 245597.

TEST PARAMETER	SPECIFICATION	TEST RESULTS
LEFT KNEE		
Temperature	66 - 78 Deg F	71
Relative Humidity	10% - 70%	35
Probe Velocity	6.8 - 7.0 Ft/s	6.92
Peak Knee Impact Force	1060 - 1300 Lbs	1110.0
RIGHT KNEE		
Temperature	66 - 78 Deg F	71
Relative Humidity	10% - 70%	35
Probe Velocity	6.8 - 7.0 Ft/s	6.80
Peak Knee Impact Force	1060 - 1300 Lbs	1204.0

Remarks:

Laboratory Technician: B. Swiecicki

PART 572E
EXTERNAL DIMENSIONS

Dummy Serial Number 245
 Calspan Sequential Test Number 5
 Date 11/17/97

TEST PARAMETER		SPECIFICATION	TEST RESULTS
Temperature			71
Relative Humidity			35
Location for Chest Circumference	AA	16.9 - 17.1 in	17.0
Location for Waist Circumference	BB	8.9 - 9.1 in	9.0
Chest Circumference (With Jacket)	Y	38.2 - 39.4 in	39.0
Waist Circumference	Z	32.9 - 34.1 in	33.7
Chest Depth	O	8.4 - 9.0 in	8.4
H-Point Height	C	3.3 - 3.5 in	3.4
H-Point from Backline	D	5.3 - 5.5 in	5.4
Skull Cap to Backline	H	1.6 - 1.8 in	1.7
Total Sitting Height	A	34.6 - 35.0 in	34.9
Thigh Clearance	F	5.5 - 6.1 in	6.0
Buttock Knee Length	K	22.8 - 23.8 in	23.4
Buttock Popliteal Length	N	17.8 - 18.8 in	18.3
Popliteal Height	L	16.9 - 17.9 in	17.5
Knee Pivot Height	M	19.1 - 19.7 in	19.2
Foot Length	P	9.9 - 10.5 in	10.2
Foot Breadth	W	3.6 - 4.2 in	3.8
Shoulder Pivot from Backline	E	3.3 - 3.7 in	3.6
Shoulder Breadth	V	16.6 - 17.2 in	16.8
Shoulder Pivot Height	B	19.9 - 20.5 in	20.2
Elbow Rest Height	J	7.5 - 8.3 in	8.0
Shoulder - Elbow Length	I	13.0 - 13.6 in	13.2
Back of Elbow to Wrist Pivot	G	11.4 - 12.0 in	11.6

Remarks:

Laboratory Technician: B. Swiecicki

Appendix D

DUMMY, VEHICLE AND LABORATORY INSTRUMENT CALIBRATION

INSTRUMENT CALIBRATION FOR DRIVER DUMMY

(6 Month Calibration Minimum)

	Serial #	Manufacturer	Calibration	
			Last	Next
DRIVER DUMMY (S/N 064)				
Head				
X	AF5B3	ENDEVCO	8/97	2/98
Y	AF5F7	ENDEVCO	8/97	2/98
Z	AF5E1	ENDEVCO	8/97	2/98
Chest				
X	A08A	ENDEVCO	8/97	2/98
Y	ADL42	ENDEVCO	8/97	2/98
Z	A28F	ENDEVCO	8/97	2/98
Right Femur Load Cell	952	GSE	9/97	3/98
Left Femur Load Cell	951	GSE	9/97	3/98
Neck Load Cell				
X	076	DENTON	10/97	4/98
Y	076	DENTON	10/97	4/98
Z	076	DENTON	10/97	4/98
Neck Moment				
X	076	DENTON	10/97	4/98
Y	076	DENTON	10/97	4/98
Z	076	DENTON	10/97	4/98
Chest Deflection Gauge	064	HUMANOID	10/97	4/98
Hybrid III Use Only				
Lap Belt Load Cells	706	LEBOW	6/97	12/97
Shoulder Belt Load Cells	707	LEBOW	6/97	12/97
Spool-Out Potentiometer	N/A	MAGNETEK	-	-
Belt Stretch Transducer	E4	CALSPAN	9/97	3/98

INSTRUMENT CALIBRATION FOR DRIVER DUMMY

(6 Month Calibration Minimum)

DRIVER DUMMY	Serial #	Manufacturer	Calibration	
			Last	Next
Head				
X (R)	J17965	ENDEVCO	8/97	2/98
Y (R)	J18649	ENDEVCO	8/97	2/98
Z (R)	J18400	ENDEVCO	8/97	2/98
Chest				
X (R)	B11407	ENDEVCO	6/97	12/97
Y (R)	B11073	ENDEVCO	6/97	12/97
Z (R)	B11408	ENDEVCO	6/97	12/97
Pelvic				
X	C14953	ENDEVCO	8/97	2/98
Y	C14966	ENDEVCO	8/97	2/98
Z	C14968	ENDEVCO	8/97	2/98
Left Upper Tibia				
Mx	038	DENTON	10/97	4/98
Left Upper Tibia				
My	038	DENTON	10/97	4/98
Left Lower Tibia				
Fy	032	DENTON	10/97	4/98
Left Lower Tibia				
Fz	032	DENTON	10/97	4/98
Left Lower Tibia				
Mx	032	DENTON	10/97	4/98
Right Upper Tibia				
Mx	045	DENTON	10/97	4/98
Right Upper Tibia				
My	045	DENTON	10/97	4/98
Right Lower Tibia				
Fy	041	DENTON	10/97	4/98
Right Lower Tibia				
Fz	041	DENTON	10/97	4/98
Right Lower Tibia				
Mx	041	DENTON	10/97	4/98

INSTRUMENT CALIBRATION FOR DRIVER DUMMY

(6 Month Calibration Minimum)

DRIVER DUMMY	Serial #	Manufacture	Calibration		
			Last	Next	
Left Foot Front	Z	A14058	ENDEVCO	9/97	3/98
Left Foot Rear	X	A13929	ENDEVCO	9/97	3/98
Left Foot Rear	Z	A14150	ENDEVCO	9/97	3/98
Right Foot Front	Z	A14124	ENDEVCO	9/97	3/98
Right Foot Rear	X	A14181	ENDEVCO	9/97	3/98
Right Foot Rear	Z	A14126	ENDEVCO	9/97	3/98

INSTRUMENT CALIBRATION FOR PASSENGER DUMMY

(6 Month Calibration Minimum)

PASSENGER DUMMY (S/N 245)	Serial #	Manufacturer	Calibration	
			Last	Next
Head				
X	ADL98	ENDEVCO	8/97	2/98
Y	AE8K0	ENDEVCO	8/97	2/98
Z	ADMB6	ENDEVCO	8/97	2/98
Chest				
X	A26A	ENDEVCO	8/97	2/98
Y	A27A	ENDEVCO	8/97	2/98
Z	A51A	ENDEVCO	8/97	2/98
Right Femur Load Cell	232	GSE	9/97	3/98
Left Femur Load Cell	231	GSE	9/97	3/98
Neck Load Cell	440	DENTON	8/97	2/98
X	440	DENTON	8/97	2/98
Y	440	DENTON	8/97	2/98
Z	440	DENTON	8/97	2/98
Neck Moment	440	DENTON	8/97	2/98
X	440	DENTON	8/97	2/98
Y	440	DENTON	8/97	2/98
Z	440	DENTON	8/97	2/98
Chest Deflection Gauge	245	HUMANOID	10/97	4/98
Hybrid III Use Only				
Lap Belt Load Cells	635	LEBOW	6/97	12/97
Shoulder Belt Load Cells	711	LEBOW	6/97	12/97
Spool-Out Potentiometer	N/A	MAGNETEK	-	-
Belt Stretch Transducer	E4	CALSPAN	9/97	3/98

INSTRUMENT CALIBRATION FOR PASSENGER DUMMY

(6 Month Calibration Minimum)

PASSENGER DUMMY	Serial #	Manufacturer	Calibration	
			Last	Next
Head				
X (R)	A13829	ENDEVCO	11/97	5/98
Y (R)	AC8F6	ENDEVCO	8/97	2/98
Z (R)	ACCW0	ENDEVCO	8/97	2/98
Chest				
X (R)	AHRC9	ENDEVCO	8/97	2/98
Y (R)	ACTW8	ENDEVCO	8/97	2/98
Z (R)	ACC06	ENDEVCO	8/97	2/98
Pelvic				
X	AL6N5	ENDEVCO	8/97	2/98
Y	AL6R7	ENDEVCO	8/97	2/98
Z	A12C	ENDEVCO	8/97	2/98
Left Upper Tibia				
Mx	015	DENTON	10/97	4/98
Left Upper Tibia				
My	015	DENTON	10/97	4/98
Left Lower Tibia				
Fy	011	DENTON	10/97	4/98
Left Lower Tibia				
Fz	011	DENTON	10/97	4/98
Left Lower Tibia				
Mx	011	DENTON	10/97	4/98
Right Upper Tibia				
Mx	016	DENTON	10/97	4/98
Right Upper Tibia				
My	016	DENTON	10/97	4/98
Right Lower Tibia				
Fy	012	DENTON	10/97	4/98
Right Lower Tibia				
Fz	012	DENTON	10/97	4/98
Right Lower Tibia				
Mx	012	DENTON	10/97	4/98

INSTRUMENT CALIBRATION FOR PASSENGER DUMMY

(6 Month Calibration Minimum)

PASSENGER DUMMY	Serial #	Manufacture	Calibration	
			Last	Next
Left Foot Front Z	A13011	ENDEVCO	9/97	3/98
Left Foot Rear X	A13506	ENDEVCO	9/97	3/98
Left Foot Rear Z	A12268	ENDEVCO	9/97	3/98
Right Foot Front Z	J18418	ENDEVCO	8/97	2/98
Right Foot Rear X	AEWK1	ENDEVCO	8/97	2/98
Right Foot Rear Z	AKD92	ENDEVCO	8/97	2/98

INSTRUMENT CALIBRATION FOR VEHICLE ACCELEROMETERS

(6 Month Calibration Minimum)

	Serial #	Manufacturer	Calibration	
			Last	Next
Left Seat Rear Crossmember	X26	ICS	9/97	3/98
Right Rear Seat Crossmember	X91	ICS	10/97	4/98
Top of Engine	Y89	ICS	8/97	2/98
Bottom of Engine	AZ17	ICS	10/97	4/98
Left Disc Brake Caliper	A44	CEC	10/97	4/98
Right Disc Brake Caliper	A56	CEC	10/97	4/98
Instrument Panel	A129	CEC	10/97	4/98
Left Seat Rear Crossmember (R)	D79	ICS	9/97	3/98
Right Seat Rear Crossmember (R)	Y25	ICS	10/97	4/98