

2256

REPORT NUMBER: 208-CAL-95-9
212-CAL-95-9
301-CAL-95-9

**VEHICLE SAFETY COMPLIANCE TESTING FOR OCCUPANT CRASH PROTECTION
WINDSHIELD MOUNTING, WINDSHIELD ZONE INTRUSION (PARTIAL)
AND FUEL SYSTEM INTEGRITY**

FORD MOTOR COMPANY, U.S.A.
1995 Ford Explorer XLT
4-door 4 x 4

NHTSA NUMBER: CS0212

CALSPAN TEST NUMBER: 8221-13

February 23, 1995

CALSPAN CORPORATION
ADVANCED TECHNOLOGY CENTER
P.O. BOX 400
BUFFALO, NEW YORK 14225



FINAL REPORT

PREPARED FOR:

U. S. Department of Transportation
National Highway Traffic Safety Administration
ENFORCEMENT
Office of Vehicle Safety Compliance
400 Seventh Street, S. W.
Room No. 6115 (NEF-30)
Washington, DC 20590

*Rec'd
7/14/95*

This publication is distributed by the U.S. Department of Transportation, National Highway Traffic Safety Administration, in the interest of information exchange. The opinions, findings and conclusions expressed in this publication are those of the author(s) and not necessarily those of the Department of Transportation or the National Highway Traffic Safety Administration. The United States Government assumes no liability for its contents or use thereof. If trade or manufacturers' names or products are mentioned, it is only because they are considered essential to the object of the publication and should not be construed as an endorsement. The United States Government does not endorse products or manufacturers.

Prepared By: *Reginald E. Evans*
Reginald E. Evans, Project Engineer

Approved By: *David J. Travale*
David J. Travale, Program Manager
Transportation Sciences Center

Approval Date: June 21, 1995

FINAL REPORT ACCEPTANCE BY OVSC:

Accepted By: *Chris K...*

Acceptance Date: 4/11/96

TECHNICAL REPORT STANDARD TITLE PAGE

1. Report No. 208-CAL-95-9 212-CAL-95-9 301-CAL-95-9		2. Government Accession No.		3. Recipient's Catalog No.	
4. Title and Subtitle Final Report of FMVSS 208, 212, 219 (Partial), and 301 Compliance Testing of a 1995 Ford Explorer XLT 4-door 4 x 4 NHTSA No. CS0212				5. Report Date February 23, 1995	
				6. Performing Organization Code CAL	
7. Author(s) Reginald E. Evans, Project Engineer David J. Travale, Program Manager				8. Performing Organization Report No. 8221-13	
9. Performing Organization Name and Address Calspan Advanced Technology Center P.O. Box 400 Buffalo, New York 14225				10. Work Unit No.	
				11. Contract or Grant No. DTNH22-93-D-11089	
12. Sponsoring Agency Name and Address U.S. Department of Transportation National Highway Traffic Safety Administration Office of Vehicle Safety Compliance (NEF-30) 400 Seventh St , S.W., Rm. 6115, Washington, D.C. 20590				13. Type of Report and Period Covered Final - Feb.-June 1995	
				14. Sponsoring Agency Code NEF-30	
15. Supplementary Notes					
16. Abstract A 30 mph vehicle safety compliance test was conducted on a 1995 Ford Explorer XLT 4-door 4 x 4. This test was performed at the Calspan Advanced Technology Center in Buffalo, New York on February 23, 1995. The purpose of this test was to determine compliance with the performance requirements of the following Federal Motor Vehicle Safety Standards: <ol style="list-style-type: none"> 1. FMVSS No. 208, "Occupant Crash Protection" 2. FMVSS No. 212, "Windshield Mounting" 3. FMVSS No. 219 (partial), "Windshield Zone Intrusion" 4. FMVSS No. 301, "Fuel System Integrity" <p>The test mode was perpendicular (0°) and the impact velocity was 29.4 mph. The ambient temperature at the impact face was 70 °F.</p> <p>The subject test vehicle appears to comply with the requirements of FMVSS Nos. 208, 212, 219 (partial) and 301.</p> <p><u>Type of Restraint System:</u> The test vehicle was equipped with a driver air bag and a passenger air bag restraint system. The manual seat belts were not used for this test.</p>					
17. Key Words Compliance Testing Safety Engineering FMVSS 208			18. Distribution Statement Copies of this report are available from: NHTSA Technical Reference Division ; Mail Code: NAD-52 400 Seventh , S.W., Room 5108, Washington, D.C. 20590 Telephone No. (202) 366-4946 Attn: Robert Hornickle		
19. Security Classif. (of this report) UNCLASSIFIED		20. Security Classif. (of this page) UNCLASSIFIED		21. No. of Pages 154	22. Price

TABLE OF CONTENTS

<u>Section</u>		<u>Page No.</u>
1	PURPOSE AND TEST PROCEDURE	1-1
2	SUMMARY OF FRONTAL BARRIER IMPACT TEST	2-1
3	OCCUPANT AND VEHICLE INFORMATION	3-1
4	SUMMARY OF RESULTS FOR: FMVSS 208, "Occupant Crash Protection" FMVSS 212, " Windshield Mounting" FMVSS 219 (Partial), "Windshield Zone Intrusion" FMVSS 301, "Fuel System Integrity"	4-1
APPENDIX A	PHOTOGRAPHS	A-1
APPENDIX B	VEHICLE AND DUMMY RESPONSE DATA	B-1
APPENDIX C	VEHICLE OWNER'S MANUAL OCCUPANT RESTRAINT SYSTEM INSTRUCTIONS	C-1

LIST OF FIGURES

<u>Figure No.</u>		<u>Page No.</u>
1	TEST VEHICLE INFORMATION	3-2
2	PART 572 DUMMY IN-VEHICLE POSITION	3-3
3	SEAT BELT POSITIONING DATA	3-5
4	VEHICLE ACCELEROMETER LOCATIONS	3-6
5	CAMERA POSITION FOR FRONTAL IMPACT	3-8
6	VEHICLE TARGET LOCATIONS	3-10
7	TEST VEHICLE MEASUREMENTS	3-11
8	FMVSS NO. 212 - "WINDSHIELD MOUNTING" DATA SHEET	4-12
9	FMVSS NO. 219 - (PARTIAL) - "WINDSHIELD ZONE INTRUSION" DATA SHEET	4-13

LIST OF TABLES

<u>Table No.</u>		<u>Page No.</u>
1	CRASH TEST SUMMARY	2-2
2	GENERAL TEST AND VEHICLE PARAMETER DATA	2-3
3	POST-IMPACT DATA	2-5
4	FRONT SEAT OCCUPANT MEASUREMENTS	3-4
5	VEHICLE ACCELEROMETER LOCATIONS AND DATA SUMMARY	3-7
6	HIGH SPEED CAMERA LOCATIONS	3-9
7	VEHICLE MEASUREMENTS	3-12
8	DUMMY INJURY CRITERIA VALUES	4-2
9	FMVSS NO. 208 - SEAT BELT WARNING SYSTEM CHECK	4-3
10	FMVSS NO. 208 - LABELING AND DRIVER'S MANUAL INFORMATION	4-4
11	FMVSS NO. 208 - READINESS INDICATOR	4-5
12	FMVSS NO. 208 - COMFORT AND CONVENIENCE TEST SUMMARY	4-6
13	FMVSS NO. 301 - "FUEL SYSTEM INTEGRITY" POST-IMPACT TEST DATA	4-14
14	FMVSS NO. 301 - STATIC ROLLOVER DATA SHEET	4-15
15	POST TEST AIR BAG DATA	4-19
16	ACCIDENT INVESTIGATION DIVISION DATA	4-20
17	TEST VEHICLE NONCOMPLIANCE NOTICE	4-21

Section 1

PURPOSE AND TEST PROCEDURE

This 30 mph frontal barrier impact test is part of the Federal Motor Vehicle Safety Standard (FMVSS) 208, 212, 219 (partial) and 301 compliance test program conducted for the National Highway Traffic Safety Administration (NHTSA) by Calspan Advanced Technology Center under Contract No. DTNH22-93-D-11089. The purpose of this test was to determine if the subject vehicle, a 1995 Ford Explorer XLT 4-door 4 x 4, meets the performance requirements of FMVSS 208, "Occupant Crash Protection"; FMVSS No. 212, "Windshield Mounting"; FMVSS No. 219 (partial), "Windshield Zone Intrusion"; and FMVSS No. 301, "Fuel System Integrity". This compliance test was conducted using the requirements found in the OVSC Laboratory Test Procedure No. TP-208-09, dated March 15, 1993.

Section 2

SUMMARY OF TEST NUMBER CS0212

A frontal barrier was impacted by a 1995 Ford Explorer XLT 4-door 4 x 4 at a velocity of 29.4 mph. The test was performed at the Calspan Corporation Advanced Technology Center on February 23, 1995. Pre- and Post-test photographs of the vehicle and dummies can be found in Appendix A.

The frontal barrier impact event was documented by one real-time camera and 14 high-speed cameras. Camera locations and other pertinent camera information can be found in this report.

Two Part 572E, 50th percentile male anthropomorphic test devices (ATDs), were placed in the driver and right-front passenger seating positions according to dummy placement instructions specified in the OVSC Laboratory Test Procedure.

Both ATDs were fully instrumented with head and chest three axis (x, y, and z) accelerometers, chest displacement potentiometers and left/right femur load cells. These ATDs had been certified prior to the test.

The 26 channels of data were recorded on a P.C. based data acquisition system. Appendix B contains the vehicle and dummy response data traces.

The driver's HIC was 309.36. The maximum chest deceleration over 3 milliseconds was 53.158 g's with -1.5 inches of deflection. The maximum force on the driver's left femur was -1500.4 pounds and -1565.3 pounds on the right femur.

The right front passenger's HIC was 199.89. The maximum chest deceleration over 3 milliseconds was 44.611 g's with -0.7 inches of deflection. Loads of -1375.7 and -1753.2 pounds were recorded on the left and right femurs respectively.

Table 1

CRASH TEST SUMMARY

Vehicle NHTSA No. :	<u>CS0212</u>	Test Mode :	<u>30 mph Frontal Barrier</u>
Test Date :	<u>February 23, 1995</u>	Time:	<u>13:30</u> Temperature : <u>70</u> °F
Vehicle Make/Model/Body Style :	<u>1995 Ford Explorer XLT 4-door 4 x 4</u>		
Vehicle Test Weight :	<u>4850</u>	lbs	
Vehicle/Barrier Impact Angle :	<u>0</u>	°	
Impact Velocity :	<u>29.4</u>	mph	
Maximum Static Crush :	<u>18.2</u>	inches	
Vehicle Rebound :	<u>* 1.1</u>	inches	
<u>DUMMIES:</u>	<u>DRIVER</u>		<u>PASSENGER</u>
Type :	<u>Part 572 E</u>		<u>Part 572 E</u>
Restraint System :	<u>Air bag</u>		<u>Air bag</u>
Number of Data Channels :	<u>26</u>		
Number of Cameras :	<u>1</u>	Real Time	
	<u>14</u>	High Speed	
<u>DOOR OPENING DATA :</u>	<u>Operable</u>		<u>- Left Front</u>
	<u>Operable</u>		<u>- Right Front</u>
Front Seat(s) Data :	<u>DRIVER</u>		<u>PASSENGER</u>
Seat Track Failure :	<u>None</u>		<u>None</u>
			Inches of shift
Seat Back Failure :	<u>0.0</u>		<u>0.0</u>
<u>VISIBLE DUMMY CONTACT POINTS :</u>	<u>DRIVER</u>		<u>PASSENGER</u>
Head :	<u>Face with air bag, rear of head with seat back.</u>		<u>Face with air bag.</u>
Abdomen :	<u>Air bag</u>		<u>Air bag</u>
Chest	<u>Air bag</u>		<u>Air bag</u>
Knees	<u>Lower dash panel</u>		<u>Glove box door</u>

* Center line rebound measurement unobtainable due to vehicle position. This figure was averaged from right and left rebound distances only.

Table 2

GENERAL TEST AND VEHICLE PARAMETER DATA

TEST VEHICLE INFORMATION :

Year/Make/Model/Body Style : 1995 Ford Explorer XLT 4-door 4 x 4
 NHTSA No. : CS0212 ; VIN: 1FMDU34X1SUA24748 ; Color : Green
 Engine Data: 6 cylinders; - CID; 4.0 Liters; - cc
 Placement : X Longitudinal or In-Line; - Transverse of Lateral
 Transmission Data : 4 speeds; - Manual; X Automatic; X Overdrive
 Final Drive : X Rear Wheel Drive; X Front Wheel Drive; X Four Wheel Drive
 Major Options : X A/C; X Pwr.Strg.; X Pwr. Brakes
X Pwr. Windows; X Pwr. Door Locks; X Tilt Wheel
 Date Received : 1-26-95 ; Odometer Reading 26.0 miles
 Selling Dealer : WEST - HERR FORD, INC.
 & Address: S 5025 Camp Road, Hamburg, N.Y. 14075

DATA FROM TIRE VEHICLE'S CERTIFICATION LABEL:

Vehicle Manufactured by : FORD MOTOR COMPANY, U.S.A.
 Date of Manufacture January, 1995
 GVWR : 5280 lbs.; GAWR: 2710 lbs. FRONT; 2900 lbs. REAR

DATA FROM TIRE PLACARD:

Tire Pressure with Maximum Capacity Vehicle Load : 26 psi FRONT
26 psi REAR
 Recommended Tire Size : P235 / 75 R15 M
 * Recommended Cold Tire Pressure : 26 psi FRONT; 26 psi REAR
 Size of Tires on Test Vehicle: P235 / 75 R15 M ; Manufacturer: Goodyear
 Vehicle Capacity Data :
 Type of Front Seats: - Bench; X Bucket; - Split Bench
 Number of Occupants: 2 Front; 3 Rear; 5 Total
 Vehicle Capacity Weight (VCW) = 974 lbs.
 No. of Occupants x 150 lbs. = 750 lbs.
 Rated Cargo/Luggage Weight (RCLW) = 224 lbs.

*Tire pressure used for test

Table 2

GENERAL TEST AND VEHICLE PARAMETER DATA (cont.)

WEIGHT OF TEST VEHICLE AS RECEIVED FROM DEALER (with maximum fluids)= UDW:

Right Front	=	<u>1087</u>	lbs.	Right Rear	=	<u>1000</u>	lbs.
Left Front	=	<u>1153</u>	lbs.	Left Rear	=	<u>1066</u>	lbs.
TOTAL FRONT	=	<u>2,240</u>	lbs.	TOTAL REAR	=	<u>2,066</u>	lbs.
TOTAL DELIVERED WEIGHT = <u>4,306.0</u> lbs.							
% of Total Front of Vehicle Weight = <u>52.0</u> %				% of Total Rear Weight = <u>48.0</u> %			

CALCULATION OF VEHICLE'S TARGET TEST WEIGHT :

Total Delivered Weight	=	<u>4,306</u>	lbs.
Rated Cargo/Luggage Weight (RCLW)	=	<u>224</u>	lbs.
Weight of 2 p.572 Dummies @ 167 each	=	<u>334</u>	lbs.
TARGET TEST WEIGHT	=	<u>4,864</u>	lbs.

WEIGHT OF TEST VEHICLE WITH TWO DUMMIES AND 210 POUNDS OF CARGO WEIGHT:

Right Front	=	<u>1185</u>	lbs.	Right Rear	=	<u>1192</u>	lbs.
Left Front	=	<u>1244</u>	lbs.	Left Rear	=	<u>1229</u>	lbs.
TOTAL FRONT	=	<u>2,429</u>	lbs.	TOTAL REAR	=	<u>2,421</u>	lbs.
TOTAL TEST WEIGHT = <u>4,850.0</u> lbs.							
% of Total Front Weight = <u>50.1</u> %				% of Total Rear Weight = <u>49.9</u> %			
Weight of Ballast Secured in Vehicle Trunk Area = <u>252</u> lbs.							
Vehicle Components Removed for Weight Reduction: <u>None</u>							

VEHICLE ATTITUDE (all dimension in inches) :

AS DELIVERED :	RF	<u>34.4</u>	LF	<u>34.4</u>	RR	<u>33.8</u>	LR	<u>33.1</u>
FULLY LOADED :	RF	<u>34.4</u>	LF	<u>34.3</u>	RR	<u>32.5</u>	LR	<u>31.9</u>
AS TESTED :	RF	<u>34.4</u>	LF	<u>34.3</u>	RR	<u>32.6</u>	LR	<u>32.2</u>
Vehicle's Wheel Base : <u>111.8</u> in.								
Location of Vehicle's C.G. : <u>55.8</u> inches rearward of front wheel center.								

FUEL SYSTEM DATA :

Fuel System Capacity From Owner's Manual	=	<u>22.0</u>	gallons
Usable Capacity Figure Furnished by COTR	=	<u>22.0</u>	gallons
Test Volume Range (92 to 94% of Usable Capacity)	=	<u>20.2</u>	to <u>20.7</u> gallons
ACTUAL TEST VOLUME	=	<u>20.4</u>	gallons (with entire fuel system filled)

Table 3

POST IMPACT DATA

TYPE OF TEST:

Type of Test : Frontal Barrier Impact Angle : 0°
 Test Date : February 23, 1995 Time: 13:30 Temperature: 70 °F
 Vehicle NHTSA No. : CS0212
 Required Impact Velocity Range : 28.9 to 29.9 mph

BARRIER IMPACT VELOCITY: (Speed traps within 5 feet of impact plane.)

Trap No. 1 = 29.4 mph; Trap No. 2 = 29.4 mph
 Distance from vehicle to barrier : (1) entering trap = 52 inches
 (2) exiting trap = 12 inches

VEHICLE STATIC CRUSH: (For frontal and rear impacts only.)

Vehicle Length:

Pre-Test Right = 186.2 ; C/L = 188.5 ; Left = 186.2
 Post-Test Right = 170.2 ; C/L = 170.3 ; Left = 169.5
 Crush Right = 16.0 ; C/L = 18.2 ; Left = 16.7
 AVERAGE = 17.0 inches

VEHICLE REBOUND: (From rigid barrier only.)

Distance from front of test vehicle to impact point :

Right = 1.3 ; C/L = * N/A ; Left = 2.0
 AVERAGE = * 1.1 inches

DOOR OPENING :

	Left	Right
Front	<u>Operable</u>	<u>Operable</u>
Rear	<u>Operable</u>	<u>Operable</u>

SEAT MOVEMENT :

	Seat Back Failure	Seat Shift
Front	<u>None</u>	<u>0.0</u>
Rear	<u>N/A</u>	<u>N/A</u>

* Center line rebound measurement unobtainable due to vehicle position. This figure was averaged from right and left rebound distances only.

Table 3

POST IMPACT (cont.)

GLAZING DAMAGE :

None

OTHER NOTABLE IMPACT FEATURES :

Steering column stroked upward.

Section 3
OCCUPANT AND VEHICLE DATA

Figure 1

TEST VEHICLE INFORMATION

VEHICLE IDENTIFICATION:

Model Year : 1995 Vehicle Model: Ford Explorer XLT Body Style : 4-door 4 x 4

1. Nominal Design Riding Position for adjustable driver and passenger seat backs. Please describe how to position the inclinometer to measure the seat back angle. Include description of the location of the adjustment latch detent, if applicable.

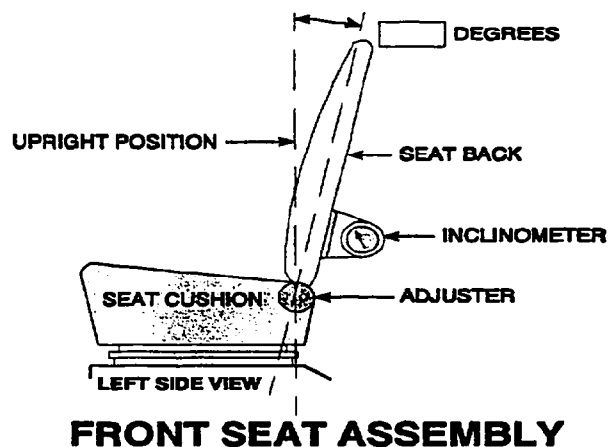

Seat back angle for driver's seat : 18 deg.

Measurement instructions : Place inclinometer at seat back frame 13 inches up from pivot point.

Seat back angle for passenger's seat : 18 deg.

Measurement instructions : Same as driver seating position.

2. Seat Fore and Aft Positioning

Positioning of the driver's seat : Seat set at mid position, 4.9 inches from foremost locking position. Total seat travel equals 9.8 inches.

Positioning of the passenger's seat (if applicable) : Same as driver seating position.

3. Fuel Tank Capacity Data

A. "Usable Capacity" of the standard equipment fuel tank is 22.0 gallons

B. "Usable Capacity" of the optional equipment fuel tank is - gallons

4. Steering Column Position :

Steering column set at third locking position (mid) of five notches total.

5. Other:

Seat belt anchorages set in third locking positions (mid) of five total. (belts not used for test)

Figure 2

PART 572 DUMMY IN-VEHICLE POSITION

DUMMY MEASUREMENT FOR FRONT SEAT PASSENGERS

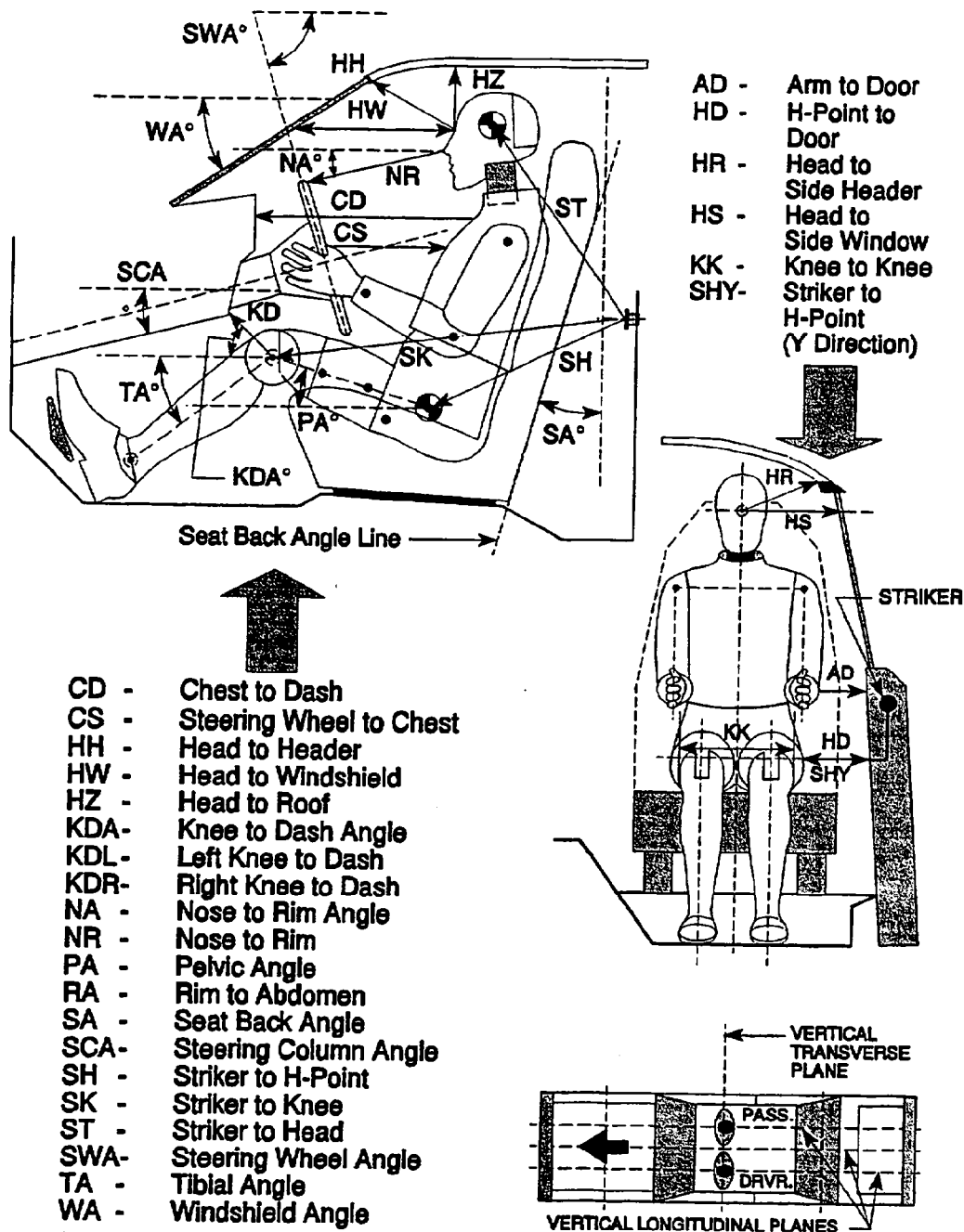

Table 4

FRONT SEAT OCCUPANT MEASUREMENTS

(All dimensions excluding angles are in inches).

	DRIVER (Serial #290)			PASSENGER (Serial #313)		
WA°	36.5 deg.			-		
SWA°	69 deg.			-		
SCA°	21 deg.			-		
SA°	18 deg.			18 deg.		
HZ	8.2			8.0		
HH	13.3			15.0		
HW	19.2			21.0		
HR	9.7			9.6		
NR	12.2	Angle	11 deg.	-		
CD	19.2			21.7		
CS	9.9			-		
RA	6.0			-		
KDL/KDA	6.7	Angle	31 deg.	6.0		
KDR/KDA	6.7			6.2	Angle	25 deg.
PA°	22 deg.			22 deg.		
TA°	31 deg.			35 deg.		
KK	10.7			10.5		
ST	21.5	Angle	18 deg.	21.2	Angle	10 deg.
SK	23.9	Angle	94 deg.	23.7	Angle	94 deg.
SH	10.5	Angle	125 deg.	9.6	Angle	122 deg.
SHY	8.5			9.0		
HS	14.5			13.5		
HD	4.8			5.8		
AD	4.2			3.8		

Figure 3

SEAT BELT POSITIONING DATA

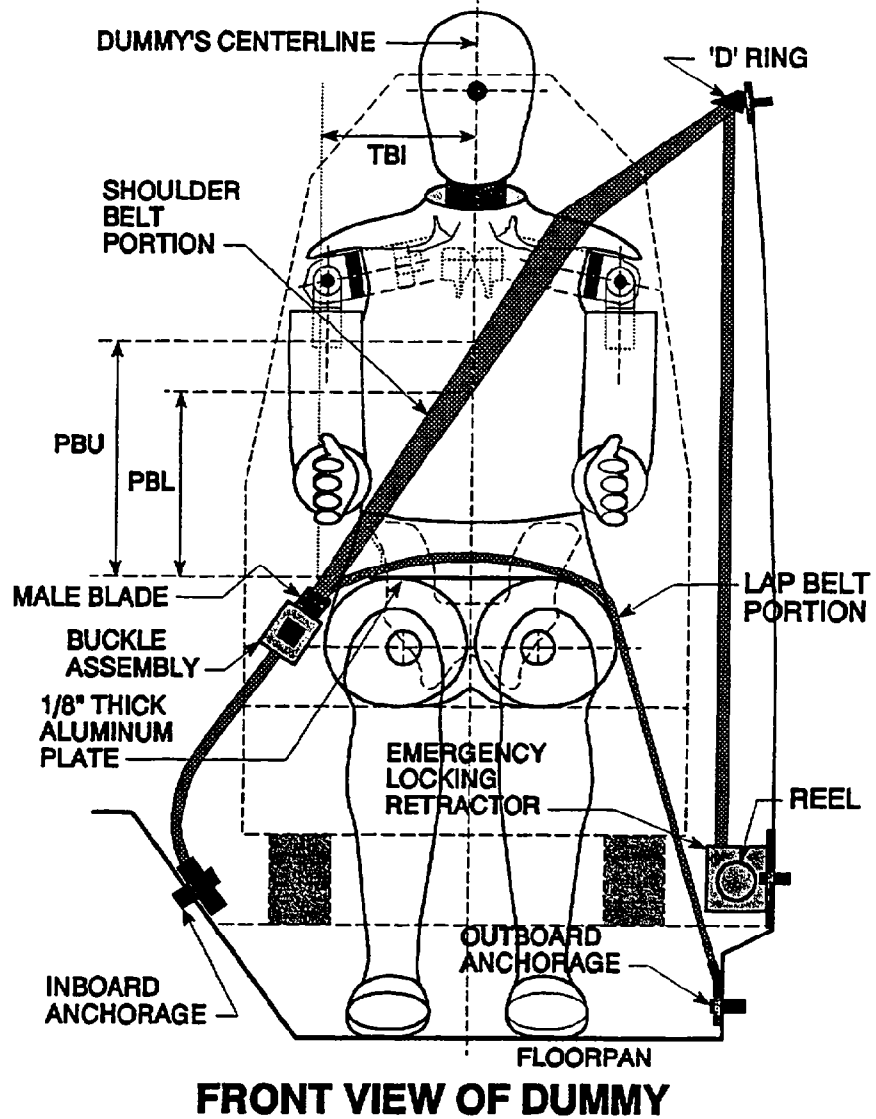

FRONT VIEW OF DUMMY

	DRIVER DUMMY (inches)	PASSENGER DUMMY (inches)
<u>PBU</u> -- Top surface of alum. plate to upper edge	*	*
<u>PBL</u> -- Top surface of alum. plate to belt lower edge	*	*
<u>TBI</u> -- Distance from torso centerline to buckle	*	*

* Vehicle equipped with air bag, manual seat belt not used for this position.

Figure 4

VEHICLE ACCELEROMETER LOCATION AND DATA SUMMARY

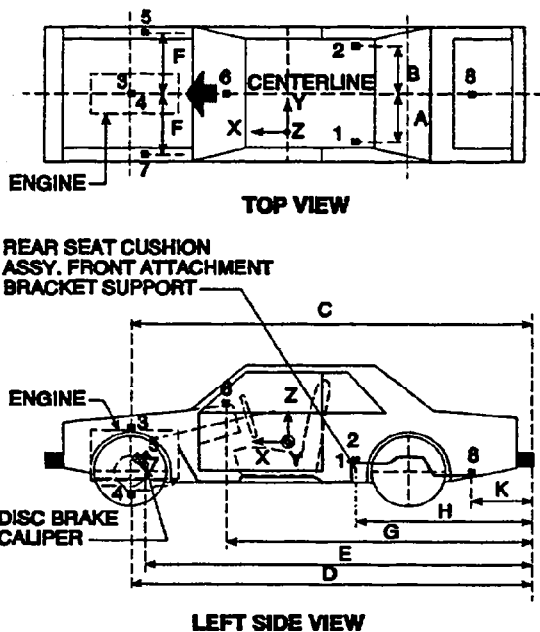

ACCELEROMETER NUMBER*	ACCELEROMETER LOCATION	DIRECTION		
		X	Y	Z
1	Left Rear Seat Crossmember	X		
2	Right Rear Seat Crossmember	X		
3	Top of Engine	X		
4	Bottom of Engine	X		
5	Right Disc Brake Caliper	X		
6	Instrument Panel	X		
7	Left Disc Brake Caliper	X		
8	Trunk Z			X

*The accelerometer pack number can be correlated with the vehicle response data traces found in Appendix B.

Table 5

VEHICLE ACCELEROMETER LOCATIONS AND DATA SUMMARY

DIMENSION	LENGTH (Inches)	
	PRE-TEST VALUES	POST-TEST VALUES
A Left Rear Seat Crossmember Y	22.7	22.7
B Right Rear Seat Crossmember Y	22.7	22.7
C Top of Engine X	149.5	143.5
D Bottom of Engine X	147.7	144.0
E Disc Brake Calipers X	152.2	Right = 151.7 Left = 152.2
F Disc Brake Calipers Y	18.3	18.5
G Instrument Panel X	123.0	126.2
H Rear Seat Crossmembers X	63.5	63.5
K Trunk X	18.4	18.4

LOCATION NUMBER	DESCRIPTION	MAXIMUM VALUE			
		Pos.	msec.	Neg.	msec.
1	Rear Seat X-Member @ Left Side	3.0	145.8	-32.6	30.2
2	Rear Seat X-Member @ Right Side	2.2	164.8	-36.4	30.6
3	Top of Engine Block	30.4	72.1	-66.8	35.5
4	Bottom of Engine	4.5	63.1	-51.9	40.8
5	Disc Brake Caliper @ Right Side	20.4	31.0	-81.8	49.8
6	Instrument Panel	34.5	37.6	-85.3	61.7
7	Disc Brake Caliper @ Left Side	13.8	31.4	-51.3	47.9
8	Trunk	39.9	175.1	-29.6	111.2

Figure 5

CAMERA POSITIONS FOR FRONTAL IMPACTS

NOTE: Camera Information shown on Table 5.

CAMERA POSITIONS FOR FRONTAL IMPACTS

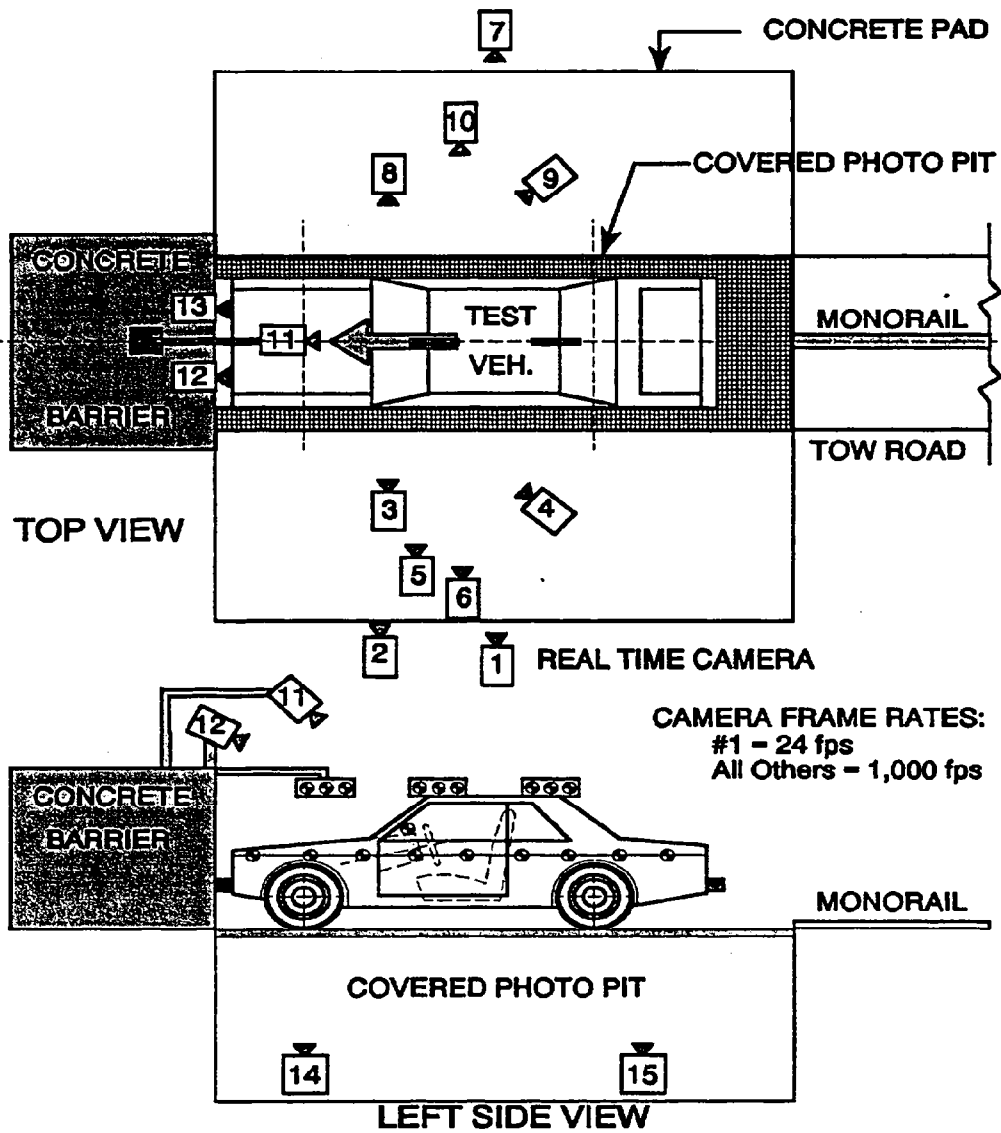

Table 6

HIGH-SPEED CAMERA LOCATIONS

Camera No.	VIEW	CAMERA POSITIONS (In.)*			ANGLE** (deg)	FILM PLANE TO HEAD TARGET (In.)	LENS (mm)	SPEED (fps)
		X	Y	Z				
1	Real-Time Camera	-	-	-	-	-	24	
2	Overall Left Side	246	65	41	-2	228.2	1030	
3	Left Side View	324	53	41	-2	306.2	1000	
4	Driver and Interior View	112	115	75	-18	-	1000	
5	Steering Column (Bottom)	295	87	46	-2	277.2	1140	
6	Steering Column (Top)	295	87	70	-6	277.2	1155	
7	Overall Right Side	258	81	43	-1	240.2	1060	
8	Right Side View	322	58	41	0	304.2	1030	
9	Passenger and Interior View	306	79	56	-1	-	1105	
10	Right Passenger View	103	116	72	-16	-	1050	
11	Windshield View	22	20	73	-34	-	1060	
12	Driver Front View	22	20	73	-34	-	1000	
13	Passenger Front View	10	0	127	-57	-	1010	
14	Pit View of Engine	36	0	-86	90	-	1050	
15	Pit View of Fuel Tank	118	0	-86	90	-	910	

*X = film plane to monorail centerline
 Y = film plane to impact location
 Z = film plane to ground
 ** = referenced to horizontal plane

Figure 6

VEHICLE TARGET LOCATIONS
(All dimensions in inches)

Key (Inches)

A =	14.8
B =	24.6

C =	48.0
D =	87.3
E =	0.0
F =	63.2
G =	35.0
H =	35.3
I =	6.3
J =	55.2
K =	41.6
L =	56.7

M =	0.0
N =	6.5
O =	35.0
P =	35.3
Q =	56.7
R =	41.5
S =	55.0

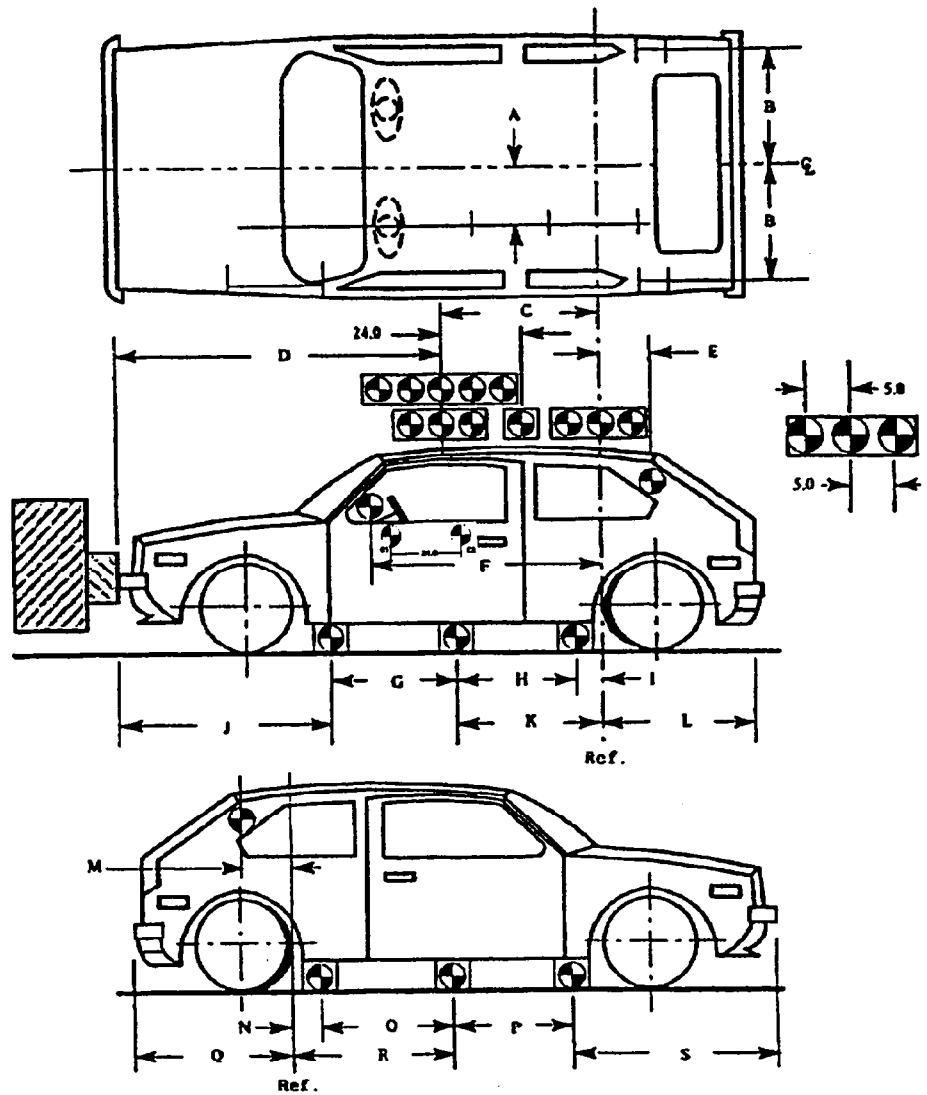

Note: Targets on front fender are 12.0 inches apart.
Targets rearward of front fender are 24.0 inches apart.

Figure 7

TEST VEHICLE MEASUREMENTS

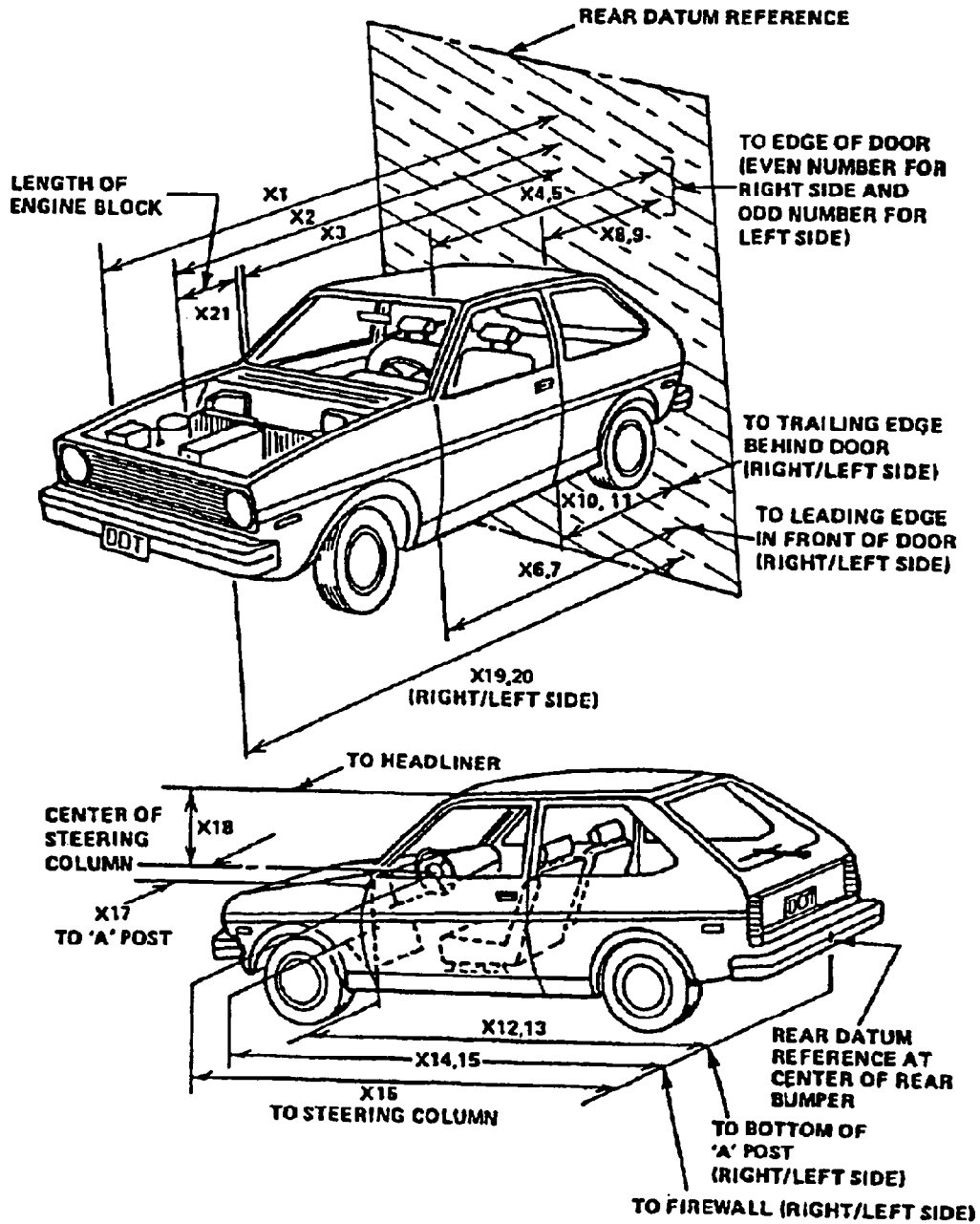

Table 7

VEHICLE MEASUREMENTS

No.		All Dimensions in inches		
		Pre-Test	Post-Test	Differences
X1	Total Length of Vehicle at Centerline	188.5	170.3	18.2
X2	Rear Surface of Vehicle to Front of Engine	160.6	157.7	2.9
X3	Rear Surface of Vehicle to Firewall	142.0	143.0	-1.0
X4	Rear Surface of Vehicle to Upper Leading Edge of Right Door	130.7	130.3	0.4
X5	Rear Surface of Vehicle to Upper Leading Edge of Left Door	130.8	130.4	0.4
X6	Rear Surface of Vehicle to Lower Leading Edge of Right Door	128.7	128.1	0.6
X7	Rear Surface of Vehicle to Lower Leading Edge of Left Door	128.9	127.9	1.0
X8	Rear Surface of Vehicle to Upper Trailing Edge of Right Door	89.3	89.6	-0.3
X9	Rear Surface of Vehicle to Upper Trailing Edge of Left Door	89.3	89.6	-0.3
X10	Rear Surface of Vehicle to Lower Trailing Edge of Right Door	90.1	89.5	0.6
X11	Rear Surface of Vehicle to Lower Trailing Edge of Left Door	90.0	89.4	0.6
X12	Rear Surface of Vehicle to Bottom of "A" Post of Right Side	134.0	133.4	0.6
X13	Rear Surface of Vehicle to Bottom of "A" Post of Left Side	134.0	133.4	0.6
X14	Rear Surface of Vehicle to Firewall, Right Side	139.5	140.7	-1.2
X15	Rear Surface of Vehicle to Firewall, Left Side	140.0	141.2	-1.2
X16	Rear Surface of Vehicle to Steering Column	113.0	115.0	-2.0
X17	Center of Steering Column to "A" Post	12.5	13.5	-1.0
X18	Center of Steering Column to Headliner	17.0	14.5	2.5
X19	Rear Surface of Vehicle to Right Side of Front Bumper	186.2	170.2	16.0
X20	Rear Surface of Vehicle to Left Side of Front Bumper	186.2	169.5	16.7
X21	Length of Engine Block	19.0	19.0	0.0

Section 4

SUMMARY OF RESULTS OF FMVSS NOS. 208, 212, 219 AND 301

- "Occupant Crash Protection," FMVSS No. 208 Data
- "Windshield Mounting," FMVSS No. 212 Data
- "Windshield Zone Intrusion," FMVSS No. 219 (Partial) Data
- "Fuel System Integrity," FMVSS No. 301

Table 8

DUMMY INJURY CRITERIA VALUES

NHTSA No. : CS0212 Vehicle : 1995 Ford Explorer XLT 4-door 4 x 4

	MAXIMUM ACCELERATION (g's)								
	HEAD				CHEST				
	X	Y	Z	R	X	Y	Z	R*	Displacement
Dummy (1)	-49.2	7.6	16.8	51.3	-51.8	-6.2	15.1	53.158	-1.5
Dummy (2)	-32.0	-21.1	25.3	43.4	-41.7	-10.1	20.4	44.611	-0.7

	MAXIMUM FORCE - FEMUR LOAD (lbs.)	
	LEFT FEMUR	RIGHT FEMUR
Dummy (1)	-1500.4	-1565.3
Dummy (2)	-1375.7	-1753.2

	HEAD INJURY CRITERIA**			
	HIC	36 millisecond Maximum		Avg. Acc (g)
		t ₁ (msec)	t ₂ (msec)	t ₁ TO t ₂
Dummy (1)	309.36	58.560	94.440	37.52
Dummy (2)	199.89	54.600	88.080	32.39

* Defined as exceeding 0.003 sec. duration

**As defined in FMVSS No. 208

Table 9

FMVSS NO. 208 - SEAT BELT WARNING SYSTEM CHECK

With occupant in driver's position, the lap belt in stowed position, and ignition switch placed in "Start/On" position:

Log time duration of audible warning signal = 6.0 sec.

Log time duration of reminder light operation = Continuous sec.

With occupant in driver's position, lap belt in use, and the ignition switch placed in "Start/On" position :

Log time duration of audible warning signal
(audible warning should not operate) = 0.0 sec.

Log time duration of reminder light operation = 0.0 sec.

Note wording of visual warning :

Fasten Seat Belt -

Fasten Belt -

Symbol 101 √

Table 10

FMVSS NO. 208 - LABELING AND DRIVER'S MANUAL INFORMATION

Locate label which describes manufacturers maintenance or replacement schedule for crash-deployed occupant protection system.

Describe location :

Label located on inside panels of driver and passenger sunvisors.

The label states, "See owner's manual for information and explanations."

Were appropriate instructions concerning maintenance and/or replacement of this system provided ?

YES √ NO -

Was a description of the functional operation of the system provided ?

YES √ NO -

Is there a reference to the instructions and description of the system on the label ?

YES √ NO -

Was an owner's manual provided ?

YES √ NO -

Did the owner's manual contain appropriate information concerning maintenance and/or replacement and a description of the functional operation of the system ?

YES √ NO -

Table 11

FMVSS NO. 208 - READINESS INDICATOR

An occupant restraint system that deploys in the event of a crash shall have a monitoring system with a readiness indicator. A totally mechanical system is exempt from this requirement.

Is the system totally mechanical ?

YES - NO √

Describe the location of the readiness indicator :

Readiness indicator located at top right of instrument cluster.

Is the readiness indicator clearly visible to the driver ?

YES √ NO -

Is a list of the elements in the occupant restraint system, being monitored by the readiness indicator, provided ?

YES √ NO -

Table 12

FMVSS NO. 208 - COMFORT AND CONVENIENCE TEST SUMMARY

Test Vehicle NHTSA No. :	CS0212
Make/Model :	1995 Ford Explorer XLT 4-door 4 x 4
Date of Comfort/Convenience Check :	2-21-95
Technician Performing Check :	R. E.
GVWR :	5280 lbs.

Seat belt comfort and convenience requirements cover vehicles manufactured on or after September 1, 1986, which have a gross vehicle weight rating of 10,000 pounds or less. Exemptions to this rule are belts installed in a walk-in, van-type vehicle and manual Type 2 belt systems installed in the front outboard seating positions of passenger automobiles. On or after September 1, 1989, the exemption of the type 2 manual seat belts installed in the front outboard seating positions of passenger automobiles will change depending on the states' enactment of mandatory usage laws.

Was vehicle built after or on September 1, 1986, and is it equipped with :

1. Automatic seat belts YES - NO √

If yes, go to requirements D1, D2, and D3

2. Manual seat belts* YES √ NO -

a. The seat belts, other than Type 2 lap/shoulder belts, are located in the front outboard seating positions of a passenger automobile.

YES - NO √

(Go to requirements D3, D4, D5, and D6)

b. The seat belt system is Type 2 lap/shoulder belt in the front outboard seating positions or the seat belts are located in a walk-in van.

STOP

* If the seat belts are voluntarily installed by the manufacturer they do not have to comply.

Table 12 (cont.)

D1

CONVENIENCE HOOKS

A convenience hook or other device is provided to stow seat belt webbing to facilitate entering or exiting the vehicle.

YES - NO √

Check the option which applies to this test vehicle:

1. A convenience hook or other device automatically releases the webbing when the automatic belt system is operational and remains in the released mode as long as the vehicle's ignition switch is moved to the "on" or "start" position and the vehicle's drivetrain is engaged.

YES N/A NO N/A

2. A convenience hook or other device automatically releases the webbing when the automatic belt system is operational and remains in the released mode as long as the vehicle's ignition switch is moved to the "on" or "start" position and the vehicle's parking brake is in the released mode (non-engaged)

YES N/A NO N/A

D2

WEBBING TENSION - RELIEVING DEVICE

The seat belt assembly installed in the outboard designated seating position has either manual or automatic tension relieving devices permitting the introduction of slack in the webbing of the shoulder belt ("comfort clips" or "window shade" devices).

YES - NO √

Check the owner's manual and determine the maximum amount of slack recommended by the manufacturer in inches. The recommended slack is N/A inches. Introduce this slack into the shoulder belt before testing the vehicle to comply with the requirements of FMVSS 208 S5.1. A warning is included in the owner's manual that introducing slack beyond the amount specified can significantly reduce the effectiveness of the shoulder belt.

YES N/A NO N/A

(If NO, provide explanation.)

Check the option which applies to this test vehicle:

1. This vehicle is equipped with automatic seat belts and the tension relieving device is cancelled each time the adjacent door is opened.

YES N/A NO N/A

(If NO, provide explanation.)

Table 12 (cont.)

2. This vehicle is equipped with manual belts, required to meet FMVSS 208 S4.6, and the tension relieving device is cancelled each time one of the following options occurs:
- | | | | | |
|---|-----|------------|----|------------|
| a. The adjacent door is opened. | YES | <u>N/A</u> | NO | <u>N/A</u> |
| b. The latch plate is released from the buckle. | YES | <u>N/A</u> | NO | <u>N/A</u> |
3. This is an open-body vehicle, without doors. Does the manual mean to cancel any shoulder belt slack introduced by a tension relieving device to operate properly ?
- | | | | | |
|--|-----|------------|----|------------|
| | YES | <u>N/A</u> | NO | <u>N/A</u> |
|--|-----|------------|----|------------|

(If NO, provide explanation.)

D3
BELT CONTACT FORCE

1. Do not measure the belt contact force if the manual or automatic seat belt assemblies in this vehicle incorporate a webbing tension relieving device. Does the vehicle incorporate a tension relieving device?
- | | | | | |
|--|-----|----------|----|----------|
| | YES | <u>-</u> | NO | <u>√</u> |
|--|-----|----------|----|----------|
2. Seat are adjusted according to instructions in Appendix B.
- | | | | | |
|--|-----|----------|----|----------|
| | YES | <u>√</u> | NO | <u>-</u> |
|--|-----|----------|----|----------|
3. The test dummies are positioned according to dummy position placement instructions in Appendix B and Appendix C.
- | | | | | |
|--|-----|----------|----|----------|
| | YES | <u>√</u> | NO | <u>-</u> |
|--|-----|----------|----|----------|
4. Close the vehicle's adjacent door, pull either 12 inches of belt webbing or the maximum available amount of belt webbing, whichever is less, from the retractor and then release it, allowing the belt webbing to return to the dummy's chest, then fasten the latch. Locate the point where the centerline of the upper torso belt webbing crosses the midsagittal line on the dummy's chest. At that point, pull the belt webbing out 3 inches from the dummy's chest and release until it is within one inch from the dummy's chest. Measure the contact force exerted by the belt webbing on the dummy's chest. The contact force is 0.3 pounds. Contact the COTR if the contact force exceeds 0.7 pounds.

Table 12 (cont.)

D4
LATCHPLATE ACCESSIBILITY

- | | | | | | |
|----|--|-----|--------------|----|--------------|
| 1. | Position the test dummy in the driver's seat or passenger's seat in its forward most adjustment position. | YES | <u> √ </u> | NO | <u> - </u> |
| 2. | Attach the inboard and outboard reach string. | YES | <u> √ </u> | NO | <u> - </u> |
| 3. | Extend each line backward and outboard to generate arcs of the reach envelope of the test dummy's arms. With the latchplate in the normal stowed position, check to assure that the latchplates are within the reach envelope. | YES | <u> √ </u> | NO | <u> - </u> |
| 4. | Using the clearance test block, determine if there is sufficient clearance between the vehicle seat and the side of vehicle interior to allow the test block to move unhindered to the latchplate or buckle. | YES | <u> √ </u> | NO | <u> - </u> |

D5
RETRACTION

- | | | | | | |
|----|--|-----|--------------|----|--------------|
| 1. | Seats and seat backs are adjusted according to instructions in Appendix B "General Test Conditions" in TP-208-09, dated March 15, 1993. | YES | <u> √ </u> | NO | <u> - </u> |
| 2. | Use anthropomorphic test dummies whose arms have been removed and position the dummies in the front outboard designated seating positions according to instructions in Appendix B and restrain the dummies, using the belt systems for the positions being tested. | YES | <u> √ </u> | NO | <u> - </u> |
| 3. | Outboard armrests which are capable of being stowed on vehicle seats shall be placed in their stowed positions. | YES | <u> √ </u> | NO | <u> - </u> |
| 4. | Check the option which applies to this test vehicle: | | | | |
| a. | The torso and lap belt webbing of the seat belt system automatically retract to a stowed position when the adjacent vehicle door is in an open position and the seat belt latch plate is released. | YES | <u> √ </u> | NO | <u> - </u> |

Table 12 (cont.)

- b. The torso and lap belt webbing of the seat belt system automatically retract when the seat belt latchplate is released.
- YES √ NO -
5. With the webbing and hardware in the stowed position, close the door to assure that the webbing and hardware are prevented from being pinched.
- YES √ NO -
6. If this test vehicle has an open body (without doors) and has a belt system with a tension-relieving device, check to assure that the belt system fully retracts when the tension-relief device is manually deactivated.
- YES N/A NO N/A

**D6
ACCESSIBILITY**

The requirements for accessibility do not apply to:

1. Seats whose seat cushions are removable so that the seat back serves a function other than seating;
2. Seats which are removable;
3. Seats which are movable so that the space formerly occupied by the seat can be used for a secondary function.

If the seats in this vehicle are different than the criteria above, then determine if:

1. Each manual seat belt assembly whose webbing is designed to pass through the seat cushion or between the seat cushion and seat back has one of the following three parts (the seat belt latchplate, the buckle, or the seat belt webbing) on top of or above the seat cushion under normal conditions (i.e., conditions other than when belt hardware is intentionally pushed behind the seat by a vehicle occupant).

YES √ NO -

2. The remaining two seat belt parts are accessible under normal conditions.

YES √ NO -

Table 12 (cont.)

- | | | | | |
|----|--|-----|--------------|-----------------|
| 3. | The buckle and latchplate pass through the guides or conduits provided and do not fall behind the seat when the following events occur in order: | | | |
| | a. The belt is completely retracted or, if the belt is non-retractable, the belt is unattached. | YES | <u> √ </u> | NO <u> - </u> |
| | b. The seat is moved to any position to which it is designed to be adjusted. | YES | <u> √ </u> | NO <u> - </u> |
| | c. The seat back, if foldable, is folded forward as far as possible and then moved backward into positions. | YES | <u> √ </u> | NO <u> - </u> |
| 4. | Is the inboard receptacle end of the seat belt assembly which is installed in the outboard designated seating position accessible with the center arm rest in any position to which it can be adjusted without moving the armrest? | YES | <u> √ </u> | NO <u> - </u> |

D7
LATCH MECHANISM

A seat belt assembly installed in a passenger car, except an automatic belt assembly, shall have a latch mechanism:

- | | | | | |
|----|--|-----|--------------|-----------------|
| 1. | Whose components are accessible to a seated occupant in both the stowed and operational positions. | YES | <u> √ </u> | NO <u> - </u> |
| 2. | That releases both the upper torso restraint and the lap belt simultaneously, if the assembly has a lap belt and an upper torso restraint that require unlatching for release of the occupant. | YES | <u> √ </u> | NO <u> - </u> |
| 3. | That releases at a single point by a push button action. | YES | <u> √ </u> | NO <u> - </u> |

Figure 8

FMVSS NO. 212 - "WINDSHIELD MOUNTING" DATA SHEET

DETAILS OF WINDSHIELD MOUNTING SUCH AS RETENTION METHOD, TRIM TYPE, ETC. :

The windshield is bonded in place with 0.8 inch rubber molding along top and sides. Bottom of windshield is covered by a plastic shroud.

FMVSS 212 REQUIREMENTS :

The Post - Test periphery retention amount must be at least 75% of the Pre - Test periphery measurement for vehicle NOT equipped with automatic restraints, and 50% for each side of windshield for vehicles equipped with automatic restraint systems for front occupants.

FMVSS 212 TEST DATA :

	WINDSHIELD PERIPHERY		PERCENT RETENTION
	PRE - TEST (in.)	POST - TEST (in.)	
RIGHT SIDE	83.1	83.1	100.0
LEFT SIDE	83.1	83.1	100.0
TOTAL	166.2	166.2	100.0

AREA OF RETENTION FAILURE:

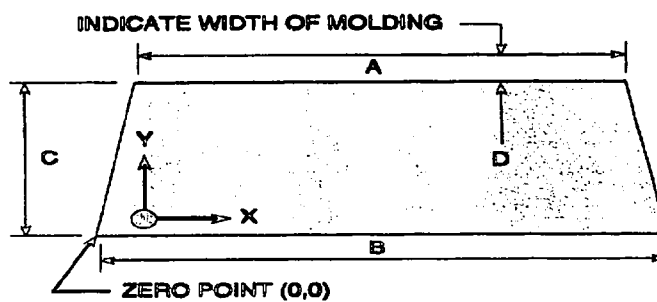

FRONT VIEW OF WINDSHIELD

FAILURE DETAILS :

none

Figure 9

FMVSS NO. 219 (PARTIAL) - "WINDSHIELD ZONE INTRUSION" DATA SHEET

PROTECTED ZONE LOWER EDGE REQUIREMENT :

The lower edge of the protected zone is determined by placing a 6.5" dia. rigid sphere weighing 15 pounds in a position such that it simultaneously contacts the inner surface of the windshield and the top surface of the instrument panel including padding. The locus of points is drawn on the inner surface of the windshield contacted by the sphere across the width of the instrument panel. From the outermost contactable points, extend the locus line horizontally to the edges of the windshield, and then draw a line on the inner surface of the windshield below and 1/2" distant from the locus line. The LOWER EDGE OF THE PROTECTED ZONE is the longitudinal projection of this line onto the outer surface of the windshield

FMVSS 219 TEST DATA : (Dimensions in inches.)

KEY:

A =	51.5
B =	15.5
C =	62.5
D =	26.1
E =	18.5
F =	33.5

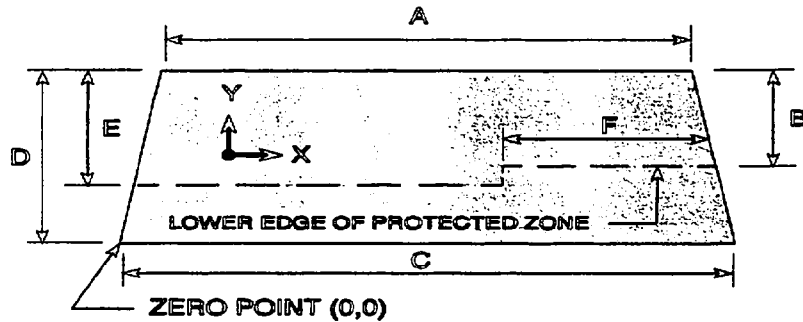

FRONT VIEW OF WINDSHIELD

DETAILS OF WINDSHIELD GLASS PENETRATION GREATER THAN 1/4" :

(Show location of penetration on above sketch)

none

COORDINATES		
	X	Y
1		
2		
3		
4		

Table 13

FUEL SYSTEM INTEGRITY POST IMPACT TEST DATA

FMVSS NO. 301

TEST VEHICLE NHTSA NO. : CS0212 TEST DATE : February 23, 1995

Vehicle Mfr./Make/Model : 1995 Ford Explorer XLT 4-door 4 x 4

Test vehicle fuel tank filled to 92% to 94% of manufacturer's "usable" capacity and with electric fuel pump operating (if it will operate without engine operation). Part 572 test dummies located at each front designated seating position.

TEST VEHICLE IMPACT TYPE : X Frontal (30 mph)
- Oblique (30 mph) with - °barrier face first
contacting -
(driver/passenger) side
- Rear Moving Barrier (30 mph)
- Lateral Moving Barrier (20 mph)

FUEL SPILLAGE MEASUREMENT:

1. From impact until vehicle motion ceases
2. For five minute period after vehicle motion ceases
3. For next 25 minutes

ACTUAL	MAX ALLOWED
0	1 oz.
0	5 oz.
0	1 oz./1 min.

SOLVENT SPILLAGE DETAILS :

None

Table 14

FMVSS NO. 301 STATIC ROLLOVER DATA SHEET

TEST PHASE :
0-90 Deg.

Vehicle NHTSA ID No. :
CS0212

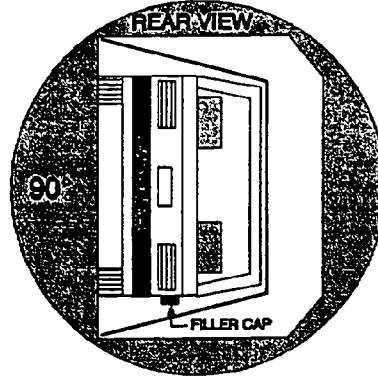

I. DETERMINATION OF SOLVENT COLLECTION TIME PERIOD :

Rollover Fixture 90° Rotation Time (Spec. Range = 1 to 3 minutes)	1	minutes	57	seconds
FMVSS 301 Position Hold Time +	5	minutes	00	seconds
TOTAL	6	minutes	57	seconds
Next whole minute interval	7	minutes		

II. FMVSS 301 REQUIREMENTS :

(1) Time Period

First 5 minutes FROM onset of rotation	6th min.	7th min.	8th min. if reqd.
--	----------	----------	----------------------

(2) Maximum Allowable Solvent Spillage

5 ounces	1 ounce	1 ounce	1 ounce
----------	---------	---------	---------

III. ACTUAL TEST VEHICLE SOLVENT SPILLAGE :

0	0	0	N/A
---	---	---	-----

Note: Record spillage for whole minute intervals only as determined above.

IV. SOLVENT SPILLAGE LOCATION(S) :

None

Table 14
 FMVSS NO. 301 STATIC ROLLOVER DATA SHEET (cont.)

TEST PHASE :
 90-180 Deg.

Vehicle NHTSA ID No. :
 CS0212

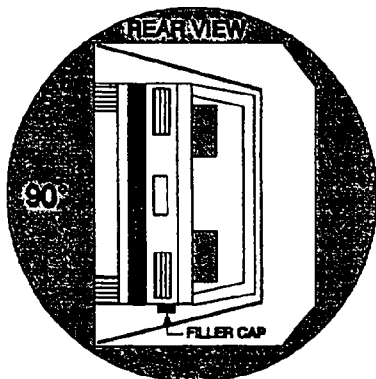

I. DETERMINATION OF SOLVENT COLLECTION TIME PERIOD :

Rollover Fixture 90° Rotation Time (Spec. Range = 1 to 3 minutes)	1	minutes	54	seconds
FMVSS 301 Position Hold Time +	5	minutes	00	seconds
TOTAL	6	minutes	54	seconds
Next whole minute interval	7	minutes		

II. FMVSS 301 REQUIREMENTS :

(1) Time Period

First 5 minutes FROM onset of rotation	6th min.	7th min.	8th min. if reqd.
--	----------	----------	----------------------

(2) Maximum Allowable Solvent Spillage

5 ounces	1 ounce	1 ounce	1 ounce
----------	---------	---------	---------

III. ACTUAL TEST VEHICLE SOLVENT SPILLAGE :

0	0	0	N/A
---	---	---	-----

Note: Record spillage for whole minute intervals only as determined above.

IV. SOLVENT SPILLAGE LOCATION(S) :

None

Table 14
FMVSS NO. 301 STATIC ROLLOVER DATA SHEET (cont.)

TEST PHASE :
180-270 Deg.

Vehicle NHTSA ID No. :
CS0212

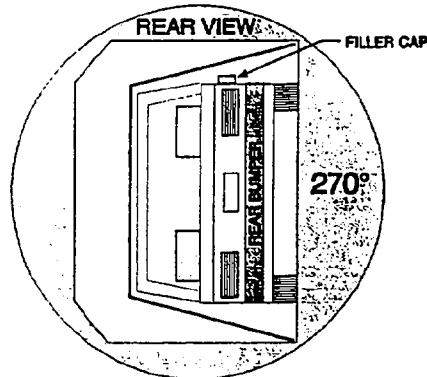
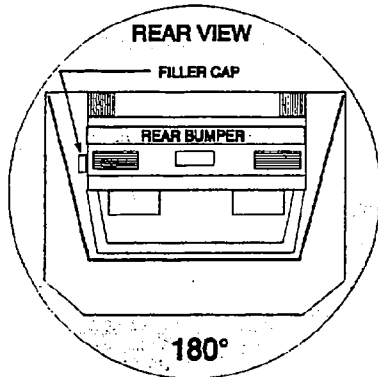

I. DETERMINATION OF SOLVENT COLLECTION TIME PERIOD :

Rollover Fixture 90° Rotation Time (Spec. Range = 1 to 3 minutes)	<u>2</u>	minutes	<u>03</u>	seconds
FMVSS 301 Position Hold Time +	<u>5</u>	minutes	<u>00</u>	seconds
TOTAL	<u>7</u>	minutes	<u>03</u>	seconds
Next whole minute interval	<u>8</u>	minutes		

II. FMVSS 301 REQUIREMENTS :

(1) Time Period

First 5 minutes FROM onset of rotation	6th min.	7th min.	8th min. if reqd.
--	----------	----------	----------------------

(2) Maximum Allowable Solvent Spillage

5 ounces	1 ounce	1 ounce	1 ounce
----------	---------	---------	---------

III. ACTUAL TEST VEHICLE SOLVENT SPILLAGE :

0	0	0	0
---	---	---	---

Note: Record spillage for whole minute intervals only as determined above.

IV. SOLVENT SPILLAGE LOCATION(S) :

None

Table 14
FMVSS NO. 301 STATIC ROLLOVER DATA SHEET (cont.)

TEST PHASE :
270-360 Deg.

Vehicle NHTSA ID No. :
CS0212

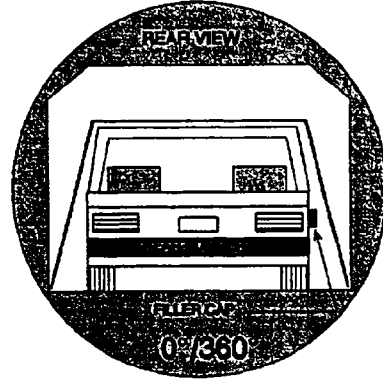
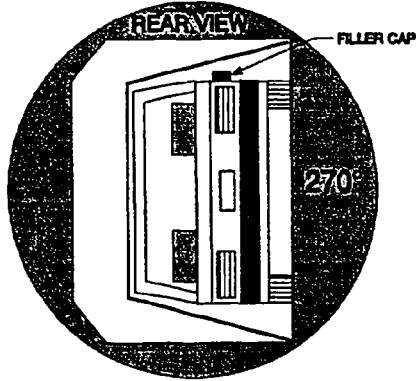

I. DETERMINATION OF SOLVENT COLLECTION TIME PERIOD :

Rollover Fixture 90° Rotation Time (Spec. Range = 1 to 3 minutes)	1	minutes	49	seconds
FMVSS 301 Position Hold Time +	5	minutes	00	seconds
TOTAL	6	minutes	49	seconds
Next whole minute interval	7	minutes		

II. FMVSS 301 REQUIREMENTS :

(1) Time Period

First 5 minutes FROM onset of rotation	6th min.	7th min.	8th min. if reqd.
--	----------	----------	----------------------

(2) Maximum Allowable Solvent Spillage

5 ounces	1 ounce	1 ounce	1 ounce
----------	---------	---------	---------

III. ACTUAL TEST VEHICLE SOLVENT SPILLAGE :

0	0	0	N/A
---	---	---	-----

Note: Record spillage for whole minute intervals only as determined above.

IV. SOLVENT SPILLAGE LOCATION(S) :

None

Table 15

POST TEST AIR BAG DATA

NHTSA No. : CS0212; Test Date: February 23, 1995; Technician: R. E.

Vehicle Model Year/Make/Model: 1995 Ford Explorer XLT

A.	No. of vent holes:	<u>2</u>	-Driver	<u>2</u>	-Passenger		
B.	Size of vent holes: (In. ²)	<u>0.2</u>	-Driver	<u>3.1</u>	-Passenger		
C.	Total vent area: (In. ²)	<u>0.4</u>	-Driver	<u>6.3</u>	-Passenger		
D.	Deflated air bag length and width dimensions or, if round,diameter. (In inches)						
	Driver:	<u>-</u>	-Length;	<u>-</u>	-Width;	<u>26.0</u>	-Diameter
	Passenger:	<u>18.0</u>	-Height;	<u>35.5</u>	-Width;	<u>20.0</u>	-Depth
E.	Is the air bag tethered?						
	Driver:	<u>√</u>	-Yes;	<u>-</u>	-No; If yes, record length of tether-	<u>10.5</u>	
	Passenger:	<u>-</u>	-Yes;	<u>√</u>	-No; If yes, record length of tether-	<u>N/A</u>	

Sketch the air bag showing the location of the vent holes, how the bag is tethered, and where the bag is tethered. Also describe how the tethers are attached to the bag and the steering wheel.
 (Note: Not to scale; V_n = Vent hole_n, T_n = Tether_n).

Driver Air bag (front view)

Passenger Air bag (right side view)

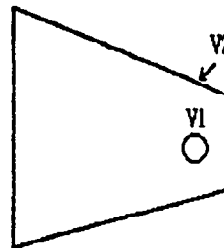
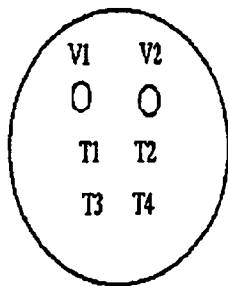

F.	Record part numbers and manufacturer name of the air bag and gas generator.	
	Driver:	<u>Air bag: 306462R</u>
		<u>Generator: NCPE314H10166 / F57B-78043B13-AEJABO / 1P8X009I30345</u>
	Passenger:	<u>Air bag: T1CP347H20163 / 2001777G</u>
		<u>Generator: F57B78044A74 ATZUCN / L500710932 / 2001170J</u>

G. Cut out a 6 inch by 6 inch swatch of the bag material and at least one tether from each bag, mark the vehicle's NHTSA number on the swatch, and send these parts to the COTR with the test report.

Table 16

ACCIDENT INVESTIGATION DIVISION DATA

VEHICLE YEAR/MAKE/MODEL/BODY STYLE: 1995 Ford Explorer XLT 4-door 4 x 4

VEHICLE NHTSA NO. : CS0212 VIN NO. : 1FMDU34X1SUA24748

WHEELBASE: 111.8 in. BUILD DATE: 1/95 TEST DATE: February 23, 1995

VEH SIZE CATEGORY: -- TEST WEIGHT: 4850 lbs.

FRONT OVERHANG: -- OVERALL WIDTH: 69.3 in.

COLLISION DEFORMATION (CDC) CODE: 12FDEW2

IMPACT MODE: 30 mph zero degree frontal barrier.

CRUSH DEPTH DIMENSIONS: (Inches)

C1 = <u>16.0</u>	C4 = <u>17.7</u>
C2 = <u>16.8</u>	C5 = <u>16.5</u>
C3 = <u>17.7</u>	C6 = <u>15.0</u>

MIDPOINT OF DAMAGE: D =
(Vehicle Longitudinal Centerline) 32.4

LENGTH OF DAMAGE
REGION: L = 64.8

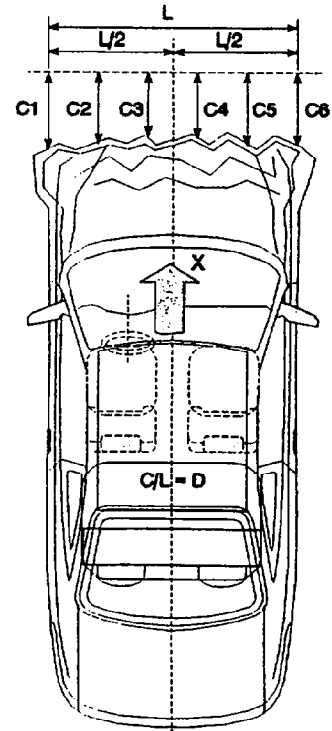

Remarks: --

Table 17
TEST VEHICLE NONCOMPLIANCE NOTICE

NHTSA Contract Lab : Calspan Advanced Technology Center
Lab Project Manager & Telephone No. : David J. Travale (716) 632 - 7500
Date of Test : February 23, 1995 Vehicle NHTSA No. : CS0212
Vehicle Manufacturer : FORD MOTOR COMPANY, U.S.A.
Model Year : 1995 VIN : 1FMDU34X1SUA24748
Model : Explorer XLT Body Style: 4-door 4 x 4 Build Date : 1/95
Dummy Stabilized Temperature at Time of Test : 70 °F (Spec. = 69 - 72 °F)
Impact Velocity : 29.4 mph; Time of Test : 13:30
Type of Automatic Restraint System :
Driver : Air bag
Passenger : Air bag

Failure Details :

The vehicle as tested, appears to comply with the requirements of FMVSS Nos. 208, 212, 219(partial), and 301.

Appendix A
PHOTOGRAPHS

LIST OF PHOTOGRAPHS

<u>Figure</u>	<u>Photograph Title</u>	<u>Page No.</u>
A-1	PRE-TEST FRONT VIEW	A-3
A-2	POST-TEST FRONT VIEW	A-4
A-3	PRE-TEST LEFT SIDE VIEW	A-5
A-4	POST-TEST LEFT SIDE VIEW	A-6
A-5	PRE-TEST RIGHT SIDE VIEW	A-7
A-6	POST-TEST RIGHT SIDE VIEW	A-8
A-7	PRE-TEST FRONT UNDERBODY VIEW	A-9
A-8	POST-TEST FRONT UNDERBODY VIEW	A-10
A-9	PRE-TEST DRIVER SIDE VIEW	A-11
A-10	POST-TEST DRIVER SIDE VIEW	A-12
A-11	PRE-TEST PASSENGER SIDE VIEW	A-13
A-12	POST-TEST PASSENGER SIDE VIEW	A-14
A-13	PRE-TEST UNDERBODY STEERING SHAFT	A-15
A-14	POST-TEST UNDERBODY STEERING SHAFT	A-16
A-15	PRE-TEST STEERING COLUMN/FIREWALL INSIDE VIEW	A-17
A-16	POST-TEST STEERING COLUMN/FIREWALL INSIDE VIEW	A-18
A-17	POST-TEST DRIVER KNEE BOLSTER	A-19
A-18	POST-TEST PASSENGER KNEE BOLSTER	A-20
A-19	VEHICLE IMPACT	A-21
A-20	CERTIFICATION PLACARD	A-22
A-21	TIRE PLACARD	A-23
A-22	POST-TEST DRIVER AIRBAG VIEW	A-24
A-23	POST-TEST PASSENGER AIRBAG VIEW	A-25

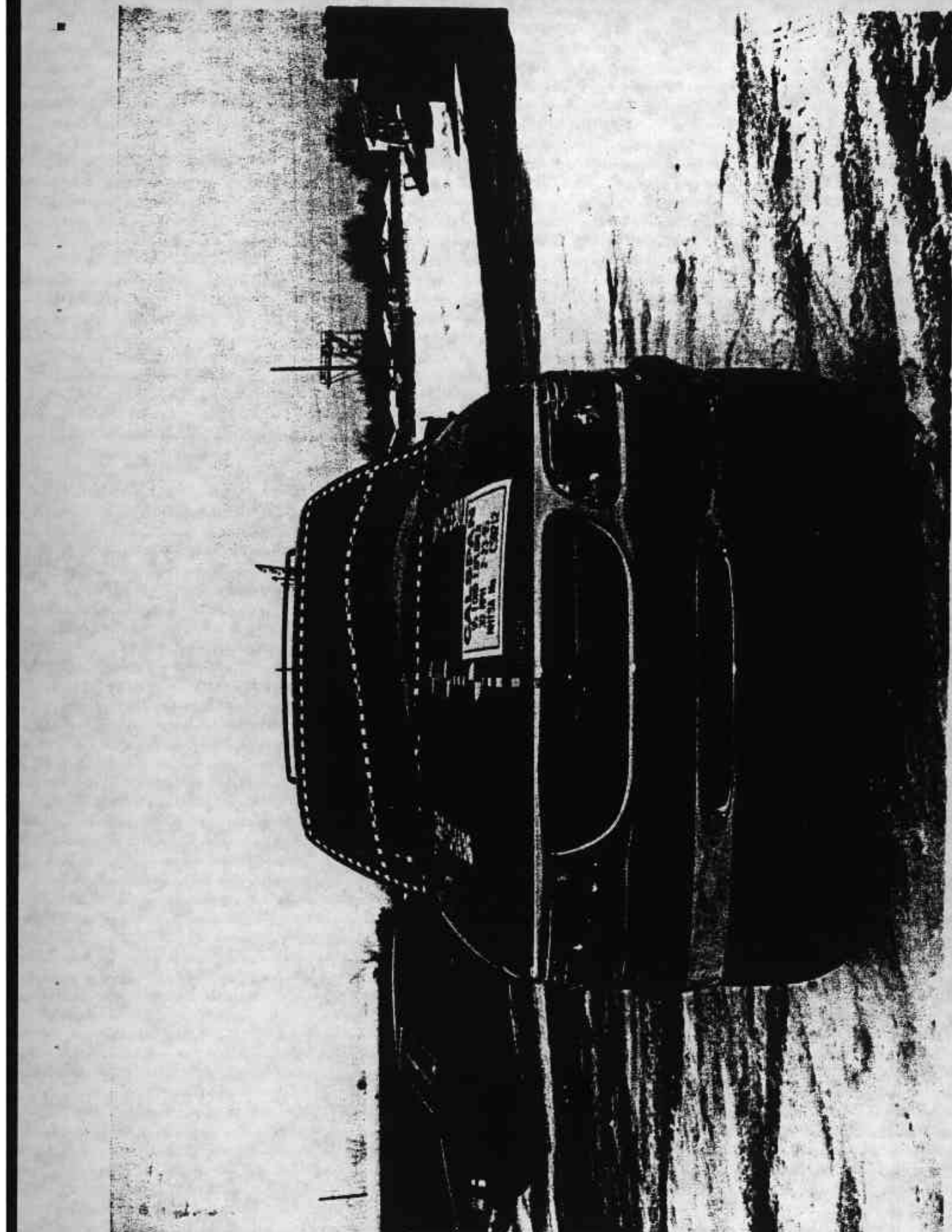
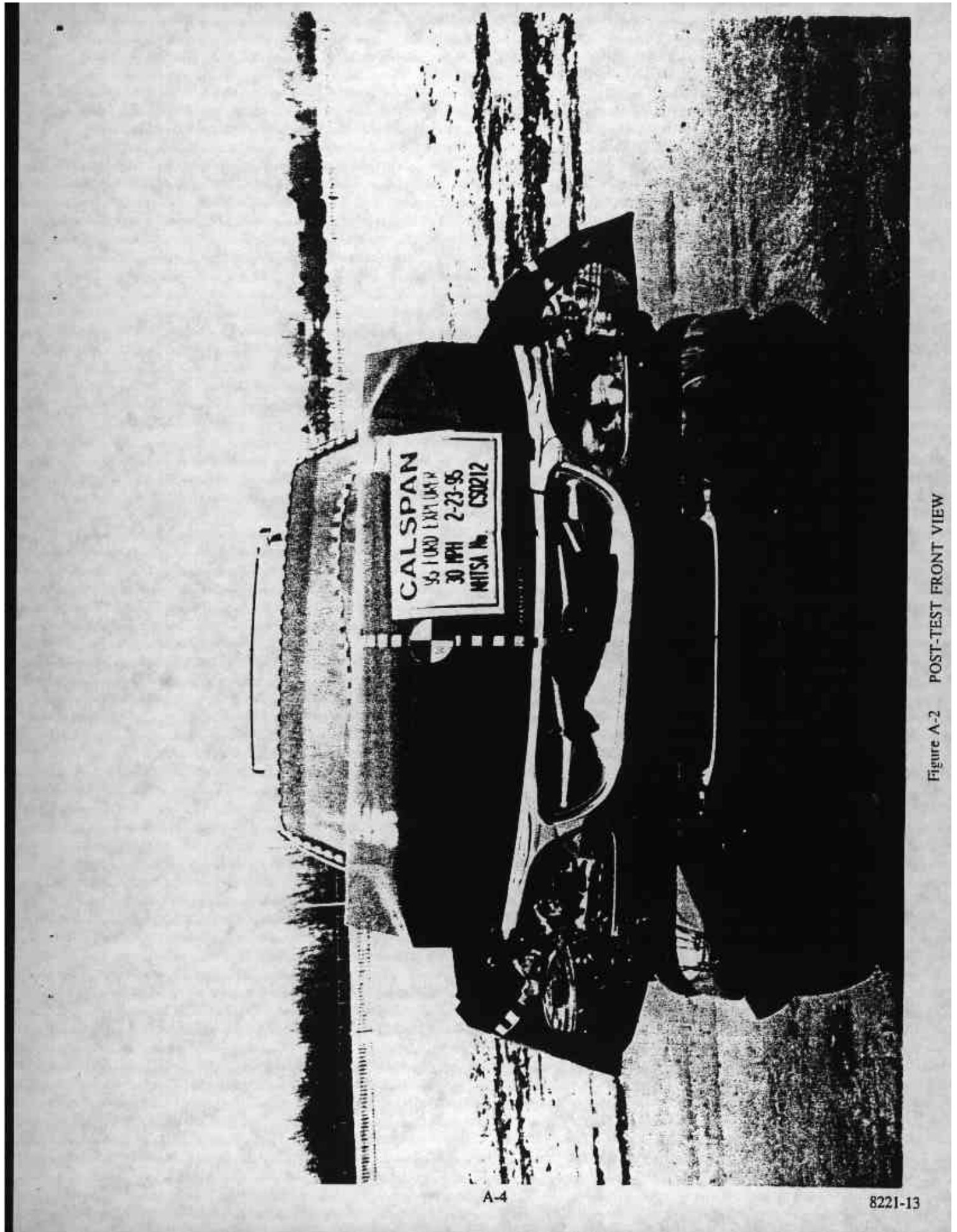

Figure A-1 PRE-TEST FRONT VIEW



A-4

8221-13

Figure A-2 POST-TEST FRONT VIEW

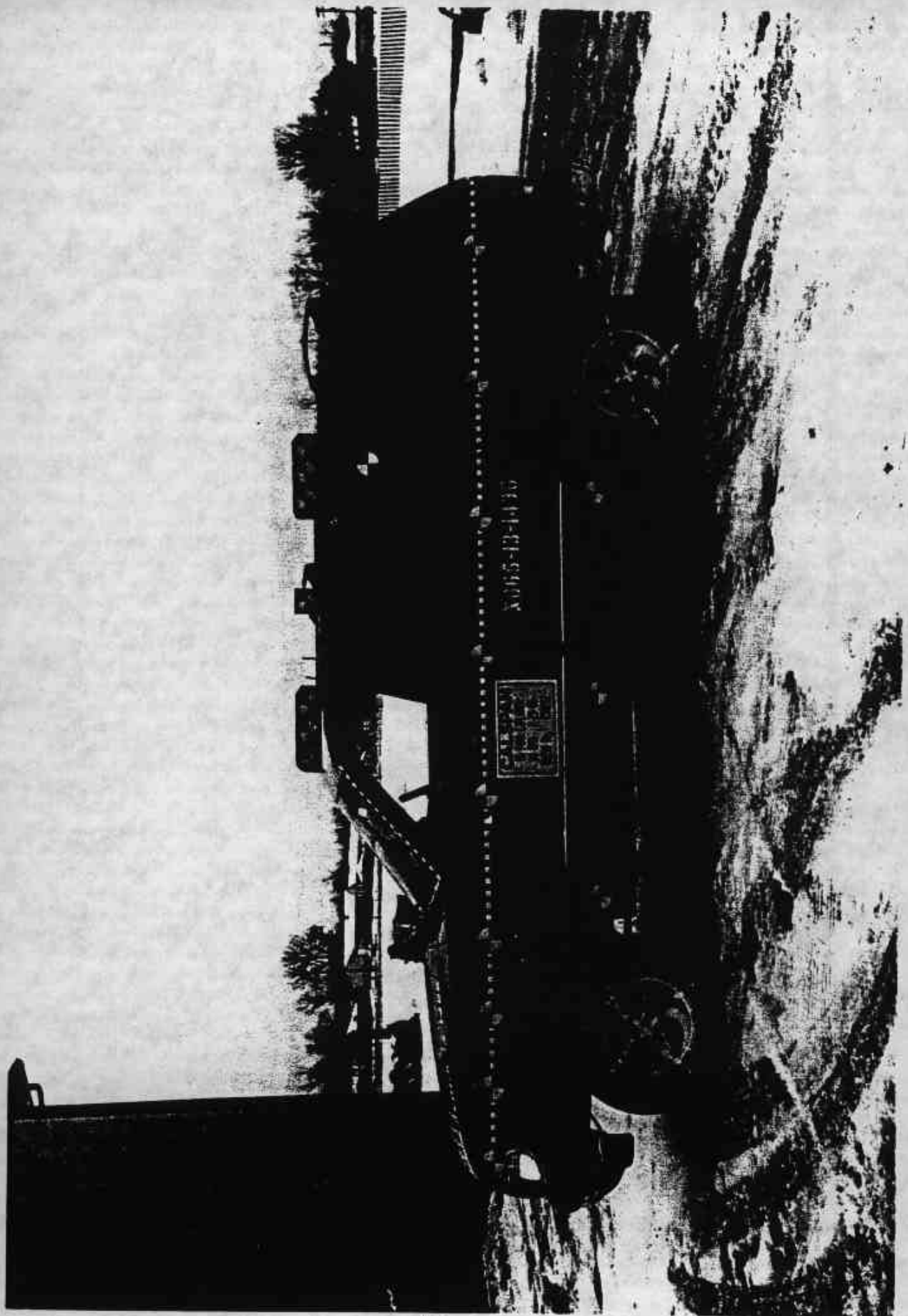

Figure A-3 PRE-TEST LEFT SIDE VIEW

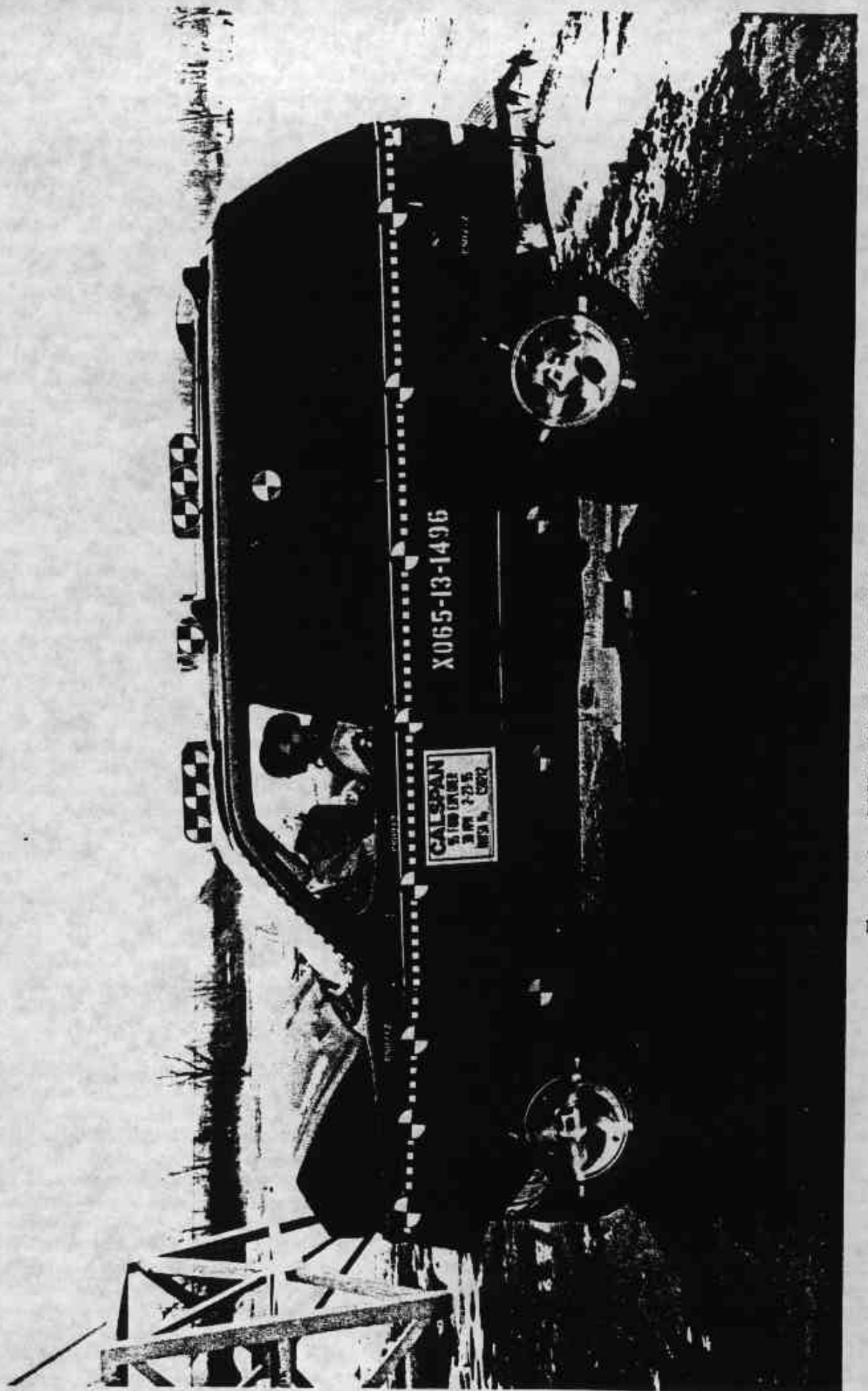

Figure A-4 POST-TEST LEFT SIDE VIEW

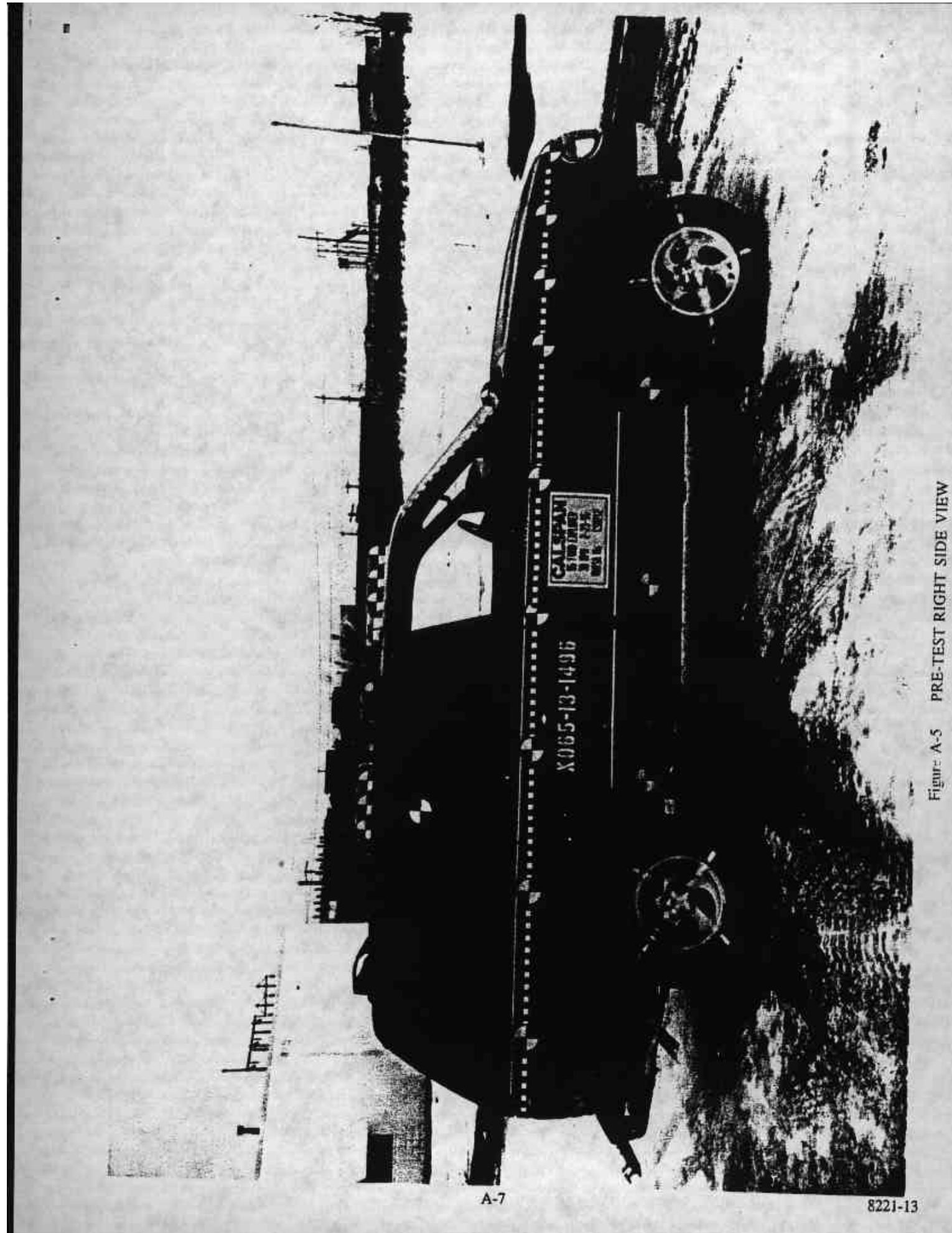
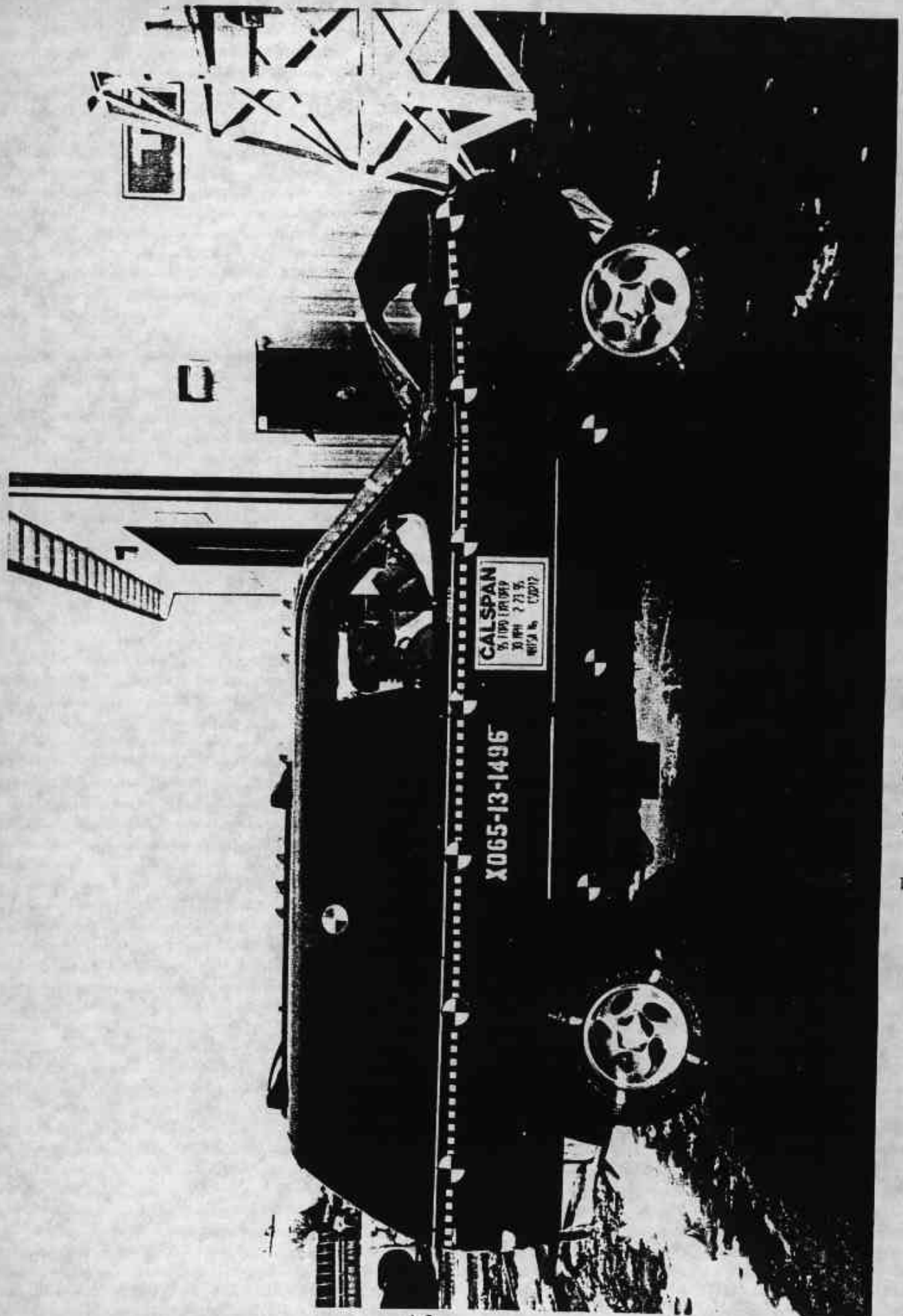

Figure A-5 PRE-TEST RIGHT SIDE VIEW



A-8

8221-13

Figure A-6 POST-TEST RIGHT SIDE VIEW

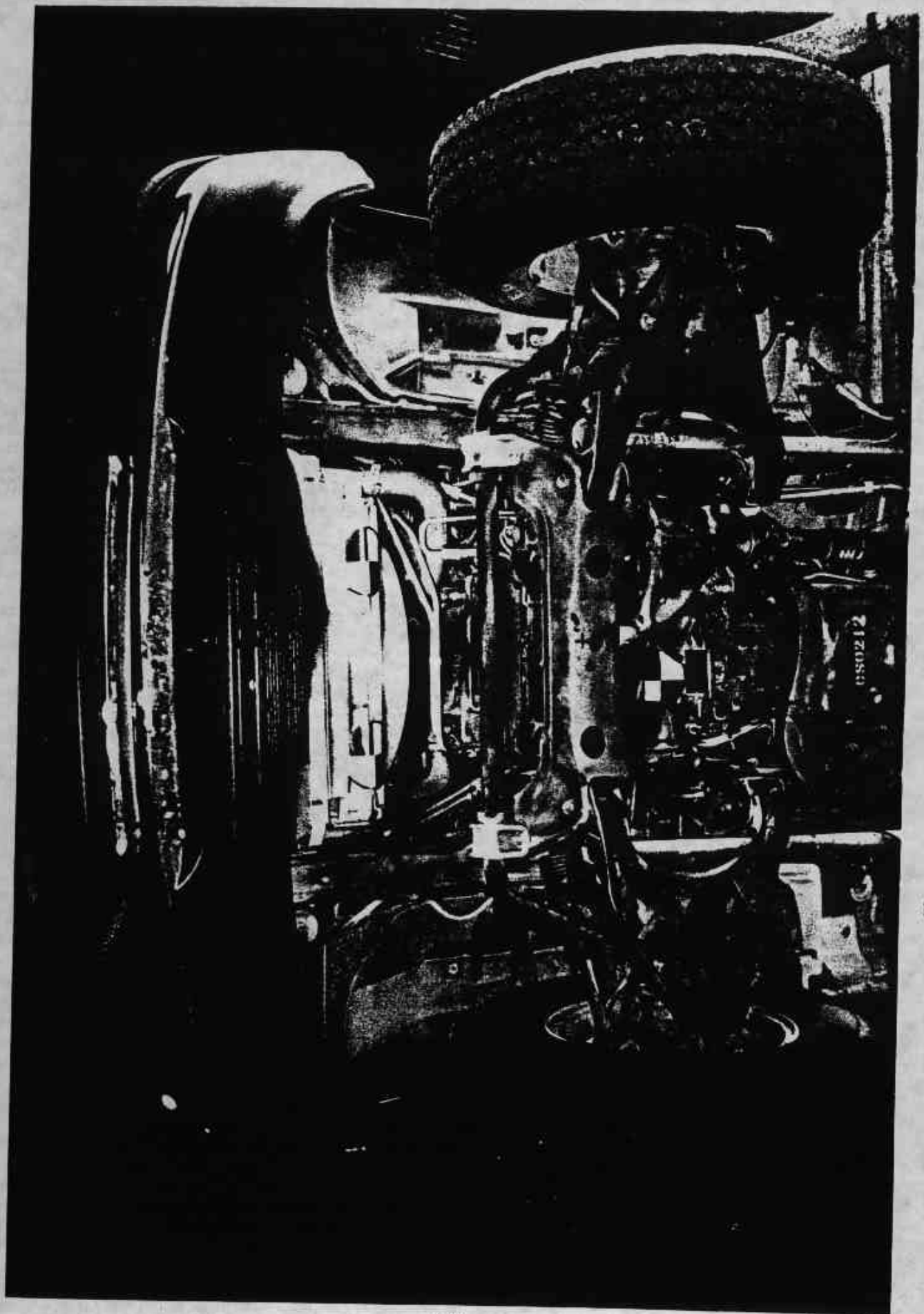

Figure A-7 PRE-TEST FRONT UNDERBODY VIEW

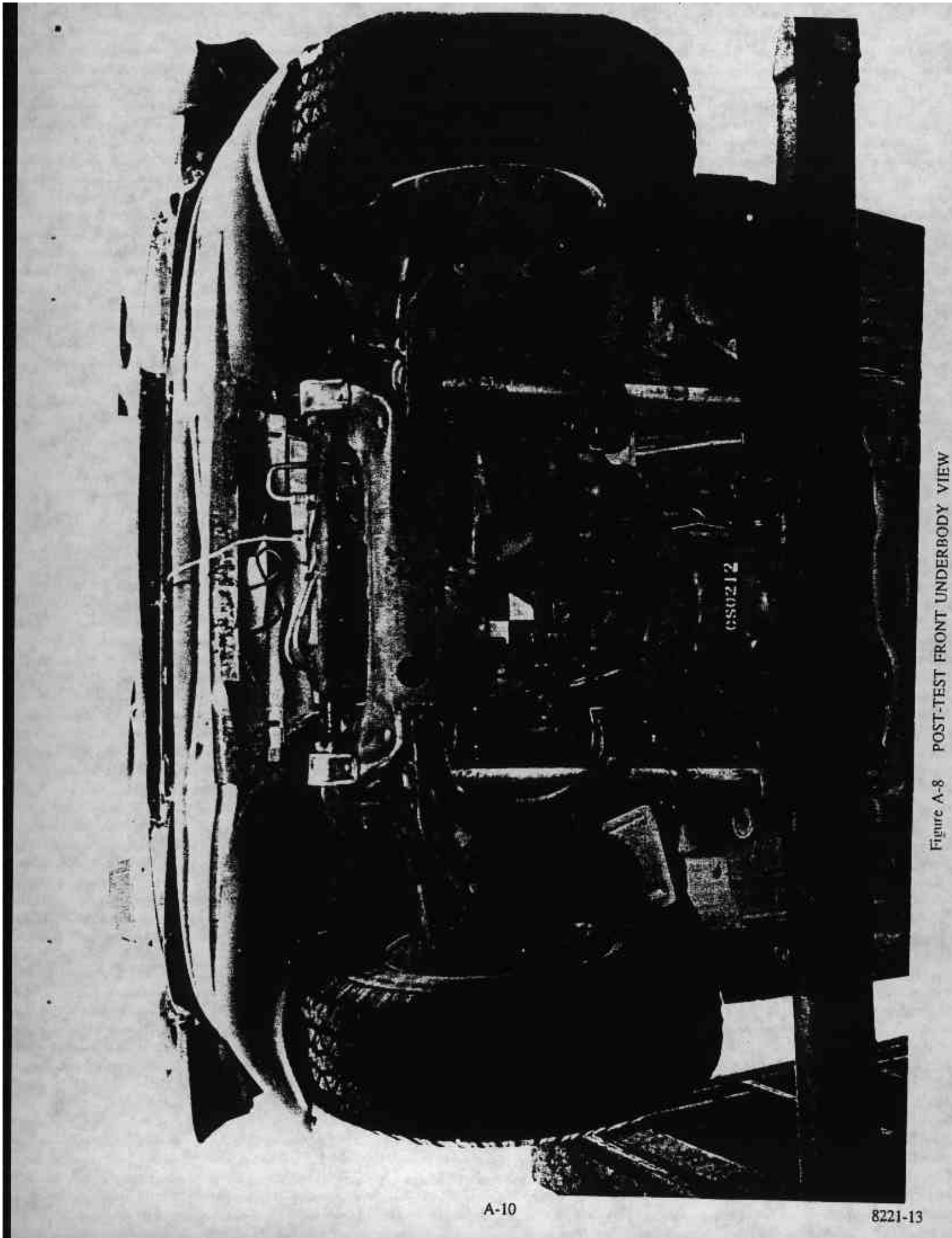

Figure A-8 POST-TEST FRONT UNDERBODY VIEW



Figure A-9 PRE-TEST DRIVER SIDE VIEW

A-11



CS0212

Figure A-10 POST-TEST DRIVER SIDE VIEW

A-12

8221-13

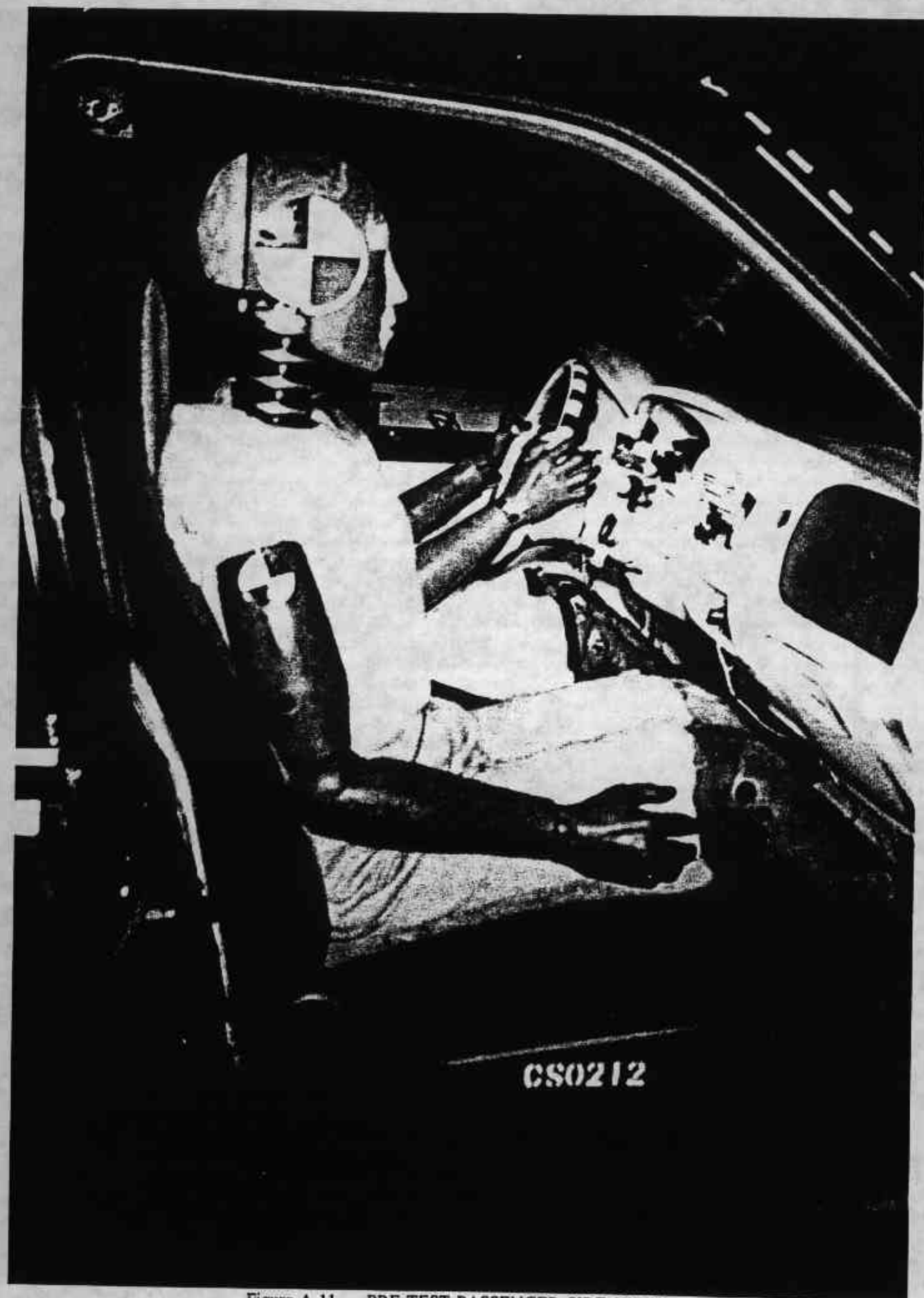

Figure A-11 PRE-TEST PASSENGER SIDE VIEW

A-13

8221-13



Figure A-12 POST-TEST PASSENGER SIDE VIEW

A-14

8221-13

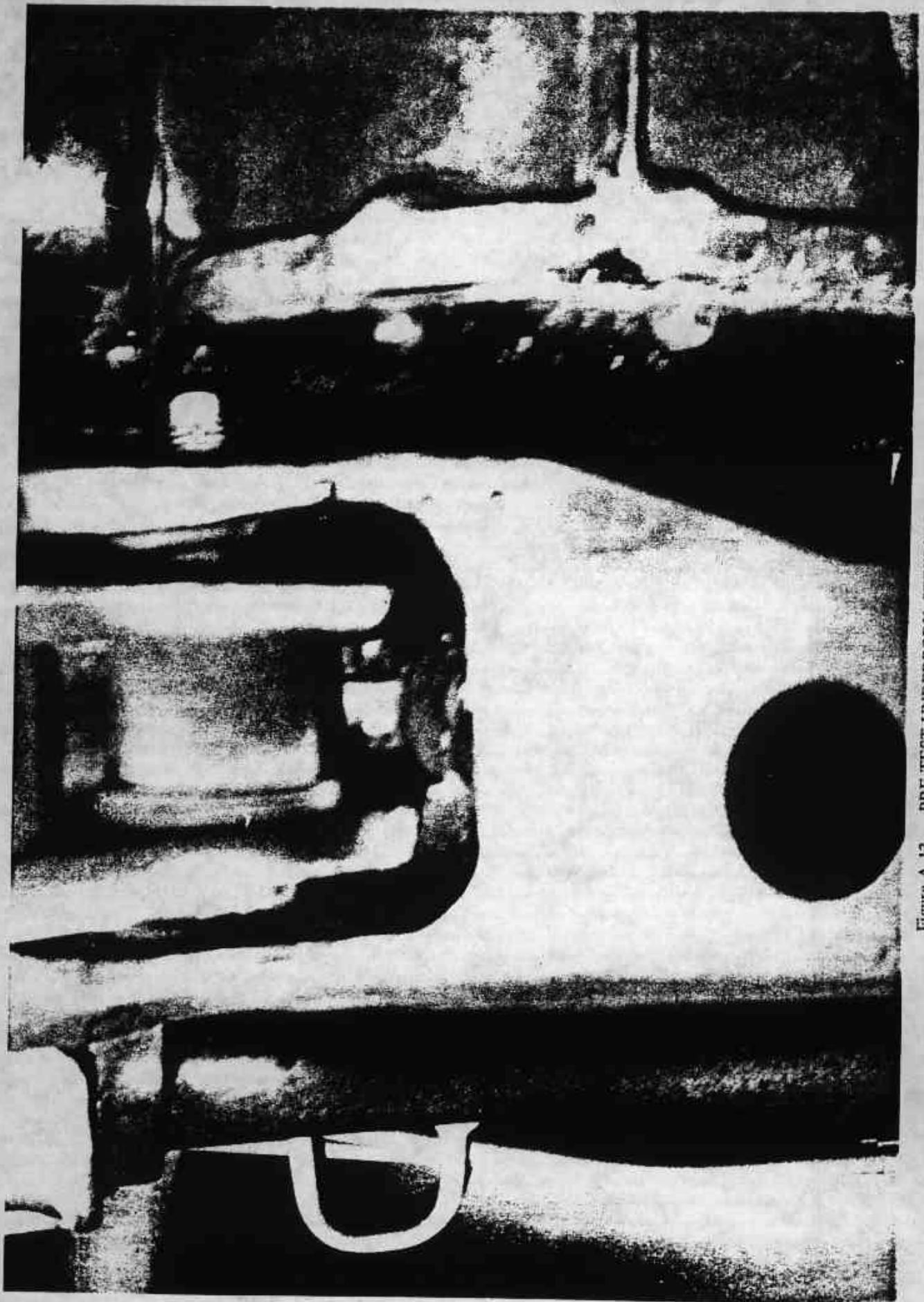

Figure A-13 PRE-TEST UNDERBODY STEERING GEAR

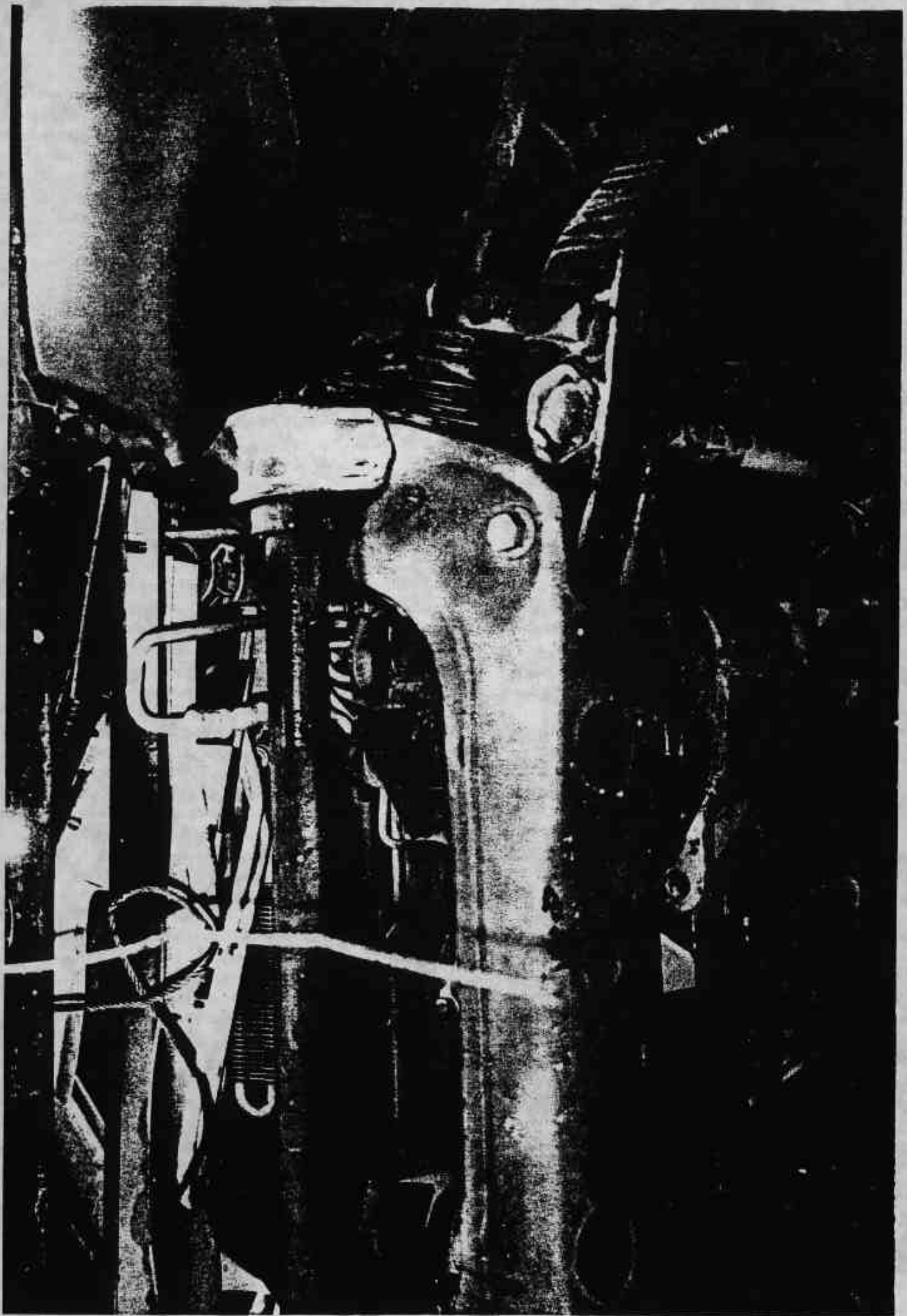

Figure A-14 POST-TEST UNDERBODY STEERING SHAFT

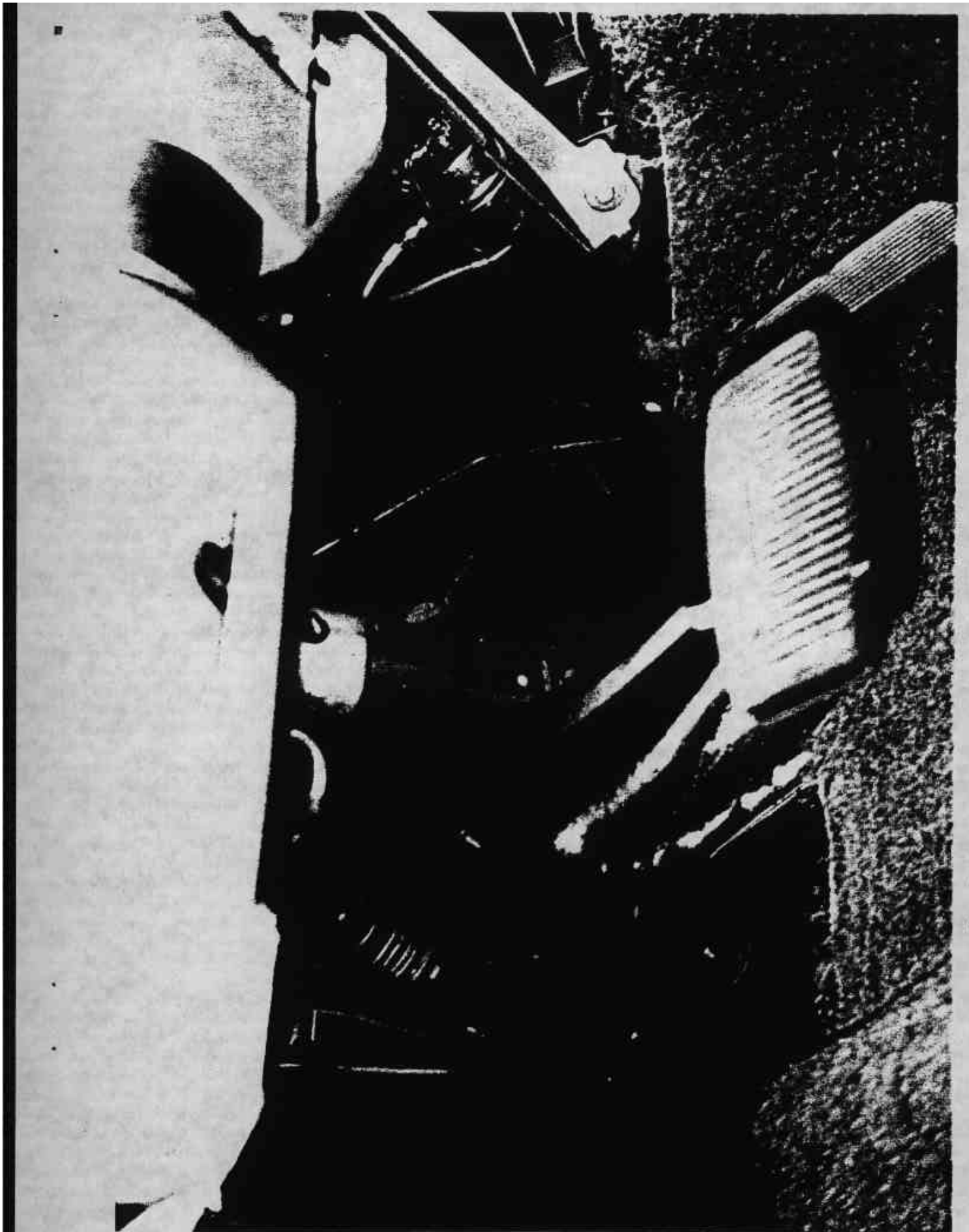

Figure A-15 PRE-TEST STEERING COLUMN/FIREWALL INSIDE VIEW

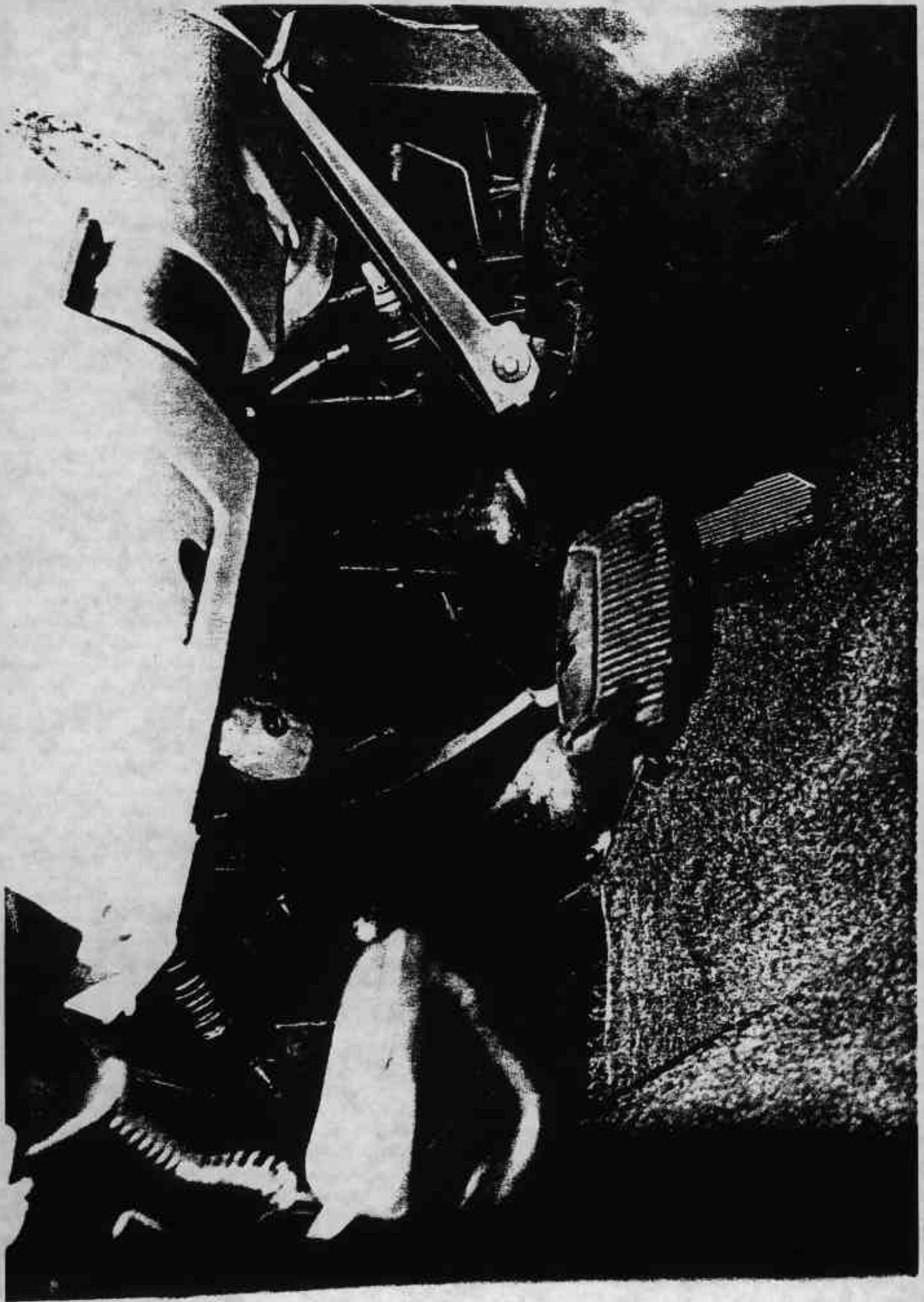

Figure A-16 POST-TEST STEERING COLUMN/FIREWALL INSIDE VIEW



Figure A-17 POST-TEST DRIVER KNEE BOLSTER

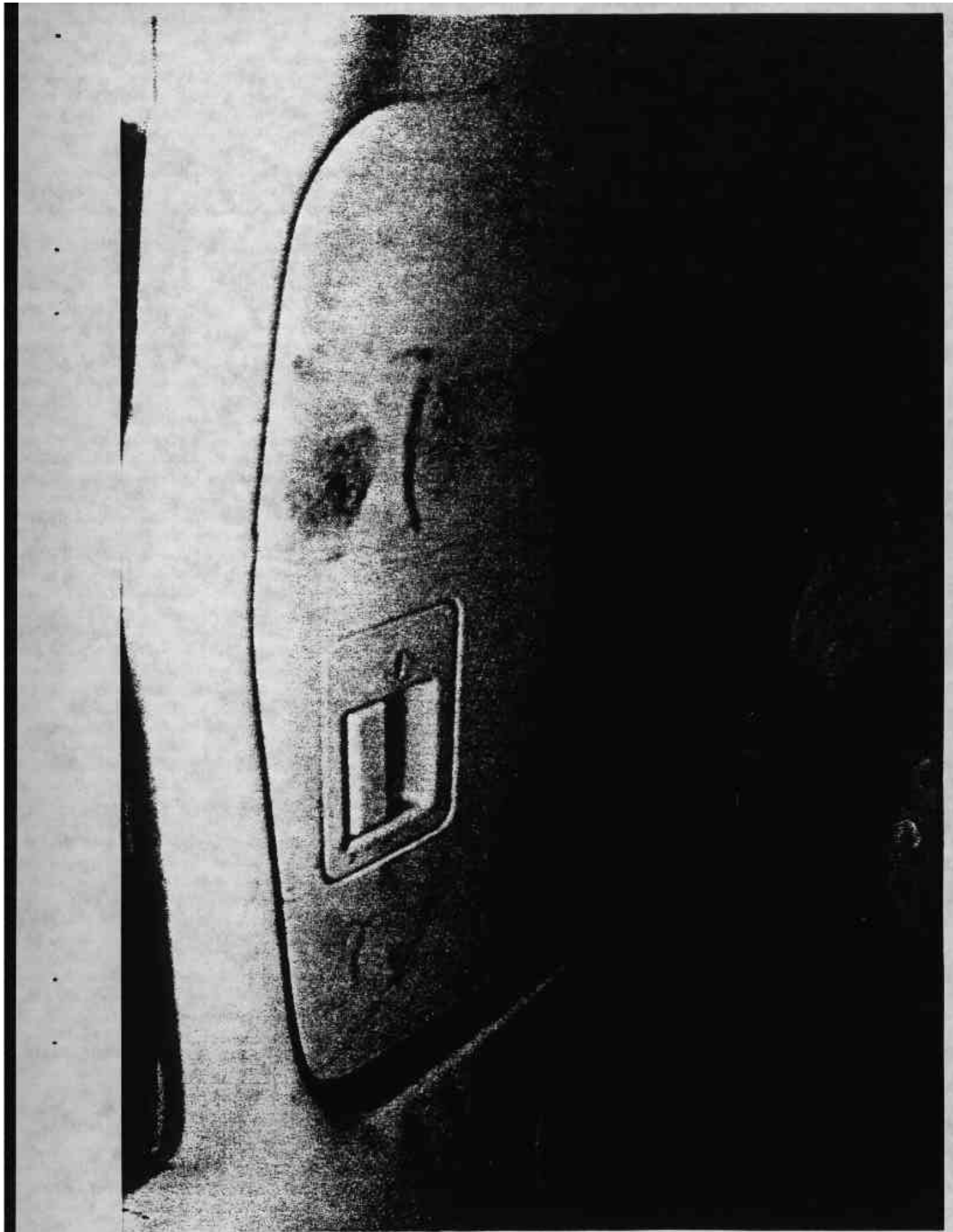

Figure A-18 POST-TEST PASSENGER KNEE BOLSTER

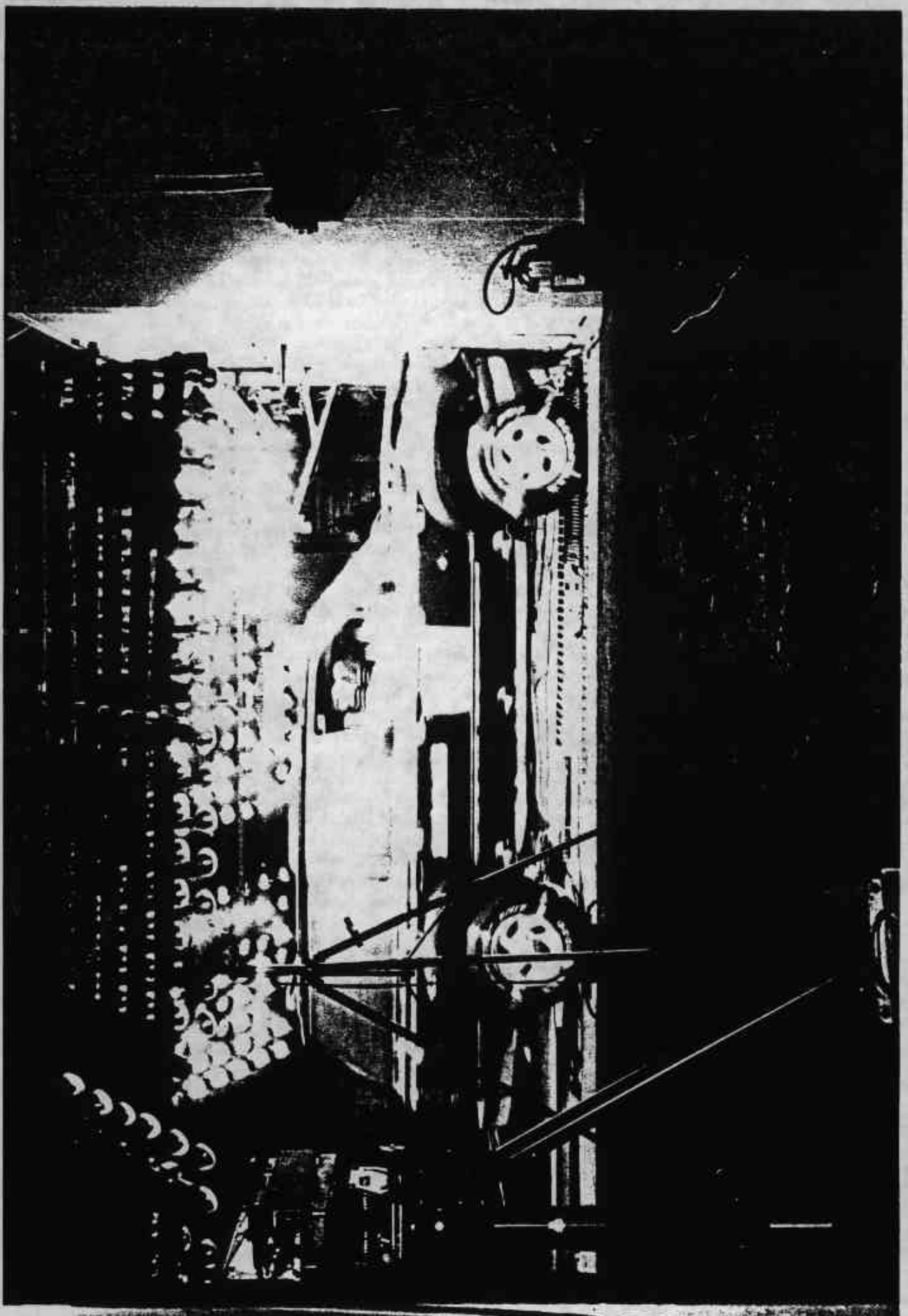

Figure A-19 VEHICLE IMPACT

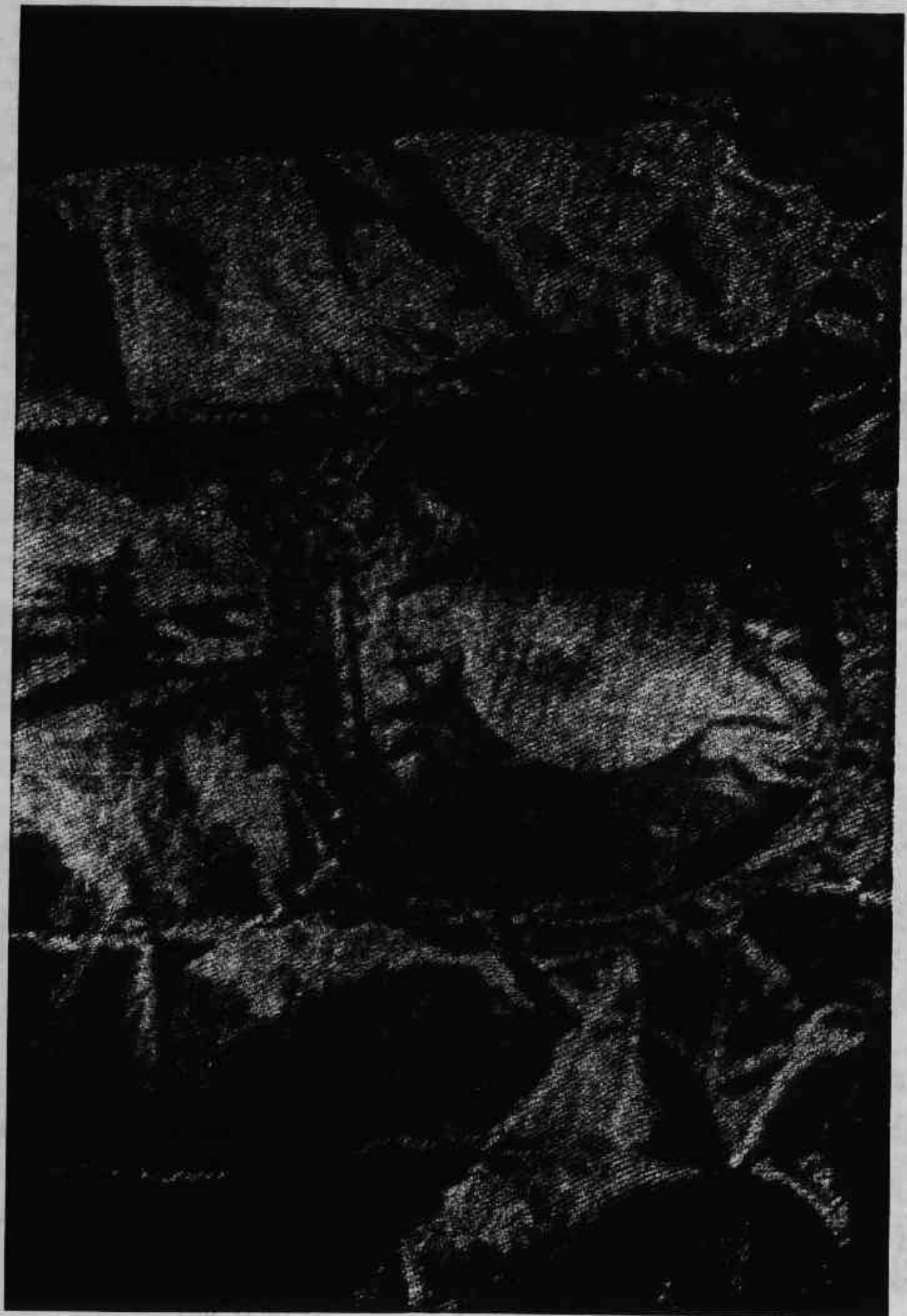

Figure A-22 POST-TEST DRIVER AIRBAG VIEW

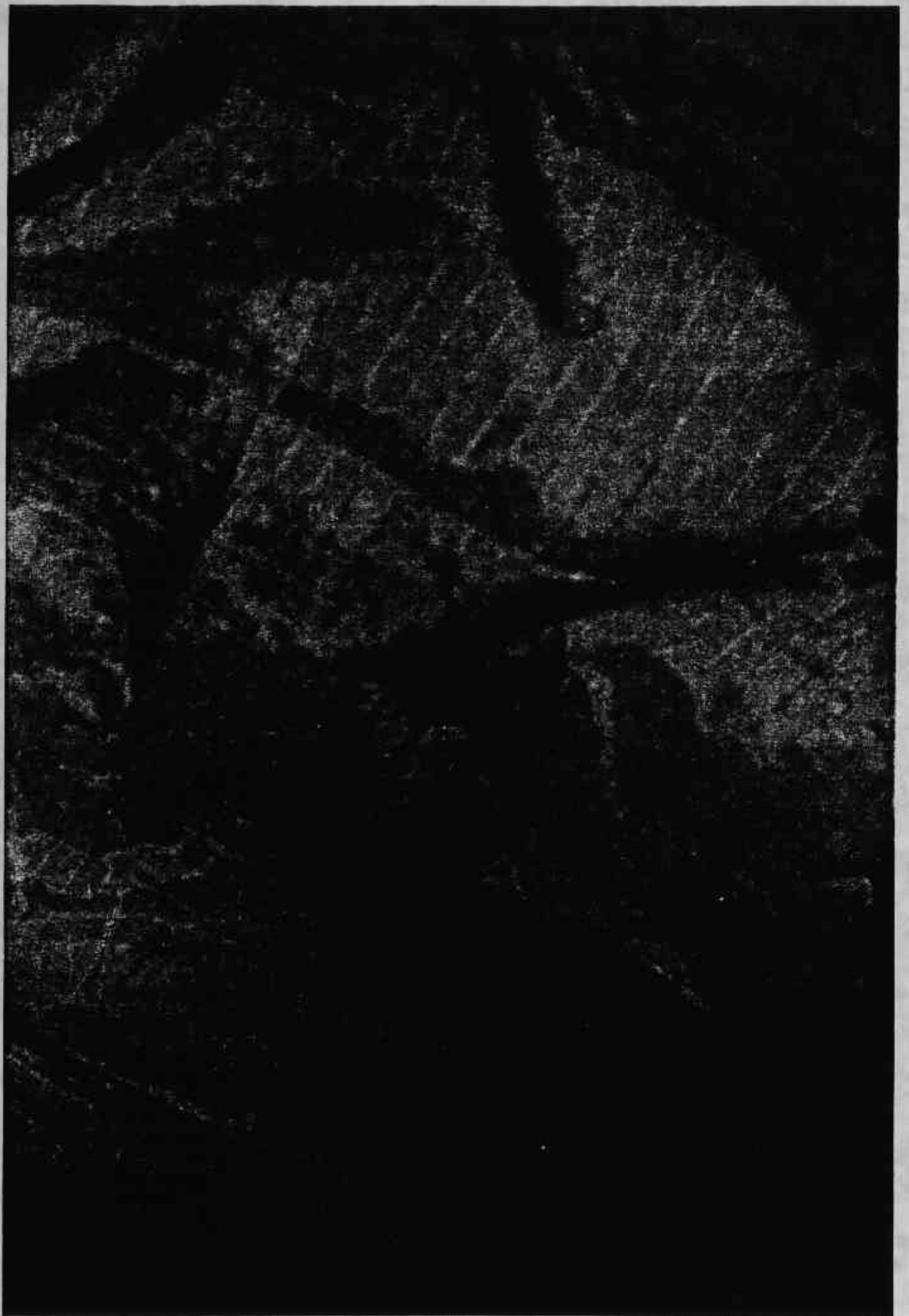

Figure A-23 POST-TEST PASSENGER AIRBAG VIEW

Appendix B

VEHICLE AND DUMMY RESPONSE DATA

NOTE : Data trace scales are automatically scaled at the
request of the COTR. Use caution when
reviewing data.

TEST NO. CS0212

VEHICLE

SAE FILTER CHANNEL CLASS

60

FACILITY: TRACK
RUN #: 1496
SERIES #: 16

TEST DATE: 23 Feb 1995
TEST TIME: 13:18:53
BOARD: b

TITLE: 208 TEST #13 - 1995 FORD EXPLORER

CHANNEL NUMBER	DESCRIPTION	ENGR UNIT	MAXIMUM		MINIMUM		FILTER CLASS
			AMP	msec	AMP	msec	
1	Left Rear X-member X	Gs	3.0	145.8	-32.6	30.2	60.0
2	Right Rear X-member X	Gs	2.2	164.8	-36.4	30.6	60.0
3	Engine Top X	Gs	30.4	72.1	-66.8	35.5	60.0
4	Engine Bottom X	Gs	4.5	63.1	-51.9	40.8	60.0
5	Right Brake Caliper X	Gs	20.4	31.0	-81.8	49.8	60.0
6	Left Brake Caliper X	Gs	13.8	31.4	-51.3	47.9	60.0
7	Instrument Panel X	Gs	34.5	37.6	-85.3	61.7	60.0
8	Pos. 1 Chest Disp.	in	.0	18.7	-1.5	83.6	180.0
9	Pos. 2 Chest Disp.	in	.0	22.6	-.7	65.5	180.0
10	Trunk Z	Gs	39.9	175.1	-29.6	111.2	60.0

FMVSS 208 - 1995 FORD EXPLORER

Max = 3.04 Gs @ 145.80 msec
Min = -32.56 Gs @ 30.24 msec

L. Rear X-member X

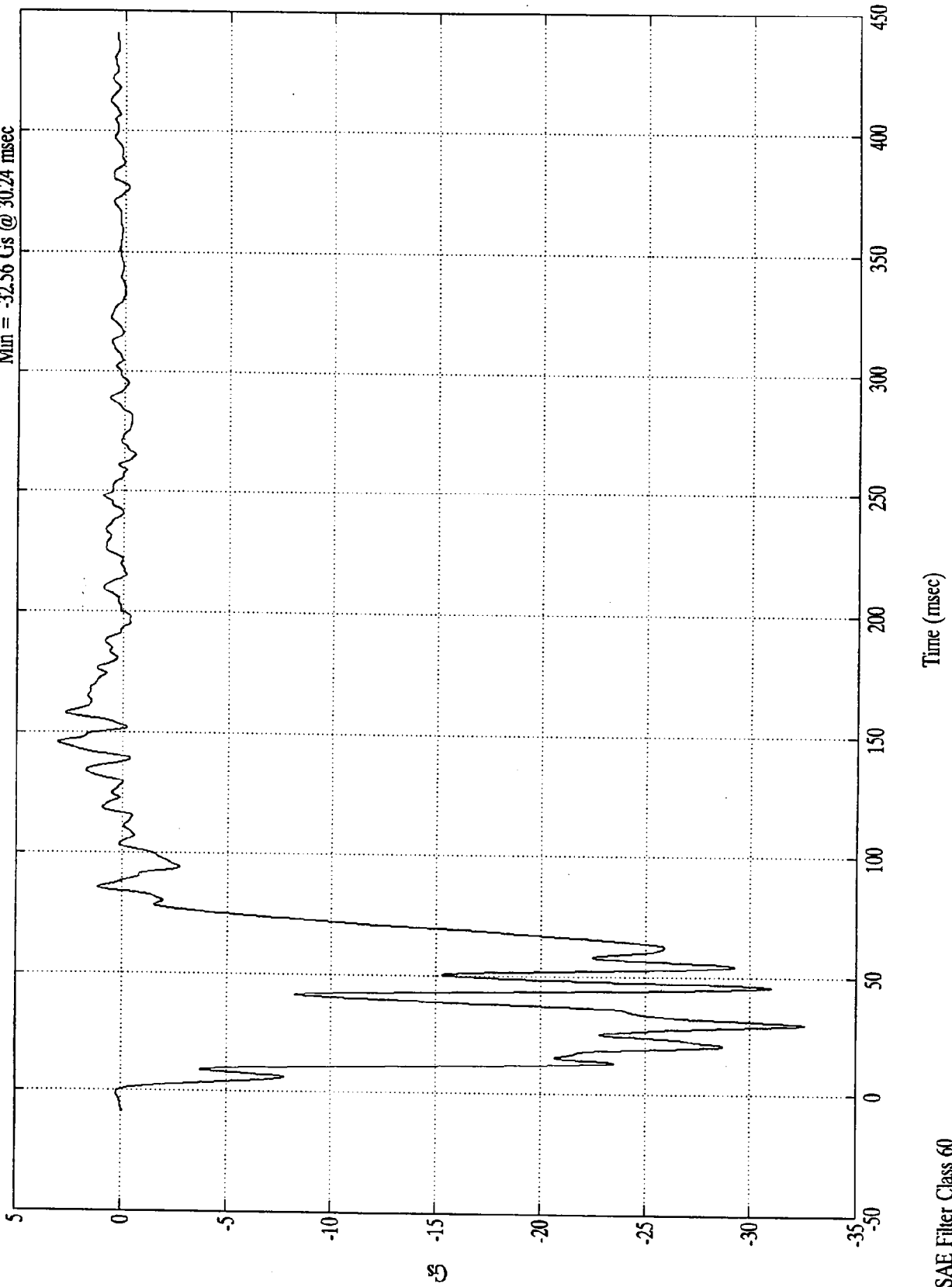

SAE Filter Class 60

FMVSS 208 - 1995 FORD EXPLORER

L Rear X-member X

Max = 29.40 mph @ 2.16 msec
Min = -3.24 mph @ 116.88 msec

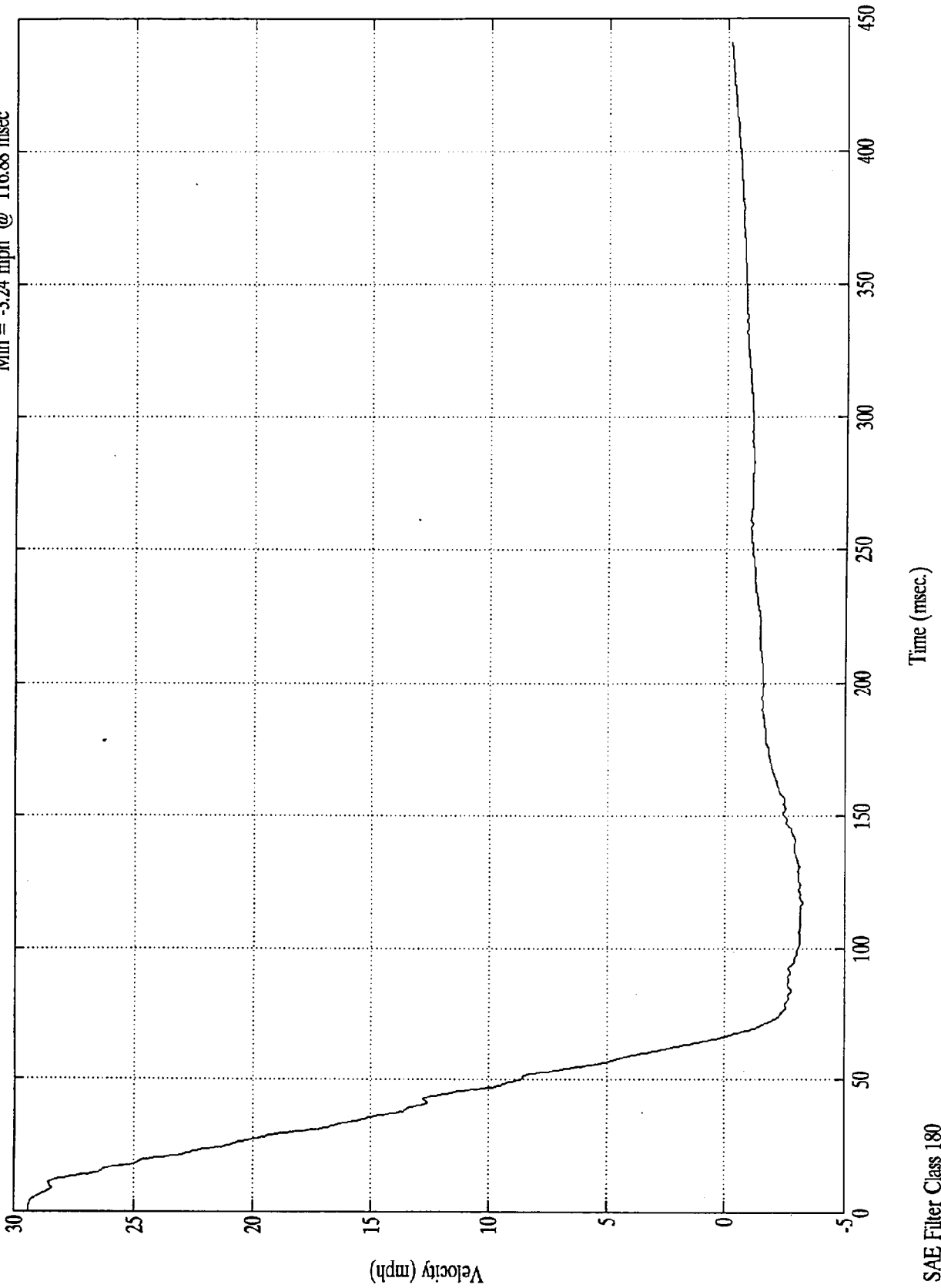

SAE Filter Class 180

FMVSS 208 - 1995 FORD EXPLORER

L-Rear X-member X

Max = 19.53 in. @ 66.72 msec
Min = 0.00 in. @ -0.00 msec

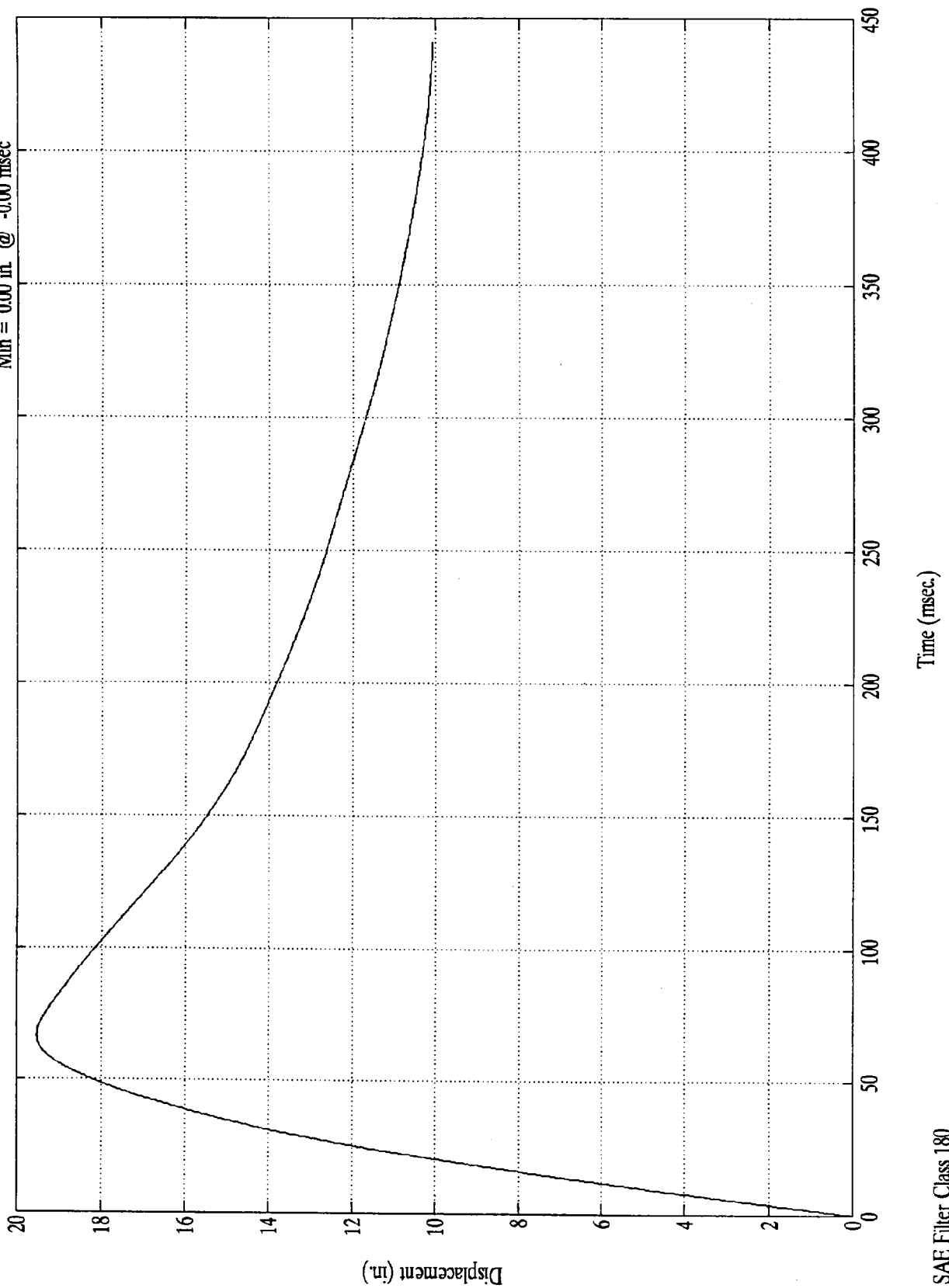

SAE Filter Class 180

FMVSS 208 - 1995 FORD EXPLORER

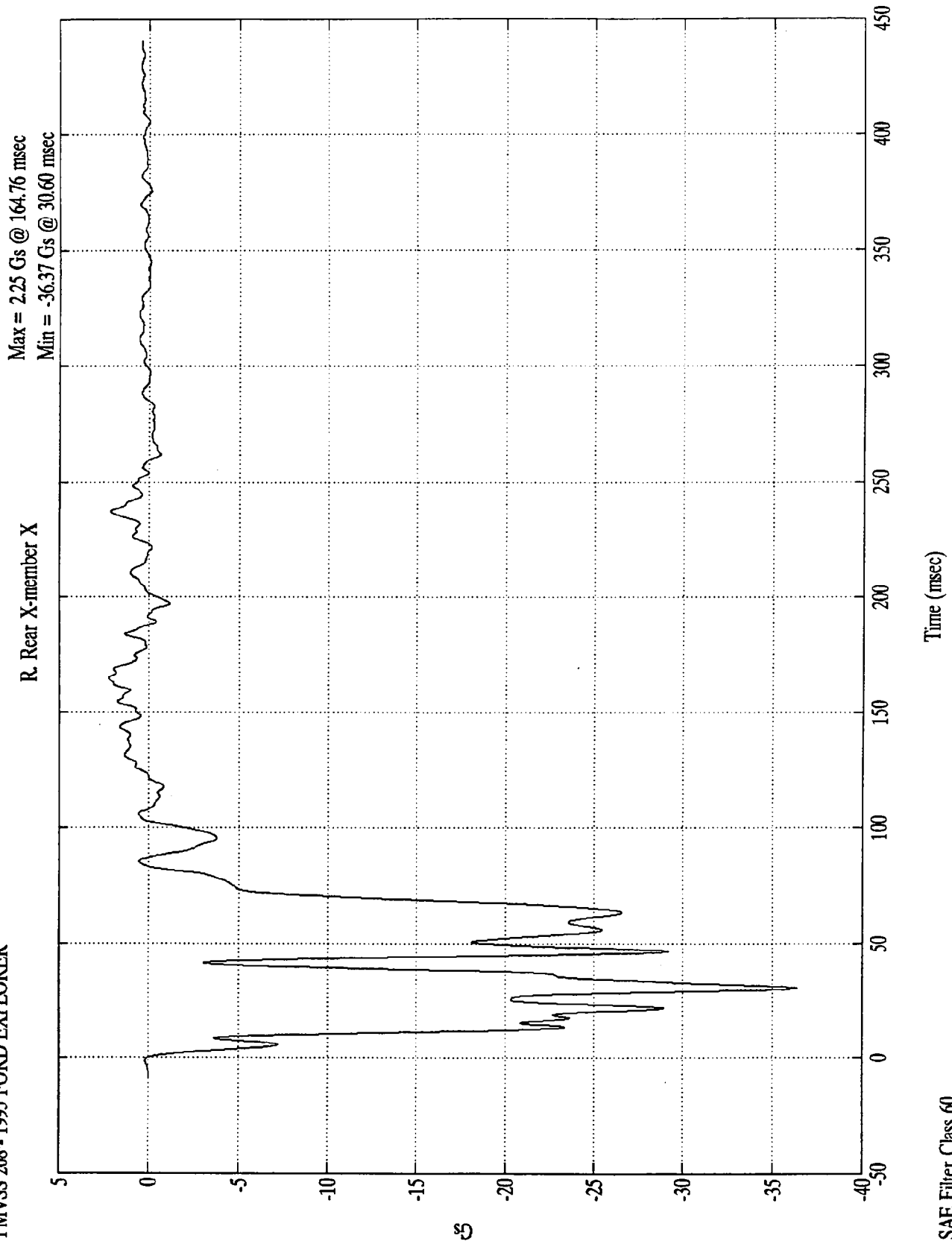

SAE Filter Class 60

FMVSS 208 - 1995 FORD EXPLORER

R. Rear X-member X

Max = 29.40 mph @ 1.68 msec
Min = -2.43 mph @ 119.52 msec

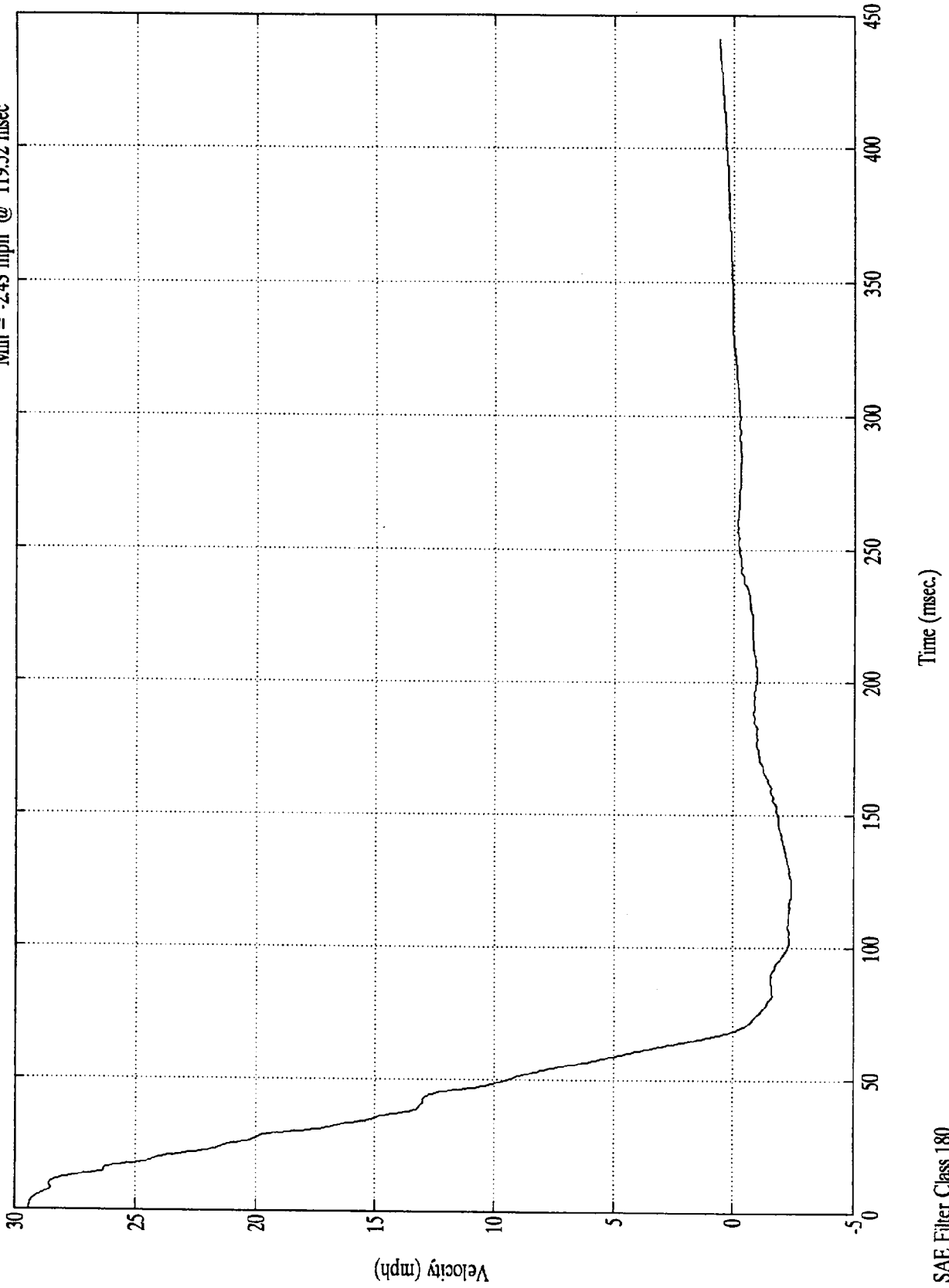

SAE Filter Class 180

FMVSS 208 - 1995 FORD EXPLORER

R. Rear X-member X

Max = 19.92 in. @ 70.32 msec
Min = 0.00 in. @ -0.00 msec



SAE Filter Class 180

FMVSS 208 - 1995 FORD EXPLORER

Engine Top X

Max = 30.42 Gs @ 72.12 msec
Min = -66.81 Gs @ 35.52 msec

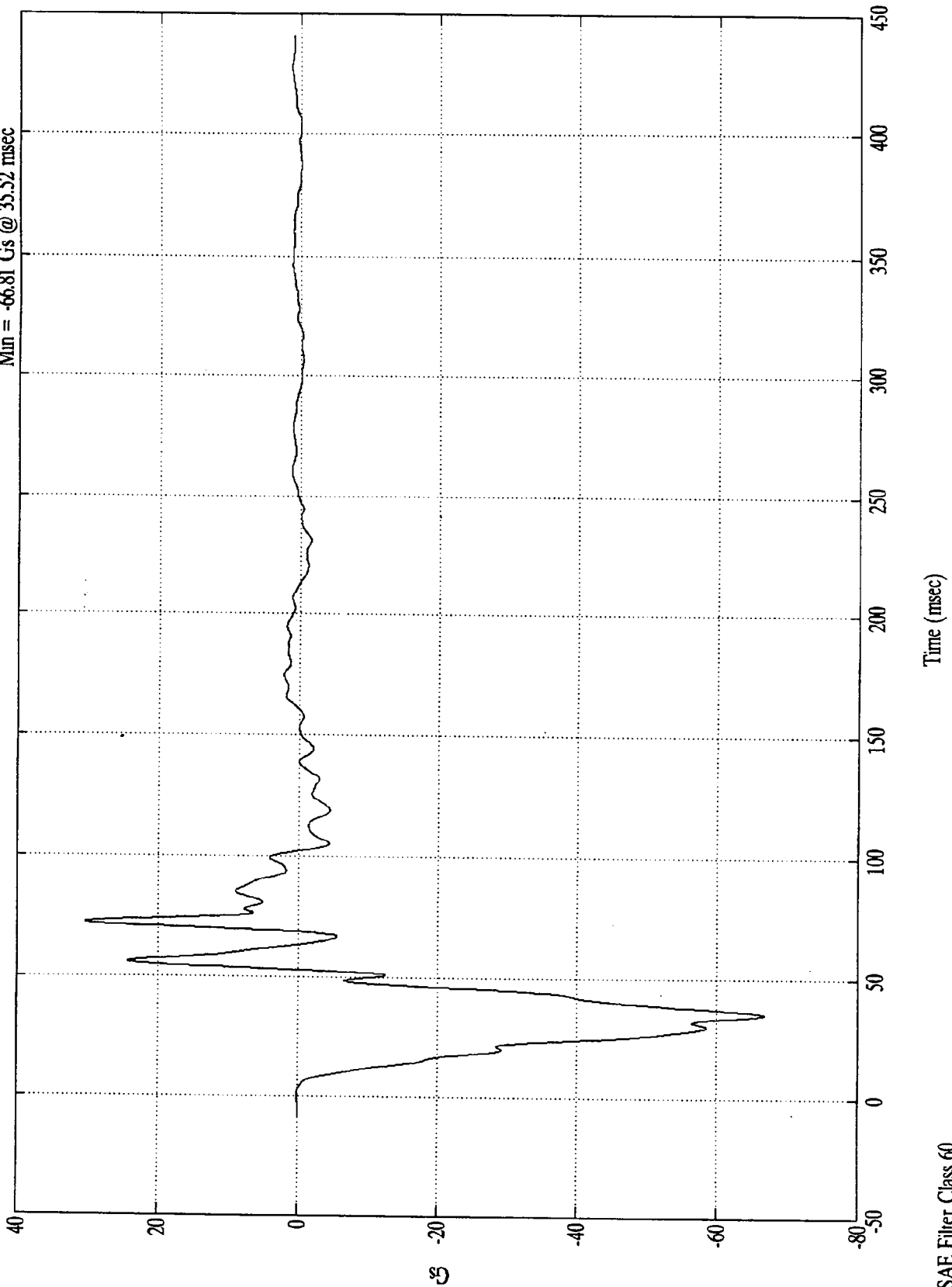

FMVSS 208 - 1995 FORD EXPLORER

Engine Top X
Max = 29.41 mph @ 4.08 msec
Min = -3.21 mph @ 52.80 msec

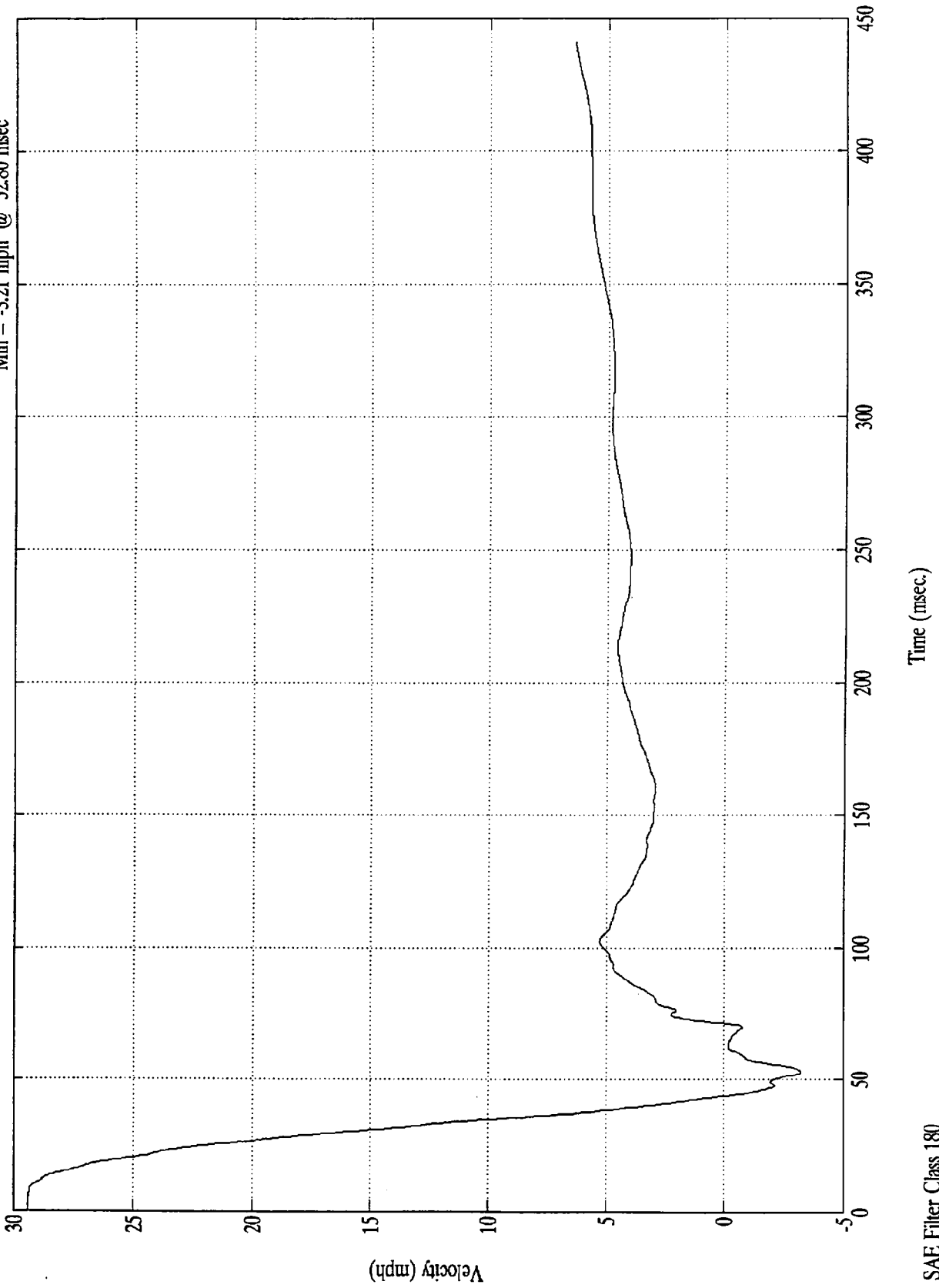

SAE Filter Class 180

FMVSS 208 - 1995 FORD EXPLORER

Engine Top X

Max = 44.66 in. @ 440.88 msec
Min = 0.00 in. @ -0.00 msec

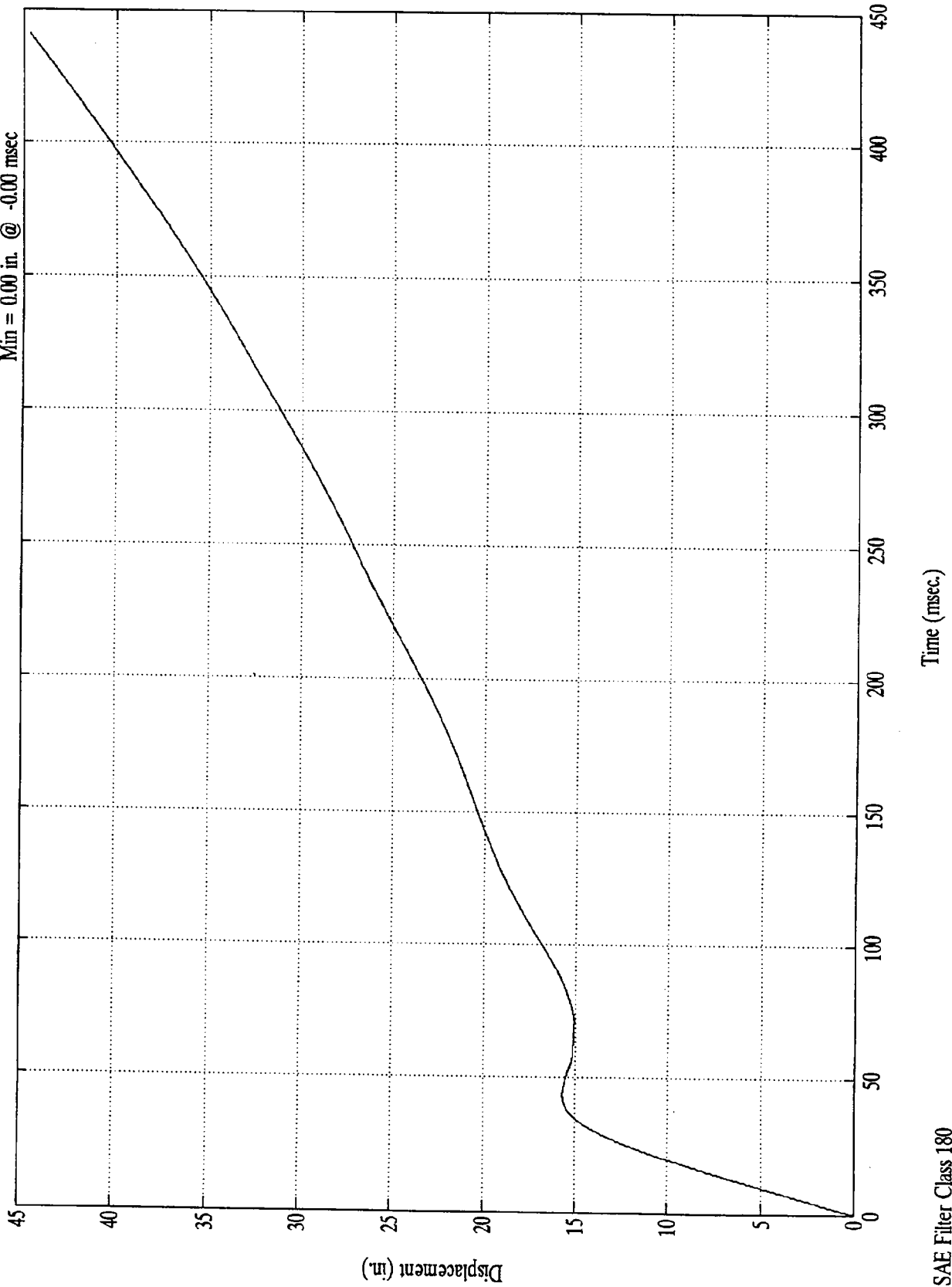

FMVSS 208 - 1995 FORD EXPLORER

Engine Bottom X

Max = 4.50 Gs @ 63.12 msec
Min = -51.91 Gs @ 40.80 msec

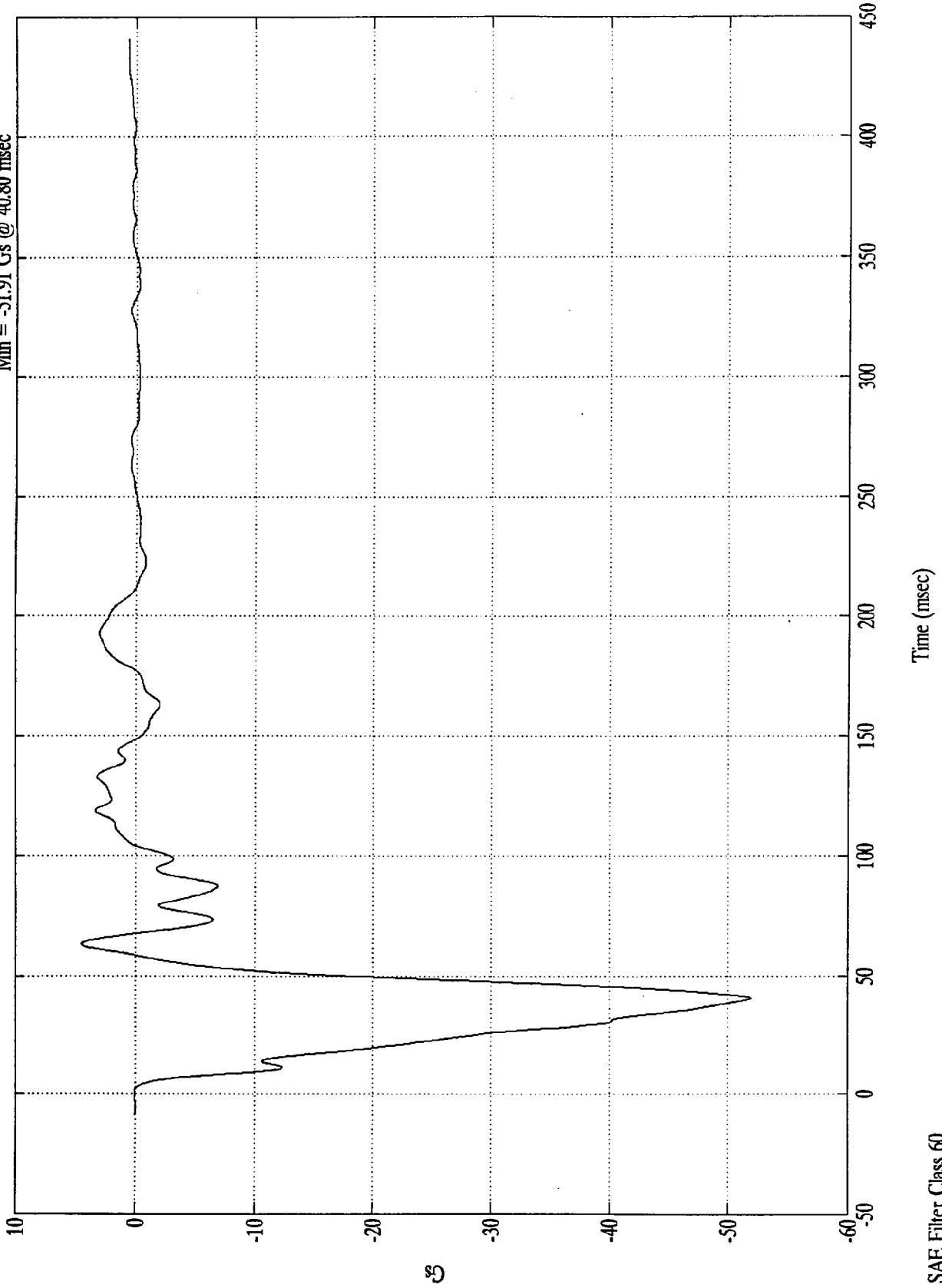

8

FMVSS 208 - 1995 FORD EXPLORER

Engine Bottom X

Max = 29.40 mph @ 3.60 msec
Min = -3.03 mph @ 103.92 msec

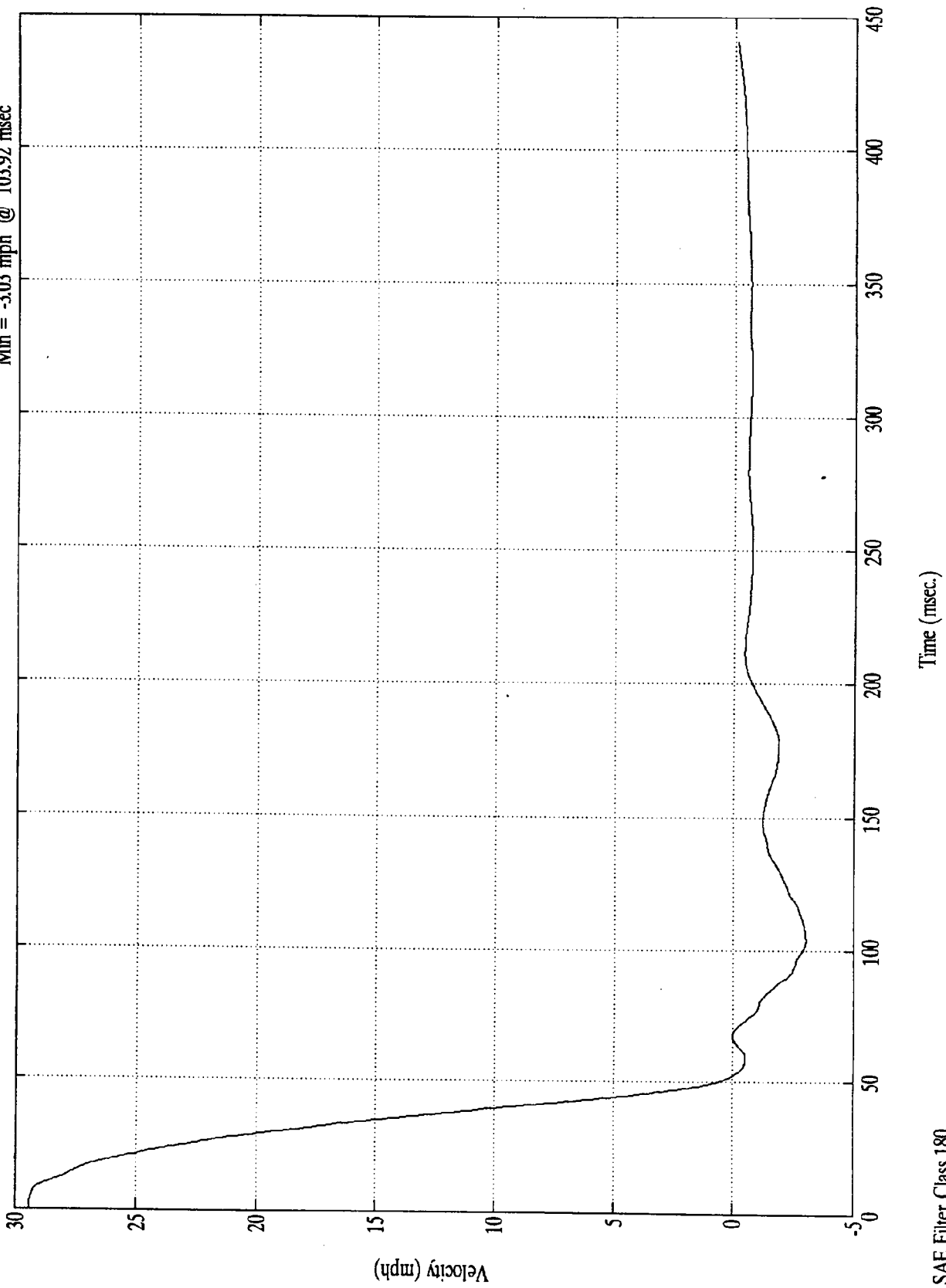

SAE Filter Class 180

FMVSS 208 - 1995 FORD EXPLORER

Engine Bottom X
Max = 17.43 in. @ 54.00 msec
Min = 0.00 in. @ -0.00 msec

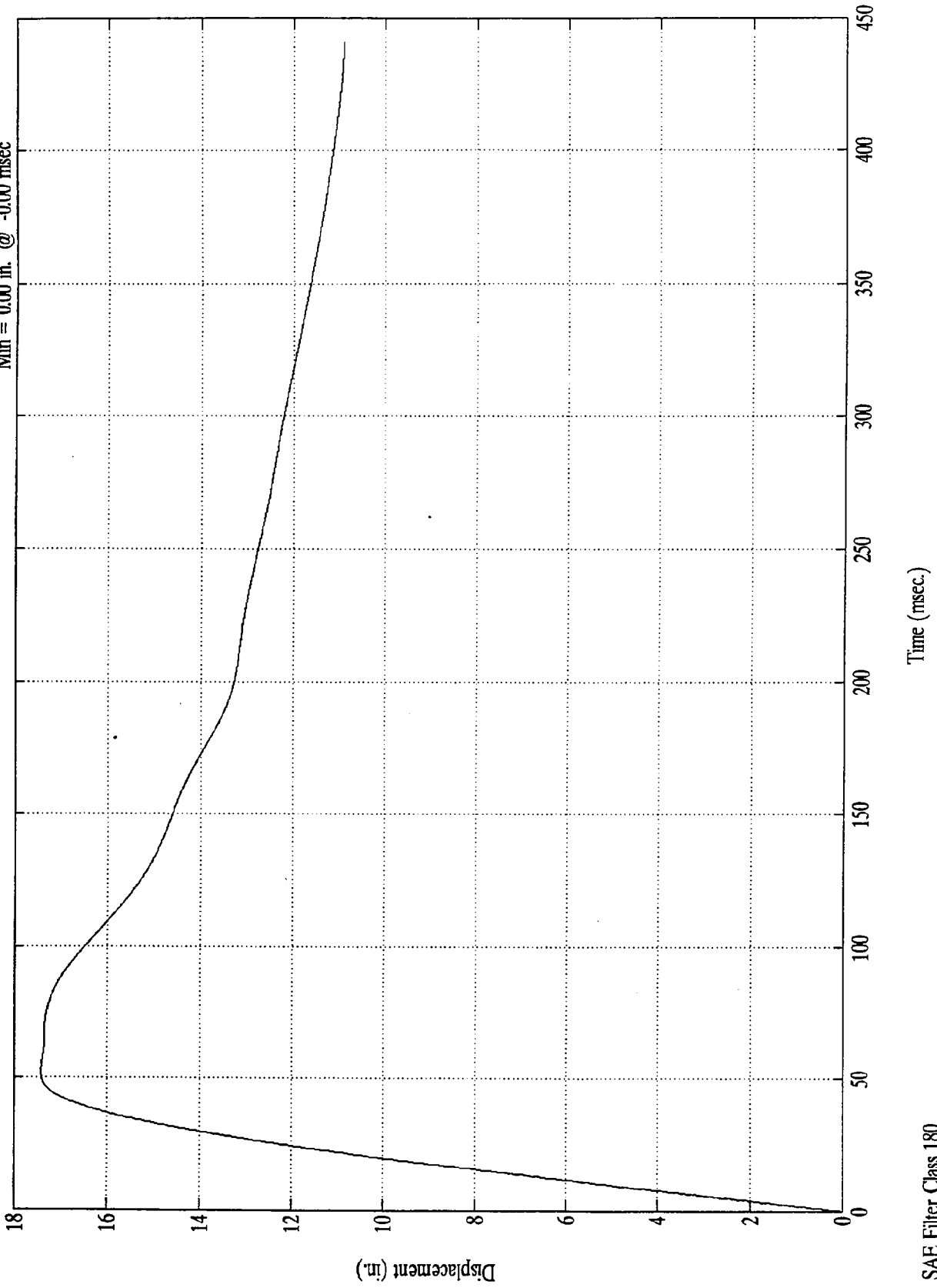

SAE Filter Class 180

FMVSS 208 - 1995 FORD EXPLORER

R. Brake Caliper X

Max = 20.36 Gs @ 30.96 msec
Min = -81.83 Gs @ 49.80 msec

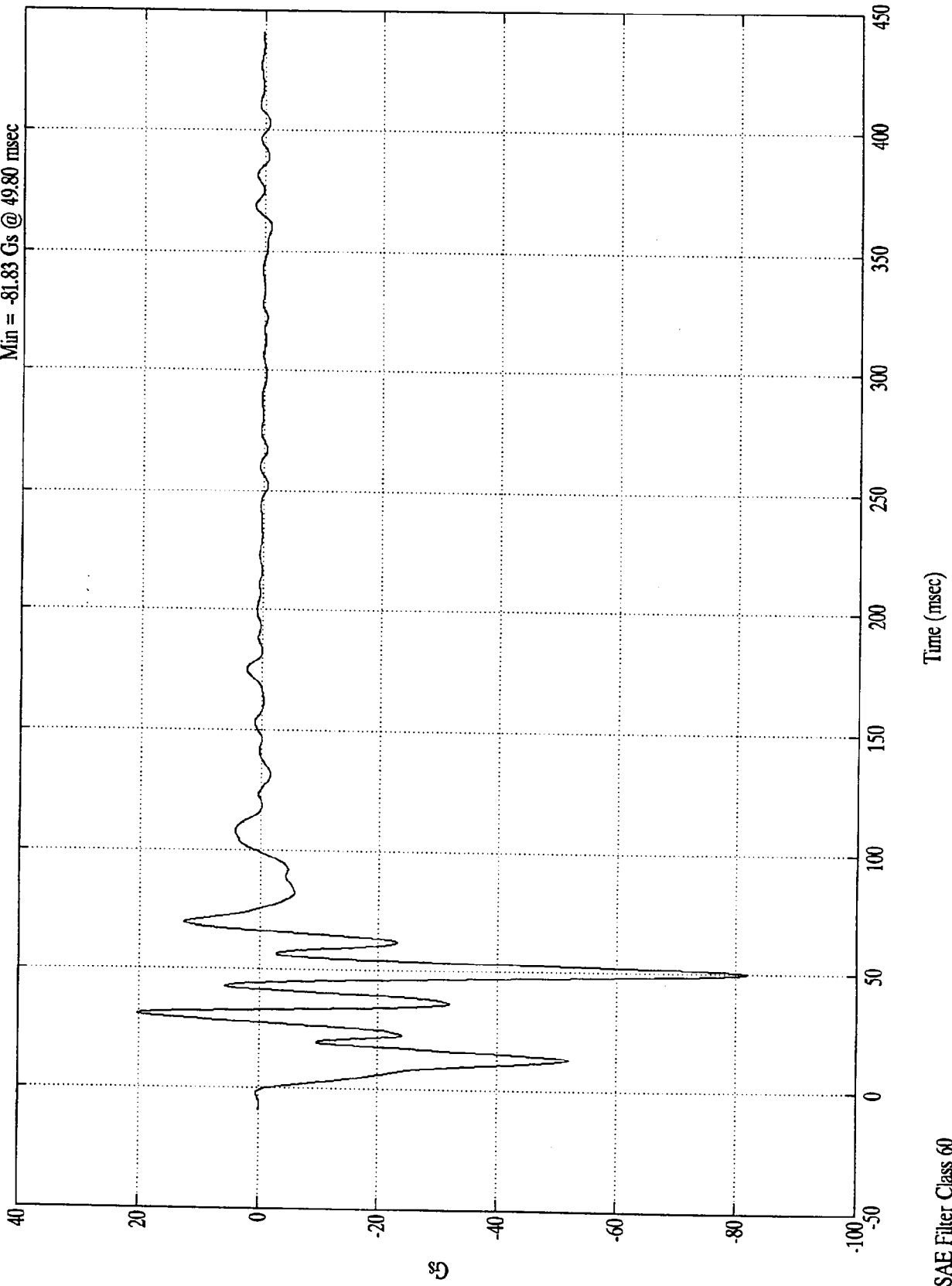

FMVSS 208 • 1995 FORD EXPLORER

R. Brake Caliper X

Max = 29.41 mph @ 0.96 msec
Min = -1.86 mph @ 100.32 msec

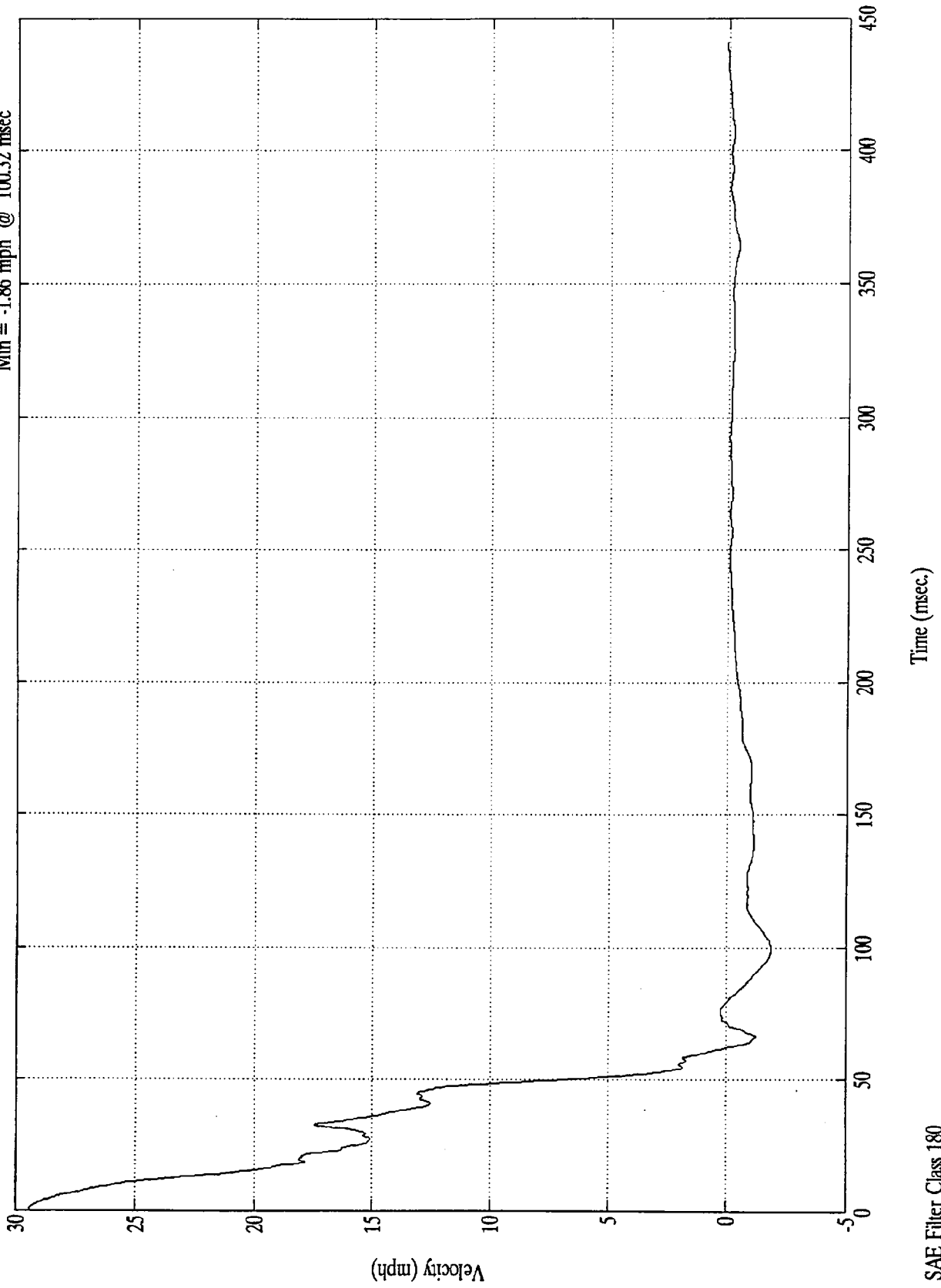

SAE Filter Class 180

FMVSS 208 - 1995 FORD EXPLORER

R. Brake Caliper X

Max = 16.83 in. @ 63.60 msec
Min = 0.00 in. @ -0.00 msec

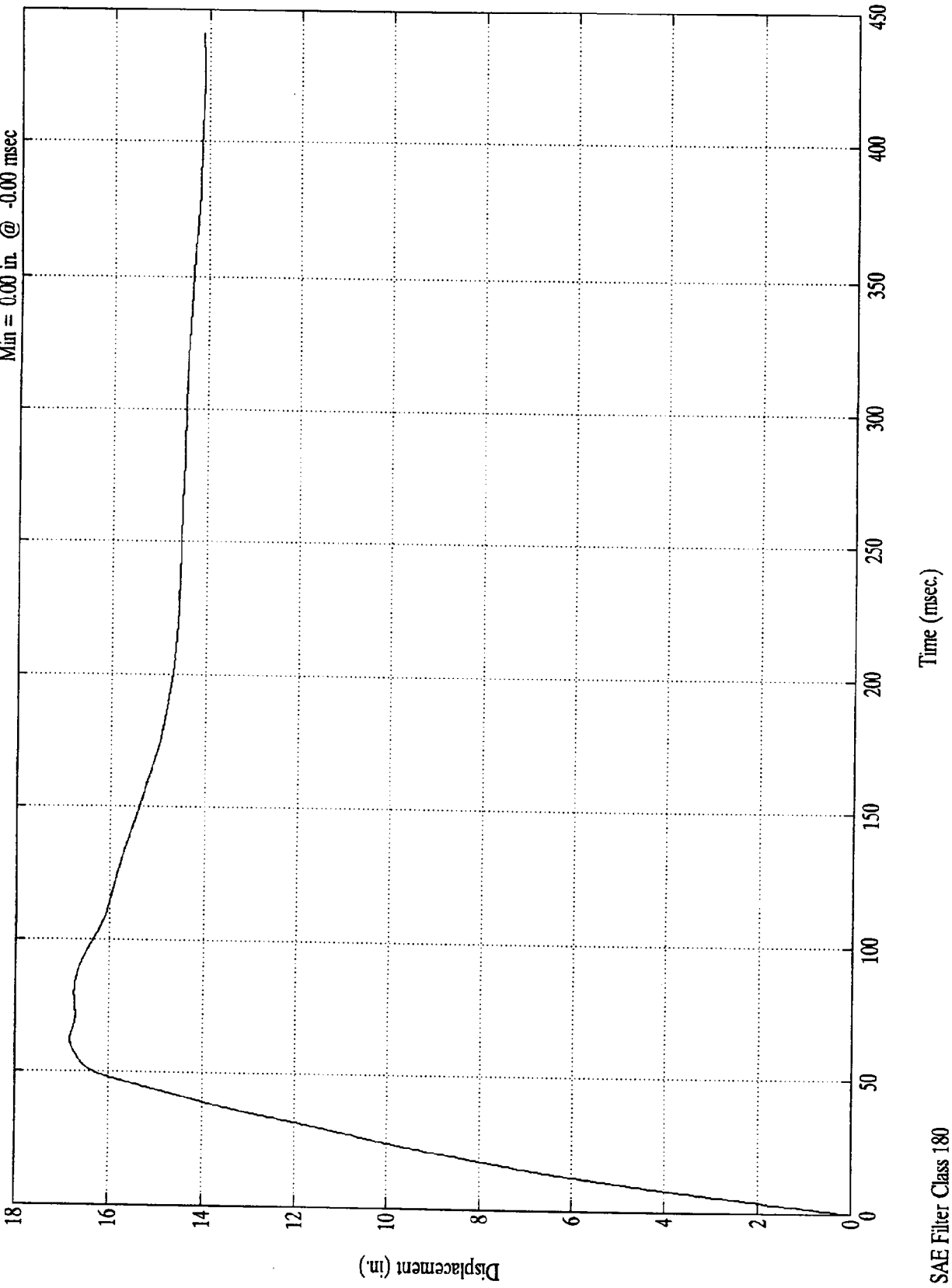

SAE Filter Class 180

FMVSS 208 - 1995 FORD EXPLORER

L. Brake Caliper X

Max = 13.81 Gs @ 31.44 msec
Min = -51.32 Gs @ 47.88 msec

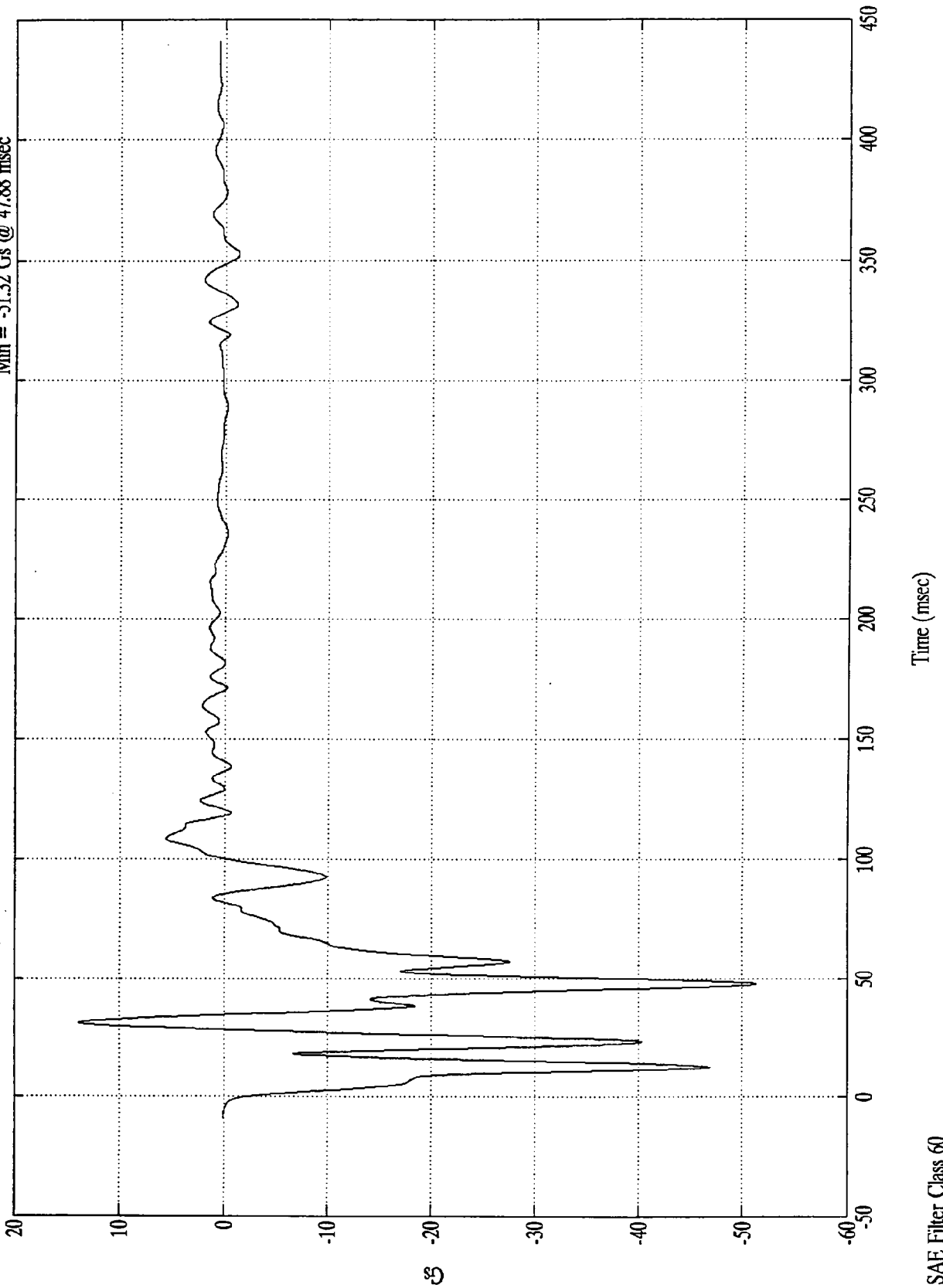

SAE Filter Class 60

FMVSS 208 - 1995 FORD EXPLORER

L Brake Caliper X

Max = 29.40 mph @ 0.24 msec
Min = -1.98 mph @ 101.28 msec

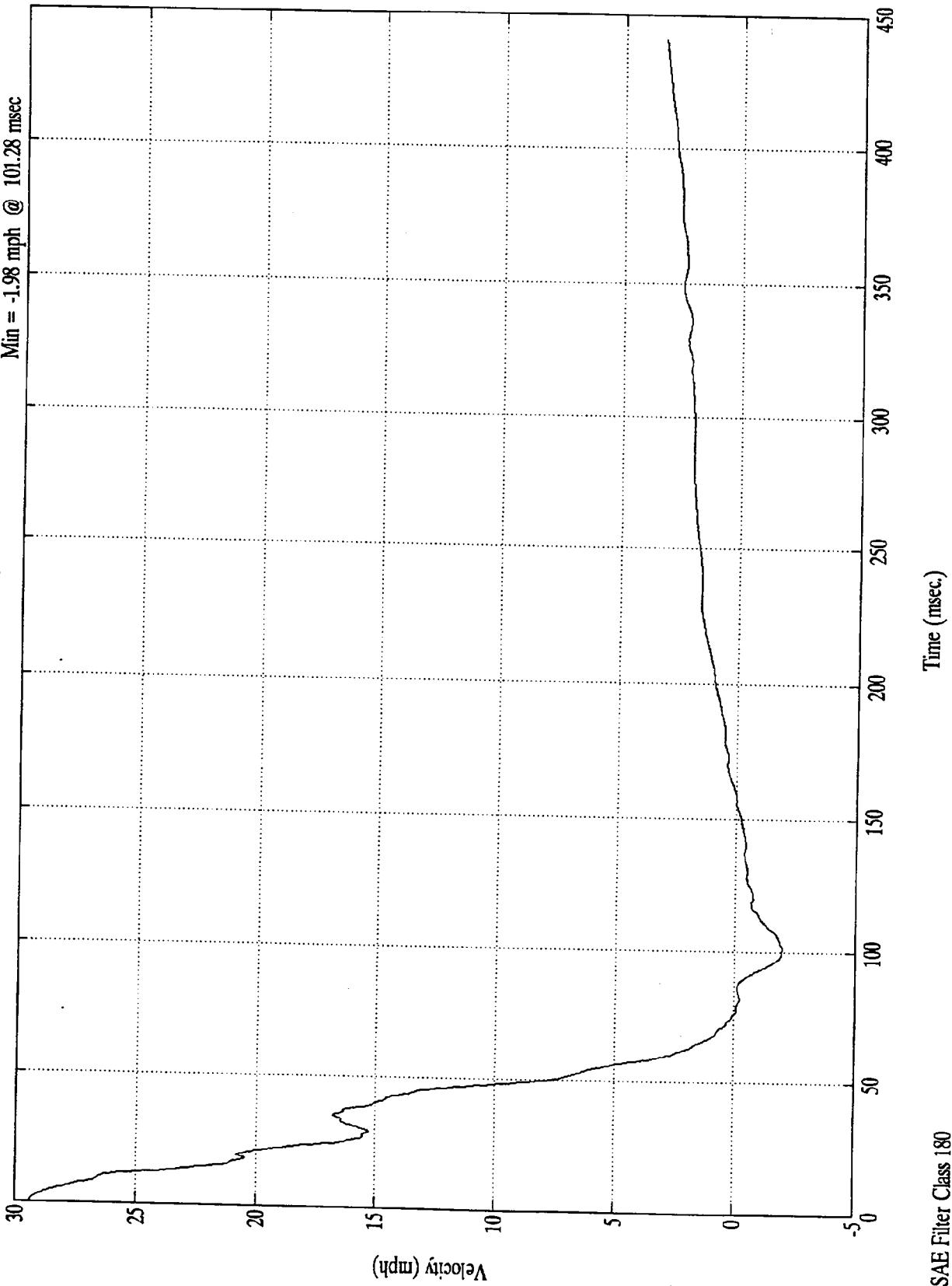

SAE Filter Class 180

L. Brake Caliper X

Max = 26.91 in. @ 440.88 msec
Min = 0.00 in. @ -0.00 msec

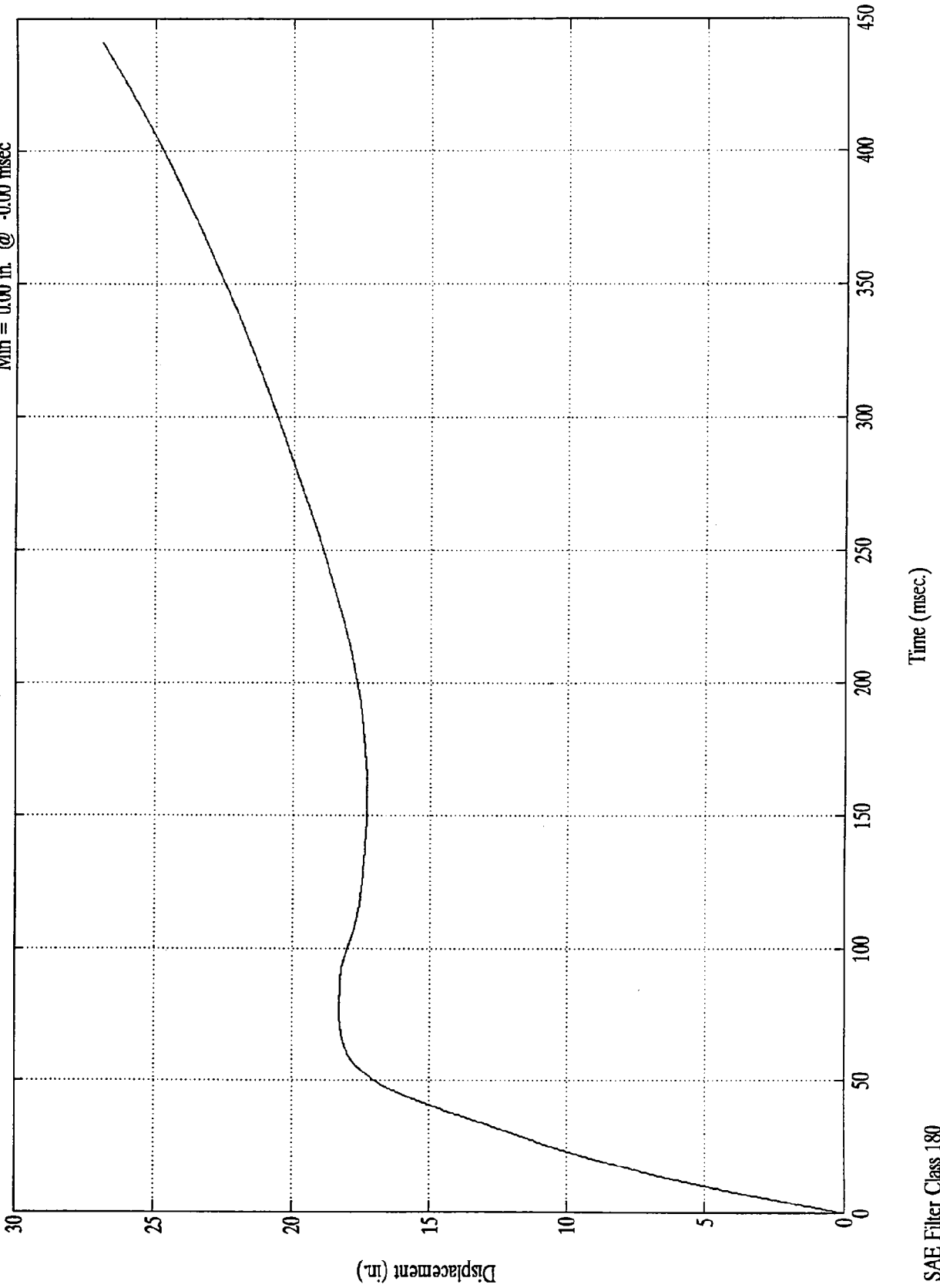

FMVSS 208 - 1995 FORD EXPLORER

Instrument Panel X

Max = 34.52 Gs @ 37.56 msec
Min = -85.31 Gs @ 61.68 msec

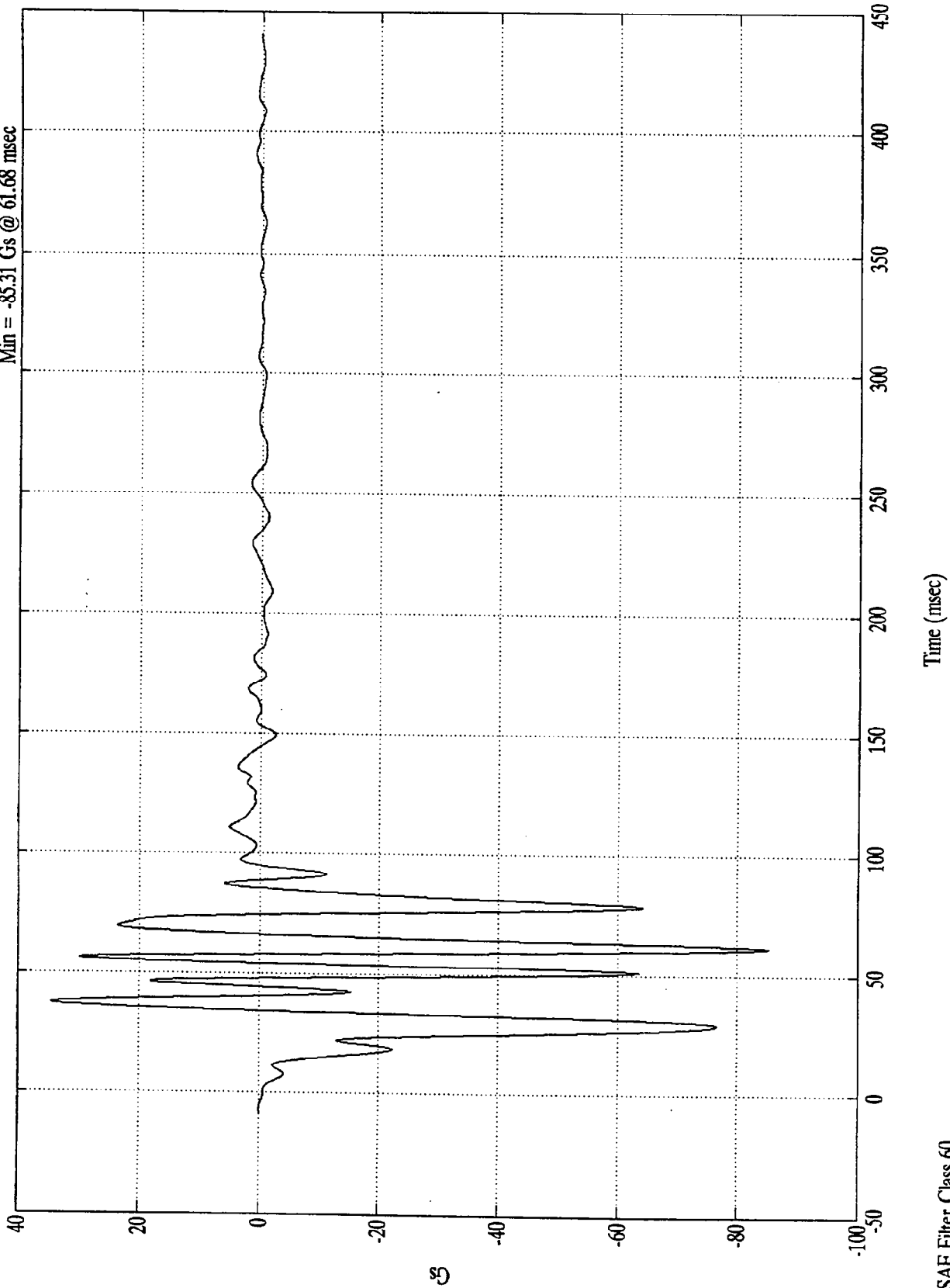

FMVSS 208 - 1995 FORD EXPLORER

Max = 29.40 mph @ -0.00 msec
Min = -3.71 mph @ 94.08 msec

Instrument Panel X

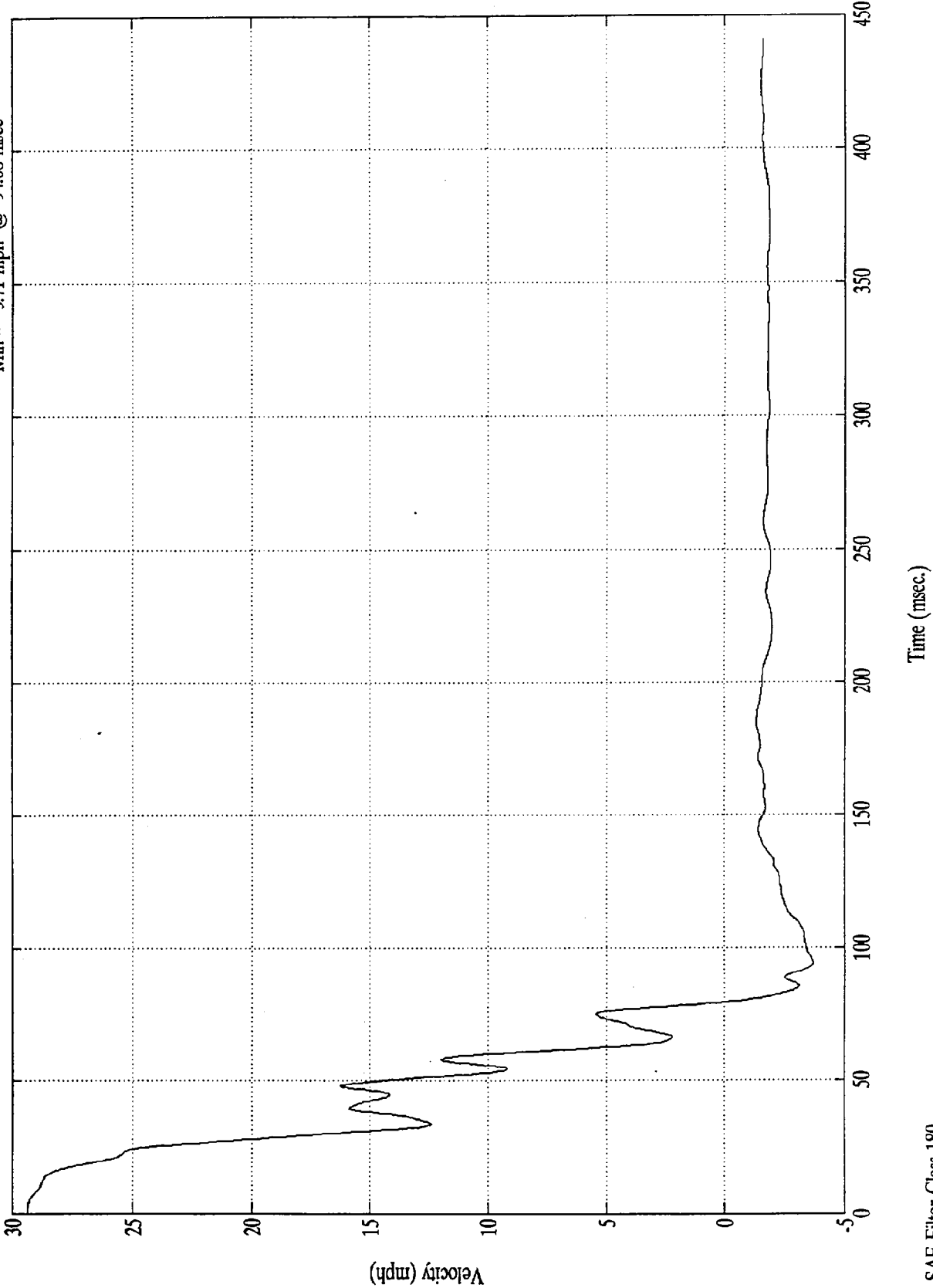

SAE Filter Class 180

FMVSS 208 - 1995 FORD EXPLORER

Max = 22.68 in. @ 80.16 msec
Min = 0.00 in. @ -0.00 msec

Instrument Panel X

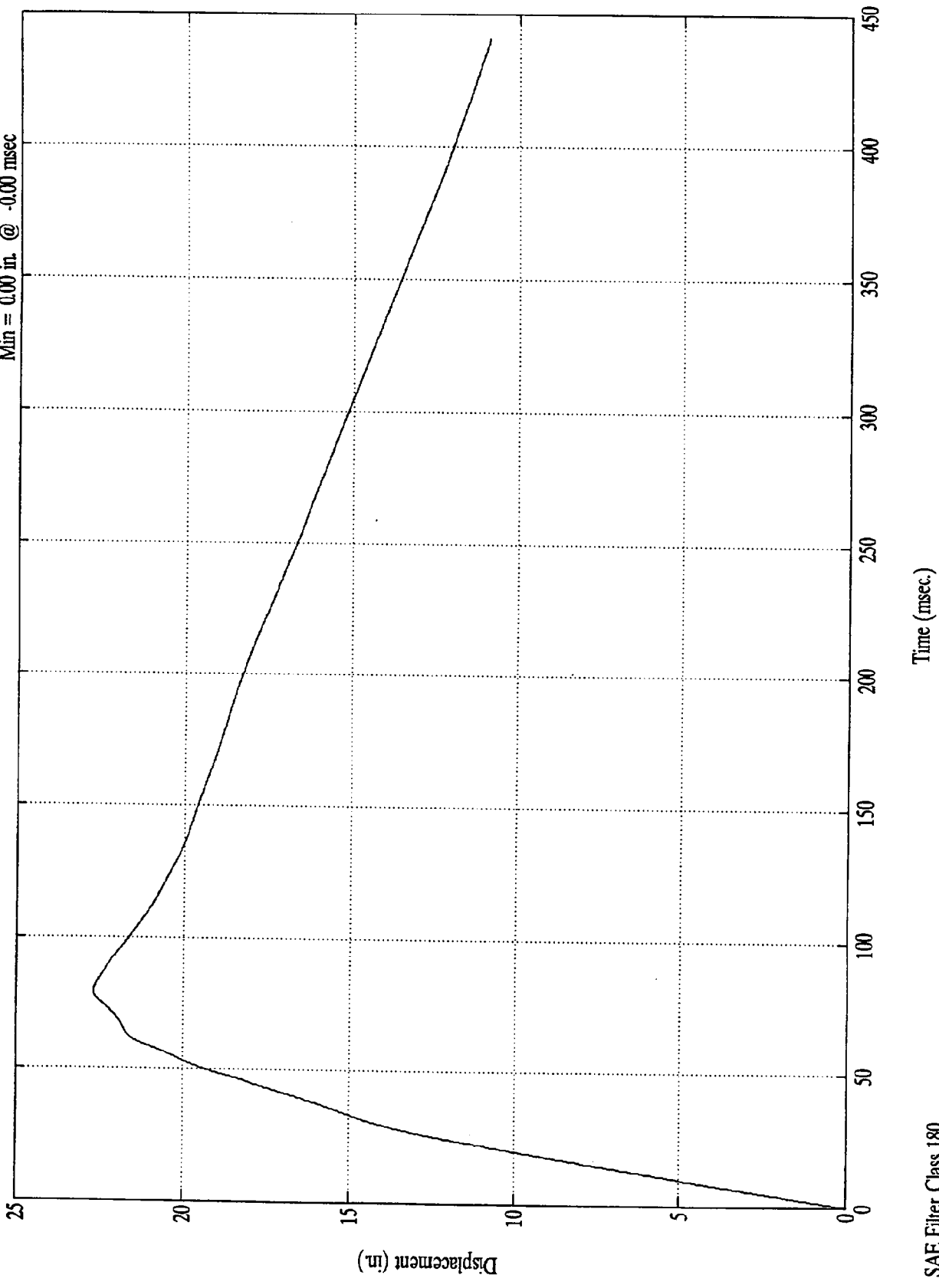

SAE Filter Class 180

FMVSS 208 - 1995 FORD EXPLORER

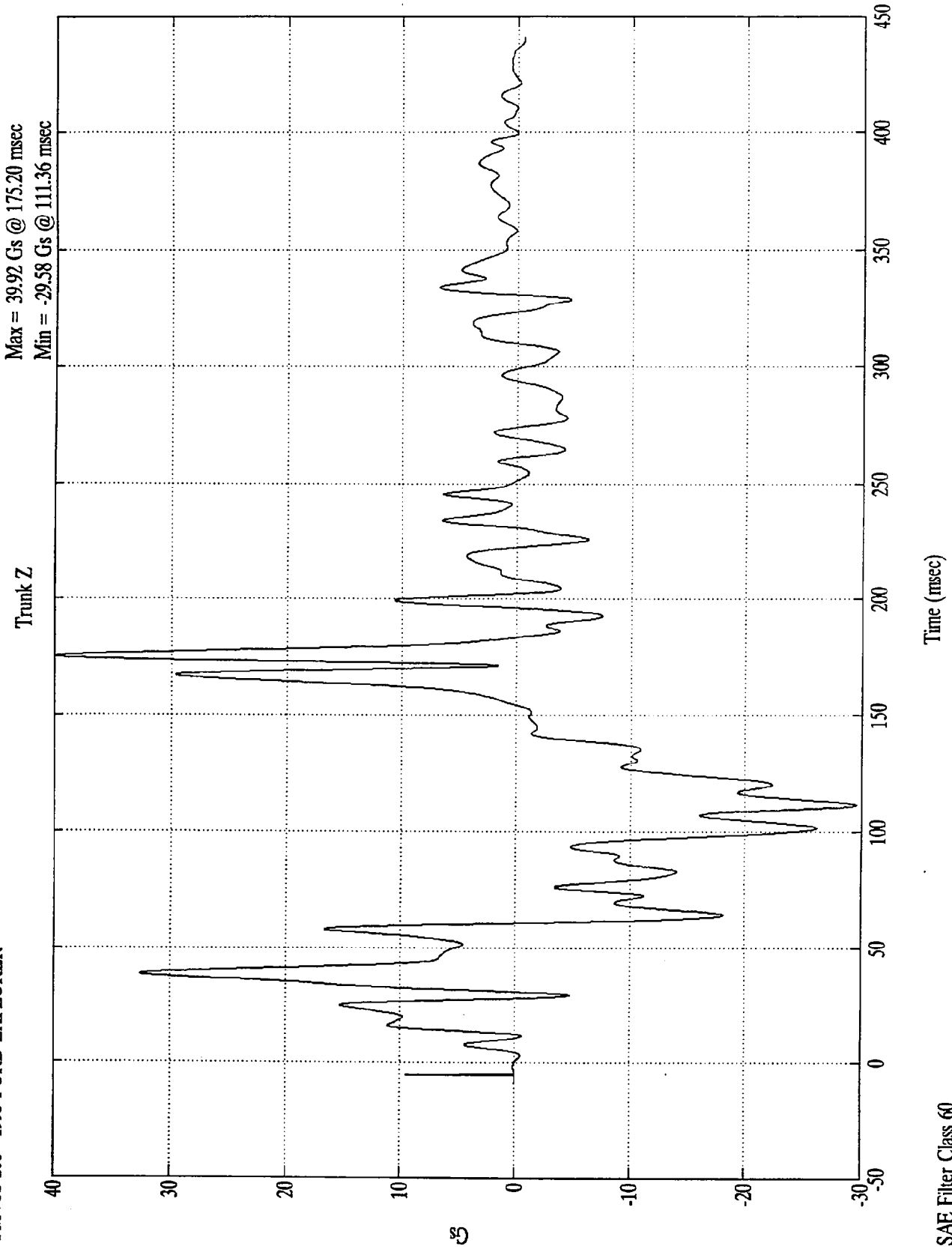

FMVSS 208 - 1995 FORD EXPLORER

Trunk Z
Max = 12.06 mph @ 60.48 msec
Min = -12.70 mph @ 154.08 msec

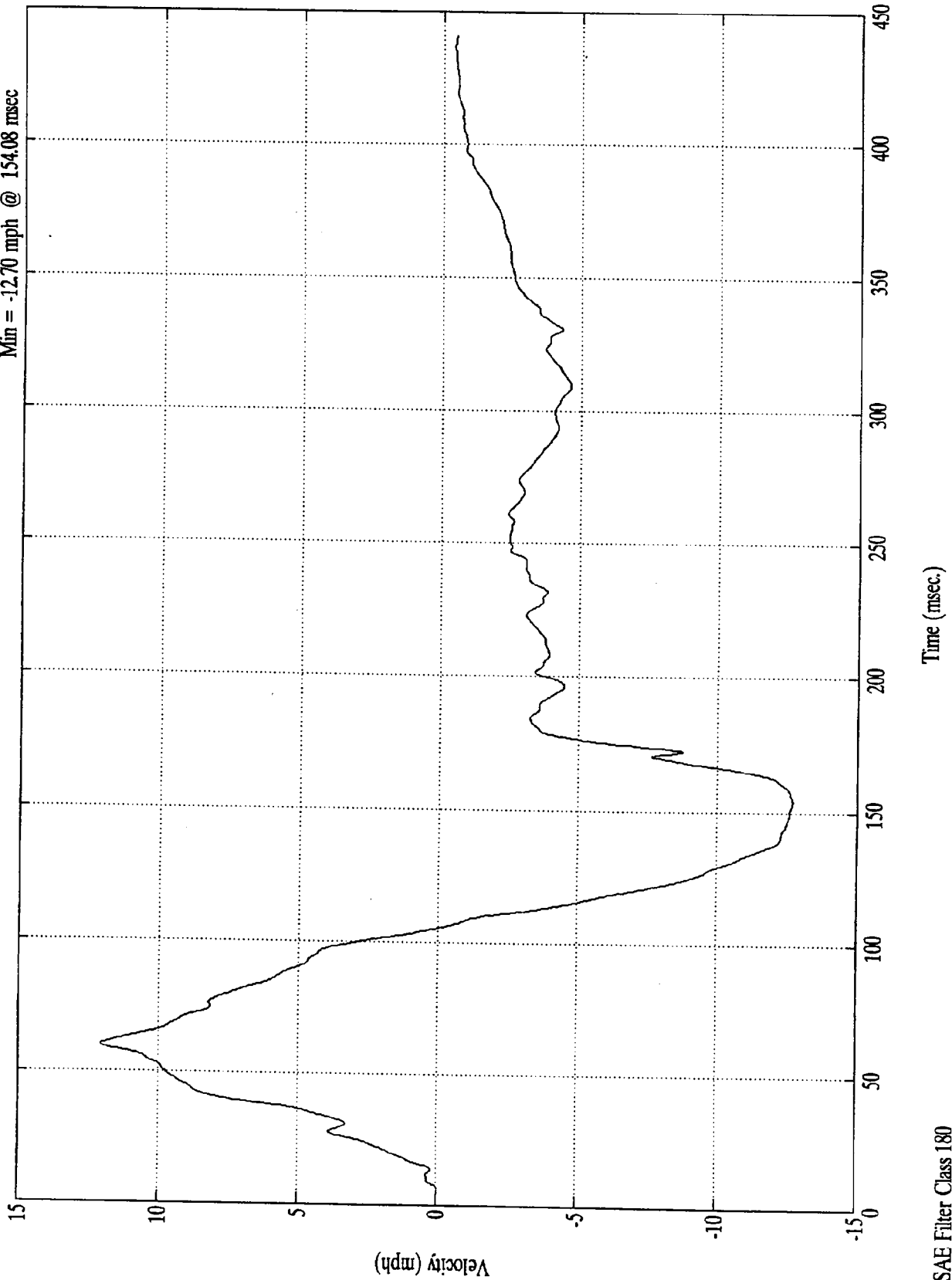

SAE Filter Class 180

FMVSS 208 - 1995 FORD EXPLORER

Max = 10.21 in. @ 106.56 msec
Min = -14.16 in. @ 440.88 msec

Trunk Z

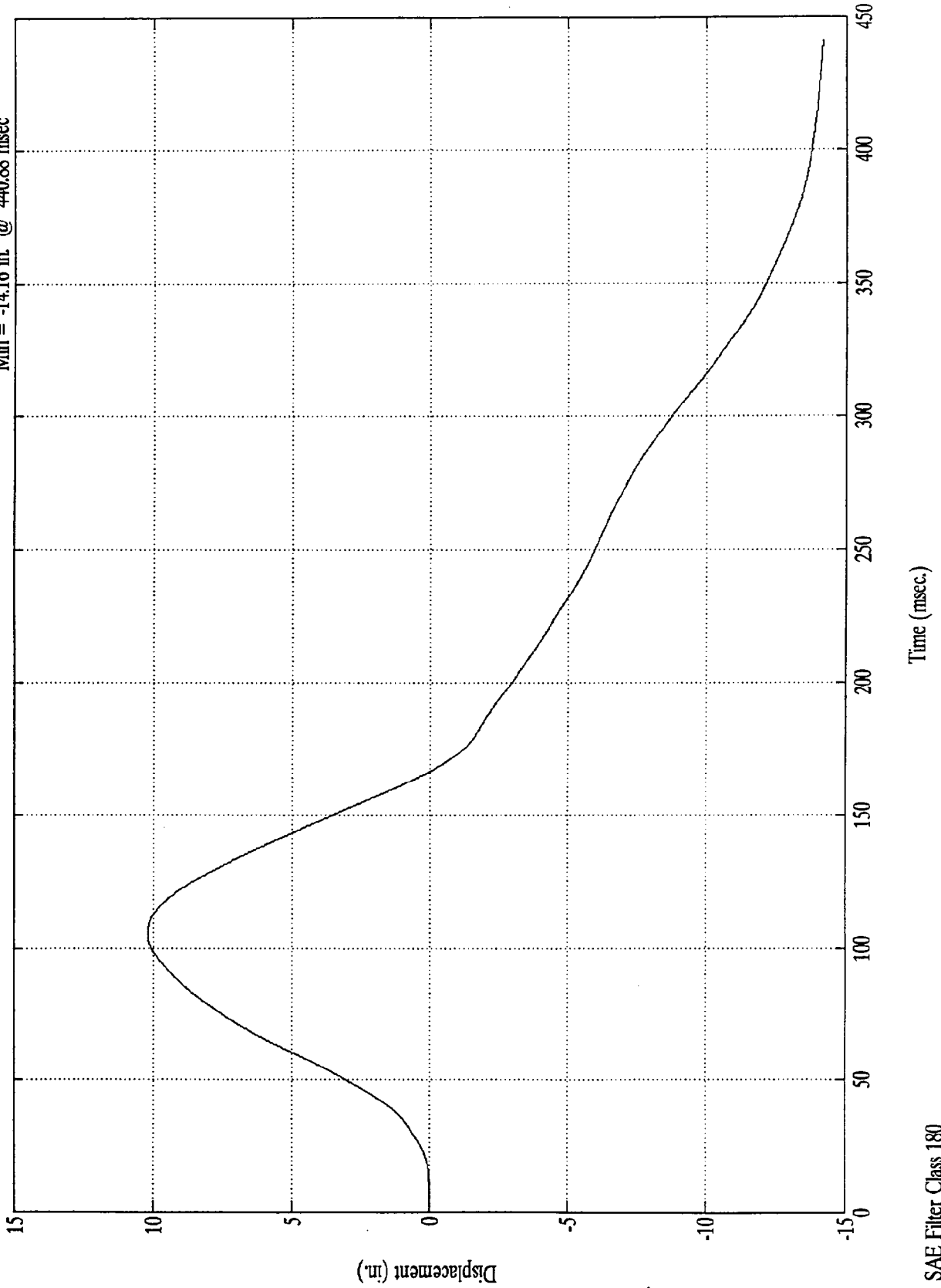

SAE Filter Class 180

TEST NO. CS0212

DUMMY	SAE FILTER CHANNEL CLASS
Head Accelerations	1000
Chest Accelerations	180
Femur Forces	600

FACILITY: TRACK
 RUN #: 1496
 SERIES #: 16

TEST DATE: 23 Feb 1995
 TEST TIME: 13:18:53
 BOARD: a

TITLE: 208 TEST #13 - 1995 FORD EXPLORER

CHANNEL NUMBER	DESCRIPTION	ENGR UNIT	MAXIMUM		MINIMUM		FILTER CLASS
			AMP	msec	AMP	msec	
1	Pos. 1 Head X	Gs	25.0	206.2	-49.2	74.6	1000.0
2	Pos. 1 Head Y	Gs	7.6	85.3	-5.6	24.4	1000.0
3	Pos. 1 Head Z	Gs	16.8	63.4	-6.8	97.7	1000.0
4	Pos. 1 Left Femur	lbs	107.6	397.8	-1500.4	48.7	600.0
5	Pos. 1 Chest X	Gs	9.4	163.8	-51.8	76.4	180.0
6	Pos. 1 Chest Y	Gs	3.6	75.8	-6.2	41.4	180.0
7	Pos. 1 Chest Z	Gs	15.1	78.2	-4.0	43.8	180.0
8	Pos. 1 Right Femur	lbs	50.0	166.7	-1565.3	39.8	600.0
9	Pos. 2 Head X	Gs	7.6	37.4	-32.0	73.8	1000.0
10	Pos. 2 Head Y	Gs	7.0	31.4	-21.1	81.2	1000.0
11	Pos. 2 Head Z	Gs	25.3	75.2	-14.7	109.6	1000.0
12	Pos. 2 Left Femur	lbs	42.6	182.5	-1375.7	50.6	600.0
13	Pos. 2 Chest X	Gs	3.8	167.5	-41.7	77.3	180.0
14	Pos. 2 Chest Y	Gs	2.5	136.2	-10.1	74.0	180.0
15	Pos. 2 Chest Z	Gs	20.4	72.8	-9.4	114.4	180.0
16	Pos. 2 Right Femur	lbs	51.6	115.0	-1753.2	77.5	600.0
17	Pos. 1 Head Resultant	Gs	51.3	74.6	.0	-1.6	1000.0
18	Pos. 1 Chest Resultant	Gs	53.9	76.4	.0	-6.7	180.0
19	Pos. 2 Head Resultant	Gs	43.4	75.0	.0	20.8	1000.0
20	Pos. 2 Chest Resultant	Gs	45.0	75.6	.0	.6	180.0

36 ms Fixed Duration HIC SUMMARY: Pos. 1 Head Resultant

hic: 309.36
 t1 = 58.560 msec
 t2 = 94.440 msec
 Average G's Over Hic Duration = 37.52

36 ms Fixed Duration HIC SUMMARY: Pos. 2 Head Resultant

hic: 199.89
 t1 = 54.600 msec
 t2 = 88.080 msec
 Average G's Over Hic Duration = 32.39

CLIP SUMMARY: Pos. 1 Chest Resultant

Peak Resultant (3 ms CLIPPED DURATION) = 53.158 G's
 Tstart = 75.1200 ms
 Tend = 78.2400 ms
 CSI = 423.974

CLIP SUMMARY: Pos. 2 Chest Resultant

Peak Resultant (3 ms CLIPPED DURATION) = 44.611 G's
 Tstart = 74.8800 ms
 Tend = 77.8800 ms
 CSI = 306.589

FMVSS 208 - 1995 FORD EXPLORER

Pos. 1 Head X

Max = 25.02 Gs @ 206.16 msec
Min = -49.17 Gs @ 74.64 msec

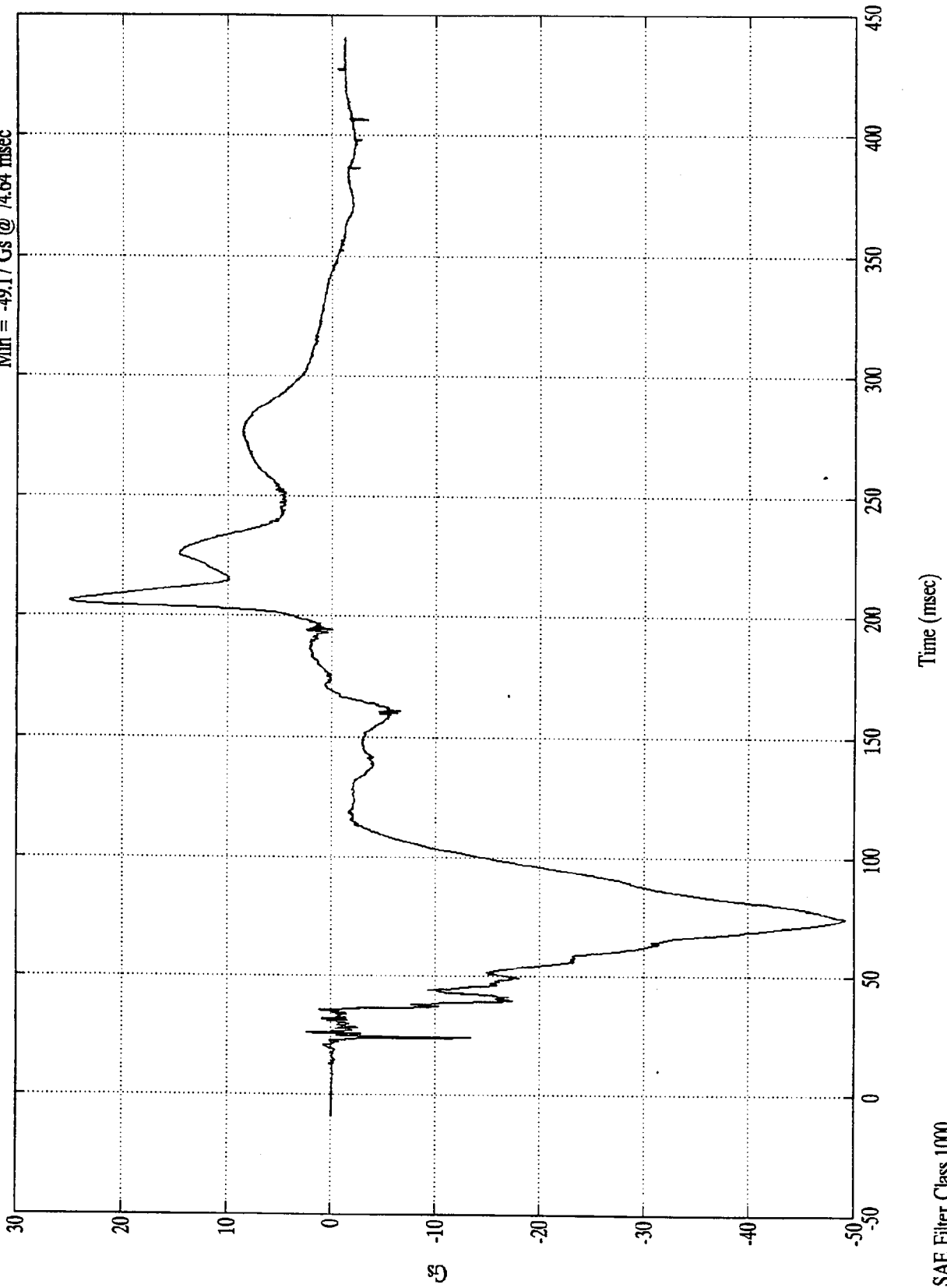

SAE Filter Class 1000

FMVSS 208 - 1995 FORD EXPLORER

Max = 7.63 Gs @ 85.32 msec
Min = -5.59 Gs @ 24.36 msec

Pos. 1 Head Y

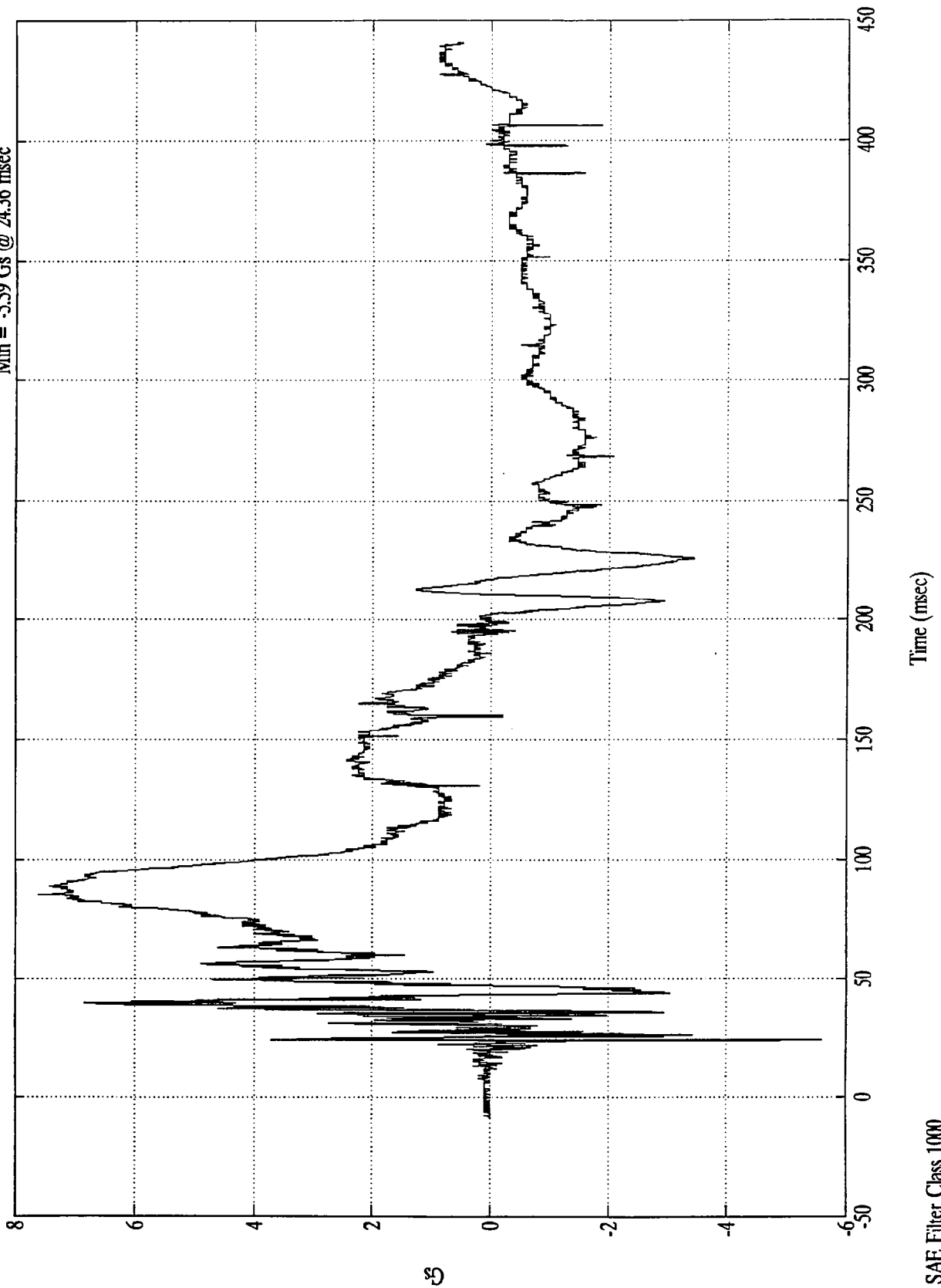

SAE Filter Class 1000

FMVSS 208 - 1995 FORD EXPLORER

Pos. 1 Head Z

Max = 16.76 Gs @ 63.36 msec
Min = -6.81 Gs @ 97.68 msec

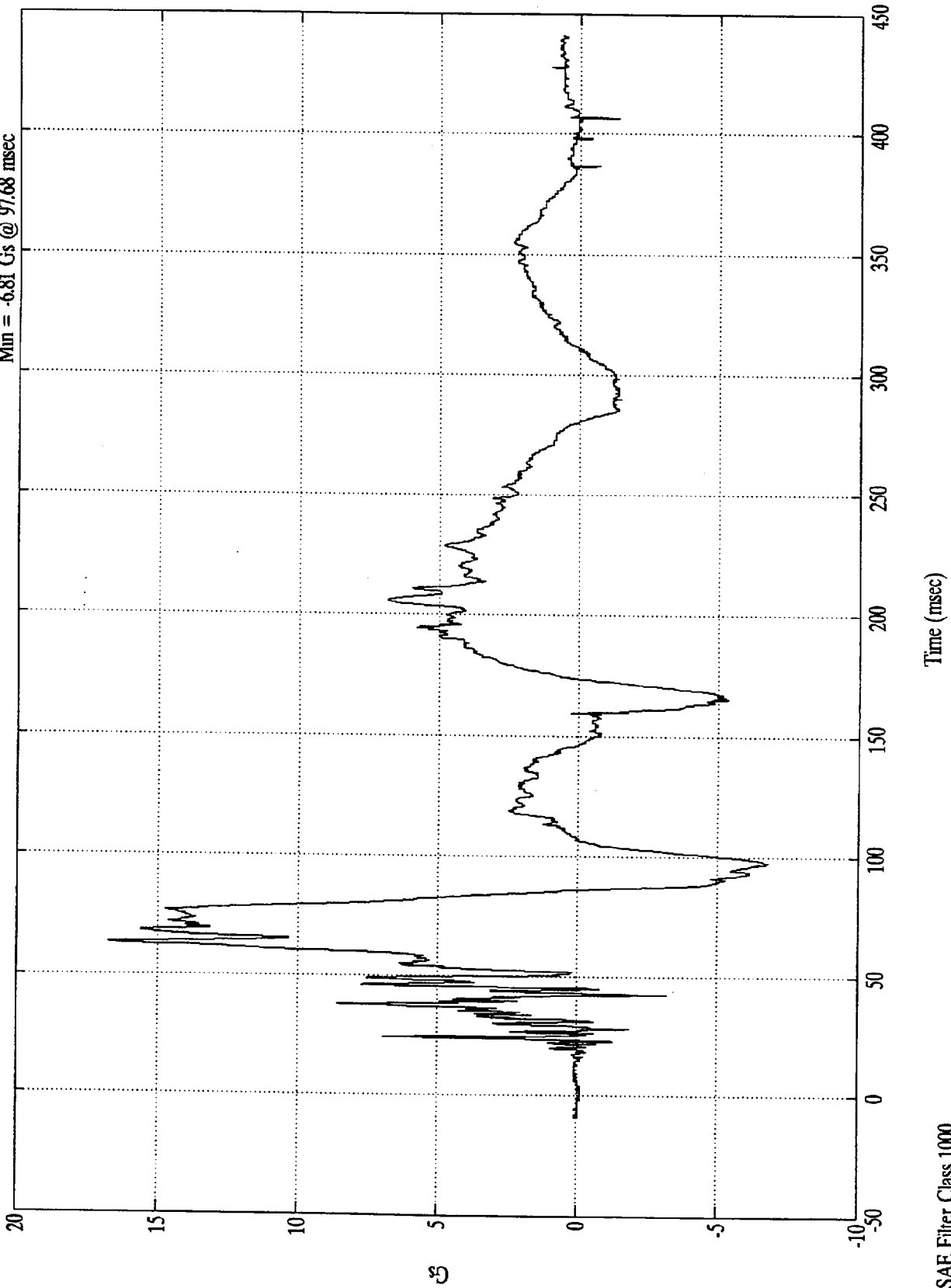

SAE Filter Class 1000

FMVSS 208 - 1995 FORD EXPLORER

Pos. 1 Head Resultant

Max = 51.27 Gs @ 74.64 msec
Min = 0.04 Gs @ -1.56 msec

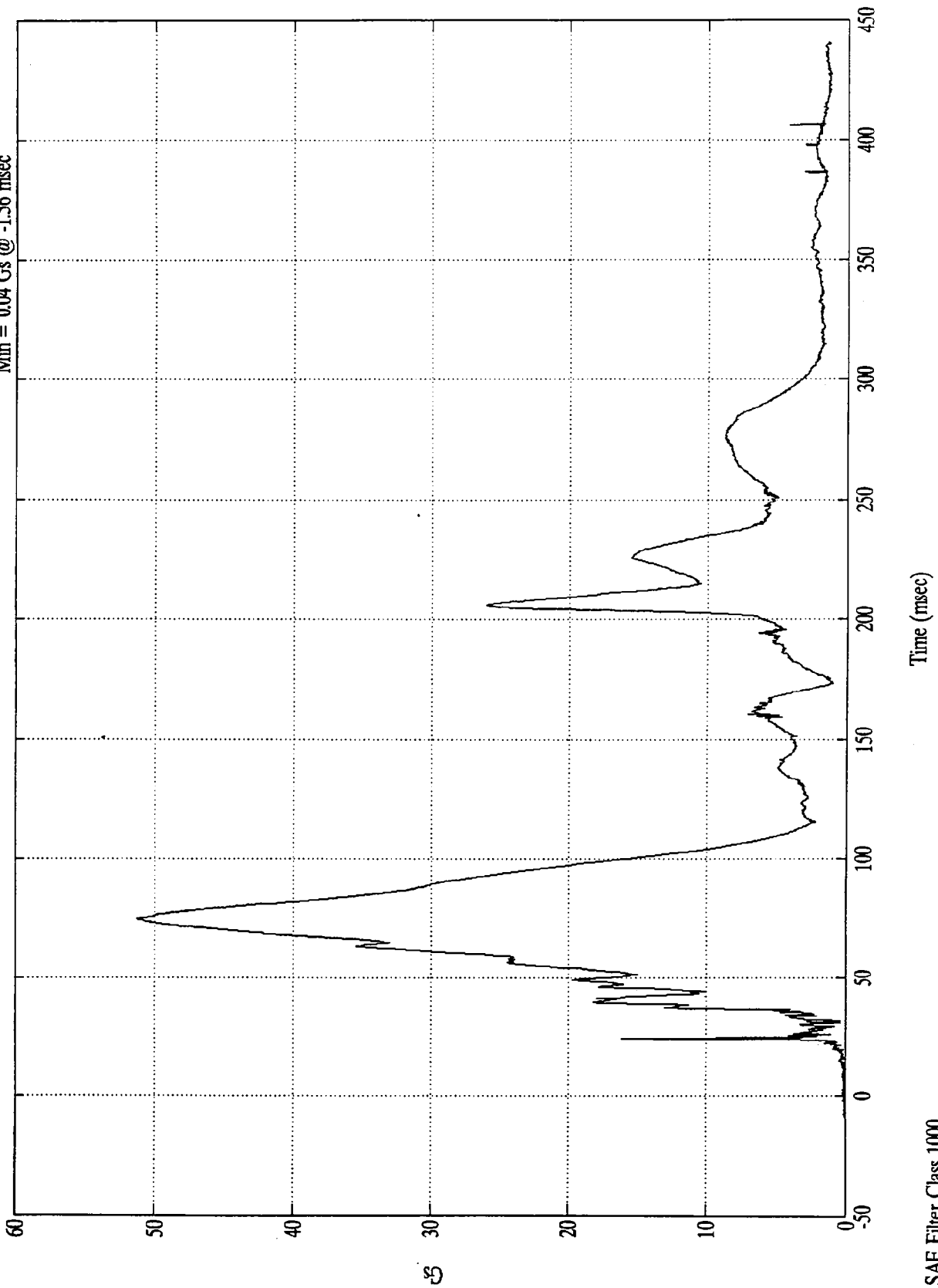

SAE Filter Class 1000

FMVSS 208 - 1995 FORD EXPLORER

Pos. 1 Chest X

Max = 9.45 Gs @ 163.80 msec
Min = -51.79 Gs @ 76.44 msec

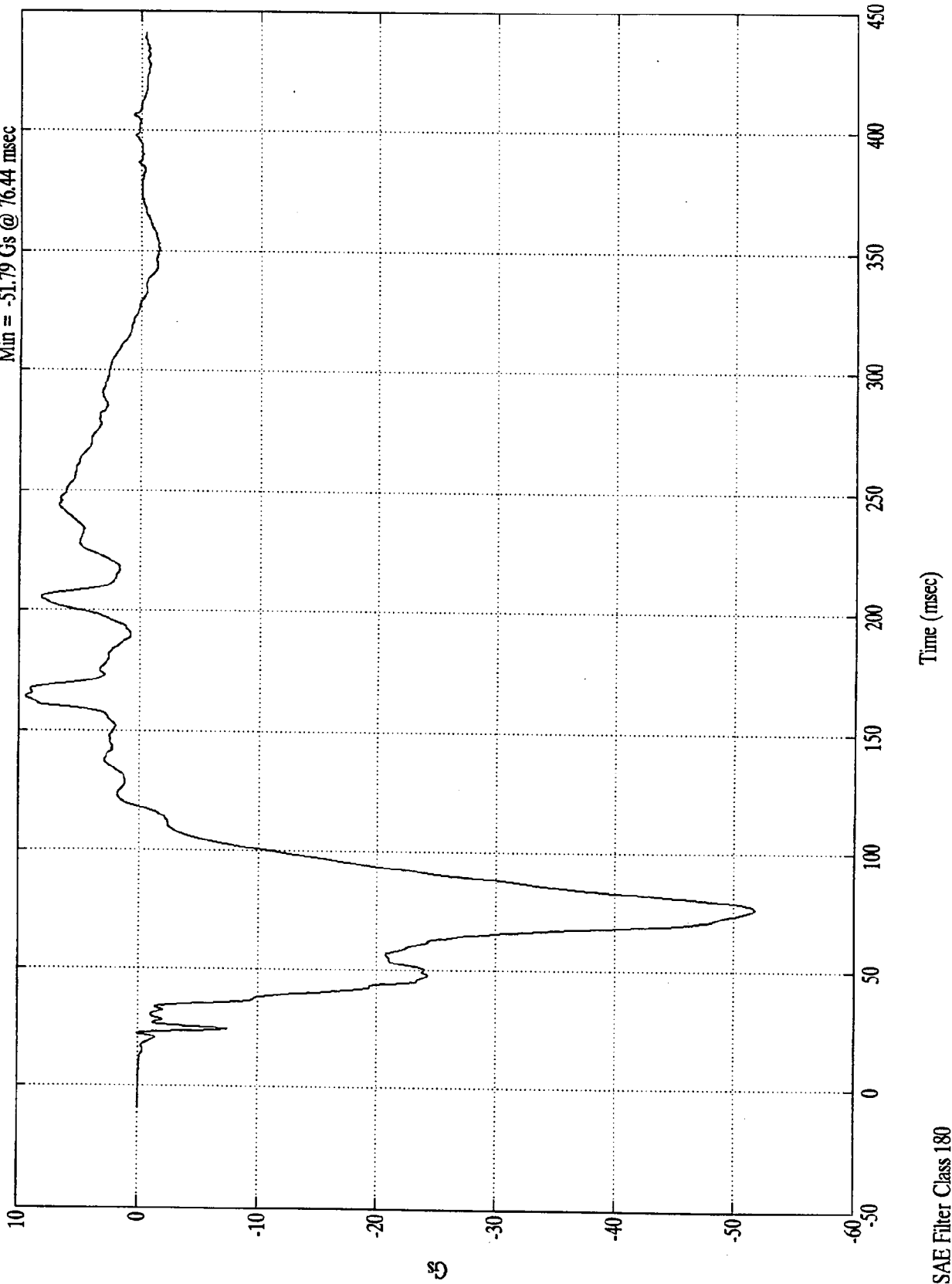

FMVSS 208 - 1995 FORD EXPLORER

Pos. 1 Chest Y

Max = 3.62 Gs @ 75.84 msec
Min = -6.19 Gs @ 41.40 msec

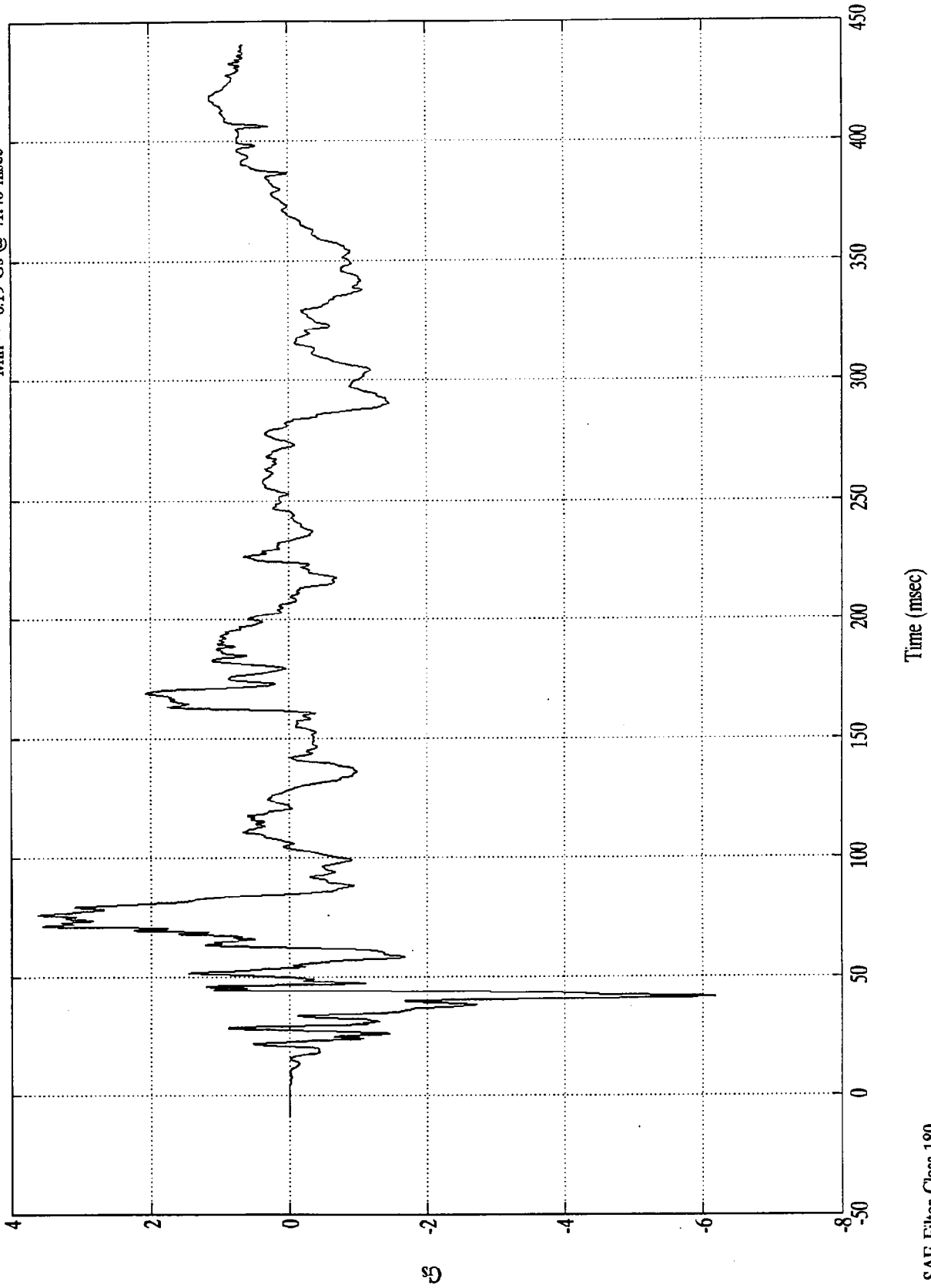

SAE Filter Class 180

FMVSS 208 - 1995 FORD EXPLORER

Pos. 1 Chest Z
Max = 15.10 Gs @ 78.24 msec
Min = -3.97 Gs @ 43.80 msec

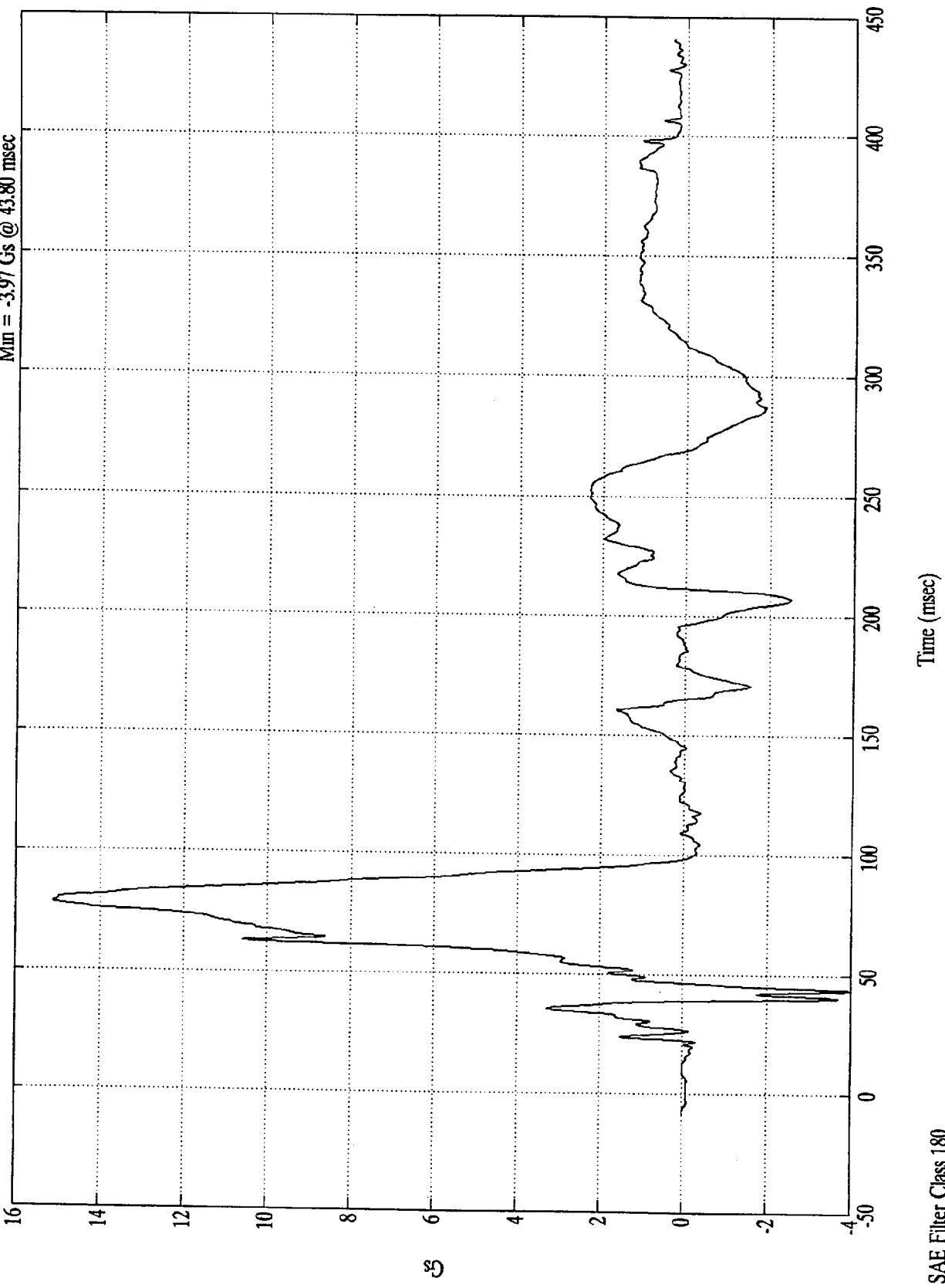

SAE Filter Class 180

FMVSS 208 - 1995 FORD EXPLORER

Pos. 1 Chest Resultant
Max = 53.87 Gs @ 76.56 msec
Min = 0.00 Gs @ -6.72 msec

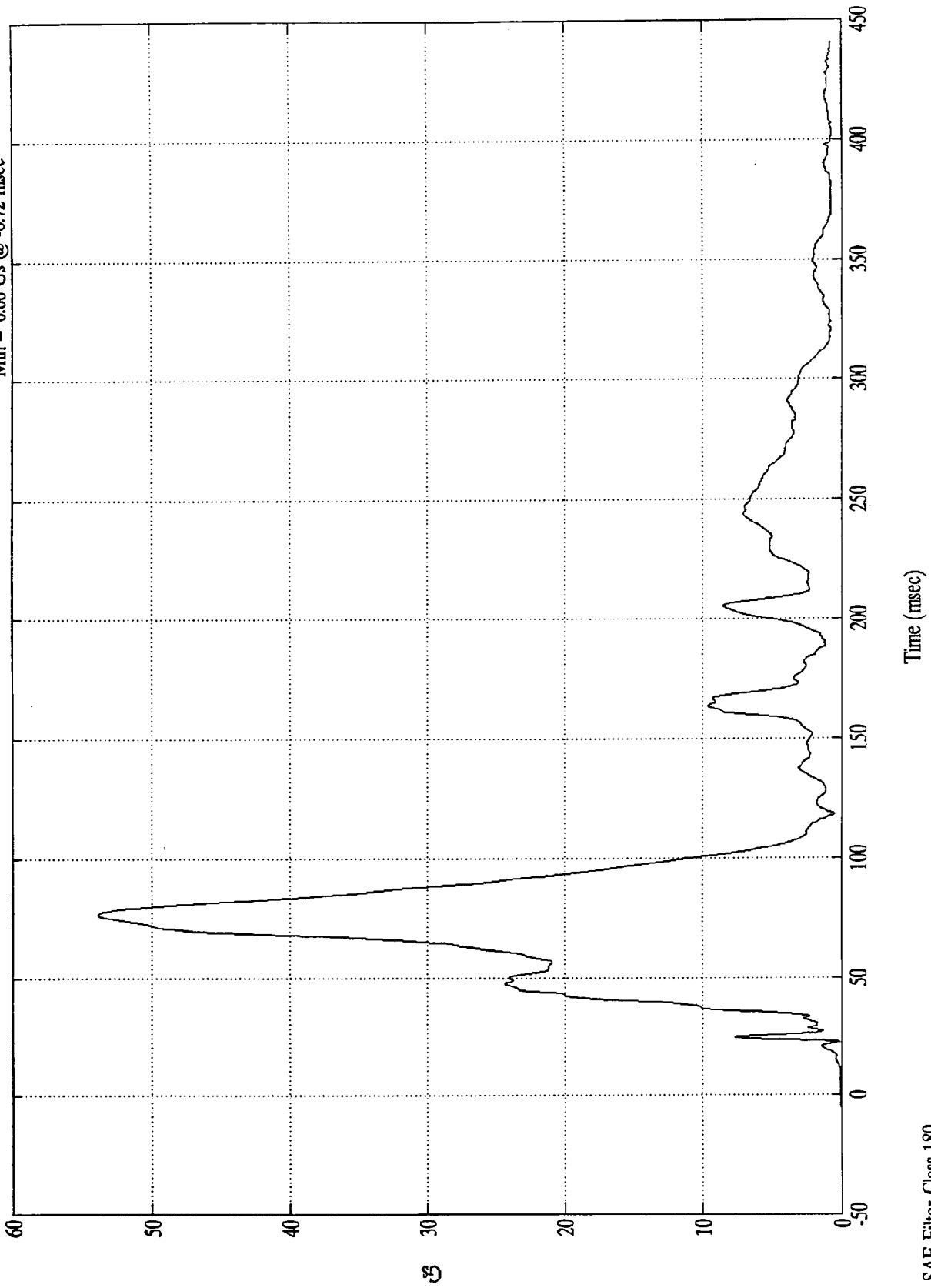

SAE Filter Class 180

FMVSS 208 - 1995 FORD EXPLORER

Pos. 1 Chest displacement

Max = 0.00 in. @ 18.72 msec
Min = -1.50 in. @ 83.64 msec

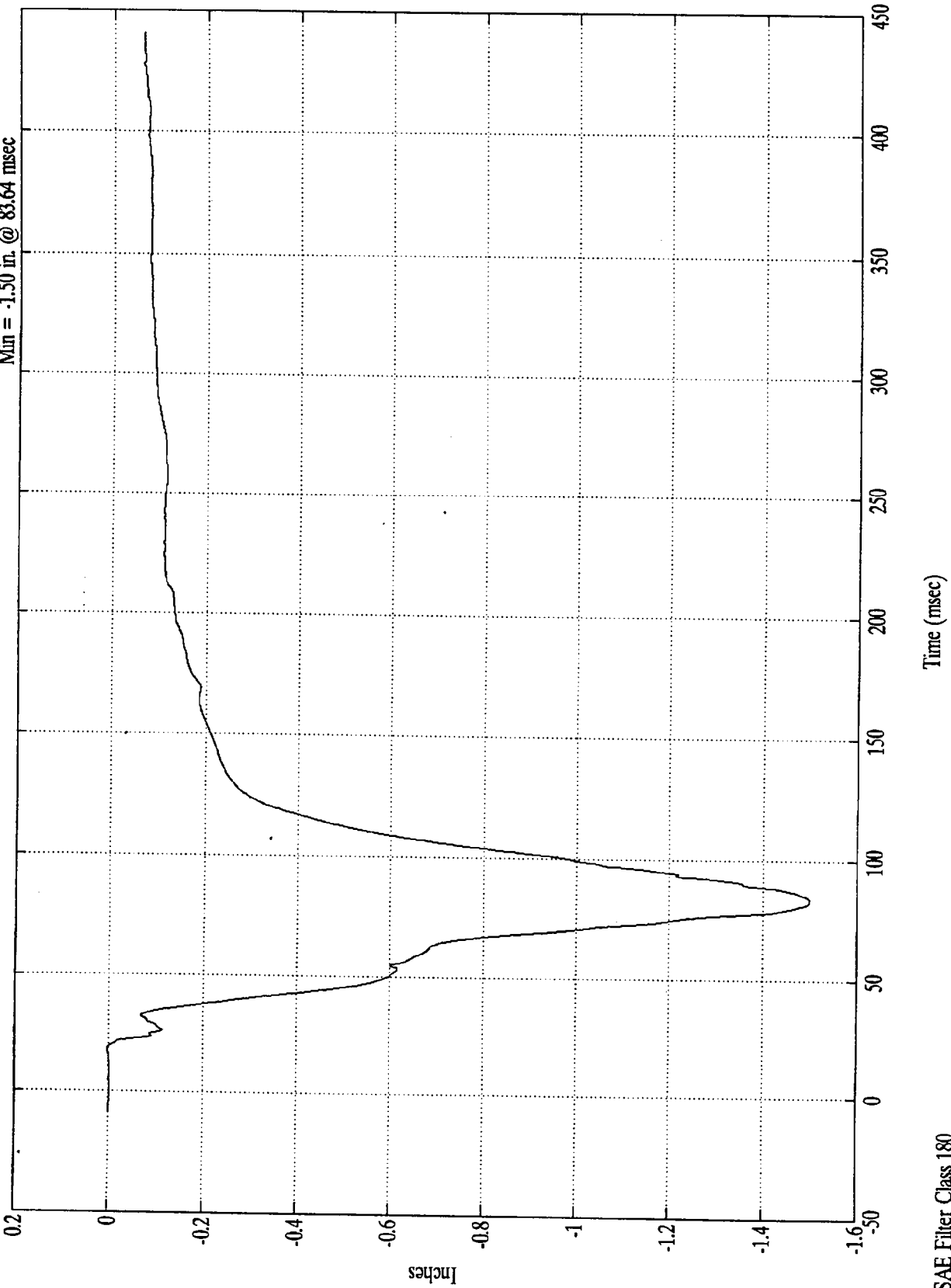

SAE Filter Class 180

FMVSS 208 - 1995 FORD EXPLORER

Pos. 1 Left Femur
Max = 107.56 lbs @ 397.80 msec
Min = -1500.40 lbs @ 48.72 msec

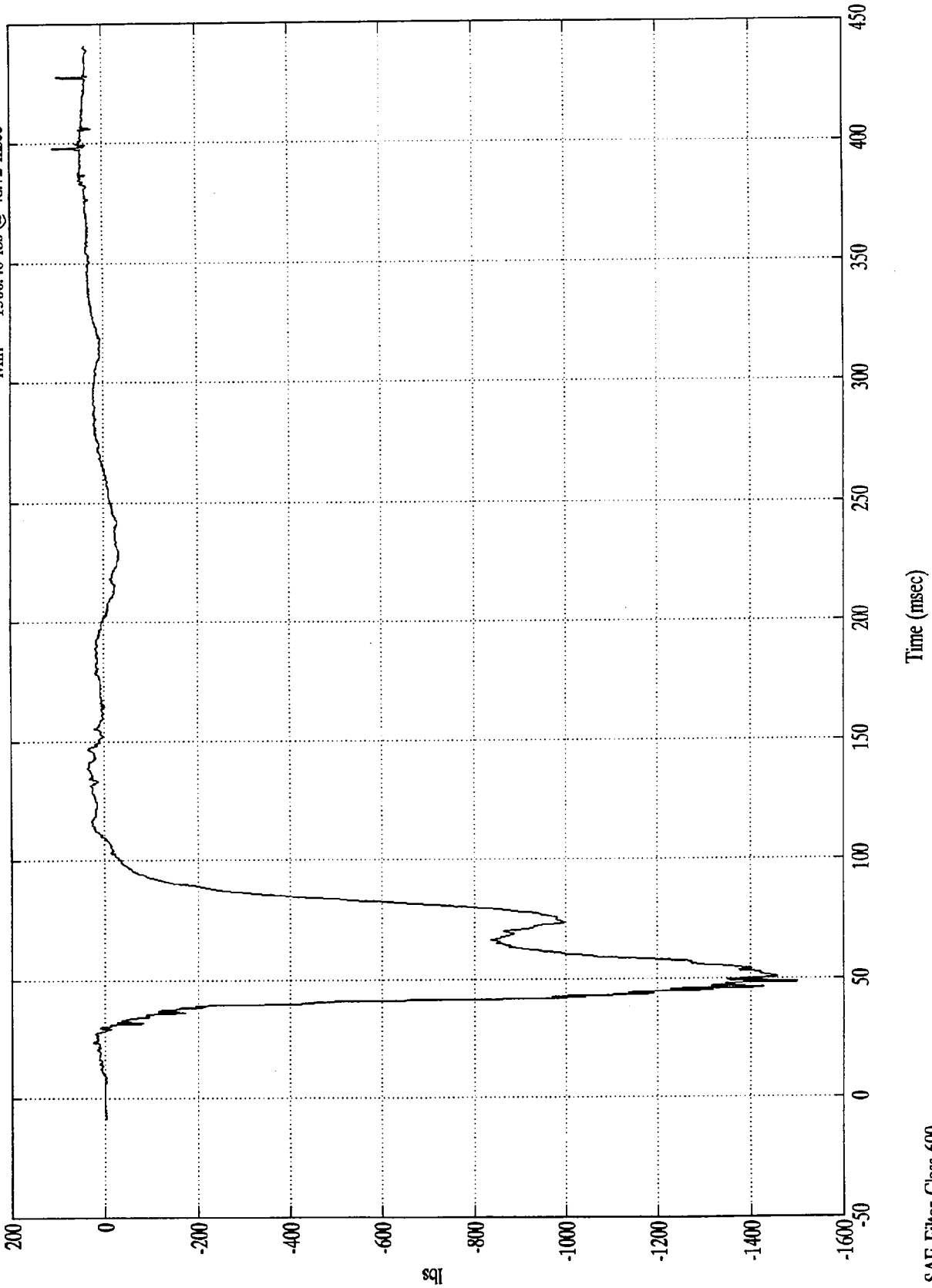

SAE Filter Class 600

FMVSS 208 - 1995 FORD EXPLORER

Pos. 1 Right Femur

Max = 50.02 lbs @ 166.68 msec
Min = -1565.30 lbs @ 39.84 msec

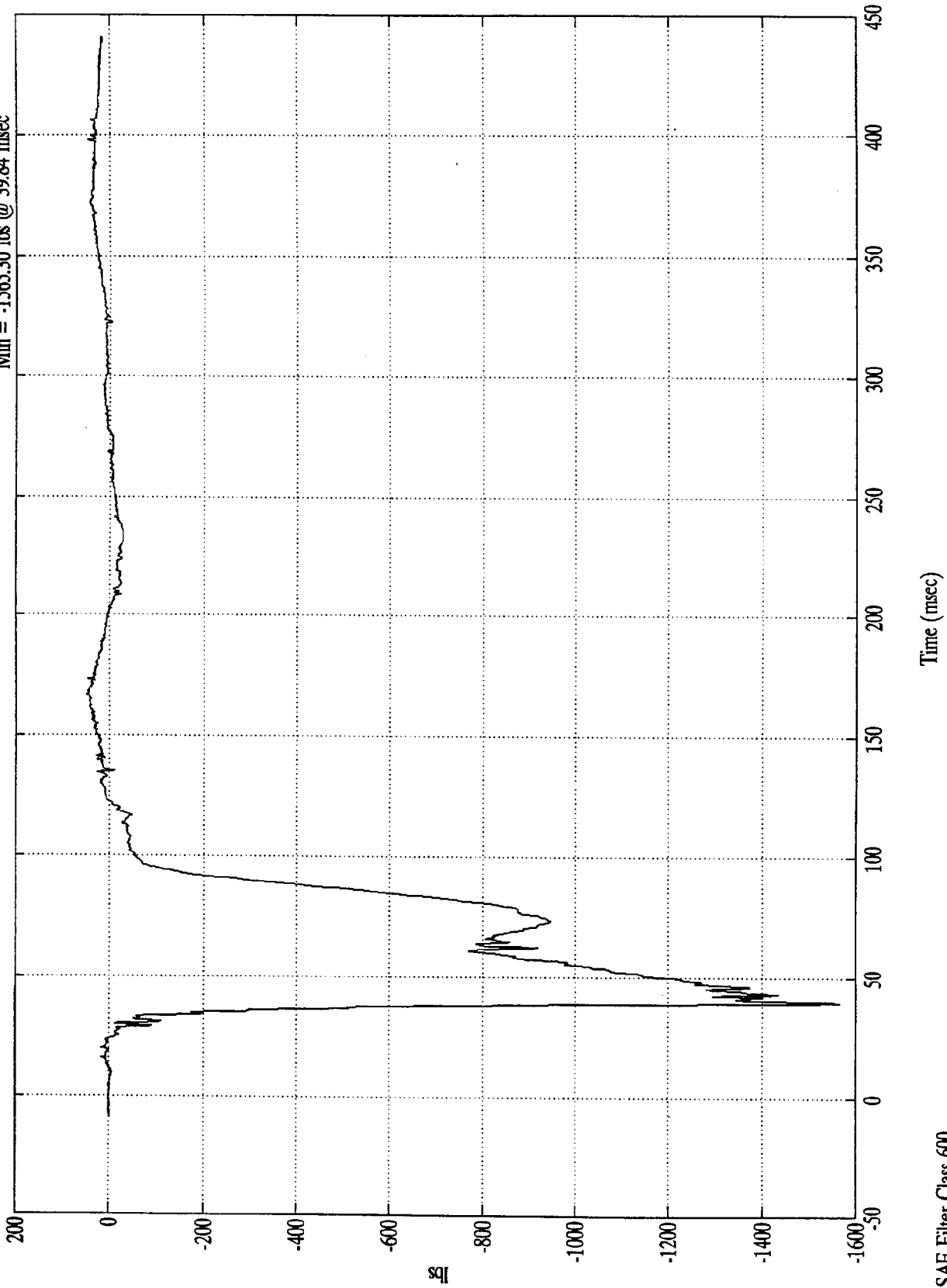

SAE Filter Class 600

FMVSS 208 - 1995 FORD EXPLORER

Pos. 2 Head X

Max = 7.58 Gs @ 37.44 msec
Min = -32.00 Gs @ 73.80 msec

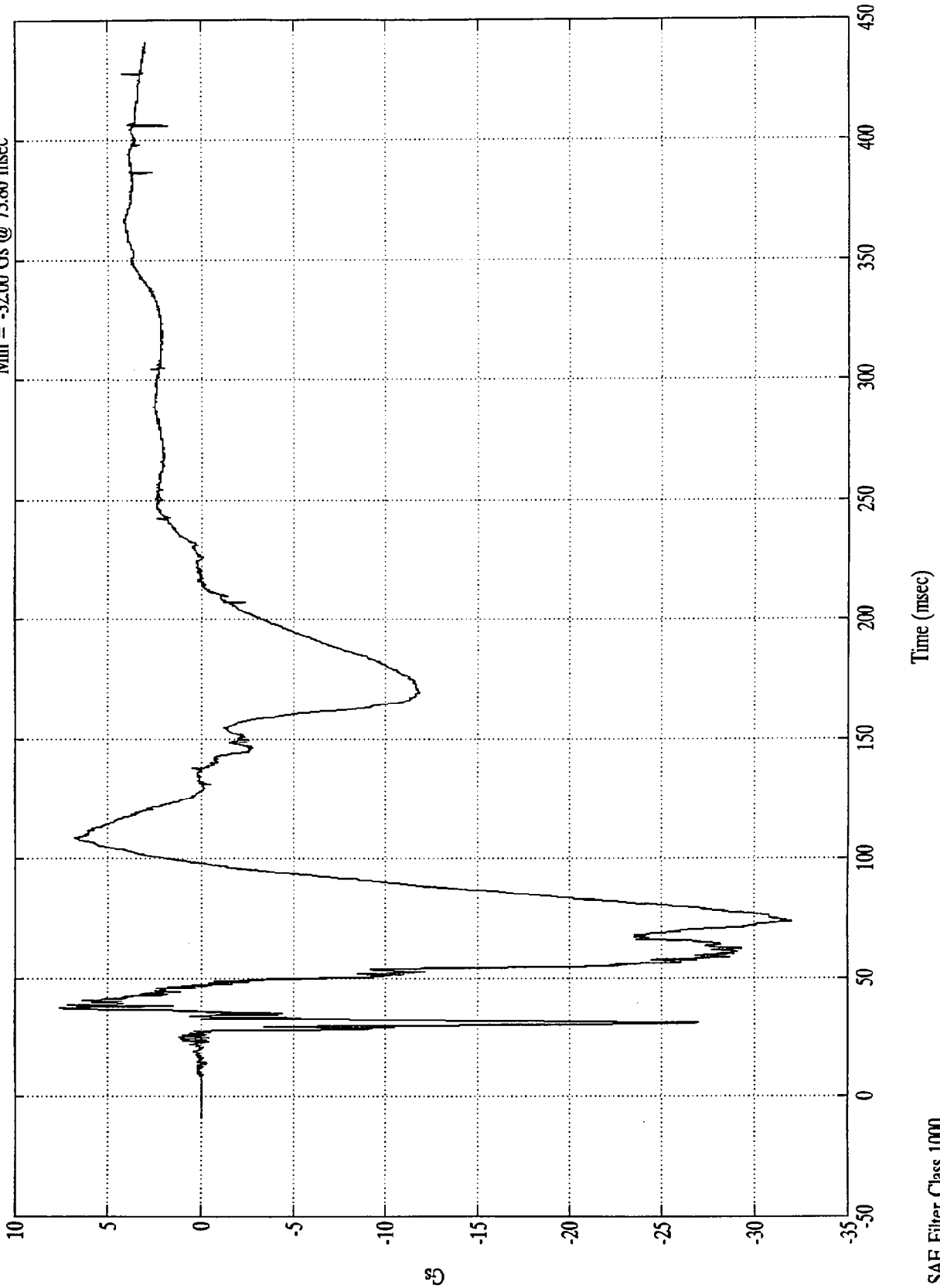

FMVSS 208 - 1995 FORD EXPLORER

Pos. 2 Head Y

Max = 6.96 Gs @ 31.44 msec
Min = -21.08 Gs @ 81.24 msec

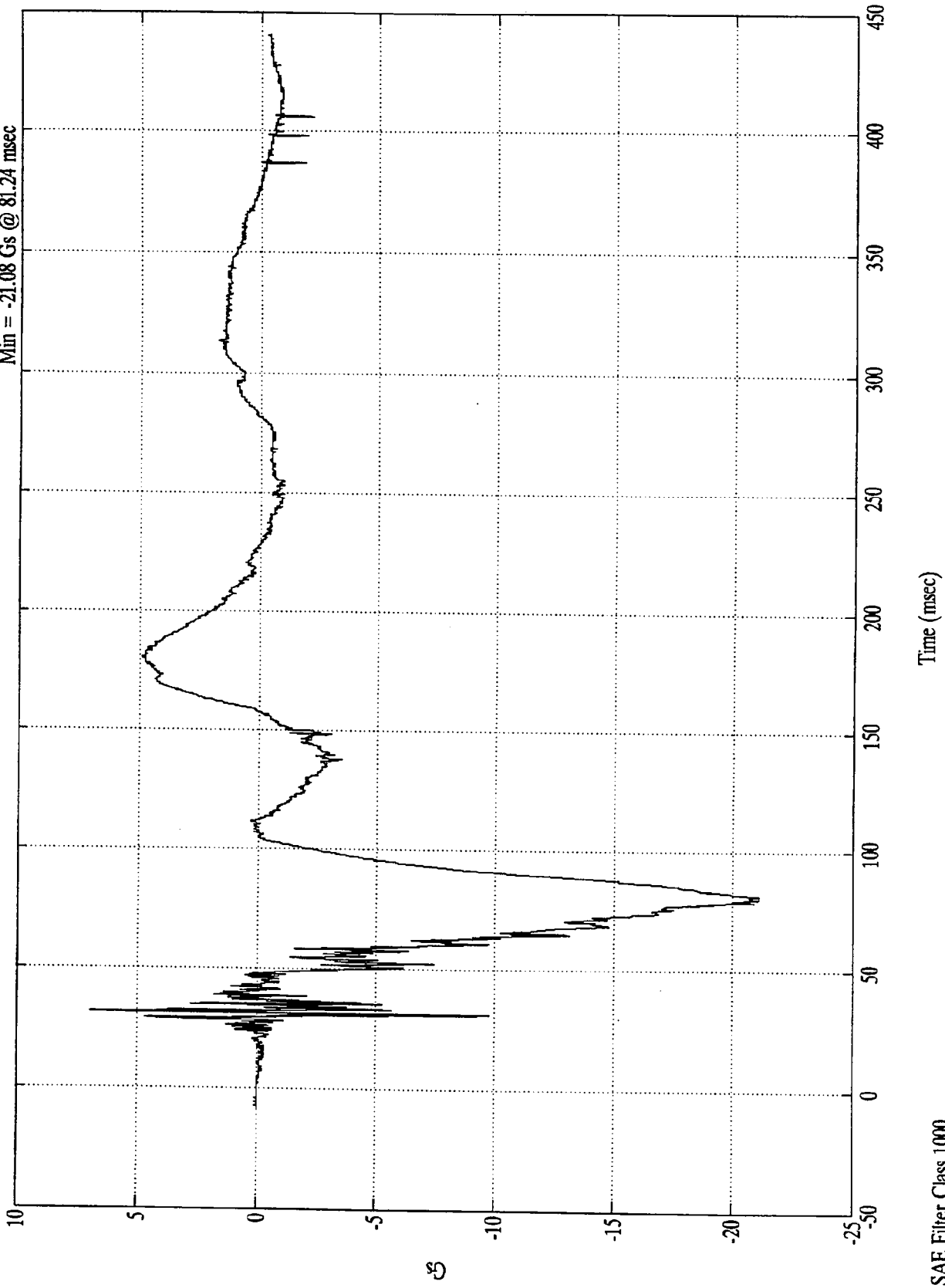

FMVSS 208 - 1995 FORD EXPLORER

Pos. 2 Head Z

Max = 25.33 Gs @ 75.24 msec
Min = -14.69 Gs @ 109.56 msec

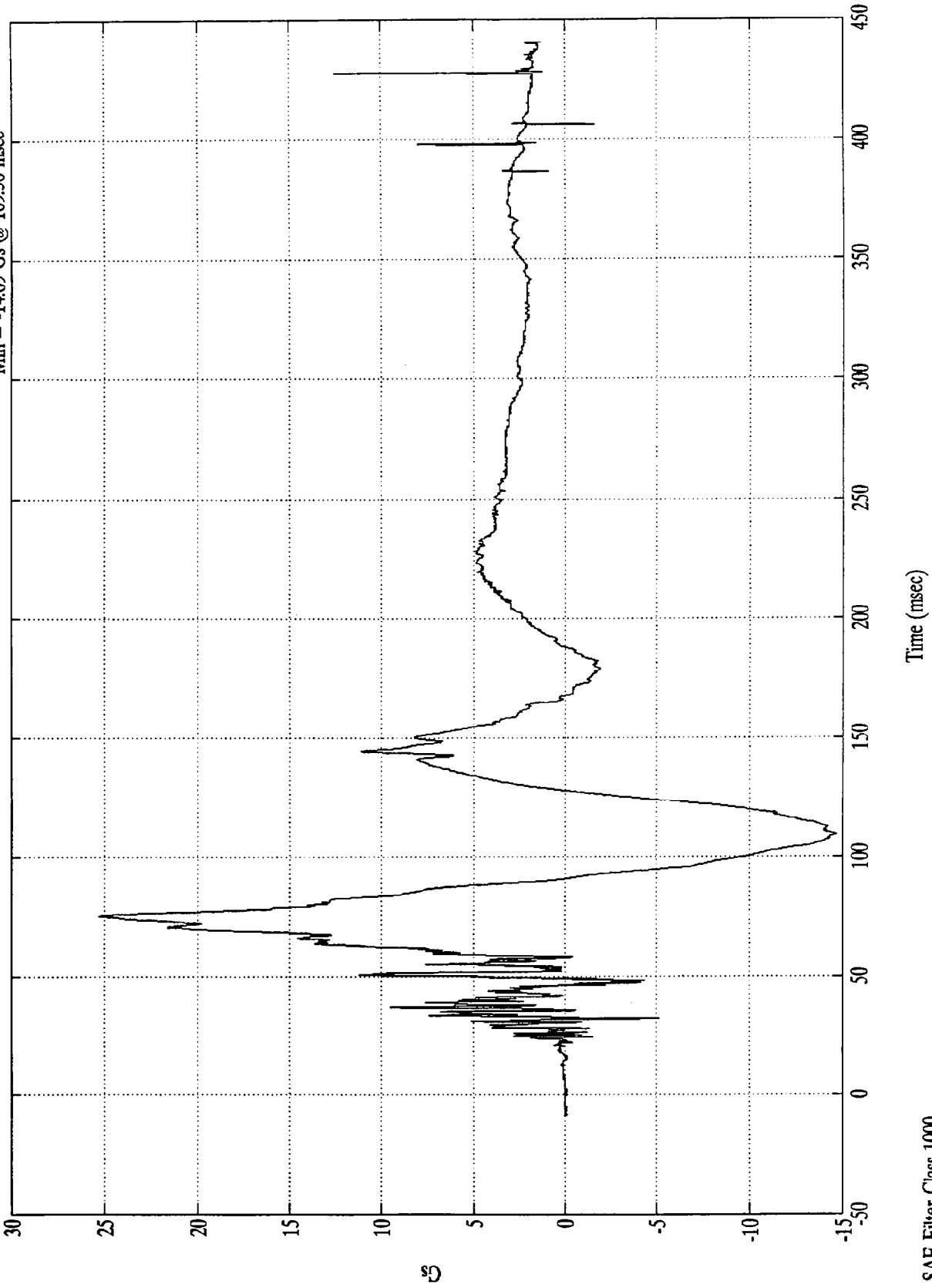

SAE Filter Class 1000

FMVSS 208 - 1995 FORD EXPLORER

Pos. 2 Head Resultant

Max = 43.43 Gs @ 75.00 msec
Min = 0.03 Gs @ 20.76 msec

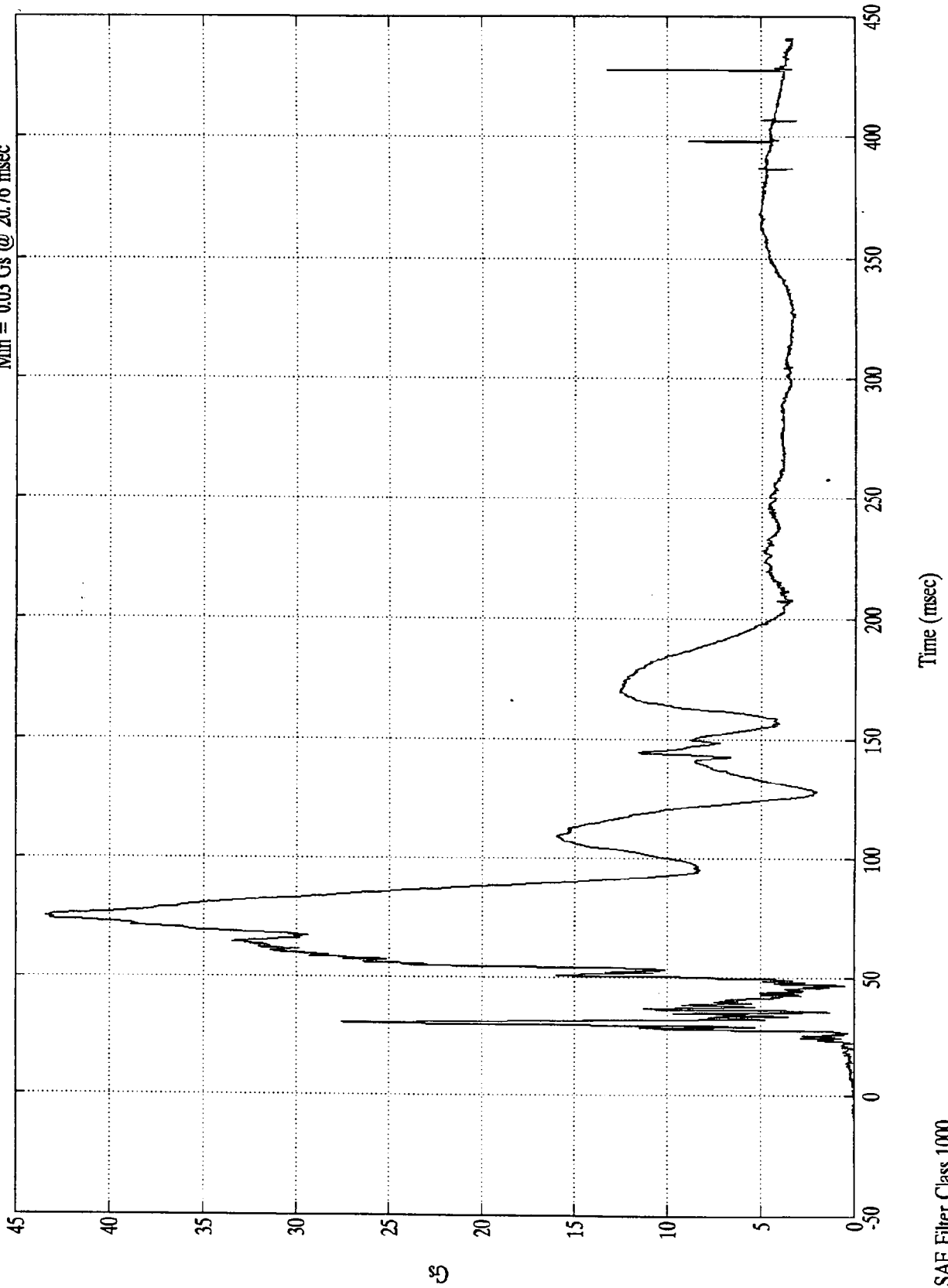

SAE Filter Class 1000

5

FMVSS 208 - 1995 FORD EXPLORER

Pos. 2 Chest X

Max = 3.78 Gs @ 167.52 msec
Min = -41.67 Gs @ 77.28 msec

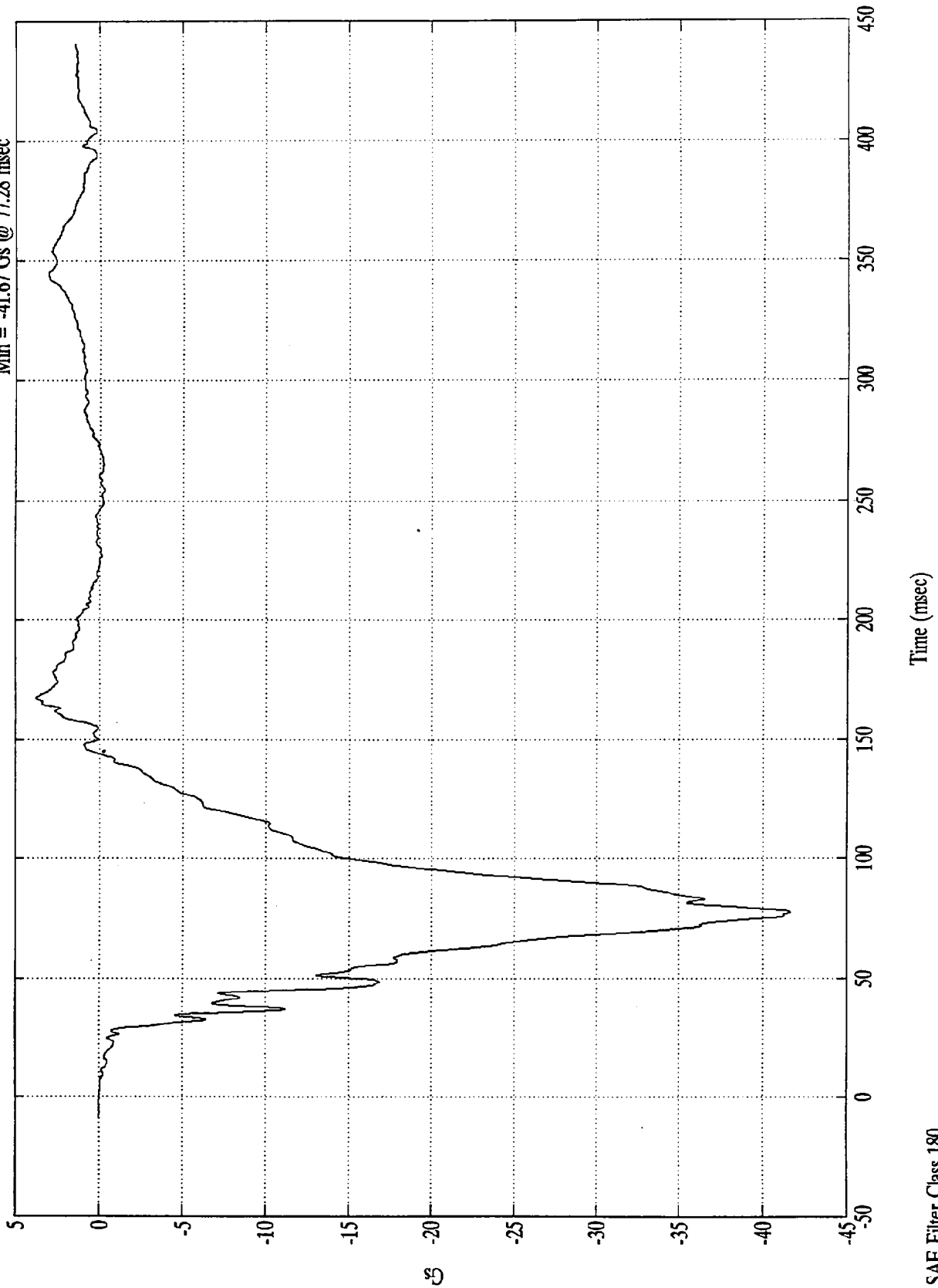

SAE Filter Class 180

FMVSS 208 - 1995 FORD EXPLORER

Pos. 2 Chest Y

Max = 2.53 Gs @ 136.20 msec
Min = -10.05 Gs @ 74.04 msec

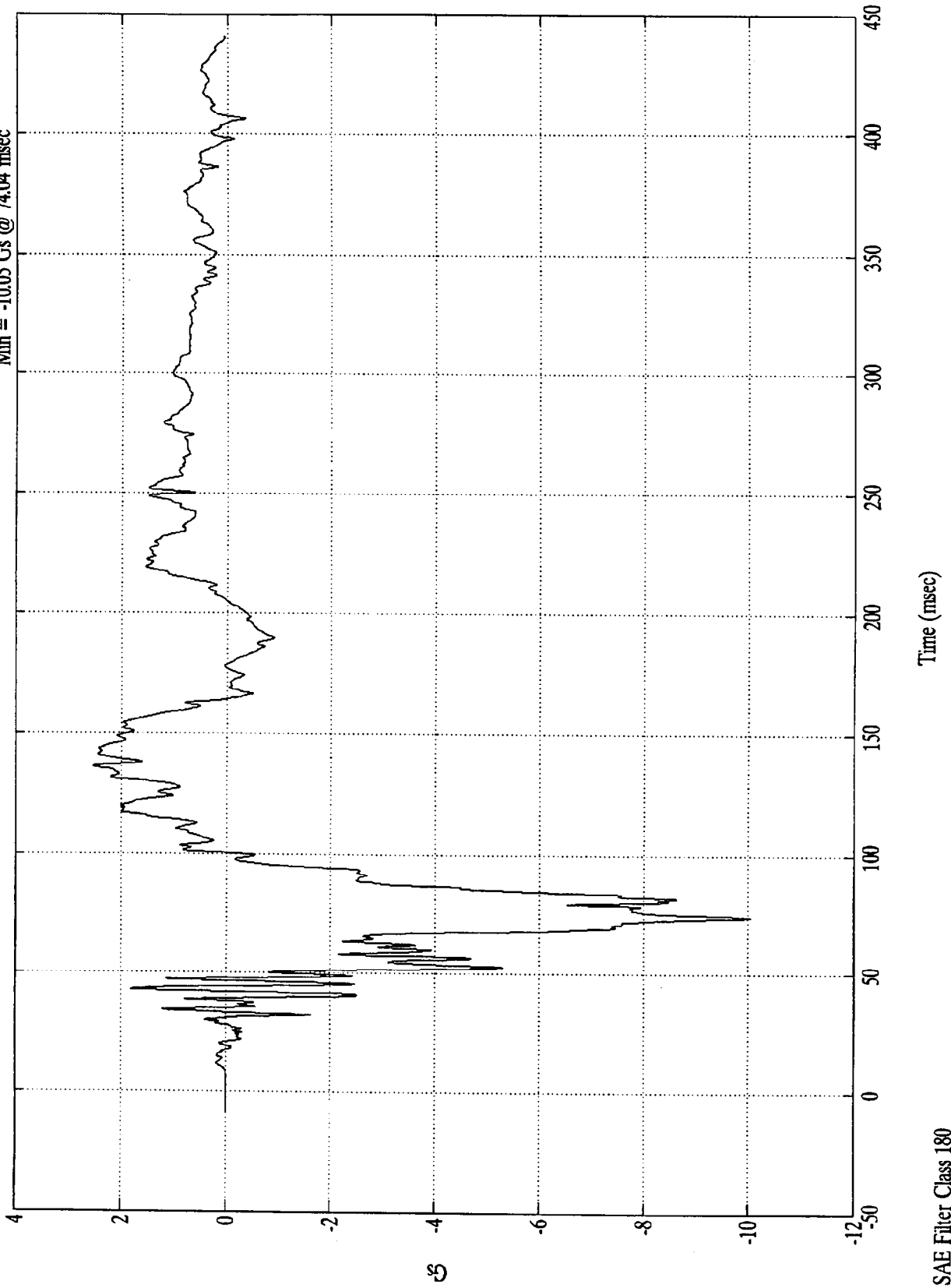

SAE Filter Class 180

FMVSS 208 - 1995 FORD EXPLORER

Pos. 2 Chest Z

Max = 20.39 Gs @ 72.84 msec
Min = -9.38 Gs @ 114.36 msec

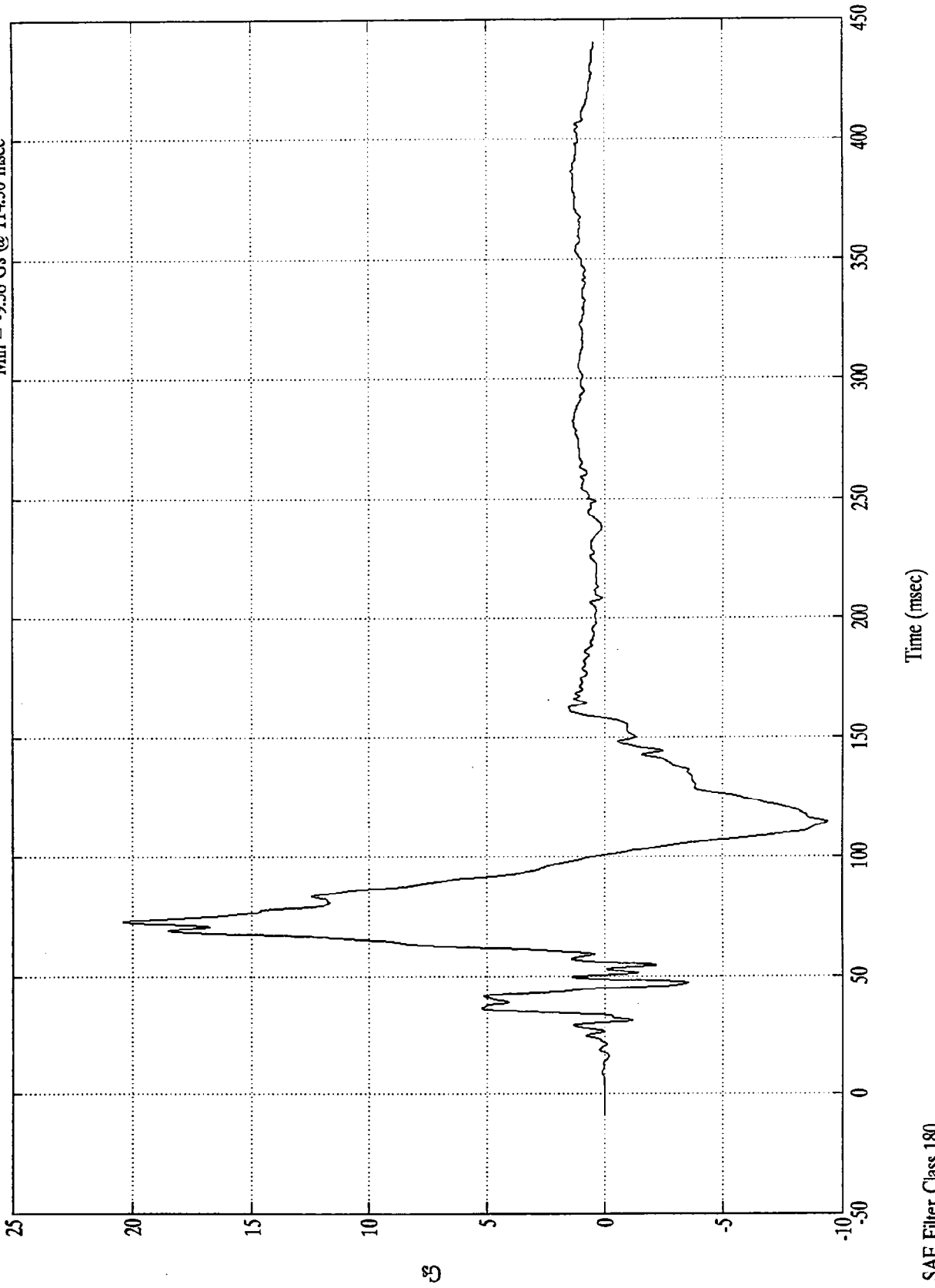

8

FMVSS 208 - 1995 FORD EXPLORER

Pos. 2 Chest Resultant

Max = 44.99 Gs @ 75.60 msec
Min = 0.00 Gs @ 410.88 msec

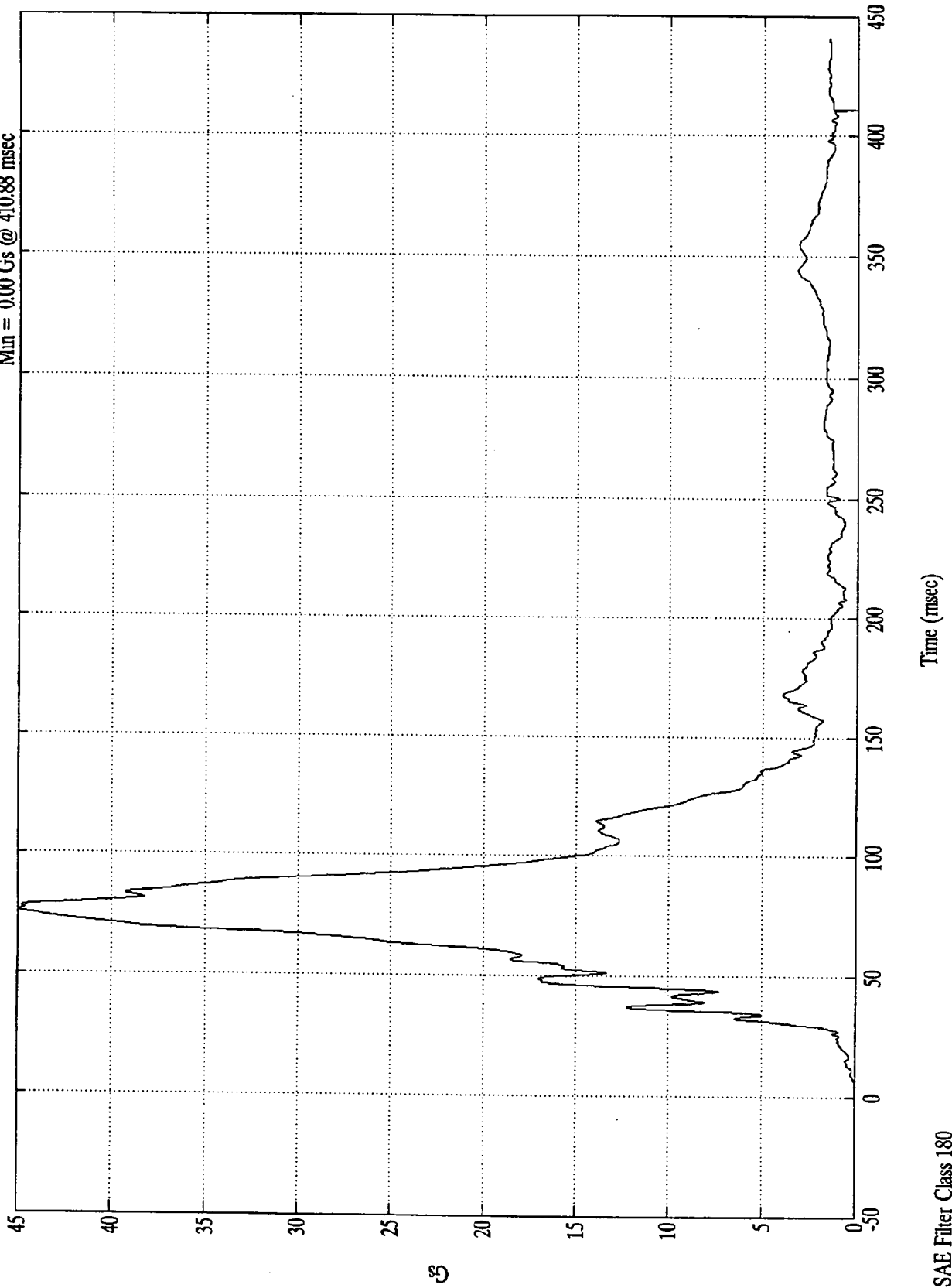

5

FMVSS 208 - 1995 FORD EXPLORER

Pos. 2 Chest displacement
Max = 0.00 in. @ 22.56 msec
Min = -0.67 in. @ 65.52 msec

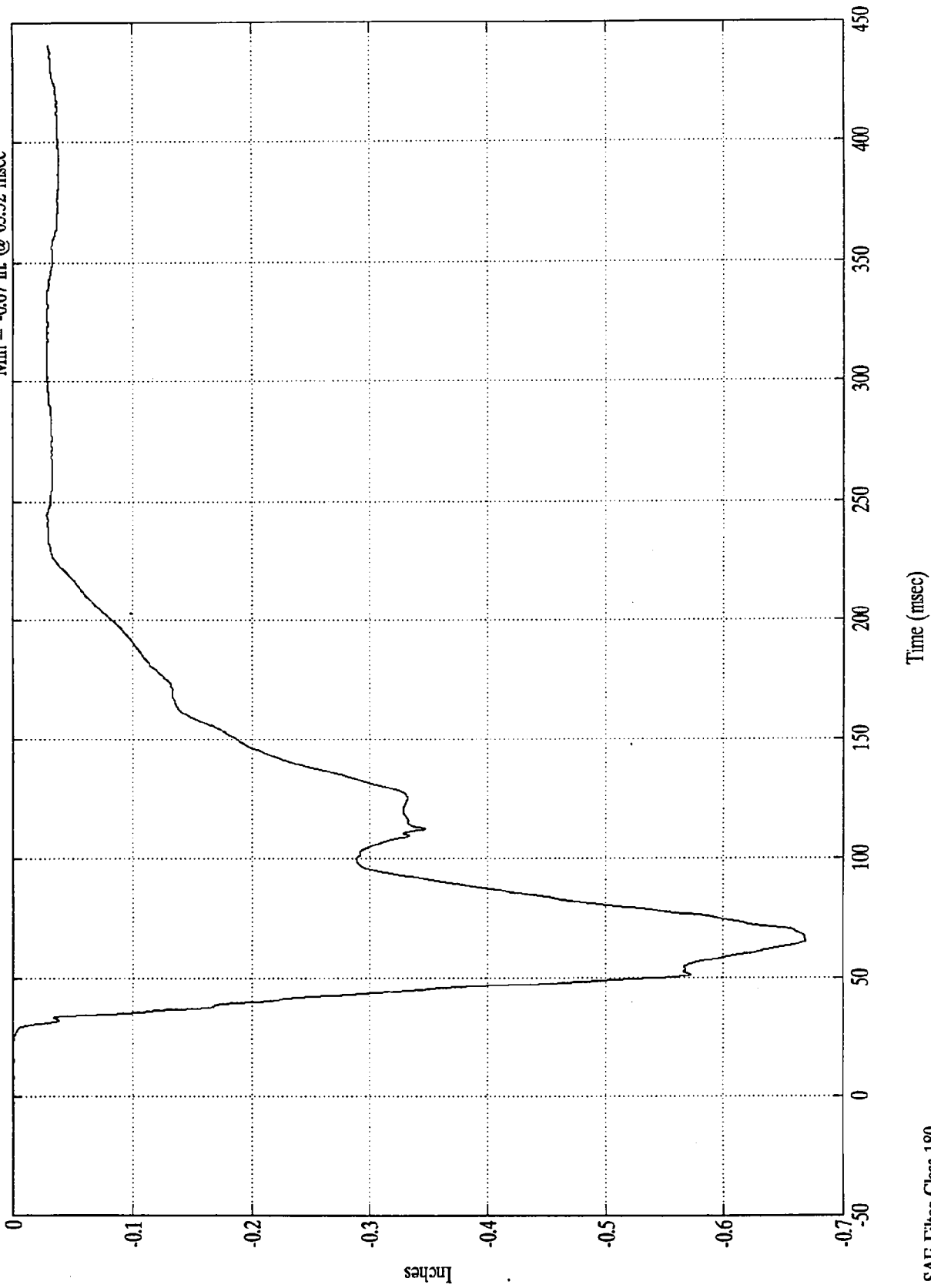

SAE Filter Class 180

FMVSS 208 - 1995 FORD EXPLORER

Pos. 2 Left Femur

Max = 42.55 lbs @ 182.52 msec
Min = -1375.70 lbs @ 50.64 msec

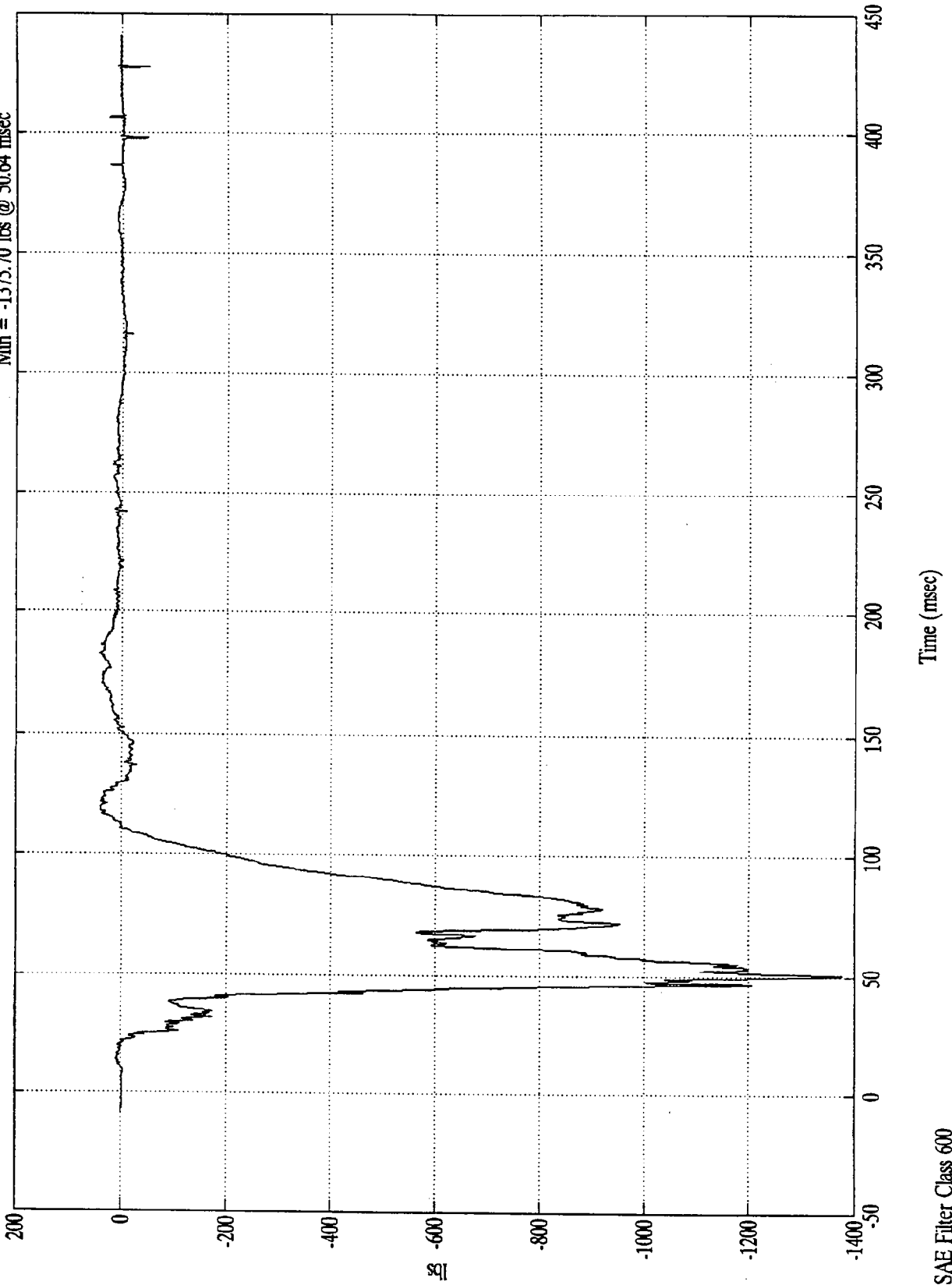

SAE Filter Class 600

FMVSS 208 - 1995 FORD EXPLORER

Pos. 2 Right Femur

Max = 51.55 lbs @ 114.96 msec
Min = -1753.20 lbs @ 77.52 msec

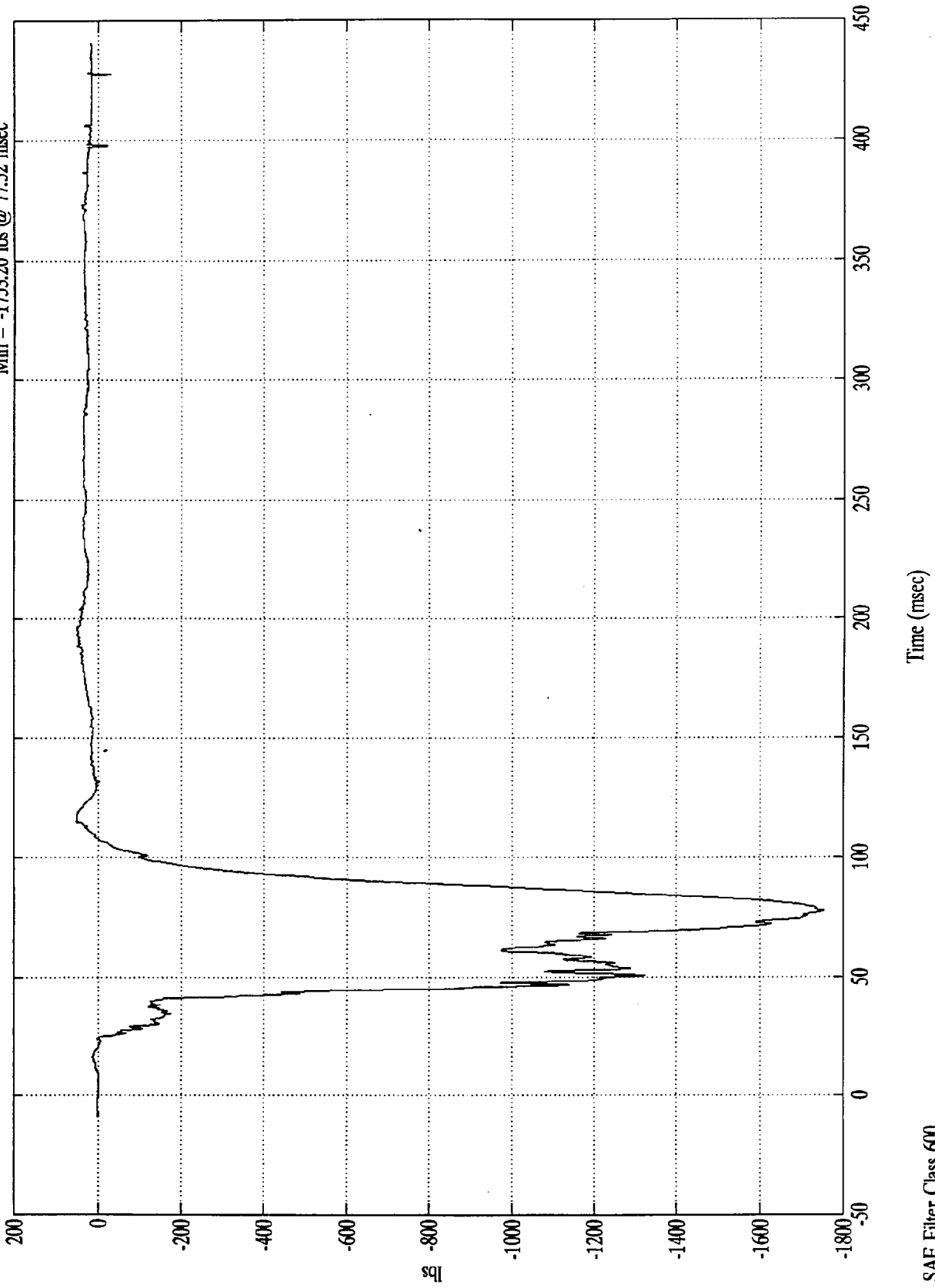

SAE Filter Class 600

Appendix C

VEHICLE OWNERS MANUAL OCCUPANT RESTRAINT SYSTEM INSTRUCTIONS

Safety Restraints

Using Safety Restraints Properly

Safety Belts

The use of safety belts helps to restrain you and your passengers in case of a collision. In most states and in Canada, the law requires their use. We strongly recommend that you use them every time you travel in your vehicle.

Safety belts provide best restraint when:

- the seatback is upright
- the occupant is sitting upright (not slouched)
- the lap belt is snug and low on the hips
- the shoulder belt is snug against the chest
- the knees are straight forward

For your safety, your vehicle has different types of safety belts:

- Combination lap and shoulder belts - for people who sit next to the side windows in either the front or rear seats
- Rear lap belt with retractor (4 door only) -for the center rear seat
- Front lap belt without retractor - if your vehicle has a center front seat

See the following sections in this chapter for directions on how to properly use these safety belts. Also see *Safety Restraints for Children* in this chapter for special instructions about using safety belts for children.

WARNING



Make sure that you and your passengers, including pregnant women, wear safety belts. Be sure that the lap belt portion of your safety belt fits snugly and as low as possible around the hips. If safety belts are not used properly, the risk of you or your passengers being injured in a collision greatly increases.

WARNING



Always drive and ride with your seatback upright and the lap belt portion of your safety belt snug and low across the hips. This will reduce the risk of serious injury to the abdomen or neck that could be caused by sliding under the safety belts in a collision.

Do not allow any people to ride in the cargo area of your vehicle. People who are not riding in seats with their safety belts fastened are much more likely to be injured in a collision.

Never let a passenger hold a child on his or her lap while the vehicle is moving. The passenger cannot protect the child from injury in a collision.

WARNING



Children should always ride with the seatback in the fully upright position. When the seatback is not fully upright, there is a greater risk that the child will slide under the safety belt and be seriously injured in a collision.

Safety Restraints

WARNING



Never use a single belt for more than one person or across more than one seating position. This greatly increases the risk that one or both of the people will be injured in a collision. Each seating position in your vehicle has a specific safety belt assembly which is made up of one buckle and one tongue that are designed to be used as a pair.

WARNING

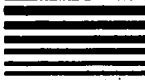

Use the shoulder belt on the outside shoulder only. Never wear the shoulder belt under the arm. Never swing it around the neck over the inside shoulder. Never use a single belt for more than one person. Failure to follow these precautions could increase the risk and/or severity of injury in a collision.

WARNING

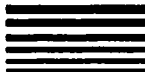

Lock the doors of your vehicle before driving to lessen the risk of the door coming open in a collision.

Combination Lap and Shoulder Belts

While your vehicle is in motion, the combination lap and shoulder belts adjust to your movement. However, if you brake hard, corner hard or if your vehicle receives an impact of 5 mph (8 km/h) or more, the lap and shoulder belt locks and helps reduce your forward movement. The front seat belt systems can also be made to lock by jerking on the belt.

After you get into your vehicle, close the door and lock it. Then adjust the seat to the position that suits you best.

To **fasten the belt**, pull the lap/shoulder belt from the retractor so that the shoulder portion of the belt crosses your shoulder and chest. Be sure the belt is not twisted. If it is, remove the twist. Insert the belt tongue into the proper buckle until you

hear a snap and feel it latch. Make sure the tongue is securely fastened to the buckle.

The driver and right front passenger shoulder belt height is adjustable to one of five (5) positions. To adjust the belt down, push the release button on the adjuster down and slide the adjuster down. Then release the button and make sure the adjuster is firmly in one of the five (5) positions. To adjust the belt up, slide the adjuster up. (You do not have to push the release button.) Slide it up or down until the belt rests across the middle of your shoulder.

WARNING If the shoulder belt is off your shoulder or on your upper arm, there is a greater risk of severe injury in a collision.

NOTE: Be sure the belt is properly positioned on your shoulder each time you use the belt.

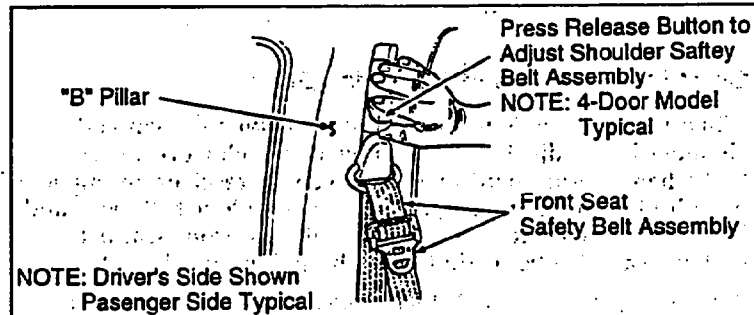

Adjusting shoulder belt height (2 door models)

Safety Restraints

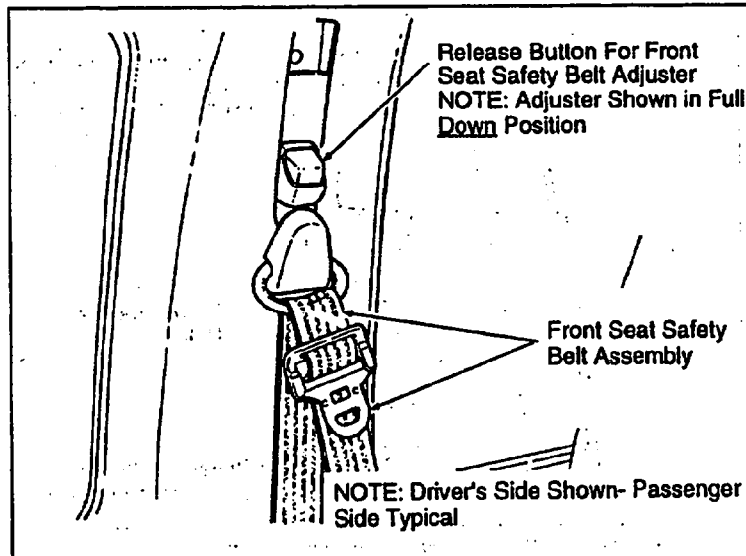

Shoulder belt height adjuster – full down position (2 door models)

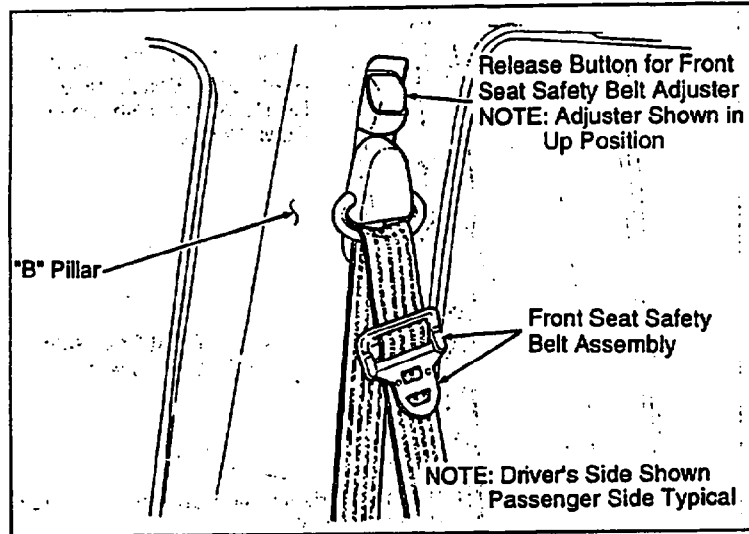

Shoulder belt height adjuster — full up position (4 door models)

Safety Restraints

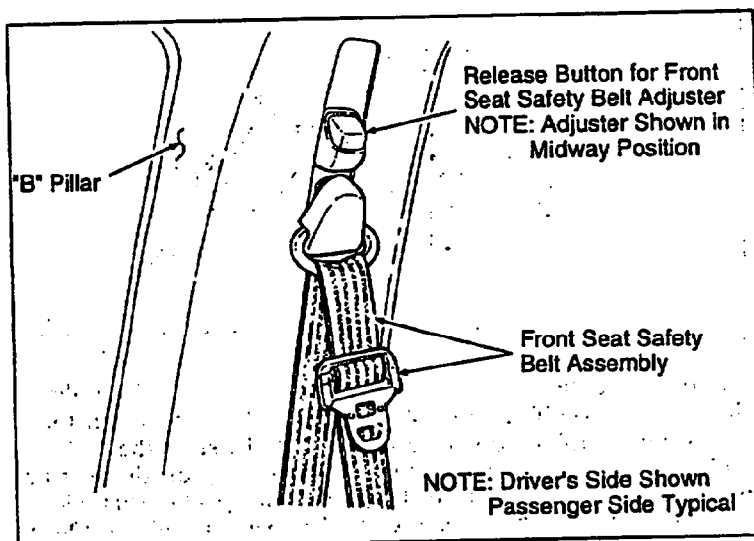

Shoulder belt height adjuster — mid-way position (4 door models)

WARNING



Use the shoulder belt only on the shoulder that is closest to the side of the vehicle. Never wear the belt under your arm. Never swing it around your neck over the inside shoulder. If you do not use the shoulder belt properly, the chances of your being injured in a collision greatly increase.

To tighten the lap portion of the belt, pull up on the shoulder belt until it fits you snugly. The belt should rest as low on your hips as possible.

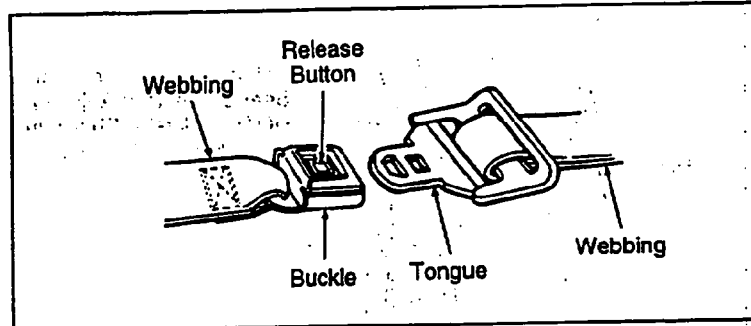

Unfastening the outboard lap/shoulder belts

The rear seat shoulder safety belts have a feature which allows the seat belt webbing to be stowed out of the way when the rear seats are folded down (2 door only). To stow the belt while the seat is folded, attach the plastic snap on the seat belt to the metal mating part on the plastic trim panel. This will keep the belt out of the way while the seats are folded. Once the rear seats have been returned to their upright position, unsnap the belt from the trim panel.

WARNING *It is important that the rear seat belt snap be detached from the trim panel prior to wearing the belt.*



Safety Restraints

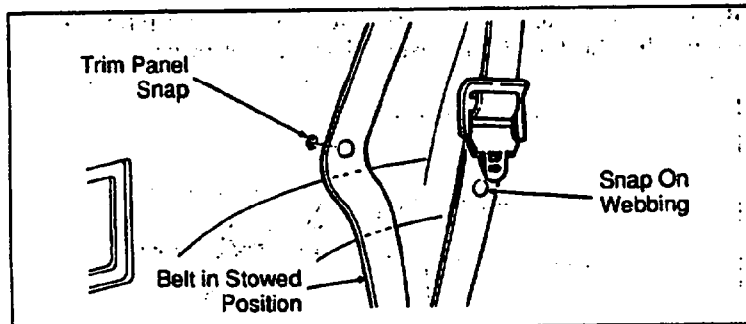

Rear combination lap and shoulder belts (2 door model)

Center Front Lap Belt (If equipped)

The lap belt in the center of the front seat does not adjust automatically. You must adjust it to fit snugly around your hips. Do not wear it around your waist.

Before you fasten your center position lap belt in the front seat, you may need to lengthen it.

To lengthen the belt, tip the belt tongue at a right angle to the belt. Pull the belt tongue over your lap until it reaches the buckle.

To fasten the belt, pull the belt across your hips and insert the tongue into the correct buckle on your seat until you hear a snap and feel it lock. Make sure the buckle is securely fastened.

Adjust the belt so that it fits snugly around your hips:

- If you need to lengthen the belt, unfasten it and repeat the procedure above.
- If you need to shorten the belt, pull on the loose end of the webbing.

To unfasten the belt, push the release button on the buckle. This allows the tongue to unlatch from the buckle.

Because the center front lap belt does not have a retractor, it should be shortened and fastened when not in use.

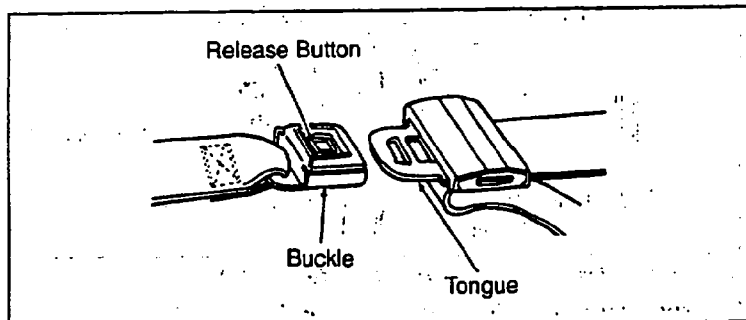

Fastening and unfastening the front center safety belt

Rear Lap Belt with Retractor

Pull the belt out of the retractor with a steady motion and insert the tongue into the proper buckle until you hear a snap and feel the latch engage.

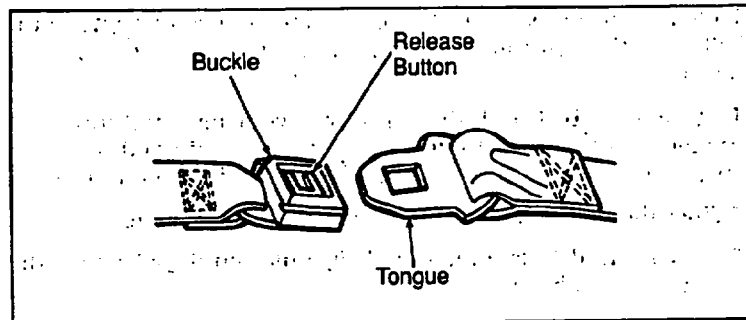

Fastening and unfastening the rear center safety belts (4-door model)

Safety Restraints

To Unfasten the Safety Belts with Retractors:

1. Push the release button on the buckle. This allows the tongue to unlatch from the buckle.
2. While the belt retracts, guide the tongue to its original position. If you do not guide the tongue, it may strike you or part of the vehicle.

How to Untwist or Unjam a Safety Belt Retractor

If you should jam the lap belt retractor by allowing the belt to retract when it is twisted, you can free the webbing with this procedure:

1. Pull on the belt with both hands to tighten it on the retractor spool.
2. Feed the belt back into the retractor until it is completely retracted. Repeat previous step if necessary.
3. Pull the belt out of its holder as far as it will go and untwist the belt or remove the object that is jamming the belt. Let the belt retract.
4. Then, pull the belt out and let it retract several times to make sure that the belt works properly.

Procedure to Correct a Twisted Safety Belt at the "D" Ring (if so equipped) Front and/or Rear Outboard Seating Positions

NOTE: The restraint system shown in the following figures may be different than the restraint system in your vehicle. However, use these figures and this procedure to correct a twisted safety belt at any outboard seating position that has a "D" ring.

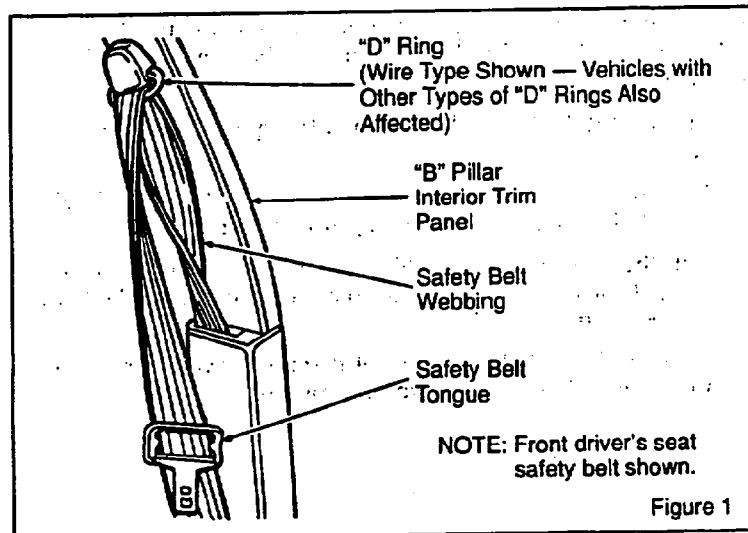

Safety Restraints

1. Grasp the belt webbing at the "D" ring. See Figure 2.

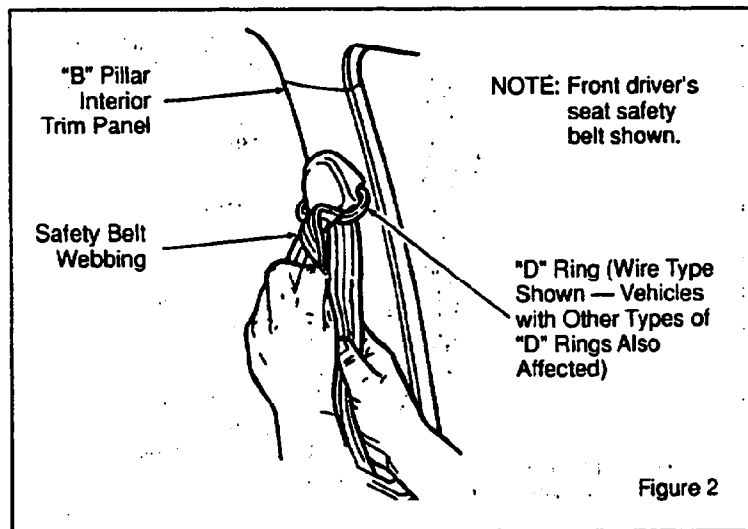

2. Rotate and fold the belt webbing over itself as required to remove the twist.
3. Feed the folded portion of the belt through the "D" ring.

4. When completed, the safety belt should look like Figure 3.

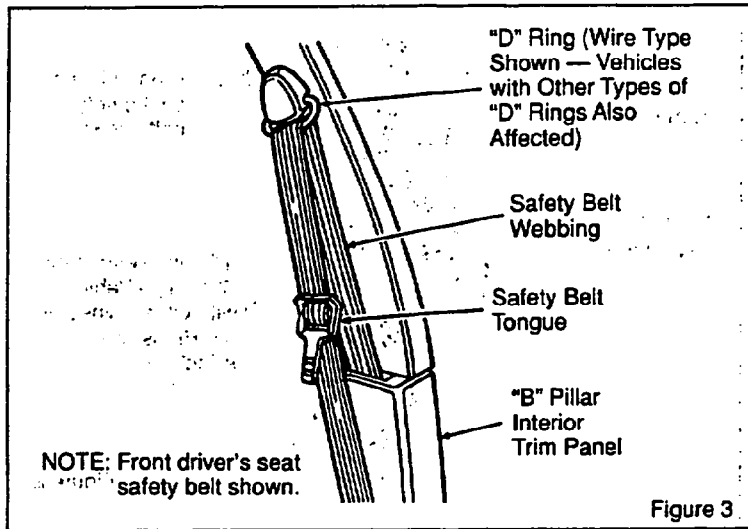

Safety Restraints

Procedure to Correct a Rotated Tongue on the Safety Belt (Front and/or Rear Outboard Seating Positions)

NOTE: The restraint system shown in the following figures may be different than the restraint system in your vehicle. However, use these figures and this procedure to correct a rotated tongue on the safety belt at any seating position that has a "D" ring.

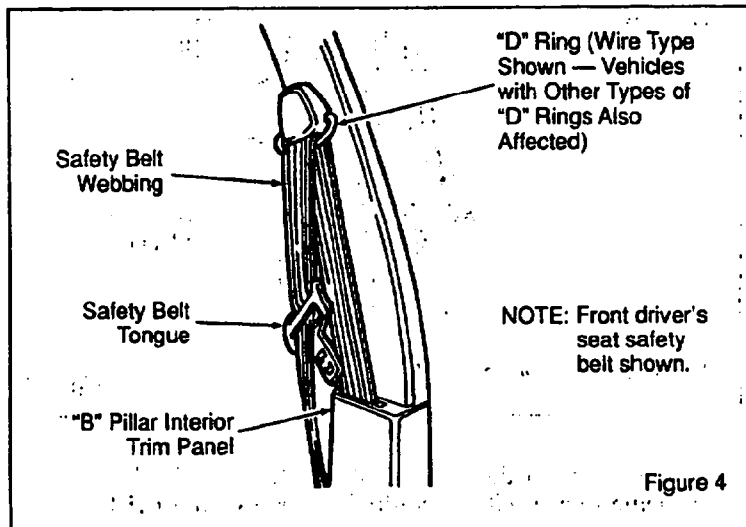

1. Grasp the belt tongue and pull down on the belt webbing closest to you to form a loop through the upper (narrow and longer) slot in the tongue. See Figure 5.

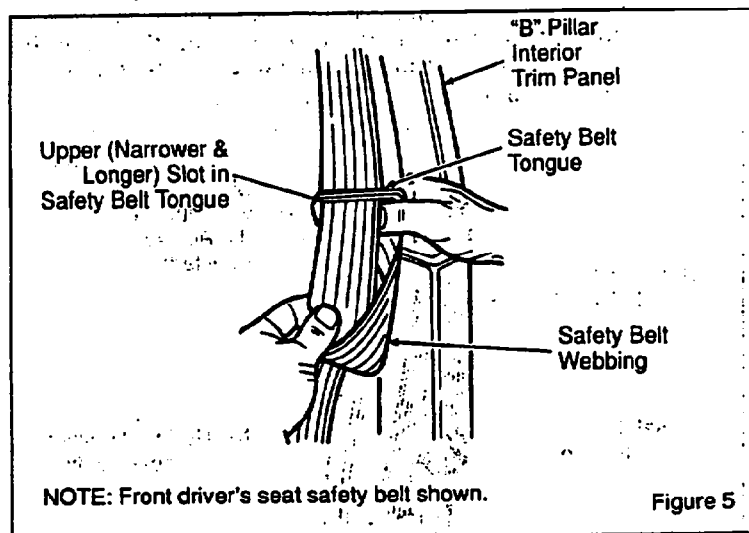

2. Working within the upper slot, rotate and fold the belt webbing over itself as required to remove the twist.
3. Pull the excess belt webbing back through the upper slot in the tongue.

Safety Restraints

- Repeat the above steps to complete the removal of the twist at the lower (wider and shorter) slot in the tongue. See Figure 6.

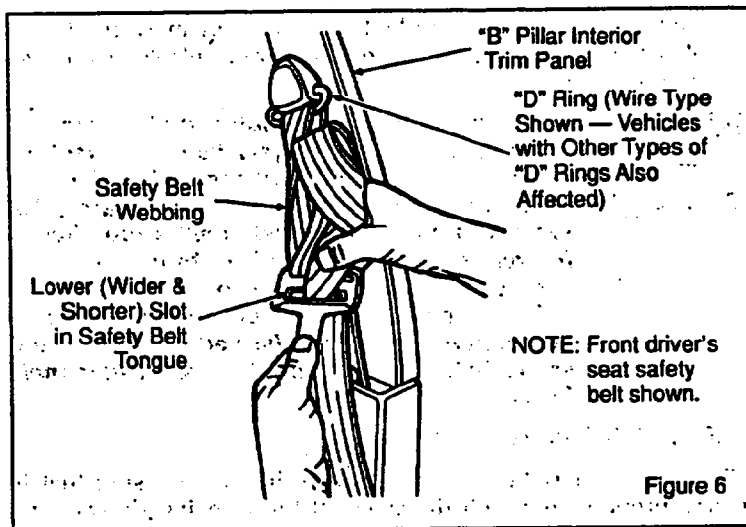

- When completed, the safety belt should look like Figure 3.

Safety Belt Extension Assembly

For some people, the safety belt may be too short even when it is fully extended. You can add about eight inches (20 cm) to the belt length with a safety belt extension assembly (Part number 611C22). Safety belt extensions are available at no cost from your dealer.

WARNING



Use only extensions manufactured by the same supplier as the safety belt. Manufacturer identification is located at the end of the webbing on the label. Also, use the safety belt extension only if the safety belt is too short for you when fully extended. Do not use extension to change the fit of the shoulder belt across the torso. Failure to follow these instructions will affect the performance of the safety belts and increase the risk of personal injury.

Safety Belt Maintenance

Check your safety belt system periodically to make sure that it works properly and isn't damaged. If the webbing shows any wear, nicks or cuts, have it examined by a qualified technician to determine if replacement is necessary. Always have your safety belt system checked after a collision.

The short plastic boot on the front safety belt at the passenger outboard anchor location covers an energy absorbing sew pattern on the safety belt. In the event of an accident, sew pattern may release, and the colored label (REPLACE BELT) may become visible. If this occurs, the safety belt must be replaced.

Safety Restraints

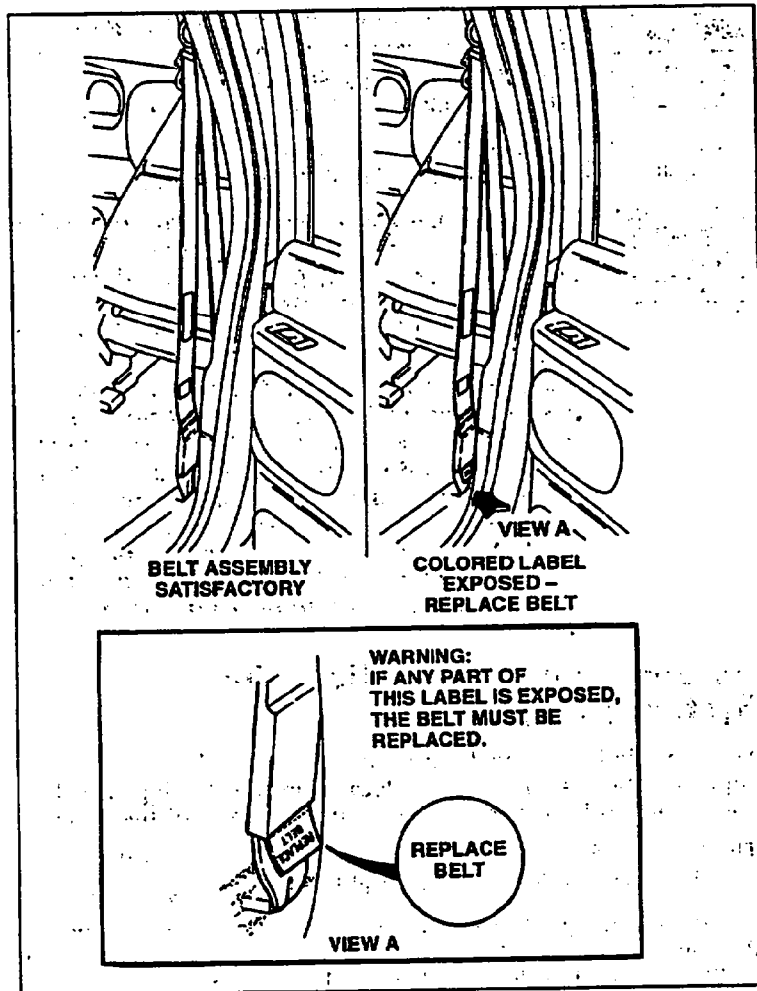

Energy absorbing sew pattern

WARNING

FAILURE TO REPLACE THE SAFETY BELT ASSEMBLY UNDER THE ABOVE CONDITIONS COULD RESULT IN SEVERE PERSONAL INJURIES IN THE EVENT OF A COLLISION.

For information on cleaning the webbing of seat belt assemblies, see "Cleaning the Safety Belts" in the Index.

WARNING

All safety belt assemblies, including retractors, buckles, front seat belt buckle support assemblies (slide bar) (if so equipped), child safety seat tether bracket assemblies (if so equipped), and attaching hardware, should be inspected after any collision. Ford recommends that all safety belt assemblies used in vehicles involved in a collision be replaced. However, if the collision was minor and a qualified technician finds that the belts do not show damage and continue to operate properly, they do not need to be replaced. Safety belt assemblies not in use during a collision should also be inspected and replaced if either damage or improper operation is noted.

Air Bag Supplemental Restraint System (SRS)

Your vehicle is equipped with a driver side air bag supplemental restraint system, located in the steering wheel and identified by the letters "SRS" in the center of the wheel.

The letters "SRS" above the glove compartment indicate your vehicle is also equipped with a right front passenger air bag.

The driver and right front passenger air bags are Supplemental Restraint Systems (SRS), provided at these seating positions in addition to the lap/shoulder belt, and are designed to supplement the protection provided to properly belted

Safety Restraints

occupants in moderate to severe frontal collisions. The supplemental air bag system does not provide restraint to the lower body.

The Importance of Wearing Safety Belts

WARNING

ALWAYS WEAR YOUR SAFETY BELT!

WARNING

All occupants of the vehicle, including the driver, should always wear their safety belts, whether or not an air bag Supplemental Restraint System is also provided at their seating position. Failure to do so may increase the risk of severe injury or death in the event of a collision.

There are four very important reasons to use safety belts even with an air bag system. Use your safety belts to:

- help keep you in the proper position (away from the air bag) when it inflates
- reduce the risk of harm in rollover, side or rear impact collisions, because an air bag is not designed to inflate in such situations
- reduce the risk of harm in frontal collisions that are not severe enough to activate the supplemental air bag
- reduce the risk of being thrown from your vehicle

WARNING

The right front passenger air bag is not designed to restrain occupants in the center front seating position.

The Importance of Being Properly Seated

In a collision, the air bag must inflate extremely fast to help provide additional protection for you. In order to do this, the air bag must inflate with considerable force. If you are not seated in a normal riding position with your back against the seatback, the air bag may not protect you properly and could possibly hurt you as it inflates.

Important Information About The Passenger Air Bag

Your vehicle has a right front passenger air bag. It is important for the front seat passengers' safety that they remain properly seated whenever the vehicle is moving. This means that small children should be secured in appropriate child safety seats, and all other occupants should sit upright, with their backs against the seatback, and restrained by lap and shoulder belts. No passenger should sit toward the front edge of the seat, or stand or lean near the air bag cover (which is near the glove box).

**WARNING**

If a passenger is not properly seated and restrained, an inflating air bag could cause serious injury.

**WARNING**

Rear-facing infant seats should never be placed in the front seat. In rear-facing infant seats, the infant's head is closer to the passenger air bag. The force of the rapidly inflating air bag could push the top of the rear-facing seat against the vehicle seatback.
REAR-FACING INFANT SEATS MUST ALWAYS BE SECURED IN THE REAR SEAT.

Safety Restraints

WARNING



Your vehicle is equipped with a right front passenger air bag. Front passengers, especially children and small adults, should never sit on the edge of the seat, stand near the glove compartment on the instrument panel, or lean over with their faces near the glove compartment when the vehicle is moving. All occupants should sit with their backs against the seatback and use the safety belts. Children weighing less than 40 lbs. (18 kg) should use child or infant seats. Forward-facing child seats must have the passenger seat moved as far back from the instrument panel as possible. REAR-FACING INFANT SEATS SHOULD NEVER BE USED IN THE FRONT SEAT, BECAUSE THE FORCE OF THE RAPIDLY INFLATING PASSENGER AIR BAG COULD PUSH THE TOP OF THE REAR-FACING SEAT AGAINST THE VEHICLE SEATBACK OR CENTER CONSOLE/ARMRESTS. REAR-FACING INFANT SEATS MUST ALWAYS BE PLACED IN THE REAR SEAT.

WARNING



Do not place objects or mount equipment on or near the air bag module covers (identified by the letters "SRS") on the steering wheel and instrument panel, or in front seat areas that may come in contact with a deploying air bag, because any such objects could cause harm if the vehicle is in a collision severe enough to cause the air bag to inflate. Failure to follow this instruction may increase the risk of personal injury in the event of a collision.

For additional important safety information on the proper use of seat belts, child seats, and infant seats, please read the other sections of this part of the Owner Guide, especially sections entitled *Safety Belts for Children* and *Safety Seats for Children*.

For further information about the proper mounting of equipment in the front seat of this vehicle, please refer to Ford's brochure entitled *Some Important Information About Air Bag Supplemental Restraint System* which can be obtained by calling Helm Inc. at 1-800-782-4356. Ask for brochure FPS-8602.

How the Air Bag Supplemental Restraint System Operates

The air bag supplemental restraint system has two main parts. One part is the air bag system with driver and passenger-side air bags and inflators. The second part is the electrical system, which has impact sensors and a diagnostic module. The diagnostic module monitors its own internal circuits and the supplemental air bag electrical system readiness (including the impact sensors), the system wiring, the air bag system readiness light, air bag back up power, and the air bag igniters.

The driver air bag is in the center of the steering wheel. The front passenger seat air bag is in the upper right hand section of the instrument panel ledge above the glove compartment.

Safety Restraints

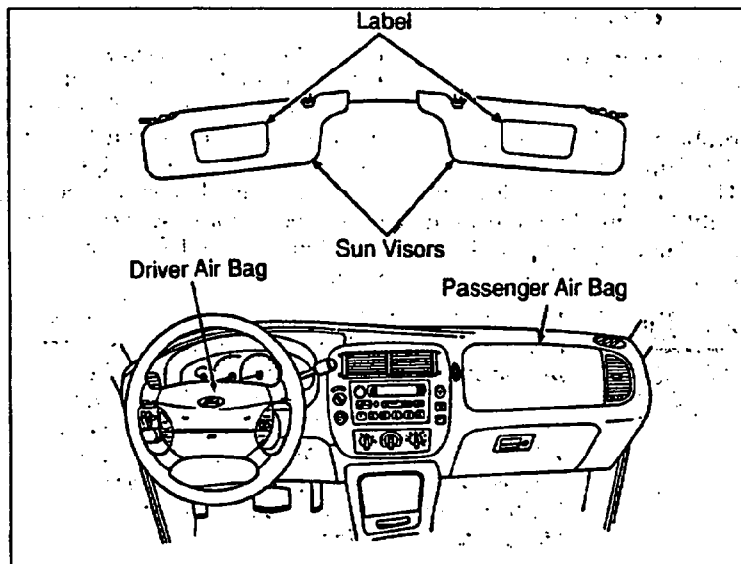

The location of the air bag and warning labels

The air bag system uses a readiness light and a tone to indicate the condition of the system. The readiness light is in the instrument cluster. When you turn the ignition key to ON, this light will illuminate for approximately six (6) seconds and then turn off. This indicates that the system is operating normally.

NOTE: Maintenance of the air bag system is not required.

WARNING



A problem with the system is indicated by one or more of the following: the readiness light will either flash or stay lit, or it will not light, or a group of five beeps will be heard.

If any of these things happen, even intermittently, have the air bag system serviced at your Ford or Lincoln-Mercury dealer immediately.

Tone generator

The air bag readiness light indicates the air bag system condition. However, a series of five sets of five beeps will be heard only if the readiness light does not work and there is a problem with the air bag system. This also means that the Air Bag Supplemental Restraint System (SRS) is in need of service. The tone pattern will repeat (five sets of five beeps) periodically until the problem and light are repaired. Unless serviced, the Air Bag Supplemental Restraint System may not function properly in the event of a collision.

WARNING



Do not attempt to service, repair, or modify the Air Bag Supplemental Restraint System; tampering could cause activation of the system and increase the risk of personal injury. DO NOT REPLACE OR OTHERWISE TAMPER WITH THE AIR BAG FUSES. For servicing of the Air Bag Supplemental Restraint System, see your Ford or Lincoln-Mercury dealer.

The air bag system is designed to stay out of sight until it is activated. The air bag system is designed to deploy in frontal and front-angled collisions more severe than hitting a parked vehicle of similar size and weight head-on at about 28 mph (45 km/h). Because the system senses the crash severity rather than vehicle speed, some frontal collisions at speeds above 28 mph (45 km/h) will not inflate the air bag.

The following four steps show how the air bag system works:

1. Sensors in the vehicle will detect the degree of severity of a frontal impact. When the sensor system is activated, electric current flows to the inflator and the system ignites the gas generant.

Safety Restraints

2. The propellant then rapidly burns in the metal container. The rapid burning produces nitrogen gas and small amounts of dust. The nitrogen gas and dust are cooled and filtered during inflation of the air bag.
3. The inflating supplemental air bags split open the trim covers. The supplemental air bags then rapidly unfold and inflate in front of the driver and front seat passenger.

NOTE: STEPS 1-3 TAKE PLACE IN A FRACTION OF A SECOND.

4. After inflation, the gas empties through holes in the air bag. The air bag deflates at once.

The surface of the air bags and the vehicle interior may be dusted with a powdery residue. The powder is cornstarch or talcum powder, which is used to lubricate the air bag as it inflates, and sodium compounds such as sodium carbonates (e.g., baking soda), and possibly a very small amount of sodium hydroxide that may be irritating to the skin and eyes, but is not toxic.

Right after air bag inflation, you may notice smoke (from the powder and dust) and smell the burnt propellant. This is normal.



Several air bag system components get hot after inflation. Do not try to touch them after inflation.

Air bags may not inflate in certain frontal collisions, even though the vehicle may be badly damaged. The fact that your air bag did not inflate in such a collision does not mean that something is wrong with the air bag system. Rather, it means the crash forces were not severe enough to need an air bag to prevent serious injury.



Inflated driver-side air bag

Safety Restraints

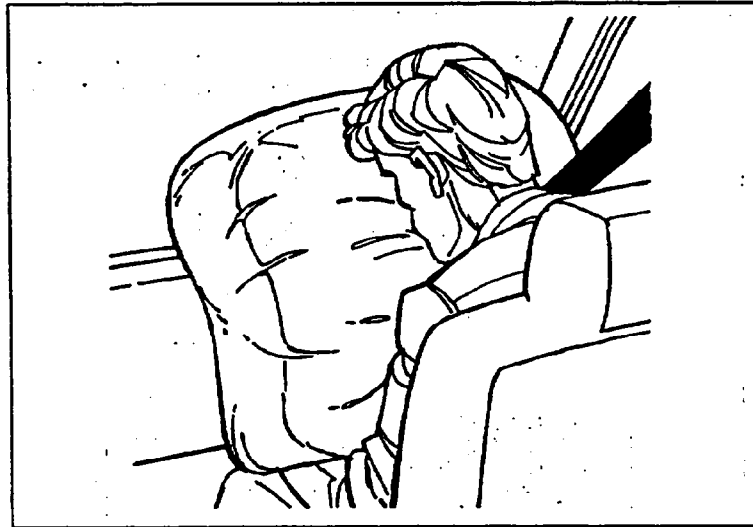

Inflated passenger-side air bag

WARNING

*The air bag will inflate only once. The system is designed to function on a one-time-only basis. If the air bag is inflated, **THE AIR BAG WILL NOT FUNCTION AGAIN AND MUST BE REPLACED IMMEDIATELY.** If the air bag is not replaced, the unrepaired area will increase the risk of injury in a collision.*

Disposal of supplemental air bag equipped vehicles

For disposal of air bags or air bag equipped vehicles, see your local Ford or Lincoln-Mercury dealer, or refer to the procedures in the 1995 Ford Service Manual. Information on how to order a service manual is available at an authorized Ford or Lincoln-Mercury dealer. You can also order a service manual using the order form in the *Accessories* chapter of your Owner Guide.

Service and Information labels

Service and information labels are attached to the sun visors and to the radiator support shield in the engine compartment.

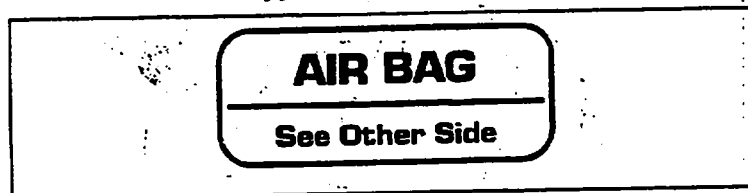

Label located on front of driver's and passenger's visors

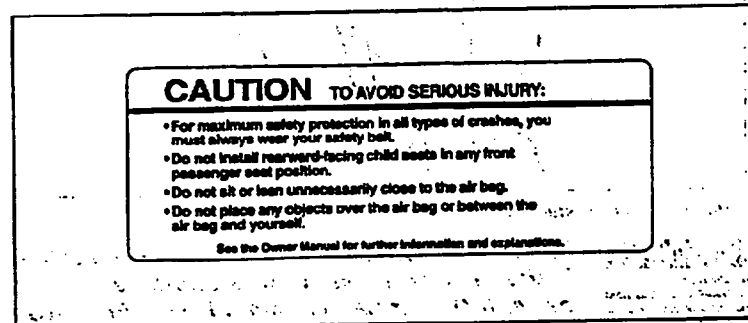

Label located on back of passenger's visors

Safety Restraints

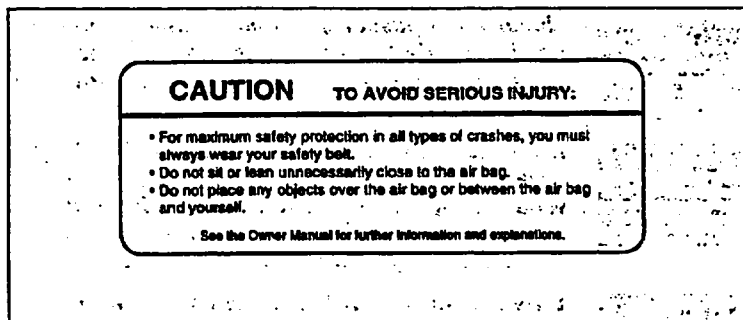

Label located on back of driver's visor

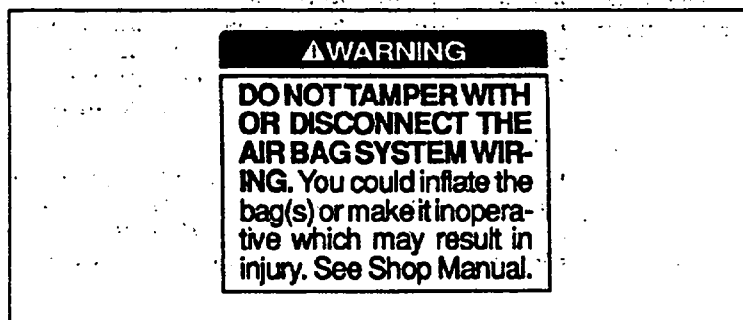

Air bag label on the radiator support in the engine compartment

Safety Restraints for Children

In the U.S. and Canada, you are required by law to use safety restraints for children. If small children ride in your vehicle — this generally includes children who are four years old or younger and who weigh 40 pounds (18 kg) or less — you must put them in safety seats that are made specially for children. Safety belts alone do not provide maximum protection for these children. Check your local and state laws for specific requirements.