



U.S. Department
of Transportation

**National Highway
Traffic Safety
Administration**

2152

DOT HS 808 300

October 1993

Final Report

Final Report of a 1992 Dodge Ram B250 Van Rear Impact CNG Fuel Tank Integrity

Transportation Research Center Inc. does not endorse or certify products of manufacturers. The manufacturer's name appears solely to identify the test article. Transportation Research Center Inc. assumes no liability for the report or use thereof. It is responsible for the facts and the accuracy of the data presented herein. This report does not constitute a standard, specification, or regulation.

This publication is distributed by the U. S. Department of Transportation, National Highway Traffic Safety Administration, in the interest of information exchange. The opinions, findings and conclusions expressed in this publication are those of the author(s) and not necessarily those of the Department of Transportation or the National Highway Traffic Safety Administration. The United States Government assumes no liability for its contents or use thereof. If trade or manufacturers' names or products are mentioned, it is only because they are considered essential to the object of the publication and should not be construed as an endorsement. The United States Government does not endorse products or manufacturers.

1. Report No. DOT HS 808 300	2. Government Accession No.	3. Recipient's Catalog No. VRTC-83-0307	
4. Title and Subtitle FINAL REPORT OF A 1992 DODGE RAM B250 VAN REAR IMPACT CNG FUEL TANK INTEGRITY		5. Report Date OCTOBER 1993	6. Performing Organization Code
7. Author(s) K. W. Looker, Project Engineer, TRC		8. Performing Organization Report No. 930925	
9. Performing Organization Name and Address National Highway Traffic Safety Admin. Vehicle Research and Test Center P. O. BOX 37 East Liberty, OH 43319		10. Work Unit No. (TRAILS)	11. Contract or Grant No. DTNH22-88-C-07292
12. Sponsoring Agency Name and Address U. S. Department of Transportation National Highway Traffic Safety Administration 400 Seventh St., S.W. Washington, DC 20590		13. Type of Report and Period Covered FINAL REPORT SEPT. - NOV. 1993	
15. Supplemental Notes		14. Sponsoring agency Code DOT/NHTSA/VRTC	
16. Abstract <p>This 30 mph rear impact test was conducted at Transportation Research Center Inc. on September 25, 1993. The subject vehicle, a Dodge Ram 250 Model B van, VIN 2B4HB25TXNK135503 was impacted in the rear by the FMVSS 301 moving barrier at 29.3 mph. The purpose of this test was to investigate and demonstrate the practicality of the proposed FMVSS 303 test procedure for evaluating the fuel system integrity of a CNG fueled vehicle.</p>			
17. Key Words CNG Fuel System Integrity		18. Distribution Statement Document is available to the public through the National Technical Information Service, Springfield, VA 22161	
19. Security Classif. (of this report) UNCLASSIFIED	20. Security Classif. (of this page) UNCLASSIFIED	21. No. of Pages 60	22. Price

TABLE OF CONTENTS

<u>SECTION</u>	<u>DESCRIPTION</u>	<u>PAGE</u>
1.0	PURPOSE AND TEST PROCEDURE	1-1
2.0	REAR IMPACT TEST SUMMARY	2-1
3.0	CAMERA INFORMATION	4-1
APPENDIX A	PHOTOGRAPHS	A-1
APPENDIX B	DATA PLOTS	B-1

LIST OF TABLES

<u>NUMBER</u>	<u>TITLE</u>	<u>PAGE</u>
1	CRASH TEST SUMMARY	2-4
2	TEST VEHICLE INFORMATION	2-5
3	POST-IMPACT DATA	2-8
4	POST-IMPACT DUMMY/VEHICLE DATA	2-10
5	VEHICLE ACCELEROMETER LOCATIONS AND DATA SUMMARY	2-13
6	MOVING BARRIER ACCELEROMETER LOCATIONS AND DATA SUMMARY	2-15
7	FUEL SYSTEM DATA	2-16
8	MOTION PICTURE CAMERA INFORMATION	3-3

LIST OF FIGURES

<u>NUMBER</u>	<u>TITLE</u>	<u>PAGE</u>
1	IMPACT VELOCITY MEASUREMENT SYSTEM	2-9
2	VEHICLE CRUSH	2-11
3	VEHICLE ACCELEROMETER PLACEMENT	2-12
4	MOVING BARRIER ACCELEROMETER PLACEMENT	2-14
5	CAMERA POSITIONS	3-2

LIST OF PHOTOGRAPHS

<u>DESCRIPTION</u>	<u>FIGURE</u>
PRE-TEST FRONT VIEW	A-1
POST-TEST FRONT VIEW	A-2
PRE-TEST LEFT SIDE VIEW	A-3
POST-TEST LEFT SIDE VIEW	A-4
PRE-TEST REAR VIEW	A-5
POST-TEST REAR VIEW	A-6
PRE-TEST RIGHT SIDE VIEW	A-7
POST-TEST RIGHT SIDE VIEW	A-8
PRE-TEST RIGHT FRONT THREE-QUARTER VIEW	A-9
POST-TEST RIGHT FRONT THREE-QUARTER VIEW	A-10
PRE-TEST RIGHT REAR THREE-QUARTER VIEW	A-11
POST-TEST RIGHT REAR THREE-QUARTER VIEW	A-12
PRE-TEST LEFT FRONT THREE-QUARTER VIEW	A-13
POST-TEST LEFT FRONT THREE-QUARTER VIEW	A-14
PRE-TEST LEFT REAR THREE-QUARTER VIEW	A-15
POST-TEST LEFT REAR THREE-QUARTER VIEW	A-16
PRE-TEST OVERHEAD VIEW	A-17
PRE-TEST FUEL TANK - VIEW 1	A-18
PRE-TEST FUEL TANK - VIEW 2	A-19
POST-TEST FUEL TANK VIEW	A-20
PRE-TEST FRONT UNDERBODY VIEW	A-21
POST-TEST FRONT UNDERBODY VIEW	A-22
PRE-TEST REAR UNDERBODY VIEW	A-23
POST-TEST REAR UNDERBODY VIEW	A-24

SECTION 1.0

PURPOSE AND TEST PROCEDURE

PURPOSE

This 30 mph moving barrier rear impact test was conducted for Vehicle Research and Test Center by Transportation Research Center Inc. (TRC). The purpose of this test was to investigate and demonstrate the practicality of the proposed FMVSS 303 test procedure for evaluating the fuel system integrity of a CNG fueled vehicle. The subject vehicle for this test was a Dodge Ram 250 Model B van.

TEST PROCEDURE

This test was conducted in accordance with the applicable portions of NHTSA's Office of Vehicle Safety Compliance (OVSC) Laboratory Test Procedure No. TP-301-00, with the addition of vehicle accelerometers. Data was obtained relative to fuel system integrity.

The test vehicle was instrumented with six (6) accelerometers to measure longitudinal, lateral, and vertical axis accelerations, three (3) thermocouples to measure tank, tube, and ambient temperatures, and a pressure transducer to measure fuel system pressure. The moving barrier was instrumented with three (3) accelerometers to measure longitudinal, lateral, and vertical axis accelerations. The moving barrier impacted the test vehicle's rear in the specified impact velocity range of 28.9 to 29.9

The test vehicle contained two (2) uninstrumented Part 572 B 50th percentile adult anthropomorphic test devices (dummies) positioned in the front outboard designated seating positions. The fuel system was filled with nitrogen gas at 3000 psi at 70° F.

The eight (8) acceleration data channels were multiplexed and recorded on a 14-track tape drive. The acceleration data was digitally sampled at 8000 samples per second and processed according to SAE J211 OCT88. The pressure and temperature data was recorded by a Fluke 2625A Data Logger. The data logger sampled the data at 2.7 sec/sample.

The crash event was recorded by one (1) real-time panning motion picture camera and seven (7) high-speed motion picture cameras. The pre-test and post-test conditions were recorded by one (1) real-time motion picture camera.

The rear impact data are presented in Section 2.0. The camera information is presented in Section 3.0. Appendix A contains the still photographic prints. Appendix B contains the vehicle and moving barrier data plots.

SECTION 2.0

REAR IMPACT TEST SUMMARY

TEST RESULTS SUMMARY

This rear impact moving barrier test was conducted at TRC on September 25, 1993.

The test vehicle, a 1992 Dodge Ram B250 van, appeared to comply with the proposed performance requirements of FMVSS 303 in the rear moving barrier impact mode. No gas appeared to leak from the vehicle's fuel system following the impact.

The test vehicle was equipped with a 5.2-liter inline engine, automatic transmission, power steering, and power brakes. The vehicle's test weight was 5711 pounds. The vehicle's maximum static crush was 7.2 inches. The moving barrier's test weight was 3989 pounds. The moving barrier's impact speed was 29.3 mph.

DATA ACQUISITION EXPLANATIONS

The vehicle center of gravity X-axis acceleration, VCGXG1, recorded anomalous data after 54 milliseconds.

The vehicle center of gravity Y-axis acceleration, VCGYG1, recorded a questionable data spike at 7 milliseconds.

The vehicle center of gravity Z-axis acceleration, VCGZG1, recorded a questionable data spike at 7 milliseconds.

The vehicle center of gravity resultant acceleration, VCGRG1, calculation was affected by the above anomalies.

The fuel tank pressure recorded an anomalous step down in the data at 34 minutes after impact.

All of the temperature channels recorded anomalous spikes at 5 minutes and at 8 minutes after impact.

TABLE 1 CRASH TEST SUMMARY

TEST TYPE: Rear Moving Barrier Impact

TEST DATE: 09/25/93 TEST TIME: 1230 AMBIENT TEMP. (°F): 60

VEHICLE: 1992 Dodge Ram B250 van

VEHICLE TEST WEIGHT (LBS.): 5711

MOVING BARRIER TEST WEIGHT (LBS.): 3989

IMPACT ANGLE¹ (DEG): 180

IMPACT VELOCITY² (MPH): PRIMARY = 29.3 SECONDARY = 28.7

MAXIMUM STATIC CRUSH (IN): 7.3

DUMMIES:	Driver	Passenger
TYPE:	Part 572 B	Part 572 B
LOCATION:	Left front	Right front
RESTRAINT:	Three-point unbelt	Three-point unbelt
NUMBER OF DATA CHANNELS:	16	
NUMBER OF CAMERAS:	HIGH-SPEED 7	REAL-TIME 1

¹With respect to tow track centerline.

²Speed trap measurement ($\pm .05$ mph accuracy)

TABLE 2 TEST VEHICLE INFORMATION

VEHICLE MANUFACTURER: Chrysler Corporation

MAKE/MODEL: Dodge/Ram B250

VIN: 2B4HB25TXNK135503

BODY STYLE: VAN

MODEL YEAR: 1992

COLOR: Blue

ENGINE DATA: TYPE: Inline CYLINDERS: 8 DISPLACEMENT: 5.2 liters

TRANSMISSION DATA: 3 SPEED, ___MANUAL, X AUTOMATIC, ___FWD, X RWD, ___4WD

DATE VEHICLE RECEIVED: NA

ODOMETER READING: 1870

DEALER'S NAME AND ADDRESS: NA

ACCESSORIES:

POWER STEERING	Yes	AUTOMATIC TRANSMISSION	Yes
POWER BRAKES	Yes	AUTOMATIC SPEED CONTROL	No
POWER SEATS	No	TILTING STEERING WHEEL	Yes
POWER WINDOWS	Yes	TELESCOPING STEERING WHEEL	No
TINTED GLASS	Yes	AIR CONDITIONING	Yes
RADIO	Yes	ANTI-SKID BRAKE	No
CLOCK	Yes	REAR WINDOW DEFROSTER	Yes
OTHER	None		

REMARKS:

1. IS THE VEHICLE STOCK THROUGHOUT? No¹
2. DOES VEHICLE SHOW EVIDENCE OF PRIOR ACCIDENT HISTORY? No
3. DOES VEHICLE SHOW ANY SIGNIFICANT CORROSION? No
4. CONDITION OF THE FRONT/REAR BUMPER AND FRAME: Good

CERTIFICATION DATA FROM VEHICLE'S LABEL:

VEHICLE MANUFACTURED BY: Chrysler Corporation

DATE OF MANUFACTURE: 03/92

VIN: 2B4HB25TXNK135503

GVWR: 6400 LBS.

GAWR: FRONT: 3300 LBS.
REAR: 3700 LBS.

¹The vehicle was modified to operate on compressed natural gas.

TABLE 2 TEST VEHICLE INFORMATION, CONT'D.

TIRES ON VEHICLE (MFR., LINE, SIZE): Michelin, XW4, P235/75R15 XW4

TIRE PRESSURE WITH MAXIMUM CAPACITY VEHICLE LOAD: FRONT: 44 PSI
REAR: 44 PSI

SPARE TIRE (MFR., LINE, SIZE): NA

TYPE OF SEATS: FRONT: Bucket
REAR: Bench

TYPE OF FRONT SEAT BACKS: Manually adjustable

WHEELBASE: 127.5 INCHES

LOCATION OF LABEL STATING TIRE & CAPACITY DATA:

The label was located on the driver's B-pillar.

TIRE & CAPACITY DATA FROM VEHICLE'S LABEL:

RECOMMENDED TIRE SIZE: P235/75R15XL

RECOMMENDED COLD TIRE PRESSURE: FRONT: 35 PSI; REAR: 41 PSI

DESIGNATED SEATING CAPACITY: ---FRONT ---REAR ---TOTAL

VEHICLE CAPACITY WEIGHT: --- LBS.

TEST VEHICLE ATTITUDE (ALL MEASUREMENTS ARE IN INCHES):

DELIVERED ATTITUDE:	LF	31.0;	RF	31.6;	LR	30.8;	RR	31.1
FULLY LOADED ATTITUDE:	LF	30.4;	RF	31.3;	LR	30.0;	RR	30.5
PRE-TEST ATTITUDE:	LF	30.4;	RF	30.8;	LR	30.8;	RR	30.8
POST-TEST ATTITUDE:	LF	30.2;	RF	31.0;	LR	31.1;	RR	31.3

TABLE 2 TEST VEHICLE INFORMATION, CONT'D.

WEIGHT OF TEST VEHICLE AS RECEIVED (WITH MAXIMUM FLUIDS):

RIGHT FRONT	1339 LBS.	RIGHT REAR	1141 LBS.
LEFT FRONT	1409 LBS.	LEFT REAR	1202 LBS.
TOTAL FRONT WEIGHT	2748 LBS.	(54.0% OF TOTAL VEHICLE WEIGHT)	
TOTAL REAR WEIGHT	2343 LBS.	(46.0% OF TOTAL VEHICLE WEIGHT)	
TOTAL DELIVERED WEIGHT 5091 LBS.			

CALCULATION OF TEST VEHICLE'S TARGET TEST WEIGHT:

RCLW¹ = RATED CARGO AND LUGGAGE WEIGHT

UDW = UNLOADED DELIVERED WEIGHT (5091 LBS.)

VCW¹ = VEHICLE CAPACITY WEIGHT (LBS.)

DSC¹ = DESIGNATED SEATING CAPACITY ()

RCLW¹ = VCW - 150 (DSC) = 300

TARGET TEST WEIGHT = UDW + RCLW¹ + (NO. OF HYBRID II DUMMIES X 164 LBS./DUMMY)

TARGET TEST WEIGHT = 5719 LBS.

WEIGHT OF TEST VEHICLE WITH REQUIRED DUMMIES AND 292 LBS. OF CARGO WEIGHT:

RIGHT FRONT	1580 LBS.	RIGHT REAR	1249 LBS.
LEFT FRONT	1305 LBS.	LEFT REAR	1577 LBS.
TOTAL FRONT WEIGHT	2885 LBS.	(50.5% OF TOTAL VEHICLE WEIGHT)	
TOTAL REAR WEIGHT	2826 LBS.	(49.5% OF TOTAL VEHICLE WEIGHT)	
TOTAL TEST WEIGHT	5711 LBS.	(0.1% UNDER TARGET TEST WEIGHT)	

WEIGHT OF BALLAST SECURED IN VEHICLE: 150 LBS.

COMPONENTS REMOVED TO MEET TARGET TEST WEIGHT: None

CG = 63.1 INCHES REARWARD OF FRONT WHEEL CENTERLINE

¹Cargo weight for multipurpose passenger vehicles, trucks, and buses is the vehicle's rated cargo and luggage weight from the vehicle's label or 300 pounds, whichever is less.

TABLE 3 POST-IMPACT DATA

TEST NUMBER: 930925

TEST DATE: 09/25/93

TEST TIME: 1230

TEST TYPE: Rear Moving Barrier Impact

IMPACT ANGLE: 180°

AMBIENT TEMPERATURE AT IMPACT AREA: 60° F

TEMPERATURE IN OCCUPANT COMPARTMENT: 60° F

IMPACT VELOCITY: PRIMARY = 29.3 MPH

SECONDARY = 28.7 MPH

(SPECIFIED RANGE = 28.9 TO 29.9 MPH)

DISTANCE FROM VEHICLE TO BARRIER: ENTERING VELOCITY TRAP = 14.0 IN.

EXITING VELOCITY TRAP = 2.0 IN.

TEST VEHICLE STATIC CRUSH (ALL MEASUREMENTS ARE IN INCHES):

OVERALL LENGTH OF TEST VEHICLE: PRE-TEST: L 199.5; C 199.0; R 199.2

POST-TEST: L 193.8; C 193.2; R 193.8

TOTAL CRUSH: L 5.7; C 5.8; R 5.4

AVERAGE CRUSH: 5.6

FIGURE 1 IMPACT VELOCITY MEASUREMENT SYSTEM

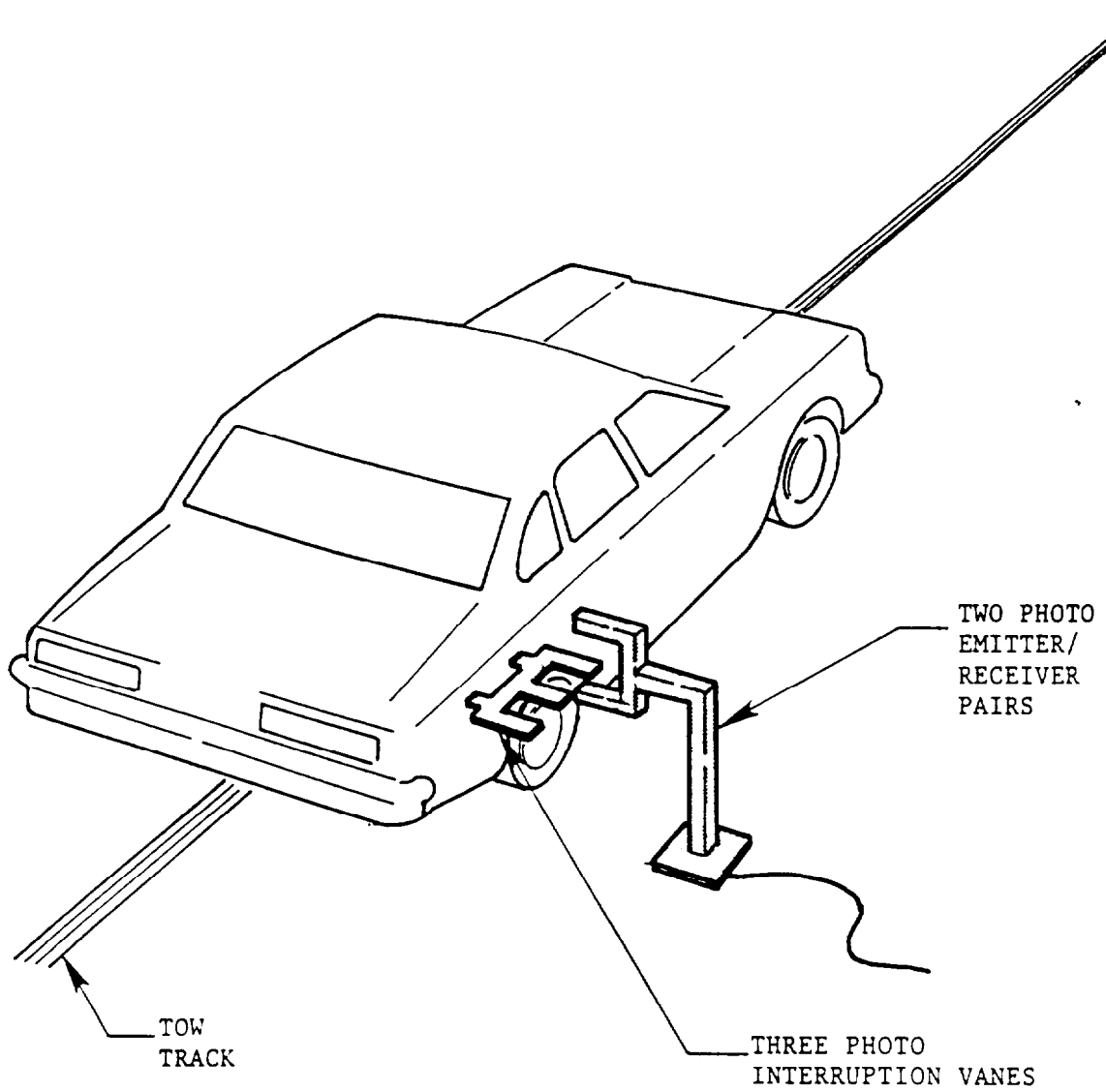

The final vane clears emitter/receiver two inches before impact.

The vanes have one-foot spacing.

TABLE 4 POST-IMPACT DUMMY/VEHICLE DATA

VISIBLE DUMMY CONTACT POINTS:

	DRIVER	PASSENGER
HEAD	NA _____	NA _____
CHEST	NA _____	NA _____
ABDOMEN	NA _____	NA _____
LEFT KNEE	NA _____	NA _____
RIGHT KNEE	NA _____	NA _____

DOOR OPENING:

	LEFT	RIGHT
FRONT	Opened easily _____	Opened easily _____
REAR	NA _____	Opened easily _____

SEAT MOVEMENT:

	SEAT BACK FAILURE	SEAT SHIFT
FRONT	Both back seats failed _____	No _____
REAR	No _____	No _____

GLAZING DAMAGE:

The rear window and two side windows broke during
the crash.

OTHER NOTABLE IMPACT EFFECTS:

None _____

FIGURE 2 VEHICLE CRUSH

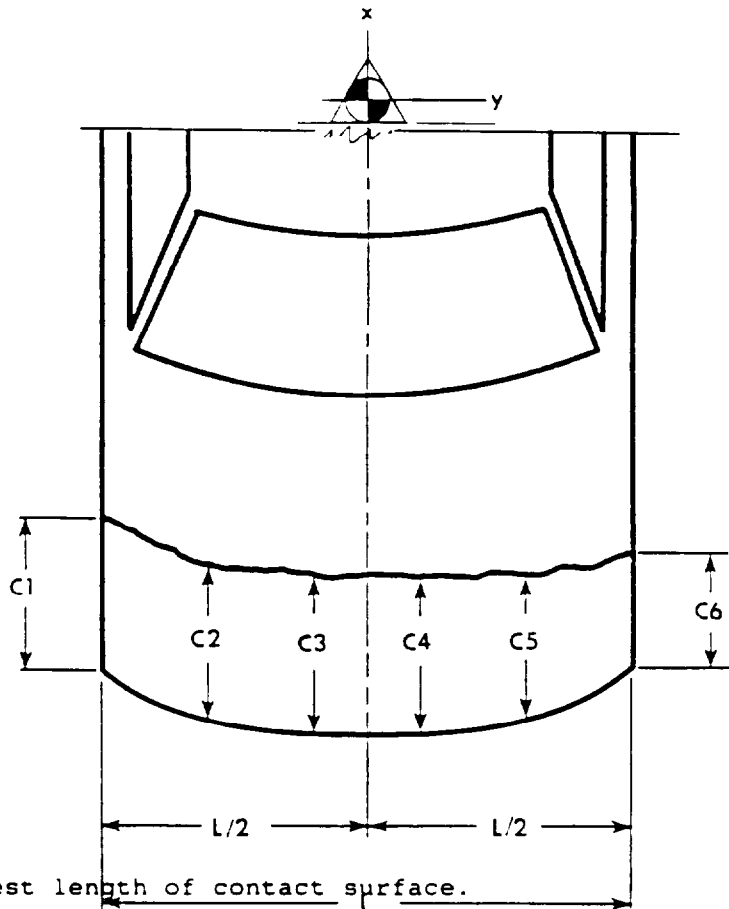

NOTES: L is pre-test length of contact surface.
 C1 through C6 are spaced equally apart.
 CL is vehicle centerline.
 All measurements are in inches.

Vehicle Dodge Ram B250 van

	PRE-TEST	POST-TEST	CRUSH
L	<u>75.0</u>		
C1	<u>199.5</u>	C1 <u>193.8</u>	C1 <u>5.7</u>
C2	<u>201.1</u>	C2 <u>193.8</u>	C2 <u>7.3</u>
C3	<u>199.0</u>	C3 <u>193.2</u>	C3 <u>5.8</u>
C4	<u>199.2</u>	C4 <u>193.2</u>	C4 <u>6.0</u>
C5	<u>201.0</u>	C5 <u>193.8</u>	C5 <u>7.2</u>
C6	<u>199.2</u>	C6 <u>193.8</u>	C6 <u>5.4</u>
CL	<u>199.0</u>	CL <u>193.2</u>	CL <u>5.8</u>

FIGURE 3 VEHICLE ACCELEROMETER PLACEMENT

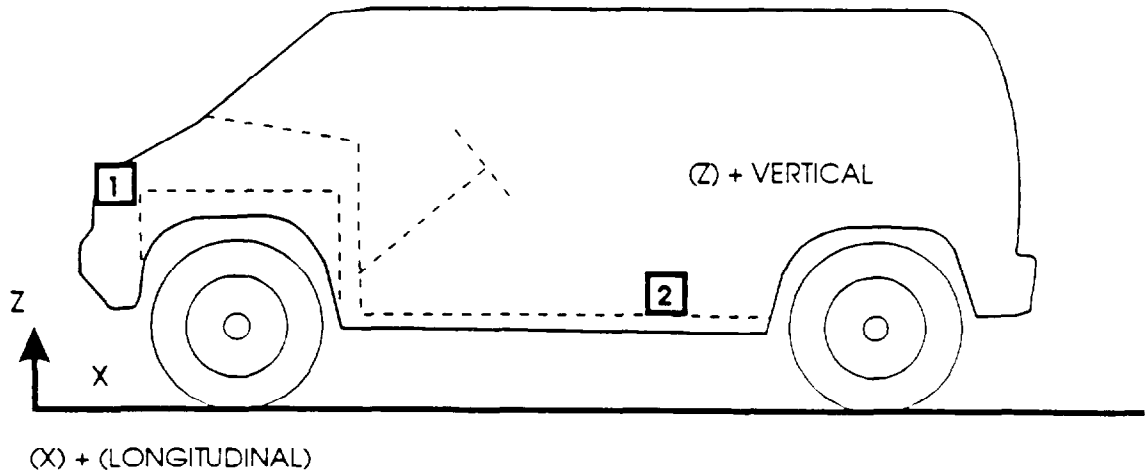

SIDE VIEW

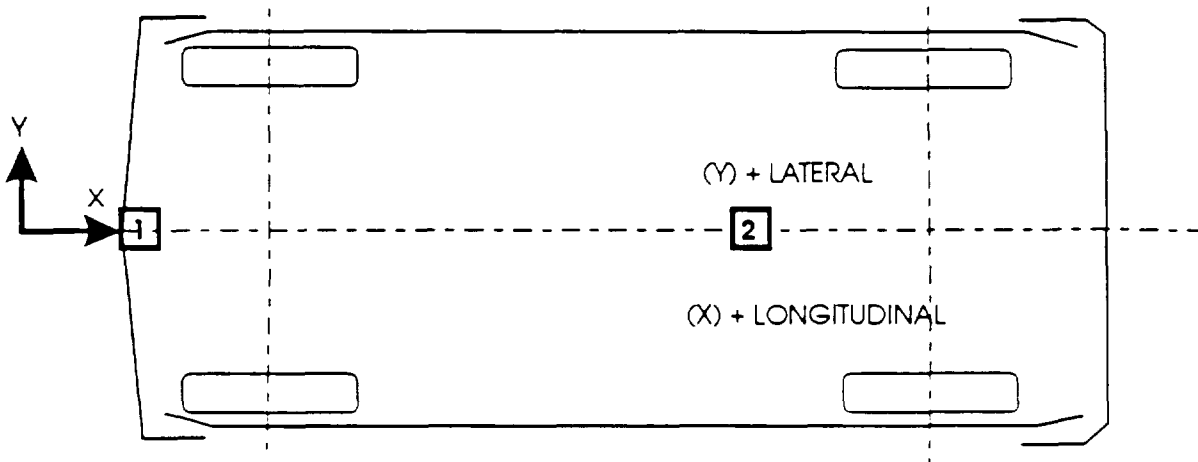

BOTTOM VIEW

TABLE 5

VEHICLE ACCELEROMETER LOCATIONS AND DATA SUMMARY

TEST NUMBER 930925

No. LOCATION	X*	Y*	Z*	POSITIVE DIRECTION MAX G MSEC	NEGATIVE DIRECTION MAX G MSEC
1 FRONT FRAME CROSSMEMBER	190.6	0.0	39.0		
LONGITUDINAL				41.2 34.8	23.4 57.0
LATERAL				4.9 32.8	5.3 75.0
VERTICAL				22.9 26.6	17.5 34.1
RESULTANT				44.5 34.5	
2 VEHICLE CENTER OF GRAVITY	136.0	0.0	23.9		
LONGITUDINAL ¹				---	---
LATERAL ¹				4.8 1.0	112.6 6.9
VERTICAL ¹				214.7 7.5	9.7 92.3
RESULTANT ¹				---	---

* ALL MEASUREMENTS OF ACCELEROMETER LOCATIONS ARE IN INCHES.

REFERENCE: X: + FORWARD FROM REAR BUMPER
 Y: + LEFTWARD FROM VEHICLE CENTERLINE
 Z: + UPWARD FROM GROUND LEVEL

¹ See DATA ACQUISITION EXPLANATIONS

FIGURE 4 MOVING BARRIER ACCELEROMETER PLACEMENT

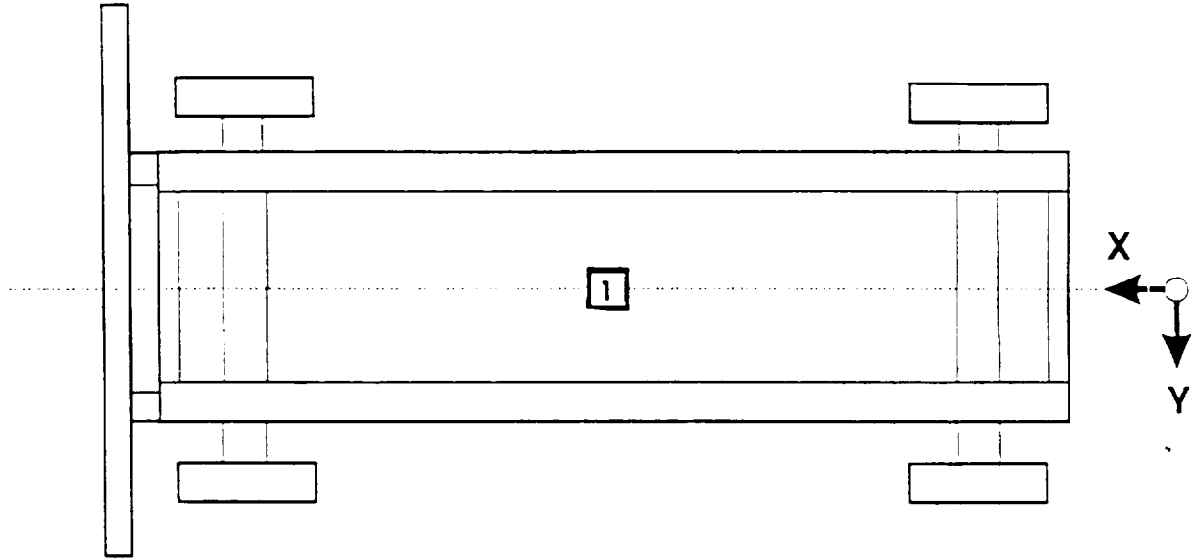

TOP VIEW

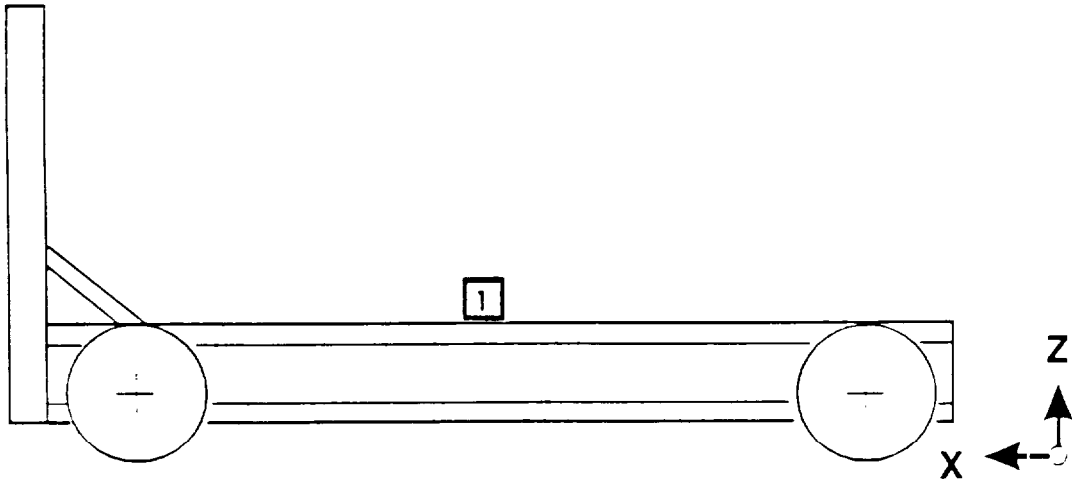

SIDE VIEW

TABLE 6

MOVING BARRIER ACCELEROMETER LOCATIONS AND DATA SUMMARY

TEST NUMBER 930925

No. LOCATION	X*	Y*	Z*	POSITIVE DIRECTION MAX G MSEC	NEGATIVE DIRECTION MAX G MSEC
1 CENTER OF GRAVITY	74.8	0.0	12.6	1.4	32.2
LONGITUDINAL				66.4	20.6
LATERAL				11.3	32.9
VERTICAL				21.1	15.4
RESULTANT				36.1	20.9

* ALL MEASUREMENTS OF ACCELEROMETER LOCATIONS ARE IN INCHES.

REFERENCE: X: + FORWARD FROM REAR POINT OF FRAME
 Y: + LEFTWARD FROM BARRIER CENTERLINE
 Z: + UPWARD FROM GROUND LEVEL

TABLE 7 FUEL SYSTEM DATA

MAKE/MODEL: Dodge/Ram B250

FUEL SYSTEM CAPACITY: 150.7 LITERS (FROM OWNER'S MANUAL)

RATED SERVICE PRESSURE: 3000 PSI AT 70° F

ACTUAL TEST PRESSURE: 2980 PSI AT 64° F

TEST GAS TYPE: NITROGEN

DETAILS OF FUEL SYSTEM: Two fuel tanks were located behind the rear axle
and one fuel tank was located outside of the left frame rail. The fuel
filler neck was located on the left side of the vehicle. The fuel
lines followed the right frame rail to the engine compartment.

ELECTRIC FUEL PUMP: NA

FUEL INJECTION: Yes

DOES ELECTRIC FUEL PUMP OPERATE WITH IGNITION SWITCH "ON" AND THE ENGINE NOT OPERATING? NA

SECTION 3.0

CAMERA INFORMATION

FIGURE 5

CAMERA POSITIONS

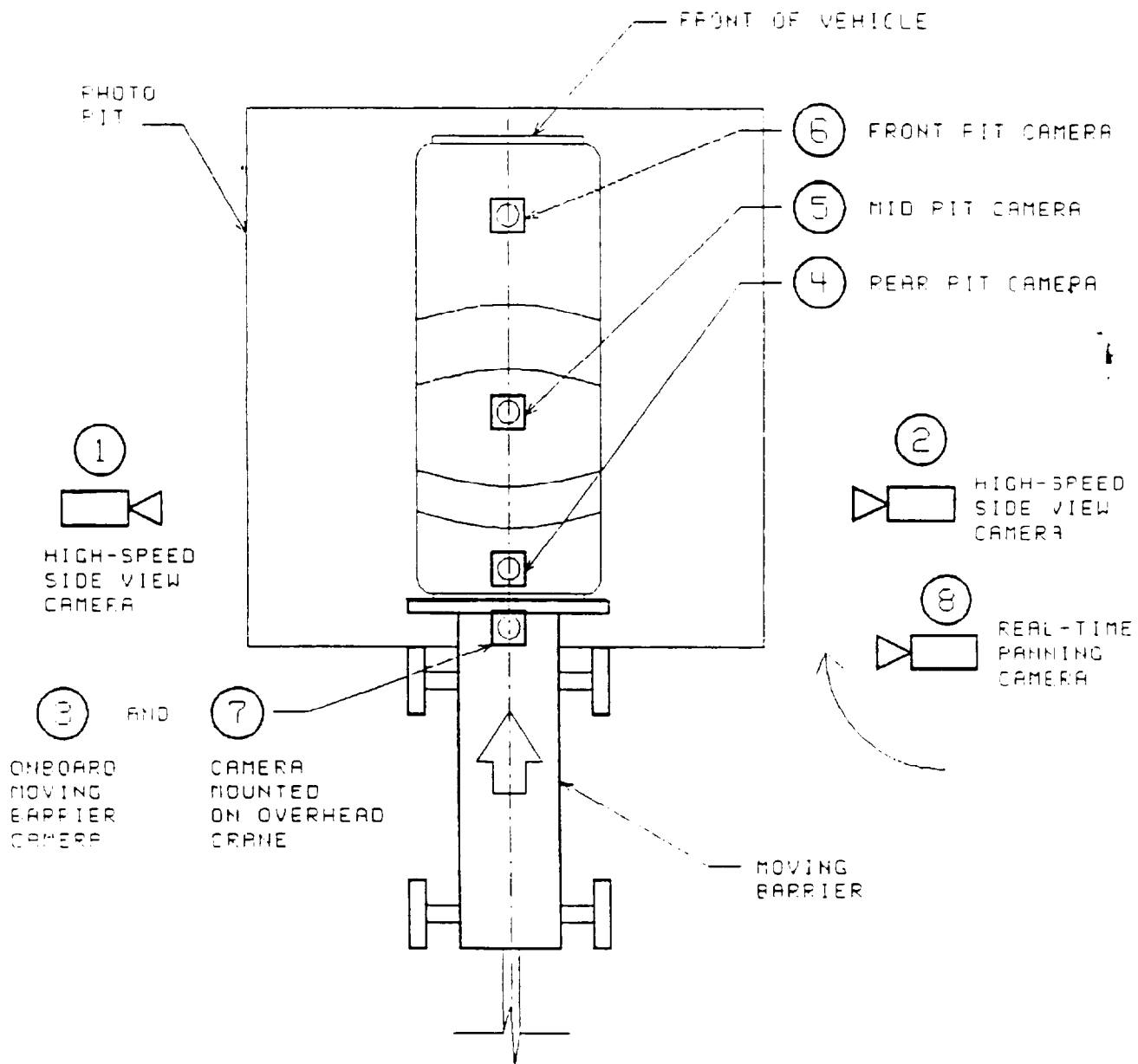

TABLE 3 MOTION PICTURE CAMERA INFORMATION

<u>CAMERA NUMBER</u>	<u>LOCATION</u>	<u>TYPE</u>	<u>LENS (MM)</u>	<u>SPEED (FPS)</u>	<u>PURPOSE OF CAMERA DATA</u>
1	Left wide	Photosonic	13	500	Vehicle crush
2	Right wide	Photosonic	13	513	Vehicle crush
3	Onboard Mvg. Bar.	Photosonic	13	500	Vehicle crush
4	Pit - rear	Photosonic	8.5	948	Vehicle crush
5	Pit - mid	Photosonic	17	800	Vehicle crush
6	Pit - front	Photosonic	25	800	Vehicle crush
7	Overhead wide	Photosonic	17	800	Vehicle crush
8	Right panning	Beaulieu	12-120	24	Real-time panning

APPENDIX A

PHOTOGRAPHS

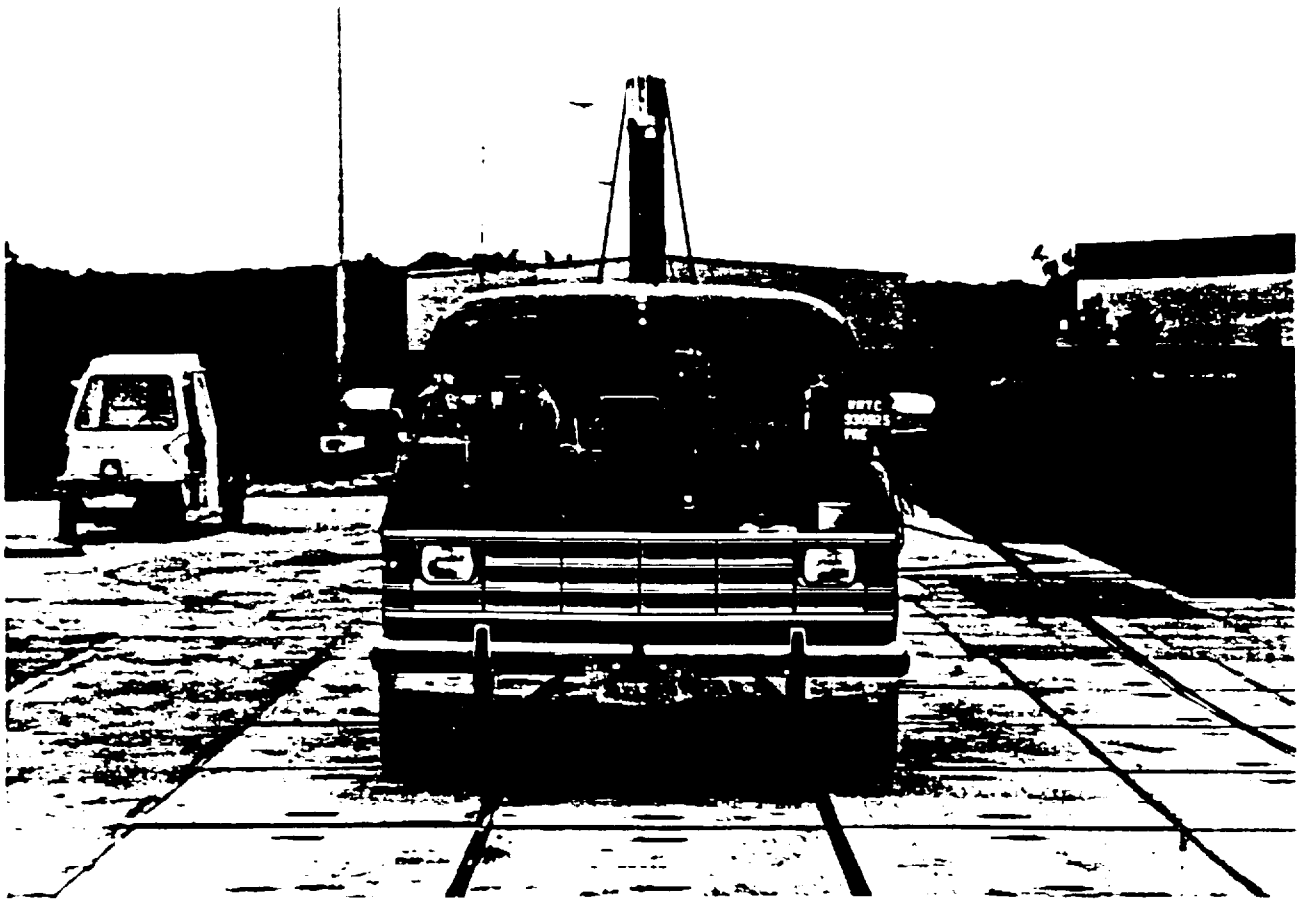

Figure A-1. PRE-TEST FRONT VIEW



Figure A-2. POST-TEST FRONT VIEW



Figure A-3. PRE-TEST LEFT SIDE VIEW

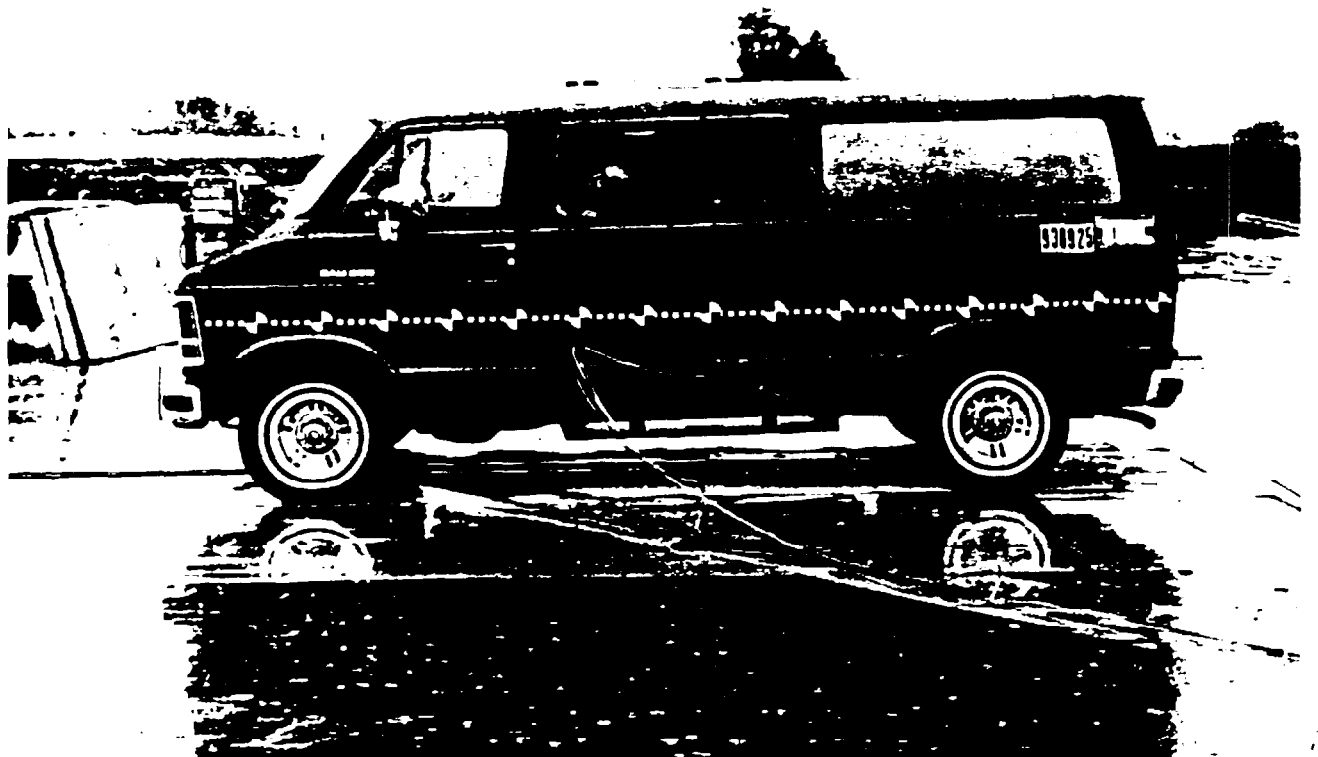

Figure A-4. POST-TEST LEFT SIDE VIEW



Figure A-5. PRE-TEST REAR VIEW



Figure A-6. POST-TEST REAR VIEW



Figure A-7. PRE-TEST RIGHT SIDE VIEW

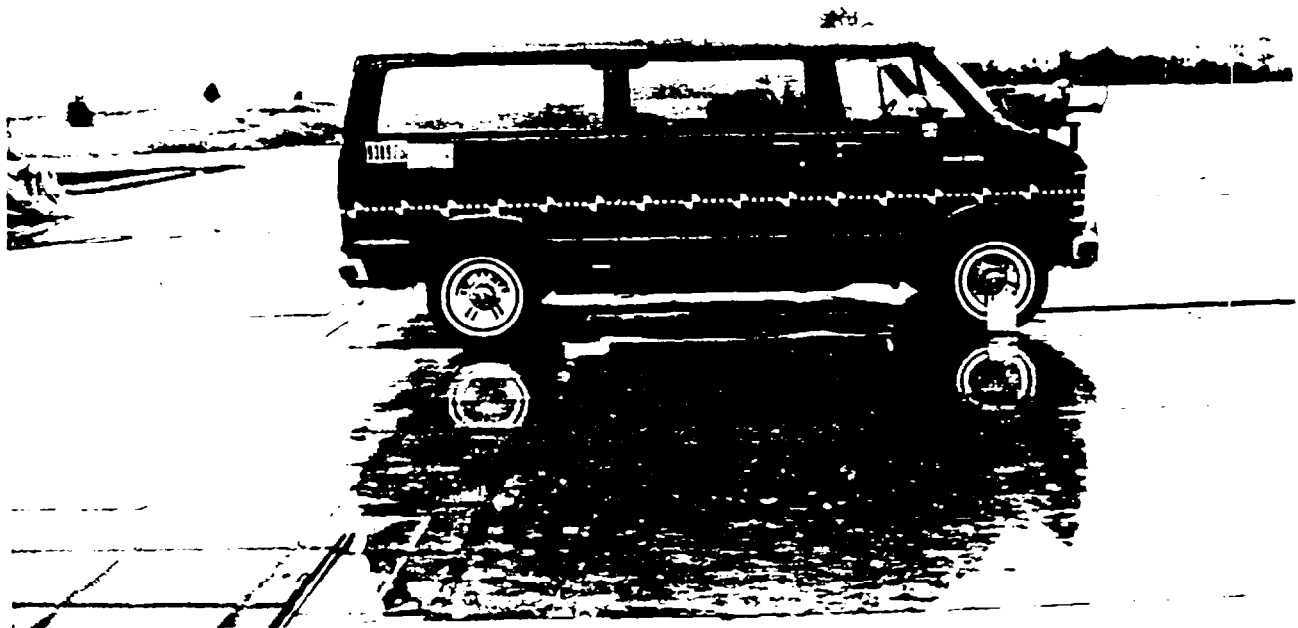

Figure A-8. POST-TEST RIGHT SIDE VIEW

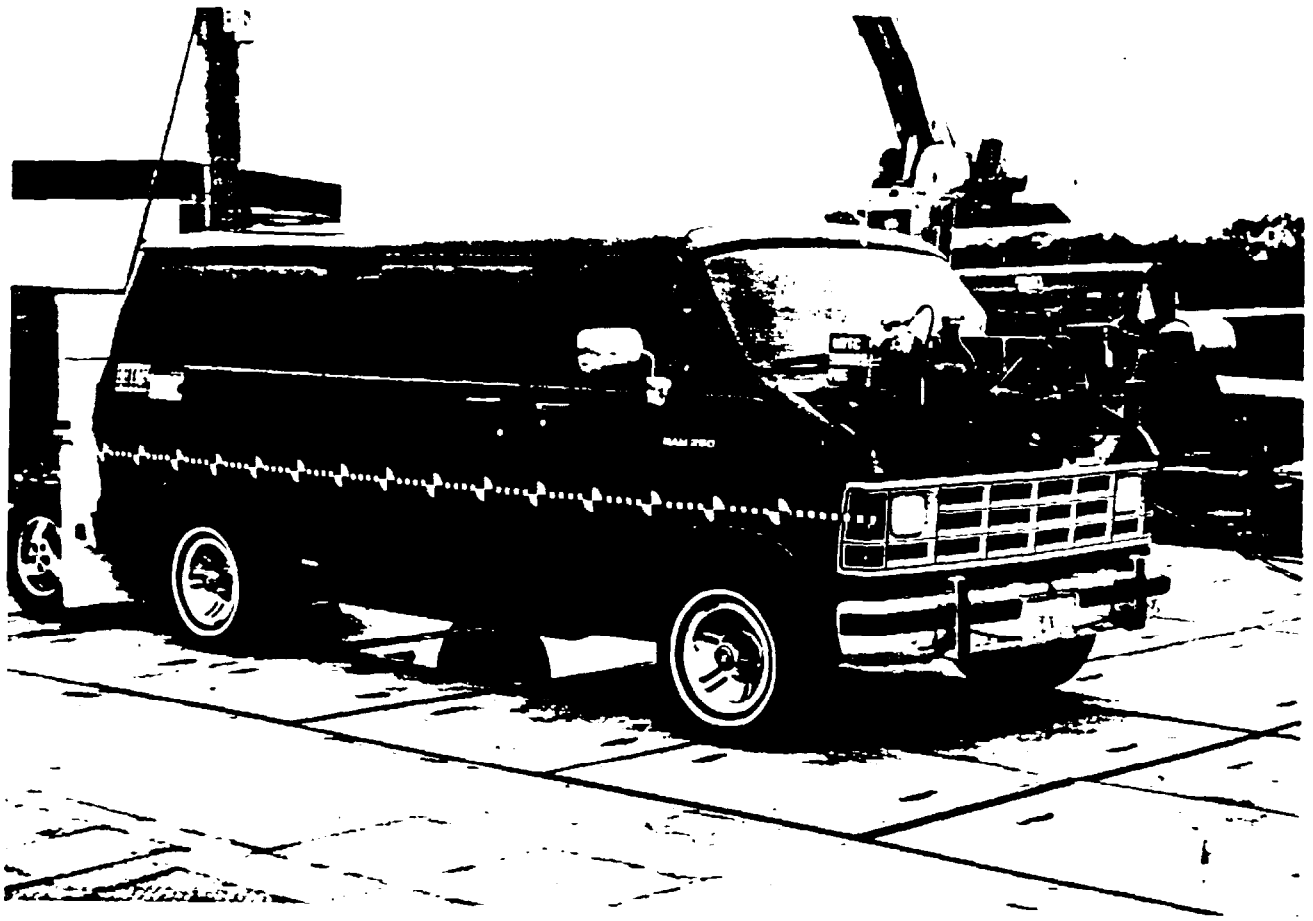

Figure A-9. PRE-TEST RIGHT FRONT THREE-QUARTER VIEW

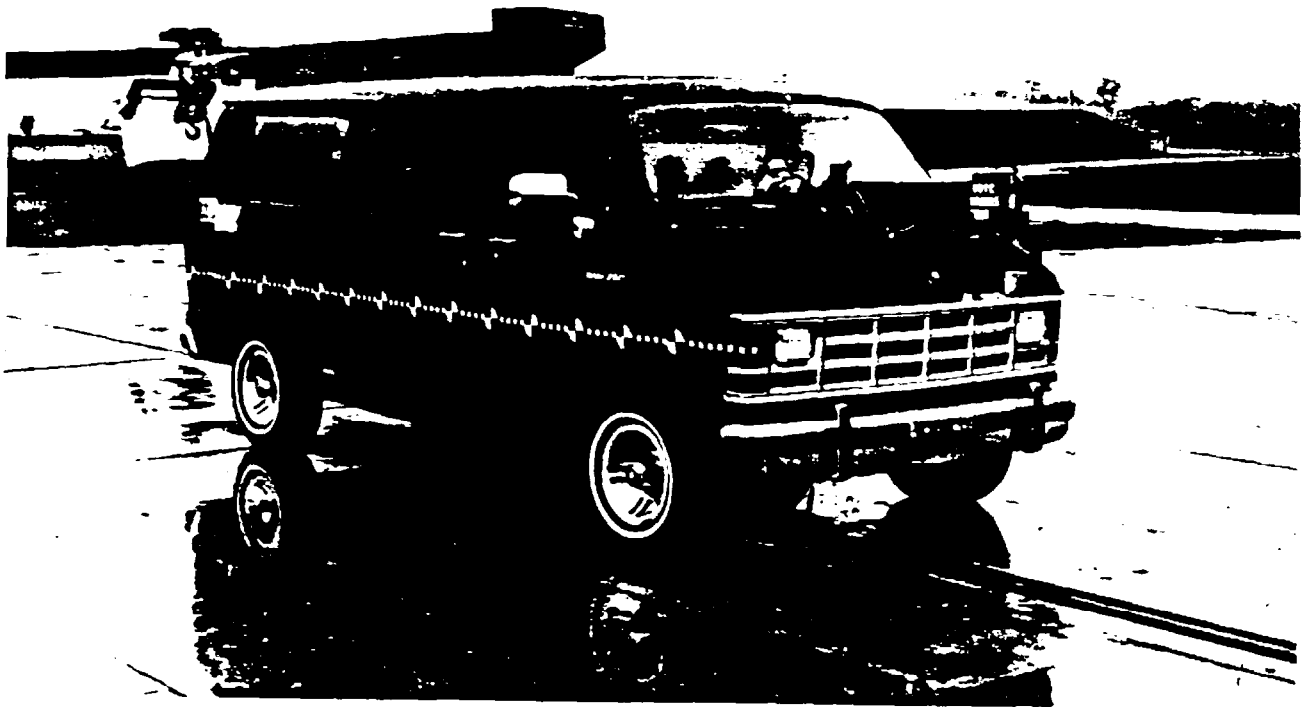

Figure A-10. POST-TEST RIGHT FRONT THREE-QUARTER VIEW



Figure A-11. PRE-TEST RIGHT REAR THREE-QUARTER VIEW

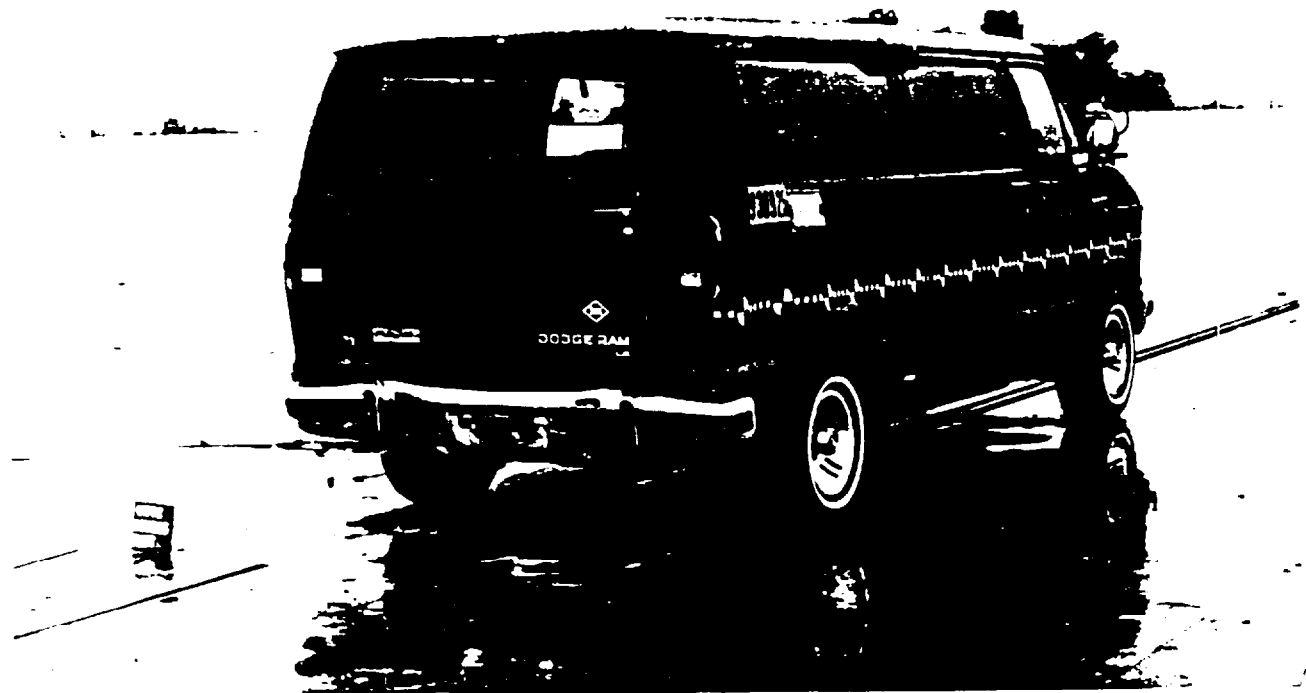

Figure A-12. POST-TEST RIGHT REAR THREE-QUARTER VIEW

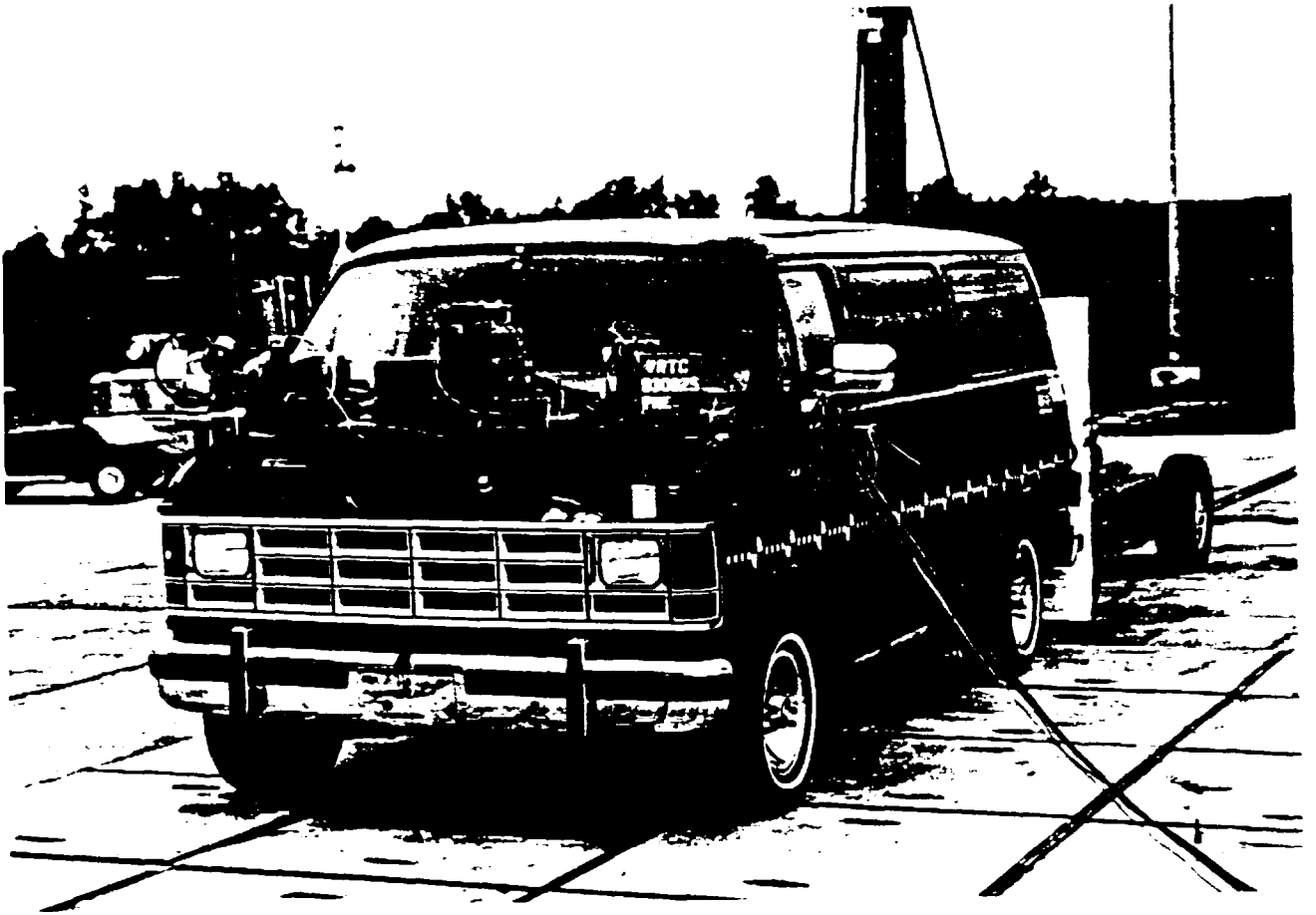

Figure A-13. PRE-TEST LEFT FRONT THREE-QUARTER VIEW

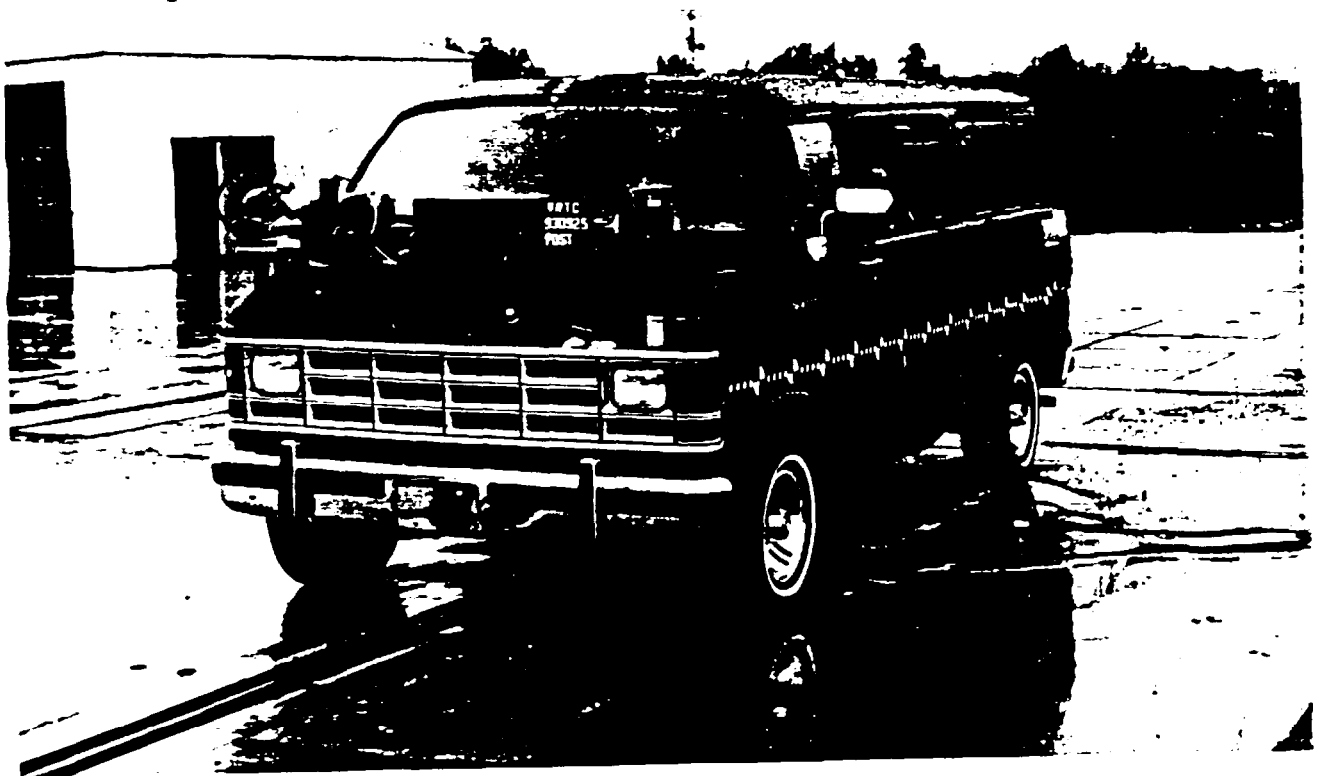

Figure A-14. POST-TEST LEFT FRONT THREE-QUARTER VIEW

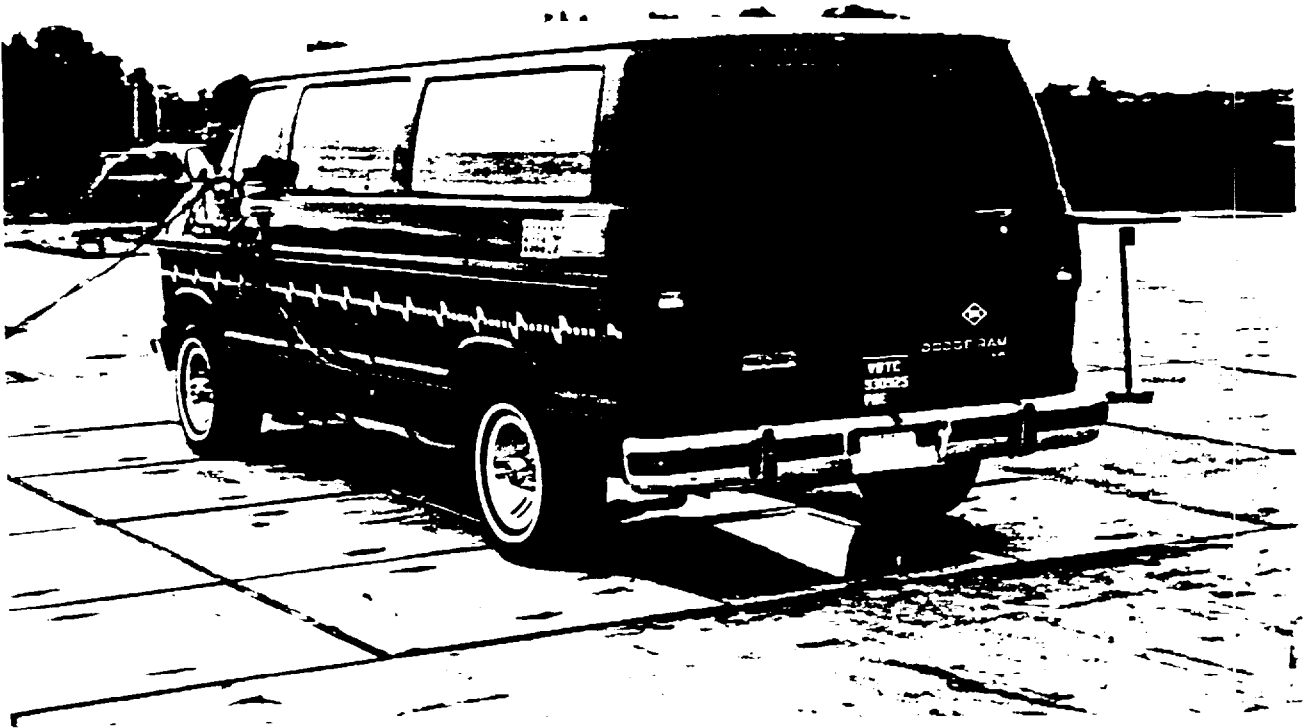

Figure A-15. PRE-TEST LEFT REAR THREE-QUARTER VIEW

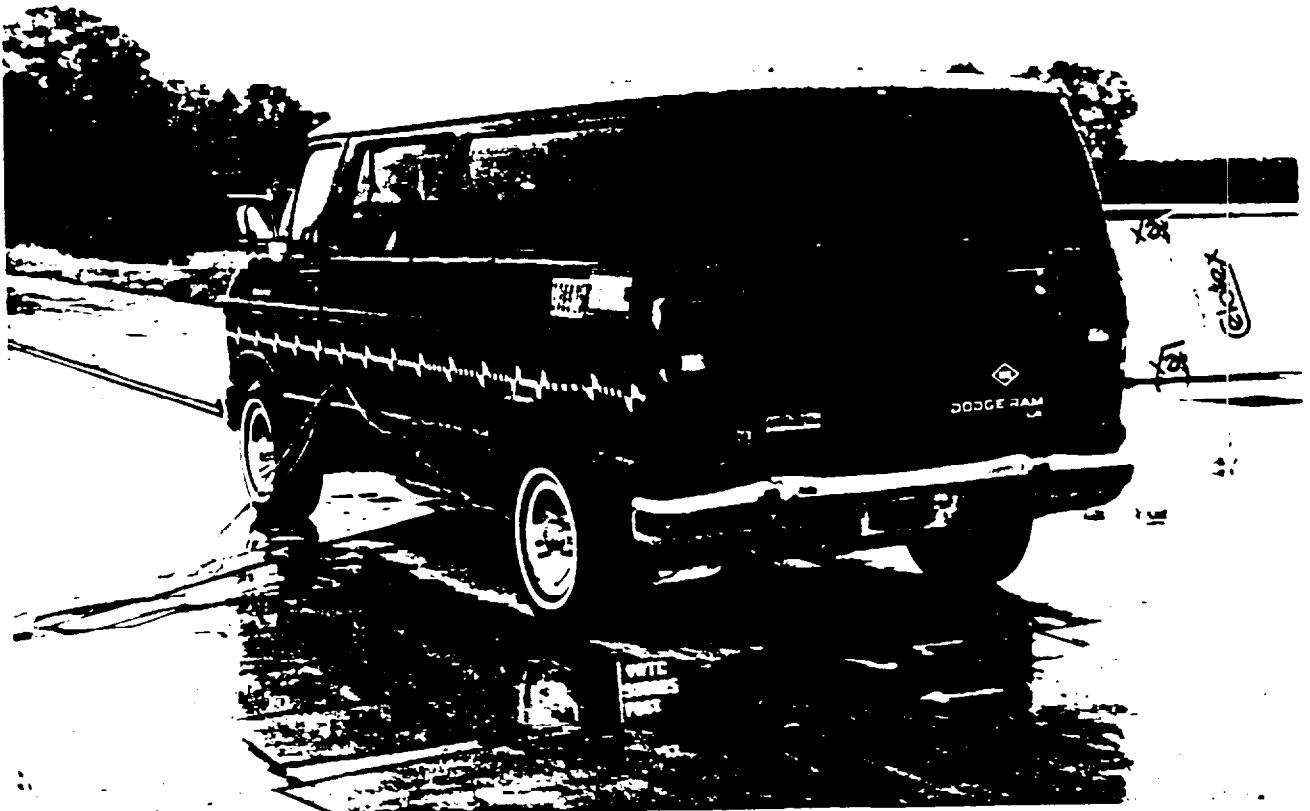

Figure A-16. POST-TEST LEFT REAR THREE-QUARTER VIEW

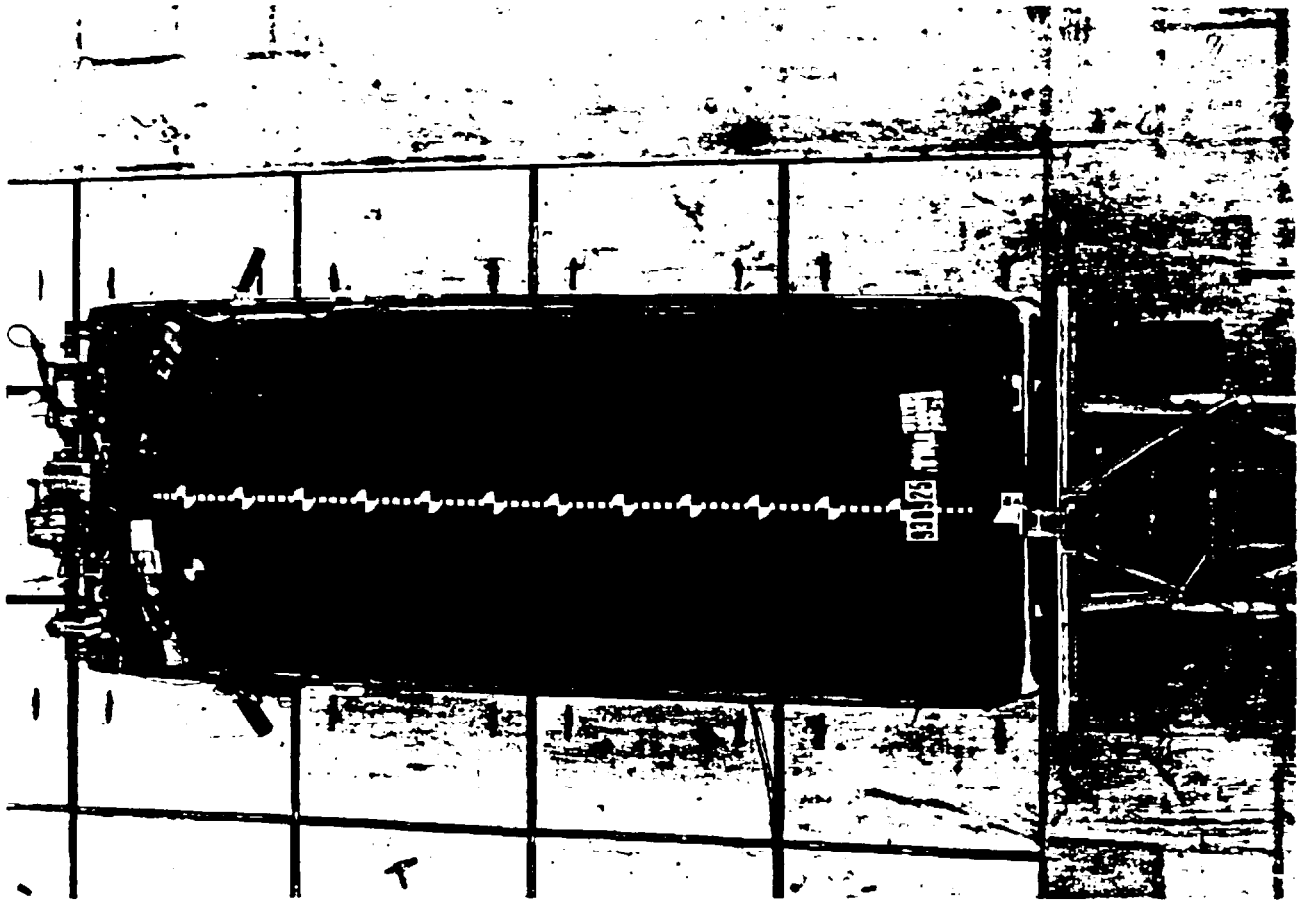

Figure A-17. PRE-TEST OVERHEAD VIEW

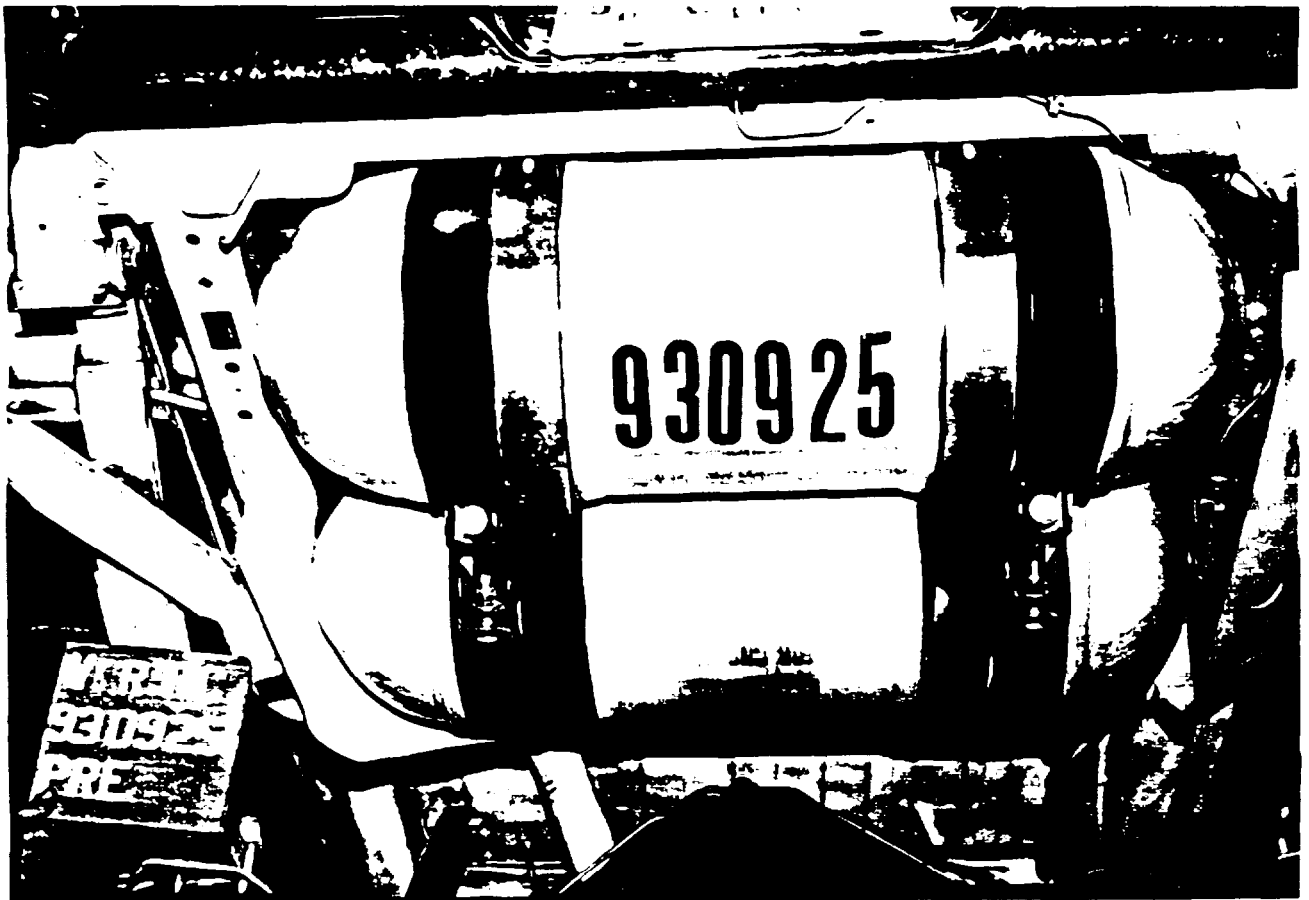

Figure A-18. PRE-TEST FUEL TANK - VIEW 1

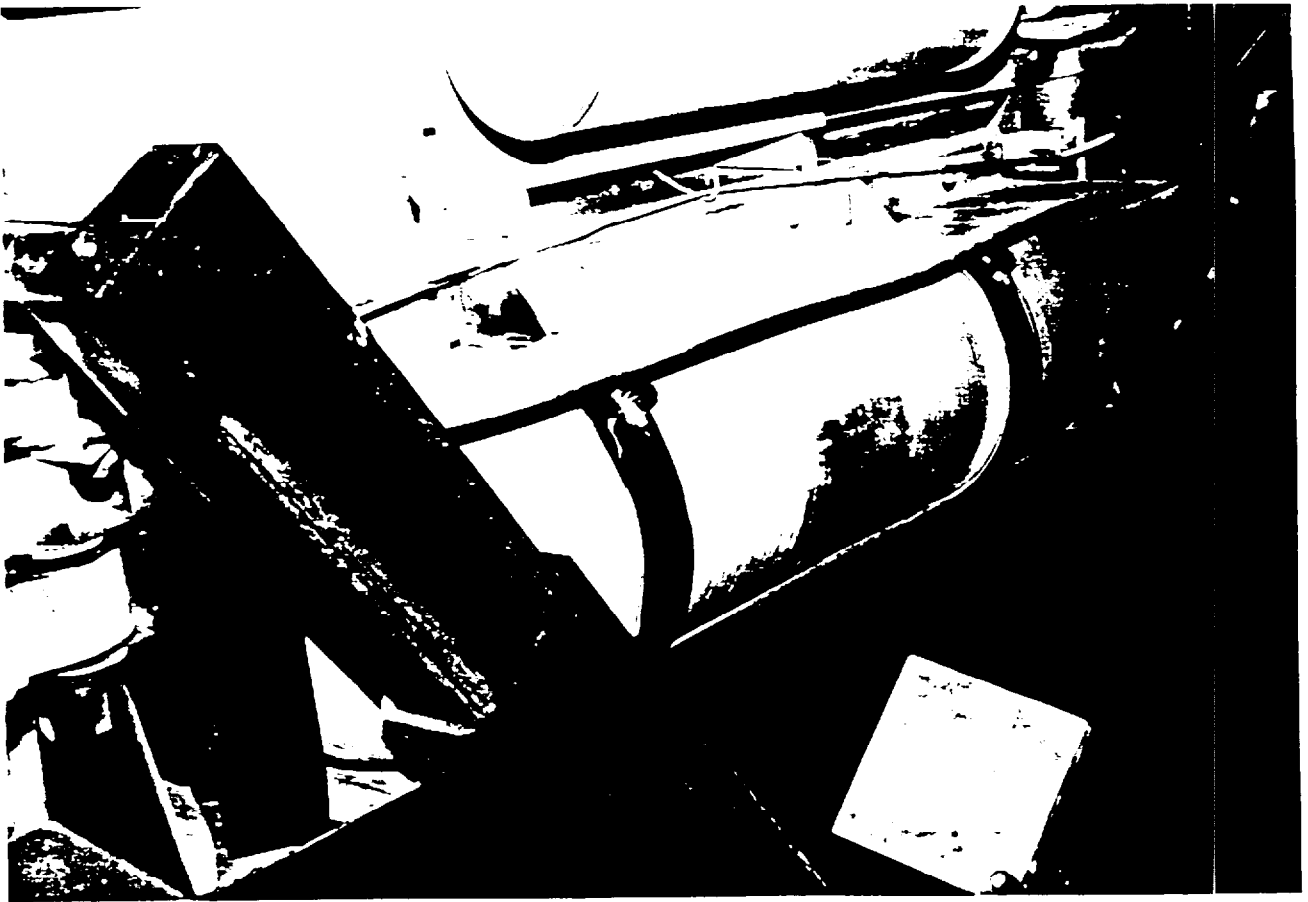

Figure A-19. PRE-TEST FUEL TANK - VIEW 2

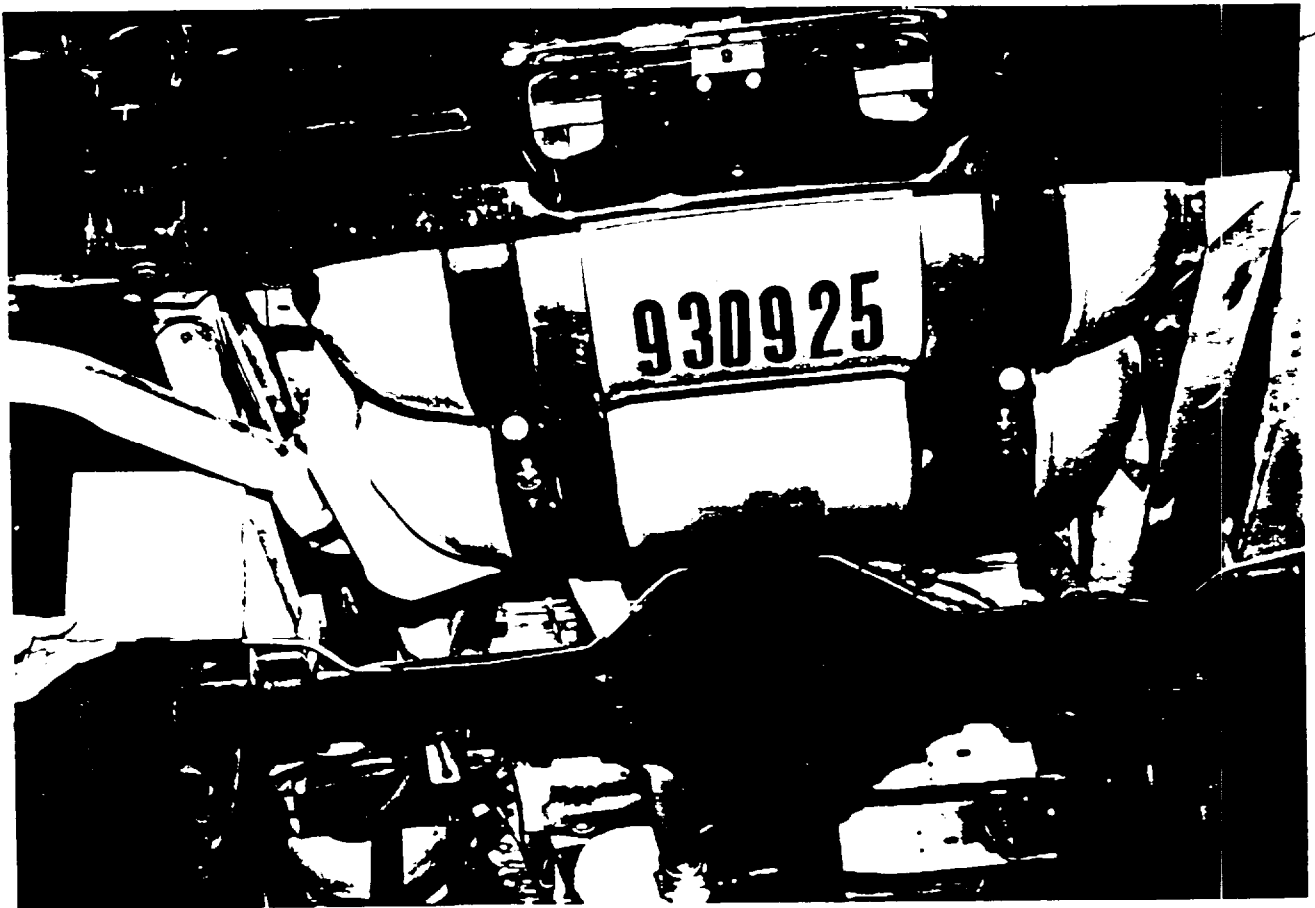

Figure A-20. POST-TEST FUEL TANK VIEW

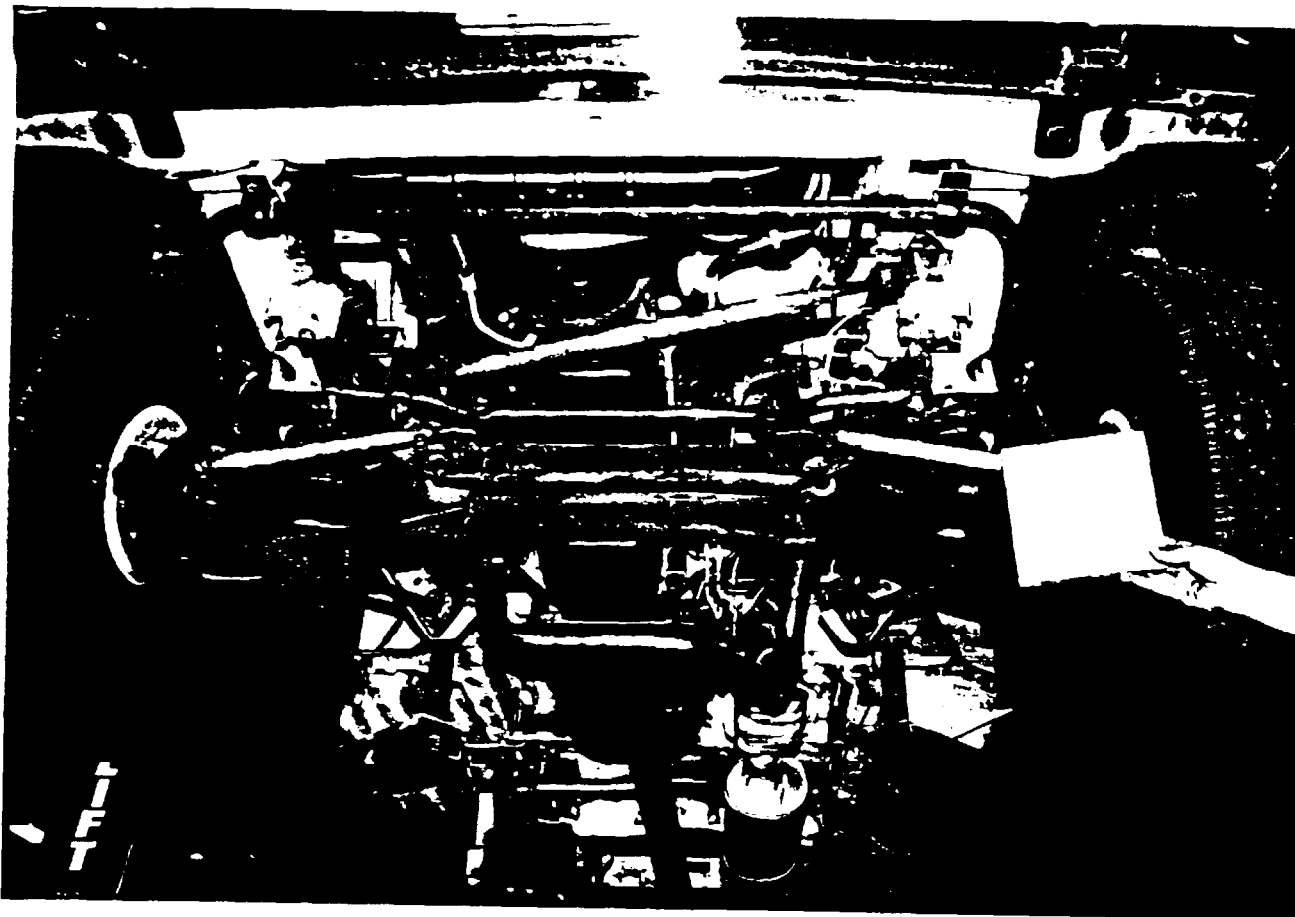

Figure A-21. PRE-TEST FRONT UNDERBODY VIEW

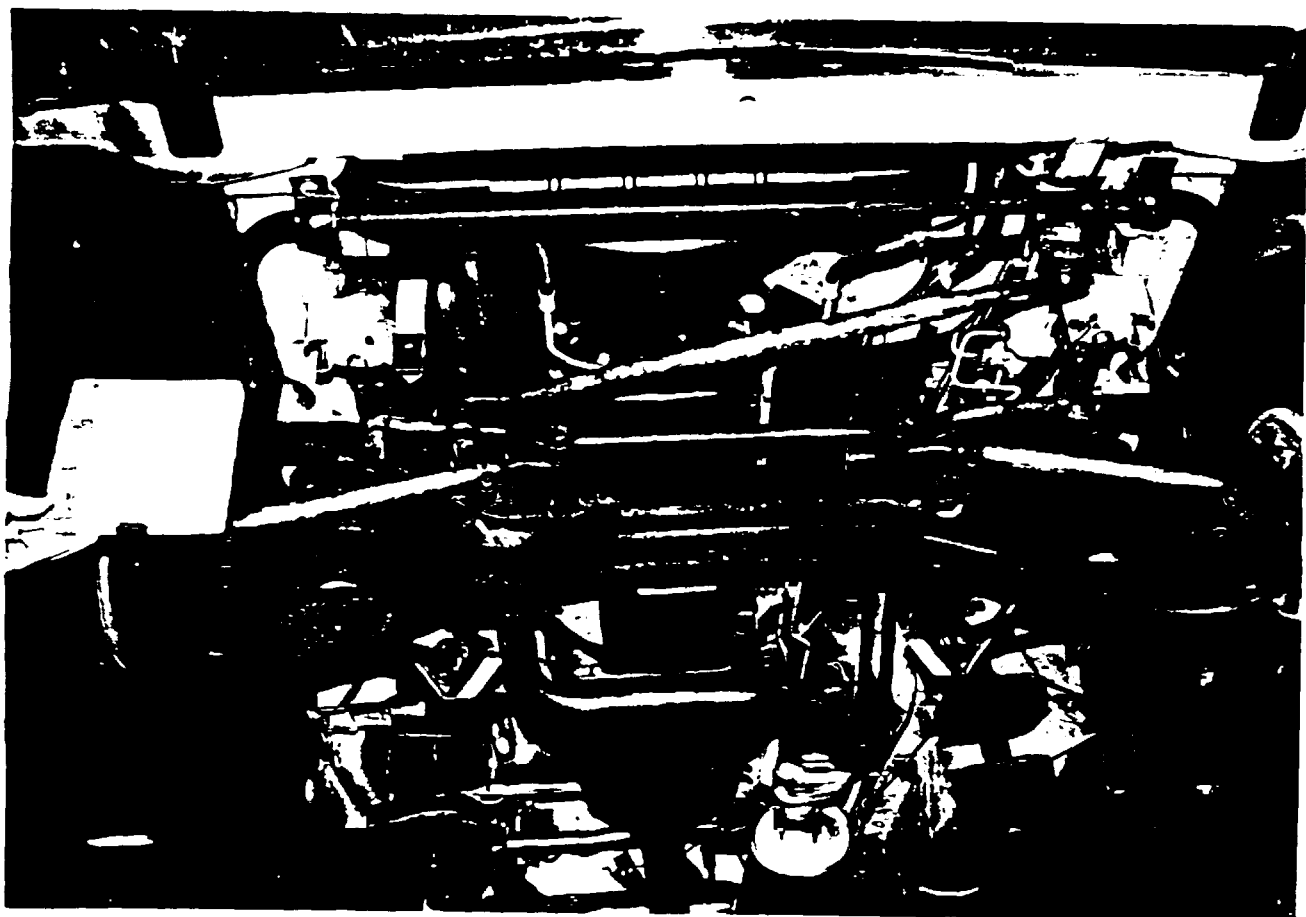

Figure A-22. POST-TEST FRONT UNDERBODY VIEW



Figure A-23. PRE-TEST REAR UNDERBODY VIEW



Figure A-24. POST-TEST REAR UNDERBODY VIEW

APPENDIX B

DATA PLOTS

1992 DODGE B250 VAN REAR IMPACT
FRONT FRAME CROSSMEMBER X-AXIS ACCELERATION
CNG FUEL TANK INTEGRITY

TEST NUMBER 930925

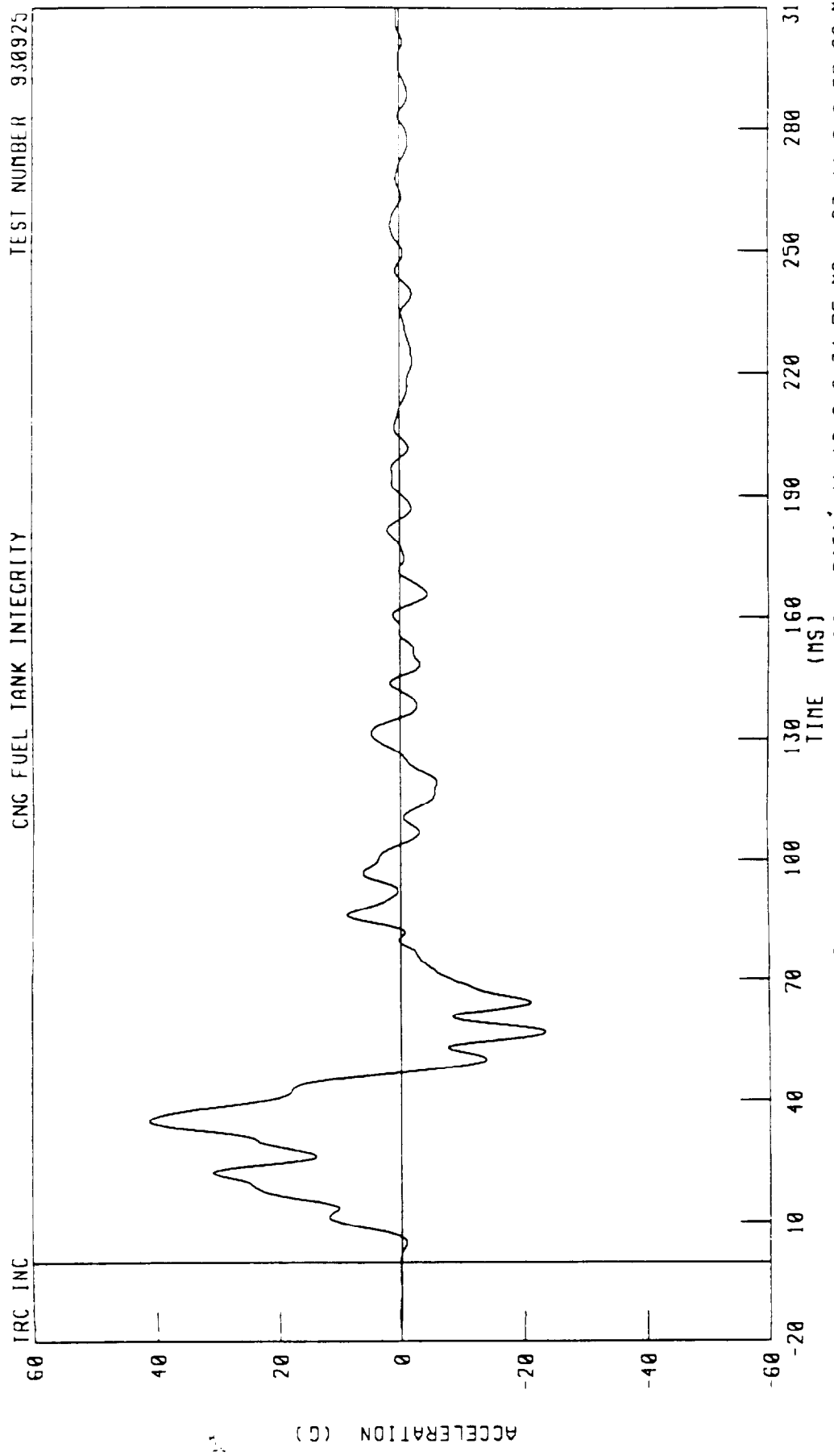

1992 DODGE B250 VAN REAR IMPACT
FRONT FRAME CROSSMEMBER Y-AXIS ACCELERATION
CNC FUEL TANK INTEGRITY

TEST NUMBER 930925

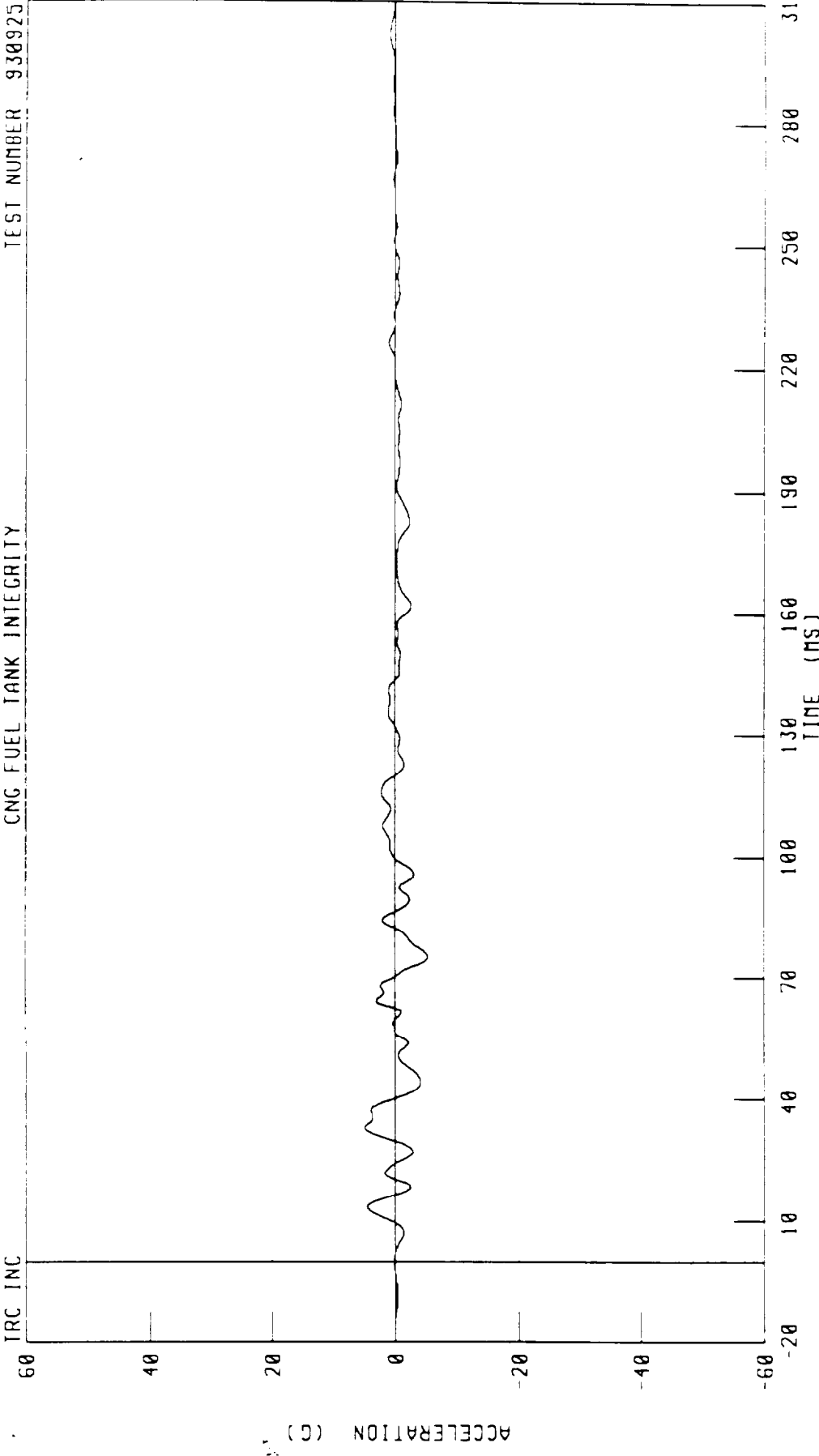

CHANNEL FFCYGI FILTER CH CLASS 60

PEAK DATA 4 90 G @ 32 75 MS, -5 29 G @ 75 00 MS

1992 DODGE B250 VAN REAR IMPACT
FRONT FRAME CROSSMEMBER Z-AXIS ACCELERATION
CNC FUEL TANK INTEGRITY

TEST NUMBER 930925

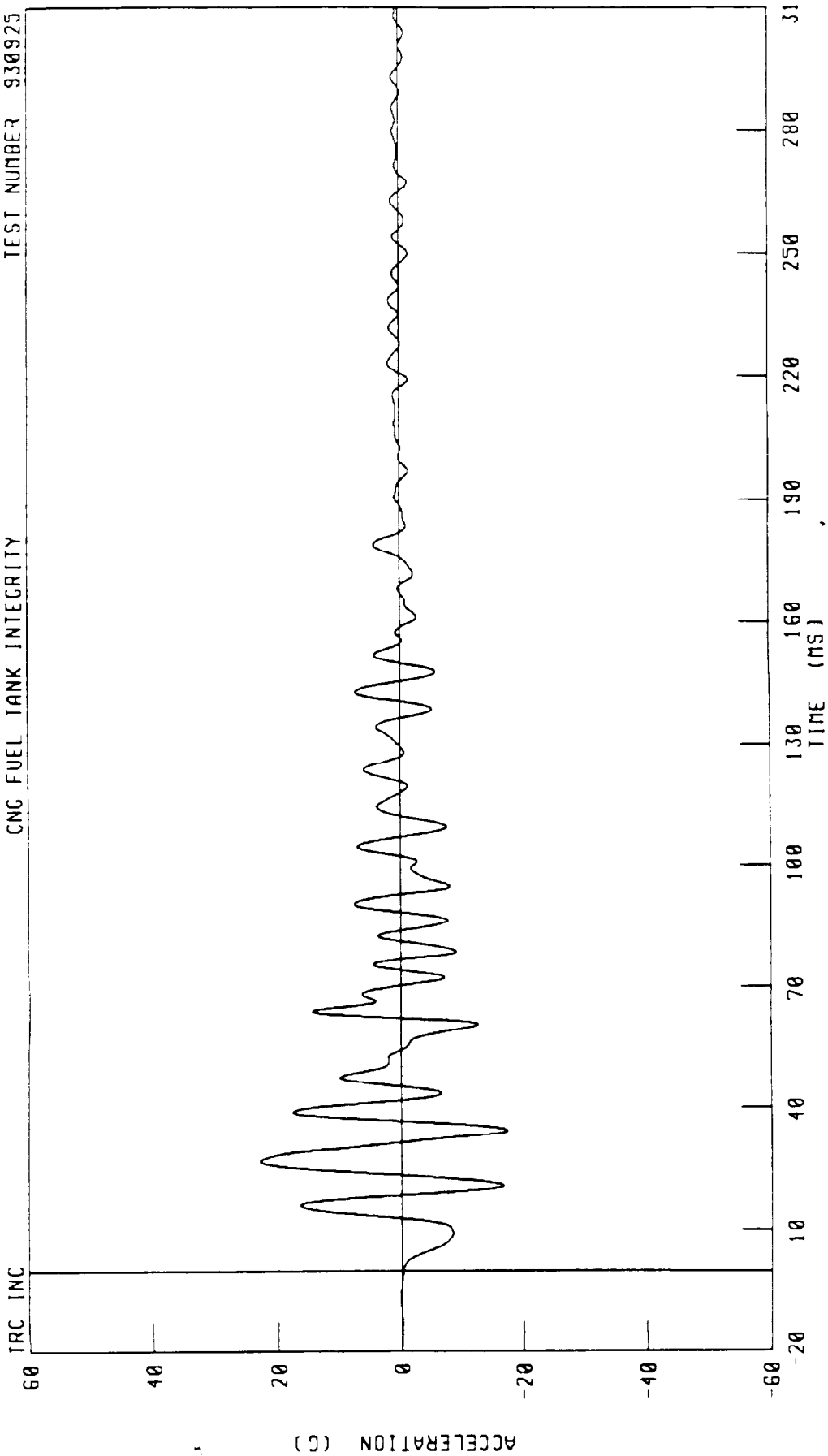

CHANNEL FFCZG1 FILTER CH CLASS 60

PEAK DATA 22 89 G @ 26 63 MS, -17 49 G @ 34 13 MS

1992 DODGE B250 VAN REAR IMPACT
FRONT FRAME CROSSMEMBER RESULTANT ACCELERATION
CNG FUEL TANK INTEGRITY

TEST NUMBER 930925

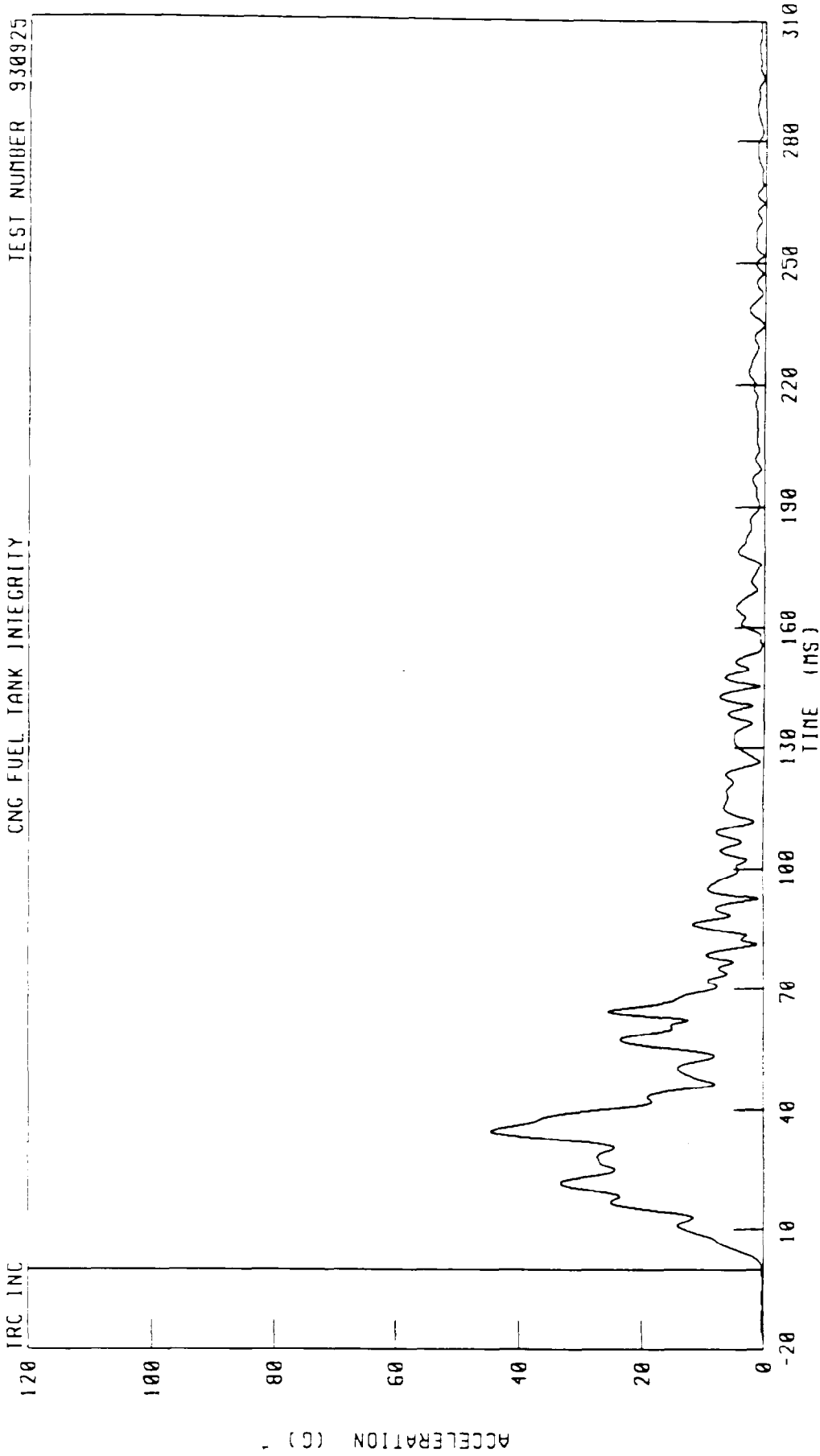

CHANNEL FFCRG1 FILTER CH CLASS 60

PEAK DATA 44 52 G @ 34 50 MS, 0 07 G @ -19 25 MS

1992 DODGE B250 VAN REAR IMPACT
VEHICLE CENTER OF GRAVITY X-AXIS ACCELERATION
CNG FUEL TANK INTEGRITY

TEST NUMBER 930925

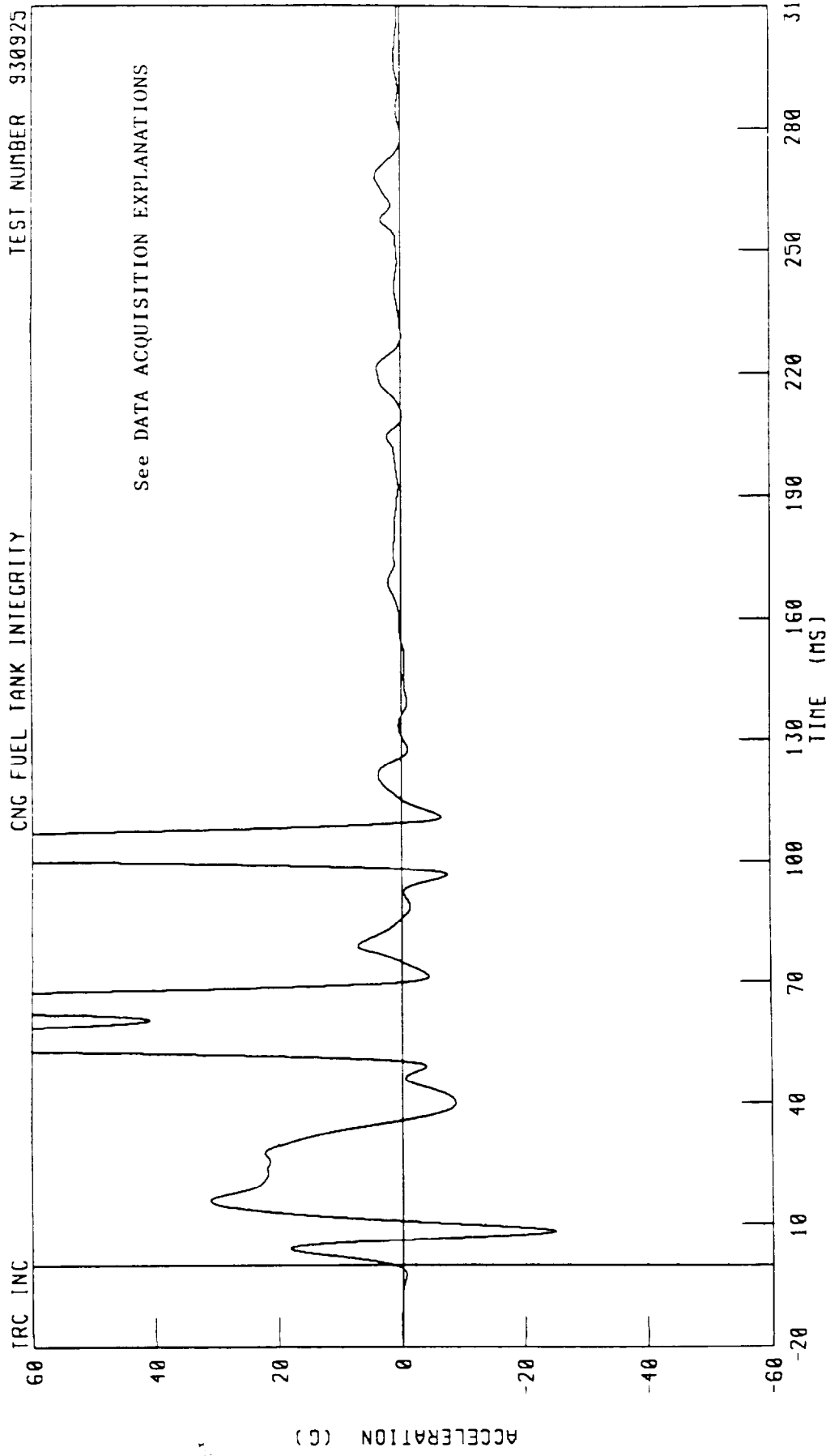

PEAK DATA 192 54 G @ 102 75 MS, -24 85 G @ 8 13 MS

1992 DODGE B250 VAN REAR IMPACT
VEHICLE CENTER OF GRAVITY Y-AXIS ACCELERATION
CNG FUEL TANK INTEGRITY

TEST NUMBER 930925

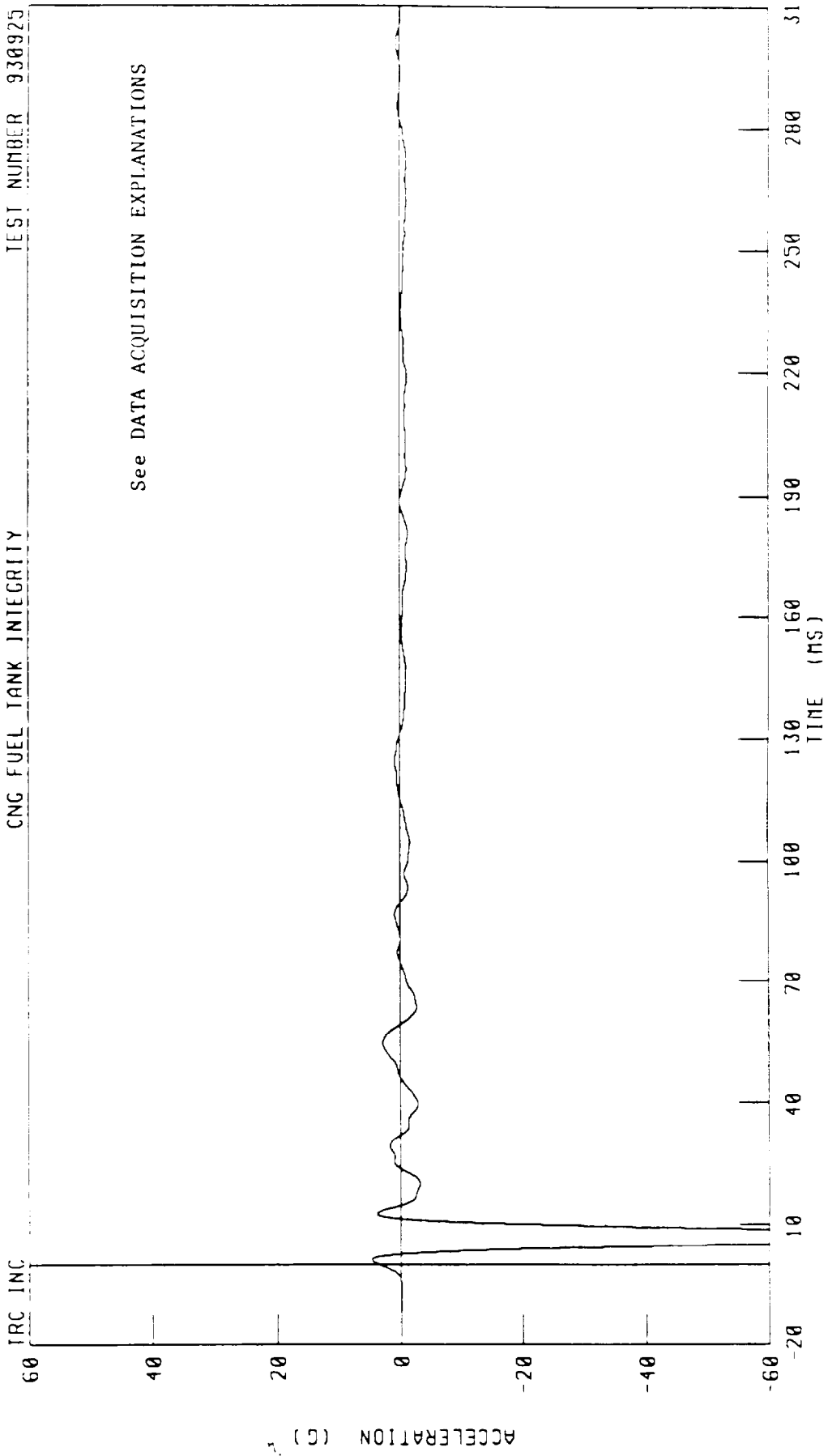

CHANNEL VCCYGI FILTER CH CLASS 60

PEAK DATA 4 79 G @ 1 00 MS, -112 61 G @ 6 88 MS

1992 DODGE B250 VAN REAR IMPACT
VEHICLE CENTER OF GRAVITY Z-AXIS ACCELERATION
CNC FUEL TANK INTEGRITY

TEST NUMBER 930925

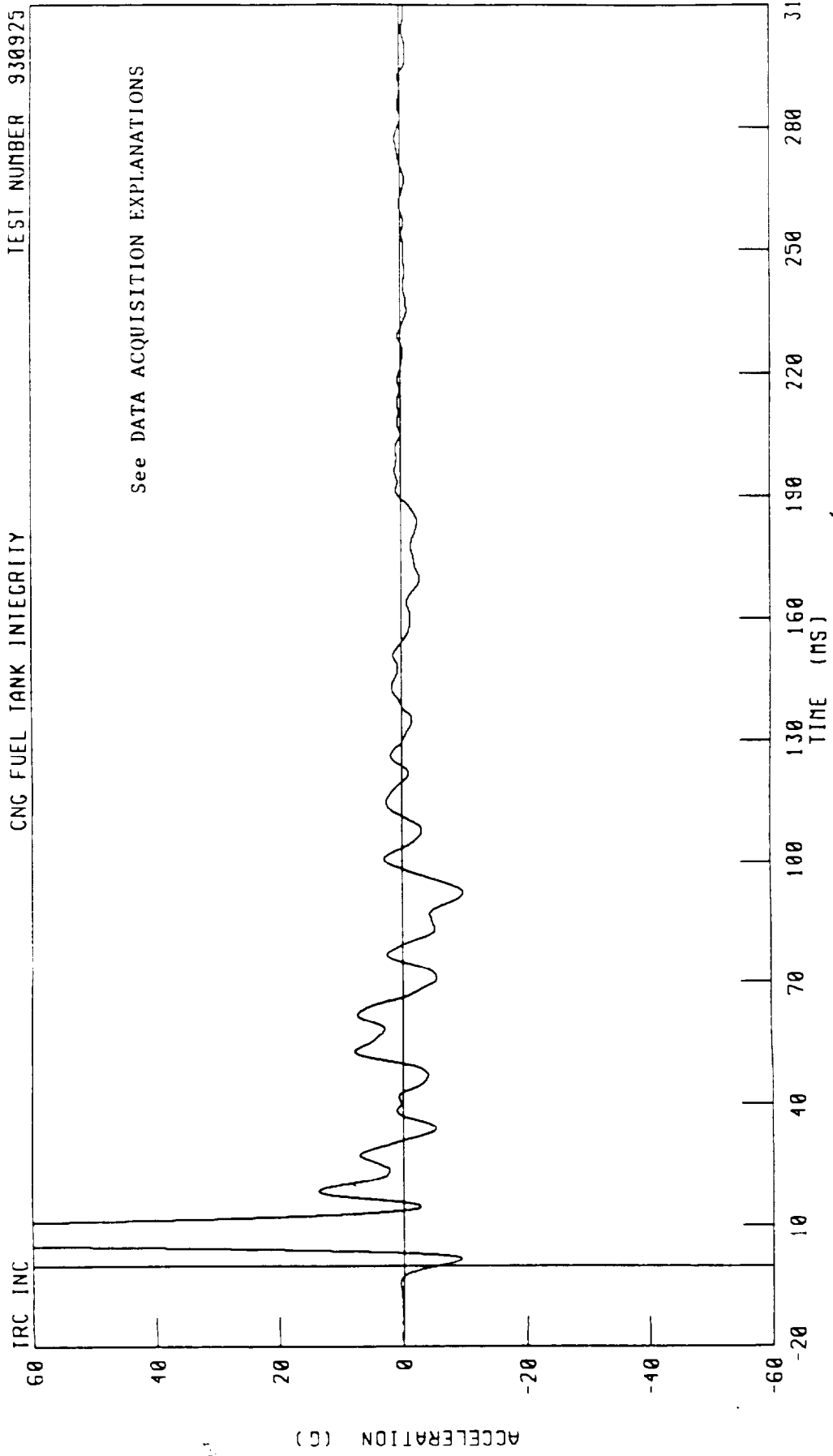

CHANNEL VCGZG1 FILTER CH CLASS 60 PEAK DATA 214 67 G @ 7 50 MS, -9 68 G @ 92 25 MS

1992 DODGE B250 VAN REAR IMPACT
VEHICLE CENTER OF GRAVITY RESULTANT ACCELERATION

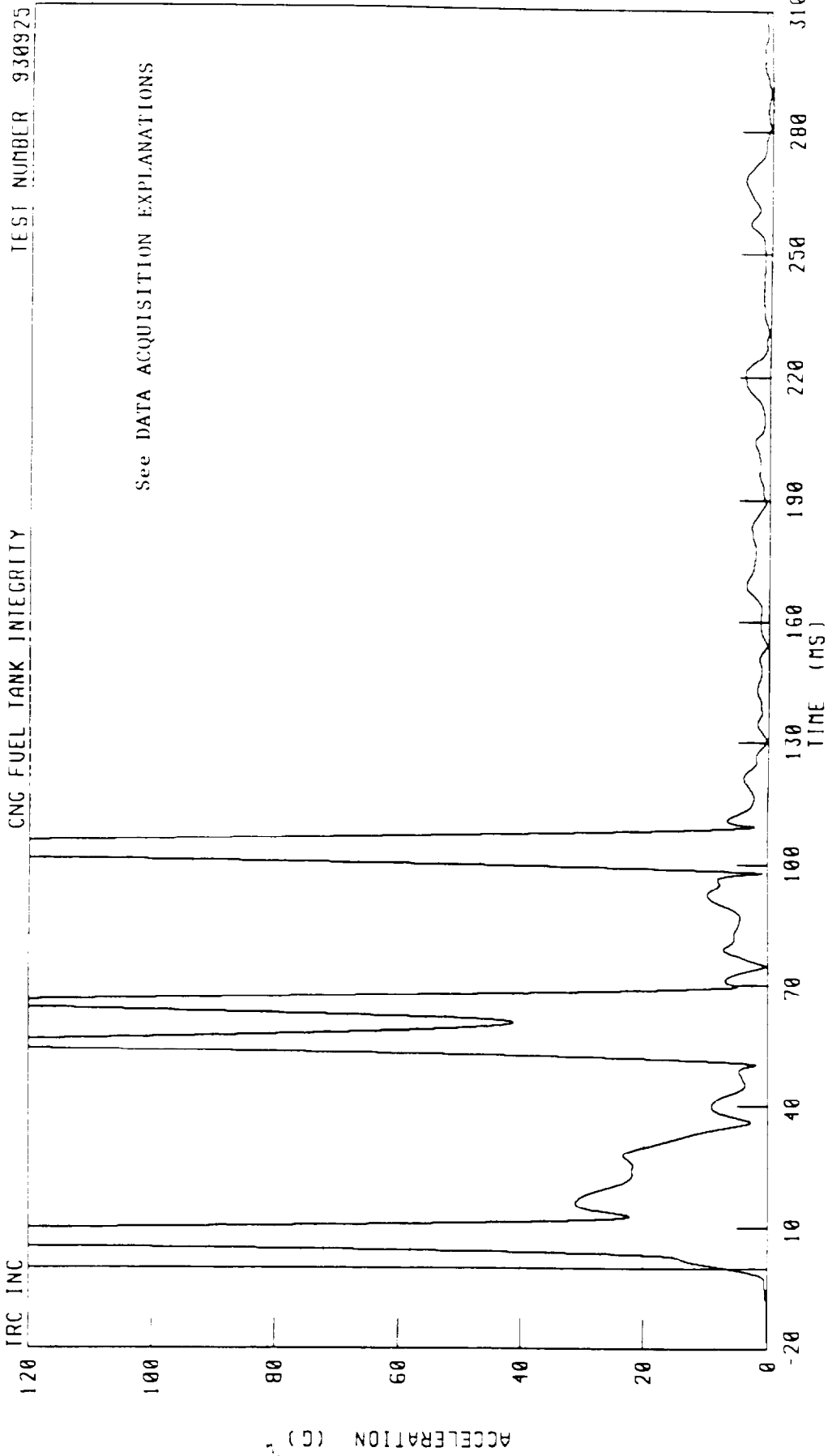

TEST NUMBER 930925

CNG FUEL TANK INTEGRITY

CHANNEL VCGRG1 FILTER CH CLASS 60

PEAK DATA 240 29 G @ 7 38 MS, 0 06 G @ 19 38 MS

1992 DODGE B250 VAN REAR IMPACT
MOVING BARRIER CENTER OF GRAVITY X-AXIS ACCELERATION
CNG FUEL TANK INTEGRITY

TEST NUMBER 930925

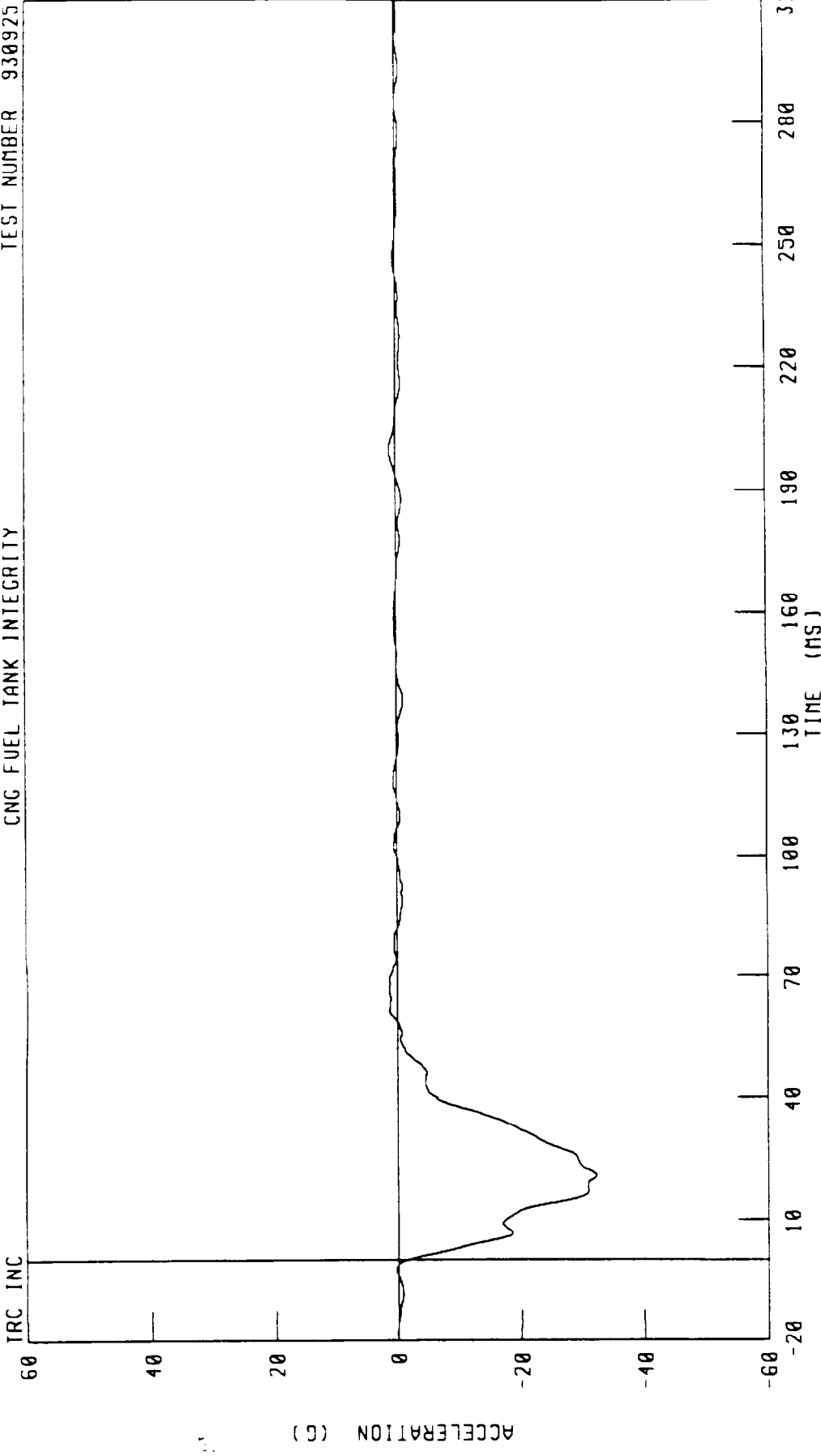

CHANNEL VCCXGA FILTER CH CLASS 60

PEAK DATA 1 38 G @ 66 38 MS, -32 21 G @ 20 63 MS

1992 DODGE B250 VAN REAR IMPACT
MOVING BARRIER CENTER OF GRAVITY Y-AXIS ACCELERATION
CNC FUEL TANK INTEGRITY

TEST NUMBER 930925

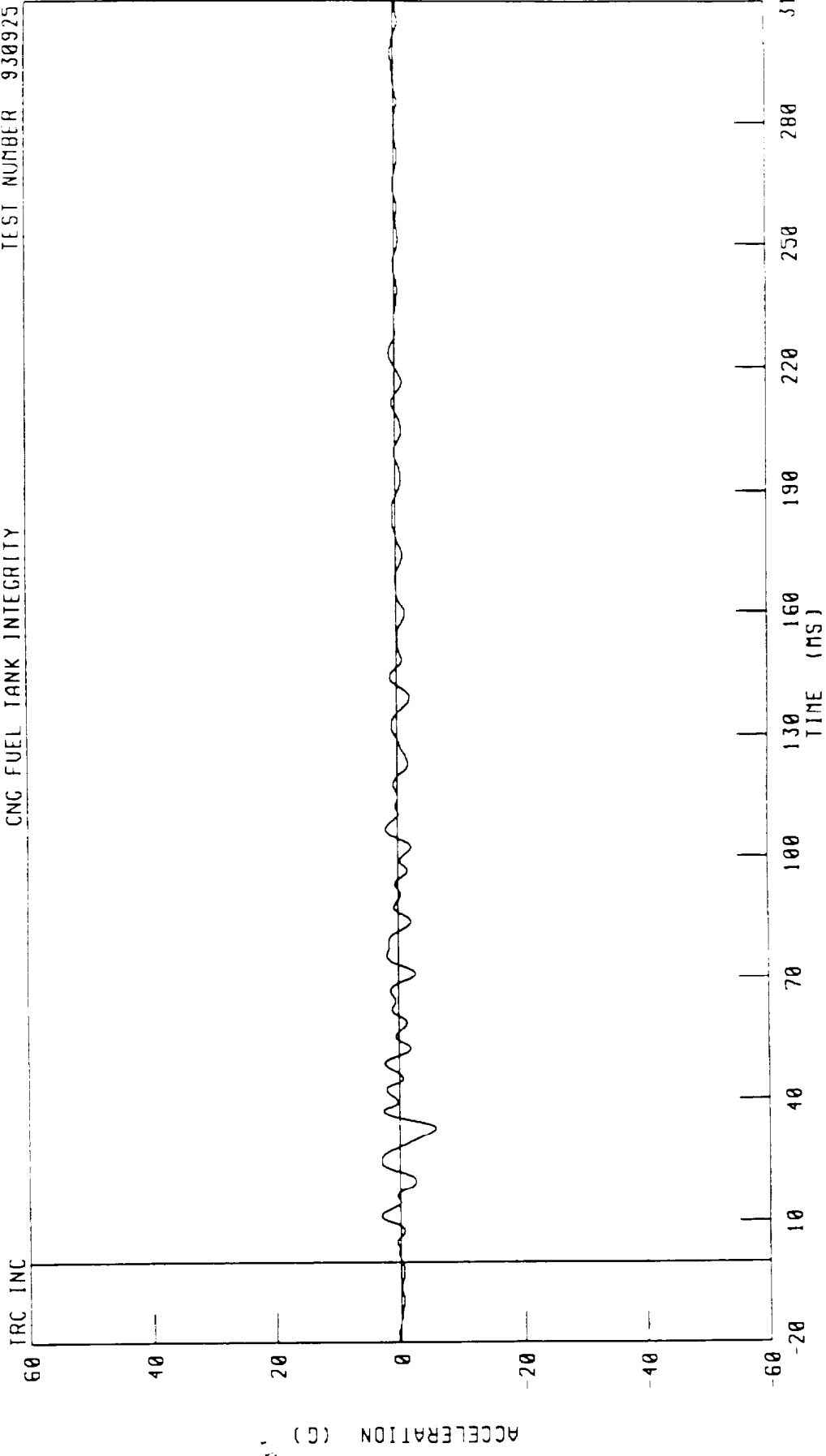

CHANNEL VCGYGA FILTER CH CLASS 60

PEAK DATA 3 04 G @ 11 25 MS, -5 80 G @ J2 88 MS

1992 DODGE B250 VAN REAR IMPACT
MOVING BARRIER CENTER OF GRAVITY Z-AXIS ACCELERATION
CNG FUEL TANK INTEGRITY

TEST NUMBER 930925

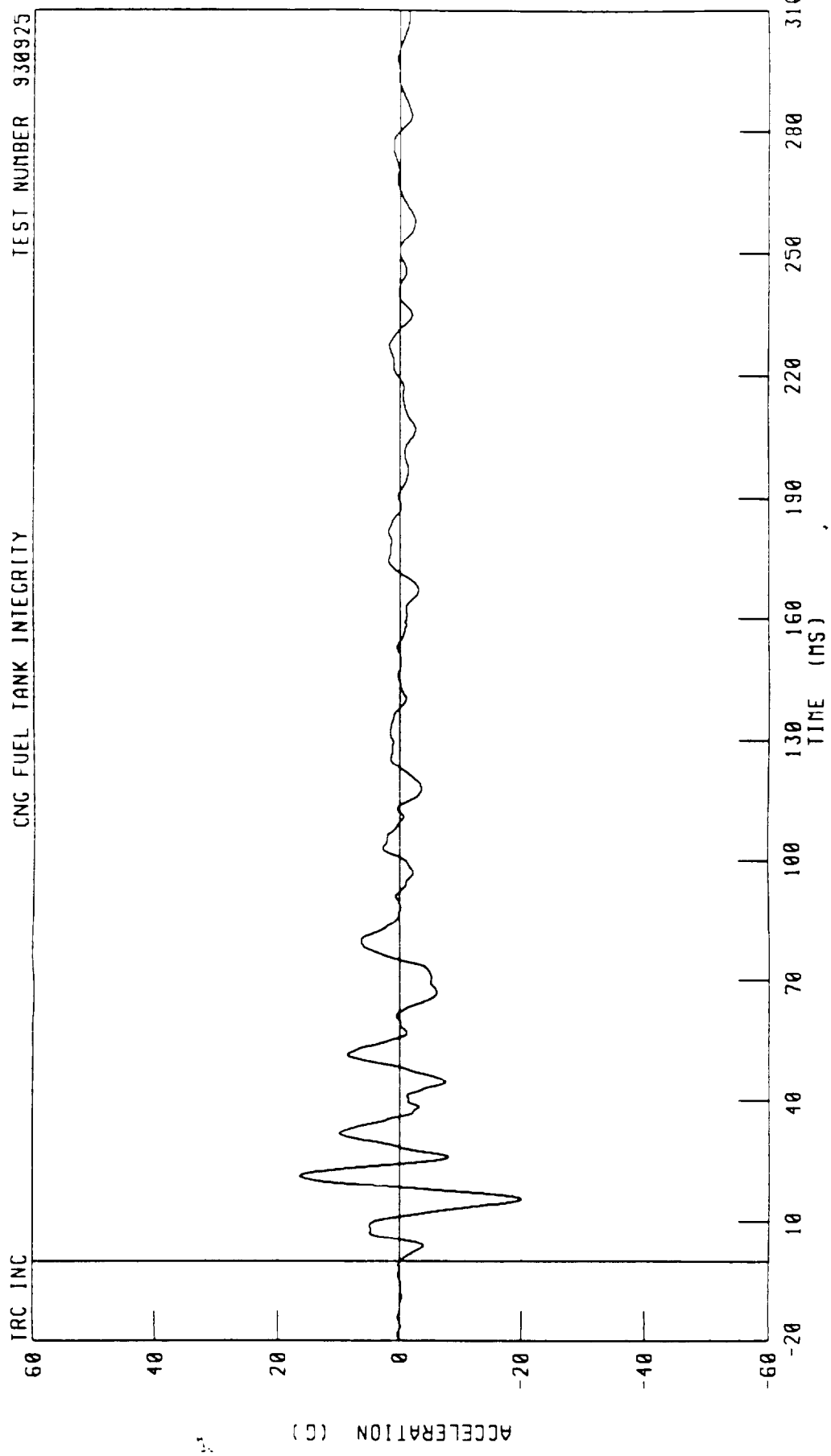

CHANNEL VCGZCA FILTER CH CLASS 60
TIME (MS) PEAK DATA 16 37 G @ 21 13 MS, -20 05 G @ 15 38 MS

1992 DODGE B250 VAN REAR IMPACT
MOVING BARRIER CENTER OF GRAVITY RESULTANT ACCELERATION
CNG FUEL TANK INTEGRITY

TEST NUMBER 930925

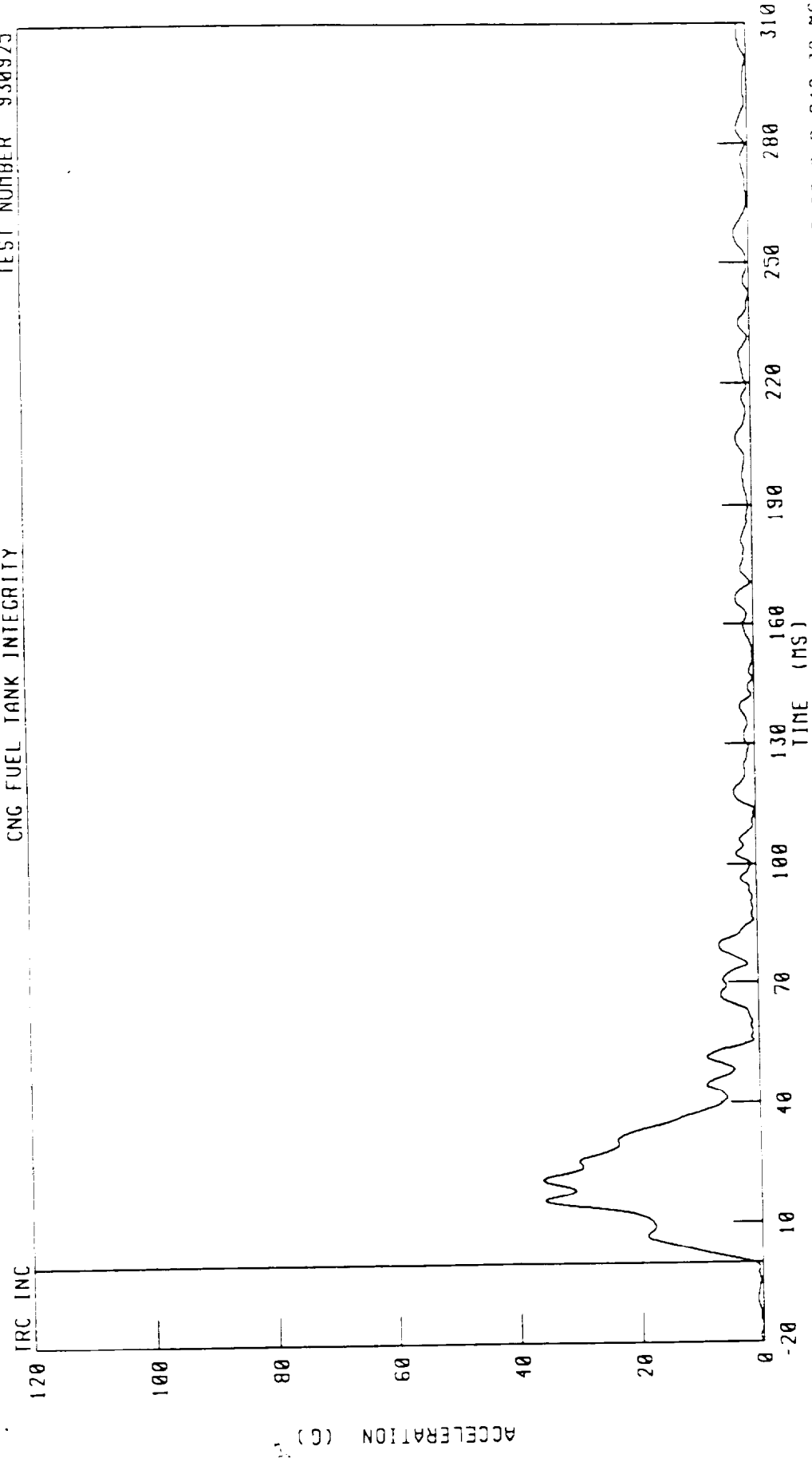

PEAK DATA 36 09 G @ 20 88 MS, 0 09 G @ 242 38 MS

CHANNEL VCGRGA FILTER CH CLASS 60

1992 DODGE B250 VAN REAR IMPACT
FUEL TANK PRESSURE
CNG FUEL TANK INTEGRITY

See DATA ACQUISITION EXPLANATIONS

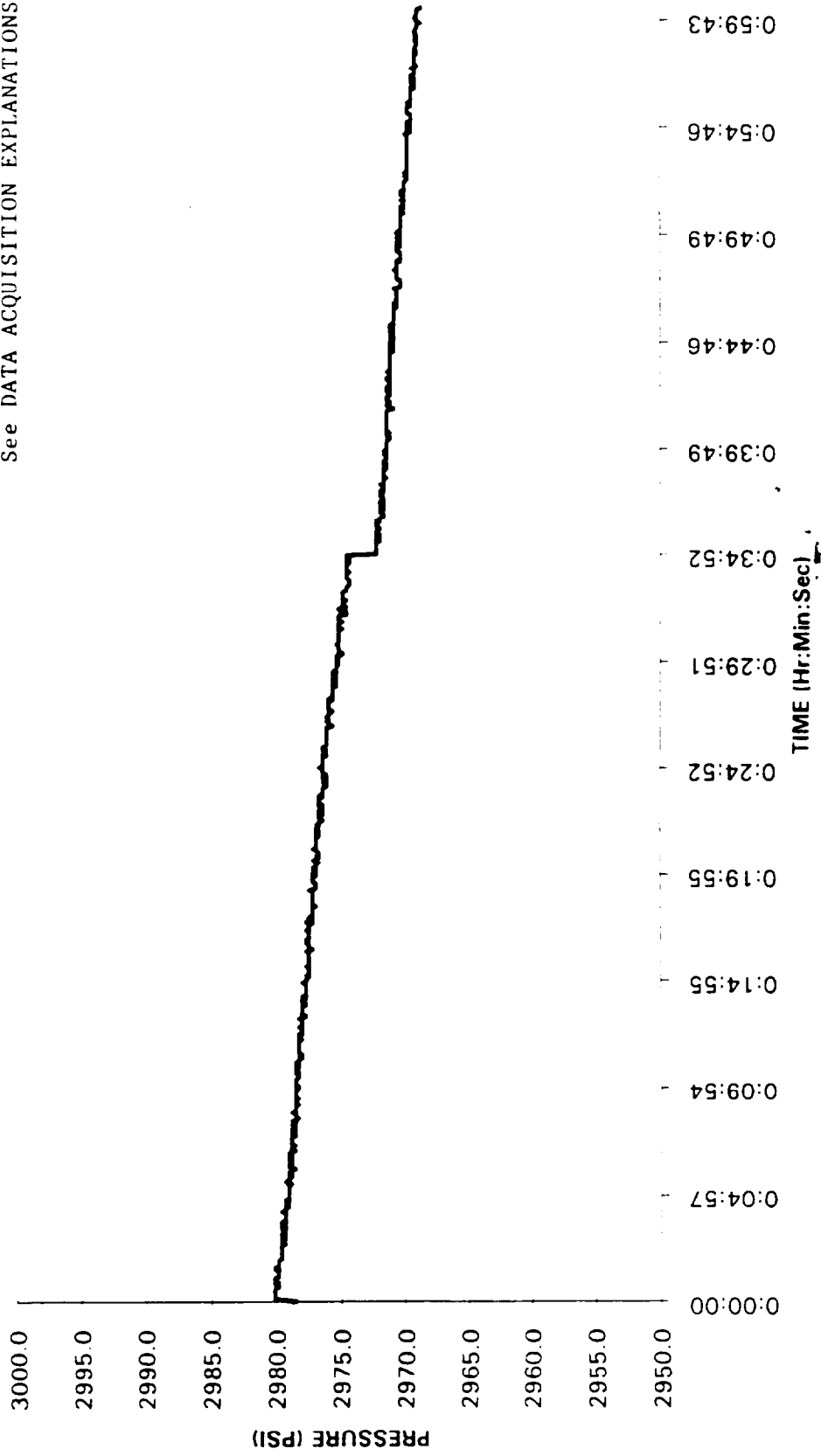

1992 DODGE B250 VAN REAR IMPACT
FUEL TEMPERATURE
CNG FUEL TANK INTEGRITY

See DATA ACQUISITION EXPLANATIONS

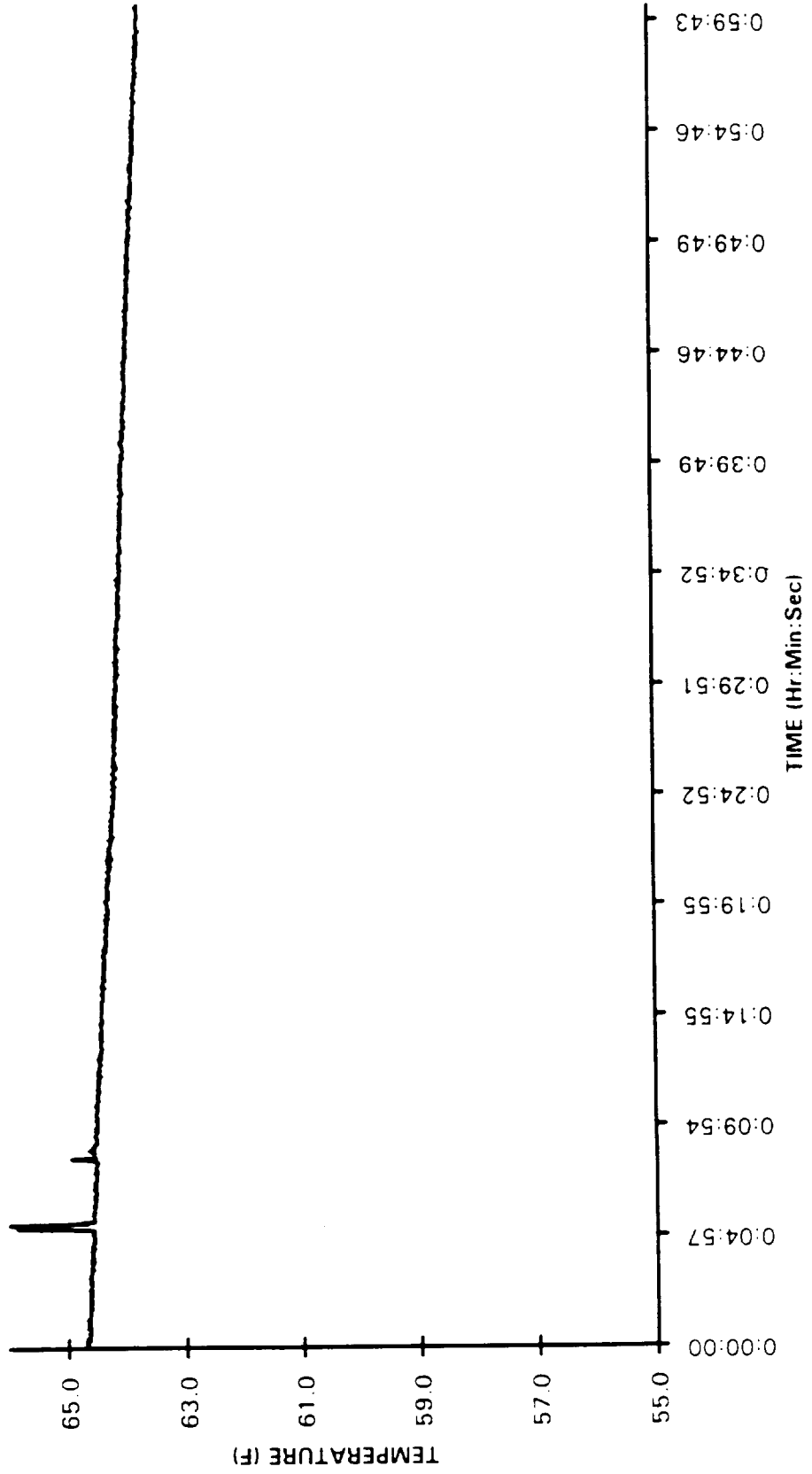

1992 DODGE B250 VAN REAR IMPACT
TUBE TEMPERATURE
CNG FUEL TANK INTEGRITY

See DATA ACQUISITION EXPLANATIONS

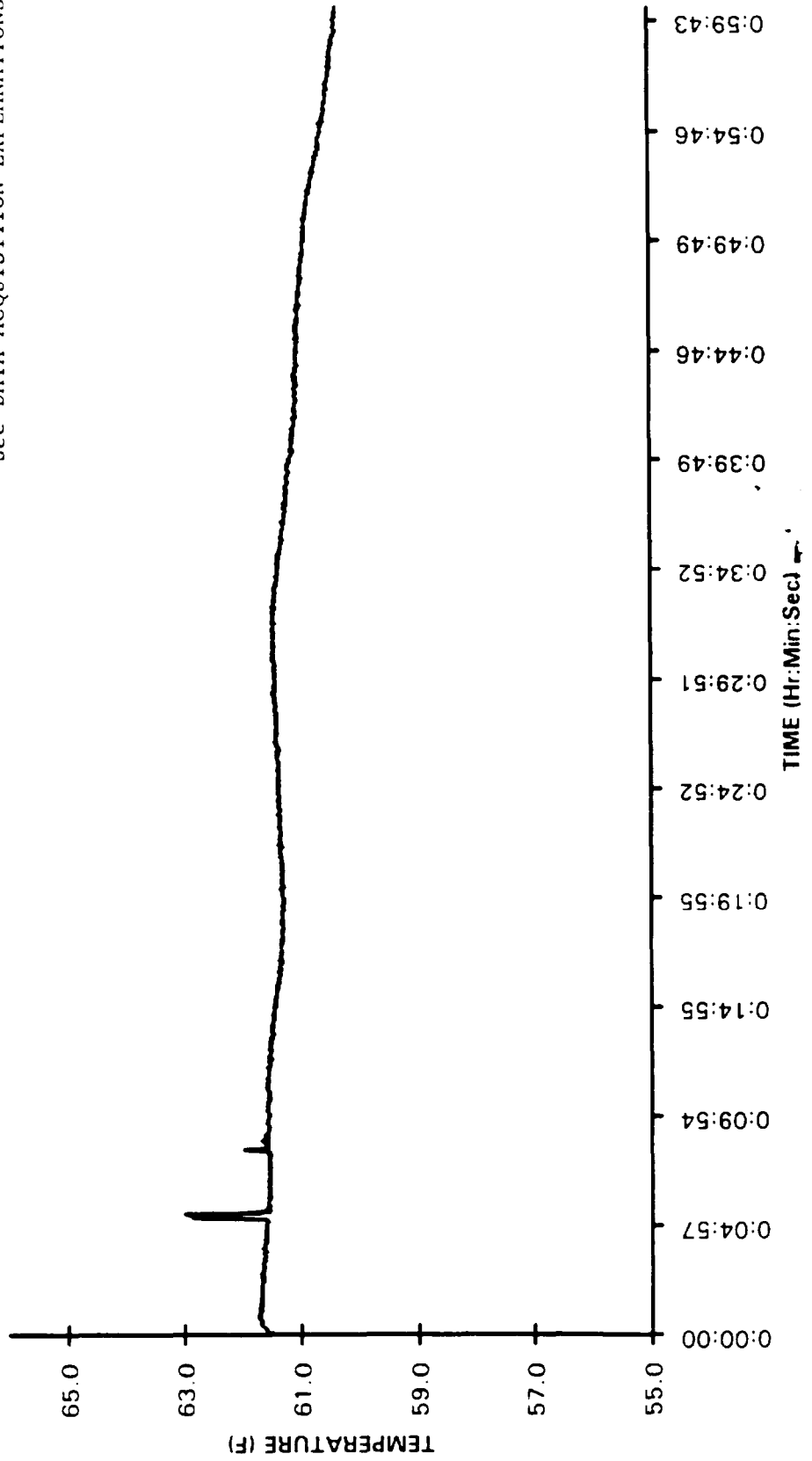

1992 DODGE B250 VAN REAR IMPACT
VEHICLE AMBIENT TEMPERATURE
CNG FUEL TANK INTEGRITY

See DATA ACQUISITION EXPLANATIONS

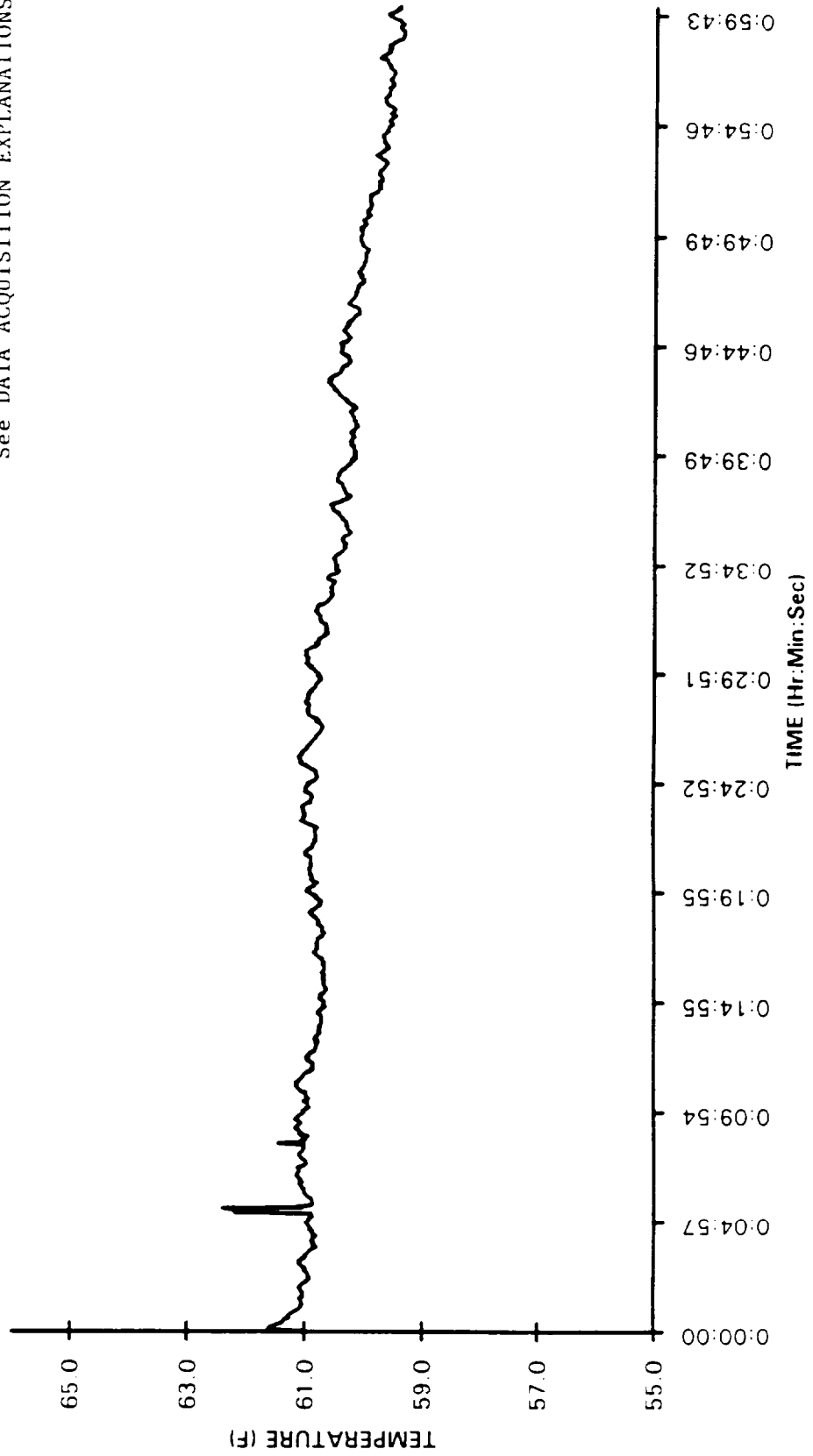

1992 DODGE B250 VAN REAR IMPACT
OUTSIDE AMBIENT TEMPERATURE
CNG FUEL TANK INTEGRITY

See DATA ACQUISITION EXPLANATIONS

