

REPORT NUMBER: 208-CAL-94-16  
212-CAL-94-16  
213-CAL-94-53  
301-CAL-94-16

**VEHICLE SAFETY COMPLIANCE TESTING FOR OCCUPANT CRASH PROTECTION  
WINDSHIELD MOUNTING, WINDSHIELD ZONE INTRUSION (PARTIAL)  
BUILT-IN CHILD RESTRAINT SYSTEM  
AND FUEL SYSTEM INTEGRITY**

CHRYSLER CORPORATION  
1994 Dodge Caravan

NHTSA NUMBER: CR0313

CALSPAN TEST NUMBER: 8183-7

July 12, 1994

CALSPAN CORPORATION  
ADVANCED TECHNOLOGY CENTER  
P.O. BOX 400  
BUFFALO, NEW YORK 14225



FINAL REPORT

PREPARED FOR:

U. S. Department of Transportation  
National Highway Traffic Safety Administration  
ENFORCEMENT  
Office of Vehicle Safety Compliance  
400 Seventh Street, S. W.  
Room No. 6115 (NEF-30)  
Washington, DC 20590

This publication is distributed by the U.S. Department of Transportation, National Highway Traffic Safety Administration, in the interest of information exchange. The opinions, findings and conclusions expressed in this publication are those of the author(s) and not necessarily those of the Department of Transportation or the National Highway Traffic Safety Administration. The United States Government assumes no liability for its contents or use thereof. If trade or manufacturers' names or products are mentioned, it is only because they are considered essential to the object of the publication and should not be construed as an endorsement. The United States Government does not endorse products or manufacturers.

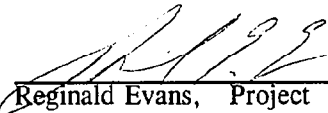
Prepared By:   
Reginald Evans, Project Engineer

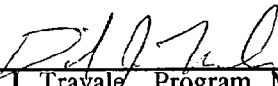
Approved By:   
David J. Travala, Program Manager  
Transportation Sciences Center

Approval Date: \_\_\_\_\_

FINAL REPORT ACCEPTANCE BY OVSC:

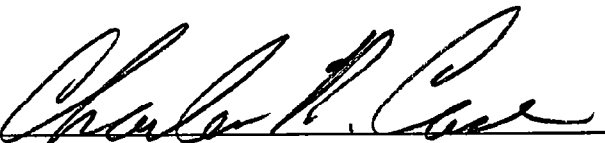
Accepted By: 

Acceptance Date: 11/1/95

## TECHNICAL REPORT STANDARD TITLE PAGE

1. Report No. 208-CAL-94-16 212-CAL-94-16 213-CAL-94-53 301-CAL-94-16	2. Government Accession No.	3. Recipient's Catalog No.
4. Title and Subtitle Final Report of FMVSS 208, 212, 219 (Partial), 301 Compliance Testing and FMVSS 213 testing of a 1994 Dodge Caravan NHTSA No. CR0313	5. Report Date July 12, 1994	6. Performing Organization Code CAL
	7. Author(s) Reginald Evans, Project Engineer David J. Travale, Program Manager	
9. Performing Organization Name and Address Calspan Advanced Technology Center P.O. Box 400 Buffalo, New York 14225	8. Performing Organization Report No. 8183-7	10. Work Unit No.
12. Sponsoring Agency Name and Address U.S. Department of Transportation National Highway Traffic Safety Administration Office of Vehicle Safety Compliance (NEF-30) 400 Seventh St , S.W., Rm. 6115, Washington, D.C. 20590	11. Contract or Grant No. DTNH22-93-D-11089	
	13. Type of Report and Period Covered Final -	
14. Sponsoring Agency Code NEF-30		15. Supplementary Notes
16. Abstract <p style="margin-left: 40px;">A 30 mph vehicle safety compliance test was conducted on a 1994 Dodge Caravan.</p> <p style="margin-left: 40px;">This test was performed at the Calspan Advanced Technology Center in Buffalo, New York on July 12, 1994. The purpose of this test was to determine compliance with the performance requirements of the following Federal Motor Vehicle Safety Standards:</p> <ol style="list-style-type: none"> <li>1. FMVSS No. 208, "Occupant Crash Protection"</li> <li>2. FMVSS No. 212, "Windshield Mounting"</li> <li>3. FMVSS No. 219 (partial), "Windshield Zone Intrusion"</li> <li>4. FMVSS No. 301, "Fuel System Integrity"</li> </ol> <p style="margin-left: 40px;">The test mode was perpendicular (0°) and the impact velocity was 29.1 mph. The ambient temperature at the impact face was 70 °F.</p> <p style="margin-left: 40px;">The subject test vehicle appears to comply with the requirements of FMVSS Nos. 208, 212, 219 (partial), 301 and an FMVSS 213.</p> <p style="margin-left: 40px;"><u>Type of Restraint System:</u> The test vehicle was equipped with a driver air bag and a passenger air bag restraint system. The driver and passenger manual seat belts were not used for this test. The test vehicle however, was equipped with integrated child restraints located in the mid passenger seating positions which were used to perform the FMVSS 213 test. The mid-passenger seats contained two Part 572 three year old dummies.</p>		
17. Key Words Compliance Testing Safety Engineering FMVSS 208	18. Distribution Statement Copies of this report are available from: NHTSA Technical Reference Division ; Mail Code: NAD-52 400 Seventh , S.W., Room 5108, Washington, D.C. 20590 Telephone No. (202) 366-4946 Attn: Robert Hornickle	
19. Security Classif. (of this report) UNCLASSIFIED	20. Security Classif. (of this page) UNCLASSIFIED	21. No. of Pages
22. Price		

## TABLE OF CONTENTS

<u>Section</u>		<u>Page No.</u>
1	PURPOSE AND TEST PROCEDURE	1-1
2	SUMMARY OF FRONTAL BARRIER IMPACT TEST	2-1
3	OCCUPANT AND VEHICLE INFORMATION	3-1
4	SUMMARY OF RESULTS FOR: FMVSS 208, "Occupant Crash Protection" FMVSS 212, "Windshield Mounting" FMVSS 219 (Partial), "Windshield Zone Intrusion" FMVSS 301, "Fuel System Integrity"	4-1
APPENDIX A	PHOTOGRAPHS	A-1
APPENDIX B	VEHICLE AND DUMMY RESPONSE DATA (Front outboard seats only)	B-1
APPENDIX C	DUMMY RESPONSE DATA (Mid outboard seats only)	C-1
APPENDIX D	VEHICLE OWNER'S MANUAL OCCUPANT SYSTEM INSTRUCTIONS	D-1
APPENDIX E	BUILT-IN CHILD RESTRAINT SYSTEM TESTS - FMVSS NO. 213	E-1
APPENDIX F	PERFORMANCE CALIBRATION REPORT FOR PART 572 THREE-YEAR-OLD CHILD TEST DUMMY NO. 066	F-1
APPENDIX G	PERFORMANCE CALIBRATION REPORT FOR PART 572 THREE-YEAR-OLD CHILD TEST DUMMY NO. 159	G-1

LIST OF FIGURES

<u>Figure No.</u>		<u>Page No.</u>
1	TEST VEHICLE INFORMATION	3-2
2	PART 572 DUMMY IN-VEHICLE POSITION	3-3
3	SEAT BELT POSITIONING DATA	3-5
4	VEHICLE ACCELEROMETER LOCATIONS	3-6
5	CAMERA POSITION FOR FRONTAL IMPACT	3-8
6	VEHICLE TARGET LOCATIONS	3-10
7	TEST VEHICLE MEASUREMENTS	3-11
8	FMVSS NO. 212 - "WINDSHIELD MOUNTING" DATA SHEET	4-12
9	FMVSS NO. 219 - (PARTIAL) - "WINDSHIELD ZONE INTRUSION" DATA SHEET	4-13

LIST OF TABLES

<u>Table No.</u>		<u>Page No.</u>
1	CRASH TEST SUMMARY	2-2
2	GENERAL TEST AND VEHICLE PARAMETER DATA	2-3
3	POST-IMPACT DATA	2-5
4	FRONT SEAT OCCUPANT MEASUREMENTS	3-4
5	VEHICLE ACCELEROMETER LOCATIONS AND DATA SUMMARY	3-7
6	HIGH SPEED CAMERA LOCATIONS	3-9
7	VEHICLE MEASUREMENTS	3-12
8	DUMMY INJURY CRITERIA VALUES	4-2
9	FMVSS NO. 208 - SEAT BELT WARNING SYSTEM CHECK	4-3
10	FMVSS NO. 208 - LABELING AND DRIVER'S MANUAL INFORMATION	4-4
11	FMVSS NO. 208 - READINESS INDICATOR	4-5
12	FMVSS NO. 208 - COMFORT AND CONVENIENCE TEST SUMMARY	4-6
13	FMVSS NO. 301 - "FUEL SYSTEM INTEGRITY" POST-IMPACT TEST DATA	4-14
14	FMVSS NO. 301 - STATIC ROLLOVER DATA SHEET	4-15
15	POST TEST AIR BAG DATA	4-19
16	ACCIDENT INVESTIGATION DIVISION DATA	4-20
17	TEST VEHICLE NONCOMPLIANCE NOTICE	4-21

Section 1

PURPOSE AND TEST PROCEDURE

This 30 mph frontal barrier impact test is part of the Federal Motor Vehicle Safety Standard (FMVSS) 208, 212, 219 (partial) and 301 compliance test program conducted for the National Highway Traffic Safety Administration (NHTSA) by Calspan Advanced Technology Center under Contract No. DTNH22-93-D-11089. The purpose of this test was to determine if the subject vehicle, a 1994 Dodge Caravan Mini-Van, meets the performance requirements of FMVSS 208, "Occupant Crash Protection"; FMVSS No. 212, "Windshield Mounting"; FMVSS No. 219 (partial), "Windshield Zone Intrusion"; and FMVSS No. 301, "Fuel System Integrity". This compliance test was conducted using the requirements found in the OVSC Laboratory Test Procedure No. TP-208-09, dated March 15, 1993. In addition, a FMVSS 213 "Child Restraint System" test was performed on the mid outboard integrated child restraints.

## Section 2

### SUMMARY OF TEST NUMBER CR0313

A frontal barrier was impacted by a 1994 Dodge Caravan at a velocity of 29.1 mph. The test was performed at the Calspan Corporation Advanced Technology Center on July 12, 1994. Pre- and Post-test photographs of the vehicle and dummies can be found in Appendix A.

The frontal barrier impact event was documented by one real-time camera and 14 high-speed cameras. Camera locations and other pertinent camera information can be found in this report.

Two Part 572E, 50th percentile male anthropomorphic test devices (ATDs), dummies were placed in the driver and right-front passenger seating positions according to dummy placement instructions specified in the OVSC Laboratory Test Procedure. In addition, a FMVSS 213 test was performed using two part 572 three year old dummies placed in the mid-passenger seating position rearward of the front seat passengers. To film three-year old ATD's, the vehicle's mid-location windows were removed to locate high-speed cameras on each side.

Both 50th percentile ATDs (driver and right front passenger occupants) were fully instrumented with head and chest three axis (x, y, and z) accelerometers, chest displacement potentiometers and left/right femur load cells. The ATD's were all certified prior to the test.

The 56 channels of data were recorded on a P.C. based data acquisition system. Appendix B contains the vehicle and dummy response data traces. The driver and right front passenger data channels contain noise spikes at a 10 Hz frequency. This noise was introduced by a short in an outboard timing circuit needed for the FMVSS 213 onboard cameras. The noise is particularly visible in the head and neck channels where no filter is applied. Table 8 of this report contains data for which these noise spikes were ignored and the actual data value was estimated through a point by point analysis. The left rear passenger three-year old chest Z data was not obtained due to a cut wire.

The driver's HIC was 95.98. The maximum chest deceleration over 3 milliseconds was 48.040 g's with 2.7 inches of deflection. The maximum force on the driver's left femur was -1718.0 pounds and -1112.2 pounds on the right femur.

The right front passenger's HIC was 79.56. The maximum chest deceleration over 3 milliseconds was 30.898 g's with 0.7 inches of deflection. Loads of -1609.0 and -1640.0 pounds were recorded on the left and right femurs respectively.

The FMVSS 213 test and calibration information can be found in Appendix E,F, and G.

Table 1

CRASH TEST SUMMARY

Vehicle NHTSA No. :	<u>CR0313</u>	Test Mode :	<u>30 mph Frontal Barrier</u>
Test Date :	<u>July 12, 1994</u>	Time:	<u>14:33</u> Temperature : <u>85</u> °F
Vehicle Make/Model/Body Style :	<u>1994 Dodge Caravan</u>		
Vehicle Test Weight :	<u>3950</u>	lbs	
Vehicle/Barrier Impact Angle :	<u>0</u>	°	
Impact Velocity :	<u>29.1</u>	mph	
Maximum Static Crush :	<u>19.9</u>	inches	
Vehicle Rebound :	<u>11.4</u>	inches	
<u>DUMMIES:</u>	<u>DRIVER</u>		<u>PASSENGER</u>
Type :	<u>Part 572E</u>		<u>Part 572E</u>
Restraint System :	<u>Air bag</u>		<u>Air bag</u>
Number of Data Channels :	<u>56</u>		
Number of Cameras :	<u>1</u>	Real Time	
	<u>14</u>	High Speed	
<u>DOOR OPENING DATA :</u>	<u>Closed/Operable</u>		<u>- Left Front</u>
	<u>Closed/Operable</u>		<u>- Right Front</u>
Front Seat(s) Data :	<u>DRIVER</u>		<u>PASSENGER</u>
Seat Track Failure :	<u>None</u>		<u>None</u>
			<u>Inches of shift</u>
Seat Back Failure :	<u>0.0</u>		<u>0.0</u>
<u>VISIBLE DUMMY CONTACT POINTS :</u>	<u>DRIVER</u>		<u>PASSENGER</u>
Head :	<u>Face with air bag</u>		<u>Face with air bag, rear of head with head rest</u>
Abdomen :	<u>No contact.</u>		<u>Air bag</u>
Chest	<u>Lower steering wheel rim</u>		<u>Air bag</u>
Knees	<u>Lower dash</u>		<u>Knees and lower legs with glove box door.</u>

Table 2

GENERAL TEST AND VEHICLE PARAMETER DATATEST VEHICLE INFORMATION :

Year/Make/Model/Body Style : 1994 Dodge Caravan  
 NHTSA No. : CR0313 ; VIN: 2B4GH25K3RR625683 ; Color : Blue  
 Engine Data: 4 cylinders; - CID; 2.5 Liters; - cc  
 Placement : - Longitudinal or In-Line; X Transverse of Lateral  
 Transmission Data : 3 speeds; - Manual; X Automatic; - Overdrive  
 Final Drive : - Rear Wheel Drive; X Front Wheel Drive; - Four Wheel Drive  
 Major Options : X A/C; X Pwr.Strg.; X Pwr. Brakes  
- Pwr. Windows; - Pwr. Door Locks; - Tilt Wheel  
 Date Received : March 23, 1994 ; Odometer Reading 23.0 miles  
 Selling Dealer : TRANSITOWN DODGE  
 & Address: 7408 Transit Road Williamville, N.Y. 14221

DATA FROM TIRE VEHICLE'S CERTIFICATION LABEL:

Vehicle Manufactured by : CHRYSLER CORPORATION  
 Date of Manufacture 12/93  
 GVWR : 5040 lbs.; GAWR: 2544 lbs. FRONT; 2544 lbs. REAR

DATA FROM TIRE PLACARD:

Tire Pressure with Maximum Capacity Vehicle Load : 35 psi FRONT  
35 psi REAR  
 Recommended Tire Size : P195/75 R14  
 \* Recommended Cold Tire Pressure : 35 psi FRONT; 35 psi REAR  
 Size of Tires on Test Vehicle: P195/75 R14 ; Manufacturer: GOODYEAR  
 Vehicle Capacity Data :  
 Type of Front Seats: - Bench; X Bucket; - Split Bench  
 Number of Occupants: 2 Front; 5 Rear; 7 Total  
 Vehicle Capacity Weight (VCW) = 1100 lbs.  
 No. of Occupants x 150 lbs. = 1,050 lbs.  
 Rated Cargo/Luggage Weight (RCLW) = 50 lbs.

\*Tire pressure used for test

Table 2

GENERAL TEST AND VEHICLE PARAMETER DATA ( cont. )

WEIGHT OF TEST VEHICLE AS RECEIVED FROM DEALER (with maximum fluids)= UDW:

Right Front	=	<u>1010</u>	lbs.	Right Rear	=	<u>760</u>	lbs.
Left Front	=	<u>1000</u>	lbs.	Left Rear	=	<u>740</u>	lbs.
TOTAL FRONT	=	<u>2,010</u>	lbs.	TOTAL REAR	=	<u>1,500</u>	lbs.
TOTAL DELIVERED WEIGHT = <u>3,510.0</u> lbs.							

% of Total Front of Vehicle Weight = 57.3 % of Total Rear Weight = 42.7 %

CALCULATION OF VEHICLE'S TARGET TEST WEIGHT :

Total Delivered Weight	=	<u>3,510</u>	lbs.
Rated Cargo/Luggage Weight (RCLW)	=	<u>50</u>	lbs.
Weight of 2 p.572 Dummies @ 167 each	=	<u>334</u>	lbs.
Weight of 2 p.572 3 yr. old Dummies @ 35 ea.	=	<u>70</u>	lbs.
TARGET TEST WEIGHT	=	<u>3,964</u>	lbs.

WEIGHT OF TEST VEHICLE WITH FOUR DUMMIES AND 36 POUNDS OF CARGO WEIGHT:

Right Front	=	<u>1130</u>	lbs.	Right Rear	=	<u>860</u>	lbs.
Left Front	=	<u>1070</u>	lbs.	Left Rear	=	<u>890</u>	lbs.
TOTAL FRONT	=	<u>2,200</u>	lbs.	TOTAL REAR	=	<u>1,750</u>	lbs.
TOTAL TEST WEIGHT = <u>3,950.0</u> lbs.							

% of Total Front Weight = 55.7 % % of Total Rear Weight = 44.3 %

Weight of Ballast Secured in Vehicle Trunk Area = 0.0 lbs.

Vehicle Components Removed for Weight Reduction: None

VEHICLE ATTITUDE (all dimension in inches) :

AS DELIVERED :	RF	<u>29.4</u>	LF	<u>29.6</u>	RR	<u>29.5</u>	LR	<u>29.7</u>
FULLY LOADED :	RF	<u>28.7</u>	LF	<u>28.4</u>	RR	<u>28.4</u>	LR	<u>28.7</u>
AS TESTED :	RF	<u>29.0</u>	LF	<u>28.9</u>	RR	<u>28.5</u>	LR	<u>28.8</u>
Vehicle's Wheel Base : <u>112.3</u> in.								

Location of Vehicle's C.G. : 49.8 inches rearward of front wheel center.

FUEL SYSTEM DATA :

Fuel System Capacity From Owner's Manual	=	<u>20.0</u>	gallons
Usable Capacity Figure Furnished by COTR	=	<u>20.0</u>	gallons
Test Volume Range (92 to 94% of Usable Capacity)	=	<u>18.4</u>	to <u>18.8</u> gallons
ACTUAL TEST VOLUME=		<u>18.6</u>	gallons (with entire fuel system filled)

Table 3

POST IMPACT DATA

TYPE OF TEST:

Type of Test : Frontal Barrier Impact Angle : 0°  
 Test Date : July 12, 1994 Time: 14:33 Temperature: 85 °F  
 Vehicle NHTSA No. : CR0313  
 Required Impact Velocity Range : 28.9 to 29.9 mph

BARRIER IMPACT VELOCITY: (Speed traps within 5 feet of impact plane.)

Trap No. 1 = 29.1 mph; Trap No. 2 = 29.1 mph  
 Distance from vehicle to barrier : (1) entering trap = 52 inches  
 (2) exiting trap = 12 inches

VEHICLE STATIC CRUSH: (For frontal and rear impacts only.)

Vehicle Length:

Pre-Test Right = 175.2 ; C/L = 178.6 ; Left = 175.2  
 Post-Test Right = 160.6 ; C/L = 158.7 ; Left = 159.7  
 Crush Right = 14.6 ; C/L = 19.9 ; Left = 15.5  
 AVERAGE = 16.7 inches

VEHICLE REBOUND: (From rigid barrier only.)

Distance from front of test vehicle to impact point :

Right = 8.8 ; C/L = 13.0 ; Left = 12.3  
 AVERAGE = 11.4 inches

DOOR OPENING :

	Left	Right
Front	<u>Closed/Operable</u>	<u>Closed/Operable</u>
Rear	<u>N/A</u>	<u>N/A</u>

SEAT MOVEMENT :

	Seat Back Failure	Seat Shift
Front	<u>None</u>	<u>0.0 in.</u>
Rear	<u>None</u>	<u>0.0 in.</u>

Table 3  
POST IMPACT (cont.)

GLAZING DAMAGE :

Windshield remained intact.

---

---

---

---

---

OTHER NOTABLE IMPACT FEATURES :

Steering column stroked upward. Steering wheel rotated 100 degrees to right.

---

Driver and Passenger Toe-pan intrusion.

---

---

---

---

Section 3

OCCUPANT AND VEHICLE DATA

Figure 1

TEST VEHICLE INFORMATION

VEHICLE IDENTIFICATION:

Model Year : 1994 Vehicle Model: Dodge Caravan Body Style : Van

1. Nominal Design Riding Position for adjustable driver and passenger seat backs. Please describe how to position the inclinometer to measure the seat back angle. Include description of the location of the adjustment latch detent, if applicable.

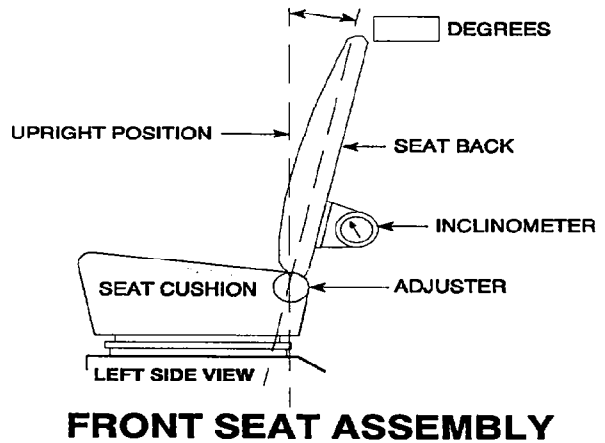

Seat back angle for driver's seat : 27 deg.

Measurement instructions : Place inclinometer along flat surface of seat back rotating seat back rearward to measure 27 degrees from vertical position.

Seat back angle for passenger's seat : 27 deg.

Measurement instructions : Same as driver seating position.

2. Seat Fore and Aft Positioning

Positioning of the driver's seat : Driver seat set at 6th (mid) locking position rearward of foremost position (1). There are 11 detents total.

Positioning of the passenger's seat (if applicable) : Passenger seat set at 5th (mid) locking position rearward of foremost position (1). There are 9 detents total.

3. Fuel Tank Capacity Data

A. "Usable Capacity" of the standard equipment fuel tank is 20.0 gallons

B. "Usable Capacity" of the optional equipment fuel tank is - gallons

4. Steering Column Position :

Mid-Position

5. Other:

None

Figure 2

PART 572 DUMMY IN-VEHICLE POSITION

**DUMMY MEASUREMENT FOR FRONT SEAT PASSENGERS**

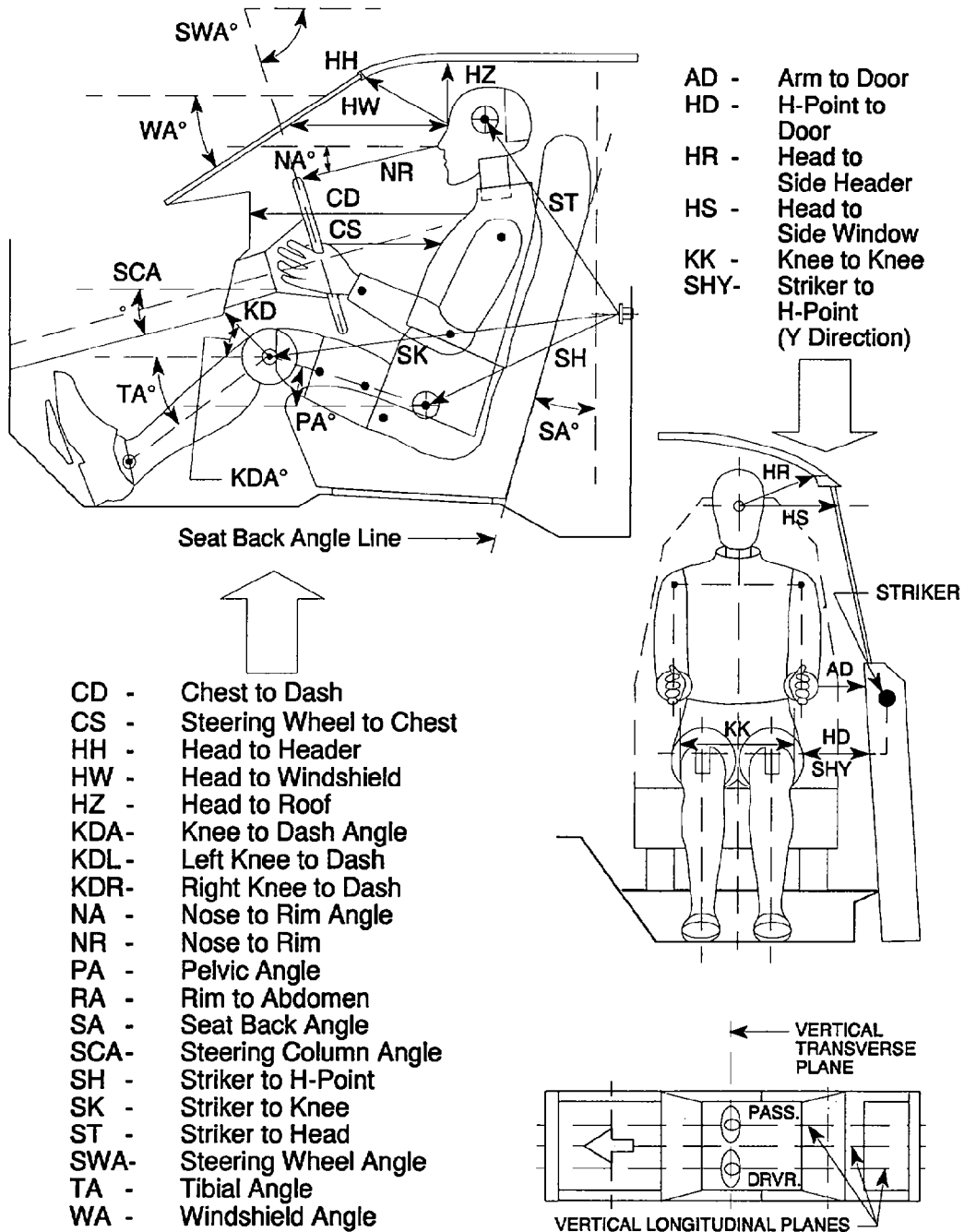

Table 4

FRONT SEAT OCCUPANT MEASUREMENTS

	DRIVER (Serial #341)	PASS. (Serial #342)
WA°	34 deg.	-
SWA°	55 deg.	-
SCA°	35 deg. (Non-adjustable)	-
SA°	27deg.	27 deg.
HZ	8.2	8.1
HH	17.5	15.1
HW	23.9	22.7
HR	9.8	8.9
NR	16.5 Angle 15 deg.	-
CD	19.9	20.4
CS	11.6	-
RA	6.3	-
KDL	6.9 Angle (KDA) 21 deg.	6.3
KDR	7.3	6.2 Angle (KDA) 24 deg.
PA°	24 deg.	24 deg.
TA°	52 deg.	59 deg.
KK	10.9	10.6
ST	24.0 Angle 14 deg.	24.9 Angle 17 deg.
SK	24.4 Angle 89 deg.	25.9 Angle 87 deg.
SH	9.0 Angle 107 deg.	10.2 Angle 106 deg.
SHY	8.3	7.6
HS	12.9	12.1
HD	5.6	5.1
AD	3.4	2.8

Figure 3

### SEAT BELT POSITIONING DATA

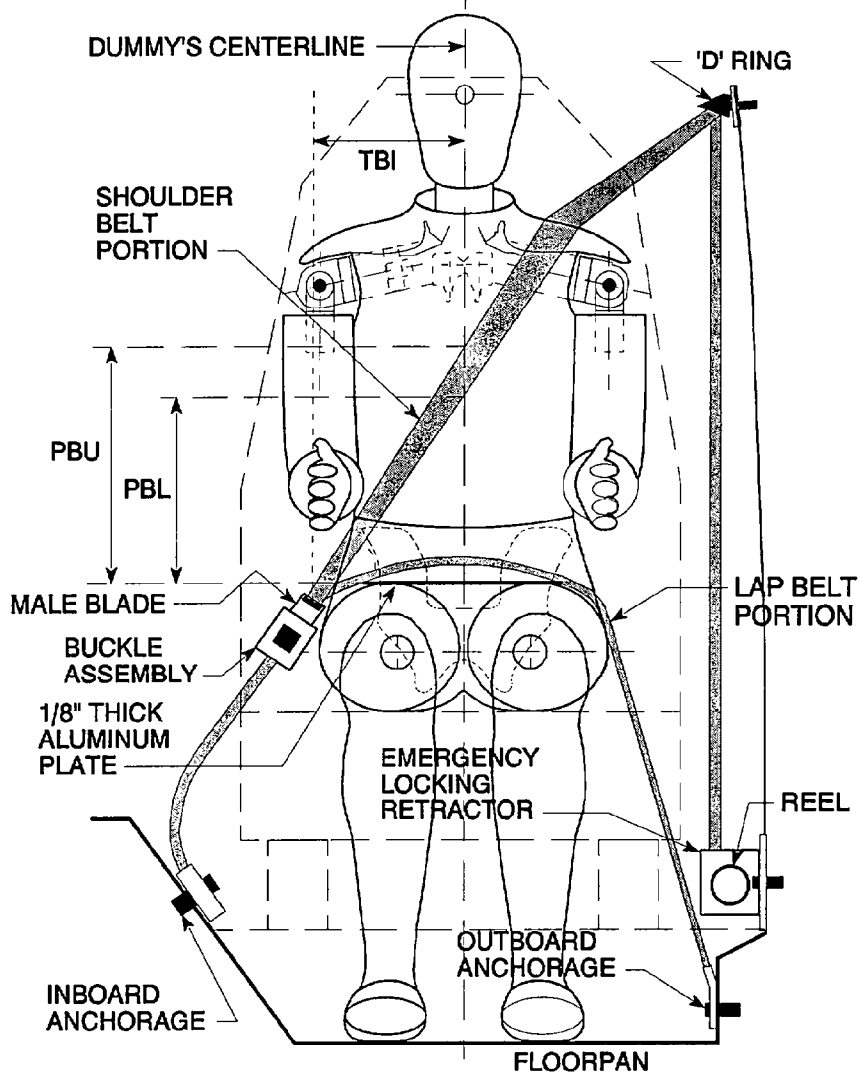

**FRONT VIEW OF DUMMY**

	DRIVER DUMMY (inches)	PASSENGER DUMMY (inches)
<u>PBU</u> -- Top surface of alum. plate to upper edge	*	*
<u>PBL</u> -- Top surface of alum. plate to belt lower edge	*	*
<u>TBI</u> -- Distance from torso centerline to buckle	*	*

\* Vehicle equipped with air bag, manual seat belt not used for this position.

Figure 4

**VEHICLE ACCELEROMETER LOCATION AND DATA SUMMARY**

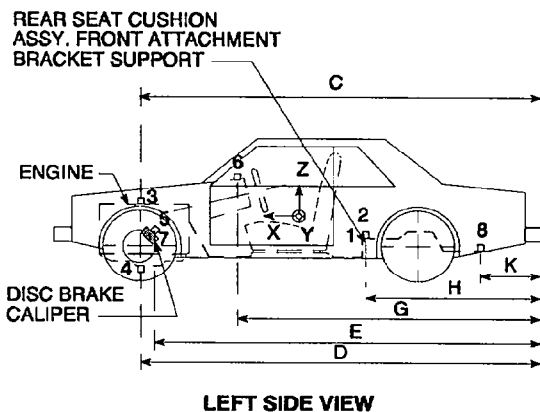
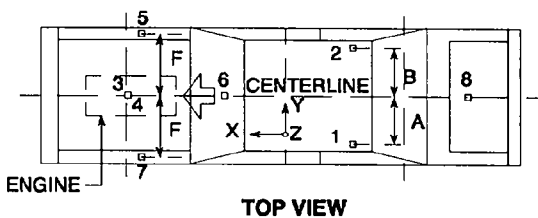

ACCELEROMETER NUMBER*	ACCELEROMETER LOCATION	DIRECTION		
		X	Y	Z
1	Left Rear Seat Crossmember	X		
2	Right Rear Seat Crossmember	X		
3	Top of Engine	X		
4	Bottom of Engine	X		
5	Right Disc Brake Caliper	X		
6	Instrument Panel	X		
7	Left Disc Brake Caliper	X		
8	Trunk Z			X

\*The accelerometer pack number can be correlated with the vehicle response data traces found in Appendix B.

Table 5

VEHICLE ACCELEROMETER LOCATIONS AND DATA SUMMARY

DIMENSION	LENGTH (Inches)	
	PRE-TEST VALUES	POST-TEST VALUES
A	22.5	22.5
B	23.6	23.6
C	150.3	143.2
D	154.1	140.8
E	141.3	Left = 137.3 Right = 136.2
F	Left = 23.7 Right = 24.3	Left = 24.8 Right = 22.5
G	117.1	117.3
H	Left = 52.2 Right = 48.3	Left = 52.2 Right = 48.3
K	14.7	14.7

LOCATION NUMBER	DESCRIPTION	MAXIMUM VALUE			
		Pos.	msec.	Neg.	msec.
1	Rear Seat X-Member @ Left Side	5.2	124.1	-42.7	63.5
* 2	Rear Seat X-Member @ Right Side	260.3	224.0	-247.4	96.0
3	Top of Engine Block	6.3	90.7	-68.2	24.4
* 4	Bottom of Engine	260.1	225.4	-253.8	217.0
* 5	Disc Brake Caliper @ Right Side	236.0	52.6	-102.4	44.5
6	Instrument Panel	10.6	95.5	-65.1	72.5
7	Disc Brake Caliper @ Left Side	30.2	60.1	-105.5	42.2
8	Trunk	58.8	54.0	-109.9	46.7

\* Questionable Data on these data channels

Figure 5

CAMERA POSITIONS FOR FRONTAL IMPACTS

NOTE: Camera Information shown on Table 5.

CAMERA POSITIONS FOR FRONTAL IMPACTS

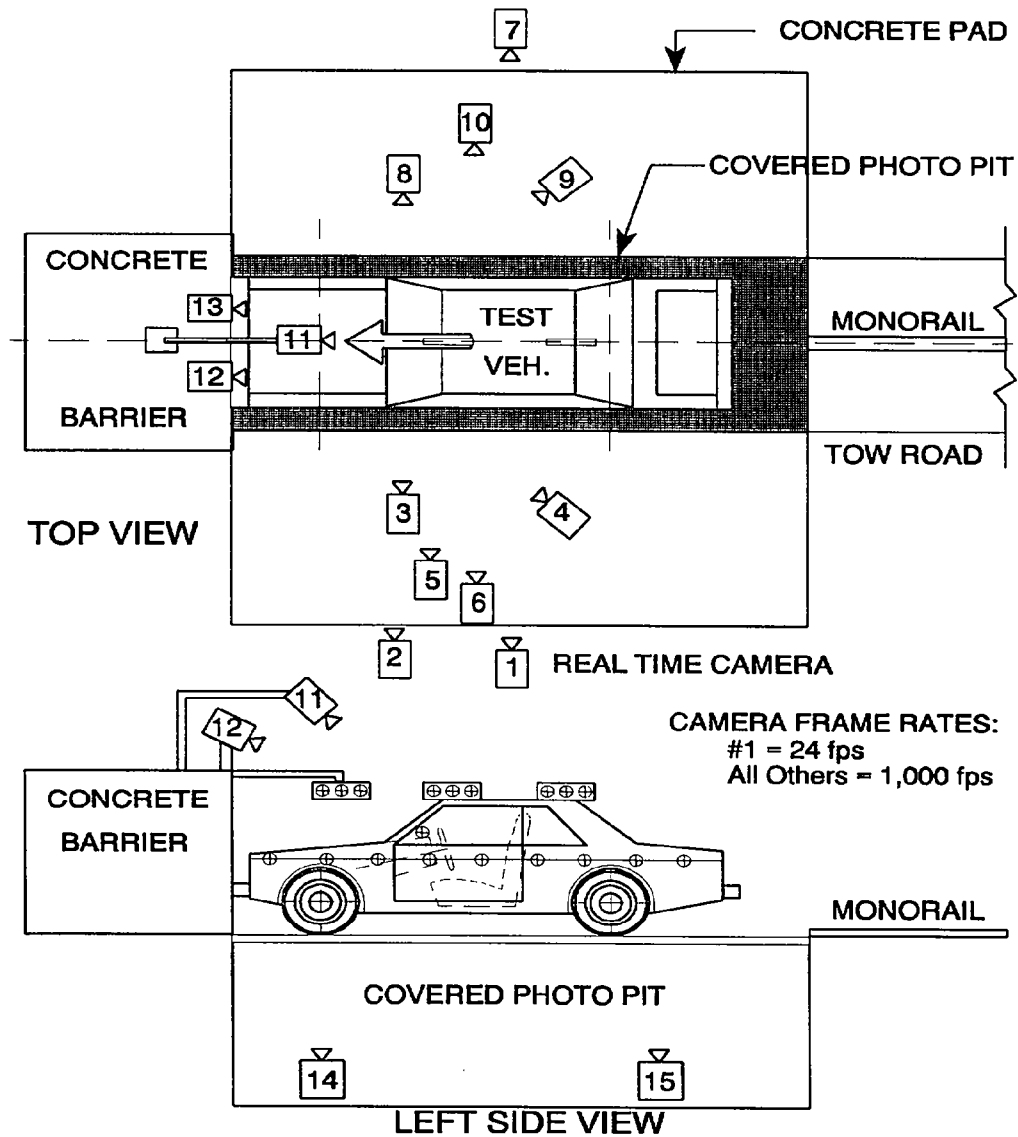

Table 6

## HIGH-SPEED CAMERA LOCATIONS

Camera No.	VIEW	CAMERA POSITIONS (In.)*			ANGLE** (deg)	FILM PLANE TO HEAD TARGET	LENS (mm)	SPEED (fps)
		X	Y	Z				
1	Real-Time Camera	-	-	-	-	-	24	
2	Overall Left Side	242	71	41	-1	223.7 in.	1000	
3	Left Side View	310	41	41	-2	291.7 in.	1000	
4	Driver and Interior View	114	101	73	-14	-	1100	
5	Steering Column (Bottom)	287	86	46	-3	268.7 in.	1020	
6	Steering Column (Top)	287	86	70	-7	268.7 in.	1100	
7	Overall Right Side	238	72	41	-2	219.7 in.	800	
8	Right Side View	304	54	41	-2	285.3 in.	960	
9	Right Passenger View	330	71	58	-3	311.7 in.	N.T.	
10	Passenger and Interior View	105	103	74	-19	-	850	
11	Passenger Front View	29	-5	137	59	-	1050	
12	Driver Front View	27	-5	139	58	-	1050	
13	Windshield View	0	10	126	63	-	1070	
14	Pit View of Engine	28	0	-86	90	-	680	
15	Pit View of Fuel Tank	96	0	-86	90	-	670	

\*X = film plane to monorail centerline  
 Y = film plane to impact location  
 Z = film plane to ground  
 \*\* = referenced to horizontal plane

Figure 6

VEHICLE TARGET LOCATIONS  
(All dimensions in inches)

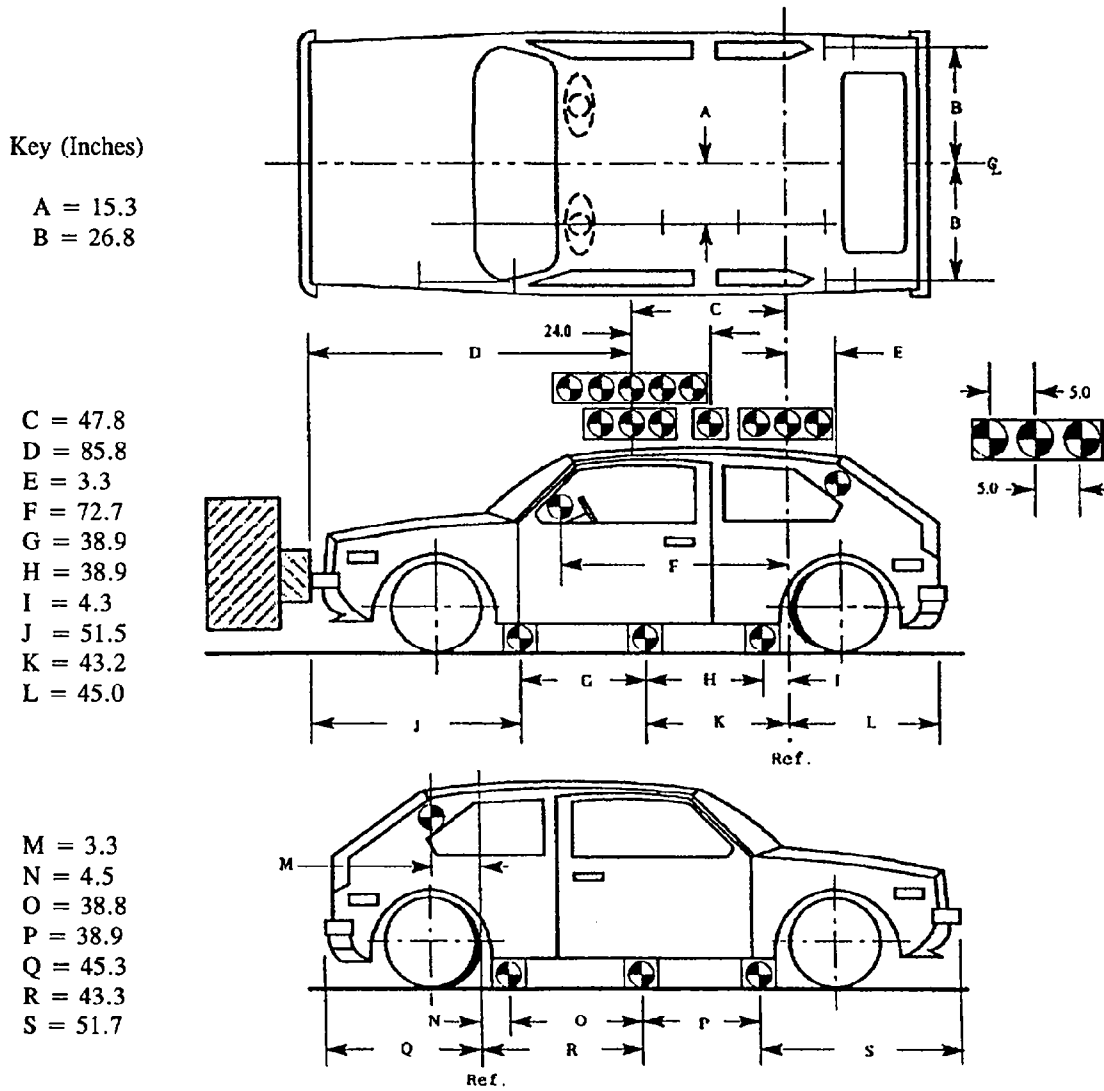

Note: Targets on front fender are 12.0 inches apart.  
Targets rearward of front fender are 24.0 inches apart.

Figure 7

TEST VEHICLE MEASUREMENTS

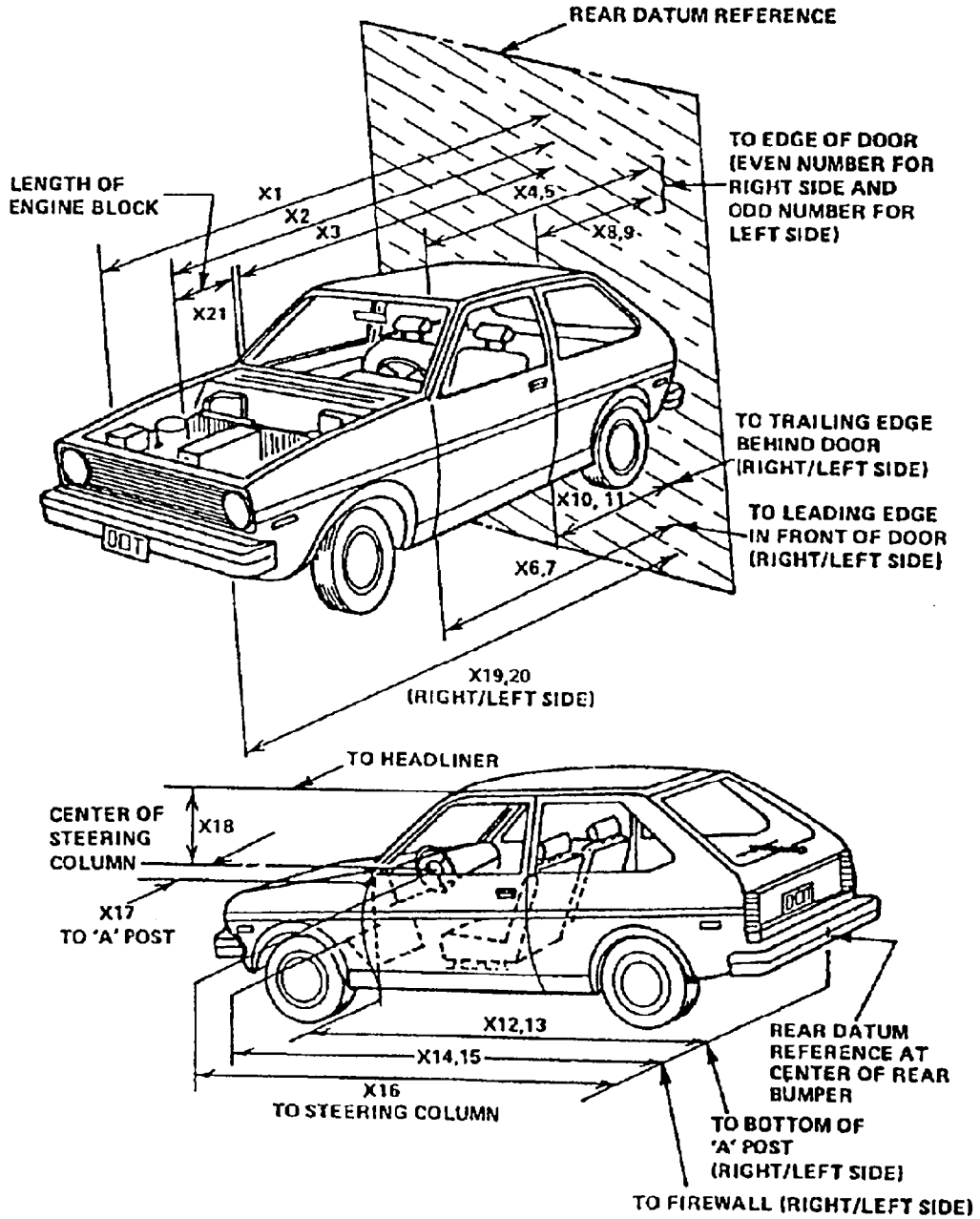

Table 7

## VEHICLE MEASUREMENTS

No.		All Dimensions in inches		
		Pre-Test	Post-Test	Differences
X1	Total Length of Vehicle at Centerline	178.6	158.7	19.9
X2	Rear Surface of Vehicle to Front of Engine	151.0	145.7	5.3
X3	Rear Surface of Vehicle to Firewall	138.0	133.2	4.8
X4	Rear Surface of Vehicle to Upper Leading Edge of Right Door	129.2	128.0	1.2
X5	Rear Surface of Vehicle to Upper Leading Edge of Left Door	129.0	127.9	1.1
X6	Rear Surface of Vehicle to Lower Leading Edge of Right Door	126.3	125.4	0.9
X7	Rear Surface of Vehicle to Lower Leading Edge of Left Door	126.0	125.9	0.1
X8	Rear Surface of Vehicle to Upper Trailing Edge of Right Door	86.9	85.9	1.0
X9	Rear Surface of Vehicle to Upper Trailing Edge of Left Door	87.0	86.3	0.7
X10	Rear Surface of Vehicle to Lower Trailing Edge of Right Door	86.3	85.9	0.4
X11	Rear Surface of Vehicle to Lower Trailing Edge of Left Door	86.3	86.8	-0.5
X12	Rear Surface of Vehicle to Bottom of "A" Post of Right Side	127.6	127.0	0.6
X13	Rear Surface of Vehicle to Bottom of "A" Post of Left Side	127.5	127.4	0.1
X14	Rear Surface of Vehicle to Firewall, Right Side	140.0	138.0	2.0
X15	Rear Surface of Vehicle to Firewall, Left Side	140.8	139.5	1.3
X16	Rear Surface of Vehicle to Steering Column	109.9	111.8	-1.9
X17	Center of Steering Column to "A" Post	15.3	16.3	-1.0
X18	Center of Steering Column to Headliner	18.2	15.0	3.2
X19	Rear Surface of Vehicle to Right Side of Front Bumper	175.2	160.6	14.6
X20	Rear Surface of Vehicle to Left Side of Front Bumper	175.2	159.7	15.5
X21	Length of Engine Block	19.0	19.0	0.0

Section 4

SUMMARY OF RESULTS OF FMVSS NOS. 208, 212, 219 AND 301-75

- "Occupant Crash Protection," FMVSS No. 208 Data
- "Windshield Mounting," FMVSS No. 212 Data
- "Windshield Zone Intrusion," FMVSS No. 219 (Partial) Data
- "Fuel System Integrity," FMVSS No. 301-75

Table 8

DUMMY INJURY CRITERIA VALUESNHTSA No. : CR0313 Vehicle : 1994 Dodge Caravan

	MAXIMUM ACCELERATION (g's)								
	HEAD				CHEST				
	X	Y	Z	R	X	Y	Z	R*	Displacement
Dummy (1)	-25.2	15.2	-15.4	28.4	-44.0	5.9	23.2	48.040	-2.7
Dummy (2)	-26.2	-14.4	18.2	28.5	-30.4	5.7	14.2	30.898	-0.7

	MAXIMUM FORCE - FEMUR LOAD (lbs.)	
	LEFT FEMUR	RIGHT FEMUR
Dummy (1)	-1718.0	-1112.2
Dummy (2)	-1609.0	-1640.0

	HEAD INJURY CRITERIA**			
	HIC	36 millisecond Maximum		Avg. Acc (g)
		t <sub>1</sub> (msec)	t <sub>2</sub> (msec)	t <sub>1</sub> TO t <sub>2</sub>
Dummy (1)	95.98	54.600	90.480	23.49
Dummy (2)	79.56	51.120	87.000	21.79

\* Defined as exceeding 0.003 sec. duration

\*\*As defined in FMVSS No. 208

Table 9

FMVSS NO. 208 - SEAT BELT WARNING SYSTEM CHECK

With occupant in driver's position, the lap belt in stowed position, and ignition switch placed in "Start/On" position:

Log time duration of audible warning signal = 6 sec.

Log time duration of reminder light operation = 6 sec.

With occupant in driver's position, lap belt in use, and the ignition switch placed in "Start/On" position :

Log time duration of audible warning signal  
(audible warning should not operate) = 0 sec.

Log time duration of reminder light operation = 6 sec.

Note wording of visual warning :

Fasten Seat Belt -

Fasten Belt -

Symbol 101 X

Table 10

FMVSS NO. 208 - LABELING AND DRIVER'S MANUAL INFORMATION

Locate label which describes manufacturers maintenance or replacement schedule for crash-deployed occupant protection system.

Describe location :

Label located in glove compartment.

The label states, "SRS system designed to be maintenance free, however, if air bag light fails to illuminate when ignition is turned to on position or if air bag light flashes while driving then the system must be serviced by authorized dealer."

Were appropriate instructions concerning maintenance and/or replacement of this system provided ?

YES   X   NO   -  

Was a description of the functional operation of the system provided ?

YES   X   NO   -  

Is there a reference to the instructions and description of the system on the label ?

YES   X   NO   -  

Was an owner's manual provided ?

YES   X   NO   -  

Did the owner's manual contain appropriate information concerning maintenance and/or replacement and a description of the functional operation of the system ?

YES   X   NO   -

Table 11

FMVSS NO. 208 - READINESS INDICATOR

An occupant restraint system that deploys in the event of a crash shall have a monitoring system with a readiness indicator. A totally mechanical system is exempt from this requirement.

Is the system totally mechanical ? YES - NO X

Describe the location of the readiness indicator :

Readiness indicator located at top right of instrument cluster.

Is the readiness indicator clearly visible to the driver ? YES X NO -

Is a list of the elements in the occupant restraint system, being monitored by the readiness indicator, provided ?

YES X NO -

Table 12

FMVSS NO. 208 - COMFORT AND CONVENIENCE TEST SUMMARY

Test Vehicle NHTSA No. :	CR0313
Make/Model :	1994 Dodge Caravan
Date of Comfort/Convenience Check :	July 11, 1994
Technician Performing Check :	R. E.
GVWR :	5040 lbs.

Seat belt comfort and convenience requirements cover vehicles manufactured on or after September 1, 1986, which have a gross vehicle weight rating of 10,000 pounds or less. Exemptions to this rule are belts installed in a walk-in, van-type vehicle and manual Type 2 belt systems installed in the front outboard seating positions of passenger automobiles. On or after September 1, 1989, the exemption of the type 2 manual seat belts installed in the front outboard seating positions of passenger automobiles will change depending on the states' enactment of mandatory usage laws.

Was vehicle built after or on September 1, 1986, and is it equipped with :

1. Automatic seat belts YES - NO X

If yes, go to requirements D1, D2, and D3

2. Manual seat belts\* YES X\*\* NO -

a. The seat belts, other than Type 2 lap/shoulder belts, are located in the front outboard seating positions of a passenger automobile.

YES - NO X

(Go to requirements D3, D4, D5, and D6)

b. The seat belt system is Type 2 lap/shoulder belt in the front outboard seating positions or the seat belts are located in a walk-in van.

STOP

\* If the seat belts are voluntarily installed by the manufacturer they do not have to comply.

\*\* Manual seat belts not used for front seat occupants during this test.

Table 12 (cont.)

D1  
CONVENIENCE HOOKS

A convenience hook or other device is provided to stow seat belt webbing to facilitate entering or exiting the vehicle.

YES       -       NO       X      

Check the option which applies to this test vehicle:

1. A convenience hook or other device automatically releases the webbing when the automatic belt system is operational and remains in the released mode as long as the vehicle's ignition switch is moved to the "on" or "start" position and the vehicle's drivetrain is engaged.

YES       N/A       NO       N/A      

2. A convenience hook or other device automatically releases the webbing when the automatic belt system is operational and remains in the released mode as long as the vehicle's ignition switch is moved to the "on" or "start" position and the vehicle's parking brake is in the released mode (non-engaged)

YES       N/A       NO       N/A      

D2  
WEBBING TENSION - RELIEVING DEVICE

The seat belt assembly installed in the outboard designated seating position has either manual or automatic tension relieving devices permitting the introduction of slack in the webbing of the shoulder belt ("comfort clips" or "window shade" devices).

YES       -       NO       X      

Check the owner's manual and determine the maximum amount of slack recommended by the manufacturer in inches. The recommended slack is N/A inches. Introduce this slack into the shoulder belt before testing the vehicle to comply with the requirements of FMVSS 208 S5.1. A warning is included in the owner's manual that introducing slack beyond the amount specified can significantly reduce the effectiveness of the shoulder belt.

YES       N/A       NO       N/A      

(If NO, provide explanation.)

Check the option which applies to this test vehicle:

1. This vehicle is equipped with automatic seat belts and the tension relieving device is cancelled each time the adjacent door is opened.

YES       N/A       NO       N/A      

(If NO, provide explanation.)

Table 12 (cont.)

2. This vehicle is equipped with manual belts, required to meet FMVSS 208 S4.6, and the tension relieving device is cancelled each time one of the following options occurs:
- |   |     |            |    |            |
|---|-----|------------|----|------------|
| a. The adjacent door is opened.                 | YES | <u>N/A</u> | NO | <u>N/A</u> |
| b. The latch plate is released from the buckle. | YES | <u>N/A</u> | NO | <u>N/A</u> |
3. This is an open-body vehicle, without doors. Does the manual mean to cancel any shoulder belt slack introduced by a tension relieving device to operate properly ?
- |  |     |            |    |            |
|--|-----|------------|----|------------|
|  | YES | <u>N/A</u> | NO | <u>N/A</u> |
|--|-----|------------|----|------------|

(If NO, provide explanation.)

D3  
BELT CONTACT FORCE

1. Do not measure the belt contact force if the manual or automatic seat belt assemblies in this vehicle incorporate a webbing tension relieving device. Does the vehicle incorporate a tension relieving device?
- |  |     |          |    |          |
|--|-----|----------|----|----------|
|  | YES | <u>-</u> | NO | <u>X</u> |
|--|-----|----------|----|----------|
2. Seat are adjusted according to instructions in Appendix B.
- |  |     |          |    |          |
|--|-----|----------|----|----------|
|  | YES | <u>X</u> | NO | <u>-</u> |
|--|-----|----------|----|----------|
3. The test dummies are positioned according to dummy position placement instructions in Appendix B and Appendix C.
- |  |     |          |    |          |
|--|-----|----------|----|----------|
|  | YES | <u>X</u> | NO | <u>-</u> |
|--|-----|----------|----|----------|
4. Close the vehicle's adjacent door, pull either 12 inches of belt webbing or the maximum available amount of belt webbing, whichever is less, from the retractor and then release it, allowing the belt webbing to return to the dummy's chest, then fasten the latch. Locate the point where the centerline of the upper torso belt webbing crosses the midsagittal line on the dummy's chest. At that point, pull the belt webbing out 3 inches from the dummy's chest and release until it is within one inch from the dummy's chest. Measure the contact force exerted by the belt webbing on the dummy's chest. The contact force is 0.3 pounds. Contact the COTR if the contact force exceeds 0.7 pounds.

Table 12 (cont.)

D4  
LATCHPLATE ACCESSIBILITY

- |    |  |     |              |    |              |
|----|--|-----|--------------|----|--------------|
| 1. | Position the test dummy in the driver's seat or passenger's seat in its forward most adjustment position.  | YES | <u>  X  </u> | NO | <u>  -  </u> |
| 2. | Attach the inboard and outboard reach string.  | YES | <u>  X  </u> | NO | <u>  -  </u> |
| 3. | Extend each line backward and outboard to generate arcs of the reach envelope of the test dummy's arms. With the latchplate in the normal stowed position, check to assure that the latchplates are within the reach envelope. | YES | <u>  X  </u> | NO | <u>  -  </u> |
| 4. | Using the clearance test block, determine if there is sufficient clearance between the vehicle seat and the side of vehicle interior to allow the test block to move unhindered to the latchplate or buckle.                   | YES | <u>  X  </u> | NO | <u>  -  </u> |

D5  
RETRACTION

- |    |  |     |              |    |              |
|----|--|-----|--------------|----|--------------|
| 1. | Seats and seat backs are adjusted according to instructions in Appendix B "General Test Conditions" in TP-208-09, dated March 15, 1993.  | YES | <u>  X  </u> | NO | <u>  -  </u> |
| 2. | Use anthropomorphic test dummies whose arms have been removed and position the dummies in the front outboard designated seating positions according to instructions in Appendix B and restrain the dummies, using the belt systems for the positions being tested. | YES | <u>  X  </u> | NO | <u>  -  </u> |
| 3. | Outboard armrests which are capable of being stowed on vehicle seats shall be placed in their stowed positions.  | YES | <u>  X  </u> | NO | <u>  -  </u> |
| 4. | Check the option which applies to this test vehicle:   | YES | <u>  X  </u> | NO | <u>  -  </u> |
| a. | The torso and lap belt webbing of the seat belt system automatically retract to a stowed position when the adjacent vehicle door is in an open position and the seat belt latch plate is released.   | YES | <u>  X  </u> | NO | <u>  -  </u> |

Table 12 (cont.)

- b. The torso and lap belt webbing of the seat belt system automatically retract when the seat belt latchplate is released.
- YES      X      NO      -
5. With the webbing and hardware in the stowed position, close the door to assure that the webbing and hardware are prevented from being pinched.
- YES      X      NO      -
6. If this test vehicle has an open body (without doors) and has a belt system with a tension-relieving device, check to assure that the belt system fully retracts when the tension-relief device is manually deactivated.
- YES      N/A      NO      N/A

D6  
ACCESSIBILITY

The requirements for accessibility do not apply to:

1. Seats whose seat cushions are removable so that the seat back serves a function other than seating;
2. Seats which are removable;
3. Seats which are movable so that the space formerly occupied by the seat can be used for a secondary function.

If the seats in this vehicle are different than the criteria above, then determine if:

1. Each manual seat belt assembly whose webbing is designed to pass through the seat cushion or between the seat cushion and seat back has one of the following three parts (the seat belt latchplate, the buckle, or the seat belt webbing) on top of or above the seat cushion under normal conditions (i.e., conditions other than when belt hardware is intentionally pushed behind the seat by a vehicle occupant).

YES      X      NO      -  

2. The remaining two seat belt parts are accessible under normal conditions.

YES      X      NO      -

Table 12 (cont.)

- |    |  |     |              |                 |
|----|--|-----|--------------|-----------------|
| 3. | The buckle and latchplate pass through the guides or conduits provided and do not fall behind the seat when the following events occur in order:   |     |              |                 |
|    | a. The belt is completely retracted or, if the belt is non-retractable, the belt is unattached.  | YES | <u>  X  </u> | NO <u>  -  </u> |
|    | b. The seat is moved to any position to which it is designed to be adjusted.   | YES | <u>  X  </u> | NO <u>  -  </u> |
|    | c. The seat back, if foldable, is folded forward as far as possible and then moved backward into positions.  | YES | <u>  X  </u> | NO <u>  -  </u> |
| 4. | Is the inboard receptacle end of the seat belt assembly which is installed in the outboard designated seating position accessible with the center arm rest in any position to which it can be adjusted without moving the armrest? | YES | <u>  X  </u> | NO <u>  -  </u> |

D7  
LATCH MECHANISM

A seat belt assembly installed in a passenger car, except an automatic belt assembly, shall have a latch mechanism:

- |    |  |     |              |                 |
|----|--|-----|--------------|-----------------|
| 1. | Whose components are accessible to a seated occupant in both the stowed and operational positions.   | YES | <u>  X  </u> | NO <u>  -  </u> |
| 2. | That releases both the upper torso restraint and the lap belt simultaneously, if the assembly has a lap belt and an upper torso restraint that require unlatching for release of the occupant. | YES | <u>  X  </u> | NO <u>  -  </u> |
| 3. | That releases at a single point by a push button action.   | YES | <u>  X  </u> | NO <u>  -  </u> |

Figure 8

FMVSS NO. 212 - "WINDSHIELD MOUNTING" DATA SHEET

DETAILS OF WINDSHIELD MOUNTING SUCH AS RETENTION METHOD, TRIM TYPE, ETC. :

The windshield is bonded in place with 0.5" rubber molding around top and sides of windshield, bottom of windshield is covered by a plastic shroud.

FMVSS 212 REQUIREMENTS :

The Post - Test periphery retention amount must be at least 75% of the Pre - Test periphery measurement for vehicle NOT equipped with automatic restraints, and 50% for each side of windshield for vehicles equipped with automatic restraint systems for front occupants.

FMVSS 212 TEST DATA :

	WINDSHIELD PERIPHERY		PERCENT RETENTION
	PRE - TEST (in.)	POST - TEST (in.)	
RIGHT SIDE	87.3	87.3	100.0
LEFT SIDE	87.3	87.3	100.0
TOTAL	174.6	174.6	100.0

AREA OF RETENTION FAILURE:

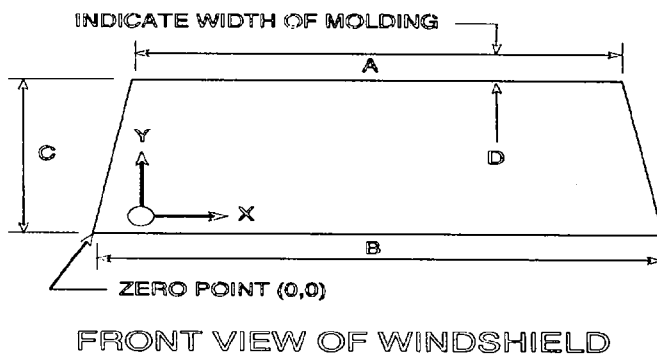

FAILURE DETAILS :

None

Figure 9

FMVSS NO. 219 (PARTIAL) - "WINDSHIELD ZONE INTRUSION" DATA SHEET

PROTECTED ZONE LOWER EDGE REQUIREMENT :

The lower edge of the protected zone is determined by placing a 6.5" dia. rigid sphere weighing 15 pounds in a position such that it simultaneously contacts the inner surface of the windshield and the top surface of the instrument panel including padding. The locus of points is drawn on the inner surface of the windshield contacted by the sphere across the width of the instrument panel. From the outermost contactable points, extend the locus line horizontally to the edges of the windshield, and then draw a line on the inner surface of the windshield below and 1/2" distant from the locus line. The LOWER EDGE OF THE PROTECTED ZONE is the longitudinal projection of this line onto the outer surface of the windshield

FMVSS 219 TEST DATA : (Dimensions in inches.)

**KEY:**

- A = 54.2
- B = 15.5
- C = 64.4
- D = 28.0
- E = 17.9
- F = 39.4

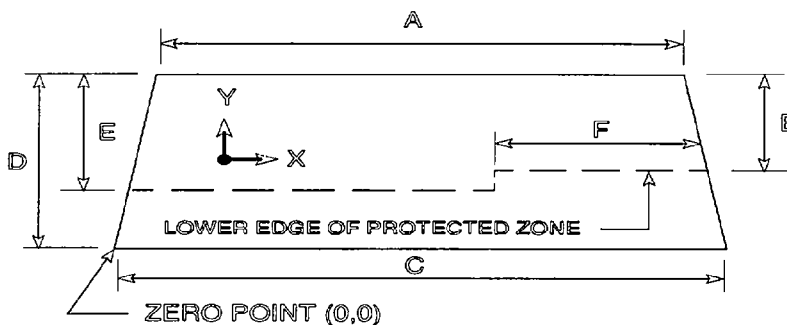

FRONT VIEW OF WINDSHIELD

DETAILS OF WINDSHIELD GLASS PENETRATION GREATER THAN 1/4" :

(Show location of penetration on above sketch)

None

COORDINATES		
	X	Y
1		
2		
3		
4		

Table 13

FUEL SYSTEM INTEGRITY POST IMPACT TEST DATA

FMVSS NO. 301

TEST VEHICLE NHTSA NO. : CR0313 TEST DATE : July 12, 1994

Vehicle Mfgr./Make/Model : 1994 Dodge Caravan

Test vehicle fuel tank filled to 92% to 94% of manufacturer's "usable" capacity and with electric fuel pump operating (if it will operate without engine operation). Part 572 test dummies located at each front designated seating position.

\*\*\*\*\*

TEST VEHICLE IMPACT TYPE : X Frontal (30 mph)  
- Oblique (30 mph) with - ° barrier face first  
contacting -  
(driver/passenger) side  
- Rear Moving Barrier (30 mph)  
- Lateral Moving Barrier (20 mph)

FUEL SPILLAGE MEASUREMENT:

1. From impact until vehicle motion ceases
2. For five minute period after vehicle motion ceases
3. For next 25 minutes

ACTUAL	MAX ALLOWED
0	1 oz.
0	5 oz.
0	1 oz./1 min.

SOLVENT SPILLAGE DETAILS :

None.

Table 14

FMVSS NO. 301 STATIC ROLLOVER DATA SHEET

TEST PHASE :  
0-90 Deg.

Vehicle NHTSA ID No. :  
CR0313

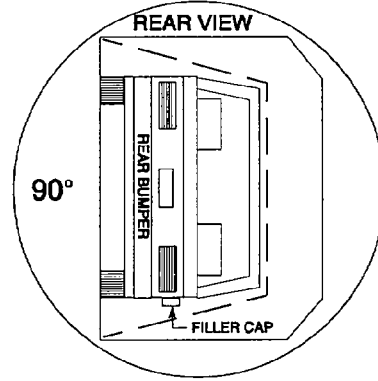
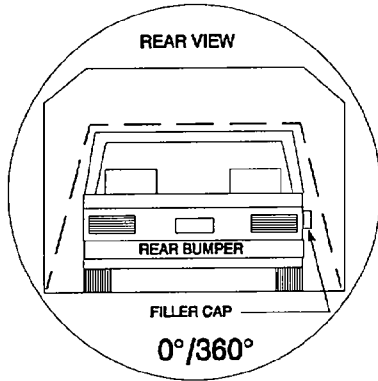

I. DETERMINATION OF SOLVENT COLLECTION TIME PERIOD :

Rollover Fixture 90° Rotation Time (Spec. Range = 1 to 3 minutes)	1	minutes	38	seconds
FMVSS 301 Position Hold Time +	5	minutes	00	seconds
TOTAL	6	minutes	38	seconds
Next whole minute interval	7	minutes		

II. FMVSS 301 REQUIREMENTS :

(1) Time Period

First 5 minutes FROM onset of rotation	6th min.	7th min.	8th min. if reqd.
--	----------	----------	----------------------

(2) Maximum Allowable Solvent Spillage

5 ounces	1 ounce	1 ounce	1 ounce
----------	---------	---------	---------

III. ACTUAL TEST VEHICLE SOLVENT SPILLAGE :

0	0	0	N/A
---	---	---	-----

Note: Record spillage for whole minute intervals only as determined above.

IV. SOLVENT SPILLAGE LOCATION(S) :

None

Table 14  
FMVSS NO. 301 STATIC ROLLOVER DATA SHEET (cont.)

TEST PHASE :  
90-180 Deg.

Vehicle NHTSA ID No. :  
CR0313

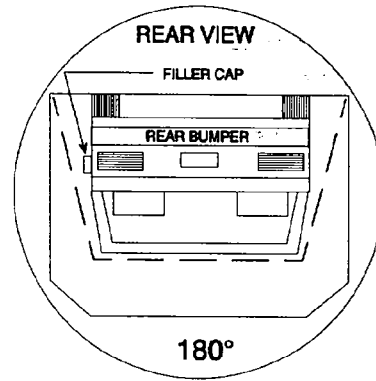
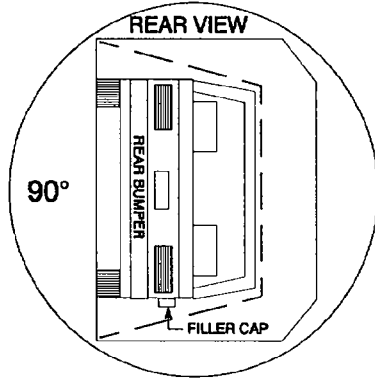

I. DETERMINATION OF SOLVENT COLLECTION TIME PERIOD :

Rollover Fixture 90° Rotation Time (Spec. Range = 1 to 3 minutes)	1	minutes	46	seconds
FMVSS 301 Position Hold Time +	5	minutes	00	seconds
TOTAL	6	minutes	46	seconds
Next whole minute interval	7	minutes		

II. FMVSS 301 REQUIREMENTS :  
 (1) Time Period

First 5 minutes FROM onset of rotation	6th min.	7th min.	8th min. if reqd.
--	----------	----------	----------------------

(2) Maximum Allowable Solvent Spillage

5 ounces	1 ounce	1 ounce	1 ounce
----------	---------	---------	---------

III. ACTUAL TEST VEHICLE SOLVENT SPILLAGE :

0	0	0	N/A
---	---	---	-----

Note: Record spillage for whole minute intervals only as determined above.

IV. SOLVENT SPILLAGE LOCATION(S) :  
 None

Table 14  
FMVSS NO. 301 STATIC ROLLOVER DATA SHEET (cont.)

TEST PHASE :  
 180-270 Deg.

Vehicle NHTSA ID No. :  
 CR0313

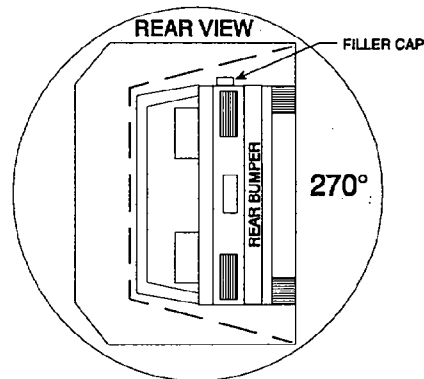
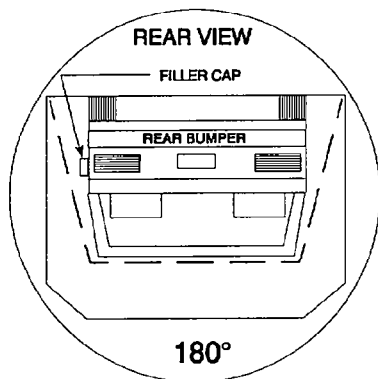

**I. DETERMINATION OF SOLVENT COLLECTION TIME PERIOD :**

Rollover Fixture 90° Rotation Time (Spec. Range = 1 to 3 minutes)	2	minutes	19	seconds
FMVSS 301 Position Hold Time +	5	minutes	00	seconds
<b>TOTAL</b>	7	minutes	19	seconds
Next whole minute interval	8	minutes		

**II. FMVSS 301 REQUIREMENTS :**

(1) Time Period

First 5 minutes FROM onset of rotation	6th min.	7th min.	8th min. if reqd.
--	----------	----------	----------------------

(2) Maximum Allowable Solvent Spillage

5 ounces	1 ounce	1 ounce	1 ounce
----------	---------	---------	---------

**III. ACTUAL TEST VEHICLE SOLVENT SPILLAGE :**

0	0	0	0
---	---	---	---

Note: Record spillage for whole minute intervals only as determined above.

**IV. SOLVENT SPILLAGE LOCATION(S) :**

None

Table 14  
FMVSS NO. 301 STATIC ROLLOVER DATA SHEET (cont.)

TEST PHASE :  
 270-360 Deg.

Vehicle NHTSA ID No. :  
 CR0313

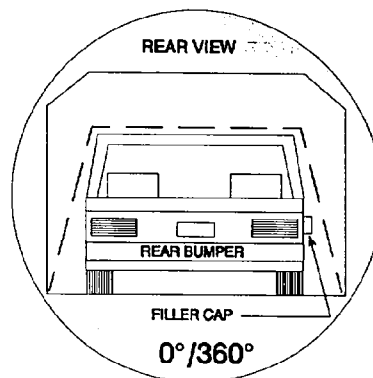
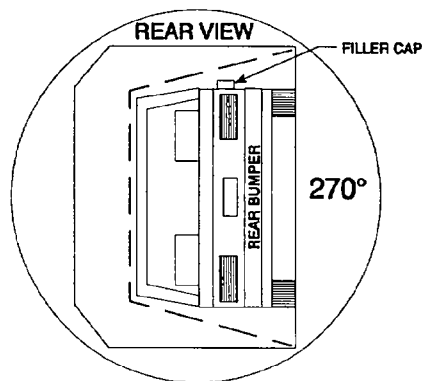

**I. DETERMINATION OF SOLVENT COLLECTION TIME PERIOD :**

Rollover Fixture 90° Rotation Time (Spec. Range = 1 to 3 minutes)	<u>1</u>	minutes	<u>27</u>	seconds
FMVSS 301 Position Hold Time + Next whole minute interval	<u>5</u>	minutes	<u>00</u>	seconds
<b>TOTAL</b>	<u>6</u>	minutes	<u>27</u>	seconds
	<u>7</u>	minutes		

**II. FMVSS 301 REQUIREMENTS :**

(1) Time Period

First 5 minutes FROM onset of rotation	6th min.	7th min.	8th min. if reqd.
--	----------	----------	----------------------

(2) Maximum Allowable Solvent Spillage

5 ounces	1 ounce	1 ounce	1 ounce
----------	---------	---------	---------

**III. ACTUAL TEST VEHICLE SOLVENT SPILLAGE :**

0	0	0	N/A
---	---	---	-----

Note: Record spillage for whole minute intervals only as determined above.

**IV. SOLVENT SPILLAGE LOCATION(S) :**

None

Table 15

POST TEST AIR BAG DATA

NHTSA No. : CR0313; Test Date: July 12, 1994; Technician: R.E.

Vehicle Model Year/Make/Model: 1994 Dodge Caravan

- A. No. of vent holes: 2 -Driver 0 -Passenger
- B. Size of vent holes: (In.<sup>2</sup>) 0.8 -Driver N/A -Passenger
- C. Total vent area: (In.<sup>2</sup>) 1.6 -Driver N/A -Passenger
- D. Deflated air bag length and width dimensions or, if round,diameter. (In inches)
- Driver:                      -Length;                      -Width; 25.0 -Diameter
- Passenger: 29.5 -Height; 19.0 -Width; 25.0 -Depth
- E. Is the air bag tethered?
- Driver: - -Yes; X -No; If yes, record length of tether N/A
- Passenger: X -Yes; - -No; If yes, record length of tether 16.0

Sketch the air bag showing the location of the vent holes, how the bag is tethered, and where the bag is tethered. Also describe how the thethers are attached to the bag and the steering wheel.

(Note: Not to scale;  $V_n$  = Vent hole<sub>n</sub>,  $T_n$  = Tether<sub>n</sub>).

DRIVER AIR BAG

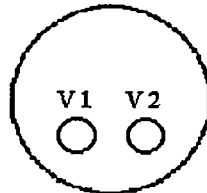

PASSENGER AIR BAG (Right side view)

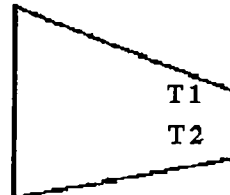

- F. Record part numbers and manufacturer name of the air bag and gas generator.
- Driver: Air bag/Inflator: PUT 11446-02 / TX 933133499 / CBADYJ 12 ANW
- Passenger: BENDIX TB 7332610601 / OJX75 04680375 / 73427A
- G. Cut out a 6 inch by 6 inch swatch of the bag material and at least one tether from each bag, mark the vehicle's NHTSA number on the swatch, and send these parts to the COTR with the test report.

Table 16

ACCIDENT INVESTIGATION DIVISION DATA

VEHICLE YEAR/MAKE/MODEL/BODY STYLE: 1994 Dodge Caravan Mini-Van  
 VEHICLE NHTSA NO. : CR0313 VIN NO. : 2B4GH25K3RR625683  
 WHEELBASE: 112.3 in. BUILD DATE: 12/93 TEST DATE: July 12, 1994  
 VEH SIZE CATEGORY: -- TEST WEIGHT: 3950  
 FRONT OVERHANG: -- OVERALL WIDTH: 72.0 inches  
 COLLISION DEFORMATION (CDC) CODE: 12FDEW2  
 IMPACT MODE: FRONTAL BARRIER

CRUSH DEPTH DIMENSIONS: (Inches)

C1 = 13.6 C4 = 18.6  
 C2 = 17.3 C5 = 16.2  
 C3 = 19.9 C6 = 13.3

MIDPOINT OF DAMAGE: D = 31.5  
 (Vehicle Longitudinal Centerline)  
 LENGTH OF DAMAGE REGION: L = 63.0

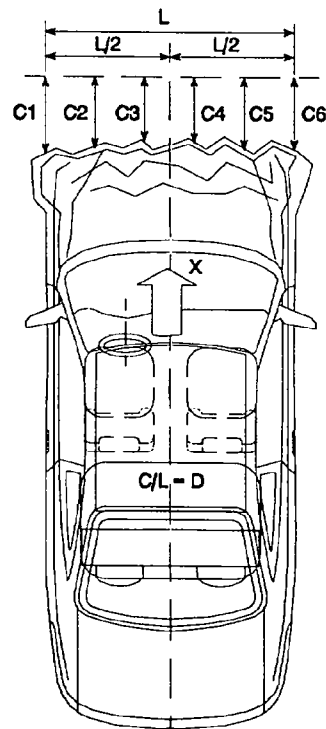

Remarks: None

Table 17  
TEST VEHICLE NONCOMPLIANCE NOTICE

NHTSA Contract Lab : Calspan Advanced Technology Center  
Lab Project Manager & Telephone No. : David J.Travale (716) 632 - 7500  
Date of Test : July 12, 1994 Vehicle NHTSA No. : CR0313  
Vehicle Manufacturer : CHRYSLER CORPORATION  
Model Year : 1994 VIN : 2B4GH25K3RR625683  
Model : Caravan Body Style: Van Build Date : 12/93  
Dummy Stabilized Temperature at Time of Test : 70 °F (Spec. = 69 - 72 °F)  
Impact Velocity : 29.1 mph; Time of Test : 14:33  
Type of Automatic Restraint System :  
Driver : Air bag  
Passenger : Air bag

Failure Details :

The vehicle, as tested, appears to meet the requirements of FMVSS Nos. 208, 212, 219 (partial), and 301.

---

Appendix A  
PHOTOGRAPHS

## LIST OF PHOTOGRAPHS

<u>Figure</u>	<u>Photograph Title</u>	<u>Page No.</u>
A-1	PRE-TEST FRONT VIEW . . . . .	A-3
A-2	POST-TEST FRONT VIEW . . . . .	A-4
A-3	PRE-TEST LEFT SIDE VIEW . . . . .	A-5
A-4	POST-TEST LEFT SIDE VIEW . . . . .	A-6
A-5	PRE-TEST RIGHT SIDE VIEW . . . . .	A-7
A-6	POST-TEST RIGHT SIDE VIEW . . . . .	A-8
A-7	PRE-TEST RIGHT FRONT THREE-QUARTER VIEW . . . . .	A-9
A-8	POST-TEST RIGHT FRONT THREE-QUARTER VIEW . . . . .	A-10
A-9	PRE-TEST LEFT REAR THREE-QUARTER VIEW . . . . .	A-11
A-10	POST-TEST LEFT REAR THREE-QUARTER VIEW . . . . .	A-12
A-11	PRE-TEST WINDSHIELD VIEW . . . . .	A-13
A-12	POST-TEST WINDSHIELD VIEW . . . . .	A-14
A-13	PRE-TEST ENGINE COMPARTMENT VIEW . . . . .	A-15
A-14	POST-TEST ENGINE COMPARTMENT VIEW . . . . .	A-16
A-15	PRE-TEST FUEL FILLER CAP PHOTO . . . . .	A-17
A-16	POST-TEST FUEL FILLER CAP PHOTO . . . . .	A-18
A-17	PRE-TEST FRONT UNDERBODY VIEW . . . . .	A-19
A-18	POST-TEST FRONT UNDERBODY VIEW . . . . .	A-20
A-19	PRE-TEST FRONT SIDE UNDERBODY VIEW . . . . .	A-21
A-20	POST-TEST FRONT SIDE UNDERBODY VIEW . . . . .	A-22
A-21	PRE-TEST REAR UNDERBODY VIEW . . . . .	A-23
A-22	POST-TEST REAR UNDERBODY VIEW . . . . .	A-24
A-23	PRE-TEST DRIVER SIDE VIEW . . . . .	A-25
A-24	POST-TEST DRIVER SIDE VIEW . . . . .	A-26
A-25	PRE-TEST DRIVER FRONT VIEW . . . . .	A-27
A-26	POST-TEST DRIVER FRONT VIEW . . . . .	A-28
A-27	PRE-TEST DRIVER DUMMY AND INTERIOR VIEW . . . . .	A-29
A-28	POST-TEST DRIVER DUMMY AND INTERIOR VIEW . . . . .	A-30
A-29	PRE-TEST PASSENGER SIDE VIEW . . . . .	A-31
A-30	POST-TEST PASSENGER SIDE VIEW . . . . .	A-32
A-31	PRE-TEST PASSENGER FRONT VIEW . . . . .	A-33
A-32	POST-TEST PASSENGER FRONT VIEW . . . . .	A-34
A-33	PRE-TEST PASSENGER DUMMY AND INTERIOR VIEW . . . . .	A-35
A-34	POST-TEST PASSENGER DUMMY AND INTERIOR VIEW . . . . .	A-36
A-35	PRE-TEST STEERING SHAFT . . . . .	A-37
A-36	POST-TEST STEERING SHAFT (Not Available) . . . . .	A-38
A-37	PRE-TEST STEERING COLUMN/FIREWALL INSIDE VIEW . . . . .	A-39
A-38	POST-TEST STEERING COLUMN/FIREWALL INSIDE VIEW . . . . .	A-40
A-39	POST-TEST DRIVER KNEE BOLSTER . . . . .	A-41
A-40	POST-TEST PASSENGER GLOVE BOX DOOR . . . . .	A-42
A-41	POST-TEST VEHICLE TOP VIEW . . . . .	A-43
A-42	VEHICLE IMPACT . . . . .	A-44
A-43	CERTIFICATION PLACARD . . . . .	A-45
A-44	TIRE PLACARD . . . . .	A-46
A-45	POST-TEST DRIVER AIRBAG VIEW . . . . .	A-47
A-46	POST-TEST PASSENGER AIRBAG VIEW . . . . .	A-48
A-47	POST-TEST DRIVER HEAD CONTACT . . . . .	A-49
A-48	POST-TEST DRIVER ABDOMEN CONTACT . . . . .	A-50
A-49	PRE-TEST INTEGRATED CHILD SEATS LEFT SIDE VIEW . . . . .	A-51
A-50	POST-TEST INTEGRATED CHILD SEATS LEFT SIDE VIEW . . . . .	A-52

LIST OF PHOTOGRAPHS (Cont'd)

<u>Figure</u>	<u>Photograph Title</u>	<u>Page No.</u>
A-51	PRE-TEST INTEGRATED CHILD SEATS LEFT FRONT QUARTER VIEW	A-53
A-52	POST-TEST INTEGRATED CHILD SEATS LEFT FRONT QUARTER VIEW	A-54
A-53	PRE-TEST INTEGRATED CHILD SEATS RIGHT SIDE VIEW . . . . .	A-55
A-54	POST-TEST INTEGRATED CHILD SEATS RIGHT SIDE VIEW . . . . .	A-56
A-55	PRE-TEST INTEGRATED CHILD SEATS RIGHT FRONT QUARTER VIEW	A-57
A-56	POST-TEST INTEGRATED CHILD SEATS RIGHT FRONT QUARTER VIEW	A-58

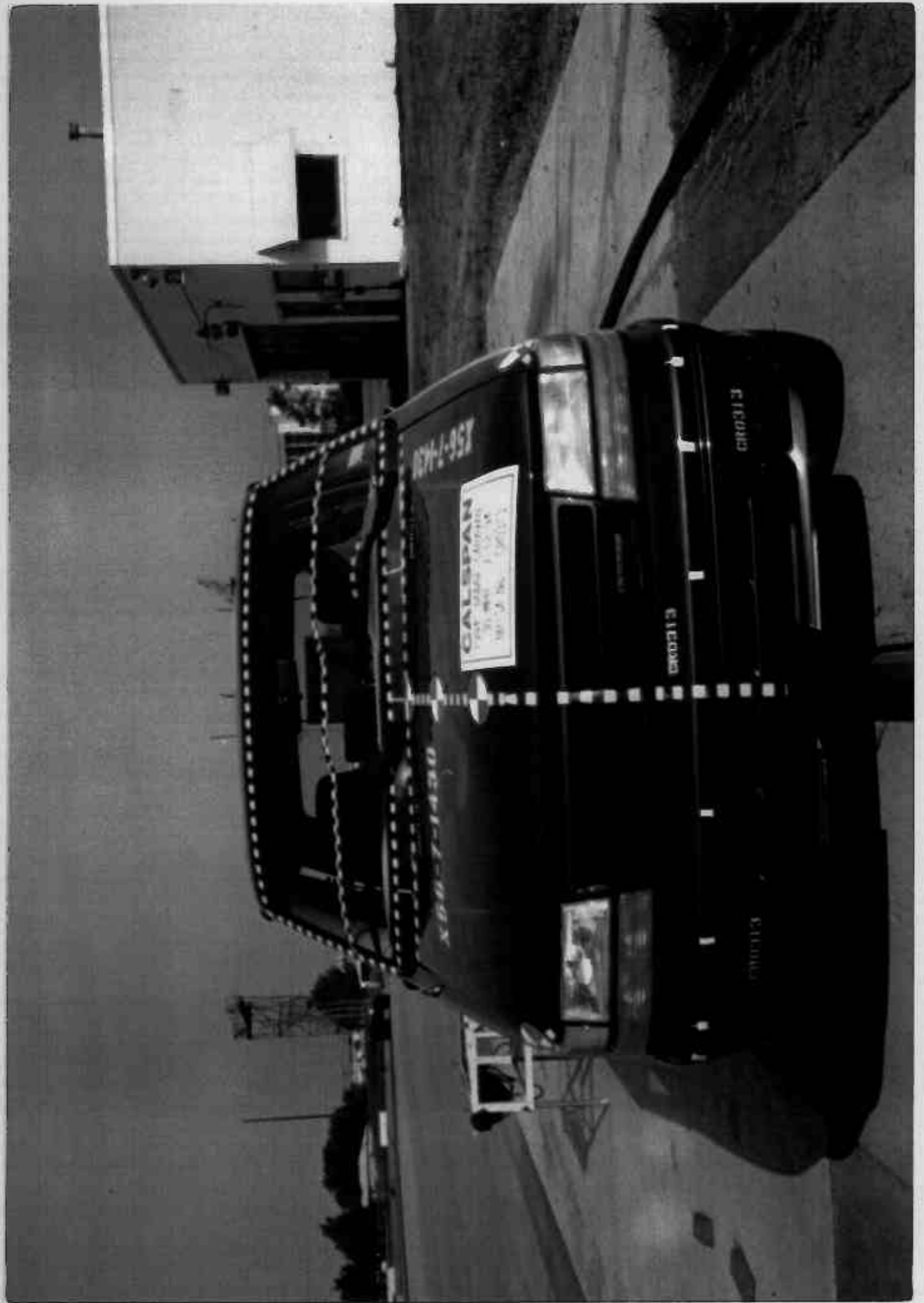

Figure A-1 PRE-TEST FRONT VIEW



Figure A-2 POST-TEST FRONT VIEW

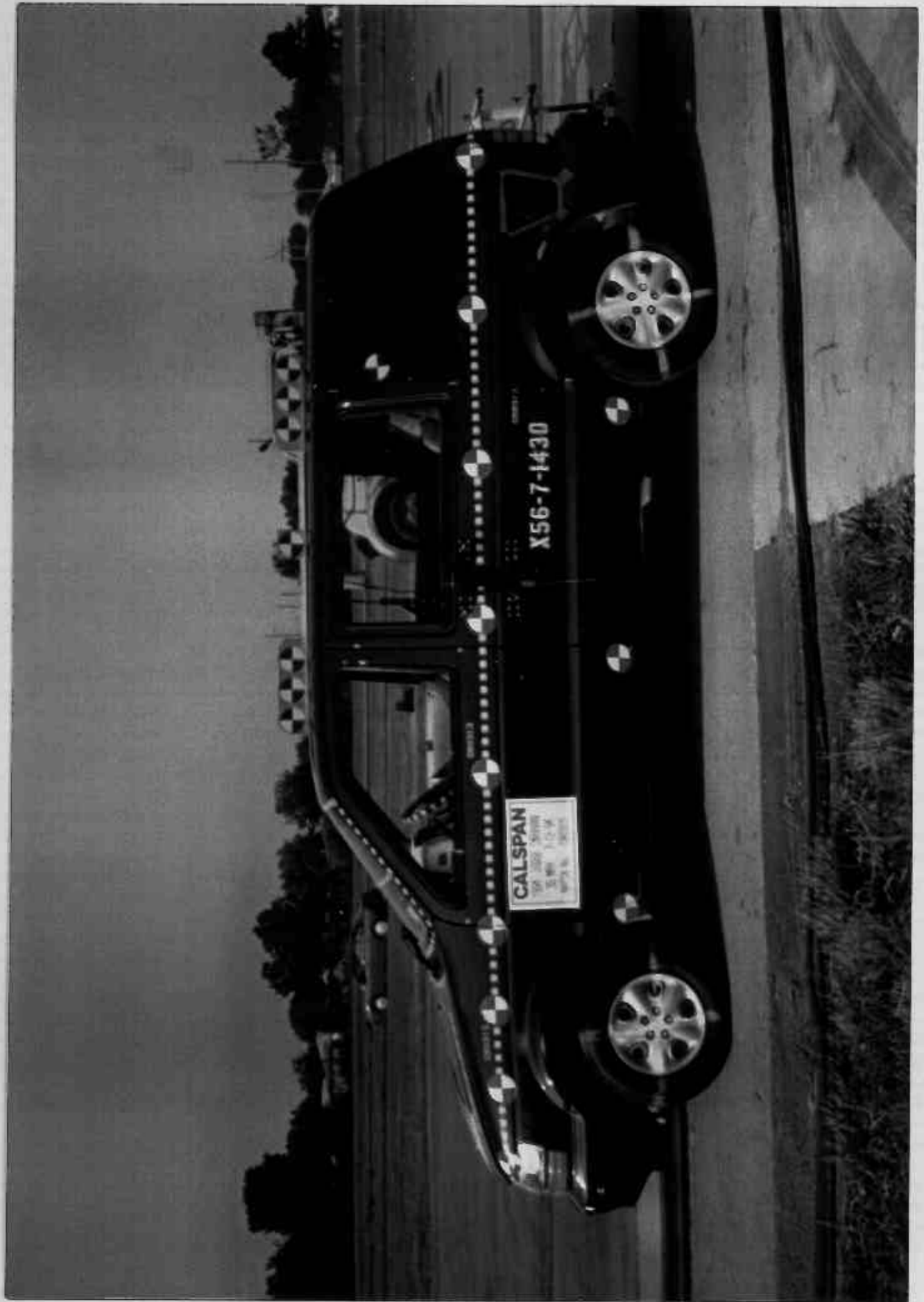

Figure A-3 PRE-TEST LEFT SIDE VIEW

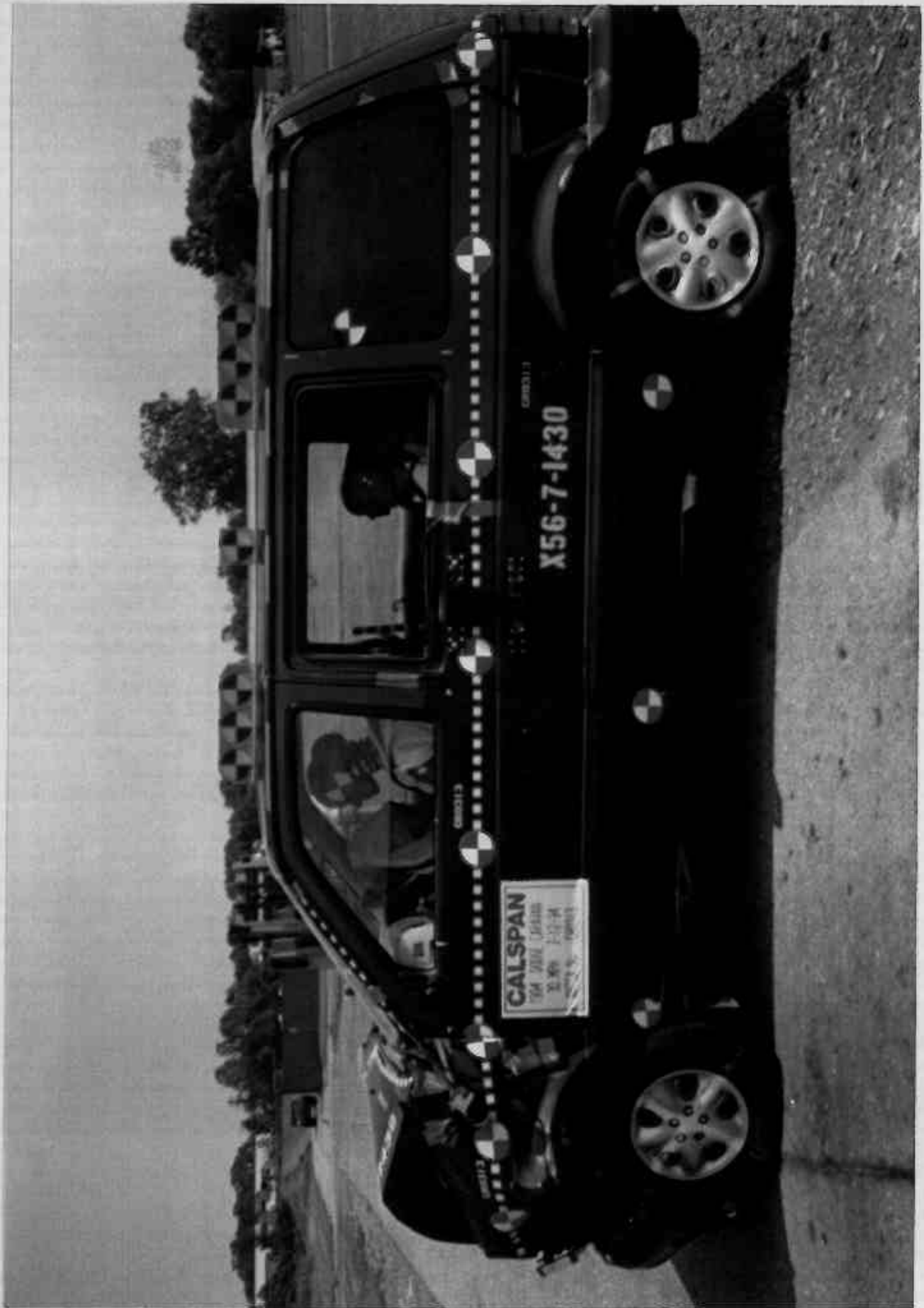

Figure A-4 POST-TEST LEFT SIDE VIEW

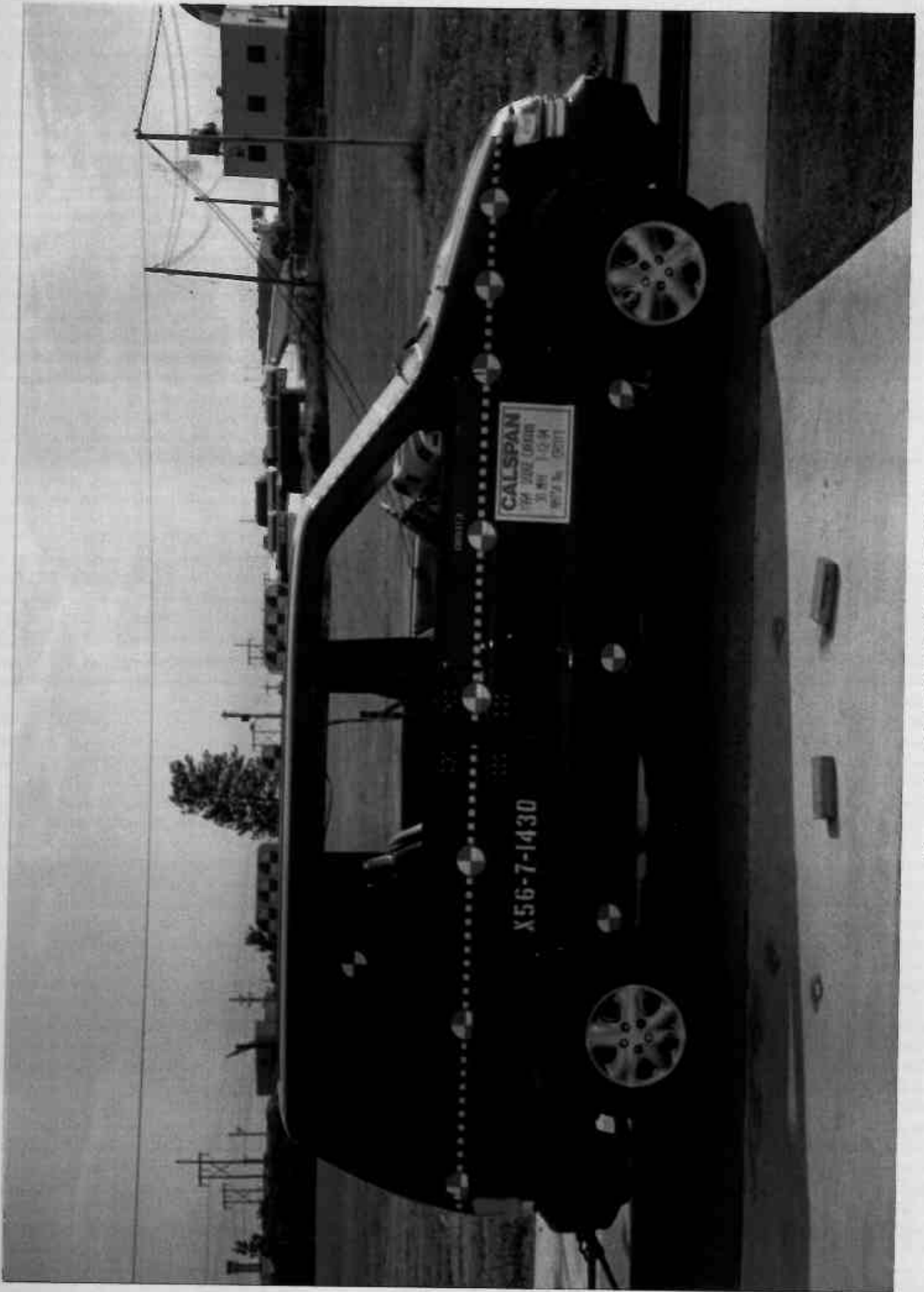

Figure A-5 PRE-TEST RIGHT SIDE VIEW

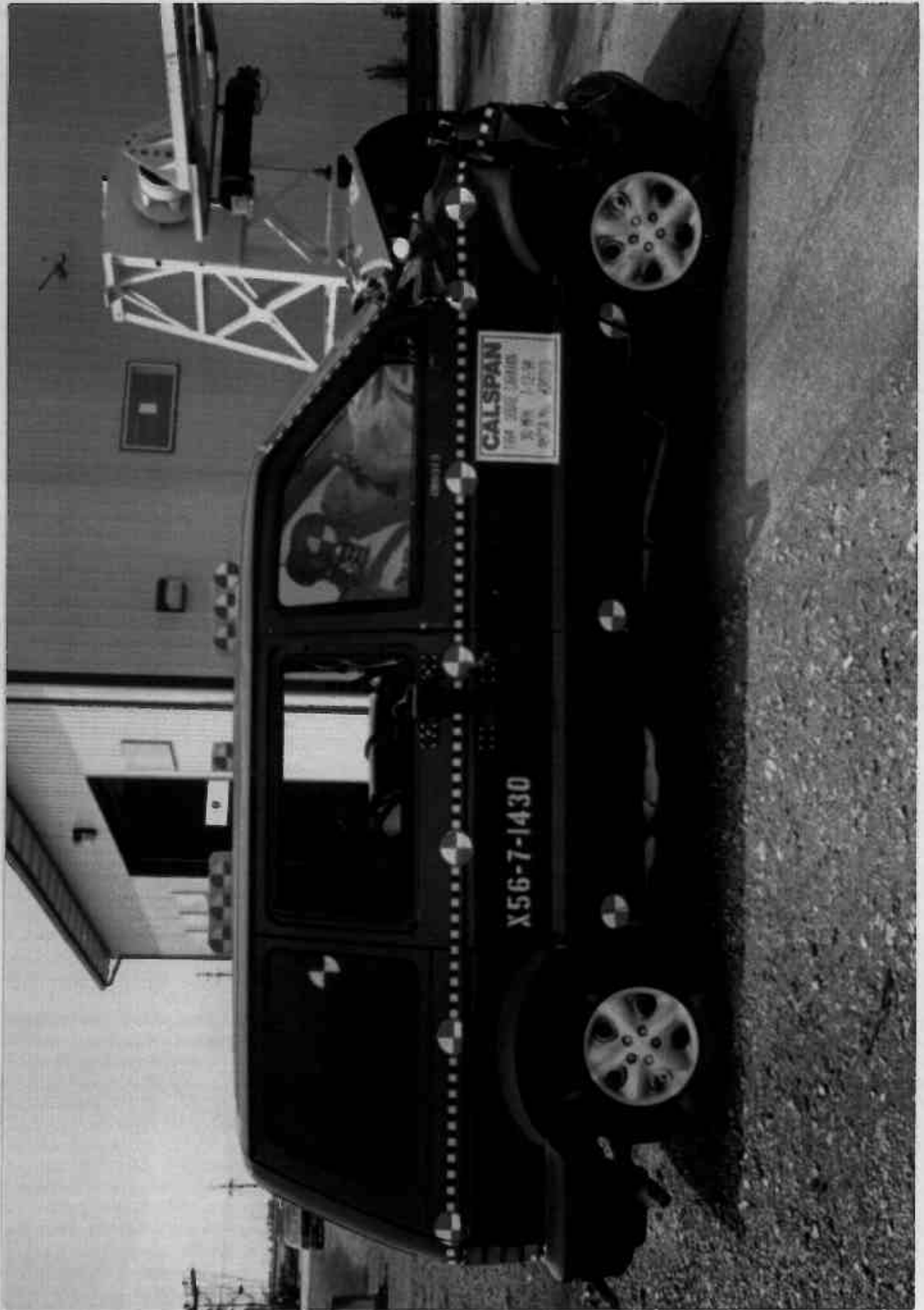

Figure A-6 POST-TEST RIGHT SIDE VIEW

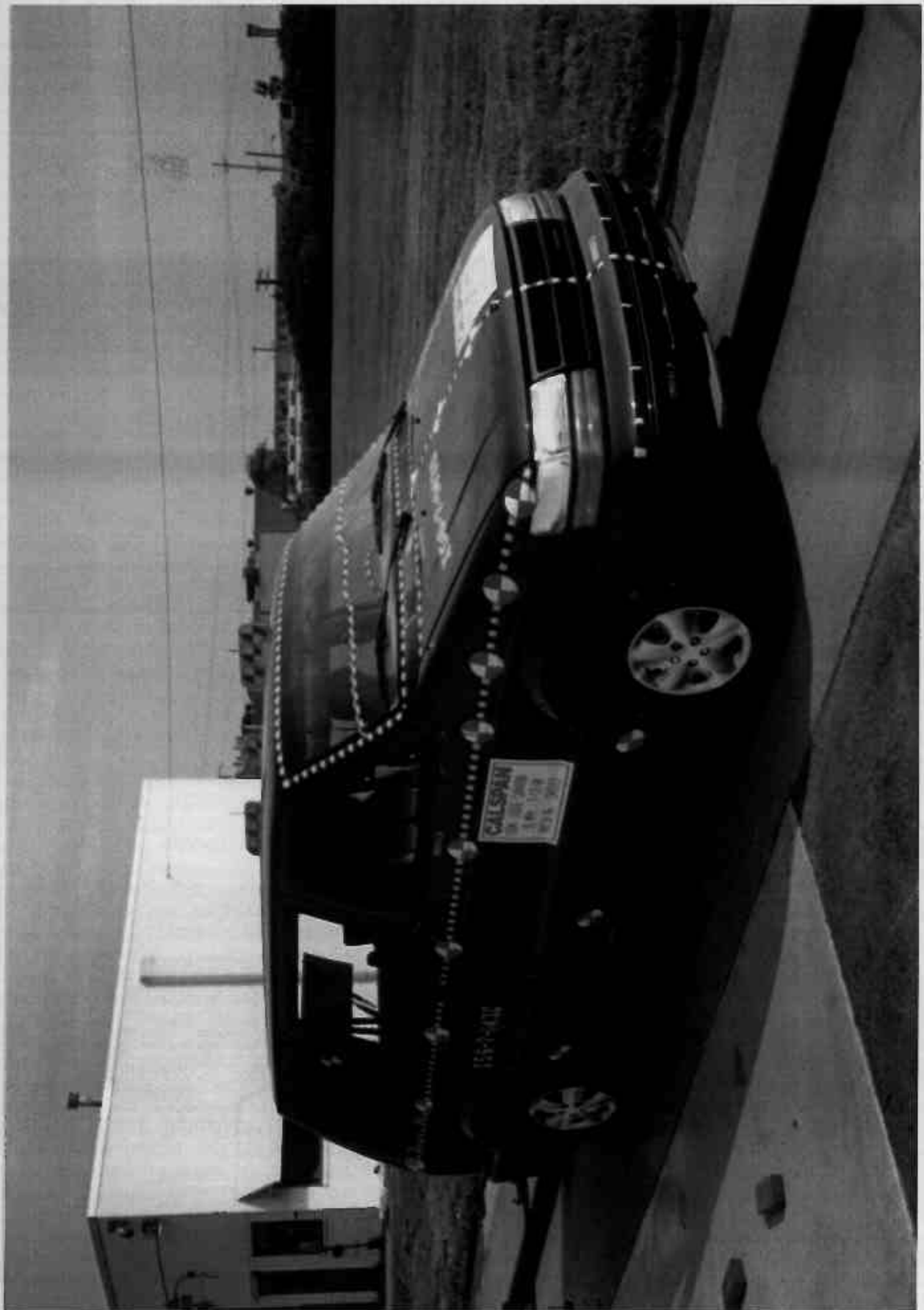

Figure A-7 PRE-TEST RIGHT FRONT THREE-QUARTER VIEW



Figure A-8 POST-TEST RIGHT FRONT THREE-QUARTER VIEW



Figure A-9 PRE-TEST LEFT REAR THREE-QUARTER VIEW



Figure A-10 POST-TEST LEFT REAR THREE-QUARTER VIEW

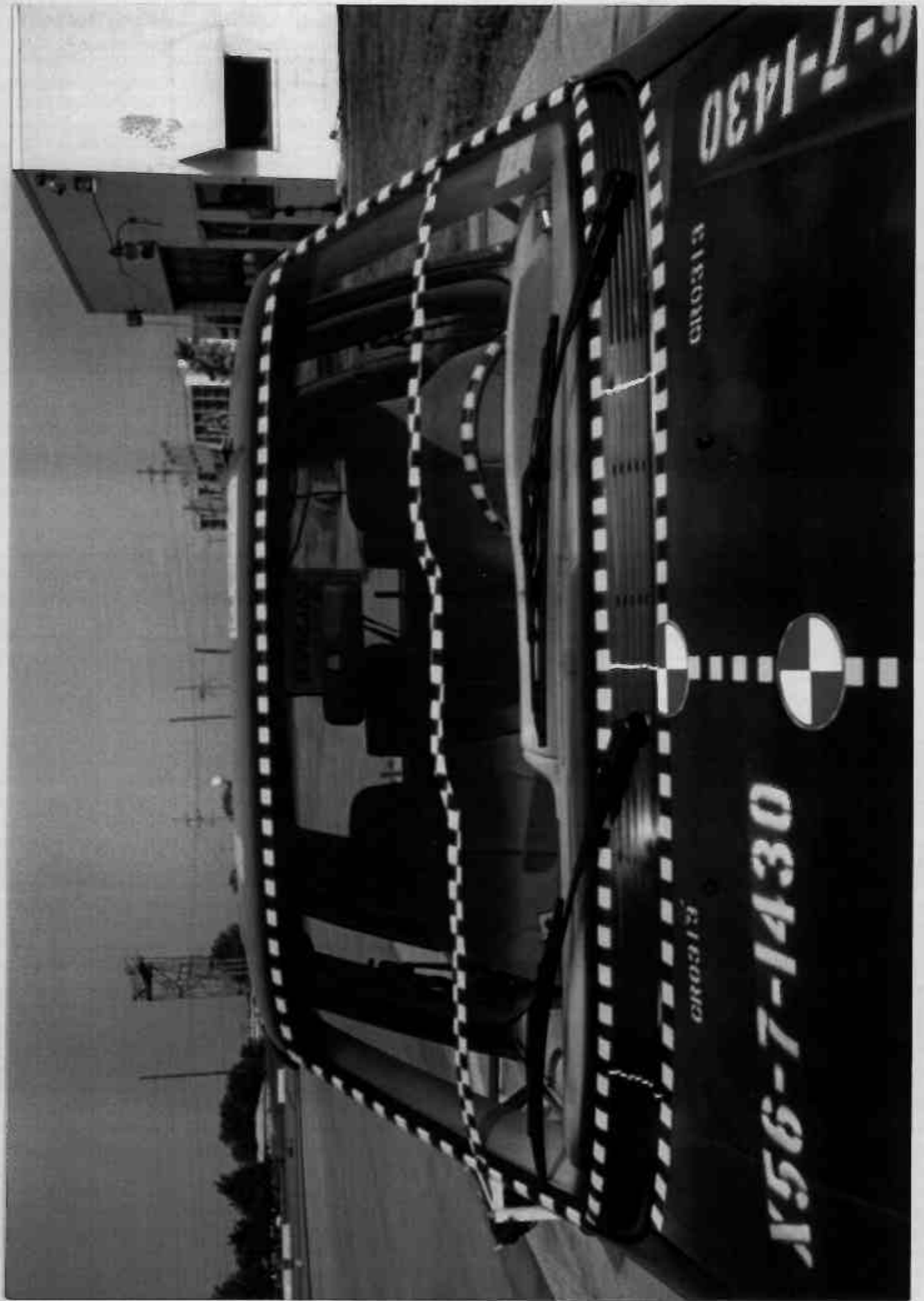

CR0313

6-7-1430

CR0313

156-7-1430

Figure A-11 PRE-TEST WINDSHIELD VIEW



Figure A-12 POST-TEST WINDSHIELD VIEW



Figure A-13 PRE-TEST ENGINE COMPARTMENT VIEW



Figure A-14 POST-TEST ENGINE COMPARTMENT VIEW



Figure A-15 PRE-TEST FUEL FILLER CAP PHOTO

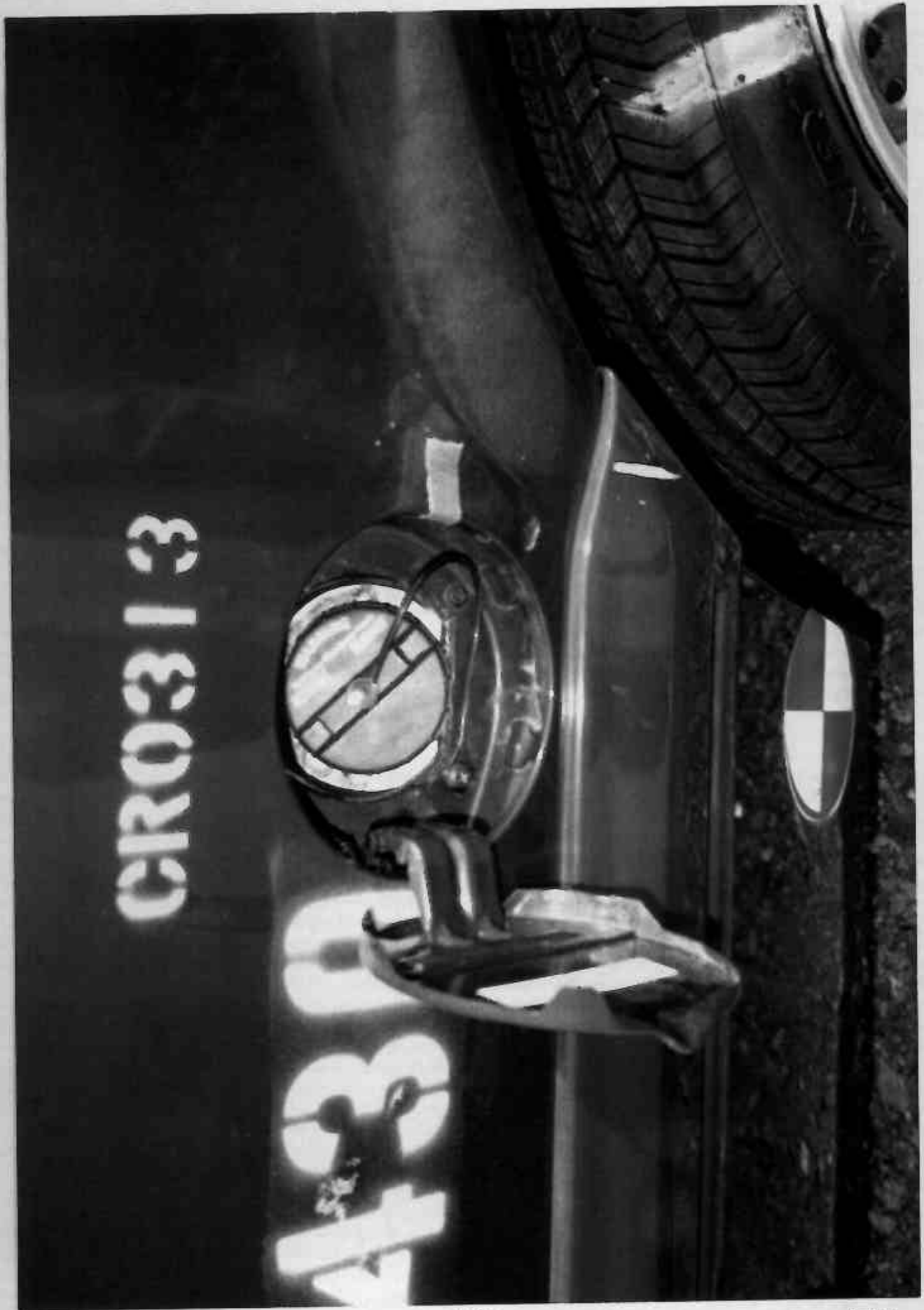

Figure A-16 POST-TEST FUEL FILLER CAP PHOTO



Figure A-17 PRE-TEST FRONT UNDERBODY VIEW



Figure A-18 POST-TEST FRONT UNDERBODY VIEW



Figure A-19 PRE-TEST FRONT SIDE UNDERBODY VIEW



Figure A-20 POST-TEST FRONT SIDE UNDERBODY VIEW

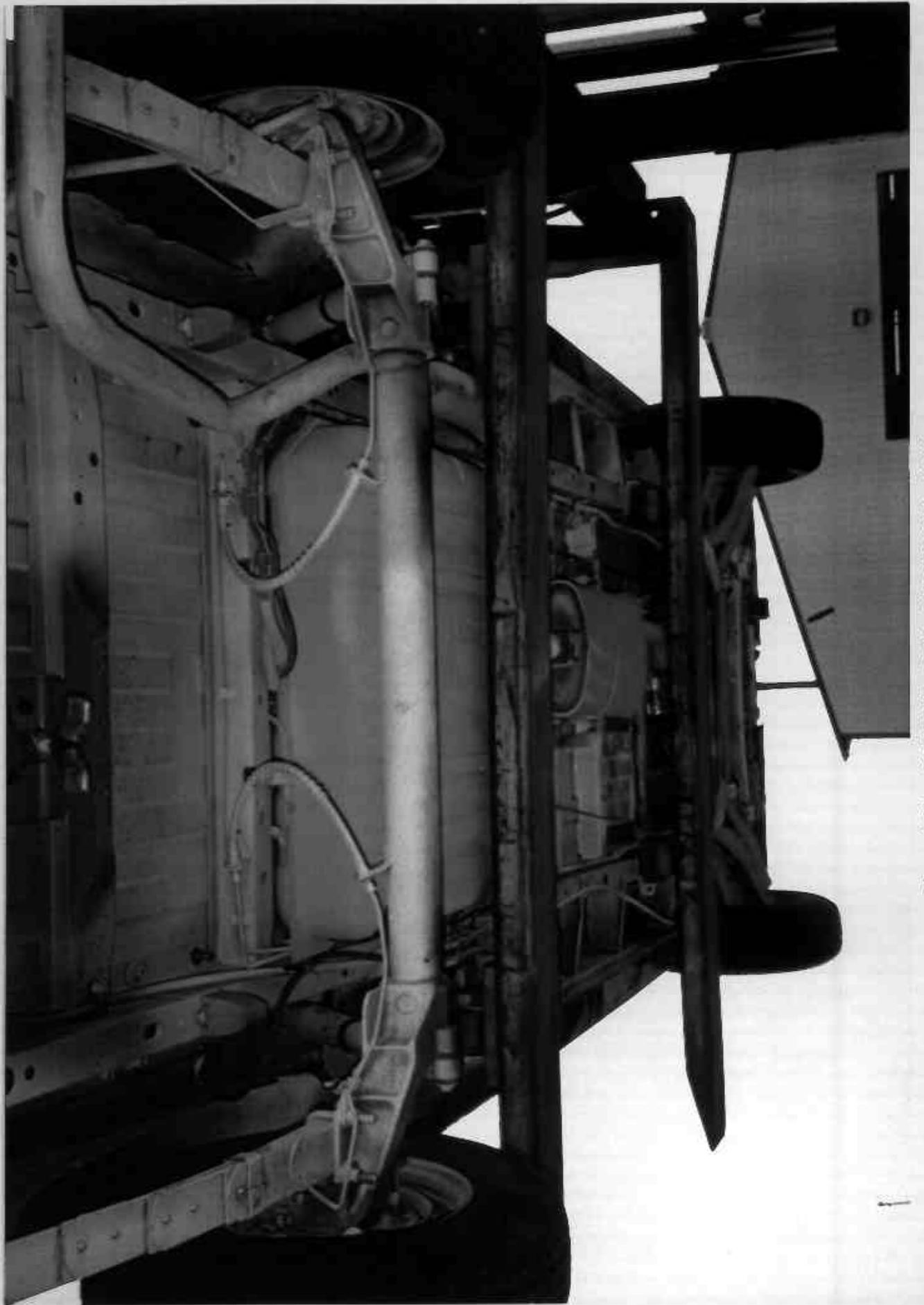

Figure A-21 PRE-TEST REAR UNDERBODY VIEW

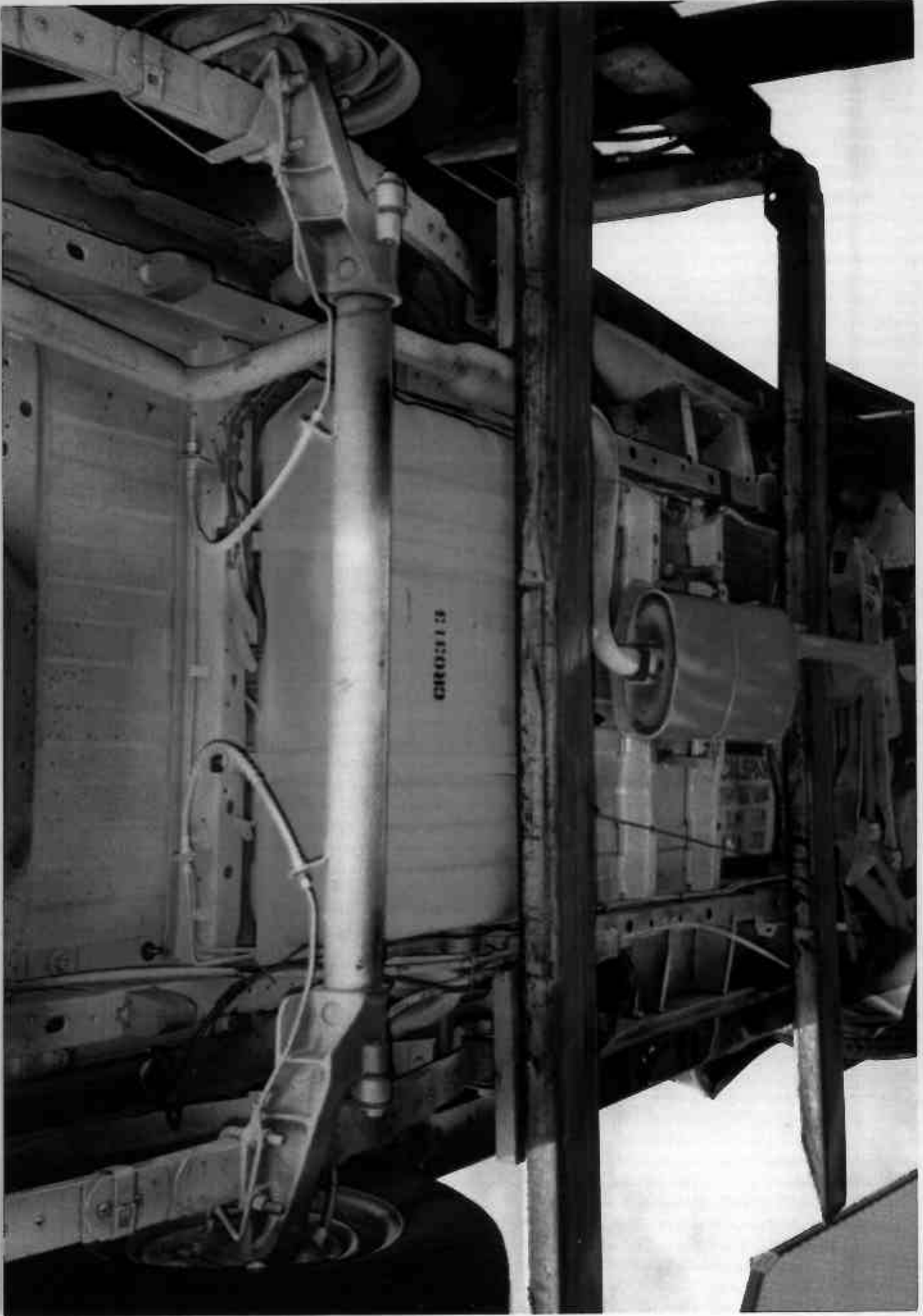

Figure A-22 POST-TEST REAR UNDERBODY VIEW



Figure A-23 PRE-TEST DRIVER SIDE VIEW  
A-26



Figure A-24 POST-TEST DRIVER SIDE VIEW  
A-27



Figure A-25 PRE-TEST DRIVER FRONT VIEW  
A-28



Figure A-26 POST-TEST DRIVER FRONT VIEW  
A-29

8183-7



Figure A-27 PRE-TEST DRIVER DUMMY AND INTERIOR VIEW

A-30

8183-7



Figure A-28 POST-TEST DRIVER DUMMY AND INTERIOR VIEW

A-31

8183-7



Figure A-29 PRE-TEST PASSENGER SIDE VIEW  
A-32



Figure A-30 POST-TEST PASSENGER SIDE VIEW  
A-33



Figure A-31 PRE-TEST PASSENGER FRONT VIEW  
A-34

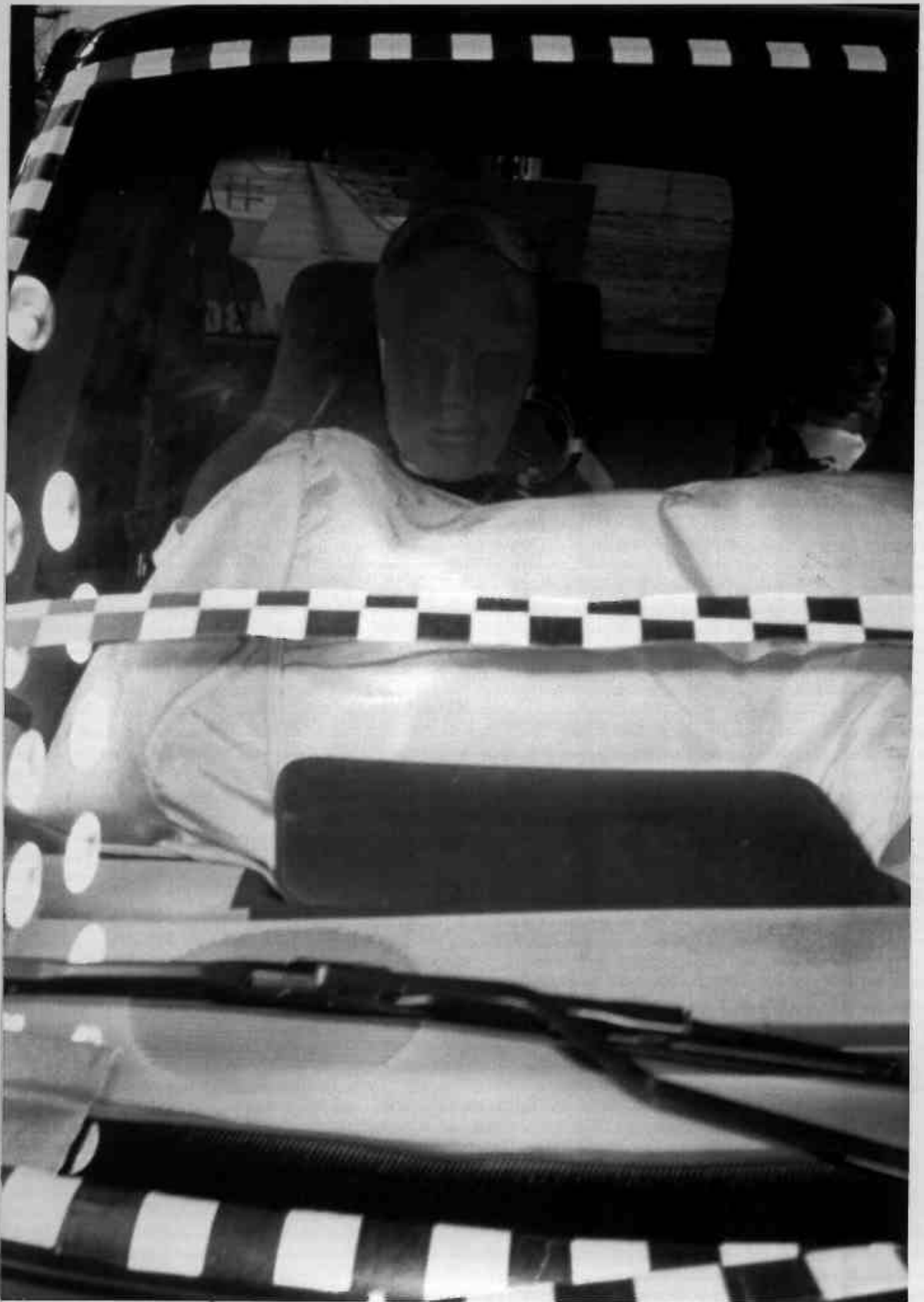

Figure A-32 POST-TEST PASSENGER FRONT VIEW  
A-35

8183-7



Figure A-33 PRE-TEST PASSENGER DUMMY AND INTERIOR VIEW

A-36

8183-7



Figure A-34 POST-TEST PASSENGER DUMMY AND INTERIOR VIEW

A-37

8183-7



Figure A-35 PRE-TEST STEERING SHAFT

A-38

8183-7

PHOTOGRAPH NOT AVAILABLE



Figure A-37 PRE-TEST STEERING COLUMN/FIREWALL INSIDE VIEW



Figure A-38 . POST-TEST STEERING COLUMN/FIREWALL INSIDE VIEW

A-41

8183-7



Figure A-39 POST-TEST DRIVER KNEE BOLSTER



Figure A-40 POST-TEST PASSENGER GLOVE BOX DOOR

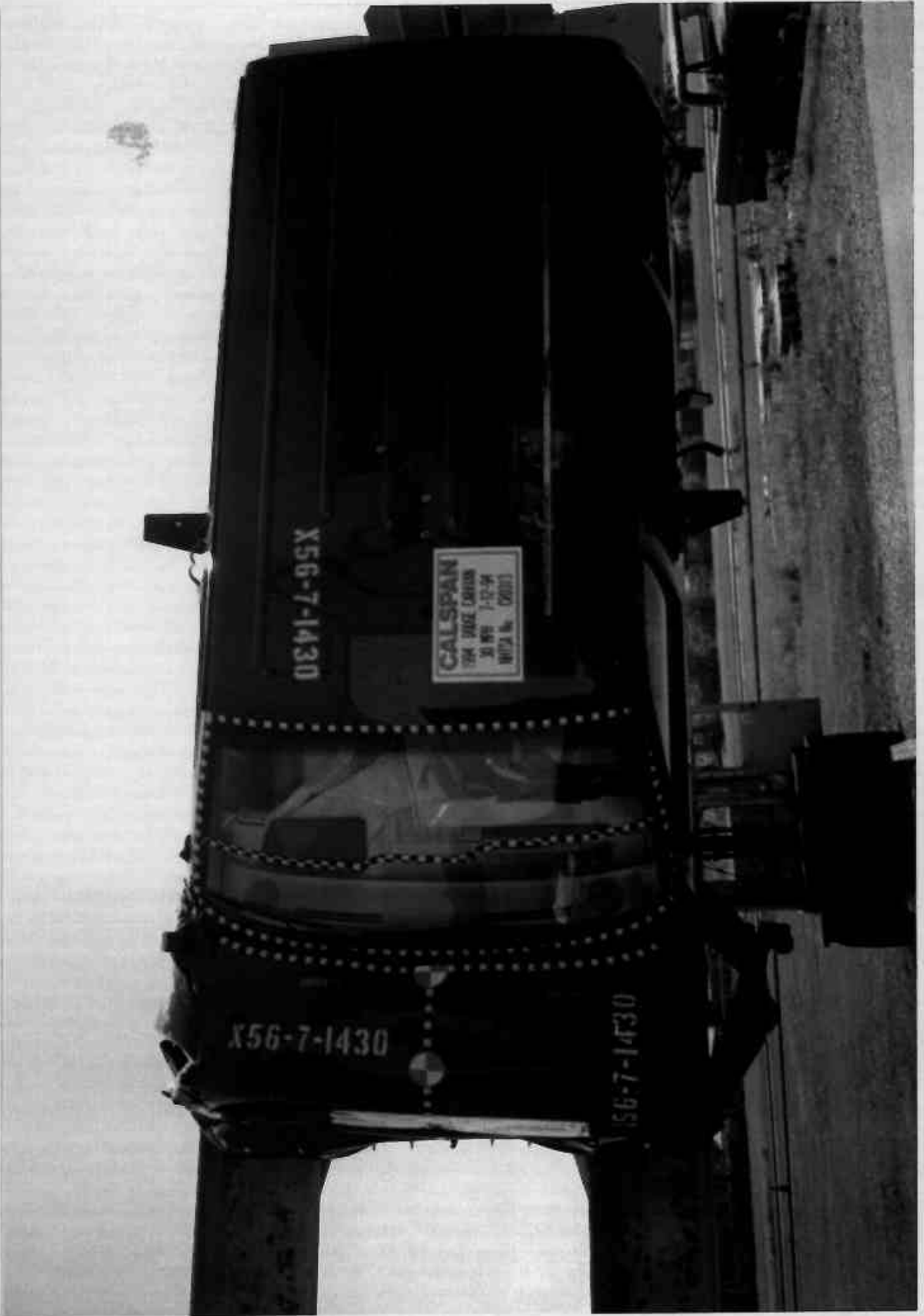

Figure A-41 POST-TEST VEHICLE TOP VIEW

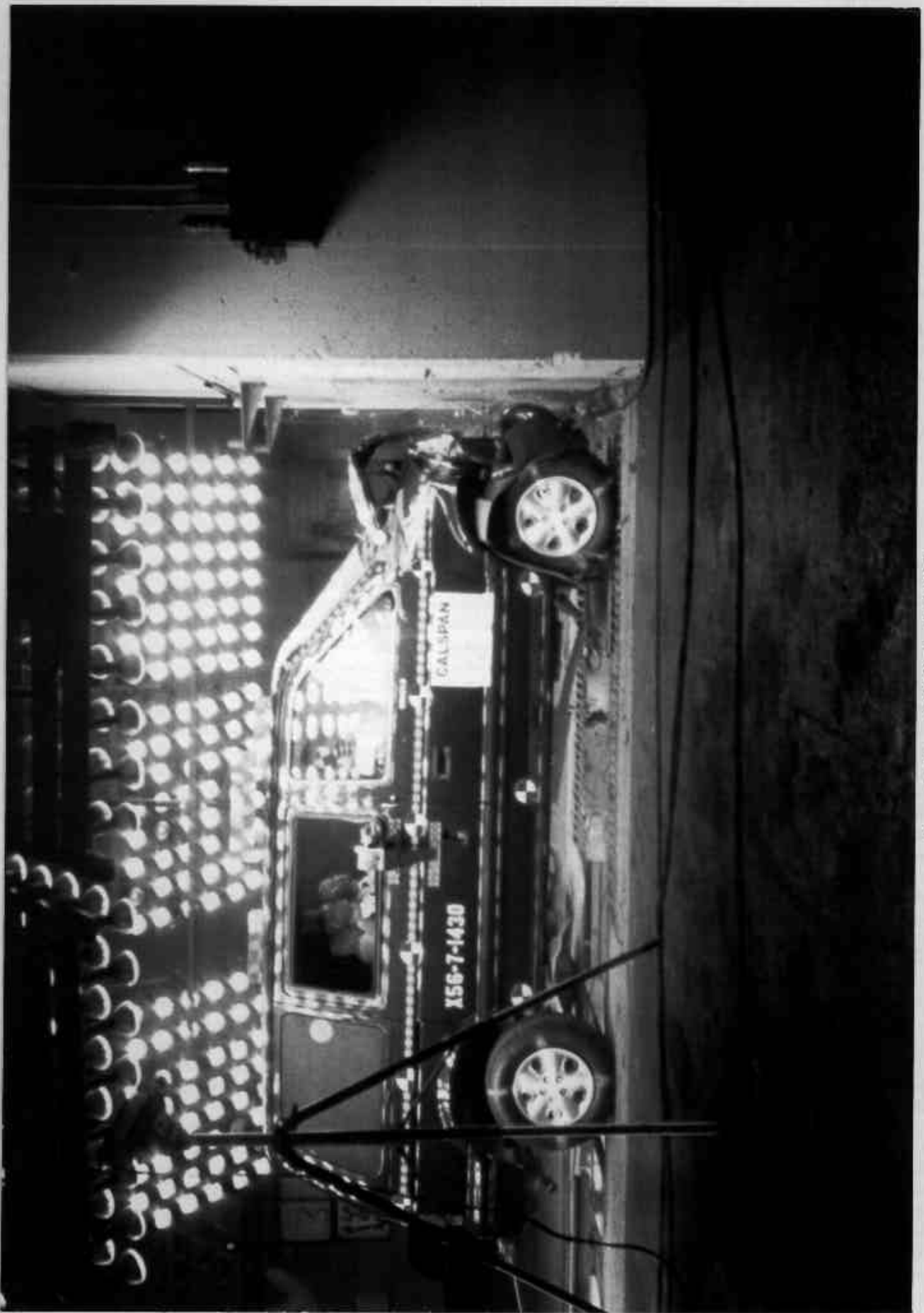

Figure A-42 VEHICLE IMPACT

DATE OF MFG	12-83	DATE OF MFG	12-83
CHRYSLER CORPORATION		CHRYSLER CORPORATION	
25-44 J 1:54 CG	P185/75R14	25-44 J 1:54 CG	P185/75R14
25-44 J 1:54 CG	P185/75R14	25-44 J 1:54 CG	P185/75R14

THIS VEHICLE CONFORMS TO ALL APPLICABLE FEDERAL MOTOR VEHICLE SAFETY STANDARDS IN EFFECT ON THE DATE OF MANUFACTURE SHOWN ABOVE.

VIN: 2B4GJ25K300025560 TYPE: TPV SINGLE X 20A

128721 528 VEHICLE MADE IN CANADA

65044 LB 2287 CG  
 14 X 5.5 P185/75R14  
 14 X 5.5 P185/75R14

Figure A-43 CERTIFICATION LABEL





Figure A-45 POST-TEST DRIVER AIRBAG VIEW



Figure A-46 POST-TEST PASSENGER AIRBAG VIEW

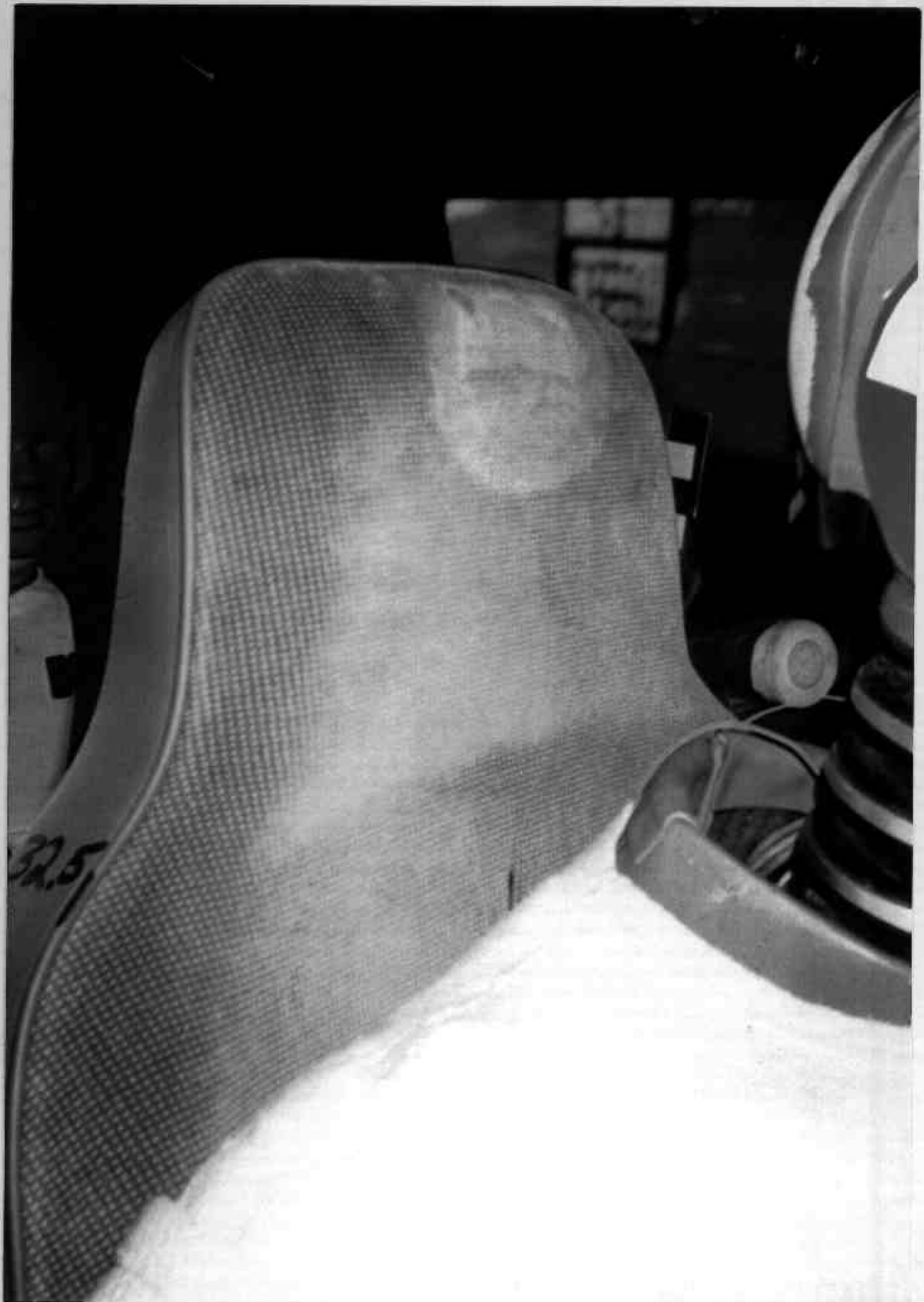

Figure A-47 POST-TEST DRIVER HEAD CONTACT  
A-50



Figure A-48 POST-TEST DRIVER ABDOMEN CONTACT

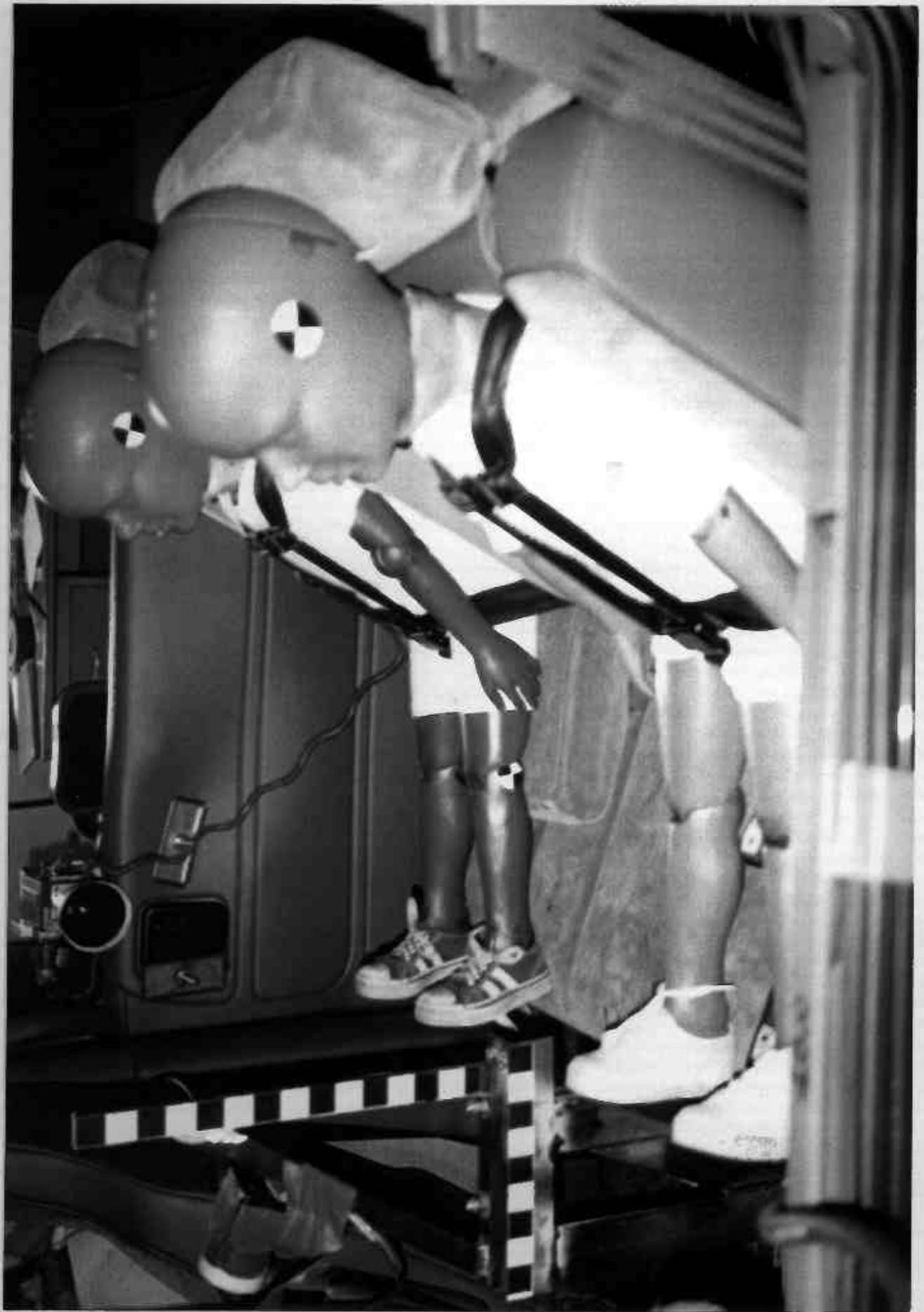

Figure A-49 PRE-TEST INTEGRATED CHILD SEATS LEFT SIDE VIEW

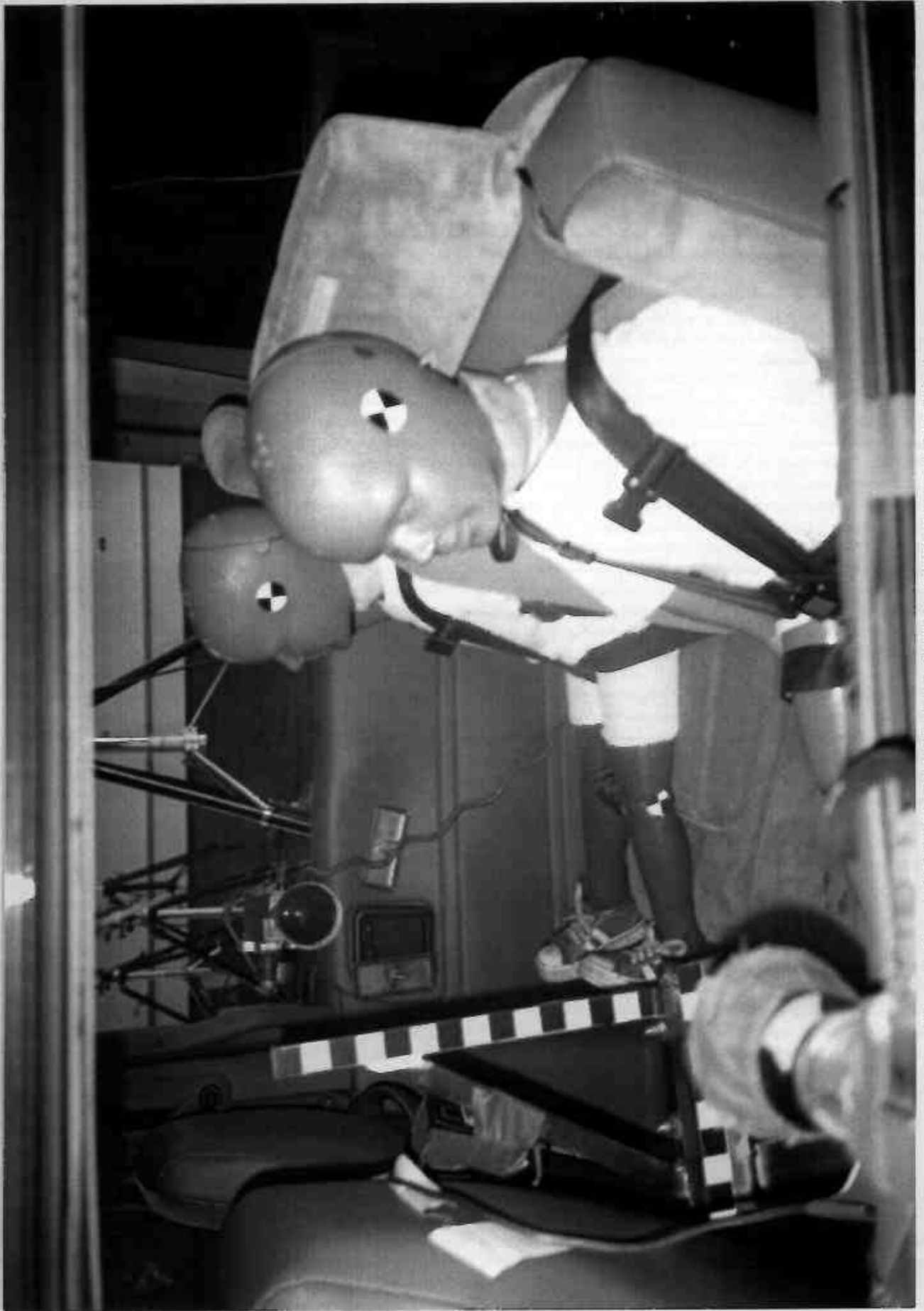

Figure A-50 POST-TEST INTEGRATED CHILD SEATS LEFT SIDE VIEW



Figure A-51 PRE-TEST INTEGRATED CHILD SEATS LEFT FRONT QUARTER VIEW



Figure A-52 POST-TEST INTEGRATED CHILD SEATS LEFT FRONT QUARTER VIEW



Figure A-53 PRE-TEST INTEGRATED CHILD SEATS RIGHT SIDE VIEW

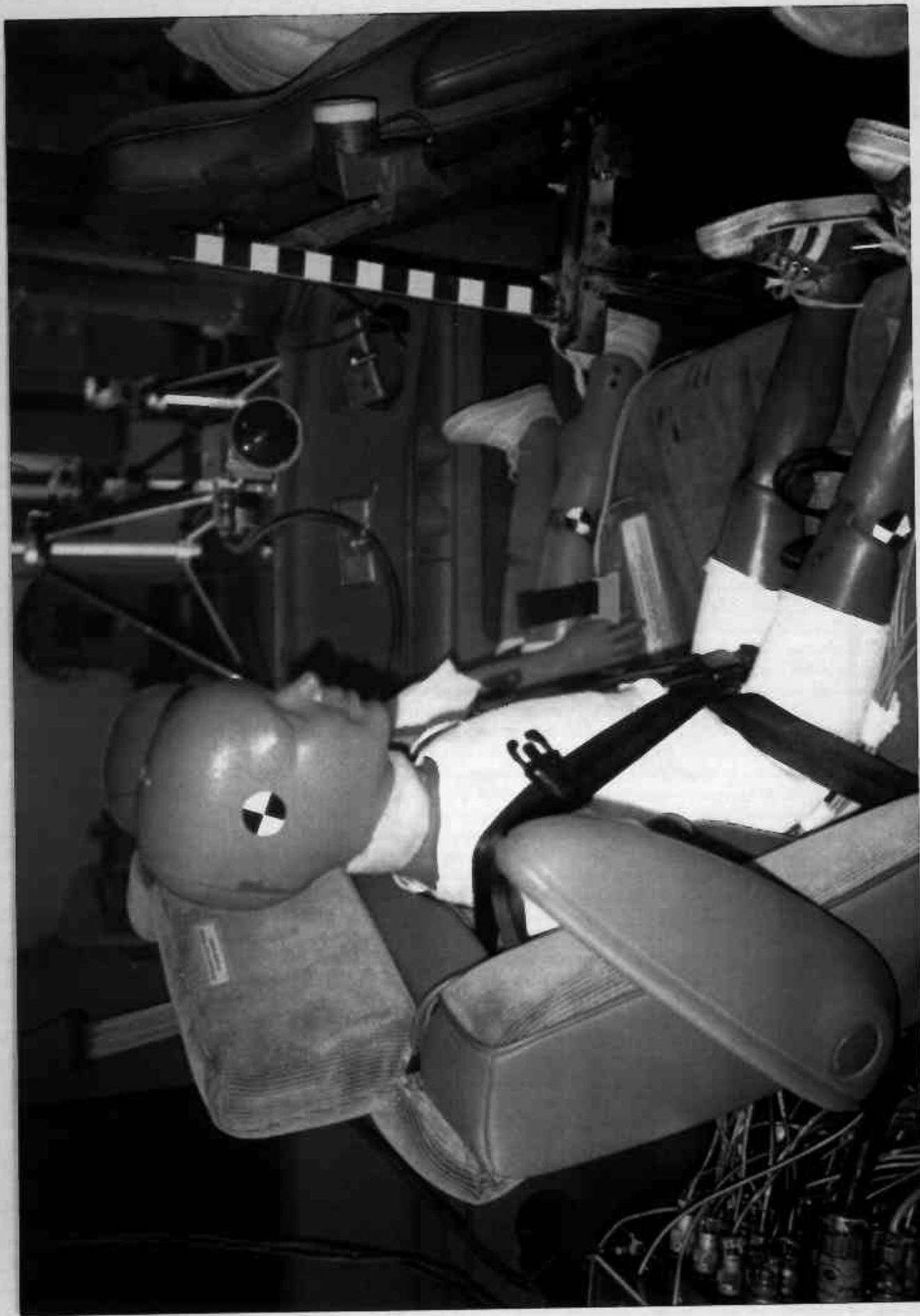

Figure A-54 POST-TEST INTEGRATED CHILD SEATS RIGHT SIDE VIEW



Figure A-55 PRE-TEST INTEGRATED CHILD SEATS RIGHT QUARTER VIEW



Figure A-56 POST-TEST INTEGRATED CHILD SEATS RIGHT FRONT QUARTER VIEW

Appendix B

VEHICLE AND DUMMY RESPONSE DATA

(Part 572E 50th percentile ATD's only)

NOTE : Data trace scales are automatically scaled at the  
request of the COTR. Use caution when  
reviewing data.

TEST NO. CR0313

VEHICLE

SAE FILTER CHANNEL CLASS

60

NHTSA 208 TEST #16 - 1994 Dodge Caravan

L Rear X-member X (#1)

Max = 5.15 Gs @ 124.08 msec  
Min = -42.67 Gs @ 63.48 msec

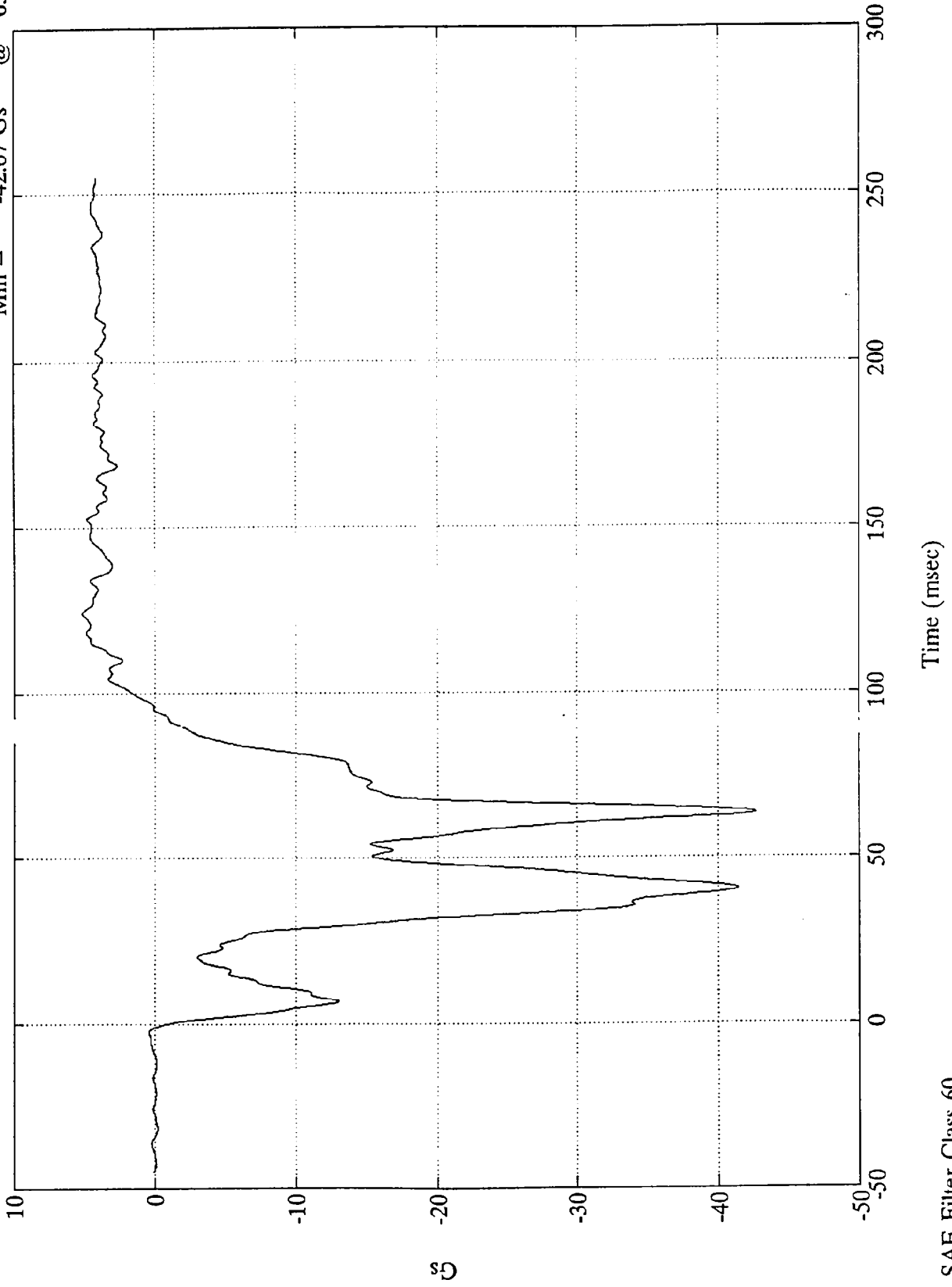

SAE Filter Class 60

NHTSA 208 TEST #16 - 1994 Dodge Caravan

L. Rear X-member X (#1)

Max = 29.10 mph @ 1.68 msec  
Min = -4.06 mph @ 93.84 msec

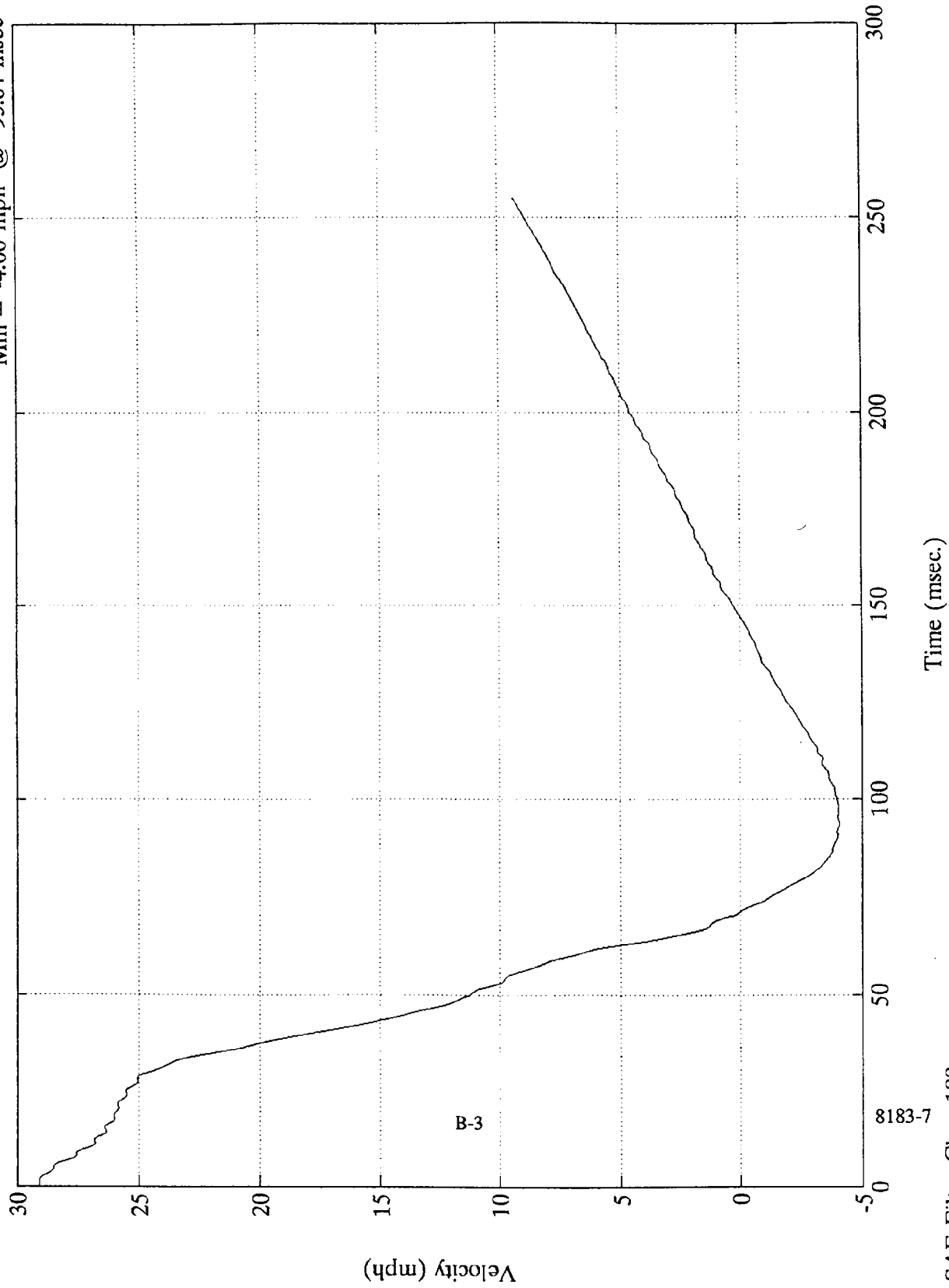

B-3

8183-7

SAE Filter Class 180

NHTSA 208 TEST #16 - 1994 Dodge Caravan

L. Rear X-member X (#1)

Max = 28.17 in. @ 254.88 msec  
Min = 0.00 in. @ -0.00 msec

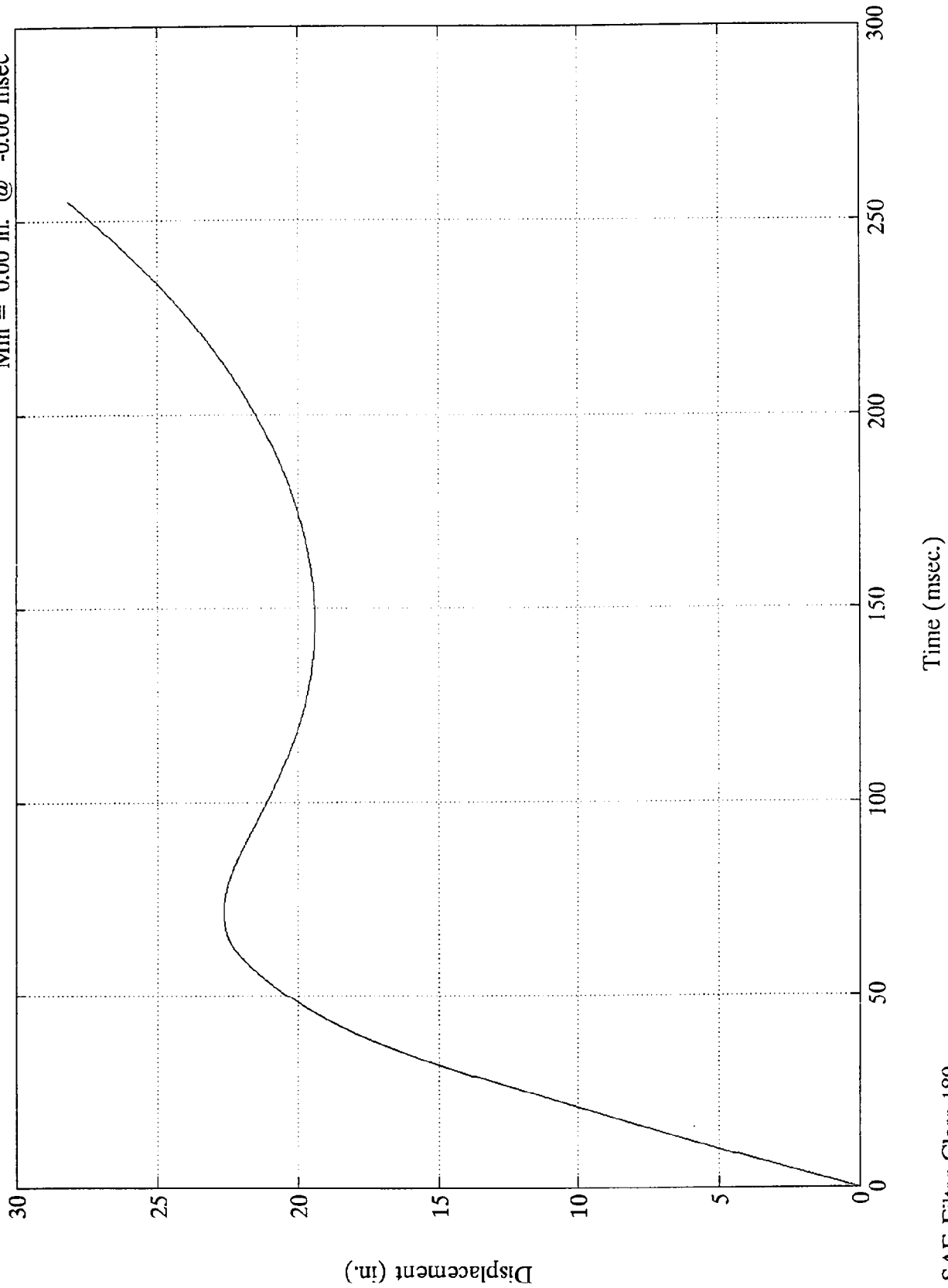

SAE Filter Class 180

NHTSA 208 TEST #16 - 1994 Dodge Caravan

R. Rear X-member X (#2)

Max = 260.34 Gs @ 224.04 msec  
Min = -247.40 Gs @ 96.00 msec

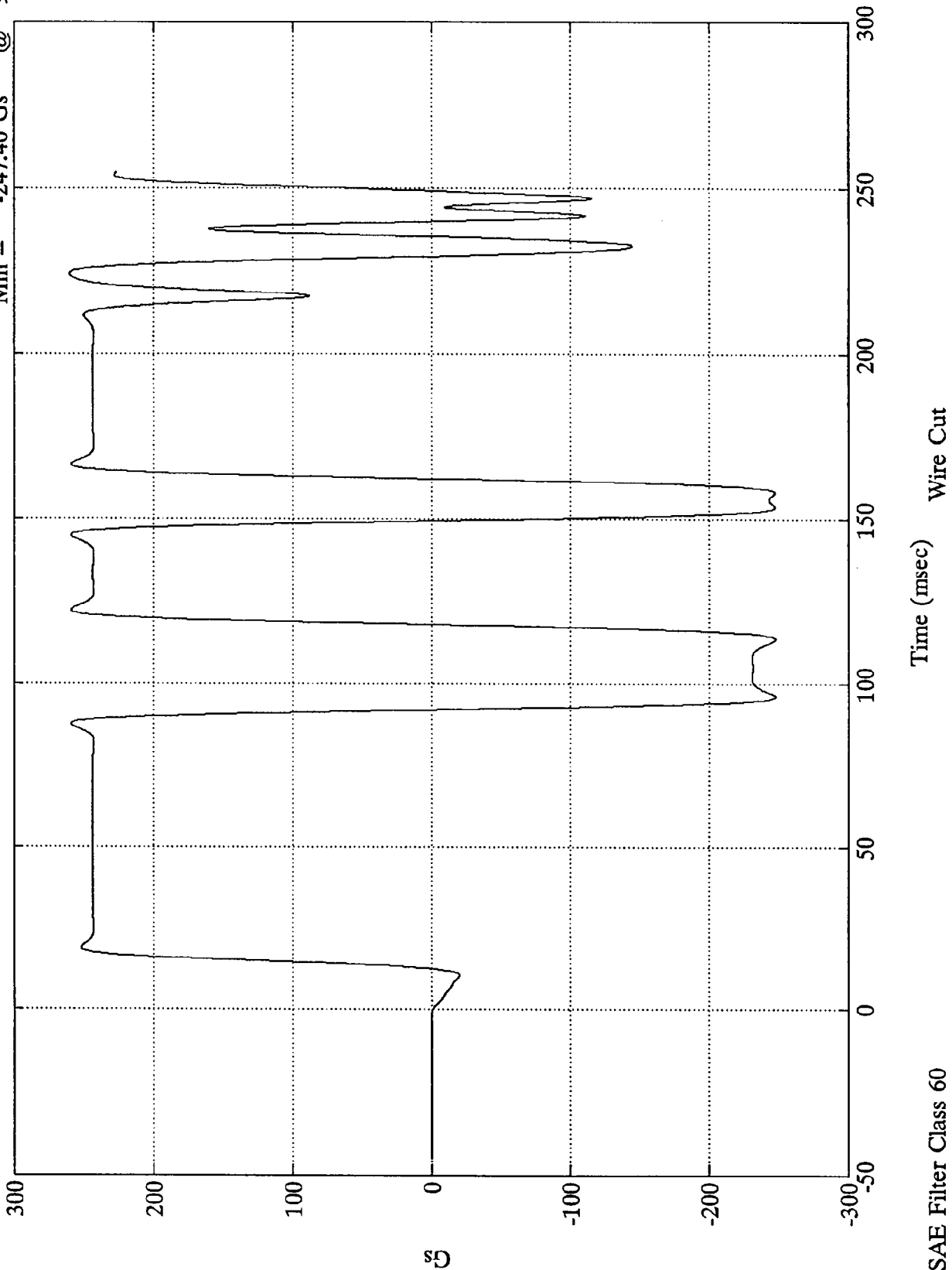

SAE Filter Class 60

Wire Cut

NHTSA 208 TEST #16 - 1994 Dodge Caravan

R. Rear X-member X (#2)

Max = 751.36 mph @ 254.88 msec  
Min = 26.15 mph @ 13.92 msec

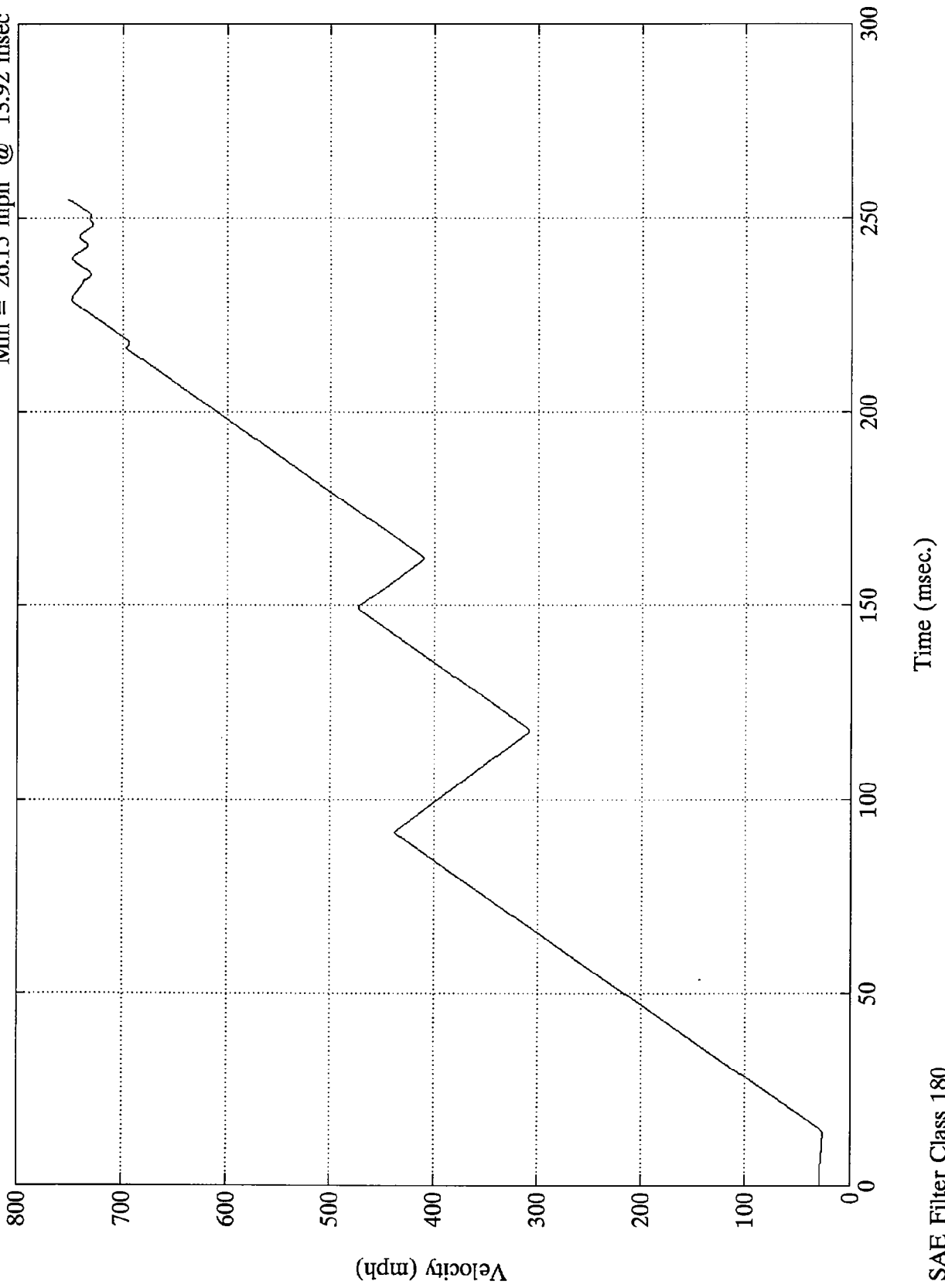

SAE Filter Class 180

NHTSA 208 TEST #16 - 1994 Dodge Caravan

R. Rear X-member X (#2)

Max = 1835.00 in. @ 254.88 msec  
Min = 0.00 in. @ -0.00 msec

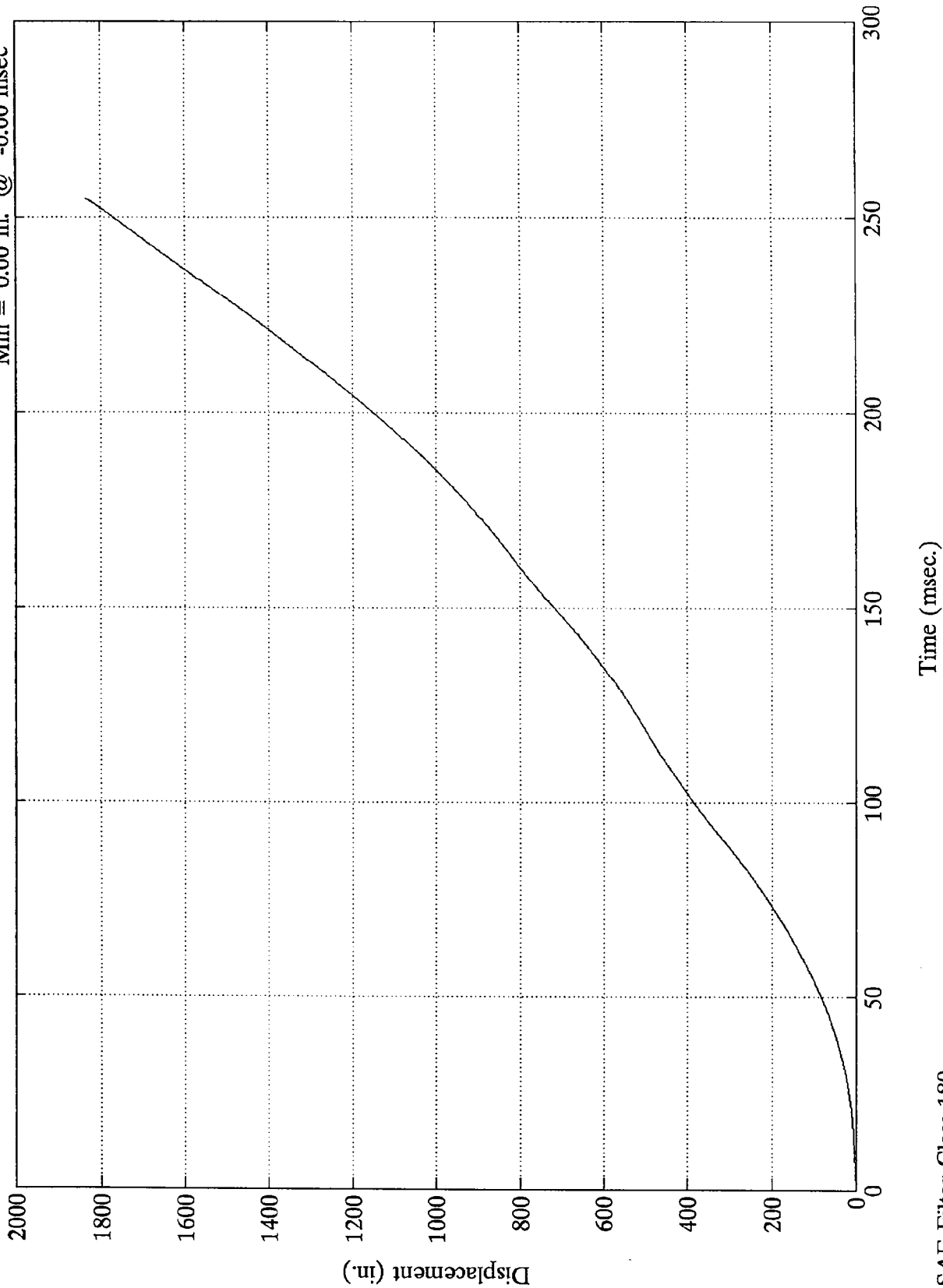

SAE Filter Class 180

NHTSA 208 TEST #16 - 1994 Dodge Caravan

Max = 6.35 Gs @ 90.72 msec  
Min = -68.22 Gs @ 24.35 msec

Engine Top X (#3)

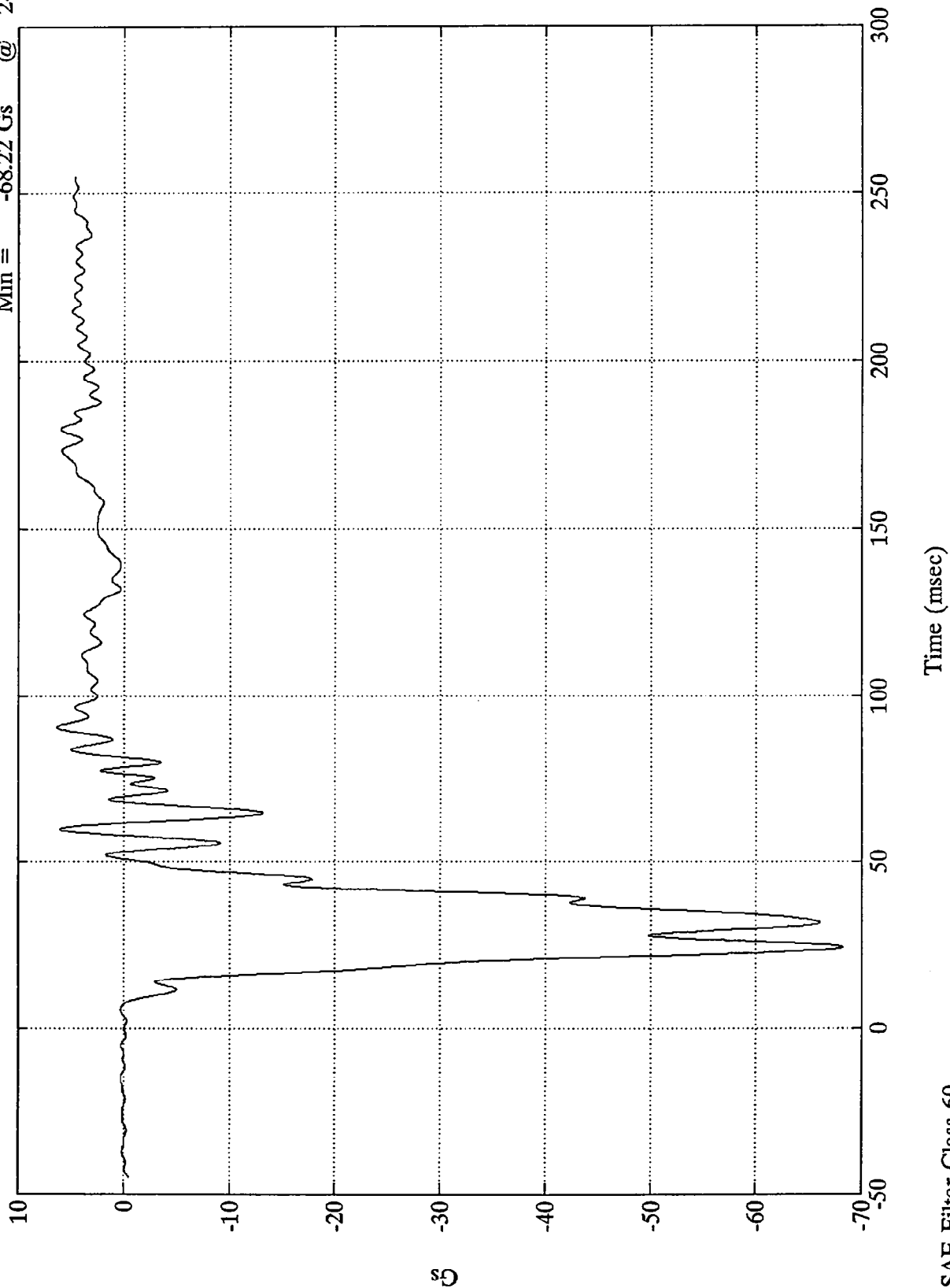

NHTSA 208 TEST #16 - 1994 Dodge Caravan

Engine Top X (#3)

Max = 29.11 mph @ 1.44 msec  
Min = -2.83 mph @ 76.80 msec

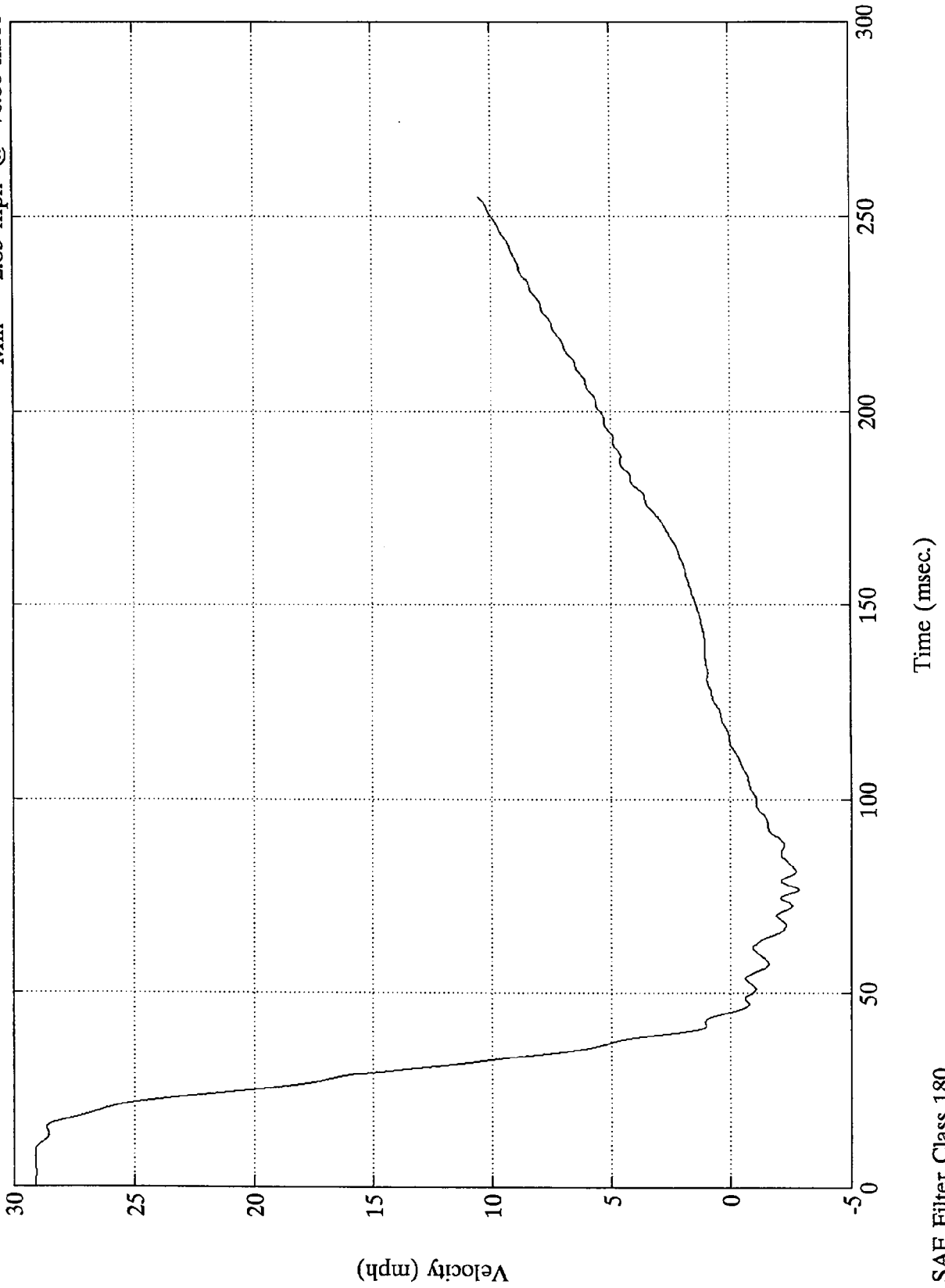

SAE Filter Class 180

NHTSA 208 TEST #16 - 1994 Dodge Caravan

Engine Top X (#3)

Max = 24.50 in. @ 254.88 msec

Min = 0.00 in. @ -0.00 msec

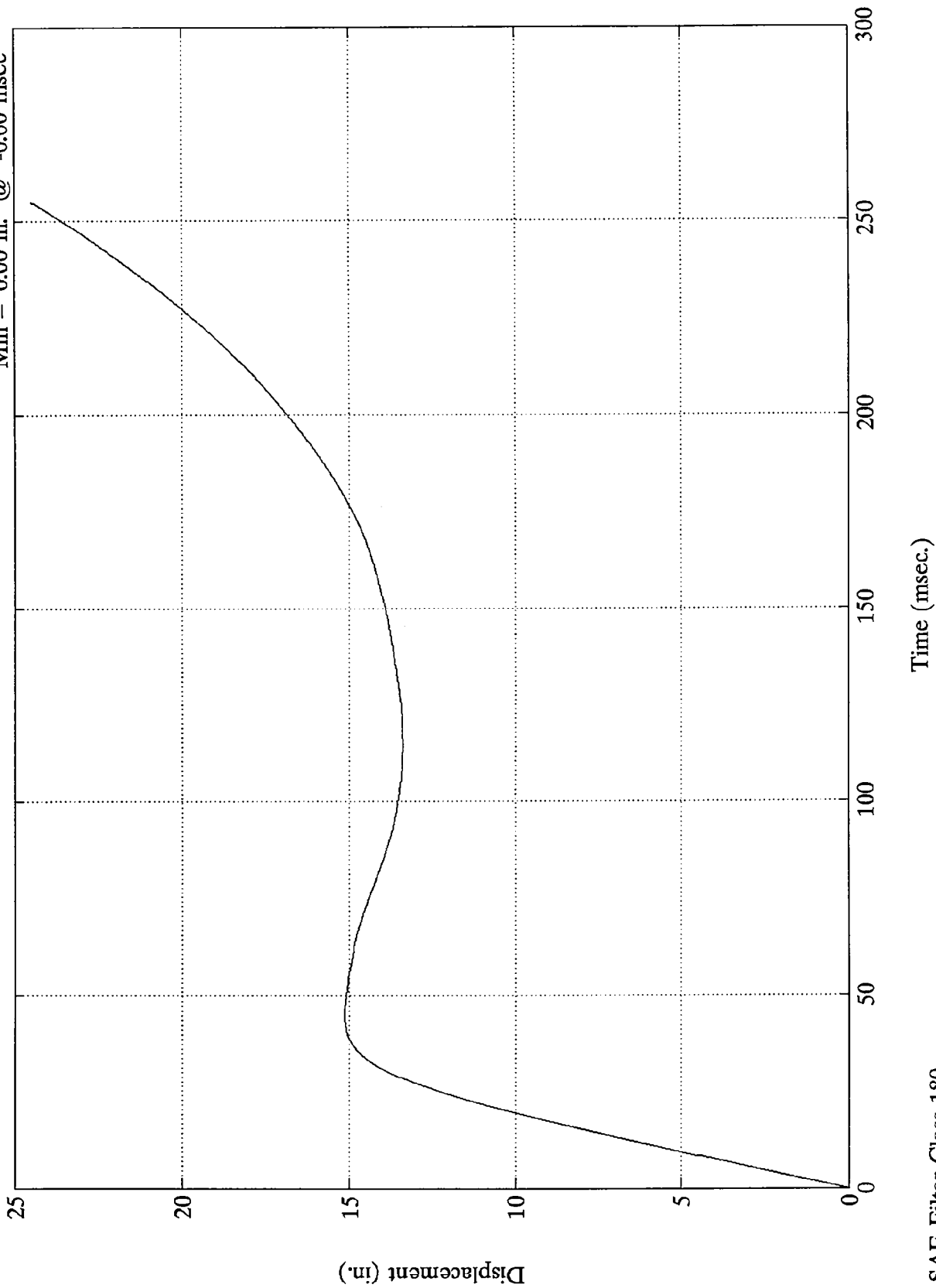

SAE Filter Class 180

NHTSA 208 TEST #16 - 1994 Dodge Caravan

Engine Bottom X (#4)  
Max = 260.11 Gs @ 225.36 msec  
Min = -253.77 Gs @ 216.96 msec

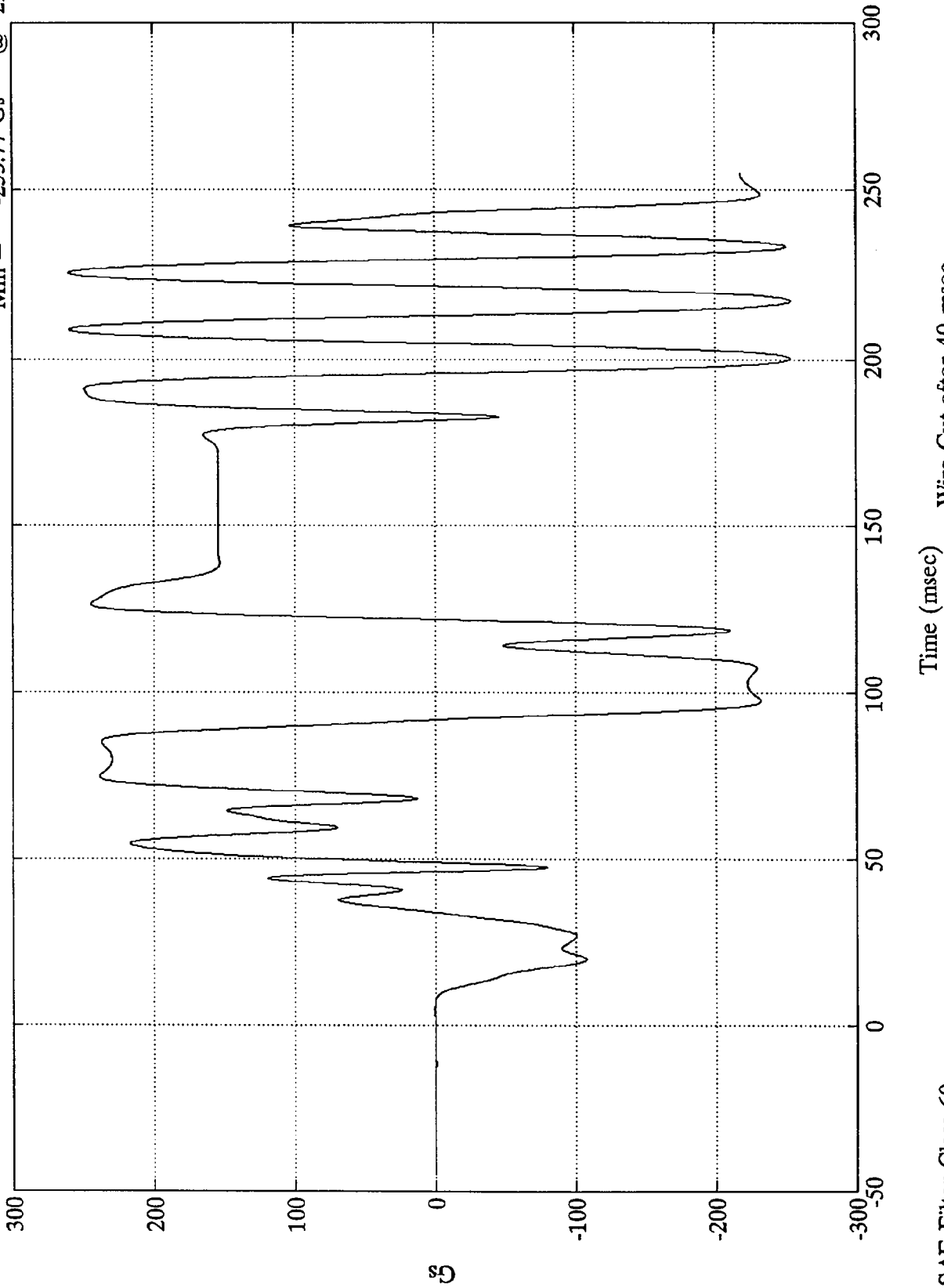

SAE Filter Class 60

NHTSA 208 TEST #16 - 1994 Dodge Caravan

Engine Bottom X (#4)

Max = 306.27 mph @ 195.84 msec

Min = -6.89 mph @ 34.08 msec

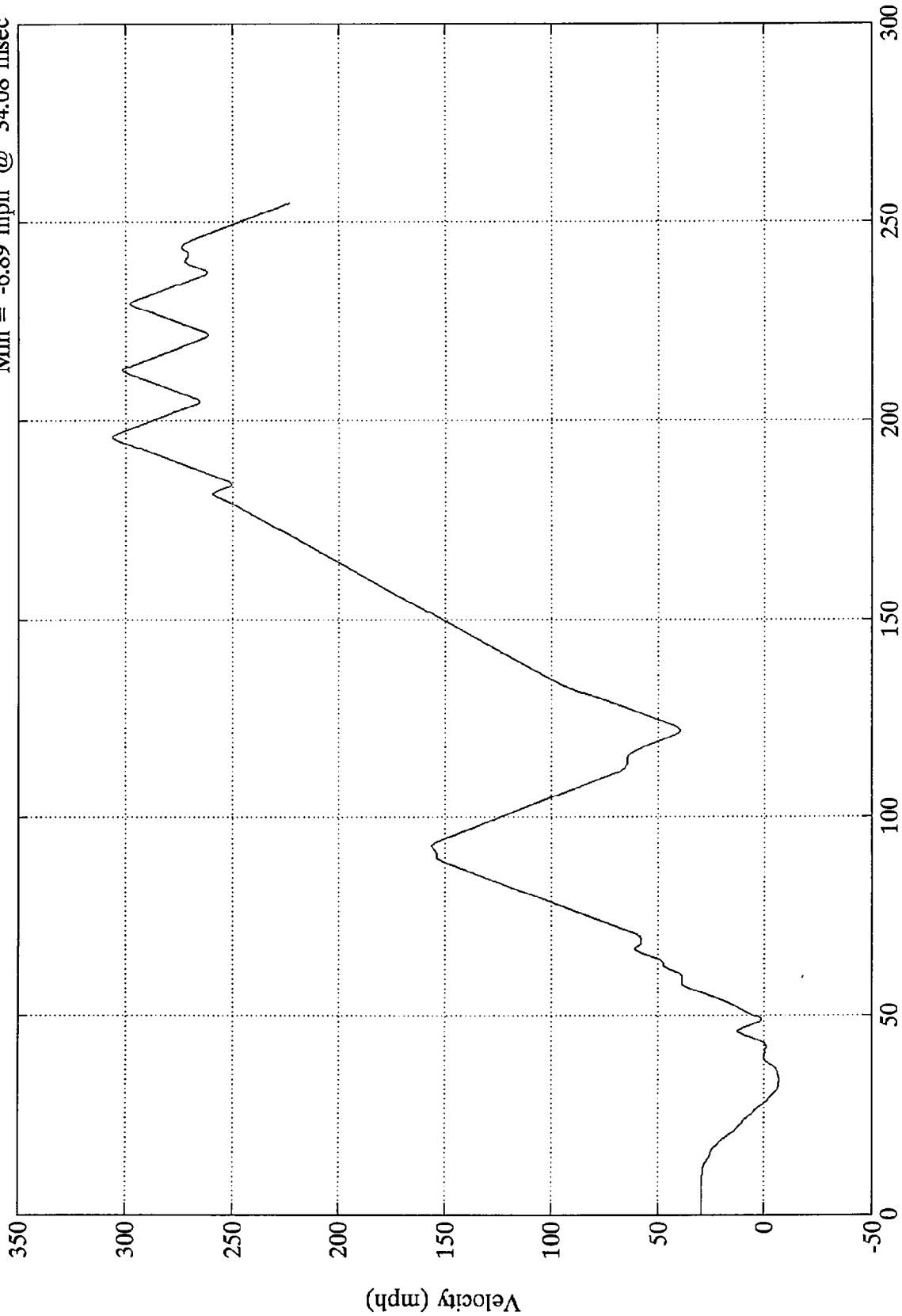

Time (msec.)

SAE Filter Class 180

NHTSA 208 TEST #16 - 1994 Dodge Caravan

Engine Bottom X (#4)

Max = 634.10 in. @ 254.88 msec  
Min = 0.00 in. @ -0.00 msec

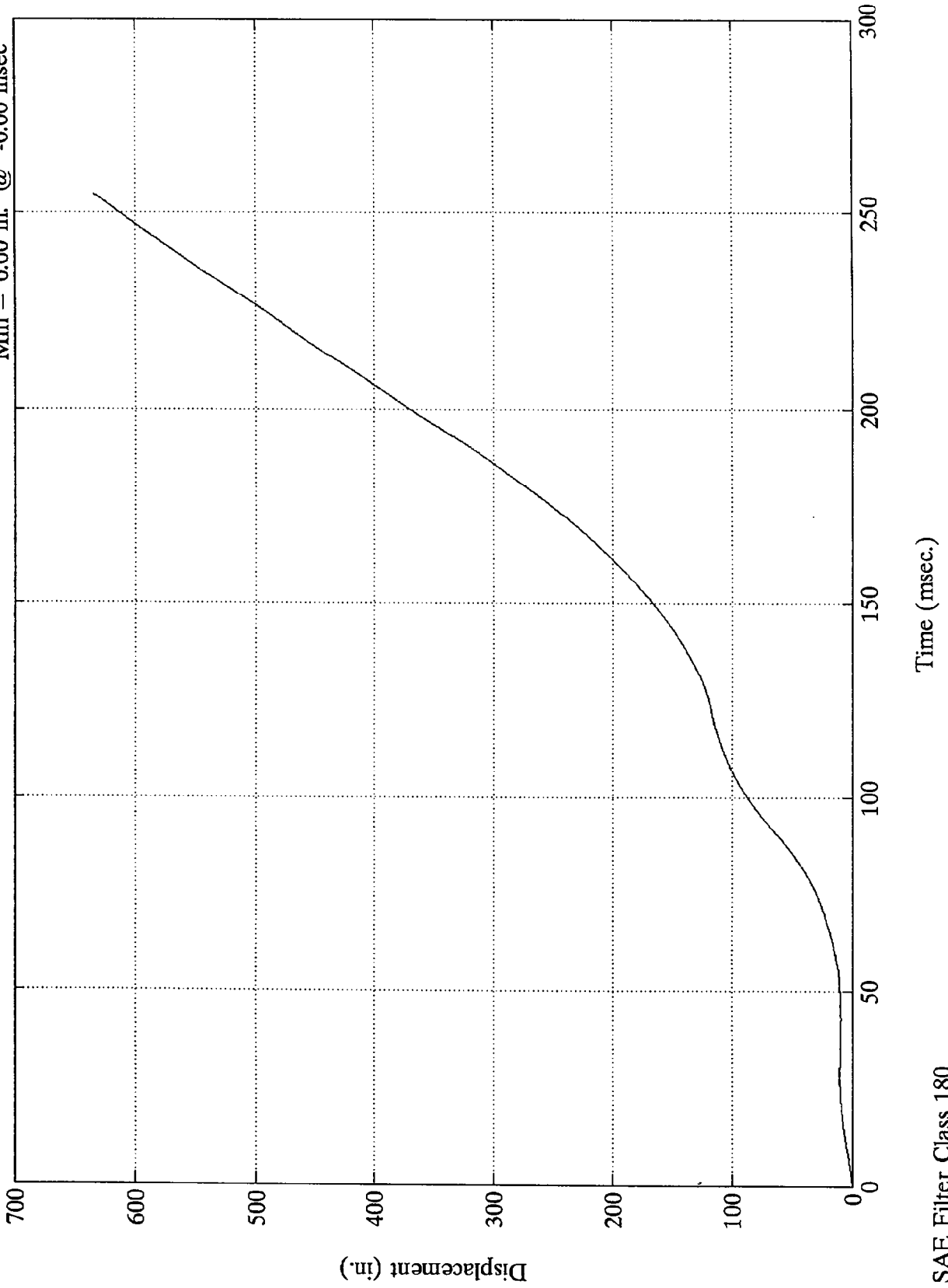

SAE Filter Class 180

NHTSA 208 TEST #16 - 1994 Dodge Caravan

R. Brake Caliper X (#5)

Max = 235.98 Gs @ 52.56 msec  
Min = -102.35 Gs @ 44.52 msec

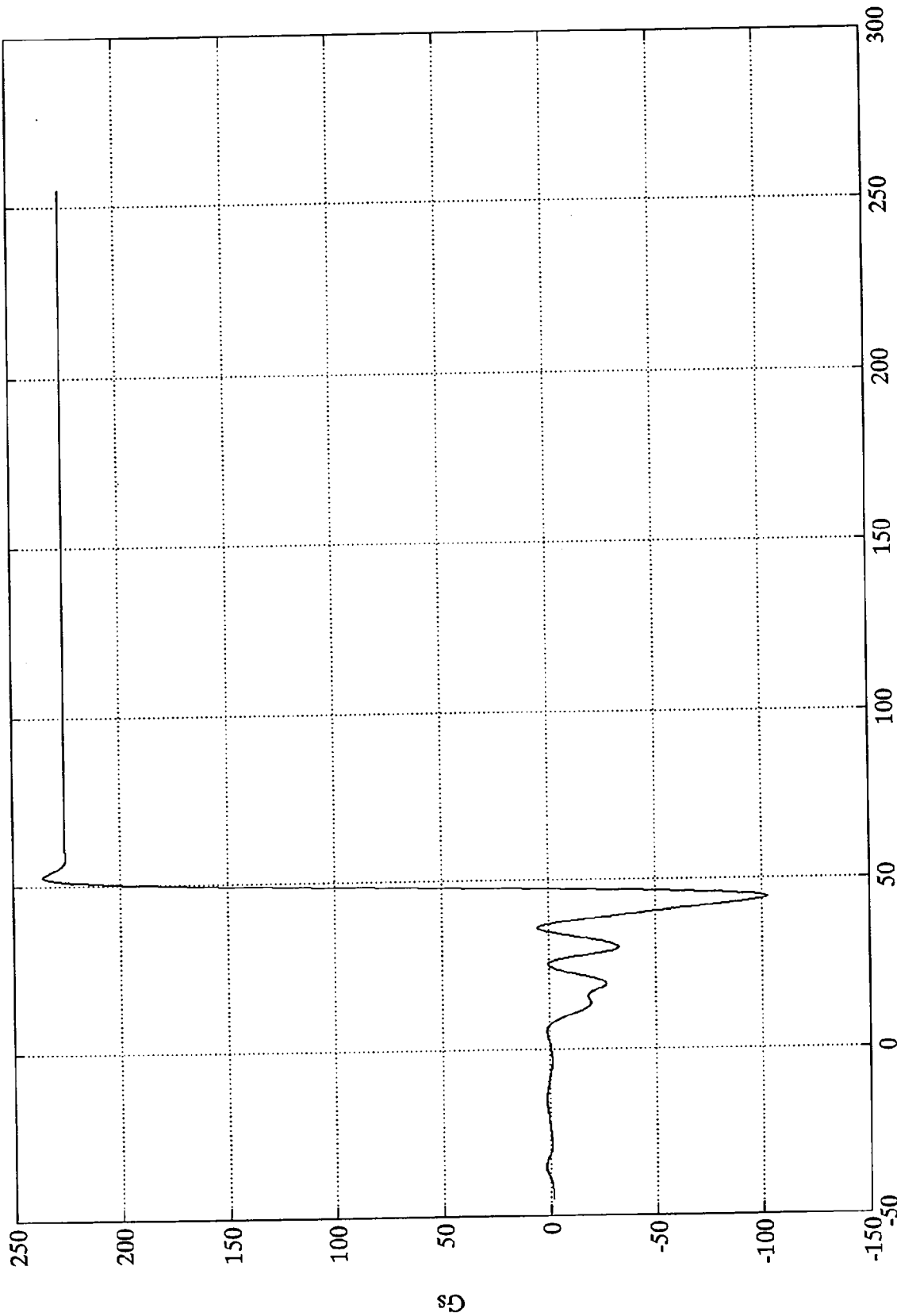

Time (msec) Wire Cut after 45 msec

SAE Filter Class 60

NHTSA 208 TEST #16 - 1994 Dodge Caravan

R. Brake Caliper X (#5)

Max = 1028.18 mph @ 254.88 msec

Min = 5.35 mph @ 47.76 msec

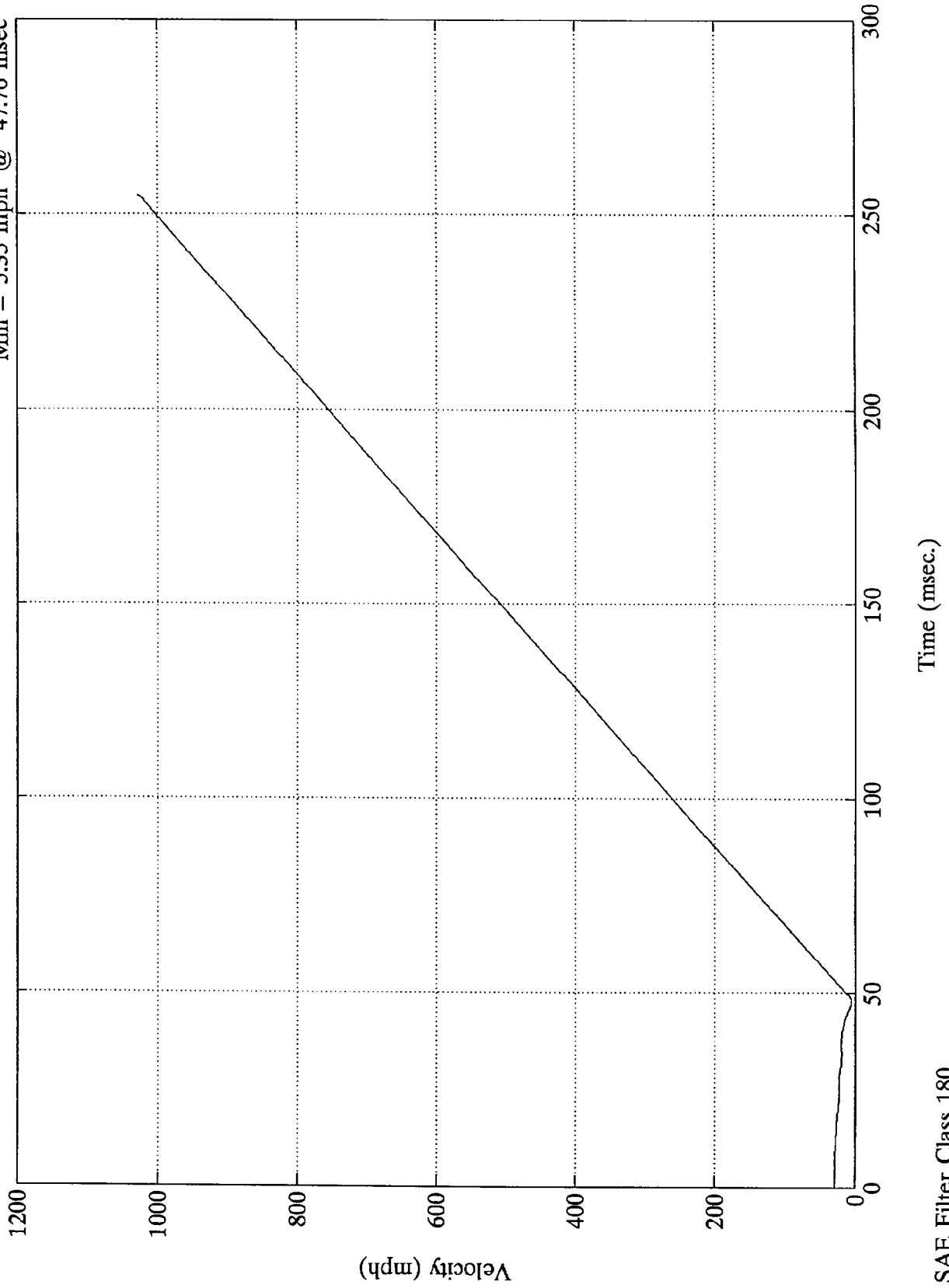

SAE Filter Class 180

NHTSA 208 TEST #16 - 1994 Dodge Caravan

R. Brake Caliper X (#5)

Max = 1896.00 in. @ 254.88 msec

Min = 0.00 in. @ -0.00 msec

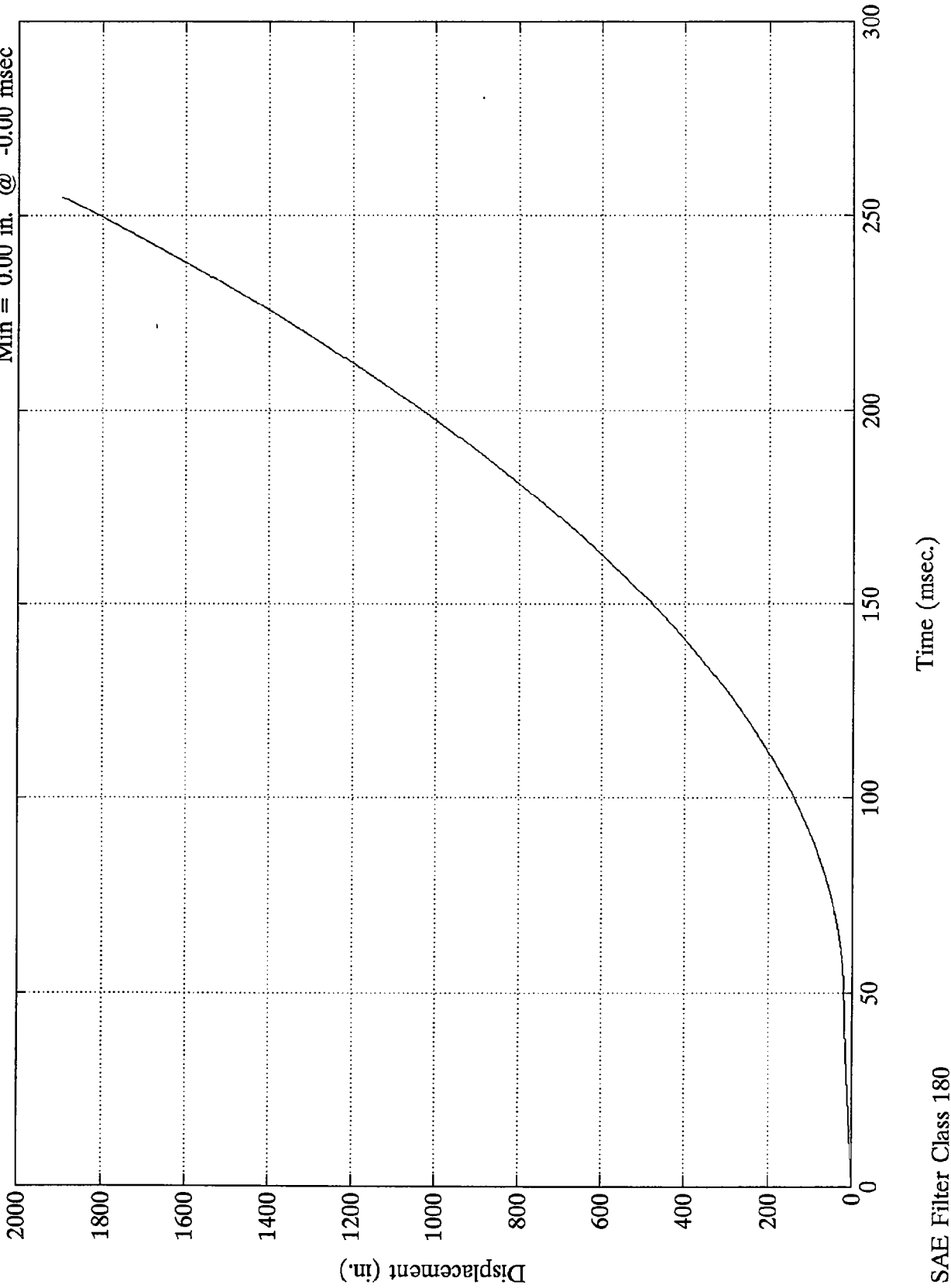

SAE Filter Class 180

NHTSA 208 TEST #16 - 1994 Dodge Caravan

L. Brake Caliper X (#6)  
Max = 30.24 Gs @ 60.12 msec  
Min = -105.46 Gs @ 42.24 msec

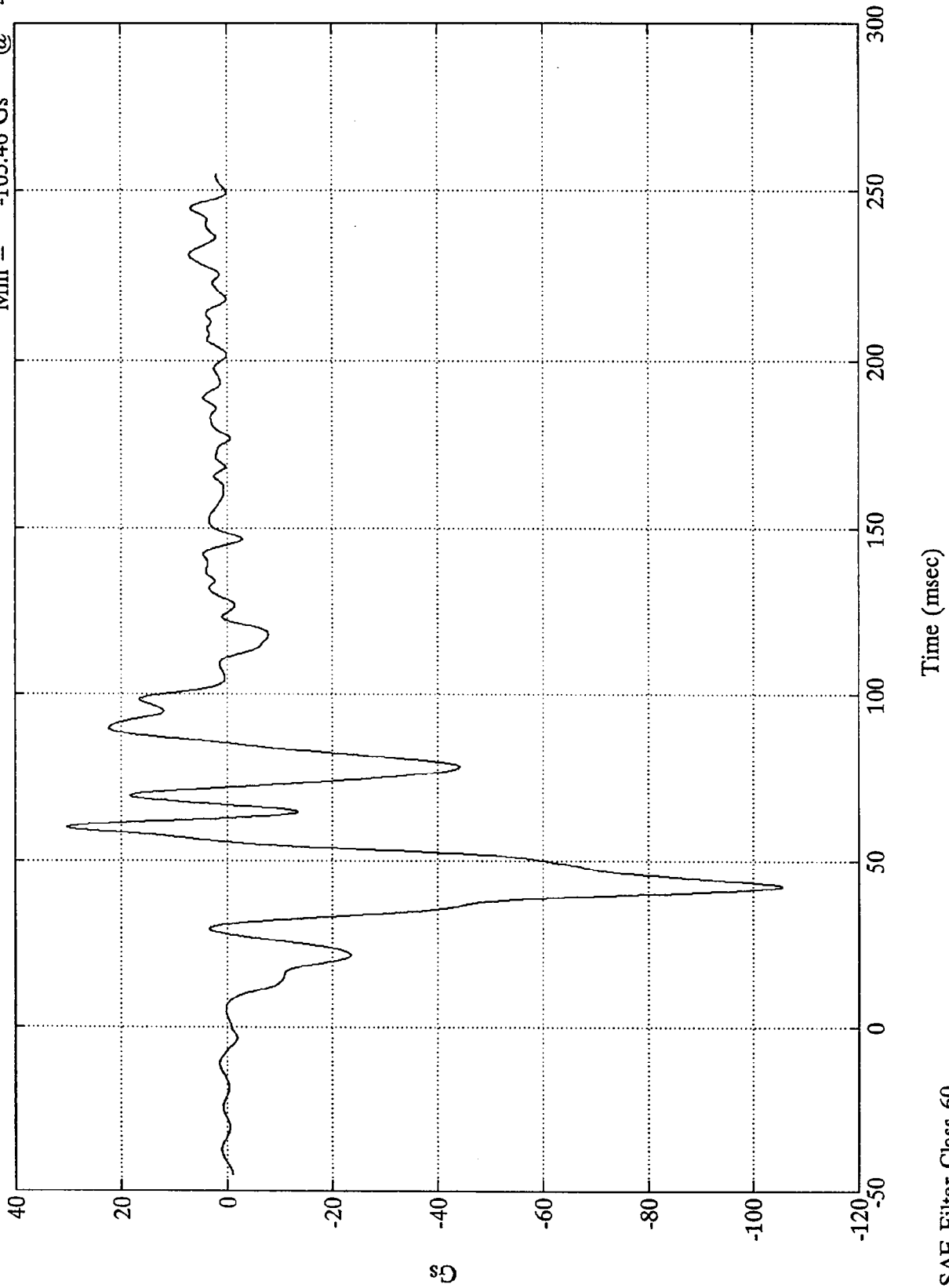

SAE Filter Class 60

NHTSA 208 TEST #16 - 1994 Dodge Caravan

L. Brake Caliper X (#6)

Max = 29.10 mph @ 0.24 msec  
Min = -11.00 mph @ 86.64 msec

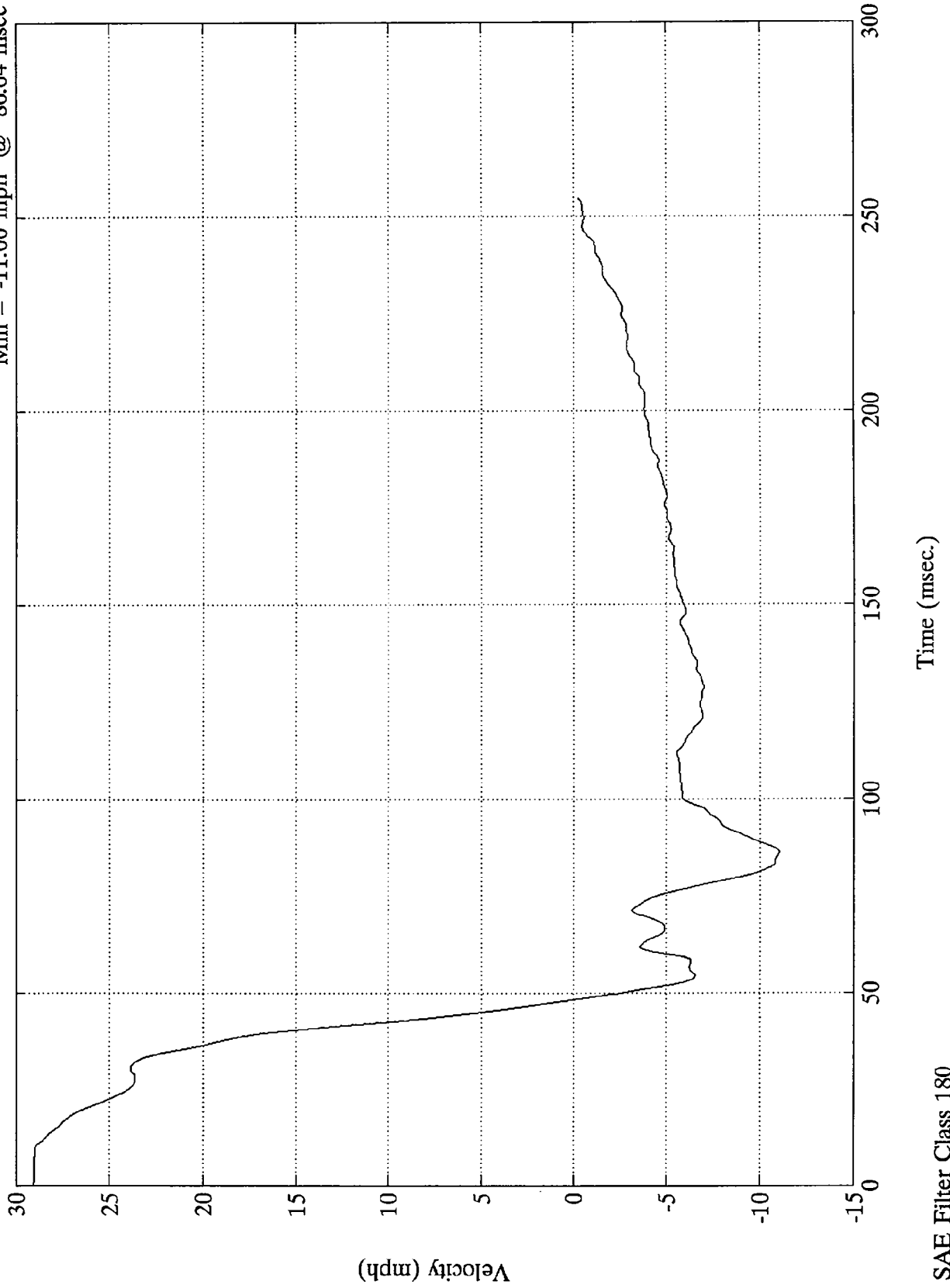

NHTSA 208 TEST #16 - 1994 Dodge Caravan

L. Brake Caliper X (#6)

Max = 19.16 in. @ 48.96 msec  
Min = 0.00 in. @ -0.00 msec

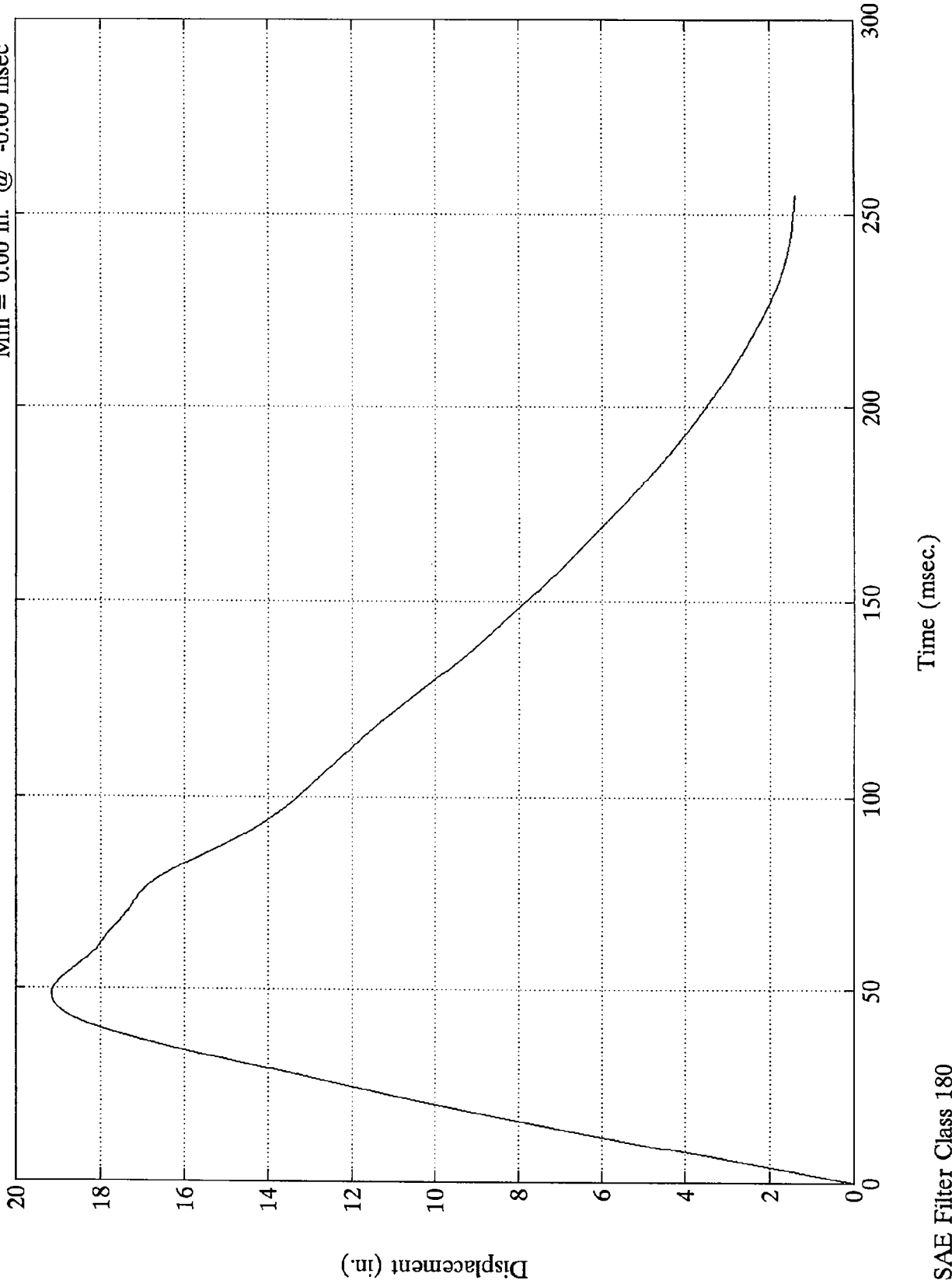

SAE Filter Class 180

NHTSA 208 TEST #16 - 1994 Dodge Caravan

Instrument Panel X (#7)

Max = 10.59 Gs @ 95.52 msec  
Min = -65.10 Gs @ 72.48 msec

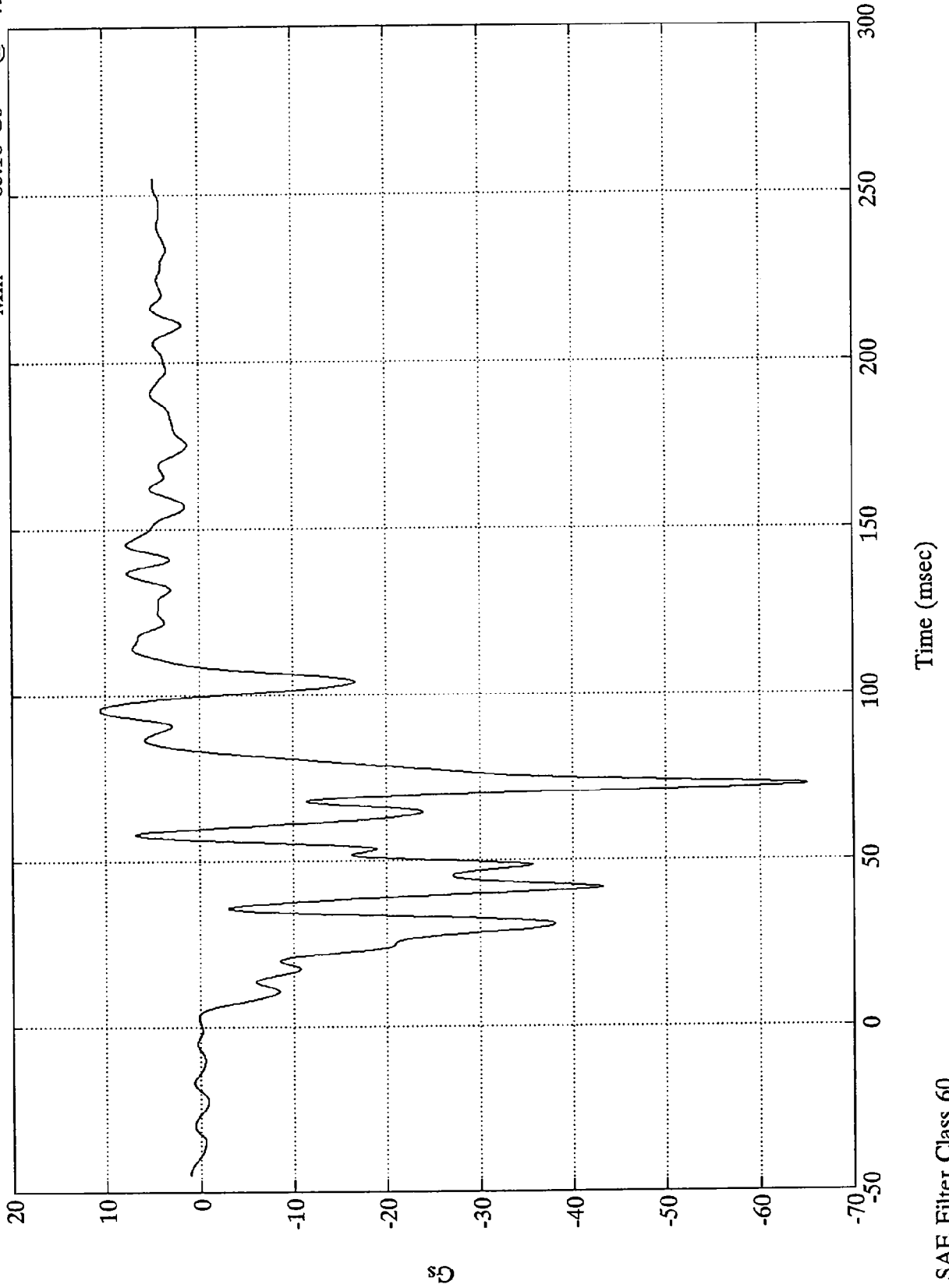

SAE Filter Class 60

NHTSA 208 TEST #16 - 1994 Dodge Caravan

Instrument Panel X (#7)

Max = 29.10 mph @ 6.00 msec  
Min = -3.93 mph @ 82.32 msec

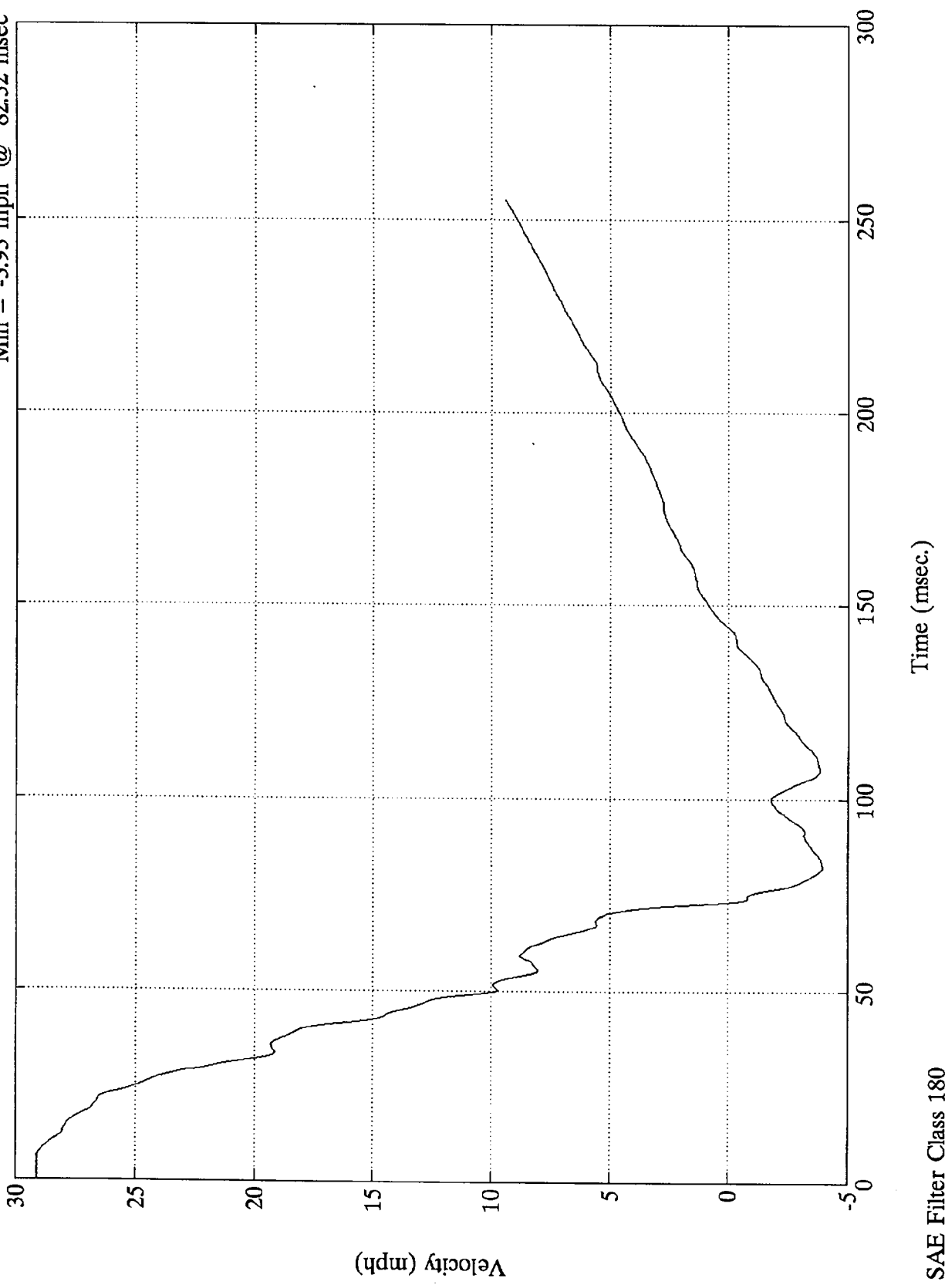

SAE Filter Class 180

Time (msec.)

NHTSA 208 TEST #16 - 1994 Dodge Caravan

Instrument Panel X (#7)

Max = 29.38 in. @ 254.88 msec

Min = 0.00 in. @ -0.00 msec

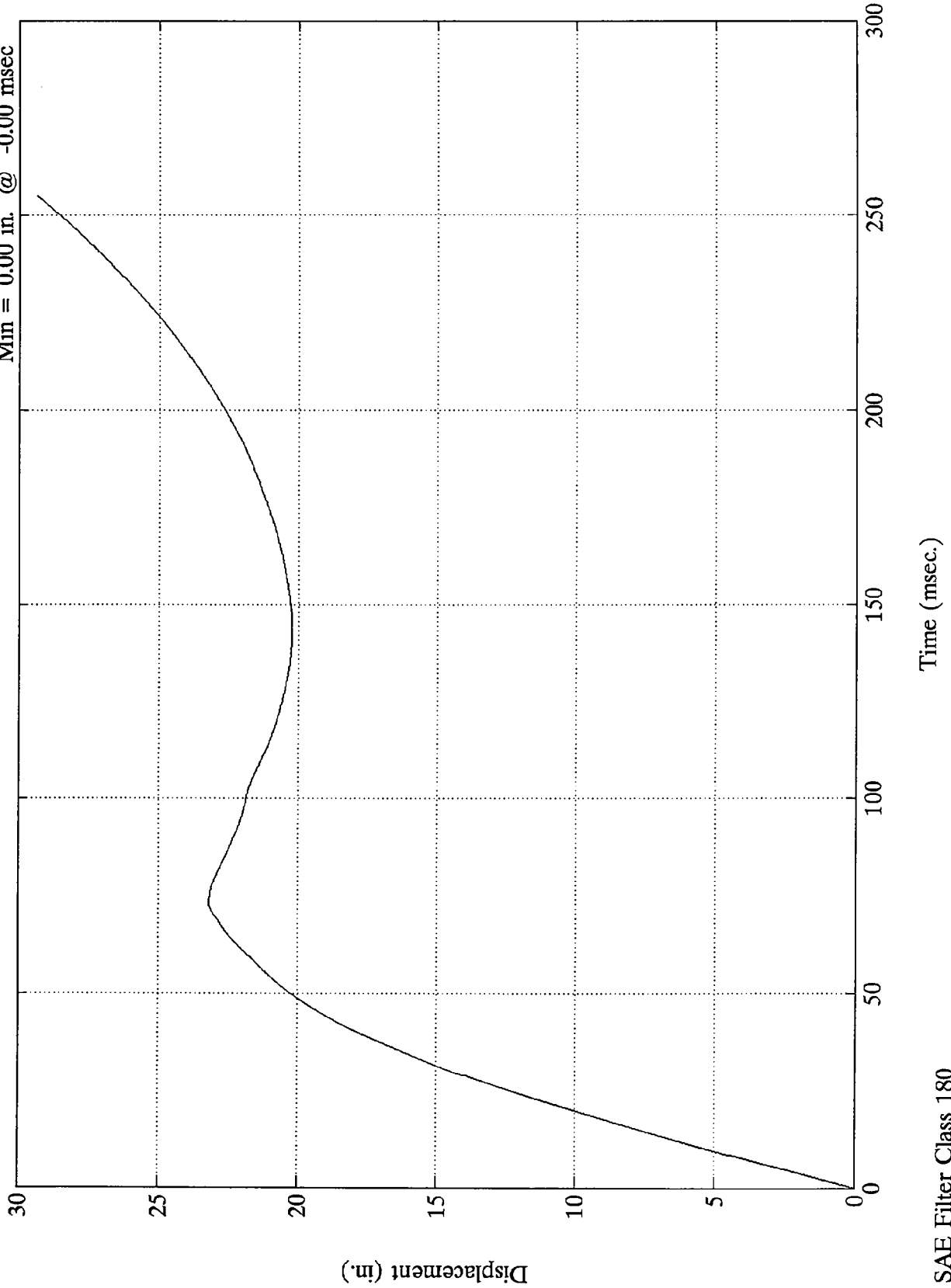

SAE Filter Class 180

NHTSA 208 TEST #16 - 1994 Dodge Caravan

Max = 58.76 Gs @ 54.00 msec  
Min = -109.88 Gs @ 46.58 msec

Trunk Z

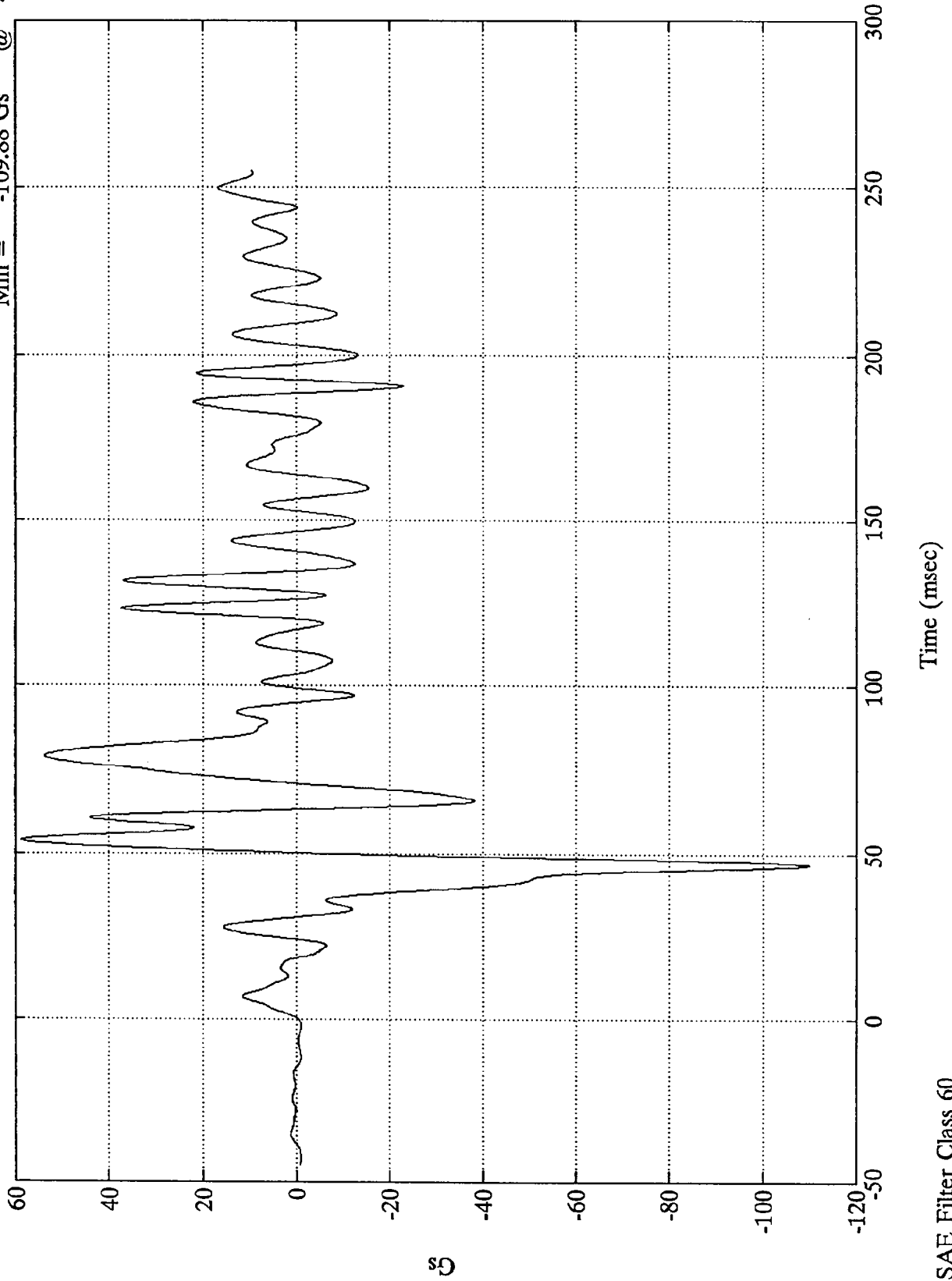

SAE Filter Class 60

Gs

Time (msec)

NHTSA 208 TEST #16 - 1994 Dodge Caravan

Max = 14.52 mph @ 253.68 msec  
Min = -14.72 mph @ 48.96 msec

Trunk Z

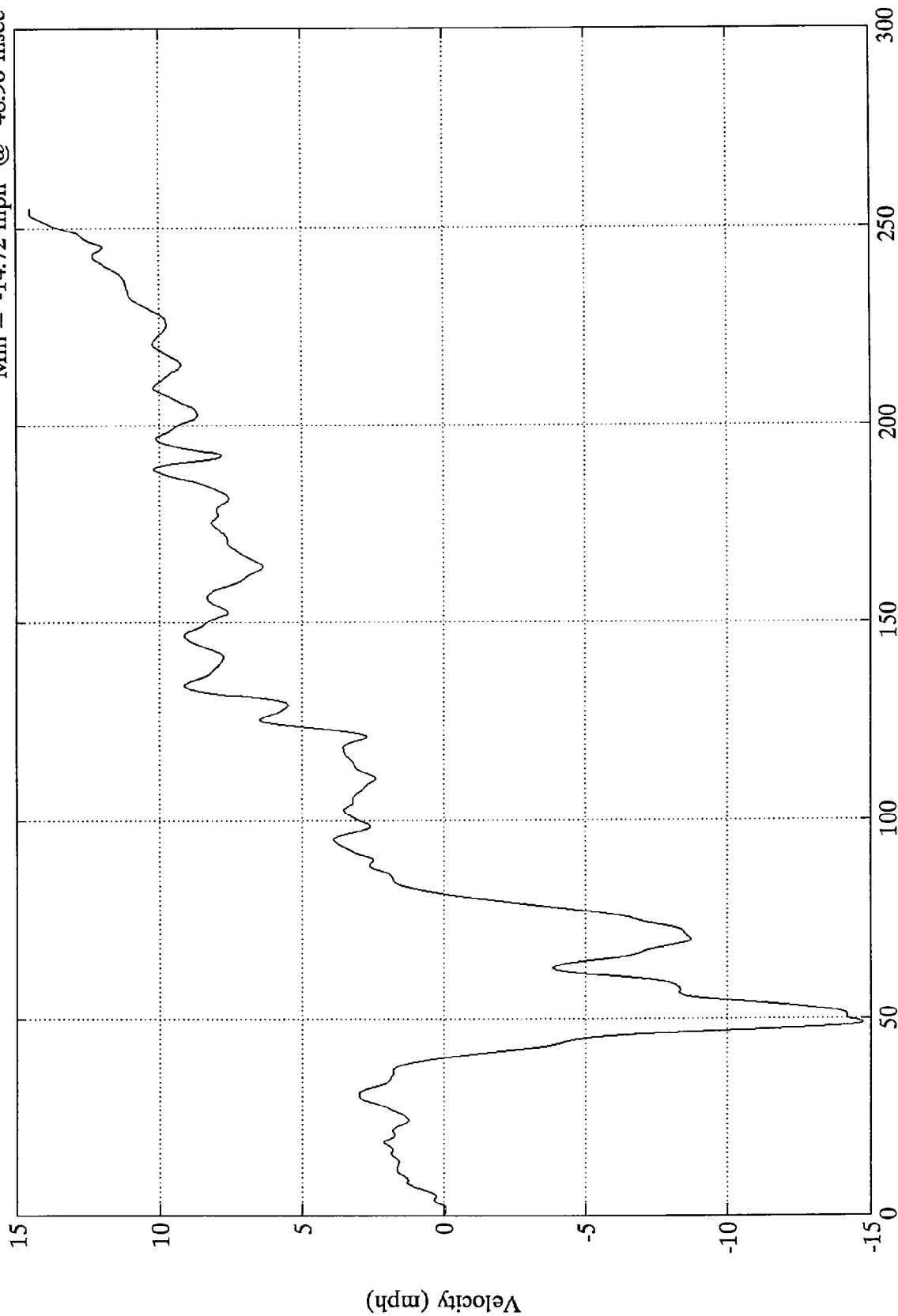

Time (msec.)

SAE Filter Class 180

NHTSA 208 TEST #16 - 1994 Dodge Caravan

Trunk Z  
Max = 19.14 in. @ 254.88 msec  
Min = -4.24 in. @ 81.84 msec

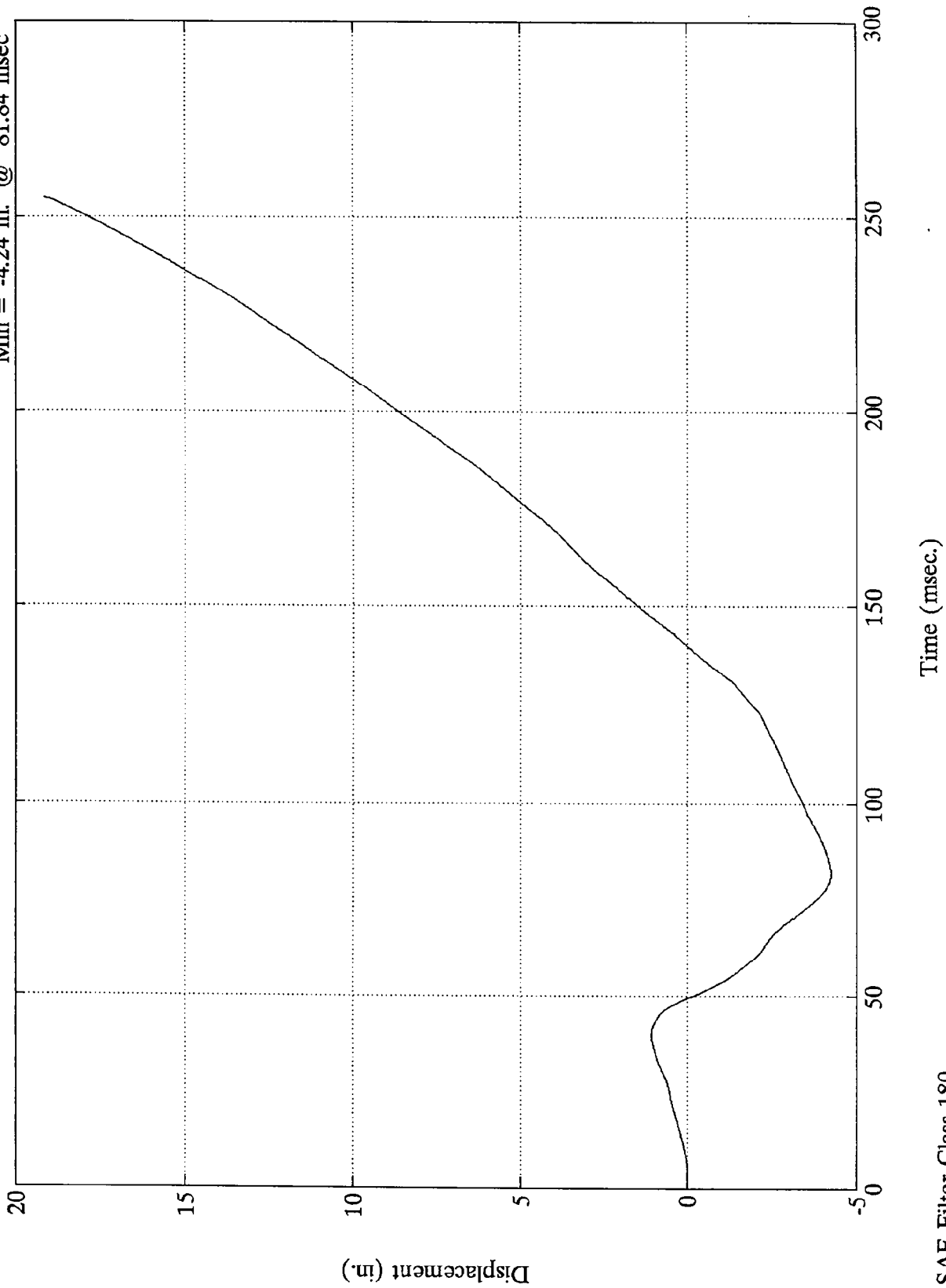

SAE Filter Class 180

TEST NO. CR0313

DUMMY	SAE FILTER CHANNEL CLASS
Head Accelerations	1000
Chest Accelerations	180
Femur Forces	600
Neck Forces	1000
Neck Moments	600
Chest Displacements	180
Pelvic Accelerations	1000

FACILITY: TRACK  
RUN #: 1430  
SERIES #: 16

TEST DATE: 12 Jul 1994  
TEST TIME: 14:33:35  
BOARD: a

TITLE: NHTSA 208 TEST #16 - 1994 Dodge Caravan

CHANNEL NUMBER	DESCRIPTION	ENGR UNIT	MAXIMUM		MINIMUM		FILTER CLASS
			AMP	msec	AMP	msec	
1	Pos. 1 Head X	Gs	7.8	234.6	-25.2	66.2	1000.0
2	Pos. 1 Head Y	Gs	15.2	88.2	-2.4	38.5	1000.0
3	Pos. 1 Head Z	Gs	13.5	134.4	-15.4	61.9	1000.0
4	Pos. 1 Left Femur	lbs	10.6	13.6	-1718.0	66.1	600.0
5	Pos. 1 Chest X	Gs	9.6	144.5	-44.0	90.2	180.0
6	Pos. 1 Chest Y	Gs	5.9	160.0	-1.3	57.5	180.0
7	Pos. 1 Chest Z	Gs	9.7	64.8	-23.2	93.8	180.0
8	Pos. 1 Right Femur	lbs	55.6	42.8	-1112.2	63.1	600.0
9	Pos. 2 Head X	Gs	9.9	244.8	-26.2	57.4	1000.0
10	Pos. 2 Head Y	Gs	8.3	33.8	-14.4	65.3	1000.0
11	Pos. 2 Head Z	Gs	18.2	84.4	-5.6	32.2	1000.0
12	Pos. 2 Left Femur	lbs	238.5	45.7	-1609.0	68.6	600.0
13	Pos. 2 Chest X	Gs	8.8	174.6	-30.4	87.2	180.0
14	Pos. 2 Chest Y	Gs	5.7	99.7	-1.9	50.2	180.0
15	Pos. 2 Chest Z	Gs	14.2	100.1	-4.9	66.6	180.0
16	Pos. 2 Right Femur	lbs	165.3	46.9	-1640.0	63.2	600.0
17	Pos. 1 Head Resultant	Gs	28.4	61.9	.0	-25.2	1000.0
18	Pos. 1 Chest Resultant	Gs	49.0	90.2	.0	-21.7	180.0
19	Pos. 2 Head Resultant	Gs	28.5	62.0	.1	-37.9	1000.0
20	Pos. 2 Chest Resultant	Gs	31.9	87.2	.0	-27.0	180.0

36 ms Fixed Duration HIC SUMMARY: Pos. 1 Head Resultant

hic: 95.98  
t1 = 54.600 msec  
t2 = 90.480 msec  
Average G's Over Hic Duration = 23.49

36 ms Fixed Duration HIC SUMMARY: Pos. 2 Head Resultant

hic: 79.56  
t1 = 51.120 msec  
t2 = 87.000 msec  
Average G's Over Hic Duration = 21.79

CLIP SUMMARY: Pos. 1 Chest Resultant

Peak Resultant (3 ms CLIPPED DURATION) = 48.040 G's  
Tstart = 89.4000 ms  
Tend = 92.4000 ms  
CSI = 357.858

CLIP SUMMARY: Pos. 2 Chest Resultant

Peak Resultant (3 ms CLIPPED DURATION) = 30.898 G's  
Tstart = 86.0400 ms  
Tend = 89.1600 ms  
CSI = 191.026

NHTSA 208 TEST #16 - 1994 Dodge Caravan

Pos. 1 Head X  
Max = 7.80 Gs @ 234.60 msec  
Min = -25.18 Gs @ 66.23 msec

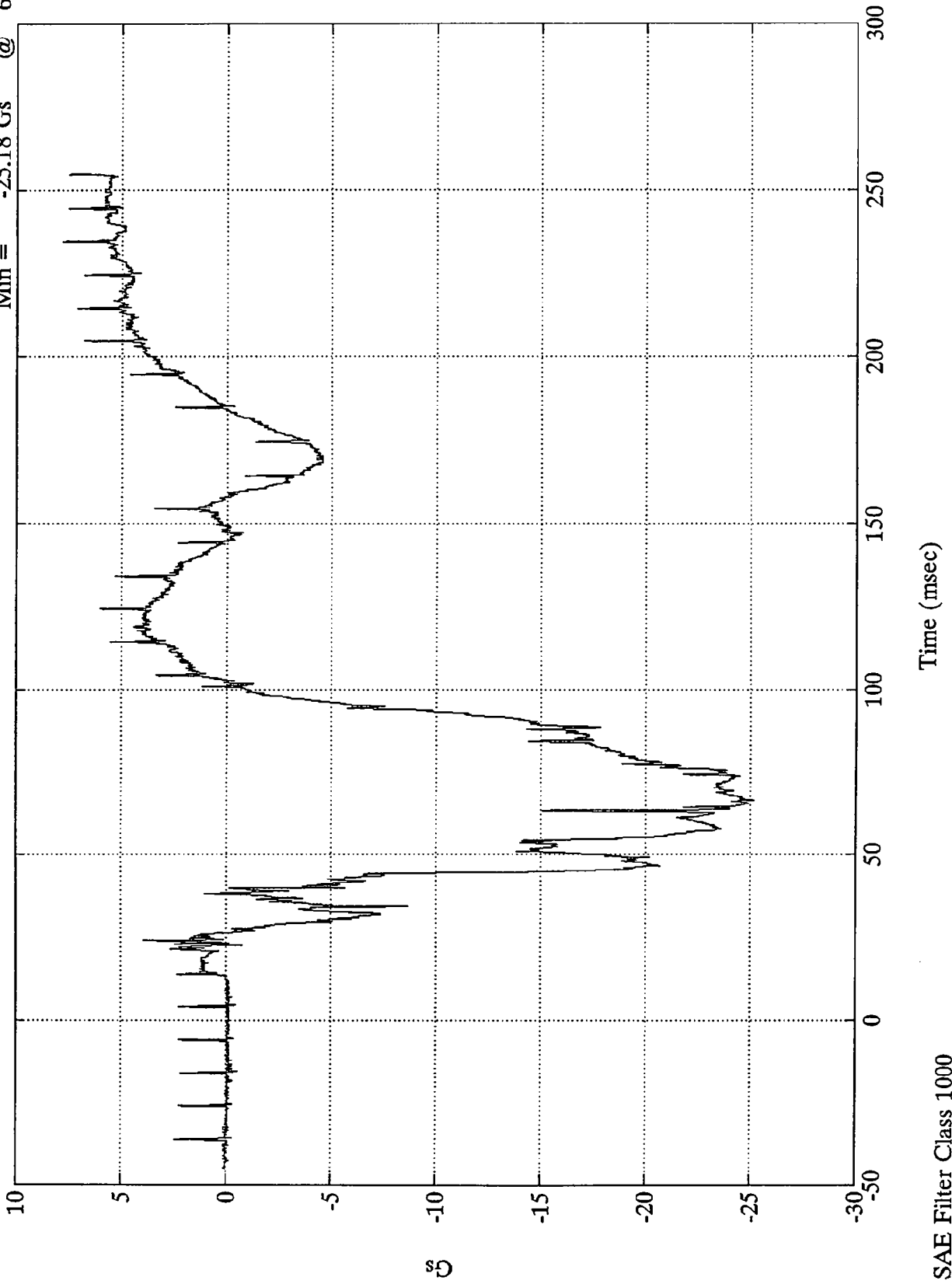

SAE Filter Class 1000

NHTSA 208 TEST #16 - 1994 Dodge Caravan

Pos. 1 Head Y

Max = 15.18 Gs @ 88.20 msec  
Min = -2.42 Gs @ 38.52 msec

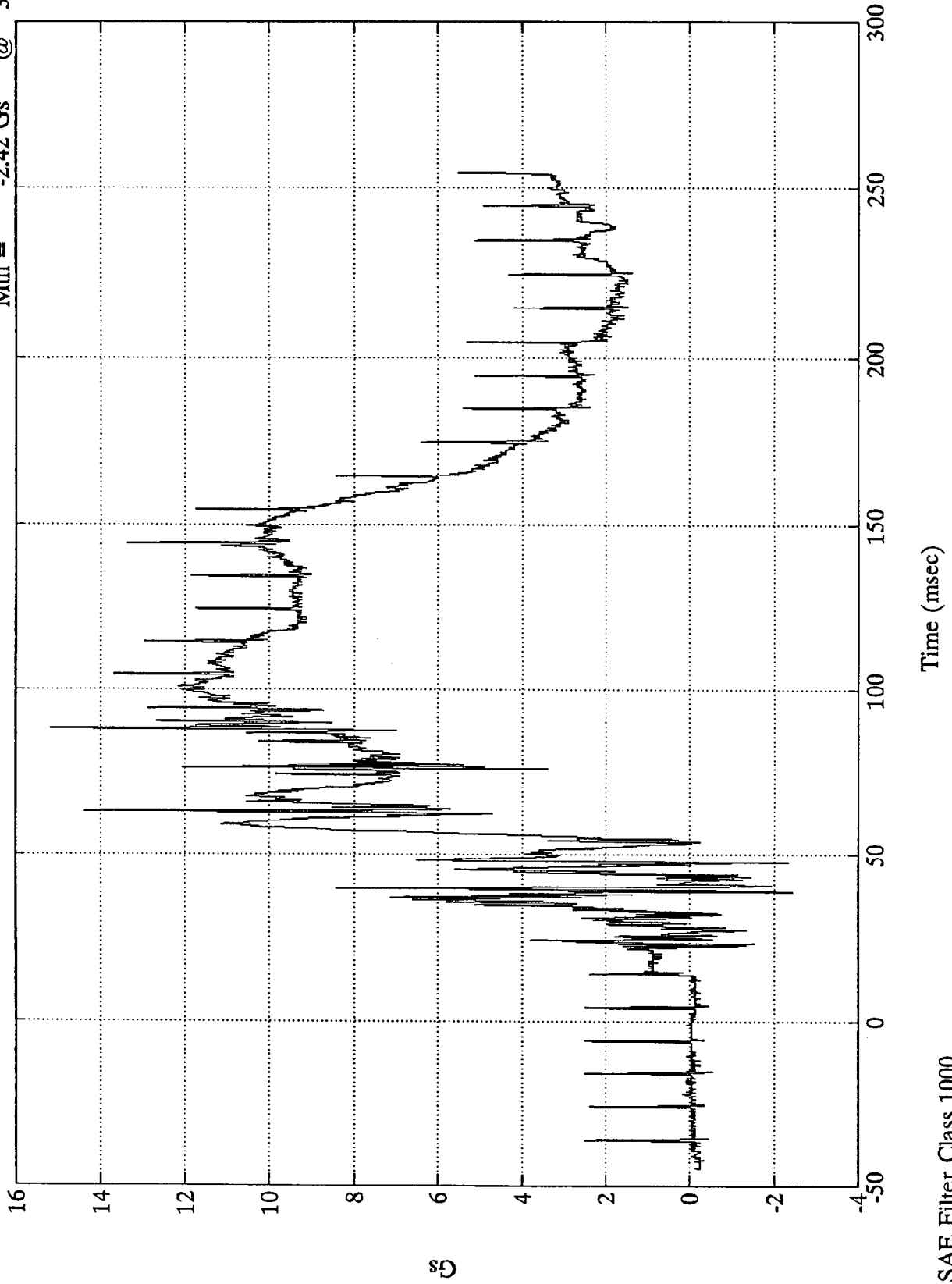

NHTSA 208 TEST #16 - 1994 Dodge Caravan

Max = 13.55 Gs @ 134.40 msec  
Min = -15.41 Gs @ 61.92 msec

Pos. 1 Head Z

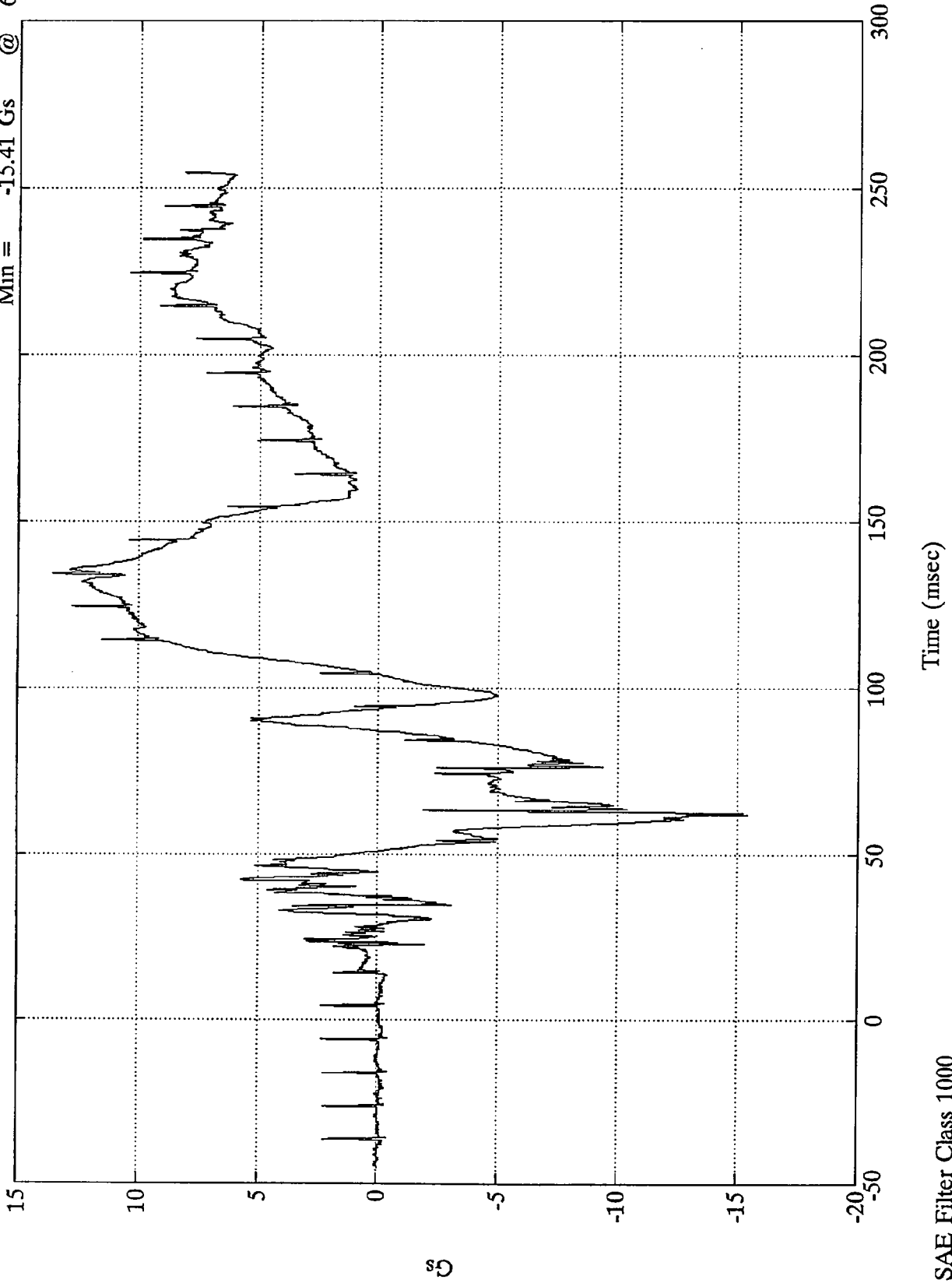

Gs

NHTSA 208 TEST #16 - 1994 Dodge Caravan

Max = 28.40 Gs @ 61.92 msec  
Min = .05 Gs @ -25.20 msec

Pos. 1 Head Resultant

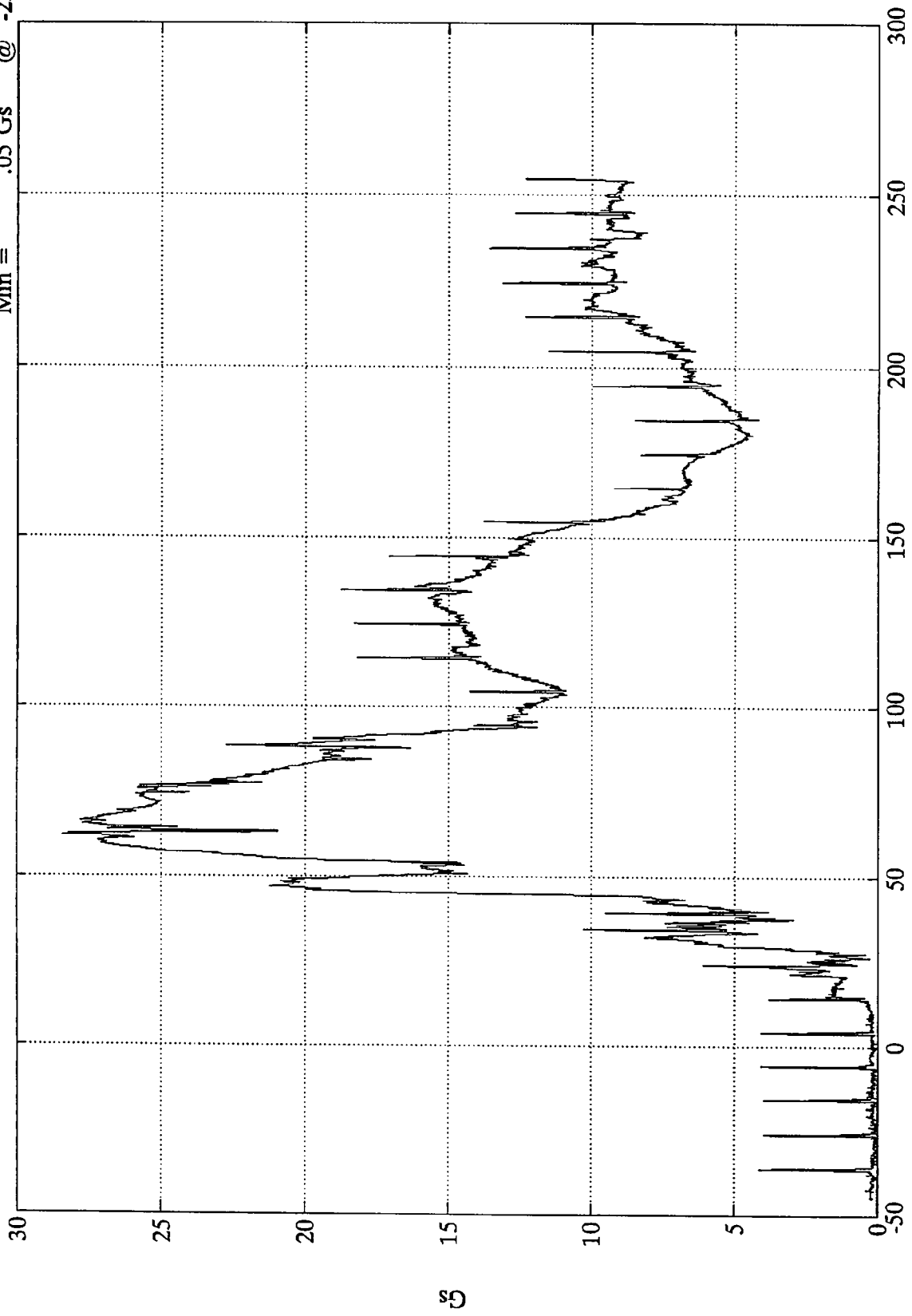

Time (msec)

SAE Filter Class 1000

NHTSA 208 TEST #16 - 1994 Dodge Caravan

Max = 9.60 Gs @ 144.48 msec  
Min = -44.01 Gs @ 90.24 msec

Pos. 1 Chest X

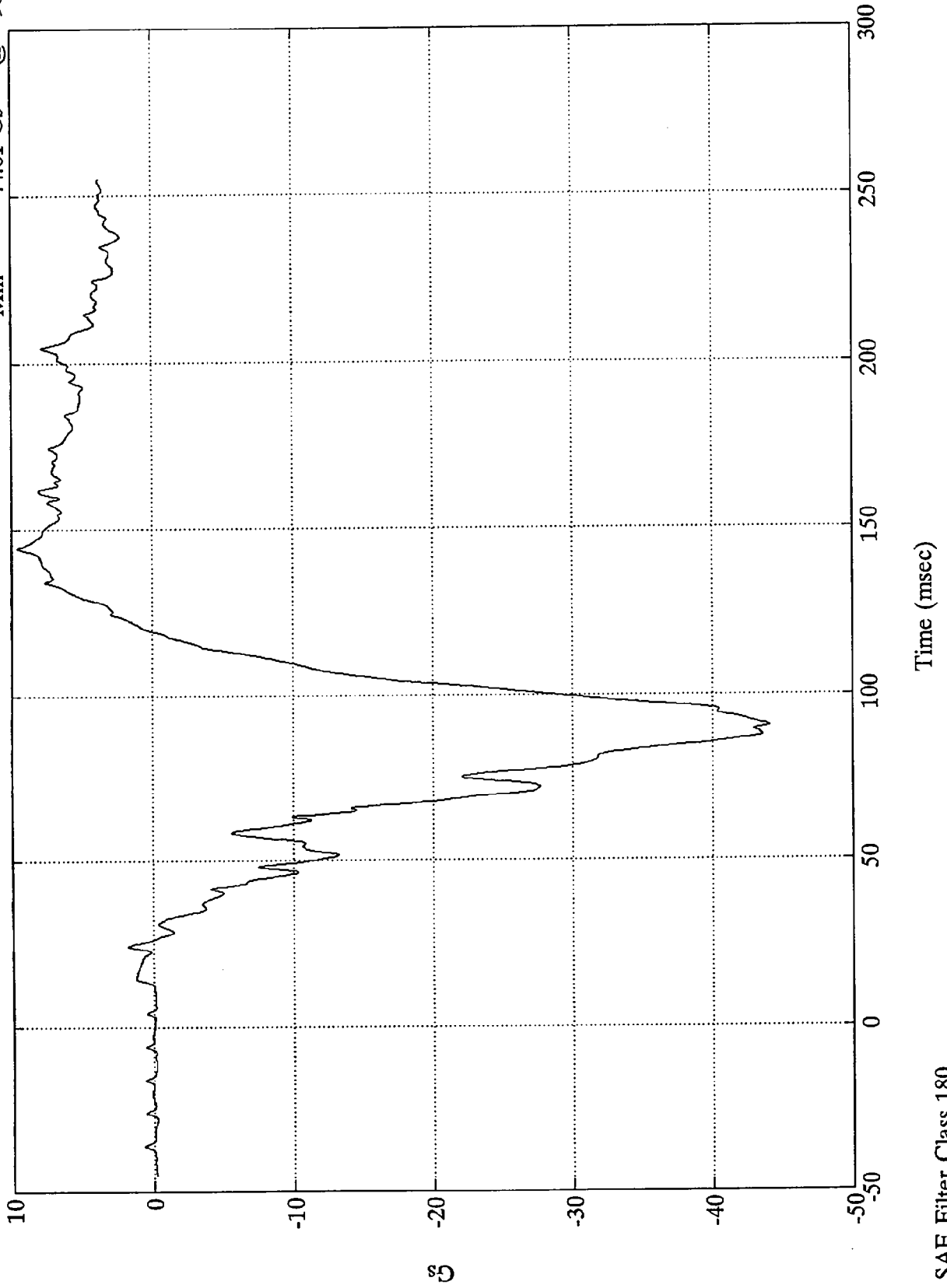

SAE Filter Class 180

NHTSA 208 TEST #16 - 1994 Dodge Caravan

Pos. 1 Chest Y

Max = 5.87 Gs @ 159.96 msec  
Min = -1.32 Gs @ 57.47 msec

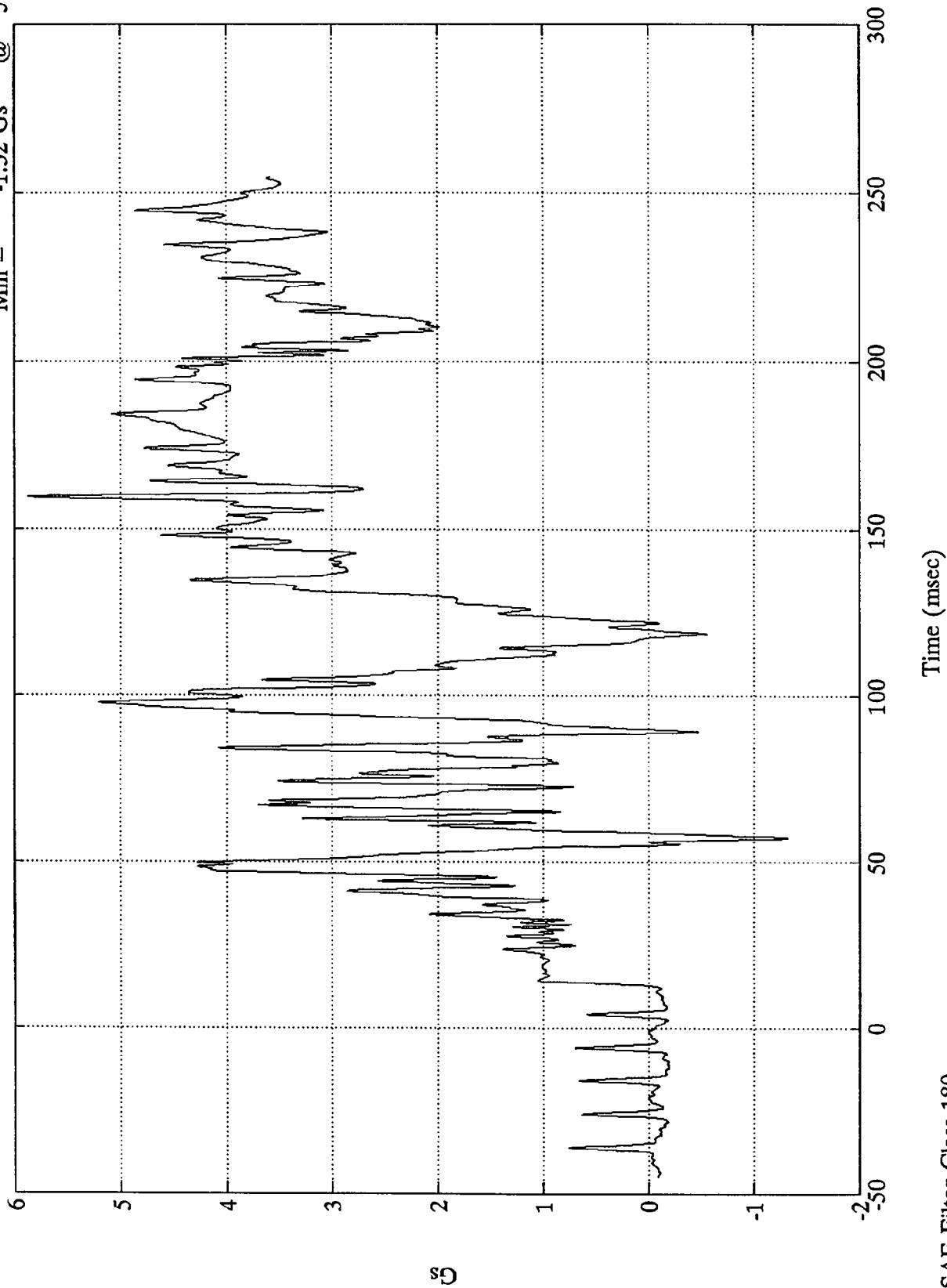

SAE Filter Class 180

NHTSA 208 TEST #16 - 1994 Dodge Caravan

Max = 9.66 Gs @ 64.80 msec  
Min = -23.19 Gs @ 93.84 msec

Pos. 1 Chest Z

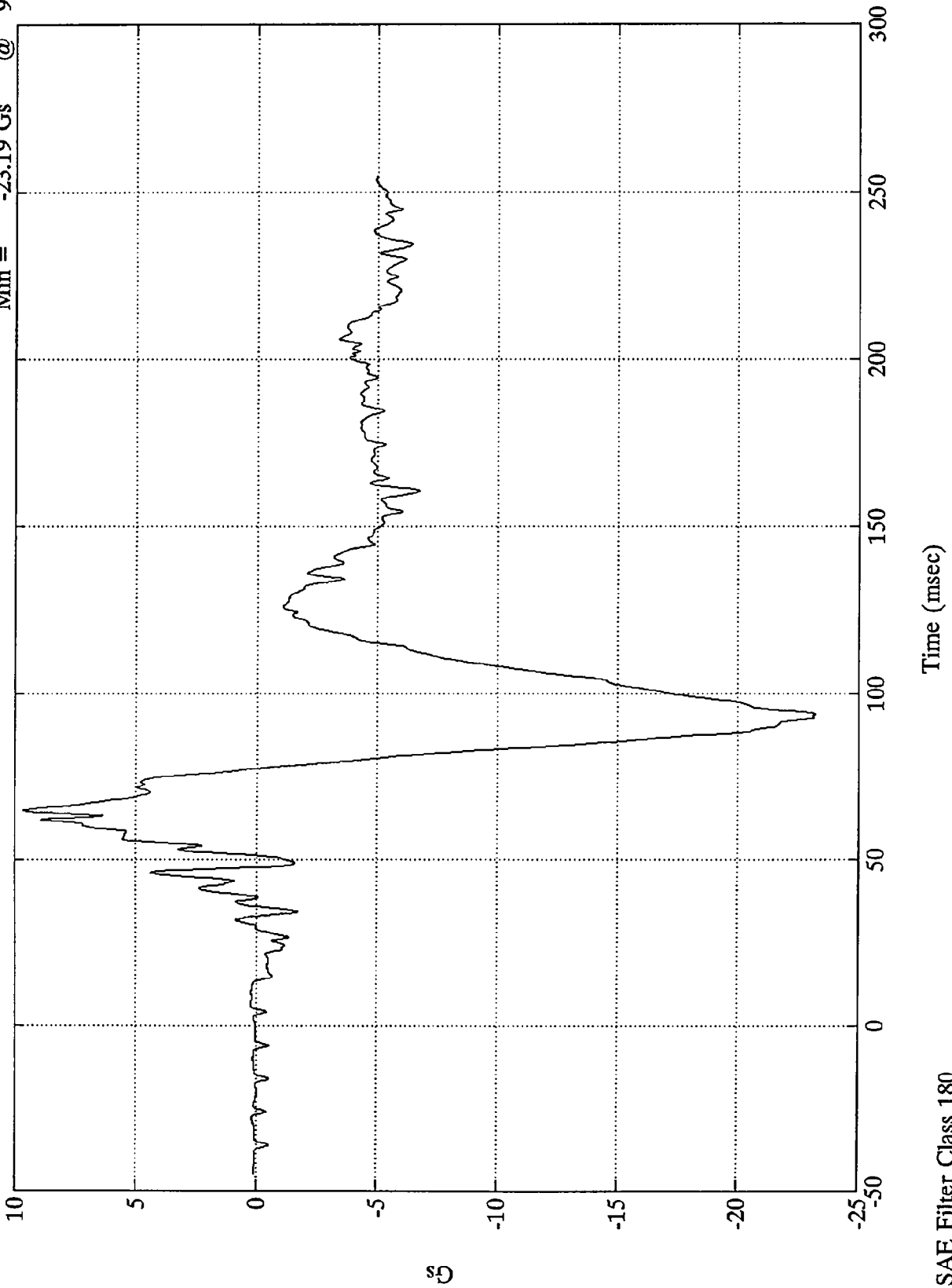

G

Time (msec)

SAE Filter Class 180

NHTSA 208 TEST #16 - 1994 Dodge Caravan

Max = 49.00 Gs @ 90.24 msec  
Min = .02 Gs @ -21.72 msec

Pos. 1 Chest Resultant

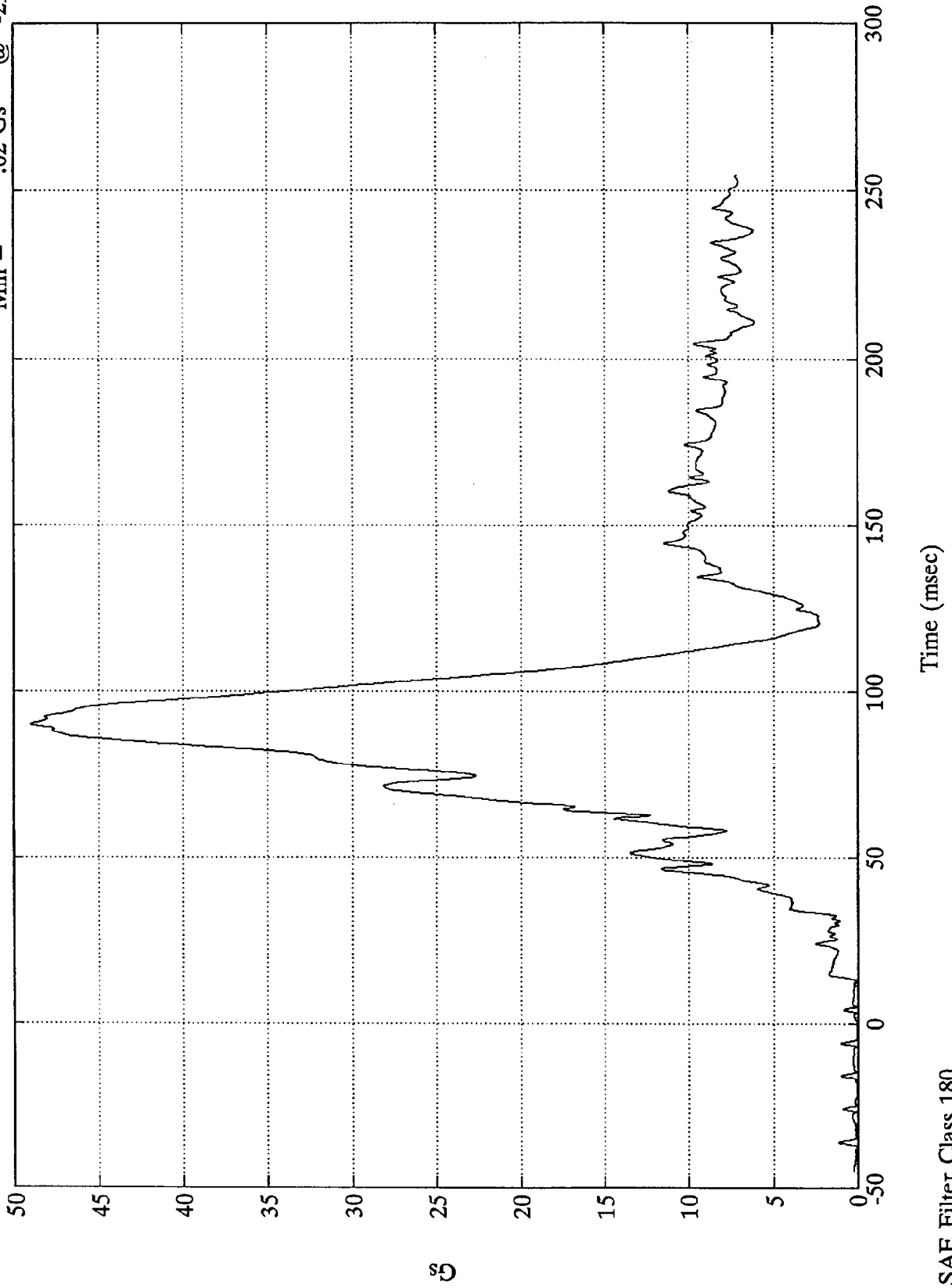

SAE Filter Class 180

NHTSA 208 TEST #16 - 1994 Dodge Caravan

Max = 10.65 lbs @ 13.55 msec  
Min = -1718.01 lbs @ 66.11 msec

Pos. 1 Left Femur

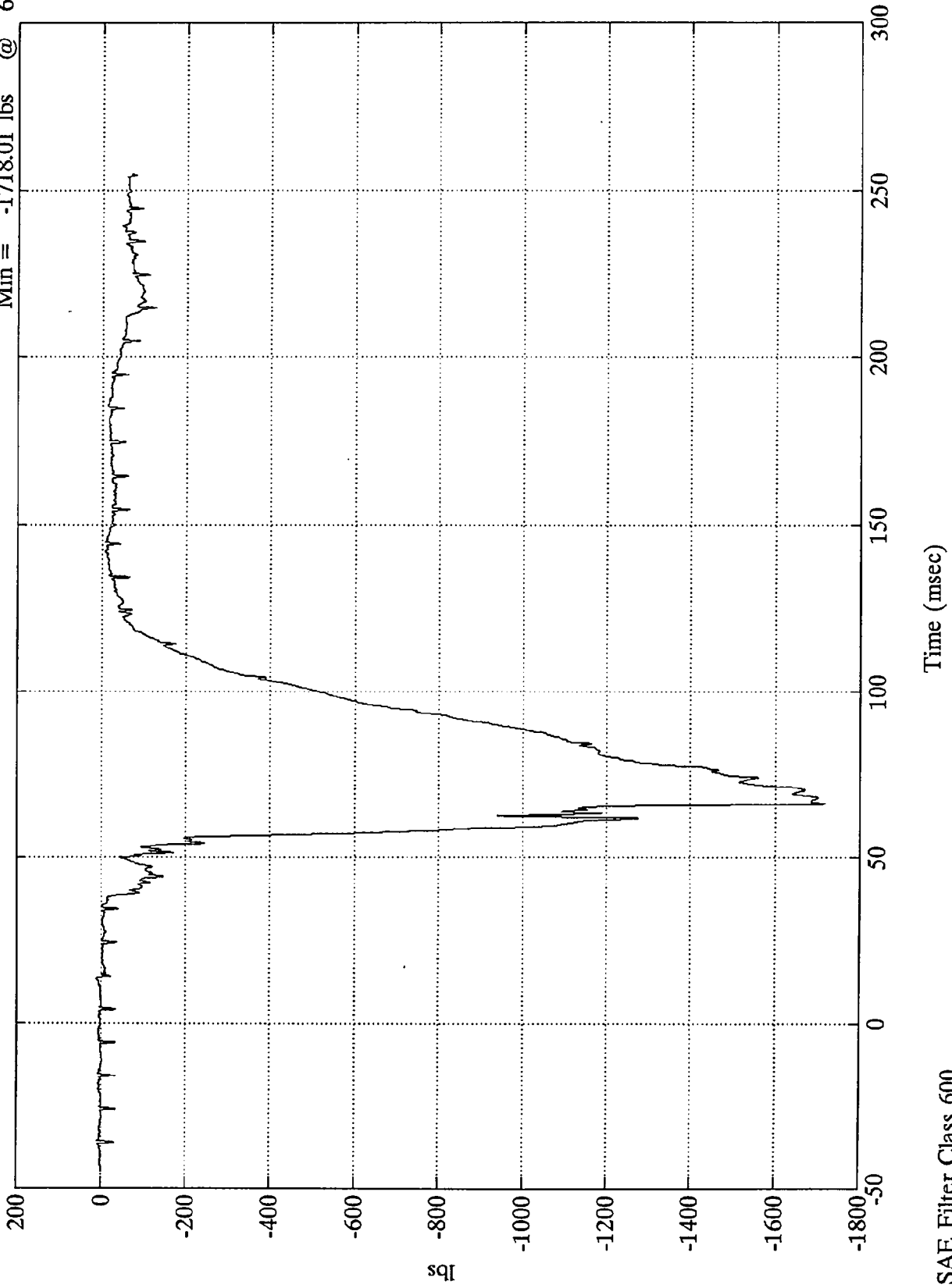

SAE Filter Class 600

NHTSA 208 TEST #16 - 1994 Dodge Caravan

Pos. 1 Right Femur

Max = 55.63 lbs @ 42.84 msec  
Min = -1112.24 lbs @ 63.11 msec

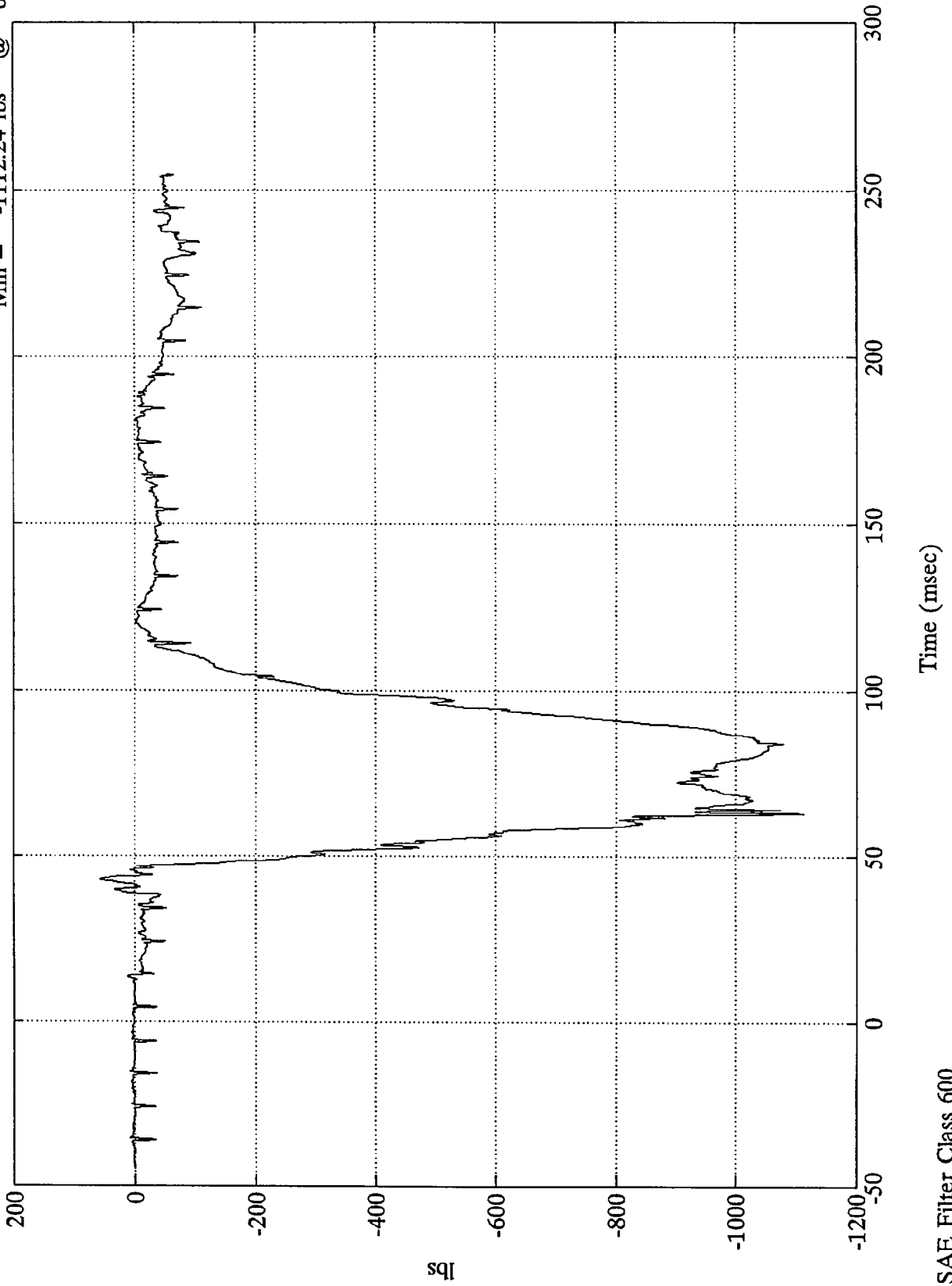

SAE Filter Class 600

NHTSA 208 TEST #16 - 1994 Dodge Caravan

Max = 219.63 Lbs @ 63.11 msec  
Min = -49.12 Lbs @ 61.92 msec

Pos.1 Upper Neck Fx

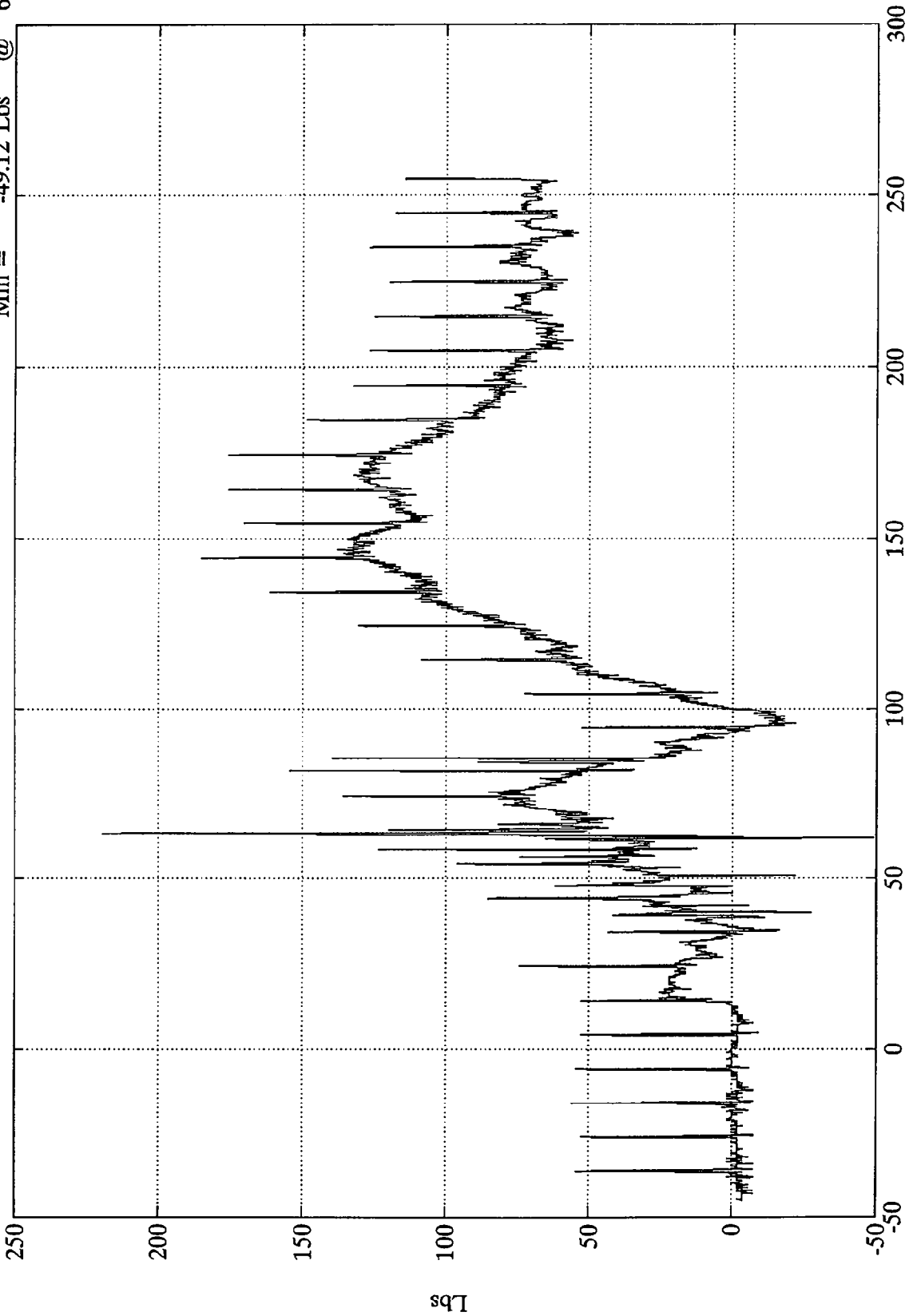

Time (msec)

SAE Filter Class 1000

NHTSA 208 TEST #16 - 1994 Dodge Caravan

Pos.1 Upper Neck Fy  
Max = 3925.41 Lbs @ 99.24 msec  
Min = -3814.61 Lbs @ 97.80 msec

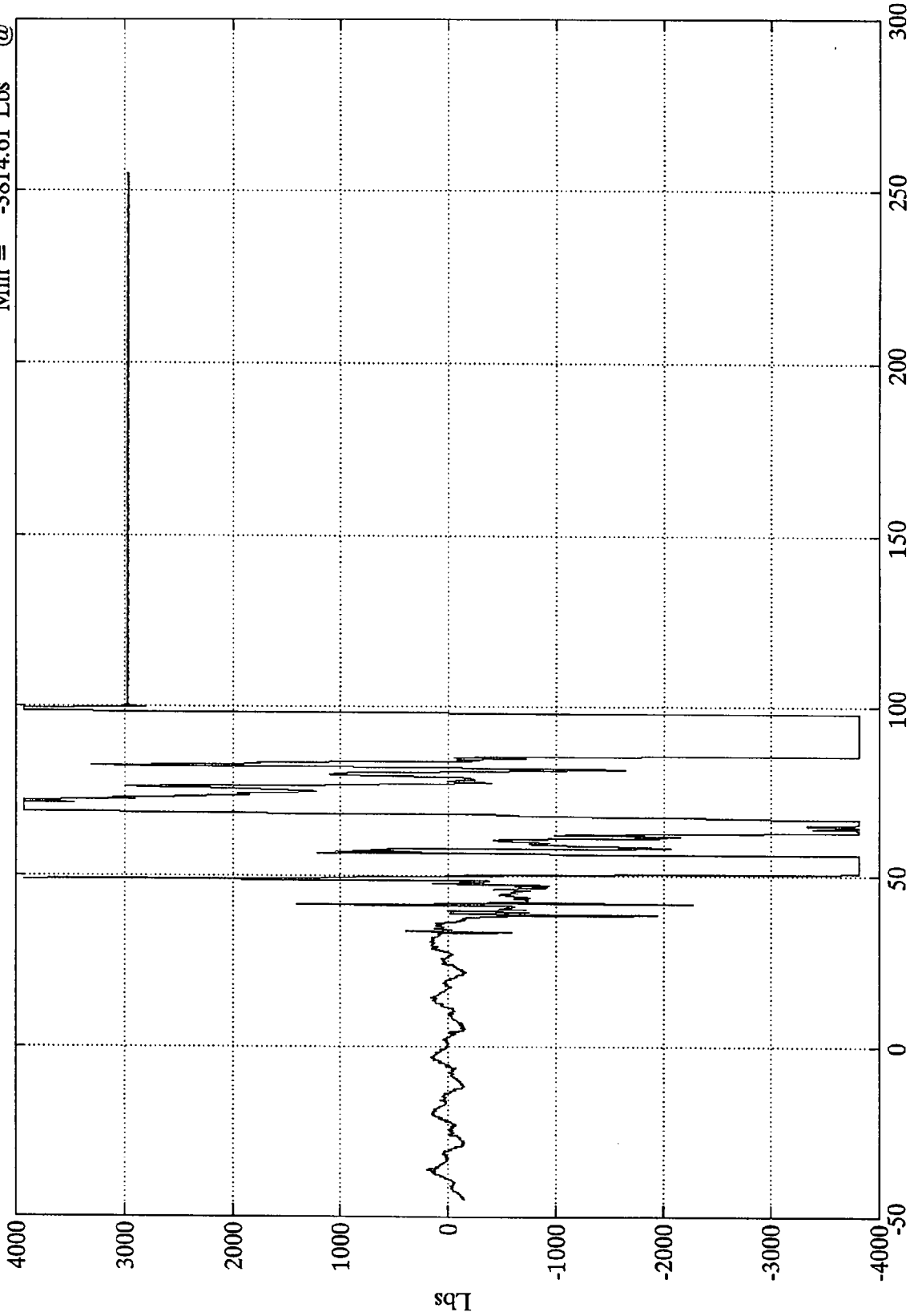

Time (msec) Data Questionable

SAE Filter Class 1000

NHTSA 208 TEST #16 - 1994 Dodge Caravan

Pos.1 Upper Neck Fz

Max = 1001.56 Lbs @ 71.63 msec  
Min = -52.49 Lbs @ 116.87 msec

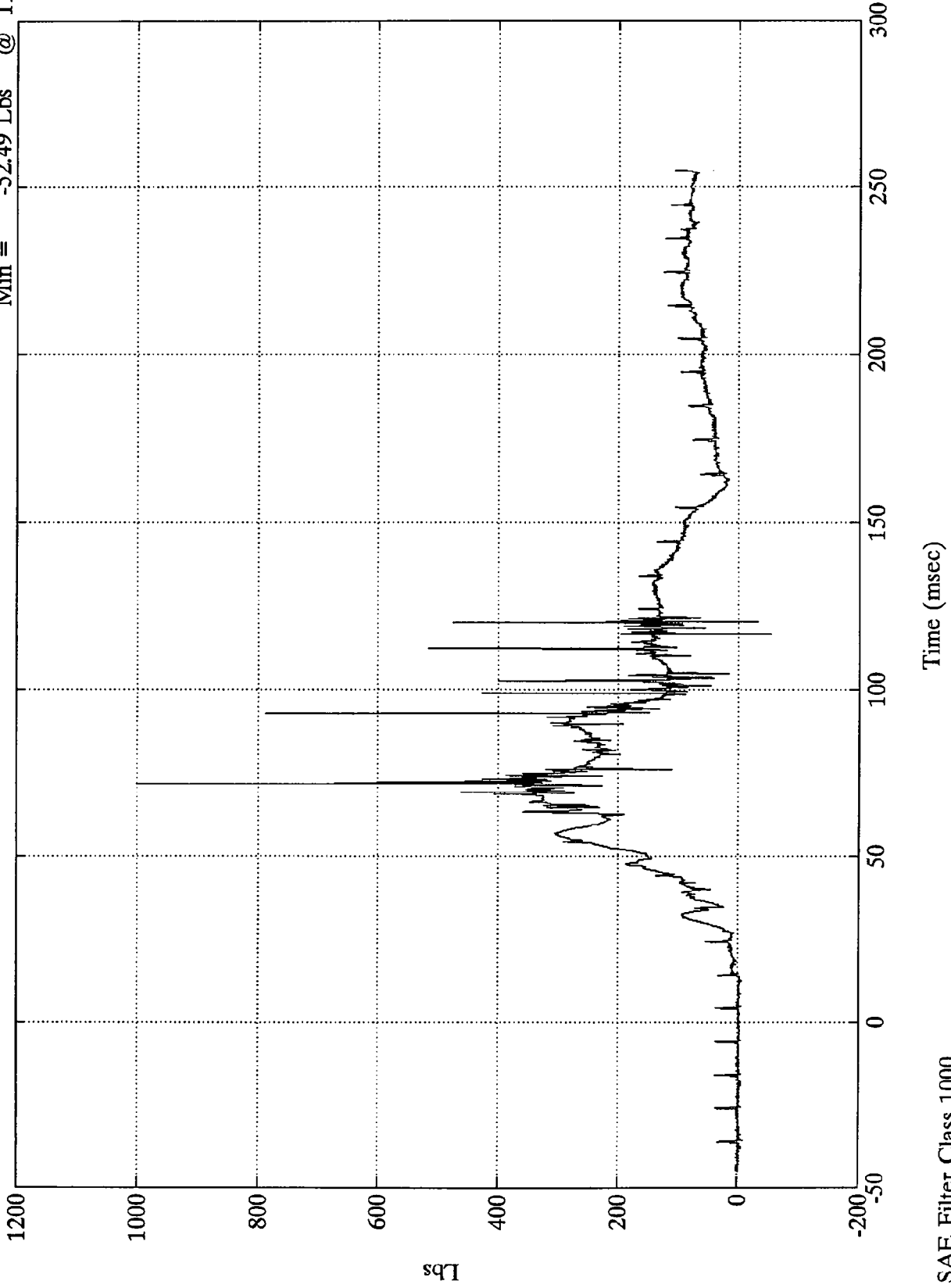

SAE Filter Class 1000

NHTSA 208 TEST #16 - 1994 Dodge Caravan

Max = 4051.85 Lbs @ 71.63 msec  
Min = 1.66 Lbs @ 0.11 msec

Pos.1 Neck Force Res.

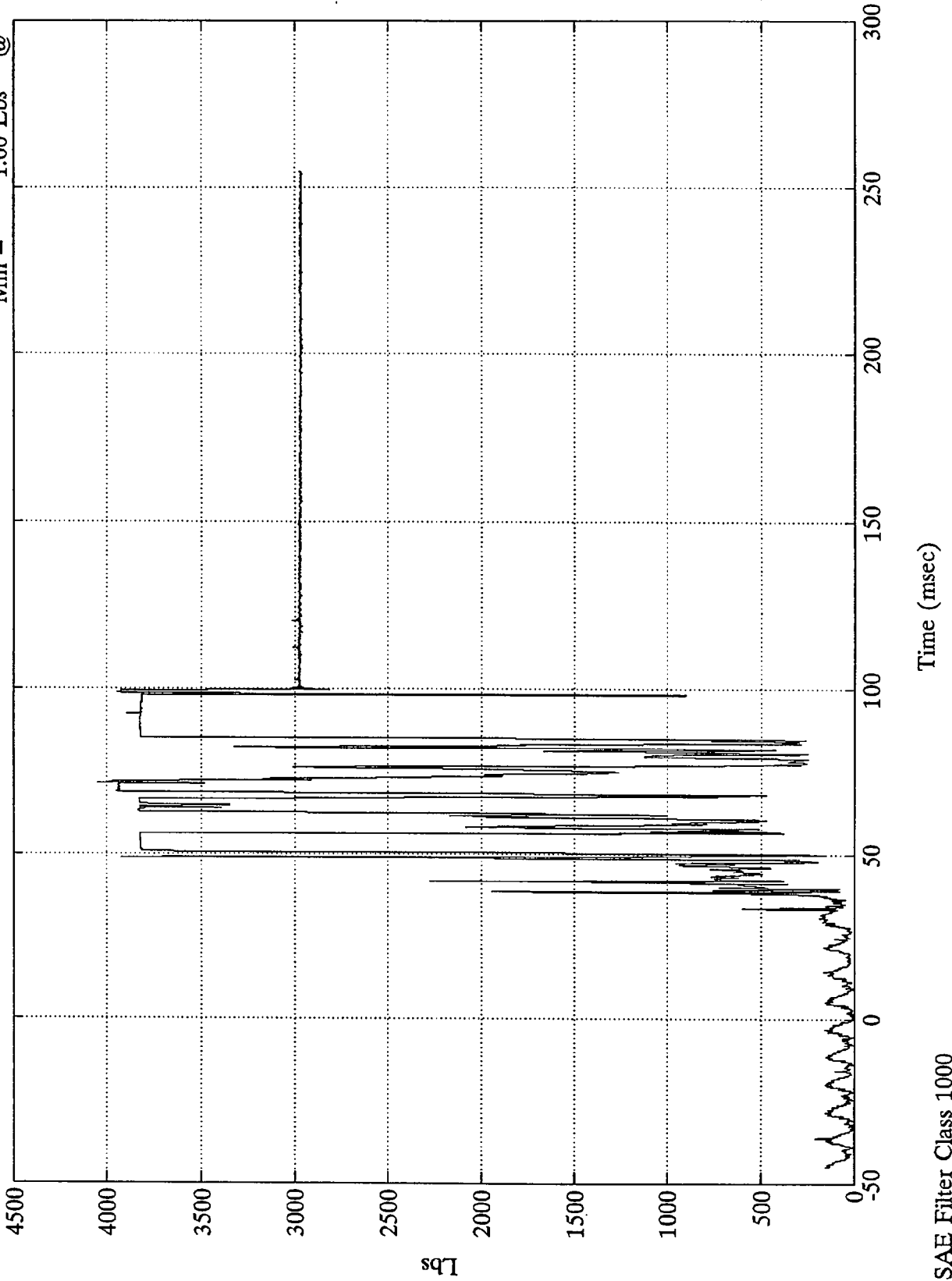

SAE Filter Class 1000

NHTSA 208 TEST #16 - 1994 Dodge Caravan

Pos.1 Upper Neck Mx

Max = 27.22 Ftlb @ 63.11 msec  
Min = -7.18 Ftlb @ 144.96 msec

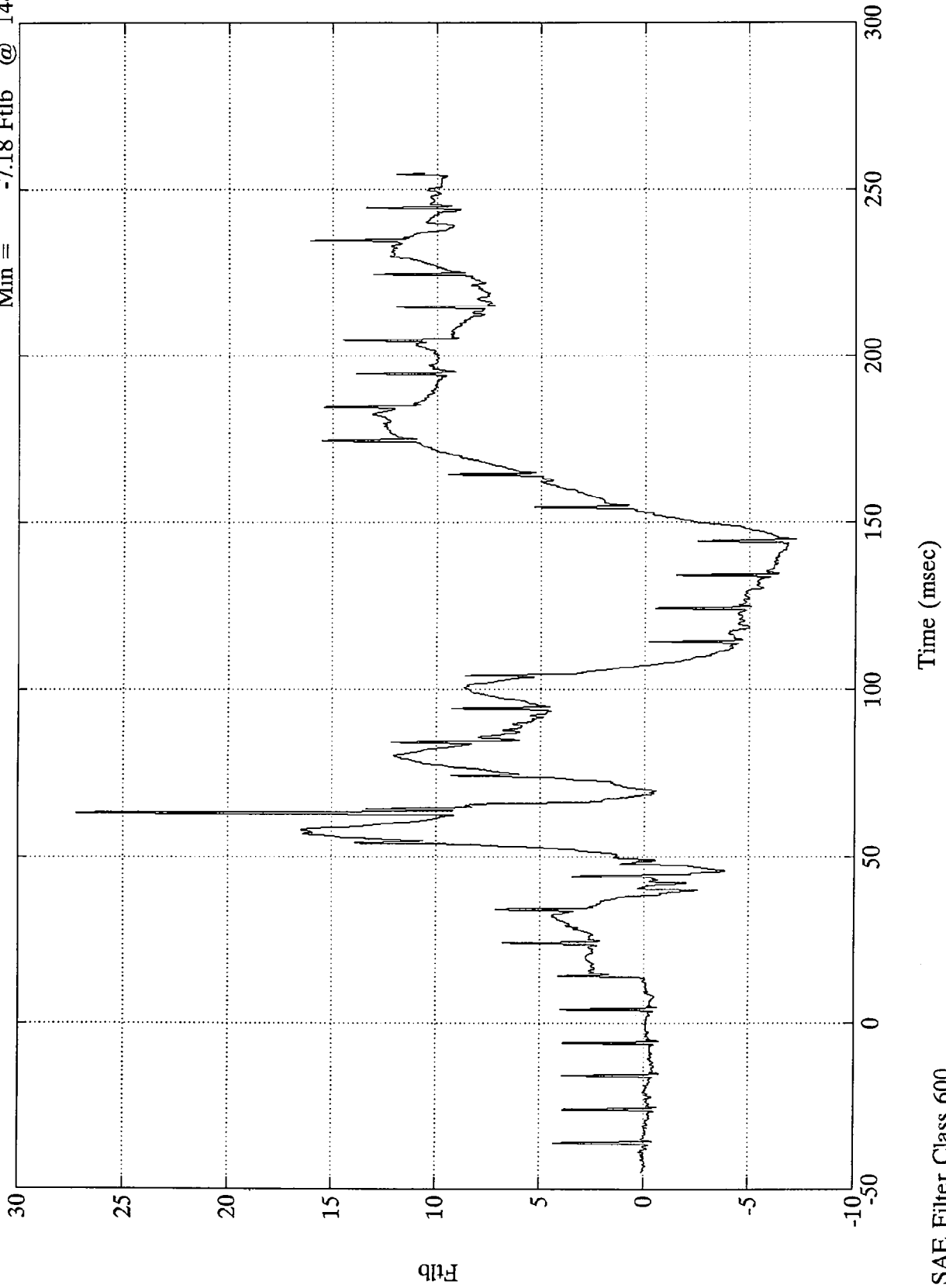

SAE Filter Class 600

NHTSA 208 TEST #16 - 1994 Dodge Caravan

Pos.1 Upper Neck My  
Max = 39.91 Ftlb @ 159.60 msec  
Min = -20.26 Ftlb @ 76.80 msec

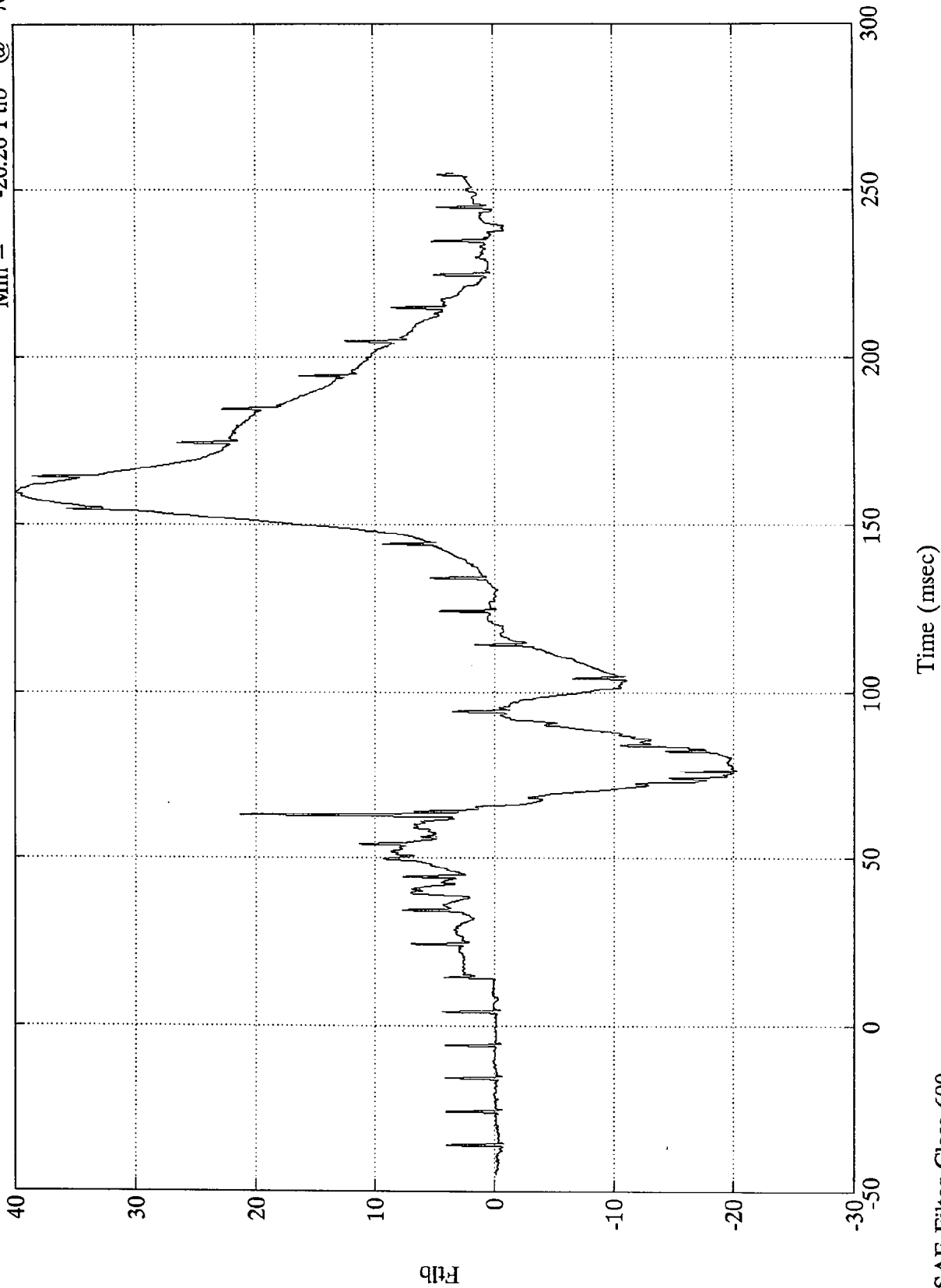

SAE Filter Class 600

NHTSA 208 TEST #16 - 1994 Dodge Caravan

Pos.1 Upper Neck Mz

Max = 12.87 Ftlb @ 174.48 msec  
Min = -19.29 Ftlb @ 101.16 msec

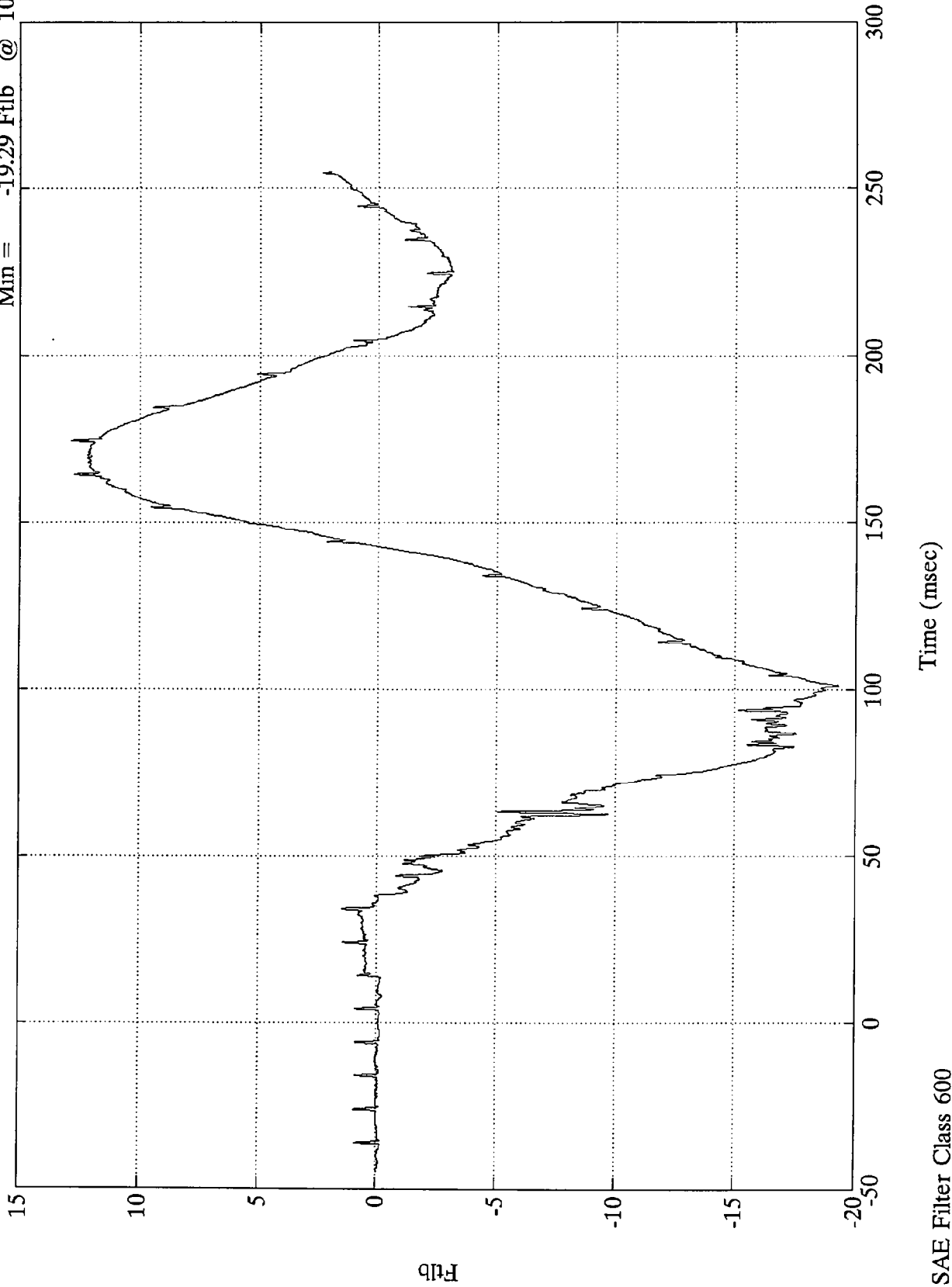

SAE Filter Class 600

NHTSA 208 TEST #16 - 1994 Dodge Caravan

Pos.1 Neck Moment Res.

Max = 41.74 Ftlb @ 164.40 msec  
Min = .06 Ftlb @ -21.12 msec

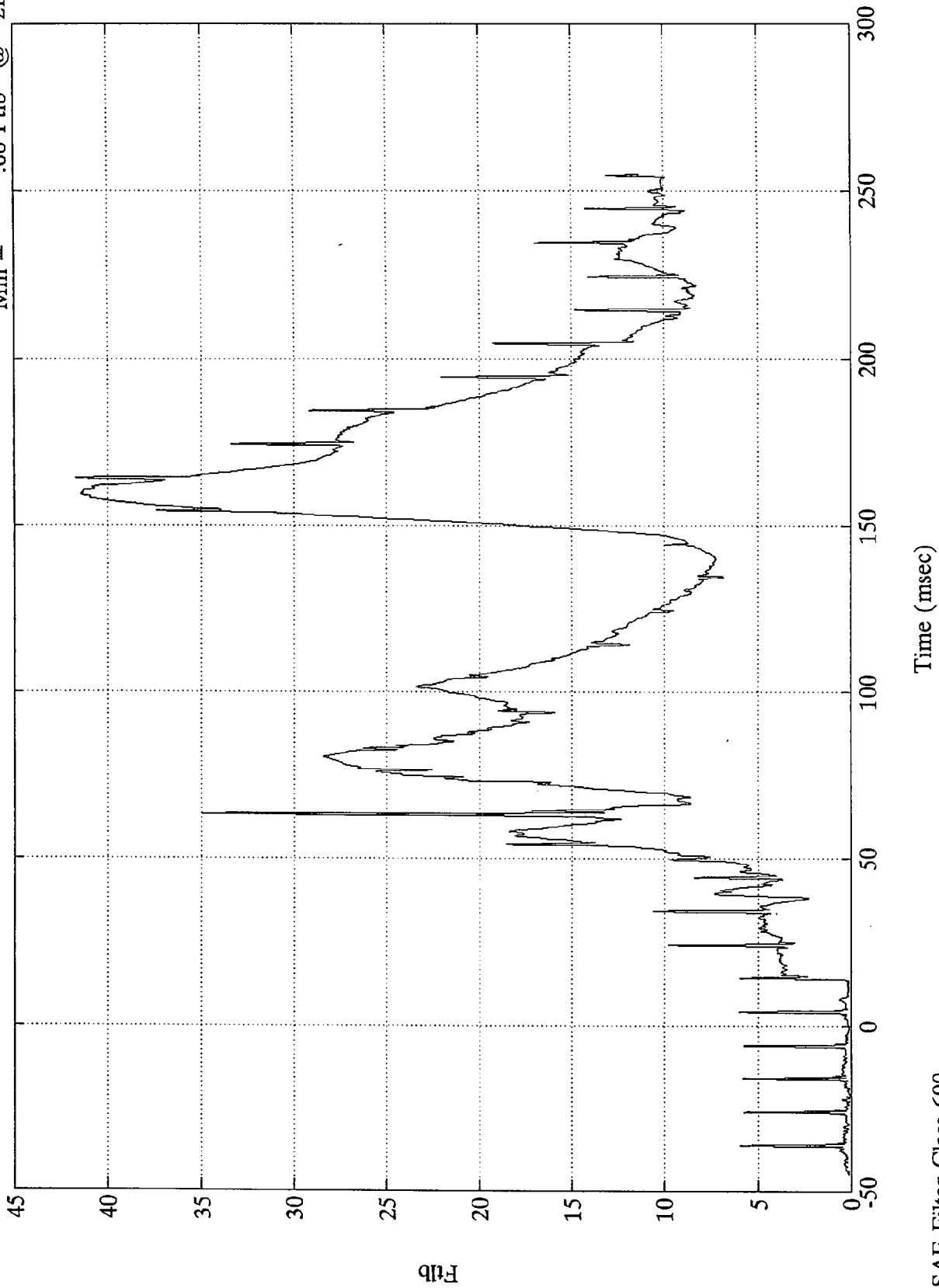

SAE Filter Class 600

NHTSA 208 TEST #16 - 1994 Dodge Caravan

Pos.1 Chest Displacement  
Max = .01 ins @ -28.32 msec  
Min = -2.74 ins @ 96.12 msec

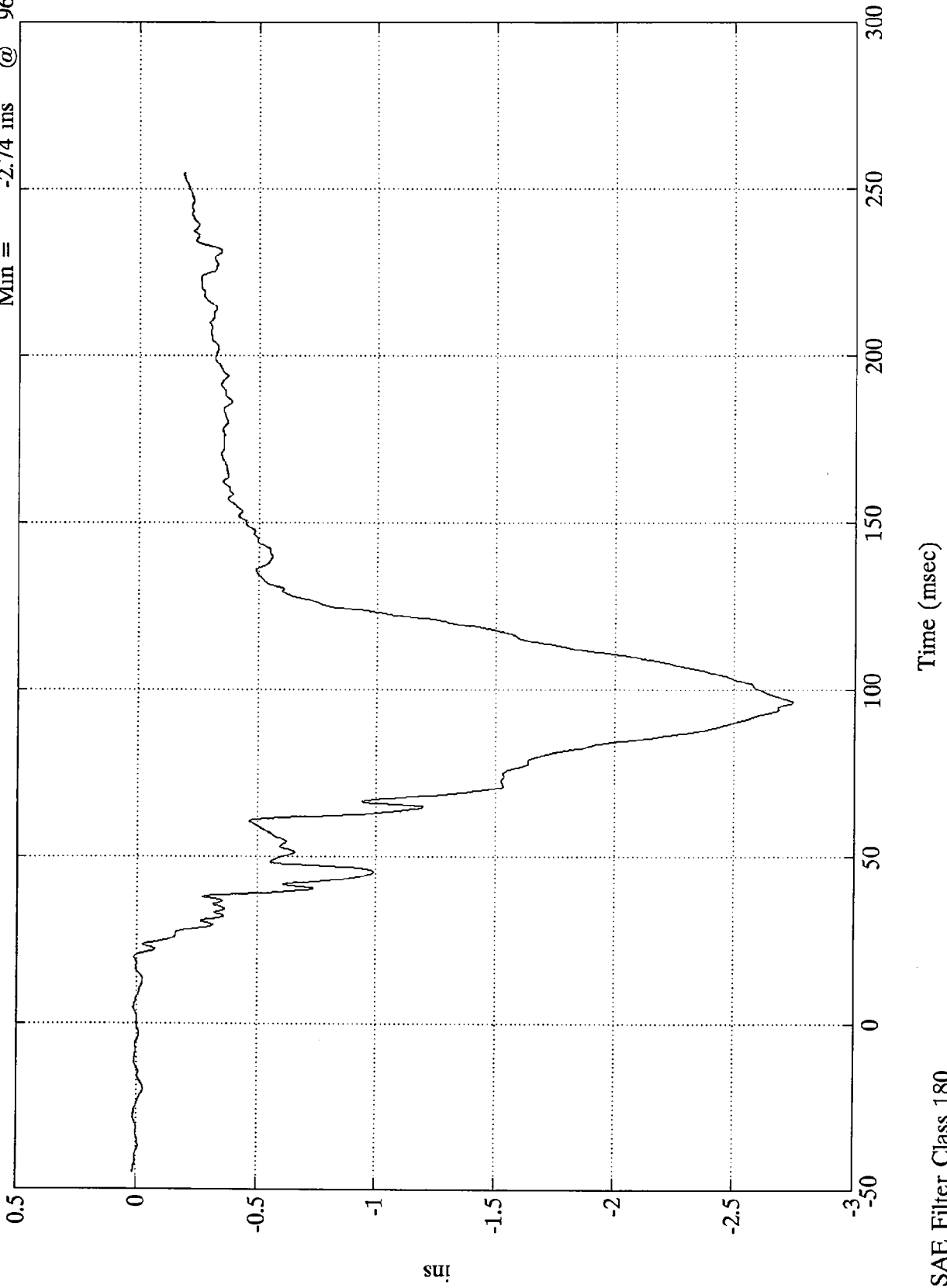

NHTSA 208 TEST #16 - 1994 Dodge Caravan

Max = 10.37 Gs @ 214.55 msec  
Min = -46.57 Gs @ 67.32 msec

Pos. 1 Pelvic X

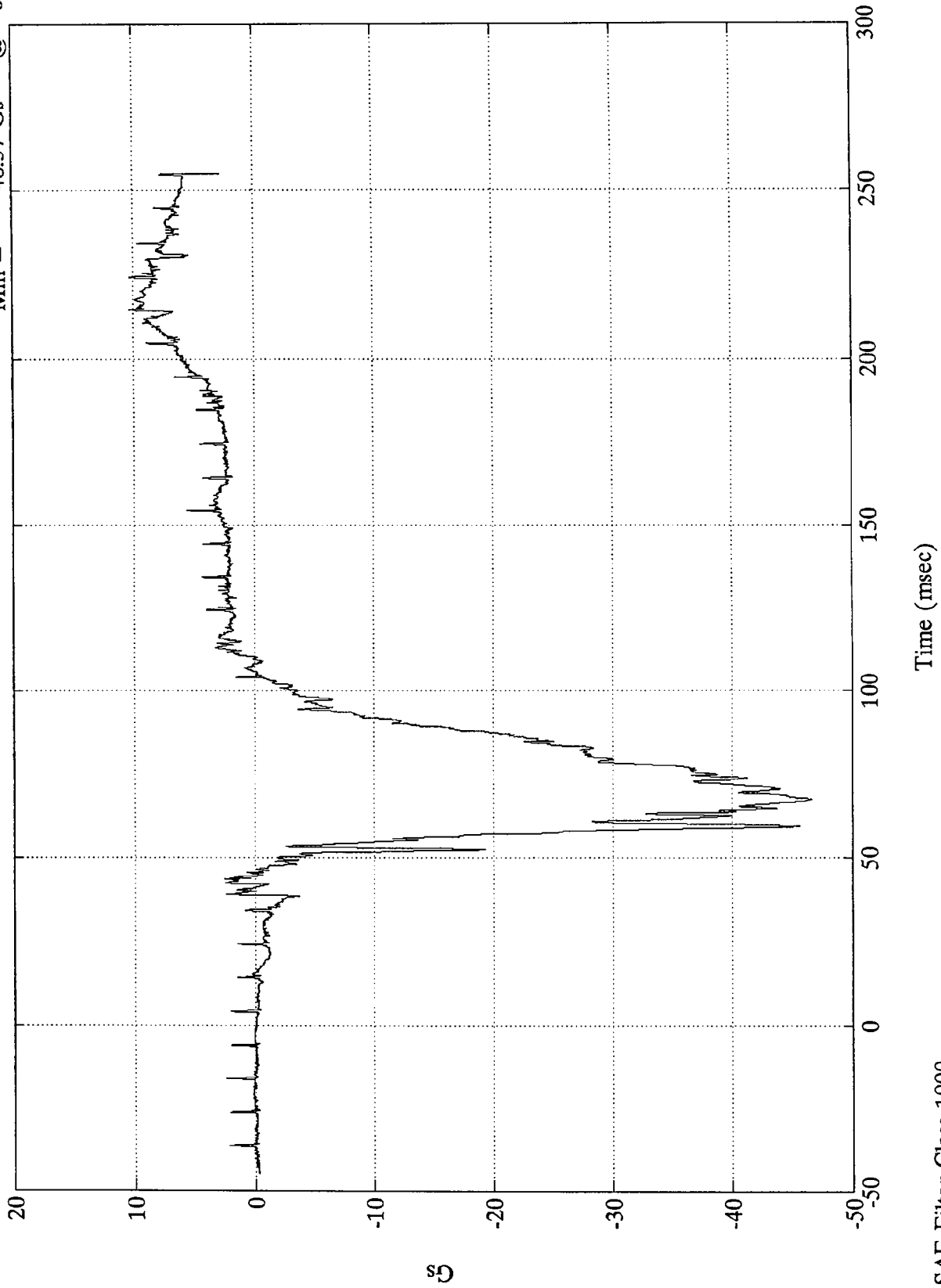

SAE Filter Class 1000

Gs

Time (msec)

NHTSA 208 TEST #16 - 1994 Dodge Caravan

Max = 9.72 Gs @ 59.52 msec  
Min = -6.57 Gs @ 52.20 msec

Pos. 1 Pelvic Y

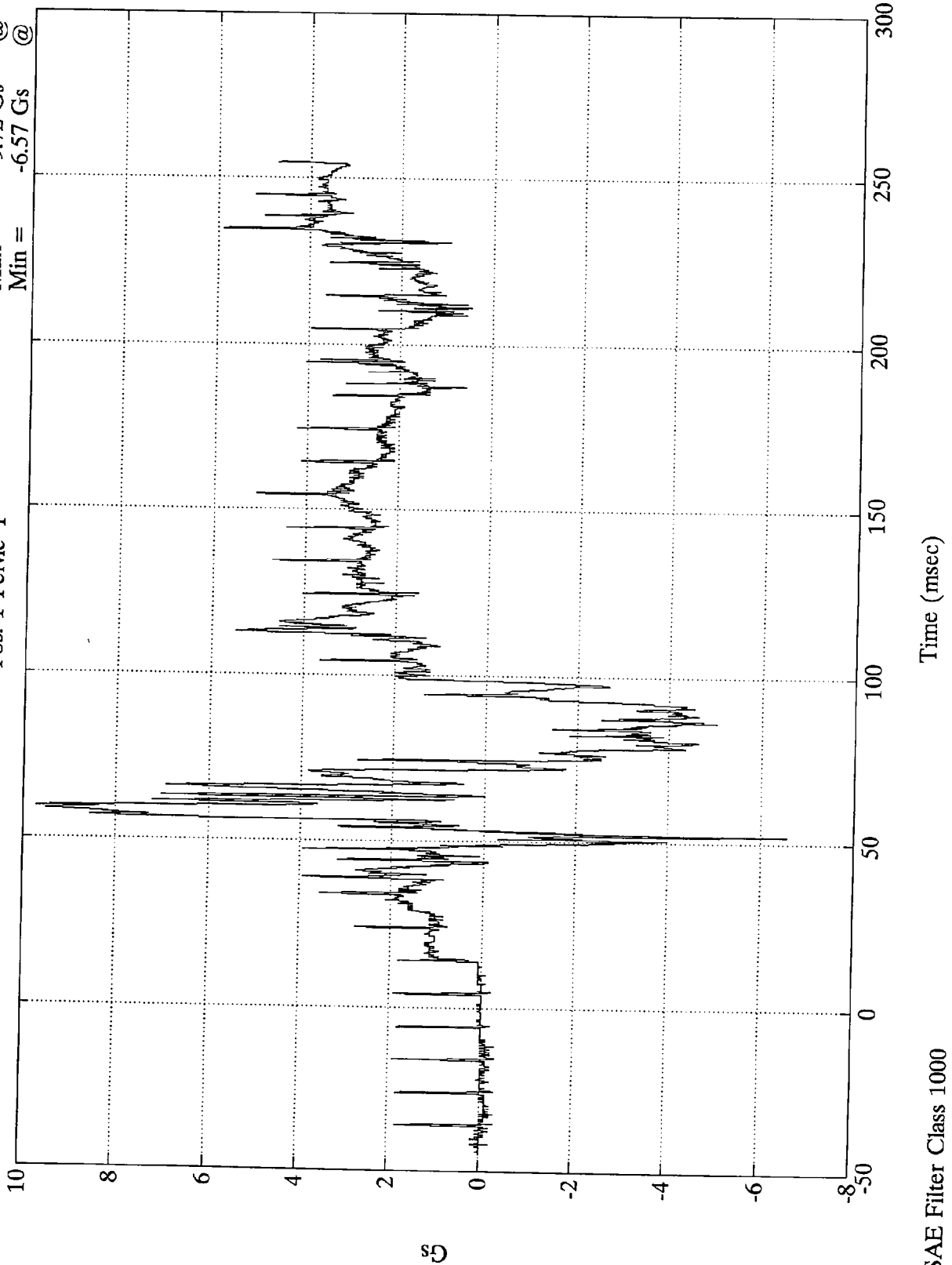

Gs

SAE Filter Class 1000

NHTSA 208 TEST #16 - 1994 Dodge Caravan

Max = 11.16 Gs @ 99.00 msec  
Min = -19.76 Gs @ 72.12 msec

Pos. 1 Pelvic Z

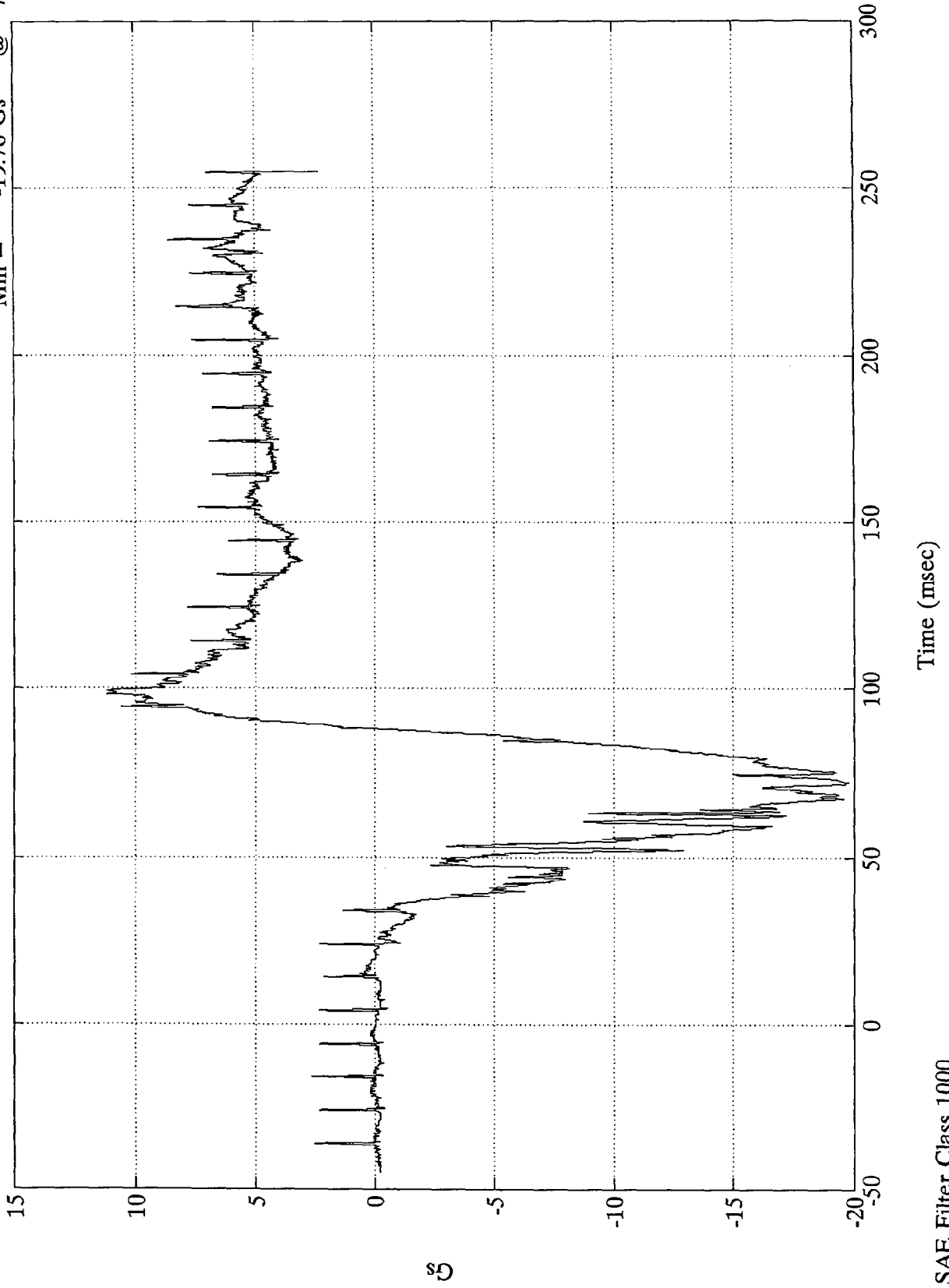

5



NHTSA 208 TEST #16 - 1994 Dodge Caravan

Max = 50.51 Gs @ 67.32 msec  
Min = .05 Gs @ -4.92 msec

Pos. 1 Pelvic Resultant

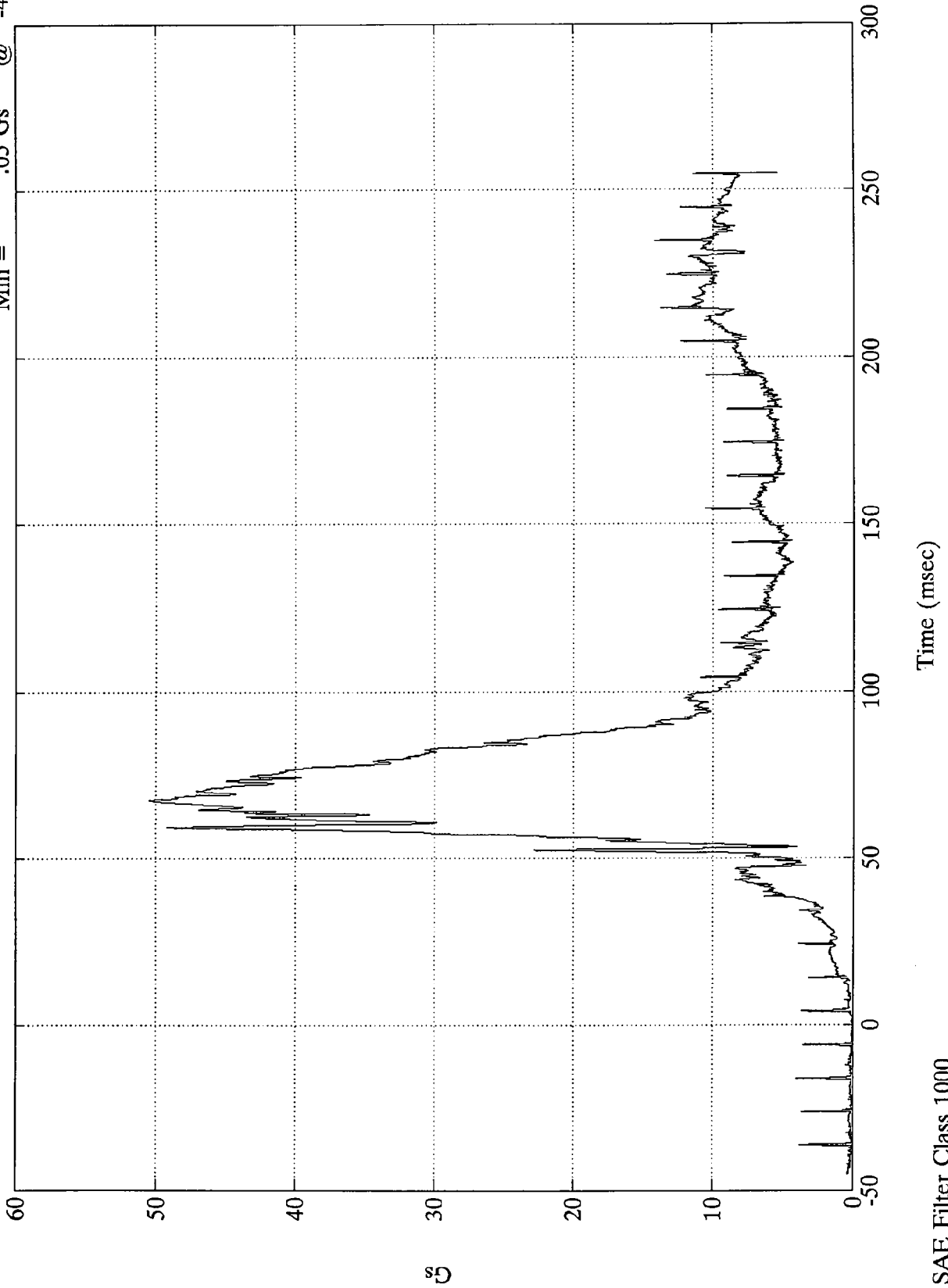

SAE Filter Class 1000

NHTSA 208 TEST #16 - 1994 Dodge Caravan

Max = 9.94 Gs @ 244.80 msec  
Min = -26.23 Gs @ 57.36 msec

Pos. 2 Head X

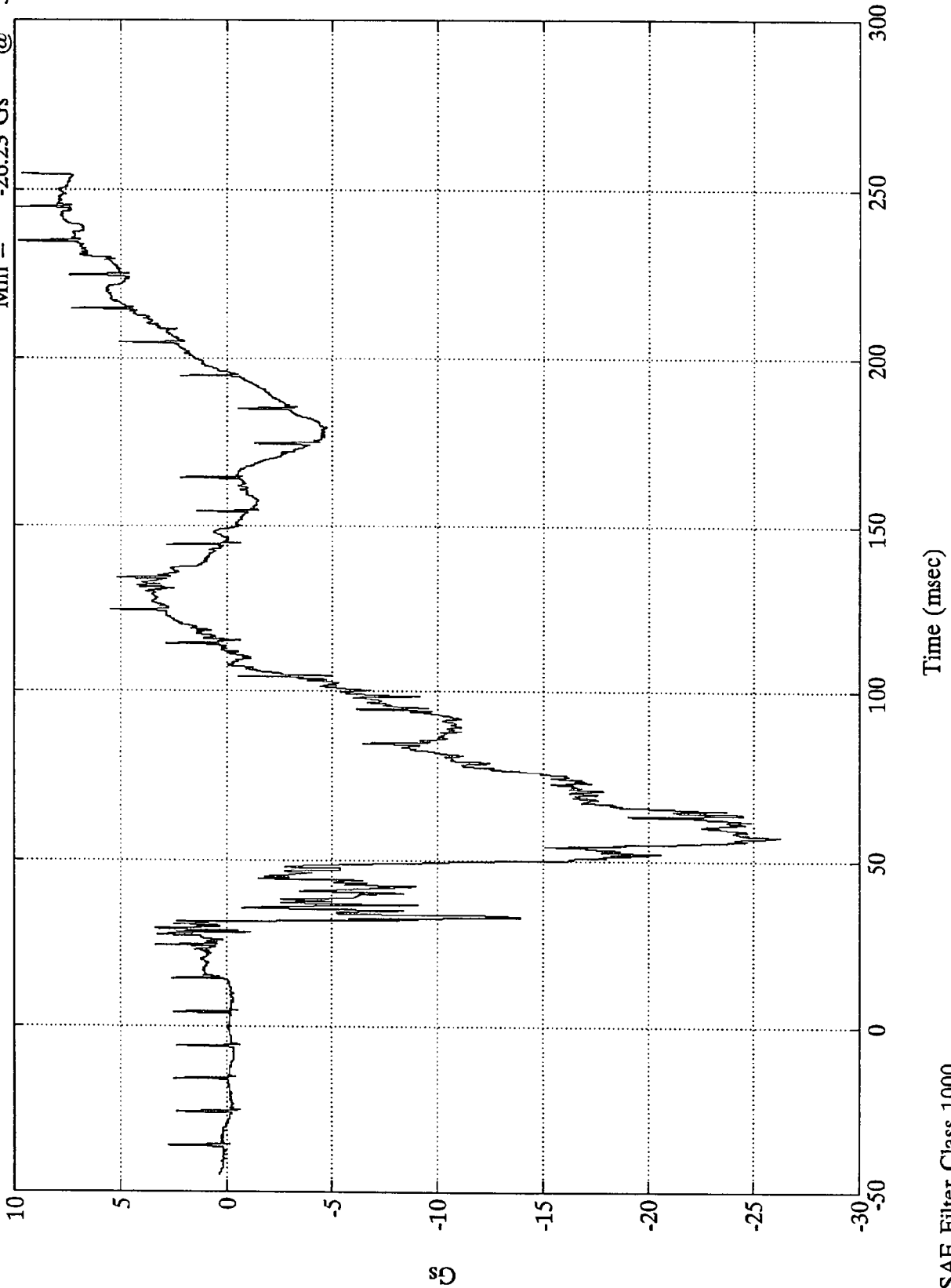

SAE Filter Class 1000

NHTSA 208 TEST #16 - 1994 Dodge Caravan

Pos. 2 Head Y

Max = 8.27 Gs @ 33.84 msec  
Min = -14.36 Gs @ 65.27 msec

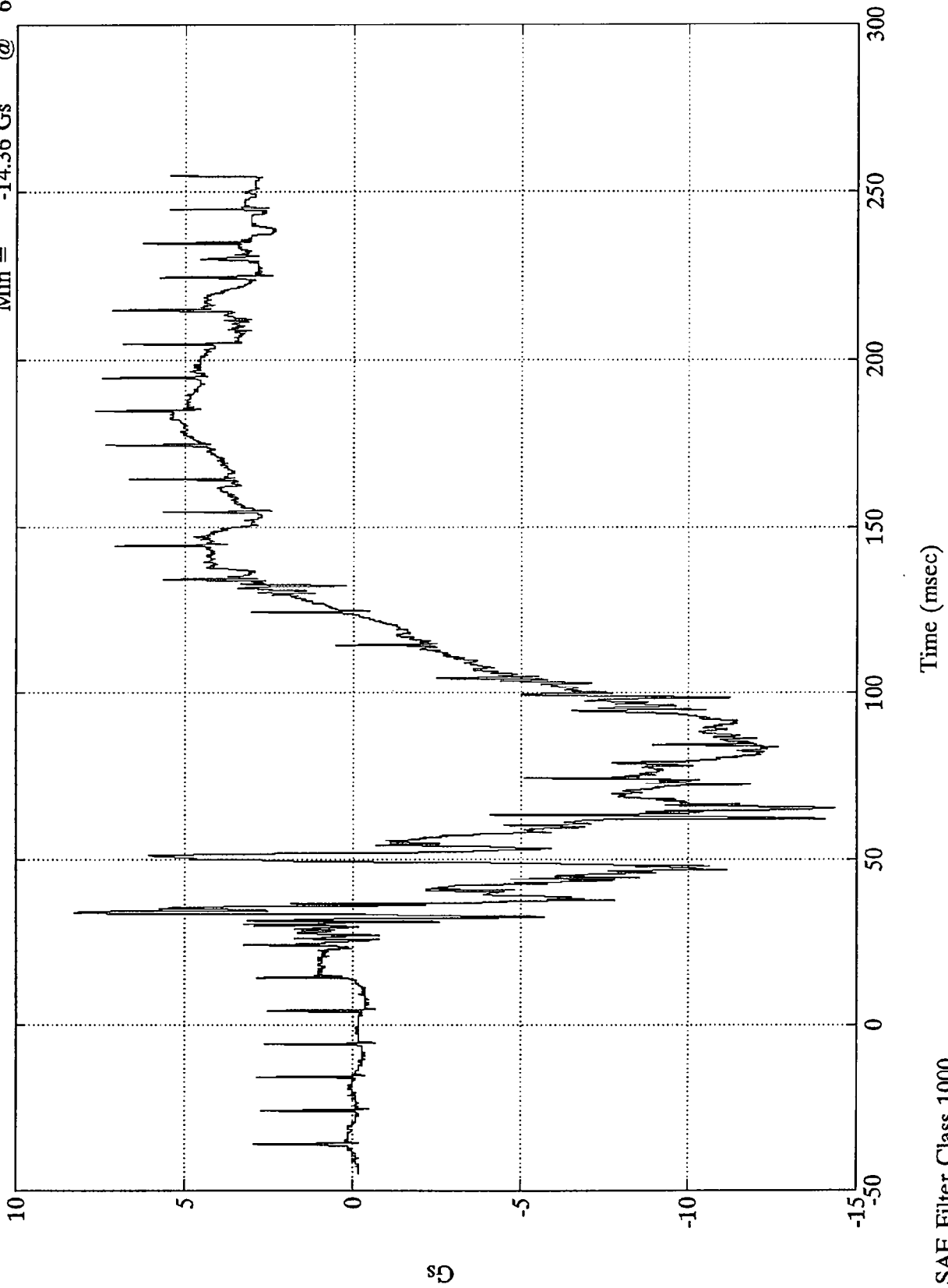

NHTSA 208 TEST #16 - 1994 Dodge Caravan

Max = 18.22 Gs @ 84.36 msec  
Min = -5.57 Gs @ 32.15 msec

Pos. 2 Head Z

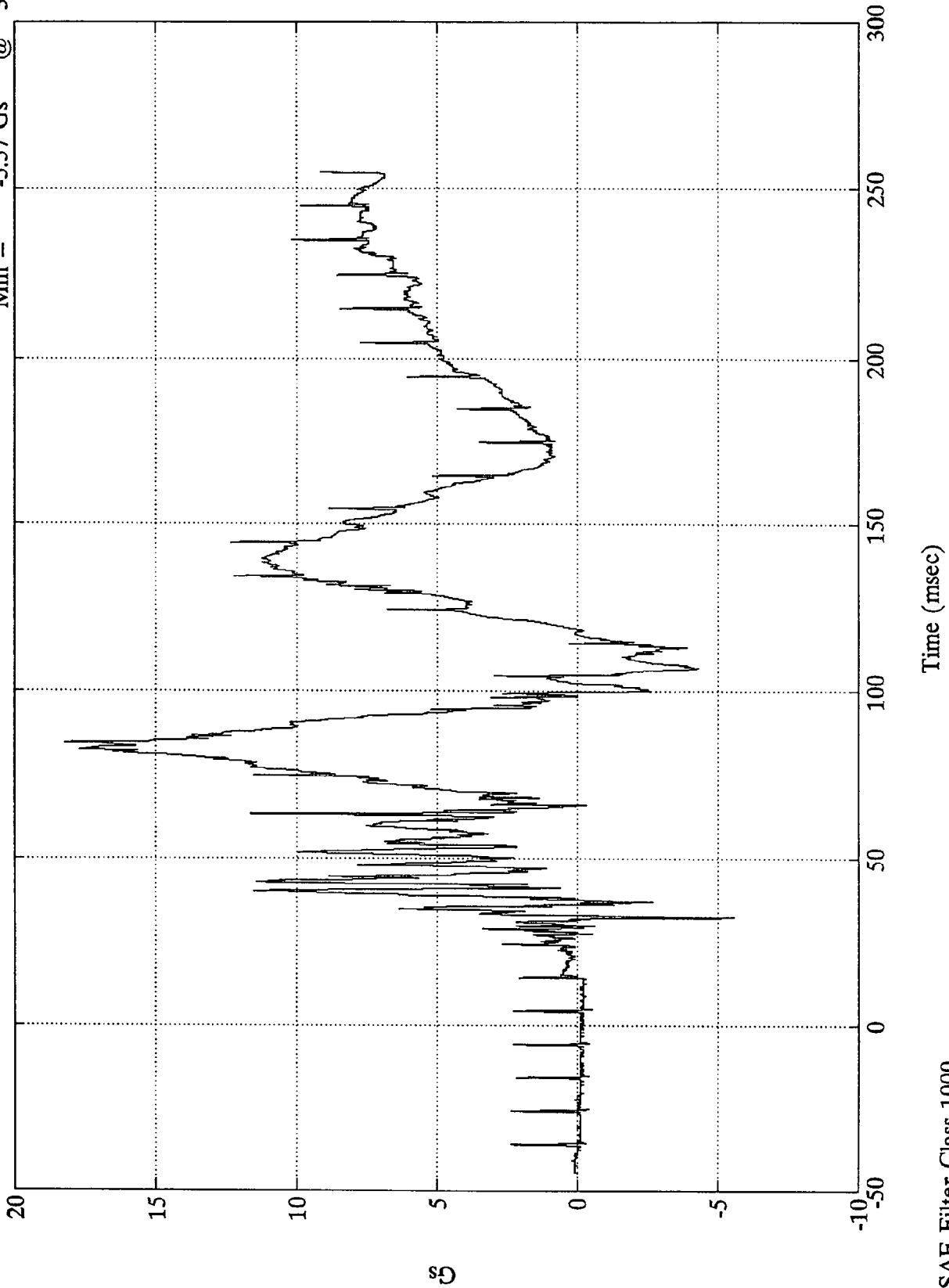

SAE Filter Class 1000

NHTSA 208 TEST #16 - 1994 Dodge Caravan

Pos. 2 Head Resultant

Max = 28.47 Gs @ 62.04 msec  
Min = .05 Gs @ -37.92 msec

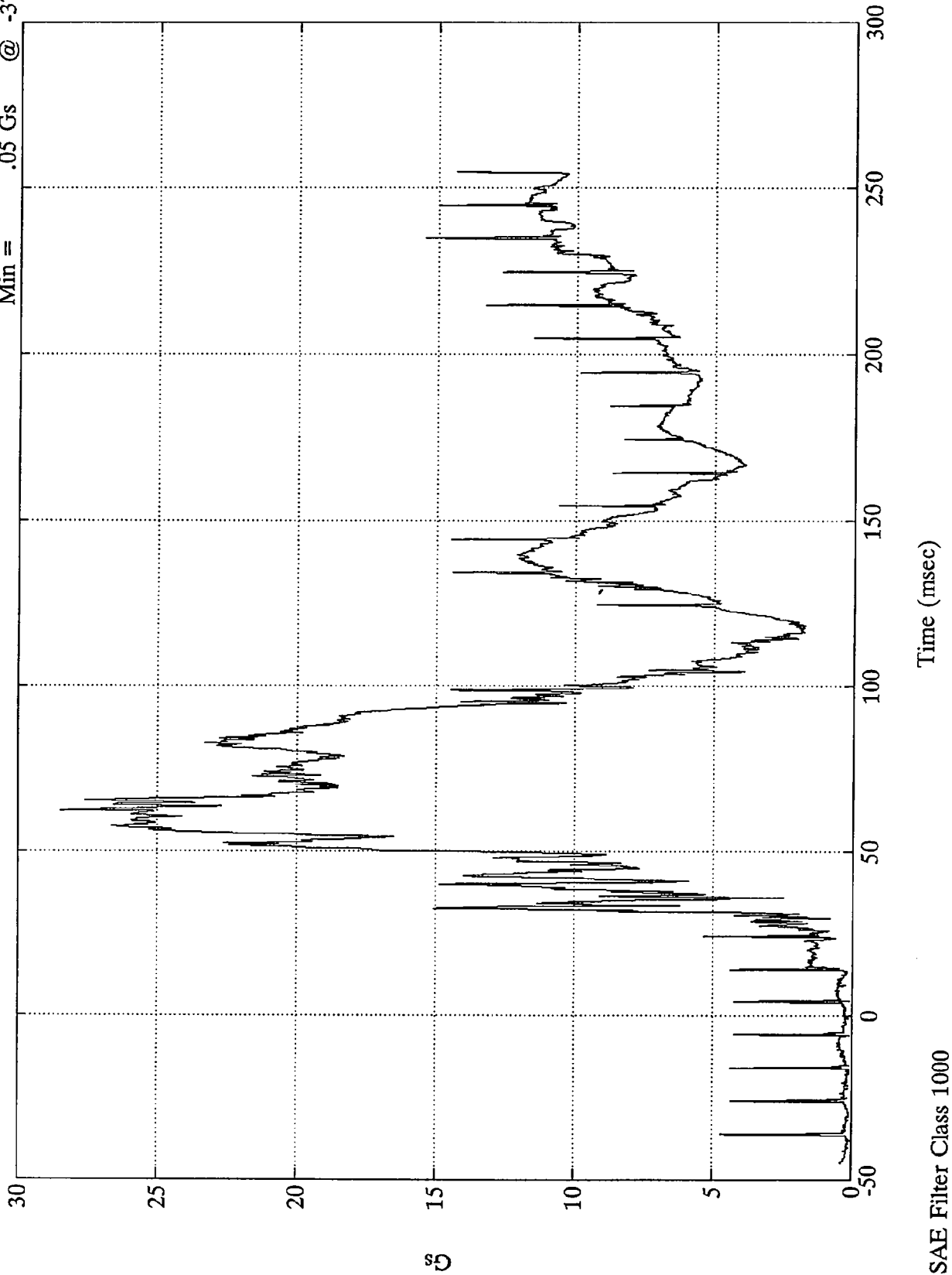

SAE Filter Class 1000

NHTSA 208 TEST #16 - 1994 Dodge Caravan

Max = 8.85 Gs @ 174.60 msec  
Min = -30.41 Gs @ 87.24 msec

Pos. 2 Chest X

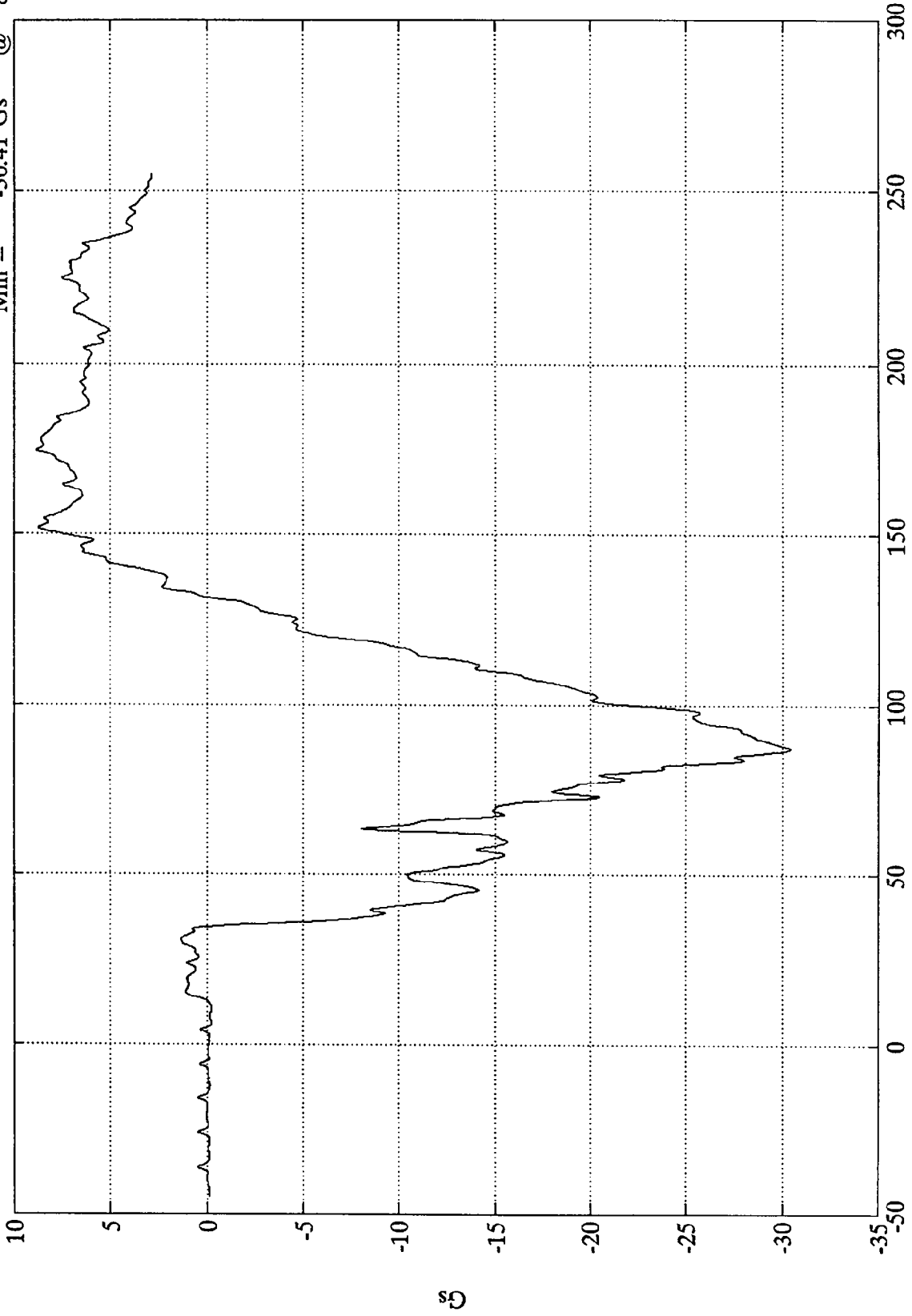

Time (msec)

SAE Filter Class 180

NHTSA 208 TEST #16 - 1994 Dodge Caravan

Pos. 2 Chest Y

Max = 5.69 Gs @ 99.72 msec  
Min = -1.87 Gs @ 50.16 msec

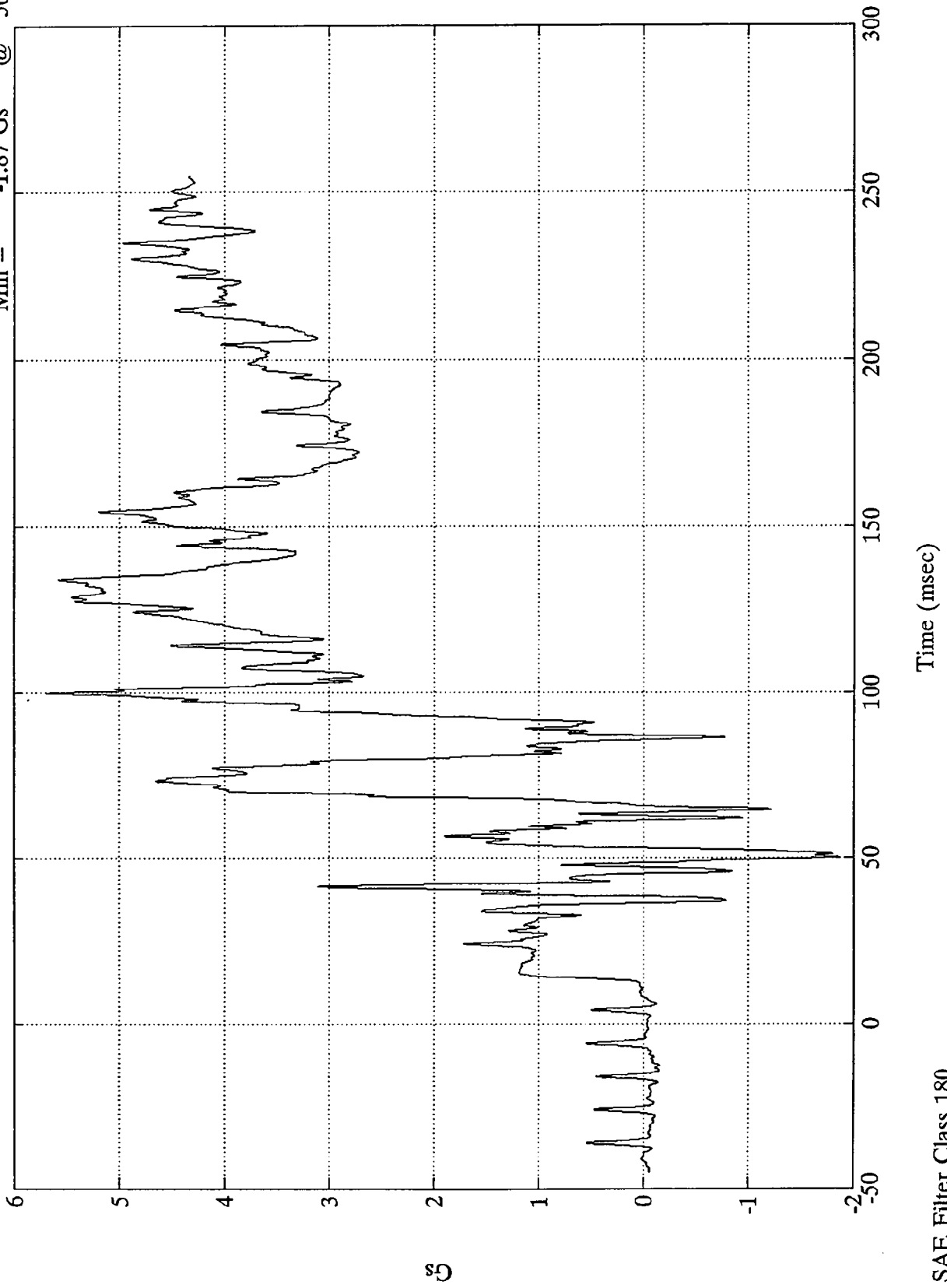

SAE Filter Class 180

NHTSA 208 TEST #16 - 1994 Dodge Caravan

Max = 14.24 Gs @ 100.08 msec  
Min = -4.91 Gs @ 66.60 msec

Pos. 2 Chest Z

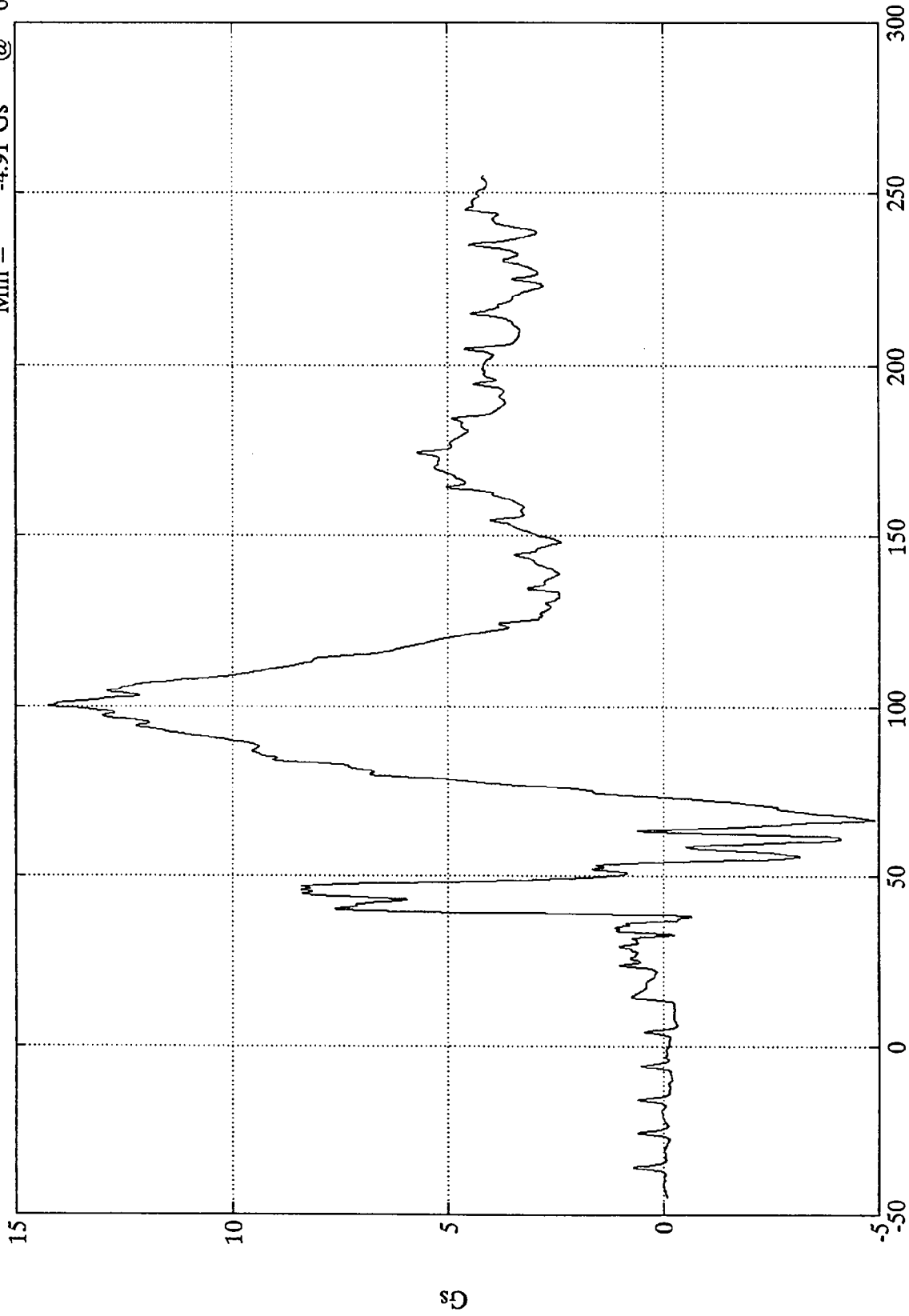

Time (msec)

SAE Filter Class 180

NHTSA 208 TEST #16 - 1994 Dodge Caravan

Pos. 2 Chest Resultant

Max = 31.87 Gs @ 87.24 msec  
Min = .01 Gs @ -27.00 msec

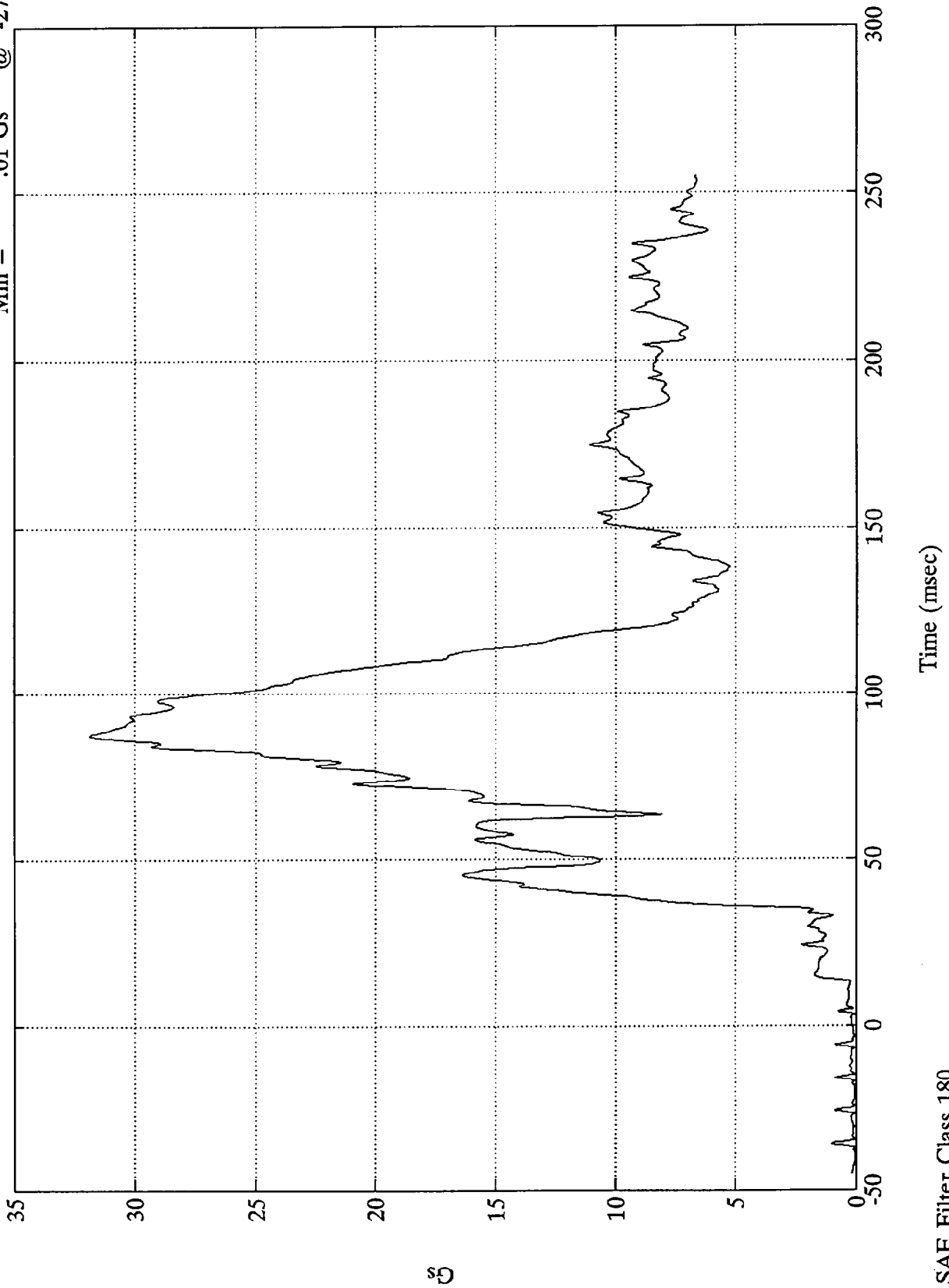

Gs

Time (msec)

SAE Filter Class 180

NHTSA 208 TEST #16 - 1994 Dodge Caravan

Max = 238.46 lbs @ 45.72 msec  
Min = -1608.96 lbs @ 68.63 msec

Pos. 2 Left Femur

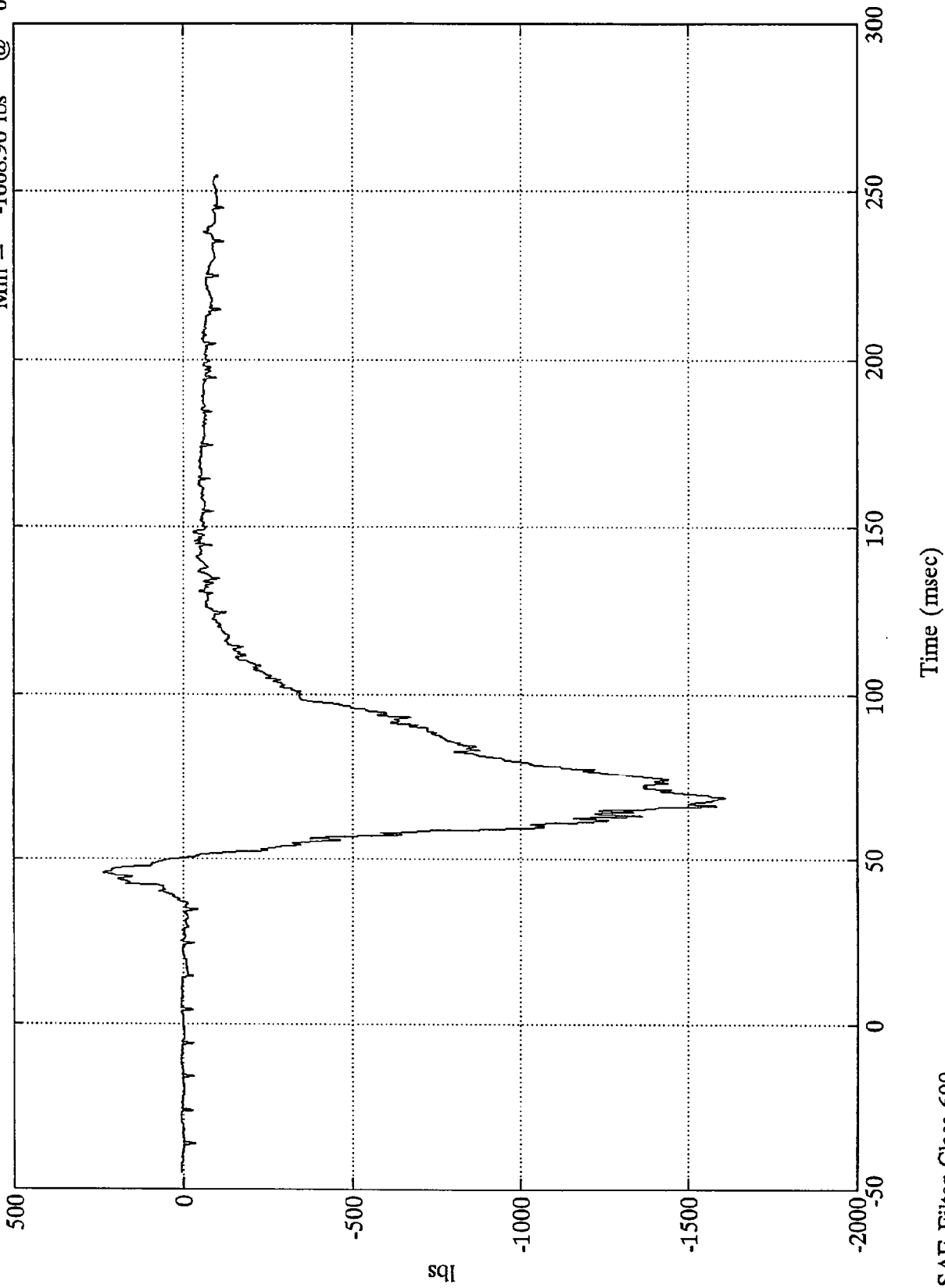

SAE Filter Class 600

NHTSA 208 TEST #16 - 1994 Dodge Caravan

Pos. 2 Right Femur

Max = 165.27 lbs @ 46.92 msec  
Min = -1640.03 lbs @ 63.23 msec

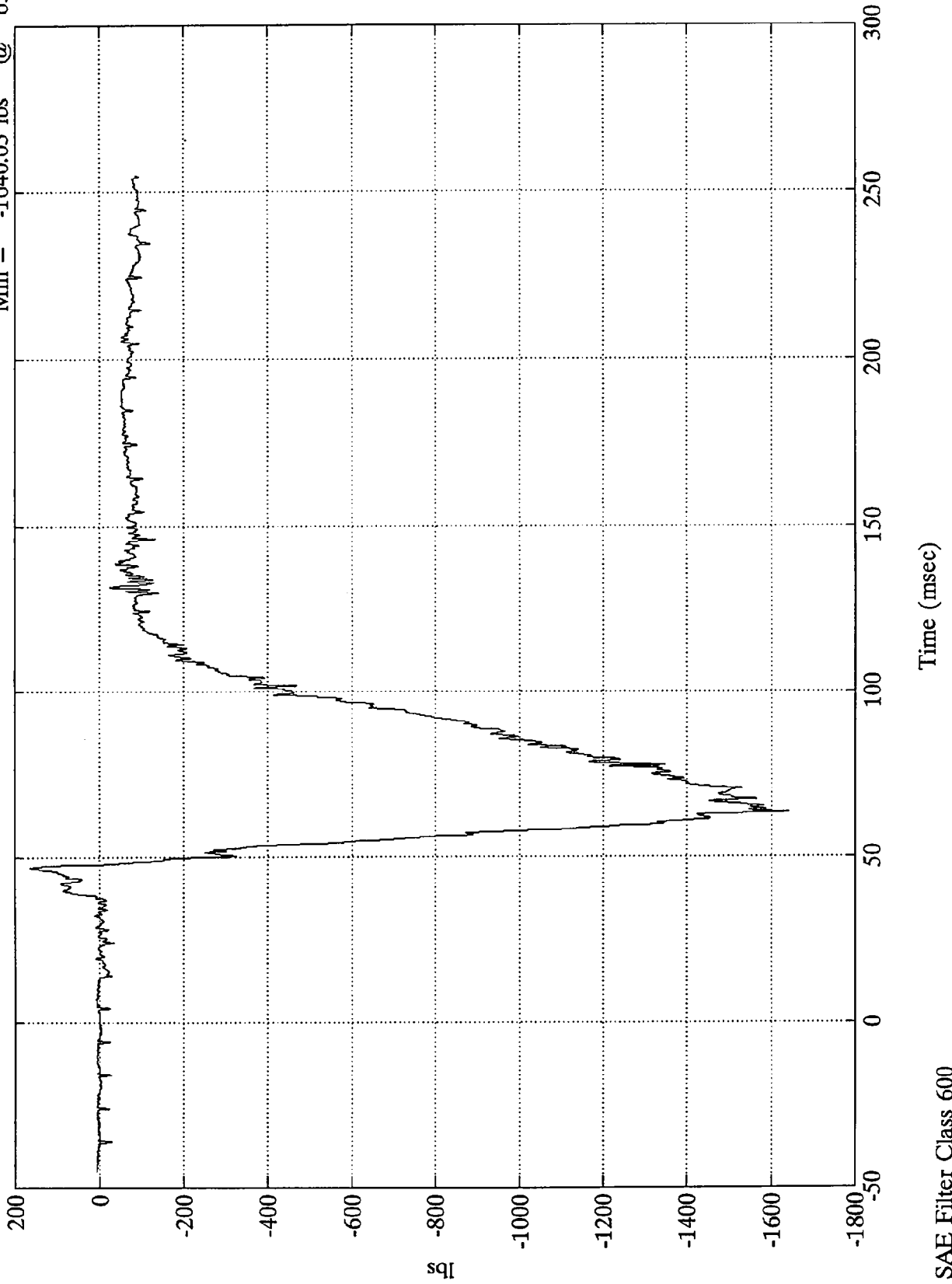

SAE Filter Class 600

NHTSA 208 TEST #16 - 1994 Dodge Caravan

Max = 188.57 Lbs @ 154.55 msec  
Min = -235.30 Lbs @ 94.80 msec

Pos.2 Upper Neck Fx

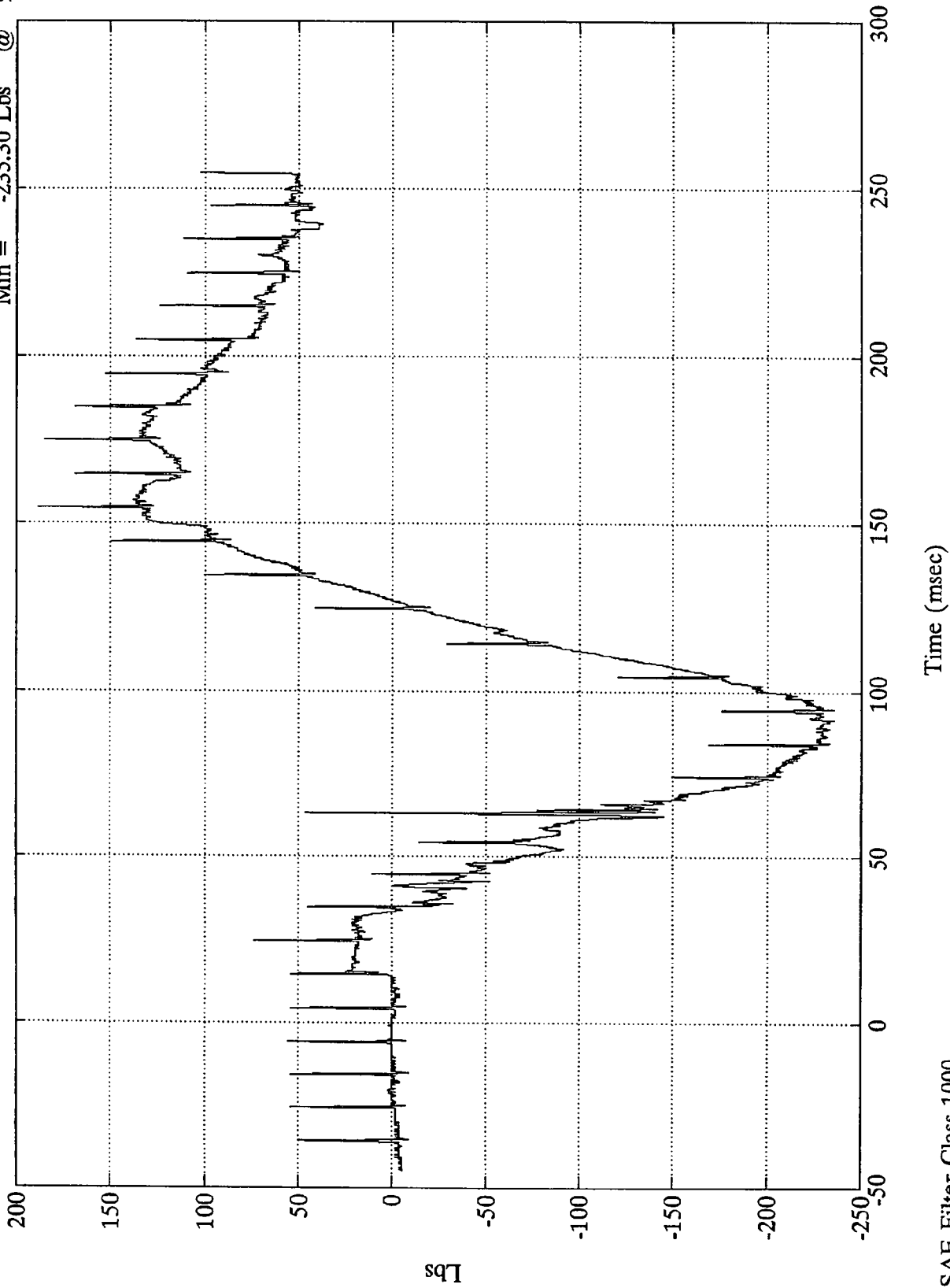

SAE Filter Class 1000

NHTSA 208 TEST #16 - 1994 Dodge Caravan

Pos.2 Upper Neck Fy  
Max = 327.12 Lbs @ 94.44 msec  
Min = -10.40 Lbs @ 4.67 msec

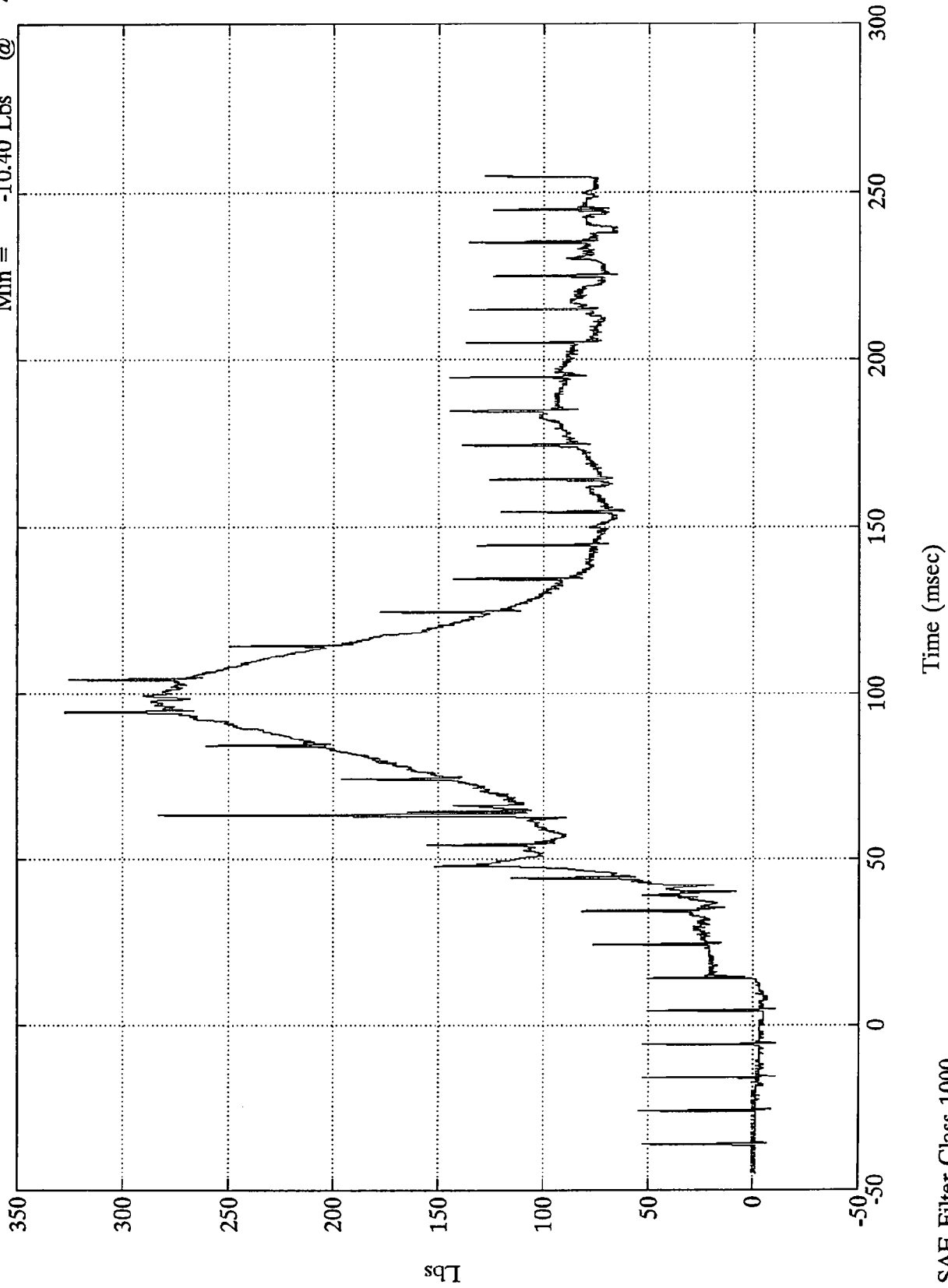

SAE Filter Class 1000

NHTSA 208 TEST #16 - 1994 Dodge Caravan

Max = 150.52 Lbs @ 144.48 msec  
Min = -167.34 Lbs @ 100.80 msec

Pos.2 Upper Neck Fz

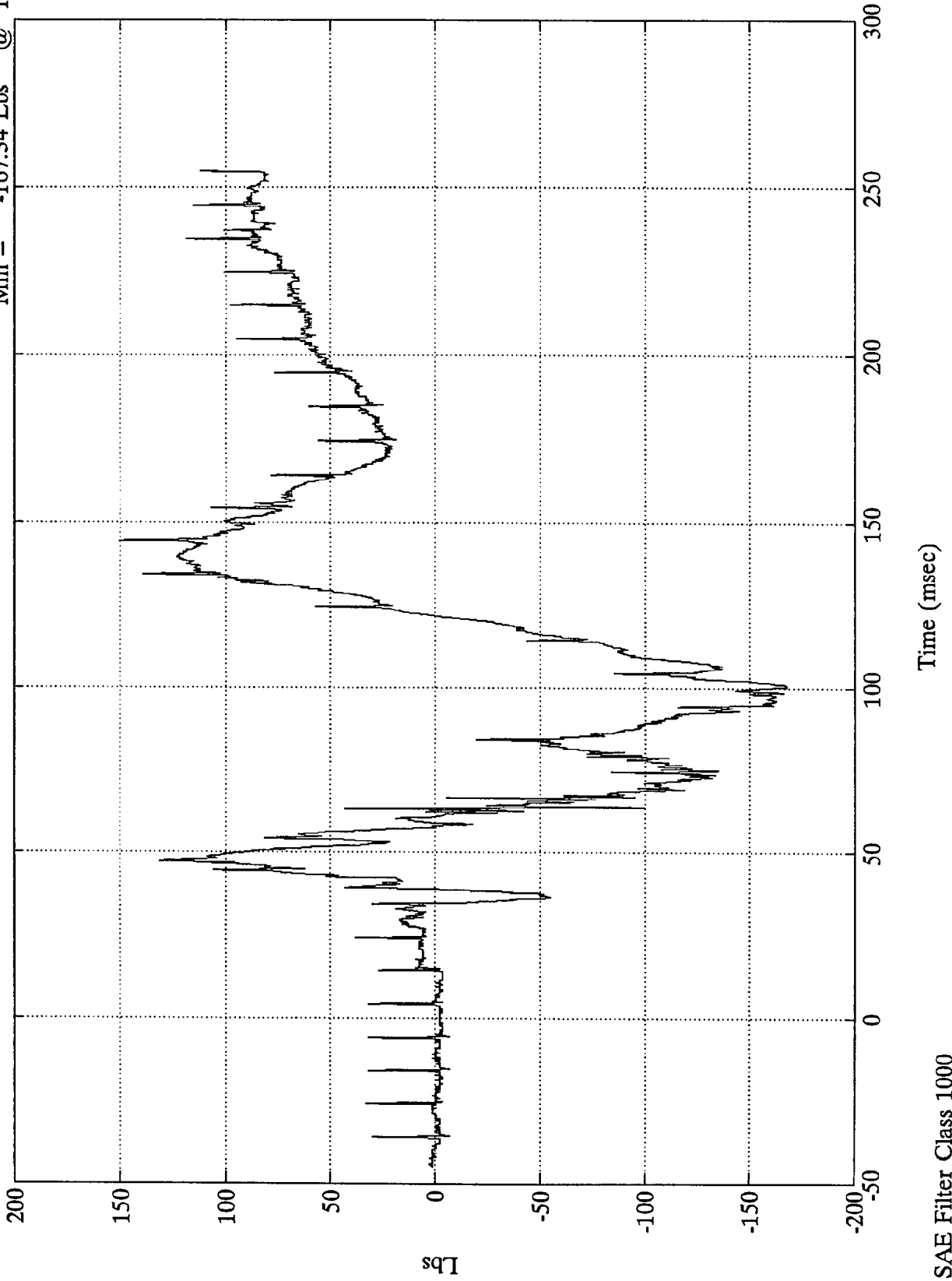

SAE Filter Class 1000

NHTSA 208 TEST #16 - 1994 Dodge Caravan

Max = 396.32 Lbs @ 97.68 msec  
Min = .77 Lbs @ -17.28 msec

Pos.2 Neck Force Res.

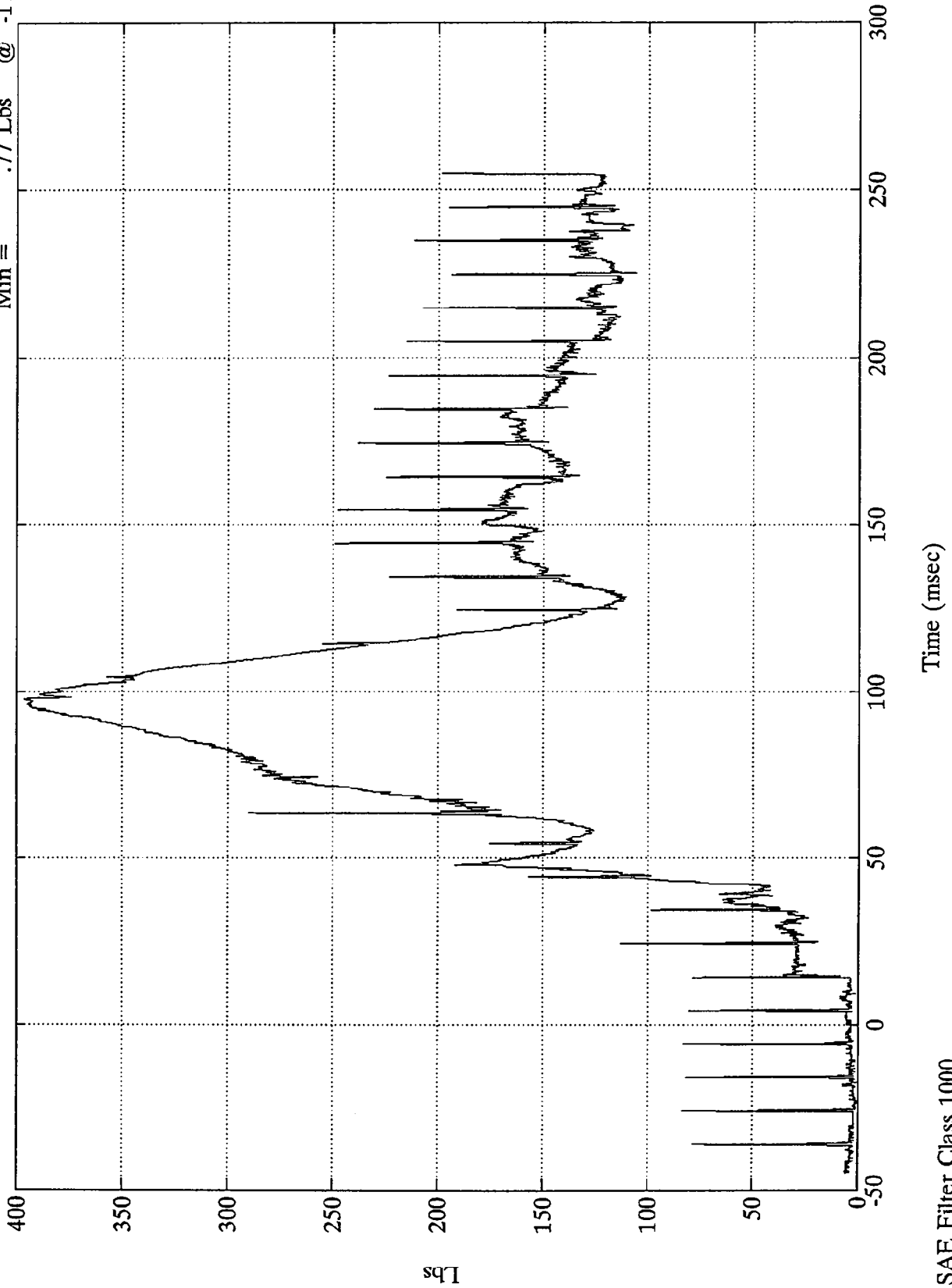

SAE Filter Class 1000

NHTSA 208 TEST #16 - 1994 Dodge Caravan

Pos.2 Upper Neck Mx

Max = 52.45 Ftlb @ 63.23 msec  
Min = -1.07 Ftlb @ -35.40 msec

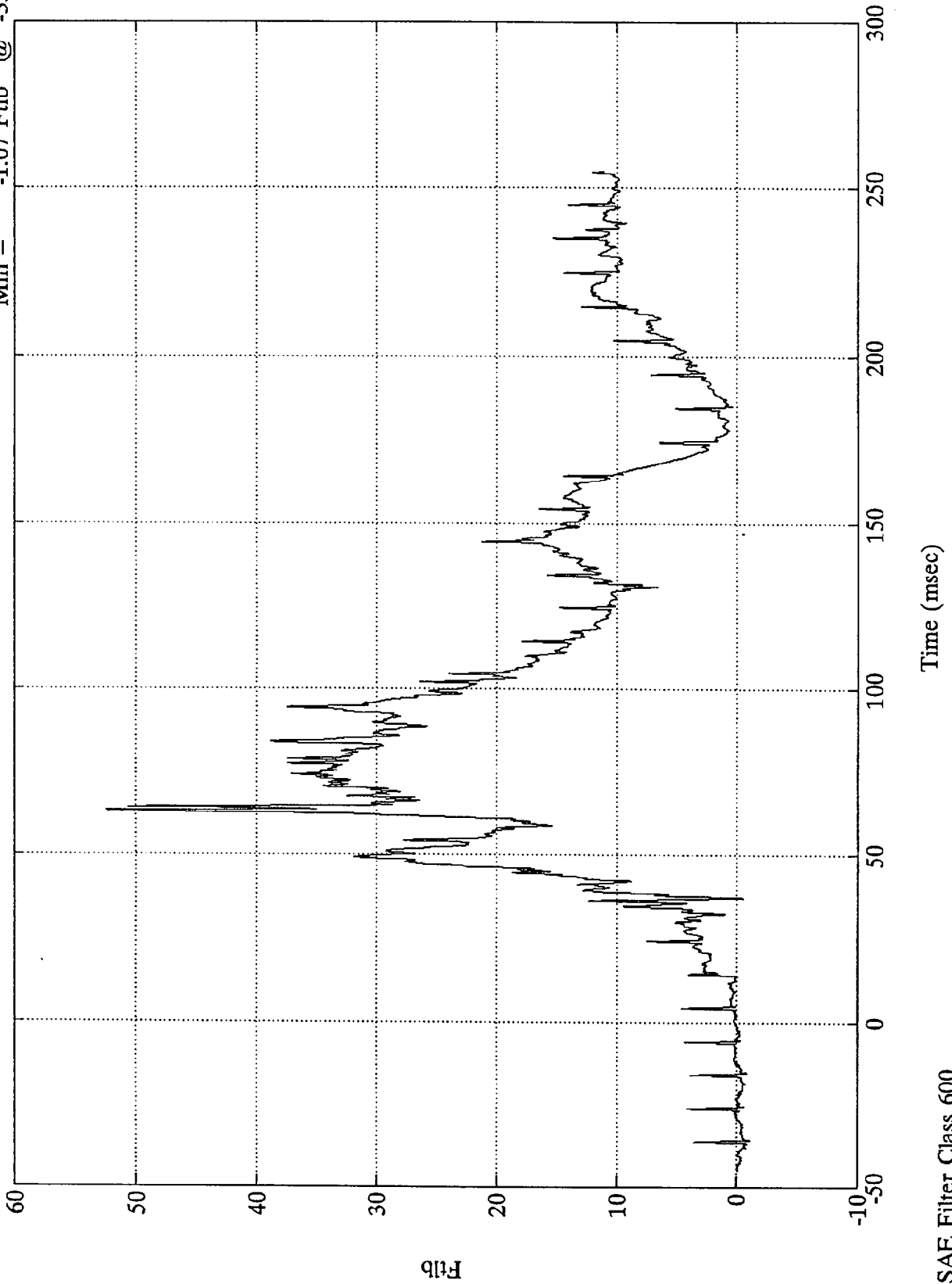

SAE Filter Class 600

NHTSA 208 TEST #16 - 1994 Dodge Caravan

Pos.2 Upper Neck My  
Max = 94.09 Ftlb @ 74.27 msec  
Min = -5.37 Ftlb @ 145.08 msec

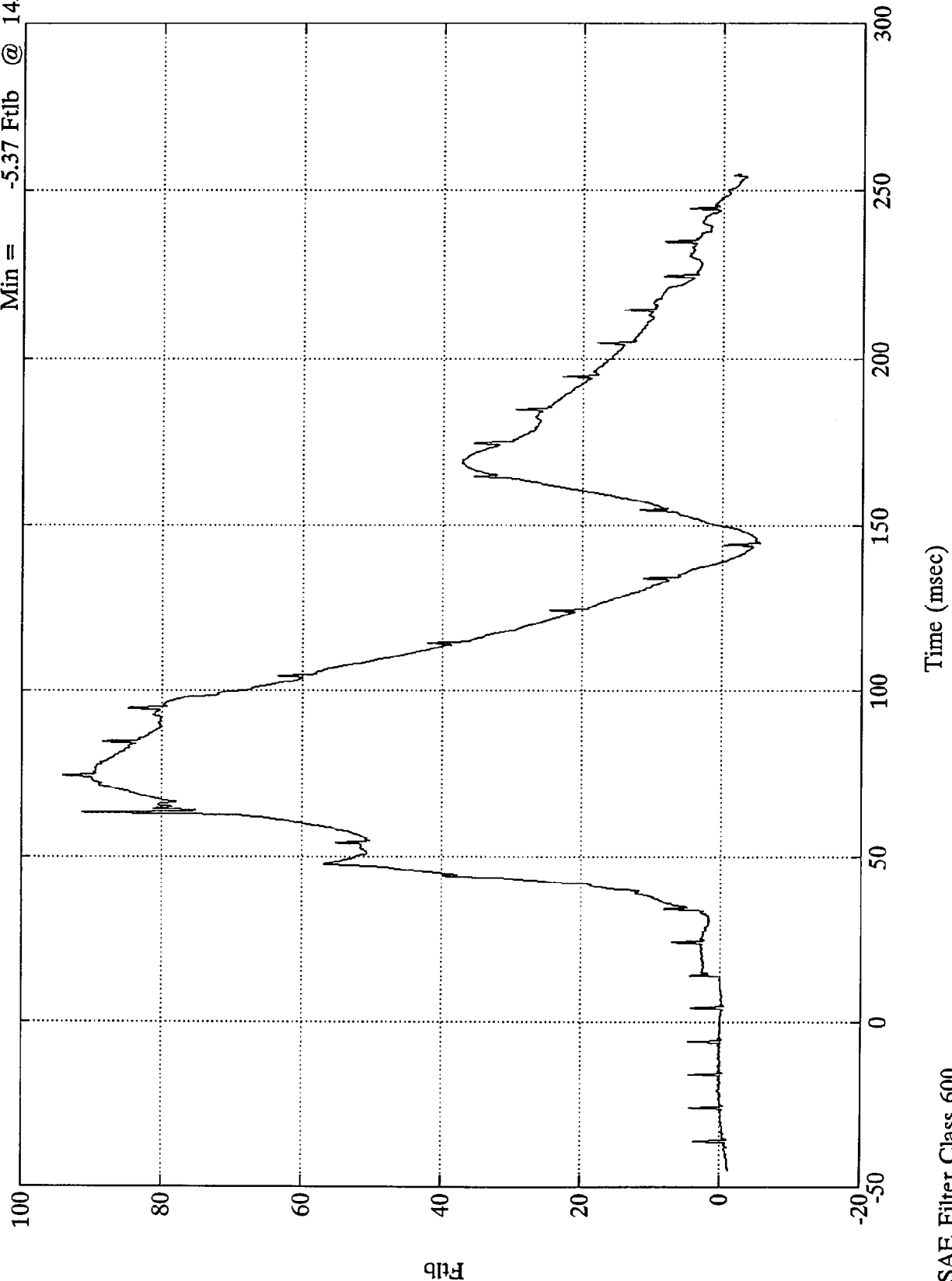

SAE Filter Class 600

NHTSA 208 TEST #16 - 1994 Dodge Caravan

Pos.2 Upper Neck Mz  
Max = 32.87 Ftlb @ 99.24 msec  
Min = -9.30 Ftlb @ 178.32 msec

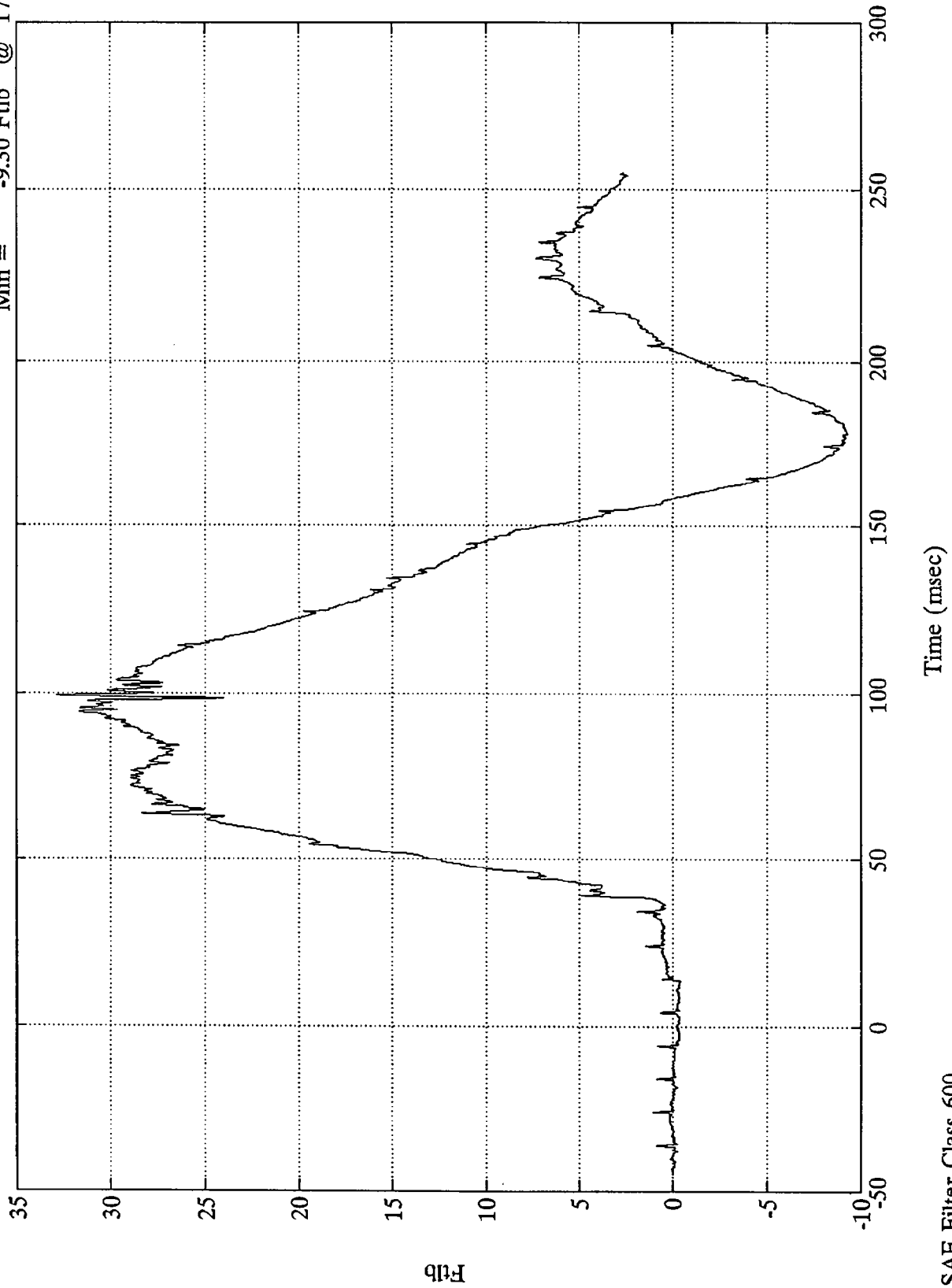

SAE Filter Class 600

NHTSA 208 TEST #16 - 1994 Dodge Caravan

Pos.2 Neck Moment Res.

Max = 109.04 Ftlb @ 63.23 msec  
Min = .06 Ftlb @ -24.96 msec

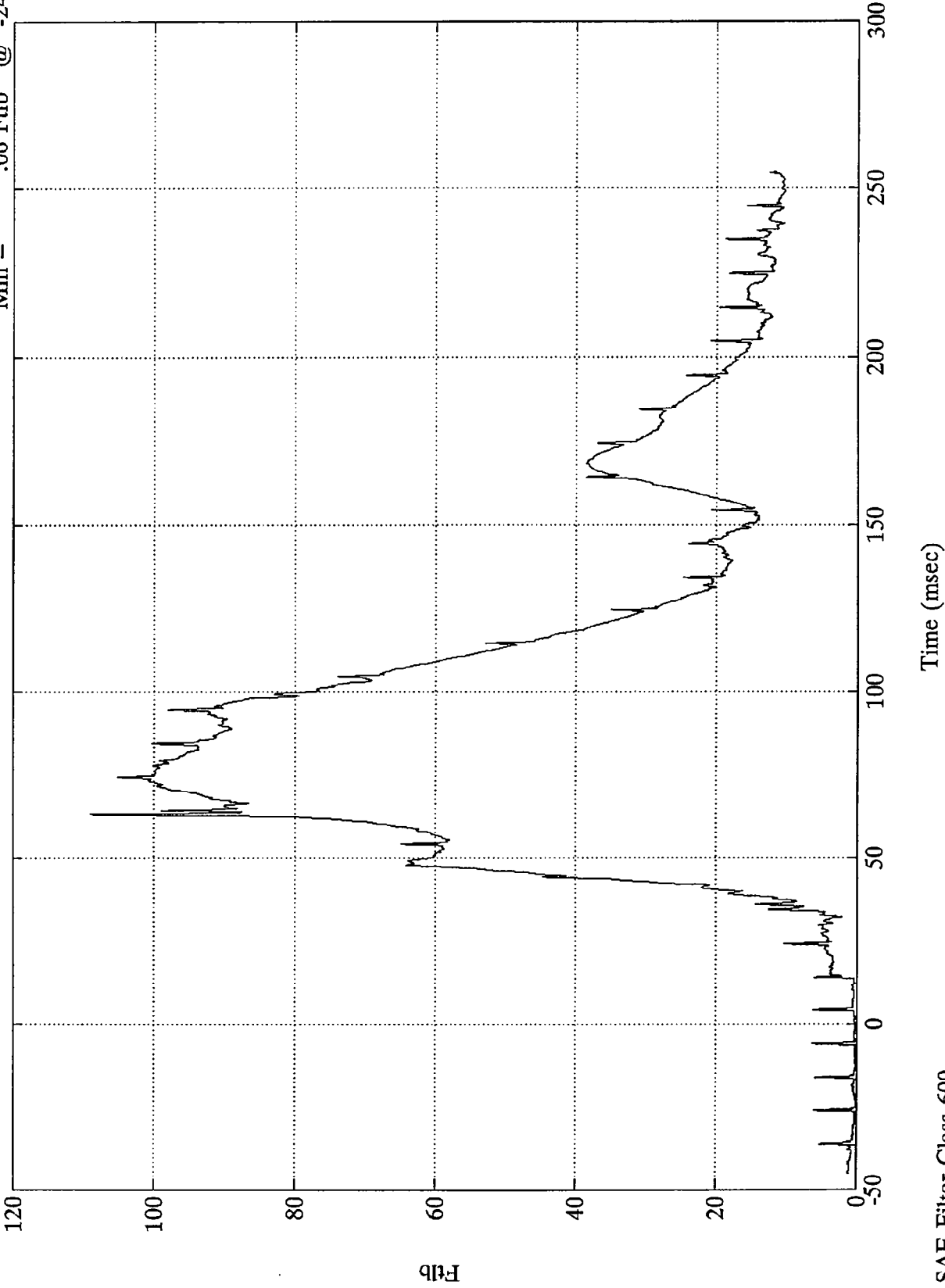

SAE Filter Class 600

NHTSA 208 TEST #16 - 1994 Dodge Caravan

Max = .14 ins @ 224.64 msec  
Min = -.66 ins @ 35.51 msec

Pos.2 Chest Displacement

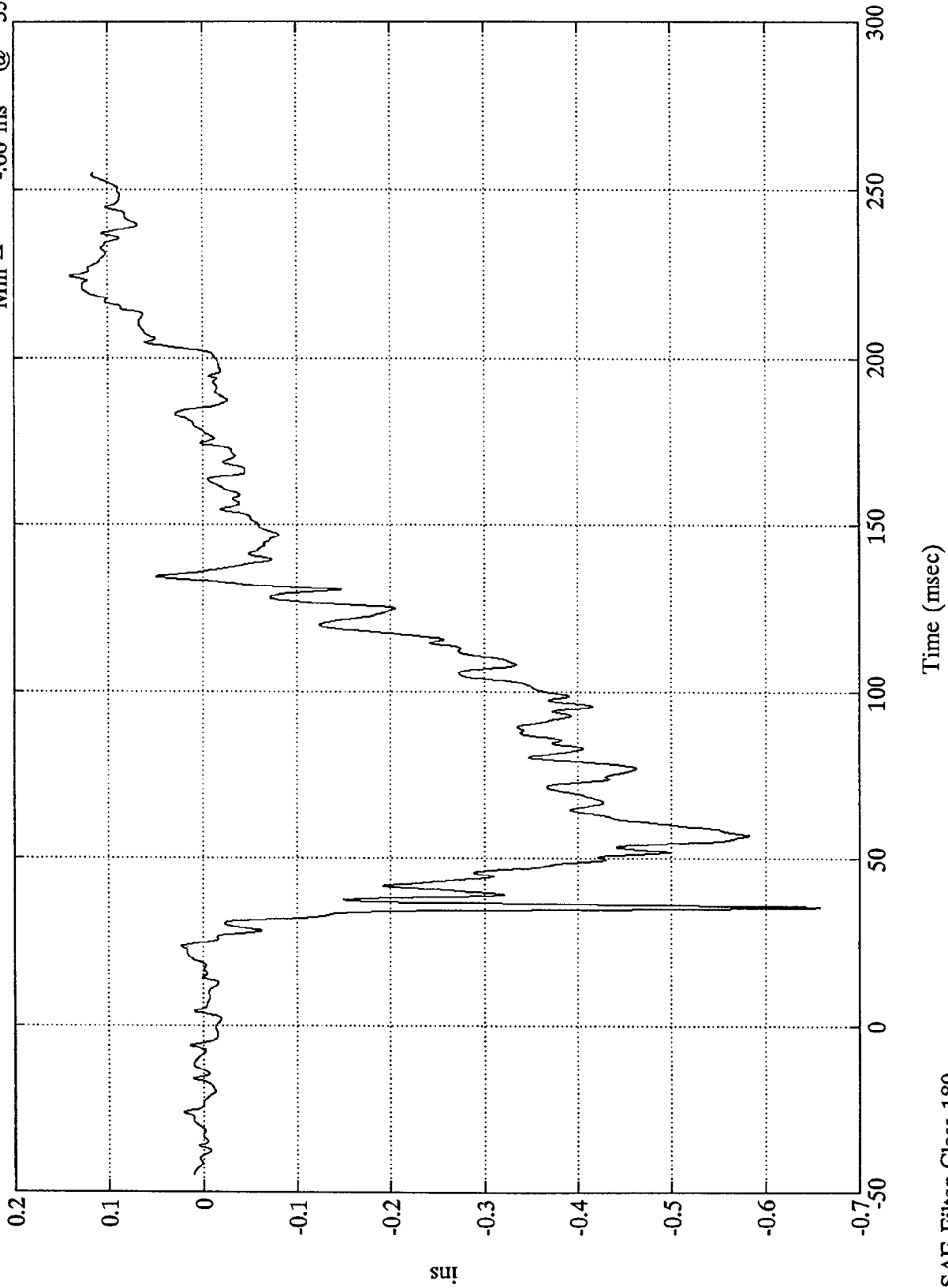

SAE Filter Class 180

NHTSA 208 TEST #16 - 1994 Dodge Caravan

Max = 7.84 Gs @ 234.60 msec  
Min = -58.22 Gs @ 62.27 msec

Pos. 2 Pelvic X

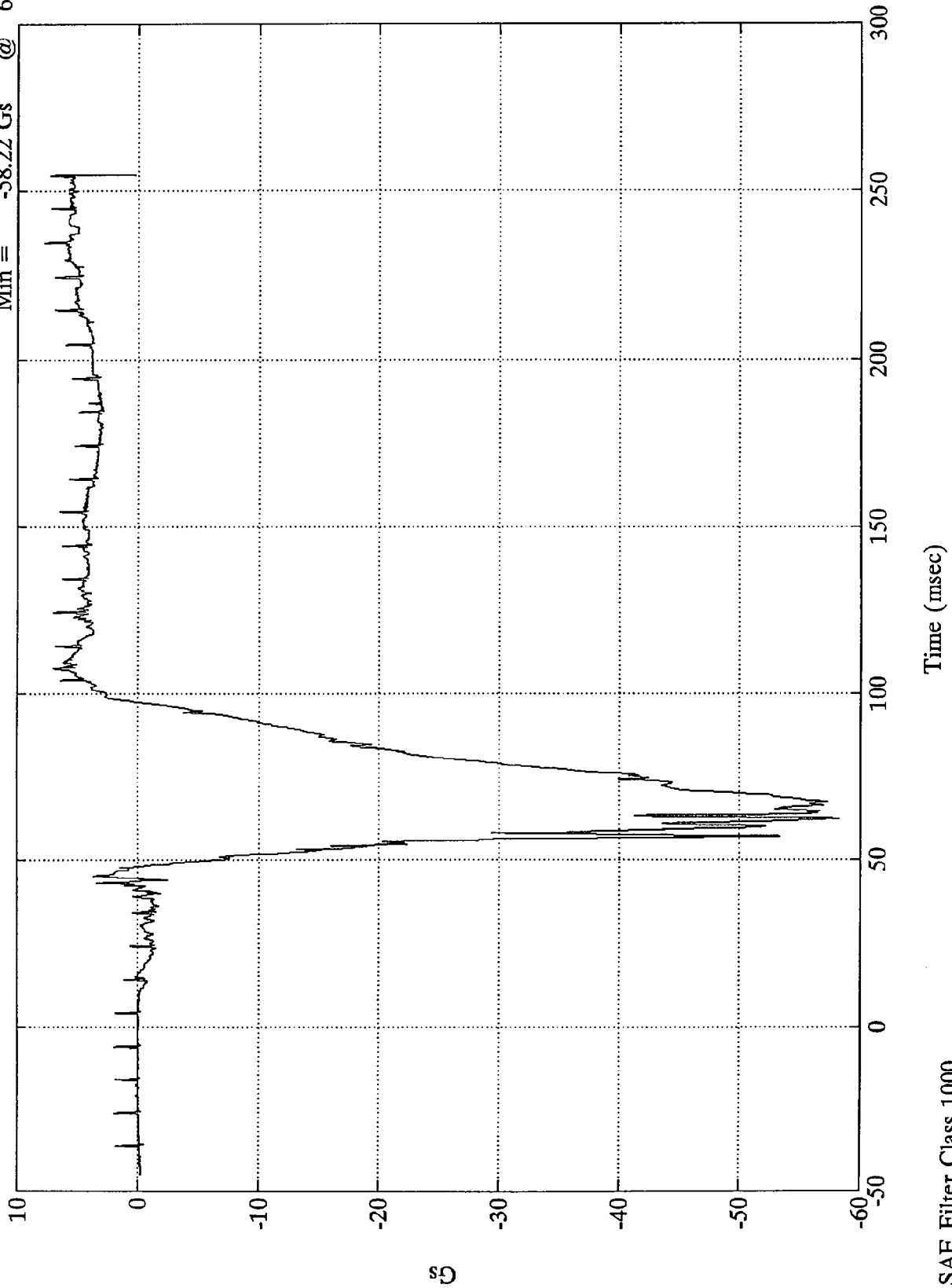

SAE Filter Class 1000

Gs

Time (msec)

NHTSA 208 TEST #16 - 1994 Dodge Caravan

Max = 16.03 Gs @ 57.11 msec  
Min = -3.45 Gs @ 55.56 msec

Pos. 2 Pelvic Y

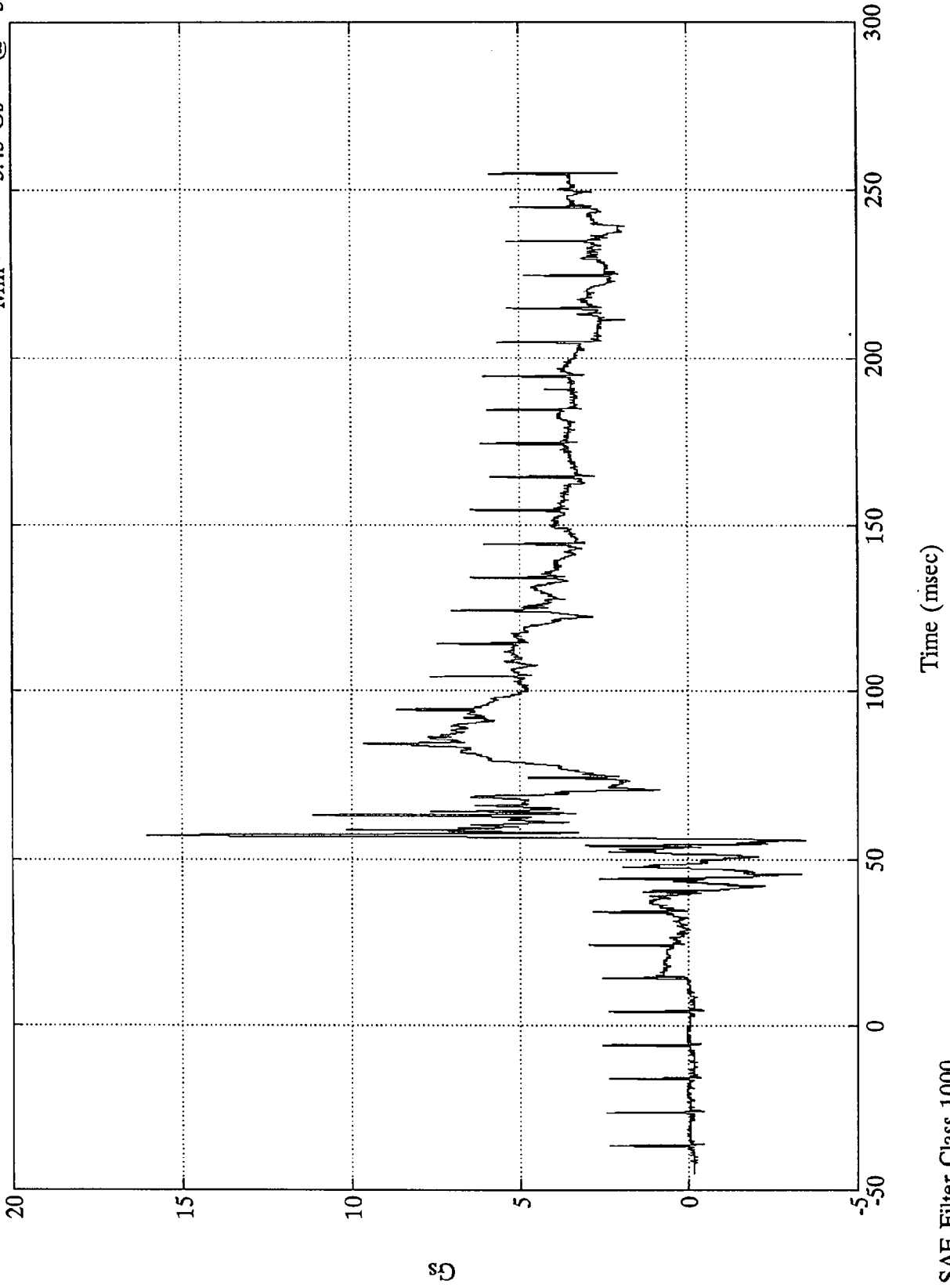

SAE Filter Class 1000

NHTSA 208 TEST #16 - 1994 Dodge Caravan

Max = 35.75 Gs @ 14.27 msec  
Min = -28.46 Gs @ 63.95 msec

Pos. 2 Pelvic Z

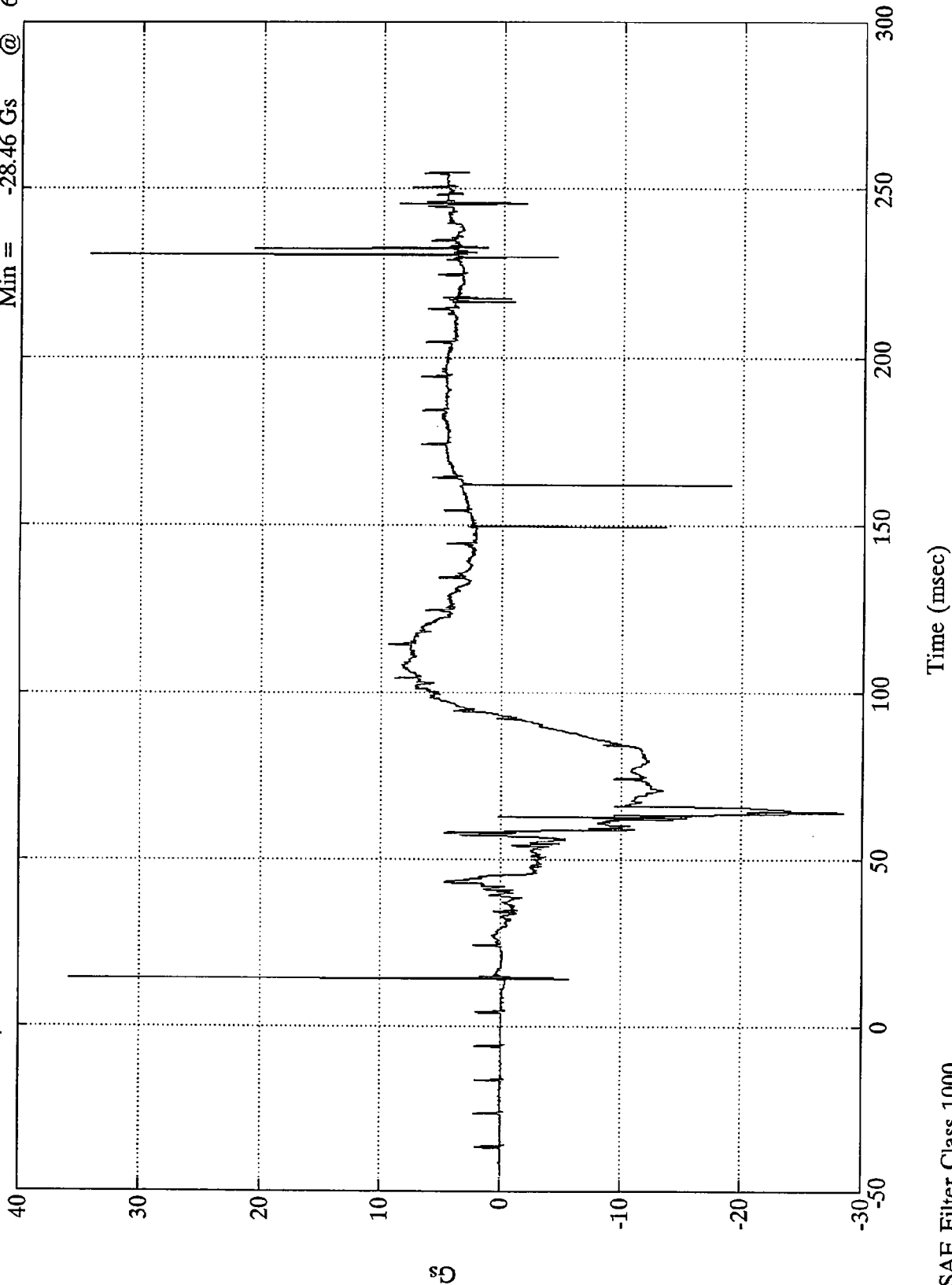

SAE Filter Class 1000

NHTSA 208 TEST #16 - 1994 Dodge Caravan

Pos. 2 Pelvic Resultant

Max = 63.42 Gs @ 63.95 msec  
Min = -0.96 Gs @ -0.96 msec

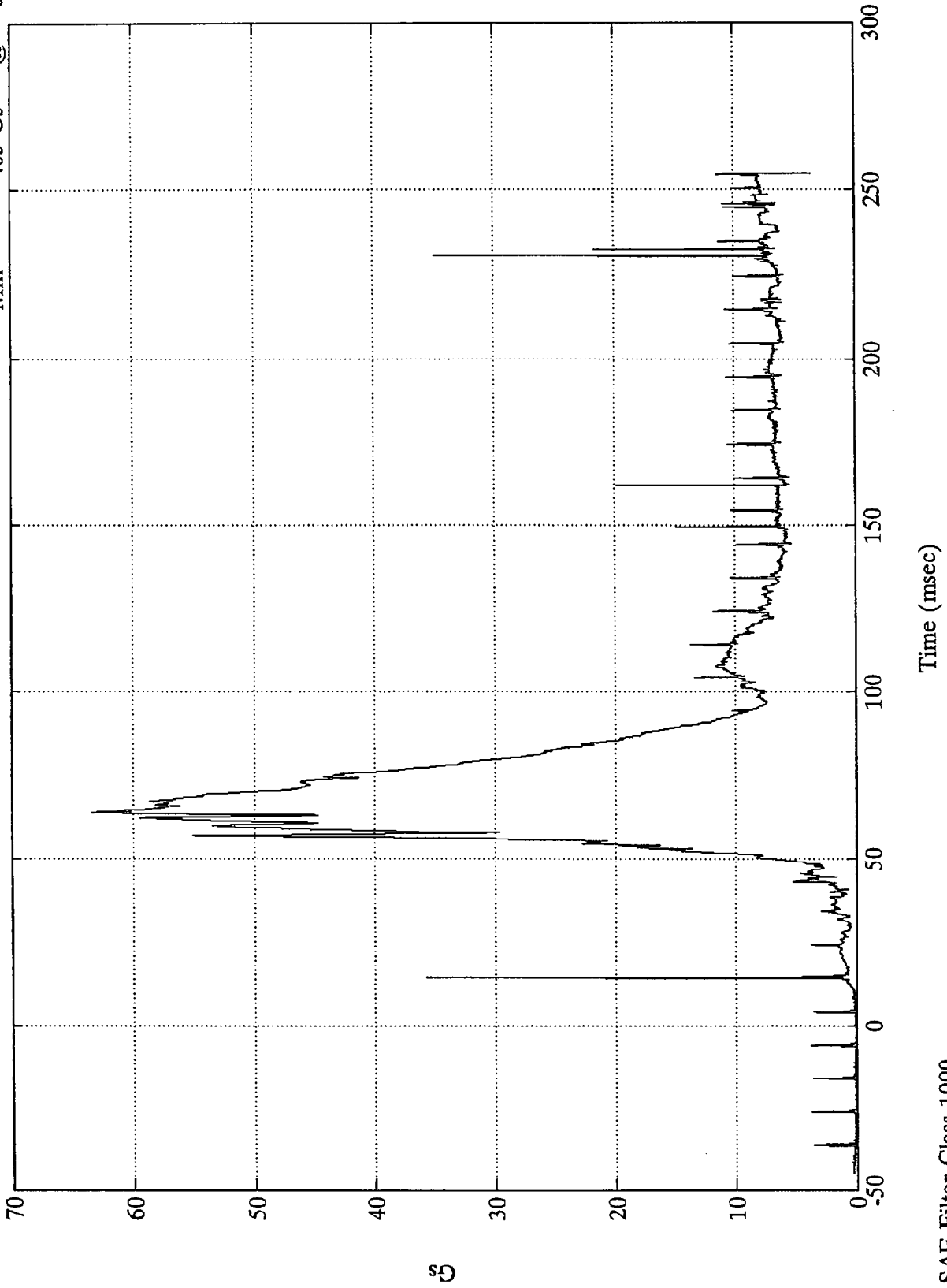

SAE Filter Class 1000

Gs

Time (msec)

Appendix C

DUMMY RESPONSE DATA

(Part 572 3 Year old ATD's only)

NOTE : Data trace scales are automatically scaled at the  
request of the COTR. Use caution when  
reviewing data.

FACILITY: TRACK  
 RUN #: 1430  
 SERIES #: 16

TEST DATE: 12 Jul 1994  
 TEST TIME: 14:33:35  
 BOARD: d

TITLE: NHTSA 208 TEST #16 - 1994 Dodge Caravan

CHANNEL NUMBER	DESCRIPTION	ENGR UNIT	MAXIMUM		MINIMUM		FILTER CLASS
			AMP	msec	AMP	msec	
1	RRP Head X	Gs	43.0	225.6	-26.3	143.9	1000.0
2	RRP Head Y	Gs	28.5	65.6	-28.3	62.0	1000.0
3	RRP Head Z	Gs	44.3	101.4	-18.0	41.8	1000.0
4	RRP Chest X	Gs	4.8	47.5	-9.0	116.5	180.0
5	RRP Chest Y	Gs	16.3	98.8	-12.4	70.9	180.0
6	RRP Chest Z	Gs	27.7	62.0	-16.5	227.0	180.0
7	LRP Head X	Gs	41.8	222.5	-24.7	146.2	1000.0
8	LRP Head Y	Gs	27.9	65.6	-27.5	62.0	1000.0
9	LRP Head Z	Gs	43.0	98.2	-13.2	39.6	1000.0
10	LRP Chest X	Gs	4.7	62.0	-7.4	116.8	180.0
11	LRP Chest Y	Gs	14.8	96.7	-17.5	62.0	180.0
12	LRP Chest Z	Gs	.0	254.9	.0	254.9	180.0
17	RRP Head Resultant	Gs	46.9	126.8	.0	-25.0	.0
18	RRP Chest Resultant	Gs	30.8	62.0	.1	-27.6	.0
19	LRP Head Resultant	Gs	43.1	98.2	.1	-16.6	.0
20	LRP Chest Resultant	Gs	18.2	62.0	.0	-34.8	.0

Full Duration HIC SUMMARY: RRP Head Resultant

hic: 377.82  
 t1 = 78.480 msec  
 t2 = 254.640 msec  
 Average G's Over Hic Duration = 21.51

Full Duration HIC SUMMARY: LRP Head Resultant

hic: 371.42  
 t1 = 78.240 msec  
 t2 = 254.640 msec  
 Average G's Over Hic Duration = 21.35

CLIP SUMMARY: RRP Chest Resultant

Peak Resultant (3 ms CLIPPED DURATION) = 27.059 G's  
 Tstart = 61.2000 ms  
 Tend = 64.3200 ms  
 CSI = 204.324

CLIP SUMMARY: LRP Chest Resultant

Peak Resultant (3 ms CLIPPED DURATION) = 14.354 G's  
 Tstart = 104.1600 ms  
 Tend = 107.2800 ms  
 CSI = 35.435

NHTSA 208 TEST #16 - 1994 Dodge Caravan

RRP Head X

Max = 42.98 Gs @ 225.60 msec  
Min = -26.28 Gs @ 143.88 msec

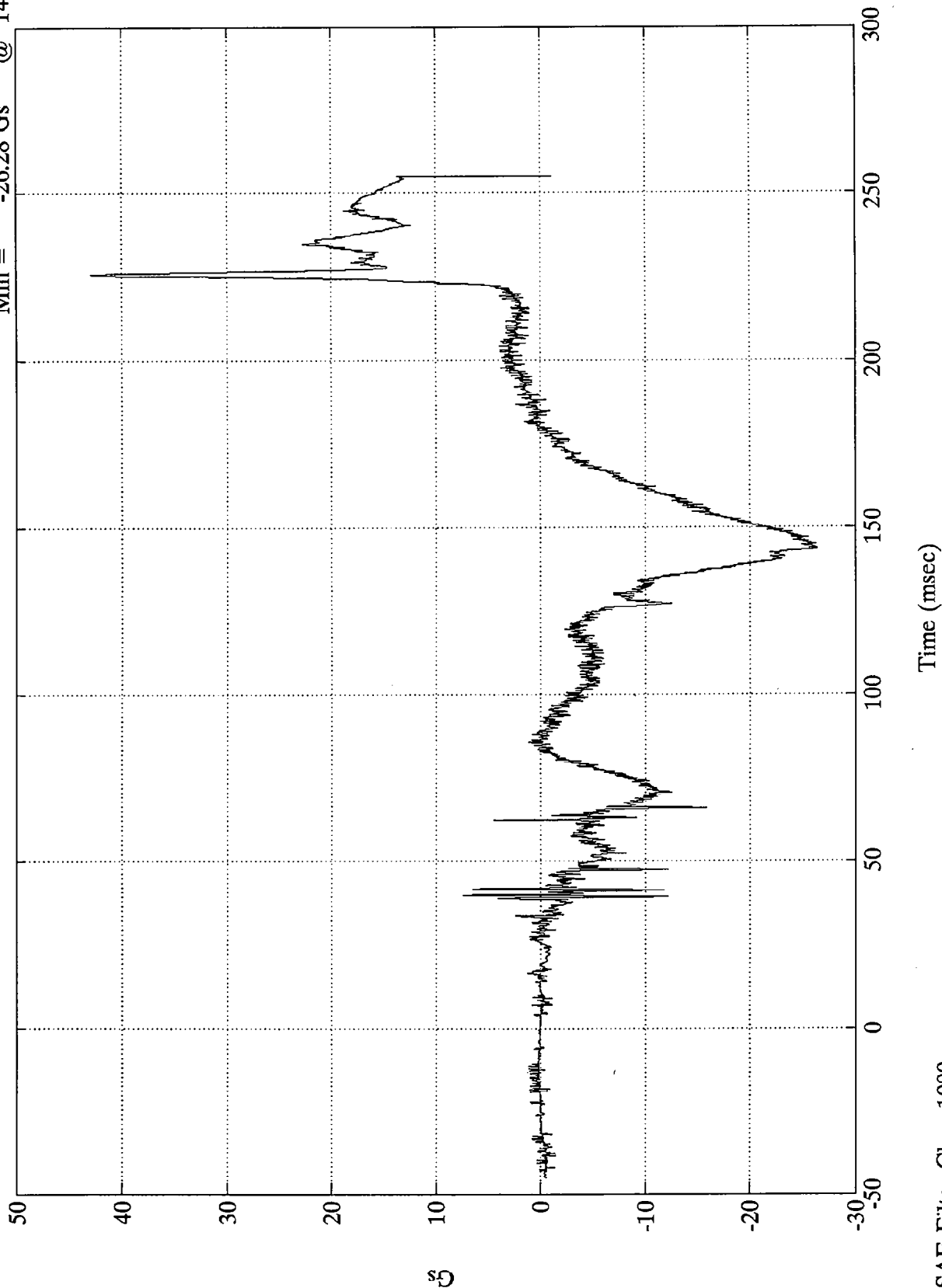

SAE Filter Class 1000

NHTSA 208 TEST #16 - 1994 Dodge Caravan

Max = 28.48 Gs @ 65.63 msec  
Min = -28.30 Gs @ 62.04 msec

RRP Head Y

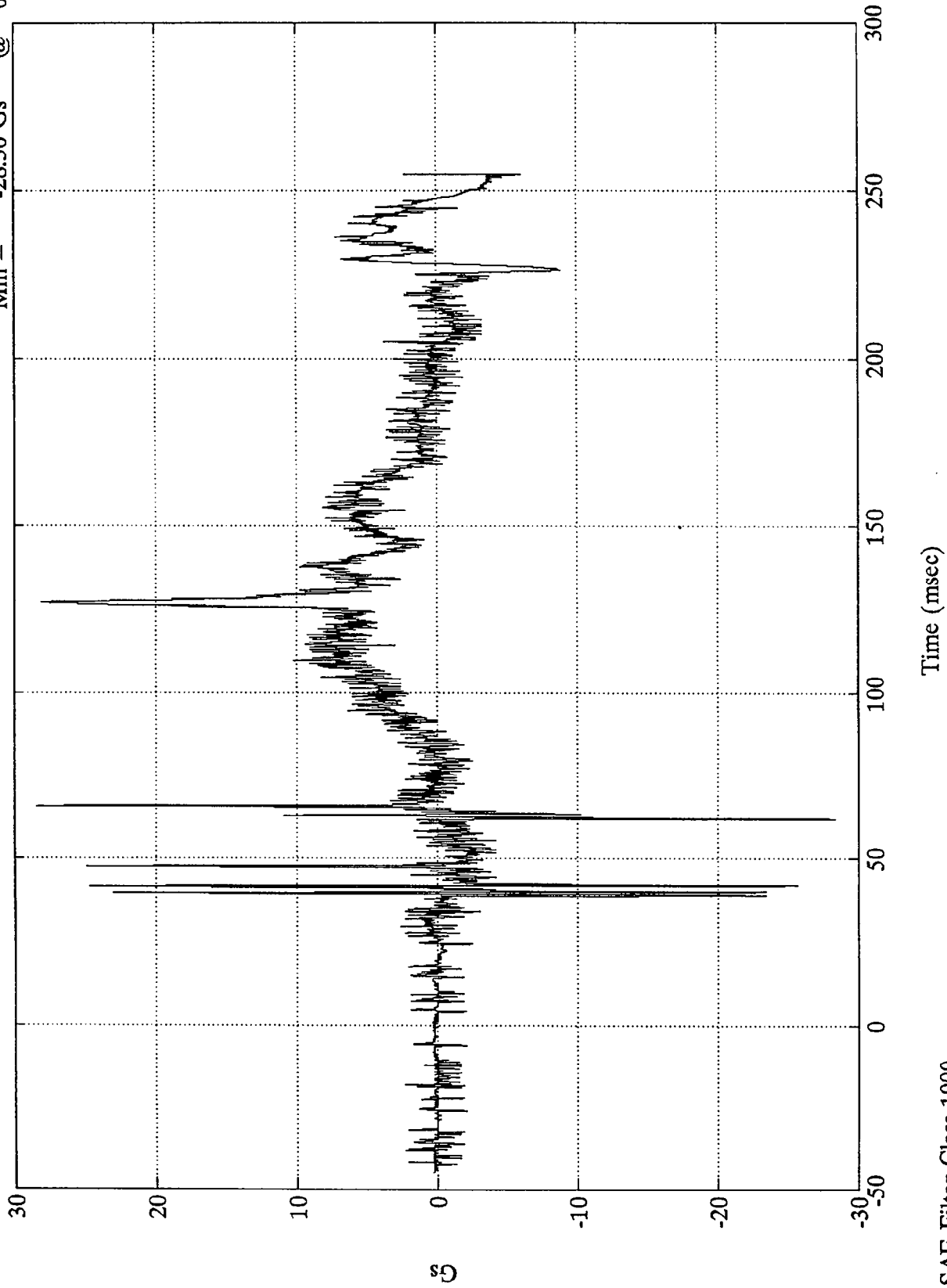

SAE Filter Class 1000

NHTSA 208 TEST #16 - 1994 Dodge Caravan

Max = 44.27 Gs @ 101.40 msec  
Min = -17.97 Gs @ 41.76 msec

RRP Head Z

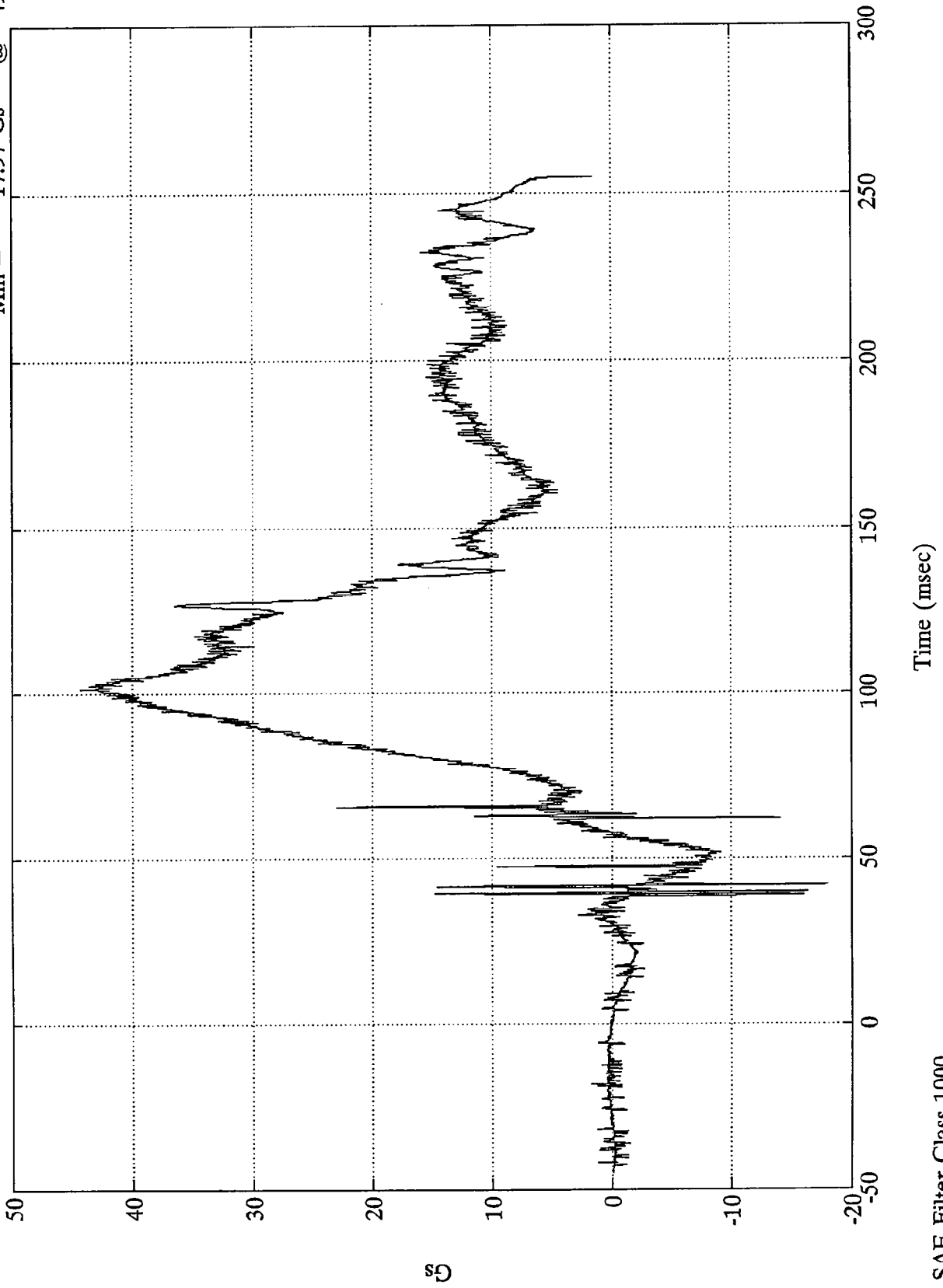

SAE Filter Class 1000

NHTSA 208 TEST #16 - 1994 Dodge Caravan

Max = 46.86 Gs @ 126.84 msec  
Min = .04 Gs @ -24.96 msec

RRP Head Resultant

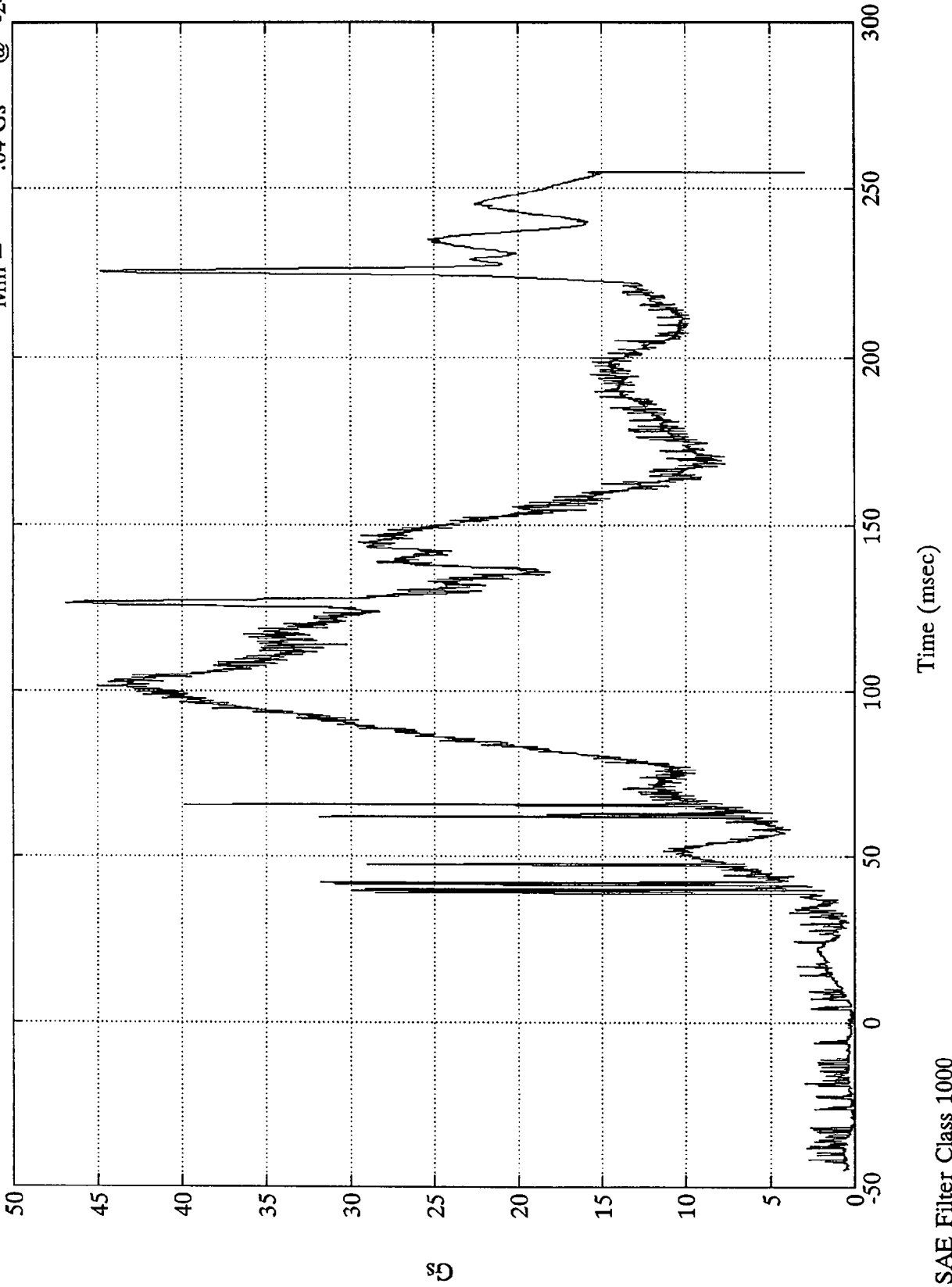

SAE Filter Class 1000

NHTSA 208 TEST #16 - 1994 Dodge Caravan

RRP Chest X  
Max = 4.78 Gs @ 47.52 msec  
Min = -9.03 Gs @ 116.52 msec

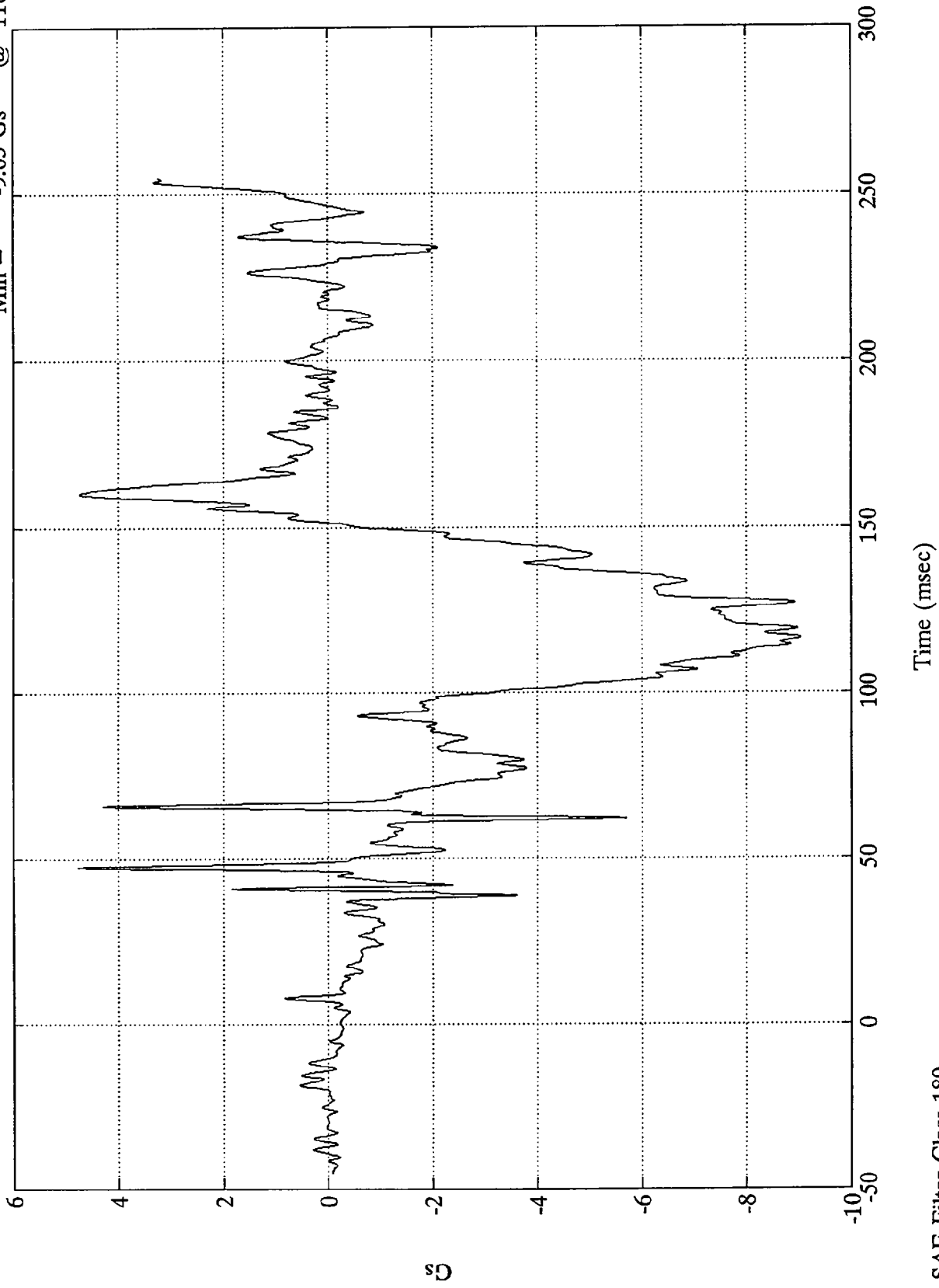

SAE Filter Class 180

NHTSA 208 TEST #16 - 1994 Dodge Caravan

Max = 16.30 Gs @ 98.76 msec  
Min = -12.41 Gs @ 70.91 msec

RRP Chest Y

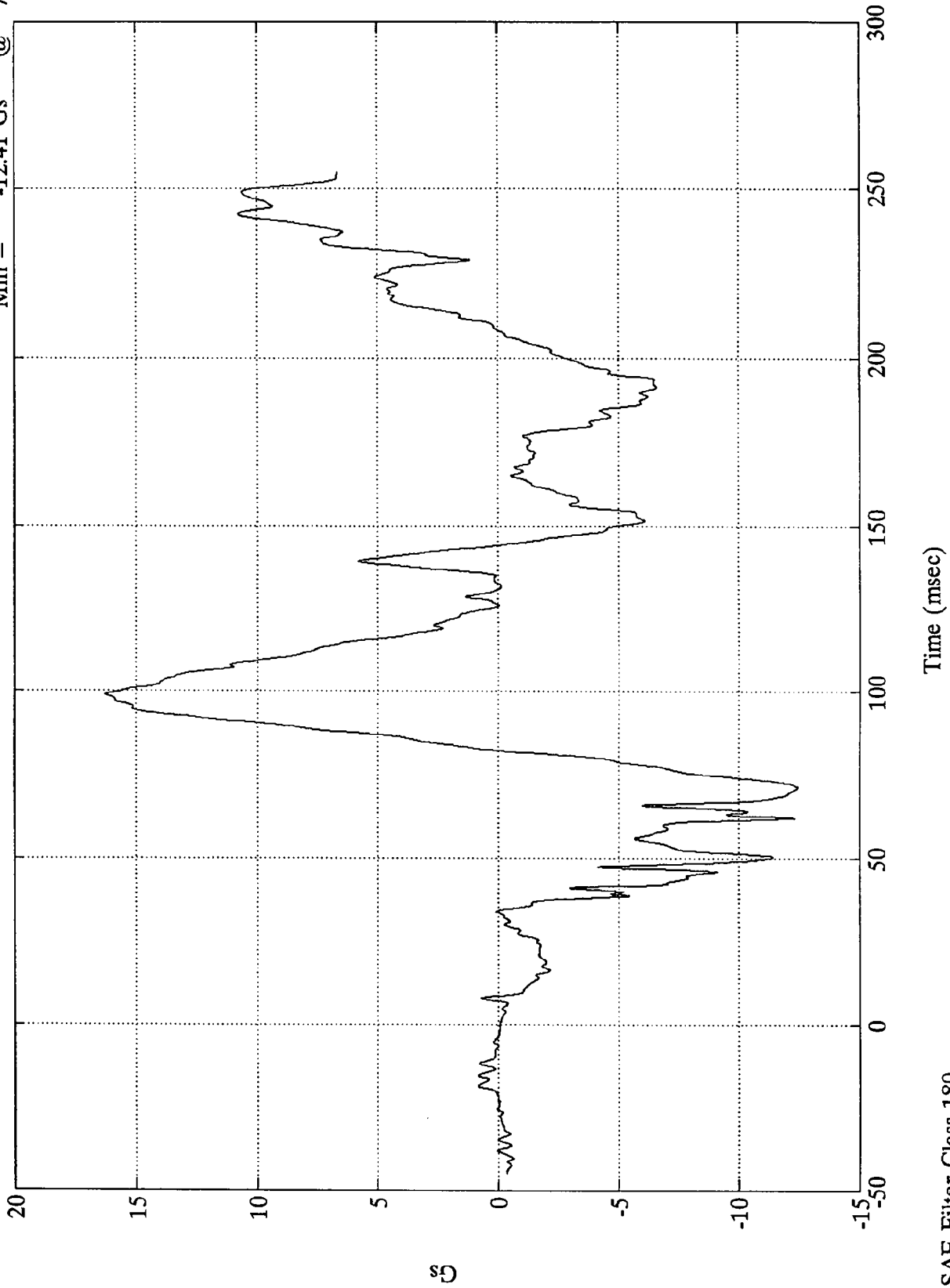

SAE Filter Class 180

NHTSA 208 TEST #16 - 1994 Dodge Caravan

Max = 27.69 Gs @ 62.04 msec  
Min = -16.51 Gs @ 227.04 msec

RRP Chest Z

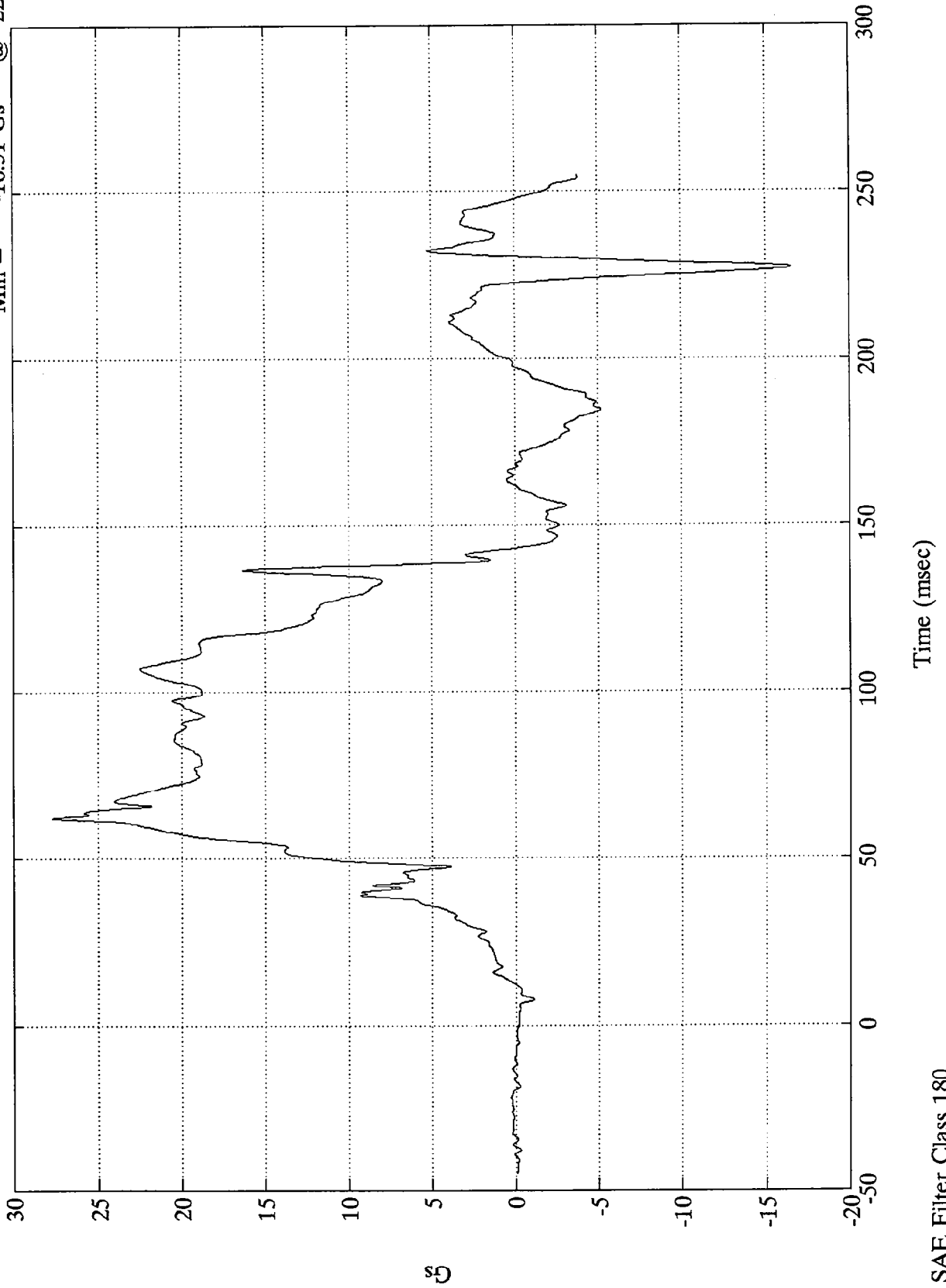

SAE Filter Class 180

NHTSA 208 TEST #16 - 1994 Dodge Caravan

Max = 30.82 Gs @ 62.04 msec  
Min = .13 Gs @ -27.60 msec

RRP Chest Resultant

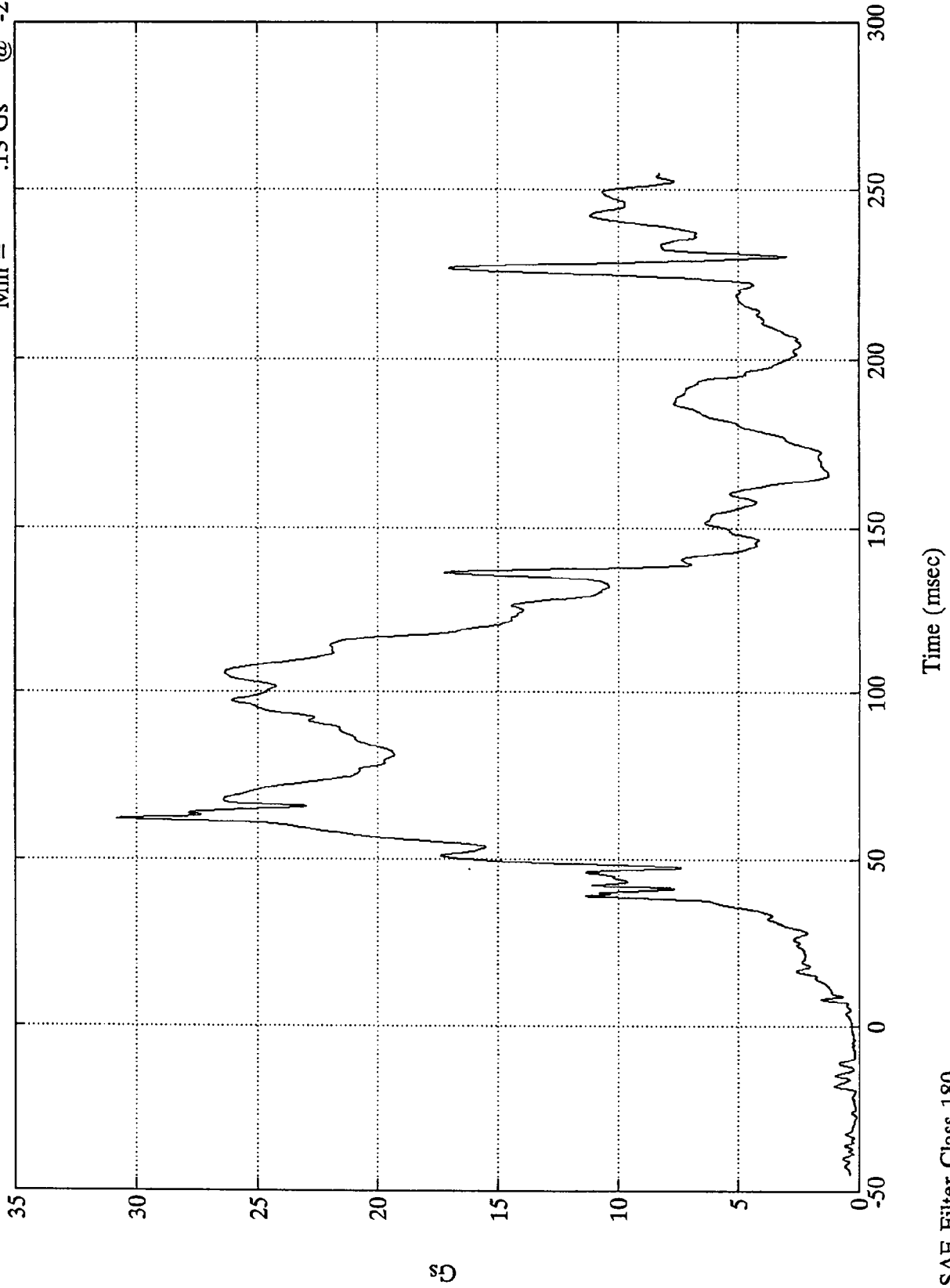

SAE Filter Class 180

NHTSA 208 TEST #16 - 1994 Dodge Caravan

LRP Head X

Max = 41.82 Gs @ 222.48 msec  
Min = -24.65 Gs @ 146.16 msec

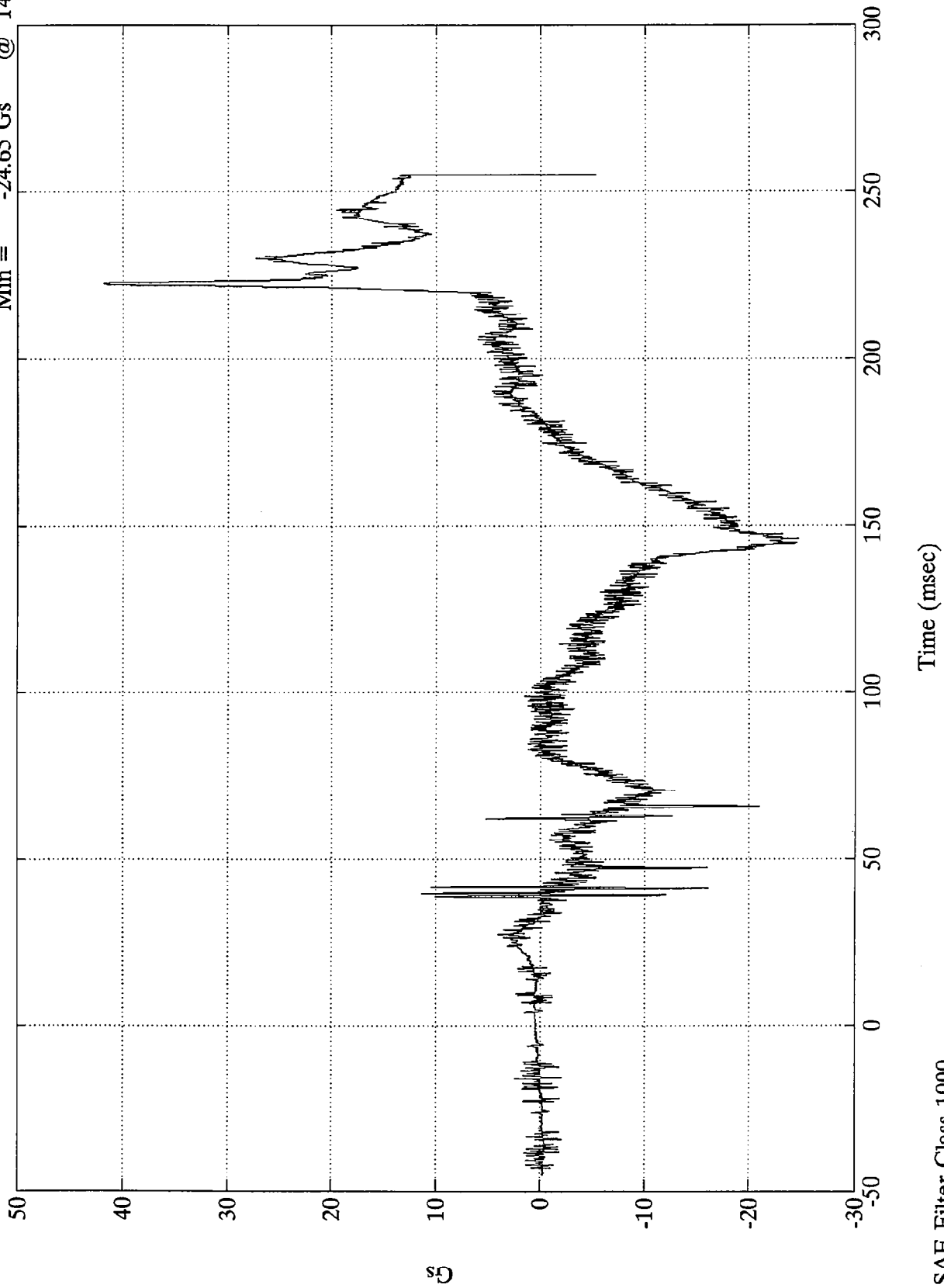

SAE Filter Class 1000

NHTSA 208 TEST #16 - 1994 Dodge Caravan

LRP Head Y  
Max = 27.93 Gs @ 65.63 msec  
Min = -27.47 Gs @ 62.04 msec

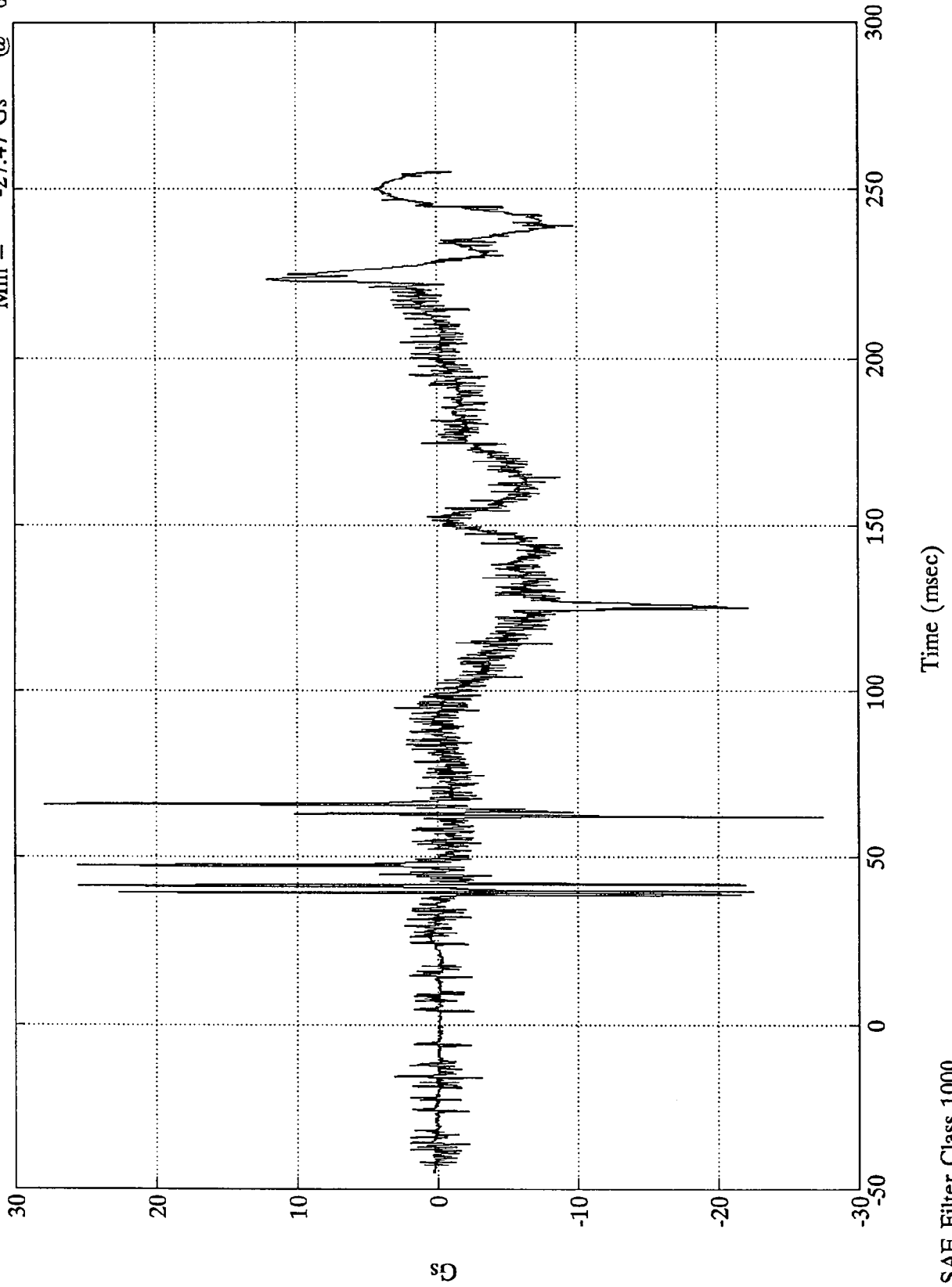

SAE Filter Class 1000

NHTSA 208 TEST #16 - 1994 Dodge Caravan

LRP Head Z  
Max = 43.00 Gs @ 98.15 msec  
Min = -13.19 Gs @ 39.59 msec

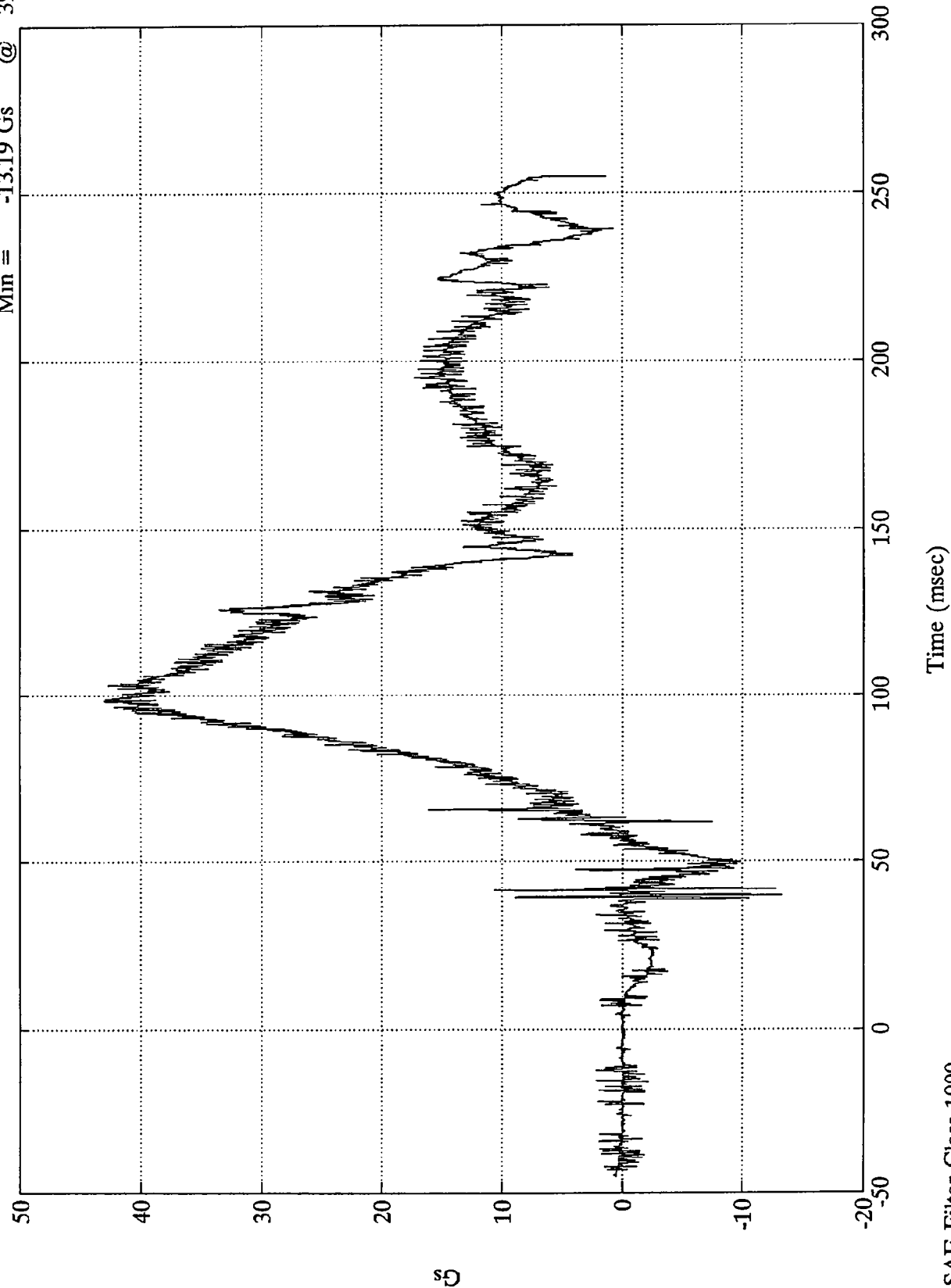

SAE Filter Class 1000

NHTSA 208 TEST #16 - 1994 Dodge Caravan

Max = 43.07 Gs @ 98.15 msec  
Min = .07 Gs @ -16.56 msec

LRP Head Resultant

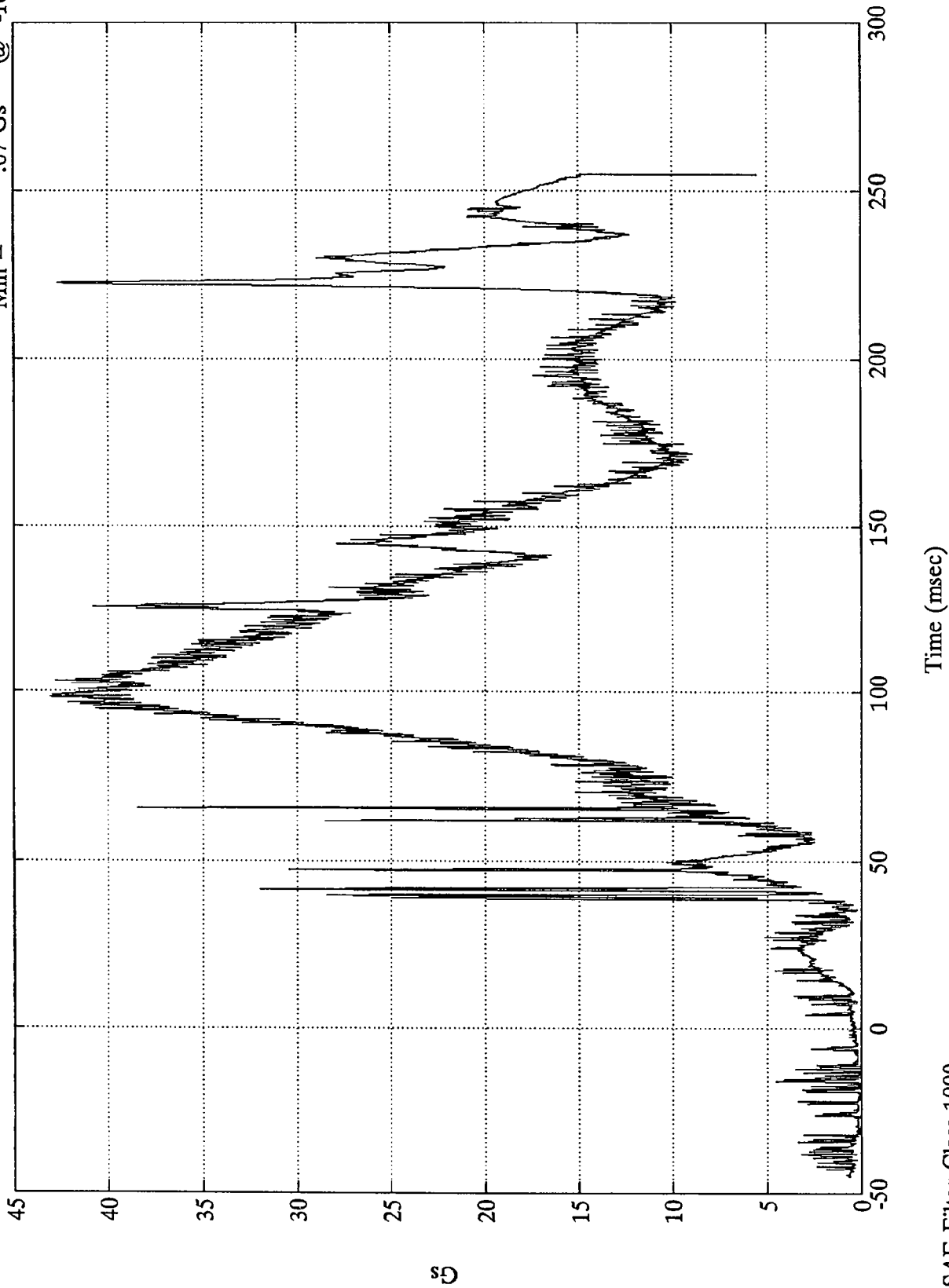

SAE Filter Class 1000

NHTSA 208 TEST #16 - 1994 Dodge Caravan

LRP Chest X

Max = 4.75 Gs @ 62.04 msec  
Min = -7.36 Gs @ 116.76 msec

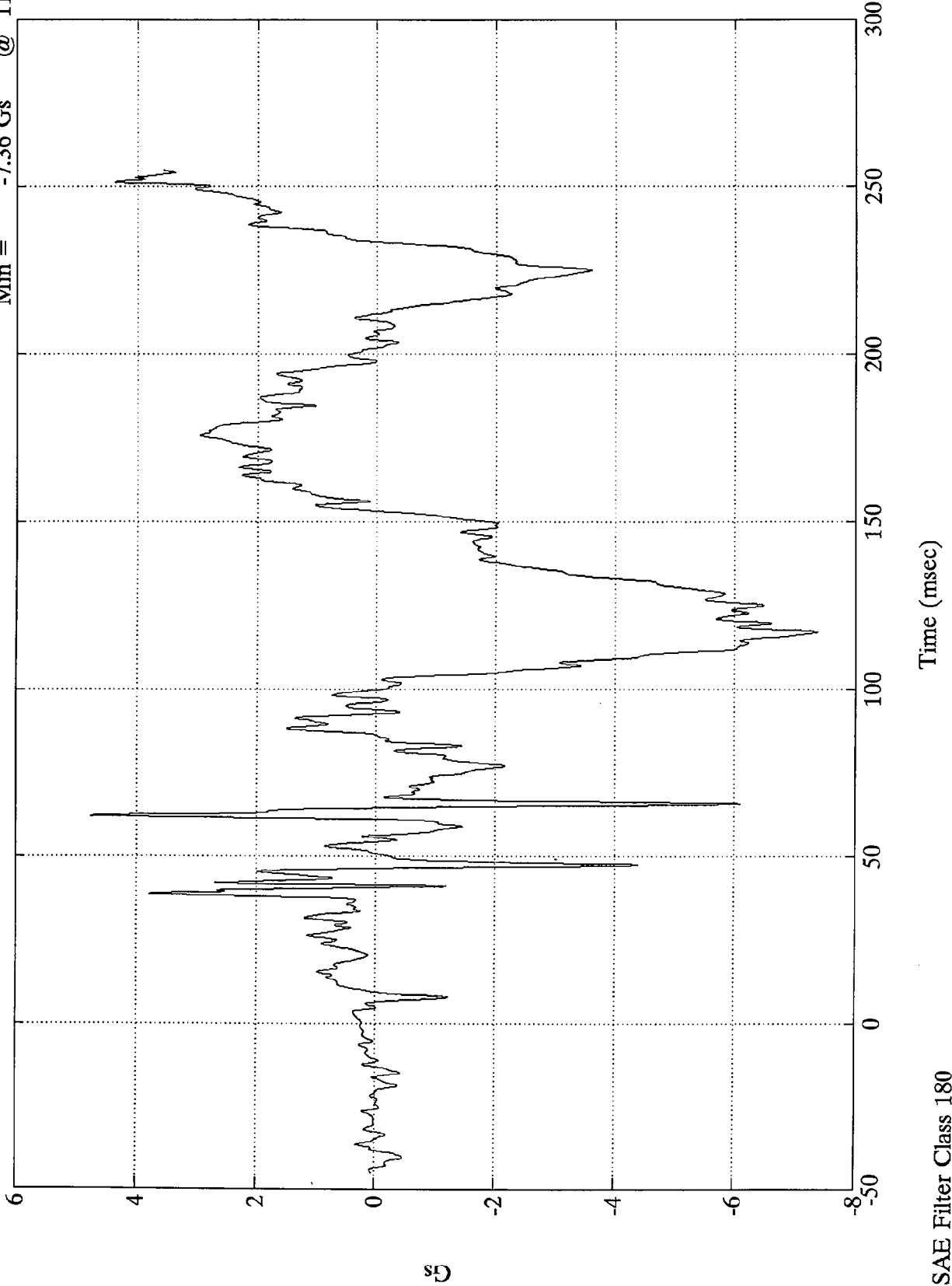

Gs

Time (msec)

SAE Filter Class 180

NHTSA 208 TEST #16 - 1994 Dodge Caravan

Max = 14.81 Gs @ 96.72 msec  
Min = -17.54 Gs @ 62.04 msec

LRP Chest Y

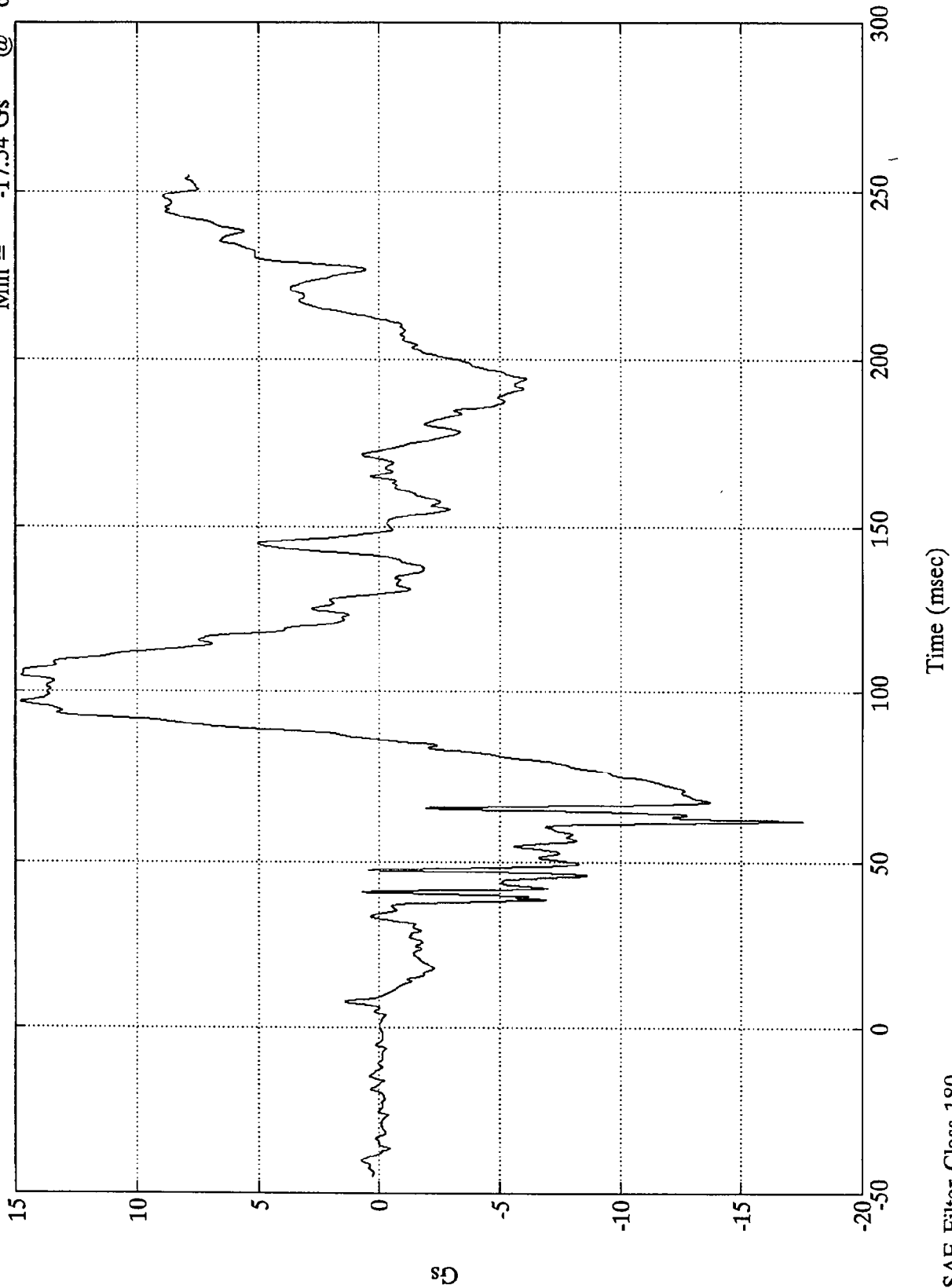

SAE Filter Class 180

50

NHTSA 208 TEST #16 - 1994 Dodge Caravan

LRP Chest Z  
Max = .00 Gs @ 254.88 msec  
Min = .00 Gs @ 254.88 msec

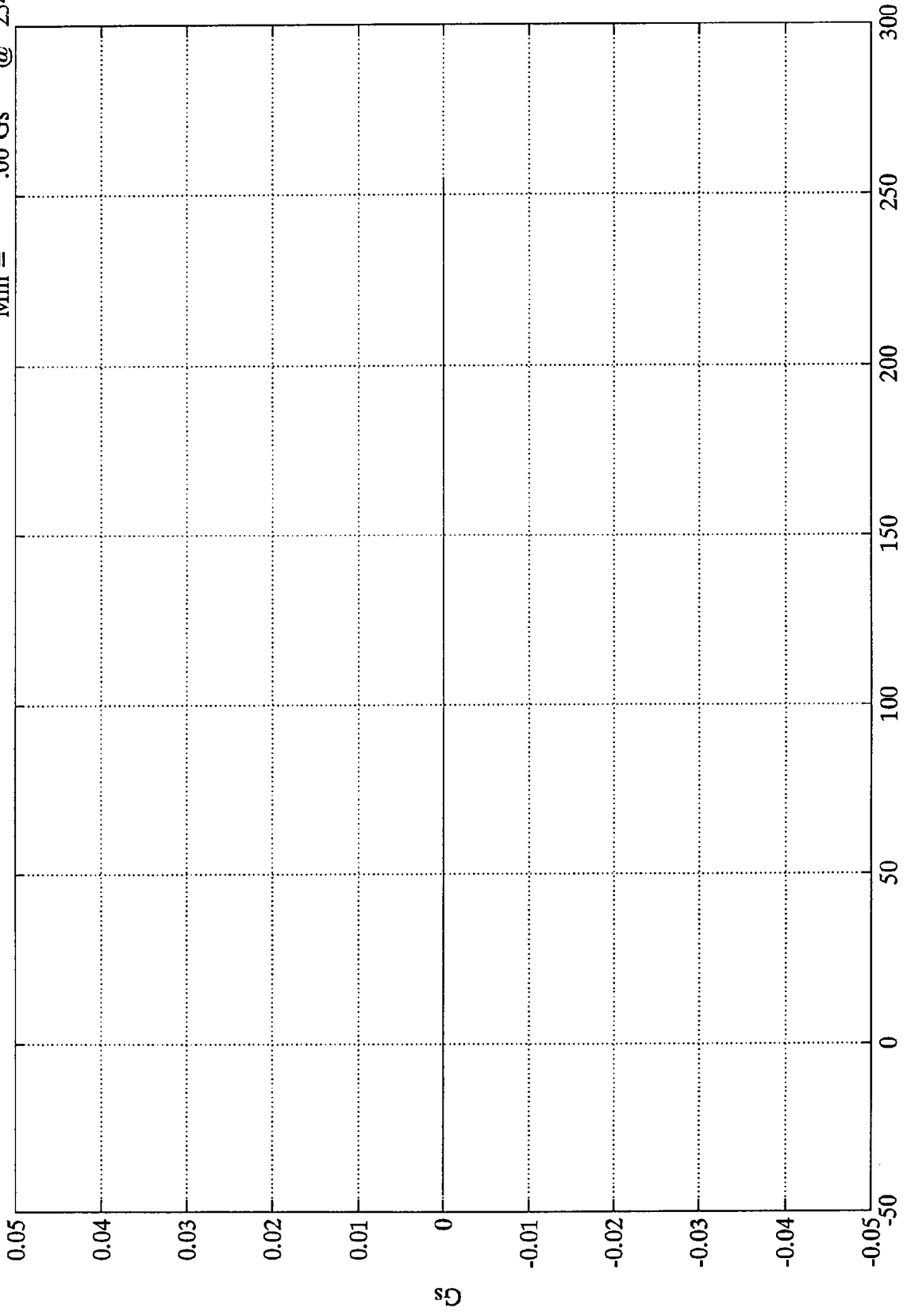

SAE Filter Class 180 Accelerometer Wire Cut in Rib Cage

NHTSA 208 TEST #16 - 1994 Dodge Caravan

Max = 18.17 Gs @ 62.04 msec  
Min = .01 Gs @ -34.80 msec

LRP Chest Resultant

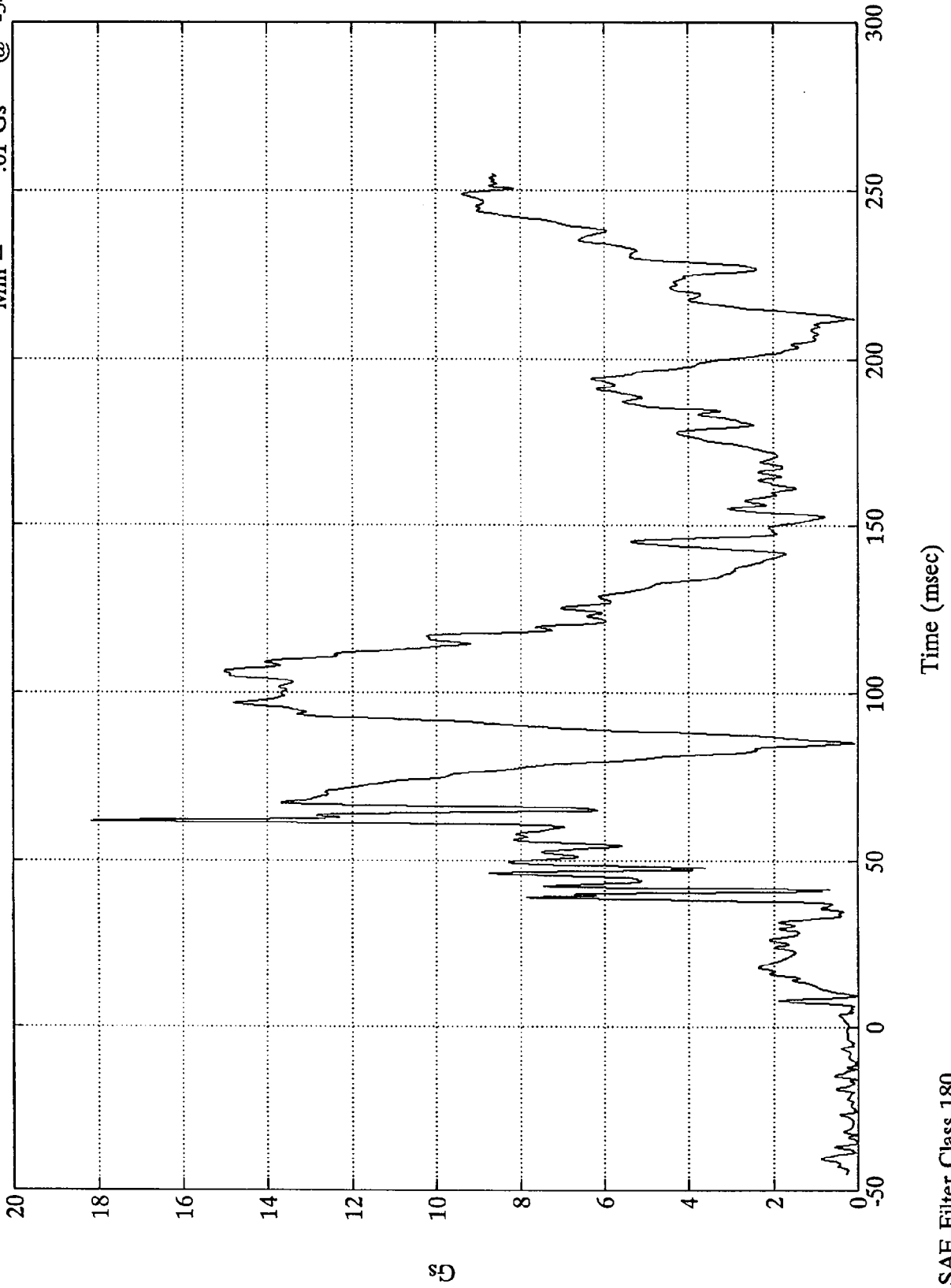

SAE Filter Class 180

Appendix D

VEHICLE OWNERS MANUAL OCCUPANT RESTRAINT SYSTEM INSTRUCTIONS

**BEFORE STARTING YOUR VEHICLE**

**WINDOWS**

**Manual Rear Vent Windows**

A lever at the rear of each window releases the window so that it can be pushed out for ventilation.

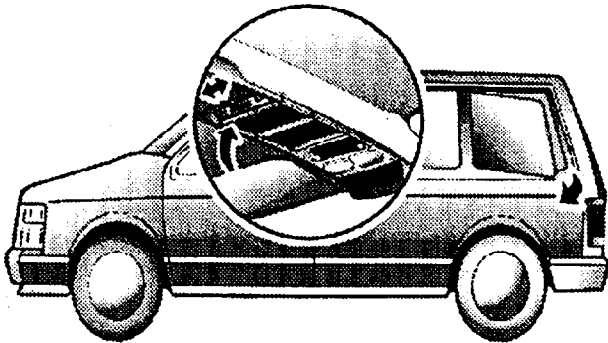

**Power Vent Windows (optional)**

Switches on the overhead console, let you or the front seat passenger operate the two vent windows from the front seat.

**Power Windows (optional)**

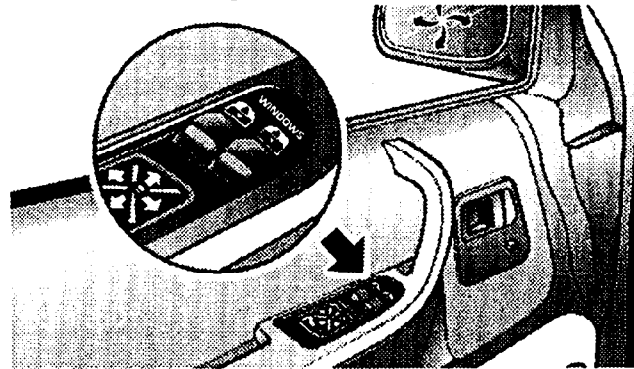

You can control either front window using switches on the door armrest. There is a single switch on the passenger's armrest. The switches will operate only when the ignition is in the ON or ACCESSORY position.

**OCCUPANT RESTRAINTS**

One of the most important safety features in your vehicle is the restraint system. This system includes the

front and rear seat belts and the driver's and passenger side airbags. Your seat belts can also be used to hold infant and child restraint systems if you will be carrying children too small for adult-size belts.

Please pay close attention to the information in this section. It tells you how to use your restraint system properly to keep you and your passengers as safe as possible.

**WARNING!**

**In a collision, you and your passengers can suffer much greater injuries if you are not properly buckled up. You can strike parts on the inside of your vehicle or other passengers, or you can be thrown out of the vehicle. Always be sure you and others in your vehicle are buckled up properly.**

Buckle up even though you are an excellent driver. Even on short trips. Someone on the road may be a poor

driver and cause a collision which includes you. And this can happen far away from home or on your own street.

Research has shown that seat belts save lives and they can reduce the seriousness of injuries in a collision. Some of the worst injuries happen when people are thrown from the vehicle. Seat belts provide protection against that, and they reduce the risk of injury caused by striking the inside of the vehicle. **Everyone** in a motor vehicle needs to be buckled up **all the time**.

**UNIBELTS**

The UNIBELT, or single continuous-belt restraint system, is installed for the driver, front seat passenger, and right and left rear seating positions.

Each unibelt is a combined lap/shoulder belt system. The belt webbing retractor will lock only during very sudden stops or impacts. This feature allows the shoulder part of the belt to move freely with you under

**BEFORE STARTING YOUR VEHICLE**

normal conditions. But in a collision, the belt will lock and reduce the risk of your striking the inside of the vehicle or being thrown out.

**WARNING!**

Wearing a seat belt incorrectly is dangerous. Seat belts are designed to go around the large bones of your body. These are the strongest parts of your body and can take the forces of a collision the best. Wearing your belt in the wrong place could make your injuries in a collision much worse. You might suffer internal injuries, or you could even slide out of part of the belt. Follow these instructions to wear your seat belt safely and to keep your passengers safe, too.

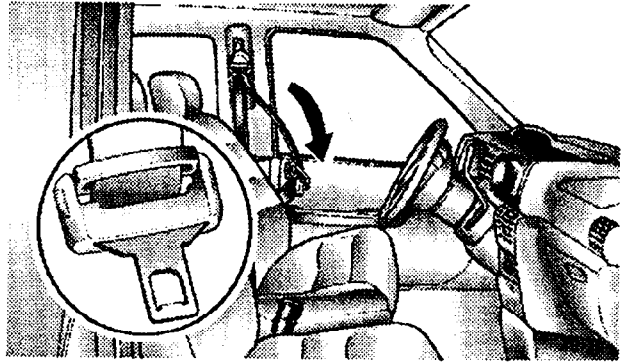

**Unibelt Operating Instructions**

1. Enter the vehicle and close the door. Sit back and adjust the seat
2. The seat belt latch plate is above the back of your seat. Grasp the latch plate and pull out the belt. Slide the latch plate up the webbing as far as necessary to make the belt go around your lap.

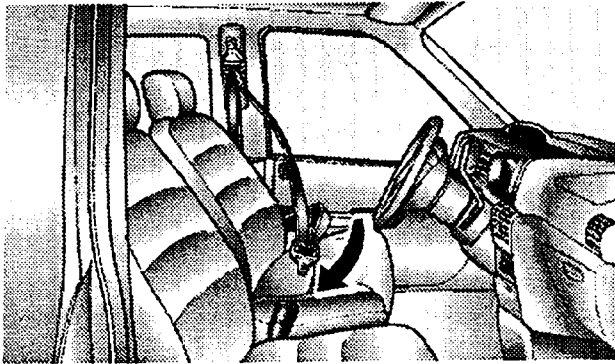

3. When the belt is long enough to fit, insert the latch plate into the buckle until you hear a "click."

**WARNING!**

A belt that is buckled into the wrong buckle will not protect you properly. The lap portion could ride too high on your body, possibly causing internal injuries. Always buckle your belt into the buckle nearest you.

A belt that is too loose will not protect you as well. In a sudden stop you could move too far forward, increasing the possibility of injury. Wear your seat belt snugly.

A belt that is worn under your arm is very dangerous. Your body could fall into the inside surfaces of the vehicle in a collision, increasing head and neck injury. And a belt worn under the arm can cause internal injuries. Ribs aren't as strong as shoulder bones. Wear the belt over your shoulder so that your strongest bones will take the force in a collision.

**BEFORE STARTING YOUR VEHICLE**

4. Position the lap belt across your thighs, below your abdomen. To remove slack in the lap belt portion, pull up a bit on the shoulder belt. To loosen the lap belt if it is too tight, tilt the latch plate and pull on the lap belt. A snug lap belt reduces the risk of sliding under the belt in a collision.

**WARNING!**

A lap belt worn too high can increase the risk of internal injury in a collision. The belt forces won't be at the strong hip and pelvic bones, but across your abdomen. Always wear the lap belt as low as possible and keep it snug.

5. Position the lap/shoulder belt on your chest so that it is comfortable and not resting on your neck. The retractor will withdraw any slack in the belt.

**WARNING!**

A twisted belt can't do its job as well. In a collision it could even cut into you. Be sure the belt is straight. If you can't straighten a belt in your vehicle, take it to your dealer and have it fixed.

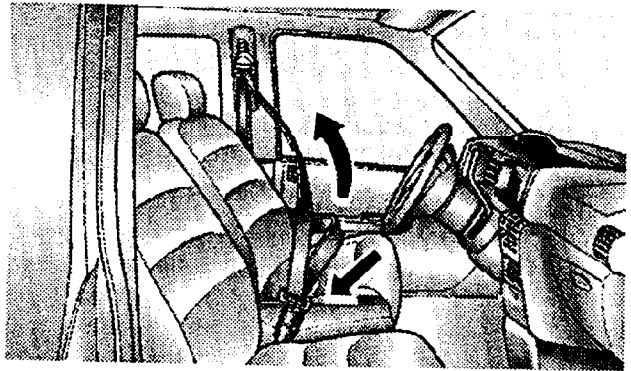

6. To release the belt, push the red button on the buckle. The belt will automatically retract to its

stowed position. If necessary, slide the latch plate down the webbing to allow it to retract fully.

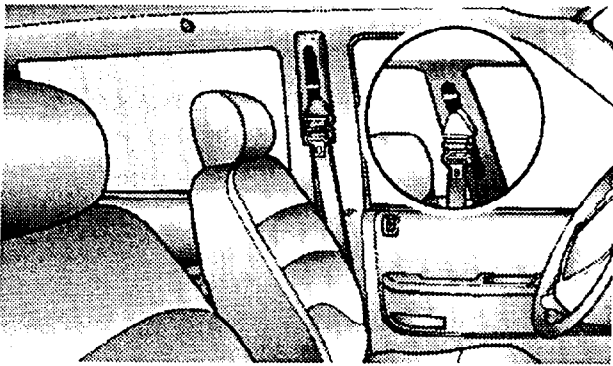

**Adjustable Upper Shoulder Belt Anchorage**

In the front seat, the shoulder belt can be adjusted upward or downward to position the belt away from your neck. Push on the release lever to release the anchorage, and then move it up or down to the position that serves you best.

As a guide, if you are shorter than average, you will prefer a lower position, and if you are taller than average, you'll prefer a higher position. When you release the anchorage, try to move it up or down to make sure that it is locked in position.

In the rear seat, move toward the center of the seat to position the belt away from your neck.

**SEAT BELTS AND PREGNANT WOMEN**

We recommend that pregnant women use the seat belts throughout their pregnancies. Keeping the mother safe is the best way to keep the baby safe.

Pregnant women should wear the lap part of the belt across the thighs and as snug across the hips as possible. Keep the belt low so that it does not come across the abdomen. That way the strong bones of the hips will take the force if there is a collision.

**BEFORE STARTING YOUR VEHICLE**

**CENTER SEAT LAP BELTS**

Center seating positions have a lap belt only. To fasten a lap belt, slip the latch plate into the buckle. To lengthen a lap belt, tilt the latch plate and pull. To remove slack, pull the loose end of the webbing.

Wear the belt snug against the hips. Sit back and erect in the seat, then adjust the belt as tightly as is comfortable.

**WARNING!**

**A lap belt worn too loose or too high is dangerous.**

**A belt worn too loose can allow you to slip down and under the belt in a collision.**

**A belt that is too high will apply crash forces to the abdomen, not to the stronger hip bones.**

**In either case, the risk of internal injuries is greater. Wear the lap belt low and snug.**

**WARNING!**

**A frayed or torn belt could rip apart in a collision and leave you with no protection. Inspect the belt system periodically, checking for cuts, frays, or loose parts. Damaged parts must be replaced immediately. Do not disassemble or modify the system. Seat belt assemblies must be replaced after an accident if they have been damaged (bent retractor, torn webbing, etc).**

**WARNING!**

**Belting two people into one seat belt can lead to greater injury. People belted together can crash into one another in an accident, hurting one another badly. Never use a unbelt or a lap belt for more than one person, no matter what their size.**

**SEAT BELT EXTENDER**

If a seat belt is too short, even when fully extended, your dealer can provide you with a seat belt extender. This extender should be used only if the existing belt is not long enough. When it is not required, remove the extender and stow it.

**SECOND ROW REAR SEAT BELT ANCHOR**

The seat belt anchor at the right end of the second row seat has a hook which allows the anchor to be moved to work properly with different seats.

If the vehicle has a two passenger seat in the second row, the anchor must be installed in the floor mounting position, marked with an "A", next to the seat. To make it easier to enter and leave the third seat, rotate the end of the seat belt toward the right side of the vehicle. An adhesive patch on the belt will align with a similar patch on the carpet. Press the patches together and the belt will lie flat on the floor. The belt must be pulled up and away from the floor when it is being used.

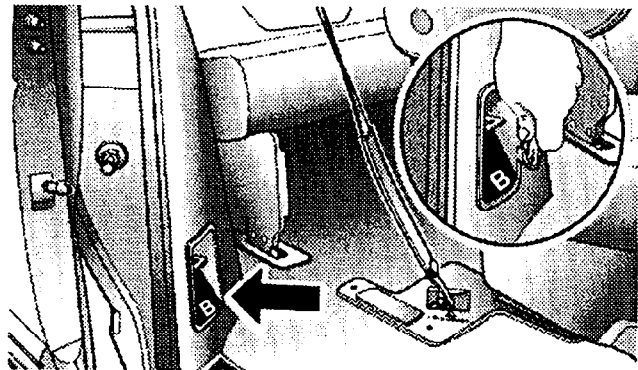

If the vehicle has a three passenger seat or bucket seat in the second row, the seat belt must be installed in the side mounting position. This position is on the lower part of the trim panel, marked with a "B", just rearward of the side door opening.

**WARNING!**

The seat belt must be properly installed at the correct location. Failure to do so may result in an injury in the event of a collision.

**CHRYSLER INTEGRATED CHILD SEAT (optional)**

Operating instructions for this seat are included with the seat. If the instructions are not with the seat or in the Owner's Manual Package, replacement instructions can be obtained.

**To obtain replacement instructions:**

Use the order form at the rear of this manual and specify publication number 81-016-2050.

**CHILD RESTRAINT**

Everyone in your vehicle needs to be buckled up all the time, babies and children, too.

**WARNING!**

In a collision, an unrestrained child, even a tiny baby, can become a missile inside the vehicle. The force required to hold even an infant on your lap could become so great that you could not hold the child, no matter how strong you are. The child and others could be badly injured. Any child riding in your vehicle should be in a proper restraint for the child's size.

All states and Canadian provinces require small children to ride in proper restraint systems. This is the law, and you can be prosecuted for ignoring it.

**Infants and Small Children**

There are different sizes and types of restraints for children from newborn size to the bigger child almost large enough for an adult safety belt. Use the restraint that is correct for your child.

Two different child restraint systems are generally available:

- The infant carrier for babies weighing up to 20 lbs. (9 kg.)
- The child seat for small children over 20 lbs.

In addition, some manufacturers make systems that can be first used as an infant carrier, and then converted to a child seat as the child grows.

Here are some tips on getting the most out of your child restraint:

- Before buying any restraint system, make sure that it has a label certifying that it meets Motor Vehicle Safety Standard 213. Chrysler also recommends that before you buy a child restraint, you try it in the vehicle seats where you will use it.
- The restraint must be appropriate for your child's weight and height. Check the label on the restraint for this, too.

- Install the restraint in the rear seat if possible. According to accident statistics, children are safer when properly restrained in the rear seats than in the front.
- Carefully follow the instructions that come with the restraint. If you install the restraint improperly, it may not work when you need it.

**WARNING!**

**Improper installation can lead to failure of an infant or child restraint. It could come loose in a collision. The child could be badly injured or killed. Follow the manufacturer's directions exactly when installing an infant or child restraint.**

- Infant and child restraints are secured in the vehicle seats by the lap belt or the lap part of the lap/shoulder belt. In the rear seats, you may have trouble tightening the belt on the child restraint because the buckle or latch plate interferes with the belt path opening on the restraint. Disconnect the latch plate from the

## BEFORE STARTING YOUR VEHICLE

buckle and twist the short buckle-end belt several turns to shorten it. Reassemble the latch plate to the buckle with the release button so that it is facing out.

- In the front seat, move the seat forward to reposition the buckle against the side of the child restraint.
- In the center rear seat, if the belt still can't be tightened, or if pulling and pushing on the restraint loosens the belt, you may need to do something more. Disconnect the latch plate from the buckle, turn it over, and reconnect it to the buckle. If you still can't make the child restraint secure, try a different seating position.
- Some child seat manufacturer's recommend the use of a top anchorage (tether) strap in addition to the lap belt. Your vehicle has tether strap anchorages behind some rear seating positions for use with these child seats. Your dealer can provide you with anchorage hardware and installation instructions.

- Buckle the child into the seat exactly as the seat manufacturer's directions tell you. The cinching latch plate will keep the belt tight.
- When your infant carrier or child seat is not in use, secure it with the seat belt or remove it from the vehicle. Don't leave it loose in the vehicle. In a sudden stop or collision, it could strike occupants and injure them.

### Children Too Large For Child Seats

Children who are too large for child seats and who can sit upright by themselves should use the available lap/shoulder belts for best protection.

- Make sure that the child is seated upright in the seat.
- The lap belt should be fastened low on the hips and as snug as possible.
- Check belt fit periodically. A child's squirming or slouching can move the belt out of position.

**BEFORE STARTING YOUR VEHICLE**

If the shoulder belt contacts the face or neck, move the child closer to the middle of the vehicle. If this doesn't solve the problem, move the child to the center rear seating position and use the lap belt.

Booster seats that may help overcome this problem are also available for use with lap/shoulder belts. Before buying a booster seat, make sure that it has a label certifying that it meets applicable Motor Vehicle Safety Standards. Make sure that is satisfactory for use in this vehicle.

**DRIVER AND RIGHT FRONT PASSENGER  
SUPPLEMENTAL MINIVAN RESTRAINT SYSTEM -  
AIRBAG**

This vehicle has airbags for the driver and right front passenger as a supplement to the seat belt restraint systems. The driver's airbag is mounted in the steering wheel. The passenger side airbag is mounted in the instrument panel above the glove compartment. These airbags inflate in higher speed frontal impacts. They

work with the instrument panel knee bolsters and the seat belts to provide improved protection for the driver and right front passenger.

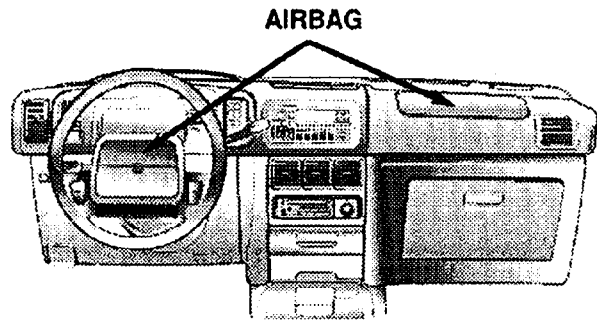

**WARNING!**

Relying on airbags alone could lead to more severe injuries in a collision. The airbags do not provide any restraint in side or rear collisions or rollovers. Always wear the seat belt.

The seat belt system is designed to protect you in many types of collisions. The airbags deploy only in frontal collisions. They will not deploy in collisions at slow speed. But even in collisions where the airbags deploy, you need the seat belt to keep you in the right position for the airbags to protect you properly.

Ignoring the AIRBAG light in your message center could mean you won't have the airbags to protect you in a collision. If the light does not come on, stays on after you start the vehicle, or if it comes on as you drive, have the airbag system checked right away.

The airbag system consists of the following:

- Airbag Control Module
- AIRBAG Light
- Driver and Passenger Airbag/Inflator Units
- Unique Steering Wheel and Column
- Unique Instrument Panel
- Interconnecting Wiring
- Knee Impact Bolster

**How The Airbag System Works**

- **Airbag Control Module** in the occupant compartment determines if a frontal impact is severe enough to require the airbag. The sensor in the control module will not detect side, rollover, or rear impacts. Switches in the control module are connected to the airbag/inflator unit.

This module also monitors the readiness of the electronic parts of the system whenever the ignition switch is in the START or RUN positions. These include all of the items listed above except the knee bolster. The airbag control module also turns on the Airbag light in the instrument panel for 6 to 8 seconds when the ignition is first turned on, then turns the light off. If it detects a malfunction in any part of the system, it turns on the light either momentarily or continuously.

- The **Airbag/Inflator Units** are in the center of the steering wheel and the instrument panel. The words SRS/AIRBAG are embossed on the airbag covers.

**WARNING!**

**Do not put anything on or around the airbag covers or attempt to manually open them. You may damage the airbags and you could be injured because the airbags are not there to protect you. These protective covers for the airbag cushions are designed to open only when the airbags are inflating.**

- When the crash sensor detects an impact requiring the airbags, the control module signals the inflator units. A large quantity of non-toxic nitrogen or argon gas is generated to inflate the airbags. The airbag covers separate and fold out of the way as the airbags inflate to their full size. The airbags fully inflate in about 50 milliseconds. This is only about half of the time it takes you to blink your eyes. The airbags then quickly deflate while helping to restrain the driver and right front passenger. The airbag gas is vented

**BEFORE STARTING YOUR VEHICLE**

through the airbag material towards the instrument panel. In this way the airbags do not interfere with your control of the vehicle.

The **Knee Impact Bolsters** help protect the knees and position you for the best interaction with the airbags.

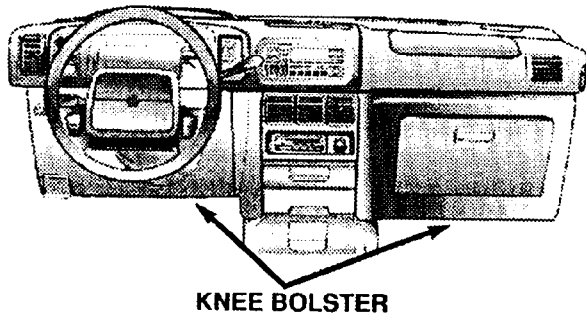

**WARNING!**

- You could be more seriously injured in a collision if you rely on the airbag alone for restraint. Wear your seat belt even though you have an airbag.
- Being too close to the steering wheel or instrument panel during airbag deployment could cause serious injury. Airbags need room to inflate. Sit back, comfortably extending your arms to reach the steering wheel or instrument panel.
- A rearward-facing child restraint should only be used in a rear seat. A child may be seriously or fatally injured in a rearward-facing child restraint placed in the front seat if the restraint is struck by a deploying passenger airbag.

**If A Deployment Occurs**

The airbag system is designed to deploy when the impact sensors detect a moderate-to-severe frontal collision, to help restrain the driver and right front passenger, and then immediately deflate.

**NOTE:** A frontal collision that is not severe enough to need airbag protection will not activate the system. This does not mean something is wrong with the airbag system.

If you do have a collision which deploys the airbag, any or all of the following may occur:

- The nylon airbag material may sometimes cause abrasions and/or skin reddening to the driver and right front passenger as the airbags deploy and unfold.

The abrasions are similar to friction rope burns or those you might get sliding along a carpet or gymnasium floor. They are not caused by contact with chemicals. They are not permanent and normally heal quickly. However, if you haven't healed significantly within a few days, or if you have any blistering, see your doctor immediately.

- As the airbags deflate you may see some smoke-like particles. The particles are a normal by-product of the process that generates the non-toxic nitrogen or argon gas used for airbag inflation. These airborne

particles may irritate the skin, eyes, nose, or throat. If you have skin or eye irritation, rinse the area with cool water. For nose or throat irritation, move to fresh air. If the irritation continues, see your doctor.

If these particles settle on your clothing, follow the garment manufacturer's instructions for cleaning.

- Your vehicle may be safely driveable after the airbags deploy. If so, you can tuck the deployed airbags inside the opening in the steering wheel hub and instrument panel trim covers to make driving somewhat easier.

**WARNING!**

Deployed airbags cannot protect you in another collision. Have the airbags replaced by an authorized dealer as soon as possible.

**BEFORE STARTING YOUR VEHICLE**

**Transporting Pets**

Airbags deploying in the front seat could harm your pet. An unrestrained pet will be thrown about and possibly injured, or injure a passenger during panic braking or in a collision.

Pets should be restrained in the rear seat in pet harnesses or pet carriers that are secured by seat belts.

**MAINTAINING YOUR AIRBAG SYSTEM**

**WARNING!**

- Modifications to any part of the airbag system could cause it to fail when you need it. You could be injured because the airbag is not there to protect you. Do not modify the components or wiring, including adding any kind of badges or stickers to the airbag covers. Do not modify the front bumper or vehicle body structure.
- You need proper knee impact protection in a collision. Do not mount or locate any aftermarket equipment on or behind the knee bolsters.
- You can be injured if you are too close to either airbag cover when the airbags inflate. It is dangerous to try to repair any part of the airbag system yourself. Don't try to repair the airbag system. Be sure to tell anyone who works on your vehicle that it has airbags.

You will want to have the airbags ready for your protection in a collision. While the airbag Supplemental Restraint System (SRS) is designed to be maintenance free, if any of the following occurs, have an authorized dealer service the system immediately.

- The AIRBAG light does not come on or flickers during the 6 to 8 seconds when the ignition switch is first turned on.
- The light remains on or flickers after the 6 to 8 second interval.
- The light flickers or comes on and remains on while driving.

#### STORAGE BIN (if so equipped)

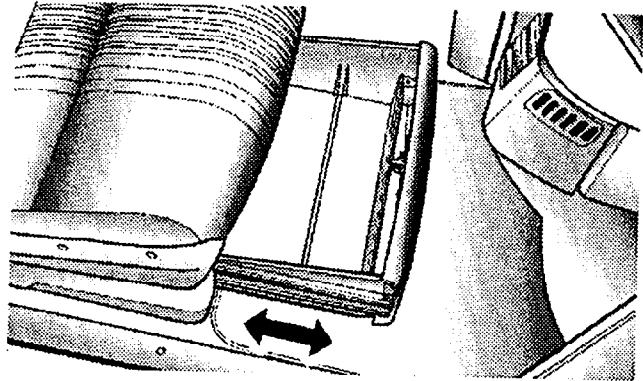

The storage bin located under the front passenger's seat can be locked with the master key. If you must leave your vehicle with a parking attendant, give the attendant the "valet" key to maintain secure storage.

Appendix E

**BUILT-IN CHILD RESTRAINT SYSTEM TESTS - FMVSS NO. 213**

Chrysler Corporation  
Chrysler Integrated Child Seat, Type AS

**TECHNICAL REPORT STANDARD TITLE PAGE**

1. Report No.		2. Government Accession No.		3. Recipient's Catalog No.	
4. Title and Subtitle Child Restraint Systems Tests - FMVSS 213 Chrysler Corporation Chrysler Integrated Child Seat, Type AS			5. Report Date August 1994		
			6. Performing Organization Code		
7. Author(s) Robert F. Hathaway			8. Performing Organization Report No.		
9. Performing Organization Name and Address Calspan Advanced Technology Center 4455 Genesee Street Buffalo, New York 14225			10. Work Unit No.		
			11. Contract or Grant No. DTNH22-93-D-11089		
12. Sponsoring Agency Name and Address U.S. Department of Transportation National Highway Traffic Safety Administration 400 Seventh, S.W. Washington, D.C. 20590			13. Type of Report and Period Covered Final Report		
			14. Sponsoring Agency Code		
15. Supplementary Notes					
Reviewed by :		<u>Robert F. Hathaway</u>		Program Manager	
Approved by :		<u>David Roberts</u>		Head, Safety Research Section Transportation Sciences Center	
16. Abstract This report contains the results of tests performed in accordance with FMVSS 213, Child Restraint Systems, on the Chrysler Corporation, Chrysler Integrated Child Seat, Type AS built-in child restraint. The child restraint appears to comply with all the requirements of FMVSS 213. Final determination of compliance is made by the National Highway Traffic Safety Administration.					
17. Key Words FMVSS 213 Child Restraint Systems Compliance Testing			18. Distribution Statement		
19. Security Classif. (of this report) UNCLASSIFIED		20. Security Classif. (of this page) UNCLASSIFIED		21. No. of Pages	22. Price

## TABLE OF CONTENTS

<u>Section</u>		<u>Page No.</u>
I	PURPOSE AND TEST PROCEDURE	1-1
II	INTRODUCTION AND SUMMARY	2-1
III	INSPECTION AND TEST DATA	3-1
APPENDIX A	EQUIPMENT LIST AND CALIBRATION SCHEDULES	A-1
APPENDIX B	PHOTOGRAPHS OF EQUIPMENT	B-1

SECTION I  
PURPOSE AND TEST PROCEDURE

Purpose: The purpose of the test was to determine if the production built-in child restraint systems in the 1994 Dodge Caravan met the requirements of Federal Motor Vehicle Safety Standard (FMVSS) No. 213, Child Restraint Systems.

Test Procedure: The "Calspan Operating Test Procedure for FMVSS No. 213", submitted to and approved by the Office of Vehicle Safety Compliance, National Highway Traffic Safety Administration, contains the specific procedures used to conduct this test. This procedure shall not be interpreted to be in conflict with any portion of FMVSS No. 213 and amendments in effect as noted in the applicable contract.

## SECTION II

### INTRODUCTION AND SUMMARY

This report presents all of the FMVSS 213 compliance inspection and test data obtained on the Chrysler Corporation, Chrysler Integrated Child Seat, Type AS built-in child restraint system. This test was performed in conjunction with a full-scale FMVSS 208 compliance test of a 1994 Dodge Caravan. Both built-in child restraints were dynamically tested in the forward-facing position.

The Chrysler Integrated Child Seat(s) is comprised of two separate units which are built into a common bench seat. This bench seat is non-adjustable in terms of fore and aft travel (bench seat mounts into a fixed location) and in terms of vertical height adjustment. The results from all inspections and tests indicate that the Chrysler Corporation, Chrysler Integrated Child Seat, Type AS child restraint complied with all of the requirements of FMVSS 213.

Restraint system inspection and, full-scale dynamic testing were performed by Calspan Advanced Technology Center (ATC). Compliance test data sheets for all tests are found in Section III of this report.

SECTION III  
INSPECTION AND TEST DATA  
FMVSS 213 - BUILT-IN CHILD RESTRAINT SYSTEMS

Child Restraint System Identification

Manufacturer:

Name Chrysler Corporation  
Address Highland Park, Michigan  
\_\_\_\_\_  
\_\_\_\_\_

Model No. Type AS  
Group No. N/A

- |   |   |
|---|---|
| 1. Item Code <u>001-CAS-01-DTUD (1)</u><br>Date of Manufacture <u>12/93</u><br>Test No. <u>1430</u> | 2. Item Code <u>001-CAS-02-DTUP (1)</u><br>Date of Manufacture <u>12/93</u><br>Test No. <u>1430</u> |
| 3. Item Code _____<br>Date of Manufacture _____<br>Test No. _____                                   | 4. Item Code _____<br>Date of Manufacture _____<br>Test No. _____                                   |
| 5. Item Code _____<br>Date of Manufacture _____<br>Test No. _____                                   | 6. Item Code _____<br>Date of Manufacture _____<br>Test No. _____                                   |

Remarks: (1) The Chrysler Integrated Child Seat(s) is comprised of two separate units which are built into a common bench seat, therefore, the units will be differentiated by the addition of a "D" or a "P" (for Driver's side or Passenger's side) to the end of the item code.

Technician Donald W. Hess

Program Manager Robert F. Hathaway

COMPLIANCE TEST DATA: FMVSS 213

Labeling  
(FMVSS 213, S5.5)

Date of Test 7/14/94 Item Code 001-CAS-01-DTUD  
001-CAS-01-DTUP

Pass / Fail

S5.5.4

(a) Each built-in child restraint system other than a factory-installed built-in restraint shall be permanently labeled with the information specified in S5.5 (a) through (k). The information specified in S5.5 (a) through (j) shall be visible when the system is activated for use.

N/A (1)

(b) Each factory-installed built-in child restraint shall be permanently labeled with the information specified in S5.5.5 (f) through (j), so that the information is visible when the restraint is activated for use. The information shall also be included in the vehicle owner's manual.

Pass (2)

S5.5.5 The information specified in paragraphs (a) through (k) of this section that is required by S5.5.4 shall be stated in the English and lettered in letters and numbers that are not smaller than 10-point type and are on a contrasting background.

Pass

The following information is included:

(a) The model name or number of the system.

N/A

(b) The manufacturer's name. A distributor's or dealer's name may be used instead if the distributor or dealer assumes all responsibility for all duties and liabilities imposed on the manufacturer with respect to the system by the National Traffic and Motor Vehicle Safety Act, as amended.

N/A

Remarks: (1) These restraints are factory-installed built-in units.

(2) Labels may be seen in photographs presented in Appendix B.

Technician Donald W. Hess

Program Manager Robert F. Hathaway

COMPLIANCE TEST DATA: FMVSS 213

Labeling (cont'd)

- (c) The statement: "Manufactured in \_\_\_\_\_," inserting the month and year of manufacture. N/A
- (d) The place of manufacture (city and State, or foreign country). However, if the manufacturer uses the name of the distributor or dealer, then it shall state the location (city and State, or foreign country) of the principle offices of the distributor or dealer. N/A
- (e) The statement: "This child restraint system conforms to all applicable Federal Motor Vehicle Safety Standards." N/A
- (f) One of the following statements, inserting the manufacturer's recommendations for the maximum weight and height of children who can safely occupy the system: Pass
- (i) THIS INFANT RESTRAINT IS DESIGNED FOR USE BY CHILDREN WHO WEIGH \_\_\_\_\_ POUNDS OR LESS AND WHOSE HEIGHT IS \_\_\_\_\_ INCHES OR LESS ; or
  - (ii) THIS CHILD RESTRAINT IS DESIGNED FOR USE ONLY BY CHILDREN WHO WEIGH BETWEEN \_\_\_\_\_ AND \_\_\_\_\_ POUNDS AND WHOSE HEIGHT IS \_\_\_\_\_ INCHES OR LESS AND WHO ARE CAPABLE OF SITTING UPRIGHT ALONE ; or
  - (iii) THIS CHILD RESTRAINT IS DESIGNED FOR USE ONLY BY CHILDREN WHO WEIGH BETWEEN \_\_\_\_\_ AND \_\_\_\_\_ POUNDS AND ARE BETWEEN \_\_\_\_\_ AND \_\_\_\_\_ INCHES IN HEIGHT.
- (g) The statement specified in paragraph (1), and if appropriate, the statement in paragraph (2). Pass
- (1) WARNING! FAILURE TO FOLLOW THE MANUFACTURER'S INSTRUCTIONS ON THE USE OF THIS CHILD RESTRAINT SYSTEM CAN RESULT IN YOUR CHILD STRIKING THE VEHICLE'S INTERIOR DURING A SUDDEN STOP OR CRASH. Pass
  - (2) In the case of each built-in child restraint system which is not intended for use in the motor vehicle at certain adjustment positions or under certain circumstances an appropriate statement of the manufacturer's restrictions regarding those positions or circumstances, in capitalized letters.  
  
DO NOT USE THE \_\_\_\_\_ ADJUSTMENT POSITION(S) OF THIS CHILD RESTRAINT WHILE THE VEHICLE IS IN MOTION. Pass (3) (4)

Remarks:

Technician Donald W. Hess

Program Manager Robert F. Hathaway

COMPLIANCE TEST DATA: FMVSS 213

Labeling (cont'd)

- (h) In the case of each built-in child restraint system that has belts designed to restrain children using them, the statement: Pass

SNUGLY ADJUST THE BELTS PROVIDED WITH THIS CHILD RESTRAINT AROUND YOUR CHILD.

- (i) In the case of each built-in child restraint system which can be used in a rear-facing position, the following statement: N/A

PLACE AN INFANT IN A REAR-FACING POSITION IN THIS CHILD RESTRAINT.

- (j) A diagram or diagrams showing the fully activated child restraint system in infant and/or child configurations. Pass (5) (6)

- (k) The following statement, inserting an address and telephone number: N/A

"Child restraints could be recalled for safety reasons. You must register this restraint to be reached in a recall. Send your name, address and the restraint's model number and manufacturing date to *(insert address)* or call *(insert telephone number)*. For recall information, call the U.S. Government's Auto Safety Hotline at 1-800-424-9393 (202-366-0123 in D.C. area)."

Remarks:

- (3) The label on the passenger-side restraint states: " Do not use the passenger's side child seat with the adult seat belt."
- (4) The label on the driver's-side restraint states: " The driver's side child seat can be used with the adult shoulder and lap belt for children over 40 pounds."
- (5) The label on the passenger's-side depicts the activated unit (without an occupant) in the forward-facing configuration.
- (6) The label on the driver's-side depicts the activated unit (without an occupant) utilizing the adult shoulder and lap belt system.

Technician Donald W. Hess

Program Manager Robert F. Hathaway

COMPLIANCE TEST DATA: FMVSS 213

Installation Instructions  
(FMVSS 213, S5.6)

Date of Test 7/14/94 Item Code 001-CAS-01-DTUD  
001-CAS-02-DTUP

Pass / Fail

S5.6.2

(a) Each built-in child restraint system shall be accompanied by printed instructions in the English that provide a step-by-step procedure, including diagrams, for activating the restraint system, positioning a child in the system, adjusting the restraint and, if provided, the restraint harness to fit the child. The instructions for each built-in car bed shall explain that the child should be positioned in the bed in such a way that the child's head is near the center of the vehicle.

Pass

(b) Each motor vehicle equipped with a factory-installed built-in child restraint shall have the information specified in paragraph (a) of this section included in its vehicle owner's manual.

Pass (1)

S5.6.2.1 The instructions shall explain the primary consequences of not following the manufacturer's warnings for proper use of the child restraint system in accordance with S5.5.5 (f) through (i).

Pass

S5.6.2.2 The instructions for each built-in child restraint system, other than a factory-installed restraint, shall include the following statement, inserting an address and telephone number:

N/A (2)

"Child restraints could be recalled for safety reasons. You must register this restraint to be reached in a recall. Send your name, address and the restraint's model number and manufacturing date to *(insert address)* or call *(insert telephone number)*. For recall information, call the U.S. Government's Auto Safety Hotline at 1-800-424-9393 (202-366-0123 in D.C. area)."

Remarks:

- (1) The vehicles's owner's manual does not refer to the built-in child restraint, however the built-in restraints are accompanied by an " Owner's Manual Supplement, Operating Instructions for Chrysler Integrated Child Seat, Type AS."
- (2) These restraint's are factory-installed built-in units.

Technician Donald W. Hess

Program Manager Robert F. Hathaway

COMPLIANCE TEST DATA: FMVSS 213

Installation Instructions (cont'd)

S5.6.2.3 Each built-in child restraint system other than a factory-installed built-in restraint, shall have a location on the restraint for storing the instructions.

N/A (2)

S5.6.3 Each built-in child restraint system, other than a system that has been installed in a vehicle or a factory-installed built-in system that is designed for a specific vehicle model and seating position, shall be accompanied by instructions in English that provide a step-by-step procedure for installing the system in a motor vehicle. The instructions shall specify the types of vehicles and the seating positions into which the restraint can or cannot be installed. The instructions for each car bed shall explain that the car bed should be installed so that the child's head will be near the center of the vehicle.

N/A (2)

Remarks:

(2) These restraints are factory-installed built-in units.

Technician Donald W. Hess

Program Manager Robert F. Hathaway

COMPLIANCE TEST DATA: FMVSS 213

Registration Form  
(FMVSS 213, S5.8)

Date of Test 7/14/94 Item Code 001-CAS-01-DTUD  
001-CAS-02-DTUP

Pass / Fail

S5.8 Information requirements - registration form.

- (a) Each child restraint system, except a factory-installed built-in restraint system, shall have a registration form attached to any surface of the restraint that contacts the dummy when the dummy is positioned in the system in accordance with S6.1.2 of Standard 213. N/A (1)
- (b) Each form shall:
- (1) Consist of a postcard that is attached at a perforation to an informational card; N/A (1)
  - (2) Conform in size, content and format to Figures 9a and 9b of Standard 213; N/A (1)
  - (3) Have a thickness of at least 0.007 inches and not more than 0.0095 inches. N/A (1)
- (c) Each postcard shall provide the model name or number and date of manufacture (month, year) of the child restraint system to which the form is attached, shall contain space for the purchaser to record his or her name and mailing address, shall be addressed to the manufacturer, and shall be postage paid. No other information shall appear on the postcard, except identifying information that distinguishes a particular child restraint system from other systems of that model name or number may be preprinted in the shaded area of the postcard, as shown in Figure 9a of Standard 213. N/A (1)

Remarks:

- (1) These restraints are factory-installed built-in units.

Technician Donald W. Hess

Program Manager Robert F. Hathaway

COMPLIANCE TEST DATA: FMVSS 213

Minimum Head Support Surface  
(FMVSS 213, S5.2.1)

Date of Test 7/14/94 Item Code 001-CAS-01-DTUD  
001-CAS-02-DTUP

S5.2.1.2 The child restraint system is low enough to be exempt  
from this requirement.

Yes (1)  
(yes, no)

S5.2.1.1

Back Support Height

Maximum Child Weight (lbs.)	Required Minimum Height (in.)	Measured Height (in.)	Pass / Fail
40	22	22 1/2	Pass

Back Support Width

Required Minimum Width (in.)	Measured Width (in.)	Side Wing Depth (in.)	Pass / Fail
8	12 3/4	3 1/2	Pass

Remarks:

(1) These restraints are exempt from this requirement, however Seat Back Height and Width measurements were performed, and are listed for informational purposes only.

Technician Donald W. Hess

Program Manager Robert F. Hathaway

COMPLIANCE TEST DATA: FMVSS 213

Torso Impact Protection  
(FMVSS 213, S5.2.2)

Date of Test 7/14/94 Item Code 001-CAS-01-DTUD  
001-CAS-02-DTUP

S5.2.2.1

Test	Compliance Requirement	Test Result	Pass / Fail
Back Support Surface	Flat or concave	Flat	Pass
	Area $\geq$ 85 sq. in.	> 85 sq. in.	Pass
Side Support Surface	Flat or concave	Flat	Pass
Max. weight $\geq$ 20 lb.	Area $\geq$ 24 sq. in.	> 24 sq. in.	Pass
Max. weight < 20 lb.	Area $\geq$ 48 sq. in.	N/A	N/A
Forward Restraining Surface			
Horiz. Cross Section	Flat or concave	N/A	N/A
Vertical Longitudinal Cross Section	Flat or convex	N/A	N/A
	Radius of curvature $\geq$ 2 in.	N/A	N/A

S5.2.2.2 Forward Fixed or Movable Surface Yes / No Pass / Deferred  
No Pass

Remarks:

Technician Donald W. Hess

Program Manager Robert F. Hathaway

COMPLIANCE TEST DATA: FMVSS 213

Protrusion Limitation  
(FMVSS 213, S5.2.4)

Date of Test 7/14/94 Item Code 001-CAS-01-DTUD  
001-CAS-02-DTUP

Test	Compliance Requirement (in.)	Test Result (in.)	Pass / Fail
Height	$\leq 3/8$ in.	$< 3/8$	Pass
Edge Radius	$\geq 1/4$ in.	$> 1/4$	Pass

Remarks:

Technician Donald W. Hess

Program Manager Robert F. Hathaway

COMPLIANCE TEST DATA: FMVSS 213

Dynamic Impact Test Conditions  
(FMVSS 213, S6.1)

Date of Test 7/12/94 Test No. 1430  
Item Code 001-CAS-01-DTUD

Laboratory Ambient Conditions During Testing

Temperature Range 72 to 72 Degrees F  
Relative Humidity Range 64 % to 64 %

Test Device 1994 Dodge Caravan  
Nominal velocity (mph) 30 (+0, -3)

Dummy Used 3 year old toddler S/N:159

Child Restraint System

Location Driver's-side  
Installation mode Forward-facing  
Adjustment mode Upright - Non-adjustable  
"Misuse" mode N/A

Test Results

Actual velocity 42.7 ft/s  
29.1 mph

Vehicle Seat Position

Vertical position N/A (1)  
Horizontal position N/A (1)  
Vehicle seat back position 21 deg.

Include pre- and post-test photographs and acceleration-time history plot.

Remarks:

(1) The bench seat that contains these units is not adjustable in the horizontal or vertical directions.

The shoulder belt clip was positioned approximately 3 inches below the dummy's chin as specified in the manufacturer's installation instructions.

Pre- and post-test photographs are presented in Appendix B.

Technician Donald W. Hess Program Manager Robert F. Hathaway

NHTSA 208 TEST #16 - 1994 Dodge Caravan

L. Rear X-member X (#1)      Max = 5.15 Gs      @ 124.08 msec  
Min = -42.67 Gs      @ 63.48 msec

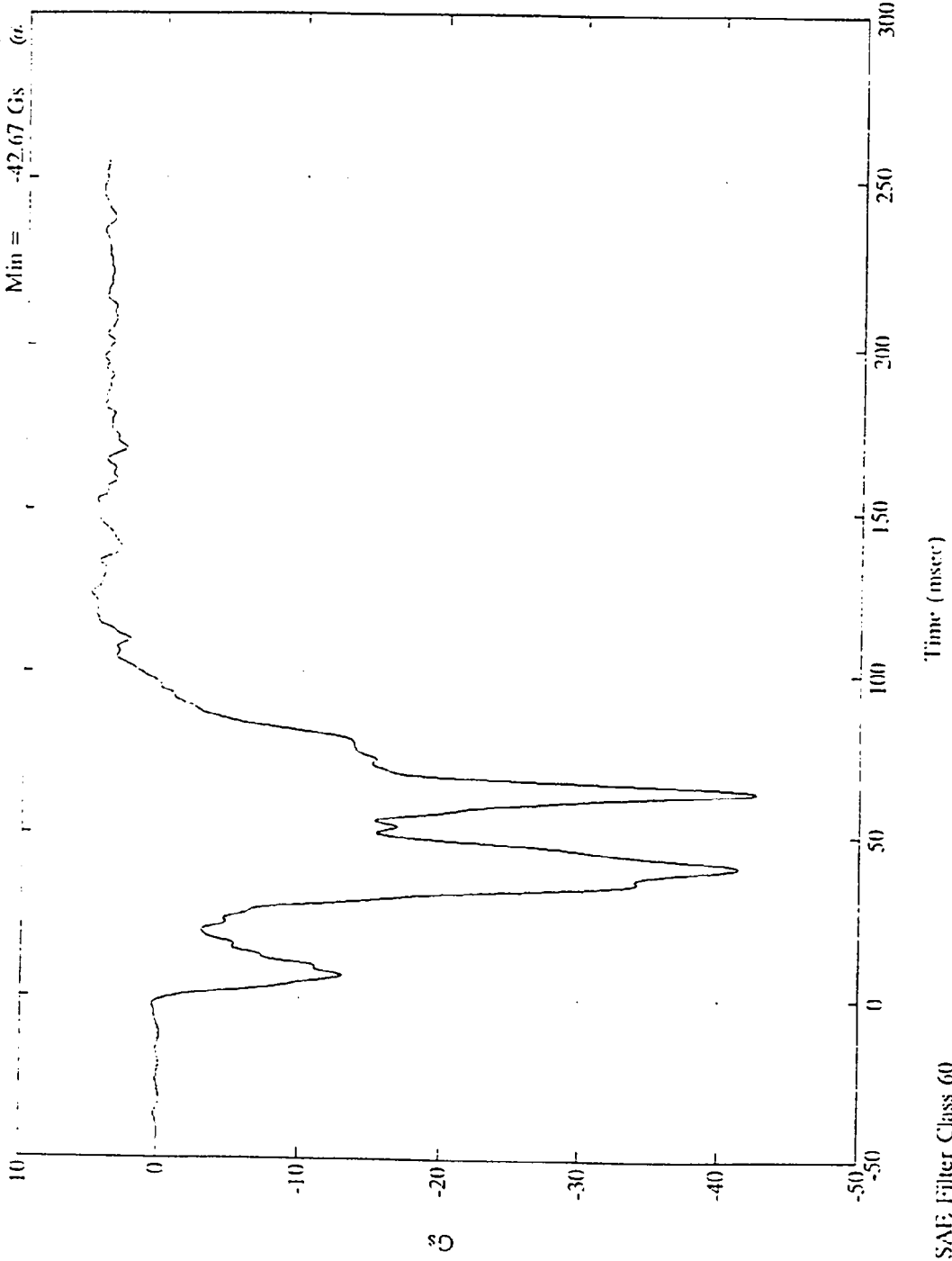

SAE Filter Class 60

COMPLIANCE TEST DATA: FMVSS 213

Belt Restraint  
(FMVSS 213, S5.4.3)

Date of Test 7/12/94 Test No. 1430  
Item Code 001-CAS-01-DTUD

Pass / Fail

S5.4.3.1 Snug Fit of Belts Pass

Extra Webbing

Dummy	Each Shoulder Belt (in.)	Each Lap Belt Side (in.)	Crotch Belt (in.)
3 yr. old	11	(1)	(1)

S5.4.3.2 Direct Restraint Belts Pass

	<u>Yes / No</u>
(1) Belt / dummy contact for restraint	<u>No</u>
(2) Rigid structure behind dummy	<u>Yes</u>
(3) Belt / child restraint slip possible	<u>No</u>

Note : If all "yes", restraint fails.

S5.4.3.3 Seating System Belts and / or Shields Pass

(1) Upper torso	<u>Yes</u>
(2) Lower torso	<u>Yes</u>
(3) Crotch restraint	<u>Yes</u>

S5.4.3.4 Child Harness Belts N/A N/A

(1) Upper torso	<u>N/A</u>
(2) Lower torso	<u>N/A</u>
(3) Prevent standing	<u>N/A</u>

Remarks:

(1) The shoulder and lap belts are a continuous system with both ends of the belt connected through a yoke to a single strap adjustable at the front of the seat. The crotch belt is non-adjustable.

Technician Donald W. Hess

Program Manager Robert F. Hathaway

COMPLIANCE TEST DATA: FMVSS 213

Buckle Release  
(FMVSS 213, S5.4.3.5, S6.2)

Date of Test 7/12/94

Test No. 1430

Item Code 001-CAS-01-DTUD

Test	Compliance Requirement	Test Result	Pass / Fail
Buckle Minimum Surface Area	Area $\geq 0.6 \text{ in.}^2$	0.68 in. <sup>2</sup>	Pass
Pre - Impact Release Force	Force range : 9 to 14 lbs.	Right: 11.9 lbs. Left: 11.9 lbs. (1)	Pass
Buckle Integrity	Not release during test	No Release	Pass
Post - Impact Release Force	Force range : $\leq 16 \text{ lbs.}$	Right: 14.1 lbs. Left: 14.0 lbs. (1)	Pass

Remarks:

The buckle is an integral part of the seat and, therefore, the buckle release test was performed on the entire seat assembly.

(1) The buckle is comprised of right and left buckle tangs that do not always release at the same force.

Shoulder belt clip opened during dynamic test.

Technician Donald W. Hess

Program Manager Robert F. Hathaway

COMPLIANCE TEST DATA: FMVSS 213

Restraint System Integrity  
(FMVSS 213, S5.1.1)

Date of Test 7/12/94

Test No. 1430

Item Code 001-CAS-01-DTUD

Test	Compliance Requirement	Test Result	Pass / Fail
Structural Integrity	No complete separation	None	Pass
	No partial separation with exposed edge radius < 1/4 in.	None	Pass
	No partial separation with protrusions > 3/8 in.	None	Pass
Adjustment Position	No change	No Change	Pass
Back Surface / Seating Surface Angle	Not < 45 degrees	N/A	N/A

Remarks:

The back of the bench seat bowed toward the front of the vehicle approximately 5 inches during the dynamic test.

Technician Donald W. Hess

Program Manager Robert F. Hathaway

COMPLIANCE TEST DATA: FMVSS 213

Injury Criteria  
(FMVSS 213, S5.1.2)

Date of Test 7/12/94

Test No. 1430

Item Code 001-CAS-01-DTUD

Test	Compliance Requirement	Test Result	Pass / Fail
Head Injury Criterion	$\leq 1000$	270	Pass
Chest Injury Criterion	Cumulative duration over 60 g $\leq 3$ ms	Clipped Peak g = <u>14.4 (1)</u>  Duration exceeding 60 g = <u>0.0</u>	Pass (1)

Remarks:

- (1) Chest Injury Criterion based on X axis and Y axis calculations only. The wire from the Z axis element of the chest accelerometer was broken during the dynamic test, and therefore Z axis data was not available. The COTR was aware of, and approved this modification.

Technician Donald W. Hess

Program Manager Robert F. Hathaway

COMPLIANCE TEST DATA: FMVSS 213

Occupant Excursion  
(FMVSS 213, S5.1.3, S5.1.4, S5.2.1.1 (c))

Date of Test 7/12/94

Test No. 1430

Item Code 001-CAS-01-DTUD

Forward-Facing Restraints

Test	Compliance Requirement	Test Result	Pass / Fail
Torso Retention (FMVSS 213, S5.1.3.1)	Retain within system	Retained	Pass
Knee Target Excursion (FMVSS 213, S5.1.3.1)	≤ 36 in.	17.9 in.	Pass (1)
Head - Torso Angle (FMVSS 213, S5.2.1.1 (c))	Rearward change ≤ 45 degrees	< 45 deg.	Pass

Rear-Facing Restraints

Test	Compliance Requirement	Test Result	Pass / Fail
Torso Retention (FMVSS 213, S5.1.3.2)	Retain within system	N/A	N/A
Head Target Excursion (FMVSS 213, S5.1.3.2)	Not beyond restraint's top and forward edge	N/A	N/A
Back Support Angle (FMVSS 213, S5.1.4)	≤ 70 degrees	N/A	N/A
Head - Torso Angle (FMVSS 213 S5.2.1.1 (c))	Rearward change ≤ 45 degrees	N/A	N/A

Remarks:

(1) Excursion measured from actual pivot point of the bench seat that contained the built-in restraints.

Technician Donald W. Hess

Program Manager Robert F. Hathaway

COMPLIANCE TEST DATA: FMVSS 213

Dynamic Impact Test Conditions  
(FMVSS 213, S6.1)

Date of Test 7/12/94 Test No. 1430  
Item Code 001-CAS-02-DTUP

Laboratory Ambient Conditions During Testing

Temperature Range 72 to 72 Degrees F  
Relative Humidity Range 64 % to 64 %

Test Device 1994 Dodge Caravan  
Nominal velocity (mph) 30 (+0, -3)  
Dummy Used 3 year old toddler S/N: 066  
Child Restraint System  
Location Passenger-side  
Installation mode Forward-facing  
Adjustment mode Upright  
"Misuse" mode N/A

Test Results

Actual velocity 42.7 ft/s  
29.1 mph

Vehicle Seat Position

Vertical position N/A (1)  
Horizontal position N/A (1)  
Vehicle seat back position 21 deg.

Include pre- and post-test photographs and acceleration-time history plot.

Remarks:

(1) The bench seat that contains these units is not adjustable in the horizontal or vertical direction.

The shoulder belt clip was positioned approximately 3 inches below the dummy's chin as specified in the manufacturer's installation instructions.

Pre- and post-test photographs are presented in Appendix B.

Technician Donald W. Hess Program Manager Robert F. Hathaway

NHTSA 208 TEST #16 - 1994 Dodge Caravan

L. Rear X-member X (#1)      Max = 5.15 Gs      @ 124.08 msec  
Min = -42.67 Gs      @ 63.48 msec

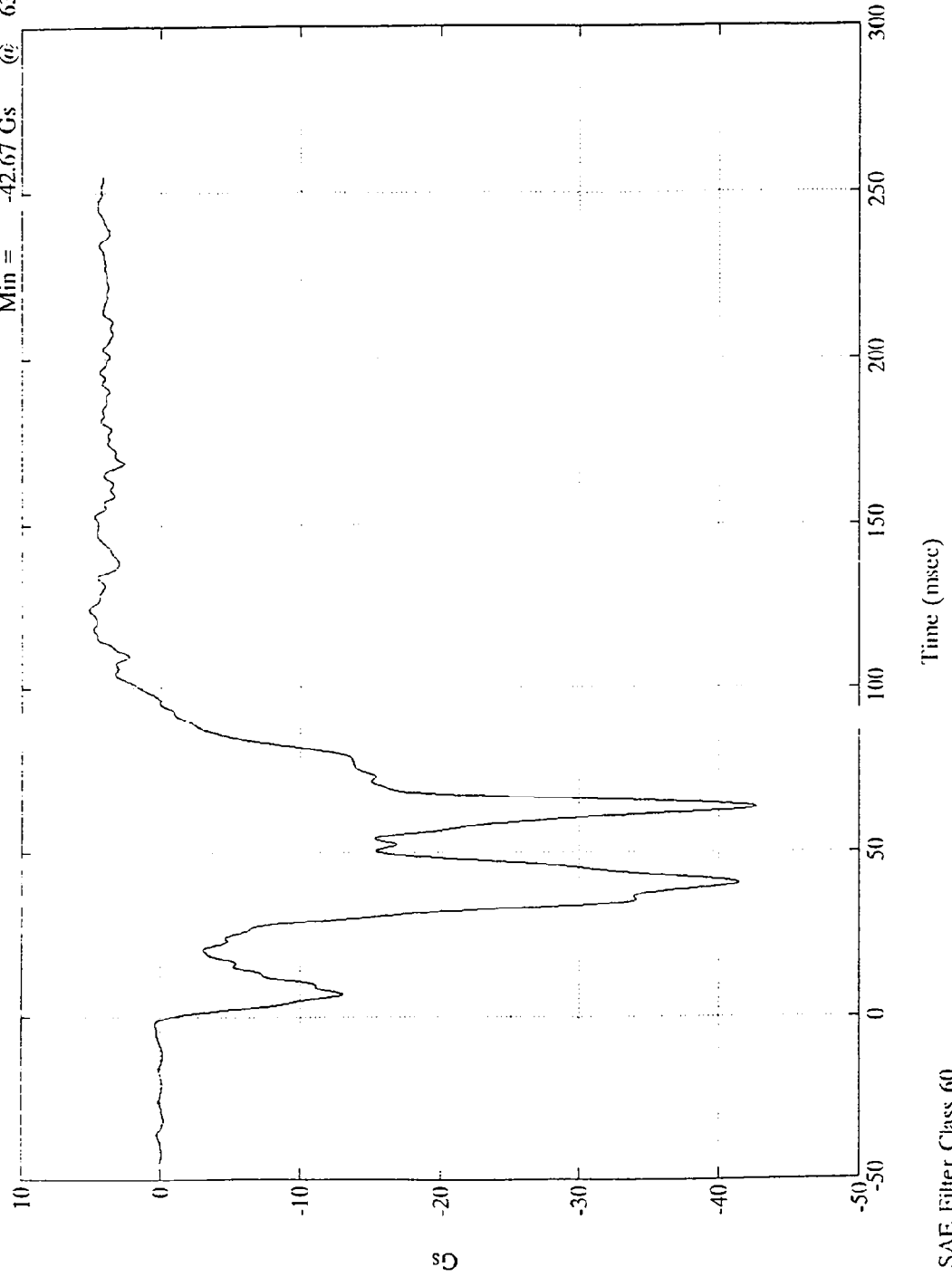

COMPLIANCE TEST DATA: FMVSS 213

Belt Restraint  
(FMVSS 213, S5.4.3)

Date of Test 7/12/94

Test No. 1430

Item Code 001-CAS-02-DTUP

Pass / Fail

S5.4.3.1 Snug Fit of Belts

Pass

Extra Webbing

Dummy	Each Shoulder Belt (in.)	Each Lap Belt Side (in.)	Crotch Belt (in.)
3 yr. old	12	(1)	(1)

S5.4.3.2 Direct Restraint Belts

Pass

- |  | <u>Yes / No</u> |
|--|-----------------|
| (1) Belt / dummy contact for restraint   | <u>No</u>       |
| (2) Rigid structure behind dummy         | <u>Yes</u>      |
| (3) Belt / child restraint slip possible | <u>No</u>       |

Note : If all "yes", restraint fails.

S5.4.3.3 Seating System Belts and / or Shields

Pass

- |                      |            |
|----------------------|------------|
| (1) Upper torso      | <u>Yes</u> |
| (2) Lower torso      | <u>Yes</u> |
| (3) Crotch restraint | <u>Yes</u> |

S5.4.3.4 Child Harness Belts N/A

N/A

- |                      |            |
|----------------------|------------|
| (1) Upper torso      | <u>N/A</u> |
| (2) Lower torso      | <u>N/A</u> |
| (3) Prevent standing | <u>N/A</u> |

Remarks:

(1) The shoulder and lap belts are a continuous system with both ends of the belt connected through a yoke to a single strap adjustable at the front of the seat. The crotch belt is non-adjustable.

Technician Donald W. Hess

Program Manager Robert F. Hathaway

COMPLIANCE TEST DATA: FMVSS 213

Buckle Release  
(FMVSS 213, S5.4.3.5, S6.2)

Date of Test 7/12/94

Test No. 1430

Item Code 001-CAS-02-DTUP

Test	Compliance Requirement	Test Result	Pass / Fail
Buckle Minimum Surface Area	Area $\geq$ 0.6 in. <sup>2</sup>	0.68 in. <sup>2</sup>	Pass
Pre - Impact Release Force	Force range : 9 to 14 lbs.	Right: 11.8lbs. Left: 11.8 lbs.(1)	Pass
Buckle Integrity	Not release during test	No Release	Pass
Post - Impact Release Force	Force range : $\leq$ 16 lbs.	Right: 13.9 lbs. Left: 13.9 lbs.(1)	Pass

Remarks:

The buckle is an integral part of the seat and, therefore, the buckle release test was performed on the entire seat assembly.

(1) The buckle is comprised of right and left buckle tangs that do not always release at the same force.

The shoulder belt clip opened during the dynamic test.

Technician Donald W. Hess

Program Manager Robert F. Hathaway

COMPLIANCE TEST DATA: FMVSS 213

Restraint System Integrity  
(FMVSS 213, S5.1.1)

Date of Test 7/12/94

Test No. 1430

Item Code 001-CAS-02-DTUP

Test	Compliance Requirement	Test Result	Pass / Fail
Structural Integrity	No complete separation	None	Pass
	No partial separation with exposed edge radius < 1/4 in.	None	Pass
	No partial separation with protrusions > 3/8 in.	None	Pass
Adjustment Position	No change	No Change	Pass
Back Surface / Seating Surface Angle	Not < 45 degrees	N/A	N/A

Remarks:

The back of the bench seat bowed toward the front of the vehicle approximately 5 inches during the dynamic test.

Technician Donald W. Hess

Program Manager Robert F. Hathaway

COMPLIANCE TEST DATA: FMVSS 213

Injury Criteria  
(FMVSS 213, S5.1.2)

Date of Test 7/12/94

Test No. 1430

Item Code 001-CAS-02-DTUP

Test	Compliance Requirement	Test Result	Pass / Fail
Head Injury Criterion	$\leq 1000$	285	Pass
Chest Injury Criterion	Cumulative duration over 60 g $\leq 3$ ms	Clipped Peak g = <u>27.1</u>  Duration exceeding 60 g = <u>0.0</u>	Pass

Remarks:

Technician Donald W. Hess

Program Manager Robert F. Hathaway

COMPLIANCE TEST DATA: FMVSS 213

Occupant Excursion  
(FMVSS 213, S5.1.3, S5.1.4, S5.2.1.1 (c))

Date of Test 7/12/94

Test No. 1430

Item Code 001-CAS-02-DTUP

Forward-Facing Restraints

Test	Compliance Requirement	Test Result	Pass / Fail
Torso Retention (FMVSS 213, S5.1.3.1)	Retain within system	Retained	Pass
Knee Target Excursion (FMVSS 213, S5.1.3.1)	≤ 36 in.	18.0 in.	Pass (1)
Head - Torso Angle (FMVSS 213, S5.2.1.1 (c))	Rearward change ≤ 45 degrees	< 45 deg.	Pass

Rear-Facing Restraints

Test	Compliance Requirement	Test Result	Pass / Fail
Torso Retention (FMVSS 213, S5.1.3.2)	Retain within system	N/A	N/A
Head Target Excursion (FMVSS 213, S5.1.3.2)	Not beyond restraint's top and forward edge	N/A	N/A
Back Support Angle (FMVSS 213, S5.1.4)	≤ 70 degrees	N/A	N/A
Head - Torso Angle (FMVSS 213 S5.2.1.1 (c))	Rearward change ≤ 45 degrees	N/A	N/A

Remarks:

(1) Excursion measured from actual pivot point of the bench seat that contains the built-in restraints.

Technician Donald W. Hess

Program Manager Robert F. Hathaway

APPENDIX A  
EQUIPMENT LIST AND CALIBRATION SCHEDULES

CERTIFICATION INSTRUMENTATION

<u>Instrument<sup>1</sup></u>	<u>Certification Test</u>	<u>Calibration Date</u>	<u>Due Date</u>
Slide Potentiometer Oceanside Mfg. Co. Model LCP20-50 2.00 inches travel, 10,000 ohms	Neck Pendulum	3/94	9/94
C.G. Head Potentiometer Oceanside Mfg. Co. Model SP221 Serial HNR2 10K, linearity = 1.5%	Neck Pendulum	3/94	9/94
C.G. Pend. Potentiometer Oceanside Mfg. Co. Serial HNR2 10K, linearity = 1.5%	Neck Pendulum	3/94	9/94
Bourns Potentiometer Model 3520S--1-502 5K +/-, linearity = 0.3%	Lumbar Spine Flexion	3/94	9/94
Transducer Inc. Load Cell S/N 20051, 50#	Lumbar Spine Flexion	6/94	12/94
Hewlett Packard 7035B X-Y Recorder +/- .02% Full Scale Accuracy	Lumbar Spine Flexion	6/94	6/95
Hewlett Packard 7045B X-Y Recorder +/- .02% Full Scale Accuracy	Lumbar Spine Flexion	6/94	6/95
Endevco Accelerometers S/N 160 +/- .075% Accuracy CEC 4-202	Neck Pendulum (ATD)	6/94	12/94

CERTIFICATION INSTRUMENTATION (cont'd)

<u>Instrument<sup>1</sup></u>	<u>Certification Test</u>	<u>Calibration Date</u>	<u>Due Date</u>
Endevco Triaxial Accelerometers 7267A			
S/N BH83	Head Impact (ATD)	5/94	11/94
S/N BB21	Chest Impact (ATD)	5/94	11/94
S/N 0025	Head Impact (ATD)	5/94	11/94
S/N BA71	Chest Impact (ATD)	5/94	11/94
Systron/Donner Counter +/- 1 count	Head Impact Chest Impact Neck Pendulum	7/93	7/94
White Box Temp. & Humidity Recorder S/N C7485-RS-009556		5/20/94	11/20/94
Chatillon 20 Pound Gauge +/- 8 oz. Accuracy		5/94	11/94
Chatillon 40 Pound Gauge +/- 1% Accuracy		5/94	11/94
Force Gauge, Chatillon Model DPTH 250		6/94	12/94
Dillon Force Gauge Model E Serial # 4346 50#		8/93	8/94

---

<sup>1</sup>Pendulum velocity measurements for the Head Impact, Chest Impact and Neck Pendulum tests are measured by a Calspan-designed light beam velocity trap which consists of two .040 inch field stops placed 5.020 inches apart. This system includes General Electric light sources #SL520D6 and Texas Instruments photo diodes.

APPENDIX B

PHOTOGRAPHS OF EQUIPMENT

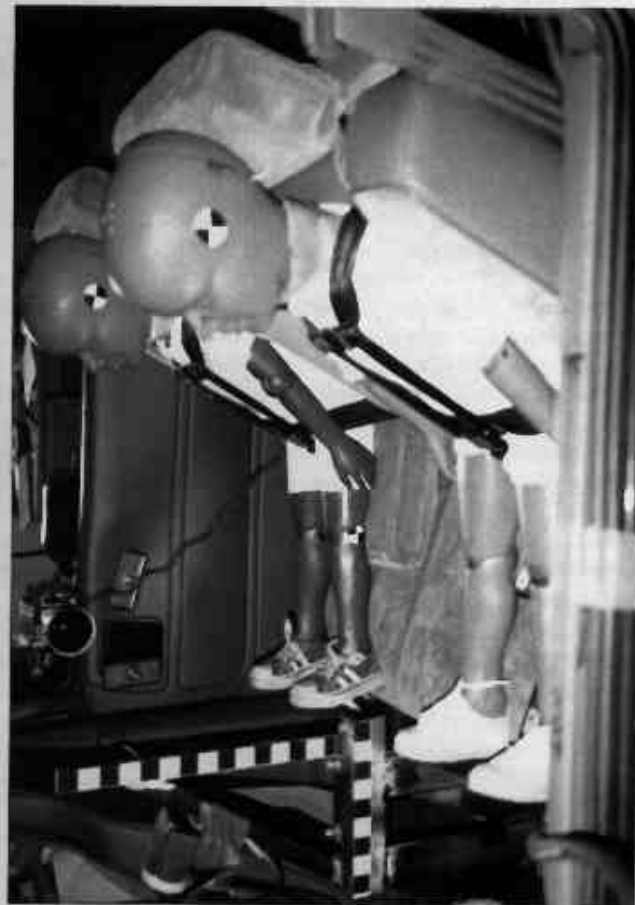

PRE-TEST  
FULL-SCALE TEST 1430

ITEM CODE: 001-CAS-01-DTUD  
001-CAS-02-DTUP

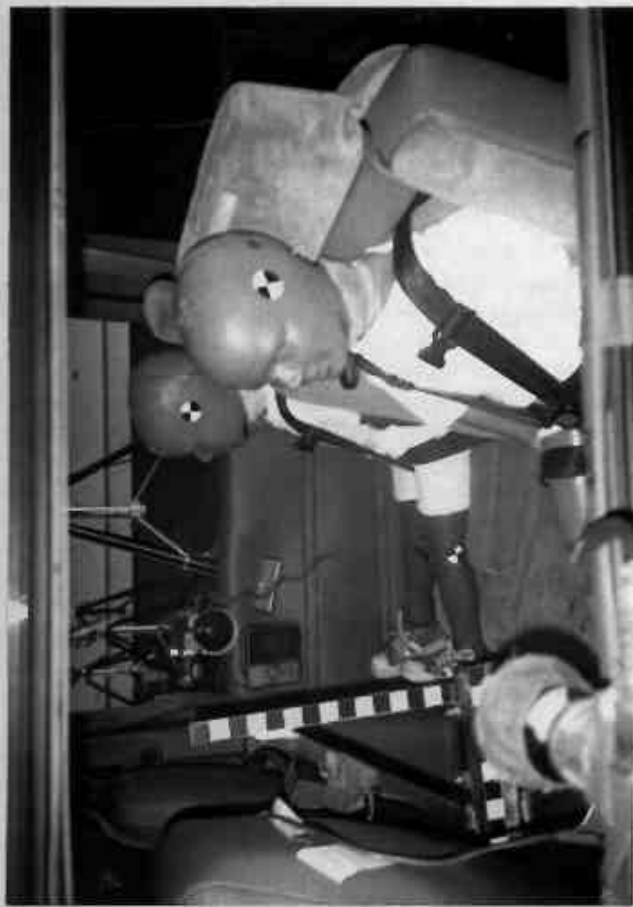

FULL-SCALE TEST 1430 POST-TEST

ITEM CODE : 001-CAS-01-DTUD  
001-CAS-02-DTUP

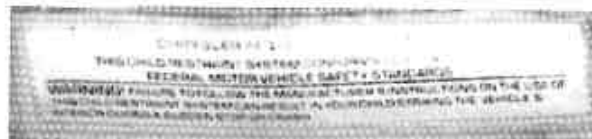
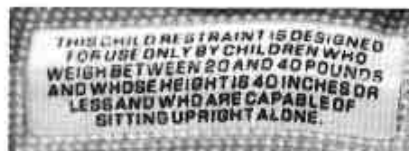

### LABELS

ITEM CODES : 001-CAS-01-DTUD

001-CAS-02-DTUP



Note:

The three-point belt system was not utilized during this test and is shown for demonstration purposes only.



CONFIGURATION

ITEM CODES : 001-CAS-01-DTUD

001-CAS-02-DTUP

Appendix F

**Performance Calibration Report for Part 572**

**Three-Year-Old Child Test Dummy No. 066**

Prepared for the United States Department of Transportation, National Highway Traffic Safety Administration, under Contract No. DTNH22-93-D-11089. This publication is distributed by the U.S. Department of Transportation, National Highway Traffic Safety Administration, in the interest of information exchange. The opinions, findings and conclusions expressed in this publication are those of the author(s) and not necessarily those of the Department of Transportation or the National Highway Traffic Safety Administration. The United States Government assumes no liability for its contents or use thereof. If trade or manufacturers' names or products are mentioned, it is only because they are considered essential to the object of the publication and should not be construed as an endorsement. The United States Government does not endorse products or manufacturers.

REPORT ACCEPTED BY:

\_\_\_\_\_  
Contract Technical Manager  
Office of Vehicle Safety Compliance

\_\_\_\_\_  
Acceptance Date

TECHNICAL REPORT STANDARD TITLE PAGE

1. Report No.		2. Government Accession No.		3. Recipient's Catalog No.	
4. Title and Subtitle Performance Calibration Report for Part 572 Three-Year-Old Child Test Dummy No. 066				5. Report Date November 1994	
				6. Performing Organization Report No.	
7. Author(s) Robert F. Hathaway				8. Performing Organization Report No.	
9. Performing Organization Name and Address Calspan Advanced Technology Center 4455 Genesee Street Buffalo, New York 14225				10. Work Unit No.	
				11. Contract or Grant No. DTNH22-93-D-11089	
12. Sponsoring Agency Name and Address U.S. Department of Transportation National Highway Traffic Safety Administration 400 Seventh, S.W. Washington, D.C. 20590				13. Type of Report and Period Covered Final Report	
				14. Sponsoring Agency Code	
15. Supplementary Notes Reviewed by : <u>Robert F. Hathaway</u> Program Manager Approved by : <u>David Roberts</u> Head, Safety Research Section Transportation Sciences Center					
16. Abstract This report contains results of performance calibration tests performed on a Part 572 three-year-old size child test dummy at the Calspan Advanced Technology Center dummy certification test facility. The following tests were performed:  <ol style="list-style-type: none"> <li>1. Head Impact Test</li> <li>2. Chest Impact Test</li> <li>3. Lumbar Flexion Test</li> <li>4. Head-Neck Pendulum Test</li> </ol> <p>The child test dummy manufactured by Alderson Research Laboratories, Serial No. 066 met the performance calibration requirements of CFR 49 Part 572, Subpart C.</p>					
17. Key Words Part 572, Subpart C - Three-Year-Old Child Dummy FMVSS 213 - Child Restraint Systems			18. Distribution Statement Copies of this report are available from: Technical Reference Division National Highway Traffic Safety Admin. Nassif Building, Room 5108 400 Seventh St., SW, Washington, DC 20590		
19. Security Classif. (of this report) Unclassified		20. Security Classif. (of this page) Unclassified		21. No. of Pages	22. Price

FORM DOT F1700.7 (8-69)

TABLE OF CONTENTS

<u>Section</u>		<u>Page No.</u>
I	INTRODUCTION AND SUMMARY	1
II	DUMMY CALIBRATION TEST DATA	2
III	INSTRUMENT CALIBRATION	6
APPENDIX A	CALIBRATION TEST PROCEDURES	A-1

LIST OF FIGURES

<u>Figure No.</u>		<u>Page No.</u>
A-1	SETUPS FOR HEAD AND CHEST IMPACT TESTS	A-2
A-2	SETUPS FOR LUMBAR SPINE FLEXION AND NECK PENDULUM TESTS	A-4
A-3	NECK COMPONENT TEST CIRCUIT	A-6

LIST OF TABLES

<u>Table No.</u>		<u>Page No.</u>
1	SUMMARY OF HEAD IMPACT TEST CALIBRATION DATA : PRE-TEST / POST-TEST	2
2	SUMMARY OF CHEST IMPACT TEST DATA : PRE-TEST / POST-TEST	3
3	SUMMARY OF LUMBAR FLEXION TEST DATA : PRE-TEST / POST-TEST	4
4	SUMMARY OF HEAD-NECK PENDULUM TEST DATA : PRE-TEST / POST-TEST	5
5	CERTIFICATION INSTRUMENTATION, PRE-TEST	6
6	CERTIFICATION INSTRUMENTATION, POST-TEST	8

## SECTION I

### INTRODUCTION AND SUMMARY

This report presents the results obtained during certification tests of a three-year-old size child test dummy that was manufactured in accordance with the requirements of 49 CFR Part 572, Subpart C. The objective of these tests was to demonstrate that the test dummy (Serial No. 066, manufactured by Alderson Research Laboratories) was suitable for use before and after the FMVSS 208/213 compliance full-scale test program. The tests were performed in the Dummy Certification Laboratory of Calspan's Advanced Technology Center using procedures<sup>(1)</sup> approved by the NHTSA Contract Technical Manager (CTM). These certification test procedures together with photographs of the apparatus for the four required tests (head impact, chest impact, lumbar spine flexion, and head-neck pendulum impact) are presented in Appendix A of this report. These certification tests were performed on this dummy prior to full-scale testing and after the full-scale test program was completed.

Data from these tests demonstrate that each of the dummy components (and their systems), that are required to be certifiable, were in compliance with the specifications of 49 CFR Part 572, Subpart C. All of the original data from each certification test are on file in the Calspan Dummy Certification Laboratory. Typical data traces are presented in Reference (1).

The data sheets presented in this test report were taken directly from TP-213-02 "Laboratory Procedure for Child Restraint System Testing." These data sheets use the word "calibration" when referring to certification procedures. Therefore, these words are used interchangeably in this report.

(1) "Operating Test Procedure for Test Program for FMVSS 213, Child Restraint Systems," Calspan Report No. 6974-V-1, Contract No. DTNH22-81-C-87088, Task Order No. 7.

SECTION II

Table 1

SUMMARY OF HEAD IMPACT TEST CALIBRATION DATA :

PRE-TEST / POST-TEST

CHILD DUMMY I. D. NO. 066

DATE OF CALIBRATION	6/14/94	7/26/94	
ROOM TEMPERATURE (66-78°F)	71	71	
ROOM RELATIVE HUMIDITY (10-70%)	55	54	
<b>TEST MEASUREMENTS :</b>	<b>PRE-TEST DATA</b>	<b>POST-TEST DATA</b>	<b>PART 572 REQMT.</b>
TEST PROBE IMPACT VELOCITY, fps	7.0	7.0	6.86 - 7.14
PEAK HEAD RESULTANT ACCEL., g	113.1	117.0	95 - 118
PEAK HEAD LATERAL ACCEL., g	2.8	1.3	≤7
PULSE Δ TIME @ 50 g, ms	1.75	1.75	1.3 - 2.0

REMARKS:

Technician (s) Ivan Minkewicz

Project Engineer (s) Robert Hathaway

Table 2

SUMMARY OF CHEST IMPACT TEST CALIBRATION DATA :

PRE-TEST / POST-TEST

CHILD DUMMY I. D. NO. 066

DATE OF CALIBRATION	6/14/94	7/26/94	
ROOM TEMPERATURE (66-78°F)	71	70	
ROOM RELATIVE HUMIDITY (10-70%)	51	54	
<b>TEST MEASUREMENTS :</b>	<b>PRE-TEST DATA</b>	<b>POST-TEST DATA</b>	<b>PART 572 REQMT.</b>
TEST PROBE IMPACT VELOCITY, fps	12.9	12.9	12.87-13.13
PEAK CHEST RESULTANT ACCEL., g	51.7	50.2	50-70
PEAK CHEST LATERAL ACCEL., g	2.0	0.8	≤5
PULSE Δ TIME @ 30 g, ms	4.0	4.0	2.5 - 4.0

REMARKS:

Technician (s) Ivan Minkewicz

Project Engineer (s) Robert Hathaway

Table 3

SUMMARY OF LUMBAR FLEXION TEST DATA :

PRE-TEST / POST-TEST

CHILD DUMMY I. D. NO. 066

DATE OF CALIBRATION	6/14/94	8/3/94	
ROOM TEMPERATURE (66-78°F)	72	70	
ROOM RELATIVE HUMIDITY (10-70%)	55	55	
<b>TEST MEASUREMENTS :</b>	<b>PRE-TEST DATA</b>	<b>POST-TEST DATA</b>	<b>PART 572 REQMT.</b>
FORCE @ 40° FLEXION ANGLE, lbs.	41.6	45.7	34 - 47
SPINAL COLUMN ANGLE @ 3 MIN. POST TEST, degrees	1.0	1.0	≤5

REMARKS:

Technician (s) Ivan Minkewicz

Project Engineer (s) Robert Hathaway

Table 4

**SUMMARY OF HEAD-NECK PENDULUM TEST DATA :**  
**PRE-TEST / POST-TEST**

CHILD DUMMY I. D. NO. 066

DATE OF CALIBRATION	6/17/94	8/5/94		
ROOM TEMPERATURE (66-78°F)	71	69		
ROOM RELATIVE HUMIDITY (10-70%)	51	50		
<b>TEST MEASUREMENTS :</b>	<b>PRE-TEST DATA</b>	<b>POST-TEST DATA</b>	<b>PART 572 REQMT.</b>	
PENDULUM IMPACT VELOCITY, fps	17.1	17.5	16 - 18	
PEND. MIN./MAX. DECEL. OVER ( $t_3 - t_2$ ), g	28.4	28.6	20 - 34	
PEAK HEAD RESULT. ACCEL., g	27.2	28.4	≤ 30	
PEND. DECEL. PULSE Δ TIME ( $t_2 - t_1$ ), ms	2.0	2.0	≤ 4	
PEND. DECEL. PULSE Δ TIME ( $t_3 - t_2$ ), ms	19.1	19.5	18 - 21	
PEND. DECEL. PULSE Δ TIME ( $t_4 - t_3$ ), ms	2.6	2.9	≤ 5	
HEAD ZERO POSITION TIME / PEND. REVERSAL TIME, ms	118.8/127.0	114.7/130.4	- / -	
HEAD MAX. ROTATION ANGLE, degrees	82.9	84.7	76 - 92	
TIME (ms) @ HEAD ROT. ANGLE :	0 deg.	0.0	0.0	-2 - +2
	30 deg.	22.6	23.6	17.3 - 24.7
	60 deg.	35.2	36.5	31.1 - 40.9
	Max.	64.2	61.0	55.0 - 69.0
	60 deg.	87.8	86.7	81.7 - 100.3
	30 deg.	104.3	100.8	97.4 - 118.6
	0 deg.	118.8	114.7	111.2 - 134.8
CHORDAL DISPLACEMENT (in) @ HEAD ROTATION ANGLE OF :	0 deg.	0.0	0.0	-0.8 - +0.8
	30 deg.	2.4	2.3	1.4 - 3.0
	60 deg.	4.4	4.4	3.5 - 5.1
	Max.	6.0	6.0	5.0 - 6.6
	60 deg.	4.5	4.4	3.5 - 5.1
	30 deg.	2.4	2.3	1.4 - 3.0
	0 deg.	0.1	0.1	-0.8 - +0.8

Technician (s) Ivan MinkewiczProject Engineer (s) Robert Hathaway

### SECTION III

#### INSTRUMENT CALIBRATION

Prior to pre-test certification testing, all test instrumentation was recalibrated in accordance with the requirements and procedures described in TP-213-02 and Section 3.0, Instrumentation Calibration, of the Operating Test Procedure. Table 5 lists all of the applicable test equipment for each of the certification tests and the calibration dates.

Table 5  
CERTIFICATION INSTRUMENTATION

<u>Instrument<sup>1</sup></u>	<u>Certification Test</u>	<u>Calibration Date</u>	<u>Due Date</u>
Slide Potentiometer Oceanside Mfg. Co. Model LCP20-50 2.00 inches travel, 10,000 ohms	Neck Pendulum	3/94	9/94
C.G. Head Potentiometer Oceanside Mfg. Co. Model SP221 Serial HNR2 10K, linearity = 1.5%	Neck Pendulum	3/94	9/94
C.G. Pend. Potentiometer Oceanside Mfg. Co. 10K, linearity = 1.5%	Neck Pendulum	3/94	9/94
Bourns Potentiometer Model 3520S--1-502 5K +/-, linearity = 0.3%	Lumbar Spine Flexion	6/94	12/94
Transducer Inc. Load Cell S/N 20051, 50#	Lumbar Spine Flexion	6/94	12/94
Hewlett Packard 7035B X-Y Recorder +/- .02% Full Scale Accuracy	Lumbar Spine Flexion	6/94	6/95
Hewlett Packard 7045B X-Y Recorder +/- .02% Full Scale Accuracy	Lumbar Spine Flexion	6/94	6/95
Endevco Accelerometers  S/N 160 +/- .075% Accuracy CEC 4-202	Neck Pendulum (ATD)	6/94	12/94

CERTIFICATION INSTRUMENTATION (cont'd)

<u>Instrument<sup>1</sup></u>	<u>Certification Test</u>	<u>Calibration Date</u>	<u>Due Date</u>
Endevco Triaxial Accelerometers, 7267A :			
S/N BH83	Head Impact (ATD)	5/94	11/94
S/N BB21	Chest Impact (ATD)	5/94	11/94
S/N 0025	Head Impact (ATD)	5/94	11/94
S/N BA71	Chest Impact (ATD)	5/94	11/94
Systron/Donner Counter +/- 1 count	Head Impact Chest Impact Neck Pendulum	7/93	7/94

---

<sup>1</sup>Pendulum velocity measurements for the Head Impact, Chest Impact and Neck Pendulum tests are measured by a Calspan-designed light beam velocity trap which consists of two .040 inch field stops placed 5.020 inches apart. This system includes General Electric light sources #SL520D6 and Texas Instruments photo diodes.

Prior to post-test certification testing, all test instrumentation was recalibrated in accordance with the requirements and procedures described in TP-213-02 and Section 3.0, Instrumentation Calibration, of the Operating Test Procedure. Table 6 lists all of the applicable test equipment for each of the certification tests and the calibration dates.

Table 6  
CERTIFICATION INSTRUMENTATION

<u>Instrument<sup>2</sup></u>	<u>Certification Test</u>	<u>Calibration Date</u>	<u>Due Date</u>
Slide Potentiometer Oceanside Mfg. Co. Model LCP20-50 2 inches travel, 10,000 ohms	Neck Pendulum	5/94	11/94
C.G. Head Potentiometer Oceanside Mfg. Co. Model SP221, S/N HNR2 10K linearity = 1.5%	Neck Pendulum	5/94	11/94
C.G. Pendulum Potentiometer Oceanside Mfg. Co. Model SP221, S/N HNR1 10K linearity = 1.5%	Neck Pendulum	5/94	11/94
Bourns Potentiometer Model 3520S--1-502 5K +/-, linearity = 0.3%	Lumbar Spine Flexion	6/94	12/94
Transducer Inc. Load Cell S/N 20051, 50#	Lumbar Spine Flexion	6/94	12/94
Hewlett Packard 7035B X-Y Recorder +/- .02% Full Scale Accuracy	Lumbar Spine Flexion	6/94	6/95
Hewlett Packard 7045B X-Y Recorder +/- .02% Full Scale Accuracy	Lumbar Spine Flexion	6/94	6/95
Endevco Accelerometers S/N 160 +/- .075% Accuracy CEC 4-202	Neck Pendulum (ATD)	6/94	12/94

CERTIFICATION INSTRUMENTATION (cont'd)

<u>Instrument<sup>2</sup></u>	<u>Certification Test</u>	<u>Calibration Date</u>	<u>Due Date</u>
Endevco Triaxial Accelerometers, 7267A :			
S/N BH83	Head Impact (ATD)	5/94	11/94
S/N BB21	Chest Impact (ATD)	5/94	11/94
S/N 0025	Head Impact (ATD)	5/94	11/94
S/N BA71	Chest Impact (ATD)	5/94	11/94
Systron/Donner Counter +/- 1 count	Head Impact Chest Impact Neck Pendulum	7/93	7/94

---

<sup>2</sup>Pendulum velocity measurements for the Head Impact, Chest Impact and Neck Pendulum tests are measured by a Calspan-designed light beam velocity trap which consists of two .040 inch field stops placed 5.020 inches apart. This system includes General Electric light sources #SL520D6 and Texas Instruments photo diodes.

## APPENDIX A

### CALIBRATION TEST PROCEDURES

#### 1. Head Impact Test

The Calspan linear impactor and the pre-impact position of the three-year-old size ATD are shown in Figure A-1. The impacting steel cylinder conforms dimensionally with the specifications of Part 572.21, Subpart C. Triaxial accelerometers are mounted in the head of the dummy and on the front of the cylinder. Impact velocity is measured by infrared photo reflective sensors located 6 cm apart at the rear of the impact cylinder.

The ATD head impact point is determined by aligning the center of the impact 2.9 inches below the top of the head. The flat front face of the probe is positioned adjacent to the ATD head impact point, and the light beam velocity trap is positioned with the probe interrupter at the second field stop. A dummy back support, 12.4 inches high, is employed in this test. The impactor is then pressurized to a pre-determined setting and fired. The impactor's travel is controlled by ball bearing guides encased in a metal cylinder.

Impactor velocity is immediately available on the EPUT meter and is also recorded electronically for a permanent record. All data is collected on analog tape and played back on brush recordings for quick turnaround data analysis. All head impact data traces are on file at the Calspan Dummy Certification Laboratory.

#### 2. Chest Impact Test

The pre-test chest impact setup is also shown in Figure A-1. The same impactor is used for both head and chest impact certification tests. The chest impact point is determined by seating the ATD against a rigid back surface with the chest skin jacket removed. A measurement is taken from the seating surface to the longitudinal centerline of the bolt attaching the top of the rib cage sternum to the thoracic spine box. The chest skin is then replaced and marked at a position 1.5 inches below the initial measurement.

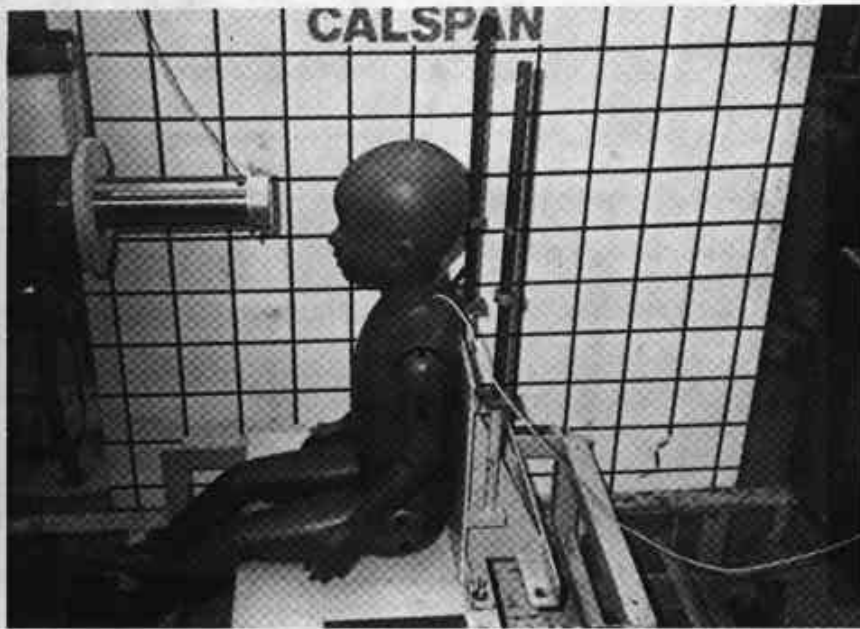

(a) HEAD IMPACT TEST

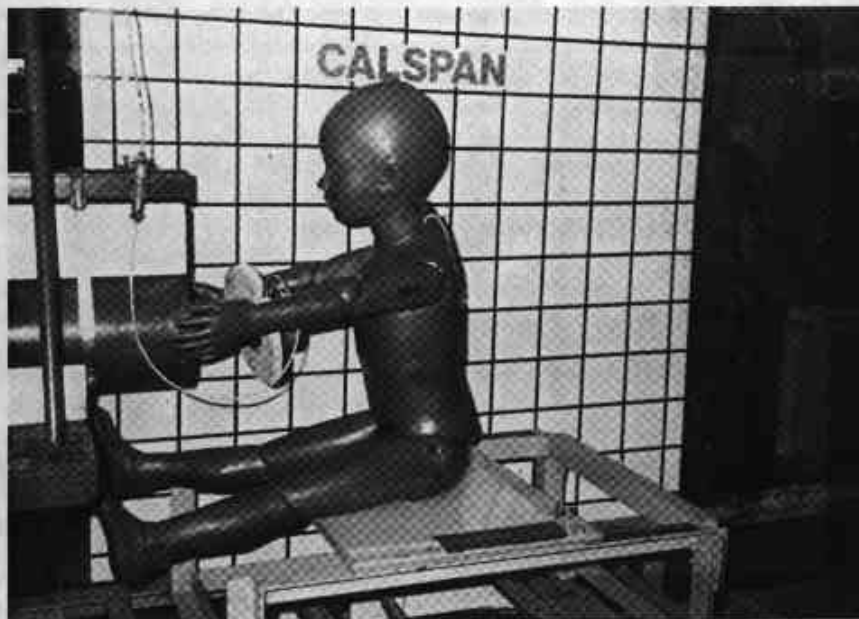

(b) CHEST IMPACT TEST

Note: Certifications and dynamic tests were performed with a Type II head, (photos depict a Type I head).

Figure A-1 SETUPS FOR HEAD AND CHEST IMPACT TESTS

The ATD is seated on the teflon seating surface and adjusted to allow the striking mass face surface to be approximately tangent to the most vertical surface of the chest. The accelerator is then pressurized to a pre-determined setting and fired.

Data is collected in the same manner as the head impact test. All data traces are on file at Calspan's Dummy Certification Laboratory.

### 3. Lumbar Spine Flexion Test

The lumbar spine flexion test apparatus is shown in Figure A-2. The pulley is positioned so that the applied force is perpendicular to the thoracic spine box when the lumbar spine reaches 40 degrees of flexion.

The ATD lower torso and upper legs are bolted to the seating surface after the neck has been replaced with a cylindrical aluminum adapter. A pull force is applied to the ATD neck adapter, through a load cell, at a continuously monitored deflection rate of between 0.5 and 1.5 degrees per second by cranking the cable through the pulley systems until 40 degrees of flexion is reached. This flexion angle is maintained for 10 seconds, the cable is cut to rapidly release the force, and the torso return angle is recorded after 3 minutes.

Rotation vs. time and flexion angle vs. force are plotted concurrently. The force required to flex the torso forward to a 40 deg. angle is recorded. Torso return angle is indicated on the flexion angle plot by a straight line through the ordinate. These plots are on file at Calspan's Dummy Certification Laboratory.

### 4. Neck Pendulum Test

The pendulum impact test apparatus used for neck certification tests is shown in Figure A-2. The inertial and dimensional properties of the rigid pendulum conform to the requirements of Part 572, Subpart C, and TP-213-02, Appendix No. 1.



(a) LUMBAR SPINE FLEXION TEST

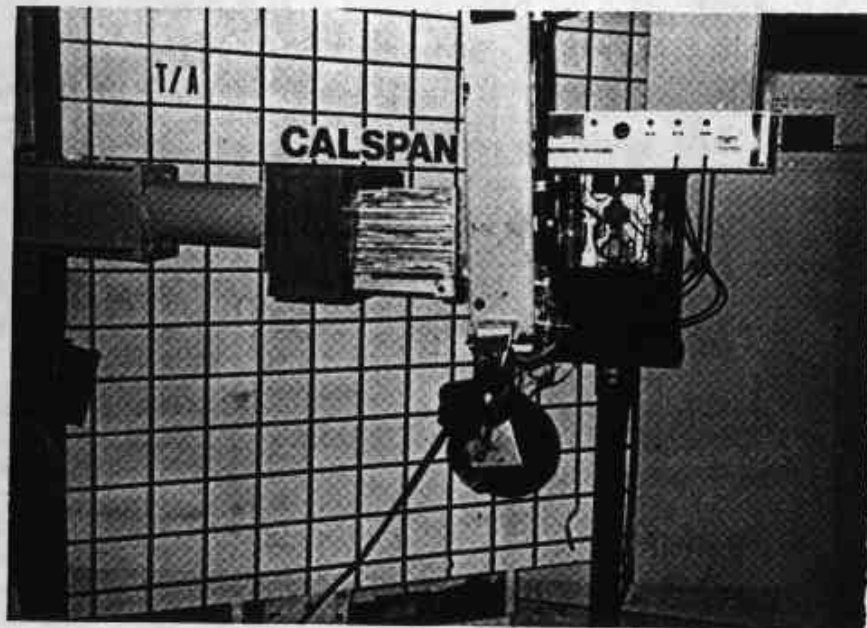

(b) NECK PENDULUM TEST

Note: Certifications and dynamic tests were performed with a Type II head, (photos depict a Type I head).

Figure A-2 SETUPS FOR LUMBAR SPINE FLEXION AND NECK PENDULUM TESTS

The ATD head and neck are mounted on the bottom of the pendulum as required (Calspan performs all neck certification tests with the appropriate ATD head attached), and the pendulum is raised and released from a pre-determined height required to achieve the desired impact velocity. The pendulum is decelerated by a block of aluminum honeycomb. Velocity is measured by means of the light beam velocity trap. The light beam interrupter is located a known distance below the center of the pendulum accelerometer in order to preclude any interference between the interrupter and the honeycomb. The velocity trap reading is corrected for this distance so the recorded velocity is that of the center of the accelerometer.

The three potentiometers, mounted on the right side of the head, are arranged to measure the linear and angular geometric components required for computation of the chordal displacements and head rotation angles. The voltage outputs of these three potentiometers are processed by the analog circuitry depicted in Figure A-3 which provides complete time histories of chordal displacement and head rotation angle. These time histories are plotted simultaneously on a brush recorder, along with a common timing trace, thus allowing for accurate correlation between chordal displacement, head rotation angle and time. These brush records are on file at Calspan's Dummy Certification Laboratory.

An electronic time zero switching device is attached to the pendulum/honeycomb contact point on the pendulum. Time zero is electronically recorded at the time of pendulum/honeycomb contact and pendulum reversal time is recorded at the end of the pendulum/honeycomb contact. These times are also plotted on a brush record concurrent with the chordal displacement and head rotation angle. This brush record allows for immediate determination of pendulum reversal time to head zero position time.

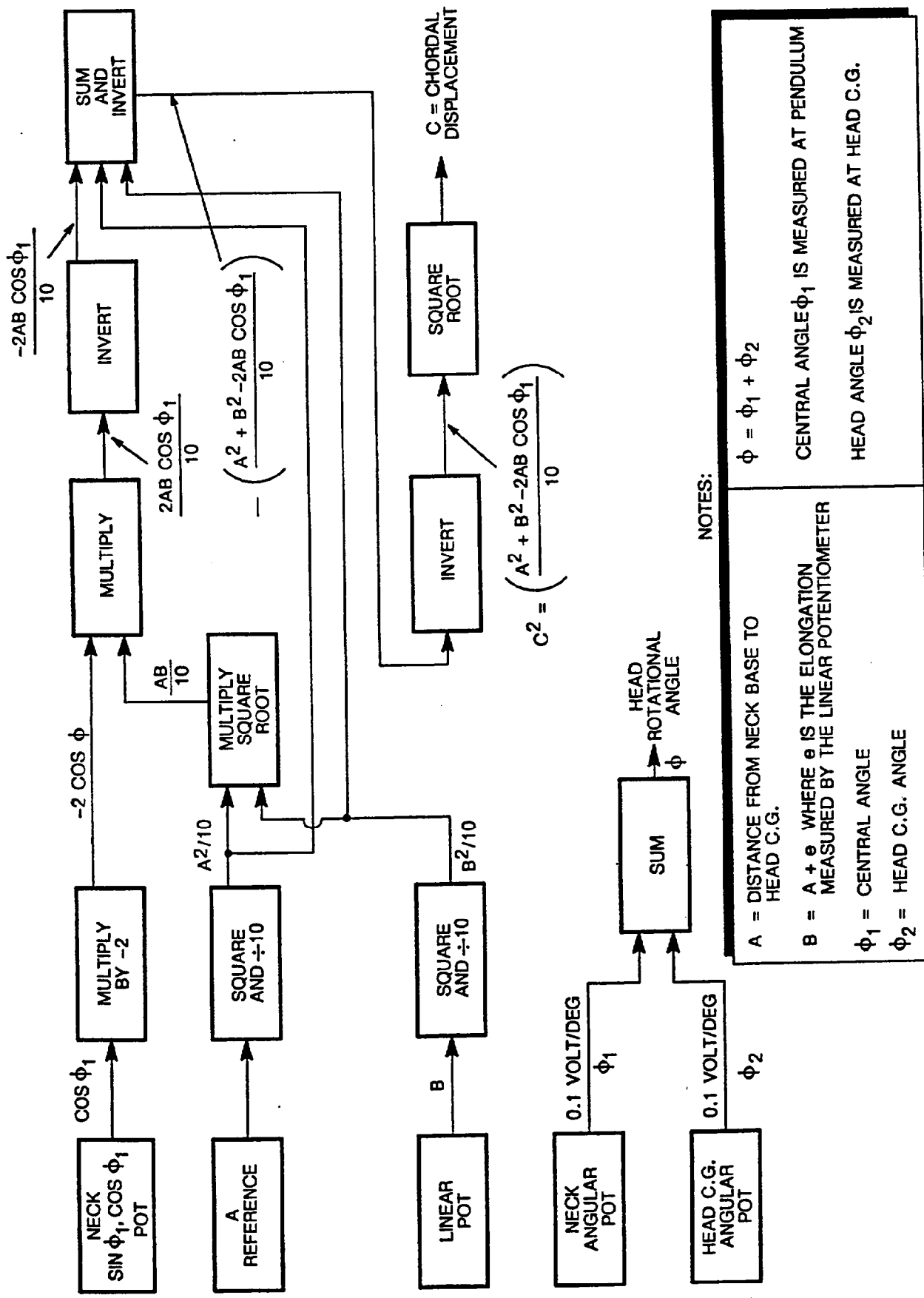

NOTES:

- A = DISTANCE FROM NECK BASE TO HEAD C.G.
- B = A + e WHERE e IS THE ELONGATION MEASURED BY THE LINEAR POTENTIOMETER
- $\phi_1$  = CENTRAL ANGLE
- $\phi_2$  = HEAD C.G. ANGLE
- $\phi = \phi_1 + \phi_2$
- CENTRAL ANGLE  $\phi_1$  IS MEASURED AT PENDULUM
- HEAD ANGLE  $\phi_2$  IS MEASURED AT HEAD C.G.

Figure A-3 NECK COMPONENT TEST CIRCUIT

Appendix G

**Performance Calibration Report for Part 572**

**Three-Year-Old Child Test Dummy No. 159**

Prepared for the United States Department of Transportation, National Highway Traffic Safety Administration, under Contract No. DTNH22-93-D-11089. This publication is distributed by the U.S. Department of Transportation, National Highway Traffic Safety Administration, in the interest of information exchange. The opinions, findings and conclusions expressed in this publication are those of the author(s) and not necessarily those of the Department of Transportation or the National Highway Traffic Safety Administration. The United States Government assumes no liability for its contents or use thereof. If trade or manufacturers' names or products are mentioned, it is only because they are considered essential to the object of the publication and should not be construed as an endorsement. The United States Government does not endorse products or manufacturers.

REPORT ACCEPTED BY:

\_\_\_\_\_  
Contract Technical Manager  
Office of Vehicle Safety Compliance

\_\_\_\_\_  
Acceptance Date

TECHNICAL REPORT STANDARD TITLE PAGE

1. Report No.	2. Government Accession No.	3. Recipient's Catalog No.	
4. Title and Subtitle Performance Calibration Report for Part 572 Three-Year-Old Child Test Dummy No. 159		5. Report Date November 1994	
		6. Performing Organization Report No.	
7. Author(s) Robert F. Hathaway		8. Performing Organization Report No.	
9. Performing Organization Name and Address Calspan Advanced Technology Center 4455 Genesee Street Buffalo, New York 14225		10. Work Unit No.	
		11. Contract or Grant No. DTNH22-93-D-11089	
12. Sponsoring Agency Name and Address U.S. Department of Transportation National Highway Traffic Safety Administration 400 Seventh, S.W. Washington, D.C. 20590		13. Type of Report and Period Covered Final Report	
		14. Sponsoring Agency Code	
15. Supplementary Notes Reviewed by : <i>Robert F. Hathaway</i> Approved by : <i>David Roberts</i> Program Manager Head, Safety Research Section Transportation Sciences Center			
16. Abstract This report contains results of performance calibration tests performed on a Part 572 three-year-old size child test dummy at the Calspan Advanced Technology Center dummy certification test facility. The following tests were performed:  <ol style="list-style-type: none"> <li>1. Head Impact Test</li> <li>2. Chest Impact Test</li> <li>3. Lumbar Flexion Test</li> <li>4. Head-Neck Pendulum Test</li> </ol> <p>The child test dummy manufactured by First Technology Safety Systems, Serial No. 159 met the performance calibration requirements of CFR 49 Part 572, Subpart C.</p>			
17. Key Words Part 572, Subpart C - Three-Year-Old Child Dummy FMVSS 213 - Child Restraint Systems		18. Distribution Statement Copies of this report are available from: Technical Reference Division National Highway Traffic Safety Admin. Nassif Building, Room 5108 400 Seventh St., SW, Washington, DC 20590	
19. Security Classif. (of this report) Unclassified	20. Security Classif. (of this page) Unclassified	21. No. of Pages	22. Price

FORM DOT F1700.7 (8-69)

TABLE OF CONTENTS

<u>Section</u>		<u>Page No.</u>
I	INTRODUCTION AND SUMMARY	1
II	DUMMY CALIBRATION TEST DATA	2
III	INSTRUMENT CALIBRATION	6
APPENDIX A	CALIBRATION TEST PROCEDURES	A-1

LIST OF FIGURES

<u>Figure No.</u>		<u>Page No.</u>
A-1	SETUPS FOR HEAD AND CHEST IMPACT TESTS	A-2
A-2	SETUPS FOR LUMBAR SPINE FLEXION AND NECK PENDULUM TESTS	A-4
A-3	NECK COMPONENT TEST CIRCUIT	A-6

LIST OF TABLES

<u>Table No.</u>		<u>Page No.</u>
1	SUMMARY OF HEAD IMPACT TEST CALIBRATION DATA : PRE-TEST / POST-TEST	2
2	SUMMARY OF CHEST IMPACT TEST DATA : PRE-TEST / POST-TEST	3
3	SUMMARY OF LUMBAR FLEXION TEST DATA : PRE-TEST / POST-TEST	4
4	SUMMARY OF HEAD-NECK PENDULUM TEST DATA : PRE-TEST / POST-TEST	5
5	CERTIFICATION INSTRUMENTATION, PRE-TEST	6
6	CERTIFICATION INSTRUMENTATION, POST-TEST	8

## SECTION I

### INTRODUCTION AND SUMMARY

This report presents the results obtained during certification tests of a three-year-old size child test dummy that was manufactured in accordance with the requirements of 49 CFR Part 572, Subpart C. The objective of these tests was to demonstrate that the test dummy (Serial No. 159, manufactured by First Technology Safety Systems) was suitable for use before and after the FMVSS 208/213 compliance full-scale test program. The tests were performed in the Dummy Certification Laboratory of Calspan's Advanced Technology Center using procedures<sup>(1)</sup> approved by the NHTSA Contract Technical Manager (CTM). These certification test procedures together with photographs of the apparatus for the four required tests (head impact, chest impact, lumbar spine flexion, and head-neck pendulum impact) are presented in Appendix A of this report. These certification tests were performed on this dummy prior to full-scale testing and after the full-scale test program was completed.

Data from these tests demonstrate that each of the dummy components (and their systems), that are required to be certifiable, were in compliance with the specifications of 49 CFR Part 572, Subpart C. All of the original data from each certification test are on file in the Calspan Dummy Certification Laboratory. Typical data traces are presented in Reference (1).

The data sheets presented in this test report were taken directly from TP-213-02 "Laboratory Procedure for Child Restraint System Testing." These data sheets use the word "calibration" when referring to certification procedures. Therefore, these words are used interchangeably in this report.

(1) "Operating Test Procedure for Test Program for FMVSS 213, Child Restraint Systems," Calspan Report No. 6974-V-1, Contract No. DTNH22-81-C-87088, Task Order No. 7.

**SECTION II**

Table 1

**SUMMARY OF HEAD IMPACT TEST CALIBRATION DATA :**

**PRE-TEST / POST-TEST**

CHILD DUMMY I. D. NO. 159

DATE OF CALIBRATION	6/13/94	7/26/94	
ROOM TEMPERATURE (66-78°F)	71	71	
ROOM RELATIVE HUMIDITY (10-70%)	54	53	
<b>TEST MEASUREMENTS :</b>	<b>PRE-TEST DATA</b>	<b>POST-TEST DATA</b>	<b>PART 572 REQMT.</b>
TEST PROBE IMPACT VELOCITY, fps	6.9	6.9	6.86 - 7.14
PEAK HEAD RESULTANT ACCEL., g	107.2	112.4	95 - 118
PEAK HEAD LATERAL ACCEL., g	0.9	3.9	≤7
PULSE Δ TIME @ 50 g, ms	1.75	1.75	1.3 - 2.0

REMARKS:

Technician (s) Ivan Minkewicz

Project Engineer (s) Robert Hathaway

Table 2

SUMMARY OF CHEST IMPACT TEST CALIBRATION DATA :

PRE-TEST / POST-TEST

CHILD DUMMY I. D. NO. 159

DATE OF CALIBRATION	6/15/94	7/26/94	
ROOM TEMPERATURE (66-78°F)	70	71	
ROOM RELATIVE HUMIDITY (10-70%)	53	53	
<b>TEST MEASUREMENTS :</b>	<b>PRE-TEST DATA</b>	<b>POST-TEST DATA</b>	<b>PART 572 REQMT.</b>
TEST PROBE IMPACT VELOCITY, fps	12.9	12.9	12.87-13.13
PEAK CHEST RESULTANT ACCEL., g	67.7	67.9	50-70
PEAK CHEST LATERAL ACCEL., g	1.9	2.1	≤5
PULSE Δ TIME @ 30 g, ms	4.0	3.8	2.5 - 4.0

REMARKS:

Technician (s) Ivan Minkewicz

Project Engineer (s) Robert Hathaway

Table 3

SUMMARY OF LUMBAR FLEXION TEST DATA :

PRE-TEST / POST-TEST

CHILD DUMMY I. D. NO. 159

DATE OF CALIBRATION	6/14/94	8/3/94	
ROOM TEMPERATURE (66-78°F)	72	70	
ROOM RELATIVE HUMIDITY (10-70%)	55	55	
<b>TEST MEASUREMENTS :</b>	<b>PRE-TEST DATA</b>	<b>POST-TEST DATA</b>	<b>PART 572 REQMT.</b>
FORCE @ 40° FLEXION ANGLE, lbs.	39.5	39.9	34 - 47
SPINAL COLUMN ANGLE @ 3 MIN. POST TEST, degrees	1.0	1.0	≤5

REMARKS:

Technician (s) Ivan Minkewicz

Project Engineer (s) Robert Hathaway

Table 4

**SUMMARY OF HEAD-NECK PENDULUM TEST DATA :**  
**PRE-TEST / POST-TEST**

CHILD DUMMY I. D. NO. 159

DATE OF CALIBRATION	6/17/94	8/5/94		
ROOM TEMPERATURE (66-78°F)	71	69		
ROOM RELATIVE HUMIDITY (10-70%)	50	49		
<b>TEST MEASUREMENTS :</b>	<b>PRE-TEST DATA</b>	<b>POST-TEST DATA</b>	<b>PART 572 REQMT.</b>	
PENDULUM IMPACT VELOCITY, fps	17.1	17.4	16 - 18	
PEND. MIN./MAX. DECEL. OVER ( $t_3 - t_2$ ), g	26.7	28.3	20 - 34	
PEAK HEAD RESULT. ACCEL., g	25.0	29.3	≤ 30	
PEND. DECEL. PULSE Δ TIME ( $t_2 - t_1$ ), ms	2.1	2.0	≤ 4	
PEND. DECEL. PULSE Δ TIME ( $t_3 - t_2$ ), ms	20.0	19.6	18 - 21	
PEND. DECEL. PULSE Δ TIME ( $t_4 - t_3$ ), ms	3.0	2.5	≤ 5	
HEAD ZERO POSITION TIME / PEND. REVERSAL TIME, ms	120.7/128.8	115.71/151.6	- / -	
HEAD MAX. ROTATION ANGLE, degrees	82.7	83.8	76 - 92	
TIME (ms) @ HEAD ROT. ANGLE :	0 deg.	0.0	0.0	-2 - +2
	30 deg.	23.3	23.7	17.3 - 24.7
	60 deg.	37.2	36.2	31.1 - 40.9
	Max.	66.8	62.8	55.0 - 69.0
	60 deg.	89.7	86.4	81.7 - 100.3
	30 deg.	105.4	101.2	97.4 - 118.6
	0 deg.	120.7	115.7	111.2 - 134.8
CHORDAL DISPLACEMENT (in) @ HEAD ROTATION ANGLE OF :	0 deg.	0.1	0.0	-0.8 - +0.8
	30 deg.	2.4	2.4	1.4 - 3.0
	60 deg.	4.5	4.3	3.5 - 5.1
	Max.	6.0	6.0	5.0 - 6.6
	60 deg.	4.5	4.5	3.5 - 5.1
	30 deg.	2.4	2.4	1.4 - 3.0
	0 deg.	0.1	0.1	-0.8 - +0.8

Technician (s) Ivan MinkewiczProject Engineer (s) Robert Hathaway

### SECTION III

#### INSTRUMENT CALIBRATION

Prior to pre-test certification testing, all test instrumentation was recalibrated in accordance with the requirements and procedures described in TP-213-02 and Section 3.0, Instrumentation Calibration, of the Operating Test Procedure. Table 5 lists all of the applicable test equipment for each of the certification tests and the calibration dates.

Table 5  
CERTIFICATION INSTRUMENTATION

<u>Instrument<sup>1</sup></u>	<u>Certification Test</u>	<u>Calibration Date</u>	<u>Due Date</u>
Slide Potentiometer Oceanside Mfg. Co. Model LCP20-50 2.00 inches travel, 10,000 ohms	Neck Pendulum	3/94	9/94
C.G. Head Potentiometer Oceanside Mfg. Co. Model SP221 Serial HNR2 10K, linearity = 1.5%	Neck Pendulum	3/94	9/94
C.G. Pend. Potentiometer Oceanside Mfg. Co. 10K, linearity = 1.5%	Neck Pendulum	3/94	9/94
Bourns Potentiometer Model 3520S--1-502 5K +/-, linearity = 0.3%	Lumbar Spine Flexion	6/94	12/94
Transducer Inc. Load Cell S/N 20051, 50#	Lumbar Spine Flexion	6/94	12/94
Hewlett Packard 7035B X-Y Recorder +/- .02% Full Scale Accuracy	Lumbar Spine Flexion	6/94	6/95
Hewlett Packard 7045B X-Y Recorder +/- .02% Full Scale Accuracy	Lumbar Spine Flexion	6/94	6/95
Endevco Accelerometers S/N 160 +/- .075% Accuracy CEC 4-202	Neck Pendulum (ATD)	6/94	12/94

CERTIFICATION INSTRUMENTATION (cont'd)

<u>Instrument<sup>1</sup></u>	<u>Certification Test</u>	<u>Calibration Date</u>	<u>Due Date</u>
Endevco Triaxial Accelerometers, 7267A :			
S/N BH83	Head Impact (ATD)	5/94	11/94
S/N BB21	Chest Impact (ATD)	5/94	11/94
S/N 0025	Head Impact (ATD)	5/94	11/94
S/N BA71	Chest Impact (ATD)	5/94	11/94
Systron/Donner Counter +/- 1 count	Head Impact Chest Impact Neck Pendulum	7/93	7/94

---

<sup>1</sup>Pendulum velocity measurements for the Head Impact, Chest Impact and Neck Pendulum tests are measured by a Calspan-designed light beam velocity trap which consists of two .040 inch field stops placed 5.020 inches apart. This system includes General Electric light sources #SL520D6 and Texas Instruments photo diodes.

Prior to post-test certification testing, all test instrumentation was recalibrated in accordance with the requirements and procedures described in TP-213-02 and Section 3.0, Instrumentation Calibration, of the Operating Test Procedure. Table 6 lists all of the applicable test equipment for each of the certification tests and the calibration dates.

Table 6  
CERTIFICATION INSTRUMENTATION

<u>Instrument<sup>2</sup></u>	<u>Certification Test</u>	<u>Calibration Date</u>	<u>Due Date</u>
Slide Potentiometer Oceanside Mfg. Co. Model LCP20-50 2 inches travel, 10,000 ohms	Neck Pendulum	5/94	11/94
C.G. Head Potentiometer Oceanside Mfg. Co. Model SP221, S/N HNR2 10K linearity = 1.5%	Neck Pendulum	5/94	11/94
C.G. Pendulum Potentiometer Oceanside Mfg. Co. Model SP221, S/N HNR1 10K linearity = 1.5%	Neck Pendulum	5/94	11/94
Bourns Potentiometer Model 3520S--1-502 5K +/-, linearity = 0.3%	Lumbar Spine Flexion	6/94	12/94
Transducer Inc. Load Cell S/N 20051, 50#	Lumbar Spine Flexion	6/94	12/94
Hewlett Packard 7035B X-Y Recorder +/- .02% Full Scale Accuracy	Lumbar Spine Flexion	6/94	6/95
Hewlett Packard 7045B X-Y Recorder +/- .02% Full Scale Accuracy	Lumbar Spine Flexion	6/94	6/95
Endevco Accelerometers S/N 160 +/- .075% Accuracy CEC 4-202	Neck Pendulum (ATD)	6/94	12/94

CERTIFICATION INSTRUMENTATION (cont'd)

<u>Instrument<sup>2</sup></u>	<u>Certification Test</u>	<u>Calibration Date</u>	<u>Due Date</u>
Endevco Triaxial Accelerometers, 7267A :			
S/N BH83	Head Impact (ATD)	5/94	11/94
S/N BB21	Chest Impact (ATD)	5/94	11/94
S/N 0025	Head Impact (ATD)	5/94	11/94
S/N BA71	Chest Impact (ATD)	5/94	11/94
Systron/Donner Counter +/- 1 count	Head Impact Chest Impact Neck Pendulum	7/93	7/94

---

<sup>2</sup>Pendulum velocity measurements for the Head Impact, Chest Impact and Neck Pendulum tests are measured by a Calspan-designed light beam velocity trap which consists of two .040 inch field stops placed 5.020 inches apart. This system includes General Electric light sources #SL520D6 and Texas Instruments photo diodes.

## APPENDIX A

### CALIBRATION TEST PROCEDURES

#### 1. Head Impact Test

The Calspan linear impactor and the pre-impact position of the three-year-old size ATD are shown in Figure A-1. The impacting steel cylinder conforms dimensionally with the specifications of Part 572.21, Subpart C. Triaxial accelerometers are mounted in the head of the dummy and on the front of the cylinder. Impact velocity is measured by infrared photo reflective sensors located 6 cm apart at the rear of the impact cylinder.

The ATD head impact point is determined by aligning the center of the impact 2.9 inches below the top of the head. The flat front face of the probe is positioned adjacent to the ATD head impact point, and the light beam velocity trap is positioned with the probe interrupter at the second field stop. A dummy back support, 12.4 inches high, is employed in this test. The impactor is then pressurized to a pre-determined setting and fired. The impactor's travel is controlled by ball bearing guides encased in a metal cylinder.

Impactor velocity is immediately available on the EPUT meter and is also recorded electronically for a permanent record. All data is collected on analog tape and played back on brush recordings for quick turnaround data analysis. All head impact data traces are on file at the Calspan Dummy Certification Laboratory.

#### 2. Chest Impact Test

The pre-test chest impact setup is also shown in Figure A-1. The same impactor is used for both head and chest impact certification tests. The chest impact point is determined by seating the ATD against a rigid back surface with the chest skin jacket removed. A measurement is taken from the seating surface to the longitudinal centerline of the bolt attaching the top of the rib cage sternum to the thoracic spine box. The chest skin is then replaced and marked at a position 1.5 inches below the initial measurement.



(a) HEAD IMPACT TEST

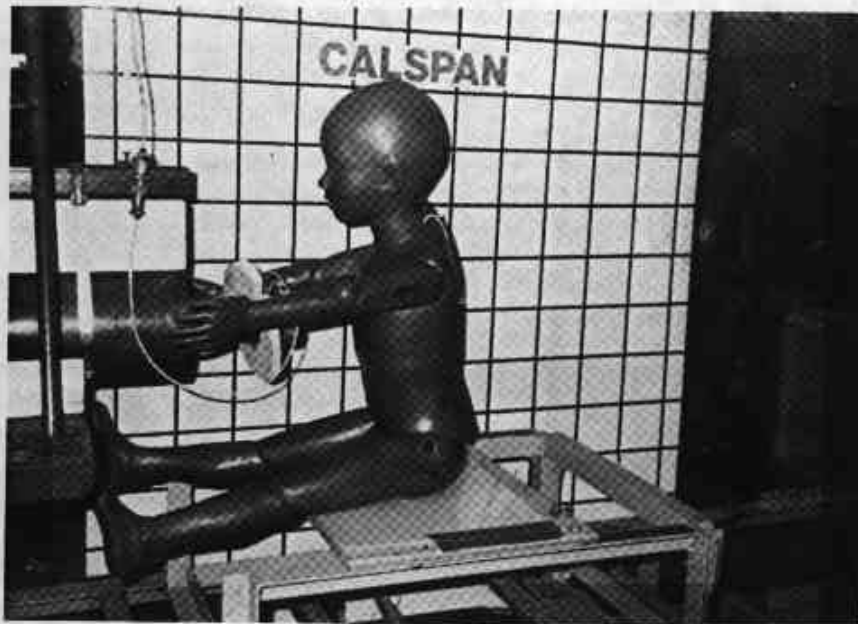

(b) CHEST IMPACT TEST

Note: Certifications and dynamic tests were performed with a Type II head, (photos depict a Type I head).

Figure A-1 SETUPS FOR HEAD AND CHEST IMPACT TESTS

The ATD is seated on the teflon seating surface and adjusted to allow the striking mass face surface to be approximately tangent to the most vertical surface of the chest. The accelerator is then pressurized to a pre-determined setting and fired.

Data is collected in the same manner as the head impact test. All data traces are on file at Calspan's Dummy Certification Laboratory.

### 3. Lumbar Spine Flexion Test

The lumbar spine flexion test apparatus is shown in Figure A-2. The pulley is positioned so that the applied force is perpendicular to the thoracic spine box when the lumbar spine reaches 40 degrees of flexion.

The ATD lower torso and upper legs are bolted to the seating surface after the neck has been replaced with a cylindrical aluminum adapter. A pull force is applied to the ATD neck adapter, through a load cell, at a continuously monitored deflection rate of between 0.5 and 1.5 degrees per second by cranking the cable through the pulley systems until 40 degrees of flexion is reached. This flexion angle is maintained for 10 seconds, the cable is cut to rapidly release the force, and the torso return angle is recorded after 3 minutes.

Rotation vs. time and flexion angle vs. force are plotted concurrently. The force required to flex the torso forward to a 40 deg. angle is recorded. Torso return angle is indicated on the flexion angle plot by a straight line through the ordinate. These plots are on file at Calspan's Dummy Certification Laboratory.

### 4. Neck Pendulum Test

The pendulum impact test apparatus used for neck certification tests is shown in Figure A-2. The inertial and dimensional properties of the rigid pendulum conform to the requirements of Part 572, Subpart C, and TP-213-02, Appendix No. 1.



(a) LUMBAR SPINE FLEXION TEST

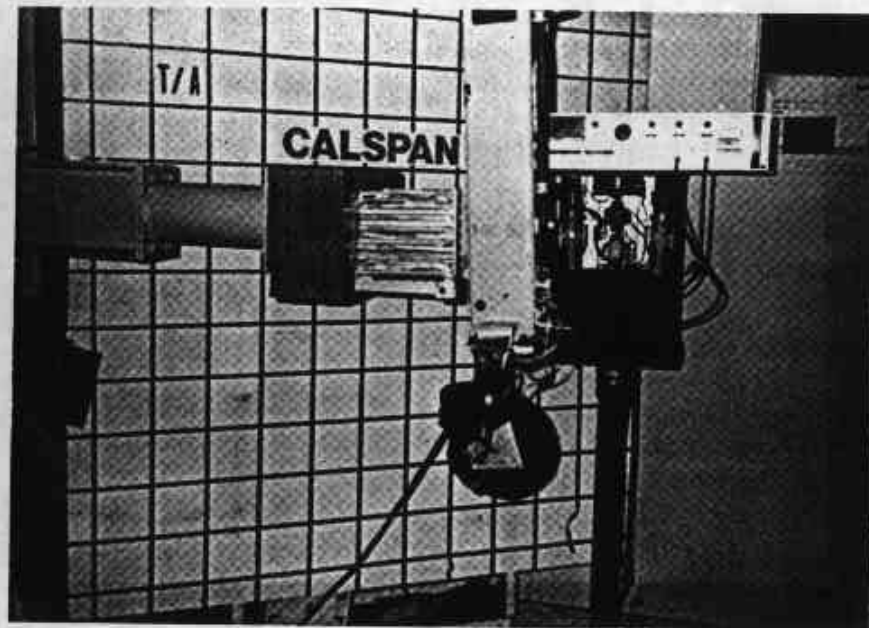

(b) NECK PENDULUM TEST

Note: Certifications and dynamic tests were performed with a Type II head, (photos depict a Type I head).

Figure A-2 SETUPS FOR LUMBAR SPINE FLEXION AND NECK PENDULUM TESTS

The ATD head and neck are mounted on the bottom of the pendulum as required (Calspan performs all neck certification tests with the appropriate ATD head attached), and the pendulum is raised and released from a pre-determined height required to achieve the desired impact velocity. The pendulum is decelerated by a block of aluminum honeycomb. Velocity is measured by means of the light beam velocity trap. The light beam interrupter is located a known distance below the center of the pendulum accelerometer in order to preclude any interference between the interrupter and the honeycomb. The velocity trap reading is corrected for this distance so the recorded velocity is that of the center of the accelerometer.

The three potentiometers, mounted on the right side of the head, are arranged to measure the linear and angular geometric components required for computation of the chordal displacements and head rotation angles. The voltage outputs of these three potentiometers are processed by the analog circuitry depicted in Figure A-3 which provides complete time histories of chordal displacement and head rotation angle. These time histories are plotted simultaneously on a brush recorder, along with a common timing trace, thus allowing for accurate correlation between chordal displacement, head rotation angle and time. These brush records are on file at Calspan's Dummy Certification Laboratory.

An electronic time zero switching device is attached to the pendulum/honeycomb contact point on the pendulum. Time zero is electronically recorded at the time of pendulum/honeycomb contact and pendulum reversal time is recorded at the end of the pendulum/honeycomb contact. These times are also plotted on a brush record concurrent with the chordal displacement and head rotation angle. This brush record allows for immediate determination of pendulum reversal time to head zero position time.

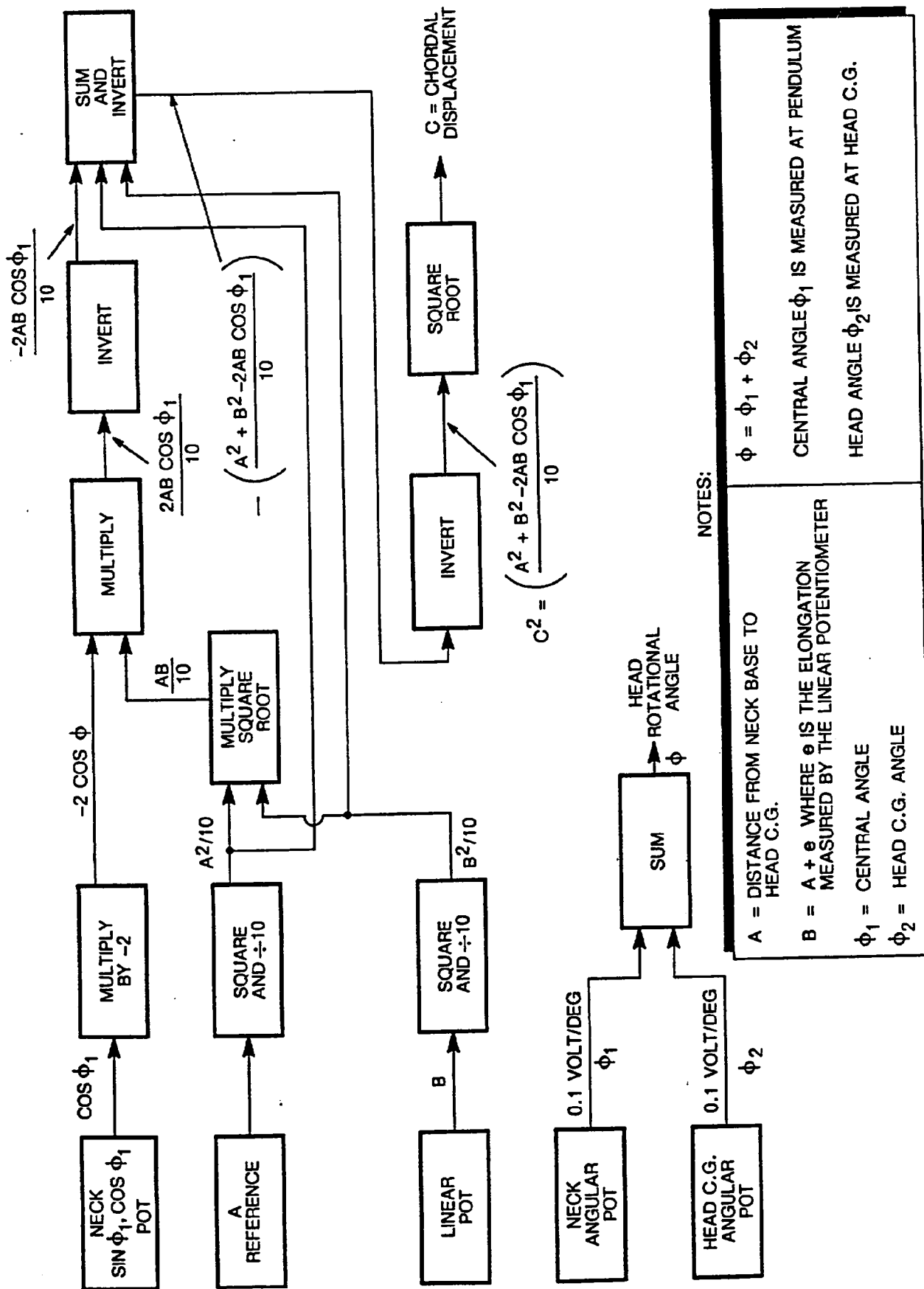

Figure A-3 NECK COMPONENT TEST CIRCUIT