

V 2050

Report Numbers: 208-TRC-94-015
212-TRC-94-015
301-TRC-94-015

Vehicle Safety Compliance Testing
for Occupant Crash Protection,
Windshield Mounting, Windshield Zone Intrusion,
and Fuel System Integrity

Kentron, Inc.
1994 Kentron SS Sport Top Van
NHTSA Number: CR1301
TRC Test Number: 940322

Transportation Research Center Inc.
10820 State Route 347
East Liberty, Ohio 43319



April 11, 1994

Final Report

Prepared For:

U.S. Department of Transportation
National Highway Traffic Safety Administration
Office of Vehicle Safety Compliance (NEF-31)
400 Seventh Street, S.W., Room No. 6115
Washington, DC 20590

0 7425 V

This Final Test Report was prepared for the U.S. Department of Transportation, National Highway Traffic Safety Administration, under Contract No. DTNH22-93-D-01089.

This publication is distributed by the U. S. Department of Transportation, National Highway Traffic Safety Administration, in the interest of information exchange. The opinions, findings, and conclusions expressed in this publication are those of the author(s) and not necessarily those of the Department of Transportation or the National Highway Traffic Safety Administration. The United States Government assumes no liability for its contents or use thereof. If trade or manufacturers' names or products are mentioned, it is only because they are considered essential to the object of the publication and should not be construed as an endorsement. The United States Government does not endorse products or manufacturers.

Report Prepared By:

Craig A. Markusic Date 4/28/94
Craig A. Markusic, Senior Project Engineer
Transportation Research Center Inc.

Report Approved By:

Jeffery W. Sankey Date 4/29/94
Jeffery W. Sankey, Engineering Supervisor
Transportation Research Center Inc.

Final Report Accepted By:

Charles R. Case Date 1/20/95
Contracting Officer's Technical Representative (COTR),
NHTSA, Office of Vehicle Safety Compliance

1. Report No. 208-TRC-94-015 212-TRC-94-015 301-TRC-94-015		2. Government Accession No.		3. Recipient's Catalog No.	
4. Title and Subtitle FINAL REPORT OF FMVSS NOS. 208, 212, 219 (PARTIAL), AND 301 COMPLIANCE TESTING OF A 1994 KENTRON VAN, NHTSA NO. CR1301				5. Report Date APRIL 11, 1994	
				6. Performing Organization Code TRC	
7. Author(s) C. A. Markusic, Senior Project Engineer, TRC				8. Performing Organization Report No. 208-TRC-94-015 212-TRC-94-015 301-TRC-94-015	
9. Performing Organization Name and Address Transportation Research Center Inc. 10820 State Route 347 East Liberty, OH 43319				10. Work Unit No. (TRAIS)	
				11. Contract or Grant No. DTNH22-93-D-01089	
12. Sponsoring Agency Name and Address U. S. Department of Transportation National Highway Traffic Safety Administration Office of Vehicle Safety Compliance (NEF-31) 400 Seventh St., S.W., Washington, DC 20590				13. Type of Report and Period Covered FINAL REPORT MARCH - APRIL 1994	
				14. Sponsoring agency Code NEF-30	
15. Supplemental Notes					
16. Abstract <p>A 30 mph flat frontal barrier impact test was conducted on a 1994 Kentron SS Sport Top van, NHTSA No. CR1301, at Transportation Research Center Inc. on March 22, 1994. This test was conducted to determine compliance with Federal Motor Vehicle Safety Standards: FMVSS 208, "Occupant Crash Protection"; 212, "Windshield Mounting"; 219 (partial), "Windshield Zone Intrusion"; and 301 "Fuel System Integrity." The barrier impact velocity was 29.6 mph. The vehicle's maximum static crush was 17.3 inches. The ambient temperature was 69° F.</p> <p>The driver's head injury criteria (HIC) was 515. The driver's chest maximum resultant acceleration with three (3) milliseconds minimum duration was 53.8 g. The driver's chest maximum deflection was 1.1 inches. The driver's left and right femur maximum axial forces were 1044 pounds and 1707 pounds, respectively.</p> <p>The passenger's HIC was 736. The passenger's chest maximum resultant acceleration with three (3) milliseconds minimum duration was 43.8 g. The passenger's chest maximum deflection was 1.3 inches. The passenger's left and right femur maximum axial forces were 580 pounds and 119 pounds, respectively.</p> <p>The vehicle appears to comply with the applicable requirements of FMVSS 208, 212, 219 (partial), and 301.</p>					
17. Key Words <p>Frontal Impact 30 mph Vehicle Safety Compliance Testing: FMVSS 208, "Occupant Crash Protection" FMVSS 212, "Windshield Mounting" FMVSS 219 (partial), "Windshield Zone Intrusion" FMVSS 301, "Fuel System Integrity"</p>			18. Distribution Statement <p>Available from: NHTSA Technical Reference Division Room 5108, (NAD-52) 400 Seventh Street, S.W. Washington, DC 20590 Attn: Mr. Robert Hornickle</p>		
19. Security Classif. (of this report) UNCLASSIFIED		20. Security Classif. (of this page) UNCLASSIFIED		21. No. of Pages 172	22. Price

METRIC CONVERSION FACTORS

Approximate Conversions to Metric Measures			Approximate Conversions from Metric Measures					
Symbol	When You Know	Multiply by	To Find	Symbol	When You Know	Multiply by	To Find	Symbol
LENGTH								
in	inches	*2.5	centimeters	cm	millimeters	0.04	inches	in
ft	feet	30	centimeters	cm	centimeters	0.4	inches	in
yd	yards	0.9	meters	m	meters	3.3	feet	ft
mi	miles	1.6	kilometers	km	kilometers	0.6	yards	yd
AREA								
in ²	square inches	6.5	square centimeters	cm ²	square centimeters	0.16	square inches	in ²
ft ²	square feet	0.09	square meters	m ²	square meters	1.2	square yards	yd ²
yd ²	square yards	0.8	square meters	m ²	square kilometers	0.4	square miles	mi ²
mi ²	square miles	2.6	square kilometers	km ²	hectares (10,000 m ²)	2.5	acres	ac
MASS (weight)								
oz	ounces	28	grams	g	grams	0.035	ounces	oz
lb	pounds	0.45	kilograms	kg	kilograms	2.2	pounds	lb
	short tons (2000 lb)	0.9	tonnes	t	tonnes (1000 kg)	1.1	short tons	st
VOLUME								
tsp	teaspoons	5	milliliters	ml	milliliters	0.03	fluid ounces	fl oz
Tbsp	tablespoons	15	milliliters	ml	liters	2.1	pints	pt
fl oz	fluid ounces	30	milliliters	ml	liters	1.06	quarts	qt
c	cups	0.24	liters	l	liters	0.26	gallons	gal
pt	pints	0.47	liters	l	cubic meters	35	cubic feet	ft ³
qt	quarts	0.95	liters	l	cubic meters	1.3	cubic yards	yd ³
gal	gallons	3.8	cubic meters	m ³				
ft ³	cubic feet	0.03	cubic meters	m ³				
yd ³	cubic yards	0.76	cubic meters	m ³				
TEMPERATURE (exact)								
°F	Fahrenheit temperature	5/9 (after subtracting 32)	Celsius temperature	°C	°C	9/5 (then add 32)	Fahrenheit temperature	°F

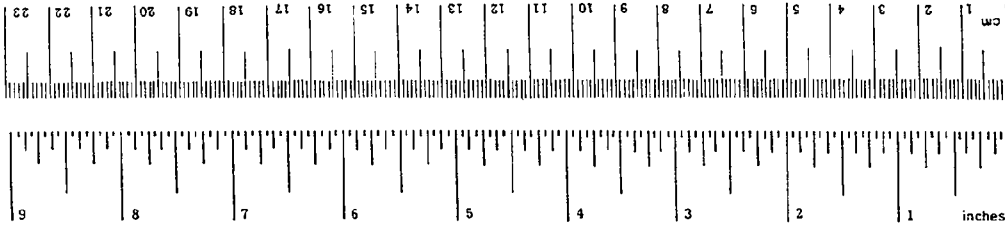

* 1 m = 2.54 (exactly). For other exact conversions and more detailed tables, see NBS Misc. Publ. 286, Units of Weights and Measures, Price \$2.25, SD Catalog No. C13.10286.

Table of Contents

<u>Section</u>	<u>Description</u>	<u>Page</u>
1.0	Purpose and Test Procedure	1
2.0	Frontal Barrier Impact Test Summary	5
3.0	FMVSS 208, 212, 219 (Partial), and 301 Data	22
4.0	Vehicle, Occupant, and Camera Measurements	39
Appendix A	Photographs	A-1
Appendix B	Data Plots	B-1
Appendix C	Manufacturer's Vehicle Information	C-1

List of Tables

<u>Number</u>	<u>Description</u>	<u>Page</u>
1	Crash Test Summary	8
2	Test Vehicle Information	10
3	Post-Impact Data	13
4	Post-test Airbag Data	16
5	Vehicle Accelerometer Locations and Data Summary	19
6	Dummy Injury Criteria	23
7	FMVSS 208 Seat Belt Comfort and Convenience Test Summary Front Outboard Designated Seating Positions	25
8	FMVSS 208 Equipment Data	28
9	Fuel System Data	33
10	FMVSS 301 Post-Impact Test Data	34
11	Impacted Vehicle Measurements	41
12	Dummy Measurement Data for Front Seat Occupants	44
13	Motion Picture Camera Locations	48

List of Figures

<u>Number</u>	<u>Description</u>	<u>Page</u>
1	Impact Velocity Measurement System	14
2	Accident Investigation Division Data for 30 mph Frontal Barrier Impact	15
3	Vehicle Accelerometer Placement	18
4	FMVSS 212 Test Data	31
5	FMVSS 219 Test Data	32
6	FMVSS 301 Static Rollover Test Data	35
7	Pre-test and Post-test Measurement Points	40
8	Vehicle Target Locations	42
9	Dummy Measurement Locations for Front Seat Occupants	43
10	Seat Belt Positioning Data	45
11	Camera Positions	46

List of Photographs

<u>Figure</u>	<u>Photograph Title</u>	<u>Page</u>
A-1.	Pre-test Front View	A-2
A-2.	Post-test Front View	A-3
A-3.	Pre-test Left Side View	A-4
A-4.	Post-test Left Side View	A-5
A-5.	Pre-test Rear View	A-6
A-6.	Post-test Rear View	A-7
A-7.	Pre-test Right Side View	A-8
A-8.	Post-test Right Side View	A-9
A-9.	Pre-test Right Front Three-Quarter View	A-10
A-10.	Post-test Right Front Three-Quarter View	A-11
A-11.	Pre-test Left Rear Three-Quarter View	A-12
A-12.	Post-test Left Rear Three-Quarter View	A-13
A-13.	Pre-test Windshield View	A-14
A-14.	Post-test Windshield View	A-15
A-15.	Pre-test Engine Compartment View	A-16
A-16.	Post-test Engine Compartment View	A-17
A-17.	Pre-test Fuel Filler Cap View	A-18
A-18.	Post-test Fuel Filler Cap View	A-19
A-19.	Pre-test Fuel Filler Neck View	A-20
A-20.	Post-test Fuel Filler Neck View	A-21
A-21.	Pre-test Fuel Filler Neck and Fuel Tank View	A-22
A-22.	Post-test Fuel Filler Neck and Fuel Tank View	A-23
A-23.	Pre-test Front Underbody View	A-24
A-24.	Post-test Front Underbody View	A-25
A-25.	Pre-test Rear Underbody View	A-26
A-26.	Post-test Rear Underbody View	A-27
A-27.	Pre-test Driver's Knee Bolster View	A-28
A-28.	Pre-test Passenger's Knee Bolster View	A-29
A-29.	Pre-test Steering Column at Firewall View	A-30
A-30.	Post-test Steering Column at Firewall View	A-31
A-31.	Pre-test Steering Column at Firewall View - Interior	A-32

List of Photographs, Cont'd.

<u>Figure</u>	<u>Photograph Title</u>	<u>Page</u>
A-32.	Post-test Steering Column at Firewall View - Interior	A-33
A-33.	Pre-test Driver Dummy Position - View 1	A-34
A-34.	Post-test Driver Dummy Position - View 1	A-35
A-35.	Pre-test Driver Dummy Position - View 2	A-36
A-36.	Post-test Driver Dummy Position - View 2	A-37
A-37.	Pre-test Passenger Dummy Position - View 1	A-38
A-38.	Post-test Passenger Dummy Position - View 1	A-39
A-39.	Pre-test Passenger Dummy Position - View 2	A-40
A-40.	Post-test Passenger Dummy Position - View 2	A-41
A-41.	Pre-test Driver Dummy & Vehicle Interior - View 1	A-42
A-42.	Post-test Driver Dummy & Vehicle Interior - View 1	A-43
A-43.	Pre-test Driver Dummy & Vehicle Interior - View 2	A-44
A-44.	Post-test Driver Dummy & Vehicle Interior - View 2	A-45
A-45.	Pre-test Passenger Dummy & Vehicle Interior - View 1	A-46
A-46.	Post-test Passenger Dummy & Vehicle Interior - View 1	A-47
A-47.	Pre-test Passenger Dummy & Vehicle Interior - View 2	A-48
A-48.	Post-test Passenger Dummy & Vehicle Interior - View 2	A-49
A-49.	Post-test Driver Dummy Head Contact - View 1	A-50
A-50.	Post-test Driver Dummy Head Contact - View 2	A-51
A-51.	Post-test Driver Dummy Head Contact - View 3	A-52
A-52.	Post-test Driver Dummy Head Contact - View 4	A-53
A-53.	Post-test Driver Dummy Knee Contact - View 1	A-54
A-54.	Post-test Driver Dummy Knee Contact - View 2	A-55
A-55.	Post-test Passenger Dummy Head Contact - View 1	A-56
A-56.	Post-test Passenger Dummy Head Contact - View 2	A-57
A-57.	Post-test Passenger Dummy Head Contact - View 3	A-58
A-58.	Post-test Passenger Dummy Knee Contact - View 1	A-59
A-59.	Post-test Passenger Dummy Knee Contact - View 2	A-60
A-60.	Pre-test Vehicle Certification and Recommended Tire Pressure Label View	A-61
A-61.	Post-test Vehicle on Static Rollover Machine View	A-62
A-62.	Pre-test Ballast Location View	A-63

Section 1.0

Purpose and Test Procedure

Purpose

This 30 mph flat frontal barrier impact test is part of the Federal Motor Vehicle Safety Standards (FMVSS) 208, 212, 219 (partial), and 301 compliance test program conducted for the National Highway Traffic Safety Administration (NHTSA) by the Transportation Research Center Inc. (TRC) under Contract No. DTNH22-93-D-01089. The purpose of this test was to determine if the subject vehicle, a 1994 Kentron SS Sport Top van, NHTSA No. CR01301, meets the performance requirements of FMVSS 208, "Occupant Crash Protection"; FMVSS 212, "Windshield Mounting"; FMVSS 219 (partial), "Windshield Zone Intrusion"; and FMVSS 301, "Fuel System Integrity," in the flat frontal barrier impact mode.

Test Procedure

This test was conducted in accordance with NHTSA's Office of Vehicle Safety Compliance (OVSC) Laboratory Test Procedure No. TP-208-09. Data was obtained relative to FMVSS 208, "Occupant Crash Protection"; FMVSS 212, "Windshield Mounting"; FMVSS 219 (partial), "Windshield Zone Intrusion"; and FMVSS 301, "Fuel System Integrity," performance.

The test vehicle was instrumented with seven (7) accelerometers to measure longitudinal axis accelerations and one (1) accelerometer to measure vertical axis acceleration. The vehicle's specified impact velocity range was 28.9 to 29.9 mph. The vehicle impacted a flat frontal barrier.

The test vehicle contained two (2) Part 572 E 50th percentile adult male anthropomorphic test devices (dummies). The dummies were positioned in the front outboard designated seating positions according to the dummy placement procedure specified in Appendix C of the Laboratory Test Procedure.

Both dummies were instrumented with head and chest accelerometers to measure longitudinal, lateral, and vertical accelerations, and with left and right femur load cells to measure axial forces. Each Part 572 E dummy's instrumentation also included a chest potentiometer to measure longitudinal deflection and a six-axis neck load cell to measure longitudinal, lateral and vertical forces and moments.

The thirty-eight (38) data channels were multiplexed and recorded on a 14-track tape drive. The data was digitally sampled at 12,500 samples per second and processed per Sections 11.13 through 11.15 of the Laboratory Test Procedure.

The crash event was recorded by one (1) real-time panning motion picture camera and fourteen (14) high-speed motion picture cameras. The pre-test and post-test conditions were recorded by one (1) real-time motion picture camera.

The vehicle and occupant data are summarized in Section 2.0. The FMVSS 208, 212, 219 (partial) and 301 data are presented in Section 3.0. The vehicle, occupant, and camera measurements are presented in Section 4.0. Appendix A contains the still photographic prints. Appendix B contains the dummy and vehicle data plots. Appendix C contains the manufacturer's vehicle information.

Section 2.0

Frontal Barrier Impact Test Summary

Test Results Summary

This flat frontal barrier test was conducted at TRC on March 22, 1994.

The test vehicle, a 1994 Kentron SS Sport Top van, NHTSA No. CR1301, appeared to comply with the performance requirements of FMVSS 208, 212, 219 (partial), and 301 in the flat frontal barrier impact mode. The Head Injury Criteria (HIC) calculations were less than 1000, the chest resultant accelerations did not exceed 60 g's, and the compressive forces transmitted through the upper legs did not exceed 2,250 pounds as measured by Part 572 E dummies seated in the front outboard designated seating positions. For each Part 572 E dummy the chest deflection did not exceed 3.0 inches. The vehicle's restraint system met the applicable comfort and convenience requirements. The windshield periphery retention was 100 percent. There was no penetration into any portion of the windshield. No fluid spilled from the vehicle's fuel system following the impact or during the static rollover test.

The test vehicle was equipped with airbags at the driver's and right front passenger's seating positions. The vehicle's test weight was 5979 pounds. The vehicle's impact speed was 29.6 mph. The vehicle's maximum static crush was 17.3 inches.

The driver's HIC was 515. The driver's chest maximum resultant acceleration with three (3) milliseconds minimum duration was 53.8 g. The driver's chest maximum deflection was 1.1 inches. The driver's left and right femur maximum compressive forces were 1044 pounds and 1707 pounds, respectively.

The right front passenger's HIC was 736. The right front passenger's chest maximum resultant acceleration with three (3) milliseconds minimum duration was 43.8 g. The right front passenger's chest maximum deflection was 1.3 inches. The right front passenger's left and right femur maximum compressive forces were 580 pounds and 119 pounds, respectively.

There was no loss of windshield periphery retention and no penetration through the windshield.

Following the impact, no fluid spilled from the vehicle's fuel system prior to the static rollover test or during any portion of the static rollover test.

Table 1 Crash Test Summary

NHTSA number:	CR1301
Test type:	Frontal barrier impact
Test date:	03/22/94
Test time:	1615
Ambient temperature at impact area:	69° F
Vehicle year/make/ model/body style:	1994/Kentron/SS Sport Top/van
Vehicle test weight:	5979 lb
Impact angle ¹ :	0°
Impact velocity ² :	
Primary:	29.6 mph
Secondary:	29.6 mph
Maximum static crush:	17.3 in
Average rebound:	7.7 in
Number of cameras:	
Real-time:	2
High-speed:	14
Door opening data:	
Left-front:	Difficult, tools required
Right-front:	Difficult, tools required
Left-rear:	NA
Right-rear:	Easy

¹ With respect to tow track centerline.

² Speed trap measurement ($\pm .05$ mph accuracy)

Table 1 Crash Test Summary, Cont'd.

Dummies:	<u>Driver #314</u>	<u>Passenger #230</u>
Type:	Part 572 E	Part 572 E
Location:	Left front	Right front
Restraint:	3-point unbelt and airbag	3-point unbelt
Number of data channels:	15	15
Front seat data:		
Seat track failure:	None	None
Seat back failure:	None	None
Visible dummy contact points:		
Head:	Airbag and seat back	Chest and seat back
Chest:	Airbag	None
Abdomen:	None	None
Left knee:	Instrument panel	Instrument panel
Right knee:	Instrument panel	Instrument panel

Table 2 Test Vehicle Information

Vehicle year/make/
model/body style: 1994/Kentron/SS Sport Top/van

Color: White

VIN: 1GBEG25K2RF110084

NHTSA number: CR1301

Engine data:

Placement: Longitudinal/inline

Cylinders: 8

Displacement: 5.7 liters

Transmission data: 4 speed, manual, X automatic, X overdrive

Final drive: fwd, X rwd, 4wd

Date vehicle received: 03/9/94

Odometer reading: 117

Dealer's name
and address: Koons of Tysons
2000 Chain Bridge Rd.
Vienna, VA 22182

Accessories:

Power steering	Yes	Automatic transmission	Yes
Power brakes	Yes	Automatic speed control	Yes
Power seats	No	Tilting steering wheel	Yes
Power windows	Yes	Telescoping steering wheel	No
Tinted glass	Yes	Air conditioning	Yes
Radio	Yes	Anti-skid brake	Yes
Clock	Yes	Rear window defroster	No
Power door locks	Yes	Other	None

Certification data from vehicle's label:

Vehicle manufactured by: Kentron, Inc.

Date of manufacture: 10/93

VIN: 1GBEG25K2RF110084

GVWR: 6600 lb

GAWR: Front: 3400 lb

Rear: 3406 lb

Table 2 Vehicle Information, Cont'd.

Size of tires on vehicle: P225/75R15

Tire pressure with maximum capacity vehicle load:

Front: 44 psi
Rear: 44 psi

Spare tire: Standard

Type of front seats: Bucket

Tire & capacity data from vehicle's label:

Recommended tire size: P225/75R15

Recommended cold tire pressure:

Front: 35 psi
Rear: 35 psi

Designated seating capacity:

Front: NA
Rear: NA
Total: NA

Vehicle capacity weight: NA lbs.

Test vehicle attitudes:

Delivered attitude:	LF: 28.9 in.	RF: 28.9 in	LR: 28.7 in	RR: 28.7 in
Fully loaded attitude:	LF: 28.8 in	RF: 28.3 in	LR: 28.2 in	RR: 28.2 in
Pre-test attitude:	LF: 28.8 in	RF: 28.4 in	LR: 28.3 in	RR: 28.2 in

Table 2 Test Vehicle Information, Cont'd.

Weight of test vehicle as received (with maximum fluids):

Right front	1372 lb	Right rear	1286 lb
Left front	1354 lb	Left rear	1344 lb
Total front weight	2726 lb	(50.9% of total vehicle weight)	
Total rear weight	2630 lb	(49.1% of total vehicle weight)	
Total delivered weight	5356 lb		

Calculation of test vehicle's target test weight:

RCLW¹ = Rated Cargo and Luggage Weight

GVWR = Gross Vehicle Weight Rating (6600 lb)

UDW = Unloaded Delivered Weight (5356 lb)

VCW = Vehicle Capacity Weight = GVWR - UDW = 6600 - 5356 = 1244 lb

DSC² = Designated Seating Capacity (6)

RCLW¹ = GVWR - UDW - 150 (DSC) = 6600 - 5356 - 150(6) = 344 lb

Target test weight = UDW + RCLW¹ + (Number of Hybrid III dummies
x 167 lb per dummy)

Target test weight = 5356 + 300 + 334 = 5990 lb

Weight of test vehicle with required dummies and 289 lb of cargo weight:

Right front	1530 lb	Right rear	1459 lb
Left front	1485 lb	Left rear	1505 lb
Total front weight	3015 lb	(50.4% of total vehicle weight)	
Total rear weight	2964 lb	(49.6% of total vehicle weight)	
Total test weight	5979 lb	(0.2% under target test weight)	

Weight of ballast secured in vehicle cargo area: 160 lb

Components removed to meet target test weight: None

CG rearward of front wheel centerline: 62.0 in

Vehicle Wheelbase: 125.0 in

¹ Cargo weight for multi-purpose passenger vehicles, trucks, and buses is the vehicle's calculated cargo and luggage weight from the vehicle's label or 300 pounds, whichever is less.

² The designated seating capacity is determined by counting the number of seat belts installed in the vehicle.

Table 3 Post-Impact Data

Test number: 940322
NHTSA number: CR1301
Test date: 03/22/94
Test time: 1615
Test type: Frontal barrier impact
Impact angle: 0°
Ambient temperature
at impact area: 69° F
Temperature in
occupant compartment: 70° F
Impact velocity:
Primary: 29.6 mph
Secondary: 29.6 mph
Specified range: 28.9 to 29.9 mph

Distance from vehicle to barrier:
Entering velocity trap: 14.0 in
Exiting velocity trap: 2.0 in

Test vehicle static crush:

Overall length of test vehicle:
Pre-test: L: 210.6 in C: 211.6 in R: 210.6 in
Post-test: L: 195.0 in C: 194.6 in R: 195.0 in
Total crush: L: 15.6 in C: 17.0 in R: 15.6 in
Average crush: 16.1 in

Test vehicle rebound from flat barrier:

Distance from test vehicle to barrier:
Post-test: L: 7.2 in C: 8.0 in R: 7.8 in
Average rebound: 7.7 in

Figure 1 Impact Velocity Measurement System

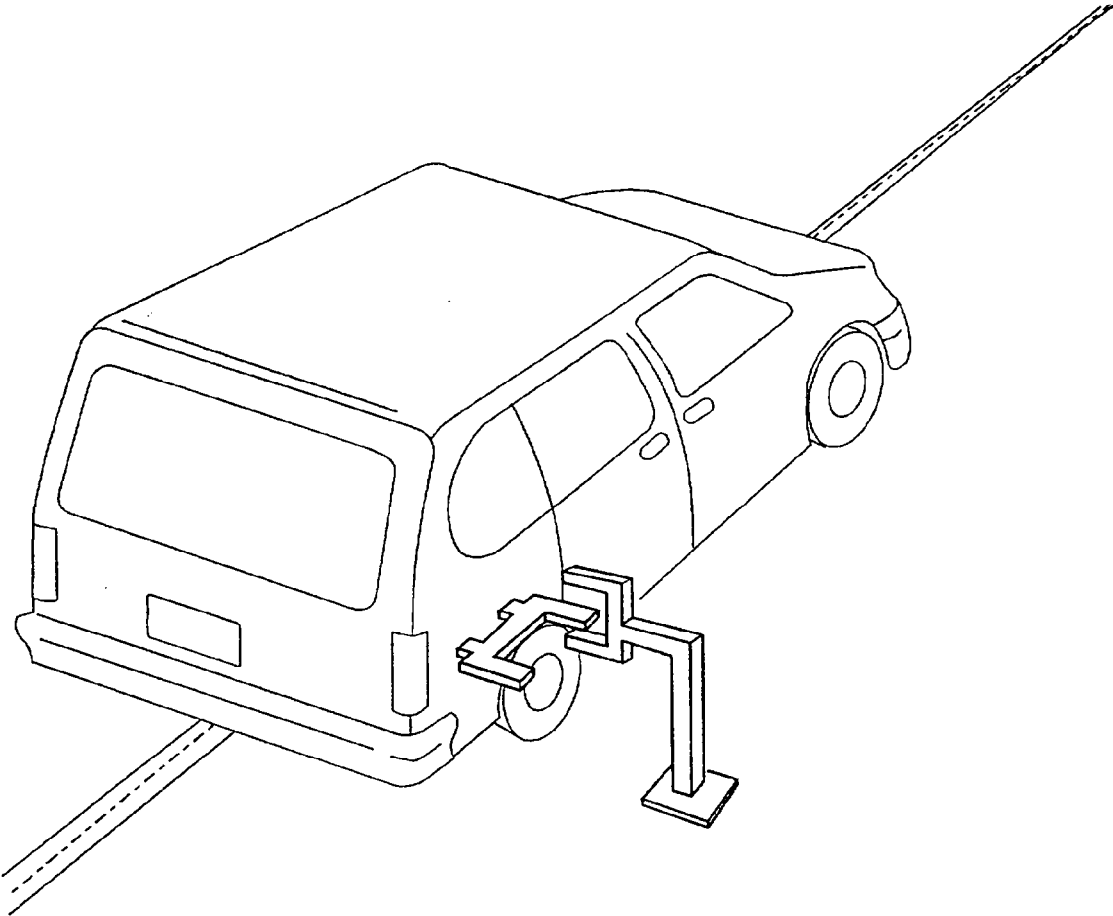

The final vane clears emitter/receiver two inches before impact.
The vanes have a one-foot spacing.

Figure 2 Accident Investigation Division Data for 30 mph Frontal Barrier Impact

NHTSA number: CR1301
 Test date: 03/22/94
 Vehicle year/make/model/body style: 1994/Kentron/van
 Vehicle size category: Van
 VIN: 1GBEG25K2RF110084
 Build date: 10/93
 Test weight: 5979 lb
 Vehicle wheelbase: 125.0 in
 Maximum width: 85.4 in
 Front overhang: 31.6 in

Collision Deformation

Classification (CDC) Code: 12FDEW4

Crush depth measurements:

C1:	15.6 in
C2:	16.2 in
C3:	16.9 in
C4:	17.3 in
C5:	17.3 in
C6:	15.6 in

Midpoint of damage: D: Vehicle Longitudinal Centerline

Length of damaged region: L: 64.4 in

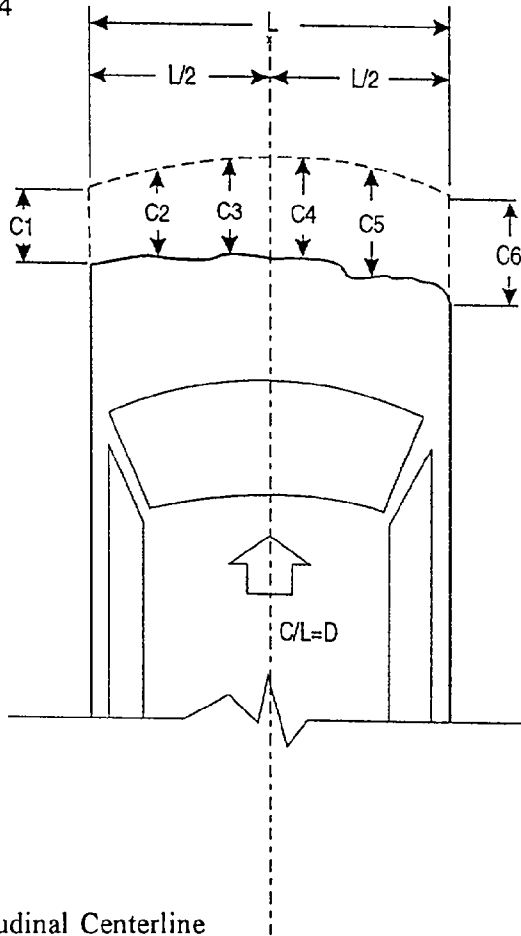

Table 4 Post-test Airbag Data

NHTSA number: CR1301
Test date: 03/22/94
Technician: Markusic
Vehicle year/make/
model/body style: 1994/Kentron/van

A. Number of airbag vent holes:

Driver: 2
Passenger: None

B. Size of airbag vent holes:

Driver: 1.2
Passenger: NA

C. Total airbag vent area:

Driver: 2.3 in²
Passenger: NA

D. Deflated airbag length and width dimensions or, if round, diameter

Driver: Length NA
Width NA
Diameter 26.5
Passenger: Length: NA
Width: NA
Diameter: NA

Table 4 Post-test Airbag Data, Cont'd.

E. Is the airbag tethered?

Driver: No

If yes, record length of tether: NA

Passenger: NA

If yes, record length of tether: NA

Driver's airbag:

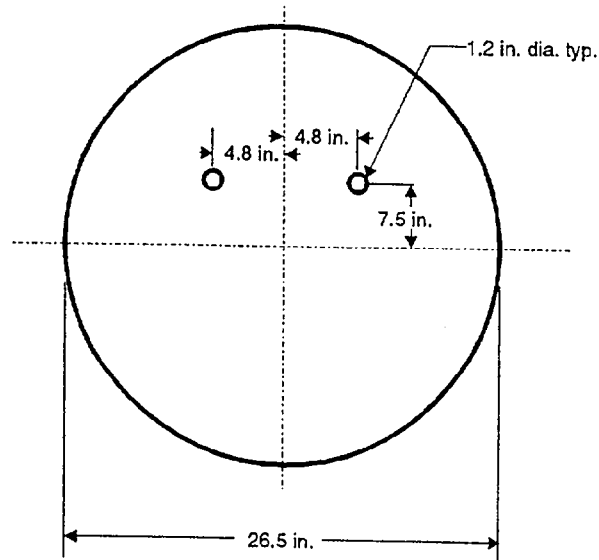

F. Airbag and gas generator part numbers and manufacturer's names.

Driver: Mfr.: NA; Airbag: PUT11789-04A; Gen: G35351C0934

Passenger: Mfr.: NA; Airbag: NA; Gen: NA

Figure 3 Vehicle Accelerometer Placement

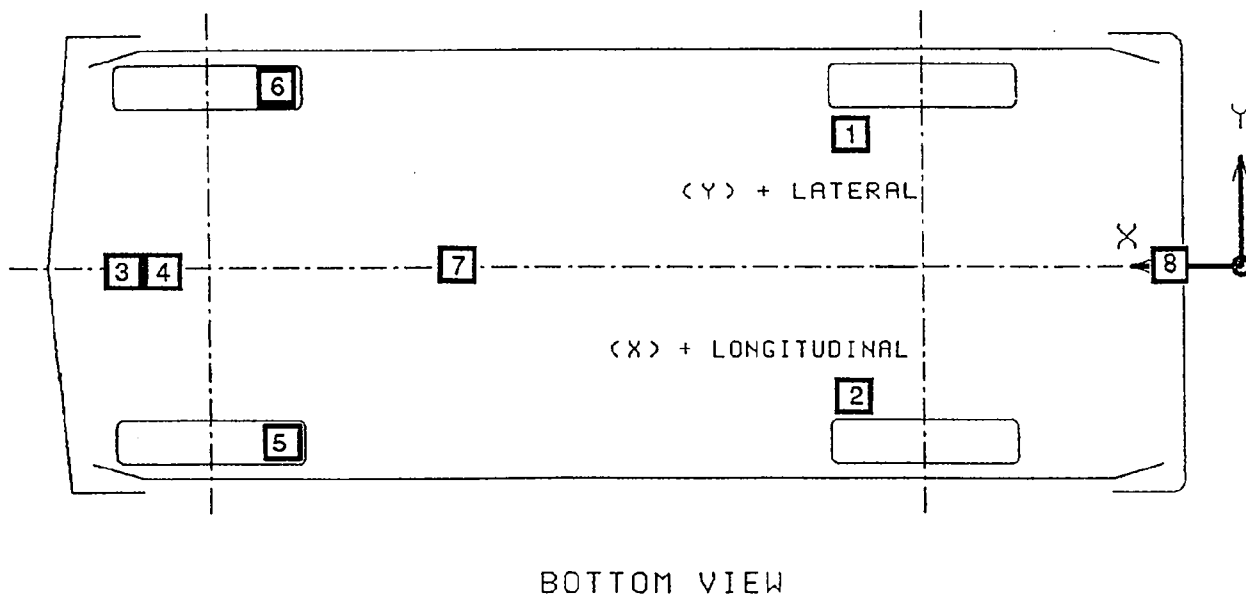
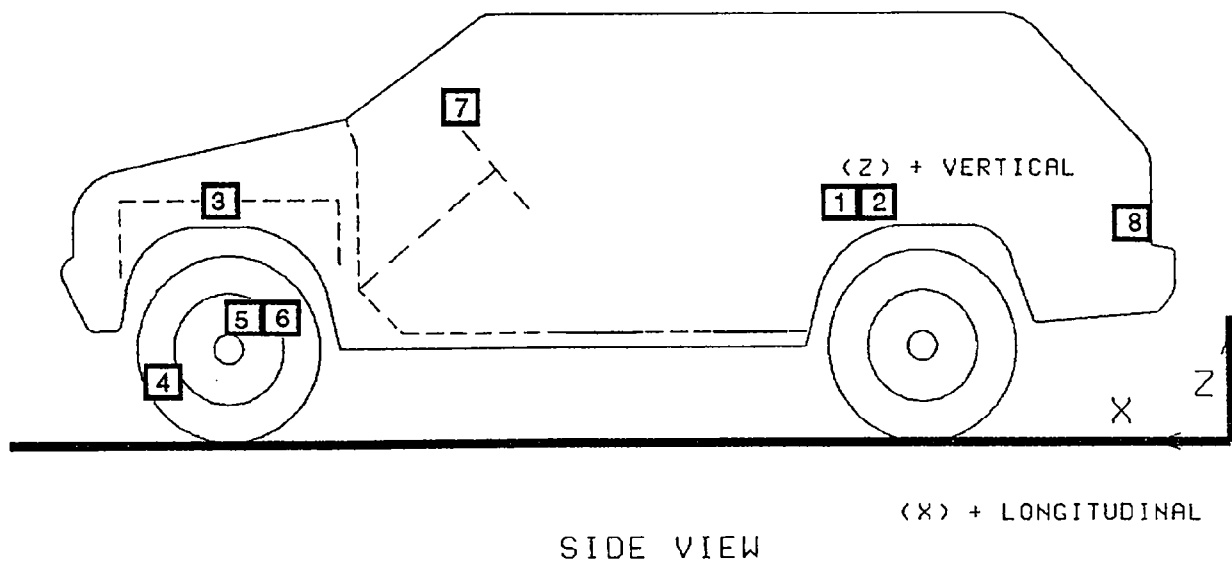

Table 5 Vehicle Accelerometer Locations and Data Summary

No. LOCATION	X	Y	Z	POSITIVE DIRECTION	NEGATIVE DIRECTION
1 LEFT REAR SEAT CROSSMEMBER LONGITUDINAL	PRE 75.9 in	23.0 in	23.9 in		
	POST 75.9 in	23.0 in	22.8 in	2.0 g @ 123.9 ms	26.9 g @ 30.7 ms
2 RIGHT REAR SEAT CROSSMEMBER LONGITUDINAL	PRE 76.5 in	-22.0 in	23.9 in		
	POST 76.5 in	-22.0 in	22.8 in	1.5 g @ 123.5 ms	29.4 g @ 43.8 ms
3 ENGINE TOP LONGITUDINAL	PRE 176.0 in	9.4 in	31.2 in		
	POST 171.1 in	9.4 in	30.7 in	33.8 g @ 51.3 ms	113.8 g @ 39.8 ms
4 ENGINE BOTTOM LONGITUDINAL	PRE 172.2 in	-4.9 in	12.4 in		
	POST 167.6 in	-4.9 in	12.0 in	26.8 g @ 52.5 ms	88.9 g @ 42.5 ms
5 RIGHT BRAKE CALIPER LONGITUDINAL	PRE 177.1 in	-27.8 in	14.5 in		
	POST 158.6 in	-27.8 in	10.3 in	40.5 g @ 73.8 ms	89.1 g @ 52.8 ms
6 LEFT BRAKE CALIPER LONGITUDINAL	PRE 177.9 in	27.8 in	14.4 in		
	POST 154.4 in	27.8 in	13.7 in	60.0 g @ 59.8 ms	83.1 g @ 41.8 ms
7 INSTRUMENT PANEL CENTER LONGITUDINAL	PRE 180.4 in	0.5 in	56.5 in		
	POST 178.1 in	0.5 in	56.5 in	33.1 g @ 70.6 ms	80.6 g @ 26.7 ms
8 VEHICLE REAR CENTER VERTICAL	PRE 17.1 in	-1.4 in	24.4 in		
	POST 17.1 in	-1.4 in	25.0 in	8.4 g @ 16.9 ms	6.9 g @ 22.7 ms

REFERENCE: X: + FORWARD FROM REAR BUMPER
 Y: + LEFTWARD FROM VEHICLE CENTERLINE
 Z: + UPWARD FROM GROUND LEVEL

Report of Vehicle Condition at the Completion of Testing

Contract number: DTNH22-93-D-01089
From: Transportation Research Center Inc.
10820 State Route 347
East Liberty, OH 43319

To: Mr. Charles Case, COTR
Office of Vehicle Safety Compliance

The following vehicle has been subjected to testing for FMVSS 208. The vehicle was inspected upon arrival at the laboratory for the test and found to contain all of the equipment listed below. All variances have been reported within 2 working days of vehicle arrival, by letter, to the NHTSA Industrial Property Manager/NAD-30, with a carbon copy to the responsible testing office. The vehicle is again inspected, after the above test has been conducted, and all changes are noted below. The final condition of the vehicle is also noted in detail.

NHTSA number: CR1301
Vehicle year/make/
model/body style: 1994/Kentron/SS Sport Top/van
Body color: White
VIN: 1GBEG25K2RF110084
Odometer (arrival): 117 Date: 03/09/94
Odometer (completion): 119 Date: 03/22/94
Cost: \$24,477.80

Air conditioner	Yes	Console	No	Brakes	Power
Tinted glass	Yes	Tachometer	No	Front	Disc ABS
Power steering	Yes	Speed control	Yes	Rear	Drum ABS
Power windows	Yes	Rear window def.	No	Front seats	Manual
Power door locks	Yes	Sun/moon roof	No	Seat type	Front-Bucket
Radio	Yes	T-top	No		Rear-Bench
Clock	Yes	Tilt steering wheel	Yes	Number of seats	6
Roof rack	No	Other options:	No		

Report of Vehicle Condition at the Completion of Testing, Cont'd.

Engine data:

Cylinders: 8
Displacement: 5.7 liters
Transmission: Automatic
Final drive: RWD
Tire size: P225/75R15
Gasoline type: Unleaded

Equipment that is no longer on the vehicle as noted above: None

Explanation:

VEHICLE CONDITION: Vehicle was subjected to a 30 mph crash test. There is severe structural damage. Various interior and exterior portions of the vehicle have been painted and have had holes drilled to facilitate attachment of instrumentation. Various trim and body parts have been removed including the rear seats. Stoddard solvent replaced the fuel in the fuel system and engine. THE VEHICLE IS FOR SALVAGE ONLY AND IS NOT TO BE REPAIRED FOR HIGHWAY USE.

Section 3.0

FMVSS 208, 212, 219 (partial), and 301 Data

Table 6 Dummy Injury Criteria

	Maximum Acceleration						
	X	Head			R	Chest	
		Y	Z	X		Y	Z
Driver	-65.8 g	8.4 g	15.2 g	66.0 g	-57.7 g	-7.2 g	-8.8 g
Passenger	-56.0 g	6.0 g	-54.4 g	61.0 g	-46.3 g	5.7 g	-10.8 g

Maximum Femur Compressive Force

	Left femur	Right femur
Driver	1044 lbf	1707 lbf
Passenger	580 lbf	119 lbf

Head Injury Criteria¹

	HIC	Time t ₁	Time t ₂
Driver	515	53.7 ms	82.7 ms
Passenger	736	73.0 ms	109.0 ms

Chest Maximum Resultant Acceleration²

	Accelerometer	Time t ₁	Time t ₂
Driver	53.8 g	71.9 ms	74.9 ms
Passenger	43.8g	67.1 ms	70.8 ms

Maximum Chest Deflection

Driver	1.1 in
Passenger	1.3 in

¹ As defined in FMVSS No. 208

² Defined as equal to or exceeding 0.003 sec. duration

Dummy Kinematic Summary

Driver Dummy

Upon impact, the driver dummy translated forward on the seat impacting both knees into the instrument panel. The dummy's head and chest impacted the airbag with the dummy's head rotating slightly rearward contacting the seat back. The driver dummy was restrained by the three-point unbelt and airbag. The dummy rebounded rearward into the seat back with the dummy's head, still rotated rearward, contacting the seat back. The driver dummy came to rest in the driver's seat restrained by the three-point unbelt.

Right Front Passenger Dummy

Upon impact, the right front passenger dummy translated forward on the seat impacting both knees into the instrument panel. The dummy's head rotated downward impacting the dummy's chest. The right front passenger dummy was restrained by the three-point unbelt. The dummy rebounded rearward into the seat back as the dummy's head rotated rearward contacting the seat back. The right front passenger dummy came to rest in the right front passenger's seat, restrained by the three-point unbelt.

Table 7 FMVSS 208 Seat Belt Comfort and Convenience Test Summary
Front Outboard Designated Seating Positions

NHTSA number: CR1301

Vehicle model year/make/model/body style: 1994/Kentron/SS Sport Top/van

Date of comfort/convenience check: 03/22/94

Technician performing check: Markusic

GVWR: 6600 lb

Automatic seat belts installed in any vehicle, other than a walk-in van-type vehicle which has a gross vehicle weight rating of 10,000 pounds or less, and is manufactured on or after September 1, 1986, shall meet the requirements for convenience hooks, webbing tension-relieving devices, and belt contact force.

Manual seat belts installed for compliance with this standard in front outboard designated seating positions of any vehicle, other than a walk-in van-type vehicle which has a gross vehicle rating of 10,000 pounds or less, and is manufactured after September 1, 1989, shall meet the requirements for belt contact force, plate access, retraction and seat belt guides, and hardware.

Vehicle Equipment:

The vehicle's front outboard seating positions were equipped with manual Type 2 seat belts which must comply with the dynamic test requirements of S5.1; requirements for webbing tension-relieving devices (S7.4.2), belt contact force (S7.4.3), latchplate access (S7.4.4), retraction (S7.4.5), and seat belt guides and hardware (S7.4.6) apply.

Convenience Hooks (S7.4.1):

Not applicable, the vehicle is not equipped with automatic seat belts.

Table 7 FMVSS 208 Seat Belt Comfort and Convenience Test Summary

Front Outboard Designated Seating Positions, Cont'd.

NHTSA number: CR1301

Vehicle model year/make/model/body style: 1994/Kentron/SS Sport Top/van

Date of comfort/convenience check: 03/22/94

Technician performing check: Markusic

GVWR: 6600 lb

Webbing Tension-Relieving Device (S7.4.2):

The front outboard seating position assemblies do not have webbing tension-relieving devices.

Belt Contact Force (S7.4.3):

The belt contact force on the chest of the test dummy is 0.2 pounds.

Latchplate Access (S7.4.4):

The seat belt latchplates, in their normal stowed position, are within the reach envelope.

The clearance test block moves unhindered to the latchplate or buckle.

Retraction (S7.4.5):

The seat belt automatically retracts when the seat belt latchplate is released.

The stowed seat belt webbing and hardware are not pinched when the door is closed.

Table 7 FMVSS 208 Seat Belt Comfort and Convenience Test Summary
Front Outboard Designated Seating Positions, Cont'd.

NHTSA number: CR1301

Vehicle model year/make/model/body style: 1994/Kentron/SS Sport Top/van

Date of comfort/convenience check: 03/22/94

Technician performing check: Markusic

GVWR: 6600 lb

Seat Belt Guides and Hardware (S7.4.6):

The seat cushion is not removable so the seat back serves a function other than seating.

The seat is not removable.

The seat is not movable so the space formerly occupied by the seat can be used for a secondary function.

Note: If the seat or seat cushion is removable or if the seat is movable so the space formerly occupied by the seat can be used for a secondary function, the seat belt guides and hardware requirements do not apply.

The webbing is not designed to pass through the seat cushion or between the cushion and seat back.

The restraint system does not include webbing guides.

The inboard receptacle end of the outboard seating position's seat belt is accessible with the center arm rest in any position to which it can be adjusted without moving the arm rest for access.

Table 8 FMVSS 208 Equipment Data

FMVSS 208 Seat Belt Warning System Data

With an occupant in the driver's position and the lap belt/unibelt in stowed position and ignition switch placed in the "start/on" position the duration of audible warning signal is 6 s and the reminder light operates 6 s.

With an occupant in the driver's position and the lap belt/unibelt in use and the ignition switch placed in the "start/on" position the duration of audible warning signal is 0 s and the duration of the reminder light operation is 6 s.

NOTE: the audible warning should not operate.

The wording of the visual seat belt warning is the symbol from Table 2 of FMVSS 101.

Table 8 FMVSS 208 Equipment Data, Cont'd.

FMVSS 208 Labeling and Driver's Manual Data

The label which describes manufacturer's maintenance or replacement schedule for the crash-deployed occupant protection system was located on the driver's sun visor.

No regular airbag maintenance is required.

Appropriate instructions concerning maintenance and/or replacement of this system were provided in the owner's manual on pages 1-20 through 1-24.

A description of the functional operation of the system was provided in the owner's manual on pages 1-20 through 1-24.

A reference to the instructions and description of the system was included on the label.

An owner's manual was provided.

The owner's manual contained appropriate information concerning maintenance and/or replacement and a description of the functional operation of the systems on pages 1-20 through 1-24.

Table 8 FMVSS 208 Equipment Data, Cont'd.

FMVSS 208 Readiness Indicator Data

The vehicle contained a crash-deployed occupant protection system which was not totally mechanical. The readiness indicator was located on the lower left side of the instrument cluster.

The readiness indicator was clearly visible to the driver.

A list of the elements in the occupant restraint system, being monitored by the readiness indicator was provided in the owner's manual on page 1-24.

All rear outboard seating positions had Type 2 seat belts.

Figure 4 FMVSS 212 Test Data

Details of windshield mounting such as retention method, trim type, etc.:

Plastic trim around outer perimeter and adhesive around inner perimeter.

Clips or brackets used to retain windshield: None

FMVSS 212 requirements: The post-test periphery retention amount must be at least 75% of the pre-test periphery measurement for vehicles NOT equipped with automatic restraints, and 50% for each side of windshield for vehicles equipped with automatic restraint systems for front occupants.

Windshield periphery measurements:

	Pre-test	Post-test	Percent Retention
Right side	89.0 in	89.0 in	100.0
Left side	89.0 in	89.0 in	100.0
Total	178.0 in	178.0 in	100.0

Pre-test windshield mounting material temperature: 70° F

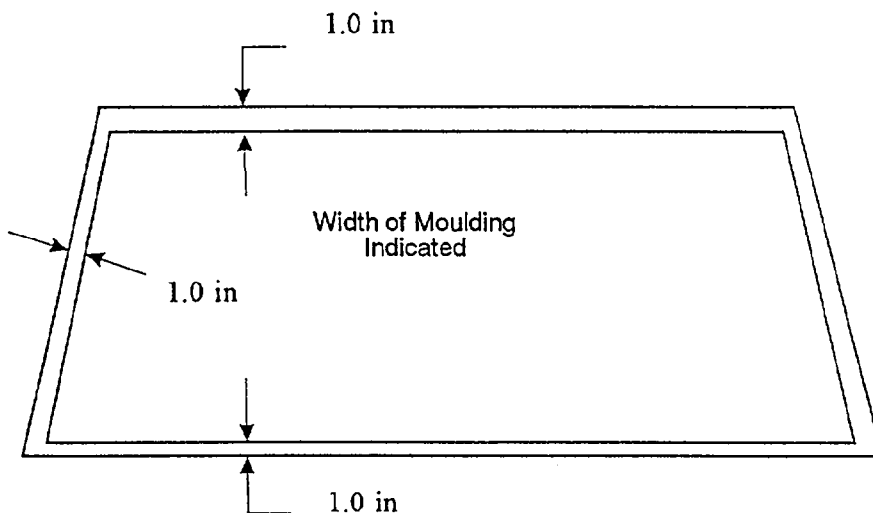

Front view of windshield¹

Loss of windshield retention lengths: None

¹ Indicate areas of loss of retention, if any, on windshield diagram.

Figure 5 FMVSS 219 Test Data

Protected zone lower edge requirement:

The lower edge of the protected zone is determined by placing a 6.5-inch diameter rigid sphere weighing 15 pounds in a position such that it simultaneously contacts the inner surface of the windshield and the top surface of the instrument panel including padding. Draw the locus of points on the inner surface of the windshield contactable by the sphere across the width of the instrument panel. From the outermost contactable points, extend the locus line horizontally to the edges of the windshield, and then draw a line on the inner surface of the windshield below and 0.5 inch from the locus line. The LOWER EDGE OF THE PROTECTED ZONE is the longitudinal projection onto the outer surface of the windshield of this line.

Windshield measurements:

- A: 64.0 in
- B: 14.1 in
- C: 73.0 in
- D: 25.0 in
- E: 16.6 in
- F: 48.8 in

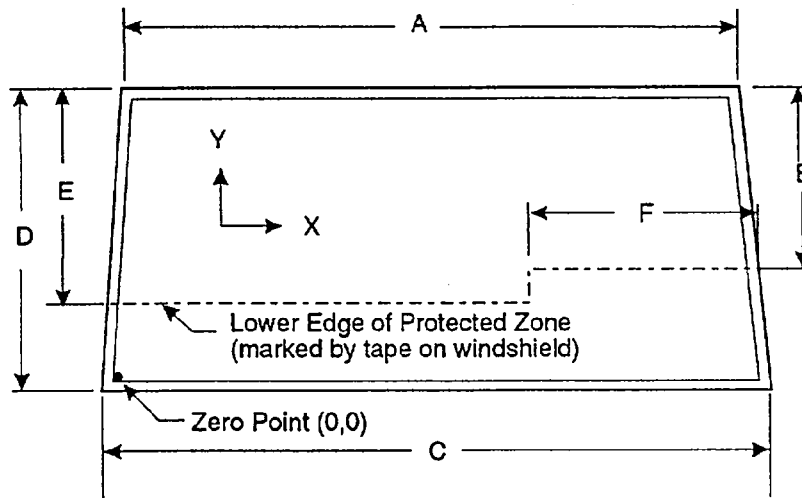

FRONT VIEW

Method of adhering protected zone template to windshield:

NA

Areas of windshield template penetration greater than 0.25 in:

NA

Coordinates

	X	Y
--	---	---

- 1.
- 2.
- 3.

Areas of windshield penetration, below the protected zone, through the inner surface of the windshield:

None

- 1.
- 2.
- 3.

Table 9 Fuel System Data

Vehicle year/make/ model/body style:	1994/Kentron/SS Sport Top/van
NHTSA number:	CR1301
Fuel system capacity:	33.0 gal (from owner's manual)
Usable capacity:	32.7 gal (furnished by COTR)
Test volume range:	30.1 gal to 30.7 gal (92-94% of usable)
Actual test volume:	30.4 gal (with entire fuel system filled)
Test fluid type:	Stoddard solvent
Specific gravity:	0.764
Kinematic viscosity:	0.99 centistokes
Test fluid color:	purple
Type of fuel pump:	electric

The electric fuel pump does not operate with ignition switch "on" and the engine not operating.

Details of fuel system:

The fuel tank is located behind the rear axle. The fuel filler neck is located on the left side. The fuel lines run along the right side to the front.

Table 10 FMVSS 301 Post-Impact Test Data

NHTSA number: CR1301
Test date: 03/22/94
Vehicle year/make/
model/body style: 1994/Kentron/SS Sport Top/van

Test requirements:

Test vehicle fuel tank filled to 92 to 94% of manufacturer's usable capacity and with electric fuel pump operating (if it will operate without engine operation). Part 572 test dummies located at each front designated seating position.

Test vehicle impact type:

- Frontal (30 mph)
- Oblique (30 mph) with ___° barrier face first contacting (driver's/passenger's) side
- Rear moving barrier (30 mph)
- Lateral moving barrier (20 mph)

Fuel system fluid spillage measurements:

	<u>Test Results</u>	<u>Maximum Allowable</u>
1. From impact until vehicle motion ceases	0 oz	1 oz
2. 5-Minute period after vehicle motion ceases	0 oz	5 oz
3. Next 25 minutes after 5-minute period	0 oz	1 oz/1 min

Fuel system fluid spillage location(s): None

Figure 6 FMVSS 301 Static Rollover Test Data

NHTSA number: CR1301

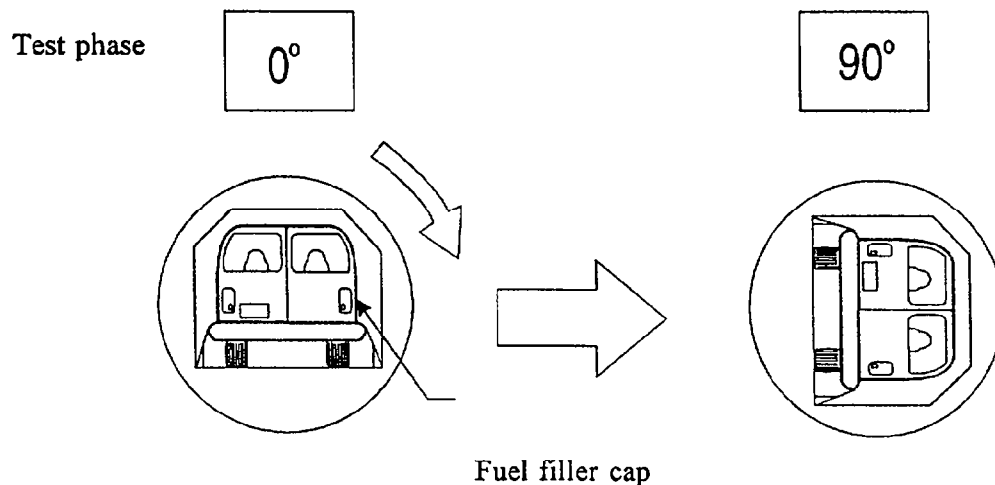

Static rollover machine rotation time information: (specified range is 1-3 minutes)

Time required for machine to rotate 90° = 2 minutes, 0 seconds
 FMVSS 301 position hold time = 5 minutes, 0 seconds
 Total = 7 minutes, 0 seconds
 Next whole minute interval = 7 minutes

Fuel system fluid spillage measurements:

<u>0° to 90° rotation (fuel filler cap down)</u>	<u>Test Results</u>	<u>Maximum Allowable</u>
1. First 5 minutes from onset of rotation	0 oz	5 oz
2. Sixth minute from onset of rotation	0 oz	1 oz
3. Seventh minute from onset of rotation	0 oz	1 oz

Fuel system fluid spillage location(s): None

Figure 6 FMVSS 301 Static Rollover Test Data, Cont'd.

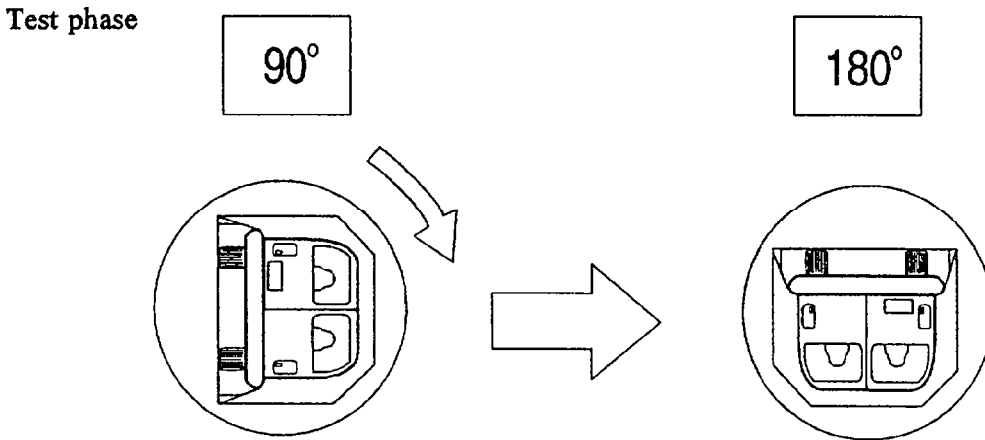

Static rollover machine rotation time information: (specified range is 1-3 minutes)

Time required for machine to rotate 90° = 2 minutes, 0 seconds
 FMVSS 301 position hold time = 5 minutes, 0 seconds
 Total = 7 minutes, 0 seconds
 Next whole minute interval = 14 minutes

Fuel system fluid spillage measurements:

<u>90° to 180° rotation</u>	<u>Test Results</u>	<u>Maximum Allowable</u>
1. First 5 minutes from onset of rotation	0 oz	5 oz
2. Sixth minute from onset of rotation	0 oz	1 oz
3. Seventh minute from onset of rotation	0 oz	1 oz

Fuel system fluid spillage location(s): None

Figure 6 FMVSS 301 Static Rollover Test Data, Cont'd.

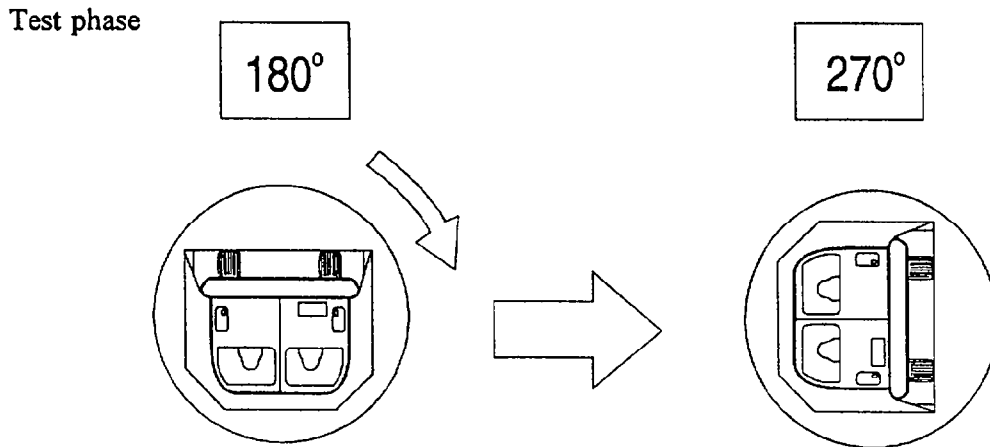

Static rollover machine rotation time information: (specified range is 1-3 minutes)

Time required for machine to rotate 90° = 2 minutes, 0 seconds
 FMVSS 301 position hold time = 5 minutes, 0 seconds
 Total = 7 minutes, 0 seconds
 Next whole minute interval = 21 minutes

Fuel system fluid spillage measurements:

<u>180 to 270° rotation</u>	<u>Test Results</u>	<u>Maximum Allowable</u>
1. First 5 minutes from onset of rotation	0 oz	5 oz
2. Sixth minute from onset of rotation	0 oz	1 oz
3. Seventh minute from onset of rotation	0 oz	1 oz

Fuel system fluid spillage location(s): None

Figure 6 FMVSS 301 Static Rollover Test Data, Cont'd.

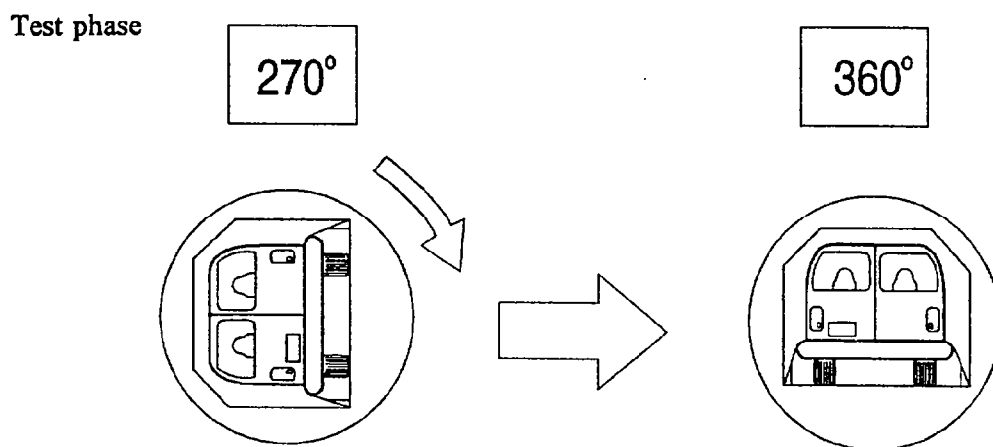

Static rollover machine rotation time information: (specified range is 1-3 minutes)

Time required for machine to rotate 90° = 2 minutes, 0 seconds
 FMVSS 301 position hold time = 5 minutes, 0 seconds
 Total = 7 minutes, 0 seconds
 Next whole minute interval = 28 minutes

Fuel system fluid spillage measurements:

<u>270° to 360° rotation</u>		Test Results	Maximum Allowable
1.	First 5 minutes from onset of rotation	0 oz	5 oz
2.	Sixth minute from onset of rotation	0 oz	1 oz
3.	Seventh minute from onset of rotation	0 oz	1 oz

Fuel system fluid spillage location(s): None

Section 4.0

Vehicle, Occupant, and Camera Measurements

Figure 7 Pre-test and Post-test Measurement Points

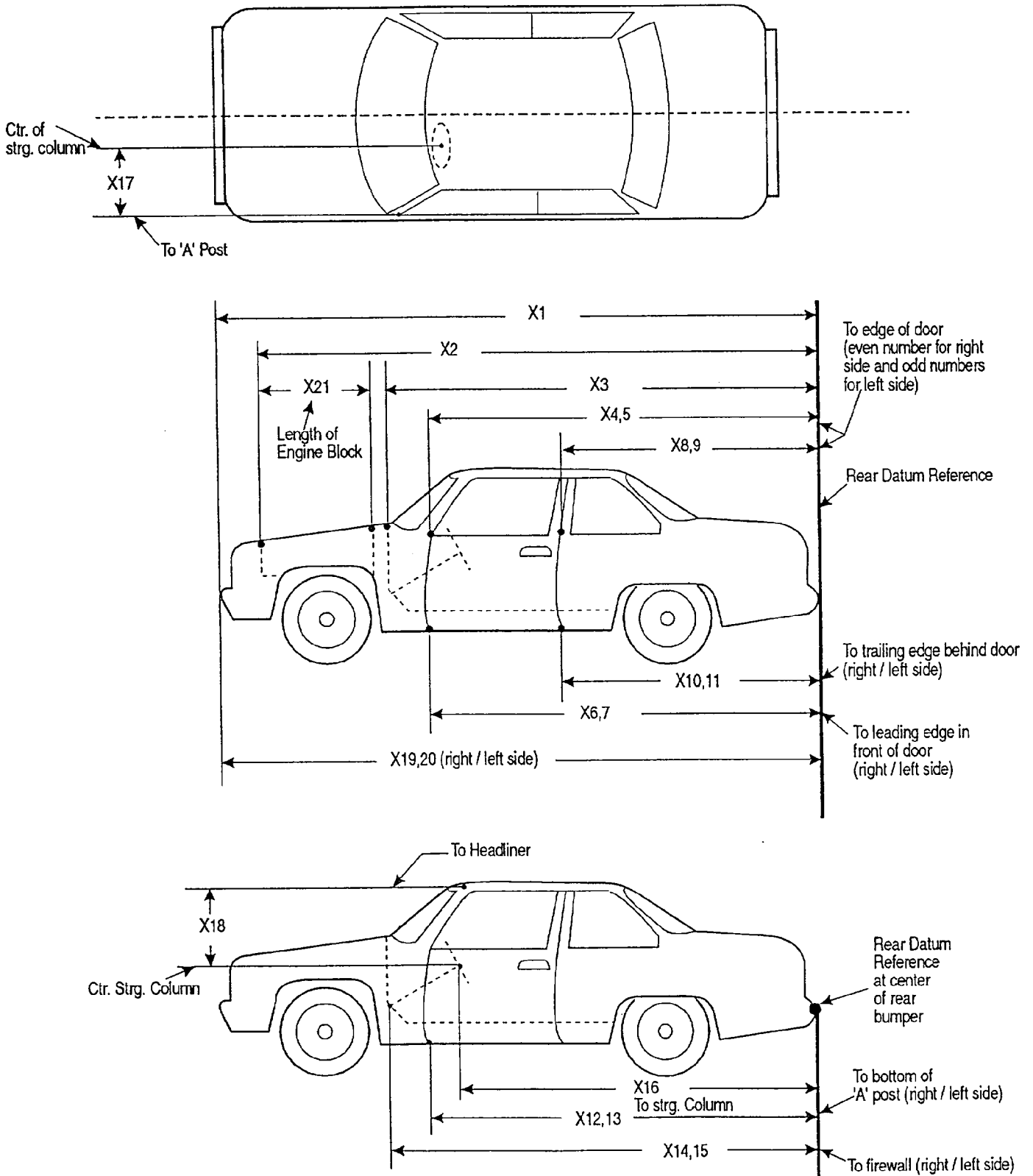

Table 11 Impacted Vehicle Measurements

Vehicle year/make/model/body style: 1994/Kentron/SS Sport Top/van

Test number: 940322

No.	Type of Measurement	Pre-test	Post-test	Difference
X1	Total length of vehicle at centerline	211.6 in	194.6 in	17.0 in
X2	Rear surface of vehicle to front of engine block	188.3 in	186.6 in	1.7 in
X3	Rear surface of vehicle to firewall	194.6 in	187.1 in	7.5 in
X4	Rear surface of vehicle to upper leading edge of right door	180.8 in	180.1 in	0.7 in
X5	Rear surface of vehicle to upper leading edge of left door	180.8 in	178.6 in	2.2 in
X6	Rear surface of vehicle to lower leading edge of right door	181.5 in	179.8 in	1.7 in
X7	Rear surface of vehicle to lower leading edge of left door	181.5 in	178.5 in	3.0 in
X8	Rear surface of vehicle to upper trailing edge of right door	142.6 in	142.2 in	0.4 in
X9	Rear surface of vehicle to upper trailing edge of left door	142.5 in	142.6 in	-0.1 in
X10	Rear surface of vehicle to lower trailing edge of right door	142.5 in	141.6 in	0.9 in
X11	Rear surface of vehicle to lower trailing edge of left door	142.6 in	143.0 in	-0.4 in
X12	Rear surface of vehicle to bottom of "A" post on right side	181.2 in	177.5 in	3.7 in
X13	Rear surface of vehicle to bottom of "A" post on left side	181.3 in	177.6 in	3.7 in
X14	Rear surface of vehicle to firewall - right side	192.4 in	189.5 in	2.9 in
X15	Rear surface of vehicle to firewall - left side	192.6 in	187.5 in	5.1 in
X16	Rear surface of vehicle to steering wheel center	165.0 in	161.2 in	3.8 in
X17	Center of steering column to "A" post	11.2 in	10.6 in	0.6 in
X18	Center of steering column to headliner	20.1 in	19.1 in	1.0 in
X19	Rear surface of vehicle to right side of front bumper	210.6 in	195.0 in	15.6 in
X20	Rear surface of vehicle to left side of front bumper	210.6 in	195.0 in	15.6 in
X21	Length of engine block	18.2 in	18.2 in	0.0 in

Figure 8 Vehicle Target Locations

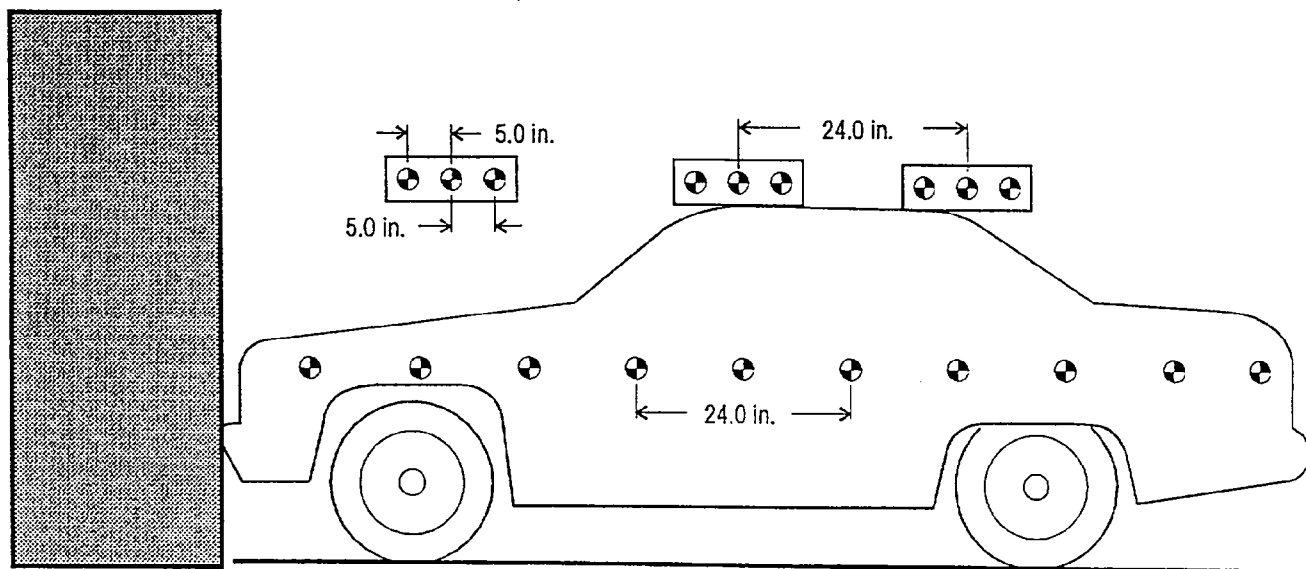
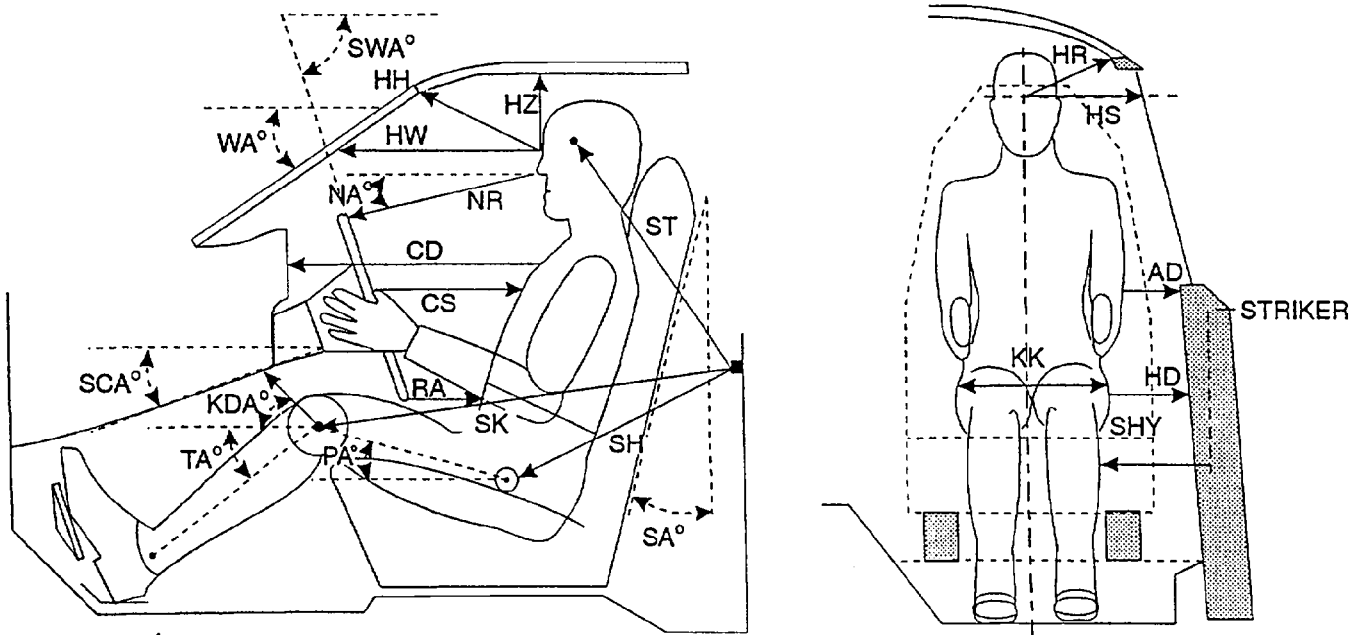
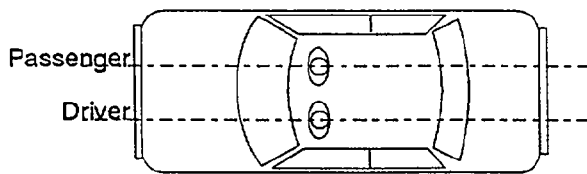

Figure 9 Dummy Measurement Locations for Front Seat Occupants



VERTICAL LONGITUDINAL PLANE



VERTICAL TRANSVERSE PLANE

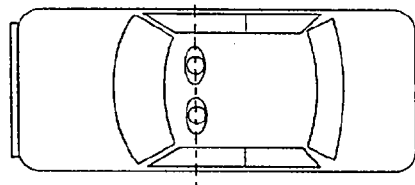

Table 12 Dummy Measurement Data for Front Seat Occupants

Designation	Type of Measurement	Driver (Serial #314)	Passenger (Serial #230)
WA	Windshield angle	45°	NA
SWA	Steering wheel angle	30°	NA
SCA	Steering column angle	60°	NA
SA	Seat back angle	21°	21°
HZ	Head to roof	9.6 in	10.6 in
HH	Head to header	23.9 in	24.8 in
HW	Head to windshield	29.1 in	30.6 in
HR	Head to side header	11.9 in	12.4 in
NR	Nose to rim	18.4 in	NA
NA	Nose to rim angle	9°	NA
CD	Chest to dash	25.8 in	28.0 in
CS	Steering wheel to chest	14.2 in	NA
RA	Rim to abdomen	9.0 in	NA
KDL	Left knee to dash	10.9 in	12.9 in
KDR	Right knee to dash	10.2 in	12.5 in
KDA	Outboard knee to dash angle	24°	9°
PA	Pelvic angle	23°	23°
TA	Tibial angle	38°	47°
KK	Knee to knee	11.0 in	10.0 in
ST ¹	Striker to head	21.9 in	20.8 in
	Striker to head angle	-90°	-90°
SK ¹	Striker to knee	21.8 in	20.4 in
	Striker to knee angle	2°	2°
SH ¹	Striker to H-point	8.5 in	7.9 in
	Striker to H-point angle	36°	41°
SHY	Striker to H-point (Y dir.)	9.4 in	8.3 in
HS	Head to side window	13.5 in	13.9 in
HD	H-point to door	6.7 in	5.8 in
AD	Arm to door	2.9 in	3.4 in

The seat back angle (SA°) is measured relative to vertical, all other angles are measured relative to horizontal.

¹ A negative angle indicates the measurement point was located above the striker.

Figure 10 Seat Belt Positioning Data

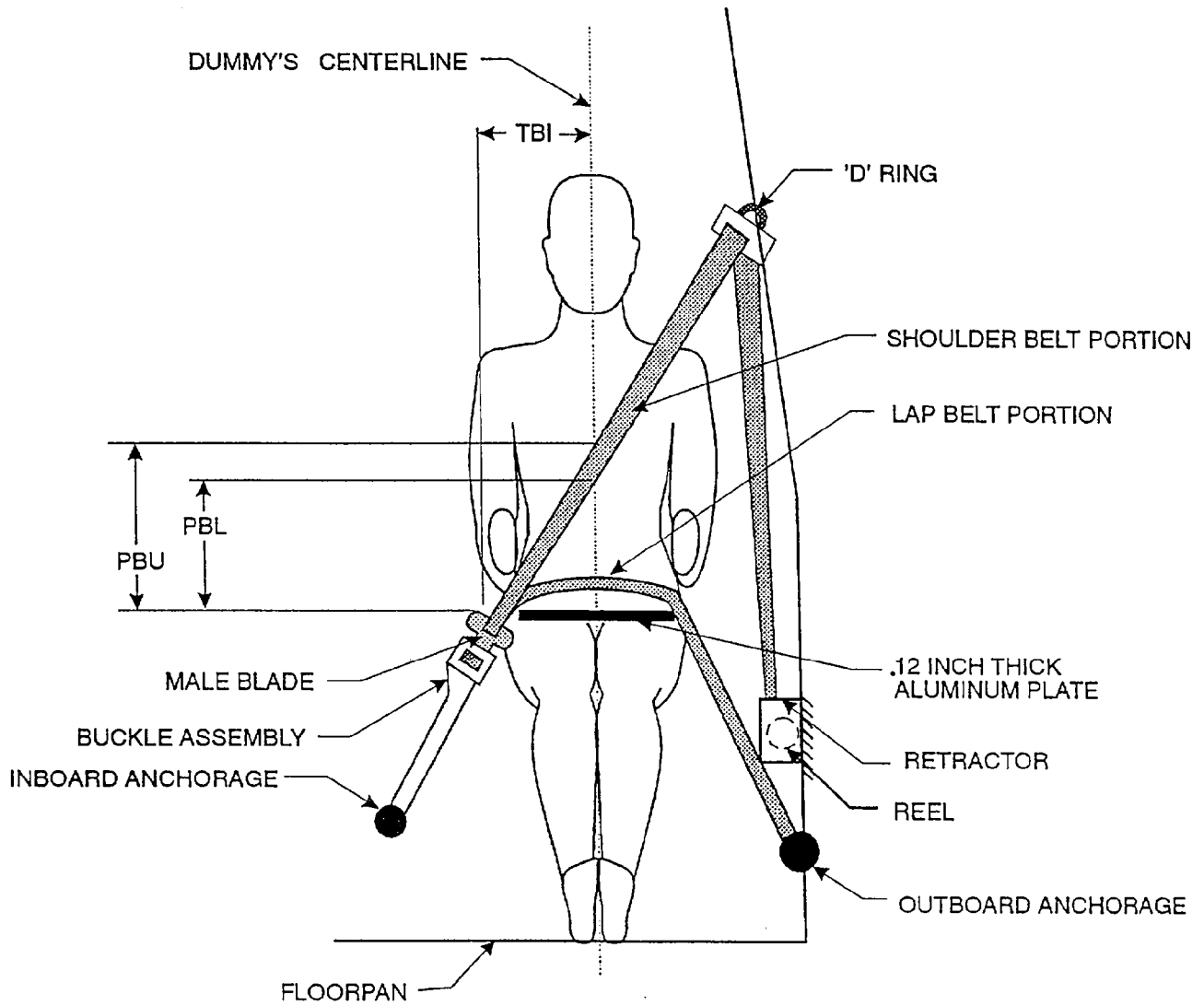

	Driver	Passenger
PBU - Top surface of aluminum plate to belt upper edge	14.1 in	14.1 in
PBU - Top surface of aluminum plate to belt upper edge	10.8 in	11.0 in
TBI - Dummy centerline to intersection of upper torso belt and lap belt	13.9 in	14.0 in

Figure 11 Camera Positions

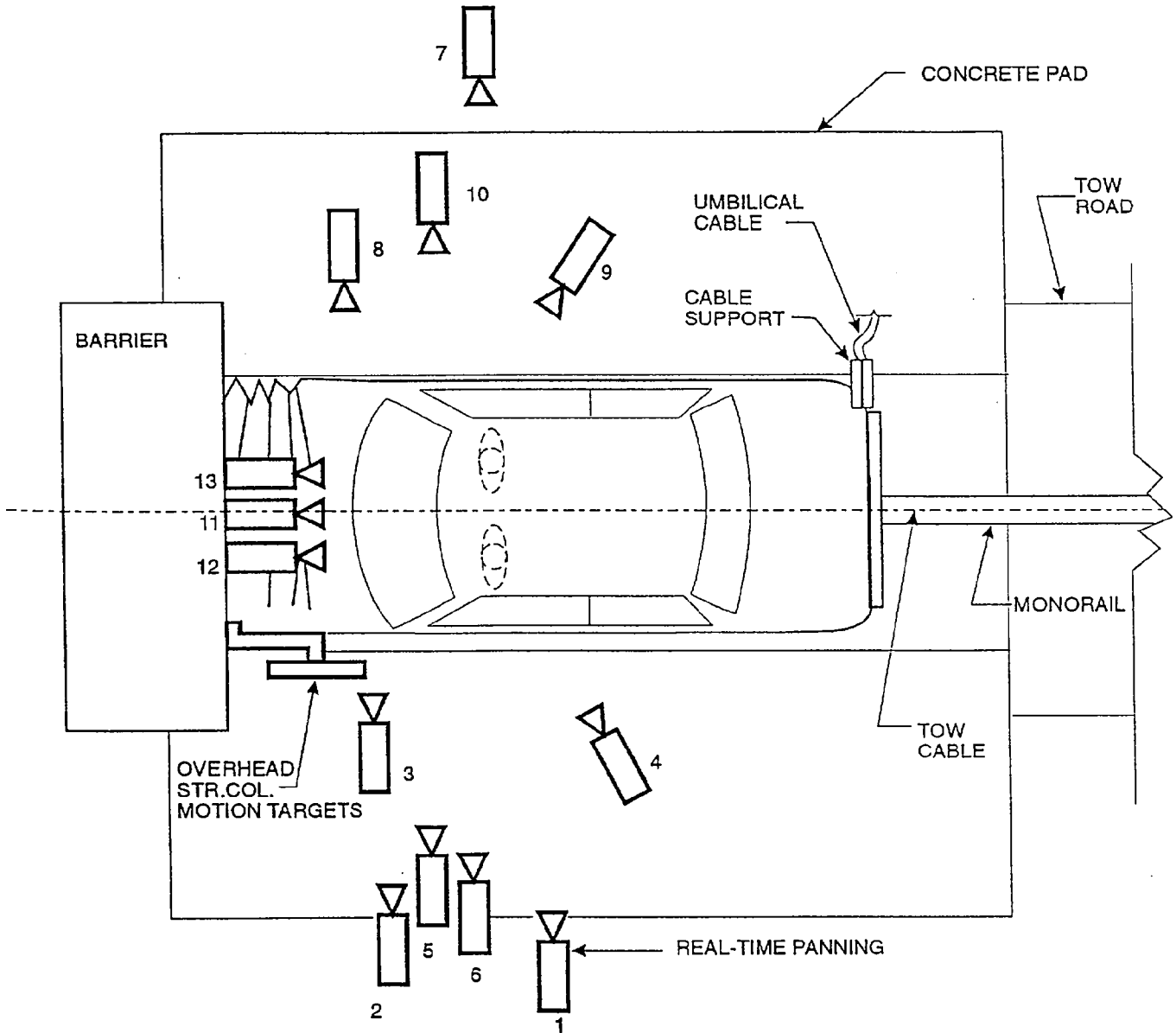

Figure 11 Camera Positions, Cont'd.

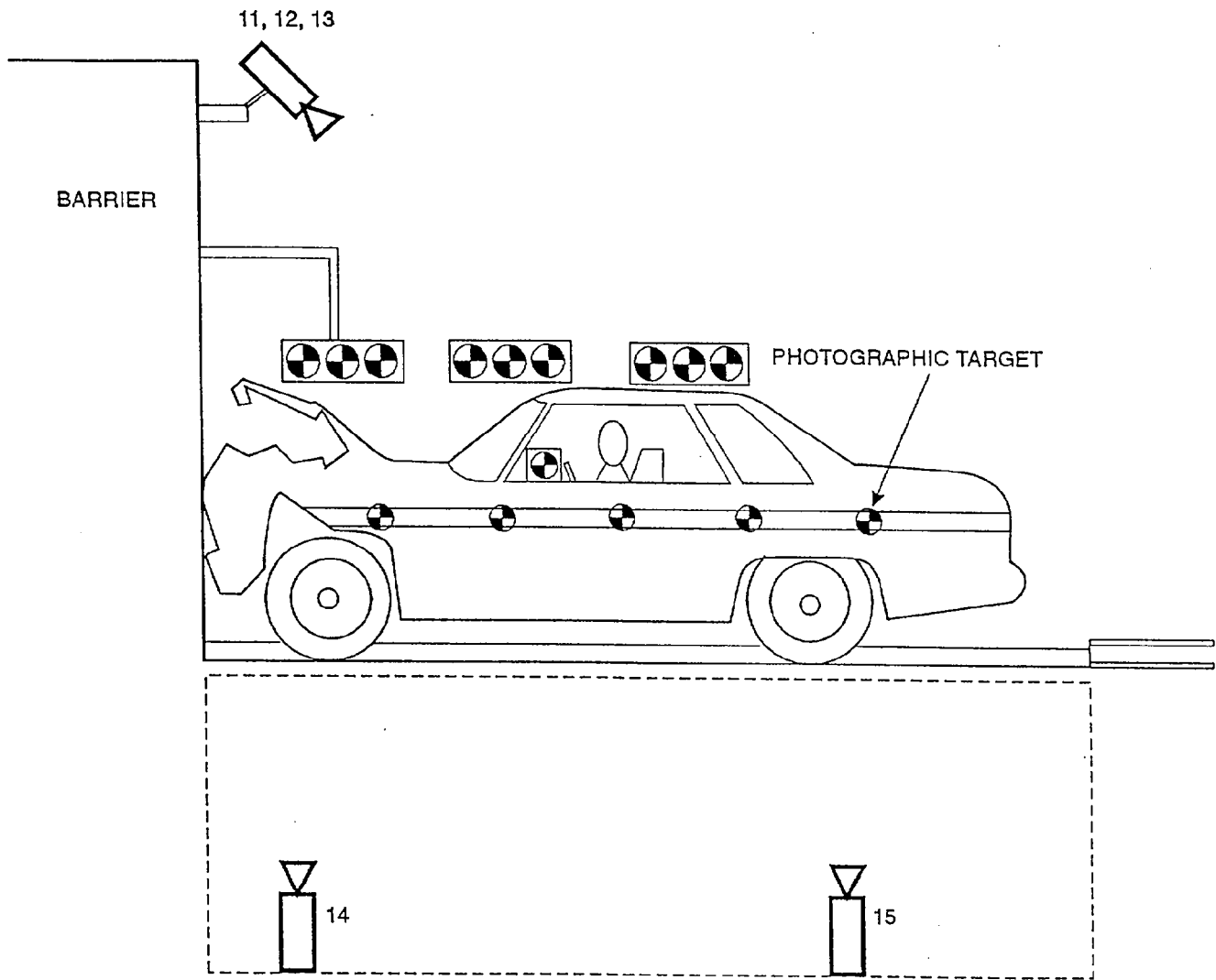

Table 13 Motion Picture Camera Locations

Vehicle year/make/model/body style: 1994/Kentron/SS Sport Top/van

Test number: 940322

Camera Number	View	X	Y	Z	Camera Angle ²	Film Plane to Head Target	Camera Lens	Film Speed
1	Real-time panning	-142.0 in	504.0 in	61.0 in	NA	NA	16 mm	24 frames/s
2	Left vehicle crush	-41.5 in	295.0 in	44.0 in	-4°	246 in	25 mm	1000 frames/s
3	Left windshield intrusion	-53.0 in	309.4 in	42.3 in	0°	NA	50 mm	1008 frames/s
4	Driver kinematics	-157.3 in	116.0 in	87.0 in	-27°	76 in	25 mm	998 frames/s
5	Steering column motion	- 82.0 in	282.0 in	98.5 in	-14°	NA	25 mm	1002 frames/s
6	Steering column motion	- 82.0 in	282.0 in	62.2 in	-9°	NA	25 mm	1008 frames/s
7	Right overall	-81.3 in	-266.4 in	37.1 in	-2°	NA	13 mm	985 frames/s
8	Right windshield intrusion	-52.0 in	-170.2 in	44.0 in	0°	NA	50 mm	1000 frames/s
9	Passenger kinematics	-152.1 in	-116.0 in	87.0 in	-26°	63 in	25 mm	998 frames/s
10	Passenger kinematics	-38.8 in	-293.0 in	45.3 in	-4°	215 in	25 mm	998 frames/s
11	Windshield front view	-6.0 in	0.0 in	85.0 in	-40°	NA	13 mm	1015 frames/s
12	Driver - front view	-6.8 in	14.5 in	75.5 in	-50°	NA	17 mm	973 frames/s
13	Passenger - front view	-4.5 in	-13.8 in	93.0 in	-50°	NA	17 mm	998 frames/s
14	Pit - front position	-50.5 in	0.0 in	-92.4 in	90°	NA	13 mm	998 frames/s
15	Pit - rear position	-99.3 in	0.0 in	-99.0 in	90°	NA	13 mm	1000 frames/s
16	Real-time documentation	NA	NA	NA	NA	NA	12-120 mm	24 frames/s

¹ +X: Film plane forward of barrier face

+Y: Film plane to left of monorail centerline

+Z: Film plane above ground level

² +Angle: Film plane angled upward from horizontal plane

Appendix A

Photographs

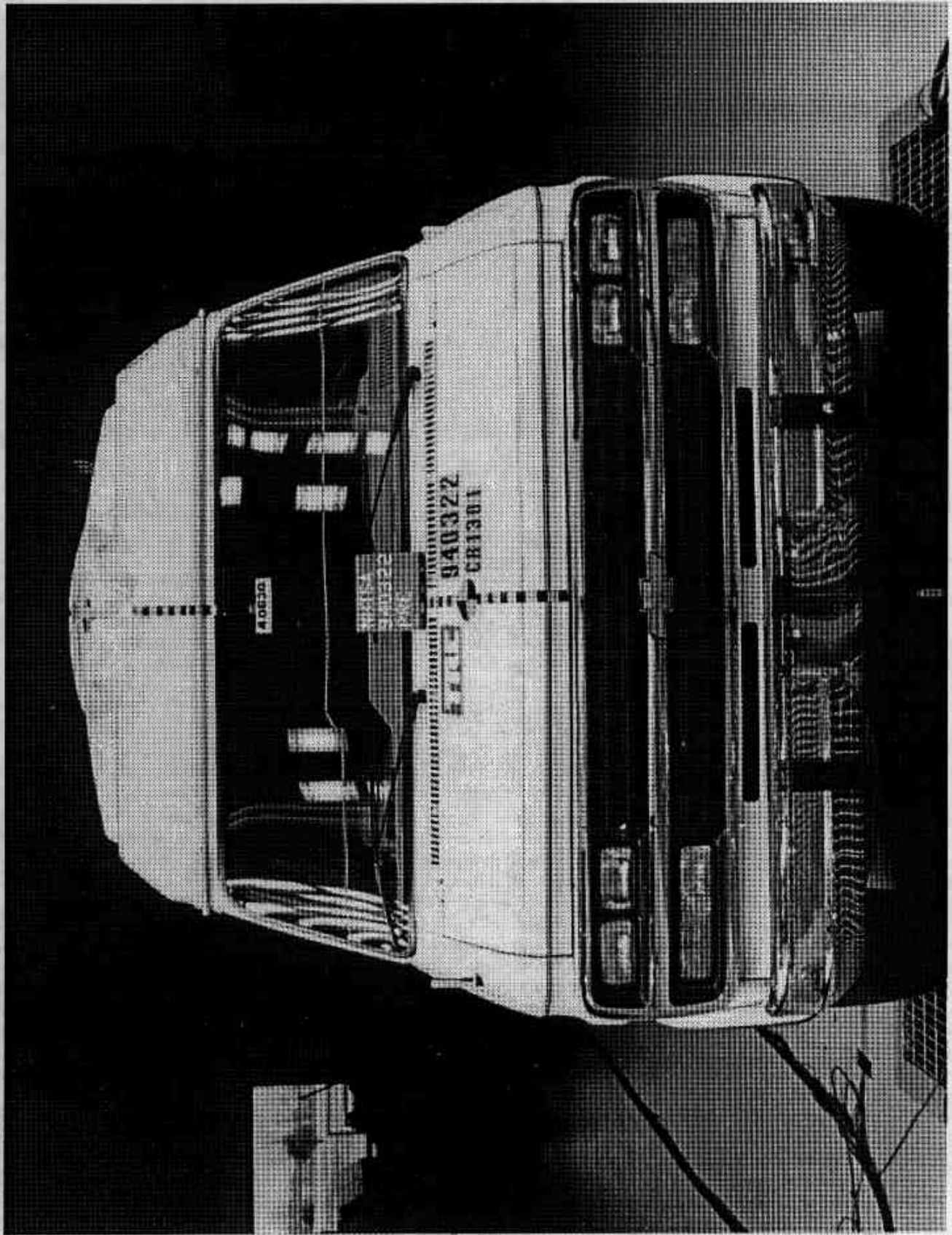

Figure A-1. Pre-test Front View
A-2

940322

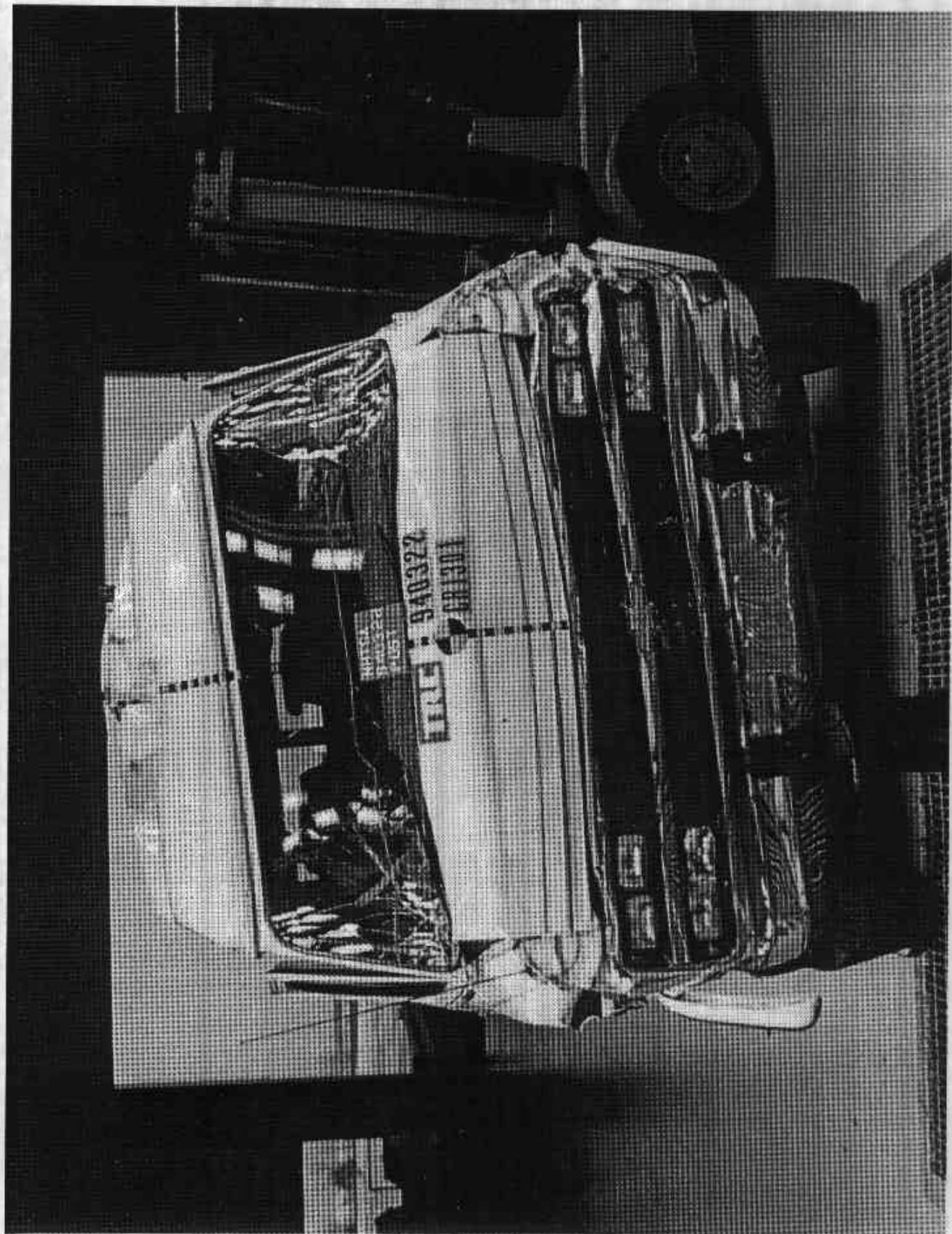

Figure A-2. Post-test Front View
A-3

940322

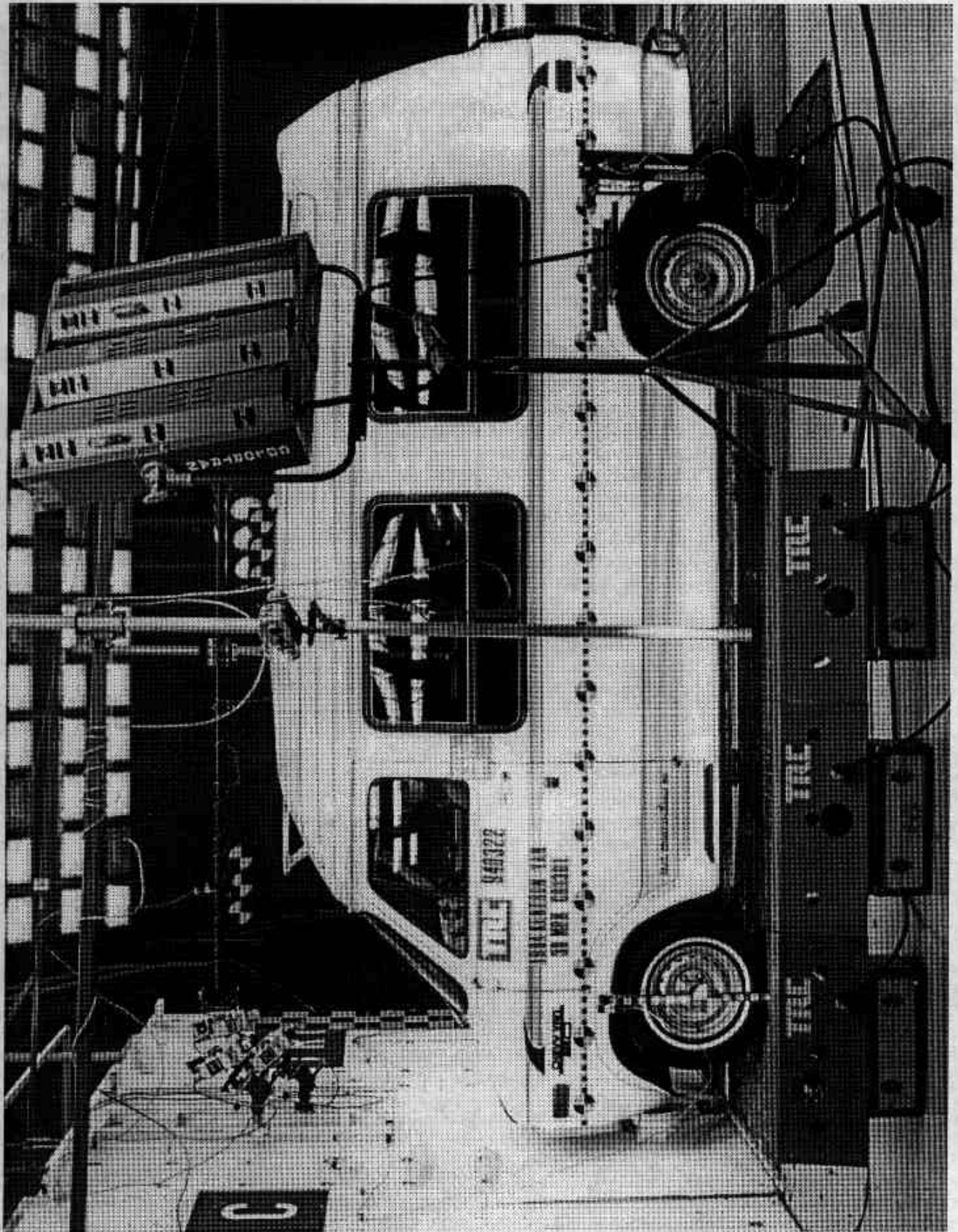

Figure A-3. Pre-test Left Side View
A-4

940322

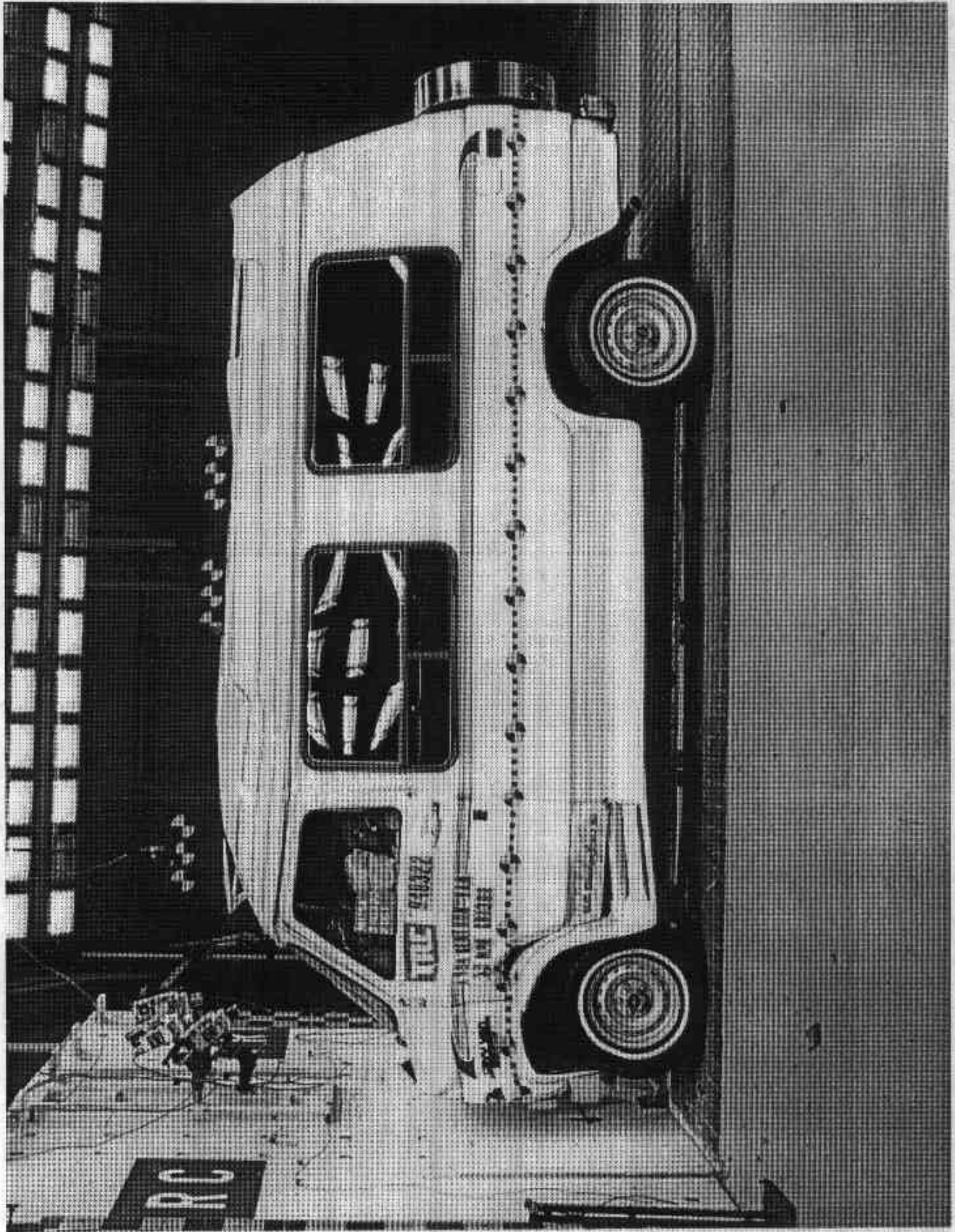

Figure A-4. Post-test Left Side View
A-5

940322

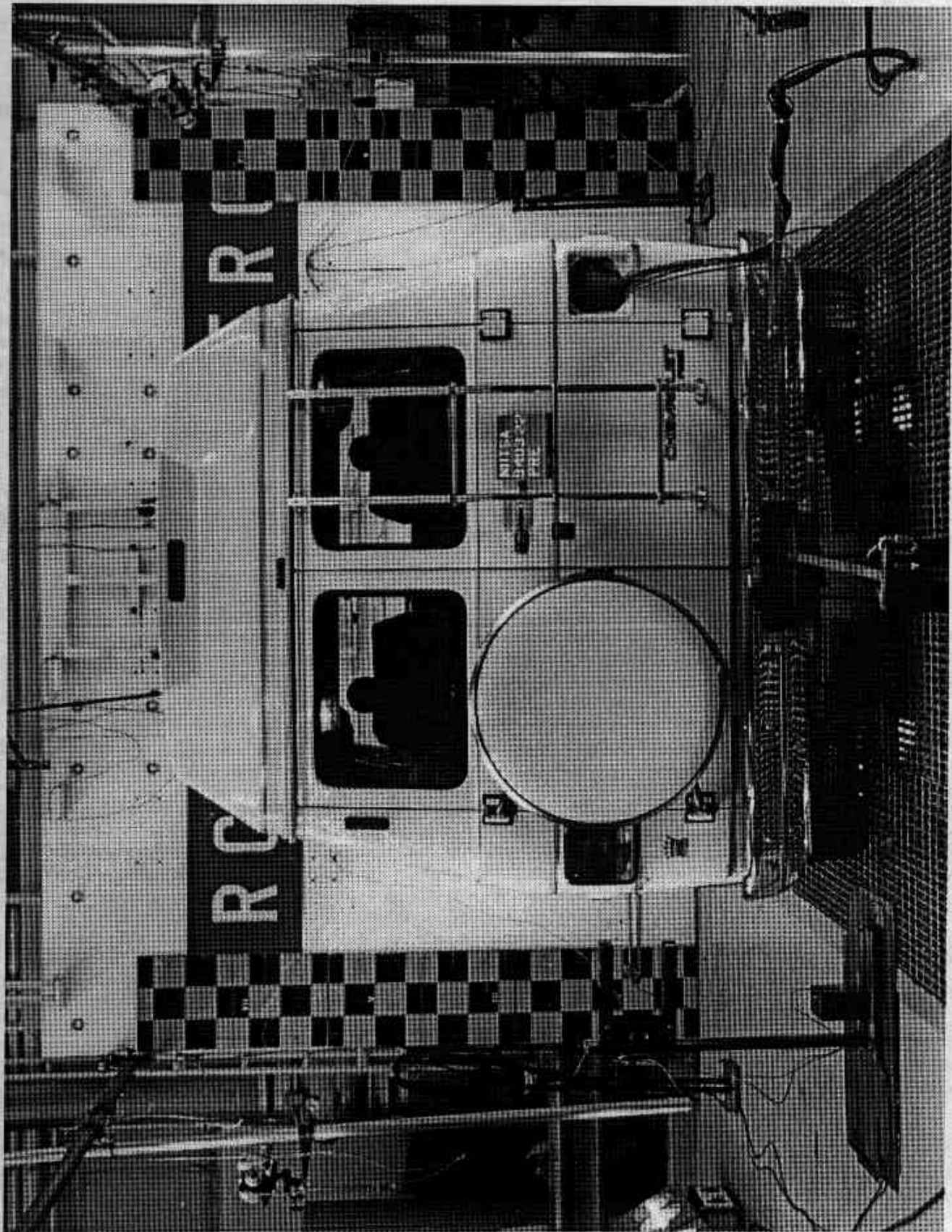

Figure A-5. Pre-test Rear View
A-6

940322

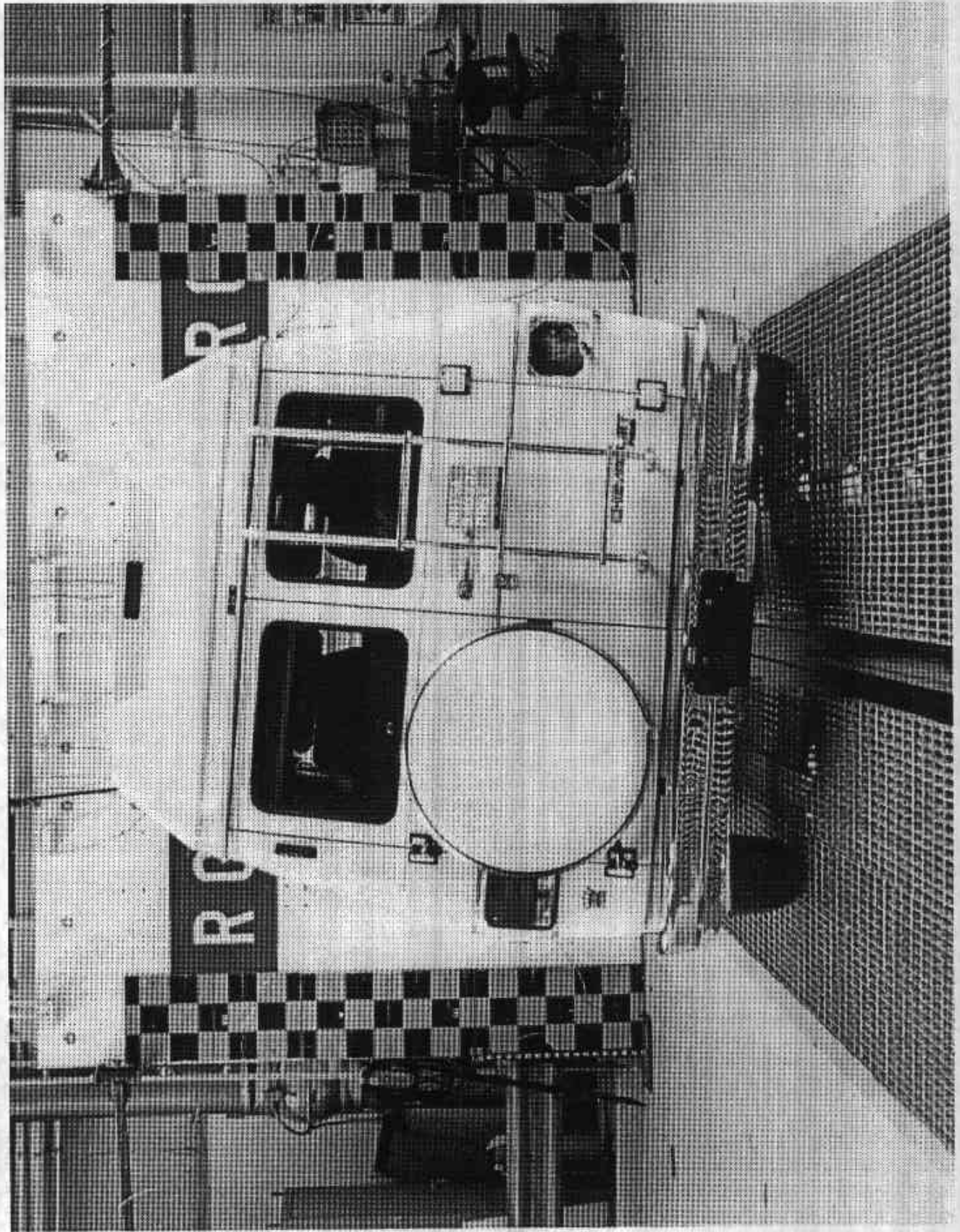

Figure A-6. Post-test Rear View
A-7

940322

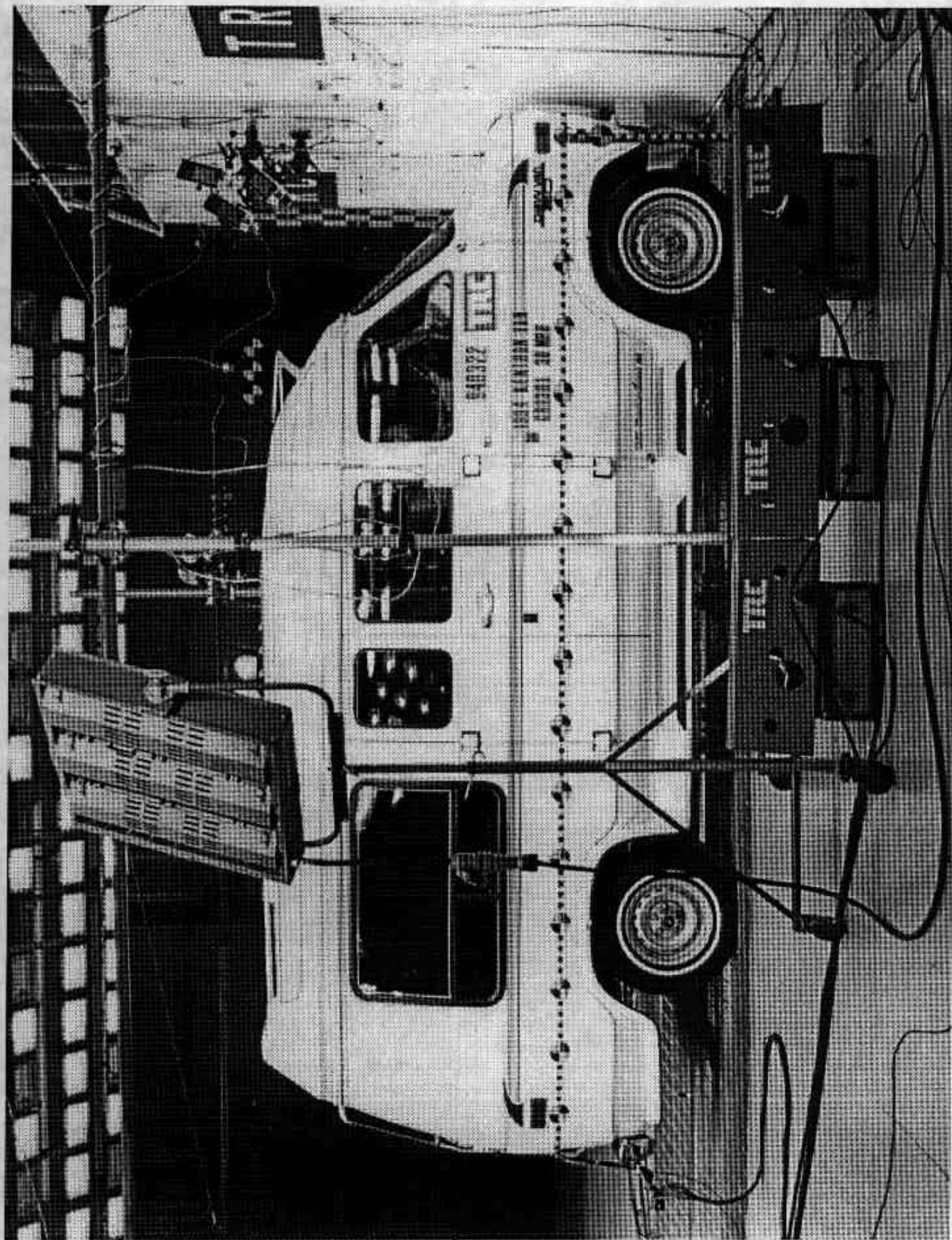

Figure A-7. Pre-test Right Side View

A-8

940322

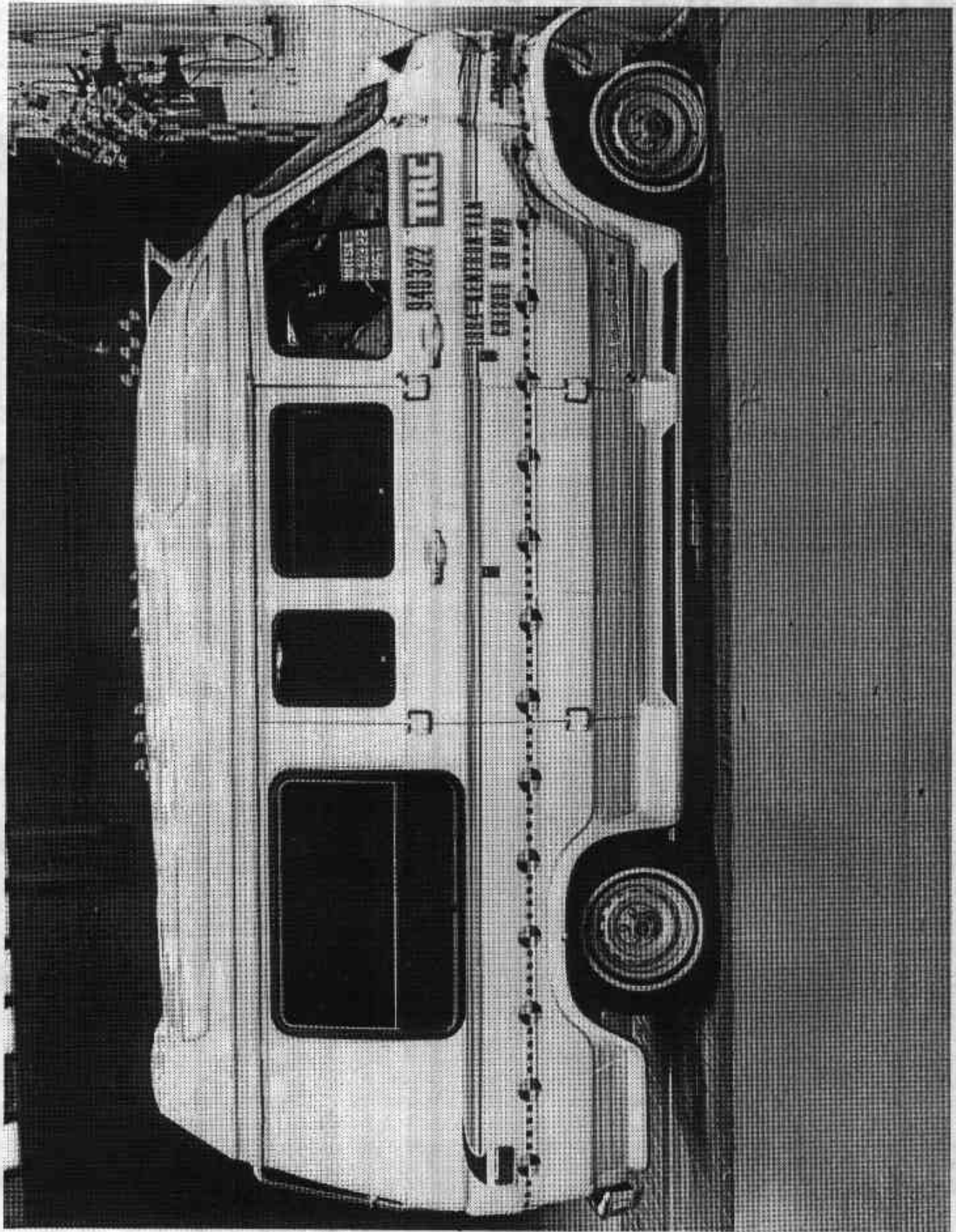

Figure A-8. Post-test Right Side View
A-9

940322

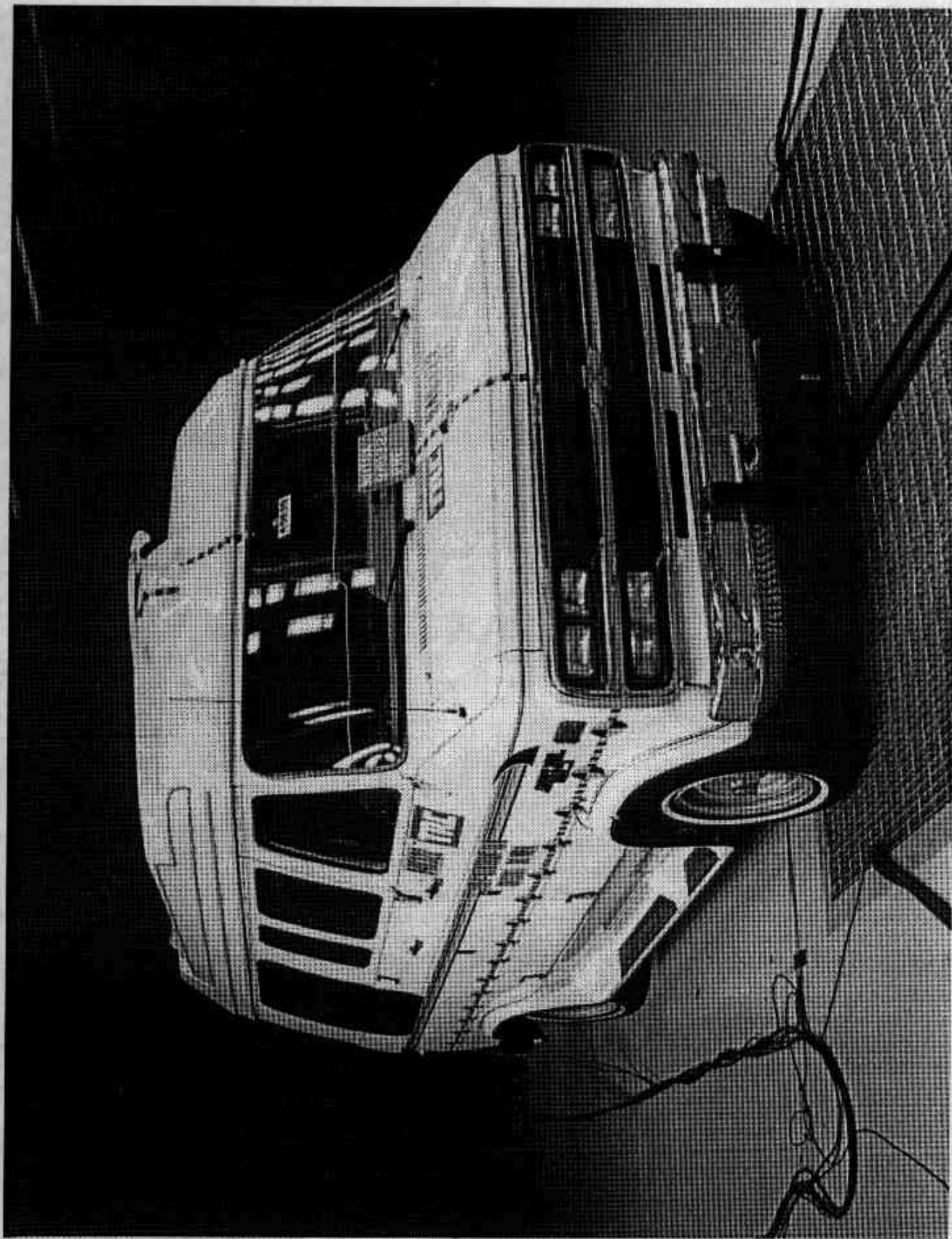

Figure A-9. Pre-test Right Front Three-quarter View
A-10

940322



Figure A-10. Post-test Right Front Three-quarter View
A-11

940322

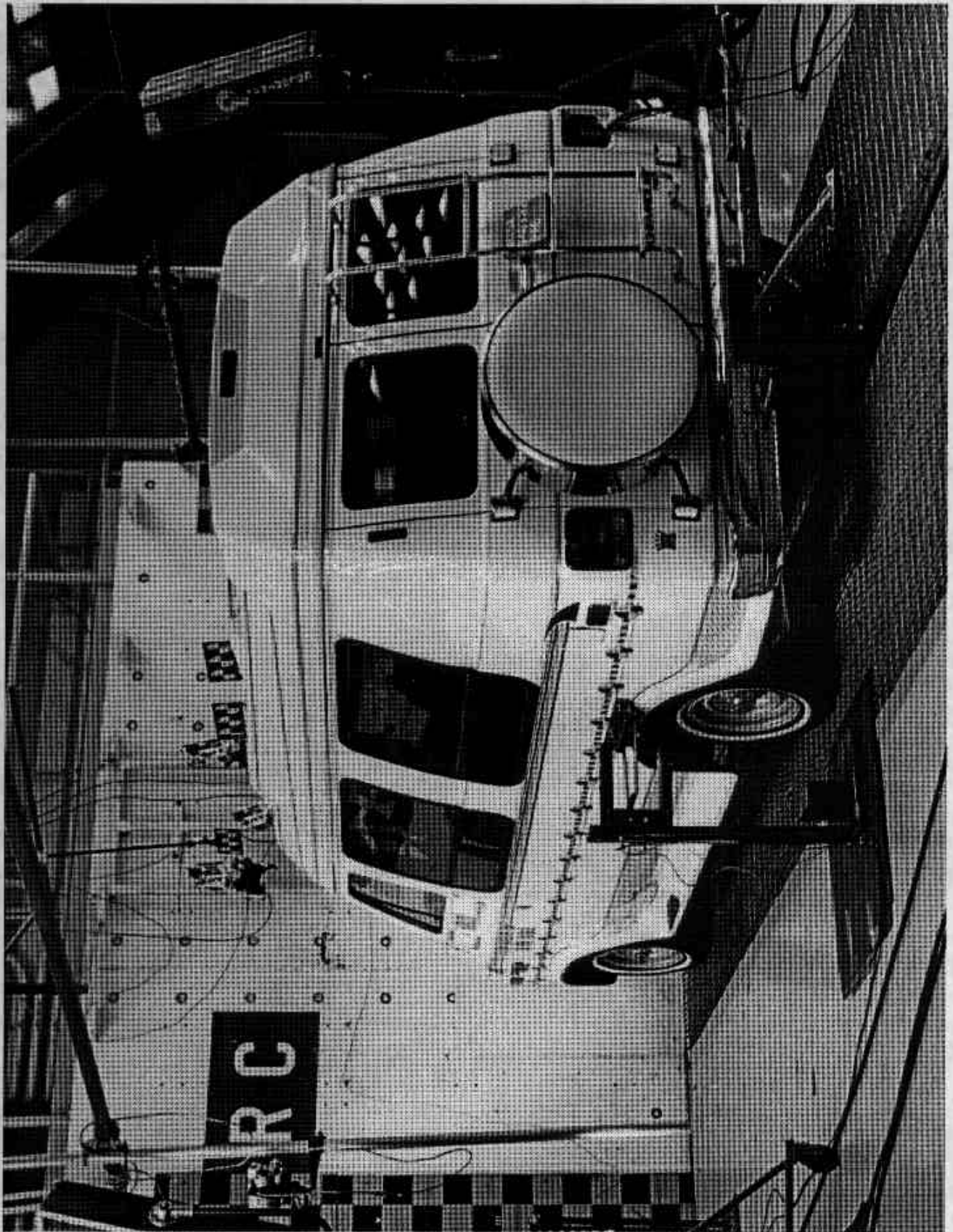

Figure A-11. Pre-test Left Rear Three-quarter View
A-12

940322

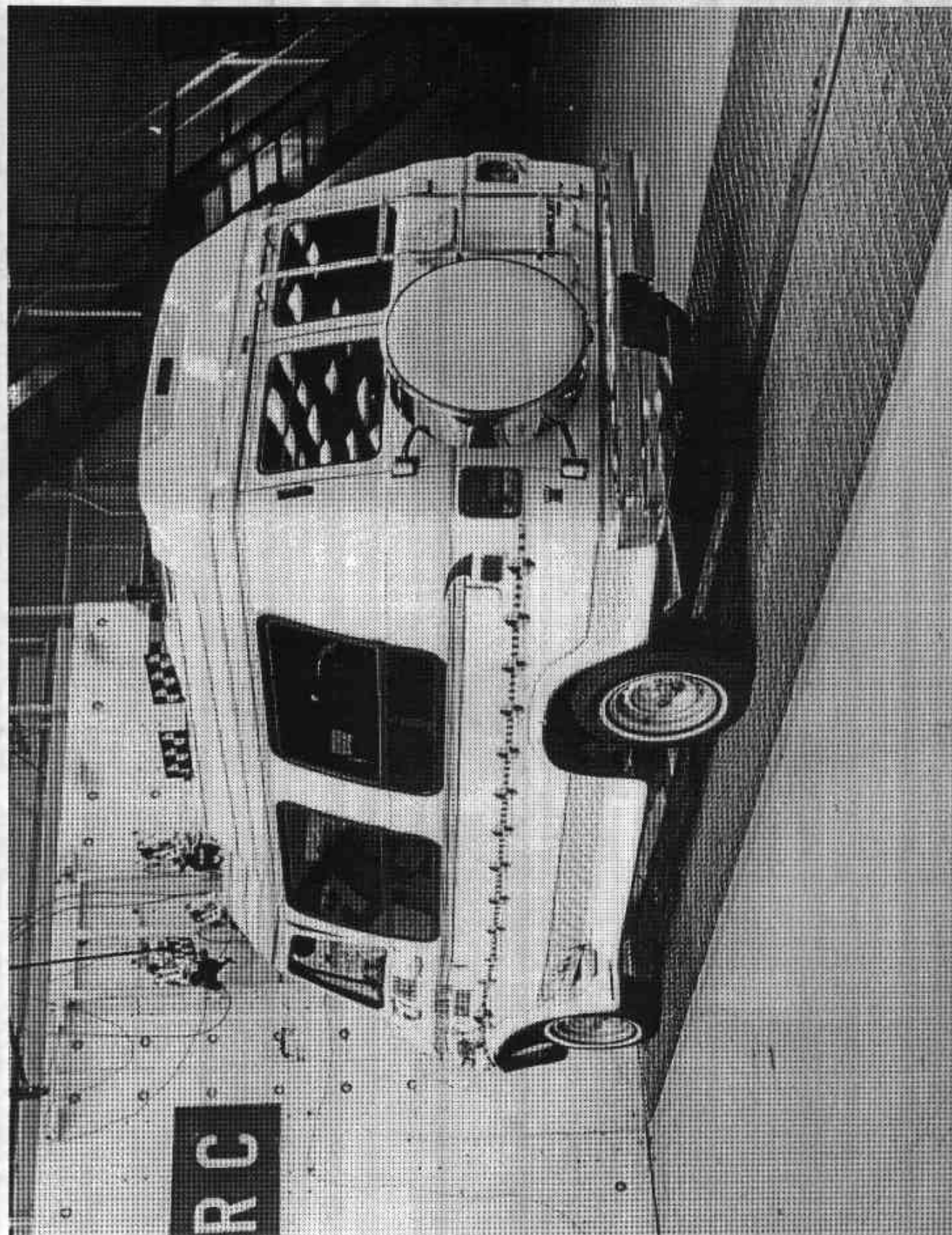

Figure A-12. Post-test Left Rear Three-quarter View
A-13

940322

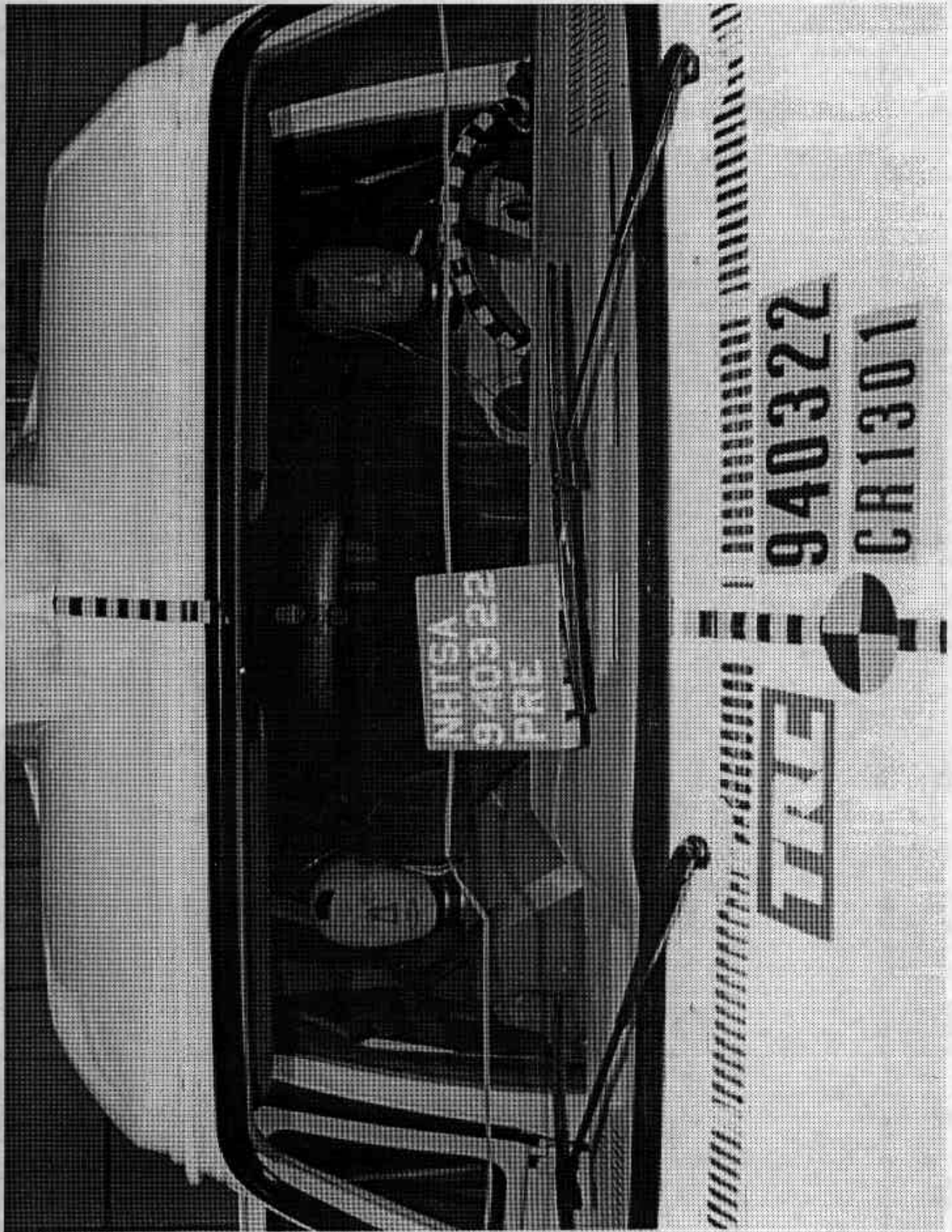

Figure A-13. Pre-test Windshield View
A-14

940322

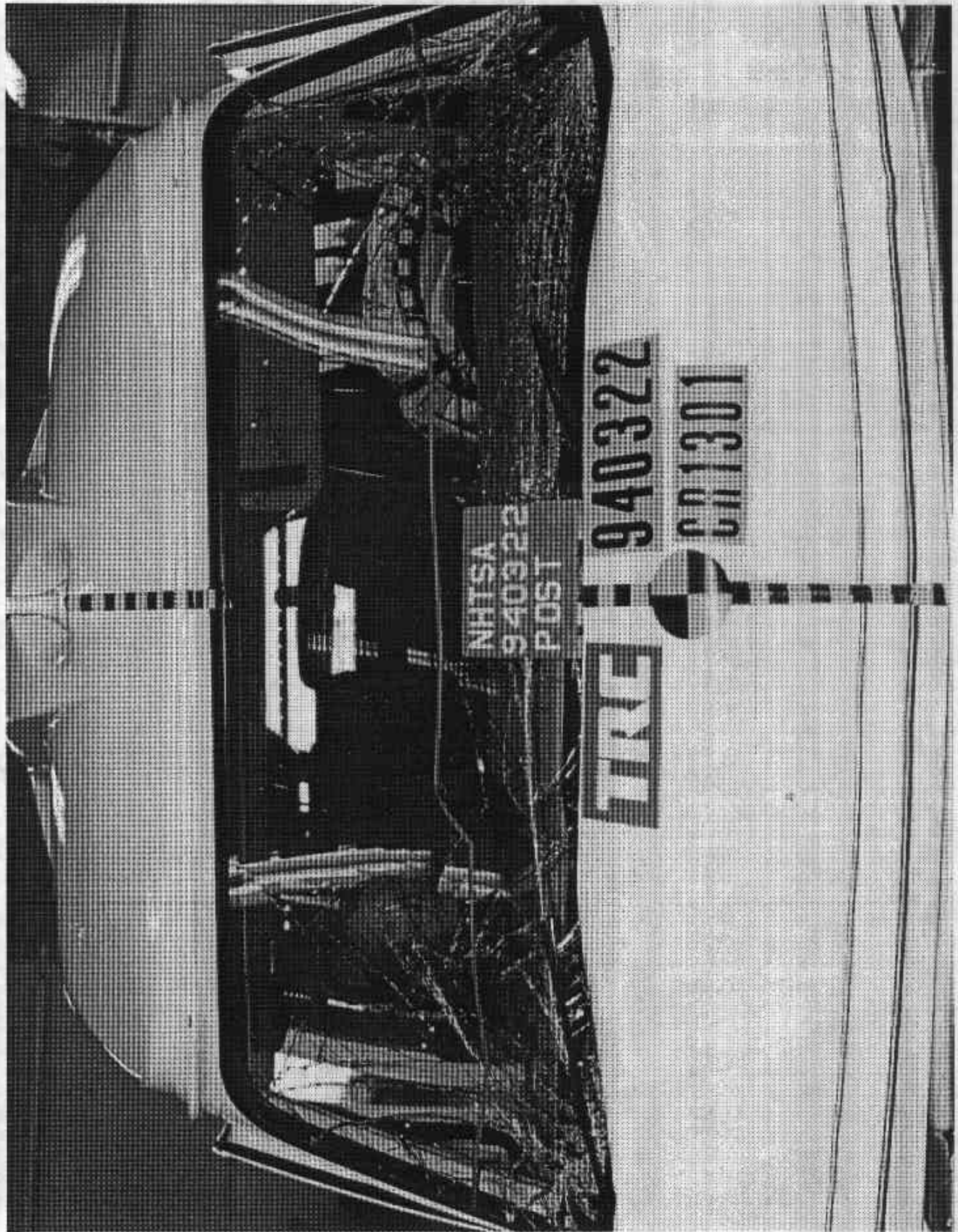

Figure A-14. Post-test Windshield View
A-15

940322

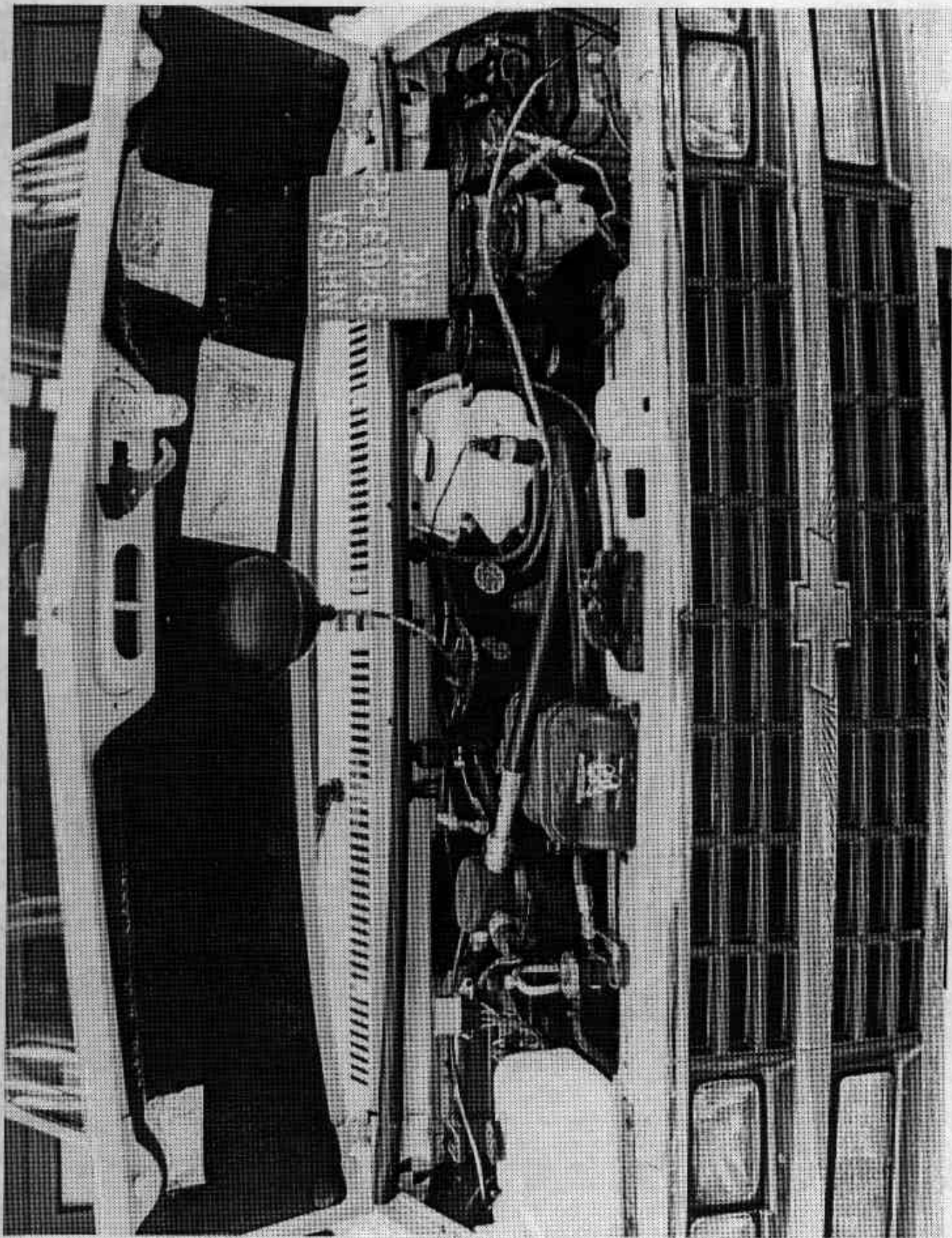

Figure A-15. Pre-test Engine Compartment View
A-16

940322



Figure A-16. Post-test Engine Compartment View
A-17

940322

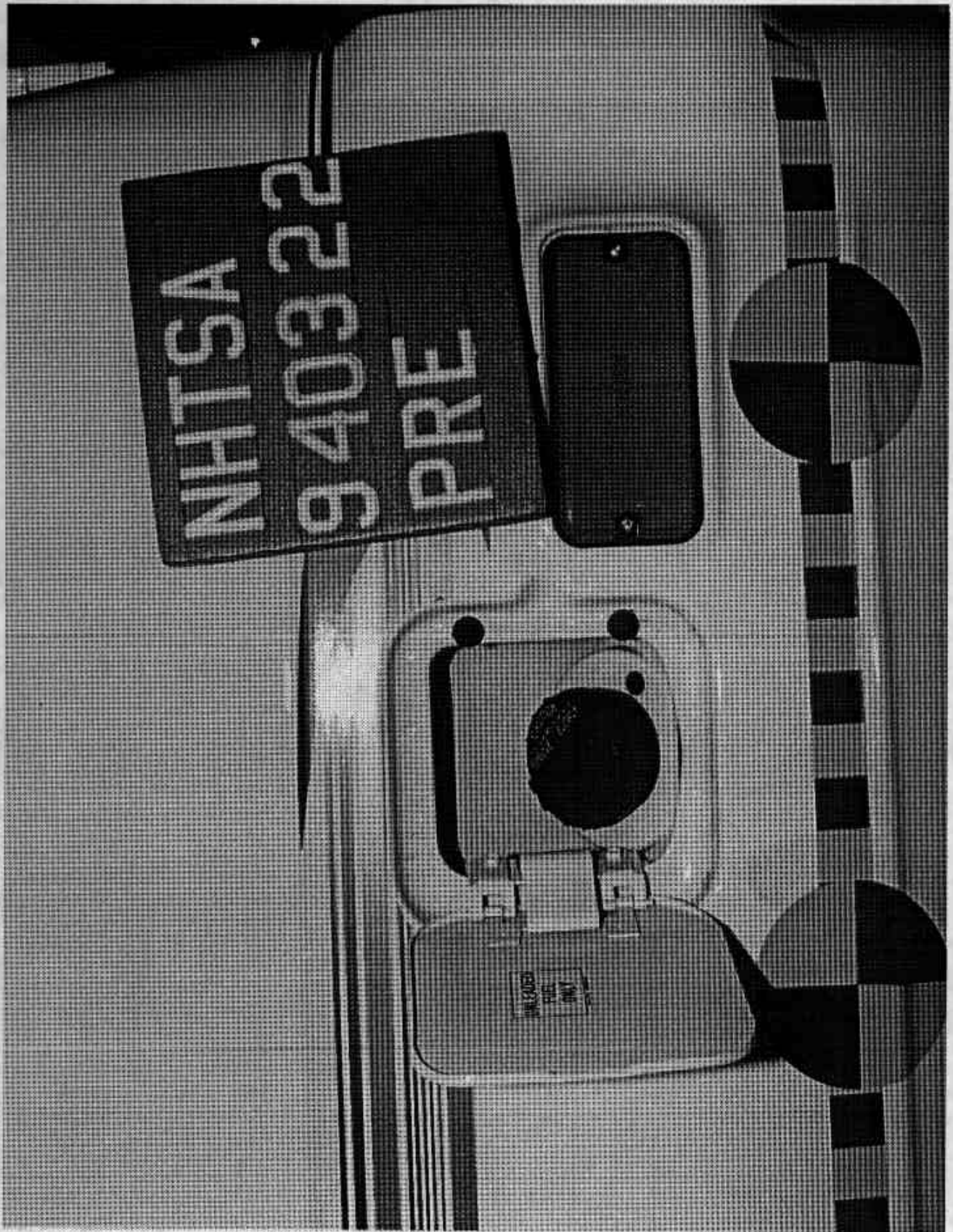

Figure A-17. Pre-test Fuel Filler Cap View
A-18

940322

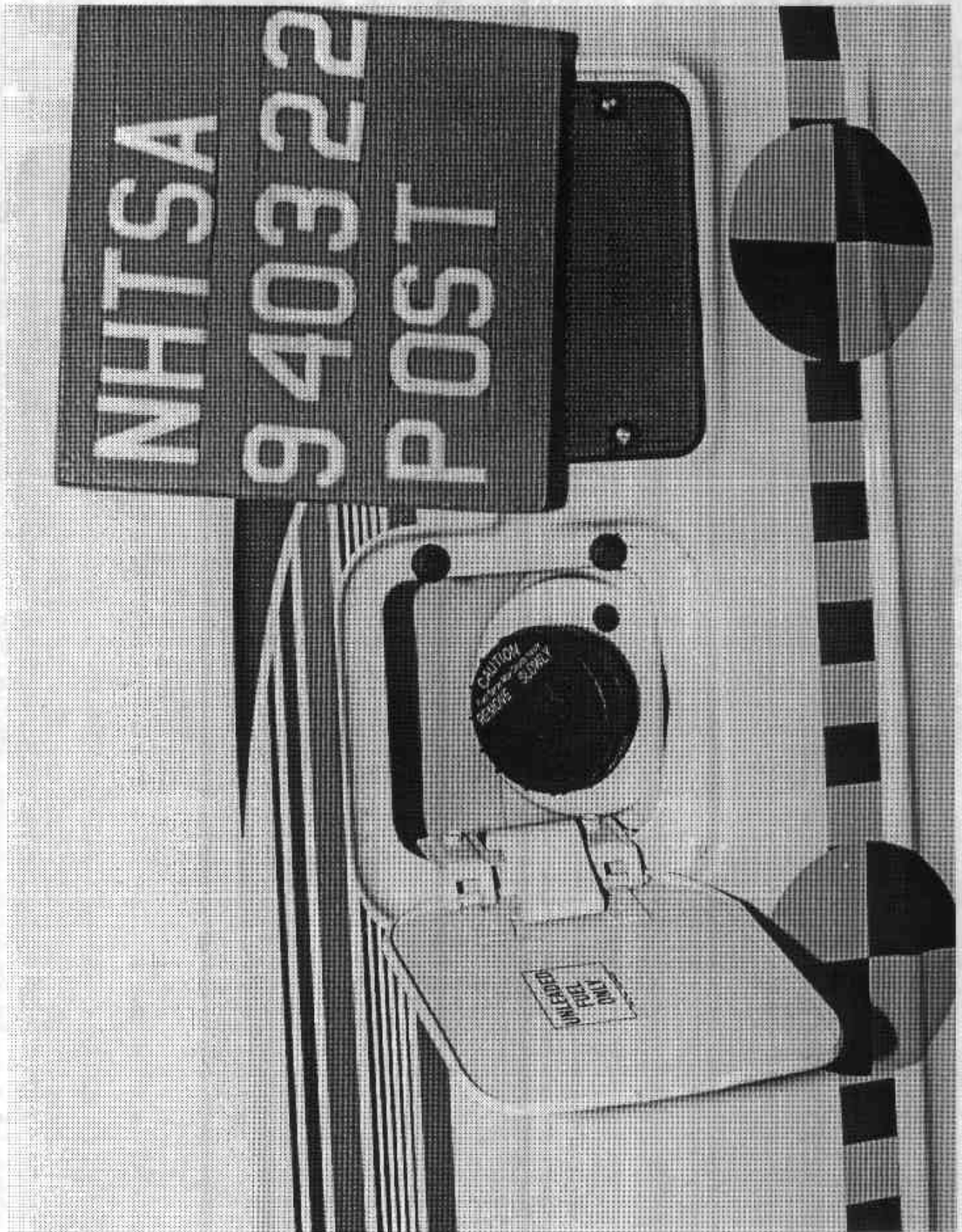

Figure A-18. Post-test Fuel Filler Cap View
A-19

940322

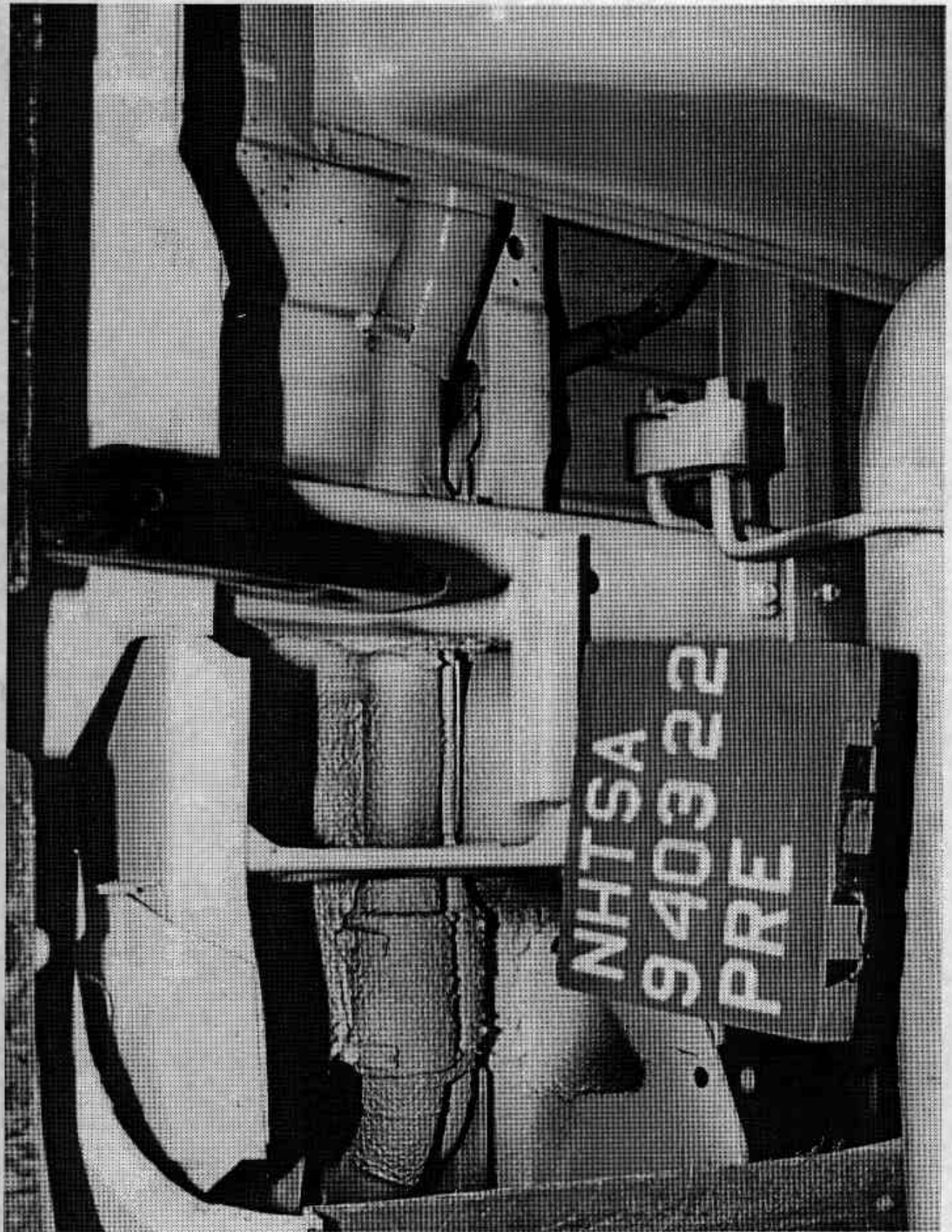

Figure A-19. Pre-test Fuel Filler Neck View
A-20

940322

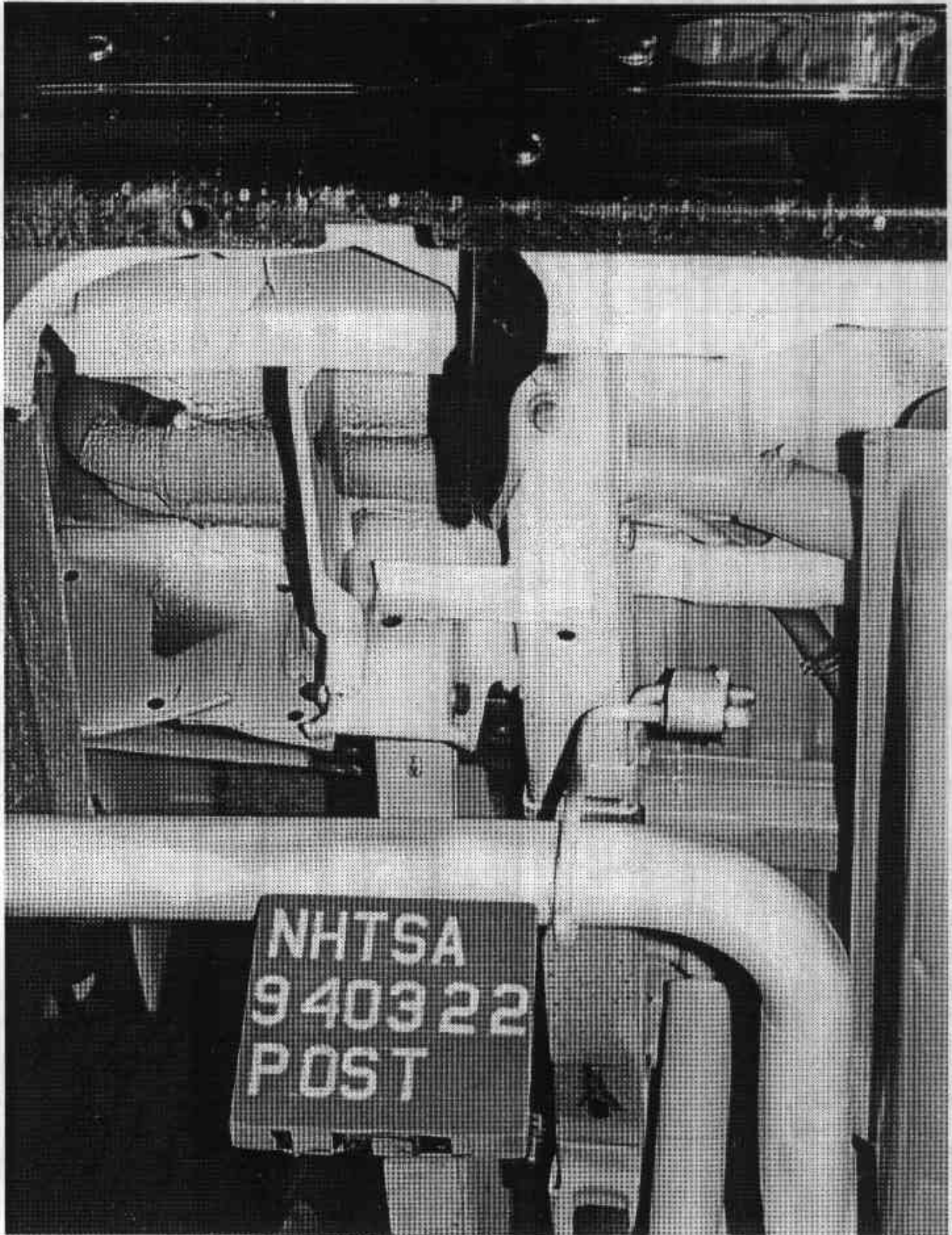

Figure A-20. Post-test Fuel Filler Neck View
A-21

940322

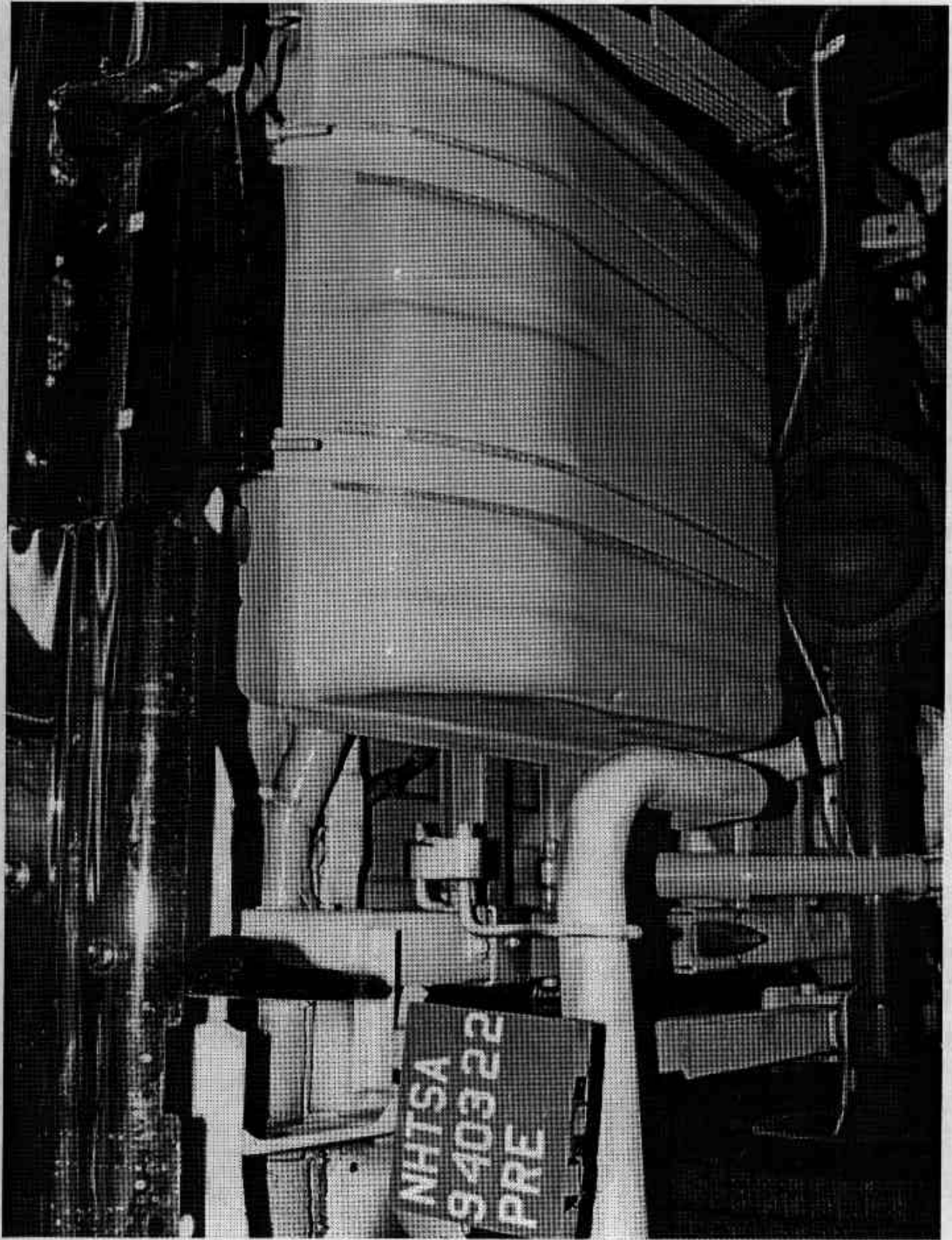

Figure A-21. Pre-test Fuel Filler Neck and Fuel Tank View
A-22

940322

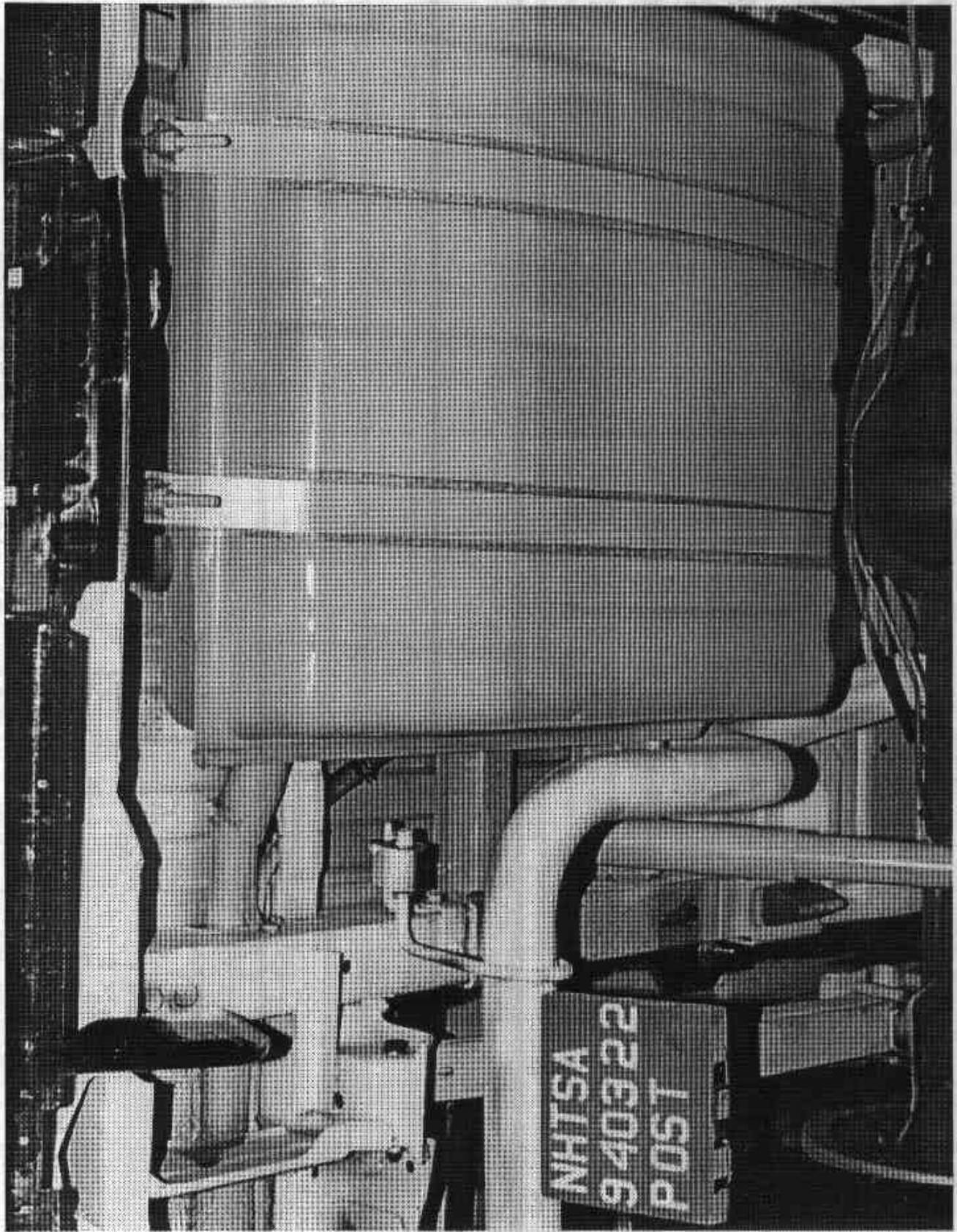

Figure A-22. Post-test Fuel Filler Neck and Fuel Tank View

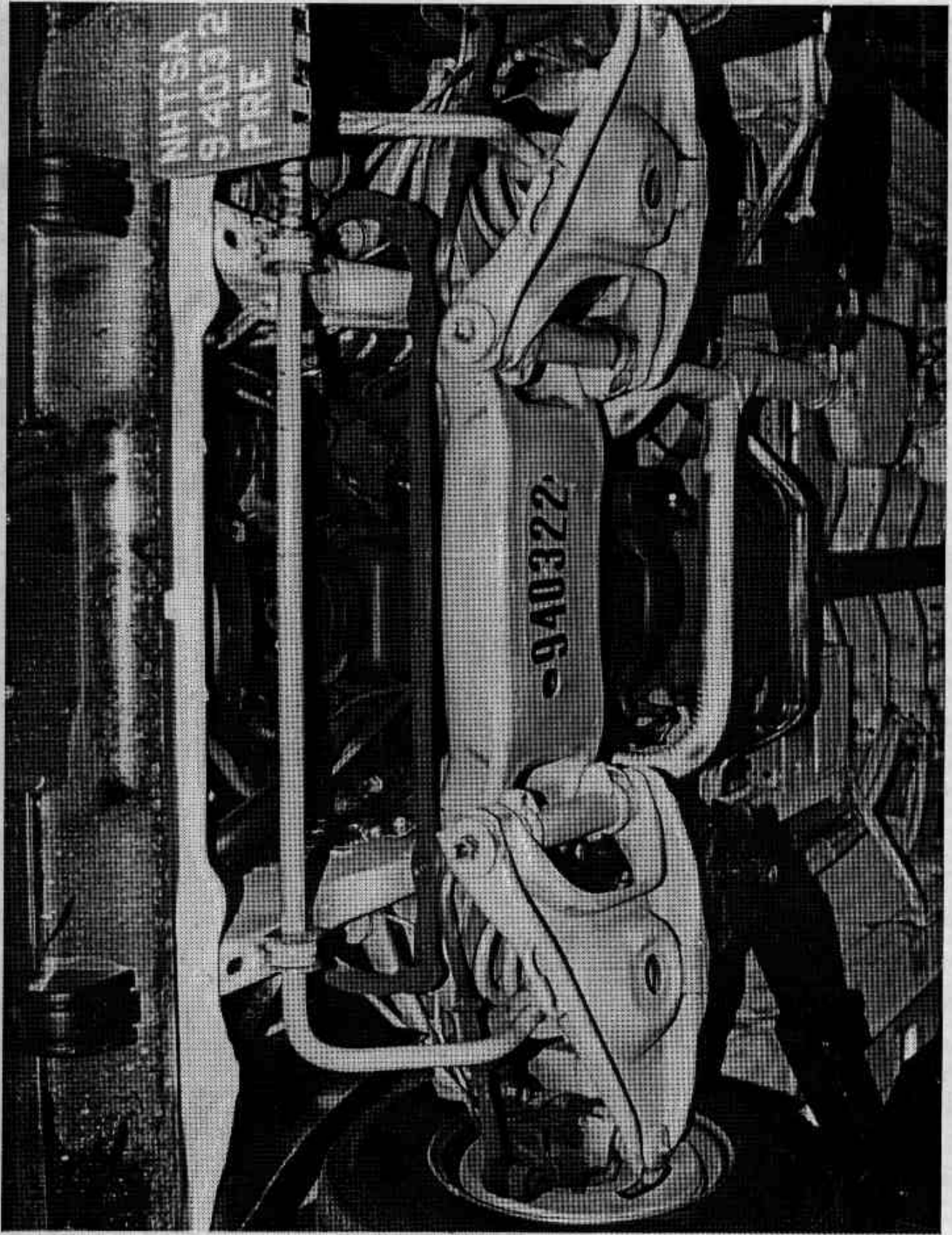

Figure A-23. Pre-test Front Underbody View

A-24

940322

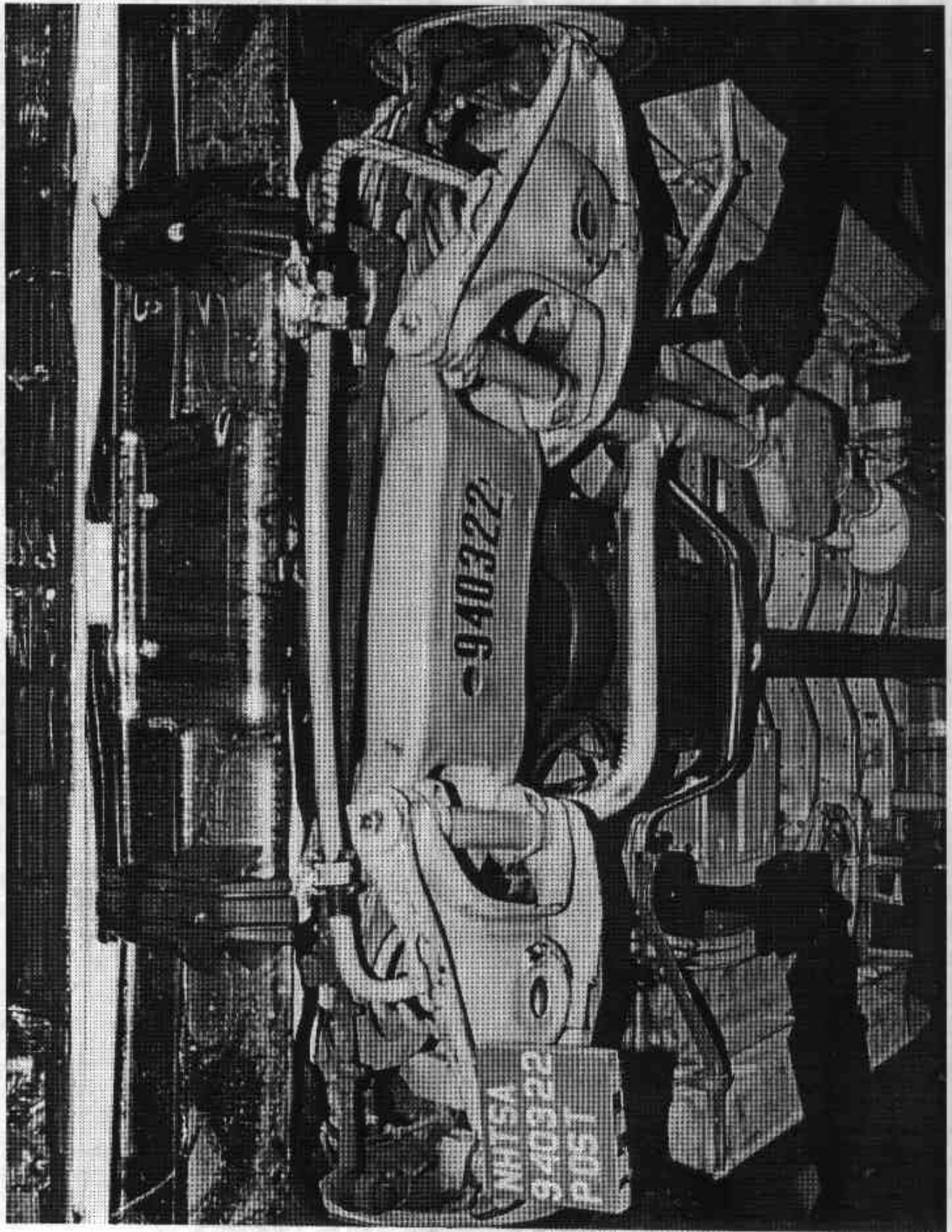

Figure A-24. Post-test Front Underbody View
A-25

940322

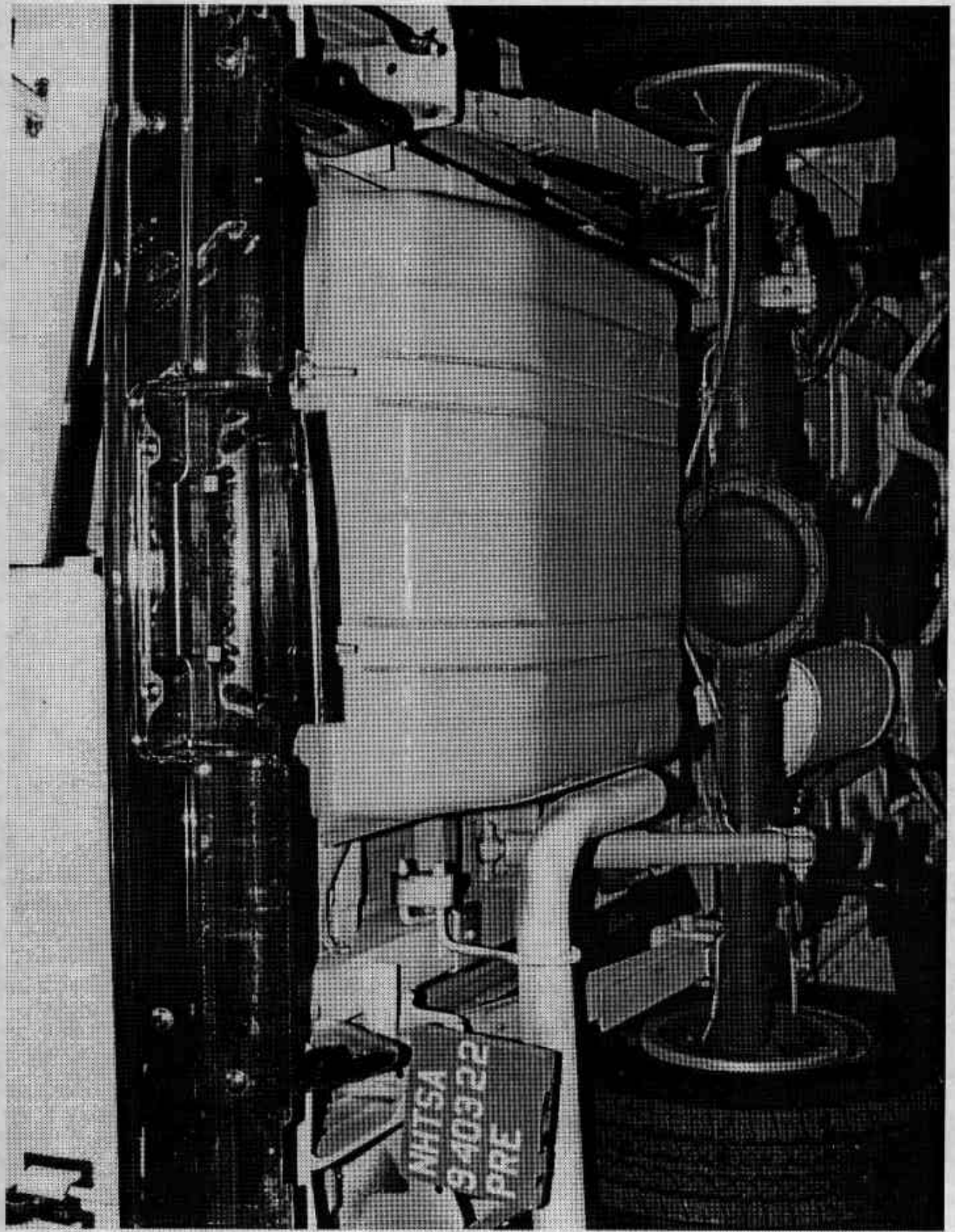

Figure A-25. Pre-test Rear Underbody View
A-26

940322

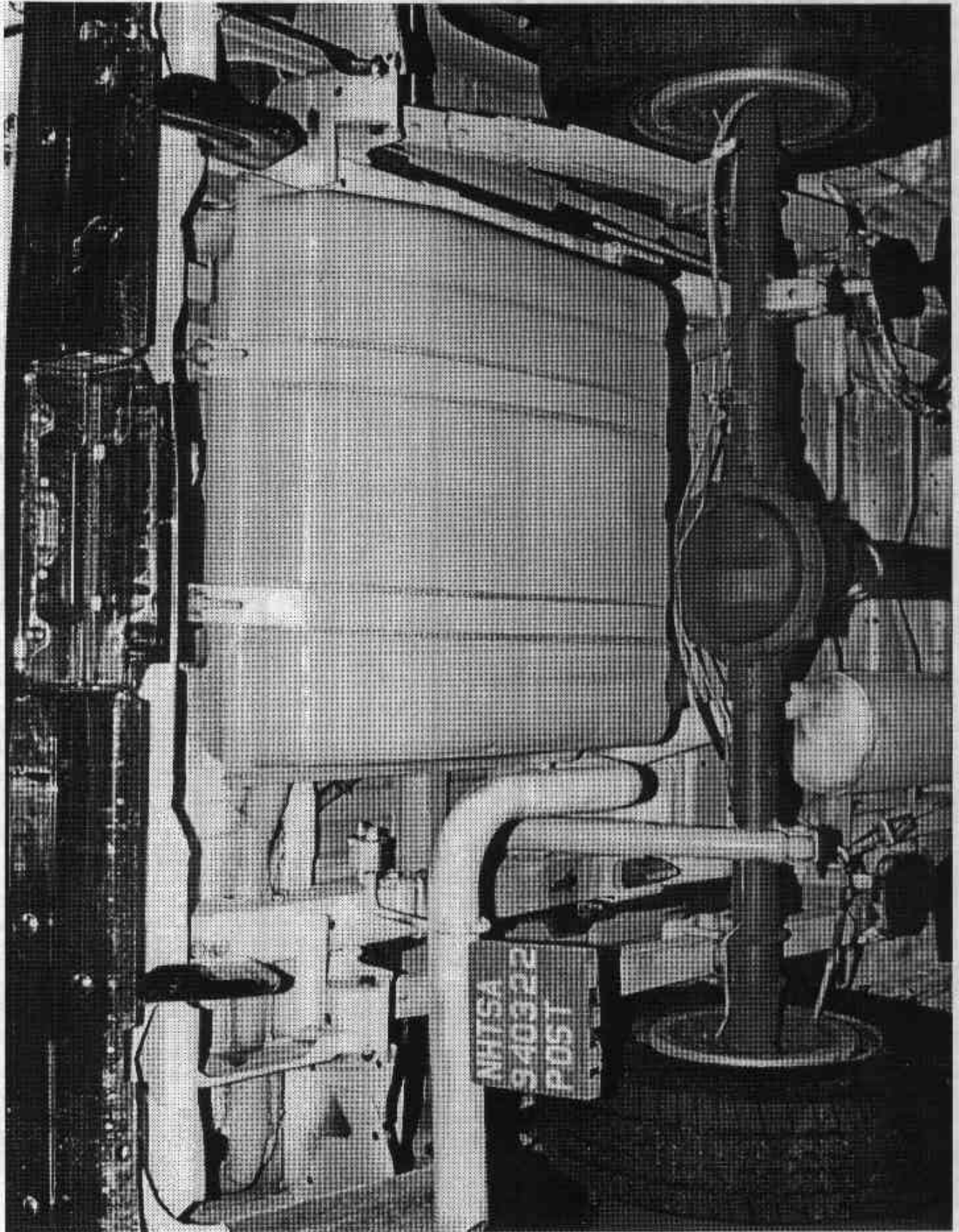

Figure A-26. Post-test Rear Underbody View
A-27

940322

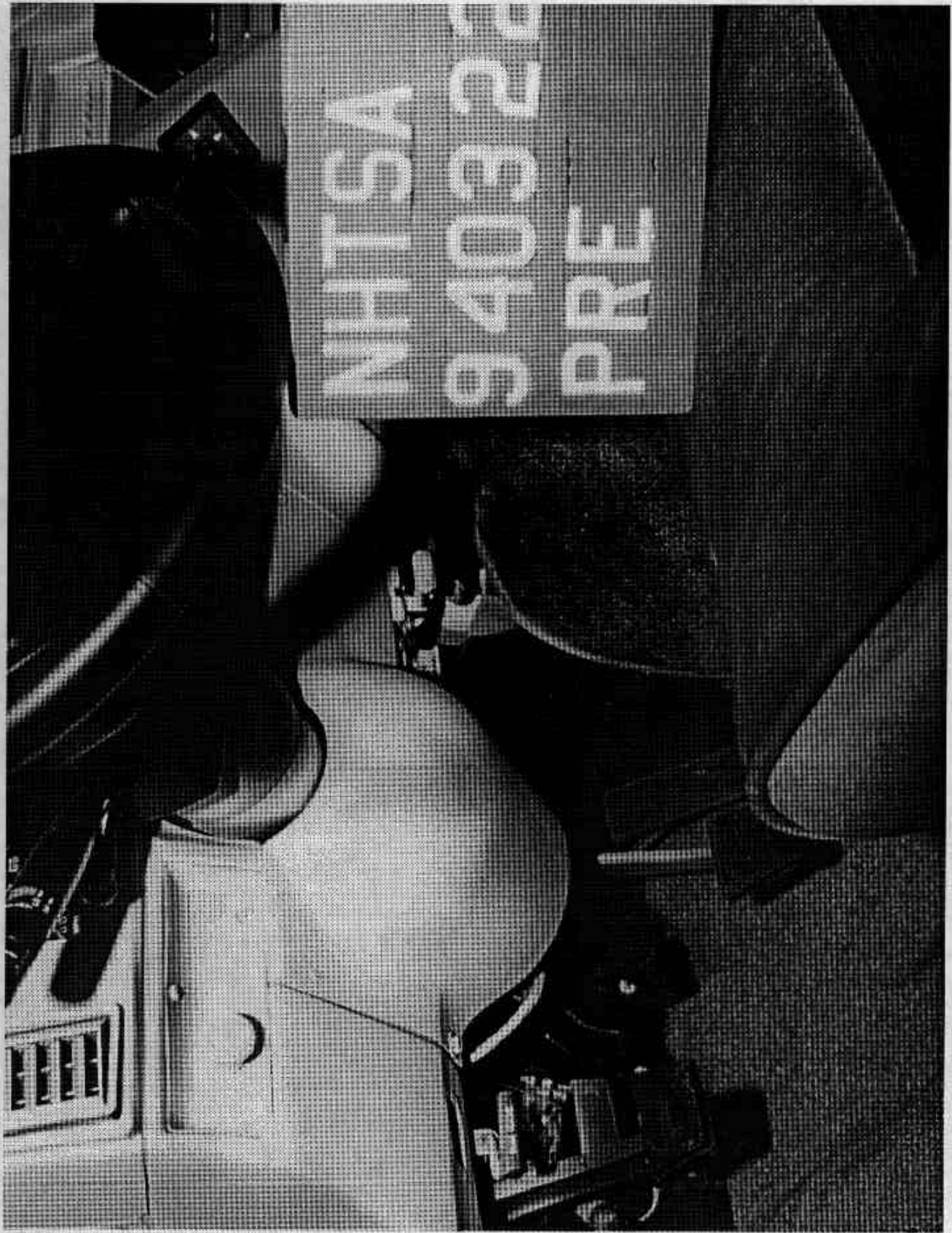

Figure A-27. Pre-test Driver's Knee Bolster View
A-28

940322

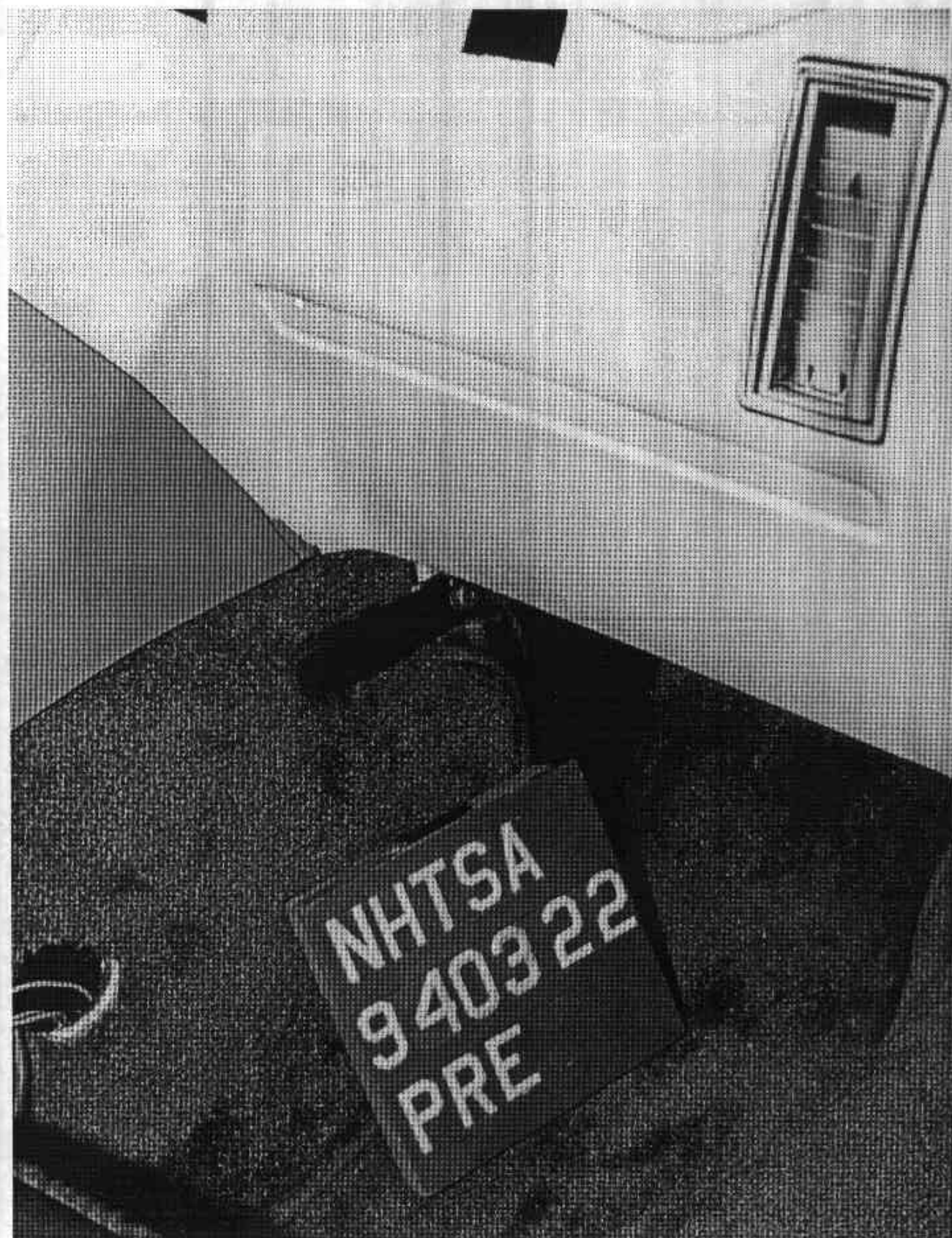

Figure A-28. Pre-test Passenger's Knee Bolster View
A-29

940322

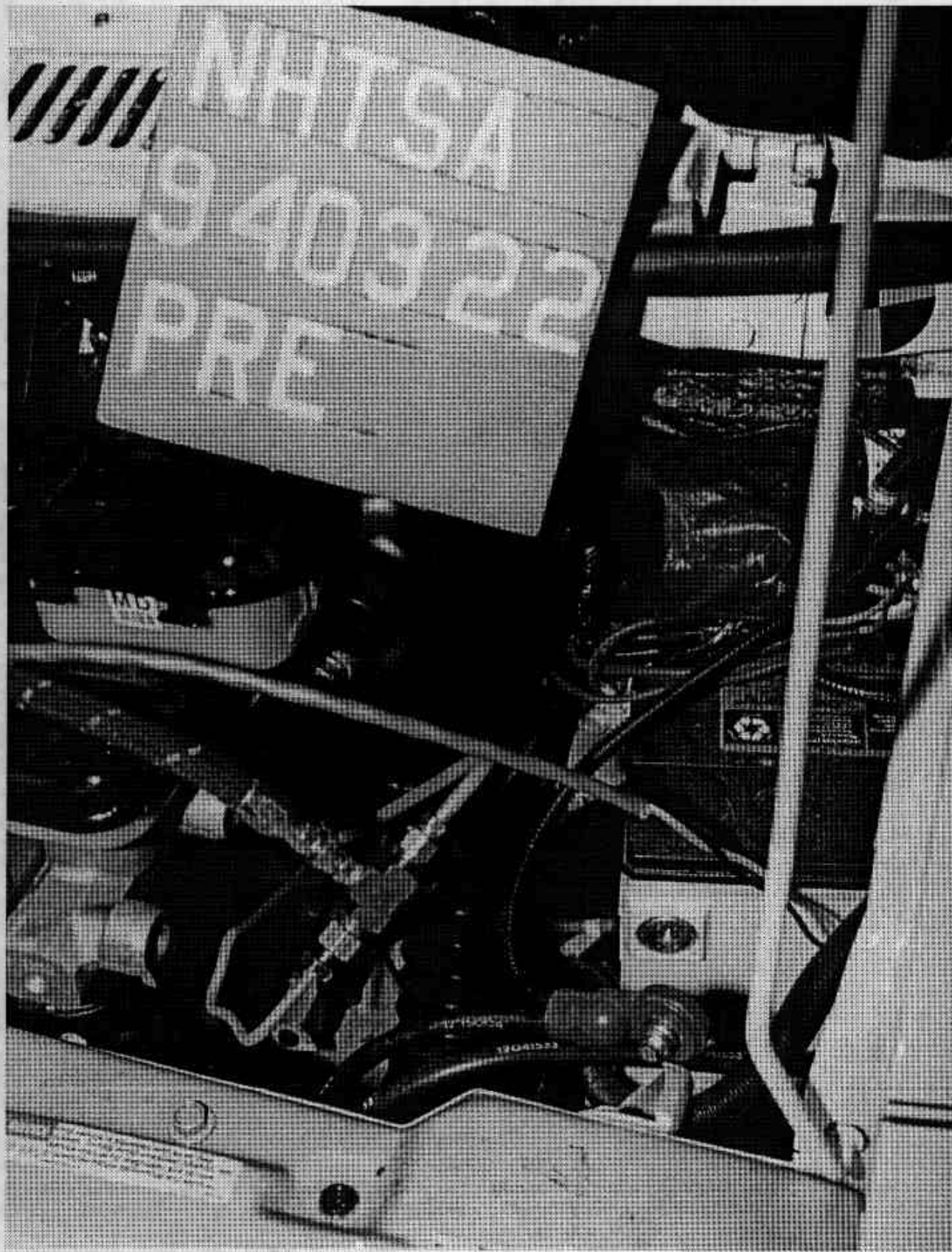

Figure A-29. Pre-test Steering Column at Firewall View
A-30

940322

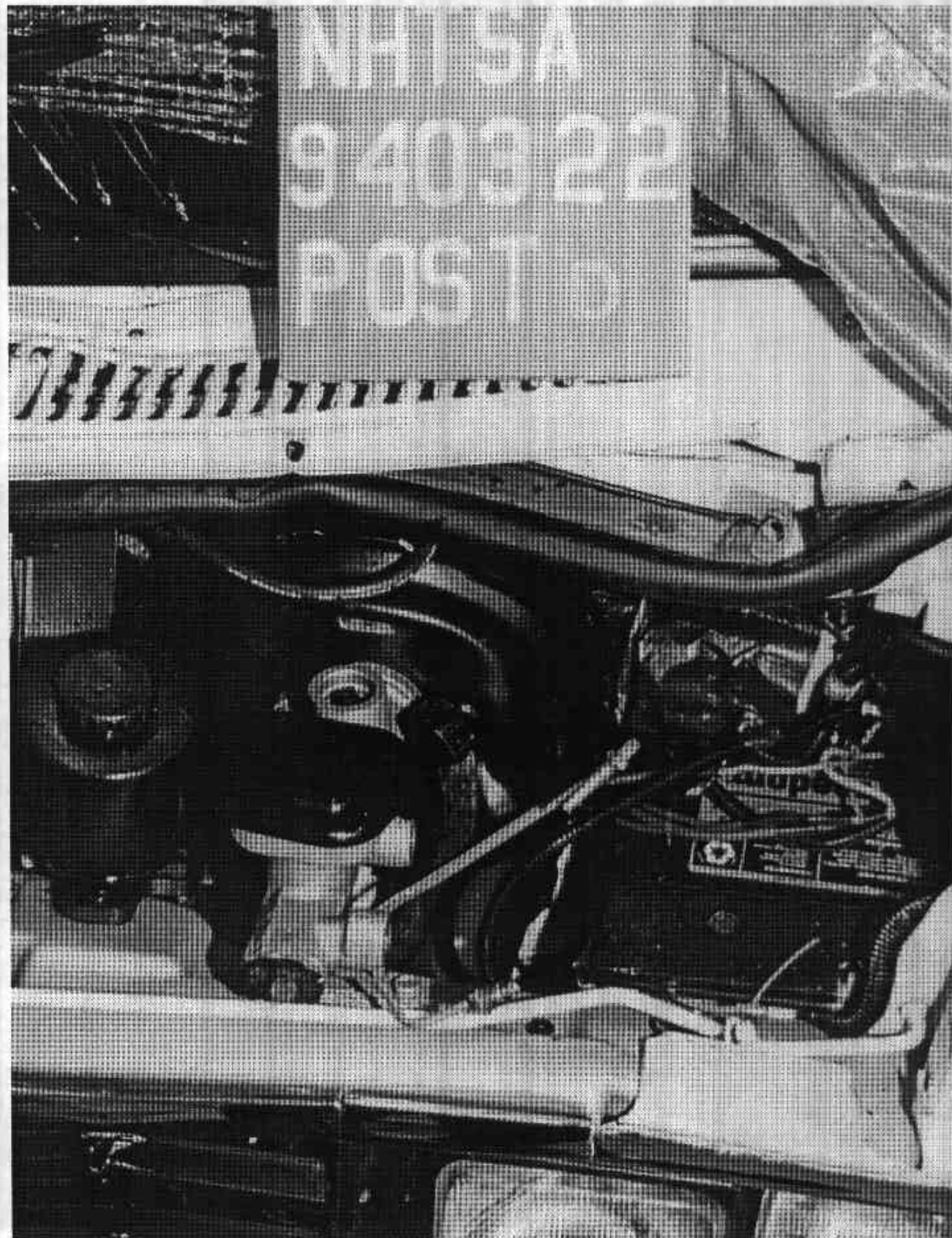

Figure A-30. Post-test Steering Column at Firewall View
A-31

940322

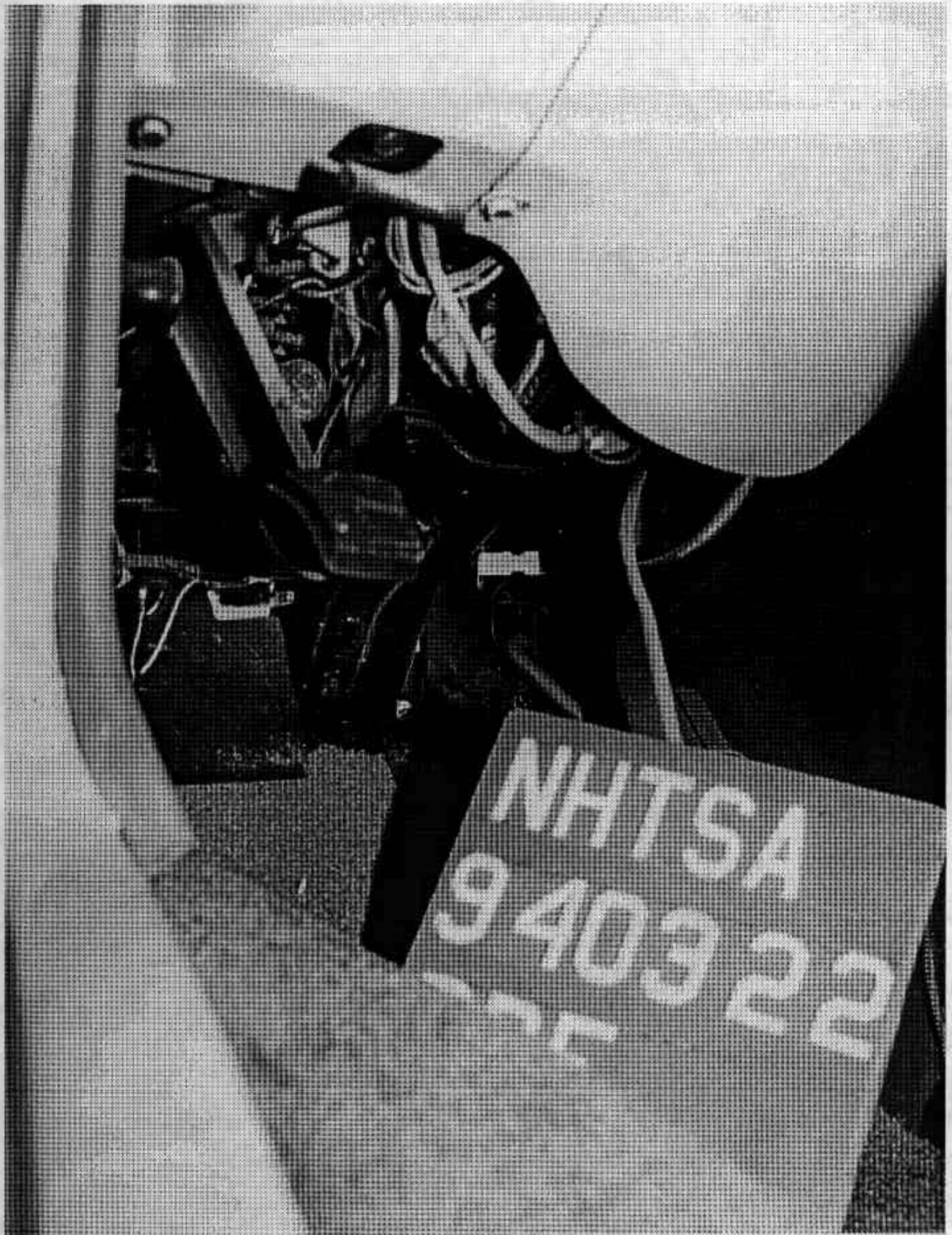

Figure A-31. Pre-test Steering Column at Firewall View - Interior
A-32

940322

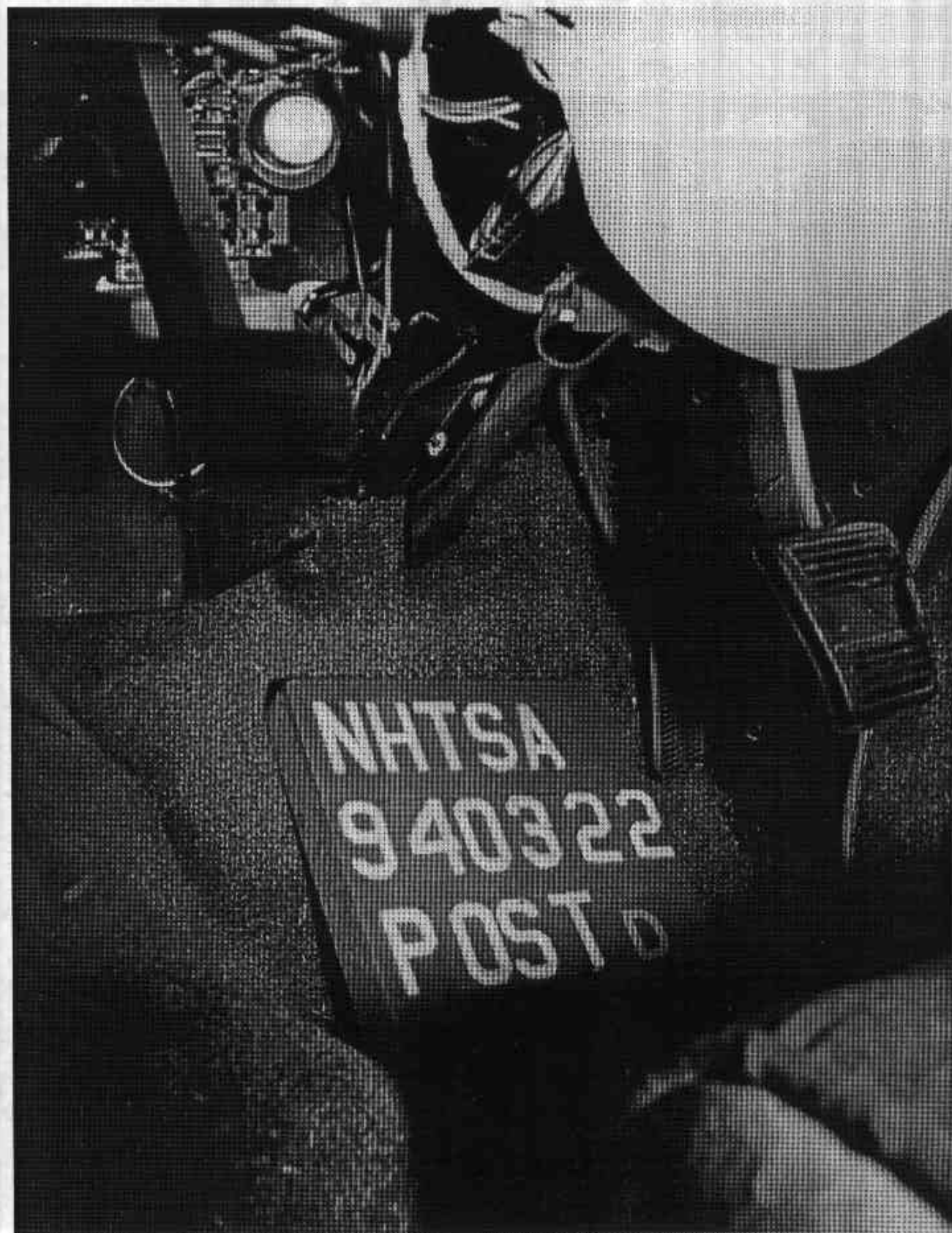

Figure A-32. Post-test Steering Column at Firewall View - Interior
A-33

940322

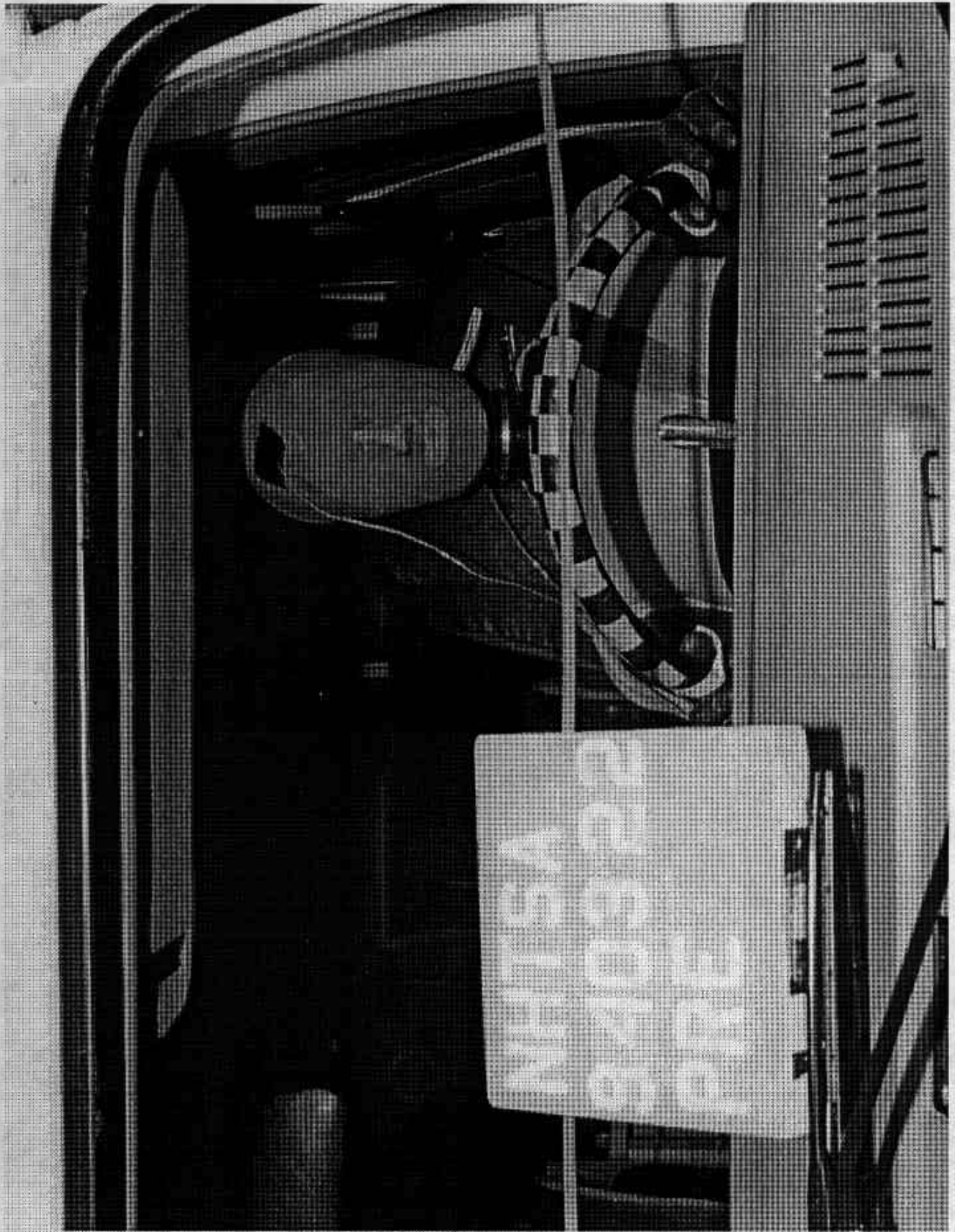

Figure A-33. Pre-test Driver Dummy Position - View 1

A-34

940322

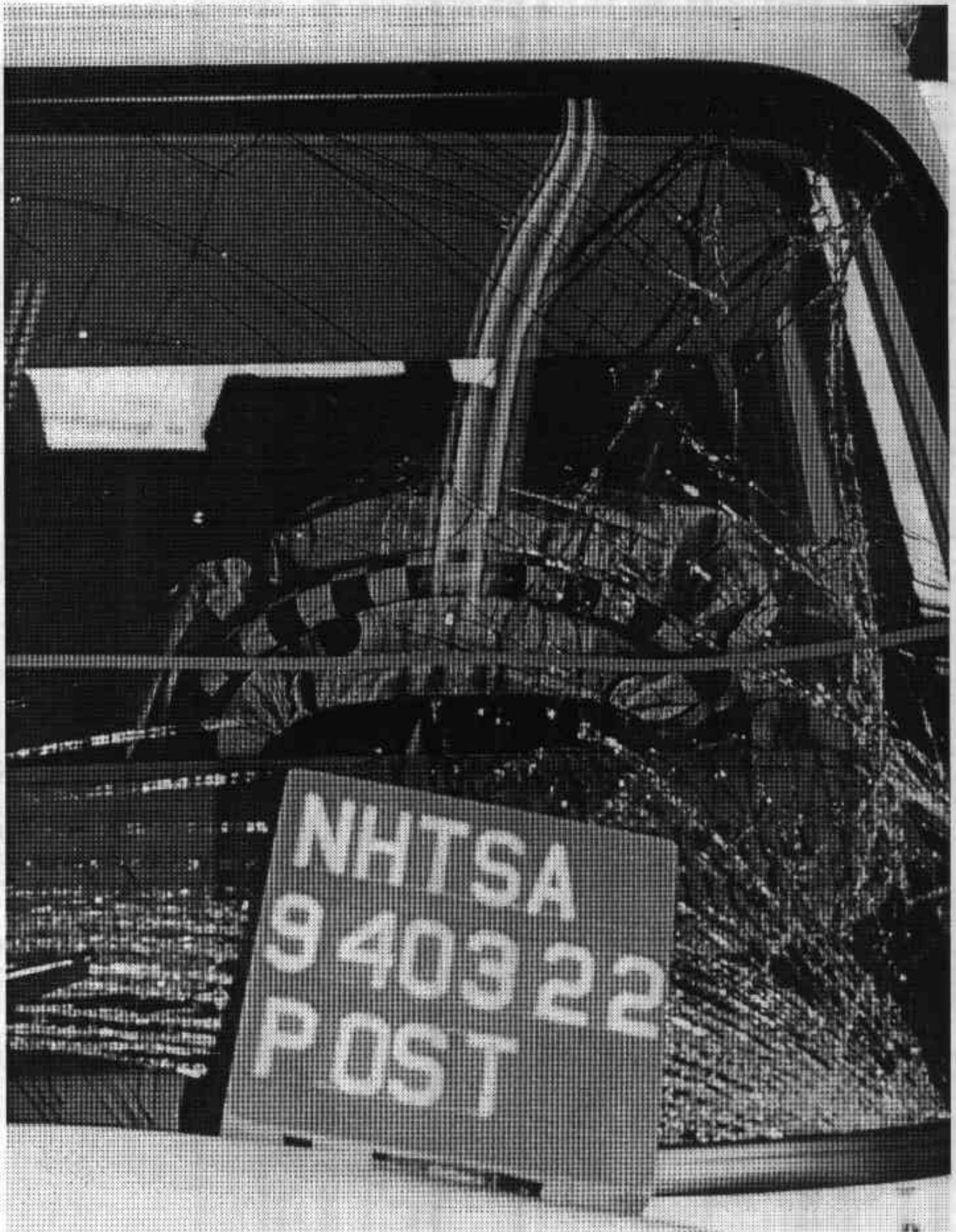

Figure A-34. Post-test Driver Dummy Position - View 1
A-35

940322

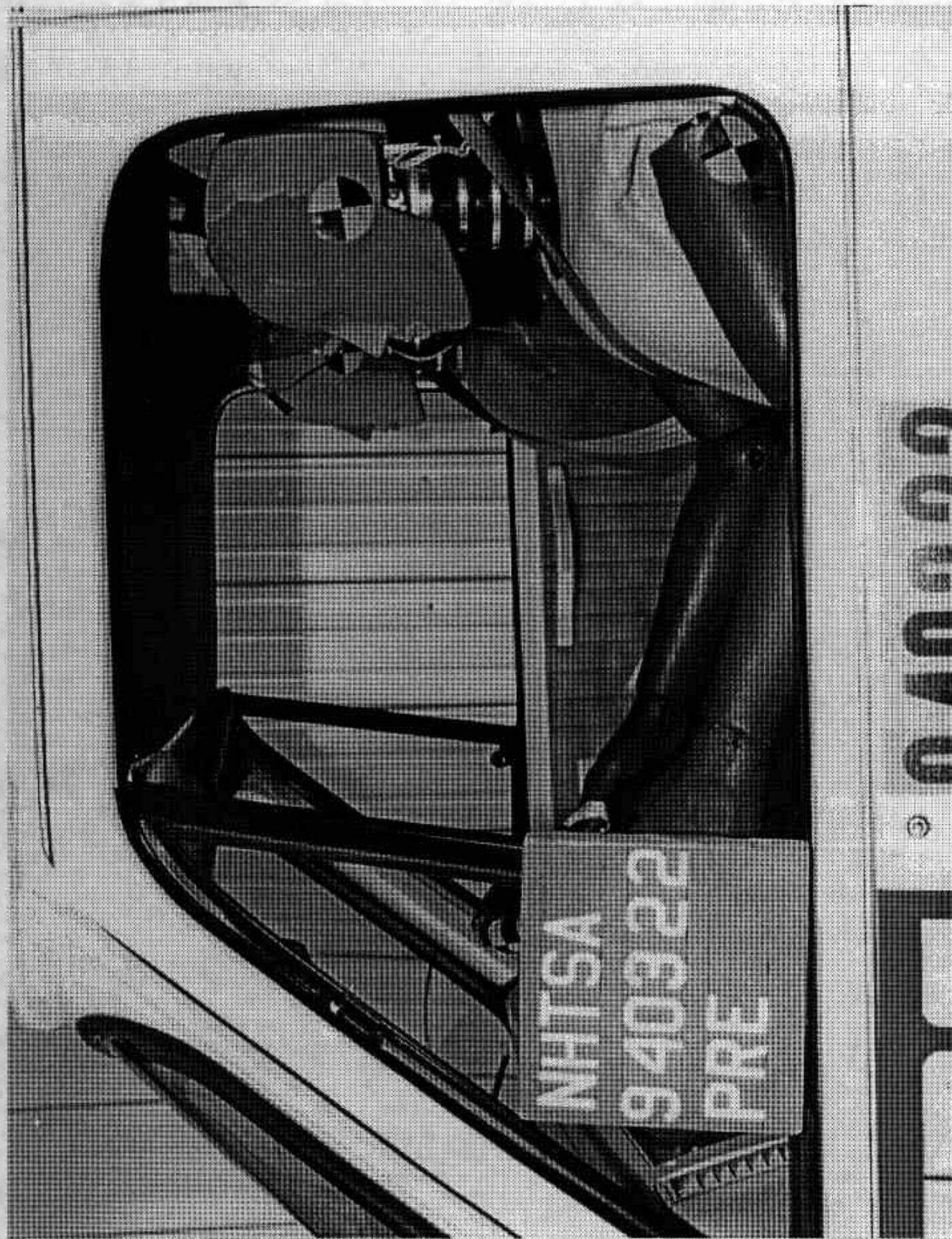

Figure A-35. Pre-test Driver Dummy Position - View 2

A-36

940322



Figure A-36. Post-test Driver Dummy Position - View 2
A-37

940322



Figure A-37. Pre-test Passenger Dummy Position - View 1

A-38

940322



Figure A-38. Post-test Passenger Dummy Position - View 1
A-39

940322

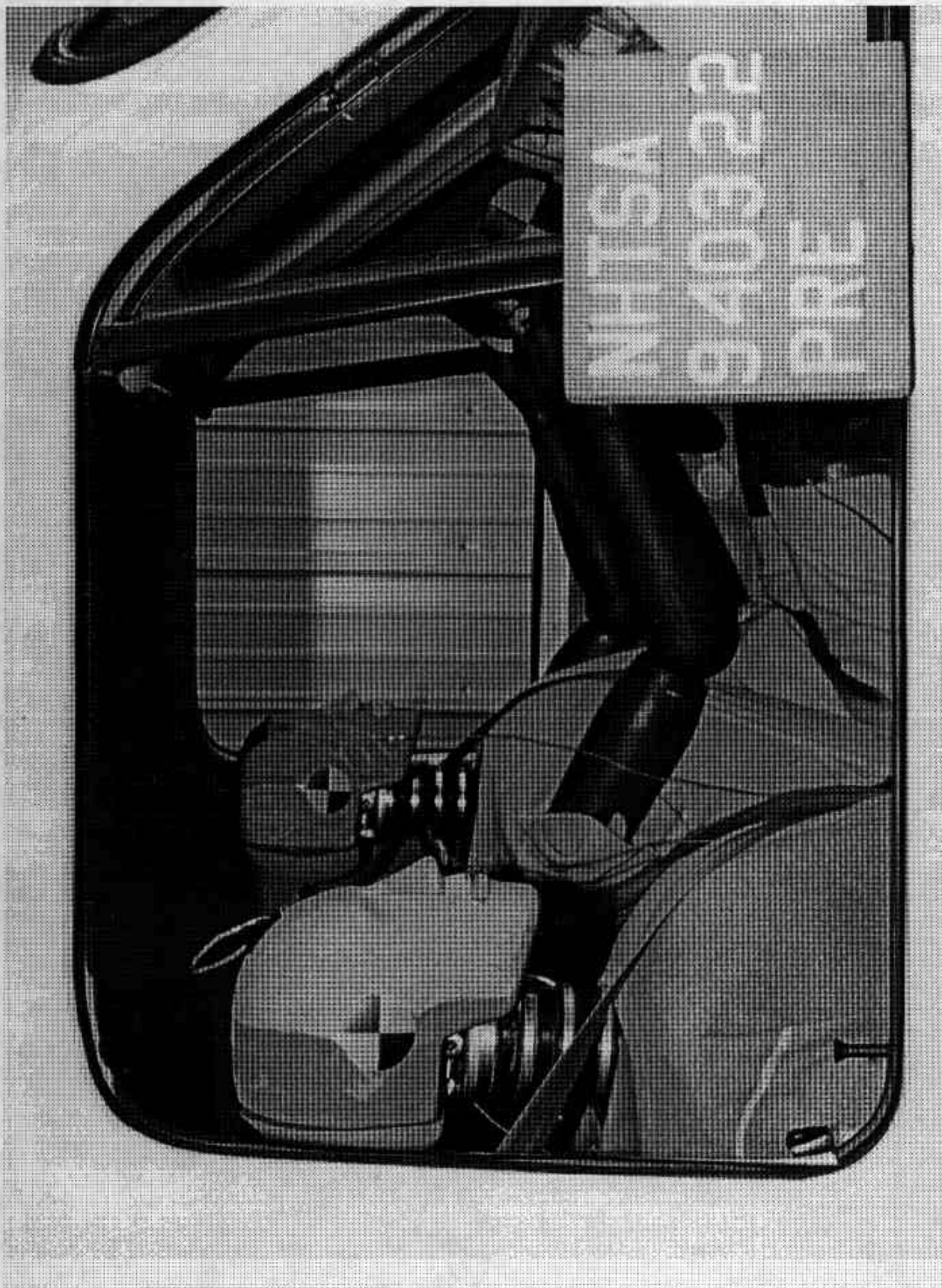

Figure A-39. Pre-test Passenger Dummy Position - View 2

A-40

940322

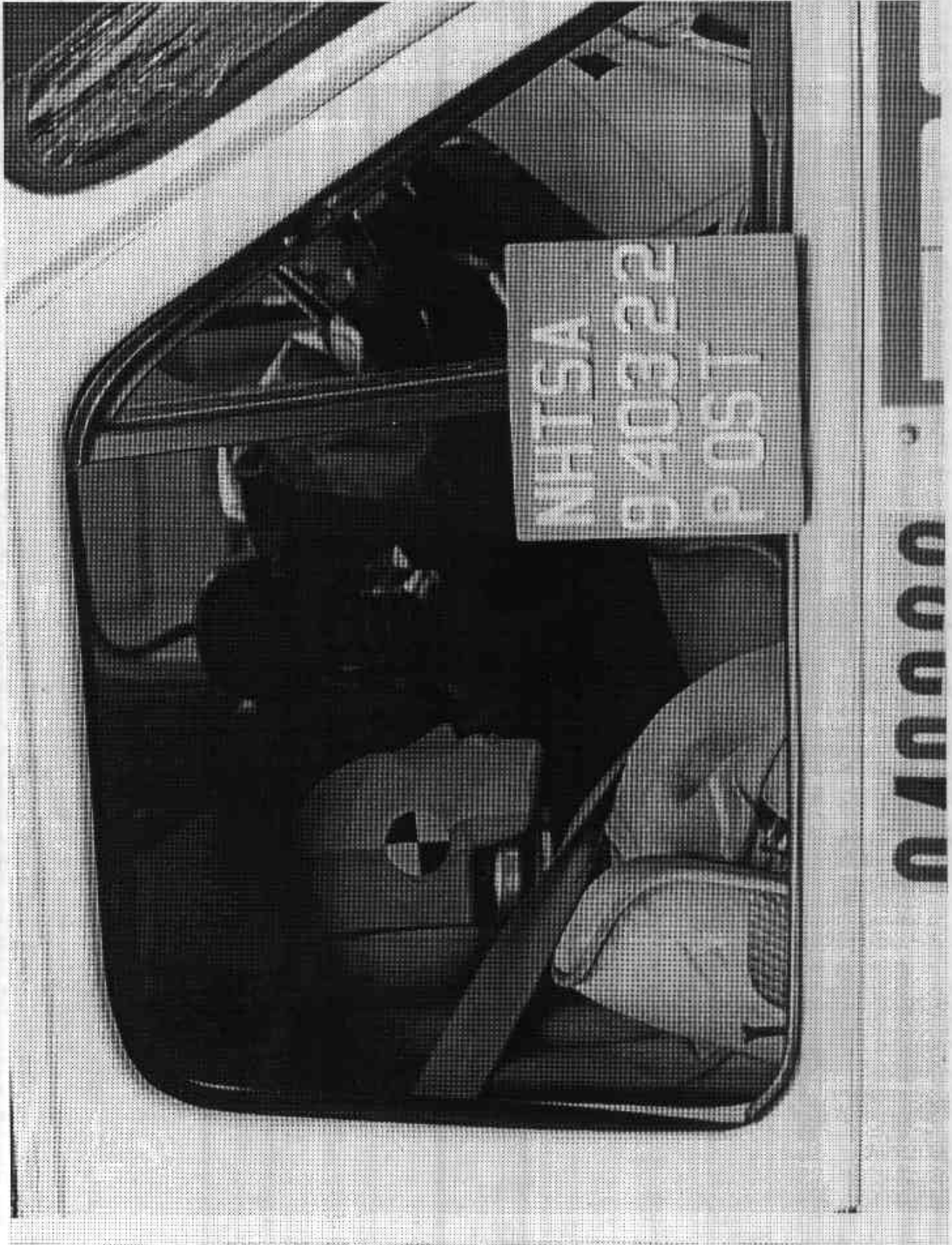

Figure A-40. Post-test Passenger Dummy Position - View 2
A-41

940322

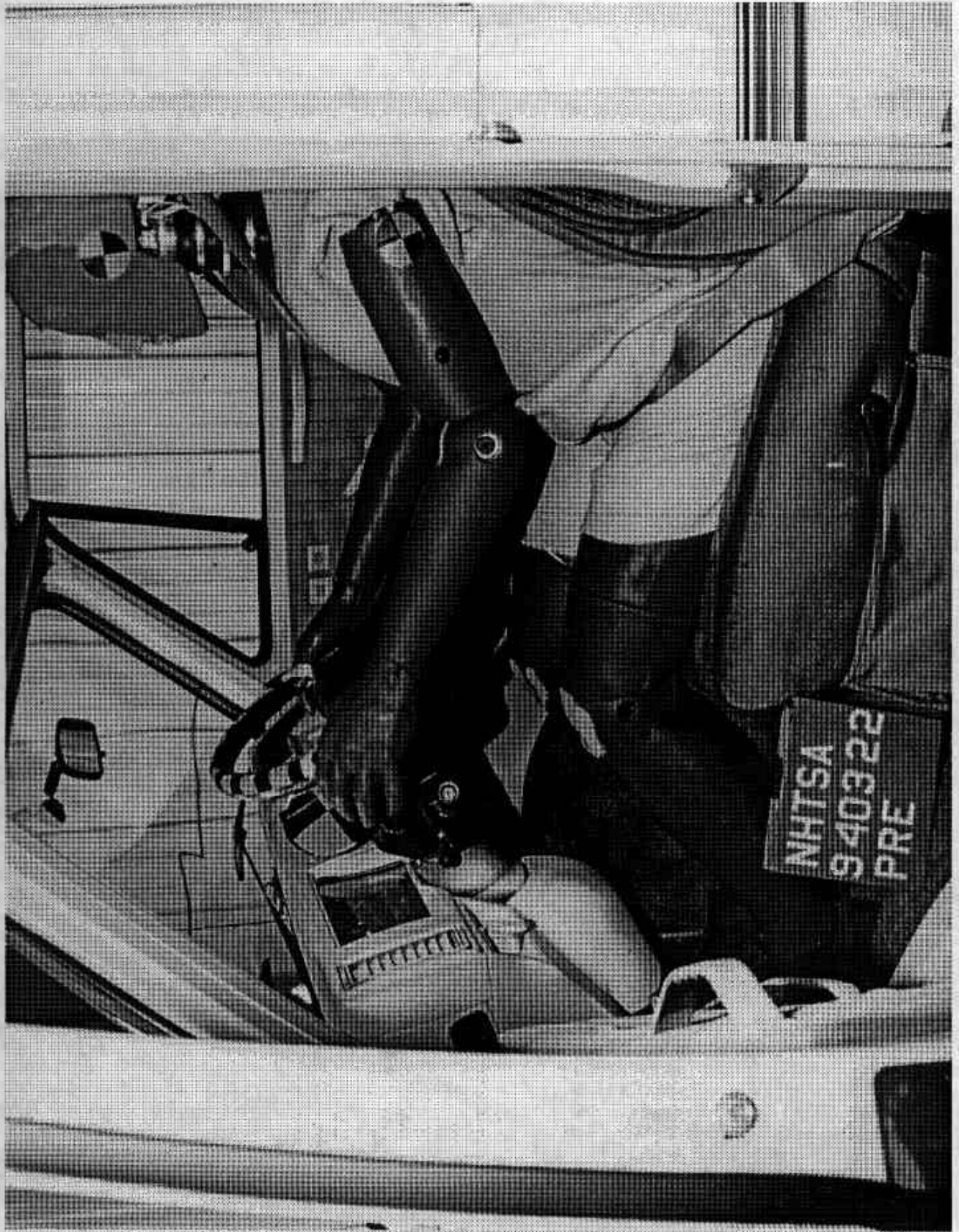

Figure A-41. Pre-test Driver Dummy & Vehicle Interior - View 1

A-42

940322

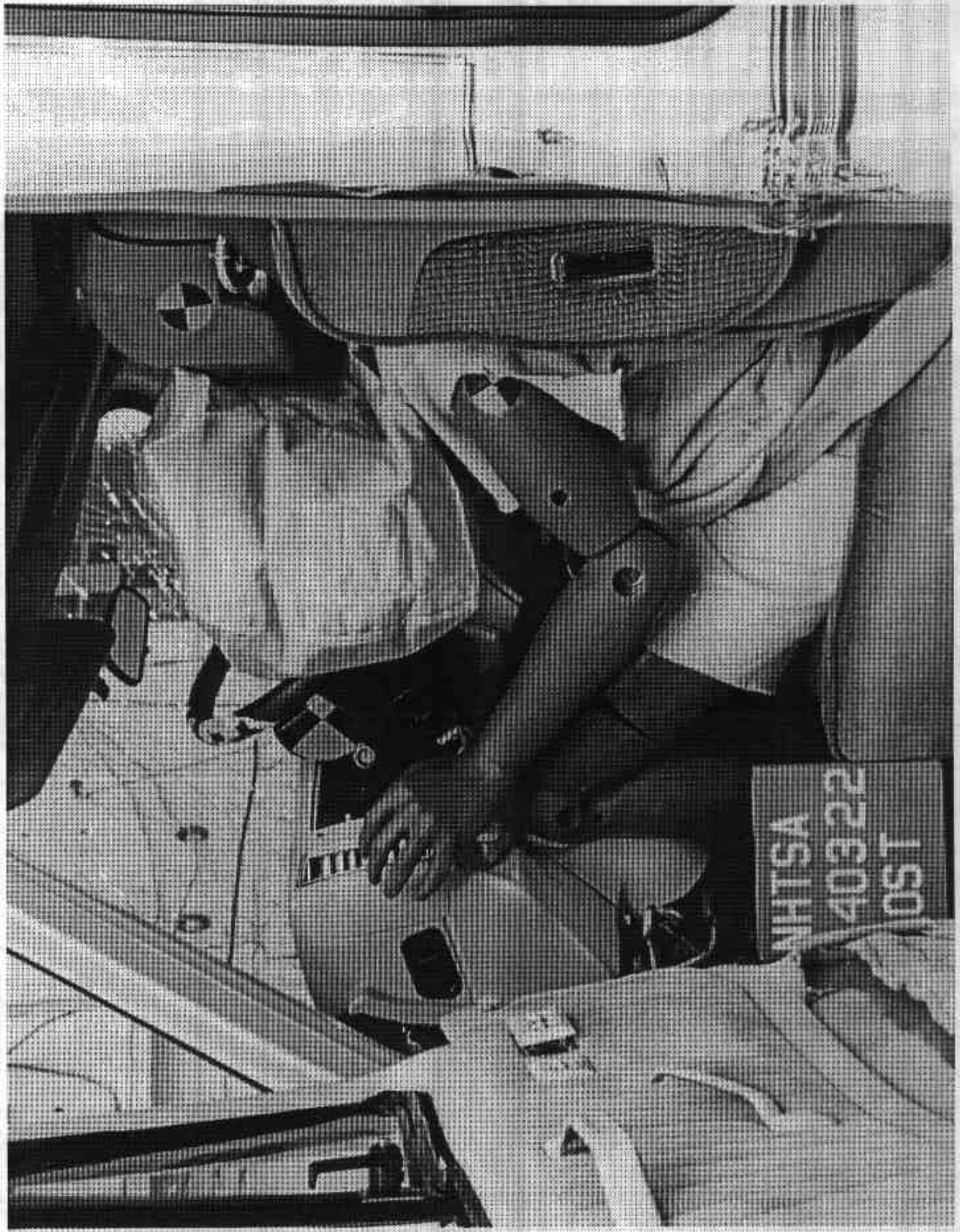

Figure A-42. Post-test Driver Dummy & Vehicle Interior - View 1

A-43

940322

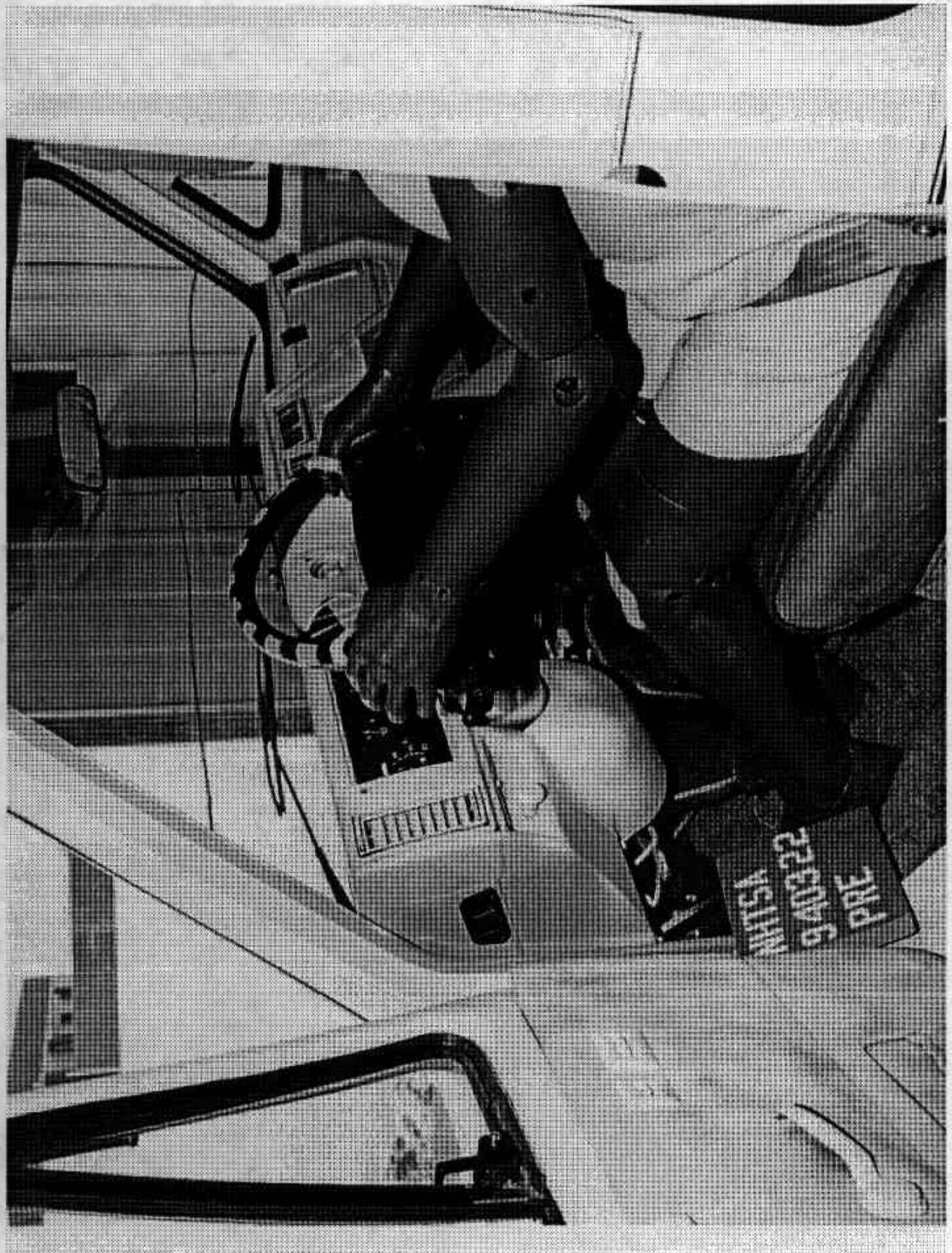

Figure A-43. Pre-test Driver Dummy & Vehicle Interior - View 2

A-44

940322

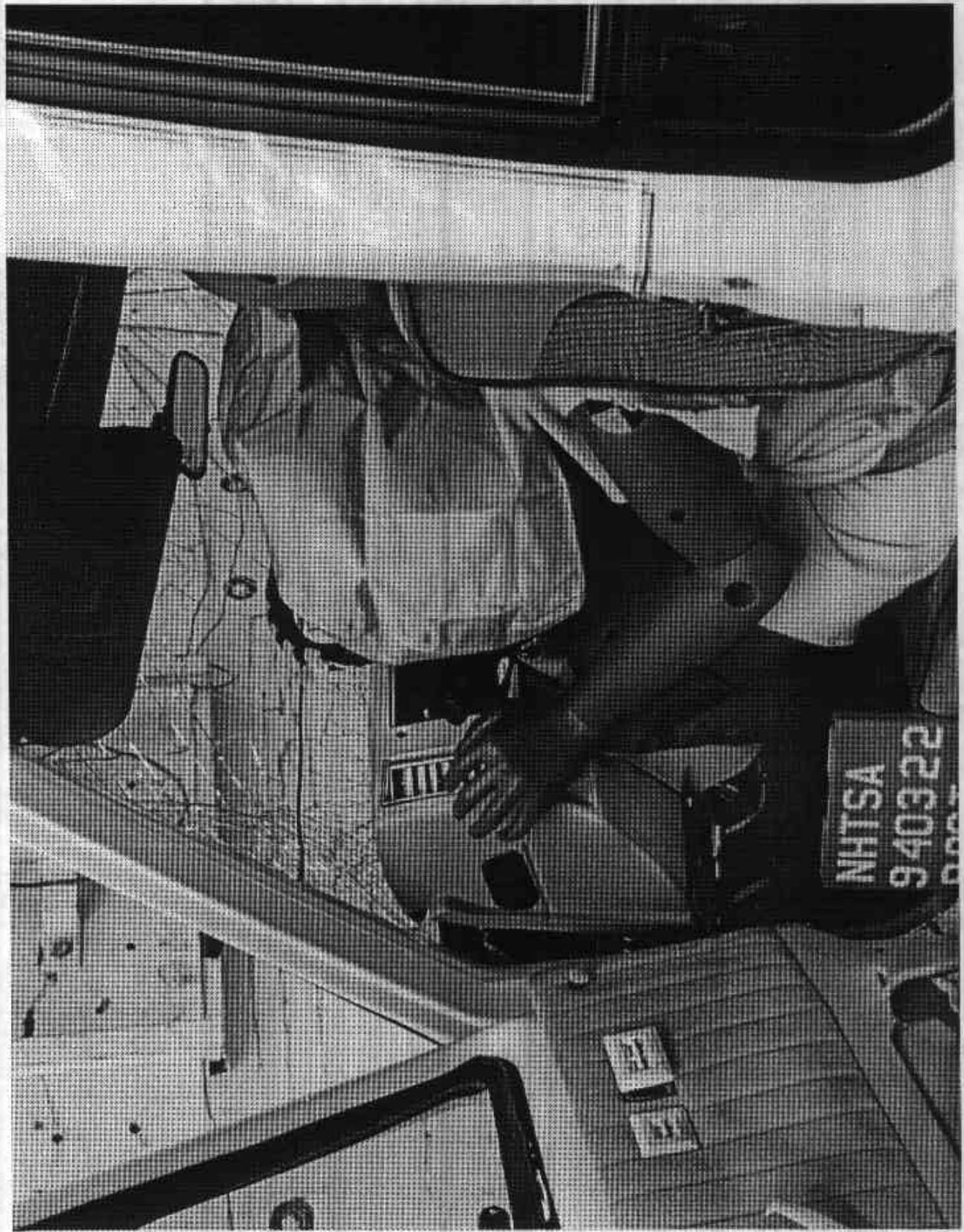

Figure A-44. Post-test Driver Dummy & Vehicle Interior - View 2

A-45

940322

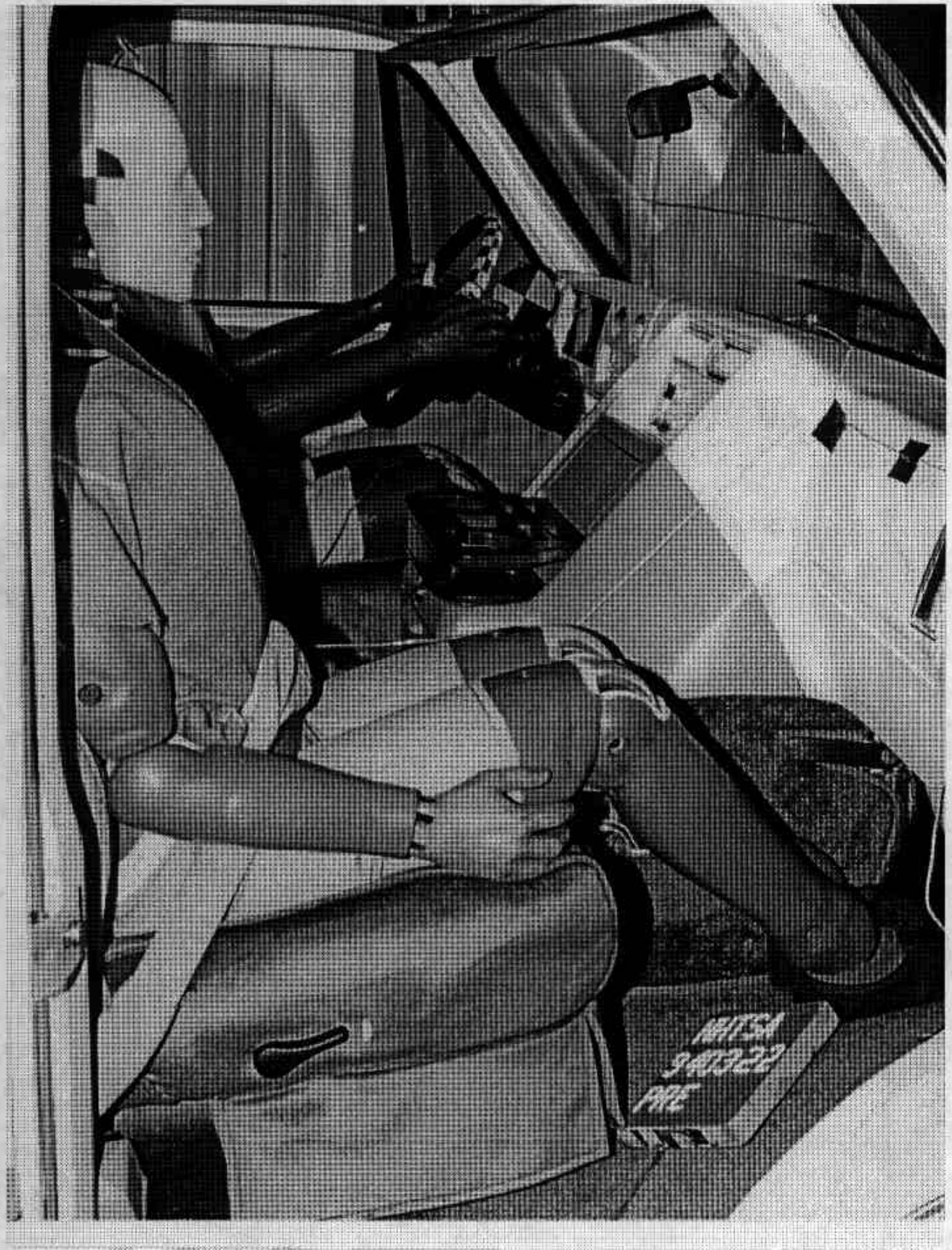

Figure A-45. Pre-test Passenger Dummy & Vehicle Interior - View 1

A-46

940322



Figure A-46. Post-test Passenger Dummy & Vehicle Interior - View 1

A-47

940322

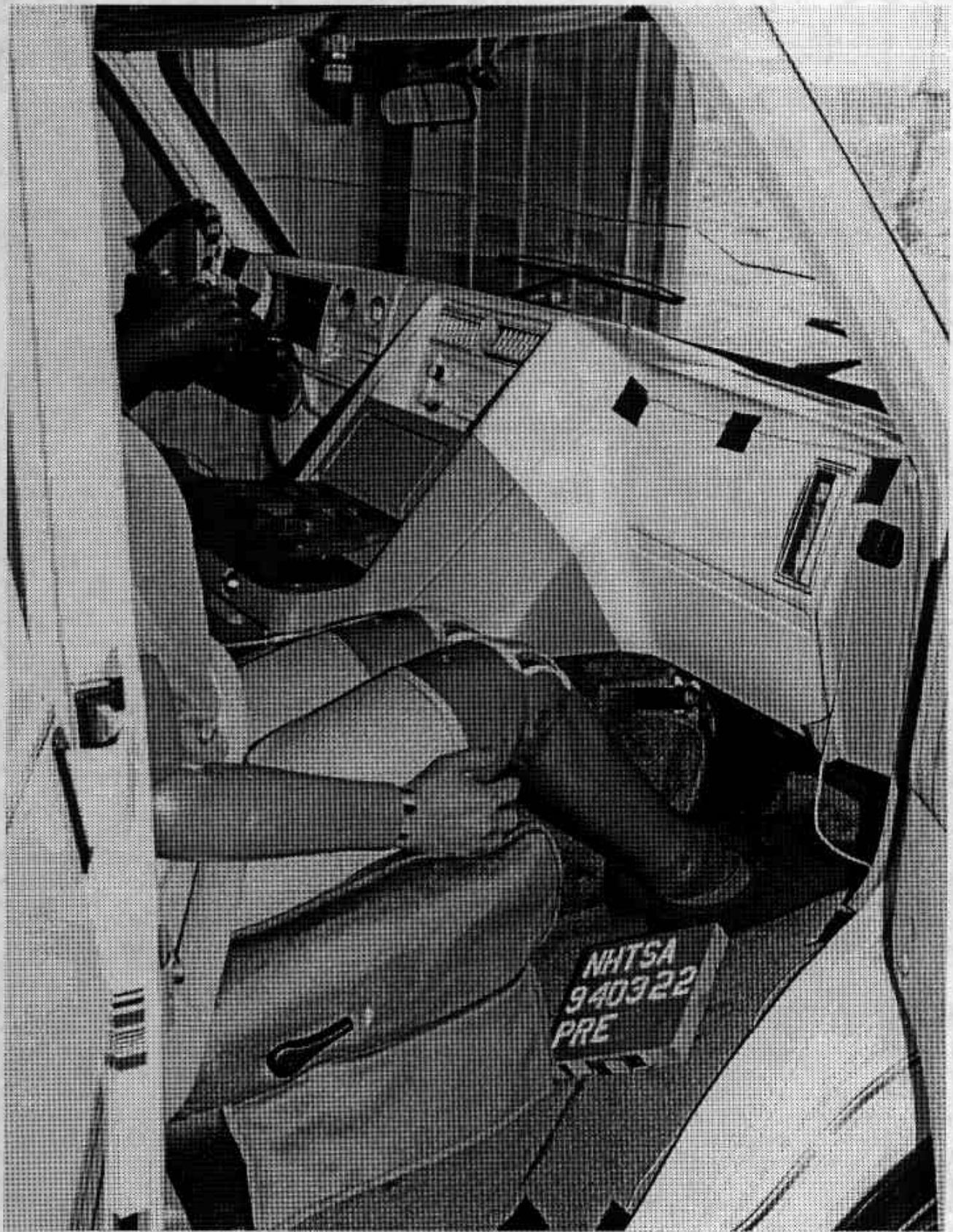

Figure A-47. Pre-test Passenger Dummy & Vehicle Interior - View 2

A-48

940322

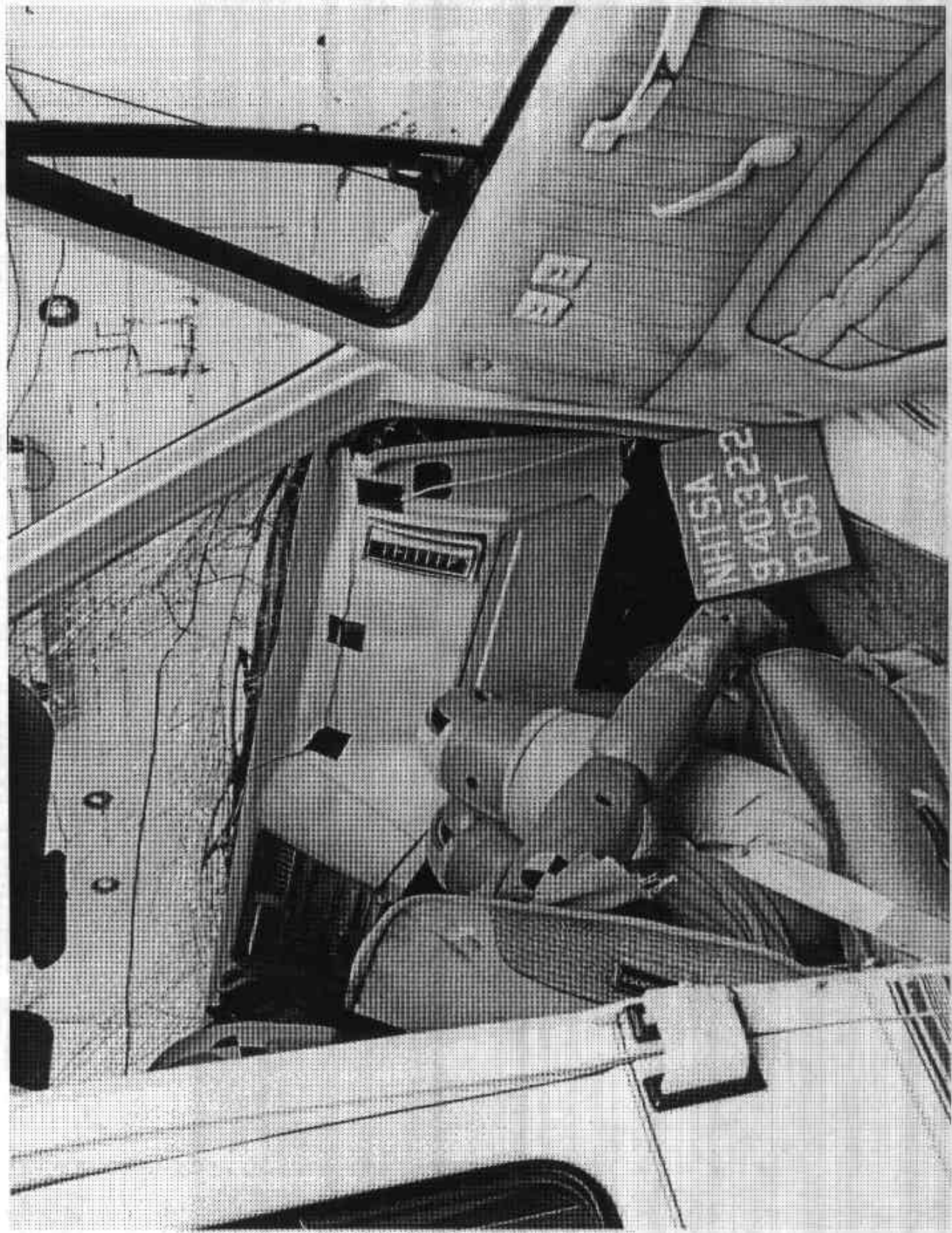

Figure A-48. Post-test Passenger Dummy & Vehicle Interior - View 2

A-49

940322

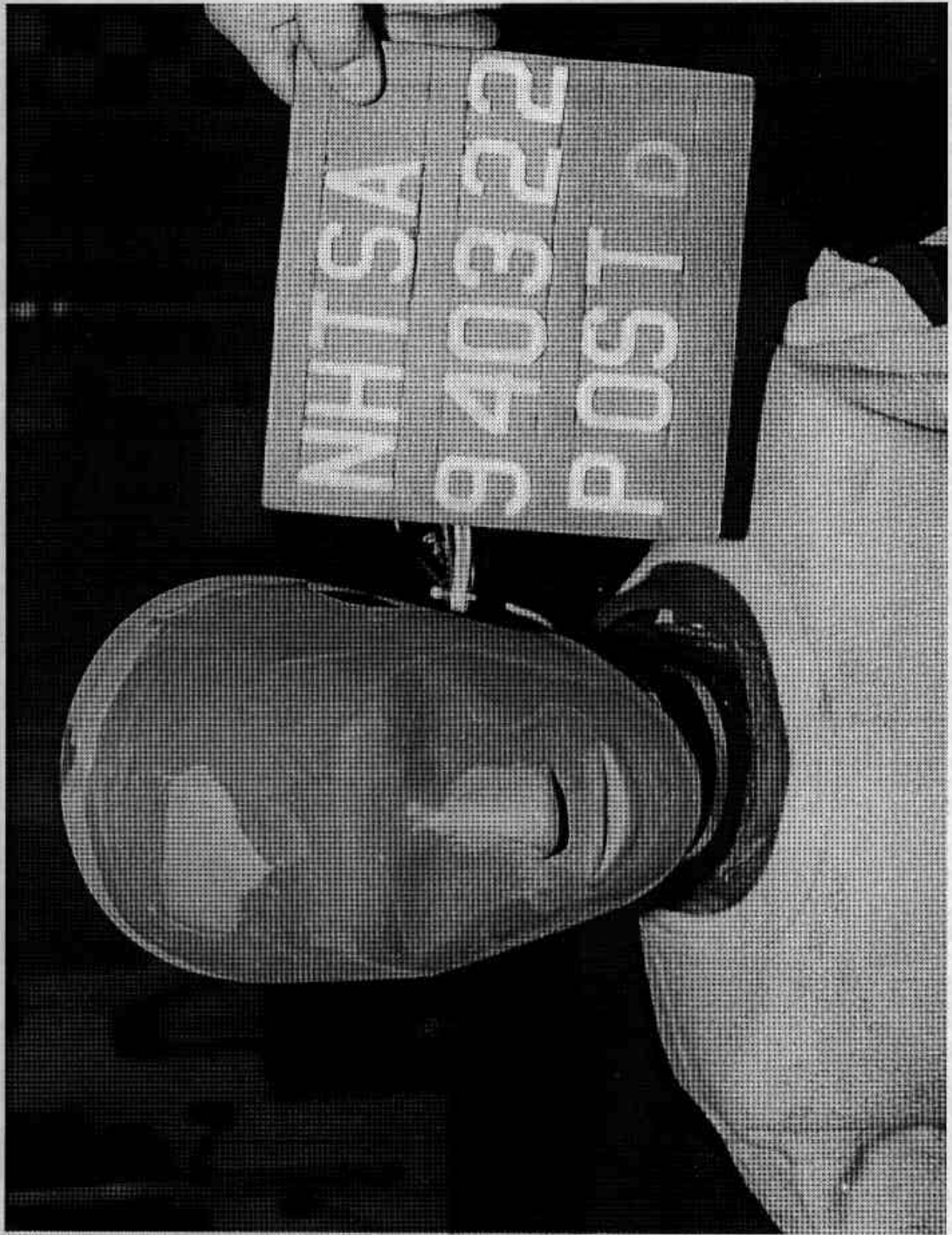

Figure A-49. Post-test Driver Dummy Head Contact - View 1

A-50

940322



Figure A-50. Post-test Driver Dummy Head Contact - View 2
A-51

940322

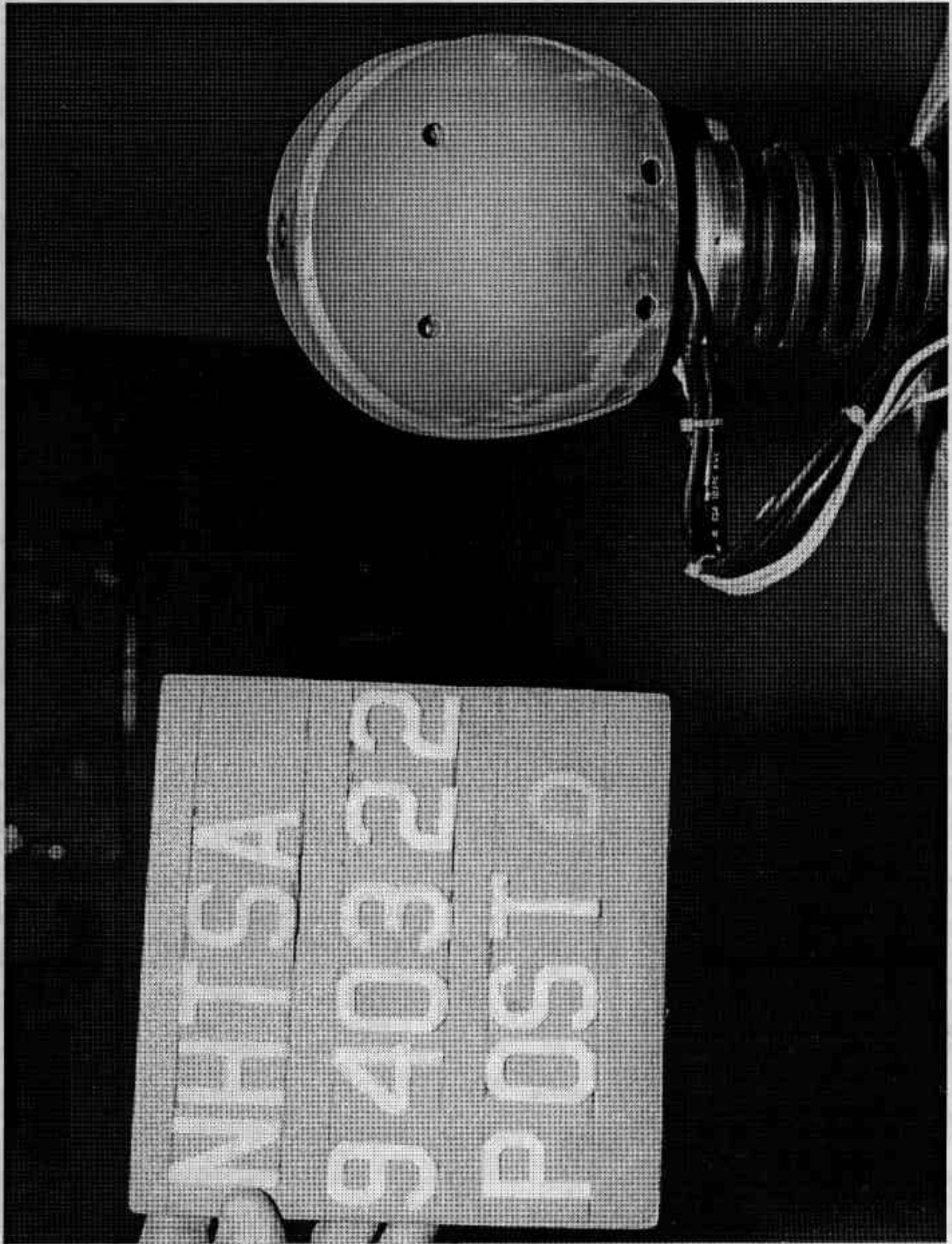

Figure A-51. Post-test Driver Dummy Head Contact - View 3

A-52

940322

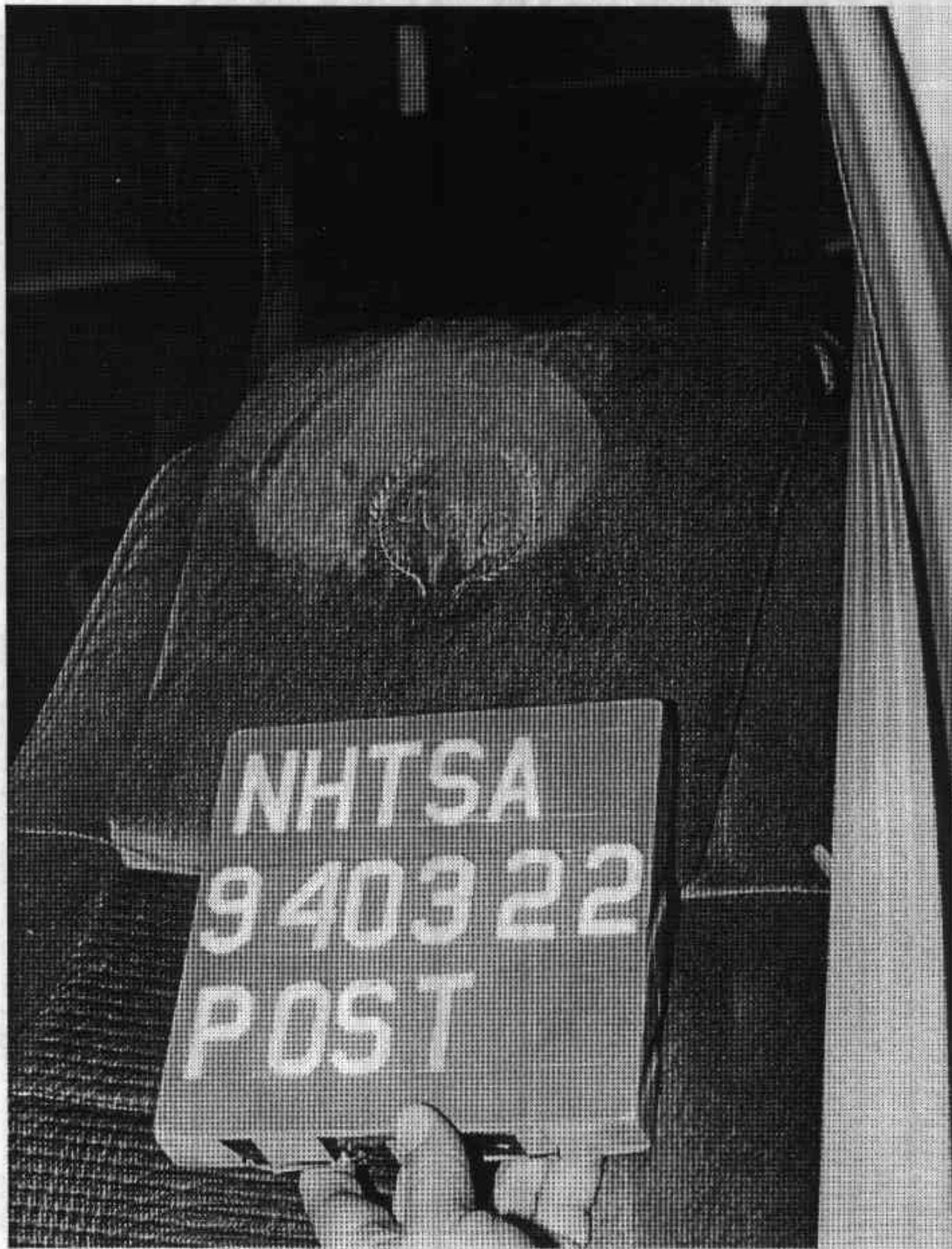

Figure A-52. Post-test Driver Dummy Head Contact - View 4
A-53

940322

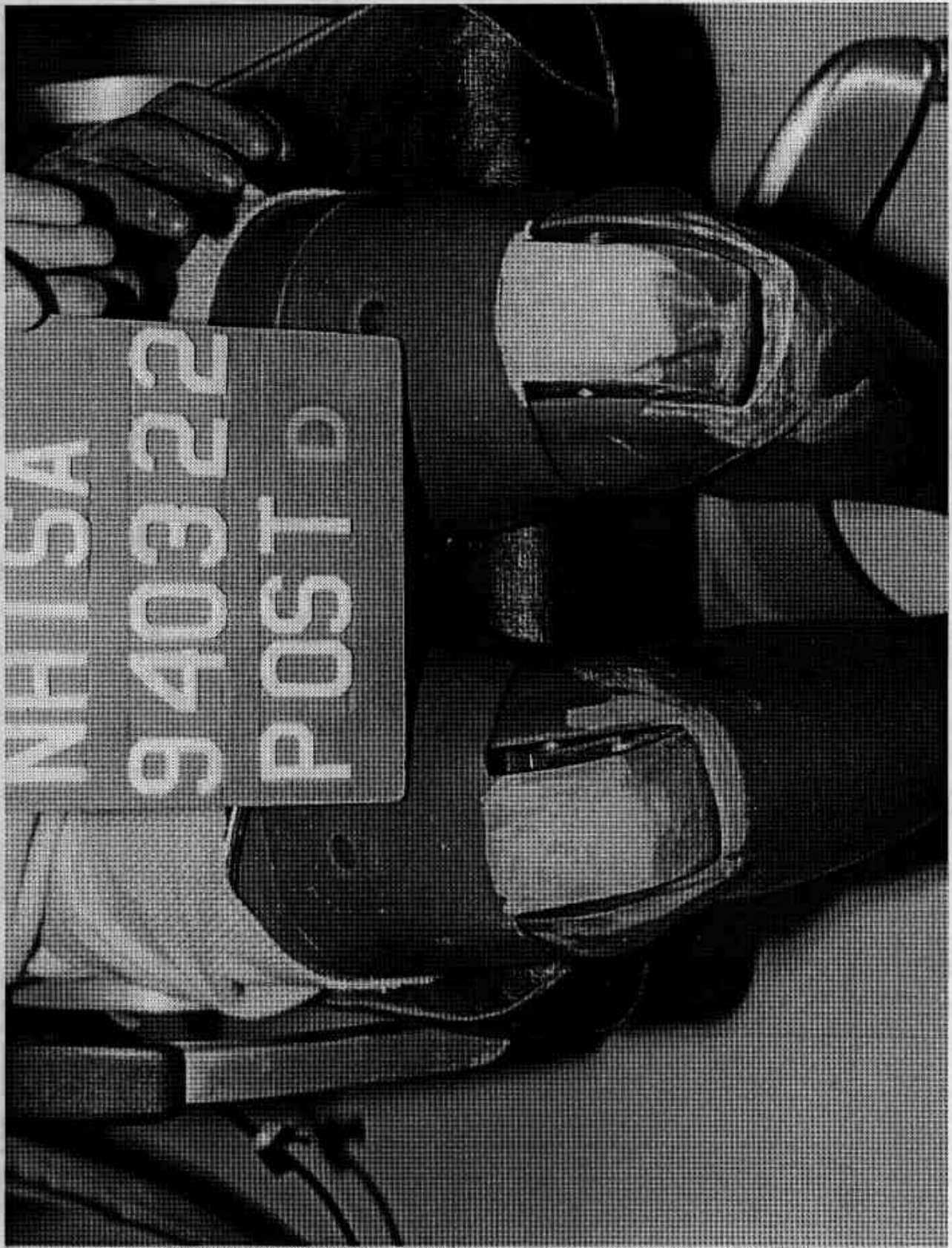

Figure A-53. Post-test Driver Dummy Knee Contact - View 1

A-54

940322

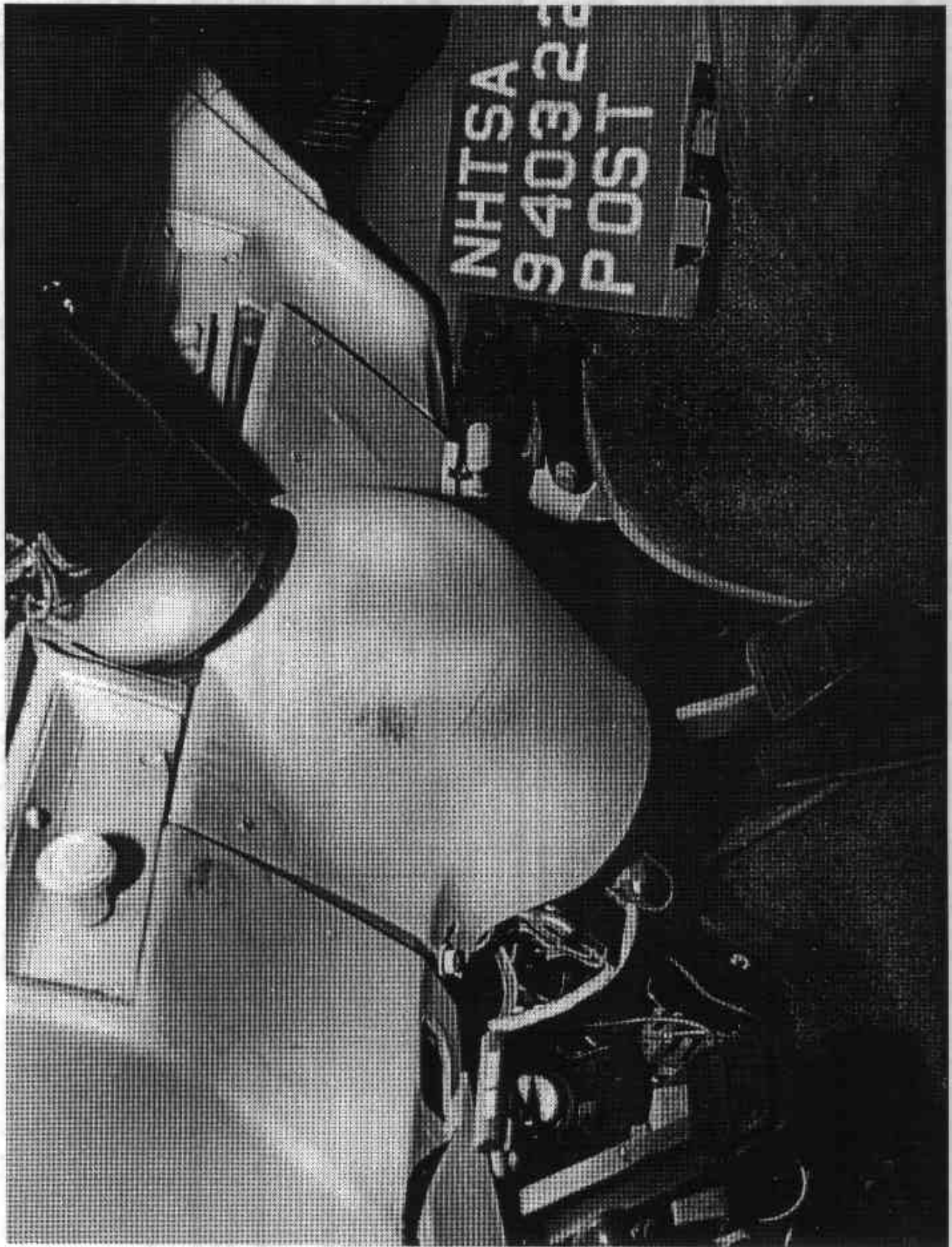

Figure A-54. Post-test Driver Dummy Knee Contact- View 2

A-55

940322

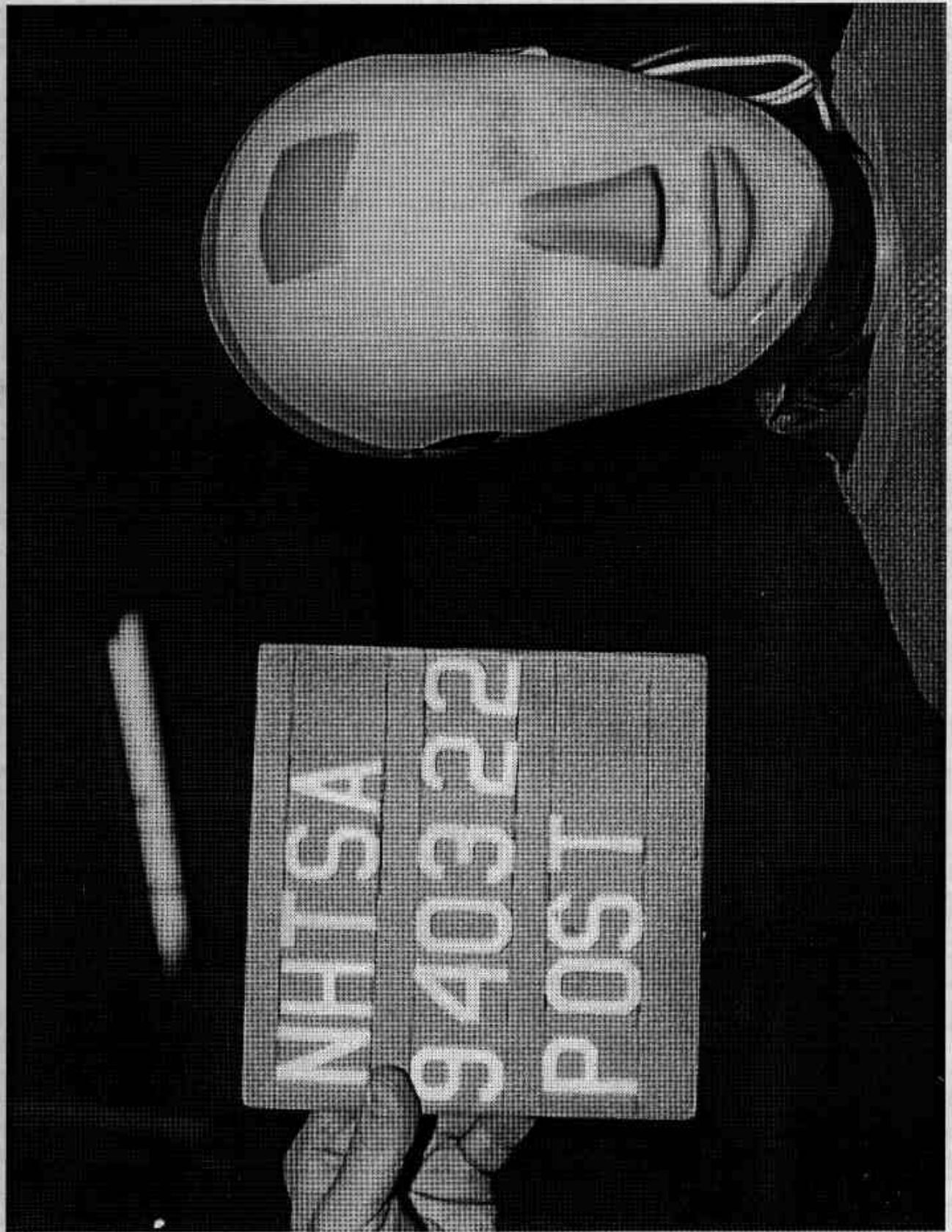

Figure A-55. Post-test Passenger Dummy Head Contact - View 1
A-56

940322

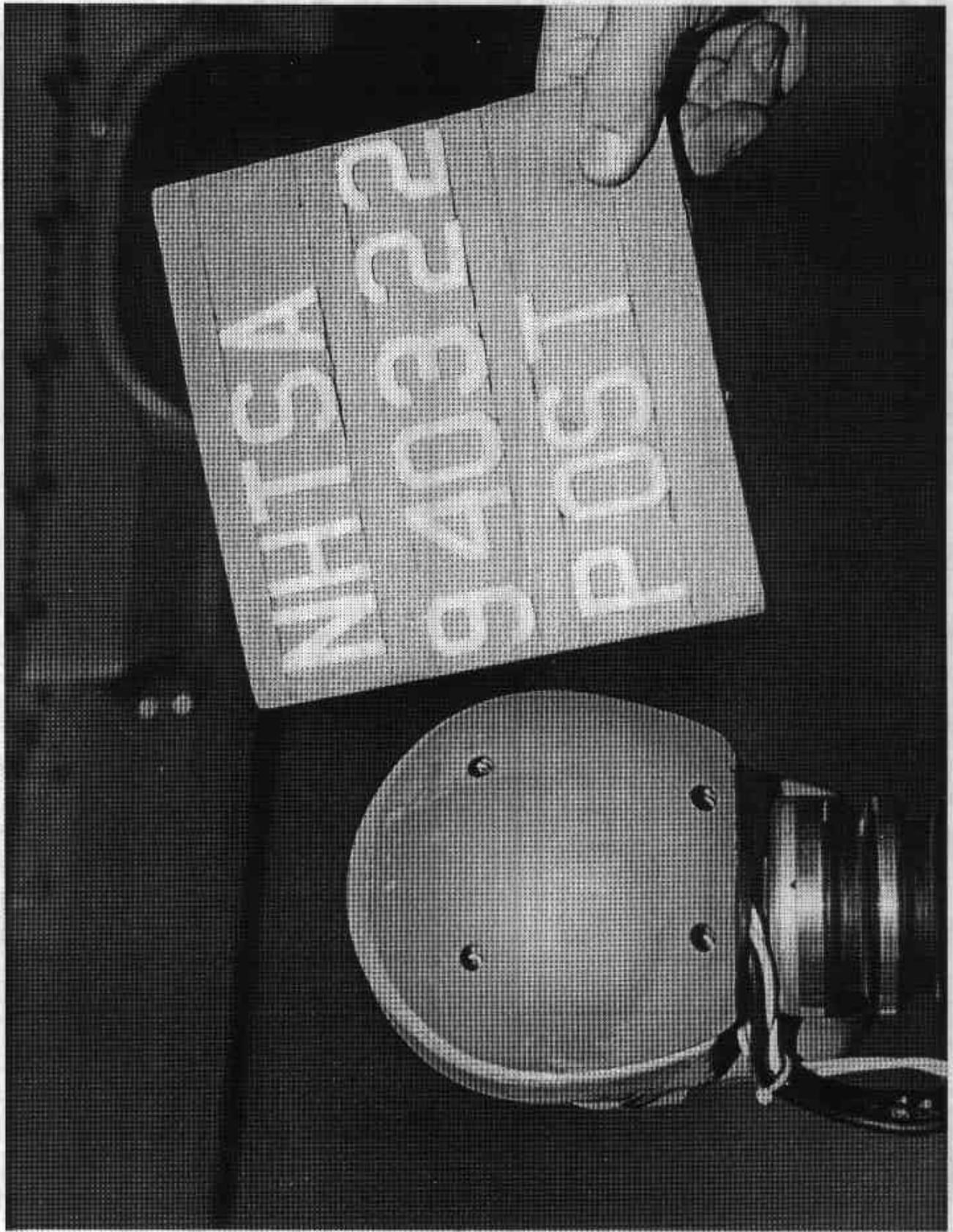

Figure A-56. Post-test Passenger Dummy Head Contact - View 2

A-57

940322

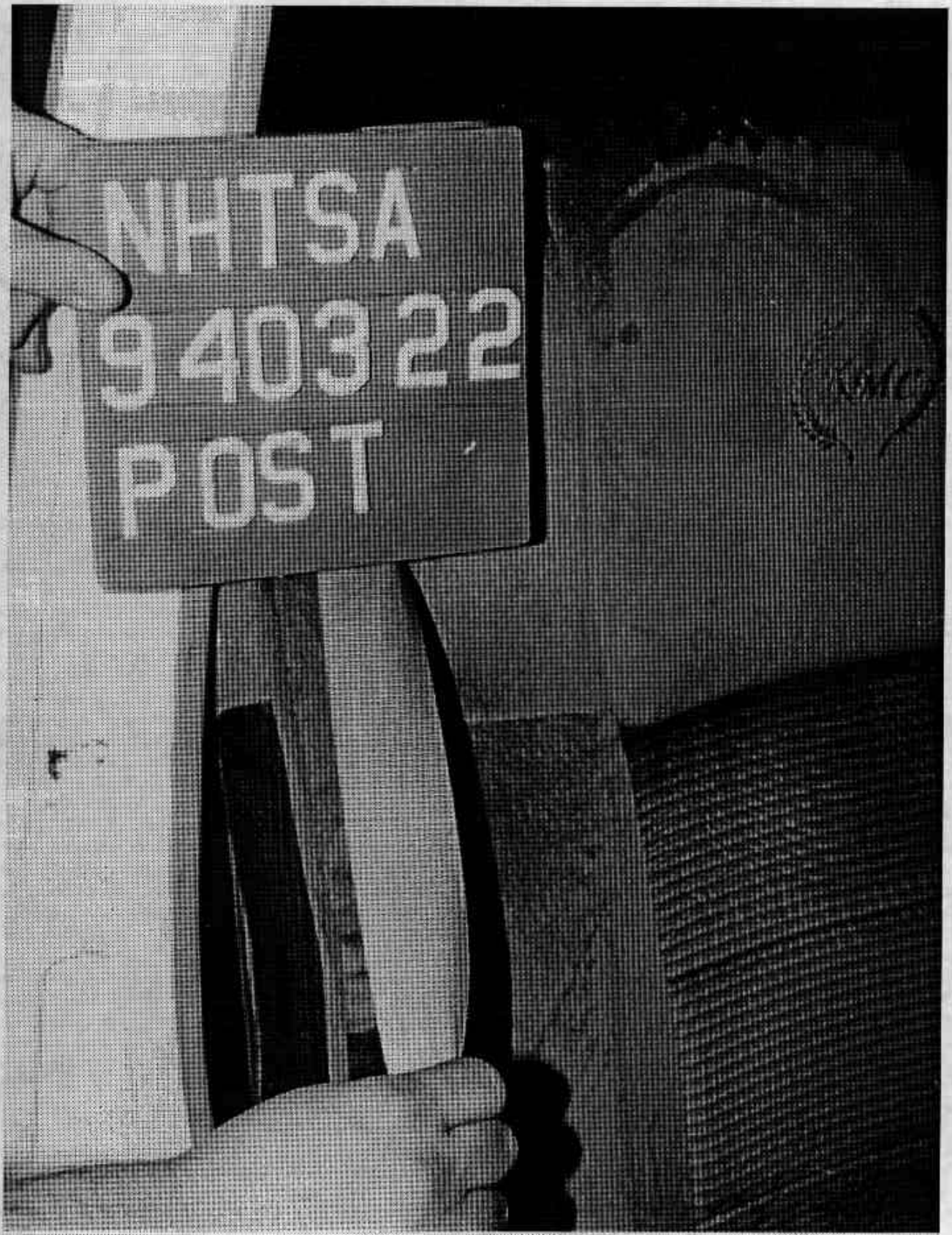

Figure A-57. Post-test Passenger Dummy Head Contact - View 3

A-58

940322



Figure A-58. Post-test Passenger Dummy Knee Contact - View 1
A-59

940322

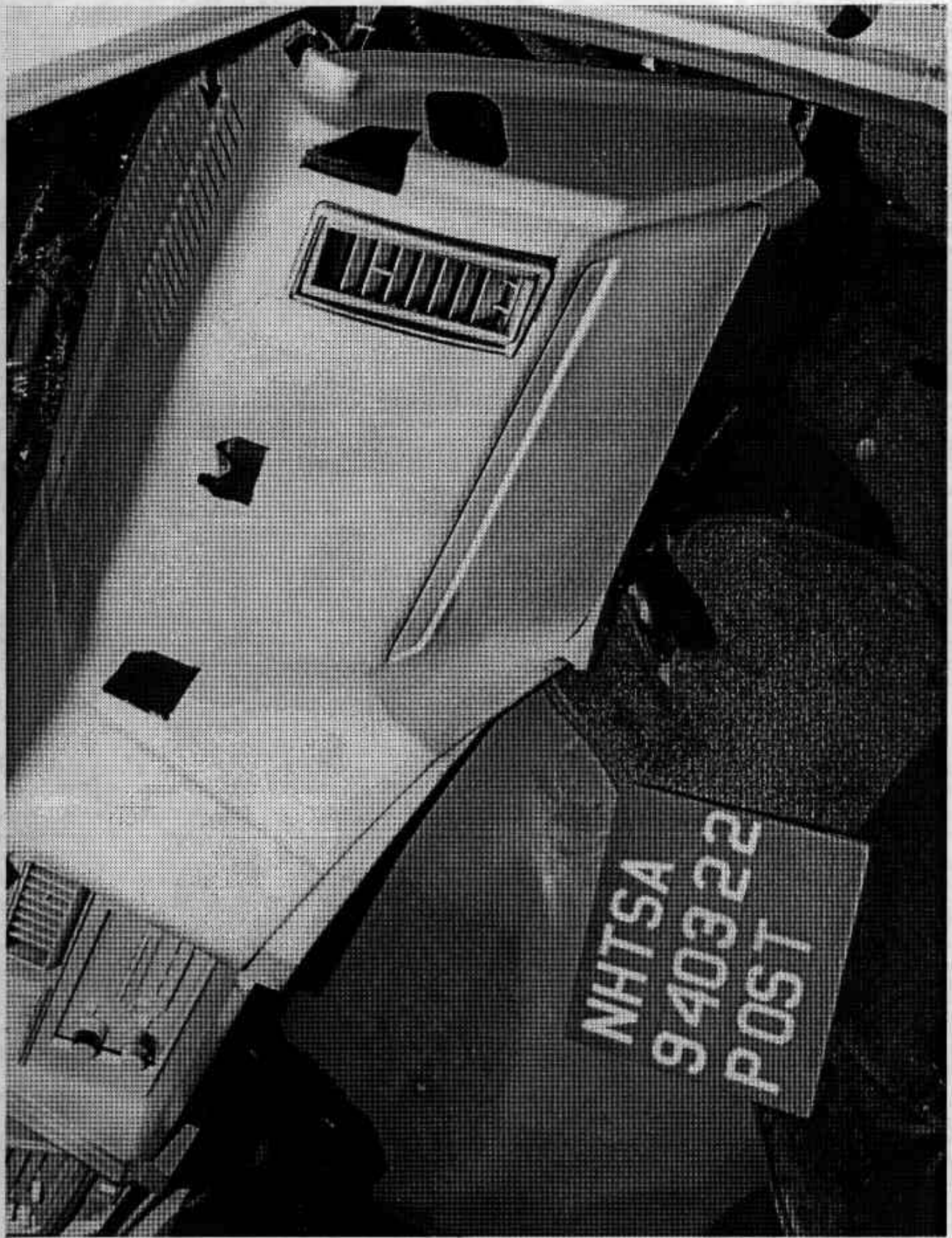

Figure A-59. Post-test Passenger Dummy Knee Contact - View 2

A-60

940322

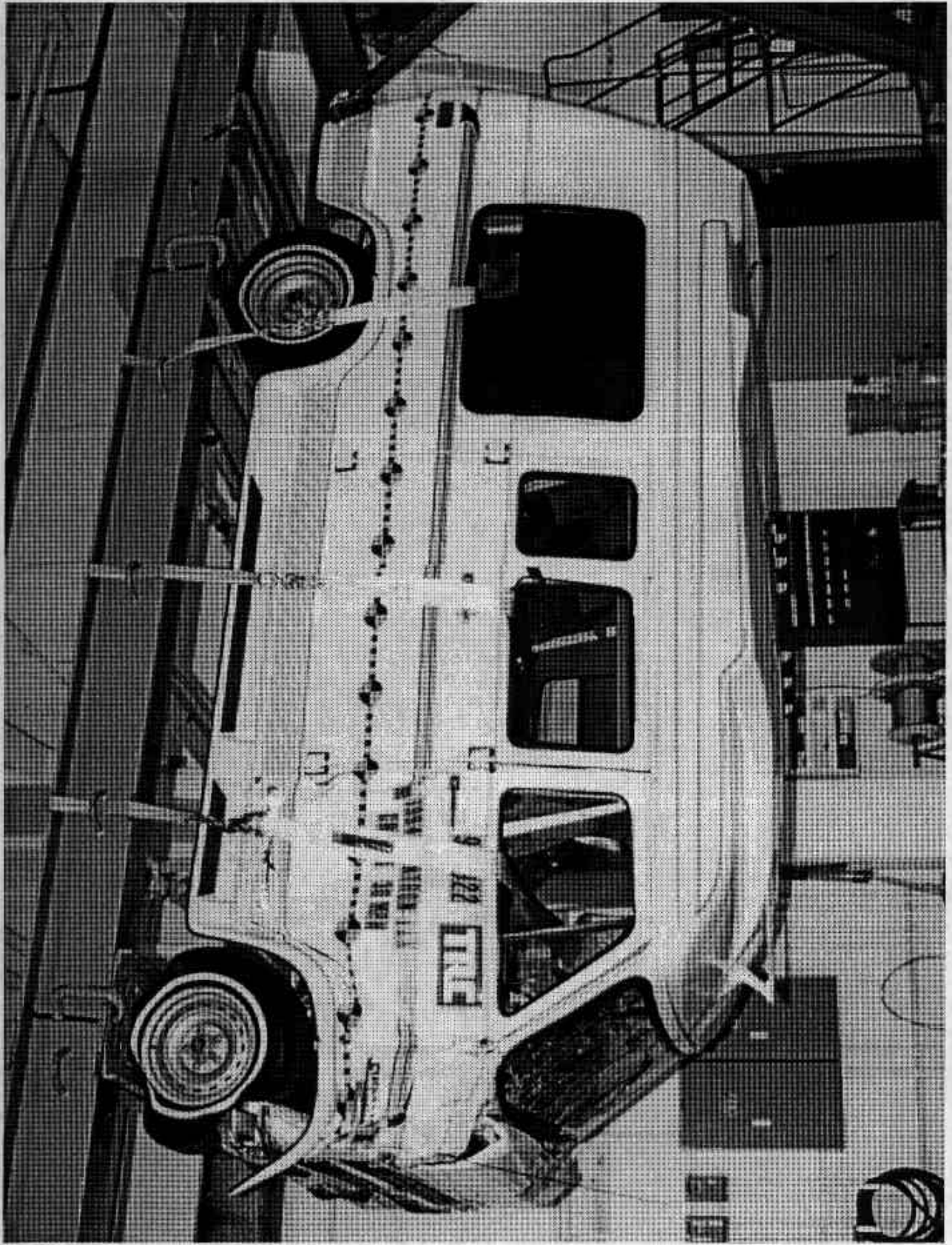

Figure A-61. Post-test Vehicle on Static Rollover Machine View

A-62

940322

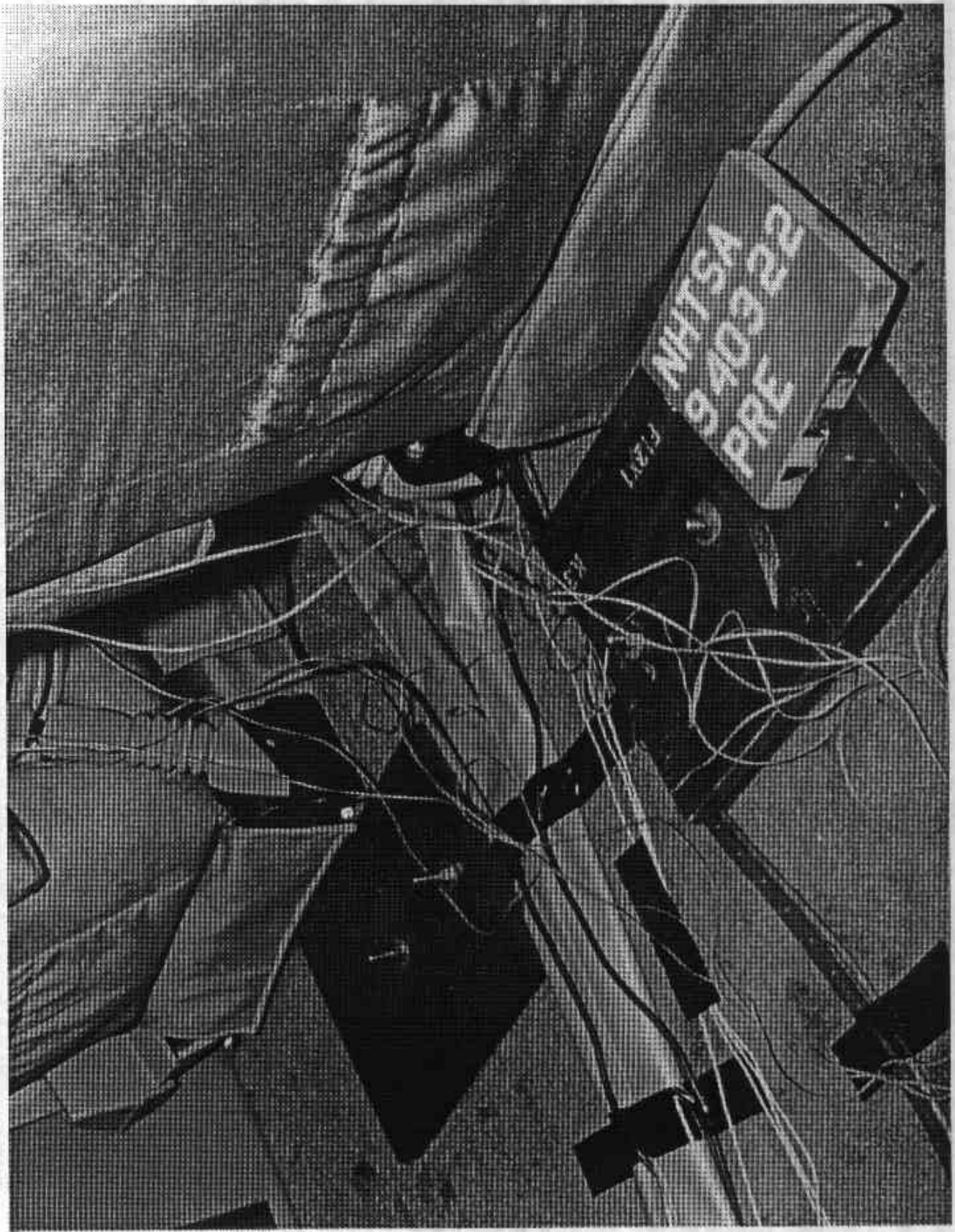

Figure A-62. Pre-test Ballast Location View
A-63

940322

Appendix B

Data Plots

1994 KENTRON SS SPORT TOP VAN INTO FLAT FRONTAL BARRIER
DRIVER HEAD X-AXIS ACCELERATION
208 COMPLIANCE TEST - CR1301

TEST NUMBER: 940322

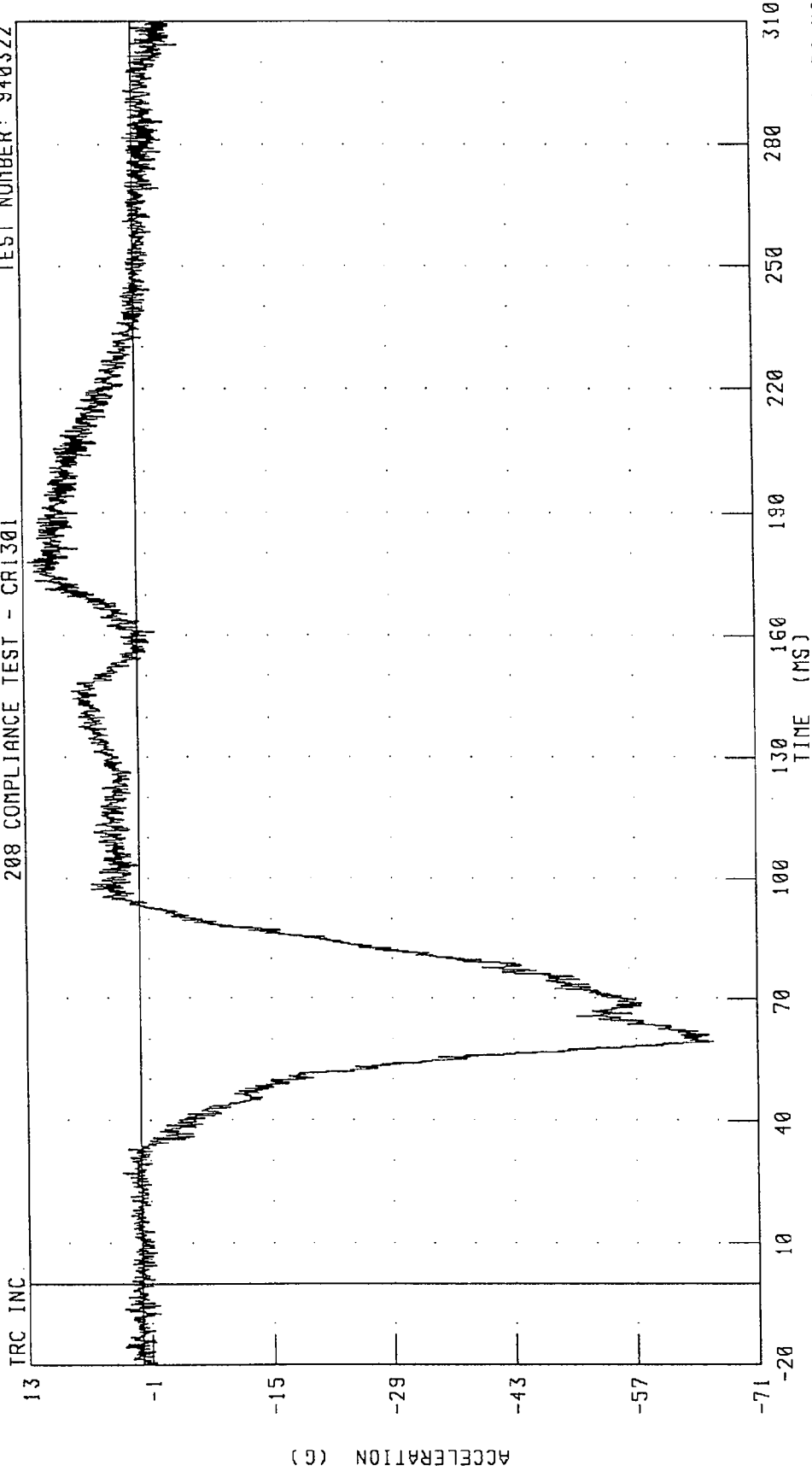

CHANNEL: HEDXG1 FILTER: CH. CLASS 1000

940322

1994 KENTRON SS SPORT TOP VAN INTO FLAT FRONTAL BARRIER
DRIVER HEAD Y-AXIS ACCELERATION
208 COMPLIANCE TEST - CR1301

TEST NUMBER: 940322

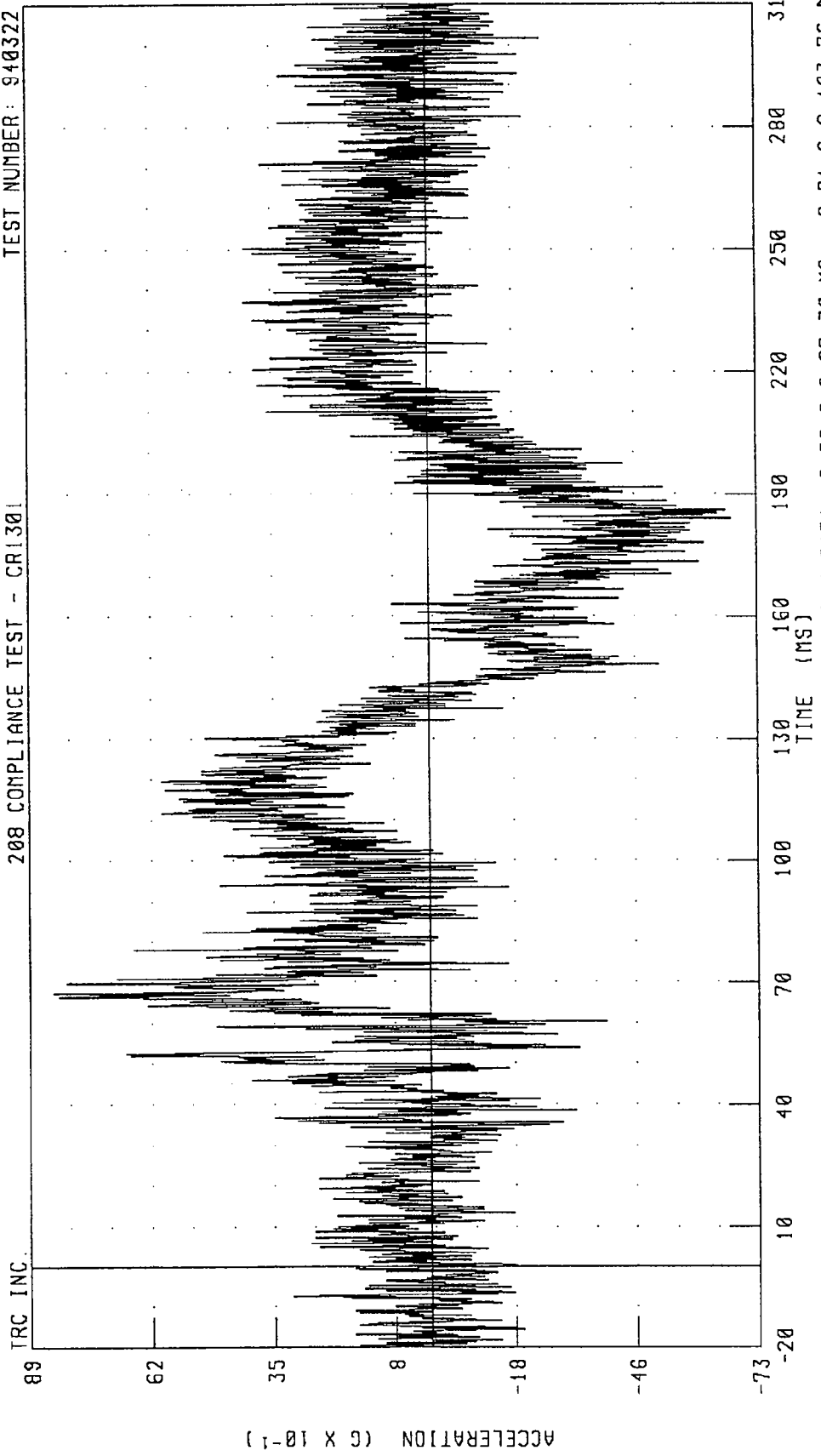

1994 KENTRON SS SPORT TOP VAN INTO FLAT FRONTAL BARRIER
DRIVER HEAD Z-AXIS ACCELERATION
208 COMPLIANCE TEST - CRI301

TEST NUMBER: 940322

TRC INC.

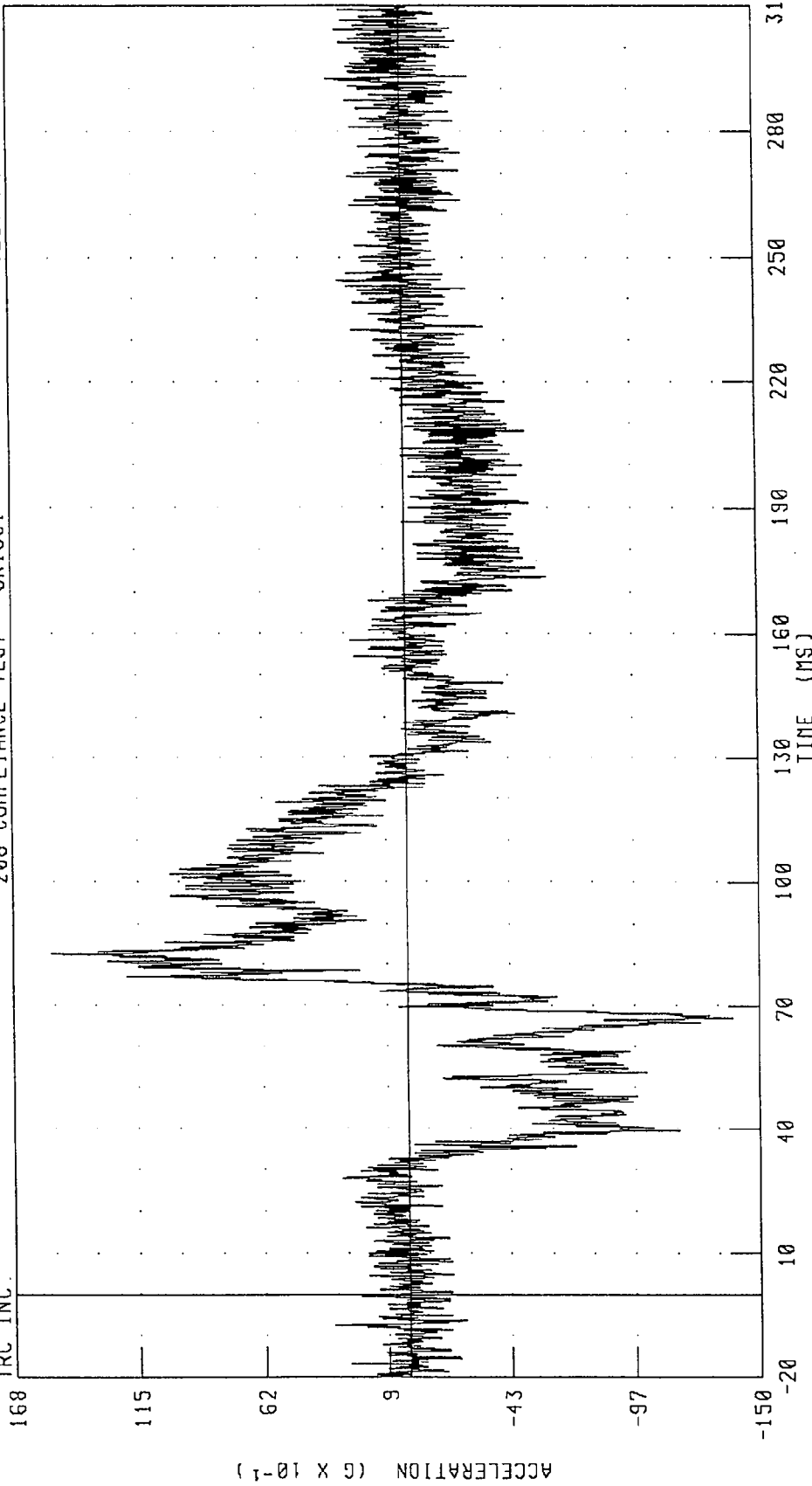

PEAK DATA: 15.18 G @ 82.64 MS; -13.88 G @ 66.96 MS

CHANNEL: HEDZG1 FILTER: CH. CLASS 1000

1994 KENTRON SS SPORT TOP VAN INTO FLAT FRONTAL BARRIER
DRIVER HEAD RESULTANT ACCELERATION
208 COMPLIANCE TEST - CRI301

TEST NUMBER: 940322

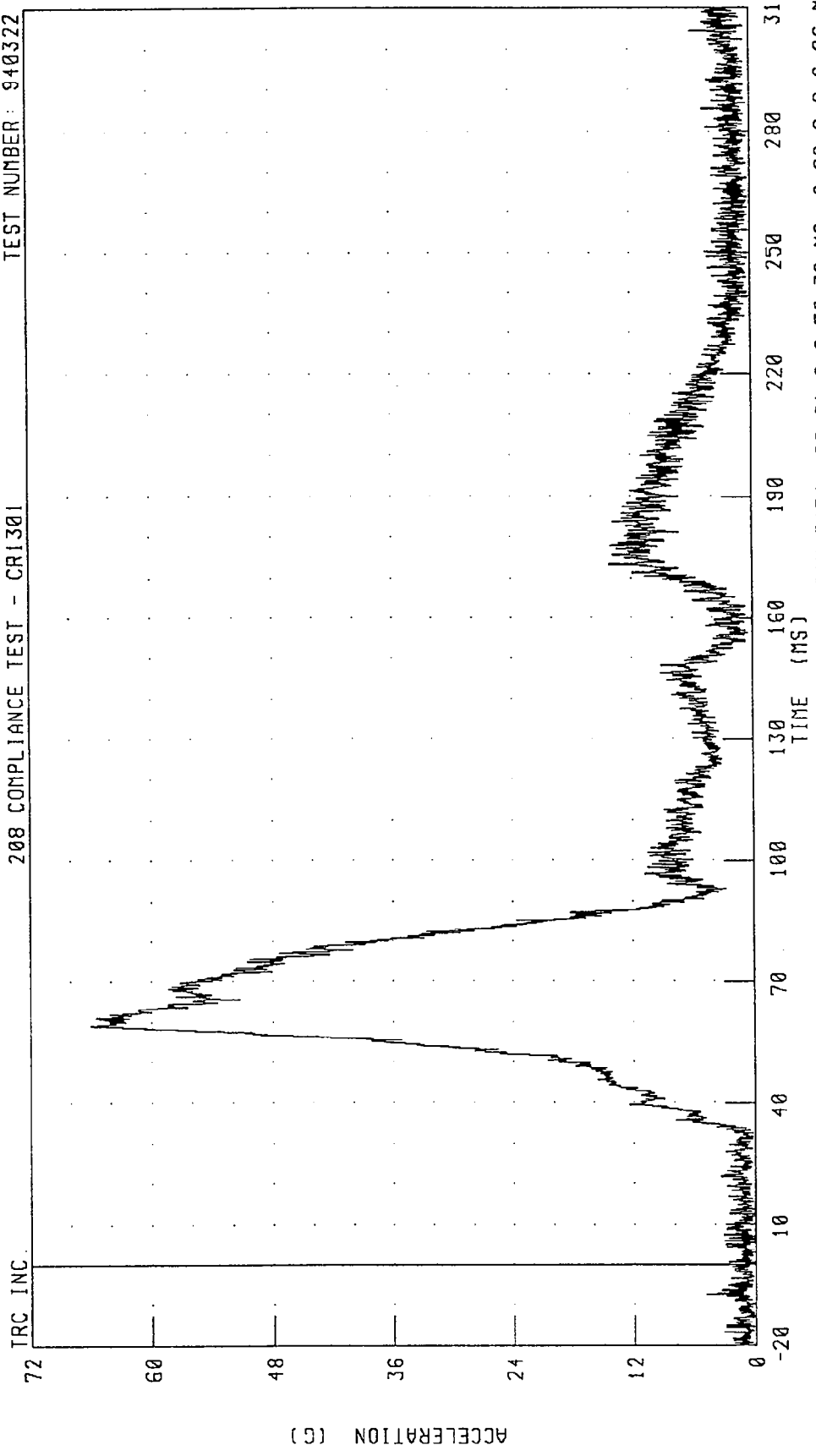

PEAK DATA: 66.01 G @ 59.36 MS; 0.08 G @ 6.96 MS

CHANNEL: HEDRG1 FILTER: CH. CLASS 1000

TRC INC.

1994 KENTRON SS SPORT TOP VAN INTO FLAT FRONTAL BARRIER
DRIVER NECK X-AXIS SHEAR FORCE
208 COMPLIANCE TEST - CR1301

TEST NUMBER: 940322

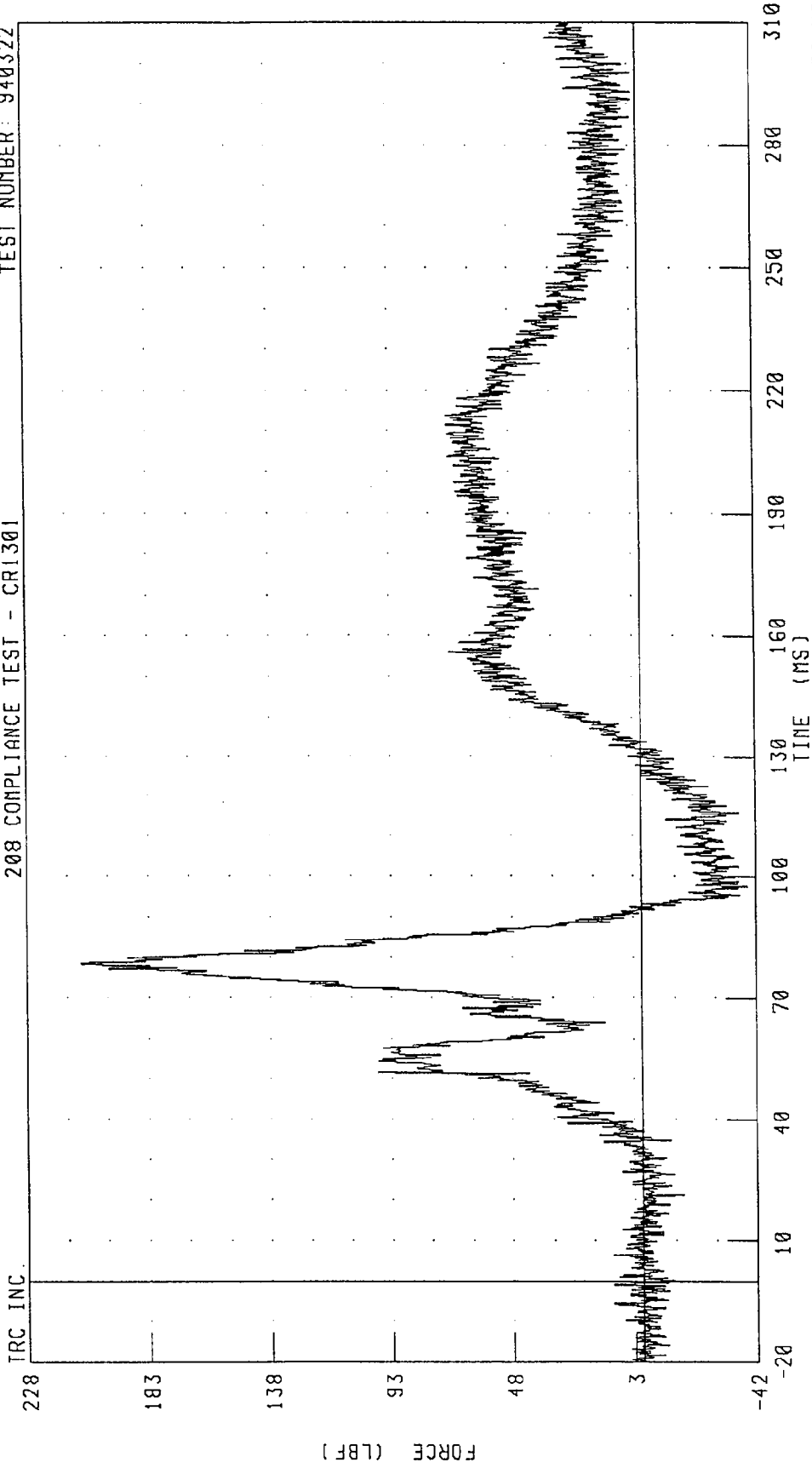

CHANNEL: NEKXF1 FILTER: CH. CLASS 1000

1994 KENTRON SS SPORT TOP VAN INTO FLAT FRONTAL BARRIER
DRIVER NECK Y-AXIS SHEAR FORCE
208 COMPLIANCE TEST - CRI301

TEST NUMBER: 940322

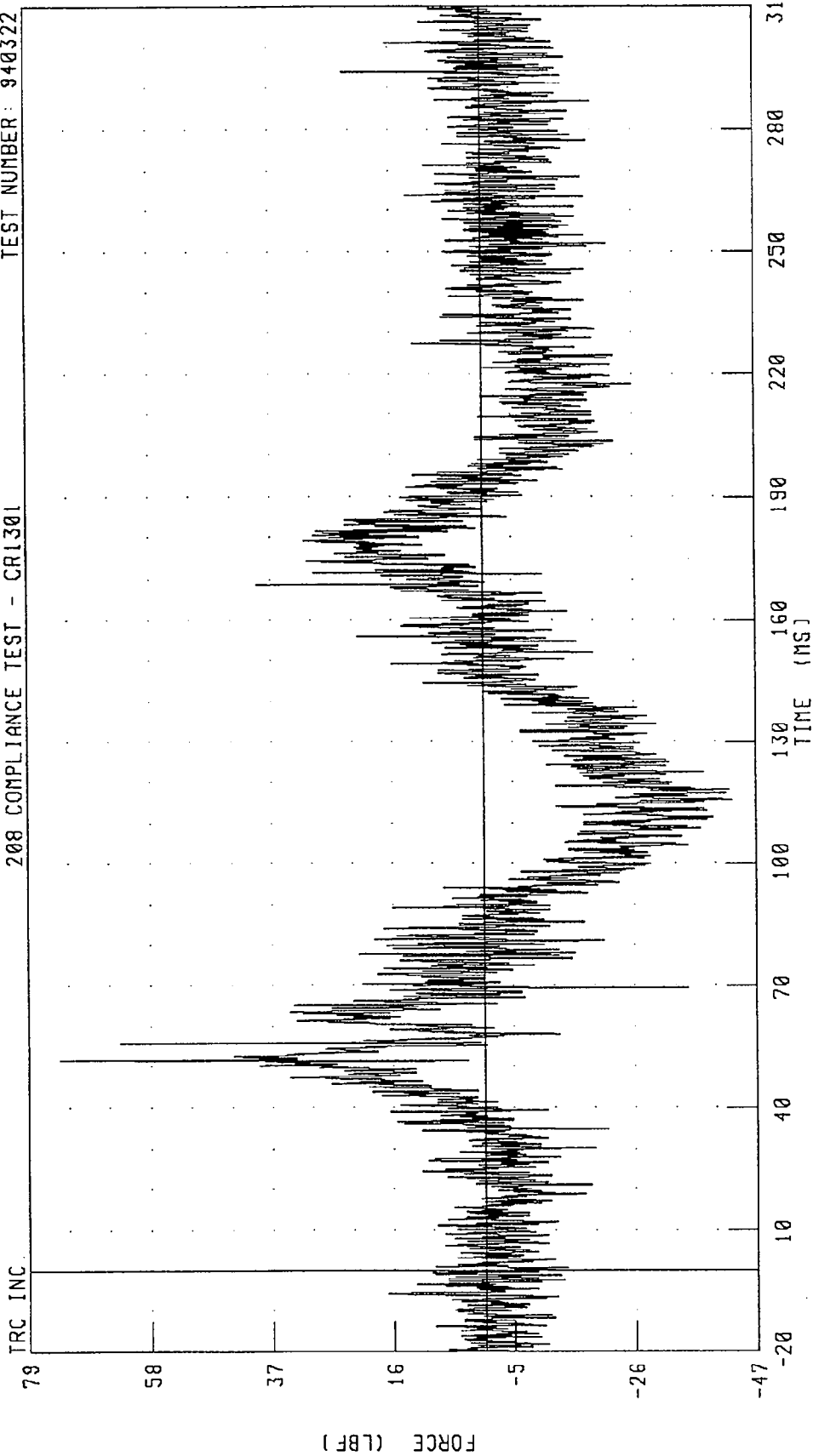

PEAK DATA: 73.64 LBF @ 51.60 MS; -42.89 LBF @ 115.68 MS

CHANNEL: NEKYF1 FILTER: CH. CLASS 1000

1994 KENTRON SS SPORT TOP VAN INTO FLAT FRONTAL BARRIER
DRIVER NECK Z-AXIS AXIAL FORCE
208 COMPLIANCE TEST - CRI301

TEST NUMBER: 940322

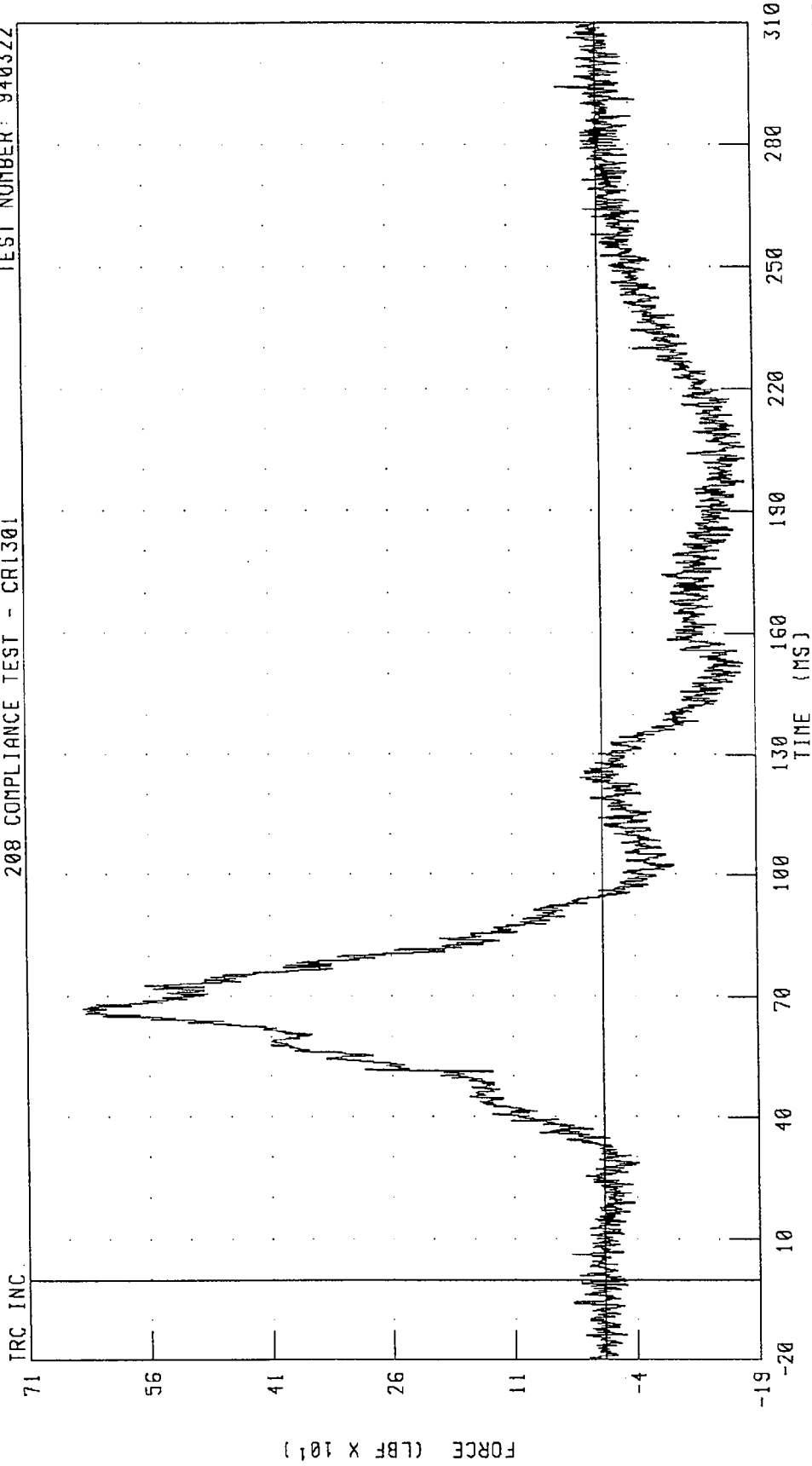

CHANNEL: NEKZF1 FILTER: CH. CLASS 1000 PEAK DATA: 640.53 LBF @ 67.20 MS; -179.79 LBF @ 202.72 MS

1994 KENTRON SS SPORT TOP VAN INTO FLAT FRONTAL BARRIER
DRIVER NECK MOMENT ABOUT X AXIS
208 COMPLIANCE TEST - CR1301

TEST NUMBER: 940322

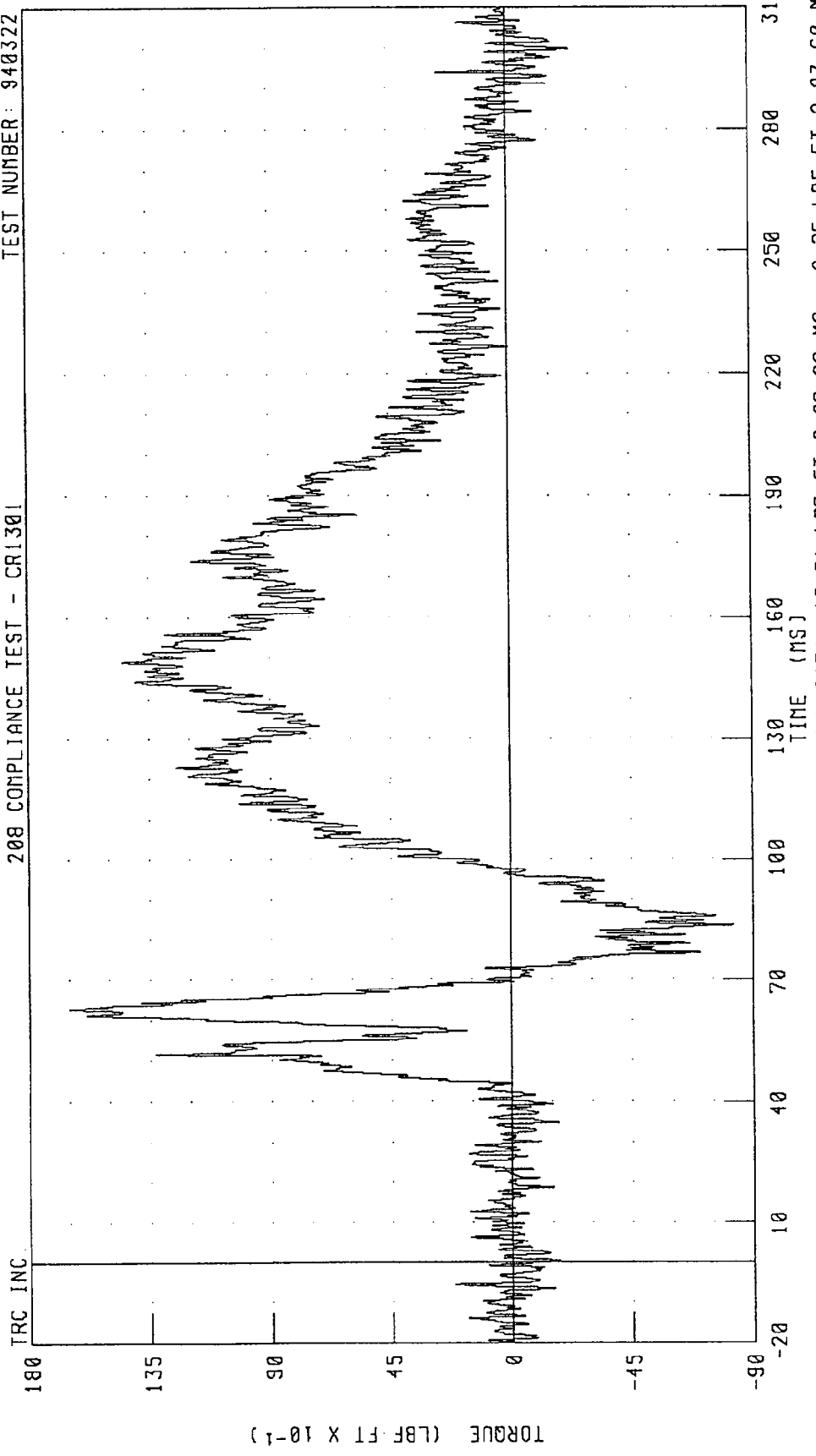

CHANNEL: NEKXMI FILTER: CH. CLASS 600
PEAK DATA: 16.51 LBF.FT @ 62.96 MS; -8.25 LBF.FT @ 83.60 MS

1994 KENTRON SS SPORT TOP VAN INTO FLAT FRONTAL BARRIER
DRIVER NECK MOMENT ABOUT Y AXIS
208 COMPLIANCE TEST - CRI301

TEST NUMBER: 940322

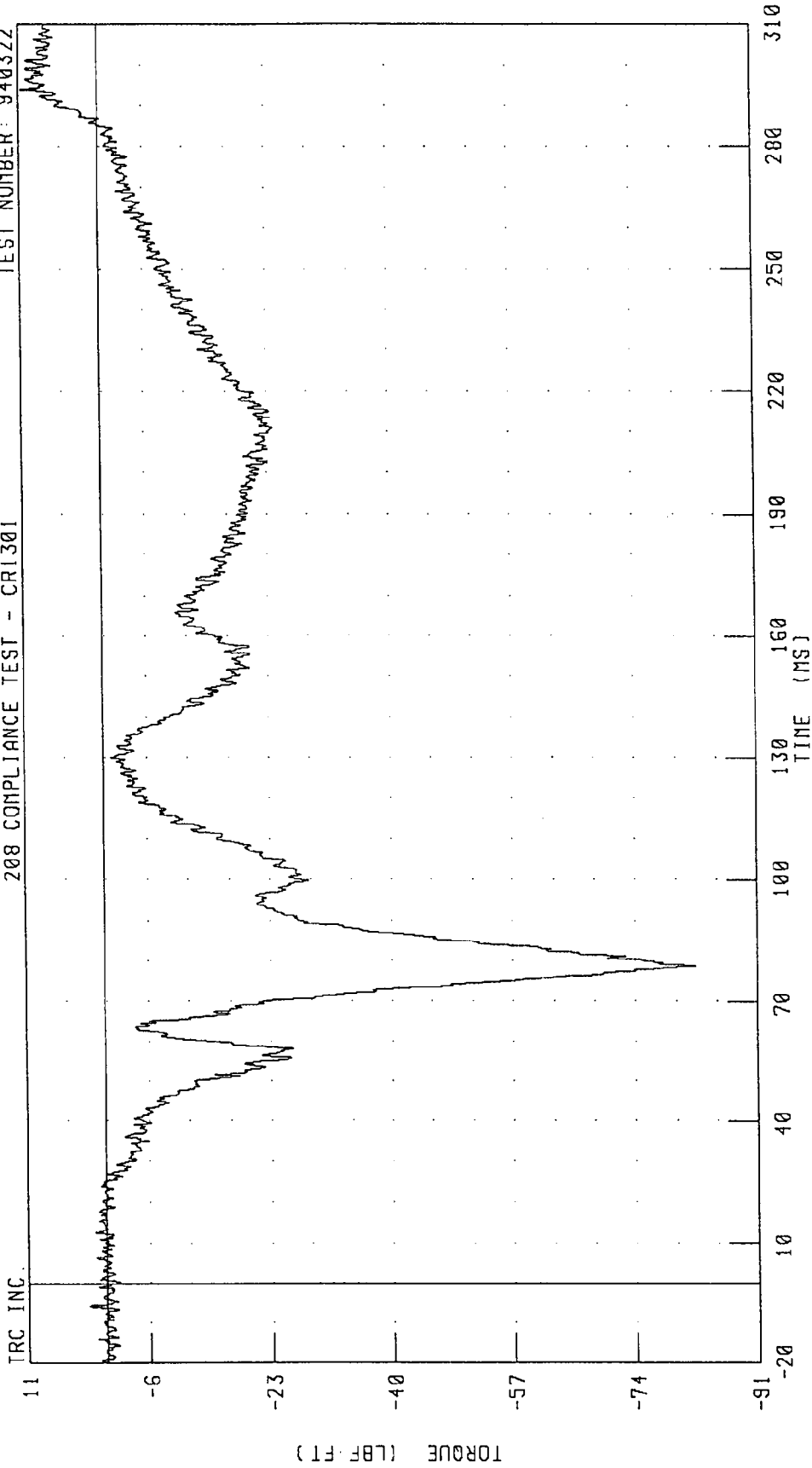

CHANNEL: NEKYMI FILTER: CH. CLASS 600

PEAK DATA: 10.71 LBF-FT @ 294.16 MS; -82.35 LBF-FT @ 78.80 MS

1994 KENTRON SS SPORT TOP VAN INTO FLAT FRONTAL BARRIER
DRIVER NECK MOMENT ABOUT Z AXIS
208 COMPLIANCE TEST - CRI301

TEST NUMBER: 940322

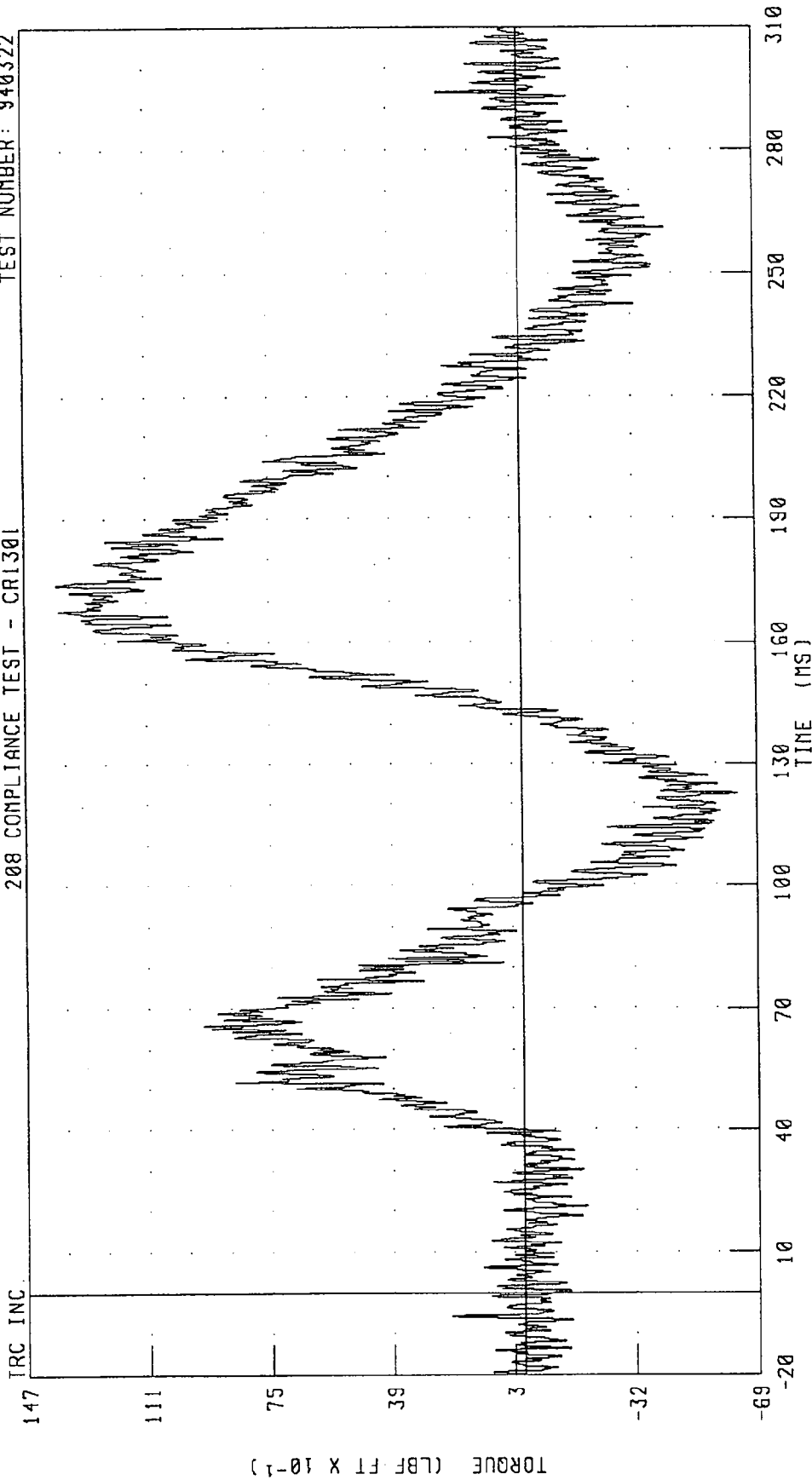

CHANNEL: NEKZM1 FILTER: CH. CLASS 600

PEAK DATA: 13.76 LBF.FT @ 174.00 MS; -6.32 LBF.FT @ 122.56 MS

1994 KENTRON SS SPORT TOP VAN INTO FLAT FRONTAL BARRIER
DRIVER CHEST X-AXIS ACCELERATION
208 COMPLIANCE TEST - CR1301

TEST NUMBER: 940322

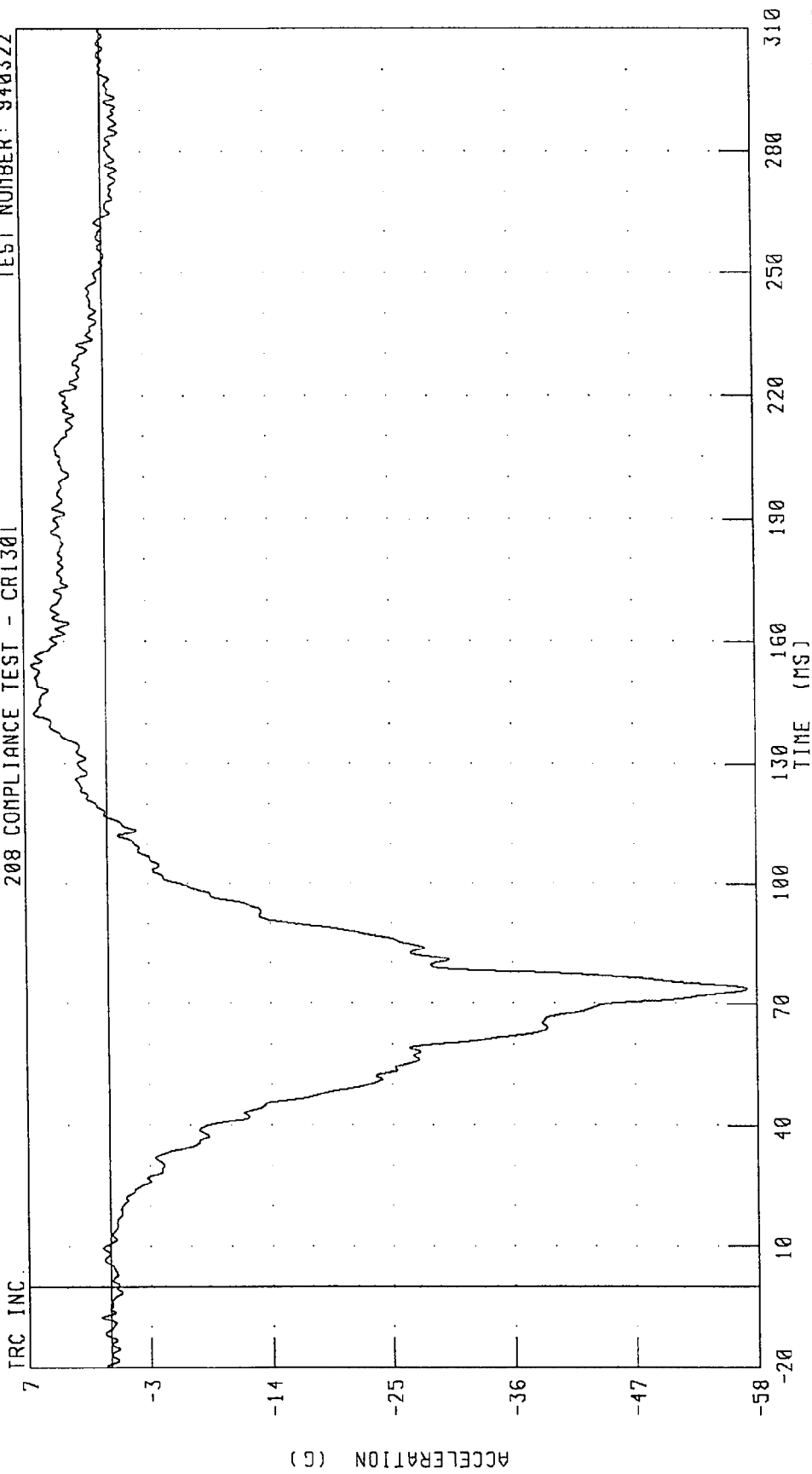

CHANNEL: CSTXG1 FILTER: CH. CLASS 180

1994 KENTRON SS SPORT TOP VAN INTO FLAT FRONTAL BARRIER
DRIVER CHEST Y-AXIS ACCELERATION
208 COMPLIANCE TEST - CRI301

TEST NUMBER: 940322

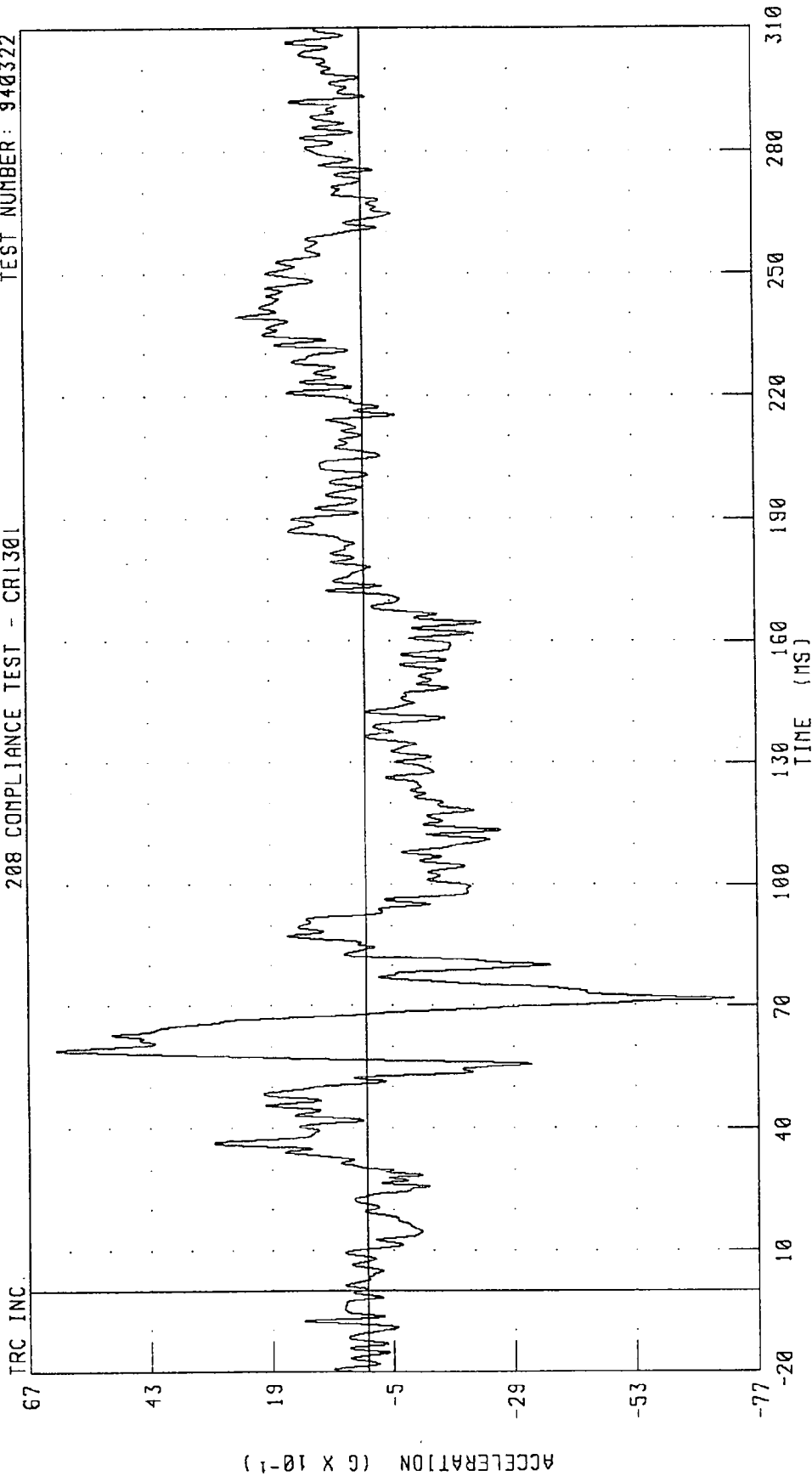

PEAK DATA: 6.15 G @ 59.20 MS; -7.23 G @ 71.60 MS

CHANNEL: CSTYG1 FILTER: CH. CLASS 180

1994 KENTRON SS SPORT TOP VAN INTO FLAT FRONTAL BARRIER
DRIVER CHEST Z-AXIS ACCELERATION
208 COMPLIANCE TEST - CRI301

TEST NUMBER: 940322

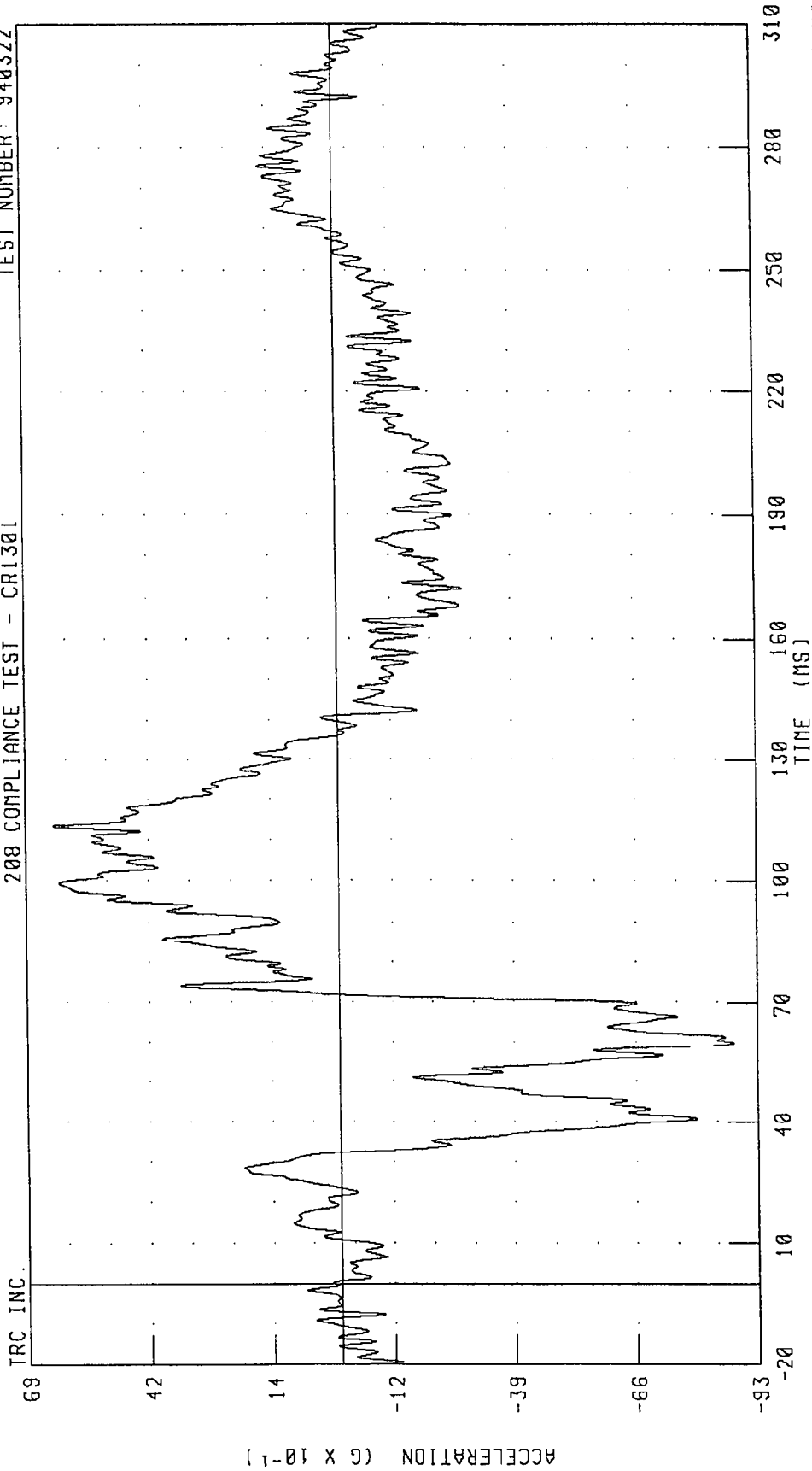

CHANNEL: CSTZG1 FILTER: CH. CLASS 180

PEAK DATA: 6.30 G @ 113.68 MS; -8.77 G @ 59.68 MS

1994 KENTRON SS SPORT TOP VAN INTO FLAT FRONTAL BARRIER
DRIVER CHEST RESULTANT ACCELERATION
208 COMPLIANCE TEST - CR1301

TEST NUMBER: 940322

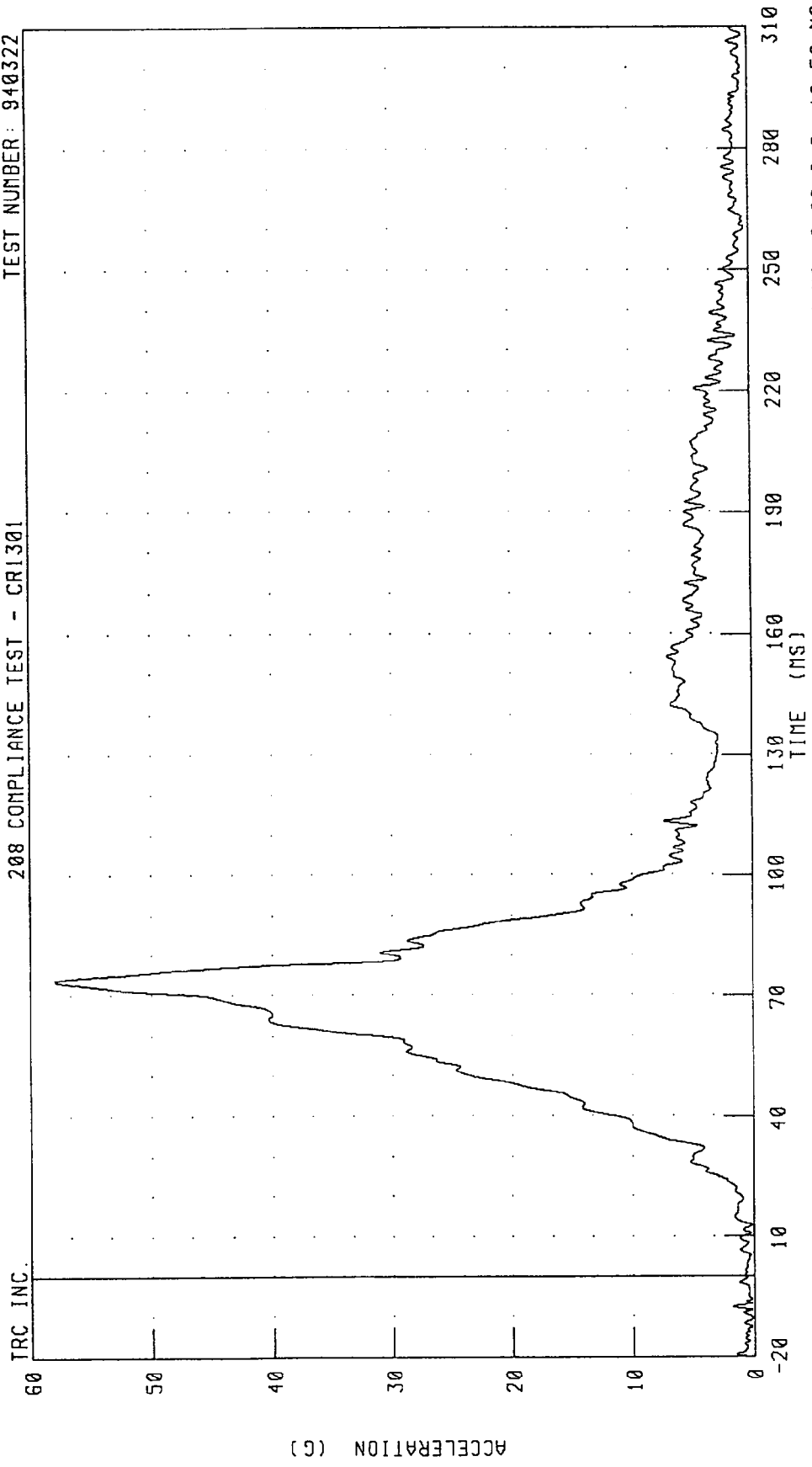

CHANNEL: CSTRG1 FILTER: CH. CLASS 180 PEAK DATA: 57.95 G @ 73.52 MS; 0.06 G @ -10.56 MS

1994 KENTRON SS SPORT TOP VAN INTO FLAT FRONTAL BARRIER
DRIVER CHEST DEFLECTION
208 COMPLIANCE TEST - CRI301

TEST NUMBER: 940322

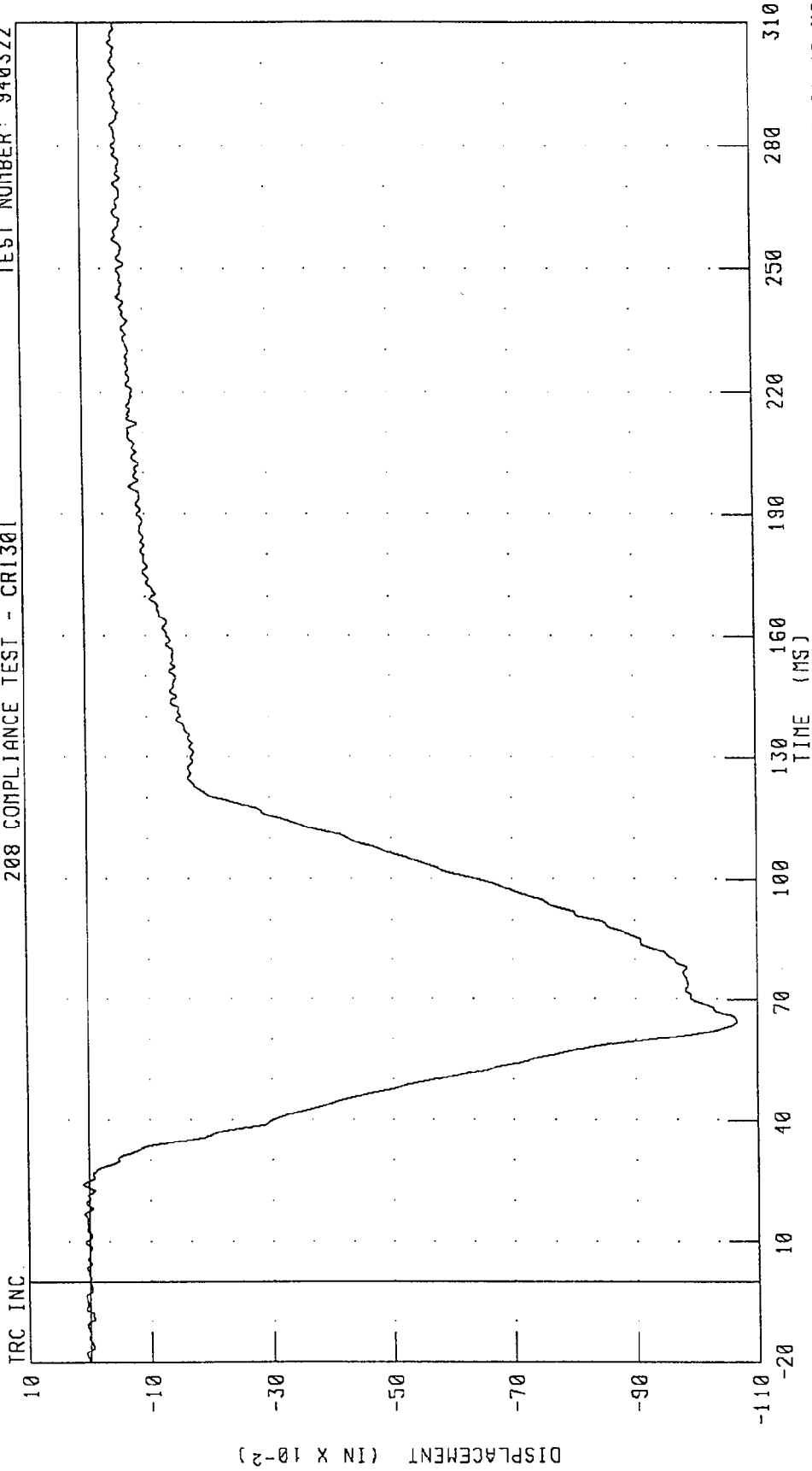

PEAK DATA: 0.01 IN @ 24.08 MS; -1.07 IN @ 64.48 MS

CHANNEL: CSTXD1 FILTER: CH. CLASS 180

TRC INC.

1984 KENTRON SS SPORT TOP VAN INTO FLAT FRONTAL BARRIER
DRIVER LEFT FEMUR FORCE
208 COMPLIANCE TEST - CR1301

TEST NUMBER: 940322

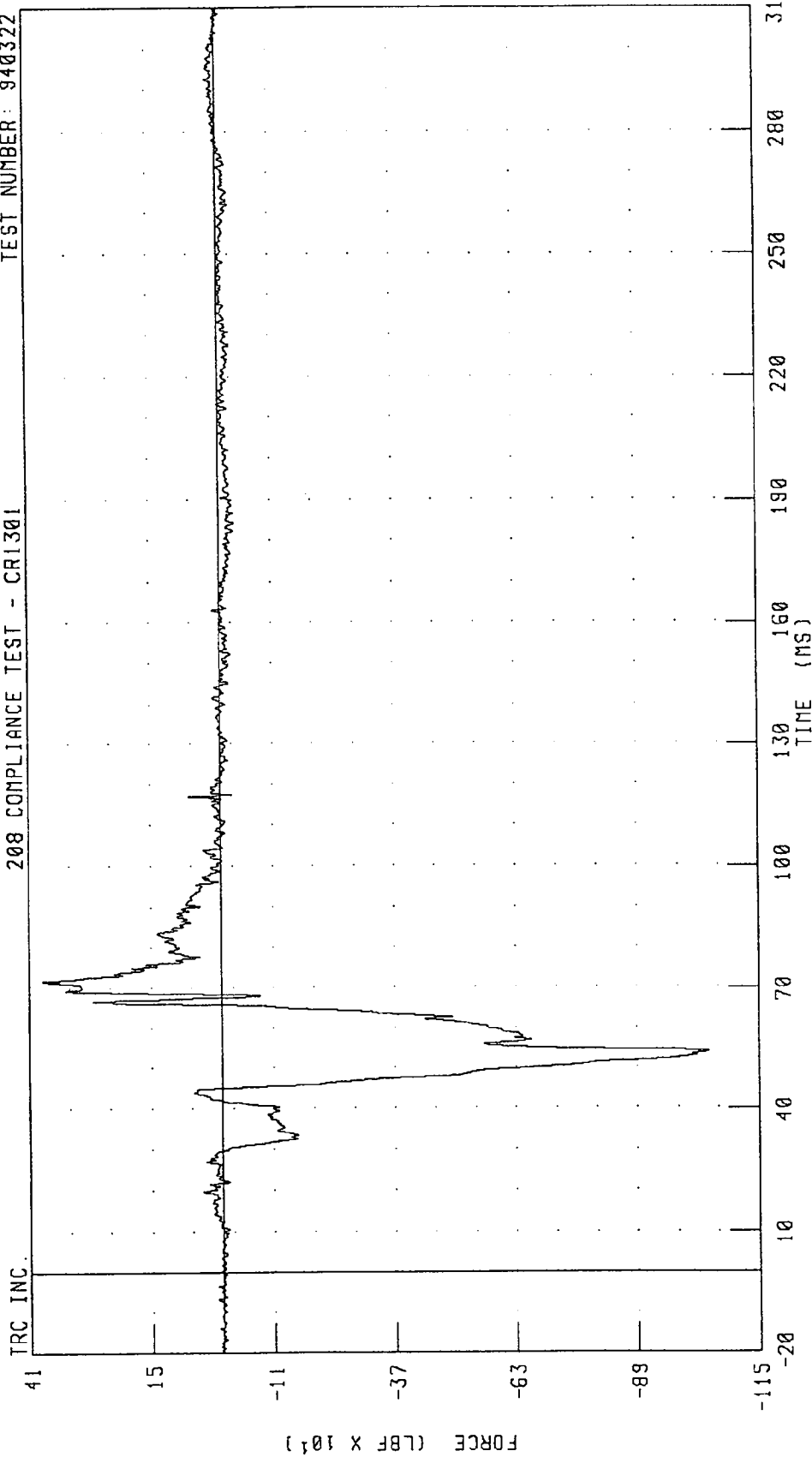

PEAK DATA: 380.73 LBF @ 71.84 MS; -1043.57 LBF @ 54.00 MS

CHANNEL: LFMF1 FILTER: CH. CLASS 600

1984 KENTRON SS SPORT TOP VAN INTO FLAT FRONTAL BARRIER
DRIVER RIGHT FEMUR FORCE
208 COMPLIANCE TEST - CR1301

TEST NUMBER: 940322

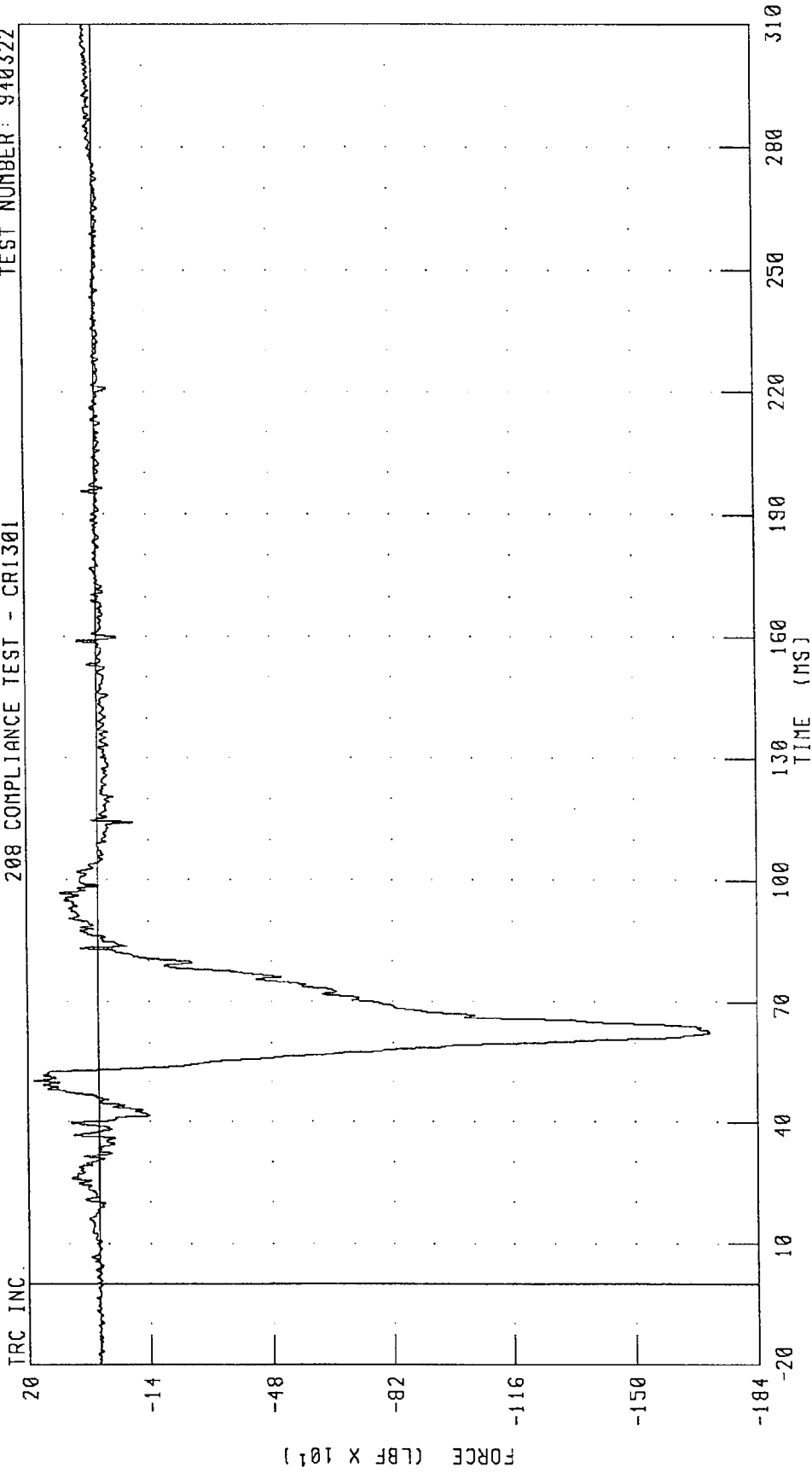

CHANNEL: RFMF1 FILTER: CH. CLASS 600

940322

1994 KENTRON SS SPORT TOP VAN INTO FLAT FRONTAL BARRIER
RIGHT FRONT PASSENGER HEAD X-AXIS ACCELERATION
208 COMPLIANCE TEST - CR1301

TEST NUMBER: 940322

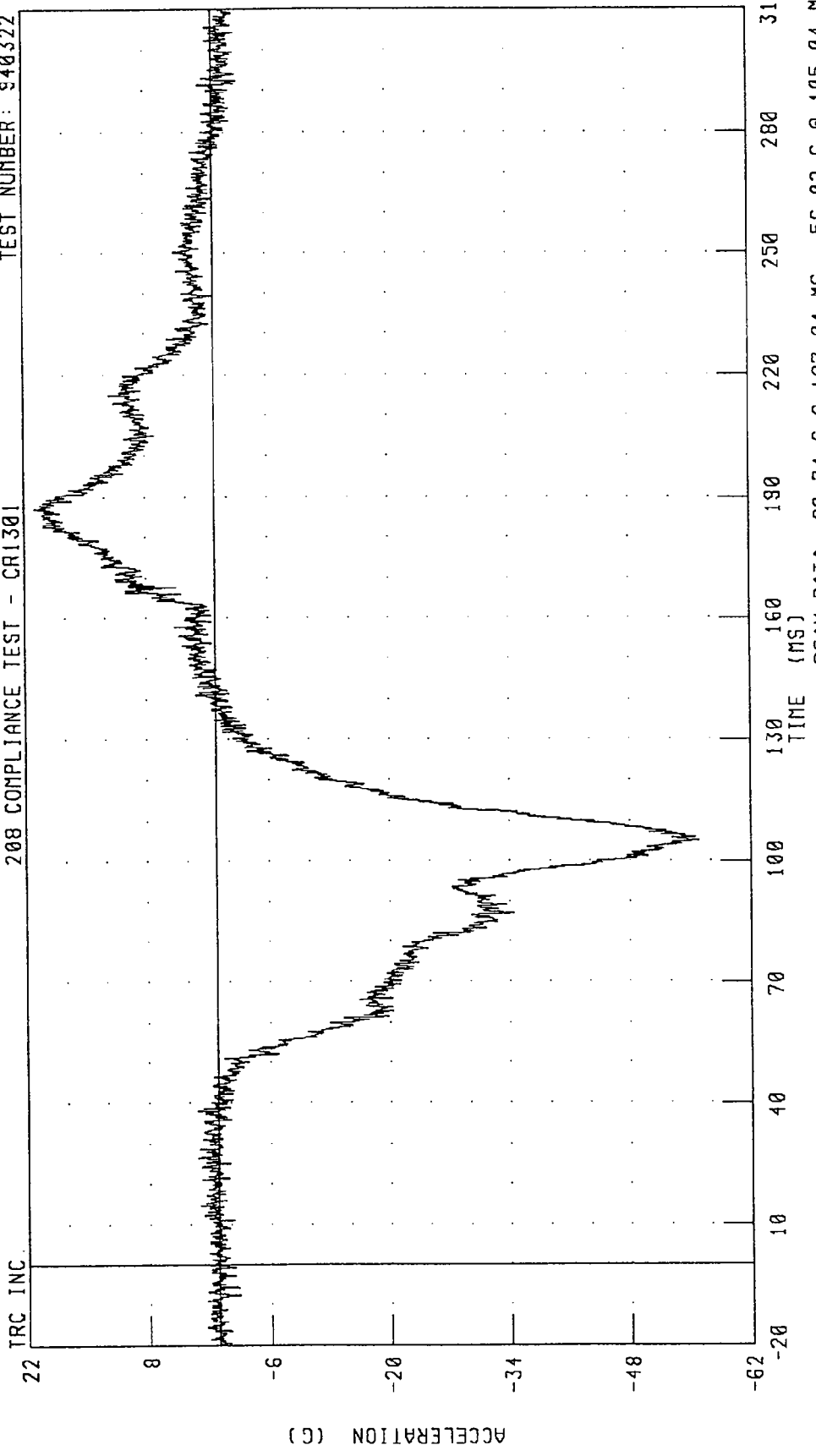

PEAK DATA: 20.74 G @ 187.04 MS, -56.02 G @ 105.04 MS

CHANNEL: HEDXC2 FILTER: CH. CLASS 1000

TRC INC.

1994 KENTRON SS SPORT TOP VAN INTO FLAT FRONTAL BARRIER
RIGHT FRONT PASSENGER HEAD Y-AXIS ACCELERATION
208 COMPLIANCE TEST - CR1301

TEST NUMBER: 940322

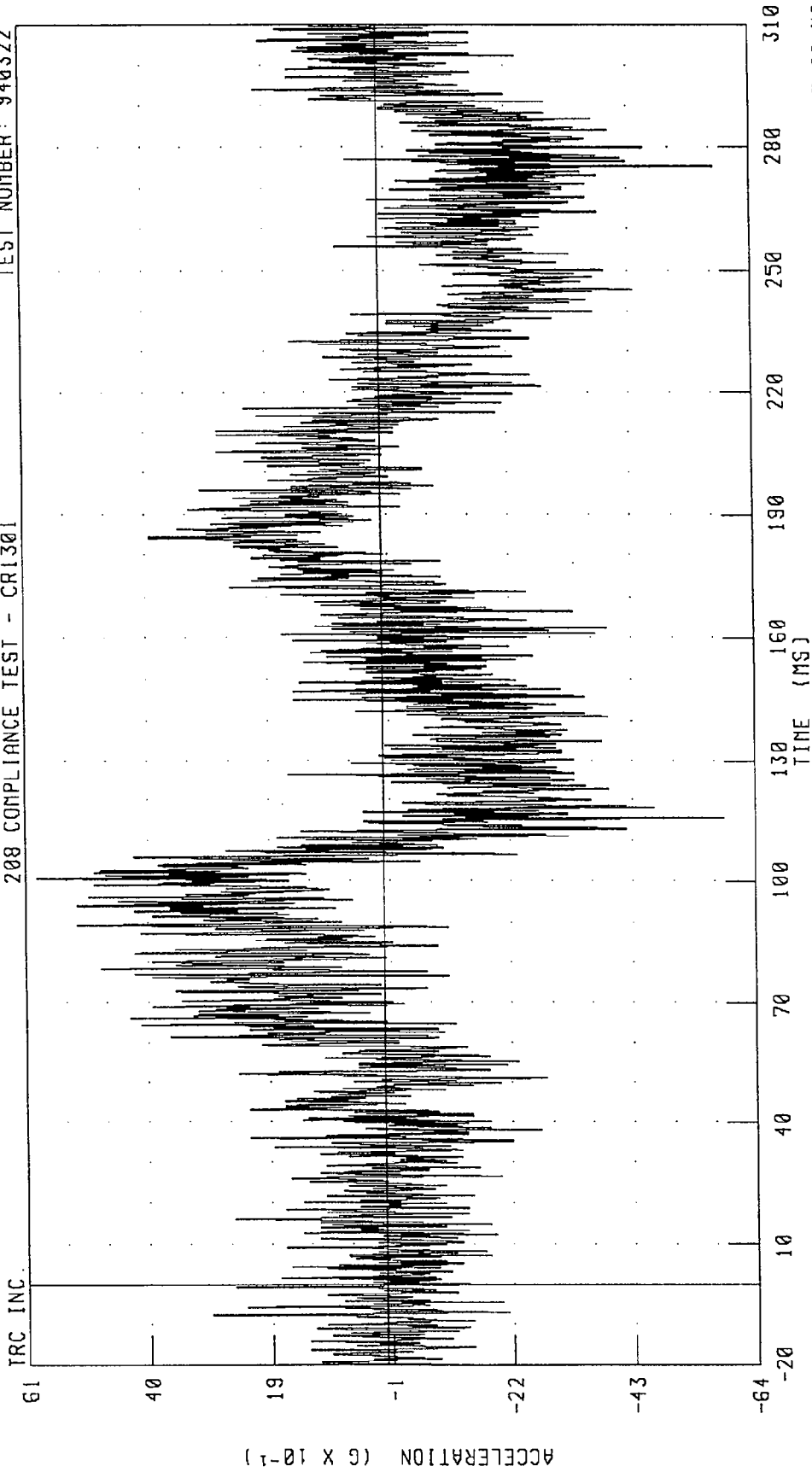

PEAK DATA: 6.01 G @ 100.72 MS; -5.86 G @ 115.68 MS

CHANNEL: HEDYG2 FILTER: CH. CLASS 1000

TRC INC.

1994 KENTRON SS SPORT TOP VAN INTO FLAT FRONTAL BARRIER
RIGHT FRONT PASSENGER HEAD Z-AXIS ACCELERATION
208 COMPLIANCE TEST - CR1301

TEST NUMBER: 940322

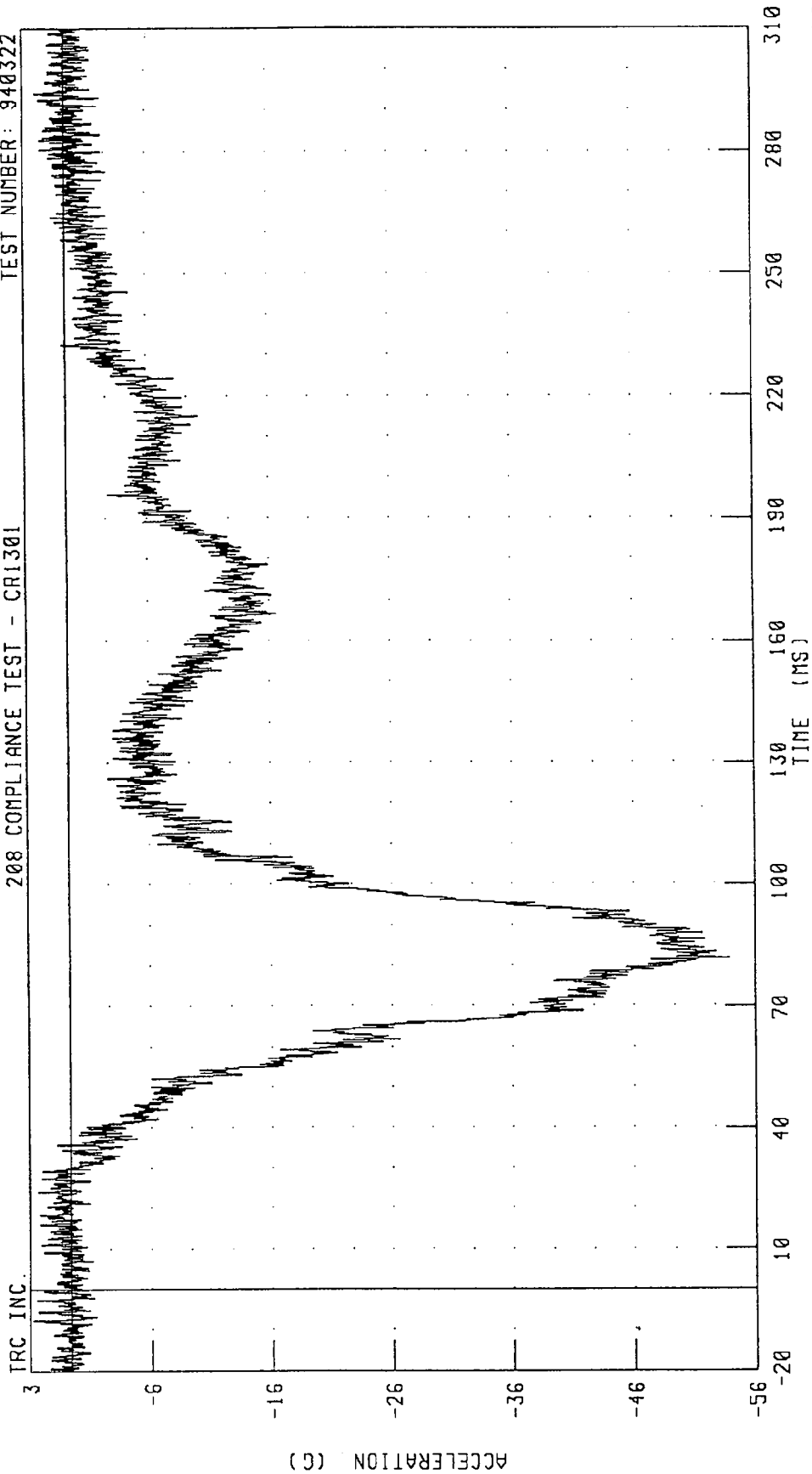

CHANNEL: HEDZG2 FILTER: CH. CLASS 1000

PEAK DATA: 3.16 G @ -7.60 MS; -54.45 G @ 81.92 MS

1994 KENTRON SS SPORT TOP VAN INTO FLAT FRONTAL BARRIER
RIGHT FRONT PASSENGER HEAD RESULTANT ACCELERATION

TEST NUMBER: 940322

208 COMPLIANCE TEST - CRI301

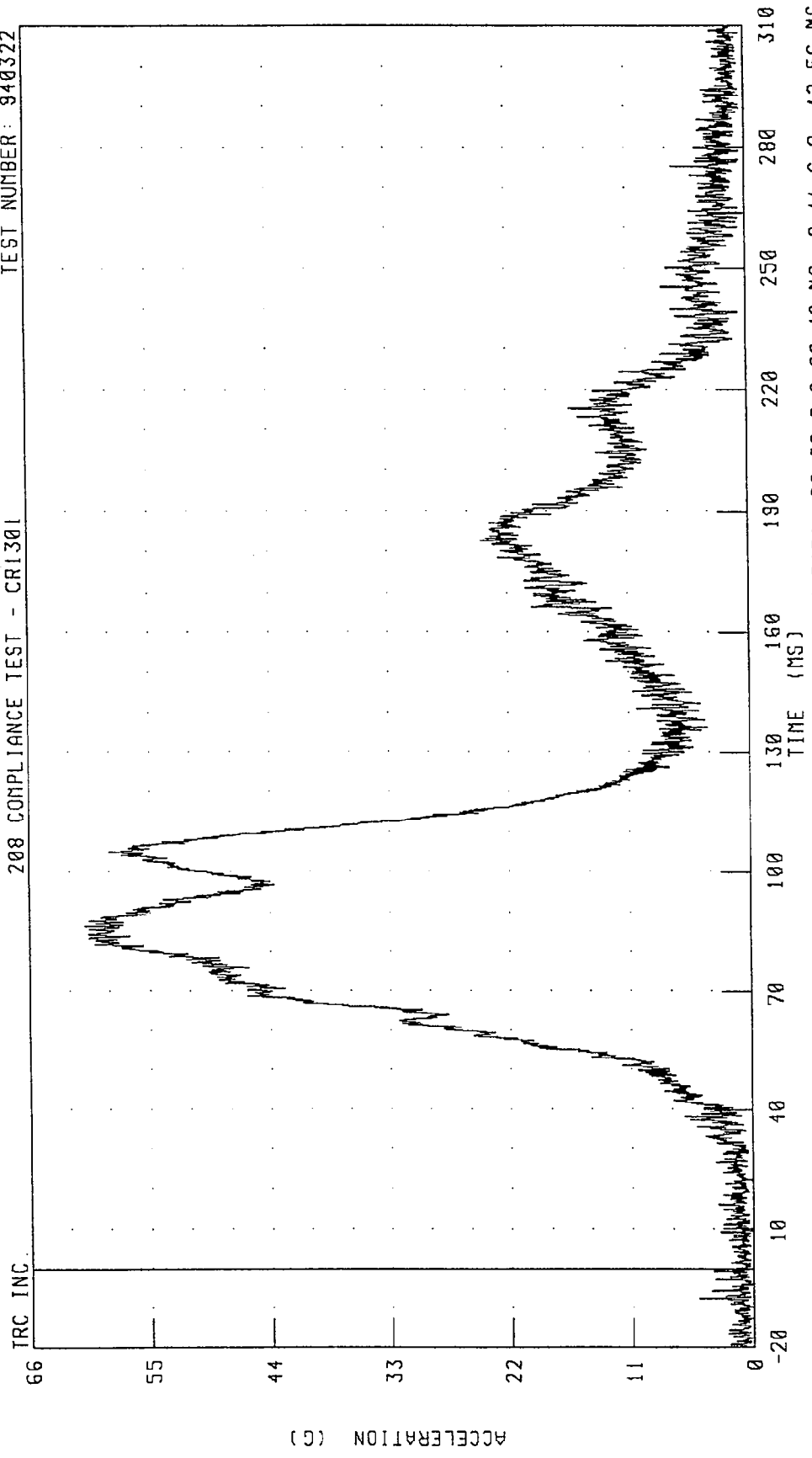

CHANNEL: HEDRG2 FILTER: CH. CLASS 1000

PEAK DATA: 60.98 G @ 86.48 MS; 0.11 G @ -12.56 MS

1994 KENTRON SS SPORT TOP VAN INTO FLAT FRONTAL BARRIER
RIGHT FRONT PASSENGER NECK X-AXIS SHEAR FORCE
208 COMPLIANCE TEST - CRI301

TEST NUMBER: 940322

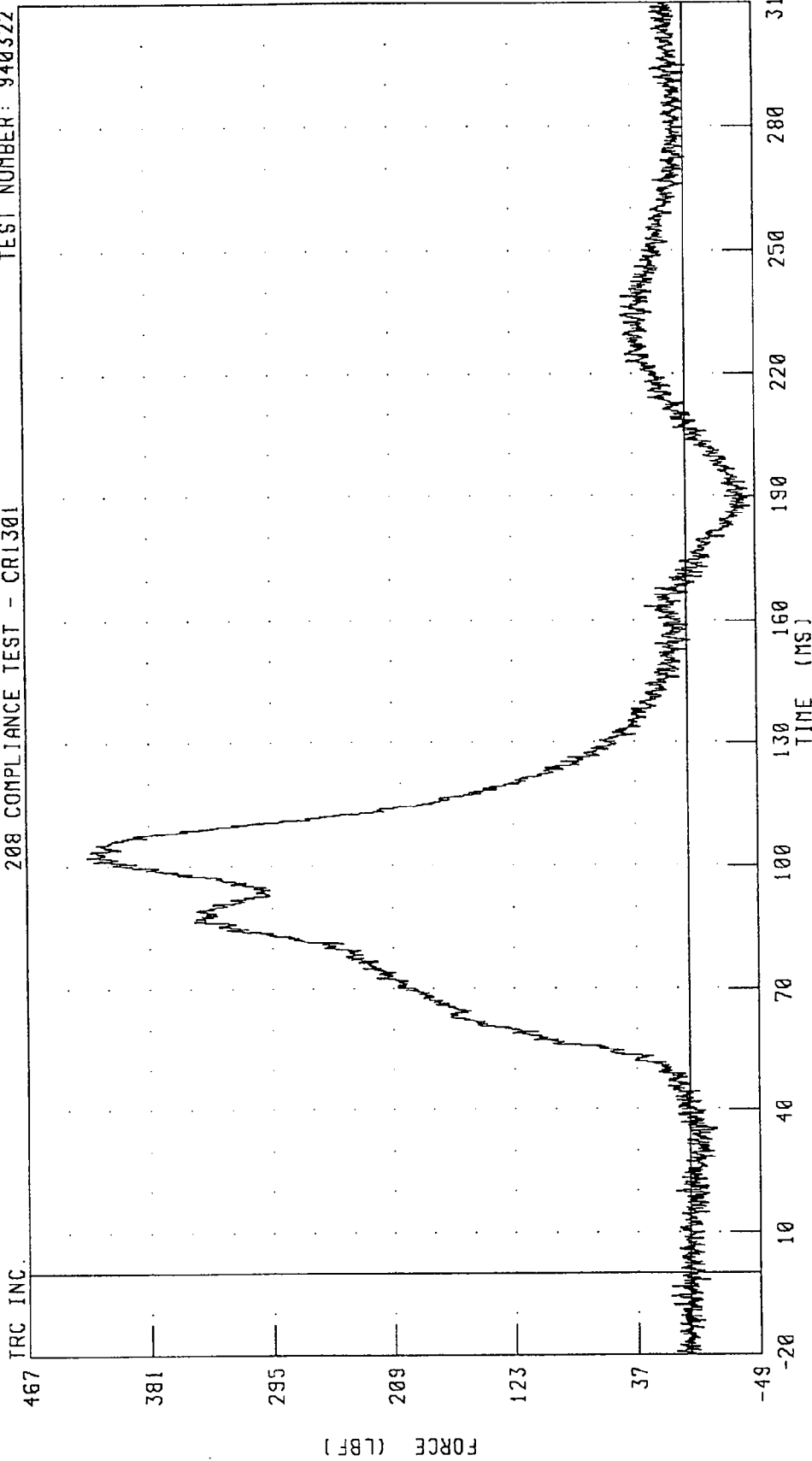

PEAK DATA: 424.30 LBF @ 102.16 MS; -44.81 LBF @ 187.36 MS

CHANNEL: NEKXF2 FILTER: CH. CLASS 1000

TRC INC.

467

381

295

209

123

37

-49

FORCE (LBF)

TIME (MS)

1994 KENTRON SS SPORT TOP VAN INTO FLAT FRONTAL BARRIER
RIGHT FRONT PASSENGER NECK Y-AXIS SHEAR FORCE
208 COMPLIANCE TEST - CR1301

TEST NUMBER: 940322

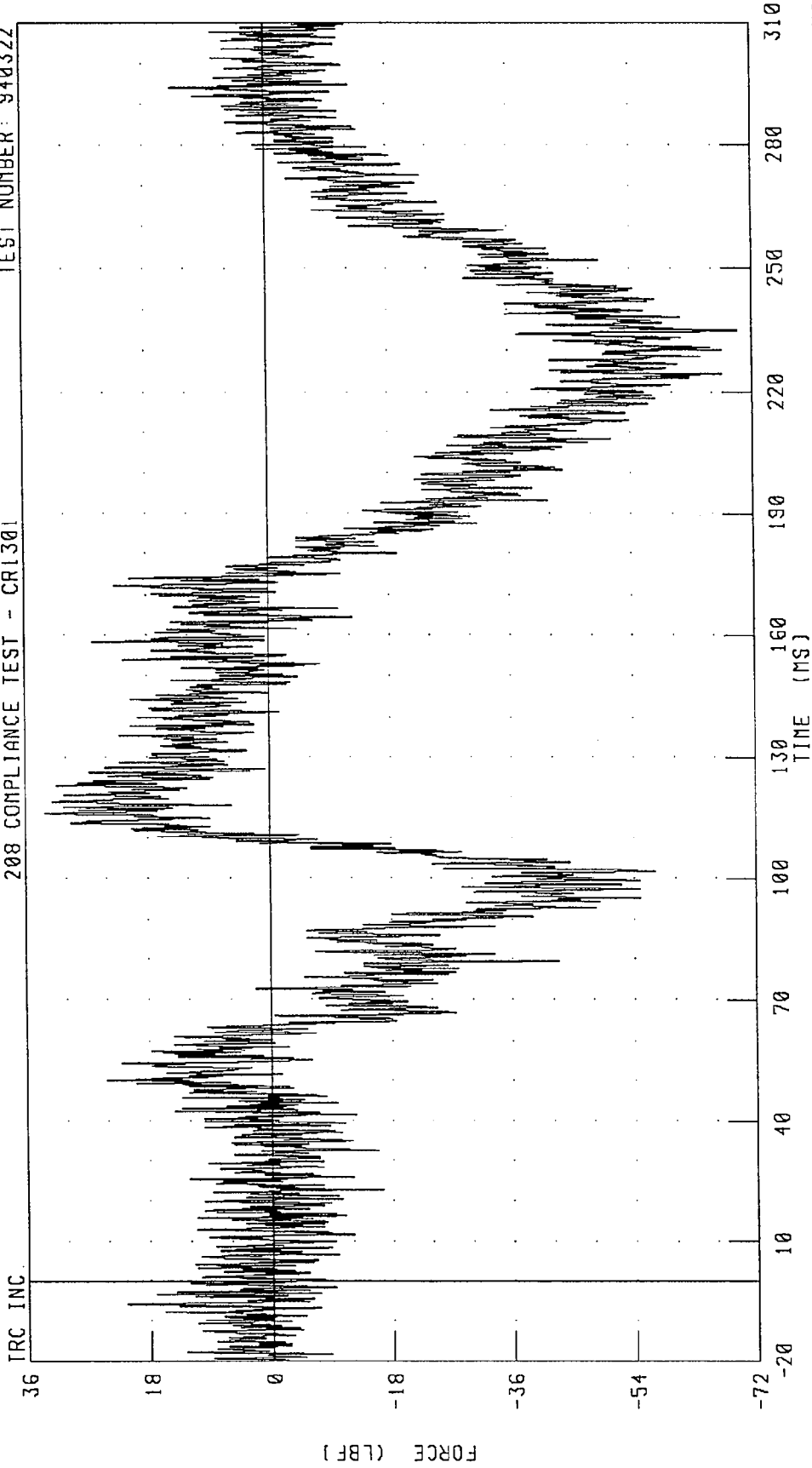

CHANNEL: NEKYF2 FILTER: CH. CLASS 1000

PEAK DATA: 33.09 LBF @ 116.24 MS; -69.75 LBF @ 234.96 MS

1994 KENTRON SS SPORT TOP VAN INTO FLAT FRONTAL BARRIER
RIGHT FRONT PASSENGER NECK Z-AXIS AXIAL FORCE

TEST NUMBER: 940322

208 COMPLIANCE TEST - CR1301

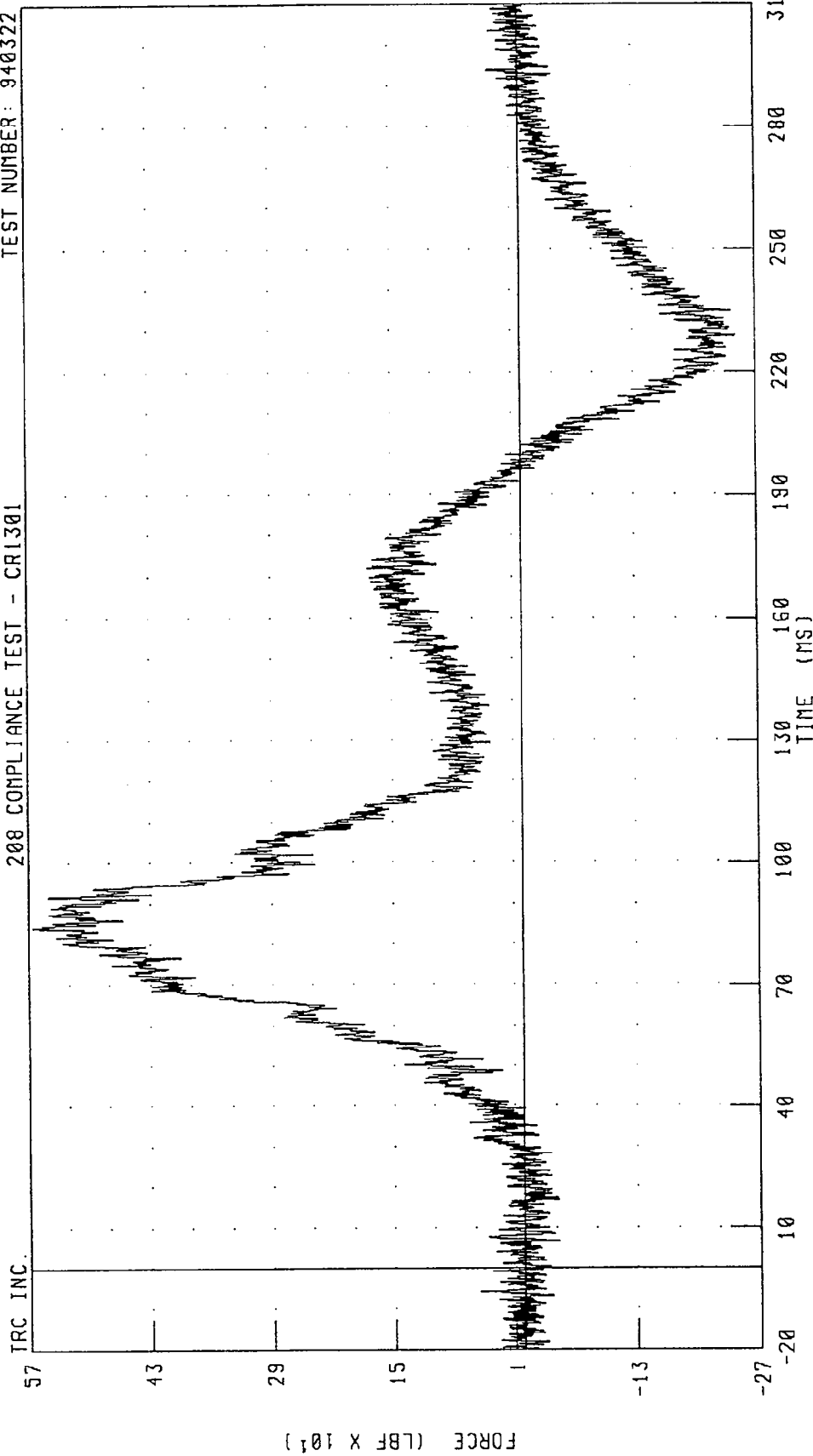

CHANNEL: NEKZF2 FILTER: CH. CLASS 1000

1994 KENTRON SS SPORT TOP VAN INTO FLAT FRONTAL BARRIER
RIGHT FRONT PASSENGER NECK MOMENT ABOUT X AXIS

TEST NUMBER: 940322

208 COMPLIANCE TEST - CR1301

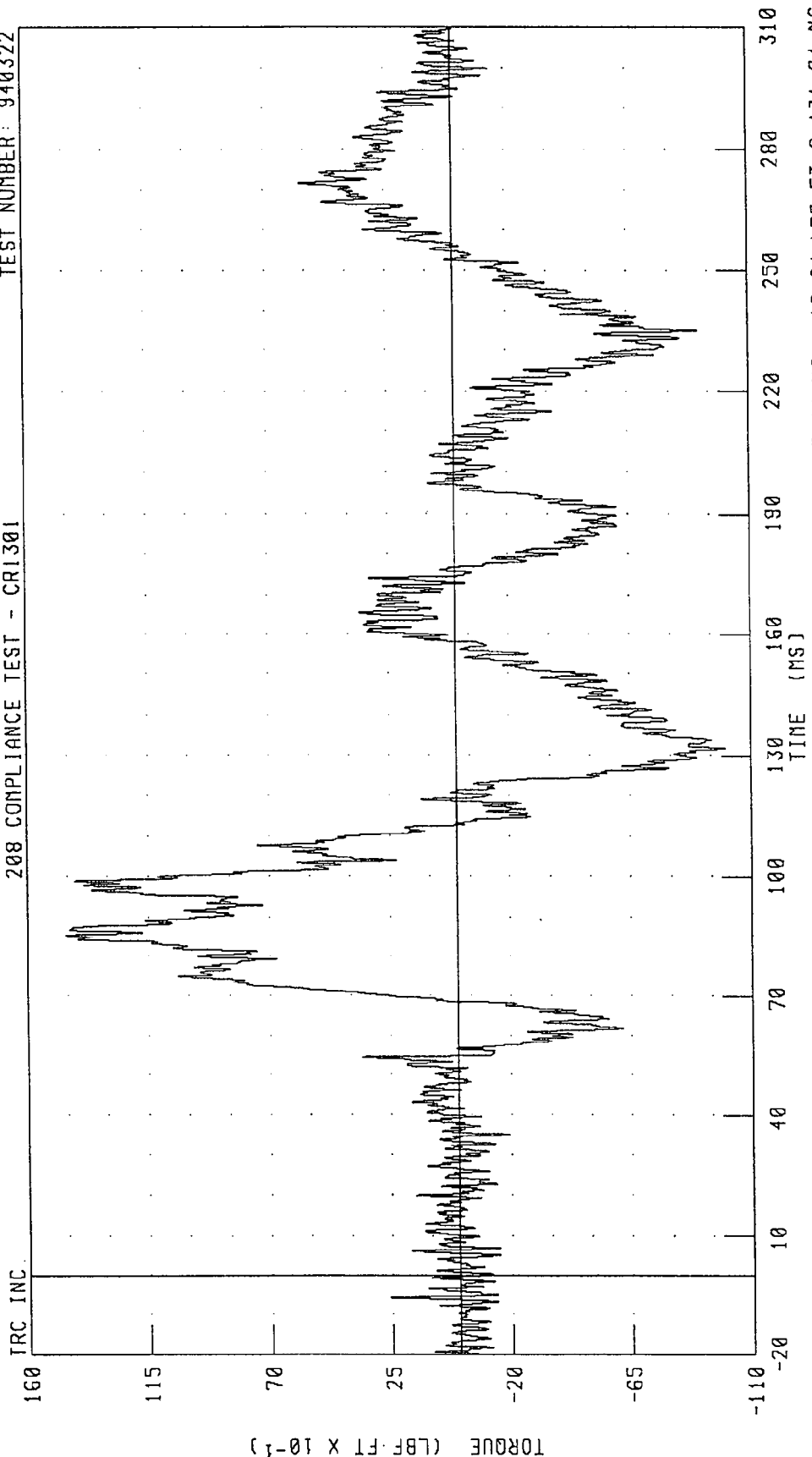

CHANNEL: NEKX12 FILTER: CH. CLASS 600 PEAK DATA: 14.57 LBF·FT @ 85.44 MS; -10.04 LBF·FT @ 131.84 MS

1994 KENTRON SS SPORT TOP VAN INTO FLAT FRONTAL BARRIER
RIGHT FRONT PASSENGER NECK MOMENT ABOUT Y AXIS
208 COMPLIANCE TEST - CR1301

TEST NUMBER: 940322

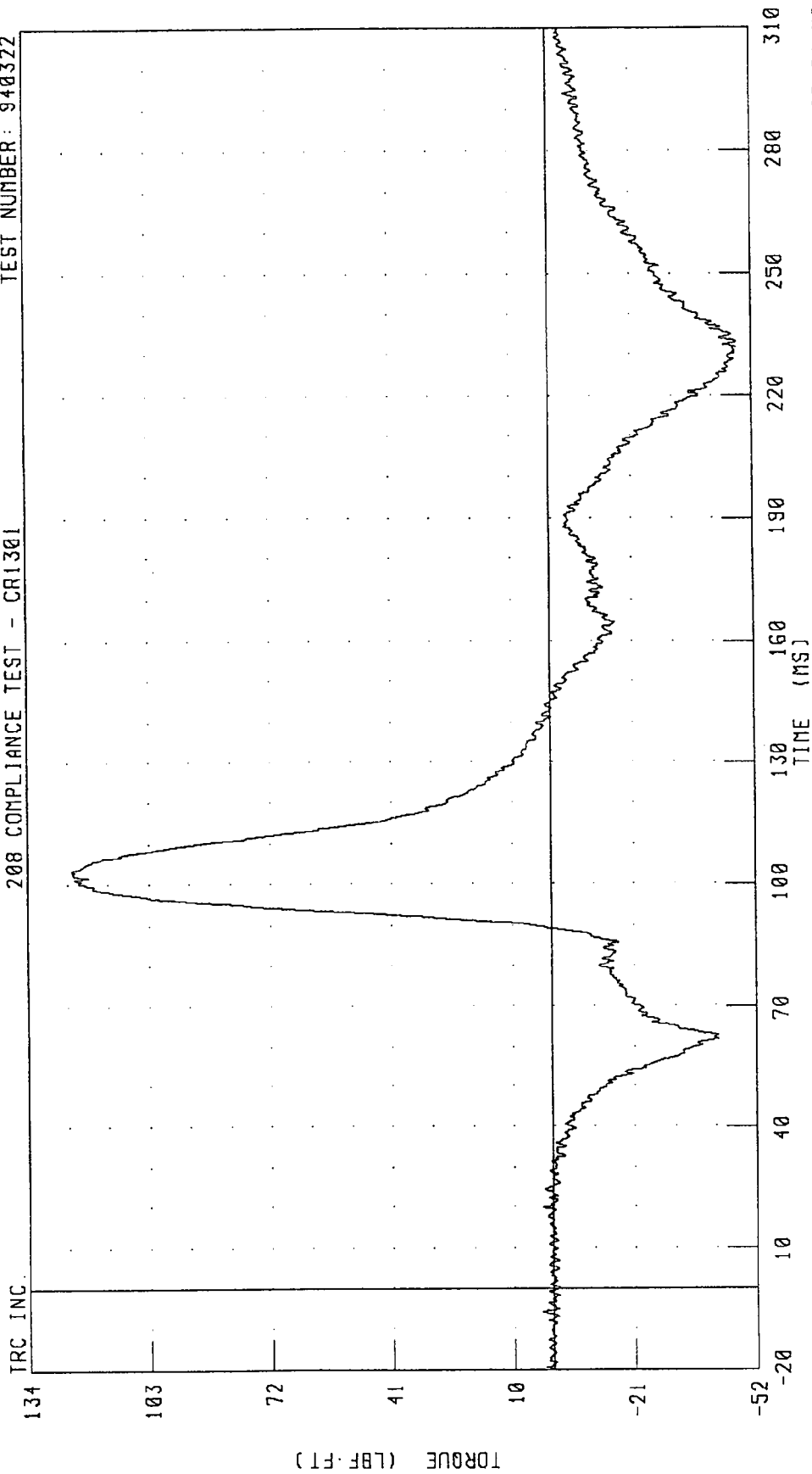

CHANNEL: NEKYM2 FILTER: CH. CLASS 600 PEAK DATA: 122.77 LBF-FT @ 103.44 MS; -47.91 LBF-FT @ 233.04 MS

1994 KENTRON SS SPORT TOP VAN INTO FLAT FRONTAL BARRIER
RIGHT FRONT PASSENGER NECK MOMENT ABOUT Z AXIS
208 COMPLIANCE TEST - CRI301

TEST NUMBER: 940322

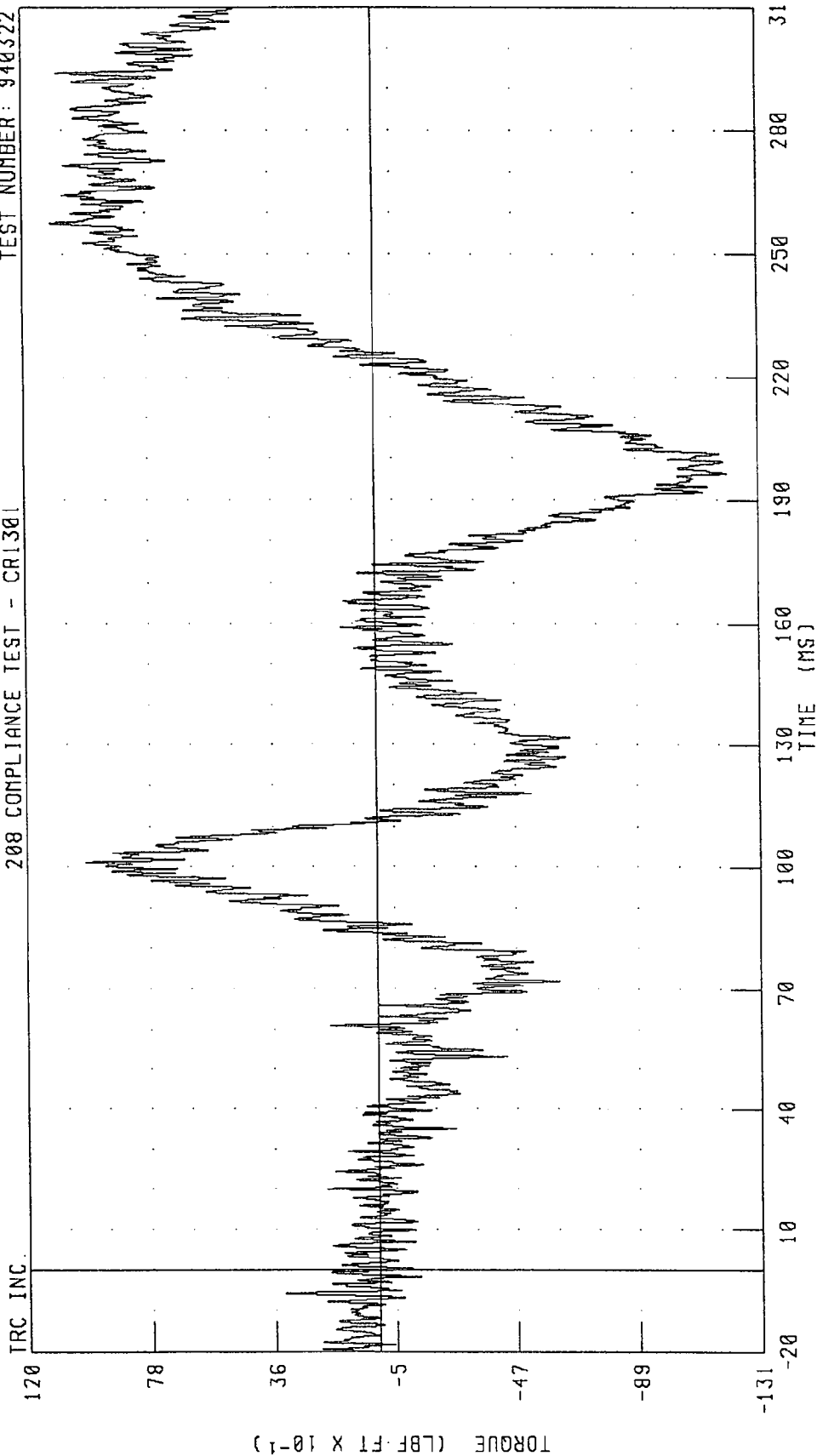

CHANNEL: NEKZM2 FILTER: CH. CLASS 600 PEAK DATA: 11.05 LBF·FT @ 257.60 MS; -12.11 LBF·FT @ 196.48 MS

1994 KENTRON SS SPORT TOP VAN INTO FLAT FRONTAL BARRIER
RIGHT FRONT PASSENGER CHEST X-AXIS ACCELERATION
208 COMPLIANCE TEST - CRI301

TEST NUMBER: 940322

TRC INC.

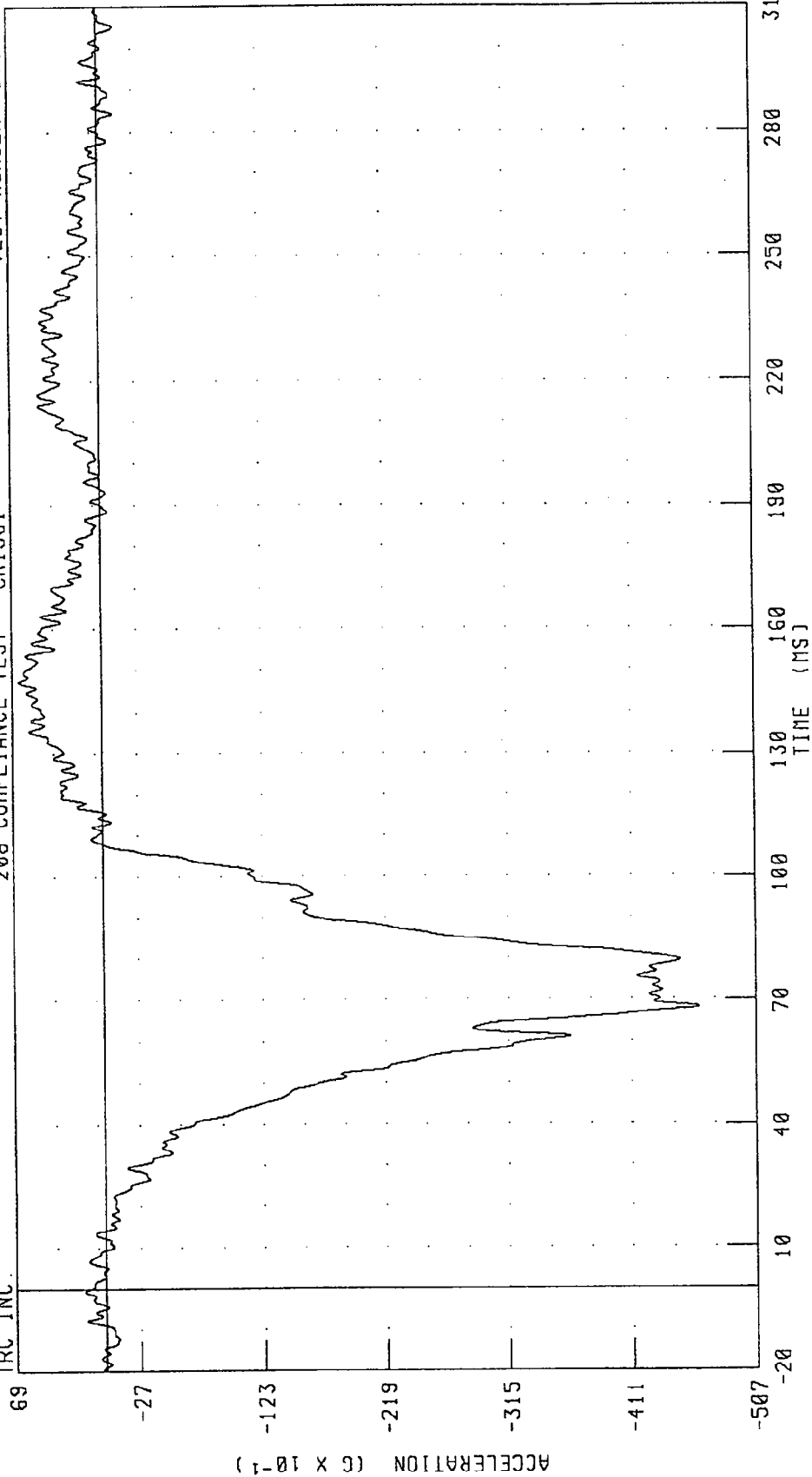

CHANNEL: CSTXG2 FILTER: CH. CLASS 180

PEAK DATA: 6.35 G @ 147.36 MS; -46.32 G @ 68.16 MS

1994 KENTRON SS SPORT TOP VAN INTO FLAT FRONTAL BARRIER
RIGHT FRONT PASSENGER CHEST Y-AXIS ACCELERATION

TEST NUMBER: 940322

208 COMPLIANCE TEST - CRI301

TRC INC.

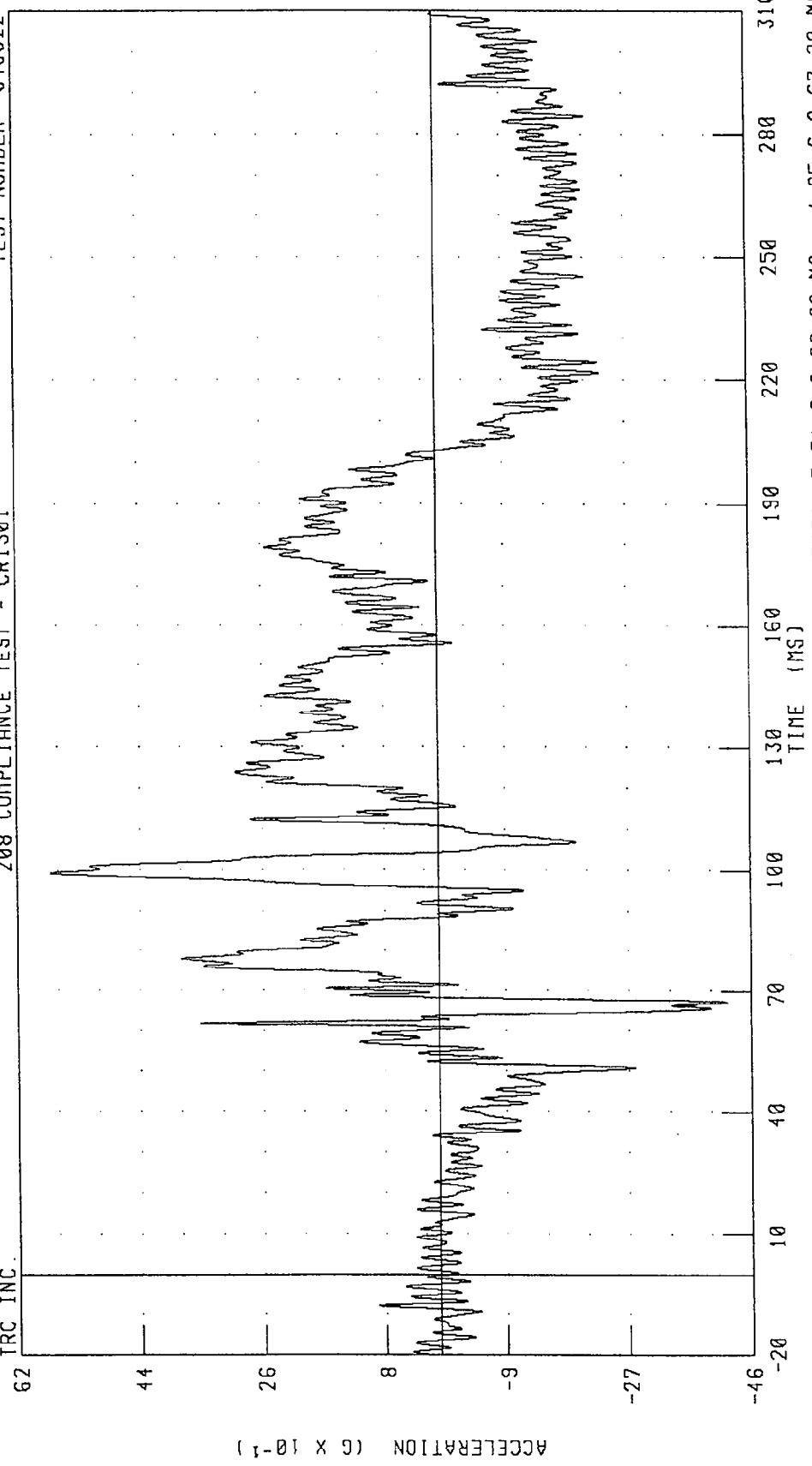

PEAK DATA: 5.71 G @ 99.28 MS; -4.25 G @ 67.20 MS

CHANNEL: CSTYG2 FILTER: CH. CLASS 180

1994 KENTRON SS SPORT TOP VAN INTO FLAT FRONTAL BARRIER
RIGHT FRONT PASSENGER CHEST Z-AXIS ACCELERATION

208 COMPLIANCE TEST - CRI301

TEST NUMBER: 940322

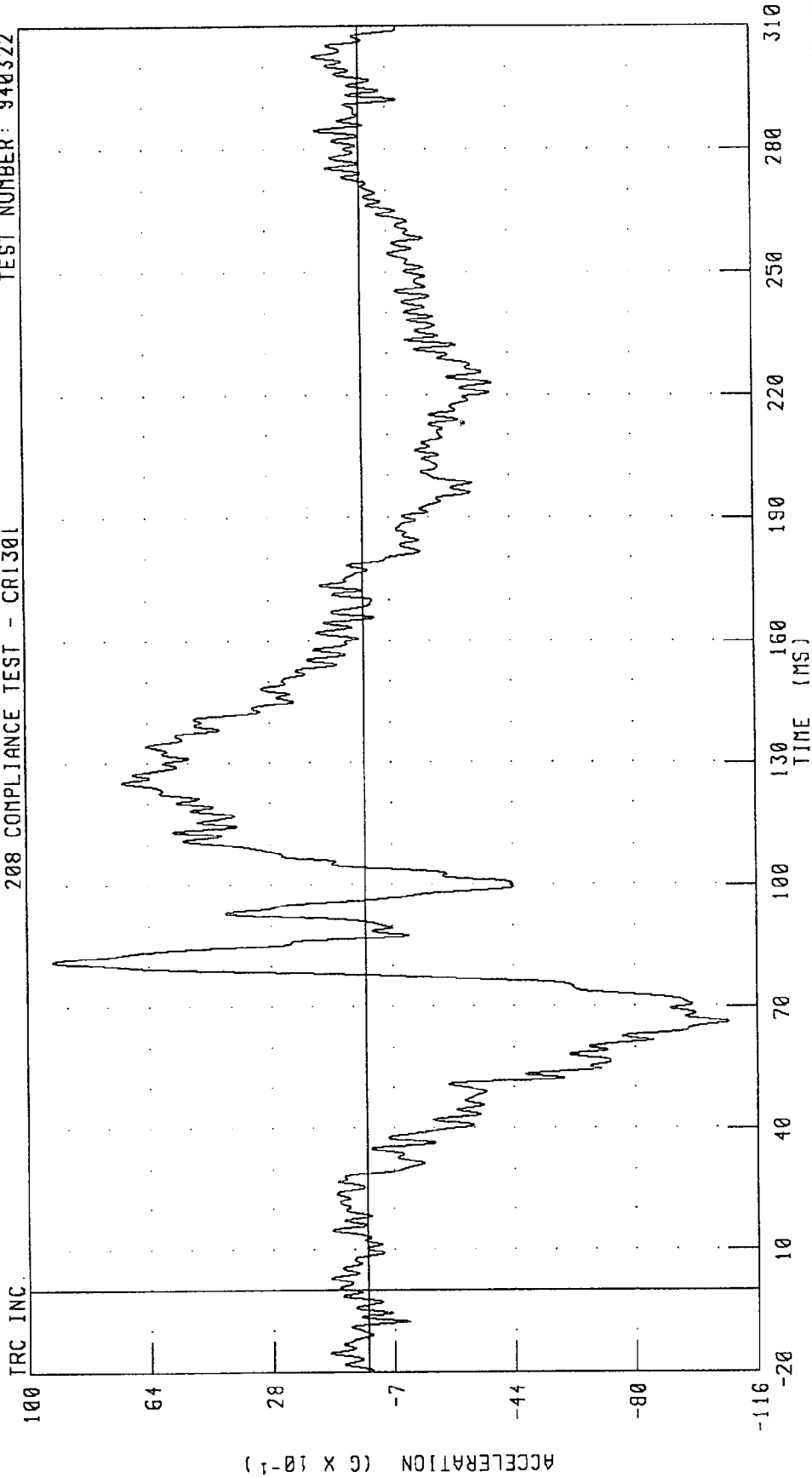

CHANNEL: CSTZG2 FILTER: CH. CLASS 180

PEAK DATA: 9.24 G @ 81.28 MS; -10.76 G @ 66.16 MS

1994 KENTRON SS SPORT TOP VAN INTO FLAT FRONTAL BARRIER
RIGHT FRONT PASSENGER CHEST RESULTANT ACCELERATION

TEST NUMBER: 940322

208 COMPLIANCE TEST - CRI301

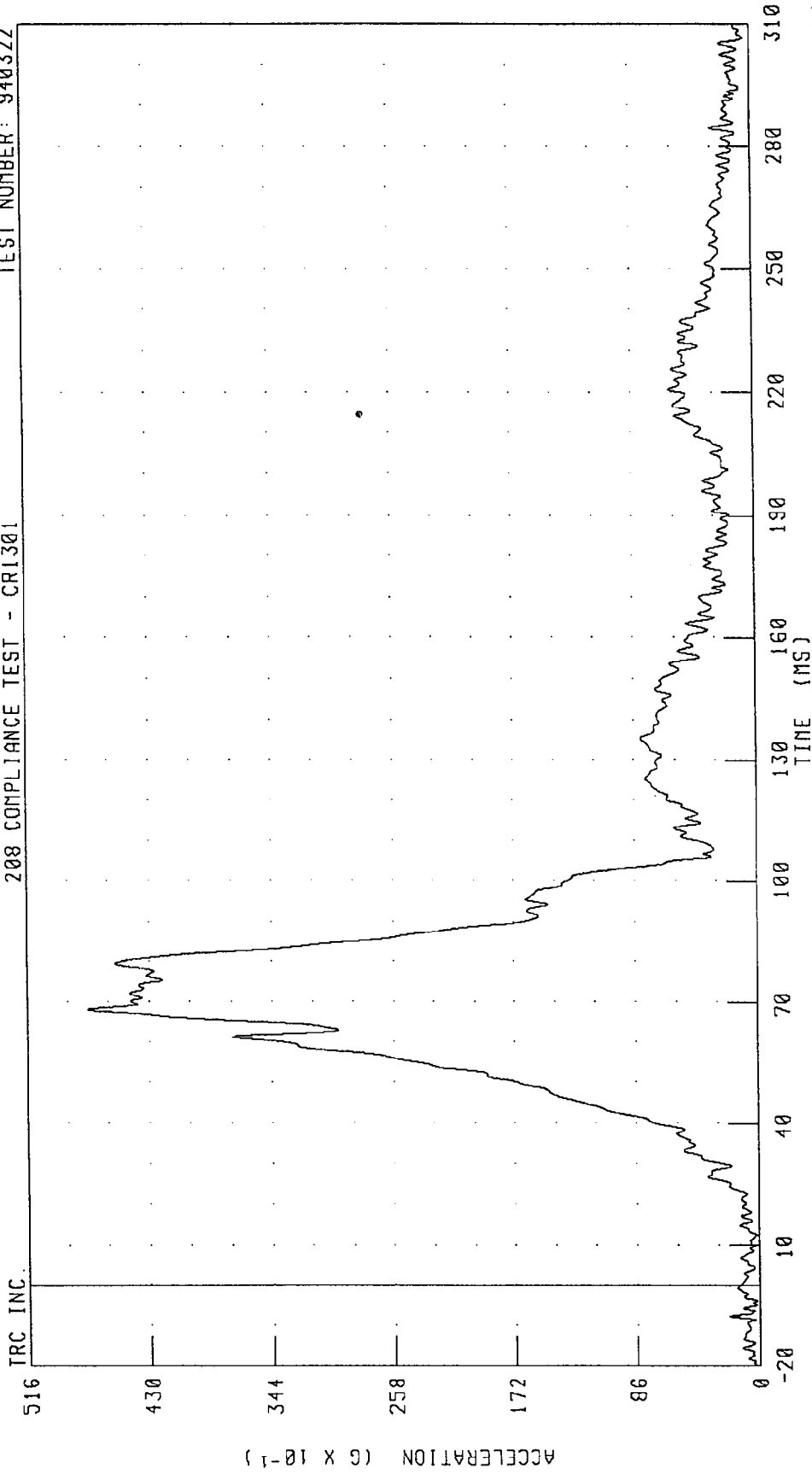

PEAK DATA: 47.34 G @ 68.16 MS; 0.05 G @ 12.40 MS

CHANNEL: CSTRG2 FILTER: CH. CLASS 180

1994 KENTRON SS SPORT TOP VAN INTO FLAT FRONTAL BARRIER
RIGHT FRONT PASSENGER CHEST DEFLECTION
208 COMPLIANCE TEST - CR1301

TEST NUMBER: 940322

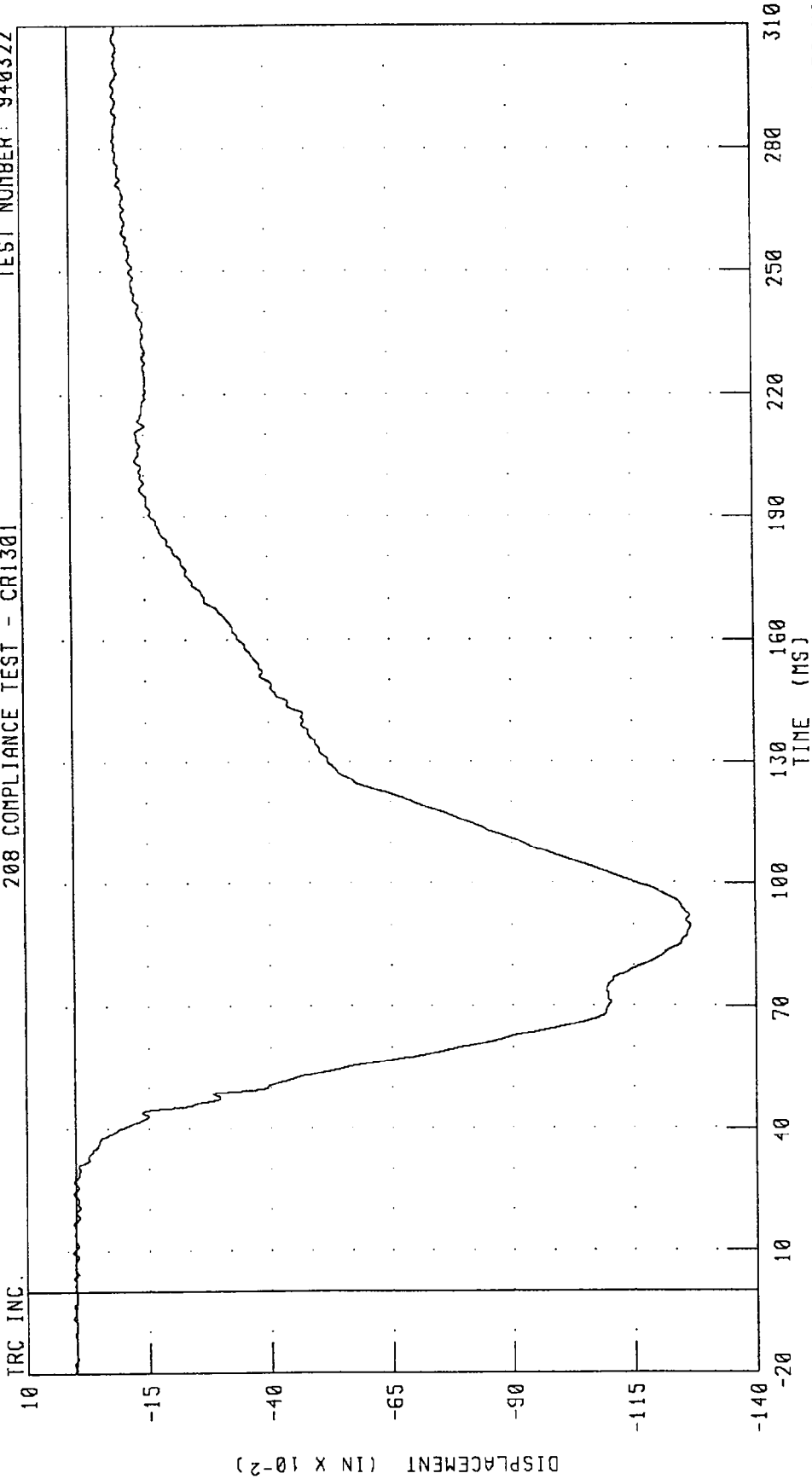

PEAK DATA: 0.01 IN @ 9.76 MS; -1.27 IN @ 89.76 MS

CHANNEL: CSTXD2 FILTER: CH. CLASS 180

1994 KENTRON SS SPORT TOP VAN INTO FLAT FRONTAL BARRIER
RIGHT FRONT PASSENGER LEFT FEMUR FORCE
208 COMPLIANCE TEST - CR1301

TEST NUMBER: 940322

TRC INC.

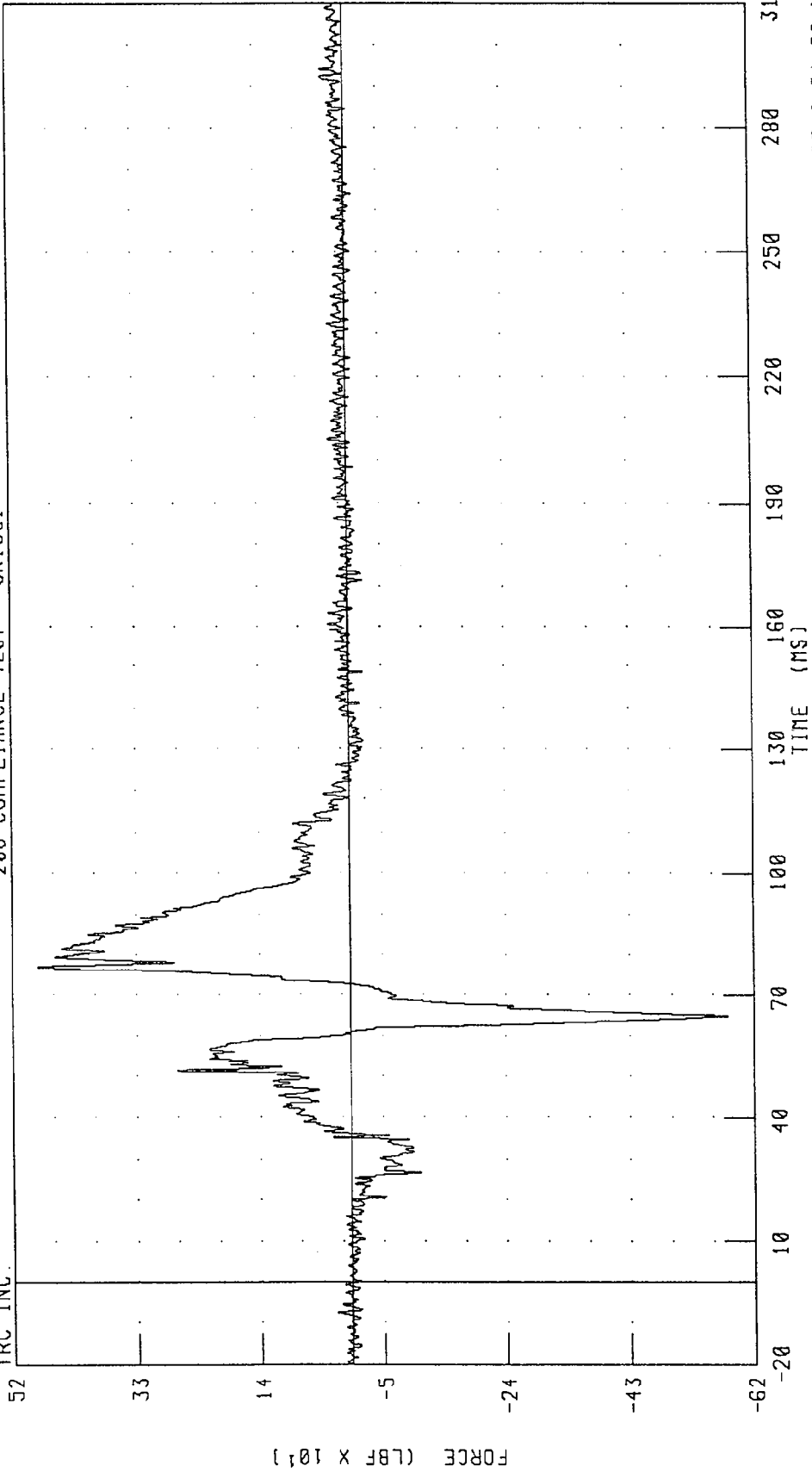

CHANNEL: LFMF2 FILTER: CH. CLASS 600

PEAK DATA: 480.92 LBF @ 76.96 MS; -579.54 LBF @ 64.88 MS

1994 KENTRON SS SPORT TOP VAN INTO FLAT FRONTAL BARRIER
RIGHT FRONT PASSENGER RIGHT FEMUR FORCE
208 COMPLIANCE TEST - CRI301

TEST NUMBER: 940322

TRC INC.

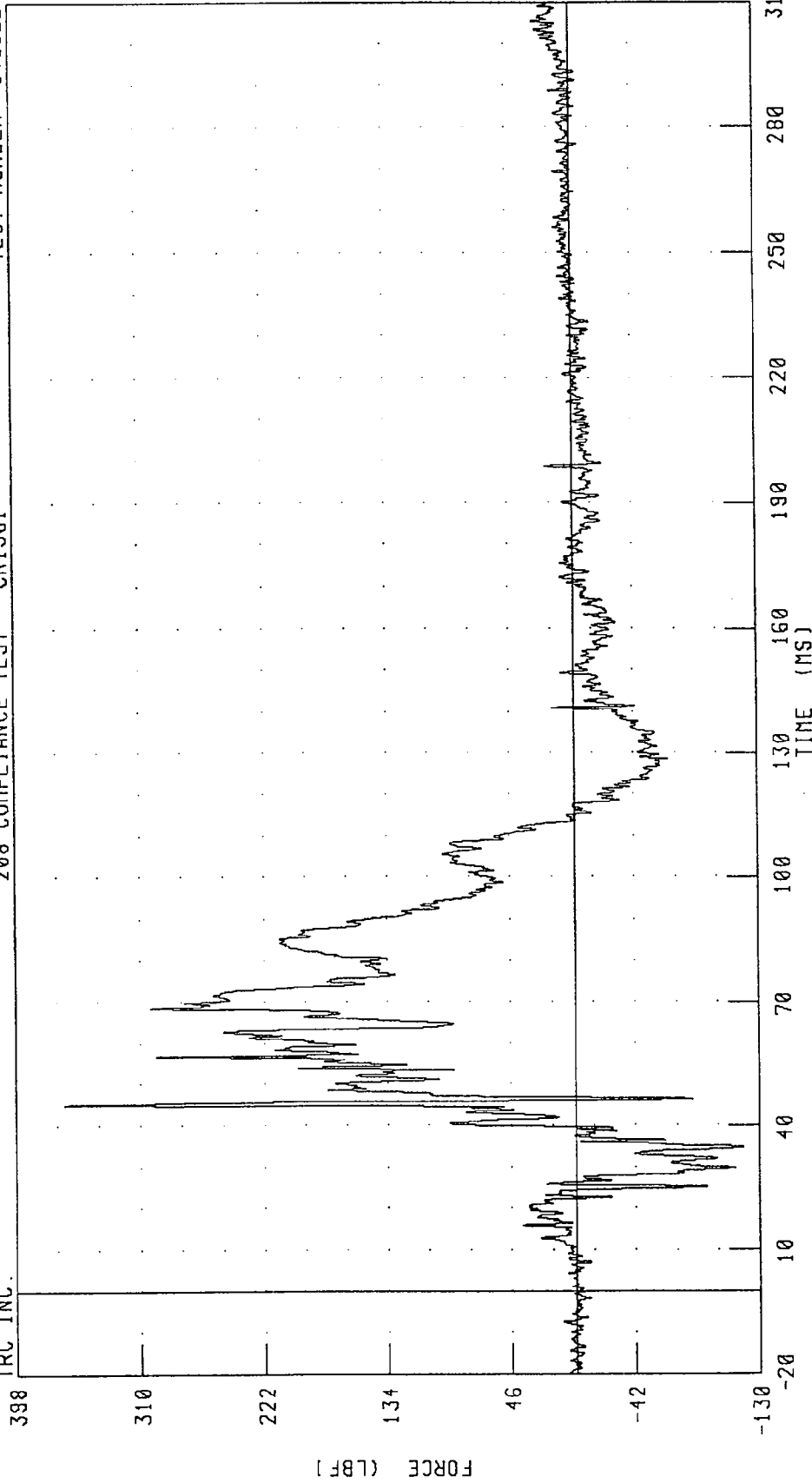

CHANNEL: RFMF2 FILTER: CH. CLASS 600

PEAK DATA: 363.75 LBF @ 45.12 MS; -118.89 LBF @ 34.88 MS

1994 KENTRON SS SPORT TOP VAN INTO FLAT FRONTAL BARRIER
LEFT REAR SEAT X-AXIS ACCELERATION
208 COMPLIANCE TEST - CR1301

TEST NUMBER: 940322

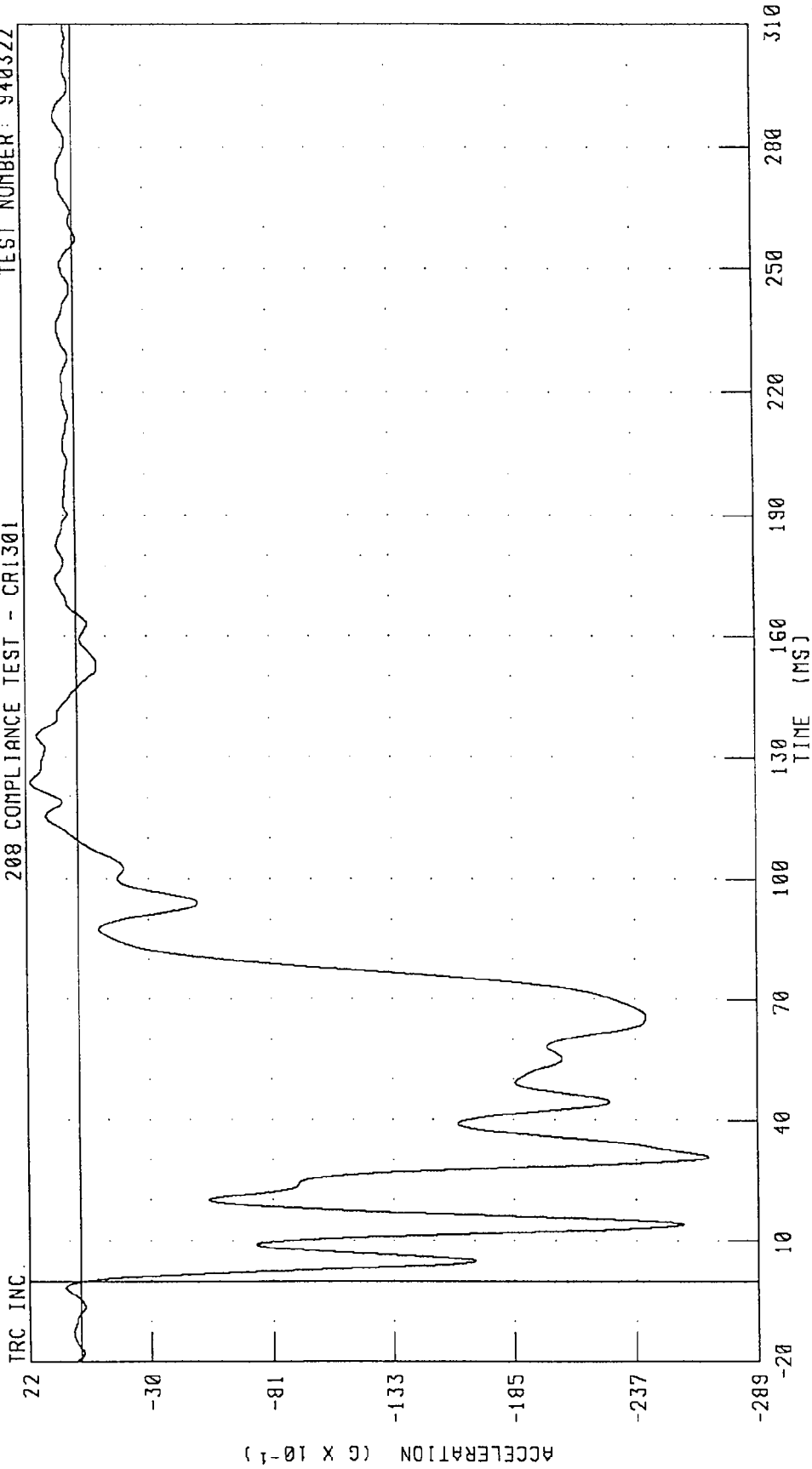

CHANNEL: TLXG1 FILTER: CH. CLASS 60

1994 KENTRON SS SPORT TOP VAN INTO FLAT FRONTAL BARRIER
RIGHT REAR SEAT X-AXIS ACCELERATION
208 COMPLIANCE TEST - CRI301

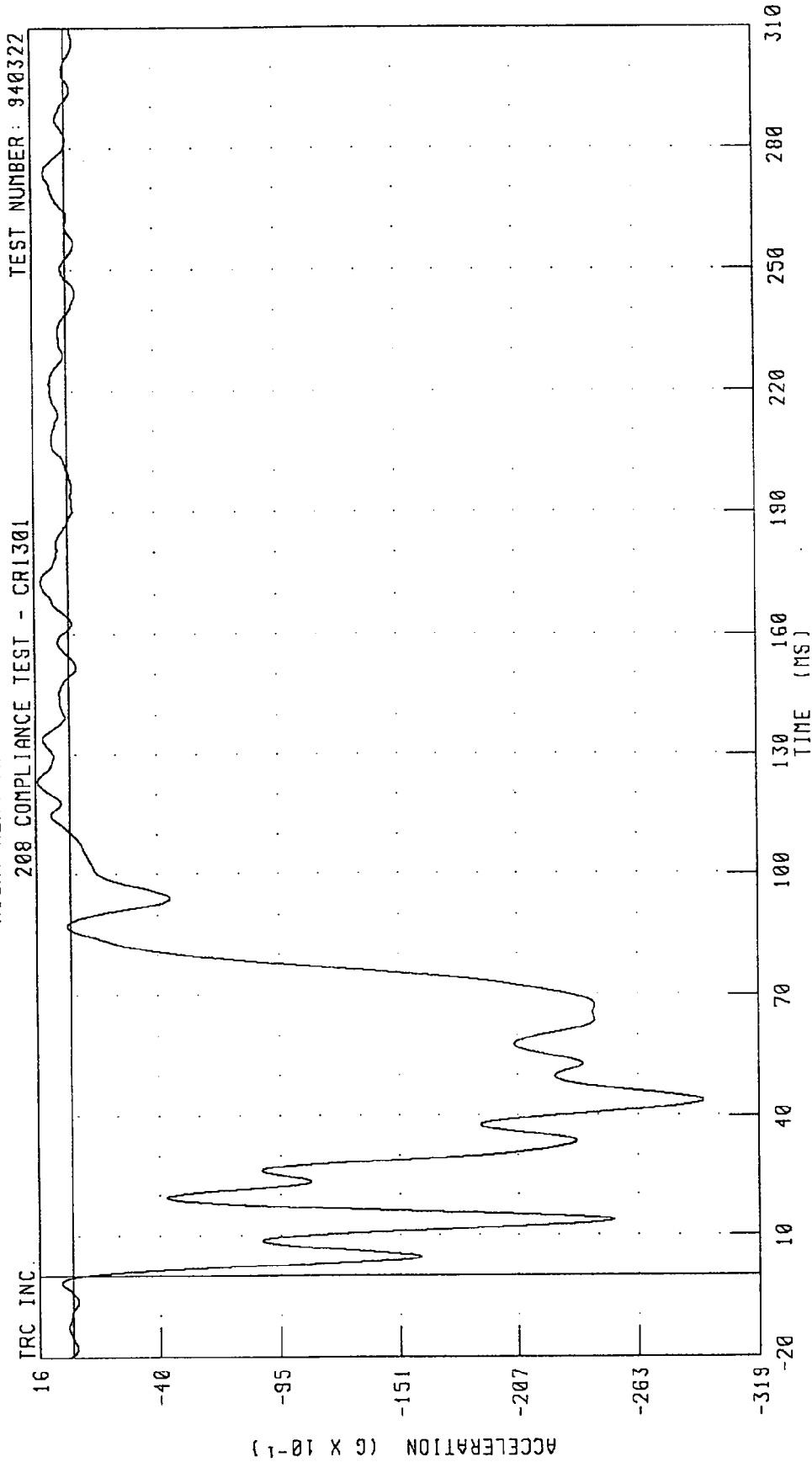

PEAK DATA: 1.49 G @ 123.52 MS; -29.42 G @ 43.76 MS

CHANNEL: TRRXG1 FILTER: CH. CLASS 60

1994 KENTRON SS SPORT TOP VAN INTO FLAT FRONTAL BARRIER
ENGINE UPPER BLOCK X-AXIS ACCELERATION
208 COMPLIANCE TEST - CR1301

TEST NUMBER: 940322

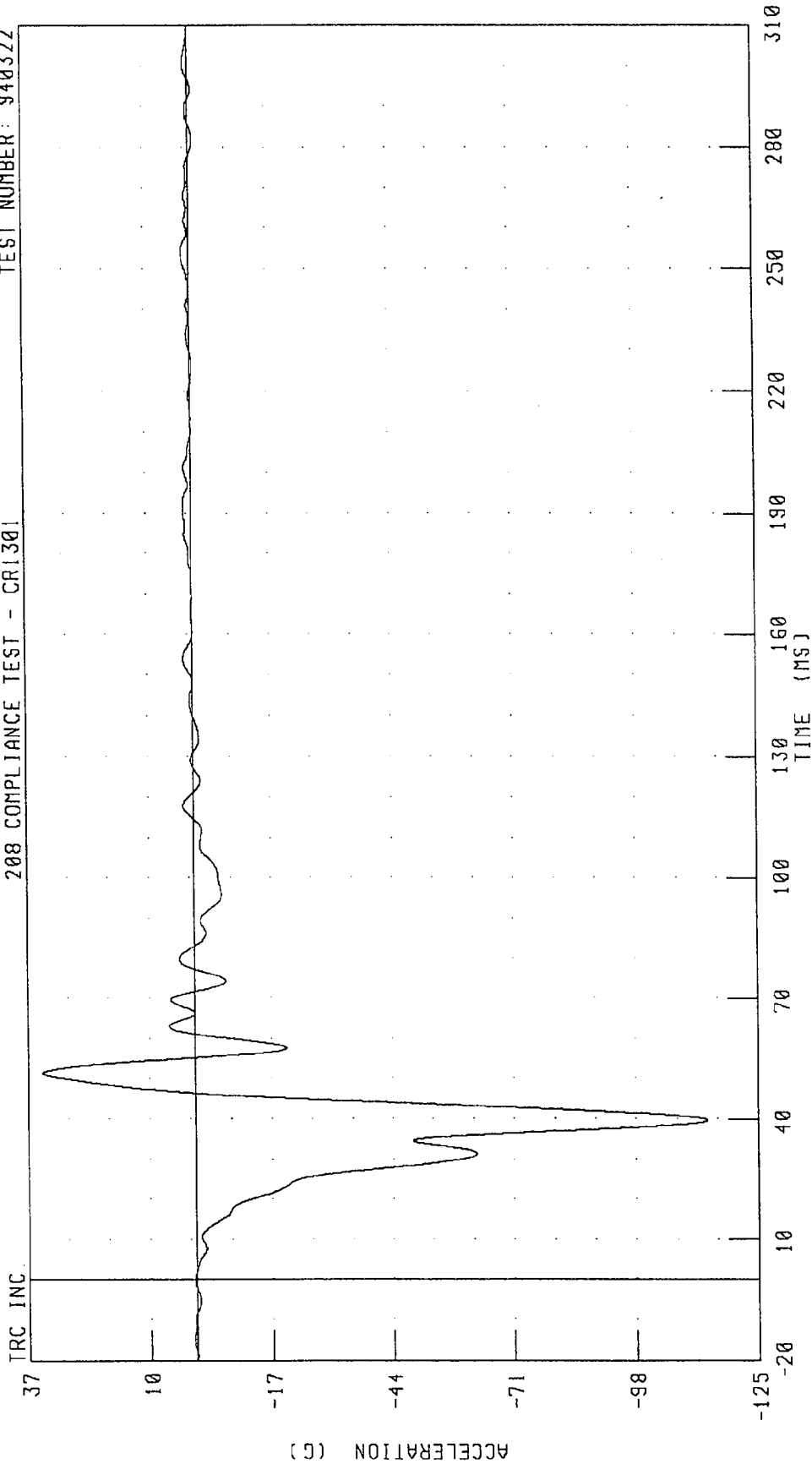

CHANNEL: ENGXG1 FILTER: CH. CLASS 60

1994 KENTRON SS SPORT TOP VAN INTO FLAT FRONTAL BARRIER
ENGINE BOTTOM BLOCK X-AXIS ACCELERATION
208 COMPLIANCE TEST - CRI301

TEST NUMBER: 940322

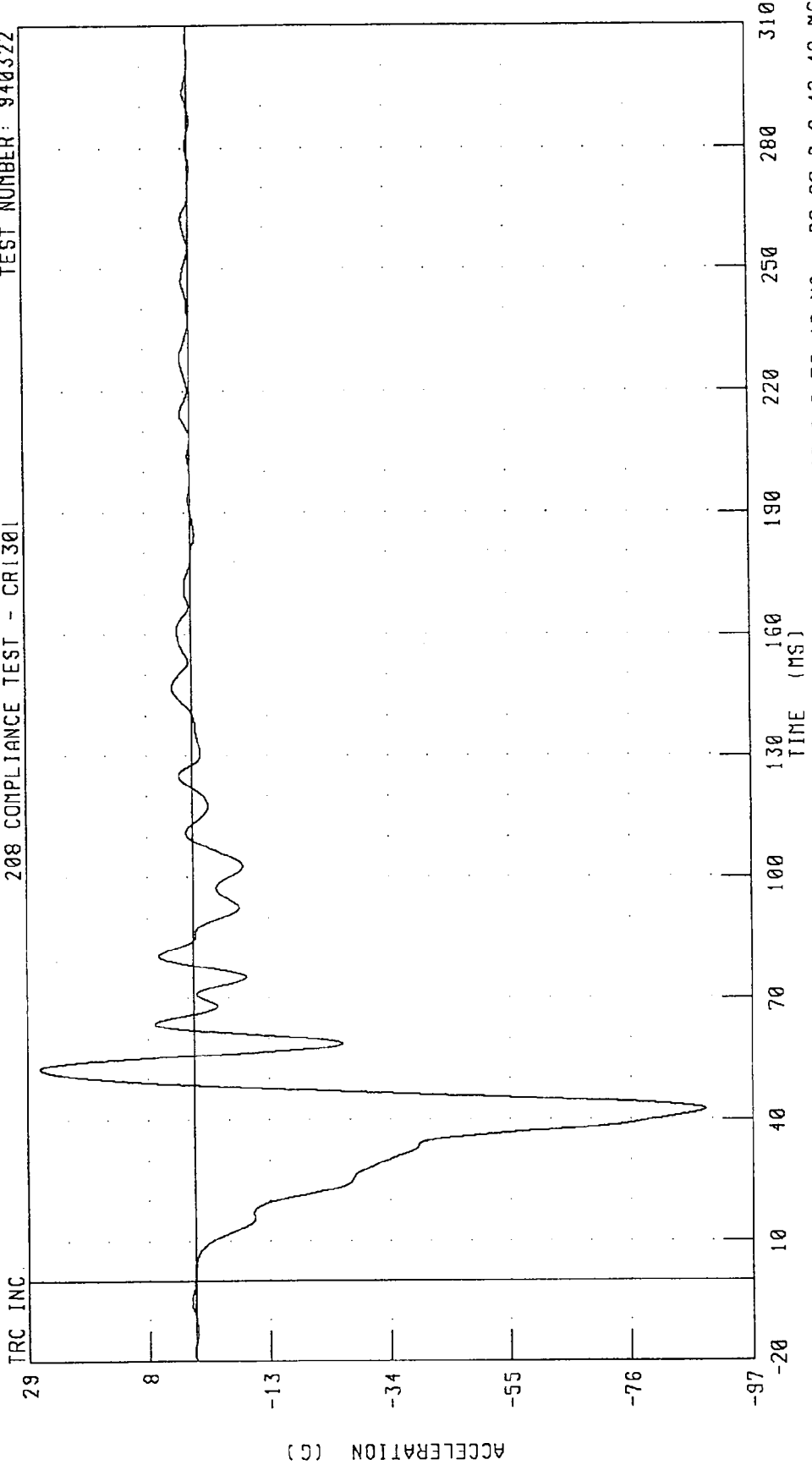

CHANNEL: ENGXC2 FILTER: CH. CLASS 60

1994 KENTRON SS SPORT TOP VAN INTO FLAT FRONTAL BARRIER
RIGHT BRAKE CALIPER X-AXIS ACCELERATION
208 COMPLIANCE TEST - CRI301

TEST NUMBER: 940322

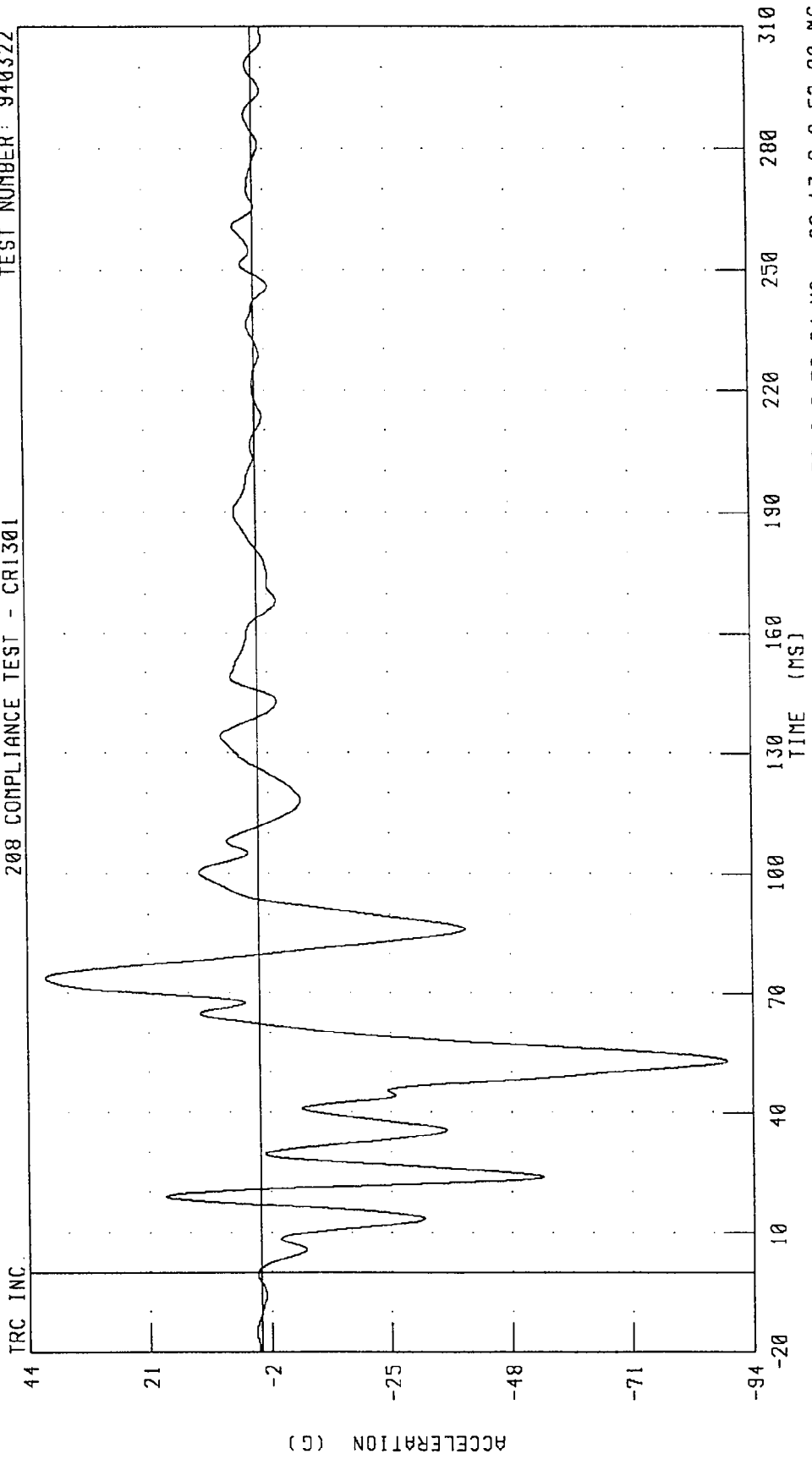

1994 KENTRON SS SPORT TOP VAN INTO FLAT FRONTAL BARRIER
LEFT BRAKE CALIPER X-AXIS ACCELERATION
208 COMPLIANCE TEST - CRI301

TEST NUMBER: 940322

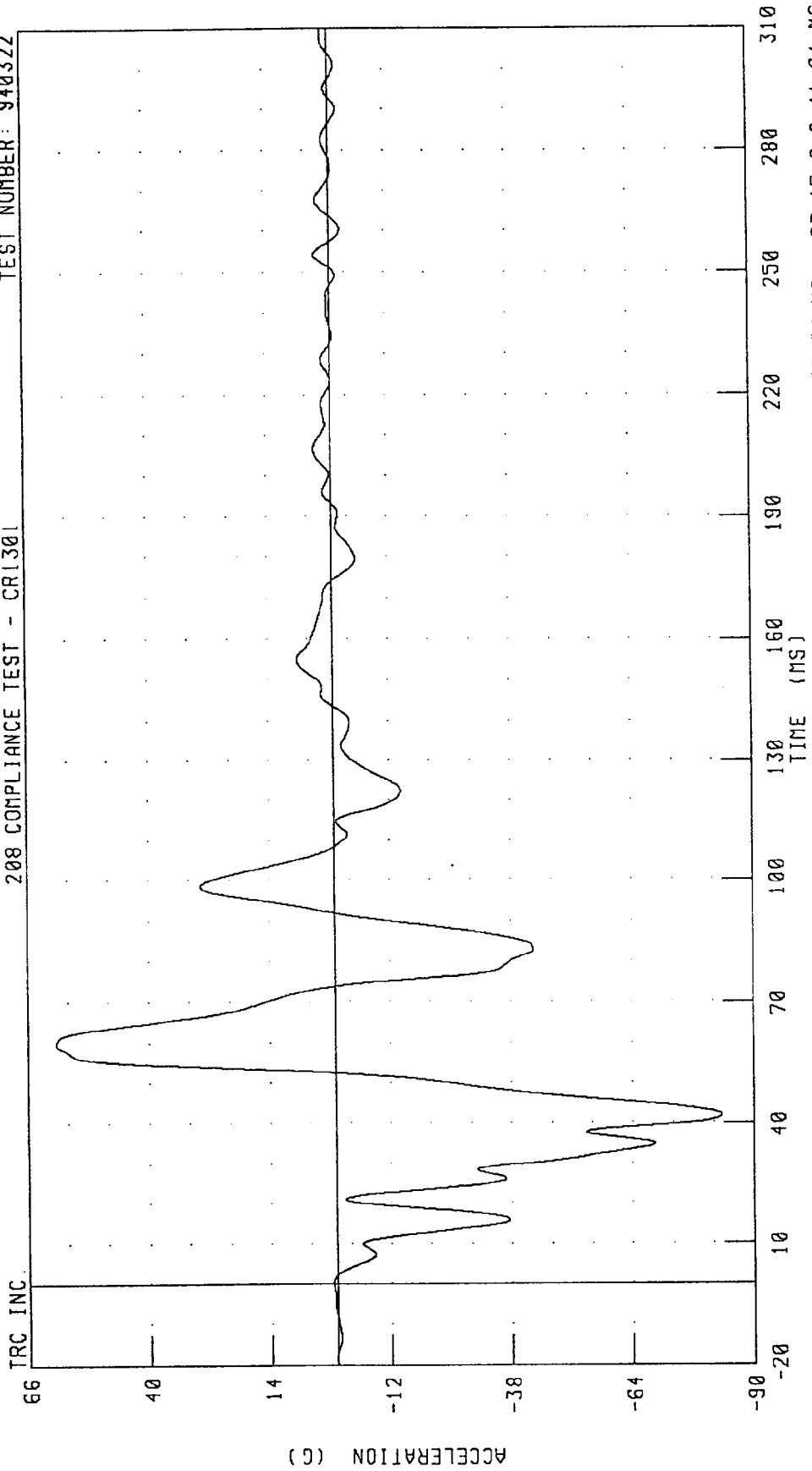

CHANNEL: BCLXG1 FILTER: CH. CLASS 60

PEAK DATA: 60.02 G @ 59.84 MS; -83.15 G @ 41.84 MS

1994 KENTRON SS SPORT TOP VAN INTO FLAT FRONTAL BARRIER
DASH PANEL CENTER X-AXIS ACCELERATION
208 COMPLIANCE TEST - CRI301

TEST NUMBER: 940322

TRC INC.

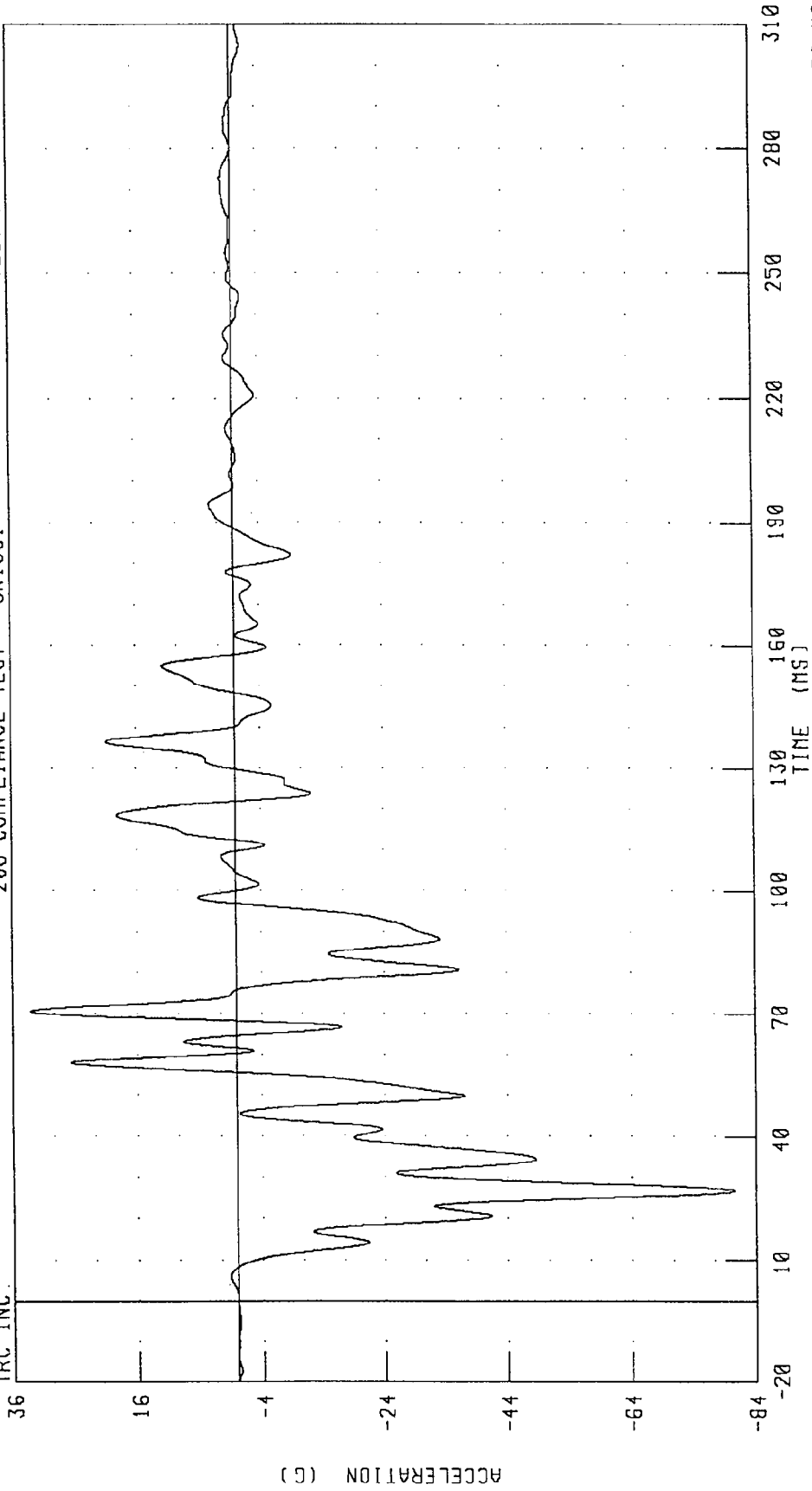

CHANNEL: DPCXG1 FILTER: CH. CLASS 60

1994 KENTRON SS SPORT TOP VAN INTO FLAT FRONTAL BARRIER
VEHICLE REAR CENTER Z-AXIS ACCELERATION
208 COMPLIANCE TEST - CR1301

TEST NUMBER: 940322

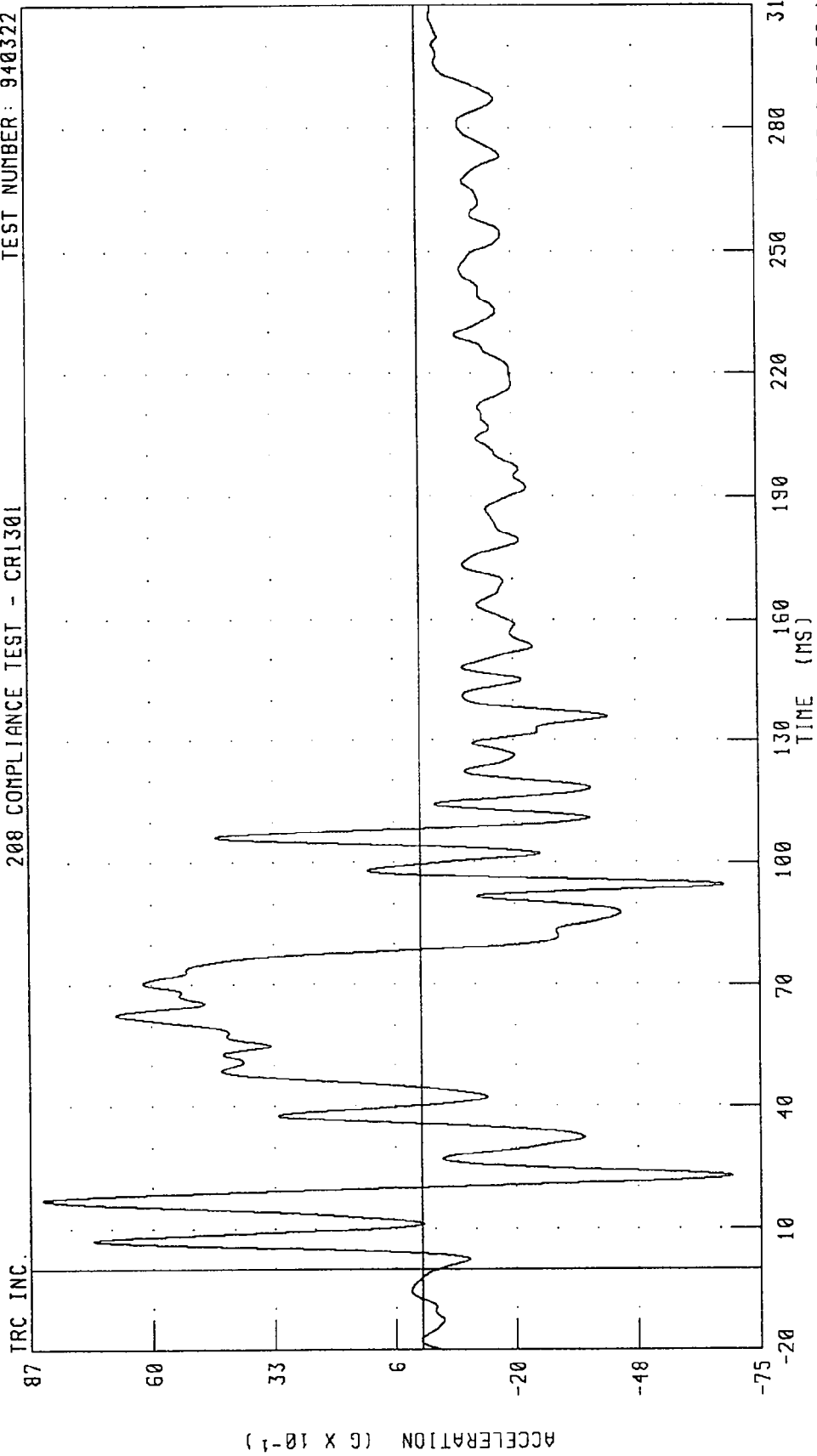

CHANNEL: RDKZG1 FILTER: CH. CLASS 60

940322

Appendix C

Manufacturer's Vehicle Information



Since 1976

Kentron
Motor Coach, Inc.

3012 Mobile Drive • Elkhart, Indiana, 46514 • Ph: (219) 262-2543 / Fax: (219) 264-5988

March 6, 1994

Mr. Robert F. Hellmuth, Director
Office of Vehicle Safety Compliance Enforcement
National Highway Traffic Safety Administration
400 Seventh Street, S.W.
Washington, D.C. 20590

Dear Mr. Hellmuth:

This letter and attachments are in response to your letter (IR 1437) where specific information was requested concerning a 1994 Chevrolet G Van (VIN IGBEG25K2RF110084). It should be noted that some data as related to the incomplete vehicle is from General Motors Corporation. Our responses to the particular items follows:

Kentron Response to Item 1

The air bag provided at the driver's designated seating position in the subject vehicle has been voluntarily installed in addition to the manual 3-point safety belt which was installed to the requirements of S4.2.2.

Since the subject vehicle's front outboard restraint systems are installed to meet the requirements of S4.2.2, no further response is required.

Kentron Response to Item 2

The manual 3-point safety belt provided at each front outboard seating position were installed to meet the requirements of S4.1.2.3 as referenced by S4.2.2.

Attachment A. includes portions of the frontal barrier test reports pertinent to the FMVSS 208 requirements.

Kentron Response to Item 3

The air bag installed in this vehicle does not incorporate a pressure vessel to inflate the system. Therefore, no response is required.

Kentron Response to Item 4

The air bag installed in this vehicle does not incorporate an explosive device to inflate the system. Therefore, no response is required.

Kentron Response to Item 5

A tension-relieving device is not incorporated into the safety belts provided in the subject vehicle.

Kentron Response to Item 6

The following lists how the windows and vents were positioned during testing:

<u>Test #</u>	<u>Dr - CV</u>	<u>Pass - CV</u>	<u>DR - Door</u>	<u>Pass - Door</u>
C9204	Removed	Closed	Open	Open
C9231	Removed	Closed	Open	Open
C9297	Closed	Closed	Open	Closed
C9232	Closed	Closed	Closed	Open
C9344	Removed	Removed	Open	Open
C9337	Removed	Closed	Open	Open
C9364	Closed	Closed	Open	Open
C9345	Removed	Closed	Open	Open
C9381	Removed	Closed	Open	Open

Kentron Response to Item 7

The Part 572(e) test dummy was used in each front outboard seat position during certifications testing for the subject vehicle. Attachment B includes the available dummy placement information.

The driver position is not equipped with a foot rest that is to be used during FMVSS 208 testing.

The vehicle is not equipped with a split front bench seat.

Kentron Response to Item 8

Attachment C includes the requested information.

Kentron Response to Item 9

The subject vehicle is not equipped with adjustable seat belt anchorages.

Kentron Response to Item 10

Attachment D includes a summary of the requested injury criteria information and the specified data plots. The requested "marked" reference points on these plots are not determined by GM in the ordinary course of our certification activities. To respond to the agency's request, however, the available information marked on the requested plots was estimated by an analysis of the data. Therefore, the specific "marked" locations should be considered our approximation of the requested reference points.

Kentron Response to Item 11

The priority of items to be removed to accommodate test weight is 1.) rear seat, 2.) spare tire and jack, 3.) rear bumper

Kentron Response to Item 12

The seats and sliders were supplied by:

Foremost Enterprises Inc.
P.O. Box 516
53452 Marina Drive
Elkhart, Indiana 46515

The pedestals were supplied by:

Adnik
53236 County Road 13
Elkhart, Indiana 46514

The front position seat belts are supplied by the incomplete vehicle manufacturer. All other seat belts are Bendix Allied Signal belts supplied by:

Elkhart Performance
29240 Phillips Street
Elkhart, Indiana 46515

Kentron Response to Item 13

The FMVSS 204 certification data for the 1994 Chevrolet G-Van (all models) is provided in the table below. Certification is established using film analysis.

Test No.	Weight (lb)	Speed (mph)	Max. Dynamic Rearward Steering Column Displacement (in)
C9275	5507	30.8	3.7

Attachment E provides the test report which forms the basis of the FMVSS 204 certifications for this vehicle. Also provided in Attachment E are plots of the steering column horizontal and vertical displacement data, and pre- and post-test photographs as requested.

Attachment F provides a general description of the test procedure. The basic General Motors Uniform Test Specification (GMUTS test procedure) used in conducting this FMVSS 204 testing is identified as "Steering Control Rearward Displacement, R-9A-204G-81." A copy of this procedure previously was provided to the NHTSA in GM's August 15, 1989 letter (USG 2691, Part III) to Mr. Robert F. Hellmuth in response to NHTSA IR 526.I, NEF-3IZFr. Additionally, details of the GM vehicle preparation and film analysis procedure used to obtain steering column displacement data previously were provided to NHTSA representatives (Messrs. W.E. Smith, R.A. Krauss, and C. L. Ragland) during a September 19, 1985 meeting at GM's Milford (MI) Proving Ground.

GM's overall procedures for obtaining this film analysis data have not changed significantly since this information was last provided to the NHTSA. However, new film analysis hardware and software have been implemented, resulting in improved efficiency.

The enclosed photographs show a steering column displacement measurement device ("scratch tube") attached to the steering column. This setup was used to provide redundant column displacement data for the test.

Attachment G provides the steering column assembly diagram and description of how the assembly works to provide energy management in frontal impact.

If there any any technical questions to these responses please contact Thomas F. Troester of Telam, Inc. (219-272-6228). Also please authorize Mr. Troester to view the FMVSS 208 test. Additionally, please note our recent address change.

Respectfully,

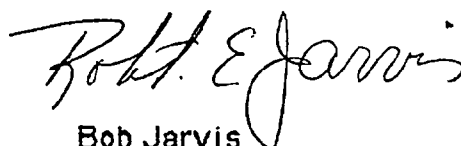

Bob Jarvis
President & C.E.O.

Vehicle Model Year & Make: 1994 CHEVROLET
 Vehicle Model & Body Style: G VAPOR REACTION SS SPORT TOP

1 NOMINAL DESIGN RIDING POSITION --

For adjustable driver and passenger seat backs.
 Please describe how to position the inclinometer to measure the seat back angle. Include description of the location of the adjustment latch detent if applicable. Indicate, if applicable, how the detents are numbered (Is the first detent "0" or "1"?).

Seat back angle for driver's seat = 32 degrees.

Measurement Instructions:

ON THE SQUARE TUBE OF SEAT
BACK AS SHOWN IN RIGHT

Seat back angle for passenger's seat = 22 degrees.

Measurement Instructions:

SAME AS DRIVER

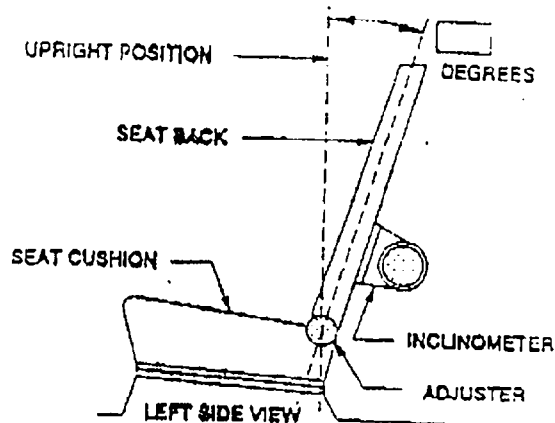

SEAT FORE & AFT POSITIONS --

Provide instructions for positioning the driver and front outboard passenger seat(s) in the center of fore and aft travel. For example, indicate how the detents are numbered (Is the first detent "0" or "1"?). Provide information to locate the detent in which the seat track is to be locked.

Positioning of the driver's seat:

THE TRAVEL IS MEASURED AND THE TRAVEL IS ÷ BY 2. THIS
DISTANCE MOVED FORWARD FROM REAR OF TRACK. IF THIS
DISTANCE IS NOT IN A LOCK OR DETENT THE SEAT IS MOVED REARWARD
TO THE FIRST DETENT

Positioning of the passenger's seat (if applicable):

SAME AS DRIVER

FUEL TANK CAPACITY DATA --

- 1 A. "Usable Capacity" of standard equipment fuel tank = 32.7 gallons.
- B. "Usable Capacity" of optional equipment fuel tank = N/A gallons.
- C. "Usable Capacity" of vehicle(s) used for certification testing to requirements of FMVSS 301 = 32.7 gallons.

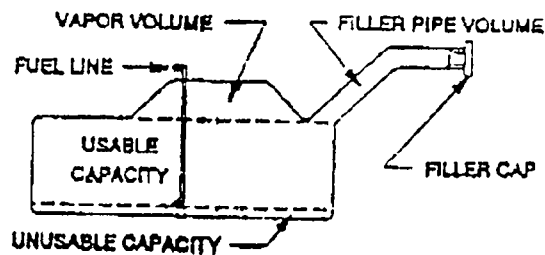

VEHICLE FUEL TANK ASSEMBLY

Operational Instructions:

TEST VEHICLE INFORMATION

3 2 Amount of Stoddard solvent added to vehicle(s) used for certification test(s) = 31.1 gallons

3 3 Is vehicle equipped with electric fuel pump? YES NO

If YES, explain the vehicle operating conditions under which the fuel pump will pump fuel.

PUMP BEGINS TO PUMP FUEL WHEN ENGINE CRANKS AND CONTINUES WHEN OIL PRESSURE REACHES PROPER LEVEL. PUMP DOES NOT WORK IF OIL PRESSURE IS NOT CORRECT.

4. STEERING COLUMN ADJUSTMENTS --

Steering wheel and column adjustments are made so that the steering wheel hub is at the geometric center of the locus it describes when it is moved through its full range of driving positions.

If the tested vehicle has any of these adjustments, does your company use any specific procedures to determine the geometric center.

Operational Instructions:

THE STEERING COLUMN HAS 5 POSITIONS
MID POINT IS 3RD POSITION UP FROM THE
BOTTOM

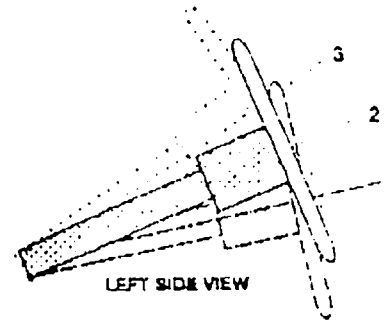

LEFT SIDE VIEW

STEERING COLUMN ASSEMBLY

DUMMY MEASUREMENTS FOR FRONT SEAT PASSENGERS

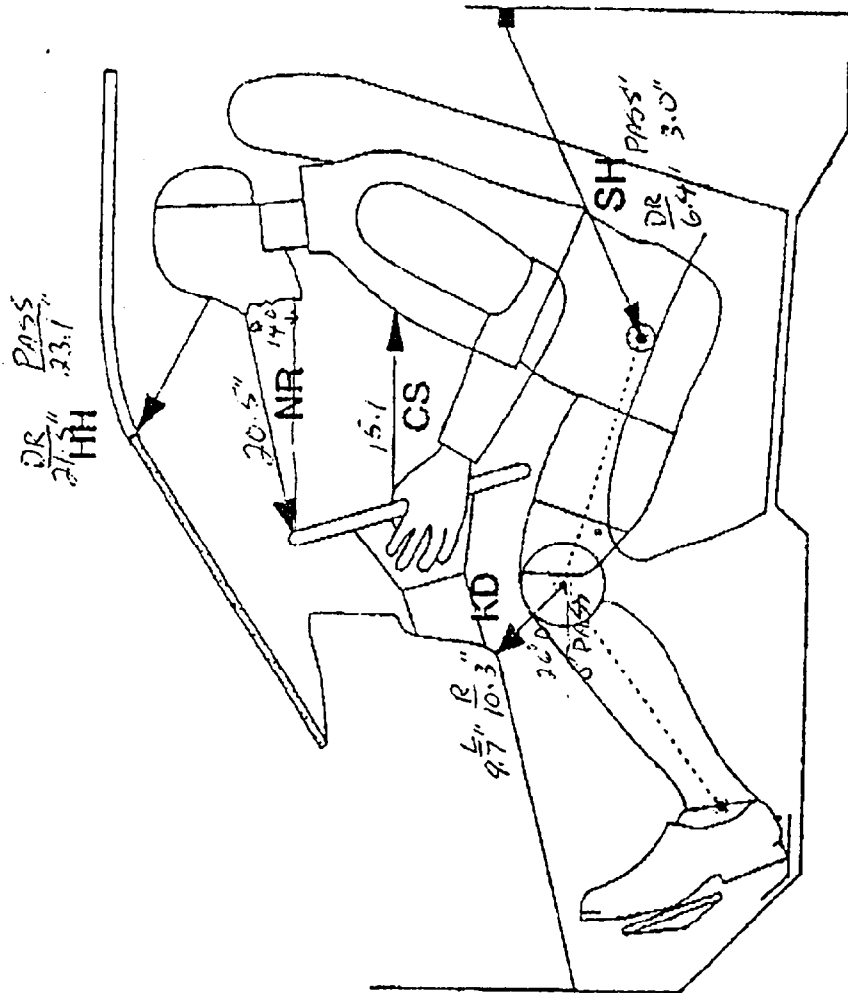

- HH - Head to Header
- NR - Nose to Rim
- CS - Steering Wheel to Chest
- KDL/KDR - Knee to Dash
- SH - Striker to H-Point

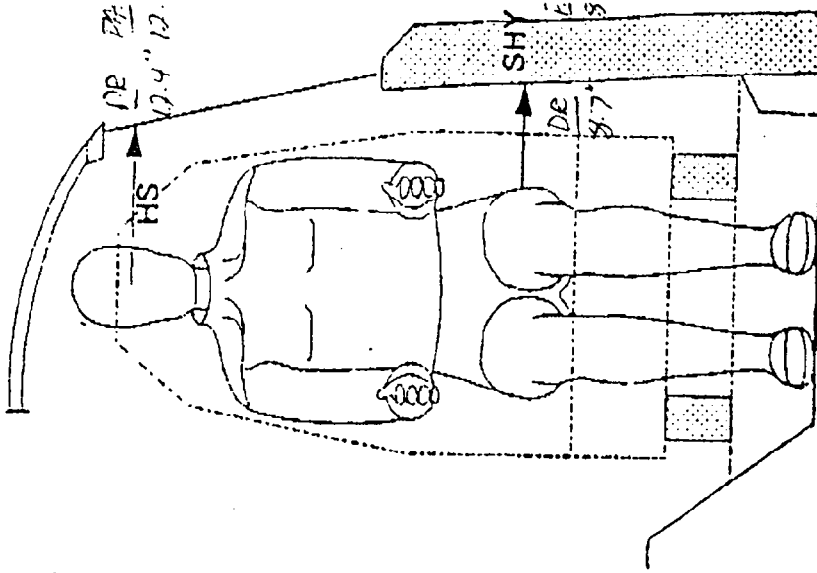

- SHY - Striker to H-Point (Y Dir.)
- HS - Head to Side Window

1994 CHEVROLET G VAN/KENTRON SS SPORT TOP

July 10, 1992