

22044

REPORT NO. MGA-94-N002

NEW CAR ASSESSMENT PROGRAM (NCAP)

FRONTAL BARRIER IMPACT TEST

Ford
1994 Ford Thunderbird
2 Door
NETSA NO. MR0202

MGA PROVING GROUNDS
5000 WARREN ROAD
BURLINGTON, WI 53105



Test Date: March 4, 1994

Report Date: March 25, 1994

FINAL REPORT

Prepared For:

U. S. DEPARTMENT OF TRANSPORTATION
NATIONAL HIGHWAY TRAFFIC SAFETY ADMINISTRATION
OFFICE OF MARKET INCENTIVES
400 SEVENTH STREET, S.W.
Room No. 5313 (NRM-22)
400 Seventh Street, S.W.
Washington, D.C. 20590

This publication is distributed by the U.S. Department of Transportation, National Highway Traffic Safety Administration, in the interest of information exchange. The opinions, findings and conclusions expressed in this publication are those of the author(s) and not necessarily those of the Department of Transportation or the National Highway Traffic Safety Administration for its contents or use thereof. If trade or manufacturers' names or products are mentioned, it is only because they are considered essential to the object of the publication and should not be construed as an endorsement. The United States Government does not endorse products or manufacturers.

This Final Test Report was prepared for the U.S. Department of Transportation, National Highway Traffic Safety Administration, under Contract No. DTNH22-90-D-12121. This document is disseminated under the sponsorship of the U.S. Dept. of Transportation in the interest of information exchange. The United States Government assumes no liability for its contents or use thereof.

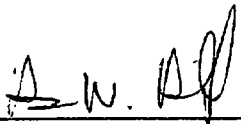
PREPARED BY: 
Hans Hauschild
MGA Research Corporation

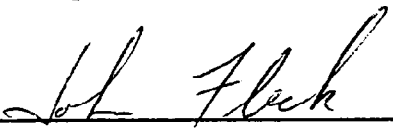
APPROVED BY: 
John Fleck
MGA Research Corporation

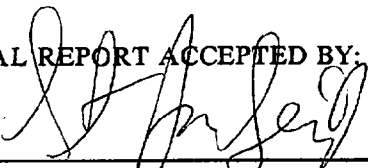
FINAL REPORT ACCEPTED BY: 
Manager, New Car Assess. Program (NCAP)

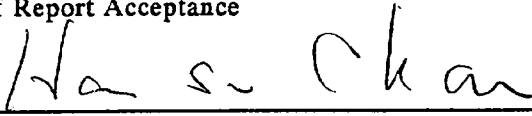
APR 20 1994
Date of Report Acceptance

Contracting Officer's Tech. Rep. (COTR)

APR 20 1994
Date of Report Acceptance

TECHNICAL REPORT STANDARD TITLE PAGE

1. Report No. MGA-93-N003	2. Government Accession No.	3. Recipient's Catalog No.	
4. Title and Subtitle NHTSA New Car Assessment Program (NCAP) Frontal Barrier Impact Test on a 1994 Ford Thunderbird requirements FMVSS No. 208, 212, 219 (partial) and 301.		5. Report Date March 25, 1994	6. Performing Organization Code MGA
7. Author(s) Hans Hauschild		8. Performing Organization Report No. MGA-OMI-003	
9. Performing Organization Name and Address MGA Research Corporation 5000 Warren Road Burlington, WI 53105		10. Work Unit No. MGA-93-DOT-1	11. Contract or Grant No. DTNH22-90-D-12121
12. Sponsoring Agency Name and Address U.S. Department of Transportation National Highway Traffic Safety Administration Office of Market Incentives (NRM-20) 400 Seventh St., S.W. Washington, D.C. 20590		13. Type of Report and Period Covered Final Report August 1993 - March 1994	
15. Supplementary Notes		14. Sponsoring Agency Code DOT/NHTSA/RM/OMI	
16. Abstract A 56 kph (35 mph) frontal barrier impact using a 30 load cell barrier was conducted on a 1994 Ford Thunderbird 2-Door at the MGA Proving Grounds and Crash Test Center in Burlington, WI. on March 4, 1994. The barrier impact velocity was 56.3 kph (35.0 mph), and the ambient temperature at the time of impact was 22° C. The post-test maximum static crush was 612 mm. The test vehicle appeared to comply with the requirements of the following Federal Motor Vehicle Safety Standards: 1. FMVSS 212, "Windshield Mounting" 2. FMVSS 219 (partial), "Windshield Zone Intrusion" 3. FMVSS 301, "Fuel System Integrity" With regard to FMVSS 208, "Occupant Crash Protection" injury criteria, the driver's HIC was 475.4 and the 3 msec. Clip (Chest g's) was 35.7 g's. The left and right femur loads for the driver were 6457 and 3860 Newtons, respectively. The passenger's HIC was 302.2 and the 3 msec Clip was 37.0. The left and right femur maximum loads were 3770 and 1559 Newtons respectively.			
17. Key Words 35 mph Frontal Barrier Impact Test New Car Assessment Program (NCAP) FMVSS 212 Indicant Testing FMVSS 219 (partial) Indicant Testing FMVSS 301 Indicant Testing		18. Distribution Statement Copies of this report are available from: Technical Ref. Division, National Highway Traffic Safety Adm., NASSIF Building, Room 5108 400 Seventh Street, S.W. Washington, D.C. 20590	
19. Security Classif. (of this report) Unclassified	20. Security Classif. (of this page) Unclassified	21. No. of Pages	22. Price

TABLE OF CONTENTS

<u>SECTION</u>	<u>DESCRIPTION</u>	<u>PAGE NO.</u>
1	Purpose and Test Procedure	1-1
2	Summary of Frontal Barrier Impact Test	2-1
3	Summary of Results for FMVSS Nos. 212, 219, & 301-75	3-1
4	Occupant and Vehicle Information	4-1
APPENDIX A	Photographs	A-1
APPENDIX B	Vehicle, Load Cell Barrier and Dummy Response Data	B-1
APPENDIX C	Dummy Configuration & Performance Verification Data	C-1
APPENDIX D	Dummy, Vehicle and Laboratory Calibration Data	D-1
APPENDIX E	Vehicle Owner's Occupant Restraint System Instructions	E-1

SECTION 1

PURPOSE AND TEST PROCEDURE

This 35 mph frontal barrier impact test is part of the Composite FY'93 Vehicle Barrier Impact Testing Program sponsored by the National Highway Traffic Safety Administration (NHTSA) under Contract No. DTNH22-90-D-12121. The purpose of this test was to obtain vehicle crashworthiness and occupant restraint system performance data for an impact speed in excess of the current 48 kph (30 mph) FMVSS 208/212/219/301-75 requirements.

The 56 kph (35 mph) frontal barrier impact test was conducted in accordance with the National Highway Traffic Safety Administration (NHTSA) Indicant Test Procedure for New Car Assessment Program (NCAP) dated January 1, 1990. Data for FMVSS No. 212, "Windshield Mounting", FMVSS No. 219 (Partial), "Windshield Zone Intrusion", FMVSS No. 301-75, "Fuel System Integrity," as well as occupant performance data are provided herein.

SECTION 2
SUMMARY OF FRONTAL BARRIER IMPACT TEST

A load cell barrier consisting of 30 load cells was impacted by a 1994 Ford Thunderbird 2-Door at a velocity of 56.3 kph (35.0 mph). The test was performed at the MGA Proving Grounds and Crash Test Center on March 4, 1994. Pre- and post-test photographs of the vehicle and dummies can be found in Appendix A.

The frontal barrier impact event was documented by one real-time camera and 16 high speed cameras. Camera locations and other pertinent camera information can be found in this report. There was no camera timing due to a short in the timing system. The cameras were set at 999 frames/sec.

Two calibrated Part 572E, 50th percentile male anthropomorphic test devices (ATDs) were placed in the driver and right-front passenger seating positions according to dummy placement instructions specified in the Laboratory Indicant Test Procedure.

The driver ATD (serial No. 36) and passenger ATD (serial No. 37) were fully instrumented with head and chest triaxial accelerometers, right/left femur load cells, neck load cells, and chest deflection sensors. Seat belt load cells were also on the driver's and passenger's lap and shoulder belts to measure dummy torso and pelvic section loading. Certification details, along with instrumentation calibration data, are found in Appendix C and D.

The 56 channels of data were recorded on 5 computers. Appendix B contains the vehicle, load cell barrier and dummy response data traces. Channel 8 had a wire cut at approximately 65 msec.

The driver's head struck the inflated airbag. The driver HIC was 475.4. The maximum chest deceleration over 3 milliseconds was 35.7 G's. The left and right femur loads were 6457 and 3860 Newtons respectively.

The passenger's head struck the inflated airbag. The right front passenger's HIC was 302.2 and maximum chest deceleration over 3 milliseconds was 37.0 g's. The left and right femur loads were 3770 and 1559 Newtons respectively.

GENERAL TEST AND VEHICLE PARAMETER DATA

Vehicle Yr/Make/Model/Body Style: 1994 Ford Thunderbird 2 Door

NHTSA No.: MR0202 VIN.: 1FALP6247RH104517

Body color: Green Date of Manufacture: 9-93

Engine: 6 Cylinders; C.I.D.; 3.8liters; CC

 Gas; Diesel; Turbocharged

 Longitudinal; Transverse

Transmission: 3 Speed; Manual; Automatic; Overdrive

Final Drive: Front Wheel; Rear Wheel; Four Wheel

Date Received: Odometer Reading: 65

 A/C; P/S; P/B; P/wdo;

 P/seats; Tilt Wheel; Cruise Control;

Type of Occupant Restraint: Type II belts and driver and passenger airbags

DATA RECORDED FROM VEHICLE'S TIRE PLACARD:

Tire Pressure (at capacity): Front 2.11 kg/cm² 30 Psi; Rear 2.11 kg/cm² 30 Psi:

Recommended Tire Size: P215/70R15

Recommended Cold Tire Pressure: Front 2.11 kg/cm²; Rear 2.11 kg/cm²

Tires on Vehicle: P215/70R15; Manufacturer: Firestone

Number of Occupants: 2 Front; 3 Rear; 3rd Seat; 5 TOTAL

Type of Front Seats: Bucket; Bench; Split Bench

Type of Front Seat Back: Fixed; Adj. With; Lever; Rot. Knob

Vehicle Capacity Weight (VCW) = 408 kg. (A)

No. of Occupants x 68 kg. = 340 kg. (B)

Rated Cargo Weight (RCW) A-B = 68 kg.

GVWR 2194 kg. GAWR: Front 1138 kg.; Rear 1066 kg.

GENERAL TEST AND VEHICLE PARAMETER DATA (Cont'd)

WEIGHT OF TEST VEHICLE AS RECEIVED FROM DEALER (WITH MAXIMUM FLUIDS) = UDW:

Right Front = 460 kg Right Rear = 311 kg
Left Front = 458 kg Left Rear = 341 kg
TOTAL FRONT WEIGHT = 918 kg (58.5% of Total Vehicle Weight)
TOTAL REAR WEIGHT = 652 kg (41.5% of Total Vehicle Weight)
TOTAL UNLOADED DELIVERED WEIGHT (UDW) = 1570 kg

CALCULATION FOR TARGET TEST WEIGHT:

UDW = Unloaded Delivered Weight 1570 kg
VCW = Vehicle Capacity Weight 408 kg DSC = Designated Seating Capacity 5
RCW = VCW - 68 (DSC) = 68 *kg
Target Test Weight = UDW + RCW + (2 dummies x 74.4 kg/dummy)
Target Test Weight = 1787 kg

WEIGHT OF TEST VEHICLE WITH REQUIRED DUMMIES AND CARGO:

Right Front = 499 kg Right Rear = 388 kg
Left Front = 489 kg Left Rear = 405 kg
TOTAL FRONT WEIGHT = 988 kg (55.5% of Total Vehicle Weight)
TOTAL REAR WEIGHT = 793 kg (44.5% of Total Vehicle Weight)
TOTAL TEST WEIGHT = 1781 kg
Weight of ballast secured in vehicle = 18 kg
Vehicle components removed to meet target weight: None

VEHICLE ATTITUDE (all dimensions in mm):

Delivered Attitude: RF 750 LF 745 RR 760 LR 755
Test Attitude: RF 737 LF 735 RR 720 LR 714
Wheel Base: 2870 mm; C.G. = 1278 mm rearward of front wheel C/L
Remarks: None

*light trucks and MPVs RCW is 136 kgs or manufacturer's value, whichever is less

GENERAL TEST AND VEHICLE PARAMETER DATA (cont'd)

<u>Door Opening</u>	<u>Front</u>		<u>Rear</u>	
	<u>Left</u>	<u>Right</u>	<u>Left</u>	<u>Right</u>
(without use of tools)	<u>Yes</u>	<u>Yes</u>	<u>N/A</u>	<u>N/A</u>

<u>Seat Movement</u>	<u>Front</u>		<u>Rear</u>	
	<u>Left</u>	<u>Right</u>	<u>Left</u>	<u>Right</u>
Seat Back Movement	<u>None</u>	<u>None</u>	<u>N/A</u>	<u>N/A</u>
Seat Shift (mm)	<u>5 mm forward 7 mm forward</u>		<u>N/A</u>	<u>N/A</u>

Glazing Damage

Backlight/Windshield Windshield cracked and separated on passenger side

Other Notable Impact Effects: None Noted

SECTION 3

SUMMARY OF RESULTS FOR-----

FMVSS 212, "Windshield Mounting"

FMVSS 219 (Partial), "Windshield Zone Intrusion"

FMVSS 301-75, "Fuel System Integrity"

FMVSS NO. 212, "WINDSHIELD MOUNTING", DATA SHEET

Details of windshield mounting such as retention method, trim type, etc.:

Rubber with glue retention

FMVSS 212 Requirements: The Post-Test periphery retention amount must be at least 75% of the Pre-Test periphery measurement for vehicles NOT equipped with automatic restraints, and 50% for each side of windshield for vehicles equipped with automatic restraint systems for front occupants.

FMVSS 212 TEST DATA:

	WINDSHIELD PERIPHERY		PERCENT RETENTION
	PRE-TEST (mm)	POST-TEST (mm)	
RIGHT SIDE	2353	2053	87.3%
LEFT SIDE	2353	2353	100%
TOTAL	4706	4406	93.6%

AREA OF RETENTION FAILURE:

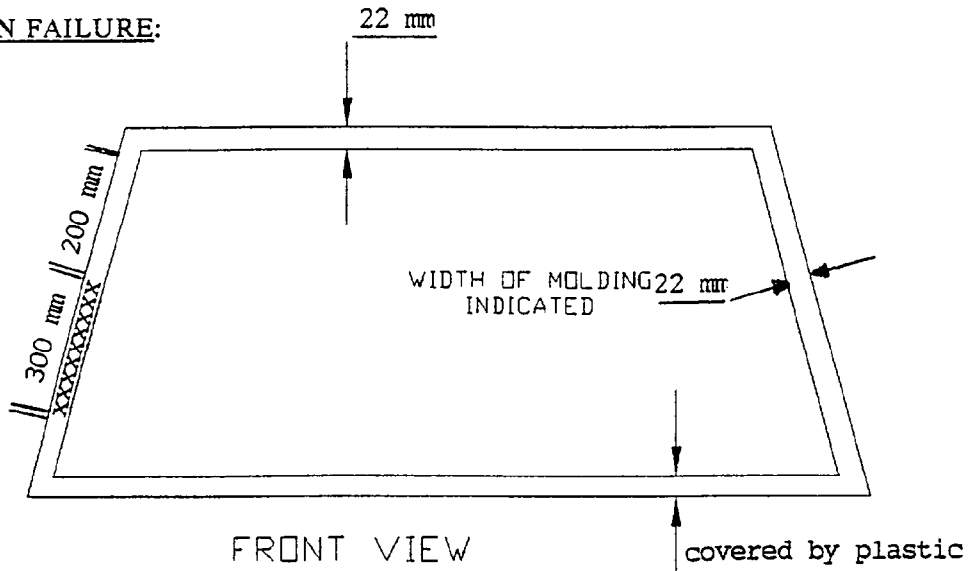

FAILURE DETAILS:

Windshield separated for a length of 300 mm on the vehicle's right side 200 mm down from the top of the windshield

FMVSS NO. 219, "WINDSHIELD ZONE INTRUSION", DATA SHEET

PROTECTED ZONE LOWER EDGE REQUIREMENT:

The lower edge of the protected zone is determined by placing a 6.5" dia. rigid sphere weighing 15 pounds in a position such that it simultaneously contacts the inner surface of the windshield and the top surface of the instrument panel including padding. Draw the locus of points on the inner surface of the windshield contacted by the sphere across the width of the instrument panel. From the outermost contact points, extend the locus line horizontally to the edges of the windshield, and then draw a line on the inner surface of the windshield below and 1/2" distant from the locus line. The LOWER EDGE OF THE PROTECTED ZONE is the longitudinal projection onto the outer surface of the windshield of this line.

FMVSS 219 TEST DATA:

A= 1294 mm
B= 481 mm
C= 1704 mm
D= 854 mm
E= 493 mm
F= 818 mm

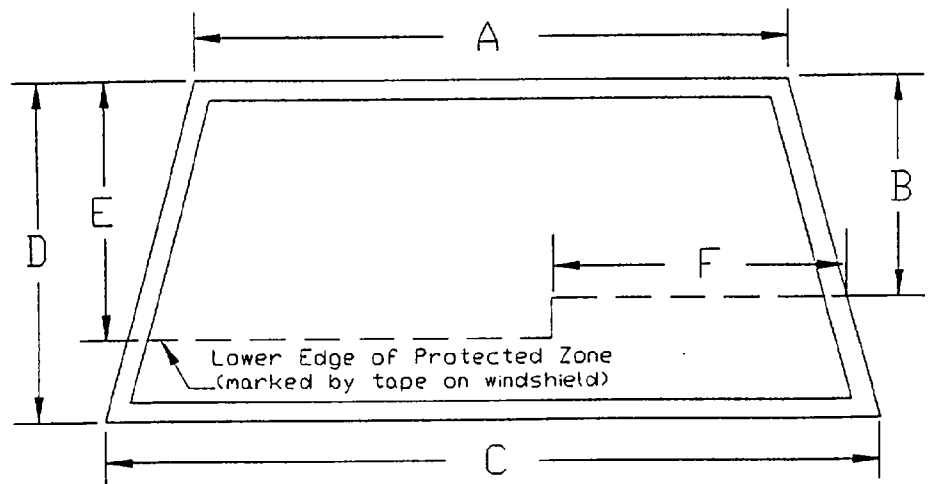

FRONT VIEW

DETAILS OF WINDSHIELD GLASS PENETRATION GREATER THAN 1/4":
(Show location of penetration)

NONE

FMVSS NO. 301 STATIC ROLLOVER DATA SHEET

TEST PHASE: 0° - 90°

Vehicle NHTSA ID No.: MR0202

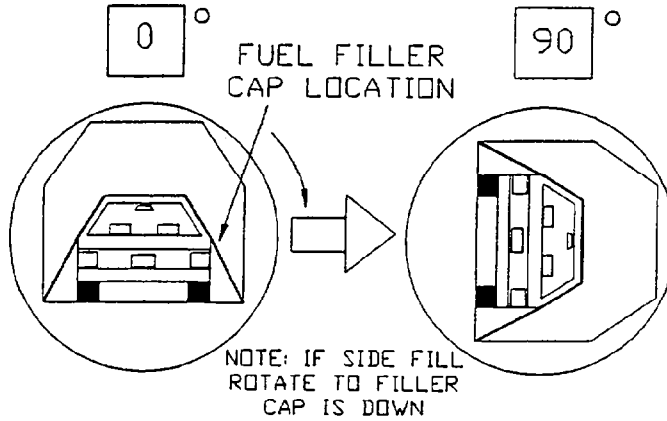

I. DETERMINATION OF SOLVENT COLLECTION TIME PERIOD:

Rollover Fixture 90° Rotation Time 2 minutes 48 seconds
(Spec. Range = 1 to 3 minutes)

FMVSS 301 Position Hold Time + 5 minutes 0 seconds

TOTAL 7 minutes 48 seconds

Next whole minute interval 8 minutes

II. FMVSS 301 REQUIREMENTS:

(1) Time Period

First 5 min FROM onset of rotation	6th min.	7th min.	8th min. if reqd.
------------------------------------	----------	----------	-------------------

(2) Maximum Allowable Solvent Spillage

5 ounces	1 ounce	1 ounce	1 ounce
----------	---------	---------	---------

III. ACTUAL TEST VEHICLE SOLVENT SPILLAGE:

0	0	0	0
---	---	---	---

Note: Record Spillage for whole minute intervals only as determined above.

IV. SOLVENT SPILLAGE LOCATIONS(S): None

FMVSS NO. 301 STATIC ROLLOVER DATA SHEET

TEST PHASE: 90° - 180°

Vehicle NHTSA ID No.: MR0202

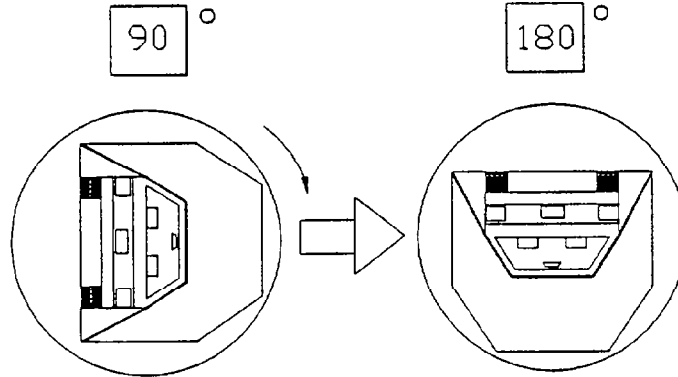

I. DETERMINATION OF SOLVENT COLLECTION TIME PERIOD:

Rollover Fixture 90° Rotation Time 2 minutes 23 seconds
 (Spec. Range = 1 to 3 minutes)

FMVSS 301 Position Hold Time + 5 minutes 0 seconds
TOTAL 7 minutes 23 seconds
 Next whole minute interval 8 minutes

II. FMVSS 301 REQUIREMENTS:

(1) Time Period

First 5 min FROM onset of rotation	6th min.	7th min.	8th min. if reqd.
------------------------------------	----------	----------	-------------------

(2) Maximum Allowable Solvent Spillage

5 ounces	1 ounce	1 ounce	1 ounce
----------	---------	---------	---------

III. ACTUAL TEST VEHICLE SOLVENT SPILLAGE:

0	0	0	0
---	---	---	---

Note: Record Spillage for whole minute intervals only as determined above.

IV. SOLVENT SPILLAGE LOCATIONS(S): None

FMVSS NO. 301 STATIC ROLLOVER DATA SHEET

TEST PHASE: 180° - 270°

Vehicle NHTSA ID No.: MR0202

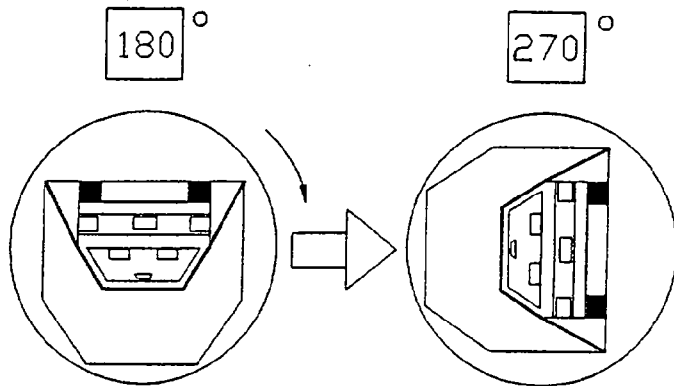

I. DETERMINATION OF SOLVENT COLLECTION TIME PERIOD:

Rollover Fixture 90° Rotation Time 2 minutes 27 seconds
 (Spec. Range = 1 to 3 minutes)

FMVSS 301 Position Hold Time + 5 minutes 0 seconds

TOTAL 7 minutes 27 seconds

Next whole minute interval 8 minutes

II. FMVSS 301 REQUIREMENTS:

(1) Time Period

First 5 min FROM onset of rotation	6th min.	7th min.	8th min. if reqd.
------------------------------------	----------	----------	-------------------

(2) Maximum Allowable Solvent Spillage

5 ounces	1 ounce	1 ounce	1 ounce
----------	---------	---------	---------

III. ACTUAL TEST VEHICLE SOLVENT SPILLAGE:

0	0	0	0
---	---	---	---

Note: Record Spillage for whole minute intervals only as determined above.

IV. SOLVENT SPILLAGE LOCATIONS(S): None

FMVSS NO. 301 STATIC ROLLOVER DATA SHEET

TEST PHASE: 270° - 360°

Vehicle NHTSA ID No.: MR0202

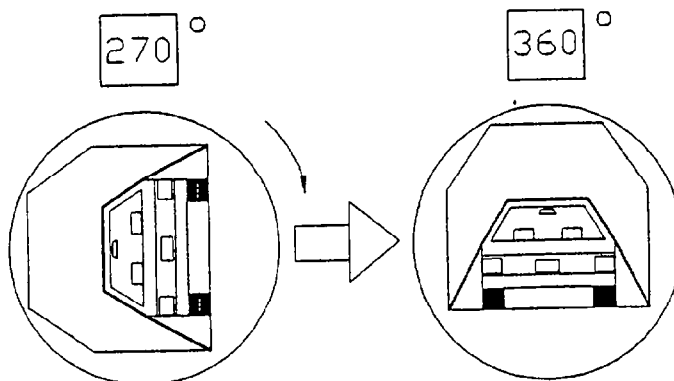

I. DETERMINATION OF SOLVENT COLLECTION TIME PERIOD:

Rollover Fixture 90° Rotation Time 2 minutes 13 seconds
(Spec. Range = 1 to 3 minutes)

FMVSS 301 Position Hold Time + 5 minutes 0 seconds

TOTAL 7 minutes 13 seconds

Next whole minute interval 8 minutes

II. FMVSS 301 REQUIREMENTS:

(1) Time Period

First 5 min FROM onset of rotation	6th min.	7th min.	8th min. if reqd.
------------------------------------	----------	----------	-------------------

(2) Maximum Allowable Solvent Spillage

5 ounces	1 ounce	1 ounce	1 ounce
----------	---------	---------	---------

III. ACTUAL TEST VEHICLE SOLVENT SPILLAGE:

0	0	0	0
---	---	---	---

Note: Record Spillage for whole minute intervals only as determined above.

IV. SOLVENT SPILLAGE LOCATIONS(S): None

SECTION 4
OMI FINAL DATA

Occupant and Vehicle Information

I. OMI DATA

1. "Occupant Crash Protection Data Sheet"
2. Dummy Positioning Data
3. Seat Belt Positioning Data
4. Seat Belt Performance Assessment Data
5. Camera Locations
6. Vehicle Target Locations

II. OVR DATA

1. Load Cell Barrier Data
2. Vehicle Accelerometer Data
3. Test Vehicle Measurements

III. AID DATA

1. Accident Investigation Damage Data Summary

FMVSS NO. 208, "OCCUPANT CRASH PROTECTION", DATA SHEET

VEH. YR./MAKE/MODEL/BODY STYLE: 1994 Ford Thunderbird 2 Door

VEH. NHTSA NO.: MR0202 TEST DATE: March 4, 1994

MAXIMUM ACCELERATION VALUES: (g's)	DRIVER DUMMY #36	PASSENGER DUMMY #37
Head Channel X	-57.1	-32.4
Head Channel Y	-15.0	-33.4
Head Channel Z	19.0	44.8
HEAD RESULTANT	60.5	57.8
Chest Channel X	-36.0	-36.7
Chest Channel Y	-7.0	-12.7
Chest Channel Z	5.2	2.8
CHEST RESULTANT (CLIP)	35.7	37.0
TIME INTERVAL (msec) [0.003 seconds minimum]	t ₁ = 73.3 t ₂ = 76.3	t ₁ = 57.7 t ₂ = 60.8

HEAD INJURY CRITERIA (HIC) VALUES:

HIC	475.4	302.2
t ₁ = (msec)	63.1	58.2
t ₂ = (msec)	99.1	94.2
Avg. Accel. t ₁ to t ₂ (g's)	44.5	37.1

[The maximum time interval from t₁ to t₂ is 36 milliseconds.]

MAXIMUM FEMUR FORCES:

Right Side (N)	-3860	-1559
Left Side (N)	-6457	-3770

MAXIMUM SEAT BELT FORCES:

Lap Belt (N)	3217	5605
Shoulder Belt (N)	4792	3883

NOTE: All values listed must occur during primary impact event.
(Head X,Y,Z and R listed must be during t₁ to t₂ HIC interval)

HYBRID III NECK AND CHEST DATA SHEET

VEHICLE YR./MAKE/MODEL/BODY STYLE: 1994 Ford Thunderbird 2 Door

VEHICLE NHTSA NO.: MR0202 TEST DATE: March 4, 1994

MAXIMUM VALUES	DRIVER DUMMY # 36	PASSENGER DUMMY #37
Neck Load X (N)	-393	424
Neck Load Y (N)	-135	-625
Neck Load Z (N)	-1700	-2749
Neck Moment X (N.M)	11.0	48.5
Neck Moment Y (N.M)	-33.5	-31.8
Neck Moment Z (N.M)	-15.8	-43.2
Chest Deflection X (mm)	29	28
Time of Max. Occurrence	74 msec	72 msec

PART 572 DUMMY IN-VEHICLE POSITION

Test No.: MR0202 Vehicle: 1994 Ford Thunderbird

SEAT TYPE:

Bench
 Bucket
 Split Bench

ADJUSTER TYPE:

Driver
 Manual
 Power

Passenger

Manual
 Power

BUCKET SEAT BACK TYPE:

Fixed
 Adjustable Reclining

Driver

Passenger

Seat 107 mm from rear most position

Seat notch 10 from rear most position

214 mm total travel for power seat

19 total manual adjustments

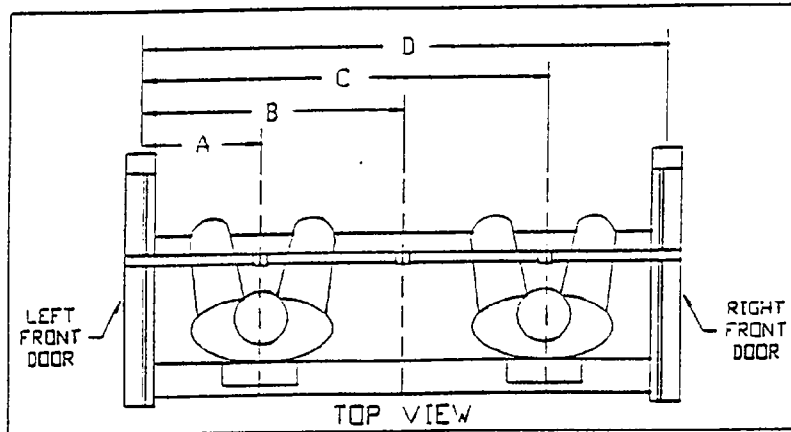

36 DUMMY ID 37

- A = Left Door to Driver Centerline 392 mm
- B = Left Door to Vehicle Centerline 763 mm
- C = Left Door to Right Passenger Centerline 1141 mm
- D = Left Door to Right Door 1525 mm

FRONT SEAT MEASUREMENT TABLE

Units (mm)

	DRIVER (Serial #36)	PASSENGER (Serial #37)
WA°	26.4°	26.4°
SWA°	19°	N/A
SCA°	N/R	N/A
SA°	21.7°	21.1°
HZ	160	144
HH	268	261
HW	518	499
HR	220	229
NR	355 Angle 14°	N/A
CD	500	598
CS	280	N/A
RA	162	N/A
KDL	145 Angle 27.8°	155
KDR	127	150 Angle 53.3°
PA°	24.6°	20.2°
TA°	35.4°	N/A
KK	303	227
ST	658 Angle -37.3°	664 Angle 49.2°
SK	932 Angle -.3°	909 Angle 2.2°
SH	574 Angle -14.8°	540 Angle 15.8°
SHY	260	265
HS	320	344
HD	138	146
AD	125	124

N/A = Not Applicable
 N/R = Not Recordable

FRONT SEAT MEASUREMENTS

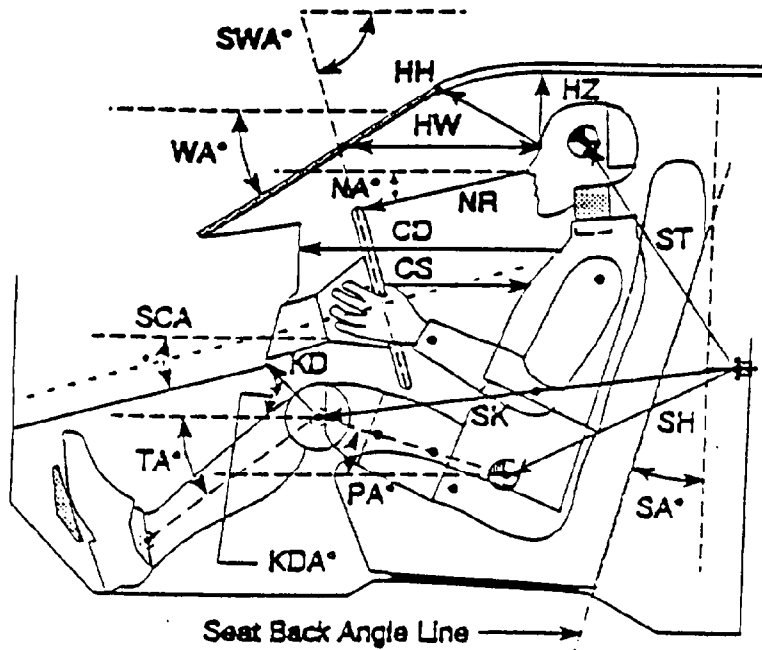

- AD - Arm to Door
- HD - H-Point to Door
- HR - Head to Side Header
- HS - Head to Side Window
- KK - Knee to Knee
- SHY - Striker to H-Point (Y Direction)

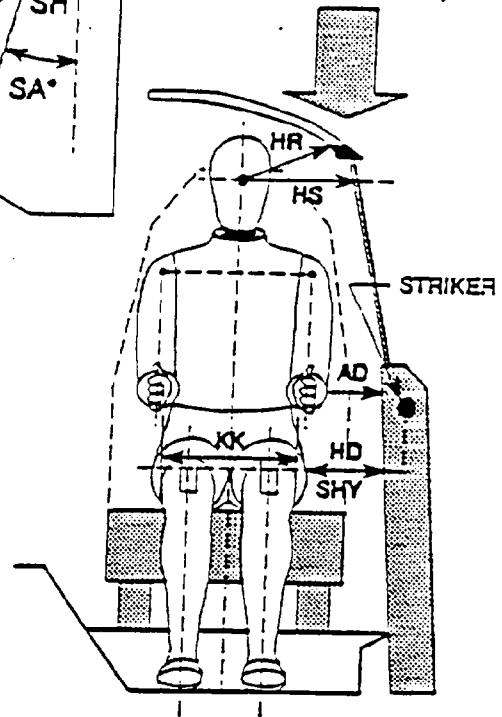

- CD - Chest to Dash
- CS - Steering Wheel to Chest
- HH - Head to Header
- HW - Head to Windshield
- HZ - Head to Roof
- KDA - Knee to Dash Angle
- KDL - Left Knee to Dash
- KDR - Right Knee to Dash
- NA - Nose to Rim Angle
- NR - Nose to Rim
- PA - Pelvic Angle
- RA - Rim to Abdomen
- SA - Seat Back Angle
- SCA - Steering Column Angle
- SH - Striker to H-Point
- SK - Striker to Knee
- ST - Striker to Head
- SWA - Steering Wheel Angle
- TA - Tibial Angle
- WA - Windshield Angle

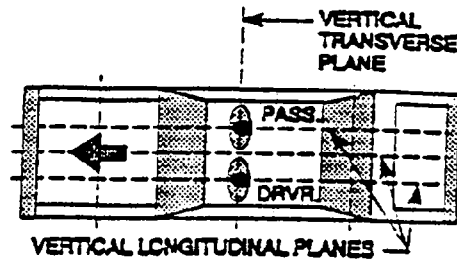

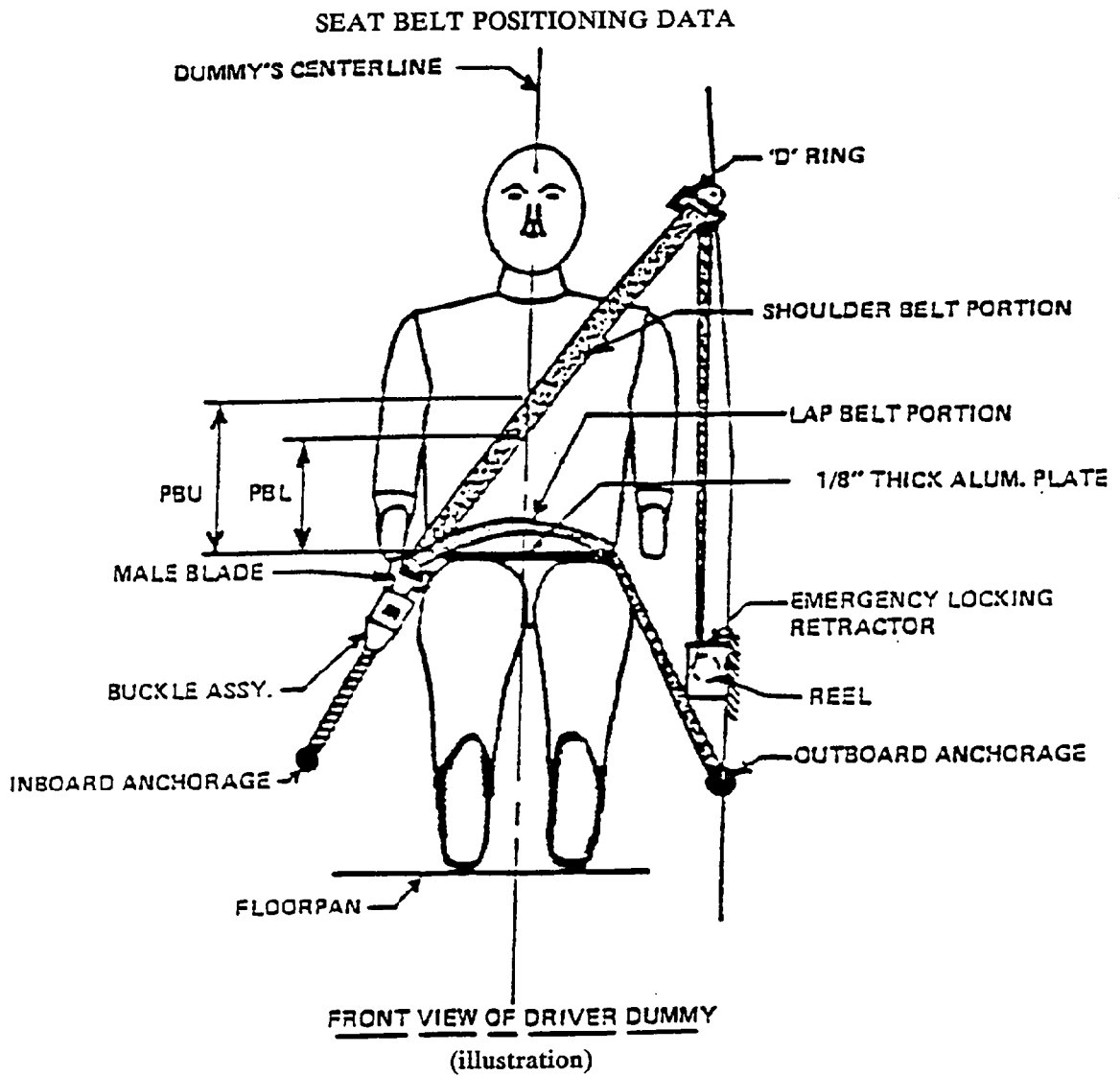

		DRIVER DUMMY	PASSENGER DUMMY
PBU --	Top surface of alum. plate to upper edge (mm)	315	340
PBL --	Top surface of alum. plate to belt lower edge (mm)	230	235
LAP BELT TENSION (kgs.)		N/A	N/A
SHOULDER BELT TENSION (kgs.)		N/A	N/A

SEAT BELT PERFORMANCE ASSESSMENT TEST DATA

<u>BELT LENGTH DATA:</u>	<u>Driver</u>	<u>Passenger</u>
Belt length from trim panel exit to bolt hole anchor point for continuous webbing systems.	<u>285 mm</u>	<u>295 mm</u>
Shoulder belt length as measured on Part 572 Dummy.	<u>995 mm</u>	<u>1010 mm</u>
Lap belt length as measured on Part 572 Dummy.	<u>770 mm</u>	<u>755 mm</u>

SHOULDER BELT SPOOL-OFF DATA:

As determined by film analysis	<u>76 mm</u>	<u>51 mm</u>
As determined mechanically	<u>79 mm</u>	<u>70 mm</u>
As determined electronically	<u>61 mm</u>	<u>54 mm</u>

BELT STRETCH DATA:

Measured electronically between shoulder belt load cell and the "D" ring.	<u>N/R</u>	<u>N/R</u>
Measured mechanically	<u>N/R</u>	<u>N/R</u>

RETRACTOR LOCK-UP TIME:

As determined by shoulder belt spool-off observed in on-board cameras*	<u>N/A</u>	<u>N/A</u>
--	------------	------------

* No camera timing
NR = Not Recorded

CAMERA LOCATIONS

VEH. NHTSA NO.: MR0202 ; TEST DATE: March 4, 1994 ; TIME: 3:50 p.m.

VEH. YEAR/MAKE/MODEL/BODY STYLE: 1994 Ford Thunderbird 2 Door

	VIEW	CAMERA POSITIONS (mm.)*			ANGLE (deg)	LENS (mm)	SPEED (fps)	DISTANCE FROM HEAD TARGET
		X	Y	Z				
1	Real-Time Left Side View					10	24	
3	Left Front View	1000	7950	1070	90°	25	**	7510
16	Steering Column Top	1950	8000	1560	90°	25	**	7560
15	Steering Column Bottom	1950	8000	1050	90°	25	**	7560
12	Left Driver Close-up	1600	8620	1050	90°	50	**	8180
9	Left Angle	5630	6570	2120	50°	50	**	
13	Driver Onboard Seat Belt					25	**	
14	Passenger Onboard Seat Belt					25	**	
2	Right Overall	2830	-7000	1100	90°	13	**	6557
17	Right Front	1300	-7350	1000	90°	25	**	6907
11	Right Passenger Close-up	1820	-6950	1000	90°	35	**	6507
10	Right Angle	7460	-5850	2400	50°	35	**	
4	Top View Wide	300	0	4370		13	**	
8	Top Driver	-400	300	2440		13	**	
7	Top Passenger	-400	-400	2440		13	**	
5	Pit Engine	1000	0	-3150		13	**	
6	Pit Fuel Tank	2750	0	-3150		13	**	

COORDINATES:

- * X = film plane to monorail centerline
- Y = film plane to barrier face
- Z = film plane to ground

ORIGIN: For X and Y it is the Impact Point. For Z it is the Floor.

** No timing marks on film, cameras set at 999 frame/second

CAMERA LOCATIONS (CONTINUED)

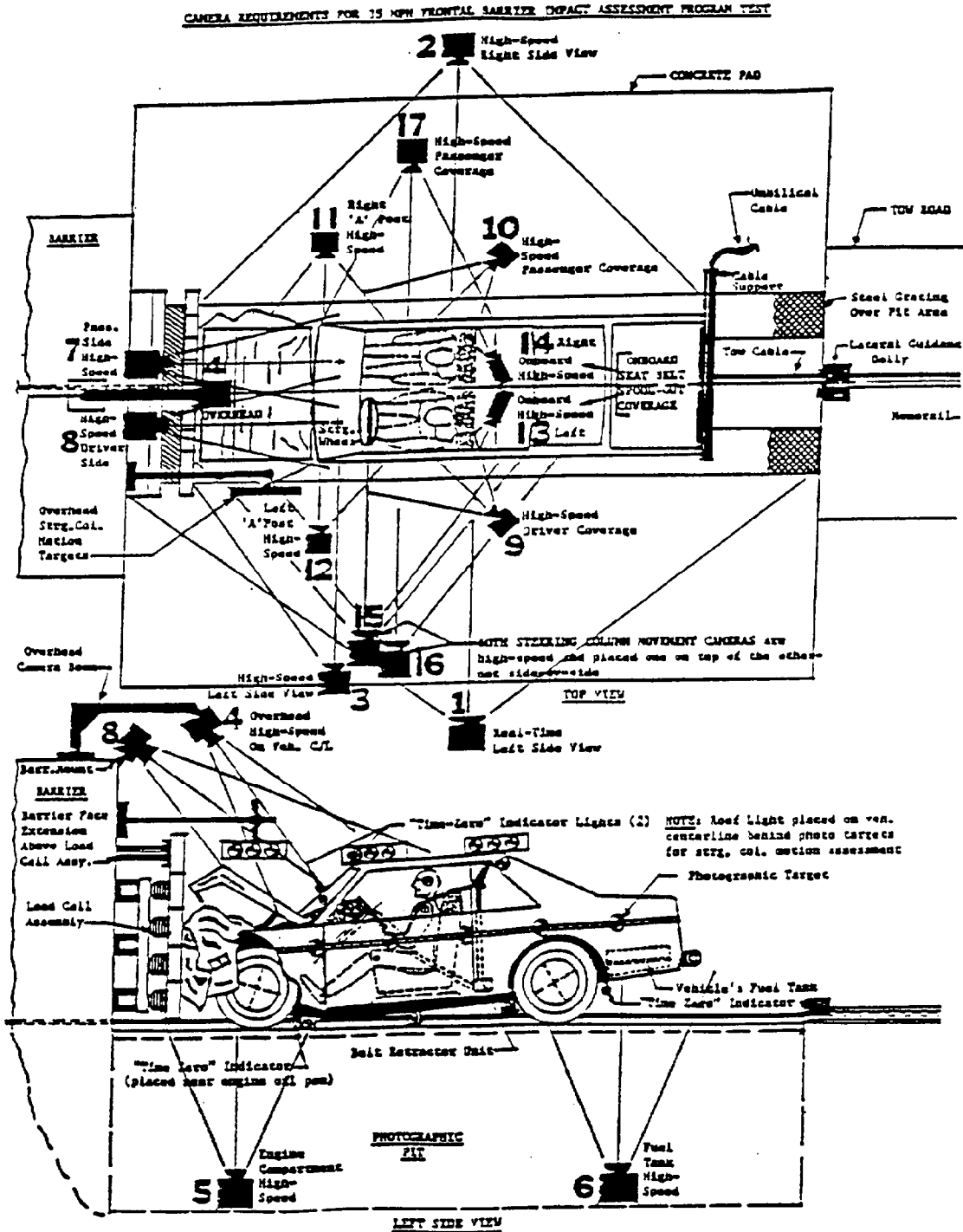

VEHICLE TARGET LOCATIONS

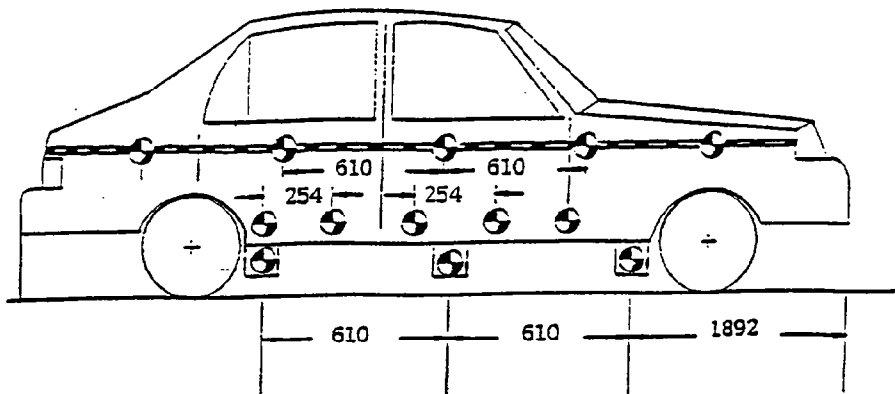
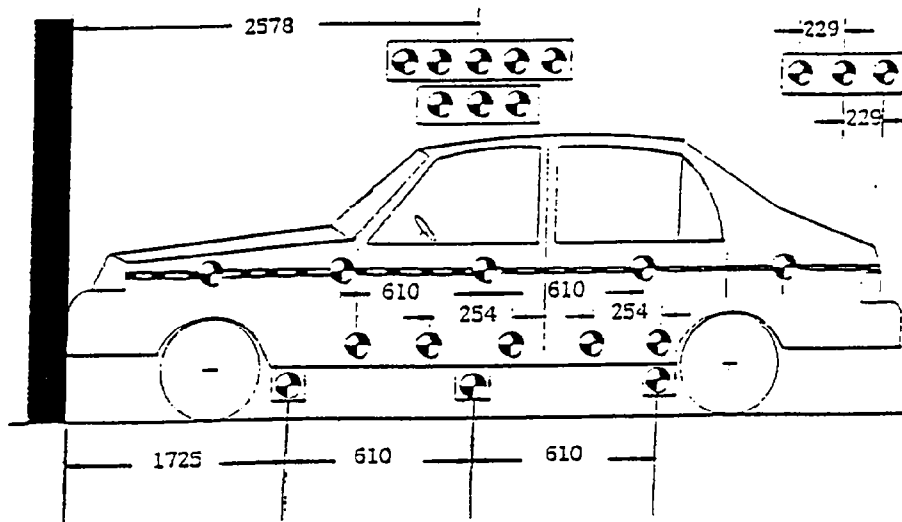
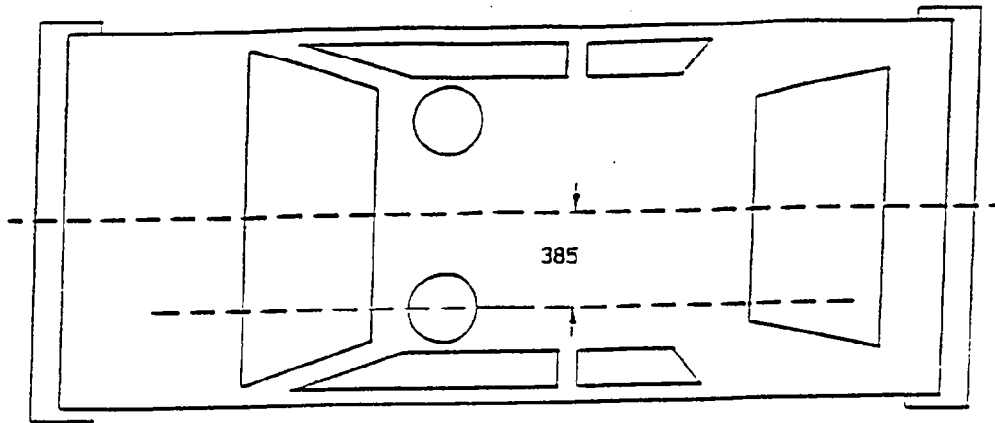

(DIMENSIONS IN MM)

LOAD CELL LOCATIONS ON FIXED BARRIER

30 Load Cells
6 Rows
9 Columns
6 Groupings (5 cells/group)

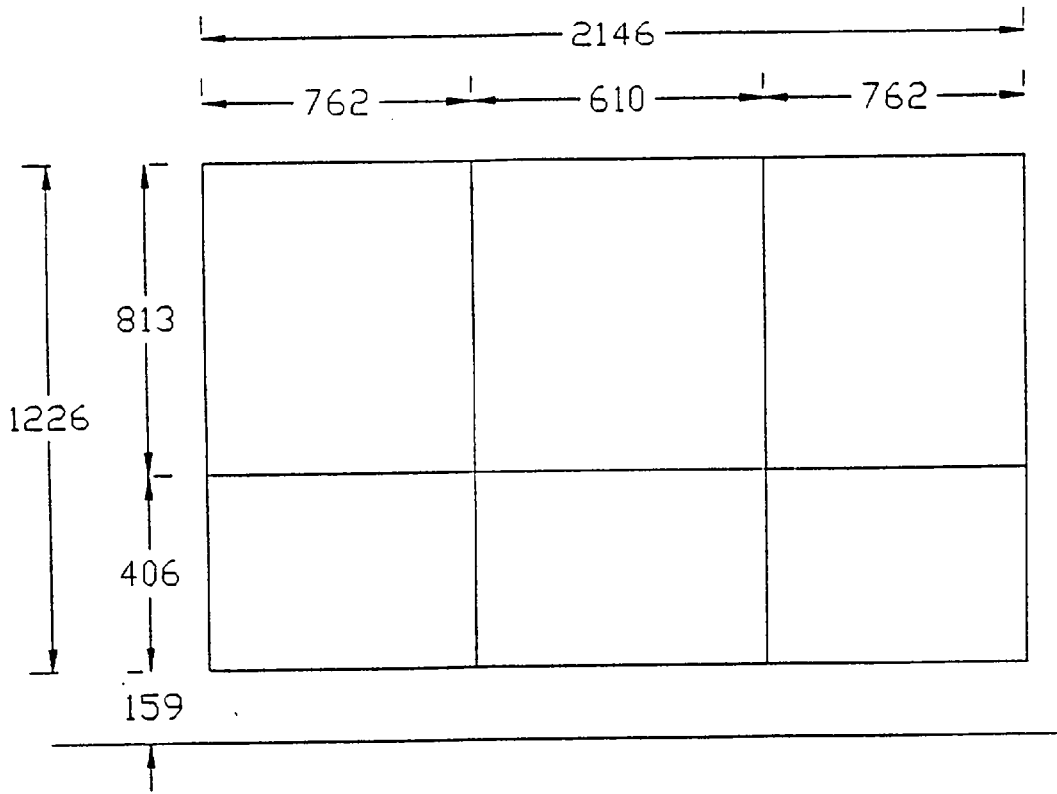

The following data is presented in Appendix B:

- (1) Total or Sum of 30 individual load cells
- (2) Data from 6 Groupings shown above (5 cells/group)

VEHICLE ACCELEROMETER LOCATION AND DATA SUMMARY

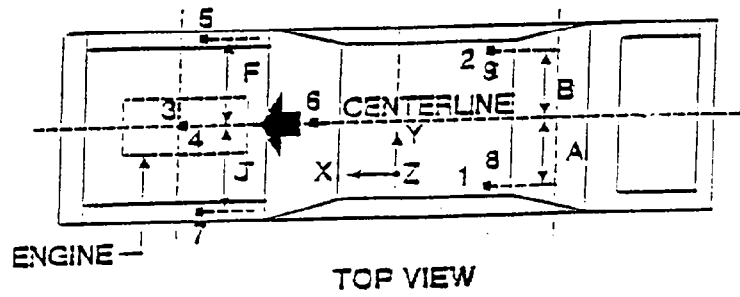

REAR SEAT CUSHION
ASSY. FRONT ATTACHMENT
BRACKET SUPPORT

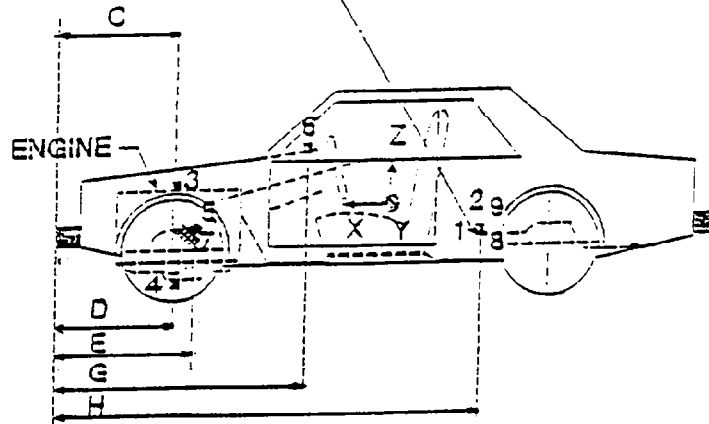

Units: (mm)

Dimension	Length
A	-730
B	730
C	1190
D	1280
E	1150
F	735
G	1830
H	3072
J	-735

ACCELEROMETER	ACCELEROMETER LOCATION	DIRECTIO
1 and 8	Left Rear Seat Crossmember	X
2 and 9	Right Rear Seat Crossmember	X
3	Top of Engine	X
4	Bottom of Engine	X
5	Right Side Brake Caliper	X
6	Instrument Panel	X
7	Left Disc Brake Caliper	X

* The accelerometer pack number can be correlated with the vehicle response data traces in Appendix B.

TEST VEHICLE MEASUREMENTS

No.	MEASUREMENT DESCRIPTION:	Pre-Test (mm)	Post-Test (mm)	Diff. (mm)
X1	Total Length of Test Vehicle at Centerline	5072	4476	596
X2	Rear Surface of Vehicle to Front of Engine	4049	3810	239
X3	Rear Surface of Vehicle to Firewall	3593	3540	53
X4	Rear Surface to Upr. Leading Edge of Rt. Door	3442	3432	10
X5	Rear Surface to Upr. Leading Edge of Left Door	3423	3405	18
X6	Rear Surface to Lwr. Leading Edge of Rt. Door	3412	3404	8
X7	Rear Surface to Lwr. Leading Edge of Left Door	3417	3402	15
X8	Rear Surface to Upr. Trailing Edge of Rt. Door	2047	2044	3
X9	Rear Surface to Upr. Trailing Edge of Left Door	2040	2035	5
X10	Rear Surface to Lwr. Trailing Edge of Rt. Door	2034	2020	14
X11	Rear Surface to Lwr. Trailing Edge of Left Door	2037	2020	17
X12	Rear Surface to Bottom of 'A' Post on Rt. Side	3416	3416	0
X13	Rear Surface to Bottom of 'A' Post on Left Side	3427	3414	13
X14	Rear Surface to Firewall on Right Side	3669	3531	138
X15	Rear Surface to Firewall on Left Side	3665	3552	113
X16	Rear Surface to Steering Column	2872	2925	-53
X17	Center of Steering Column to 'A' Post	362	355	7
X18	Center of Steering Column to Headlining	401	420	-19
X19	Rear Surface to Right Side of Front Bumper	4940	4335	605
X20	Rear Surface to Left Side of Front Bumper	4959	4324	635
X21	Length of Engine Block	405	405	0

TEST VEHICLE MEASUREMENTS

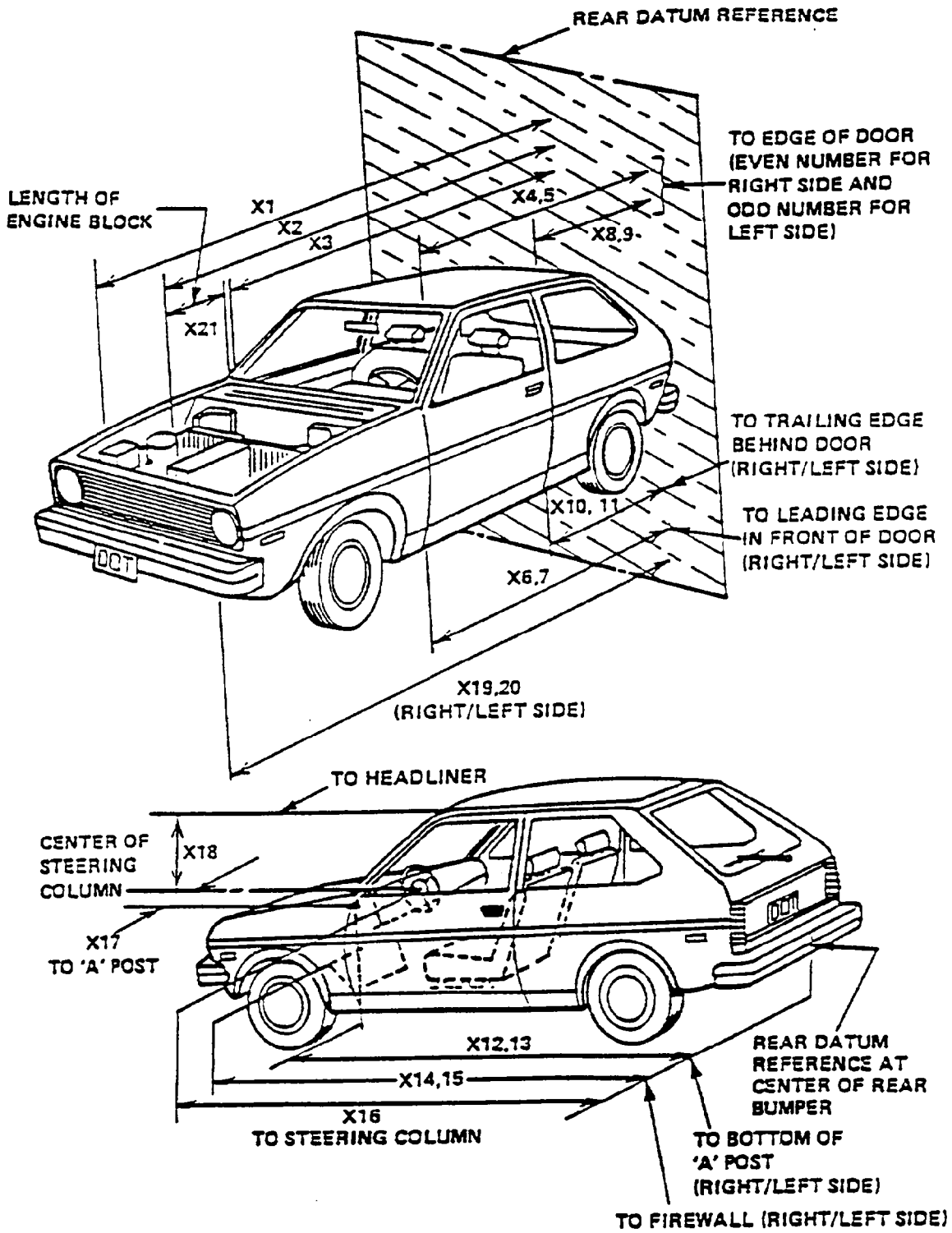

ACCIDENT INVESTIGATION DIVISION DATA
FOR 35 MPH FRONTAL BARRIER IMPACT

VEHICLE MAKE/MODEL/BODY STYLE: Ford Thunderbird 2 Door

VEH. NHTSA NO.: MR0202; VIN: 1FALP6247RH104517

MODEL YEAR: 1994; BUILD DATE: 9-93; TEST DATE: 3-4-94

VEH. SIZE CATEGORY: Mid Size; TEST WEIGHT: 1781 kg

VEH. WHEELBASE: 2870 mm; FRONT OVERHANG: 1080 mm; OVERALL WIDTH: 1530 mm

ACCELEROMETER DATA:

LOCATION: As per measurements on pages 4-13

CALIBRATION PROCEDURE: As per MGA Calibration Procedure

LINEARITY: >99.9%; INTEGRATION ALGORITHM: Trapezoidal

VEH. IMPACT SPEED: 56.3 kph; TIME OF SEPARATION: 85 msec*

VELOCITY CHANGE: 68.7 kph

COLLISION DEFORMATION CLASSIFICATION (CDC) CODE:

F (Frontal)

CRUSH DEPTH
DIMENSIONS:

C1 = 635 mm

C2 = 572 mm

C3 = 594 mm

C4 = 573 mm

C5 = 586 mm

C6 = 605 mm

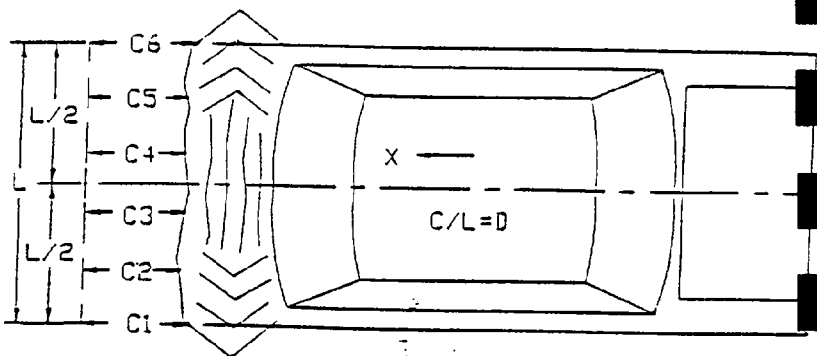

MIDPOINT OF
DAMAGE:

D = Vehicle Centerline
(Longitude)

LENGTH OF
DAMAGED REGION:

L = 1440 mm

* No camera timing, from plots



APPENDIX A
PHOTOGRAPHS

TABLE OF PHOTOGRAPHS

	<u>Page No.</u>
Photo No. 1 - Pre-Test Front View	A-1
Photo No. 2 - Post-Test Front View	A-2
Photo No. 3 - Pre-Test Left Side View	A-3
Photo No. 4 - Post-Test Left Side View	A-4
Photo No. 5 - Pre-Test Left Rear Three-Quarter View	A-5
Photo No. 6 - Post-Test Left Rear Three-Quarter View	A-6
Photo No. 7 - Pre-Test Rear View	A-7
Photo No. 8 - Post-Test Rear View	A-8
Photo No. 9 - Pre-Test Right Side View	A-9
Photo No. 10 - Post-Test Right Side View	A-10
Photo No. 11 - Pre-Test Right Front Three-Quarter View	A-11
Photo No. 12 - Post-Test Right Front Three-Quarter View	A-12
Photo No. 13 - Pre-Test Engine Compartment View	A-13
Photo No. 14 - Post-Test Engine Compartment View	A-14
Photo No. 15 - Pre-Test Fuel Filler Cap View	A-15
Photo No. 16 - Pre-Test Front Underbody View	A-16
Photo No. 17 - Pre-Test Rear Underbody View	A-17
Photo No. 18 - Pre-Test Windshield View	A-18
Photo No. 19 - Post-Test Windshield View	A-19
Photo No. 20 - Pre-Test Driver Dummy Position View	A-20
Photo No. 21 - Post-Test Driver Dummy Position View	A-21
Photo No. 22 - Pre-Test Driver Dummy Position View (Door Open)	A-22
Photo No. 23 - Post-Test Driver Dummy Position View (Door Open)	A-23
Photo No. 24 - Post-Test Driver Dummy and Steering Column View	A-24
Photo No. 25 - Pre-Test Driver Seat Position View	A-25
Photo No. 26 - Post-Test Driver Seat Position View	A-26
Photo No. 27 - Post-Test Driver Knee Position View	A-27
Photo No. 28 - Pre-Test Passenger Dummy Position View	A-28
Photo No. 29 - Post-Test Passenger Dummy Position View	A-29
Photo No. 30 - Pre-Test Passenger Dummy Position View (Door Open)	A-30

TABLE OF PHOTOGRAPHS (Cont'd)

	<u>Page No.</u>
Photo No. 31 - Post-Test Passenger Dummy Position View (Door Open)	A-31
Photo No. 32 - Post-Test Passenger Dummy Airbag Contact	A-32
Photo No. 33 - Post-Test Passenger Dash	A-33
Photo No. 34 - Pre-Test Passenger Seat Position View	A-34
Photo No. 35 - Post-Test Passenger Seat Position View	A-35
Photo No. 36 - Post-Test Passenger Knee Position View	A-36
Photo No. 37 - Rollover 90°	A-37
Photo No. 38 - Rollover 180°	A-38
Photo No. 39 - Rollover 270°	A-39
Photo No. 40 - Rollover 360°	A-40
Photo No. 41 - Speed Trap Time	A-41

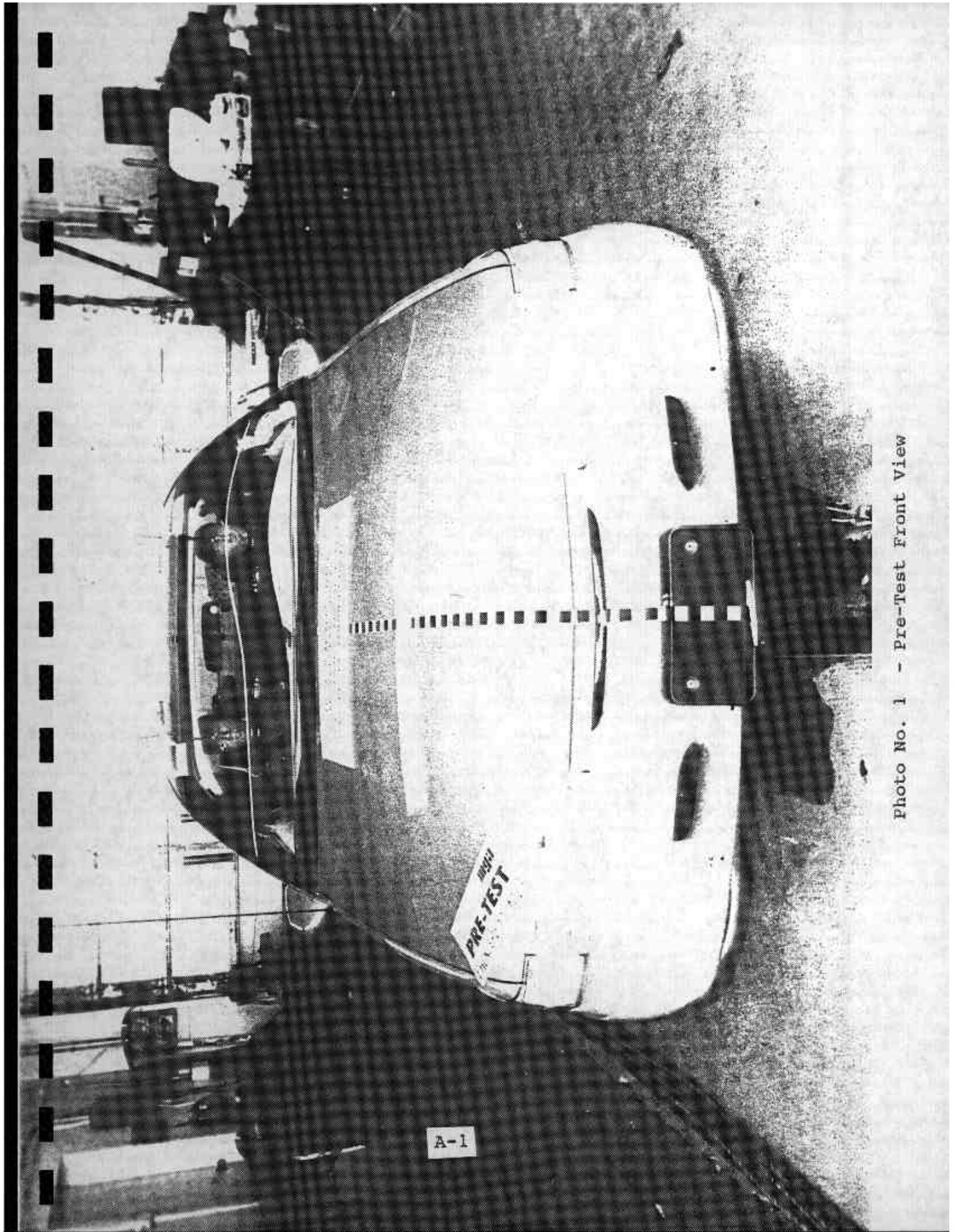

Photo No. 1 - Pre-Test Front View

A-1

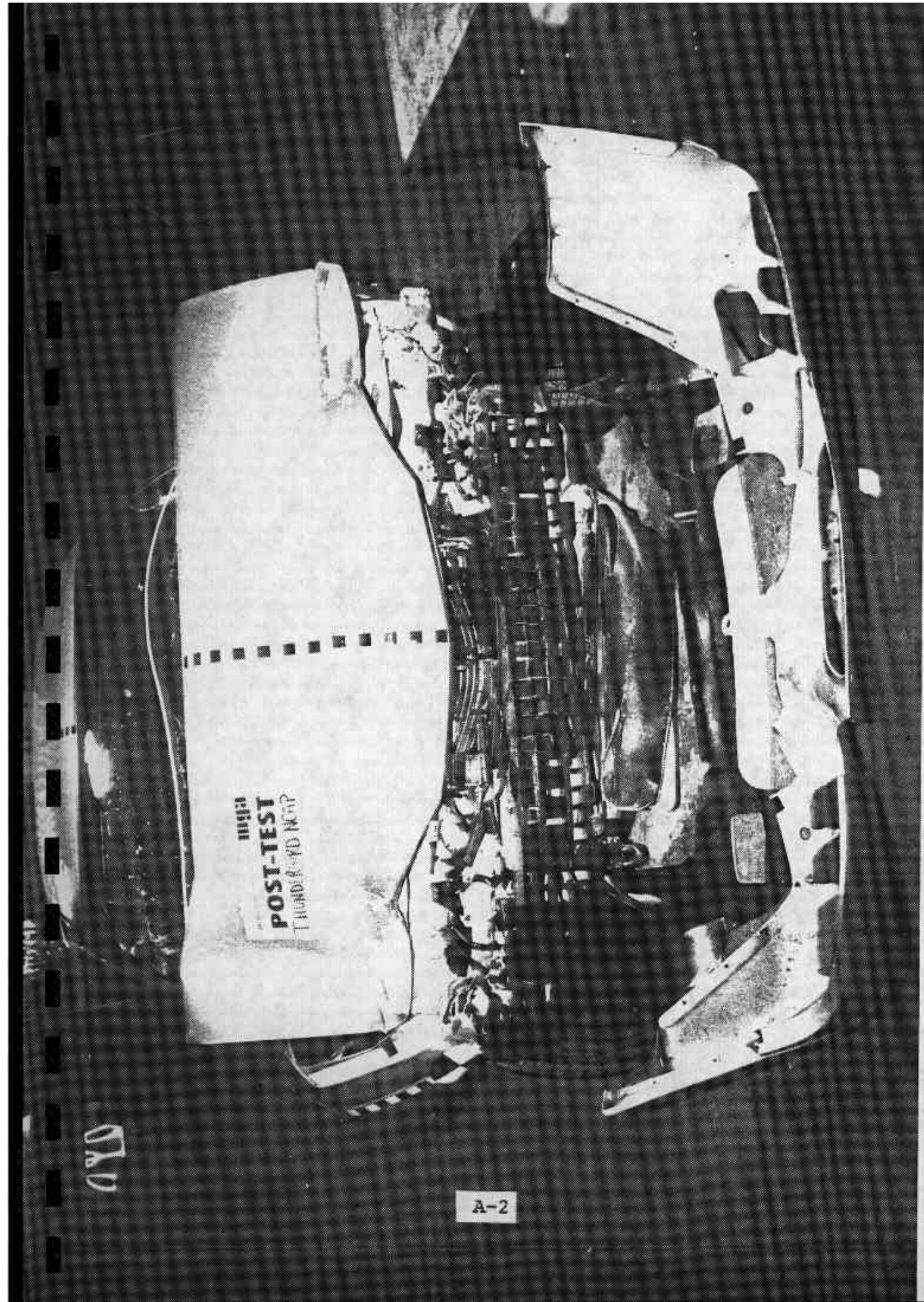
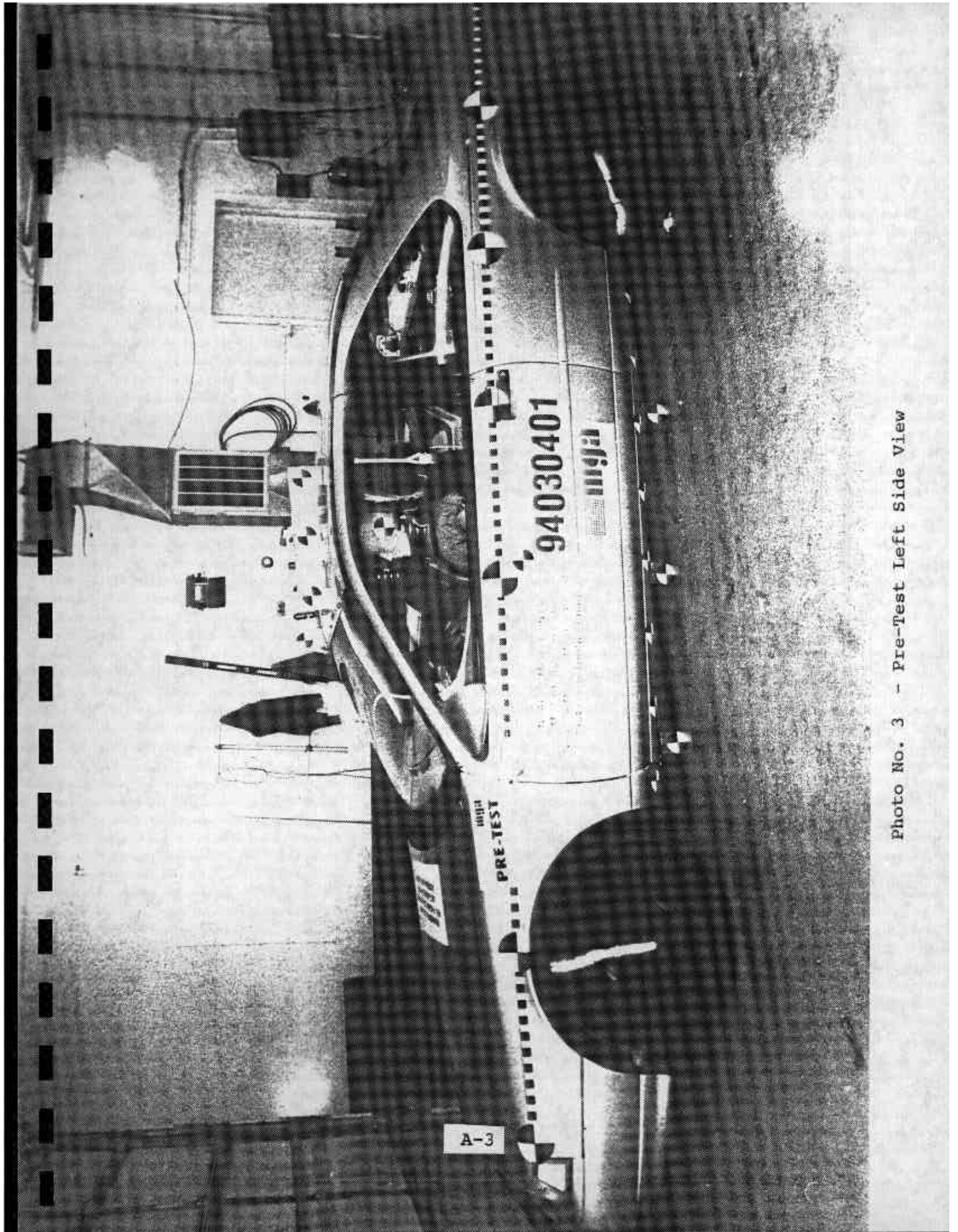

Photo No. 2 - Post-Test Front View

A-2



A-3

Photo No. 3 - Pre-Test Left Side View

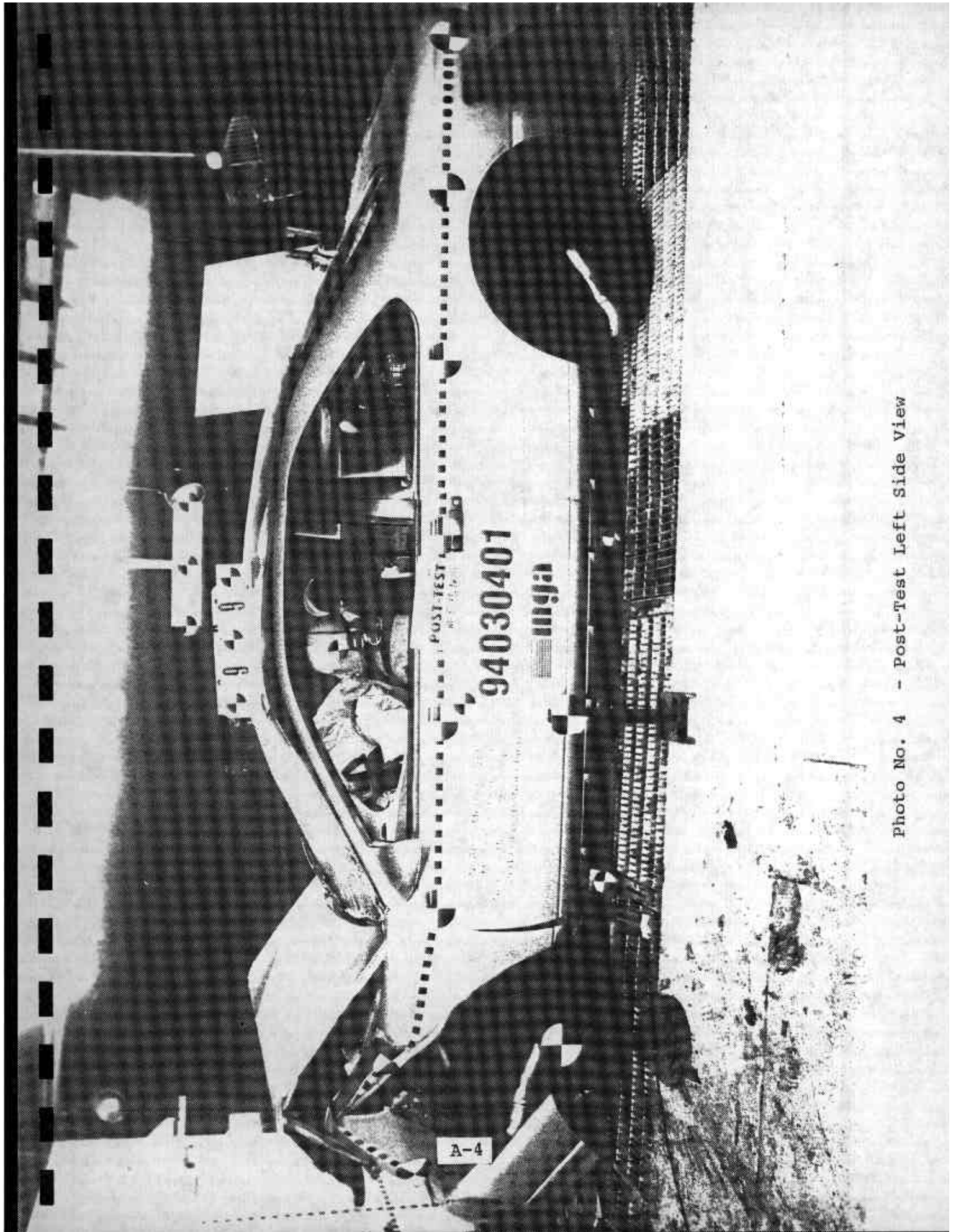

Photo No. 4 - Post-Test Left Side View

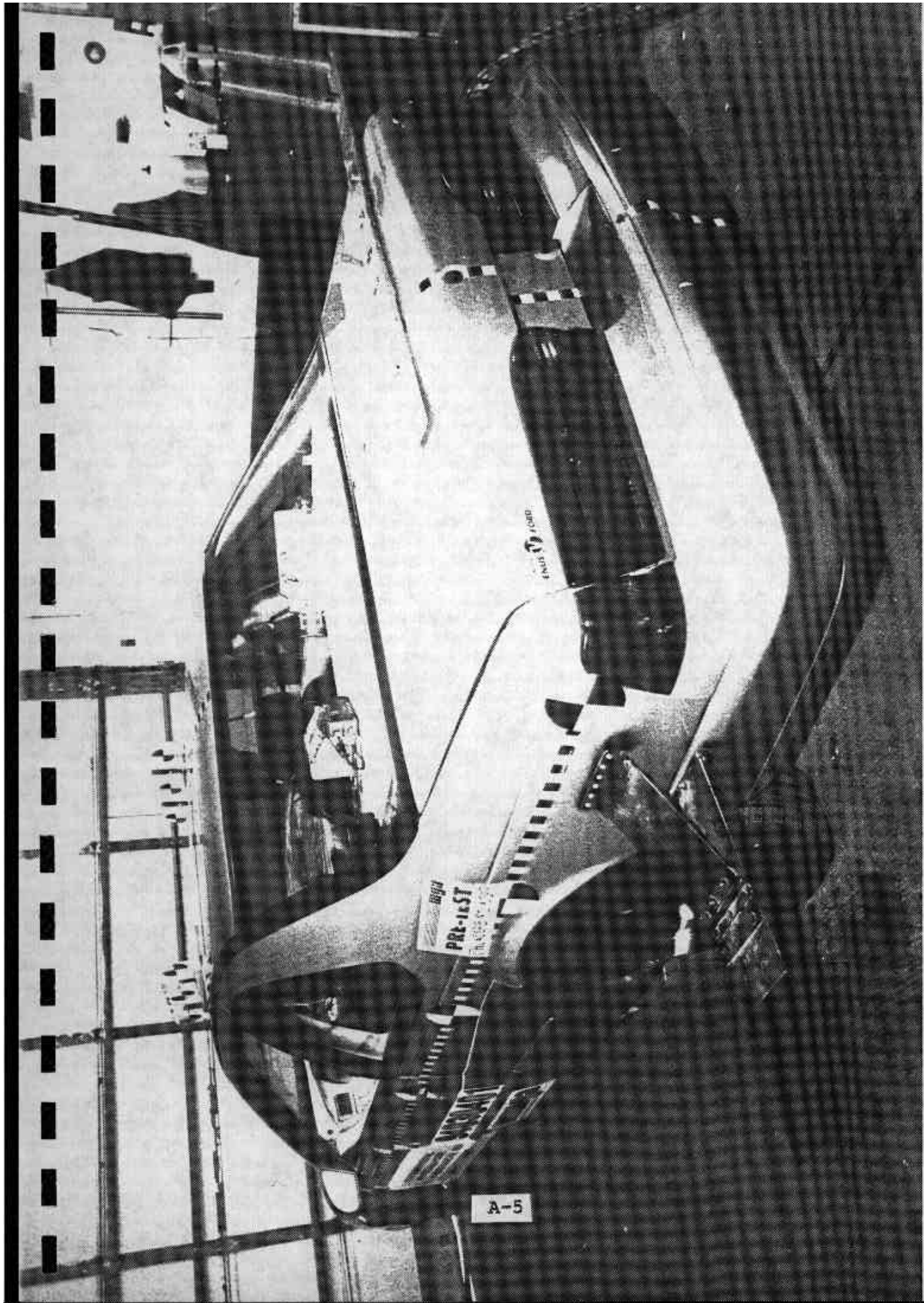

Photo No. 5 - Pre-Test Left Rear Three-Quarter View

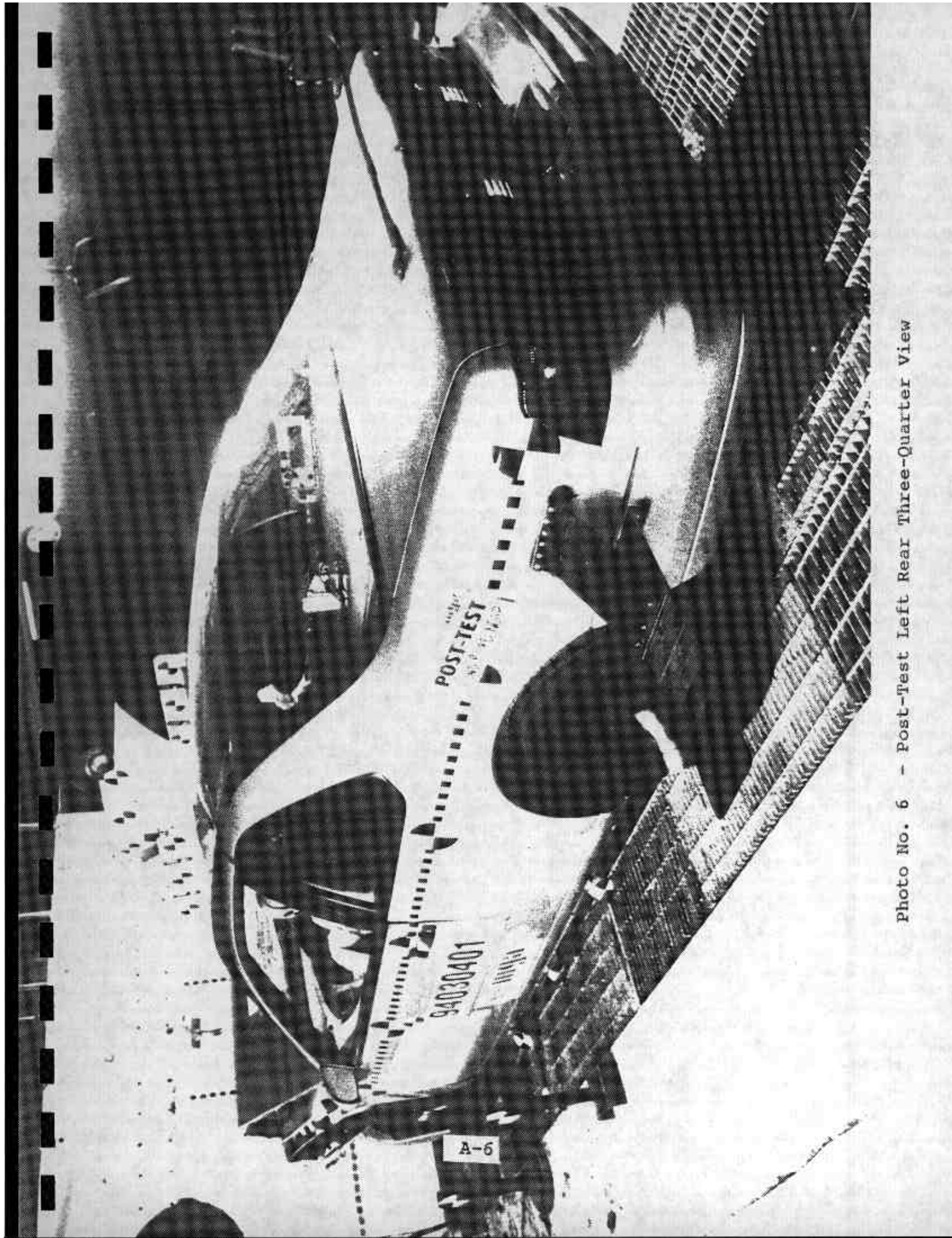
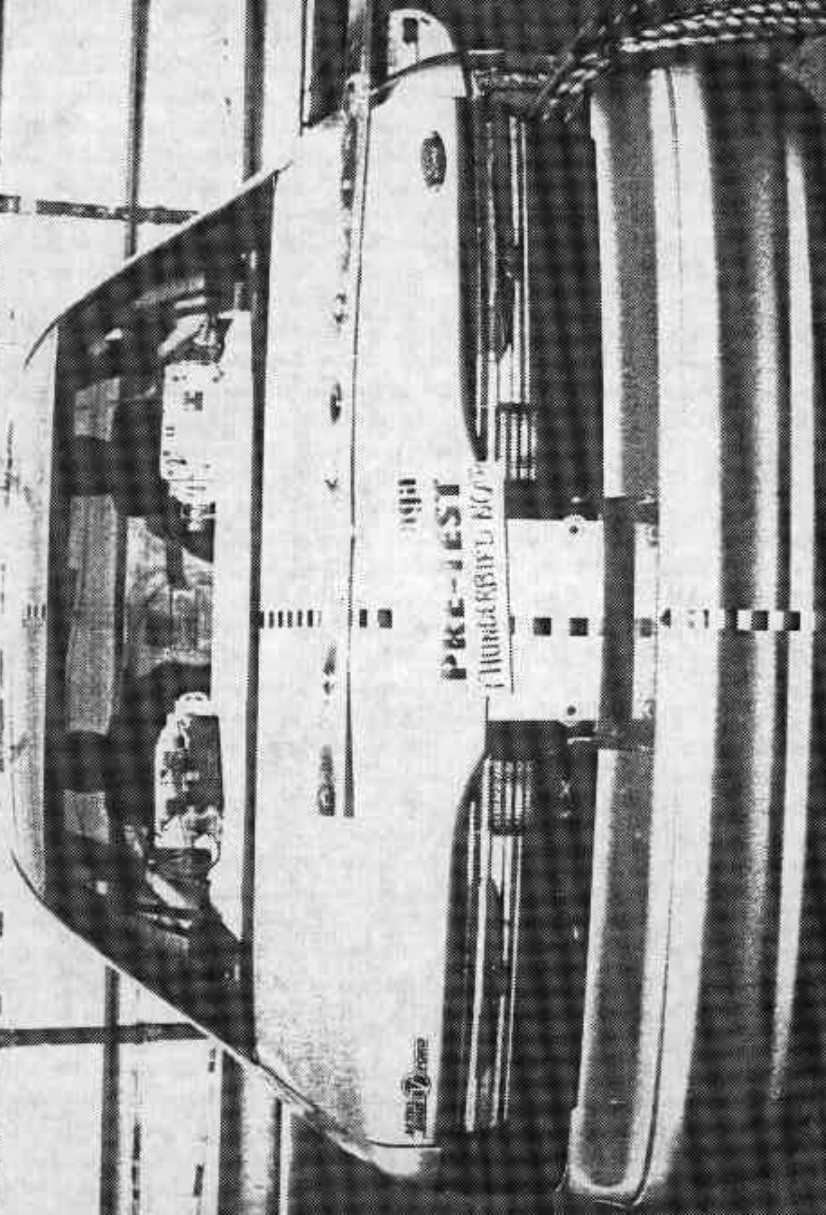
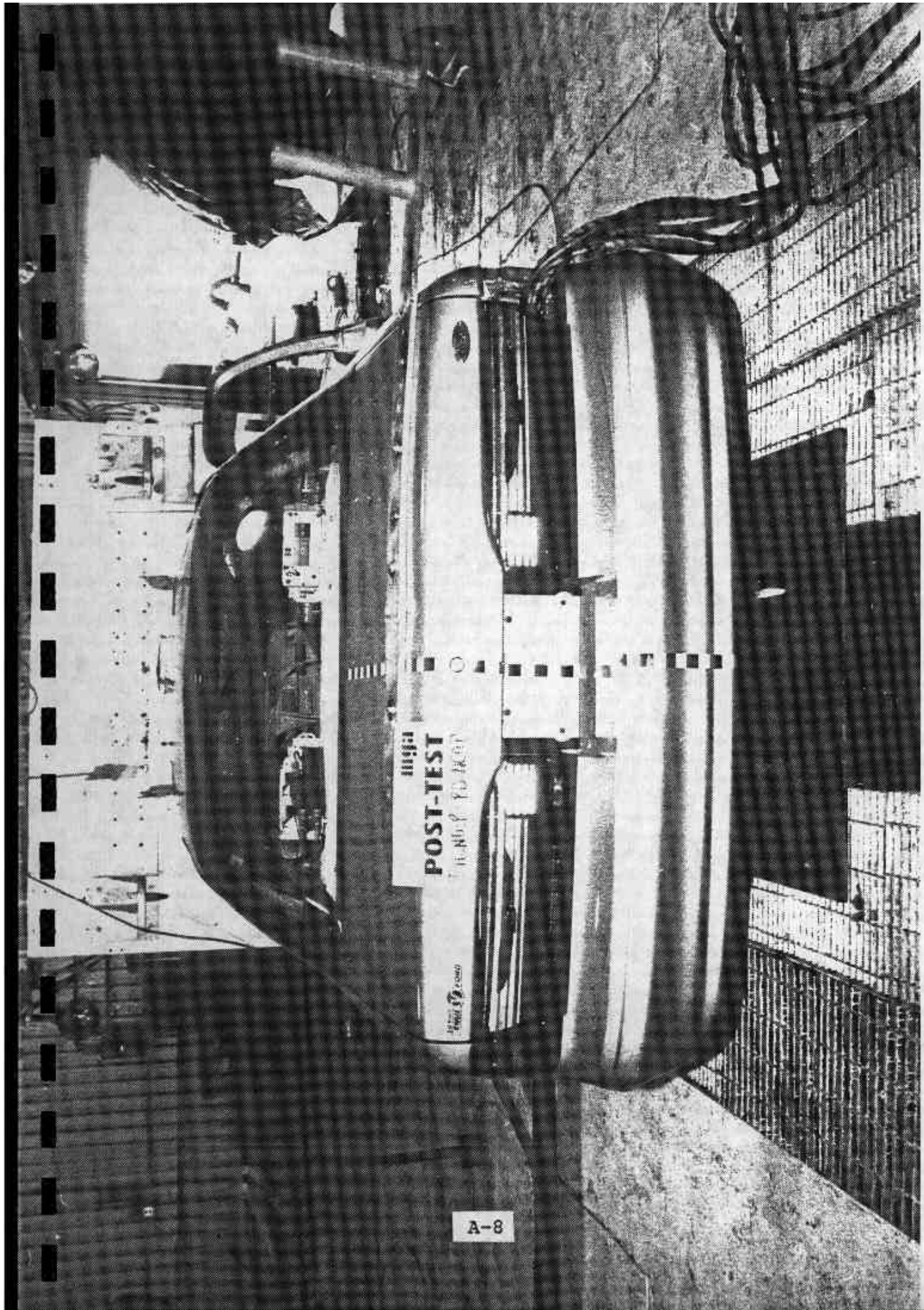

Photo No. 6 - Post-Test Left Rear Three-Quarter View



A-7

Photo No. 7 - Pre-Test Rear View



A-8

Photo No. 8 - Post-Test Rear View

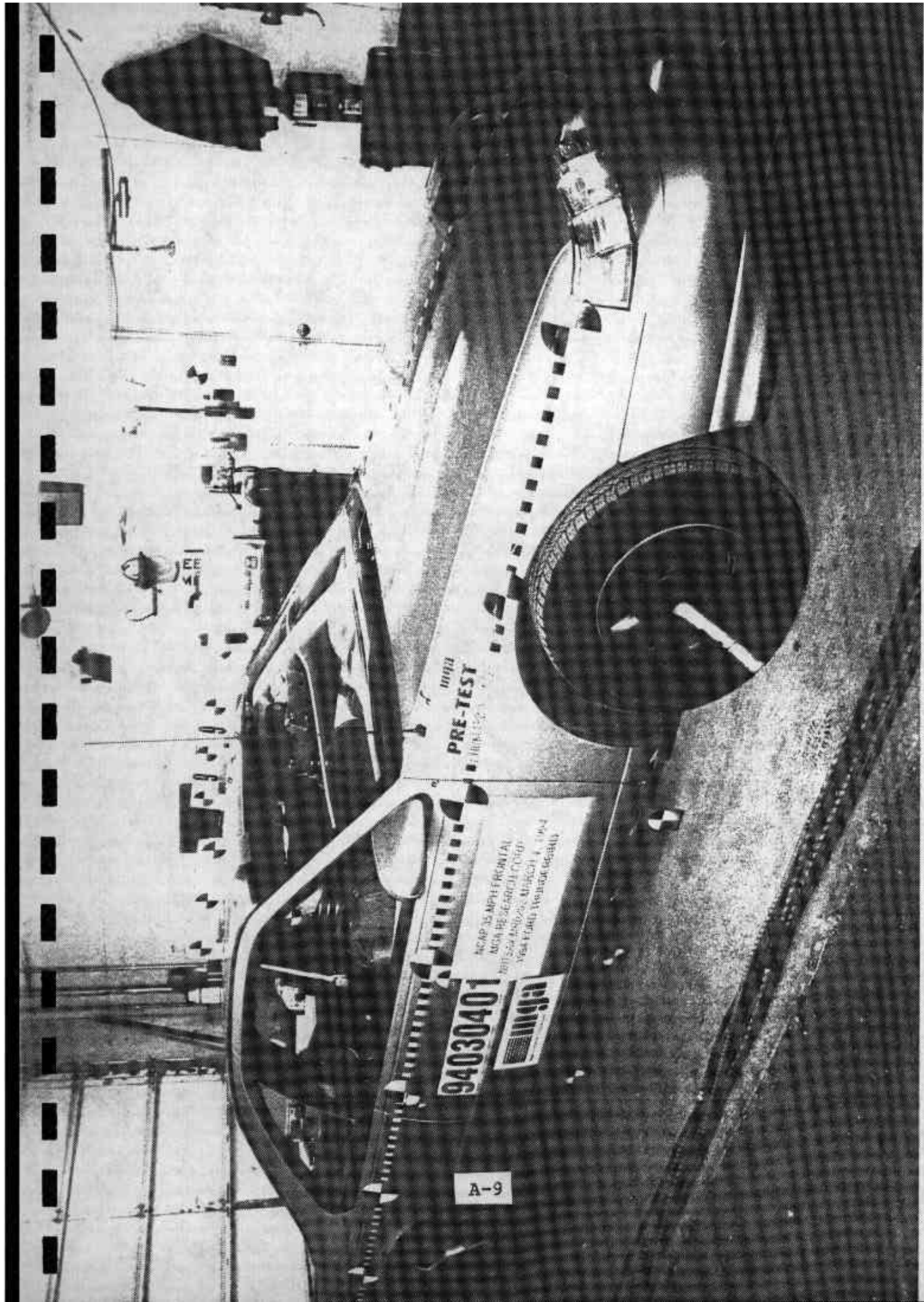

Photo No. 9 - Pre-Test Right Side View

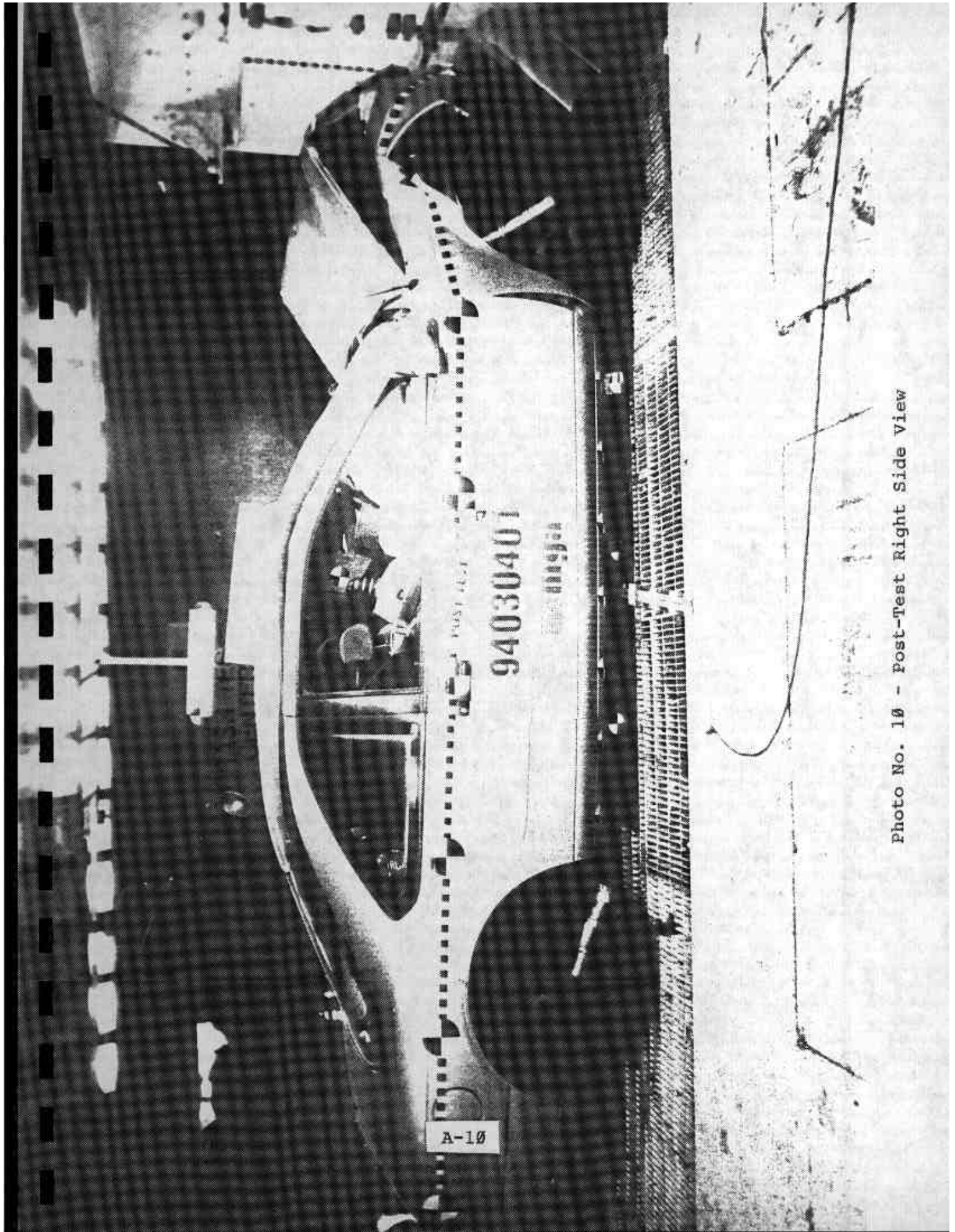
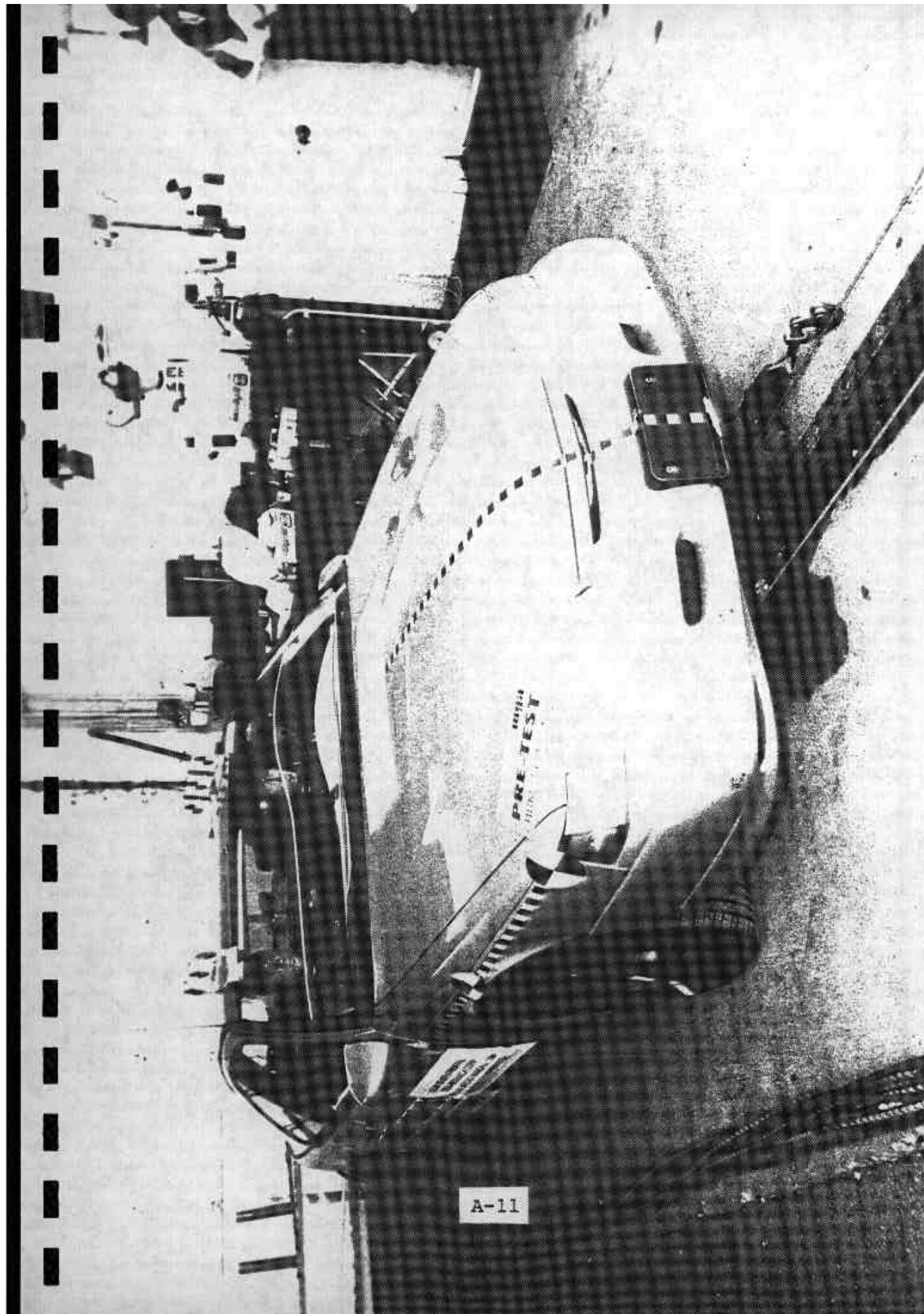
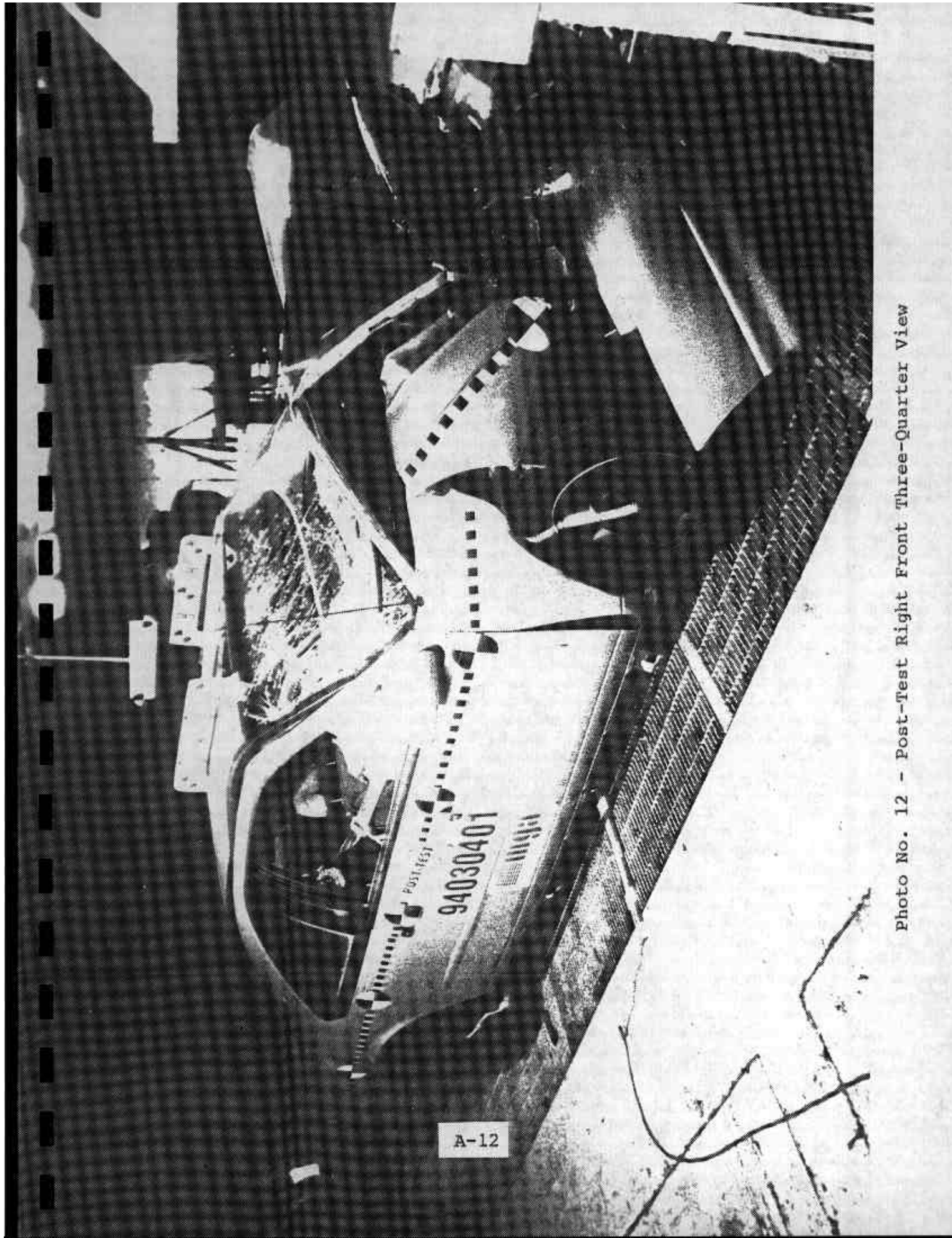

Photo No. 10 - Post-Test Right Side View



A-11

Photo No. 11 - Pre-Test Right Front Three-Quarter View



A-12

Photo No. 12 - Post-Test Right Front Three-Quarter View



Photo No. 13 - Pre-Test Engine Compartment View

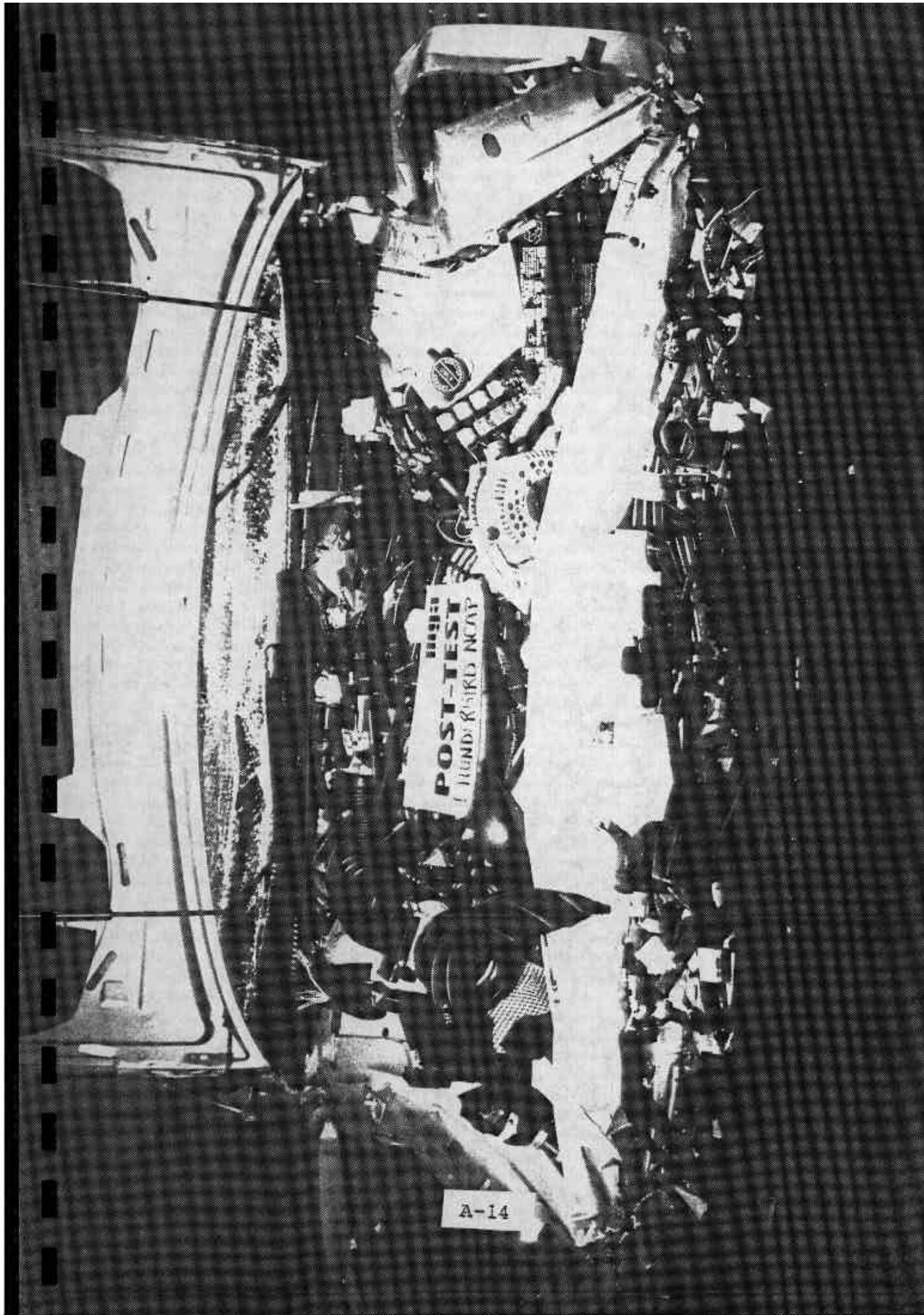

Photo No. 14 - Post-Test Engine Compartment View

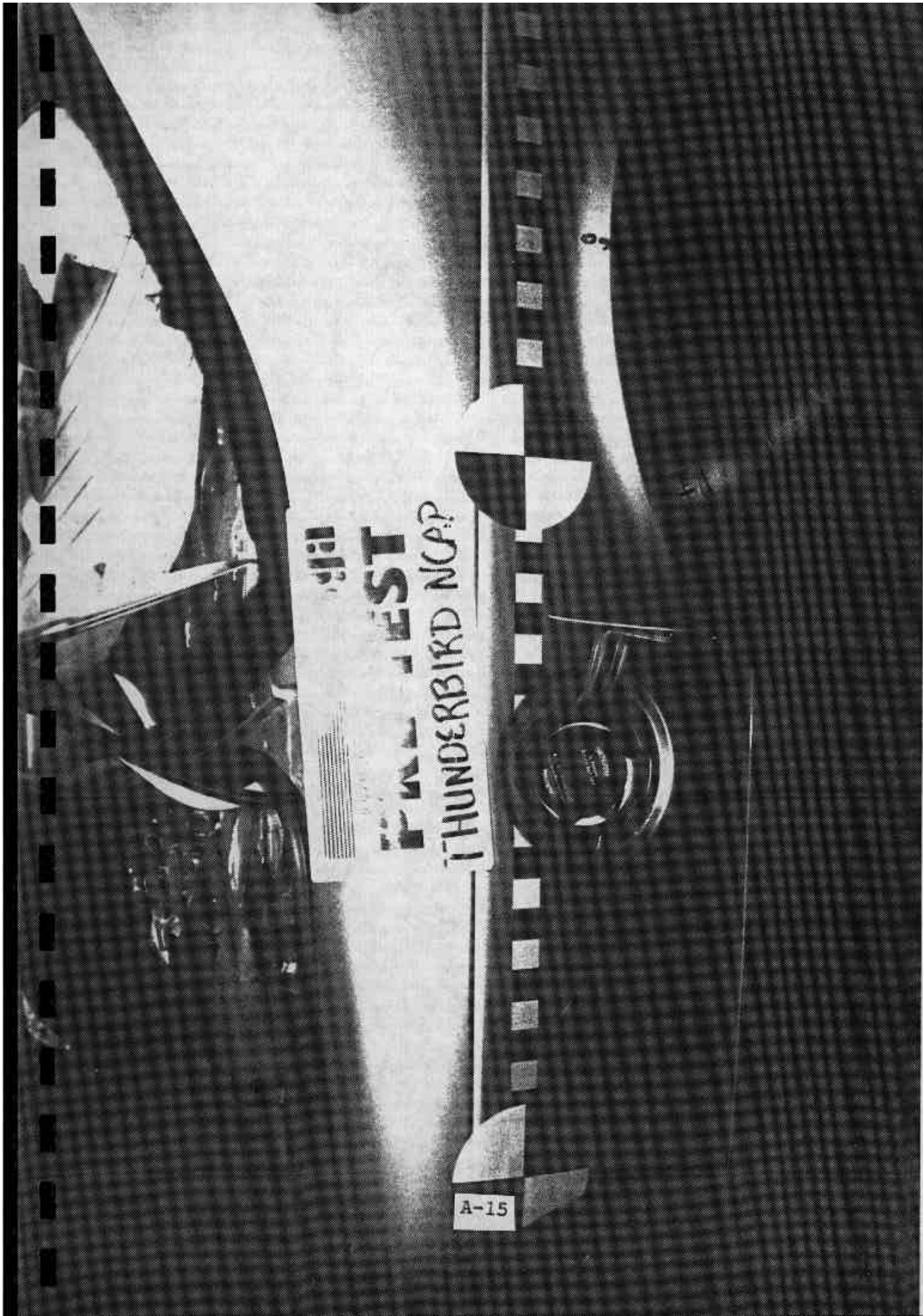

Photo No. 15 - Pre-Test Fuel Filler Cap View

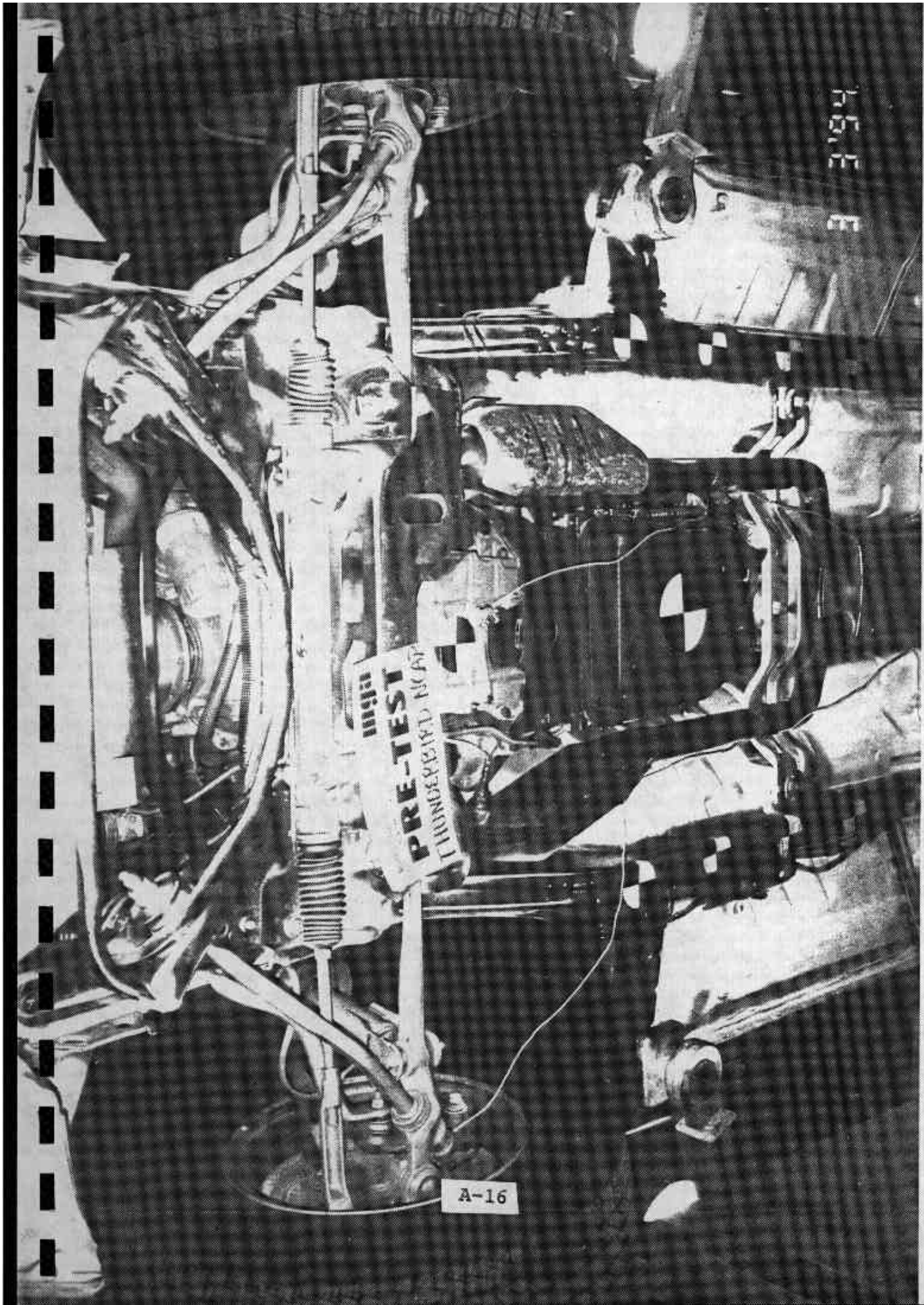

Photo No. 16 - Pre-Test Front Underbody View

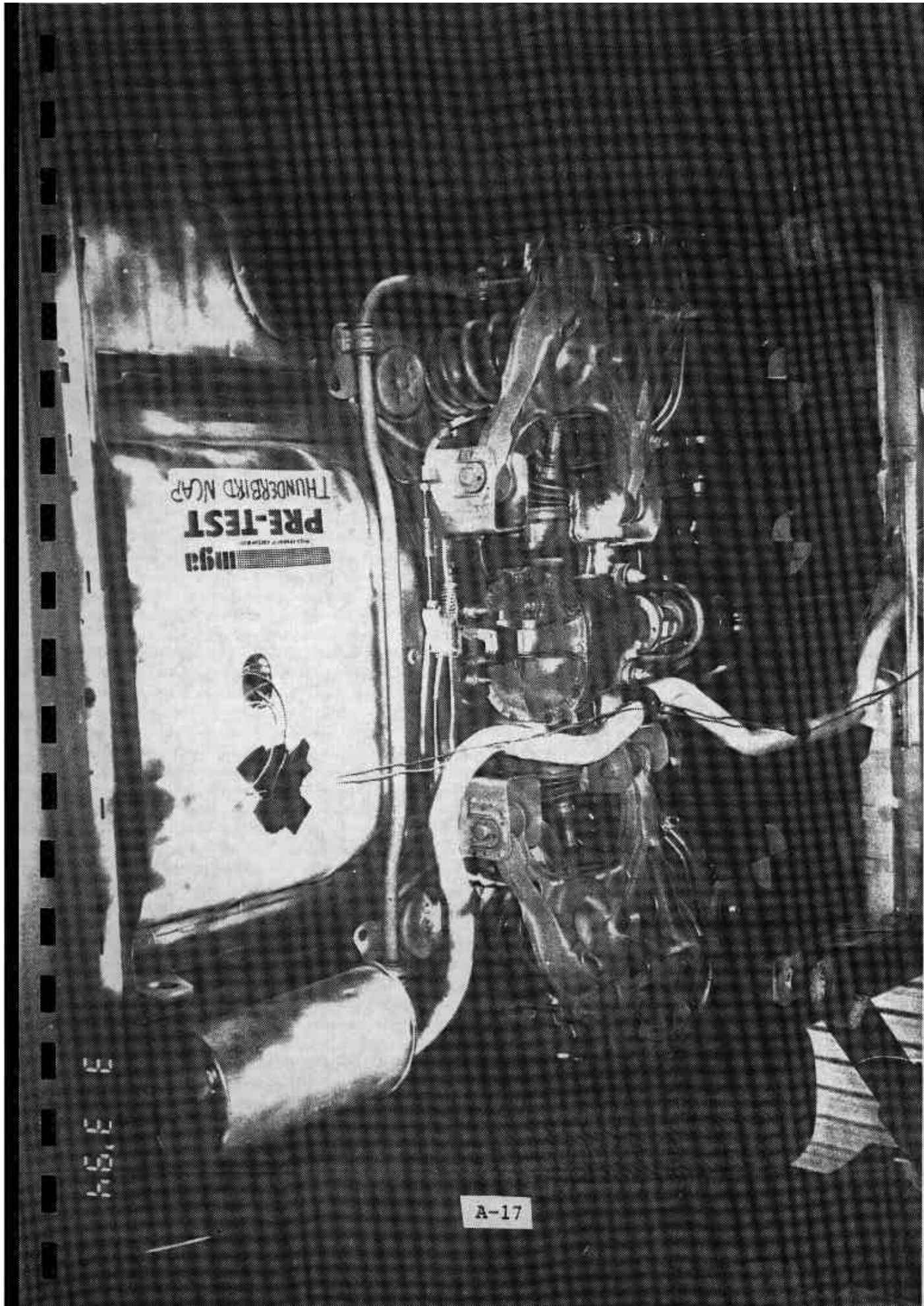
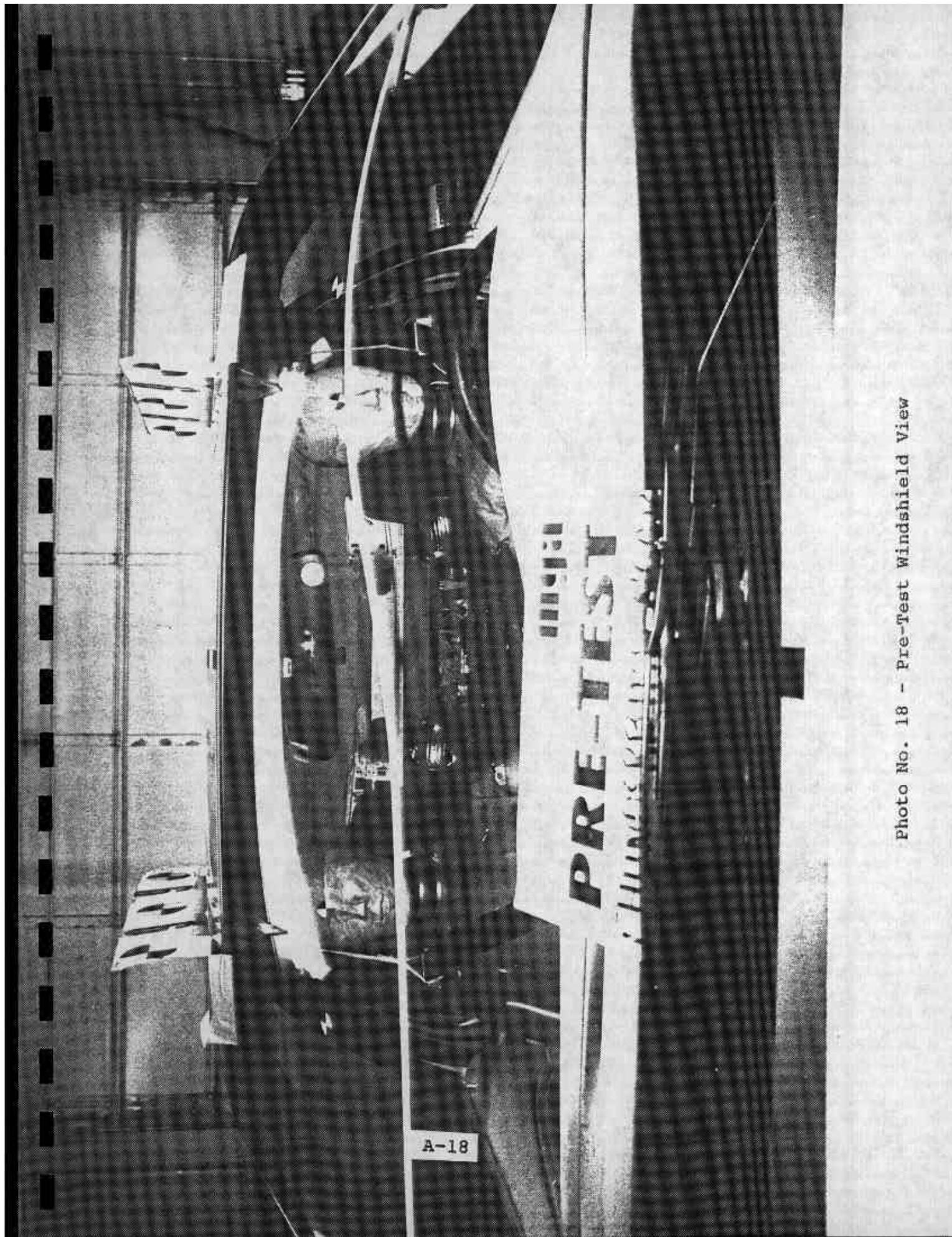

Photo No. 17 - Pre-Test Rear Underbody View



A-18

Photo No. 18 - Pre-Test Windshield View



A-19

Photo No. 19 - Post-Test Windshield View

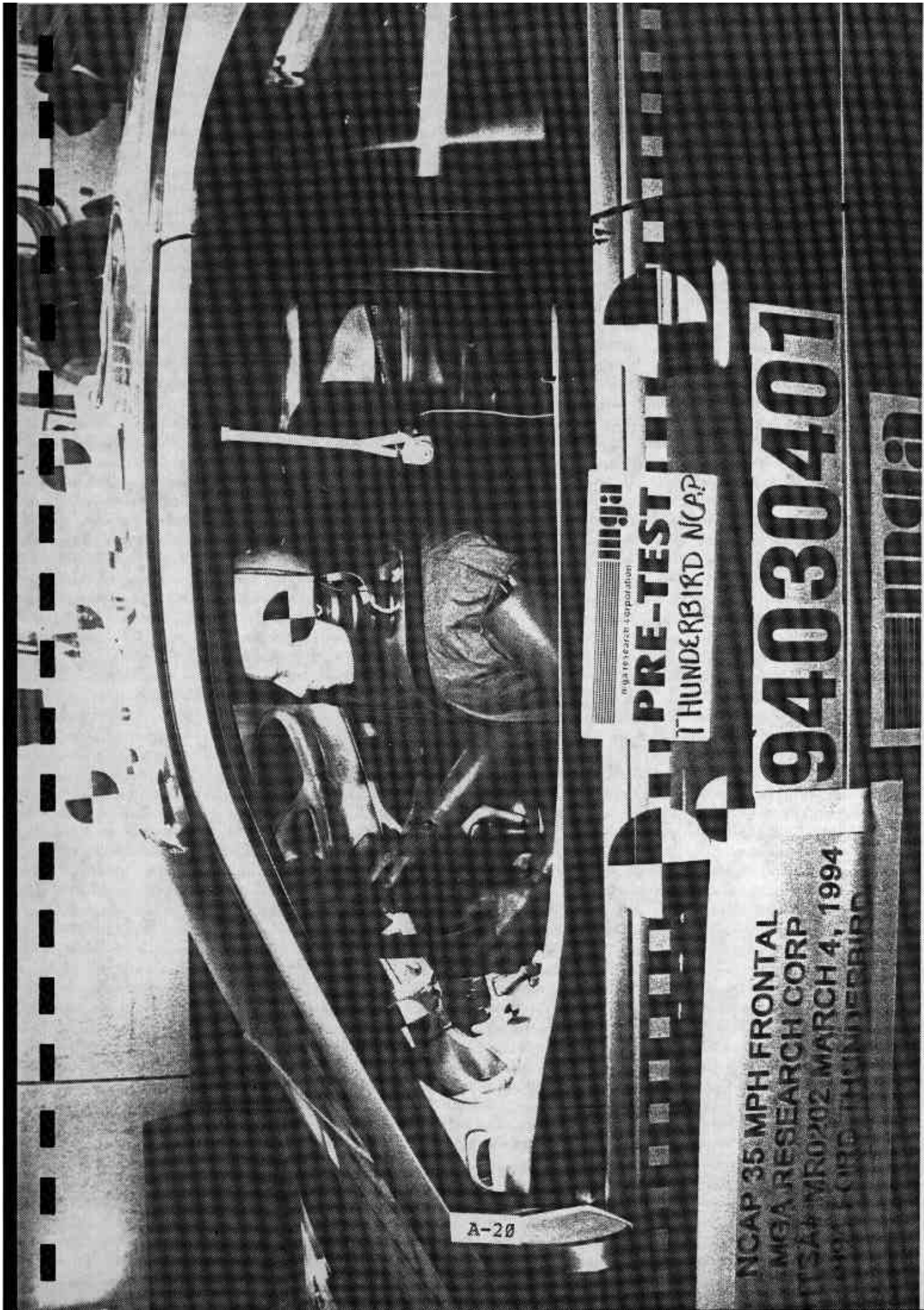

NCAP 35 MPH FRONTAL
MGA RESEARCH CORP
TEST # MR0202 MARCH 4, 1994
FORD THUNDERBIRD

 **PRE-TEST**
THUNDERBIRD NCAP

94030401

Photo No. 20 - Pre-Test Driver Dummy Position View



A-21



POST-TEST
THUNDERBIRD NCAP

NCAP 35 MPH FRONTAL
MGA RESEARCH CORP
NEWS# MR0202 MARCH 4, 1994
1994 FORD THUNDERBIRD

94030401



Photo No. 21 - Post-Test Driver Dummy Position View

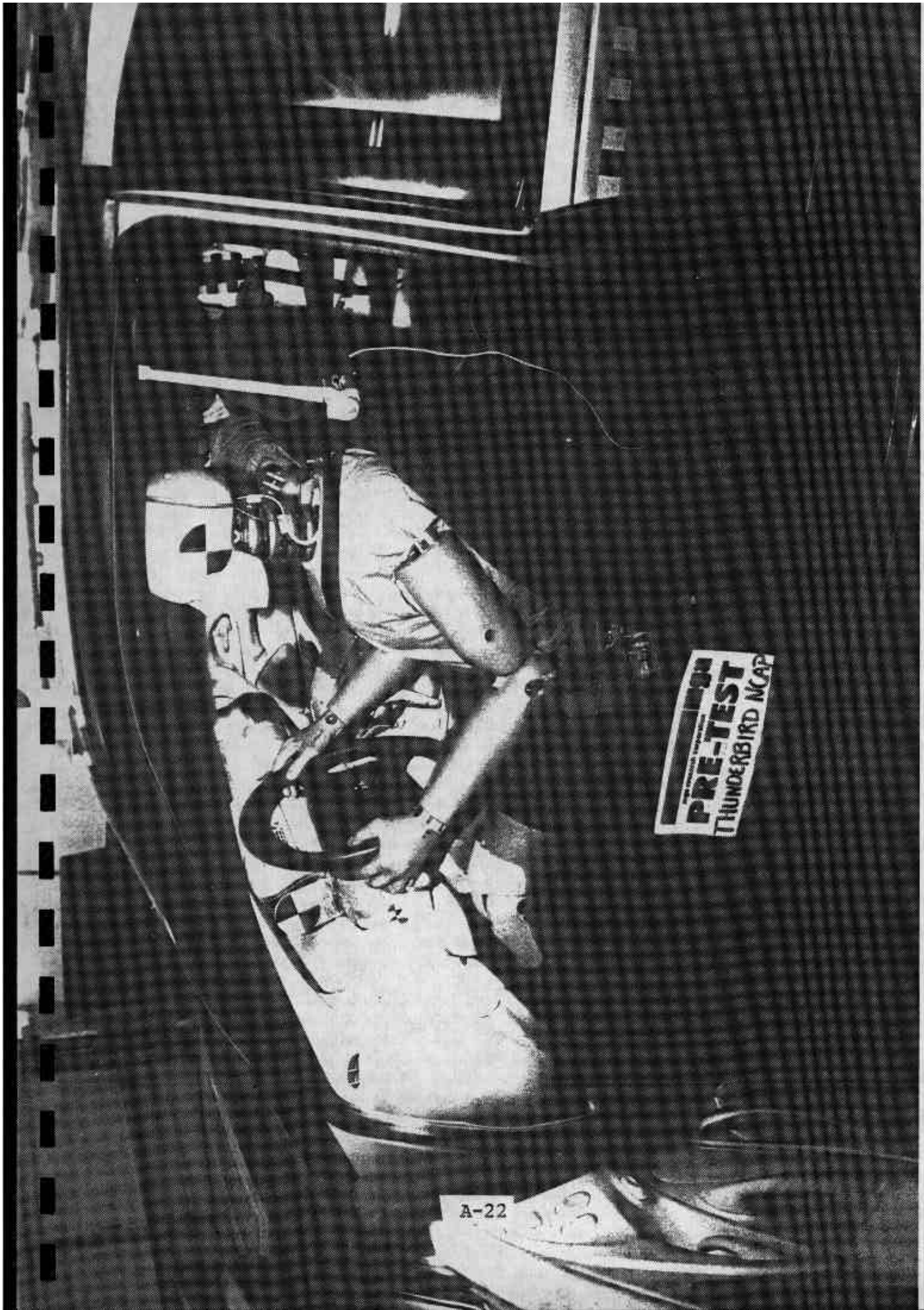
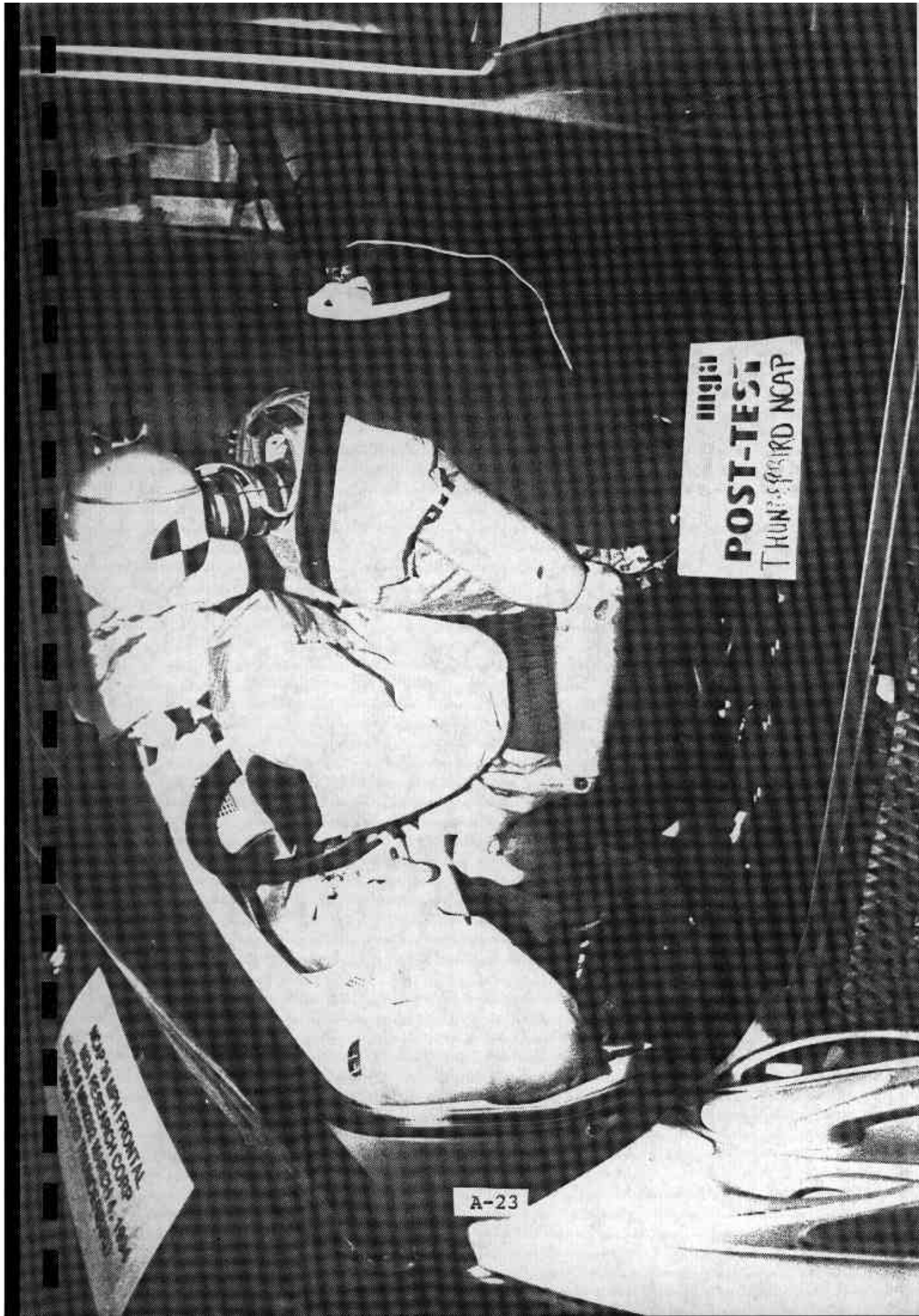

Photo No. 22 - Pre-Test Driver Dummy Position View (Door Open)



FOR FRONTAL
IMPACT TESTS
SEE NCAP
TEST PROCEDURE

POST-TEST
THUNDERBOLT NCAP

A-23

Photo No. 23 - Post-Test Driver Dummy Position View (Door Open)



A-24

Photo No. 24 - Post-Test Driver Dummy and Steering Column View

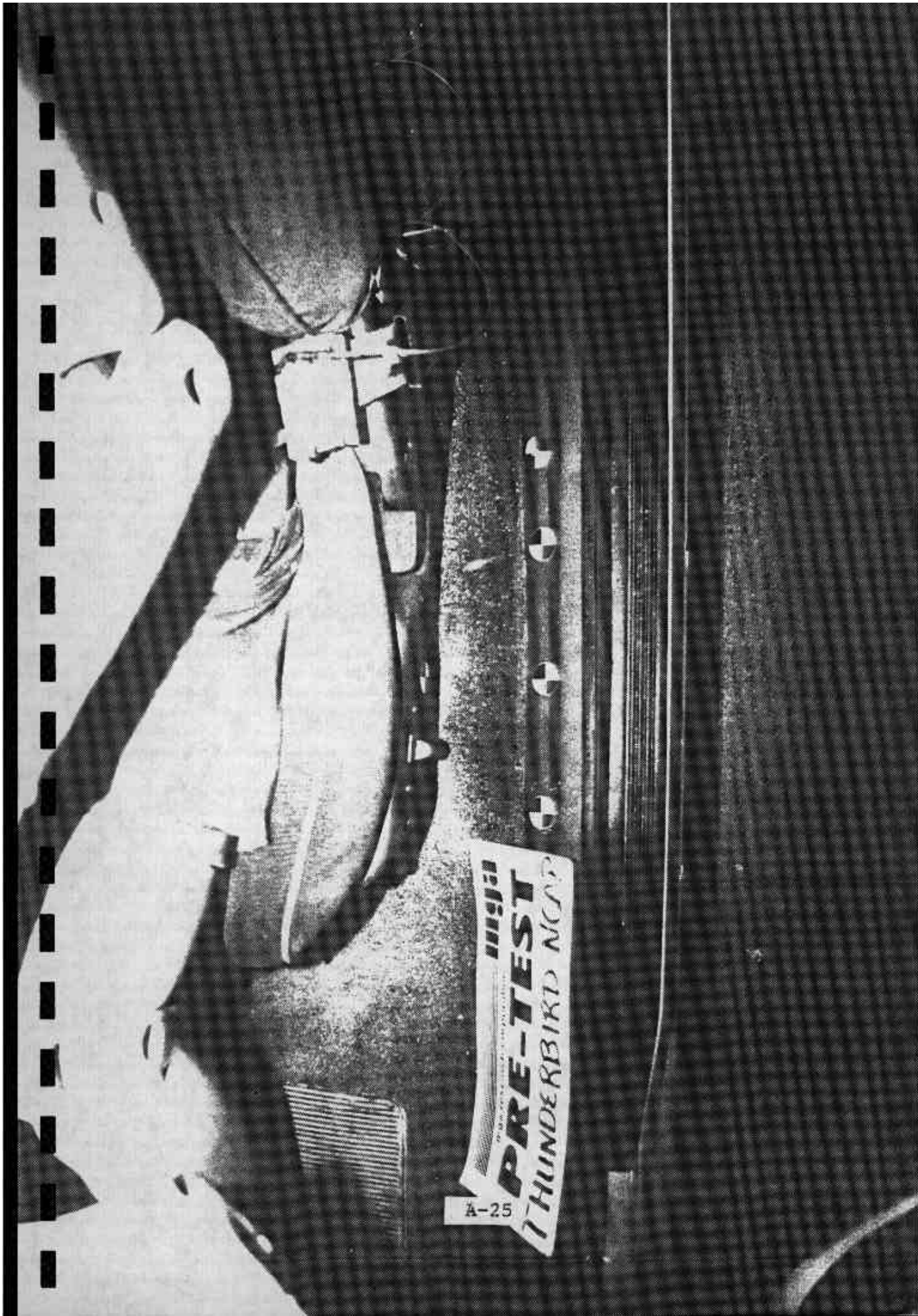

Photo No. 25 - Pre-Test Driver Seat Position View



ipbmi
POST-TEST
UNDERWARD NCAP

A-26

Photo No. 26 - Post-Test Driver Seat Position View



A-27

Photo No. 27 - Post-Test Driver Knee Position View

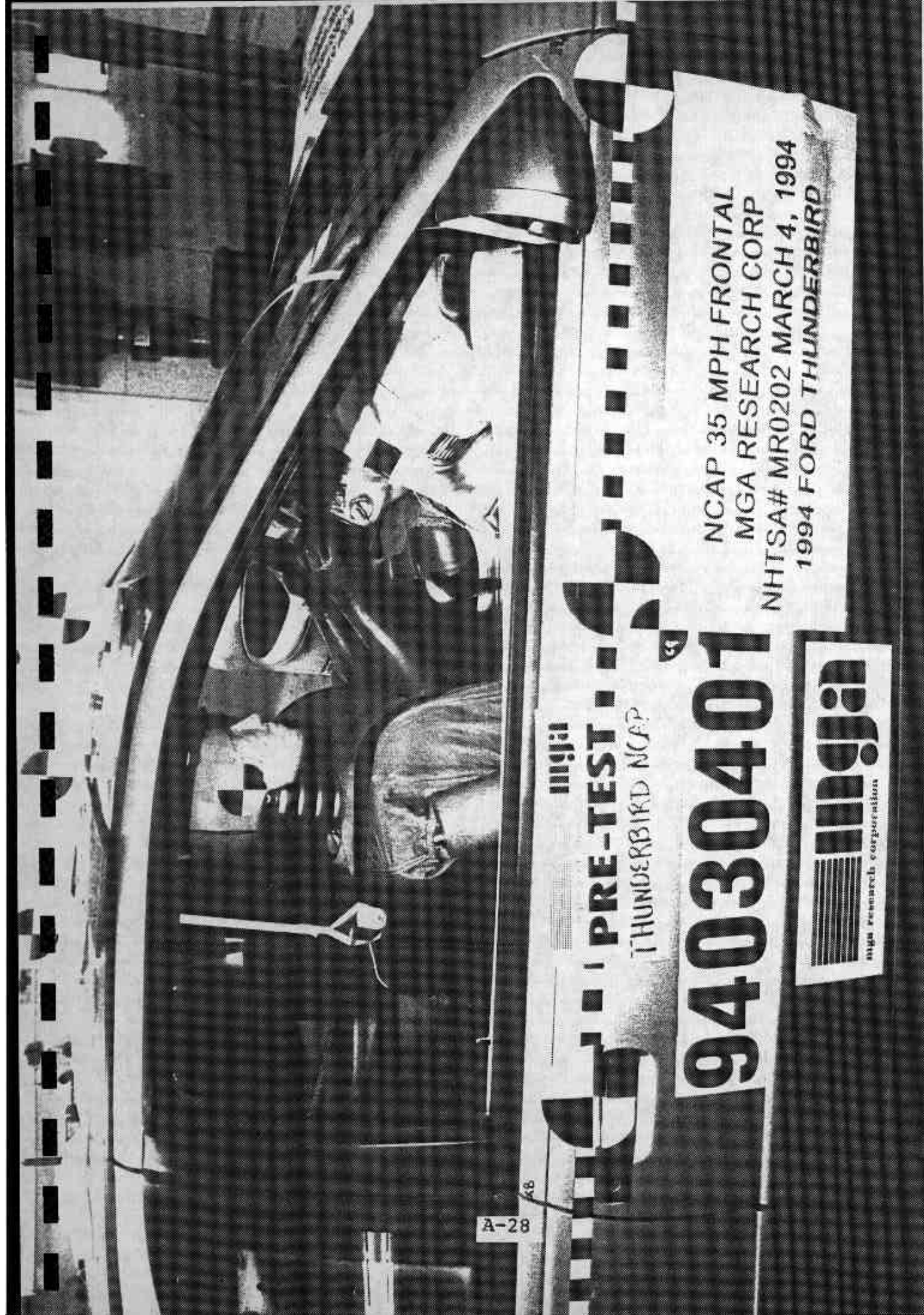

NCA 35 MPH FRONTAL
MGA RESEARCH CORP
NHTSA# MR0202 MARCH 4, 1994
1994 FORD THUNDERBIRD

mga

PRE-TEST
THUNDERBIRD NCA

94030401



A-28

Photo No. 28 - Pre-Test Passenger Dummy Position View



A-29

ingja
POST-TEST
THUNDERBIRD NCAP

94030401

NCAP 35 MPH FRONTAL
MGA RESEARCH CORP.
NHTSA# MR0202 MARCH 1991

Photo No. 29 - Post-Test Passenger Dummy Position View

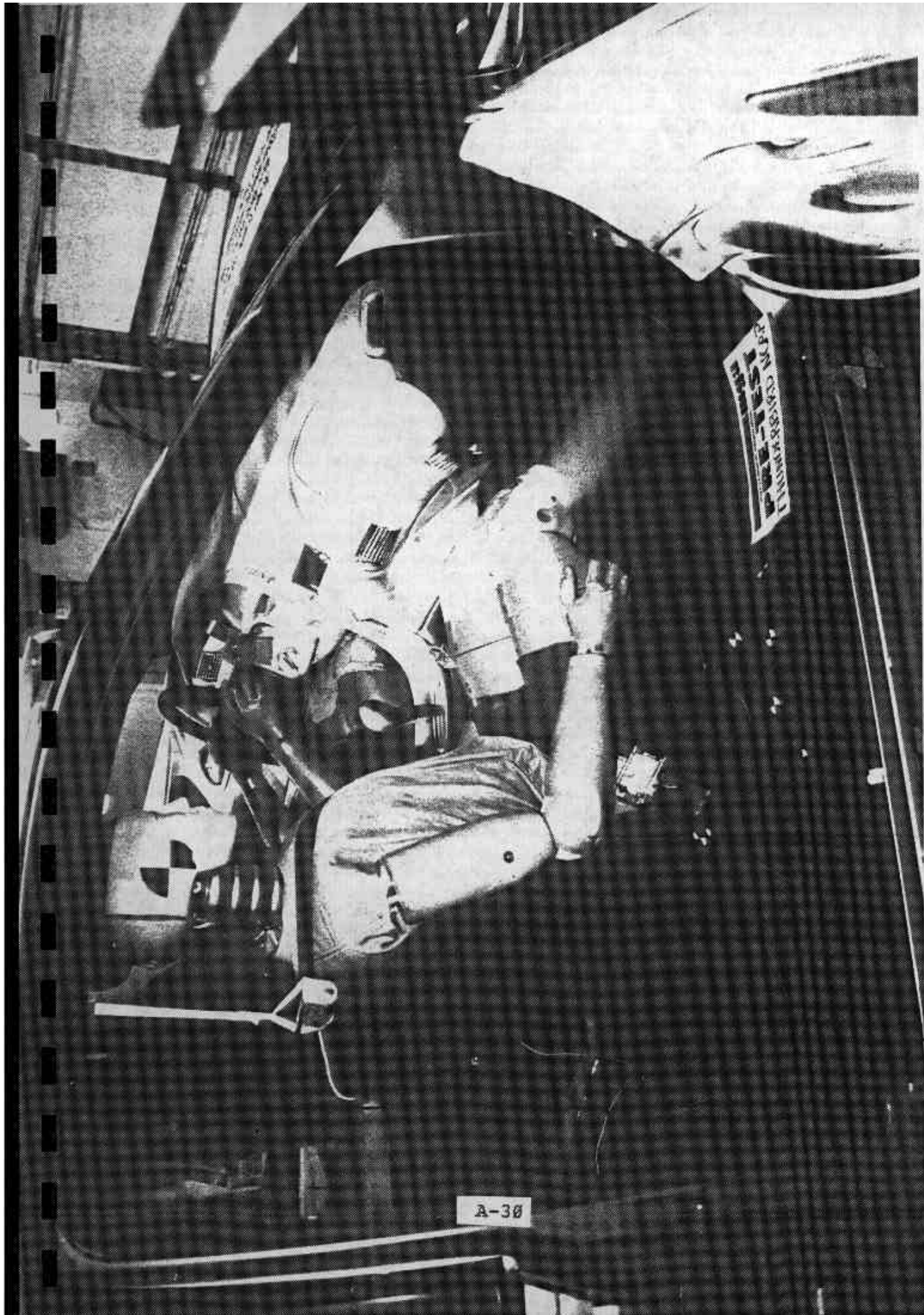

Photo No. 30 - Pre-Test Passenger Dummy Position View (Door Open)

A-30



REAR VIEW OF DUMMY
IN SEAT POSITION
P. 100

POST-TEST
THUNDERBIRD NCAT

A-31

Photo No. 31 - Post-Test Passenger Dummy Position View
(Door Open)

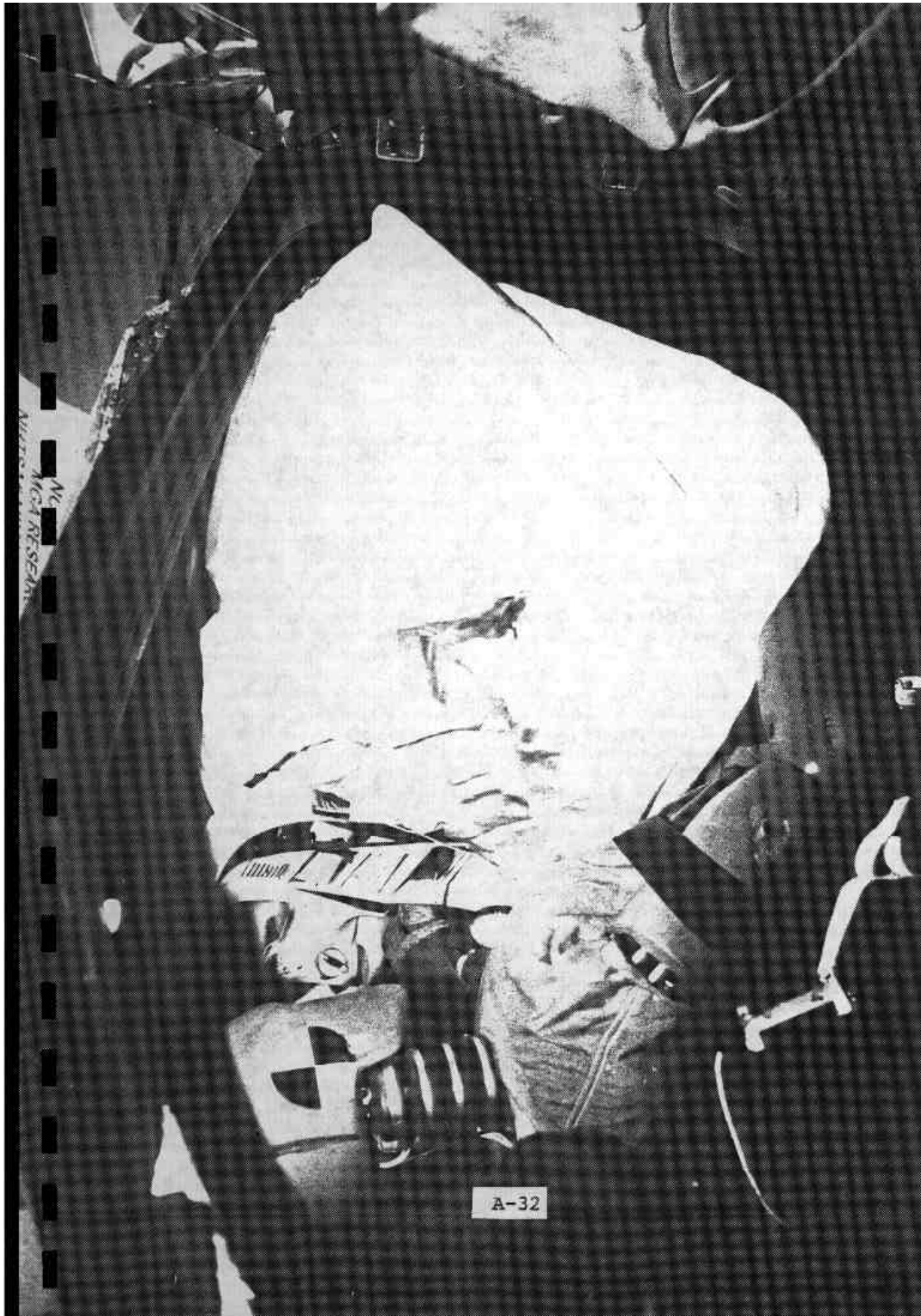

Photo No. 32 - Post-Test Passenger Dummy Airbag Contact



Photo No. 33 - Post-Test Passenger Dash



Photo No. 34 - Pre-Test Passenger Seat Position View



ingja

A-35

POST-TEST

THUNDERBIRD NCAP

Photo No. 35 - Post-Test Passenger Seat Position View

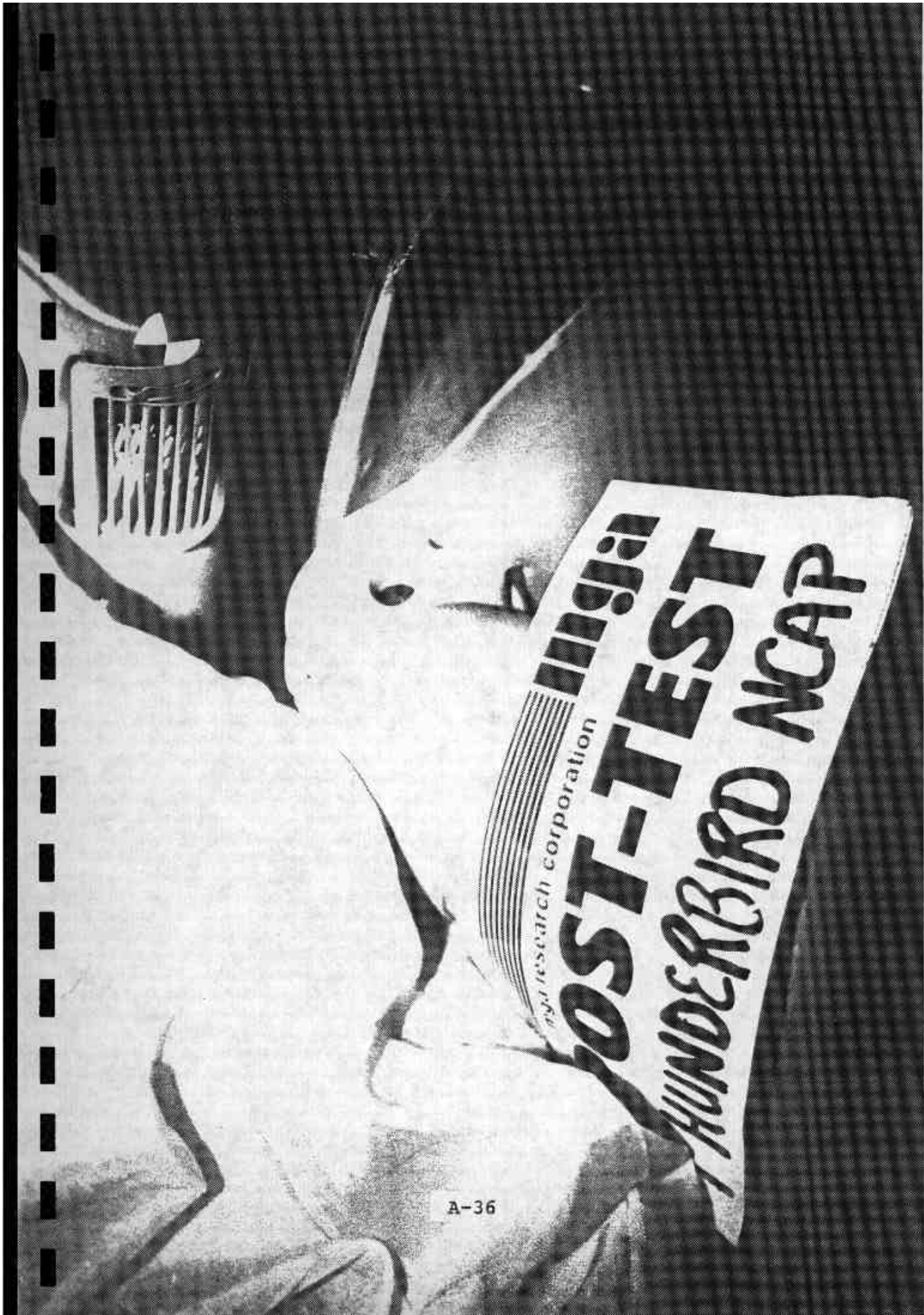

A-36

Photo No. 36 - Post-Test Passenger Knee Position View

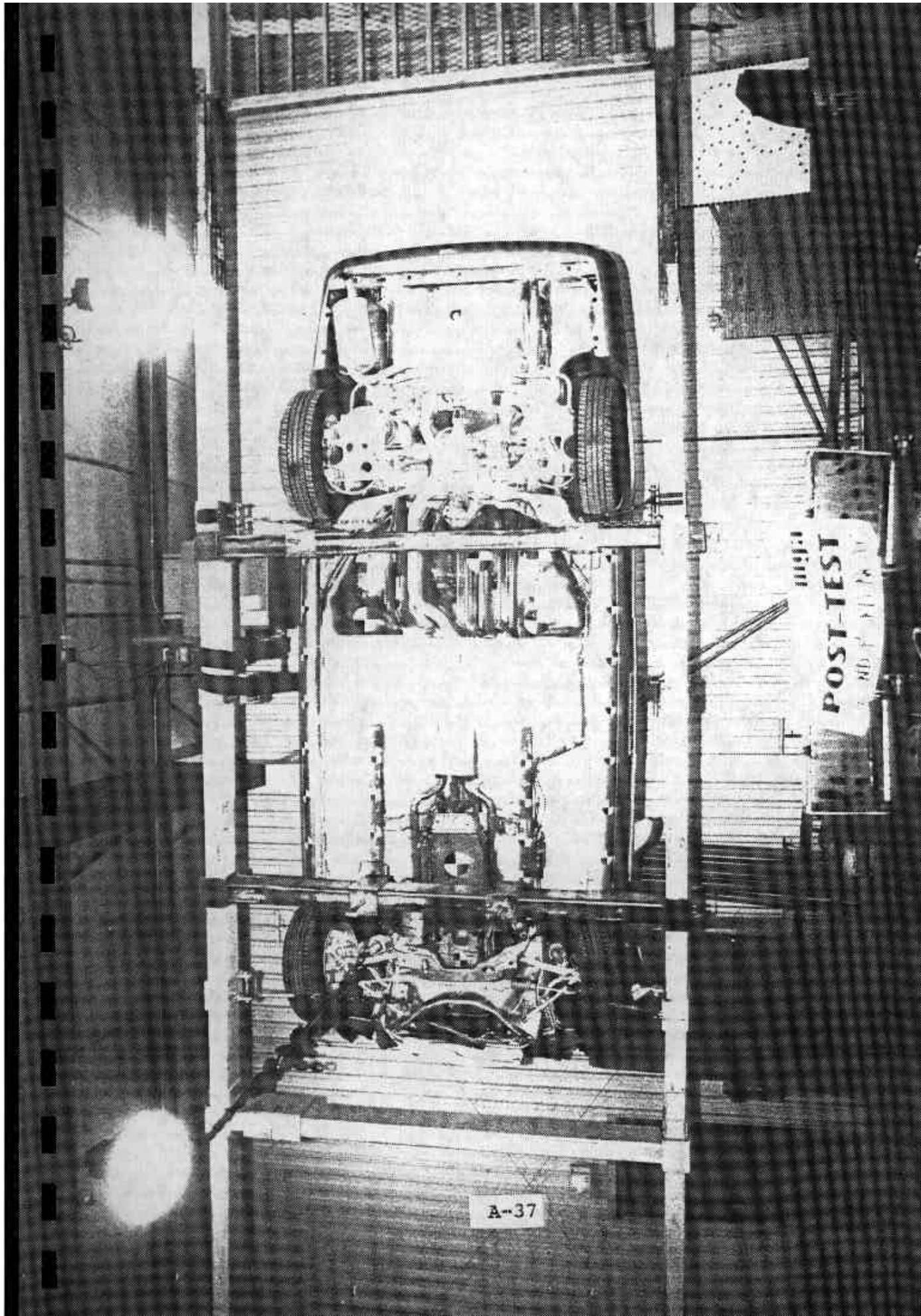

Photo No. 37 - Rollover 90°

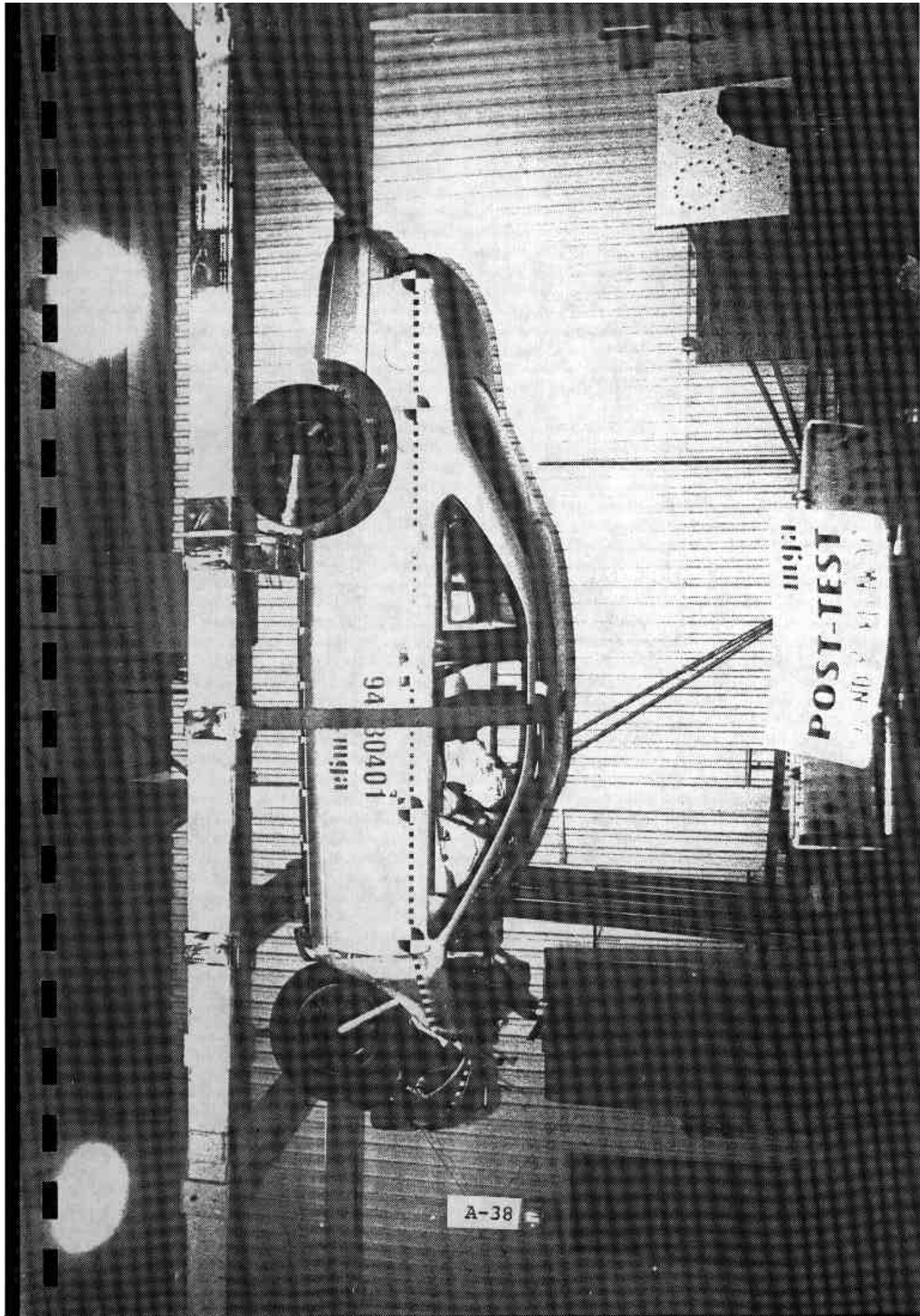
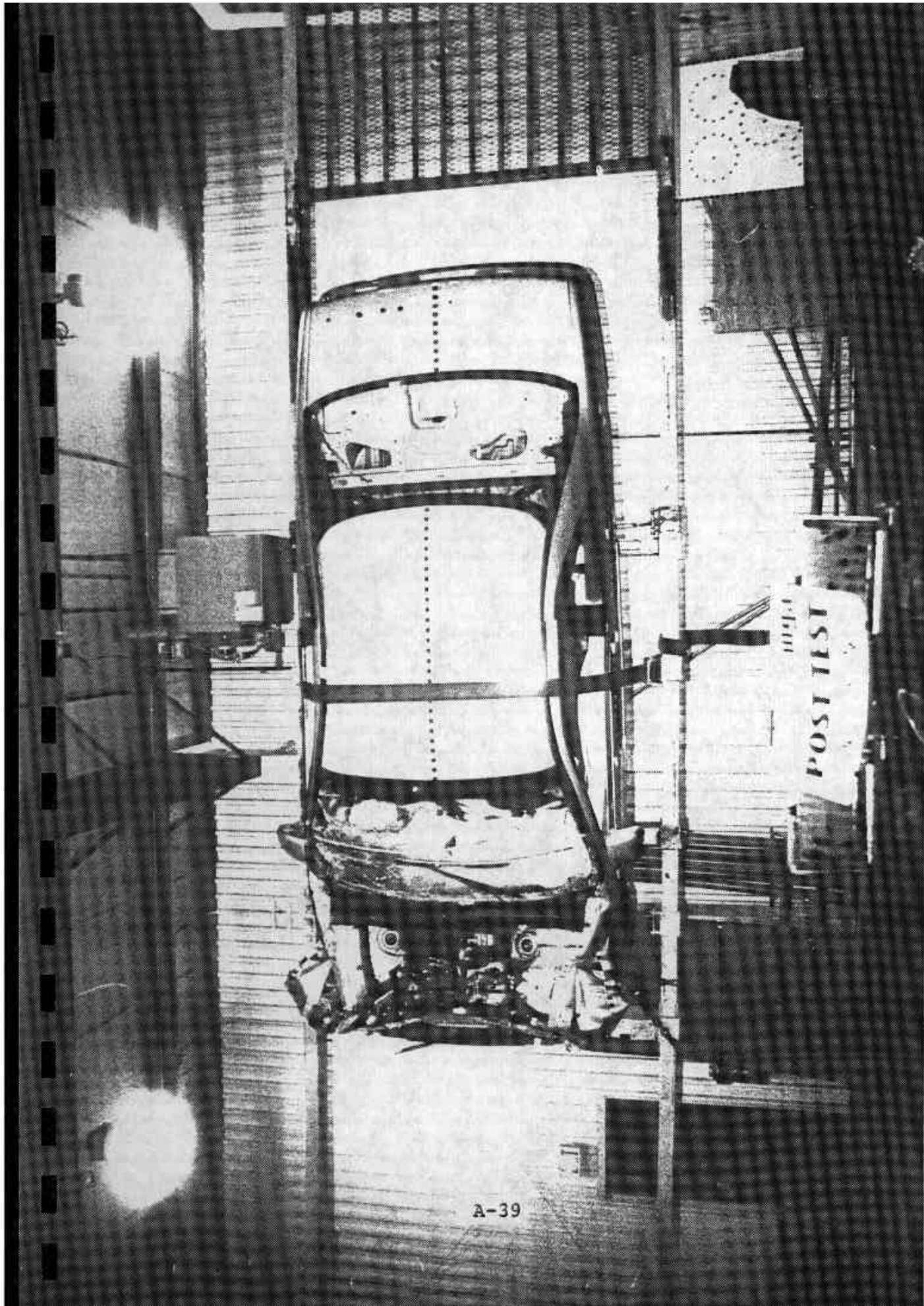

Photo No. 38 - Rollover 180°



A-39

Photo No. 39 - Rollover 270°

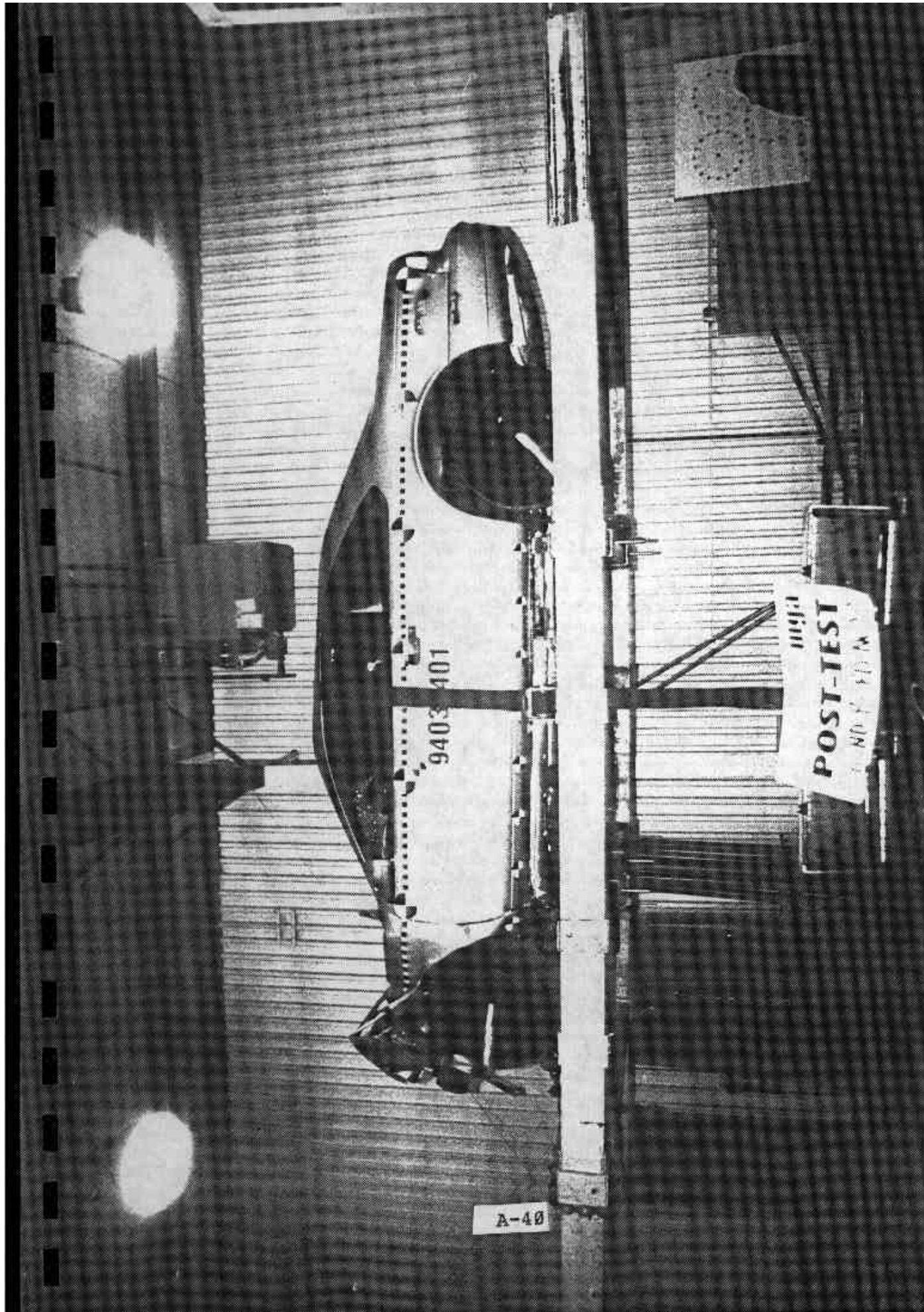

Photo No. 40 - Rollover 360°

DCI
START STOP RESET
DJR

DCI
START STOP RESET
DJR

POST-TIES
THUNDERBIRD NCAP

A-41

Photo No. 41 - Speed Trap Time

APPENDIX B

Vehicle, Load Cell Barrier and Dummy Response Data

1994 FORD THUNDERBIRD 2-DOOR

NHTSA NO.: MR0202

VEHICLE DATA

FILTER CHANNEL CLASS

Head Accelerations	1000	(1650 Hz)
Chest Accelerometers	180	(300 Hz)
Vehicle Accelerometers	60	(100 Hz)
Barrier Load Cells	60	(100 Hz)
Femur Load Cells	600	(1000 Hz)
Lap and Torso Belts	60	(100 Hz)

Data Plot

Page No.

Figure B-1 - Right Rear Seat Crossmember X Accel. vs. Time	B-1
Figure B-2 - Right Rear Seat Crossmember X Velocity vs. Time	B-2
Figure B-3 - Right Rear Seat Crossmember X Displacement vs. Time	B-3
Figure B-4 - Right Rear Seat Crossmember X Redundant Acceleration vs. Time	B-4
Figure B-5 - Right Rear Seat Crossmember X Redundant Velocity vs. Time	B-5
Figure B-6 - Right Rear Seat Crossmember X Redundant Displacement vs. Time	B-6
Figure B-7 - Left Rear Seat Crossmember X Acceleration vs. Time	B-7
Figure B-8 - Left Rear Seat Crossmember X Velocity vs. Time	B-8
Figure B-9 - Left Rear Seat Crossmember X Displacement vs. Time	B-9
Figure B-10 - Left Rear Seat Crossmember X Redundant Acceleration vs. Time	B-10
Figure B-11 - Left Rear Seat Crossmember X Redundant Velocity vs. Time	B-11
Figure B-12 - Left Rear Seat Crossmember X Redundant Displacement vs. Time	B-12
Figure B-13 - Upper Engine Block X Acceleration vs. Time	B-13
Figure B-14 - Upper Engine Block X Velocity vs. Time	B-14
Figure B-15 - Bottom of Engine Block X Acceleration vs. Time	B-15
Figure B-16 - Bottom of Engine Block X Velocity vs. Time	B-16
Figure B-17 - Instrument Panel X Acceleration vs. Time	B-17
Figure B-18 - Instrument Panel X Velocity vs. Time	B-18
Figure B-19 - Left Brake Caliper X Acceleration vs. Time	B-19
Figure B-20 - Left Brake Caliper X Velocity vs. Time	B-20
Figure B-21 - Right Brake Caliper X Acceleration vs. Time	B-21
Figure B-22 - Right Brake Caliper X Velocity vs. Time	B-22
Figure B-23 - Upper Left Barrier Force vs. Time	B-23

Data Plot

Page No.

Figure B-24 - Upper Center Barrier Force vs. Time	B-24
Figure B-25 - Upper Right Barrier Force vs. Time	B-25
Figure B-26 - Lower Left Barrier Force vs. Time	B-26
Figure B-27 - Lower Center Barrier Force vs. Time	B-27
Figure B-28 - Lower Right Barrier Force vs. Time	B-28
Figure B-29 - Sum of Barrier Forces vs. Time	B-29
Figure B-30 - Driver Head X Acceleration vs. Time	B-30
Figure B-31 - Driver Head Y Acceleration vs. Time	B-31
Figure B-32 - Driver Head Z Acceleration vs. Time	B-32
Figure B-33 - Driver Head Resultant Acceleration vs. Time	B-33
Figure B-34 - Driver Head X Velocity vs. Time	B-34
Figure B-35 - Driver Chest X Acceleration vs. Time	B-35
Figure B-36 - Driver Chest Y Acceleration vs. Time	B-36
Figure B-37 - Driver Chest Z Acceleration vs. Time	B-37
Figure B-38 - Driver Chest Resultant vs. Time	B-38
Figure B-39 - Driver Chest Compression vs. Time	B-39
Figure B-40 - Driver Chest X Velocity vs. Time	B-40
Figure B-41 - Driver Right Femur Force vs. Time	B-41
Figure B-42 - Driver Left Femur Force vs. Time	B-42
Figure B-43 - Driver Lap Belt Force vs. Time	B-43
Figure B-44 - Driver Torso Belt Force vs. Time	B-44
Figure B-45 - Driver Belt Spoolout	B-45
Figure B-46 - Driver Neck Force X vs. Time	B-46
Figure B-47 - Driver Neck Force Y vs. Time	B-47
Figure B-48 - Driver Neck Force Z vs. Time	B-48
Figure B-49 - Driver Neck Force Resultant vs. Time	B-49
Figure B-50 - Driver Neck Moment X vs. Time	B-50
Figure B-51 - Driver Neck Moment Y vs. Time	B-51
Figure B-52 - Driver Neck Moment Z vs. Time	B-52
Figure B-53 - Driver Neck Moment Resultant vs. Time	B-53
Figure B-54 - Passenger Head X Acceleration vs. Time	B-54
Figure B-55 - Passenger Head Y Acceleration vs. Time	B-55
Figure B-56 - Passenger Head Z Acceleration vs. Time	B-56

Data Plot

Page No.

Figure B-57 - Passenger Head Resultant Acceleration vs. Time	B-57
Figure B-58 - Passenger Head X Velocity vs. Time	B-58
Figure B-59 - Passenger Chest X Acceleration vs. Time	B-59
Figure B-60 - Passenger Chest Y Acceleration vs. Time	B-60
Figure B-61 - Passenger Chest Z Acceleration vs. Time	B-61
Figure B-62 - Passenger Chest Resultant vs. Time	B-62
Figure B-63 - Passenger Chest Compression vs. Time	B-63
Figure B-64 - Passenger Chest X Velocity vs. Time	B-64
Figure B-65 - Passenger Right Femur Force vs. Time	B-65
Figure B-66 - Passenger Left Femur Force vs. Time	B-66
Figure B-67 - Passenger Lap Belt Force vs. Time	B-67
Figure B-68 - Passenger Torso Belt Force vs. Time	B-68
Figure B-69 - Passenger Belt Spoolout	B-69
Figure B-70 - Passenger Neck Force X vs. Time	B-70
Figure B-71 - Passenger Neck Force Y vs. Time	B-71
Figure B-72 - Passenger Neck Force Z vs. Time	B-72
Figure B-73 - Passenger Neck Force Resultant vs. Time	B-73
Figure B-74 - Passenger Neck Moment X vs. Time	B-74
Figure B-75 - Passenger Neck Moment Y vs. Time	B-75
Figure B-76 - Passenger Neck Moment Z vs. Time	B-76
Figure B-77 - Passenger Neck Moment Resultant vs. Time	B-77

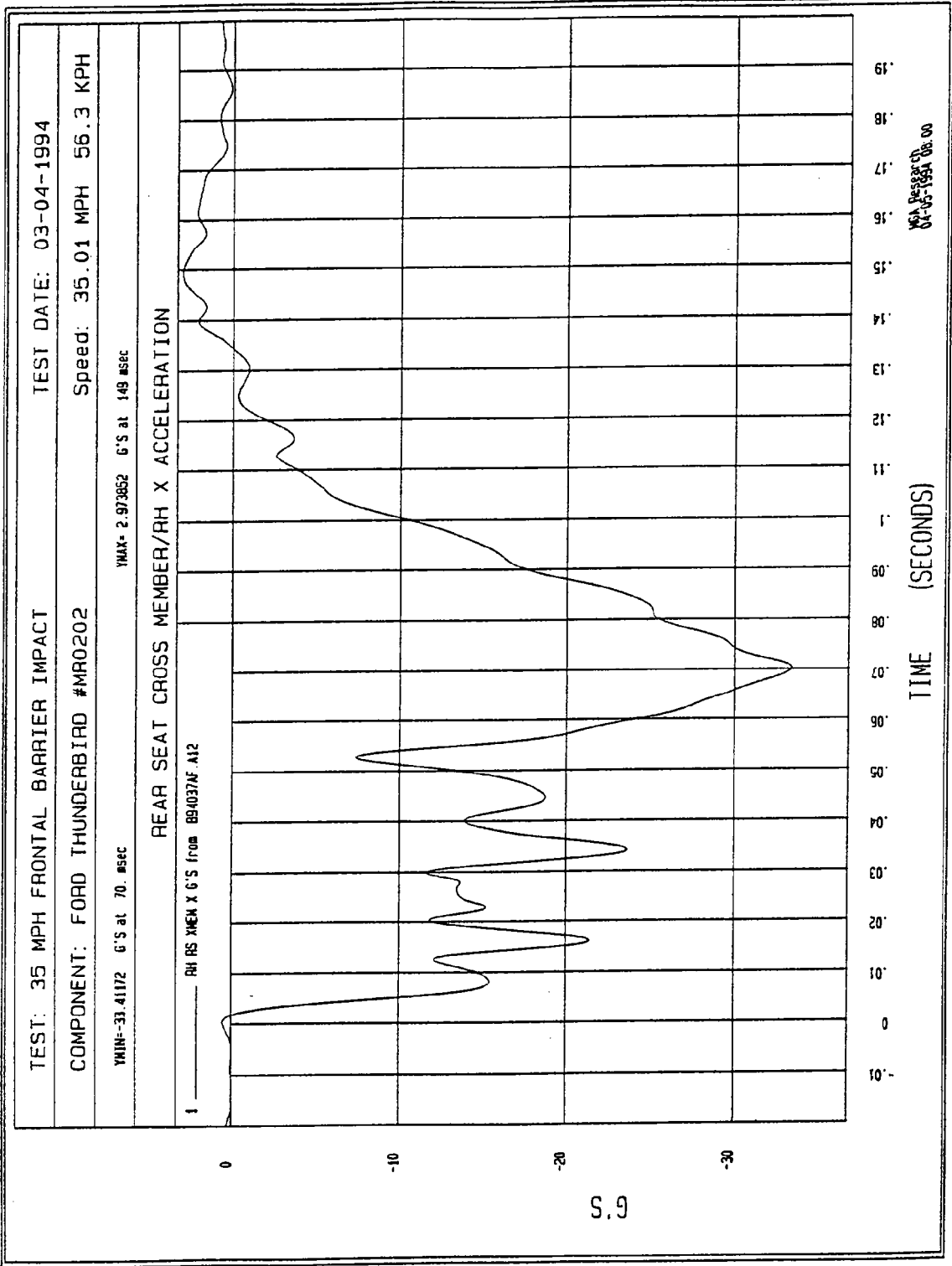

TIME (SECONDS)

MOA DE-33287-01
03-05-1994 08:00

Figure B-1 - Right Rear Seat Crossmember X Accel. vs. Time

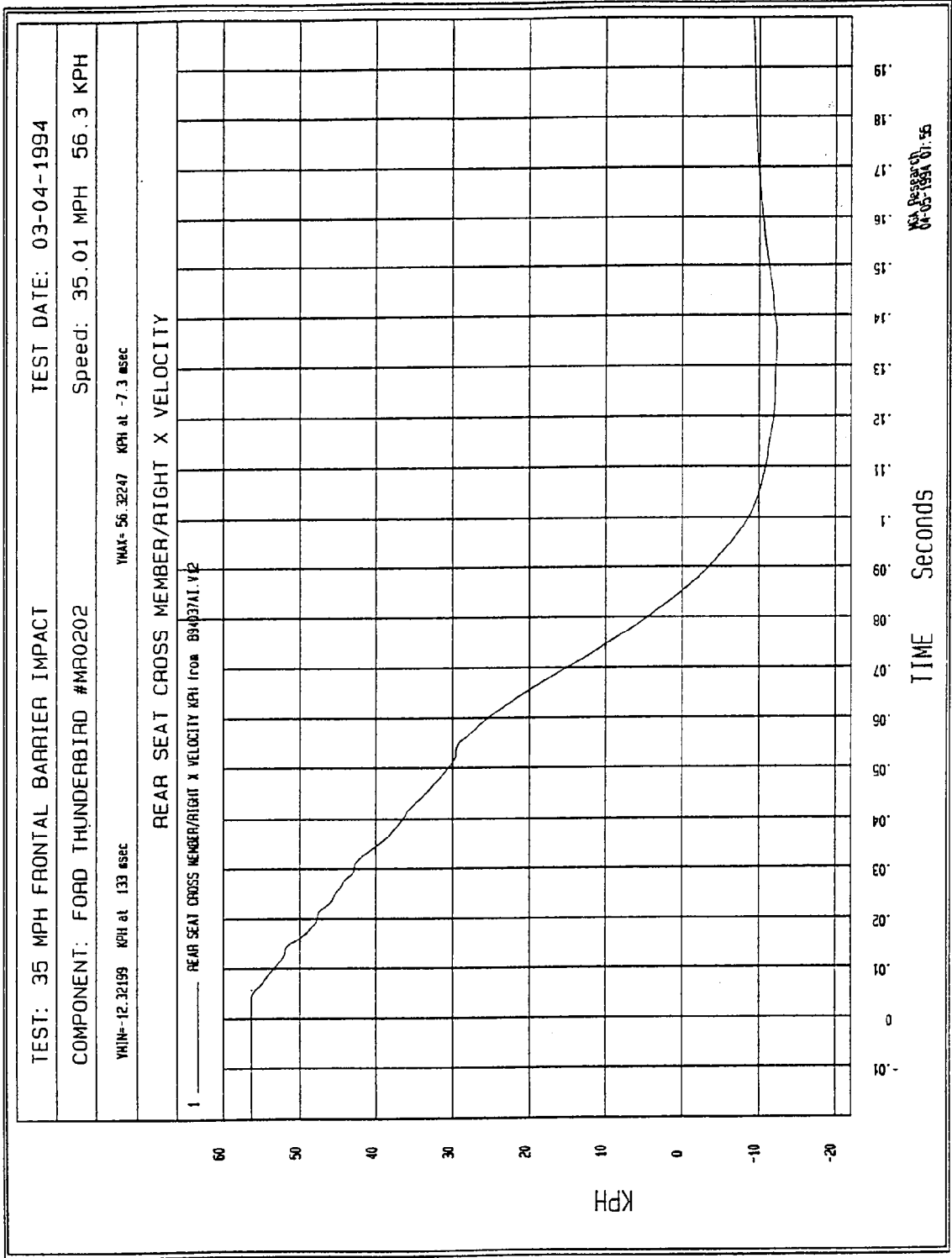

Figure B-2 - Right Rear Seat Crossmember X Velocity vs. Time

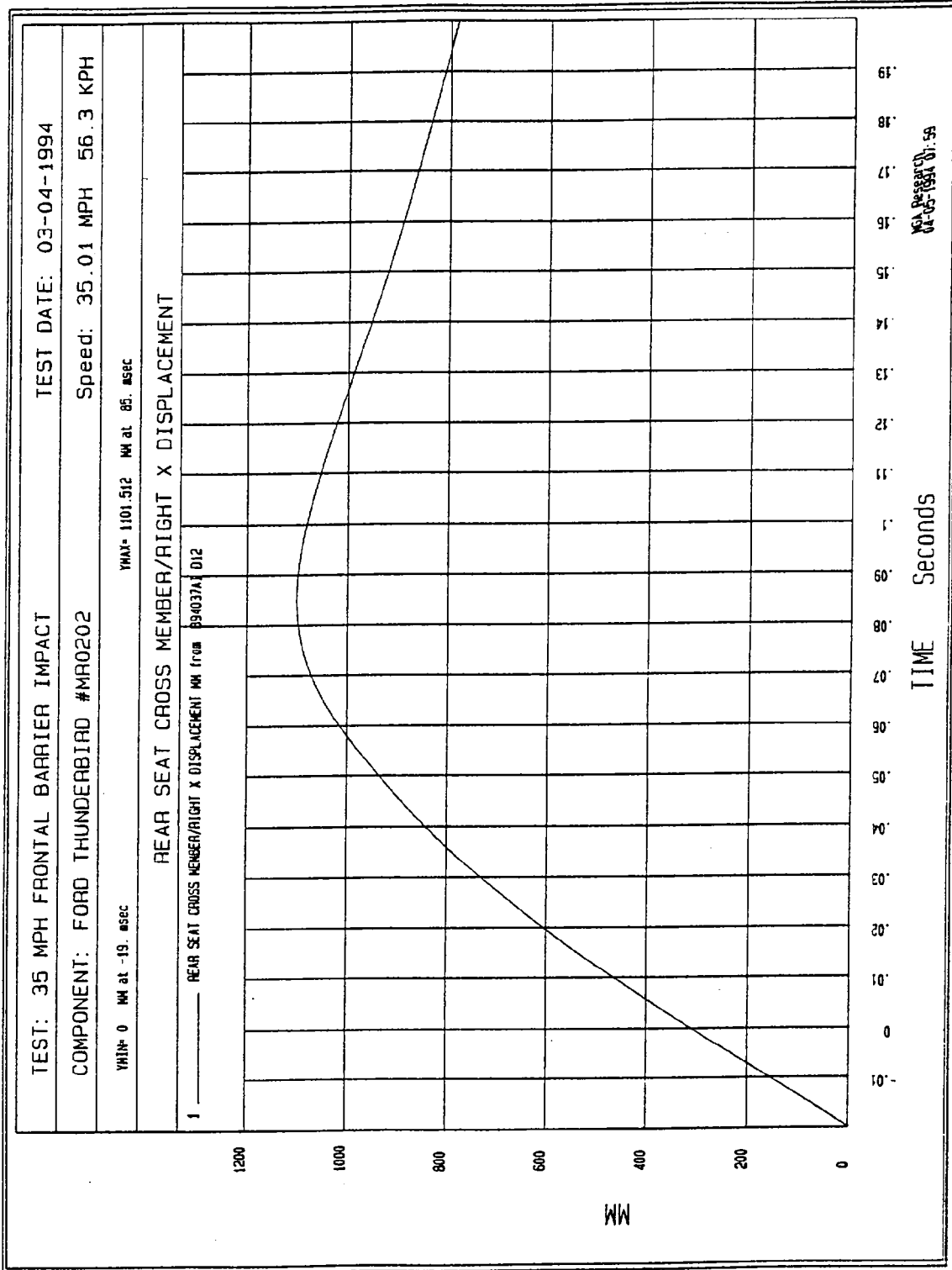

Figure B-3 - Right Rear Seat Crossmember X Displacement vs. Time

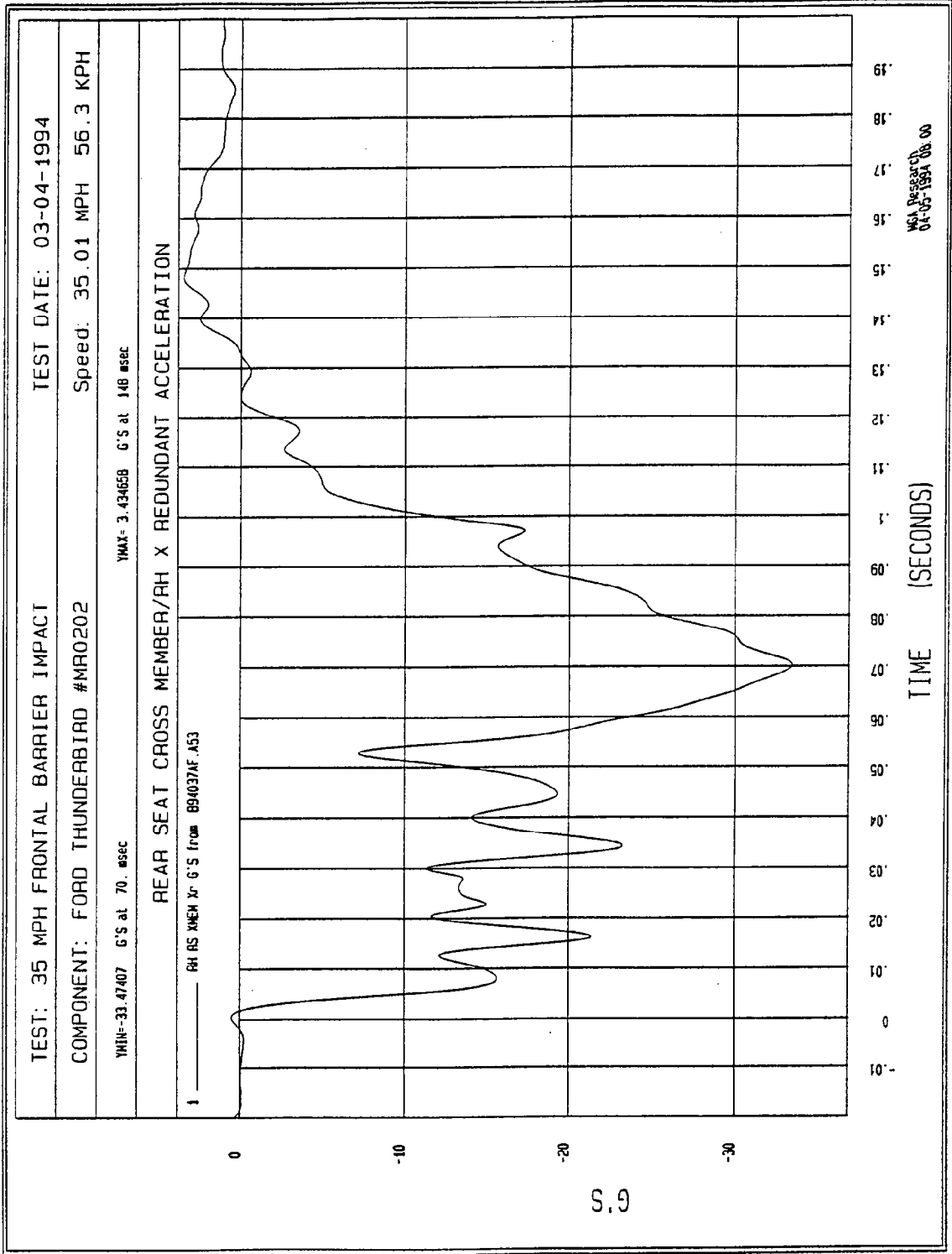

Figure B-4 - Right Rear Seat Crossmember X Redundant Acceleration vs. Time

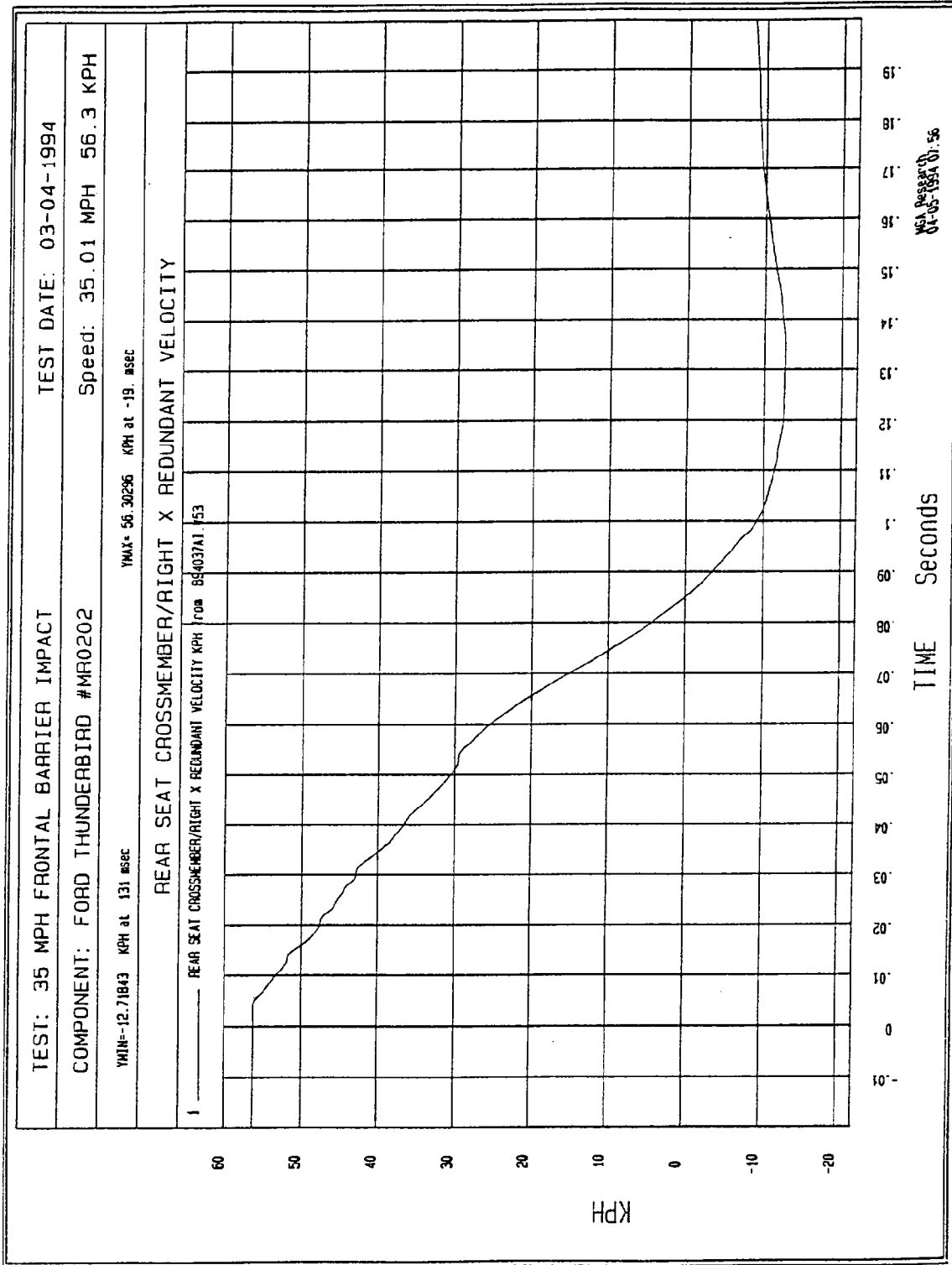

Figure B-5 - Right Rear Seat Crossmember X Redundant Velocity vs. Time

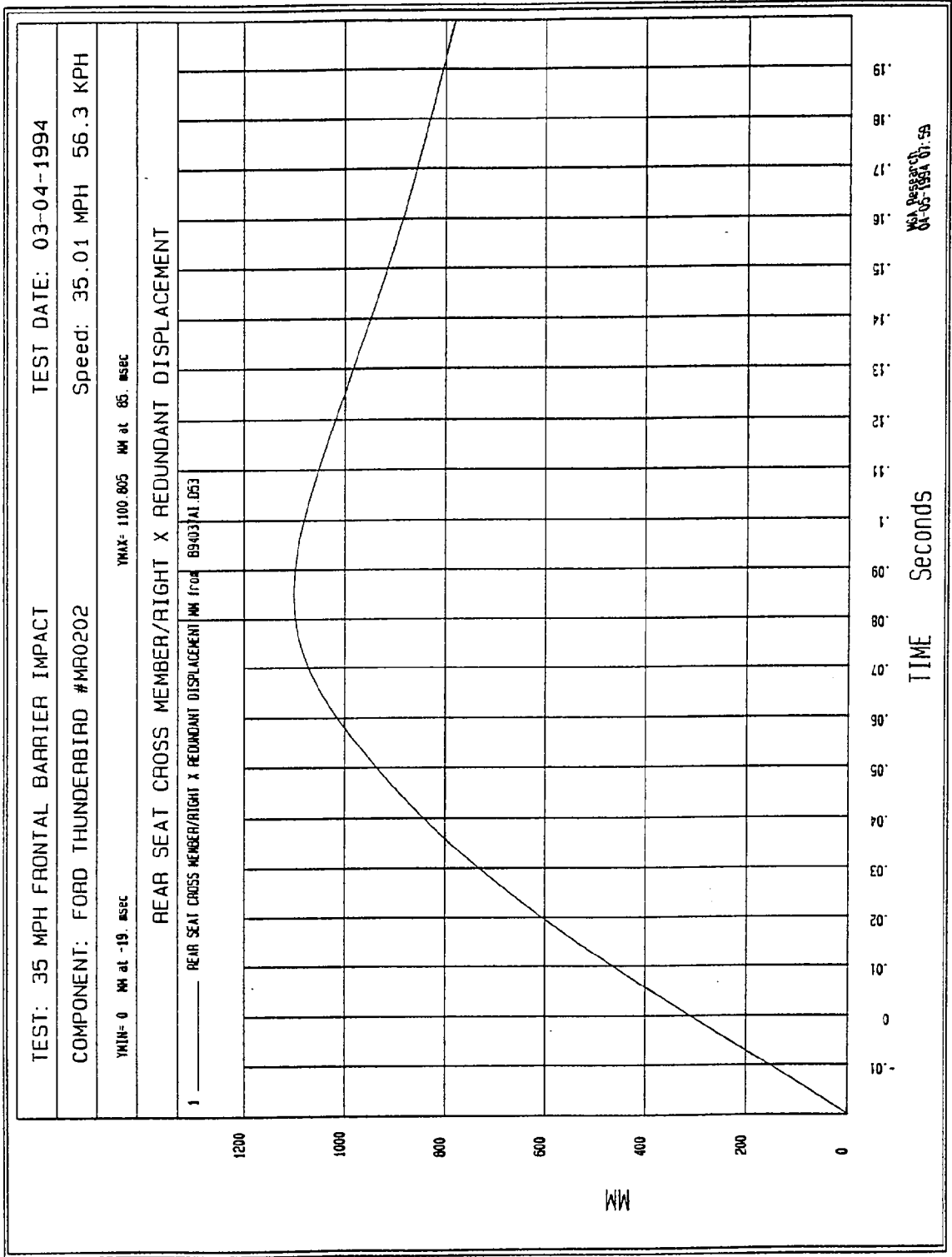

Figure B-6 - Right Rear Seat Crossmember X Redundant Displacement vs. Time

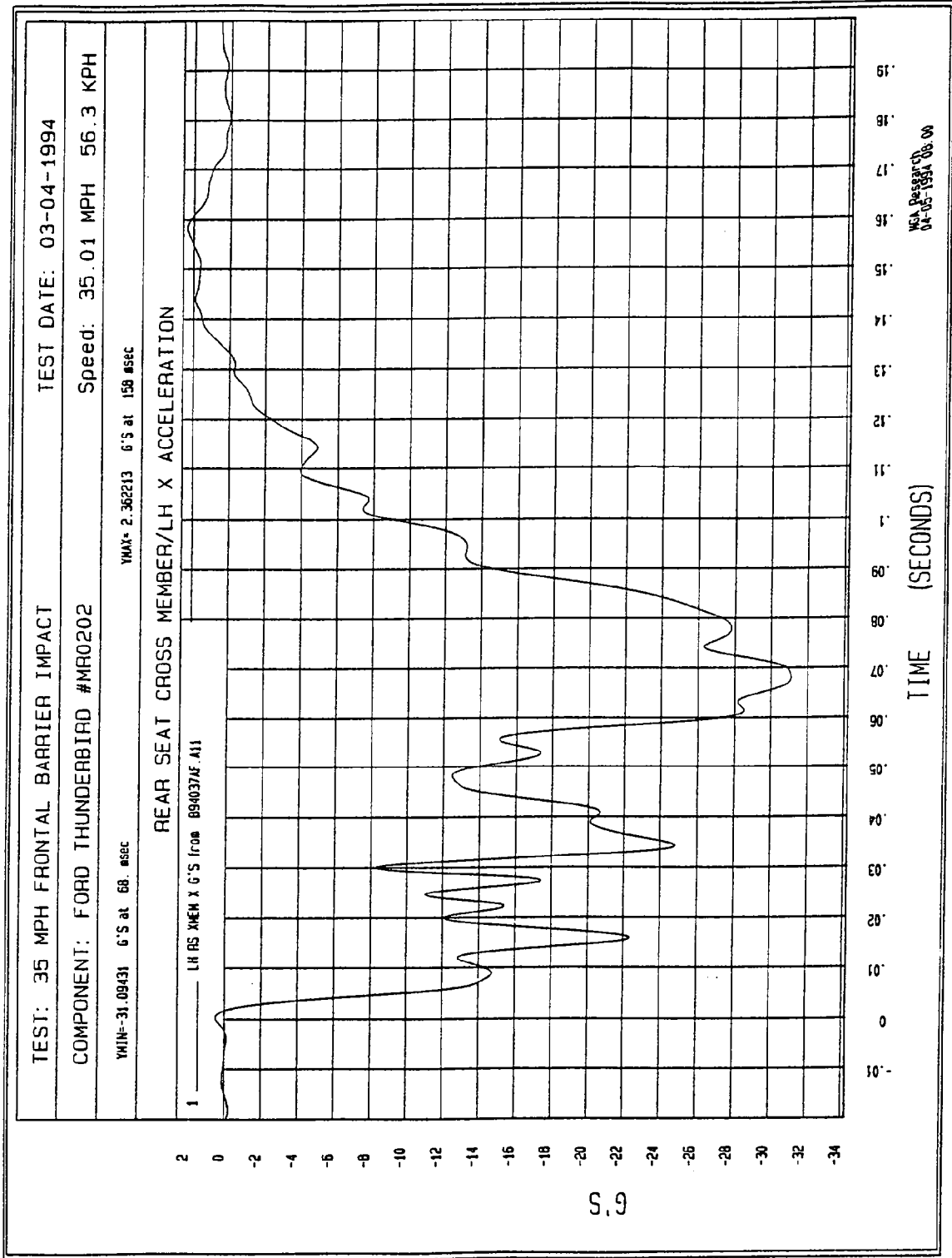

Figure B-7 - Left Rear Seat Crossmember X Acceleration vs. Time

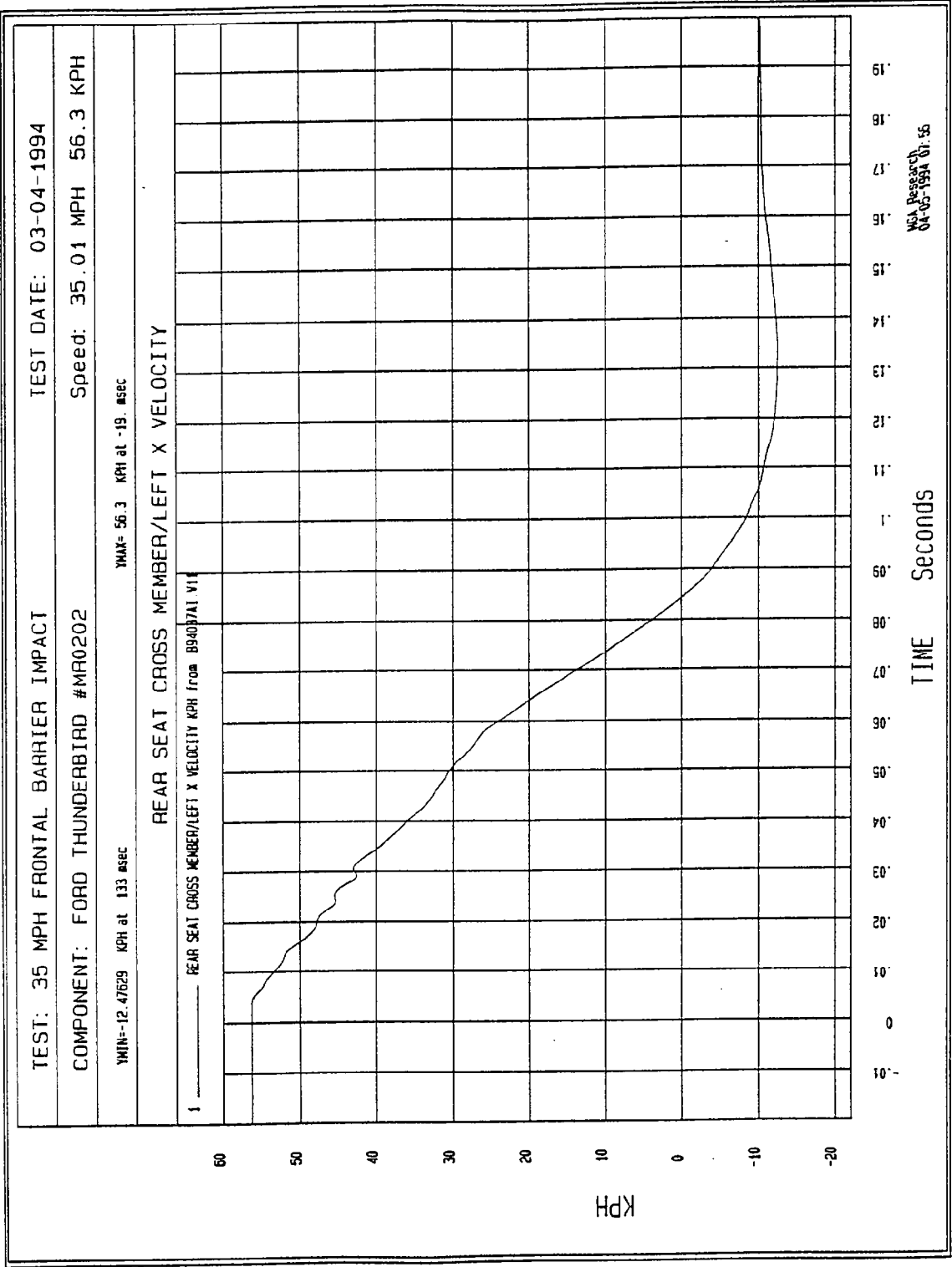

Figure B-8 - Left Rear Seat Crossmember X Velocity vs. Time

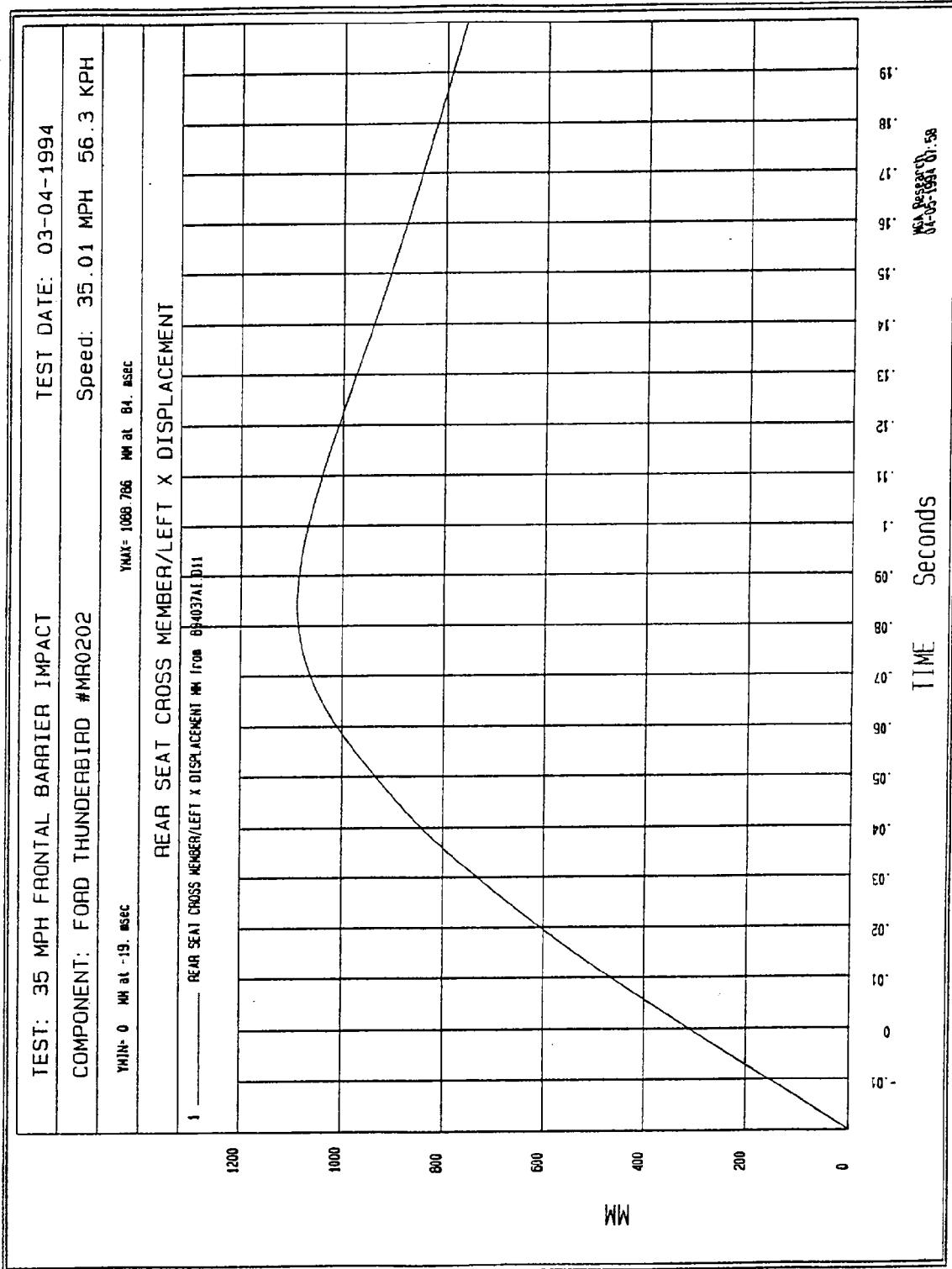
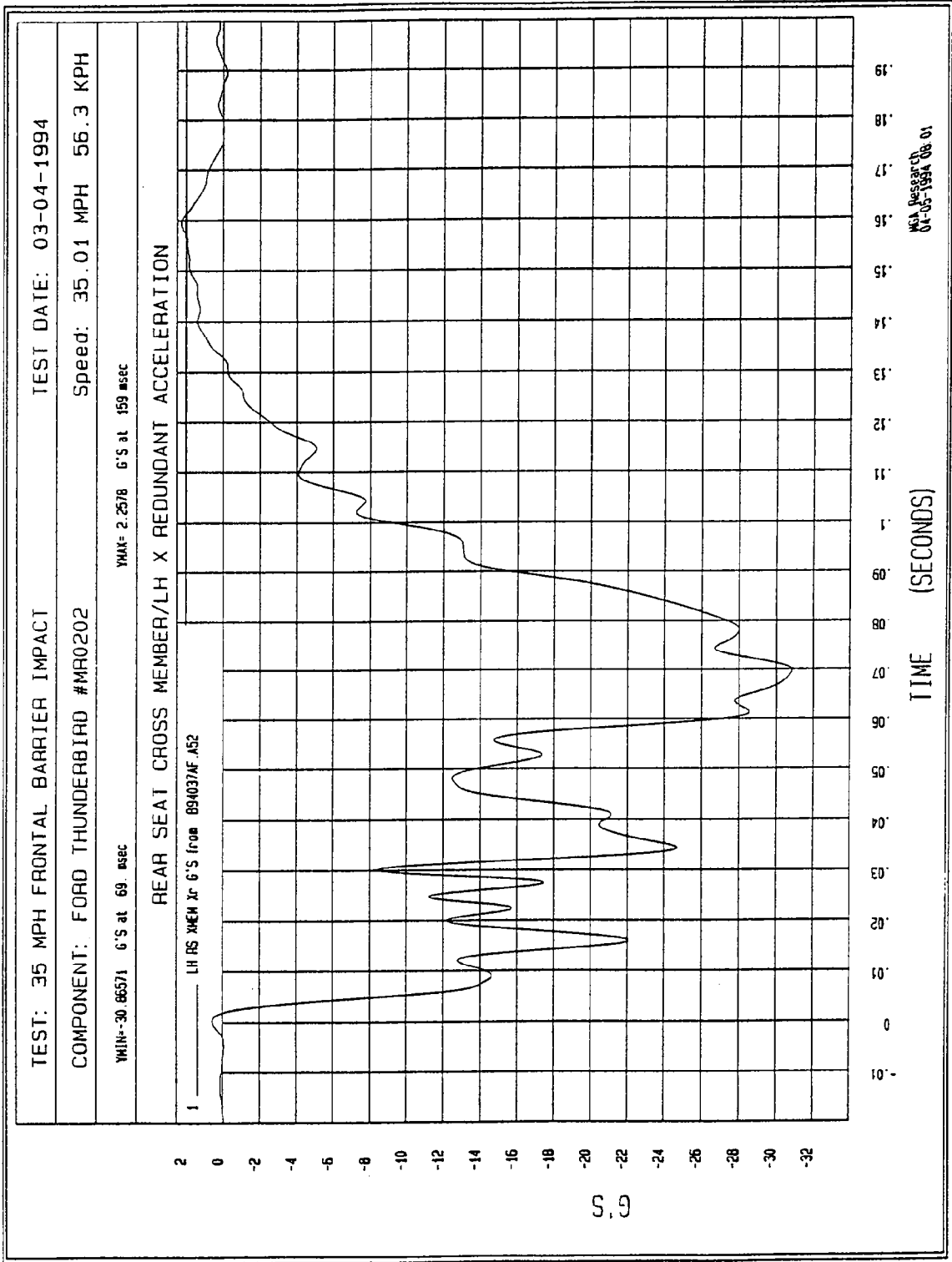

Figure B-9 - Left Rear Seat Crossmember X Displacement vs. Time



TIME (SECONDS)

MCA Research
01-05-1994 08:01

Figure B-10 - Left Rear Seat Crossmember X Redundant Acceleration vs. Time

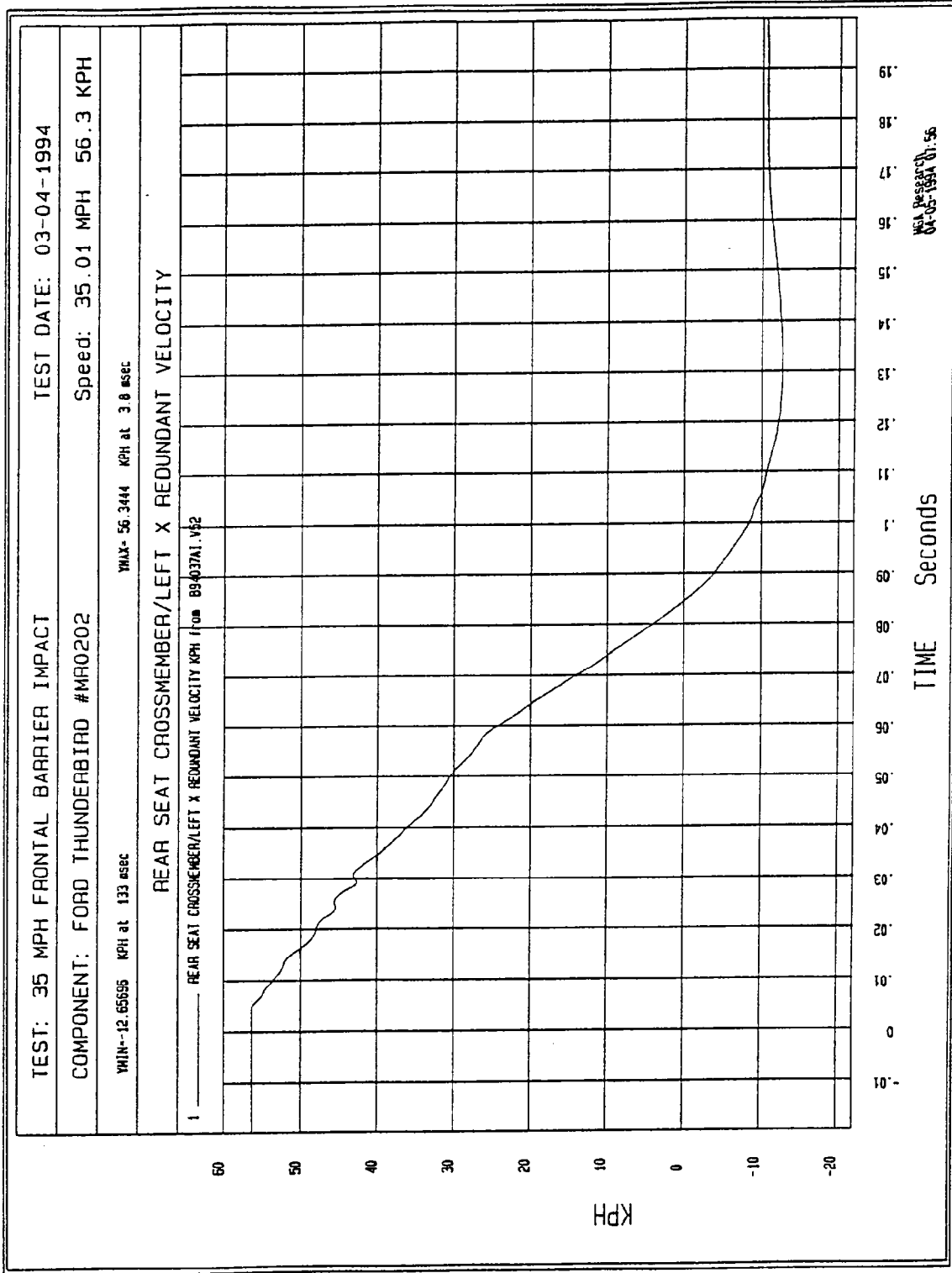
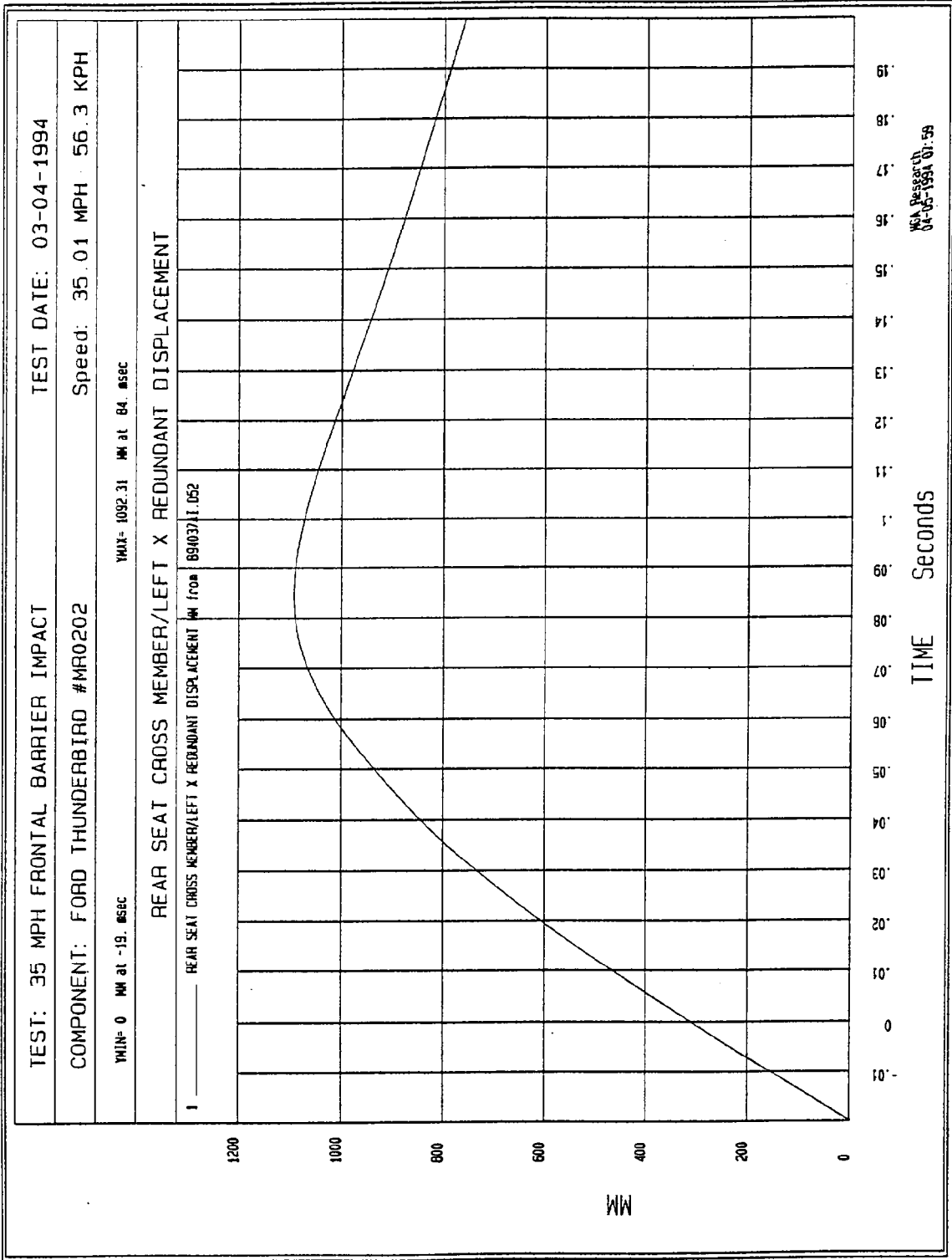

Figure B-11 - Left Rear Seat Crossmember X Redundant Velocity vs. Time



TIME Seconds

NSA Research
04-05-1994 01:59

Figure B-12 - Left Rear Seat Crossmember X Redundant Displacement vs. Time

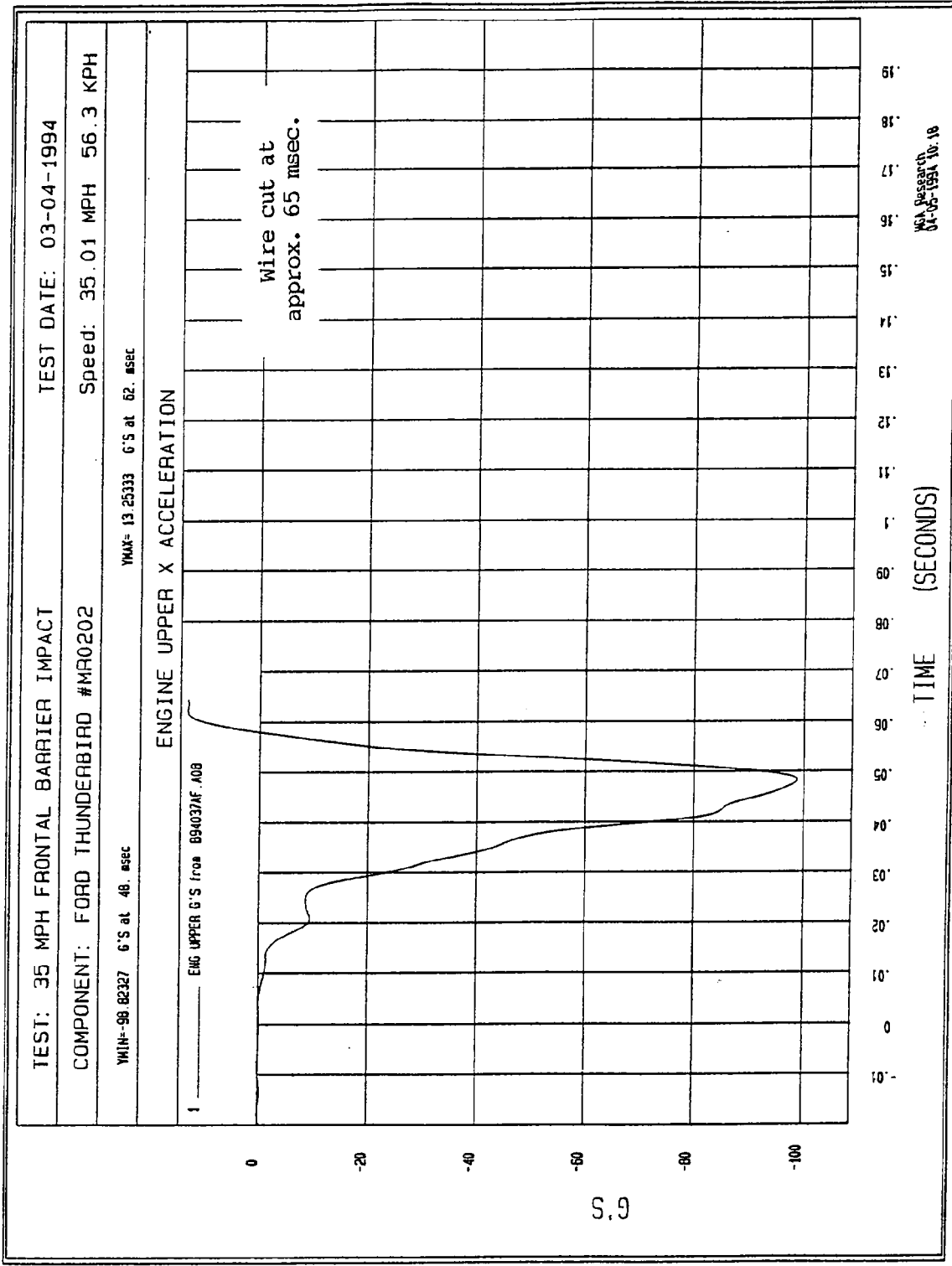

Figure B-13 - Upper Engine Block X Acceleration vs. Time

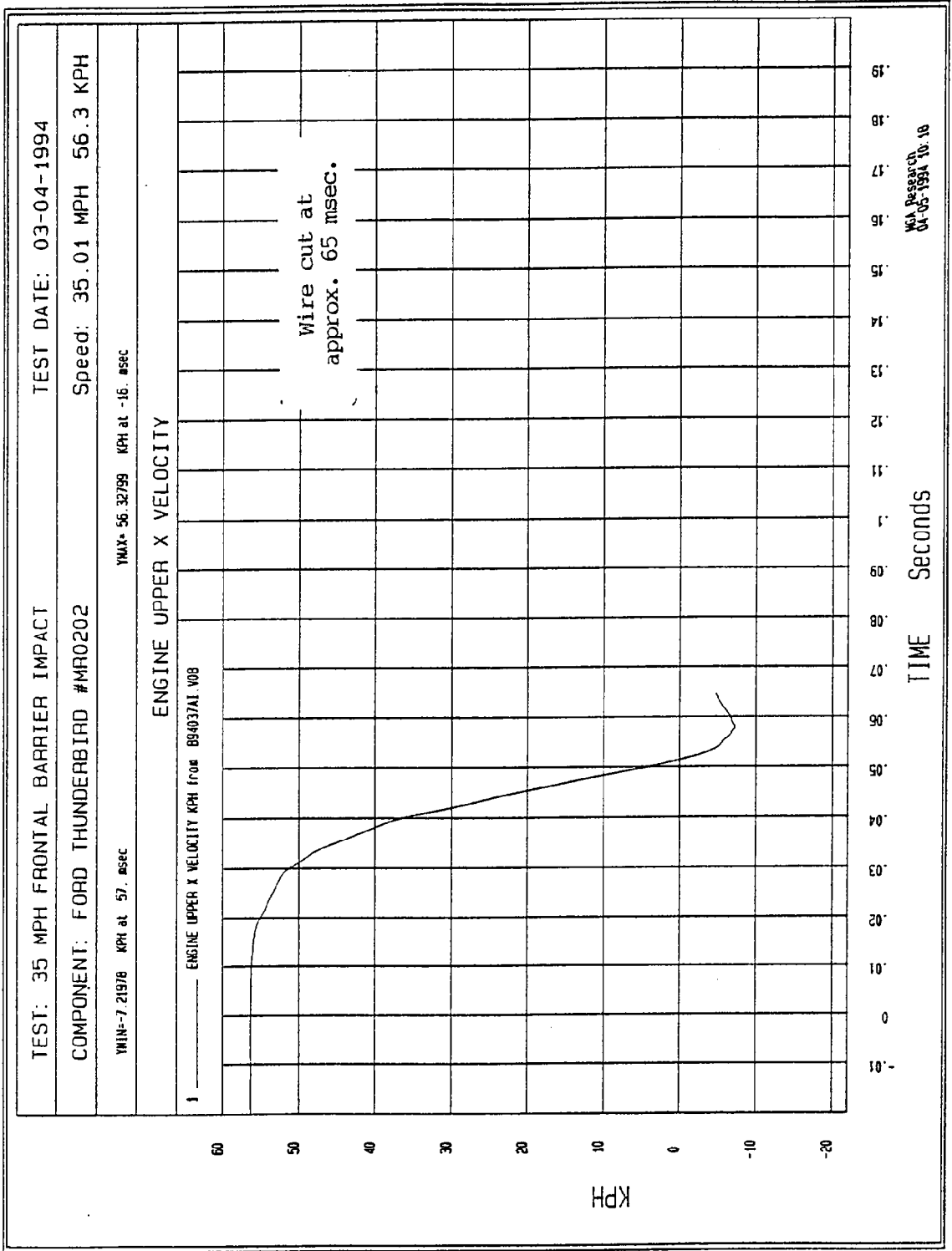

Figure B-14 - Upper Engine Block X Velocity vs. Time

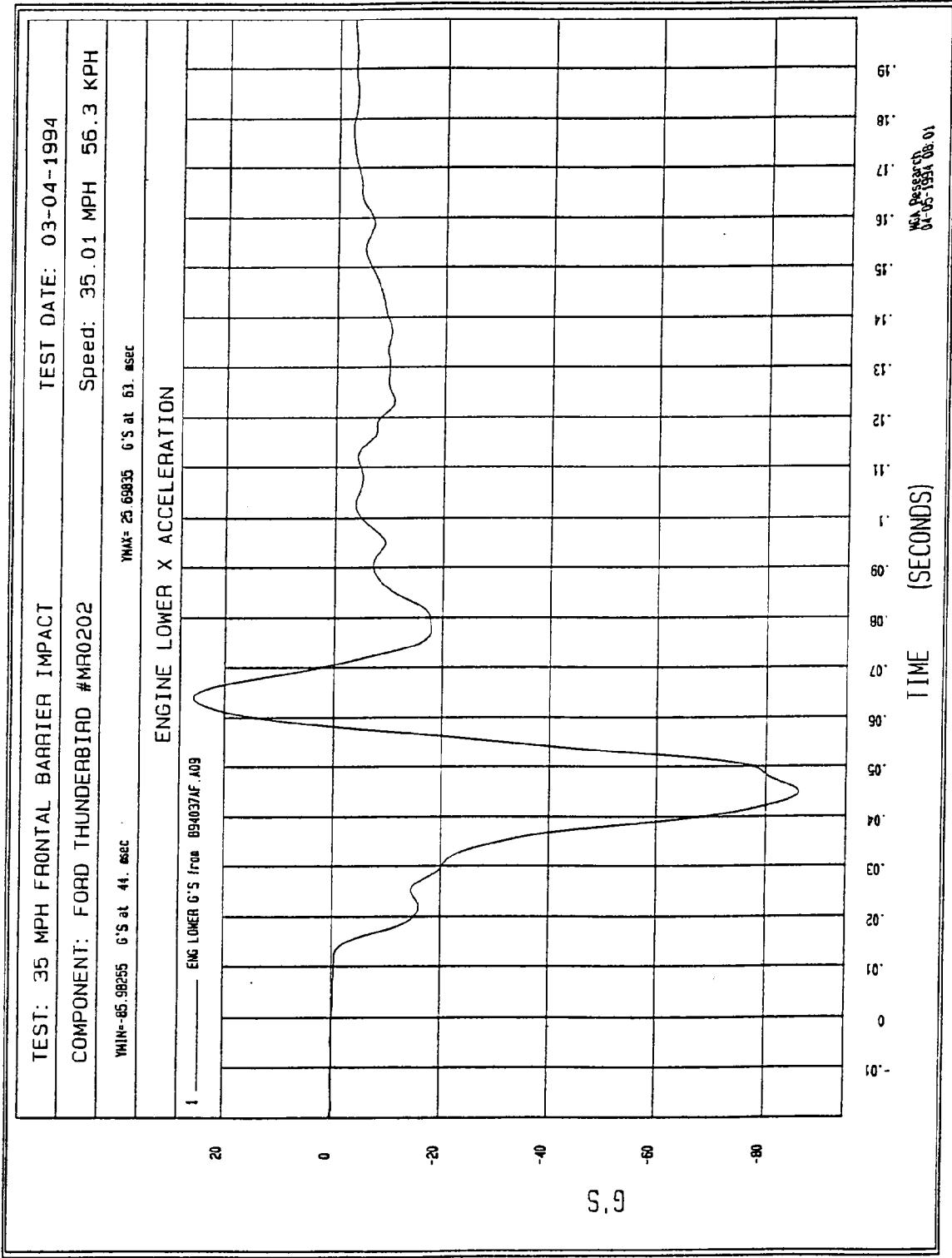

Figure B-15 - Bottom of Engine Block X Acceleration vs. Time

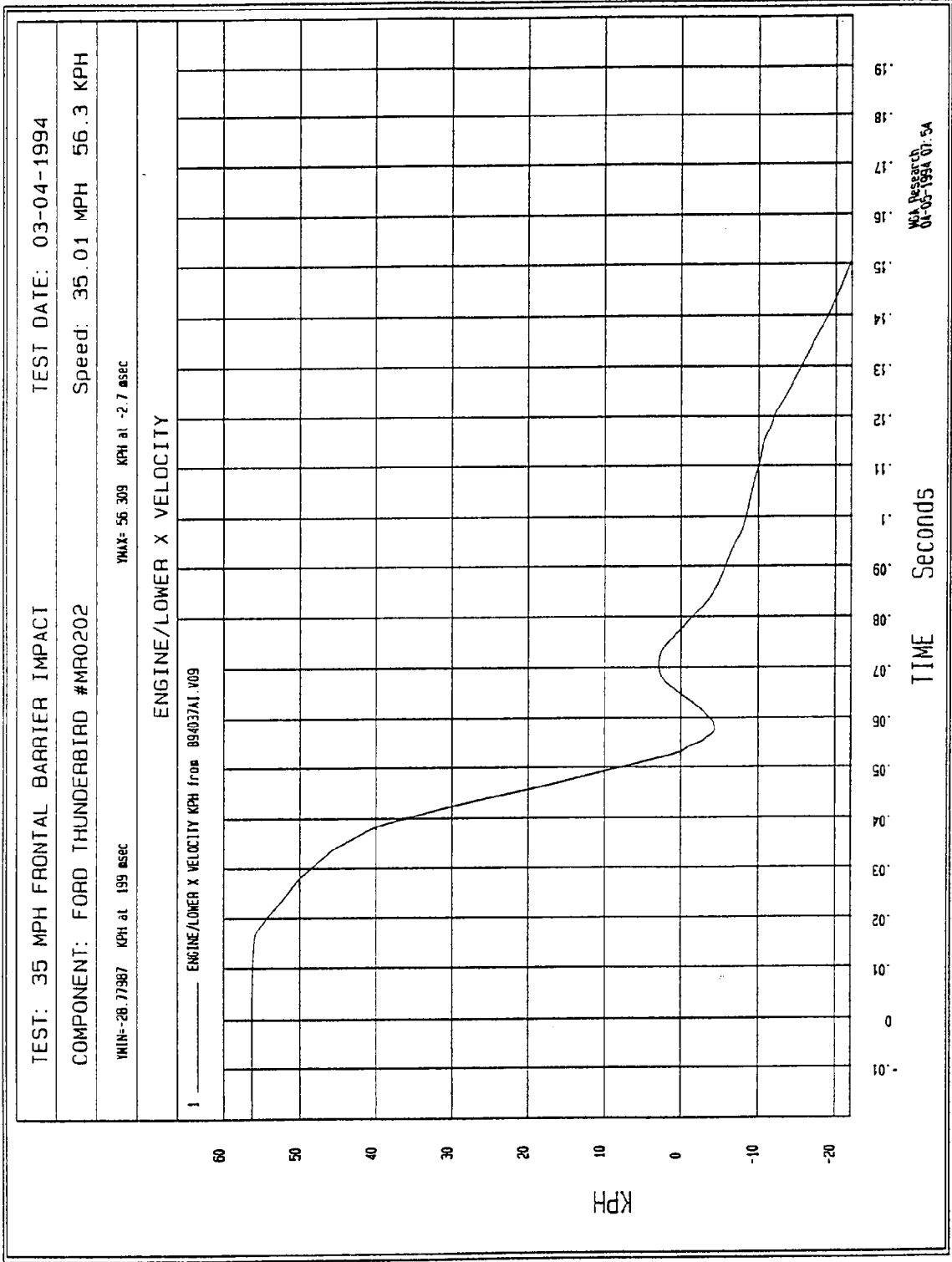

Figure B-16 - Bottom of Engine Block X Velocity vs. Time

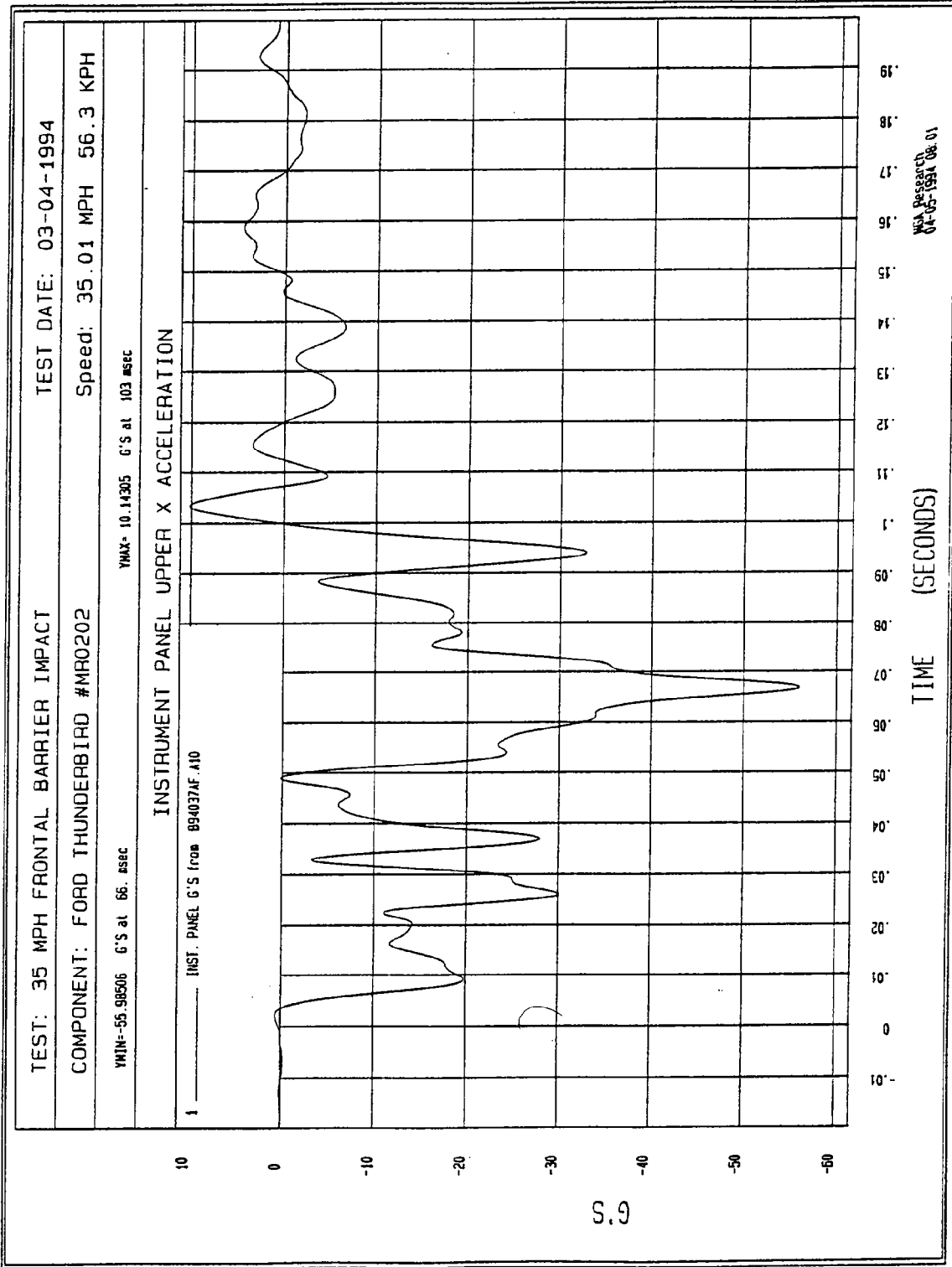

Figure B-17 - Instrument Panel X Acceleration vs. Time

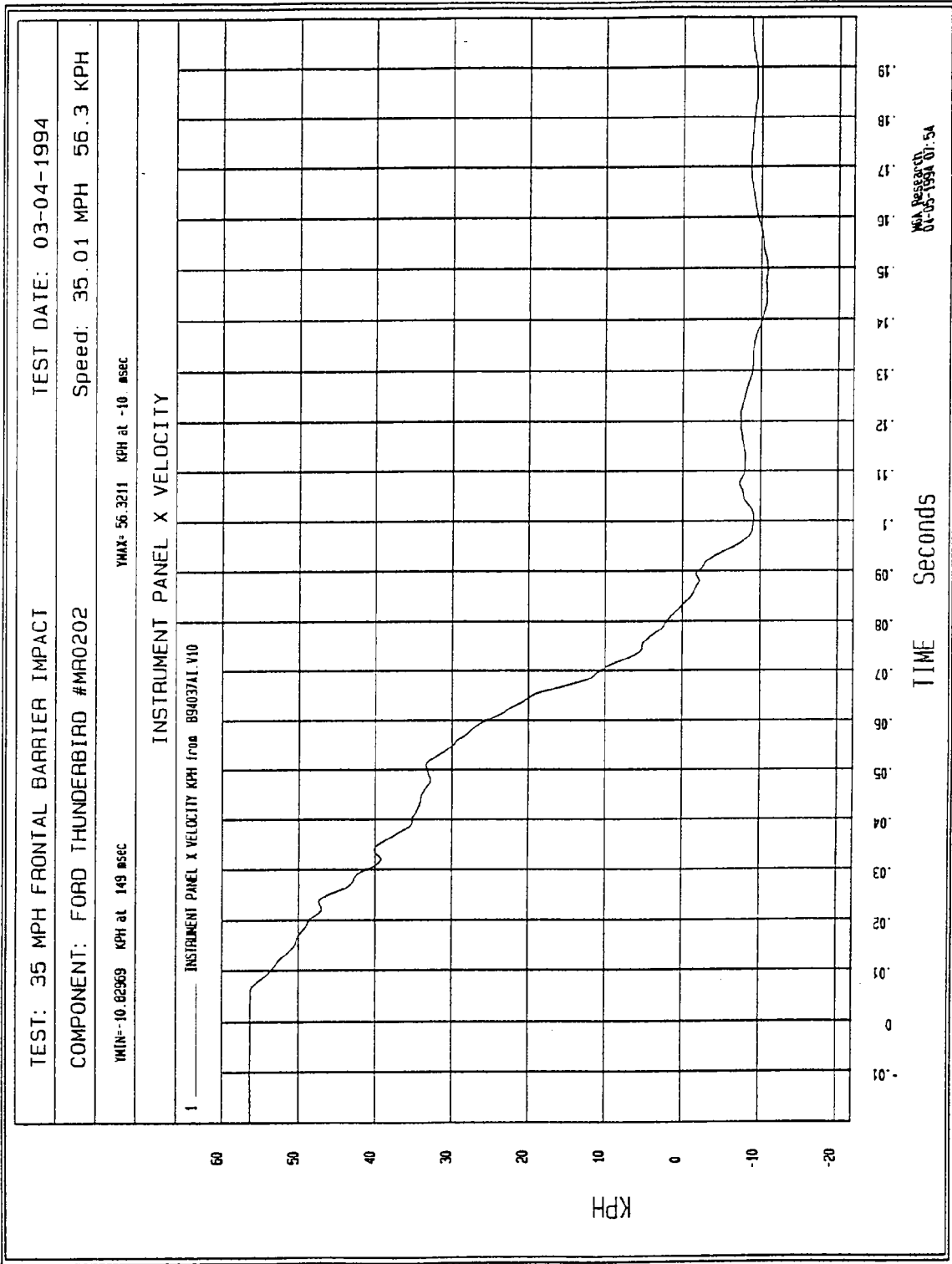

Figure B-18 - Instrument Panel X Velocity vs. Time

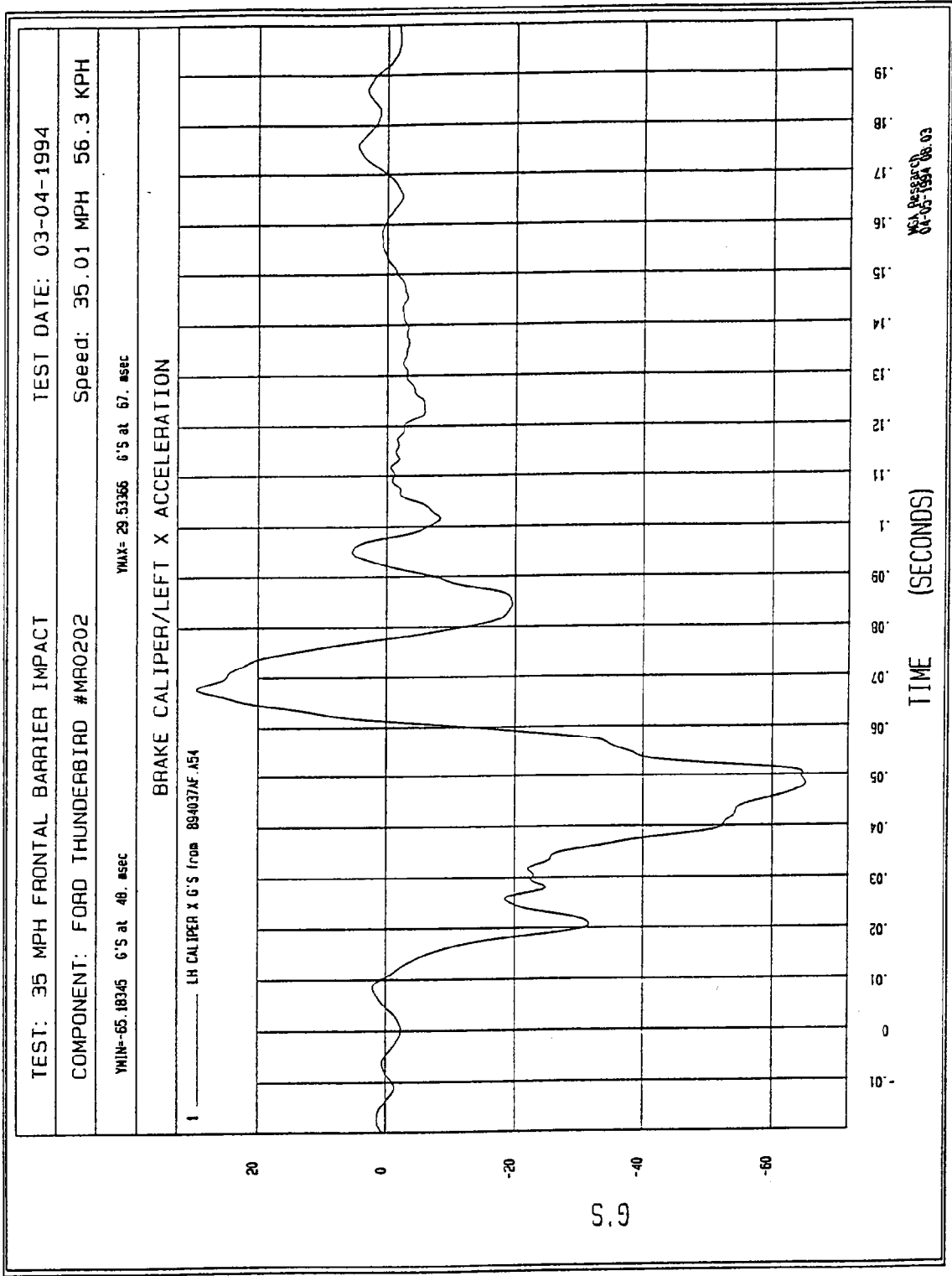

Figure B-19 - Left Brake Caliper X Acceleration vs. Time

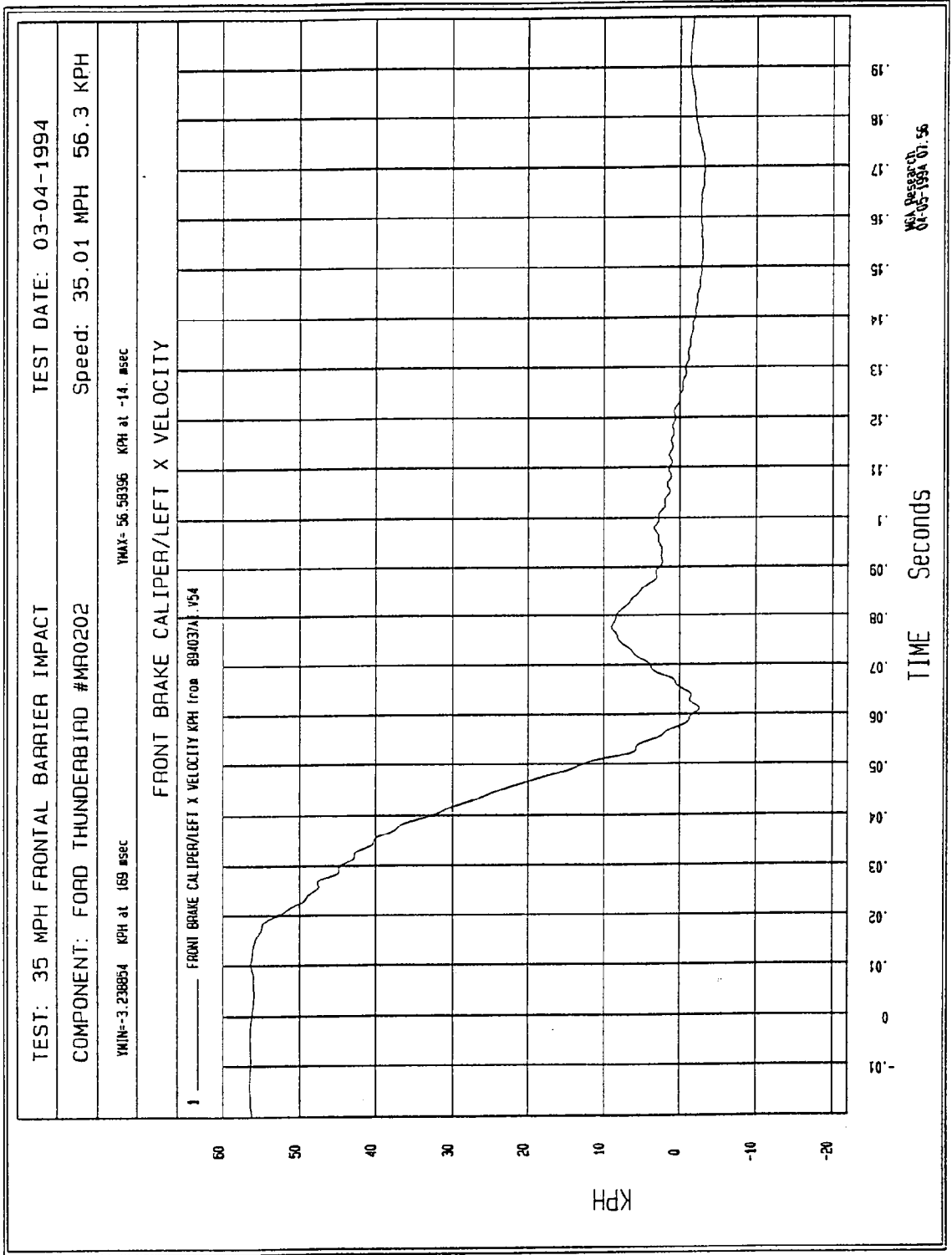

Figure B-20 - Left Brake Caliper X Velocity vs. Time

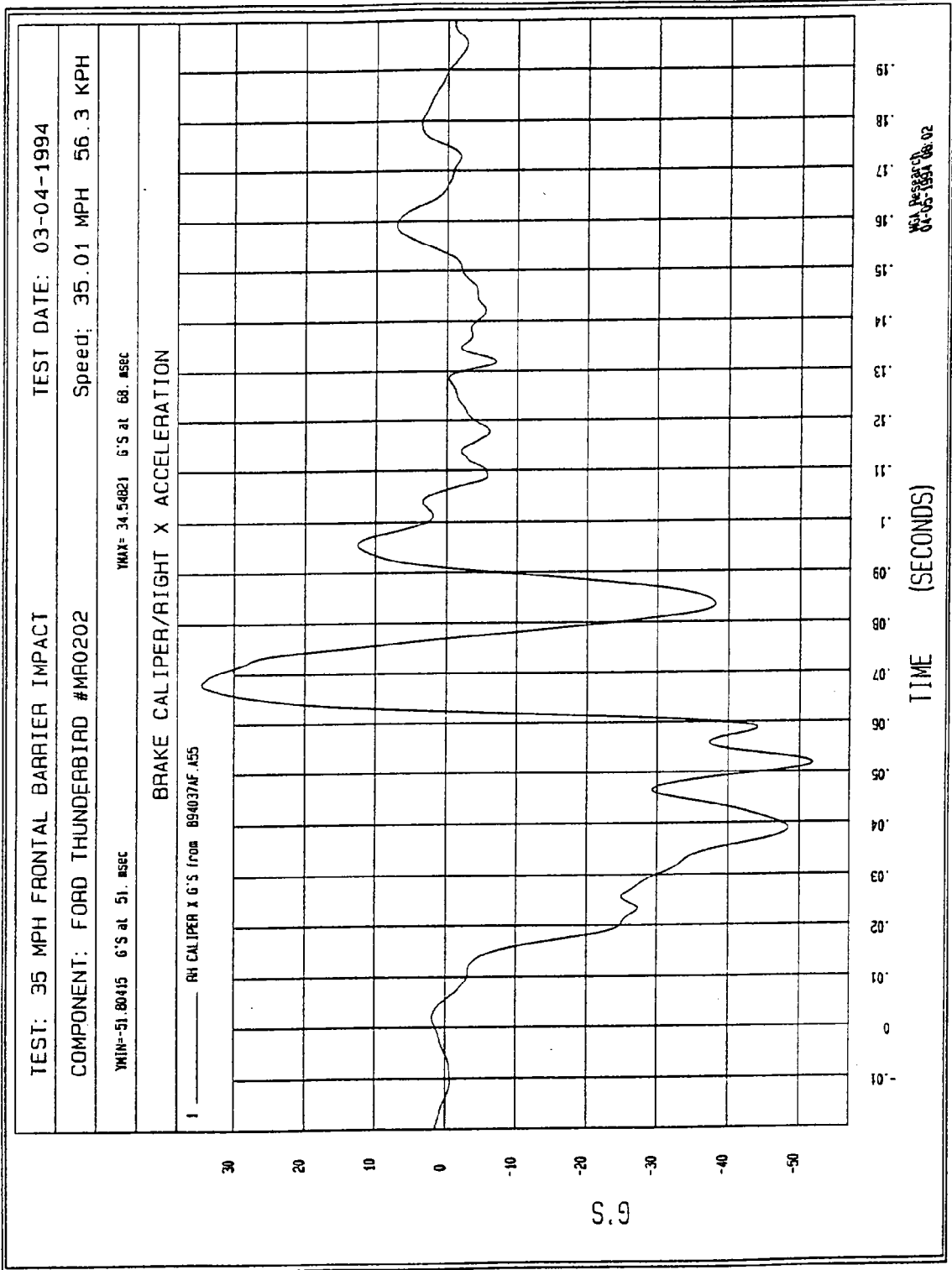
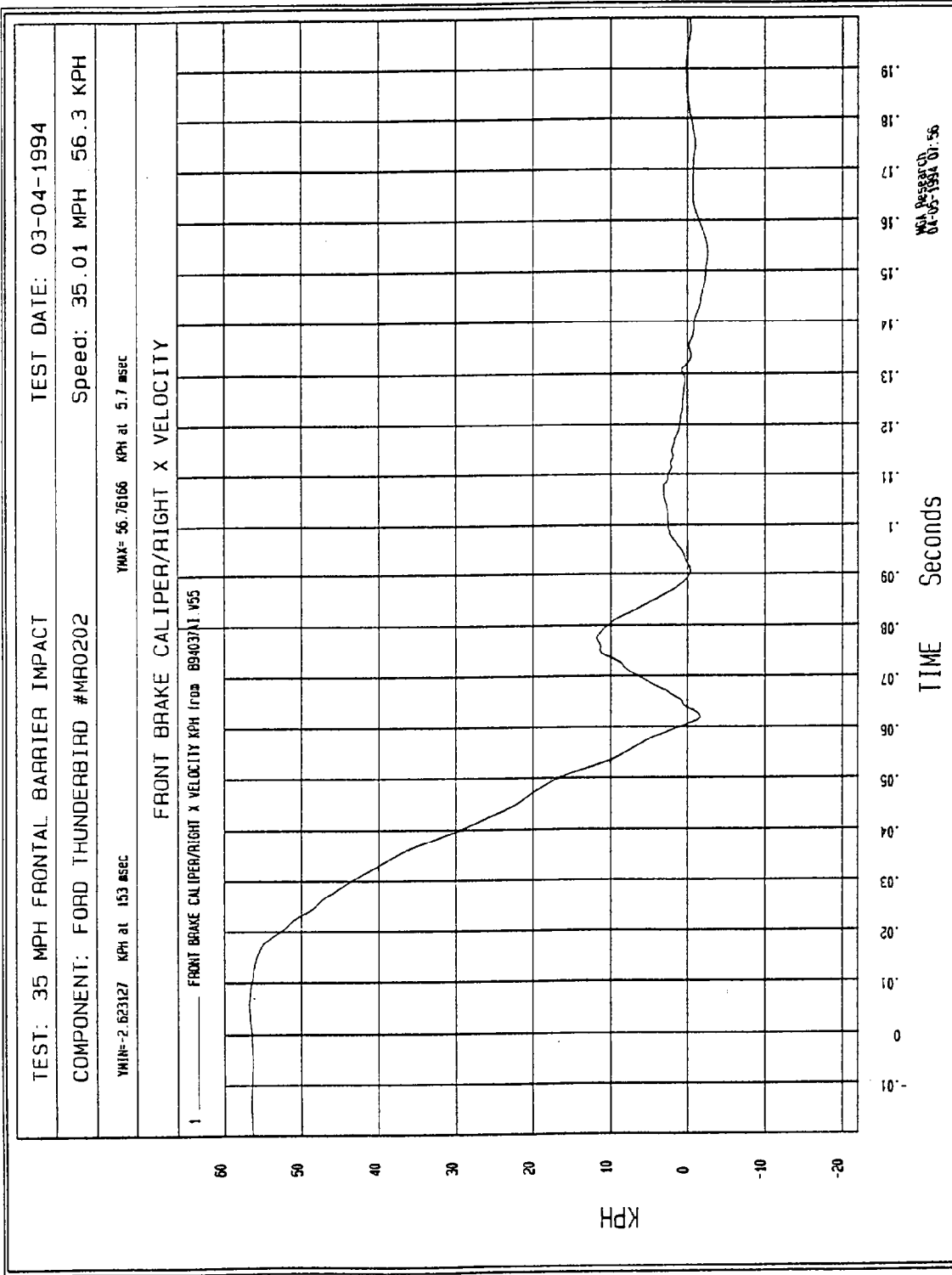
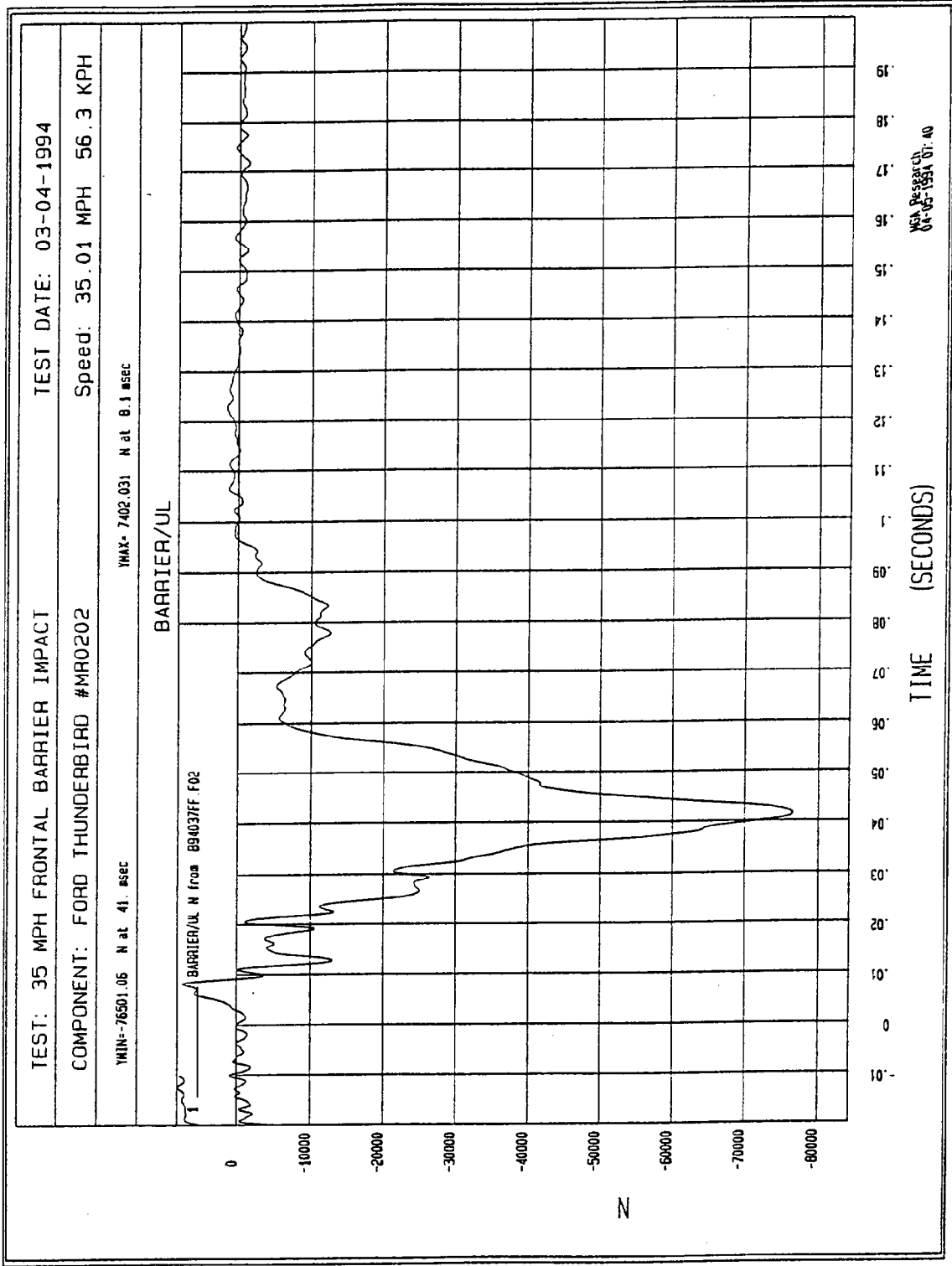

Figure B-21 - Right Brake Caliper X Acceleration vs. Time



NVA Research
 03-05-1994 01:56

Figure B-22 - Right Brake Caliper X Velocity vs. Time



NSA RESEARCH
04-05-1994 07:40

Figure B-23 - Upper Left Barrier Force vs. Time

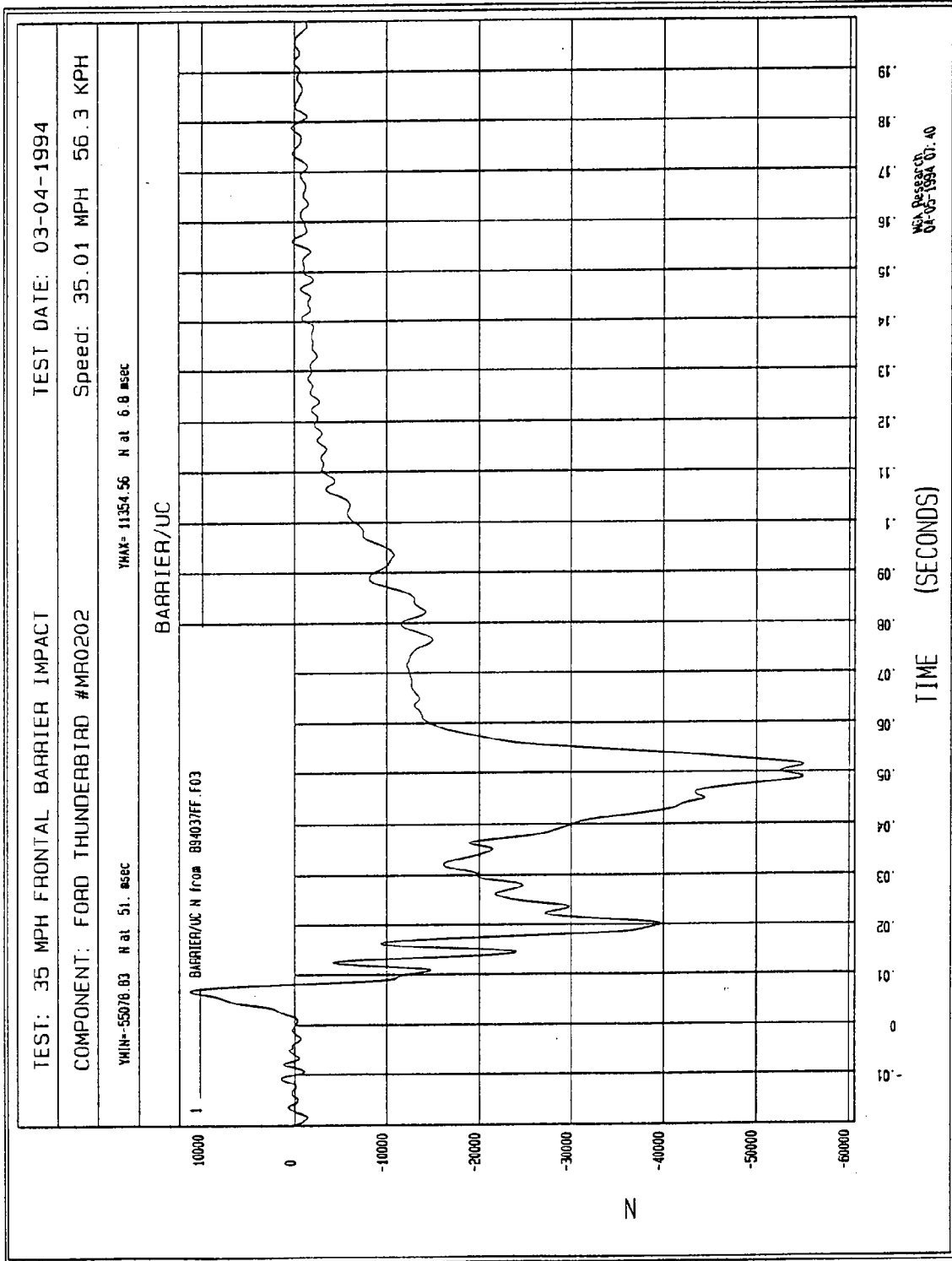

Figure B-24 - Upper Center Barrier Force vs. Time

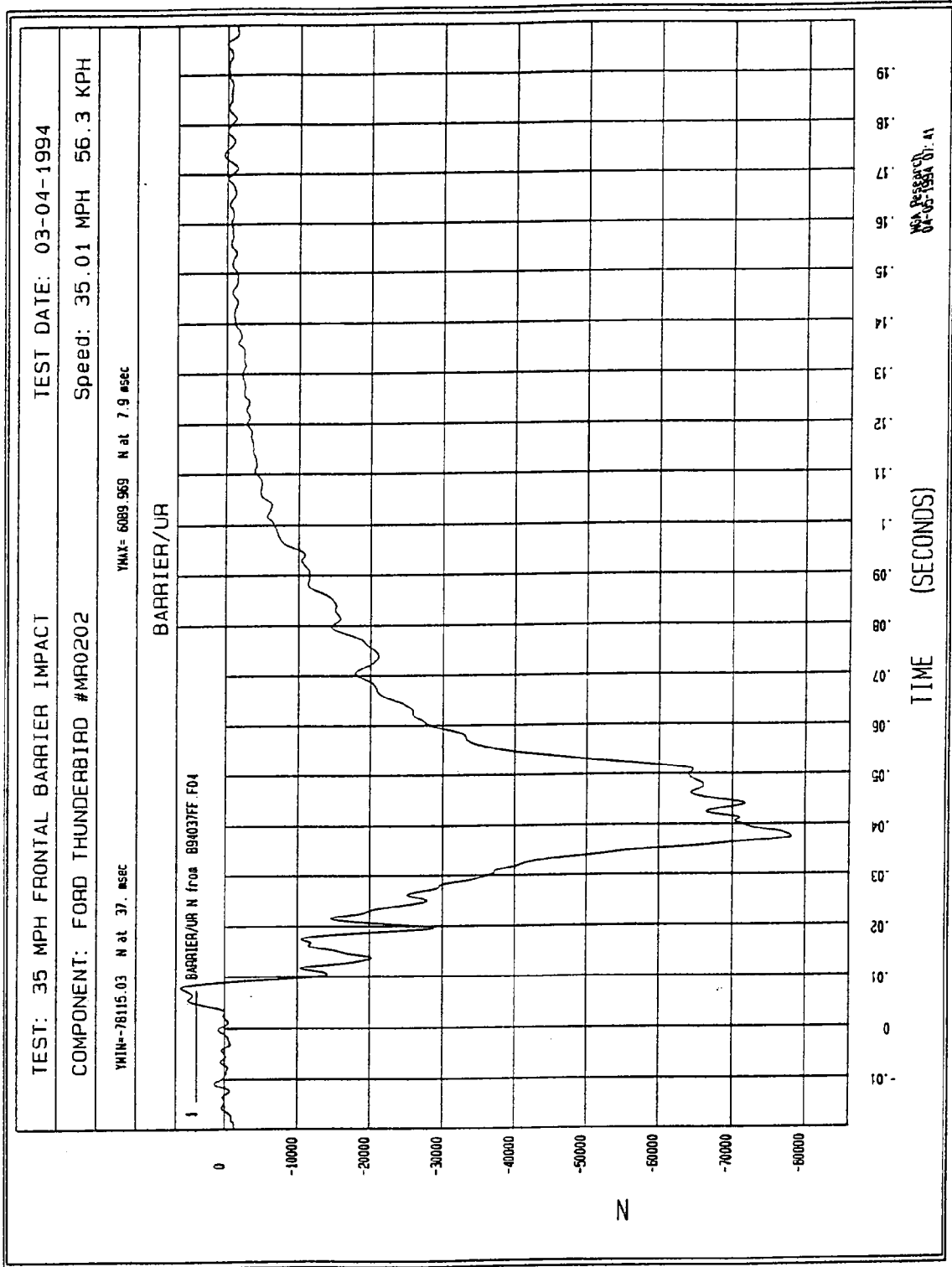

Figure B-25 - Upper Right Barrier Force vs. Time

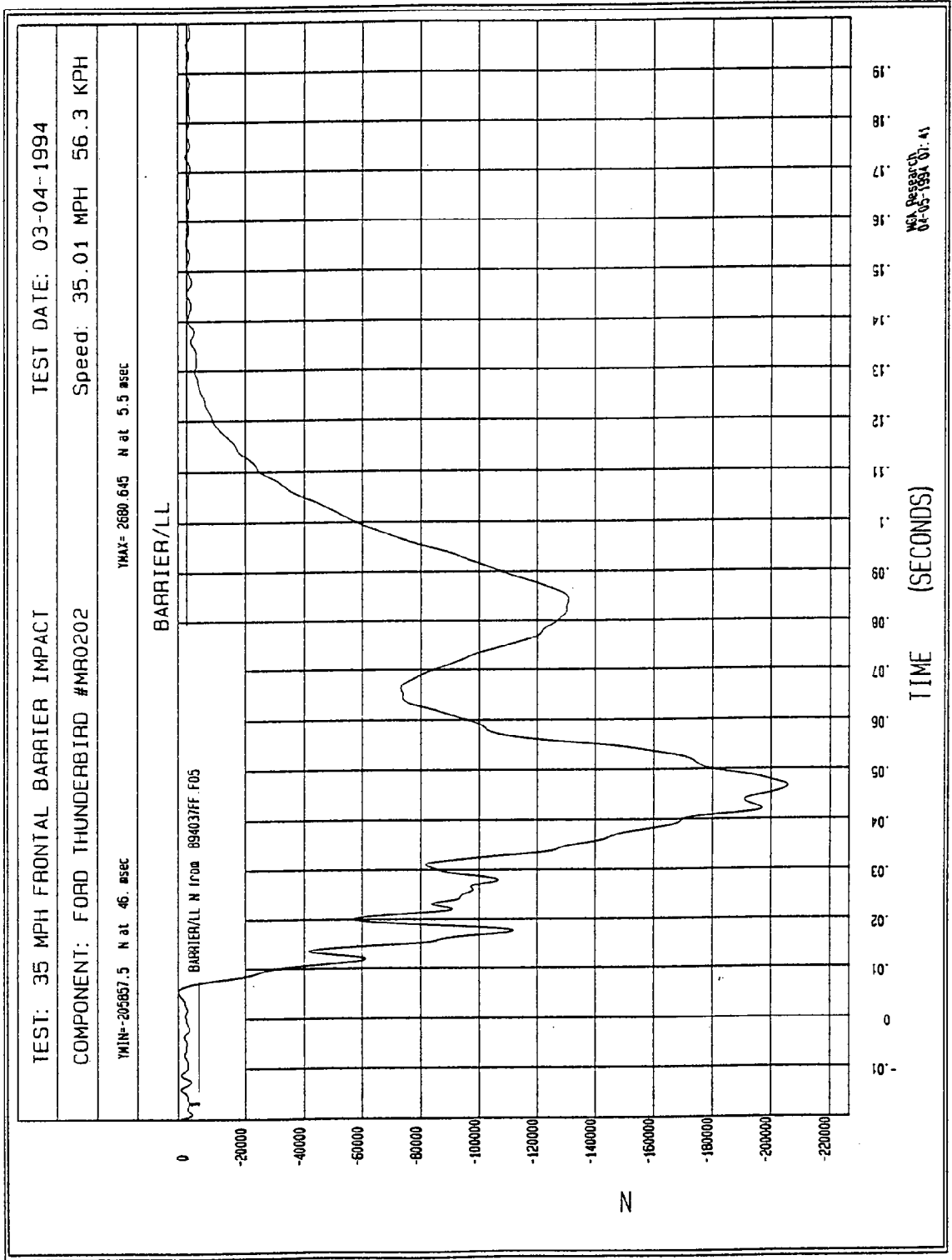

Figure B-26 - Lower Left Barrier Force vs. Time

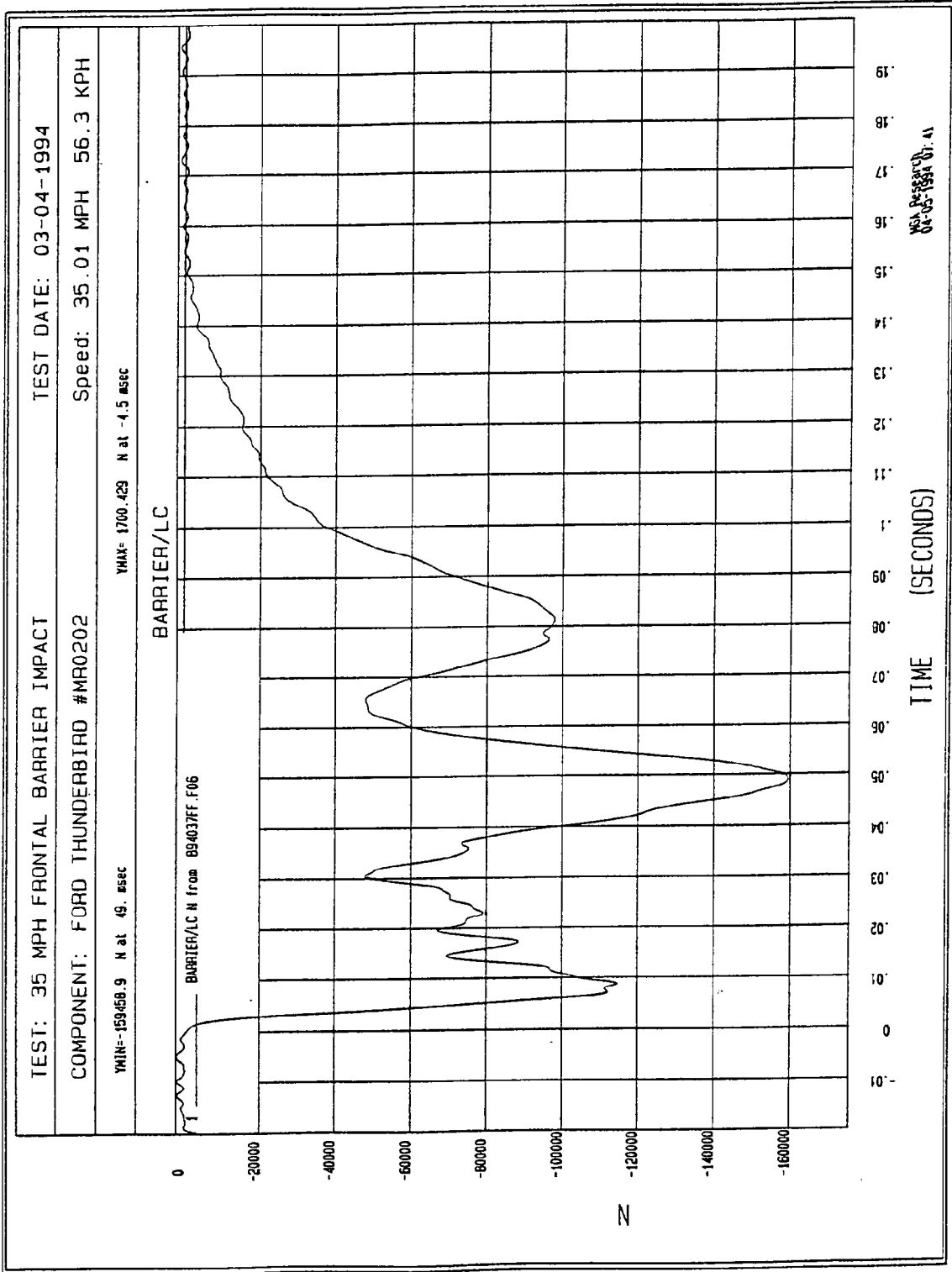

Figure B-27 - Lower Center Barrier Force vs. Time

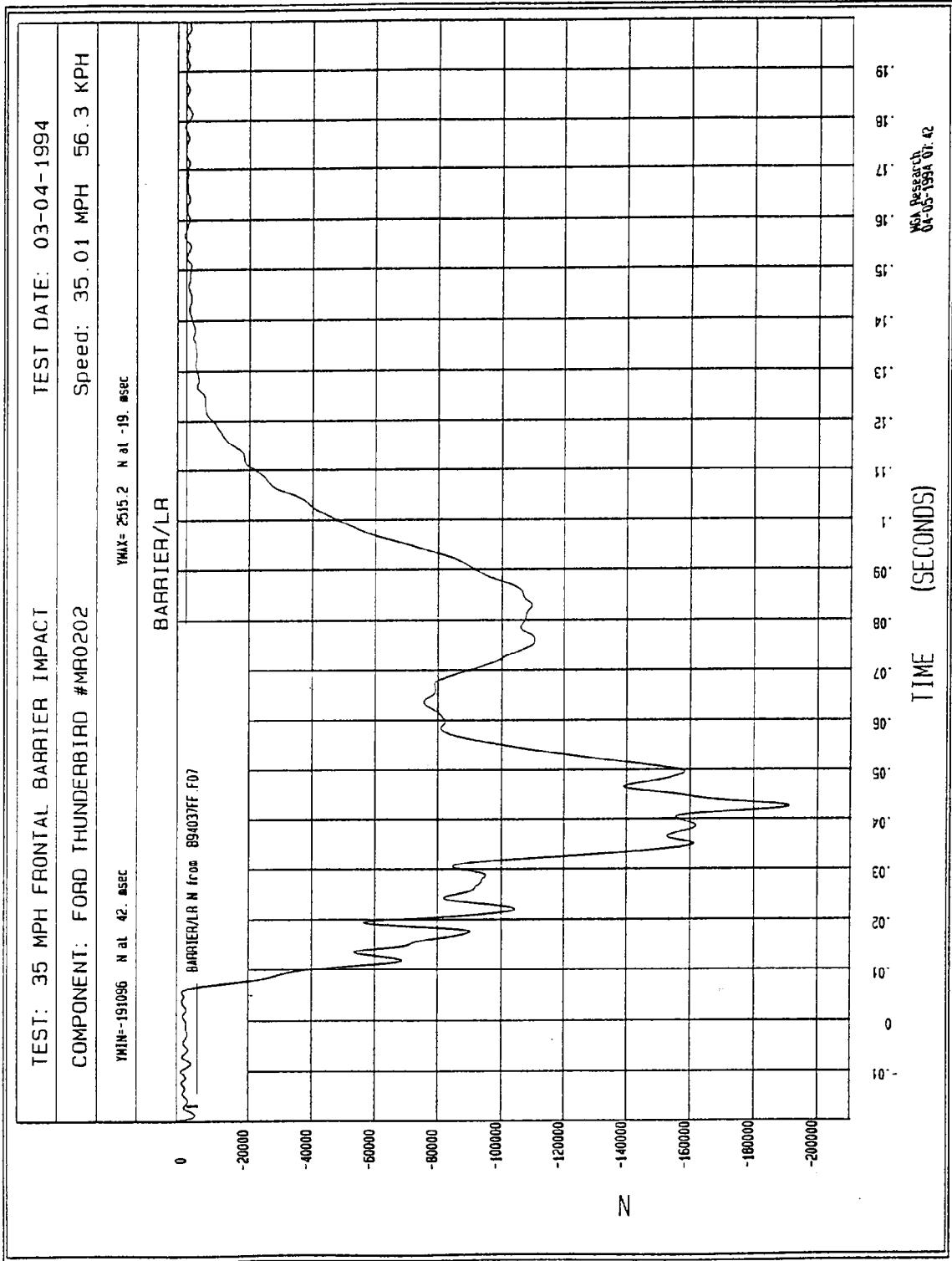

Figure B-28 - Lower Right Barrier Force vs. Time

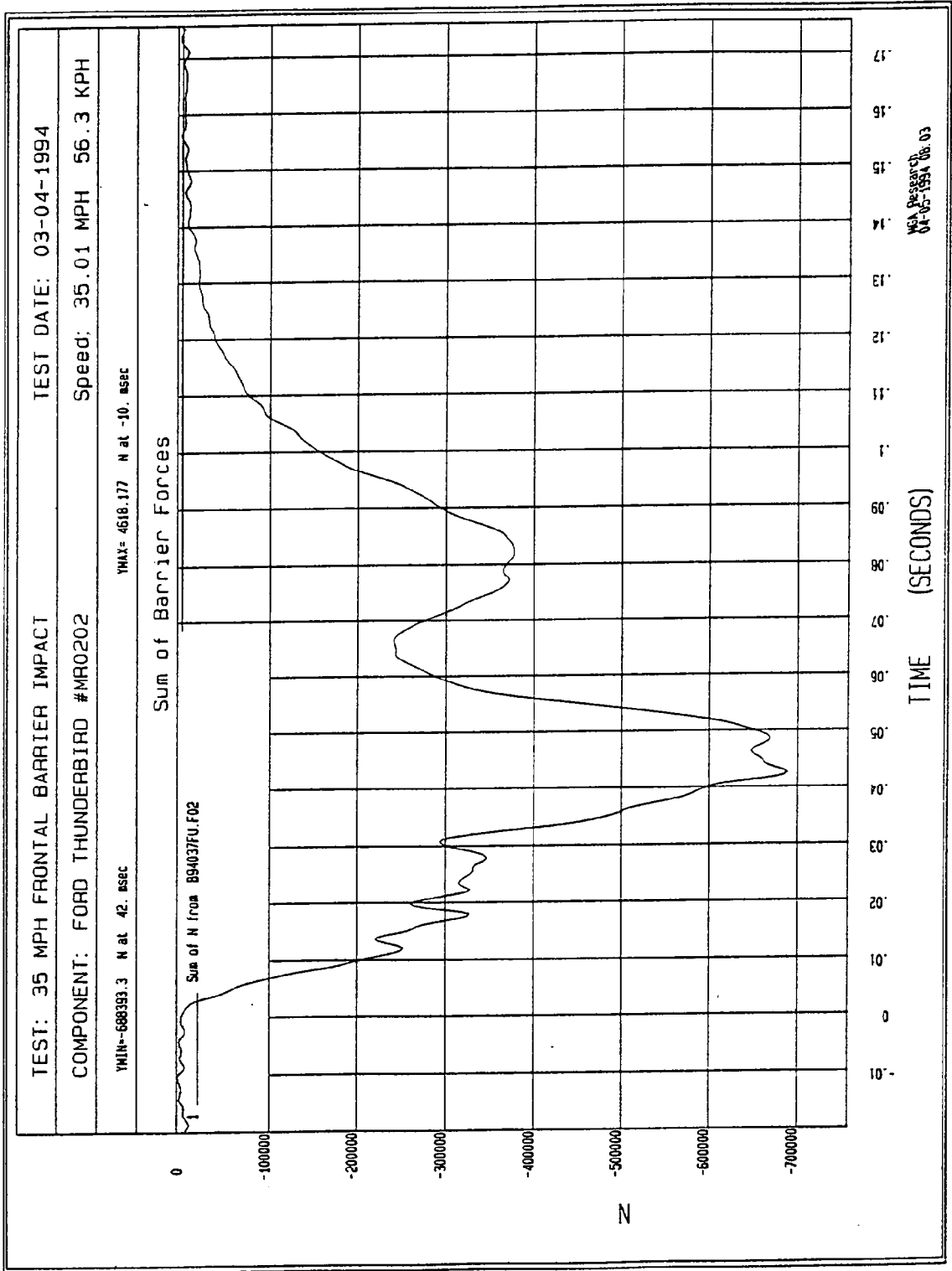
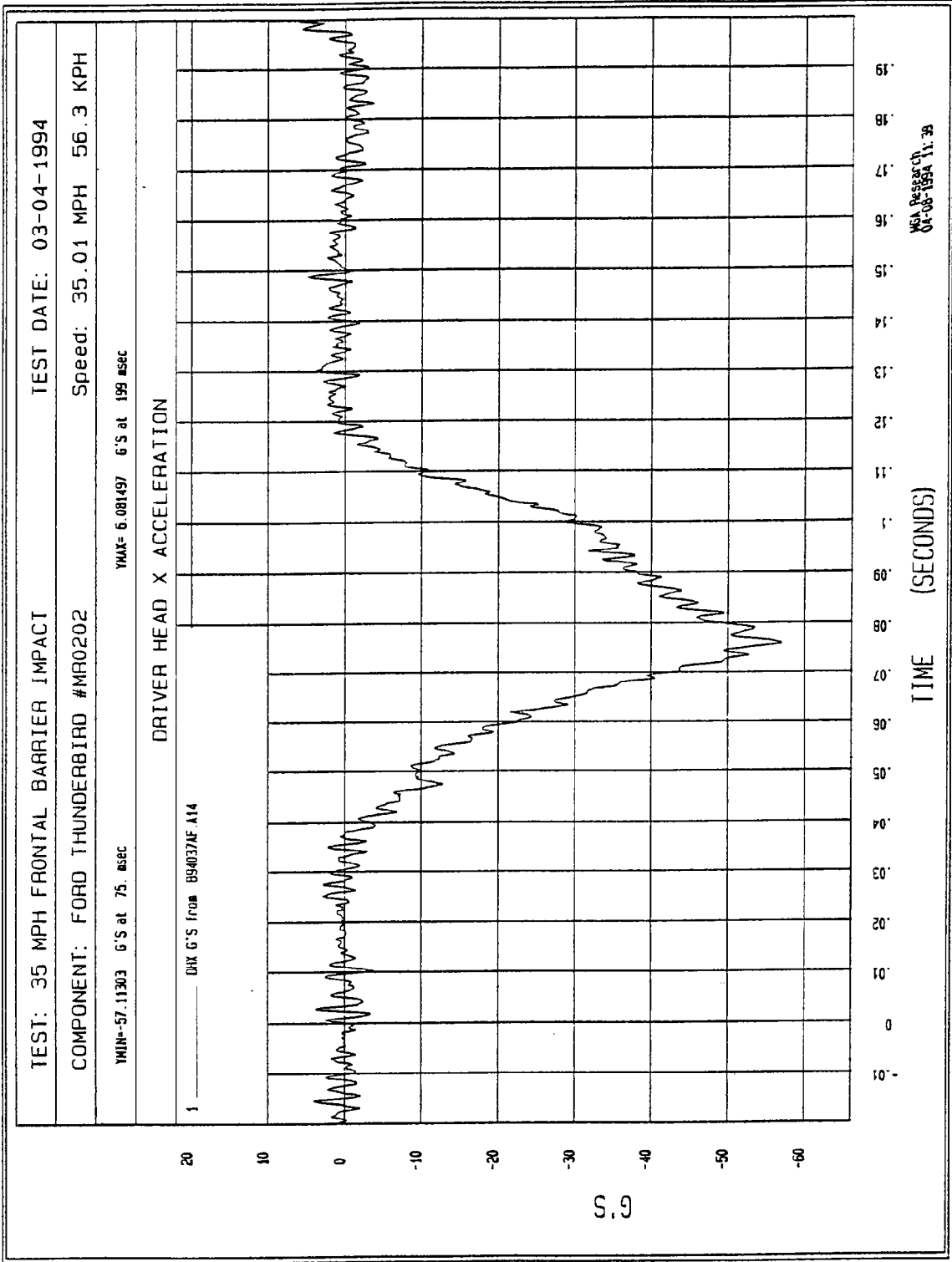
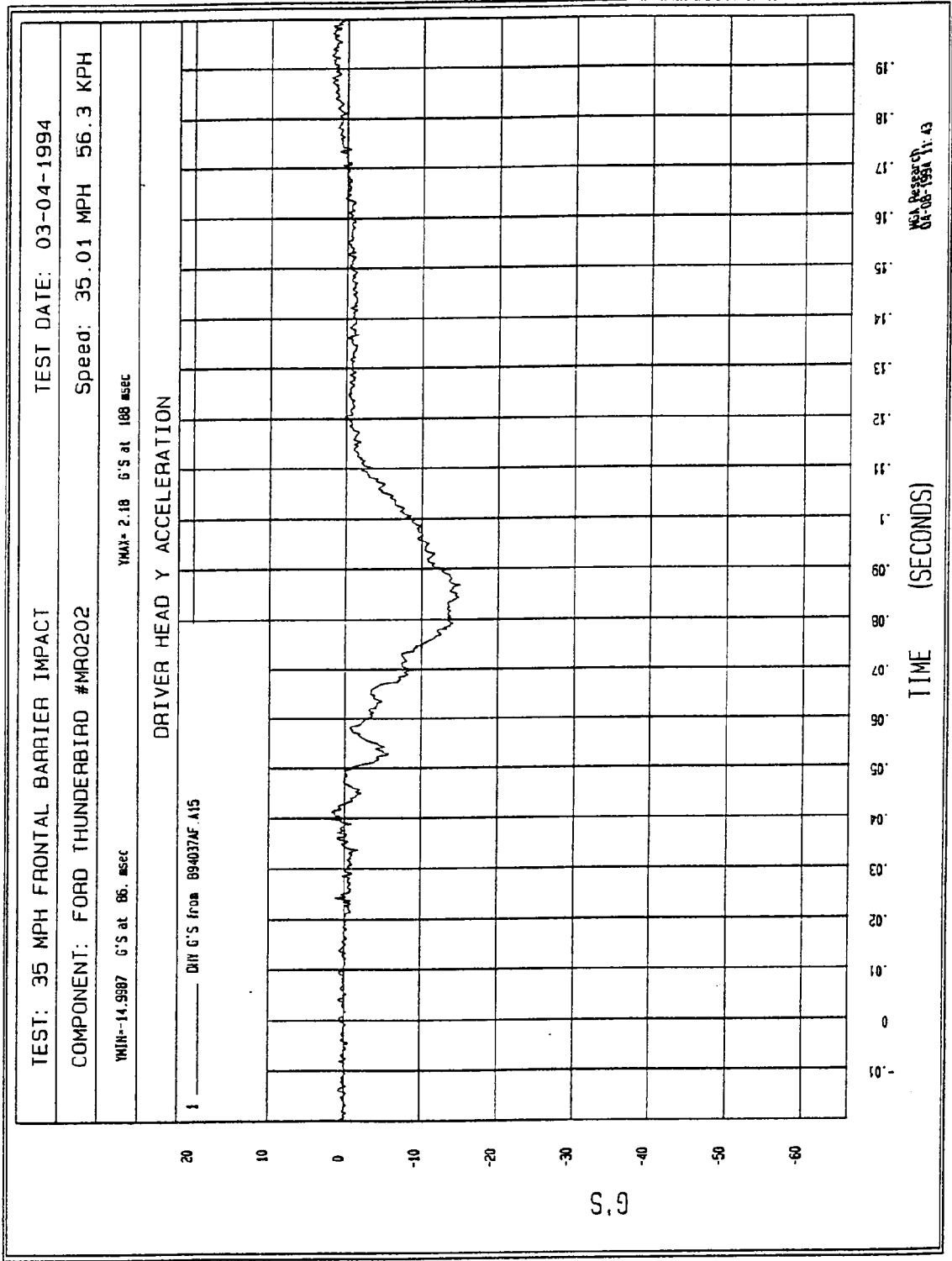

Figure B-29 - Sum of Barrier Forces vs. Time



B-30

Figure B-30 - Driver Head X Acceleration vs. Time



WCA Reference
01-08-1994 11.43

Figure B-31 - Driver Head Y Acceleration vs. Time

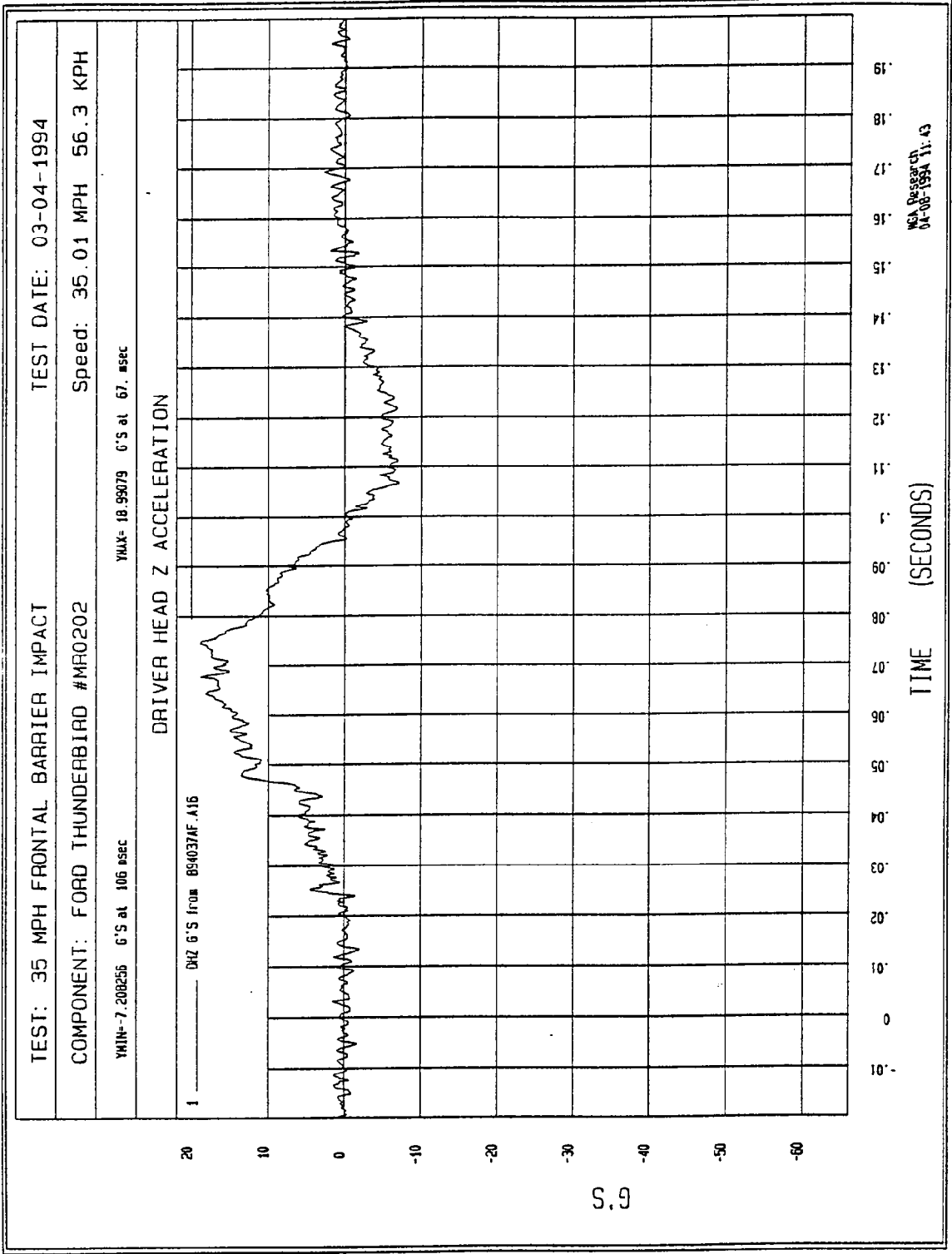

Figure B-32 - Driver Head Z Acceleration vs. Time

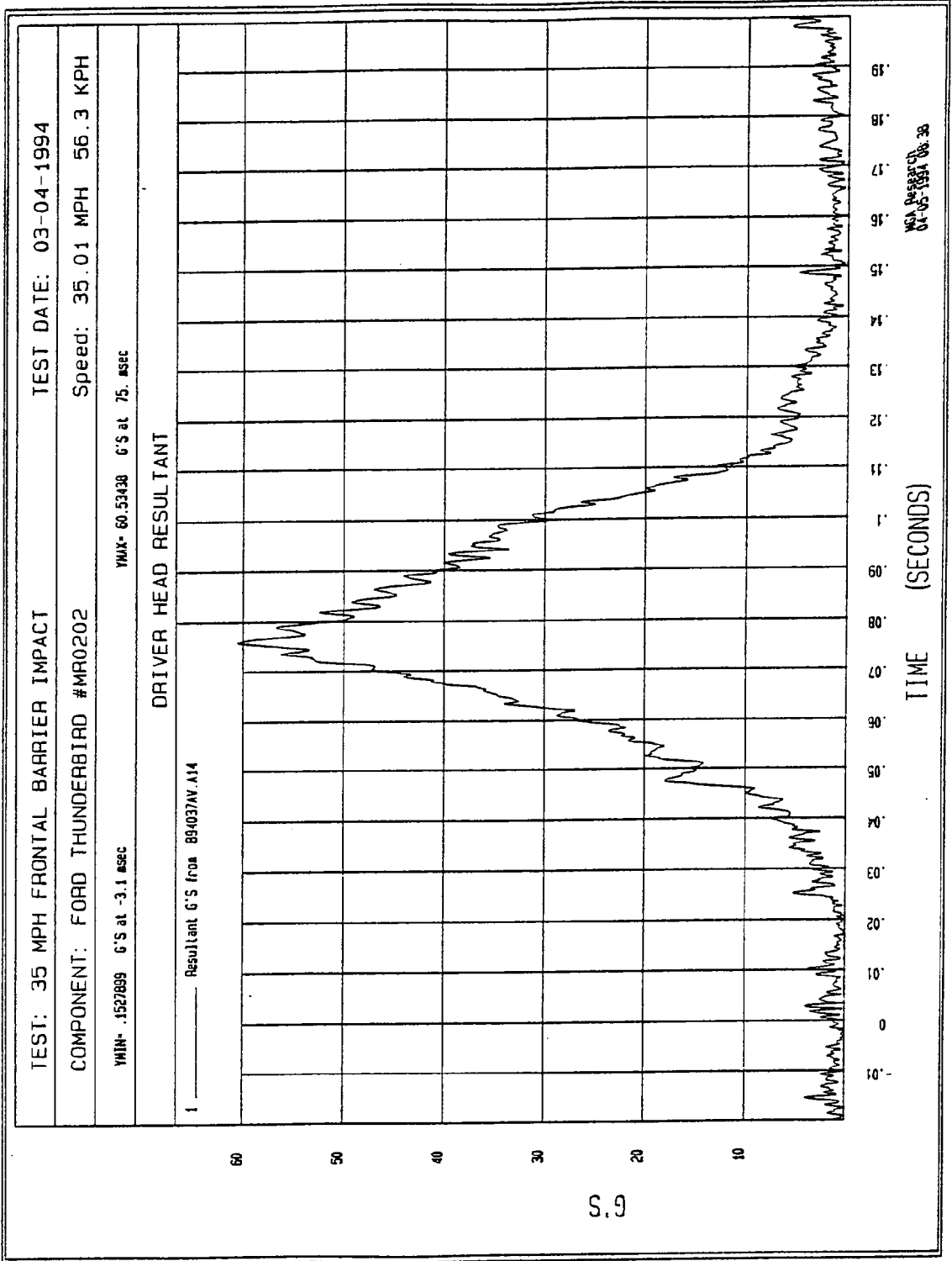

Figure B-33 - Driver Head Resultant Acceleration vs. Time

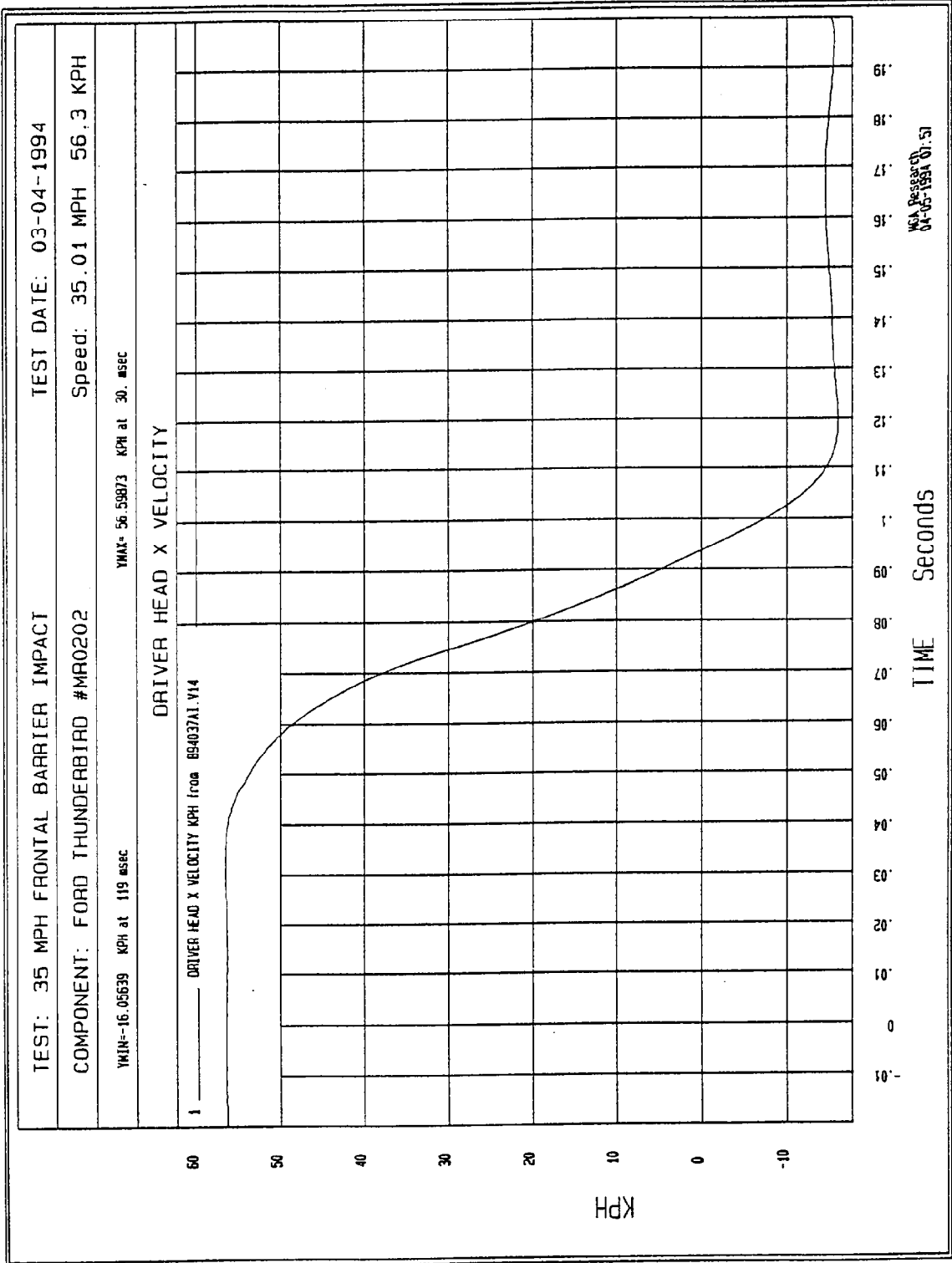
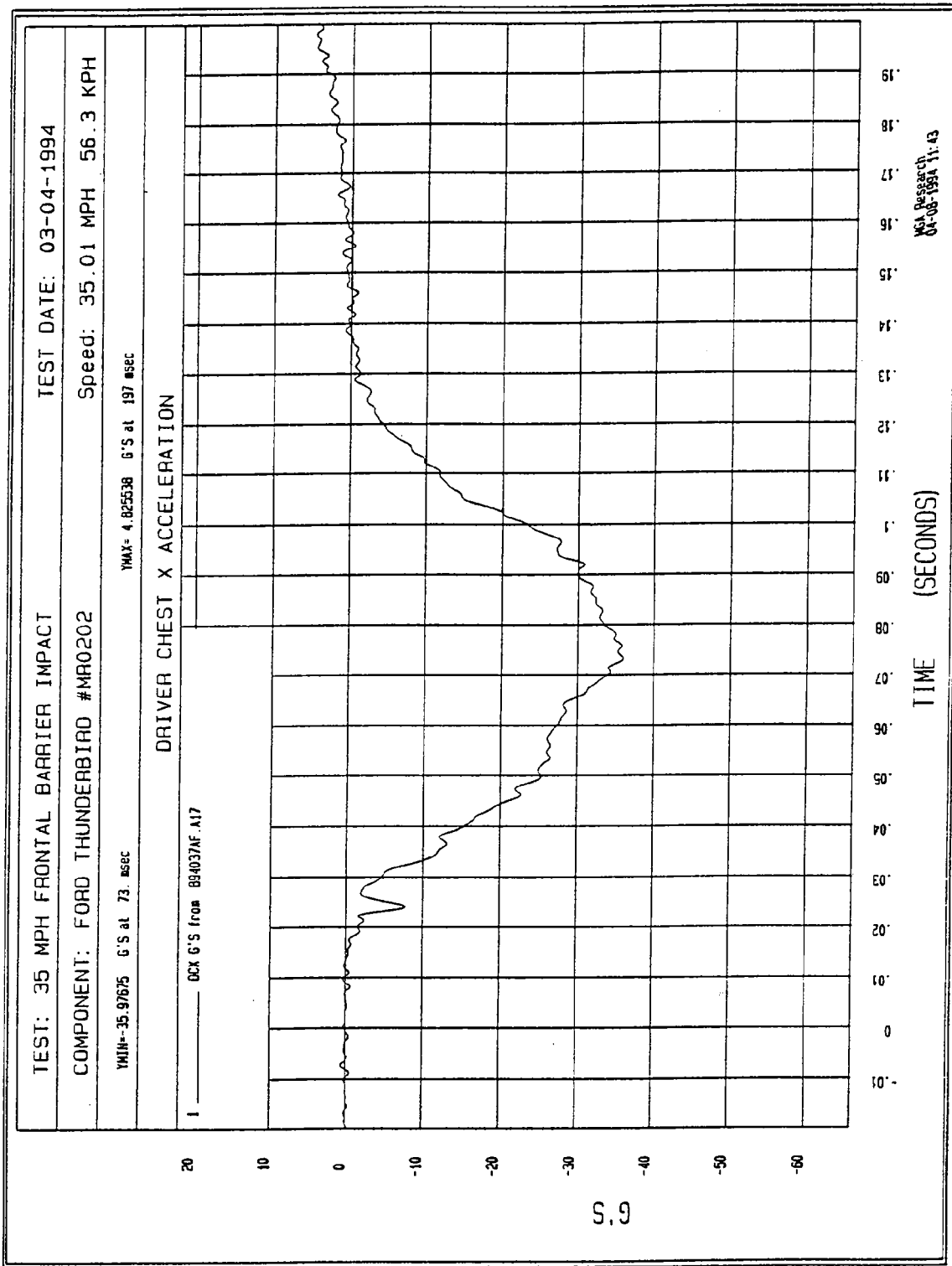

Figure B-34 - Driver Head X Velocity vs. Time



MCA Research
04-06-1994 11:43

Figure B-35 - Driver Chest X Acceleration vs. Time

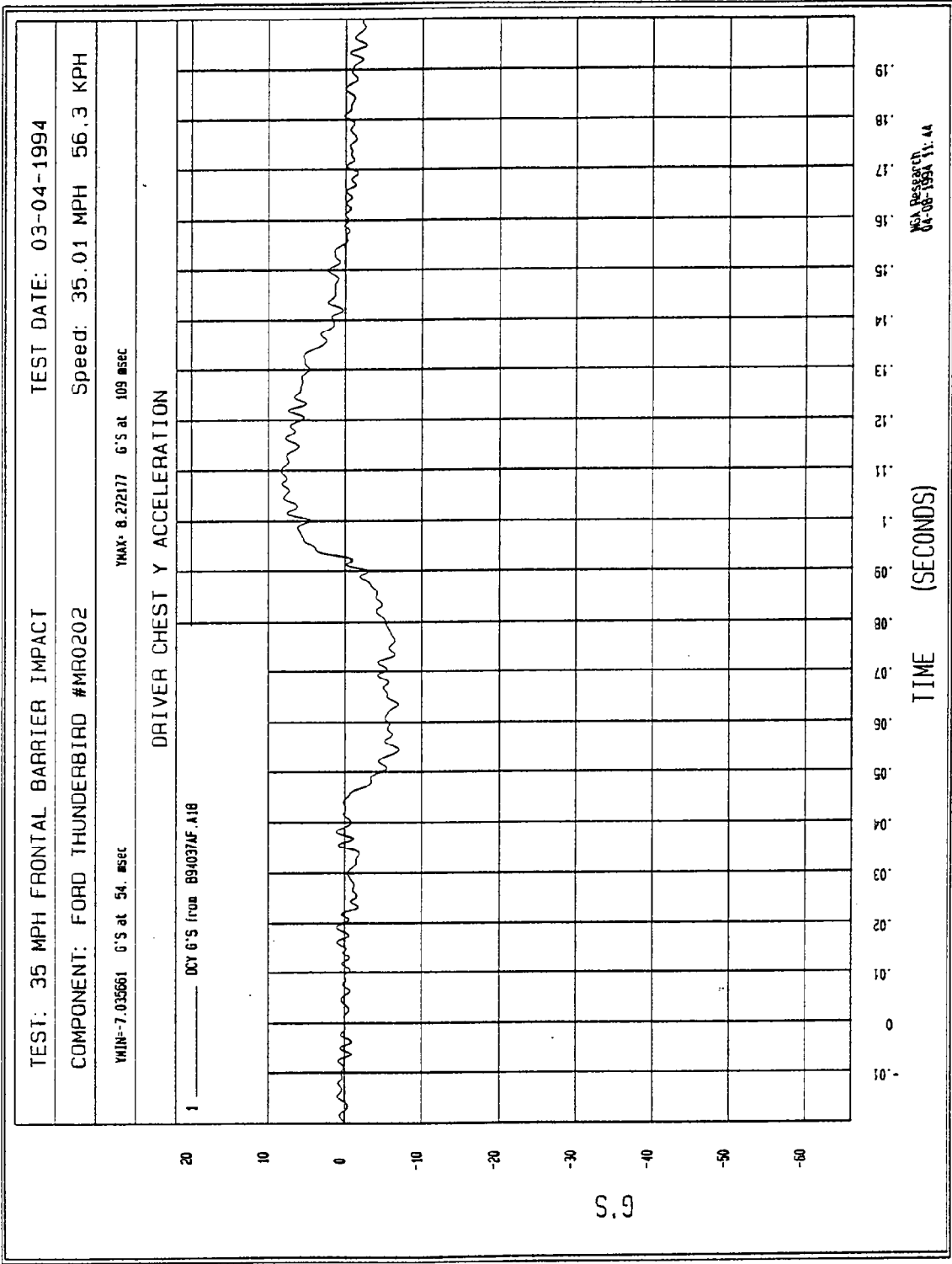

Figure B-36 - Driver Chest Y Acceleration vs. Time

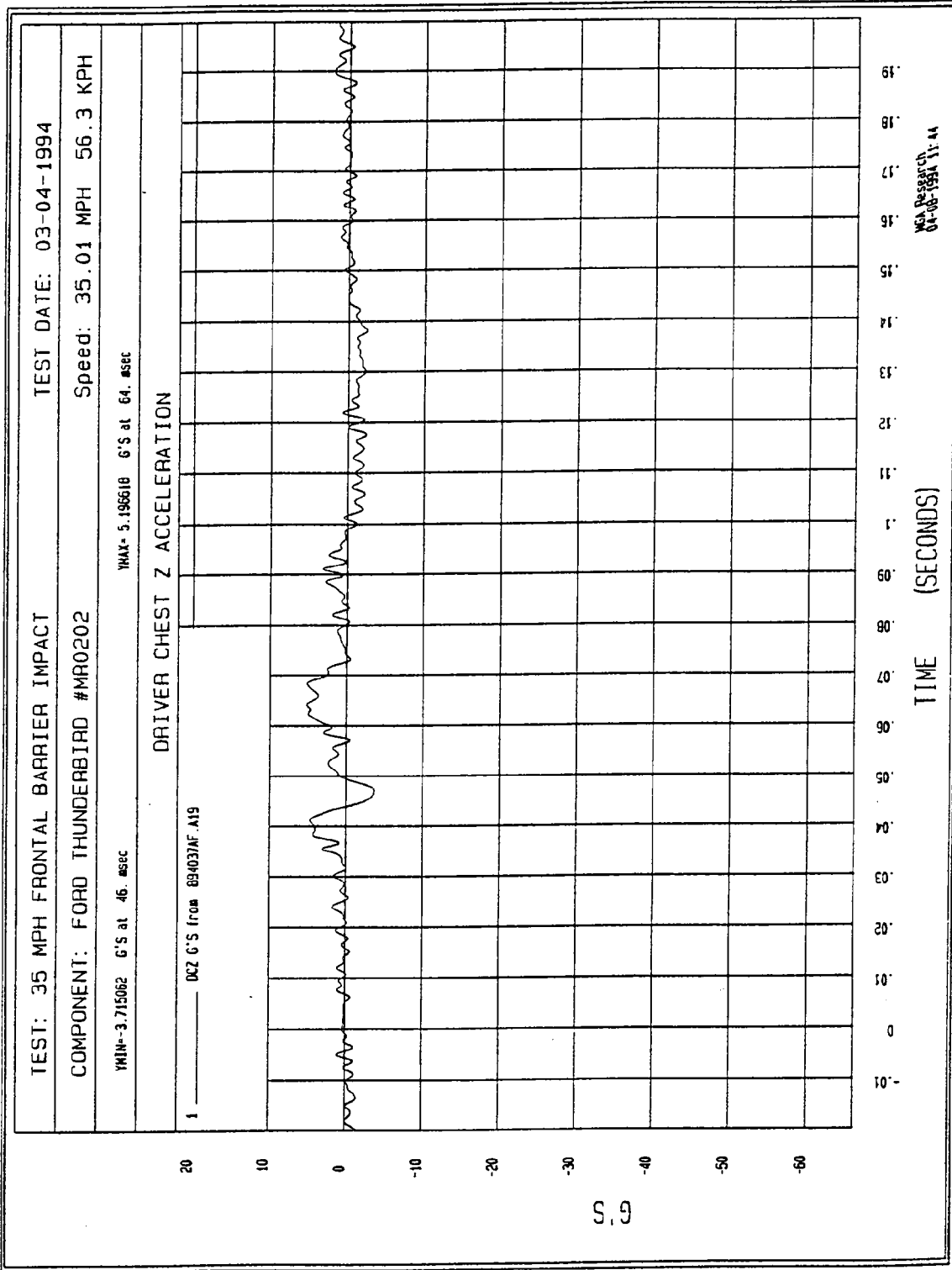

Figure B-37 - Driver Chest Z Acceleration vs. Time

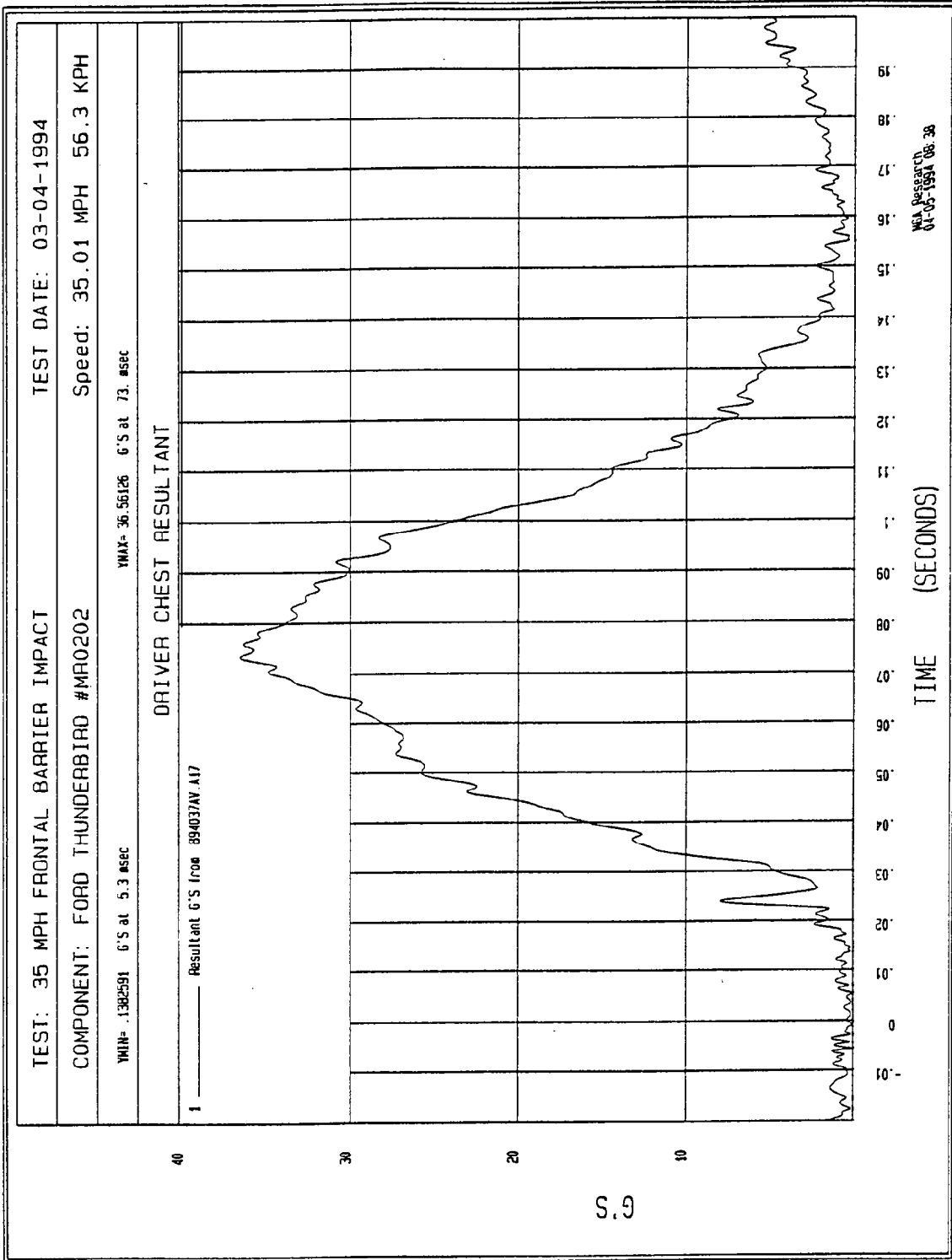

Figure B-38 - Driver Chest Resultant vs. Time

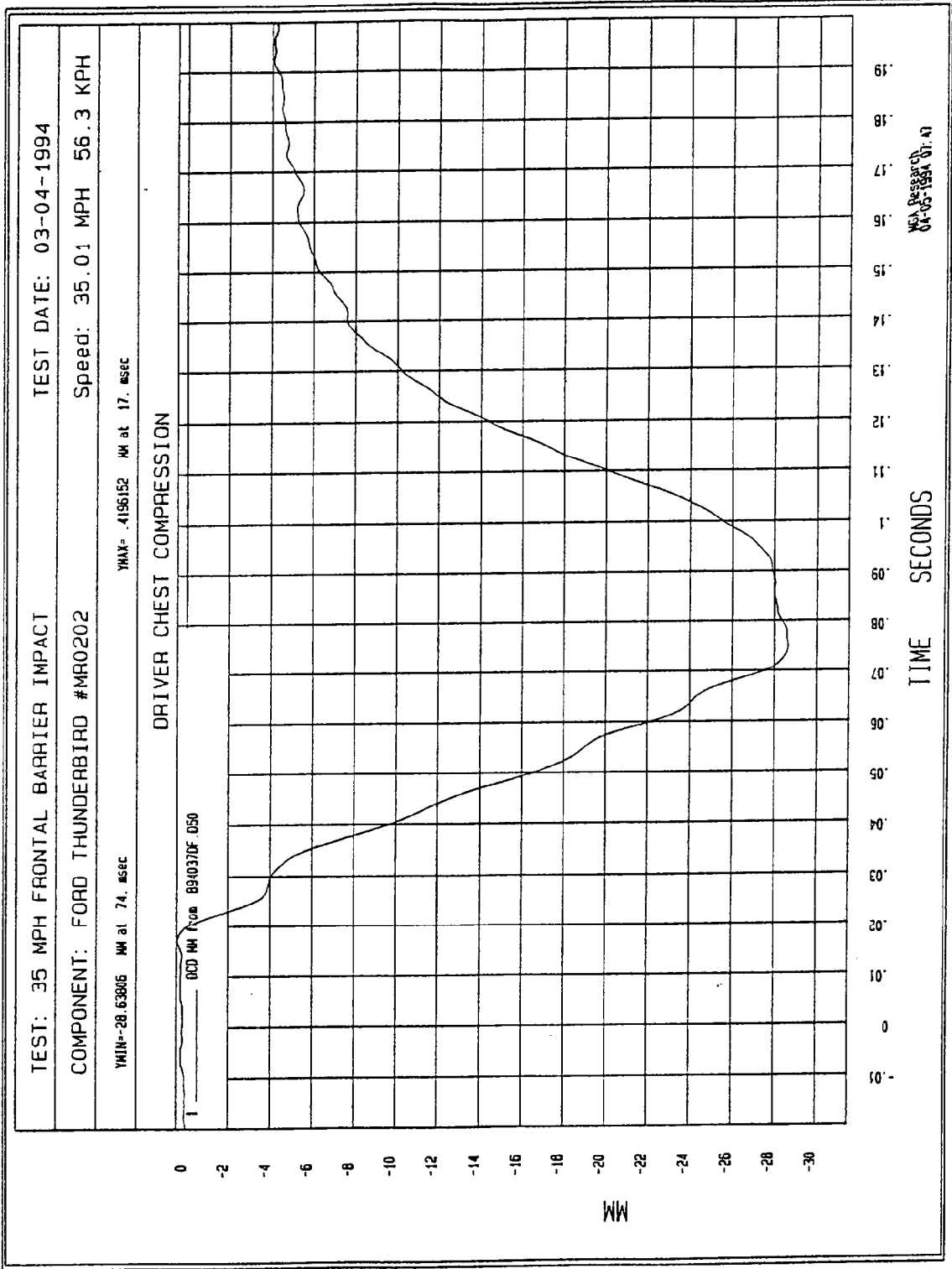
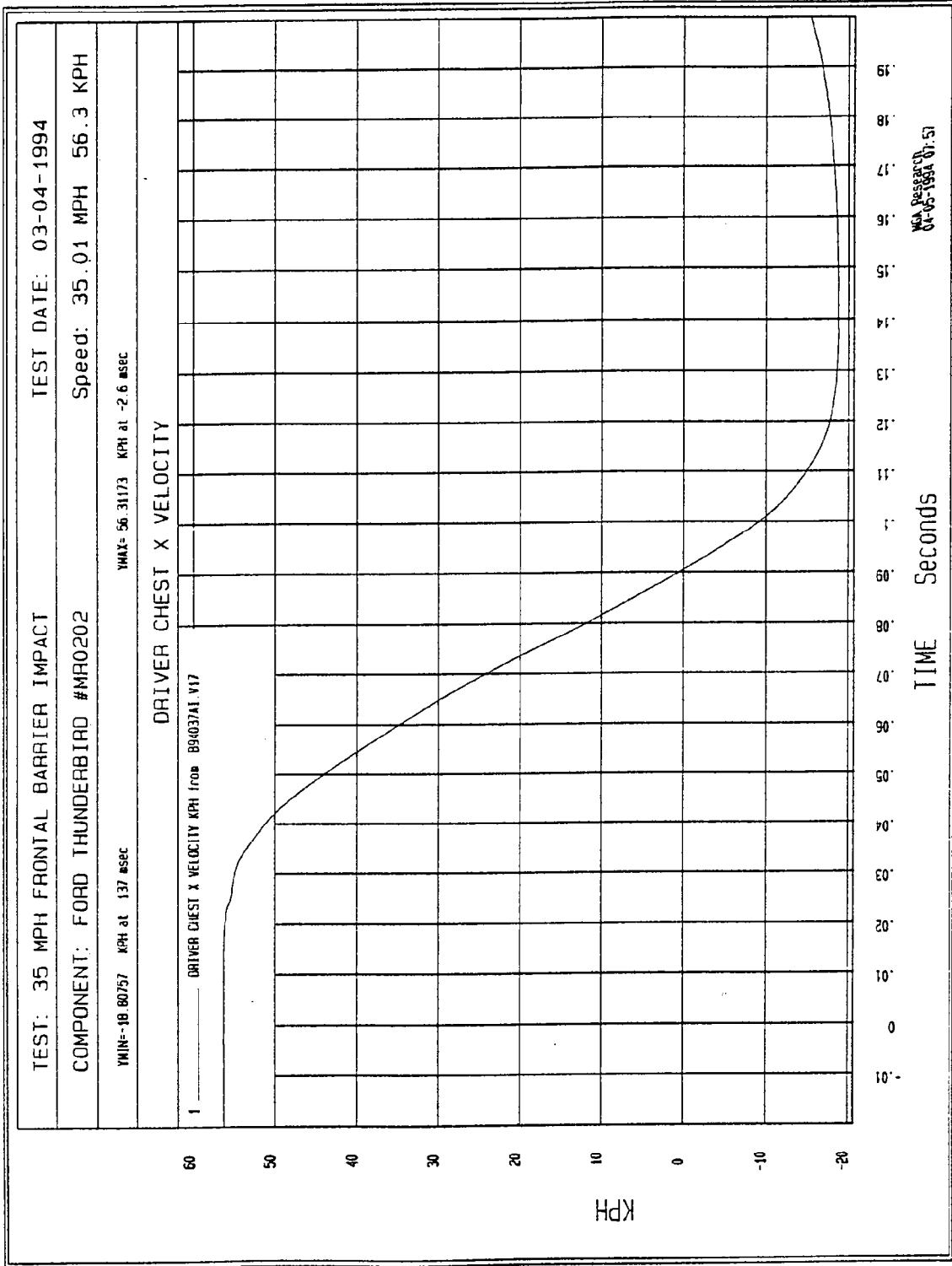
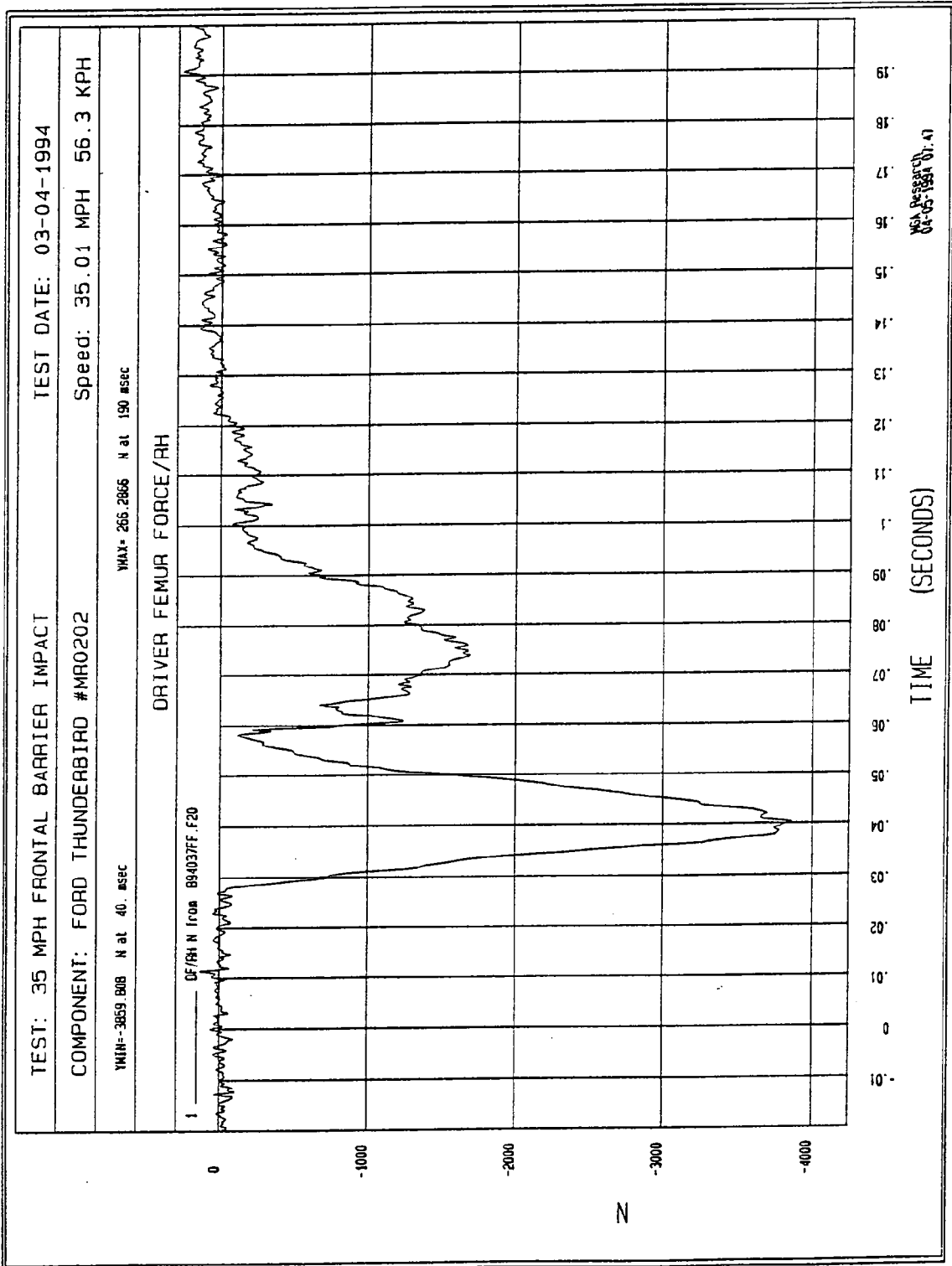

Figure B-39 - Driver Chest Compression vs. Time



B-40

Figure B-40 - Driver Chest X Velocity vs. Time



TIME (SECONDS)

0 0.01 0.02 0.03 0.04 0.05 0.06 0.07 0.08 0.09 0.10 0.11 0.12 0.13 0.14 0.15 0.16 0.17 0.18 0.19

MGA Research
03-05-1994 07.4)

Figure B-41 - Driver Right Femur Force vs. Time

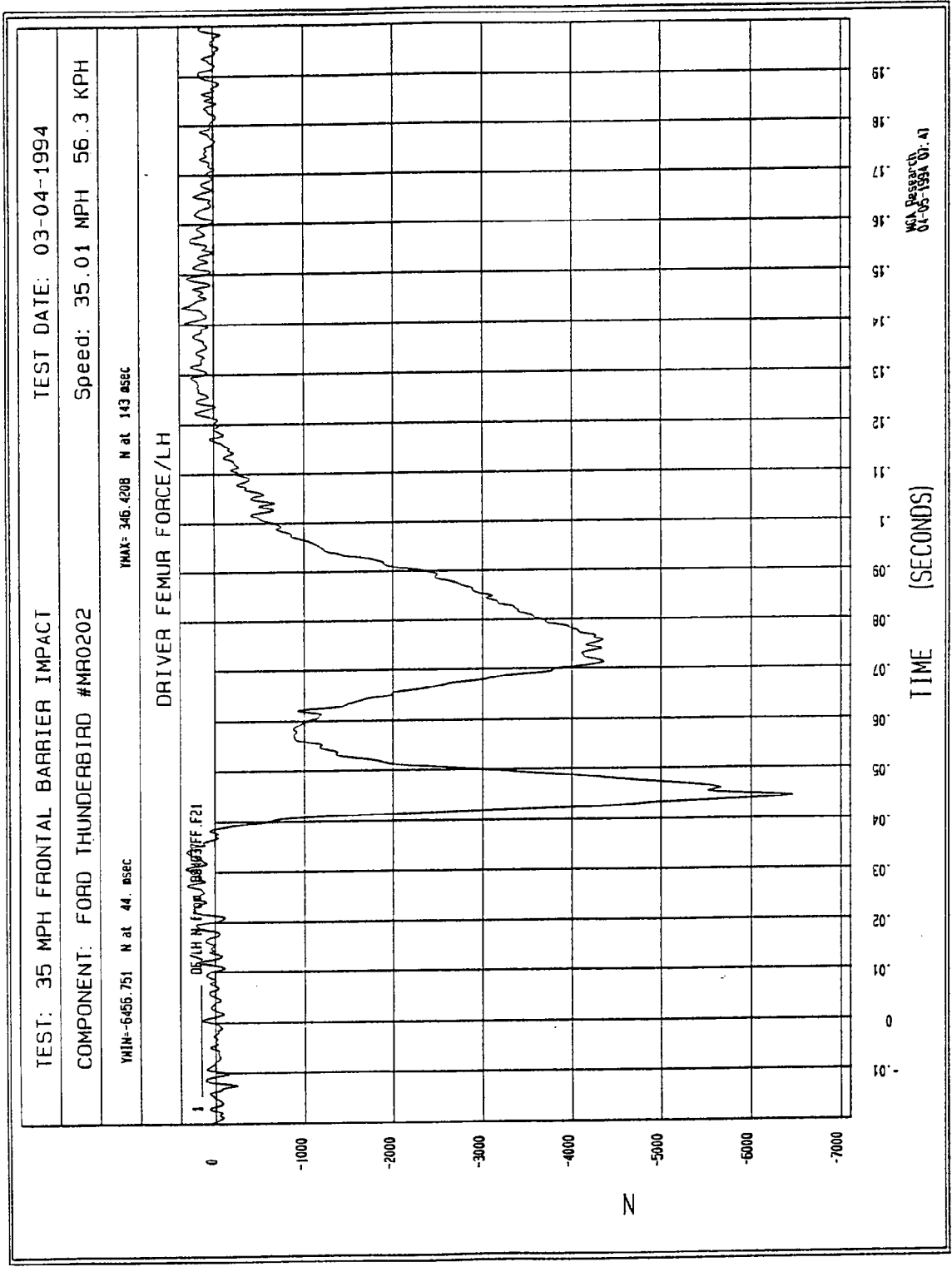

Figure B-42 - Driver Left Femur Force vs. Time

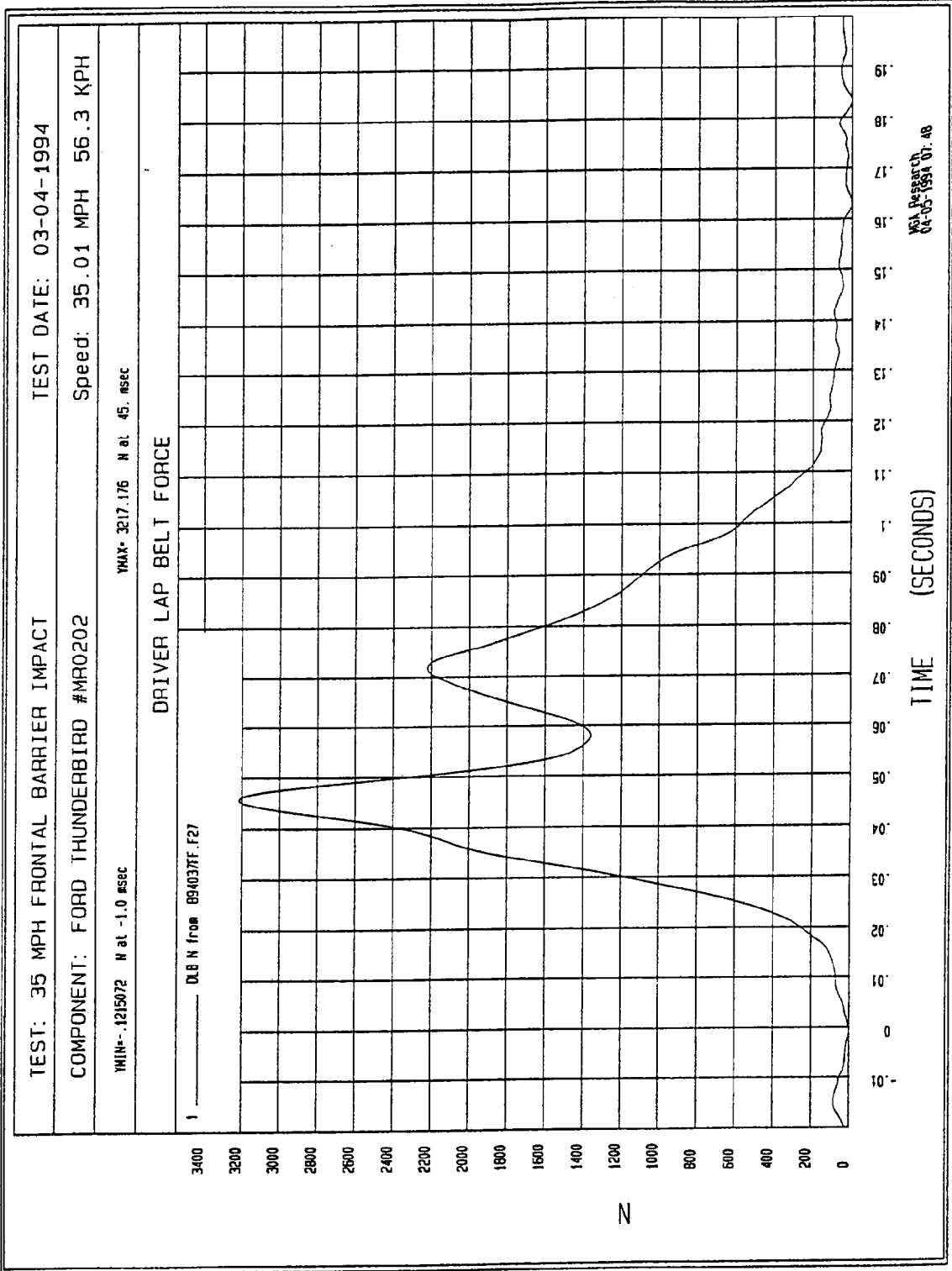

Figure B-43 - Driver Lap Belt Force vs. Time

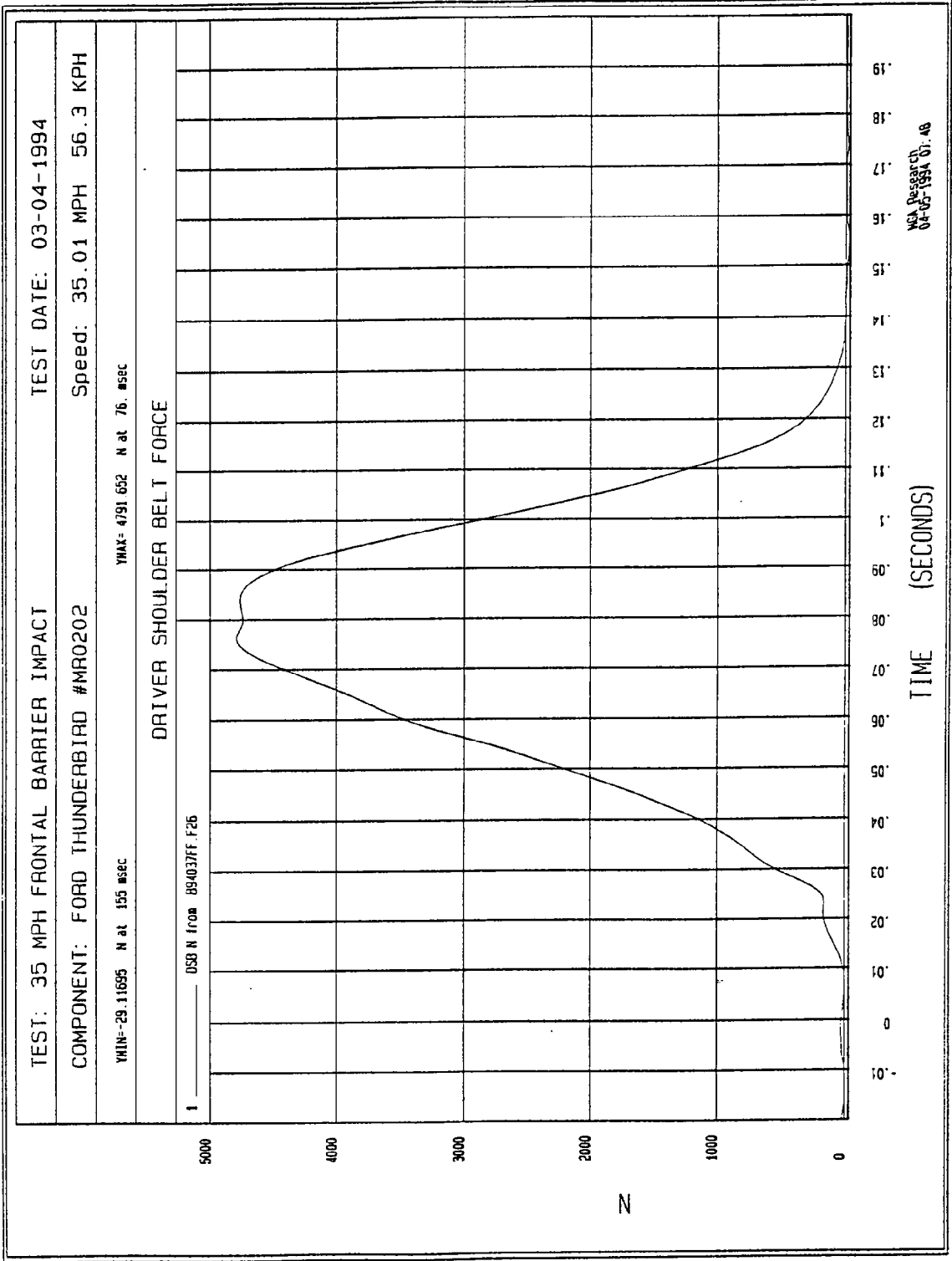
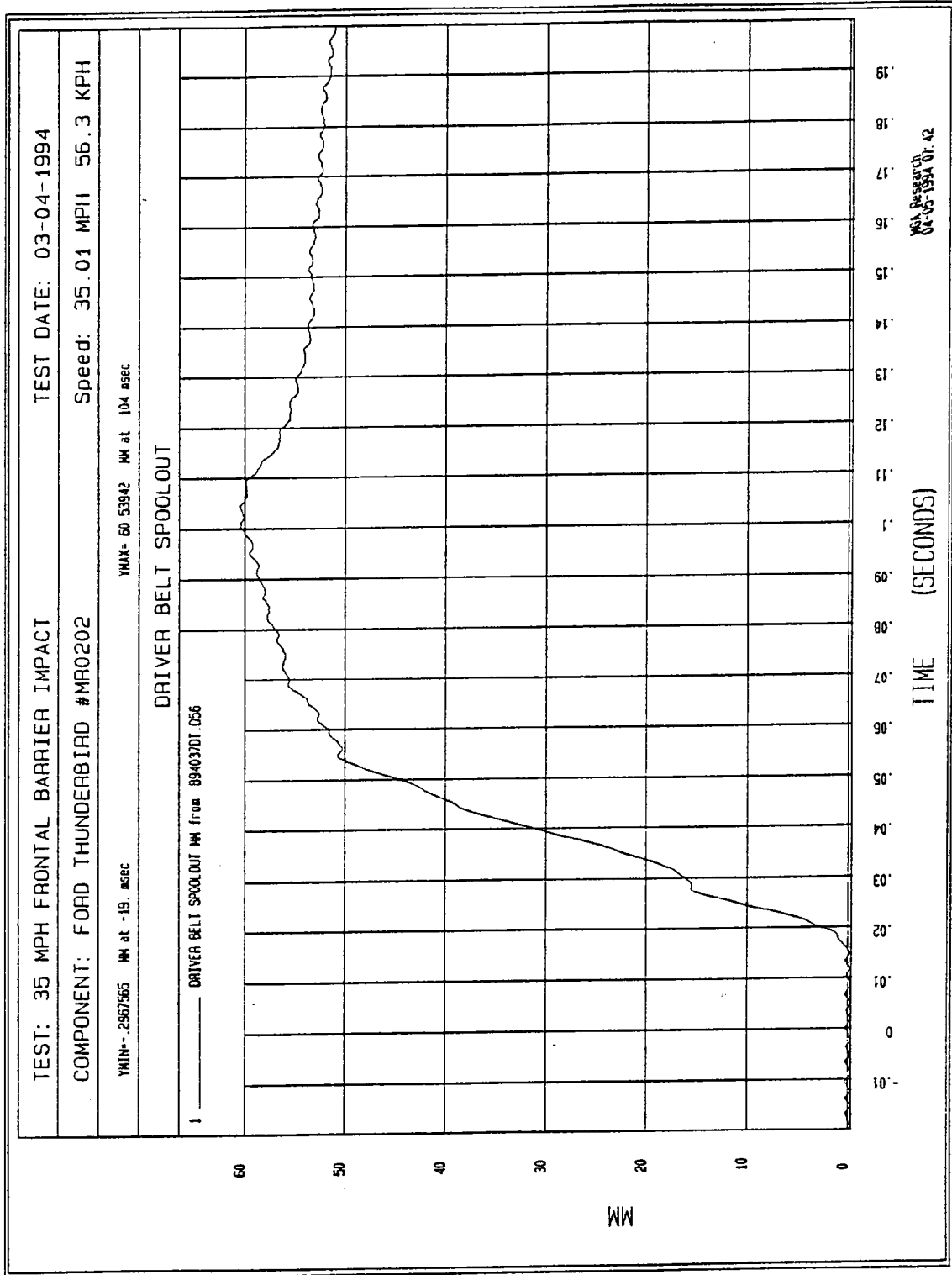

Figure B-44 - Driver Torso Belt Force vs. Time



WSA Research
 04-05-1994 01:42

Figure B-45 - Driver Belt Spoolout

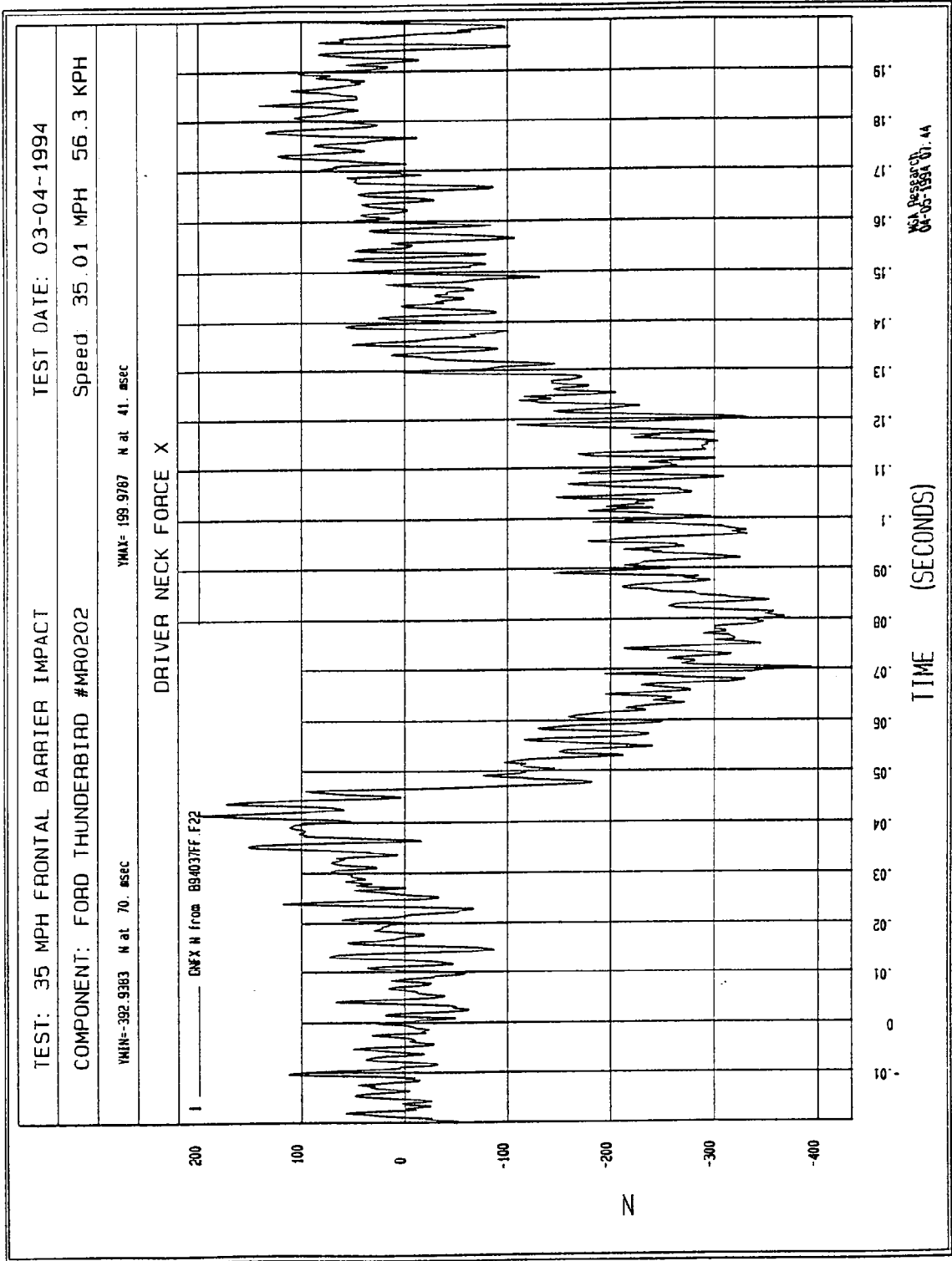

Figure B-46 - Driver Neck Force X vs. Time

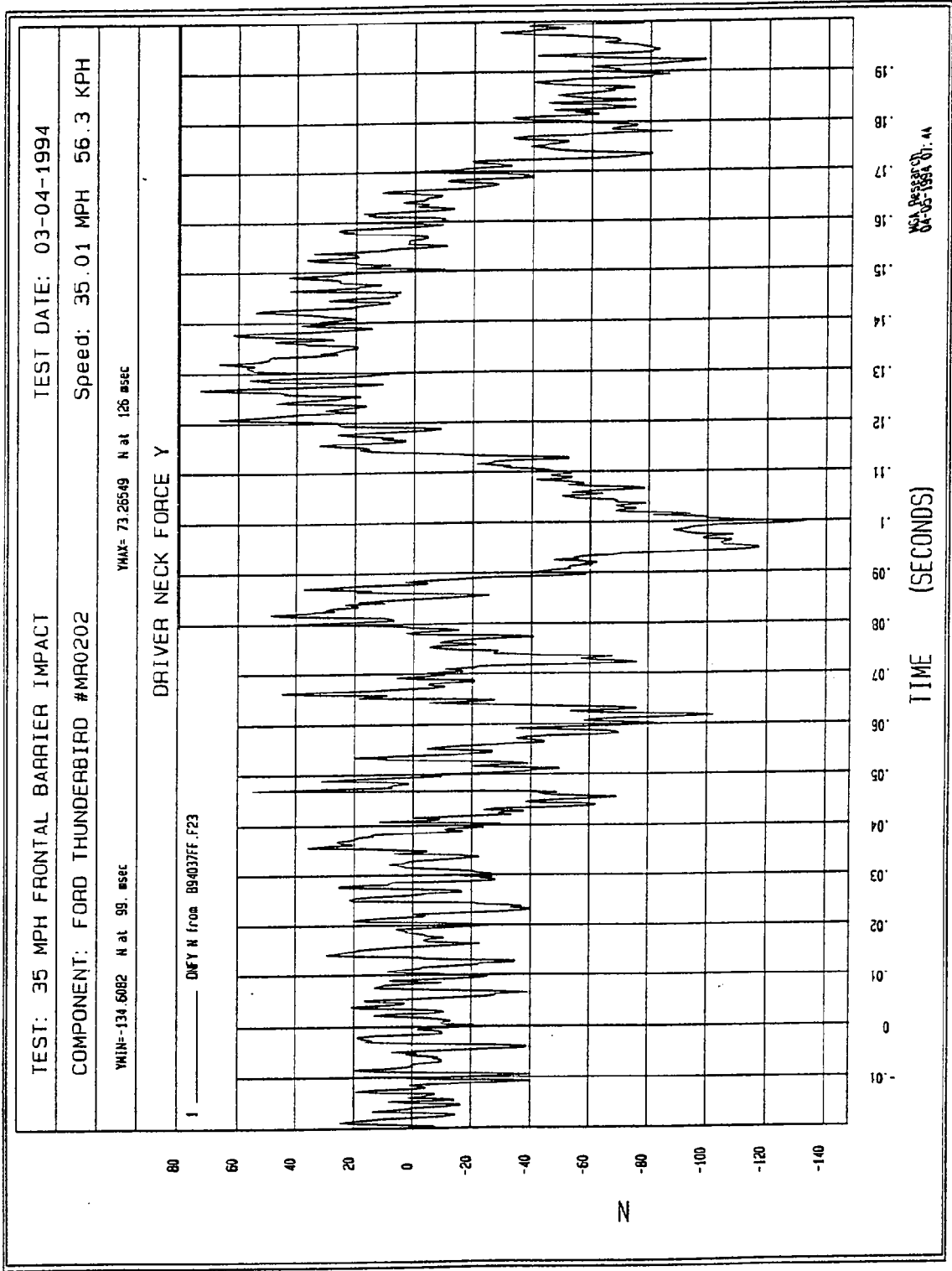

Figure B-47 - Driver Neck Force Y vs. Time

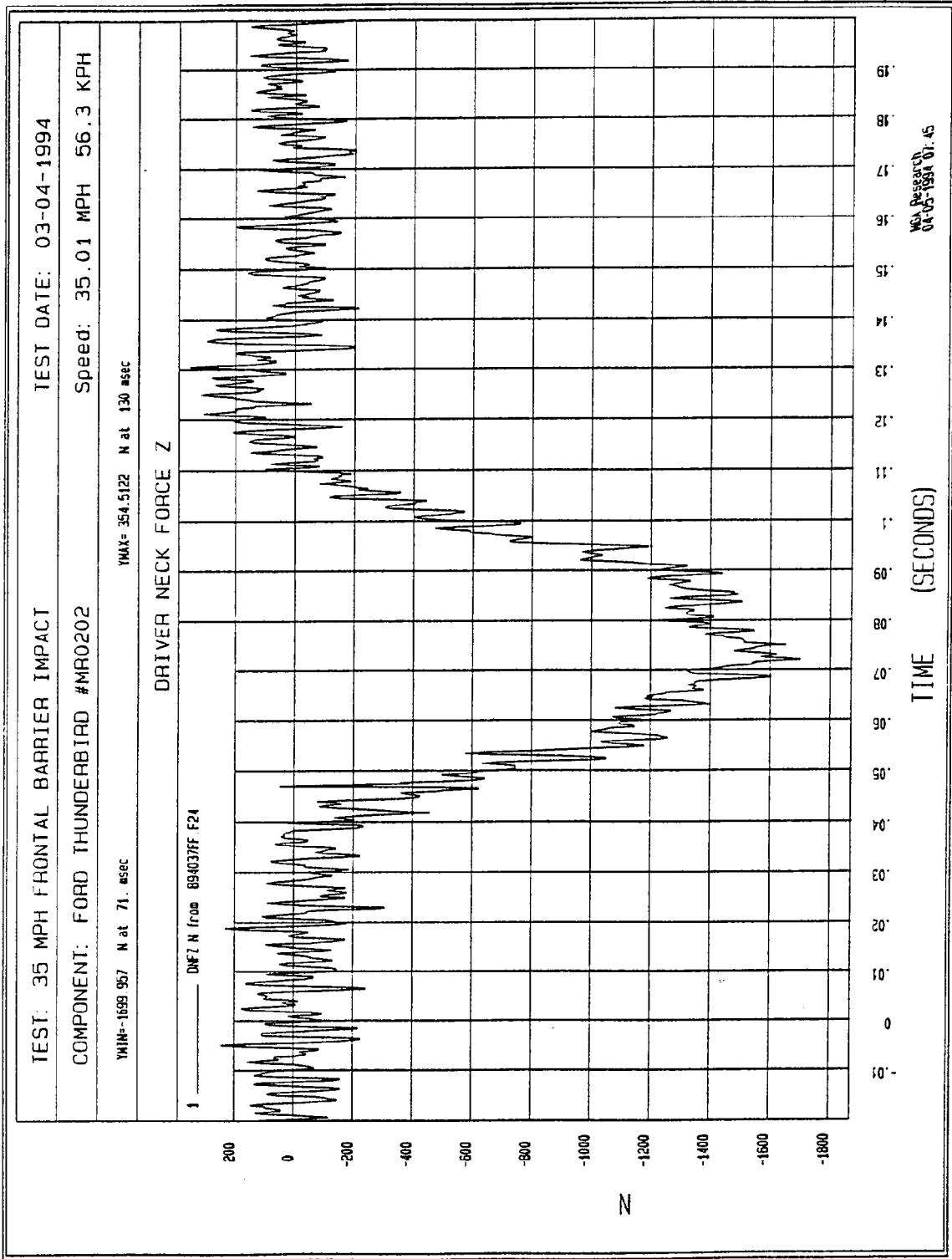

Figure B-48 - Driver Neck Force Z vs. Time

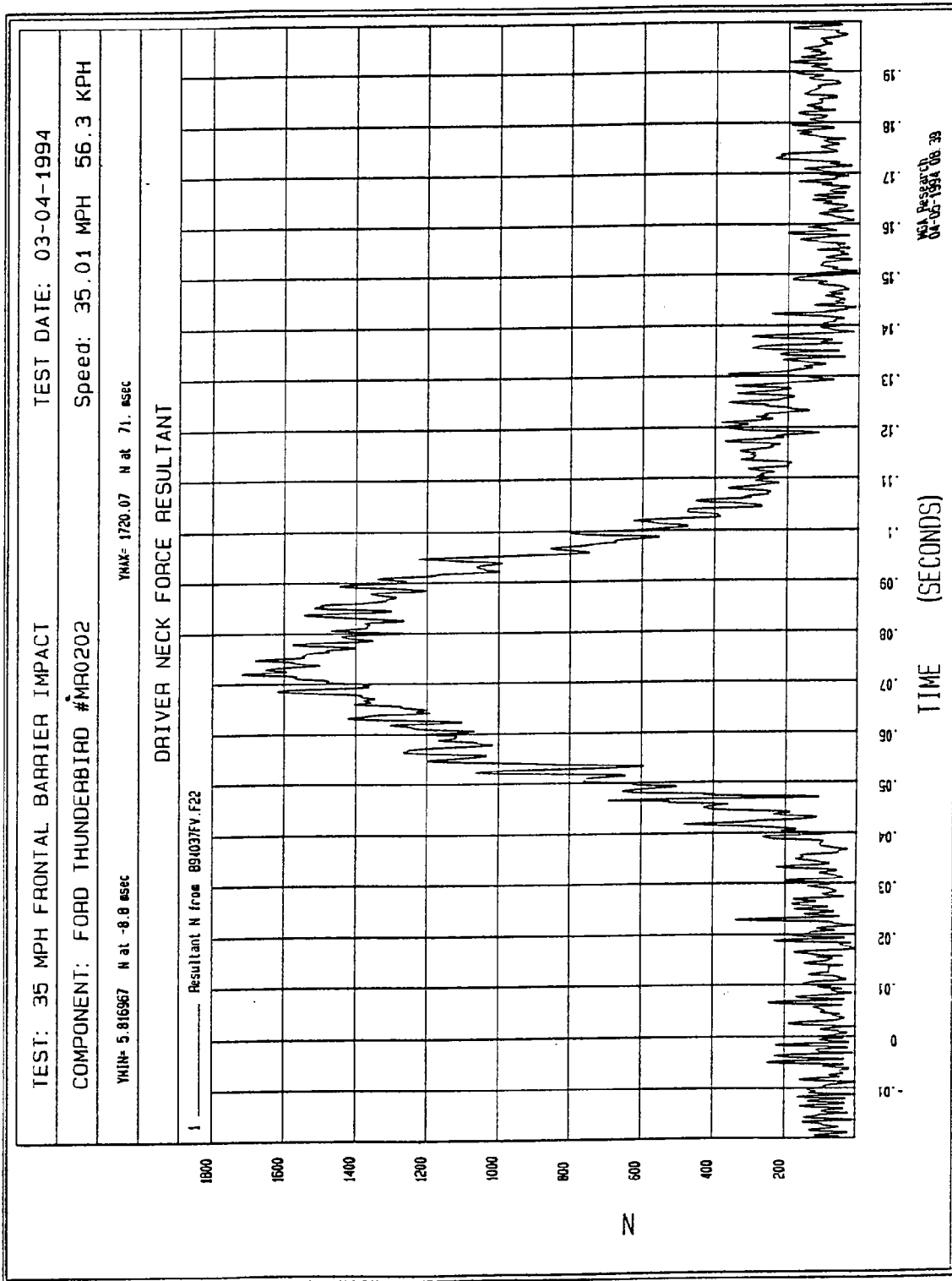

Figure B-49 - Driver Neck Force Resultant vs. Time

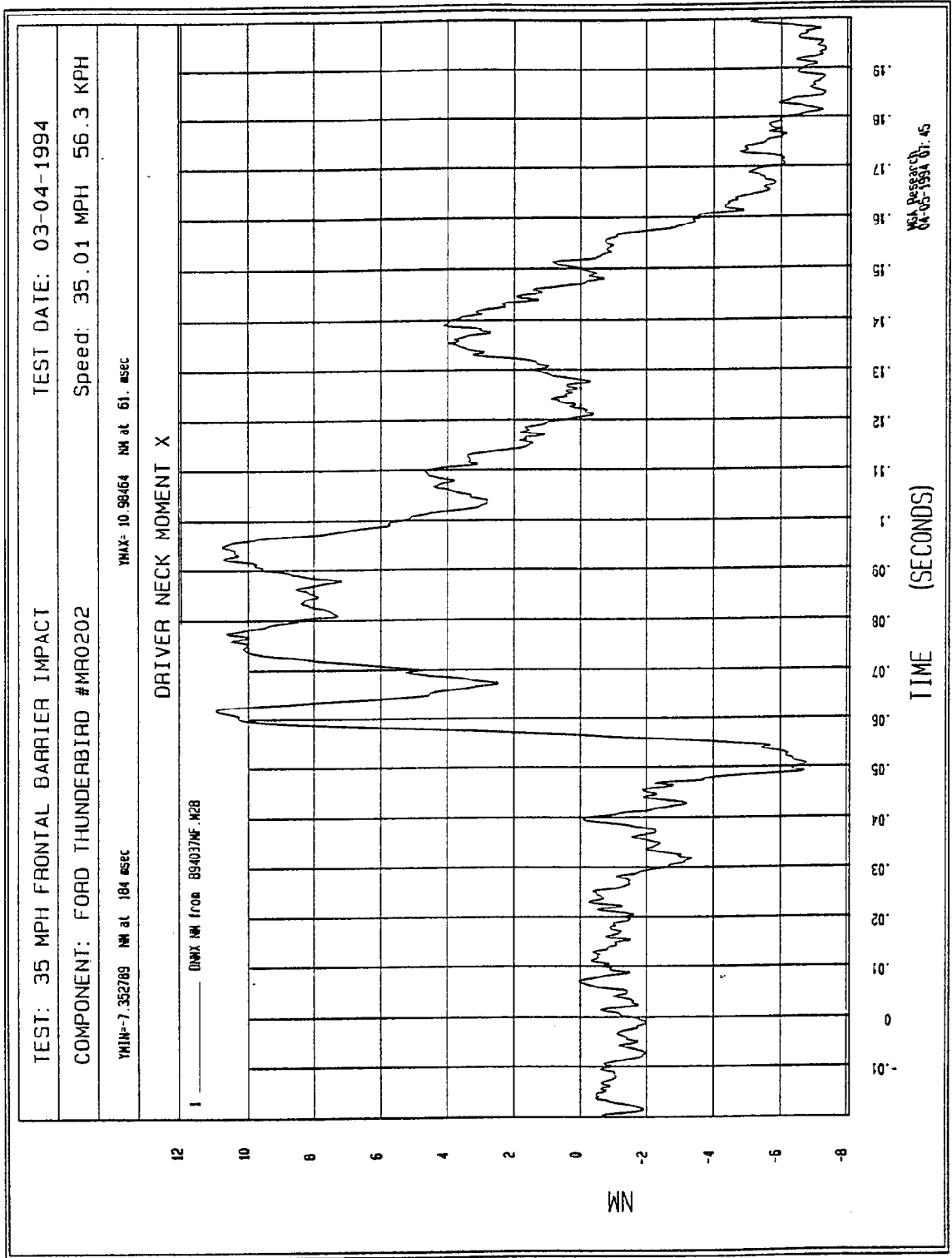

Figure B-50 - Driver Neck Moment X vs. Time

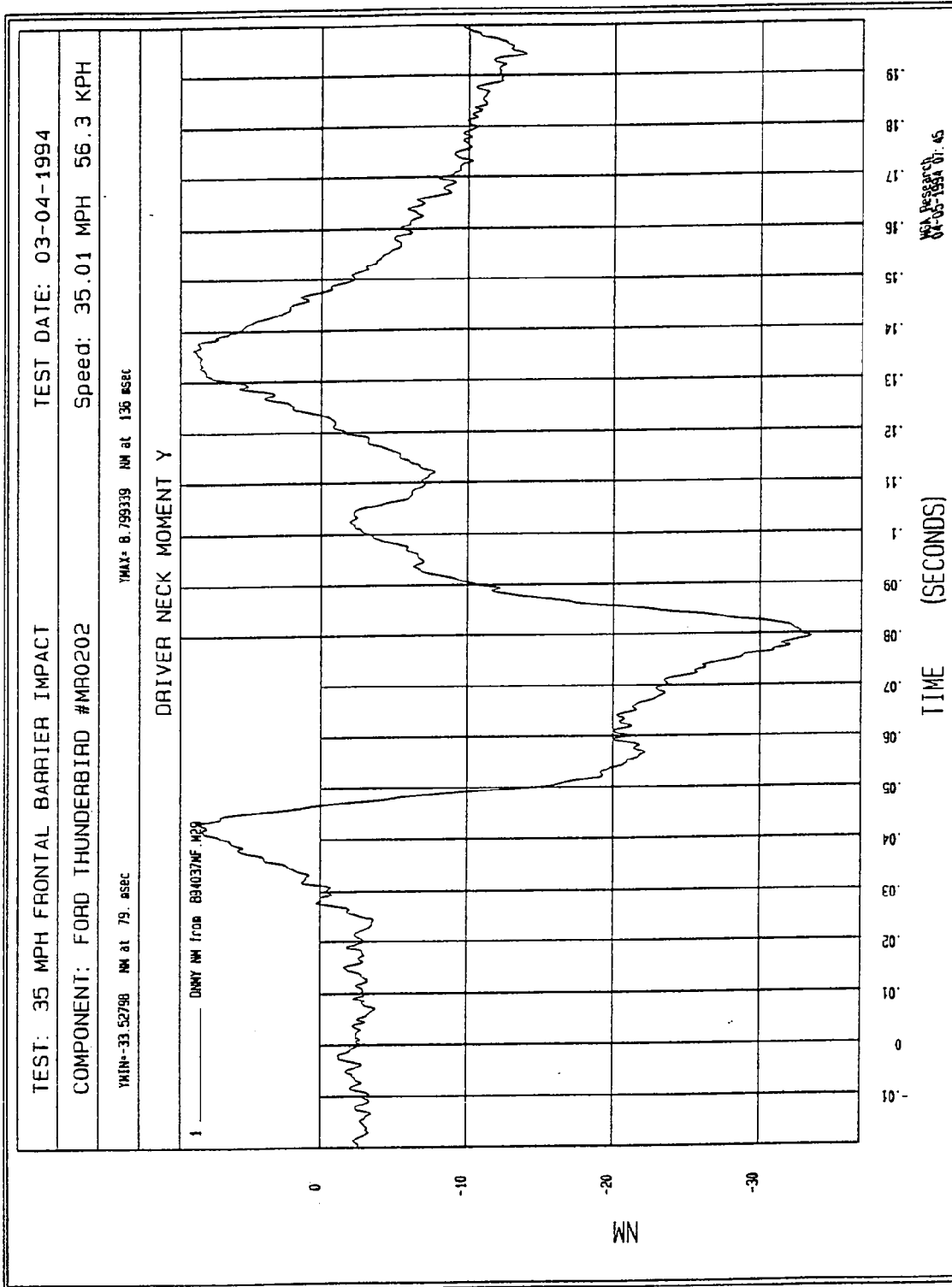

Figure B-51 - Driver Neck Moment Y vs. Time

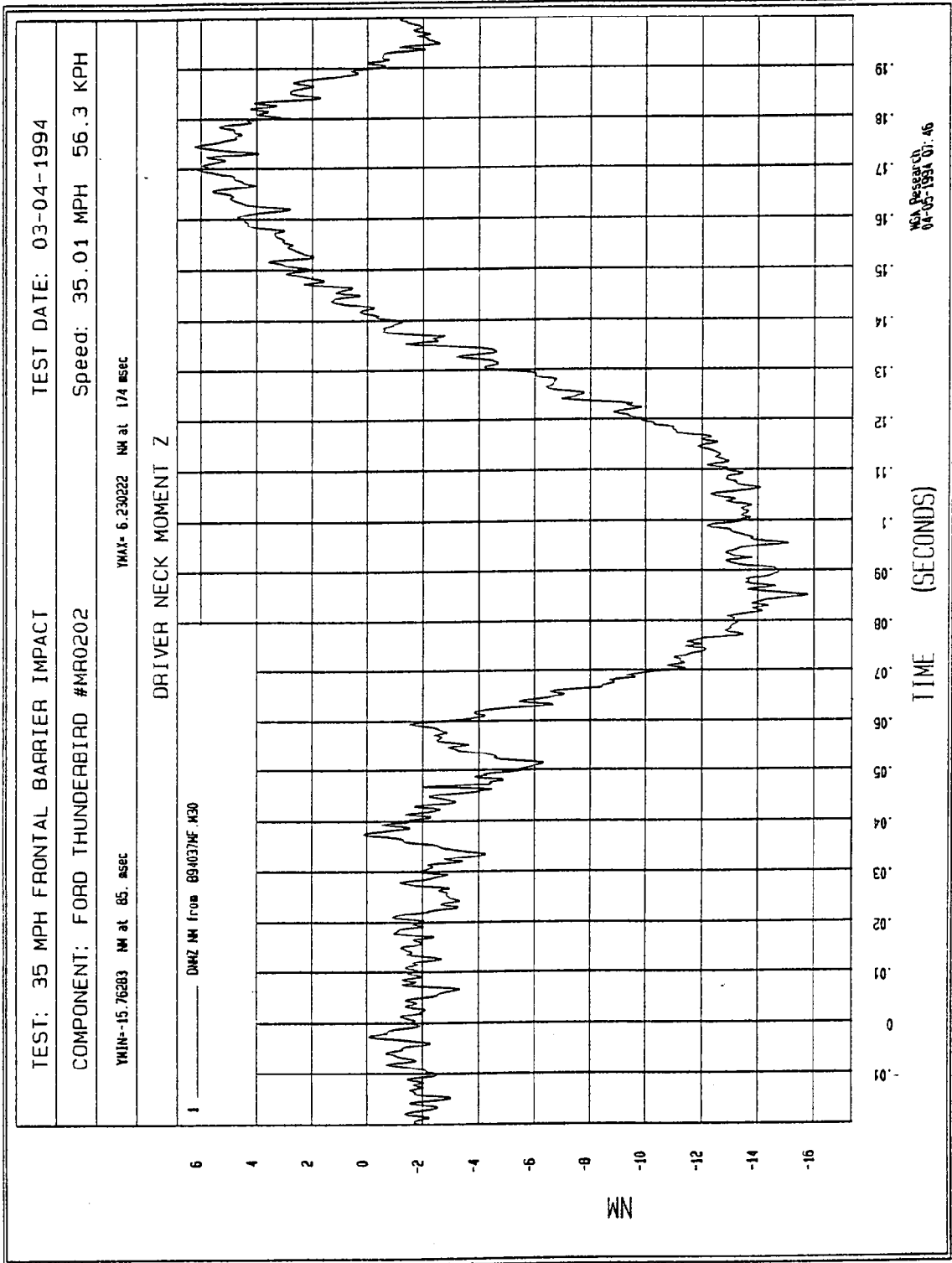

Figure B-52 - Driver Neck Moment Z vs. Time

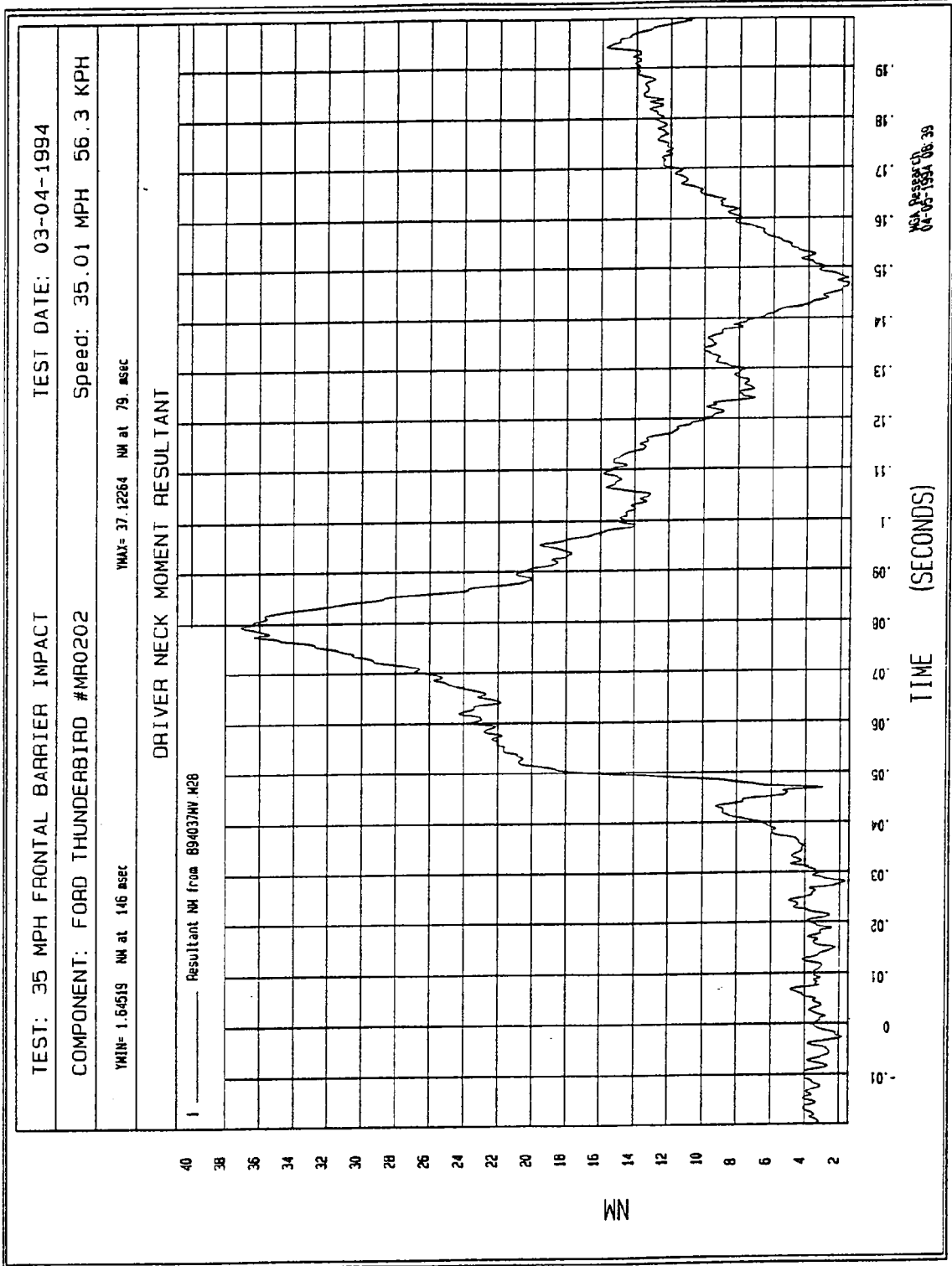

Figure B-53 - Driver Neck Moment Resultant vs. Time

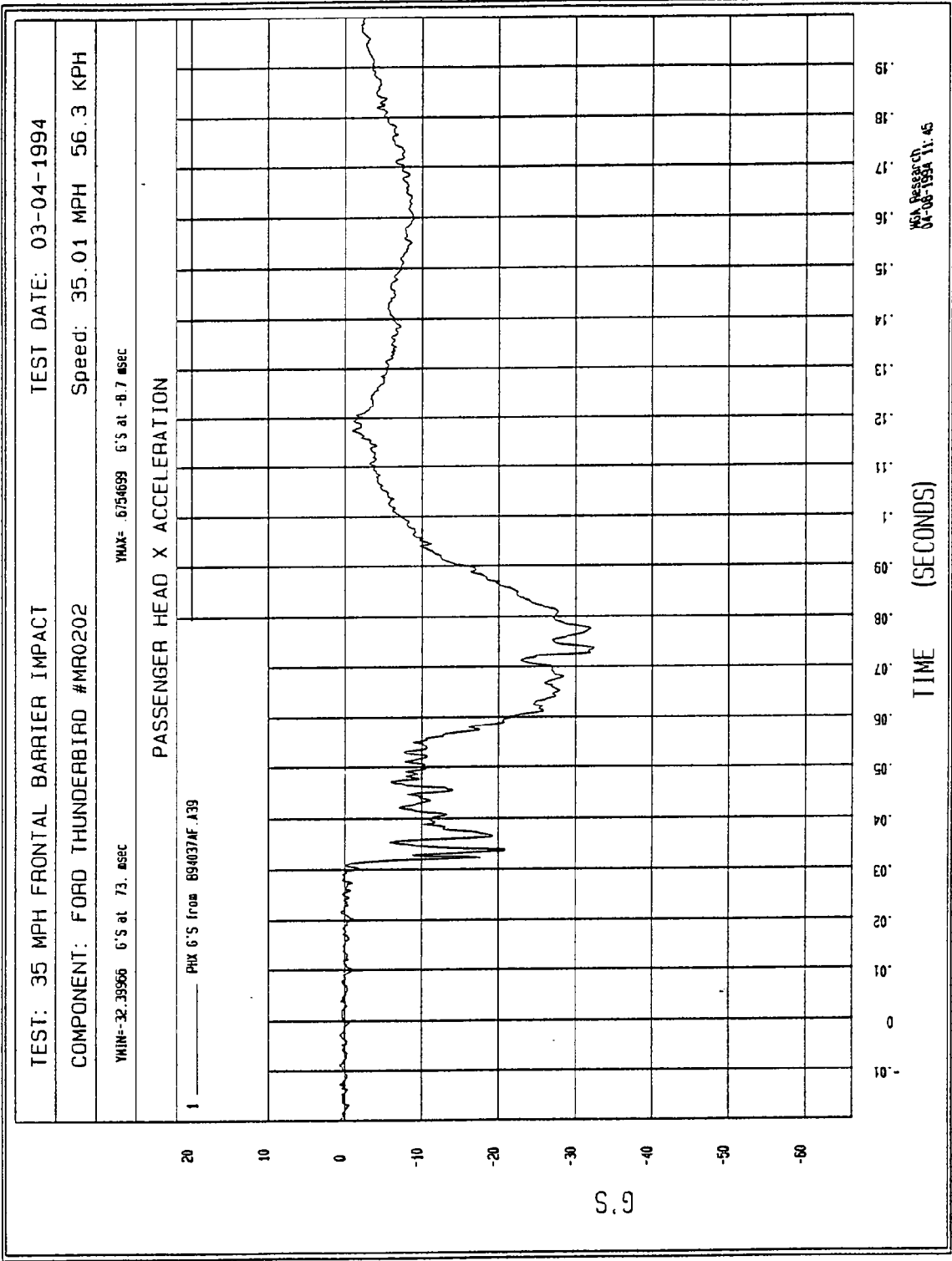

Figure B-54 - Passenger Head X Acceleration vs. Time

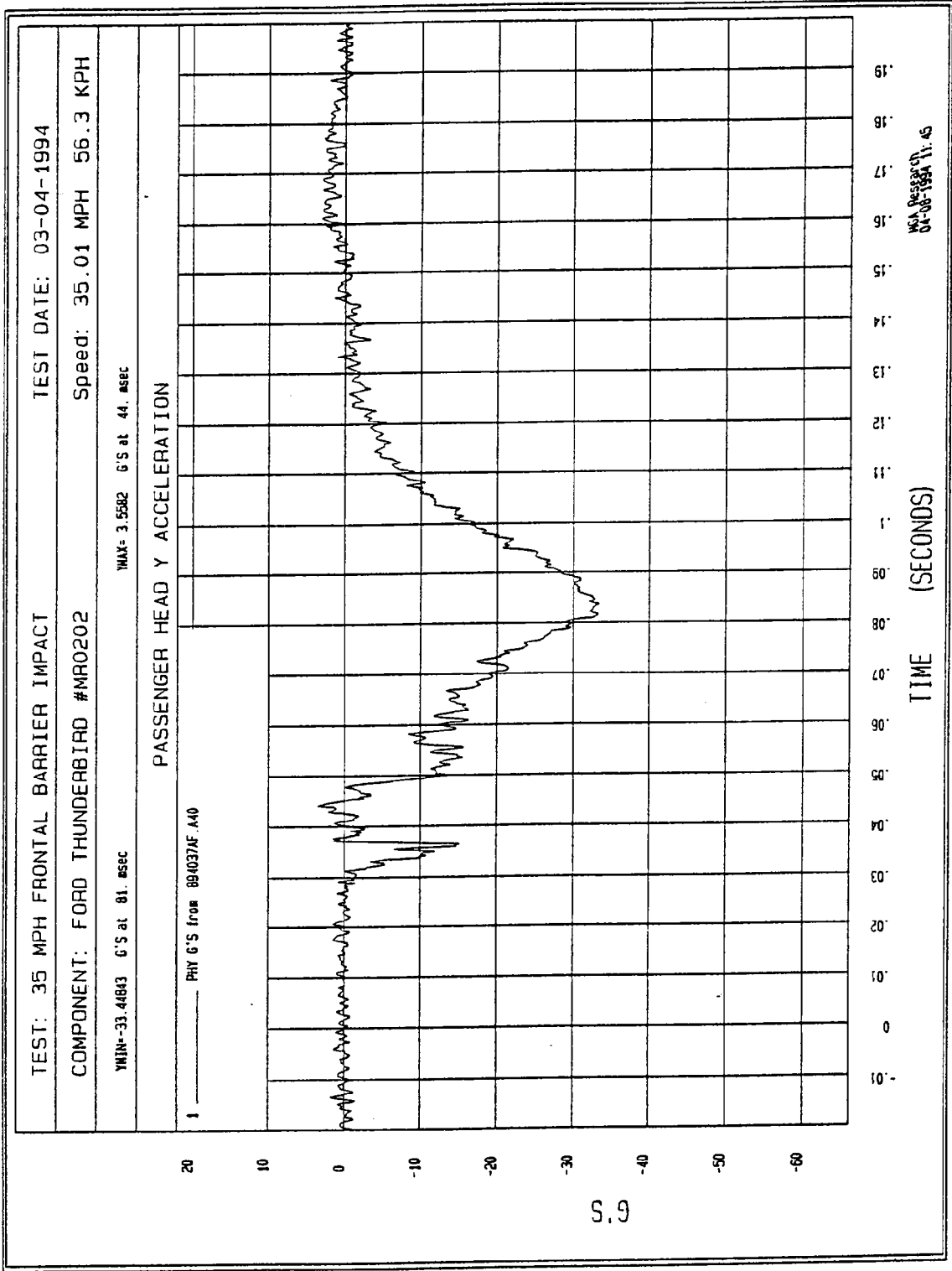

Figure B-55 - Passenger Head Y Acceleration vs. Time

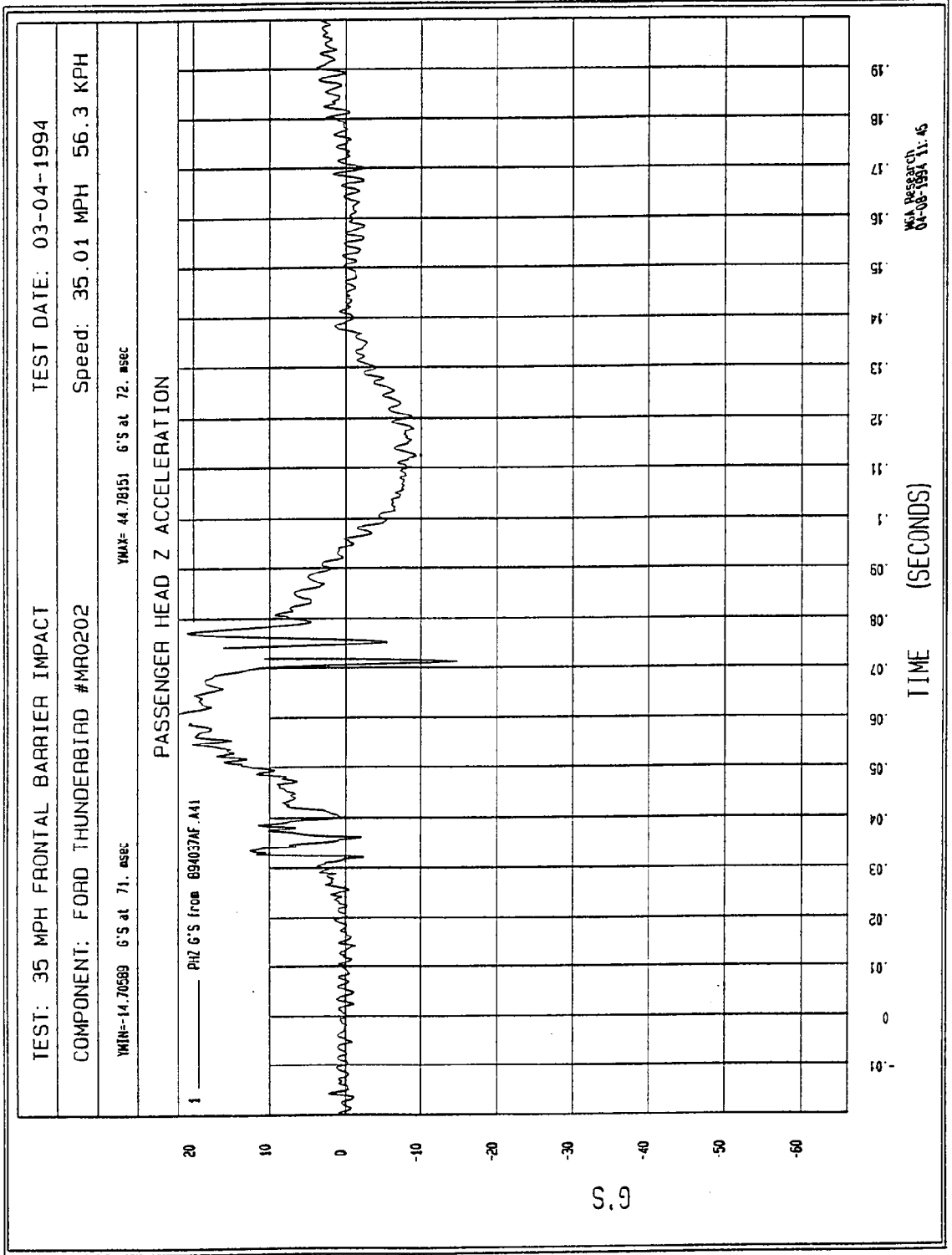

Figure B-56 - Passenger Head Z Acceleration vs. Time

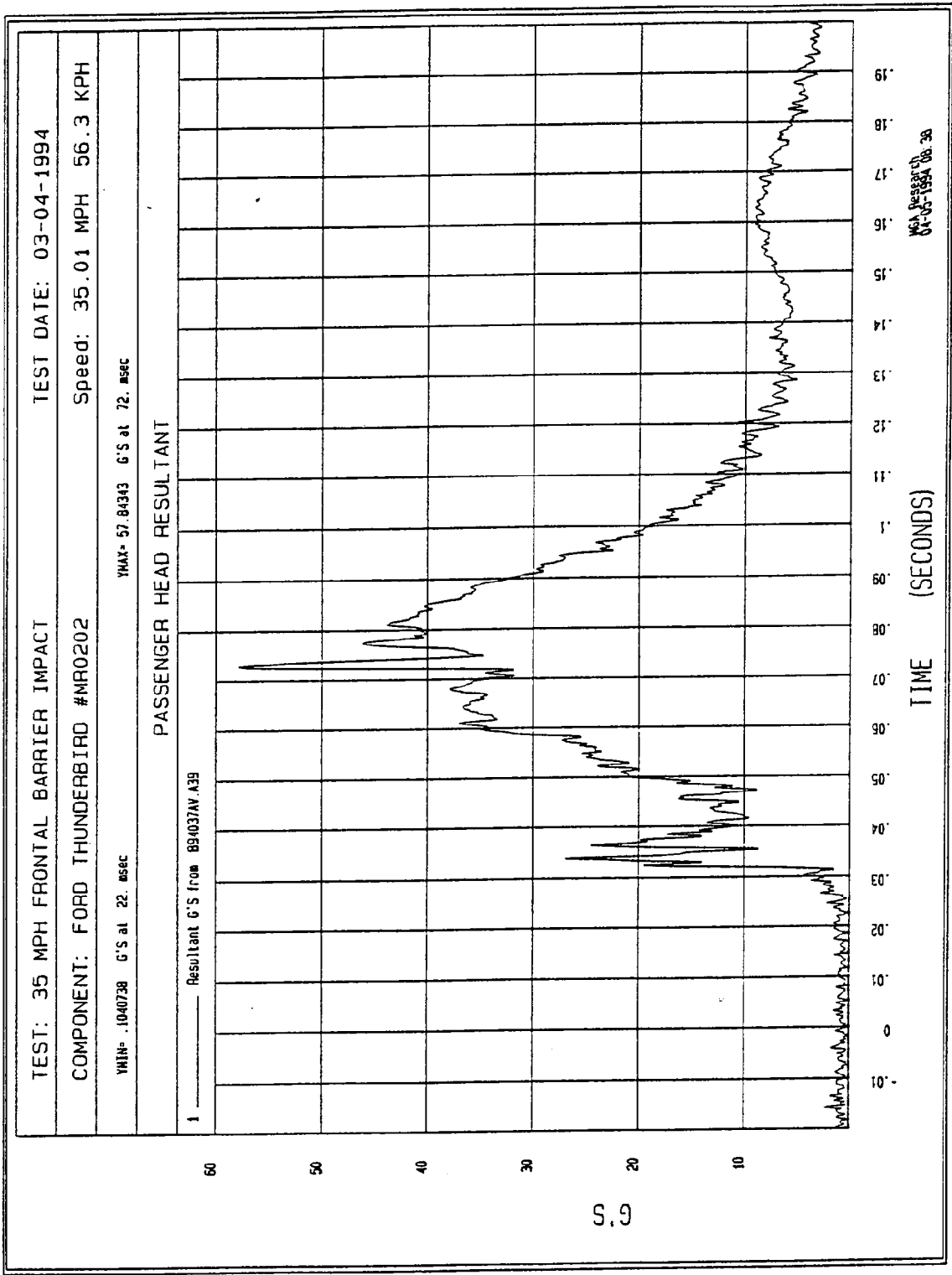

Figure B-57 - Passenger Head Resultant Acceleration vs. Time

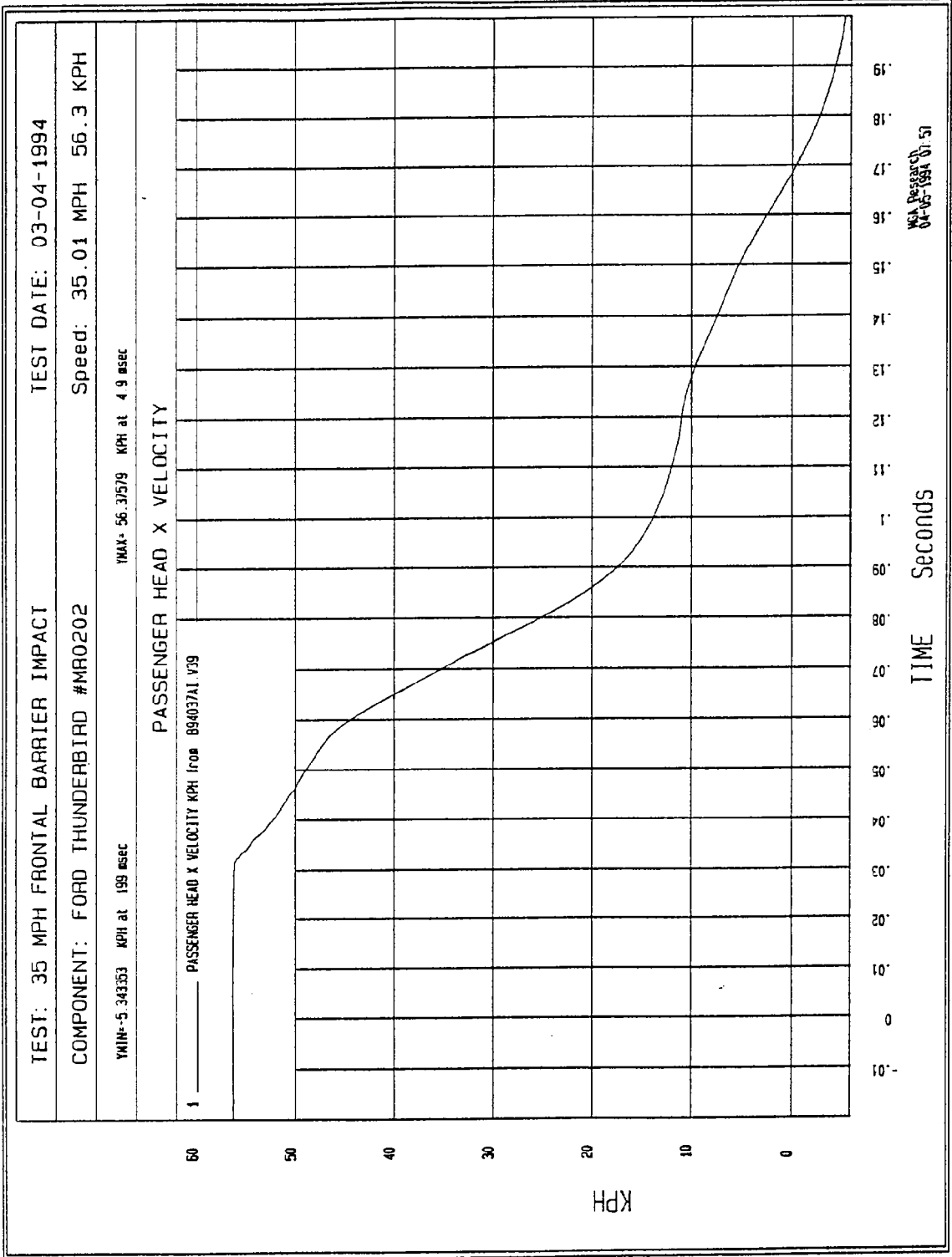

Figure B-58 - Passenger Head X Velocity vs. Time

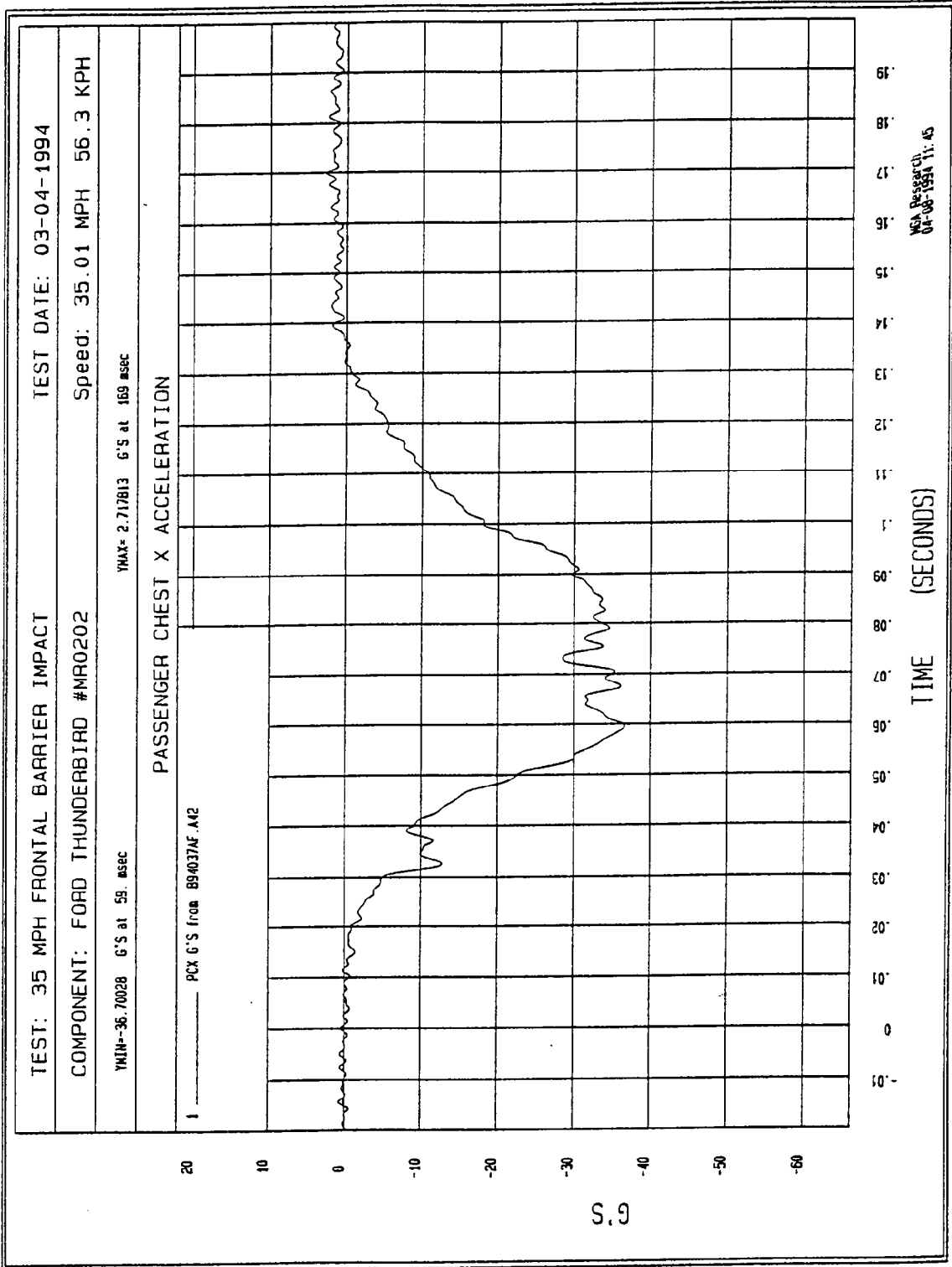

Figure B-59 - Passenger Chest X Acceleration vs. Time

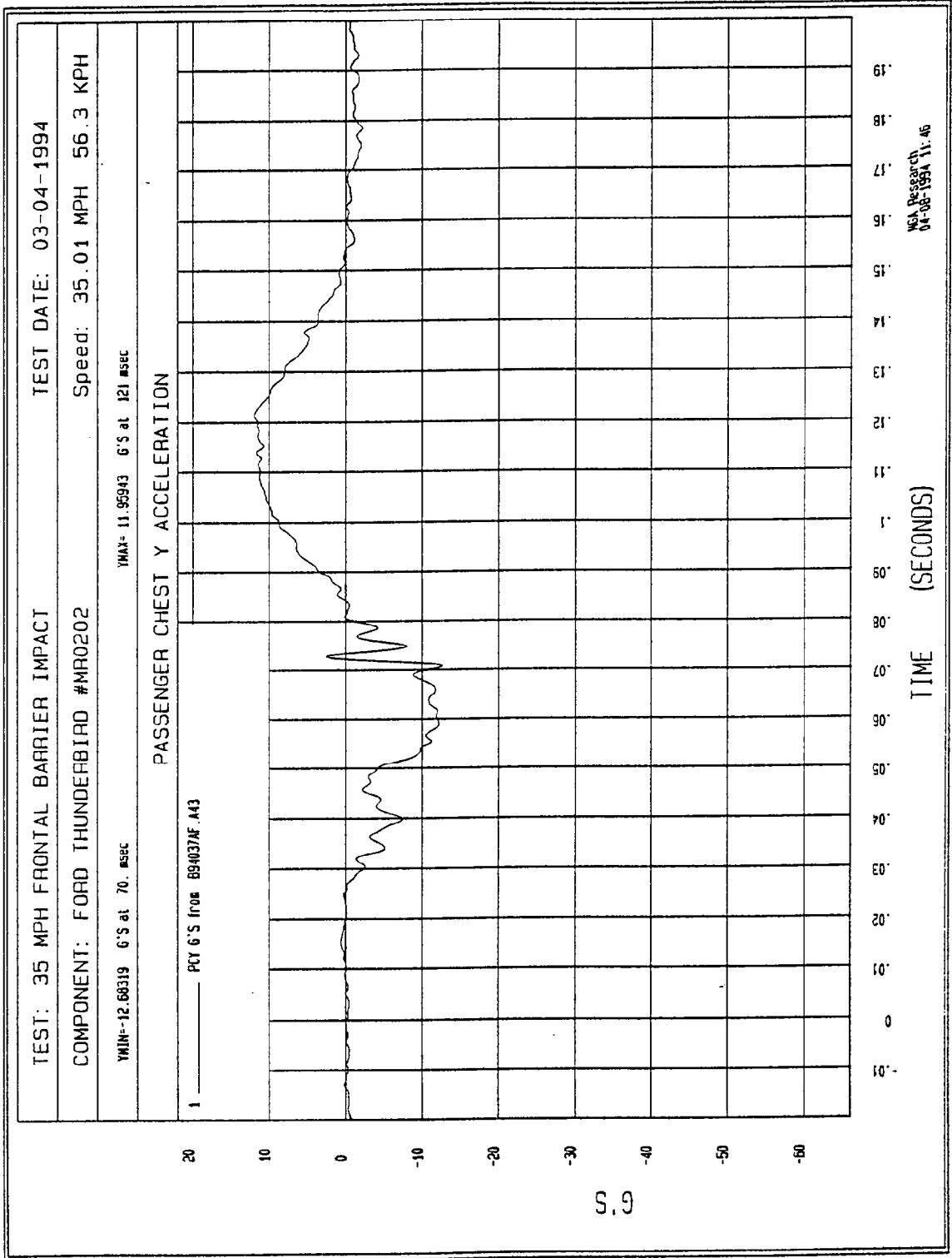

Figure B-60 - Passenger Chest Y Acceleration vs. Time

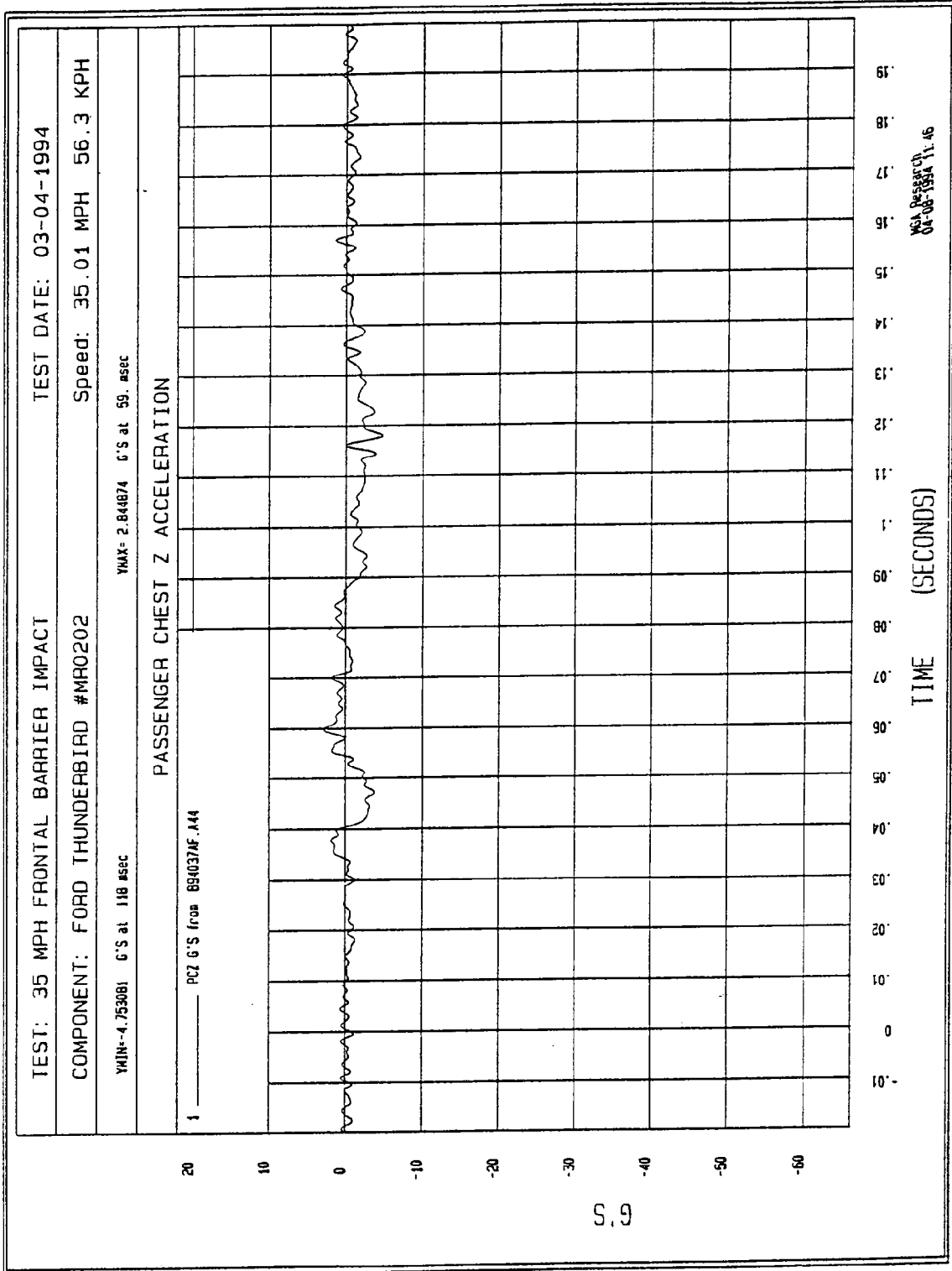

Figure B-61 - Passenger Chest Z Acceleration vs. Time

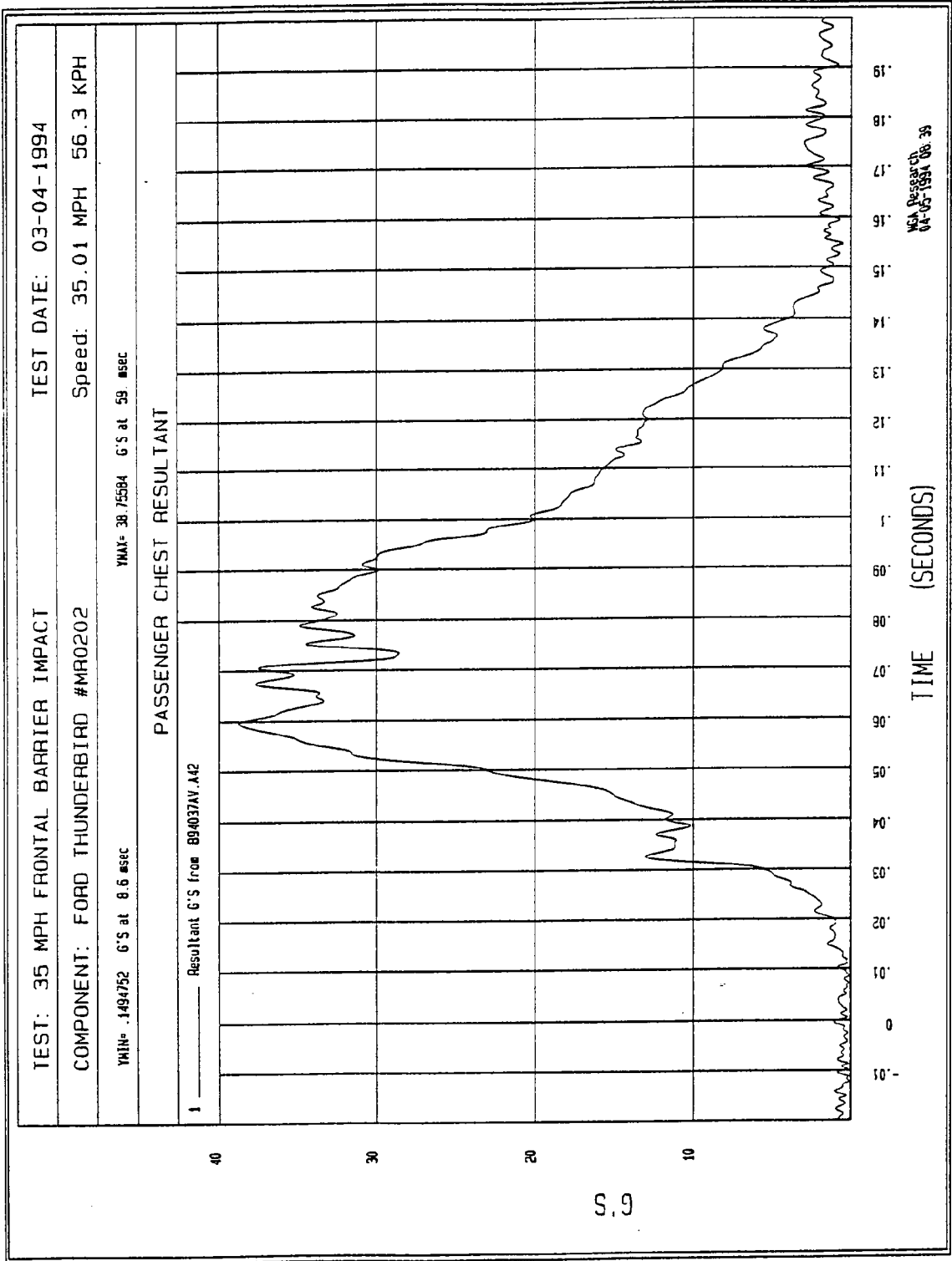

Figure B-62 - Passenger Chest Resultant vs. Time

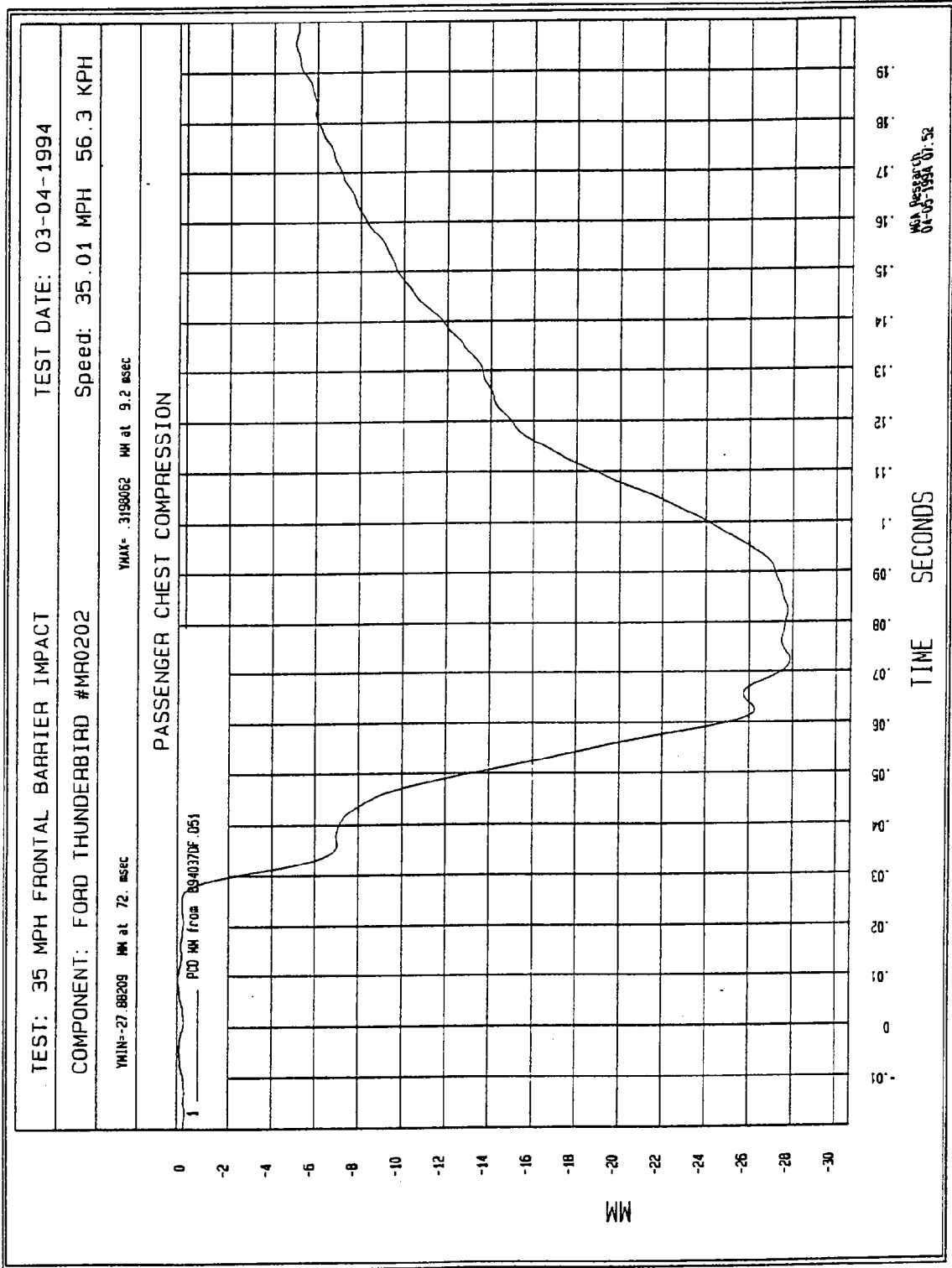

Figure B-63 - Passenger Chest Compression vs. Time

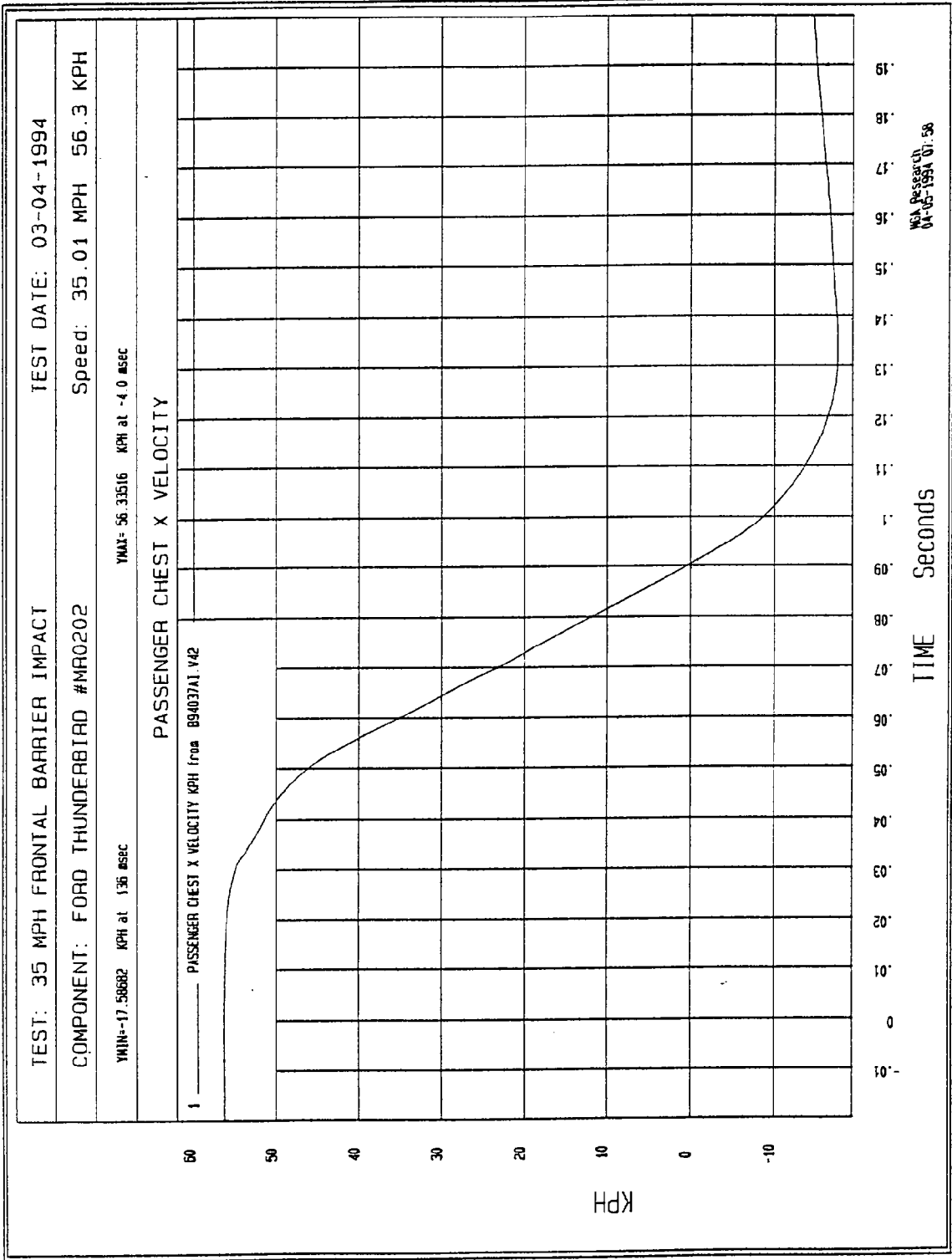

Figure B-64 - Passenger Chest X Velocity vs. Time

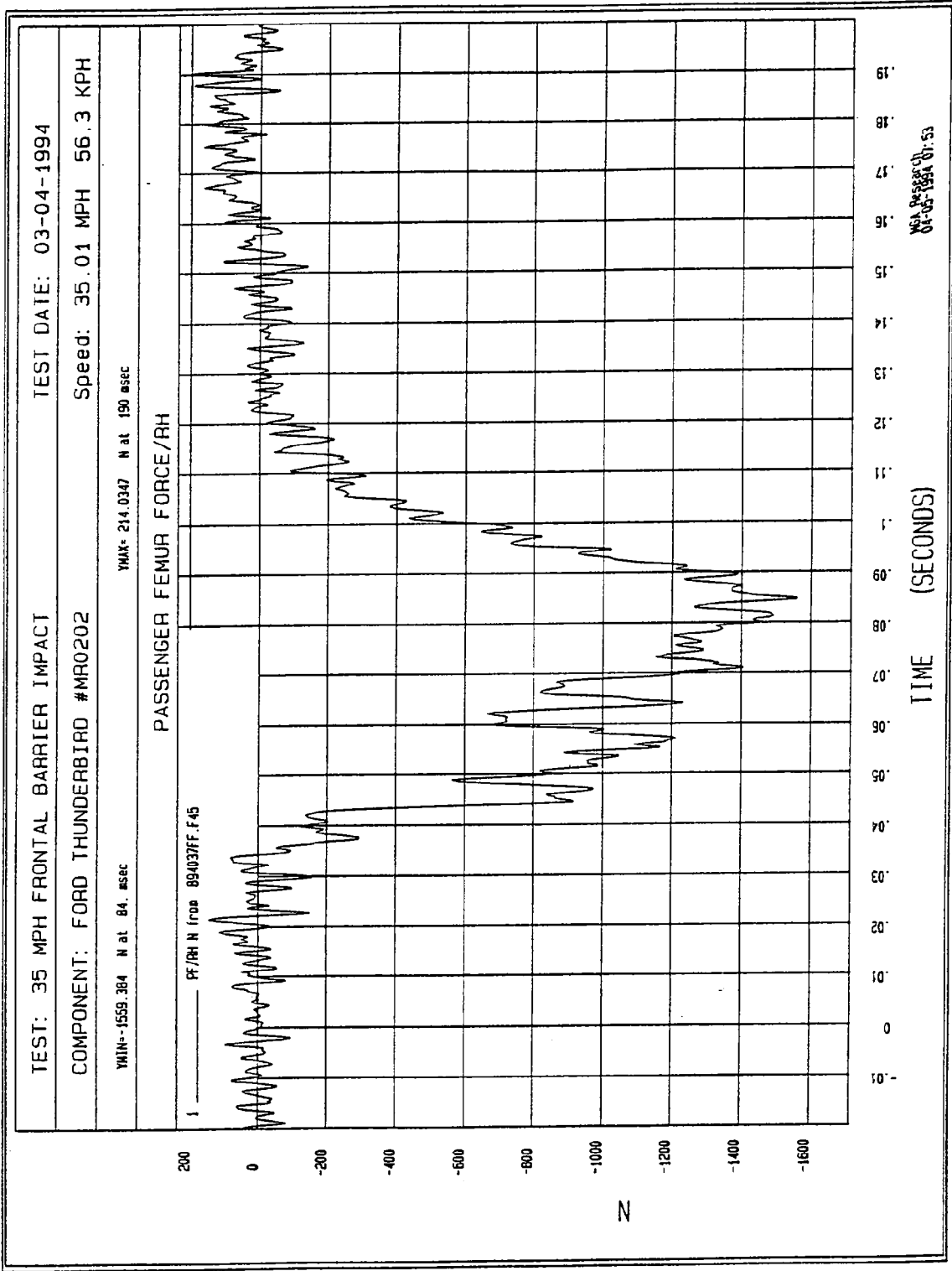

Figure B-65 - Passenger Right Femur Force vs. Time

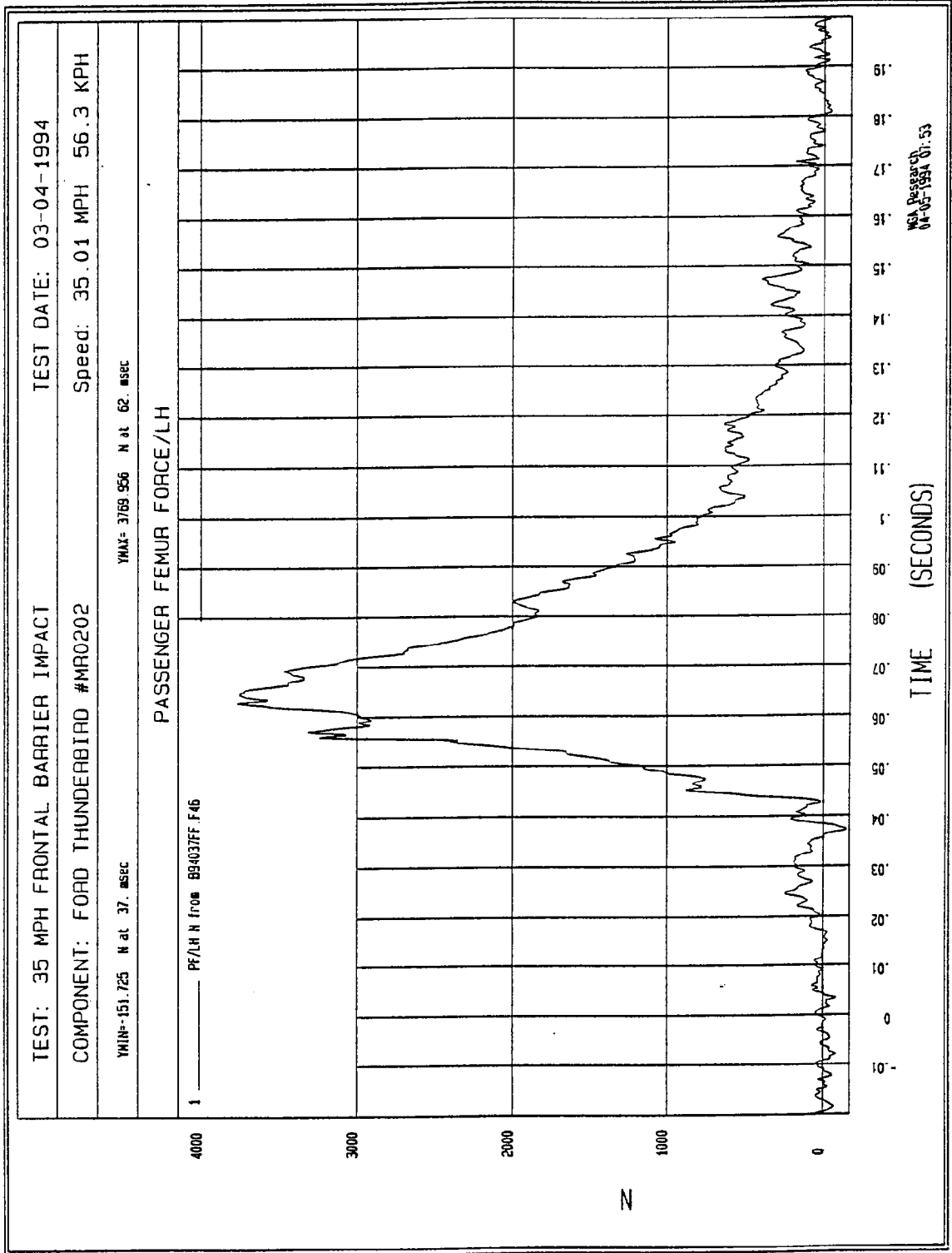

Figure B-66 - Passenger Left Femur Force vs. Time

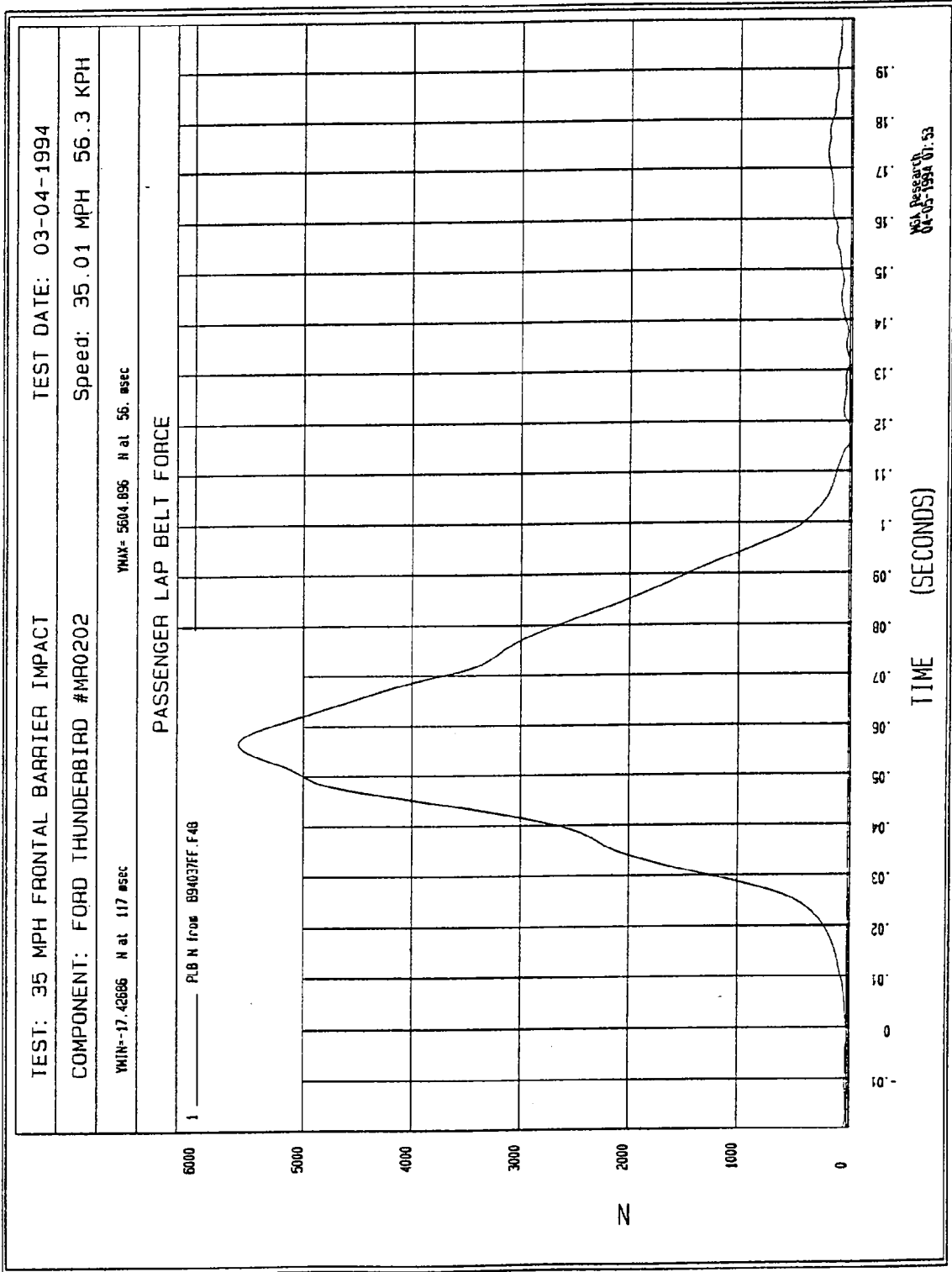

Figure B-67 - Passenger Lap Belt Force vs. Time

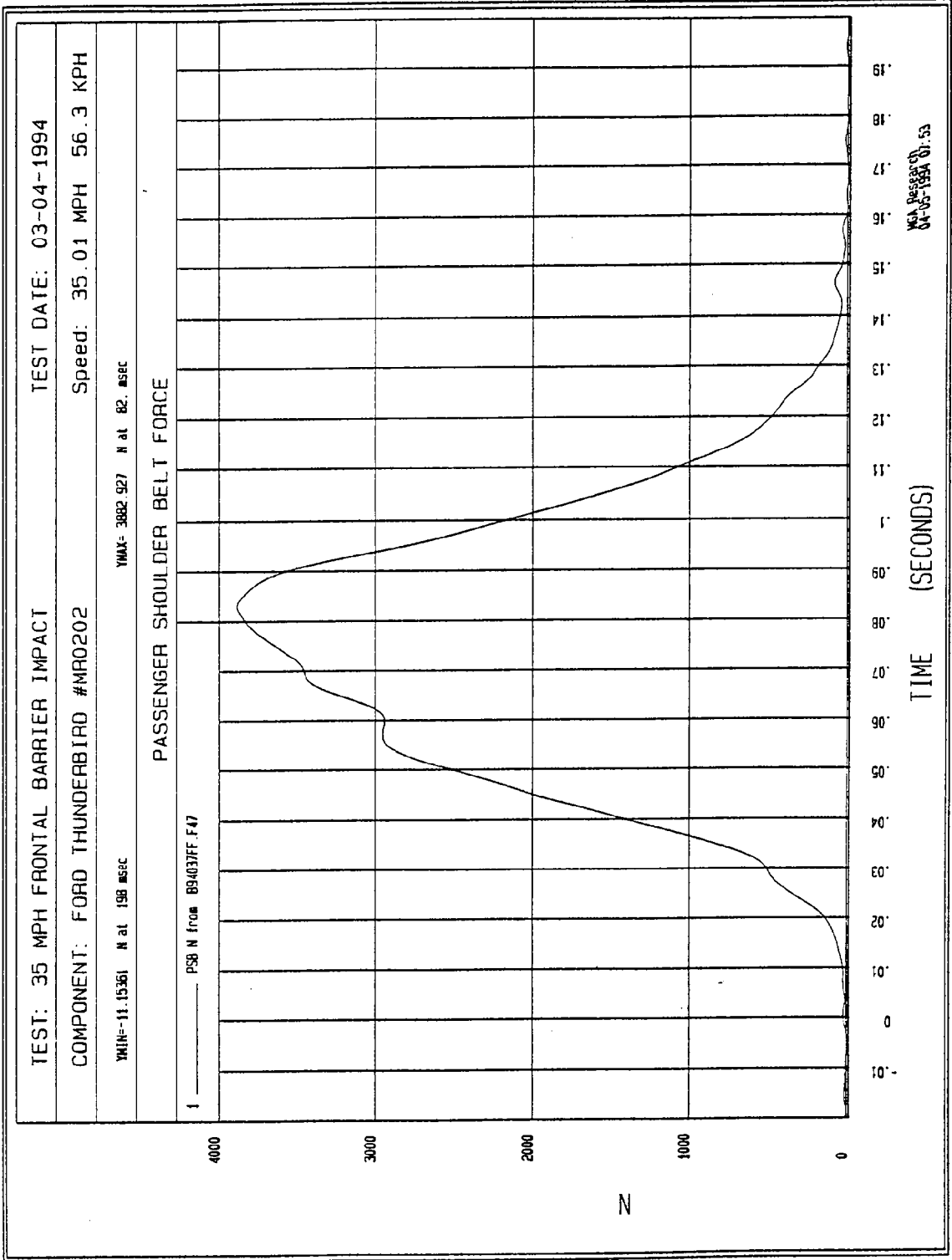

Figure B-68 - Passenger Torso Belt Force vs. Time

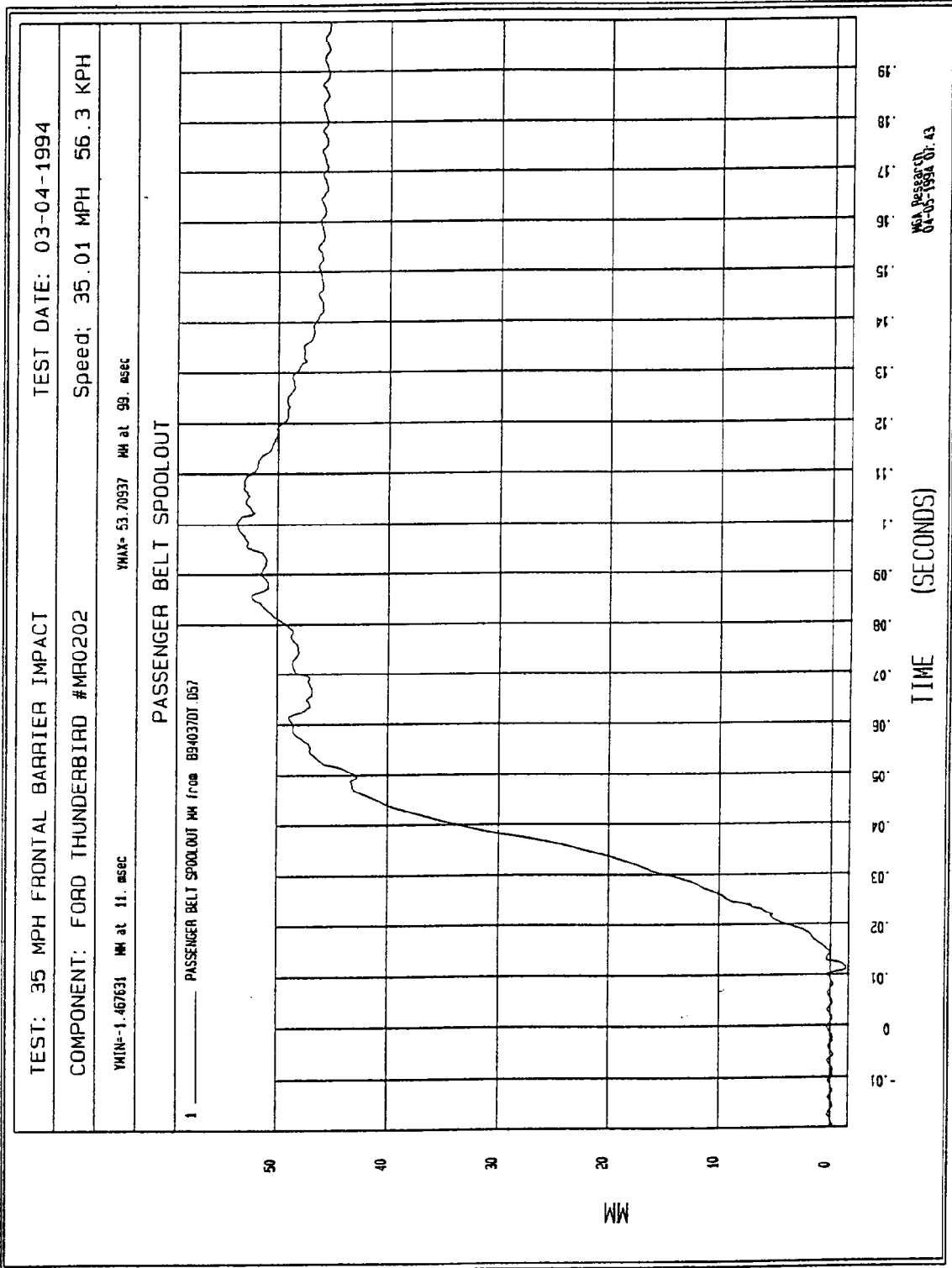

Figure B-69 - Passenger Belt Spoolout

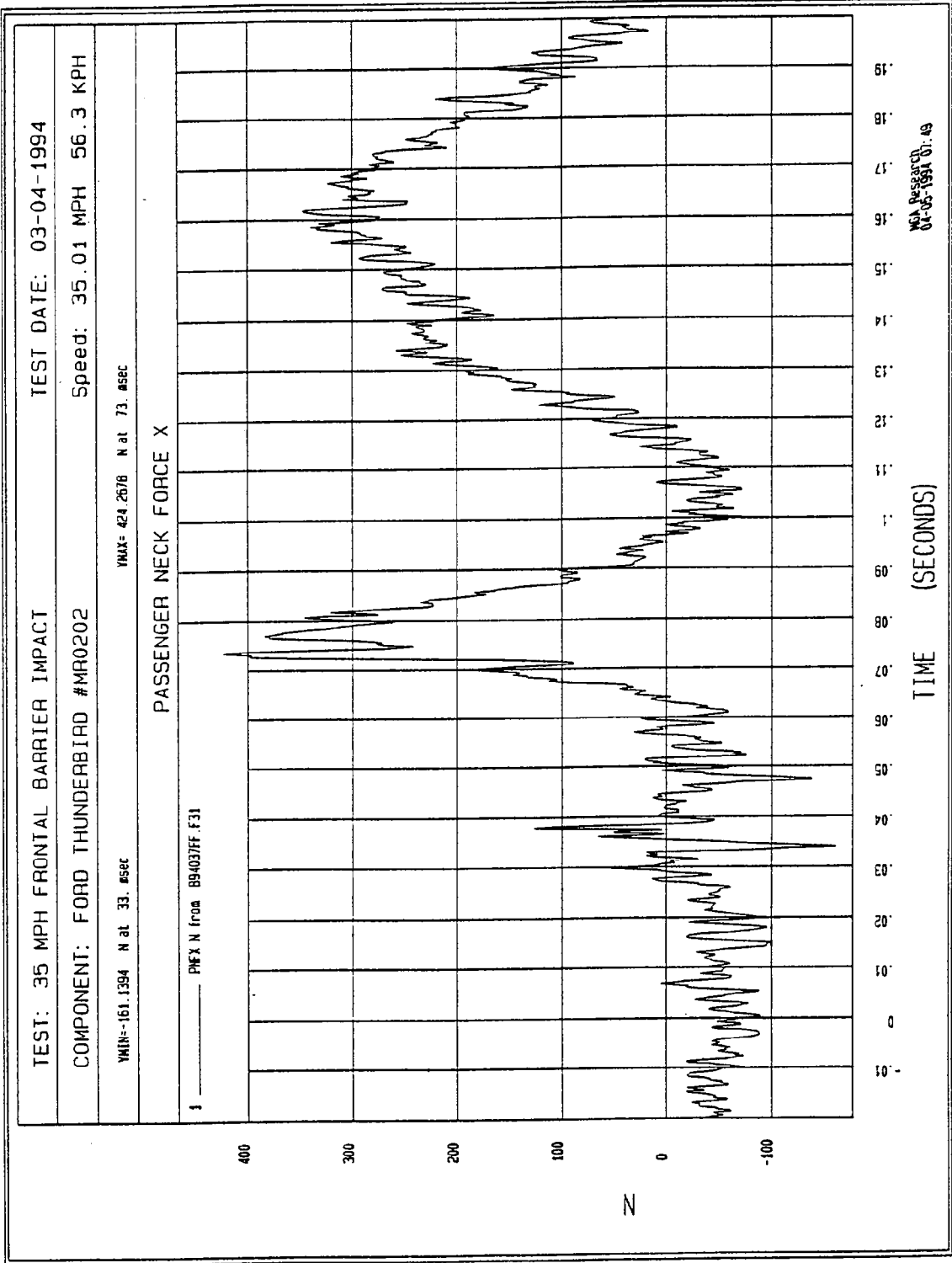

Figure B-70 - Passenger Neck Force X vs. Time

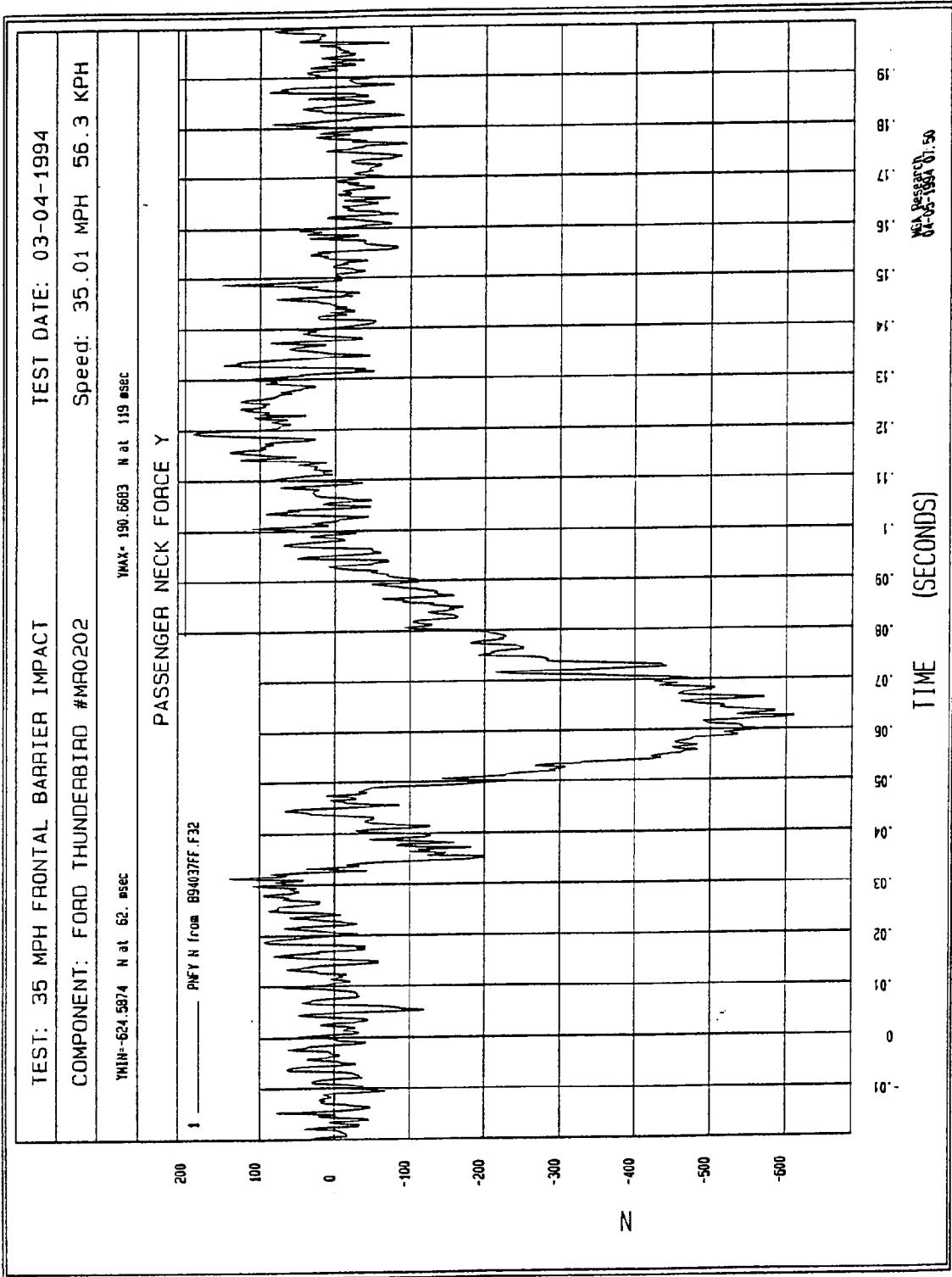

Figure B-71 - Passenger Neck Force Y vs. Time

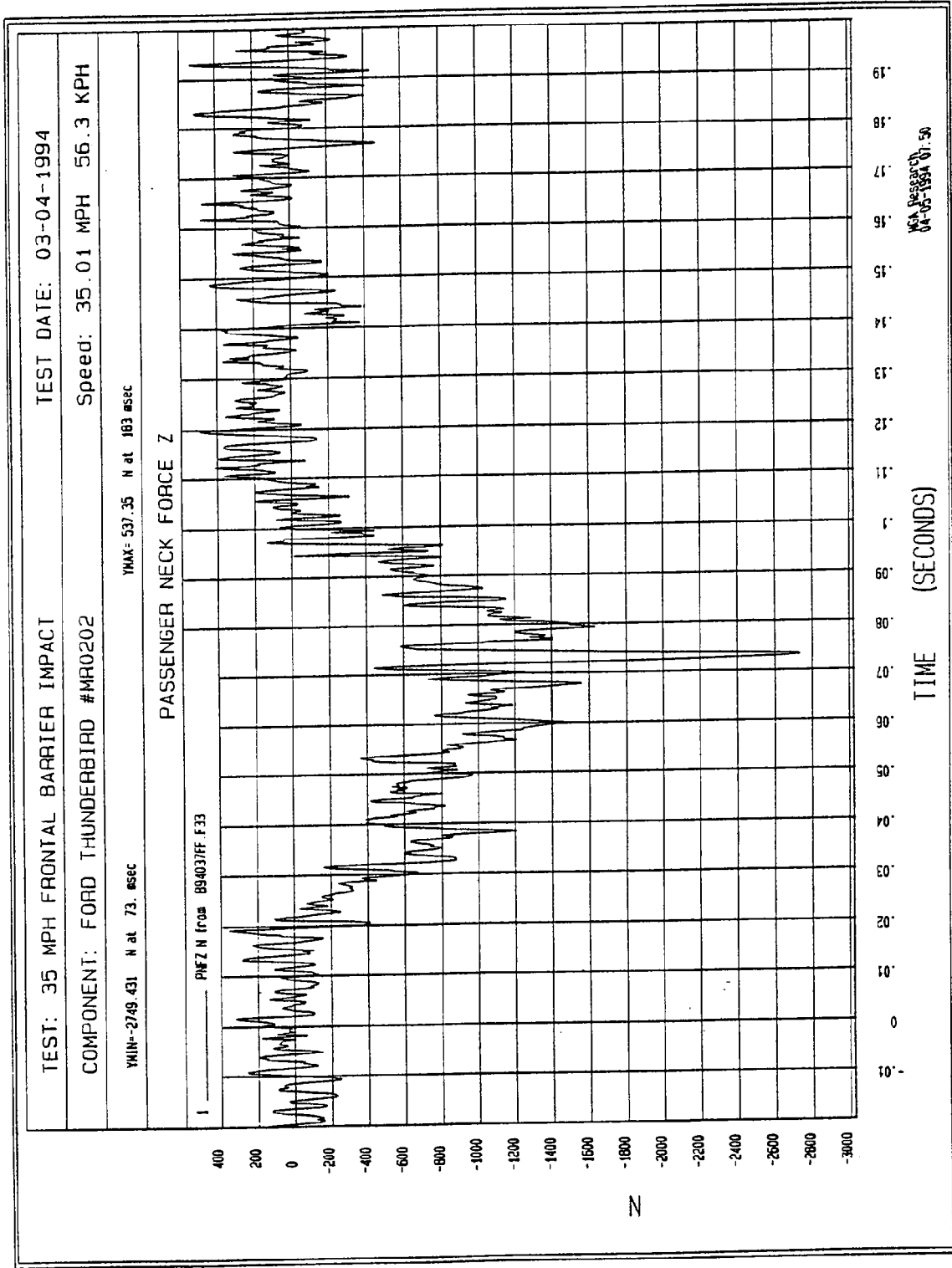

Figure B-72 - Passenger Neck Force Z vs. Time

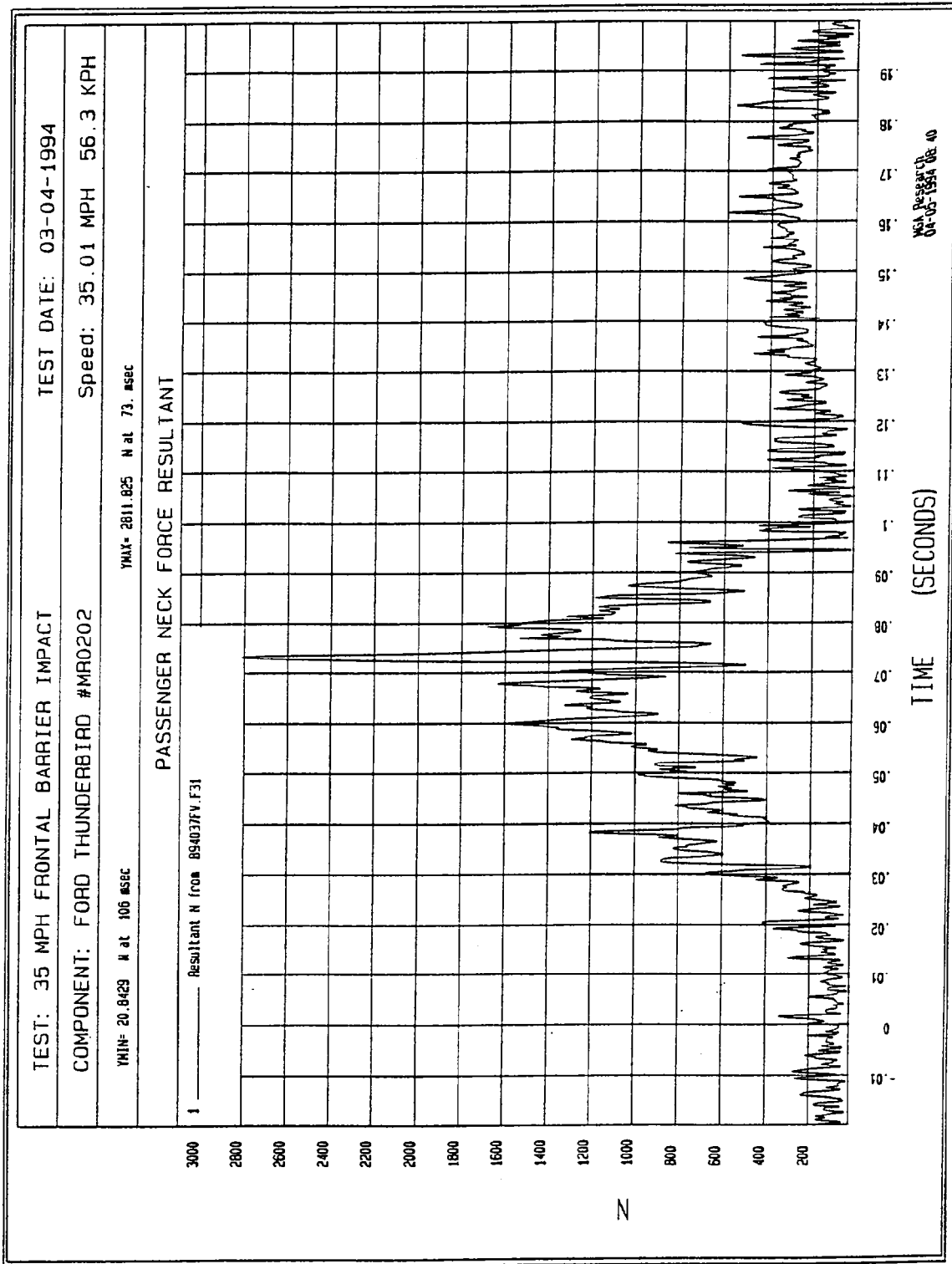

Figure B-73 - Passenger Neck Force Resultant vs. Time

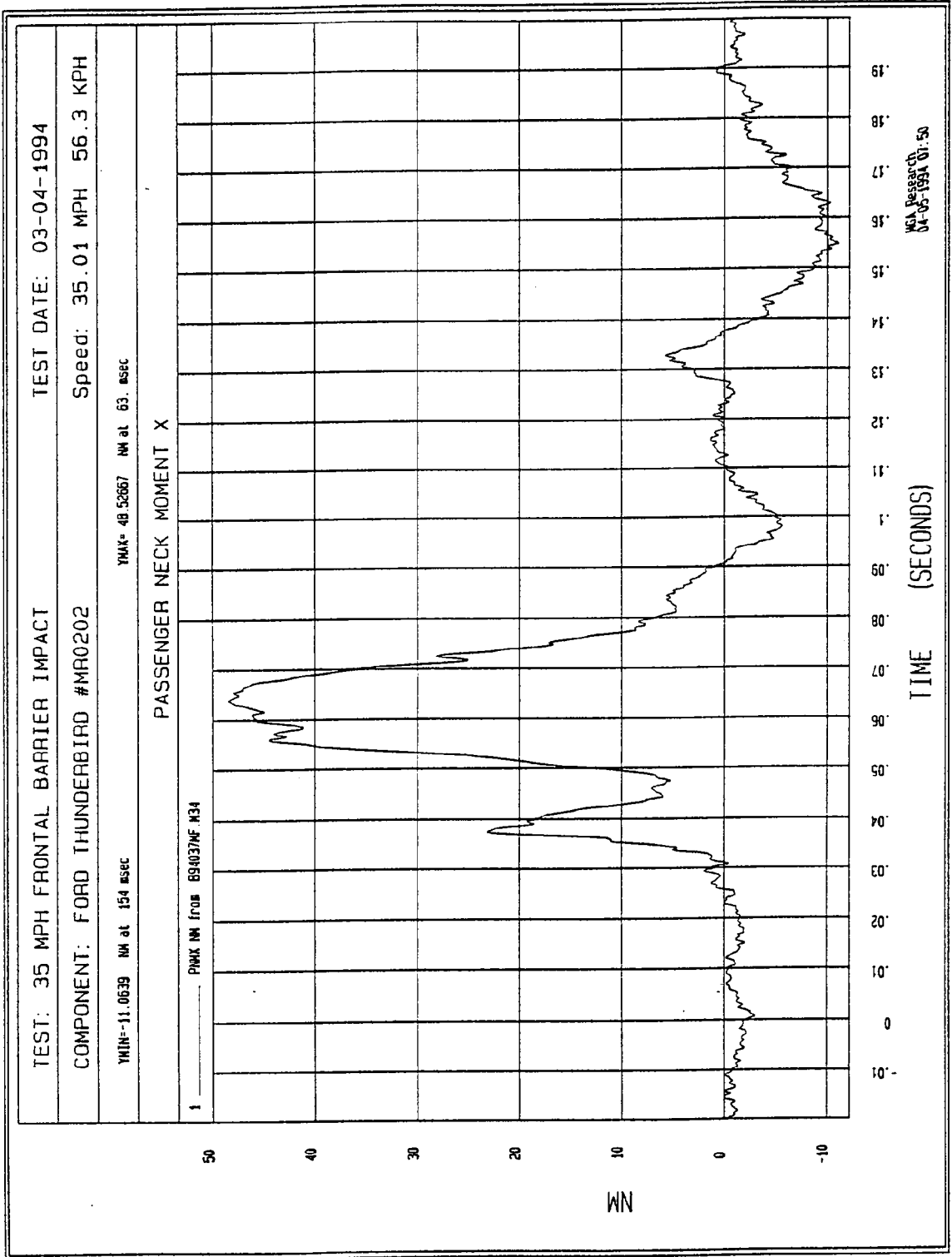

Figure B-74 - Passenger Neck Moment X vs. Time

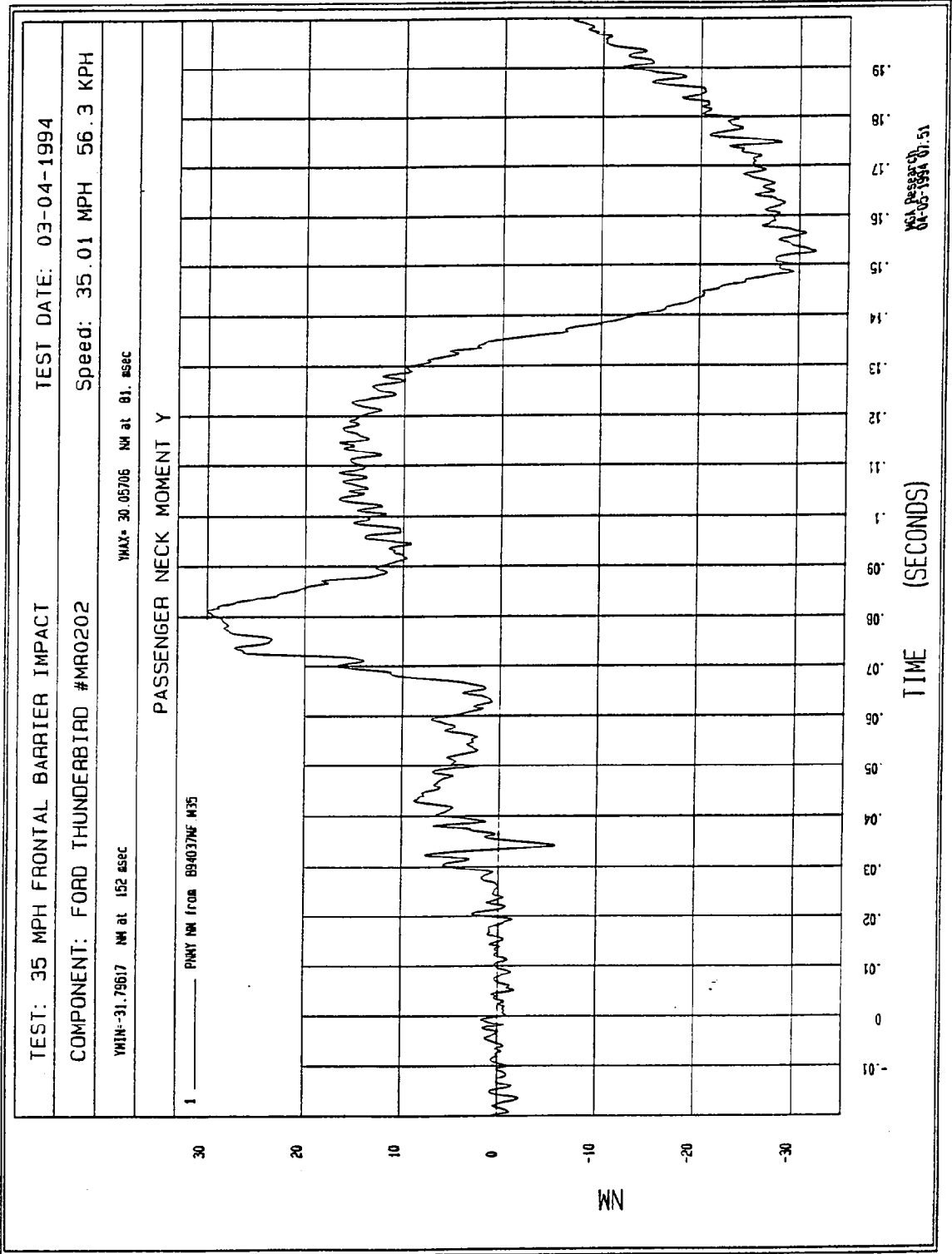
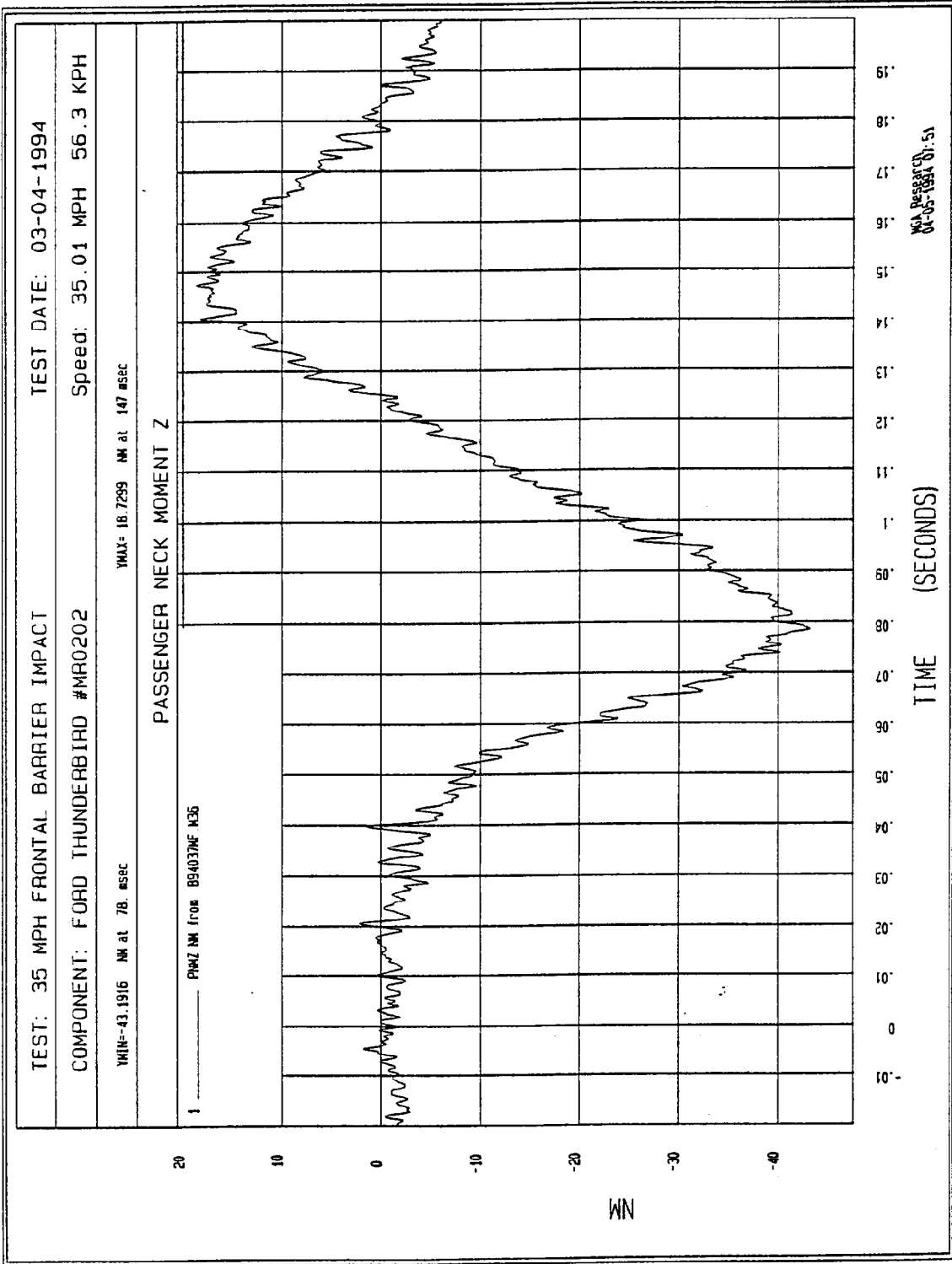

Figure B-75 - Passenger Neck Moment Y vs. Time



WPA Research
03-05-1994 01:51

Figure B-76 - Passenger Neck Moment Z vs. Time

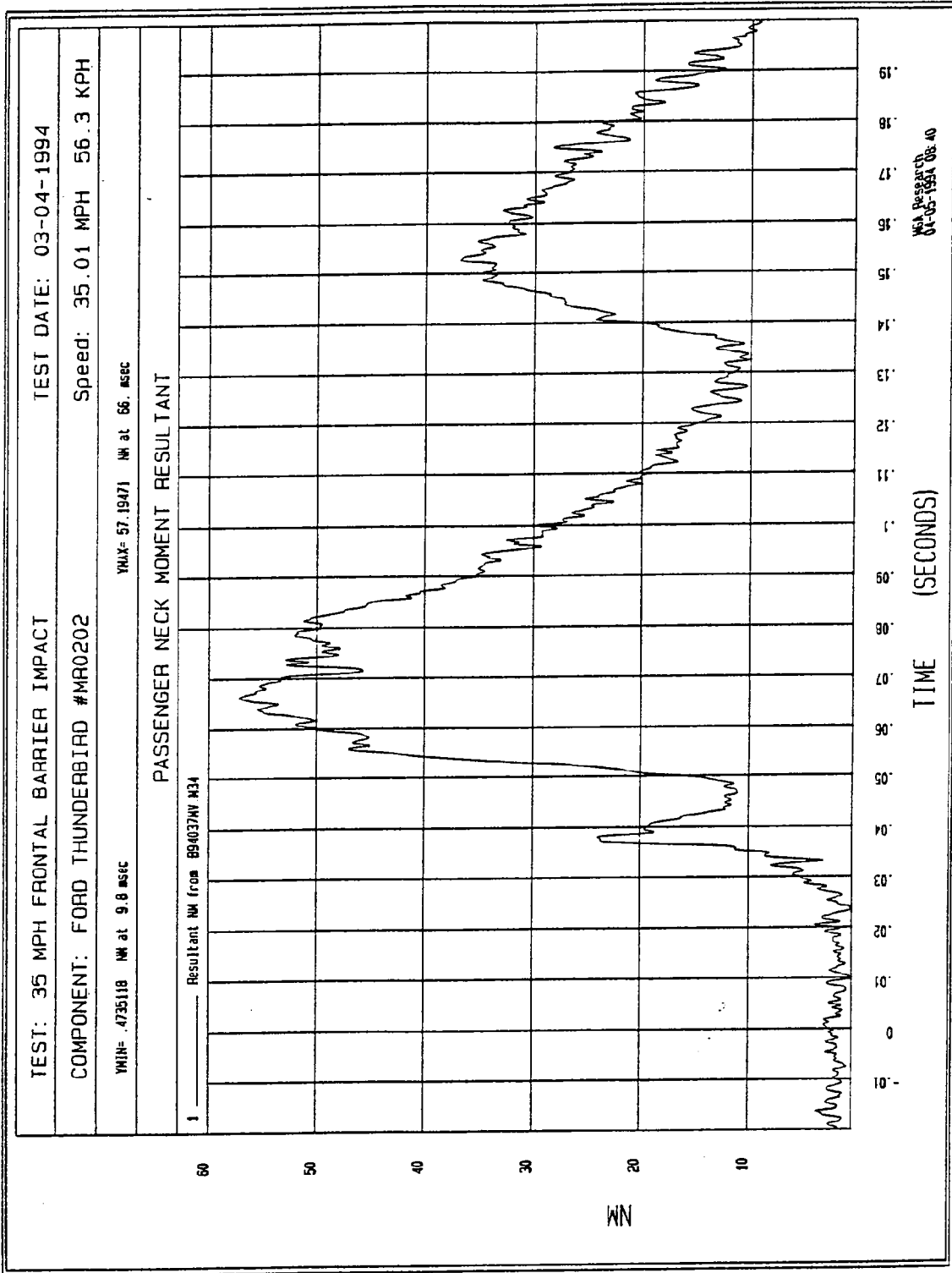

Figure B-77 - Passenger Neck Moment Resultant vs. Time

APPENDIX C

Dummy Configuration & Performance Verification Data

HYBRID III DUMMY CONFIGURATION AND PERFORMANCE VERIFICATION DATA

DUMMY NO.: 36 DUMMY CALIBRATION BY: Rod McClelland

I. CONFIGURATION VERIFICATION DATA

DATE OF VERIFICATION: 01-25-94

DESCRIPTION	SPECIFICATION (inches)	ACTUAL MEASUREMENT (inches)
A - Total Sitting Height	34.6 - 35.0	34.8
B - Shoulder Pivot Height	19.9 - 20.5	20.5
C - "H" Point Height	3.3 - 3.5	3.5
D - "H" Point from Seat Back	5.3 - 5.5	5.5
E - Shoulder Pivot From Backline	3.3 - 3.7	3.5
F - Thigh Clearance	5.5 - 6.1	6.1
G - Back of Elbow to Wrist Pivot	11.4 - 12.0	11.5
H - Skull Cap Skin to Backline	1.6 - 1.8	1.7
I - Shoulder - Elbow Length	13.0 - 13.6	13.0
J - Elbow Rest Height	7.5 - 8.3	8.0
K - Buttock to Knee Length	22.8 - 23.8	23.5
L - Popliteal Height	16.9 - 17.9	17.0
M - Knee Pivot Height	19.1 - 19.9	19.5
N - Buttock Popliteal Length	17.8 - 18.8	18.5
O - Chest Depth at 3rd Rib	8.4 - 9.0	8.8
P - Foot Length	9.9 - 10.5	10.3
V - Shoulder Breadth	16.6 - 17.2	16.8
W - Foot Breadth	3.6 - 4.2	4.0
Y - Chest Circumference	38.2 - 39.4	39.0
Z - Waist Circumference	32.9 - 34.1	33.5

Note: (See next page for external dimensions)

HYBRID III EXTERNAL DIMENSIONS

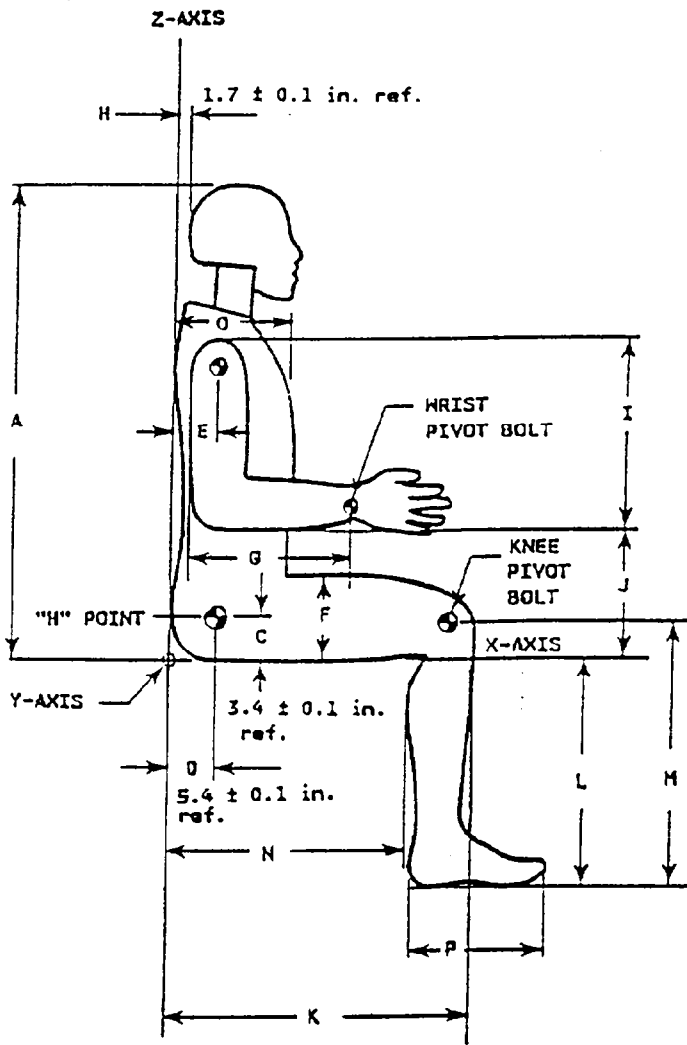

SIDE VIEW

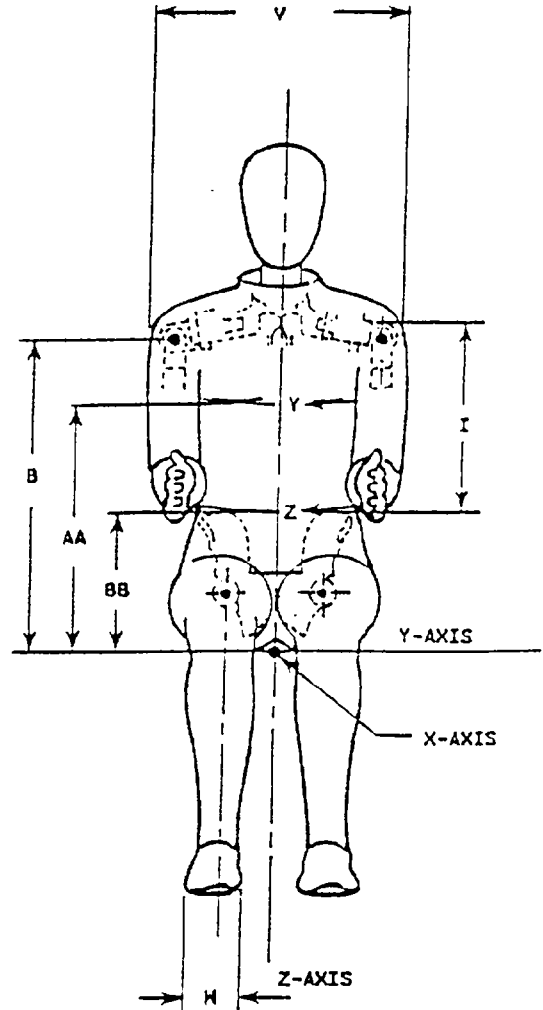

FRONT VIEW

Note: Figure is referenced to the erect seated position. The curved lumbar does not allow the hybrid III to be positioned in a perfect erect attitude.

HYBRID III DUMMY CALIBRATION DATA SUMMARY SHEET

DUMMY NO.: 36 DUMMY CALIBRATION BY: Jeff Robbins

VERIFICATION DATE: 01-25-94

VERIFICATION LABORATORY TEMPERATURE (66° - 78°): 70°

1.0 HEAD DROP TEST

	SPECIFICATION	MEASUREMENT
Peak Resultant Acceleration	225 - 275 G	259
Peak Lateral Acceleration	15 G. MAX	3
Is Acceleration Curve Unimodal	within 10% of peak	Yes

2.0 NECK FLEXION TEST

		SPECIFICATION	MEASUREMENT
Pendulum Speed		22.6 - 23.4 FT/SEC	23.00
Pendulum Deceleration	10 MS	22.50 - 27.50 G	25.00
	20 MS	17.60 - 22.60 G	19.62
	30 MS	12.50 - 18.50 G	15.60
Max. Pendulum G Above 30 MS		29.0 G MAX	15.7
Deceleration - Time Curve Decay Time to 5 G		34 - 42 MS	38
D Plane Rotation	MAX	64 - 78 DEG.	75
	TIME	57 - 64 MS	57
Rotation Angle - Time Curve Decay Time to Zero		113 - 128 MS	114
Moment About Occipital Condyle	MIN.	65 - 80 FT.LBS	70
	TIME	47 - 58 MS	52
Positive Moment - Time Curve Decay Time to Zero		97 - 107 MS	100

HYBRID III DUMMY CALIBRATION DATA SUMMARY SHEET (CONT.)

3.0 NECK EXTENSION TEST

		SPECIFICATION	MEASUREMENT
Pendulum Speed		19.50 - 20.30 F/S	20.05
Pendulum Deceleration	10 MS	17.20 - 21.20 G	18.48
	20 MS	14.00 - 19.00 G	15.03
	30 MS	11.00 - 16.00 G	12.32
Max. Pendulum G Above 30 MS		22 G Max	12
Deceleration - Time Curve Decay Time to 5 G		38 - 46 MS	45
D Plane Rotation	MAX	81 - 106 DEG.	95
	TIME	72 - 82 MS	82
Rotation Angle - Time Curve Decay Time to Zero		147 - 174 MS	155
Moment About Occipital Condyle	MIN.	-59.0/-39.0 FT LBS	-47.2
	TIME	65 - 79 MS	72
Positive Moment - Time Curve Decay Time to Zero		120 - 148 MS	144

4.0 CHEST IMPACT TESTS

	SPECIFICATION	MEASUREMENT
Probe Speed	21.6 to 22.4 F/S	21.7
Peak Deflection	2.50 to 2.86 IN.	2.52
Peak Resistive Force	1160 to 1325 LBS.	1277
Internal Hysteresis	69 to 85%	70

5.0 KNEE IMPACT TESTS

LEFT KNEE	SPECIFICATION	MEASUREMENT
Probe Speed	6.8 to 7.0 F/S	6.9
Maximum Force	1060 - 1300 LBS.	1073

RIGHT KNEE	SPECIFICATION	MEASUREMENT
Probe Speed	6.8 to 7.0 F/S	6.9
Maximum Force	1060 - 1300 LBS.	1077

HYBRID III DUMMY CONFIGURATION AND PERFORMANCE VERIFICATION DATA

DUMMY NO.: 37 DUMMY CALIBRATION BY: Jeff Robbins

I. CONFIGURATION VERIFICATION DATA

DATE OF VERIFICATION: 02-21-94

DESCRIPTION	SPECIFICATION (Inches)	ACTUAL MEASUREMENT (inches)
A - Total Sitting Height	34.6 - 35.0	34.9
B - Shoulder Pivot Height	19.9 - 20.5	20.5
C - "H" Point Height	3.3 - 3.5	3.5
D - "H" Point from Seat Back	5.3 - 5.5	5.5
E - Shoulder Pivot From Backline	3.3 - 3.7	3.5
F - Thigh Clearance	5.5 - 6.1	6.1
G - Back of Elbow to Wrist Pivot	11.4 - 12.0	11.5
H - Skull Cap Skin to Backline	1.6 - 1.8	1.7
I - Shoulder Elbow Length	13.0 - 13.6	13.0
J - Elbow Rest Height	7.5 - 8.3	8.0
K - Buttock Knee Length	22.8 - 23.8	23.5
L - Popliteal Height	16.9 - 17.9	17.0
M - Knee Pivot Height	19.1 - 19.9	19.5
N - Buttock Popliteal Length	17.8 - 18.8	18.5
O - Chest Depth at 3rd Rib	8.4 - 9.0	8.8
P - Foot Length	9.9 - 10.5	10.3
V - Shoulder Breadth	16.6 - 17.2	16.8
W - Foot Breadth	3.5 - 4.2	4.0
Y - Chest Circumference	38.2 - 39.4	39.0
Z - Waist Circumference	32.9 - 34.1	33.5

Note: (See next page for external dimensions)

HYBRID III EXTERNAL DIMENSIONS

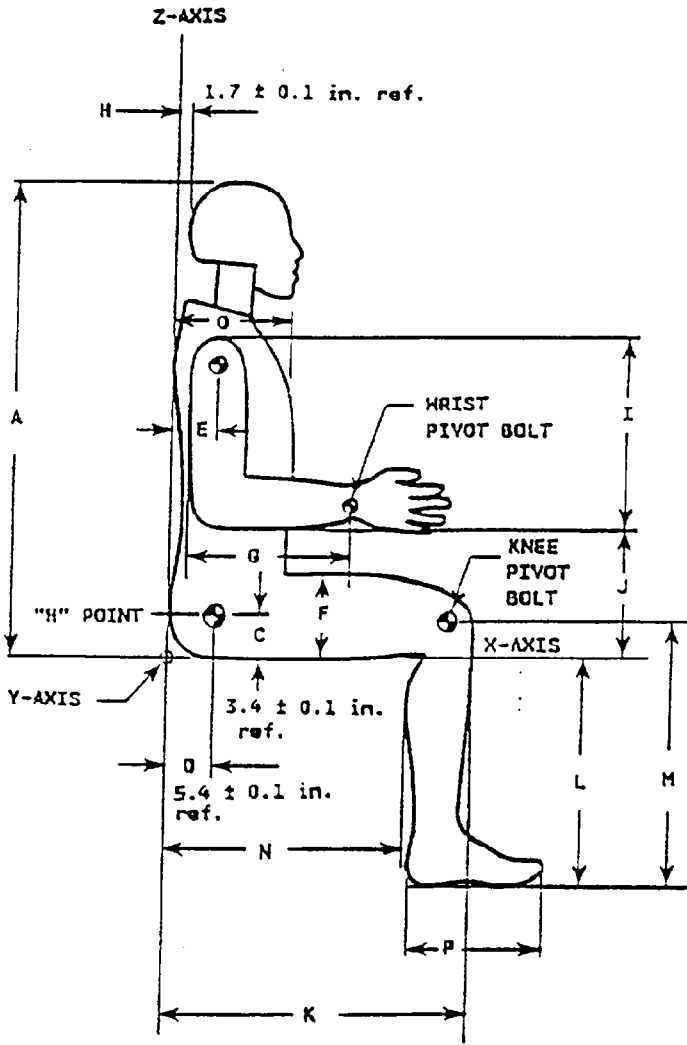

SIDE VIEW

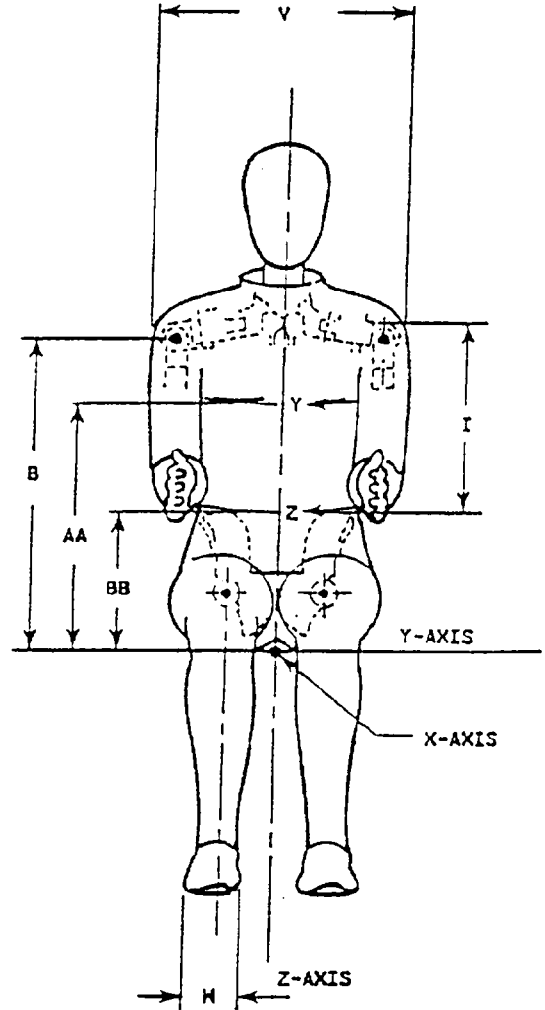

FRONT VIEW

Note: Figure is referenced to the erect seated position. The curved lumbar does not allow the hybrid III to be positioned in a perfect erect attitude.

HYBRID III DUMMY CALIBRATION DATA SUMMARY SHEET (CONT.)

DUMMY NO.: 37 DUMMY CALIBRATION BY: Jeff Robbins

VERIFICATION DATE: 02-21-94

VERIFICATION LABORATORY TEMPERATURE (66° - 78°): 70°

1.0 HEAD DROP TEST

	SPECIFICATION	MEASUREMENT
Peak Resultant Acceleration	225 - 275 G	233
Peak Lateral Acceleration	-15 G. MAX	3.41
Is Acceleration Curve Unimodal	within 10% of peak	Yes

2.0 NECK FLEXION TEST

		SPECIFICATION	MEASUREMENT
Pendulum Speed		22.6 - 23.4 FT/SEC	22.9
Pendulum Deceleration	10 MS	22.50 - 27.50 G	24.55
	20 MS	17.60 - 22.60 G	19.97
	30 MS	12.50 - 18.50 G	14.20
Max. Pendulum G Above 30 MS		29.0 G MAX	14.1
Deceleration - Time Curve Decay Time to 5 G		34 - 42 MS	40
D Plane Rotation	MAX	64 - 78 DEG.	74
	TIME	57 - 64 MS	59
Rotation Angle - Time Curve Decay Time to Zero		113 - 128 MS	117
Moment About Occipital Condyle	MIN.	65 - 80 FT.LBS	66
	TIME	47 - 58 MS	54
Positive Moment - Time Curve Decay Time to Zero		97 - 107 MS	106

HYBRID III DUMMY CALIBRATION DATA SUMMARY SHEET (CONT.)

3.0 NECK EXTENSION TEST

		SPECIFICATION	MEASUREMENT
Pendulum Speed		19.50 - 20.30 F/S	19.95
Pendulum Deceleration	10 MS	17.20 - 21.20 G	18.38
	20 MS	14.00 - 19.00 G	16.70
	30 MS	11.00 - 16.00 G	12.52
Max. Pendulum G Above 30 MS		22 G Max	13
Deceleration - Time Curve Decay Time to 5 G		38 - 46 MS	45
D Plane Rotation	MAX	81 - 106 DEG.	97
	TIME	72 - 82 MS	81
Rotation Angle - Time Curve Decay Time to Zero		147 - 174 MS	159
Moment About Occipital Condyle	MIN.	-59.0/-39.0 FT LBS	-45.5
	TIME	65 - 79 MS	69
Positive Moment - Time Curve Decay Time to Zero		120 - 148 MS	141

4.0 CHEST IMPACT TESTS

	SPECIFICATION	MEASUREMENT
Probe Speed	21.6 to 22.4 F/S	21.75
Peak Deflection	2.50 to 2.86 IN.	2.84
Peak Resistive Force	1160 to 1325 LBS.	1186.02
Internal Hysteresis	69 to 85%	76.4

5.0 KNEE IMPACT TESTS

LEFT KNEE	SPECIFICATION	MEASUREMENT
Probe Speed	6.8 to 7.0 F/S	7.04
Maximum Force	1060 - 1300 LBS.	1077

RIGHT KNEE	SPECIFICATION	MEASUREMENT
Probe Speed	6.8 to 7.0 F/S	7.01
Maximum Force	1060 - 1300 LBS.	1062

APPENDIX D

Dummy, Vehicle and Laboratory Calibration Data

DUMMY, VEHICLE AND LABORATORY INSTRUMENT CALIBRATION

INSTRUMENTS FOR DUMMY NO. 36

	DRIVER		
	SERIAL NO.	MANUFACTURER	CALIBRATION DATE
Head X	ACDE7	Endevco	1/25/94
Head Y	ACC70	Endevco	1/25/94
Head Z	ACCW9	Endevco	1/25/94
Chest X	ACC78	Endevco	1/25/94
Chest Y	ACCE6	Endevco	1/25/94
Chest Z	ACC93	Endevco	1/25/94
Right Femur Load Cell	259	GSE	1/27/94
Left Femur Load Cell	260	GSE	1/27/94
Neck Load Cell X	442	Denton	2/9/94
Neck Load Cell Y	442	Denton	2/9/94
Neck Load Cell Z	442	Denton	2/9/94
Neck Moment X	442	Denton	2/9/94
Neck Moment Y	442	Denton	2/9/94
Neck Moment Z	442	Denton	2/9/94
Chest Deflection Gauge	36G	Bourns	2/21/94
Lap Belt Load Cell	211	Eaton	11/22/93
Torso Belt Load Cell	661	Eaton	11/22/93

DUMMY, VEHICLE AND LABORATORY INSTRUMENT CALIBRATION

INSTRUMENTS FOR DUMMY NO. 37

PASSENGER		
SERIAL NO.	MANUFACTURER	CALIBRATION DATE
ACC46	Endevco	1/25/94
ACCH1	Endevco	1/25/94
AAMW5	Endevco	1/25/94
ACCY1	Endevco	1/25/94
ACCC8	Endevco	1/25/94
ACCT7	Endevco	1/25/94
261	GSE	1/27/94
262	GSE	1/27/94
443	Denton	2/9/94
443	Denton	2/9/94
443	Denton	2/9/94
443	Denton	2/9/94
443	Denton	2/9/94
443	Denton	2/9/94
443	Denton	2/9/94
37G	Bourns	2/21/94
657	Lebow	11/22/93
691	Lebow	11/22/93

DUMMY, VEHICLE AND LABORATORY INSTRUMENT CALIBRATION

VEHICLE ACCELEROMETERS			
	SERIAL NO.	MANUFACTURER	CALIBRATION DATE
Left Rear Seat Crossmember X	MGA129	Entran	11/16/93
Right Rear Seat Crossmember X	MGA097	Entran	8/31/93
Top of Engine X	MGA042	Entran	11/30/93
Bottom of Engine X	AC9D5	Endevco	1/10/94
Left Brake Caliper X	MGA118	Entran	10/22/93
Right Brake Caliper X	MGA116	Entran	10/11/93
Instrument Panel X	MGA078	Entran	2/3/93
Redundant Left Rear Seat Crossmember X	A84	Endevco	12/13/93
Redundant Right Rear Seat Crossmember X	MGA136	Entran	12/22/93

LABORATORY INSTRUMENTS			
	SERIAL NO.	MANUFACTURER	CALIBRATION DATE
Neck Bending Pendulum Accelerometer	MGA126	Entran	10/22/93
Neck Bending Rotary Potentiometer	N/A	Bourns	Prior to use
Neck Bending Linear Potentiometer	N/A	Bourns	Prior to use
Femur/Chest/Thorax Probe Accelerometer	282396	Sensotech	2/1/94
Abdomen Compression Force Gauge	N/A	Transducers Inc.	N/A

APPENDIX E

Vehicle Owner's Occupant Restraint System Instructions

Safety Restraints

Using Safety Restraints Properly

Safety Belts

The use of safety belts help to restrain you and your passengers in case of a collision. In most states, the law requires their use. We strongly recommend that you use them every time you travel in your vehicle.

Warning: Always drive and ride with your seatback upright and the lap belt portion of your safety belt snug and low across the hips. This will reduce the risk of serious injury to the abdomen or neck that could be caused by sliding under the safety belts in a collision.

Safety belts provide best restraint when:

- the seatback is upright
- the occupant is sitting upright (not slouched)
- the lap belt is snug and low on the hips
- the shoulder belt is snug against the chest
- the knees are straight forward

For your safety, your vehicle has different types of safety belts:

- Lap Belts** – for people who sit in the middle seat in the front or the rear seat.
- Lap and Shoulder Belts** – for people who sit in the front seat.

See the following sections for directions on how to properly use these safety belts. Also see *Safety Restraints for Children* in this chapter for special instructions about using safety belts for children.

Warning: Make sure that you and your passengers, including pregnant women, wear safety belts. Be sure that the lap belt portion of your safety belt fits snugly and as low as possible around the hips. If safety belts are not used properly, the risk of you or your passengers being injured in a collision greatly increases.

Warning: Use the shoulder belt on the outside shoulder only. Never wear the shoulder belt under the arm. Never swing it around the neck over the inside shoulder. Never use a single belt for more than one person. Failure to follow these precautions could increase the risk and/or severity of injury in a collision.

Do not allow any people to ride in the cargo area of your vehicle. People who are not riding in seats with their safety belts fastened are much more likely to be injured in a collision.

Never let a passenger hold a child on his or her lap while the vehicle is moving. The passenger cannot protect the child from injury in a collision.

Children should always ride with the seatback in the fully upright position. When the seatback is not fully upright, there is a greater risk that the child will slide under the safety belt and be seriously injured in a collision.

Never use a single belt for more than one person or across more than one seating position. This greatly increases the risk that one or both of the people will be injured in a collision. Each seating position in your vehicle has a specific safety belt assembly which is made up of one buckle and one tongue that are designed to be used as a pair.

Warning: Lock the doors of your vehicle before driving to lessen the risk of the door coming open in a collision.

Warning: All safety belt assemblies, including retractors, buckles, front seat belt buckle support assemblies (slide bar) (if so equipped), and attaching hardware, should be inspected after any collision. Ford recommends that all safety belt assemblies used in vehicles involved in a collision be replaced. However, if the collision was minor and a qualified technician finds that the belts do not show damage and continue to operate properly, they do not need to be replaced. Safety belt assemblies not in use during a collision should also be inspected and replaced if either damage or improper operation is noted.

Safety Belt Maintenance

Check the safety belt systems periodically to make sure that they work properly and are not damaged.

Combination Lap and Shoulder Belts

While your vehicle is in motion, the combination lap and shoulder belt adjusts to your movement. However, if you brake hard, corner hard or if your vehicle receives an impact of 5 mph (8 km/h) or more, the lap and shoulder belt locks and helps reduce your forward movement.

After you get into your vehicle, close the door and lock it. Then adjust the seat to the position that suits you best.

To fasten the belt, pull the lap/shoulder belt from the retractor so that the shoulder portion of the belt crosses your shoulder and chest. Be sure the belt is not twisted. If it is, remove the twist. Insert the belt tongue into the proper buckle until you hear a snap and feel it latch. Make sure the tongue is securely fastened in the buckle.

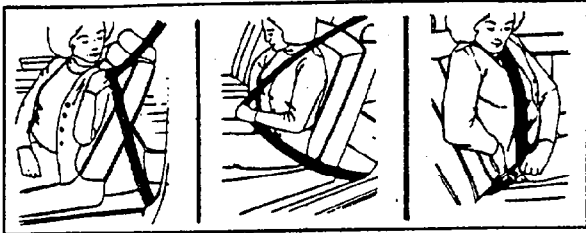

Fastening the front seat lap and shoulder belt

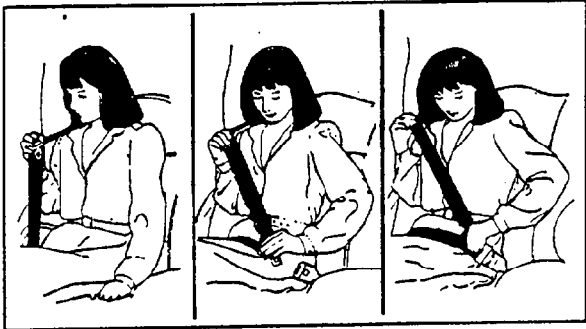

Fastening the rear seat lap and shoulder belt

Warning: Make sure that the lap belt is as low around your hips as possible. Do not wear the lap belt around your waist. If you do not use the lap belts properly, the risk of being injured in a collision greatly increases.

Warning: All front and rear seat outboard occupants (including pregnant women) should wear lap and shoulder belts, for optimum protection in a collision.

Warning: Use the shoulder belt on the outside shoulder only. Never wear the shoulder belt under the arm. Never swing it around your neck over the inside shoulder. Never use a single belt for more than one person. Failure to follow these precautions could increase the risk and/or severity of injury in a collision.

To adjust the lap part of the belt, pull up on the shoulder belt until the lap belt fits snugly and as low as possible around your hips.

To unfasten the belt:

1. Push the release-button on the end of the buckle. This allows the tongue to unlatch from the buckle.

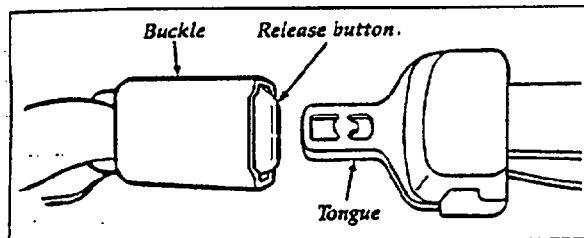

Unfastening the outboard lap/shoulder belts

2. While the belt retracts, guide the tongue to its original position. If you do not guide the tongue, it may strike you or part of the vehicle.

Then, pull the belt out and let it retract several times to be sure that the belt works properly.

Procedure to Correct a Twisted Safety Belt at the "D" Ring (if so equipped) Front and/or Rear Outboard Seating Positions

NOTE: The restraint system shown in the following figures may be different than your vehicle. However, use these figures and this procedure to correct a twisted safety belt at any outboard seating position that has a "D" ring.

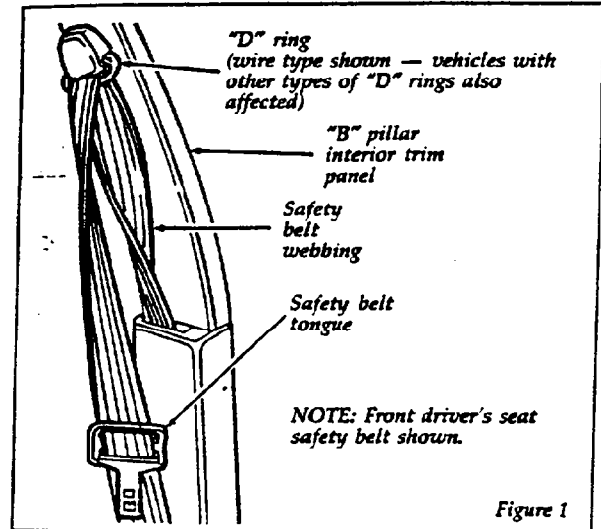

1. Grasp the belt webbing at the "D" ring. See Figure 2.

Safety Belt Light/Chime

This warning light and chime remind you to fasten your safety belt. The following conditions will take place:

- If safety belt is not buckled when the key is turned to the ON position, the light comes on for 1 to 2 minutes and the chime sounds for 4 to 8 seconds.
- If safety belt is buckled while the light is on and the chime is sounding, both the light and chime turn off.
- If safety belt is buckled before the key is turned to the ON position, both the light and chime will not turn on.



The safety belt light

How to Untwist or Unjam a Safety Belt Retractor

If you should jam the belt retractor by allowing the belt to retract when it is twisted, you can free the webbing with this procedure:

1. Pull on the belt with both hands to tighten it on the retractor spool.
2. Feed the belt back into the retractor until it is completely retracted. Repeat previous step if necessary.
3. Pull the belt out of its holder as far as it will go and untwist the belt or remove the object that is jamming the belt. Let the belt retract.

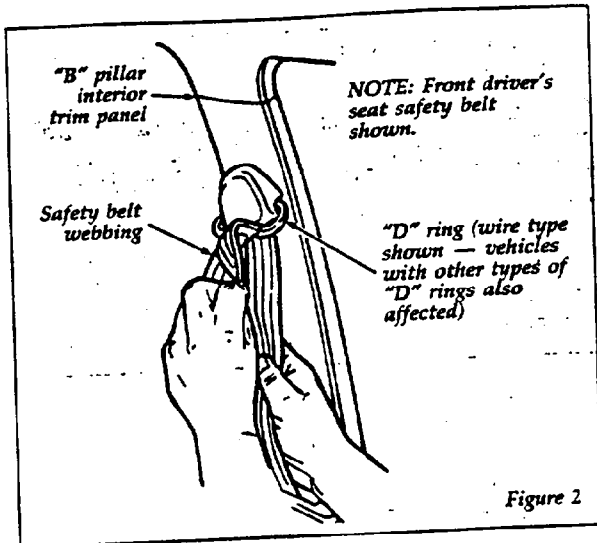

2. Rotate and fold the belt webbing over itself as required to remove the twist.
3. Feed the folded portion of the belt through the "D" ring.
4. When completed, safety belt should look like Figure 3.

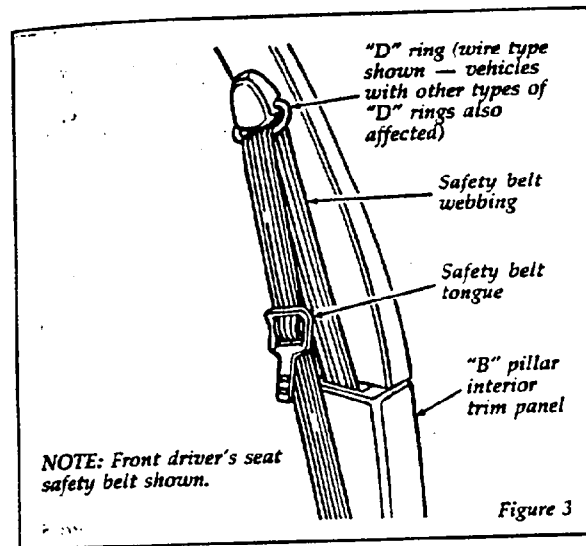

Procedure to Correct a Rotated Tongue on the Safety Belt (Front and/or Rear Outboard Seating Positions)

NOTE: The restraint system shown in the following figures may be different than your vehicle. However, use these figures and this procedure to correct a rotated tongue on the safety belt at any outboard seating position that has a "D" ring.

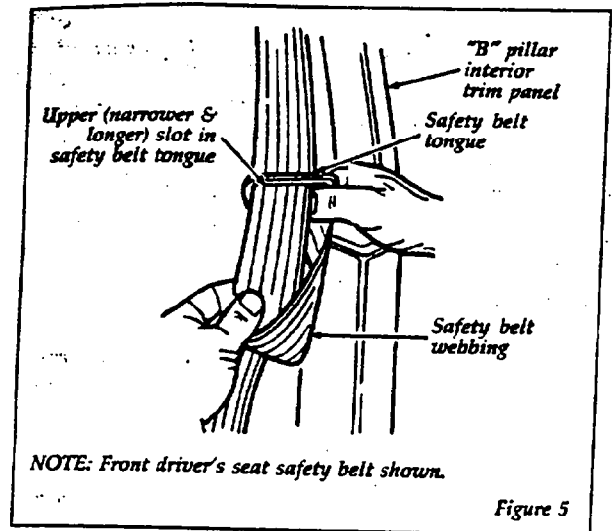

2. Working within the upper slot, rotate and fold the belt webbing over itself as required to remove the twist.
3. Pull the excess belt webbing back through the upper slot in the tongue.
4. Repeat the above steps to complete the removal of the twist at the lower (wider and larger) slot in the tongue. See Figure 6.

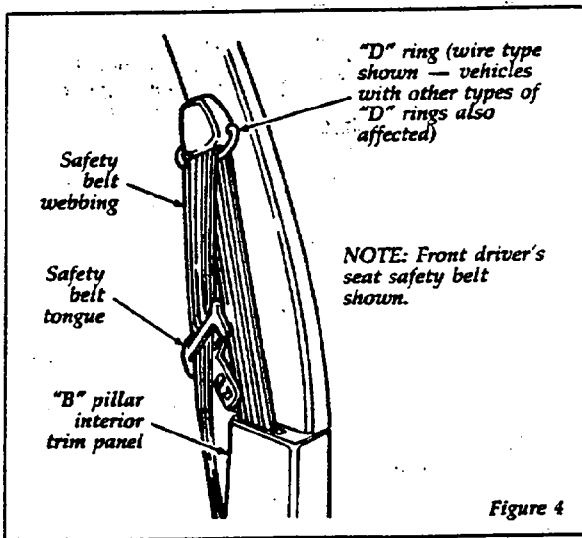

1. Grasp the belt tongue and pull down on the belt webbing closest to you to form a loop through the upper (narrower and longer) slot in the tongue. See Figure 5.

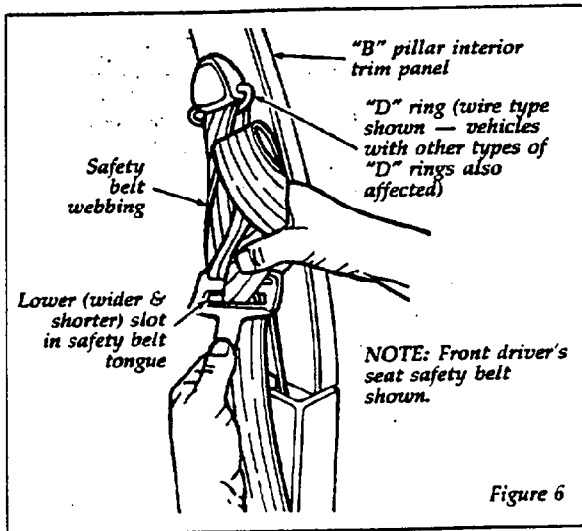

Figure 6

5. When completed, the safety belt should look like Figure 3.

Center Rear Seat Lap Belt

The lap belt in the center of the rear seat does not adjust automatically. You must adjust it to fit snugly and as low as possible around your hips. Do not wear it around your waist.

Before you fasten your center position lap belt in the rear seat, you may need to lengthen it.

To lengthen the belt, tip the belt tongue at a right angle to the belt. Pull the belt tongue over your lap until it reaches the buckle.

To fasten the belt, pull the belt across your hips and insert the tongue into the correct buckle on your seat until you hear a snap and feel it lock. Make sure the buckle is securely fastened.

Adjust the belt so that it fits snugly around your hips:

If you need to shorten the belt, pull on the loose end of the webbing.

To unfasten the belt, push the release button on the buckle. This allows the tongue to unlatch from the buckle.

Because the center lap belt does not have a retractor, it should be shortened and fastened when not in use.

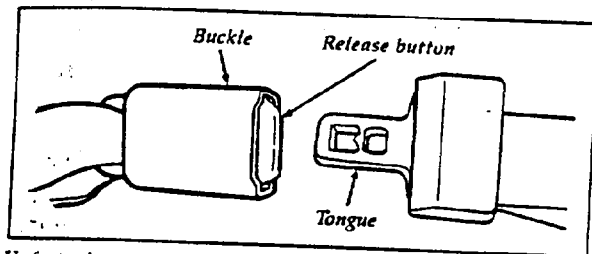

Unfastening center rear seat lap belt

Safety Belt Extension Assembly

A safety belt that is too short even when fully extended can be lengthened. Available from your dealer at no cost is a safety belt extension assembly. This assembly will add approximately eight inches (20 cm) to the length of the belt.

- reduce the risk of being thrown from your vehicle

The Importance of Being Properly Seated

In a collision, the air bag must inflate extremely fast to help provide additional protection for you. In order to do this, the air bag must inflate with considerable force. If you are not seated in a normal riding position with your back against the seatback, the air bag may not protect you properly and could possibly hurt you as it inflates.

Warning: Your vehicle is equipped with a right front passenger air bag. Front passengers, especially children and small adults, should never sit on the edge of the seat, stand near the glove compartment of the instrument panel, or lean over with their faces near the glove compartment when the vehicle is moving. All occupants should sit with their backs against the seatback and use the safety belts. Children weighing less than 40 lbs. (18 kg) should use child or infant seats. Forward-facing child seats must have the passenger seat moved as far back from the instrument panel as possible. REAR-FACING INFANT SEATS SHOULD NEVER BE USED IN THE FRONT SEAT, BECAUSE THE FORCE OF THE RAPIDLY INFLATING PASSENGER AIR BAG COULD PUSH THE TOP OF THE REAR-FACING SEAT AGAINST THE VEHICLE SEATBACK OR CENTER ARMRESTS. REAR-FACING INFANT SEATS MUST ALWAYS BE PLACED IN THE REAR SEAT.

Warning: Use only extensions manufactured by the same supplier as the safety belt. Manufacturer identification is located at the end of the webbing on a label. Also, use the safety belt extension only if the safety belt is too short for you when fully extended. Do not use extension to change the fit of the shoulder belt across the torso. Failure to follow these instructions will affect the performance of the safety belts and increase the risk of personal injury.

Air Bag Supplemental Restraint System (SRS)

Driver and Right Front Passenger Air Bag

An air bag is a Supplemental Restraint System (SRS) designed to help reduce the risk of injury to a properly belted driver and front outboard passenger in moderate to severe frontal collisions. The supplemental air bag system does not provide restraint to the lower body.

Warning: ALWAYS WEAR THE SAFETY BELT!

The Importance of Wearing Safety Belts

There are four very important reasons to use safety belts even with an air bag system. Use your safety belts to:

- help keep you in the proper position (away from the air bag) when it inflates
- reduce the risk of harm in rollover, side or rear impact collisions, because an air bag is not designed to inflate in such situations
- reduce the risk of harm in frontal collisions that are not severe enough to activate the air bag

Warning: Do not place objects or mount equipment in front of the air bag module cover or in front seat areas that may come in contact with a deploying air bag. Failure to follow this instruction could result in personal injury.

How the Air Bag Supplemental Restraint System Operates

The air bag supplemental restraint system has two main parts. One part is the air bag system with driver and passenger-side air bags and inflators. The second part is the electrical system, which has impact sensors and a diagnostic module. The diagnostic module monitors its own internal circuits and the supplemental air bag electrical system readiness, including the impact sensors, the system wiring, the air bag system readiness light, air bag back up power, and the air bag igniters.

The driver air bag is in the center of the steering wheel. The front passenger seat air bag is in the upper right hand section of the instrument panel ledge above the glove compartment.

The air bag system uses a readiness light and a tone to indicate the condition of the system. The readiness light is in the instrument cluster. When you turn the ignition key to ON, this light will illuminate for approximately six (6) seconds and then turn off. This indicates that the system is operating normally. **NOTE:** Maintenance of the air bag system is not required.

Warning: A problem with the system is indicated by one or more of the following:

- the readiness light will either flash or stay lit,
- or it will not light immediately after the ignition is turned on,
- or a group of five beeps will be heard.

If any of these things happens, have the air bag system serviced at your Ford or Lincoln-Mercury Dealer immediately.

Tone generator

The air bag readiness light indicates the air bag system condition. However, a series of five sets of five beeps will be heard only if the readiness light doesn't work and there is a problem with the air bag system. This also means that the Air Bag Supplemental Restraint System (SRS) is in need of service. The tone pattern will repeat (five sets of five beeps) periodically until the problem and light are repaired. Unless serviced, the Air Bag Supplemental Restraint System may not function properly in the event of a collision.

Warning: Do not attempt to service, repair, or modify the Air Bag Supplemental Restraint System; tampering could cause activation of the system and increase the risk of personal injury. For servicing of the Air Bag Supplemental Restraint System, see your dealer.

The air bag system is designed to stay out of sight until it is activated. The air bag system is designed to deploy in frontal and front-angled collisions more severe than hitting a parked vehicle of similar size and weight head-on at about 28 mph (45 km/h). Because the system

Warning: Several air bag system components get hot after inflation. Do not try to touch them after inflation.

Air bags may not inflate in certain frontal collisions, even though the vehicle may be badly damaged. The fact that your air bag did not inflate in such a collision does not mean that something is wrong with the air bag system. Rather, it means the crash forces were not severe enough to need an air bag to prevent serious injury.

senses the crash severity rather than vehicle speed, some frontal collisions at speeds above 28 mph (45 km/h) will not inflate the air bag.

The following four steps show how the air bag system works:

1. Sensors in the vehicle will detect the degree of severity of a frontal impact. When two sensors (one primary and one safing) close at the same time, electric current flows to the inflator and the system ignites the gas generant.
2. The propellant then rapidly burns in the metal container. The rapid burning produces nitrogen gas and small amounts of dust. The nitrogen gas and dust are cooled and filtered during inflation of the air bag.
3. The inflating air bag splits open the trim cover. The air bag then rapidly unfolds and inflates in front of the occupant.

NOTE: STEPS 1-3 TAKE PLACE IN A FRACTION OF A SECOND.

4. After inflation, the gas empties through holes in the air bag. The air bag deflates at once.

The surface of the air bags and the vehicle interior may be dusted with a powdery residue. The powder is corn starch or talcum powder, which is used to lubricate the air bag as it inflates, and sodium compounds such as sodium carbonates (e.g., baking soda), and possibly a very small amount of sodium hydroxide that may be irritating to the skin and eyes, but is not toxic.

Right after air bag inflation, you may notice smoke (from the powder and dust) and smell the burnt propellant. This is normal.

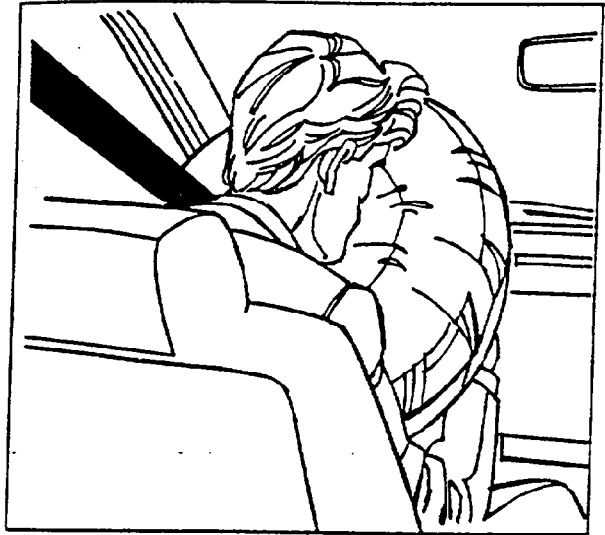

Inflated driver side air bag

Warning: The air bag will inflate only once. The system is designed to function on a one-time-only basis. If the air bag is inflated, **THE AIR BAG WILL NOT FUNCTION AGAIN AND MUST BE REPLACED IMMEDIATELY.** If the air bag is not replaced, the unrepaired area will increase the risk of injury in a collision.

Disposal of air bag equipped vehicles

For disposal of air bags or air bag equipped vehicles, see your local Ford or Lincoln-Mercury dealer, or refer to the procedures in the 1994 Ford Service Manual. Information on how to order a service manual is available at an authorized Ford or Lincoln-Mercury Dealer. You can also order a service manual using the order form in the *Accessories* chapter of your Owner Guide.

Service and information labels

Service and information labels are attached to the sun visor (USA vehicles), on the headliner above the driver's seat (Canadian vehicles), and the radiator support in the engine compartment.

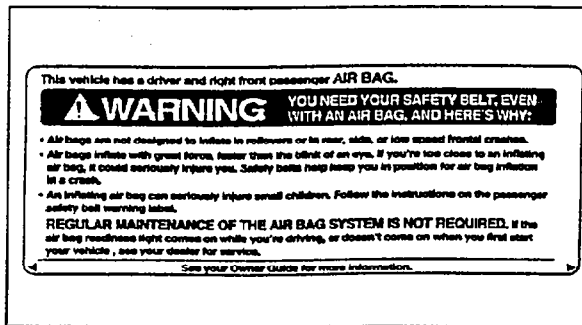

The label on the sun visors in the down position