

V2043

Report Numbers: 208-TRC-94-012
212-TRC-94-012
301-TRC-94-012

Vehicle Safety Compliance Testing
for Occupant Crash Protection,
Windshield Mounting, Windshield Zone Intrusion (partial),
and Fuel System Integrity

Ford Motor Company
1994 Ford Probe
3-door hatchback
NHTSA Number: CR0210
TRC Test Number: 940302

Transportation Research Center Inc.
10820 State Route 347
East Liberty, Ohio 43319



March 18, 1994

Final Report

Prepared For:
U.S. Department of Transportation
National Highway Traffic Safety Administration
Office of Vehicle Safety Compliance (NEF-30)
400 Seventh Street, S.W., Room No. 6115
Washington, DC 20590

This Final Test Report was prepared for the U.S. Department of Transportation, National Highway Traffic Safety Administration, under Contract No. DTNH22-93-D-01089.

This publication is distributed by the U. S. Department of Transportation, National Highway Traffic Safety Administration, in the interest of information exchange. The opinions, findings, and conclusions expressed in this publication are those of the author(s) and not necessarily those of the Department of Transportation or the National Highway Traffic Safety Administration. The United States Government assumes no liability for its contents or use thereof. If trade or manufacturers' names or products are mentioned, it is only because they are considered essential to the object of the publication and should not be construed as an endorsement. The United States Government does not endorse products or manufacturers.

Report Prepared By:

Craig A. Markusic Date 4/6/94
Craig A. Markusic, Senior Project Engineer
Transportation Research Center Inc.

Report Approved By:

Jeffery W. Sankey Date 4/6/94
Jeffery W. Sankey, Engineering Supervisor
Transportation Research Center Inc.

Final Report Accepted By:

Charles R. Case Date 10/27/94
Contracting Officer's Technical Representative (COTR),
NHTSA, Office of Vehicle Safety Compliance

<p>1. Report No. 208-TRC-94-012 212-TRC-94-012 301-TRC-94-012</p>	<p>2. Government Accession No.</p>	<p>3. Recipient's Catalog No.</p>	
<p>4. Title and Subtitle FINAL REPORT OF FMVSS NOS. 208, 212, 219 (PARTIAL), AND 301 COMPLIANCE TESTING OF A 1994 FORD PROBE 3-DOOR HATCHBACK, NHTSA NO. CRO210</p>		<p>5. Report Date MARCH 18, 1994</p>	<p>6. Performing Organization Code TRC</p>
<p>7. Author(s) C. A. Markusic, Senior Project Engineer, TRC</p>	<p>8. Performing Organization Report No. 208-TRC-94-012 212-TRC-94-012 301-TRC-94-012</p>		
<p>9. Performing Organization Name and Address Transportation Research Center Inc. 10820 State Route 347 East Liberty, OH 43319</p>		<p>10. Work Unit No. (TR AIS)</p>	<p>11. Contract or Grant No. DTNH22-93-D-01089</p>
<p>12. Sponsoring Agency Name and Address U. S. Department of Transportation National Highway Traffic Safety Administration Office of Vehicle Safety Compliance (NEF-31) 400 Seventh St., S.W., Washington, DC 20590</p>		<p>13. Type of Report and Period Covered FINAL REPORT MARCH - APRIL 1994</p>	
<p>15. Supplemental Notes</p>		<p>14. Sponsoring agency Code NEF-30</p>	
<p>16. Abstract</p> <p>A 30 mph flat frontal barrier impact test was conducted on a 1994 Ford Probe 3-door hatchback, NHTSA No. CRO210, at Transportation Research Center Inc. on March 2, 1994. This test was conducted to determine compliance with Federal Motor Vehicle Safety Standards: FMVSS 208, "Occupant Crash Protection"; 212, "Windshield Mounting"; 219 (partial), "Windshield Zone Intrusion"; and 301 "Fuel System Integrity." The barrier impact velocity was 29.6 mph. The vehicle's maximum static crush was 15.2 inches. The ambient temperature was 68° F.</p> <p>The driver's head injury criteria (HIC) was 341. The driver's chest maximum resultant acceleration with three (3) milliseconds minimum duration was 52.7 g. The driver's left and right femur maximum axial forces were 1248 pounds and 1349 pounds, respectively.</p> <p>The passenger's HIC was 107. The passenger's chest maximum resultant acceleration with three (3) milliseconds minimum duration was 31.4 g. The passenger's left and right femur maximum axial forces were 1407 pounds and 1641 pounds, respectively.</p> <p>The vehicle appears to comply with the applicable requirements of FMVSS 208, 212, 219 (partial), and 301.</p>			
<p>17. Key Words</p> <p>Frontal Impact 30 mph Vehicle Safety Compliance Testing: FMVSS 208, "Occupant Crash Protection" FMVSS 212, "Windshield Mounting" FMVSS 219 (partial), "Windshield Zone Intrusion" FMVSS 301, "Fuel System Integrity"</p>		<p>18. Distribution Statement</p> <p>Available from: NHTSA Technical Reference Division Room 5108, (NAD-52) 400 Seventh Street, S.W. Washington, DC 20590 Attn: Mr. Robert Hornickle</p>	
<p>19. Security Classif. (of this report) UNCLASSIFIED</p>	<p>20. Security Classif. (of this page) UNCLASSIFIED</p>	<p>21. No. of Pages 158</p>	<p>22. Price</p>

METRIC CONVERSION FACTORS

Symbol	When You Know	Multiply by	To Find	Symbol
LENGTH				
mm	millimeters	0.04	inches	in
cm	centimeters	0.4	inches	in
m	meters	3.3	feet	ft
m	meters	1.1	yards	yd
km	kilometers	0.6	miles	mi
AREA				
cm ²	square centimeters	0.16	square inches	in ²
m ²	square meters	1.2	square yards	yd ²
km ²	square kilometers	0.4	square miles	mi ²
ha	hectares (10,000 m ²)	2.5	acres	
MASS (weight)				
g	grams	0.035	ounces	oz
kg	kilograms	2.2	pounds	lb
t	tonnes (1000 kg)	1.1	short tons	
VOLUME				
ml	milliliters	0.03	fluid ounces	fl oz
l	liters	2.1	pints	pt
l	liters	1.06	quarts	qt
l	liters	0.26	gallons	gal
m ³	cubic meters	35	cubic feet	ft ³
m ³	cubic meters	1.3	cubic yards	yd ³
TEMPERATURE (exact)				
°C	Celsius temperature	9/5 (then add 32)	Fahrenheit temperature	°F

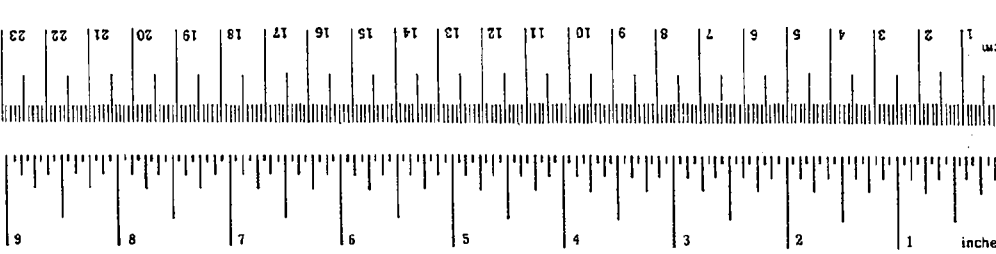

Symbol	When You Know	Multiply by	To Find	Symbol
LENGTH				
in	inches	*7.5	centimeters	cm
ft	feet	30	centimeters	cm
yd	yards	0.9	meters	m
mi	miles	1.6	kilometers	km
AREA				
in ²	square inches	6.5	square centimeters	cm ²
ft ²	square feet	0.09	square meters	m ²
yd ²	square yards	0.8	square meters	m ²
mi ²	square miles	2.6	square kilometers	km ²
	acres	0.4	hectares	ha
MASS (weight)				
oz	ounces	28	grams	g
lb	pounds	0.45	kilograms	kg
	short tons (2000 lb)	0.9	tonnes	t
VOLUME				
tsp	teaspoons	5	milliliters	ml
Tbsp	tablespoons	15	milliliters	ml
fl oz	fluid ounces	30	milliliters	ml
c	cups	0.24	liters	l
pt	pints	0.47	liters	l
qt	quarts	0.95	liters	l
gal	gallons	3.8	liters	l
ft ³	cubic feet	0.03	cubic meters	m ³
yd ³	cubic yards	0.76	cubic meters	m ³
TEMPERATURE (exact)				
°F	Fahrenheit temperature	5/9 (after subtracting 32)	Celsius temperature	°C

* 1 in = 2.54 (exactly). For other exact conversions and more detailed tables, see NBS Misc. Publ. 296, Units of Weights and Measures, Price \$2.25, SD Catalog No. C33.10266.

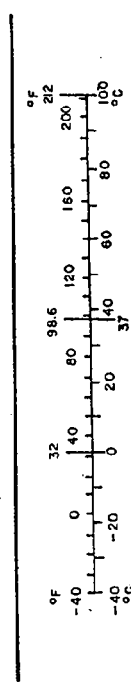

Table of Contents

<u>Section</u>	<u>Description</u>	<u>Page</u>
1.0	Purpose and Test Procedure	1
2.0	Frontal Barrier Impact Test Summary	5
3.0	FMVSS 208, 212, 219 (Partial), and 301 Data	22
4.0	Vehicle, Occupant, and Camera Measurements	39
Appendix A	Photographs	A-1
Appendix B	Data Plots	B-1
Appendix C	Manufacturer's Vehicle Information	C-1

List of Tables

<u>Number</u>	<u>Description</u>	<u>Page</u>
1	Crash Test Summary	8
2	Test Vehicle Information	10
3	Post-Impact Data	13
4	Post-test Airbag Data	16
5	Vehicle Accelerometer Locations and Data Summary	19
6	Dummy Injury Criteria	23
7	FMVSS 208 Seat Belt Comfort and Convenience Test Summary Front Outboard Designated Seating Positions	25
8	FMVSS 208 Equipment Data	28
9	Fuel System Data	33
10	FMVSS 301 Post-Impact Test Data	34
11	Impacted Vehicle Measurements	41
12	Dummy Measurement Data for Front Seat Occupants	44
13	Motion Picture Camera Locations	47

List of Figures

<u>Number</u>	<u>Description</u>	<u>Page</u>
1	Impact Velocity Measurement System	14
2	Accident Investigation Division Data for 30 mph Frontal Barrier Impact	15
3	Vehicle Accelerometer Placement	18
4	FMVSS 212 Test Data	31
5	FMVSS 219 Test Data	32
6	FMVSS 301 Static Rollover Test Data	35
7	Pre-test and Post-test Measurement Points	40
8	Vehicle Target Locations	42
9	Dummy Measurement Locations for Front Seat Occupants	43
10	Camera Positions	45

List of Photographs

<u>Figure</u>	<u>Photograph Title</u>	<u>Page</u>
A-1.	Pre-test Front View	A-2
A-2.	Post-test Front View	A-3
A-3.	Pre-test Left Side View	A-4
A-4.	Post-test Left Side View	A-5
A-5.	Pre-test Rear View	A-6
A-6.	Post-test Rear View	A-7
A-7.	Pre-test Right Side View	A-8
A-8.	Post-test Right Side View	A-9
A-9.	Pre-test Right Front Three-Quarter View	A-10
A-10.	Post-test Right Front Three-Quarter View	A-11
A-11.	Pre-test Left Rear Three-Quarter View	A-12
A-12.	Post-test Left Rear Three-Quarter View	A-13
A-13.	Pre-test Windshield View	A-14
A-14.	Post-test Windshield View	A-15
A-15.	Pre-test Engine Compartment View	A-16
A-16.	Post-test Engine Compartment View	A-17
A-17.	Pre-test Fuel Filler Cap View	A-18
A-18.	Post-test Fuel Filler Cap View	A-19
A-19.	Pre-test Fuel Filler Neck View	A-20
A-20.	Post-test Fuel Filler Neck View	A-21
A-21.	Pre-test Fuel Filler Neck and Fuel Tank View	A-22
A-22.	Post-test Fuel Filler Neck and Fuel Tank View	A-23
A-23.	Pre-test Front Underbody View	A-24
A-24.	Post-test Front Underbody View	A-25
A-25.	Pre-test Rear Underbody View	A-26
A-26.	Post-test Rear Underbody View	A-27
A-27.	Pre-test Driver's Knee Bolster View	A-28
A-28.	Pre-test Passenger's Knee Bolster View	A-29
A-29.	Pre-test Steering Column at Firewall View	A-30
A-30.	Post-test Steering Column at Firewall View	A-31

List of Photographs, Cont'd.

<u>Figure</u>	<u>Photograph Title</u>	<u>Page</u>
A-31.	Pre-test Steering Column at Firewall View - Interior	A-32
A-32.	Post-test Steering Column at Firewall View - Interior	A-33
A-33.	Pre-test Driver Dummy Position - View 1	A-34
A-34.	Post-test Driver Dummy Position - View 1	A-35
A-35.	Pre-test Driver Dummy Position - View 2	A-36
A-36.	Post-test Driver Dummy Position - View 2	A-37
A-37.	Pre-test Passenger Dummy Position - View 1	A-38
A-38.	Post-test Passenger Dummy Position - View 1	A-39
A-39.	Pre-test Passenger Dummy Position - View 2	A-40
A-40.	Post-test Passenger Dummy Position - View 2	A-41
A-41.	Pre-test Driver Dummy & Vehicle Interior - View 1	A-42
A-42.	Post-test Driver Dummy & Vehicle Interior - View 1	A-43
A-43.	Pre-test Driver Dummy & Vehicle Interior - View 2	A-44
A-44.	Post-test Driver Dummy & Vehicle Interior - View 2	A-45
A-45.	Pre-test Passenger Dummy & Vehicle Interior - View 1	A-46
A-46.	Post-test Passenger Dummy & Vehicle Interior - View 1	A-47
A-47.	Pre-test Passenger Dummy & Vehicle Interior - View 2	A-48
A-48.	Post-test Passenger Dummy & Vehicle Interior - View 2	A-49
A-49.	Post-test Driver Dummy Head Contact - View 1	A-50
A-50.	Post-test Driver Dummy Head Contact - View 2	A-51
A-51.	Post-test Driver Dummy Head Contact - View 3	A-52
A-52.	Post-test Driver Dummy Knee Contact - View 1	A-53
A-53.	Post-test Driver Dummy Knee Contact - View 2	A-54
A-54.	Post-test Passenger Dummy Head Contact - View 1	A-55
A-55.	Post-test Passenger Dummy Head Contact - View 2	A-56
A-56.	Post-test Passenger Dummy Knee Contact - View 1	A-57
A-57.	Post-test Passenger Dummy Knee Contact - View 2	A-58
A-58.	Pre-test Vehicle Certification Label View	A-59
A-59.	Pre-test Vehicle Recommended Tire Pressure Label View	A-60
A-60.	Post-test Vehicle on Static Rollover Machine View	A-61

Section 1.0

Purpose and Test Procedure

Purpose

This 30 mph flat frontal barrier impact test is part of the Federal Motor Vehicle Safety Standards (FMVSS) 208, 212, 219 (partial), and 301 compliance test program conducted for the National Highway Traffic Safety Administration (NHTSA) by the Transportation Research Center Inc. (TRC) under Contract No. DTNH22-93-D-01089. The purpose of this test was to determine if the subject vehicle, a 1994 Ford Probe 3-door hatchback, NHTSA No. CR0210, meets the performance requirements of FMVSS 208, "Occupant Crash Protection"; FMVSS 212, "Windshield Mounting"; FMVSS 219 (partial), "Windshield Zone Intrusion"; and FMVSS 301, "Fuel System Integrity," in the flat frontal barrier impact mode.

Test Procedure

This test was conducted in accordance with NHTSA's Office of Vehicle Safety Compliance (OVSC) Laboratory Test Procedure No. TP-208-09. Data was obtained relative to FMVSS 208, "Occupant Crash Protection"; FMVSS 212, "Windshield Mounting"; FMVSS 219 (partial), "Windshield Zone Intrusion"; and FMVSS 301, "Fuel System Integrity," performance.

The test vehicle was instrumented with seven (7) accelerometers to measure longitudinal axis accelerations and one (1) accelerometer to measure vertical axis acceleration. The vehicle's specified impact velocity range was 28.9 to 29.9 mph. The vehicle impacted a flat frontal barrier.

The test vehicle contained two (2) Part 572 B 50th percentile adult male anthropomorphic test devices (dummies). The dummies were positioned in the front outboard designated seating positions according to the dummy placement procedure specified in Appendix B of the Laboratory Test Procedure.

Both dummies were instrumented with head and chest accelerometers to measure longitudinal, lateral, and vertical accelerations, and with left and right femur load cells to measure axial forces.

The twenty-four (24) data channels were multiplexed and recorded on a 14-track tape drive. The data was digitally sampled at 12,500 samples per second and processed per Sections 11.13 through 11.15 of the Laboratory Test Procedure.

The crash event was recorded by one (1) real-time panning motion picture camera and fourteen (14) high-speed motion picture cameras. The pre-test and post-test conditions were recorded by one (1) real-time motion picture camera.

The vehicle and occupant data are summarized in Section 2.0. The FMVSS 208, 212, 219 (partial) and 301 data are presented in Section 3.0. The vehicle, occupant, and camera measurements are presented in Section 4.0. Appendix A contains the still photographic prints. Appendix B contains the dummy and vehicle data plots. Appendix C contains the manufacturer's vehicle information.

Section 2.0

Frontal Barrier Impact Test Summary

Test Results Summary

This flat frontal barrier test was conducted at TRC on March 2, 1994.

The test vehicle, a 1994 Ford Probe 3-door hatchback, NHTSA No. CR0210, appeared to comply with the performance requirements of FMVSS 208, 212, 219 (partial), and 301 in the flat frontal barrier impact mode. The Head Injury Criteria (HIC) calculations were less than 1000, the chest resultant accelerations did not exceed 60 g's, and the compressive forces transmitted through the upper legs did not exceed 2,250 pounds as measured by Part 572 B dummies seated in the front outboard designated seating positions. The vehicle's restraint system met the applicable comfort and convenience requirements. The windshield periphery retention was 100 percent. There was no penetration into any portion of the windshield. No fluid spilled from the vehicle's fuel system following the impact or during the static rollover test.

The test vehicle was equipped with airbags at the driver's and right front passenger's seating positions. The vehicle's test weight was 2989 pounds. The vehicle's impact speed was 29.6 mph. The vehicle's maximum static crush was 15.2 inches.

The driver's HIC was 341. The driver's chest maximum resultant acceleration with three (3) milliseconds minimum duration was 52.7 g. The driver's left and right femur maximum compressive forces were 1248 pounds and 1349 pounds, respectively.

The right front passenger's HIC was 107. The right front passenger's chest maximum resultant acceleration with three (3) milliseconds minimum duration was 31.4 g. The right front passenger's left and right femur maximum compressive forces were 1407 pounds and 1641 pounds, respectively.

There was no loss of windshield periphery retention.

There was no penetration through the windshield.

Following the impact, no fluid spilled from the vehicle's fuel system prior to the static rollover test or during any portion of the static rollover test.

Table 1 Crash Test Summary

NHTSA number:	CR0210
Test type:	Frontal barrier impact
Test date:	03/02/94
Test time:	1434
Ambient temperature at impact area:	68° F
Vehicle year/make/ model/body style:	1994/Ford/Probe/3-door hatchback
Vehicle test weight:	2989 lb
Impact angle ¹ :	0°
Impact velocity ² :	
Primary:	29.6 mph
Secondary:	29.6 mph
Maximum static crush:	15.2 in
Average rebound:	11.5 in
Number of cameras:	
Real-time:	2
High-speed:	14
Door opening data:	
Left front:	Easy
Right front:	Easy

¹ With respect to tow track centerline.

² Speed trap measurement ($\pm .05$ mph accuracy)

Table 1 Crash Test Summary, Cont'd.

Dummies:	<u>Driver #1173</u>	<u>Passenger #354</u>
Type:	Part 572 B	Part 572 B
Location:	Left front	Right front
Restraint:	Airbag	Airbag
Number of data channels:	8	8
Front seat data:		
Seat track failure:	None	None
Seat back failure:	None	None
Visible dummy contact points:		
Head:	Airbag, sun visor, and head restraint	Airbag and sun visor
Chest:	Airbag	Airbag
Abdomen:	None	None
Left knee:	Instrument panel	Instrument panel
Right knee:	Instrument panel	Instrument panel

Table 2 Test Vehicle Information

Vehicle year/make/
model/body style: 1994/Ford/Probe/3-door hatchback

Color: Red

VIN: 1ZVLT20AXR5104419

NHTSA number: CR0210

Engine data:

Placement: Lateral/transverse

Cylinders: 4

Displacement: 2.0 liters

Transmission data: 5 speed, X manual, ___ automatic, ___ overdrive

Final drive: X fwd, ___ rwd, ___ 4wd

Date vehicle received: 01/31/94

Odometer reading: 58

Dealer's name
and address: Gambino Ford Inc.
6157 S. Transit Rd.
Lockport NY 14095

Accessories:

Power steering	Yes	Automatic transmission	No
Power brakes	Yes	Automatic speed control	No
Power seats	No	Tilting steering wheel	Yes
Power windows	No	Telescoping steering wheel	No
Tinted glass	Yes	Air conditioning	No
Radio	Yes	Anti-skid brake	No
Clock	Yes	Rear window defroster	Yes
Power door locks	No	Other	Power mirrors

Certification data from vehicle's label:

Vehicle manufactured by: Autoalliance International Inc. for Ford Motor Co.

Date of manufacture: 09/22/93

VIN: 1ZVLT20AXR5104419

GVWR: 3616 lb

GAWR: Front: 2105 lb

Rear: 1984 lb

Table 2 Vehicle Information, Cont'd.

Size of tires on vehicle: P195/65R14

Tire pressure with maximum capacity vehicle load:

Front: 35 psi

Rear: 35 psi

Spare tire: Space saver

Type of front seats: Bucket

Tire & capacity data from vehicle's label:

Recommended tire size: P195/65R14

Recommended cold tire pressure:

Front: 32 psi

Rear: 26 psi

Designated seating capacity:

Front: 2

Rear: 2

Total: 4

Vehicle capacity weight: 680 lbs.

Test vehicle attitudes:

Delivered attitude: LF: 27.6 in. RF: 27.5 in LR: 26.8 in RR: 26.6 in

Fully loaded attitude: LF: 26.9 in RF: 26.9 in LR: 25.7 in RR: 25.6 in

Pre-test attitude: LF: 27.2 in RF: 27.0 in LR: 25.9 in RR: 25.8 in

Table 2 Test Vehicle Information, Cont'd.

Weight of test vehicle as received (with maximum fluids):

Right front	822 lb	Right rear	479 lb
Left front	794 lb	Left rear	504 lb
Total front weight	1616 lb	(62.2% of total vehicle weight)	
Total rear weight	983 lb	(37.8% of total vehicle weight)	
Total delivered weight	2599 lb		

Calculation of test vehicle's target test weight:

RCLW¹ = Rated Cargo and Luggage Weight

UDW = Unloaded Delivered Weight (2599 lb)

VCW = Vehicle Capacity Weight (680 lb)

DSC = Designated Seating Capacity (4)

RCLW¹ = VCW - 150 (DSC) = 680 - 150(4) = 80

Target test weight = UDW + RCLW¹ + (Number of Hybrid II dummies
x 164 lb per dummy)

Target test weight = 2599 + 80 + 328 = 3007 lb

Weight of test vehicle with required dummies and 62 lb of cargo weight:

Right front	892 lb	Right rear	633 lb
Left front	863 lb	Left rear	601 lb
Total front weight	1755 lb	(58.7% of total vehicle weight)	
Total rear weight	1234 lb	(41.3% of total vehicle weight)	
Total test weight	2989 lb	(0.6% under target test weight)	

Weight of ballast secured in vehicle cargo area: 0 lb

Components removed to meet target test weight: None

CG rearward of front wheel centerline: 42.5 in

Vehicle Wheelbase: 103.0 in

¹ Cargo weight for multi-purpose passenger vehicles, trucks, and buses is the vehicle's rated cargo and luggage weight from the vehicle's label or 300 pounds, whichever is less.

Table 3 Post-Impact Data

Test number: 940302
NHTSA number: CR0210
Test date: 03/02/94
Test time: 1434
Test type: Frontal barrier impact
Impact angle: 0°
Ambient temperature
at impact area: 68° F
Temperature in
occupant compartment: 70° F
Impact velocity:
Primary: 29.6 mph
Secondary: 29.6 mph
Specified range: 28.9 to 29.9 mph

Distance from vehicle to barrier:

Entering velocity trap: 14.0 in
Exiting velocity trap: 2.0 in

Test vehicle static crush:

Overall length of test vehicle:

Pre-test:	L:	169.4 in	C:	179.1 in	R:	172.7 in
Post-test:	L:	162.5 in	C:	164.2 in	R:	162.0 in
Total crush:	L:	6.9 in	C:	14.9 in	R:	10.7 in
Average crush:		10.8 in				

Test vehicle rebound from flat barrier:

Distance from test vehicle to barrier:

Post-test:	L:	11.5 in	C:	12.5 in	R:	10.4 in
Average rebound:		11.5 in				

Figure 1 Impact Velocity Measurement System

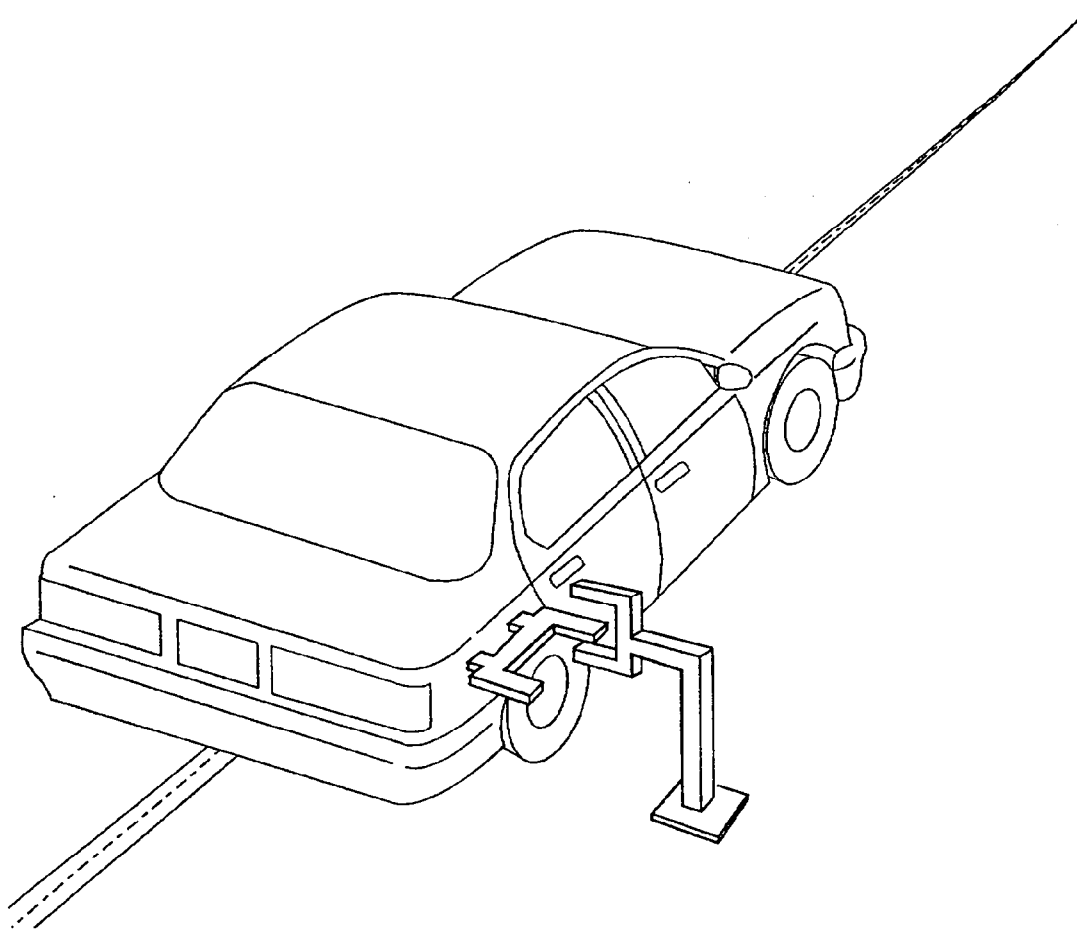

The final vane clears emitter/receiver two inches before impact.

The vanes have a one-foot spacing.

Figure 2 Accident Investigation Division Data for 30 mph Frontal Barrier Impact

NHTSA number: CR0210
 Test date: 03/02/94
 Vehicle year/make/
 model/body style: 1994/Ford/Probe/3-door hatchback
 Vehicle size category: Subcompact
 VIN: 1ZVLT20AXR5104419
 Build date: 09/22/93
 Test weight: 2989 lb
 Vehicle wheelbase: 103.0 in
 Maximum width: 69.8 in
 Front overhang: 39.0 in

Collision Deformation

Classification (CDC) Code: 12FDEW2

Crush depth
 measurements:

C1:	6.9 in
C2:	10.9 in
C3:	13.5 in
C4:	15.2 in
C5:	14.9 in
C6:	10.7 in

Midpoint of damage: D: Vehicle Longitudinal Centerline

Length of damaged
 region: L: 60.0 in

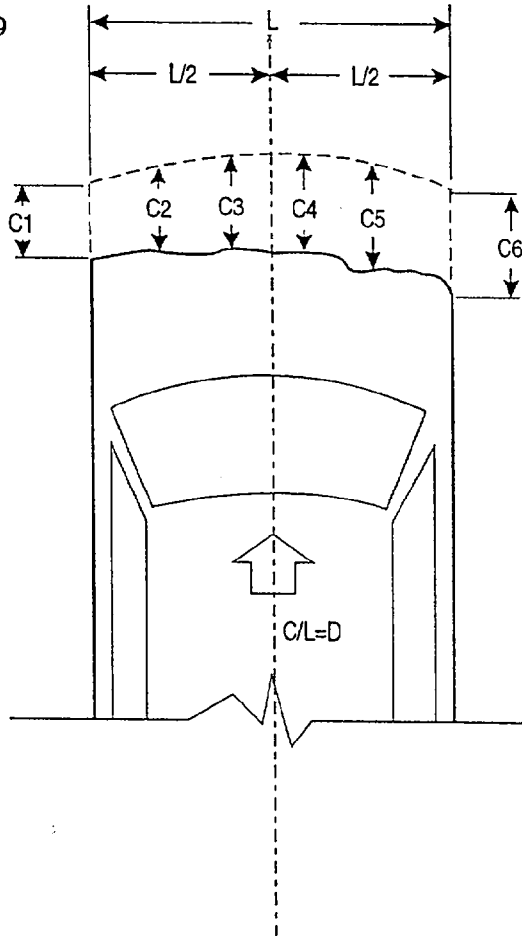

Table 4 Post-test Airbag Data

NHTSA number: CR0210
Test date: 03/02/94
Technician: Markusic
Vehicle year/make/
model/body style: 1994/Ford/Probe/3-door hatchback

A. Number of airbag vent holes:

Driver: 2

Passenger: 2

B. Size of airbag vent holes:

Driver: 1.2 in dia

Passenger: 2.2 in dia

C. Total airbag vent area:

Driver: 2.3 in²

Passenger: 7.6 in²

D. Deflated airbag length and width dimensions or, if round, diameter

Driver: Length NA

Width NA

Diameter 25.5

Passenger: Length: 35.5

Width: 15.0

Diameter: NA

Table 4 Post-test Airbag Data, Cont'd.

E. Is the airbag tethered?

Driver: No

If yes, record length of tether: NA

Passenger: No

If yes, record length of tether: NA

Driver's airbag:

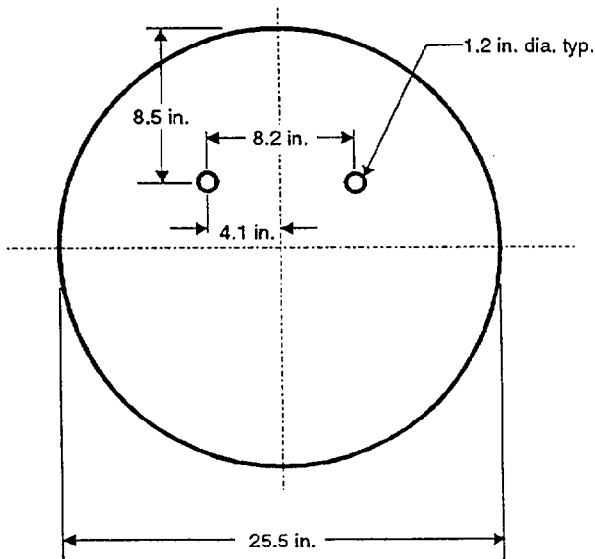

Passenger's airbag:

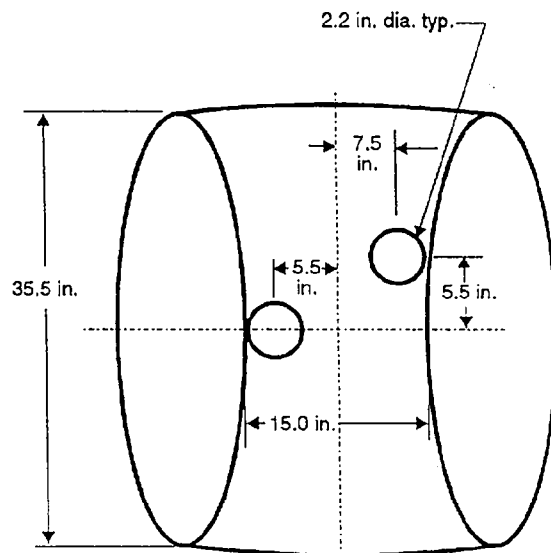

F. Airbag and gas generator part numbers and manufacturer's names.

Driver: Morton International, Airbag: P114074-01C, Gen: DEAD7G3VBLM

Passenger: TRW, Airbag: 2000812C, Gen: MP2B270G10092

Figure 3 Vehicle Accelerometer Placement

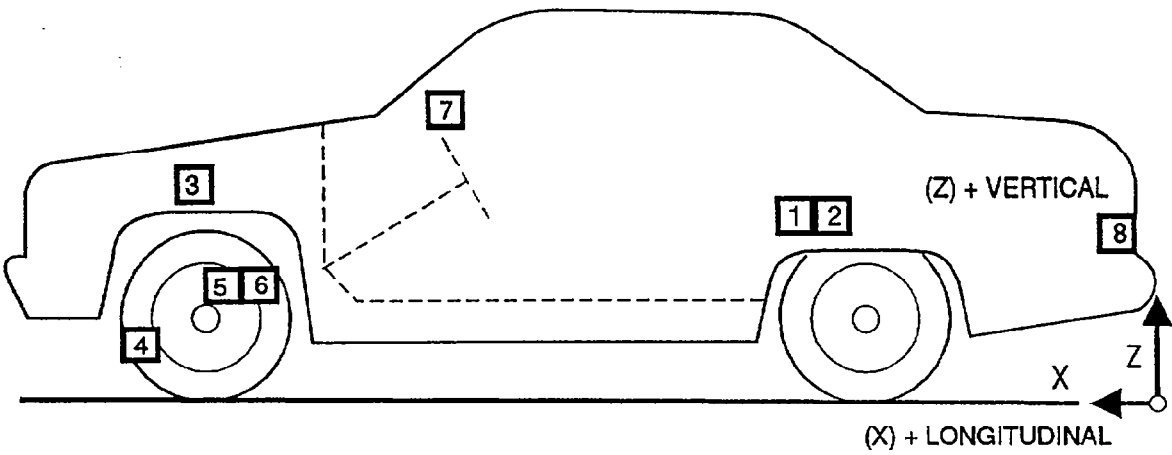

SIDE VIEW

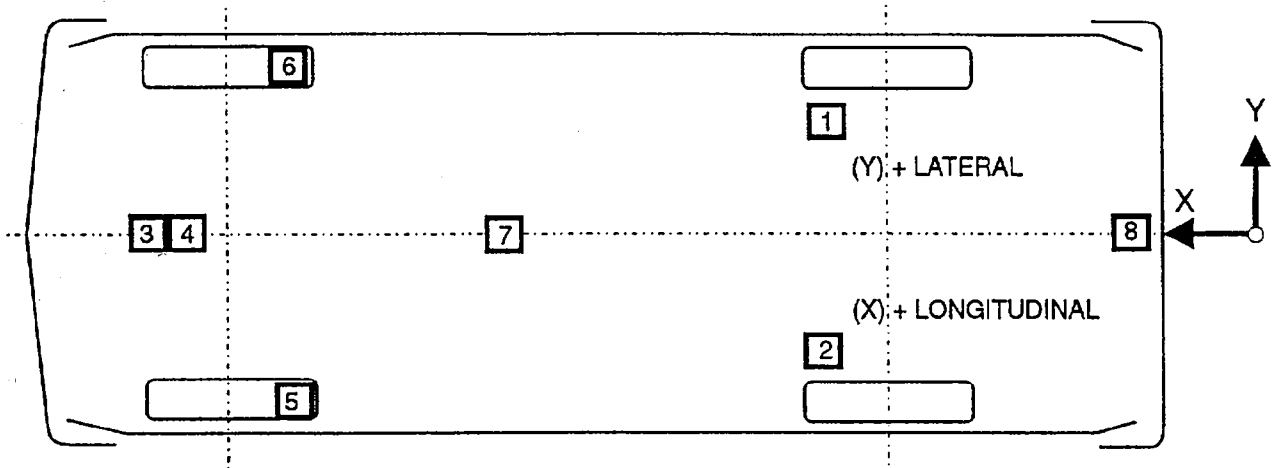

BOTTOM VIEW

Table 5 Vehicle Accelerometer Locations and Data Summary

No. LOCATION	X	Y	Z	POSITIVE DIRECTION	NEGATIVE DIRECTION
1 LEFT REAR SEAT CROSSMEMBER LONGITUDINAL	PRE 64.5 in	23.9 in	12.4 in		
	POST 65.3 in	23.9 in	14.1 in	1.4 g @ 130.8 ms	43.8 g @ 49.1 ms
2 RIGHT REAR SEAT CROSSMEMBER LONGITUDINAL	PRE 65.2 in	-23.9 in	12.4 in		
	POST 65.2 in	-23.9 in	13.8 in	2.8 g @ 141.3 ms	46.9 g @ 50.4 ms
3 ENGINE TOP LONGITUDINAL	PRE 150.0 in	-2.2 in	30.4 in		
	POST 147.2 in	-2.2 in	31.4 in	3.3 g @ 180.0 ms	60.9 g @ 43.0 ms
4 ENGINE BOTTOM LONGITUDINAL	PRE 145.2 in	-9.3 in	9.7 in		
	POST 143.2 in	-9.3 in	10.7 in	41.9 g @ 50.0 ms	93.9 g @ 39.6 ms
5 RIGHT BRAKE CALIPER LONGITUDINAL	PRE 145.6 in	-26.1 in	13.4 in		
	POST 143.9 in	-26.1 in	13.5 in	5.7 g @ 101.4 ms	56.8 g @ 51.3 ms
6 LEFT BRAKE CALIPER LONGITUDINAL	PRE 145.5 in	26.1 in	12.8 in		
	POST 144.9 in	26.1 in	12.4 in	3.1 g @ 124.7 ms	69.5 g @ 50.4 ms
7 INSTRUMENT PANEL CENTER LONGITUDINAL	PRE 122.6 in	0.0 in	34.1 in		
	POST 123.0 in	0.0 in	34.4 in	4.3 g @ 93.2 ms	42.4 g @ 69.7 ms
8 VEHICLE REAR CENTER VERTICAL	PRE 7.9 in	0.0 in	26.4 in		
	POST 8.2 in	0.0 in	29.2 in	19.2 g @ 52.8 ms	8.0 g @ 40.7 ms

REFERENCE: X: + FORWARD FROM REAR BUMPER
 Y: + LEFTWARD FROM VEHICLE CENTERLINE
 Z: + UPWARD FROM GROUND LEVEL

Report of Vehicle Condition at the Completion of Testing

Contract number: DTNH22-93-D-01089
From: Transportation Research Center Inc.
10820 State Route 347
East Liberty, OH 43319

To: Mr. Charles Case, COTR
Office of Vehicle Safety Compliance

The following vehicle has been subjected to testing for FMVSS 208. The vehicle was inspected upon arrival at the laboratory for the test and found to contain all of the equipment listed below. All variances have been reported within 2 working days of vehicle arrival, by letter, to the NHTSA Industrial Property Manager/NAD-30, with a carbon copy to the responsible testing office. The vehicle is again inspected, after the above test has been conducted, and all changes are noted below. The final condition of the vehicle is also noted in detail.

NHTSA number: CR0210
Vehicle year/make/
model/body style: 1994/Ford/Probe/3-door hatchback
Body color: Red
VIN: 1ZVLT20AXR5104419
Odometer (arrival): 58 Date: 01/31/94
Odometer (completion): 59 Date: 03/02/94
Cost: \$13,449.00

Air conditioner	No	Console	Yes	Brakes	Power
Tinted glass	Yes	Tachometer	No	Front	Disc
Power steering	Yes	Speed control	No	Rear	Drum
Power windows	No	Rear window def.	No	Front seats	Man. adjustable
Power door locks	No	Sun/moon roof	No	Seat type	Front-Bucket
Radio	Yes	T-top	No		Rear-Bench
Clock	Yes	Tilt steering wheel	Yes	Number of seats	4
Roof rack	No	Other options:	None		

Report of Vehicle Condition at the Completion of Testing, Cont'd.

Engine data:

Cylinders: 4
Displacement: 2.0 liters
Transmission: Manual
Final drive: FWD
Tire size: P195/65R14
Gasoline type: Unleaded

Equipment that is no longer on the vehicle as noted above:

rear seat
spare tire
trunk trim

Explanation:

Items removed to allow installation of data acquisition system.

VEHICLE CONDITION: Vehicle was subjected to a 30 mph crash test. There is severe structural damage. Various interior and exterior portions of the vehicle have been painted and have had holes drilled to facilitate attachment of instrumentation. Various trim and body parts have been removed including the rear seats. Stoddard solvent replaced the fuel in the fuel system and engine. **THE VEHICLE IS FOR SALVAGE ONLY AND IS NOT TO BE REPAIRED FOR HIGHWAY USE.**

Section 3.0

FMVSS 208, 212, 219 (partial), and 301 Data

Table 6 Dummy Injury Criteria

	Maximum Acceleration						
	Head				Chest		
	X	Y	Z	R	X	Y	Z
Driver	-62.1 g	11.9 g	-33.0 g	69.2 g	-52.8 g	-8.8 g	-13.7 g
Passenger	-31.0 g	16.9 g	-21.5 g	32.6 g	-31.4 g	8.4 g	-23.8 g

	Maximum Femur Compressive Force	
	Left femur	Right femur
Driver	1248 lbf	1349 lbf
Passenger	1407 lbf	1641 lbf

	Head Injury Criteria ¹		
	HIC	Time t_1	Time t_2
Driver	341	70.2 ms	97.3 ms
Passenger	107	58.5 ms	91.0 ms

	Chest Maximum Resultant Acceleration ²		
	Accelerometer	Time t_1	Time t_2
Driver	52.7 g	94.0 ms	97.0 ms
Passenger	31.4 g	66.0 ms	69.0 ms

¹ As defined in FMVSS No. 208

² Defined as equal to or exceeding 0.003 sec. duration

Dummy Kinematic Summary

Driver Dummy

Upon impact, the driver dummy translated forward on the seat impacting both knees into the instrument panel. The dummy's head and chest impacted the airbag with the dummy's head rotating slightly forward. The driver dummy was restrained by the airbag. The dummy rebounded rearward into the seat back as the dummy's head rotated rearward contacting the driver's sunvisor and the head restraint. The driver dummy came to rest in the driver's seat.

Right Front Passenger Dummy

Upon impact, the right front passenger dummy translated forward on the seat impacting both knees into the instrument panel. The dummy's head contacted the passenger's sunvisor and airbag and the dummy's chest impacted the airbag. The right front passenger dummy was restrained by the airbag. The right front passenger dummy came to rest in the right front passenger's seat, leaning forward with the dummy's head resting on the airbag and instrument panel.

Table 7 FMVSS 208 Seat Belt Comfort and Convenience Test Summary
Front Outboard Designated Seating Positions

NHTSA number: CR0210

Vehicle model year/make/model/body style: 1994/Ford/Probe/ 3-door hatchback

Date of comfort/convenience check: 03/01/94

Technician performing check: Markusic

GVWR: 3616 lb

Automatic seat belts installed in any vehicle, other than a walk-in van-type vehicle which has a gross vehicle weight rating of 10,000 pounds or less, and is manufactured on or after September 1, 1986, shall meet the requirements for convenience hooks, webbing tension-relieving devices, and belt contact force.

Manual seat belts installed for compliance with this standard in front outboard designated seating positions of any vehicle, other than a walk-in van-type vehicle which has a gross vehicle rating of 10,000 pounds or less, and is manufactured after September 1, 1989, shall meet the requirements for belt contact force, plate access, retraction and seat belt guides, and hardware.

Vehicle Equipment:

The vehicle's front outboard seating positions were equipped with manual Type 2 seat belts which must comply with the dynamic test requirements of S5.1; requirements for webbing tension-relieving devices (S7.4.2), belt contact force (S7.4.3), latchplate access (S7.4.4), retraction (S7.4.5), and seat belt guides and hardware (S7.4.6) apply.

Convenience Hooks (S7.4.1):

Not applicable, the vehicle is not equipped with automatic seat belts.

Table 7 FMVSS 208 Seat Belt Comfort and Convenience Test Summary
Front Outboard Designated Seating Positions, Cont'd.

NHTSA number: CR0210

Vehicle model year/make/model/body style: 1994/Ford/Probe/3-door hatchback

Date of comfort/convenience check: 03/01/94

Technician performing check: Markusic

GVWR: 3616 lb

Webbing Tension-Relieving Device (S7.4.2):

The front outboard position seat belt assemblies do not have webbing tension-relieving devices.

Belt Contact Force (S7.4.3):

The belt contact force on chest of the test dummy is 0.1 pounds.

Latchplate Access (S7.4.4):

The seat belt latchplates, in their normal stowed position, are within the reach envelope.

The clearance test block moves unhindered to the latchplate or buckle.

Retraction (S7.4.5):

The seat belt automatically retracts when the seat belt latchplate is released.

The stowed seat belt webbing and hardware are not pinched when the door is closed.

Table 7 FMVSS 208 Seat Belt Comfort and Convenience Test Summary
Front Outboard Designated Seating Positions, Cont'd.

NHTSA number: CR0210

Vehicle model year/make/model/body style: 1994/Ford/Probe/3-door hatchback

Date of comfort/convenience check: 03/01/94

Technician performing check: Markusic

GVWR: 3616 lb

Seat Belt Guides and Hardware (S7.4.6):

The seat cushion is movable but the seat back does not serve a function other than seating.

The seat is not removable.

The seat is movable but the space formerly occupied by the seat cannot be used for a secondary function.

Note: If the seat or seat cushion is removable or if the seat is movable so the space formerly occupied by the seat can be used for a secondary function, the seat belt guides and hardware requirements do not apply.

The webbing is not designed to pass through the seat cushion or between the cushion and seat back.

The restraint system does not provide guides.

The vehicle does not contain a center arm rest.

Table 8 FMVSS 208 Equipment Data

FMVSS 208 Seat Belt Warning System Data

With an occupant in the driver's position and the lap belt/unibelt in stowed position and ignition switch placed in the "start/on" position the duration of audible warning signal is 6 s and the reminder light operates continuously.

With an occupant in the driver's position and the lap belt/unibelt in use and the ignition switch placed in the "start/on" position the duration of audible warning signal is 0 s and the duration of the reminder light operation is 0 s.

NOTE: the audible warning should not operate.

The wording of the visual seat belt warning is the symbol from Table 2 of FMVSS 101.

Table 8 FMVSS 208 Equipment Data, Cont'd.

FMVSS 208 Labeling and Driver's Manual Data

The labels which describe manufacturer's maintenance or replacement schedule for the crash-deployed occupant protection system were located on the driver's and passenger's sun visors.

The airbag system does not require maintenance.

Appropriate instructions concerning maintenance and/or replacement of this system were provided in the owner's manual on page 35 and on a label on the vehicle.

A description of the functional operation of the system was provided in the owner's manual on pages 34 and 35.

A reference to the instructions and description of the system was included on the label.

An owner's manual was provided.

The owner's manual contained appropriate information concerning maintenance and/or replacement and a description of the functional operation of the systems on pages 34 and 35.

Table 8 FMVSS 208 Equipment Data, Cont'd.

FMVSS 208 Readiness Indicator Data

The vehicle contained a crash-deployed occupant protection system which was not totally mechanical. The readiness indicator was located on the lower right side of the instrument cluster.

The readiness indicator was clearly visible to the driver.

A list of the elements in the occupant restraint system, being monitored by the readiness indicator was provided in the owner's manual on page 34.

All rear outboard seating positions had Type 2 seat belts.

Figure 4 FMVSS 212 Test Data

Details of windshield mounting such as retention method, trim type, etc.:

Plastic trim around outer perimeter and adhesive around inner perimeter.

Clips or brackets used to retain windshield: None

FMVSS 212 requirements: The post-test periphery retention amount must be at least 75% of the pre-test periphery measurement for vehicles NOT equipped with automatic restraints, and 50% for each side of windshield for vehicles equipped with automatic restraint systems for front occupants.

Windshield periphery measurements:

	Pre-test	Post-test	Percent Retention
Right side	80.2 in	80.2 in	100
Left side	80.2 in	80.2 in	100
Total	160.4 in	160.4 in	100

Pre-test windshield mounting material temperature: 70° F

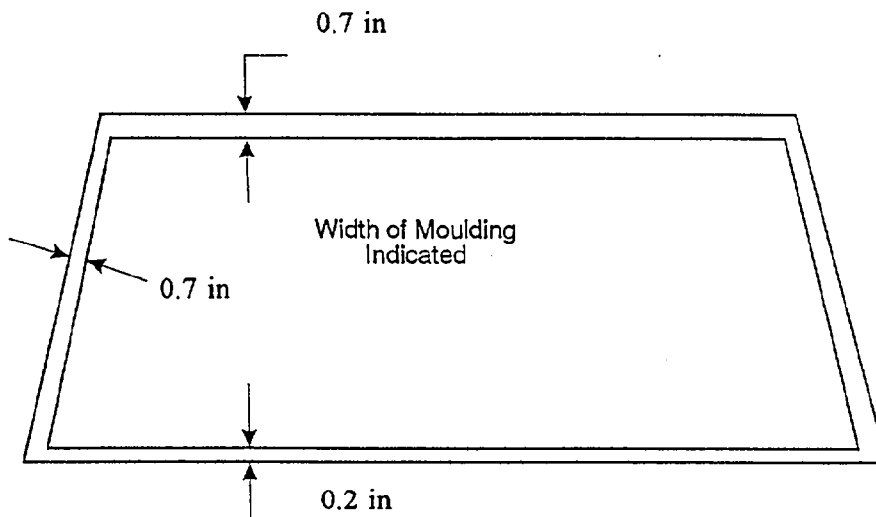

Front view of windshield¹

Loss of windshield retention lengths: None

¹ Indicate areas of loss of retention, if any, on windshield diagram.

Figure 5 FMVSS 219 Test Data

Protected zone lower edge requirement:

The lower edge of the protected zone is determined by placing a 6.5-inch diameter rigid sphere weighing 15 pounds in a position such that it simultaneously contacts the inner surface of the windshield and the top surface of the instrument panel including padding. Draw the locus of points on the inner surface of the windshield contactable by the sphere across the width of the instrument panel. From the outermost contactable points, extend the locus line horizontally to the edges of the windshield, and then draw a line on the inner surface of the windshield below and 0.5 inch from the locus line. The LOWER EDGE OF THE PROTECTED ZONE is the longitudinal projection onto the outer surface of the windshield of this line.

Windshield measurements:

- A: 42.9 in
- B: 19.0 in
- C: 61.5 in
- D: 30.2 in
- E: 18.4 in
- F: 20.0 in

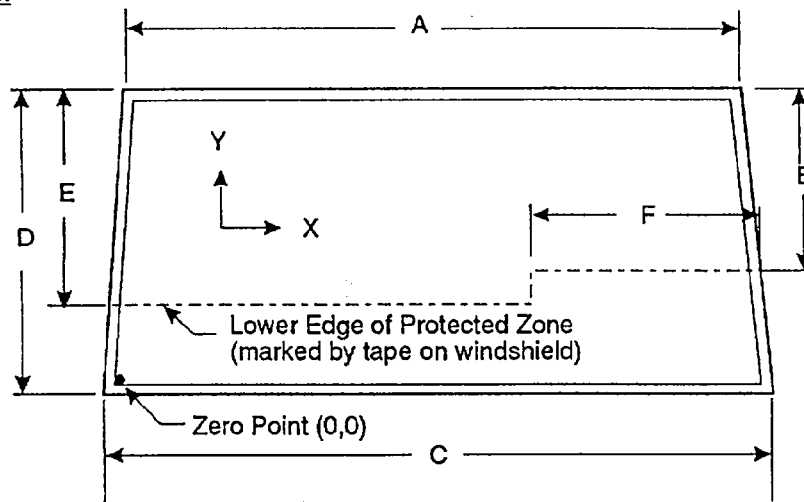

FRONT VIEW

Method of adhering protected zone template to windshield:

NA

Areas of windshield template penetration greater than 0.25 in:

NA

Coordinates

	X	Y
1.		
2.		
3.		

1.

2.

3.

Areas of windshield penetration, below the protected zone, through the inner surface of the windshield:

None

1.

2.

3.

Table 9 Fuel System Data

Vehicle year/make/
model/body style: 1994/Ford/Probe/3-door hatchback
NHTSA number: CR0210
Fuel system capacity: 15.5 gal (from owner's manual)
Usable capacity: 14.5 gal (furnished by COTR)
Test volume range: 13.3 gal to 13.6 gal (92-94% of usable)
Actual test volume: 13.5 gal (with entire fuel system filled)
Test fluid type: Stoddard solvent
Specific gravity: 0.764
Kinematic viscosity: 0.99 centistokes
Test fluid color: purple
Type of fuel pump: electric

Does electric fuel pump operate with ignition switch "on" and the engine not operating? No

Details of fuel system:

The fuel tank is located in front of the rear axle. The fuel filler neck is located on the left side. The fuel lines run along the left side to the front.

Table 10 FMVSS 301 Post-Impact Test Data

NHTSA number: CR0210
Test date: 03/02/94
Vehicle year/make/
model/body style: 1994/Ford/Probe/3-door hatchback

Test requirements:

Test vehicle fuel tank filled to 92 to 94% of manufacturer's usable capacity and with electric fuel pump operating (if it will operate without engine operation). Part 572 test dummies located at each front designated seating position.

Test vehicle impact type:

- Frontal (30 mph)
- Oblique (30 mph) with ___° barrier face first contacting (driver's/passenger's) side
- Rear moving barrier (30 mph)
- Lateral moving barrier (20 mph)

Fuel system fluid spillage measurements:

	<u>Test Results</u>	<u>Maximum Allowable</u>
1. From impact until vehicle motion ceases	0 oz	1 oz
2. 5-Minute period after vehicle motion ceases	0 oz	5 oz
3. Next 25 minutes after 5-minute period	0 oz	1 oz/1 min

Fuel system fluid spillage location(s): None

Figure 6 FMVSS 301 Static Rollover Test Data

NHTSA number: CR0210

Test phase

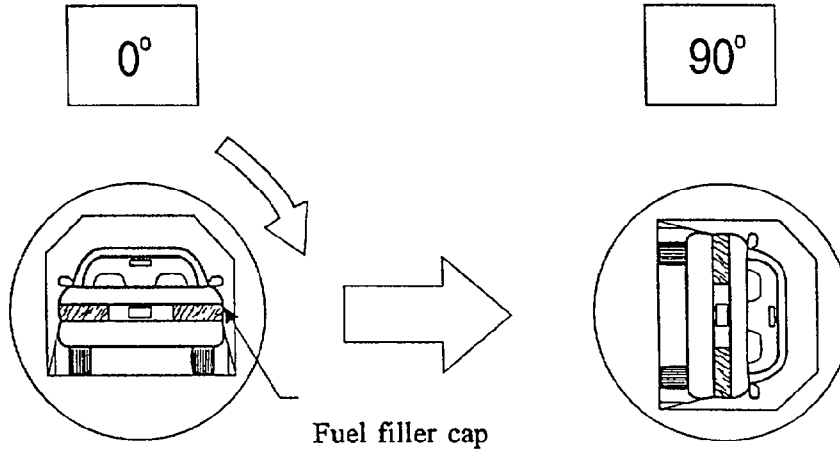

Static rollover machine rotation time information: (specified range is 1-3 minutes)

Time required for machine to rotate 90° = 2 minutes, 0 seconds
 FMVSS 301 position hold time = 5 minutes, 0 seconds
 Total = 7 minutes, 0 seconds
 Next whole minute interval = 7 minutes

Fuel system fluid spillage measurements:

<u>0° to 90° rotation (fuel filler cap down)</u>	<u>Test Results</u>	<u>Maximum Allowable</u>
1. First 5 minutes from onset of rotation	0 oz	5 oz
2. Sixth minute from onset of rotation	0 oz	1 oz
3. Seventh minute from onset of rotation	0 oz	1 oz

Fuel system fluid spillage location(s): None

Figure 6 FMVSS 301 Static Rollover Test Data, Cont'd.

Test phase

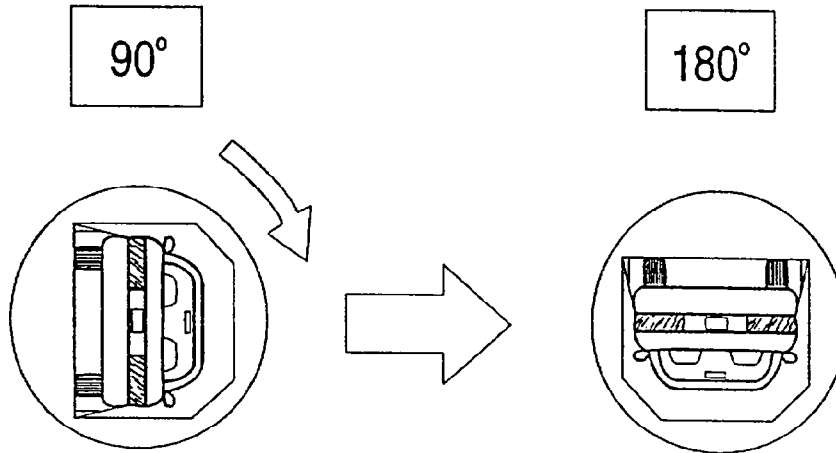

Static rollover machine rotation time information: (specified range is 1-3 minutes)

Time required for machine to rotate 90° = 2 minutes, 0 seconds
 FMVSS 301 position hold time = 5 minutes, 0 seconds
 Total = 7 minutes, 0 seconds
 Next whole minute interval = 14 minutes

Fuel system fluid spillage measurements:

<u>90° to 180° rotation</u>		<u>Test Results</u>	<u>Maximum Allowable</u>
1.	First 5 minutes from onset of rotation	0 oz	5 oz
2.	Sixth minute from onset of rotation	0 oz	1 oz
3.	Seventh minute from onset of rotation	0 oz	1 oz

Fuel system fluid spillage location(s): None

Figure 6 FMVSS 301 Static Rollover Test Data, Cont'd.

Test phase

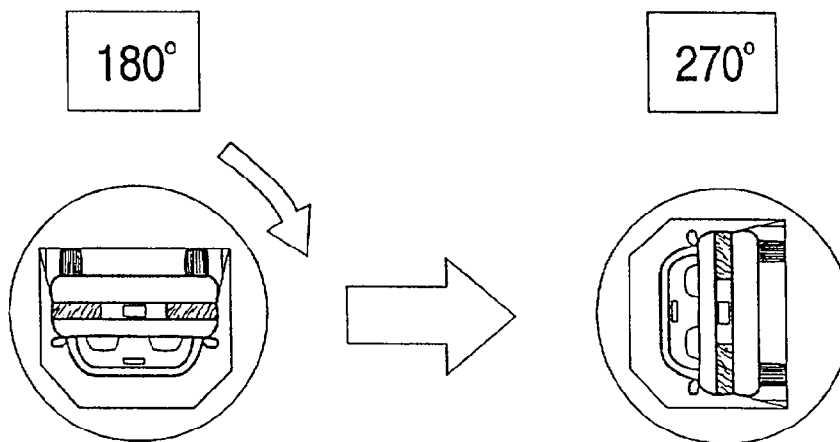

Static rollover machine rotation time information: (specified range is 1-3 minutes)

Time required for machine to rotate 90° = 2 minutes, 0 seconds

FMVSS 301 position hold time = 5 minutes, 0 seconds

Total = 7 minutes, 0 seconds

Next whole minute interval = 21 minutes

Fuel system fluid spillage measurements:

<u>180 to 270° rotation</u>	<u>Test Results</u>	<u>Maximum Allowable</u>
1. First 5 minutes from onset of rotation	0 oz	5 oz
2. Sixth minute from onset of rotation	0 oz	1 oz
3. Seventh minute from onset of rotation	0 oz	1 oz

Fuel system fluid spillage location(s): None

Figure 6 FMVSS 301 Static Rollover Test Data, Cont'd.

Test phase

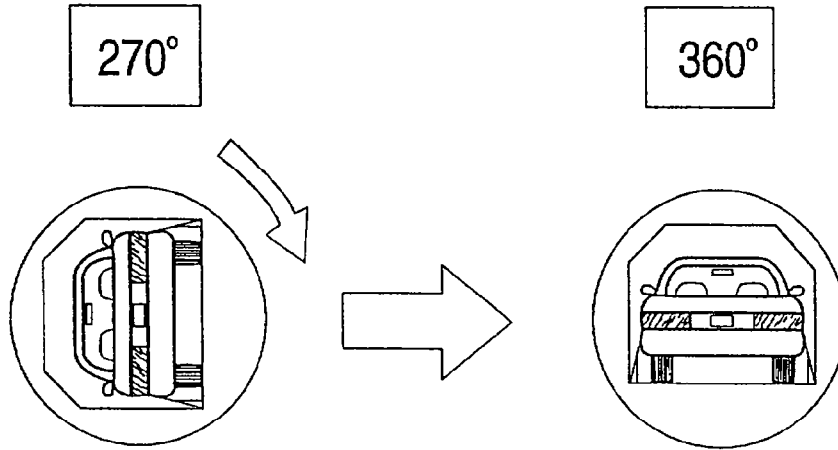

Static rollover machine rotation time information: (specified range is 1-3 minutes)

Time required for machine to rotate 90° = 2 minutes, 0 seconds
 FMVSS 301 position hold time = 5 minutes, 0 seconds
 Total = 7 minutes, 0 seconds
 Next whole minute interval = 28 minutes

Fuel system fluid spillage measurements:

<u>270° to 360° rotation</u>		Test Results	Maximum Allowable
1.	First 5 minutes from onset of rotation	0 oz	5 oz
2.	Sixth minute from onset of rotation	0 oz	1 oz
3.	Seventh minute from onset of rotation	0 oz	1 oz

Fuel system fluid spillage location(s): None

Section 4.0

Vehicle, Occupant, and Camera Measurements

Figure 7 Pre-test and Post-test Measurement Points

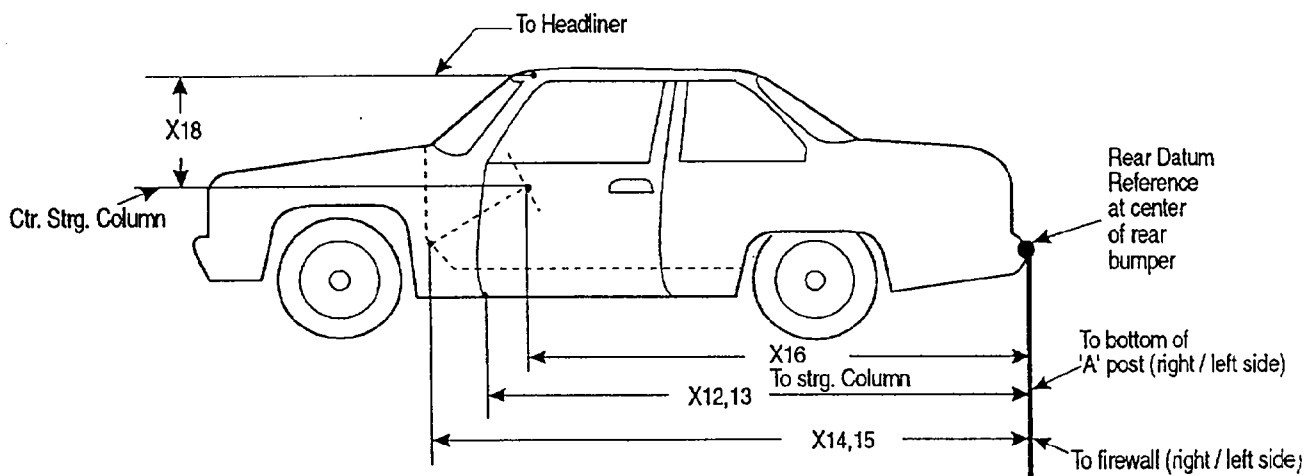
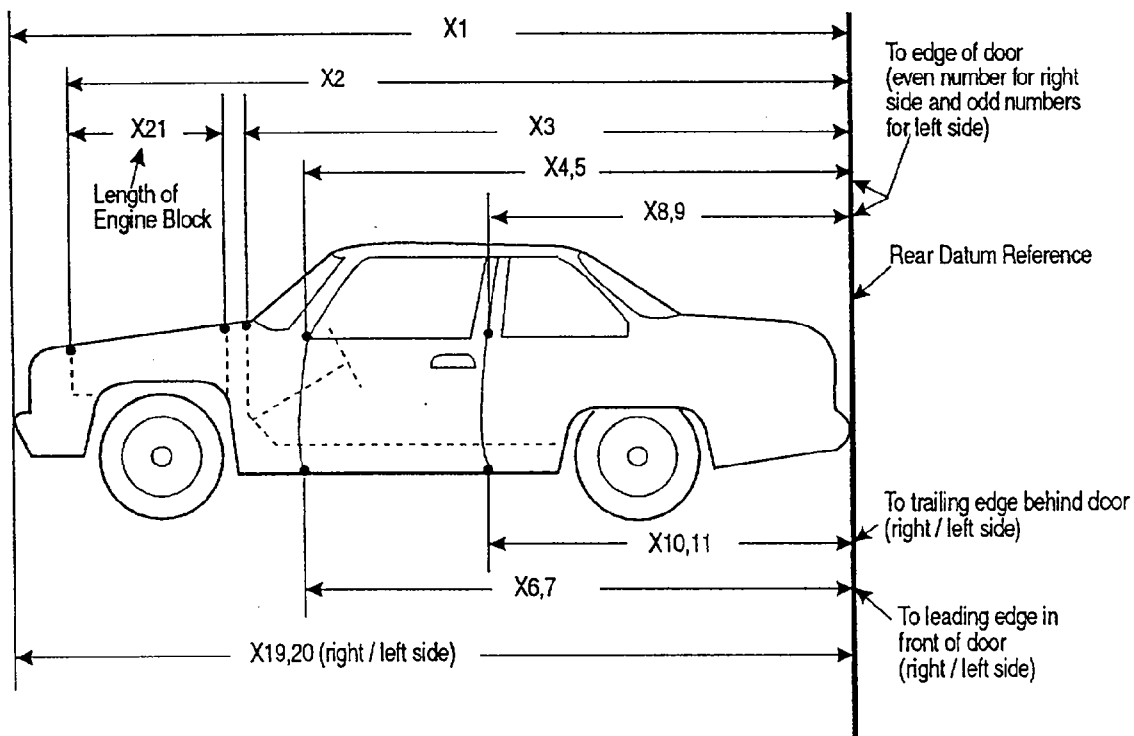
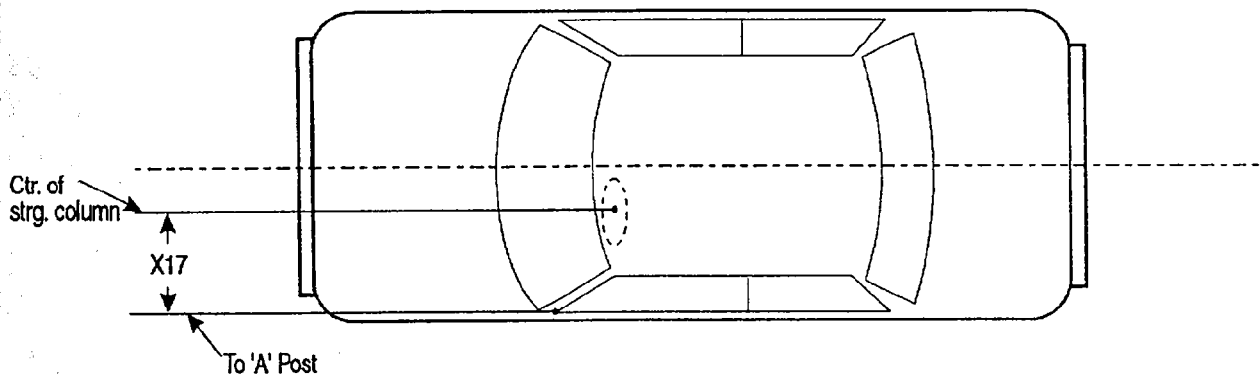

Table 11 Impacted Vehicle Measurements

Vehicle year/make/model/body style: 1994/Ford/Probe/3-door hatchback

Test number: 940302

No.	Type of Measurement	Pre-test	Post-test	Difference
X1	Total length of vehicle at centerline	179.1 in	164.2 in	14.9 in
X2	Rear surface of vehicle to front of engine block	153.0 in	148.9 in	4.1 in
X3	Rear surface of vehicle to firewall	133.5 in	132.0 in	1.5 in
X4	Rear surface of vehicle to upper leading edge of right door	117.8 in	117.6 in	0.2 in
X5	Rear surface of vehicle to upper leading edge of left door	117.8 in	117.8 in	0.0 in
X6	Rear surface of vehicle to lower leading edge of right door	117.8 in	117.8 in	0.0 in
X7	Rear surface of vehicle to lower leading edge of left door	117.8 in	118.0 in	-0.2 in
X8	Rear surface of vehicle to upper trailing edge of right door	67.2 in	67.2 in	0.0 in
X9	Rear surface of vehicle to upper trailing edge of left door	67.2 in	67.3 in	-0.1 in
X10	Rear surface of vehicle to lower trailing edge of right door	70.5 in	70.5 in	0.0 in
X11	Rear surface of vehicle to lower trailing edge of left door	70.6 in	70.9 in	-0.3 in
X12	Rear surface of vehicle to bottom of "A" post on right side	117.5 in	117.3 in	0.2 in
X13	Rear surface of vehicle to bottom of "A" post on left side	117.4 in	117.5 in	-0.1 in
X14	Rear surface of vehicle to firewall - right side	130.1 in	129.4 in	0.7 in
X15	Rear surface of vehicle to firewall - left side	131.1 in	131.4 in	-0.3 in
X16	Rear surface of vehicle to steering wheel center	98.2 in	104.2 in	-6.0 in
X17	Center of steering column to "A" post	12.1 in	14.0 in	-1.9 in
X18	Center of steering column to headliner	15.8 in	17.5 in	-1.7 in
X19	Rear surface of vehicle to right side of front bumper	172.7 in	162.0 in	10.7 in
X20	Rear surface of vehicle to left side of front bumper	169.4 in	162.5 in	6.9 in
X21	Length of engine block	19.0 in	19.0 in	0.0 in

Figure 8 Vehicle Target Locations

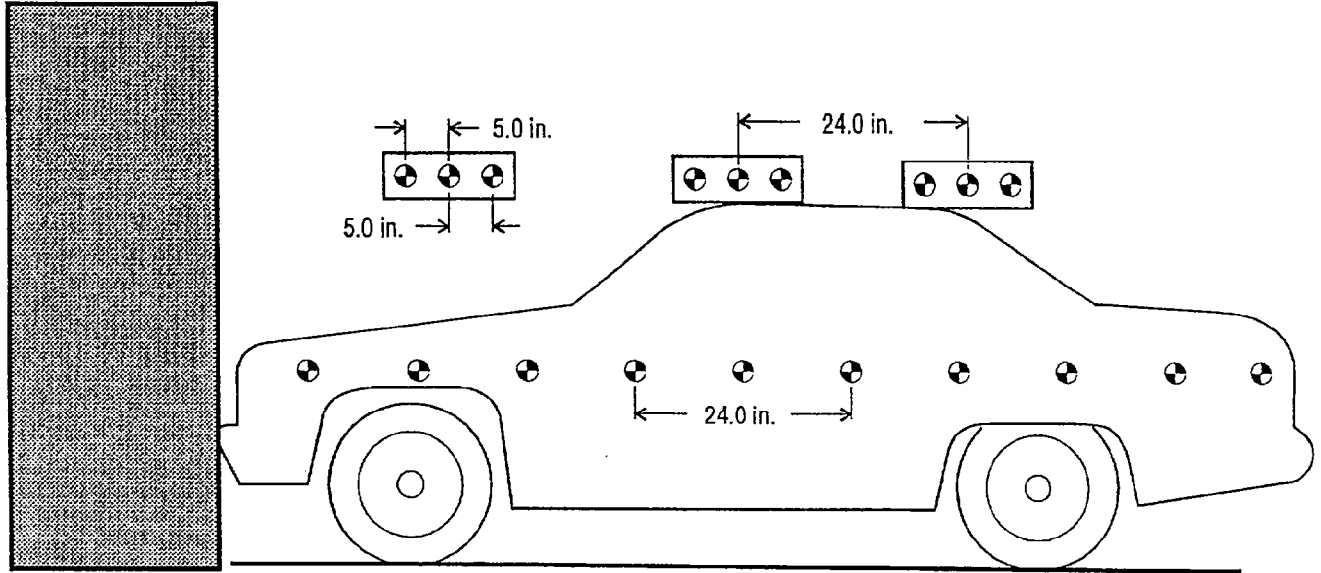
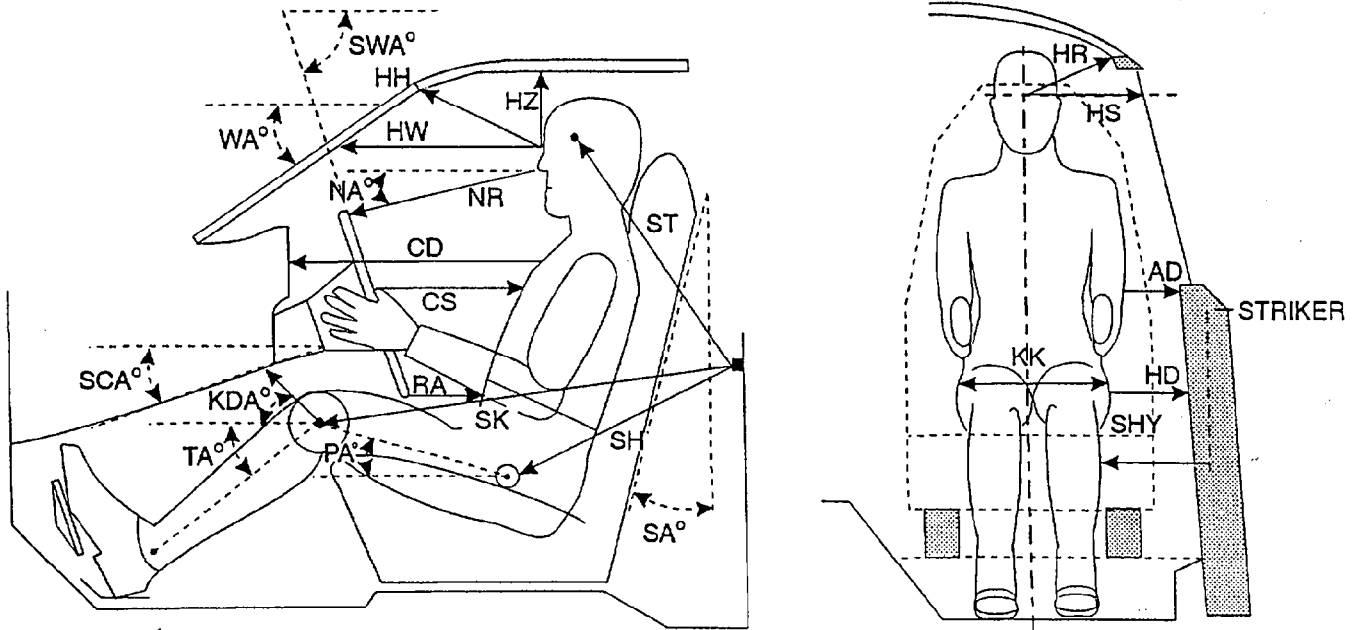
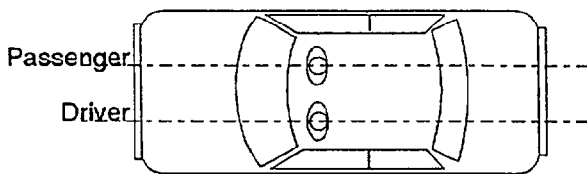

Figure 9 Dummy Measurement Locations for Front Seat Occupants



VERTICAL LONGITUDINAL PLANE



VERTICAL TRANSVERSE PLANE

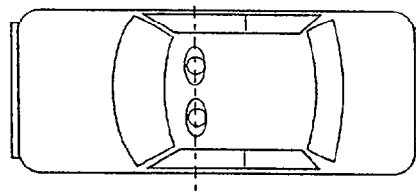

Table 12 Dummy Measurement Data for Front Seat Occupants

Designation	Type of Measurement	Driver (Serial #1173)	Passenger (Serial #354)
WA	Windshield angle	25°	NA
SWA	Steering wheel angle	71°	NA
SCA	Steering column angle	19°	NA
SA	Seat back angle	21°	21°
HZ	Head to roof	4.9 in	5.1 in
HH	Head to header	13.3 in	12.4 in
HW	Head to windshield	19.2 in	18.6 in
HR	Head to side header	5.6 in	5.9 in
NR	Nose to rim	18.1 in	NA
NA	Nose to rim angle	17°	NA
CD	Chest to dash	21.8 in	21.6 in
CS	Steering wheel to chest	15.1 in	NA
RA	Rim to abdomen	7.1 in	NA
KDL	Left knee to dash	7.7 in	5.8 in
KDR	Right knee to dash	6.9 in	6.4 in
KDA	Outboard knee to dash angle	44°	45°
PA	Pelvic angle	12°	16°
TA	Tibial angle	27°	28°
KK	Knee to knee	16.0 in	12.0 in
ST ¹	Striker to head	21.1 in	21.8 in
	Striker to head angle	-62°	-60°
SK ¹	Striker to knee	34.4 in	35.9 in
	Striker to knee angle	96°	95°
SH ¹	Striker to H-point	20.1 in	21.9 in
	Striker to H-point angle	112°	109°
SHY	Striker to H-point (Y dir.)	8.7 in	8.9 in
HS	Head to side window	10.6 in	11.0 in
HD	H-point to door	6.6 in	6.8 in
AD	Arm to door	2.8 in	2.8 in

The seat back angle (SA°) is measured relative to vertical, all other angles are measured relative to horizontal.

¹ A negative angle indicates the measurement point was located above the striker.

Figure 10 Camera Positions

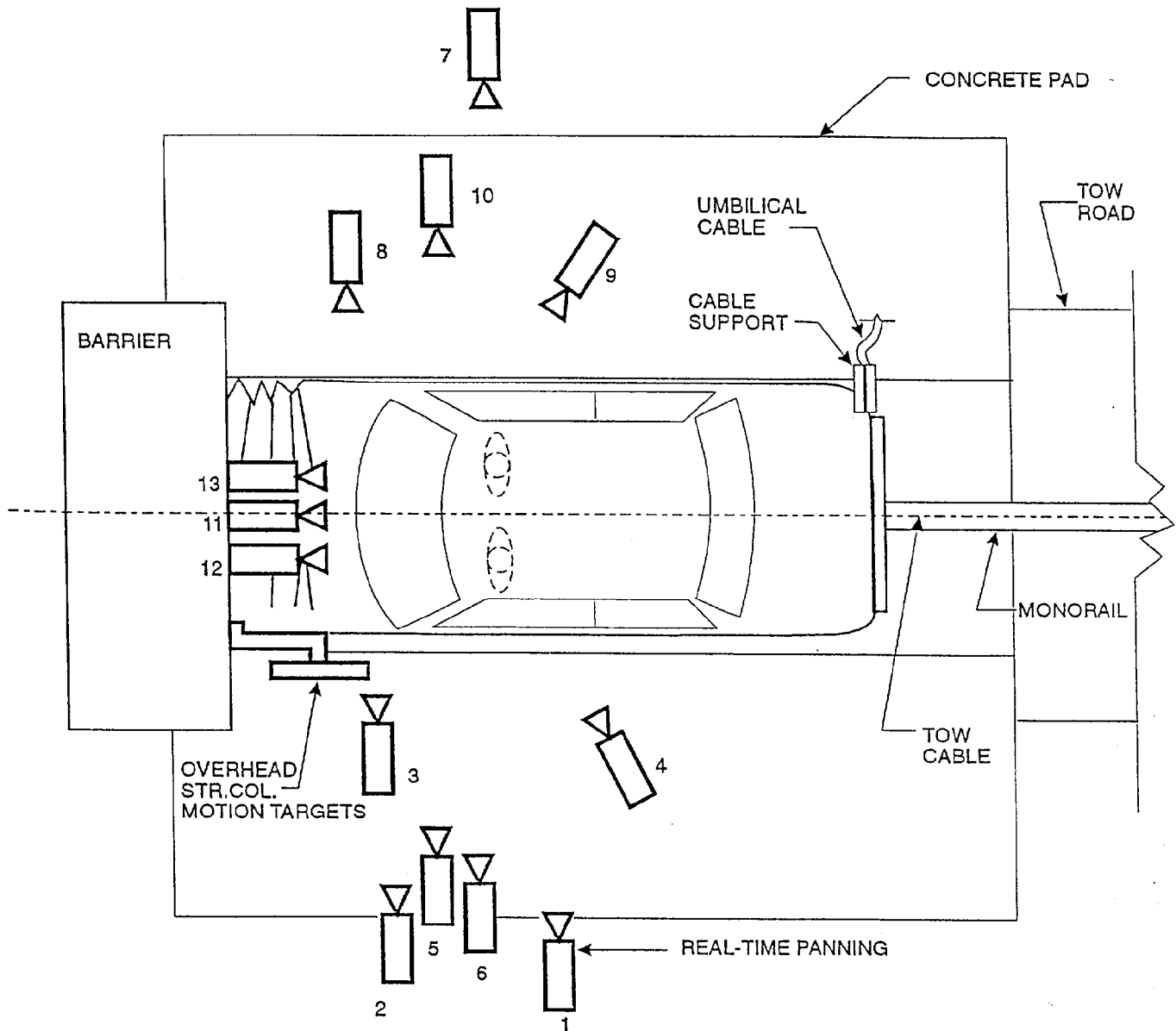

Figure 10 Camera Positions, Cont'd.

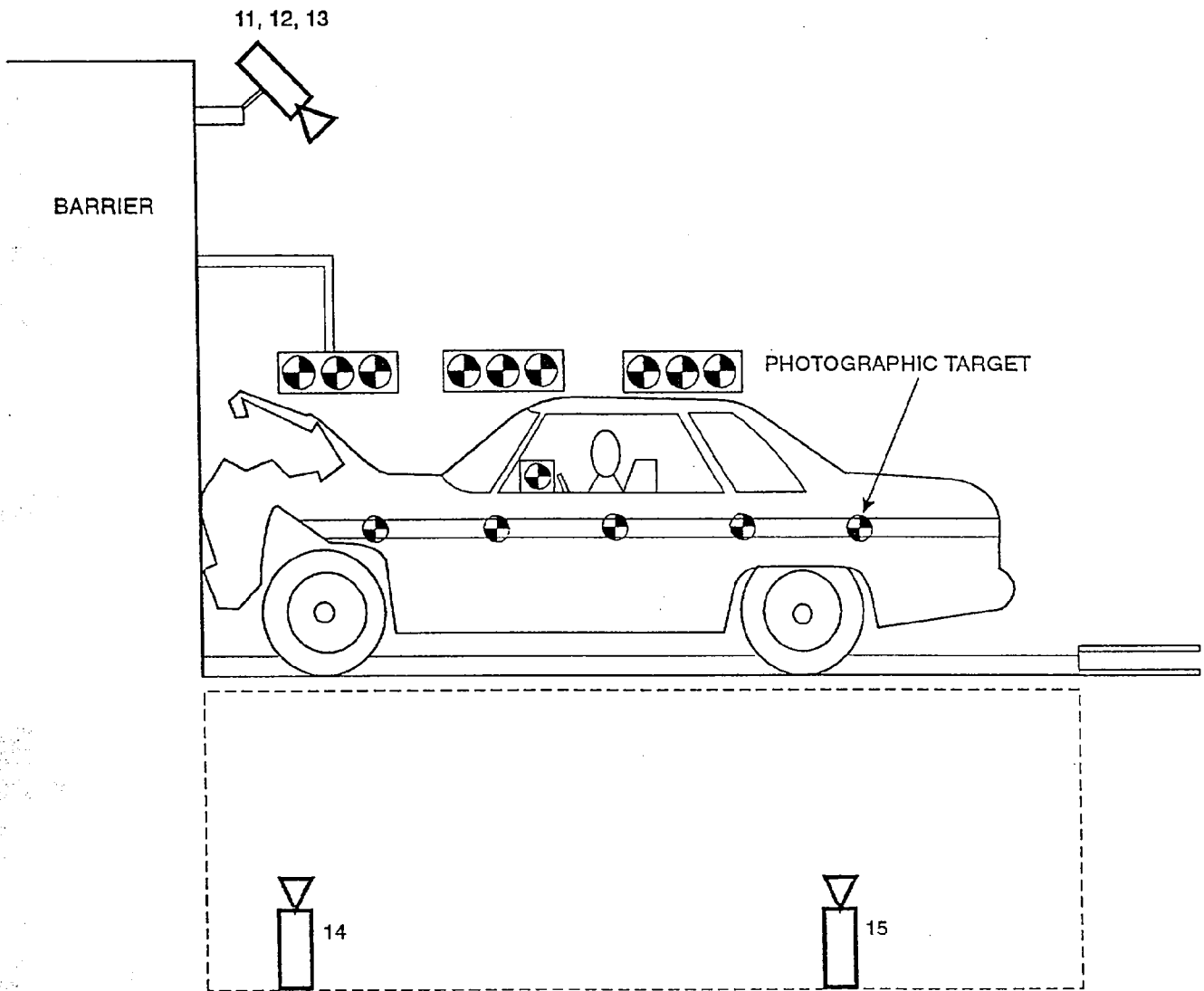

Table 13 Motion Picture Camera Locations

Vehicle year/make/model/body style: 1994/Ford/Probe/3-door hatchback

Test number: 940302

Camera Number	View	X	Y	Z	Camera Angle ²	Film Plane to Head Target	Camera Lens	Film Speed
1	Real-time panning	-142.0 in	504.0 in	61.0 in	NA	NA	16 mm	24 frames/s
2	Left vehicle crush	-41.5 in	295.0 in	44.0 in	-4°	218 in	25 mm	1005 frames/s
3	Left windshield intrusion	-53.0 in	309.4 in	42.3 in	0°	NA	50 mm	1010 frames/s
4	Driver kinematics	-157.3 in	116.0 in	87.0 in	-27°	88 in	25 mm	995 frames/s
5	Steering column motion	-80.0 in	286.0 in	103.0 in	-14°	NA	25 mm	1002 frames/s
6	Steering column motion	-80.0 in	286.0 in	75.1 in	-9°	NA	25 mm	1002 frames/s
7	Right overall	-81.3 in	-266.4 in	37.1 in	-2°	NA	13 mm	985 frames/s
8	Right windshield intrusion	-38.1 in	-306.1 in	44.0 in	0°	NA	50 mm	998 frames/s
9	Passenger kinematics	-152.1 in	-116.0 in	87.0 in	-26°	97 in	25 mm	995 frames/s
10	Passenger kinematics	-38.8 in	-293.0 in	45.3 in	-4°	196 in	25 mm	998 frames/s
11	Windshield front view	-6.0 in	0.0 in	85.0 in	-40°	NA	13 mm	1020 frames/s
12	Driver - front view	-6.8 in	14.5 in	93.0 in	-50°	NA	17 mm	1005 frames/s
13	Passenger - front view	-4.5 in	-13.8 in	93.0 in	-50°	NA	17 mm	973 frames/s
14	Pit - front position	-50.5 in	0.0 in	-92.4 in	90°	NA	13 mm	995 frames/s
15	Pit - rear position	-99.3 in	0.0 in	-99.0 in	90°	NA	13 mm	998 frames/s
16	Real-time documentation	NA	NA	NA	NA	NA	12-120 mm	24 frames/s

¹ +X: Film plane forward of barrier face

+Y: Film plane to left of monorail centerline

+Z: Film plane above ground level

² +Angle: Film plane angled upward from horizontal plane

Appendix A

Photographs

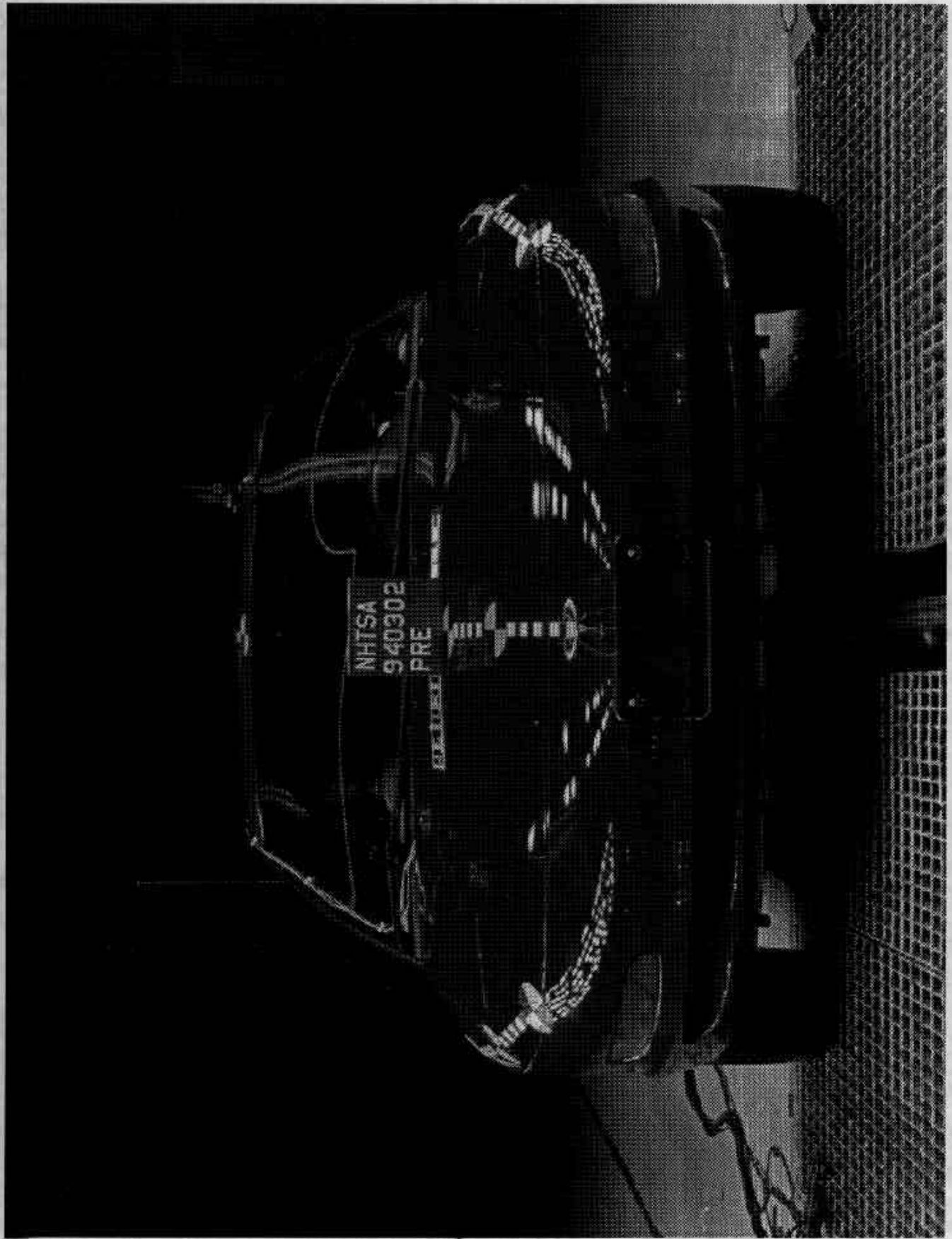

Figure A-1. Pre-test Front View
A-2

940302

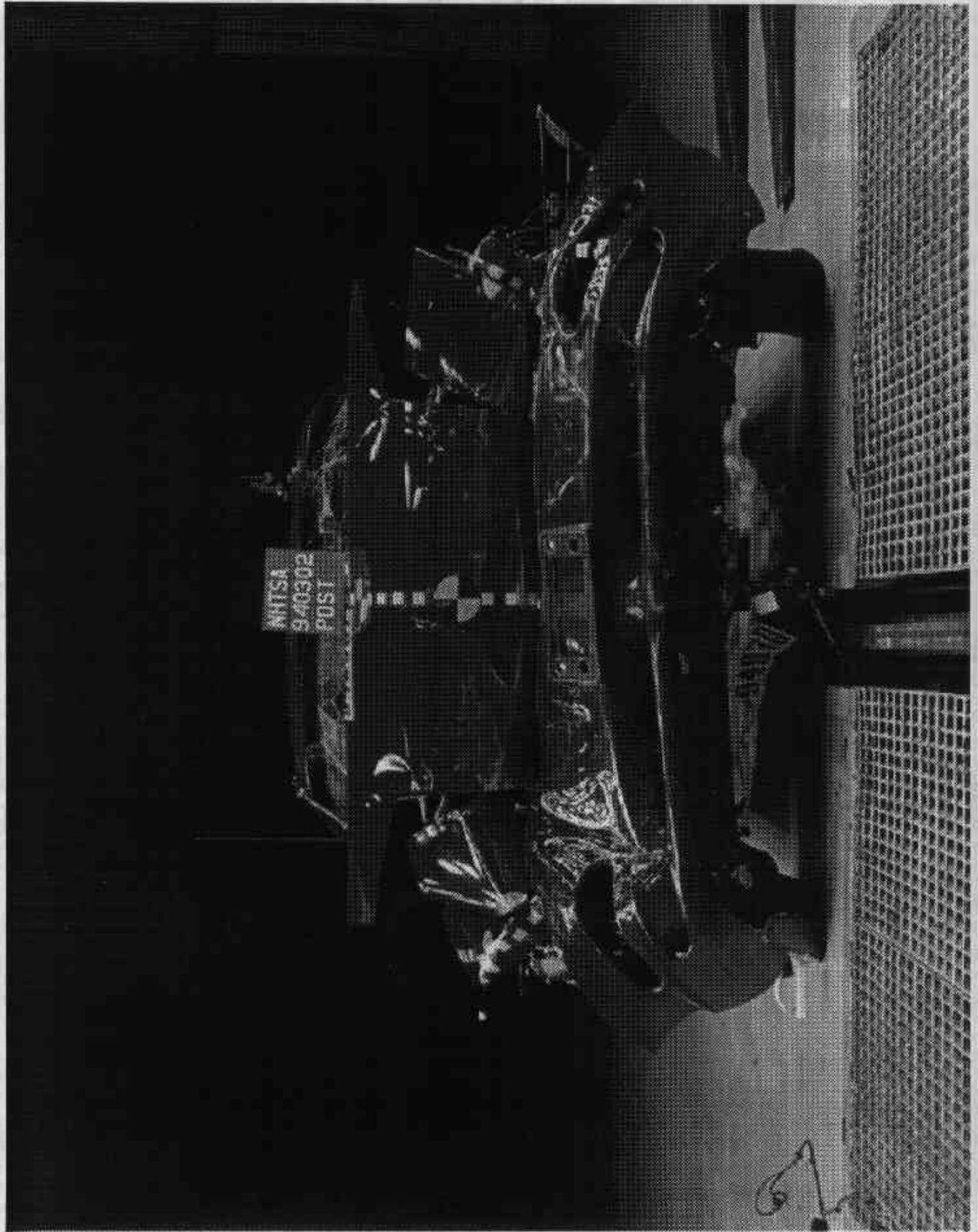

Figure A-2. Post-test Front View
A-3

940302

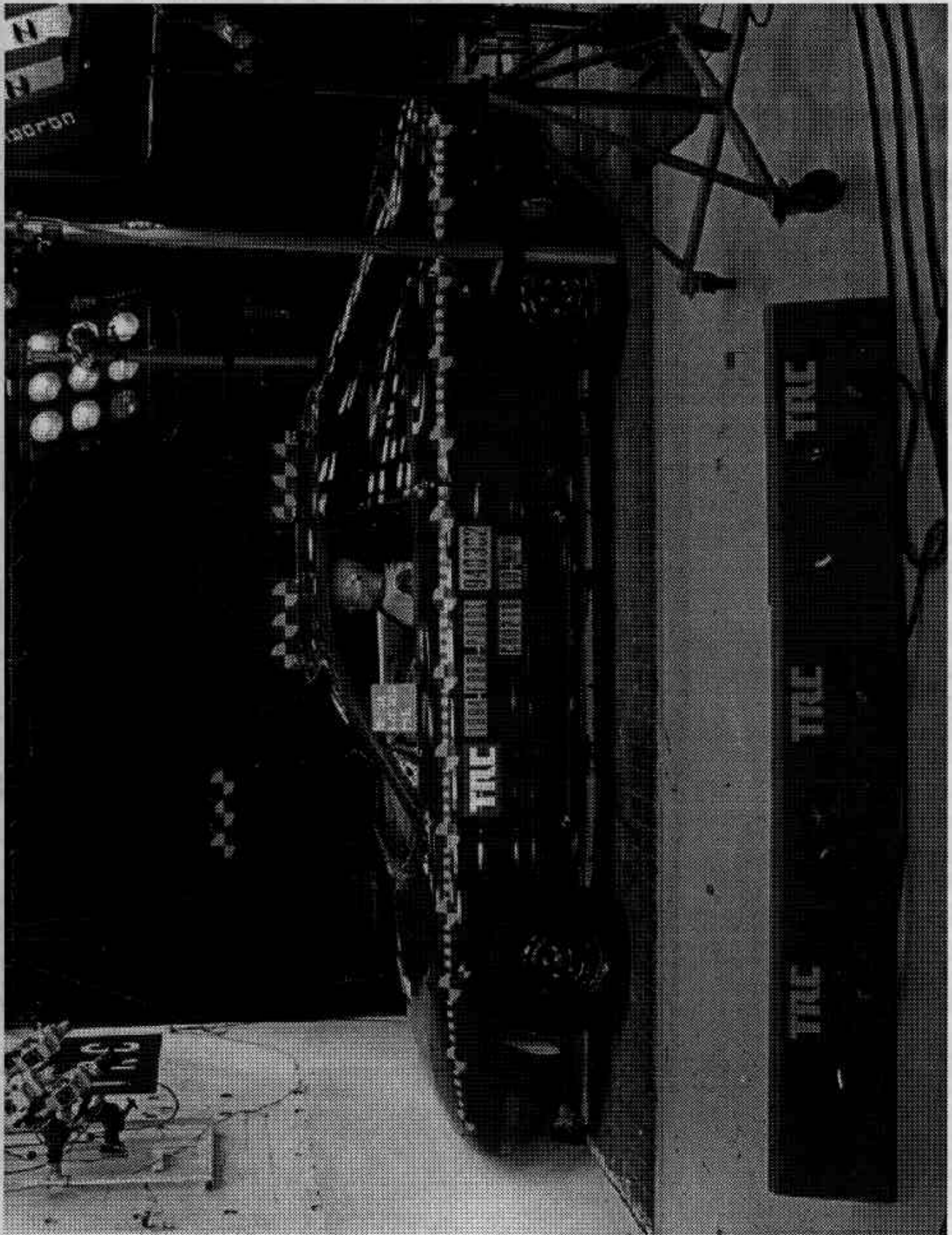

Figure A-3. Pre-test Left Side View

A-4

940302

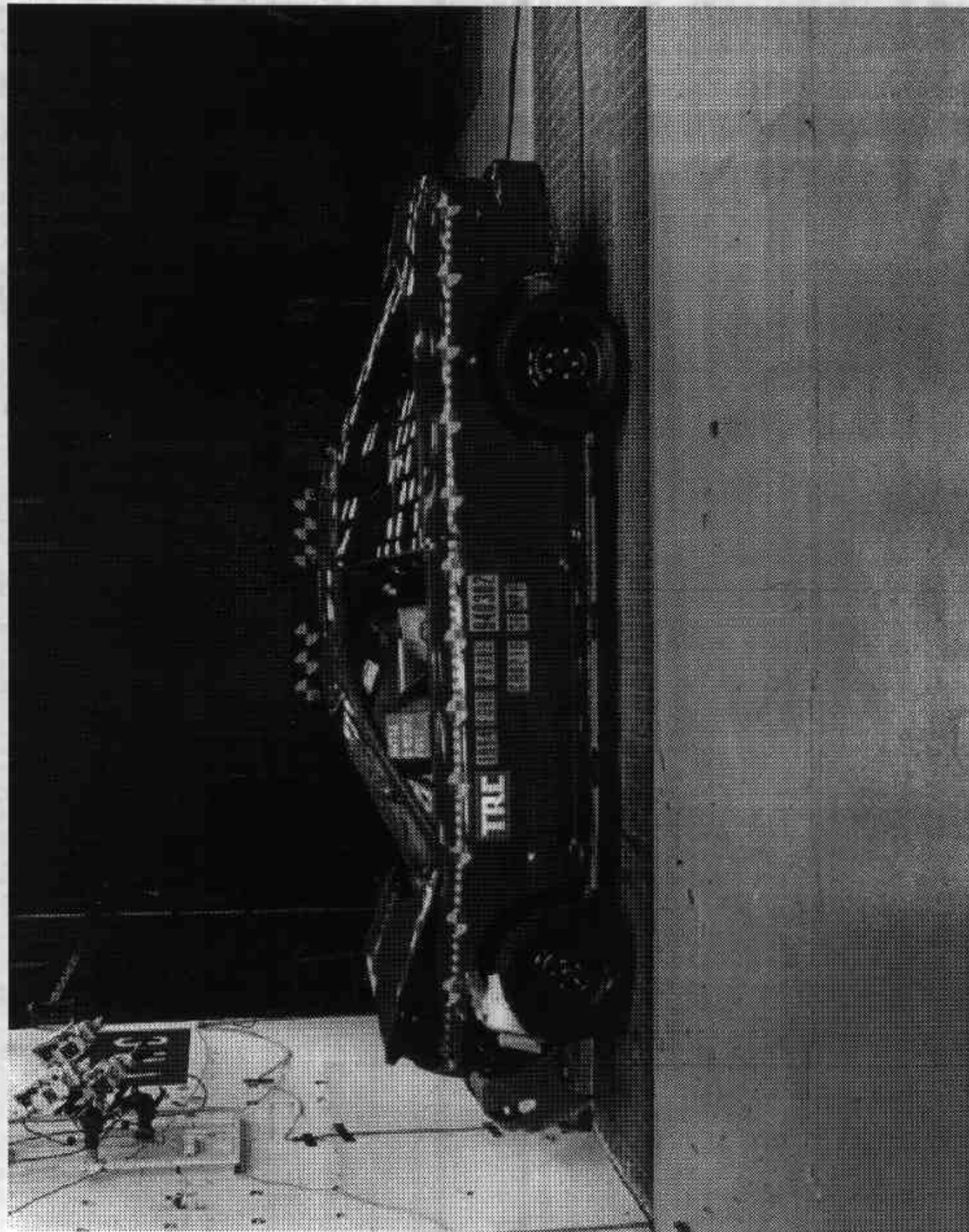

Figure A-4. Post-test Left Side View
A-5

940302

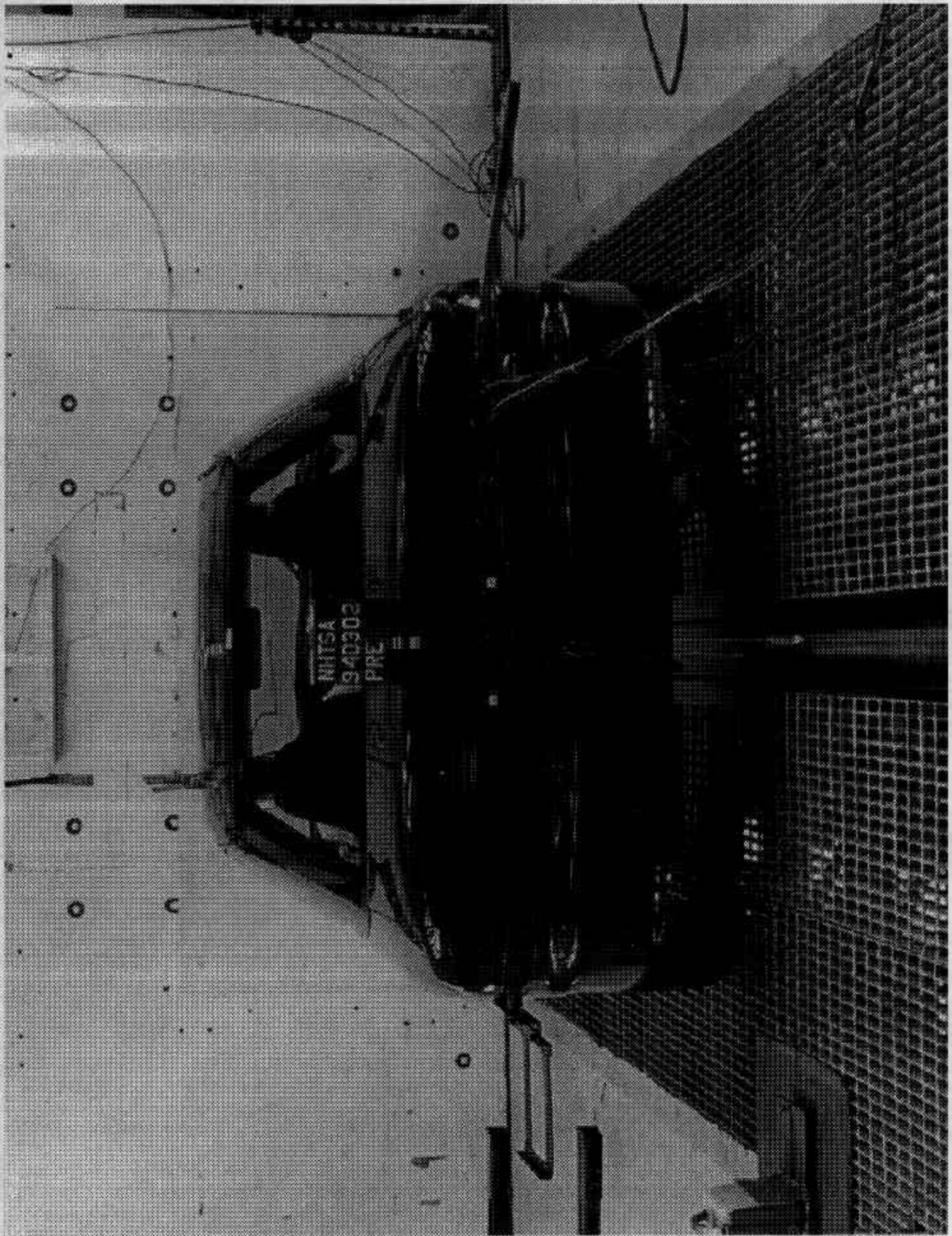

Figure A-5. Pre-test Rear View
A-6

940302

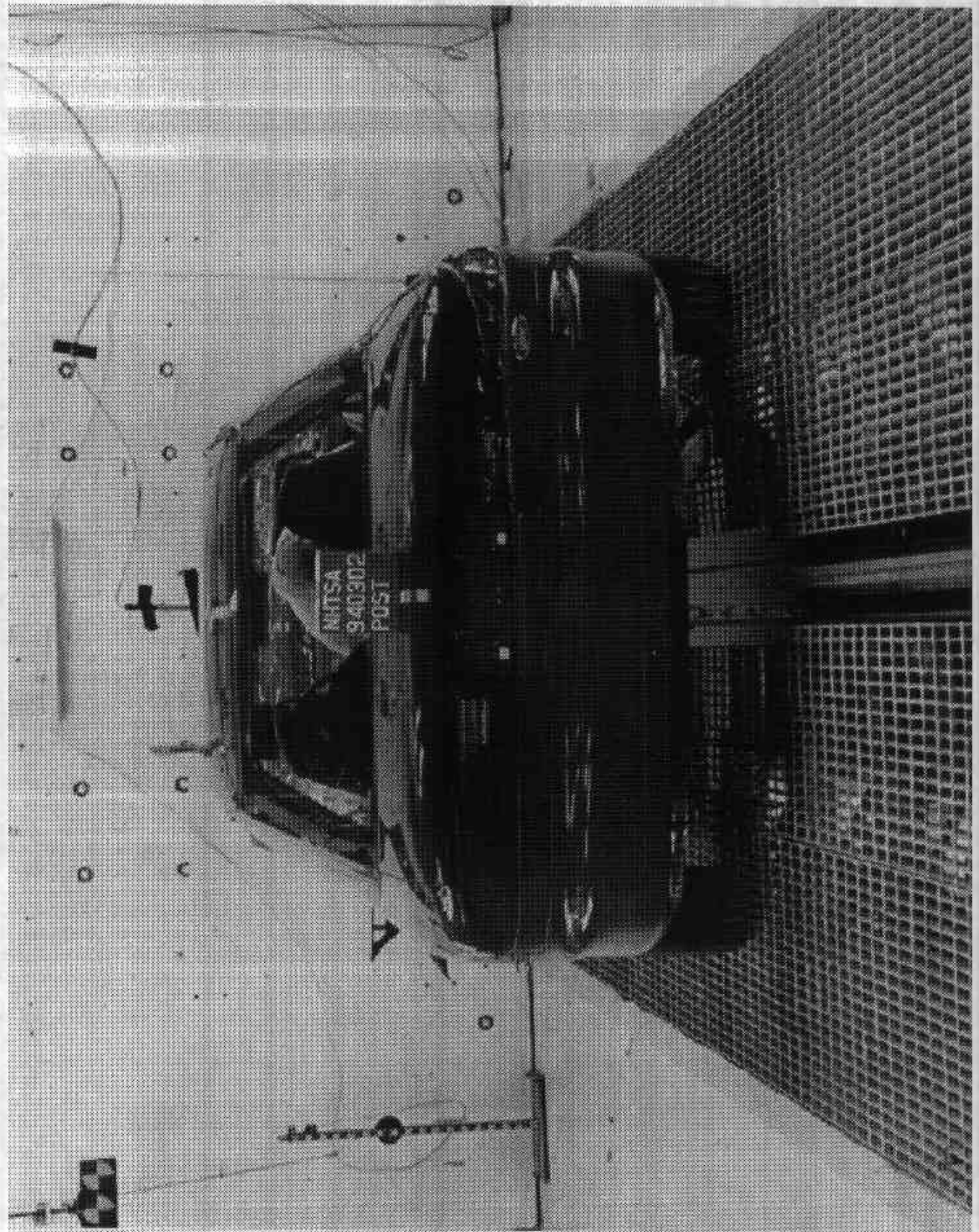

Figure A-6. Post-test Rear View
A-7

940302

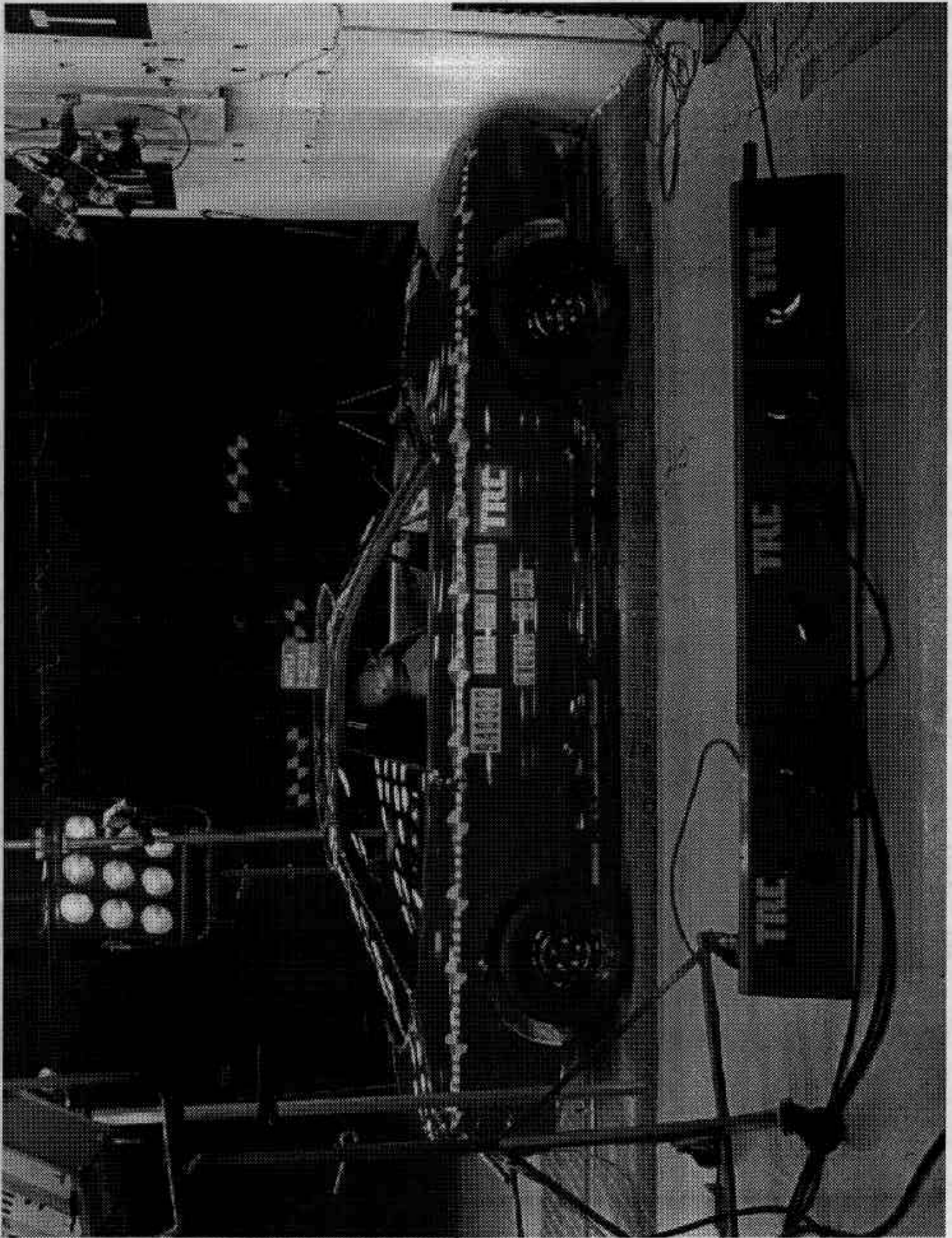

Figure A-7. Pre-test Right Side View
A-8

940302

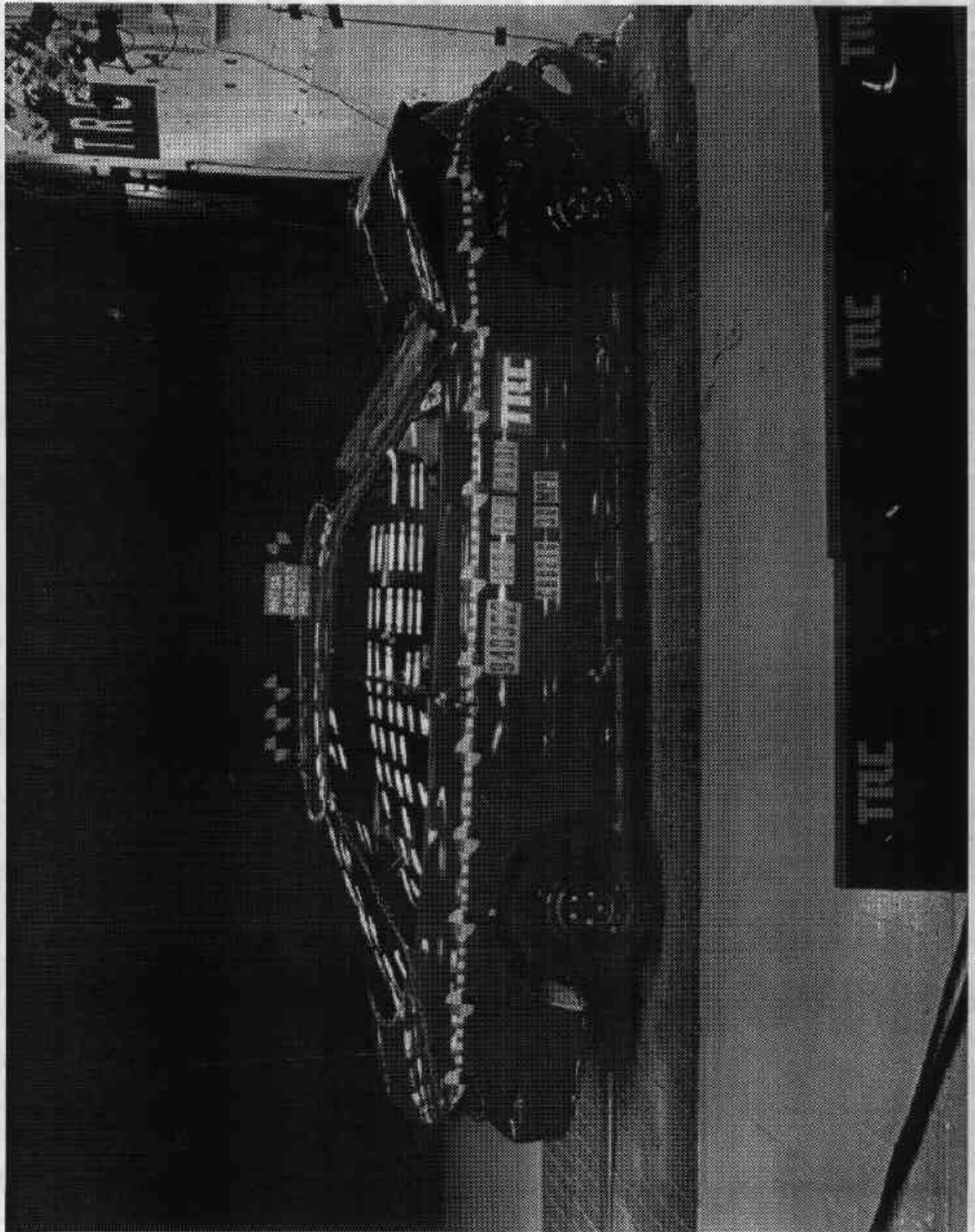

Figure A-8. Post-test Right Side View
A-9

940302



Figure A-9. Pre-test Right Front Three-quarter View
A-10

940302

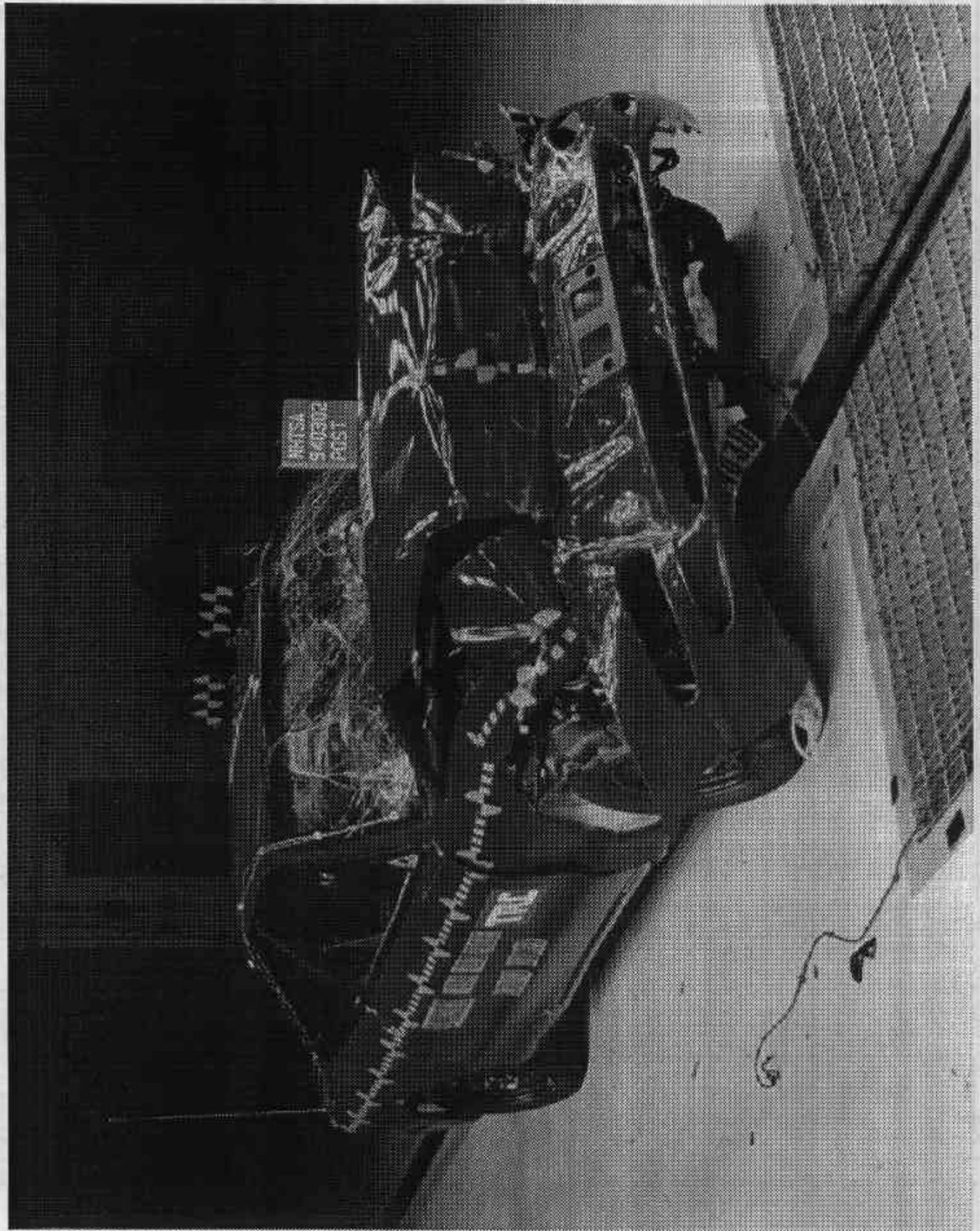

Figure A-10. Post-test Right Front Three-quarter View
A-11

940302

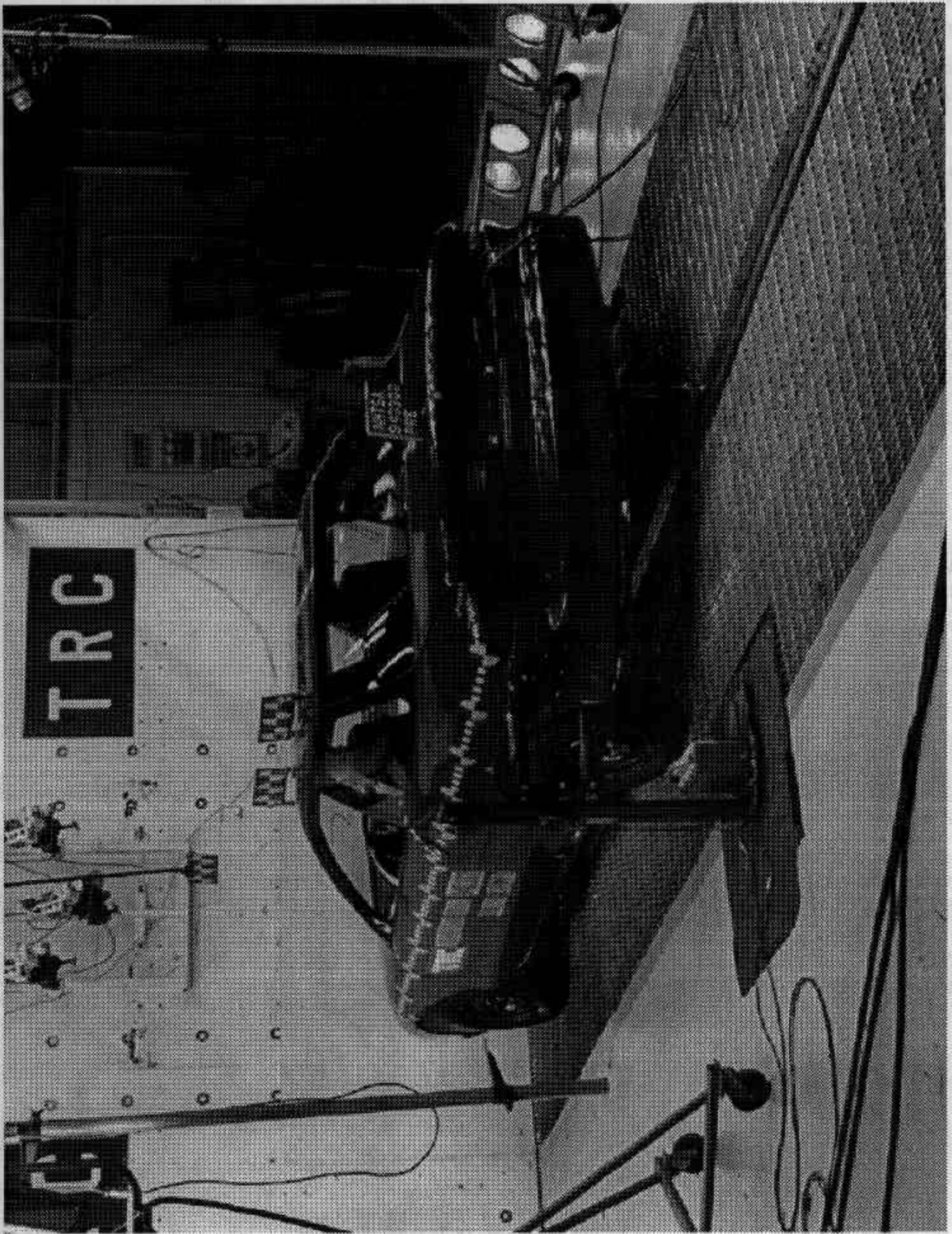

Figure A-11. Pre-test Left Rear Three-quarter View

A-12

940302

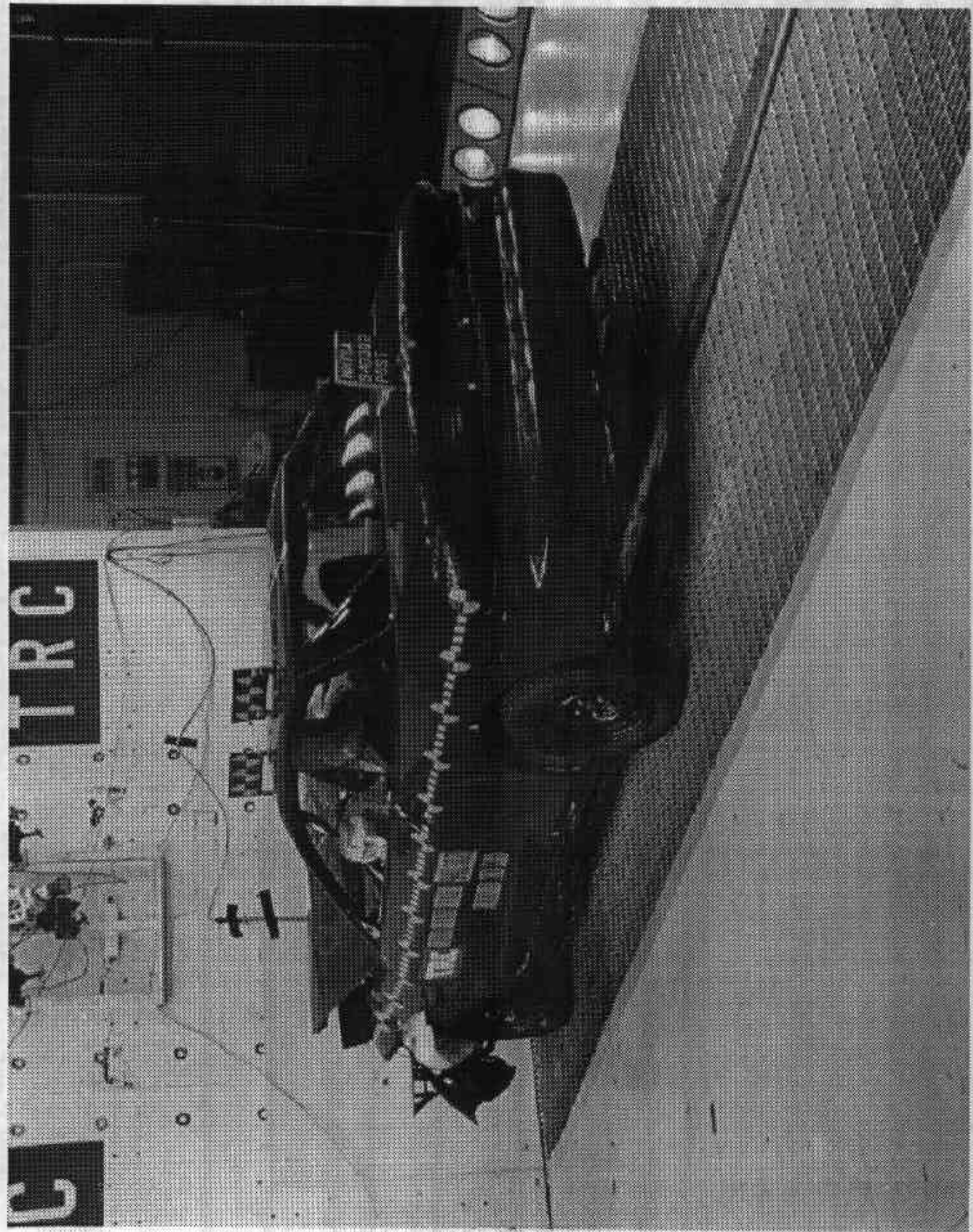

Figure A-12. Post-test Left Rear Three-quarter View
A-13

940302

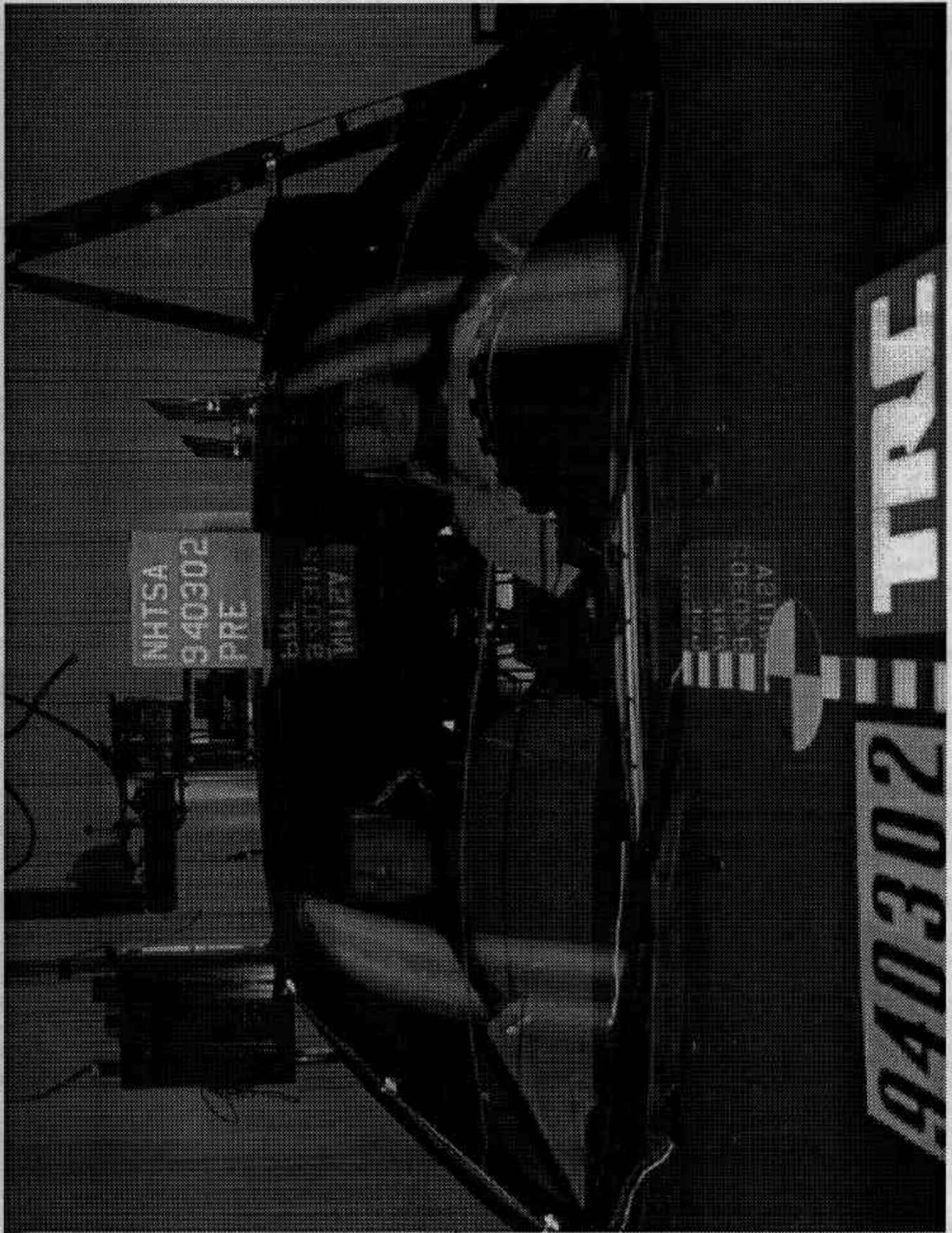

Figure A-13. Pre-test Windshield View

A-14

940302

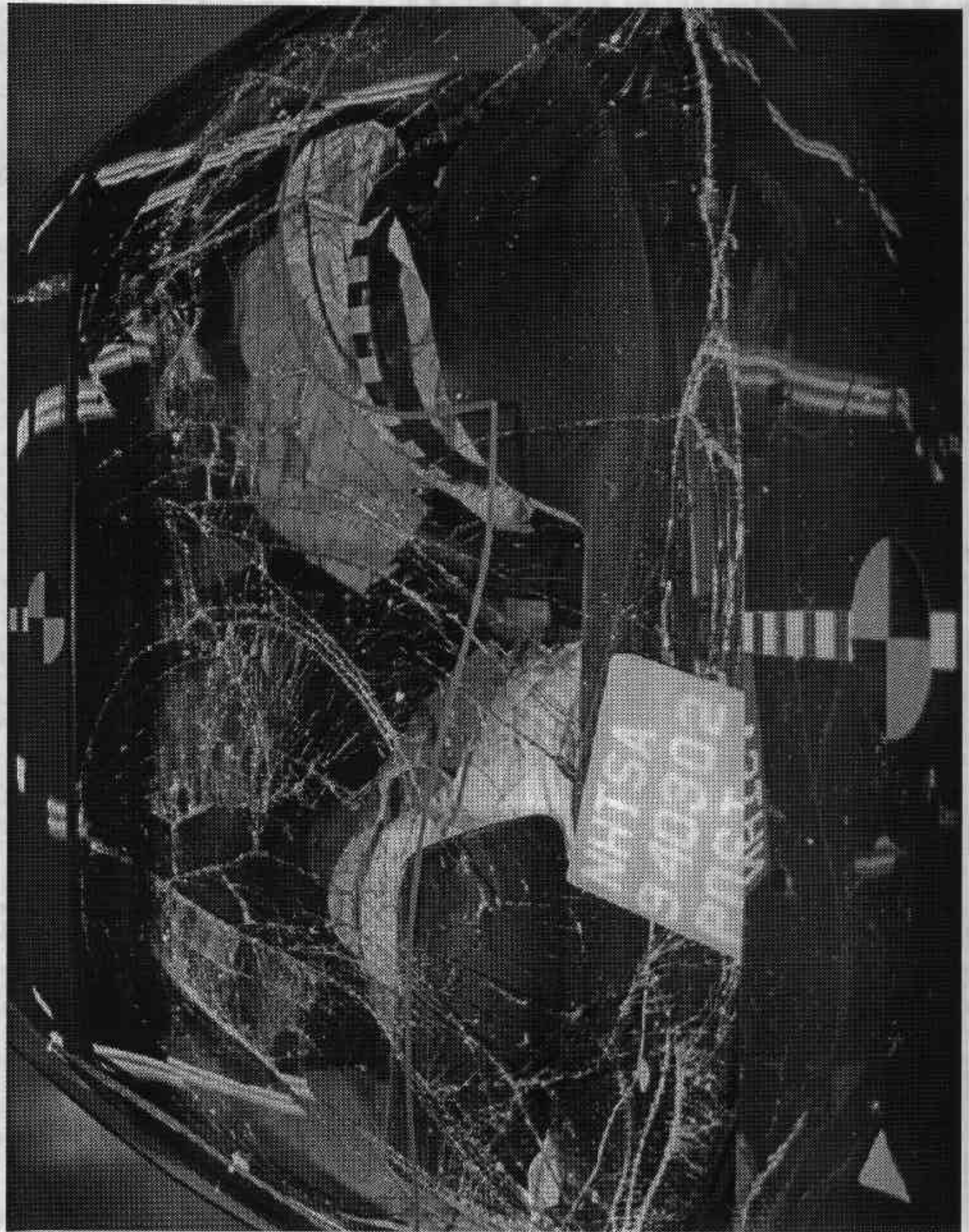

Figure A-14. Post-test Windshield View
A-15

940302

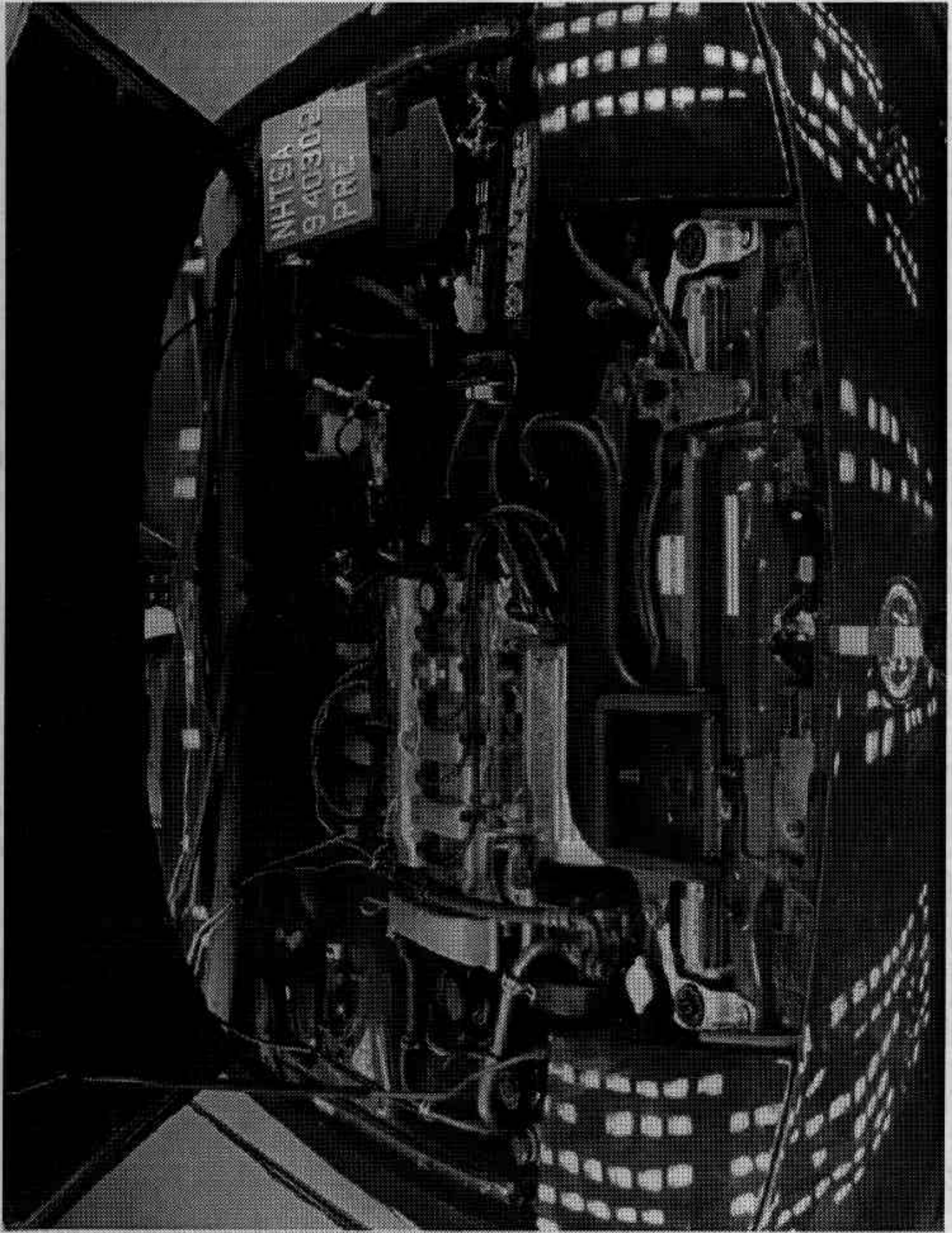

Figure A-15. Pre-test Engine Compartment View
A-16

940302

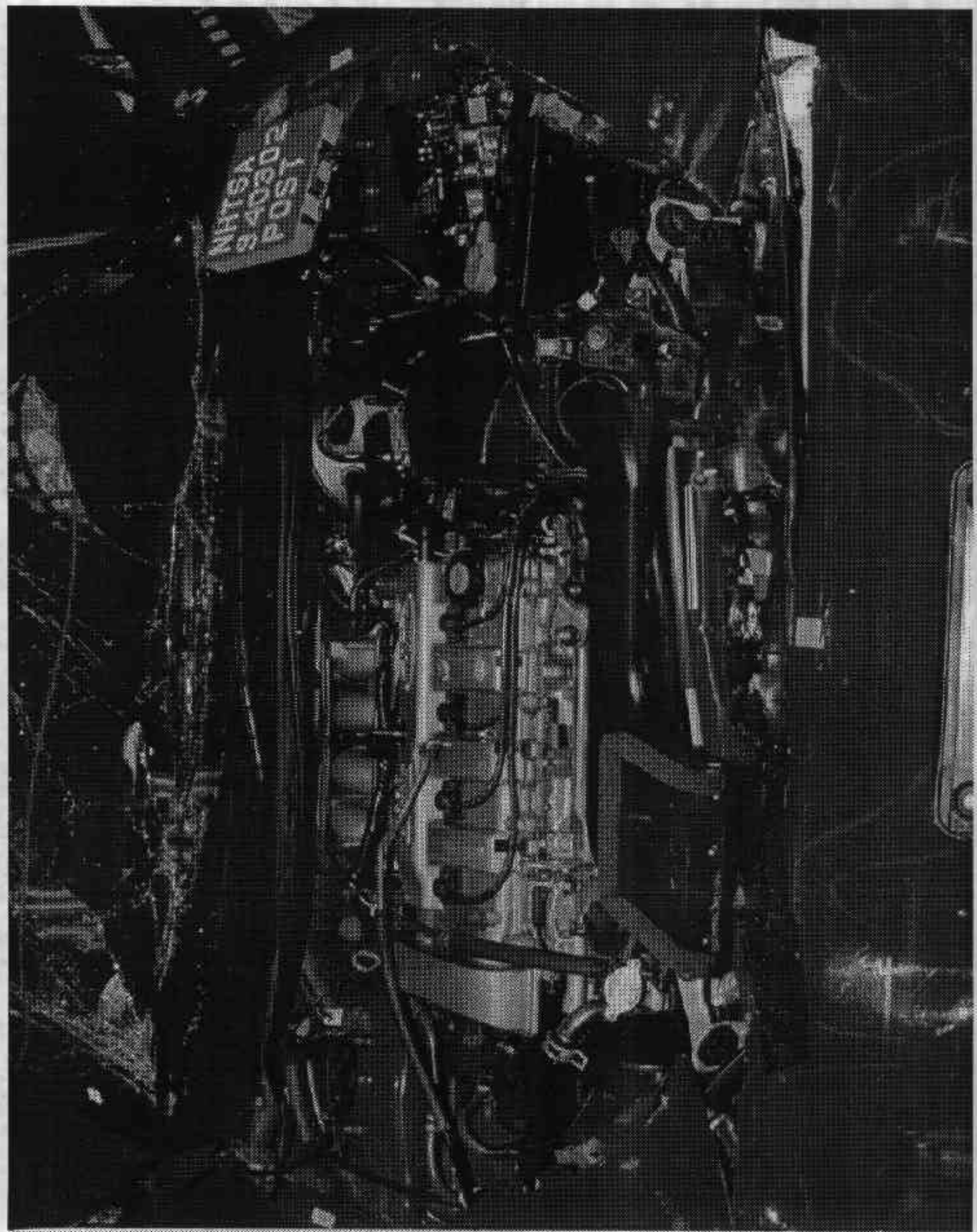

Figure A-16. Post-test Engine Compartment View
A-17

940302

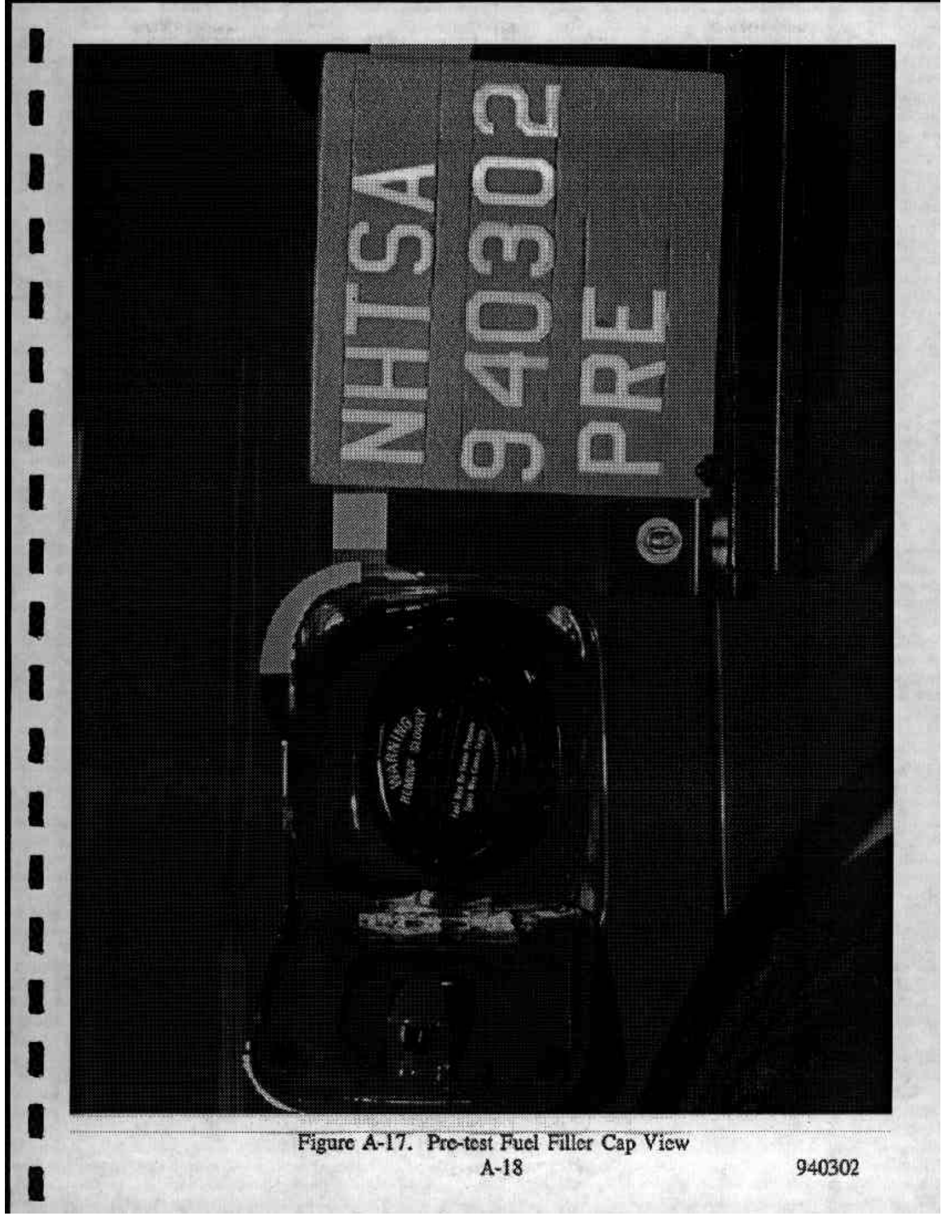

Figure A-17. Pre-test Fuel Filler Cap View

A-18

940302

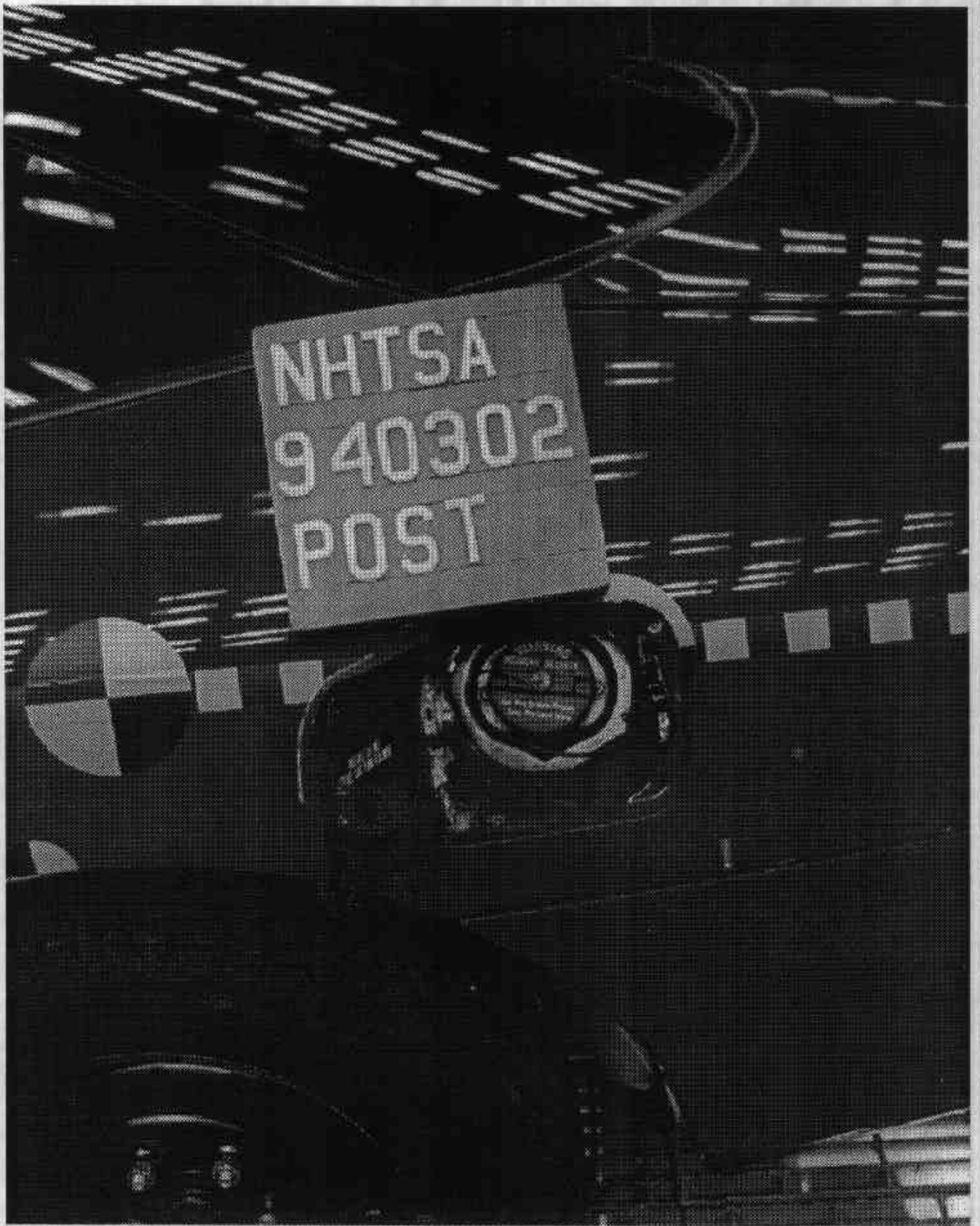

Figure A-18. Post-test Fuel Filler Cap View
A-19

940302

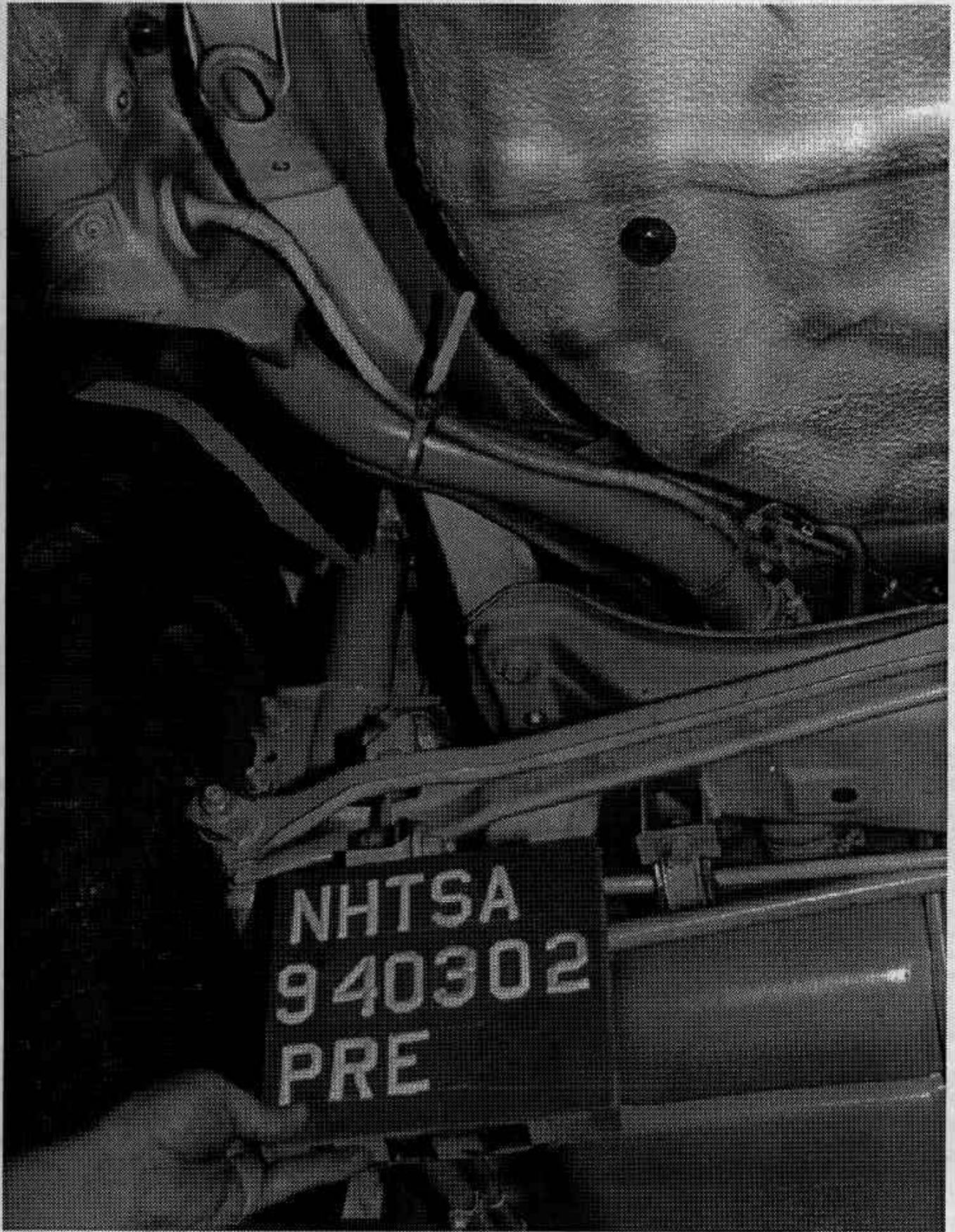

Figure A-19. Pre-test Fuel Filler Neck View
A-20

940302

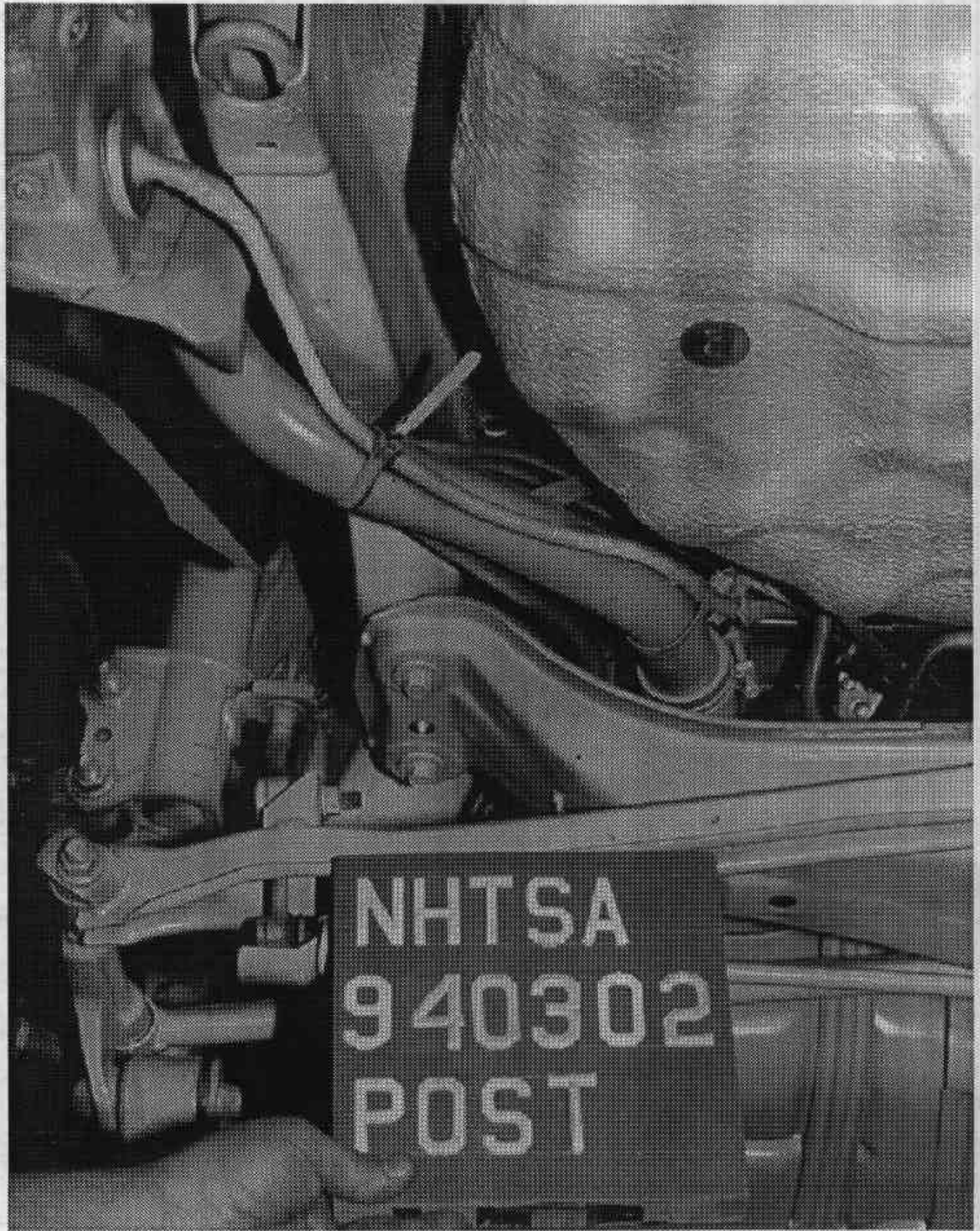

Figure A-20. Post-test Fuel Filler Neck View
A-21

940302

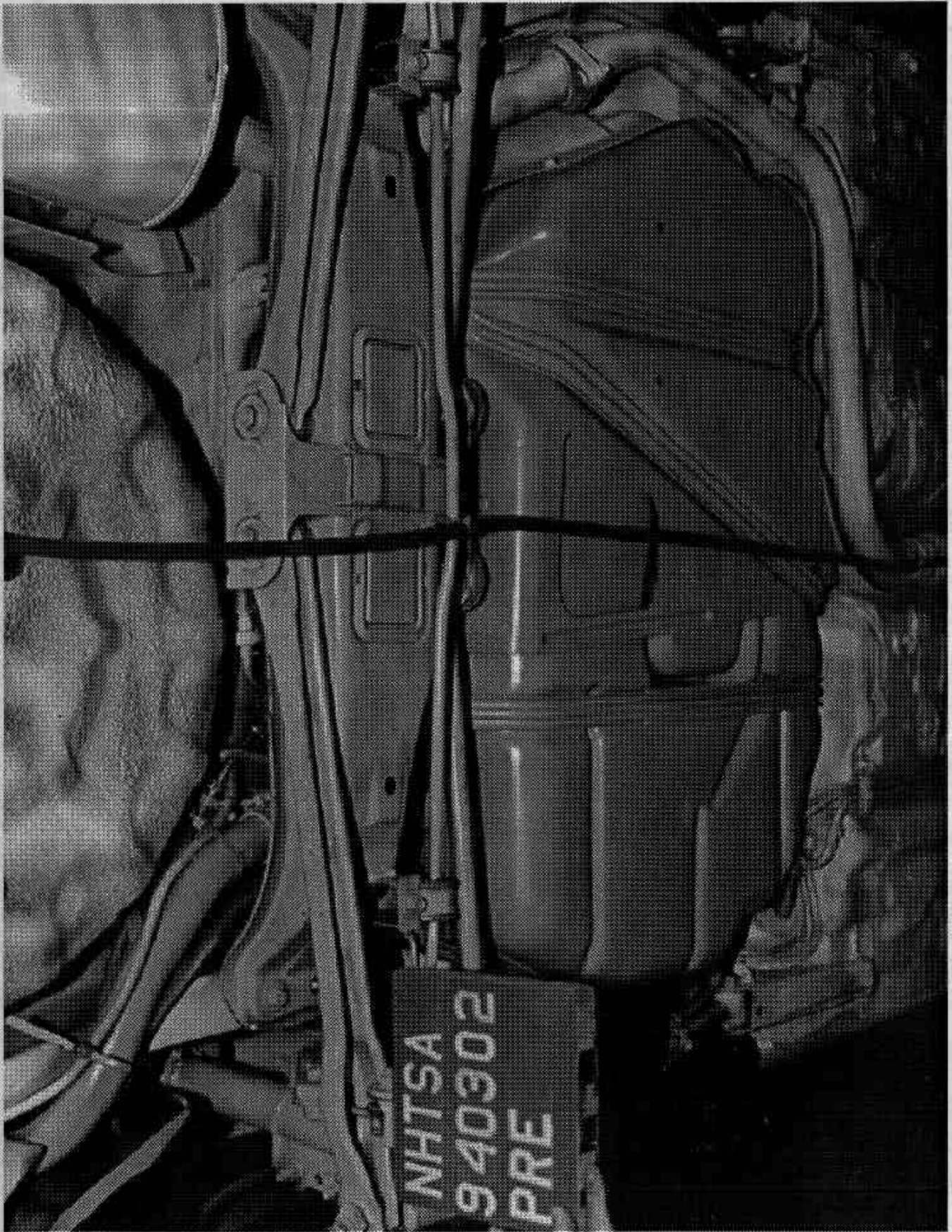

Figure A-21. Pre-test Fuel Filler Neck and Fuel Tank View

A-22

940302

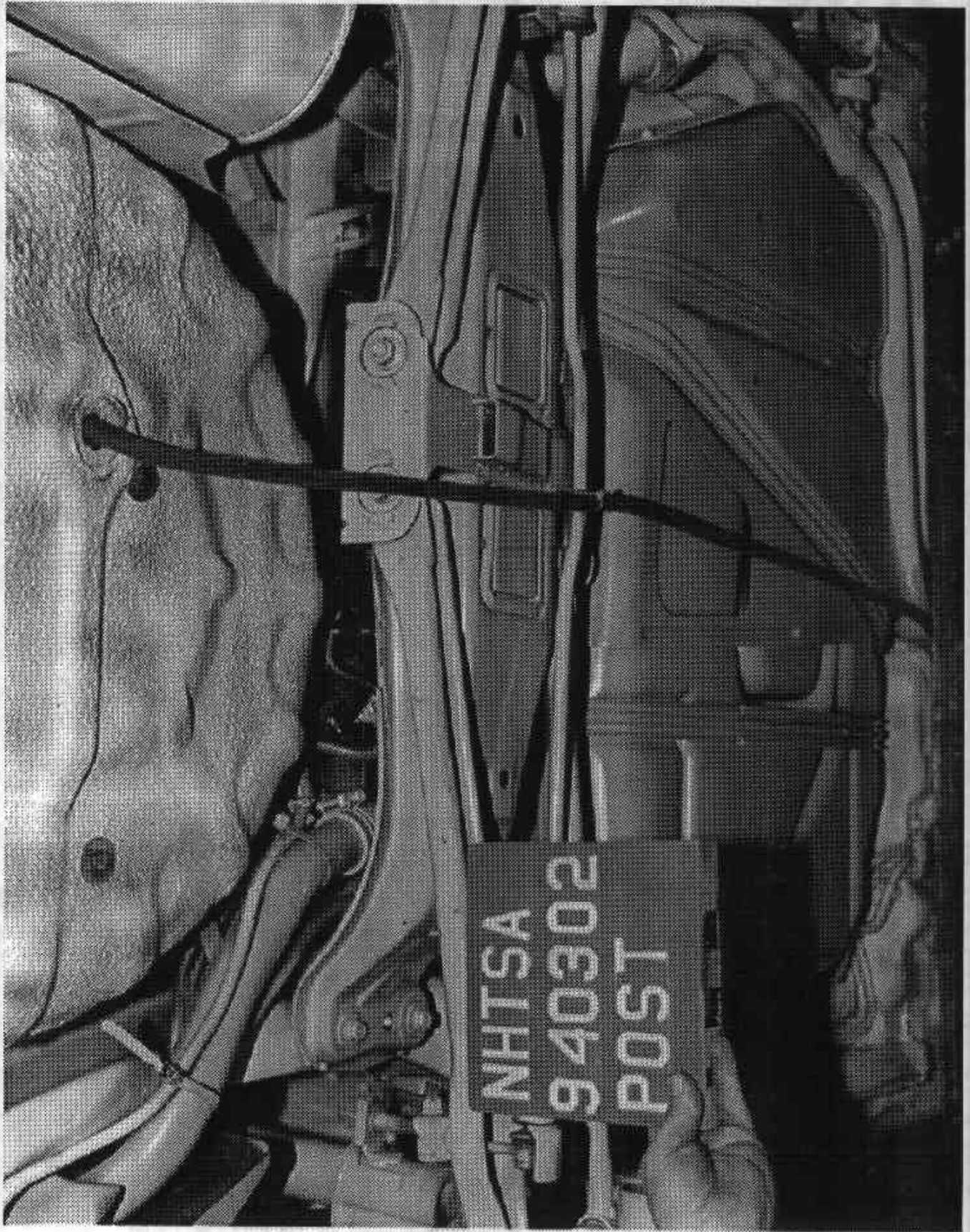

Figure A-22. Post-test Fuel Filler Neck and Fuel Tank View
A-23

940302

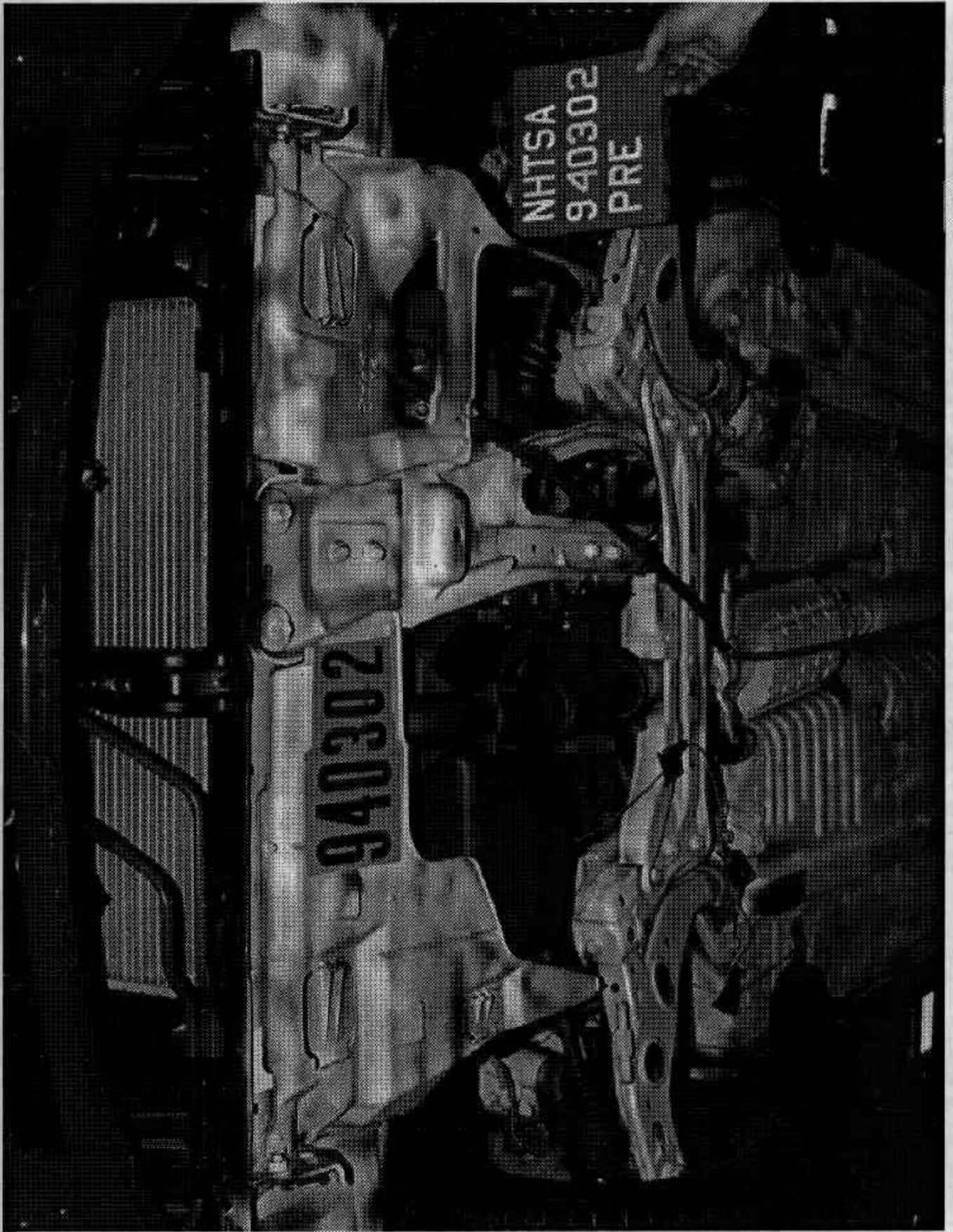

Figure A-23. Pre-test Front Underbody View
A-24

940302

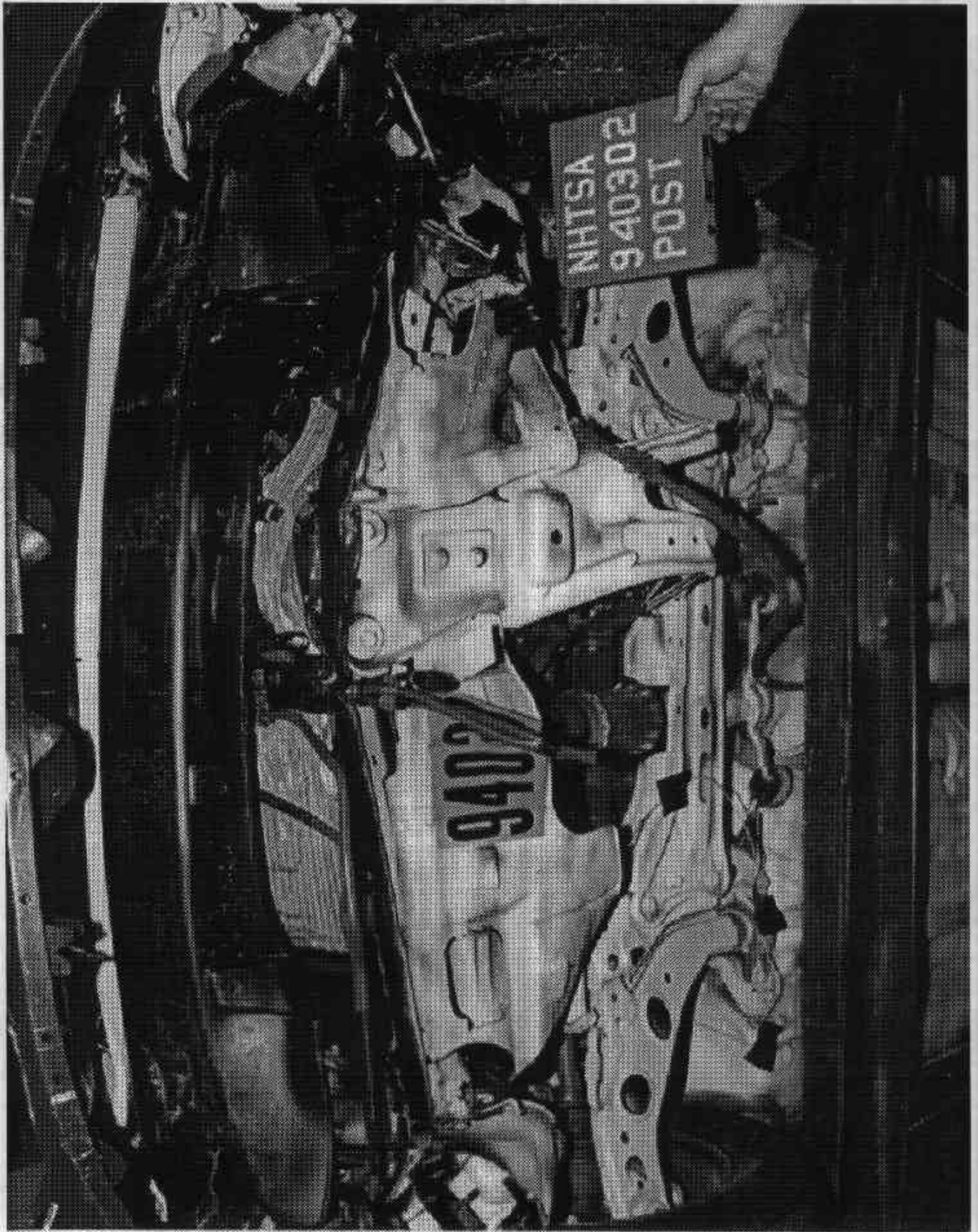

Figure A-24. Post-test Front Underbody View
A-25

940302

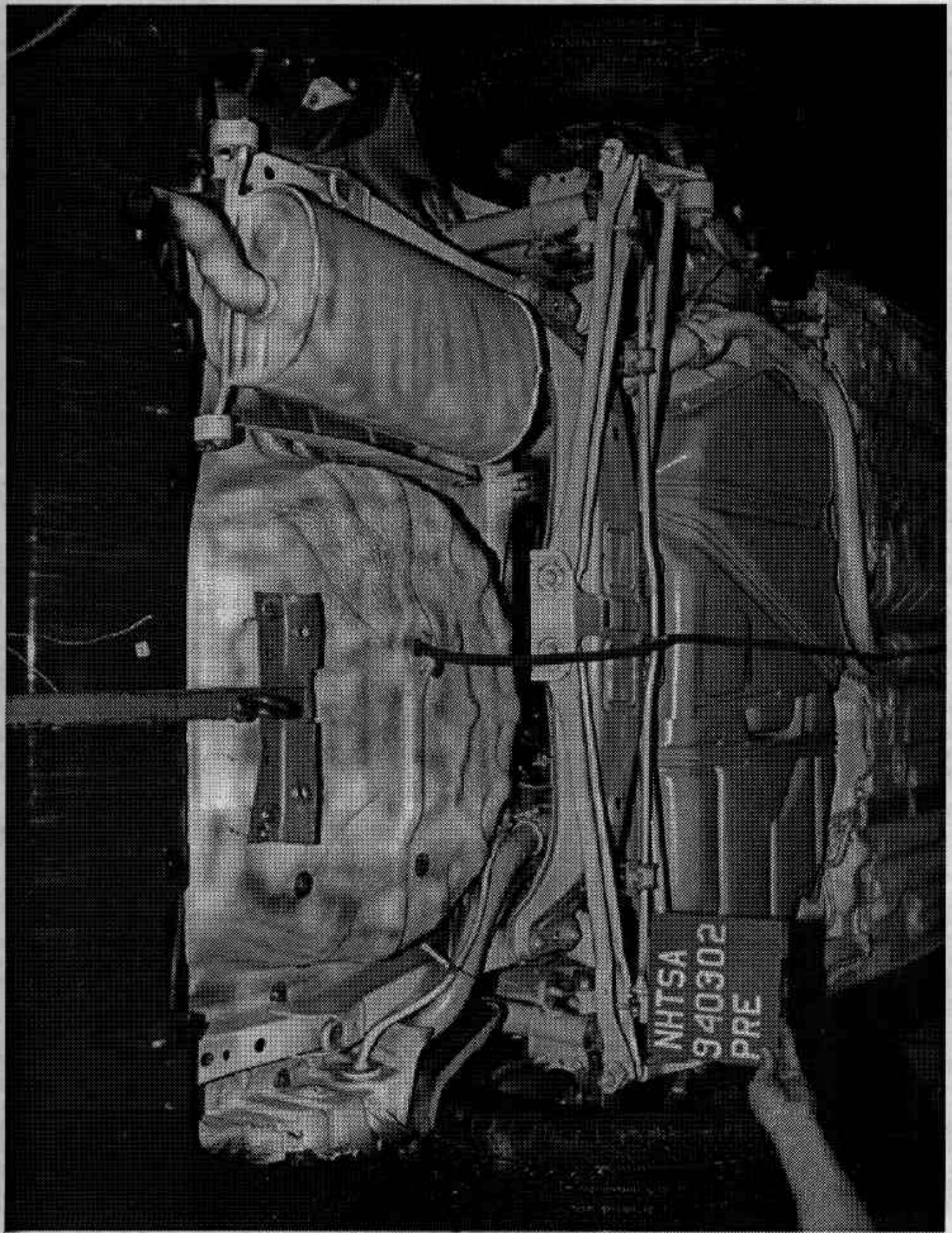

Figure A-25. Pre-test Rear Underbody View
A-26

940302

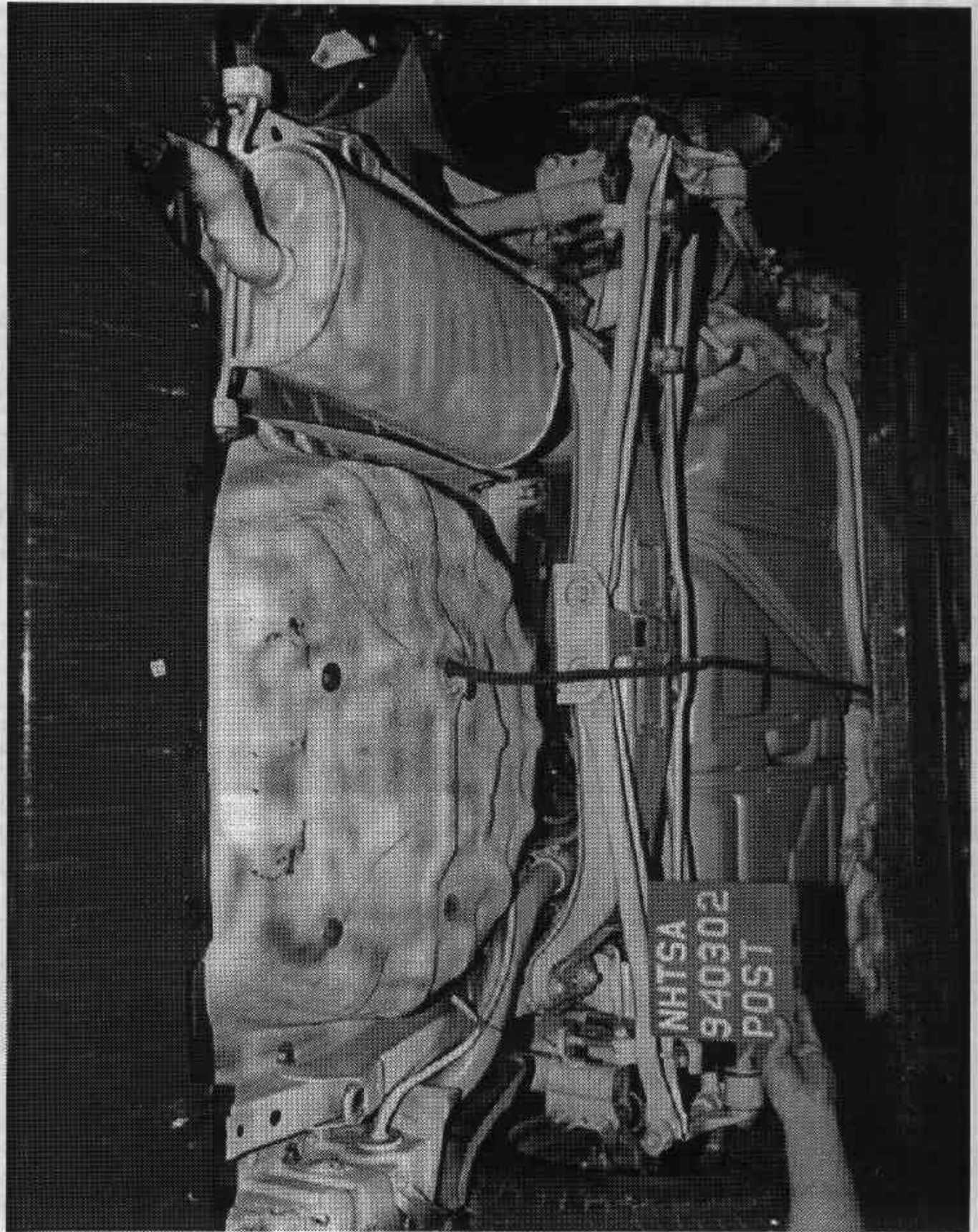

Figure A-26. Post-test Rear Underbody View
A-27

940302

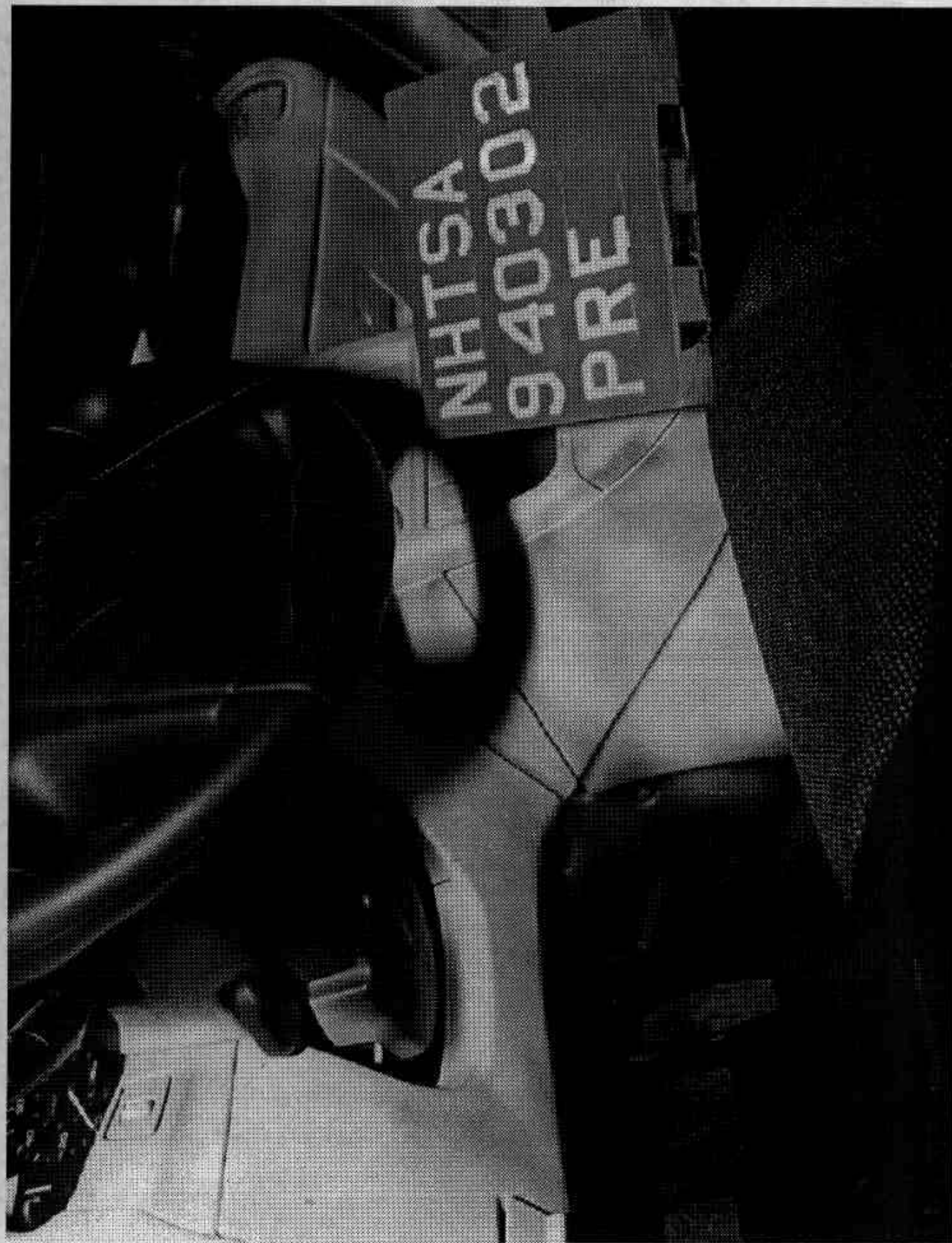

Figure A-27. Pre-test Driver's Knee Bolster View

A-28

940302



Figure A-28. Pre-test Passenger's Knee Bolster View
A-29

940302

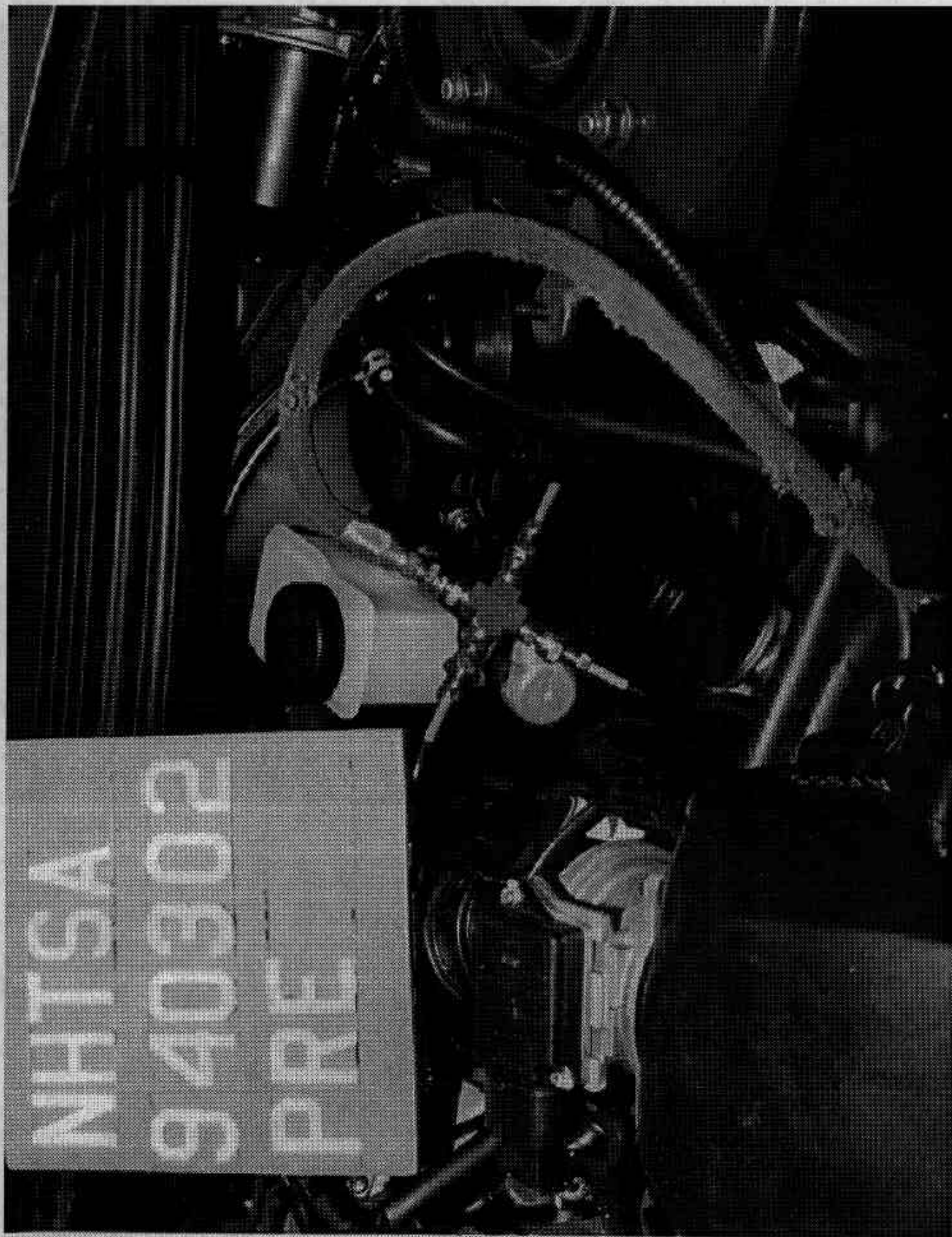

Figure A-29. Pre-test Steering Column at Firewall View
A-30

940302

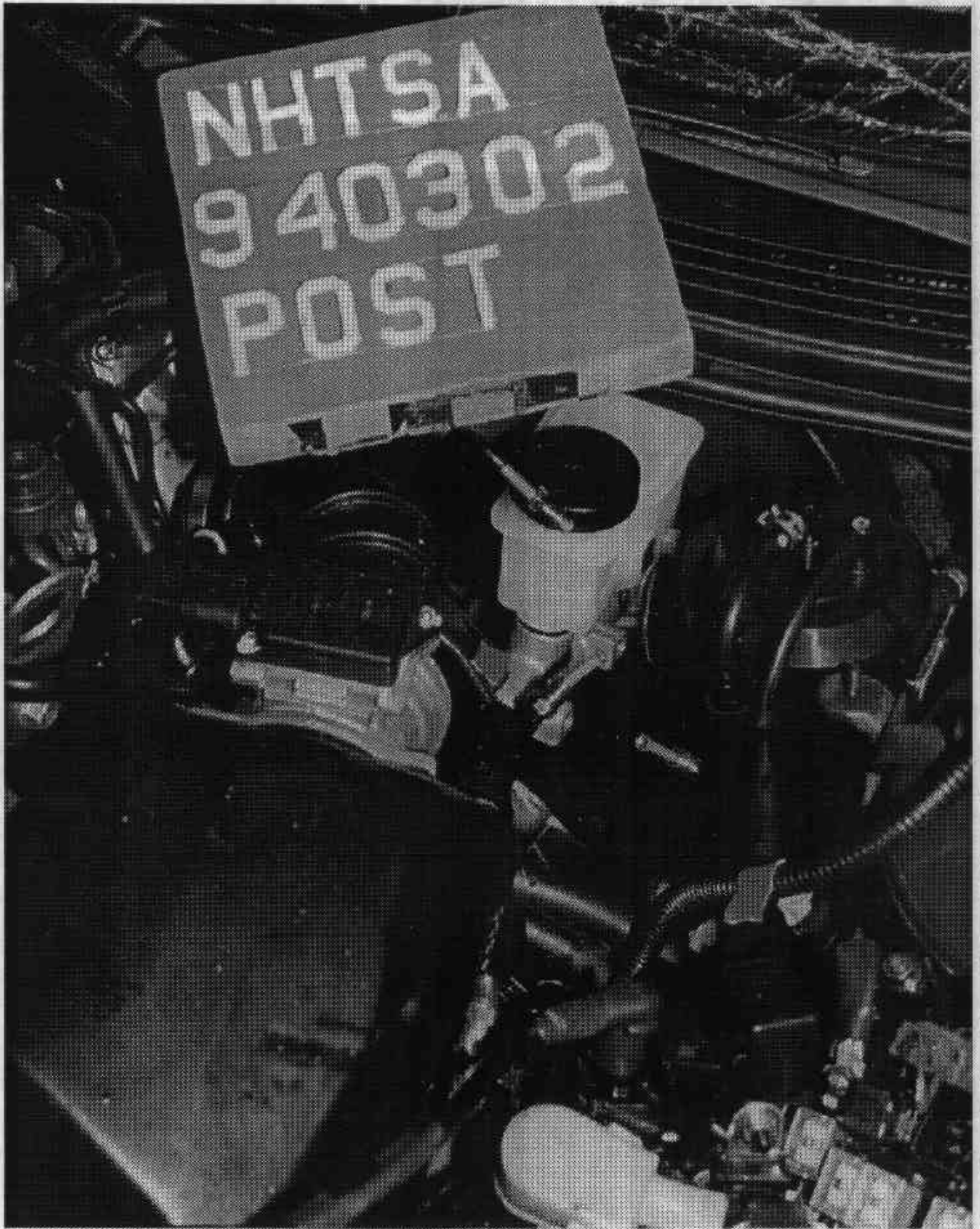

Figure A-30. Post-test Steering Column at Firewall View
A-31

940302



Figure A-31. Pre-test Steering Column at Firewall View - Interior

A-32

940302



Figure A-32. Post-test Steering Column at Firewall View - Interior

A-33

940302

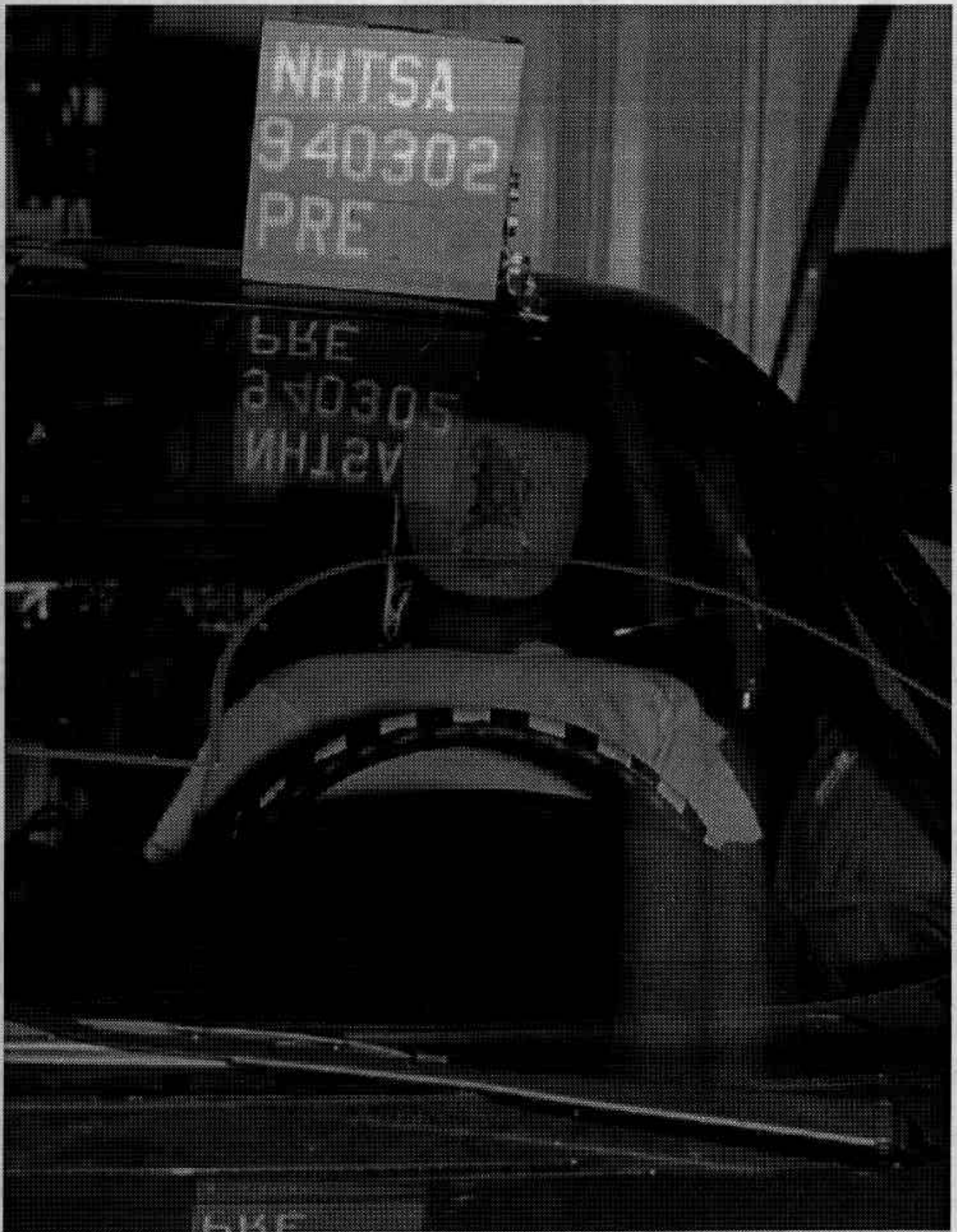

Figure A-33. Pre-test Driver Dummy Position - View 1

A-34

940302



Figure A-34, Post-test Driver Dummy Position - View 1
A-35

940302



Figure A-35. Pre-test Driver Dummy Position - View 2

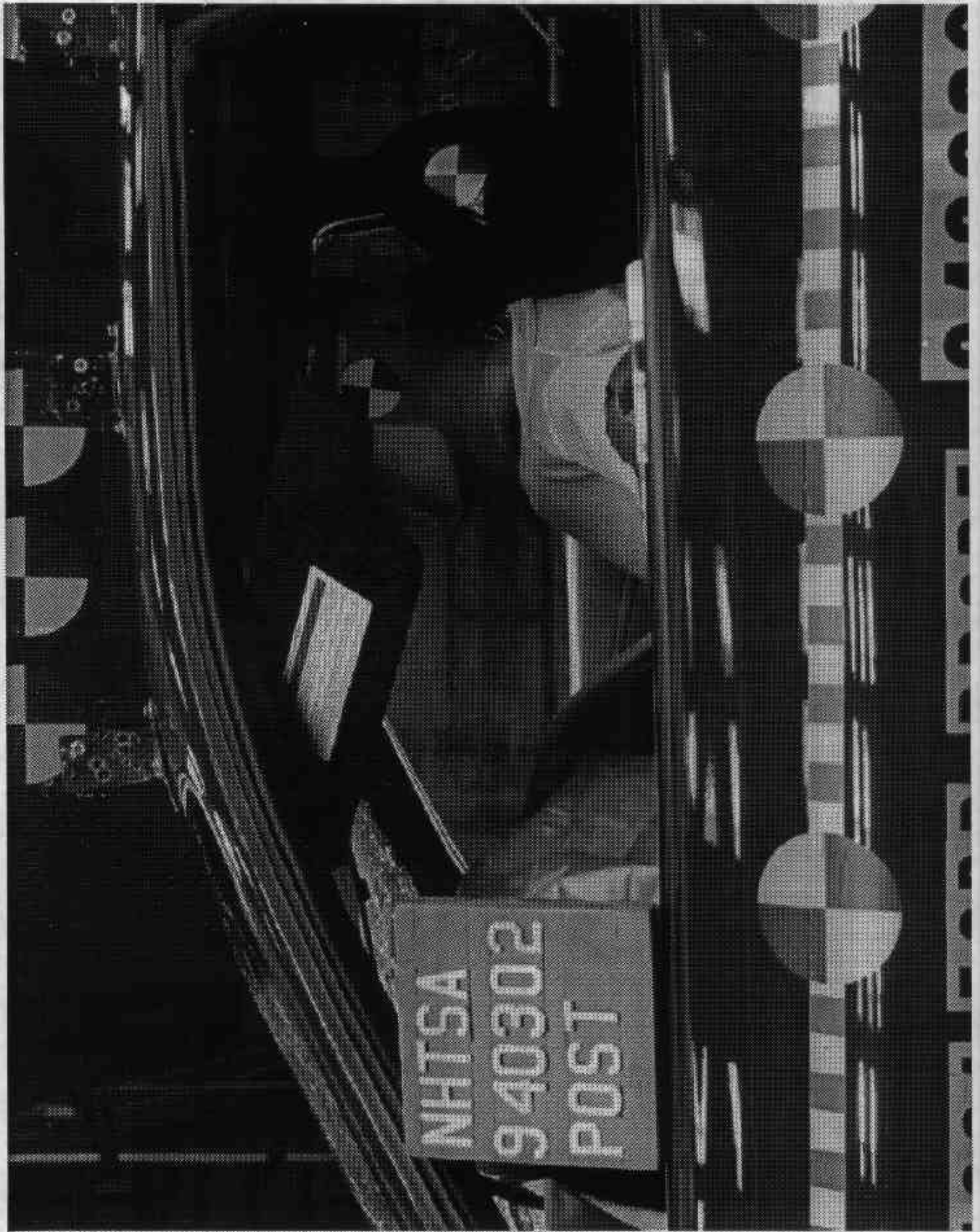

Figure A-36. Post-test Driver Dummy Position - View 2
A-37

940302

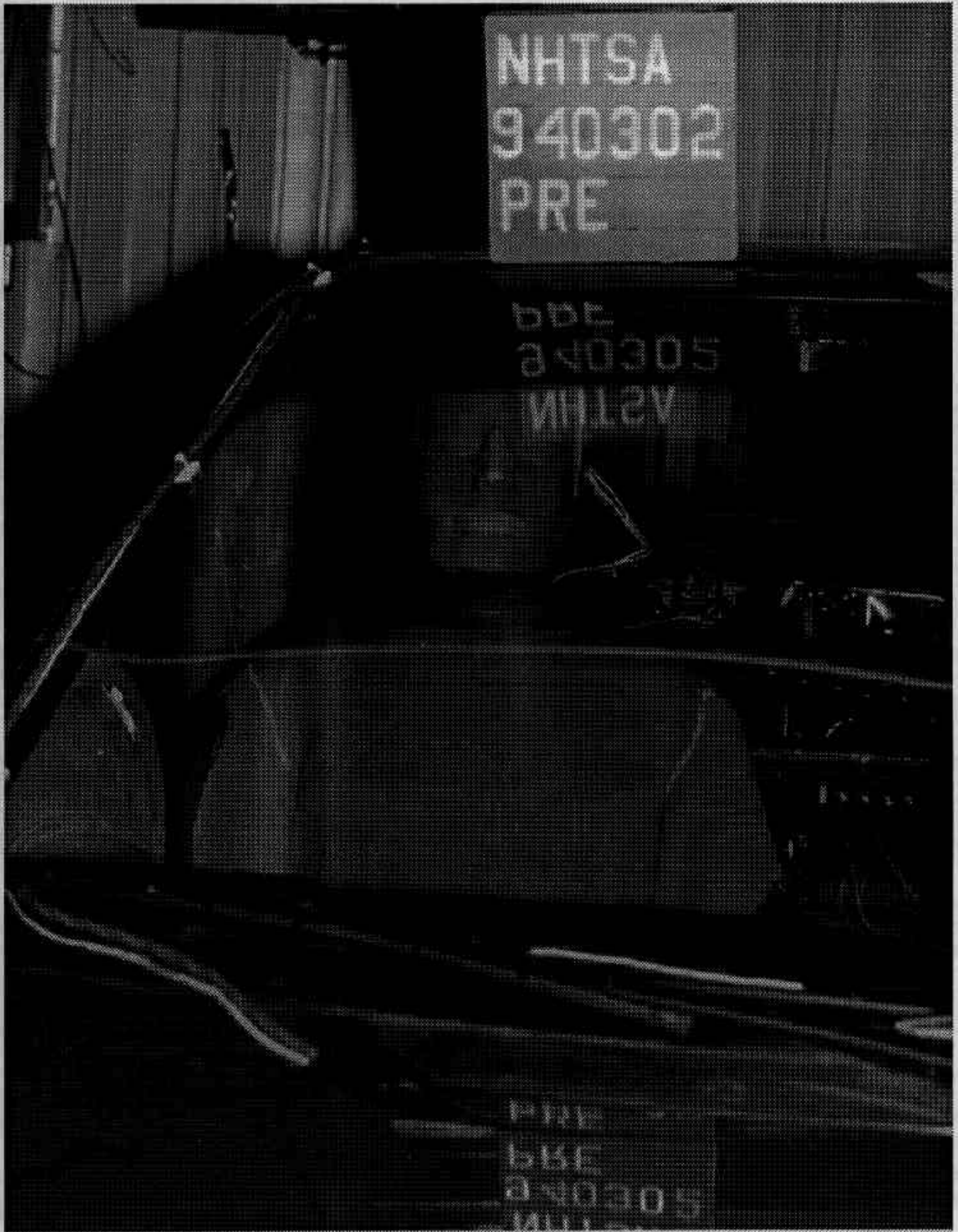

Figure A-37. Pre-test Passenger Dummy Position - View 1

A-38

940302

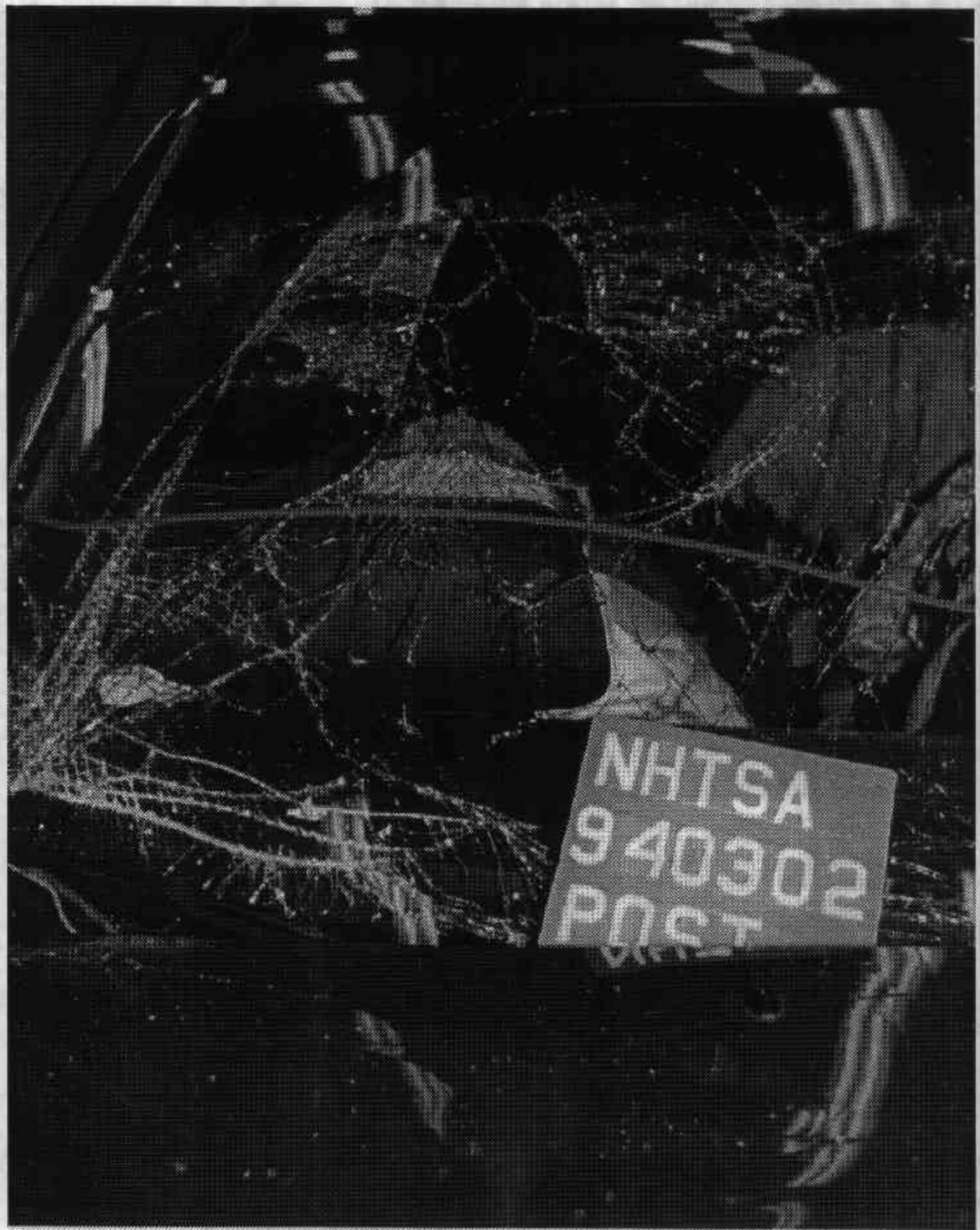

Figure A-38. Post-test Passenger Dummy Position - View 1

A-39

940302



Figure A-39. Pre-test Passenger Dummy Position - View 2
A-40

940302



Figure A-40. Post-test Passenger Dummy Position - View 2
A-41

940302

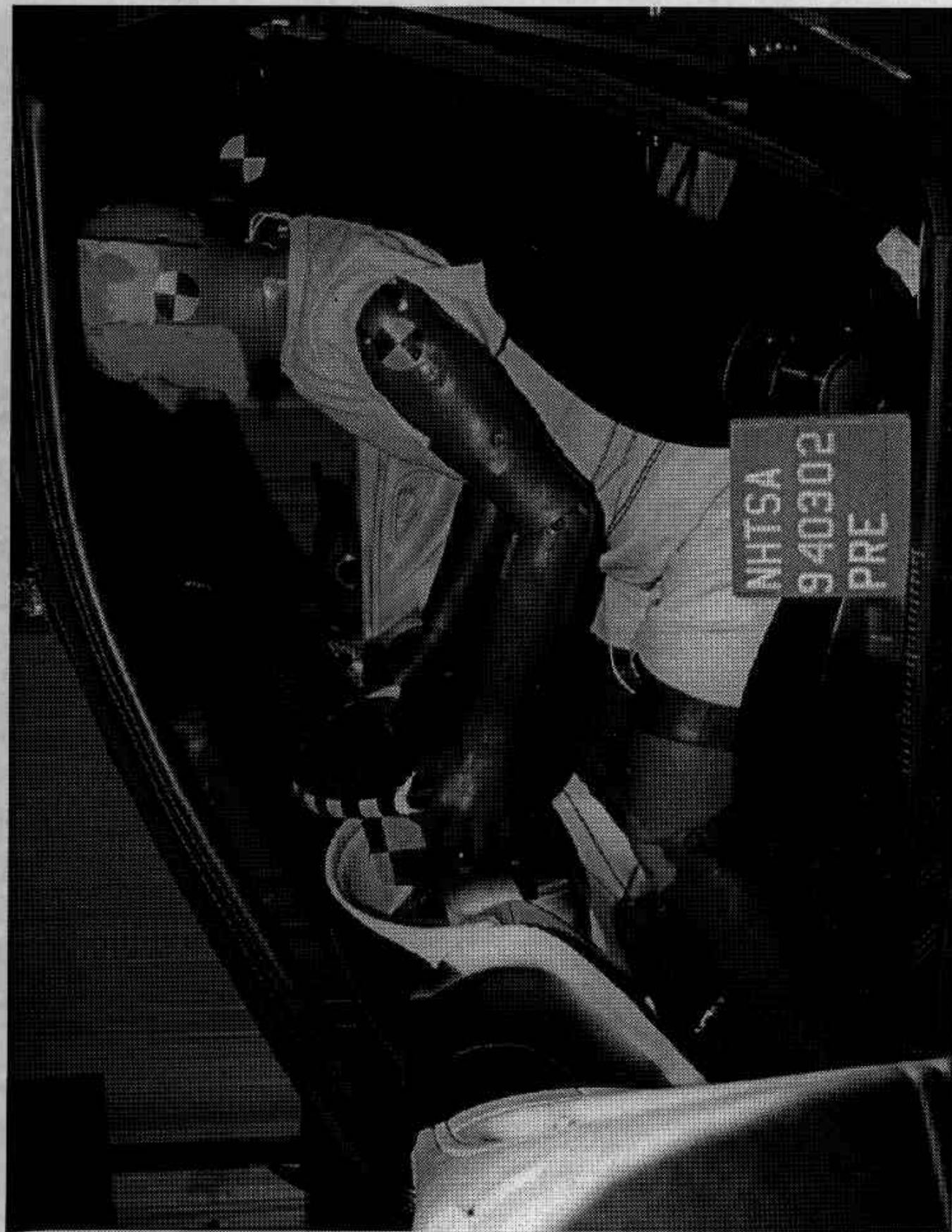

Figure A-41. Pre-test Driver Dummy & Vehicle Interior - View 1

A-42

940302



Figure A-42. Post-test Driver Dummy & Vehicle Interior - View 1

A-43

940302

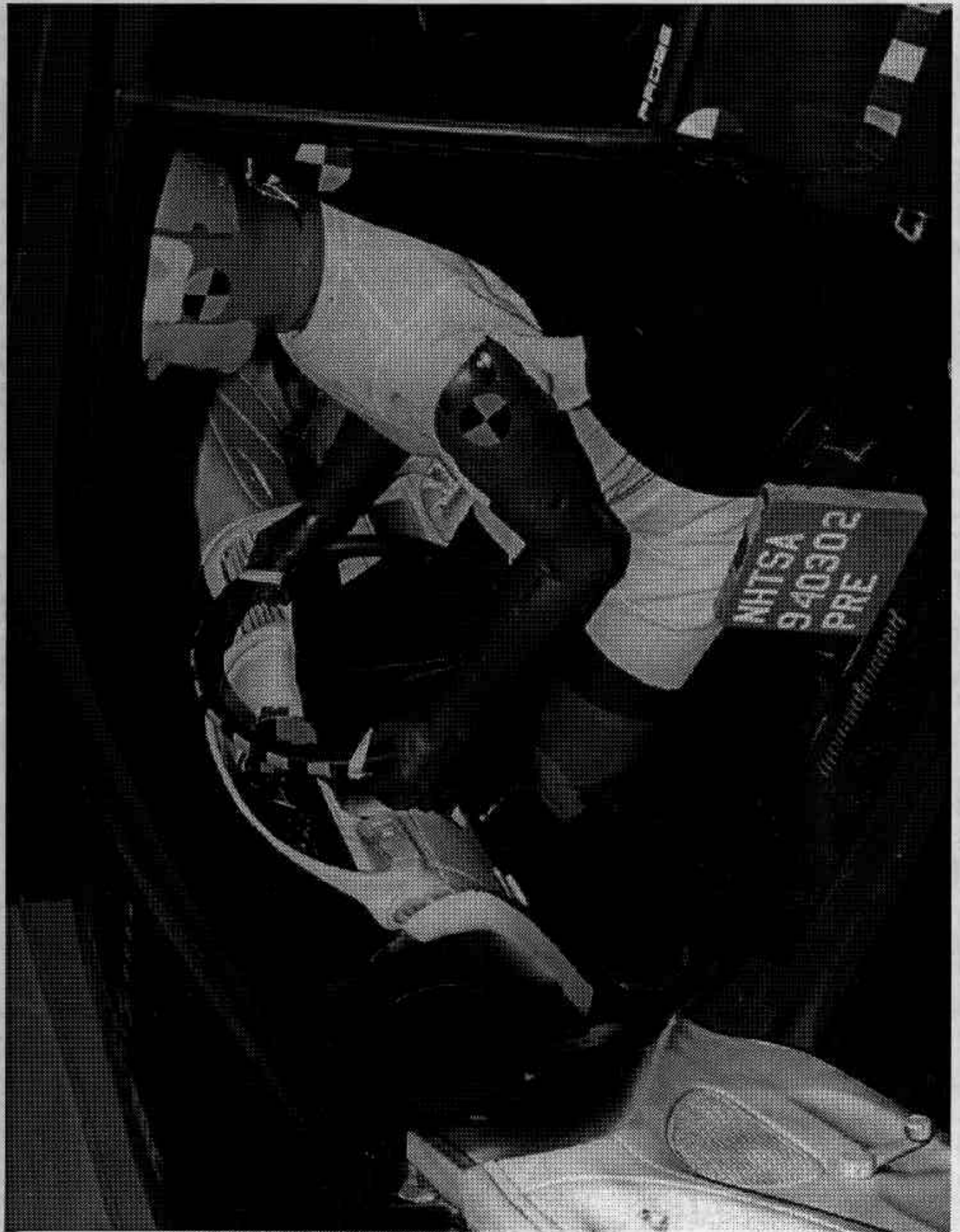

Figure A-43. Pre-test Driver Dummy & Vehicle Interior - View 2

A-44

940302



Figure A-44. Post-test Driver Dummy & Vehicle Interior - View 2

A-45

940302

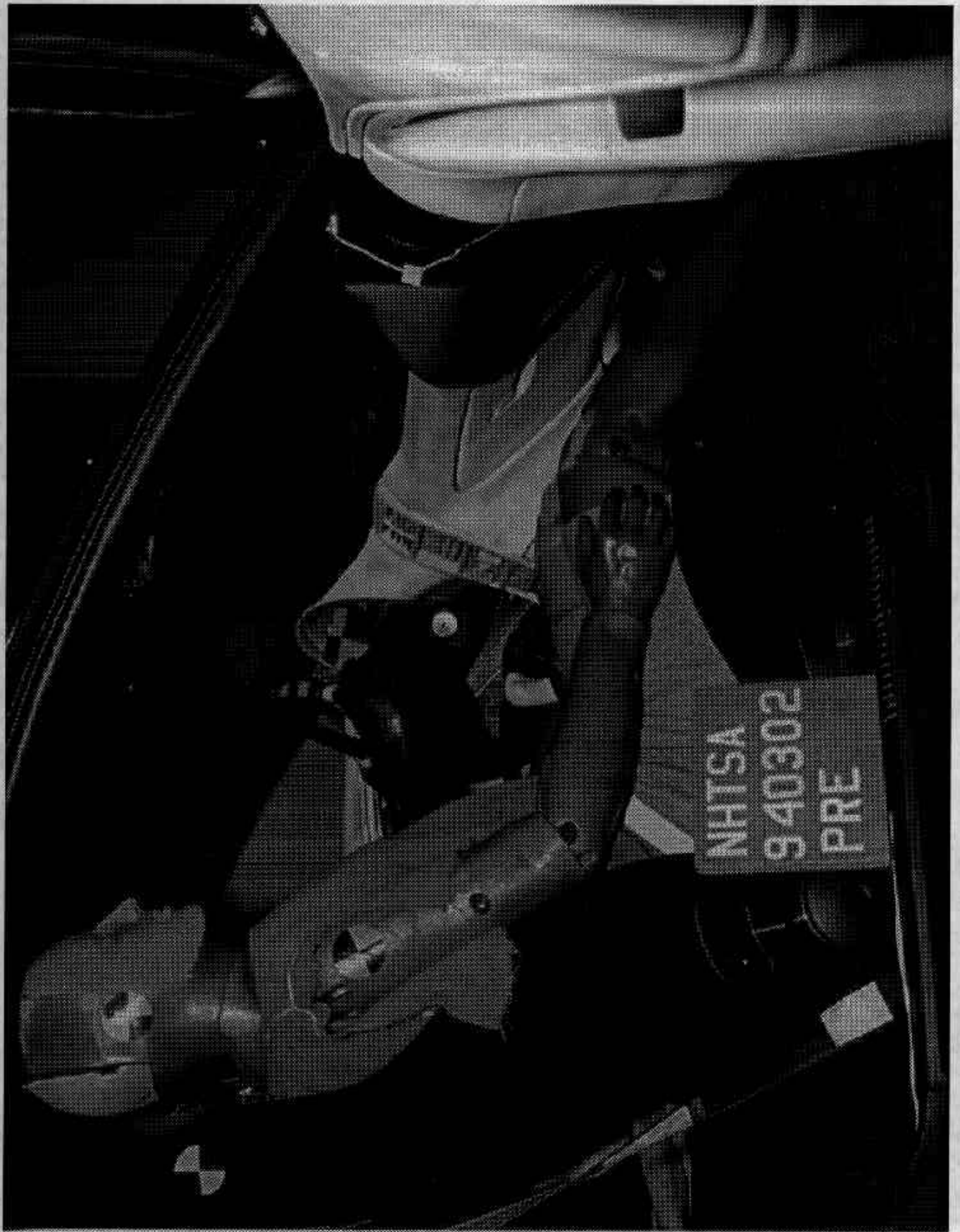

Figure A-45. Pre-test Passenger Dummy & Vehicle Interior - View 1

A-46

940302

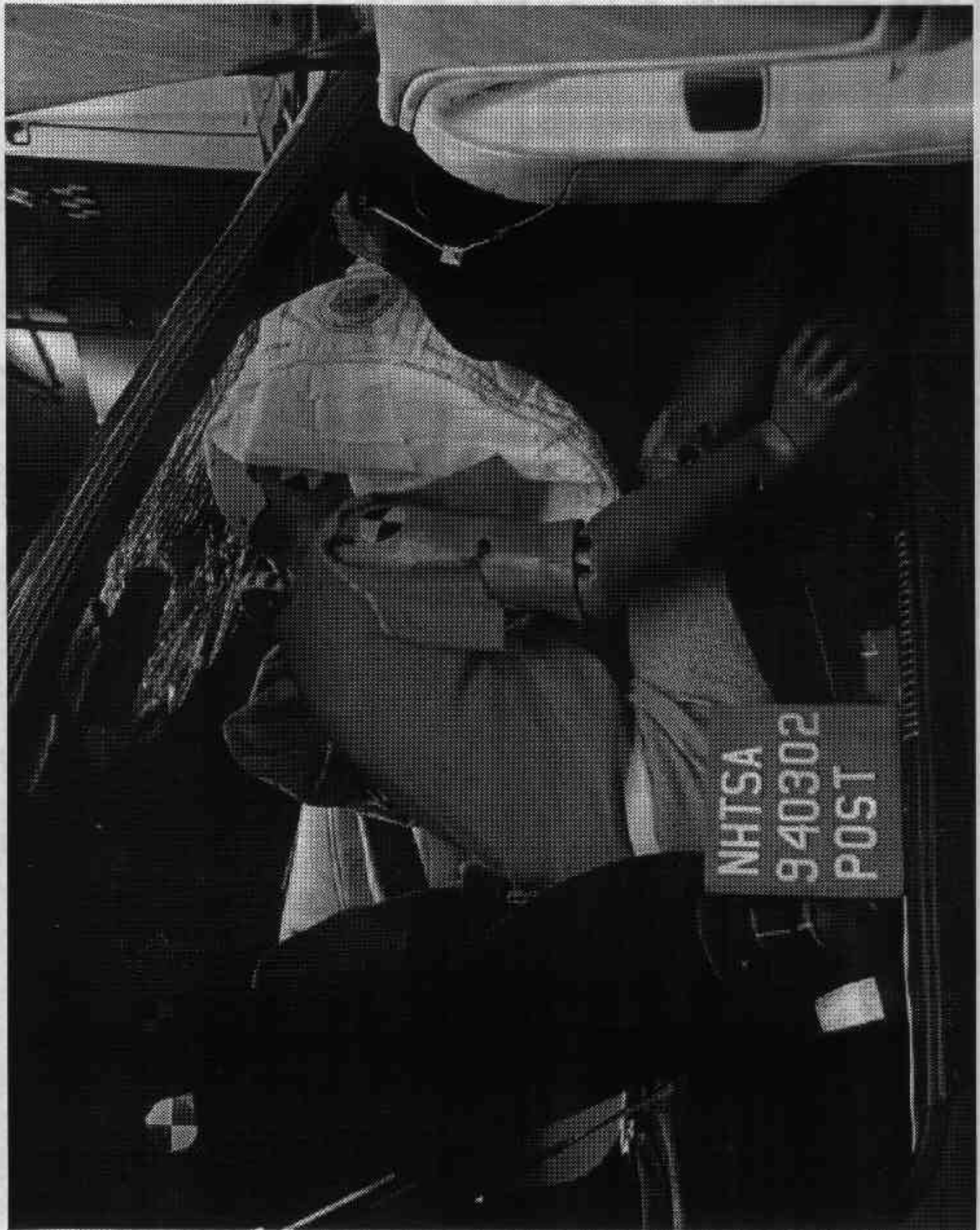

Figure A-46. Post-test Passenger Dummy & Vehicle Interior - View 1
A-47

940302

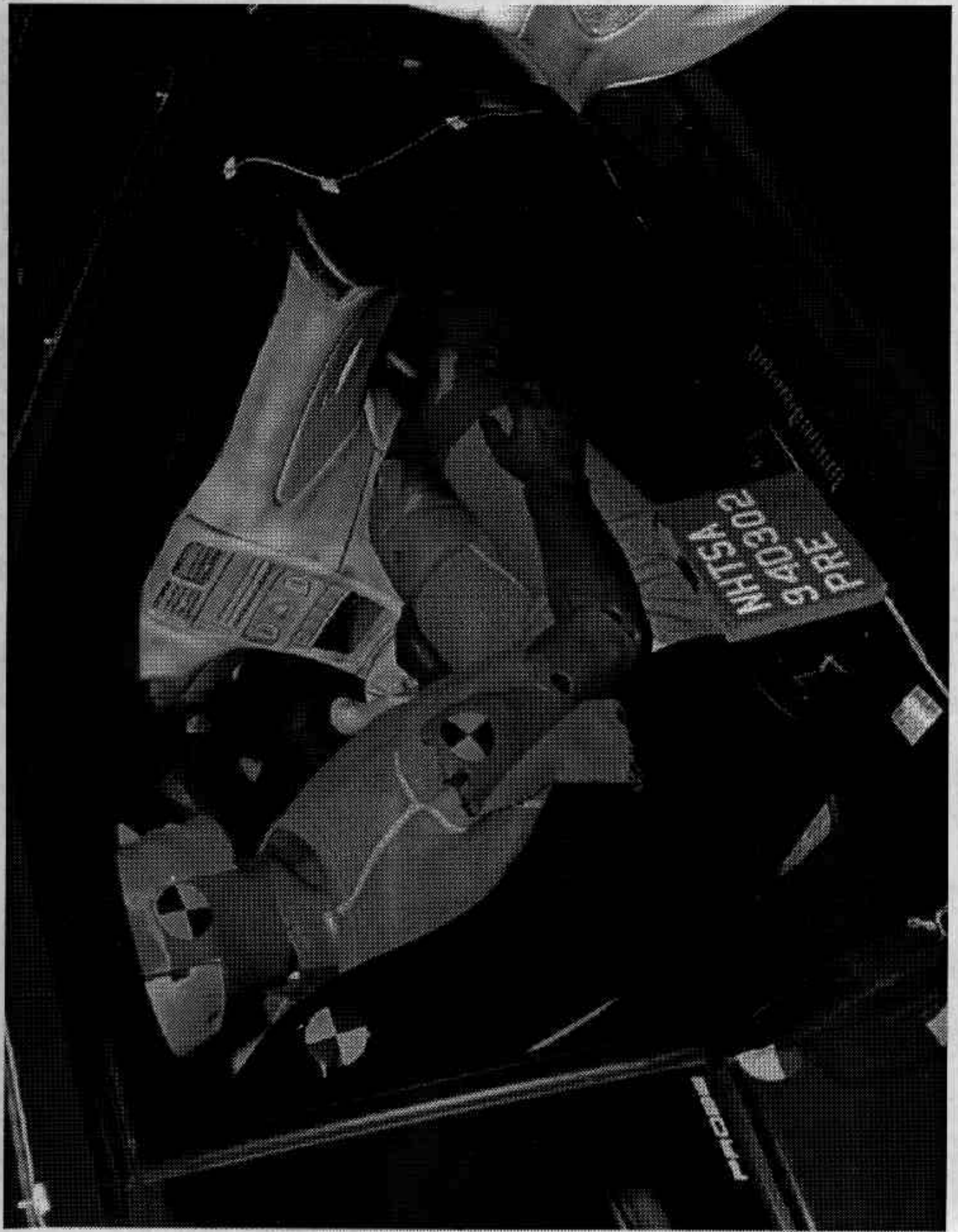

Figure A-47. Pre-test Passenger Dummy & Vehicle Interior - View 2

A-48

940302



Figure A-48. Post-test Passenger Dummy & Vehicle Interior - View 2

A-49

940302

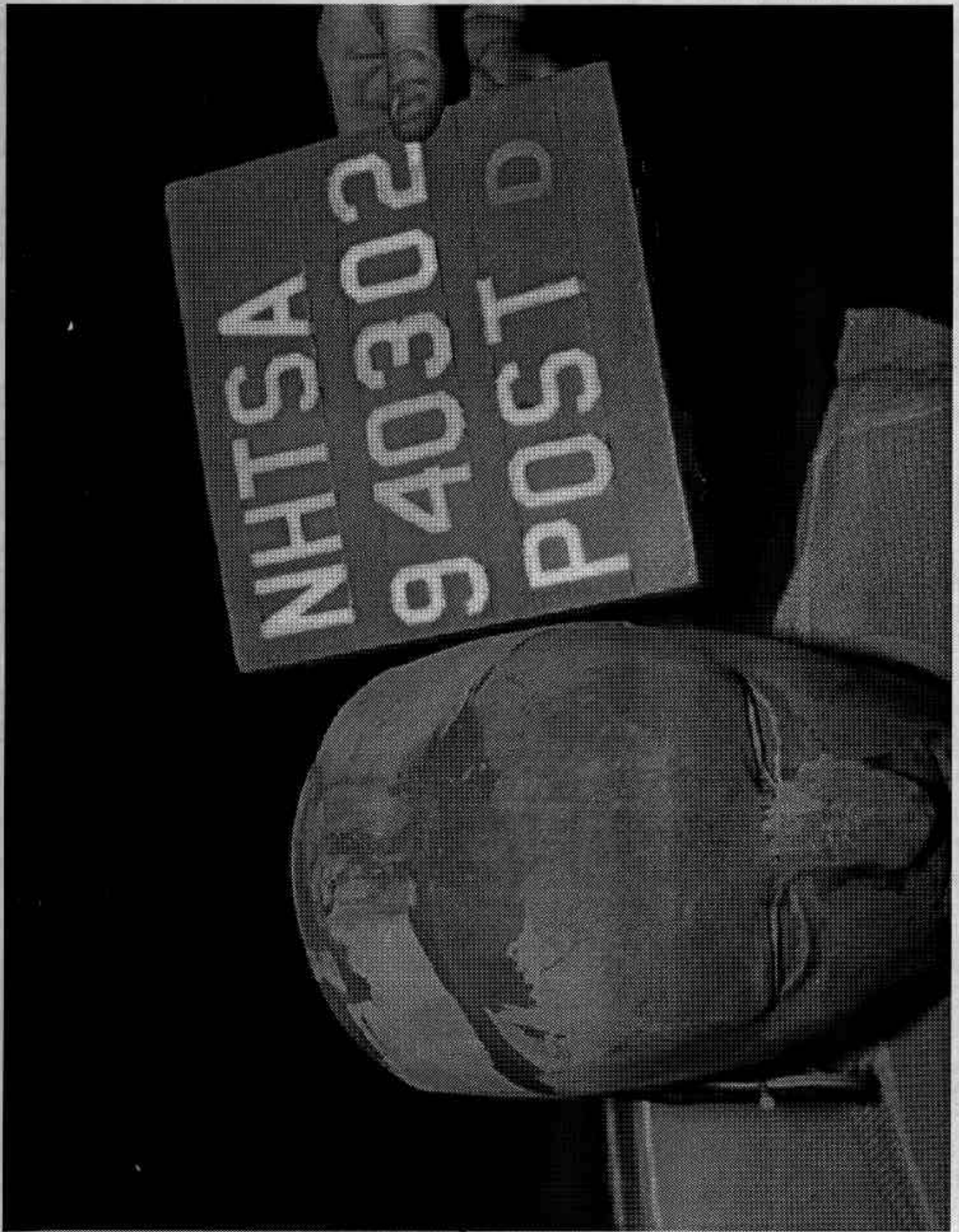

Figure A-49. Post-test Driver Dummy Head Contact - View 1

A-50

940302

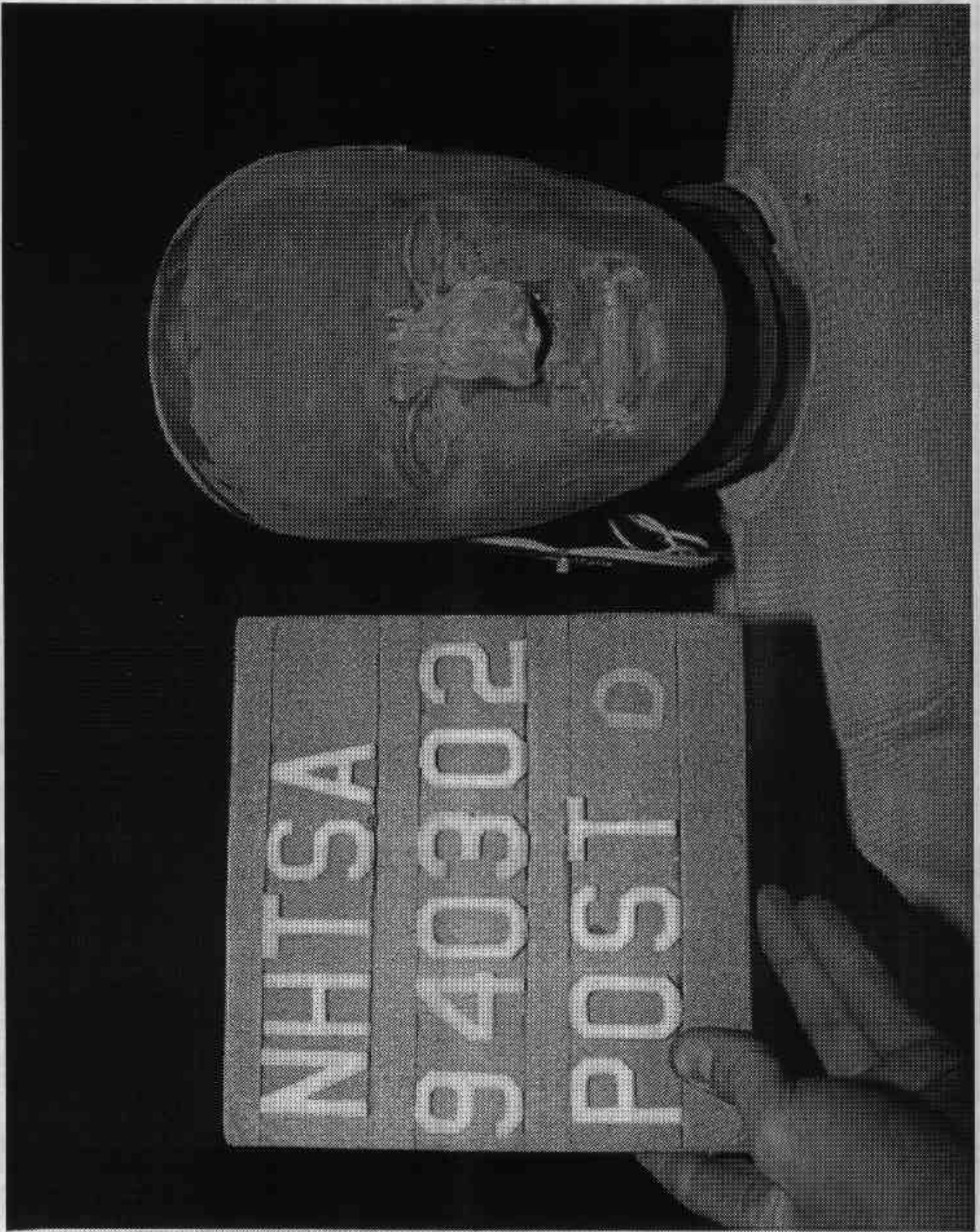

Figure A-50. Post-test Driver Dummy Head Contact - View 2
A-51

940302

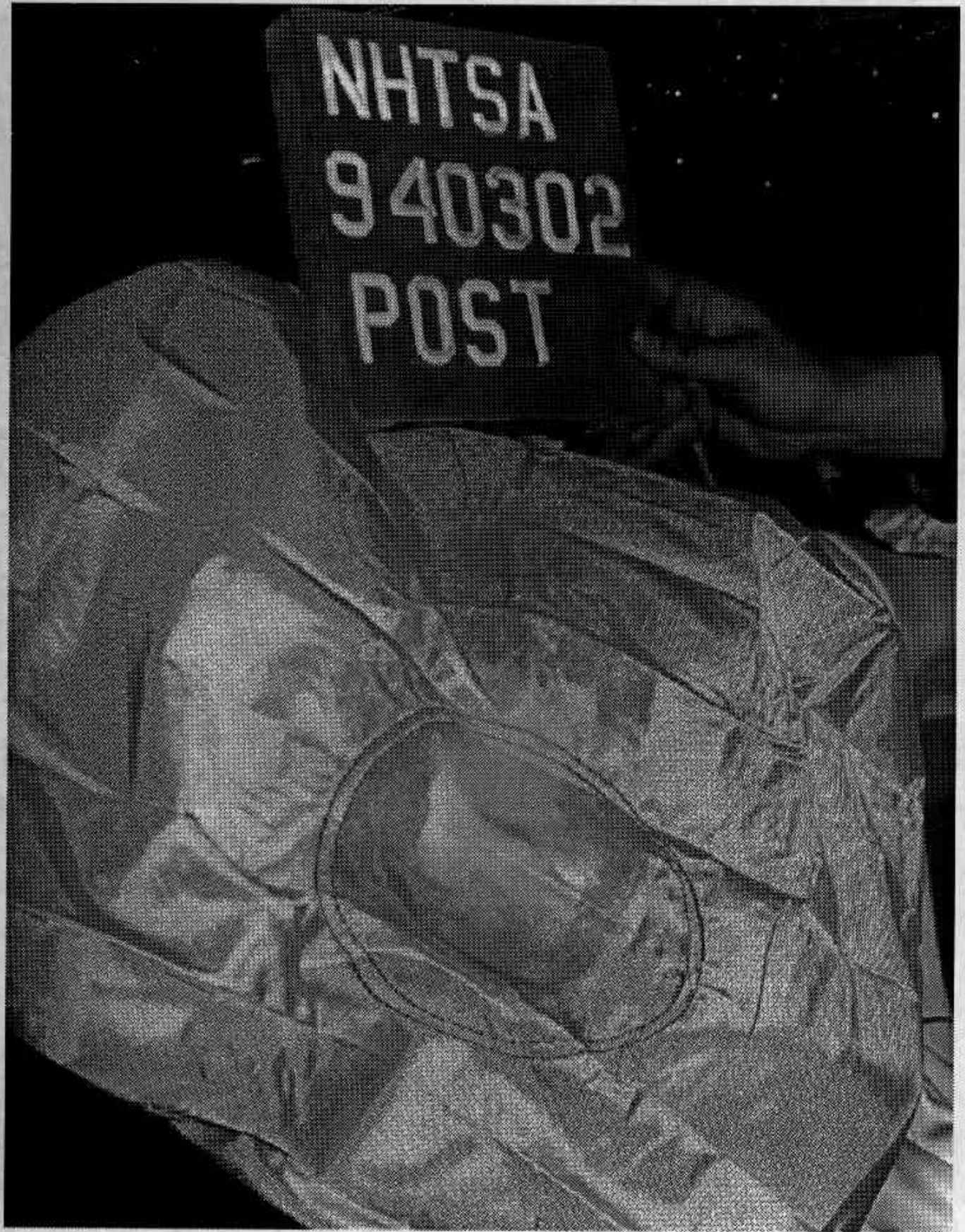

Figure A-51. Post-test Driver Dummy Head Contact - View 3

A-52

940302

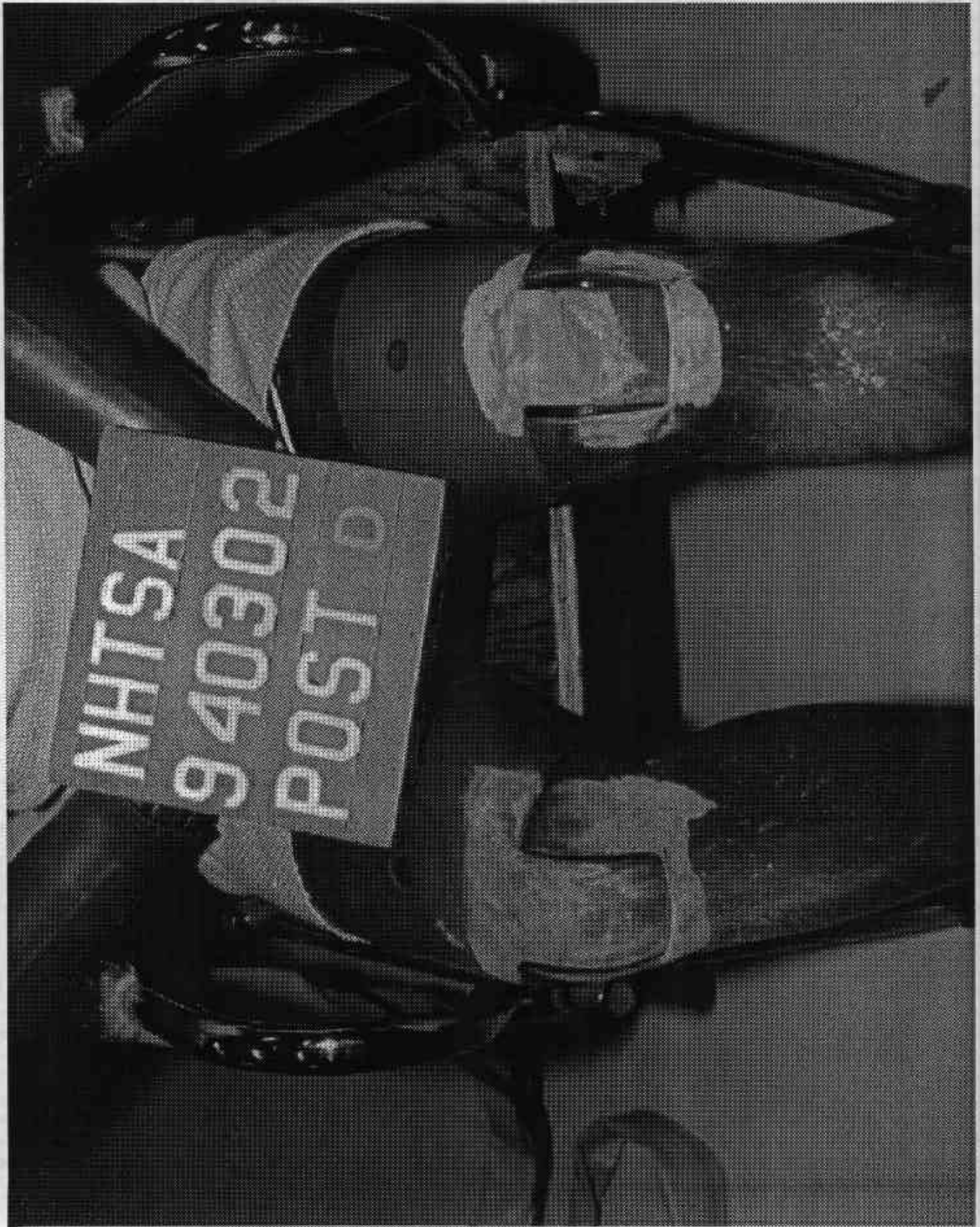

Figure A-52. Post-test Driver Dummy Knee Contact - View 1

A-53

940302

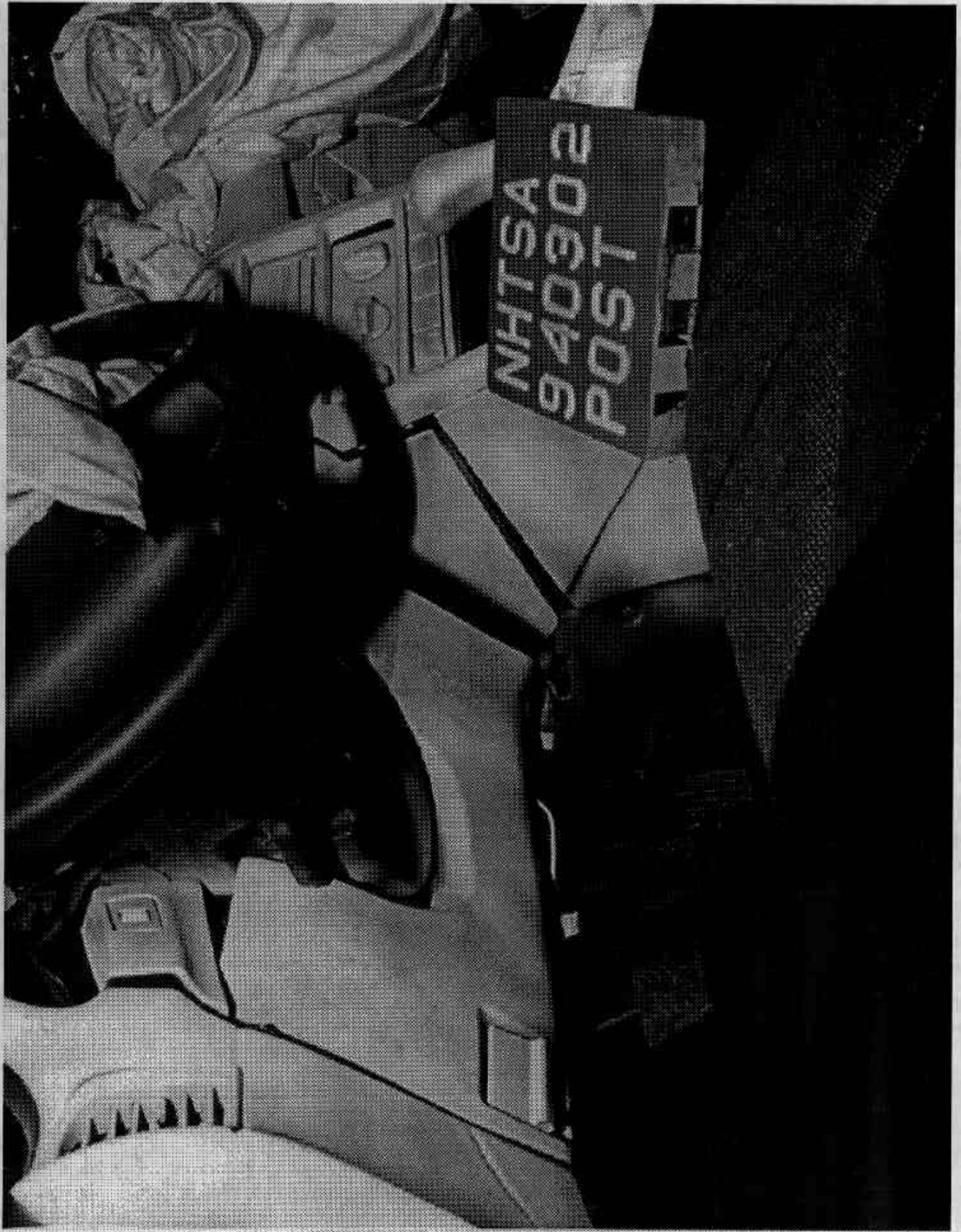

Figure A-53. Post-test Driver Dummy Knee Contact- View 2

A-54

940302

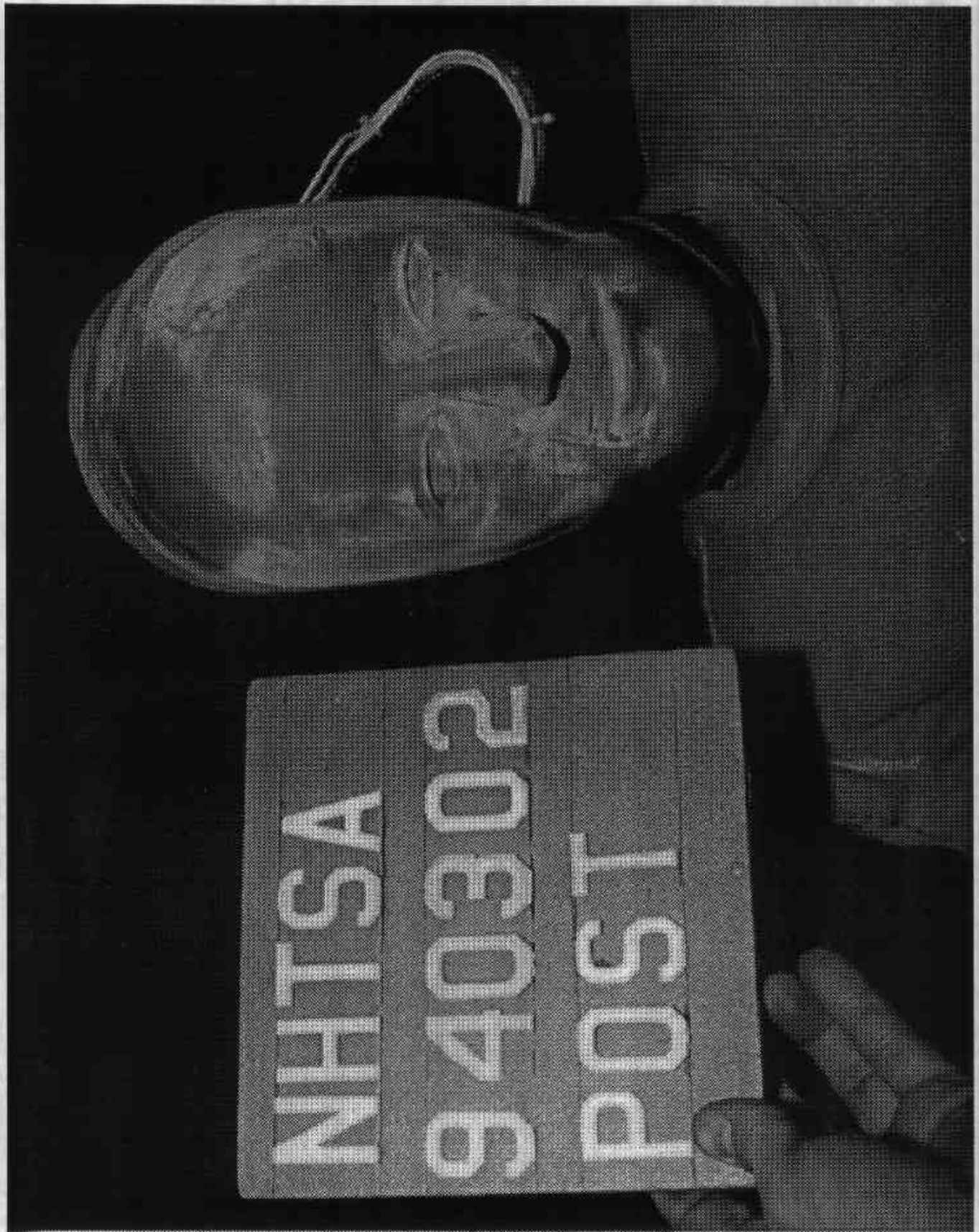

Figure A-54. Post-test Passenger Dummy Head Contact - View 1
A-55

940302

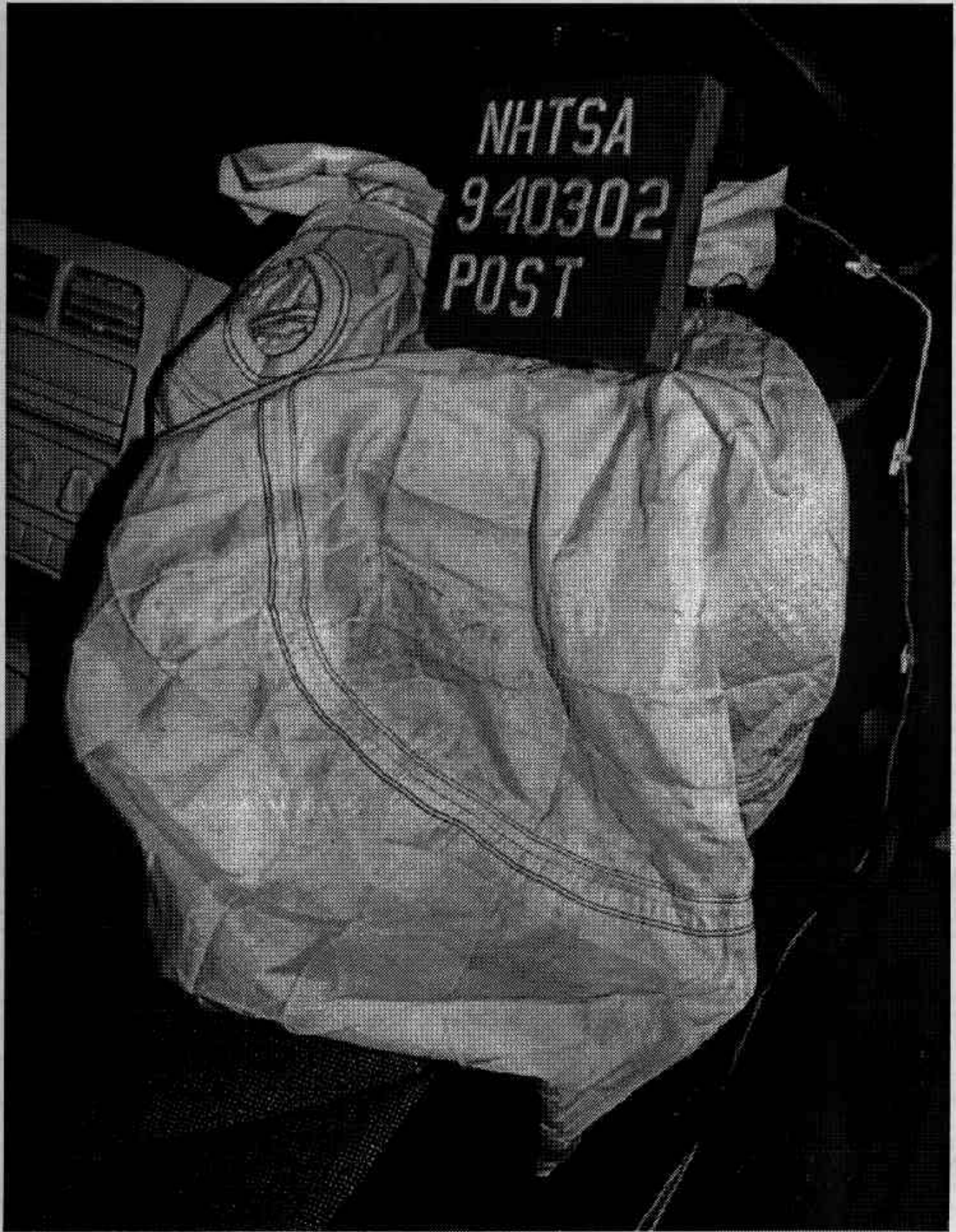

Figure A-55. Post-test Passenger Dummy Head Contact - View 2

A-56

940302

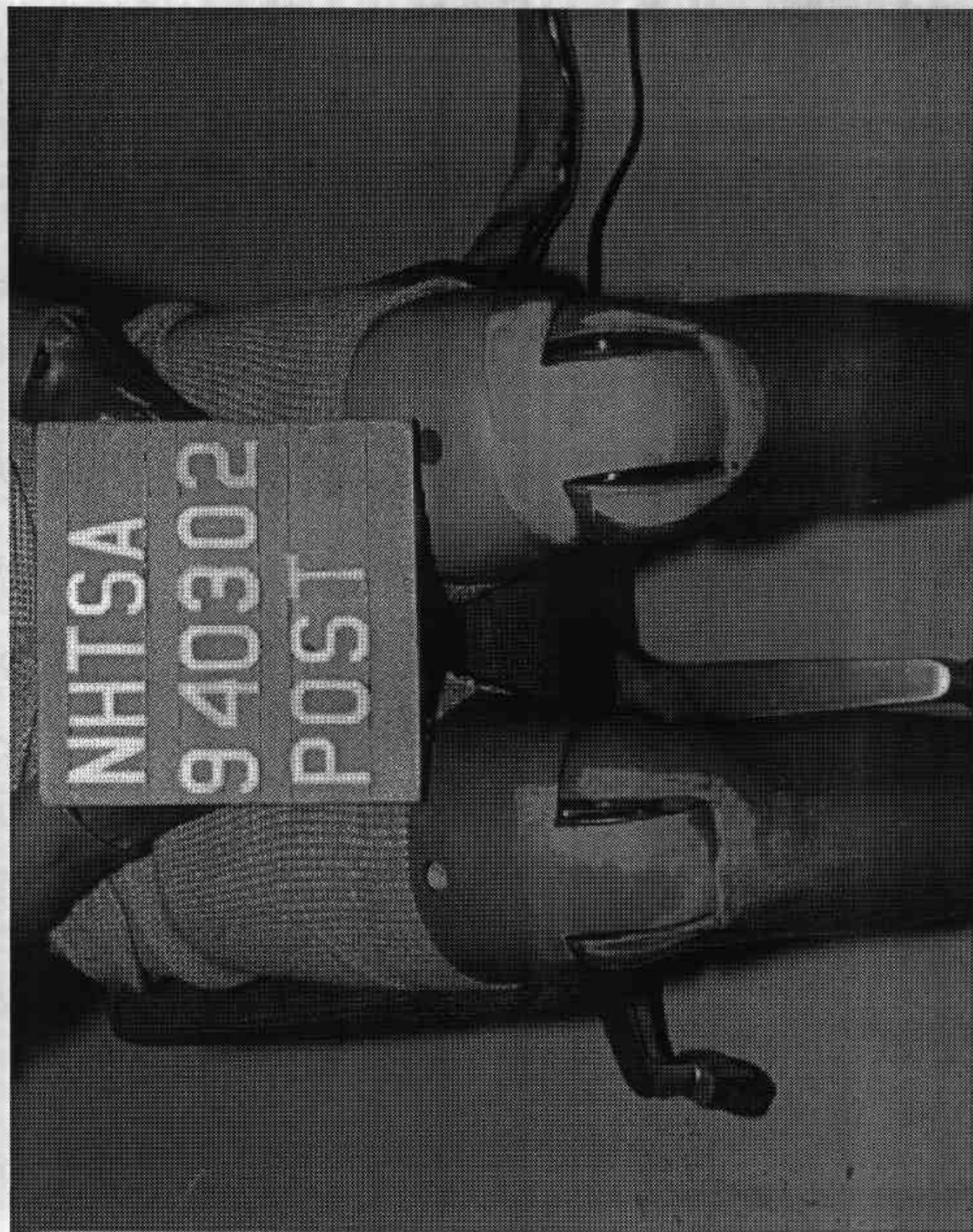

Figure A-56. Post-test Passenger Dummy Knee Contact - View 1
A-57

940302

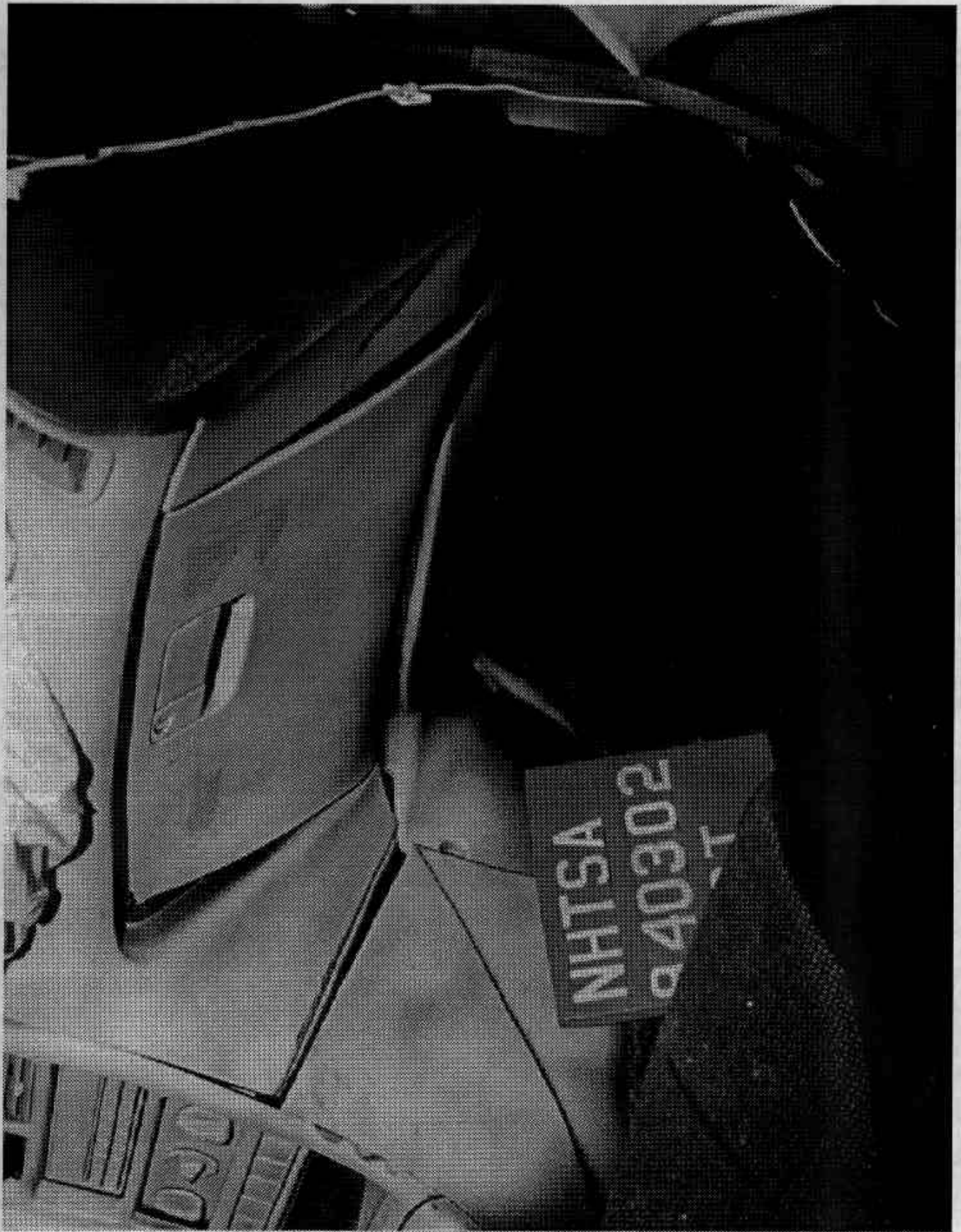

Figure A-57. Post-test Passenger Dummy Knee Contact - View 2

A-58

940302

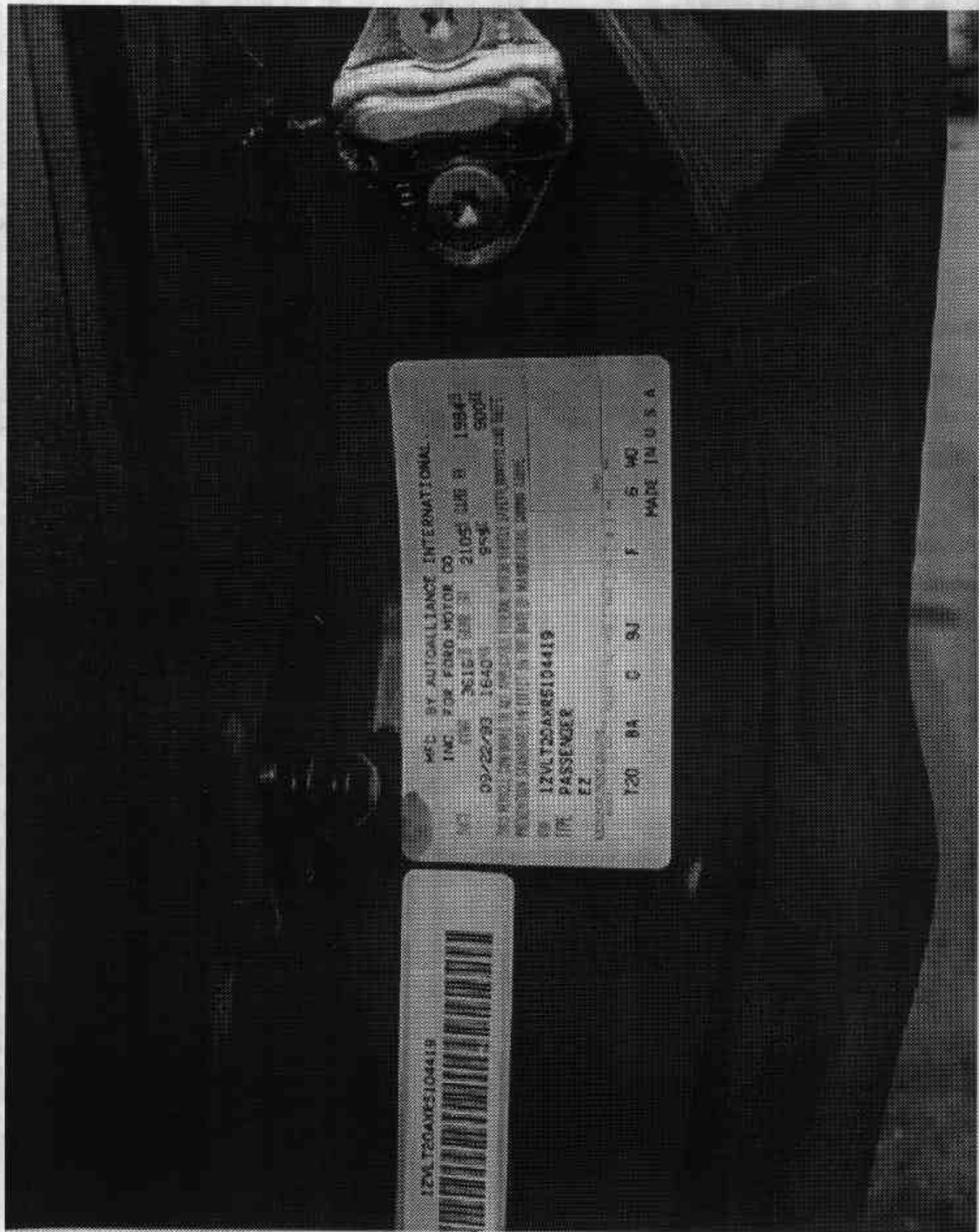

Figure A-58. Pre-test Vehicle Certification Label View
A-59

940302

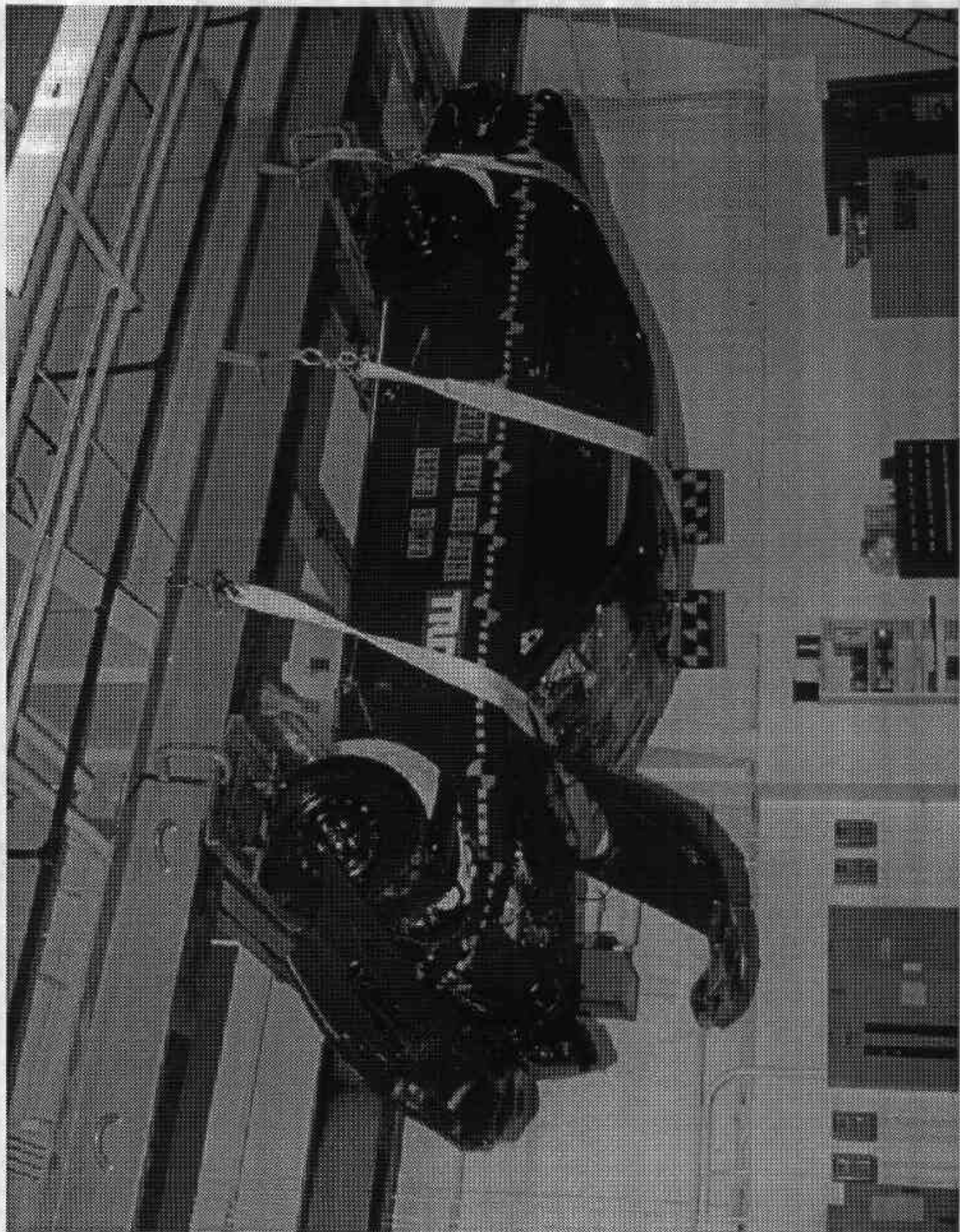

Figure A-60. Post-test Vehicle on Static Rollover Machine View
A-61

940302

Appendix B

Data Plots

1994 FORD PROBE INTO FLAT FRONTAL BARRIER
DRIVER HEAD X-AXIS ACCELERATION
208 COMPLIANCE TESTING CR0210

TEST NUMBER: 940302

TRC INC.

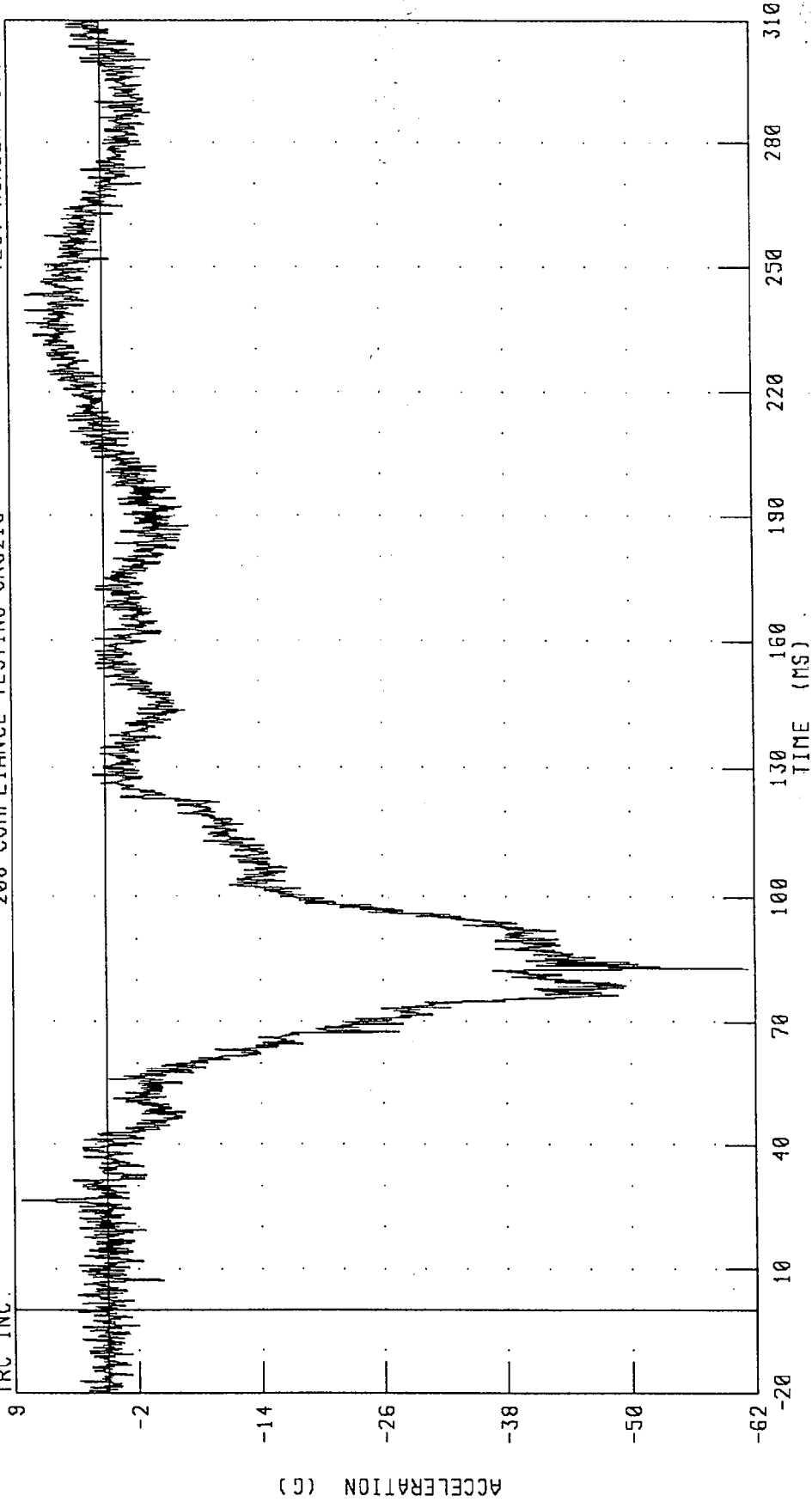

CHANNEL: HEDXG1 FILTER: CH. CLASS 1000

PEAK DATA: 8.33 G @ 26.40 MS; -62.13 G @ 82.96 MS

1984 FORD PROBE INTO FLAT FRONTAL BARRIER
DRIVER HEAD Y-AXIS ACCELERATION
208 COMPLIANCE TESTING CR0210

TEST NUMBER: 940302

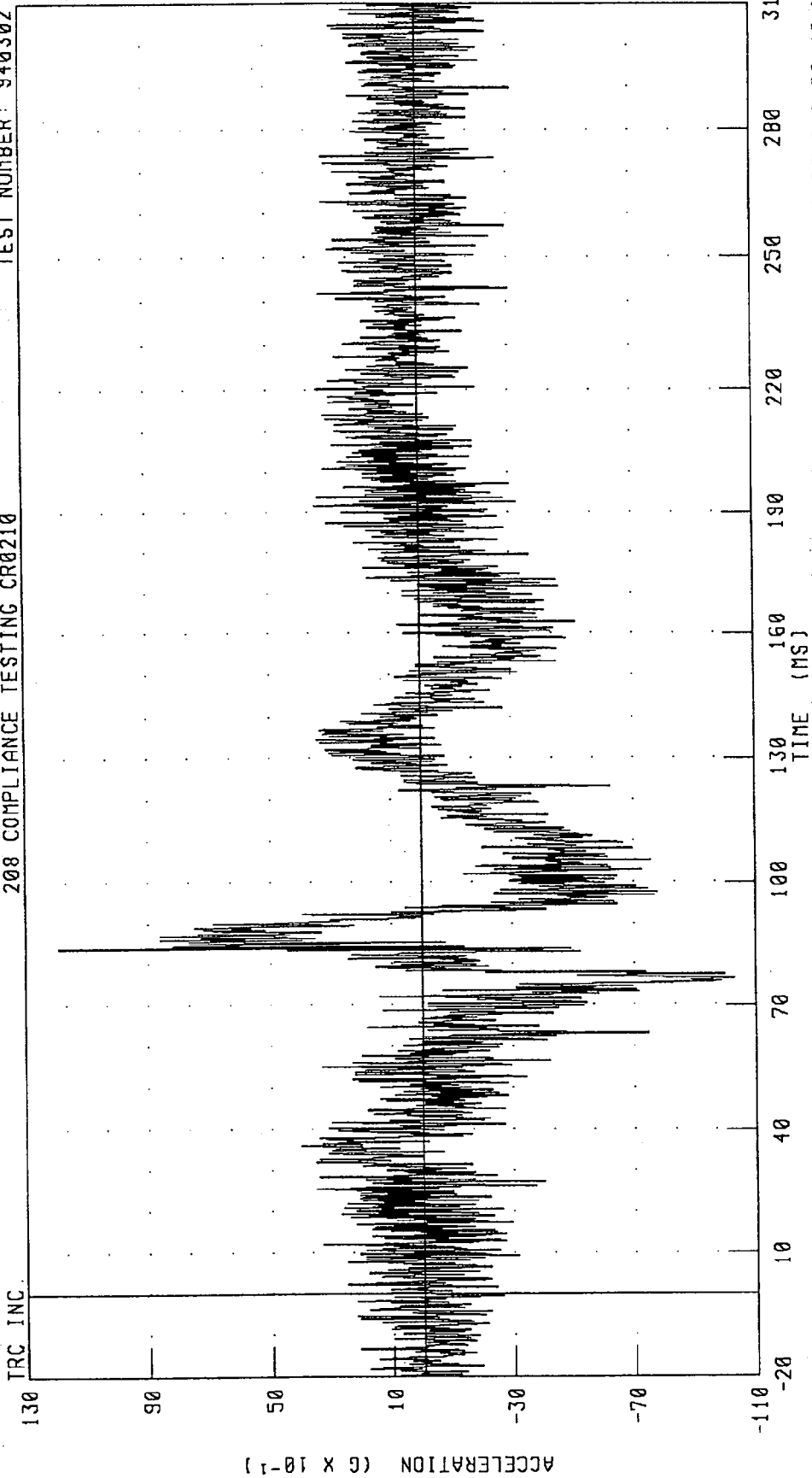

CHANNEL: HEDYGI FILTER: CH. CLASS 1000

1994 FORD PROBE INTO FLAT FRONTAL BARRIER
DRIVER HEAD Z-AXIS ACCELERATION
208 COMPLIANCE TESTING CR0210

TEST NUMBER: 940302

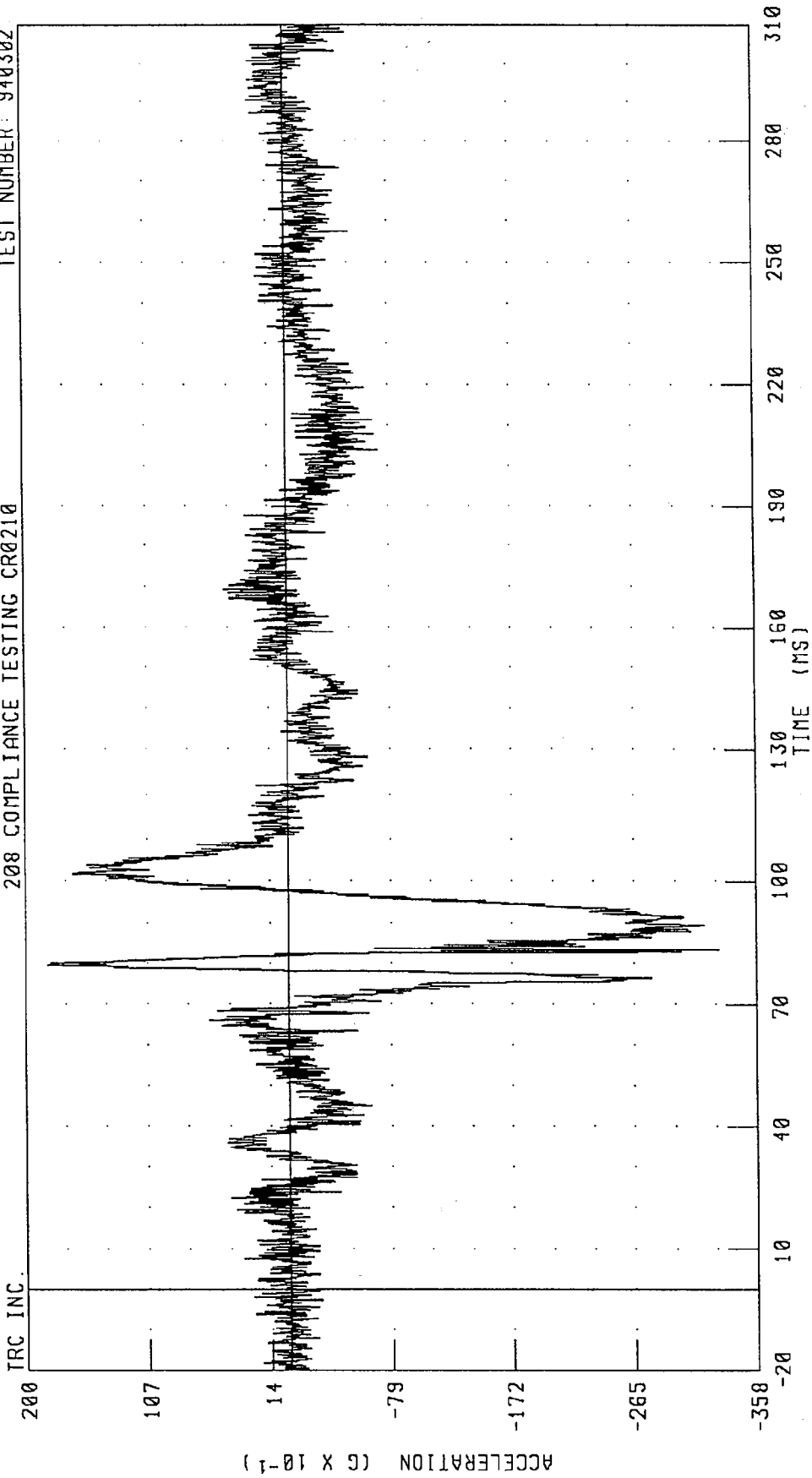

PEAK DATA: 18.30 G @ 79.60 MS; -32.97 G @ 83.36 MS

CHANNEL: HEDZG1 FILTER: CH. CLASS 1000

1994 FORD PROBE INTO FLAT FRONTAL BARRIER
DRIVER HEAD RESULTANT ACCELERATION
208 COMPLIANCE TESTING CR0210

TEST NUMBER: 940302

TRC INC.

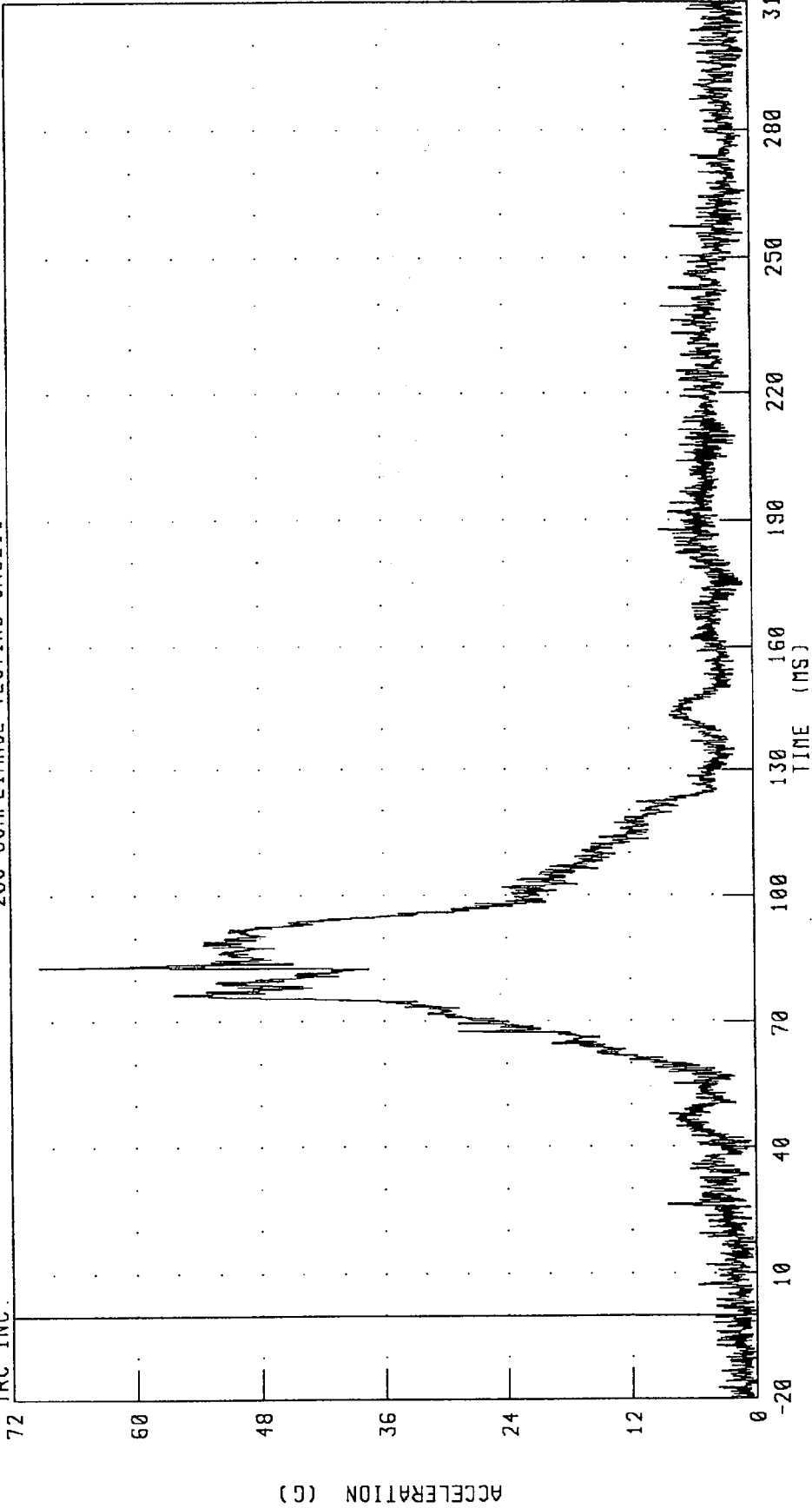

CHANNEL: HEDRG1 FILTER: CH. CLASS 1000

PEAK DATA: 69.22 G @ 82.96 MS; 0.10 G @ 17.28 MS

1994 FORD PROBE INTO FLAT FRONTAL BARRIER
DRIVER CHEST X-AXIS ACCELERATION
208 COMPLIANCE TESTING CR0210

TEST NUMBER: 940302

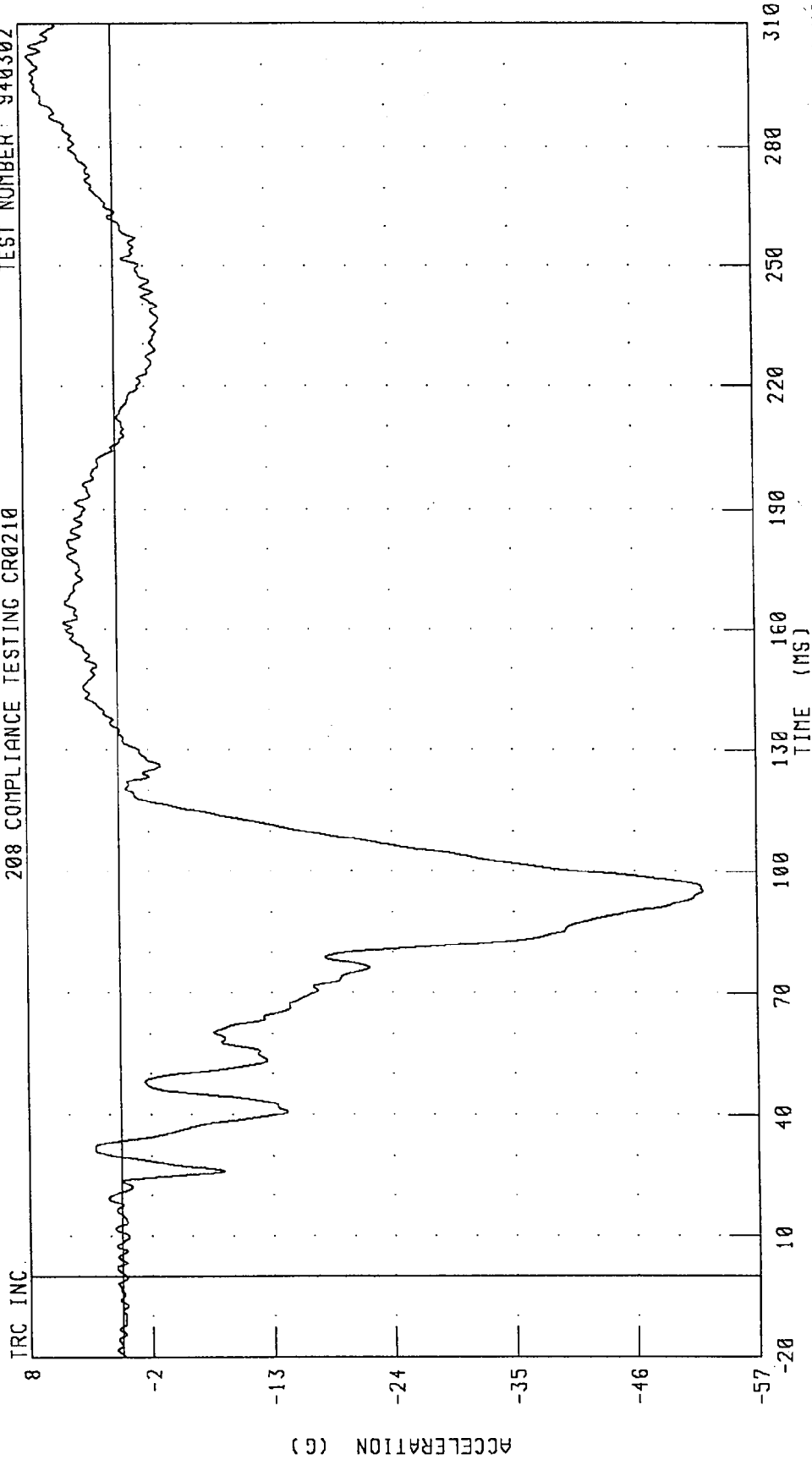

CHANNEL: CSTXG1 FILTER: CH. CLASS 180 PEAK DATA: 7.62 G @ 302.00 MS; -52.83 G @ 95.04 MS

1994 FORD PROBE INTO FLAT FRONTAL BARRIER
DRIVER CHEST Y-AXIS ACCELERATION
208 COMPLIANCE TESTING CR0210

TEST NUMBER: 940302

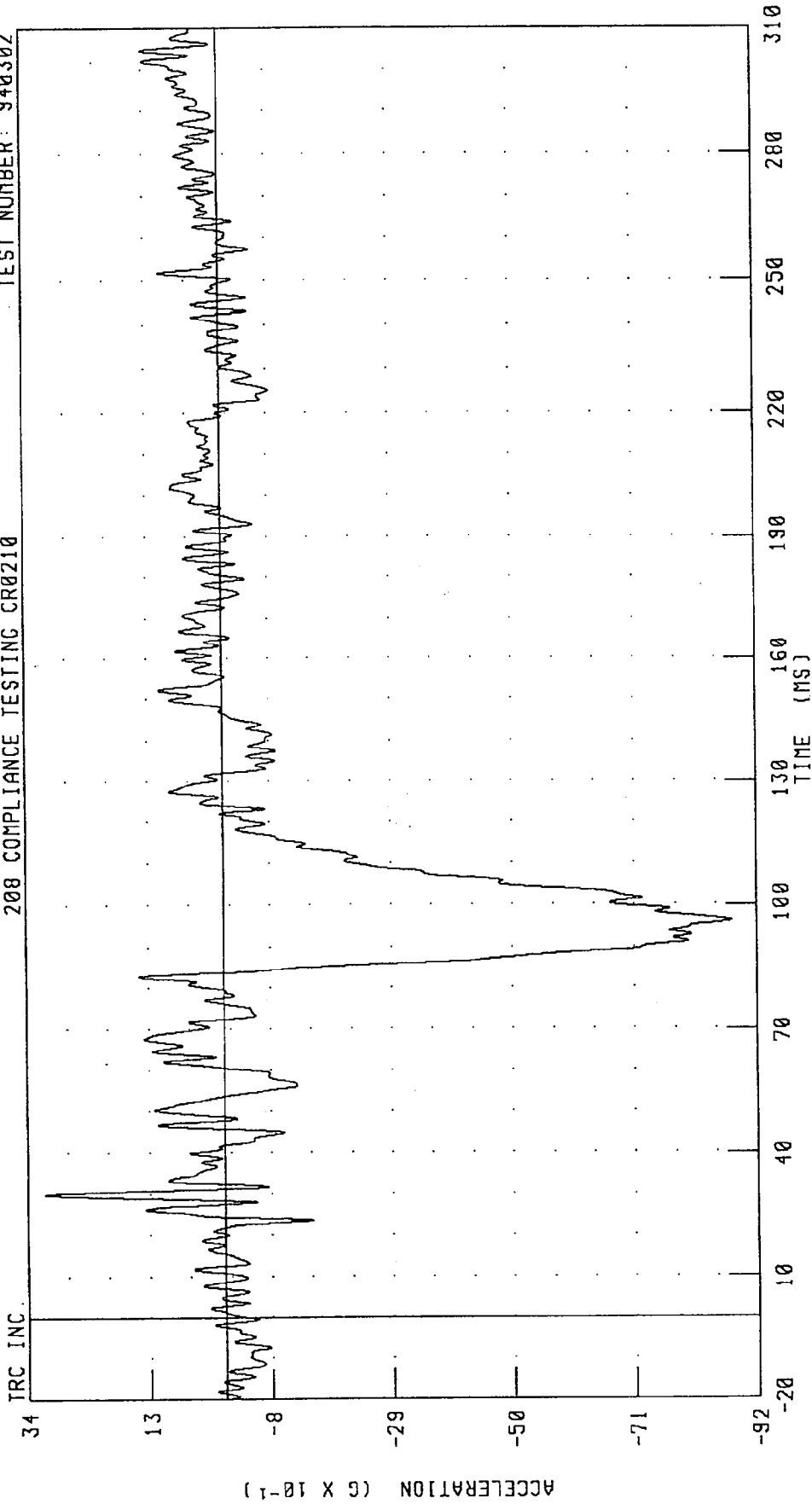

PEAK DATA: 3.10 G @ 30.00 MS; -8.77 G @ 96.16 MS

CHANNEL: CSTYG1 FILTER: CH. CLASS 180

1994 FORD PROBE INTO FLAT FRONTAL BARRIER
DRIVER CHEST Z-AXIS ACCELERATION
208 COMPLIANCE TESTING CR0210

TEST NUMBER: 940302

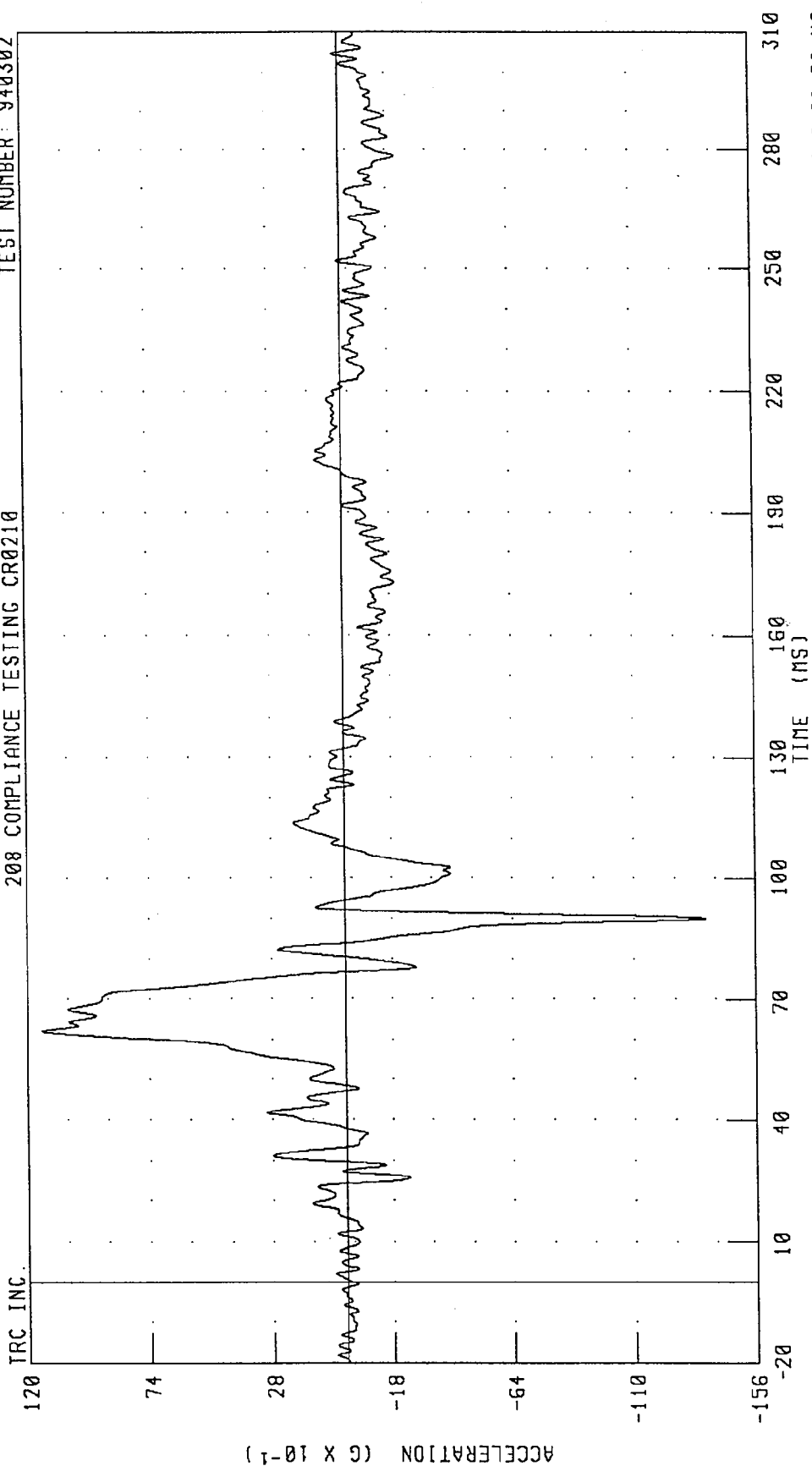

CHANNEL: CSTZG1 FILTER: CH. CLASS 180

PEAK DATA: 11.46 G @ 62.16 MS; -13.70 G @ 90.00 MS

1984 FORD PROBE INTO FLAT FRONTAL BARRIER
DRIVER CHEST RESULTANT ACCELERATION
208 COMPLIANCE TESTING CR0210

TEST NUMBER: 940302

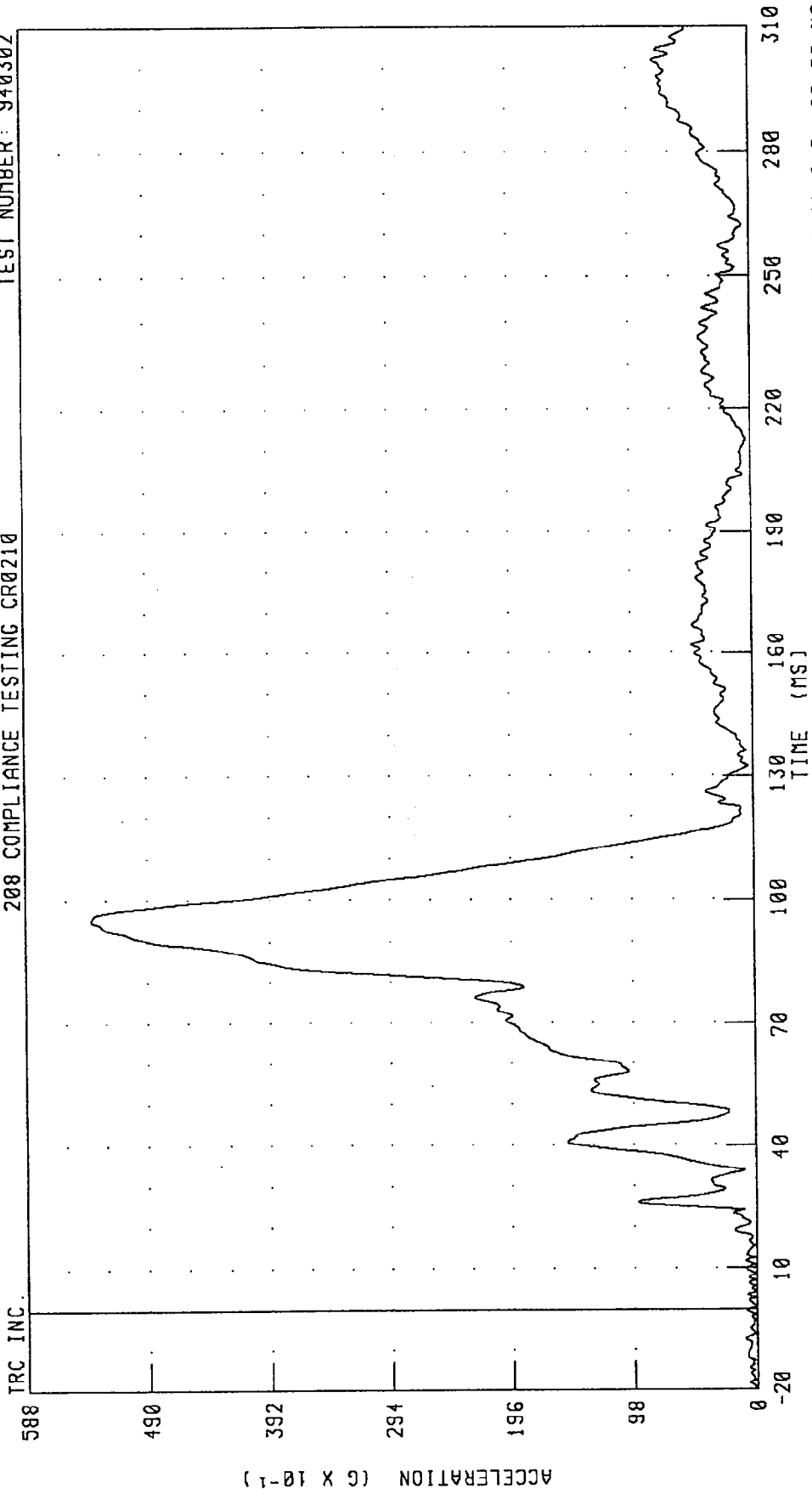

PEAK DATA: 53.46 G @ 95.12 MS; 0.01 G @ -20.00 MS

CHANNEL: CSTRG1 FILTER: CH. CLASS 180

1994 FORD PROBE INTO FLAT FRONTAL BARRIER
DRIVER LEFT FEMUR FORCE
208 COMPLIANCE TESTING CR0210

TEST NUMBER: 940302

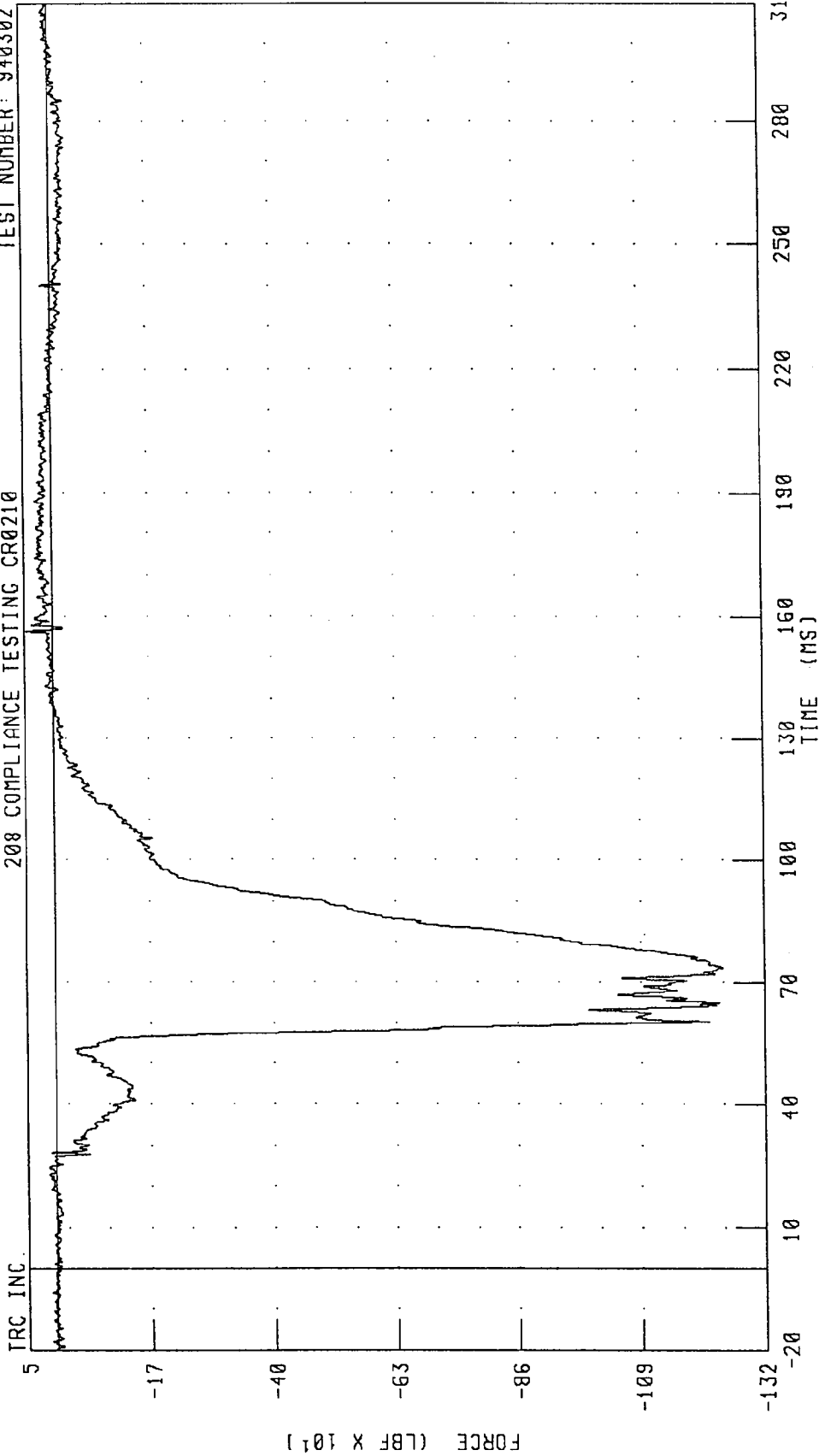

CHANNEL: LFMFI FILTER: CH. CLASS 600
PEAK DATA: 49.26 LBF @ 156.32 MS; -1248.18 LBF @ 73.68 MS

1994 FORD PROBE INTO FLAT FRONTAL BARRIER
DRIVER RIGHT FEMUR FORCE
208 COMPLIANCE TESTING CR0210

TEST NUMBER: 940302

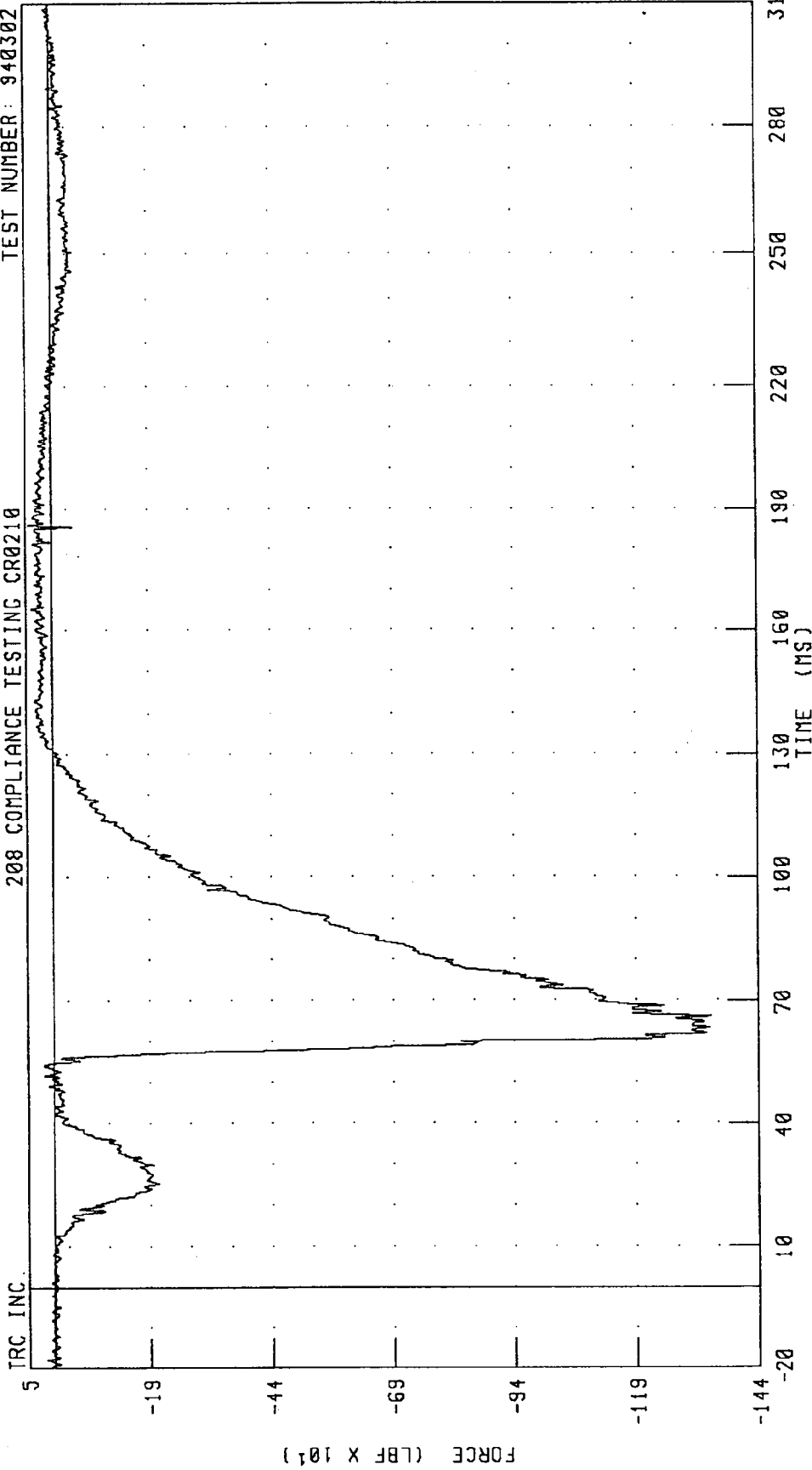

CHANNEL: RFMFI FILTER: CH. CLASS 600
PEAK DATA: 48.59 LBF @ 186.08 MS; -1349.18 LBF @ 66.08 MS

1994 FORD PROBE INTO FLAT FRONTAL BARRIER
RIGHT FRONT PASSENGER HEAD X-AXIS ACCELERATION
208 COMPLIANCE TESTING CR0210

TEST NUMBER: 940302

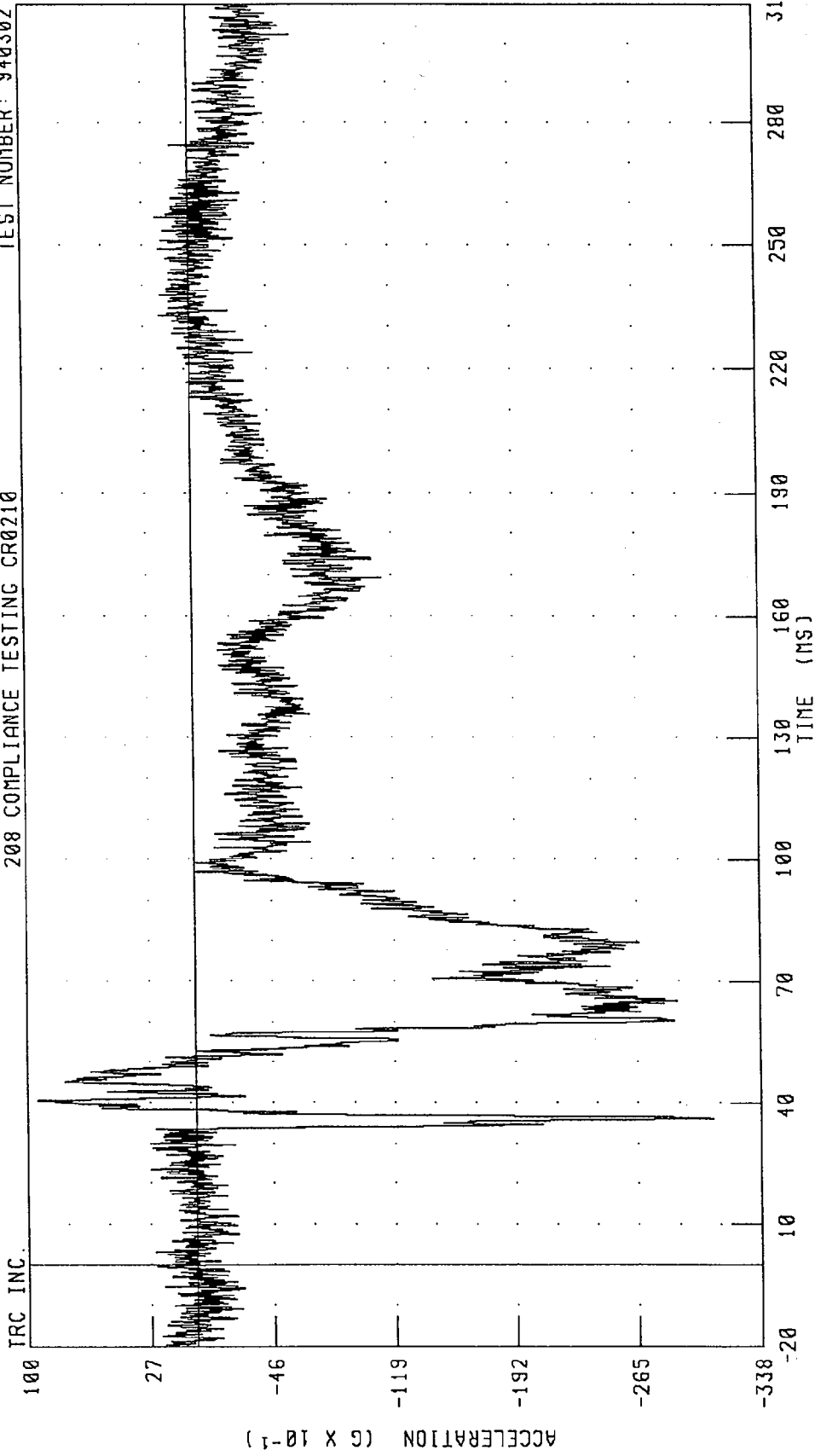

CHANNEL: HEDXG2 FILTER: CH. CLASS 1000

PEAK DATA: 9.38 G @ 40.64 MS; -30.95 G @ 36.24 MS

1994 FORD PROBE INTO FLAT FRONTAL BARRIER
RIGHT FRONT PASSENGER HEAD Y-AXIS ACCELERATION
200 COMPLIANCE TESTING CR0210

TEST NUMBER: 940302

TRC INC.

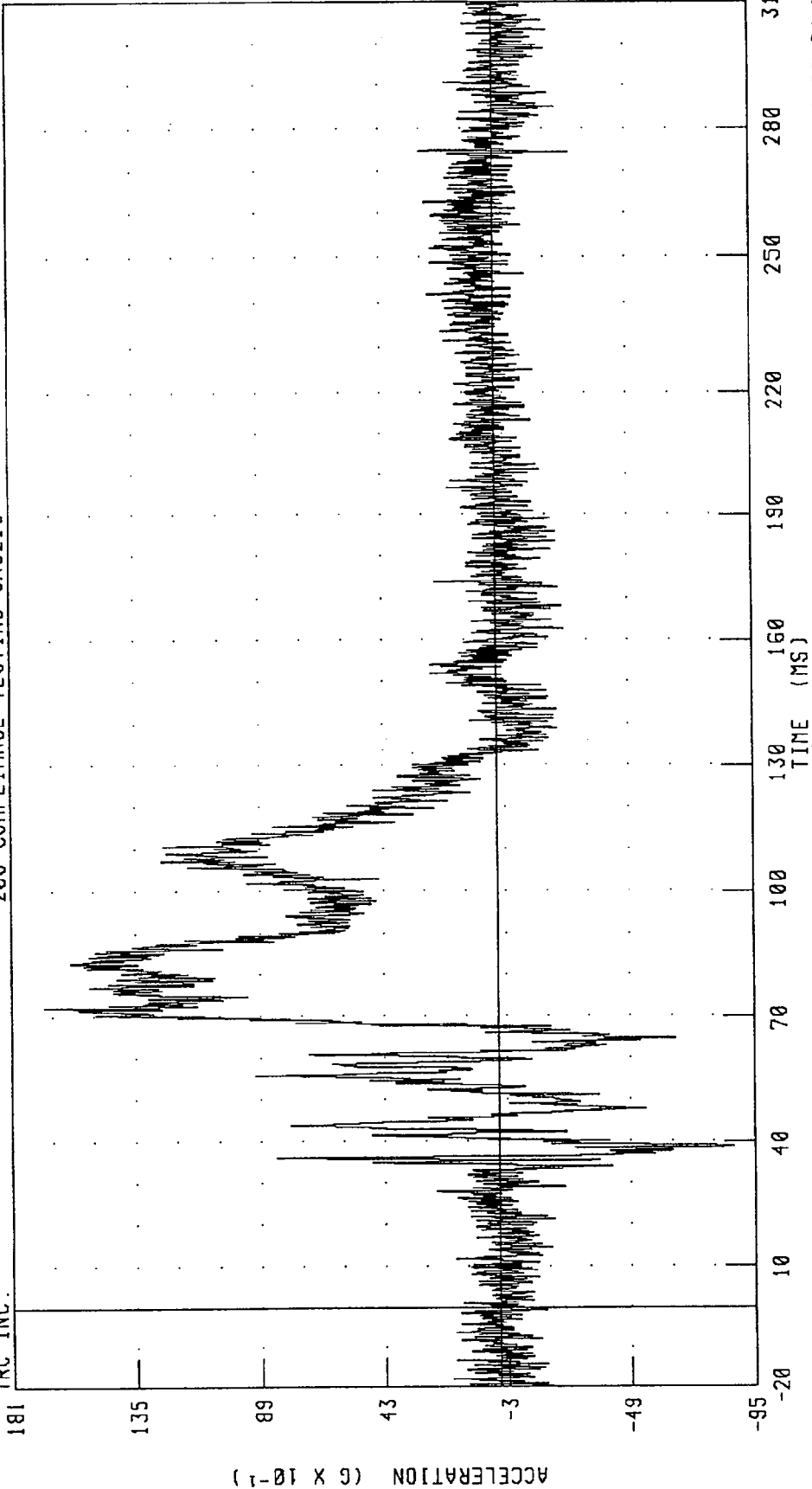

PEAK DATA: 16.86 G @ 72.24 MS; -8.72 G @ 39.04 MS

CHANNEL: HEDYG2 FILTER: CH. CLASS 1000

1984 FORD PROBE INTO FLAT FRONTAL BARRIER
RIGHT FRONT PASSENGER HEAD Z-AXIS ACCELERATION
208 COMPLIANCE TESTING CR0210

TEST NUMBER: 940302

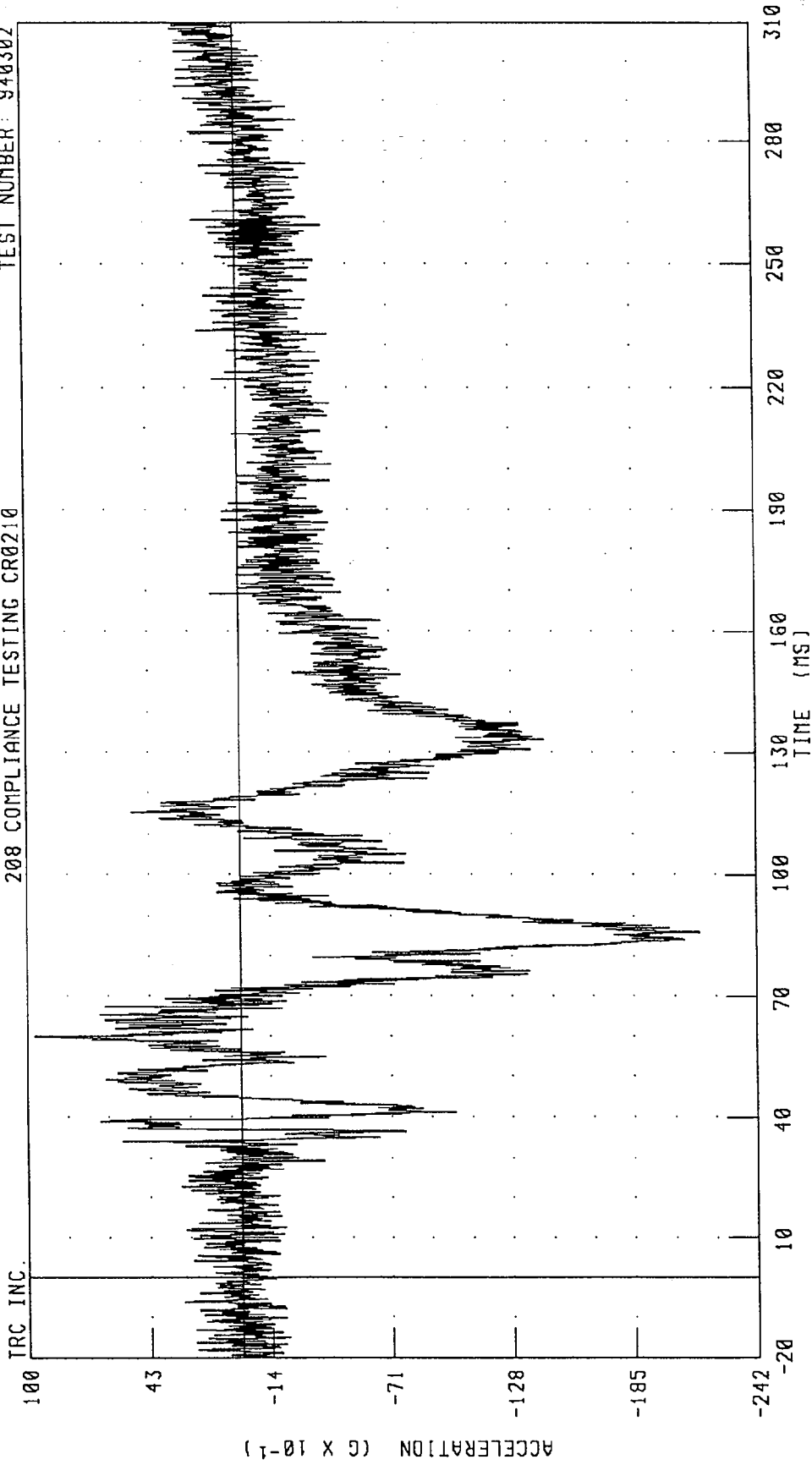

CHANNEL: HEDZG2 FILTER: CH. CLASS 1000 PEAK DATA: 9.64 G @ 59.92 MS; -21.55 G @ 86.08 MS

1994 FORD PROBE INTO FLAT FRONTAL BARRIER
RIGHT FRONT PASSENGER HEAD RESULTANT ACCELERATION
208 COMPLIANCE TESTING CR0210

TEST NUMBER: 940302

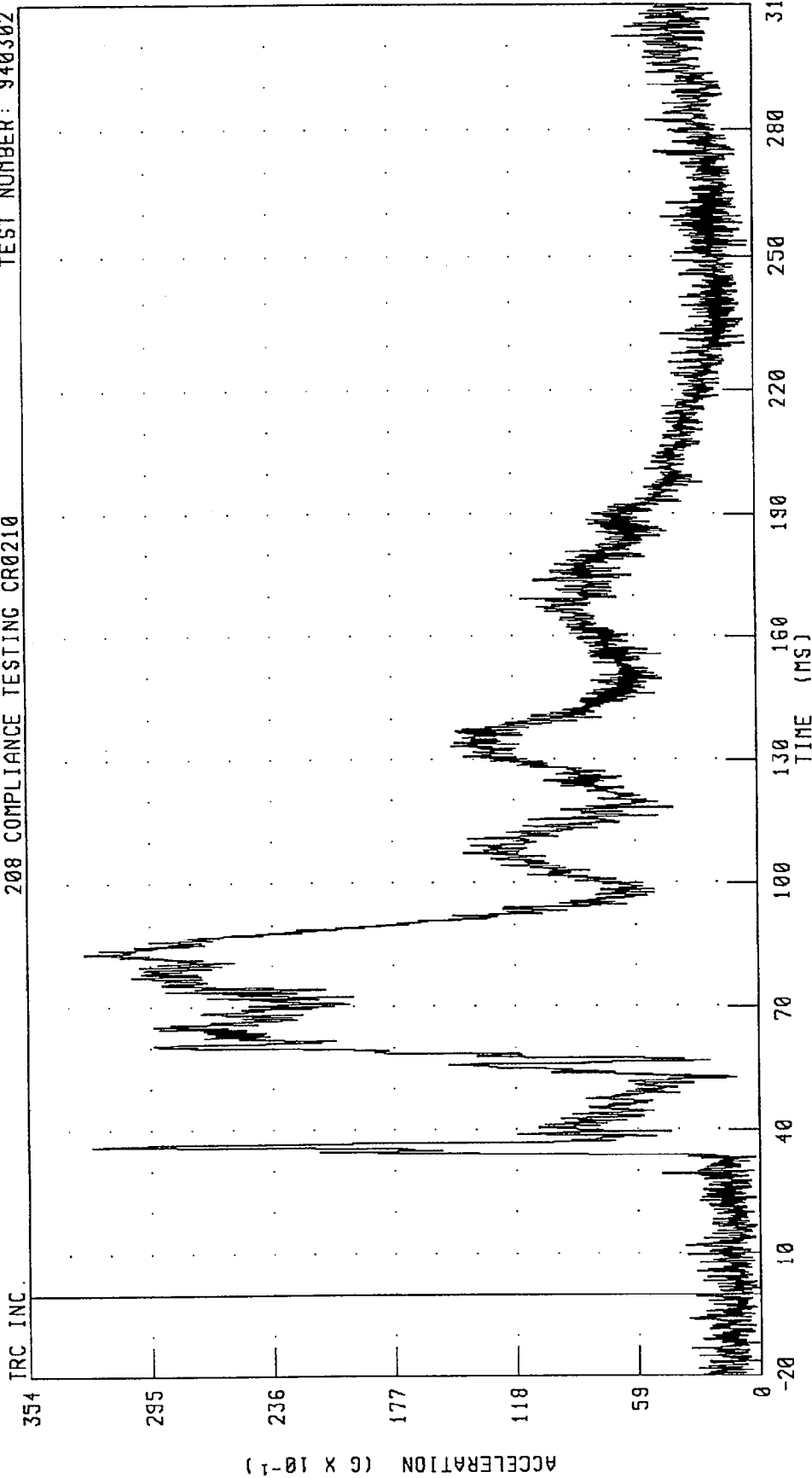

1984 FORD PROBE INTO FLAT FRONTAL BARRIER
RIGHT FRONT PASSENGER CHEST X-AXIS ACCELERATION
208 COMPLIANCE TESTING CR0210

TEST NUMBER: 940302

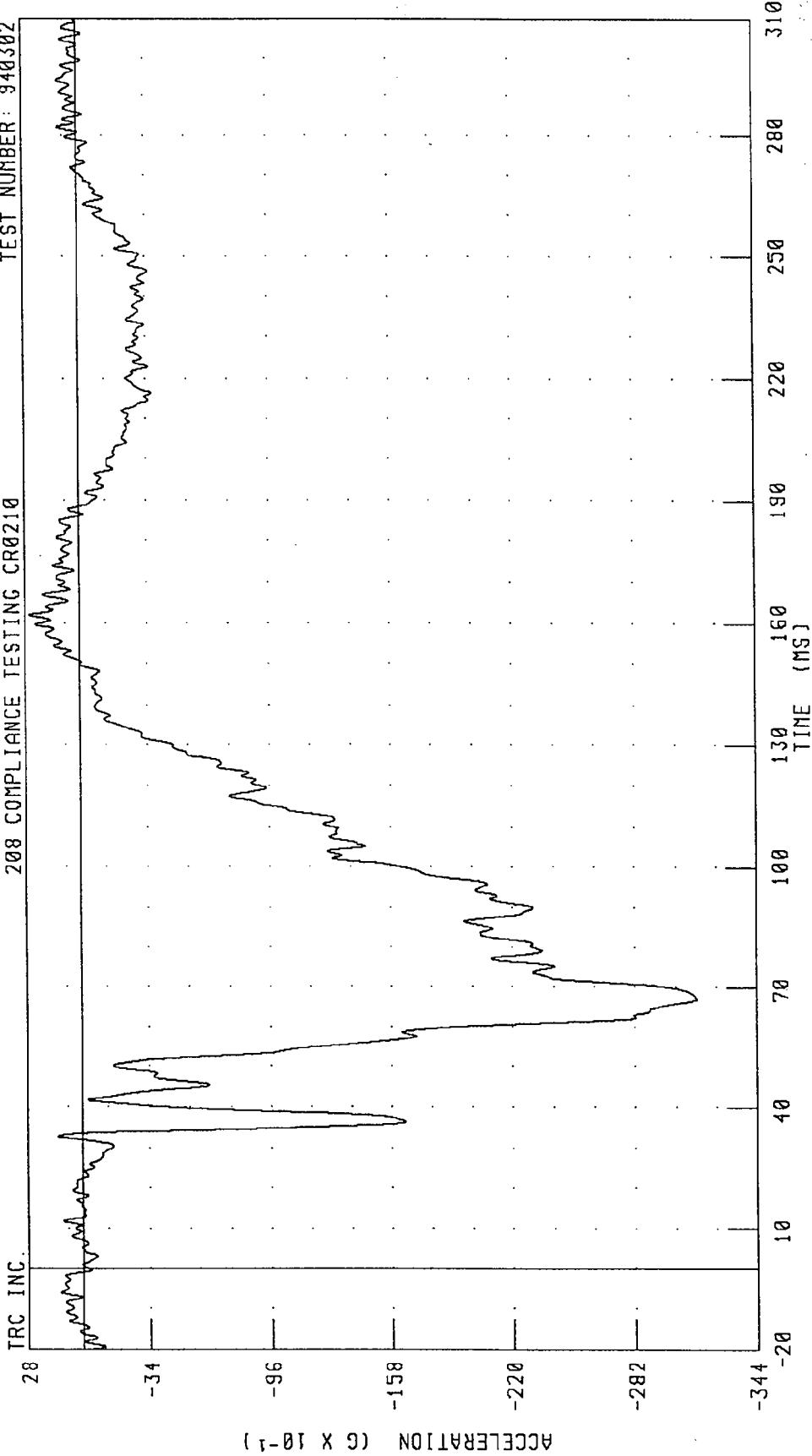

CHANNEL: CSTXG2 FILTER: CH. CLASS 180
PEAK DATA: 2.57 G @ 162.00 MS; -31.35 G @ 66.96 MS

1994 FORD PROBE INTO FLAT FRONTAL BARRIER
RIGHT FRONT PASSENGER CHEST Y-AXIS ACCELERATION
208 COMPLIANCE TESTING CR0210

TEST NUMBER: 940302

TRC INC.

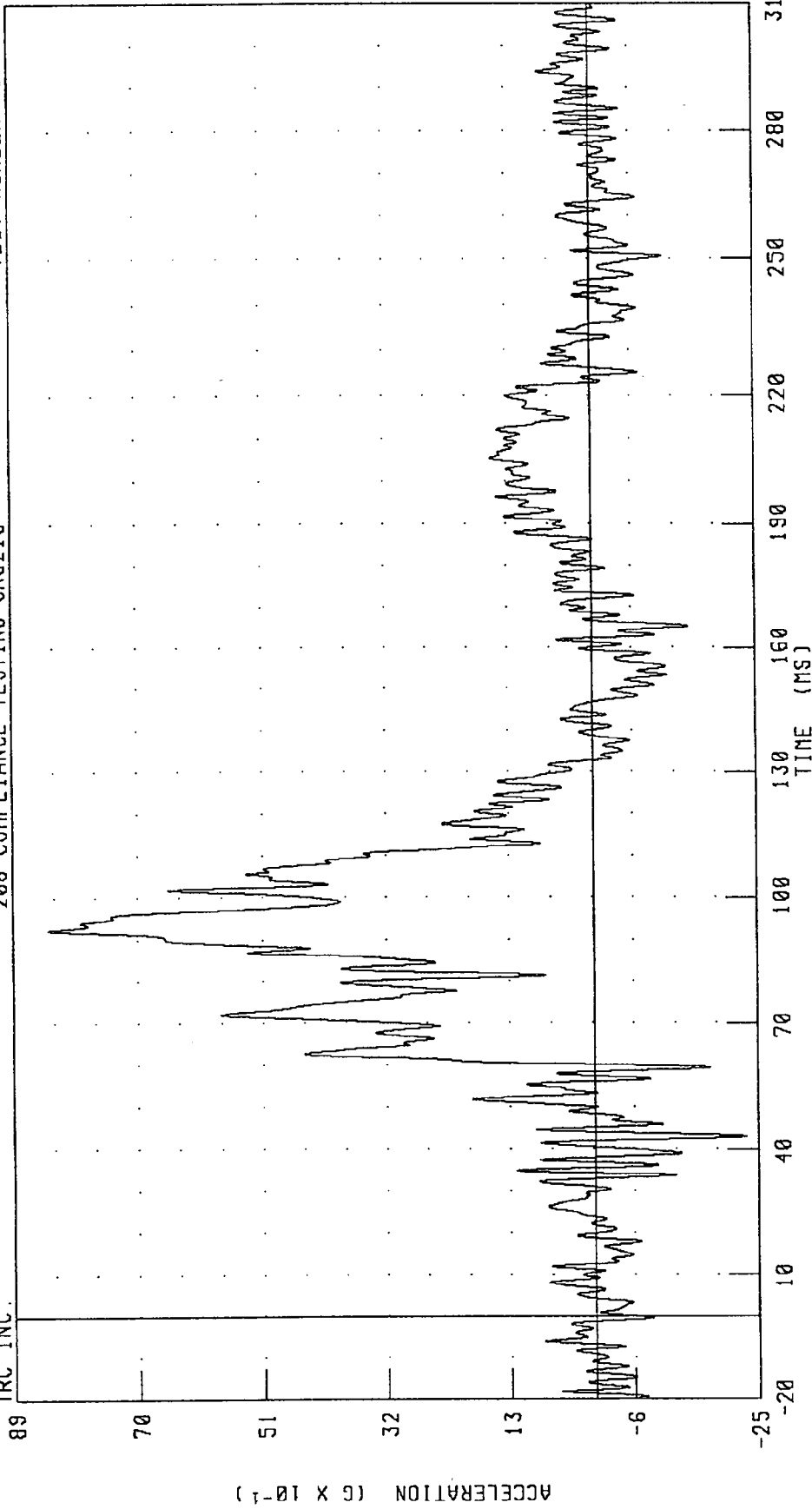

PEAK DATA: 8.37 G @ 92.32 MS; -2.31 G @ 43.04 MS

CHANNEL: CSTYG2 FILTER: CH. CLASS 180

1994 FORD PROBE INTO FLAT FRONTAL BARRIER
RIGHT FRONT PASSENGER CHEST Z-AXIS ACCELERATION
208 COMPLIANCE TESTING CR0210

TEST NUMBER: 940302

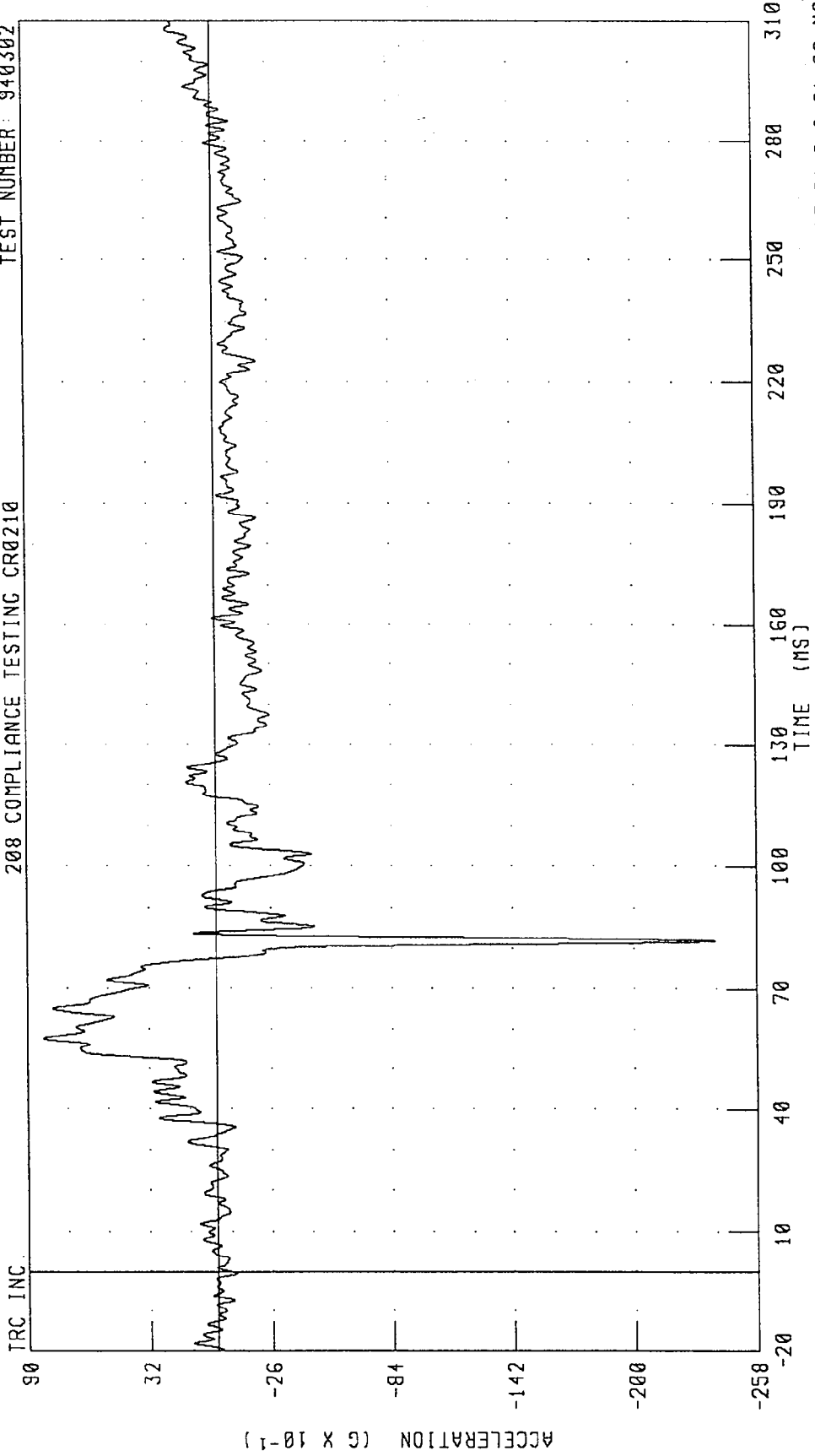

PEAK DATA: 8.27 G @ 57.68 MS, -23.81 G @ 81.92 MS

CHANNEL: CSTZG2 FILTER: CH. CLASS 180

1994 FORD PROBE INTO FLAT FRONTAL BARRIER
RIGHT FRONT PASSENGER CHEST RESULTANT ACCELERATION
208 COMPLIANCE TESTING CR0210

TEST NUMBER: 940302

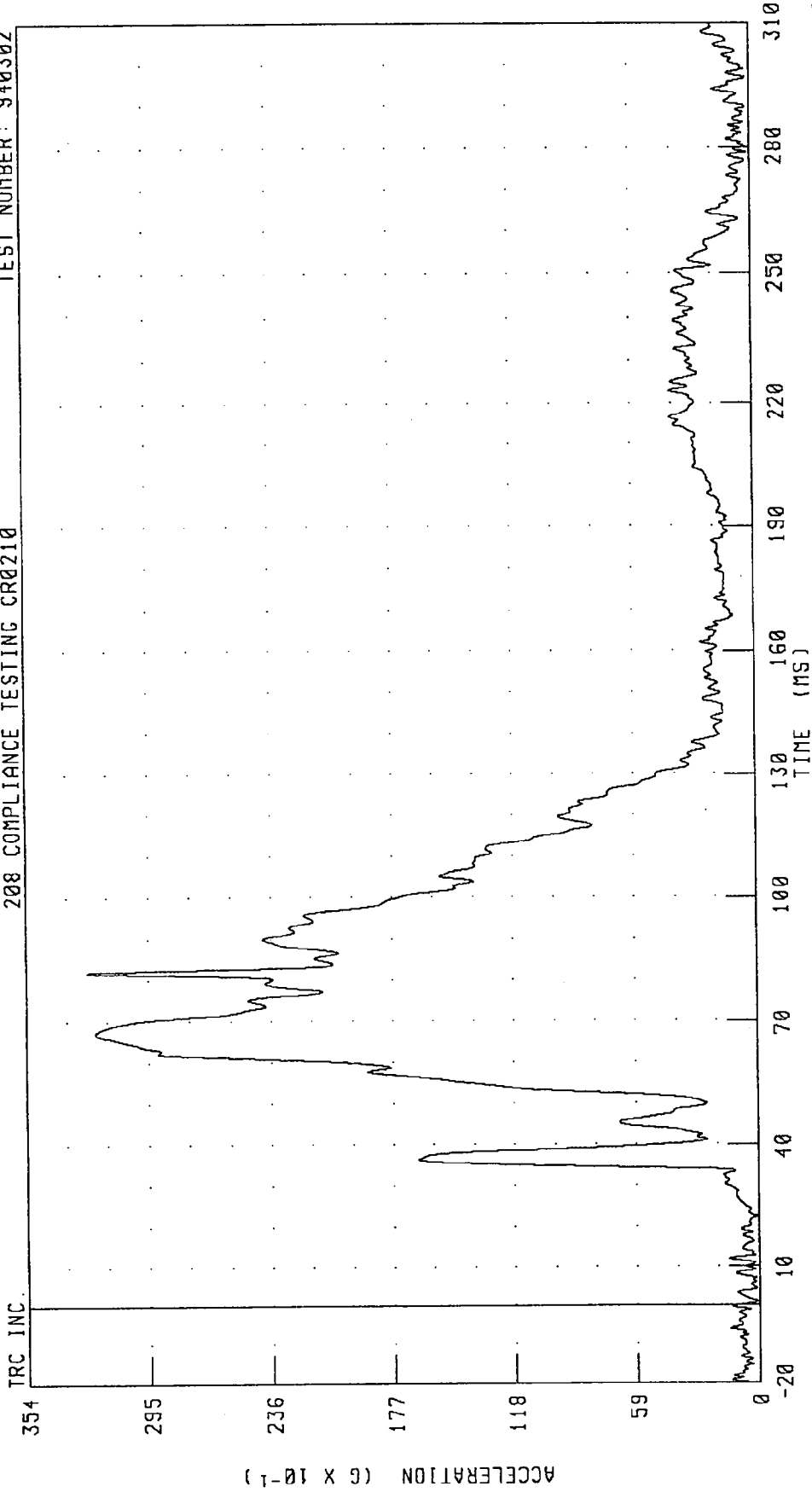

PEAK DATA: 32.44 G @ 81.92 MS; 0.09 G @ 22.48 MS

CHANNEL: CSTRG2 FILTER: CH. CLASS 180

1994 FORD PROBE INTO FLAT FRONTAL BARRIER
RIGHT FRONT PASSENGER LEFT FEMUR FORCE
208 COMPLIANCE TESTING CR0210

TEST NUMBER: 940302

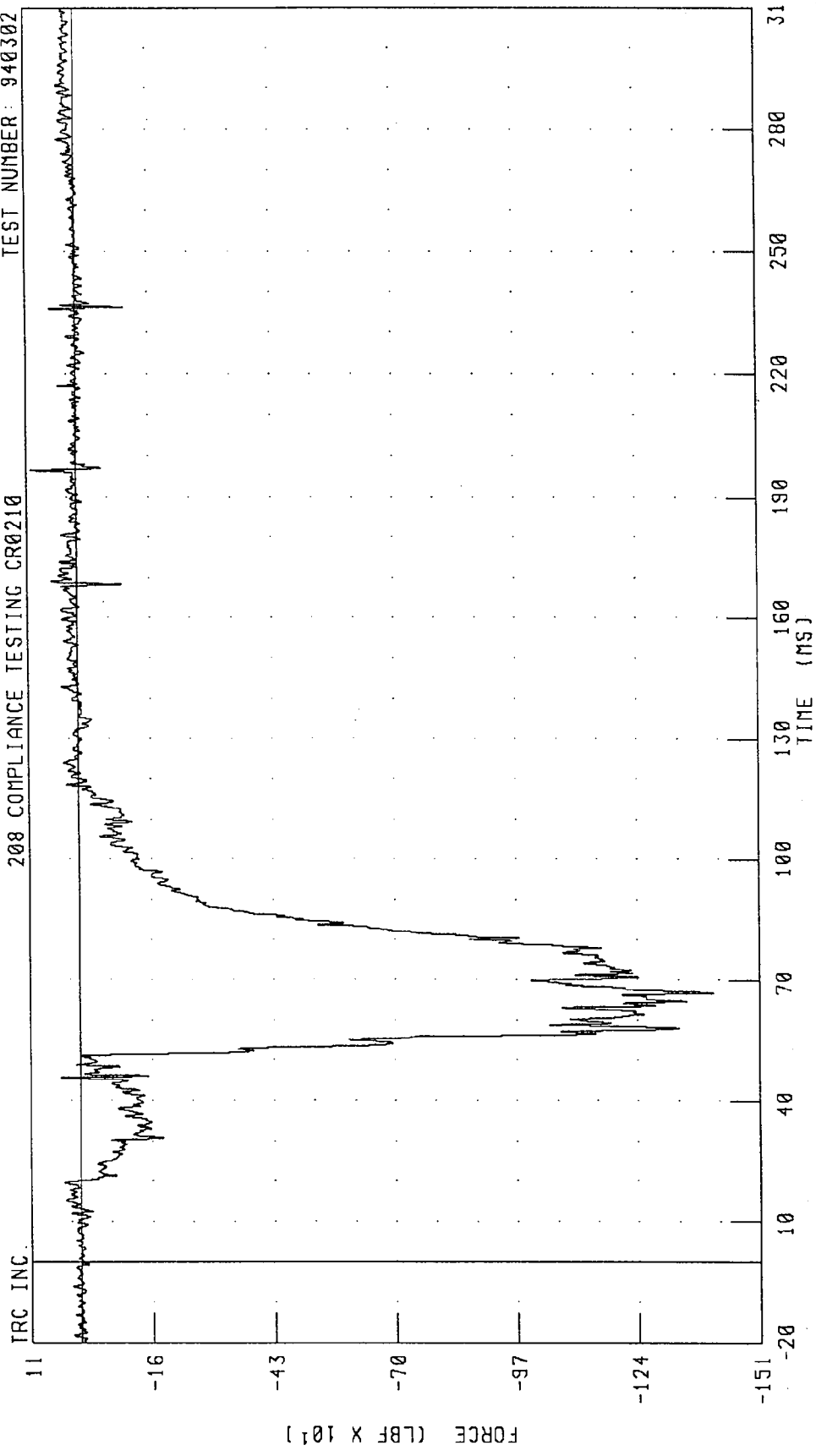

CHANNEL: LFMF2 FILTER: CH. CLASS 600 PEAK DATA: 100.74 LBF @ 196.64 MS; -1406.92 LBF @ 66.88 MS

1994 FORD PROBE INTO FLAT FRONTAL BARRIER
RIGHT FRONT PASSENGER RIGHT FEMUR FORCE
208 COMPLIANCE TESTING CR0210

TEST NUMBER: 940302

TRC INC.

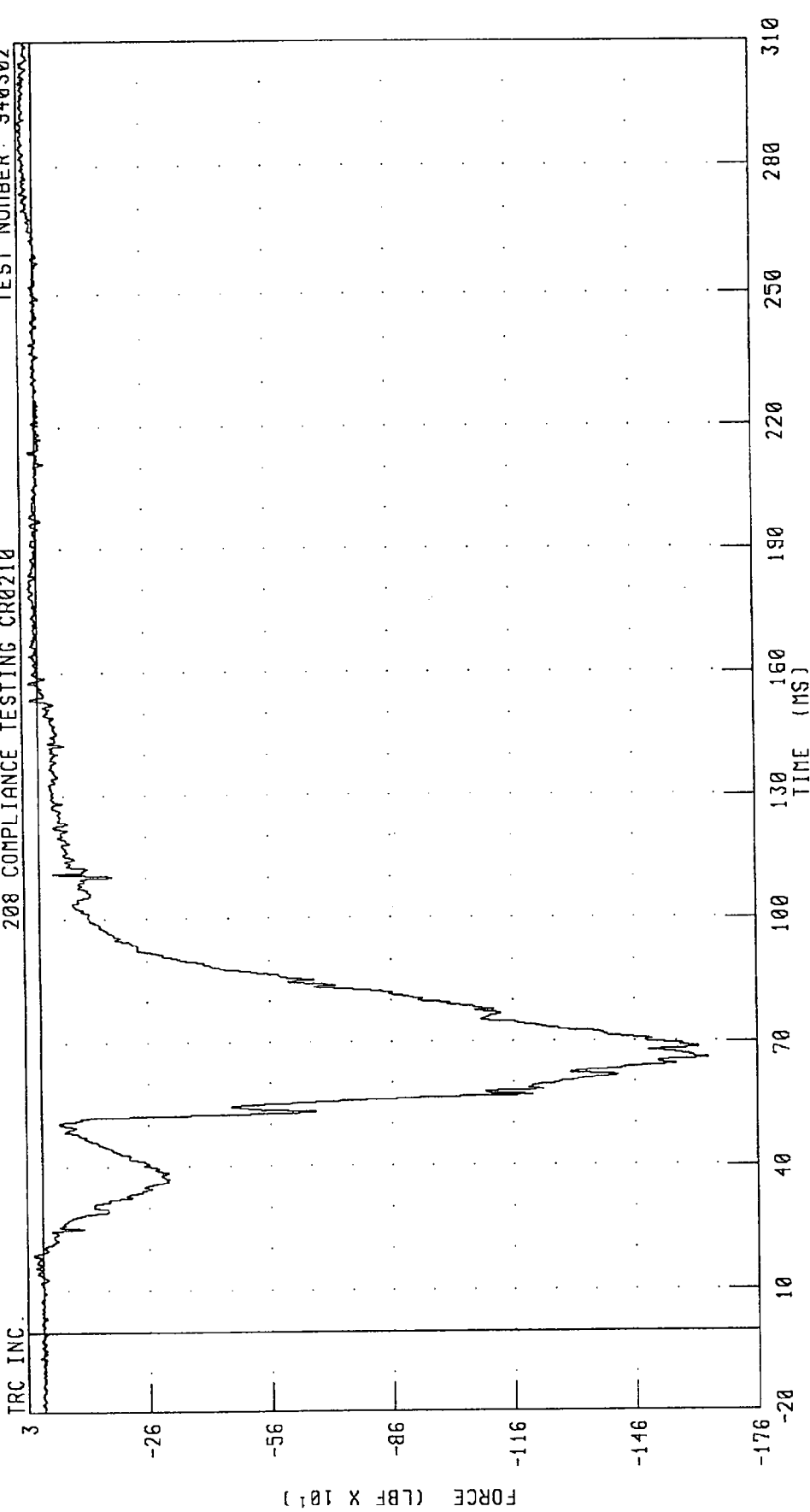

PEAK DATA: 35.06 LBF @ 288.72 MS, -1641.30 LBF @ 65.92 MS

CHANNEL: RFMF2 FILTER: CH. CLASS 600

1994 FORD PROBE INTO FLAT FRONTAL BARRIER
LEFT REAR SEAT X-AXIS ACCELERATION
208 COMPLIANCE TESTING CR0210

TEST NUMBER: 940302

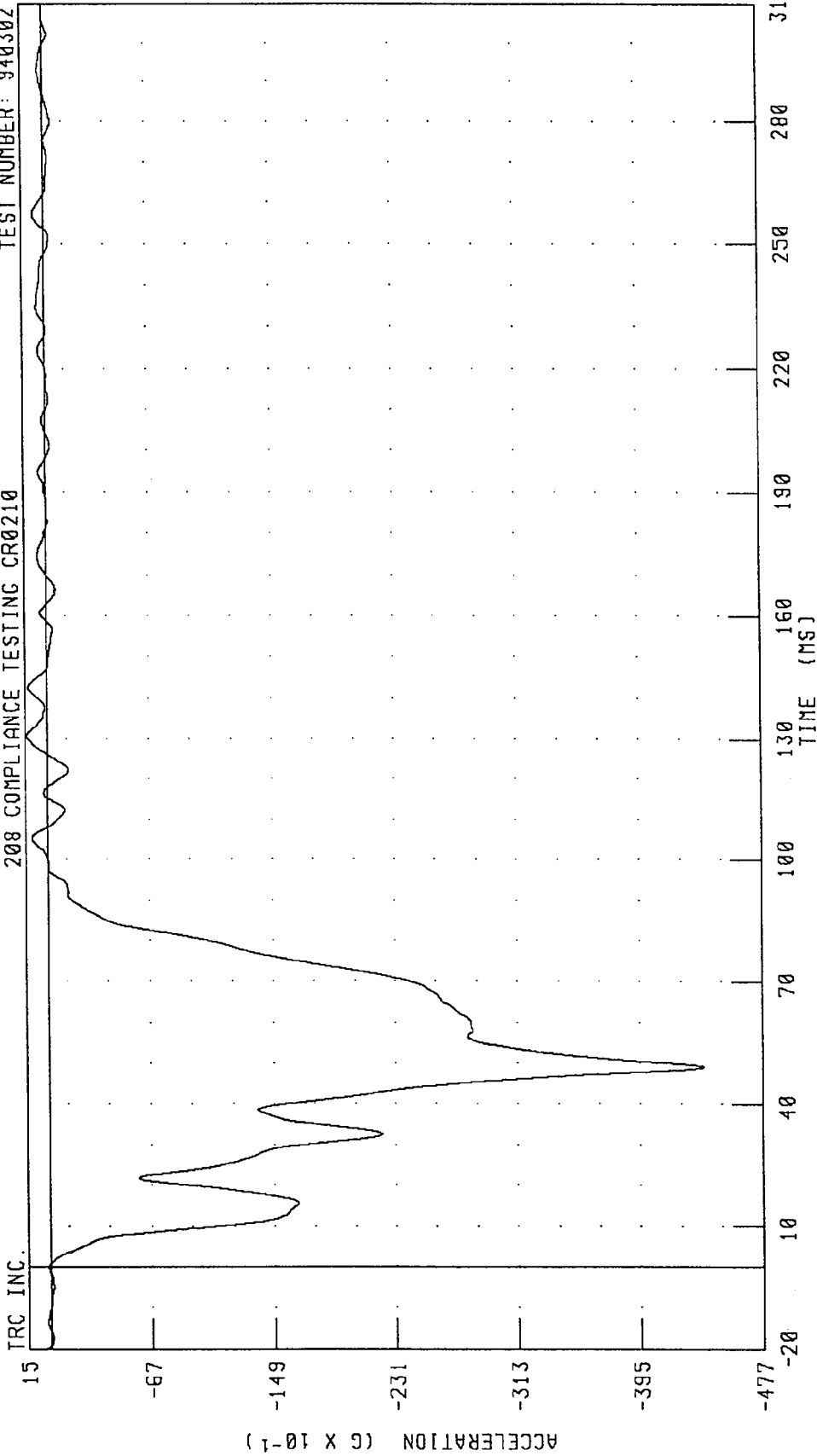

CHANNEL: TLRXG1 FILTER: CH. CLASS 60

PEAK DATA: 1.38 G @ 130.80 MS; -43.77 G @ 49.12 MS

1994 FORD PROBE INTO FLAT FRONTAL BARRIER
RIGHT REAR SEAT X-AXIS ACCELERATION
208 COMPLIANCE TESTING CR0210

TEST NUMBER: 940302

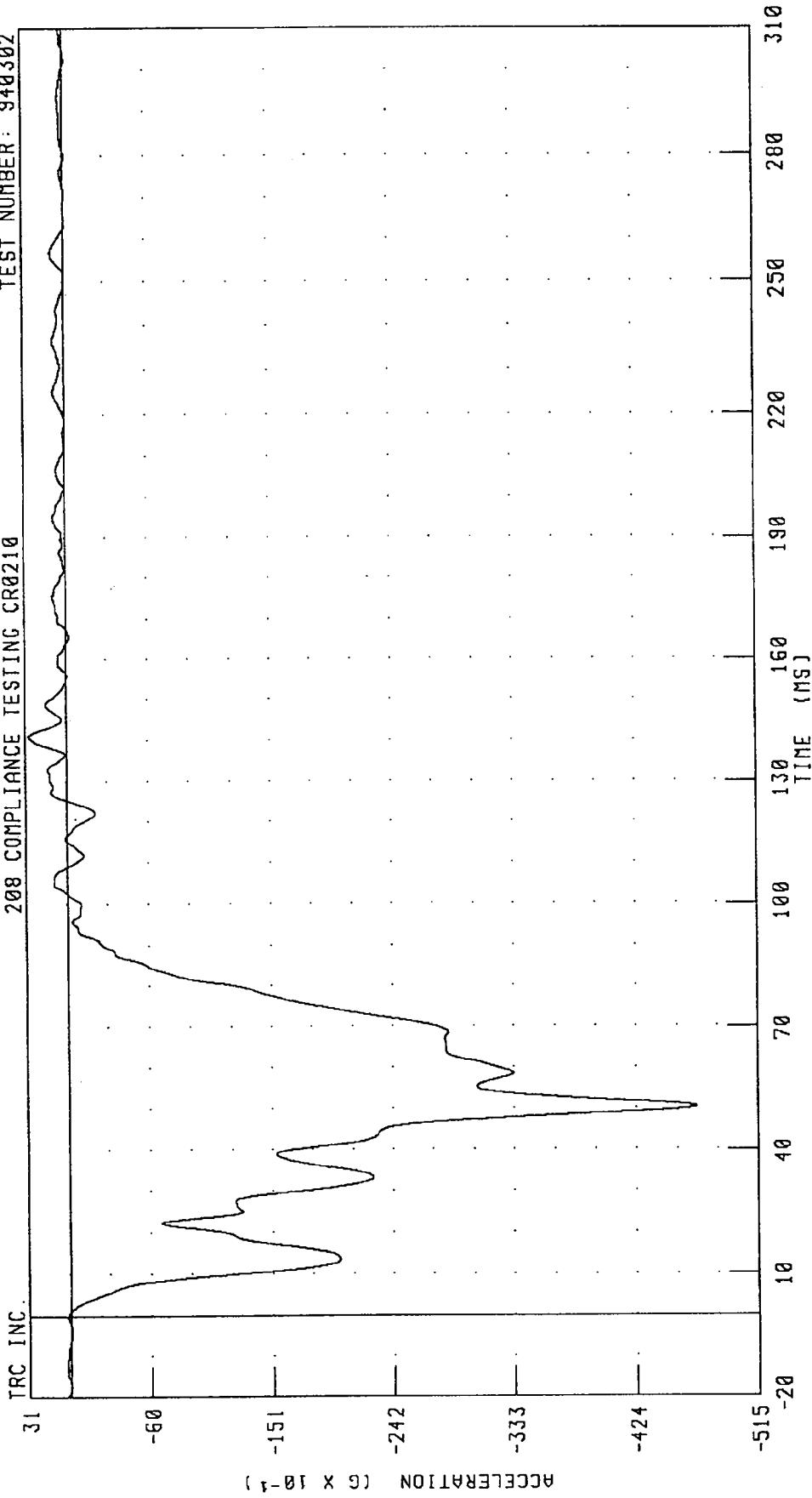

PEAK DATA: 2.83 G @ 141.28 MS; -46.89 G @ 50.40 MS

CHANNEL: TRRXG1 FILTER: CH. CLASS 60

1994 FORD PROBE INTO FLAT FRONTAL BARRIER
ENGINE UPPER BLOCK X-AXIS ACCELERATION
208 COMPLIANCE TESTING CR0210

TEST NUMBER: 940302

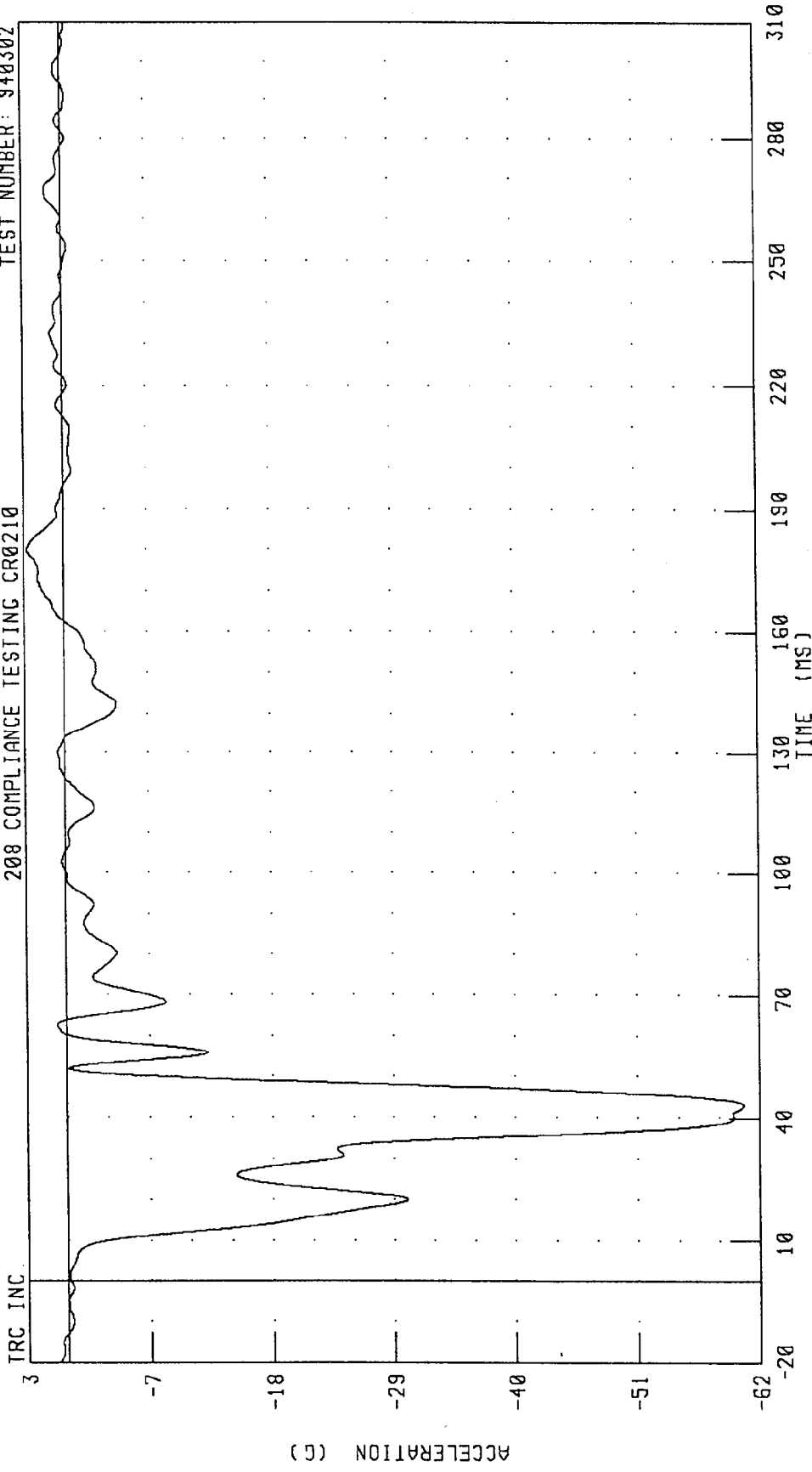

PEAK DATA: 3.30 G @ 180.00 MS; -60.94 G @ 43.04 MS

CHANNEL: ENGXG1 FILTER: CH. CLASS 60

ACCELERATION (G)

TIME (MS)

TRC INC.

1994 FORD PROBE INTO FLAT FRONTAL BARRIER
ENGINE BOTTOM BLOCK X-AXIS ACCELERATION
208 COMPLIANCE TESTING CR0210

TEST NUMBER: 940302

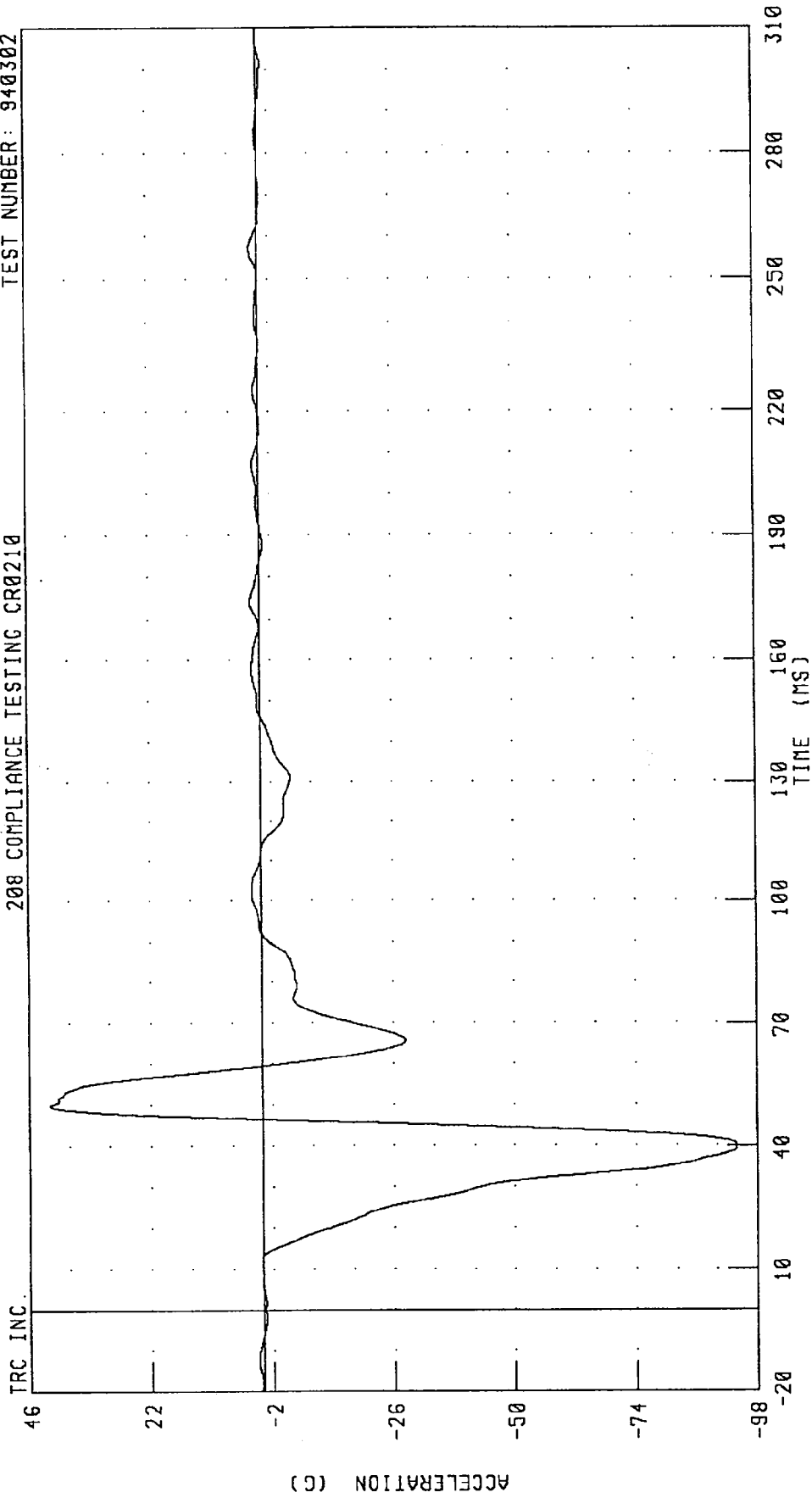

CHANNEL: ENXG2 FILTER: CH. CLASS 60

PEAK DATA: 41.93 G @ 50.00 MS; -93.95 G @ 39.60 MS

1994 FORD PROBE INTO FLAT FRONTAL BARRIER
RIGHT BRAKE CALIPER X-AXIS ACCELERATION
208 COMPLIANCE TESTING CR0210

TEST NUMBER: 940302

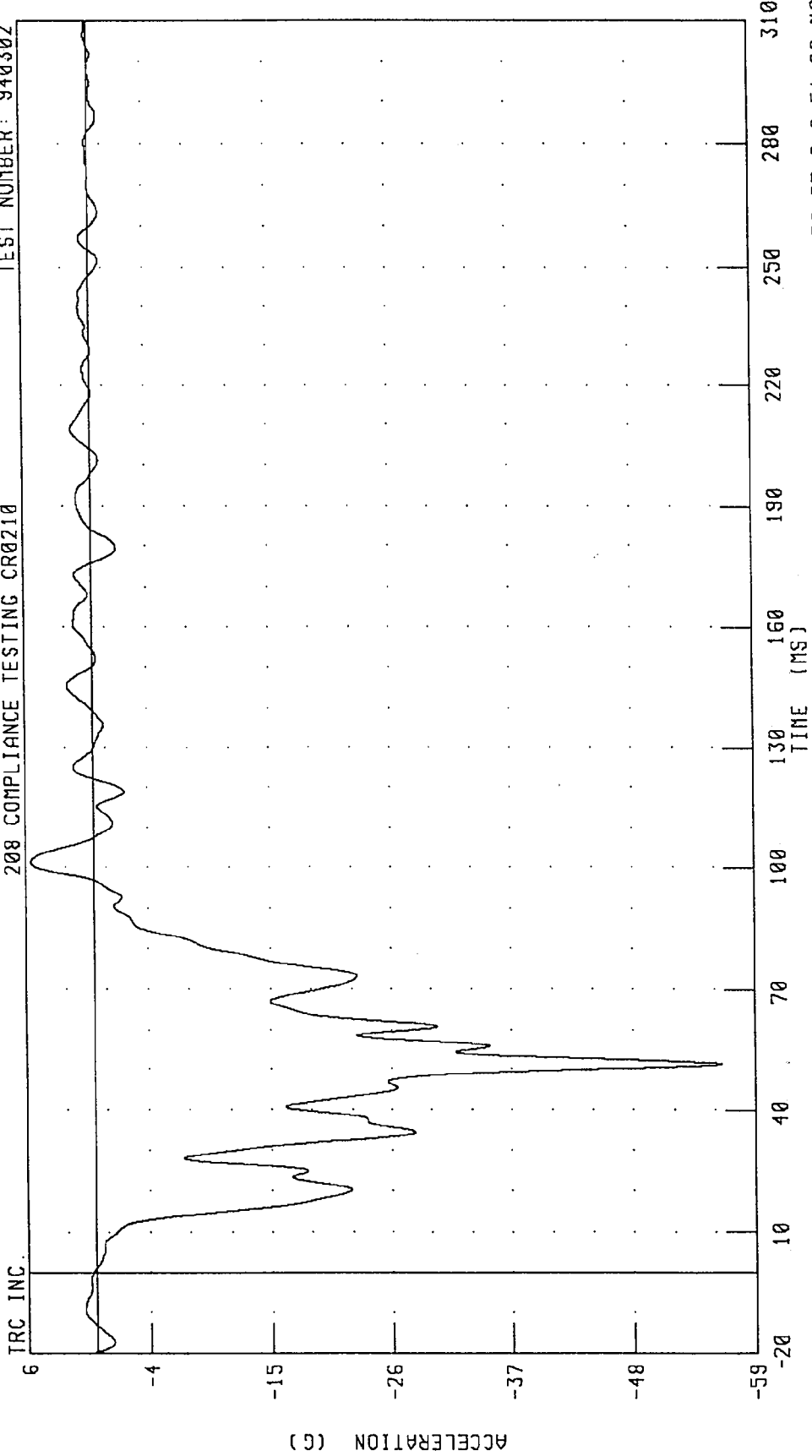

PEAK DATA: 5.71 G @ 101.36 MS; -56.75 G @ 51.28 MS

CHANNEL: BCRXG1 FILTER: CH. CLASS 60

TRC INC.

1994 FORD PROBE INTO FLAT FRONTAL BARRIER
LEFT BRAKE CALIPER X-AXIS ACCELERATION
208 COMPLIANCE TESTING CR0210

TEST NUMBER: 940302

TRC INC.

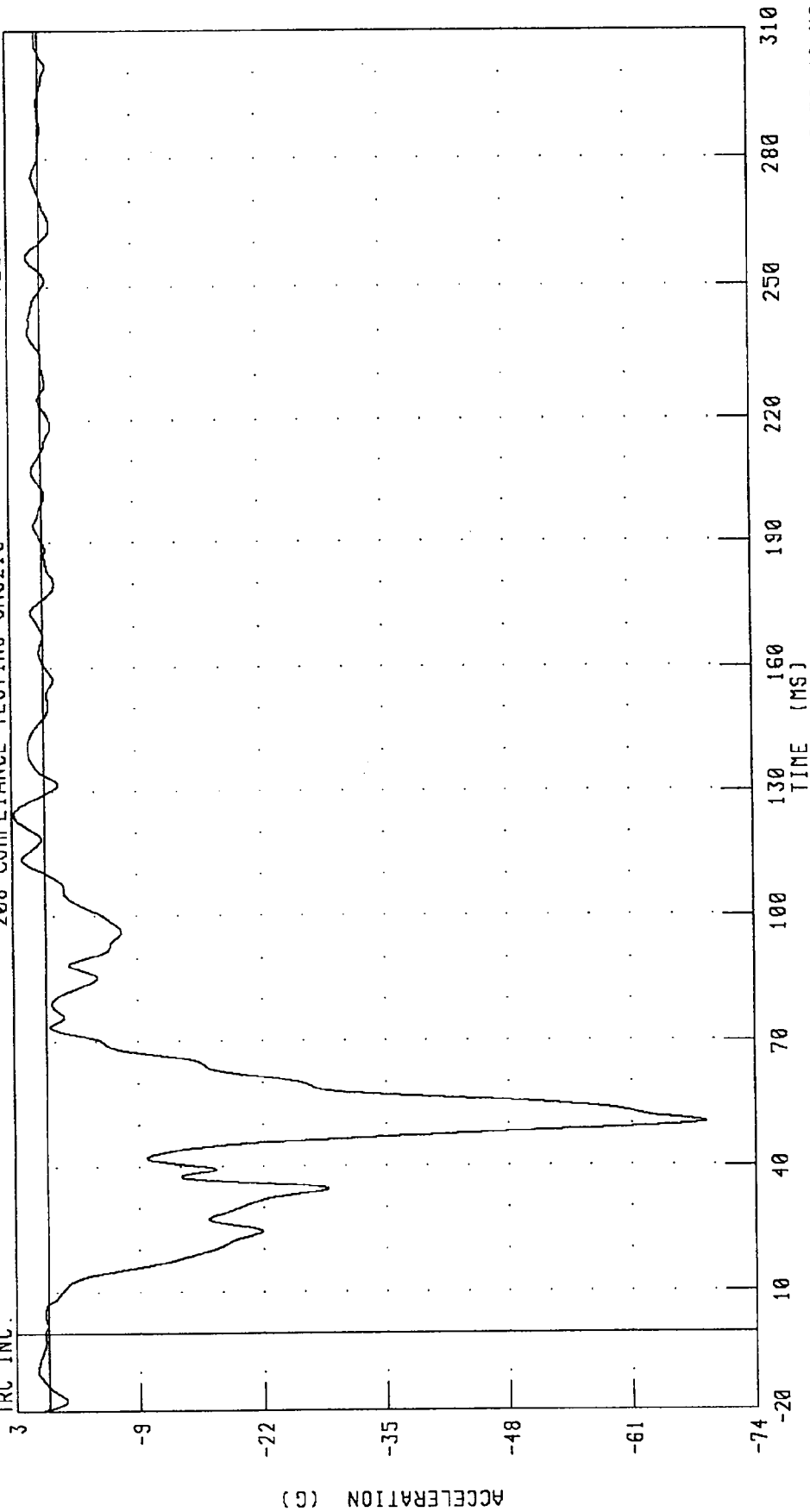

CHANNEL: BCLXG1 FILTER: CH. CLASS 60
PEAK DATA: 3.15 G @ 124.72 MS; -69.49 G @ 50.40 MS

1994 FORD PROBE INTO FLAT FRONTAL BARRIER
DASH PANEL CENTER X-AXIS ACCELERATION
208 COMPLIANCE TESTING CR0210

TEST NUMBER: 940302

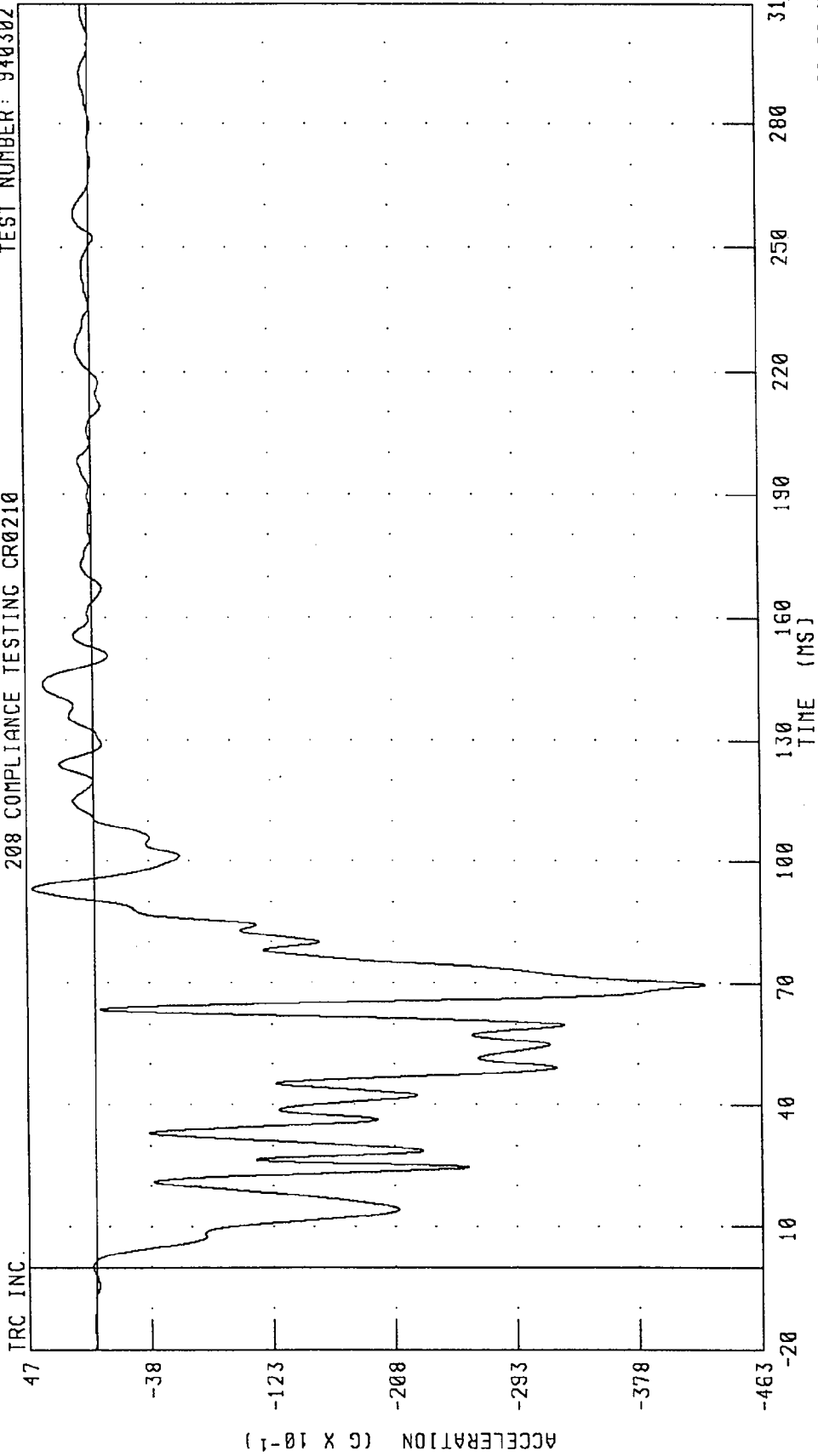

CHANNEL: DPCXG1 FILTER: CH. CLASS 60

PEAK DATA: 4.29 G @ 93.20 MS; -42.44 G @ 69.68 MS

1984 FORD PROBE INTO FLAT FRONTAL BARRIER
VEHICLE REAR CENTER Z-AXIS ACCELERATION
208 COMPLIANCE TESTING CR0210

TEST NUMBER: 940302

TRC INC.

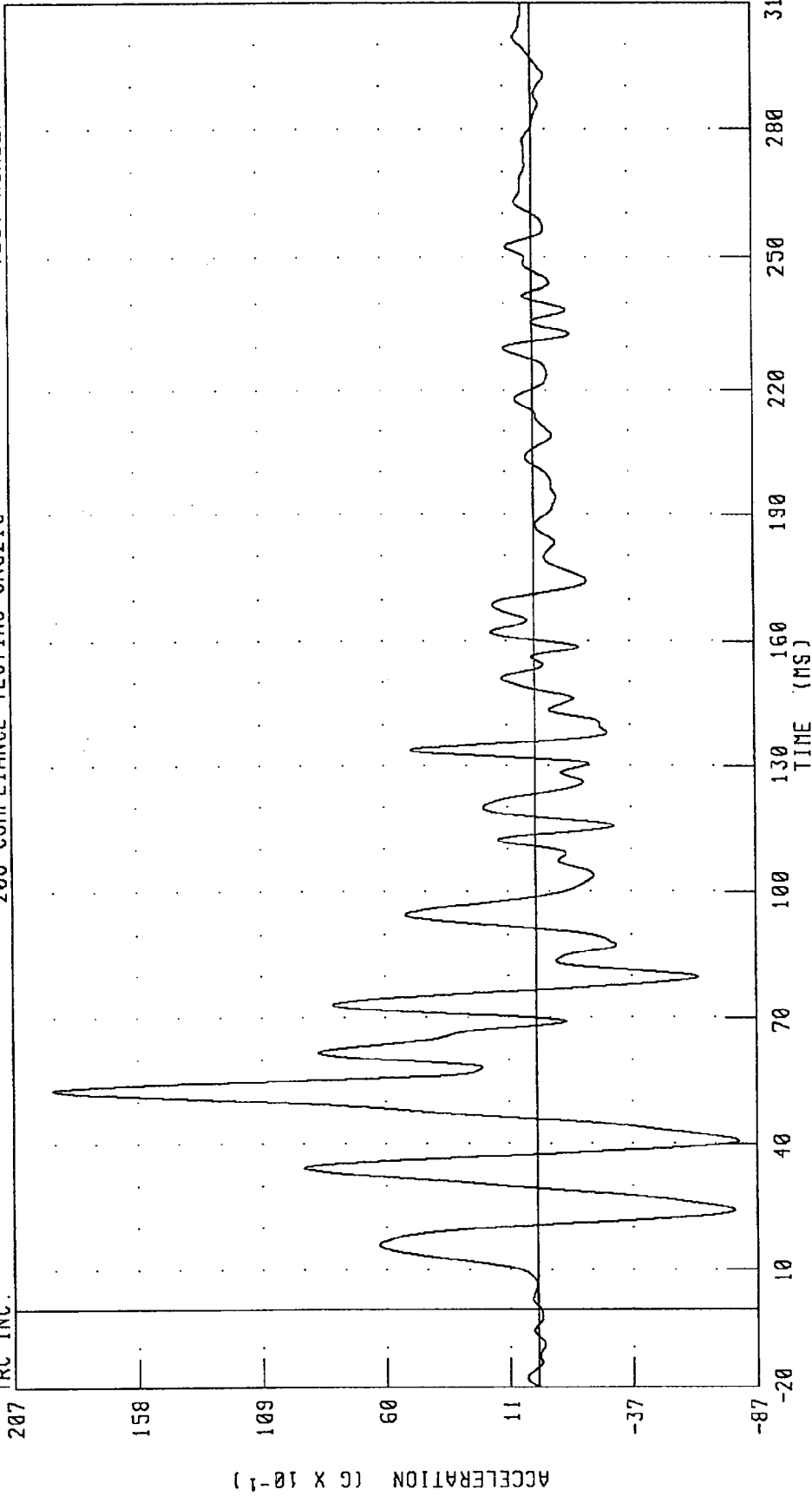

PEAK DATA: 19.16 G @ 52.80 MS; -7.97 G @ 40.72 MS

CHANNEL: RDKZG1 FILTER: CH. CLASS 60

Appendix C

Manufacturer's Vehicle Information



Robert H. Munson
Executive Director
Automotive Safety and Engineering Standards Office
Environmental and Safety
Engineering Staff

Ford Motor Company
330 Town Center Drive
Dearborn, Michigan 48126

September 21, 1993

Mr. Robert F. Hellmuth
Director
Office of Vehicle Safety Compliance
National Highway Traffic
Safety Administration
400 Seventh Street, S.W.
Washington, DC 20590

Dear Mr. Hellmuth:

Reference: NEF-31CCa; IR 1289

This is in response to your letter of July 16, 1993 requesting information relative to possible FMVSS 208 testing by OVSC of a 1994 model year Ford Probe equipped with driver and passenger air bag restraint systems. Ford's responses to your requests for information set out below are based on information provided to Ford by representatives of Mazda Motor Corporation (Mazda).

Request No. 1

"Please inform OVSC whether the air bag automatic restraint system provided at the driver's and passenger's seating positions in your vehicle is certified to meet the requirements of S4.1.2.1(c)(1) or S4.1.2.1(c)(2) for FMVSS No. 208."

Answer

The supplemental air bag automatic restraint systems provided at the driver's and passenger's seating positions of the 1994 Probe were installed to meet the requirements of S4.1.2.1(c)(2) of FMVSS No. 208.

Request No. 2

"If the automatic restraint system provided at the driver's and passenger's seating positions in the subject vehicle was



installed to meet the requirements of S4.1.2.1(c)(1), please provide a copy of the certification test reports for each of the test configurations required by that section of the standard (i.e., moving barrier lateral impact and dynamic rollover) and a copy of the certification reports for the frontal/angular barrier impact test required by S4.1.2.1."

Answer

The supplemental air bag automatic restraint systems provided at the driver's and passenger's seating positions were not installed in the 1994 Probe to meet the requirements of S4.1.2.1(c)(1).

Request No. 3

"If a manual 3-point safety belt is provided with the driver's and passenger's automatic restraint system in order to meet the requirements of S4.1.2.1(c)(2), please provide a copy of the certification test reports for each of the test configurations required by that section of the standard (i.e., frontal/angular barrier impact test of the automatic restraint system with the manual safety belt unfastened and frontal/angular barrier impact test of the automatic restraint system with the manual safety belt fastened)."

Answer

The manual three-point safety belt for the driver's and passenger's supplemental air bag restraint system in the 1994 Probe was provided to meet the requirements of S4.1.2.1(c)(2) of FMVSS No. 208. Attachment I contains summaries of Mazda's Test Reference Nos. 3397, 3459, 3365, and 3392, 90 degree frontal crash tests of prototype 1994 model Probes. Test Nos. 3397 and 3459 were conducted with the manual 3-point safety belt fastened, and Test Nos. 3365 and 3392 were conducted with the manual 3-point safety belt unfastened. The results of these tests were relied on as a basis for certifying compliance of 1994 Probe vehicles equipped with the driver's and passenger's supplemental air bag restraint system with S4.1.2.1.

Request No. 4

"If the manual safety belt provided at the driver's and passenger's seating positions was not installed to meet the requirements of S4.1.2.1(c)(2), please provide a copy of a crash test report or engineering analysis showing that the use of the manual safety belt with the automatic restraint

system does not affect the ability of the vehicle to meet the requirements of FMVSS No. 208."

Answer

As noted in our response to Request No. 3, the manual safety belt provided at the driver's and passenger's seating positions of the 1994 Probe was installed to meet the requirements of S4.1.2.1(c)(2) of FMVSS No. 208.

Request No. 5

"If the vehicle uses a pressure vessel to inflate the air bag, provide a copy of the test reports or engineering analysis to demonstrate that it meets all the requirements of S9.1."

Answer

The 1994 Probe driver and passenger air bags do not use a pressure vessel.

Request No. 6

"If the vehicle uses an explosive device to inflate the air bag, provide a copy of the test reports or engineering analysis to demonstrate that it meets all the requirements of paragraph S9.2."

Answer

Attachments II and III contain the 1994 Probe air bag supplier's test reports provided to Ford by Mazda demonstrating compliance to S9.2 of FMVSS No. 208 for the driver and passenger air bag restraint system module assemblies, respectively.

Request No. 7

"State, for any automatic safety belt system in this vehicle, whether or not it is equipped with a tension-relieving device. Provide a copy of the information furnished in accordance with S7.4.2, if the tension-relieving device is used."

Answer

The 1994 Probe is not equipped with automatic safety belt systems.

Request No. 8

"FMVSS No. 208, S8.1.5 allows the manufacturer the option of having movable vehicle windows and vents placed in the closed position. State whether the vehicle's movable windows and vents were opened or closed for the certification tests."

Answer

Frontal crash tests conducted by Mazda which are a basis for certification of 1994 Probe vehicles were conducted with moveable windows both open and closed. The specific window position for each test is identified in the test report summaries provided in Attachment I in response to Request No. 3.

Request No. 9

"FMVSS No. 208, S5.1 provides a manufacturer with the option of using either a Part 572(B) or Part(E) test dummy. Please inform OVSC which test dummy was used in each seat for each certification test. Submit dummy placement measurements, including diagrams or photographs which show exactly where measurements were taken. Enclosed is a diagram of some of OVSC's dummy measurements. Where possible, use the dimension shown in the diagram to provide the individual dummy placement measurements."

"State whether the vehicle has a foot rest for the driver."

"If the vehicle can be equipped with a split front bench seat, state whether the driver dummy was located so that the midsagittal plane was centered on the steering wheel rim or the center of the seat cushion. Also, state whether the passenger dummy was located so that the midsagittal plane was centered the same distance from the longitudinal centerline of the vehicle as the driver dummy or in the center of the seat cushion."

Answer

Part 572(B) (Hybrid II) test dummies were used at both front outboard designated seating positions of the test vehicles in those front barrier crash tests on which Mazda relies as a basis for certification of 1994 Probe vehicles to FMVSS No. 208. Attachment IV contains dummy placement measurements applicable for the 1994 Probe.

The 1994 Probe does have a foot rest for the driver.

The 1994 Probe vehicle is not available with a split front bench seat.

Request No. 10

"Provide the seat positioning, steering column positioning, and fuel tank data on the enclosed form."

Answer

Attachment V contains the NHTSA form enclosed with your letter, completed with the requested seat positioning, steering column positioning, and fuel tank data applicable to FMVSS No. 208 frontal barrier impact testing of the 1994 Probe.

Request No. 11

"If the vehicle is equipped with adjustable seat belt anchorages, provide the manufacturer's nominal design position for a 50th percentile adult male occupant."

Answer

The 1994 Probe is not equipped with adjustable seat belt anchorages.

Request No. 12

"Provide the speed at impact, vehicle test weight, and resulting injury criteria (i.e., HIC, chest acceleration, chest compression for the Part 572(E) dummy and femur loads) recorded for all certification tests conducted to meet the requirements of S4.1.2.1."

"In addition, include each dummy's head and chest acceleration versus time plots and femur loads versus time plots for the full frontal barrier impact tests. Mark these plots to indicate when the following and any other significant events occur:

- 12.1 Driver and passenger knee contact with knee bolster
- 12.2 Collapse of the driver and passenger knee bolsters
- 12.3 Steering column stroke (when it starts and when it ends)
- 12.4 Driver: Contact of the head with the air bag, steering wheel, hub, windshield, header and any other contact points
- Passenger: Contact of the head with the air bag, instrument panel, windshield, header and any other contact points

- 12.5 Contact of the driver's torso with the air bag, steering wheel and hub
- 12.6 Time during event when each air bag starts to deploy and when it is fully deployed
- 12.7 Mark on the plots any unexpected events, like steering wheel fracture, windshield contact, windshield header contact, that affected the normal loading characteristics."

Answer

The listing contained in Attachment VI includes the nominal speed at impact, vehicle test weight, and injury criteria values recorded in Mazda's tests of 1994 Probe vehicles to the requirements of FMVSS No. 208, S4.1.2.1.

Attachment VII contains resultant head and chest acceleration versus time plots and femur loads versus time plots for each dummy for Mazda Test Reference Nos. 3397, 3459, 3365, and 3392. These plots represent all the full frontal barrier (90 degree) impact tests that were used as a basis for certification of the 1994 Probe to FMVSS No. 208.

In response to your request for items 12.1 through 12.7, we have been informed by Mazda that this data is not available in the manner requested by the agency, and would require considerable analysis to produce. In the absence of any known relevance or need related to the stated purpose of your inquiry, we must respectfully decline to have Mazda undertake the substantial effort required to analyze and provide this data in the manner requested. Should the agency require this information subsequent to it's compliance testing, Ford, of course, will, with input from Mazda, provide all necessary and relevant information.

Request No. 13

"When vehicle components must be removed to obtain the proper test weight, what components do you recommend for removal and in what priority order do you recommend removal?"

Answer

The following is a suggested list of items provided by Mazda that may be removed from the test vehicle for frontal FMVSS No. 208 testing. This list below is in order of removal priority:

- Spare tire
- Jack
- Rear seat and back
- Rear seat belt

- Taillamps
- Rear Bumper

All onboard instrumentation should be included in the vehicle test weight.

Request No. 14

"Please provide FMVSS No. 204, "Steering Control Rearward Displacement" certification data. Include a copy of the test report and any engineering analysis forming the basis of the certification. The report should document the vehicle test weight, impact velocity, and the horizontal and vertical displacements of the steering control. Pre and post test photographs are also requested."

"Discuss the test procedure detailing the vehicle preparation and the measurement technique used to determine the steering control rearward displacement."

"Provide a diagram of the steering control system and describe how the components of the steering control system work to provide energy management in a frontal impact."

Answer

Attachment VIII contains a copy of a summary of Mazda's Test Reference No. 2053, a 90 degree front fixed barrier impact test of a 1994 model year Probe for FMVSS No. 204. The photographs provided by Mazda are also contained in Attachment VIII. The results of this test are a basis for certifying the 1994 Probe to the requirements of FMVSS No. 204.

Mazda has indicated that their FMVSS No. 204 test is basically conducted according to the test procedure "TP-204" issued by DOT, except that steering displacement is determined by analyzing high speed film records of the upper steering column movement. In order to facilitate this analysis, a "steering bar" is attached to the top end of the steering shaft (refer to the Figure contained in Attachment IX). The air bag is removed for the test.

FMVSS 204 does not contain any requirement for the steering control system to provide energy management. Rather, as the agency is aware, the standard sets a limit on the allowable rearward displacement of the upper end of the column. A diagram describing how various steering control system components work to provide energy management in a frontal impact therefore, is not typically available. Nevertheless, Mazda has provided to Ford an illustration of the vehicle's steering column system along with a brief description of the intended function of

Mr. R. F. Hellmuth

8

September 21, 1993

several select steering column system components during a frontal impact. This illustration is provided in Attachment X in response to this request.

We believe the information and test reports contained herein are fully responsive to your request. If you have any questions, please call Mr. R. A. Nevi on (313) 594-7688.

Very truly yours,



R. H. Munson

Attachments
IR1289.WP

1994 MY FORD PROBE

Pre-Test
OCCUPANT CLEARANCE DIMENSIONS

	DRIVER	PASSENGER
HH	13.0 in.	11.7 in.
HW	18.6 in.	17.3 in.
CD	N/D	21.81 in.
CS	15.2 in.	
KDL	5.2 in.	4.9 in.
LDR	5.4 in.	4.6 in.
SA	21 degrees	21 degrees
TA	N/D	N/D
HT	2.9 in.	2.1 in.

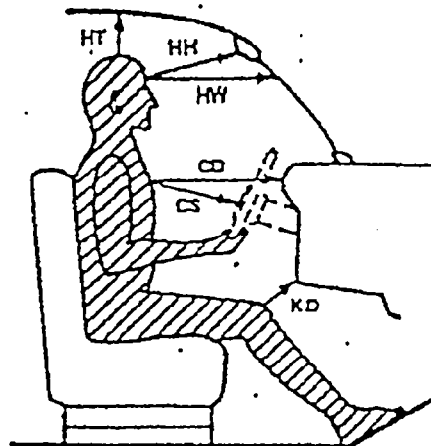

HH : Head to Windshield Header
 HW : Head to Windshield
 CD : Chest to Dash
 CS : Chest to Steering Wheel
 KD (L/R) : Knee to Dash (Left/Right)
 SA : Seat Back Angle
 TA : Torso Angle

HA : Head Target to "A" Pillar
 HR : Head to Side Roof
 HS : Head to Side Window
 AD : Arm to Door
 HD : Hip to Door
 KK : Knee to Knee (Center)
 HT : Head Top to Roof

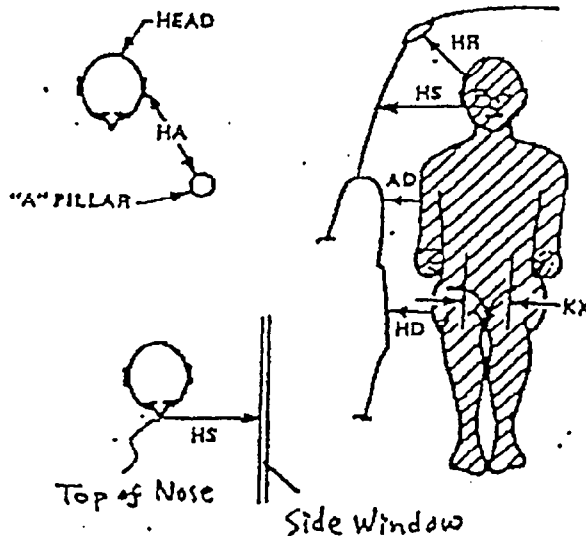

	DRIVER	PASSENGER
HR	3.3 in.	3.3 in.
HS	11.4 in.	11.0 in.
AD	2.8 in.	3.2 in.
HD	N/D	N/D
KK	11.5 in.	7.7 in.
HA	N/D	N/D

N/D : No data

1994 MY FORD PROBE

Pre-Test

DRIVER DUMMY TO STEERING COLUMN / WHEEL ASSY. REFERENCE DIMENSIONS

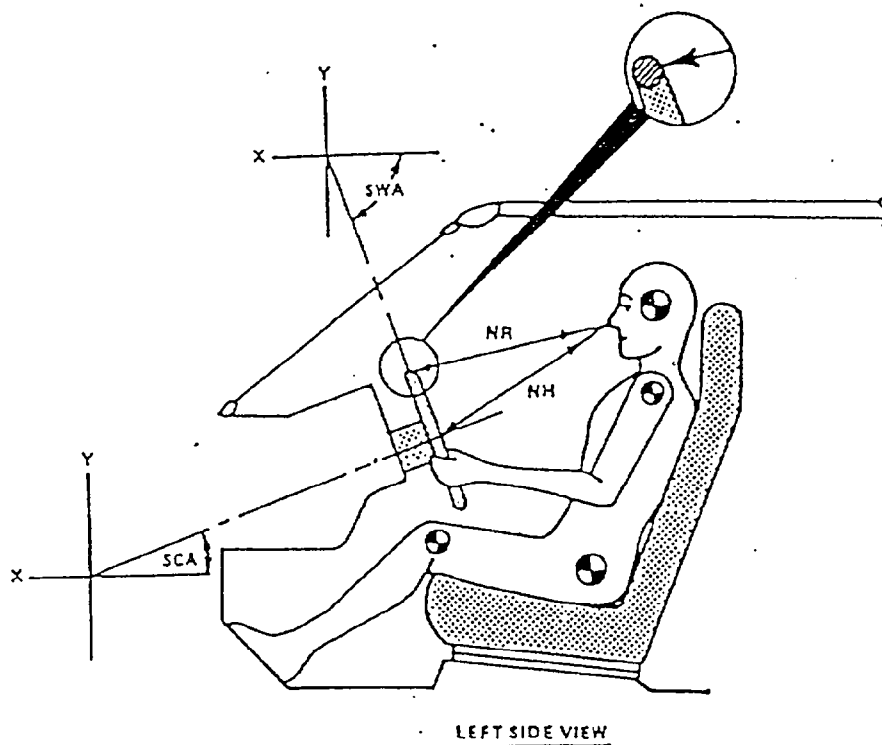

LEFT SIDE VIEW

		MEASUREMENTS	
NR	Distance from tip of dummy's nose to Top Rear surface of steering wheel rim	18.0	Inches
NH	Distance from tip of dummy's nose to center of steering column hub	18.6	Inches
SCA	Angle of steering column relative to the horizontal X axis	18.8	Degrees
SWA	Angle of steering wheel relative to the horizontal X axis	71.2	Degrees

1994 MY FORD PROBE

DUMMY MEASUREMENTS FOR FRONT SEAT PASSENGERS

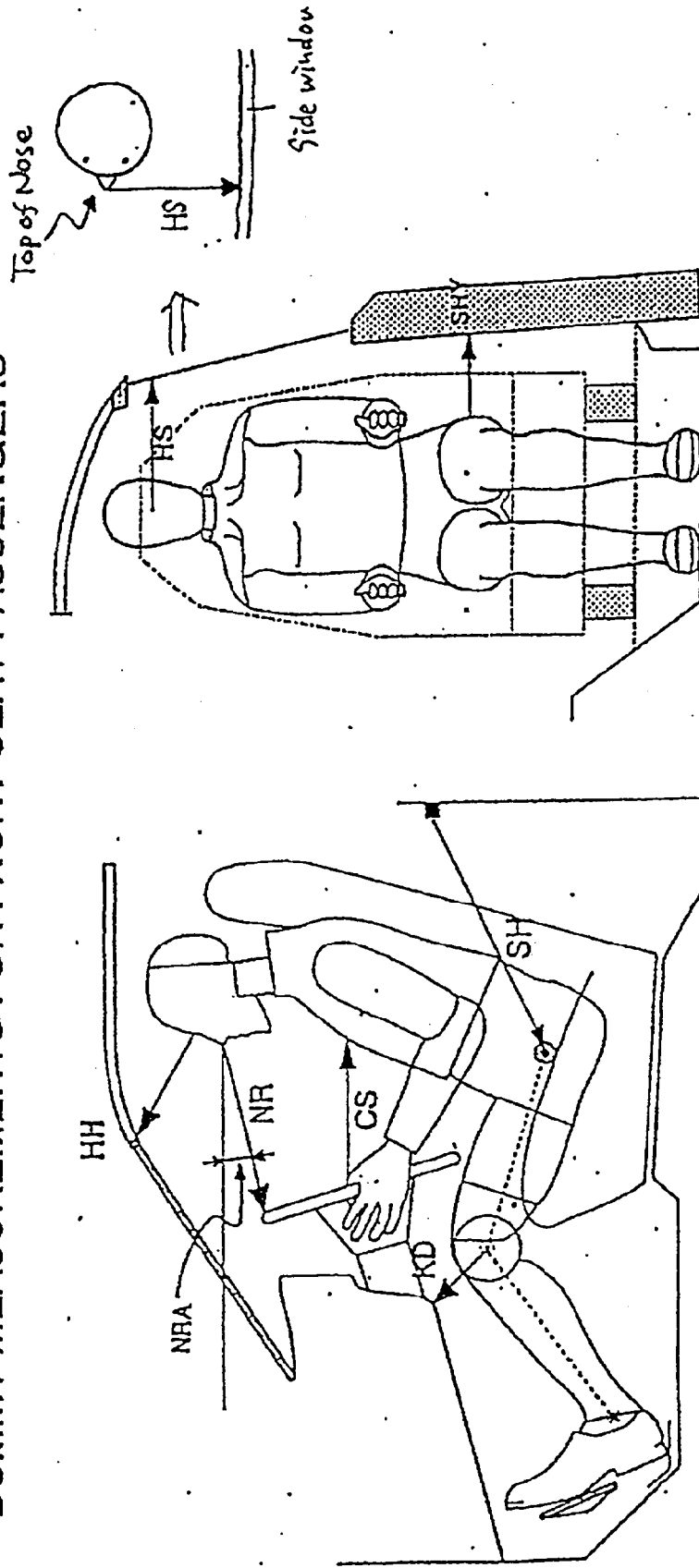

	Driver	Passenger
HH : Head to Header	13.0 in.	11.7 in.
NR : Nose to Rim	18.0 in.	
CS : Steering Wheel to Chest	15.2 in.	
KD (L/R) : Knee to Dash	7.7 / 7.9 in.	7.1 / 7.8 in.
SH : Shoulder to H-Point	22.1 in.	22.9 in.

	Driver	Passenger
SH : Shoulder to H-Point (Y Dir.)	6.7 in.	9.9 in.
HS : Head to Side Window	11.4 in.	11.0 in.

TEST VEHICLE INFORMATION

Vehicle Model Year & Make : 1994 MY / Ford Motor Company
 Vehicle Model & Body Style : Probe / 2 Door coupe

1. NOMINAL DESIGN RIDING POSITION

For adjustable driver and passenger sat backs.
 Please describe how to position the inclinometer to measure the seat back angle. Include description of the location of the adjustment latch detents if applicable. Indicate, if applicable, how the detents are numbered (Is the first detent "0" or "1"?).

Seat back angle for driver's seat = 21 degrees.

Measurement Instructions:

Seat back angle is measured along rear edge of outer seat back frame. Adjust the seat back to the 6th latch from the first detent "0".

Seat back angle for passenger's seat = 21 degrees.
 Same as driver side.

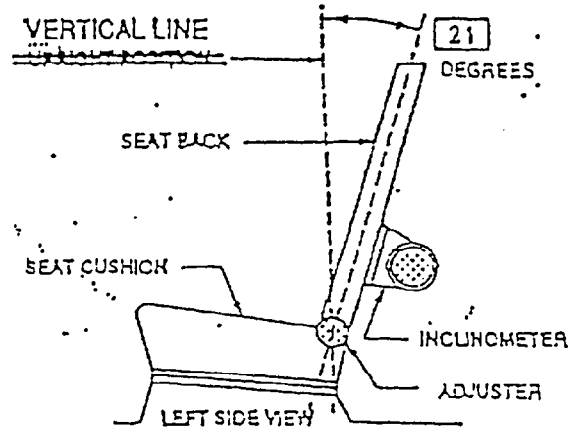

2. SEAT FORE & AFT POSITIONS

Provide instructions for positioning the driver and front outboard passenger seat(s) in the center of fore and aft travel. For example, indicate how the detents are numbered (Is the first detent "0" or "1"?). Provide information to locate the detent in which the seat track is to be locked.

Positioning of the driver's seat:

Non-power seat : Adjust the seat slider to the 12th latch position from the most forward position.
The first detent of the most forward position is "0".

Power seat : Adjust the seat slider to 4.53 in. (115mm) from the most forward position.

Positioning of the passenger's seat (if applicable):

Adjust the seat slider to the 10th latch position from the most forward position.
The first detent of the most forward position is "0".

3. FUEL TANK CAPACITY DATA

3.1 A. "Usable Capacity" of standard equipment fuel tank = 14.5 gallons.

B. "Usable Capacity" of optional equipment fuel tank = N/A gallons.

C. "Usable Capacity" of vehicle(s) used for certification testing to requirements of FMVSS 301 = 14.5 gallons.

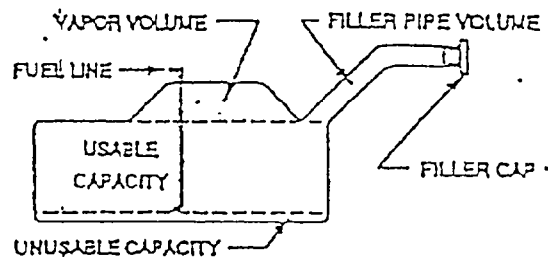

VEHICLE FUEL TANK ASSEMBLY

3.2 Amount of Stoddard solvent added to vehicle(s) used for certification test(s) = 14.68 gallons.

3.3 Is vehicle equipped with electric fuel pump? YES NO

If YES, explain the vehicle operating conditions under which the fuel pump will pump fuel.

Activate the starter or the engine.

TEST VEHICLE INFORMATION

Vehicle Model Year & Make : 1994 MY / Ford Motor Company
Vehicle Model & Body Style : Probe / 2 Door coupe

4. STEERING COLUMN ADJUSTMENTS

Steering wheel and column adjustments are made so that the steering wheel hub is at the geometric center of the locus it describes when it is moved through its full range of driving positions.

If the tested vehicle has any of these adjustments, does your company use any specific procedures to determine the geometric center.

Operational Instructions:

The mid-point position of the steering column is determined using a 3-dimensional measurement devise. At first, measure the 3-dimensional positions of the steering column when it is in the upper-most position, and in the lower-most position. Calculate the mid-point of the two measurement position, and adjust the steering column to the nearest position to the calculated mid-point position.

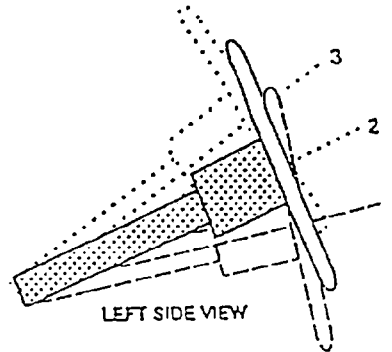

LEFT SIDE VIEW
STEERING COLUMN ASSEMBLY