

REPORT NUMBER: CAL-94-N04

**NEW CAR ASSESSMENT PROGRAM (NCAP)  
FRONTAL BARRIER IMPACT TEST**

**AUTOALLIANCE INTERNATIONAL INC.  
1994 MAZDA 626 DX  
4-DOOR SEDAN**

NHTSA NUMBER: MR5400

CALSPAN TEST NUMBER: 8120-4

NOVEMBER 4, 1993

CALSPAN CORPORATION  
ADVANCED TECHNOLOGY CENTER  
P.O. BOX 400  
BUFFALO, NEW YORK 14225



FINAL REPORT

PREPARED FOR:

U. S. Department of Transportation  
National Highway Traffic Safety Administration  
Office of Market Incentives  
400 Seventh Street, S. W.  
Room No. 5313 (NRM-20)  
Washington, DC 20590

This publication is distributed by the U. S. Department of Transportation, National Highway Traffic Safety Administration, in the interest of information exchange. The opinions, findings and conclusions expressed in this publication are those of the author(s) and not necessarily those of the Department of Transportation or the National Highway Traffic Safety Administration. The United States Government assumes no liability for its contents or use thereof. If trade or manufacturers' names or products are mentioned, it is only because they are considered essential to the object of the publication and should not be construed as an endorsement. The United States Government does not endorse products or manufacturers.

Prepared: Michael J. Kilgallon  
Michael J. Kilgallon, Project Engineer

Approved: Walter E. Levan  
Walter E. Levan, Program Manager  
Transportation Research/  
Physical Sciences Department

FINAL REPORT ACCEPTED BY:

[Signature]  
Manager, New Car Assessment Program (NCAP)

JAN 28 1994

\_\_\_\_\_  
Date of Report Acceptance

Has-Cha  
Contracting Officer's Tech. Rep. (COTR)

JAN 28 1994

\_\_\_\_\_  
Date of Report Acceptance

**TECHNICAL REPORT STANDARD TITLE PAGE**

1. <i>Report No.</i> CAL-94-N04		2. <i>Government Accession No.</i>		3. <i>Recipient's Catalog No.</i>	
4. <i>Title and Subtitle</i> NHTSA New Car Assessment Program (NCAP) Frontal Barrier Impact Test of a 1994 Mazda 626 DX 4- Door Sedan				5. <i>Report Date</i> November 4, 1993	
				6. <i>Performing Organization Code</i> CAL	
7. <i>Author(s)</i> Michael J. Kilgallon, Project Engineer Walter E. Levan, Program Manager				8. <i>Performing Organization Report No.</i> 8120-4	
9. <i>Performing Organization Name and Address</i> Calspan Advanced Technology Center 4455 Genesee Street Buffalo, New York 14225				10. <i>Work Unit No.</i> X035-040-1338	
				11. <i>Contract or Grant No.</i> DTNH22-90-D-02121	
12. <i>Sponsoring Agency Name and Address</i> U.S. Department of Transportation National Highway Traffic Safety Administration 400 Seventh , S.W. Washington, D.C. 20590				13. <i>Type of Report and Period Covered</i> Final Report November - December 1993	
				14. <i>Sponsoring Agency Code</i> DOT/NHTSA/RM/OMI	
15. <i>Supplementary Notes</i>					
<p>16. <i>Abstract</i></p> <p>A frontal load cell barrier test of a 1994 Mazda 626 DX 4-Door Sedan was performed at the Calspan Advanced Technology Center Crash Test Facility in Buffalo, New York on November 4, 1993.</p> <p>The impact velocity was 56.6 kph and the temperature at the barrier face was 11° C. The maximum post-test vehicle crush was 560 mm. The test vehicle was equipped with a 3-point continuous belt system at each of the front outboard seating positions. The vehicle was also equipped with supplemental airbags at each of the front outboard seating positions.</p> <p>With regard to FMVSS 208 "Occupant Crash Protection", injury criteria, both the driver and passenger appear to comply with the head, chest and femur requirements.</p>					
17. <i>Key Words</i>			18. <i>Distribution Statement</i>		
19. <i>Security Classif. (of this report)</i> UNCLASSIFIED		20. <i>Security Classif. (of this page)</i> UNCLASSIFIED		21. <i>No. of Pages</i>	22. <i>Price</i>

## TABLE OF CONTENTS

<u>Section</u>		<u>Page No.</u>
1	PURPOSE AND TEST PROCEDURE	1-1
2	SUMMARY OF TEST	2-1
3	OCCUPANT AND VEHICLE INFORMATION	3-1
4	SUMMARY OF RESULTS FOR: FMVSS 212, "Windshield Mounting" FMVSS 219 (Partial), "Windshield Zone Intrusion" FMVSS 301, "Fuel System Integrity"	4-1
APPENDIX A	PHOTOGRAPHS	A-1
APPENDIX B	VEHICLE, LOAD CELL BARRIER AND DUMMY RESPONSE DATA	B-1
APPENDIX C	PART 572 B/E DUMMY CONFIGURATION AND PERFORMANCE VERIFICATION TESTS	C-1
APPENDIX D	DUMMY, VEHICLE AND LABORATORY INSTRUMENT CALIBRATION	D-1
APPENDIX E	VEHICLE OWNER'S MANUAL OCCUPANT RESTRAINT SYSTEM INSTRUCTIONS	E-1

## LIST OF FIGURES

<u>Figure No.</u>		<u>Page No.</u>
1	Dummy Measurements for Front Seat Passengers	3-4
2	Seat Belt Positioning Data	3-6
3	Camera Positions for Frontal Impacts	3-8
4	Vehicle Target Locations	3-10
5	Load Cell Locations on Fixed Barrier	3-11
6	Vehicle Accelerometer Locations	3-12
7	Test Vehicle Measurements	3-13
8	FMVSS No. 212 - "Windshield Mounting" Data	4-2
9	FMVSS No. 219 (Partial) - "Windshield Intrusion" Data	4-3
10	Dummy Configuration Dimensions	C-3

## LIST OF TABLES

<u>Table No.</u>		<u>Page No.</u>
1	General Test and Vehicle Data	2-2
2	Dummy Injury Criteria Values	3-2
3	Hybrid III Neck and Chest Data Sheet	3-3
4	Front Seat Occupant Measurements	3-5
5	Seat Belt Performance Assessment Test Data	3-7
6	High Speed Camera Locations	3-9
7	Vehicle Measurements	3-14
8	Accident Investigation Division Data	3-15
9	FMVSS No. 301-75 "Fuel System Integrity" Post Impact Test Data	4-4
10	FMVSS No. 301 - "Static Rollover" Data	4-5

## Section 1

### PURPOSE AND TEST PROCEDURE

This 56.3 kph frontal barrier impact test is part of the Composite FY 92 Vehicle Barrier Impact Testing Program sponsored by the National Highway Traffic Safety Administration (NHTSA) under Contract No. DTNH22-90-D-02121. The purpose of this test was to obtain vehicle crashworthiness and occupant restraint system performance data for an impact speed in excess of the current 48.3 kph requirements.

The 56.3 kph frontal barrier impact test was conducted in accordance with the Office of Market Incentives (OMI) Laboratory Indicant Test procedure.

## Section 2

### SUMMARY OF TEST MR5400

A load cell barrier consisting of 36 load cells was impacted by a 1994 Mazda 626 DX 4-Door Sedan at a velocity of 56.6 kph. The test was performed at the Calspan Corporation Advanced Technology Center on November 4, 1993. Pre- and post-test photographs of the vehicle and dummies can be found in Appendix A.

The frontal barrier impact event was documented by 1 real-time camera and 16 high-speed cameras. Camera locations and other pertinent camera information can be found in this report.

Two Part 572, 50th percentile male anthropomorphic test devices (ATDs), were placed in the driver and right-front passenger seating positions according to dummy placement instructions specified in the Laboratory Indicant Test Procedure.

Both ATDs were fully instrumented with head and chest triaxial accelerometers and right/left femur load cells. Seat belt load cells were also on the driver's and passenger's lap and shoulder belts to measure dummy torso and pelvic section loading. The driver ATD (Serial No. 45 ) and the right-front passenger ATD (Serial No. 150 ) were calibrated previous to this test. Certification details, along with instrumentation calibration data, are found in Appendix C and D.

The 81 channels of data were recorded on a P.C. based data acquisition system. Appendix B contains the vehicle, load cell barrier and dummy response data traces. The location of the restraint system prevented measurement of belt spool-out. Pos. #1 Upper Neck Fz is not accurate after 40 milliseconds. Load Cell D3 did not record accurately. This load cell was not used in the load cell summations.

The driver's HIC was 484.5 . The maximum chest deceleration over 3 milliseconds was 53.8 g's and maximum chest deflection was 43.2 mm. Femur loads were -5364.0 newtons on the left femur and -6690.0 newtons on the right femur.

The right front passenger's HIC was 300.1 . Maximum chest deceleration over 3 milliseconds was 44.0 g's and maximum chest deflection was -39.7 mm. Femur loads were -5474.3 newtons on the left and -6360.7 newtons on the right.

Table 1

GENERAL TEST AND VEHICLE DATA

Vehicle Year/Make/Model/Body Style: 1994 Mazda 626 DX 4 Door Sedan

NHTSA Test No.: MR5400 VIN.: 1YVGE22C7R5106409

Body Color: Blue Date of Manufacture: 8-9-93

Date Received: 9-22-93

Odometer Reading: 16

Engine: 4 Cylinders; - C.I.D.; 2 Liters; - CC  
X Gas; - Diesel; - Turbocharged  
- Longitudinal; - Transverse

Transmission: 4 Speed; - Manual; X Automatic; X Overdrive

Final Drive: X Front Wheel; - Rear Wheel; - Four Wheel

Accessories: X A/C; X P/S; X P/B; - P/wdo  
X Tilt Wheel; - P/seats; - Cruise Control - Other

Type of Occupant Restraint: 3-point restraints with supplemental airbags at each of the front outboard locations

DATA RECORDED FROM VEHICLE'S TIRE PLACARD:

Tire Pressure (at capacity): Front 220 kPa, Rear 180 kPa

Recommended Tire Size: P195/65R14885

Recommended Cold Tire Pressure: Front 220 kPa, Rear 180 kPa

Tires on Vehicle: P195/65R14885 Manufacturer: Dunlop

Number of Occupants: 2 Front; 3 Rear; - 3rd Seat; 5 TOTAL

Type of Front Seats: X Bucket; - Bench; - Split Bench

Type of Front Seat Back: - Fixed; X Adj. with X Lever - Rot. Knob

Vehicle Capacity Weight (VCW) = 385 kgs. (A)

No. of Occupants x 68 kgs. = 340 kgs. (B)

Rated Cargo and Luggage Weight (RCLW) A-B = 45 kgs.

GVWR 1721 kgs. GAWR: Front 929 kgs. Rear 792 kgs.

Table 1

GENERAL TEST AND VEHICLE DATA (cont'd)

WEIGHT OF TEST VEHICLE AS RECEIVED FROM DEALER (with maximum fluids) = UDW:

Right Front =	<u>395</u>	kgs.	Right Rear =	<u>218</u>	kgs.
Left Front =	<u>395</u>	kgs.	Left Rear =	<u>245</u>	kgs.
TOTAL FRONT WEIGHT =	<u>790</u>	kgs.	(	<u>63</u>	% of Total Vehicle Weight )
TOTAL REAR WEIGHT =	<u>463</u>	kgs.	(	<u>37</u>	% of Total Vehicle Weight )
TOTAL DELIVERED WEIGHT =	<u>1253</u>	kgs.			

CALCULATION FOR TARGET TEST WEIGHT:

UDW = Unloaded Delivered Weight	<u>1253</u>	kgs.
VCW = Vehicle Capacity Weight	<u>385</u>	kgs.
DSC = Designated Seating Capacity	<u>5</u>	
RCLW = VCW - 68 (DSC) =	<u>45</u>	kgs.
Target Test Weight = UDW + RCLW + (2 dummies x 76 kgs./ dummy)		
Target Test Weight =	<u>1450</u>	kgs.

WEIGHT OF TEST VEHICLE WITH REQUIRED DUMMIES AND 46 KGS CARGO:

Right Front =	<u>408</u>	kgs.	Right Rear =	<u>304</u>	kgs.
Left Front =	<u>417</u>	kgs.	Left Rear =	<u>318</u>	kgs.
TOTAL FRONT WEIGHT =	<u>825</u>	kgs.	(	<u>57</u>	% of Total Vehicle Weight )
TOTAL REAR WEIGHT =	<u>622</u>	kgs.	(	<u>43</u>	% of Total Vehicle Weight )
TOTAL TEST WEIGHT =	<u>1447</u>	kgs.			
Weight of ballast secured in vehicle trunk area =	<u>0</u>	kgs.			

VEHICLE ATTITUDE (all dimensions in mm):

Delivered Attitude:	RF	<u>716</u>	LF	<u>706</u>	RR	<u>706</u>	LR	<u>698</u>
Test Attitude:	RF	<u>680</u>	LF	<u>685</u>	RR	<u>645</u>	LR	<u>646</u>

Wheel Base: 2610 mm.; C.G. = 1122 mm. rearward of front wheel C/L

Remarks: 51 liters of Stoddard solution was placed in the fuel tank.

Table 1

GENERAL TEST AND VEHICLE DATA (cont'd)

POST -IMPACT DATA:

Type of Test: Frontal Barrier Impact Angle: 0°  
 Date of Test: November 4, 1993 Time of Test: 12:40  
 Ambient Temperature: 11 ° C at impact area  
 Temperature in Occupant Compartment: 21 ° C  
 Windshield Molding Temperature: 21 ° C  
 Required Impact Velocity Range: 55.5 to 57.1 kph  
 Impact Velocity: primary = 56.6 kph, secondary = 56.8 kph  
 Distance From Front Bumper to Barrier Face When  
 Entering Speed Trap: 1321 mm  
 Exiting Speed Trap: 305 mm

VEHICLE REBOUND AND CRUSH (mm):

Vehicle Length:	Pre-test = R	<u>4560</u>	C <sub>L</sub>	<u>4670</u>	L	<u>4530</u>
	Post-test = R	<u>4075</u>	C <sub>L</sub>	<u>4110</u>	L	<u>4070</u>
	Crush = R	<u>485</u>	C <sub>L</sub>	<u>560</u>	L	<u>460</u>

Distance from front of test vehicle to point of impact:  
 R 621 C<sub>L</sub> 621 L 671

VISIBLE DUMMY CONTACT POINTS:

	<u>Driver</u>	<u>Passenger</u>
Head	<u>Airbag</u>	<u>Airbag</u>
Chest	<u>Airbag</u>	<u>Airbag</u>
Abdomen	<u>No Contact</u>	<u>No Contact</u>
Left Knee	<u>Lower Dashpanel</u>	<u>Glove Box Door</u>
Right Knee	<u>Lower Dashpanel</u>	<u>Glove Box Door</u>

Table 1

GENERAL TEST AND VEHICLE DATA (cont'd)

	<u>Front</u>		<u>Rear</u>	
	<u>Left</u>	<u>Right</u>	<u>Left</u>	<u>Right</u>
Door Opening	<u>Operable</u>	<u>Operable</u>	<u>Operable</u>	<u>Operable</u>
	<u>Front</u>		<u>Rear</u>	
<u>Seat Movement</u>	<u>Left</u>	<u>Right</u>	<u>Left</u>	<u>Right</u>
Seat Back Failure	<u>None</u>	<u>None</u>	<u>N/A</u>	<u>N/A</u>
Seat Shift (mm.)	<u>0.0</u>	<u>0.0</u>	<u>N/A</u>	<u>N/A</u>
<u>Glazing Damage</u>				
Backlight/Windshield:	<u>Windshield sustained stress fractures but remained intact.</u>			
Other Notable Impact Effects:	<u>None.</u>			

### Section 3

## OCCUPANT AND VEHICLE INFORMATION

### I. DATA

1. Dummy Injury Criteria Data Summary
2. Dummy Positioning Data
3. Seat Belt Performance Assessment Data
4. Camera Locations
5. Vehicle Target Locations
6. Load Cell Barrier Data
7. Vehicle Accelerometer Data
8. Test Vehicle Measurements

Table 2

DUMMY INJURY CRITERIA VALUES

NHTSA No.: MR5400 Vehicle: 1994 Mazda 626 DX 4-Door Sedan

	MAXIMUM HEAD ACCELERATION (g's)			
	X	Y	Z	R
Position #1 - Driver	-55.8	-11.4	14.8	58.7
Position #2 - Passenger	-45.8	16.6	23.5	51.6

	MAXIMUM CHEST ACCELERATION (g's)			
	X	Y	Z	R*
Position #1 - Driver	-54.8	9.5	7.6	53.8
Position #2 - Passenger	-45.6	12.2	8.6	44.0

\* The maximum chest resultant acceleration is defined as the maximum acceleration which exceeds 0.003 seconds in duration.

	MAXIMUM FORCE - FEMUR LOAD (nwt)	
	LEFT FEMUR	RIGHT FEMUR
Position #1 - Driver	-5364.0	-6690.0
Position #2 - Passenger	-5474.3	-6360.7

	MAXIMUM FORCE - SEAT BELT LOADS (nwt)		
	SHOULDER STRAP UPPER BELT LOAD	LAP STRAP RIGHT BELT LOAD	LAP STRAP LEFT BELT LOAD
Position #1 - Driver	6414.0	-	2828.1
Position #2 - Passenger	7488.1	2933.2	-

	HEAD INJURY CRITERIA (HIC)			
	HIC**	t <sub>1</sub> (mSec)	t <sub>2</sub> (mSec)	Average Acceleration t <sub>1</sub> to t <sub>2</sub>
Position #1 - Driver	484.5	60.0	93.48	46.15
Position #2 - Passenger	300.12	55.2	91.08	37.07

\*\* HIC is as defined in FMVSS 208. The maximum time interval from t<sub>1</sub> to t<sub>2</sub> is 36 milliseconds.

Table 3

HYBRID III NECK AND CHEST DATA SHEETVehicle Year/Make/Model/Body Style: 1994 Mazda 626 DX 4-Door SedanVehicle NHTSA No.: MR5400 Test Date: November 4, 1993

MAXIMUM VALUES	DRIVER DUMMY ID # : 45	PASSENGER DUMMY ID # : 150
Neck Load X ( nwt )	≈ 300.0	689.2
Neck Load Y ( nwt )	187.8	-318.1
Neck Load Z ( nwt )	N/A	1093.6
Neck Moment X ( nwt-m )	16.1	-30.8
Neck Moment Y ( nwt-m )	32.6	49.5
Neck Moment Z ( nwt-m )	14.6	-15.4
Chest Deflection X (mm.)	-43.2	-39.7
Time of Max. Occurrence (msec )	68.3	78.6

Note: All values listed occur during the primary impact event.

Figure 1

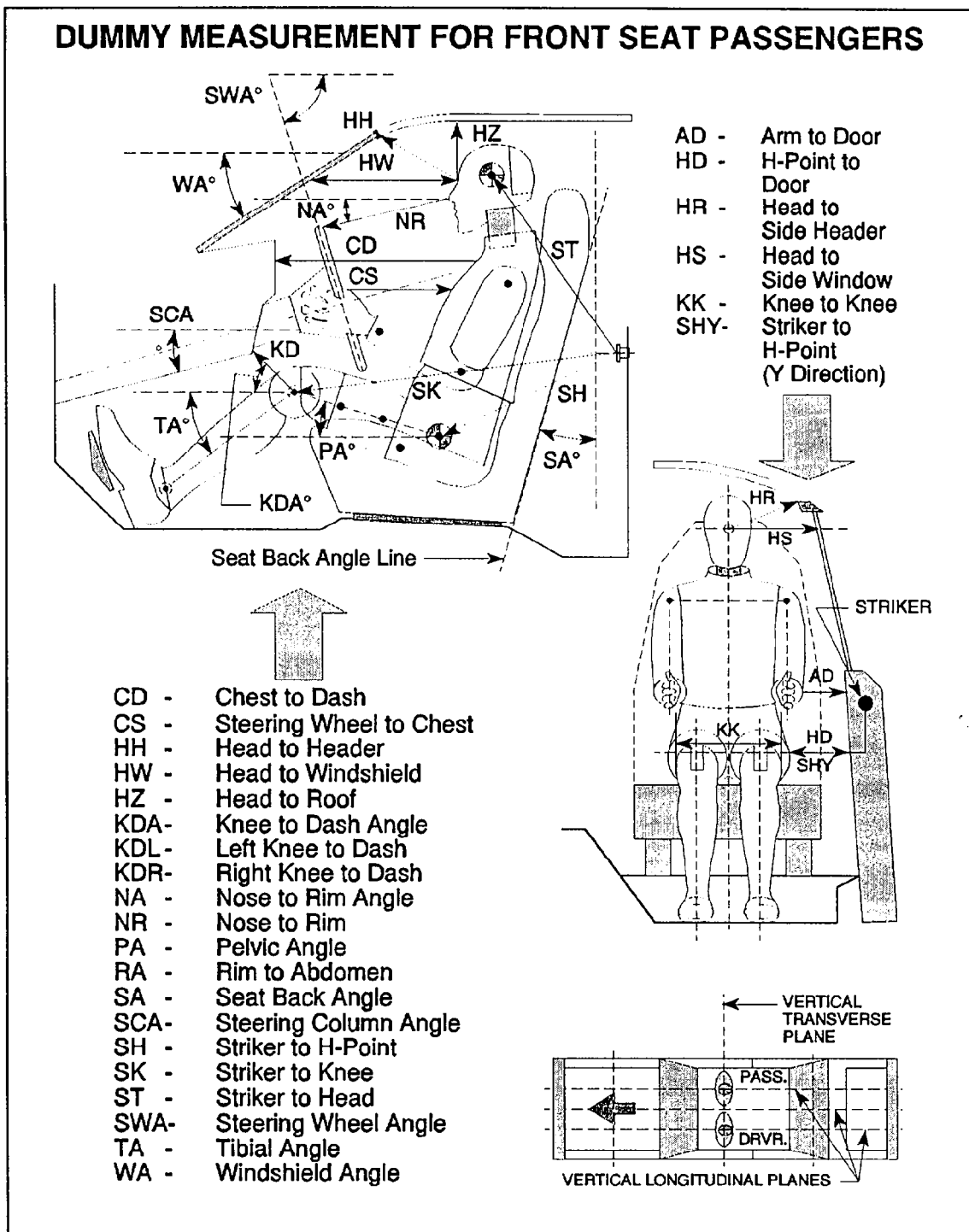
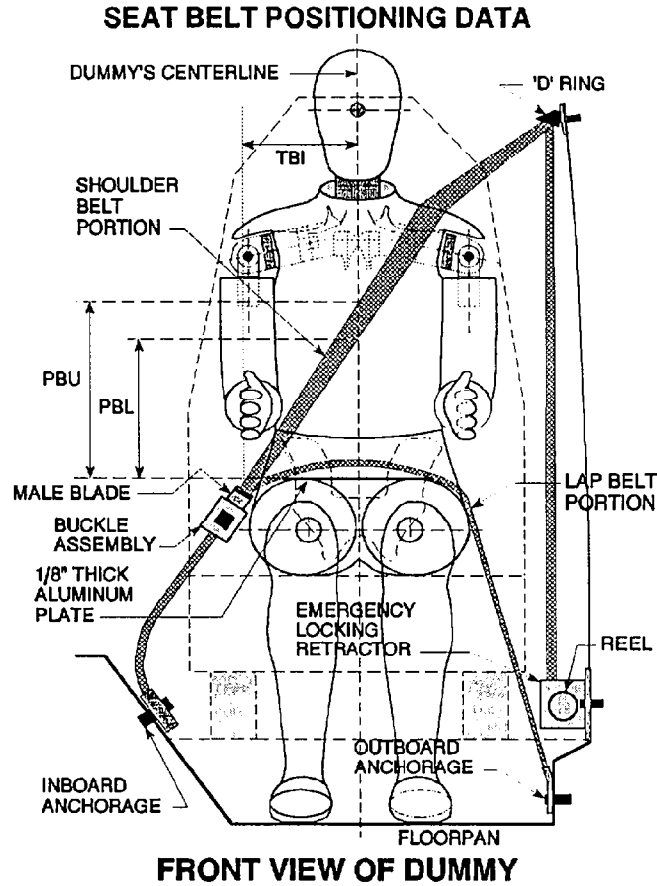

**Table 4**  
**FRONT SEAT OCCUPANT MEASUREMENTS**

	DRIVER (Serial # 45 )			PASS. (Serial # 150 )		
WA°	30°			30°		
SWA°	69°			N/A		
SCA°	21°			N/A		
SA°	6th Notch = 21°			6th Notch = 21°		
HZ	236			203		
HH	361			356		
HW	597			528		
HR	236			224		
NR	345	Angle	- 10°	N/A		
CD	579			528		
CS	262			N/A		
RA	173			N/A		
KDL	163	Angle (KDA)	35°	168		
KDR	147			137	Angle (KDA)	34°
PA°	24°			25°		
TA°	40°			36°		
KK	330			305		
ST	483	Angle	12°	488	Angle	12°
SK	572	Angle	95°	625	Angle	96°
SH	241	Angle	135°	267	Angle	134°
SHY	241			216		
HS	241			239		
HD	183			183		
AD	122			130		

Figure 2

SEAT BELT POSITIONING DATA



	DRIVER DUMMY (mm)	PASSENGER DUMMY (mm)
PBU -- Top surface of alum. plate to upper edge	310	320
PBL-- Top surface of alum. plate to belt lower edge	230	240
<u>LAP BELT TENSION</u>	0.9 kg	0.9 kg
<u>SHOULDER BELT TENSION</u>	Retractor	Retractor

Table 5

SEAT BELT PERFORMANCE ASSESSMENT TEST DATA

<u>BELT LENGTH DATA:</u>	<u>Driver</u>	<u>Passenger</u>
Belt length from trim panel exit to bolt hole anchor point for continuous webbing systems.	1780 mm	1780 mm
Shoulder belt length as measured on Part 572 Dummy.	800 mm	800 mm
Lap belt length as measured on Part 572 Dummy.	760 mm	760 mm
<u>SHOULDER BELT SPOOL-OFF DATA:</u>		
As determined by film analysis.	N/A	N/A
As determined mechanically.	36 mm	30 mm
As determined electronically.	N/A	N/A
<u>BELT STRETCH DATA:</u>		
Measured electronically between shoulder belt load cell and the "D" ring.	31.8 mm/M	41.2 mm/M
Measured mechanically.	50 mm/M	50 mm/M

Figure 3

CAMERA POSITIONS FOR FRONTAL IMPACTS

NOTE: Camera Information Shown on Table 4

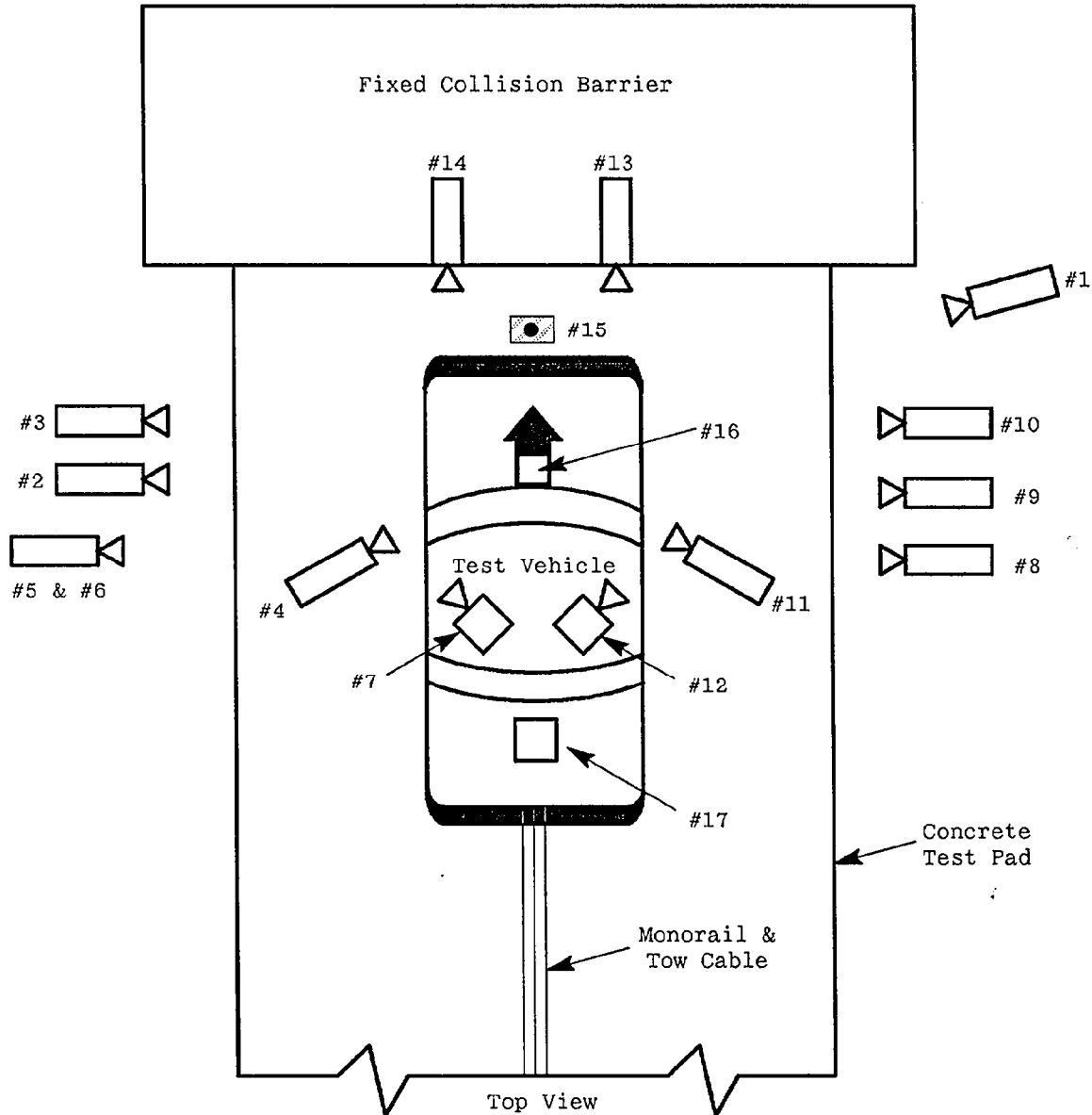

Table 6  
HIGH-SPEED CAMERA LOCATIONS

Test No. MR5400

Vehicle: 1994 Mazda 626 DX 4-Door Sedan

CAMERA NO.	VIEW	CAMERA POSITIONS (MM.)*			ANGLE** (deg)	FILM PLANE TO HEAD TARGET	LENS (mm)	SPEED (fps)
		X	Y	Z				
1	Real-Time Camera	-	-	-	-	-	-	24
2	Overall Left Side	6248	1676	1067	-4	5822	13	1030
3	Left Side View	7845	991	1041	-3	7419	25	1020
4	Driver and Interior View	2692	2667	1803	-24	2266	13	1030
5	Steering Column (Bottom)	7010	1880	1168	-5	6584	25	930
6	Steering Column (Top)	7010	1880	1778	-10	6584	25	940
7	Left Belt	-	-	-	-	-	8	650
8	Overall Right Side	6375	1803	1041	-2	5949	13	920
9	Right Side View	7645	1372	1041	-3	7219	25	750
10	Right Passenger View	7595	1905	1372	-4	7169	35	750
11	Passenger and Interior View	2743	2642	1829	-22	2317	13	1000
12	Right Belt	-	-	-	-	-	8	N.T.
13	Passenger Front View	559	127	1778	-35	-	13	990
14	Driver Front View	559	127	1778	-35	-	13	1020
15	Windshield View	0	0	3048	-45	-	13	1090
16	Pit View of Engine	0	505	-3048	90	-	13	720
17	Pit View of Fuel Tank	0	3432	-3048	90	-	13	730

\*X = film plane to monorail centerline

Y = film plane to impact location

Z = film plane to ground

\*\* = referenced to horizontal plane

N.T. indicates No Timing

Figure 4  
 VEHICLE TARGET LOCATIONS

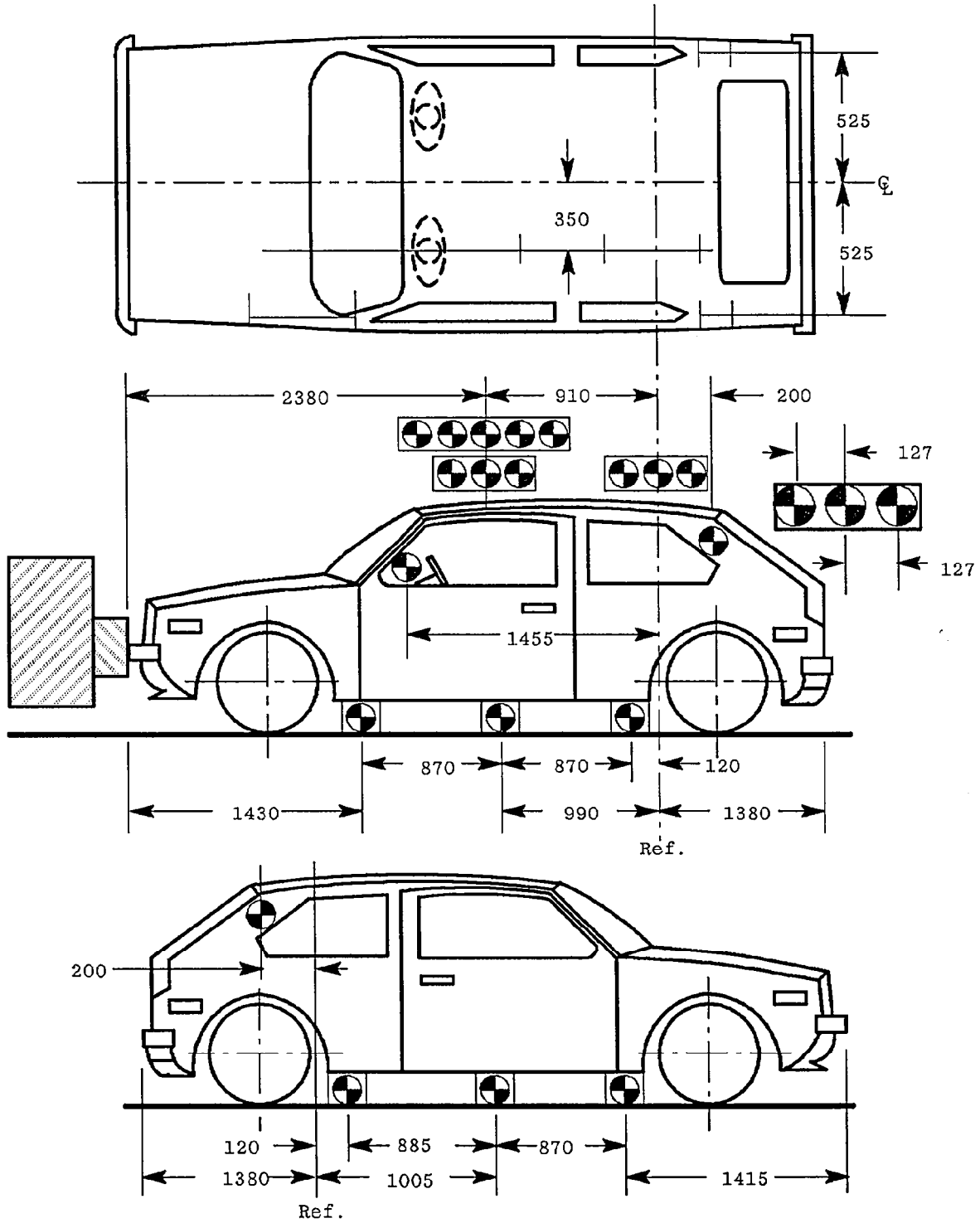

(Dimensions in millimeters)

## LOAD CELL LOCATIONS ON FIXED BARRIER

- 36 Load Cells
- 4 Rows
- 9 Columns
- 6 Groupings (6 cells/group)

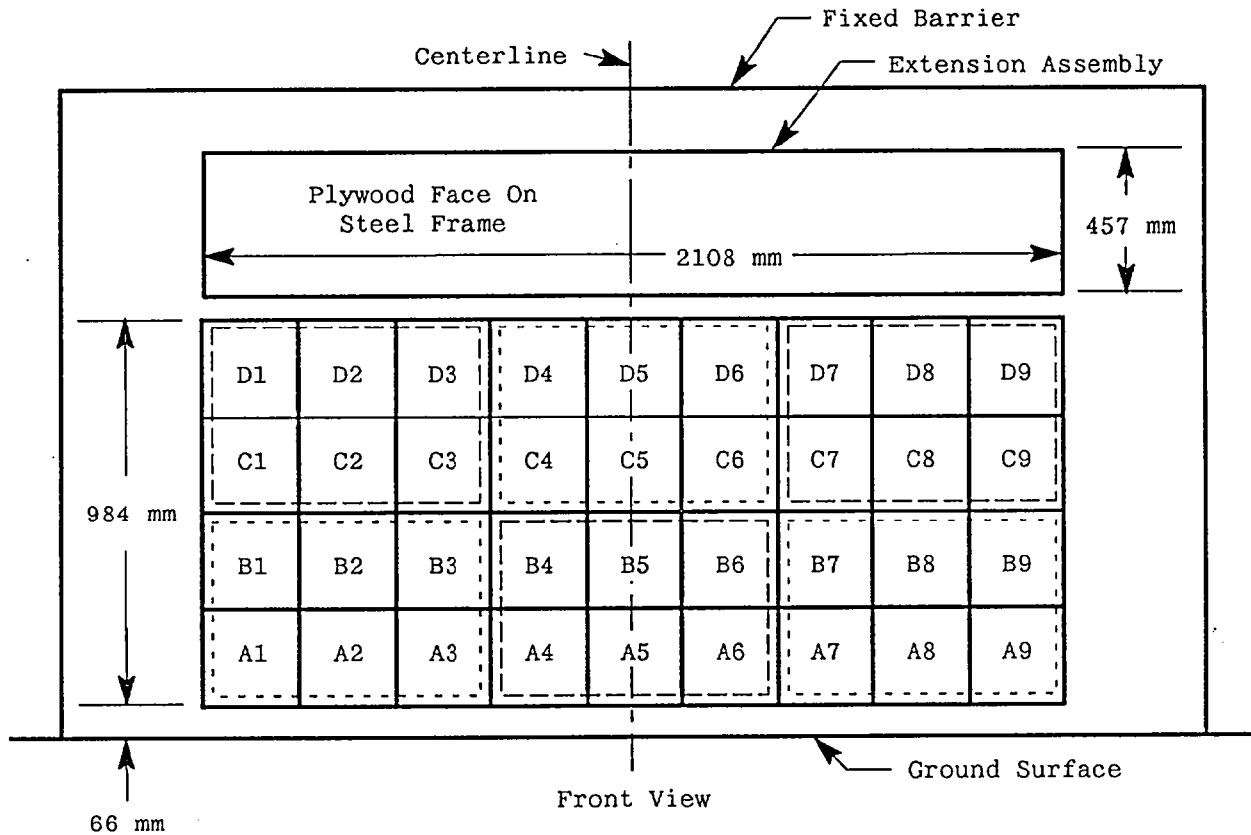

### 6 GROUPS OF 6 LOAD CELLS EACH

Group 4 C1 thru D3	Group 5 C4 thru D6	Group 6 C7 thru D9
Group 1 A1 thru B3	Group 2 A4 thru B6	Group 3 A7 thru B9

The following data is presented in Appendix B:

- (1) Data from 36 individual load cells
- (2) Total or Sum of 36 individual load cells
- (3) Data from 6 Groupings shown above (6 cells/group)

Figure 6  
VEHICLE ACCELEROMETER LOCATIONS

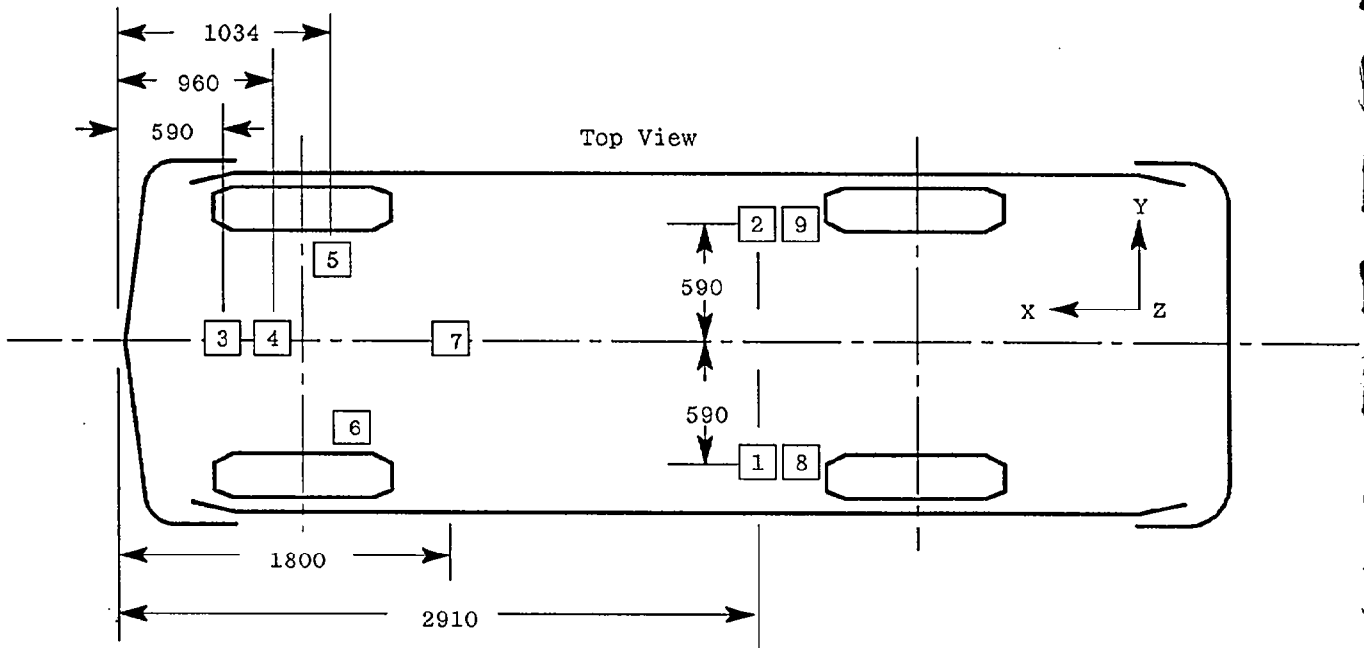

All dimensions are in millimeters

ACCELEROMETER NUMBER*	ACCELEROMETER LOCATION	LOCATION		
		X	Y	Z
1	Left Rear Seat Crossmember	X		
2	Right Rear Seat Crossmember	X		
3	Top of engine	X		
4	Bottom of engine	X		
5	Right Disc Brake Caliper	X		
6	Left Disc Brake Caliper	X		
7	Instrument Panel	X		
8	Left Rear Seat Crossmember	X		
9	Right Rear Seat Crossmember	X		

\* The accelerometer pack number can be correlated with the vehicle response data traces found in Appendix B.

Figure 7

TEST VEHICLE MEASUREMENTS

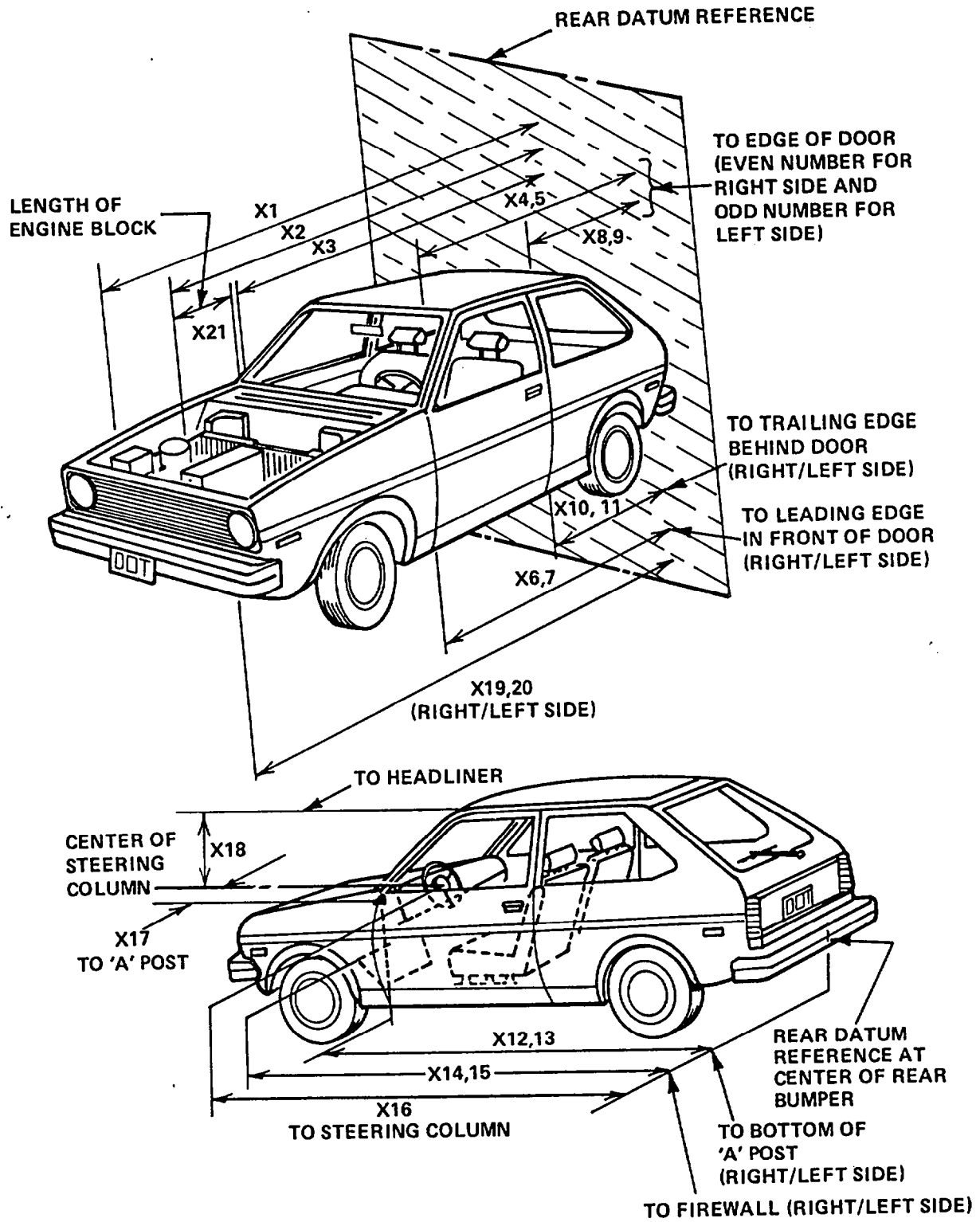

Table 7

VEHICLE MEASUREMENTS

No.	Description	All Dimensions in mm			Differences
		Pre-Test	Post-Test		
X1	Total Length of Vehicle at Centerline	4670	4110		560
X2	Rear Surface of Vehicle to Front of Engine	3995	3780		215
X3	Rear Surface of Vehicle to Firewall	3510	3380		130
X4	Rear Surface of Vehicle to Upper Leading Edge of Right Door	3088	3120		-32
X5	Rear Surface of Vehicle to Upper Leading Edge of Left Door	3089	3110		-21
X6	Rear Surface of Vehicle to Lower Leading Edge of Right Door	3122	3129		-7
X7	Rear Surface of Vehicle to Lower Leading Edge of Left Door	3123	3123		0
X8	Rear Surface of Vehicle to Upper Trailing Edge of Right Door	2128	2141		-13
X9	Rear Surface of Vehicle to Upper Trailing Edge of Left Door	2130	2149		-19
X10	Rear Surface of Vehicle to Lower Trailing Edge of Right Door	3128	2130		-2
X11	Rear Surface of Vehicle to Lower Trailing Edge of Left Door	2129	2128		1
X12	Rear Surface of Vehicle to Bottom of "A" Post of Right Side	3185	3187		-2
X13	Rear Surface of Vehicle to Bottom of "A" Post of Left Side	3186	3200		-14
X14	Rear Surface of Vehicle to Firewall, Right Side	3420	3400		20
X15	Rear Surface of Vehicle to Firewall, Left Side	3440	3340		100
X16	Rear Surface of Vehicle to Steering Column	2695	2730		-35
X17	Center of Steering Column to "A" Post	400	N/A		N/A
X18	Center of Steering Column to Headliner	450	370		80
X19	Rear Surface of Vehicle to Right Side of Front Bumper	4560	4075		485
X20	Rear Surface of Vehicle to Left Side of Front Bumper	4530	4070		460
X21	Length of Engine Block	470	470		0
RD	Rear Surface of Vehicle to Right Side of Dash Panel	3000	3010		-10
CD	Rear Surface of Vehicle to Center of Dash Panel	3025	3020		5
LD	Rear Surface of Vehicle to Left Side of Dash Panel	3020	2990		30

Table 8

ACCIDENT INVESTIGATION DIVISION DATA

FOR 56.3 KPH FRONTAL BARRIER IMPACT

Vehicle Make/Model/Body Style: 1994 Mazda 626 DX 4-Door Sedan  
 Vehicle NHTSA No.: MR5400 VIN: 1YVGE22C7R5106409  
 Model Year: 1994 Build Date: 8/9/93 Test Date: 11/4/93  
 Vehicle Size Category: Mid Size Test Weight: 1447 Kgs  
 Vehicle Wheelbase: 2610 mm; Front Overhang: 1430 mm; Overall Width: 1050 mm  
 Collision Deformation Classification (CDC) Code: 12FDEW3

Crush Depth Dimensions;

C1 = 445 mm  
 C2 = 575 mm  
 C3 = 570 mm  
 C4 = 575 mm  
 C5 = 570 mm  
 C6 = 450 mm

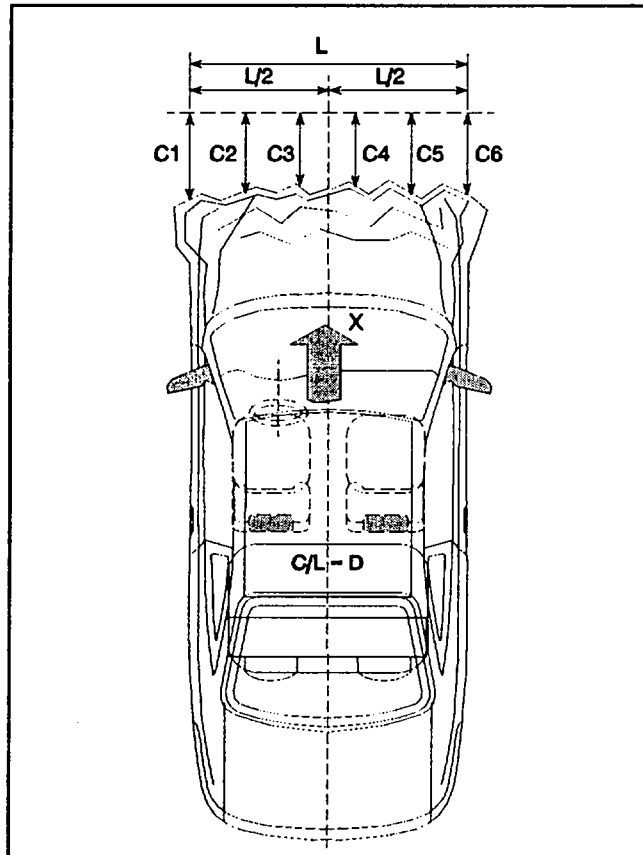

Midpoint of Damage:  $D = \text{Vehicle Centerline (Longitud.)}$

Length of Damaged Region:  $L = \underline{1050}$  mm

**Section 4**

**SUMMARY OF RESULTS OF FMVSS 212, 219 (Partial) AND 301**

**"Windshield Mounting" FMVSS No. 212 Data**

**"Windshield Zone Intrusion" FMVSS No. 219 Data**

**"Fuel System Integrity" FMVSS No. 301**

Figure 8

FMVSS NO. 212 - "WINDSHIELD MOUNTING" DATA

DETAILS OF WINDSHIELD MOUNTING SUCH AS RETENTION METHOD, TRIM TYPE, ETC.:

Windshield is bonded in place and covered with 18 mm. molding.

FMVSS 212 REQUIREMENTS:

The Post-Test periphery retention amount must be at least 75% of the Pre-Test periphery measurement for vehicles NOT equipped with automatic restraints, and 50% for each side of the windshield for vehicles equipped with automatic restraint systems for front occupants,

FMVSS 212 TEST DATA

	WINDSHIELD PERIPHERY		
	PRE-TEST (mm)	POST-TEST(mm)	% OF RETENTION
RIGHT SIDE	2040	2040	100
LEFT SIDE	2040	2040	100
TOTAL	4080	4080	100

AREA OF RETENTION FAILURE:

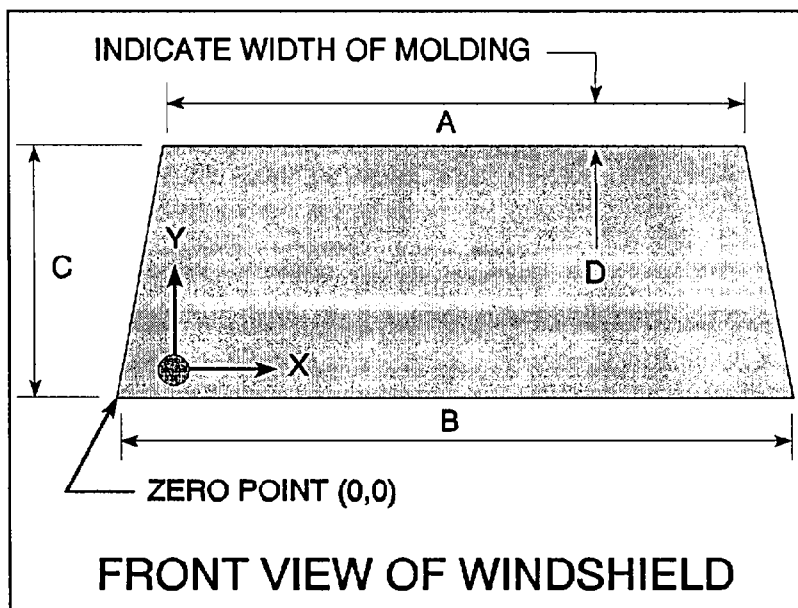

DIMENSIONS	
A	
B	
C	
D	

FAILURE DETAILS: None

FMVSS NO. 219 (PARTIAL) - "WINDSHIELD ZONE INTRUSION" DATA

PROTECTED ZONE LOWER EDGE REQUIREMENT:

The lower edge of the protected zone is determined by placing a 6.5" diameter rigid sphere weighing 15 pounds in a position such that it simultaneously contacts the inner surface of the windshield and the top surface of the instrument panel including padding. The locus of points is drawn on the inner surface of the windshield contacted by the sphere across the width of the instrument panel. From the outermost contactable points extend the locus line horizontally to the edges of the windshield, then draw a line on the inner surface of the windshield below and 1/2" distant from the locus line. The LOWER EDGE OF THE PROTECTED ZONE is the longitudinal projection of this line onto the outer surface of the windshield.

FMVSS 219 TEST DATA: (Dimensions in mm)

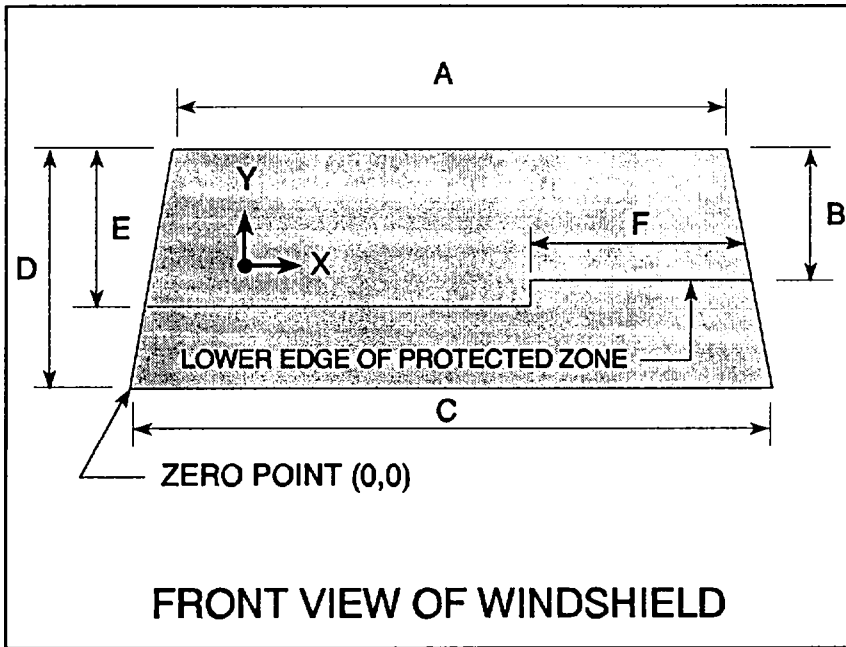

DIMENSIONS	
A	1170
B	405
C	1560
D	675
E	437
F	720

DETAILS OF WINDSHIELD GLASS PENETRATION GREATER THAN 1/4": None

(Show location of penetration on the above sketch)

	COORDINATES	
	X	Y
1.		
2.		
3.		
4.		



FMVSS NO. 301 STATIC ROLLOVER DATA SHEET

TEST PHASE:

Vehicle NHTSA ID No.  
MR5400

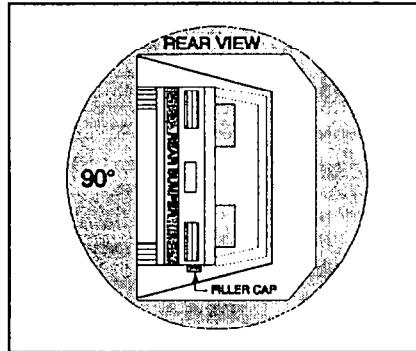
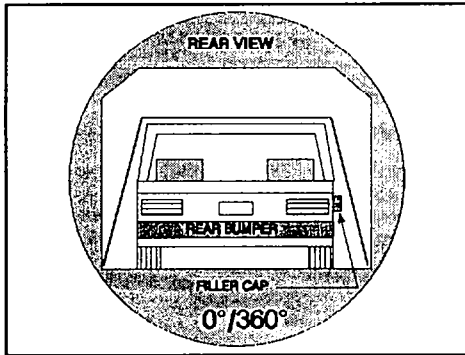

I. DETERMINATION OF SOLVENT COLLECTION TIME PERIOD:

Rollover Fixture 90 deg. Rotation Time (Spec. Range = 1 to 3 minutes)	2	minutes	50	seconds
FMVSS 301 Position Hold Time +	5	minutes	00	seconds
<b>TOTAL</b>	7	minutes	50	seconds
Next whole minute interval	8	minutes	00	seconds

II. FMVSS 301 REQUIREMENTS:

(1) Time Period

First 5 min. from onset of rotation	6th min.	7th min.	8th min. if reqd.
-------------------------------------	----------	----------	-------------------

(2) Maximum Allowable Solvent Spillage

5 ounces	1 ounce	1 ounce	1 ounce
----------	---------	---------	---------

III. ACTUAL TEST VEHICLE SOLVENT SPILLAGE:

0	0	0	0
---	---	---	---

Note: Record spillage for whole minute intervals only as determined above.

IV. SOLVENT SPILLAGE LOCATION(S): None

Table 10

FMVSS NO. 301 STATIC ROLLOVER DATA SHEET

TEST PHASE:

Vehicle NHTSA ID No.  
MR5400

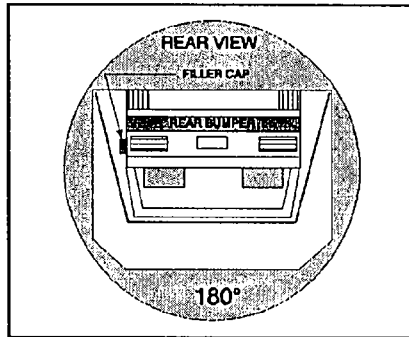
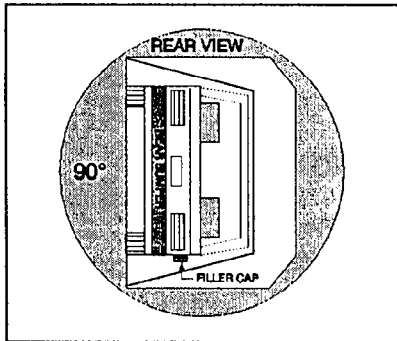

I. DETERMINATION OF SOLVENT COLLECTION TIME PERIOD:

Rollover Fixture 90 deg. Rotation Time  
(Spec. Range = 1 to 3 minutes)

2 minutes      50 seconds

FMVSS 301 Position Hold Time +

7 minutes      00 seconds

**TOTAL**

7 minutes      45 seconds

Next whole minute interval

8 minutes      00 seconds

II. FMVSS 301 REQUIREMENTS:

(1) Time Period

First 5 min. from onset of rotation	6th min.	7th min.	8th min. if reqd.
-------------------------------------	----------	----------	-------------------

(2) Maximum Allowable Solvent Spillage

5 ounces	1 ounce	1 ounce	1 ounce
----------	---------	---------	---------

III. ACTUAL TEST VEHICLE SOLVENT SPILLAGE:

0	0	0	0
---	---	---	---

Note: Record spillage for whole minute intervals only as determined above.

IV. SOLVENT SPILLAGE LOCATION(S): None

FMVSS NO. 301 STATIC ROLLOVER DATA SHEET

TEST PHASE:

Vehicle NHTSA ID No.  
MR5400

---

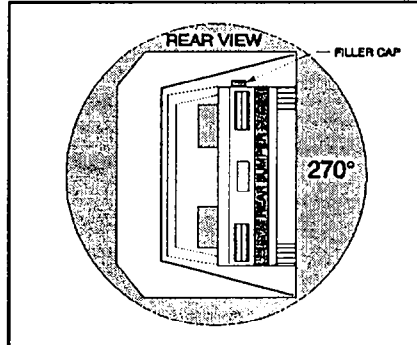
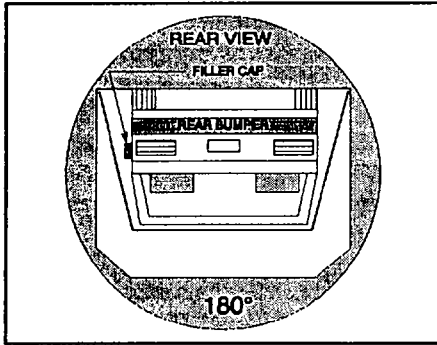

**I. DETERMINATION OF SOLVENT COLLECTION TIME PERIOD:**

Rollover Fixture 90 deg. Rotation Time (Spec. Range = 1 to 3 minutes)	<u>2</u>	minutes	<u>45</u>	seconds
FMVSS 301 Position Hold Time +	<u>5</u>	minutes	<u>00</u>	seconds
<b>TOTAL</b>	<u>7</u>	minutes	<u>45</u>	seconds
Next whole minute interval	<u>8</u>	minutes	<u>00</u>	seconds

**II. FMVSS 301 REQUIREMENTS:**

(1) Time Period

First 5 min. from onset of rotation	6th min.	7th min.	8th min. if reqd.
-------------------------------------	----------	----------	-------------------

(2) Maximum Allowable Solvent Spillage

5 ounces	1 ounce	1 ounce	1 ounce
----------	---------	---------	---------

**III. ACTUAL TEST VEHICLE SOLVENT SPILLAGE:**

0	0	0	0
---	---	---	---

Note: Record spillage for whole minute intervals only as determined above.

**IV. SOLVENT SPILLAGE LOCATION(S): None**

Table 10

FMVSS NO. 301 STATIC ROLLOVER DATA SHEET

TEST PHASE:

Vehicle NHTSA ID No.  
MR5400

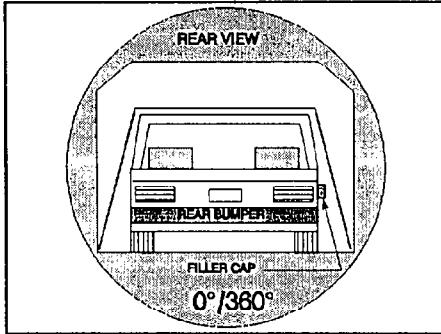
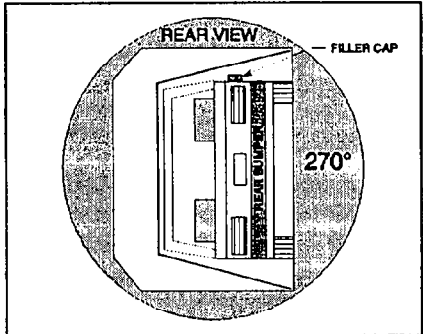

I. DETERMINATION OF SOLVENT COLLECTION TIME PERIOD:

Rollover Fixture 90 deg. Rotation Time (Spec. Range = 1 to 3 minutes)	2	minutes	50	seconds
FMVSS 301 Position Hold Time +	5	minutes	00	seconds
<b>TOTAL</b>	7	minutes	55	seconds
Next whole minute interval	8	minutes	00	seconds

II. FMVSS 301 REQUIREMENTS:

(1) Time Period

First 5 min. from onset of rotation	6th min.	7th min.	8th min. if reqd.
-------------------------------------	----------	----------	-------------------

(2) Maximum Allowable Solvent Spillage

5 ounces	1 ounce	1 ounce	1 ounce
----------	---------	---------	---------

III. ACTUAL TEST VEHICLE SOLVENT SPILLAGE:

0	0	0	0
---	---	---	---

Note: Record spillage for whole minute intervals only as determined above.

IV. SOLVENT SPILLAGE LOCATION(S): None

Appendix A  
PHOTOGRAPHS

PHOTOGRAPHS

<u>Figure</u>	<u>Title</u>	<u>Page</u>
A-1	LOAD CELL LOCATIONS.....	A-3
A-2	PRE-TEST FRONT VIEW.....	A-4
A-3	POST TEST FRONT VIEW.....	A-5
A-4	PRE-TEST LEFT SIDE VIEW.....	A-6
A-5	POST TEST LEFT SIDE VIEW.....	A-7
A-6	PRE-TEST RIGHT SIDE VIEW.....	A-8
A-7	POST TEST RIGHT SIDE VIEW.....	A-9
A-8	PRE-TEST RIGHT FRONT THREE-QUARTER VIEW.....	A-10
A-9	POST TEST RIGHT FRONT THREE-QUARTER VIEW.....	A-11
A-10	PRE-TEST LEFT REAR THREE-QUARTER VIEW.....	A-12
A-11	POST TEST LEFT REAR THREE-QUARTER VIEW.....	A-13
A-12	PRE-TEST WINDSHIELD VIEW.....	A-14
A-13	POST TEST WINDSHIELD VIEW.....	A-15
A-14	PRE-TEST ENGINE COMPARTMENT VIEW.....	A-16
A-15	FUEL CAP VIEW.....	A-17
A-16	PRE-TEST FRONT UNDERBODY VIEW.....	A-18
A-17	POST TEST FRONT UNDERBODY VIEW.....	A-19
A-18	PRE-TEST FRONT SIDE UNDERBODY VIEW.....	A-20
A-19	POST TEST FRONT SIDE UNDERBODY VIEW.....	A-21
A-20	PRE-TEST REAR UNDERBODY VIEW.....	A-22
A-21	POST TEST REAR UNDERBODY VIEW.....	A-23
A-22	PRE-TEST DRIVER POSITION VIEW.....	A-24
A-23	POST TEST DRIVER POSITION VIEW.....	A-25
A-24	PRE-TEST PASSENGER POSITION VIEW.....	A-26
A-25	POST TEST PASSENGER POSITION VIEW.....	A-27
A-26	PRE-TEST DRIVER AND INTERIOR VIEW.....	A-28
A-27	POST TEST DRIVER AND INTERIOR VIEW.....	A-29
A-28	PRE-TEST PASSENGER AND INTERIOR VIEW.....	A-30
A-29	POST TEST PASSENGER AND INTERIOR VIEW.....	A-31
A-30	IMPACT VIEW.....	A-32

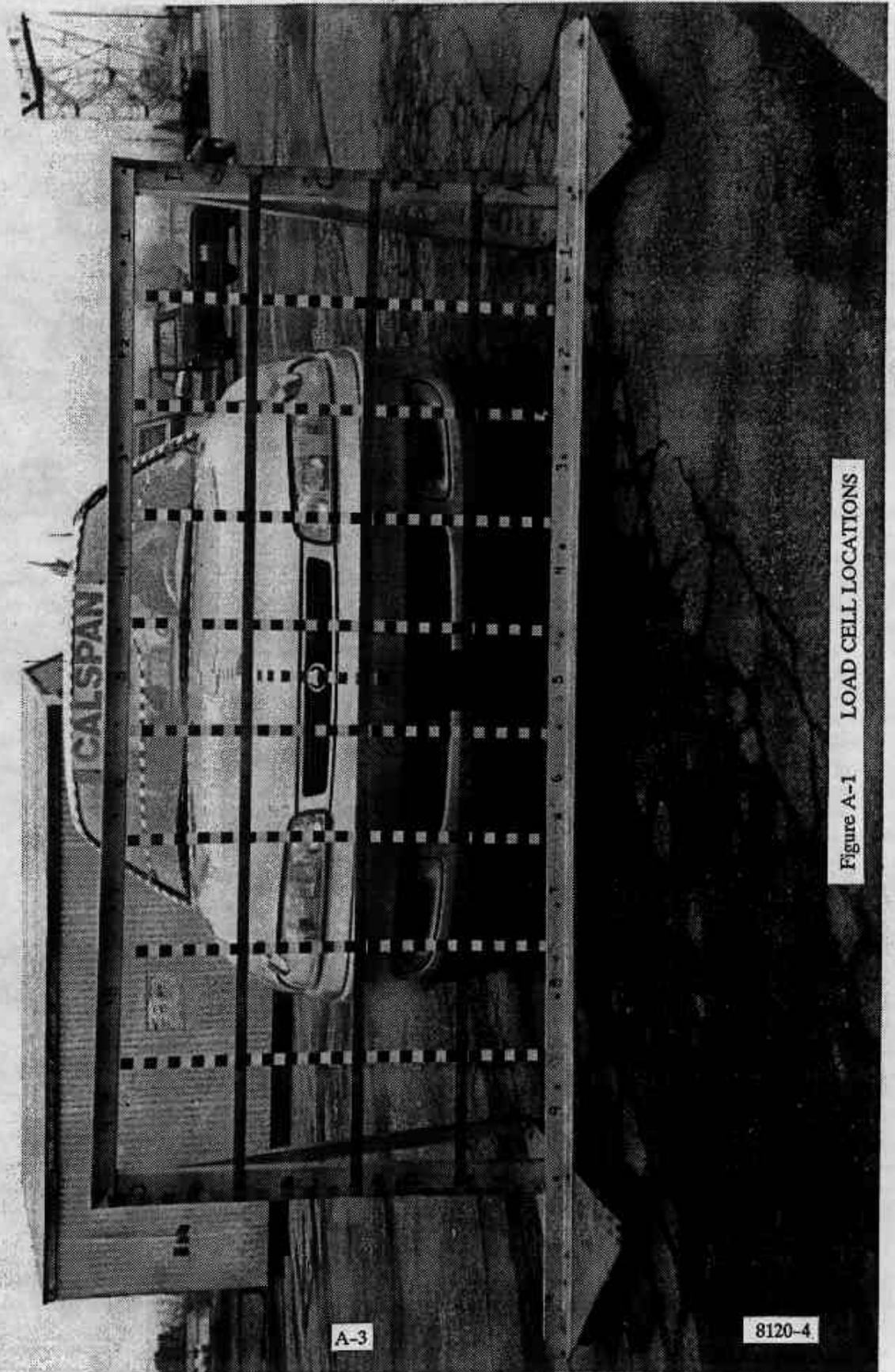

Figure A-1 LOAD CELL LOCATIONS

A-3

8120-4



Figure A-2 PRE-TEST FRONT VIEW

A-4

8120-4

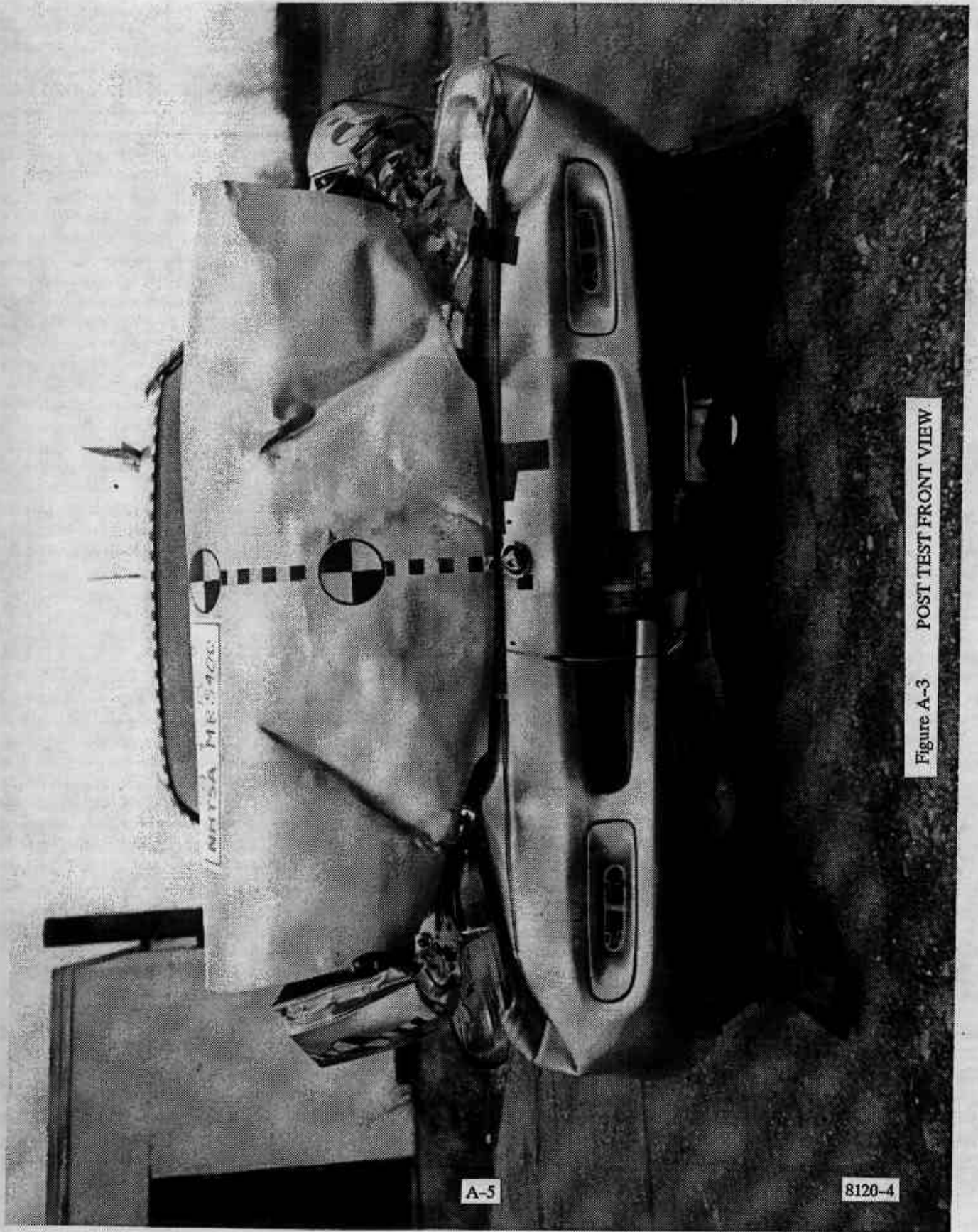

Figure A-3 POST TEST FRONT VIEW

A-5

8120-4

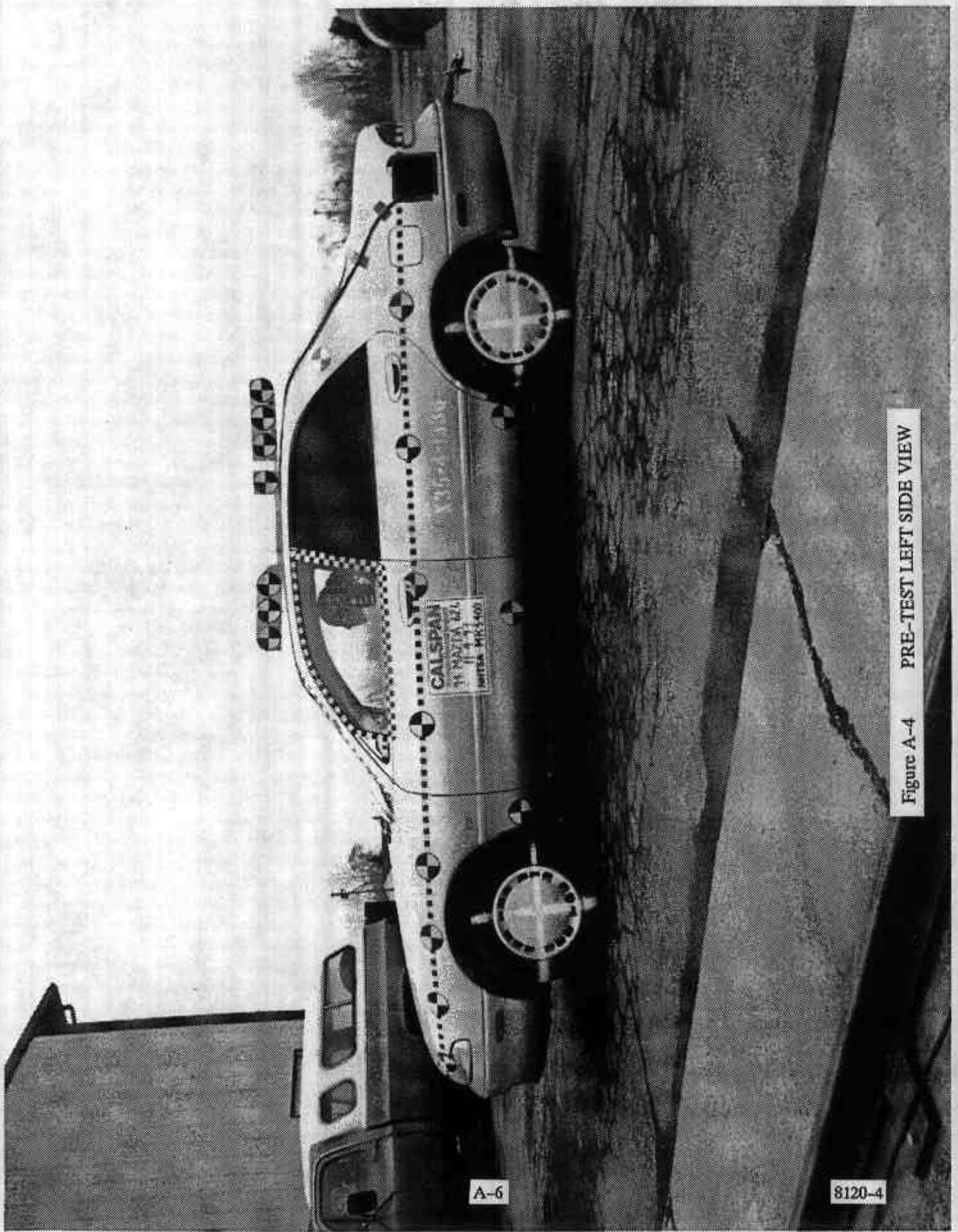

Figure A-4 PRE-TEST LEFT SIDE VIEW

A-6

8120-4

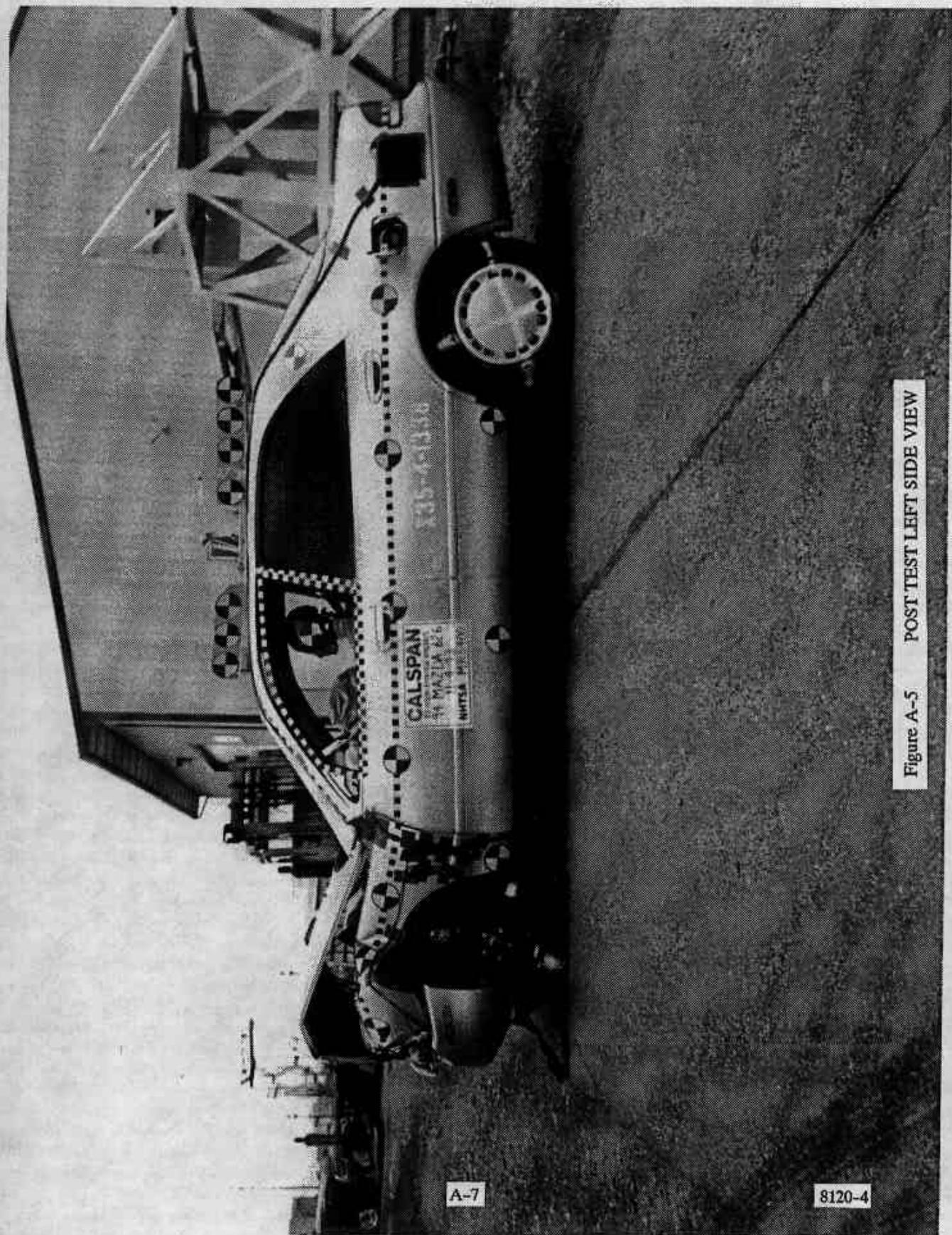

Figure A-5 POST TEST LEFT SIDE VIEW

A-7

8120-4

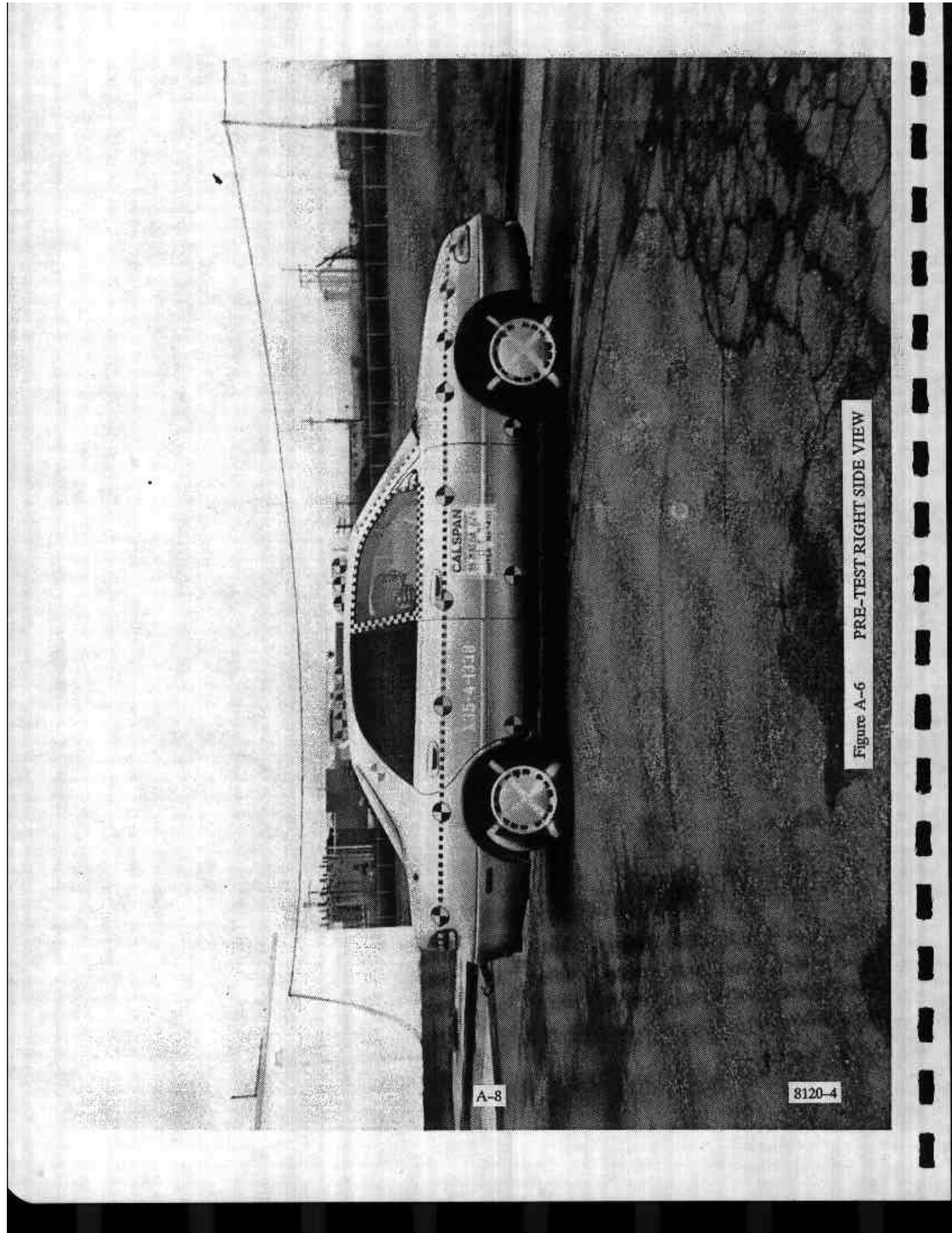

Figure A-6 PRE-TEST RIGHT SIDE VIEW

A-8

8120-4

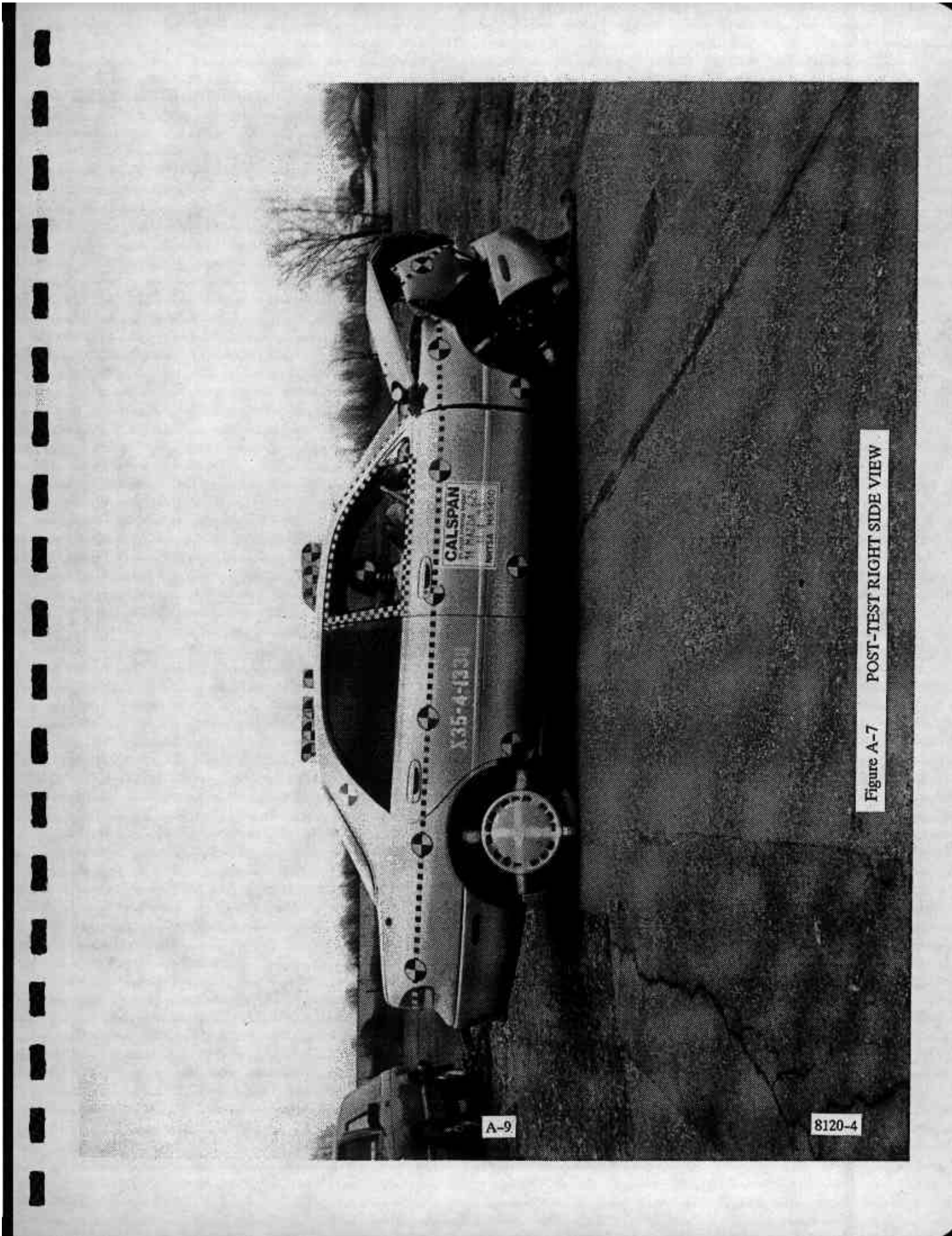
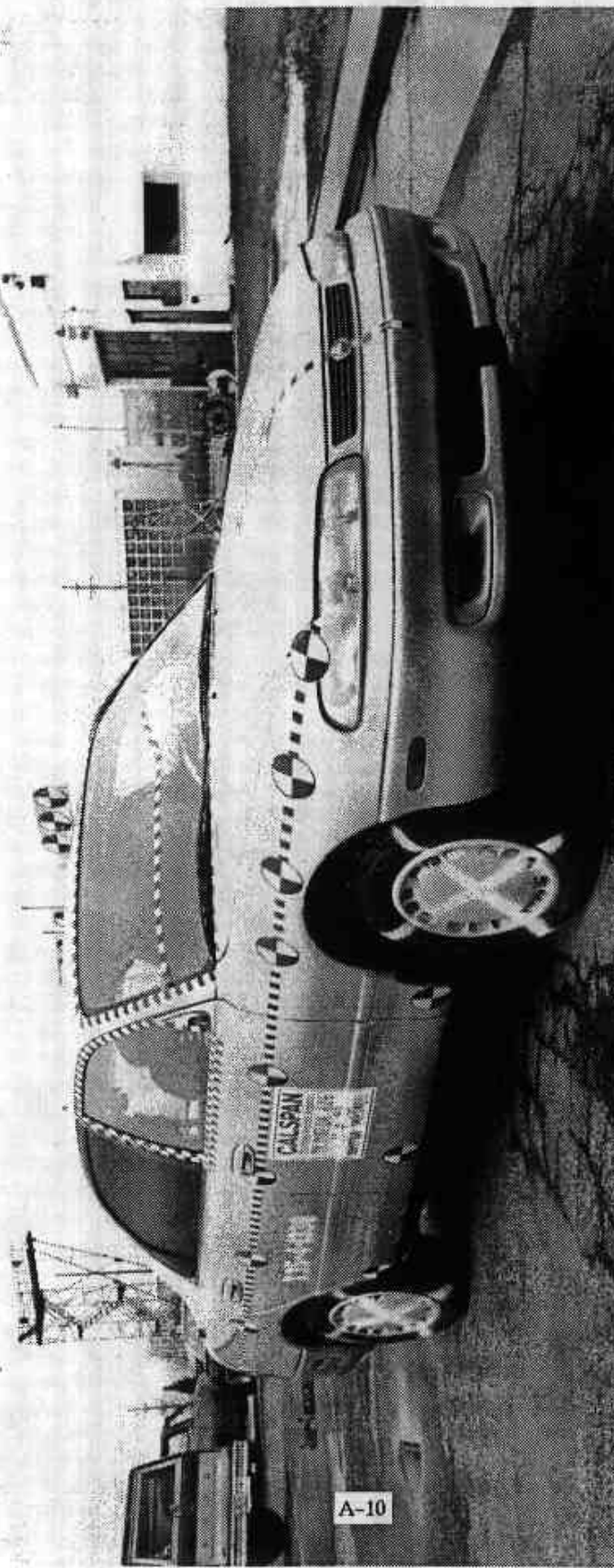

Figure A-7 POST-TEST RIGHT SIDE VIEW

A-9

8120-4



A-10

8120-4

Figure A-8 PRE-TEST RIGHT FRONT THREE-QUARTER VIEW

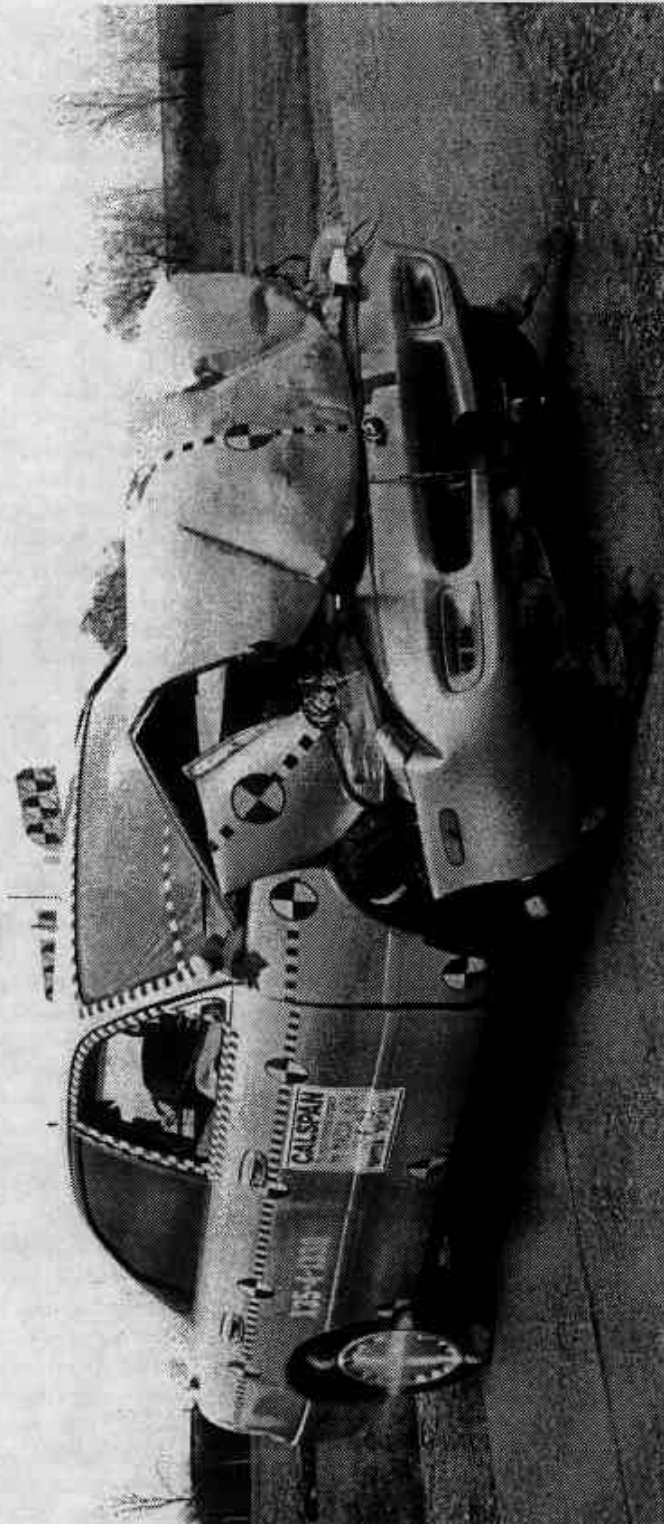

Figure A-9 POST-TEST RIGHT FRONT THREE-QUARTER VIEW

A-11

8120-4

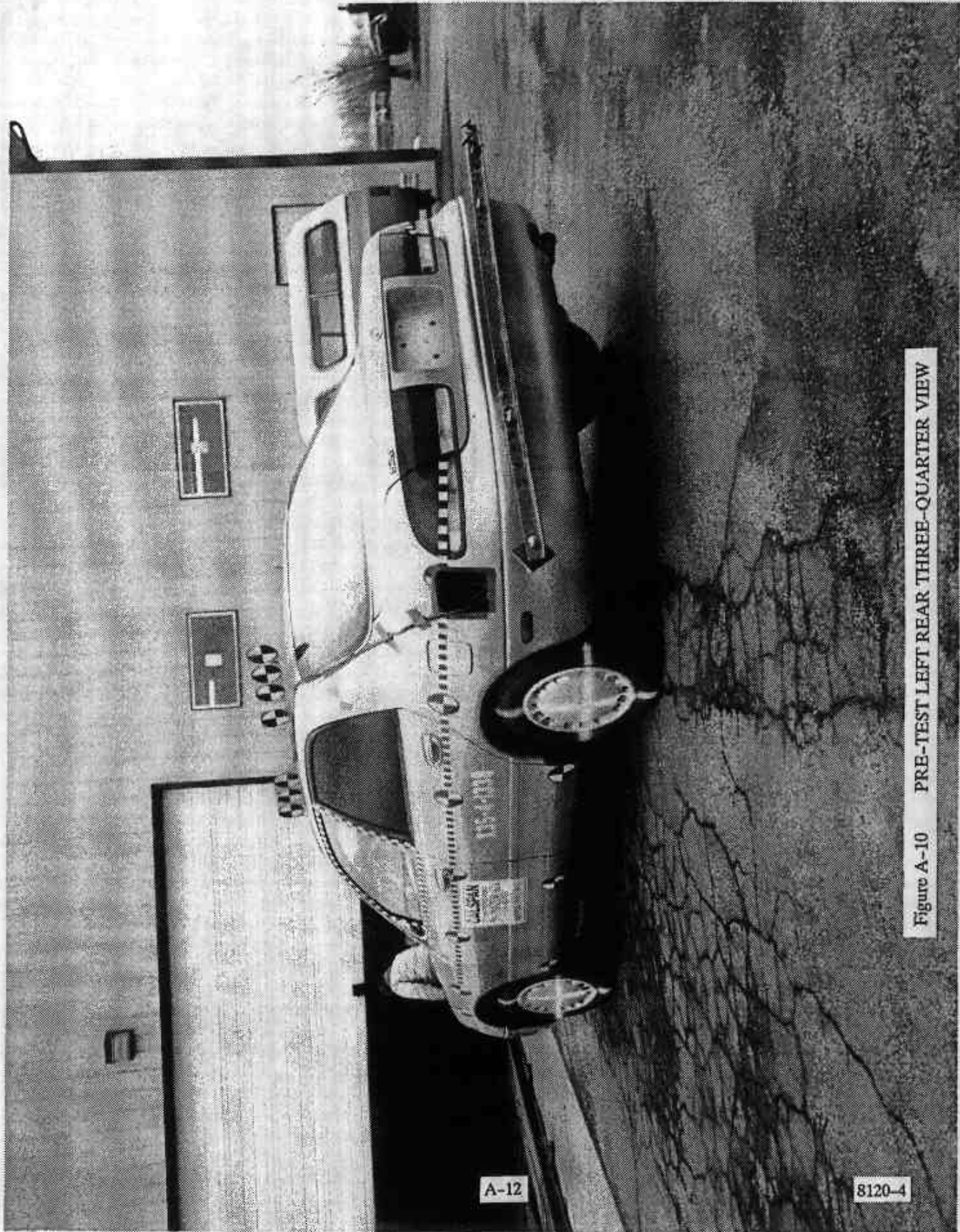

Figure A-10 PRE-TEST LEFT REAR THREE-QUARTER VIEW

A-12

8120-4

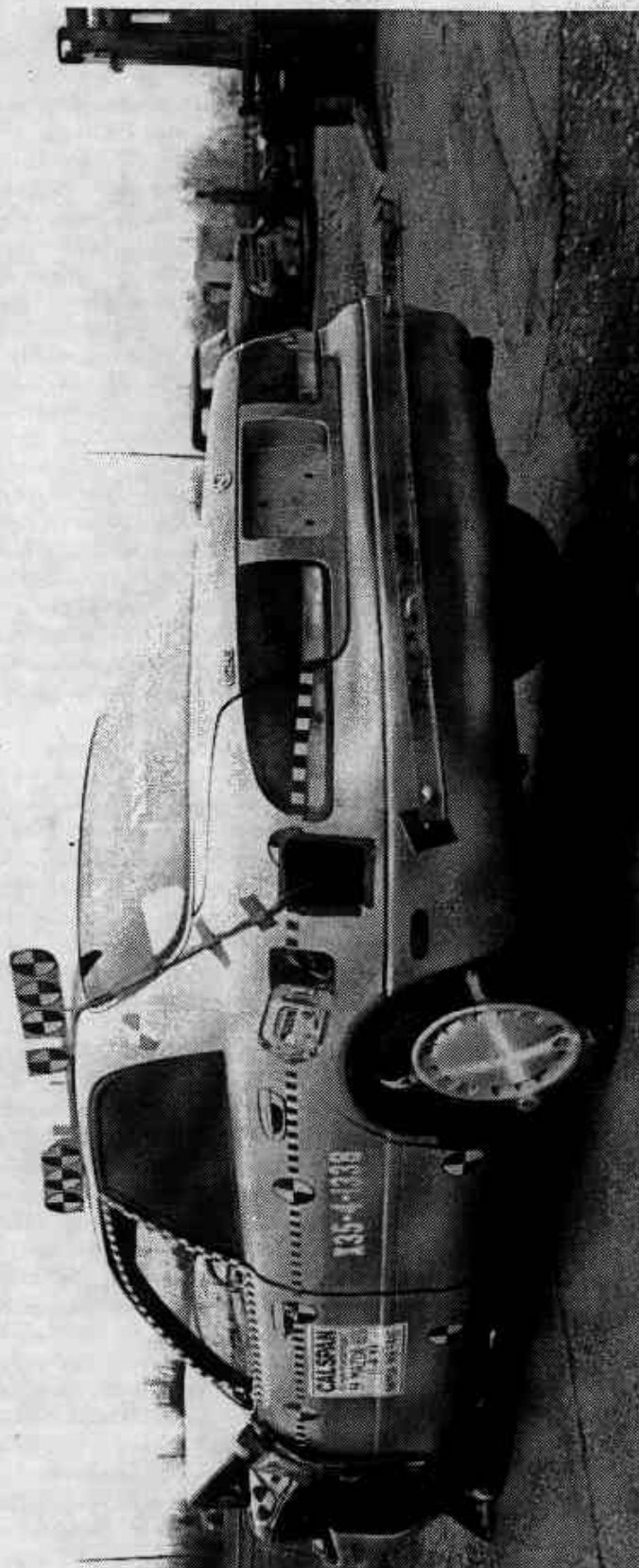

Figure A-11 POST TEST LEFT REAR THREE-QUARTER VIEW

A-13

8120-4

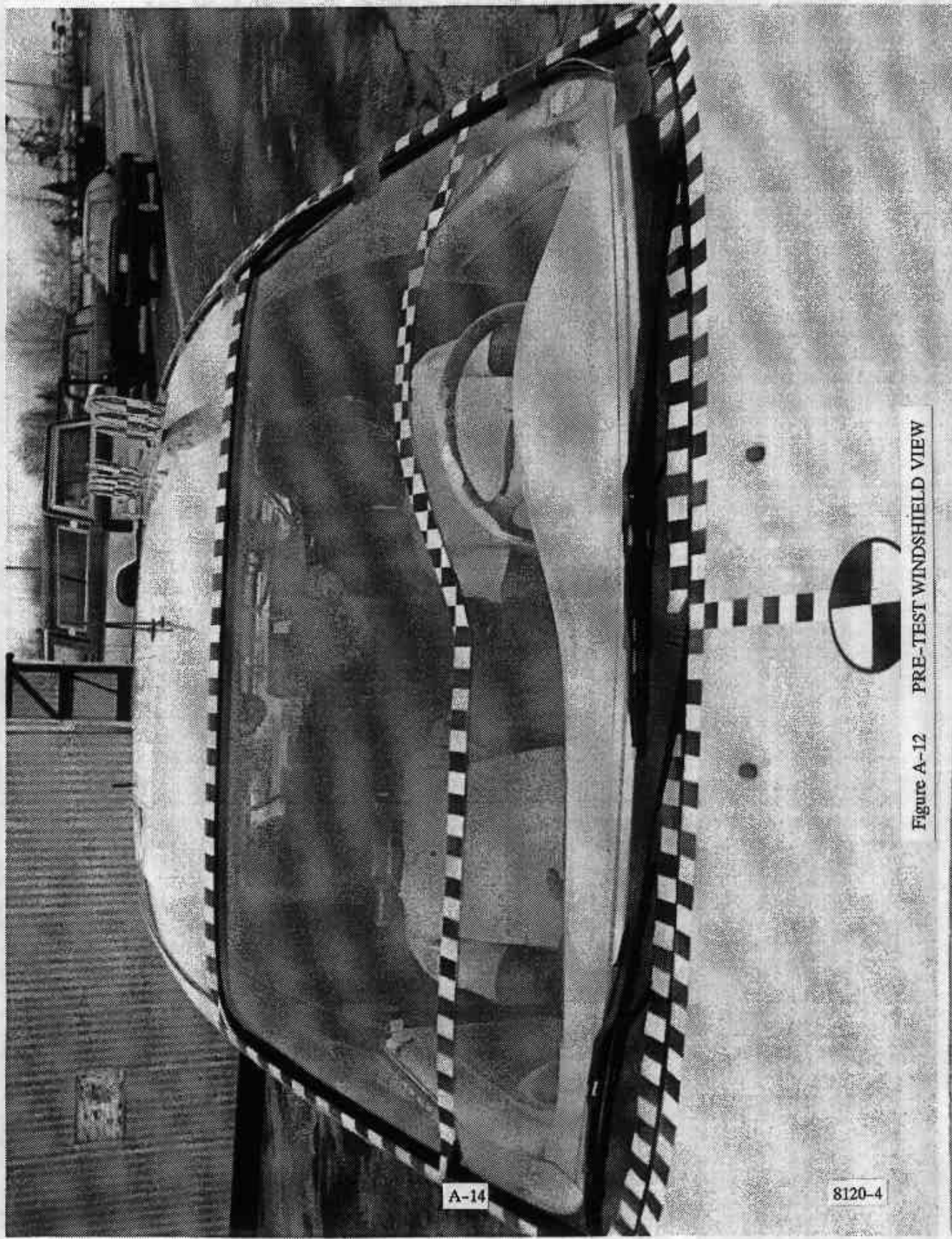

Figure A-12 PRE-TEST WINDSHIELD VIEW

A-14

8120-4

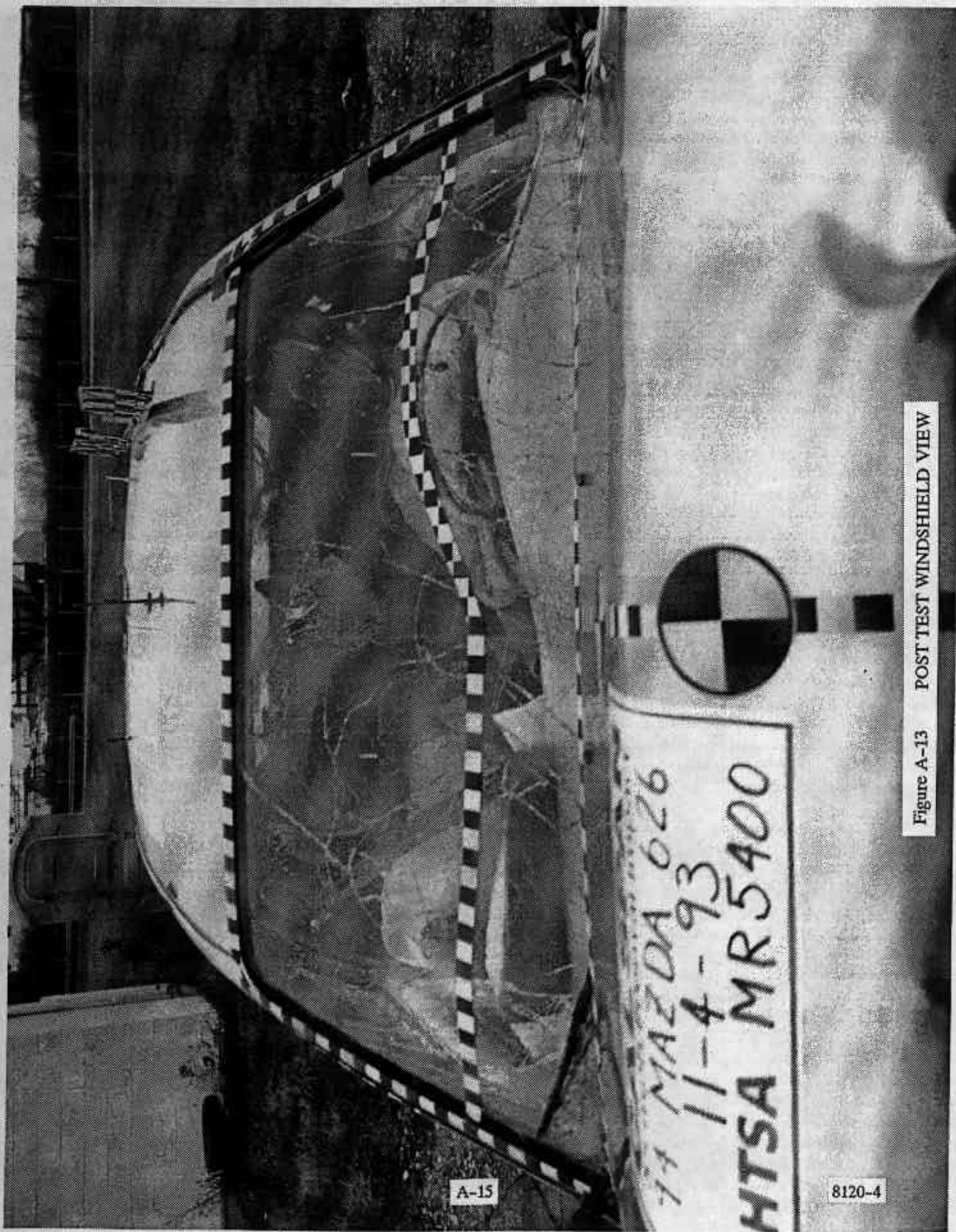

Figure A-13 POST TEST WINDSHIELD VIEW

A-15

8120-4

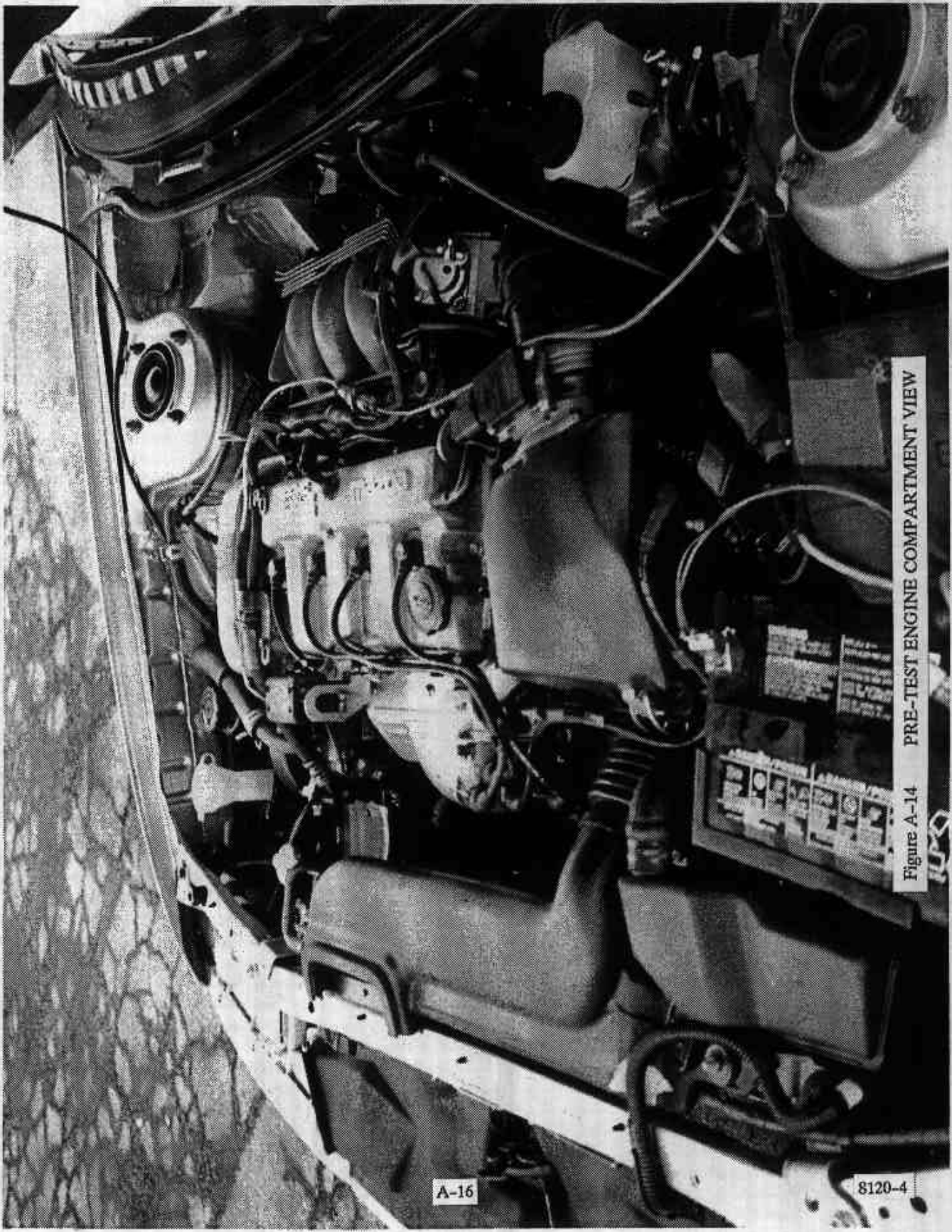

Figure A-14 PRE-TEST ENGINE COMPARTMENT VIEW

A-16

8120-4

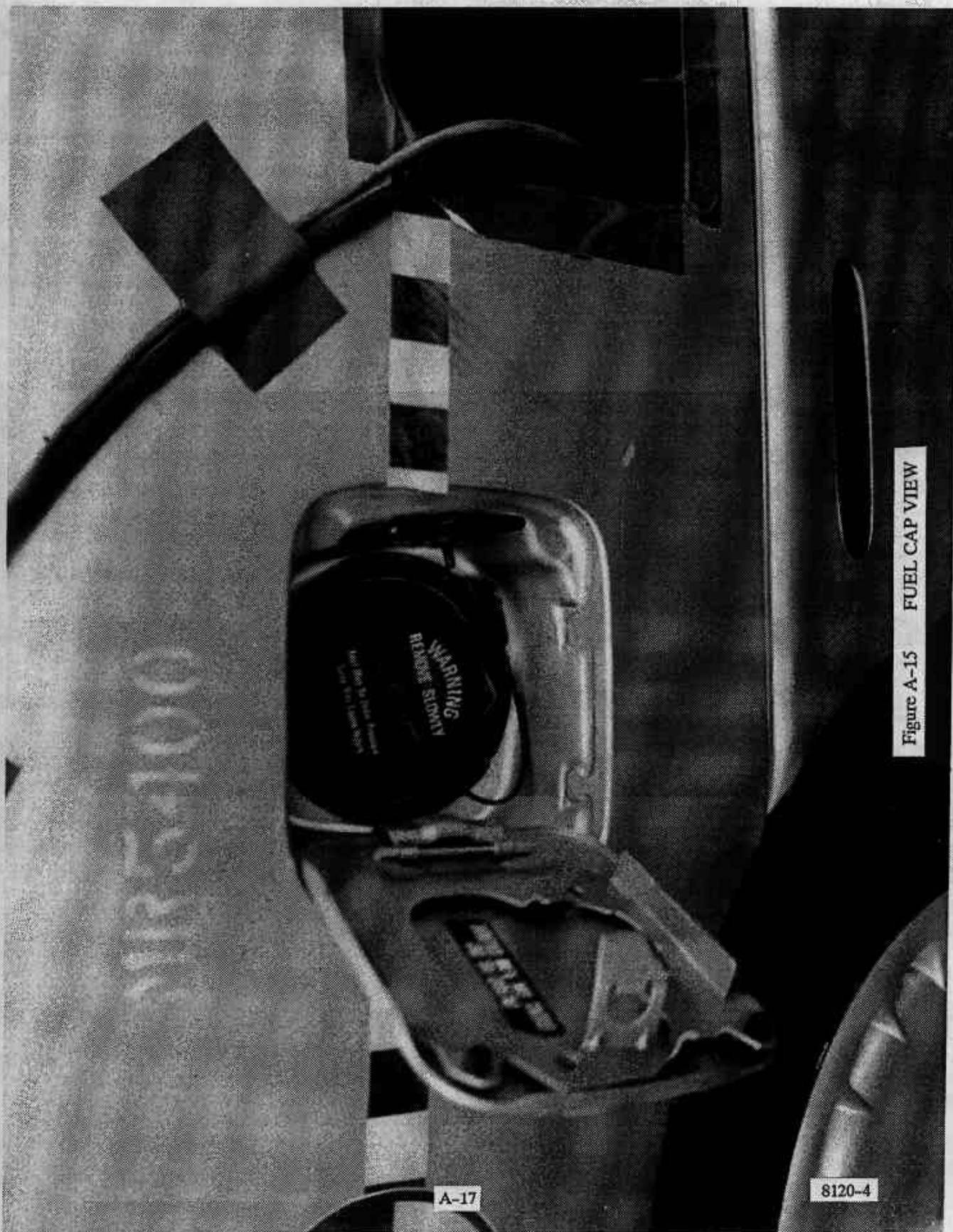

Figure A-15 FUEL CAP VIEW

A-17

8120-4

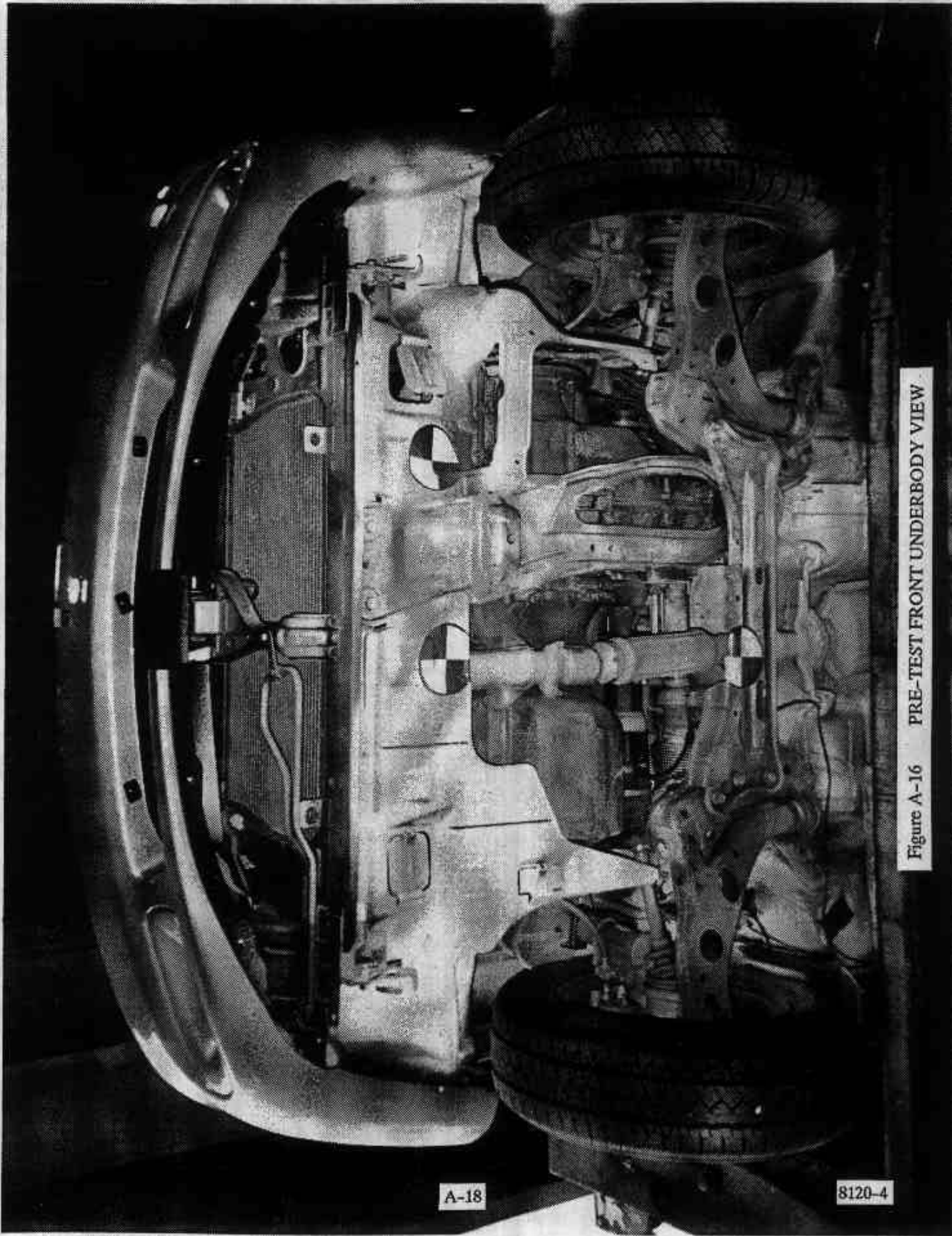

Figure A-16 PRE-TEST FRONT UNDERBODY VIEW

A-18

8120-4



Figure A-17 POST TEST FRONT UNDERBODY VIEW

A-19

8120-4

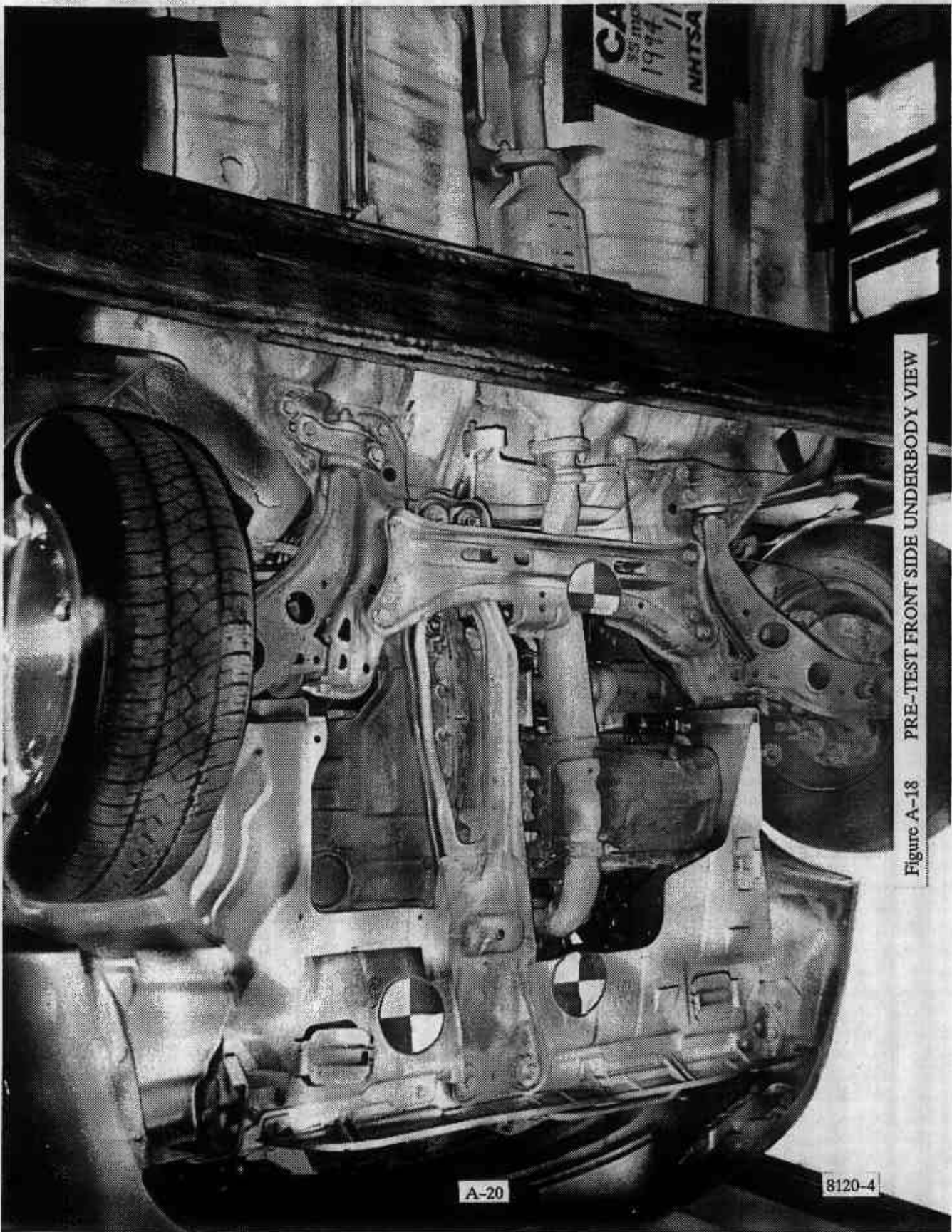

Figure A-18 PRE-TEST FRONT SIDE UNDERBODY VIEW

A-20

8120-4



Figure A-19 POST TEST FRONT SIDE UNDERBODY VIEW

A-21

8120-4

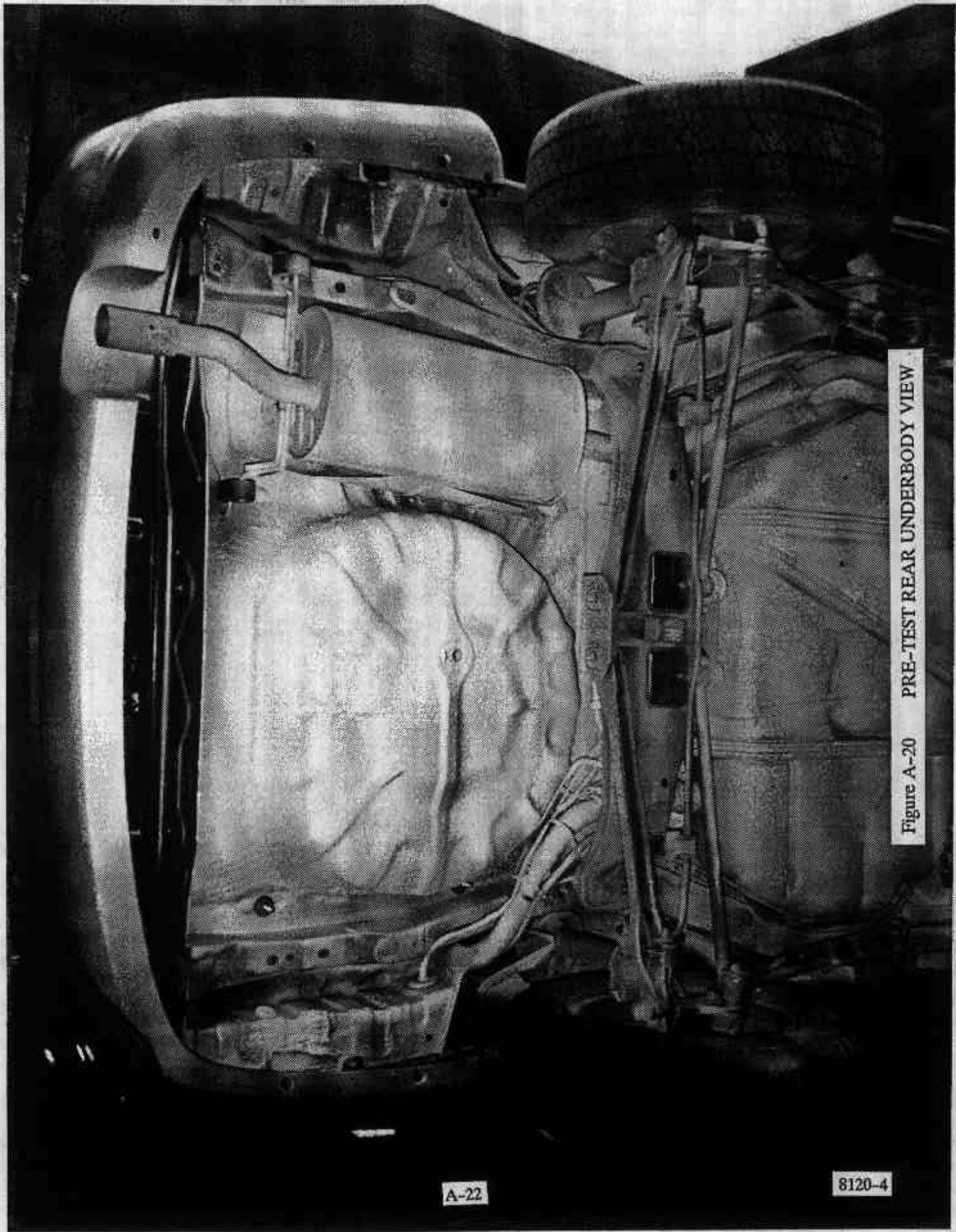

Figure A-20 PRE-TEST REAR UNDERBODY VIEW

A-22

8120-4



Figure A-21 POST TEST REAR UNDERBODY VIEW

A-23

8120-4



Figure A-22 PRE-TEST DRIVER POSITION VIEW

A-24

8120-4



Figure A-23 POST TEST DRIVER POSITION VIEW

A-25

8120-4



Figure A-24 PRE-TEST PASSENGER POSITION VIEW

CALIFORNIA  
35 mph

A-26

8120-4



Figure A-25 POST TEST PASSENGER POSITION VIEW

A-27

8120-4

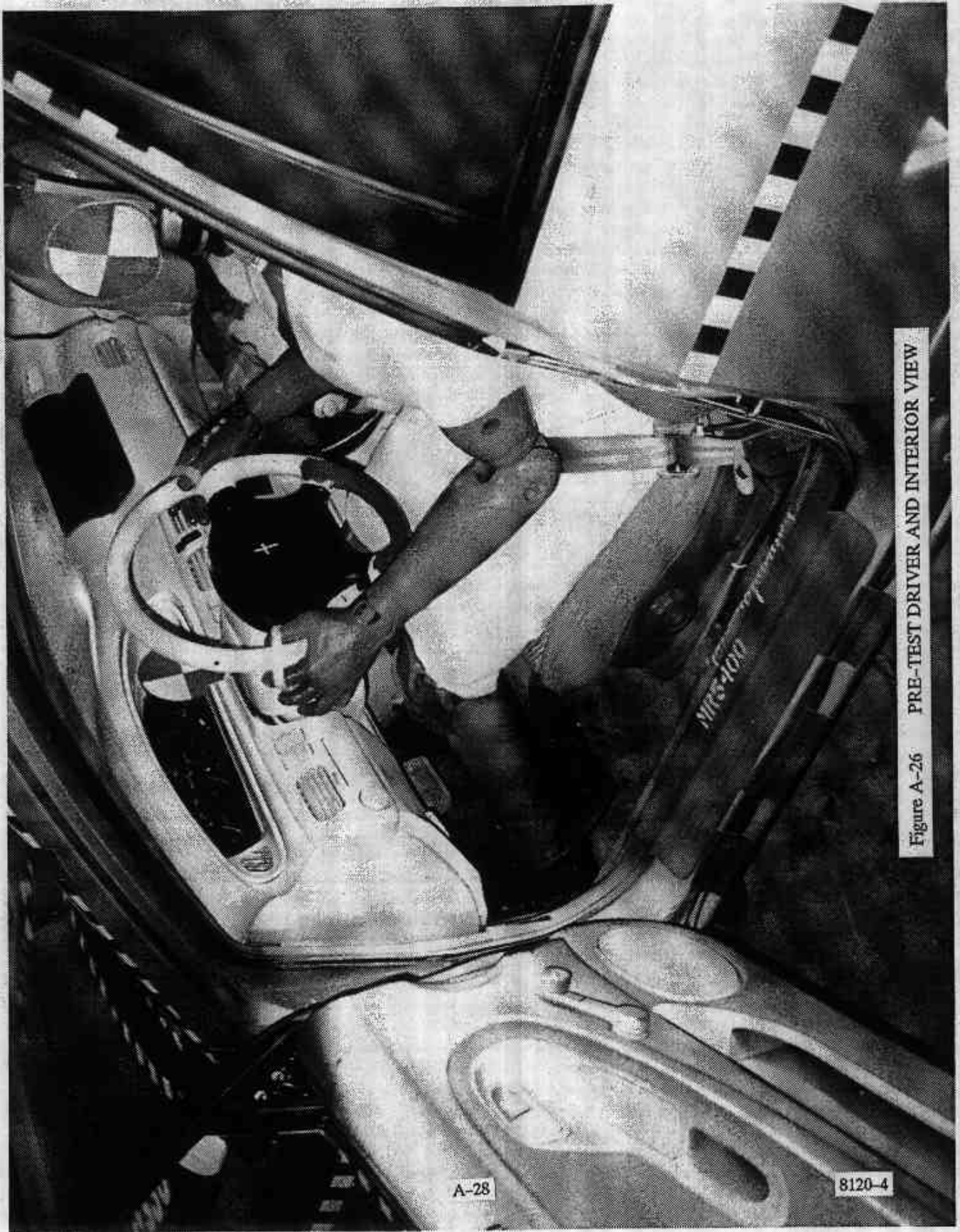

Figure A-26 PRE-TEST DRIVER AND INTERIOR VIEW

A-28

8120-4

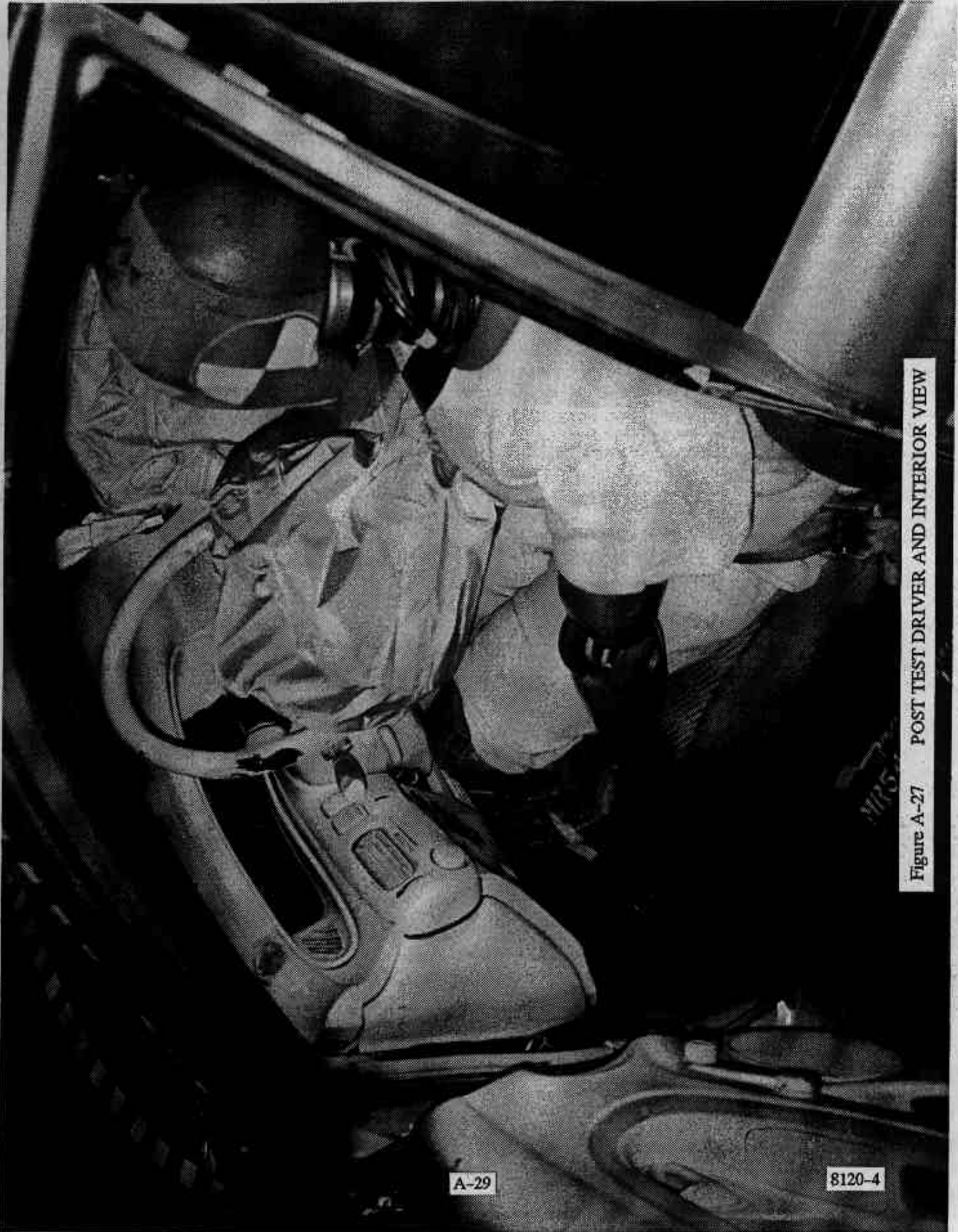

Figure A-27 POST TEST DRIVER AND INTERIOR VIEW

A-29

8120-4

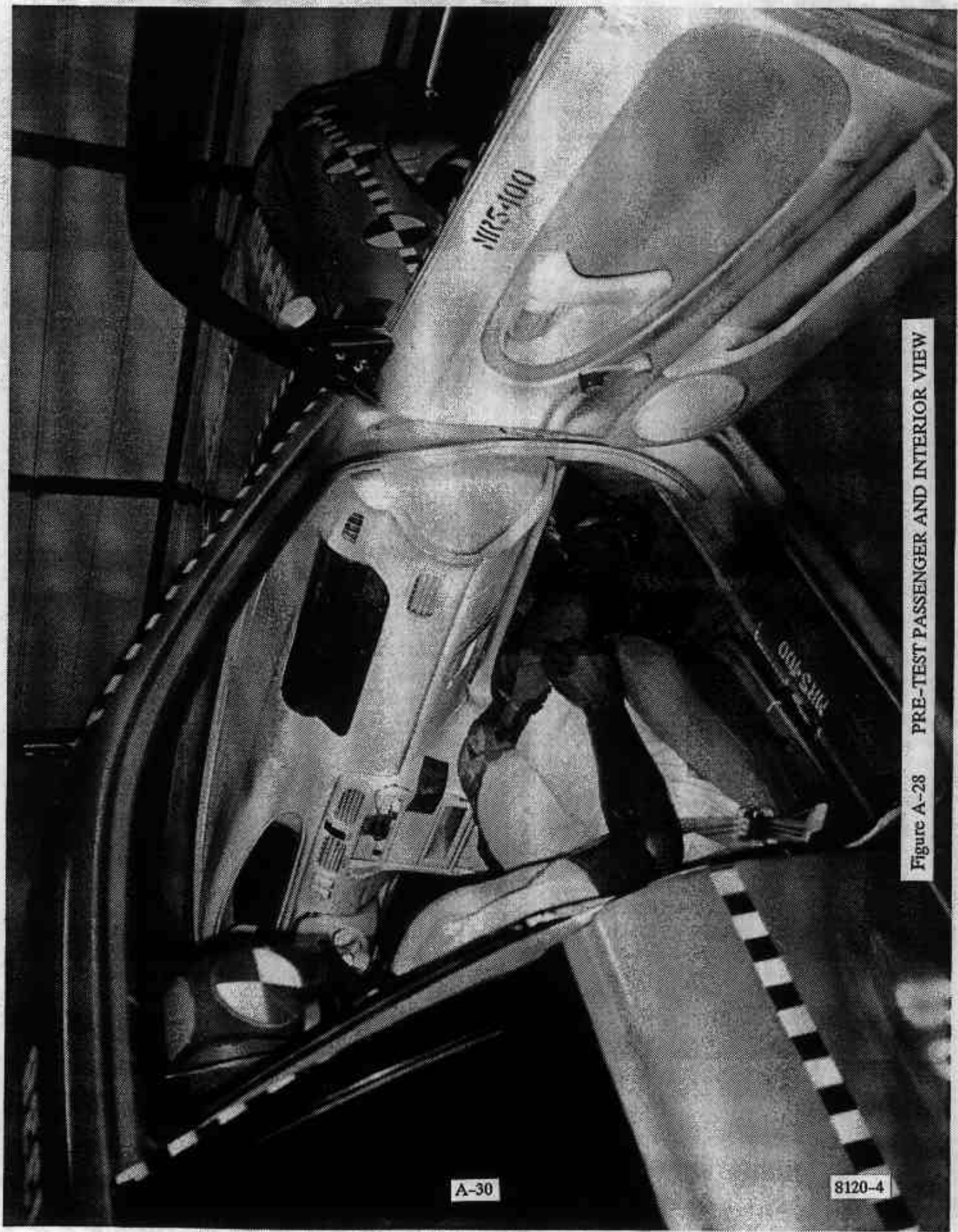

Figure A-28 PRE-TEST PASSENGER AND INTERIOR VIEW

A-30

8120-4

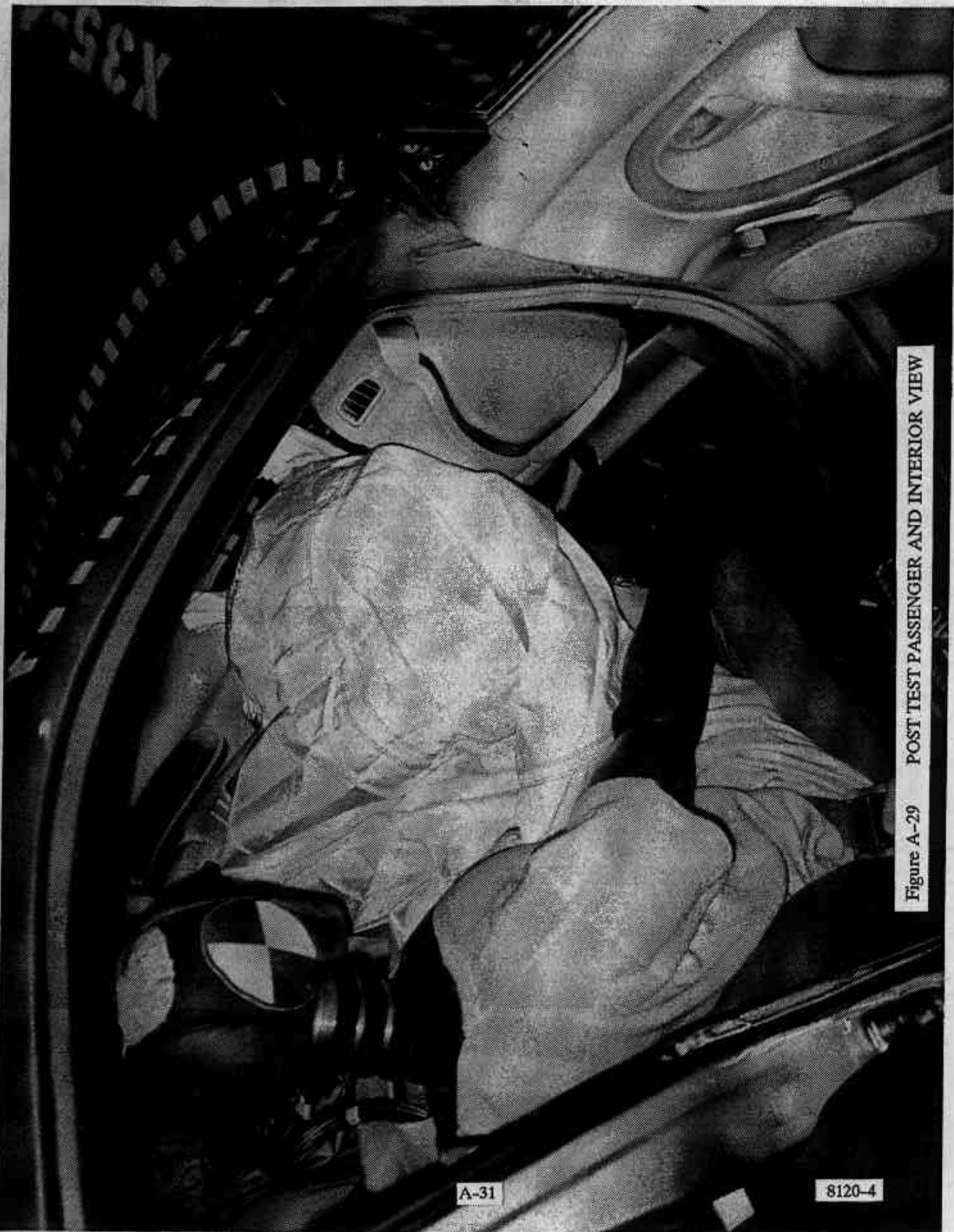

Figure A-29 POST TEST PASSENGER AND INTERIOR VIEW

A-31

8120-4

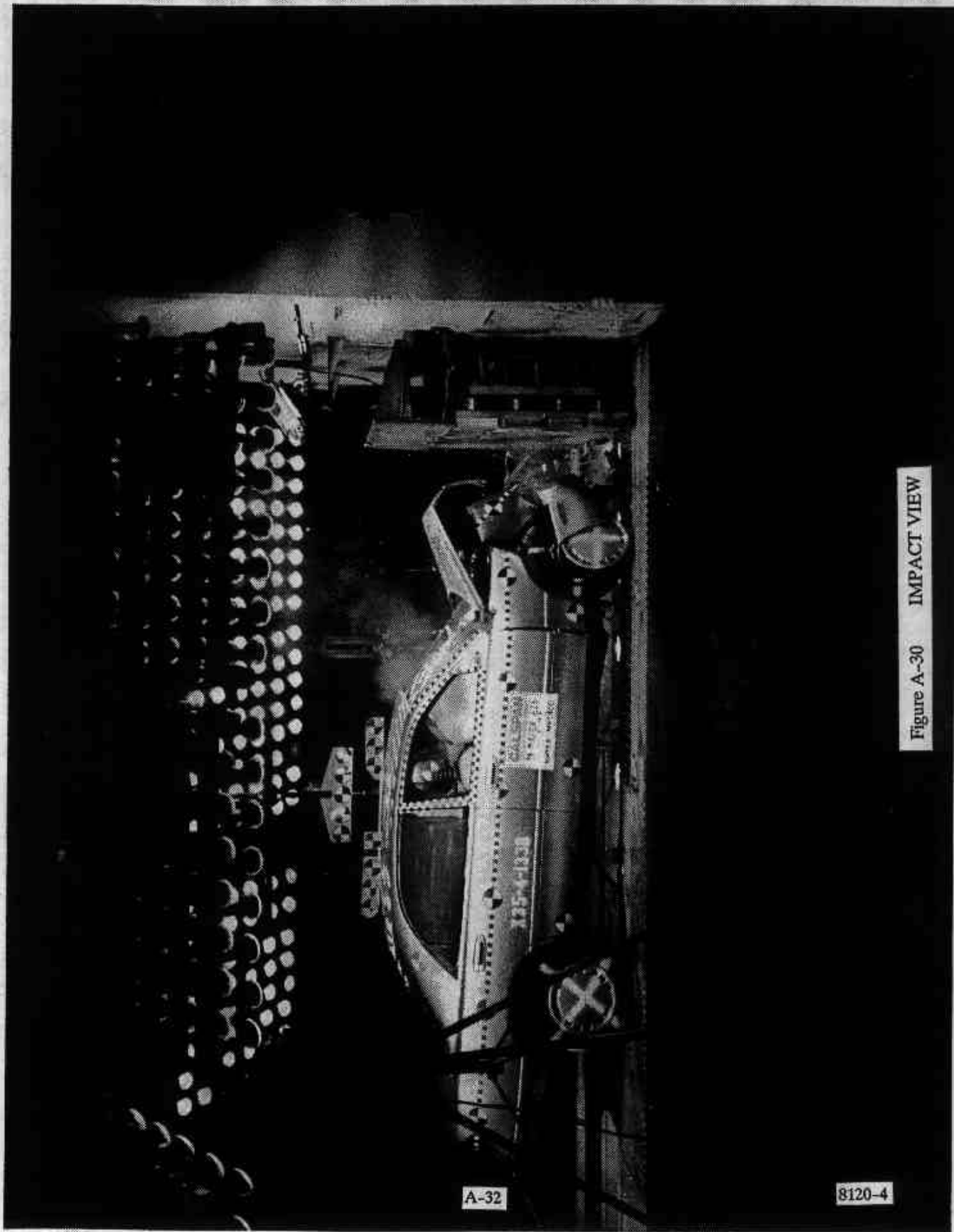

Figure A-30 IMPACT VIEW

A-32

8120-4

Appendix B

VEHICLE, LOAD CELL BARRIER AND DUMMY RESPONSE DATA

TEST NO. MR5400

VEHICLE DATA

FILTER CHANNEL CLASS

60

Acc. #1(x)

Max =

2.62 Gs

@

112.80 msec

Min =

-41.31 Gs

@

33.24 msec

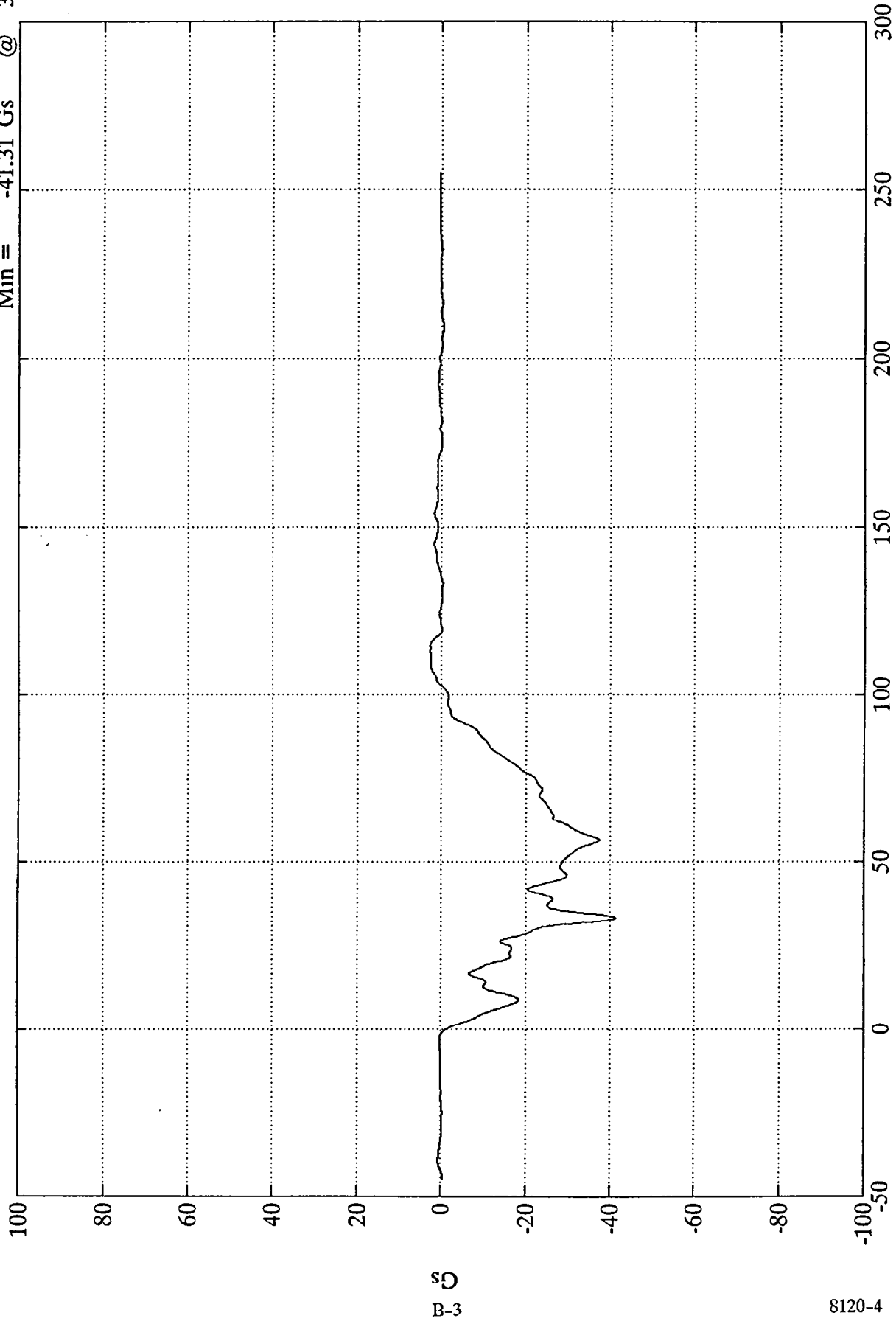

Time (msec)

SAE Filter Class 60

NCAP TEST #4 - 1994 MAZDA 626 DX

Acc. #1(x)

Max = 56.65 km/h @ -0.00 msec  
Min = -10.34 km/h @ 102.72 msec

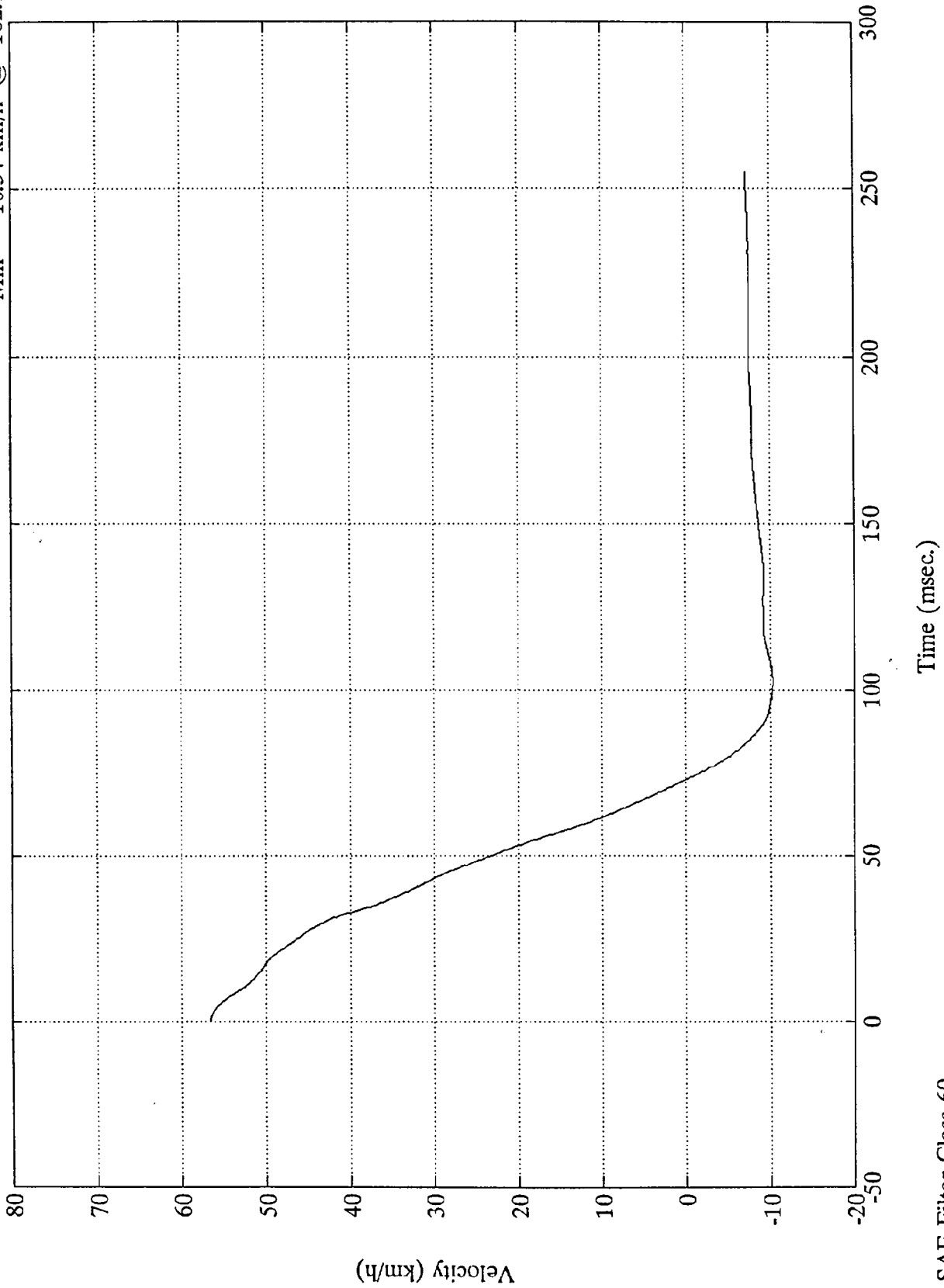

SAE Filter Class 60

Max = 67.41 cms @ 73.92 msec  
Min = 0.00 cms @ -0.00 msec

Acc. #1(x)

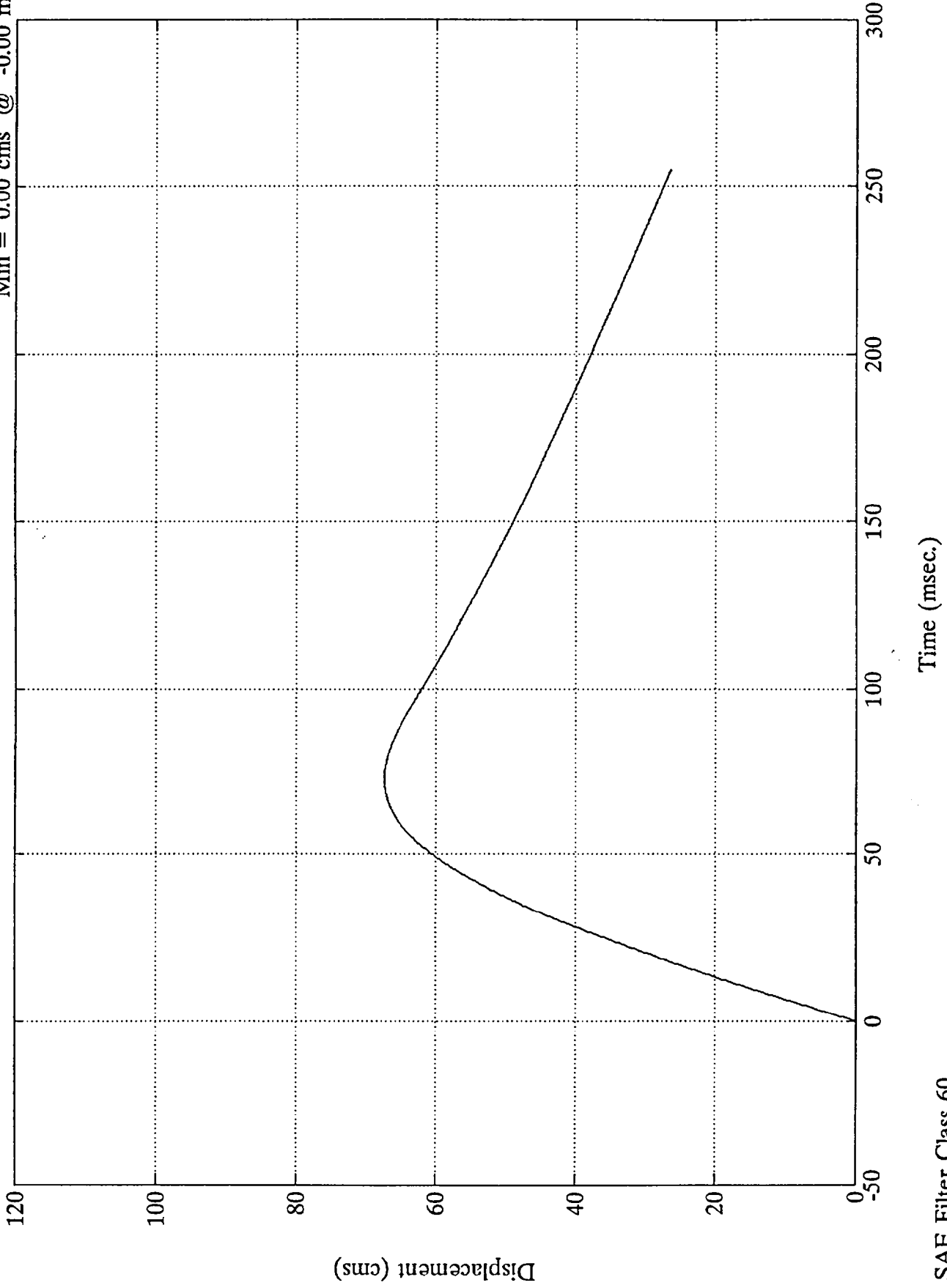

NCAP TEST #4 - 1994 MAZDA 626 DX

Max = 2.73 Gs @ 113.63 msec  
Min = -48.18 Gs @ 34.91 msec

Acc. #2(x)

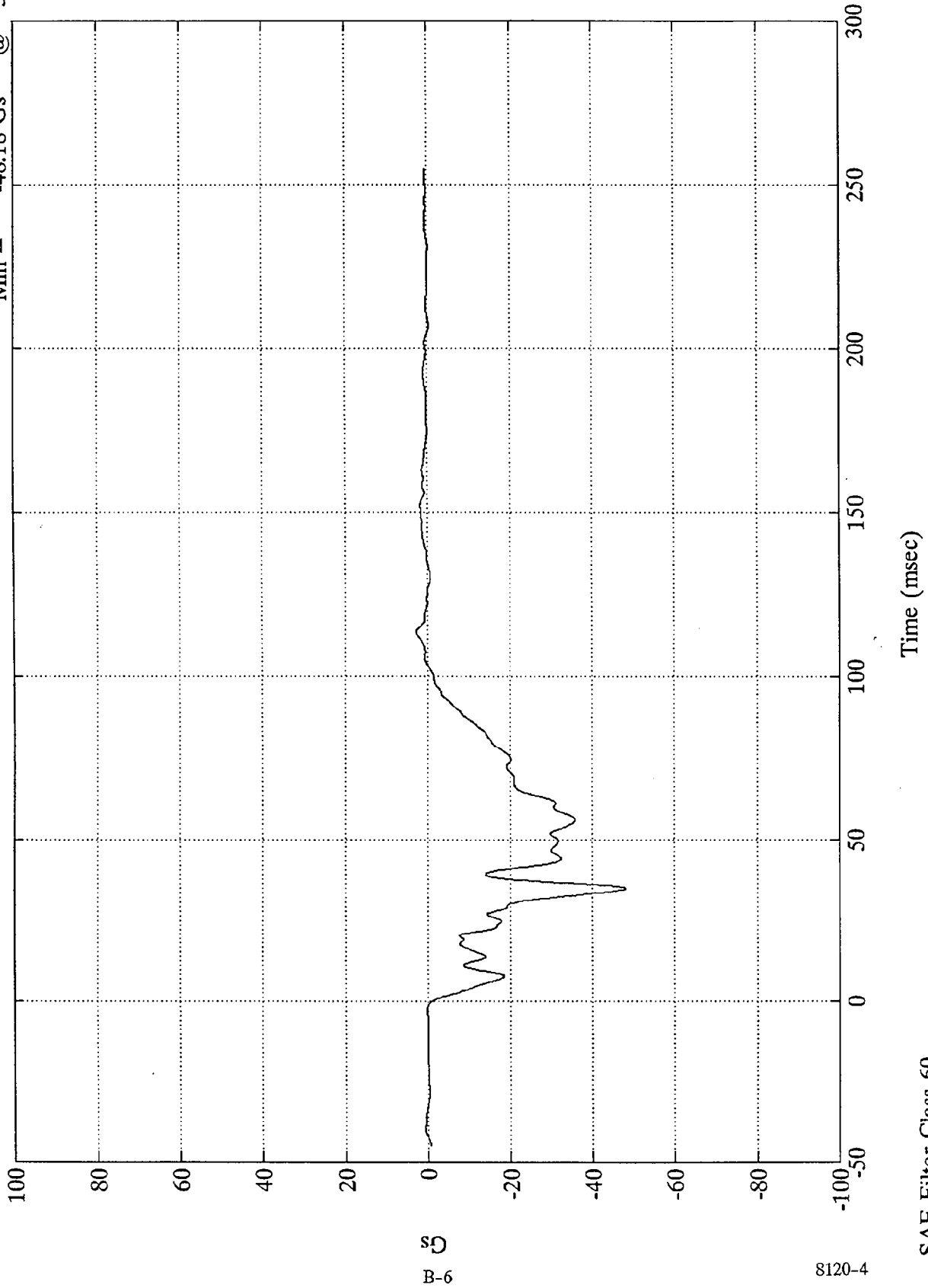

SD  
B-6

8120-4

SAE Filter Class 60

Time (msec)

Acc. #2(x)

Max = 56.65 km/h @ -0.00 msec  
Min = -9.54 km/h @ 103.44 msec

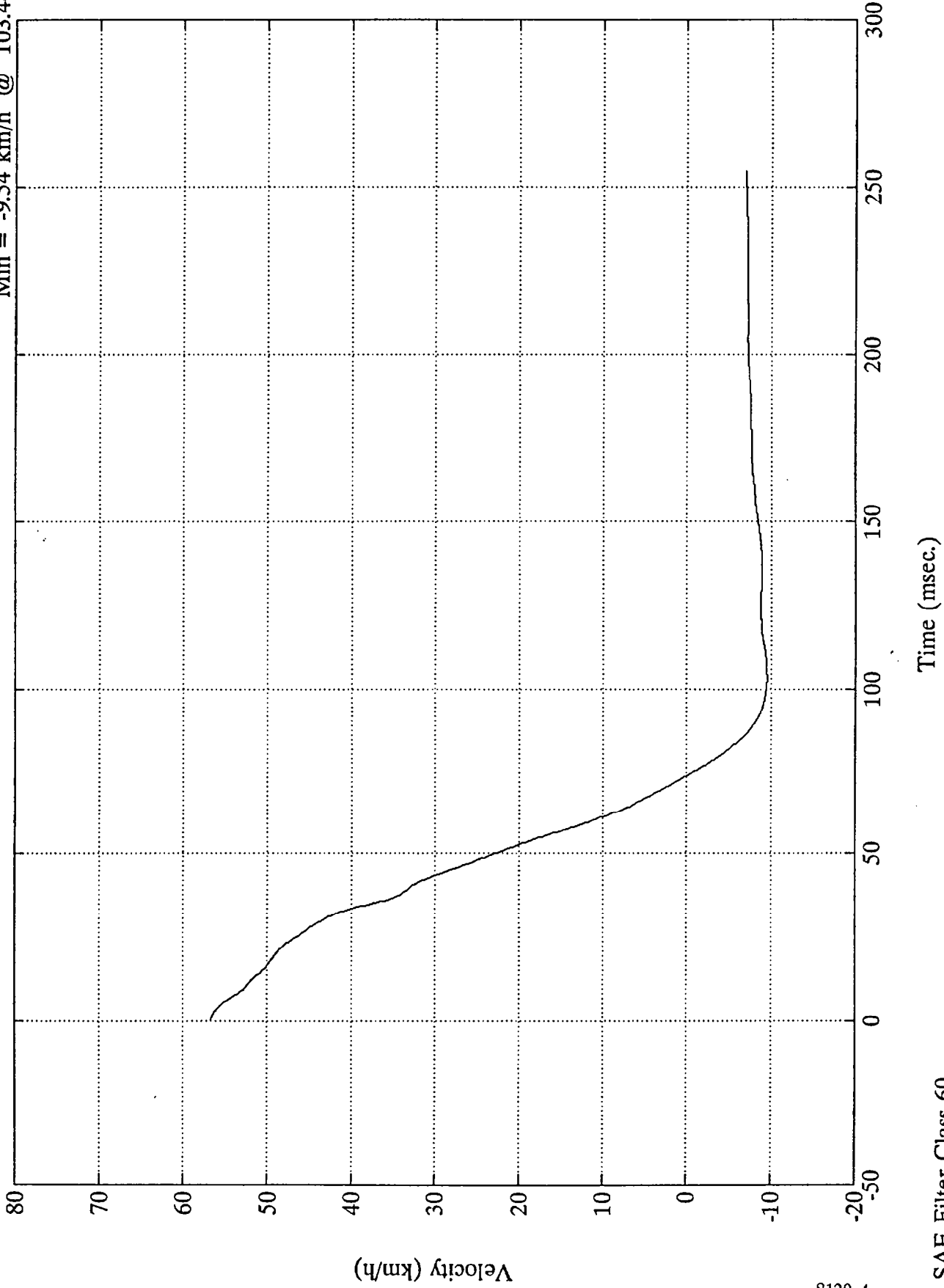

NCAP TEST #4 - 1994 MAZDA 626 DX

Max = 67.44 cms @ 74.88 msec  
Min = 0.00 cms @ -0.00 msec

Acc. #2(x)

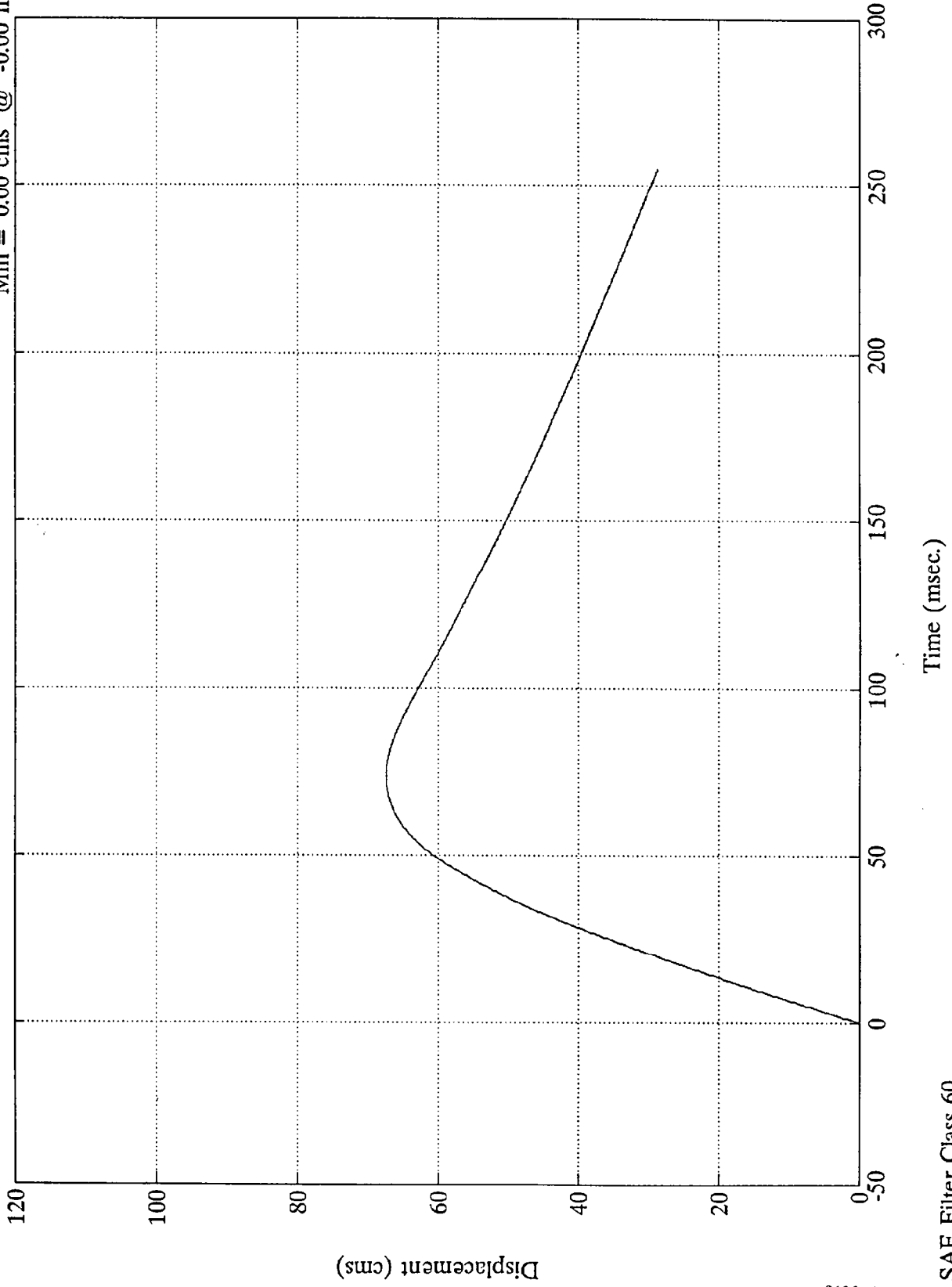

Acc. #3(x) Max = 27.20 Gs @ 44.75 ms  
Min = -150.84 Gs @ 29.39 ms

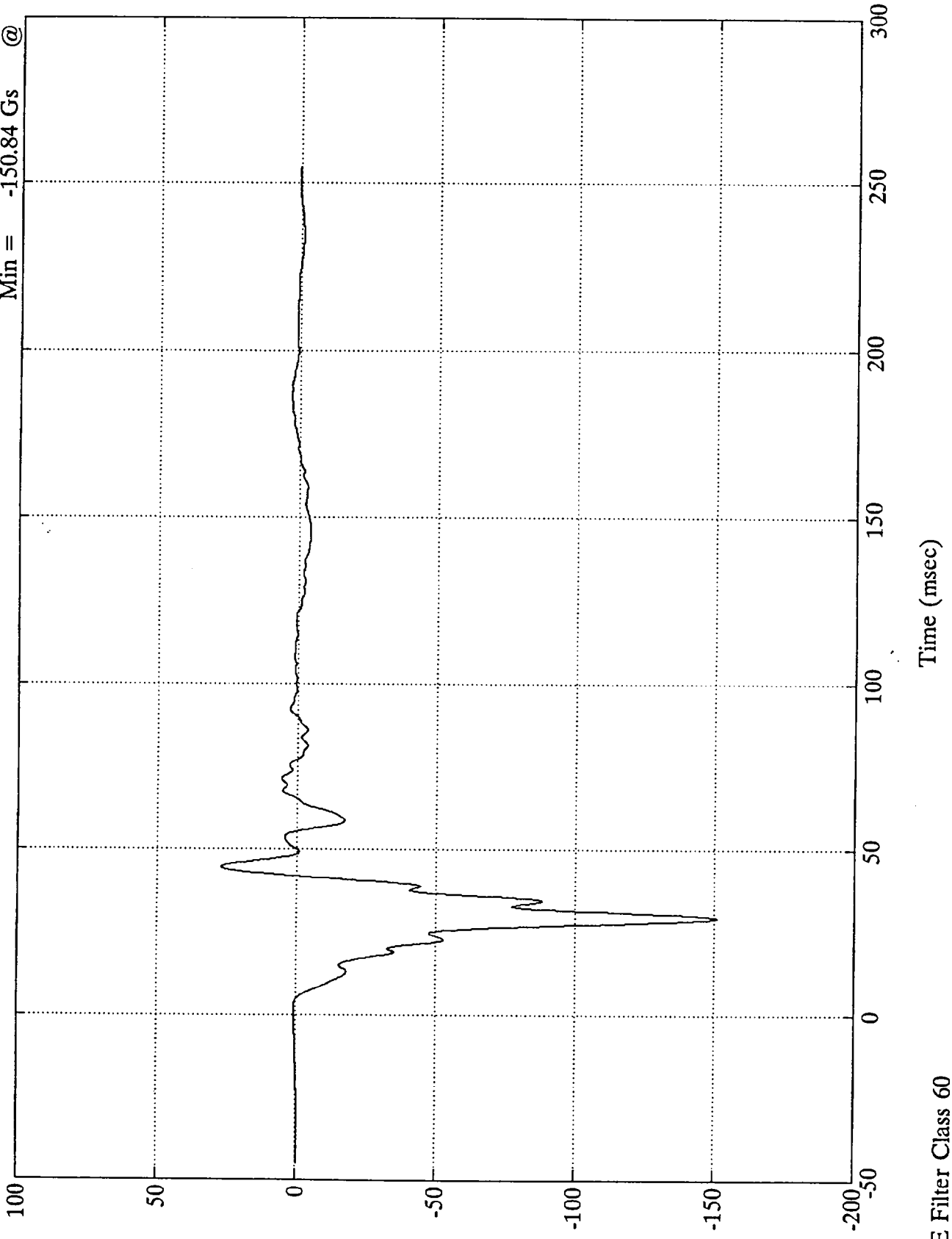

B-9

8120-4

SAE Filter Class 60

NCAP TEST #4 - 1994 MAZDA 626 DX

Acc. #3(x)

Max = 56.76 km/h @ 5.28 msec  
Min = -6.75 km/h @ 168.96 msec

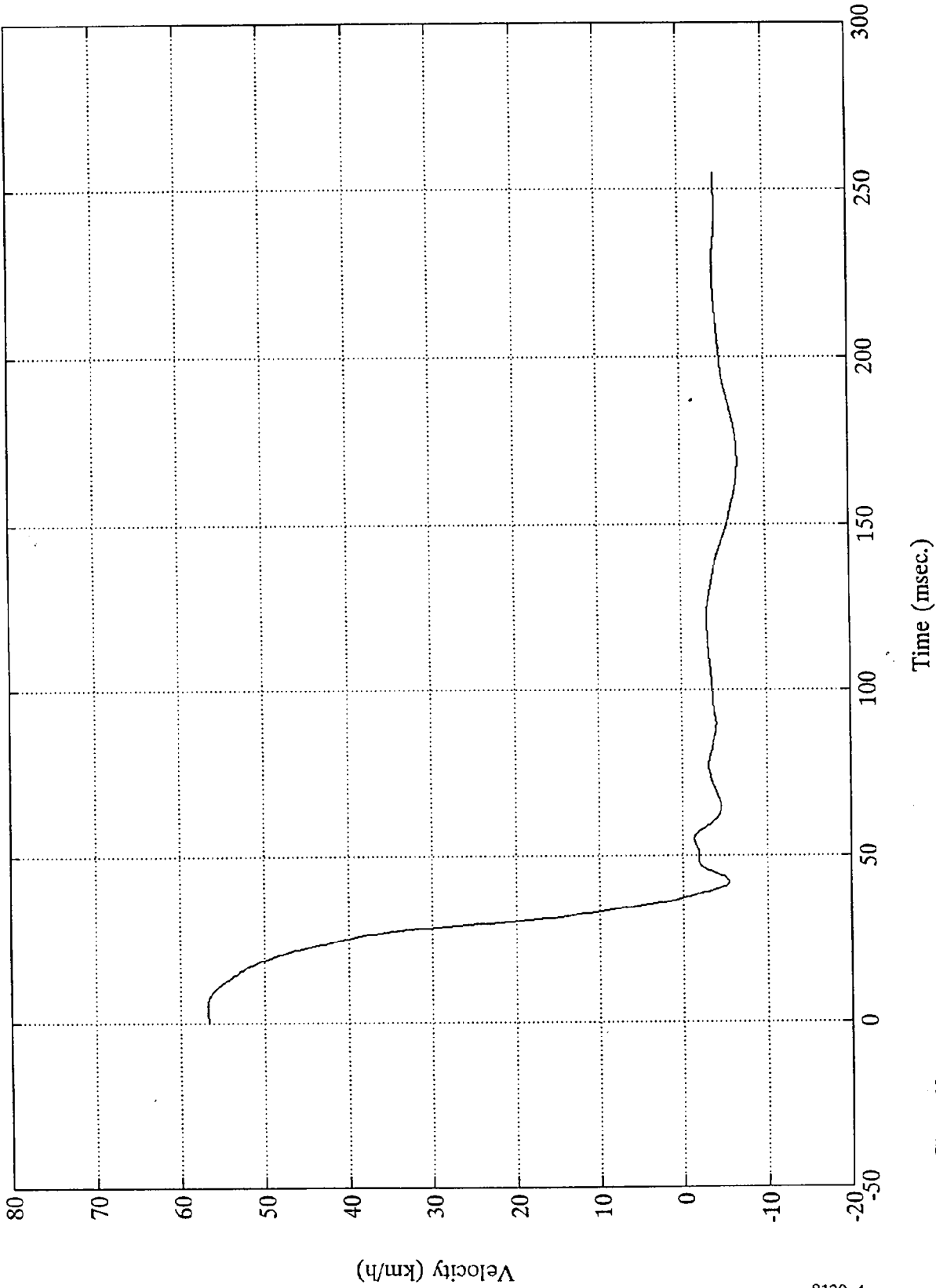

Acc. #3(x)  
Max = 43.05 cms @ 37.68 msec  
Min = 0.00 cms @ -0.00 msec

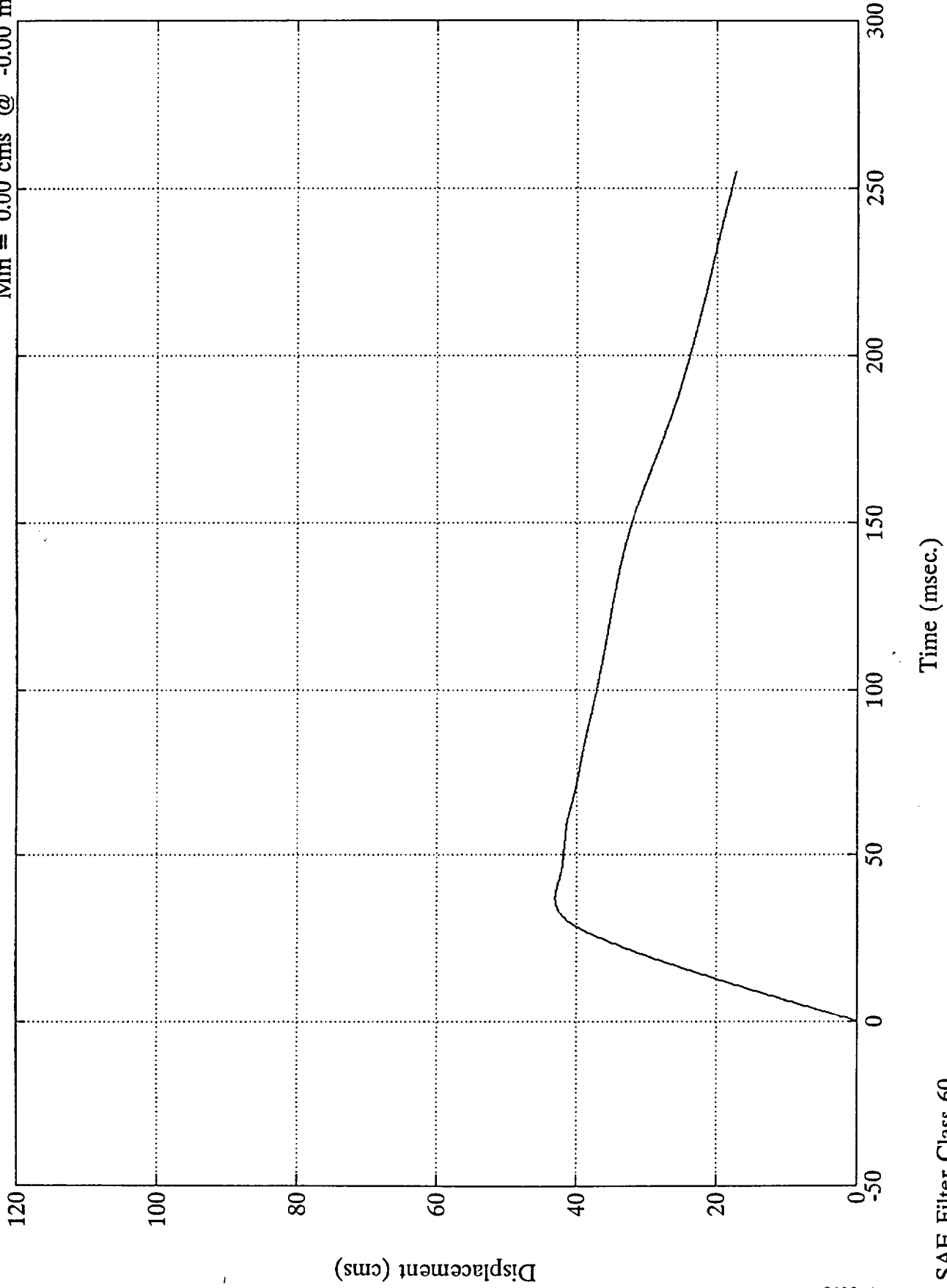

NCAP TEST #4 - 1994 MAZDA 626 DX

Max = 35.56 Gs @ 42.60 msec  
Min = -121.59 Gs @ 30.47 msec

Acc. #4(x)

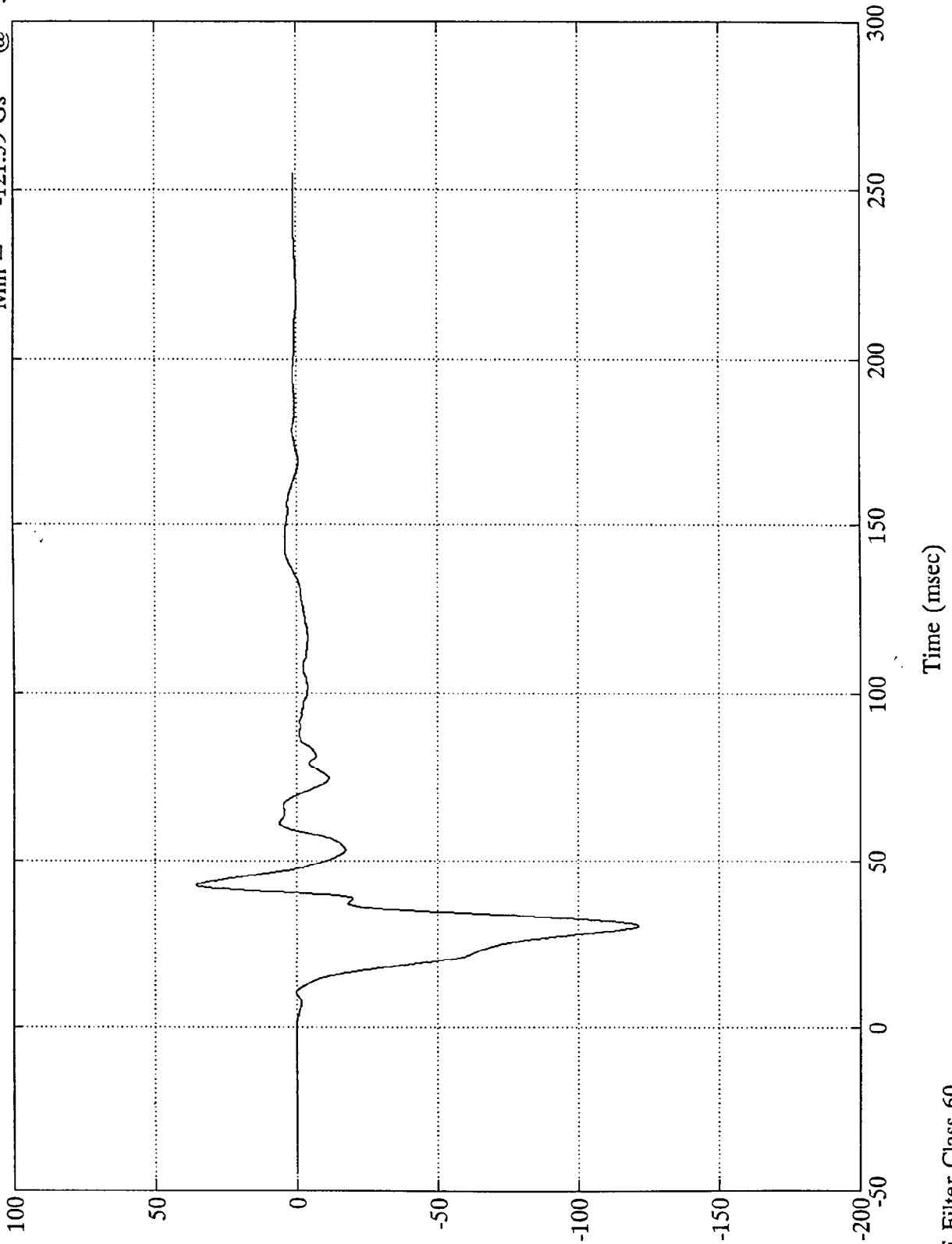

Acc. #4(x)

Max = 56.65 km/h @ 0.72 msec  
Min = -3.04 km/h @ 134.16 msec

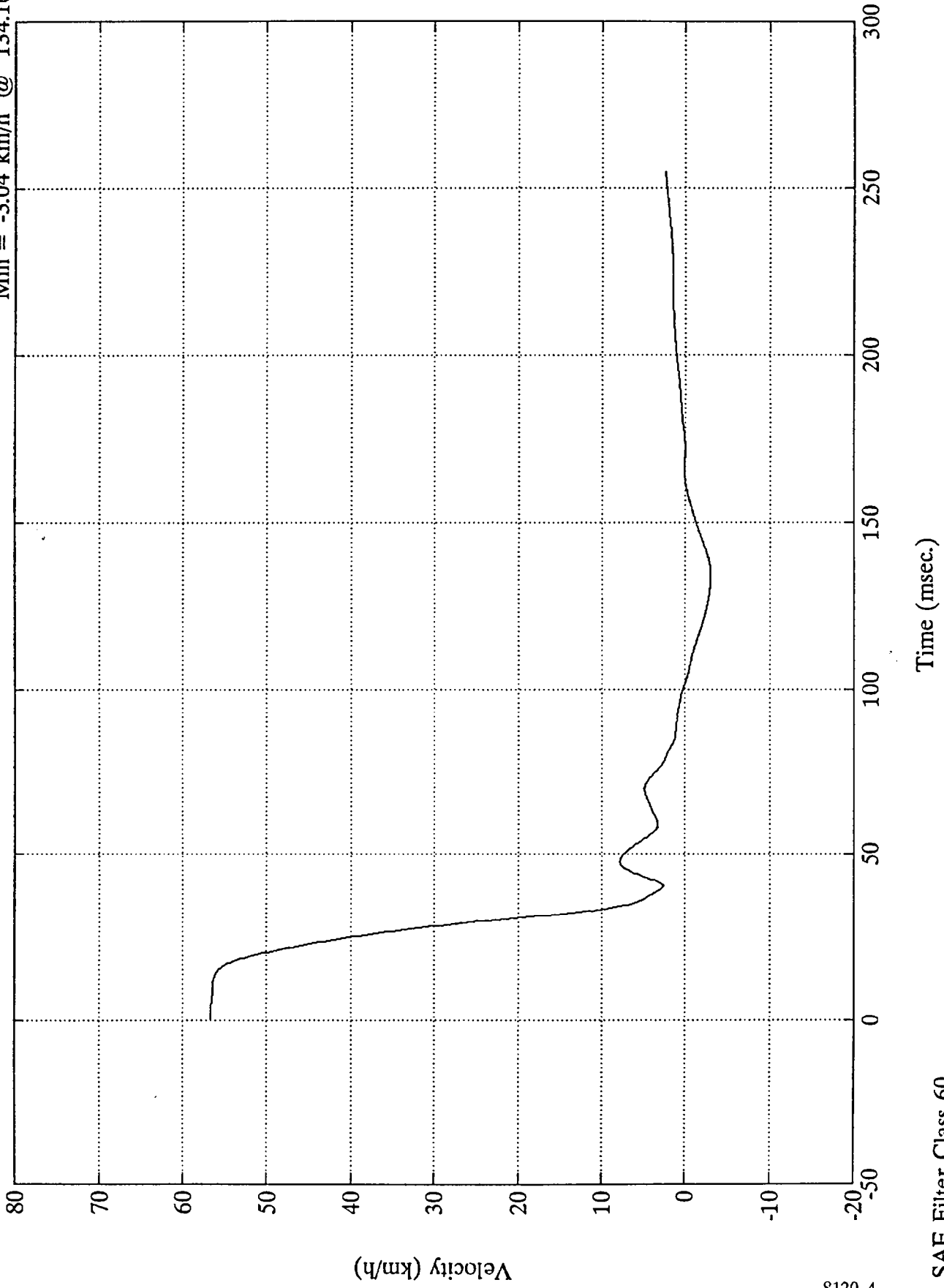

NCAP TEST #4 - 1994 MAZDA 626 DX

Acc. #4(x)

Max = 50.06 cms @ 254.88 msec  
Min = 0.00 cms @ -0.00 msec

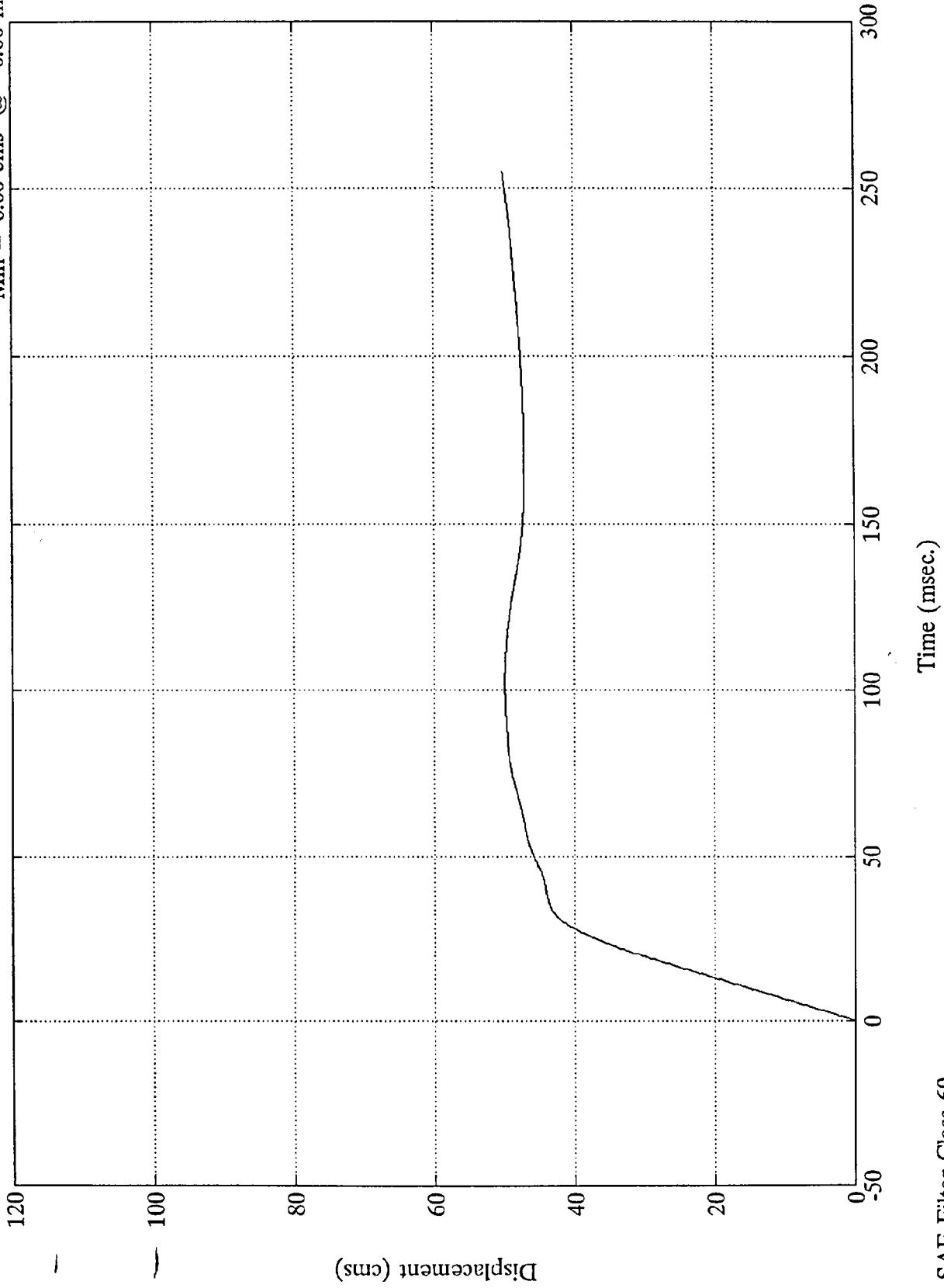

SAE Filter Class 60

Max = 31.14 Gs @ 63.00 msec  
Min = -107.76 Gs @ 50.04 msec

Acc. #5(x)

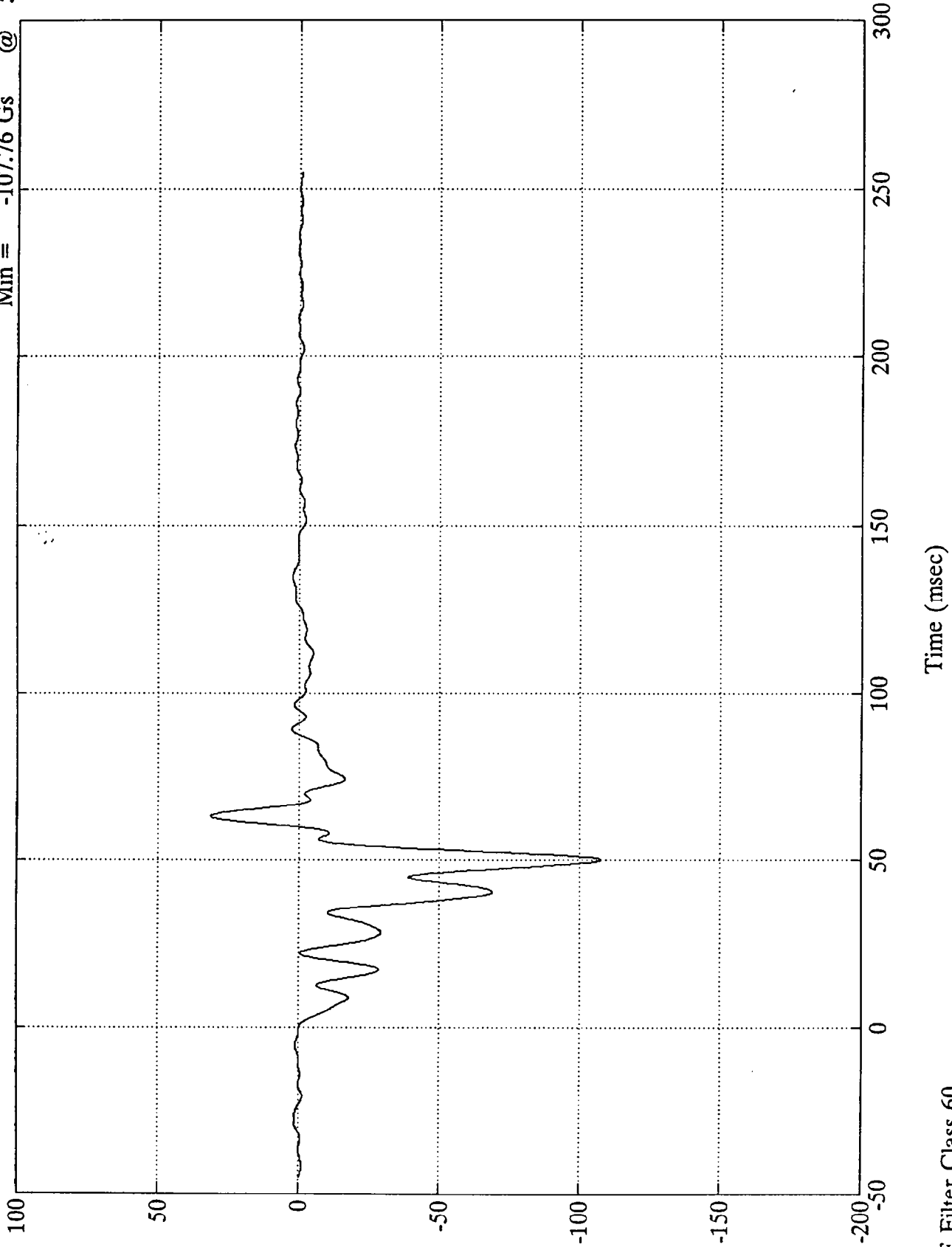

NCAP TEST #4 - 1994 MAZDA 626 DX

Acc. #5(x)

Max = 56.65 km/h @ 0.24 msec  
Min = -8.30 km/h @ 125.76 msec

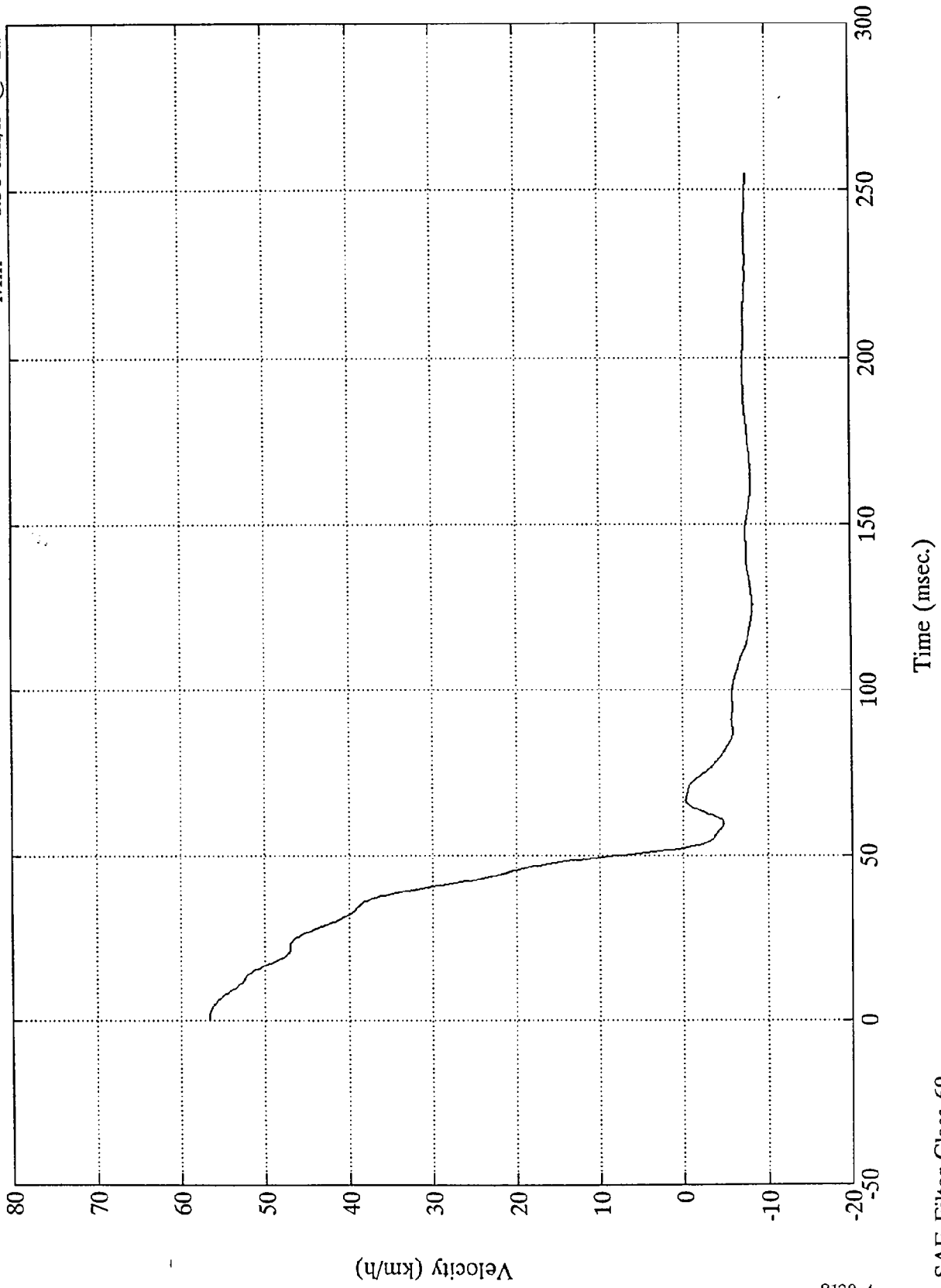

SAE Filter Class 60

Max = 58.55 cms @ 53.04 msec  
Min = 0.00 cms @ -0.00 msec

Acc. #5(x)

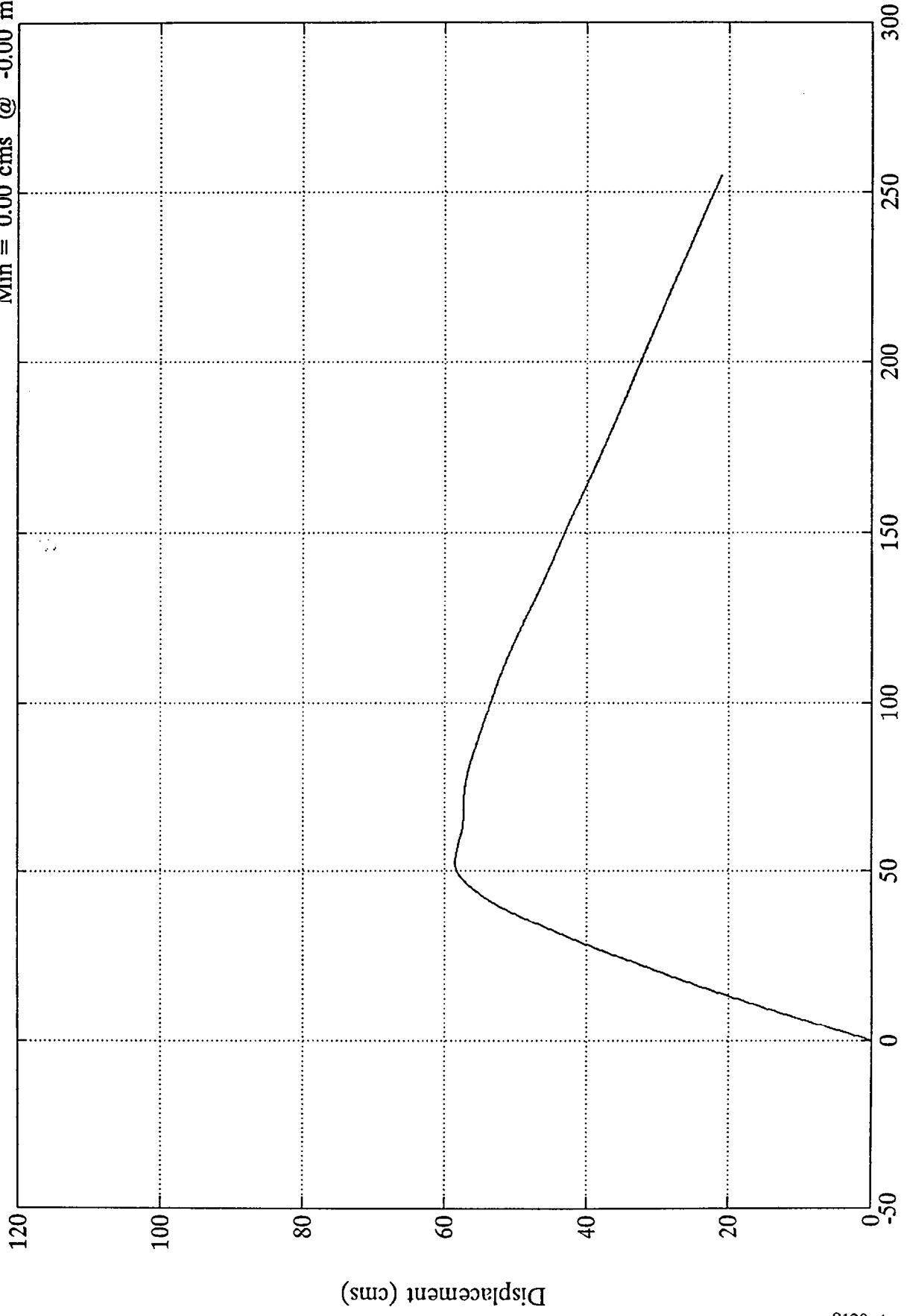

Time (msec.)

SAE Filter Class 60

NCAP TEST #4 - 1994 MAZDA 626 DX

Acc. #6(x)

Max = 17.68 Gs @ 57.36 msec  
Min = -114.40 Gs @ 43.68 msec

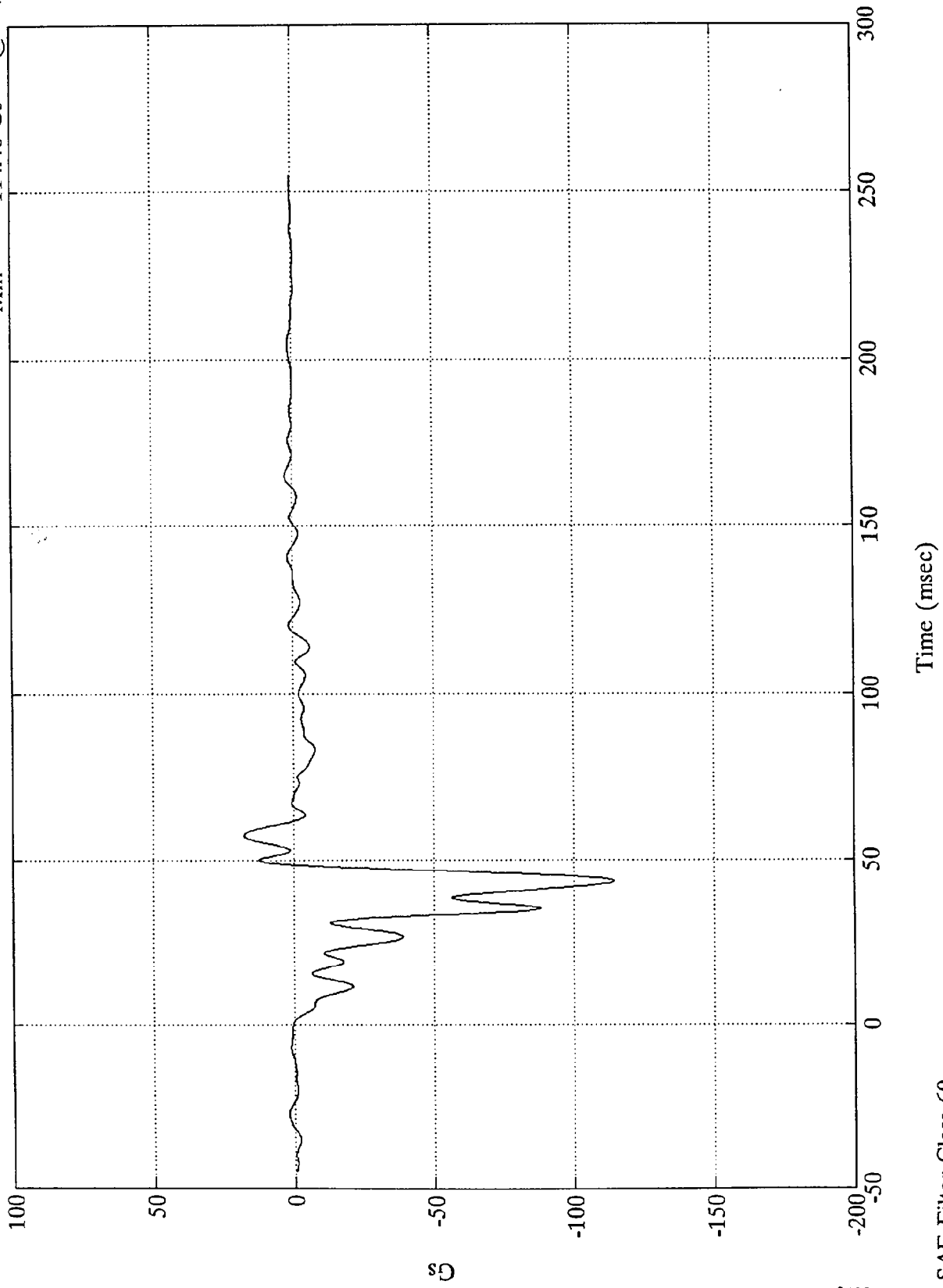

SAE Filter Class 60

Acc. #6(x)

Max = 56.65 km/h @ 1.68 msec  
Min = -4.97 km/h @ 161.52 msec

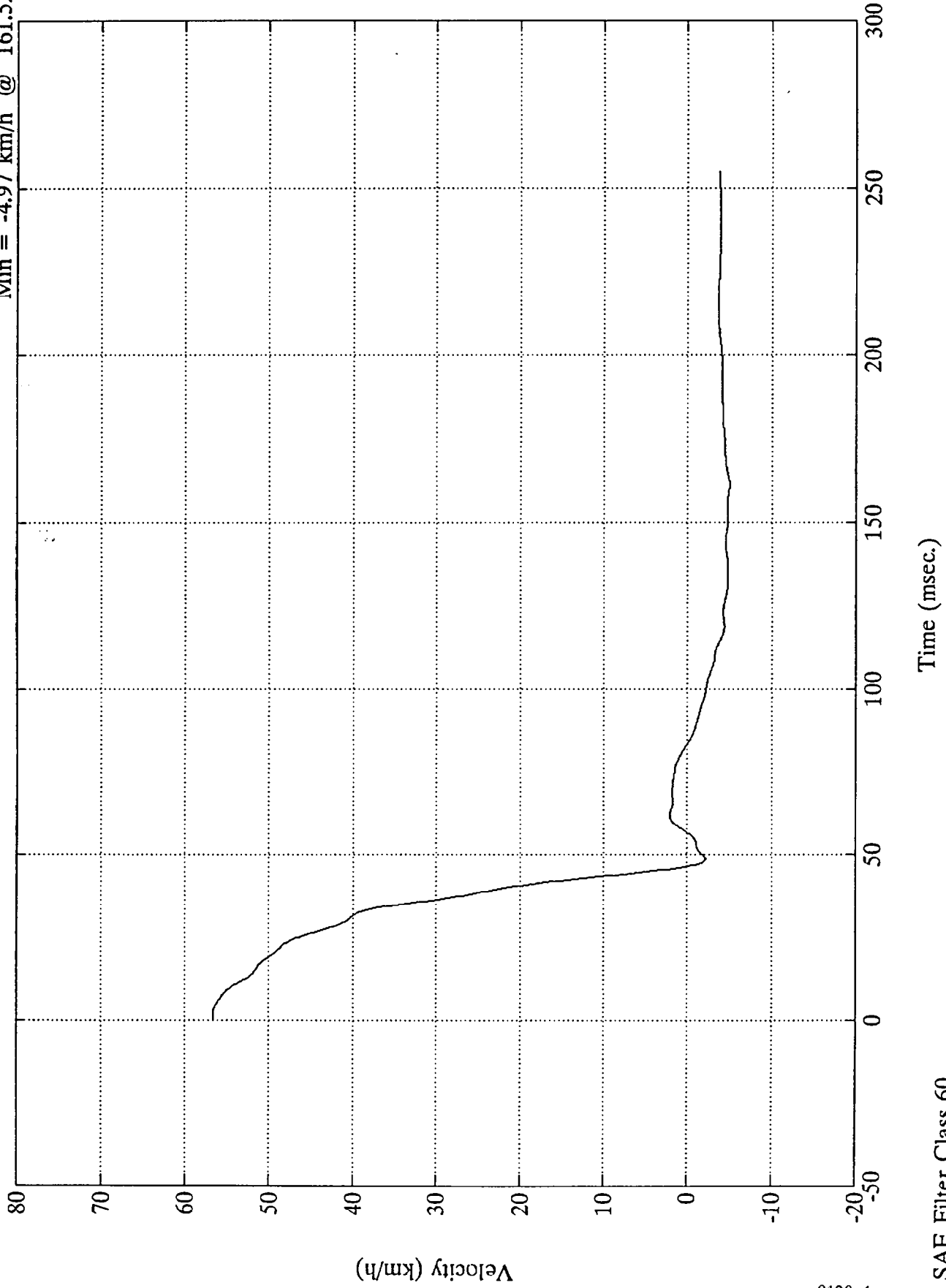

NCAP TEST #4 - 1994 MAZDA 626 DX

Acc. #6(x)

Max = 54.71 cms @ 84.72 msec  
Min = 0.00 cms @ -0.00 msec

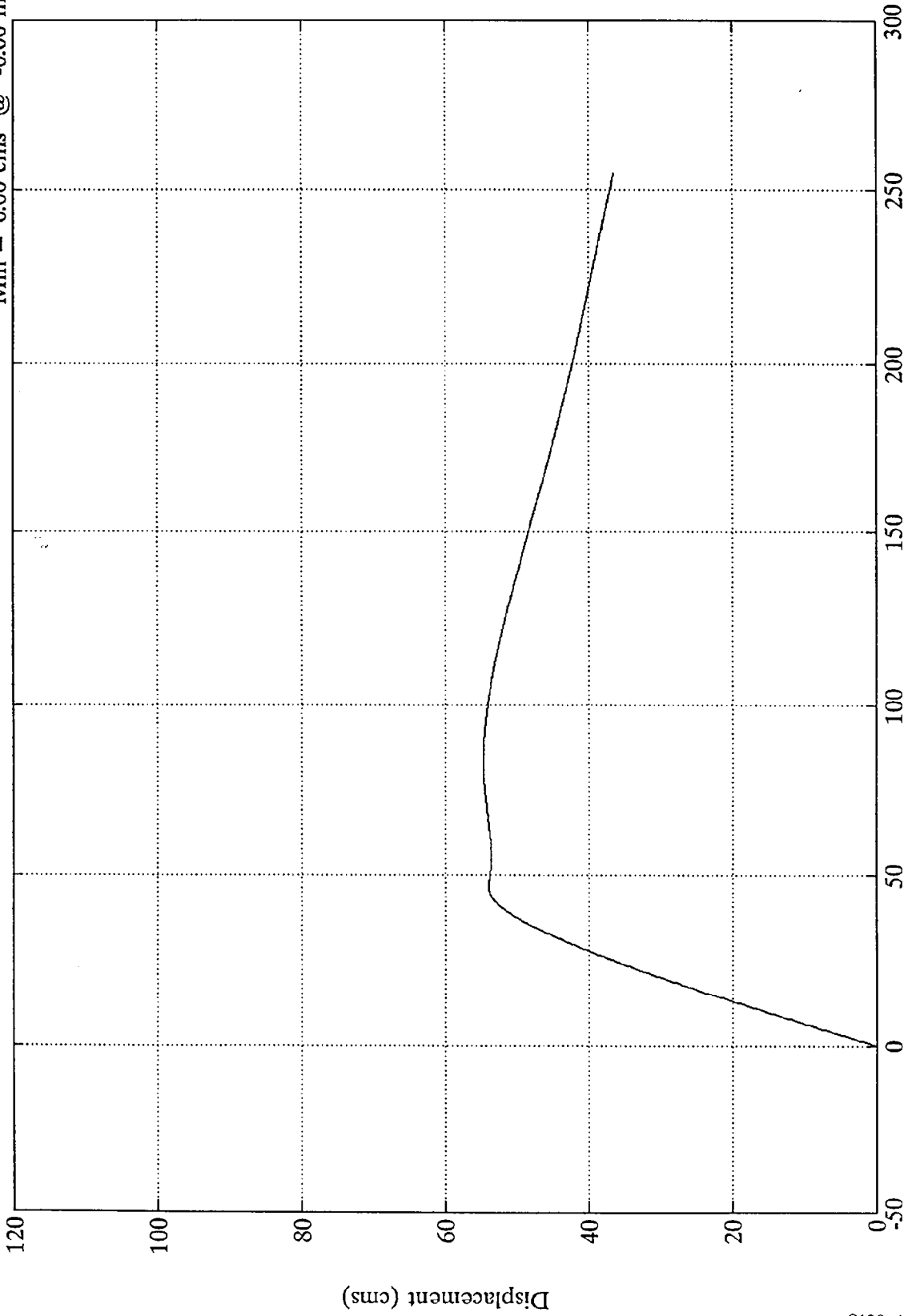

B-20

4120-8

Time (msec.)

SAE Filter Class 60

Max = 41.74 Gs @ 63.84 msec  
Min = -197.64 Gs @ 40.80 msec

Acc. #7(x)

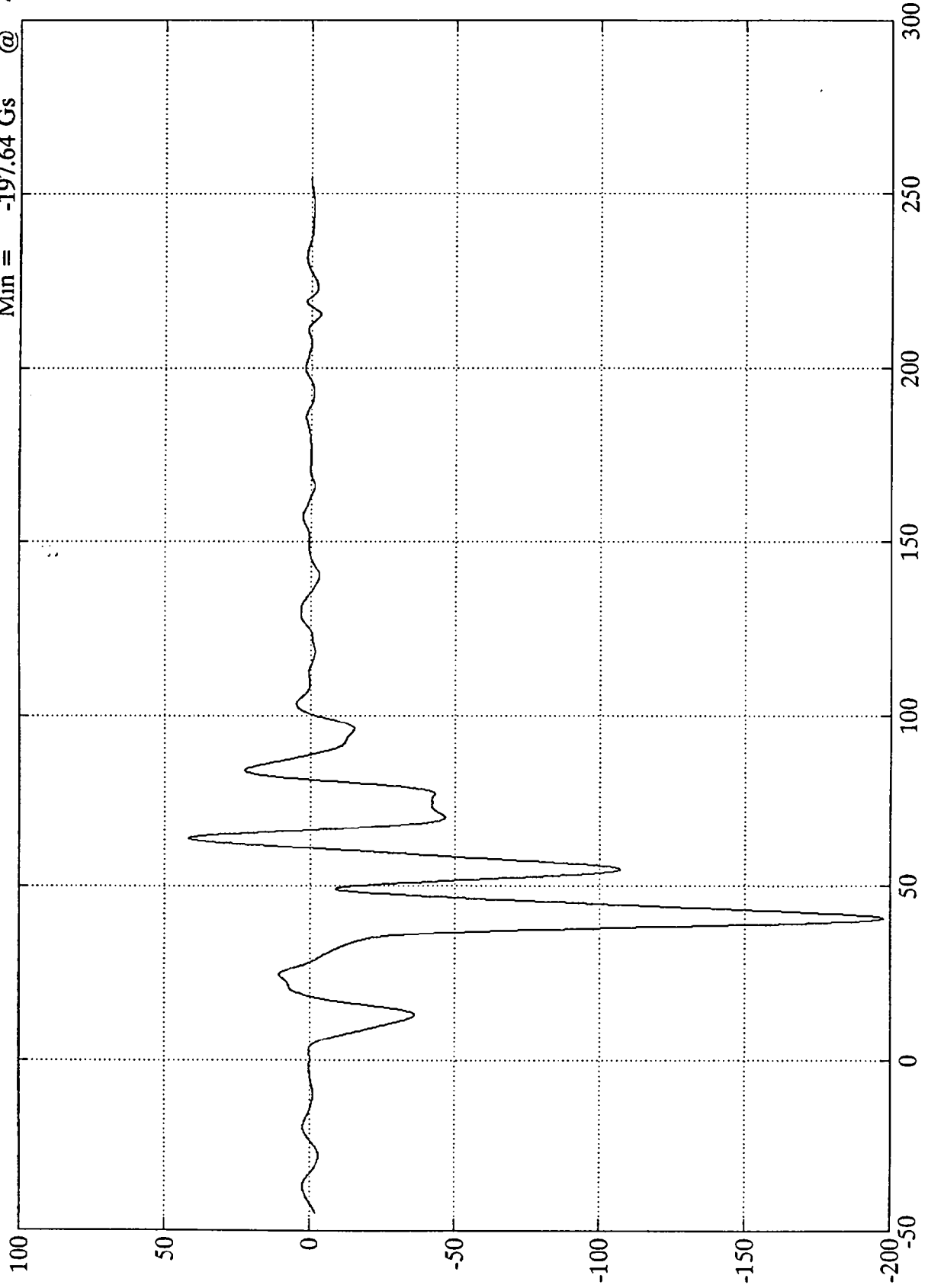

Time (msec)

SAE Filter Class 60

NCAP TEST #4 - 1994 MAZDA 626 DX

Acc. #8(x)

Max = 2.56 Gs @ 109.68 msec  
Min = -41.96 Gs @ 33.24 msec

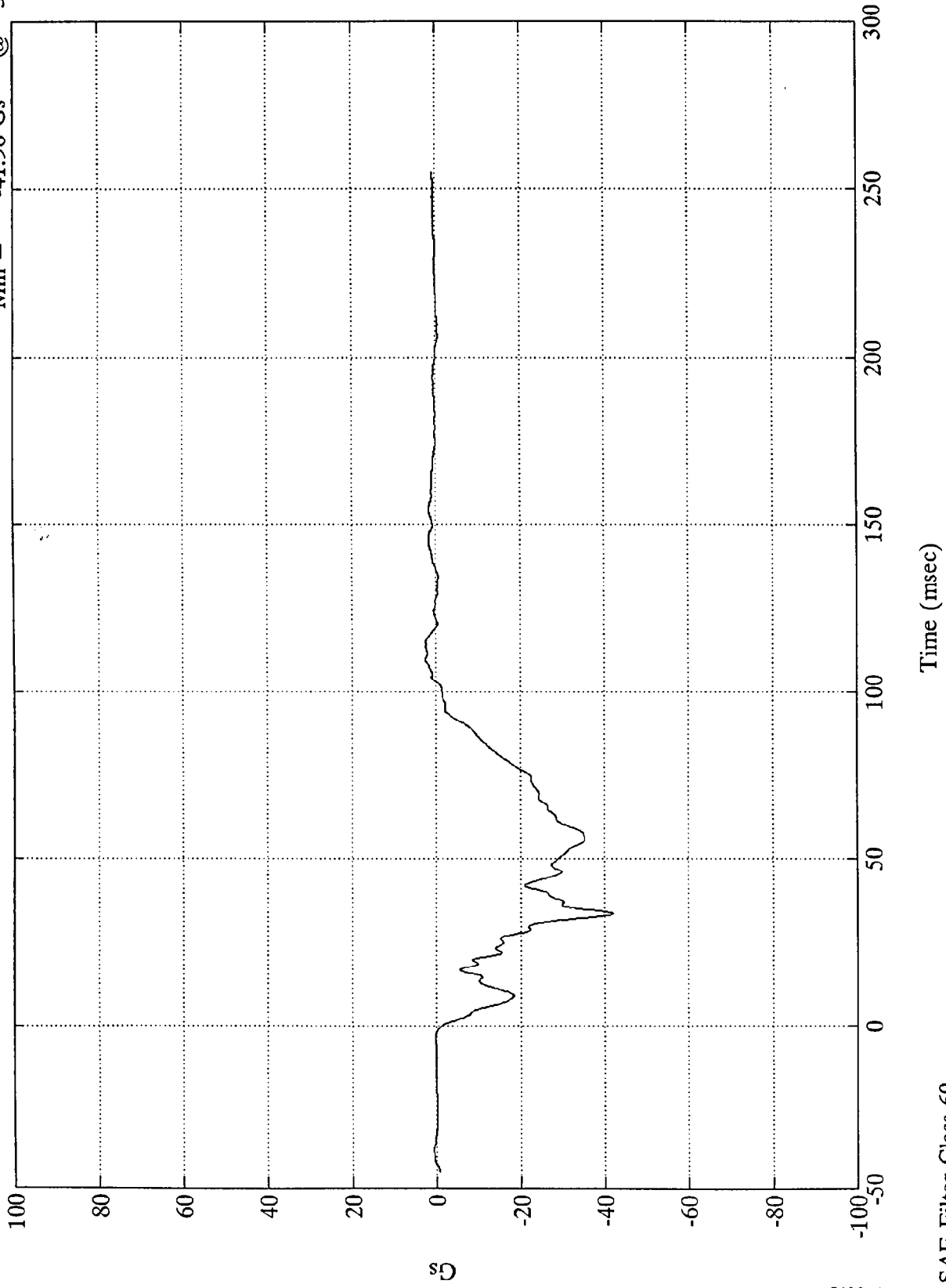

8D  
B-22

8120-4

SAE Filter Class 60

Time (msec)

Acc. #8(x)

Max = 56.65 km/h @ -0.00 msec  
Min = -10.92 km/h @ 102.96 msec

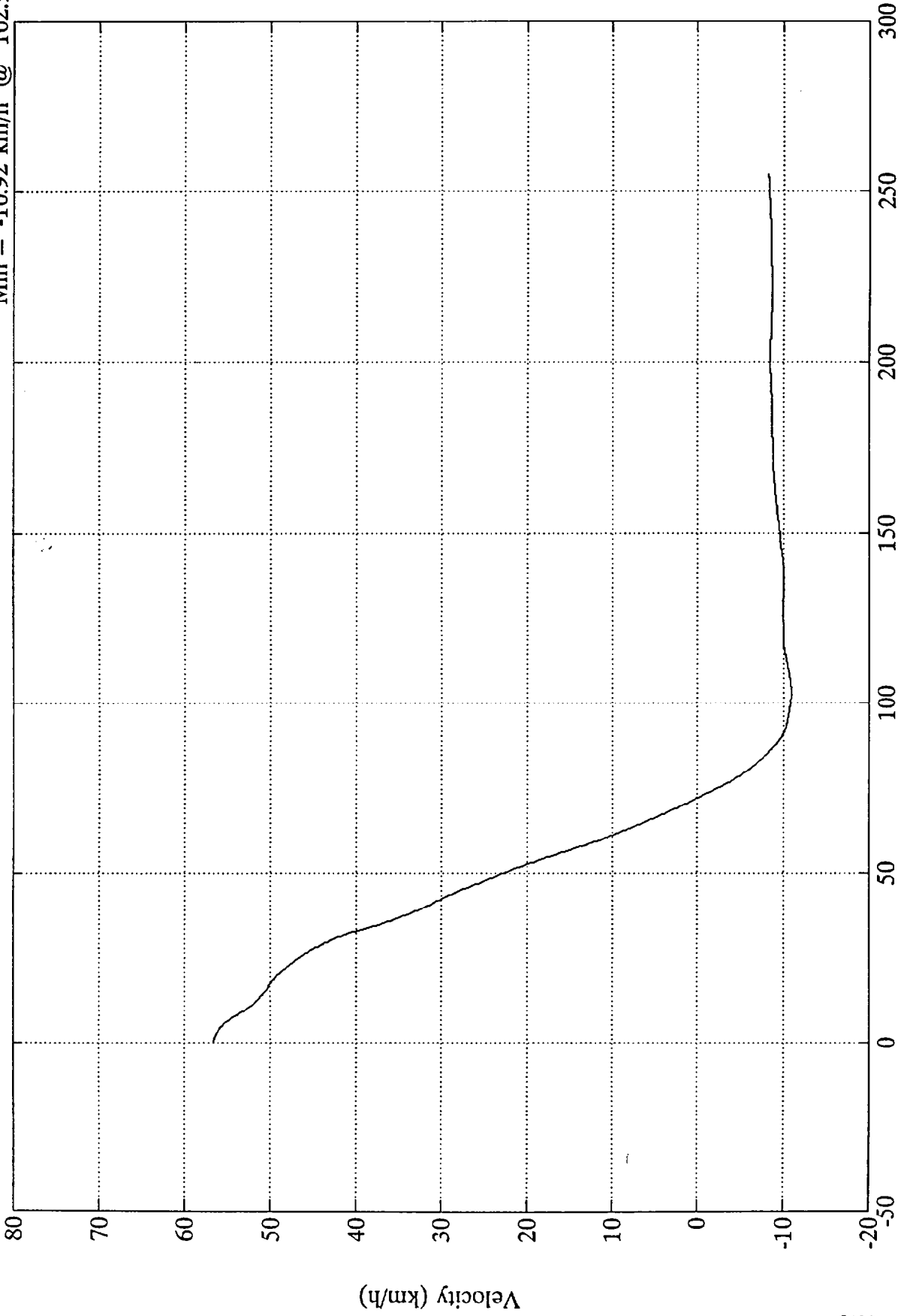

Time (msec.)

SAE Filter Class 60

NCAP TEST #4 - 1994 MAZDA 626 DX

Acc. #8(x)

Max = 67.08 cms @ 73.20 msec  
Min = 0.00 cms @ -0.00 msec

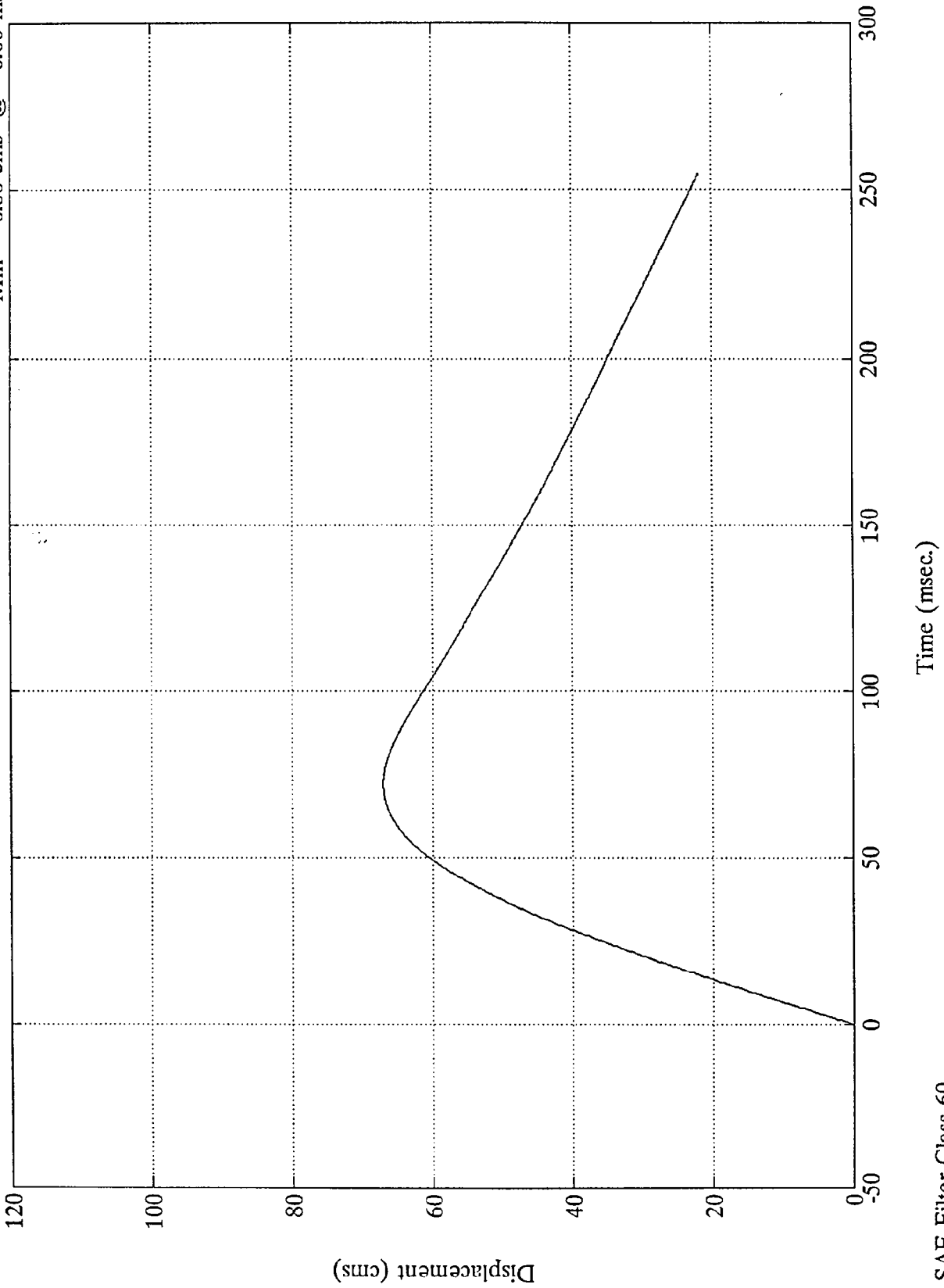

Max = 2.08 Gs @ 112.56 msec  
Min = -50.10 Gs @ 34.91 msec

Acc. #9(x)

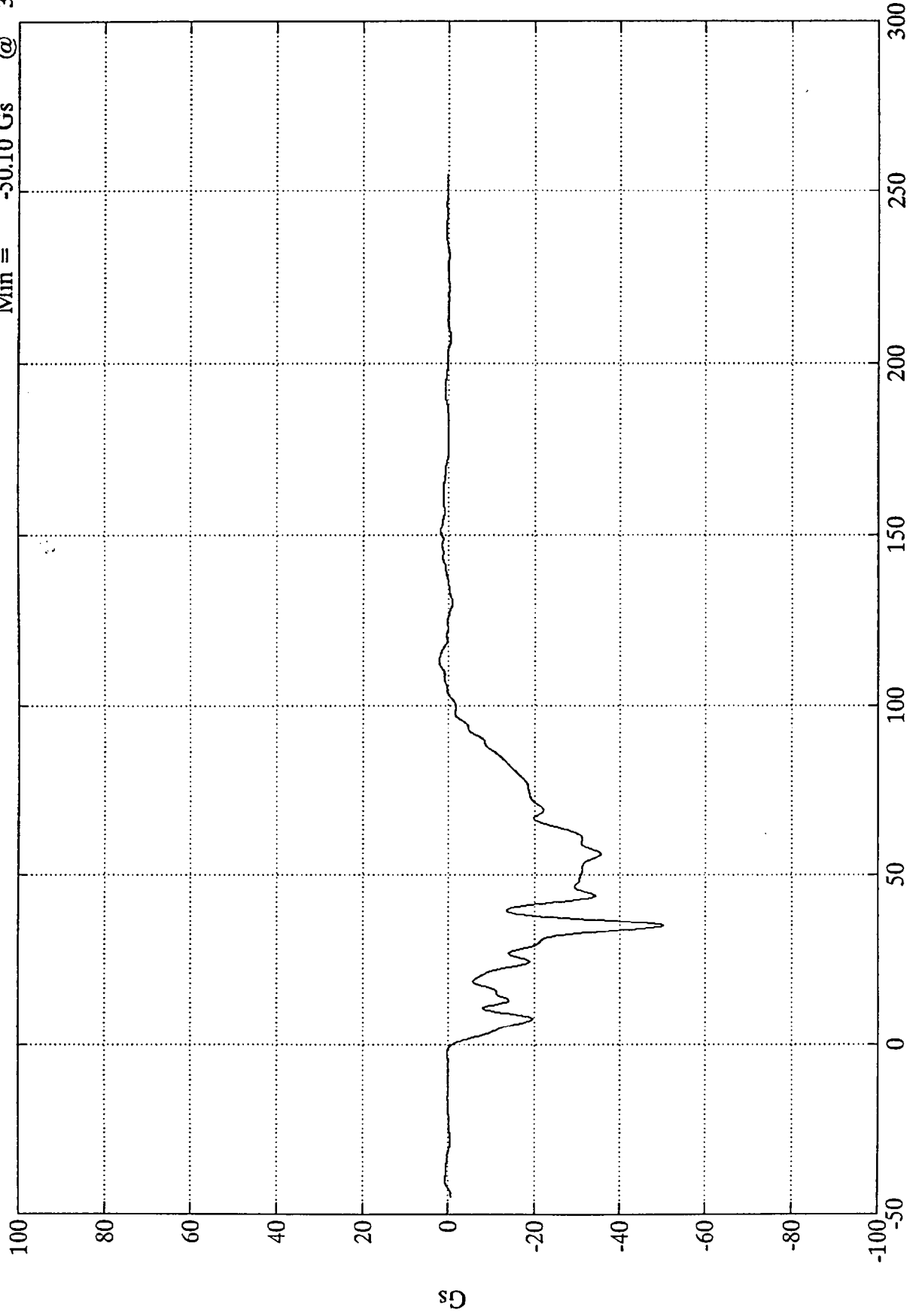

Time (msec)

SAE Filter Class 60

NCAP TEST #4 - 1994 MAZDA 626 DX

Acc. #9(x)

Max = 56.65 km/h @ -0.00 msec  
Min = -9.52 km/h @ 103.44 msec

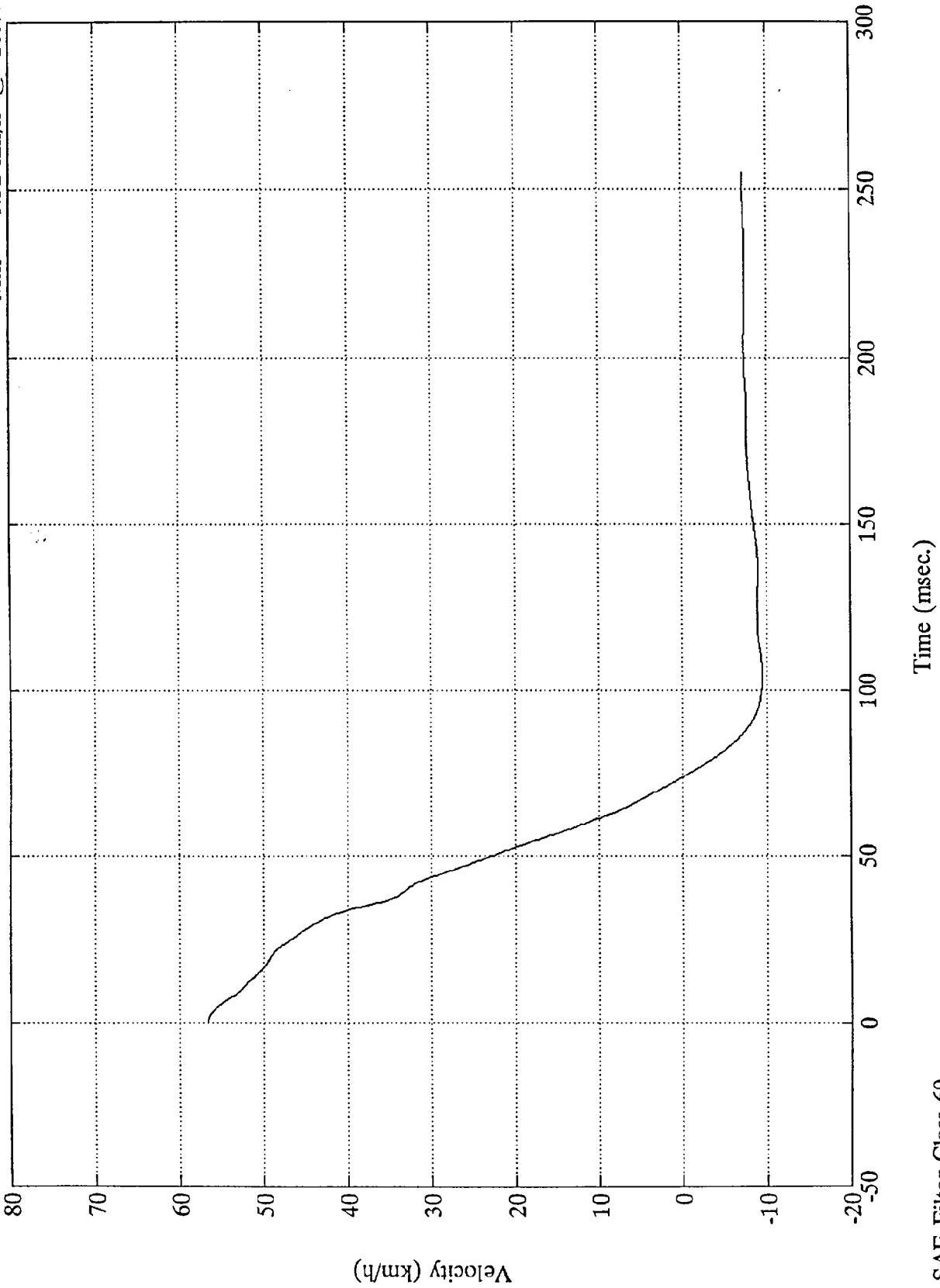

SAE Filter Class 60

Acc. #9(x)

Max = 67.46 cms @ 74.16 msec  
Min = 0.00 cms @ -0.00 msec

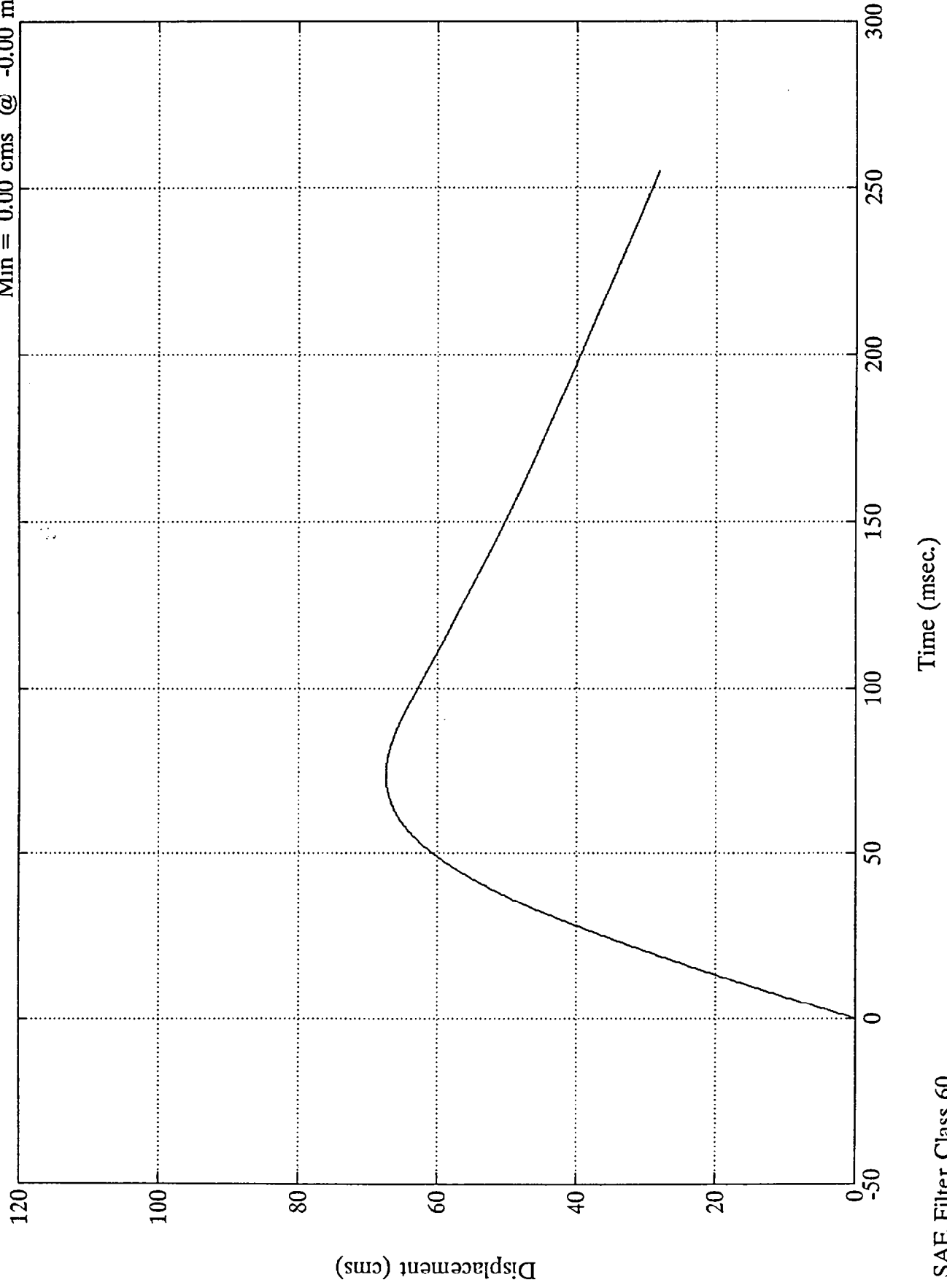

B-27

8120-4

SAE Filter Class 60

TEST NO. MR5400

LOAD CELL BARRIER DATA

FILTER CHANNEL CLASS

60

Max = 968.77 Nwt @ 29.15 msec  
Min = -1220.18 Nwt @ 33.24 msec

Barrier Load Cell A1

x10<sup>4</sup>

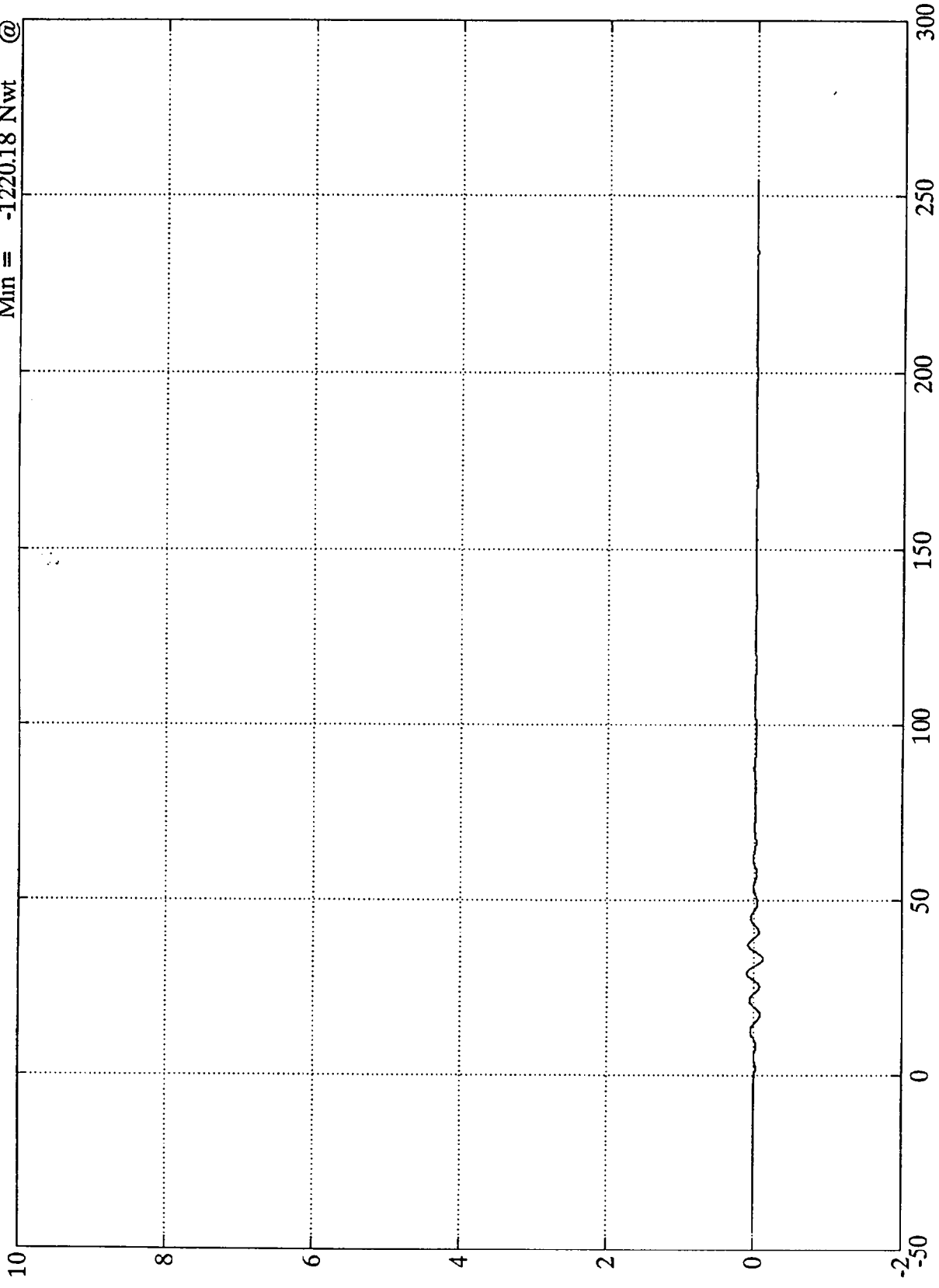

1Nwt  
B-28

8120-4

SAE Filter Class 60

Time (msec)

NCAP TEST #4 - 1994 MAZDA 626 DX

$\times 10^4$

Barrier Load Cell A2

Max = 1152.17 Nwt @ 21.95 msec  
Min = -214.83 Nwt @ 6.47 msec

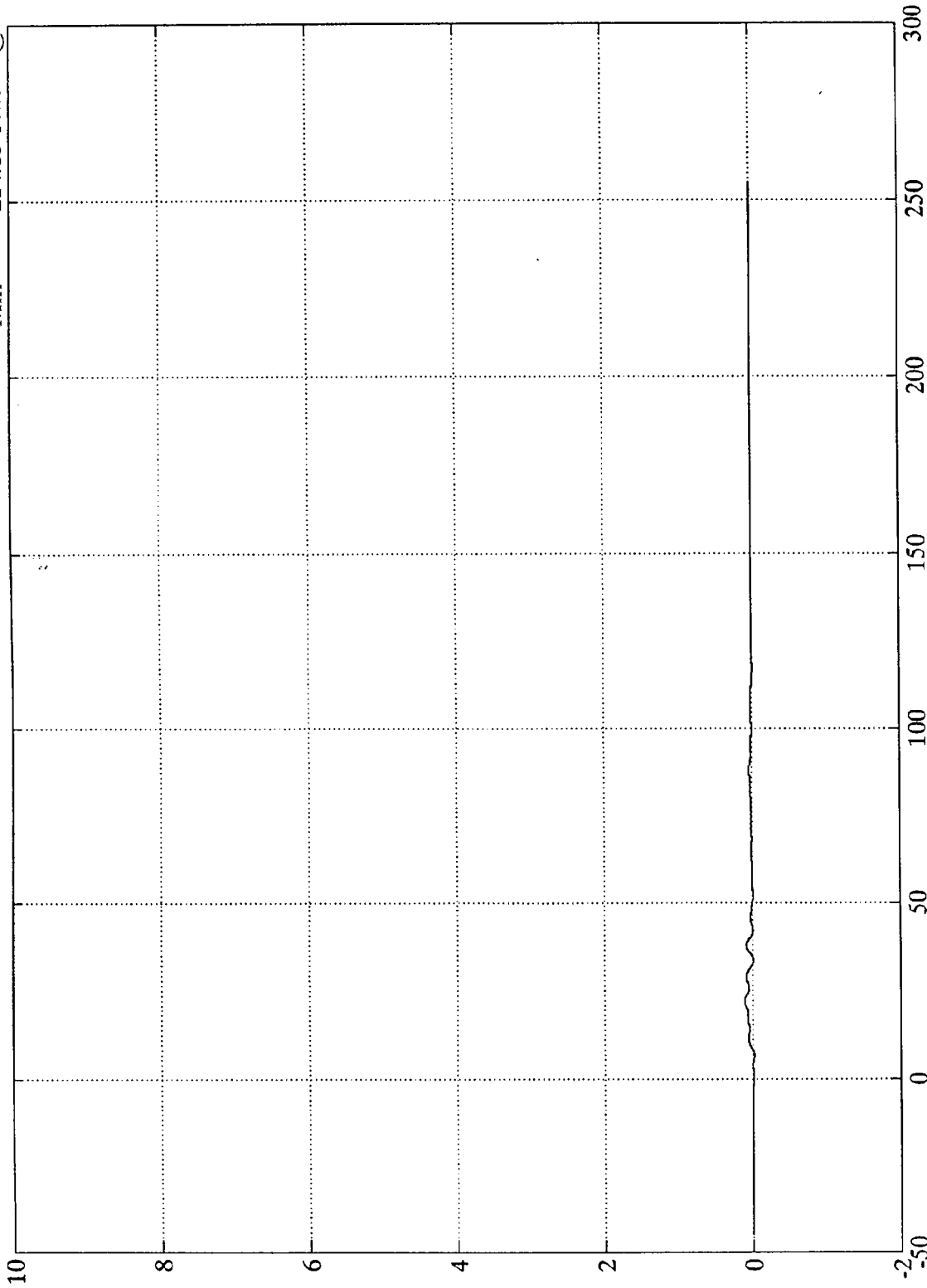

B-29  
Nwt

8120-4

Time (msec)

SAE Filter Class 60

Barrier Load Cell A3

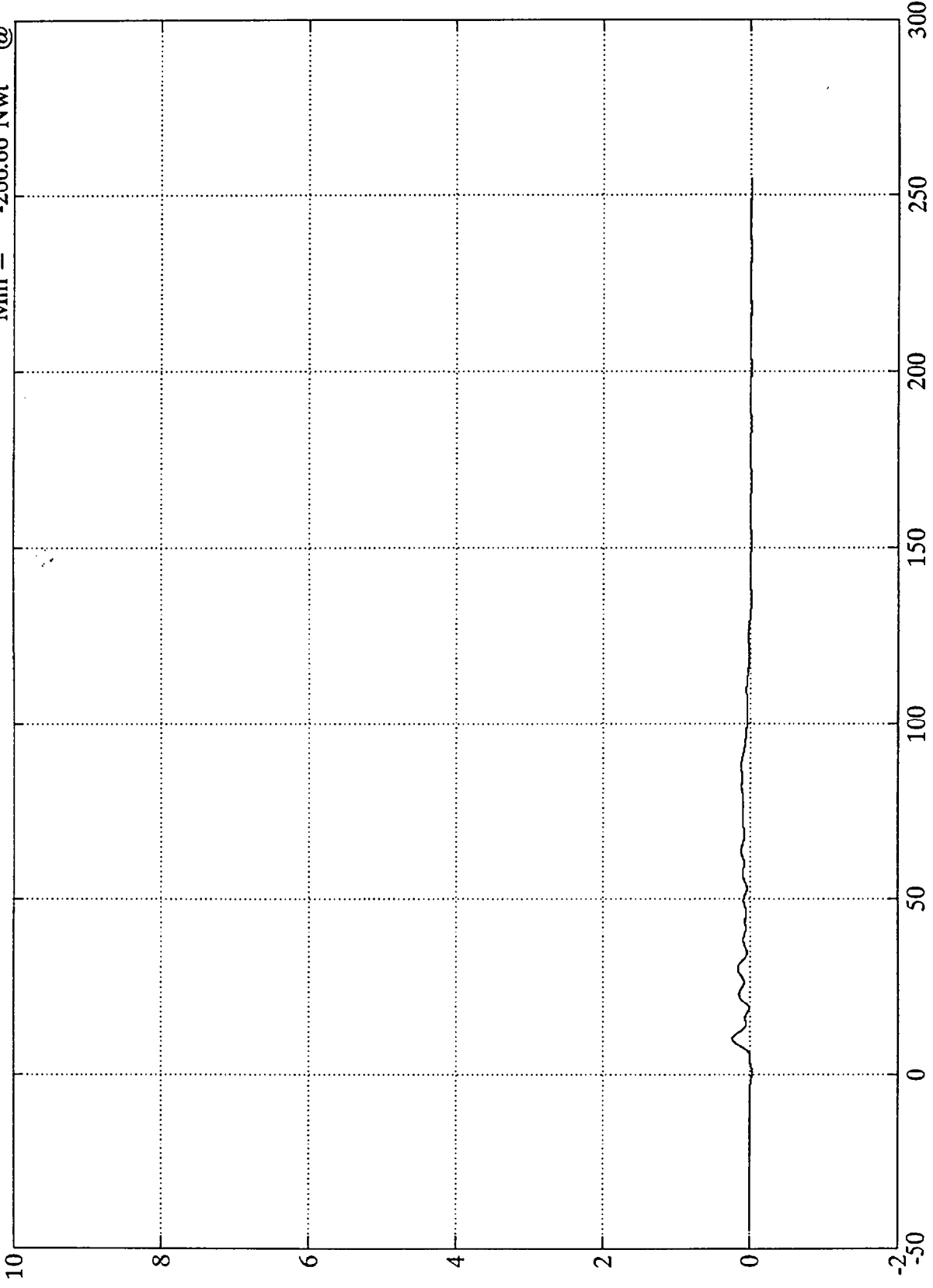

10<sup>4</sup>Nwt  
B-30

8120-4

Time (msec)

SAE Filter Class 60

NCAP TEST #4 - 1994 MAZDA 626 DX

Barrier Load Cell A4

Max = 38627.54 Nwt @ 21.00 msec  
Min = -1806.97 Nwt @ 14.15 msec

x10<sup>4</sup>

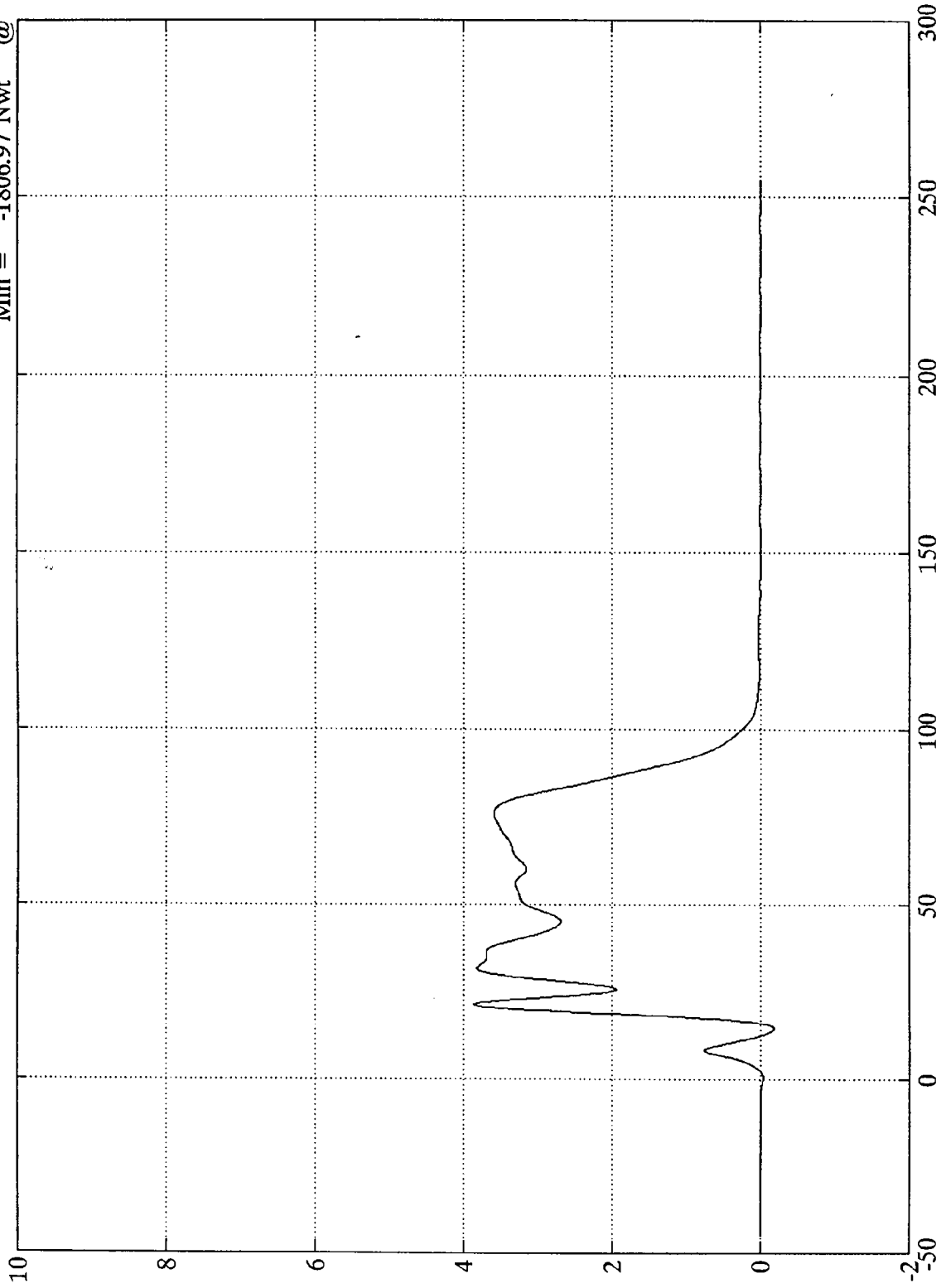

10N  
B-31

8120-4

Time (msec)

SAE Filter Class 60

Barrier Load Cell A5

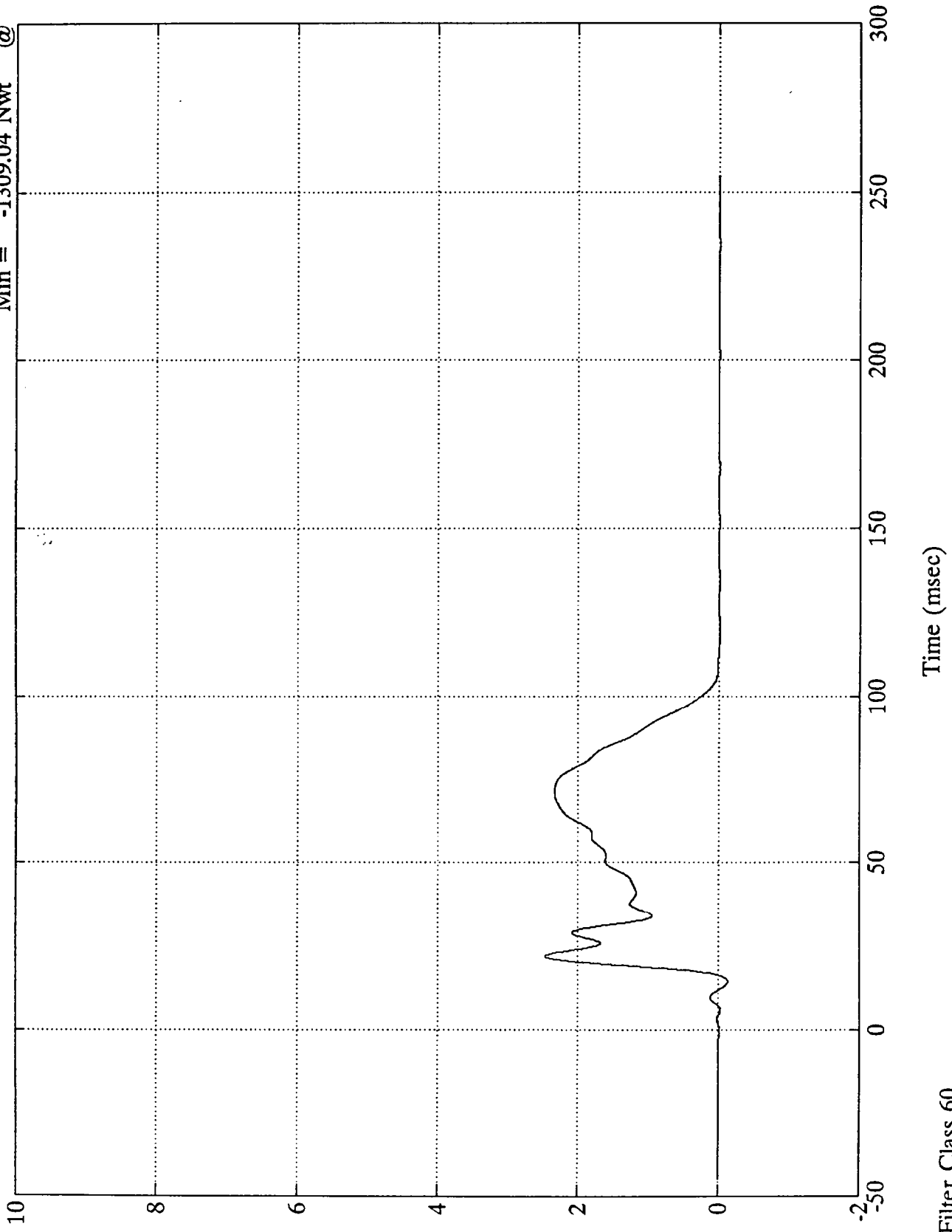

NCAP TEST #4 - 1994 MAZDA 626 DX  
x10<sup>4</sup>

Barrier Load Cell A6

Max = 2262.37 Nwt @ 30.60 msec  
Min = -412.85 Nwt @ 13.67 msec

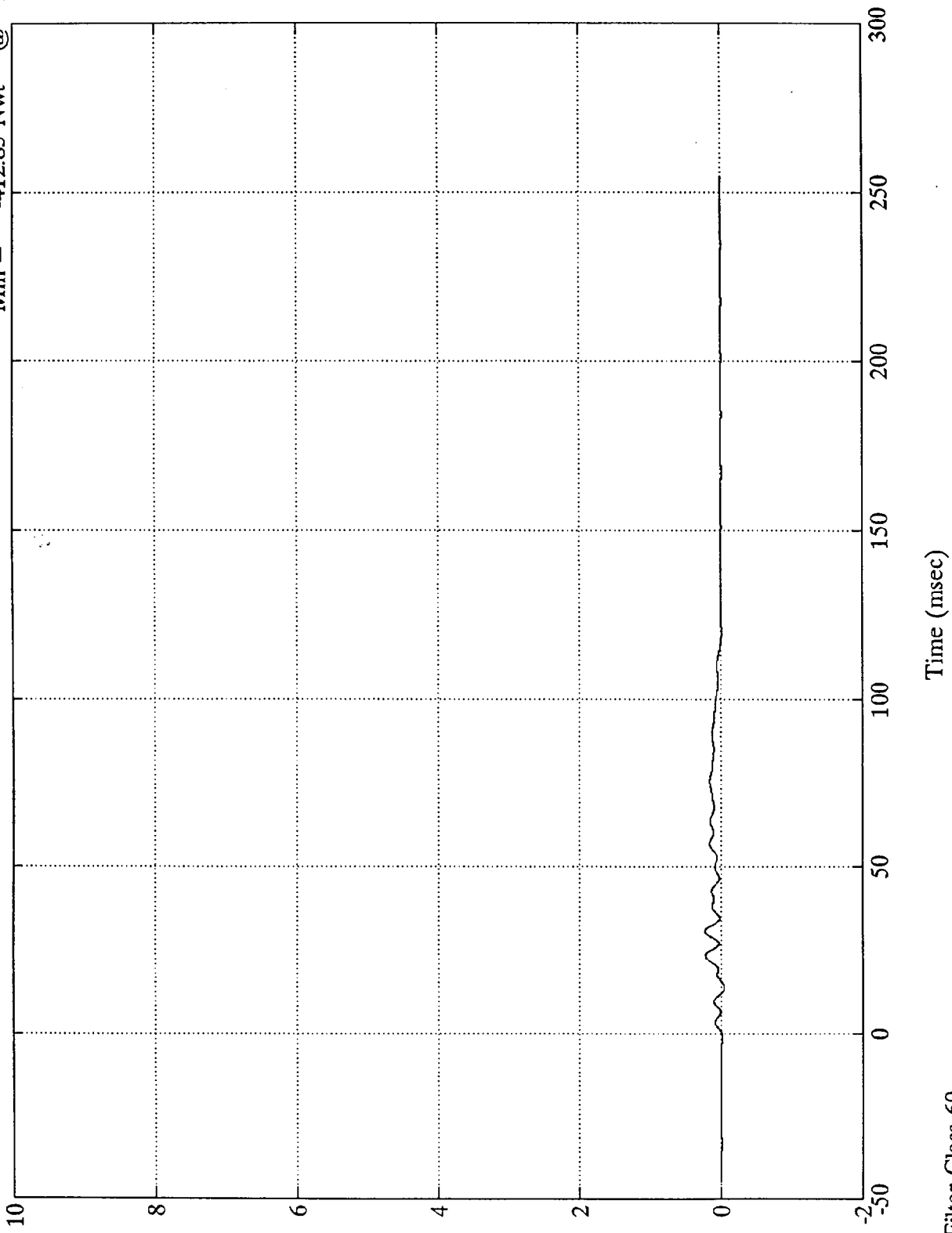

1N  
B-33

8120-4

SAE Filter Class 60



Barrier Load Cell A7

Max = 3367.87 Nwt @ 41.15 msec  
Min = -296.84 Nwt @ 34.55 msec

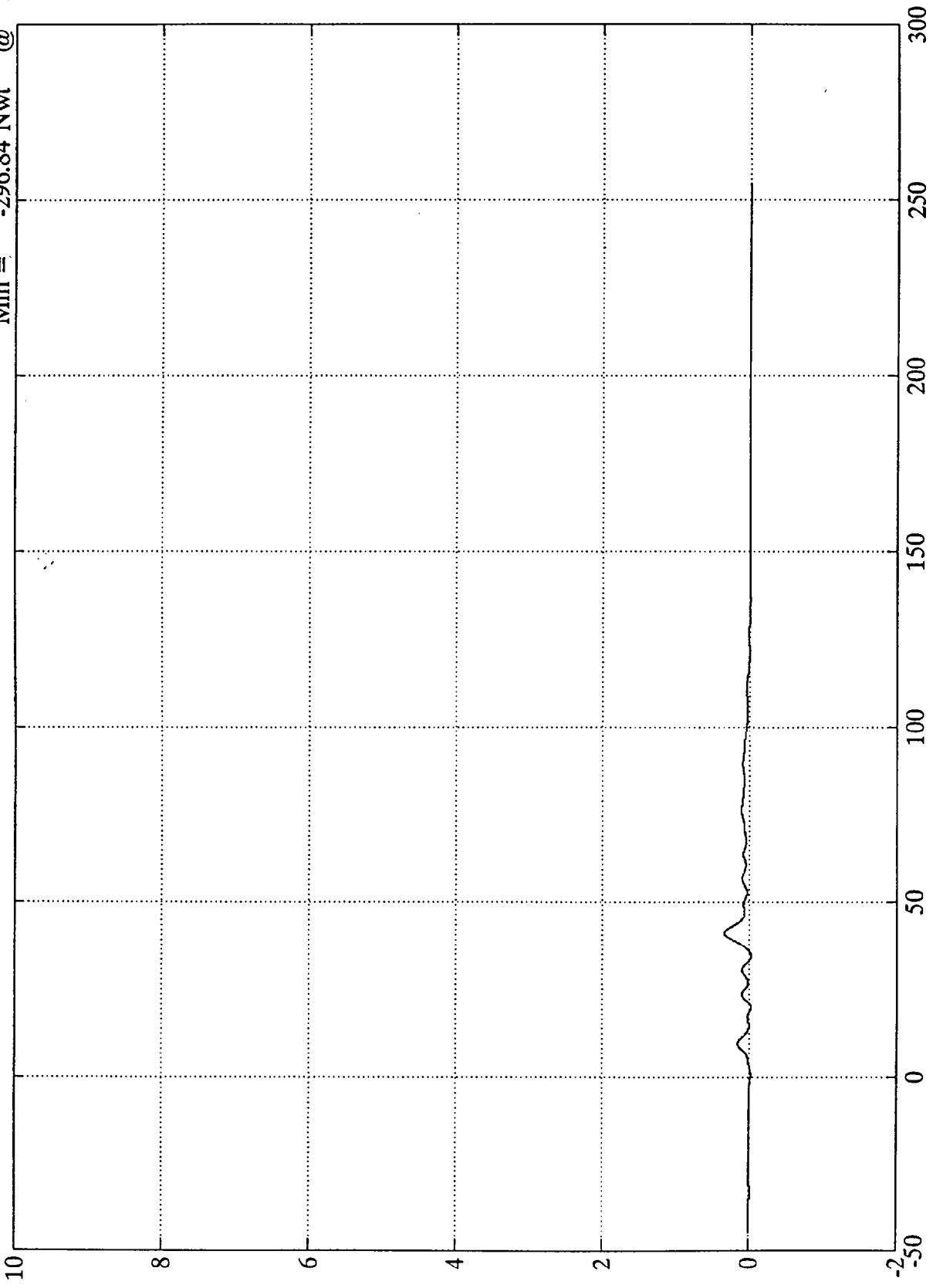

Time (msec)

NCAP TEST #4 - 1994 MAZDA 626 DX

x10<sup>4</sup>

Barrier Load Cell A8

Max = 1997.65 Nwt @ 75.12 msec  
Min = -171.28 Nwt @ 0.95 msec

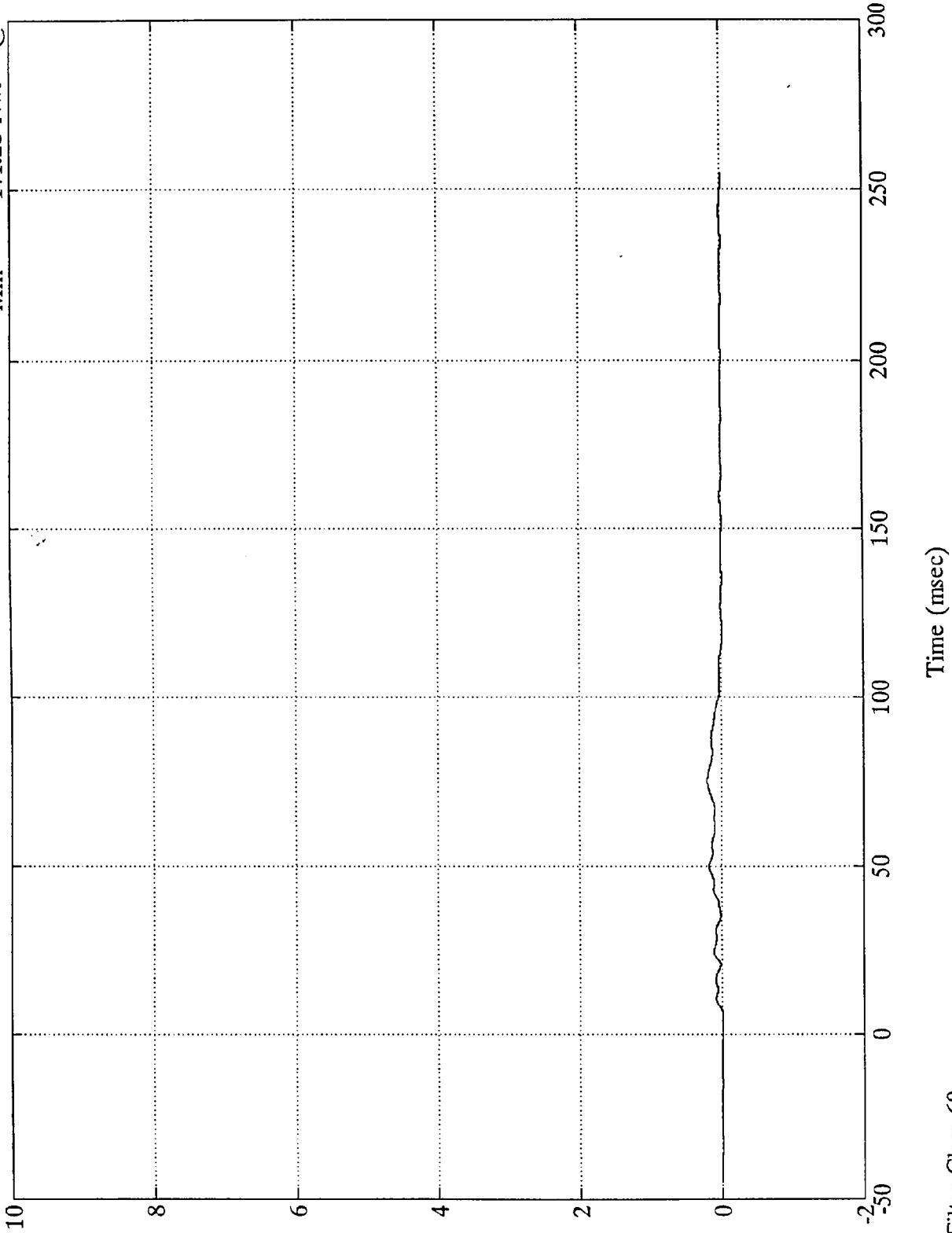

1Nwt  
B-35

8120-4

SAE Filter Class 60



Max = 778.35 Nwt @ 10.43 msec  
Min = -636.00 Nwt @ 21.84 msec

Barrier Load Cell A9

x10<sup>4</sup>

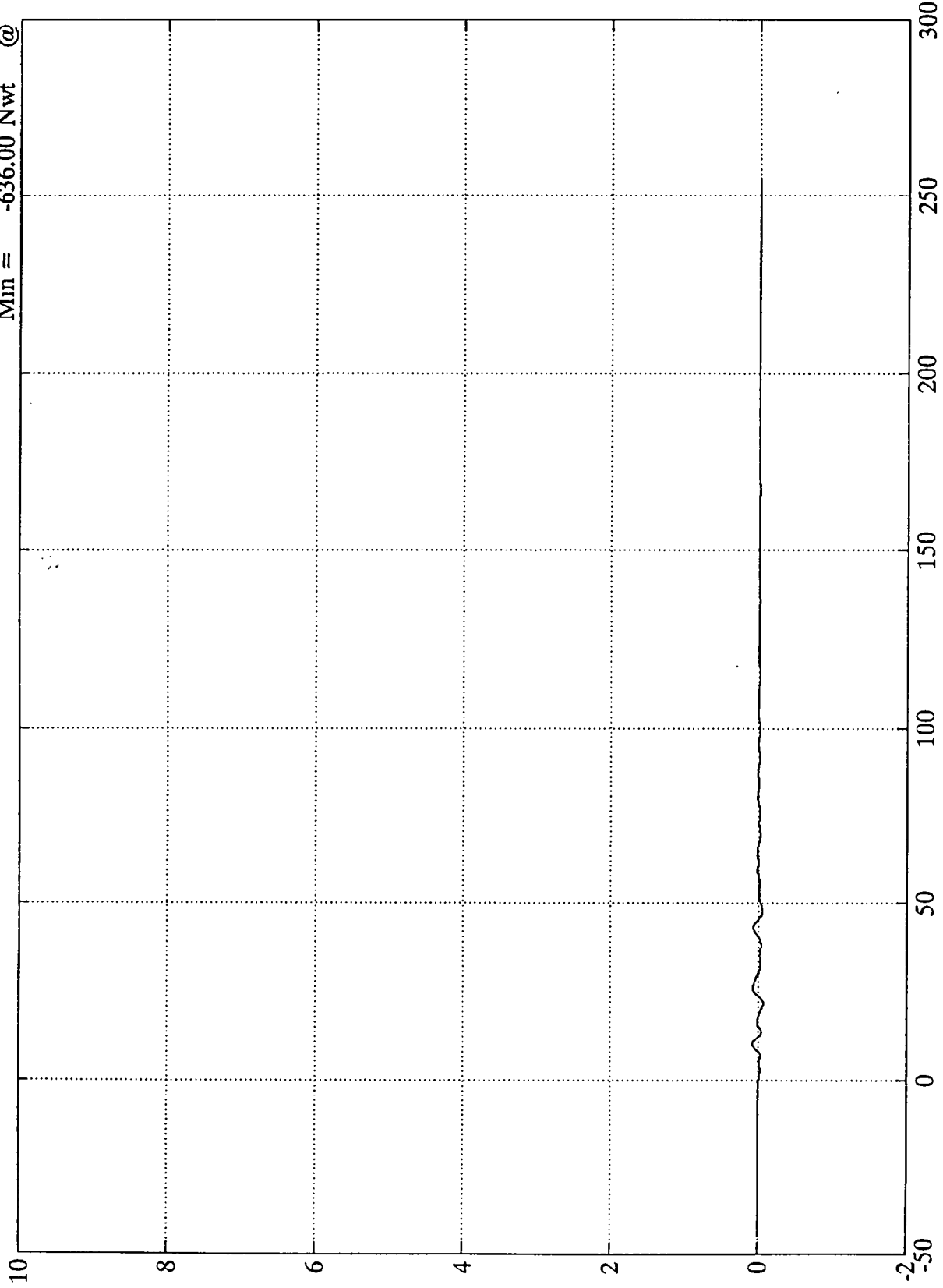

10<sup>4</sup>Nwt  
B-36

8120-4

Time (msec)

SAE Filter Class 60

NCAP TEST #4 - 1994 MAZDA 626 DX  
x10<sup>4</sup>

Barrier Load Cell B1

Max = 2035.92 Nwt @ 29.63 msec  
Min = -614.13 Nwt @ 16.79 msec

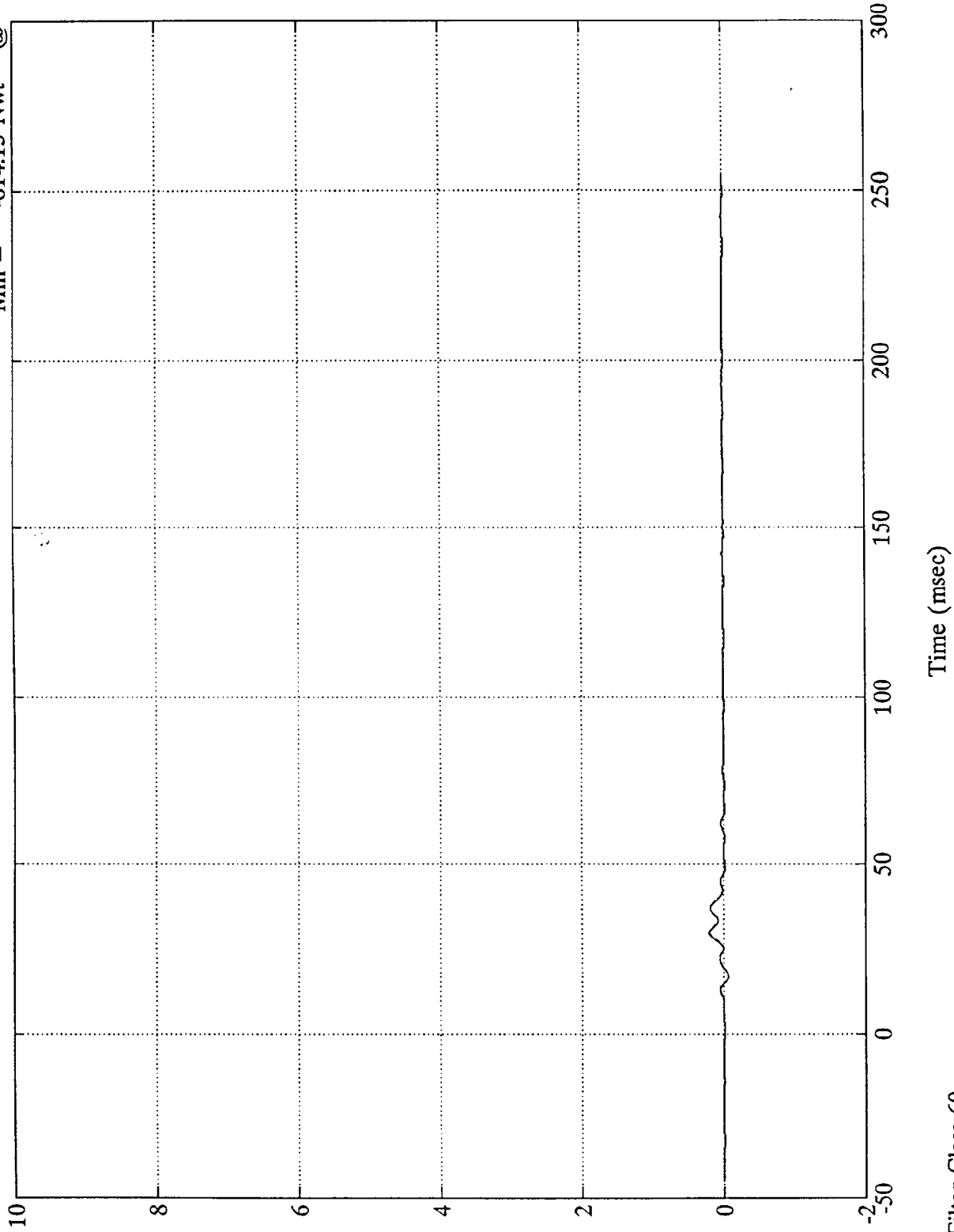

1MN  
B-37

8120-4

SAE Filter Class 60

Time (msec)



Barrier Load Cell B2

Max = 11303.88 Nwt @  
Min = -289.03 Nwt @

30.36 msec  
4.07 msec

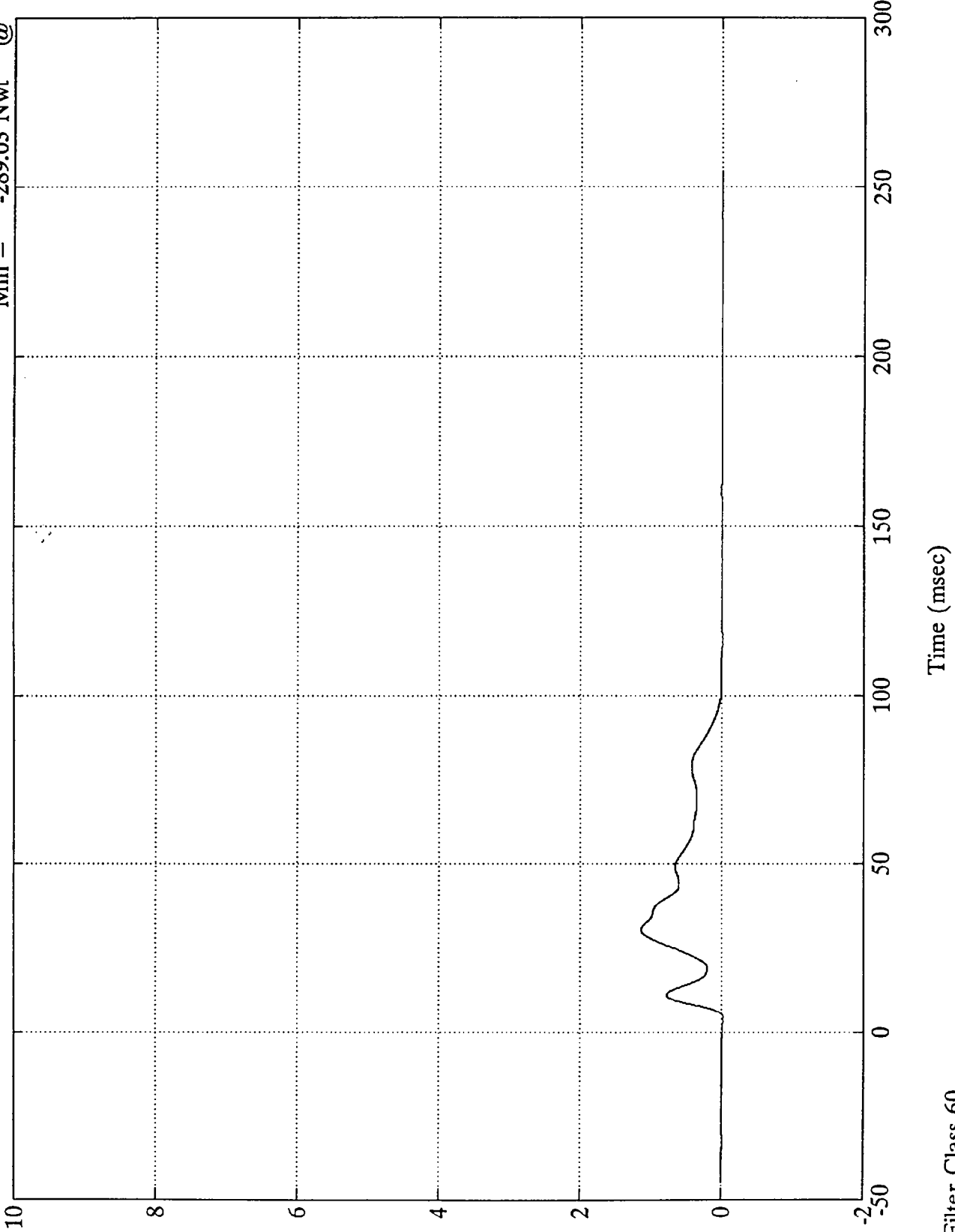

NCAP TEST #4 - 1994 MAZDA 626 DX

$\times 10^4$

Barrier Load Cell B3

Max = 90857.69 Nwt @ 30.00 msec  
Min = -1436.46 Nwt @ 1.19 msec

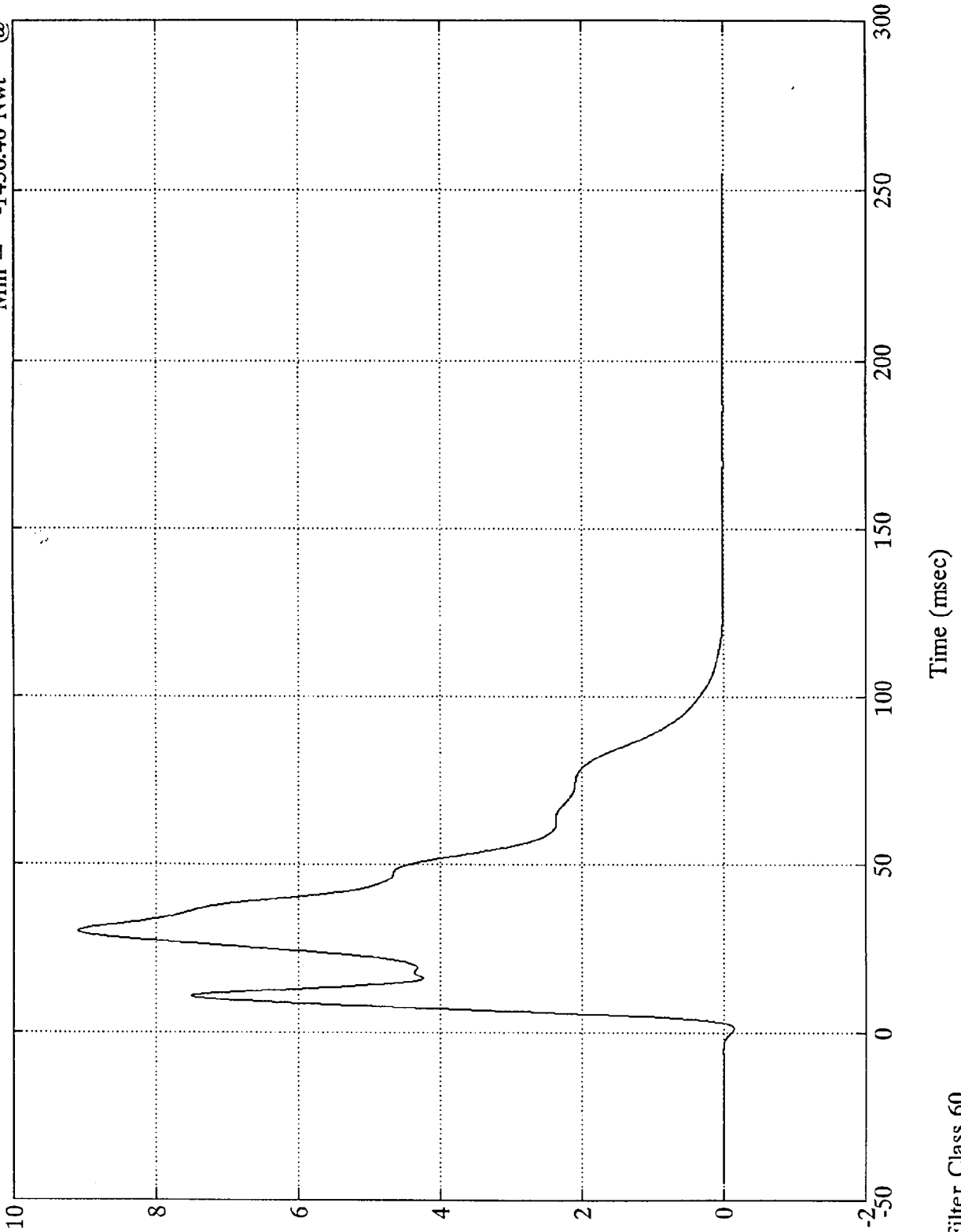

Max = 117614.27 Nwt @ 34.55  $\pi$   
Min = -548.72 Nwt @ -4.44 ms

Barrier Load Cell B4

$\times 10^5$

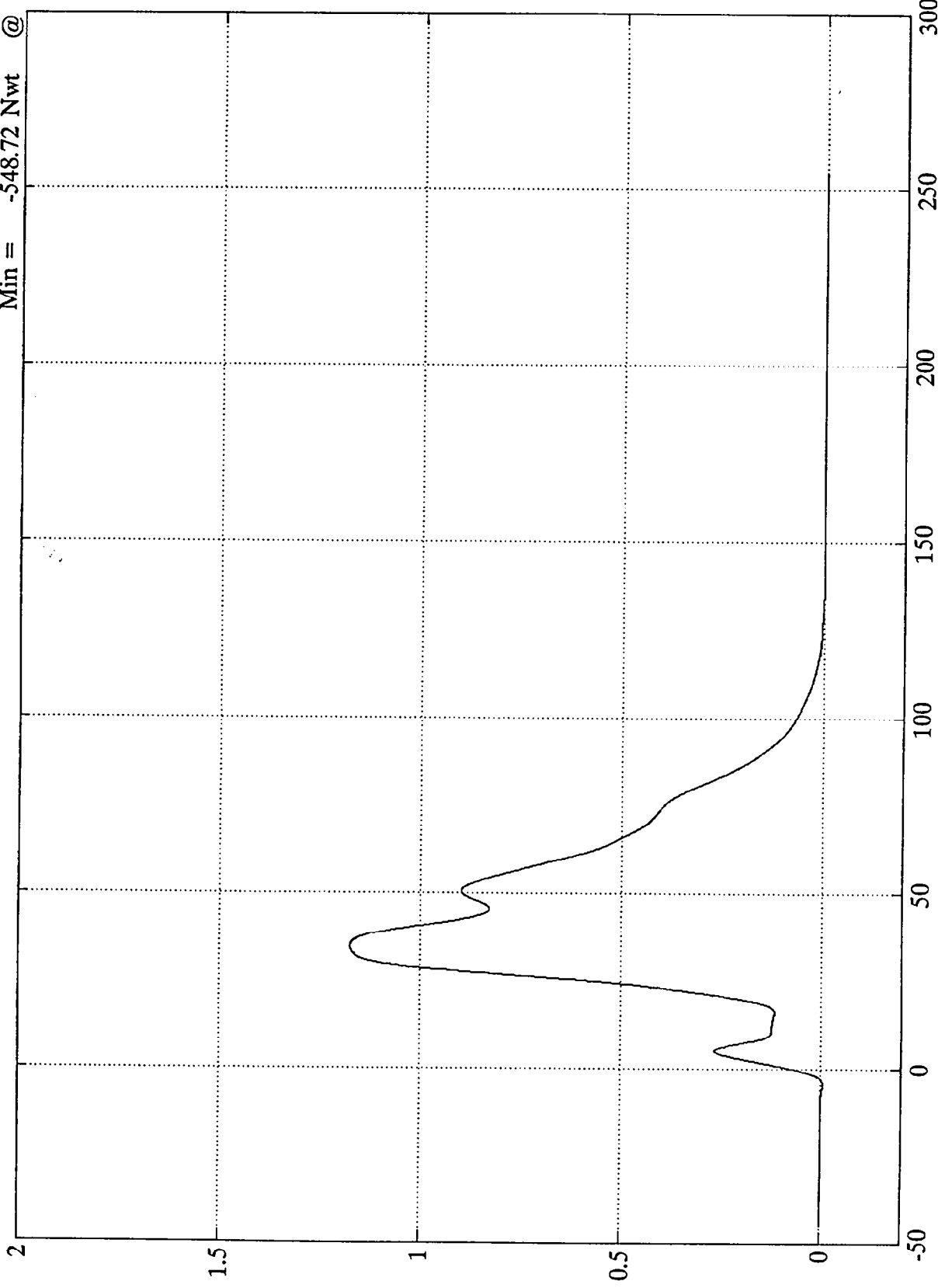

Time (msec)

1MN  
B-40

8120-4

SAE Filter Class 60

NCAP TEST #4 - 1994 MAZDA 626 DX

$\times 10^4$

Barrier Load Cell B5

Max = 80574.61 Nwt @ 29.63 msec  
Min = -1246.72 Nwt @ -5.28 msec

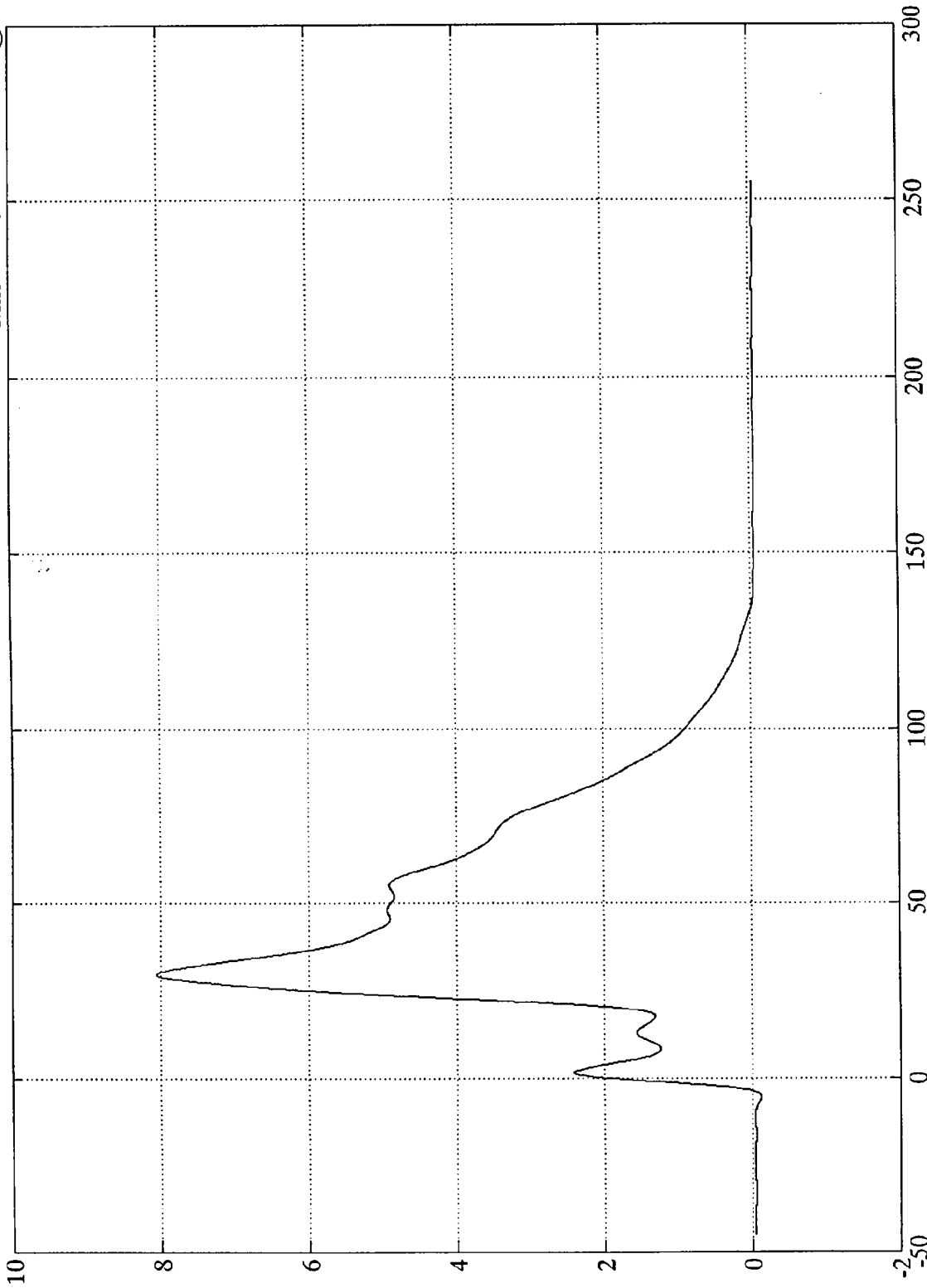

1MN  
B-41

8120-4

Time (msec)

SAE Filter Class 60

Barrier Load Cell B6

Max = 46852.82 Nwt @ 28.44 ms  
Min = -440.16 Nwt @ -3.84 msec

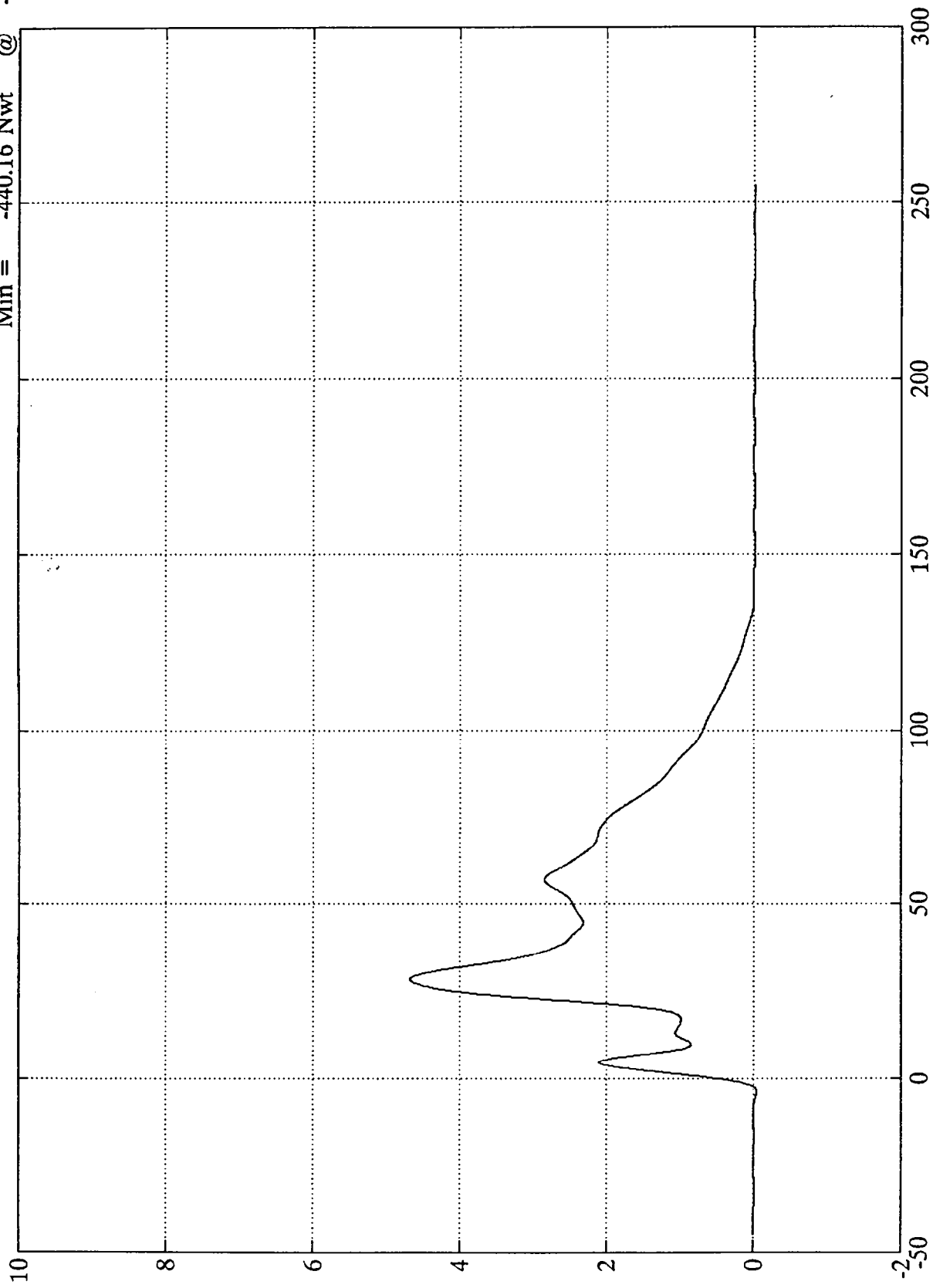

1MN  
B-42

8120-4

SAE Filter Class 60

Time (msec)

NCAP TEST #4 - 1994 MAZDA 626 DX  
x10<sup>4</sup>

Max = 83327.34 Nwt @ 8.15 msec  
Min = -2652.14 Nwt @ 0.95 msec

Barrier Load Cell B7

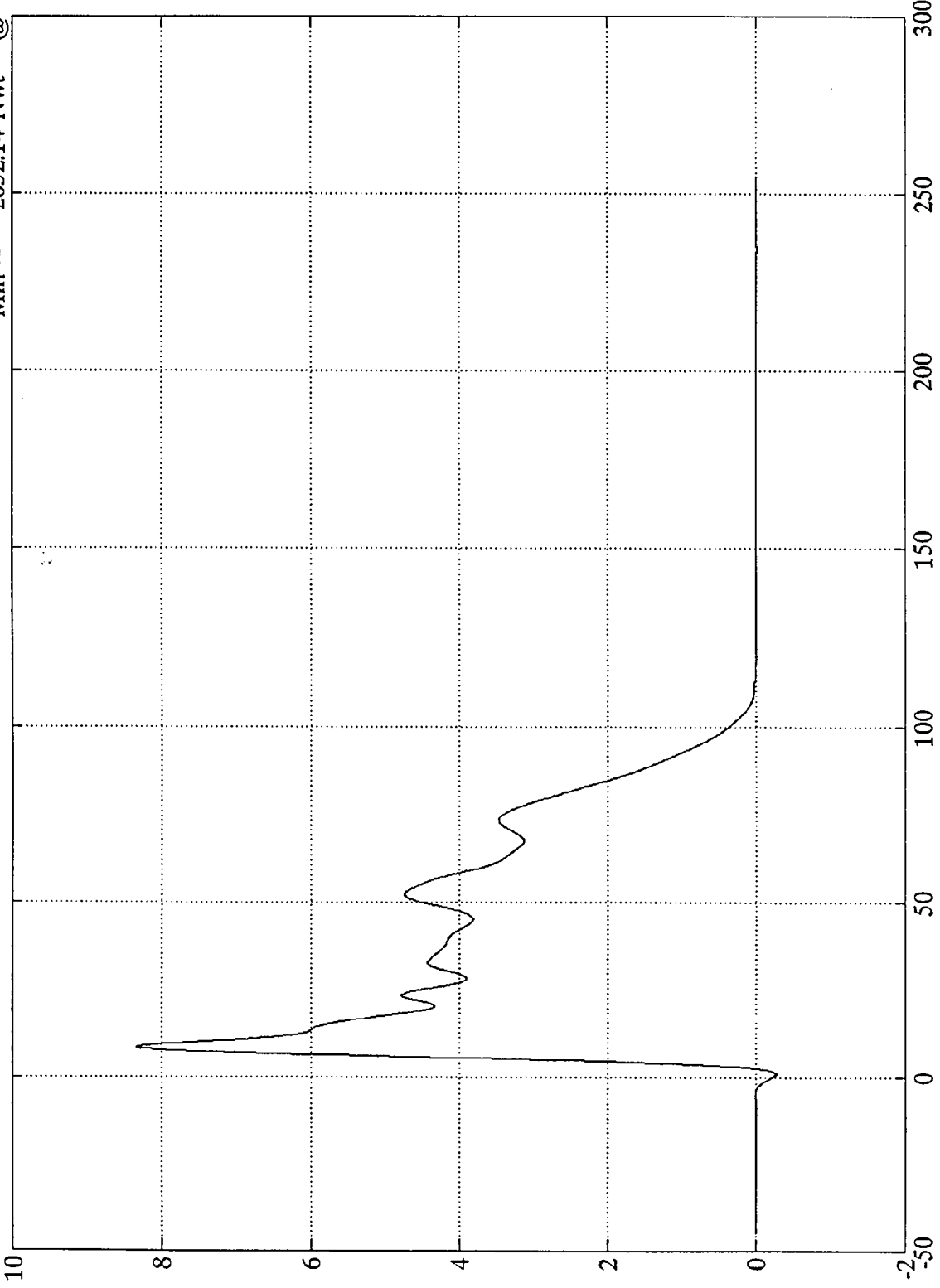

Time (msec)

SAE Filter Class 60

1Nwt  
B-43

8120-4

Barrier Load Cell B8

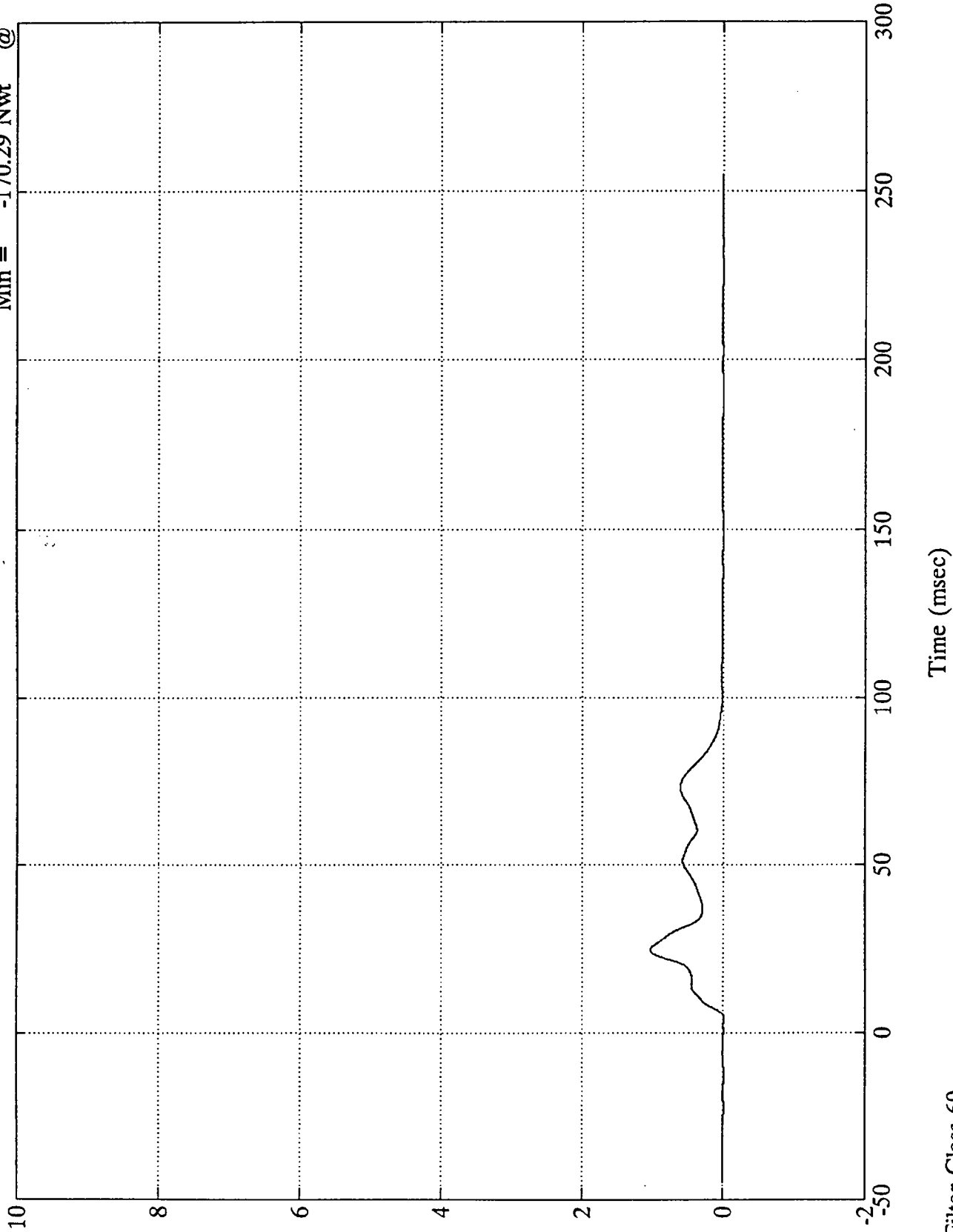

NCAP TEST #4 - 1994 MAZDA 626 DX

Barrier Load Cell B9  
Max = 628.96 Nwt @ 24.35 msec  
Min = -259.75 Nwt @ 68.87 msec

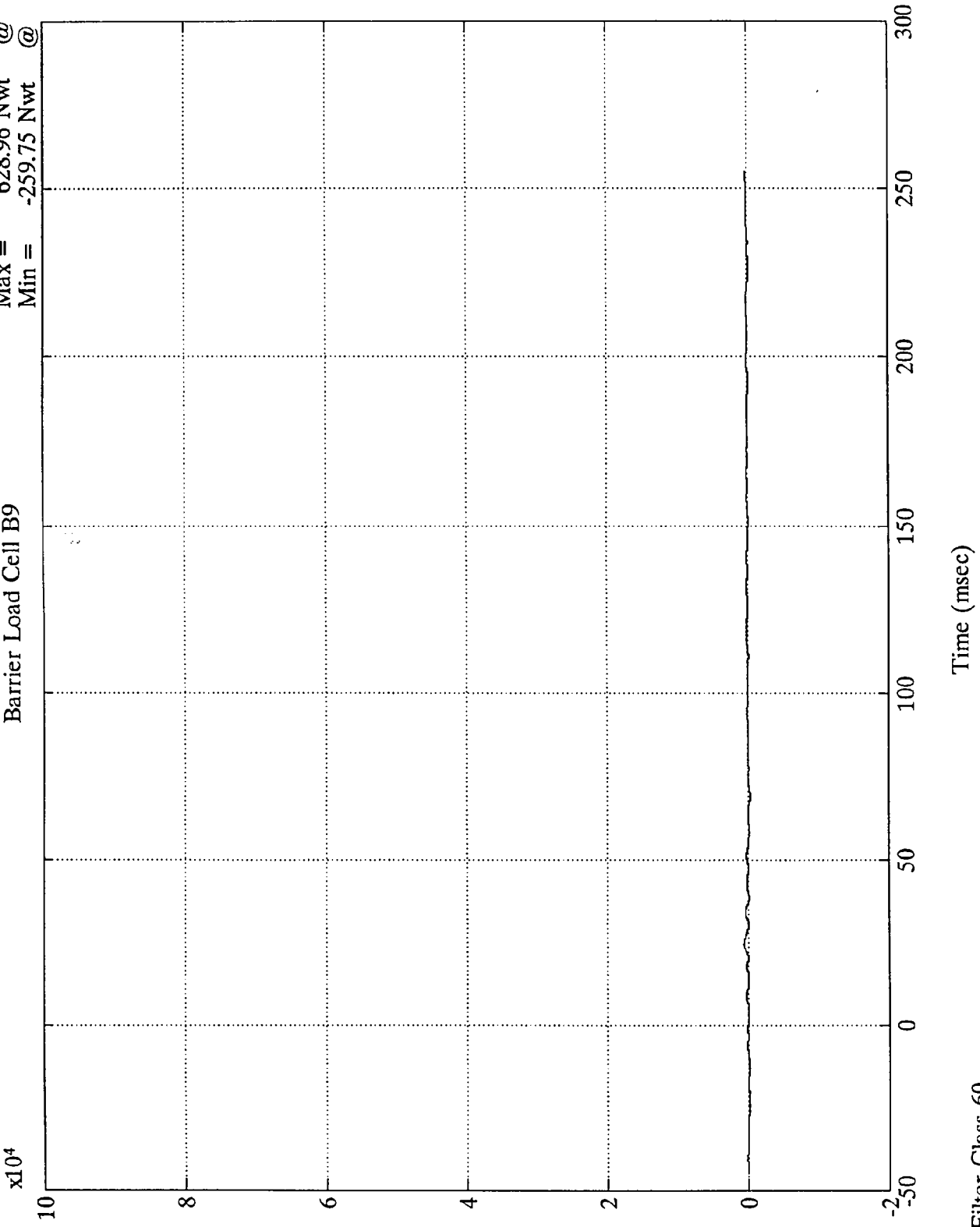

1N  
B-45

8120-4

SAE Filter Class 60

Time (msec)



Max = 1294.13 Nwt @ 29.39 msec  
Min = -492.07 Nwt @ 17.03 msec

Barrier Load Cell C1

x10<sup>4</sup>

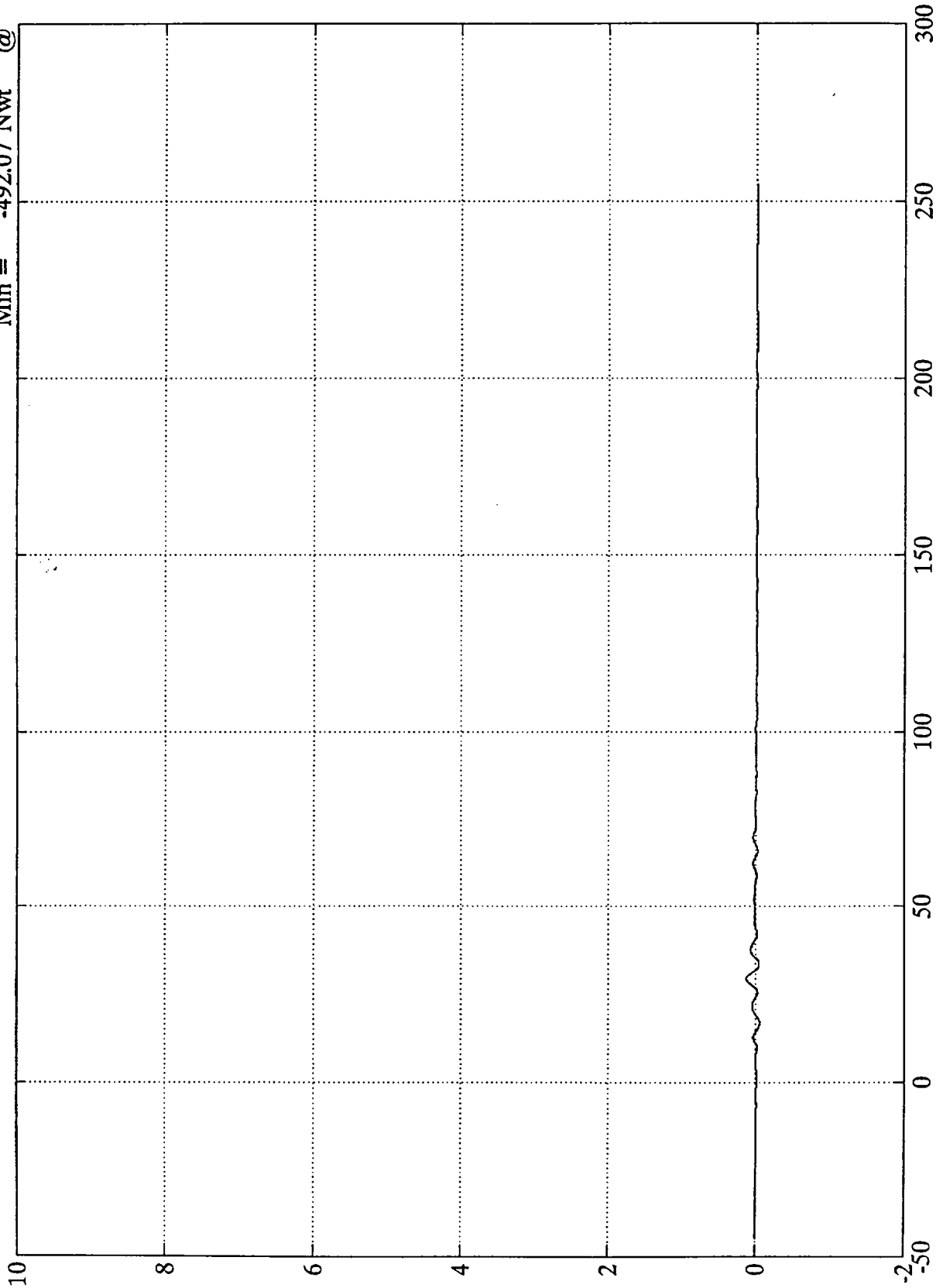

1Nwt  
B-46

8120-4

Time (msec)

SAE Filter Class 60

NCAP TEST #4 - 1994 MAZDA 626 DX  
x10<sup>4</sup>

Barrier Load Cell C2

Max = 18731.62 Nwt @ 38.15 msec  
Min = -151.82 Nwt @ 0.11 msec

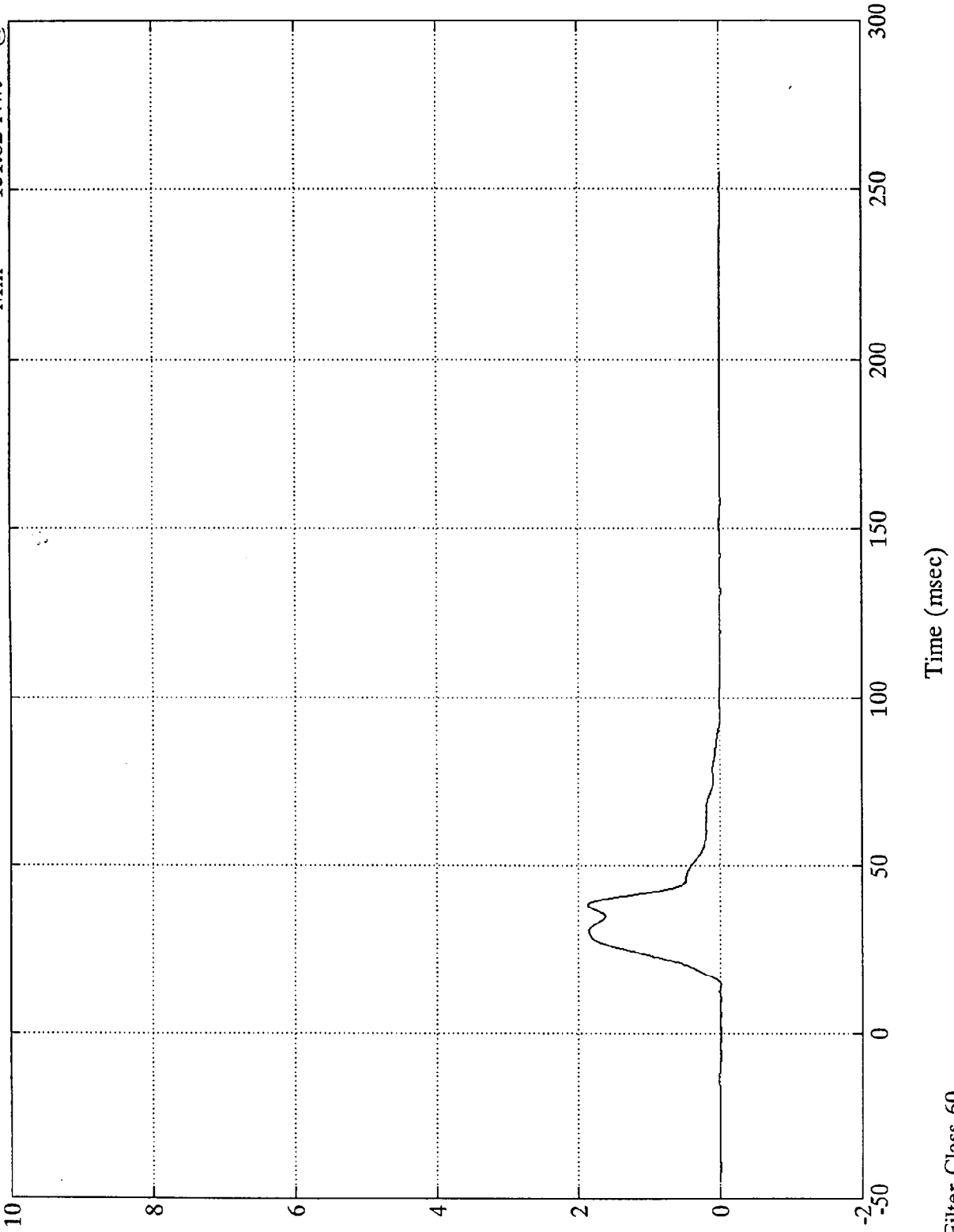

1Nwt  
B-47

8120-4

SAE Filter Class 60

Time (msec)

Barrier Load Cell C3

Max = 12255.90 Nwt @ 34.91 msec  
Min = -209.47 Nwt @ -0.12 msec

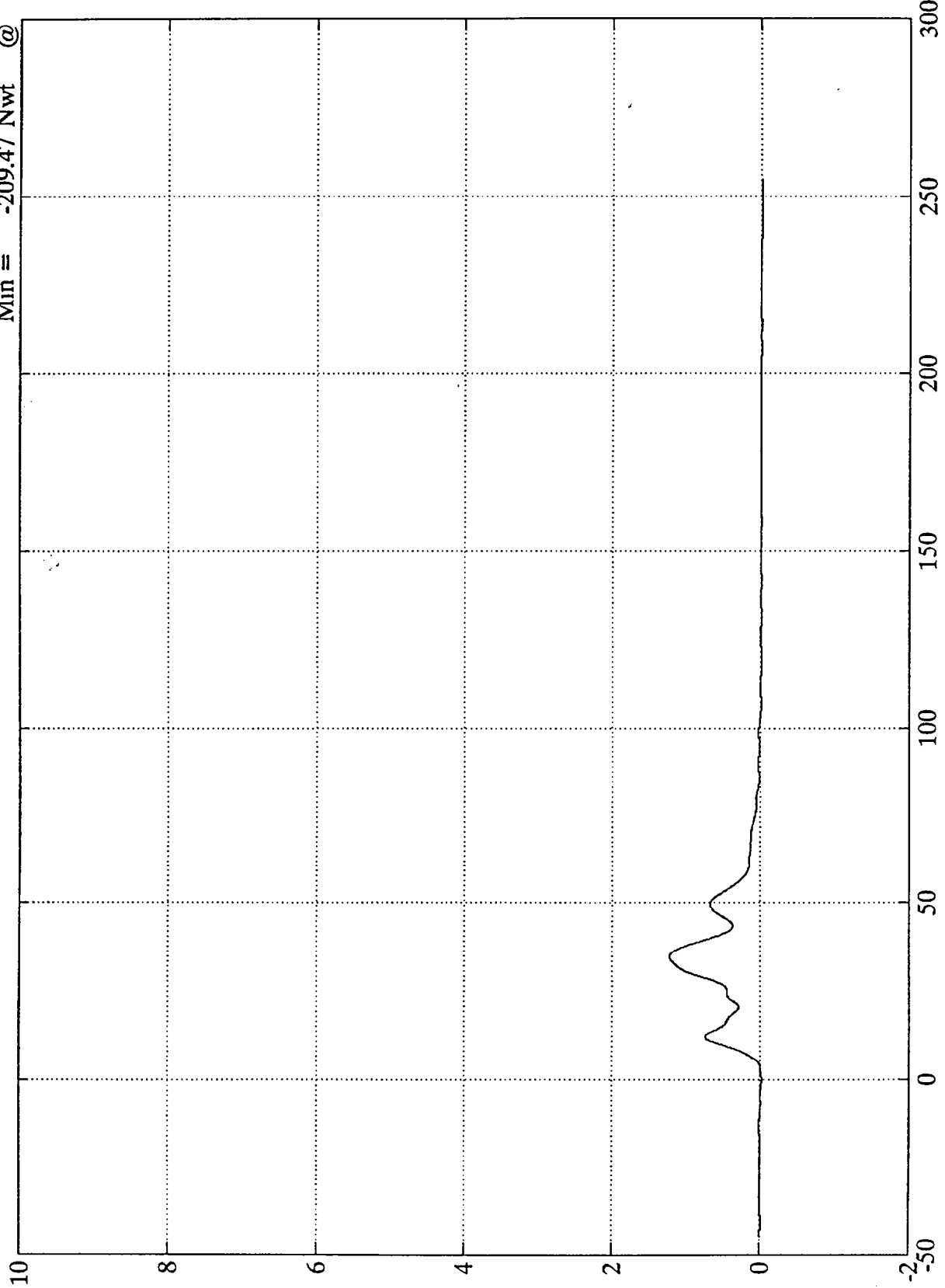

1MN  
B-48

8120-4

SAE Filter Class 60

NCAP TEST #4 - 1994 MAZDA 626 DX

$\times 10^4$

Barrier Load Cell C4

Max = 9521.37 Nwt @ 30.71 msec  
Min = -505.28 Nwt @ -0.24 msec

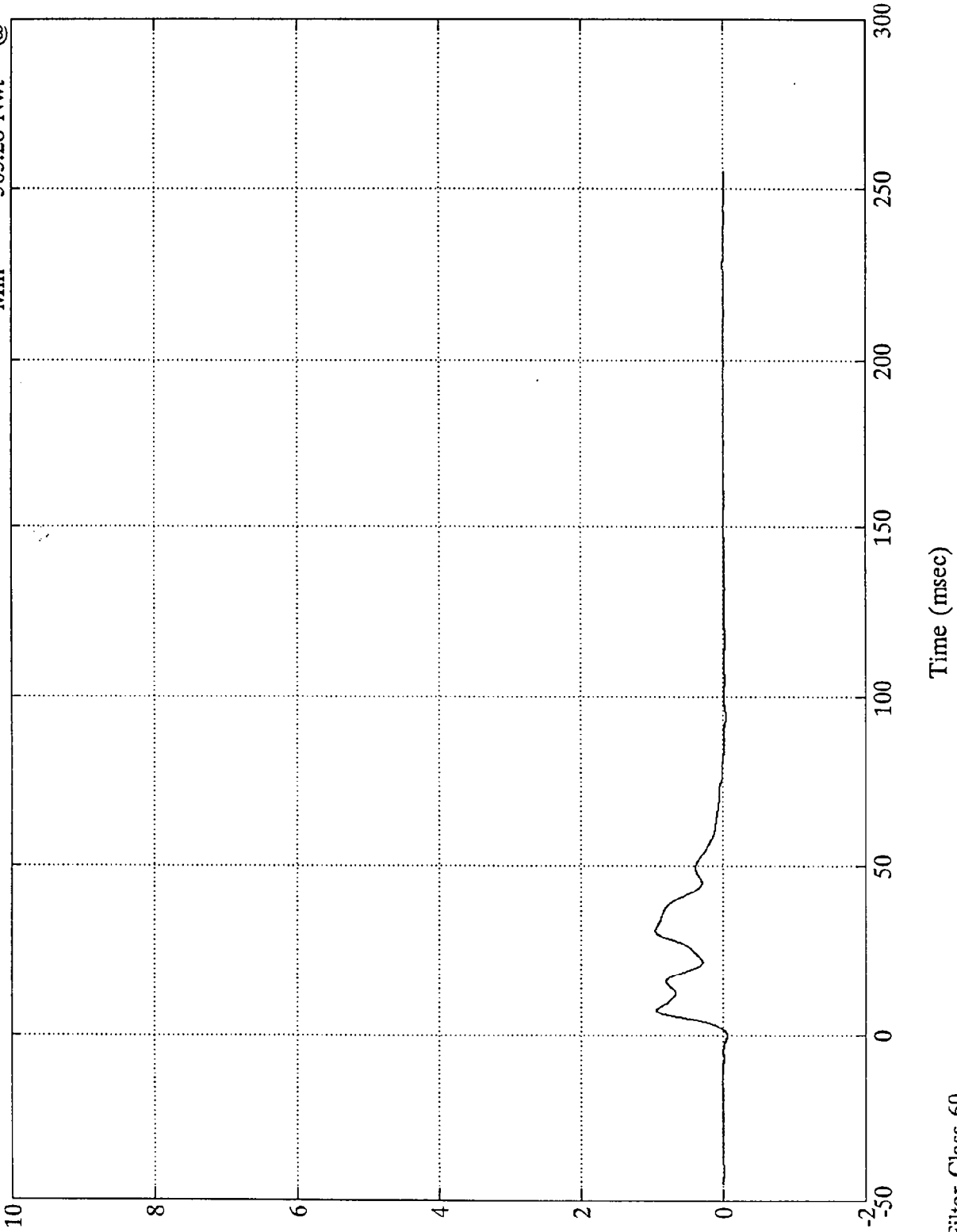

B-49

8120-4

SAE Filter Class 60

Time (msec)

x10<sup>4</sup>

Barrier Load Cell C5

Max = 14648.56 Nwt @ 36.00 msec  
Min = -232.05 Nwt @ -1.32 msec

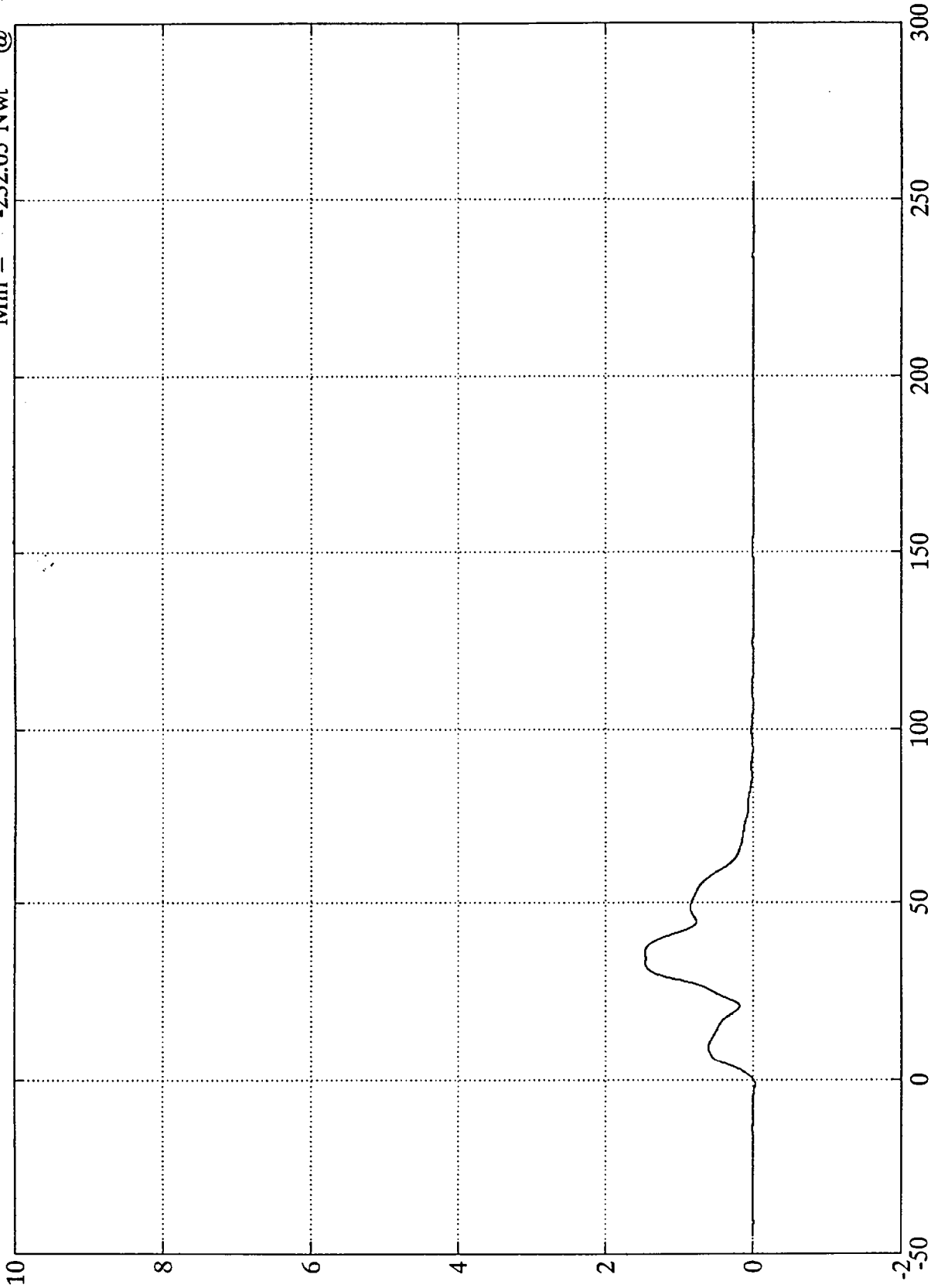

Nwt  
B-50

8120-4

Time (msec)

SAE Filter Class 60

NCAP TEST #4 - 1994 MAZDA 626 DX  
x10<sup>4</sup>

Barrier Load Cell C6

Max = 9047.02 Nwt @ 30.95 msec  
Min = -408.48 Nwt @ -0.60 msec

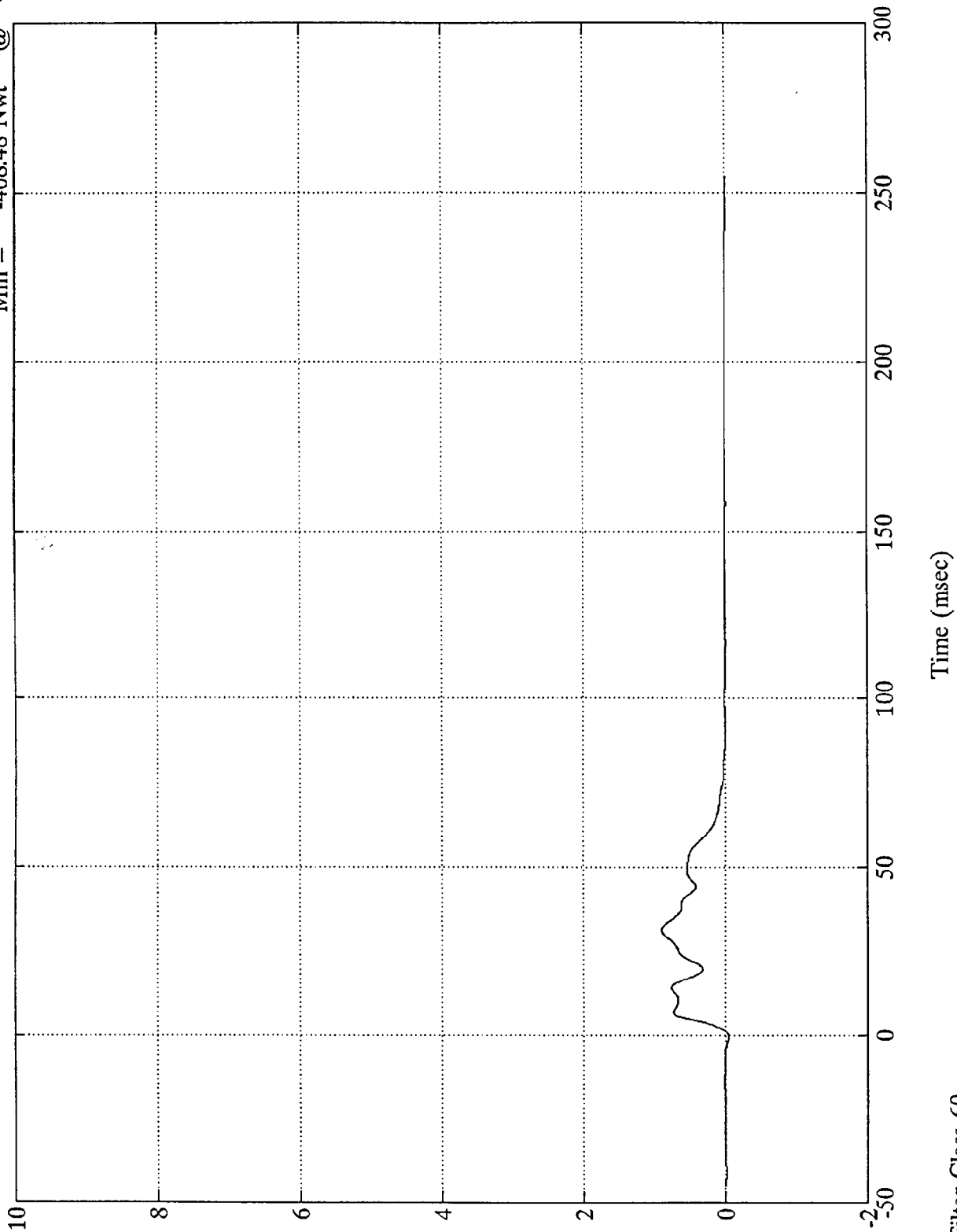

1WV  
B-51

8120-4

SAE Filter Class 60

Time (msec)

x10<sup>4</sup>

Barrier Load Cell C7

Max = 8560.48 Nwt @ 12.35 msec  
Min = -386.96 Nwt @ 4.19 msec

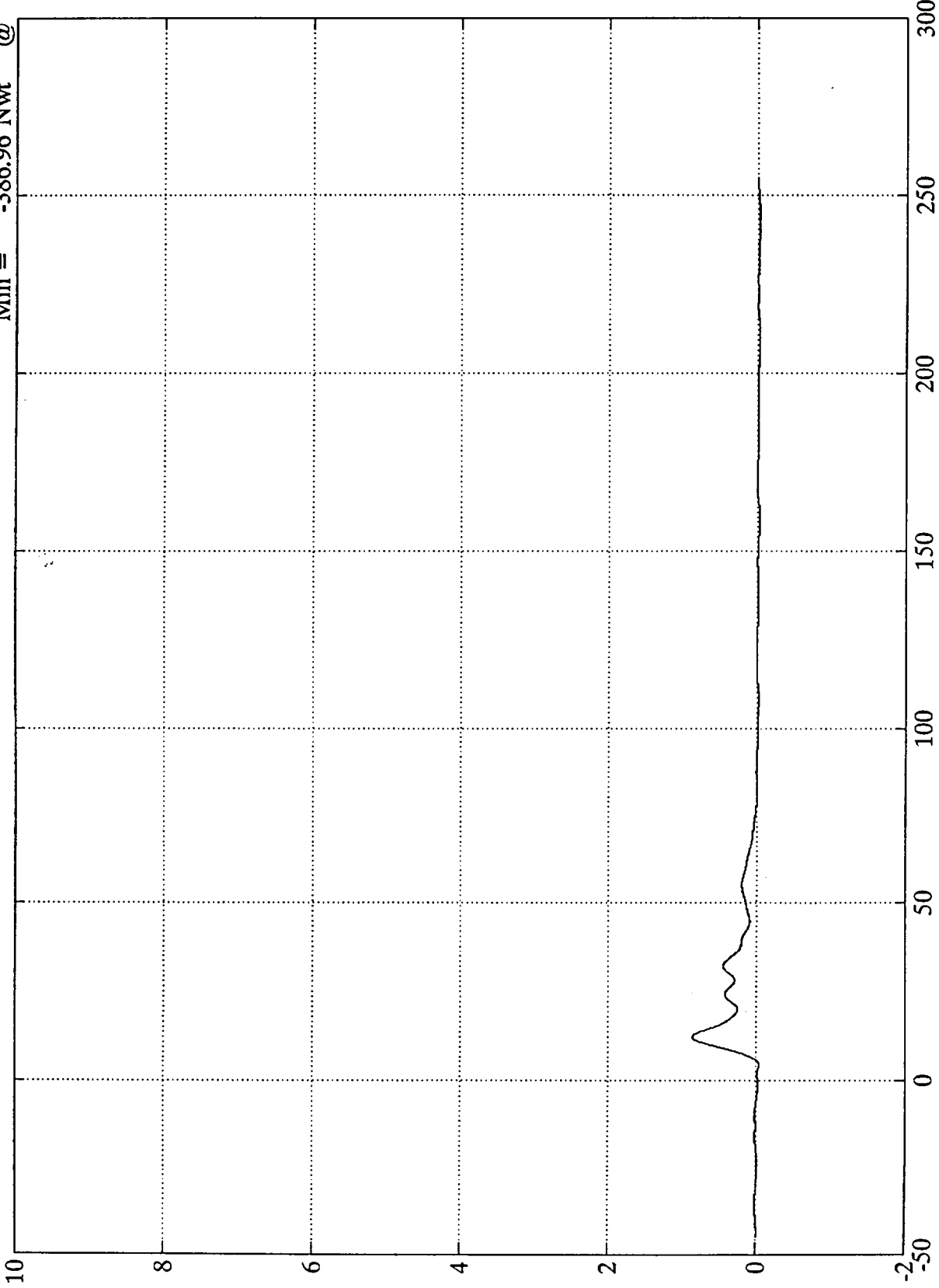

1Nwt  
B-52

8120-4

Time (msec)

SAE Filter Class 60

NCAP TEST #4 - 1994 MAZDA 626 DX  
x10<sup>4</sup>

Barrier Load Cell C8

Max = 14472.13 Nwt @ 29.39 msec  
Min = -271.28 Nwt @ 10.67 msec

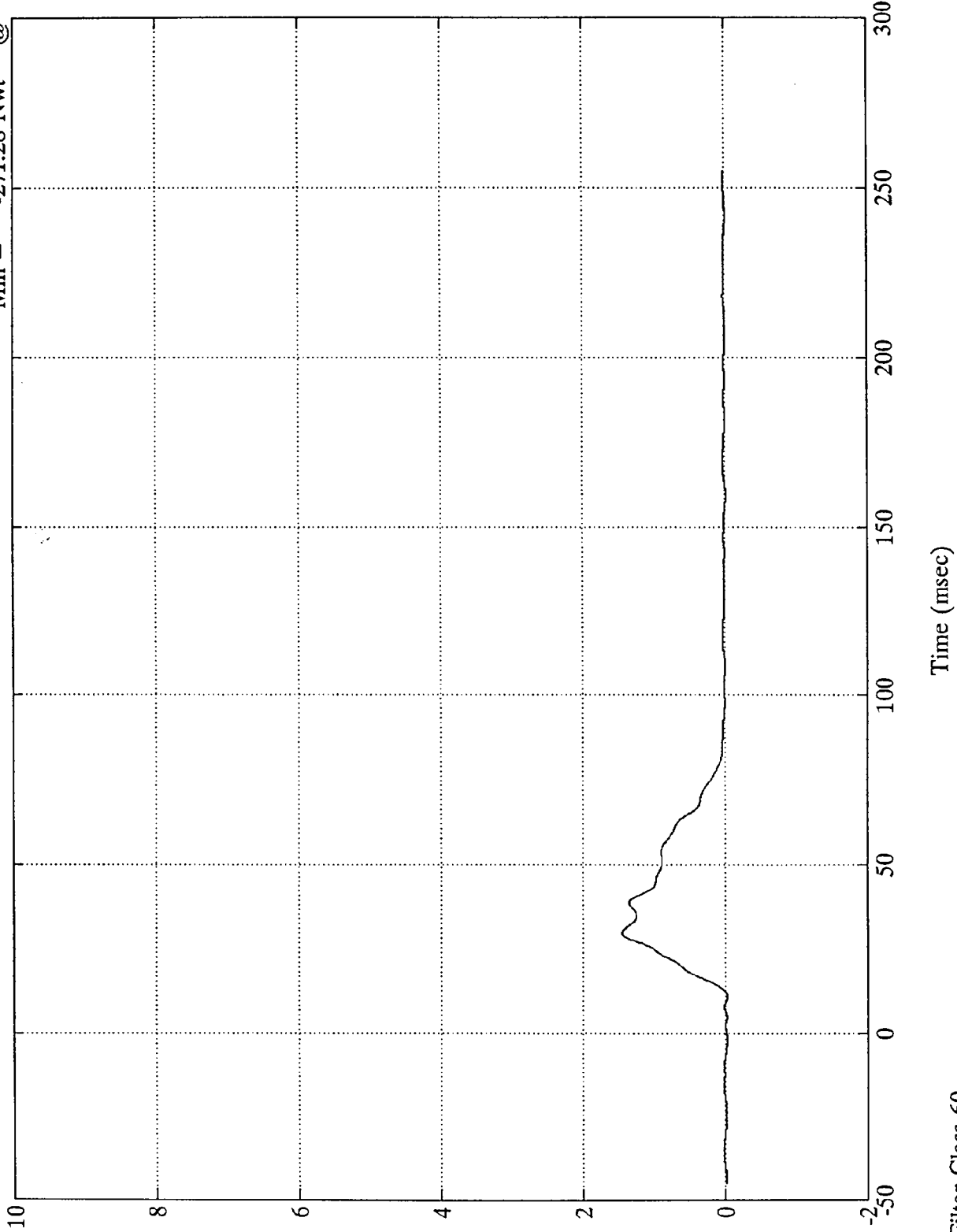

1MN  
B-53

8120-4

SAE Filter Class 60

Time (msec)

Max = 591.50 Nwt @ 17.63 ms  
Min = -405.79 Nwt @ 57.95 ms

Barrier Load Cell C9

SAE Filter Class 60

x10<sup>4</sup>

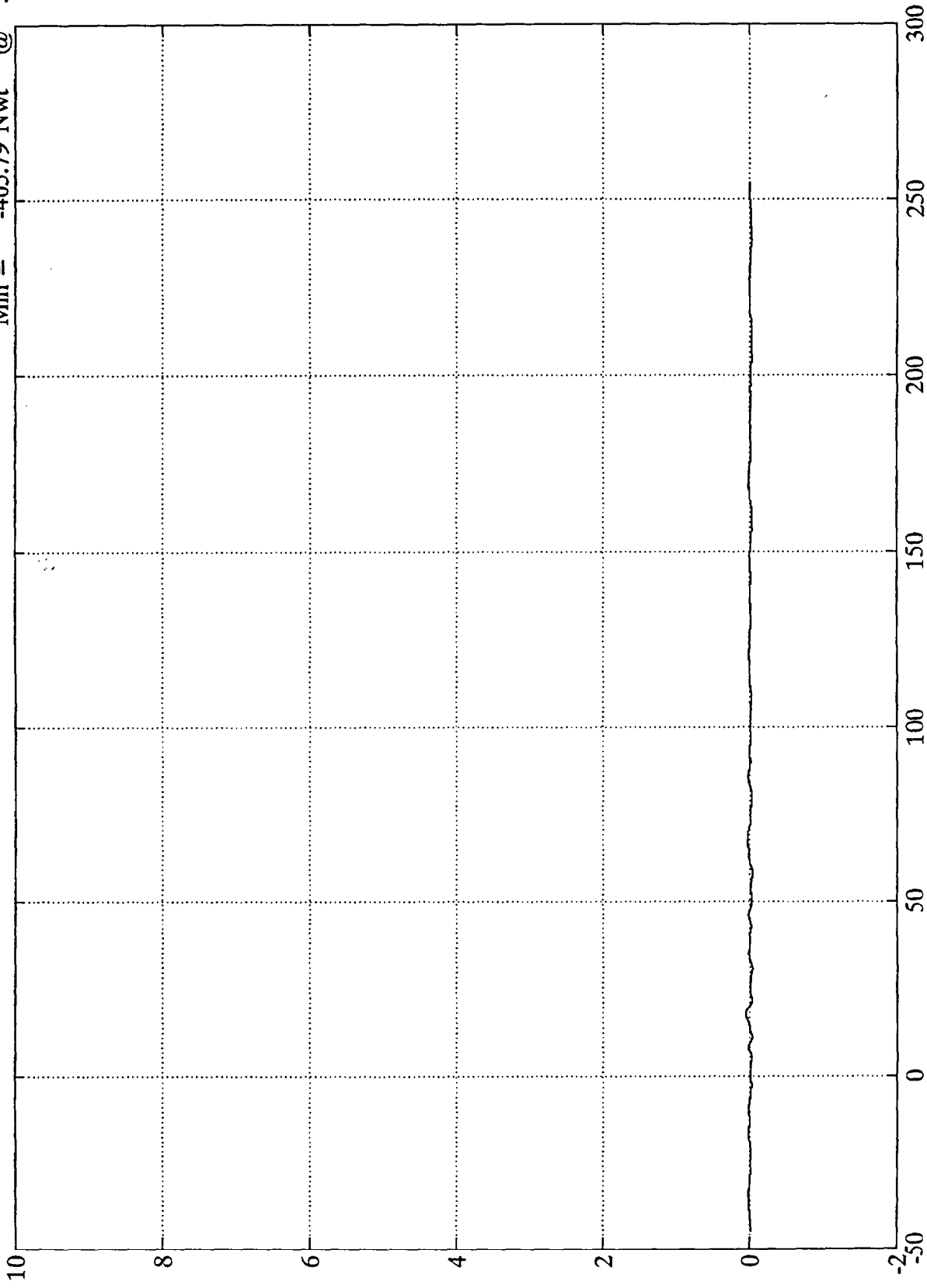

1MN  
B-54

8120-4

SAE Filter Class 60

NCAP TEST #4 - 1994 MAZDA 626 DX

Max = 323.33 Nwt @ 77.64 msec  
Min = -2045.75 Nwt @ 160.80 msec

Barrier Load Cell D1

x10<sup>4</sup>

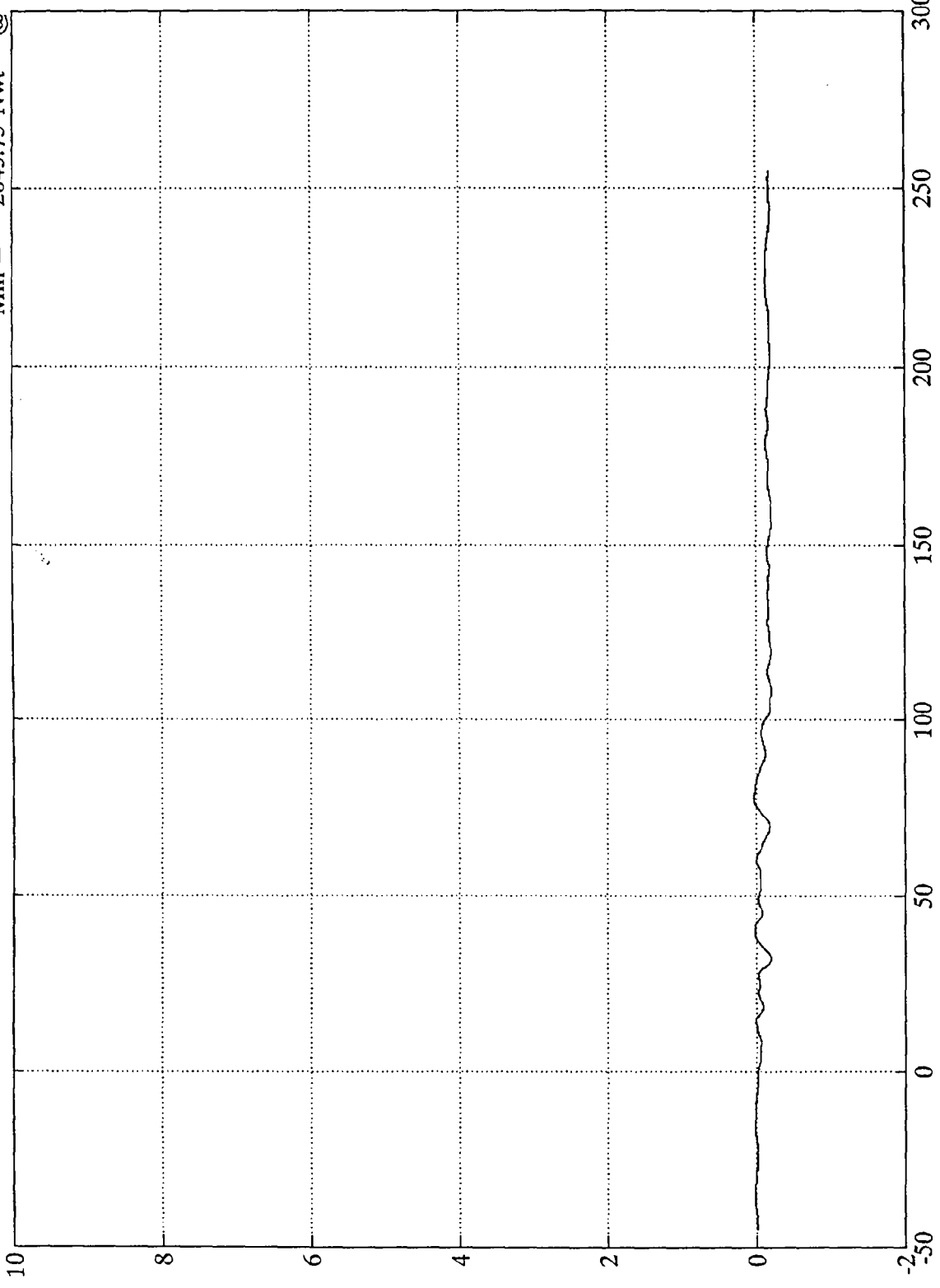

1MN  
B-55

8120-4

Time (msec)

SAE Filter Class 60

x10<sup>4</sup>

Barrier Load Cell D2

Max = 4182.51 Nwt @ 43.08 msec  
Min = -756.54 Nwt @ 28.79 msec

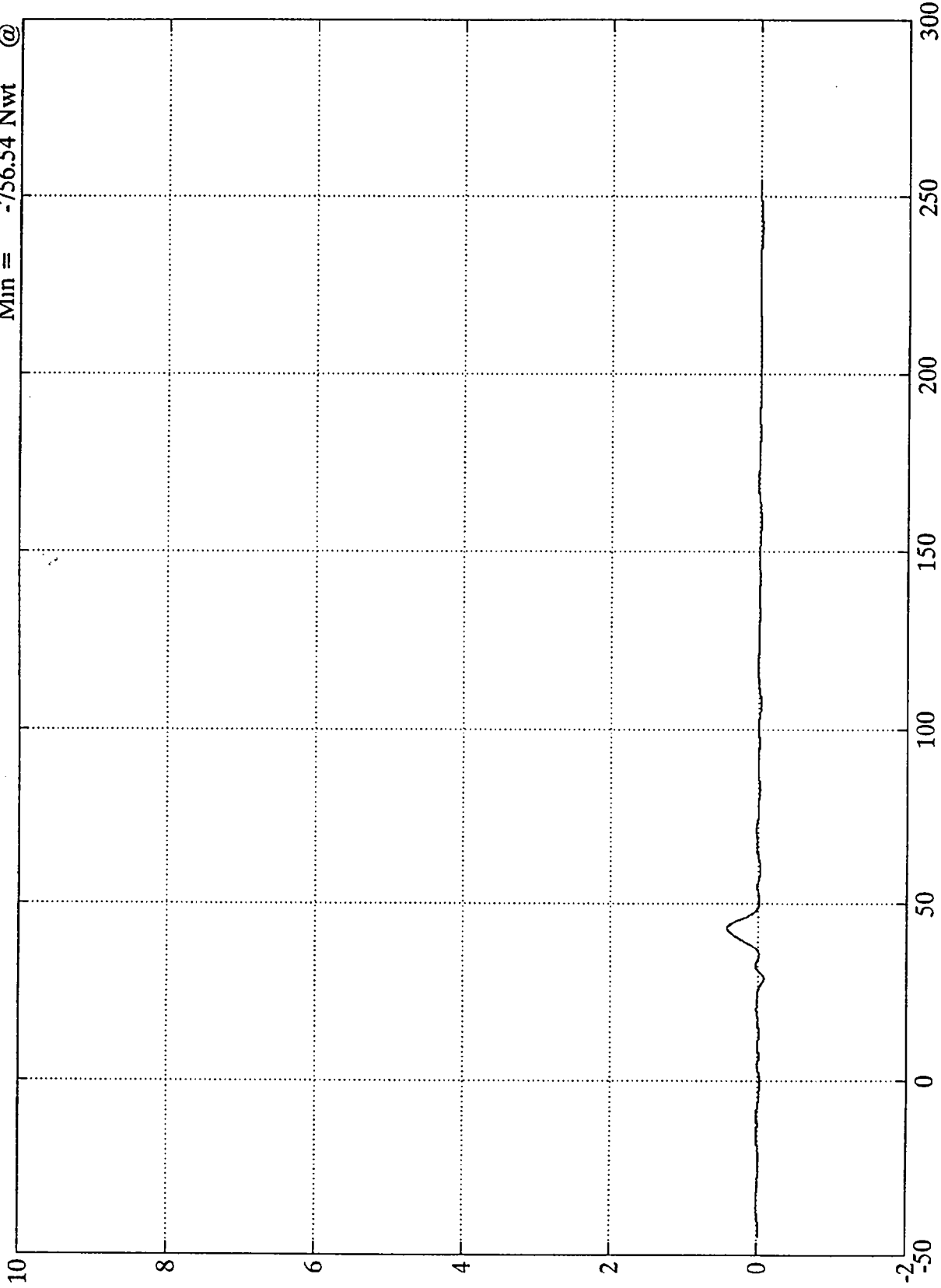

Time (msec)

SAE Filter Class 60

NCAP TEST #4 - 1994 MAZDA 626 DX  
x10<sup>5</sup>

Barrier Load Cell D3

Max = 688069.38 Nwt @ 253.68 msec  
Min = -276729.59 Nwt @ -15.36 msec

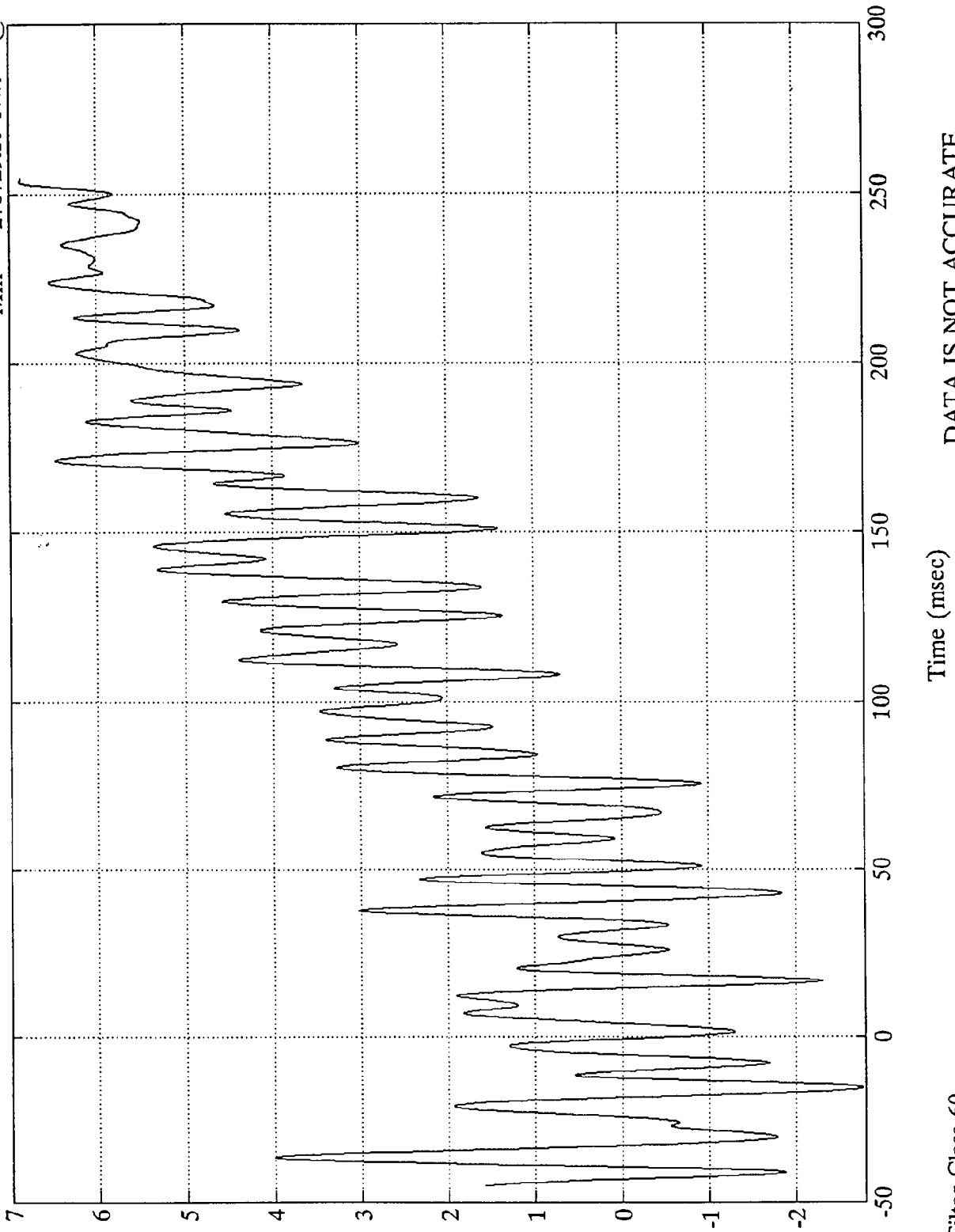

DATA IS NOT ACCURATE

SAE Filter Class 60

Barrier Load Cell D4

Max = 10119.46 Nwt @ 32.63 ms  
Min = -630.61 Nwt @ 43.56 msec

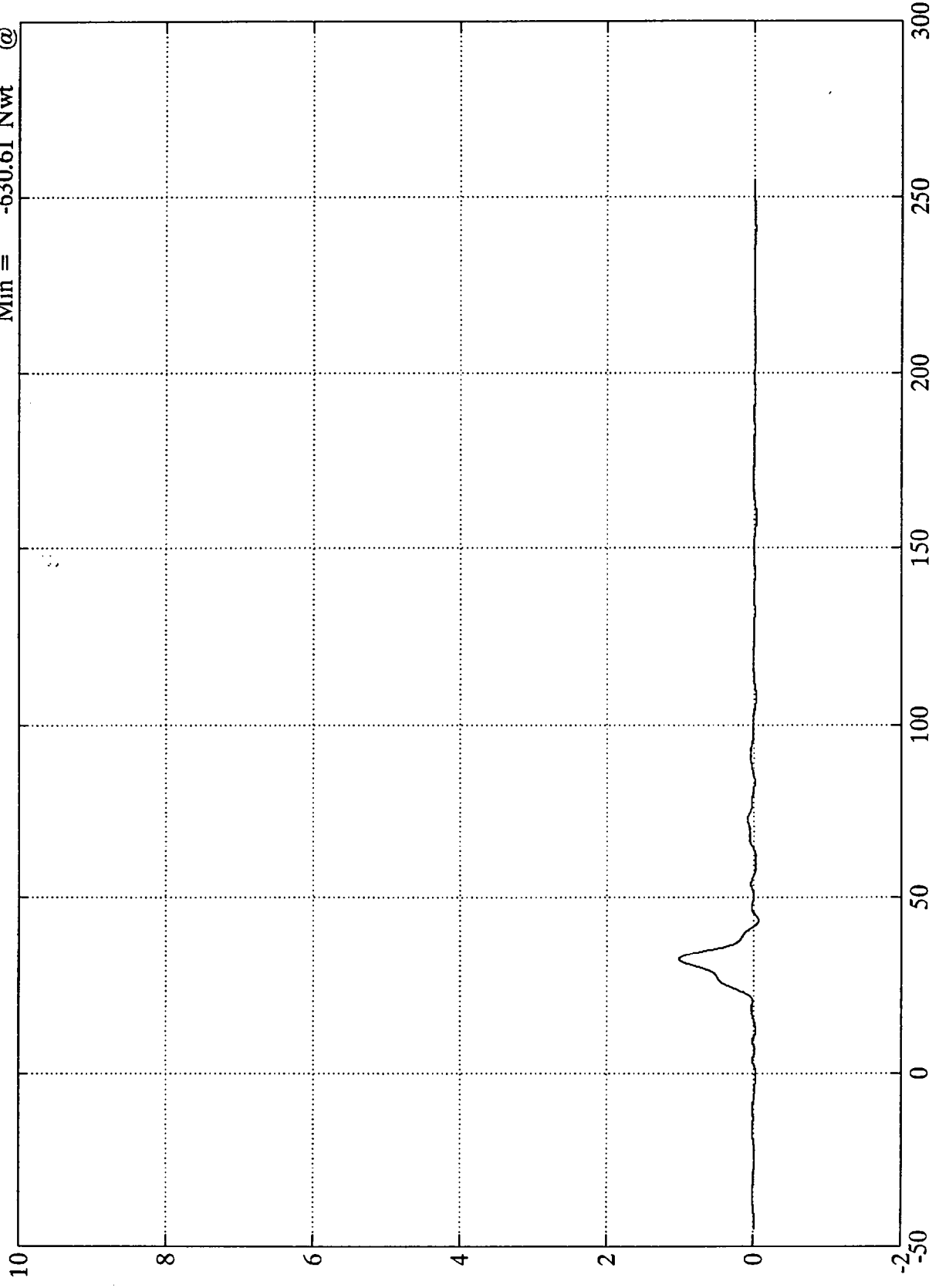

10N  
B-58

8120-4

SAE Filter Class 60

Time (msec)

NCAP TEST #4 - 1994 MAZDA 626 DX  
x10<sup>4</sup>

Barrier Load Cell D5

Max = 6310.35 Nwt @ 31.19 msec  
Min = -755.18 Nwt @ 43.79 msec

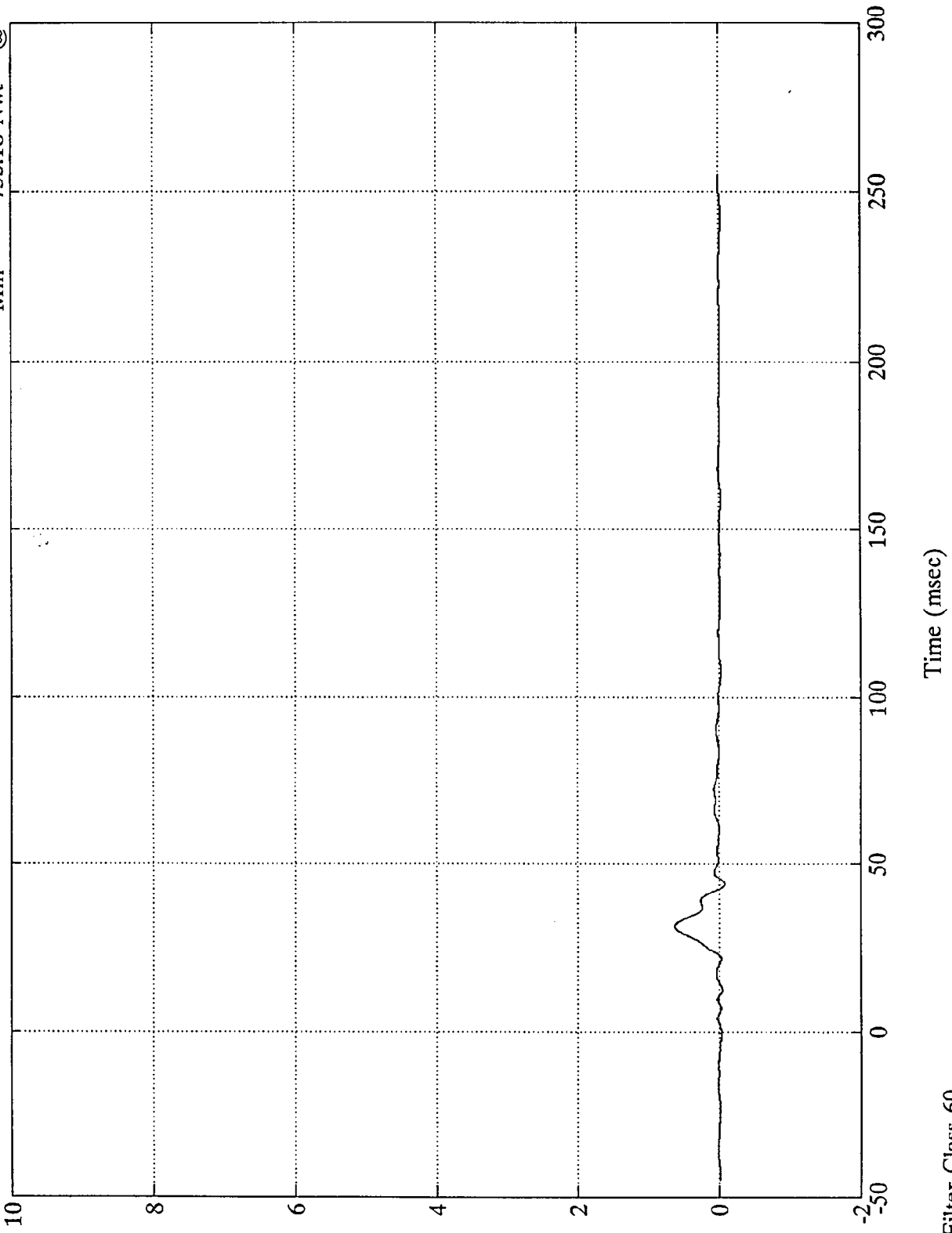

1Nwt  
B-59

8120-4

SAE Filter Class 60

Time (msec)

x10<sup>4</sup>

Barrier Load Cell D6

Max = 4233.83 Nwt @ 32.15 ms  
Min = -286.27 Nwt @ 159.96 msec

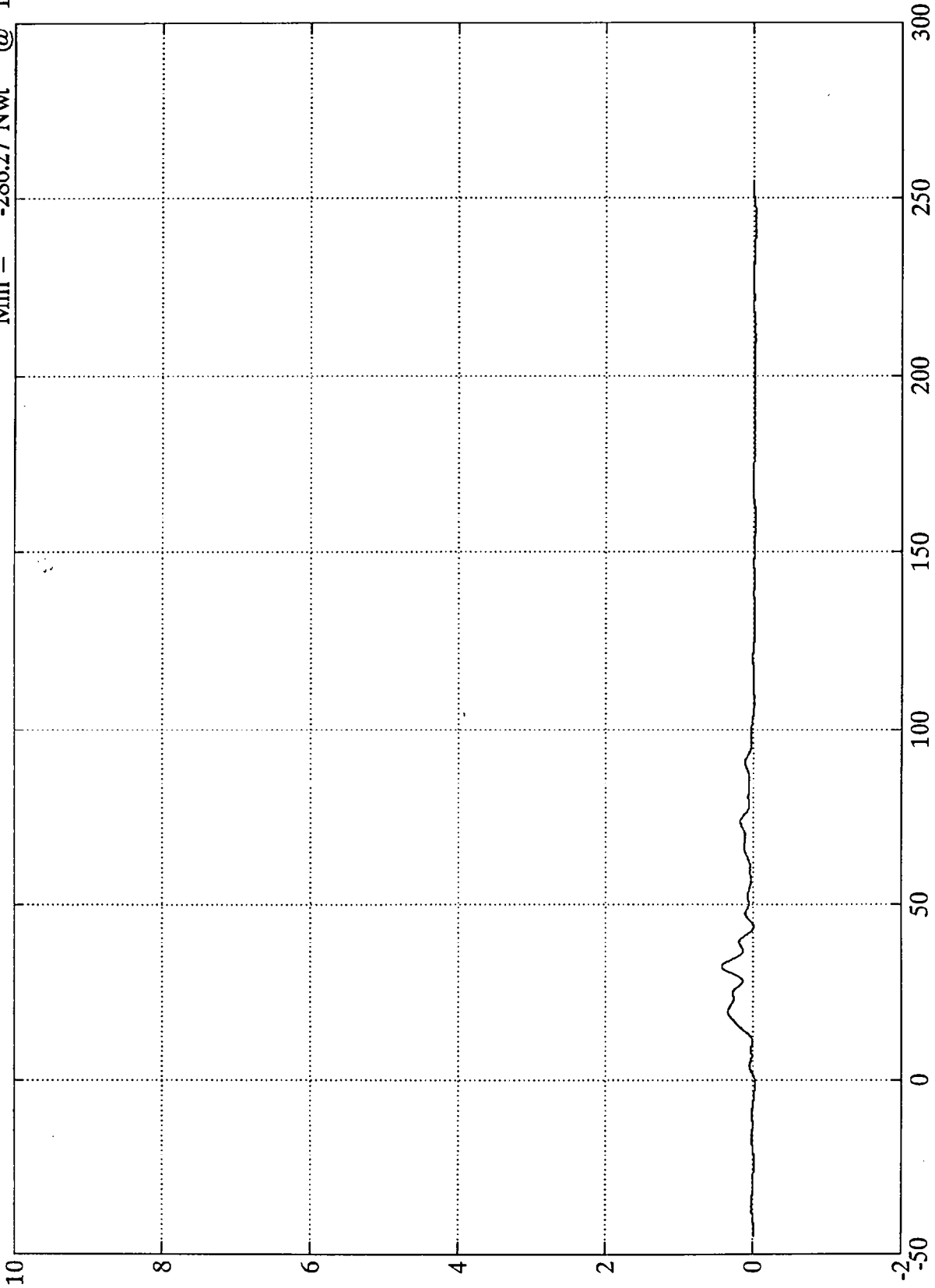

Time (msec)

SAE Filter Class 60

1wN  
B-60

8120-4

NCAP TEST #4 - 1994 MAZDA 626 DX  
x10<sup>4</sup>

Max = 261.62 Nwt @ -13.20 msec  
Min = -304.56 Nwt @ 161.52 msec

Barrier Load Cell D7

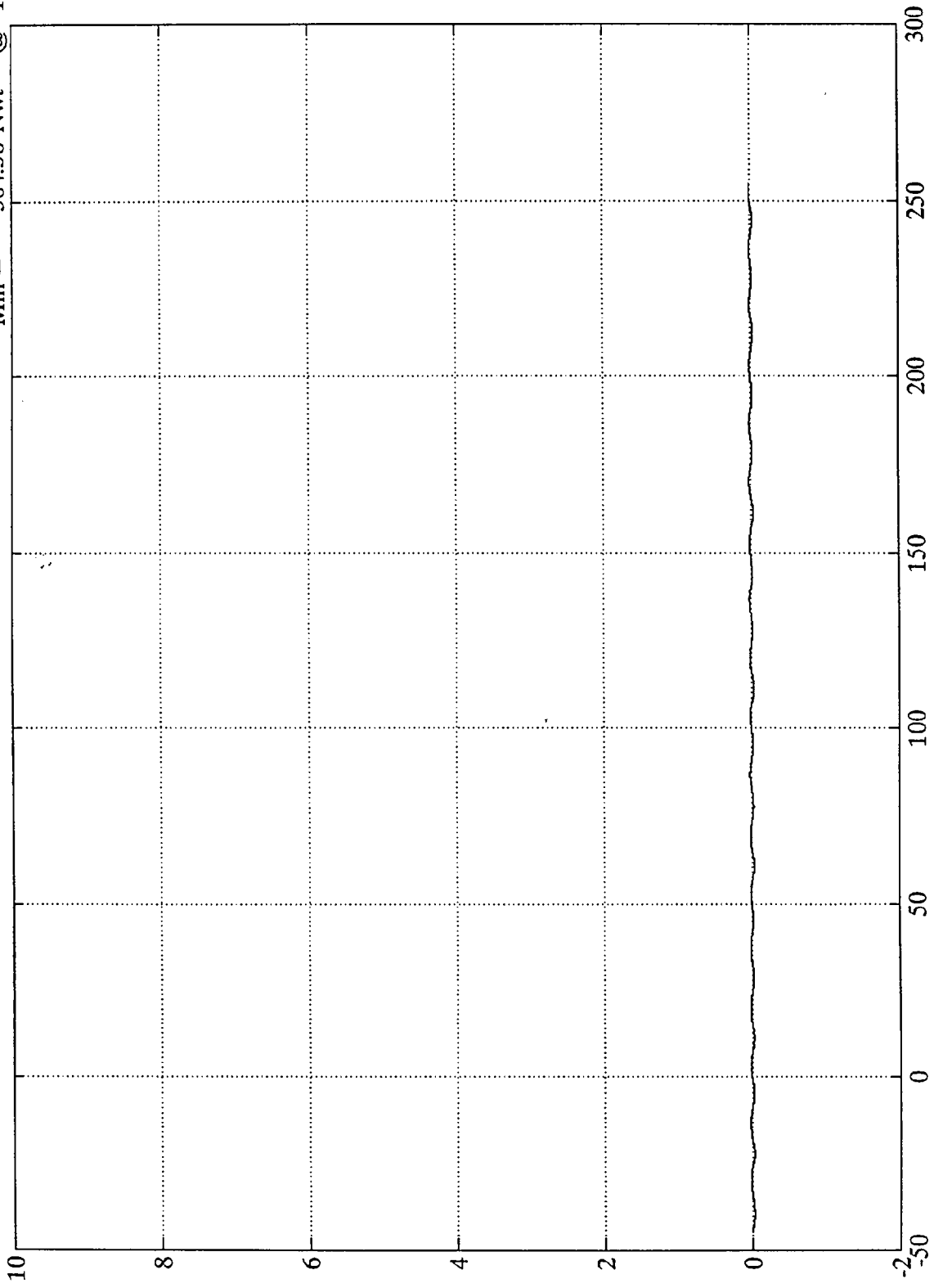

1MN  
B-61

8120-4

Time (msec)

SAE Filter Class 60



Barrier Load Cell D8

Max = 564.70 Nwt @ 16.68 msec  
Min = -618.97 Nwt @ 28.07 msec

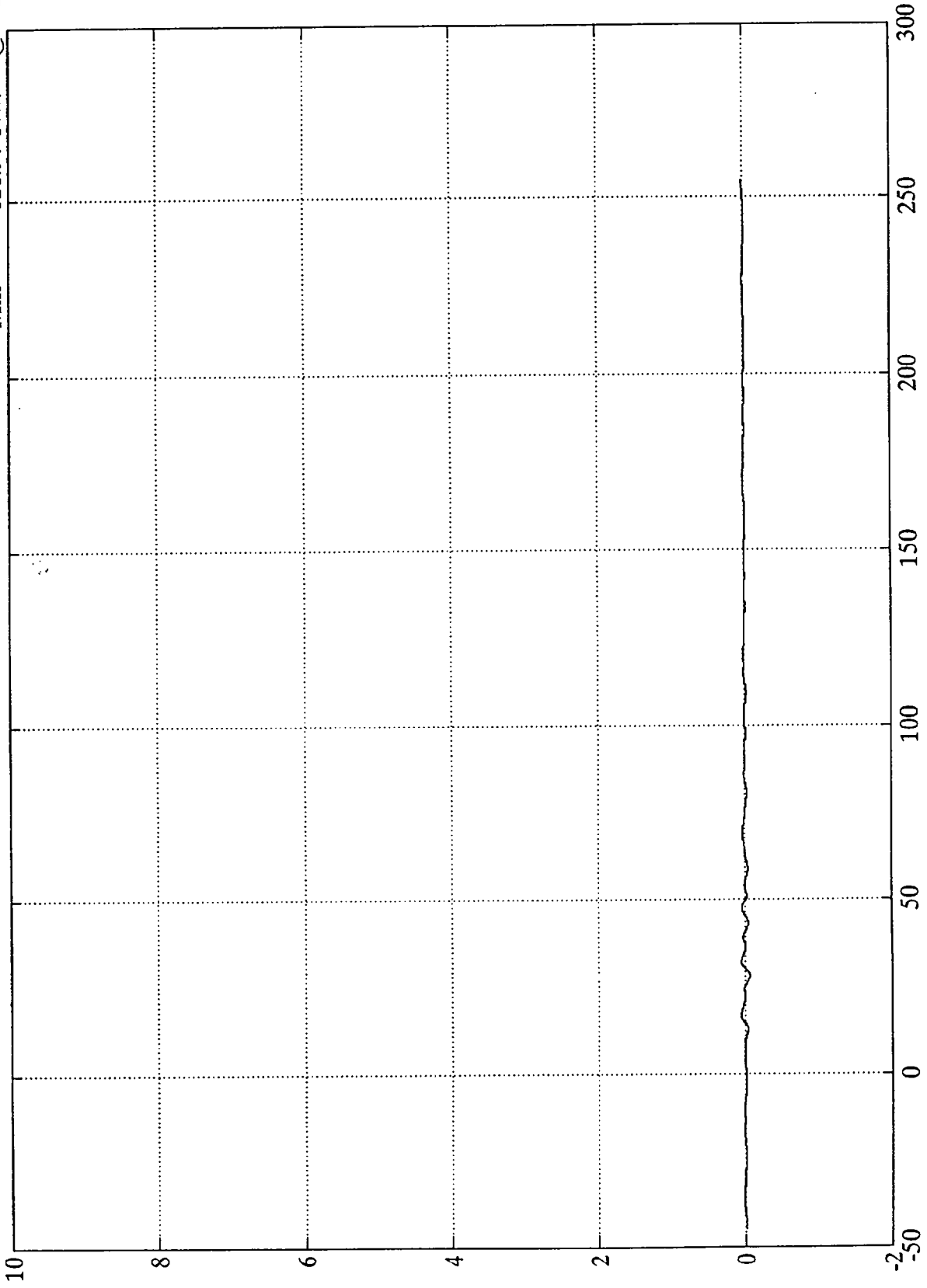

1N  
B-62

8120-4

SAE Filter Class 60

NCAP TEST #4 - 1994 MAZDA 626 DX

$\times 10^4$

Barrier Load Cell D9

Max = 1052.67 Nwt @ 16.79 msec  
Min = -938.50 Nwt @ 28.07 msec

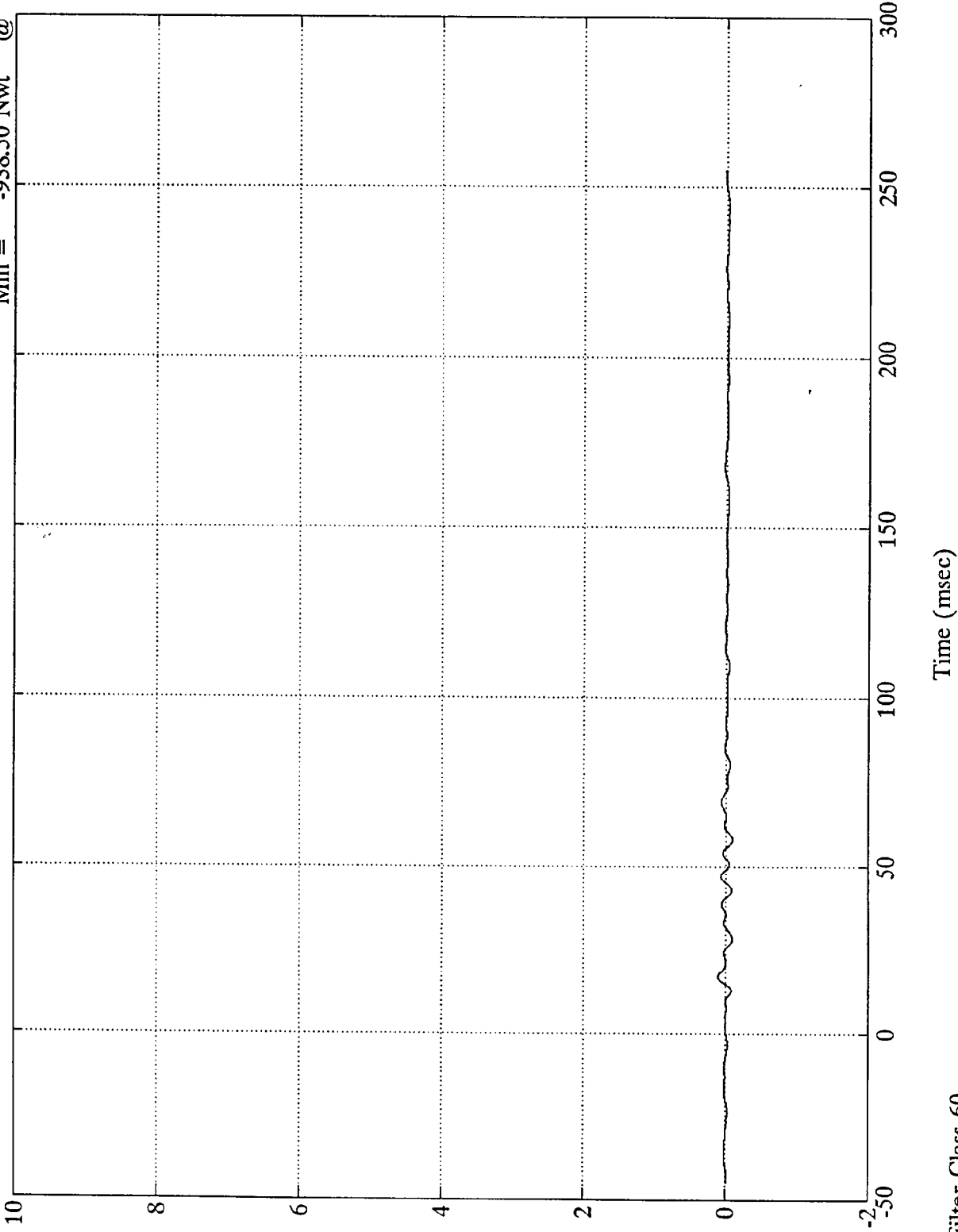

1Nwt  
B-63

8120-4

SAE Filter Class 60

Time (msec)

Group 1 Load Cell Sum

Max = 107364.00 Nwt @ 29.88 msec  
Min = -2308.78 Nwt @ 1.20 msec

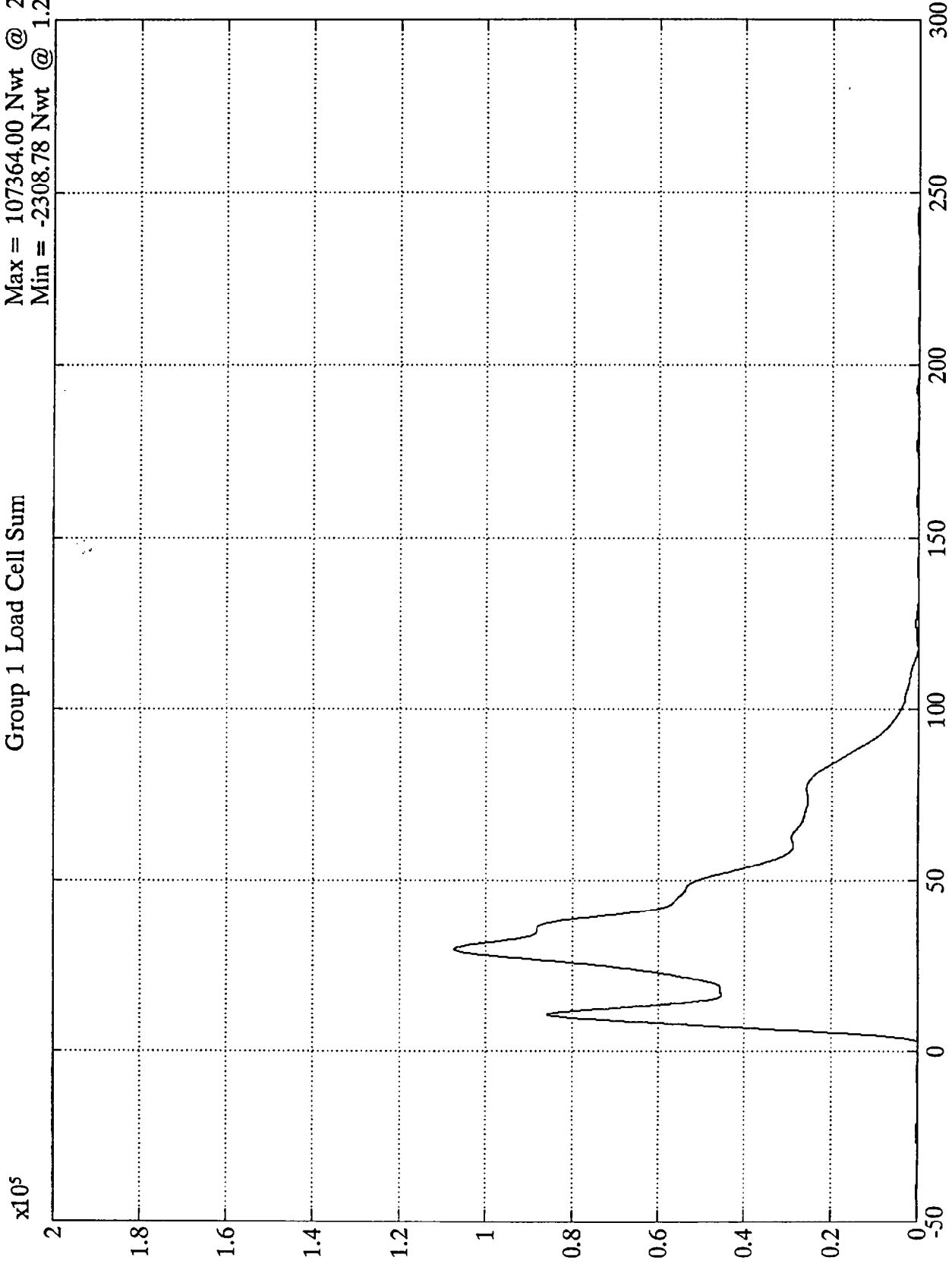

Time (msec)

Load Cells (A1,A2,A3,B1,B2,B3)

1MN  
B-64

SAE Filter Class 60

NCAP TEST #4 - 1994 MAZDA 626 DX  
x10<sup>5</sup>

Group 2 Load Cell Sum

Max = 296079.00 Nwt @ 30.24 msec  
Min = -2013.57 Nwt @ -4.80 msec

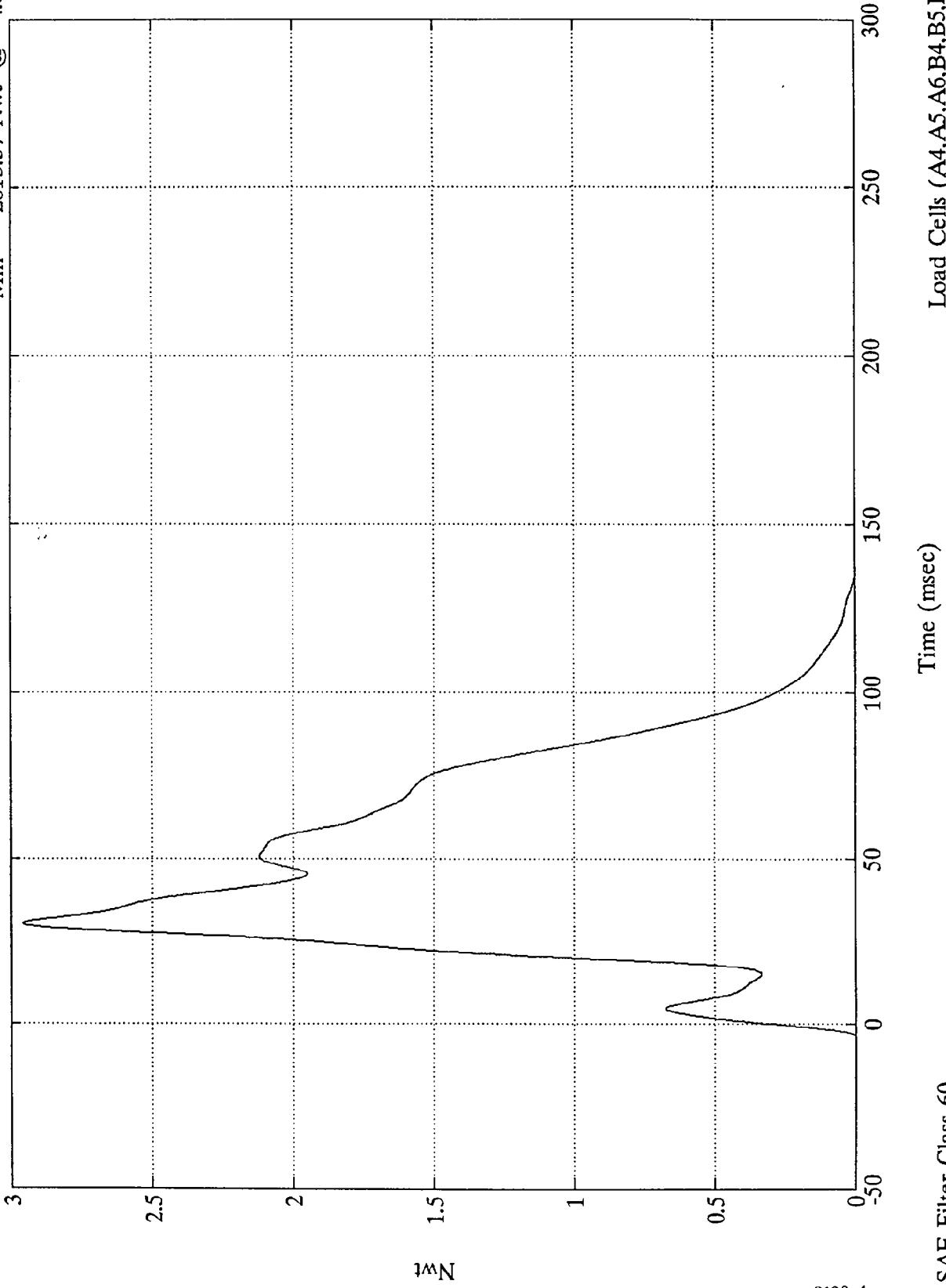

Load Cells (A4,A5,A6,B4,B5,B6)

Time (msec)

SAE Filter Class 60

Group 3 Load Cell Sum

Max = 87567.80 Nwt @ 8.40 msec  
Min = -3128.82 Nwt @ 0.96 msec

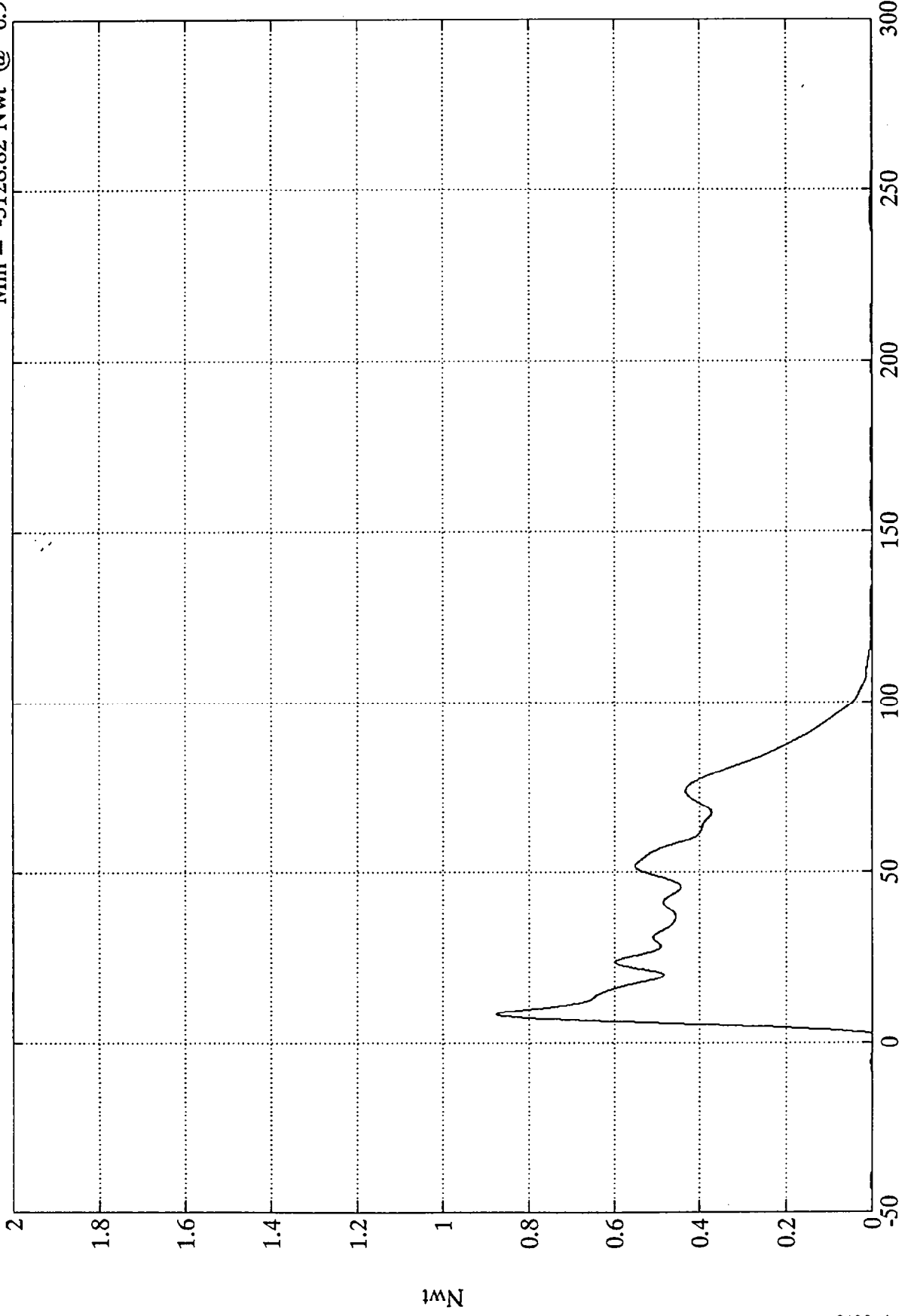

SAE Filter Class 60

Time (msec)

Load Cells (A7,A8,A9,B7,B8,B9)

NCAP TEST #4 - 1994 MAZDA 626 DX

Group 4 Load Cell Sum

Max = 30138.40 Nwt @ 37.80 msec  
Min = -2486.60 Nwt @ 158.28 msec

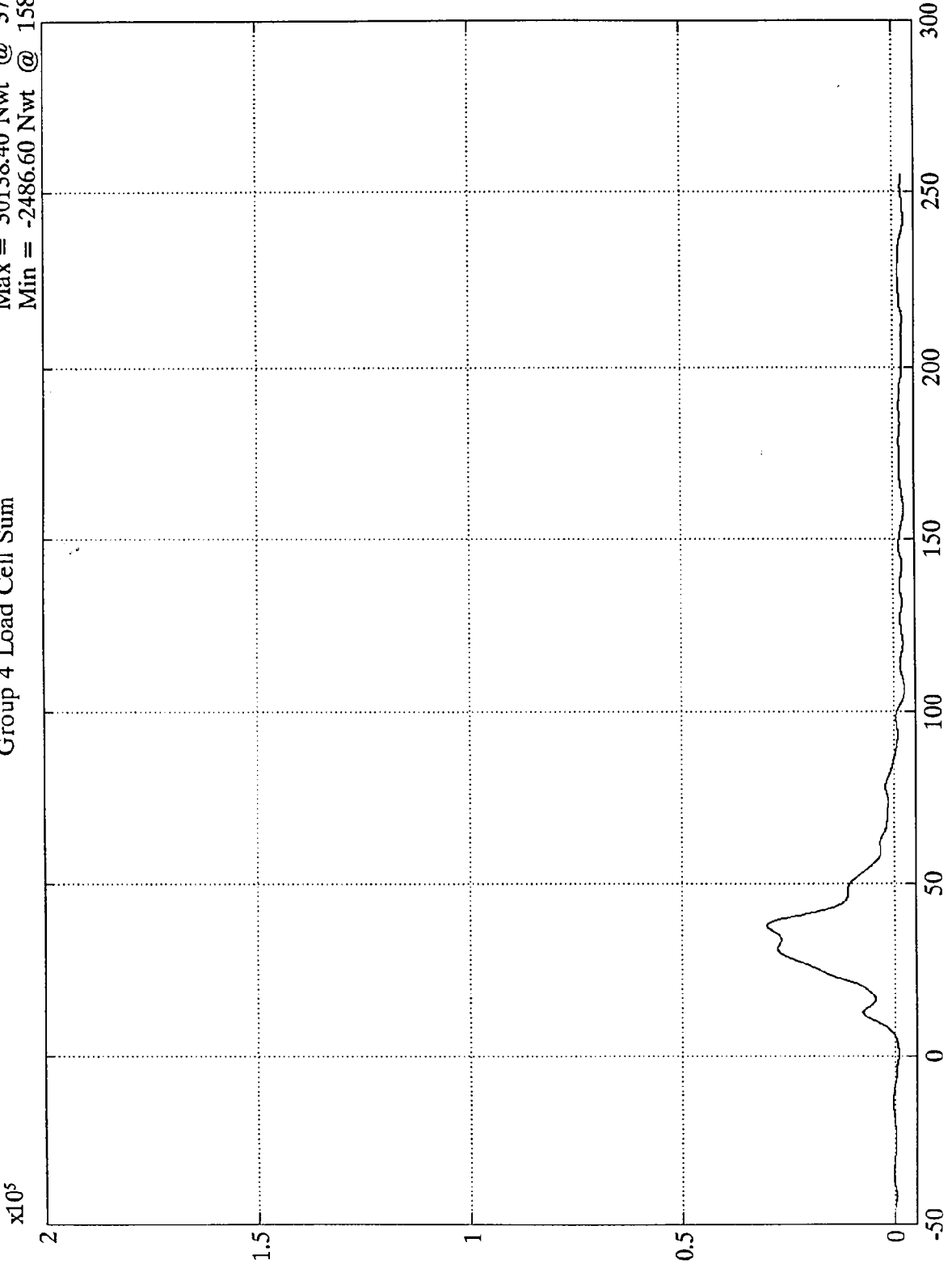

Time (msec)

SAE Filter Class 60

Load Cells (C1,C2,C3,D1,D2)

1Nwt  
B-67

8120-4

Max = 52779.80 Nwt @ 32.04 msec  
Min = -1820.64 Nwt @ -0.60 msec

Group 5 Load Cell Sum

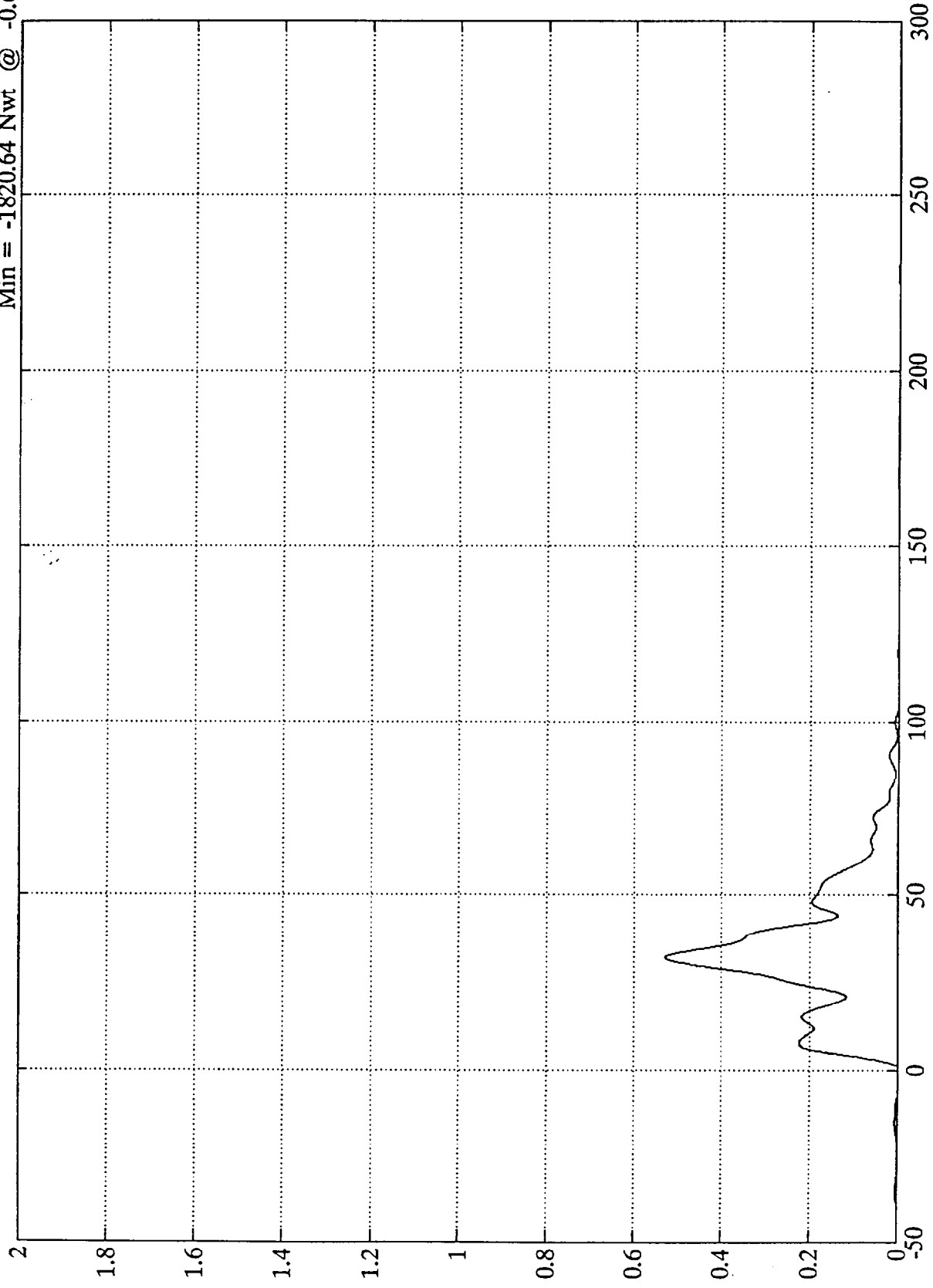

Load Cells (C4,C5,C6,D4,D5,D6)

Time (msec)

SAE Filter Class 60

NCAP TEST #4 - 1994 MAZDA 626 DX

Group 6 Load Cell Sum

Max = 18213.00 Nwt @ 31.92 msec  
Min = -1404.47 Nwt @ 109.08 msec

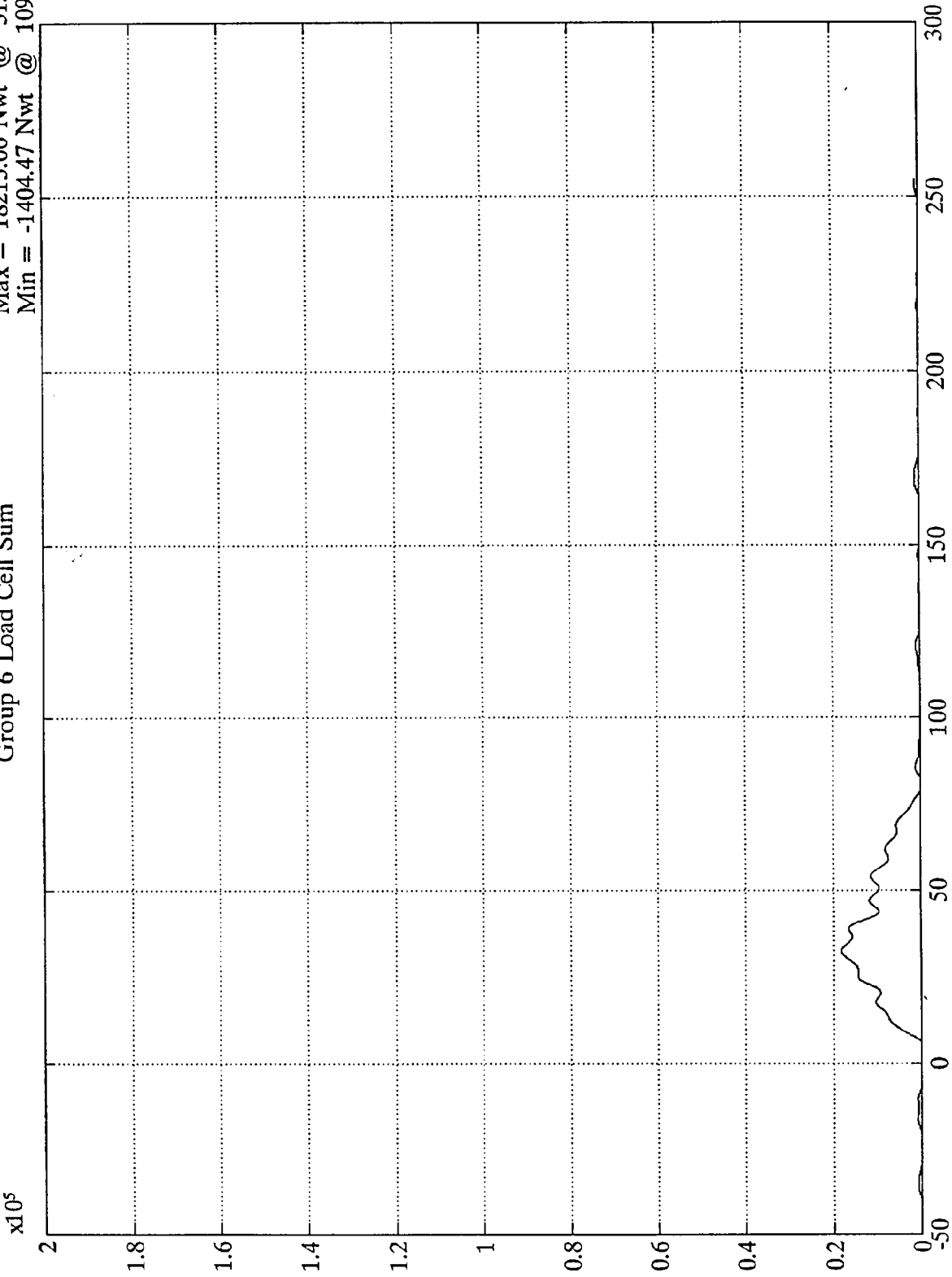

18N  
B-69

8120-4

SAE Filter Class 60

Load Cells (C7,C8,C9,D7,D8,D9)

Max = 547259.00 Nwt @ 30.60 msec  
Min = -4242.88 Nwt @ 157.32 msec

Total Load Cell Sum

$\times 10^5$

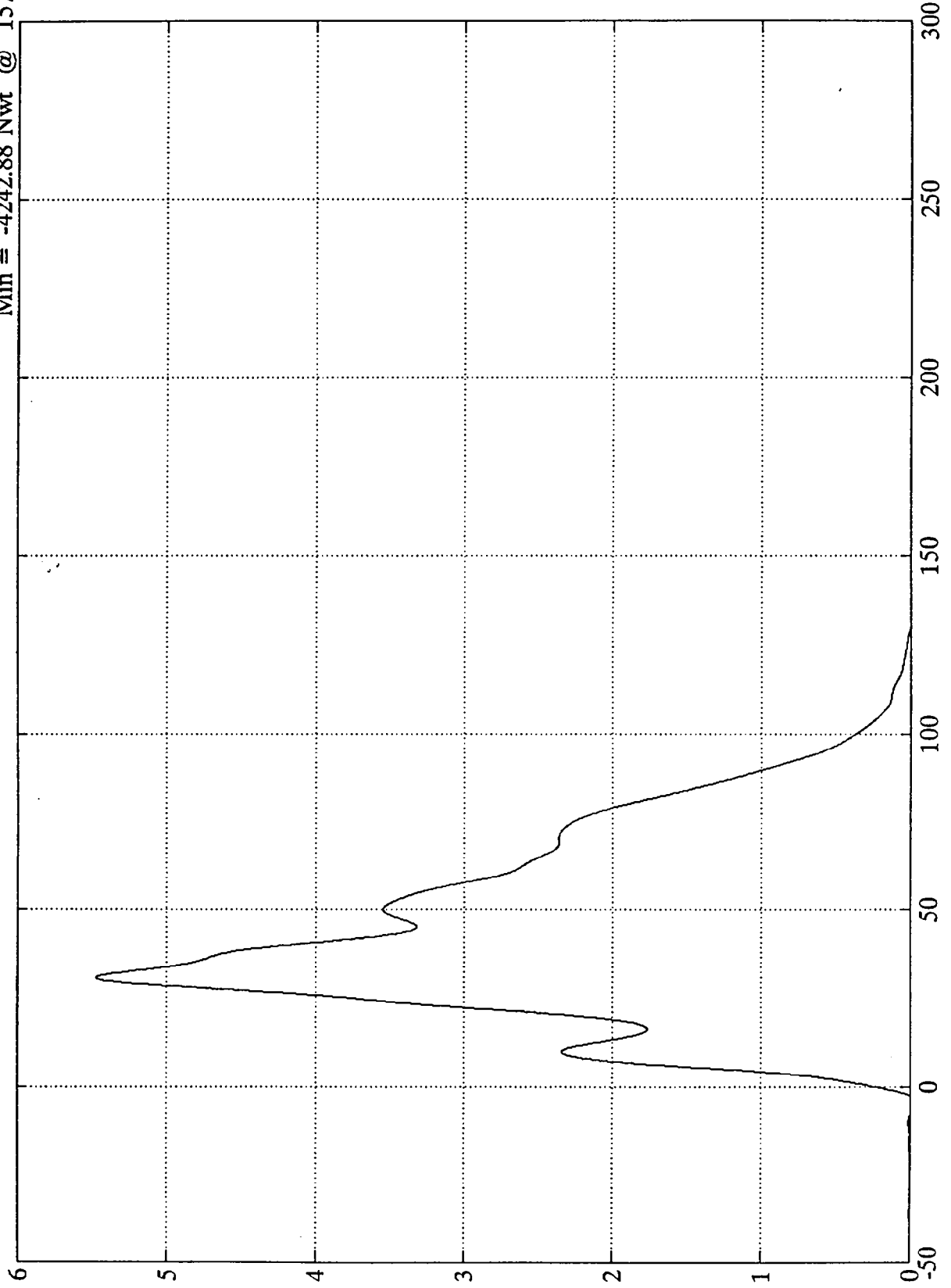

Nwt  
B-70

Time (msec)

SAE Filter Class 60

TEST NO. MR5400

DUMMY DATA

CLASS	FILTER CHANNEL
Head Accelerations	1000
Chest Accelerations	180
Chest Displacements	60
Femur Forces	600
Belt Loads	60
Belt Displacements	180
Neck Forces	1000
Neck Moments	600

Max = 46.80 Gs @ 207.48 ms  
Min = -55.67 Gs @ 74.51 msec

Pos. 1 Head X



SD  
B-72

8120-4

SAE Filter Class 1000

Time (msec)

NCAP TEST #4 - 1994 MAZDA 626 DX

Pos. 1 Head Y

Max = 36.08 Gs @ 207.60 msec  
Min = -15.08 Gs @ 22.80 msec

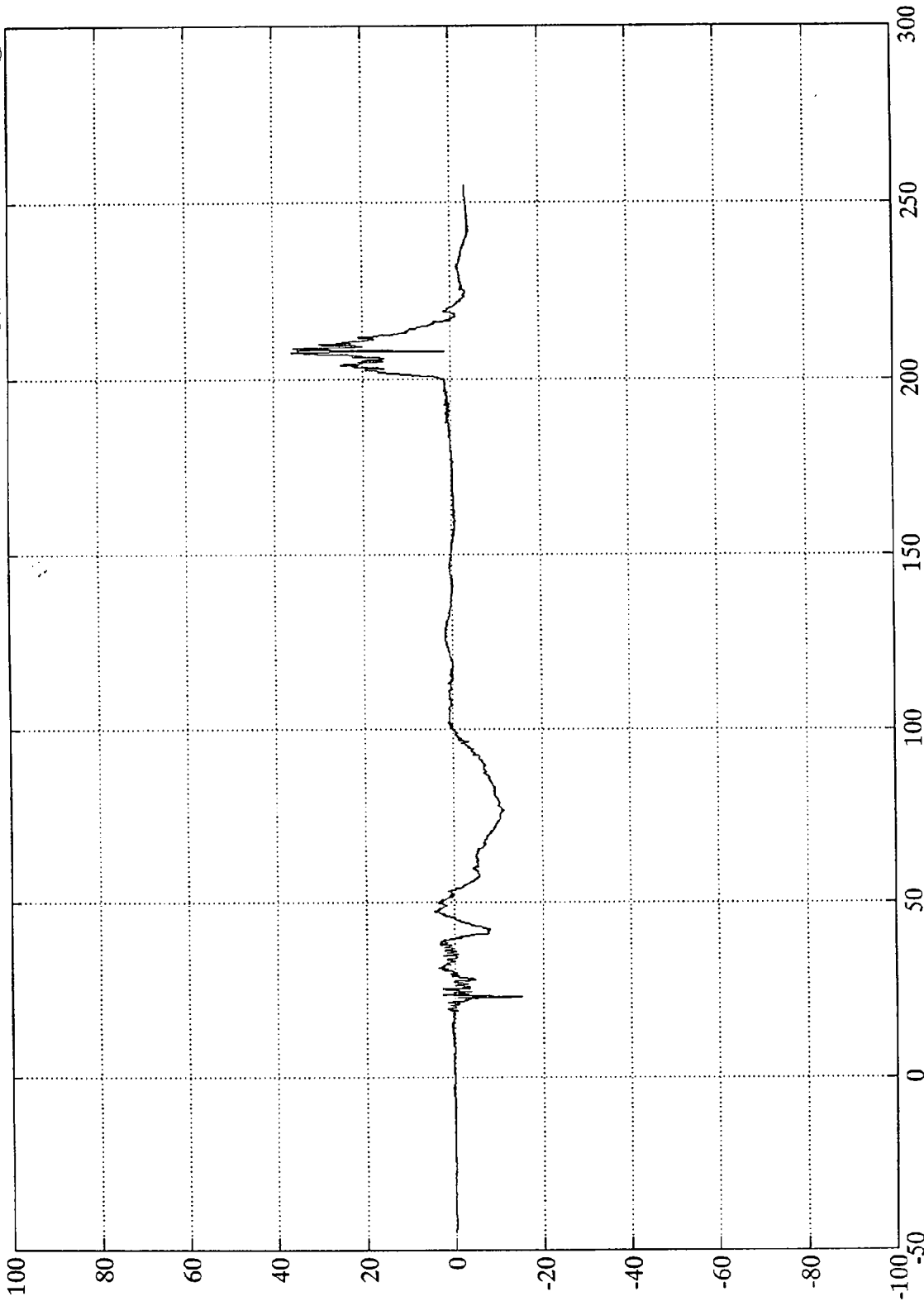

SD  
B-73

8120-4

Time (msec)

SAE Filter Class 1000

Max = 22.02 Gs @ 207.36 ms  
Min = -17.04 Gs @ 22.43 mse

Pos. 1 Head Z

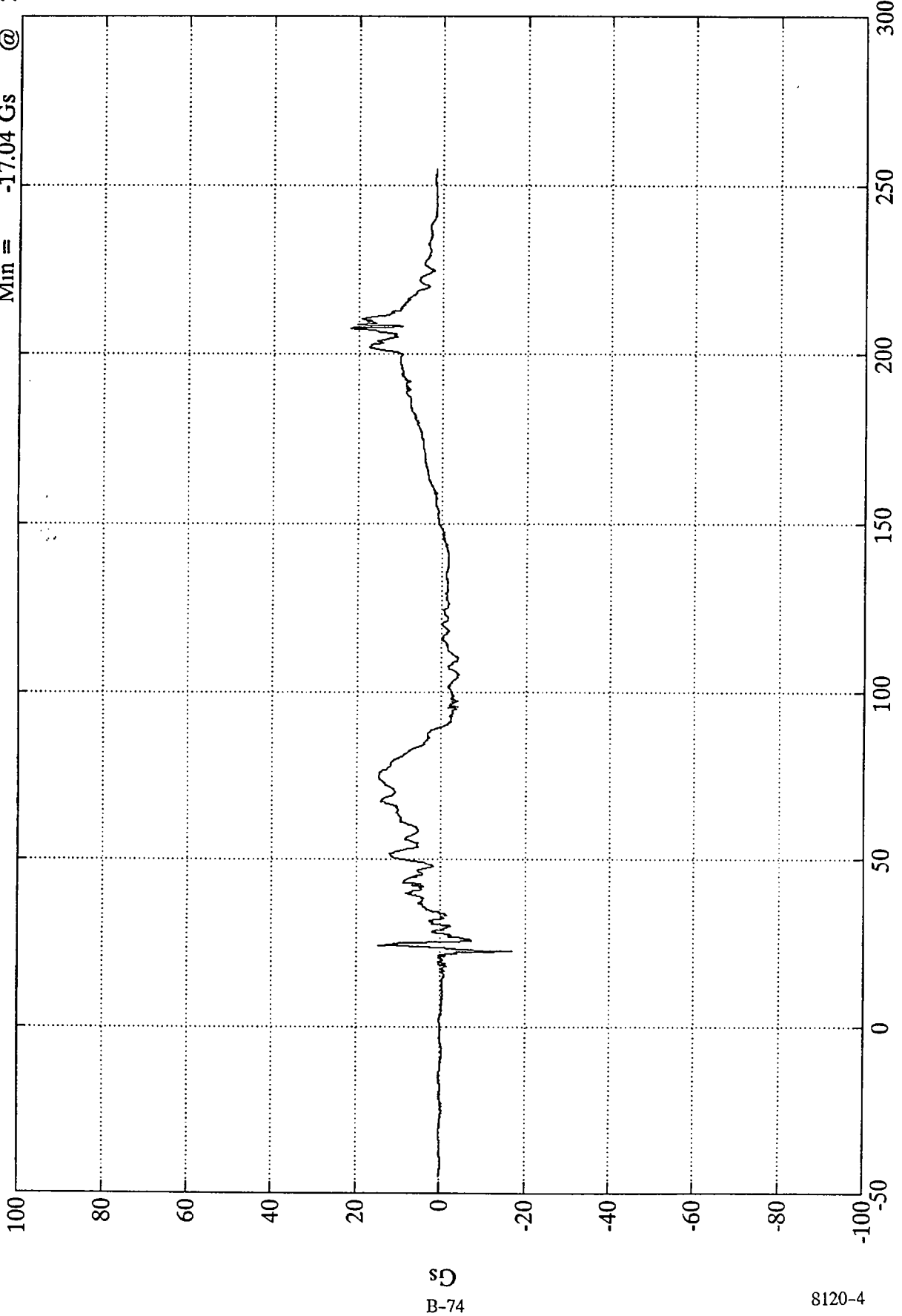

Time (msec)

SD  
B-74

8120-4

SAE Filter Class 1000

NCAP TEST #4 - 1994 MAZDA 626 DX

Pos. 1 Head Resultant

Max = 61.73 Gs @ 207.48 msec  
Min = .07 Gs @ -17.64 msec

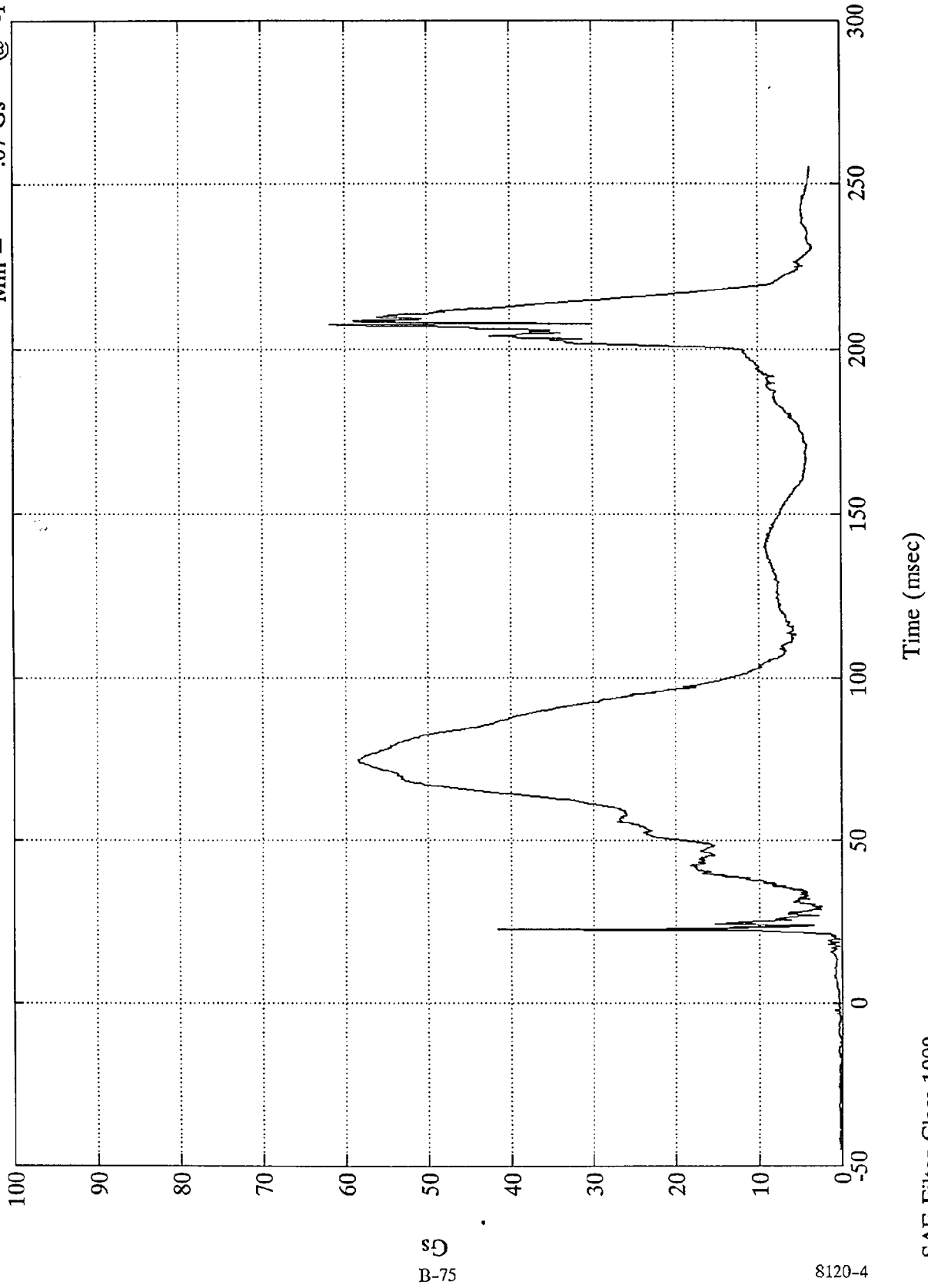

SD  
B-75

8120-4

SAE Filter Class 1000



Pos. 1 Chest X

Max = 6.12 Gs @ 221.52 msec  
Min = -54.85 Gs @ 71.16 msec

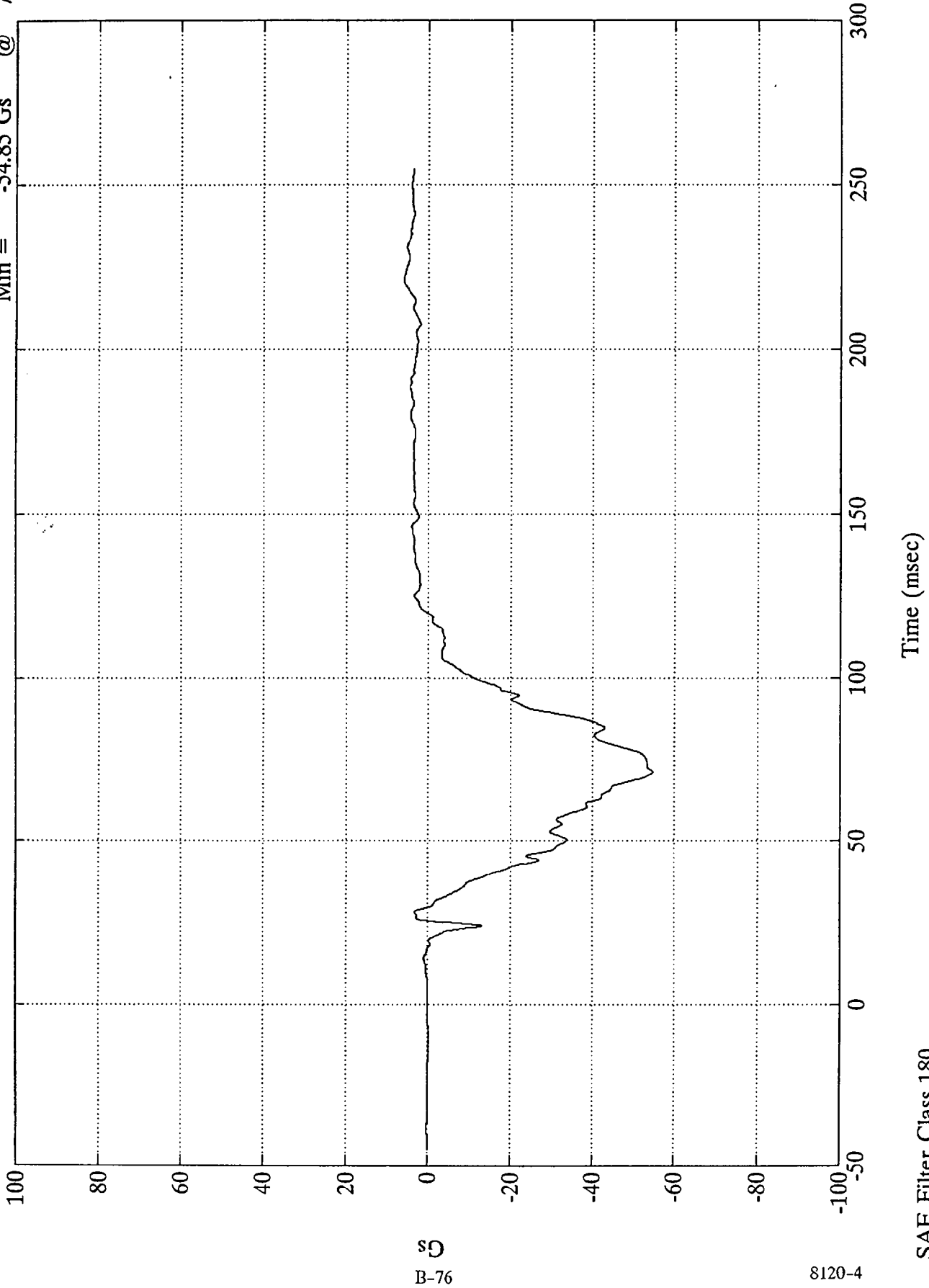

NCAP TEST #4 - 1994 MAZDA 626 DX

Pos. 1 Chest Y

Max = 9.46 Gs @ 84.72 msec  
Min = -6.58 Gs @ 47.76 msec

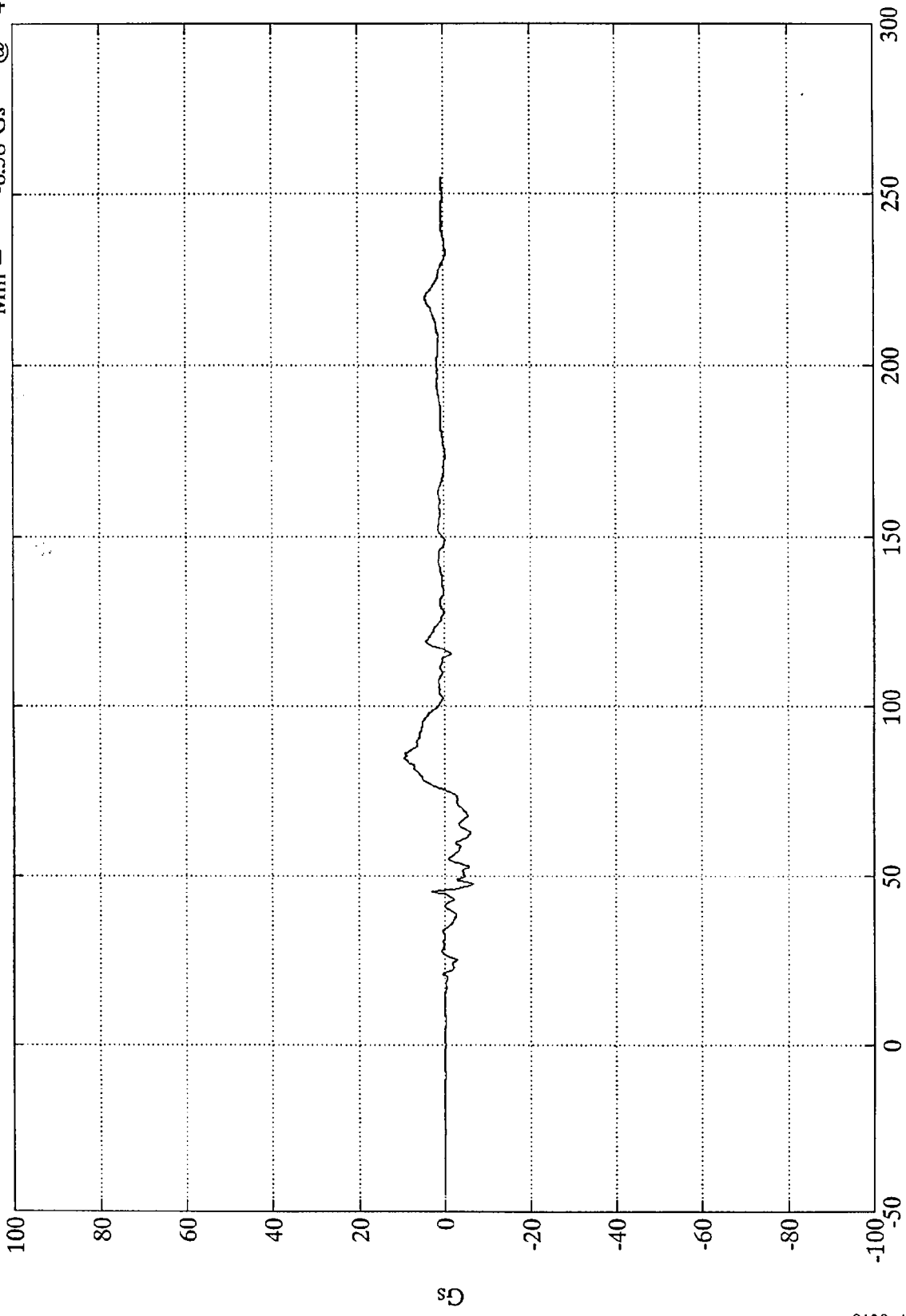

Time (msec)

SAE Filter Class 180

8120-4

B-77

Max = 7.58 Gs @ 76.20 msec  
Min = -6.06 Gs @ 107.88 msec

Pos. 1 Chest Z

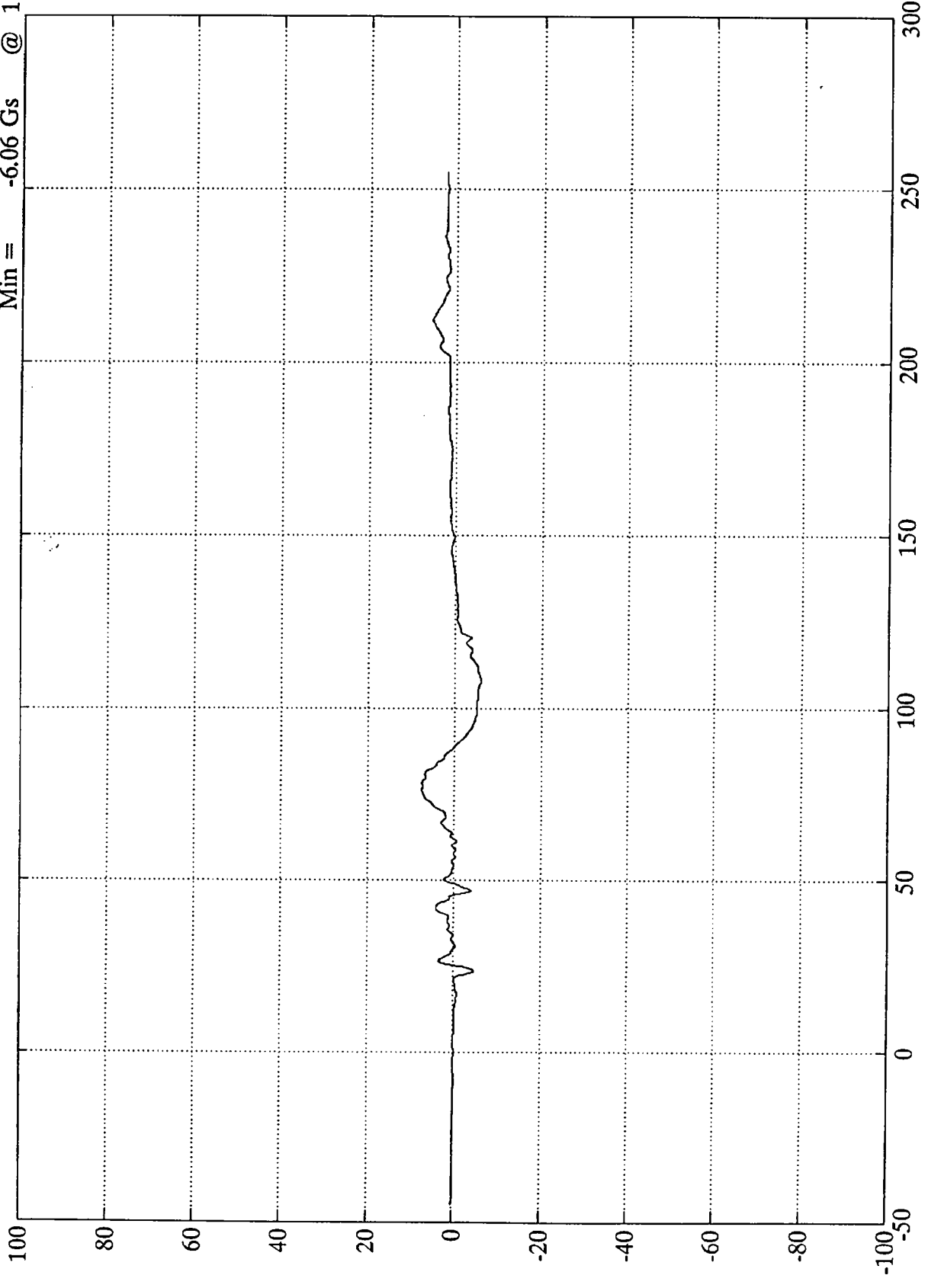

Time (msec)

8D  
B-78

8120-4

SAE Filter Class 180

NCAP TEST #4 - 1994 MAZDA 626 DX

Pos. 1 Chest Resultant

Max = 55.08 Gs @ 71.27 msec  
Min = .03 Gs @ -24.60 msec



Time (msec)

89  
B-79

8120-4

SAE Filter Class 180

Max = .32 mm @ -31.44 msec  
Min = -43.15 mm @ 68.28 msec

Pos. 1 Chest Disp.

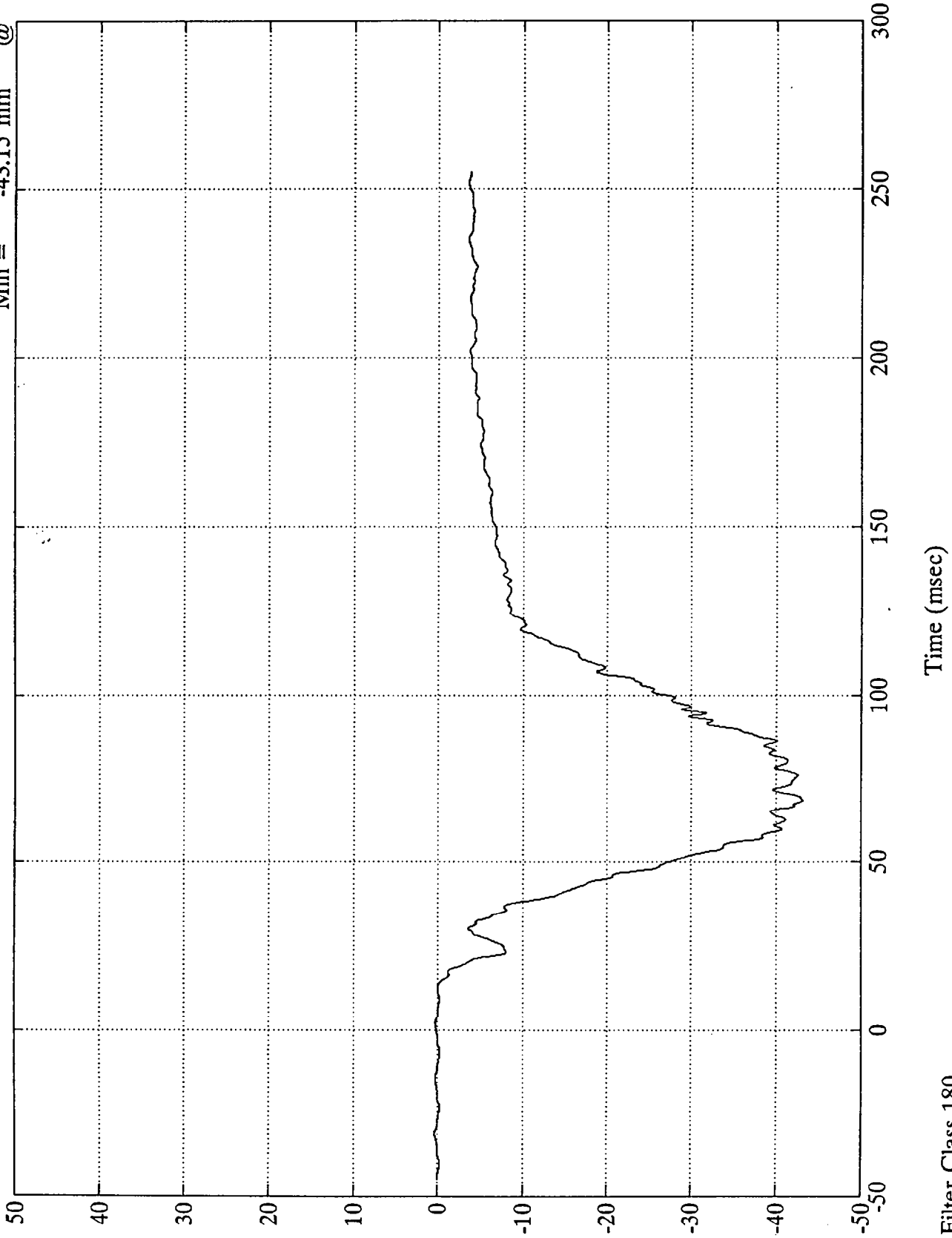

B-80

8120-4

SAE Filter Class 180

NCAP TEST #4 - 1994 MAZDA 626 DX

Pos. 1 Left Femur

Max = 197.19 Nwt @ 37.44 msec  
Min = -5364.03 Nwt @ 59.40 msec

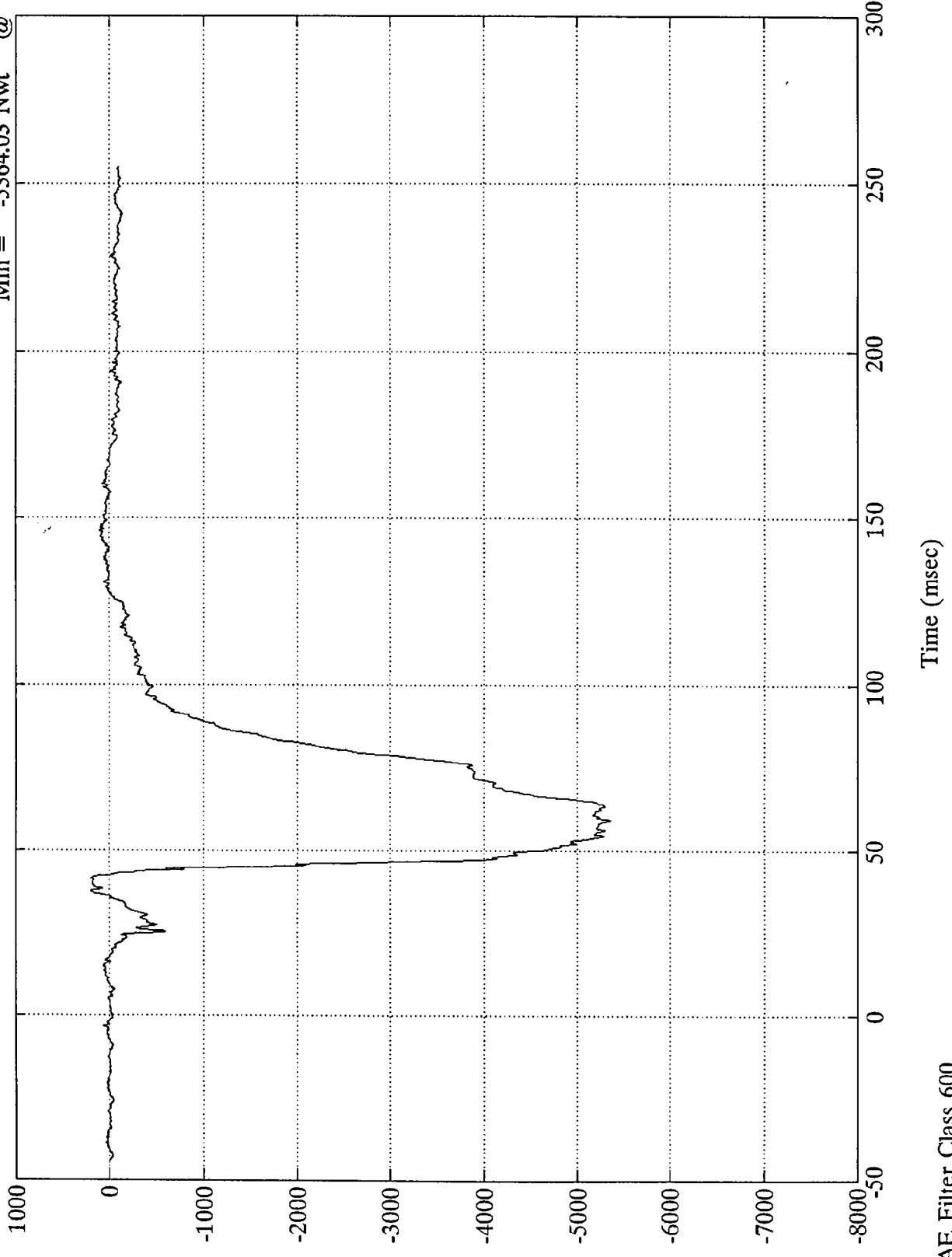

18-N  
B-81

8120-4

SAE Filter Class 600

Time (msec)

Pos. 1 Right Femur

Max = 163.40 Nwt @ 114.00 msec  
Min = -6689.57 Nwt @ 46.31 msec

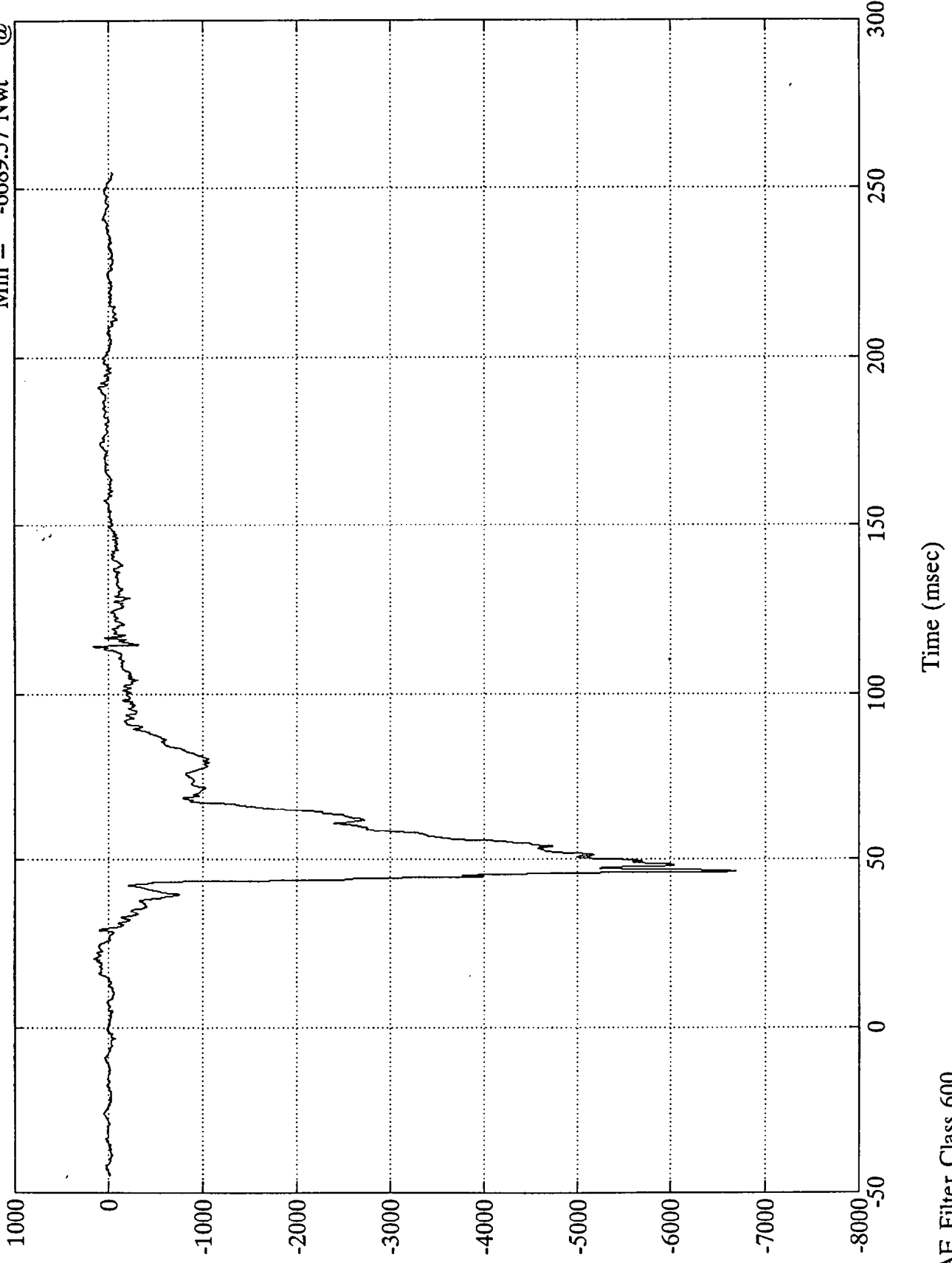

1Nwt  
B-82

8120-4

SAE Filter Class 600

NCAP TEST #4 - 1994 MAZDA 626 DX

Pos. 1 Upper Neck Fx

Max = 1439.63 Nwt @ 111.36 msec  
Min = -330.37 Nwt @ 69.83 msec

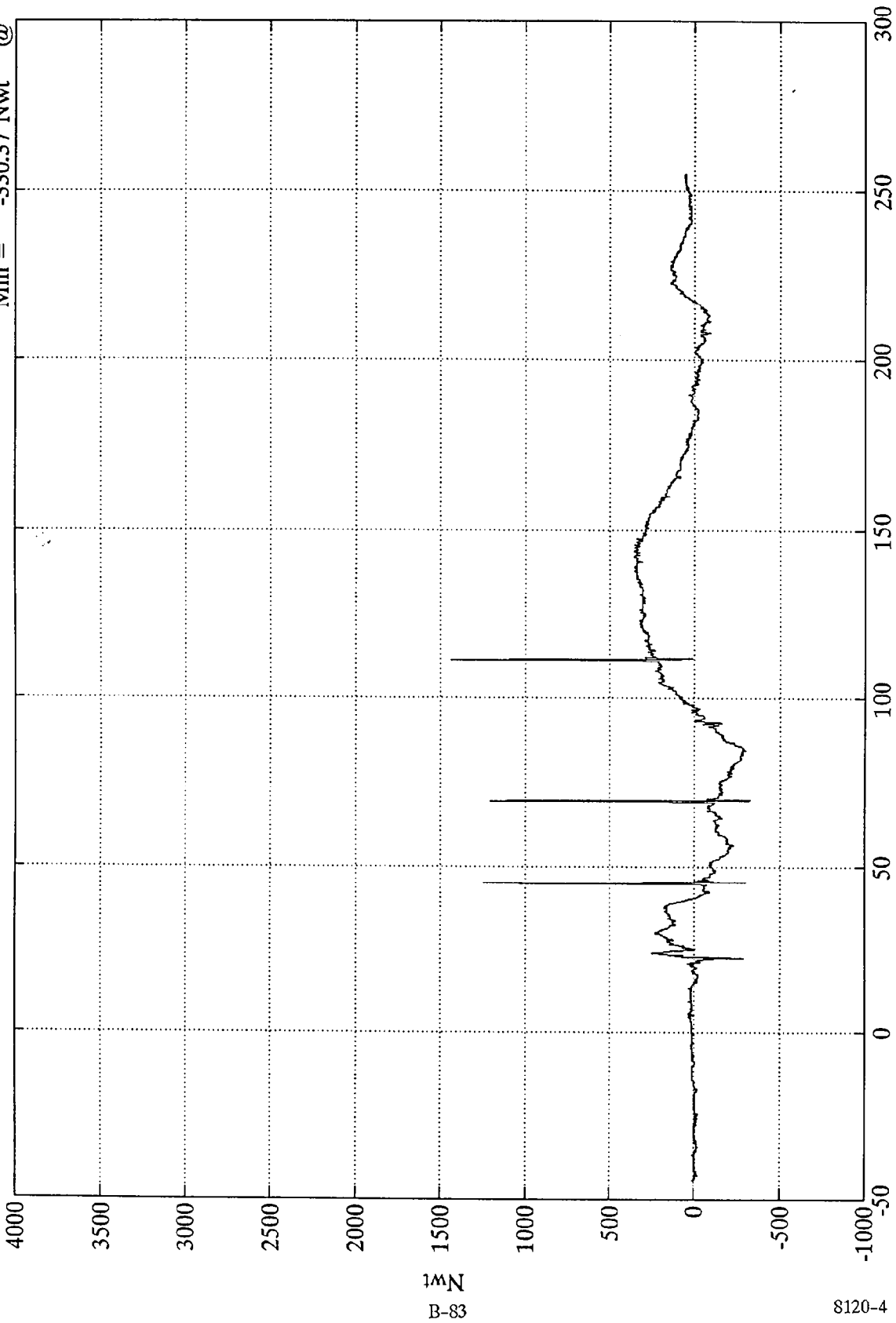

Time (msec)

SAE Filter Class 1000

14N  
B-83

8120-4

Pos. 1 Upper Neck Fy

Max = 187.79 Nwt @ 66.84 msec  
Min = -283.69 Nwt @ 218.39 msec

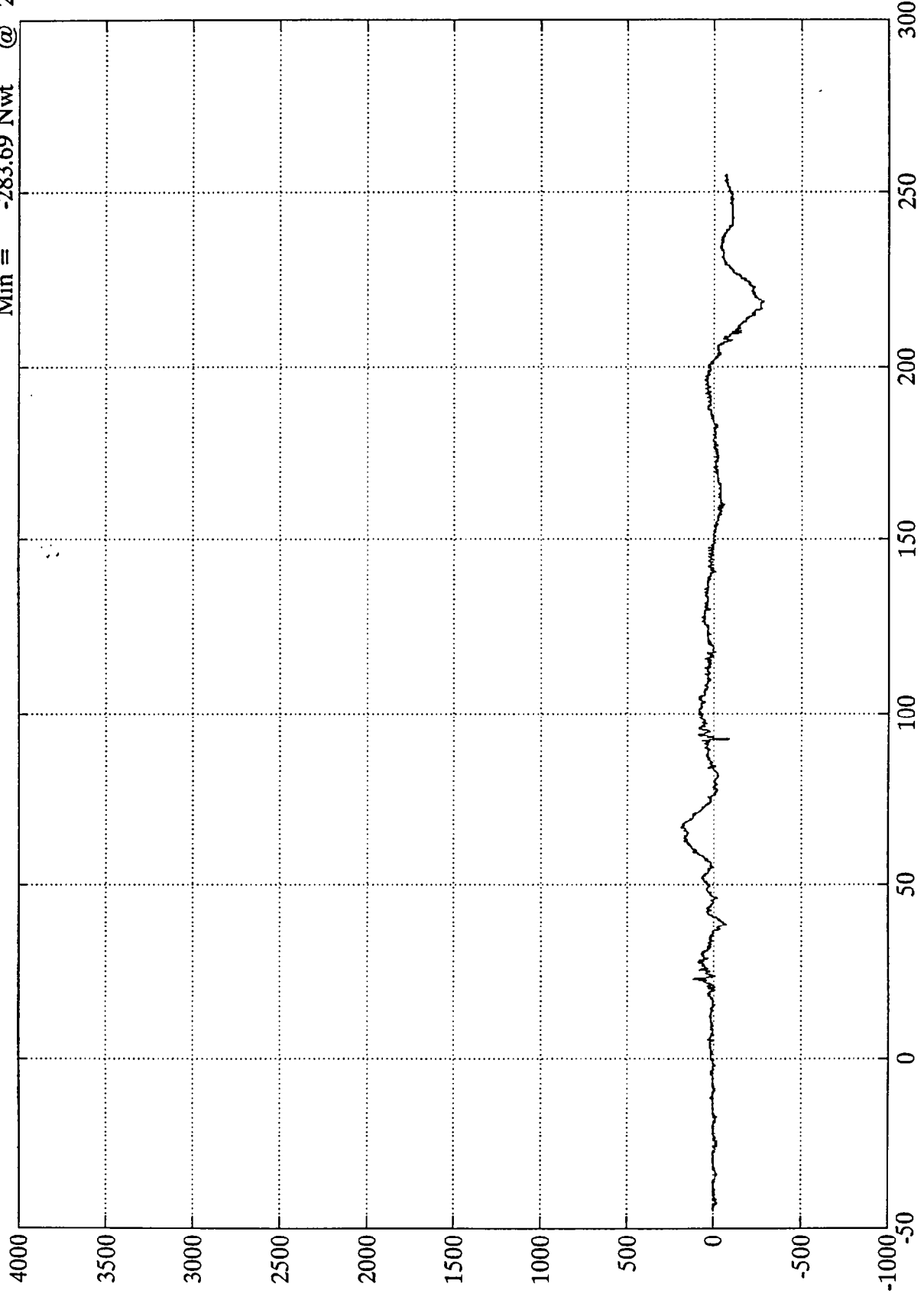

B-84

8120-4

SAE Filter Class 1000

Time (msec)

NCAP TEST #4 - 1994 MAZDA 626 DX

Pos. 1 Upper Neck Fz

Max = 4633.93 Nwt @ 76.31 msec  
Min = -22031.10 Nwt @ 254.88 msec

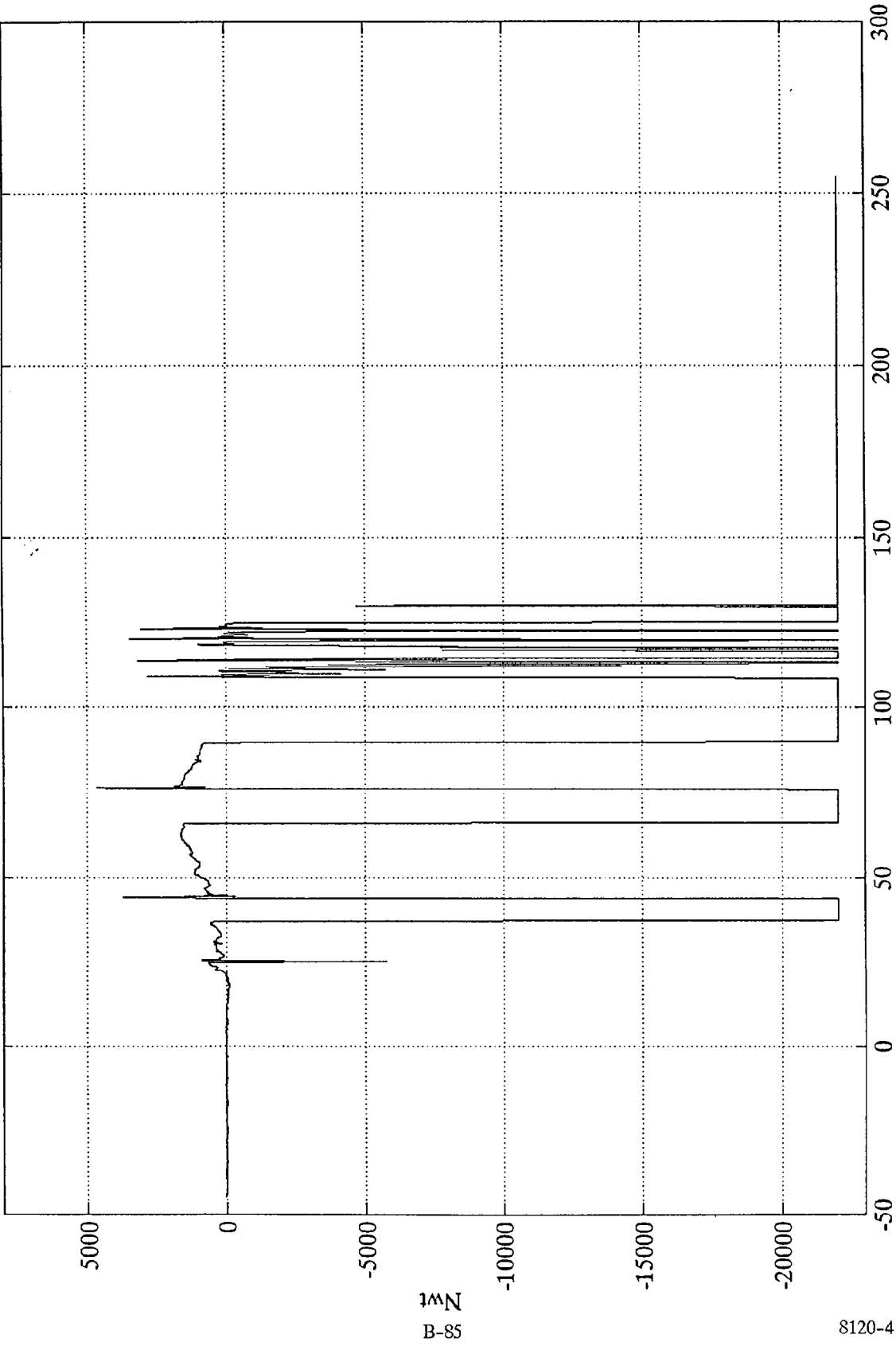

B-85

8120-4

SAE Filter Class 1000

Time (msec)

DATA IS NOT ACCURATE AFTER 40 mSEC.

Pos. 1 Upper Neck Mx

Max = 16.12 Nwt-M @ 85.08 ms  
Min = -18.11 Nwt-M @ 219.12 ms

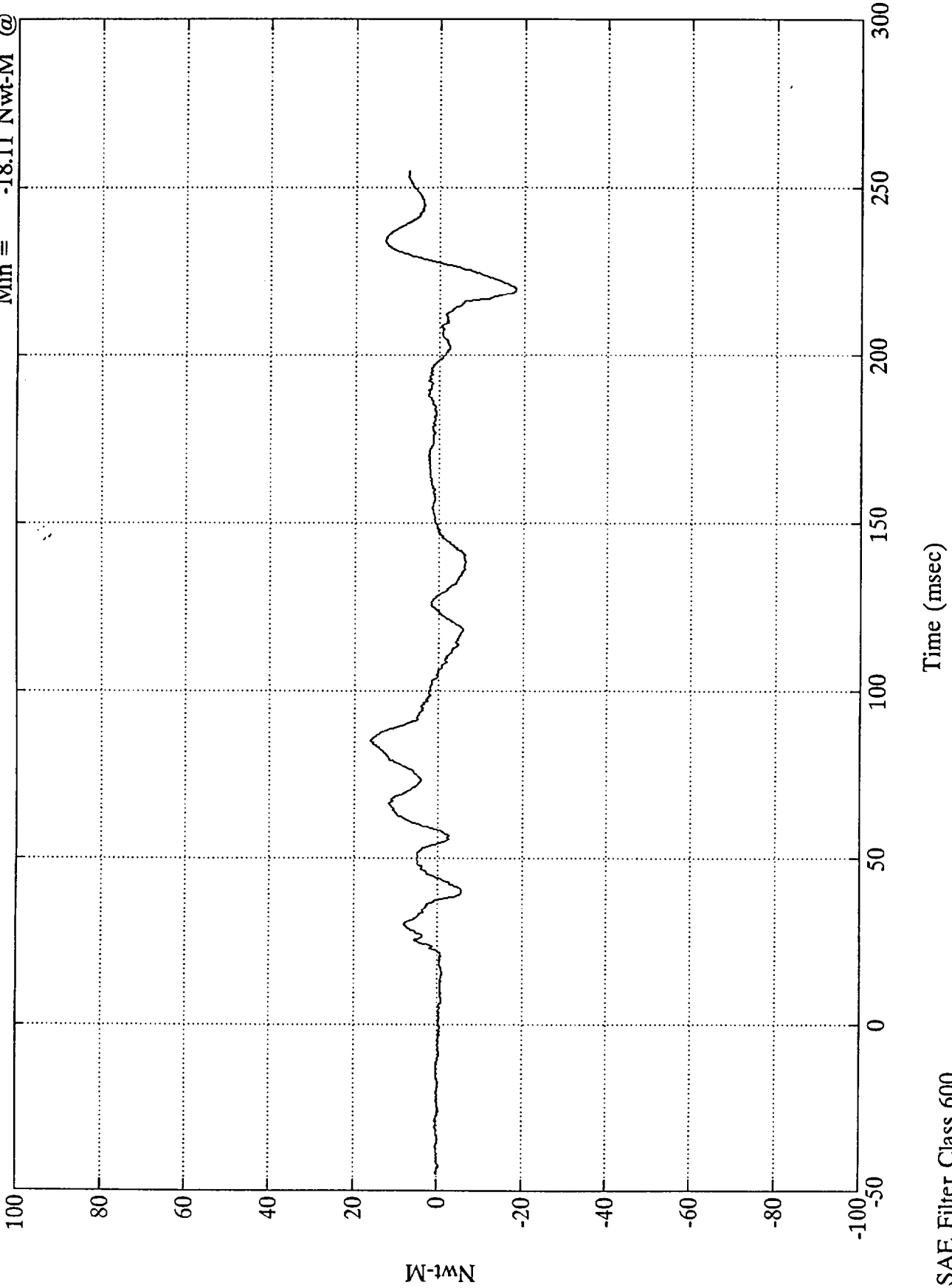

Nwt-M  
B-86

8120-4

SAE Filter Class 600

NCAP TEST #4 - 1994 MAZDA 626 DX

Pos. 1 Upper Neck My

Max = 32.55 Nwt-M @ 135.72 msec  
Min = -18.93 Nwt-M @ 36.95 msec

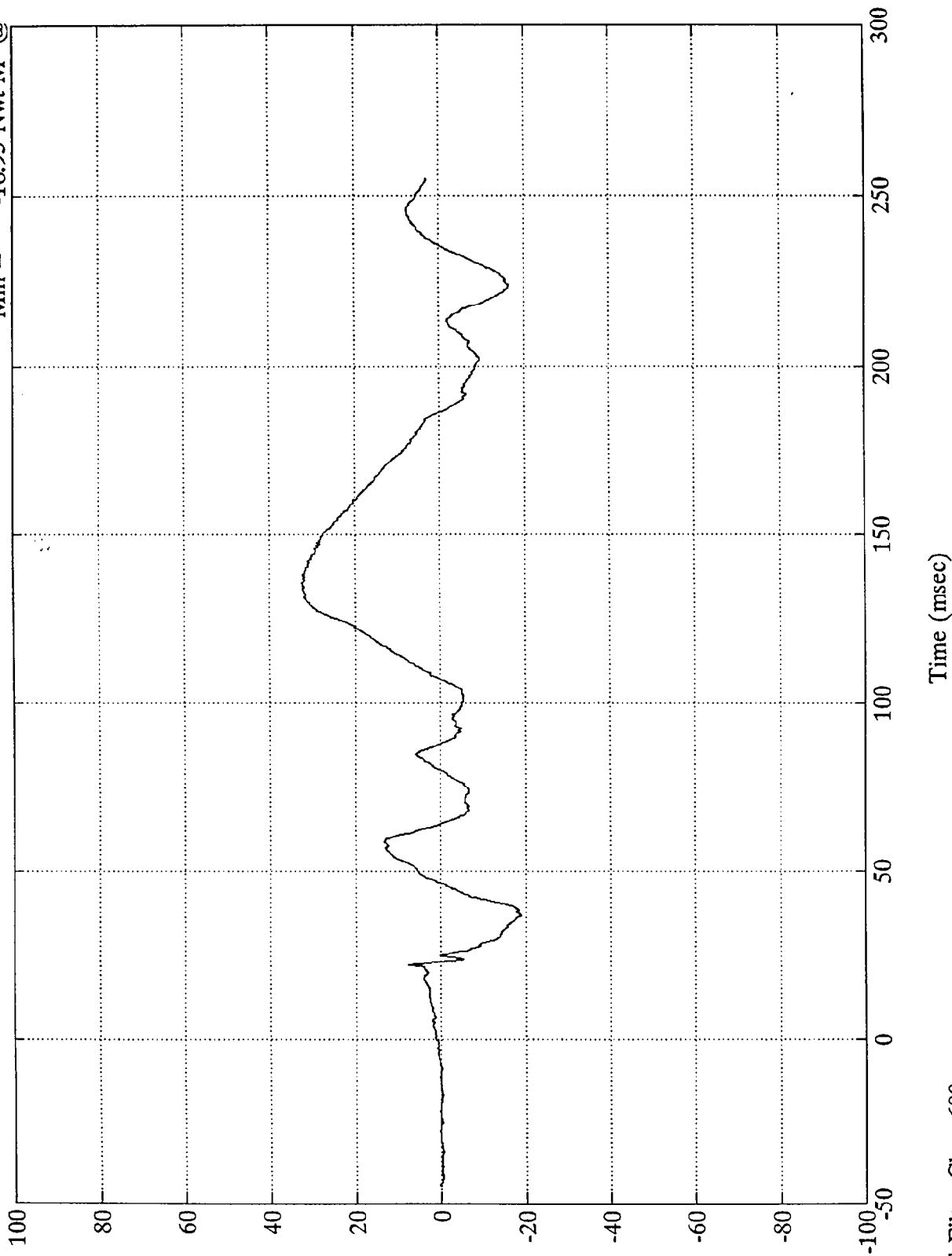

B-87

8120-4

SAE Filter Class 600

Pos. 1 Upper Neck Mz

Max = 14.65 Nwt-M @ 86.63 m:  
Min = -13.92 Nwt-M @ 232.80 m:

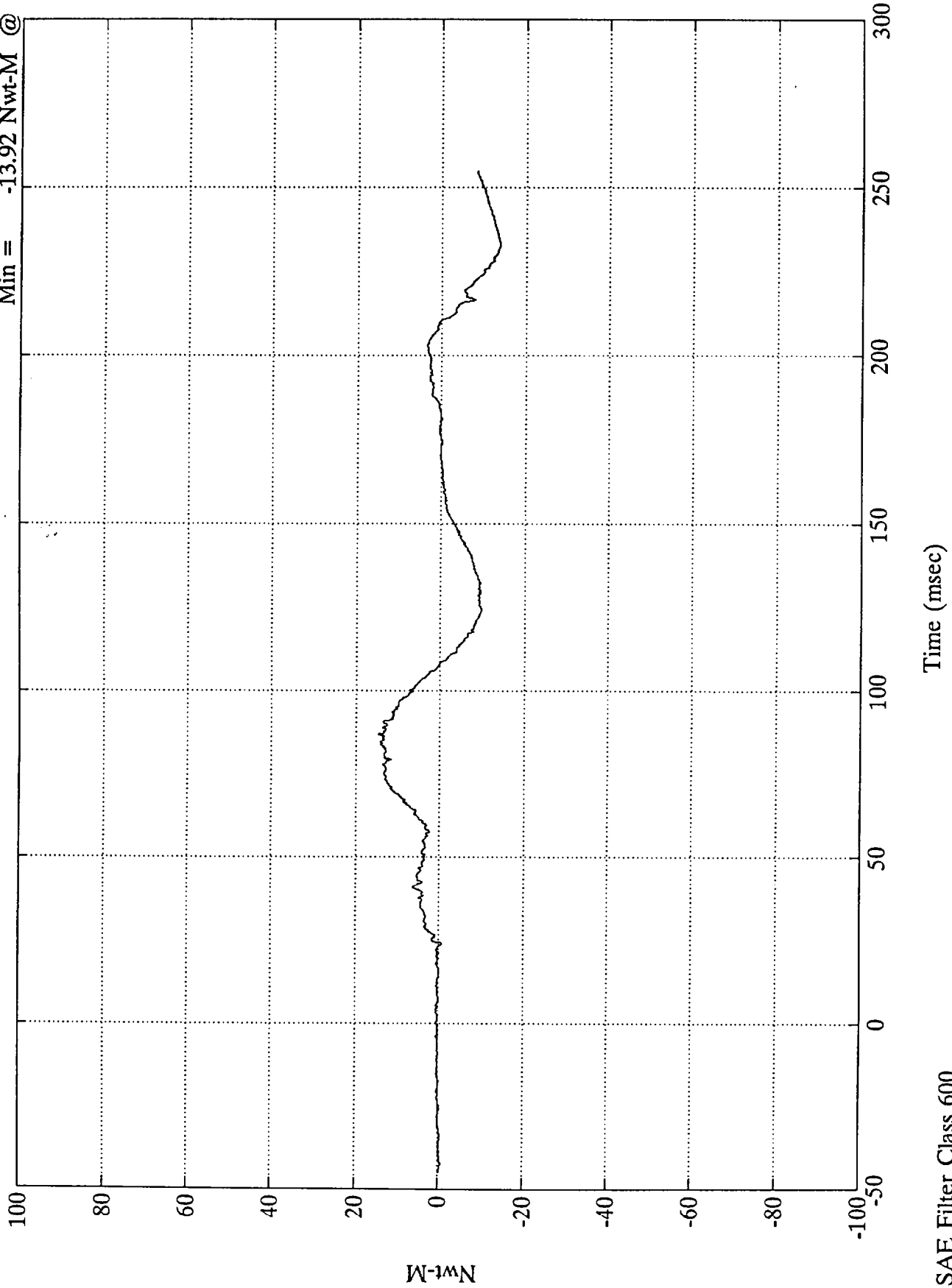

NCAP TEST #4 - 1994 MAZDA 626 DX

Pos. 1 Belt Elongation

Max = 2.02 mm @ 70.79 msec  
Min = -0.33 mm @ 219.72 msec

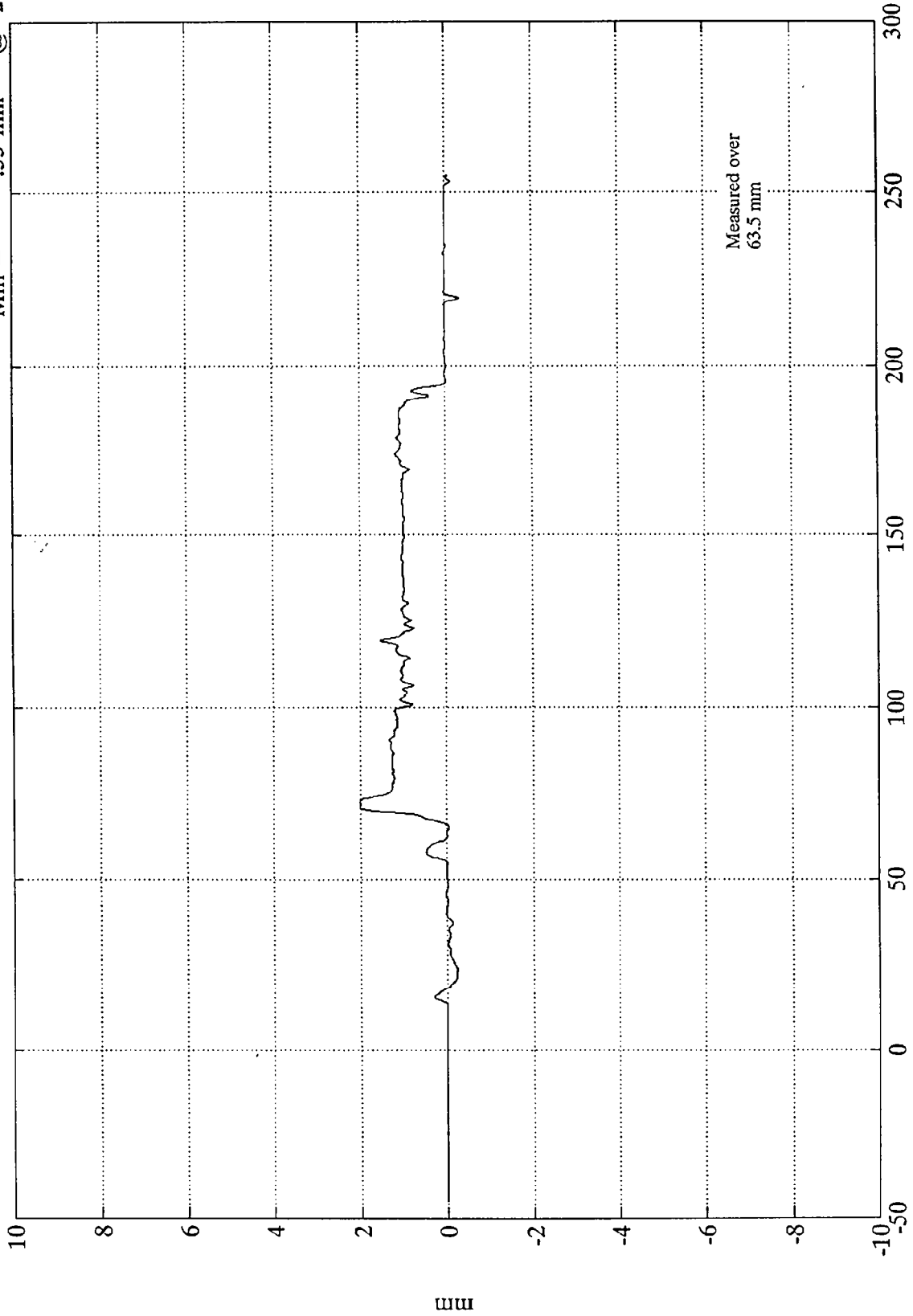

B-89

8120-4

SAE Filter Class 180

Time (msec)

Measured over  
63.5 mm

Pos. 1 Left Belt Load

Max = 2828.12 Nwt @ 80.88 ms  
Min = -5.95 Nwt @ -9.24 msec

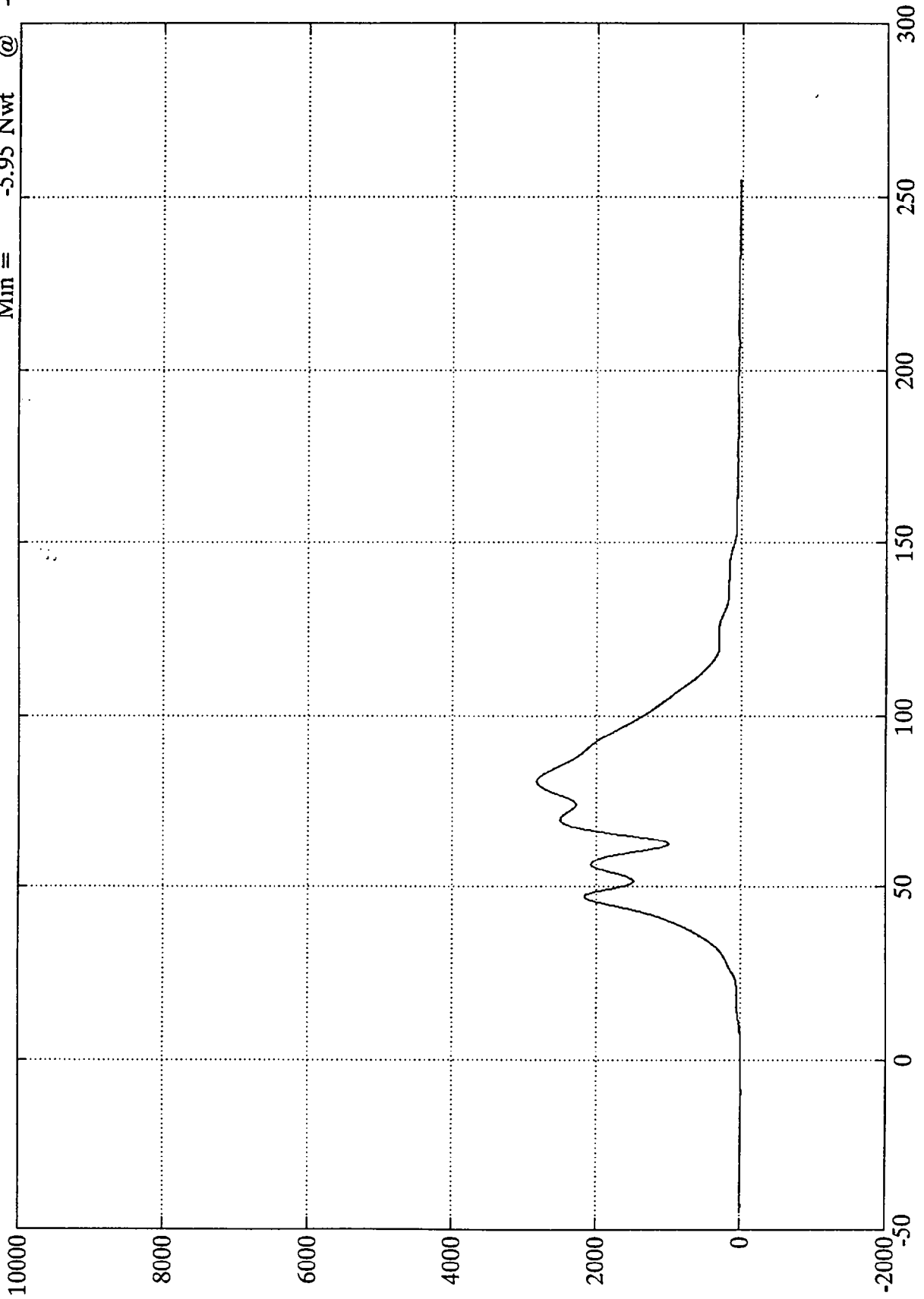

Time (msec)

SAE Filter Class 60

1kN  
B-90

8120-4

NCAP TEST #4 - 1994 MAZDA 626 DX

Pos. 1 Torso Belt Load

Max = 6413.99 Nwt @ 58.43 msec  
Min = -28.81 Nwt @ 202.80 msec

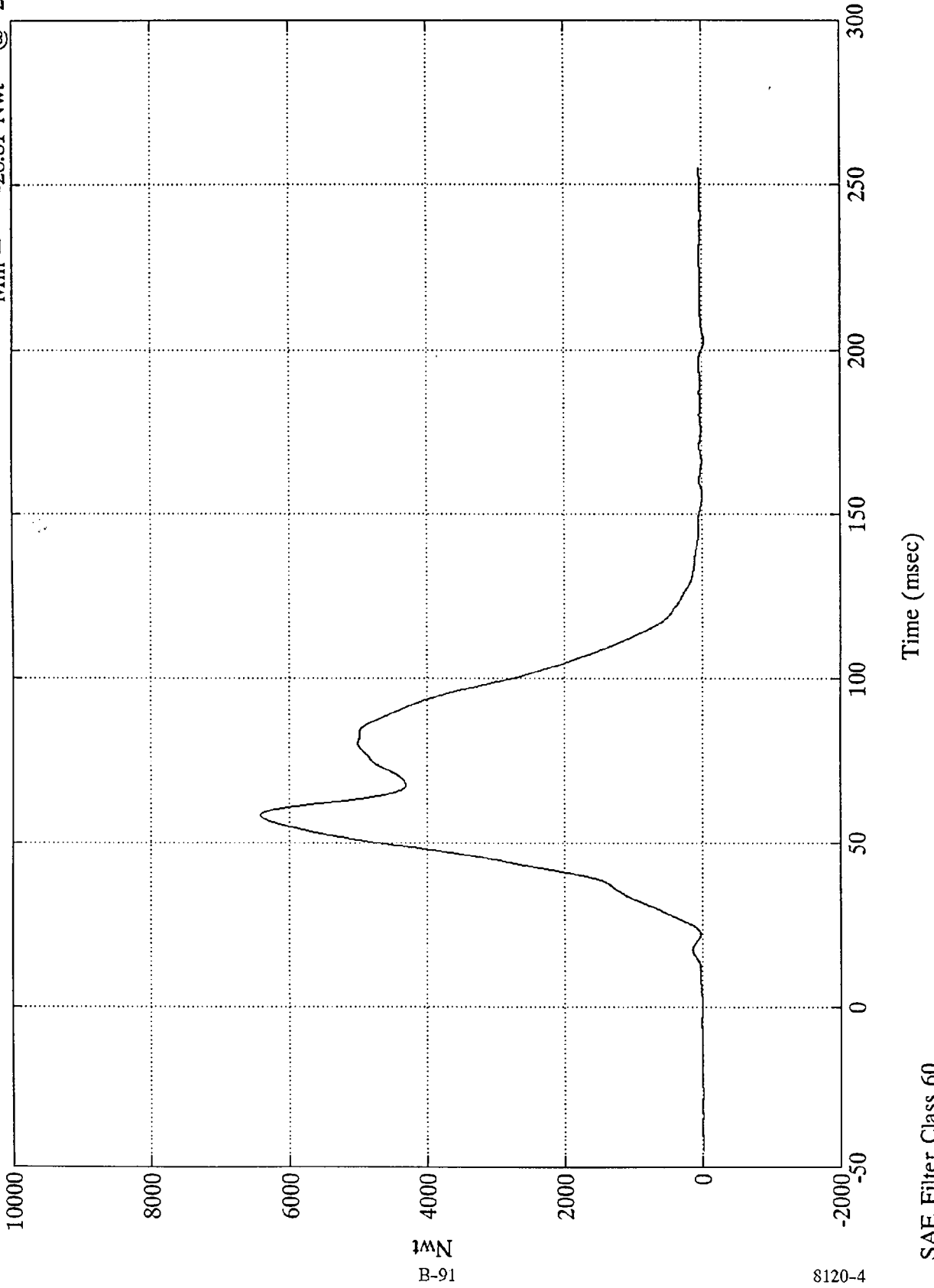

B-91

8120-4

SAE Filter Class 60

Max = 6.98 Gs @ 34.07 msec  
Min = -45.85 Gs @ 60.96 msec

Pos. 2 Head X

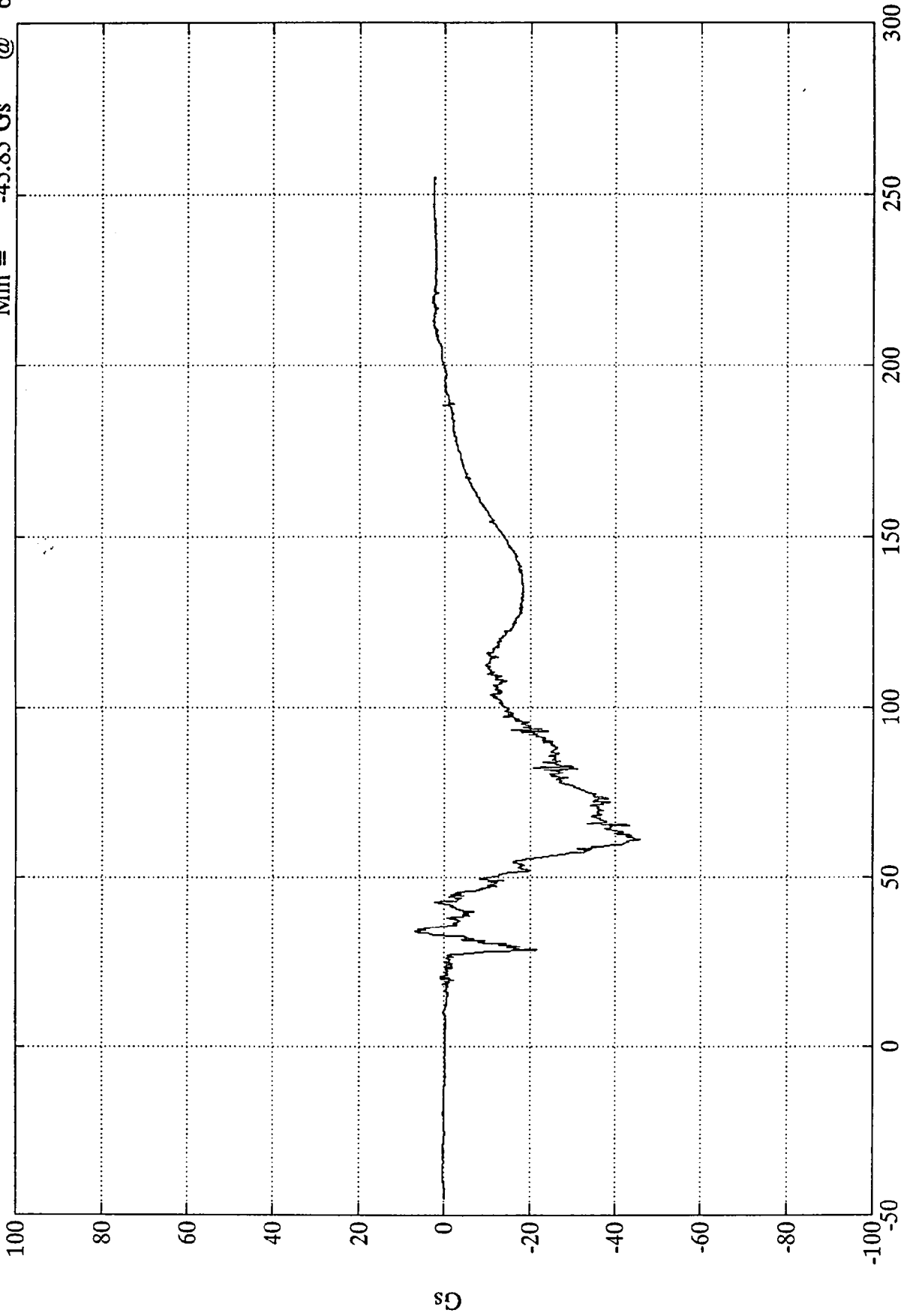

Time (msec)

SAE Filter Class 1000

NCAP TEST #4 - 1994 MAZDA 626 DX

Pos. 2 Head Y

Max = 16.59 Gs @ 29.39 msec  
Min = -10.82 Gs @ 56.52 msec

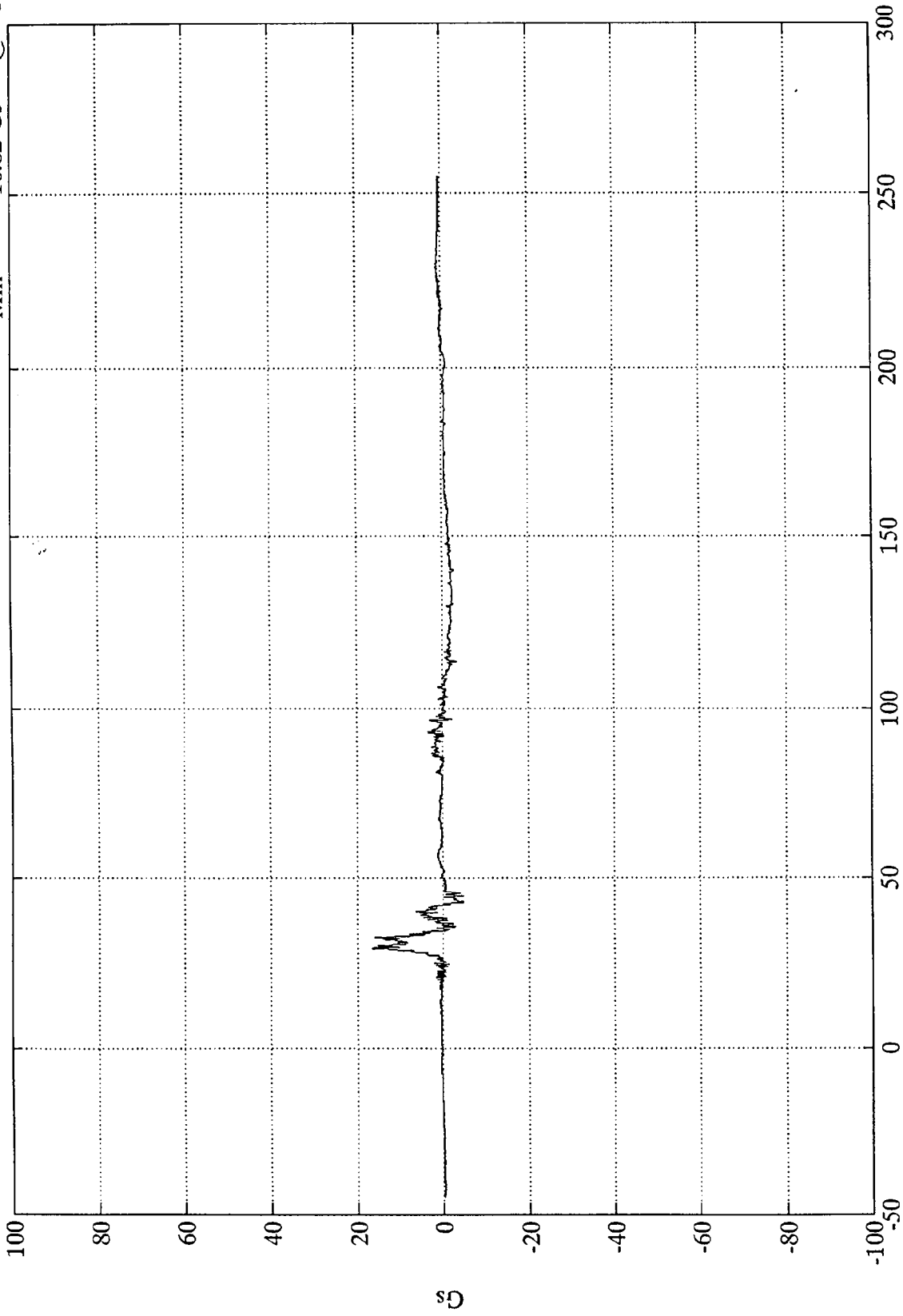

B-93

8120-4

SAE Filter Class 1000

Time (msec)

Max = 23.51 Gs @ 87.36 msec  
Min = -5.37 Gs @ 34.91 msec

Pos. 2 Head Z

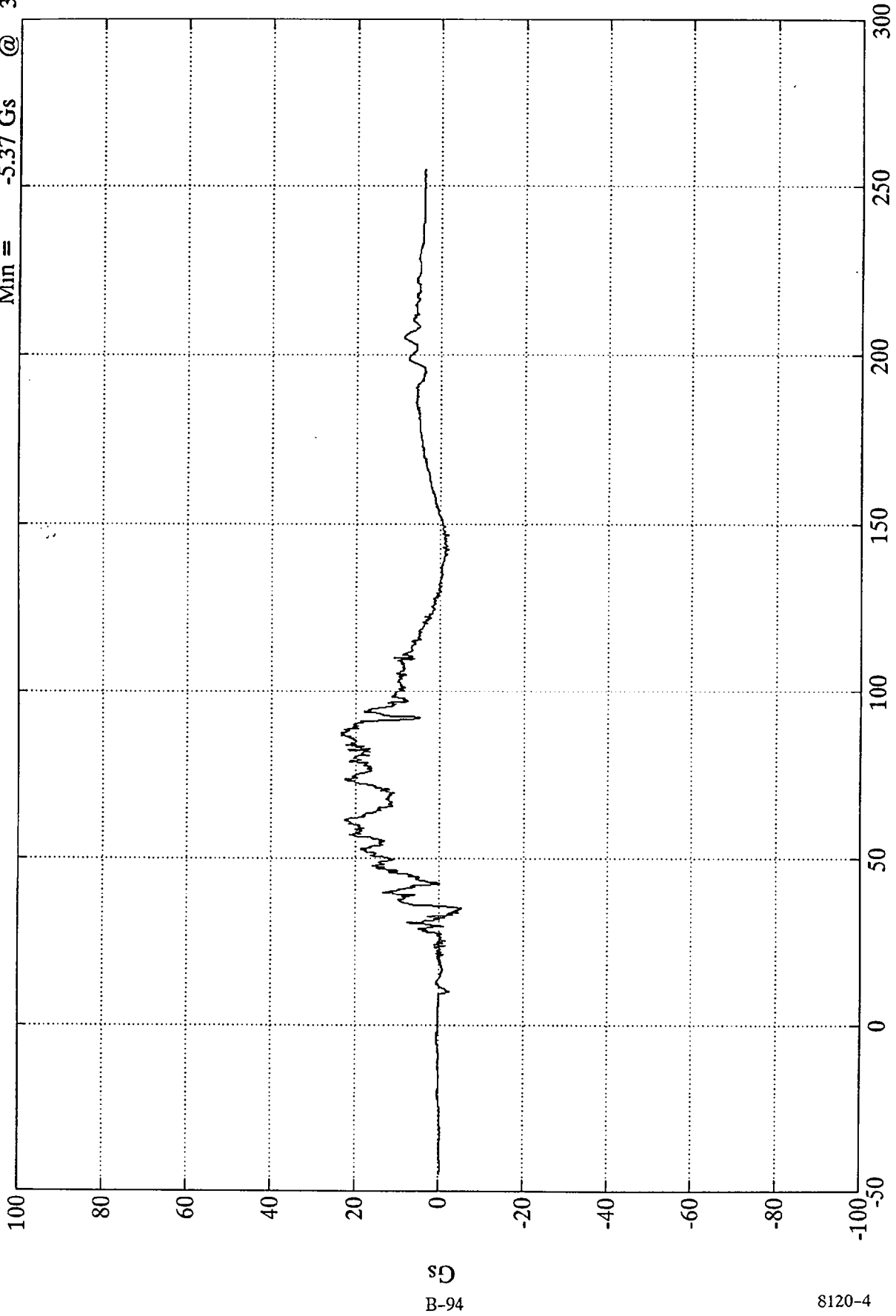

Time (msec)

SAE Filter Class 1000

NCAP TEST #4 - 1994 MAZDA 626 DX

Pos. 2 Head Resultant

Max = 51.58 Gs @ 60.96 msec  
Min = .05 Gs @ -17.40 msec

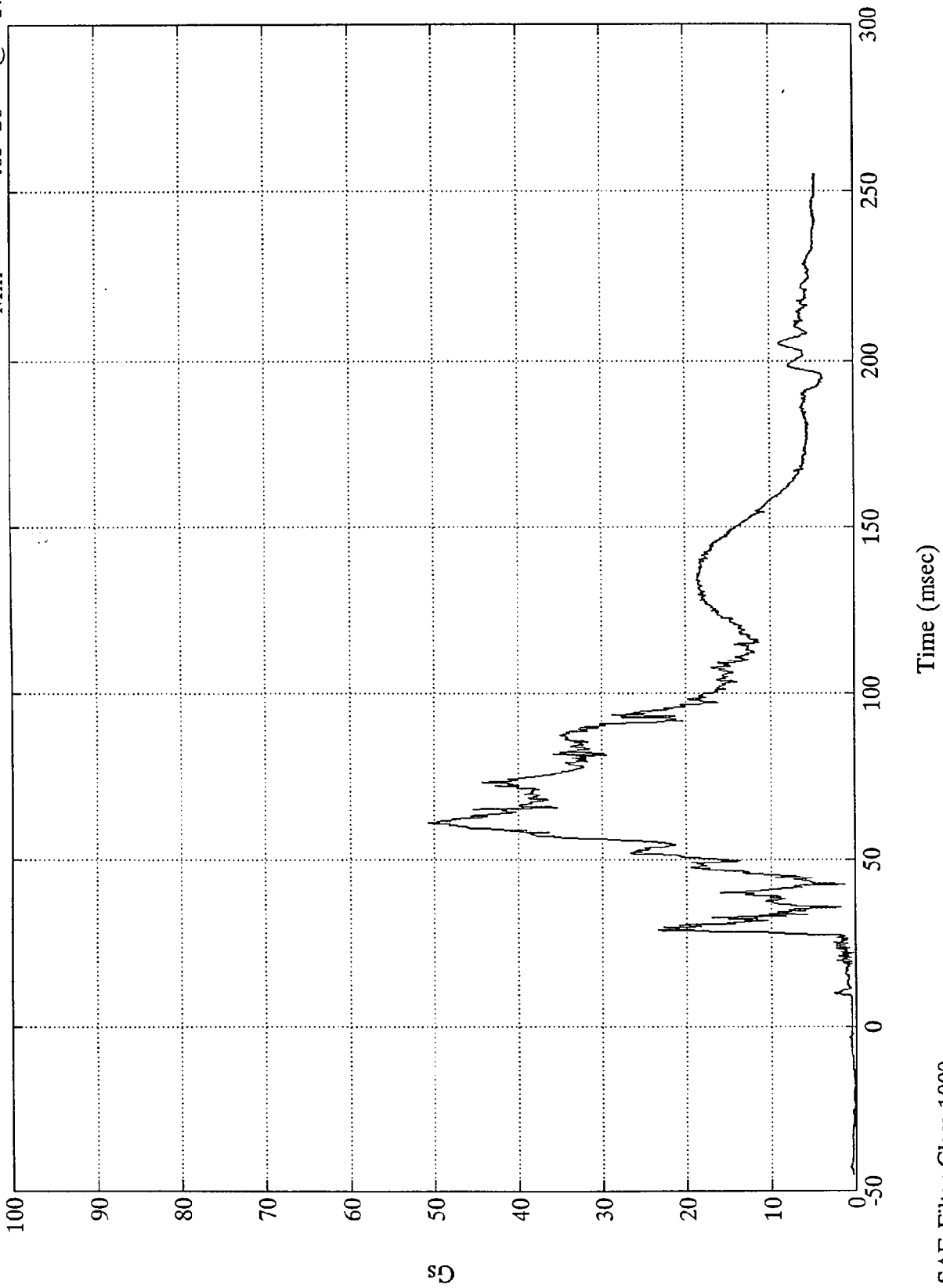

GS  
B-95

8120-4

SAE Filter Class 1000

Time (msec)

Max = 1.69 Gs @ 144.36 msec  
Min = -45.61 Gs @ 63.95 msec

Pos. 2 Chest X

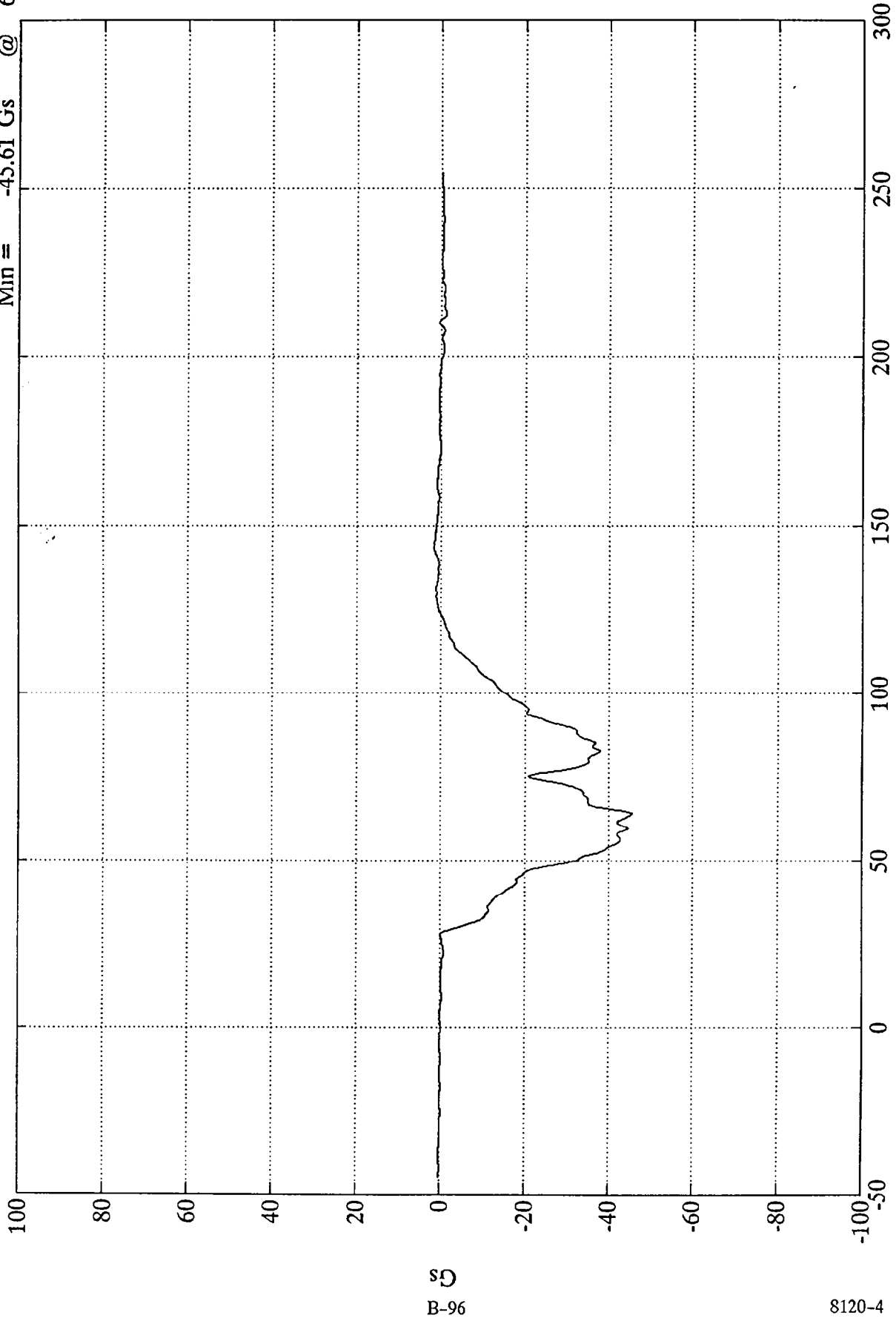

Time (msec)

SAE Filter Class 180

NCAP TEST #4 - 1994 MAZDA 626 DX

Max = 12.17 Gs @ 62.27 msec  
Min = -6.93 Gs @ 88.44 msec

Pos. 2 Chest Y

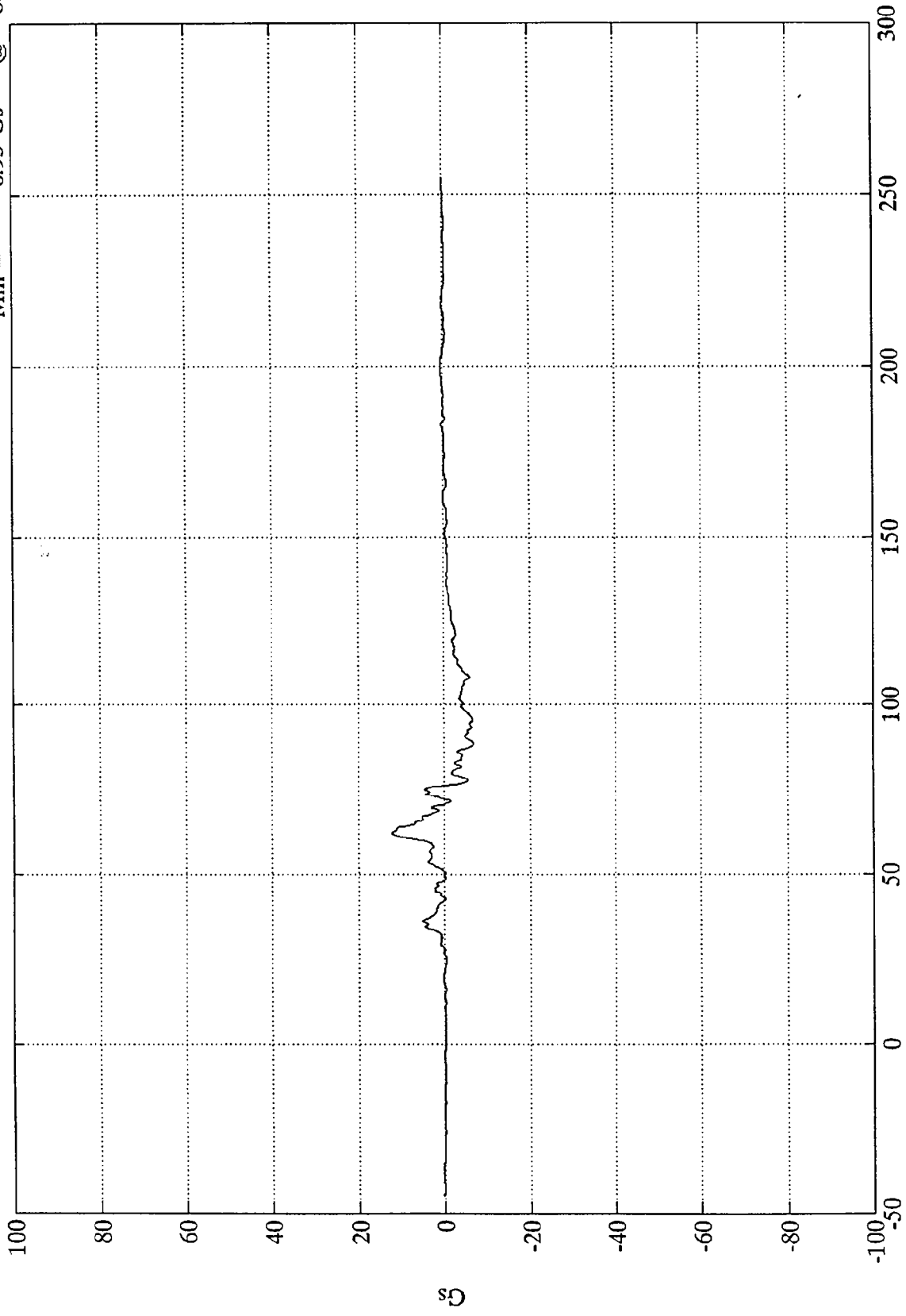

Time (msec)

SAE Filter Class 180

Max = 8.65 Gs @ 75.12 msec  
Min = -4.63 Gs @ 109.92 msec

Pos. 2 Chest Z

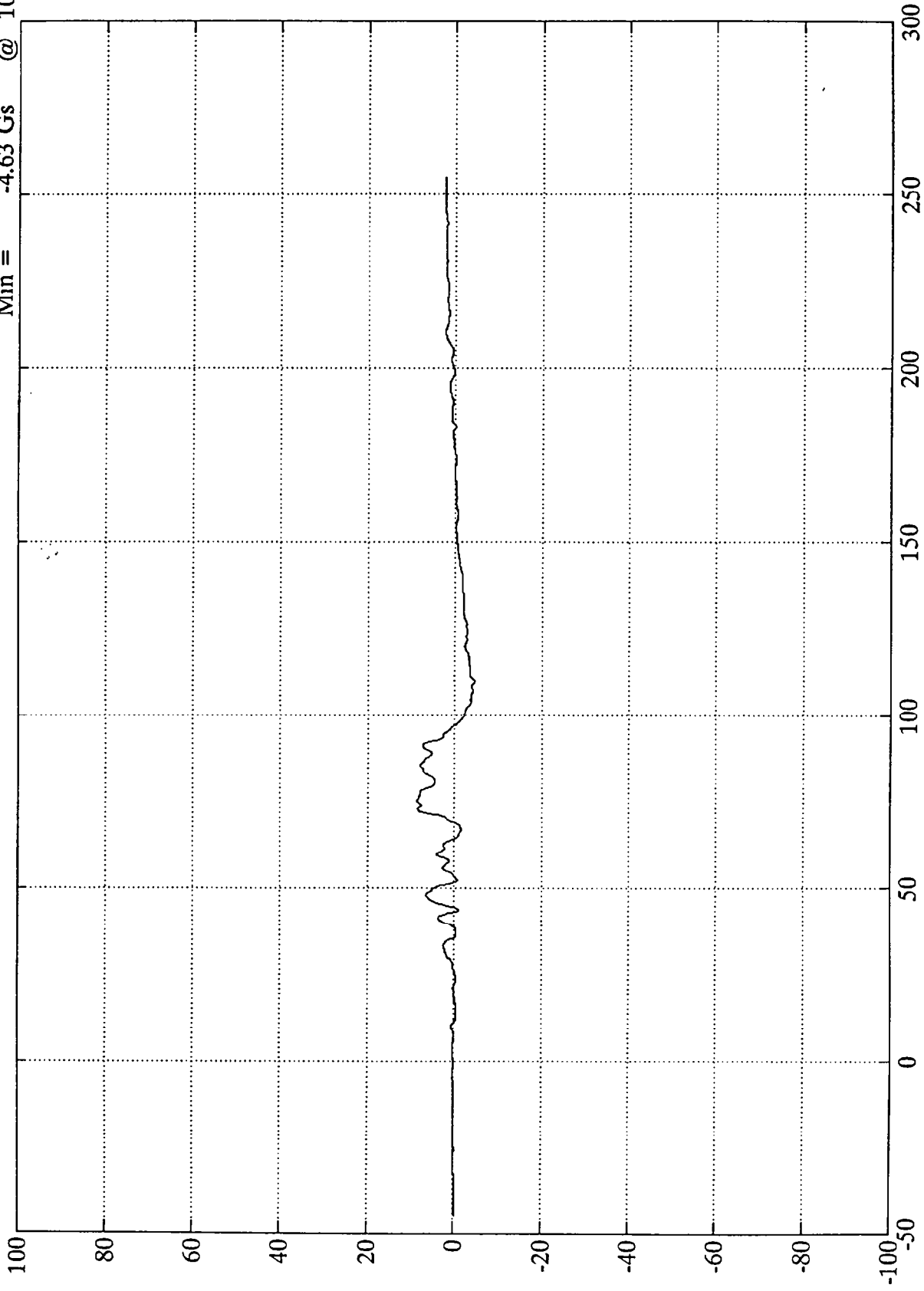

80  
B-98

8120-4

Time (msec)

SAE Filter Class 180

NCAP TEST #4 - 1994 MAZDA 626 DX

Pos. 2 Chest Resultant

Max = 46.91 Gs @ 63.84 msec  
Min = .03 Gs @ -27.60 msec

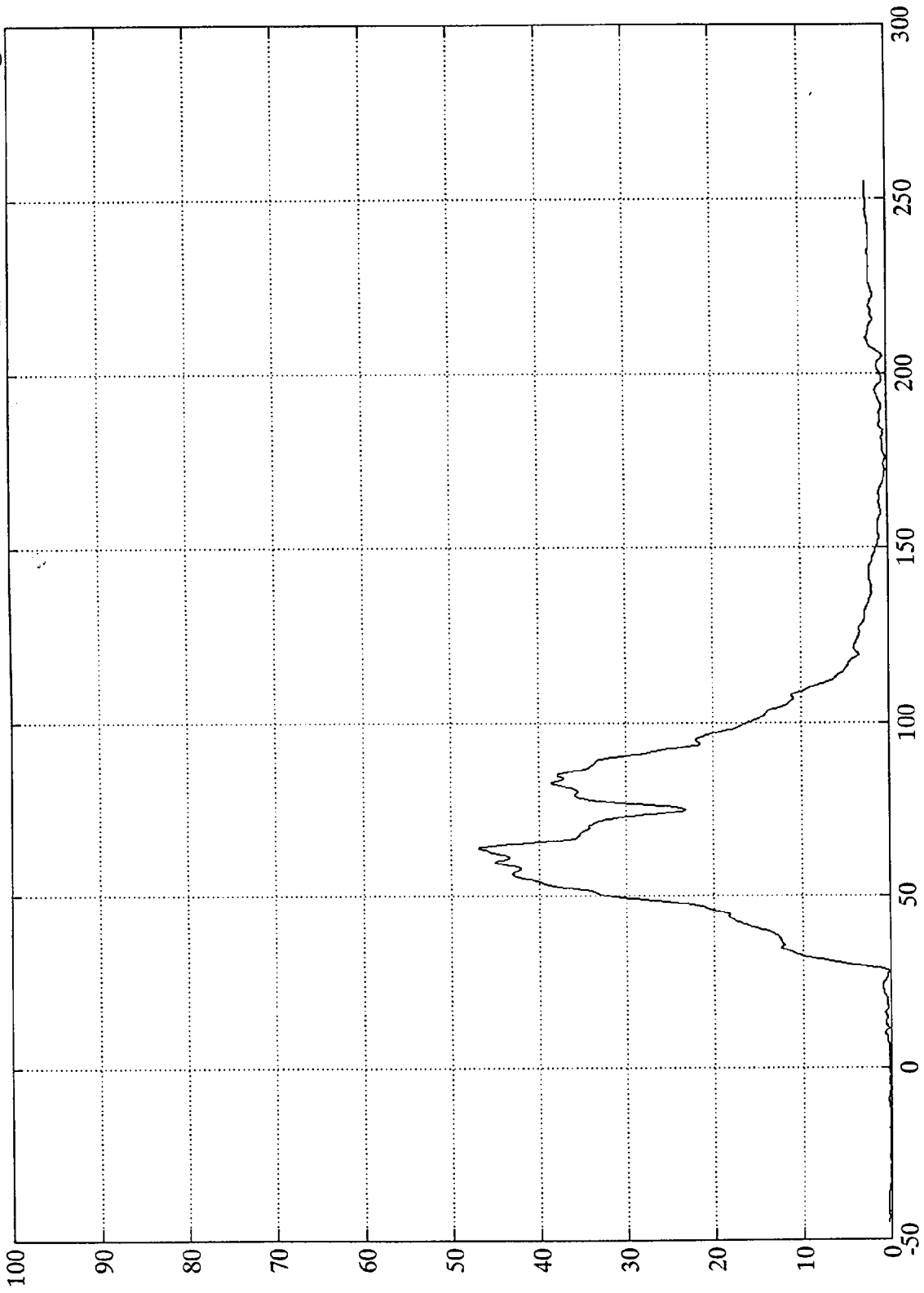

Time (msec)

SAE Filter Class 180

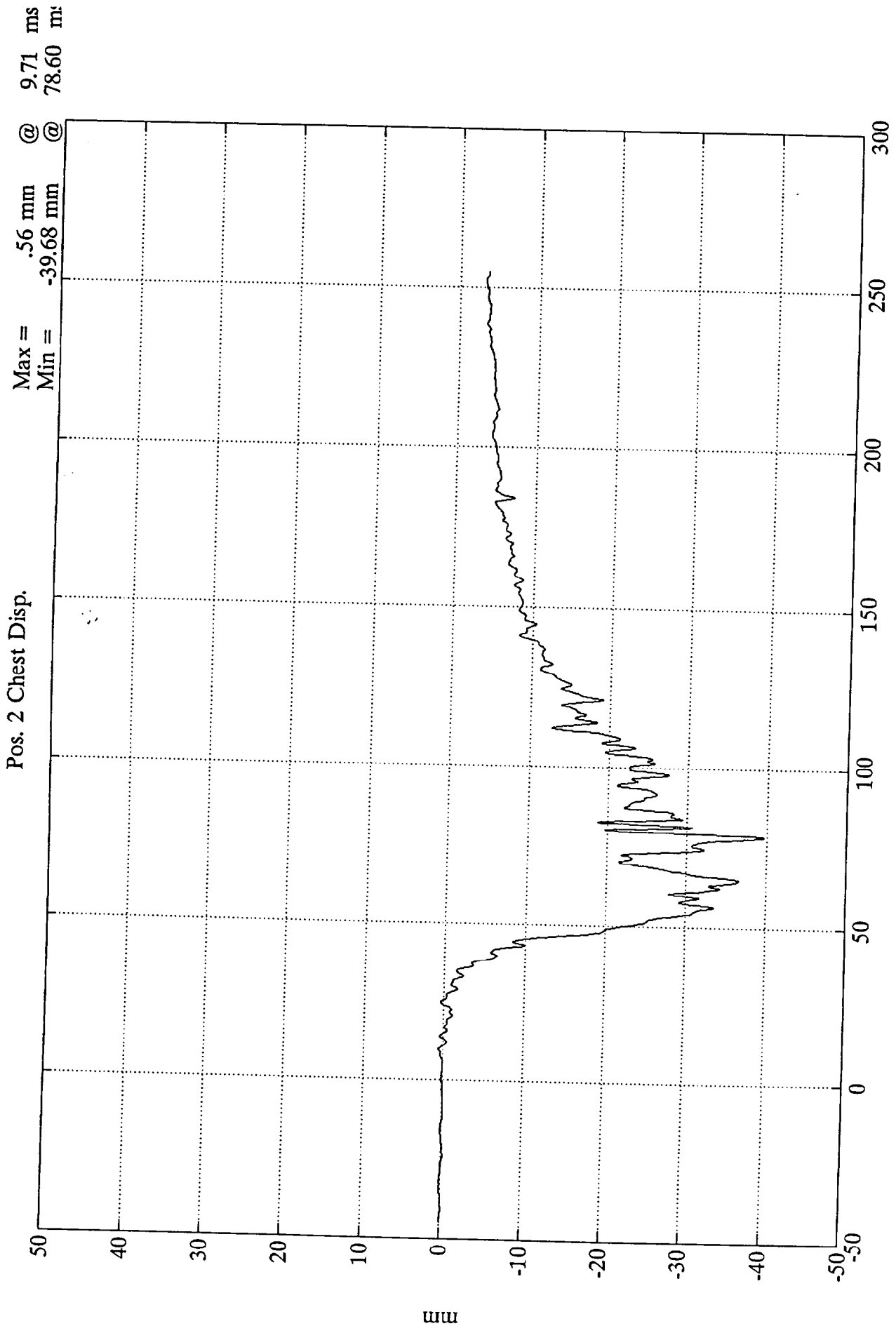

mm  
B-100

SAE Filter Class 180

NCAP TEST #4 - 1994 MAZDA 626 DX

Max = 132.60 Nwt @ 40.19 msec  
Min = -5474.26 Nwt @ 49.07 msec

Pos. 2 Left Femur

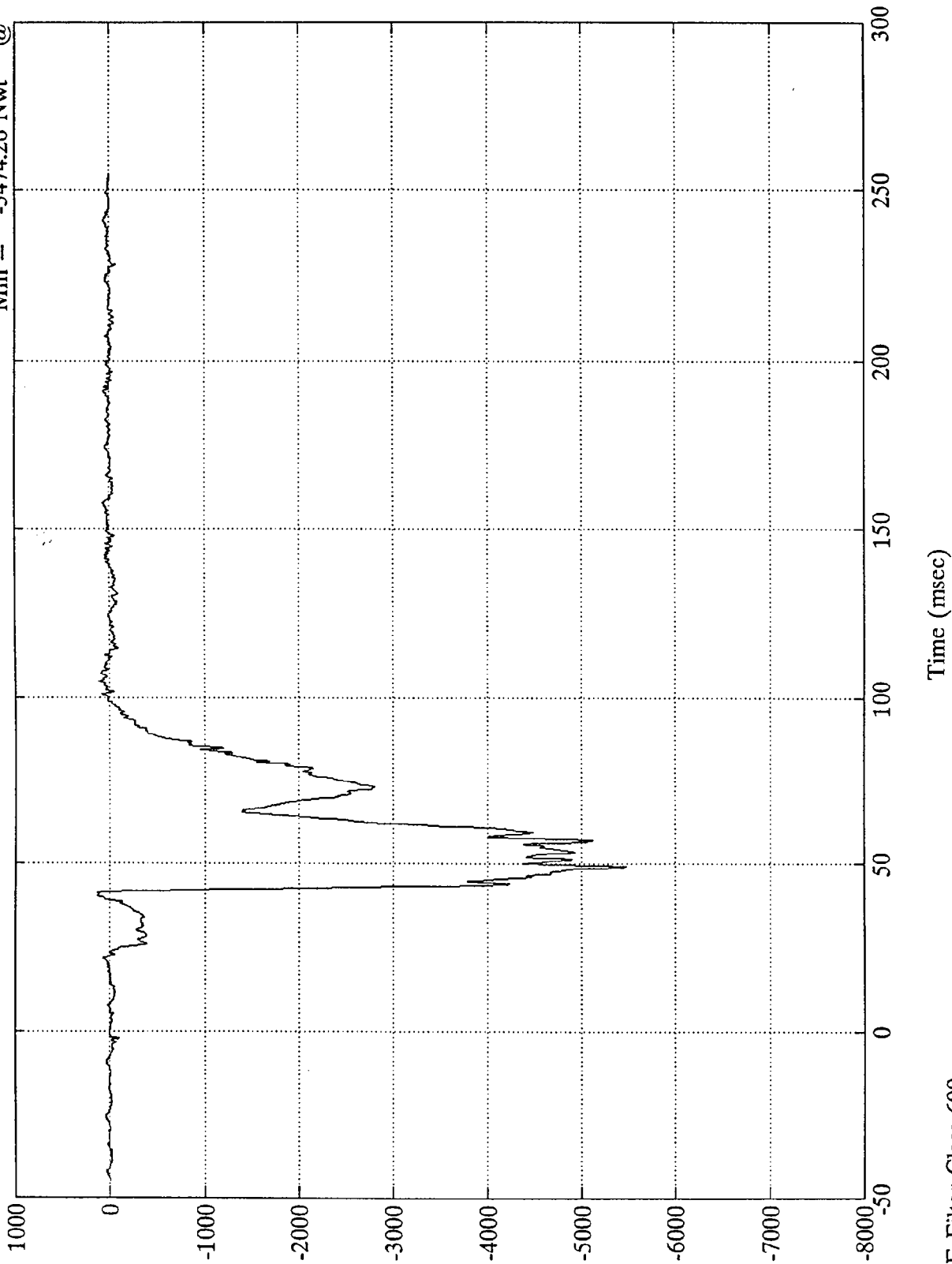

SAE Filter Class 600

1N  
B-101

8120-4

Max = 268.12 Nwt @ 144.48 ms  
Min = -6360.66 Nwt @ 52.79 ms

Pos. 2 Right Femur

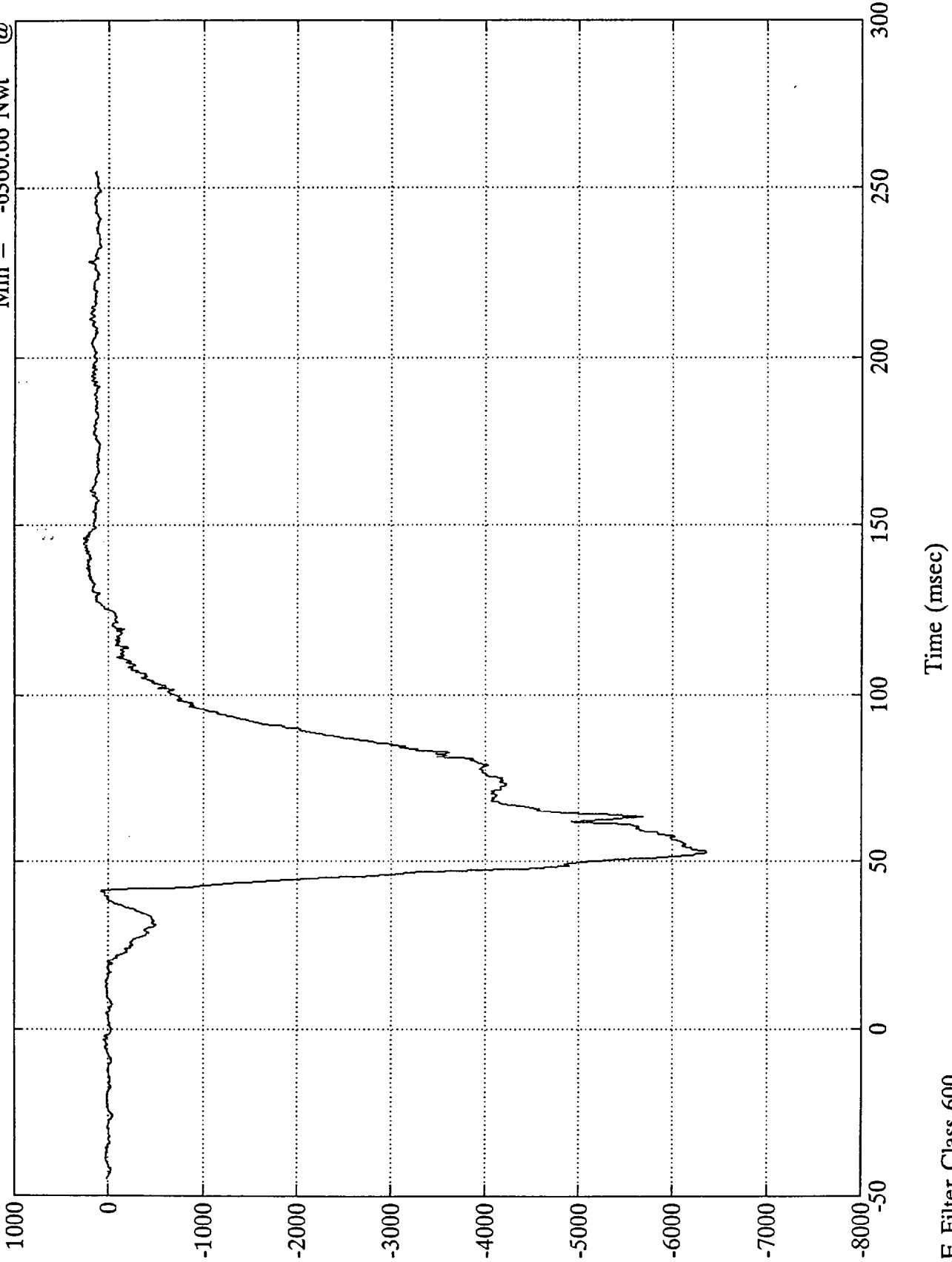

1wN  
B-102

8120-4

SAE Filter Class 600

NCAP TEST #4 - 1994 MAZDA 626 DX

Pos. 2 Upper Neck Fx

Max = 689.22 Nwt @ 135.72 msec  
Min = -412.42 Nwt @ 32.40 msec

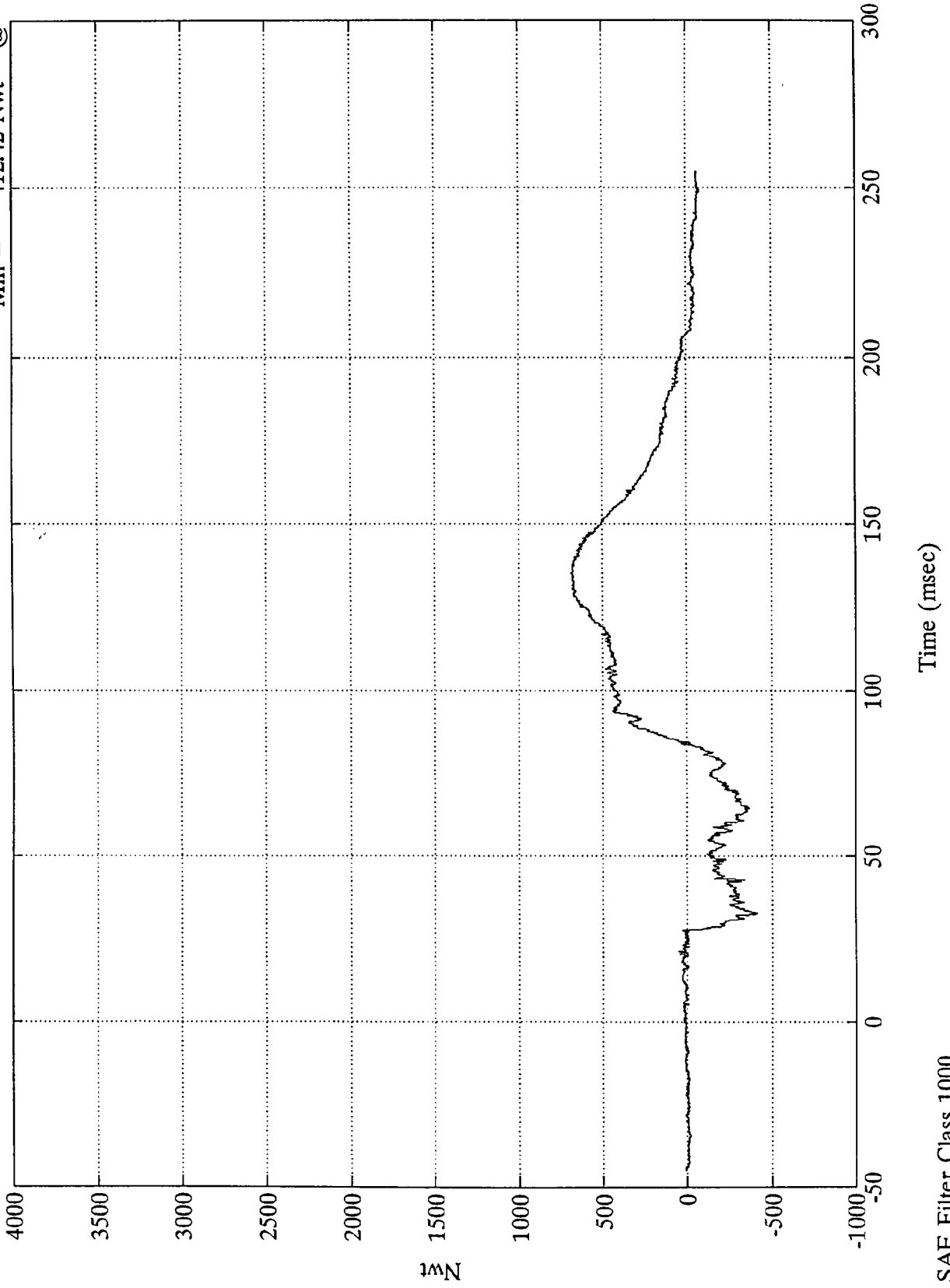

B-103

8120-4

SAE Filter Class 1000



Pos. 2 Upper Neck Fy

Max =  
Min =

82.38 Nwt  
-318.08 Nwt

@ @

94.91 msec  
63.00 msec

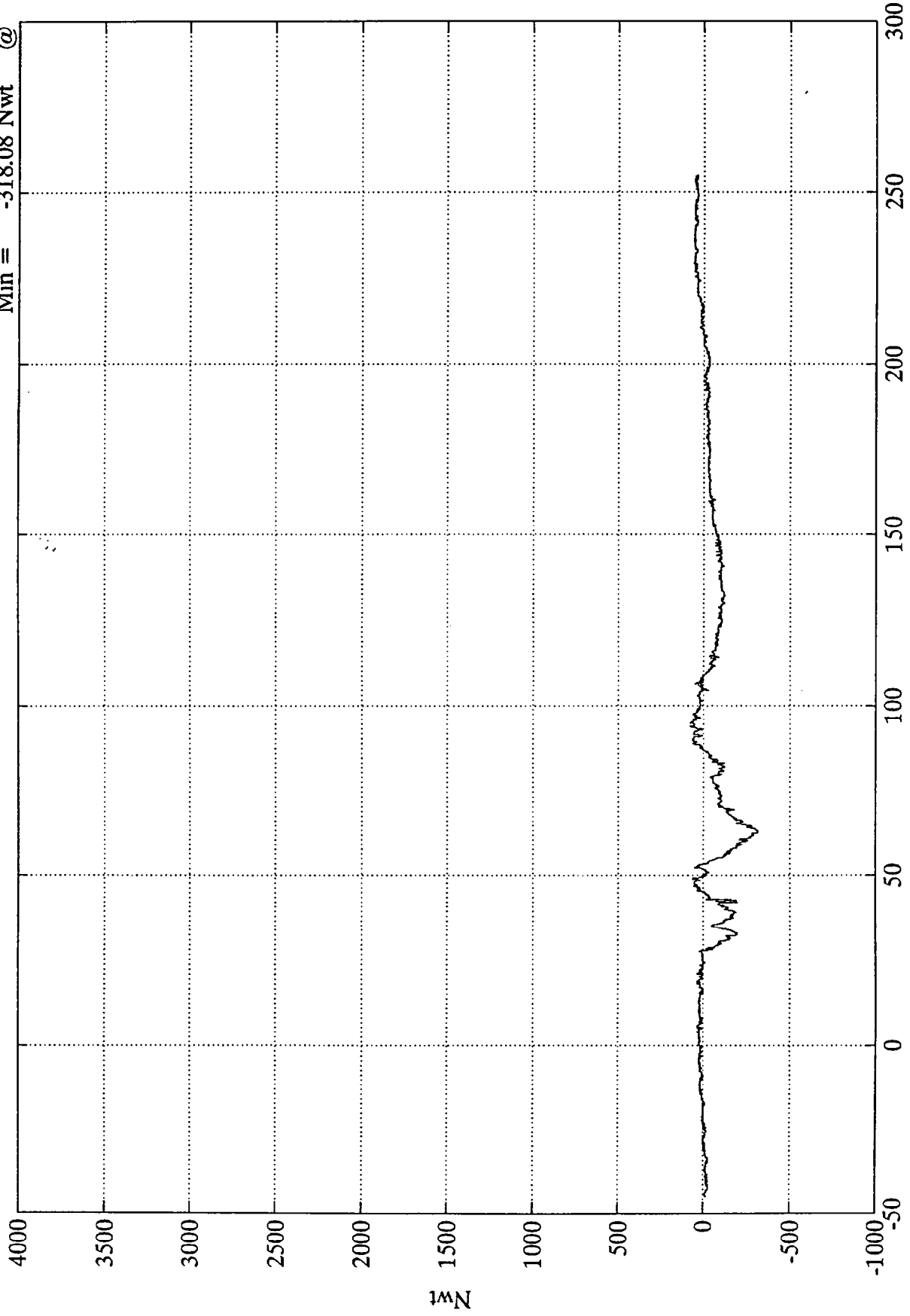

1kN  
B-104

8120-4

SAE Filter Class 1000

Time (msec)

NCAP TEST #4 - 1994 MAZDA 626 DX

Pos. 2 Upper Neck Fz

Max = 1093.63 Nwt @ 88.44 msec  
Min = -618.78 Nwt @ 32.76 msec

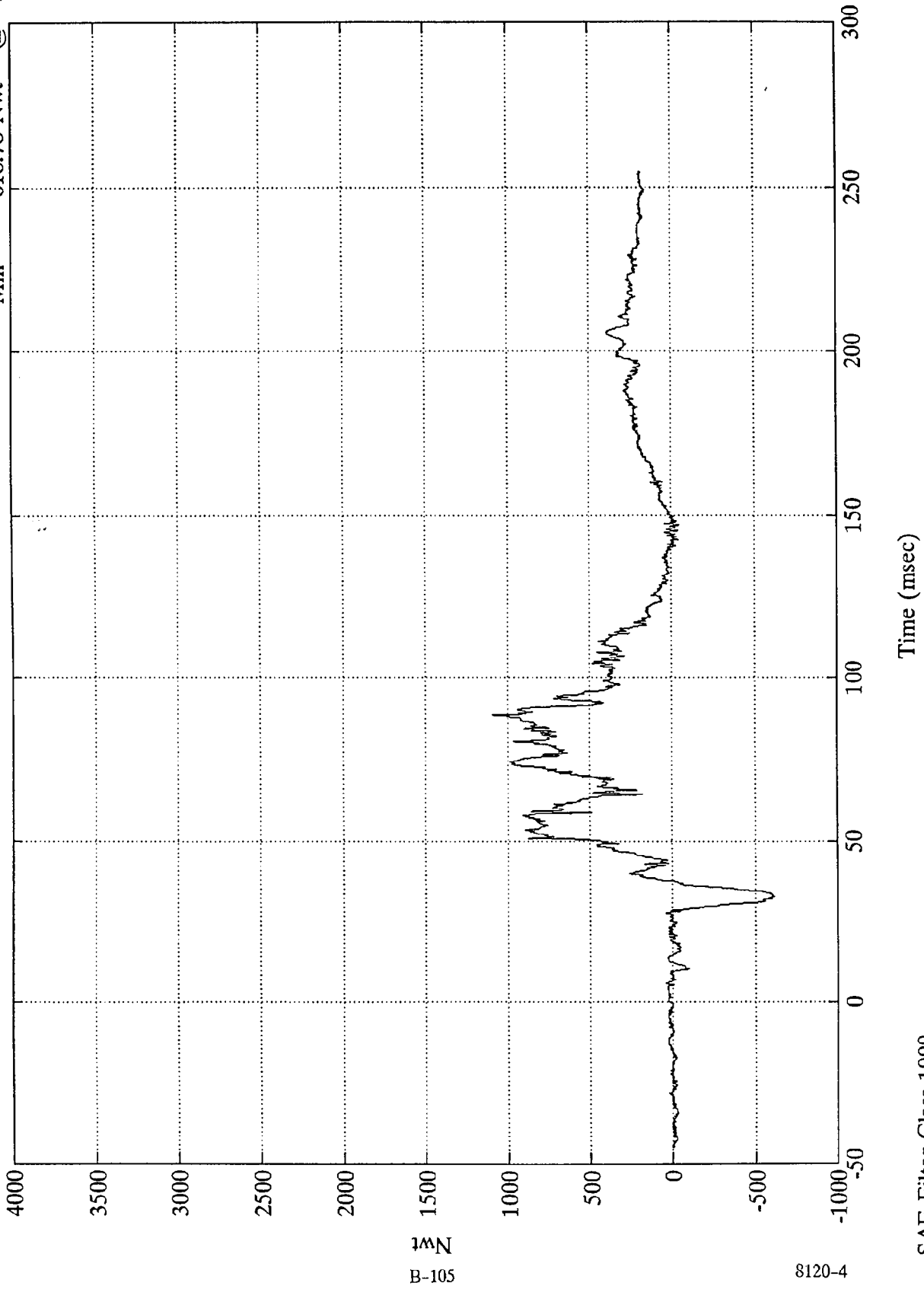

B-105

8120-4

SAE Filter Class 1000

Time (msec)

Pos. 2 Upper Neck Mx

Max = 13.36 Nwt-M @ 49.43 m:  
Min = -30.78 Nwt-M @ 63.11 ms

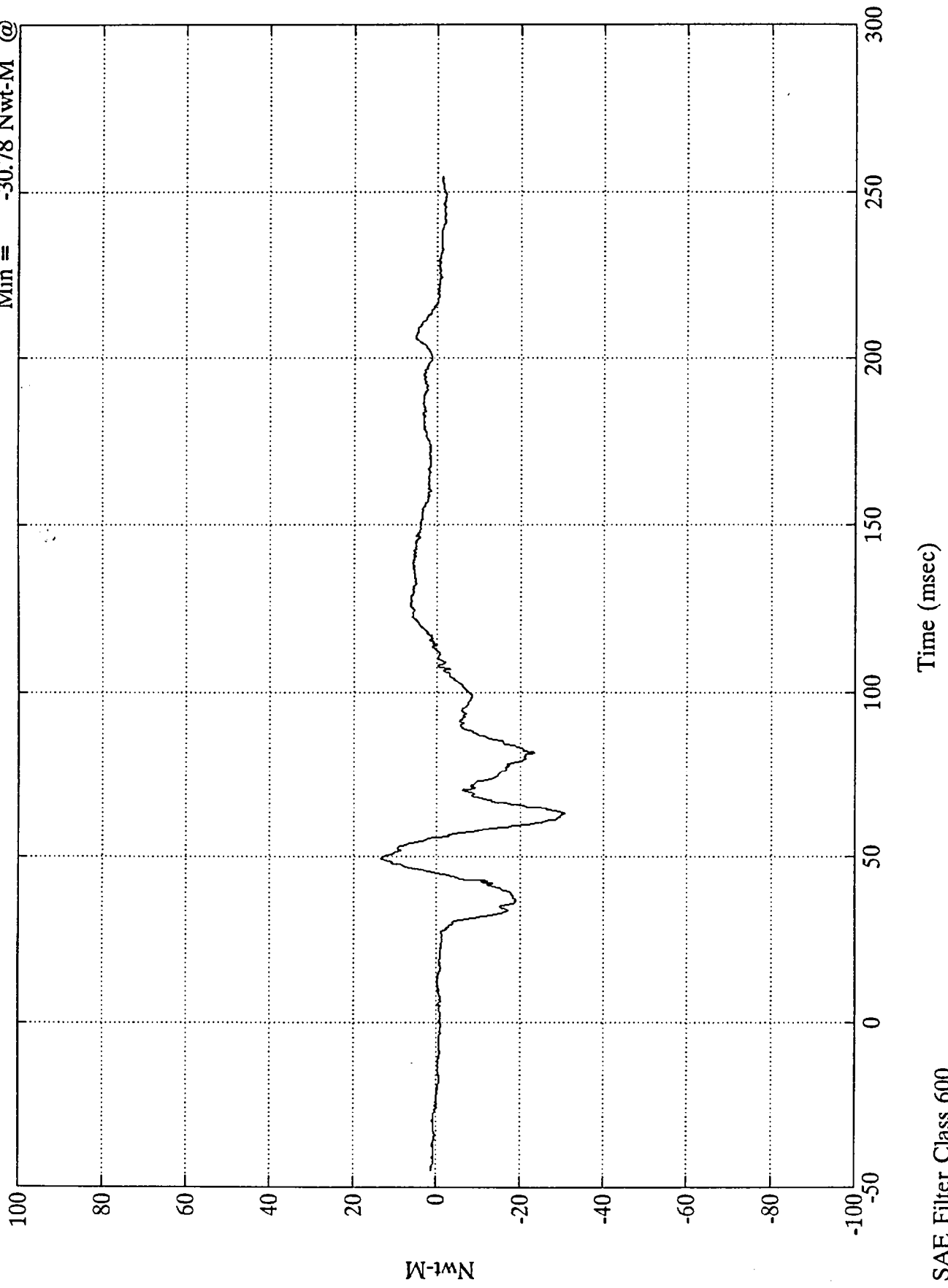

B-106

8120-4

SAE Filter Class 600

NCAP TEST #4 - 1994 MAZDA 626 DX

Pos. 2 Upper Neck My

Max = 49.54 Nwt-M @ 138.00 msec  
Min = -27.06 Nwt-M @ 93.72 msec

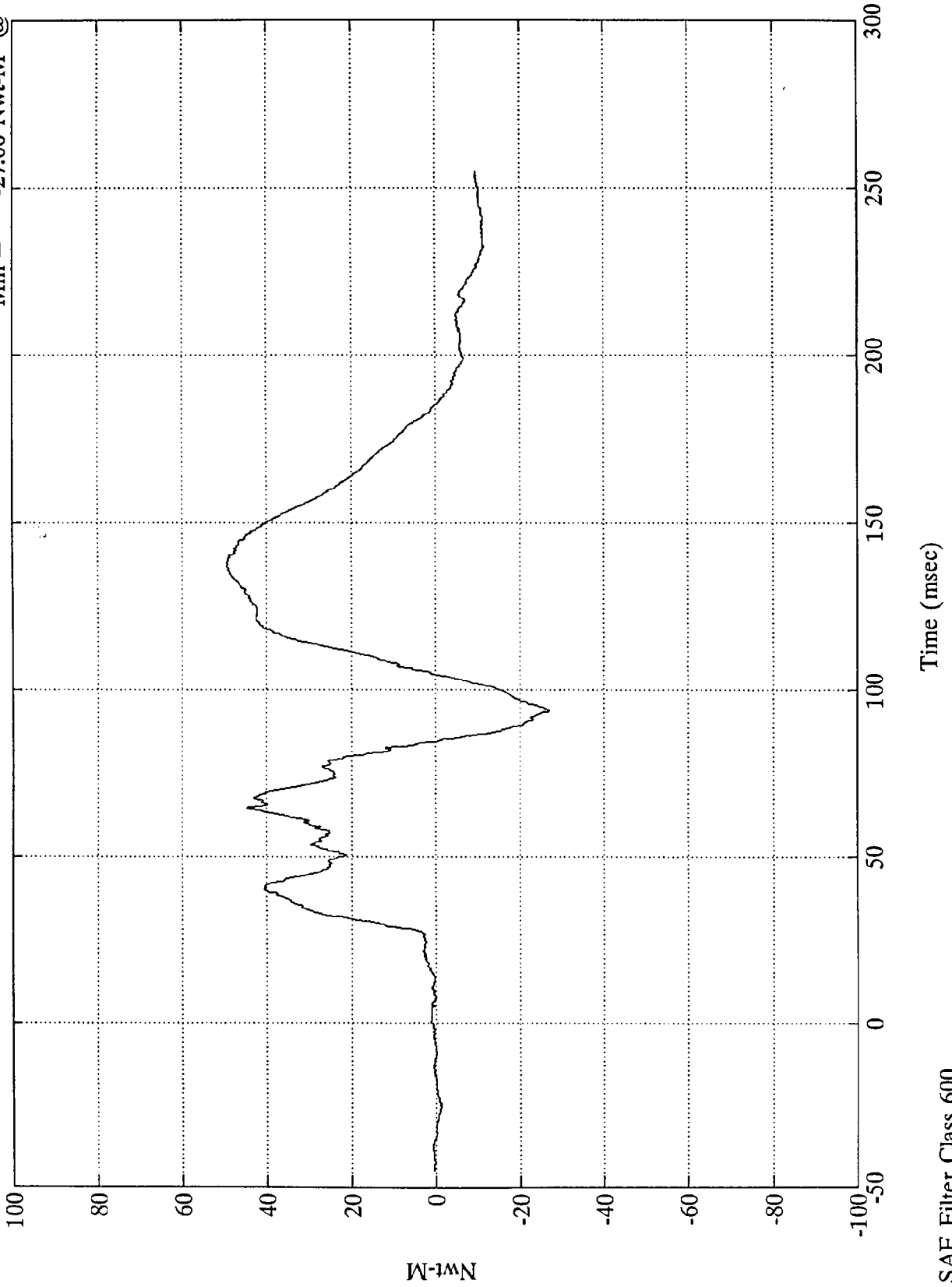

B-107

8120-4

SAE Filter Class 600



Pos. 2 Upper Neck Mz

Max = 11.96 Nwt-M @ 102.36 m  
Min = -15.45 Nwt-M @ 46.20 ms

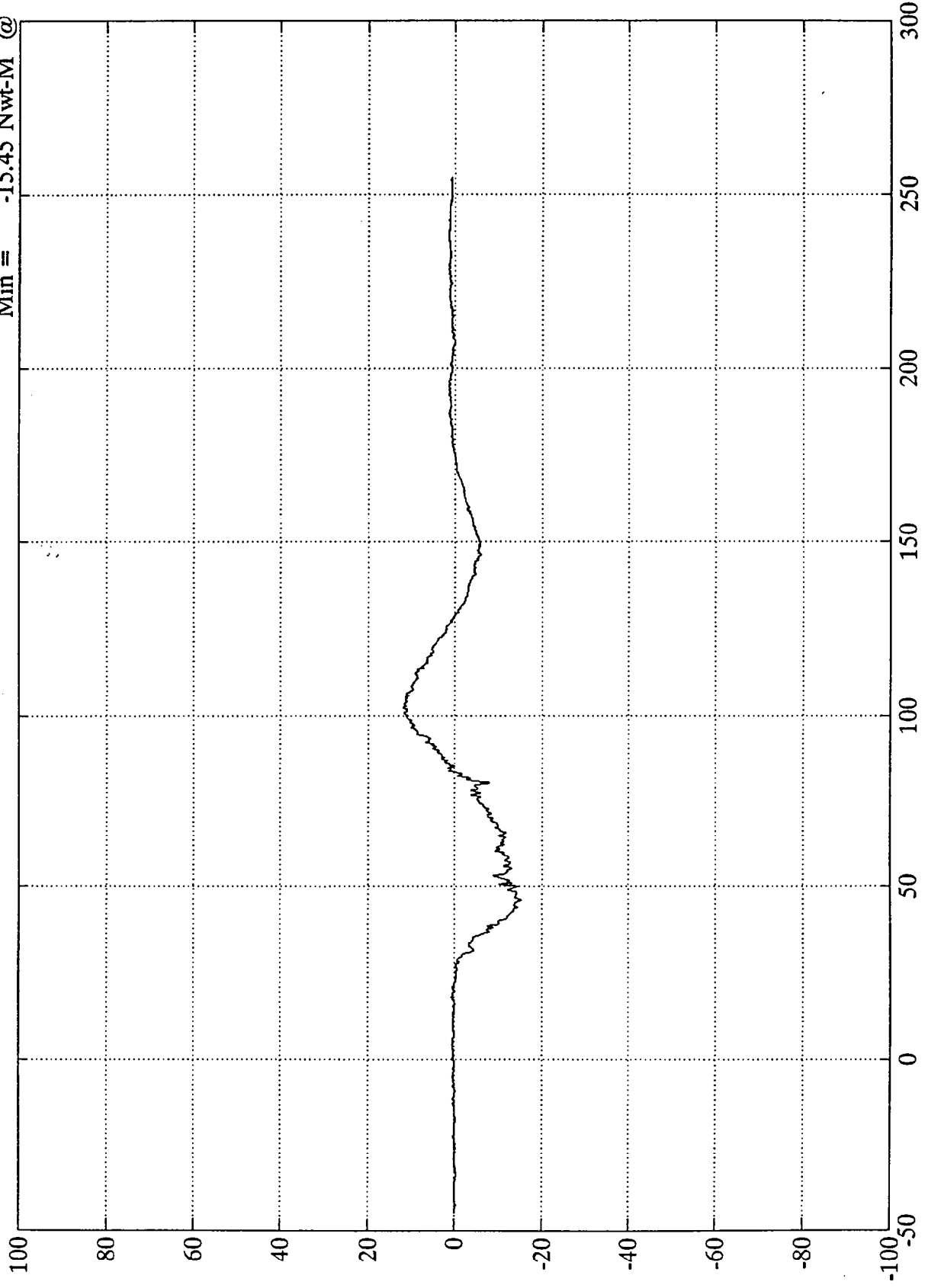

Time (msec)

SAE Filter Class 600

Pos. 2 Belt Elongation

Max = 2.62 mm @ 60.12 msec  
Min = -0.03 mm @ -31.08 msec

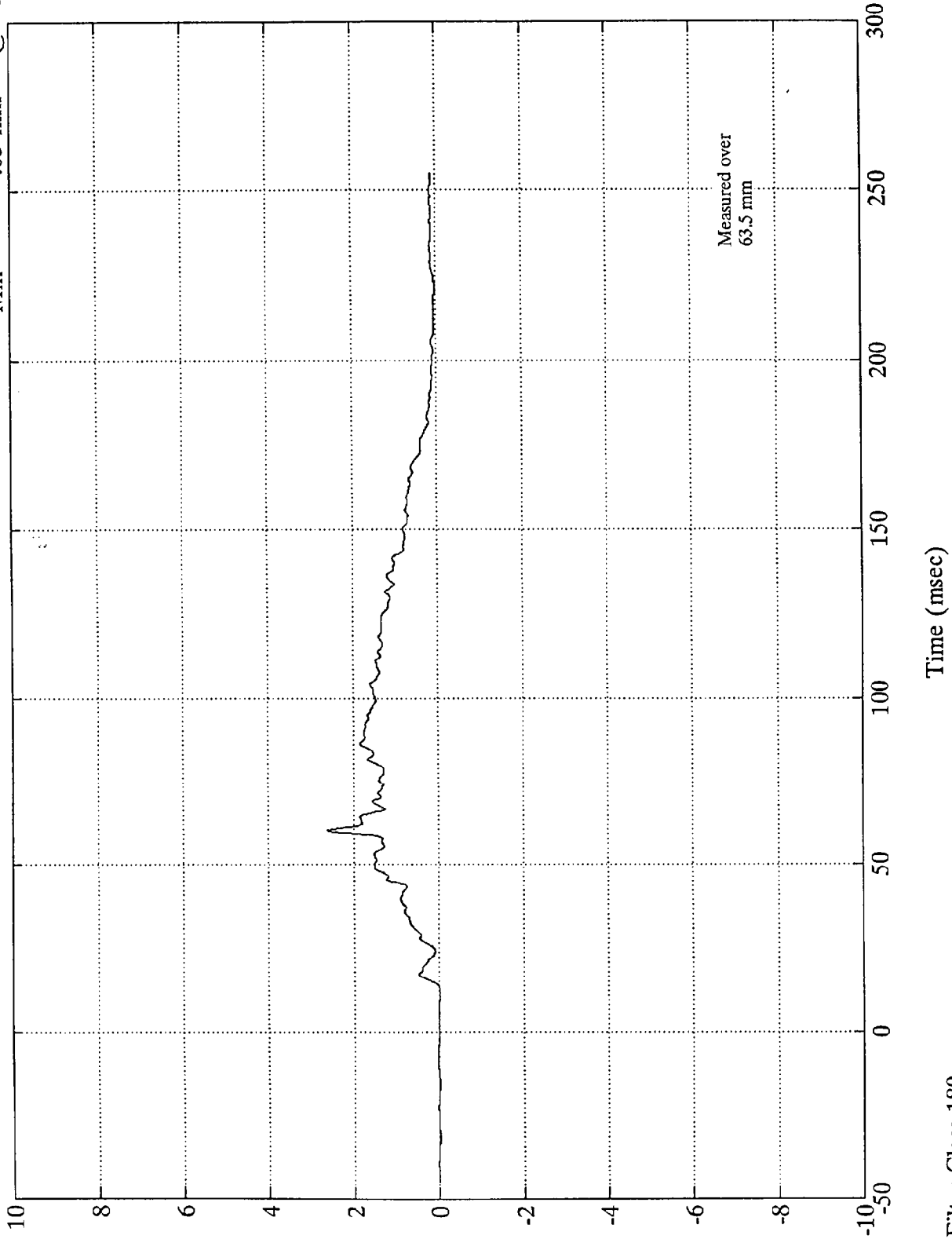

Pos. 2 Right Belt Load

Max = 2933.24 Nwt @ 74.04 ms  
Min = -19.69 Nwt @ -7.80 msec

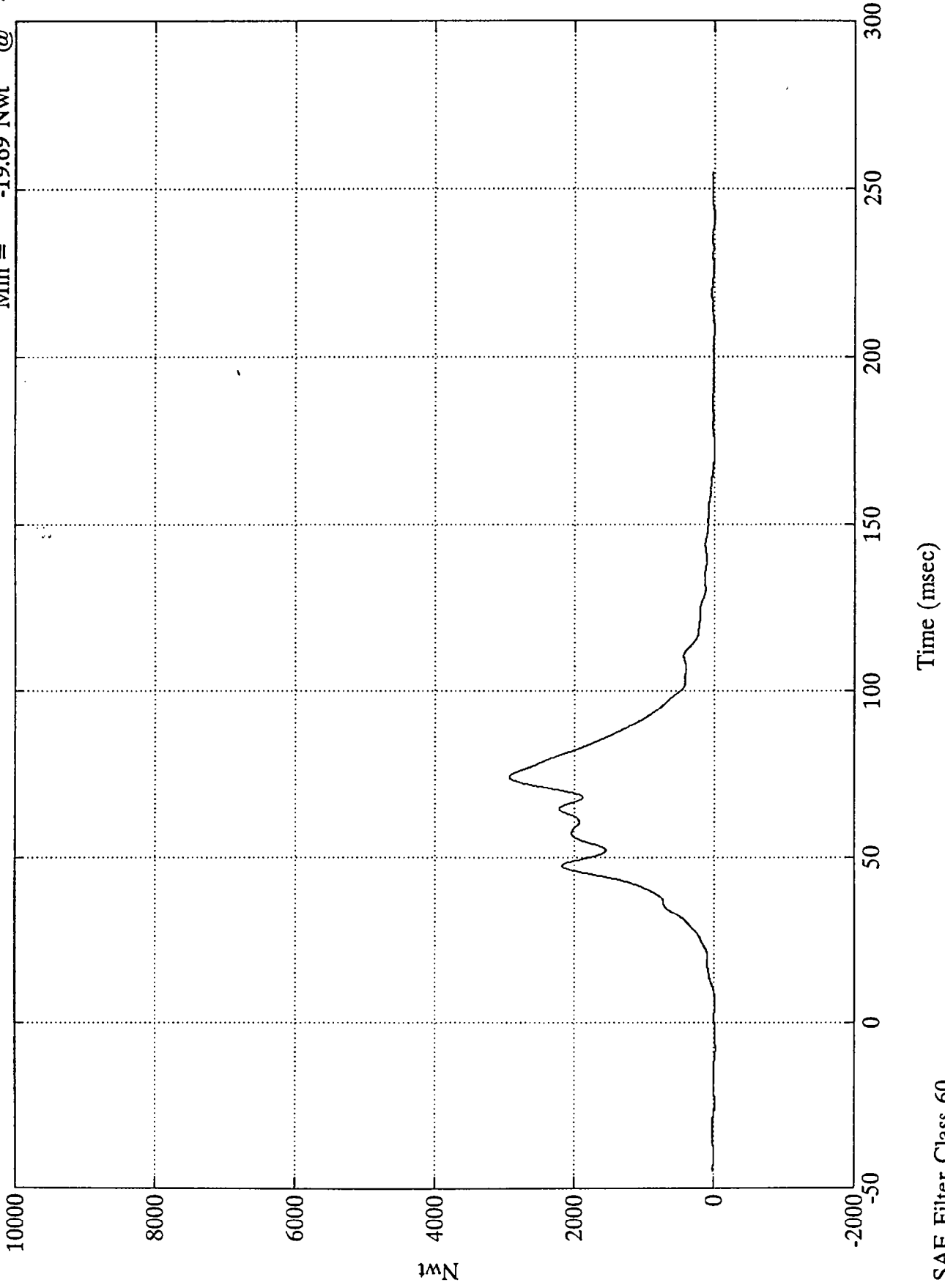

NCAP TEST #4 - 1994 MAZDA 626 DX

Pos. 2 Torso Belt Load

Max = 7488.08 Nwt @ 69.83 msec  
Min = -153.97 Nwt @ 23.28 msec

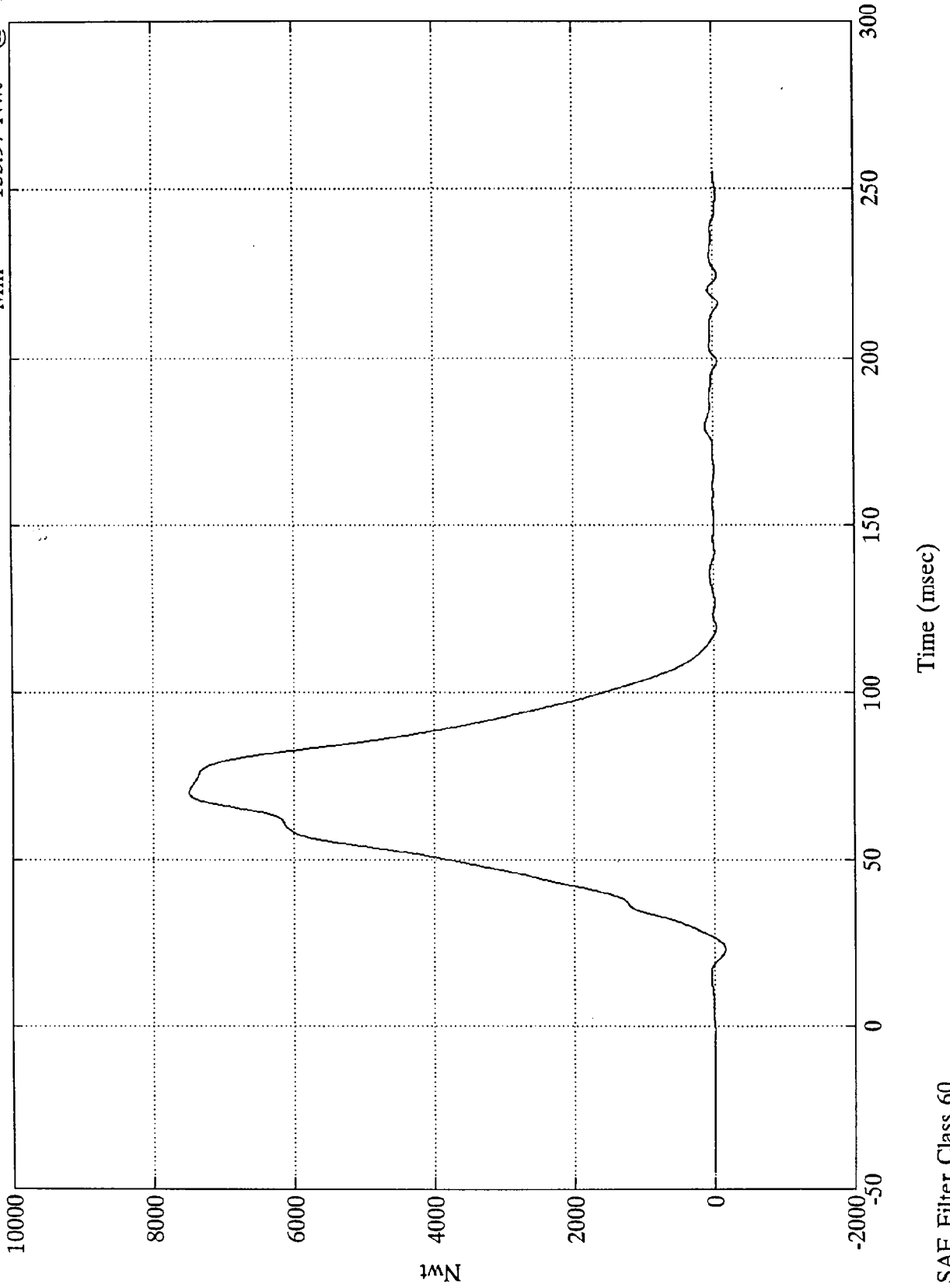

Appendix C  
PART 572B/E DUMMY CONFIGURATION  
AND PERFORMANCE VERIFICATION DATA SHEETS

Appendix C contains the results from certification tests performed on the 50th percentile male anthropomorphic test devices utilized for this crash test. The results indicate that the dummies meet all of the performance requirements of the six standard tests as specified in 49 CFR Part 572, Federal Register, Volume 42, No. 25, dated February 7, 1977.

The tests were conducted at the Dummy Certification Test Facility of Calspan Corporation, Advanced Technology Center. A summary of the test results, and Part 572 specifications are included in this Appendix.

Dummy serial numbers and certification dates are:

<u>Serial No.</u>	<u>Completion Date</u>
45	9/25/93
150	11/02/93

#### Electronic Test Equipment

The complement of signal conditioning, recording and display equipment, in conjunction with dummy certification testing, can be found in New Car Assessment and Standards Indicant Testing Final Report No. 6525-V-1.

Figure 10

DUMMY CONFIGURATION DIMENSIONS

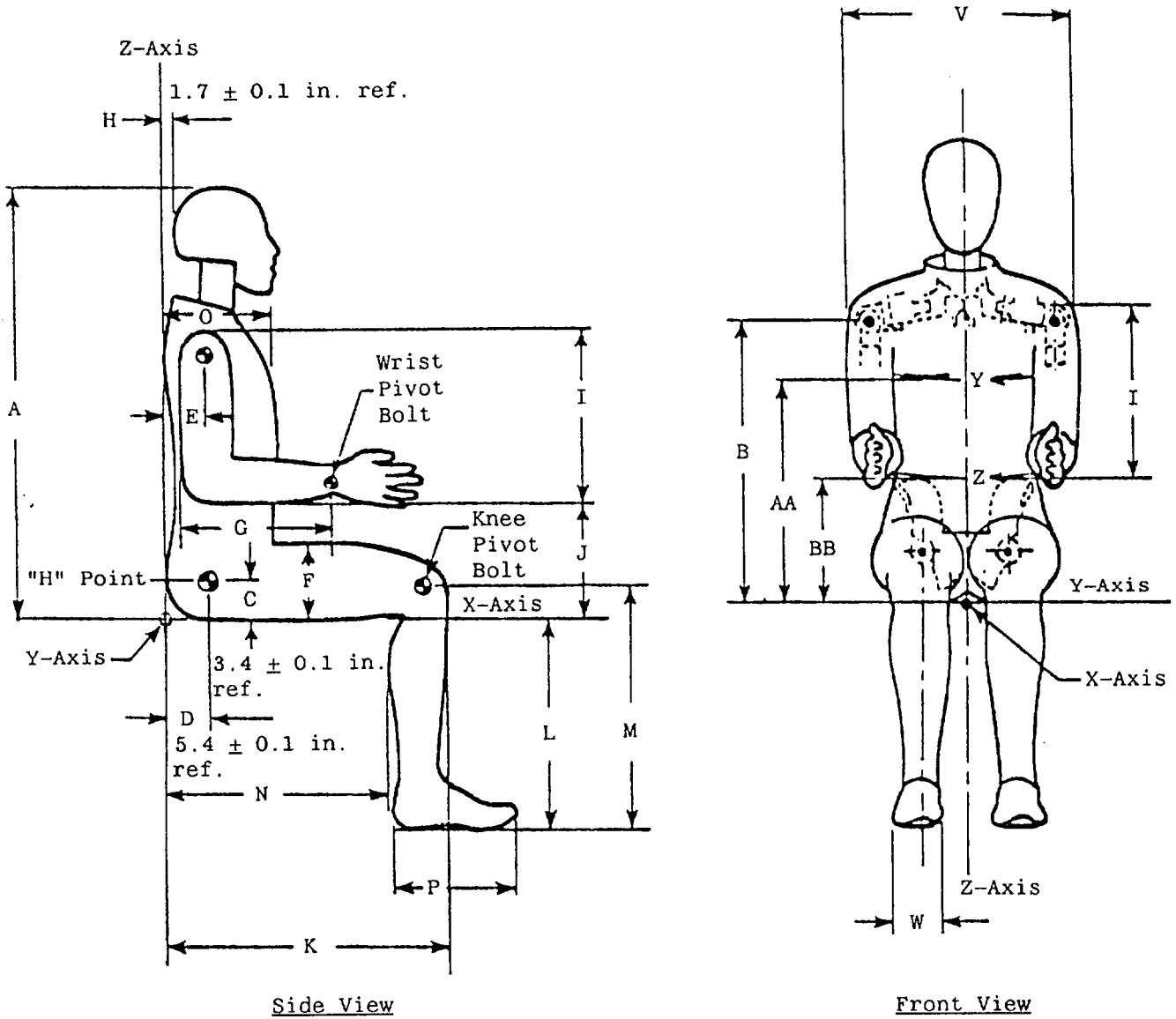

Note: Figure is referenced to the erect seated position. The curved lumbar does not allow the Hybrid III to be positioned in a perfect erect attitude.

HYBRID III EXTERNAL DIMENSIONS

S/N 45 HUMANOID

DUMMY SERIAL NO. 45

DATE: 9/25/93

TEMPERATURE		20.5 DEG. C
RELATIVE HUMIDITY		51 %
LOCATION FOR CHEST CIRCUMFERENCE (AA)	429-434 mm	432 mm
LOCATION FOR WAIST CIRCUMFERENCE (BB)	226-231 mm	228 mm
CHEST CIRCUMFERENCE (Y)	970-1001 mm	1000 mm
WAIST CIRCUMFERENCE (Z)	815-866 mm	866 mm
CHEST DEPTH (O)	213-229 mm	213 mm
H-POINT HEIGHT (C)	84-89 mm	89 mm
H-POINT FROM SEAT BACK (D)	135-140 mm	137 mm
SKULL CAP TO BACKLINE (H)	41-46 mm	43 mm
TOTAL SITTING HEIGHT (A)	879-889 mm	879 mm
THIGH CLEARANCE (F)	140-155 mm	147 mm
BUTTOCK KNEE LENGTH (K)	580-605 mm	602 mm
BUTTOCK POPLITAL LENGTH (N)	452-477 mm	475 mm
POPLITEAL LENGTH (L)	430-455 mm	447 mm
KNEE PIVOT HEIGHT (M)	485-501 mm	487 mm
FOOT LENGTH (P)	252-267 mm	259 mm
FOOT BREADTH (W)	91-107 mm	101 mm
SHOULDER PIVOT FROM BACKLINE (E)	84-94 mm	94 mm
SHOULDER BREADTH (V)	422-437 mm	426 mm
SHOULDER PIVOT HEIGHT (B)	505-521 mm	510 mm
ELBOW REST HEIGHT (J)	190-211 mm	195 mm
SHOULDER-ELBOW LENGTH (I)	330-345 mm	337 mm
BACK OF ELBOW TO WRIST PIVOT (G)	290-305 mm	292 mm

DUMMY MEETS SPECIFICATIONS

TECHNICIAN: IVAN MINKEWICZ

CALSPAN CORPORATION  
TRANSPORTATION RESEARCH DEPARTMENT  
HEAD DROP TEST  
HYBRID III

DATE : 9/9/93

CALSPAN SEQUENTIAL NUMBER 1

HY3 SN: 45 HEAD DROP CAL

TEST PARAMETER	SPECIFICATION	TEST RESULTS
TEMPERATURE	20 - 25 DEG. C	20.5 DEG. C
RELATIVE HUMIDITY	10% - 70%	51 %
PEAK RESULTANT ACCELERATION	225 - 275 G'S	231.3 G'S
PEAK LATERAL ACCELERATION	15 G'S MAX	10.6 G'S
IS ACCELERATION CURVE UNIMODAL?	YES	YES

DUMMY COMPONENT MEETS SPECIFICATIONS

TECHNICIAN IVAN MINKEWICZ

CALSPAN CORPORATION  
 TRANSPORTATION RESEARCH DEPARTMENT  
NECK FLEXION TEST

HYBRID III

DATE : 9/24/93

6 AXIS NECK TRANSDUCER

CALSPAN SEQUENTIAL NUMBER 1

HY3 SN: 45 CAL NECK FLEXION

TEST PARAMETER		SPECIFICATION	TEST RESULTS
TEMPERATURE		20.5-22.2 DEG. C	21 DEG. C
RELATIVE HUMIDITY		10% - 70%	45 %
IMPACT VELOCITY		24.8 - 25.7 KPH	24.9 KPH
PENDULUM DECELERATION	10 MS	22.50 - 27.50 G'S	26.03 G'S
	20 MS	17.60 - 22.60 G'S	22.51 G'S
	30 MS	12.50 - 18.50 G'S	17.08 G'S
MAX PENDULUM G'S ABOVE 30 MS		29 G'S MAX	17.08 G'S
DECELERATION -TIME CURVE DECAY TIME TO 5 G'S		34 - 42 MS	37.13 MS
D PLANE ROTATION	MAX	64 - 78 DEG.	72.93 DEG.
	TIME	57 - 64 MS	57.88 MS
MOMENT ABOUT OCCIPITAL CONDYLE	MAX	88 - 108 N-M	102.74 N-M
	TIME	47 - 58 MS	50.5 MS
ROTATION ANGLE-TIME CURVE DECAY TIME TO ZERO		113 - 128 MS	119.75 MS
POSITIVE MOMENT-TIME CURVE DECAY TIME TO ZERO		97 - 107 MS	99.38 MS

DUMMY COMPONENT MEETS SPECIFICATIONS

TECHNICIAN IVAN MINKEWICZ

CALSPAN CORPORATION  
 TRANSPORTATION RESEARCH DEPARTMENT  
NECK EXTENSION TEST

HYBRID III

DATE : 9/24/93

6 AXIS NECK TRANSDUCER

CALSPAN SEQUENTIAL NUMBER 1

HY3 SN: 45 CAL NECK EXTENSION

TEST PARAMETER		SPECIFICATION	TEST RESULTS
TEMPERATURE		20.5 - 22.2 DEG. C	20.5 DEG. C
RELATIVE HUMIDITY		10% - 70%	50 %
IMPACT VELOCITY		21.4 - 22.3 KPH	22.0 KPH
PENDULUM DECELERATION	10 MS	17.20 - 21.20 G'S	17.71 G'S
	20 MS	14.00 - 19.00 G'S	16.78 G'S
	30 MS	11.00 - 16.00 G'S	15.0 G'S
MAX PENDULUM G'S ABOVE 30 MS		22 G'S MAX	18.15 G'S
DECELERATION -TIME CURVE DECAY TIME TO 5 G'S		38 - 46 MS	45.38 MS
D PLANE ROTATION	MAX	81 - 106 DEG.	90.83 DEG.
	TIME	72 - 82 MS	78 MS
MOMENT ABOUT OCCIPITAL CONDYLE	MAX	-80.0/-52.9 N-M	-66.47 N-M
	TIME	65 - 79 MS	70.63 MS
ROTATION ANGLE-TIME CURVE DECAY TIME TO ZERO		147 - 174 MS	158.5 MS
POSITIVE MOMENT-TIME CURVE DECAY TIME TO ZERO		120 - 148 MS	130.75 MS

DUMMY COMPONENT MEETS SPECIFICATIONS

TECHNICIAN IVAN MINKEWICZ

CALSPAN CORPORATION  
TRANSPORTATION RESEARCH DEPARTMENT  
THORAX IMPACT TEST  
HYBRID III

DATE : 9/9/93

CALSPAN SEQUENTIAL NUMBER 1

HY3 SN 45

H.S. THORAX

CAL

TEST PARAMETER	HIGH SPEED TEST	TEST RESULTS
	SPECIFICATION	
TEMPERATURE	20.5 - 22.2 DEG. C	20.5 DEG. C
RELATIVE HUMIDITY	10% - 70%	48 %
PENDULUM VELOCITY	23.7 - 24.6 KPH	23.7 KPH
MAXIMUM DEFLECTION	64 - 73 mm	64.3 mm
MAXIMUM RESISTIVE FORCE	4804 - 5538 NEWTONS	5431 NEWTONS
INTERNAL HYSTERESIS	69% - 85%	72.2 %

DUMMY COMPONENT MEETS SPECIFICATIONS

TECHNICIAN IVAN MINKEWICZ

CALSPAN CORPORATION  
TRANSPORTATION RESEARCH DEPARTMENT

KNEE IMPACT TEST

HYBRID III

DATE : 9/9/93

KNEE: LEFT

CALSPAN SEQUENTIAL NUMBER 1

HY3 SN: 45 KNEE 4.9 KGS CAL

TEST PARAMETER	SPECIFICATION	TEST RESULTS
TEMPERATURE	20 - 25 DEG. C	20.5 DEG. C
RELATIVE HUMIDITY	10% - 70%	50 %
PROBE VELOCITY	7.5 - 7.7 KPH	7.68 KPH
PEAK KNEE IMPACT FORCE	4430 - 6965 N	4786 N
PROBE WEIGHT	4.9 KGS	

DUMMY COMPONENT MEETS SPECIFICATIONS

TECHNICIAN IVAN MINKEWICZ

CALSPAN CORPORATION  
TRANSPORTATION RESEARCH DEPARTMENT

KNEE IMPACT TEST

HYBRID III

DATE : 9/9/93

KNEE: RIGHT

CALSPAN SEQUENTIAL NUMBER 1

HY3 SN: 45 KNEE 4.9 KGS CAL

TEST PARAMETER	SPECIFICATION	TEST RESULTS
TEMPERATURE	20 - 25 DEG. C	20.5 DEG. C
RELATIVE HUMIDITY	10% - 70%	50 %
PROBE VELOCITY	7.5 - 7.7 KPH	7.68 KPH
PEAK KNEE IMPACT FORCE	4430 - 6965 N	4781 N
PROBE WEIGHT	4.9 KGS	

DUMMY COMPONENT MEETS SPECIFICATIONS

TECHNICIAN IVAN MINKEWICZ

INSTRUMENT CALIBRATION INFORMATION

NHTSA DUMMY I.D. NUMBER: 45

A. DUMMY INSTRUMENTS

	MFG	SERIAL NUMBER	DATE LAST CALIBRATED	DATE OF NEXT CALIBRATION
1. HEAD ACCELEROMETER				
HX LONGITUDINAL	ENDEVCO	ADMB8	9/93	3/94
HY LATERAL	ENDEVCO	ADL44	9/93	3/94
HZ VERTICAL	ENDEVCO	AC2J3	9/93	3/94
2. CHEST ACCELEROMETER				
CX LONGITUDINAL	ENDEVCO	ADMB6	9/93	3/94
CY LATERAL	ENDEVCO	AC209	9/93	3/94
CZ VERTICAL	ENDEVCO	ADL98	9/93	3/94
3. FEMUR LOAD CELLS				
LEFT SIDE	GSE	951	11/93	5/94
RIGHT SIDE	GSE	952	11/93	5/94

B. CALIBRATION LABORATORY INSTRUMENTS

	MFG	SERIAL NUMBER	DATE LAST CALIBRATED	DATE OF NEXT CALIBRATION
1. PENDULUM ACC.	CEC	A160	6/93	12/93
2. TEST PROBE ACCELEROMETER	CEC	A161	6/93	12/93

HYBRID III EXTERNAL DIMENSIONS

S/N 150 HUMANOID

DUMMY SERIAL NO. 150

DATE: 11/2/93

TEMPERATURE		20.5 DEG. C
RELATIVE HUMIDITY		36 %
LOCATION FOR CHEST CIRCUMFERENCE (AA)	429-434 mm	431 mm
LOCATION FOR WAIST CIRCUMFERENCE (BB)	226-231 mm	228 mm
CHEST CIRCUMFERENCE (Y)	970-1001 mm	998 mm
WAIST CIRCUMFERENCE (Z)	815-866 mm	863 mm
CHEST DEPTH (O)	213-229 mm	213 mm
H-POINT HEIGHT (C)	84-89 mm	88 mm
H-POINT FROM SEAT BACK (D)	135-140 mm	137 mm
SKULL CAP TO BACKLINE (H)	41-46 mm	43 mm
TOTAL SITTING HEIGHT (A)	879-889 mm	881 mm
THIGH CLEARANCE (F)	140-155 mm	142 mm
BUTTOCK KNEE LENGTH (K)	580-605 mm	591 mm
BUTTOCK POPLITAL LENGTH (N)	452-477 mm	470 mm
POPLITEAL LENGTH (L)	430-455 mm	452 mm
KNEE PIVOT HEIGHT (M)	485-501 mm	500 mm
FOOT LENGTH (P)	252-267 mm	259 mm
FOOT BREADTH (W)	91-107 mm	96 mm
SHOULDER PIVOT FROM BACKLINE (E)	84-94 mm	94 mm
SHOULDER BREADTH (V)	422-437 mm	429 mm
SHOULDER PIVOT HEIGHT (B)	505-521 mm	513 mm
ELBOW REST HEIGHT (J)	190-211 mm	208 mm
SHOULDER-ELBOW LENGTH (I)	330-345 mm	337 mm
BACK OF ELBOW TO WRIST PIVOT (G)	290-305 mm	292 mm

DUMMY MEETS SPECIFICATIONS

TECHNICIAN: IVAN MINKEWICZ

CALSPAN CORPORATION  
TRANSPORTATION RESEARCH DEPARTMENT

HEAD DROP TEST

HYBRID III

DATE : 9/23/93

CALSPAN SEQUENTIAL NUMBER 2

HY3 SN: 150 HEAD DROP CAL

TEST PARAMETER	SPECIFICATION	TEST RESULTS
TEMPERATURE	20 - 25 DEG. C	20.5 DEG. C
RELATIVE HUMIDITY	10% - 70%	53 %
PEAK RESULTANT ACCELERATION	225 - 275 G'S	254.9 G'S
PEAK LATERAL ACCELERATION	15 G'S MAX	9.8 G'S
IS ACCELERATION CURVE UNIMODAL?	YES	YES

DUMMY COMPONENT MEETS SPECIFICATIONS

TECHNICIAN IVAN MINKEWICZ

CALSPAN CORPORATION  
TRANSPORTATION RESEARCH DEPARTMENT

NECK FLEXION TEST

HYBRID III

DATE : 11/2/93

6 AXIS NECK TRANSDUCER

CALSPAN SEQUENTIAL NUMBER 2

HY3 SN:150 CAL NECK FLEXION

TEST PARAMETER		SPECIFICATION	TEST RESULTS
TEMPERATURE		20.5-22.2 DEG. C	20.5 DEG. C
RELATIVE HUMIDITY		10% - 70%	35 %
IMPACT VELOCITY		24.8 - 25.7 KPH	25 KPH
PENDULUM DECELERATION	10 MS	22.50 - 27.50 G'S	25.77 G'S
	20 MS	17.60 - 22.60 G'S	20.83 G'S
	30 MS	12.50 - 18.50 G'S	16.96 G'S
MAX PENDULUM G'S ABOVE 30 MS		29 G'S MAX	16.96 G'S
DECELERATION -TIME CURVE DECAY TIME TO 5 G'S		34 - 42 MS	40.25 MS
D PLANE ROTATION	MAX	64 - 78 DEG.	70.12 DEG.
	TIME	57 - 64 MS	60.5 MS
MOMENT ABOUT OCCIPITAL CONDYLE	MAX	88 - 108 N-M	103.2 N-M
	TIME	47 - 58 MS	53.25 MS
ROTATION ANGLE-TIME CURVE DECAY TIME TO ZERO		113 - 128 MS	120.38 MS
POSITIVE MOMENT-TIME CURVE DECAY TIME TO ZERO		97 - 107 MS	97.88 MS

DUMMY COMPONENT MEETS SPECIFICATIONS

TECHNICIAN IVAN MINKEWICZ

CALSPAN CORPORATION  
 TRANSPORTATION RESEARCH DEPARTMENT  
NECK EXTENSION TEST  
 HYBRID III

DATE : 11/2/93

6 AXIS NECK TRANSDUCER

CALSPAN SEQUENTIAL NUMBER 2

HY3 SN:150 CAL NECK EXTENSION

TEST PARAMETER		SPECIFICATION	TEST RESULTS
TEMPERATURE		20.5 - 22.2 DEG. C	20.5 DEG. C
RELATIVE HUMIDITY		10% - 70%	34 %
IMPACT VELOCITY		21.4 - 22.3 KPH	22.16 KPH
PENDULUM DECELERATION	10 MS	17.20 - 21.20 G'S	18.13 G'S
	20 MS	14.00 - 19.00 G'S	16.66 G'S
	30 MS	11.00 - 16.00 G'S	13.99 G'S
MAX PENDULUM G'S ABOVE 30 MS		22 G'S MAX	15.53 G'S
DECELERATION -TIME CURVE DECAY TIME TO 5 G'S		38 - 46 MS	46 MS
D PLANE ROTATION	MAX	81 - 106 DEG.	92.25 DEG.
	TIME	72 - 82 MS	74.88 MS
MOMENT ABOUT OCCIPITAL CONDYLE	MAX	-80.0/-52.9 N-M	-79.78 N-M
	TIME	65 - 79 MS	69.38 MS
ROTATION ANGLE-TIME CURVE DECAY TIME TO ZERO		147 - 174 MS	152.5 MS
POSITIVE MOMENT-TIME CURVE DECAY TIME TO ZERO		120 - 148 MS	128 MS

DUMMY COMPONENT MEETS SPECIFICATIONS

TECHNICIAN IVAN MINKEWICZ

CALSPAN CORPORATION  
TRANSPORTATION RESEARCH DEPARTMENT  
THORAX IMPACT TEST  
HYBRID III

DATE : 9/22/93

CALSPAN SEQUENTIAL NUMBER 2

HY3 SN 150 H.S. THORAX CAL

TEST PARAMETER	HIGH SPEED TEST	TEST RESULTS
	SPECIFICATION	
TEMPERATURE	20.5 - 22.2 DEG. C	21 DEG. C
RELATIVE HUMIDITY	10% - 70%	50 %
PENDULUM VELOCITY	23.7 - 24.6 KPH	23.7 KPH
MAXIMUM DEFLECTION	64 - 73 mm	65.5 mm
MAXIMUM RESISTIVE FORCE	4804 - 5538 NEWTONS	5471 NEWTONS
INTERNAL HYSTERESIS	69% - 85%	75.1 %

DUMMY COMPONENT MEETS SPECIFICATIONS

TECHNICIAN IVAN MINKEWICZ

CALSPAN CORPORATION  
TRANSPORTATION RESEARCH DEPARTMENT

KNEE IMPACT TEST

HYBRID III

DATE : 10/21/93

KNEE: LEFT

CALSPAN SEQUENTIAL NUMBER 2

HY3 SN: 150 KNEE 4.9 KGS CAL

TEST PARAMETER	SPECIFICATION	TEST RESULTS
TEMPERATURE	20 - 25 DEG. C	21 DEG. C
RELATIVE HUMIDITY	10% - 70%	41 %
PROBE VELOCITY	7.5 - 7.7 KPH	7.68 KPH
PEAK KNEE IMPACT FORCE	4430 - 6965 N	4892 N
PROBE WEIGHT	4.9 KGS	

DUMMY COMPONENT MEETS SPECIFICATIONS

TECHNICIAN IVAN MINKEWICZ

CALSPAN CORPORATION  
TRANSPORTATION RESEARCH DEPARTMENT

KNEE IMPACT TEST

HYBRID III

DATE : 10/21/93

KNEE: RIGHT

CALSPAN SEQUENTIAL NUMBER 2

HY3 SN: 150 KNEE 4.9 KGS CAL

TEST PARAMETER	SPECIFICATION	TEST RESULTS
TEMPERATURE	20 - 25 DEG. C	21 DEG. C
RELATIVE HUMIDITY	10% - 70%	41 %
PROBE VELOCITY	7.5 - 7.7 KPH	7.68 KPH
PEAK KNEE IMPACT FORCE	4430 - 6965 N	5048 N
PROBE WEIGHT	4.9 KGS	

DUMMY COMPONENT MEETS SPECIFICATIONS

TECHNICIAN IVAN MINKEWICZ

INSTRUMENT CALIBRATION INFORMATION

NHTSA DUMMY I.D. NUMBER: 150

A. DUMMY INSTRUMENTS

	MFG	SERIAL NUMBER	DATE LAST CALIBRATED	DATE OF NEXT CALIBRATION
1. HEAD ACCELEROMETER				
HX LONGITUDINAL	ENDEVCO	A39J	9/93	3/94
HY LATERAL	ENDEVCO	A33F	9/93	3/94
HZ VERTICAL	ENDEVCO	A27F	9/93	3/94
2. CHEST ACCELEROMETER				
CX LONGITUDINAL	ENDEVCO	A12C	9/93	3/94
CY LATERAL	ENDEVCO	A60C	9/93	3/94
CZ VERTICAL	ENDEVCO	A84G	9/93	3/94
3. FEMUR LOAD CELLS				
LEFT SIDE	GSE	954	11/93	5/94
RIGHT SIDE	GSE	955	11/93	5/94

B. CALIBRATION LABORATORY INSTRUMENTS

	MFG	SERIAL NUMBER	DATE LAST CALIBRATED	DATE OF NEXT CALIBRATION
1. PENDULUM ACC.	CEC	A160	6/93	12/93
2. TEST PROBE ACCELEROMETER	CEC	A161	6/93	12/93

Appendix D

DUMMY, VEHICLE AND LABORATORY INSTRUMENT CALIBRATION

INSTRUMENT CALIBRATION FOR DRIVER DUMMY  
( 6 Month Calibration Minimum )

DRIVER DUMMY	Serial # 45	Manufacturer	Calibration	
			Last	Next
Head				
X	ADMB8	ENDEVCO	9/93	3/94
Y	ADL44	ENDEVCO	9/93	3/94
Z	AC2J3	ENDEVCO	9/93	3/94
Chest				
X	ADBM6	ENDEVCO	9/93	3/94
Y	AC209	ENDEVCO	9/93	3/94
Z	ADL98	ENDEVCO	9/93	3/94
Right Femur Load Cell	952	GSE	11/93	5/94
Left Femur Load Cell	951	GSE	11/93	5/94
Neck Load Cell				
X	269	DENTON	10/93	4/94
Y	269	DENTON	10/93	4/94
Z	269	DENTON	10/93	4/94
Neck Moment				
X	269	DENTON	10/93	4/94
Y	269	DENTON	10/93	4/94
Z	269	DENTON	10/93	4/94
Chest Deflection Gauge	45	HUMANOID		
Hybrid III Use Only				
Lap Belt Load Cells	706	LEBOW	11/93	5/94
Shoulder Belt Load Cells	707	LEBOW	11/93	5/94
Spool-Out Potentiometer	N/A	SERVONIC INST.	N/A	N/A
Belt Stretch Transducer	E2	CALSPAN	5/93	11/93

( 6 Month Calibration Minimum )

PASSENGER DUMMY	Serial # 150	Manufacturer	Calibration	
			Last	Next
Head	A39J	ENDEVCO	9/93	3/94
X				
Y	A33F	ENDEVCO	9/93	3/94
Z	A27F	ENDEVCO	9/93	3/94
Chest	A12C	ENDEVCO	9/93	3/94
X				
Y	A60C	ENDEVCO	9/93	3/94
Z	A84G	ENDEVCO	9/93	3/94
Right Femur Load Cell	955	GSE	11/93	5/94
Left Femur Load Cell	954	GSE	11/93	5/94
Neck Load Cell	076	DENTON	10/93	4/94
X				
Y	076	DENTON	10/93	4/94
Z	076	DENTON	10/93	4/94
Neck Moment	076	DENTON	10/93	4/94
X				
Y	076	DENTON	10/93	4/94
Z	076	DENTON	10/93	4/94
Chest Deflection Gauge	150	HUMANOID	8/93	2/94
Hybrid III Use Only				
Lap Belt Load Cells	710	LEBOW	11/93	5/94
Shoulder Belt Load Cells	711	LEBOW	11/93	5/94
Spool-Out Potentiometer	N/A	SERVONIC INST.	N/A	N/A
Belt Stretch Transducer	E3	CALSPAN	5/93	11/93

INSTRUMENT CALIBRATION FOR VEHICLE ACCELEROMETERS  
( 6 Month Calibration Minimum )

	Serial #	Manufacturer	Calibration	
			Last	Next
Left Seat Rear Crossmember	A150	CEC	9/93	3/94
Right Rear Seat Crossmember	A175	CEC	9/93	3/94
Top of Engine	A44	CEC	9/93	3/94
Bottom of Engine	A188	CEC	10/93	4/94
Left Disc Brake Caliper	A177	CEC	10/93	4/94
Right Disc Brake Caliper	A183	CEC	10/93	4/94
Instrument Panel	A148	CEC	10/93	4/94
Left Rear Crossmember (R)	A147	CEC	10/93	4/94
Right Rear Crossmember (R)	A73	CEC	9/93	3/94

VEHICLE OWNER'S MANUAL OCCUPANT RESTRAINT SYSTEM INSTRUCTIONS

### **⚠ WARNING**

***Folding Rear Seat Latch:***

*The folding rear seat cannot be unlatched from inside the trunk. If children playing with the folded seat backs should climb inside the trunk and close the backs, they would be locked in the trunk. Keep children away from folded seat backs.*

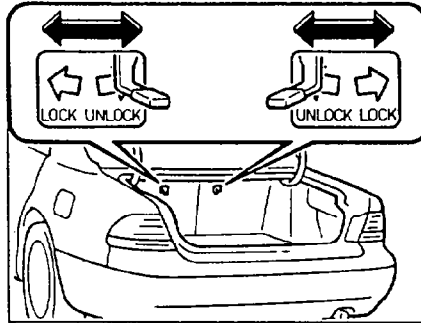

■ **Rear Seat Back Lock**

To lock or unlock a seat back, move the lever.

If you must leave your Mazda with another person, such as a parking attendant, protect valuables in the trunk by locking the rear seat backs and trunk. Give the other person only the secondary key, which does not open the trunk.

### **Seat Belt System**

Seat belts help decrease the possibility or severity of injury during accidents and sudden stops. Mazda recommends that the driver and passengers wear seat belts at all times. The front seats have a lap/shoulder belt. These belts have retractors with inertia locks that keep them out of the way when not in use. The locks allow the belts to remain comfortable on users, but they'll lock in position during a collision.

The rear seat has lap/shoulder belts that have retractors with inertia locks for the door-side seats and a lap belt with manual adjustment for the center seat.

**⚠ WARNING**

**Seat Belts:**

Passengers not wearing seat belts during a collision can be injured much worse than those wearing seat belts. They can hit things inside the vehicle or even be thrown from it. They can be seriously injured or killed. In the same collision, passengers wearing seat belts might be much safer.

**⚠ WARNING**

**Twisted Seat Belts:**

Twisted seat belts can cause injury. In a collision, the full width of the belt isn't available to absorb the impact. This puts more force on the bones beneath the belt, which could break them or cause other serious injury. Don't wear twisted seat belts.

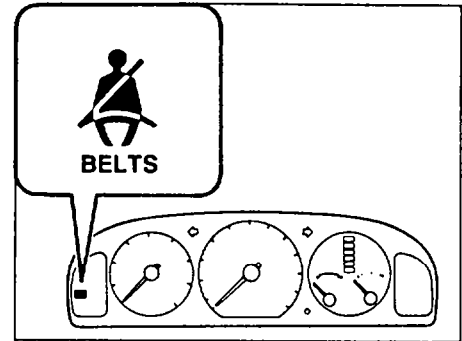

**■ Seat Belt Warning Light/Beep**

When you turn on the ignition before fastening your seat belt, a warning light will come on and a beep will sound (warning lights/beeps, page 4-25).

**⚠ WARNING**

**Damaged Seat Belts:**

An accident can damage a seat belt in use. The belt webbing can be weakened and retractors and anchors can be bent or broken. Therefore a damaged seat belt may not provide adequate protection in a collision. Have a professional inspect all seat belt systems in use during an accident before they are used again.

**⚠ WARNING**

**One Belt, One Passenger:**

Using one seat belt for more than one person at a time is dangerous. A seat belt used in this way can't spread the impact forces properly and the two passengers could be crushed together and seriously injured. Never use one belt for more than one person at a time.

## Knowing Your Mazda

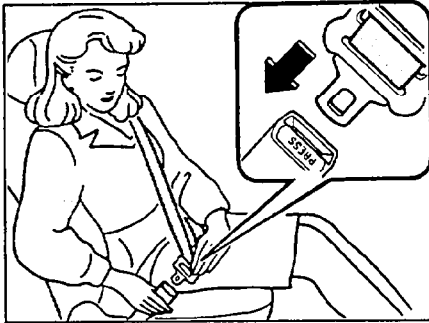

### ■ Front Seat Belts

#### To fasten:

1. Grasp the buckle and tongue plate.
2. Slowly pull out the lap/shoulder belt.
3. Insert the plate into the buckle until you hear a click.

### ⚠ WARNING

#### Wearing the Shoulder Belt:

*An improperly worn shoulder belt can be dangerous. In a collision, a shoulder belt worn under the arm will transfer the full force of impact to the ribs and cause serious injury. A shoulder belt worn behind the neck and over the inside shoulder provides no protection. Never wear a shoulder belt under the arm or place it behind the neck and over the inside shoulder.*

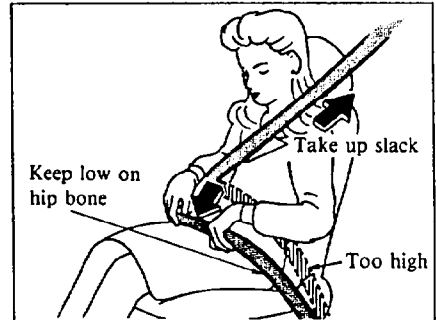

### ⚠ WARNING

#### Wearing the Lap Belt:

*A lap belt worn too high can be dangerous. In a collision, this would concentrate the impact force directly on the abdominal area, causing serious injury. Wear the lap belt snugly and as low as possible.*

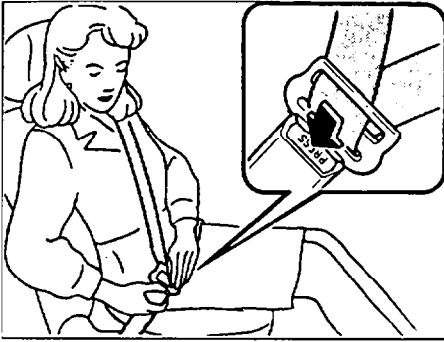

**To unfasten:**

Depress the buckle release.

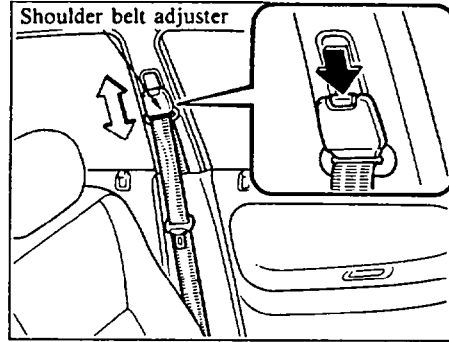

**▼ Shoulder belt adjuster**

This adjusts the shoulder belt angle for a more comfortable fit. Simply push the button, move it to the desired position, and then release it. Make sure the adjuster is locked.



**⚠ WARNING**

***Positioning the Shoulder Belt:***  
***Failure to position the shoulder belt properly reduces the amount of protection in an accident and increases the chance of injury. Make sure the belt is positioned across your shoulder near your neck, not on your neck or upper arm.***

## Knowing Your Mazda

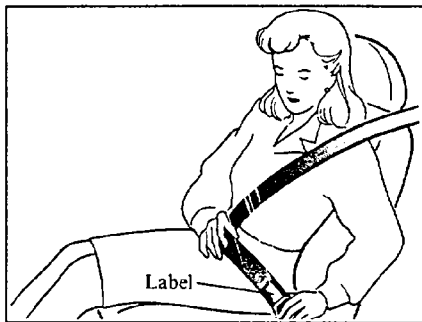

### ■ Seat Belt Caution Label

A caution label is inside the sleeve of each lap belt. If a belt is used in an accident, the stress will cause this label to be pulled from the sleeve.

This indicates that the seat belt must be replaced.

Also, if the seat belt undergoes excessive stress at any time, the belt's webbing, metal fittings, and anchor bolt may be damaged. The damage may not be apparent, so the seat belt should be replaced after this kind of stress, even if the label is not exposed.

2-26

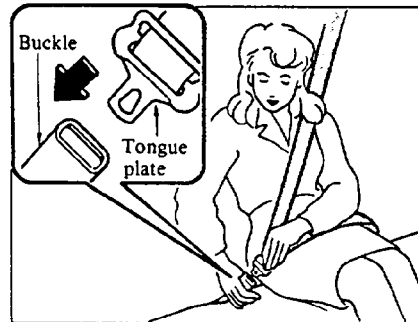

### ■ Rear Seat Belts

#### ▼ Lap/shoulder belt

##### To fasten:

1. Grasp the tongue plate and pull it to the desired length.
2. Insert this plate into the buckle until you hear a click.

The retractor will take up excess belt and maintain tension.

##### To unfasten:

Depress the button on the buckle.

#### NOTE

If a belt does not fully retract, inspect it for kinks and twists.

### ⚠ WARNING

#### Wearing the Shoulder Belt:

*An improperly worn shoulder belt can be dangerous. In a collision, a shoulder belt worn under the arm will transfer the full force of impact to the ribs and cause serious injury. A shoulder belt worn behind the neck and over the inside shoulder provides no protection. Never wear a shoulder belt under the arm or place it behind the neck and over the inside shoulder.*

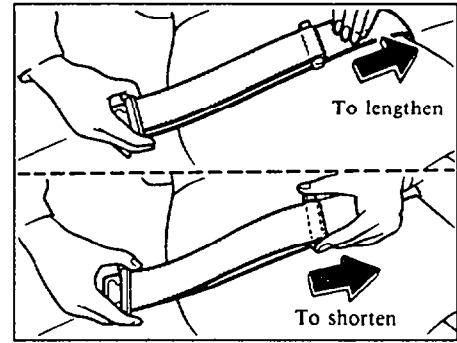
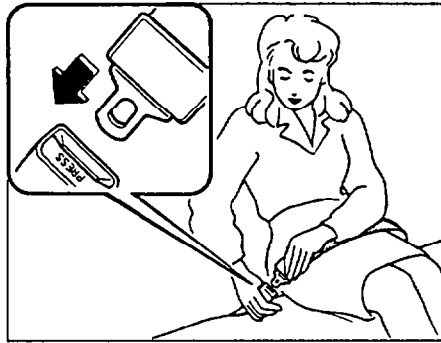
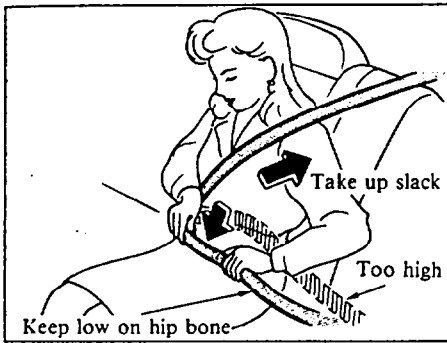

**⚠ WARNING**

**Wearing the Lap Belt:**

***A lap belt worn too high can be dangerous. In a collision, this would concentrate the impact force directly on the abdominal area, causing serious injury. Wear the lap belt snugly and as low as possible.***

**▼ Lap belt**

**To fasten:**

1. Pull the tongue to the desired length.
2. Insert it into the buckle until you hear a click.

3. To lengthen the belt, hold the tongue at a right angle to the webbing and pull; to shorten, pull the loose end of the webbing.

**To unfasten:**

Depress the button on the buckle.

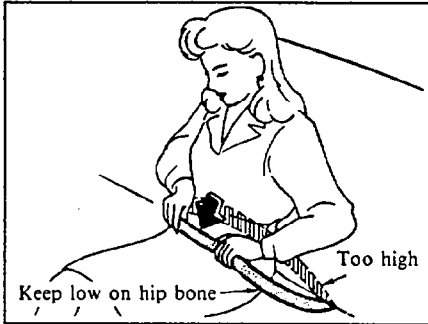

**⚠ WARNING**

**Wearing the Lap Belt:**

*A lap belt worn too high can be dangerous. In a collision, this would concentrate the impact force directly on the abdominal area, causing serious injury. Wear the lap belt snugly and as low as possible.*

**■ Pregnant Women**

Pregnant women should wear seat belt assemblies as recommended by their doctors. The lap belt should be worn **SNUGLY AND AS LOW AS POSSIBLE**.

**■ Small Children**

Small children should be protected by a child-restraint system that meets the Federal Motor Vehicle Safety Standard (FMVSS).

It should fit the seat and the child.

**NOTE**

Every child-restraint system is designed for use with a lap belt or the lap-belt portion of a lap/shoulder belt.

Follow all instructions when installing a child-restraint system, which should be secured with the lap portion of the lap/shoulder belt. Since accident statistics reveal that a child is safer in the rear seat, we recommend that the child-restraint system be placed in the rear seat.

**⚠ WARNING**

**Unsecured Restraint System:**

*A child restraint system that is not securely fastened down can be dangerous. In a sudden stop or collision, it can become a projectile and hit someone, causing serious injury. When not in use, remove it from the vehicle or fasten it with a seat belt.*

**⚠ WARNING**

**Holding a Child:**

*A child should never be held on the lap or in the arms of a passenger in a moving vehicle. No matter how strong a person may be, he or she cannot hold a child during an accident. The child may thus be injured by hitting parts of the vehicle or by being crushed by an unrestrained passenger.*

**⚠ WARNING**

**Child-Restraint Anchor:**

*Your Mazda has no child-restraint anchor. Therefore, using a child-restraint system that requires an anchor can be dangerous. In a collision, it would not be properly secured; thus it could move around in the cabin and seriously injure someone. Use only a system designed for use without an anchor.*

■ Installing a Child-Restraint System

**⚠ WARNING**

**Improperly Secured System:**

*An improperly secured child restraint may move in a sudden stop or collision and injure the child or someone else. To properly secure it, follow the restraint manufacturer's recommendations along with the installation instructions in this manual.*

**⚠ WARNING**

**Unattended Children:**

*Leaving children unattended in a vehicle can be dangerous. In hot weather, temperatures inside a parked vehicle can become high enough to cause brain damage or even death. Never leave children or animals unattended in the vehicle.*

**⚠ WARNING**

**Child Restraint Positioning:**

*Child restraints used in the front seat and which face the rear are unsafe. The restraint can be hit by a deploying air bag, moved out of position, and result in your child being seriously injured. Don't use child restraints which face the rear in the front seat.*