

DOT 4813

REPORT NO. MSE-93-N03

R92083-03

**NEW CAR ASSESSMENT PROGRAM (NCAP)
FRONTAL BARRIER IMPACT TEST**

FORD MOTOR COMPANY, LTD.
1993 FORD RANGER PICKUP

NHTSA NO. MP0203

MOBILITY SYSTEMS AND EQUIPMENT COMPANY
9920 LA CIENEGA BOULEVARD SUITE 708
INGLEWOOD, CALIFORNIA 90301



DECEMBER 23, 1992

FINAL REPORT

Prepared For:

U.S. DEPARTMENT OF TRANSPORTATION
NATIONAL HIGHWAY TRAFFIC SAFETY ADMINISTRATION
OFFICE OF MARKET INCENTIVES
400 Seventh Street, S.W.
Room No. 5313 (NRM-22)
Washington, DC 20590

This publication is distributed by the U.S. Department of Transportation, National Highway Traffic Safety Administration, in the interest of information exchange. The opinions, findings and conclusions expressed in this publication are those of the author(s) and not necessarily those of the Department of Transportation or the National Highway Traffic Safety Administration. The United States Government assumes no liability for its contents or use thereof. If trade or manufacturers' names or products are mentioned, it is only because they are considered essential to the object of the publication and should not be construed as an endorsement. The United States Government does not endorse products or manufacturers.

Prepared by: Dr. Anil V. Khadilkar, Program Manager

Mr. Brian O'Keefe, Test Engineer

Mr. Jerry Kratzke, Test Engineer

Mr. Patrick Puzzuto, Instrumentation

MOBILITY SYSTEMS AND EQUIPMENT COMPANY

Approved by: 
Dr. Anil V. Khadilkar

Date: 12/23/1992

FINAL REPORT ACCEPTED BY:

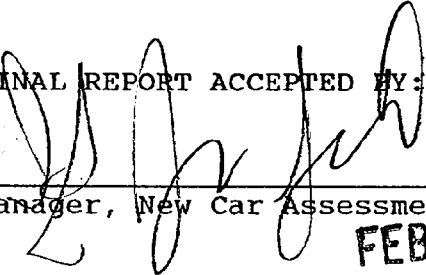
Manager, New Car Assessment Program

FEB 03 1993

Date of Report Acceptance

COTR, New Car Assessment Program

FEB 03 1993

Date of Report Acceptance

Technical Report Documentation Page

1. Report No. MSE-93-N03		2. Government Accession No.		3. Recipient's Catalog No.													
4. Title and Subtitle New Car Assessment Program Frontal Barrier Impact Test 1993 Ford Ranger Pickup NHTSA No. MP0203				5. Report Date December 23, 1992													
				6. Performing Organization Code MSE													
7. Author(s) Dr. A. V. Khadilkar / Mr. Brian O'Keefe / Mr. Patrick Puzzuto / Mr. Jerry Kratzke				8. Performing Organization Report No. R92083-03													
9. Performing Organization Name and Address Mobility Systems and Equipment Company 9920 La Cienega Boulevard, Suite 708 Inglewood, California, 90301				10. Work unit No.													
				11. Contract or Grant No. DTNH22-90-D-32121,D.O.#5													
12. Sponsoring Agency Name and Address U.S. Department of Transportation National Highway Traffic Safety Administration Office of Market Incentives (NRM-20) 400 Seventh Street, S.W., Room 5313 Washington, D.C., 20590				13. Type of Report and Period Covered FINAL													
				14. Sponsoring Agency Code DOT/NHTSA/RM/OMI													
15. Supplementary Notes																	
16. Abstract A 35 MPH Frontal barrier impact test using a load cell barrier was conducted on a 1993 Ford Ranger Pickup at the Mobility Systems and Equipment Company (MSE) crash test facility in San Bernadino, CA, on December 2, 1992. The impact velocity was 56.60 km/h, and the ambient temperature at the barrier face at the time of impact was 17 degrees C. The vehicle's maximum post-test static crush was 509 mm. Occupant injury response data summary is as follows:																	
<table border="1"> <thead> <tr> <th>Injury Criteria Threshold Value</th> <th>Driver Dummy</th> <th>Passenger Dummy</th> </tr> </thead> <tbody> <tr> <td>Head Injury Criterion HIC = 1000</td> <td align="center">948.3</td> <td align="center">396.8</td> </tr> <tr> <td>Chest Resultant Peak 60 G's (3 msec clip)</td> <td align="center">52.2</td> <td align="center">44.6</td> </tr> <tr> <td>Femur Force Left 10009 N Right</td> <td align="center">4103.1 2606.6</td> <td align="center">1884.1 2200.0</td> </tr> </tbody> </table>						Injury Criteria Threshold Value	Driver Dummy	Passenger Dummy	Head Injury Criterion HIC = 1000	948.3	396.8	Chest Resultant Peak 60 G's (3 msec clip)	52.2	44.6	Femur Force Left 10009 N Right	4103.1 2606.6	1884.1 2200.0
Injury Criteria Threshold Value	Driver Dummy	Passenger Dummy															
Head Injury Criterion HIC = 1000	948.3	396.8															
Chest Resultant Peak 60 G's (3 msec clip)	52.2	44.6															
Femur Force Left 10009 N Right	4103.1 2606.6	1884.1 2200.0															
Type of occupant restraint system: 3 point continuous webbing manual active belt system at each front outboard seating position.																	
17. Key Words 35 MPH Frontal Barrier Impact Test New Car Assessment Program (NCAP) 1993 Ford Ranger Pickup			18. Distribution Statement Copies of this report are available from: Technical Reference Division Nat'l Highway Traffic Safety Admin. Room 5108, Nassif Building 400 7th St., S.W., Wash. D.C. 20590														
19. Security Classif.(of this report) UNCLASSIFIED		20. Security Classif.(of this page) UNCLASSIFIED		21. No. of Pages 47	22. Price												

Form DOT F1700.7 (8-72)

TABLE OF CONTENTS

<u>SECTIONS</u>		<u>PAGES</u>
1	Purpose and Test Procedure	1
2	Summary of Frontal Barrier Impact Test	3
3	Occupant and Vehicle Information	9
4	Test Equipment List and Calibration Information	25
<u>DATA TABLES</u>		
1	Test Vehicle Data	5
2	Post Crash Test Data	7
3	FMVSS 208 Occupant Crash Protection Data	10
4	Test Dummy Positioning Data	11
5	Seat Belt Positioning Data	14
6	Seat Belt Performance Assessment Test Data	15
7	Camera Location Data	16
8	Vehicle Accelerometer Locations and Data Summary	18
9	Test Vehicle Measurements	19
10	Pretest Vehicle Target Locations	21
11	Load Cell Locations on Fixed Barrier	22
12	Accident Investigation Division Data	23
<u>APPENDICES</u>		
A	Photographs	39
B-1	Vehicle and Dummy Response Data	40
B-2	Load Cell Barrier Data	42
C	Dummy Configuration and Performance Verification Data	44
D	Vehicle Owner's Manual Occupant Restraint	45
E	Instrumentation and Calibration Data	47

THIS PAGE INTENTIONALLY LEFT BLANK

SECTION 1

PURPOSE AND TEST PROCEDURE

This 35 mph frontal barrier impact test is a part of the FY'93 Vehicle Barrier Impact Testing Program sponsored by the National Highway Traffic Safety Administration (NHTSA) under Contract No. DTNH22-90-D-32121. The purpose of this test was to obtain vehicle crashworthiness and occupant restraint system performance data for an impact speed in excess of the current 30 mph (48.27 km/h) FMVSS 208/212/219/301-75 requirements.

This 35 mph (56.32 km/h) frontal barrier impact test was conducted in accordance with the Office of Market Incentives (OMI) Laboratory Indicant Test Procedure, dated 01 January 1990.

THIS PAGE INTENTIONALLY LEFT BLANK

SECTION 2

SUMMARY OF FRONTAL BARRIER IMPACT TEST

A barrier was impacted by a 1993 Ford Ranger Pickup, NHTSA No. MP0203, at a velocity of 56.60 km/h. The frontal impact test was conducted by Mobility Systems and Equipment Company (MSE) on 02 December 1992. The general test and vehicle description information are presented in Tables 1 and 2. Pretest and posttest photographs of the test vehicle and dummies are shown in Appendix A.

Two (2) Part 572 50th percentile adult male Anthropomorphic Test Devices (ATDs) were placed in the driver and right front passenger designated seating positions (DSP's) according to the NHTSA test requirements.

The ATD's were instrumented with head and chest triaxial accelerometers and right/left femur load cells. In addition, load cells were placed on the driver's and passenger's lap and shoulder belts to measure dummy upper torso and pelvic section belt loading. A summary of dummy configuration and performance verification test data is presented in Appendix C.

The frontal impact event was documented by one (1) real time camera and fifteen (15) high-speed cameras. The camera location data are presented in Table 7.

Sixty-nine (69) channels of crash parameters were recorded using two (2) FM tape recorders and three (3) direct analog to digital acquisition unit and data acquisition computers. Time history plots of all recorded channels are presented in Appendix B.

2.1 GENERAL COMMENTS

The 1993 Ford Ranger Pickup, was equipped with a 140.0 cubic in, 4 cylinder engine and 5 speed manual transmission. The test weight of the 1993 Ford Ranger Pickup, with two (2) 50th percentile male dummies, instrumentation and cameras was 1677 kg.

The 1993 Ford Ranger Pickup, was involved in a frontal barrier crash at a velocity of 56.60 km/h.

The maximum static crush for the vehicle of 509 mm occurred 150 mm to the right of the centerline of the bumper. The windshield was cracked, but otherwise the vehicle glazing remained intact. Both the driver's and passenger's front doors were opened without the aid of tools.

The driver ATD's face hit the steering wheel upper rim and center hub. The top of his head hit the top of the steering wheel and grazed the sun visor. The lower steering wheel rim contacted the ATD's mid abdomen and lower right chest. The driver's left and right knees hit the dash panel. The driver ATD had a HIC value of 948, the maximum chest acceleration (resultant clipped) was 52.0 g's and the maximum femur loads were 4103 (left) and 2607 (right) Newtons.

The passenger ATD's head had no contact but his chin contacted his chest. Both of his knees hit the dash panel; the right knee also hit the glove box door. The HIC value for the passenger ATD was 397, the maximum chest acceleration (resultant clipped) was 45 g's and the maximum femur loads were 1884 (left) and 2200 (right) Newtons.

Seat belt spoolout, measured by high-speed film analysis, was 35 mm for the driver. The passenger side data could not be determined by film analysis.

There were no apparent visual indications of any standard solvent leaks, windshield periphery separations or windshield penetration.

Appendix D shows occupant restraint system instructions by the manufacturer and Appendix E shows the instrumentation and calibration data.

DATA TABLE No. 1
TEST VEHICLE DATA

VEHICLE YEAR/MAKE/MODEL/BODY STYLE: 1993/Ford/Ranger Pickup
VEHICLE NHTSA No.: M P 0 2 0 3 ; VIN: 1 F T C R 1 0 A 6 P P A 0 7 0 5 3
VEHICLE BODY COLOR: White ; MONTH AND YEAR OF MANUFACTURE: 10/92
ENGINE: 4 Cylinders; 140 cu in; 2.3 Liters; cc
X Gas; Diesel; Turbocharged
PLACEMENT: X Longitudinal; Transverse (Lateral)
TRANSMISSION: 5 Speed; X Manual; Automatic; Overdrive
FINAL DRIVE: Front Wheel Drive; X Rear Wheel Drive; Four Wheel Drive
DATE VEHICLE AVAILABLE FOR 35 MPH CRASH TESTING: 11/18/92
ODOMETER READING: 161 km; OPTIONS: A/C; X P/S; P/Window;
 Tilt Whl.; Cruise Control

DATA RECORD FROM VEHICLE'S TIRE PLACARD:

Tire Pressure (at capacity): 240 kPa Front; 240 kPa Rear
Recommended Tire Size: P225/70R14
Tires on Vehicle: P225/70R14 ; Manufacturer: Firestone
Number of Occupants: 3 Front; Rear; Third Seat; 3 TOTAL
Type of Front Seats: Bucket; Bench; X Split Bench
Type of Front Seat Back: Fixed; X Adj. Lever; Adj. Rotating Knob
Vehicle Maximum Capacity Loading: N/A kg
No. of Occupants x 68 kg: N/A kg
Cargo Capacity (Max - Occupants): 136 kg

TEST VEHICLE DELIVERED WEIGHT WITH MAXIMUM FLUIDS:

Right Front:	<u>392</u> kg		
Left Front:	<u>444</u> kg	Total Front:	<u>836</u> kg (60% of Total)
Right Rear:	<u>282</u> kg		
Left Rear:	<u>279</u> kg	Total Rear:	<u>561</u> kg (40% of Total)
		Total Weight:	<u>1397</u> kg

CALCULATION OF TEST VEHICLE TARGET WEIGHT:

Total Test Vehicle Delivered Weight With Maximum Fluids:	<u>1397</u> kg
Maximum Cargo Carrying Capacity of Test Vehicle:	<u>136</u> kg *
Weight of Two Part 572 ATD's (2 * 74.5 kg):	<u>149</u> kg
TEST VEHICLE TARGET WEIGHT:	<u>1682</u> kg

* 136 kg for light trucks and MPV's

DATA TABLE No. 1 (Cont.)
TEST VEHICLE DATA

ACTUAL WEIGHT OF TEST VEHICLE WITH 2 ATD's AND CARGO:

Right Front: 439 kg
Left Front: 477 kg Total Front: 916 kg (55% of Total)
Right Rear: 381 kg
Left Rear: 380 kg Total Rear: 761 kg (45% of Total)

Total Weight: 1677 kg (includes 37 kg of ballast secured in the cargo / luggage area)

VEHICLE COMPONENTS REMOVED TO MEET TARGET WEIGHT:

1. Jack

TEST VEHICLE ATTITUDE:

As Delivered - Right Front: 787 mm Ready for Test - Right Front: 780 mm
Left Front: 774 mm Left Front: 768 mm
Right Rear: 860 mm Right Rear: 815 mm
Left Rear: 847 mm Left Rear: 800 mm

TEST VEHICLE DIMENSIONS:

Total Vehicle Length: Right Side: 4925 mm
 Left Side: 4930 mm
 Centerline: 5015 mm

Wheelbase: 2913 mm

C. G. is 1322 mm rearward of front axle centerline.

DATA TABLE No. 2
POST CRASH TEST DATA

DATE OF 35 MPH FRONTAL BARRIER IMPACT RATING TEST: 12/02/92

TIME OF TEST: 1440 Hrs; AMBIENT TEMPERATURE AT BARRIER FACE: 17° C

VEHICLE OCCUPANT COMPARTMENT TEMPERATURE: 19° C (Req. Range 19° C to 26° C)

VEHICLE WINDSHIELD MOLDING TEMPERATURE: 19° C

VEHICLE IMPACT VELOCITY: (Req. Range 55.52 to 57.13 km/h)
 Primary Speed Trap: 56.60 km/h
 Secondary Speed Trap: 56.11 km/h
 Distance from vehicle leading edge to barrier face when:
 Entering Speed Trap: 1524 mm
 Exiting Speed Trap: 305 mm

VEHICLE STATIC CRUSH:	Pretest	Posttest	Static Crush
Right Side (mm)	<u>4925</u>	<u>4450</u>	<u>475</u>
Centerline (mm)	<u>5015</u>	<u>4586</u>	<u>429</u>
Left Side (mm)	<u>4930</u>	<u>4505</u>	<u>425</u>

VEHICLE REBOUND FROM BARRIER: Right Side: 235 mm
 Centerline: 180 mm
 Left Side: 190 mm

ATD CONTACT POINTS:

	Driver ATD (ID# 830)	Pass. ATD (ID# 814)
Top of Head	Steering Wheel Upper Rim, Visor	No Contact
Face	St. Wheel Upper Rim, Center Hub	No Contact
Lower St. Wh. Rim	Mid Abdomen & Lower Right Chest	No Contact
Right Knee	Instrument Panel	Glove Box Door, Dash
Left Knee	Instrument Panel	Instrument Panel

VEHICLE DOOR OPENING INFORMATION:

Door	Opened	Jammed
Right Front	Yes	No
Left Front	Yes	No
Right Rear	-	-
Left Rear	-	-

VEHICLE FRONT SEAT MOVEMENT DURING IMPACT EVENT:

Seat Cushion Shift - Right = 0 mm Left = 0 mm
 Seat Adjustor Failure - Right: No Left No
 Details of Any Failure: None

OTHER NOTABLE IMPACT EFFECTS: None

THIS PAGE INTENTIONALLY LEFT BLANK

SECTION 3

OCCUPANT AND VEHICLE INFORMATION

I. OMI DATA

Dummy Injury Criteria Data Summary
Dummy Positioning Data
Seat Belt Positioning Data
Seat Belt Performance Assessment Data
Driver Dummy to Steering Column Dimensions
Camera Locations

II. OVR DATA

Load Cell Barrier Data
Vehicle Accelerometer Data

DATA TABLE No. 3
FMVSS No. 208 OCCUPANT CRASH PROTECTION DATA SHEET

VEH. YEAR/MAKE/MODEL/BODY STYLE: 1993 Ford/Ranger/Pickup

VEH. NHTSA NO.: MP0203

TEST DATE: 12/02/92

MAXIMUM ACCELERATION VALUES:	DRIVER ATD No. 830	PASSENGER ATD No. 814
Head X	-146.3	-18.5
Head Y	-21.1	30.2
Head Z	86.4	51.1
HEAD RESULTANT	162.6	56.4
Chest X	-51.3	-42.5
Chest Y	-14.5	44.0
Chest Z	20.6	25.8
CHEST RESULTANT (3msec clip)	52.2	44.6
TIME INTERVAL (msec)	56.9 to 59.9	83.0 to 86.0

HEAD INJURY CRITERIA (HIC) VALUES:

HIC	948.3	396.8
t ₁ (msec)	49.5	58.1
t ₂ (msec)	85.5	94.1
Avg. Acceleration t ₁ to t ₂	58.6	41.4

MAXIMUM FEMUR FORCES:

Right Femur (N)	-2606.6	-2200.0
Left Femur (N)	-4103.1	-1884.1

MAXIMUM SEAT BELT FORCES:

Lap Belt (N)	9478.3	7650.6
Shoulder Belt (N)	9891.7	8377.0

MAXIMUM SEAT BELT WEBBING SPOOLOUT:

Lap/Shoulder Belt Combination	40 mm	31 mm
-------------------------------	-------	-------

DATA TABLE No. 4
TEST ATD POSITIONING DATA

PRE - IMPACT DATA:

Make / Model: Ford Ranger
Body Style: Pickup
Model Year: 1993
Color: White
NHTSA No.: MP0203

DATA FROM CERTIFICATION LABEL:

Vehicle Manufacturer: Ford
Date of Manufacture: 10/92
VIN: 1FTCR10A6PPA07053
GVWR: 1932 Kg
GAWR Front: 976 Kg
GAWR Rear: 999 kg

POST IMPACT DATA:

Date of Test: 12/02/92
Time: 1440 Hrs.
Temperature: 17° C
Required Impact Velocity Range: 55.52 to 57.13 km/h
Impact Velocity - Primary: 56.60 km/h
Secondary: 56.11 km/h
Seat Type: Split Bench
Adjustor Type: Lever
Bucket Seat Back Type: Fixed Head Restraint

ATD POSITIONING TECHNICIANS: Brian O'Keefe, Levi Navarro

DATA TABLE No. 4 (Cont.)
TEST ATD POSITIONING DATA

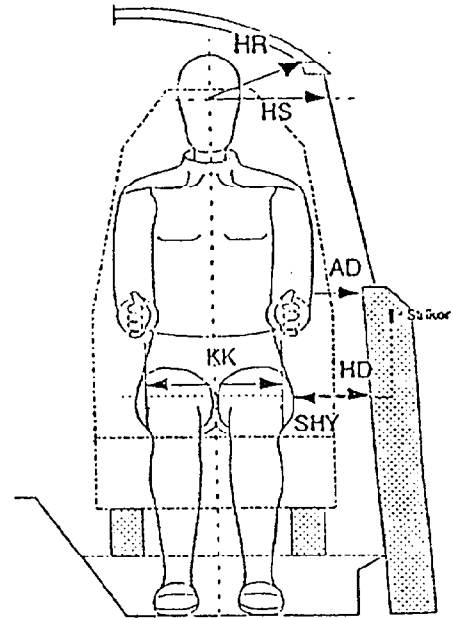
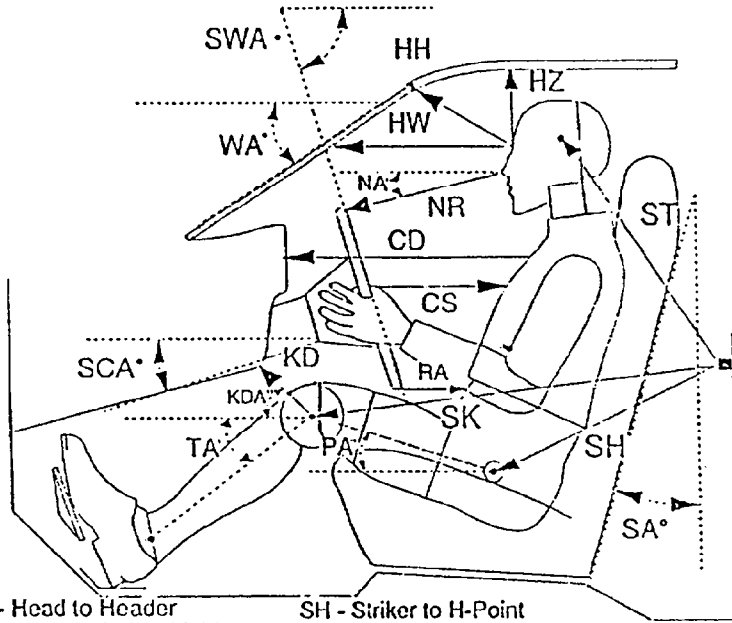

- HH - Head to Header
- HW - Head to Windshield
- HZ - Head to Roof
- NR - Nose to Rim
- CS - Steering Wheel to Chest
- CD - Chest to Dash
- RA - Rim to Abdomen
- KD/KDR - Knee to Dash
- KDA - Knee to Dash Angle
- SH - Striker to H-Point
- SK - Striker to Knee
- ST - Striker to Head
- NA - Nose to Rim Angle
- TA - Tibial Angle
- PA - Pelvic Angle
- SA - Seat Back Angle
- SCA - Steering Column Angle
- SWA - Steering Wheel Angle
- WA - Windshield Angle

- HR - Head to Side Header
- HS - Head to Side Window
- AD - Arm to Door
- HD - H-Point to Door
- SHY - Striker to H-Point (Y Dir.)
- KK - Knee to Knee

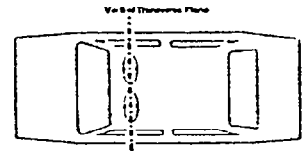
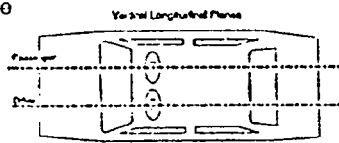

DATA TABLE No. 4 (Cont.)
TEST ATD POSITIONING DATA

Measurement	Driver (Serial No. 830)		Passenger (Serial No. 814)	
	Length (mm)	Angle (Degrees)	Length (mm)	Angle (Degrees)
WA	---	41	---	---
SWA	---	63	---	---
SCA	---	24	---	---
HZ	155	90	155	90
HH	380	---	400	---
HW	485	0	495	0
HR	205	---	230	---
NR	347	19	---	---
CD	520	---	560	---
CS	260	0	---	---
RA	170	0	---	---
KDL	230	25	245	---
KDR	260	---	265	20
PA	---	10	---	6
TA	---	-38	---	-35
KK	360	---	320	---
ST	635	66	605	75
SK	648	-3	655	-5
SH	270	-22	265	-17
SHY	170	0	170	0
HS	293	0	307	0
HD	110	0	110	0
AD	15	0	60	0

DATA TABLE No. 5
SEAT BELT POSITIONING DATA

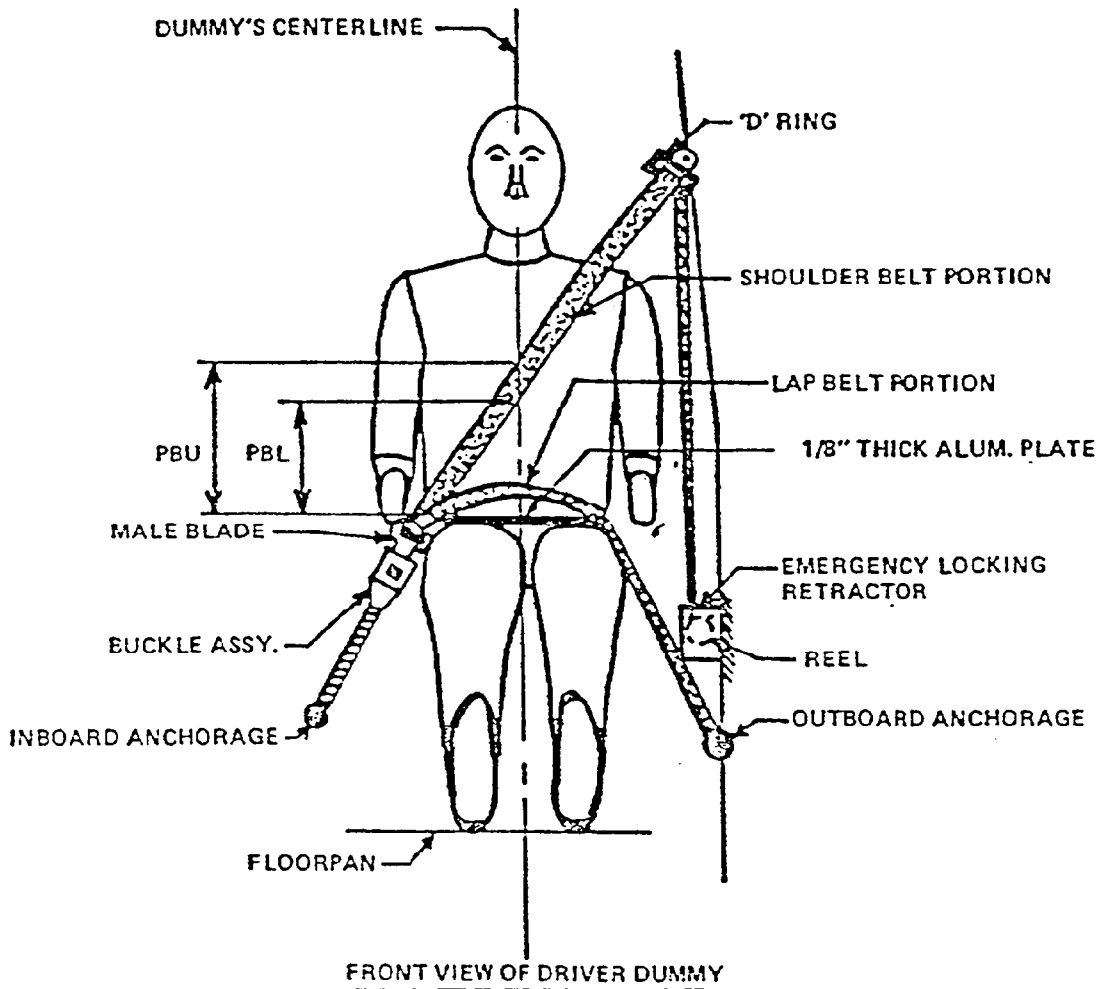

Measurement	Driver ATD	Passenger ATD
PBU - Top Surface of alum. plate to belt upper edge (mm)	350	295
PBL - Top Surface of alum. plate to belt lower edge (mm)	265	210
Lap Belt Tension (N)	-	-
Shoulder Belt Tension (N)	-	-

DATA TABLE 6
SEAT BELT PERFORMANCE ASSESSMENT TEST DATA

BELT LENGTH DATA:

Total belt length from retractor reel to bolt hole anchor point for continuous webbing systems (mm) _____

Retractor reel to 'D' ring as measured on Part 572 ATD (mm) _____

Shoulder belt length as measured on Part 572 ATD (mm) _____

Lap belt length as measured on Part 572 ATD (mm) _____

Remainder of belt webbing left on the retractor reel (mm) _____

DRIVER SIDE		PASSENGER SIDE	
PRETEST	POSTTEST	PRETEST	POSTTEST
2040	1990	2110	2030
410	410	410	410
850	800	860	820
780	780	840	800
510	560	430	510

BELT SPOOL-OFF DATA:

As determined by film analysis (mm) _____

As determined electronically (mm) _____

As determined mechanically (mm) _____

35	NO DATA
40	31
40	33

BELT STRAIN DATA: Measured on the shoulder belt

As determined electronically (%) _____

As determined mechanically (%) _____

4.39	3.05
0.0	0.0

DATA TABLE No. 7
FMVSS No. 208 CAMERA LOCATION DATA

VEH. YEAR/MAKE/MODEL/BODY STYLE: 1993/Ford/Ranger/Pickup

VEH. NHTSA NO.: MP0203

TEST DATE: 12/02/92

TIME: 1440 Hrs.

CAMERA NO.	VIEW	CAMERA POS. (mm)			ANGLE (deg)	FILM PLANE TO HEAD TARGET	LENS (mm)	SPEED (fps)
		X	Y	Z				
1	Left Side View	5867	14350	3404	-20	14436	15-70 Zoom	24
2	Right Side View	1150	7730	1160	-6	6187	13	580
3	Left Side View	1219	9906	1727	-4	9505	25	390
4	Overhead	-152	0	4039	-66	3714	13	590
5	Pit - Engine	635	25	-1829	90	3690	13	610
6	Pit - Fuel Tank	N/R	N/R	N/R	N/R	N/R	N/R	N/R
7	Front - Passenger	-406	406	2438	-41	3015	16	600
8	Front - Driver	-406	-305	2438	-36	3020	16	510
9	Left Side - Driver	2360	2810	1930	-15	2545	16	610
10	Right Side - Pass.	2300	3060	1970	-12	2879	16	600
11	Right Side - A-Post	315	4820	1155	+1	5094	28	630
12	Left Side - A-Post	635	9825	2127	-5	10887	50	710
13	Onboard - Left Side	2965	270	1315	+4	837	13	600
14	Onboard - Right Side	2965	270	1315	+4	837	13	*
15	Left Side - St. Col.	1422	9576	3277	-16	9343	28	610
16	Left Side - St. Col.	1422	9576	2896	-14	9273	28	590
17	Right Side - Pass.	1870	3580	1385	-4	3208	16	570

REFERENCE: X - Film plane to barrier face
 Y - Film plane to monorail centerline
 Z - Film plane to ground

* Film was torn and could not be processed

DATA TABLE No. 8
VEHICLE ACCELEROMETER LOCATION AND DATA SUMMARY

No.	Description	Location			Maximum Value (g's)			
		X	Y	Z	-X	msec	+X	msec
1	Left rear seat cross member	3772	-515	800	45.3	46.4	5.7	122.9
2	Right rear seat cross member	3722	515	800	45.7	61.6	7.8	120.5
3	Top of Engine Block	1000	75	880	198.6	41.4	57.1	51.0
4	Bottom of engine	1025	110	450	192.5	41.1	42.0	52.0
5	Right Brake Caliper	1025	600	330	109.8	31.2	91.1	50.8
6	Instrument Panel	1600	0	1250	62.9	40.2	36.9	34.1
7	Left Brake Caliper	1025	-600	330	101.8	31.3	64.4	51.0
8	Left rear seat cross member Redun.	3772	-515	800	40.4	46.4	4.5	123.0
9	Right rear seat cross member Redun.	3722	515	800	39.9	61.6	5.4	120.5

REFERENCE: X - Front Bumper Leading Edge
 Y - Vehicle Centerline (Right Pos., Left Neg.)
 Z - Ground Level

All dimensions in mm

DATA TABLE No. 9
TEST VEHICLE MEASUREMENTS

No.	Measurement Description	Pretest	Posttest	Change
1	Length of test vehicle at centerline	5015	4586	429
2	Rear surface of vehicle to front of engine	4335	4176	159
3	Rear of vehicle to firewall centerline	3775	3735	40
4	Rear to upper leading edge of right door	3143	3108	35
5	Rear to upper leading edge of left door	3135	3075	60
6	Rear to lower leading edge of right door	3525	3515	10
7	Rear to lower leading edge of left door	3522	3522	0
8	Rear to upper trailing edge of right door	2528	2487	41
9	Rear to upper trailing edge of left door	2525	2470	55
10	Rear to lower trailing edge of right door	2470	2462	8
11	Rear to lower trailing edge of left door	2470	2465	5
12	Rear to bottom of right 'A' pillar	3605	3575	30
13	Rear to bottom of left 'A' pillar	3620	3600	20
14	Rear surface to firewall on right side	3800	3785	15
15	Rear surface to firewall on left side	3830	3810	20
16	Rear surface to steering column	3110	3140	-30
17	Center of steering column to left 'A' pillar	330	260	70
18	Center of steering column to headlining	415	395	20
19	Rear surface to right side of front bumper	4925	4450	475
20	Rear surface to left side of front bumper	4930	4505	425
21	Length of engine block	470	470	0

All measurements in mm

DATA TABLE No. 9 (Cont.)
 TEST VEHICLE MEASUREMENTS

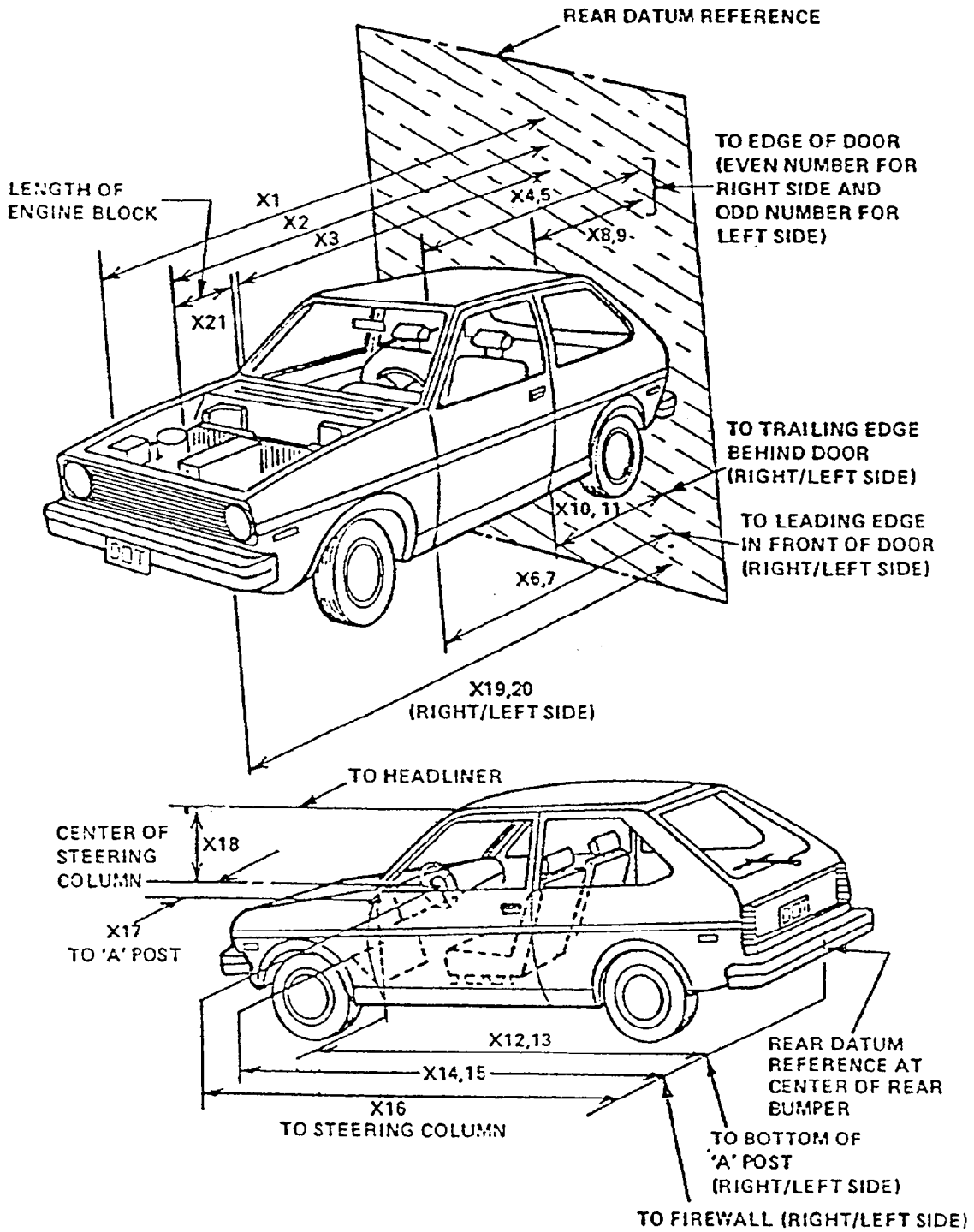

DATA TABLE No. 10
VEHICLE TARGET LOCATIONS

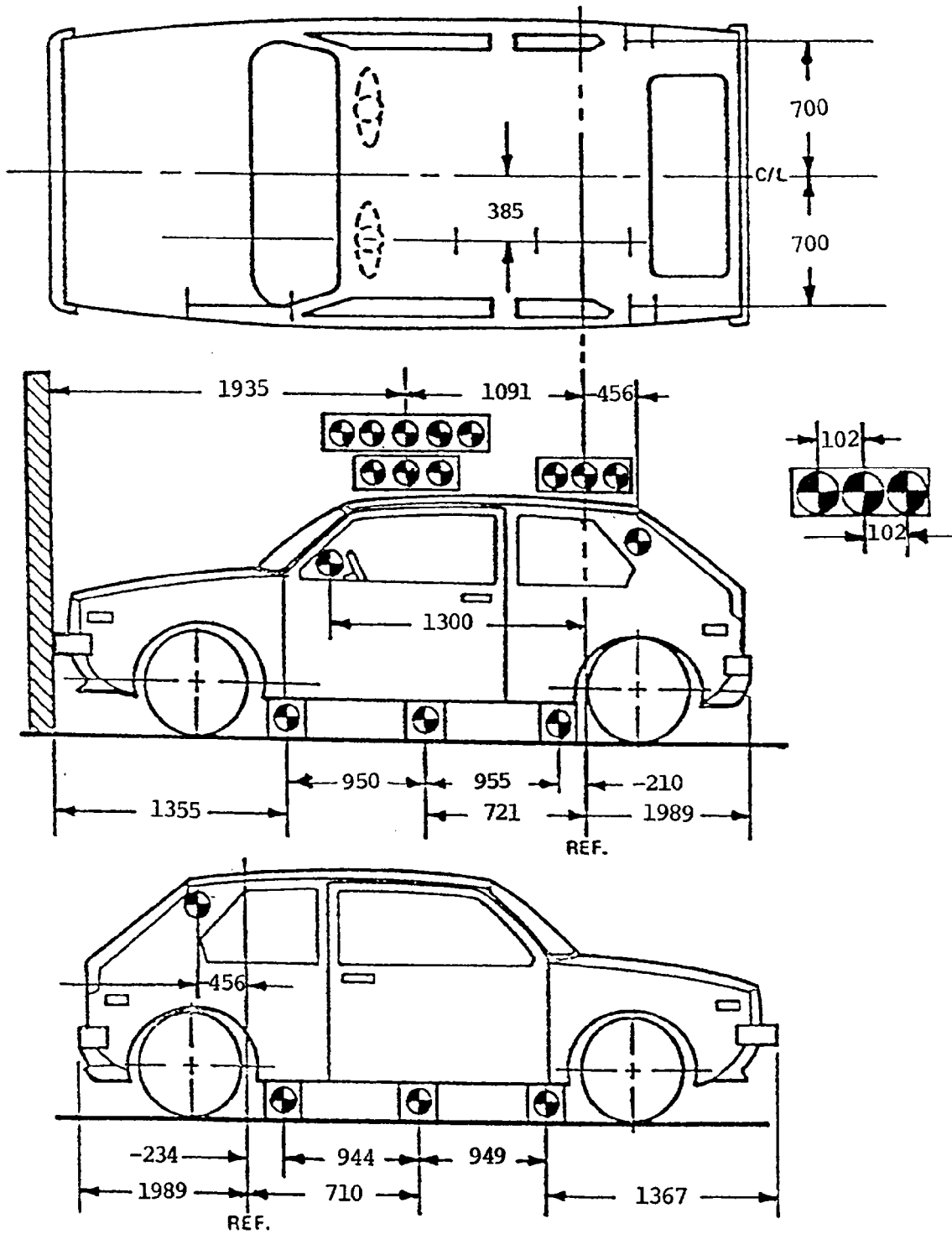

Dimensions in mm

DATA TABLE No. 11
LOAD CELL LOCATIONS ON FIXED BARRIER

- 36 Load cells
- 4 Rows
- 9 Columns
- 6 Groupings (6 cells/group)

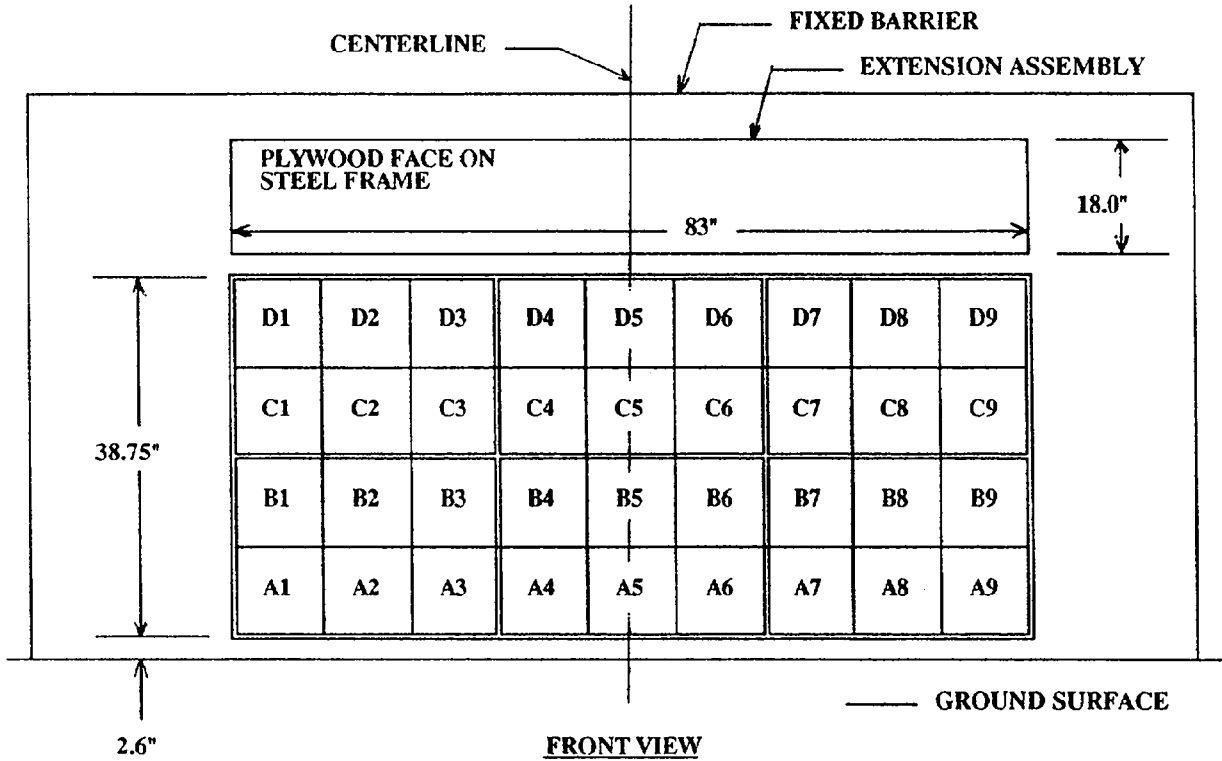

6 GROUPS OF 6 LOAD CELLS EACH

Group 4 C1 thru D3	Group 5 C4 thru D6	Group 6 C7 thru D9
Group 1 A1 thru B3	Group 2 A4 thru B6	Group 3 A7 thru B9

DATA REQUIREMENTS:

- (1) Data from 36 individual load cells
- (2) Total or sum of 36 individual load cells
- (3) Data from 6 groupings shown above (6 cells/group)
- (4) Total load vs. vehicle dynamic crush

DATA TABLE No. 12
ACCIDENT INVESTIGATION DIVISION DATA FOR 35 MPH FRONTAL BARRIER IMPACT

Vehicle Make/Model/Body Style: Ford/Ranger/Pickup

Veh. NHTSA No.: MP0203 ; VIN: 1FTCR10A6PPA07053

Model Year: 1993 ; Build Date: 10/92 ; Test Date: 12/02/92

Veh. Size Category: N/A ; Test Weight: 1677 kg

Veh. Wheelbase: 2913 mm ; Front Overhang: 854 mm ; Overall Width: 1760 mm

ACCELEROMETER DATA:

Location: Left and right side passenger compartment

Calibration Procedure: 6 months / Drop test

Linearity: Good ; Integration Algorithm: NHTSA Standard

Veh. Impact Speed: 56.60 km/h ; Time of separation: 82.8 msec

Velocity Change: 64.6 km/h (Left) ; 64.0 km/h (Right)

collision Deformation Classification (CDC) Code: F (Frontal)

Crush Depth Dimensions:

C1 = 417 mm

C2 = 467 mm

C3 = 498 mm

C4 = 509 mm

C5 = 491 mm

C6 = 462 mm

Midpoint of Damage: Vehicle Centerline

Length of Damaged Region: $L =$ 1500 mm

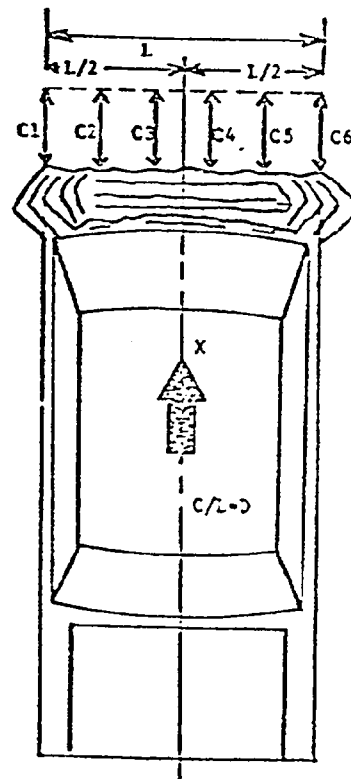

THIS PAGE INTENTIONALLY LEFT BLANK

SECTION 4

TEST EQUIPMENT LIST AND CALIBRATION INFORMATION

This section shows full list of Test Equipment and the calibration dates.

THIS PAGE INTENTIONALLY LEFT BLANK

Vehicle Information

VGID: 2 VEHNO: 1 MAKE: 02 MODEL: 10 YEAR: 93 BODY: PU
 VIN: 1FTCR10A6PPA07053 ENGINE: 4CIF ENGDSP: 2.3 LITER TRANSM: MR
 VEHTWT: 1677 WHLBAS: 291.3 VEHLLEN: 501.5 VEHWID: 178.0
 VEHCG: 131.1 STRSEP: NO COLMEC: EXA MODIND: P
 MODDSC: UNMODIFIED

BX

- 1: 501.5
- 2: 433.5
- 3: 377.5
- 4: 314.3
- 5: 313.5
- 6: 352.5
- 7: 352.2
- 8: 252.8
- 9: 252.5
- 10: 247.0
- 11: 247.0
- 12: 360.5
- 13: 362.0
- 14: 380.0
- 15: 383.0
- 16: 311.0
- 17: 33.0
- 18: 41.5
- 19: 492.5
- 20: 493.0
- 21: 47.0

VEHSPD: 56.6 CRBANG: 0 PDOF: 0 BMPENG: NA
 SILENG: NA APLENG: NA

DPD

- 1: 41.7
- 2: 46.7
- 3: 49.8
- 4: 50.9
- 5: 49.1
- 6: 46.2

VDI: 12FCAW9 LENCNT: 150.0 DAMDST: 0.0 CRHDST: 50.9

AX

- 1: 458.6
- 2: 417.6
- 3: 373.5
- 4: 310.8
- 5: 307.5
- 6: 351.5
- 7: 352.2
- 8: 248.7
- 9: 247.0
- 10: 246.2
- 11: 246.5
- 12: 357.5
- 13: 360.0
- 14: 378.5
- 15: 381.0
- 16: 314.0
- 17: 26.0
- 18: 39.5
- 19: 445.0
- 20: 450.5
- 21: 47.0

CARANG: 999 VEHOR: 999
 VEHCOM: MODEL: HARDBODY PICKUP

General Test Information

VERSNO: V2 TGID: 1
TITLE: 1993 56.35 KM/H NCAP FRONTAL BARRIER IMPACT
TSTOBJ: ACQUIRE NCAP DATA USING TWO INSTR. DUMMIES AND LOAD CELL BARRIER
TSTDAT: 02/DEC/92 TSTPRF: MSE CONNO: DTNH22-90-D-32121
TSTREF: MP0203 TSTTYP: NCA TSTCFN: VTB
TKSURF: CON TKCOND: DRY TEMP: 17 RECTYP: FMT
LINK: UMB CLSPD: 56.6 IMPANG: 0 OFFSET: 0.0
IMPNT: 9999.9 MEASUR: MET TOTCRV: 69
TSTCOM: NO COMMENTS

Barrier Information

Barrier ID: 3
BARRIG: R
BARSHP: LCB
BARANG: 0
BARDIA: 999.9
BARCOM: BARRIER INSRAT FIELDS ARE IN KILONEWTONS

Instrumentation Information

Inst. Group ID: 5 VEHNO: 1 CURNO: 001
SENTYP: AC SENLOC: 01 SENATT: HDCG
AXIS: XL UNITS: G'S PREFIL: 1650
INSMAN: MFG: ENDEVCO, MODEL: 7264-200, S/N: BJ28H
CALDAT: 02/OCT/92 INSRAT: 200 CHLMAX: 73 INIVEL: 56.6
NFP: -300 NLP: 2999 DELT: 100 DASTAT: AM
INSCOM: NO COMMENT

Instrumentation Information

Inst. Group ID: 5 VEHNO: 1 CURNO: 002
SENTYP: AC SENLOC: 01 SENATT: HDCG
AXIS: YL UNITS: G'S PREFIL: 1650
INSMAN: MFG: ENDEVCO, MODEL: 7264-200, S/N: BT28H
CALDAT: 02/OCT/92 INSRAT: 200 CHLMAX: 11 INIVEL: 0.0
NFP: -300 NLP: 2999 DELT: 100 DASTAT: AM
INSCOM: NO COMMENT

Instrumentation Information

Inst. Group ID: 5 VEHNO: 1 CURNO: 003
SENTYP: AC SENLOC: 01 SENATT: HDCG
AXIS: ZL UNITS: G'S PREFIL: 1650
INSMAN: MFG: ENDEVCO, MODEL: 7264-200, S/N: AE29
CALDAT: 02/OCT/92 INSRAT: 200 CHLMAX: 43 INIVEL: 0.0
NFP: -300 NLP: 2999 DELT: 100 DASTAT: AM
INSCOM: NO COMMENT

Instrumentation Information

Inst. Group ID: 5 VEHNO: 1 CURNO: 004
SENTYP: AC SENLOC: 01 SENATT: CHST
AXIS: XL UNITS: G'S PREFIL: 1650
INSMAN: MFG: ENDEVCO, MODEL: 7264-200, S/N: BI14H
CALDAT: 02/OCT/92 INSRAT: 200 CHLMAX: 27 INIVEL: 56.6
NFP: -300 NLP: 2999 DELT: 100 DASTAT: AM
INSCOM: NO COMMENT

Instrumentation Information

Inst. Group ID: 5 VEHNO: 1 CURNO: 005
SENTYP: AC SENLOC: 01 SENATT: CHST
AXIS: YL UNITS: G'S PREFIL: 1650
INSMAN: MFG: ENDEVCO, MODEL: 7264-200, S/N: BI19H
CALDAT: 02/OCT/92 INSRAT: 200 CHLMAX: 11 INIVEL: 0.0
NFP: -300 NLP: 2999 DELT: 100 DASTAT: AM
INSCOM: NO COMMENT

Instrumentation Information

Inst. Group ID: 5 VEHNO: 1 CURNO: 006
SENTYP: AC SENLOC: 01 SENATT: CHST
AXIS: ZL UNITS: G'S PREFIL: 1650
INSMAN: MFG: ENDEVCO, MODEL: 7264-200, S/N: BI92H
CALDAT: 02/OCT/92 INSRAT: 200 CHLMAX: 14 INIVEL: 0.0
NFP: -300 NLP: 2999 DELT: 100 DASTAT: AM
INSCOM: NO COMMENT

Instrumentation Information

Inst. Group ID: 5 VEHNO: 1 CURNO: 007
SENTYP: LC SENLOC: 01 SENATT: FMRL
AXIS: XL UNITS: NWT PREFIL: 1650
INSMAN: MFG: GSE INC. MODEL: 2430, S/N: 735
CALDAT: 09/OCT/92 INSRAT: 13350 CHLMAX: 31 INIVEL: 0.0
NFP: -300 NLP: 2999 DELT: 100 DASTAT: AM
INSCOM: NO COMMENT

Instrumentation Information

Inst. Group ID: 5 VEHNO: 1 CURNO: 008
SENTYP: LC SENLOC: 01 SENATT: FMRR
AXIS: XL UNITS: NWT PREFIL: 1650
INSMAN: MFG: GSE INC, MODEL: 2430, S/N: 710
CALDAT: 09/OCT/92 INSRAT: 13350 CHLMAX: 21 INIVEL: 0.0
NFP: -300 NLP: 2999 DELT: 100 DASTAT: AM
INSCOM: NO COMMENT

Instrumentation Information

Inst. Group ID: 5 VEHNO: 1 CURNO: 009
SENTYP: AC SENLOC: 02 SENATT: HDCG
AXIS: XL UNITS: G'S PREFIL: 1650
INSMAN: MFG: ENDEVCO, MODEL: 7264-200, S/N: BJ61H
CALDAT: 02/OCT/92 INSRAT: 200 CHLMAX: 9 INIVEL: 56.6
NFP: -300 NLP: 2999 DELT: 100 DASTAT: AM
INSCOM: NO COMMENT

Instrumentation Information

Inst. Group ID: 5 VEHNO: 1 CURNO: 010
SENTYP: AC SENLOC: 02 SENATT: HDCG
AXIS: YL UNITS: G'S PREFIL: 1650
INSMAN: MFG: ENDEVCO, MODEL: 7264-200, S/N: BG95H
CALDAT: 02/OCT/92 INSRAT: 200 CHLMAX: 15 INIVEL: 0.0
NFP: -300 NLP: 2999 DELT: 100 DASTAT: AM
INSCOM: NO COMMENT

Instrumentation Information

Inst. Group ID: 5 VEHNO: 1 CURNO: 011
SENTYP: AC SENLOC: 02 SENATT: HDCG
AXIS: ZL UNITS: G'S PREFIL: 1650
INSMAN: MFG: ENDEVCO, MODEL: 7264-200, S/N: BJ54H
CALDAT: 02/OCT/92 INSRAT: 200 CHLMAX: 26 INIVEL: 0.0
NFP: -300 NLP: 2999 DELT: 100 DASTAT: AM
INSCOM: NO COMMENT

Instrumentation Information

Inst. Group ID: 5 VEHNO: 1 CURNO: 012
SENTYP: AC SENLOC: 02 SENATT: CHST
AXIS: XL UNITS: G'S PREFIL: 1650
INSMAN: MFG: ENDEVCO, MODEL: 7264-200, S/N: BJ27H
CALDAT: 02/OCT/92 INSRAT: 200 CHLMAX: 22 INIVEL: 56.6
NFP: -300 NLP: 2999 DELT: 100 DASTAT: AM
INSCOM: NO COMMENT

Instrumentation Information

Inst. Group ID: 5 VEHNO: 1 CURNO: 013
SENTYP: AC SENLOC: 02 SENATT: CHST
AXIS: YL UNITS: G'S PREFIL: 1650
INSMAN: MFG: ENDEVCO, MODEL: 7264-200, S/N: BG78H
CALDAT: 02/OCT/92 INSRAT: 200 CHLMAX: 24 INIVEL: 0.0
NFP: -300 NLP: 2999 DELT: 100 DASTAT: AM
INSCOM: NO COMMENT

Instrumentation Information

Inst. Group ID: 5 VEHNO: 1 CURNO: 014
SENTYP: AC SENLOC: 02 SENATT: CHST
AXIS: ZL UNITS: G'S PREFIL: 1650
INSMAN: MFG: ENDEVCO, MODEL: 7264-200, S/N: AR39
CALDAT: 02/OCT/92 INSRAT: 200 CHLMAX: 14 INIVEL: 0.0
NFP: -300 NLP: 2999 DELT: 100 DASTAT: AM
INSCOM: NO COMMENT

Instrumentation Information

Inst. Group ID: 5 VEHNO: 1 CURNO: 015
SENTYP: LC SENLOC: 02 SENATT: FMRL
AXIS: XL UNITS: NWT PREFIL: 1650
INSMAN: MFG: GSE INC, MODEL: 2430, S/N: 634
CALDAT: 09/OCT/92 INSRAT: 13350 CHLMAX: 14 INIVEL: 0.0
NFP: -300 NLP: 2999 DELT: 100 DASTAT: CF
INSCOM: CHANNEL FAILED AT 43.3 MSEC

Instrumentation Information

Inst. Group ID: 5 VEHNO: 1 CURNO: 016
SENTYP: LC SENLOC: 02 SENATT: FMRR
AXIS: XL UNITS: NWT PREFIL: 1650
INSMAN: MFG: GSE INC, MODEL: 2430, S/N: 550
CALDAT: 09/OCT/92 INSRAT: 13350 CHLMAX: 17 INIVEL: 0.0
NFP: -300 NLP: 2999 DELT: 100 DASTAT: AM
INSCOM: NO COMMENT

Instrumentation Information

Inst. Group ID: 5 VEHNO: 1 CURNO: 017
SENTYP: LC SENLOC: 01 SENATT: LPBO
AXIS: OT UNITS: NWT PREFIL: 1650
INSMAN: MFG: LEBOW, MODEL: 3371, S/N: 333
CALDAT: 13/OCT/92 INSRAT: 15575 CHLMAX: 63 INIVEL: 0.0
NFP: -300 NLP: 2999 DELT: 100 DASTAT: AM
INSCOM: NO COMMENT

Instrumentation Information

Inst. Group ID: 5 VEHNO: 1 CURNO: 018
SENTYP: LC SENLOC: 01 SENATT: SHBT
AXIS: OT UNITS: NWT PREFIL: 1650
INSMAN: MFG: LEBOW, MODEL: 3371, S/N: 327
CALDAT: 13/OCT/92 INSRAT: 15575 CHLMAX: 64 INIVEL: 0.0
NFP: -300 NLP: 2999 DELT: 100 DASTAT: AM
INSCOM: NO COMMENT

Instrumentation Information

Inst. Group ID: 5 VEHNO: 1 CURNO: 019
SENTYP: LC SENLOC: 02 SENATT: LPBO
AXIS: OT UNITS: NWT PREFIL: 1650
INSMAN: MFG: LEBOW, MODEL: 3371, S/N: 330
CALDAT: 13/OCT/92 INSRAT: 15575 CHLMAX: 50 INIVEL: 0.0
NFP: -300 NLP: 2999 DELT: 100 DASTAT: AM
INSCOM: NO COMMENT

Instrumentation Information

Inst. Group ID: 5 VEHNO: 1 CURNO: 020
SENTYP: LC SENLOC: 02 SENATT: SHBT
AXIS: OT UNITS: NWT PREFIL: 1650
INSMAN: MFG: LEBOW, MODEL: 3371, S/N: 308
CALDAT: 13/OCT/92 INSRAT: 15575 CHLMAX: 54 INIVEL: 0.0
NFP: -300 NLP: 2999 DELT: 100 DASTAT: AM
INSCOM: NO COMMENT

Instrumentation Information

Inst. Group ID: 5 VEHNO: 1 CURNO: 021
SENTYP: DS SENLOC: 01 SENATT: SHBT
AXIS: OT UNITS: OTH PREFIL: 1650
INSMAN: MFG: ETI, MODEL: LCP12A-12, S/N: 1
CALDAT: 10/NOV/92 INSRAT: 50 CHLMAX: 9 INIVEL: 0.0
NFP: -300 NLP: 2999 DELT: 100 DASTAT: AM
INSCOM: PERCENT OF TOTAL BELT STRETCH

Instrumentation Information

Inst. Group ID: 5 VEHNO: 1 CURNO: 022
SENTYP: DS SENLOC: 02 SENATT: SHBT
AXIS: OT UNITS: OTH PREFIL: 1650
INSMAN: MFG: ETI, MODEL: LCP12A-12, S/N: 2
CALDAT: 10/NOV/92 INSRAT: 50 CHLMAX: 6 INIVEL: 0.0
NFP: -300 NLP: 2999 DELT: 100 DASTAT: AM
INSCOM: PERCENT OF TOTAL BELT STRETCH

Instrumentation Information

Inst. Group ID: 5 VEHNO: 1 CURNO: 023
SENTYP: DS SENLOC: 01 SENATT: SHBE
AXIS: OT UNITS: CMS PREFIL: 1650
INSMAN: MFG: CELESCO, MODEL: 20 IN., S/N: NA
CALDAT: 10/NOV/92 INSRAT: 51 CHLMAX: 8 INIVEL: 0.0
NFP: -300 NLP: 2999 DELT: 100 DASTAT: AM
INSCOM: NO COMMENT

Instrumentation Information

Inst. Group ID: 5 VEHNO: 1 CURNO: 024
SENTYP: DS SENLOC: 02 SENATT: SHBE
AXIS: OT UNITS: CMS PREFIL: 1650
INSMAN: MFG: MSE, MODEL: 24 IN. LIN., S/N: 112
CALDAT: 10/NOV/92 INSRAT: 61 CHLMAX: 5 INIVEL: 0.0
NFP: -300 NLP: 2999 DELT: 100 DASTAT: AM
INSCOM: NO COMMENT

Instrumentation Information

Inst. Group ID: 5 VEHNO: 1 CURNO: 025
SENTYP: AC SENLOC: NA SENATT: SULF
AXIS: XG UNITS: G'S PREFIL: 1650
INSMAN: MFG: I.C. SENSOR, MODEL: 3031-200, S/N: 29-200
CALDAT: 09/OCT/92 INSRAT: 200 CHLMAX: 126 INIVEL: 56.6
NFP: -300 NLP: 2999 DELT: 100 DASTAT: AM
INSCOM: NO COMMENT

Instrumentation Information

Inst. Group ID: 5 VEHNO: 1 CURNO: 026
SENTYP: AC SENLOC: NA SENATT: SURF
AXIS: XG UNITS: G'S PREFIL: 1650
INSMAN: MFG: I.C. SENSOR, MODEL: 3031-200, S/N: 25-200
CALDAT: 09/OCT/92 INSRAT: 200 CHLMAX: 158 INIVEL: 56.6
NFP: -300 NLP: 2999 DELT: 100 DASTAT: AM
INSCOM: NO COMMENT

Instrumentation Information

Inst. Group ID: 5 VEHNO: 1 CURNO: 027
SENTYP: AC SENLOC: NA SENATT: ENGN
AXIS: XG UNITS: G'S PREFIL: 1650
INSMAN: MFG: I.C. SENSOR, MODEL: 3031-200, S/N: 33-200
CALDAT: 09/OCT/92 INSRAT: 200 CHLMAX: 132 INIVEL: 56.6
NFP: -300 NLP: 2999 DELT: 100 DASTAT: CF
INSCOM: CHANNEL FAILED AT 33.1 MSEC

Instrumentation Information

Inst. Group ID: 5 VEHNO: 1 CURNO: 028
SENTYP: AC SENLOC: NA SENATT: ENGN
AXIS: XG UNITS: G'S PREFIL: 1650
INSMAN: MFG: I.C. SENSOR, MODEL: 3031-200, S/N: 27-200
CALDAT: 09/OCT/92 INSRAT: 200 CHLMAX: 89 INIVEL: 56.6
NFP: -300 NLP: 2999 DELT: 100 DASTAT: AM
INSCOM: NO COMMENT

Instrumentation Information

Inst. Group ID: 5 VEHNO: 1 CURNO: 029
SENTYP: AC SENLOC: NA SENATT: DPLC
AXIS: XG UNITS: G'S PREFIL: 1650
INSMAN: MFG: I.C. SENSOR, MODEL: 3031-200, S/N: 28-200
CALDAT: 09/OCT/92 INSRAT: 200 CHLMAX: 45 INIVEL: 56.6
NFP: -300 NLP: 2999 DELT: 100 DASTAT: AM
INSCOM: NO COMMENT

Instrumentation Information

Inst. Group ID: 5 VEHNO: 1 CURNO: 030
SENTYP: AC SENLOC: NA SENATT: FLLR
AXIS: XG UNITS: G'S PREFIL: 1650
INSMAN: MFG: I.C. SENSOR, MODEL: 3031-200, S/N: 23-200
CALDAT: 09/OCT/92 INSRAT: 200 CHLMAX: 48 INIVEL: 56.6
NFP: -300 NLP: 2999 DELT: 100 DASTAT: AM
INSCOM: NO COMMENT

Instrumentation Information

Inst. Group ID: 5 VEHNO: 1 CURNO: 031
 SENTYP: AC SENLOC: NA SENATT: FLRR
 AXIS: XG UNITS: G'S PREFIL: 1650
 INSMAN: MFG: I.C. SENSOR, MODEL: 3031-200, S/N:
 CALDAT: 09/OCT/92 INSRAT: 200 CHLMAX: 42 INIVEL: 56.6
 NFP: -300 NLP: 2999 DELT: 100 DASTAT: AM
 INSCOM: NO COMMENT

Instrumentation Information

Inst. Group ID: 5 VEHNO: 1 CURNO: 032
 SENTYP: AC SENLOC: NA SENATT: OTHR
 AXIS: XG UNITS: G'S PREFIL: 1650
 INSMAN: MFG: BELL & HOWELL, MODEL: 4-202-0001, S/N: 20839
 CALDAT: 19/OCT/92 INSRAT: 200 CHLMAX: 43 INIVEL: 56.6
 NFP: -300 NLP: 2999 DELT: 100 DASTAT: AM
 INSCOM: NO COMMENT

Instrumentation Information

Inst. Group ID: 5 VEHNO: 1 CURNO: 033
 SENTYP: AC SENLOC: NA SENATT: TRFC
 AXIS: XG UNITS: G'S PREFIL: 1650
 INSMAN: MFG: BELL & HOWELL, MODEL: 4-202-0001, S/N: 19428
 CALDAT: 19/OCT/92 INSRAT: 200 CHLMAX: 42 INIVEL: 56.6
 NFP: -300 NLP: 2999 DELT: 100 DASTAT: AM
 INSCOM: NO COMMENT

Instrumentation Information

Inst. Group ID: 5 VEHNO: 0 CURNO: 034
 SENTYP: LC SENLOC: NA SENATT: LCA1
 AXIS: XG UNITS: NWT PREFIL: 1650
 INSMAN: MFG: INTERFACE, MODEL: 1220-FS, S/N: 19349
 CALDAT: 14/MAY/85 INSRAT: 222 CHLMAX: 3 INIVEL: 0.0
 NFP: -250 NLP: 2499 DELT: 120 DASTAT: AM
 INSCOM: NO COMMENT

Instrumentation Information

Inst. Group ID: 5 VEHNO: 0 CURNO: 035
 SENTYP: LC SENLOC: NA SENATT: LCA2
 AXIS: XG UNITS: NWT PREFIL: 1650
 INSMAN: MFG: INTERFACE, MODEL: 1220-FS, S/N: 19324
 CALDAT: 14/MAY/85 INSRAT: 222 CHLMAX: 4 INIVEL: 0.0
 NFP: -250 NLP: 2499 DELT: 120 DASTAT: AM
 INSCOM: NO COMMENT

Instrumentation Information

Inst. Group ID: 5 VEHNO: 0 CURNO: 036
SENTYP: LC SENLOC: NA SENATT: LCA3
AXIS: XG UNITS: NWT PREFIL: 1650
INSMAN: MFG: INTERFACE, MODEL: 1220-FS, S/N: 19283
CALDAT: 14/MAY/85 INSRAT: 222 CHLMAX: 6 INIVEL: 0.0
NFP: -250 NLP: 2499 DELT: 120 DASTAT: AM
INSCOM: NO COMMENT

Instrumentation Information

Inst. Group ID: 5 VEHNO: 0 CURNO: 037
SENTYP: LC SENLOC: NA SENATT: LCA3
AXIS: XG UNITS: NWT PREFIL: 1650
INSMAN: MFG: INTERFACE, MODEL: 1220-FS, S/N: 19263
CALDAT: 14/MAY/85 INSRAT: 222 CHLMAX: 6 INIVEL: 0.0
NFP: -250 NLP: 2499 DELT: 120 DASTAT: AM
INSCOM: NO COMMENT

Instrumentation Information

Inst. Group ID: 5 VEHNO: 0 CURNO: 038
SENTYP: LC SENLOC: NA SENATT: LCA5
AXIS: XG UNITS: NWT PREFIL: 1650
INSMAN: MFG: INTERFACE, MODEL: 1220-FS, S/N: 19265
CALDAT: 14/MAY/85 INSRAT: 222 CHLMAX: 5 INIVEL: 0.0
NFP: -250 NLP: 2499 DELT: 120 DASTAT: AM
INSCOM: NO COMMENT

Instrumentation Information

Inst. Group ID: 5 VEHNO: 0 CURNO: 039
SENTYP: LC SENLOC: NA SENATT: LCA6
AXIS: XG UNITS: NWT PREFIL: 1650
INSMAN: MFG: INTERFACE, MODEL: 1220-FS, S/N: 19266
CALDAT: 14/MAY/85 INSRAT: 222 CHLMAX: 6 INIVEL: 0.0
NFP: -250 NLP: 2499 DELT: 120 DASTAT: AM
INSCOM: NO COMMENT

Instrumentation Information

Inst. Group ID: 5 VEHNO: 0 CURNO: 040
SENTYP: LC SENLOC: NA SENATT: LCA7
AXIS: XG UNITS: NWT PREFIL: 1650
INSMAN: MFG: INTERFACE, MODEL: 1220-FS, S/N: 19317
CALDAT: 14/MAY/85 INSRAT: 222 CHLMAX: 6 INIVEL: 0.0
NFP: -250 NLP: 2499 DELT: 120 DASTAT: AM
INSCOM: NO COMMENT

Instrumentation Information

Inst. Group ID: 5 VEHNO: 0 CURNO: 041
SENTYP: LC SENLOC: NA SENATT: LCA8
AXIS: XG UNITS: NWT PREFIL: 1650
INSMAN: MFG: INTERFACE, MODEL: 1220-FS, S/N: 19270
CALDAT: 14/MAY/85 INSRAT: 222 CHLMAX: 6 INIVEL: 0.0
NFP: -250 NLP: 2499 DELT: 120 DASTAT: AM
INSCOM: NO COMMENT

Instrumentation Information

Inst. Group ID: 5 VEHNO: 0 CURNO: 042
SENTYP: LC SENLOC: NA SENATT: LCA9
AXIS: XG UNITS: NWT PREFIL: 1650
INSMAN: MFG: INTERFACE, MODEL: 1220-FS, S/N: 19428
CALDAT: 14/MAY/85 INSRAT: 222 CHLMAX: 9 INIVEL: 0.0
NFP: -250 NLP: 2499 DELT: 120 DASTAT: AM
INSCOM: NO COMMENT

Instrumentation Information

Inst. Group ID: 5 VEHNO: 0 CURNO: 043
SENTYP: LC SENLOC: NA SENATT: LCB1
AXIS: XG UNITS: NWT PREFIL: 1650
INSMAN: MFG: INTERFACE, MODEL: 1220-FS, S/N: 19273
CALDAT: 14/MAY/85 INSRAT: 222 CHLMAX: 7 INIVEL: 0.0
NFP: -250 NLP: 2499 DELT: 120 DASTAT: AM
INSCOM: NO COMMENT

Instrumentation Information

Inst. Group ID: 5 VEHNO: 0 CURNO: 044
SENTYP: LC SENLOC: NA SENATT: LCB1
AXIS: XG UNITS: NWT PREFIL: 1650
INSMAN: MFG: INTERFACE, MODEL: 1220-FS, S/N: 19276
CALDAT: 14/MAY/85 INSRAT: 222 CHLMAX: 11 INIVEL: 0.0
NFP: -250 NLP: 2499 DELT: 120 DASTAT: AM
INSCOM: NO COMMENT

Instrumentation Information

Inst. Group ID: 5 VEHNO: 0 CURNO: 045
SENTYP: LC SENLOC: NA SENATT: LCB3
AXIS: XG UNITS: NWT PREFIL: 1650
INSMAN: MFG: INTERFACE, MODEL: 1220-FS, S/N: 19258
CALDAT: 14/MAY/85 INSRAT: 222 CHLMAX: 2 INIVEL: 0.0
NFP: -250 NLP: 2499 DELT: 120 DASTAT: AM
INSCOM: NO COMMENT

Instrumentation Information

Inst. Group ID: 5 VEHNO: 0 CURNO: 046
SENTYP: LC SENLOC: NA SENATT: LCB4
AXIS: XG UNITS: NWT PREFIL: 1650
INSMAN: MFG: INTERFACE, MODEL: 1220-FS, S/N: 19278
CALDAT: 14/MAY/85 INSRAT: 222 CHLMAX: 32 INIVEL: 0.0
NFP: -250 NLP: 2499 DELT: 120 DASTAT: AM
INSCOM: NO COMMENT

Instrumentation Information

Inst. Group ID: 5 VEHNO: 0 CURNO: 047
SENTYP: LC SENLOC: NA SENATT: LCB5
AXIS: XG UNITS: NWT PREFIL: 1650
INSMAN: MFG: INTERFACE, MODEL: 1220-FS, S/N: 19279
CALDAT: 14/MAY/85 INSRAT: 222 CHLMAX: 7 INIVEL: 0.0
NFP: -250 NLP: 2499 DELT: 120 DASTAT: AM
INSCOM: NO COMMENT

Instrumentation Information

Inst. Group ID: 5 VEHNO: 0 CURNO: 048
SENTYP: LC SENLOC: NA SENATT: LCB6
AXIS: XG UNITS: NWT PREFIL: 1650
INSMAN: MFG: INTERFACE, MODEL: 1220-FS, S/N: 19282
CALDAT: 14/MAY/85 INSRAT: 222 CHLMAX: 1 INIVEL: 0.0
NFP: -250 NLP: 2499 DELT: 120 DASTAT: AM
INSCOM: NO COMMENT

Instrumentation Information

Inst. Group ID: 5 VEHNO: 0 CURNO: 049
SENTYP: LC SENLOC: NA SENATT: LCB7
AXIS: XG UNITS: NWT PREFIL: 1650
INSMAN: MFG: INTERFACE, MODEL: 1220-FS, S/N: 19262
CALDAT: 14/MAY/85 INSRAT: 222 CHLMAX: 37 INIVEL: 0.0
NFP: -250 NLP: 2499 DELT: 120 DASTAT: AM
INSCOM: NO COMMENT

Instrumentation Information

Inst. Group ID: 5 VEHNO: 0 CURNO: 050
SENTYP: LC SENLOC: NA SENATT: LCB8
AXIS: XG UNITS: NWT PREFIL: 1650
INSMAN: MFG: INTERFACE, MODEL: 1220-FS, S/N: 19285
CALDAT: 14/MAY/85 INSRAT: 222 CHLMAX: 14 INIVEL: 0.0
NFP: -250 NLP: 2499 DELT: 120 DASTAT: AM
INSCOM: NO COMMENT

Instrumentation Information

Inst. Group ID: 5	VEHNO: 0	CURNO: 051	
SENTYP: LC	SENLOC: NA	SENATT: LCB9	
AXIS: XG	UNITS: NWT	PREFIL: 1650	
INSMAN: MFG: INTERFACE, MODEL: 1220-FS,		S/N: 19286	
CALDAT: 14/MAY/85	INSRAT: 222	CHLMAX: 11	INIVEL: 0.0
NFP: -250	NLP: 2499	DELT: 120	DASTAT: AM
INSCOM: NO COMMENT			

Instrumentation Information

Inst. Group ID: 5	VEHNO: 0	CURNO: 052	
SENTYP: LC	SENLOC: NA	SENATT: LCC1	
AXIS: XG	UNITS: NWT	PREFIL: 1650	
INSMAN: MFG: INTERFACE, MODEL: 1220-FS,		S/N: 19287	
CALDAT: 14/MAY/85	INSRAT: 222	CHLMAX: 5	INIVEL: 0.0
NFP: -250	NLP: 2499	DELT: 120	DASTAT: AM
INSCOM: NO COMMENT			

Instrumentation Information

Inst. Group ID: 5	VEHNO: 0	CURNO: 053	
SENTYP: LC	SENLOC: NA	SENATT: LCC2	
AXIS: XG	UNITS: NWT	PREFIL: 1650	
INSMAN: MFG: INTERFACE, MODEL: 1220-FS,		S/N: 19288	
CALDAT: 14/MAY/85	INSRAT: 222	CHLMAX: 11	INIVEL: 0.0
NFP: -250	NLP: 2499	DELT: 120	DASTAT: AM
INSCOM: NO COMMENT			

Instrumentation Information

Inst. Group ID: 5	VEHNO: 0	CURNO: 054	
SENTYP: LC	SENLOC: NA	SENATT: LCC3	
AXIS: XG	UNITS: NWT	PREFIL: 1650	
INSMAN: MFG: INTERFACE, MODEL: 1220-FS,		S/N: 19289	
CALDAT: 14/MAY/85	INSRAT: 222	CHLMAX: 1	INIVEL: 0.0
NFP: -250	NLP: 2499	DELT: 120	DASTAT: AM
INSCOM: NO COMMENT			

Instrumentation Information

Inst. Group ID: 5	VEHNO: 0	CURNO: 055	
SENTYP: LC	SENLOC: NA	SENATT: LCC4	
AXIS: XG	UNITS: NWT	PREFIL: 1650	
INSMAN: MFG: INTERFACE, MODEL: 1220-FS,		S/N: 19291	
CALDAT: 14/MAY/85	INSRAT: 222	CHLMAX: 34	INIVEL: 0.0
NFP: -250	NLP: 2499	DELT: 120	DASTAT: AM
INSCOM: NO COMMENT			

Instrumentation Information

Inst. Group ID: 5 VEHNO: 0 CURNO: 056
SENTYP: LC SENLOC: NA SENATT: LCC5
AXIS: XG UNITS: NWT PREFIL: 1650
INSMAN: MFG: INTERFACE, MODEL: 1220-FS, S/N: 19324
CALDAT: 14/MAY/85 INSRAT: 222 CHLMAX: 42 INIVEL: 0.0
NFP: -250 NLP: 2499 DELT: 120 DASTAT: AM
INSCOM: NO COMMENT

Instrumentation Information

Inst. Group ID: 5 VEHNO: 0 CURNO: 057
SENTYP: LC SENLOC: NA SENATT: LCC6
AXIS: XG UNITS: NWT PREFIL: 1650
INSMAN: MFG: INTERFACE, MODEL: 1220-FS, S/N: 19313
CALDAT: 14/MAY/85 INSRAT: 222 CHLMAX: 29 INIVEL: 0.0
NFP: -250 NLP: 2499 DELT: 120 DASTAT: AM
INSCOM: NO COMMENT

Instrumentation Information

Inst. Group ID: 5 VEHNO: 0 CURNO: 058
SENTYP: LC SENLOC: NA SENATT: LCC7
AXIS: XG UNITS: NWT PREFIL: 1650
INSMAN: MFG: INTERFACE, MODEL: 1220-FS, S/N: 19314
CALDAT: 14/MAY/85 INSRAT: 222 CHLMAX: 32 INIVEL: 0.0
NFP: -250 NLP: 2499 DELT: 120 DASTAT: AM
INSCOM: NO COMMENT

Instrumentation Information

Inst. Group ID: 5 VEHNO: 0 CURNO: 059
SENTYP: LC SENLOC: NA SENATT: LCC8
AXIS: XG UNITS: NWT PREFIL: 1650
INSMAN: MFG: INTERFACE, MODEL: 1220-FS, S/N: 19315
CALDAT: 14/MAY/85 INSRAT: 222 CHLMAX: 14 INIVEL: 0.0
NFP: -250 NLP: 2499 DELT: 120 DASTAT: AM
INSCOM: NO COMMENT

Instrumentation Information

Inst. Group ID: 5 VEHNO: 0 CURNO: 060
SENTYP: LC SENLOC: NA SENATT: LCC9
AXIS: XG UNITS: NWT PREFIL: 1650
INSMAN: MFG: INTERFACE, MODEL: 1220-FS, S/N: 19316
CALDAT: 14/MAY/85 INSRAT: 222 CHLMAX: 9 INIVEL: 0.0
NFP: -250 NLP: 2499 DELT: 120 DASTAT: AM
INSCOM: NO COMMENT

Instrumentation Information

Inst. Group ID: 5	VEHNO: 0	CURNO: 061	
SENTYP: LC	SENLOC: NA	SENATT: LCD1	
AXIS: XG	UNITS: NWT	PREFIL: 1650	
INSMAN: MFG: INTERFACE, MODEL: 1220-FS,		S/N: 19317	
CALDAT: 14/MAY/85	INSRAT: 222	CHLMAX: 3	INIVEL: 0.0
NFP: -250	NLP: 2499	DELT: 120	DASTAT: AM
INSCOM: NO COMMENT			

Instrumentation Information

Inst. Group ID: 5	VEHNO: 0	CURNO: 062	
SENTYP: LC	SENLOC: NA	SENATT: LCD2	
AXIS: XG	UNITS: NWT	PREFIL: 1650	
INSMAN: MFG: INTERFACE, MODEL: 1220-FS,		S/N: 19318	
CALDAT: 14/MAY/85	INSRAT: 222	CHLMAX: 21	INIVEL: 0.0
NFP: -250	NLP: 2499	DELT: 120	DASTAT: AM
INSCOM: NO COMMENT			

Instrumentation Information

Inst. Group ID: 5	VEHNO: 0	CURNO: 063	
SENTYP: LC	SENLOC: NA	SENATT: LCD3	
AXIS: XG	UNITS: NWT	PREFIL: 1650	
INSMAN: MFG: INTERFACE, MODEL: 1220-FS,		S/N: 19322	
CALDAT: 14/MAY/85	INSRAT: 222	CHLMAX: 12	INIVEL: 0.0
NFP: -250	NLP: 2499	DELT: 120	DASTAT: AM
INSCOM: NO COMMENT			

Instrumentation Information

Inst. Group ID: 5	VEHNO: 0	CURNO: 064	
SENTYP: LC	SENLOC: NA	SENATT: LCD4	
AXIS: XG	UNITS: NWT	PREFIL: 1650	
INSMAN: MFG: INTERFACE, MODEL: 1220-FS,		S/N: 19323	
CALDAT: 14/MAY/85	INSRAT: 222	CHLMAX: 18	INIVEL: 0.0
NFP: -250	NLP: 2499	DELT: 120	DASTAT: AM
INSCOM: NO COMMENT			

Instrumentation Information

Inst. Group ID: 5	VEHNO: 0	CURNO: 065	
SENTYP: LC	SENLOC: NA	SENATT: LCD5	
AXIS: XG	UNITS: NWT	PREFIL: 1650	
INSMAN: MFG: INTERFACE, MODEL: 1220-FS,		S/N: 19260	
CALDAT: 14/MAY/85	INSRAT: 222	CHLMAX: 34	INIVEL: 0.0
NFP: -250	NLP: 2499	DELT: 120	DASTAT: AM
INSCOM: NO COMMENT			

Instrumentation Information

Inst. Group ID: 5 VEHNO: 0 CURNO: 066
SENTYP: LC SENLOC: NA SENATT: LCD6
AXIS: XG UNITS: NWT PREFIL: 1650
INSMAN: MFG: INTERFACE, MODEL: 1220-FS, S/N: 19325
CALDAT: 14/MAY/85 INSRAT: 222 CHLMAX: 13 INIVEL: 0.0
NFP: -250 NLP: 2499 DELT: 120 DASTAT: AM
INSCOM: NO COMMENT

Instrumentation Information

Inst. Group ID: 5 VEHNO: 0 CURNO: 067
SENTYP: LC SENLOC: NA SENATT: LCD7
AXIS: XG UNITS: NWT PREFIL: 1650
INSMAN: MFG: INTERFACE, MODEL: 1220-FS, S/N: 19332
CALDAT: 14/MAY/85 INSRAT: 222 CHLMAX: 0 INIVEL: 0.0
NFP: -250 NLP: 2499 DELT: 120 DASTAT: MN
INSCOM: MEANINGLESS DATA, CAUSE UNKNOWN

Instrumentation Information

Inst. Group ID: 5 VEHNO: 0 CURNO: 068
SENTYP: LC SENLOC: NA SENATT: LCD8
AXIS: XG UNITS: NWT PREFIL: 1650
INSMAN: MFG: INTERFACE, MODEL: 1220-FS, S/N: 19333
CALDAT: 14/MAY/85 INSRAT: 222 CHLMAX: 30 INIVEL: 0.0
NFP: -250 NLP: 2499 DELT: 120 DASTAT: CF
INSCOM: CHANNEL FAILED AT 65.28 MSEC

Instrumentation Information

Inst. Group ID: 5 VEHNO: 0 CURNO: 069
SENTYP: LC SENLOC: NA SENATT: LCD9
AXIS: XG UNITS: NWT PREFIL: 1650
INSMAN: MFG: INTERFACE, MODEL: 1220-FS, S/N: 19338
CALDAT: 14/MAY/85 INSRAT: 222 CHLMAX: 8 INIVEL: 0.0
NFP: -250 NLP: 2499 DELT: 120 DASTAT: AM
INSCOM: NO COMMENT

THIS PAGE INTENTIONALLY LEFT BLANK

APPENDIX A
PHOTOGRAPHS

PRETEST FRONT VIEW
POSTTEST FRONT VIEW
PRETEST LEFT SIDE VIEW
POSTTEST LEFT SIDE VIEW
PRETEST RIGHT SIDE VIEW
POSTTEST RIGHT SIDE VIEW
PRETEST RIGHT FRONT 3/4 VIEW
POSTTEST RIGHT FRONT 3/4 VIEW
PRETEST LEFT REAR 3/4 VIEW
POSTTEST LEFT REAR 3/4 VIEW
PRETEST WINDSHIELD VIEW
POSTTEST WINDSHIELD VIEW
PRETEST ENGINE COMPARTMENT VIEW
POSTTEST ENGINE COMPARTMENT VIEW
PRETEST FRONT UNDERBODY VIEW
POSTTEST FRONT UNDERBODY VIEW
PRETEST REAR UNDERBODY VIEW
POSTTEST REAR UNDERBODY VIEW
PRETEST DRIVER DUMMY POSITION VIEW
POSTTEST DRIVER DUMMY POSITION VIEW
PRETEST PASSENGER DUMMY POSITION VIEW
POSTTEST PASSENGER DUMMY POSITION VIEW
PRETEST DRIVER DUMMY & VEHICLE INTERIOR VIEW (Door Open)
POSTTEST DRIVER DUMMY & VEHICLE INTERIOR VIEW (Door Open)
PRETEST PASSENGER DUMMY & VEHICLE INTERIOR VIEW (Door Open)
POSTTEST PASSENGER DUMMY & VEHICLE INTERIOR VIEW (Door Open)
POSTTEST DRIVER ATD HEAD AND KNEE CONTACT AREA
POSTTEST PASSENGER ATD KNEE CONTACT AREA

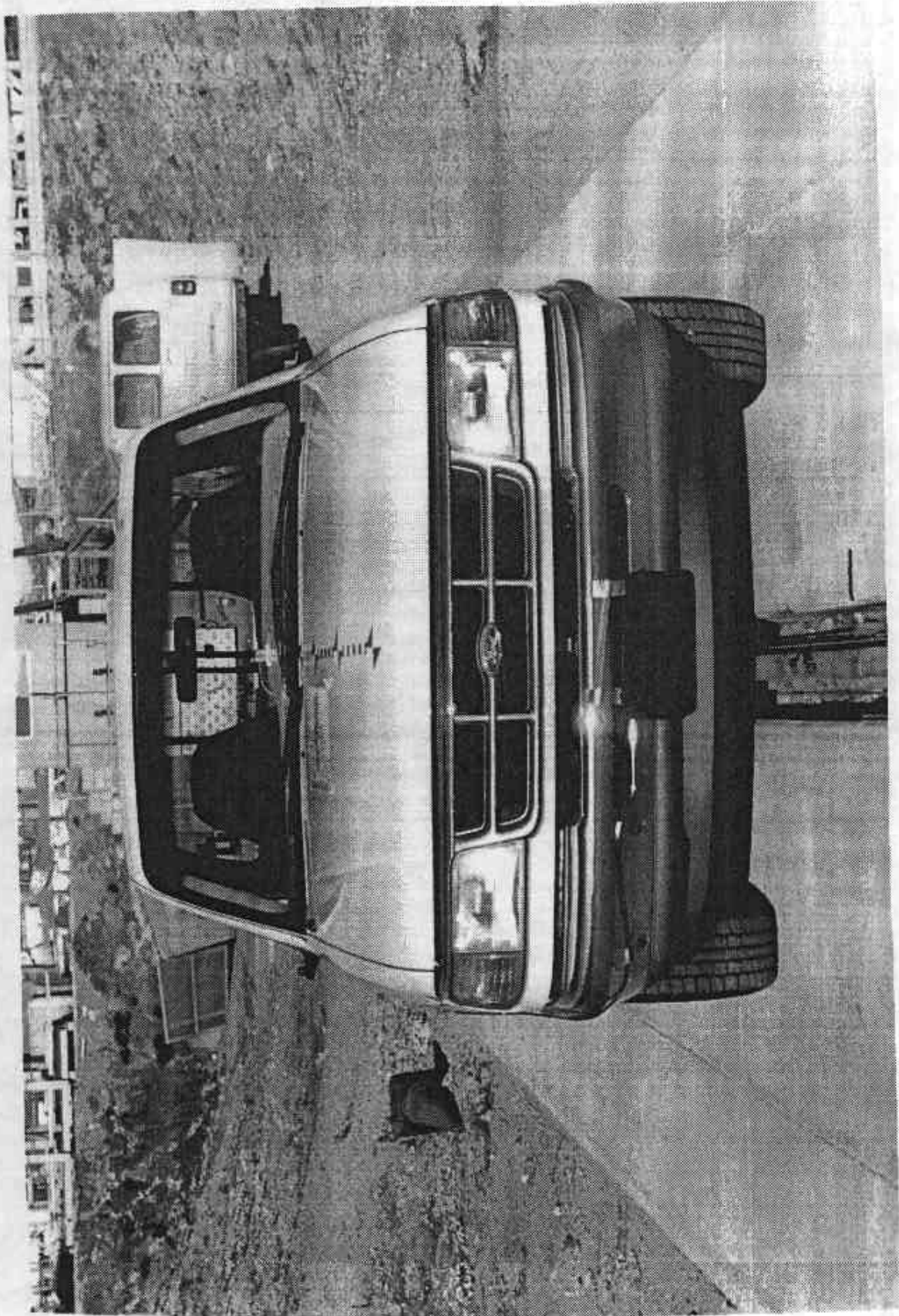

PRETEST FRONT VIEW

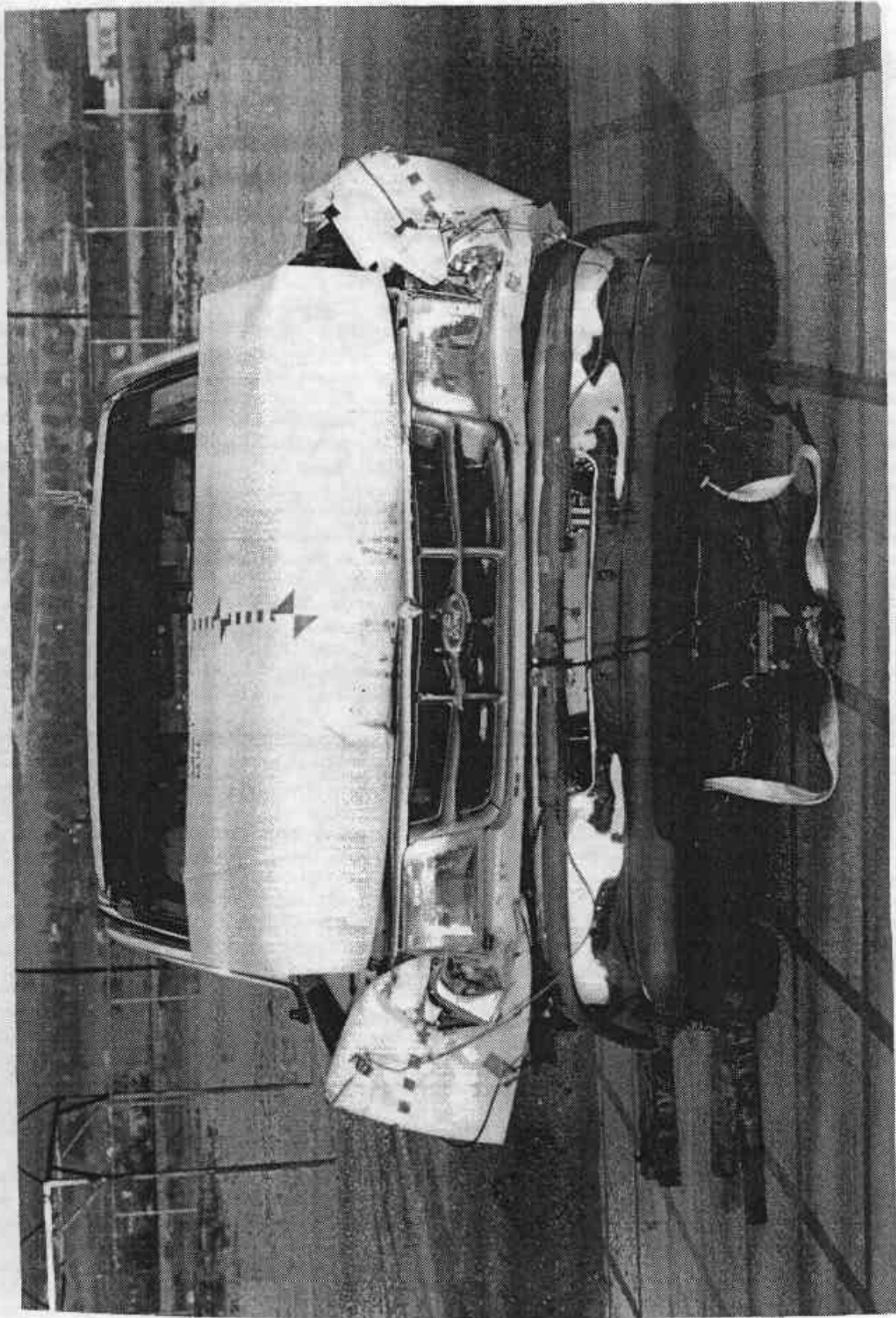

POSTTEST FRONT VIEW

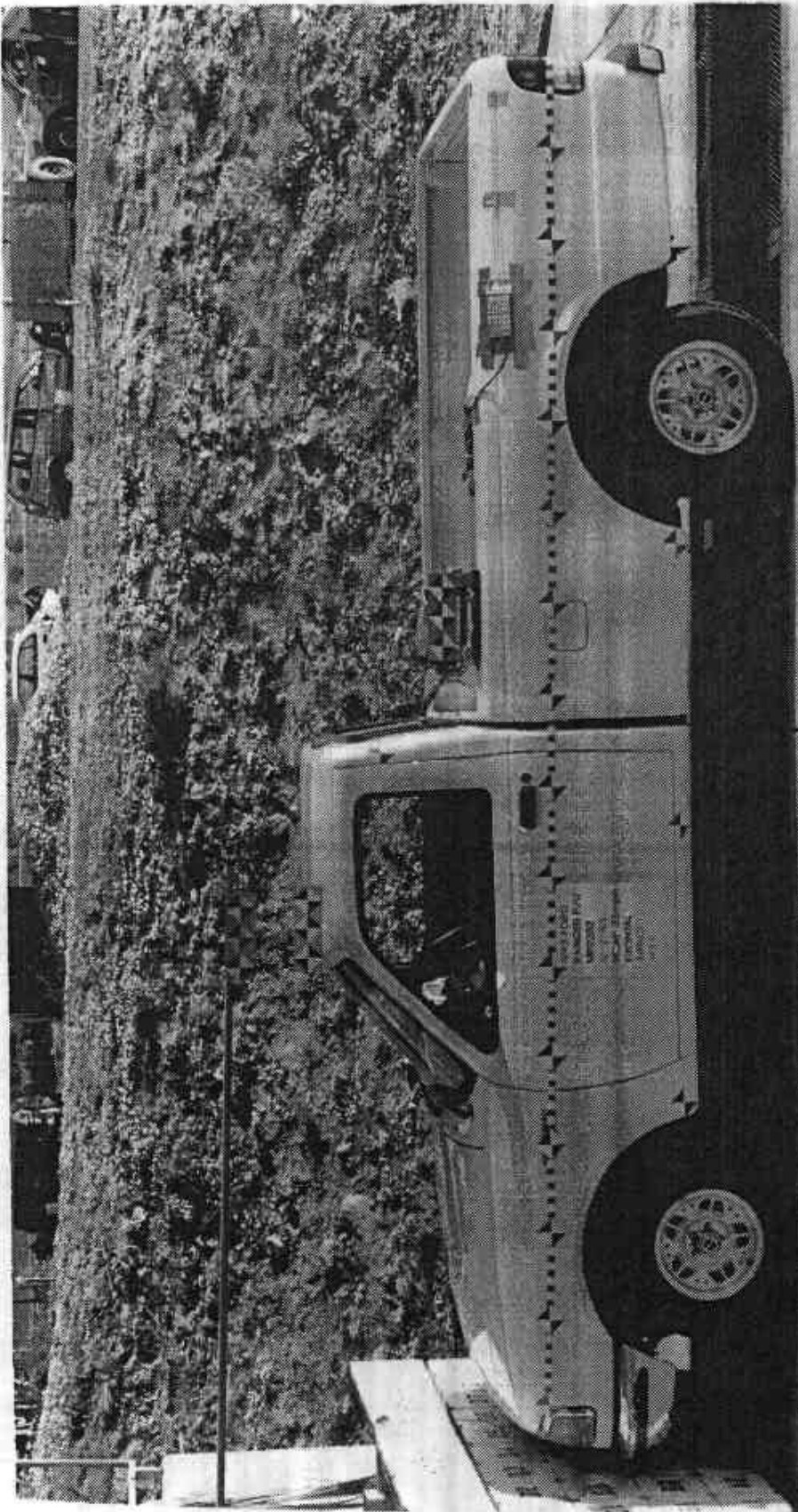

PRETEST LEFT SIDE VIEW

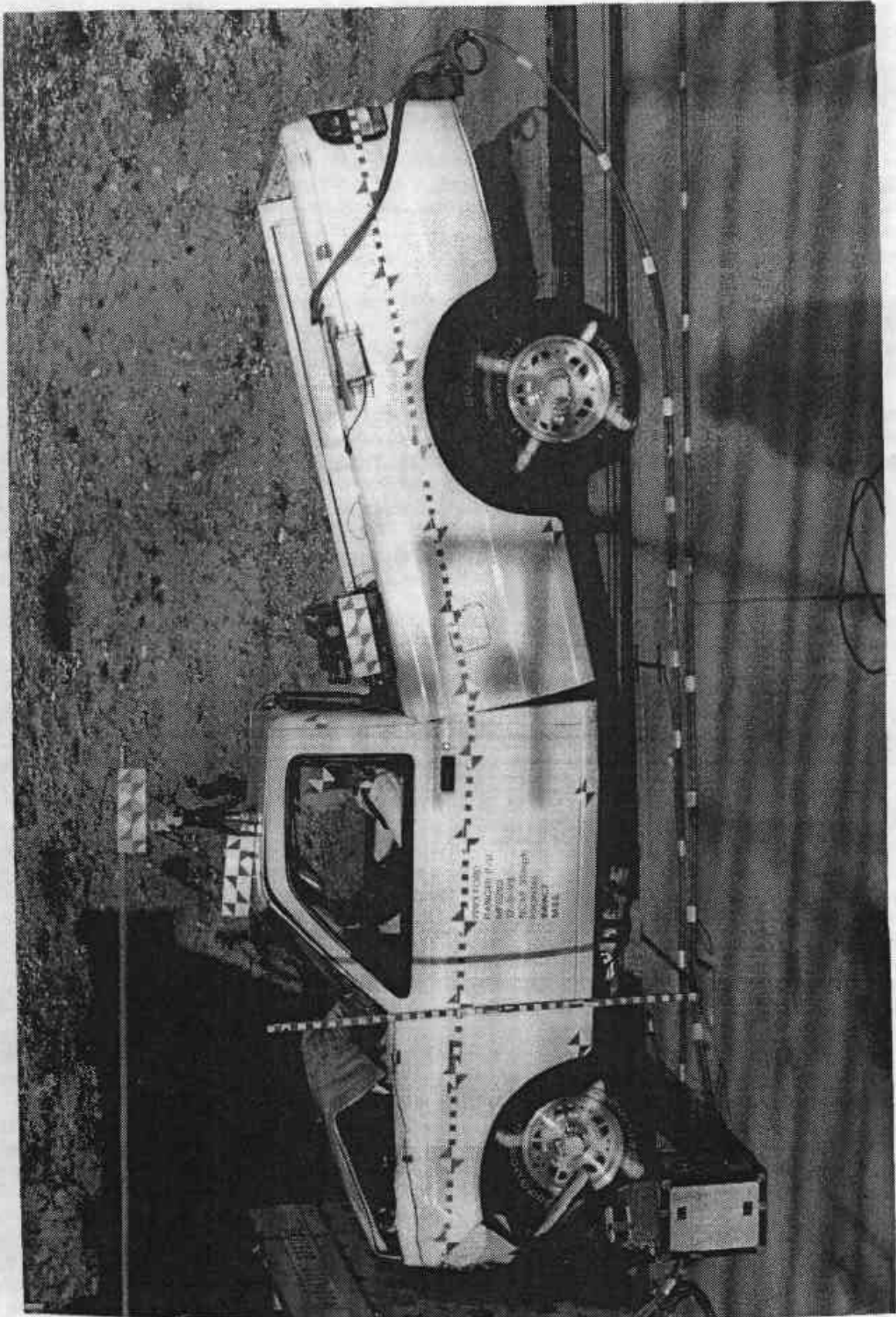

POSTTEST LEFT SIDE VIEW

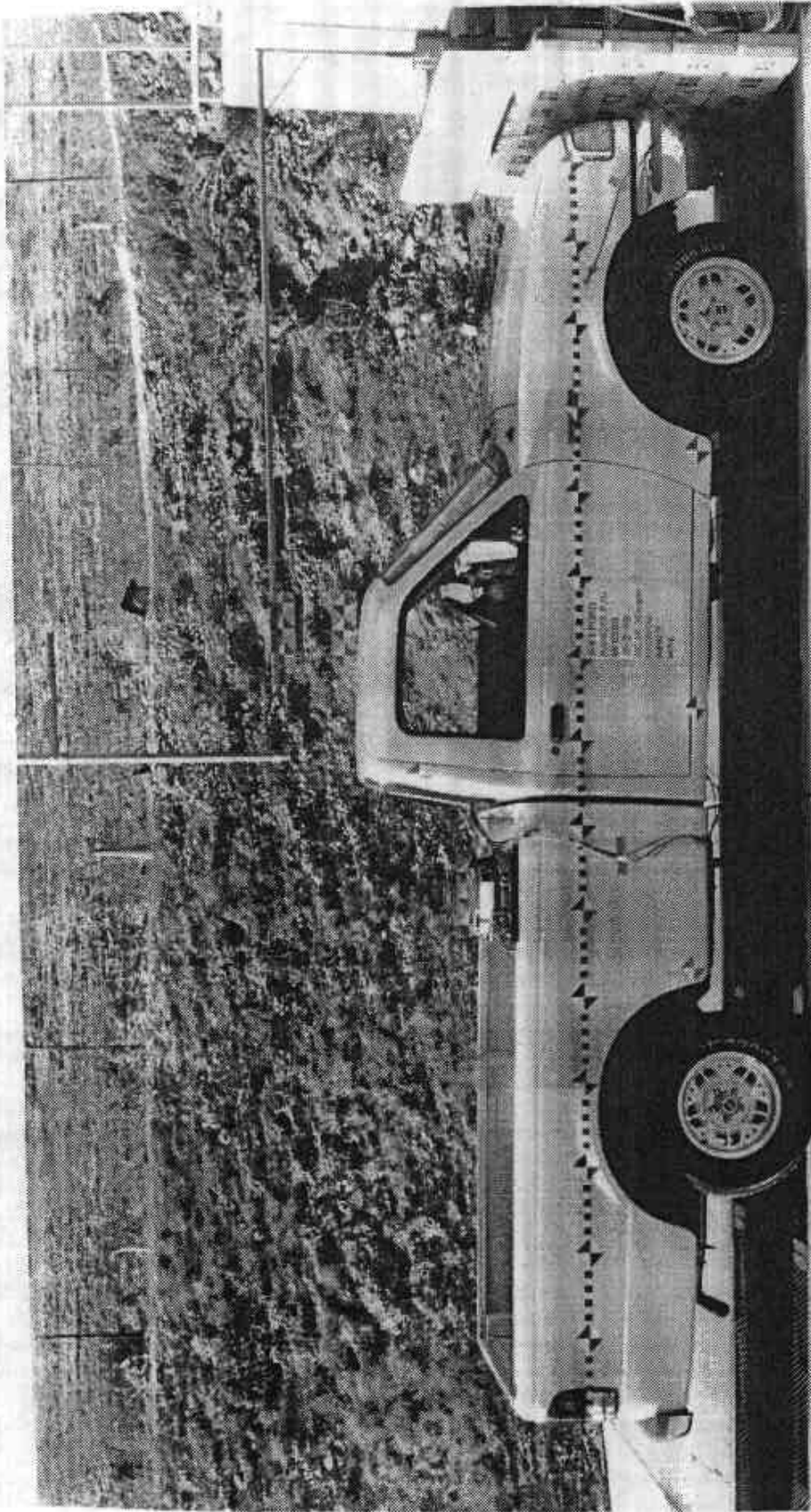

PRETEST RIGHT SIDE VIEW

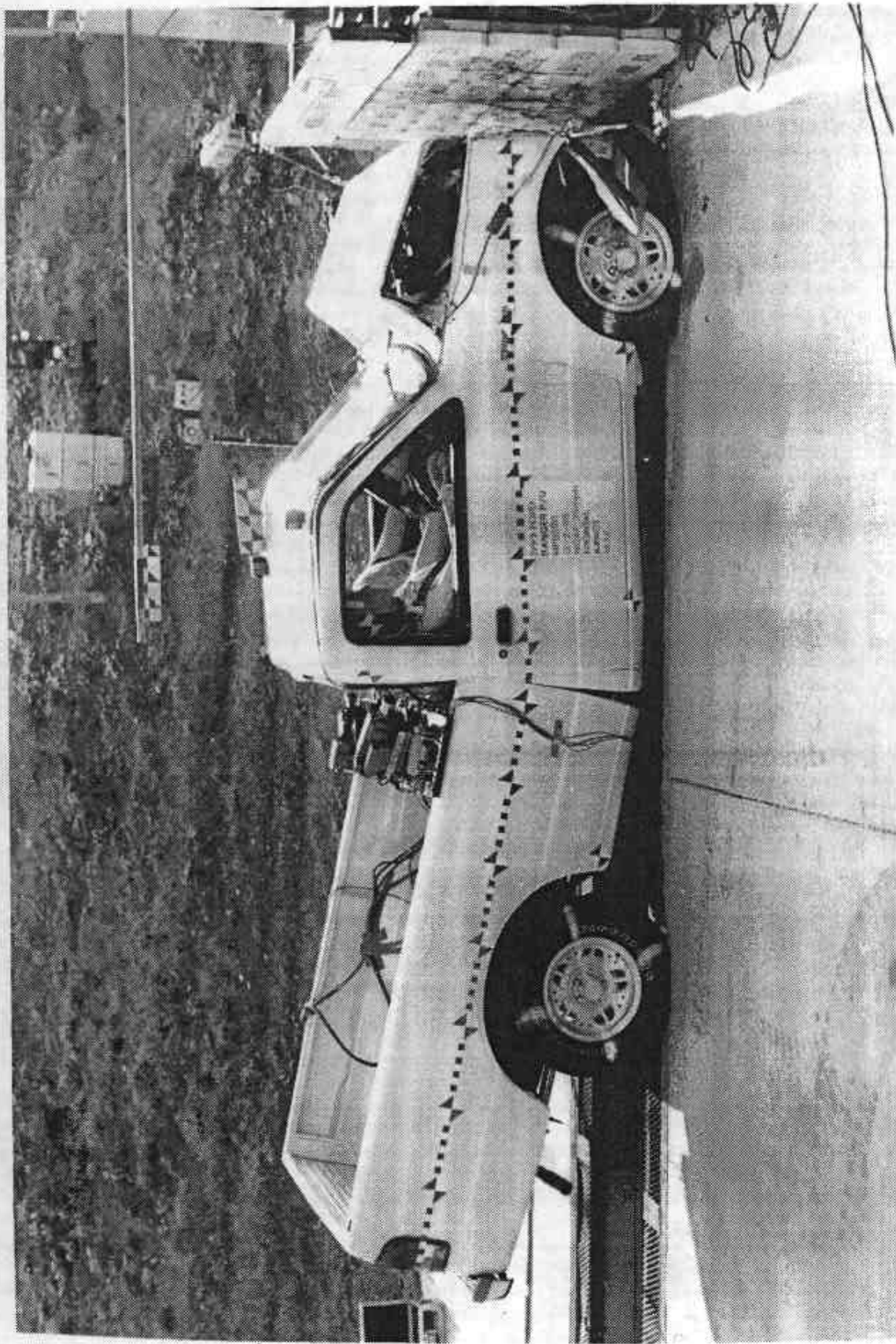

POSTTEST RIGHT SIDE VIEW



PRETEST RIGHT FRONT 3/4 VIEW

A-7

MSE-93-R92083-N03

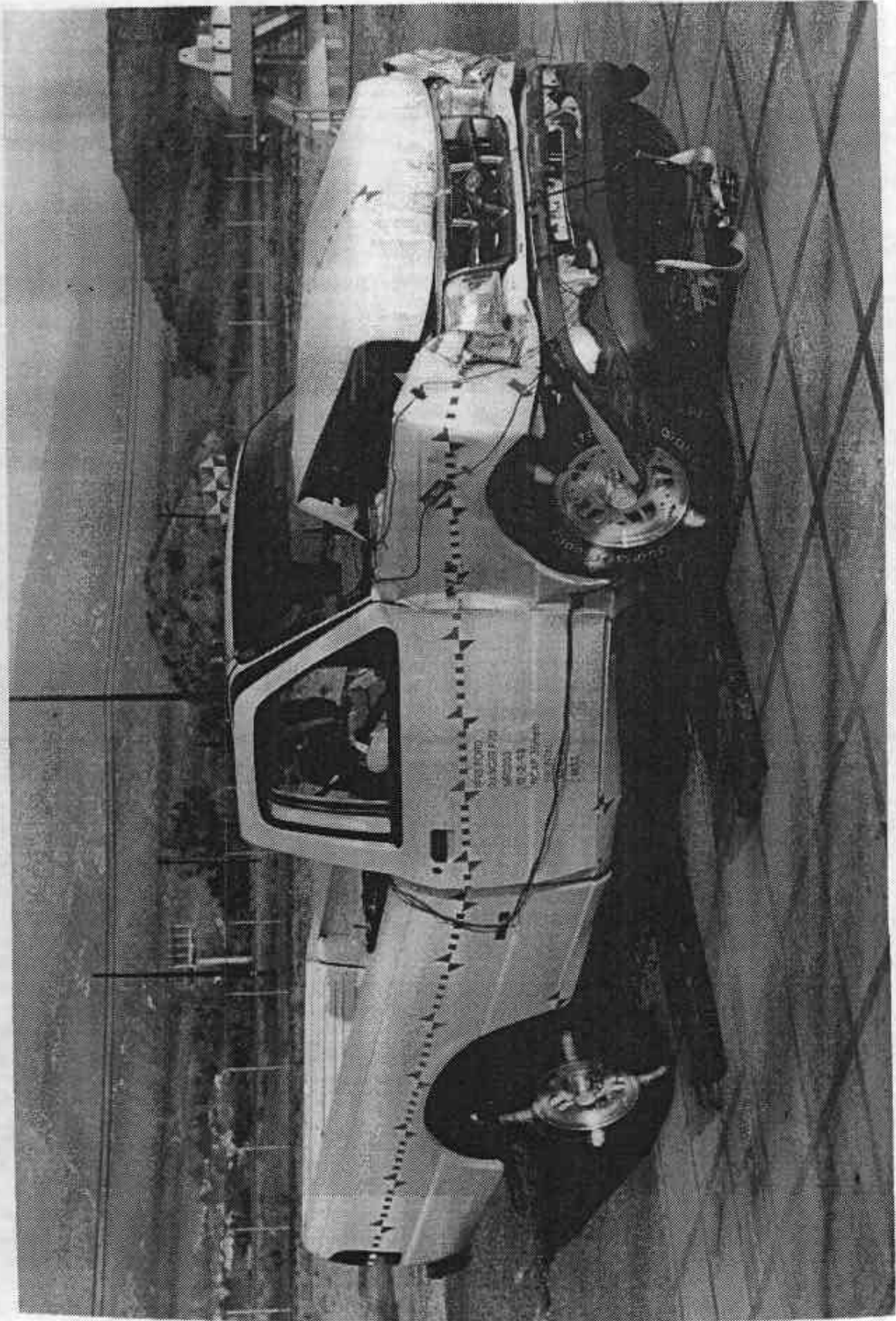

POSTTEST RIGHT FRONT 3/4 VIEW



PRETEST LEFT REAR 3/4 VIEW

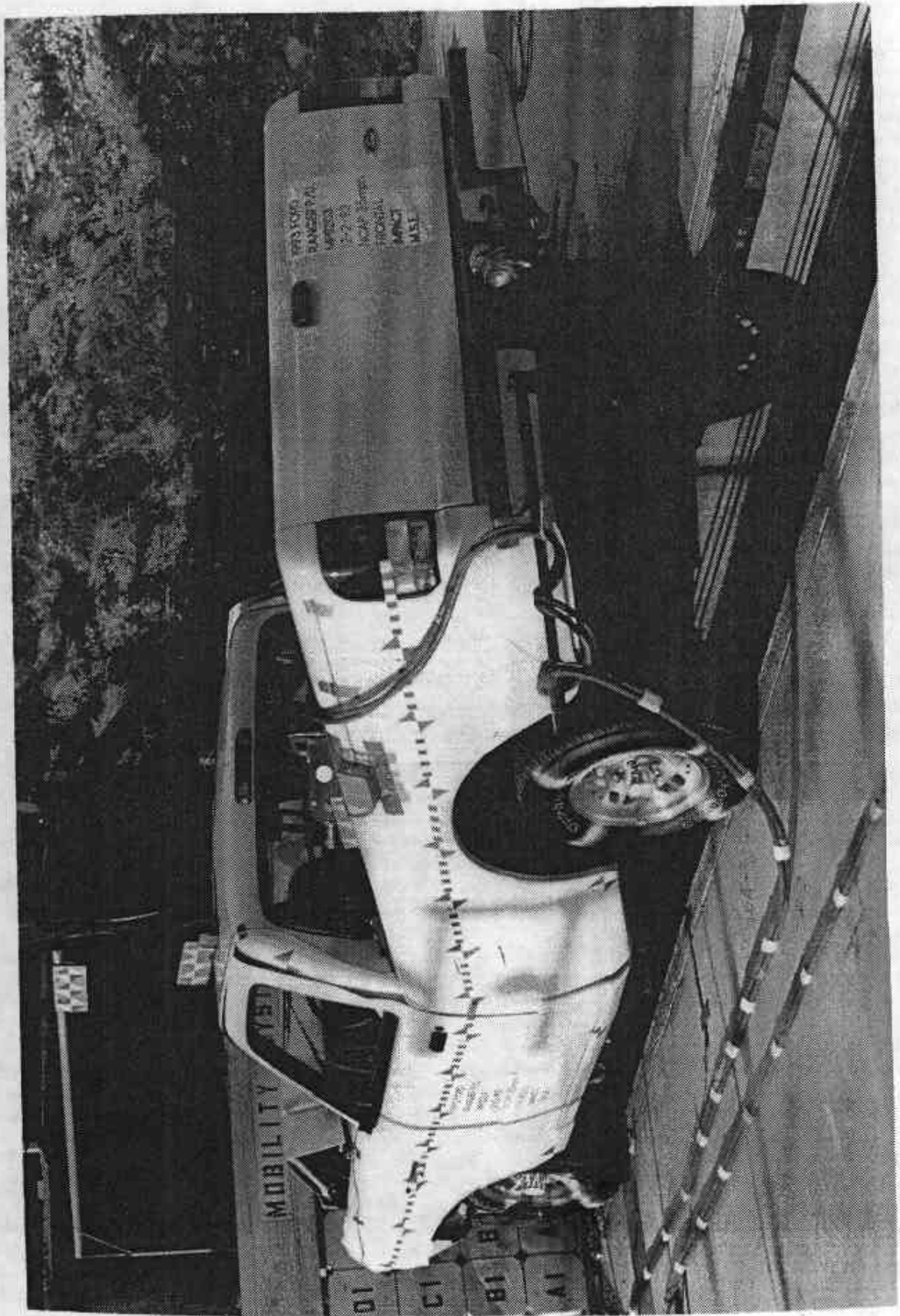

POSTTEST LEFT REAR 3/4 VIEW

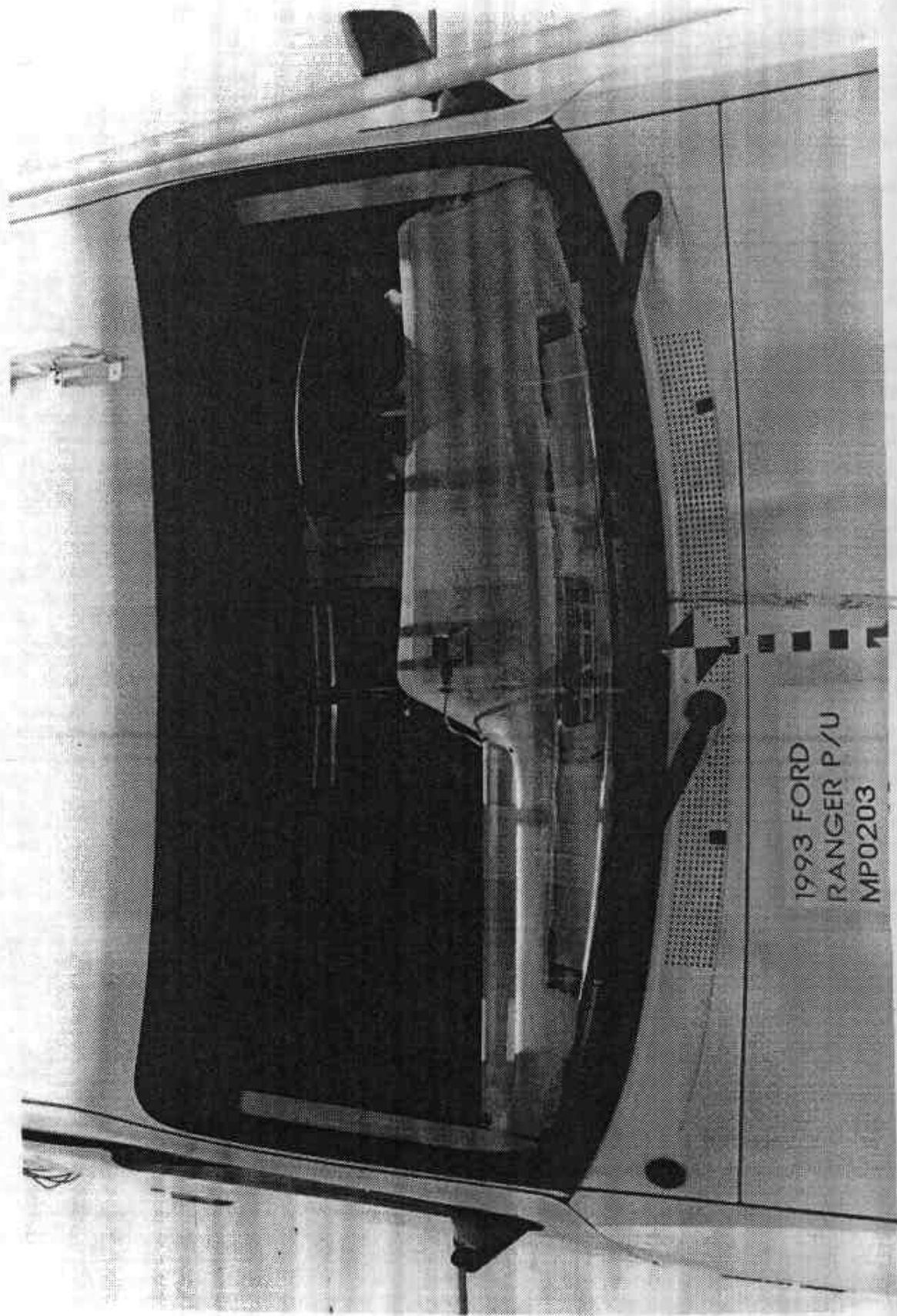

1993 FORD
RANGER P/U
MP0203

PRETEST WINDSHIELD VIEW

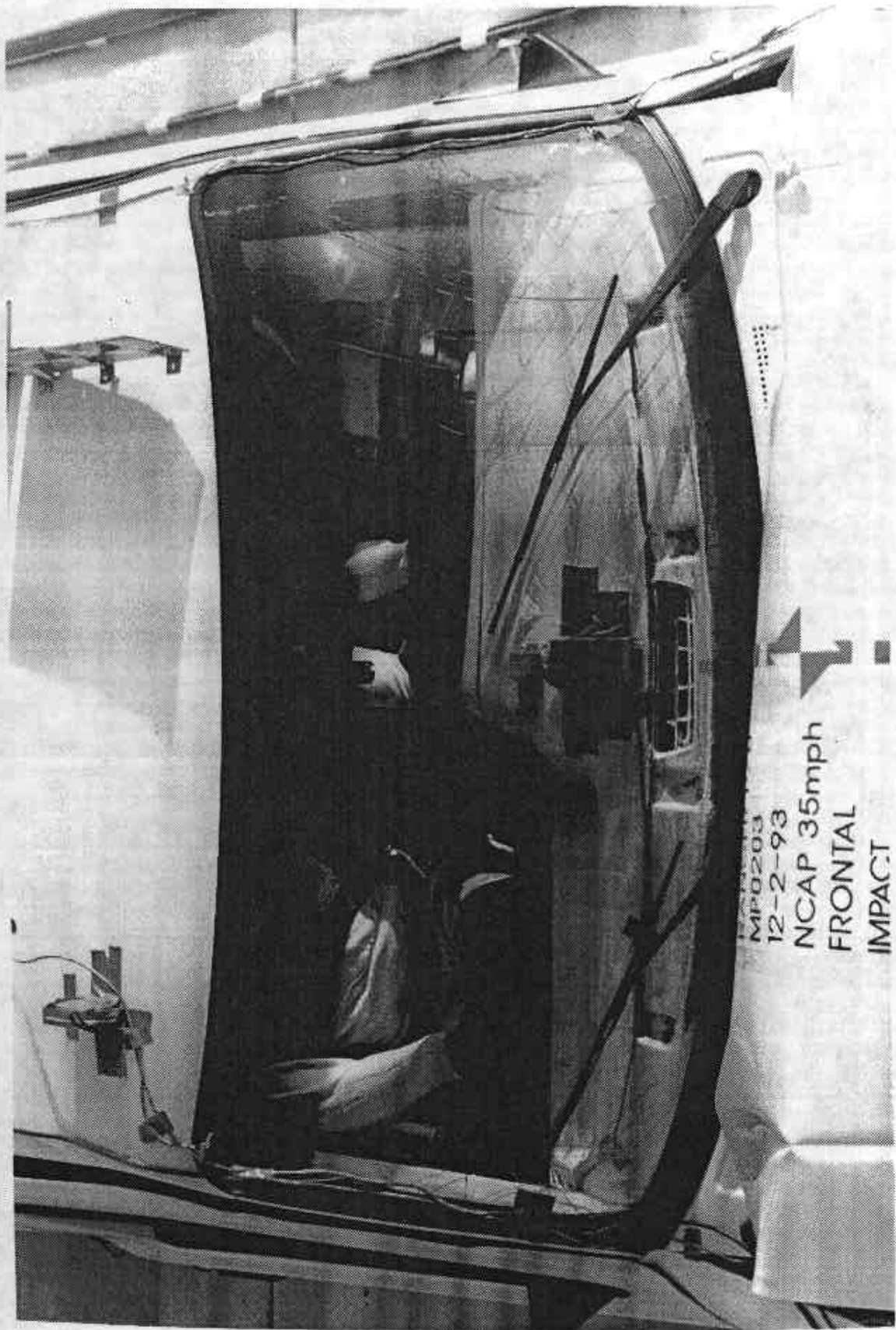

MP0203
12-2-93
NCAP 35mph
FRONTAL
IMPACT



POSTTEST WINDSHIELD VIEW

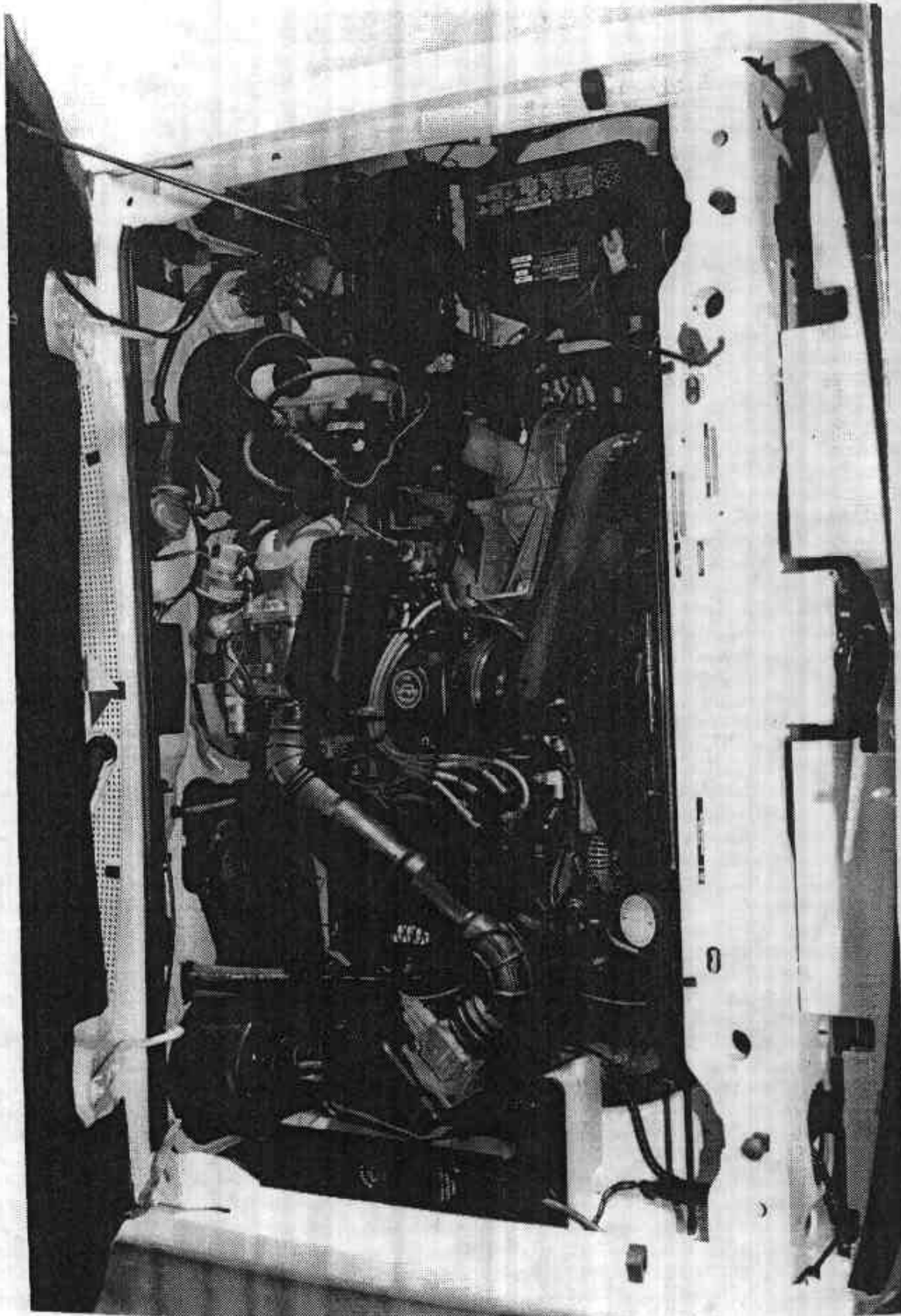

PRETEST ENGINE COMPARTMENT VIEW

A-13

MSE-93-R92083-N03

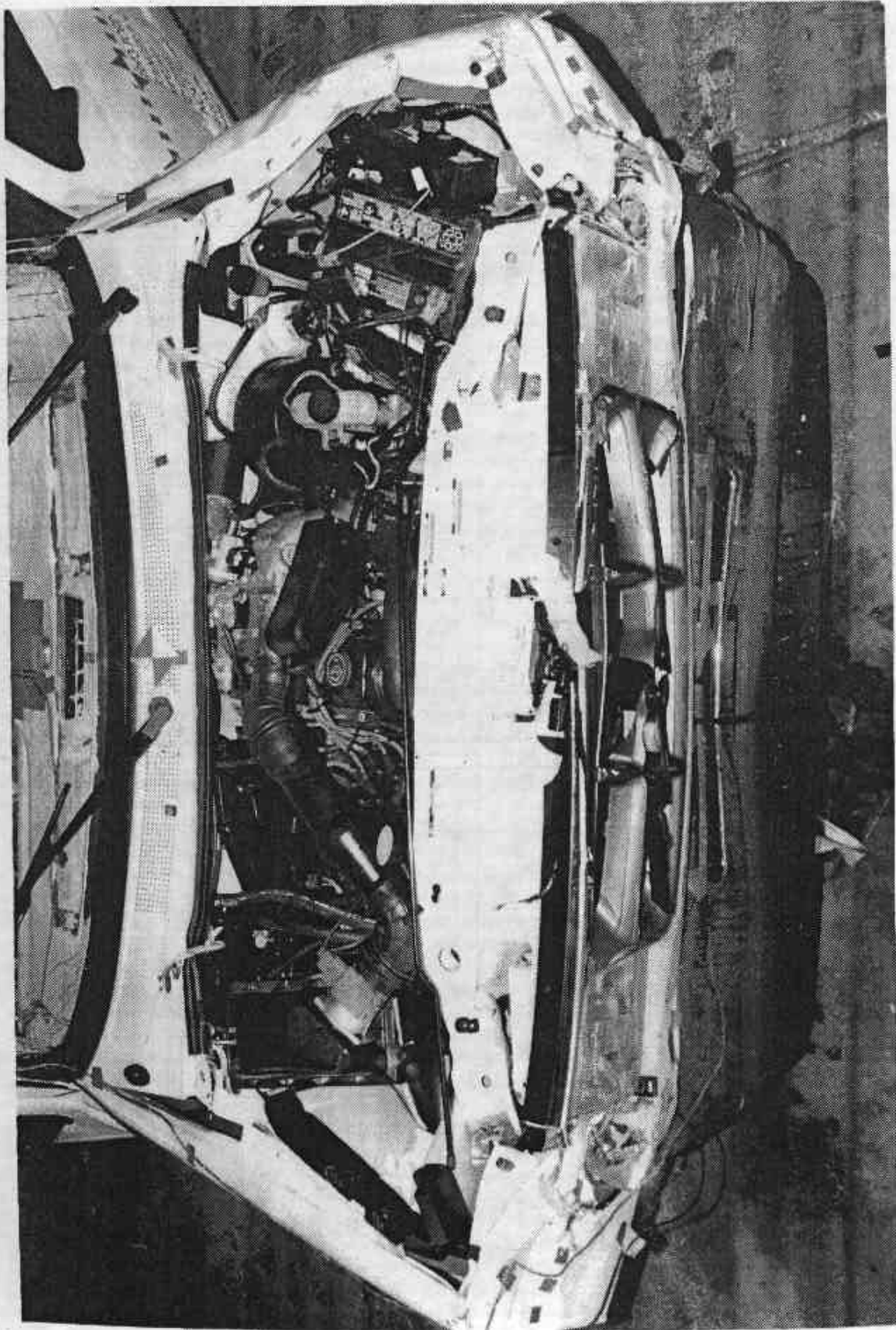

POSTTEST ENGINE COMPARTMENT VIEW

A-14

MSE-93-R92083-N03

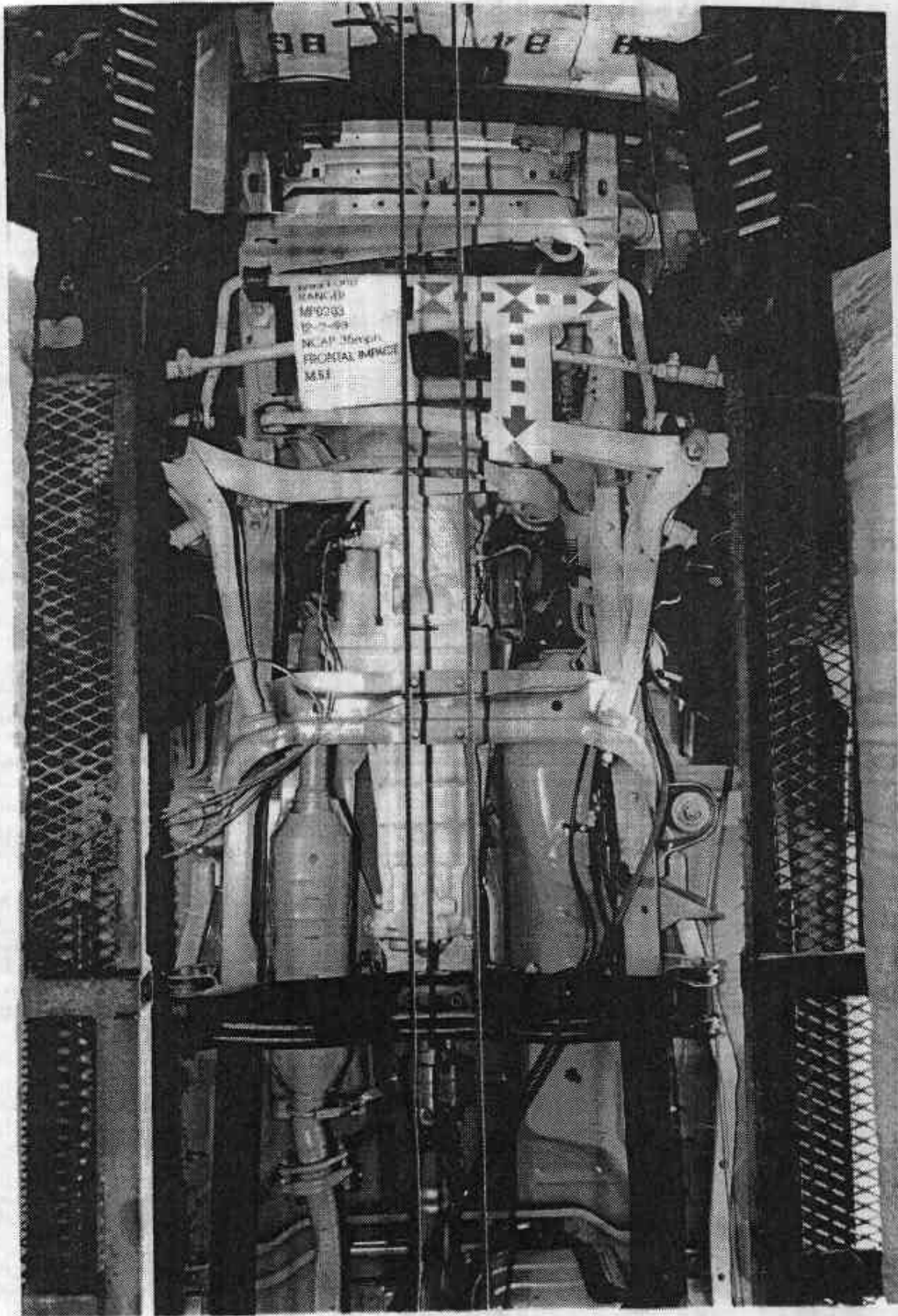

PRETEST FRONT UNDERBODY VIEW

A-15

MSE-93-R92083-N03

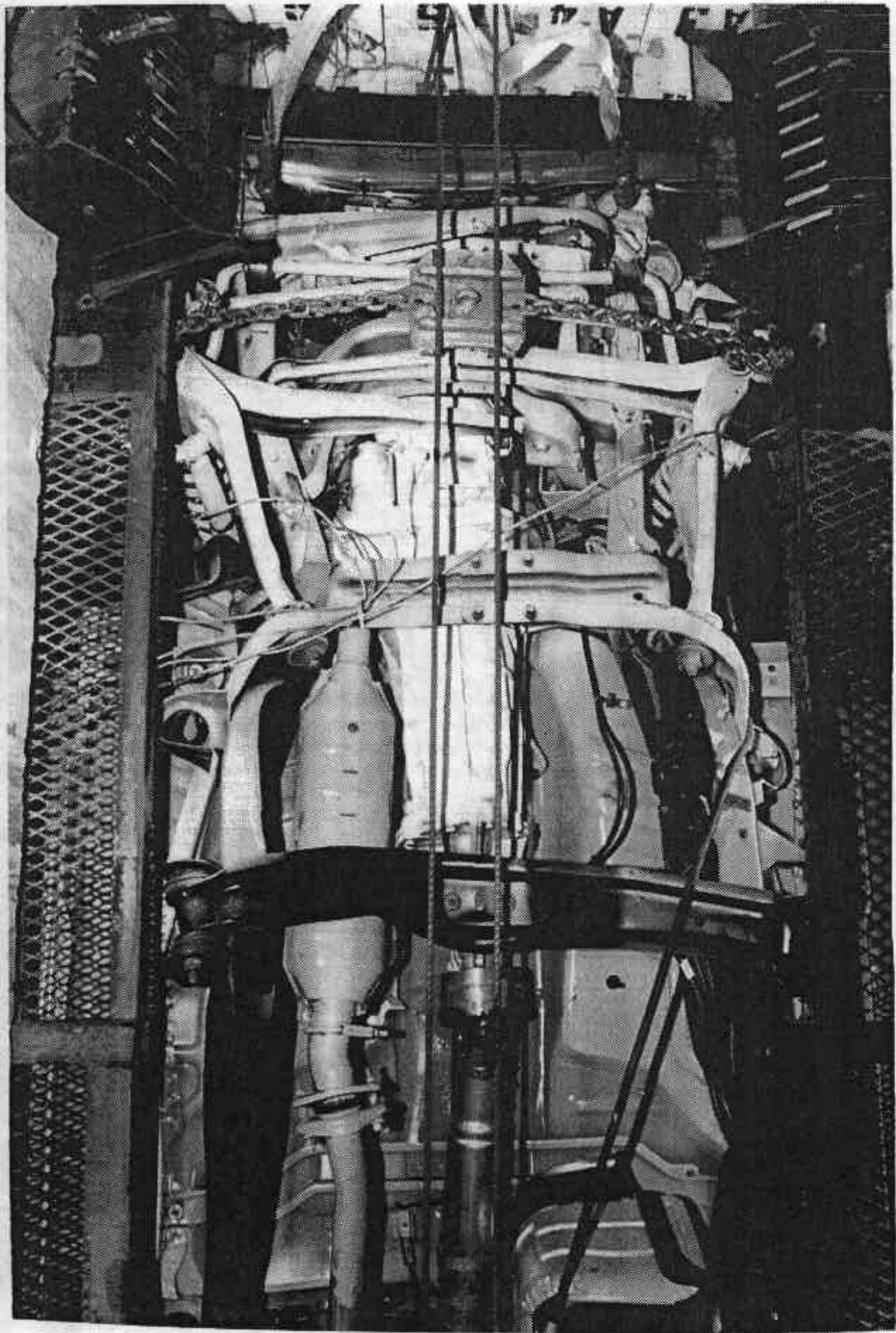

POSTTEST FRONT UNDERBODY VIEW
A-16

MSE-93-R92083-N03

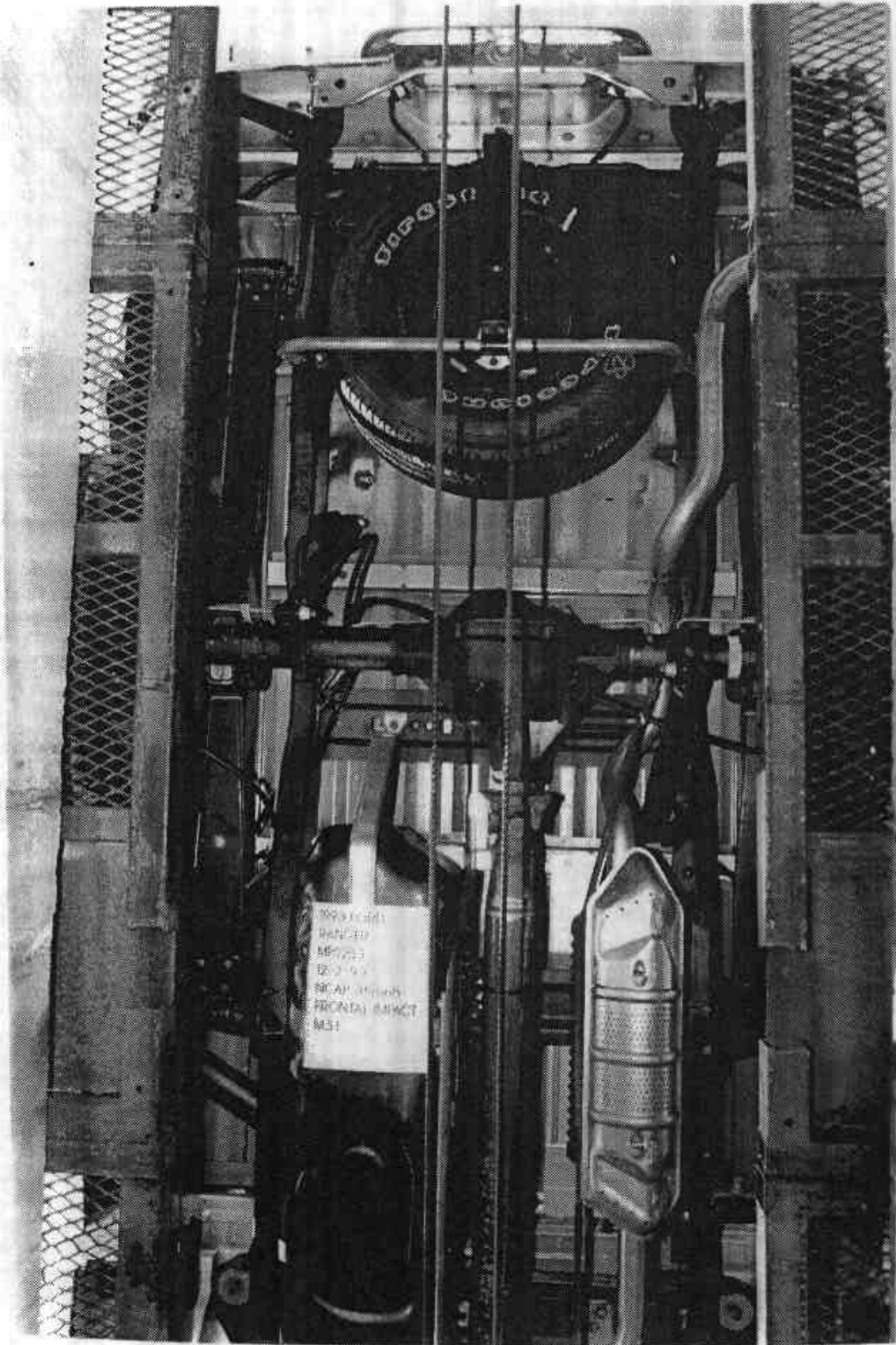

PRETEST REAR UNDERBODY VIEW
A-17

MSE-93-R92083-N03

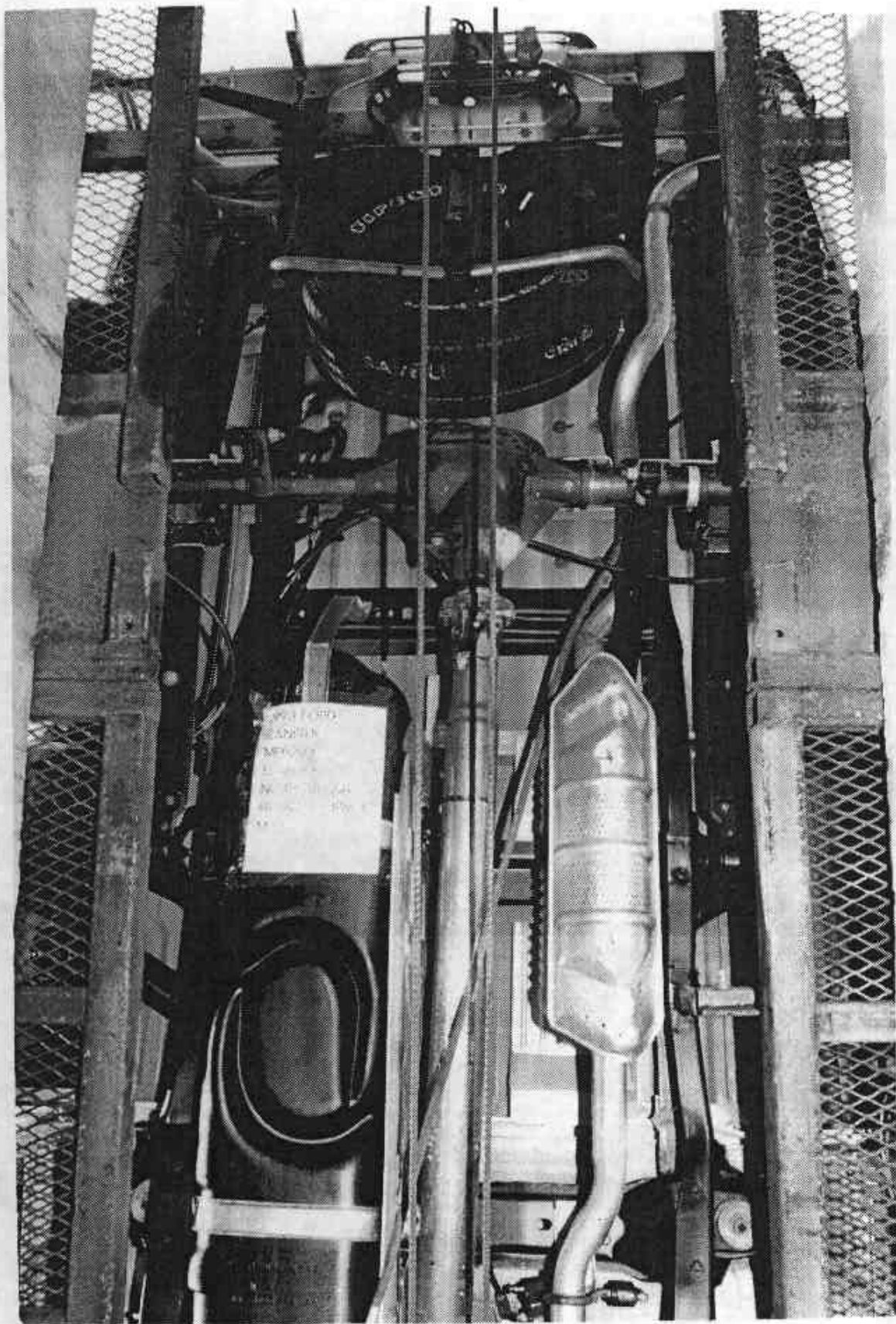

POSTTEST REAR UNDERBODY VIEW
A-18

MSE-93-R92083-N03



PRETEST DRIVER DUMMY POSITION VIEW

A-19

MSE-93-R92083-N03



POSTTEST DRIVER DUMMY POSITION VIEW



PRETEST PASSENGER DUMMY POSITION VIEW

A-21

MSE-93-R92083-N03

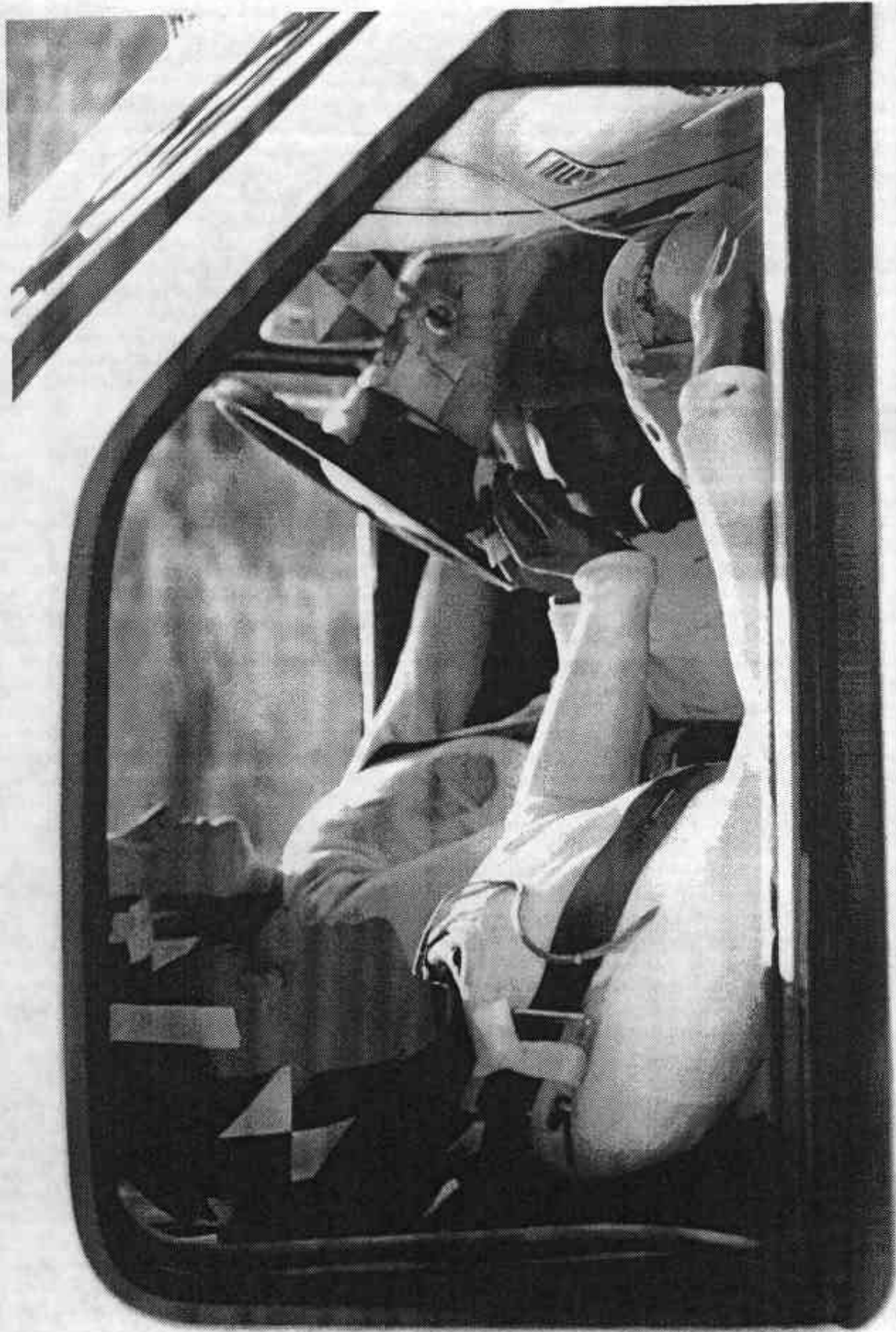

POSTTEST PASSENGER DUMMY POSITION VIEW

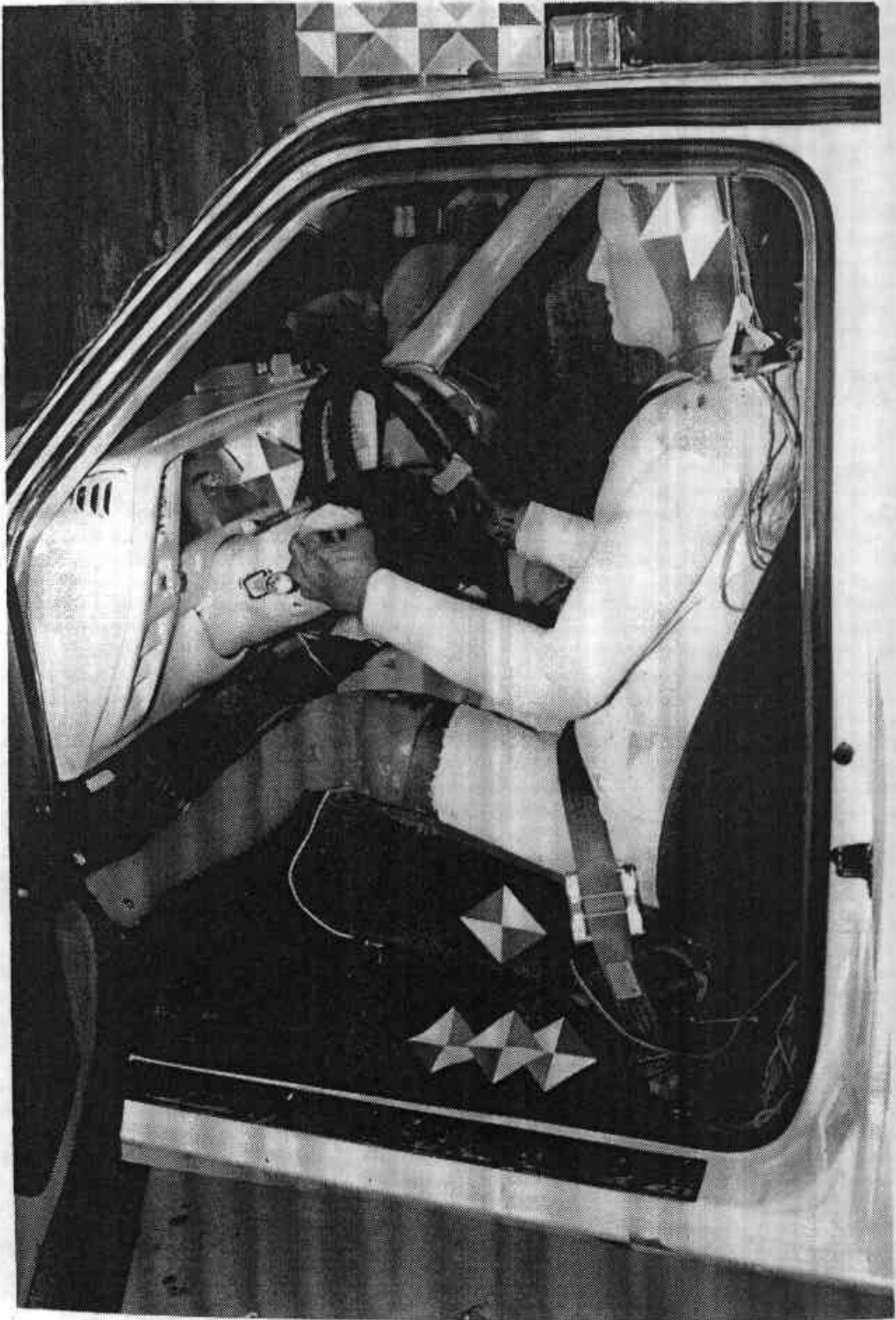

PRETEST DRIVER DUMMY & VEHICLE INTERIOR VIEW (Door Open)

A-23

MSE-93-R92083-N03



POSTTEST DRIVER DUMMY & VEHICLE INTERIOR VIEW (Door Open)

A-24

MSE-93-R92083-N03

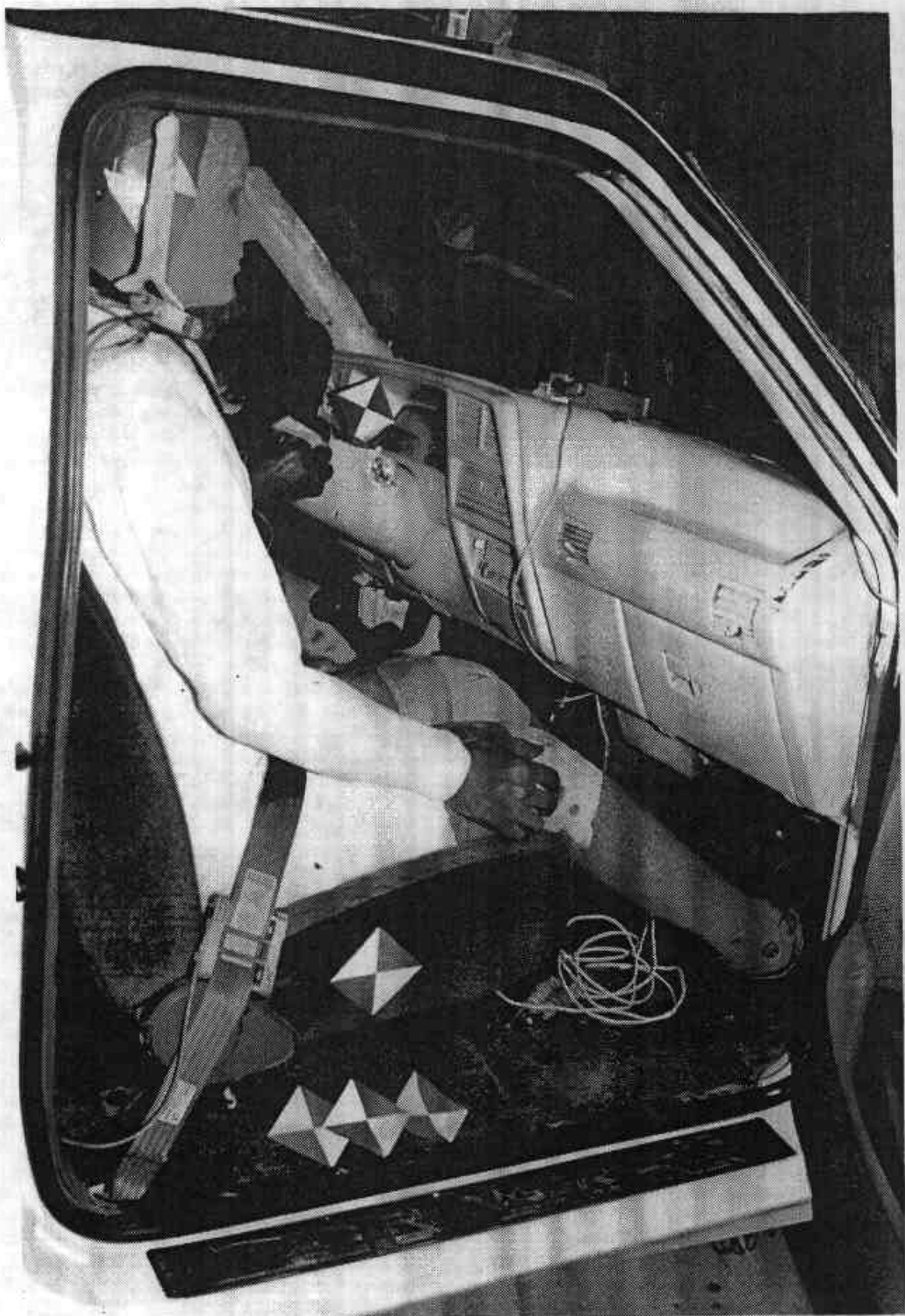

PRETEST PASSENGER DUMMY & VEHICLE INTERIOR VIEW (Door Open)

A-25

MSE-93-R92083-N03



POSTTEST PASSENGER DUMMY & VEHICLE INTERIOR VIEW (Door Open)
A-26 MSE-93-R92083-N03



POSTTEST DRIVER ATD HEAD AND KNEE CONTACT AREA



POSTTEST PASSENGER ATD KNEE CONTACT AREA

THIS PAGE INTENTIONALLY LEFT BLANK

APPENDIX B-1

VEHICLE AND DUMMY (ATD) RESPONSE DATA

DATA FILTERING:

ATD Head Channels	- Class 1000
ATD Chest Channels	- Class 180
ATD Femur Channels	- Class 600
Vehicle Channels	- Class 60

THIS PAGE INTENTIONALLY LEFT BLANK

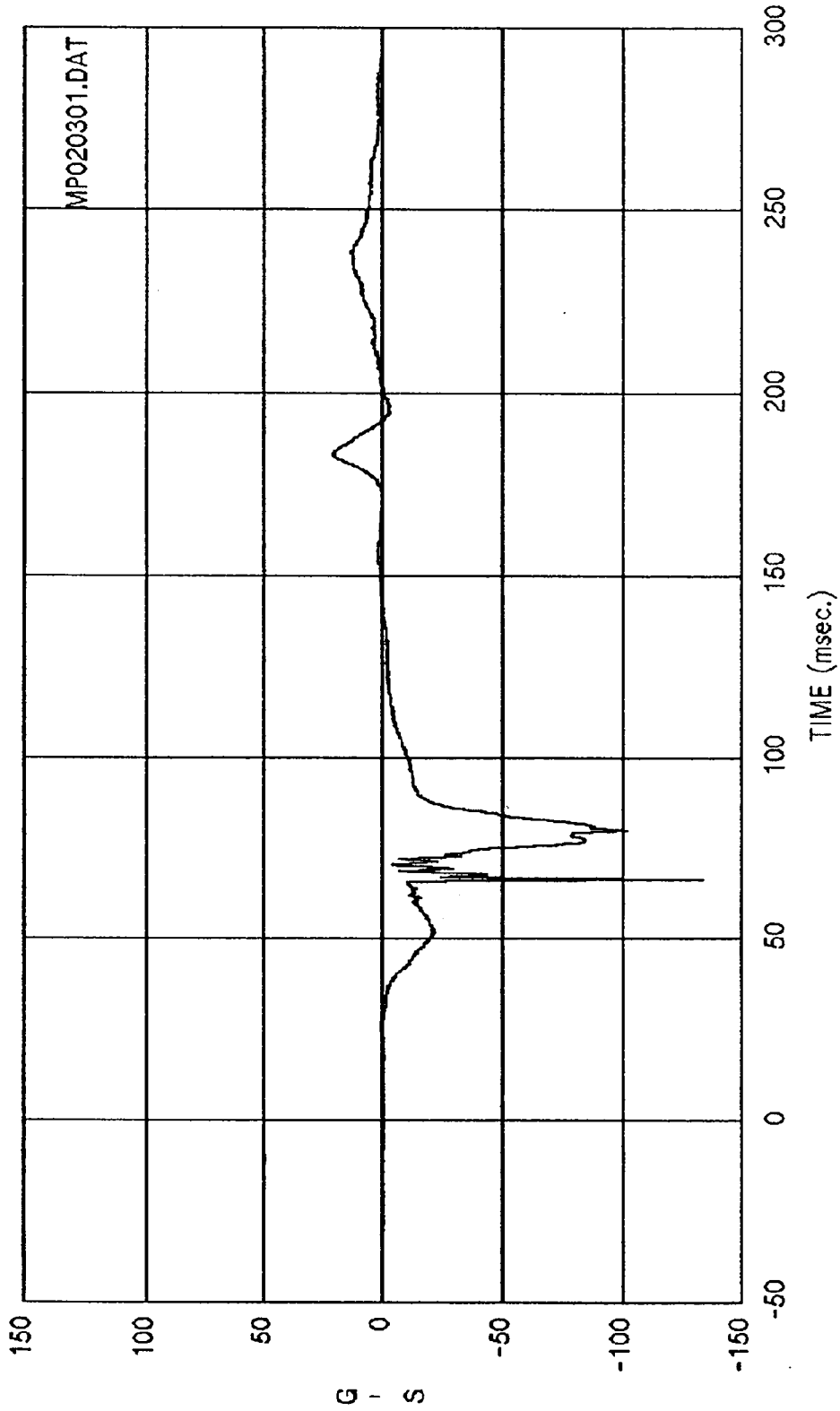

Curve: Driver head acceleration -- X axis Filter: SAE CLASS 1000 Max = 20.986 Min = -146.25

MSE Date: 12/02/92 Program: 1993 NCAP, test number 3 Vehicle: 1993 Ford Ranger Pickup

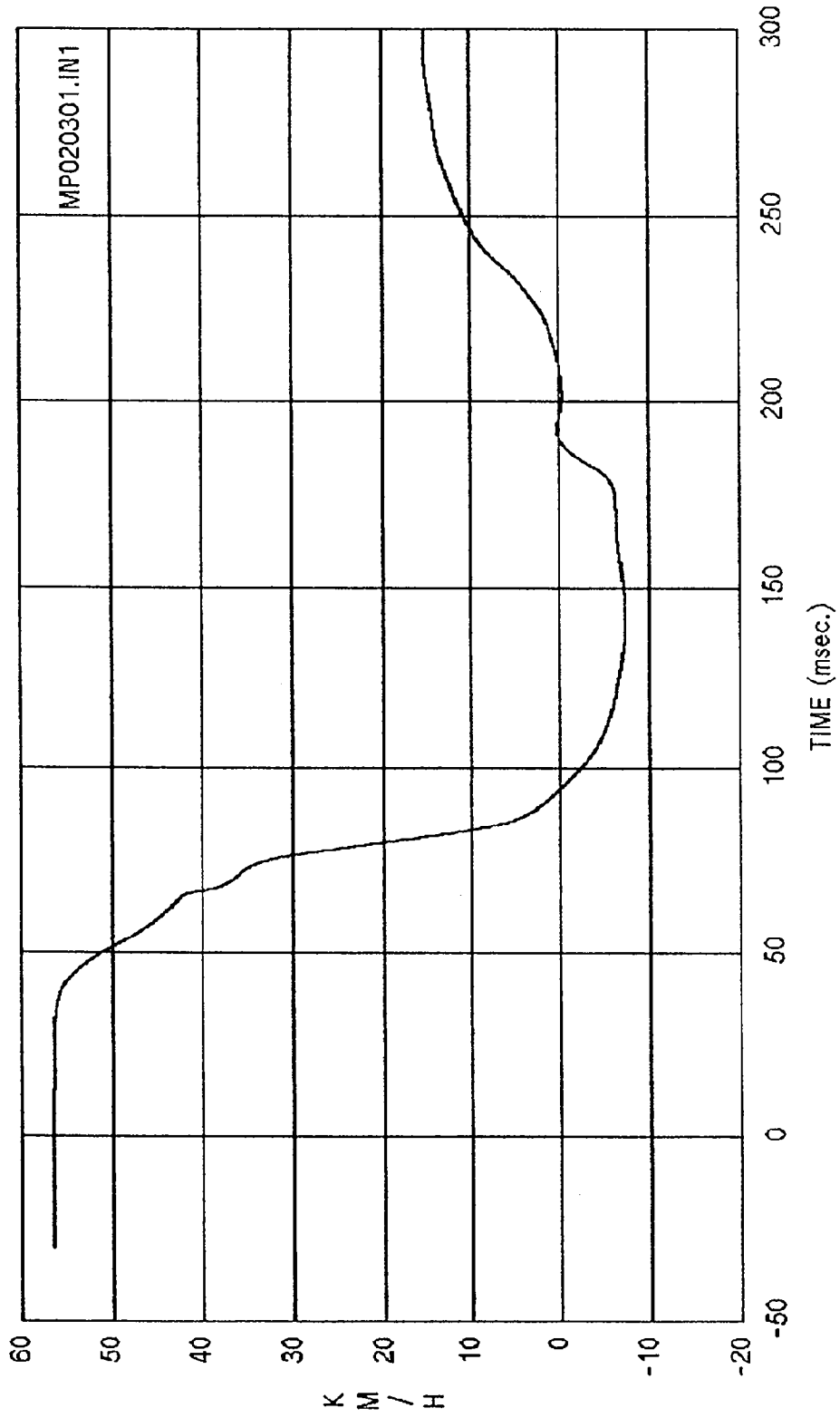

Curve: Driver head delta V -- X axis Filter: SAE CLASS 180 Max = 56.623 Min = -7.4135

MSE Date: 12/02/92 Program: 1993 NCAP, test number 3 Vehicle: 1993 Ford Ranger Pickup

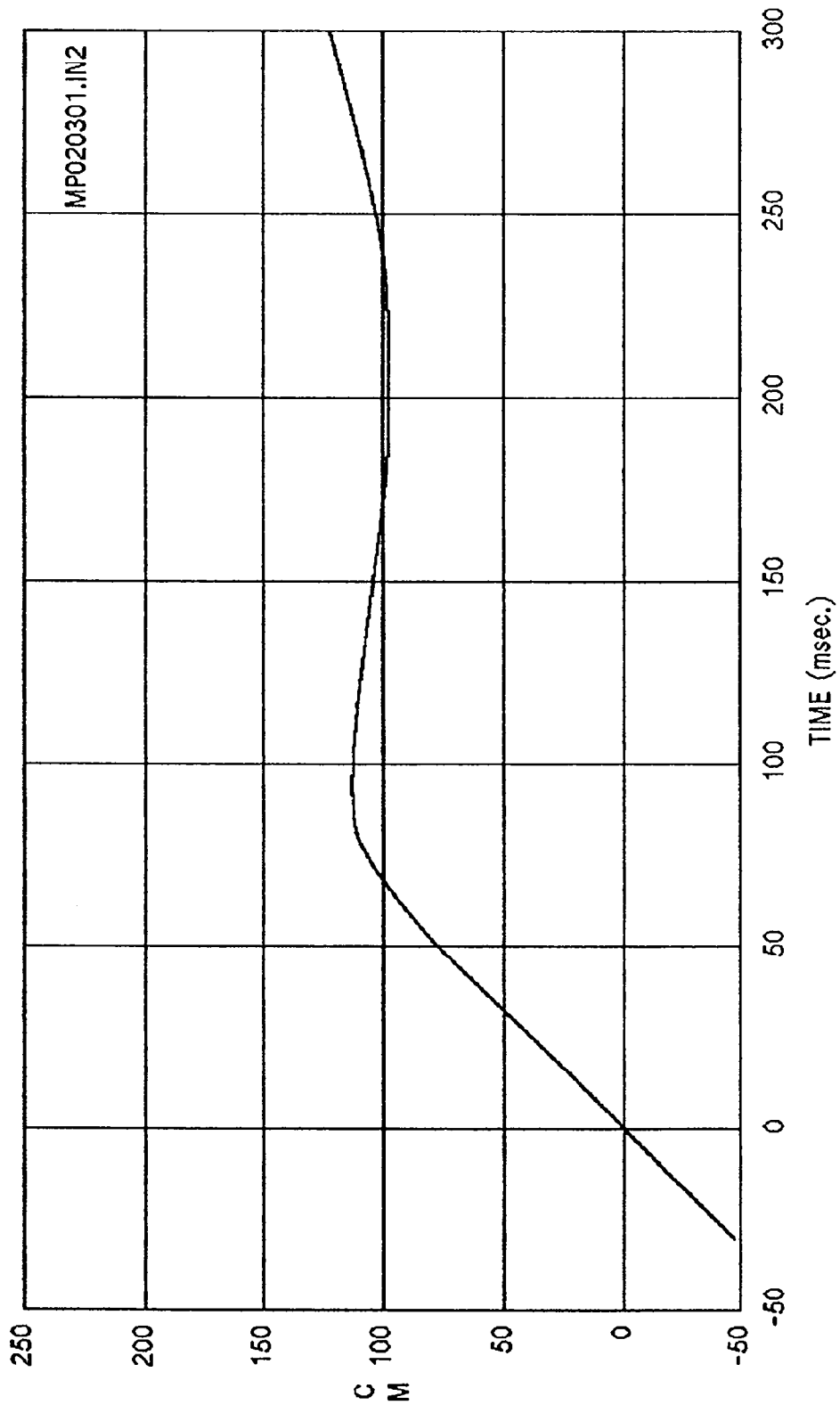

Curve: Driver head displacement -- X axis Filter: SAE CLASS 180 Max = 122.28 Min = 97.948

MSE Date: 12/02/92 Program: 1993 NCAP, test number 3 Vehicle: 1993 Ford Ranger Pickup

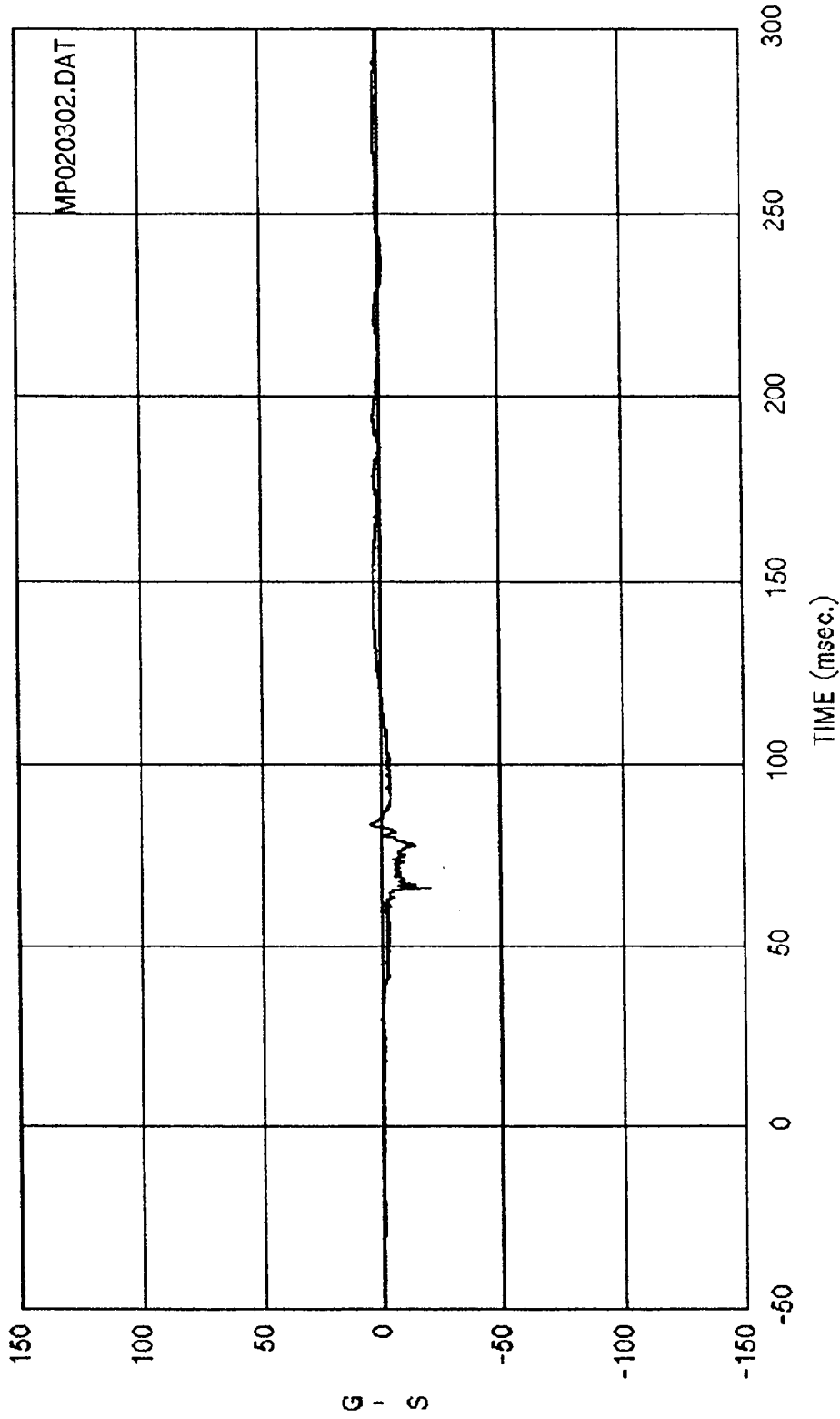

Curve: Driver head acceleration -- Y axis Filter: SAE CLASS 1000 Max = 4.4653 Min = -21.109

MSE Date: 12/02/92 Program: 1993 NCAP, test number 3 Vehicle: 1993 Ford Ranger Pickup

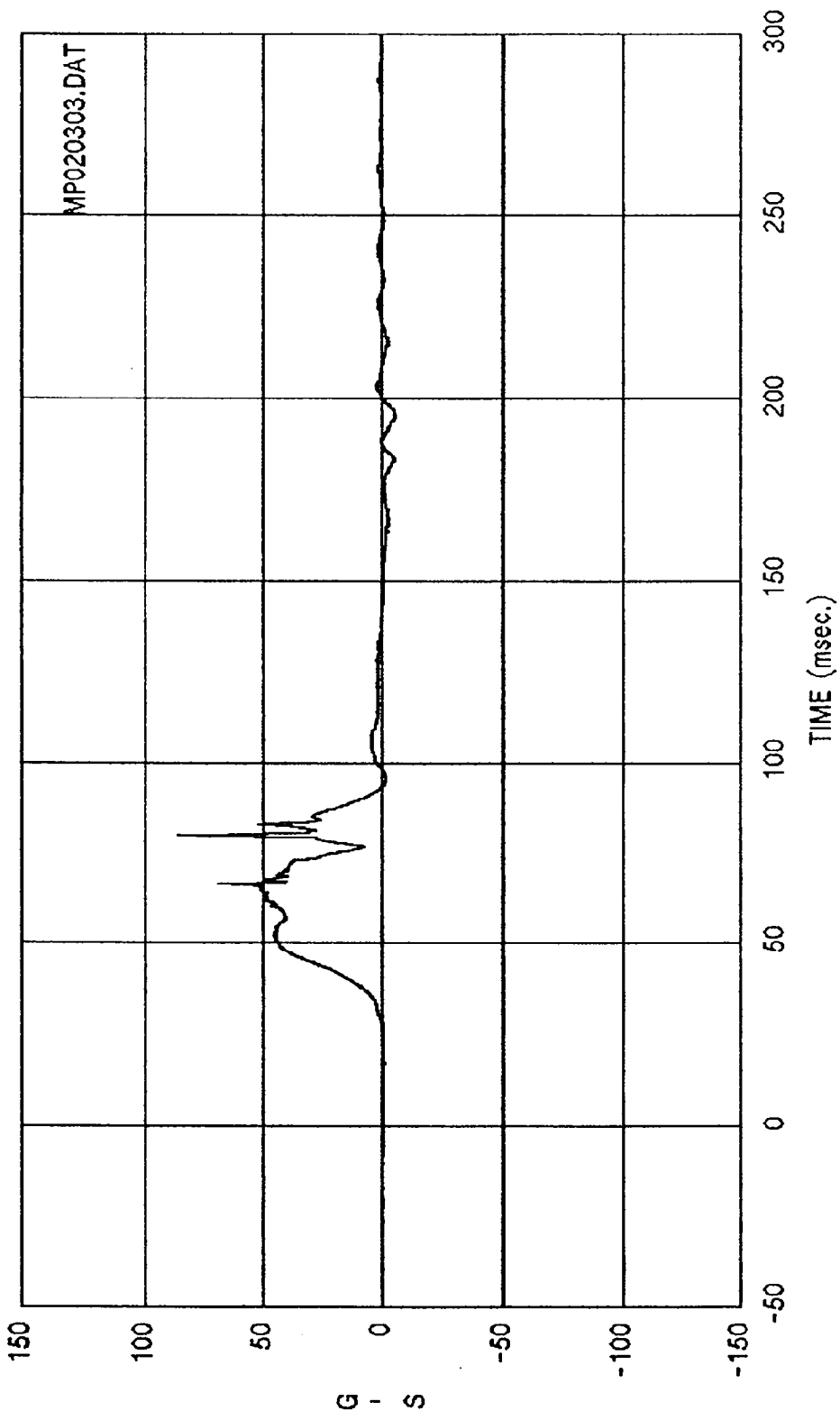

Curve: Driver head acceleration -- Z axis Filter: SAE CLASS 1000 Max = 86.366 Min = -5.4915

MSE Date: 12/02/92 Program: 1993 NCAP, test number 3 Vehicle: 1993 Ford Ranger Pickup

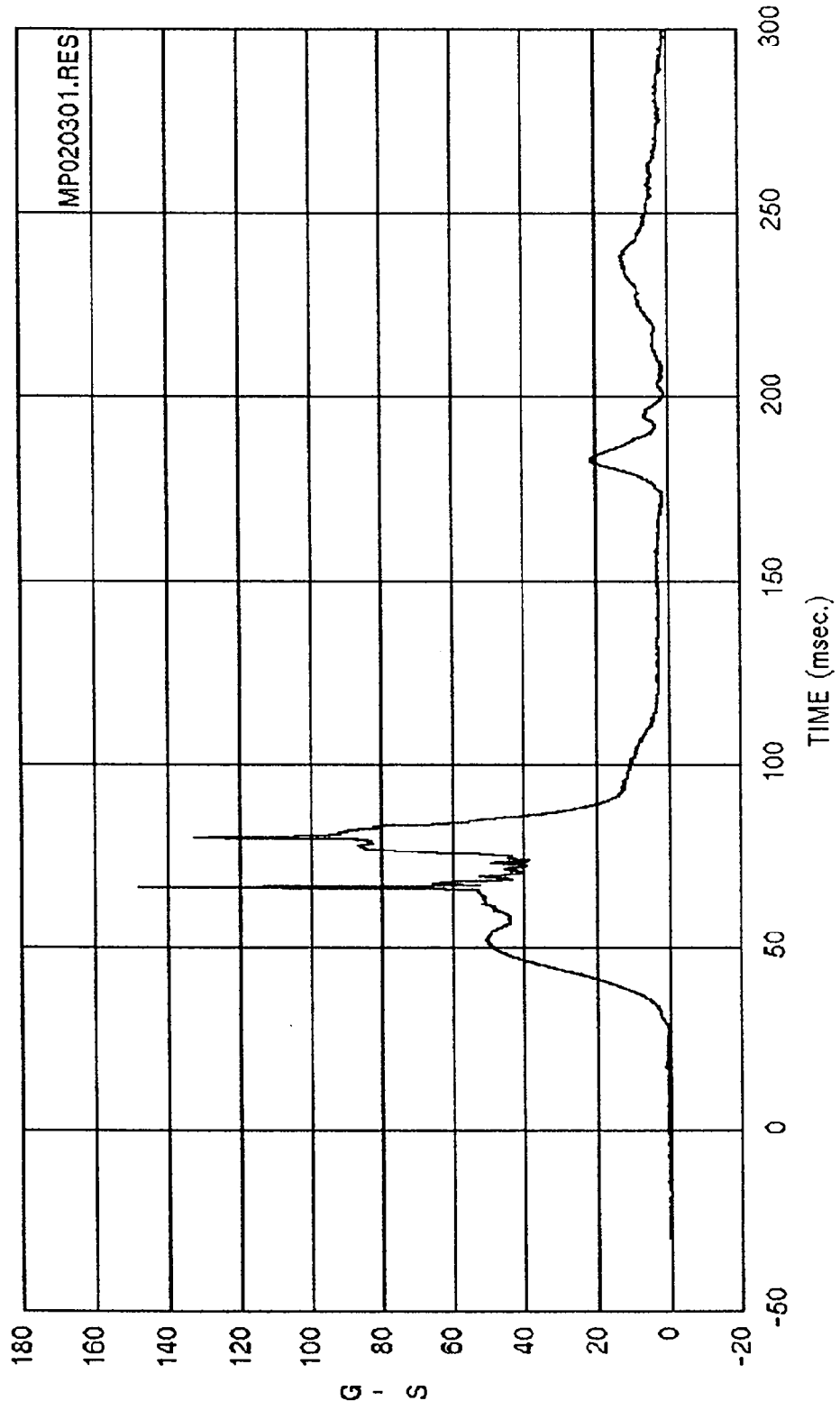

Curve: Driver head acceleration -- Resultant Filter: SAE CLASS 1000 Max = 162.62 Min = .12481

MSE Date: 12/02/92 Program: 1993 NCAP, test number 3 Vehicle: 1993 Ford Ranger Pickup

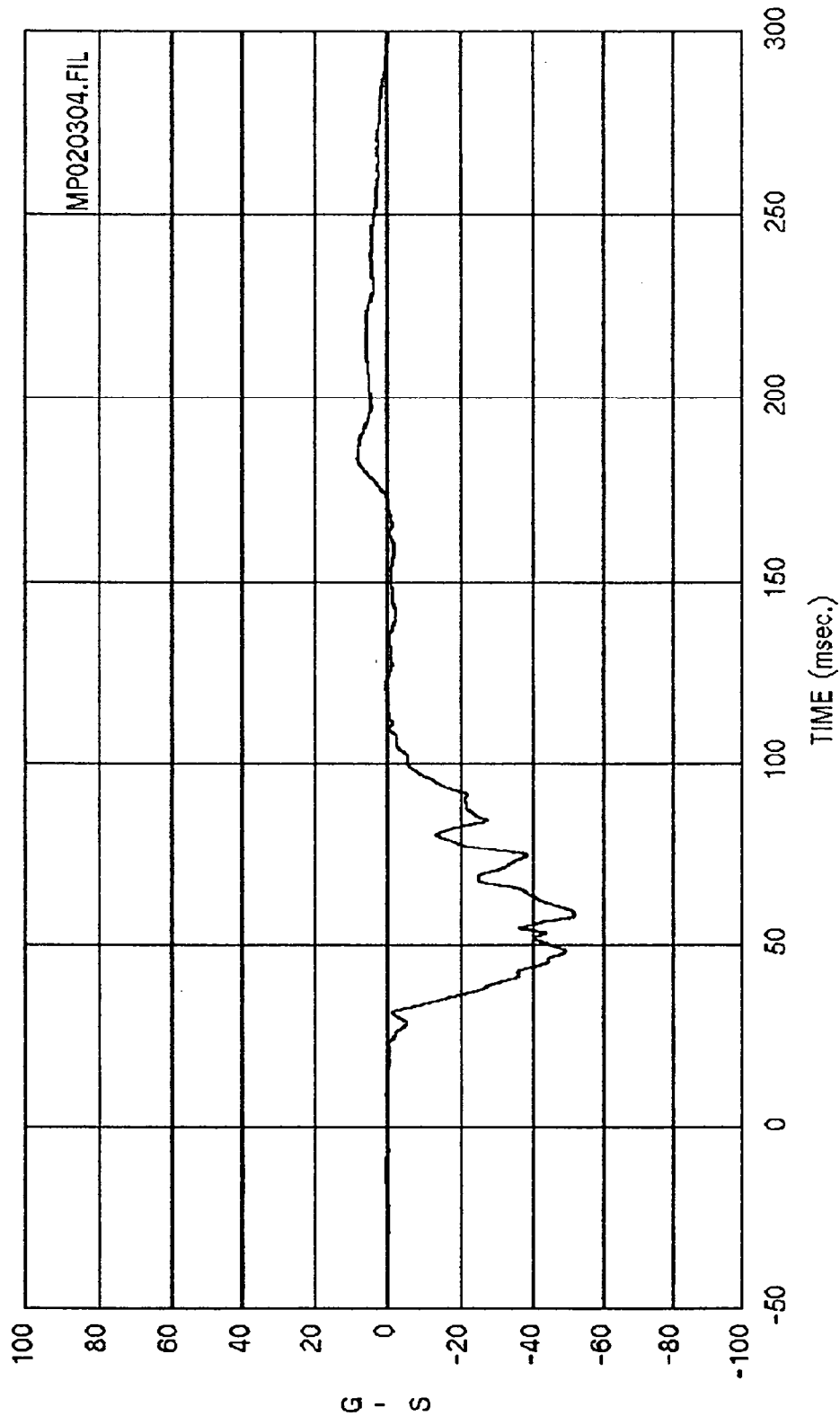

Curve: Driver chest acceleration -- X axis Filter: SAE CLASS 180 Max = 8.2193 Min = -51.315

MSE Date: 12/02/92 Program: 1993 NCAP, test number 3 Vehicle: 1993 Ford Flanger Pickup

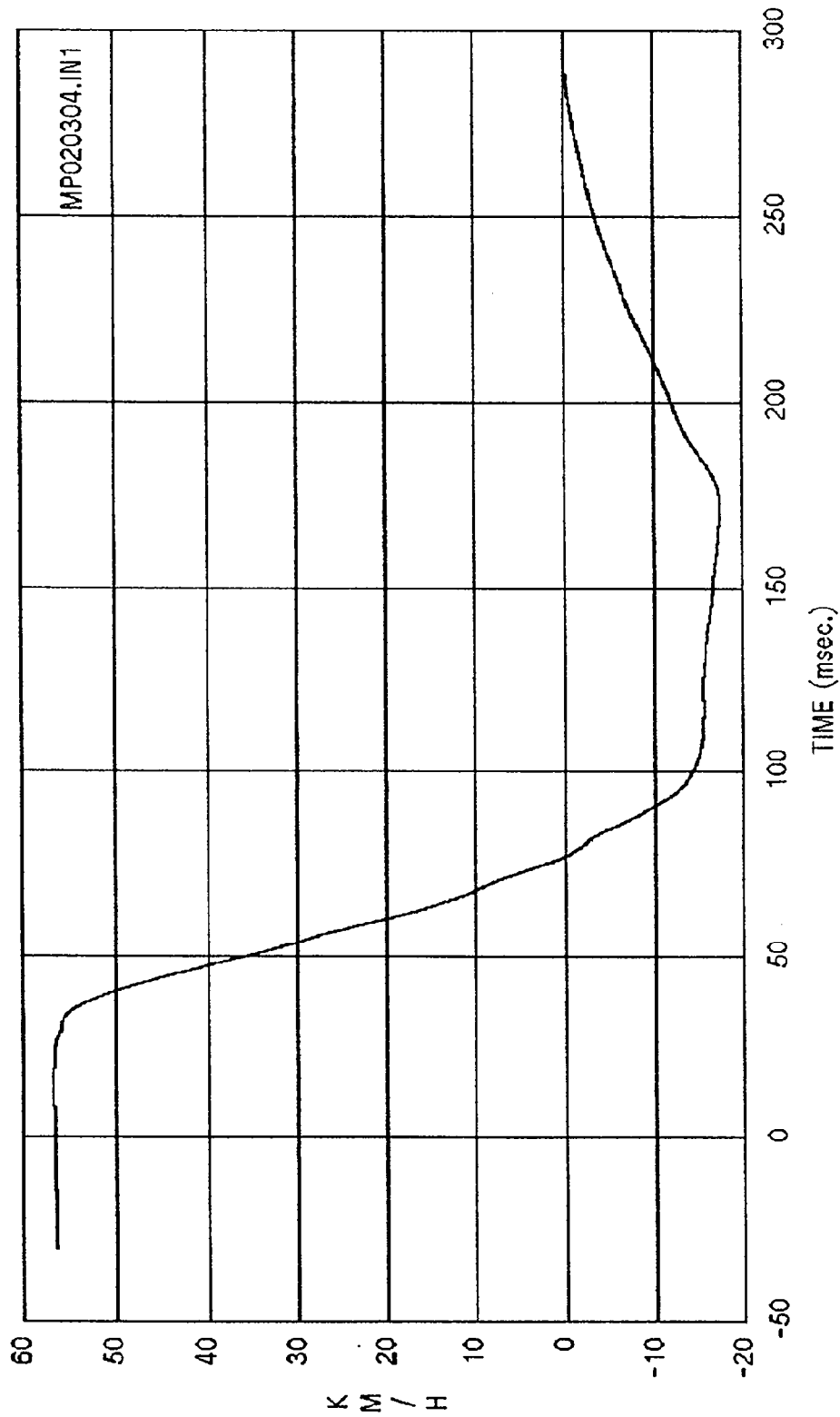

Curve: Driver chest delta V -- X axis Filter: SAE CLASS 180 Max = 56.700 Min = -17.396

MSE Date: 12/02/92 Program: 1993 NCAP, test number 3 Vehicle: 1993 Ford Ranger Pickup

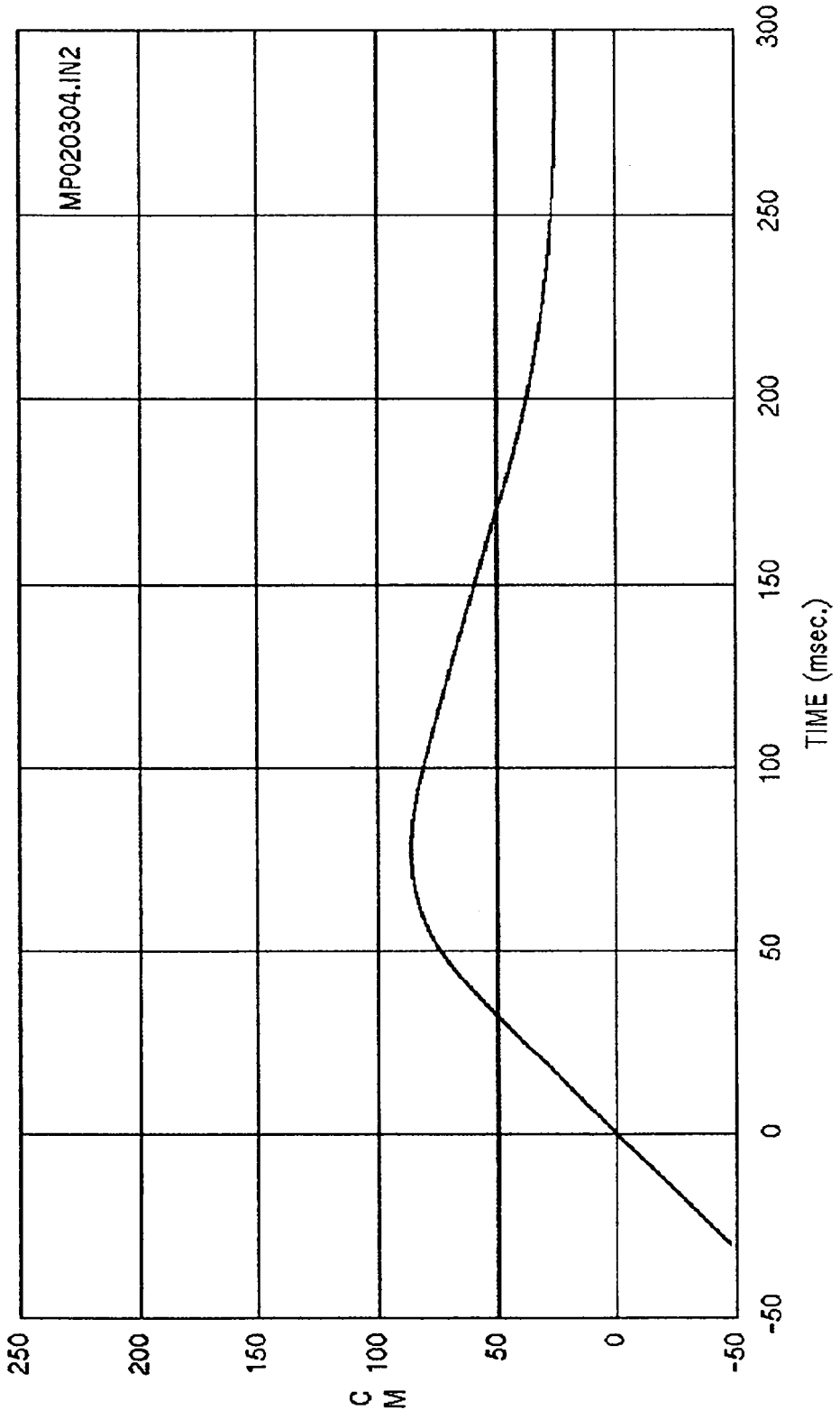

Curve: Driver chest displacement -- X axis Filter: SAE CLASS 180 Max = 86.639 Min = 25.574

MSE Date: 12/02/92 Program: 1993 NCAP, test number 3 Vehicle: 1993 Ford Ranger Pickup

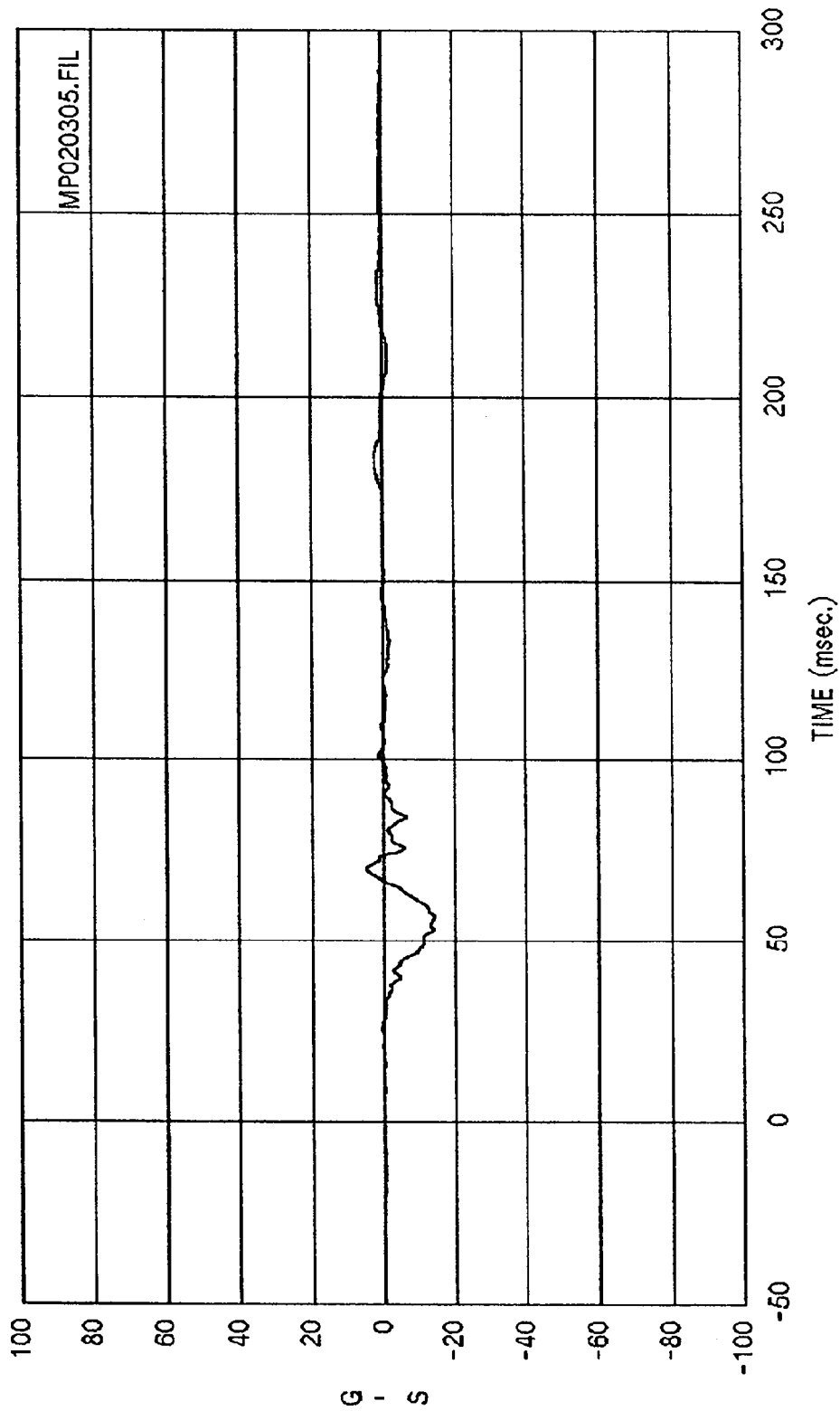

Curve: Driver chest acceleration -- Y axis Filter: SAE CLASS 180 Max = 5.0385 Min = -14.528

MSE Date: 12/02/92 Program: 1993 NCAP, test number 3 Vehicle: 1993 Ford Ranger Pickup

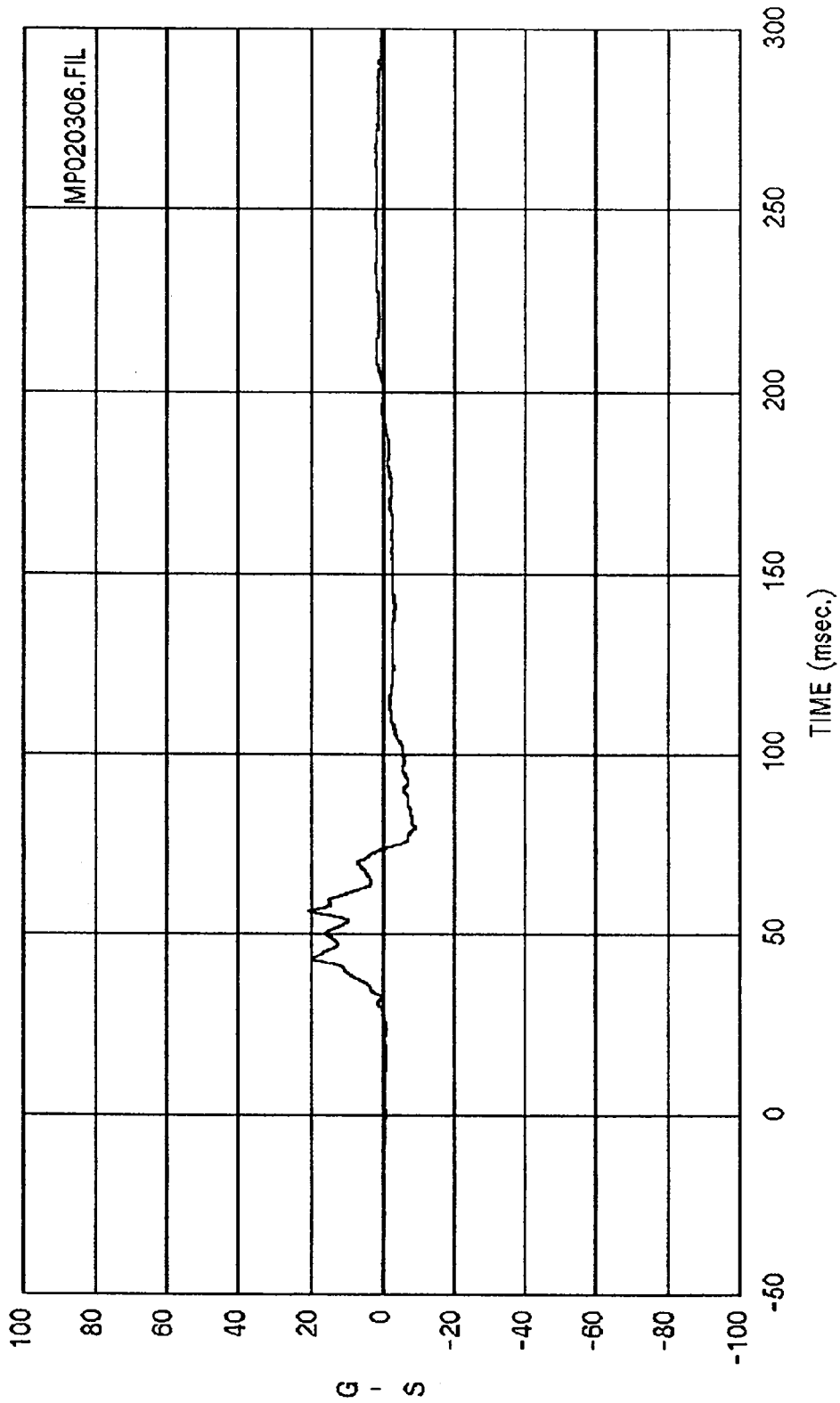

Curve: Driver chest acceleration -- Z axis Filter: SAE CLASS 180 Max = 20.608 Min = -8.9363

MSE Date: 12/02/92 Program: 1993 NCAP, test number 3 Vehicle: 1993 Ford Ranger Pickup

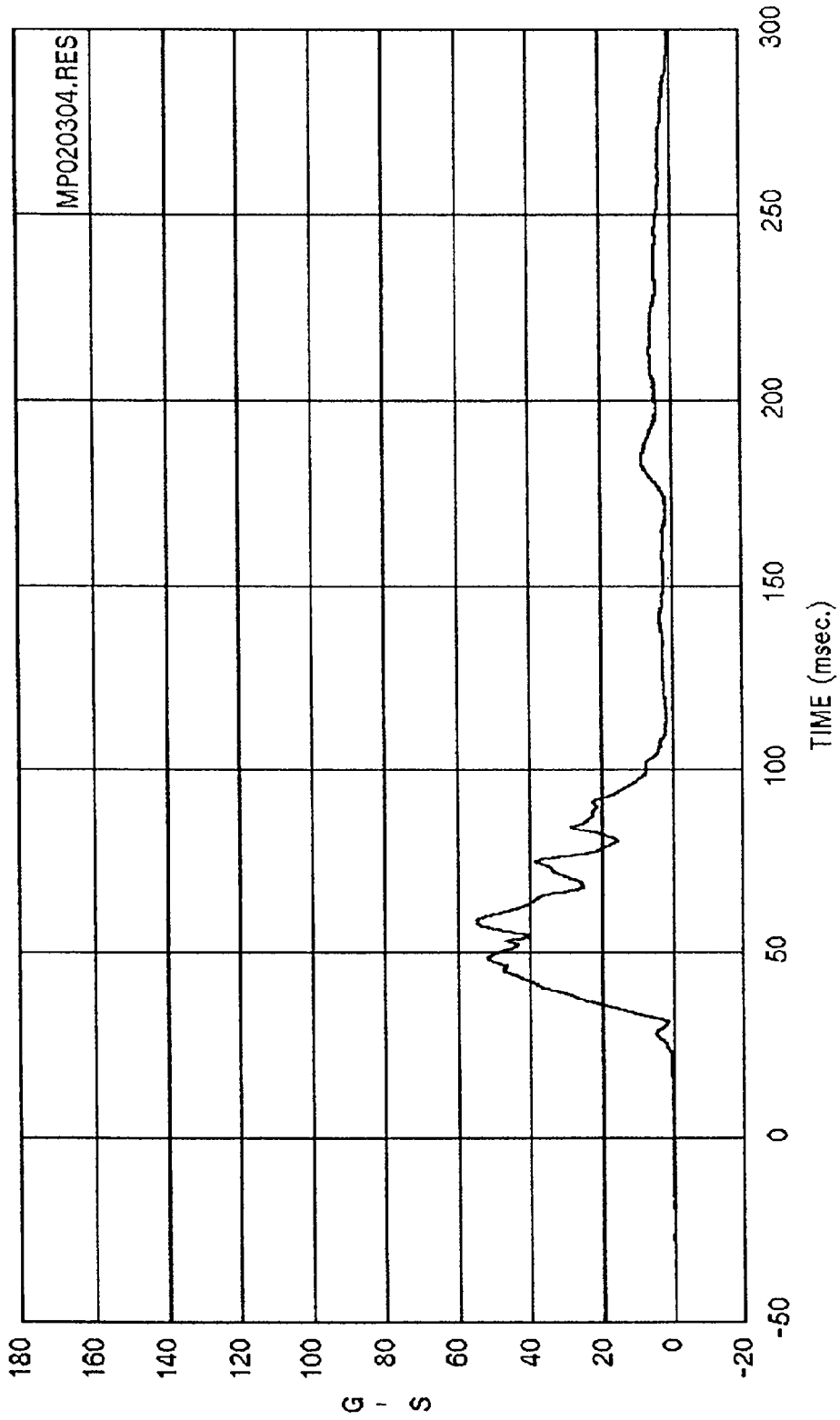

Curve: Driver chest acceleration -- Resultant Filter: SAE CLASS 180 Max = 54.858 Min = .36979

MSE Date: 12/02/92 Program: 1993 NCAP, test number 3 Vehicle: 1993 Ford Ranger Pickup

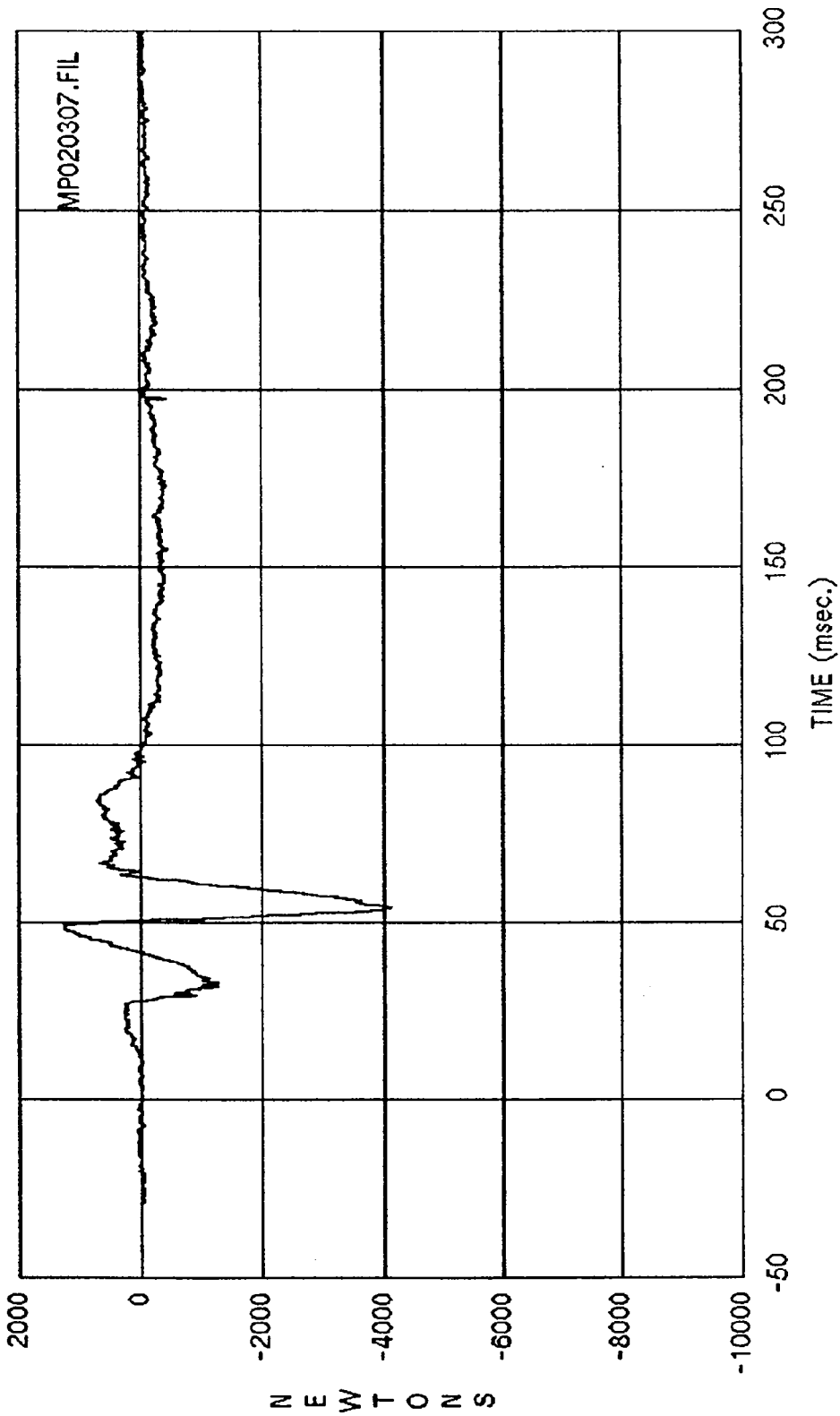

MPO20307.FIL

Curve: Driver left femur force Filter: SAE CLASS 600 Max = 1268.9 Min = -4103.1

MSE Date: 12/02/92 Program: 1993 NCAP, test number 3 Vehicle: 1993 Ford Ranger Pickup

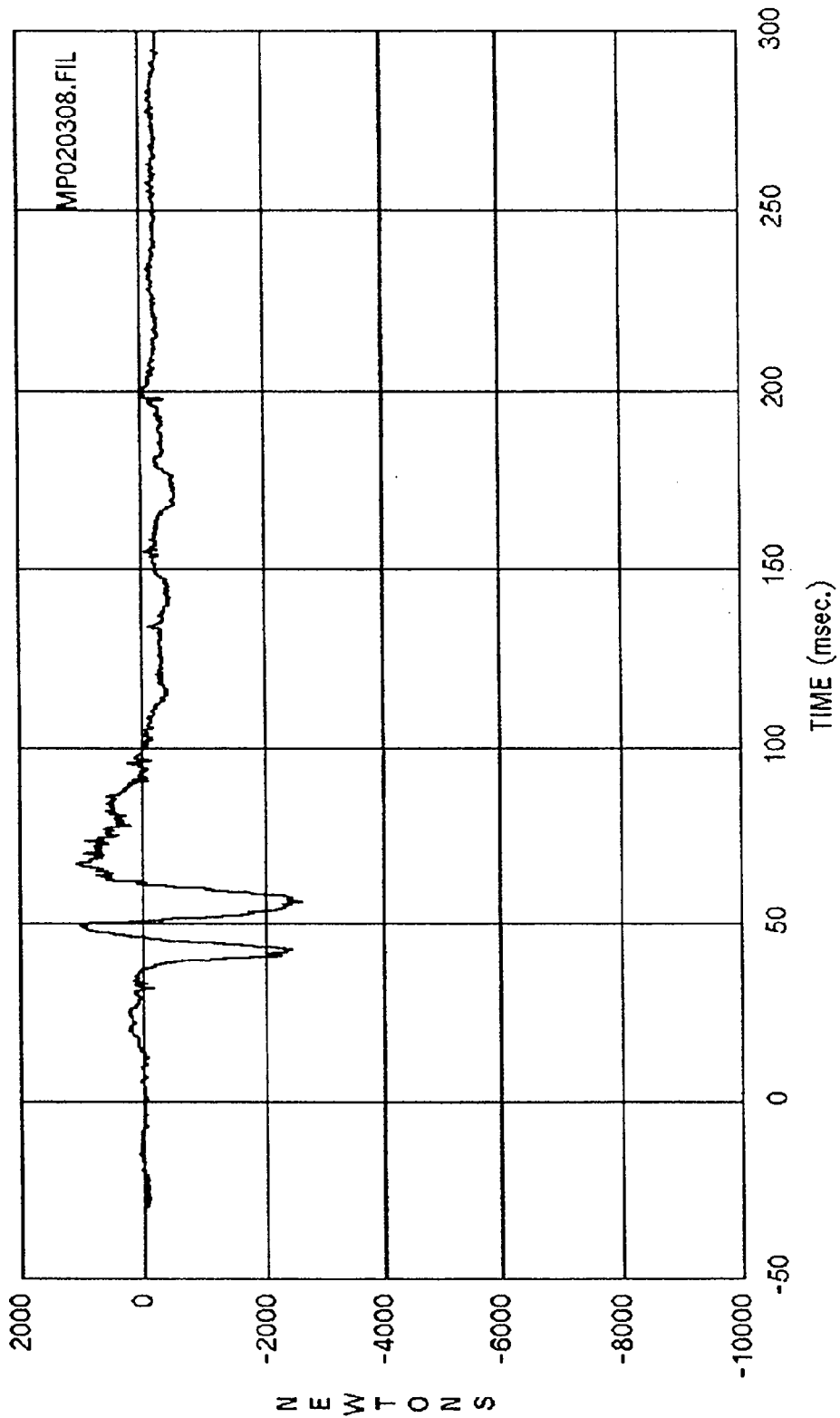

Curve: Driver right femur force Filter: SAE CLASS 600 Max = 1083.6 Min = -2606.6
 MSE Date: 12/02/92 Program: 1993 NCAP, test number 3 Vehicle: 1993 Ford Ranger Pickup

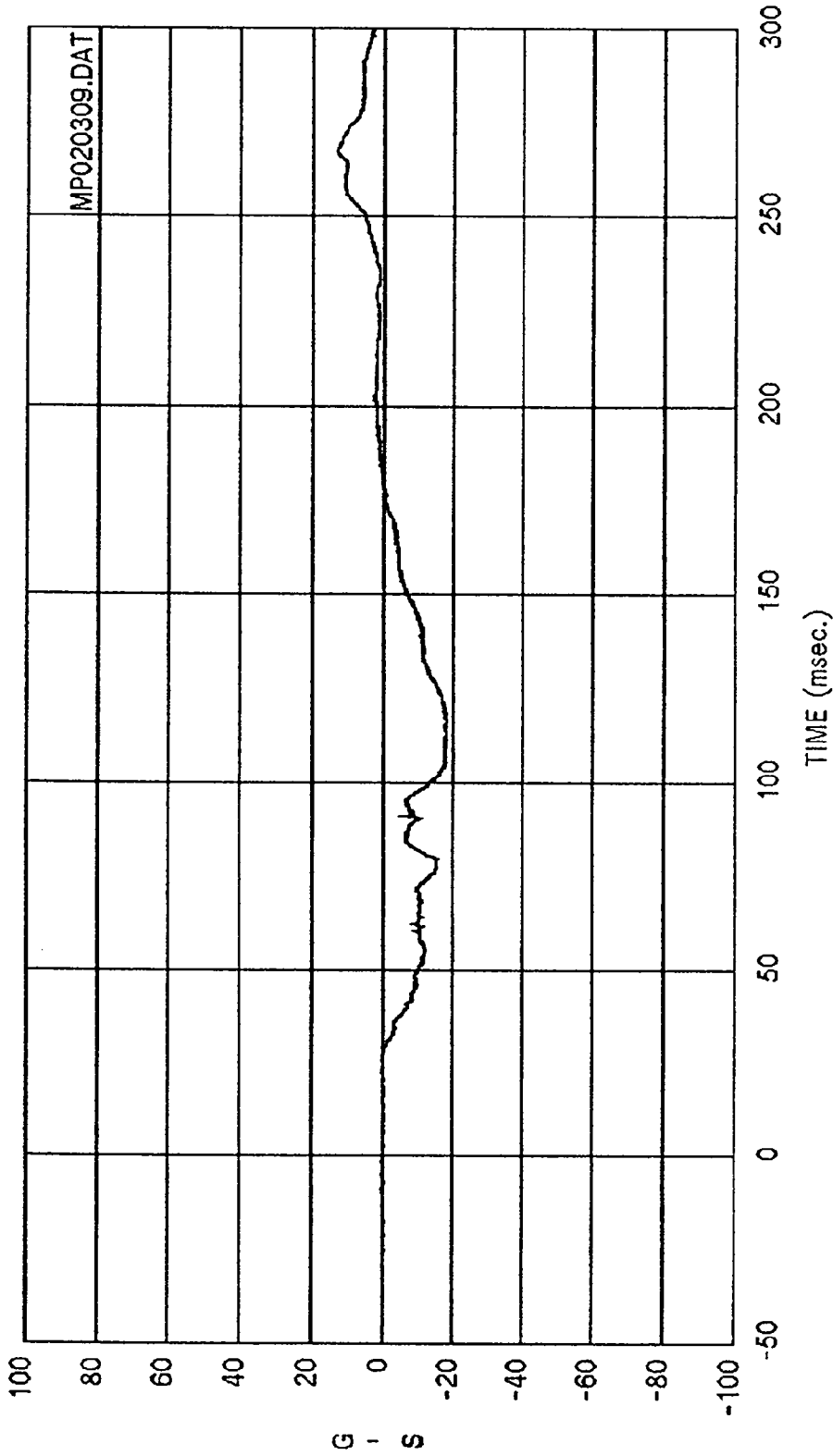

Curve: Passenger head acceleration -- X axis Filter: SAE CLASS 1000 Max = 13.100 Min = -18.511
 MSE Date: 12/02/92 Program: 1993 NCAP, test number 3 Vehicle: 1993 Ford Ranger Pickup

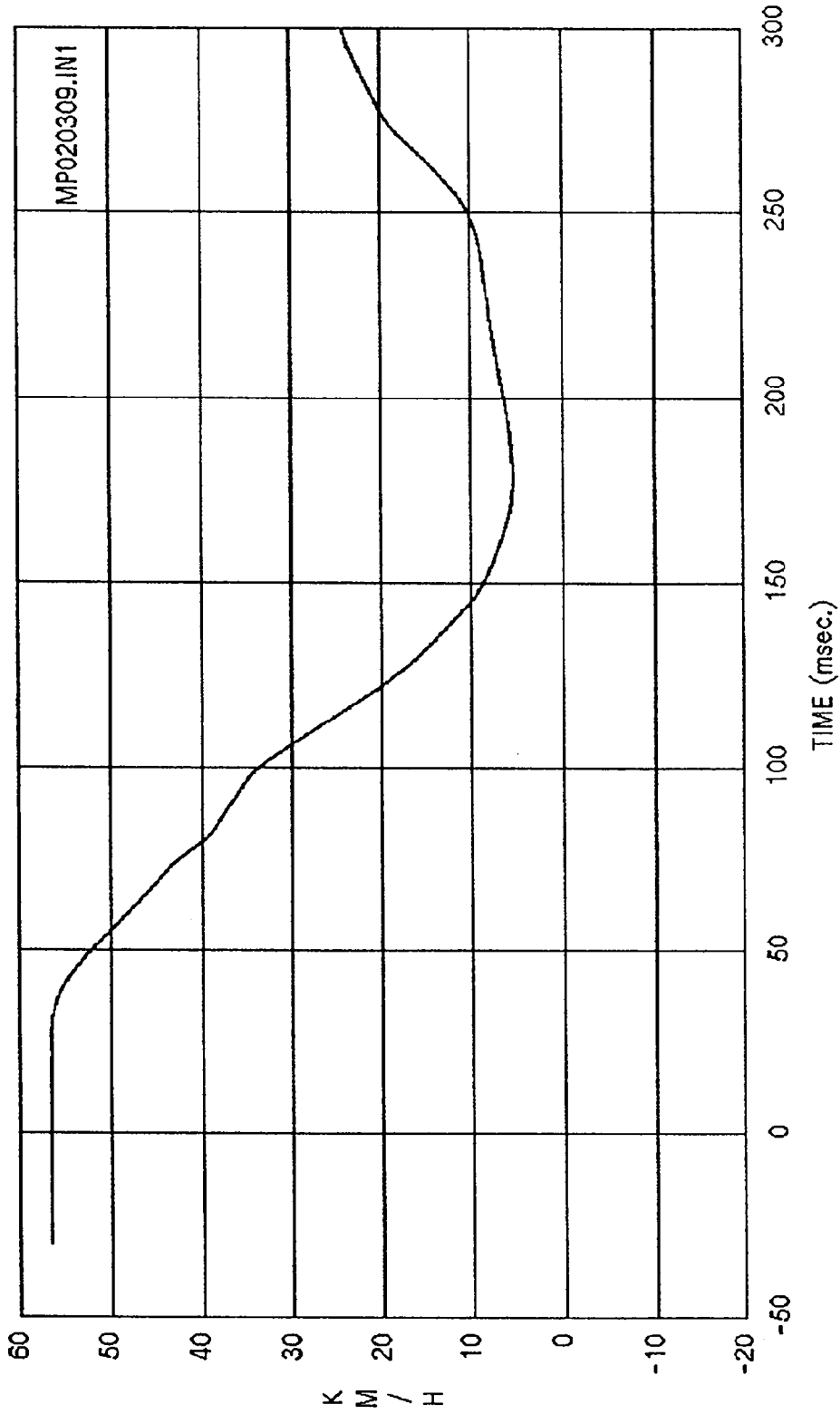

Curve: Passenger head delta V -- X axis Filter: SAE CLASS 180 Max = 56.623 Min = 5.4214

MSE Date: 12/02/92 Program: 1993 NCAP, test number 3 Vehicle: 1993 Ford Ranger Pickup

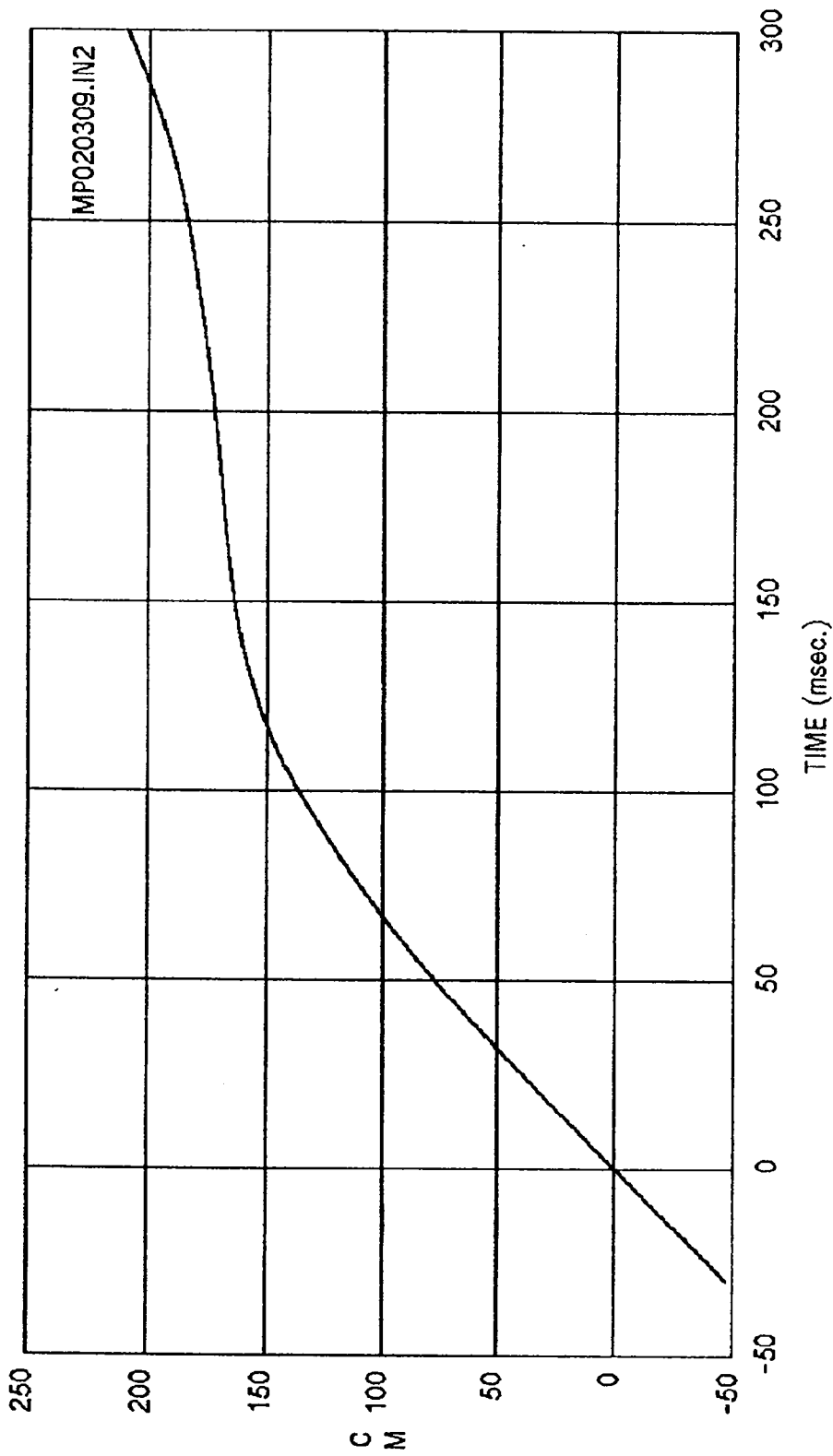

Curve: Passenger head displacement --- X axis Filter: SAE CLASS 180 Max = 209.00 Min = .10000E+11

MSE Date: 12/02/92 Program: 1993 NCAP, test number 3 Vehicle: 1993 Ford Ranger Pickup

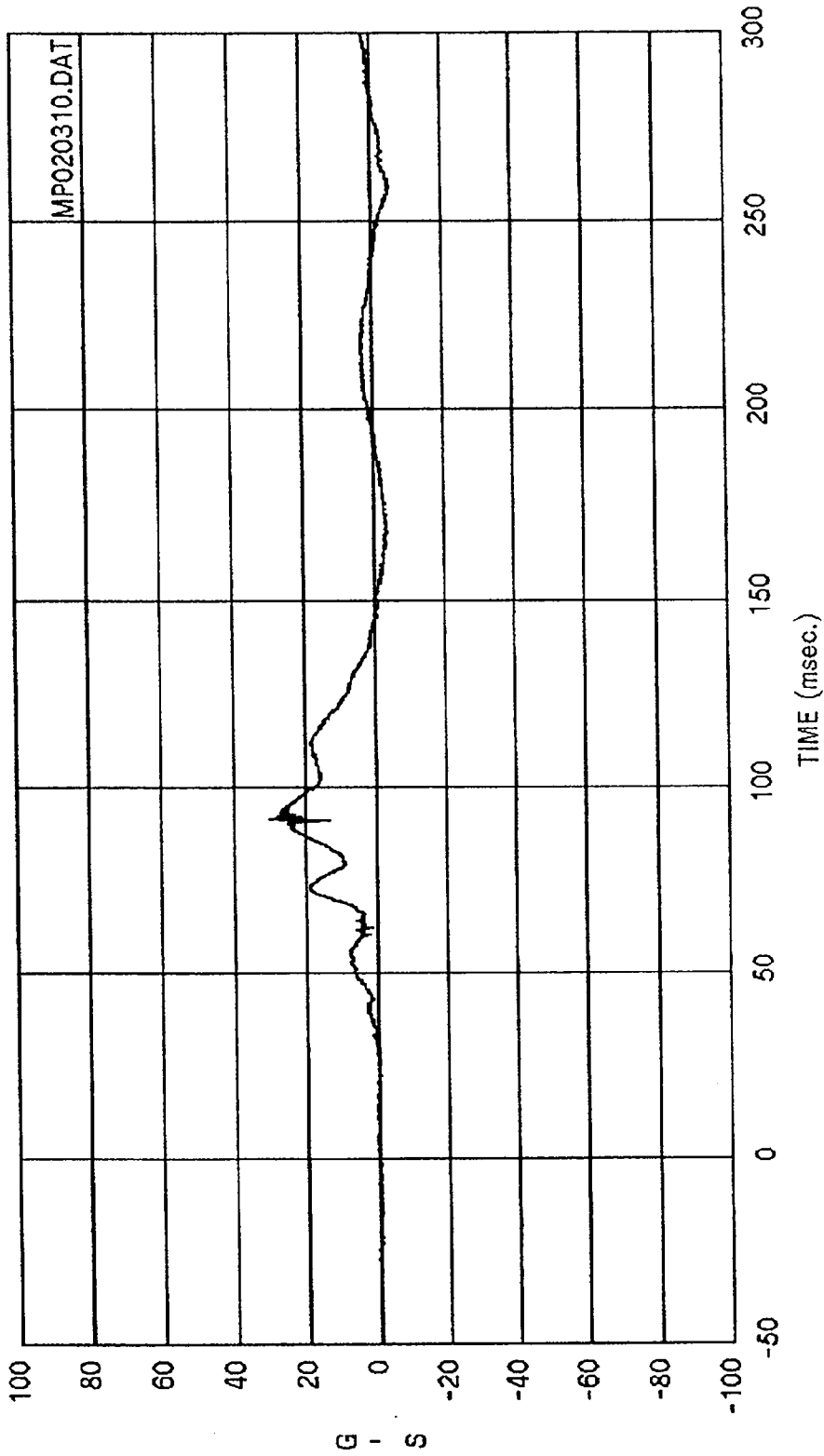

Curve: Passenger head acceleration -- Y axis Filter: SAE CLASS 1000 Max = 30.234 Min = -5.086C
MSE Date: 12/02/92 Program: 1993 NCAP, test number 3 Vehicle: 1993 Ford Ranger Pickup

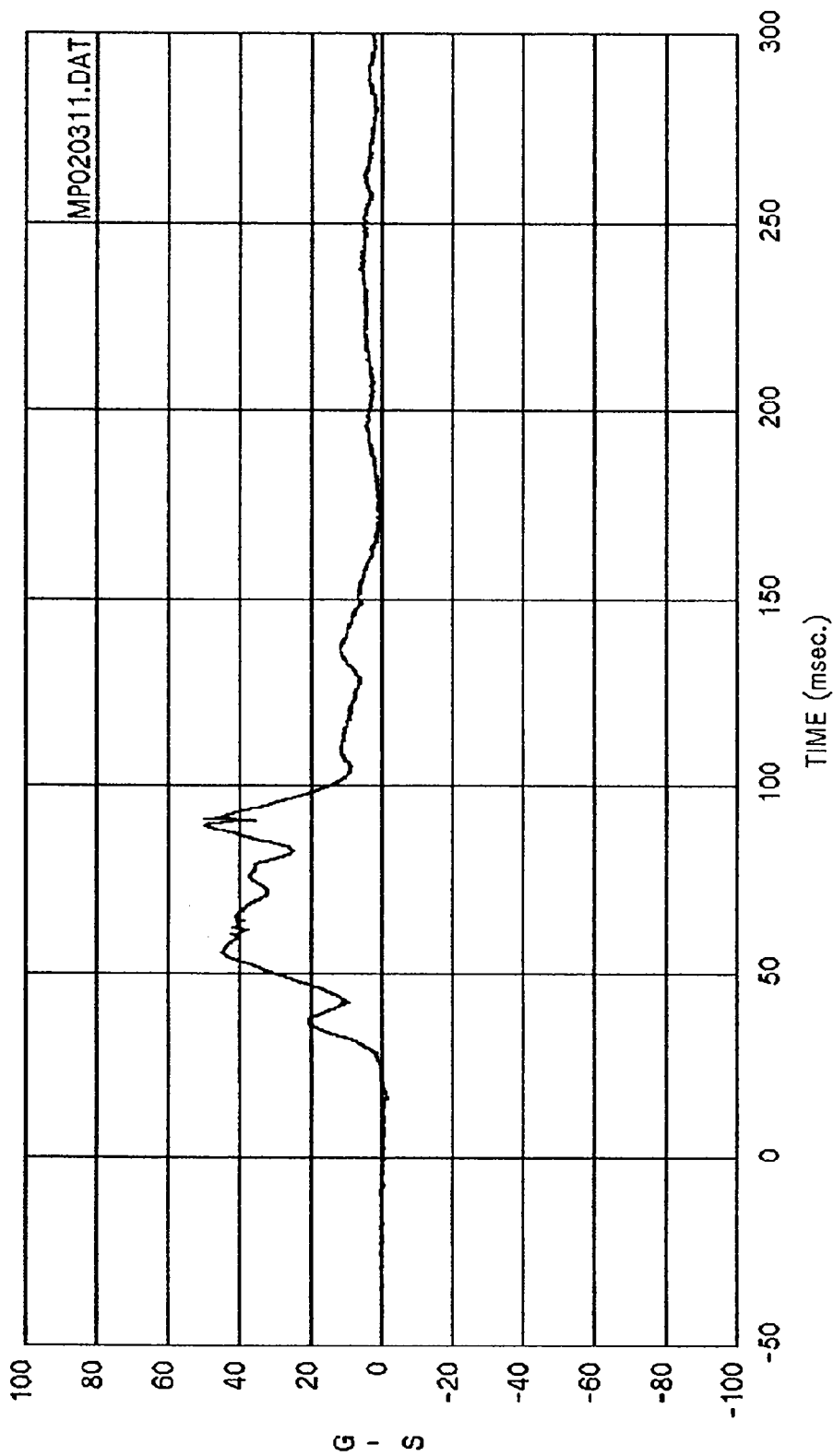

Curve: Passenger head acceleration -- Z axis Filter: SAE CLASS 1000 Max = 51.131 Min = -1.5652

MSE Date: 12/02/92 Program: 1993 NCAP, test number 3 Vehicle: 1993 Ford Ranger Pickup

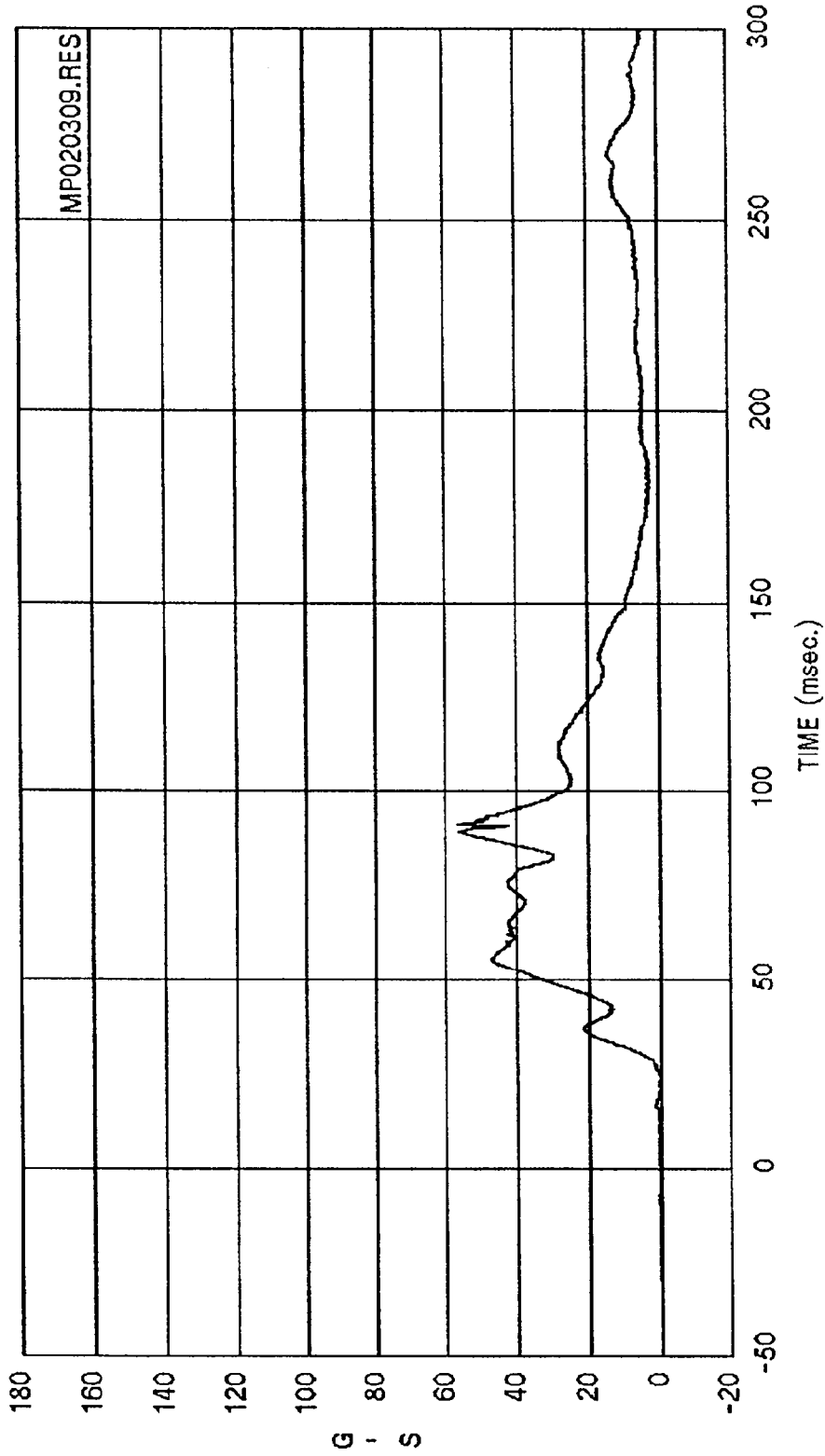

MP020309.RES

Curve: Passenger head acceleration -- Resultant Filter: SAE CLASS 1000 Max = 56.408 Min = .87334
01

MSE Date: 12/02/92 Program: 1993 NCAP, test number 3 Vehicle: 1993 Ford Ranger Pickup

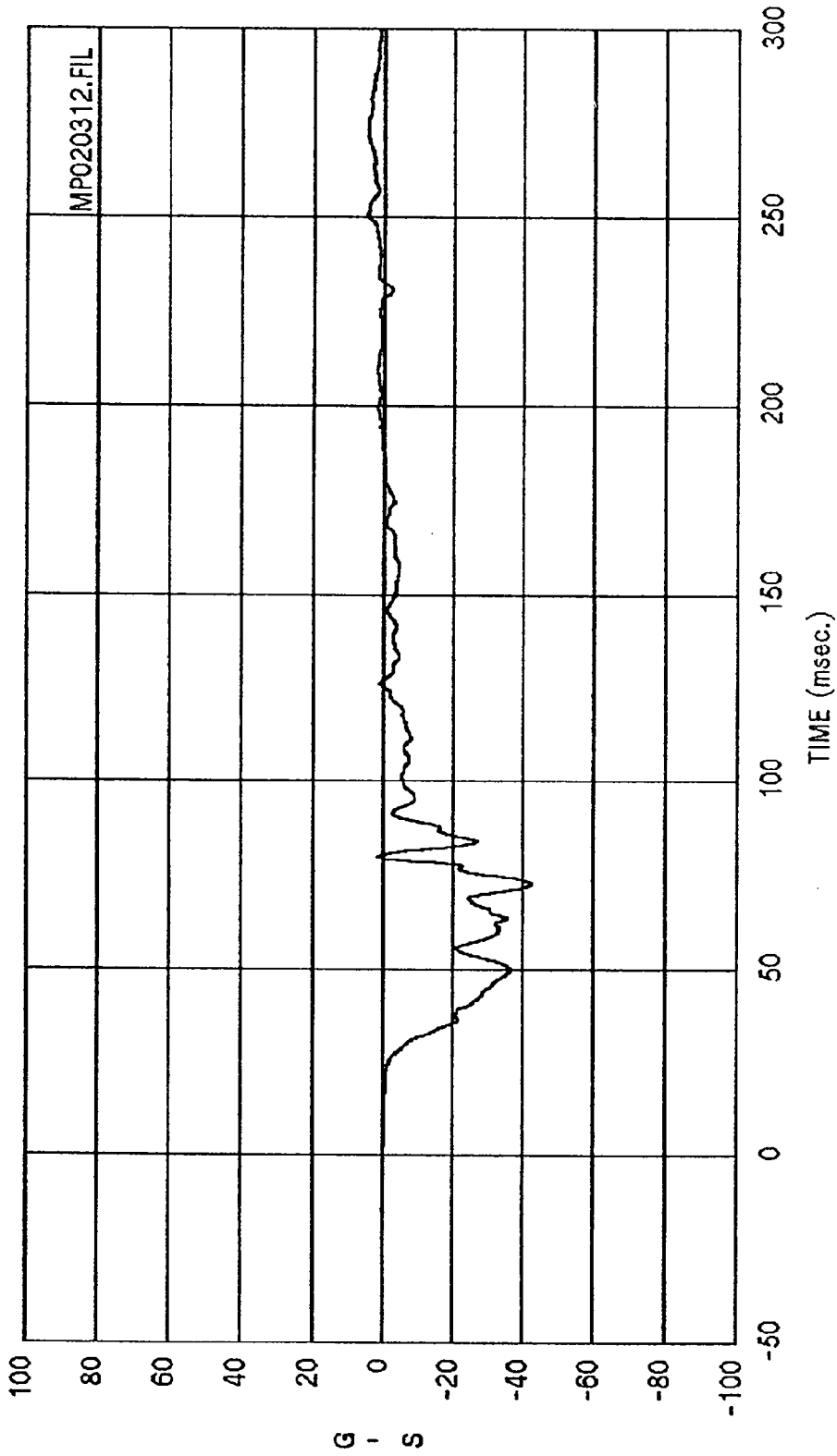

Curve: Passenger chest acceleration -- X axis Filter: SAE CLASS 180 Max = 5.0235 Min = -42.539

MSE Date: 12/02/92 Program: 1993 NCAP, test number 3 Vehicle: 1993 Ford Ranger Pickup

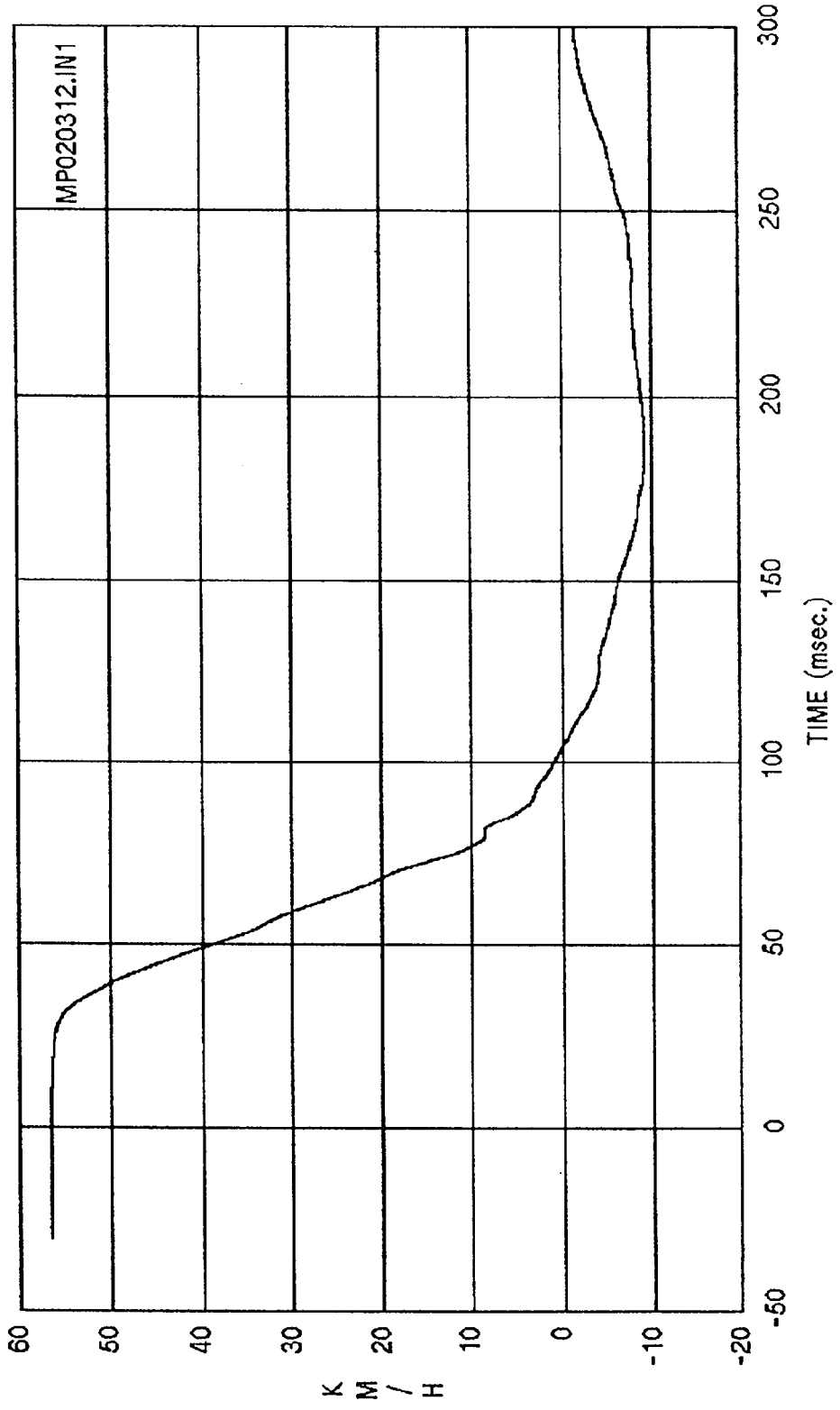

Curve: Passenger chest delta V -- X axis Filter: SAE CLASS 180 Max = 56.623 Min = -9.1754

MSE Date: 12/02/92 Program: 1993 NCAP, test number 3 Vehicle: 1993 Ford Ranger Pickup

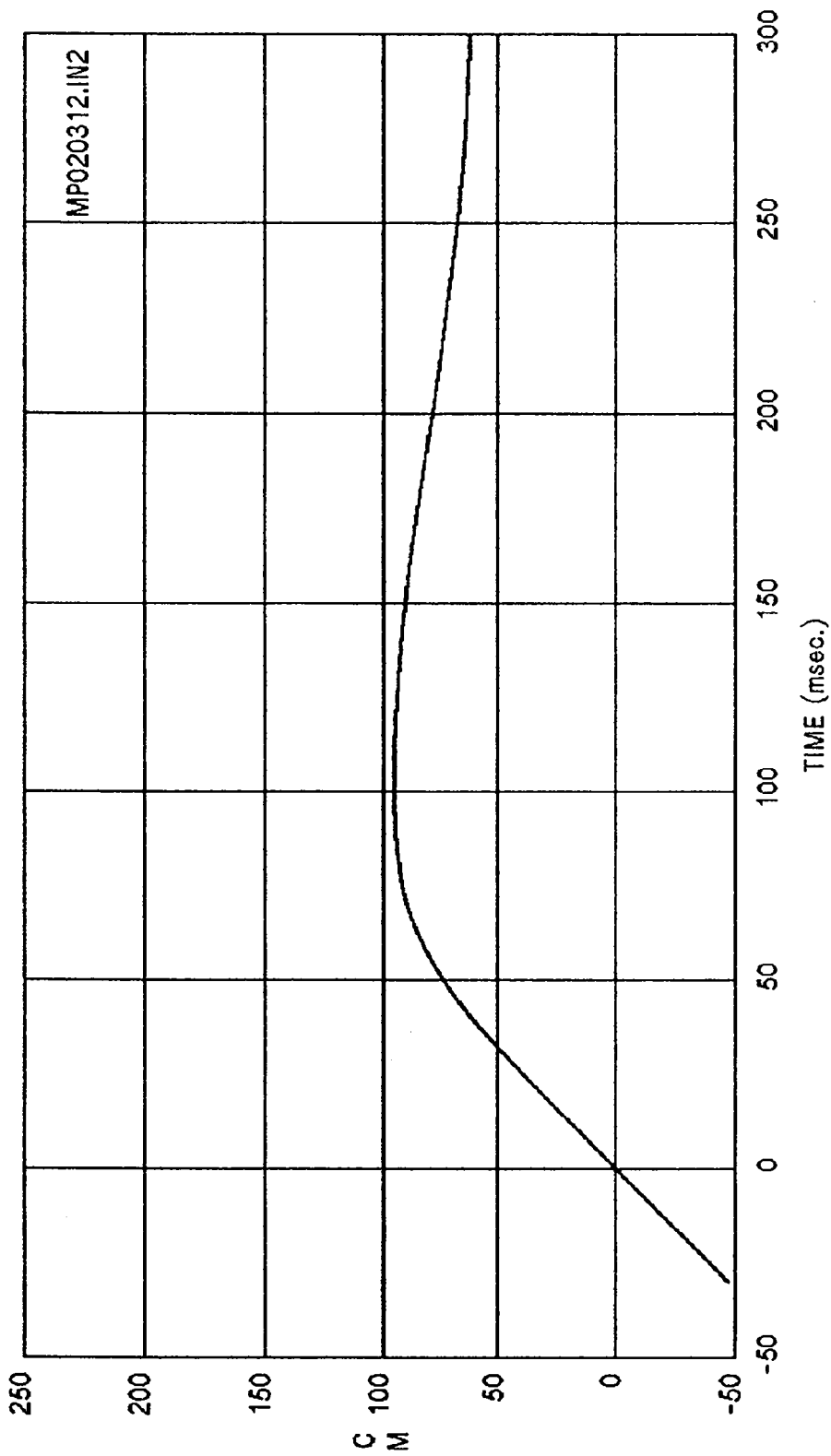

Curve: Passenger chest displacement -- X axis Filter: SAE CLASS 180 Max = 95.255 Min = 62.259
 MSE Date: 12/02/92 Program: 1993 NCAP, test number 3 Vehicle: 1993 Ford Ranger Pickup

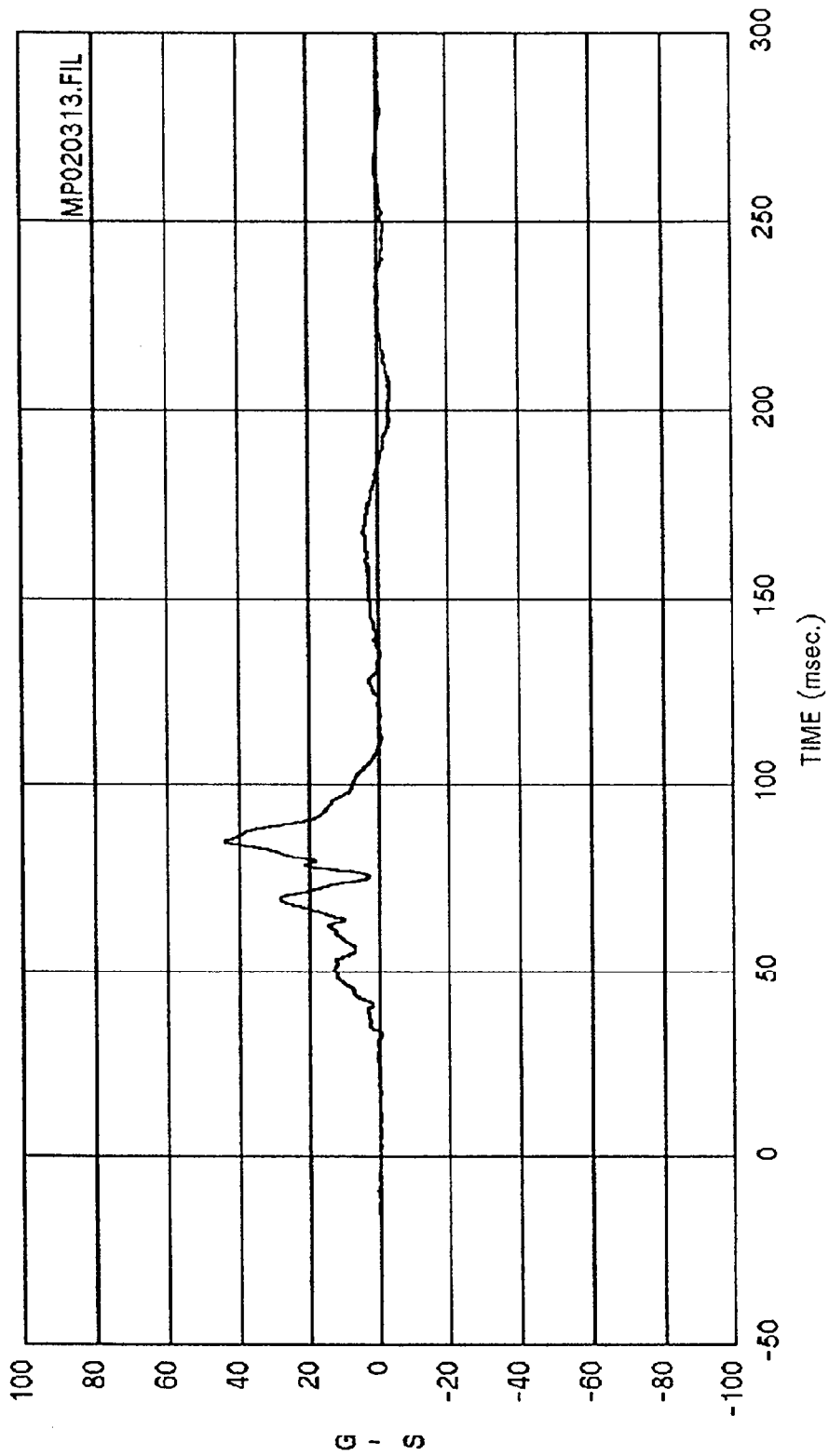

Curve: Passenger chest acceleration -- Y axis Filter: SAE CLASS 180 Max = 43.987 Min = -3.5849
 MSE Date: 12/02/92 Program: 1993 NCAP, test number 3 Vehicle: 1993 Ford Ranger Pickup

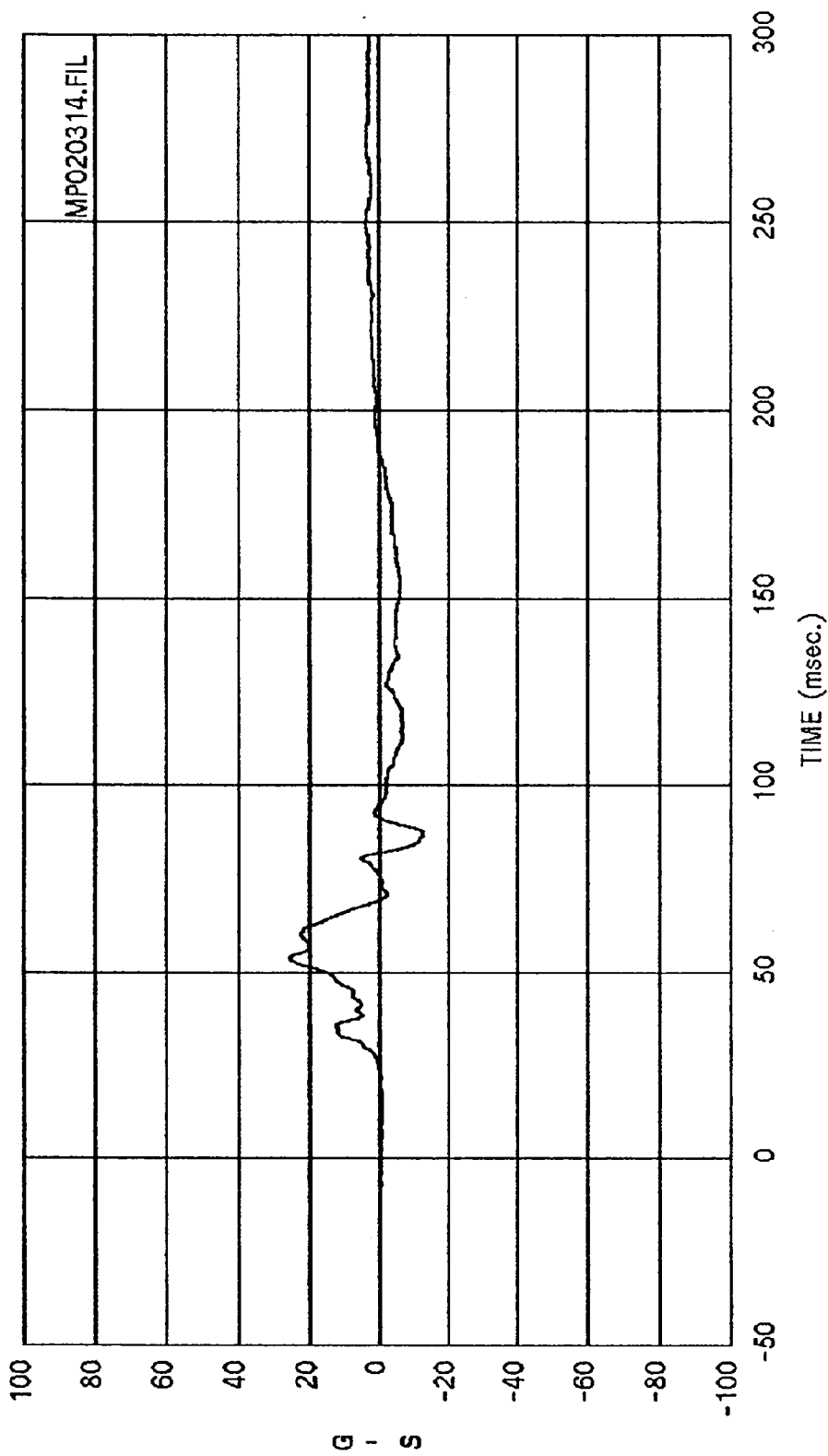

Curve: Passenger chest acceleration -- Z axis Filter: SAE CLASS 180 Max = 25.770 Min = -12.778

MSE Date: 12/02/92 Program: 1993 NCAP, test number 3 Vehicle: 1993 Ford Ranger Pickup

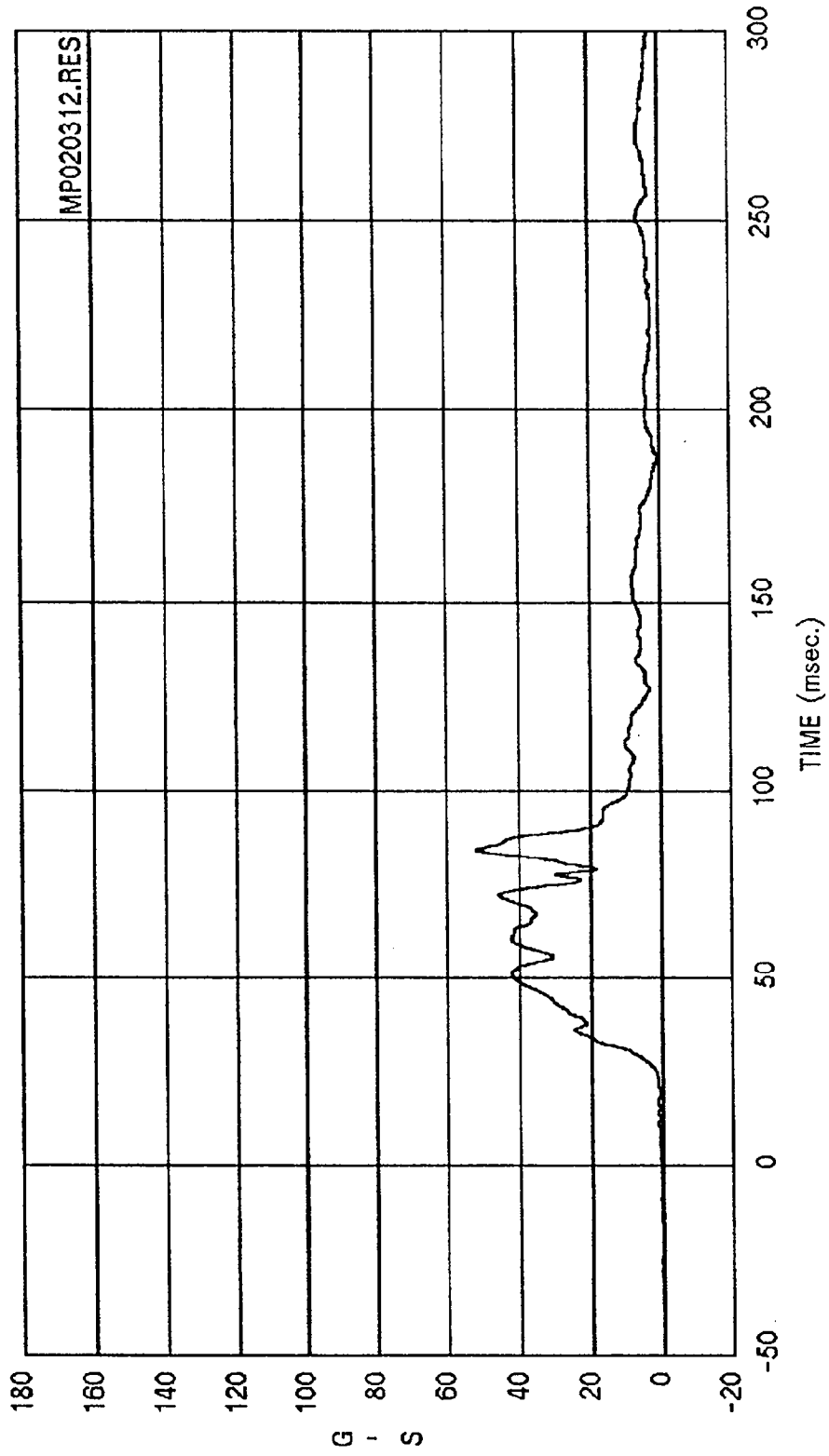

Curve: Passenger chest acceleration -- Resultant Filter: SAE CLASS 180 Max = 51.895 Min = .66201
 MSE Date: 12/02/92 Program: 1993 NCAP, test number 3 Vehicle: 1993 Ford Ranger Pickup

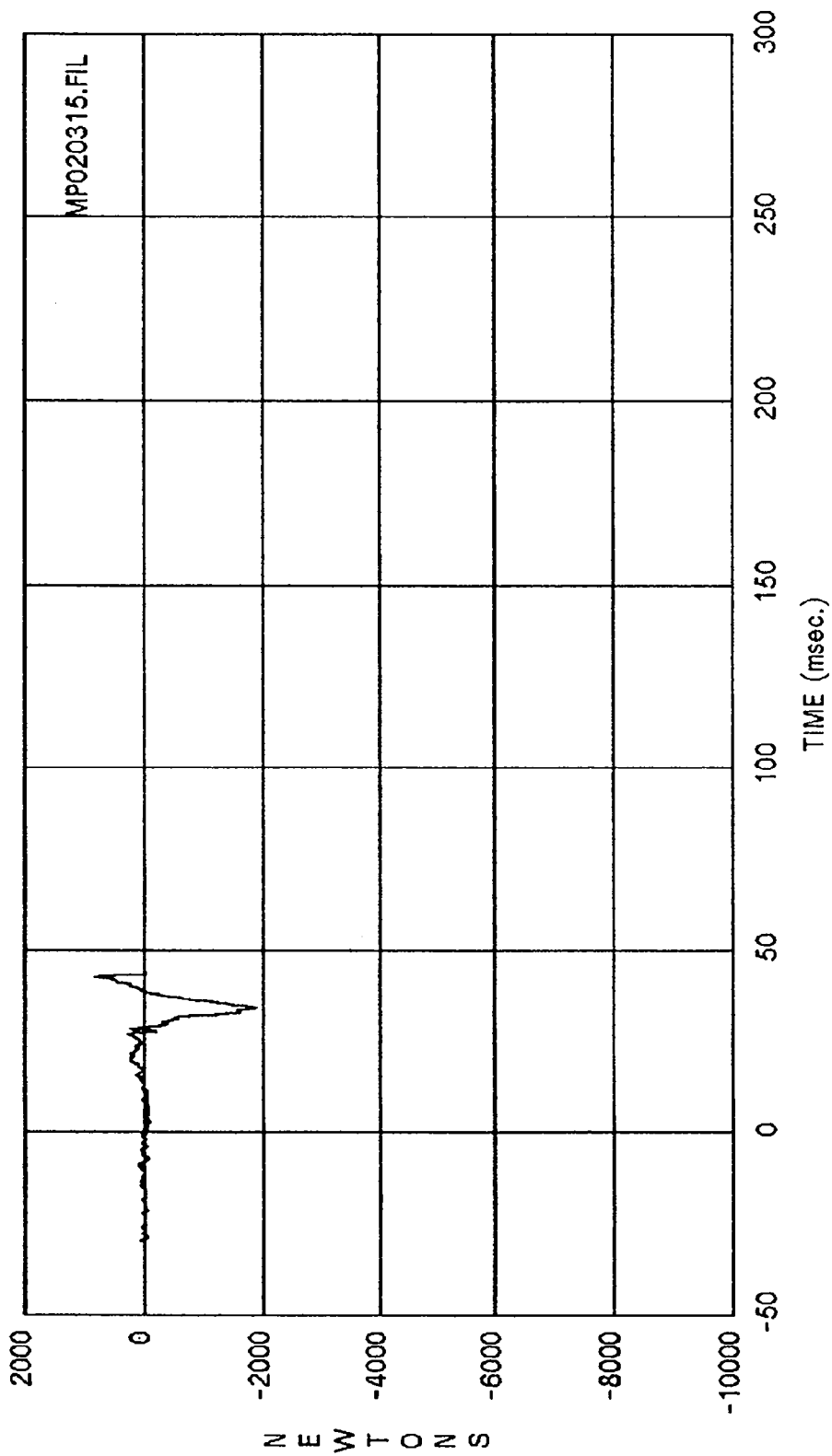

Curve: Passenger left femur force (CF at 43.3 msec) Filter: SAE CLASS 600 Max = 831.58 Min = -181

MSE Date: 12/02/92 Program: 1993 NCAP, test number 3 Vehicle: 1993 Ford Ranger Pickup

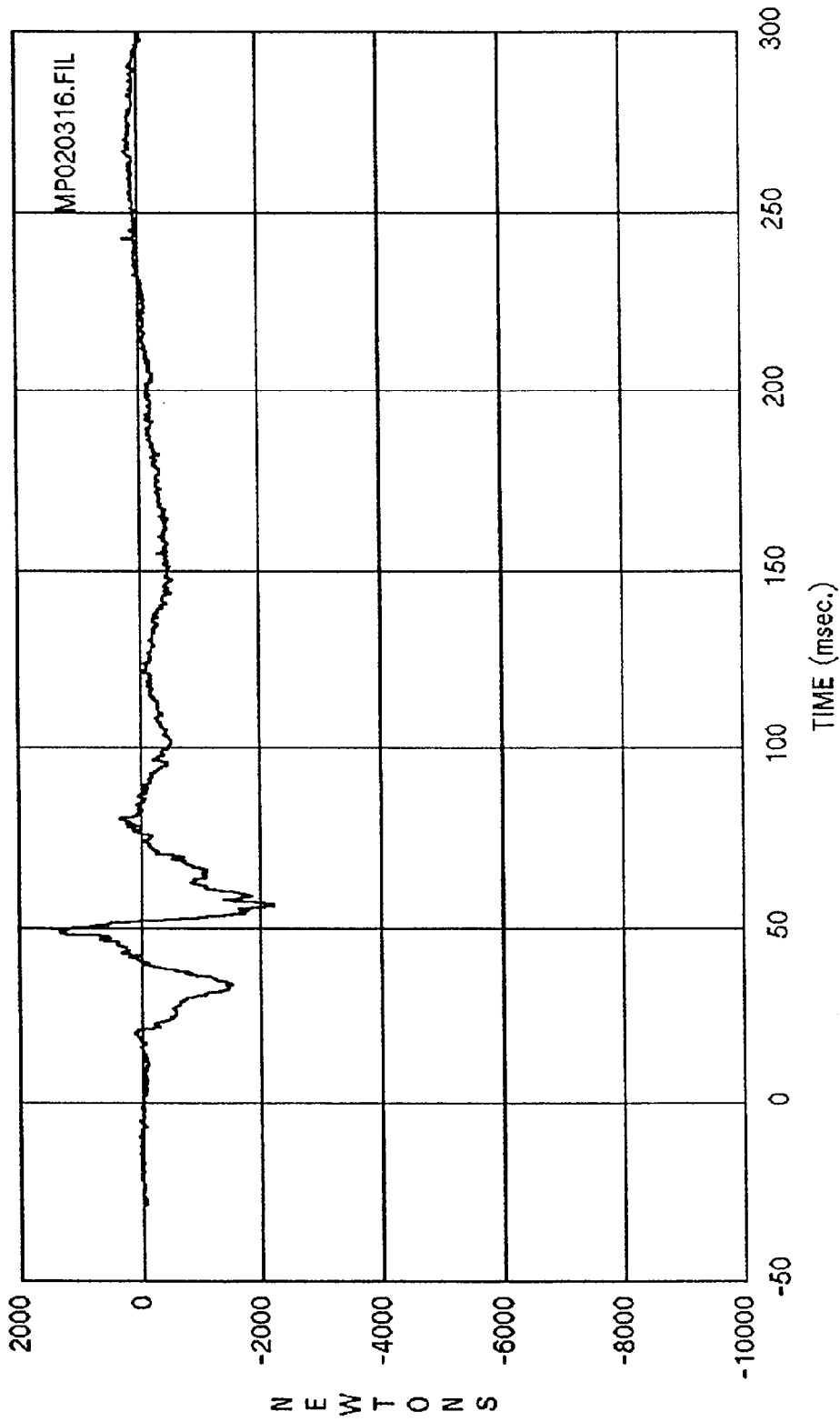

Curve: Passenger right femur force Filter: SAE CLASS 600 Max = 1465.4 Min = -2199.9

MSE Date: 12/02/92 Program: 1993 NCAP, test number 3 Vehicle: 1993 Ford Ranger Pickup

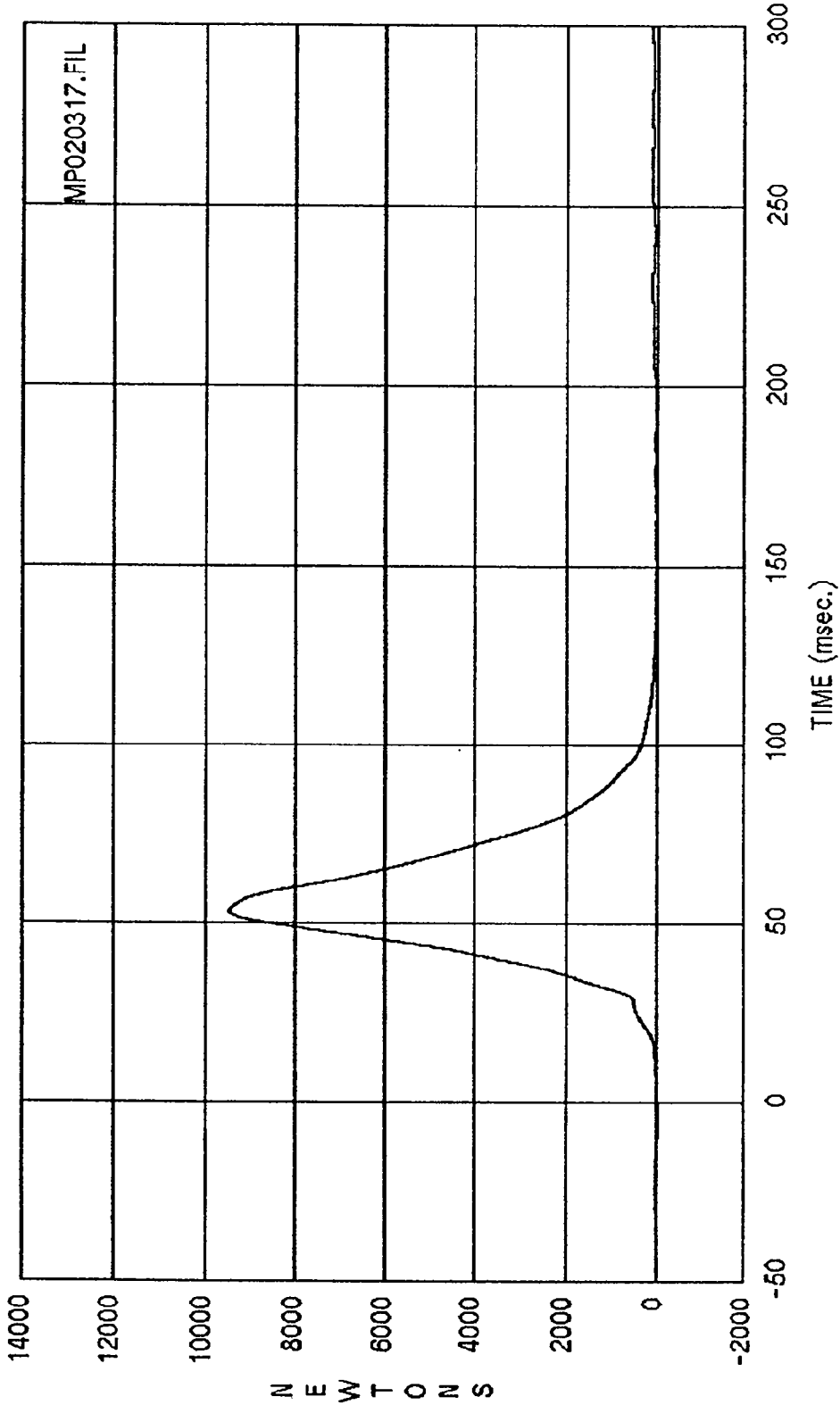

Curve: Driver lap belt load Filter: SAE CLASS 60 Max = 9478.3 Min = -16.464
 MSE Date: 12/02/92 Program: 1993 NCAP, test number 3 Vehicle: 1993 Ford Ranger Pickup

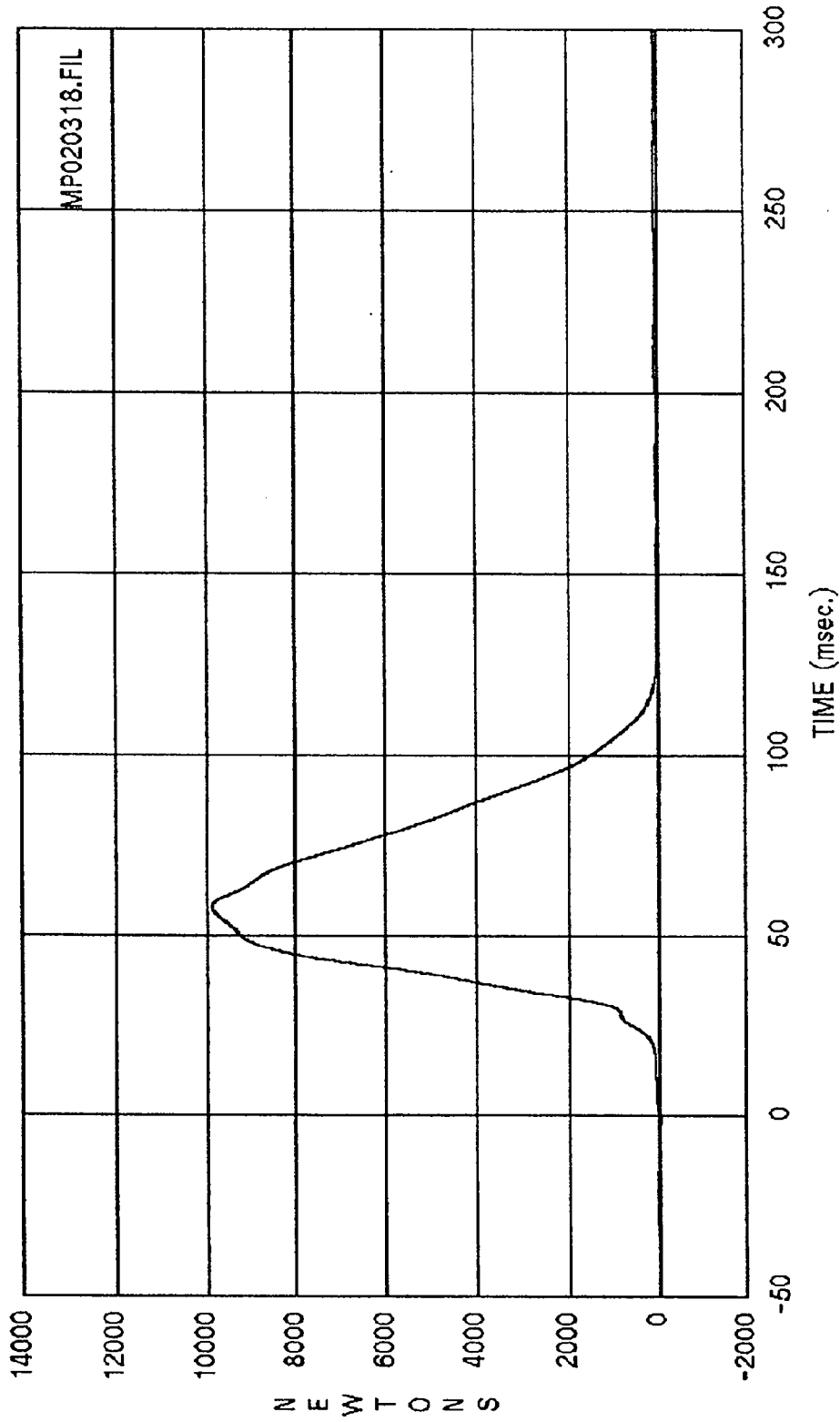

Curve: Driver shoulder belt load Filter: SAE CLASS 60 Max = 9891.7 Min = -95190

MSE Date: 12/02/92 Program: 1993 NCAP, test number 3 Vehicle: 1993 Ford Ranger Pickup

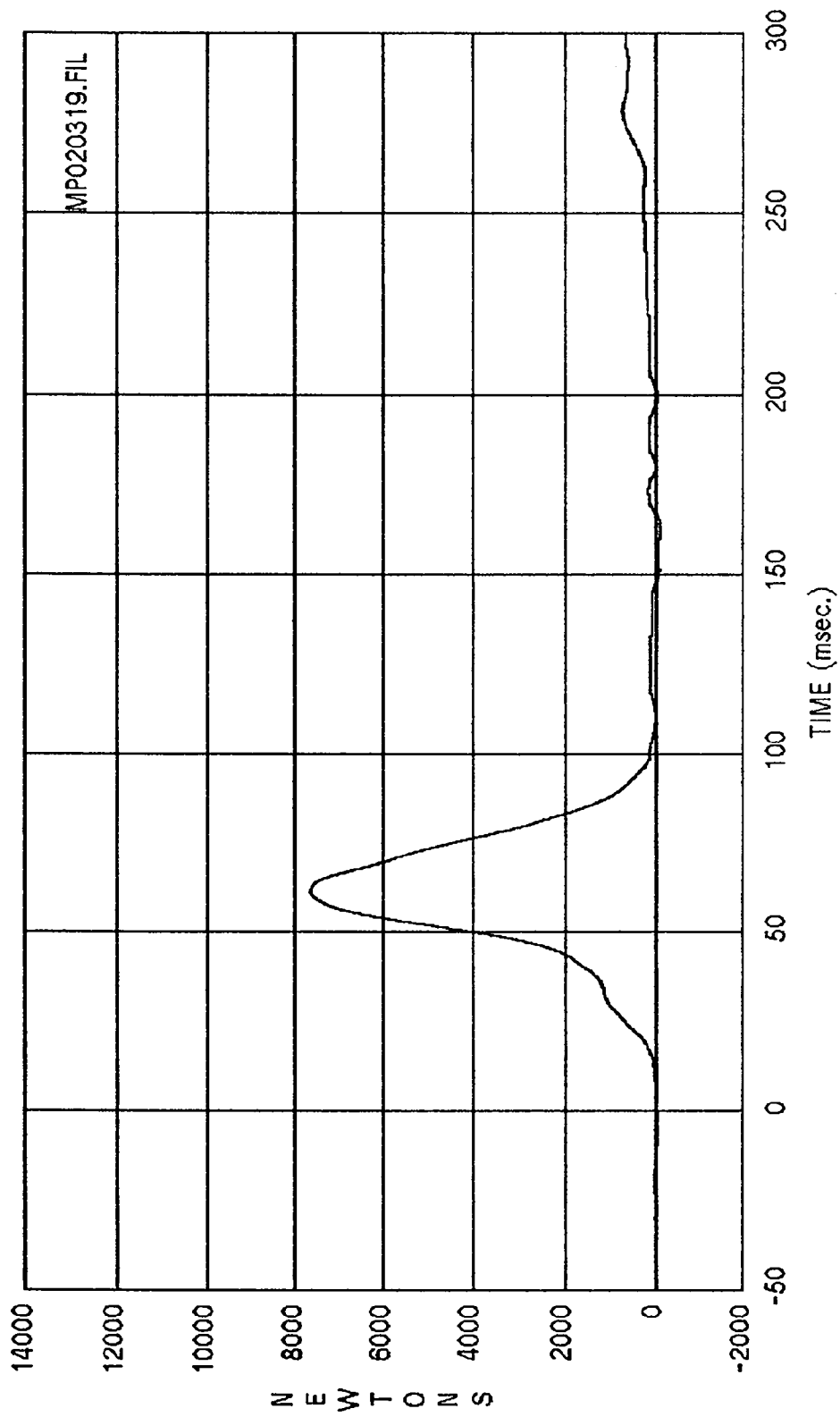

Curve: Passenger lap belt load Filter: SAE CLASS 60 Max = 7650.6 Min = -110.85

MSE Date: 12/02/92 Program: 1993 NCAP, test number 3 Vehicle: 1993 Ford Ranger Pickup

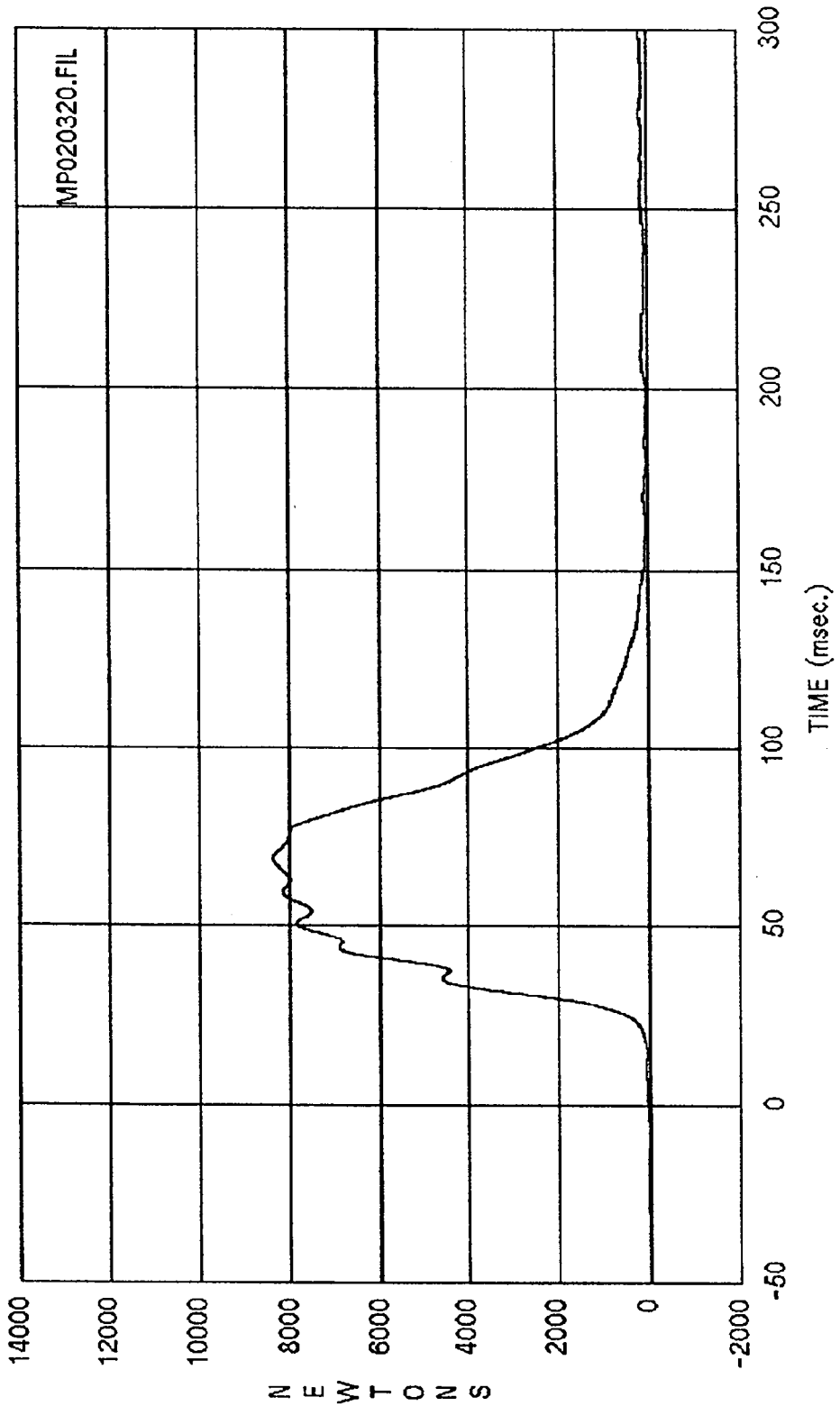

Curve: Passenger shoulder belt load Filter: SAE CLASS 60 Max = 8377.0 Min = 18.409

MSE Date: 12/02/92 Program: 1993 NCAP, test number 3 Vehicle: 1993 Ford Ranger Pickup

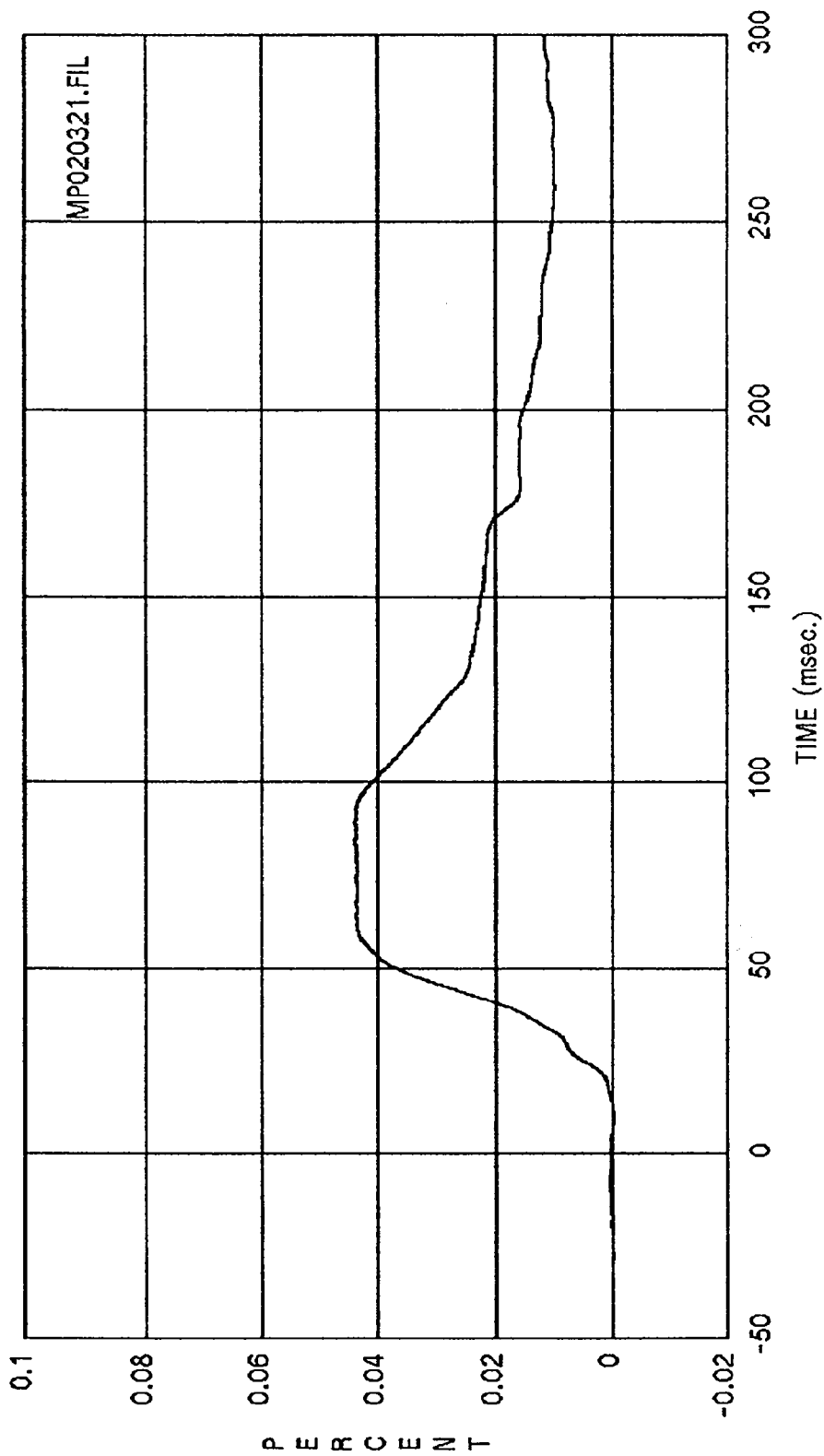

Curve: Driver shoulder belt elongation Filter: SAE CLASS 60 Max = .43883E-01 Min = -.16858E

MSE Date: 12/02/92 Program: 1993 NCAP, test number 3 Vehicle: 1993 Ford Ranger Pickup

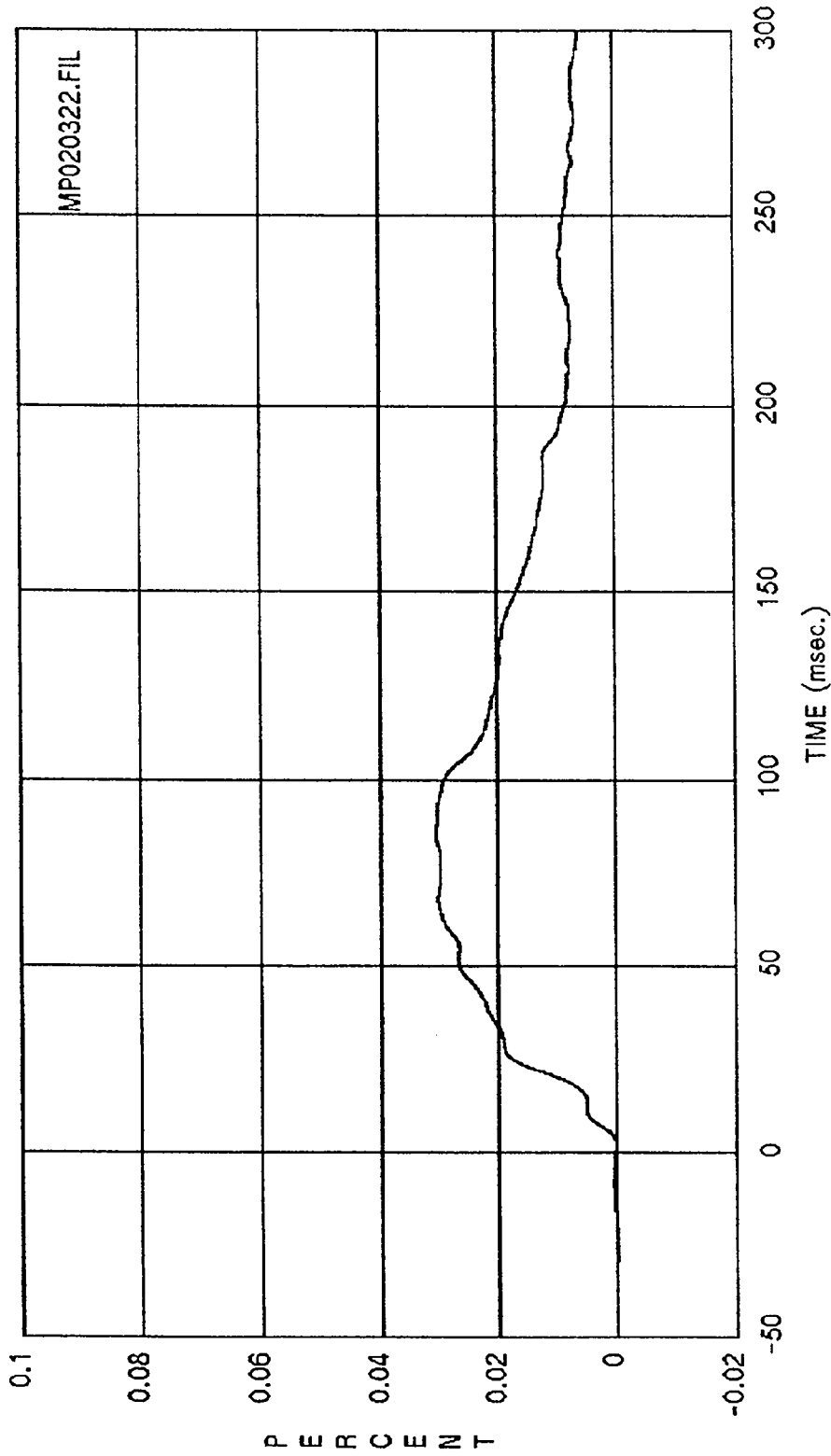

Curve: Passenger shoulder belt elongation Filter: SAE CLASS 60 Max = .30520E-01 Min = -.3113E-04

MSE Date: 12/02/92 Program: 1993 NCAP, test number 3 Vehicle: 1993 Ford Ranger Pickup

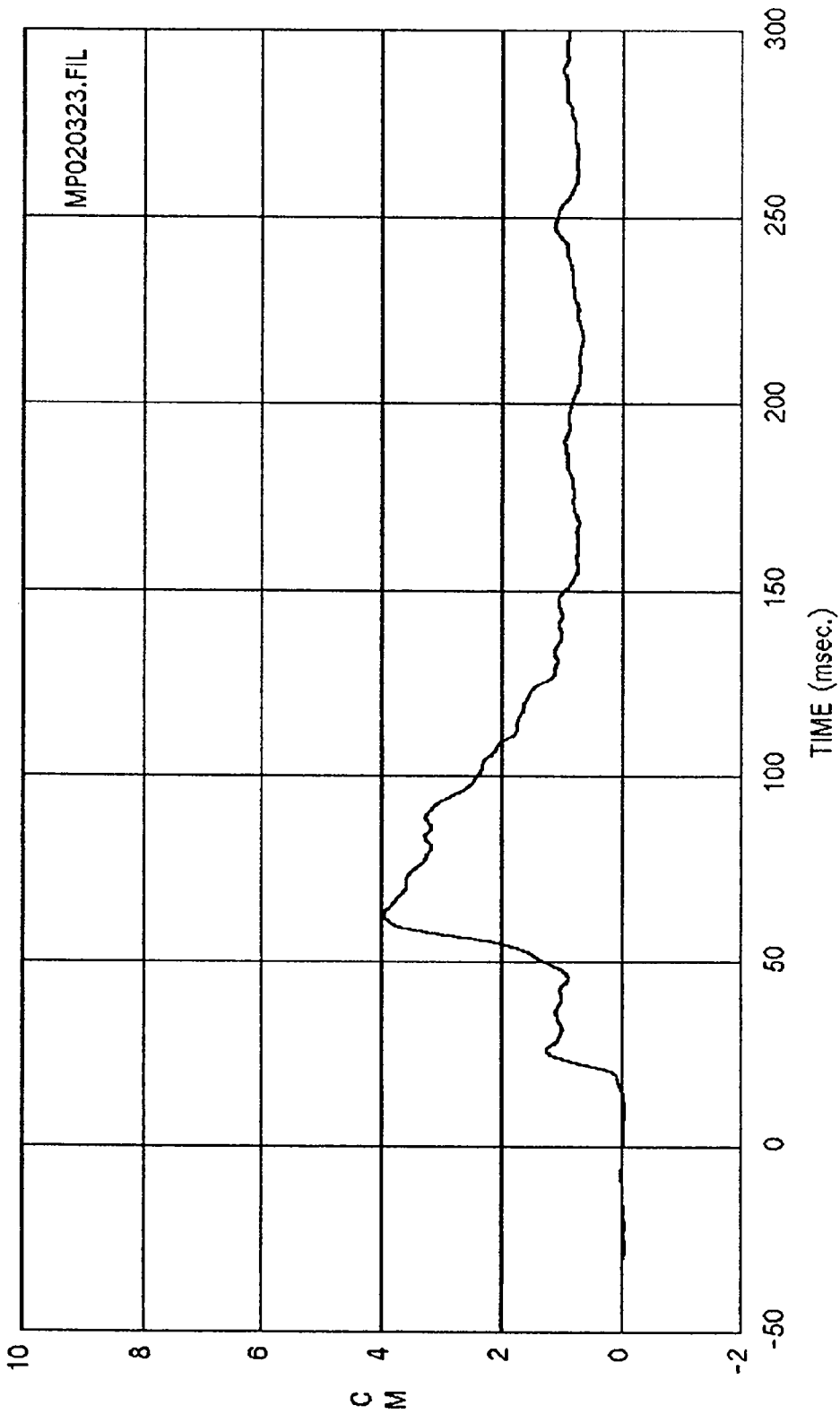

Curve: Driver shoulder belt spoolout Filter: SAE CLASS 60 Max = 3.9724 Min = -.28105E-0
 MSE Date: 12/02/92 Program: 1993 NCAP, test number 3 Vehicle: 1993 Ford Ranger Pickup

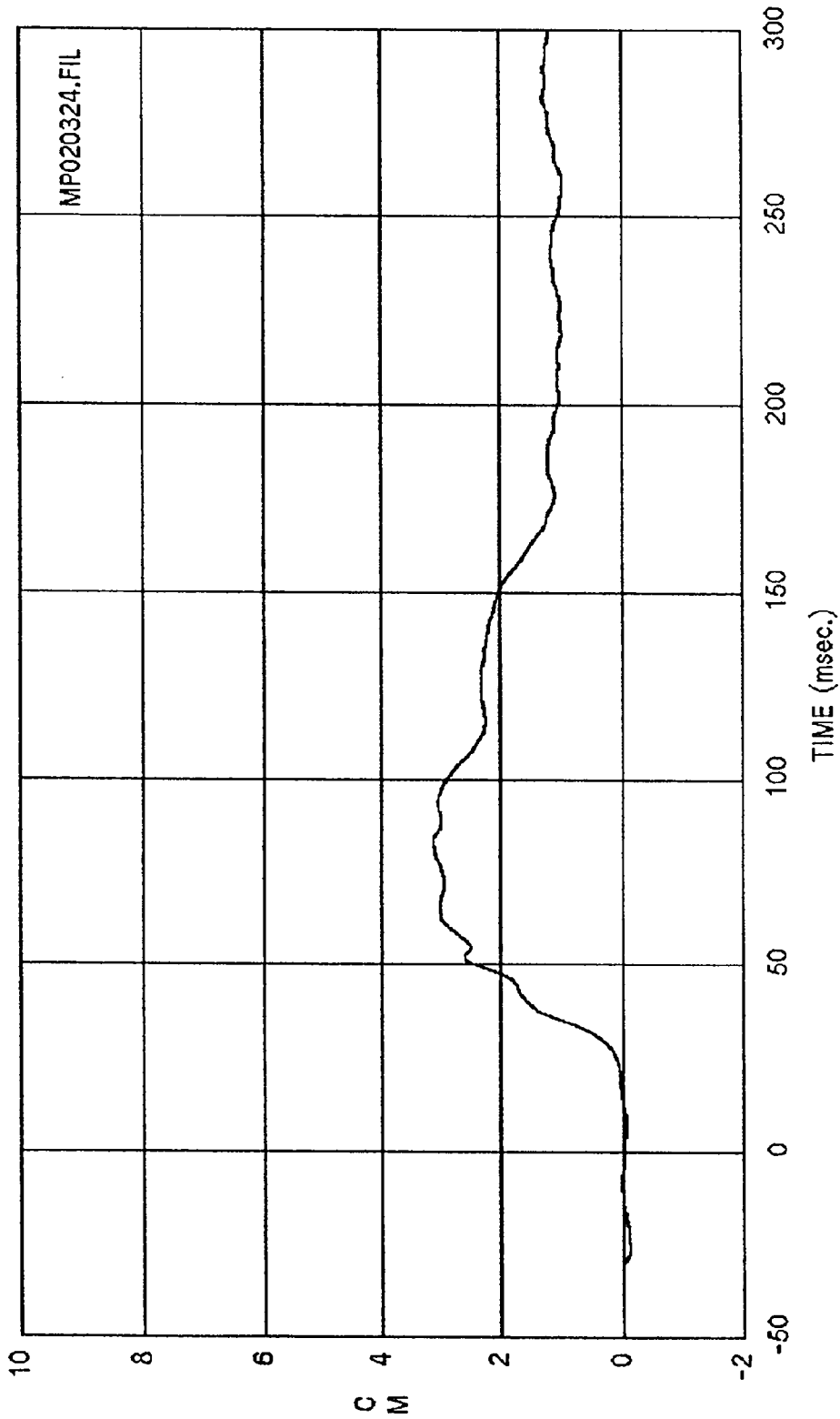

Curve: Passenger shoulder belt spoolout Filter: SAE CLASS 60 Max = 3.1388 Min = -.41690E-0
 MSE Date: 12/02/92 Program: 1993 NCAP, test number 3 Vehicle: 1993 Ford Ranger Pickup

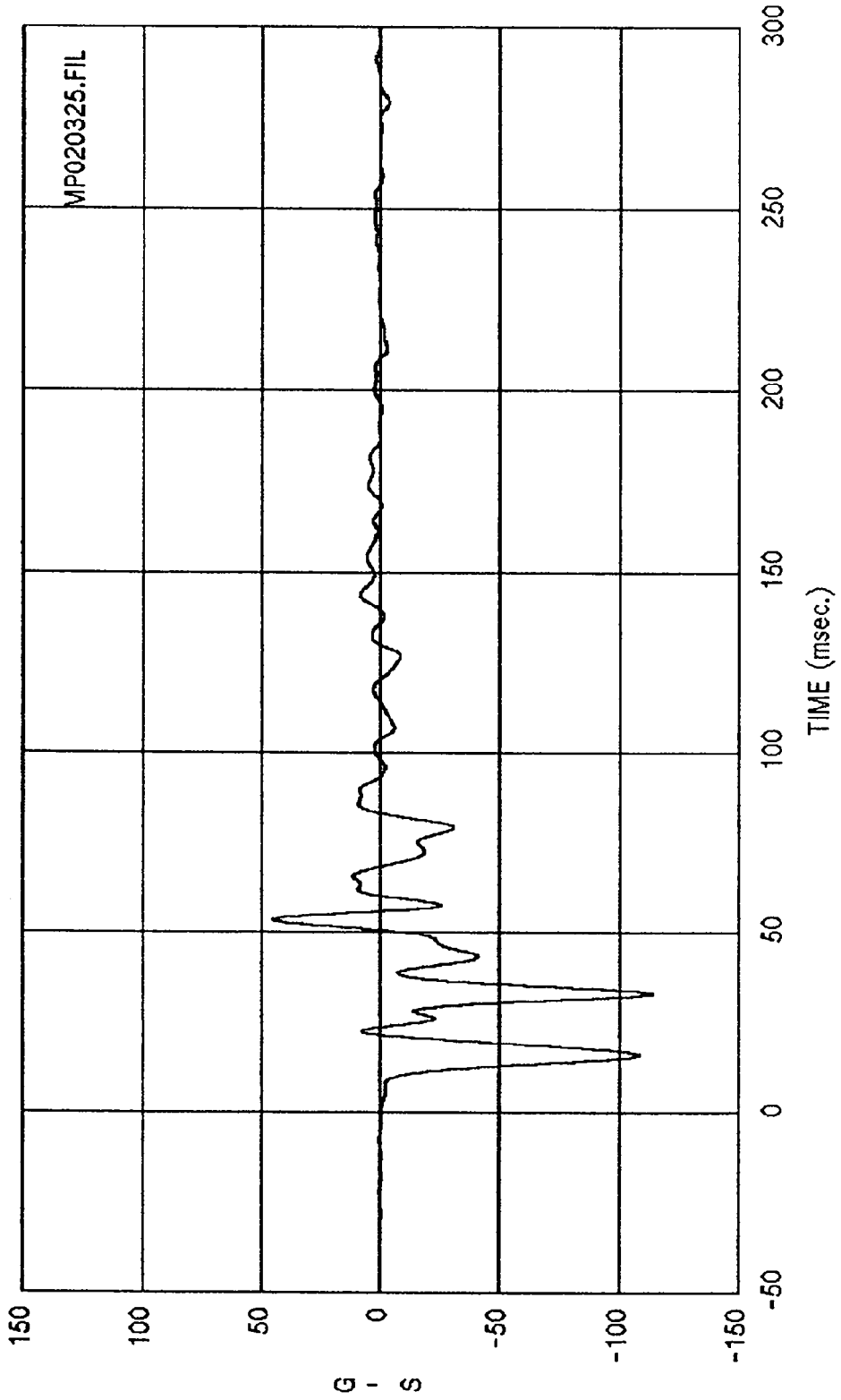

Curve: Left front calliper acceleration -- X axis Filter: SAE CLASS 60 Max = 45.680 Min = -113.79

MSE Date: 12/02/92 Program: 1993 NCAP, test number 3 Vehicle: 1993 Ford Ranger Pickup

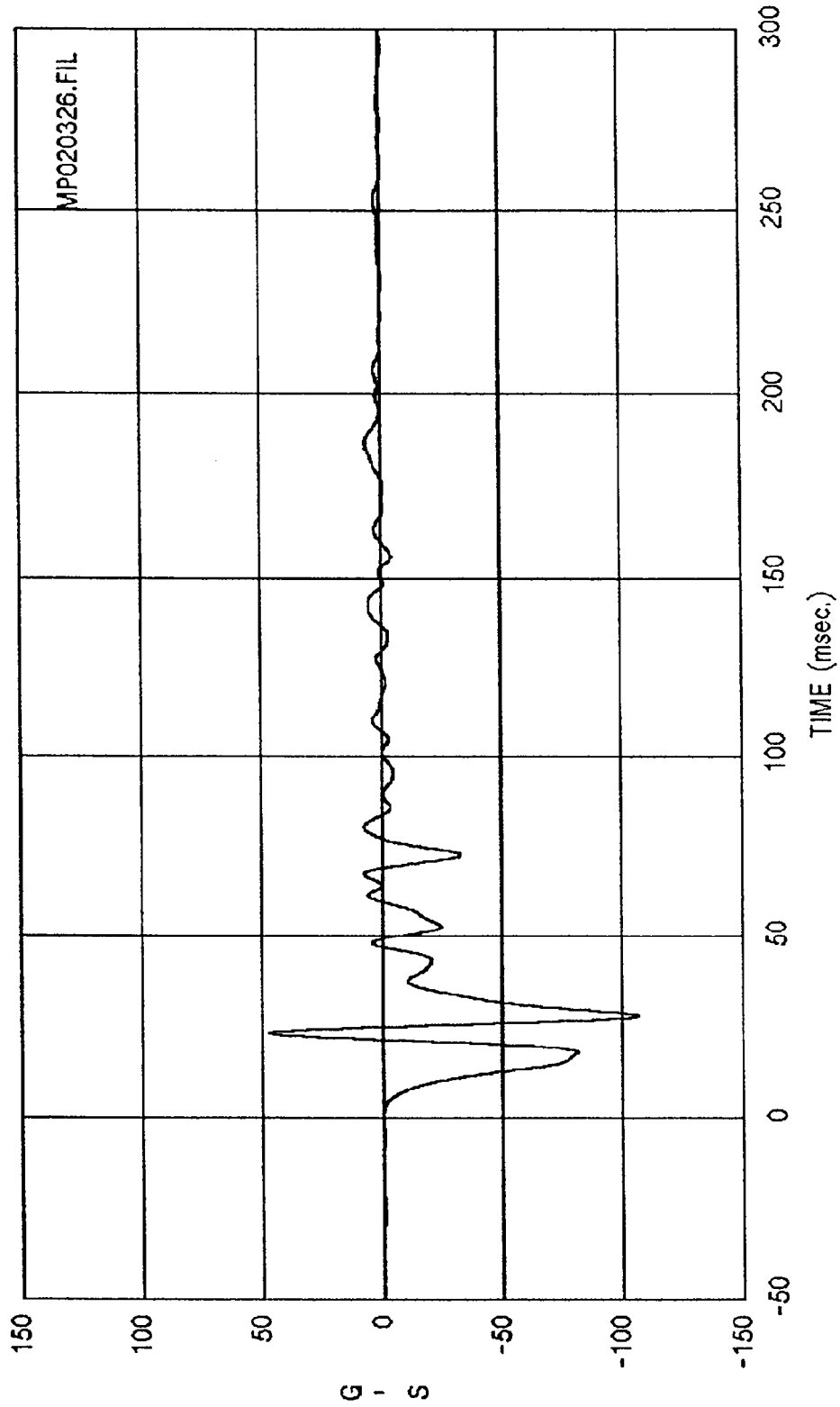

Curve: Right front caliper acceleration -- X axis Filter: SAE CLASS 60 Max = 47.466 Min = -107.23

MSE Date: 12/02/92 Program: 1993 NCAP, test number 3 Vehicle: 1993 Ford Ranger Pickup

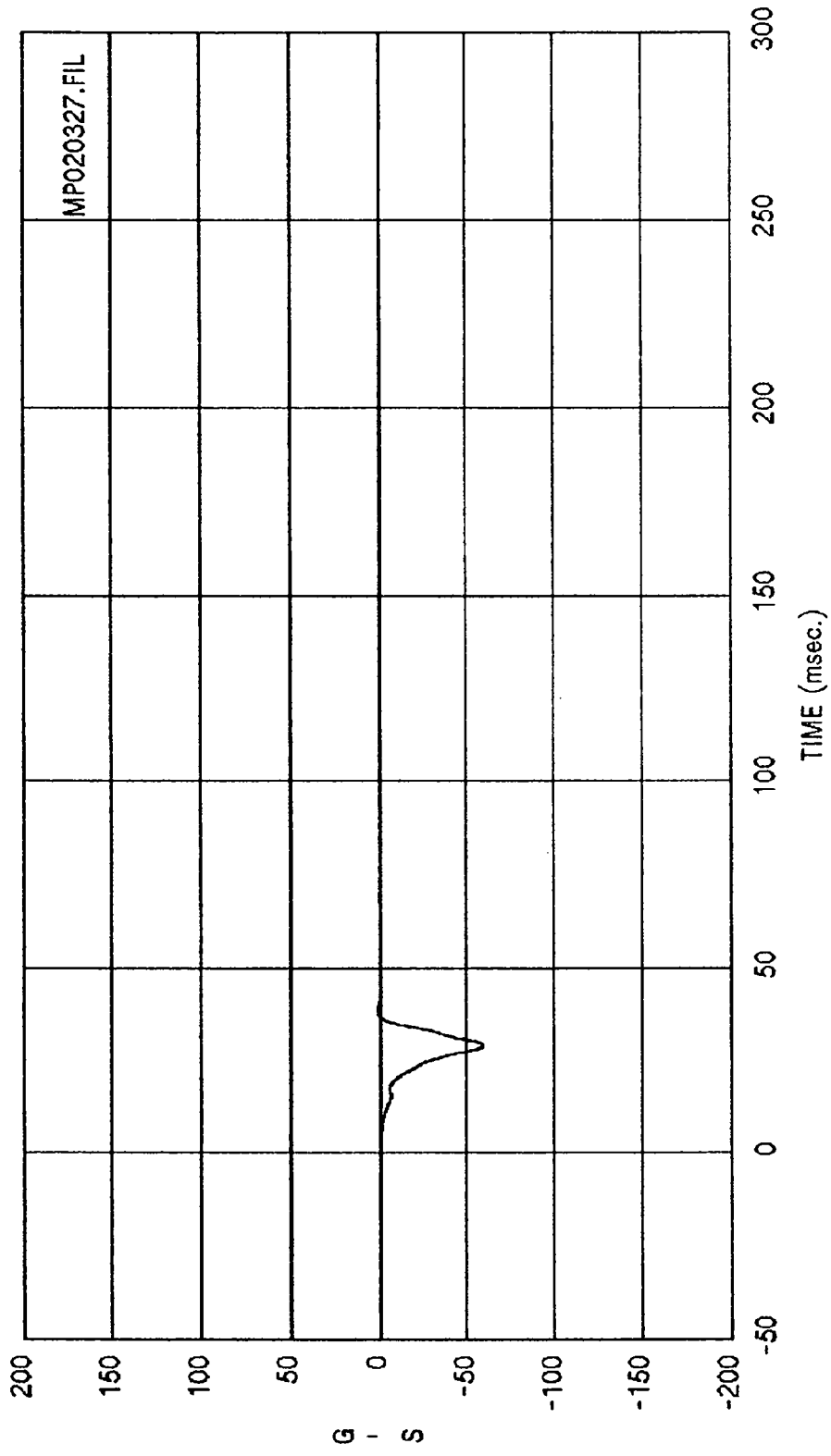

Curve: Engine bottom acceleration -- X axis (CF at 33.1) Filter: SAE CLASS 60 Max = 1.4279 Min = -58.8

MSE Date: 12/02/92 Program: 1993 NCAP, test number 3 Vehicle: 1993 Ford Ranger Pickup

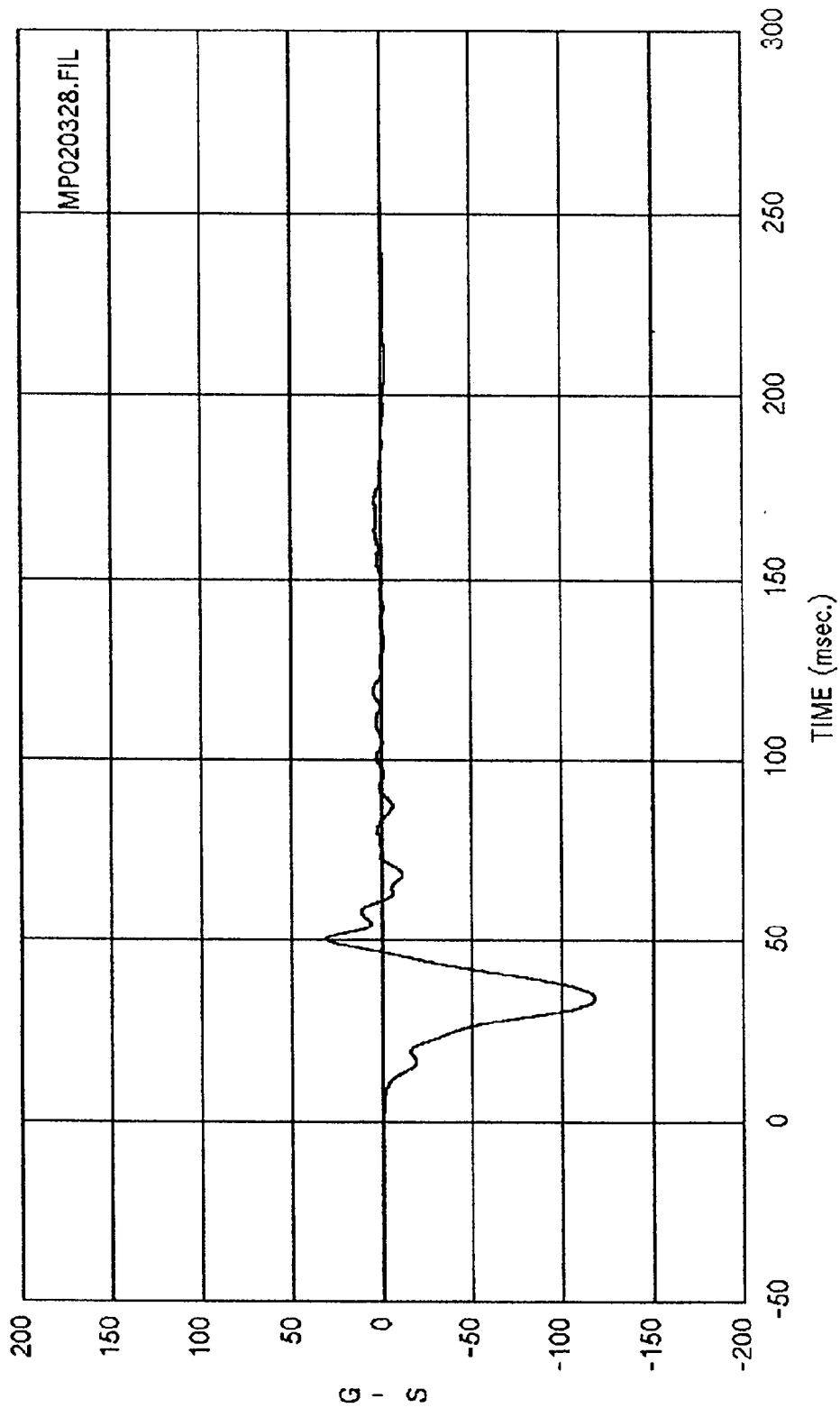

Curve: Engine top acceleration -- X axis Filter: SAE CLASS 60 Max = 31.734 Min = -118.47

MSE Date: 12/02/92 Program: 1993 NCAP, test number 3 Vehicle: 1993 Ford Ranger Pickup

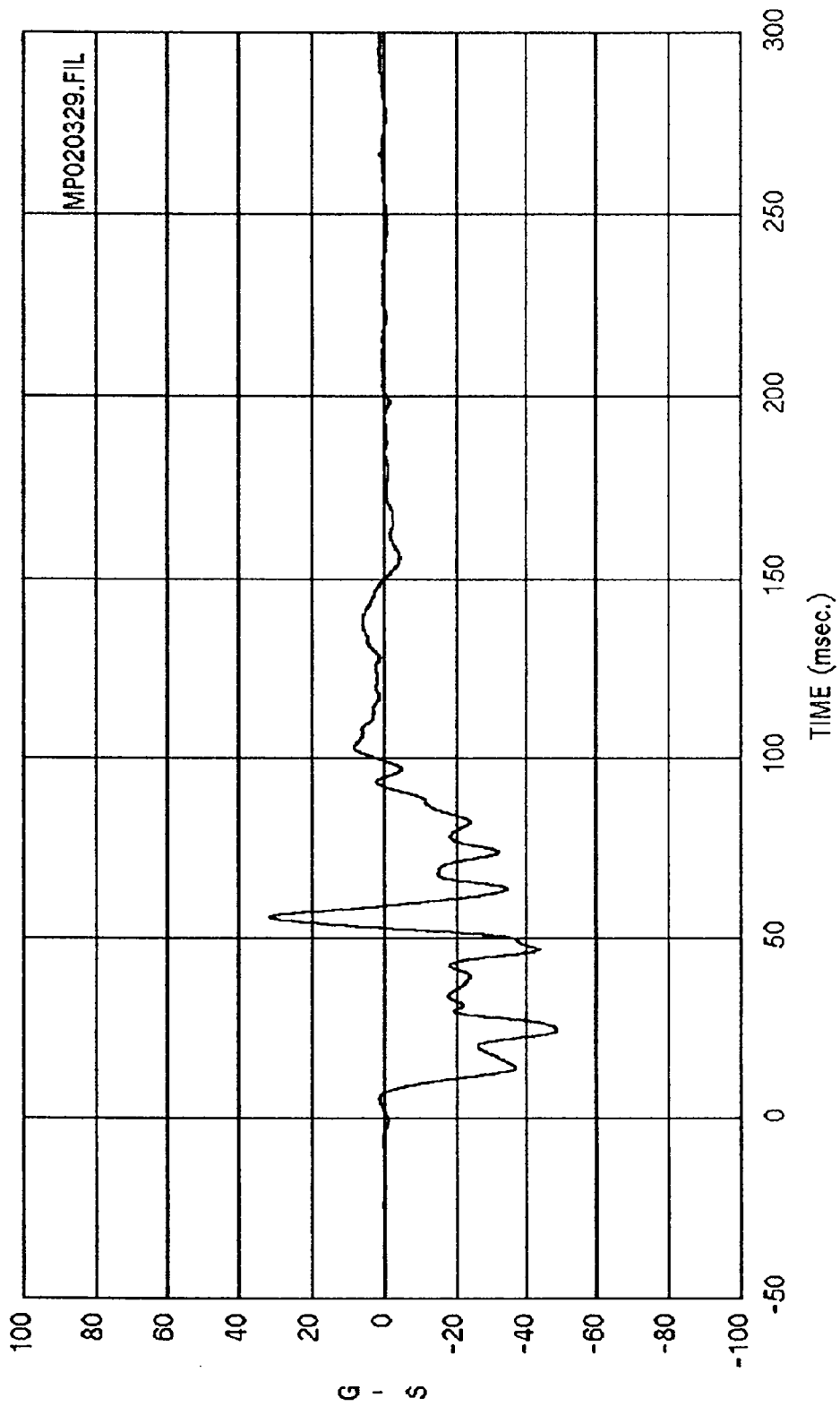

Curve: Dashpanel acceleration -- X axis Filter: SAE CLASS 60 Max = 31.670 Min = -48.711

MSE Date: 12/02/92 Program: 1993 NCAP, test number 3 Vehicle: 1993 Ford Ranger Pickup

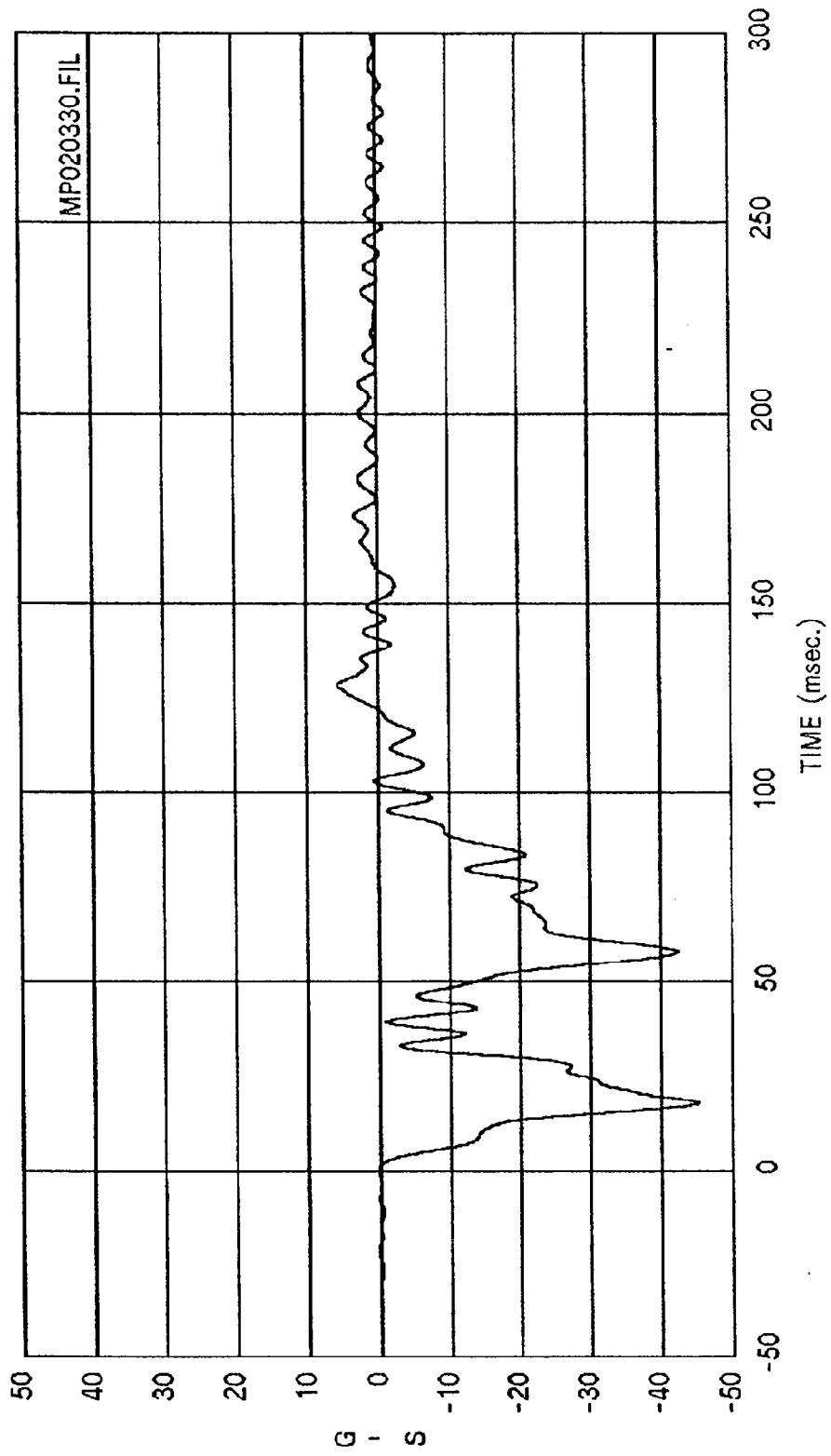

Curve: Left rear cross-member accel. - X axis (primary) Filter: SAE CLASS 60 Max = 5.7208 Min = -45.21

MSE Date: 12/02/92 Program: 1993 NCAP, test number 3 Vehicle: 1993 Ford Ranger Pickup

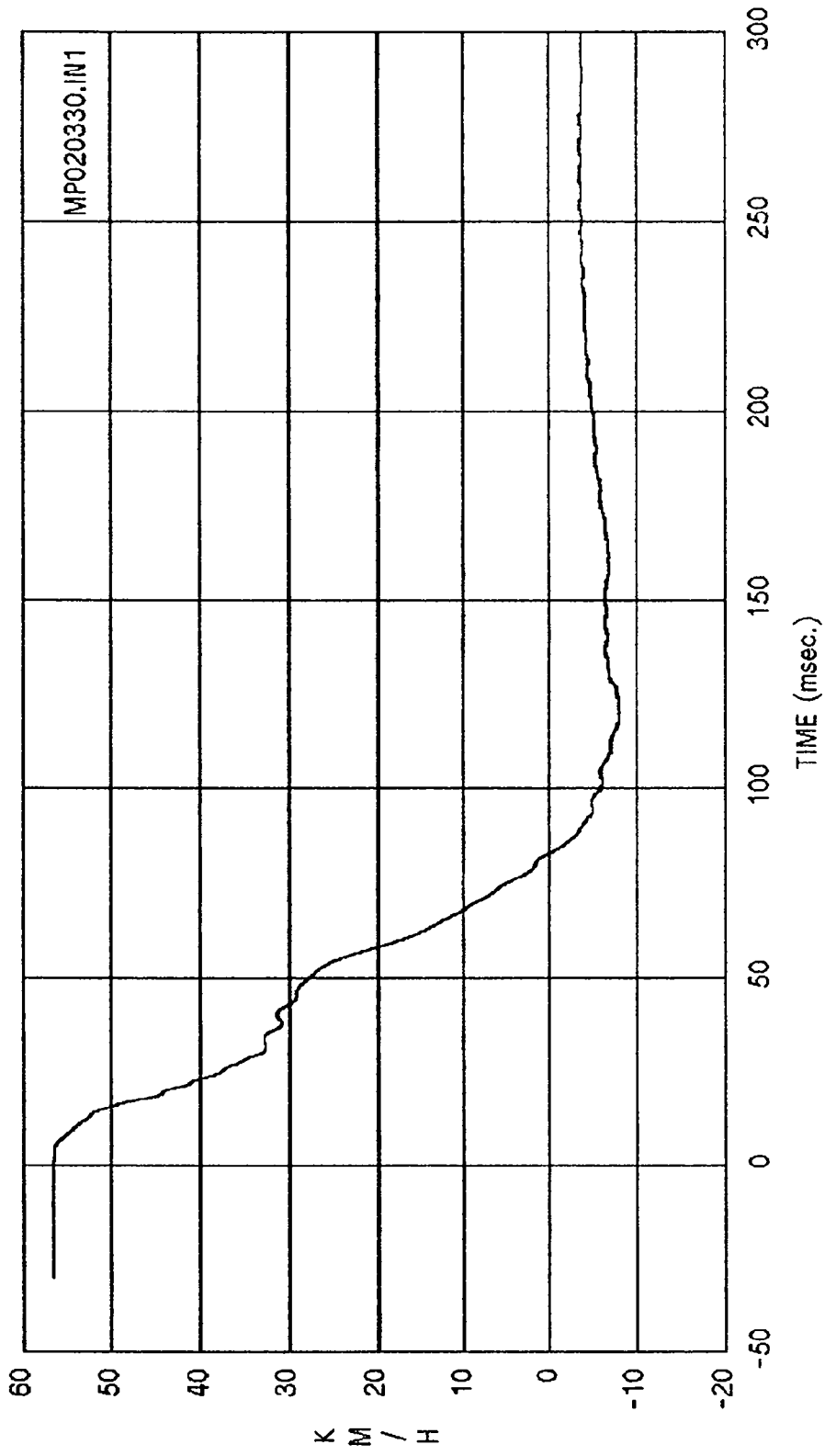

Curve: Left rear cross-member delta V -- X axis (Pri) Filter: SAE CLASS 180 Max = 56.622 Min = -8.00E

MSE Date: 12/02/92 Program: 1993 NCAP, test number 3 Vehicle: 1993 Ford Ranger Pickup

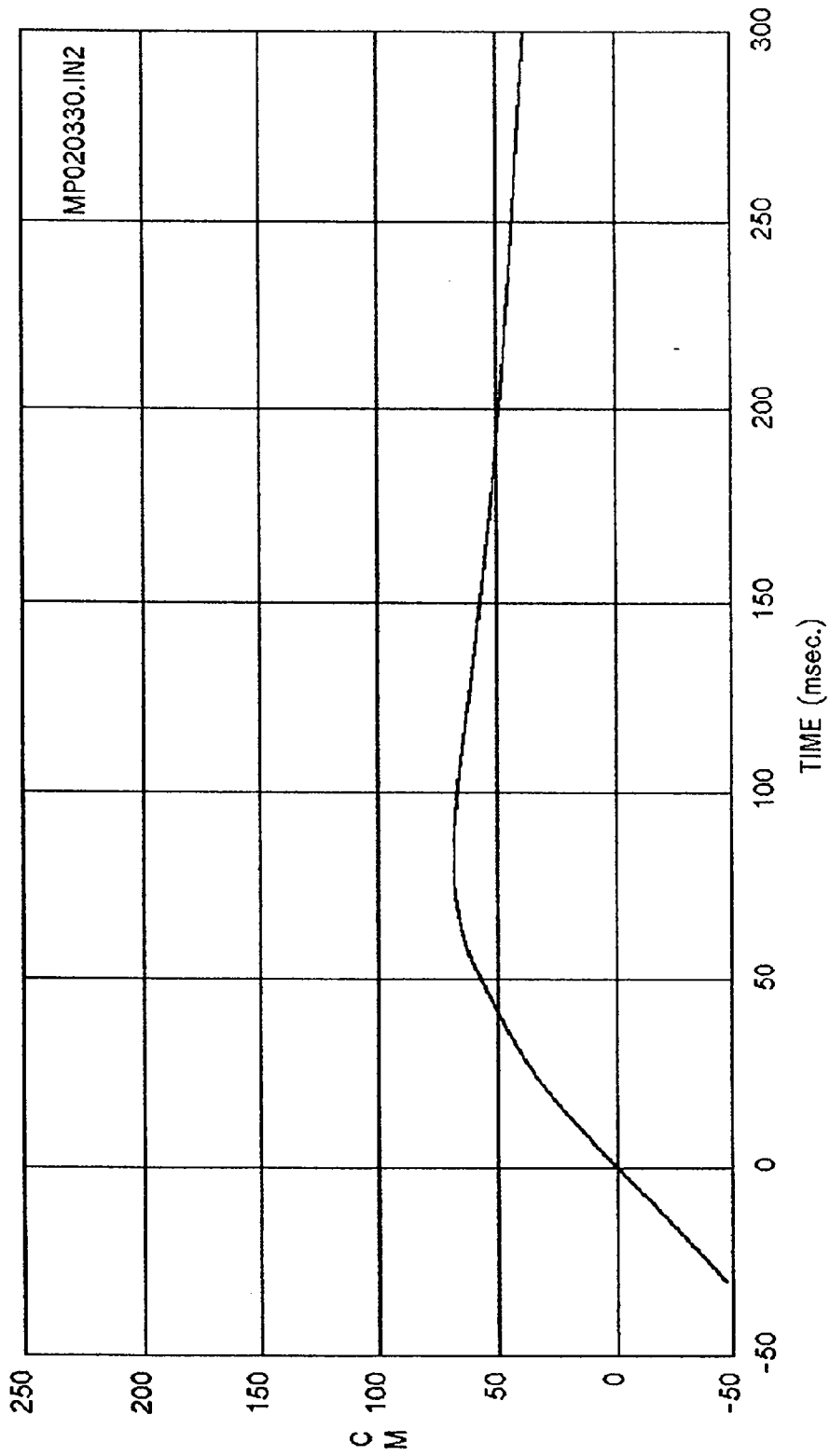

Curve: Left rear cross-member disp. - X axis (primary) Filter: SAE CLASS 180 Max = 68.446 Min = 38.262
 MSE Date: 12/02/92 Program: 1993 NCAP, test number 3 Vehicle: 1993 Ford Ranger Pickup

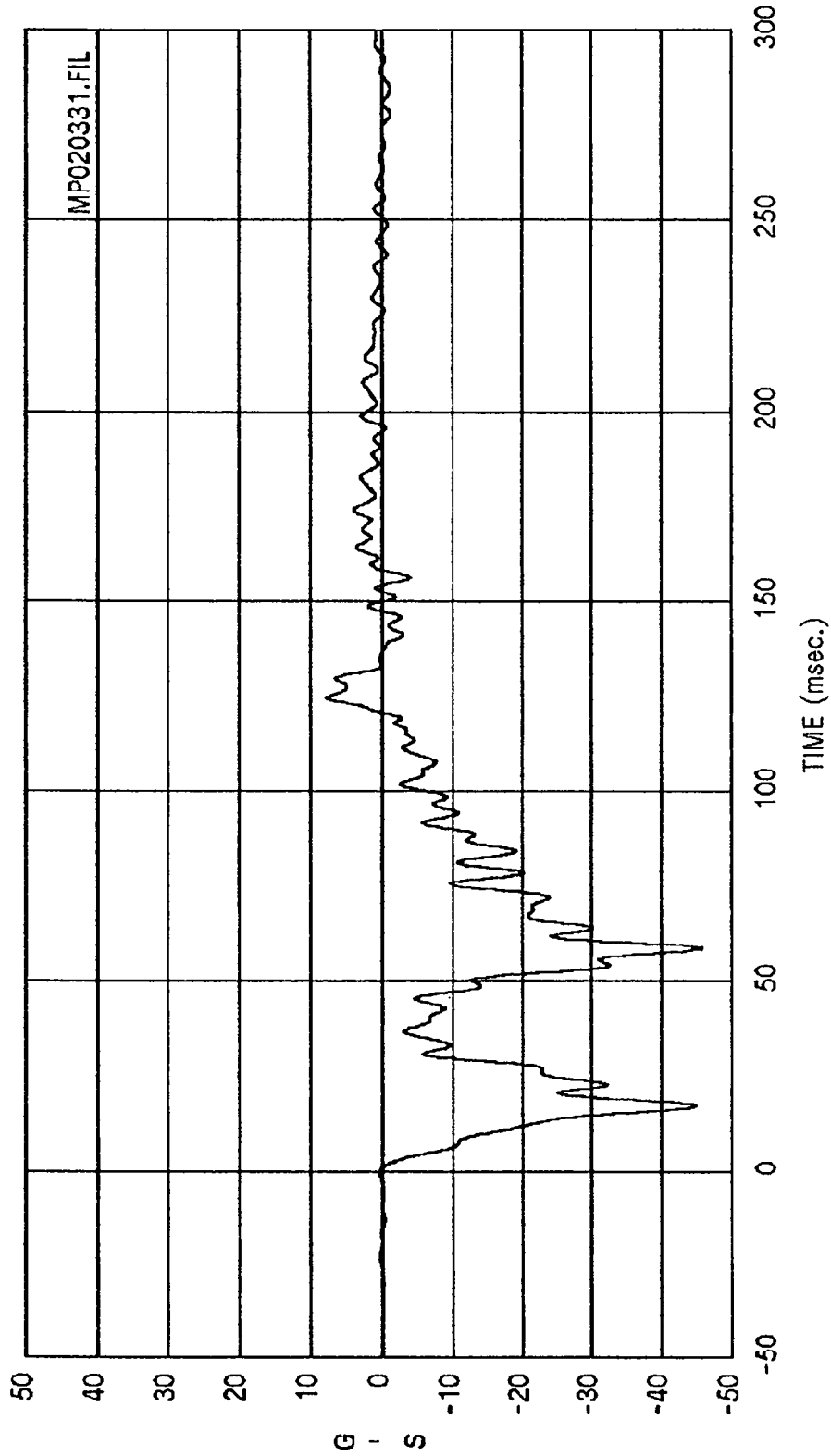

Curve: Right rear cross-member acc. - X axis (primary) Filter: SAE CLASS 60 Max = 7.8128 Min = -45.66

MSE Date: 12/02/92 Program: 1993 NCAP, test number 3 Vehicle: 1993 Ford Ranger Pickup

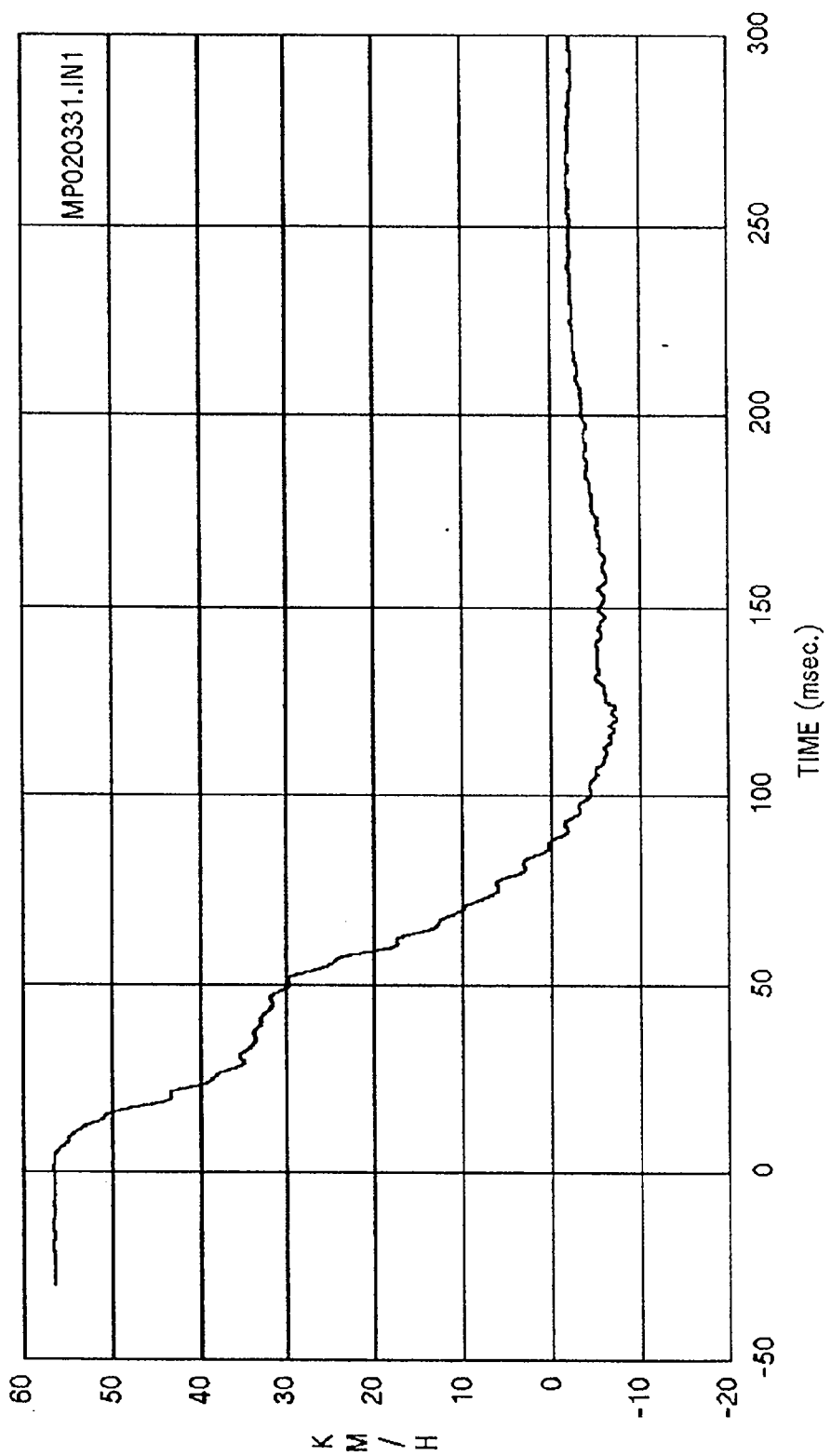

Curve: Right rear cross-member delta V -- X axis(Prf) Filter: SAE CLASS 180 Max = 56.629 Min = -7.361

MSE Date: 12/02/92 Program: 1993 NCAP, test number 3 Vehicle: 1993 Ford Ranger Pickup

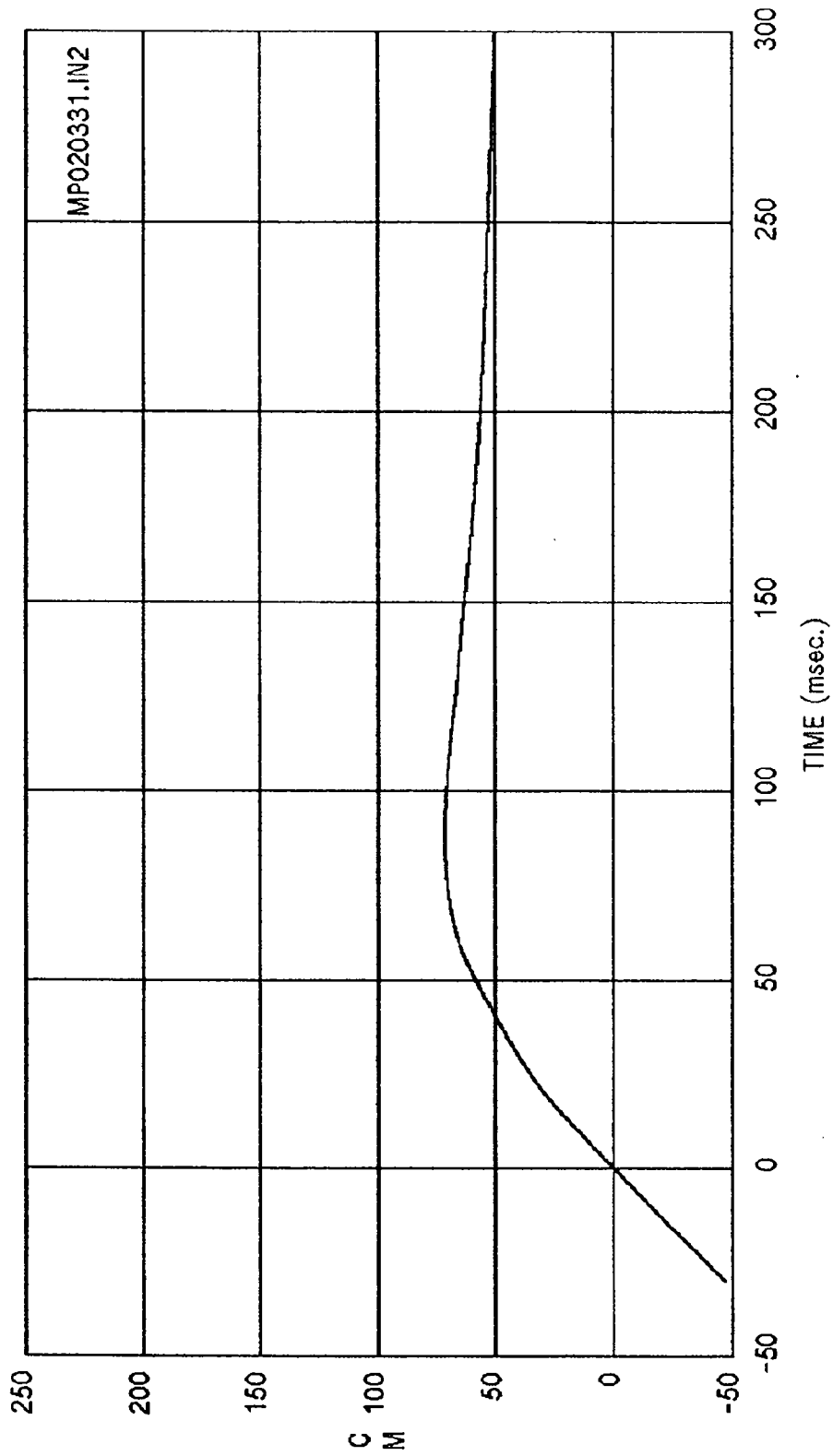

Curve: Right rear cross-member disp. - X axis (primary) Filter: SAE CLASS 180 Max = 71.671 Min = 50.162
 MSE Date: 12/02/92 Program: 1993 NCAP, test number 3 Vehicle: 1993 Ford Ranger Pickup

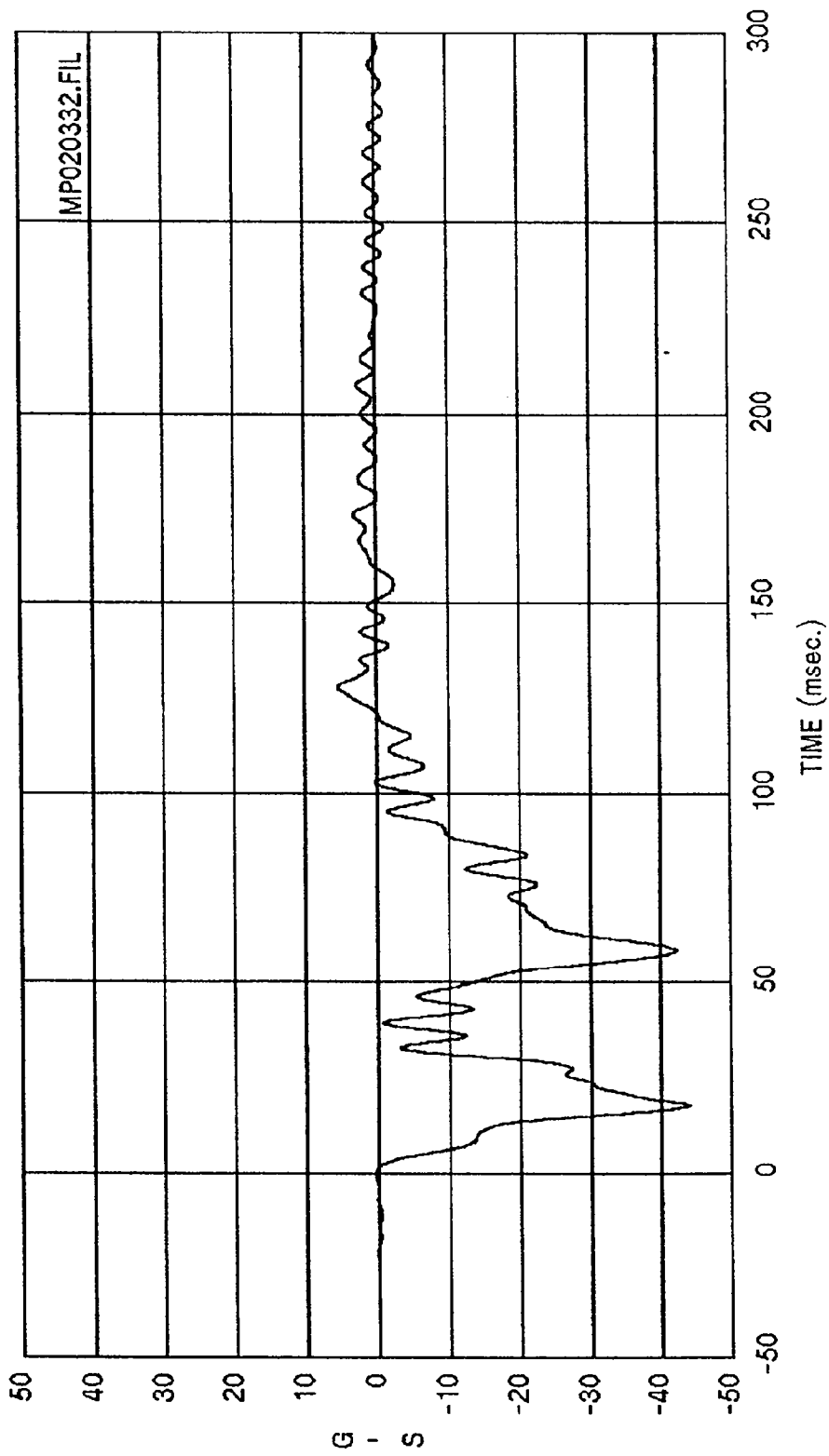

Curve: Left rear cross-member accel. - X axis(secondary) Filter: SAE CLASS 60 Max = 5.3314 Min = -44.0

MSE Date: 12/02/92 Program: 1993 NCAP, test number 3 Vehicle: 1993 Ford Ranger Pickup

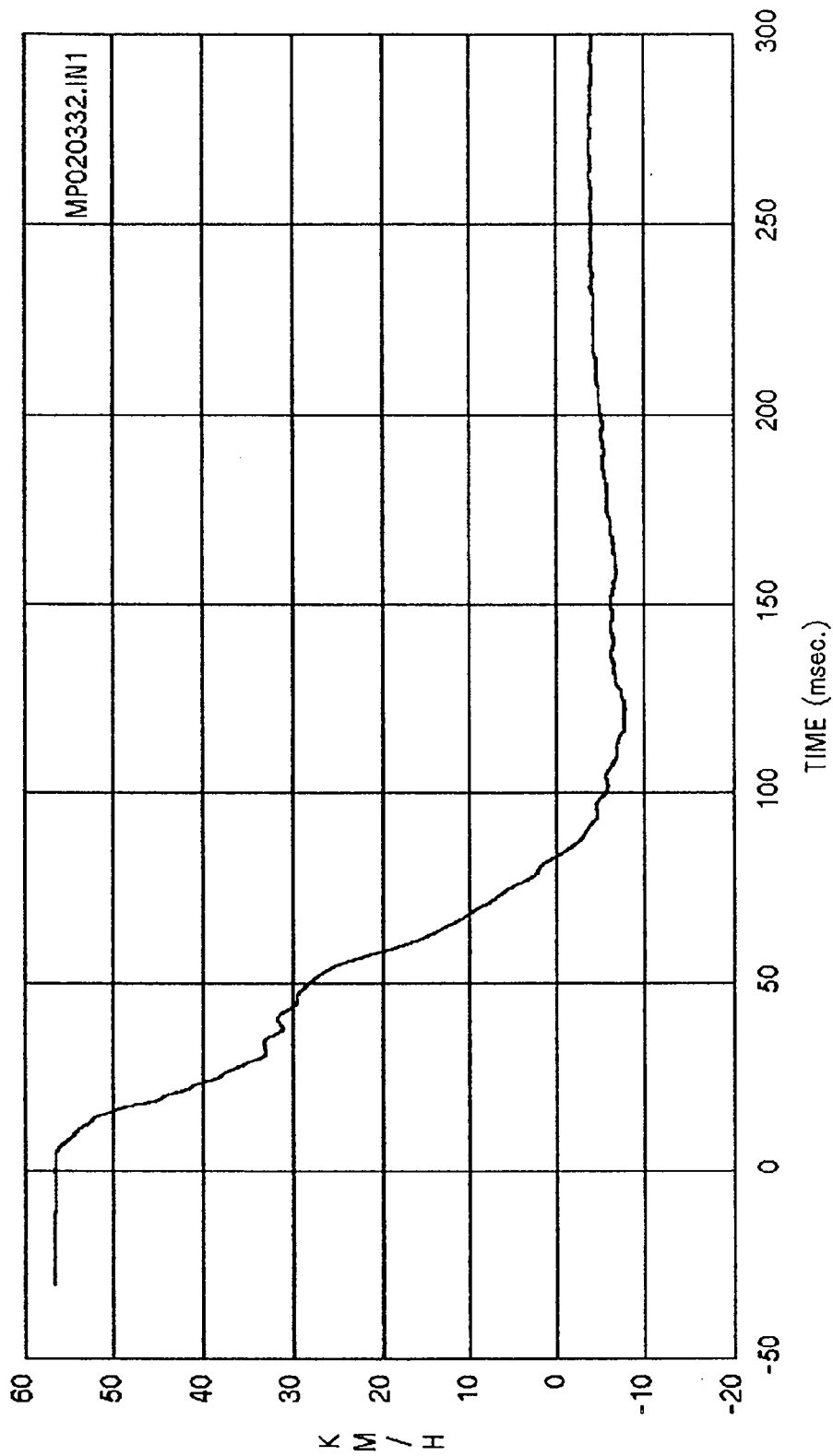

Curve: Left rear cross-member delta V -- X axis (Sec) Filter: SAE CLASS 180 Max = 56.623 Min = -7.72

MSE Date: 12/02/92 Program: 1993 NCAP, test number 3 Vehicle: 1993 Ford Ranger Pickup

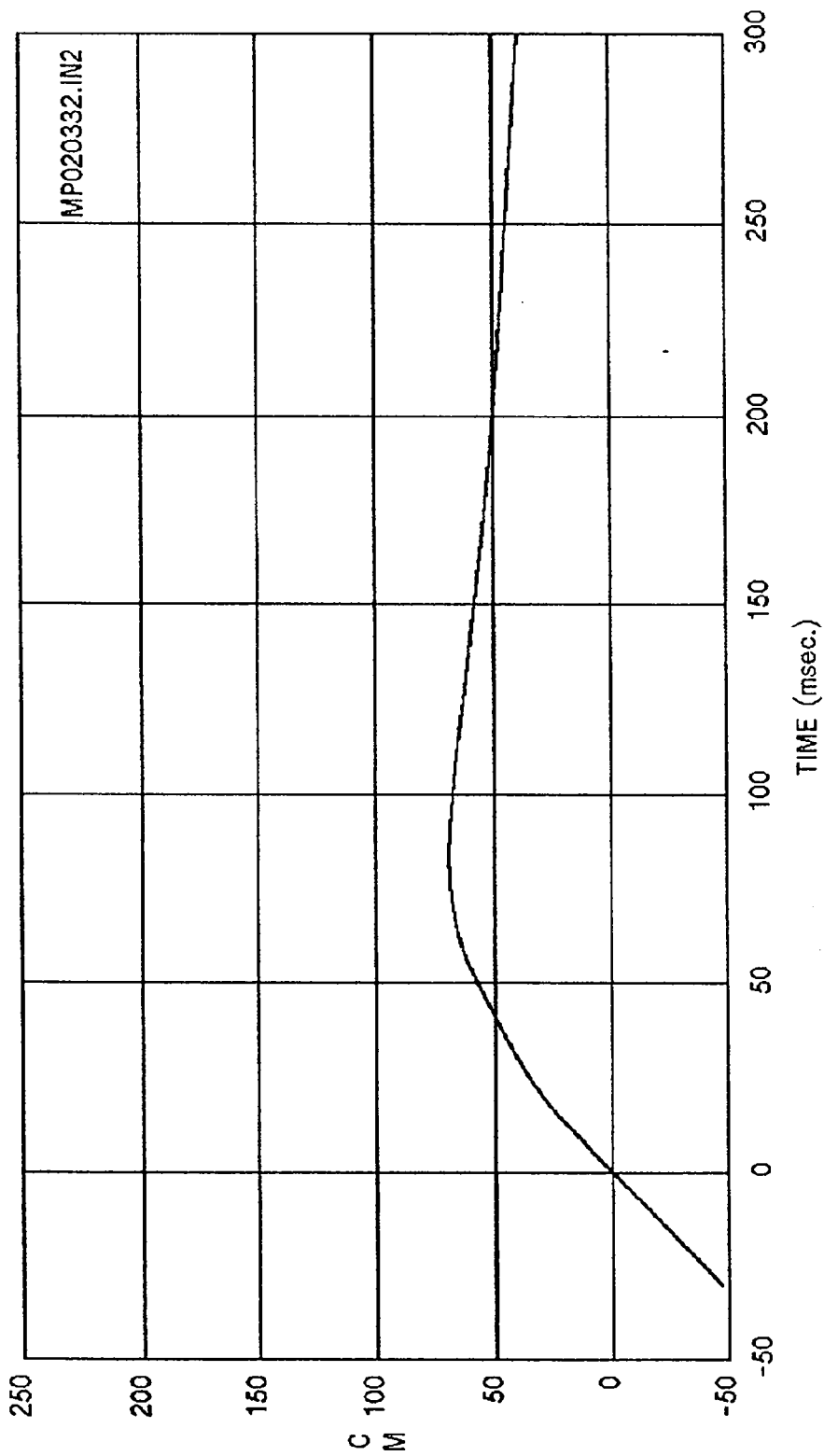

Curve: Left rear cross-member disp. - X axis(secondary) Filter: SAE CLASS 180 Max = 69.149 Min = 38.7.

MSE Date: 12/02/92 Program: 1993 NCAP, test number 3 Vehicle: 1993 Ford Ranger Pickup

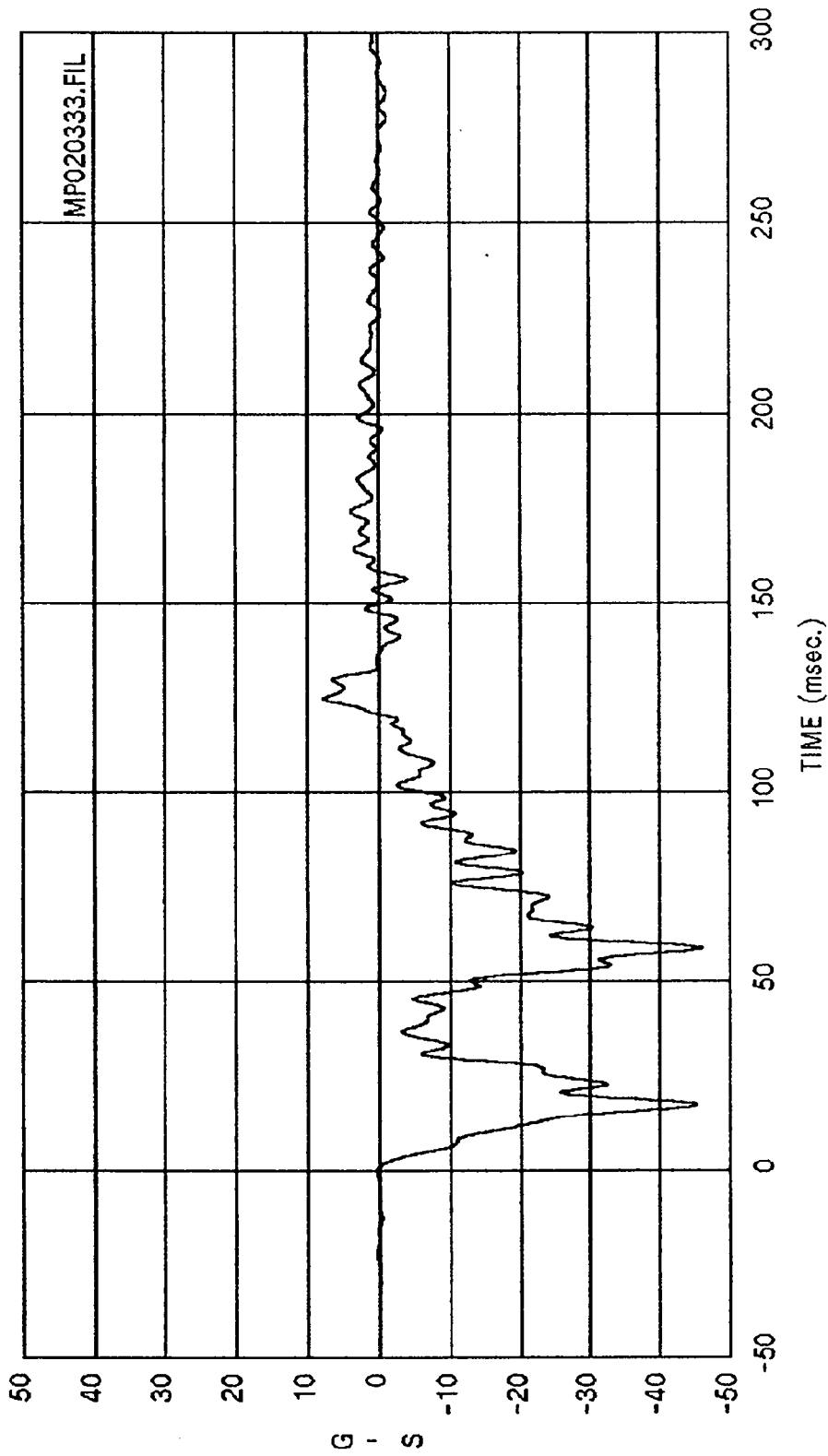

Curve: Right rear cross-member acc. - X axis (secondary) Filter: SAE CLASS 60 Max = 7.7997 Min = -46.0

MSE Date: 12/02/92 Program: 1993 NCAP, test number 3 Vehicle: 1993 Ford Ranger Pickup

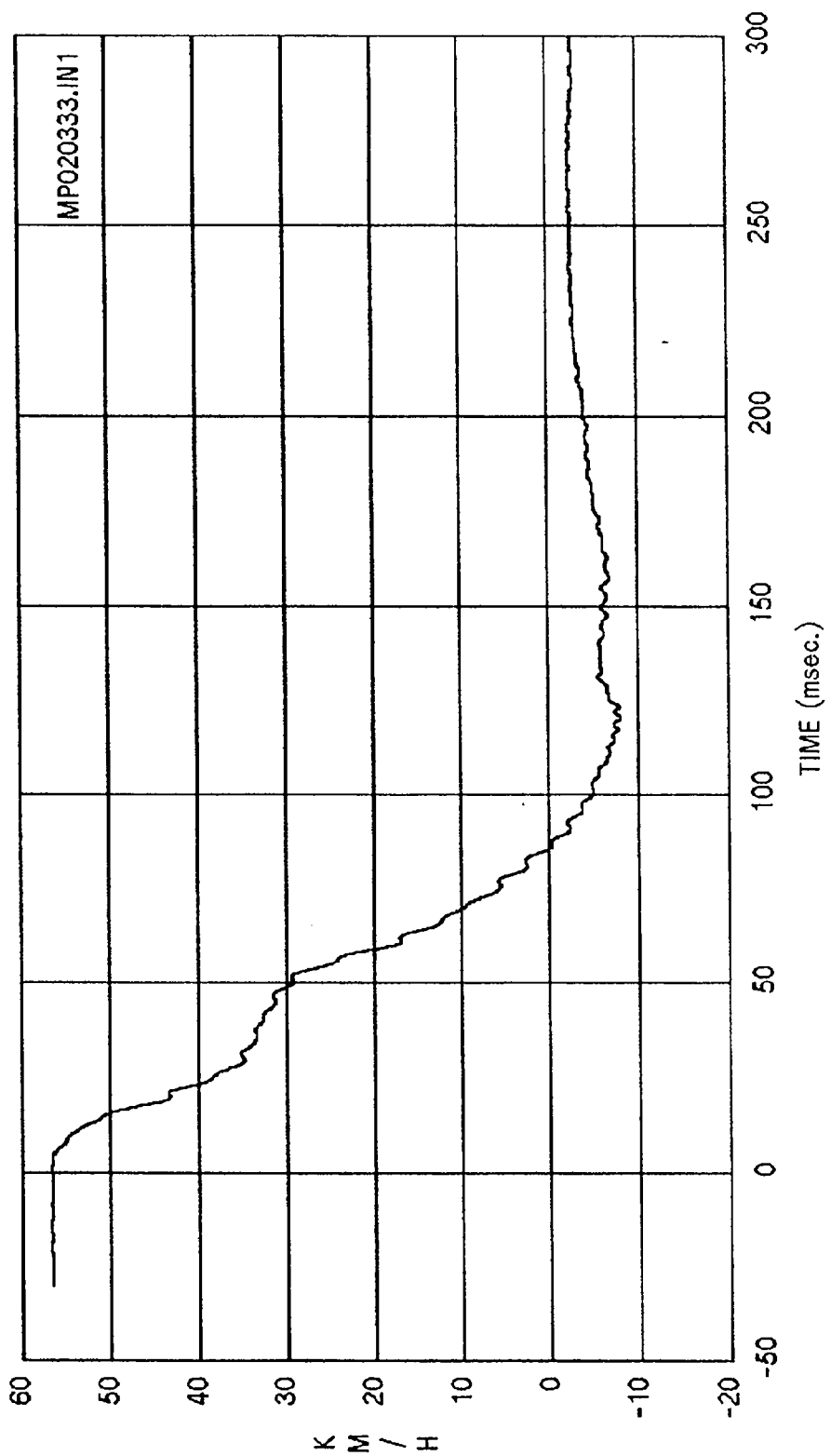

Curve: Right rear cross-member delta V -- X axis(Sec) Filter: SAE CLASS 180 Max = 56.629 Min = -7.99

MSE Date: 12/02/92 Program: 1993 NCAP, test number 3 Vehicle: 1993 Ford Ranger Pickup

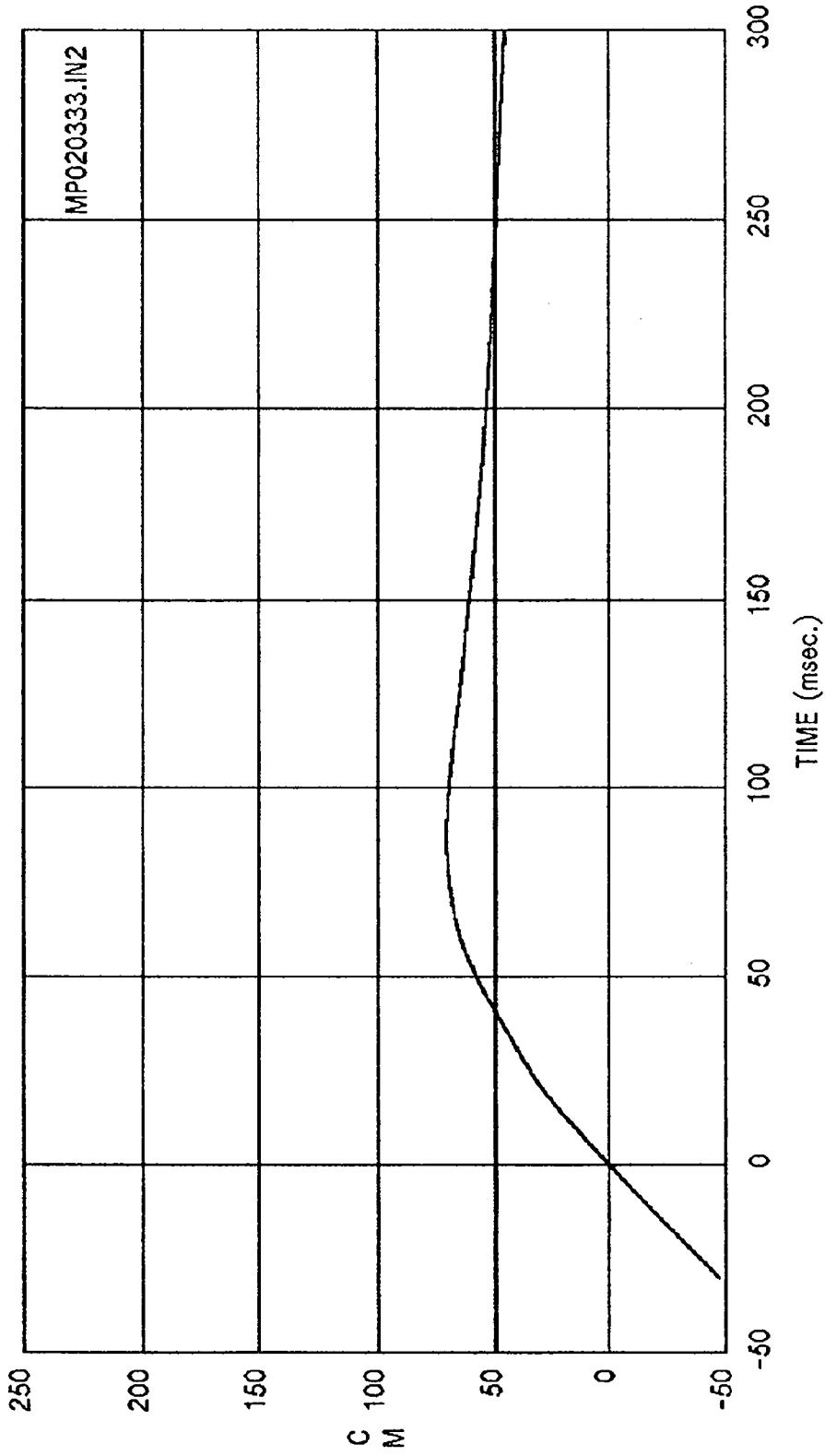

Curve: Right rear cross-member disp. - X axis(secondary) Filter: SAE CLASS 180 Max = 70.968 Min = 45.7

MSE Date: 12/02/92 Program: 1993 NCAP, test number 3 Vehicle: 1993 Ford Ranger Pickup

THIS PAGE INTENTIONALLY LEFT BLANK

APPENDIX B-2

LOAD CELL BARRIER DATA

DATA FILTERING:
Load Cell Barrier Channels - Class 60

THIS PAGE INTENTIONALLY LEFT BLANK

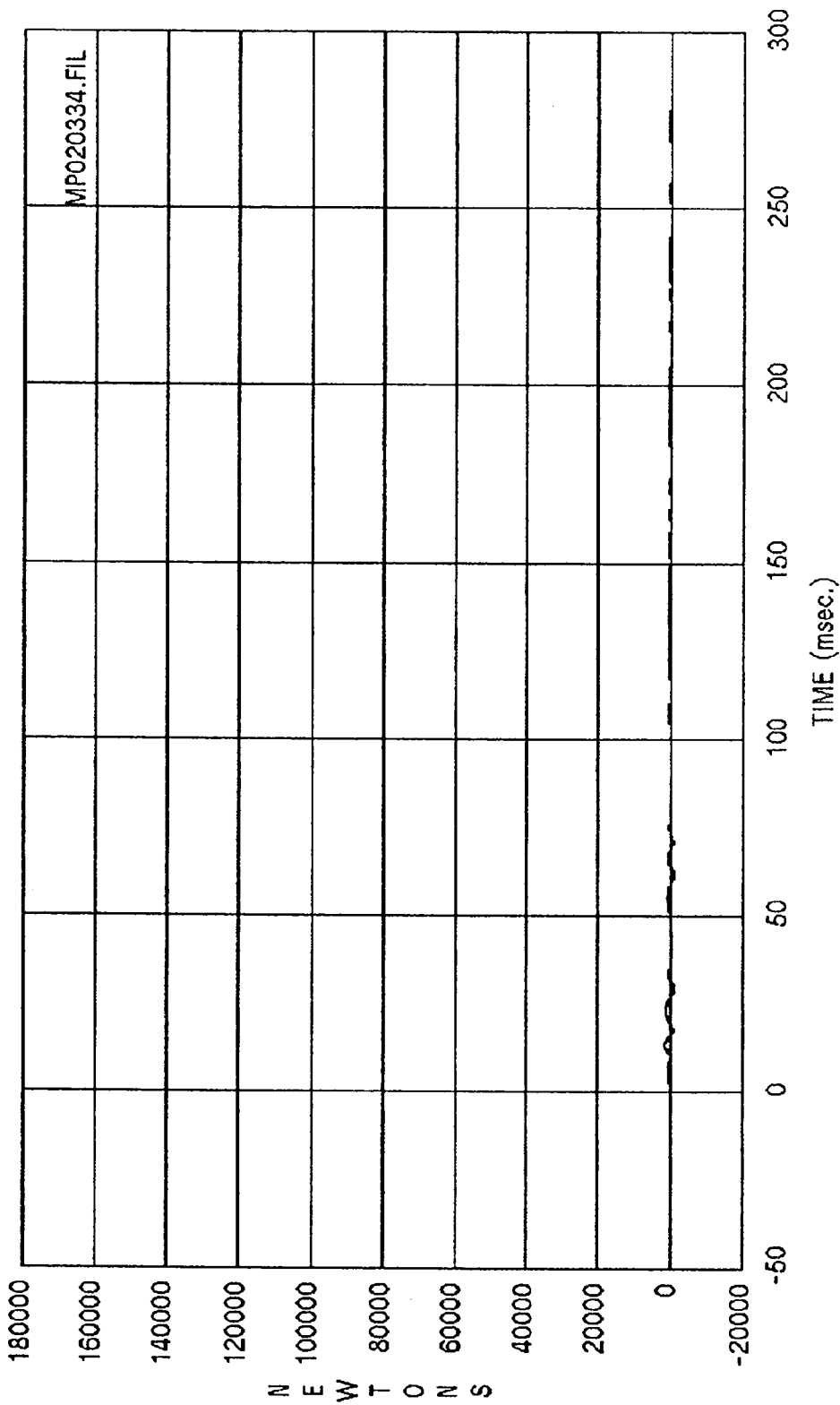

Curve: Force on barrier location A1 Filter: SAE CLASS 60 Max = 1457.8 Min = -803.29

MSE Date: 12/02/92 Program: 1993 NCAP, test number 3 Vehicle: 1993 Ford Ranger Pickup

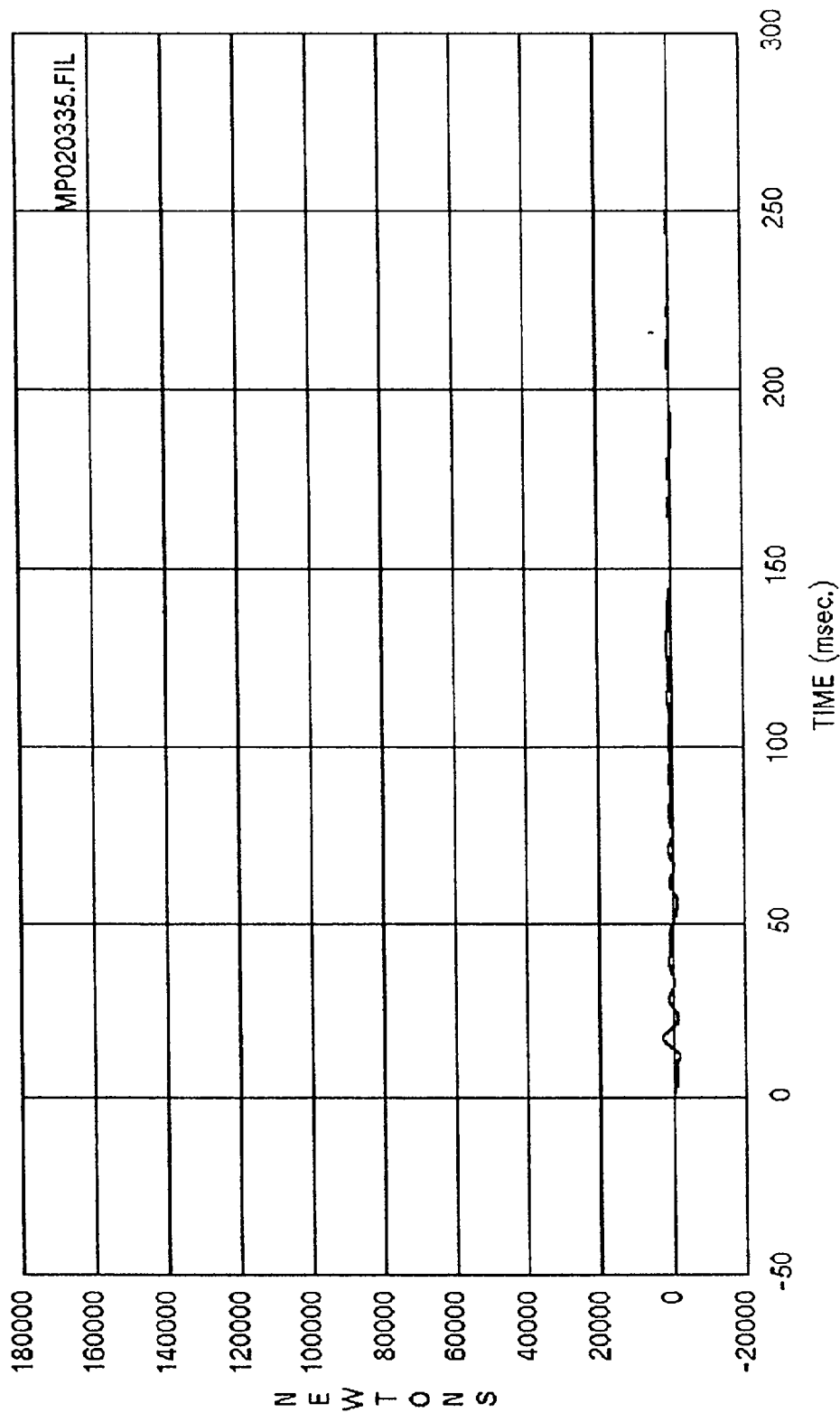

Curve: Force on barrier location A2 Filter: SAE CLASS 60 Max = 3001.1 Min = -1590.2

MSE Date: 12/02/92 Program: 1993 NCAP, test number 3 Vehicle: 1993 Ford Ranger Pickup

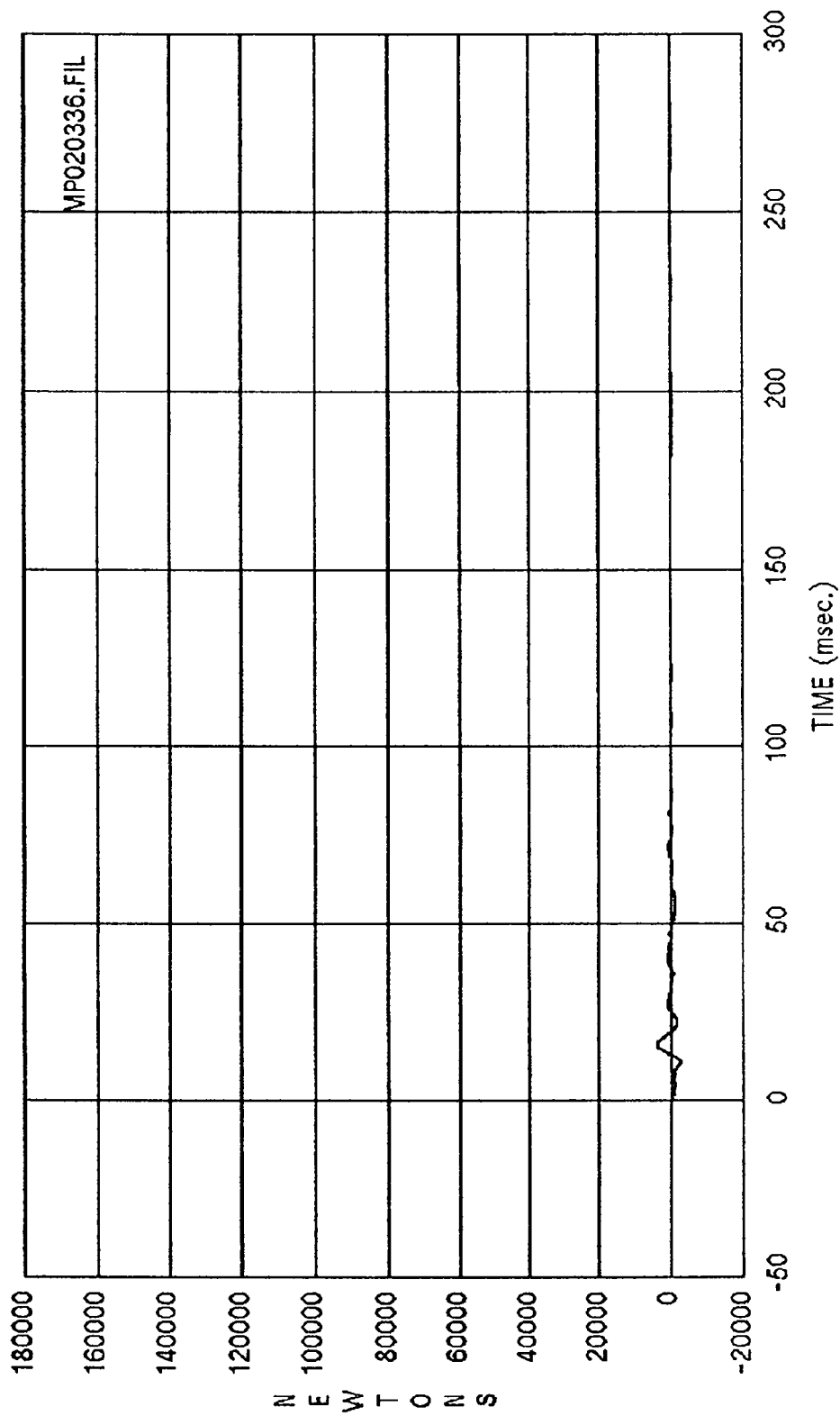

Curve: Force on barrier location A3 Filter: SAE CLASS 60 Max = 3917.7 Min = -2537.2

MSE Date: 12/02/92 Program: 1993 NCAP, test number 3 Vehicle: 1993 Ford Ranger Pickup

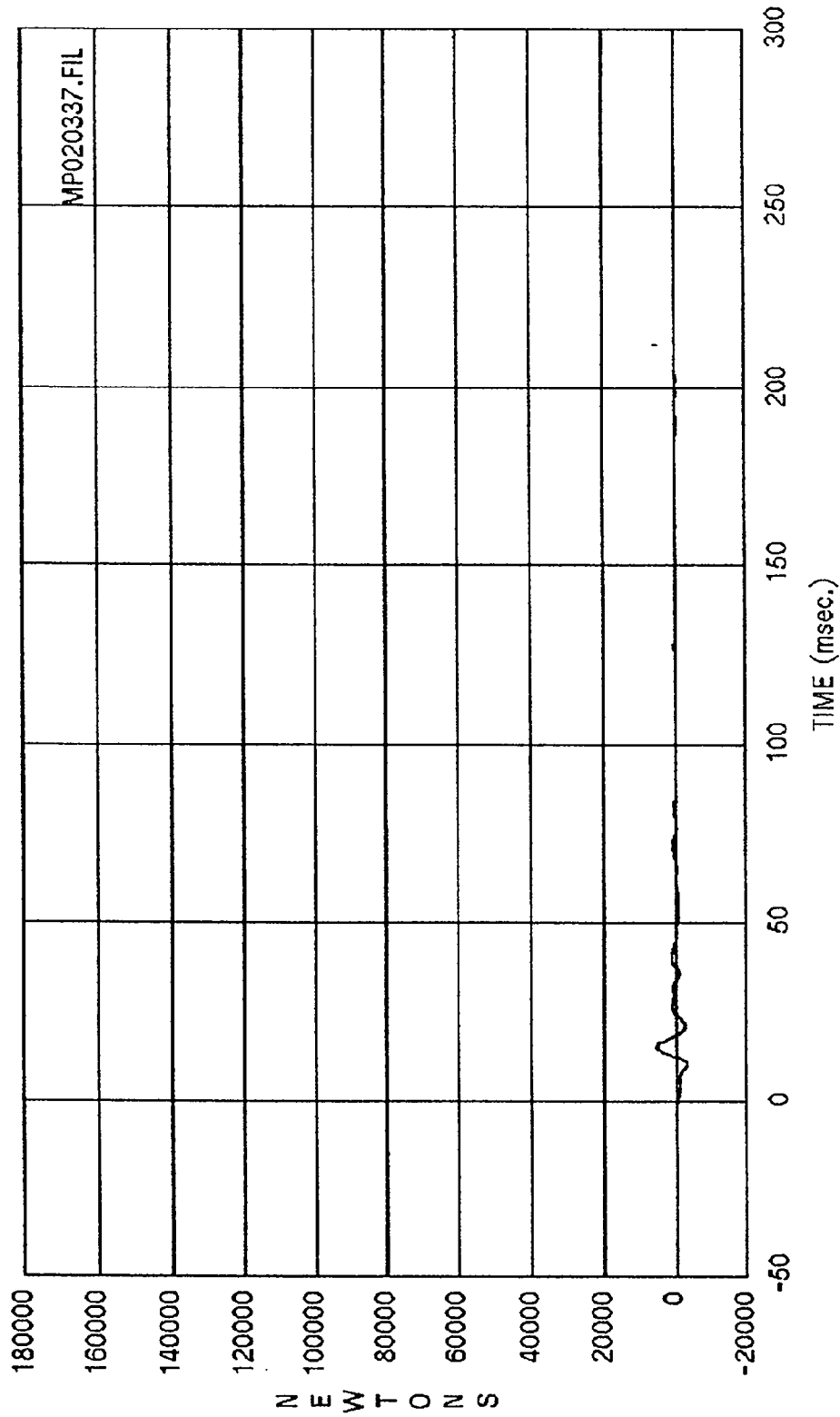

Curve: Force on barrier location A4 Filter: SAE CLASS 60 Max = 5714.9 Min = -3106.6

MSE Date: 12/02/92 Program: 1993 NCAP, test number 3 Vehicle: 1993 Ford Ranger Pickup

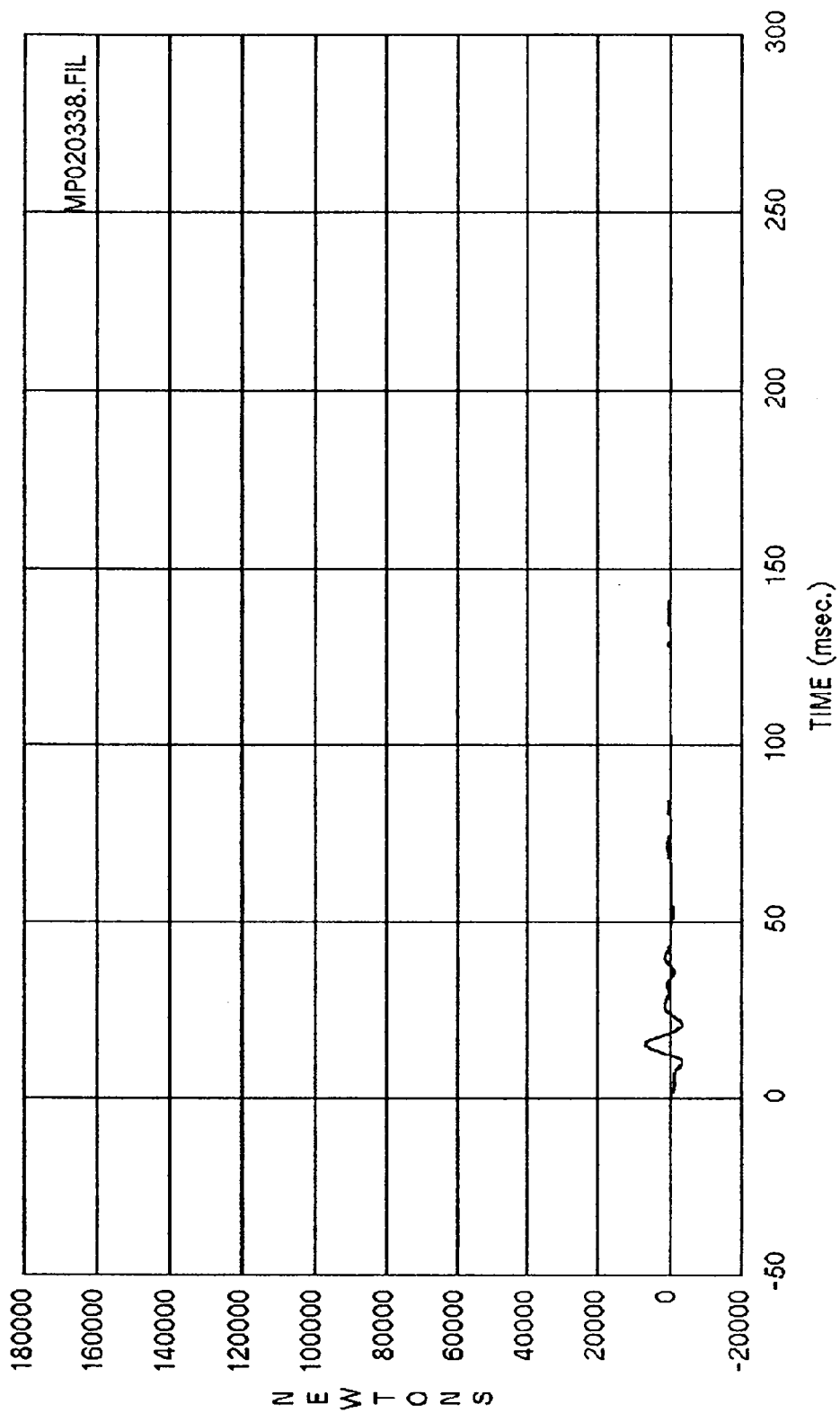

Curve: Force on barrier location A5 Filter: SAE CLASS 60 Max = 6880.0 Min = -3511.9

MSE Date: 12/02/92 Program: 1993 NCAP, test number 3 Vehicle: 1993 Ford Ranger Pickup

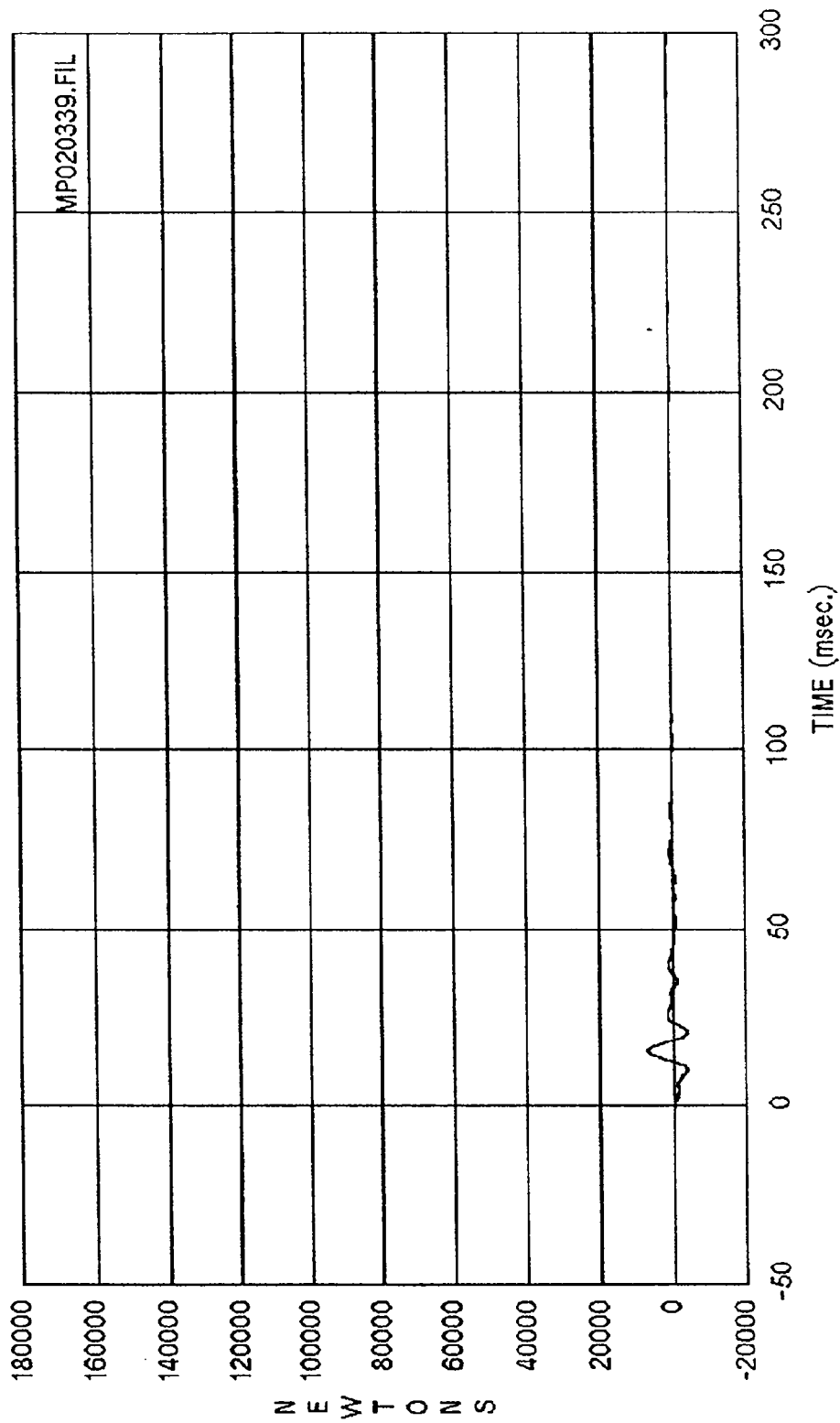

Curve: Force on barrier location A6 Filter: SAE CLASS 60 Max = 7018.8 Min = -3809.7

MSE Date: 12/02/92 Program: 1993 NCAP, test number 3 Vehicle: 1993 Ford Ranger Pickup

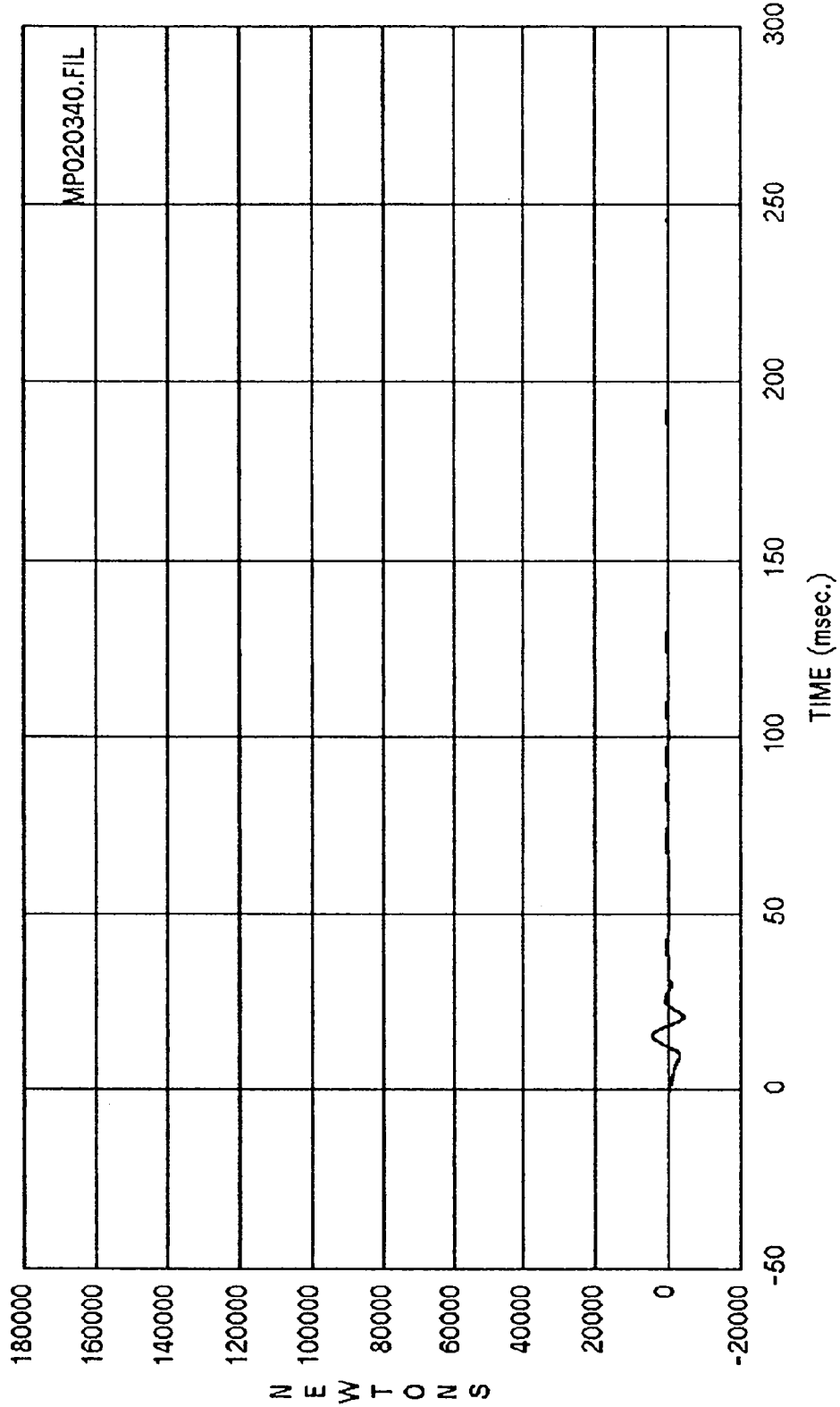

Curve: Force on barrier location A7 Filter: SAE CLASS 60 Max = 4500.9 Min = -4001.1

MSE Date: 12/02/92 Program: 1993 NCAP, test number 3 Vehicle: 1993 Ford Ranger Pickup

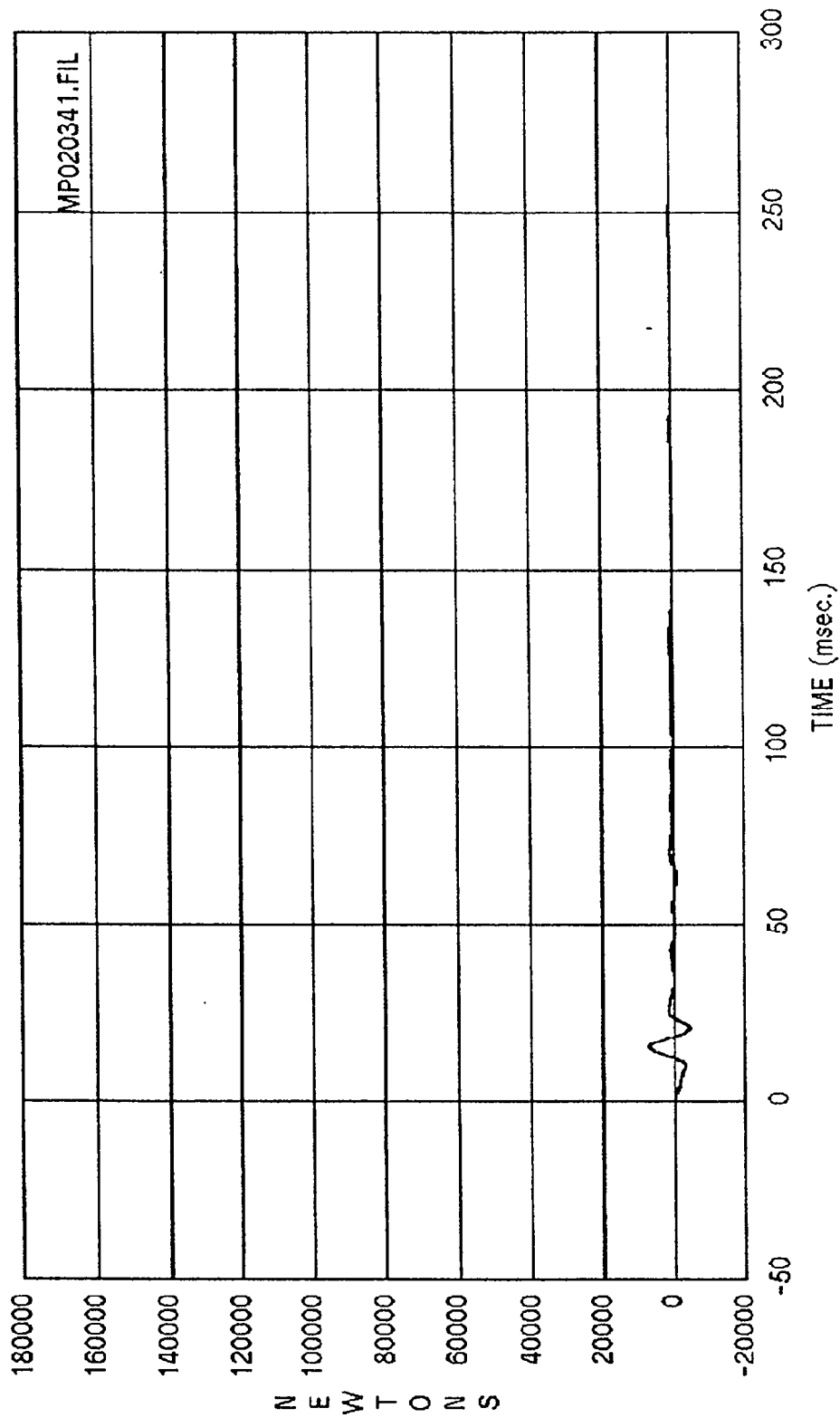

Curve: Force on barrier location A8 Filter: SAE CLASS 60 Max = 7195.1 Min = -4320.4

MSE Date: 12/02/92 Program: 1993 NCAP, test number 3 Vehicle: 1993 Ford Ranger Pickup

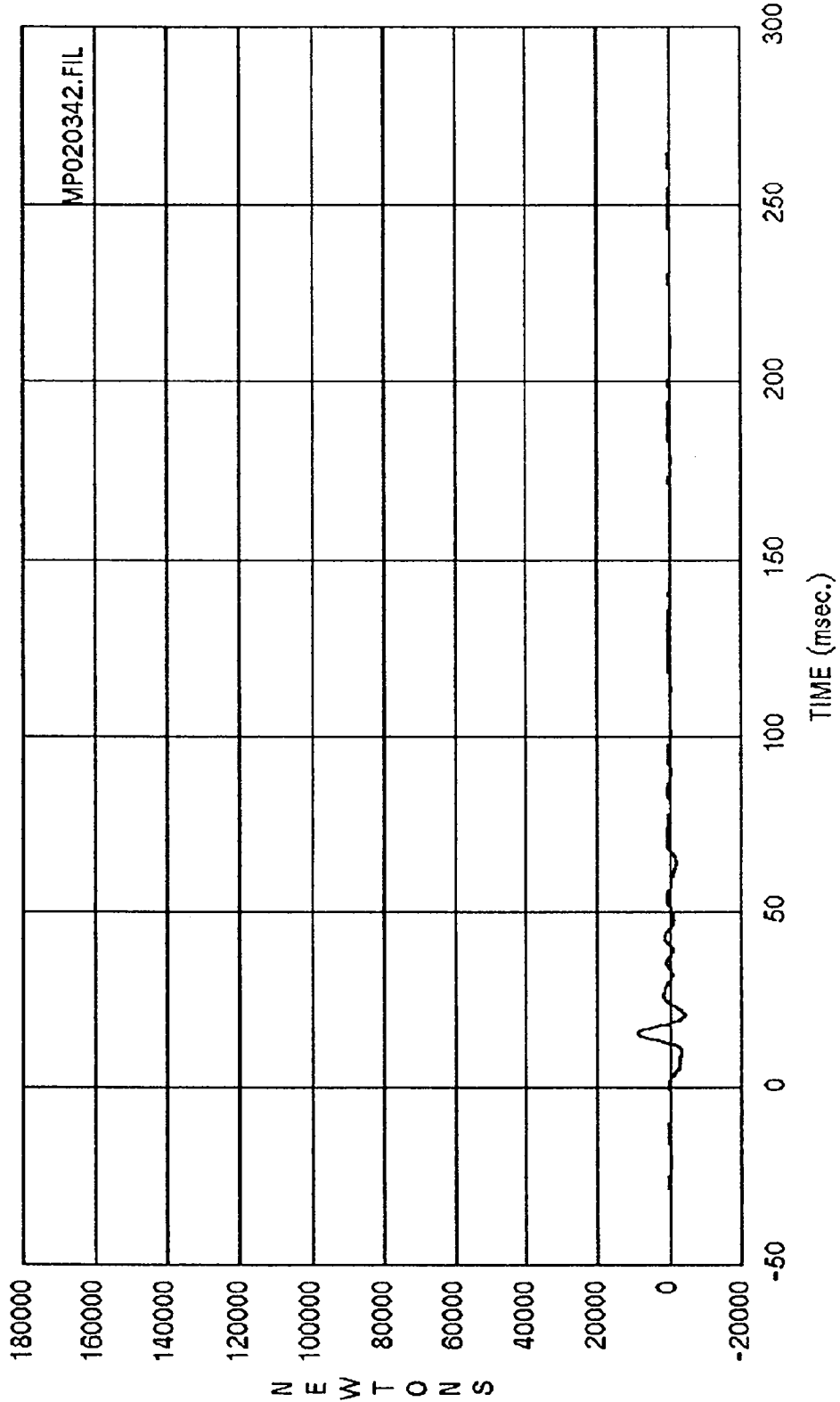

Curve: Force on barrier location A9 Filter: SAE CLASS 60 Max = 9165.5 Min = -3943.4

MSE Date: 12/02/92 Program: 1993 NCAP, test number 3 Vehicle: 1993 Ford Ranger Pickup

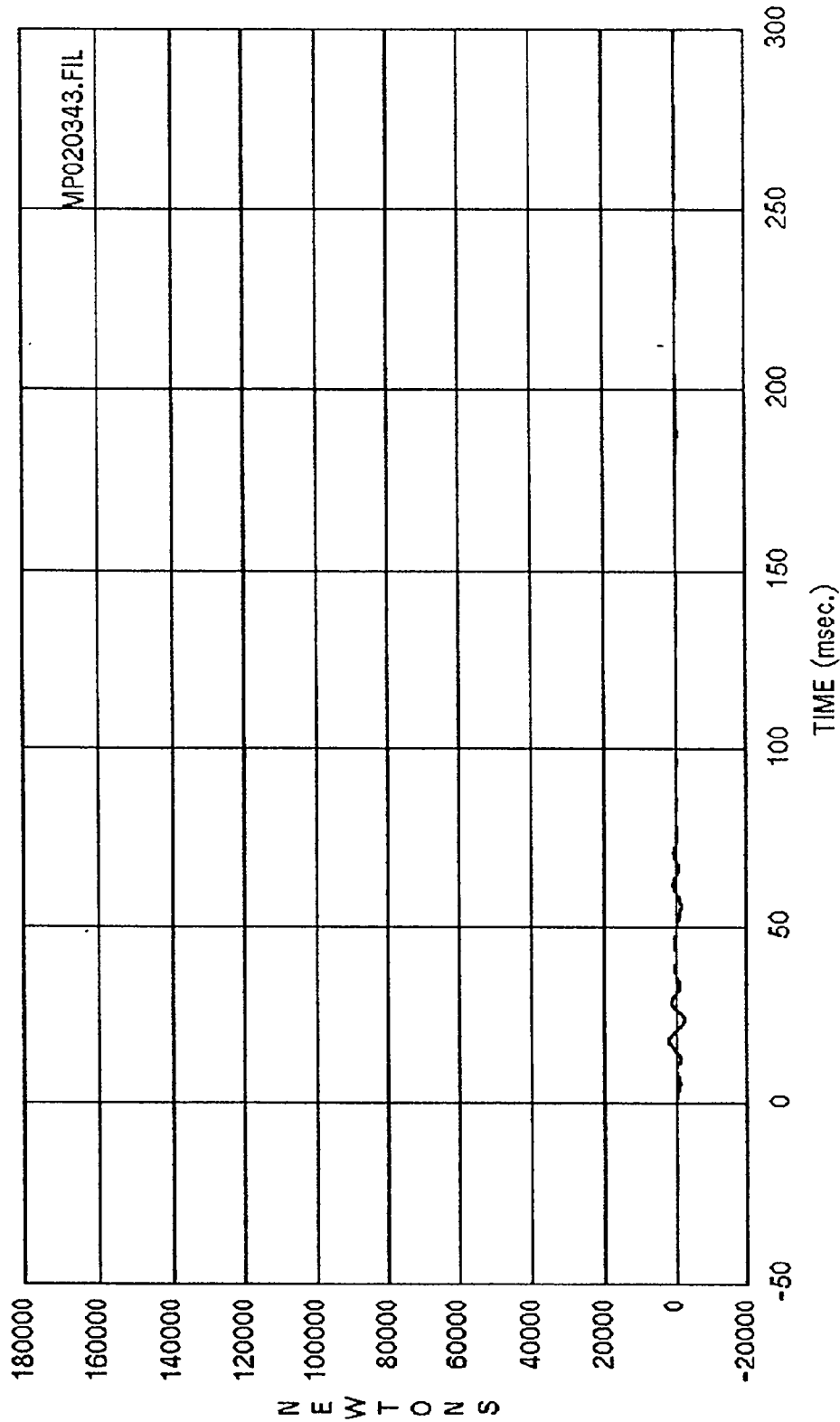

Curve: Force on barrier location B1 Filter: SAE CLASS 60 Max = 2271.6 Min = -2194.4

MSE Date: 12/02/92 Program: 1993 NCAP, test number 3 Vehicle: 1993 Ford Ranger Pickup

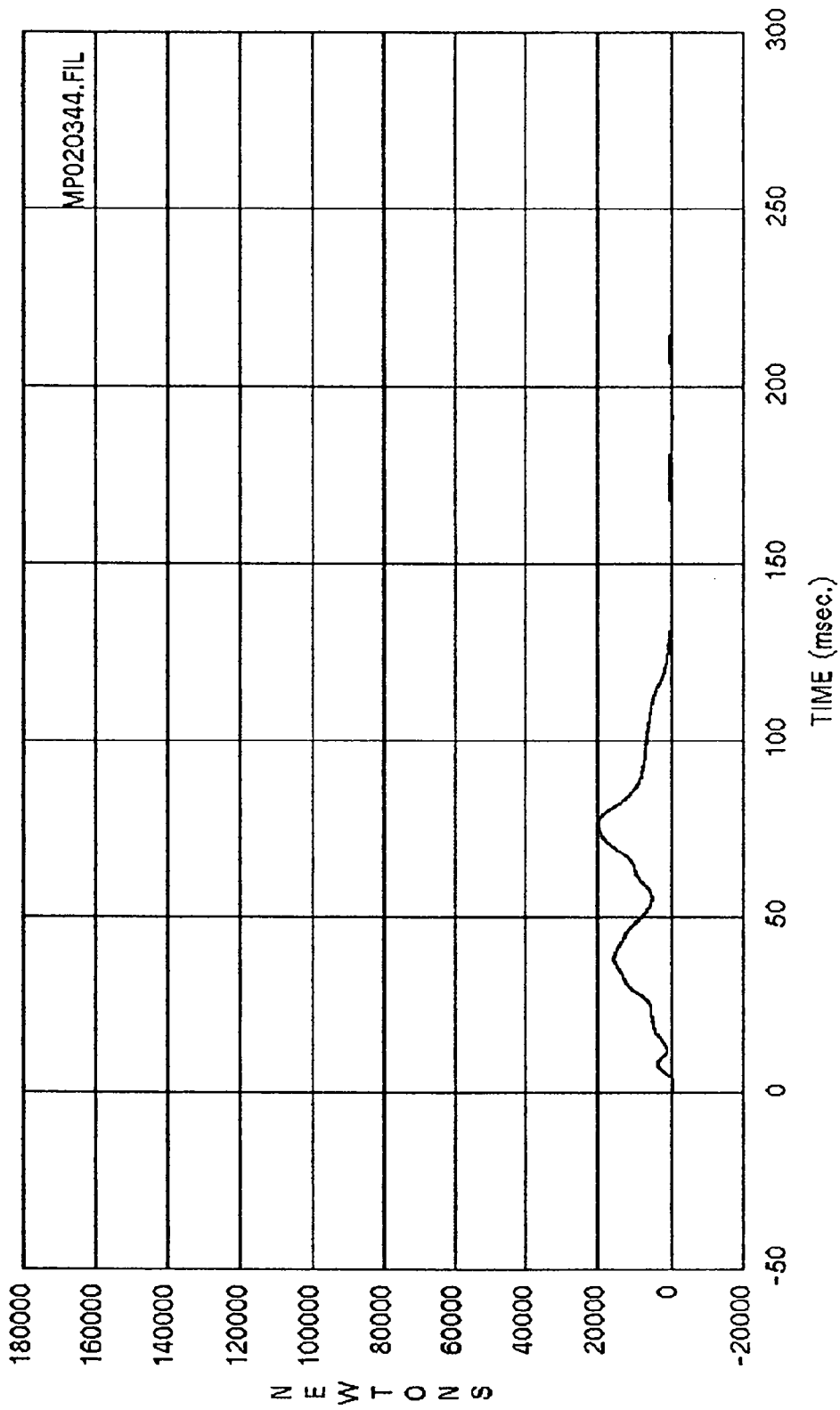

Curve: Force on barrier location B2 Filter: SAE CLASS 60 Max = 19822. Min = -527.08

MSE Date: 12/02/92 Program: 1993 NCAP, test number 3 Vehicle: 1993 Ford Ranger Pickup

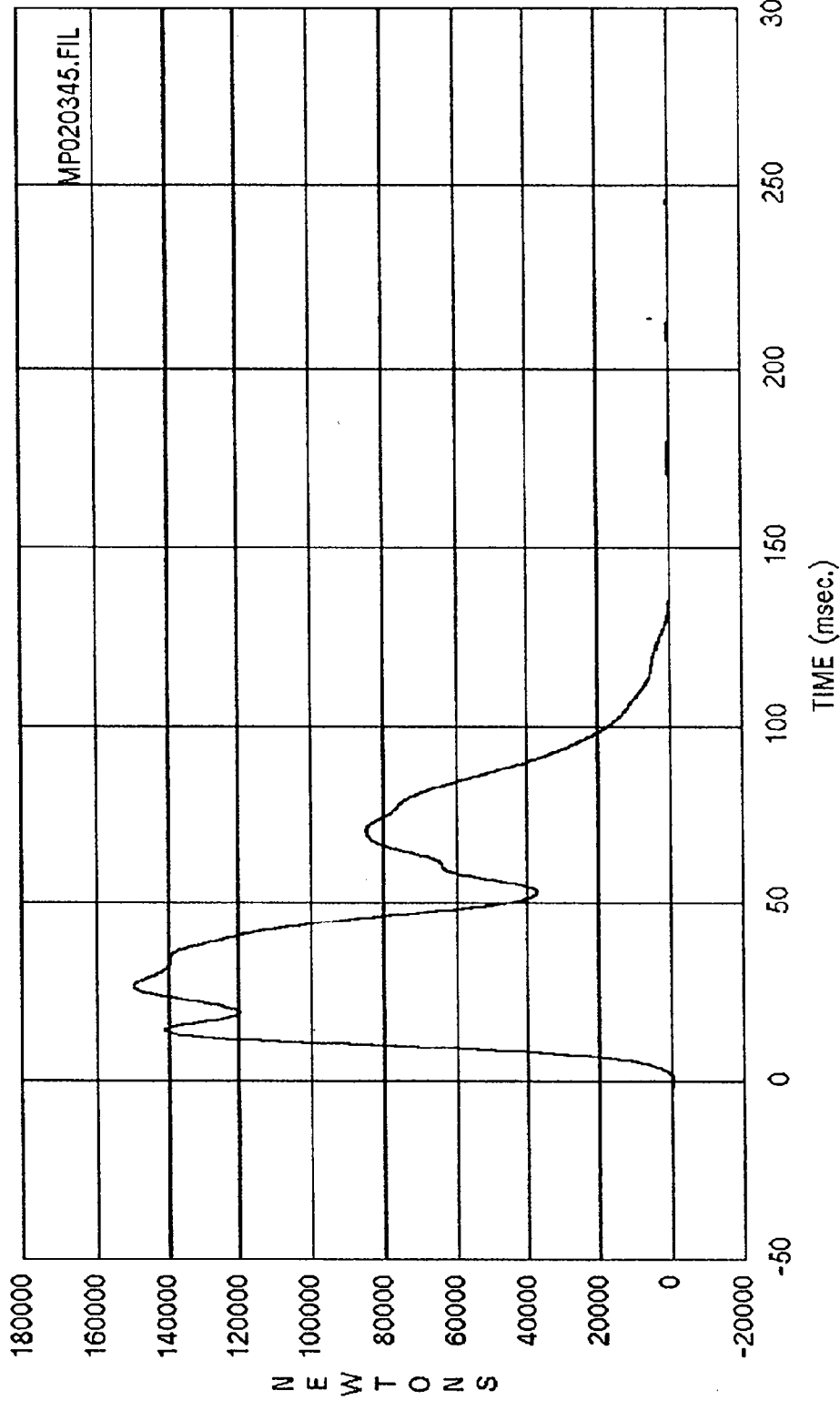

Curve: Force on barrier location B3 Filter: SAE CLASS 60 Max = .14990E+06 Min = -446.72

MSE Date: 12/02/92 Program: 1993 NCAP, test number 3 Vehicle: 1993 Ford Ranger Pickup

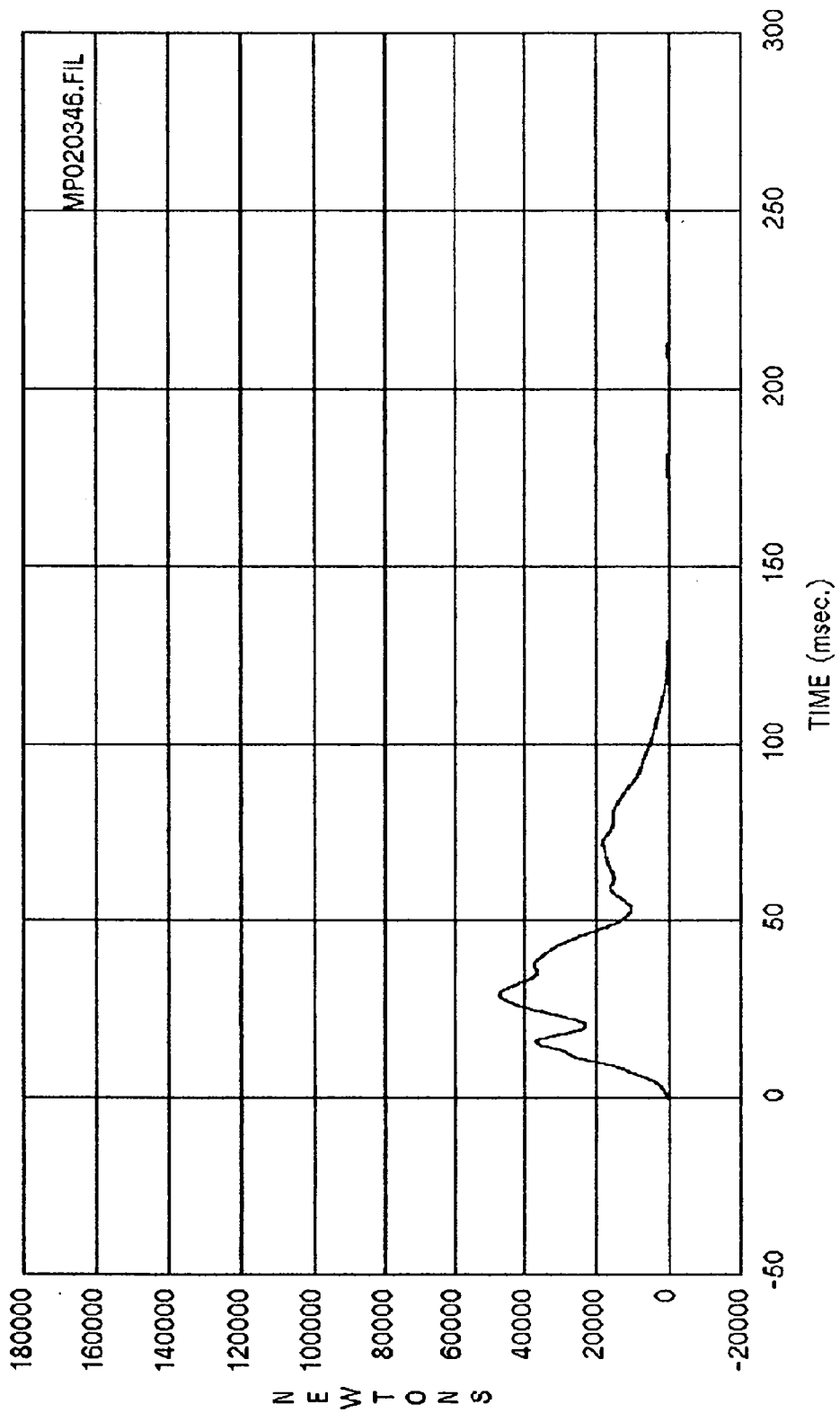

Curve: Force on barrier location B4 Filter: SAE CLASS 60 Max = 47134. Min = -45.023

MSE Date: 12/02/92 Program: 1993 NCAP, test number 3 Vehicle: 1993 Ford Ranger Pickup

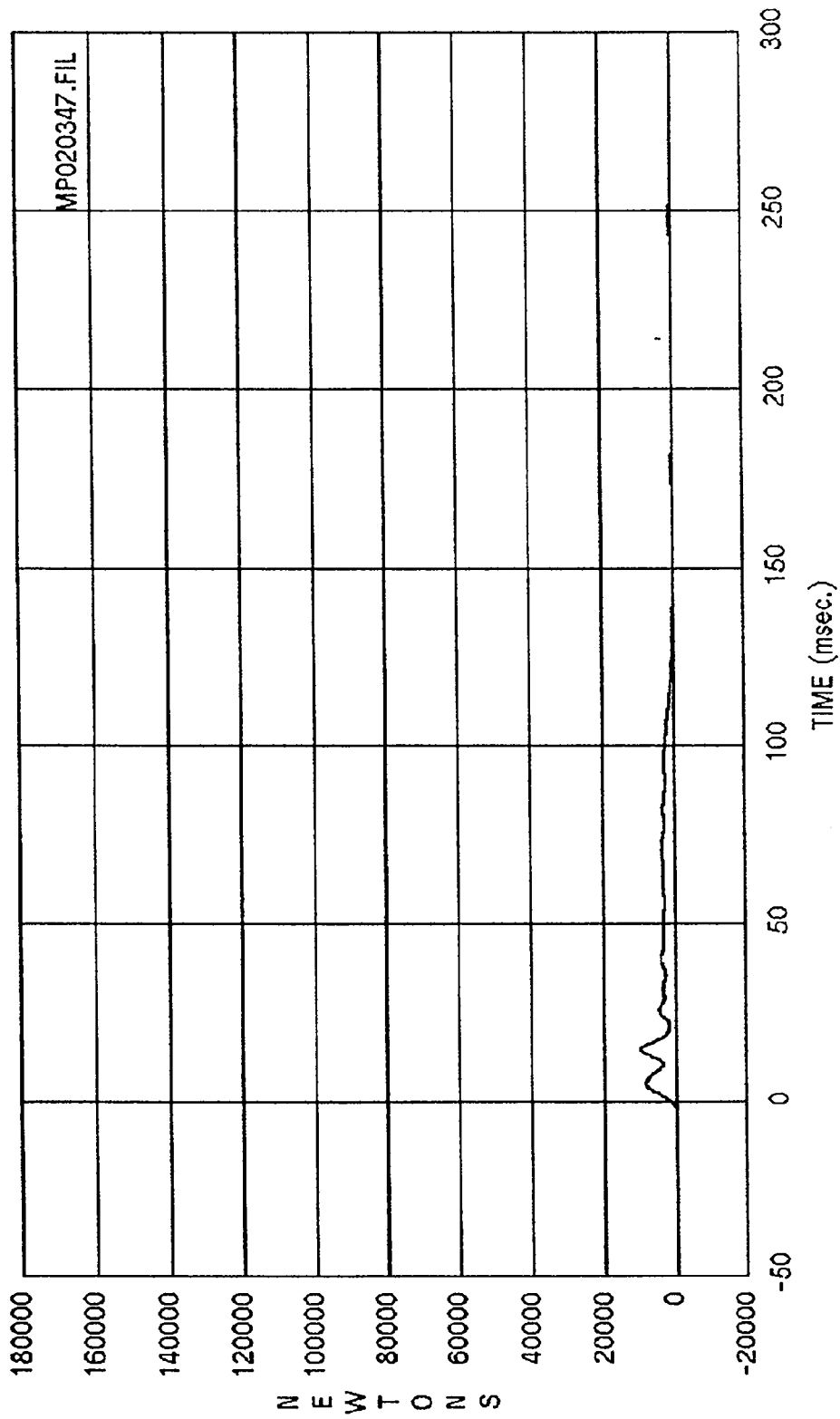

Curve: Force on barrier location B5 Filter: SAE CLASS 60 Max = 10114. Min = 38.747

MSE Date: 12/02/92 Program: 1993 NCAP, test number 3 Vehicle: 1993 Ford Ranger Pickup

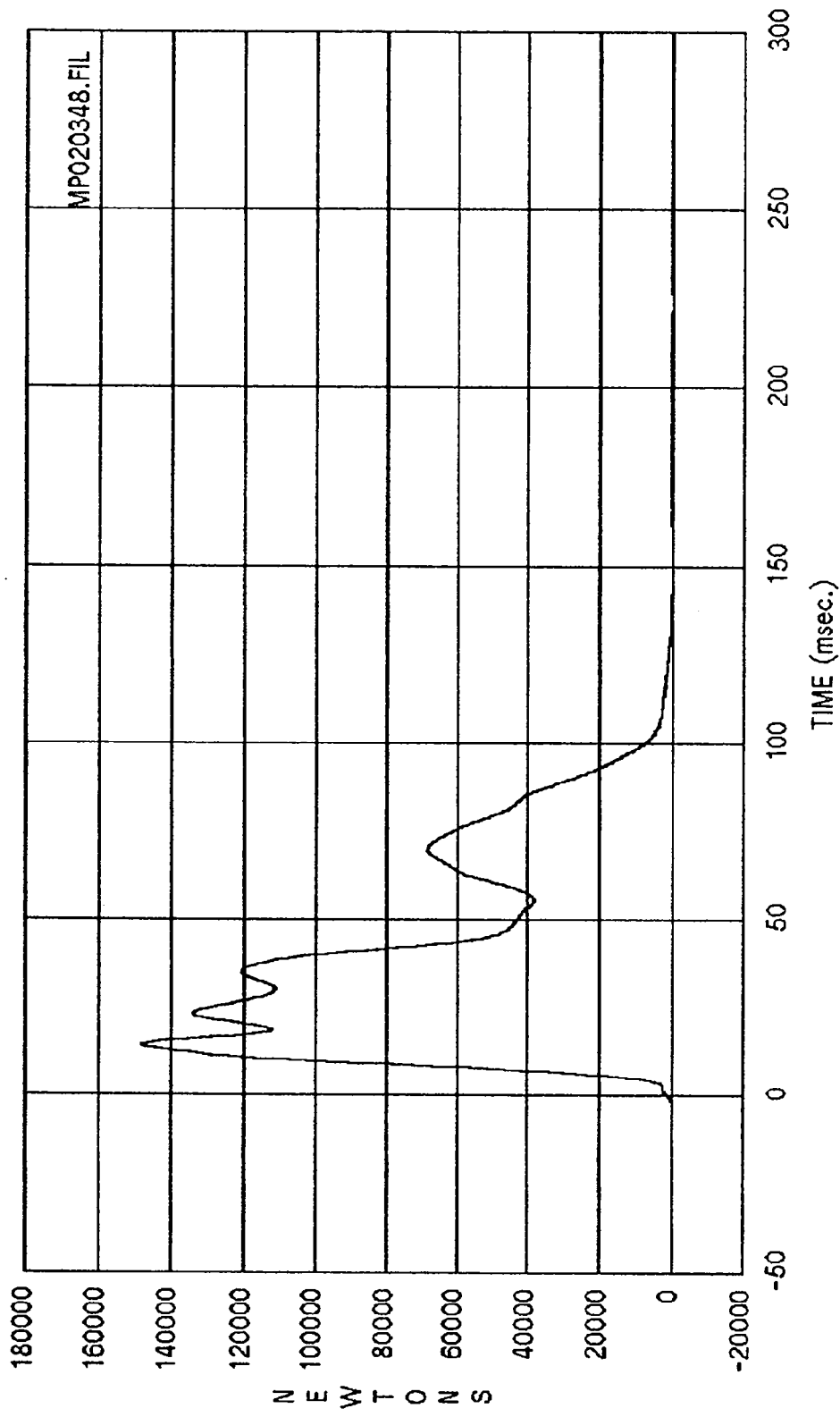

Curve: Force on barrier location B6 Filter: SAE CLASS 60 Max = .14809E+06 Min = 140.91

MSE Date: 12/02/92 Program: 1993 NCAP, test number 3 Vehicle: 1993 Ford Ranger Pickup

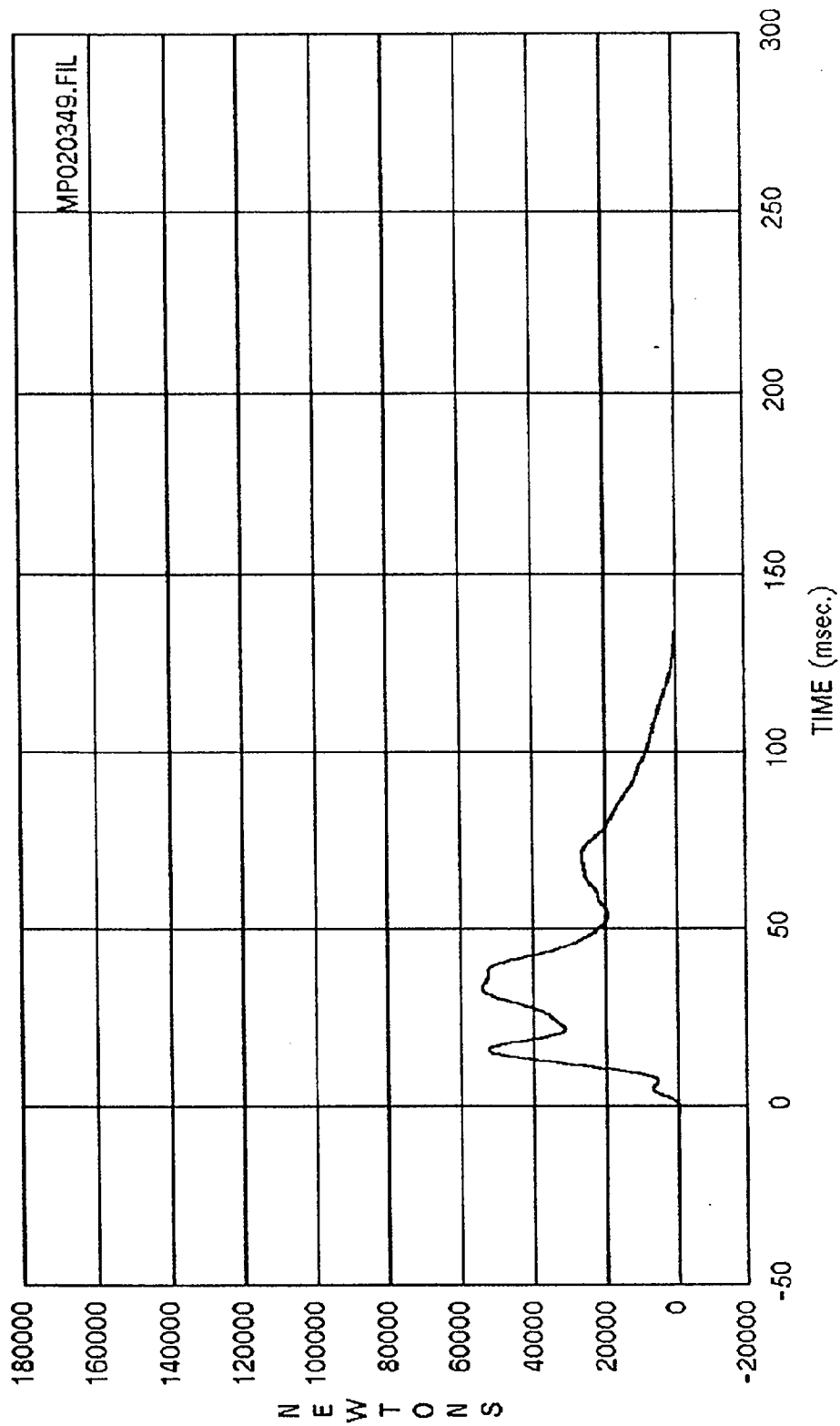

Curve: Force on barrier location B7 Filter: SAE CLASS 60 Max = 53978. Min = -169.20

MSE Date: 12/02/92 Program: 1993 NCAP, test number 3 Vehicle: 1993 Ford Ranger Pickup

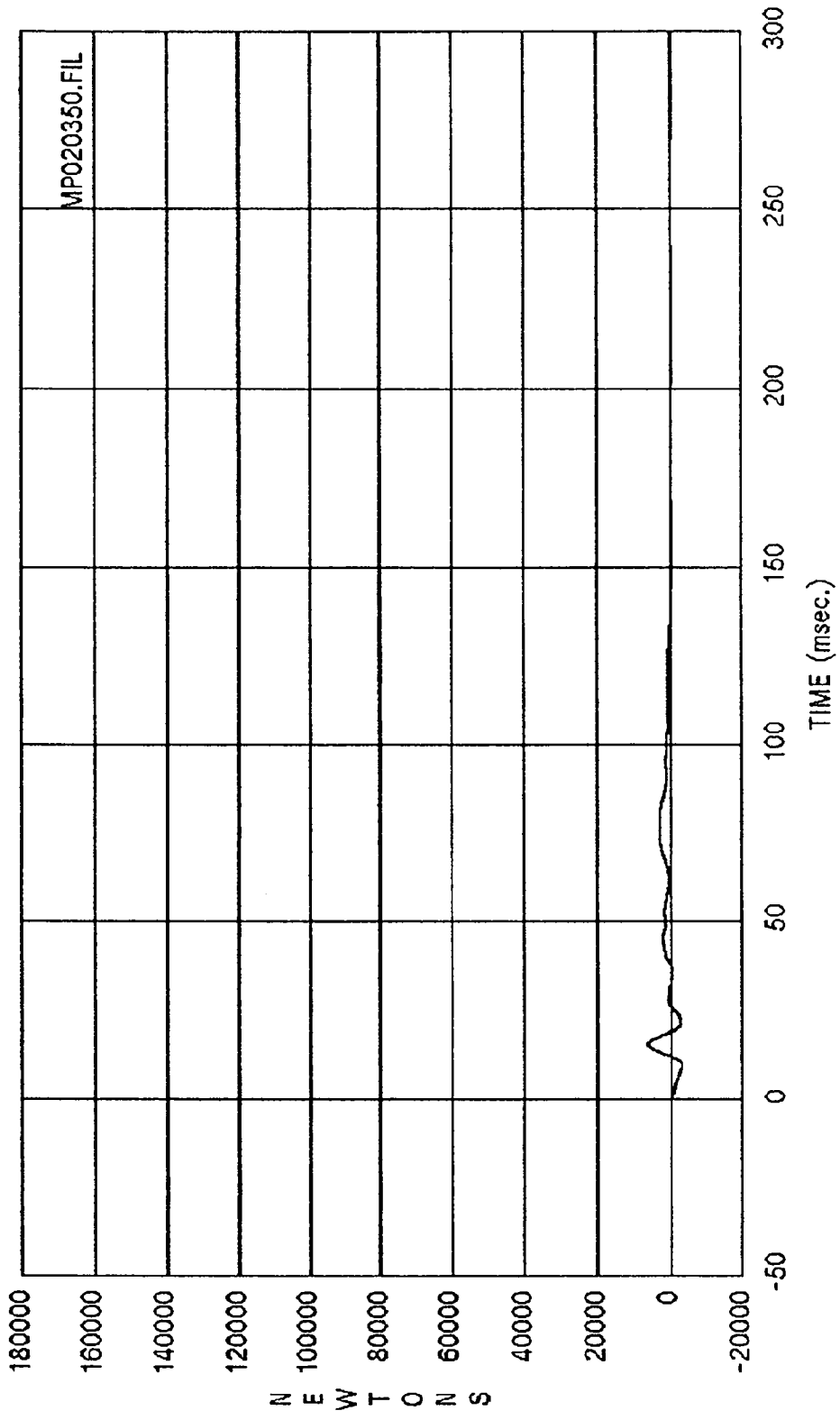

Curve: Force on barrier location B8 Filter: SAE CLASS 60 Max = 6342.6 Min = -3106.5

MSE Date: 12/02/92 Program: 1993 NCAP, test number 3 Vehicle: 1993 Ford Ranger Pickup

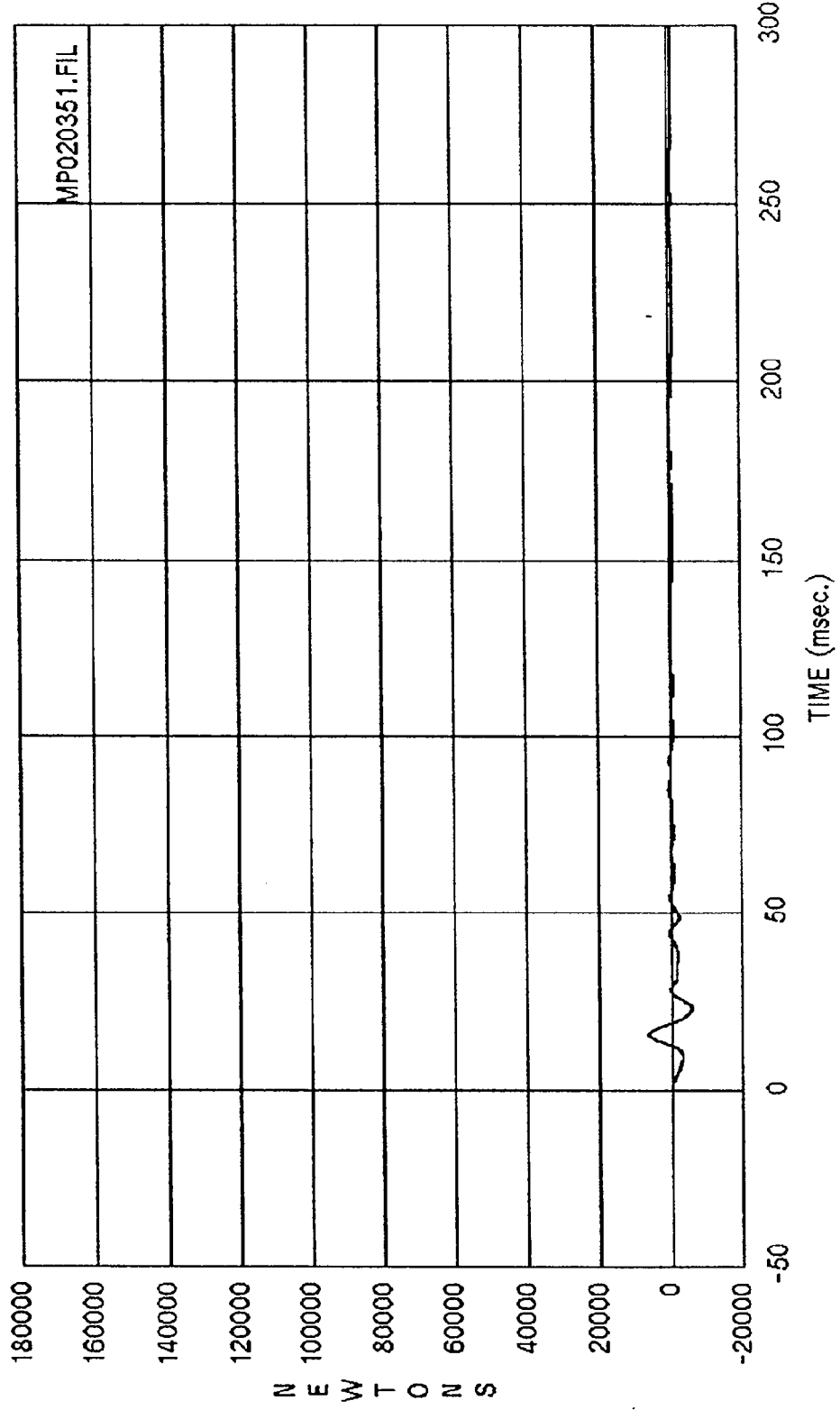

Curve: Force on barrier location B9 Filter: SAE CLASS 60 Max = 6635.0 Min = -5488.3

MSE Date: 12/02/92 Program: 1993 NCAP, test number 3 Vehicle: 1993 Ford Ranger Pickup

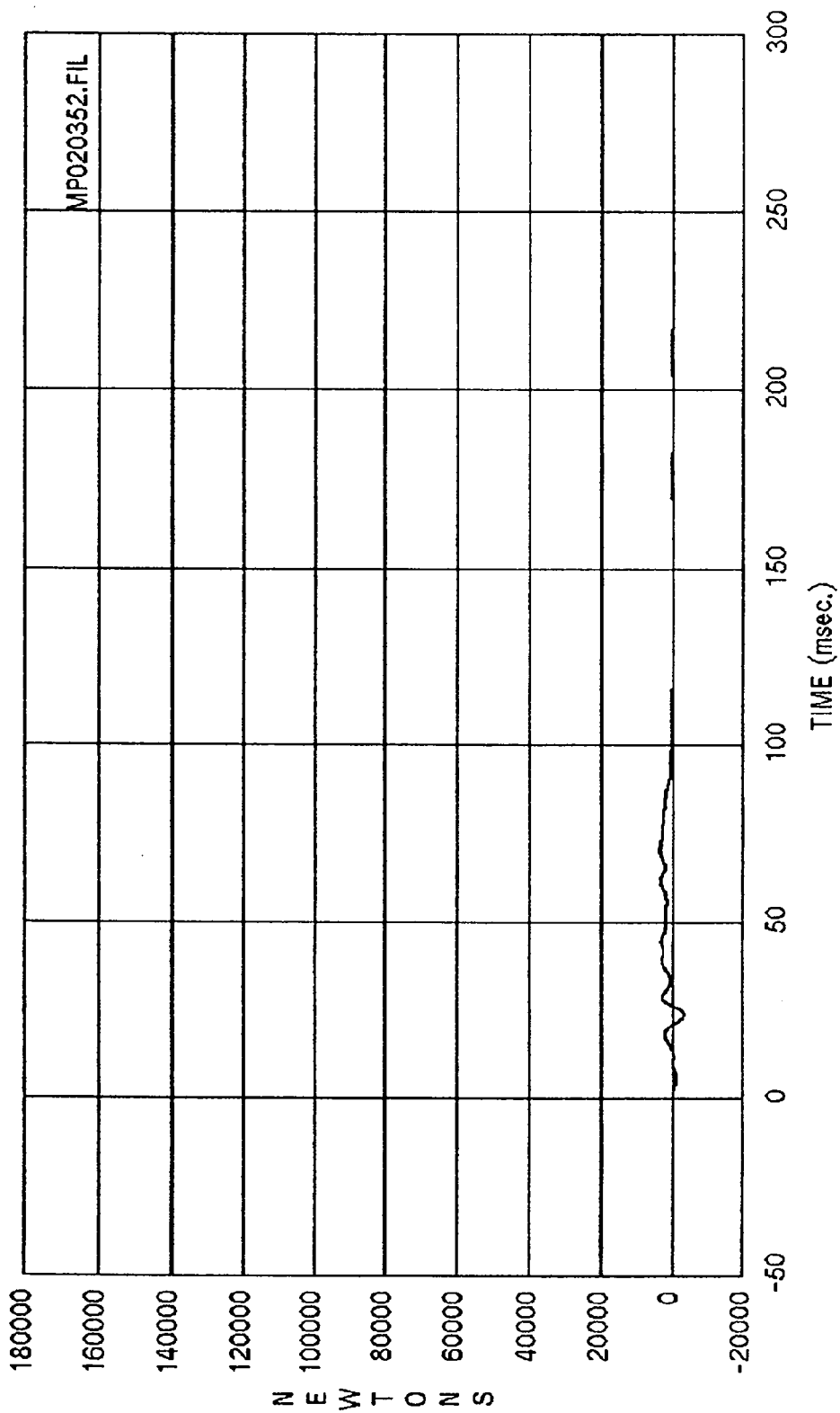

Curve: Force on barrier location C1 Filter: SAE CLASS 60 Max = 3635.6 Min = -3205.2

MSE Date: 12/02/92 Program: 1993 NCAP, test number 3 Vehicle: 1993 Ford Ranger Pickup

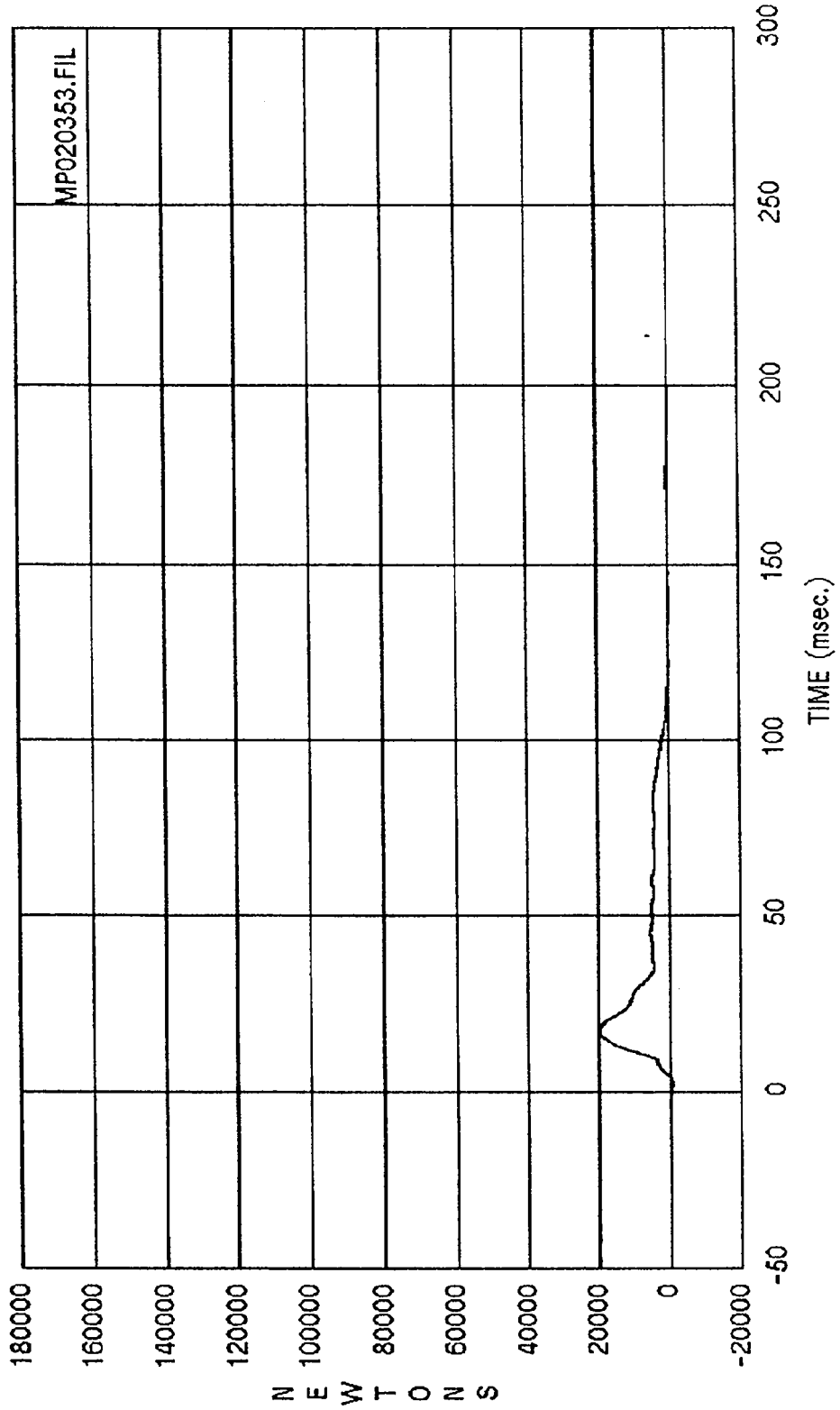

Curve: Force on barrier location C2 Filter: SAE CLASS 60 Max = 19891. Min = -579.82

MSE Date: 12/02/92 Program: 1993 NCAP, test number 3 Vehicle: 1993 Ford Ranger Pickup

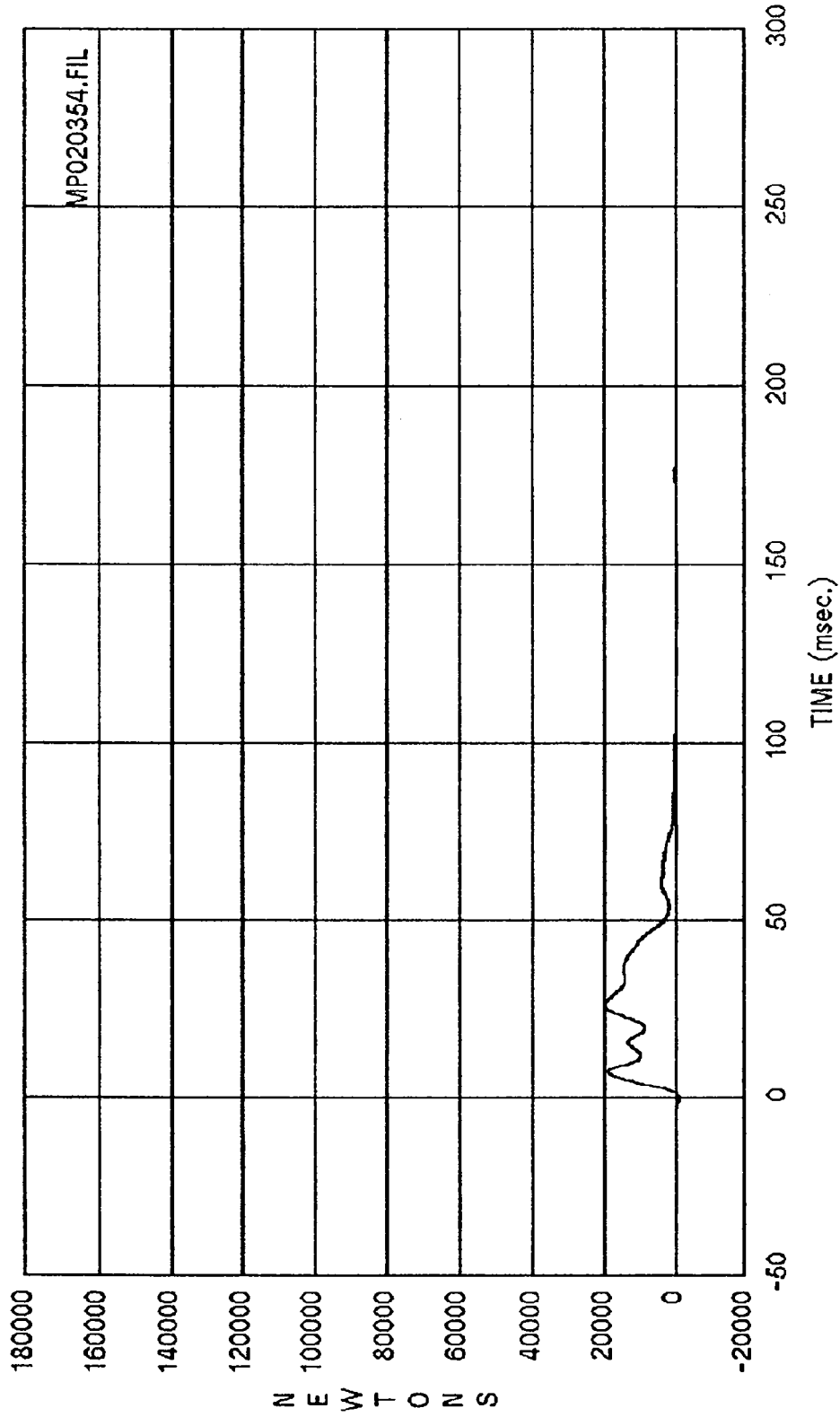

Curve: Force on barrier location C3 Filter: SAE CLASS 60 Max = 20234. Min = -241.25
 MSE Date: 12/02/92 Program: 1993 NCAP, test number 3 Vehicle: 1993 Ford Ranger Pickup

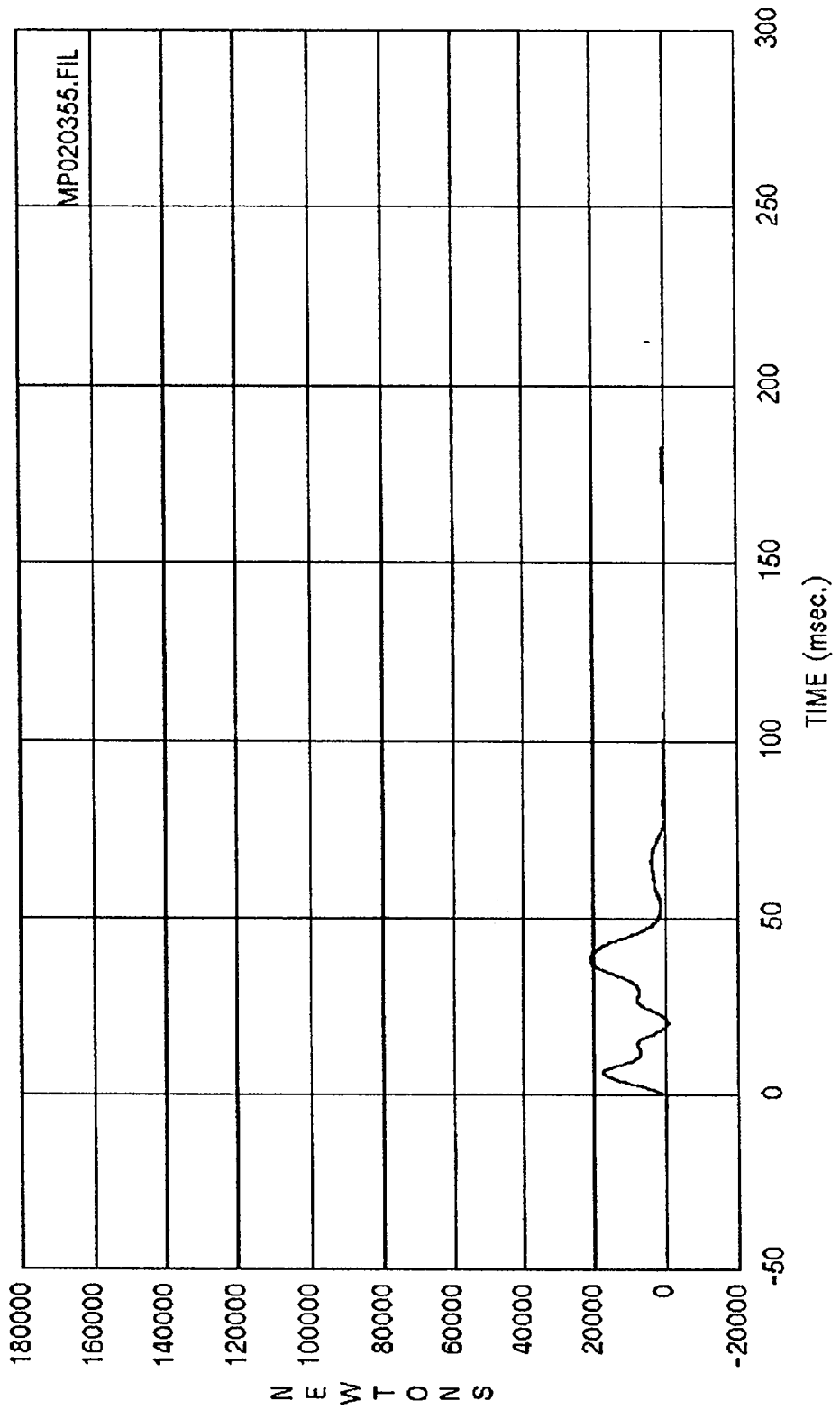

Curve: Force on barrier location C4 Filter: SAE CLASS 60 Max = 21119. Min = -561.64

MSE Date: 12/02/92 Program: 1993 NCAP, test number 3 Vehicle: 1993 Ford Ranger Pickup

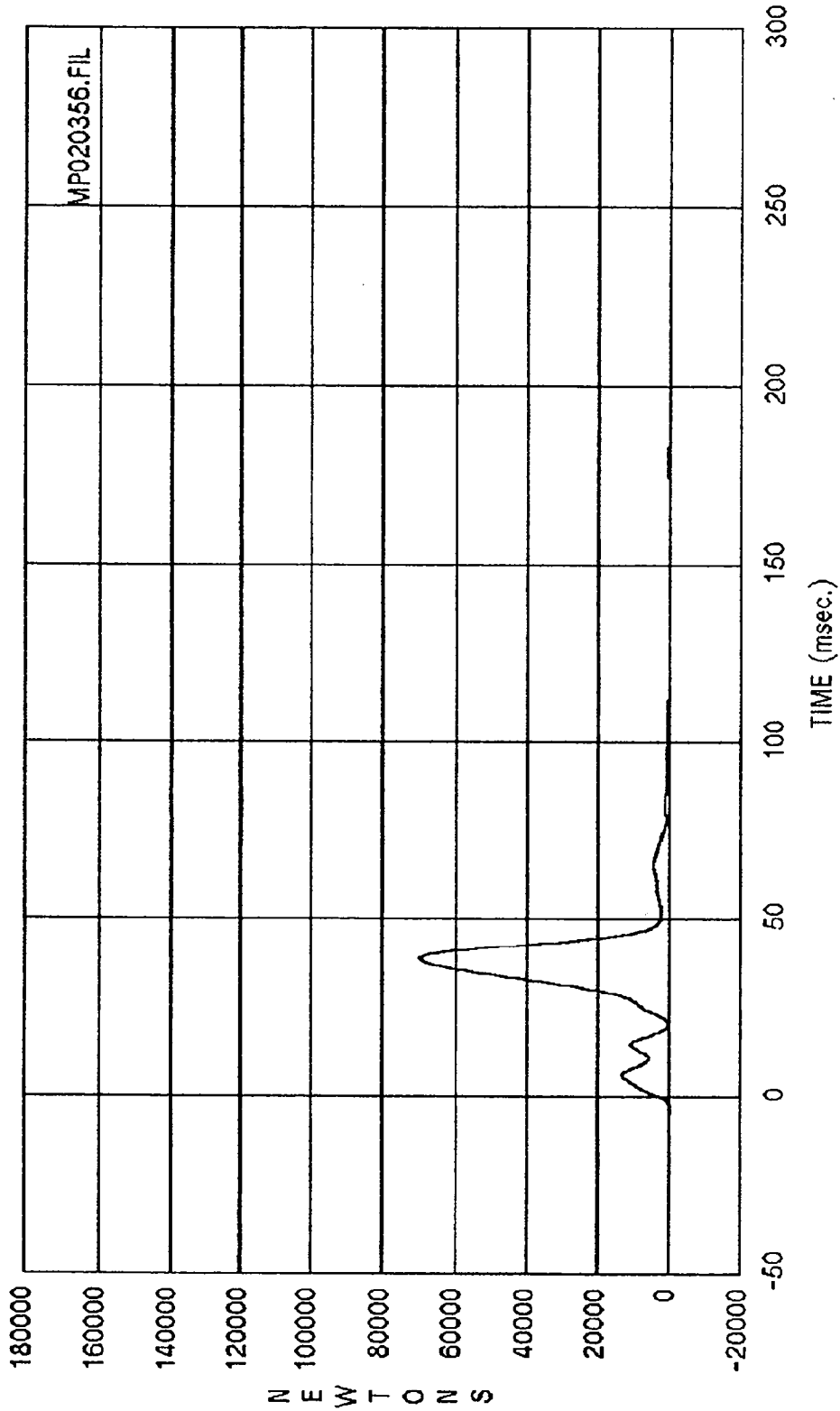

Curve: Force on barrier location C5 Filter: SAE CLASS 60 Max = 69889. Min = -111.42

MSE Date: 12/02/92 Program: 1993 NCAP, test number 3 Vehicle: 1993 Ford Ranger Pickup

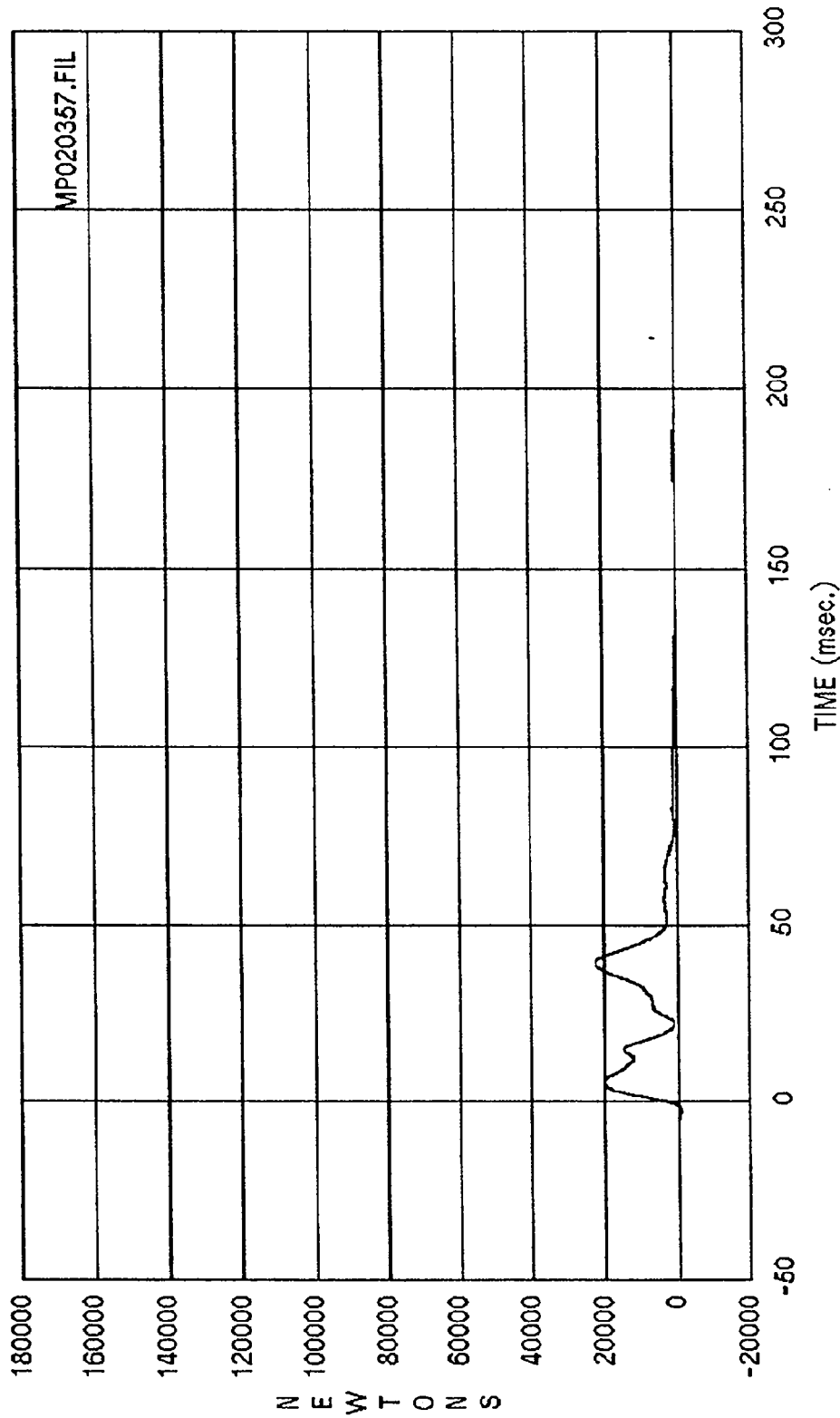

Curve: Force on barrier location C6 Filter: SAE CLASS 60 Max = 22561. Min = -100.39

MSE Date: 12/02/92 Program: 1993 NCAP, test number 3 Vehicle: 1993 Ford Ranger Pickup

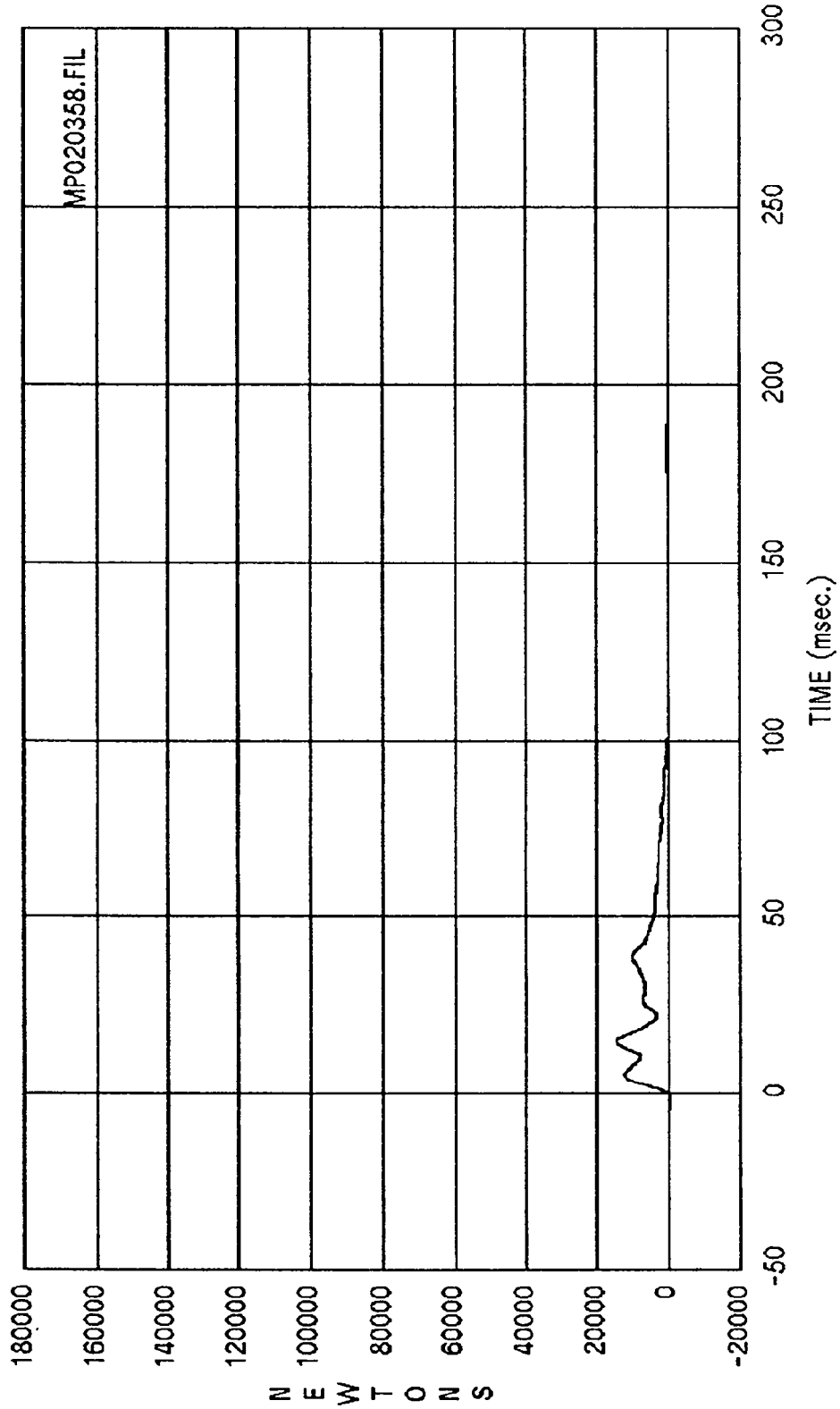

Curve: Force on barrier location C7 Filter: SAE CLASS 60 Max = 14812. Min = -151.03

MSE Date: 12/02/92 Program: 1993 NCAP, test number 3 Vehicle: 1993 Ford Ranger Pickup

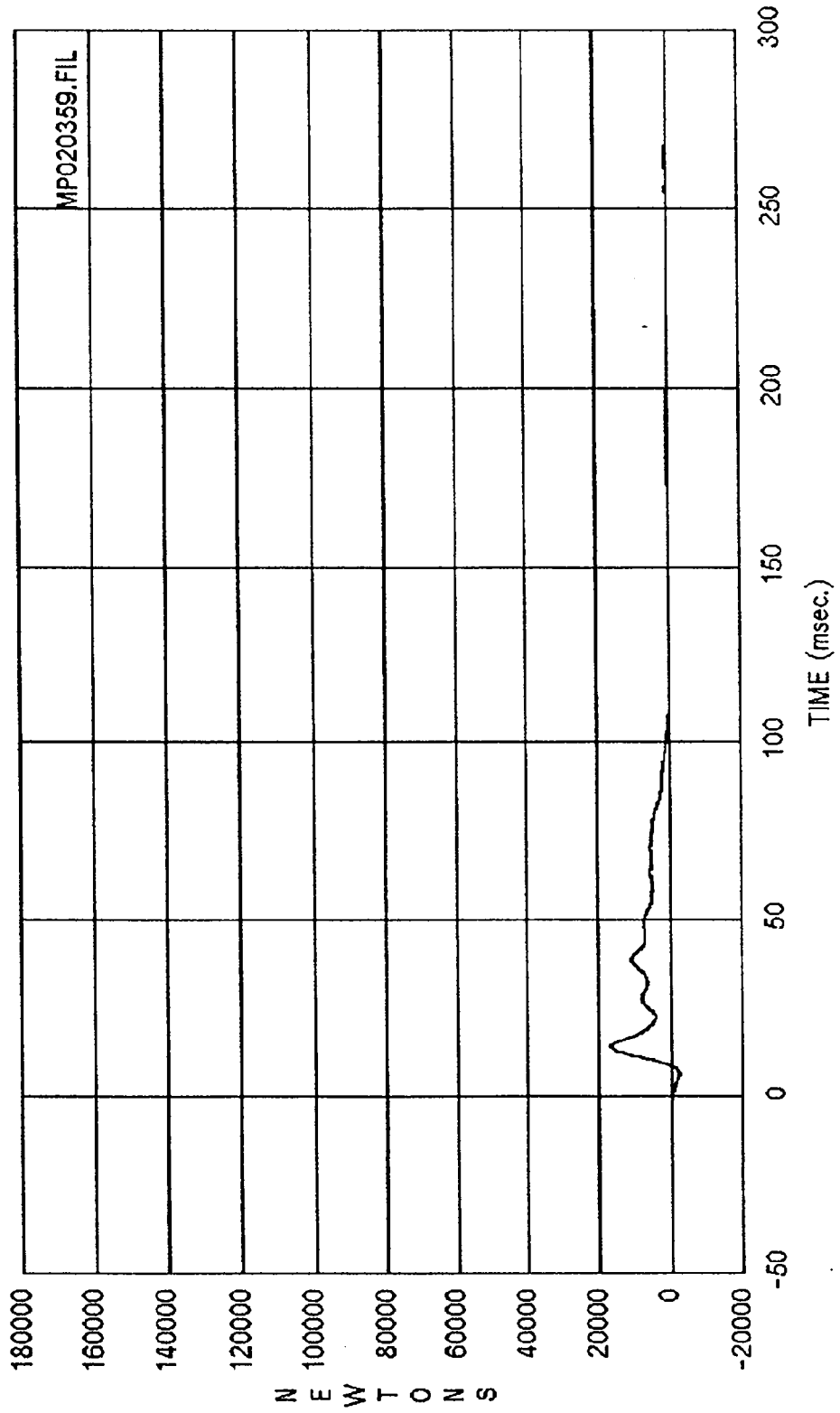

Curve: Force on barrier location C8 Filter: SAE CLASS 60 Max = 17065. Min = -2069.7

MSE Date: 12/02/92 Program: 1993 NCAP, test number 3 Vehicle: 1993 Ford Ranger Pickup

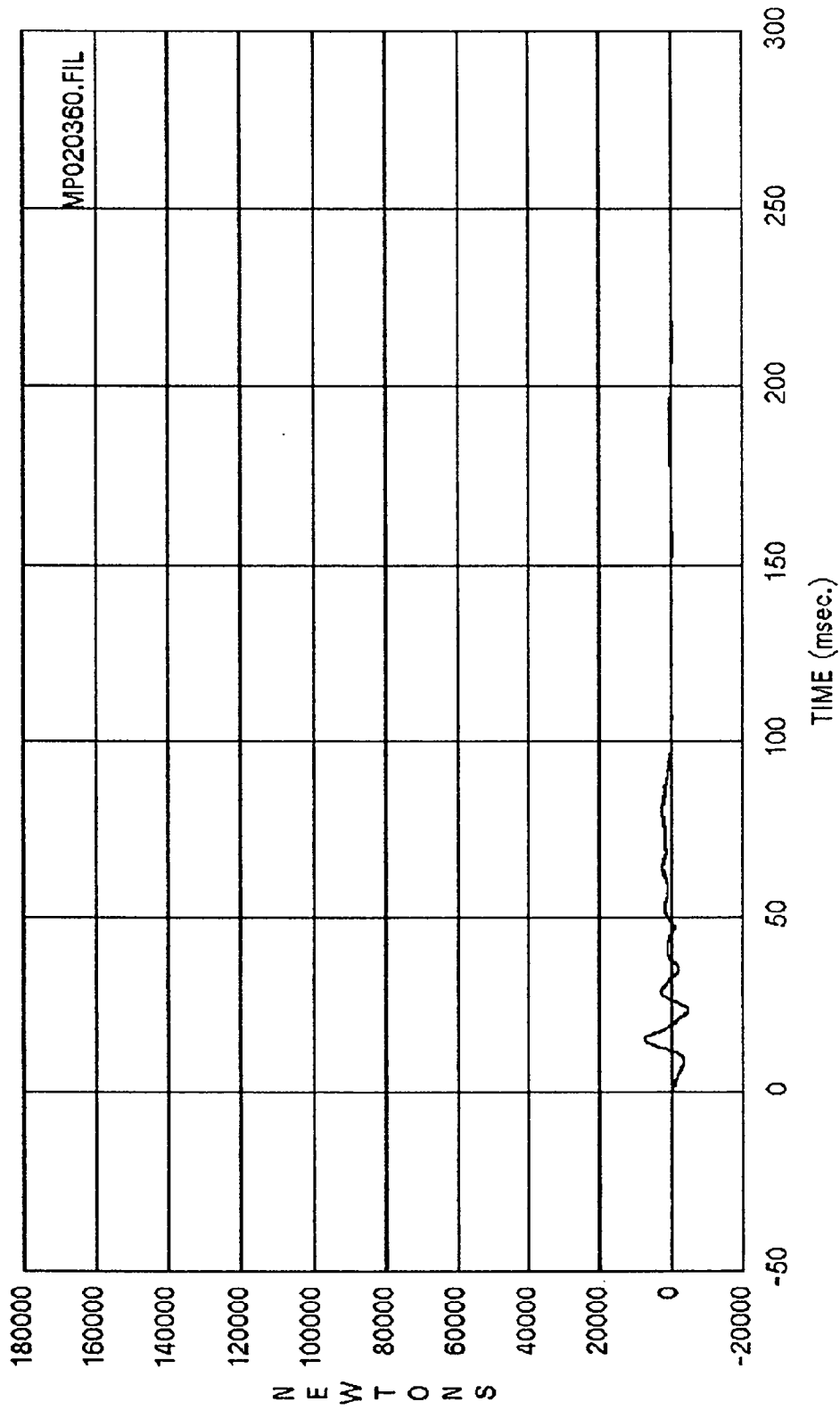

Curve: Force on barrier location C9 Filter: SAE CLASS 60 Max = 7536.9 Min = -4600.9

MSE Date: 12/02/92 Program: 1993 NCAP, test number 3 Vehicle: 1993 Ford Ranger Pickup

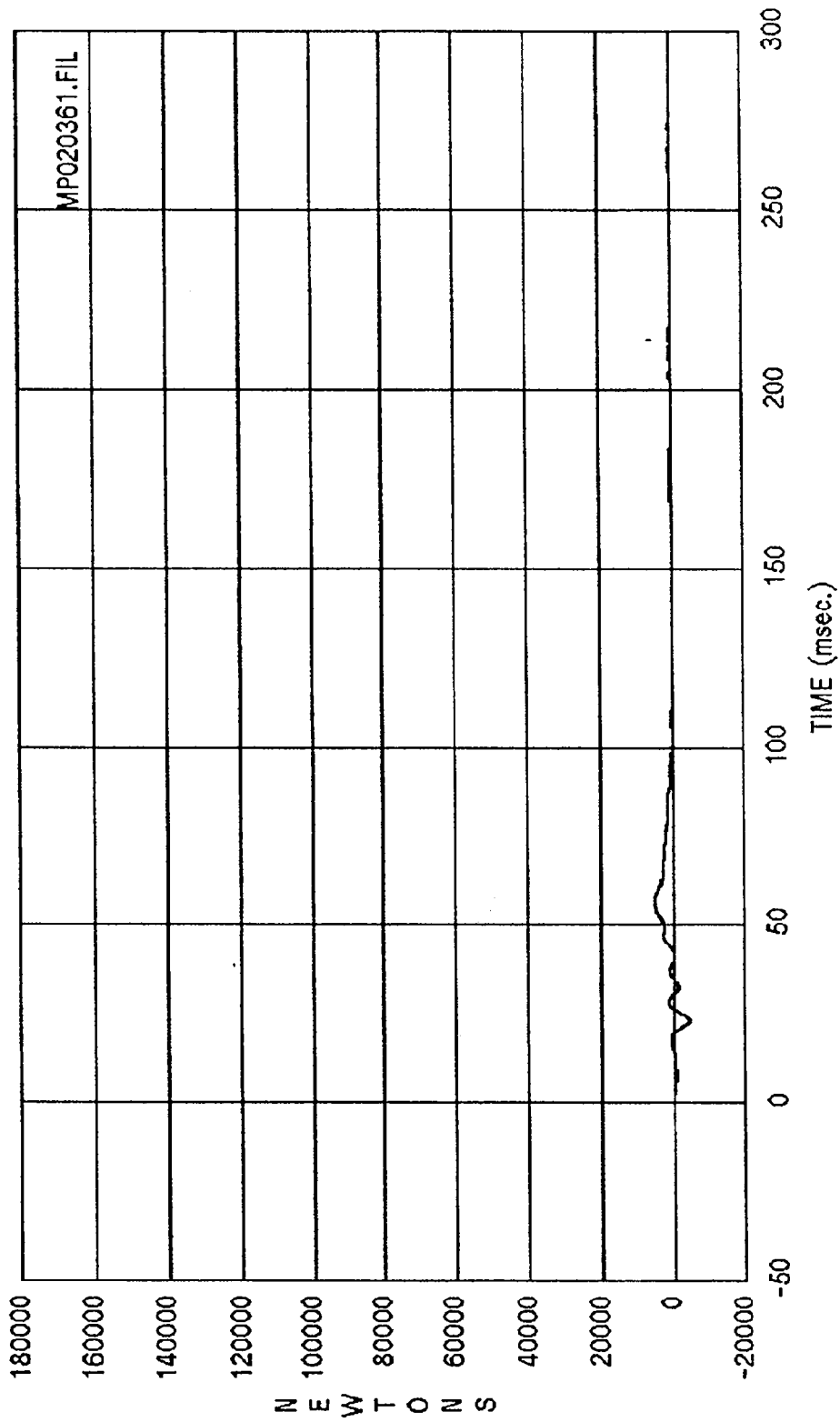

Curve: Force on barrier location D1 Filter: SAE CLASS 60 Max = 5277.1 Min = -4415.3

MSE Date: 12/02/92 Program: 1993 NCAP, test number 3 Vehicle: 1993 Ford Ranger Pickup

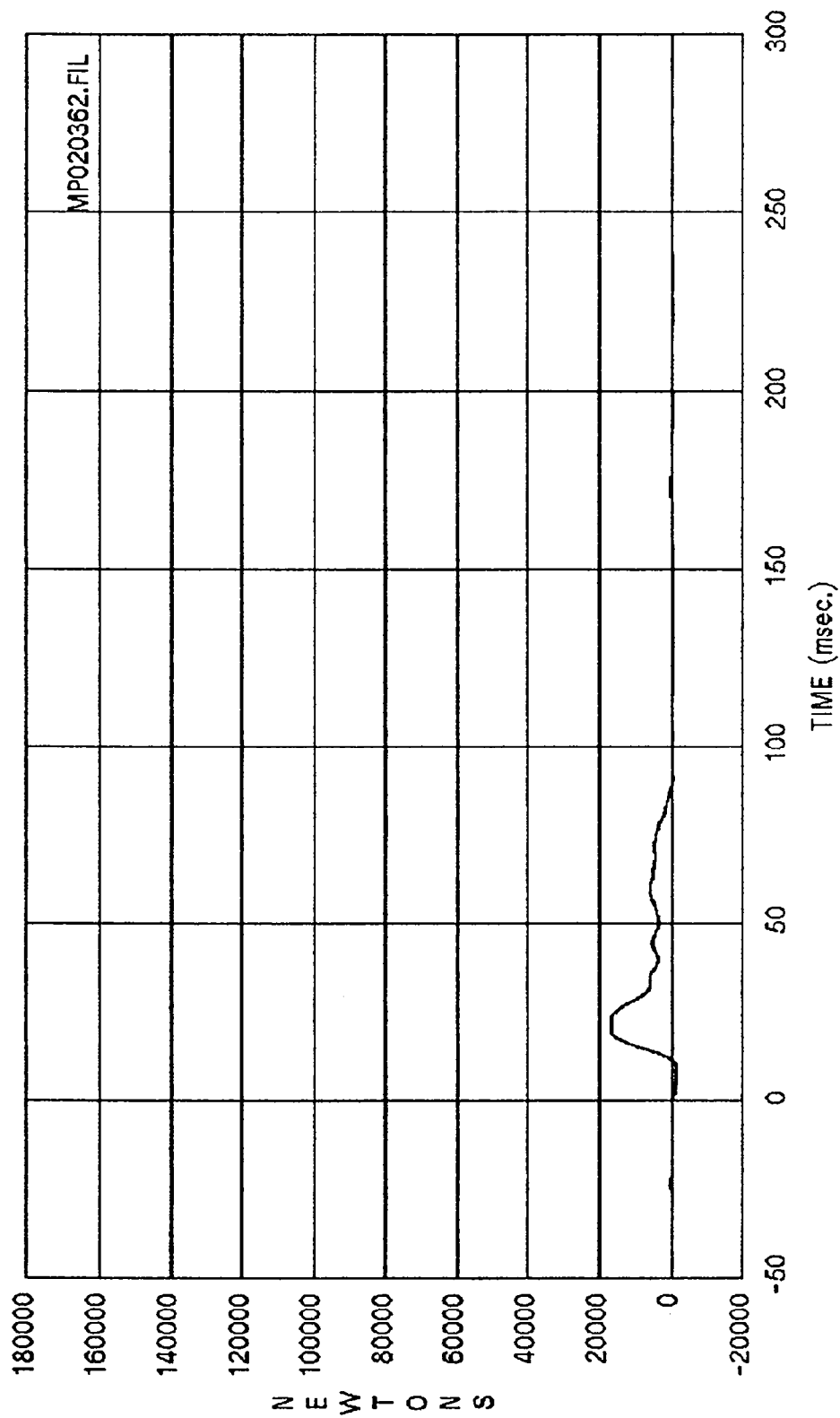

Curve: Force on barrier location D2 Filter: SAE CLASS 60 Max = 17064. Min = -1210.6

MSE Date: 12/02/92 Program: 1993 NCAP, test number 3 Vehicle: 1993 Ford Ranger Pickup

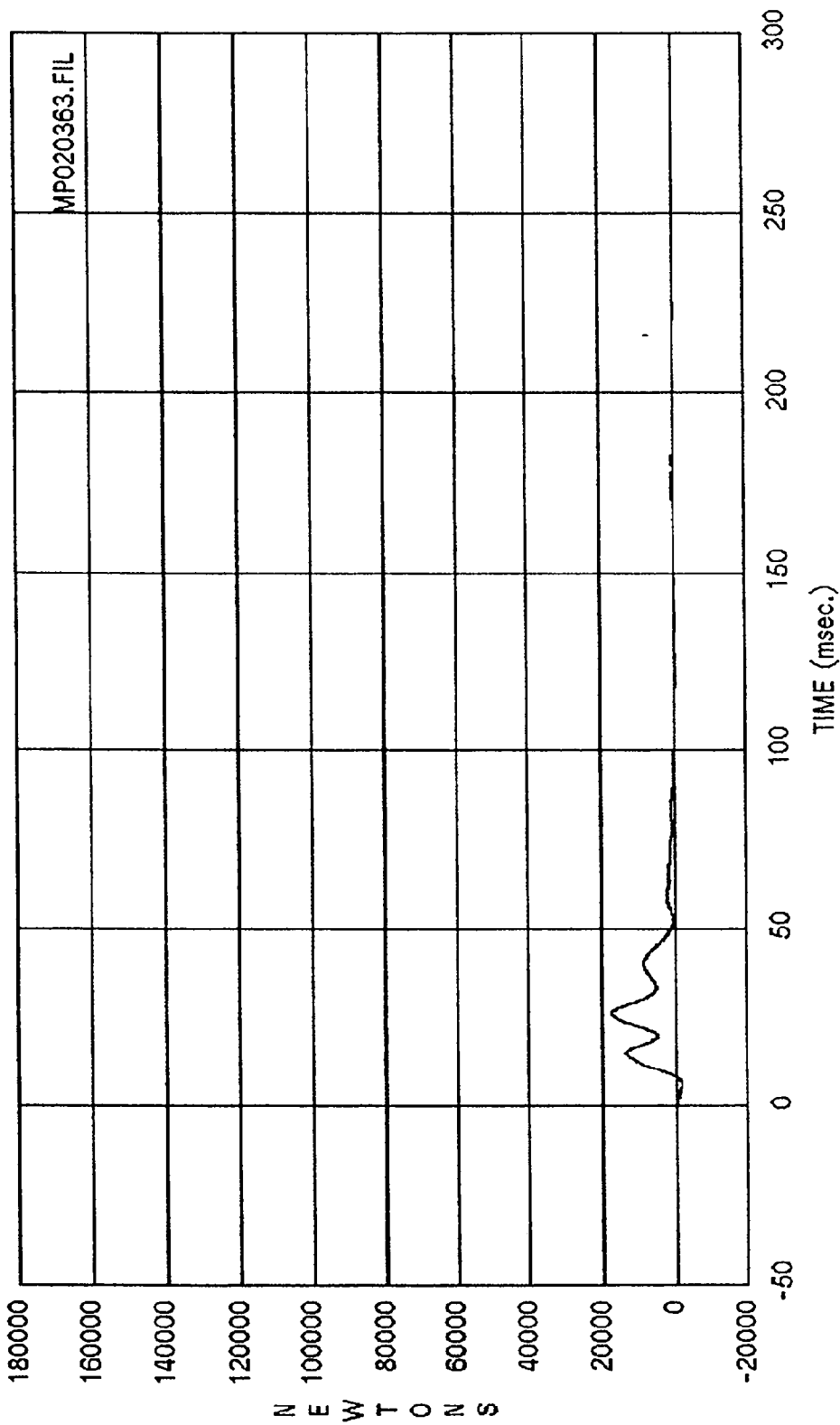

Curve: Force on barrier location D3 Filter: SAE CLASS 60 Max = 17640. Min = -1420.1
 MSE Date: 12/02/92 Program: 1993 NCAP, test number 3 Vehicle: 1993 Ford Ranger Pickup

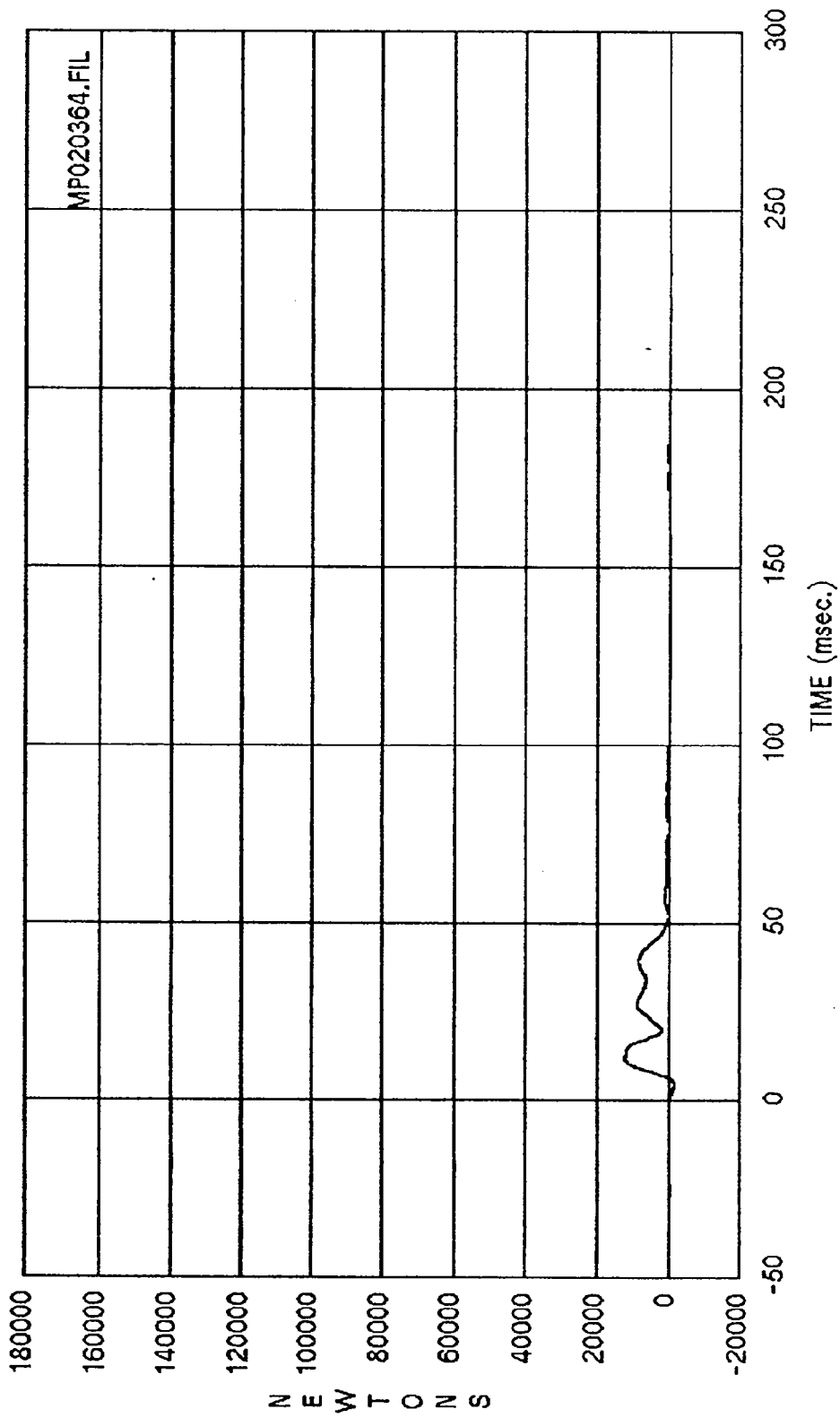

Curve: Force on barrier location D4 Filter: SAE CLASS 60 Max = 12253. Min = -1457.0

MSE Date: 12/02/92 Program: 1993 NCAP, test number 3 Vehicle: 1993 Ford Ranger Pickup

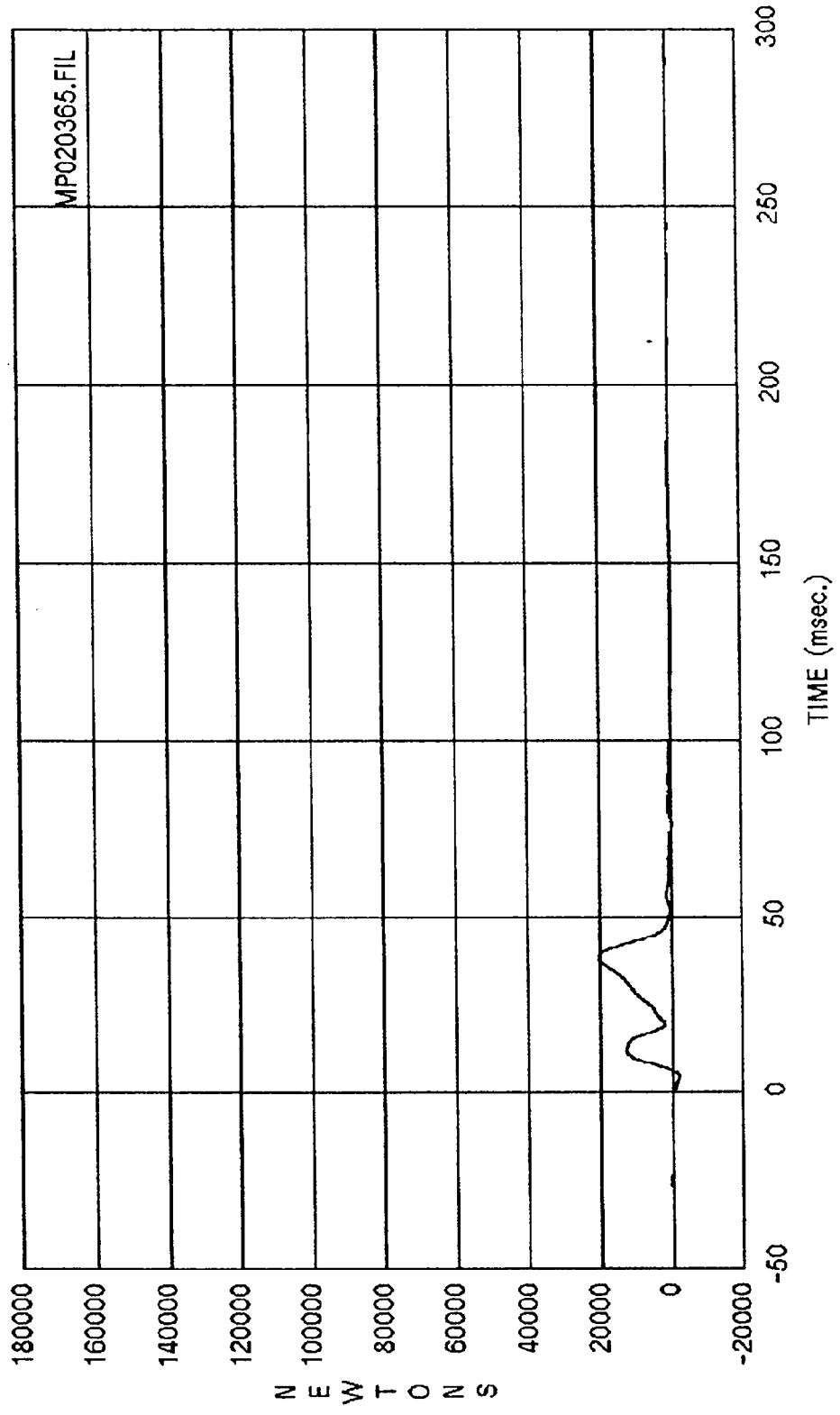

Curve: Force on barrier location D5 Filter: SAE CLASS 60 Max = 20798. Min = -1767.9

MSE Date: 12/02/92 Program: 1993 NCAP, test number 3 Vehicle: 1993 Ford Ranger Pickup

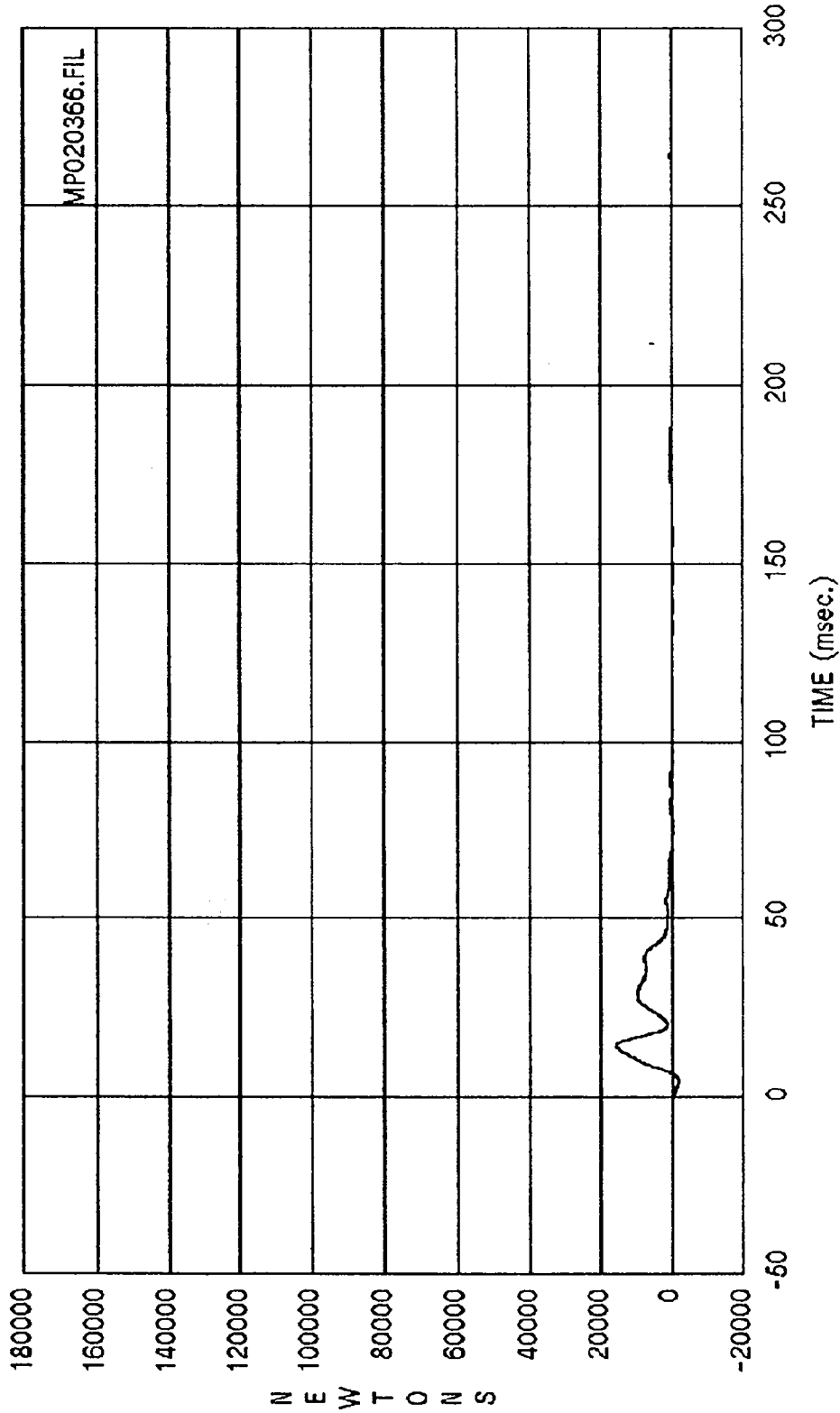

Curve: Force on barrier location D6 Filter: SAE CLASS 60 Max = 15780. Min = -1735.2

MSE Date: 12/02/92 Program: 1993 NCAP, test number 3 Vehicle: 1993 Ford Ranger Pickup

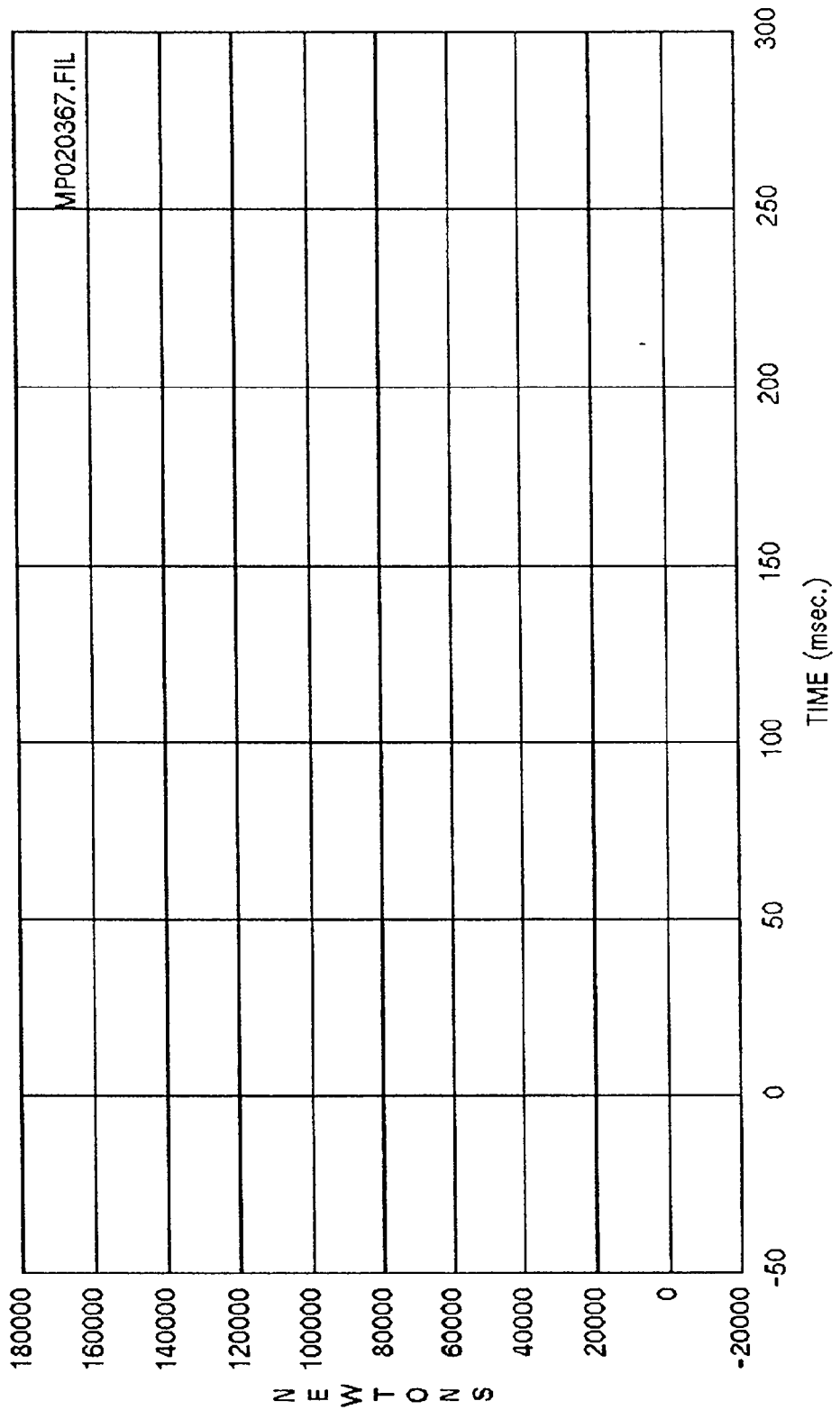

Curve: Force on barrier location D7 (No data) Filter: SAE CLASS 60 Max = .00000 Min = .00000

MSE Date: 12/02/92 Program: 1993 NCAP, test number 3 Vehicle: 1993 Ford Ranger Pickup

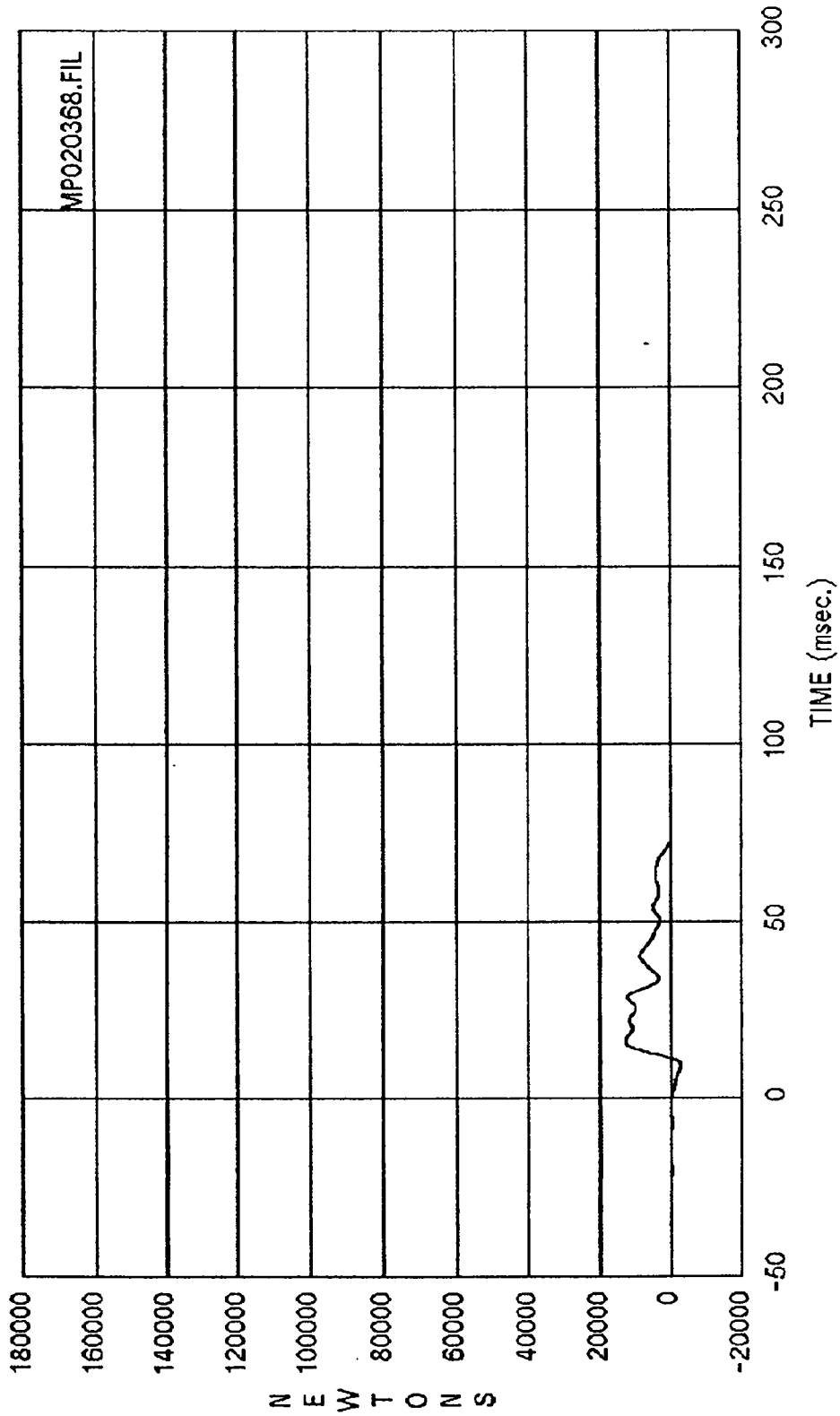

Curve: Force on barrier location D8 Filter: SAE CLASS 60 Max = 12886. Min = -2756.6

MSE Date: 12/02/92 Program: 1993 NCAP, test number 3 Vehicle: 1993 Ford Ranger Pickup

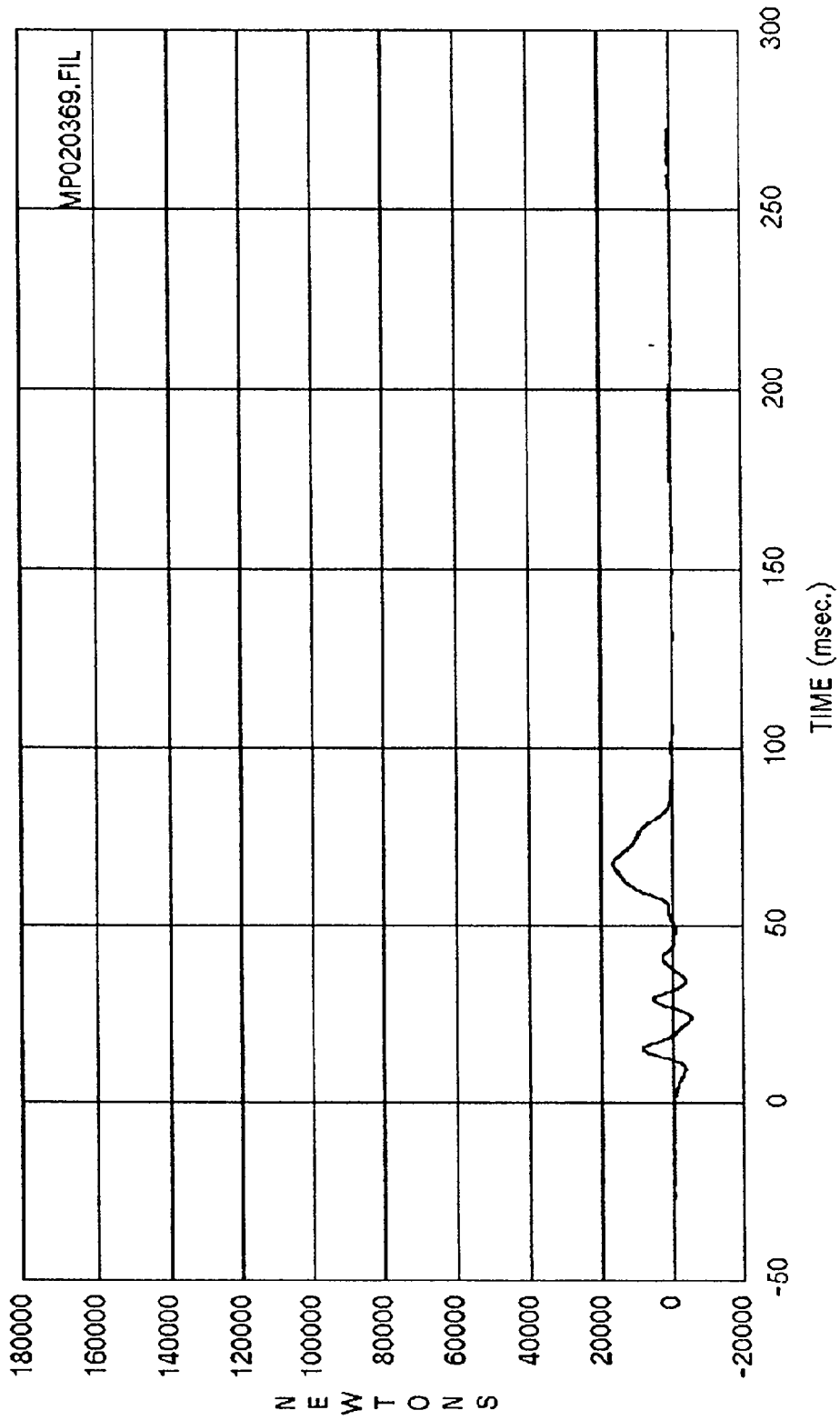

Curve: Force on barrier location D9 Filter: SAE CLASS 60 Max = 16734. Min = -5410.5

MSE Date: 12/02/92 Program: 1993 NCAP, test number 3 Vehicle: 1993 Ford Ranger Pickup

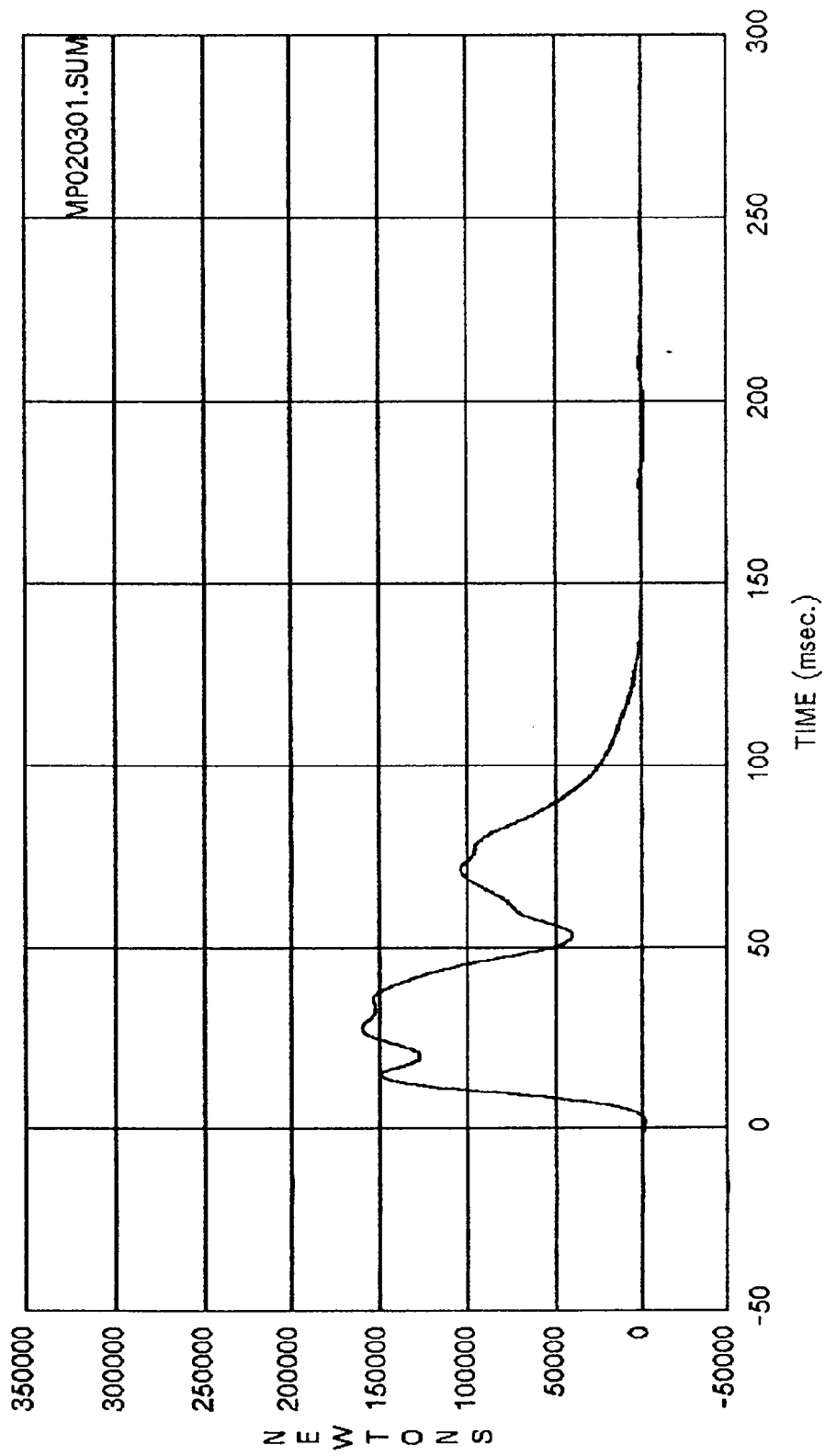

Curve: Barrier sum force A1,A2,A3,B1,B2,B3 -- Group 1 Filter: SAE CLASS 60 Max = .15946E+06 Min = 1211.3

MSE Date: 12/02/92 Program: 1993 NCAP, test number 3 Vehicle: 1993 Ford Ranger Pickup

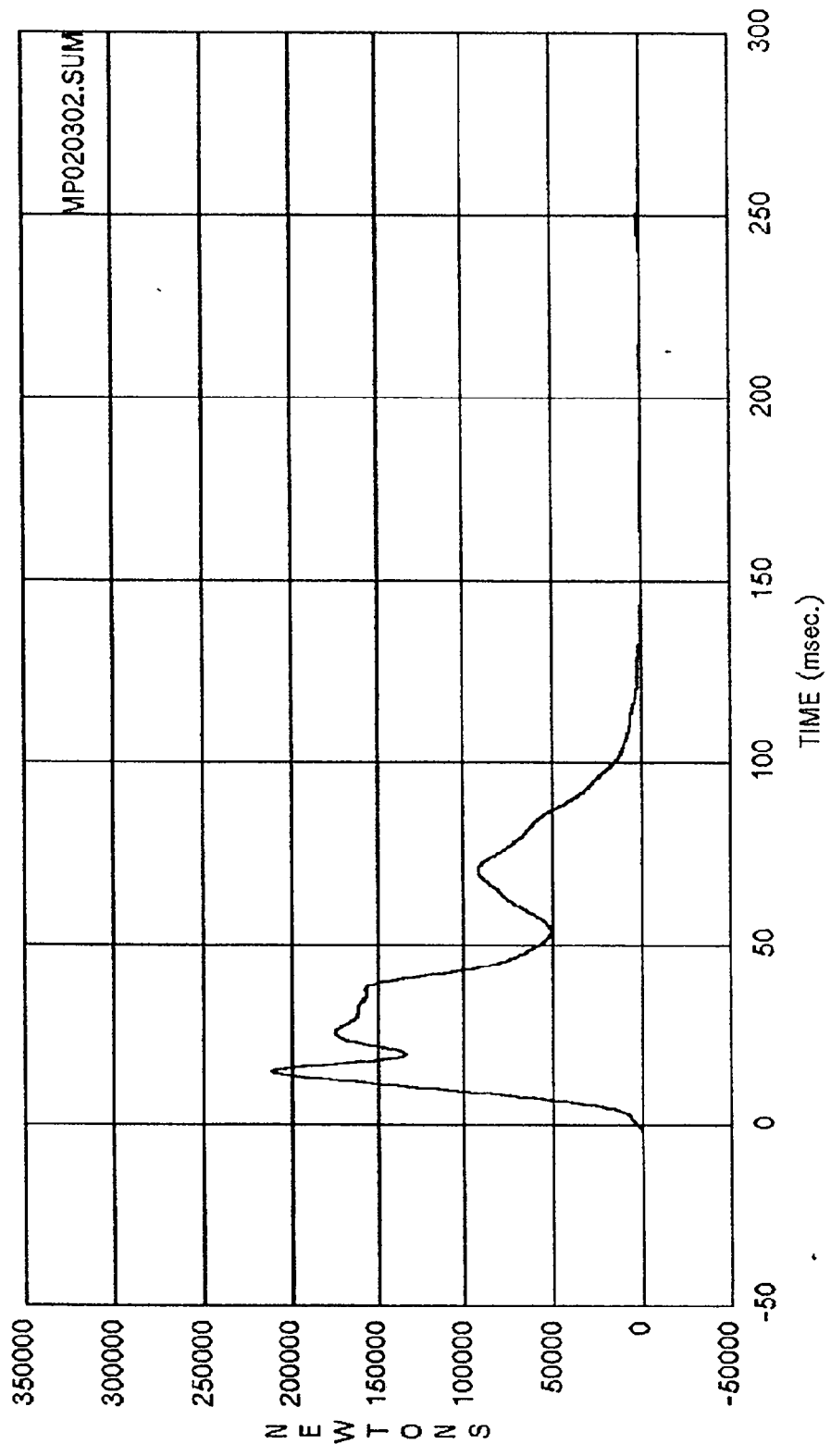

MP020302.SUM

Curve: Barrier sum force A4,A5,A6,B4,B5,B6 -- Group 2 Filter: SAE CLASS 60 Max = .21160E+06 Min = 207.29

MSE Date: 12/02/92 Program: 1993 NCAP, test number 3 Vehicle: 1993 Ford Ranger Pickup

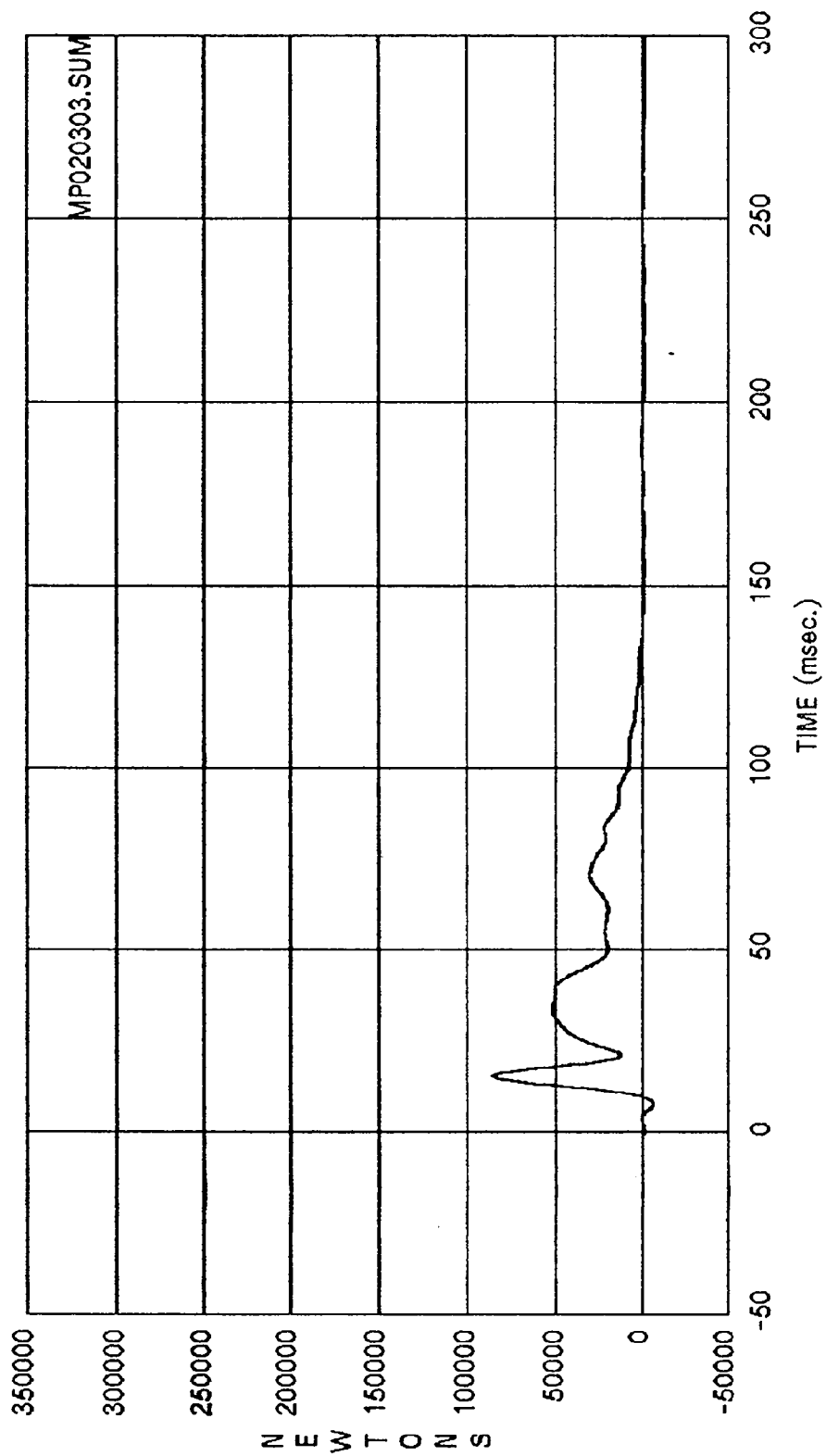

Curve: Barrier sum force A7,A8,A9,B7,B8,B9 -- Group 3 Filter: SAE CLASS 60 Max = 86015. Min = -62

MSE Date: 12/02/92 Program: 1993 NCAP, test number 3 Vehicle: 1993 Ford Ranger Pickup

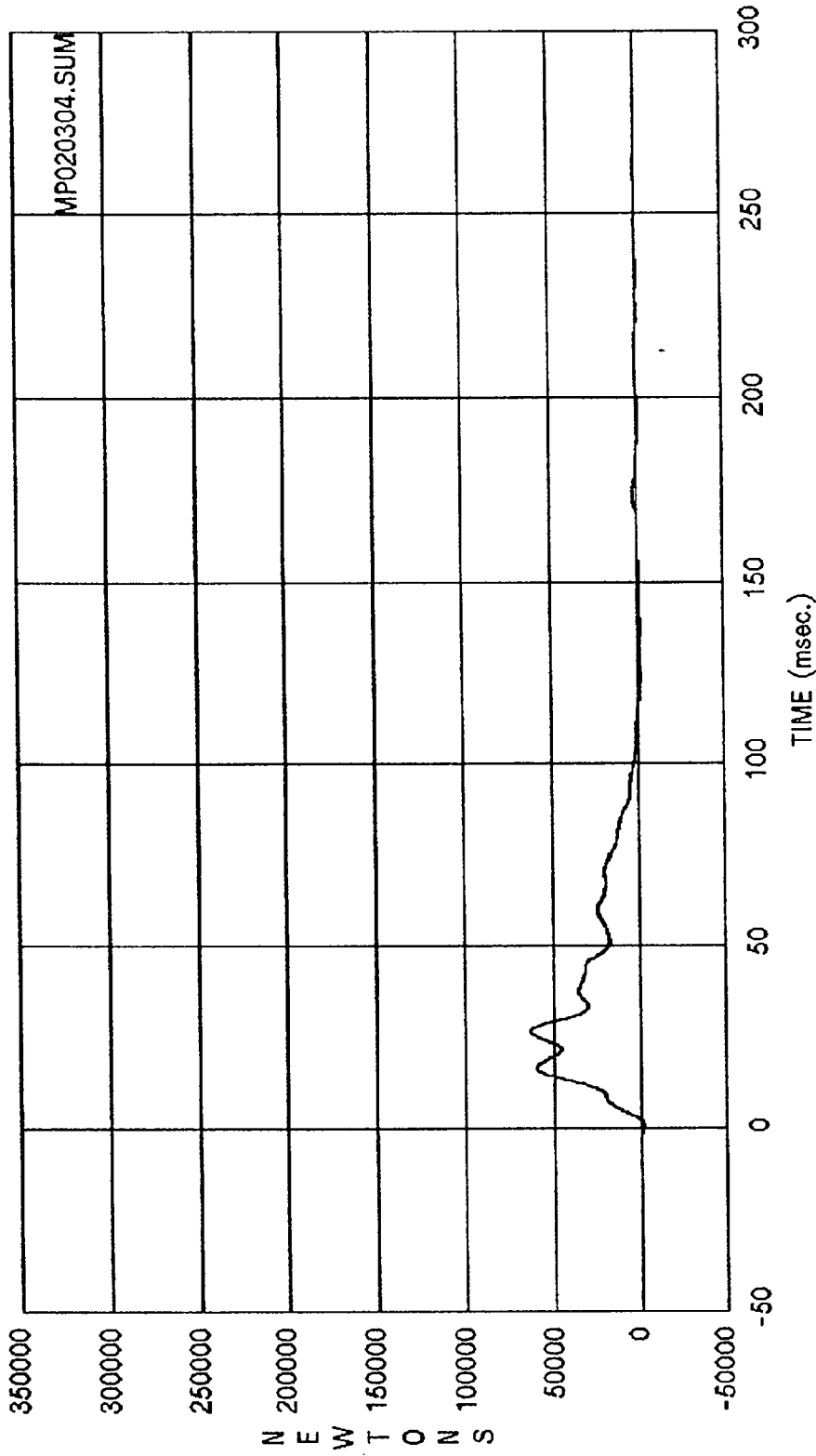

Curve: Barrier sum force C1,C2,C3,D1,D2,D3 -- Group 4 Filter: SAE CLASS 60 Max = 63514. Min = -12

MSE Date: 12/02/92 Program: 1993 NCAP, test number 3 Vehicle: 1993 Ford Ranger Pickup

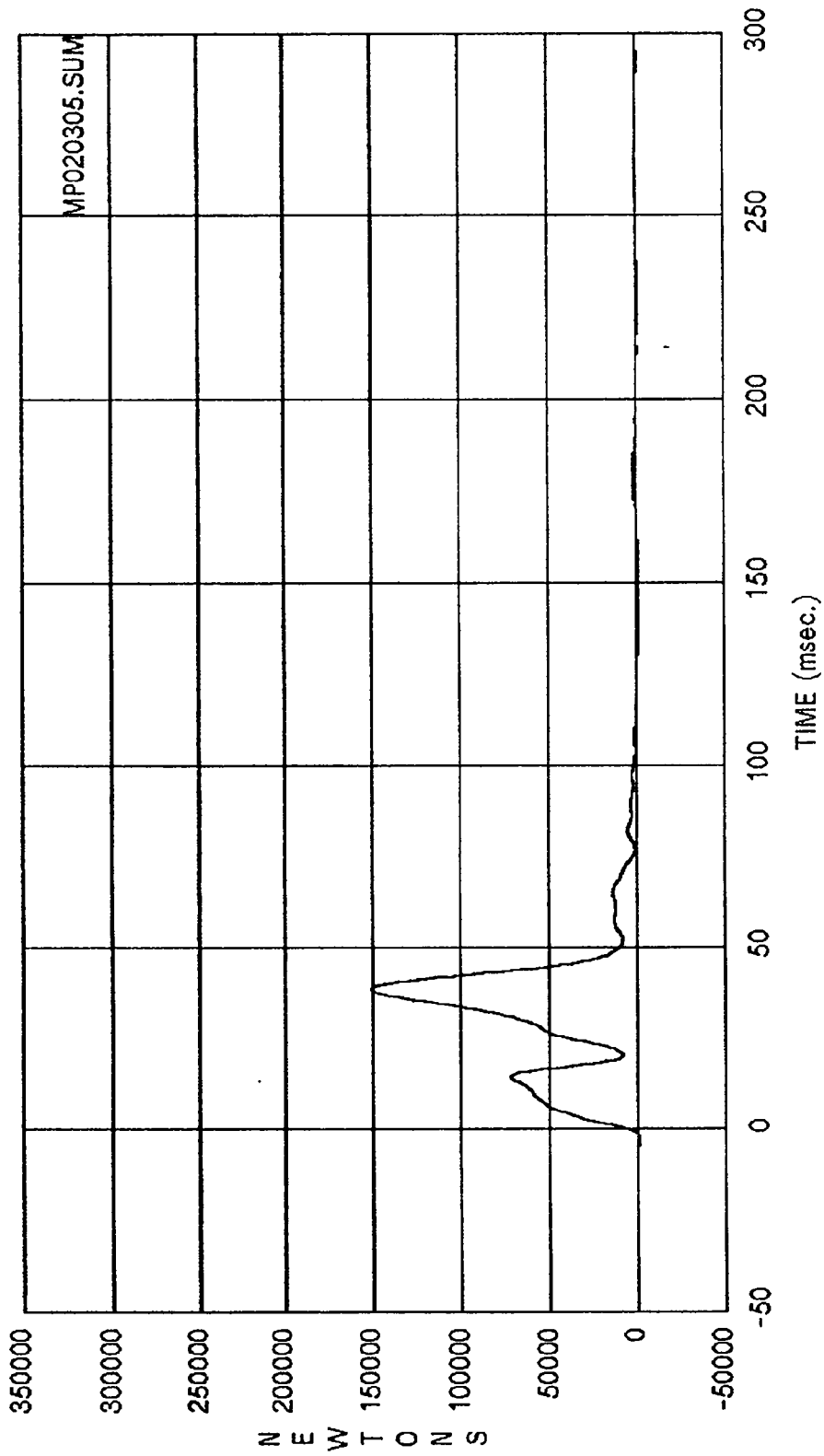

Curve: Barrier sum force C4,C5,C6,D4,D5,D6 -- Group 5 Filter: SAE CLASS 60 Max = .15049E+06 Min = 1002.2

MSE Date: 12/02/92 Program: 1993 NCAP, test number 3 Vehicle: 1993 Ford Ranger Pickup

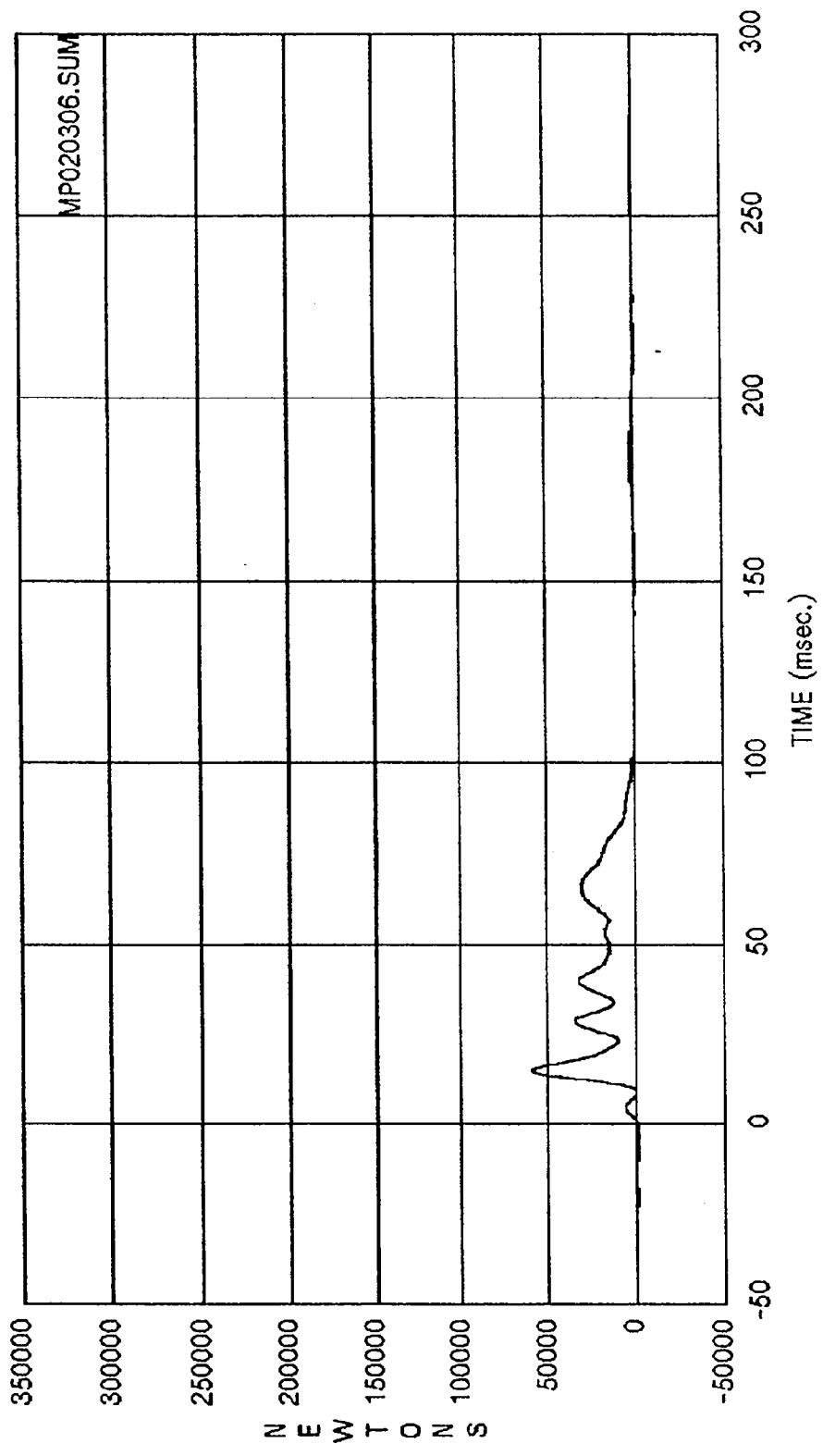

Curve: Barrier sum force C7,C8,C9,D7,D8,D9 -- Group 6 Filter: SAE CLASS 60 Max = 59047. Min = -73

MSE Date: 12/02/92 Program: 1993 NCAP, test number 3 Vehicle: 1993 Ford Ranger Pickup

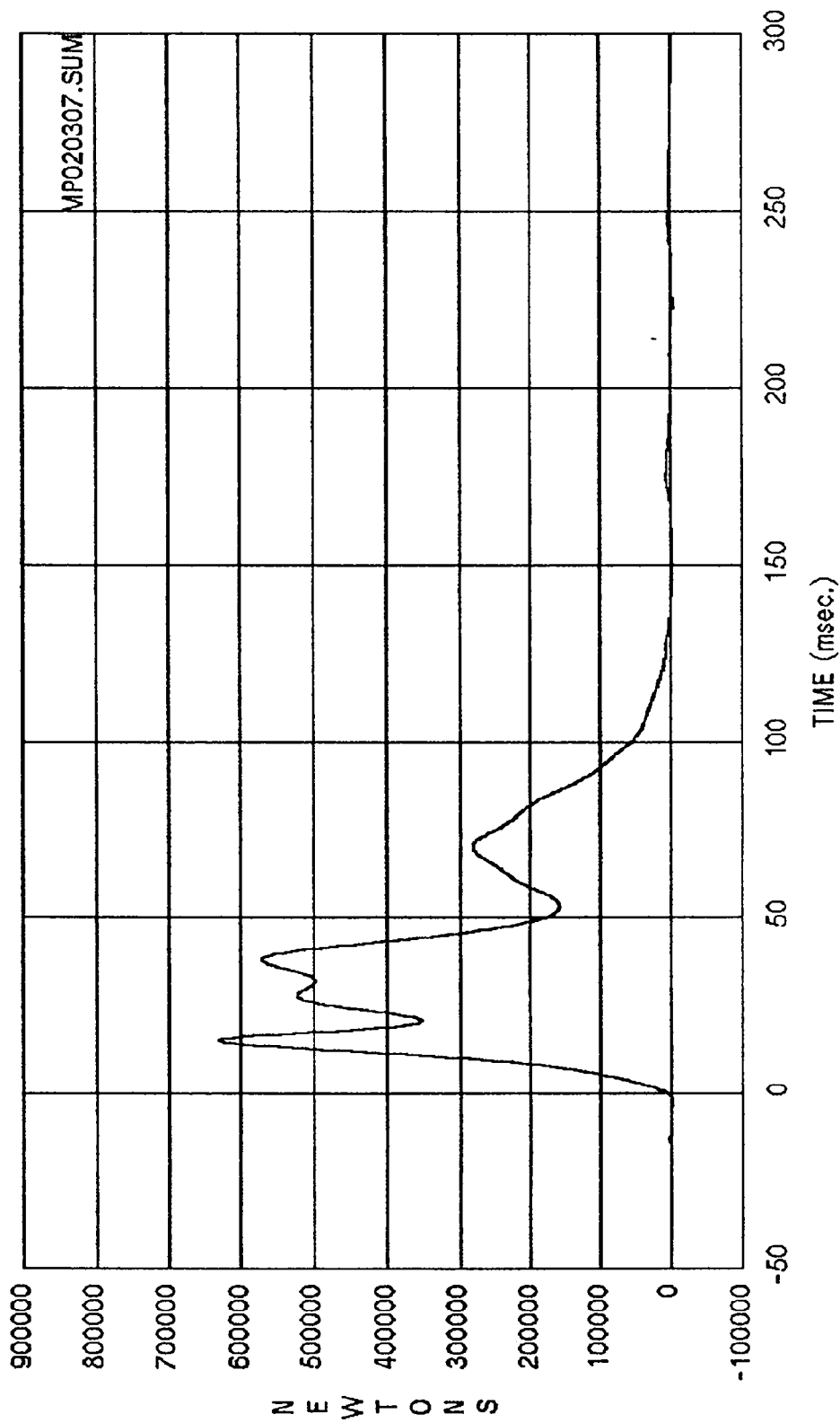

Curve: Barrier sum force -- Total Filter: SAE CLASS 60 Max = .63127E+06 Min = -3103.

MSE Date: 12/02/92 Program: 1993 NCAP, test number 3 Vehicle: 1993 Ford Ranger Pickup

THIS PAGE INTENTIONALLY LEFT BLANK

APPENDIX C

PART 572 DUMMY CONFIGURATION AND
PERFORMANCE VERIFICATION TESTS

THIS PAGE INTENTIONALLY LEFT BLANK

PART 572 ATD CONFIGURATION AND PERFORMANCE VERIFICATION DATA

NHTSA ATD I.D. NUMBER: 830

LAB TECHNICIAN: P. Puzzuto/L. Rawlings

CALIBRATION SEQUENCE: 02

CALIBRATION DATE: 11/19/92 to 11/25/92

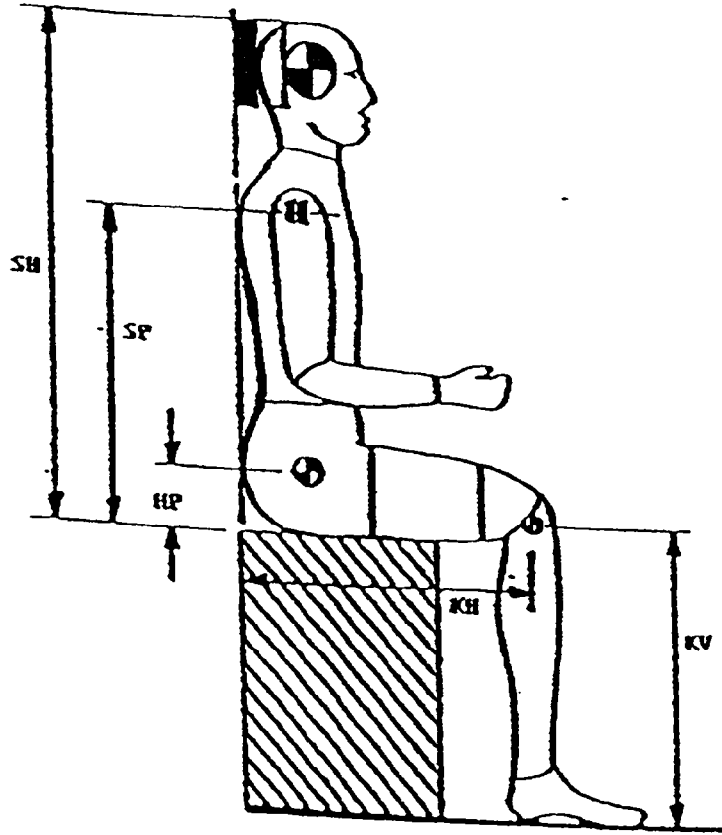

I. CONFIGURATION VERIFICATION DATA, PRETEST			
TESTED PARAMETER	UNITS	SPECIFICATION	TEST RESULTS
SH - Seated height	mm	904 - 909	906
SP - Shoulder pivot height	mm	554 - 569	556
HP - Hip pivot height	mm	99 reference	99
KH - Knee pivot from back	mm	511 - 526	522
KV - Knee pivot from floor	mm	490 - 505	504
SW - Shoulder width	mm	452 - 467	461
HW - Hip width	mm	356 - 391	381

NHTSA ATD I.D. NUMBER: 830

LAB TECHNICIAN: P. PUZZUTO/L. RAWLINGS

CALIBRATION SEQUENCE: 02

CALIBRATION DATE: 11/19/92 to 11/25/92

II. PERFORMANCE VERIFICATION DATA, PRETEST			
TESTED PARAMETER	UNITS	SPECIFICATION	TEST RESULTS
Temperature in laboratory	Deg C	18.9 - 25.6	22.2
Humidity in laboratory	%	10 - 70	45
HEAD DROP TEST			
Peak resultant acceleration	G's	210 - 260	251.8
Peak lateral acceleration	G's	less than 10	4.9
Time above 100 G's	msec	0.9 to 1.5	1.1
ABDOMINAL COMPRESSION TEST			
Force at 12mm displacement	kg	10.5 - 16.4	12.7
Force at 19mm displacement	kg	16.4 - 22.7	19.2
Force at 25mm displacement	kg	22.7 - 28.6	27.2
Force at 33mm displacement	kg	23.2 - 40.0	39.1
CHEST IMPACT TEST, HIGH ENERGY			
Probe speed	mps	6.64 - 6.77	6.71
Peak deflection	mm	43.2 maximum	42.0
Peak resistive force	kg	1023 maximum	907
Internal hysteresis	%	50 - 70	57
CHEST IMPACT TEST, LOW ENERGY			
Probe speed	mps	4.22 - 4.31	4.26
Peak deflection	mm	27.9 maximum	27.5
Peak resistive force	kg	659 maximum	564
Internal hysteresis	%	50 - 70	52

PART 572 ATD CONFIGURATION AND PERFORMANCE VERIFICATION DATA (CONT.)

NHTSA ATD I.D. NUMBER: 830

LAB TECHNICIAN: P. Puzzuto/L. Rawlings

CALIBRATION SEQUENCE: 02

CALIBRATION DATE: 11/19/92 to 11/25/92

II. PERFORMANCE VERIFICATION DATA, PRETEST				
TESTED PARAMETER		UNITS	SPECIFICATION	TEST RESULTS
NECK BEND TEST				
Pendulum speed		mps	6.55 - 7.77	6.61
Pendulum avg. decel. ($T_1 - T_2$)		G's	20 - 24	22.3
Pendulum decel. ($T_2 - T_1$)		msec	less than 3	2.6
Pendulum decel. ($T_3 - T_2$)		msec	25 - 30	29.4
Pendulum decel. ($T_4 - T_3$)		msec	less than 10	6.8
Resultant head acceleration		G's	less than 26	25.1
Maximum head rotation		deg.	63 - 73	63.9
CHORDAL DISPLACEMENT / HEAD ROTATION ANGLE				
0 deg.	Time	msec	-2.0 - 2.0	0.0
	Displ.	mm	-13 - 13	0
30 deg.	Time	msec	25.6 - 34.4	27.1
	Displ.	mm	53 - 79	58
60 deg.	Time	msec	40.3 - 51.7	44.2
	Displ.	mm	109 - 135	119
Maximum	Time	msec	53.2 - 66.8	57.1
	Displ.	mm	127 - 152	135
60 deg.	Time	msec	67.0 - 83.0	68.9
	Displ.	mm	109 - 135	122
30 deg.	Time	msec	85.4 - 104.6	89.6
	Displ.	mm	53 - 79	60
0 deg.	Time	msec	101.0 - 123.0	101.9
	Displ.	mm	-13 - 13	2

PART 572 ATD CONFIGURATION AND PERFORMANCE VERIFICATION DATA (CONT.)

NHTSA ATD I.D. NUMBER: 830

LAB TECHNICIAN: P. Puzzuto/L. Rawlings

CALIBRATION SEQUENCE: 02

CALIBRATION DATE: 11/19/92 to 11/25/92

II. PERFORMANCE VERIFICATION DATA, PRETEST			
TESTED PARAMETER	UNITS	SPECIFICATION	TEST RESULTS
KNEE IMPACT TEST, LEFT			
Probe speed	mps	2.06 to 2.15	2.10
Maximum force	kg	841 to 1136	1103
Time above 455 kg	msec	1.7 minimum	1.7
KNEE IMPACT TEST, RIGHT			
Probe speed	mps	2.06 to 2.15	2.12
Maximum force	kg	841 to 1136	1130
Time above 455 kg	msec	1.7 minimum	1.8
LUMBAR FLEXION TEST			
Force at 20 degrees	kg	10.0 to 15.5	13.4
Force at 30 degrees	kg	15.5 to 20.9	18.7
Force at 40 degrees	kg	20.9 to 26.4	25.0
Lumbar return angle	deg	12 maximum	10

PART 572 ATD CONFIGURATION AND PERFORMANCE VERIFICATION DATA

NHTSA ATD I.D. NUMBER: 814

LAB TECHNICIAN: P. Puzzuto/L. Rawlings

CALIBRATION SEQUENCE: 02

CALIBRATION DATE: 11/19/92 to 11/25/92

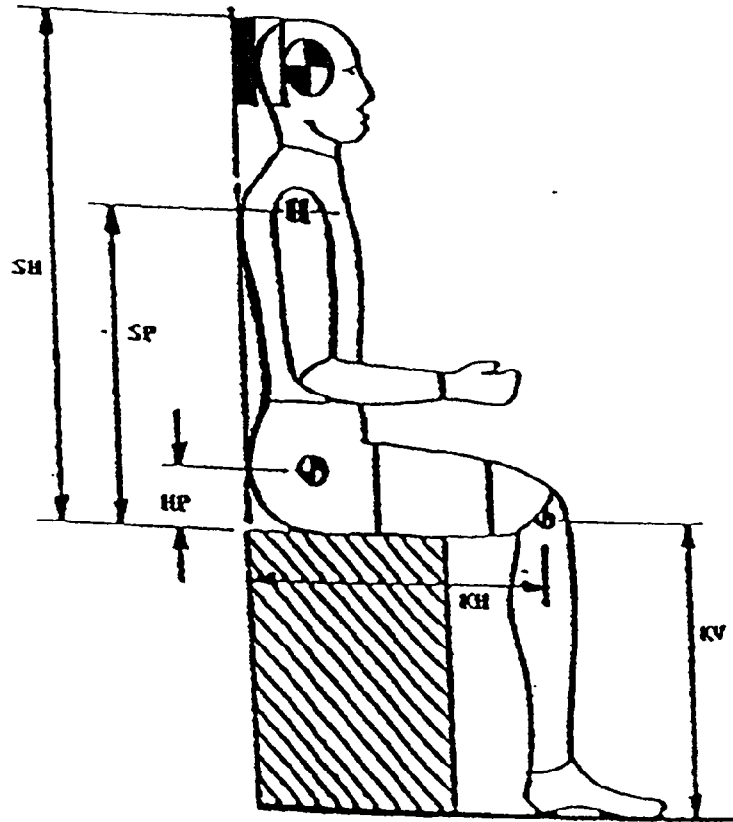

I. CONFIGURATION VERIFICATION DATA, PRETEST			
TESTED PARAMETER	UNITS	SPECIFICATION	TEST RESULTS
SH - Seated height	mm	904 - 909	907
SP - Shoulder pivot height	mm	554 - 569	560
HP - Hip pivot height	mm	99 reference	99
KH - Knee pivot from back	mm	511 - 526	520
KV - Knee pivot from floor	mm	490 - 505	503
SW - Shoulder width	mm	452 - 467	460
HW - Hip width	mm	356 - 391	369

PART 572 ATD CONFIGURATION AND PERFORMANCE VERIFICATION DATA (Cont.)

NHTSA ATD I.D. NUMBER: 814

LAB TECHNICIAN: P. PUZZUTO/L. RAWLINGS

CALIBRATION SEQUENCE: 02

CALIBRATION DATE: 11/19/92 to 11/25/92

II. PERFORMANCE VERIFICATION DATA, PRETEST			
TESTED PARAMETER	UNITS	SPECIFICATION	TEST RESULTS
Temperature in laboratory	Deg C	18.9 - 25.6	22.2
Humidity in laboratory	%	10 - 70	45
HEAD DROP TEST			
Peak resultant acceleration	G's	210 - 260	244.7
Peak lateral acceleration	G's	less than 10	6.2
Time above 100 G's	msec	0.9 to 1.5	1.3
ABDOMINAL COMPRESSION TEST			
Force at 12mm displacement	kg	10.5 - 16.4	15.2
Force at 19mm displacement	kg	16.4 - 22.7	21.9
Force at 25mm displacement	kg	22.7 - 28.6	27.9
Force at 33mm displacement	kg	23.2 - 40.0	39.2
CHEST IMPACT TEST, HIGH ENERGY			
Probe speed	mps	6.64 - 6.77	6.67
Peak deflection	mm	43.2 maximum	41.9
Peak resistive force	kg	1023 maximum	981
Internal hysteresis	%	50 - 70	61
CHEST IMPACT TEST, LOW ENERGY			
Probe speed	mps	4.22 - 4.31	4.29
Peak deflection	mm	27.9 maximum	27.6
Peak resistive force	kg	659 maximum	631
Internal hysteresis	%	50 - 70	62

PART 572 ATD CONFIGURATION AND PERFORMANCE VERIFICATION DATA (CONT.)

NHTSA ATD I.D. NUMBER: 814

LAB TECHNICIAN: P. Puzzuto/L. Rawlings

CALIBRATION SEQUENCE: 02

CALIBRATION DATE: 11/19/92 to 11/25/92

II. PERFORMANCE VERIFICATION DATA, PRETEST				
TESTED PARAMETER	UNITS	SPECIFICATION	TEST RESULTS	
NECK BEND TEST				
Pendulum speed	mps	6.55 - 7.77	6.92	
Pendulum avg. decel. ($T_1 - T_2$)	G's	20 - 24	21.0	
Pendulum decel. ($T_2 - T_1$)	msec	less than 3	1.9	
Pendulum decel. ($T_3 - T_2$)	msec	25 - 30	27.6	
Pendulum decel. ($T_4 - T_3$)	msec	less than 10	8.5	
Resultant head acceleration	G's	less than 26	24.4	
Maximum head rotation	deg.	63 - 73	66.2	
CHORDAL DISPLACEMENT / HEAD ROTATION ANGLE				
0 deg.	Time	msec	-2.0 - 2.0	0.1
	Displ.	mm	-13 - 13	1
30 deg.	Time	msec	25.6 - 34.4	32.1
	Displ.	mm	53 - 79	69
60 deg.	Time	msec	40.3 - 51.7	45.1
	Displ.	mm	109 - 135	129
Maximum	Time	msec	53.2 - 66.8	60.7
	Displ.	mm	127 - 152	141
60 deg.	Time	msec	67.0 - 83.0	71.9
	Displ.	mm	109 - 135	123
30 deg.	Time	msec	85.4 - 104.6	93.8
	Displ.	mm	53 - 79	72
0 deg.	Time	msec	101.0 - 123.0	101.6
	Displ.	mm	-13 - 13	3

PART 572 ATD CONFIGURATION AND PERFORMANCE VERIFICATION DATA (CONT.)

NHTSA ATD I.D. NUMBER: 814

LAB TECHNICIAN: P. Puzzuto/L. Rawlings

CALIBRATION SEQUENCE: 02

CALIBRATION DATE: 11/19/92 to 11/25/92

II. PERFORMANCE VERIFICATION DATA, PRETEST			
TESTED PARAMETER	UNITS	SPECIFICATION	TEST RESULTS
KNEE IMPACT TEST, LEFT			
Probe speed	mps	2.06 to 2.15	2.12
Maximum force	kg	841 to 1136	1006
Time above 455 kg	msec	1.7 minimum	1.8
KNEE IMPACT TEST, RIGHT			
Probe speed	mps	2.06 to 2.15	2.10
Maximum force	kg	841 to 1136	929
Time above 455 kg	msec	1.7 minimum	1.7
LUMBAR FLEXION TEST			
Force at 20 degrees	kg	10.0 to 15.5	11.2
Force at 30 degrees	kg	15.5 to 20.9	18.3
Force at 40 degrees	kg	20.9 to 26.4	23.9
Lumbar return angle	deg	12 maximum	11

APPENDIX D

VEHICLE OWNER'S MANUAL OCCUPANT RESTRAINT SYSTEM INSTRUCTIONS

THIS PAGE INTENTIONALLY LEFT BLANK

Safety Restraints

Using Safety Restraints Properly

Safety Belts

The use of safety belts help to restrain you and your passengers in case of a collision. In most states, the law requires their use. We strongly recommend that you use them every time you travel in your vehicle.

Safety belts provide best restraint when:

- the seatback is upright
- the occupant is sitting upright (not slouched)
- the lap belt is snug and low on the hips
- the shoulder belt is snug against the chest
- the knees are straight forward

For your safety, your vehicle has different types of safety belts:

- Combination lap and shoulder belts
- Lap belts without retractors
- Rear lap belts with retractors

See the following sections for directions on how to properly use these safety belts. Also see *Safety Restraints for Children* in this chapter for special instructions about using safety belts for children.

Warning:

Make sure that you and your passengers, including pregnant women, wear safety belts. Be sure that the lap belt portion of your safety belts fit snugly and as low as possible around the hips. If safety belts are not used properly, the risk of you or your passengers being injured in a collision greatly increases.

Warning:

Always drive and ride with your seatback upright and the lap belt portion of your safety belt snug and low across the hips. This will reduce the risk of serious injury to the abdomen or neck that could be caused by sliding under the safety belts in a collision.

Do not allow any people to ride in the cargo area of your vehicle. People who are not riding in seats with their safety belts fastened are much more likely to be injured in a collision.

Never let a passenger hold a child on his or her lap while the vehicle is moving. The passenger cannot protect the child from injury in a collision.

Children should always ride with the seatback in the fully upright position. When the seatback is not fully upright, there is a greater risk that the child will slide under the safety belt and be seriously injured in a collision.

Never use a single belt for more than one person or across more than one seating position. This greatly increases the risk that one or both of the people will be injured in a collision. Each seating position in your vehicle has a specific safety belt assembly which is made up of one buckle and one tongue that are designed to be used as a pair.

Warning: Use the shoulder belt on the outside shoulder only. Never wear the shoulder belt under the arm. Never swing it around the neck over the inside shoulder. Failure to follow these precautions could increase the risk and/or severity of injury in a collision.

Warning: Lock the doors of your vehicle before driving to lessen the risk of the door coming open in a collision.

Combination Lap and Shoulder Belts

While your vehicle is in motion, the combination lap and shoulder belts adjust to your movement. However, if you brake hard, corner hard or if your vehicle receives an impact of 5 mph (8 km/h) or more, the lap and shoulder belt locks and helps reduce your forward movement. The front seat belt systems can also be made to lock by jerking on the belt.

After you get into your vehicle, close the door and lock it. Then adjust the seat to the position that suits you best.

To fasten the belt, pull the lap-shoulder belt from the retractor so that the shoulder portion of the belt crosses your shoulder and chest. Be sure the belt is not twisted. If it is, remove the

twist. Insert the belt tongue into the proper buckle until you hear a snap and feel it latch. Make sure the tongue is securely fastened at the buckle.

Warning: Use the shoulder belt only on the shoulder that is closest to the side of the vehicle. Never wear the belt under your arm. Never swing it around your neck over the inside shoulder. If you do not use the shoulder belt properly, the chances of your being injured in a collision greatly increase.

To tighten the lap portion of the belt, pull up on the shoulder belt until it fits you snugly. The belt should rest as low on your hips as possible.

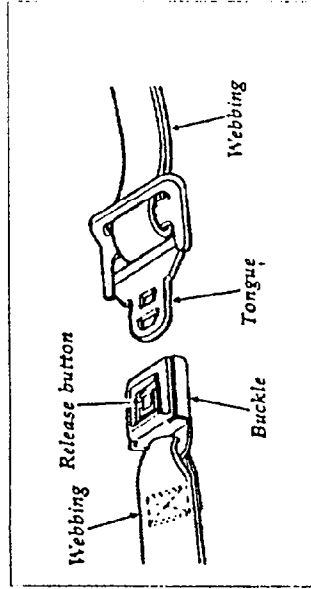

Unfastening the outboard lap shoulder belts

Center Front Lap Belt (60/40 Split Seat)

The lap belt in the center of the front seat does not adjust automatically. You must adjust it to fit snugly around your hips. Do not wear it around your waist.

Before you fasten your center position lap belt in the front seat, you may need to lengthen it.

To lengthen the belt, tip the belt tongue at a right angle to the belt. Pull the belt tongue over your lap until it reaches the buckle.

To fasten the belt, pull the belt across your hips and insert the tongue into the correct buckle on your seat until you hear a snap and feel it lock. Make sure the buckle is securely fastened.

Adjust the belt so that it fits snugly around your hips:

- If you need to shorten the belt, pull on the loose end of the webbing.

To unfasten the belt, push the release button on the buckle. This allows the tongue to unlatch from the buckle.

Because the center front lap belt does not have a retractor, it should be shortened and fastened when not in use.

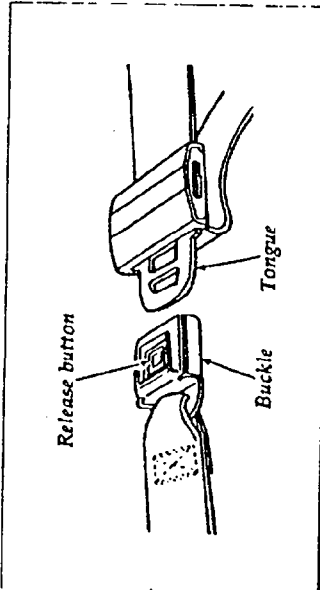

Fastening and unfastening the front center safety belt

Lap Belts Without Retractors

On the center seat of the front three-passenger bench seat, you will find a lap belt without a retractor. Shorten and fasten your belt when you are not using it. To make your belt longer, tip the tongue at a right angle to the belt and pull the belt over your lap until the tongue reaches the buckle.

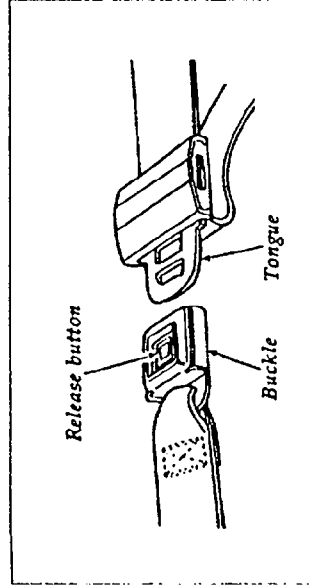

Fastening and unfastening rear occupant safety belts

To fasten the belt, pull the belt across your hips and insert the tongue into the correct buckle on your seat until you hear a snap and feel it lock. Make sure the buckle is securely fastened.

Adjust the belt so that it fits snugly and as low as possible around the hips:

- If you need to lengthen the belt, unfasten it and repeat the procedure above.
- If you need to shorten the belt, pull on the loose end of the webbing.

Rear Lap Belt with Retractor

Pull the belt out of the retractor with a steady motion and insert the tongue into the proper buckle until you hear a snap and feel the latch engage.

To Unfasten the Safety Belts with Retractors:

1. Push the release button on the buckle. This allows the tongue to unlatch from the buckle.
2. While the belt retracts, guide the tongue to its original position. If you do not guide the tongue, it may strike you or part of the vehicle.

How to Untwist or Unjam a Safety Belt Retractor

If you should jam the lap belt retractor by allowing the belt to retract when it is twisted, you can free the webbing with this procedure:

1. Pull on the belt with both hands to tighten it on the retractor spool.
2. Feed the belt back into the retractor until it is completely retracted. Repeat previous step if necessary.
3. Pull the belt out of its holder as far as it will go and untwist the belt or remove the object that is jamming the belt. Let the belt retract.
4. Then, pull the belt out and let it retract several times to make sure that the belt works properly.

Procedure to Correct a Twisted Safety Belt at the "D" Ring (if so equipped) Front and/or Rear Outboard Seating Positions

NOTE: The restraint system shown in the following figures may be different than your vehicle. However, use these figures and this procedure to correct a twisted safety belt at any outboard seating position that has a "D" ring.

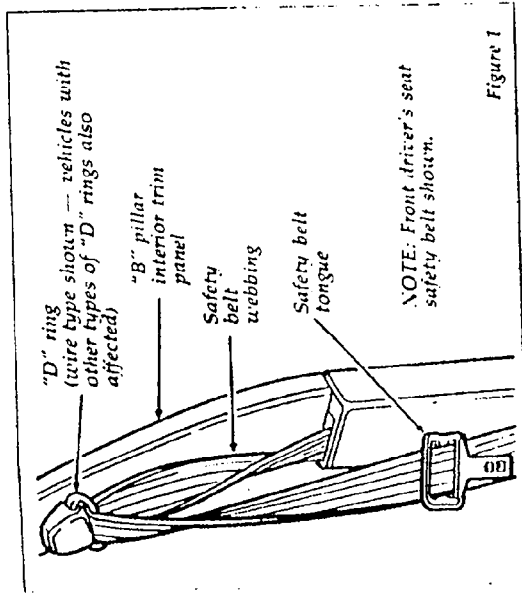

1. Grasp the belt webbing at the "D" ring. See Figure 2.

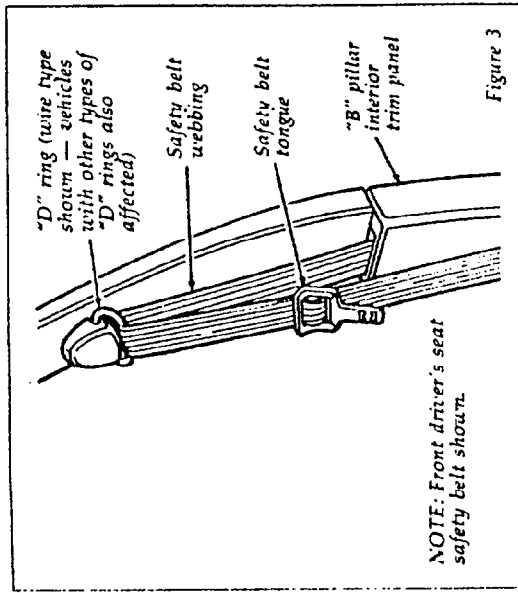
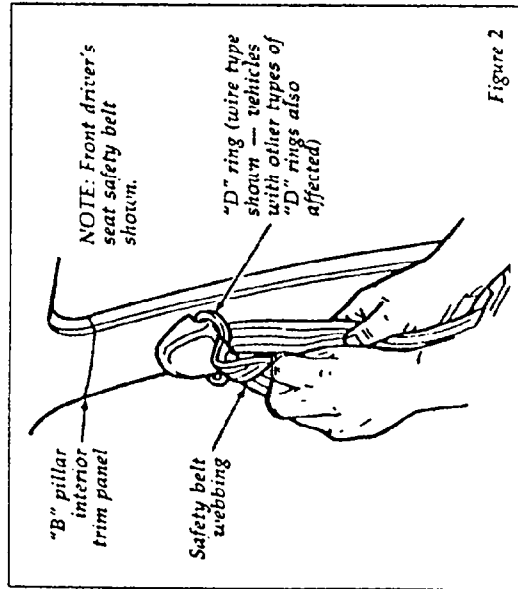

Procedure to Correct a Rotated Tongue on the Safety Belt (Front and/or Rear Outboard Seating Positions)

NOTE: The restraint system shown in the following figures may be different than your vehicle. However, use these figures and this procedure to correct a rotated tongue on the safety belt at any outboard seating position that has a "D" ring.

2. Rotate and fold the belt webbing over itself as required to remove the twist.
3. Feed the folded portion of the belt through the "D" ring.
4. When completed, safety belt should look like Figure 3.

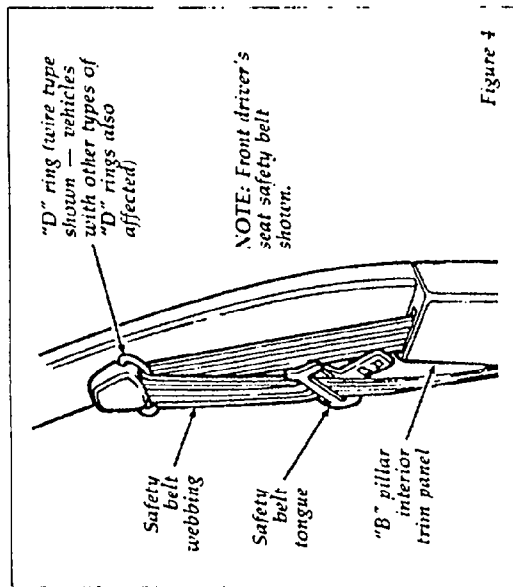

Figure 4

1. Grasp the belt tongue and pull down on the belt webbing closest to you to form a loop through the upper (narrow) and longer slot in the tongue. See Figure 5.

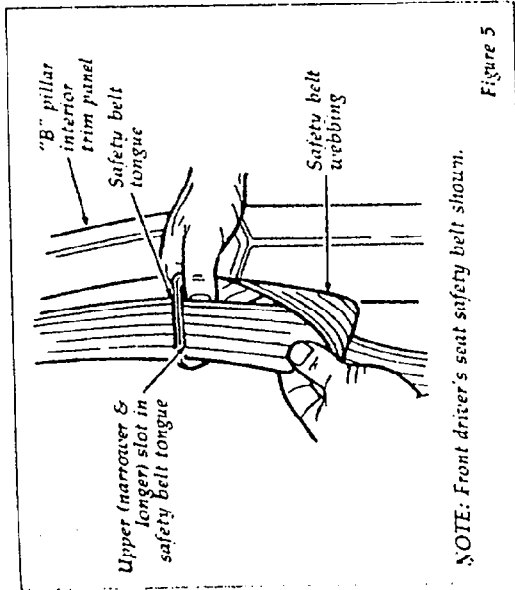

Figure 5

2. Working within the upper slot, rotate and fold the belt webbing over itself as required to remove the twist.
3. Pull the excess belt webbing back through the upper slot in the tongue.
4. Repeat the above steps to complete the removal of the twist at the lower (wider and larger) slot in the tongue. See Figure 6.

Safety Belt Maintenance

Check your safety belt system periodically to make sure that it works properly and isn't damaged. If the webbing shows any wear, nicks or cuts, have it examined by a qualified technician to determine if replacement is necessary. Always have your safety belt system checked after a collision.

For information on cleaning the webbing of seat belt assemblies, see "Cleaning the Safety Belts" in the Index.

Warning: All safety belt assemblies, including retractors and attaching hardware, should be inspected after any collision. Ford recommends that all safety belt assemblies used in vehicles involved in a collision be replaced. However, if the collision was minor and a qualified technician finds that the belts do not show damage and continue to operate properly, they do not need to be replaced. Safety belt assemblies not in use during a collision should also be inspected and replaced if either damage or improper operation is noted.

Safety Restraints for Children

In most states, you are required by law to use safety restraints for children. If small children ride in your vehicle — this generally includes children who are four years old or younger and who weigh 40 pounds (18 kg) or less — you must put them in safety seats that are made specially for children. Safety belts alone do not provide maximum protection for these children. Check your local and state laws for specific requirements.

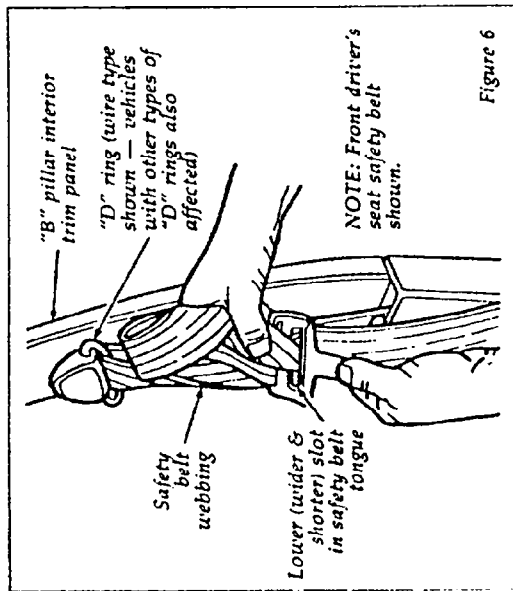

5. When completed, the safety belt should look like Figure 3.

Safety Belt Extension Assembly

For some people, the safety belt may be too short even when it is fully extended. You can add about eight inches (20 cm) to the belt length with a safety belt extension assembly (611C22). Safety belt extensions are available from your dealer.

Warning: To ensure that the safety belt extension assembly will hold in the event of a collision, only safety belt extensions manufactured by the same supplier as the safety belt should be used. Manufacturer identification is located at the end of the webbing on a label.

Warning: Never leave a child unattended in your vehicle. Always remove the key from the ignition and take it with you.

Safety Belts for Children

Children who are too large for child safety seats should always wear safety belts. (See instructions with your child seat, or contact its manufacturer, to determine maximum size of child that will safely fit in the seat.)

Warning: If safety belts are not properly worn and adjusted as described, the risk of serious injury to the child in a collision will be much greater.

If the shoulder belt portion of one of the lap and shoulder belts can be positioned so that it does not cross or rest in front of the child's face or neck, the child should wear the lap and shoulder belt. Moving the child closer to the center of the vehicle may help provide a good shoulder belt fit.

If the shoulder belt cannot be properly positioned, move the child to one of the seats with a lap belt only (preferably in a rear seat) and use the lap belt.

Lap belts and the lap belt portion of lap and shoulder belts should always be worn snugly and below the hips, touching the child's thighs.

Warning: Never let a passenger hold a child on his or her lap while the vehicle is moving. The passenger cannot protect the child from injury in a collision.

Warning: Never let children or adults ride in the cargo area of your vehicle. Make sure that they sit where they can be properly restrained. If they are not restrained, the risk of their being injured in a collision greatly increases.

Warning: When using any infant or child restraint system, it is important that you follow the instructions and warnings provided by the manufacturer concerning its installation and use. Failure to follow each of the restraint manufacturer's instructions could increase the risk or severity of an injury in the event of a collision or sudden stop.

When possible, put children in the rear seat of your vehicle. Accident statistics suggest that children are safer when properly restrained in the rear seating positions than in the front seating positions.

Do not install a child seat in a center facing jump seat. Safety seats for children are not intended for use in center facing seats.

Safety belts and seats can become hot in a vehicle that has been closed up in sunny weather; they could burn a small child. Check seat covers and buckles before you place a child anywhere near them.

Children should always ride with the seatback in the fully upright position. When the seatback is not fully upright, there is a greater risk that the child will slide under the safety belt and be seriously injured in a collision.

Safety Seats for Children

Use a safety seat that is recommended for the size and weight of the child. Always follow the safety seat manufacturer's instructions when installing and using the safety seat.

Ford recommends the use of a child safety seat having a top tether strap. Install the child safety seat in a seating position which is capable of providing a tether anchorage. For more information on top tether straps see the section on *Attaching Safety Seats with Tether Straps*.

When installing a child safety seat, be sure to use the correct safety belt buckle for that seating position, and make sure the tongue is securely fastened in the buckle.

Warning: All safety seats for children are designed to be secured to the seat of your vehicle by lap belts or by the lap portion of a lap and shoulder belt. If you do not properly secure the safety seat to the vehicle, the risk is greater that a child, occupying the seat during a collision or sudden stop, will be injured. An unsecured safety seat could also injure other passengers in the vehicle.

Warning:

Carefully follow all of the manufacturer's instructions that come with the safety seat that you put in your vehicle. Make sure that the shoulder belt (if provided at the seating position where the safety seat is being used) does not cross or rest in front of the child's face or neck. If you do not install and use the safety seat properly, the child may be injured in a sudden stop or collision.

Seat backs should be upright for use with child safety seats.

Installation Instructions for Child Safety Seat Locking Clip

Obtain the locking clip kit at no charge from an authorized Ford or Lincoln-Mercury dealer (Basic number 61248).

The locking clip must be used to secure a child seat when your vehicle has a shoulder and lap belt with a sliding tongue. Every seat belt that requires a locking clip is identified on the belt, with the label as shown in FIGURE 1. The locking clip is installed on a sample piece of webbing to show proper installation.

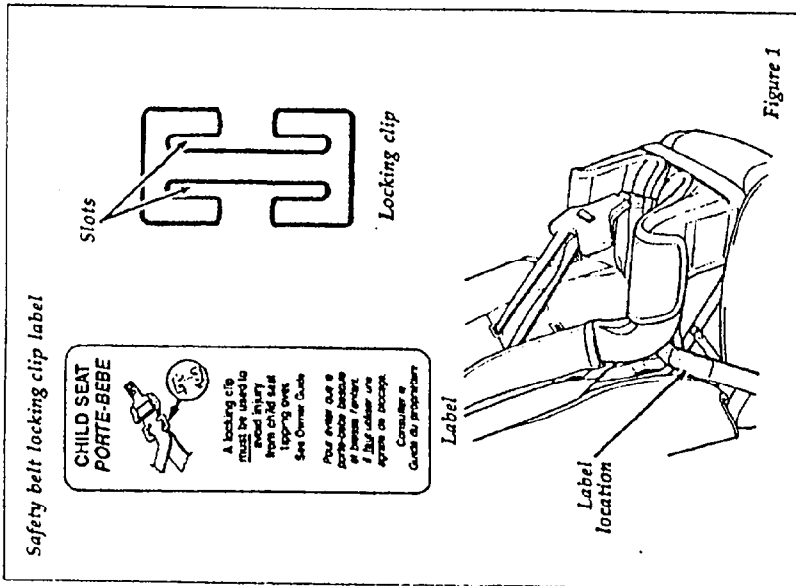

Warning: If you do not use a locking clip, injuries could result from the child seat tipping over during normal vehicle braking or cornering.

To Install the Locking Clip

1. Thread the belt webbing through the child seat according to the child seat manufacturer's instructions.

2. Buckle the seat belt.

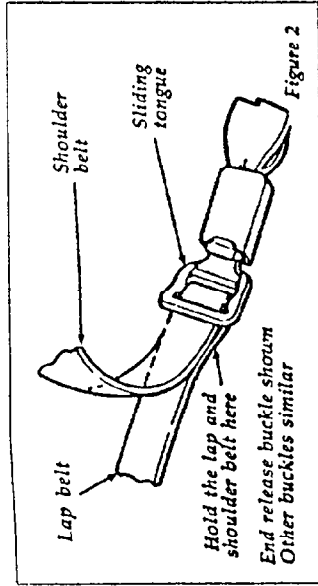

3. Pull on shoulder portion of the belt to make the lap portion fit snugly. Keeping the lap belt snug, hold the lap and shoulder belt portions of the webbing together next to the slip tongue and unbuckle the seat belt, FIGURE 2.

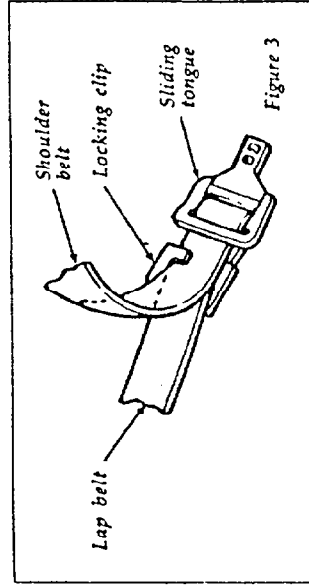

4. Slide either corner of the locking clip slot closest to the tongue over both layers of webbing as shown in FIGURE 3.

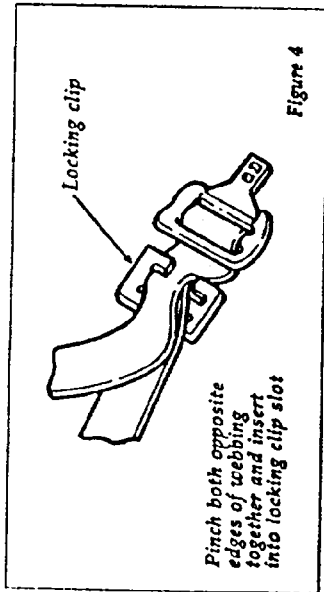

5. Pinch both opposite edges of webbing together and insert them into the locking clip slot as shown in FIGURE 4.

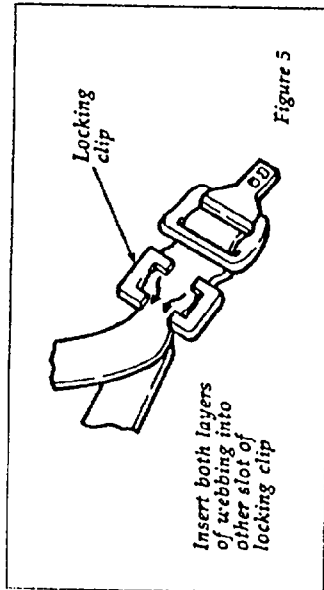

6. Pinch both layers of webbing together and insert into other slot of locking clip, FIGURE 5.

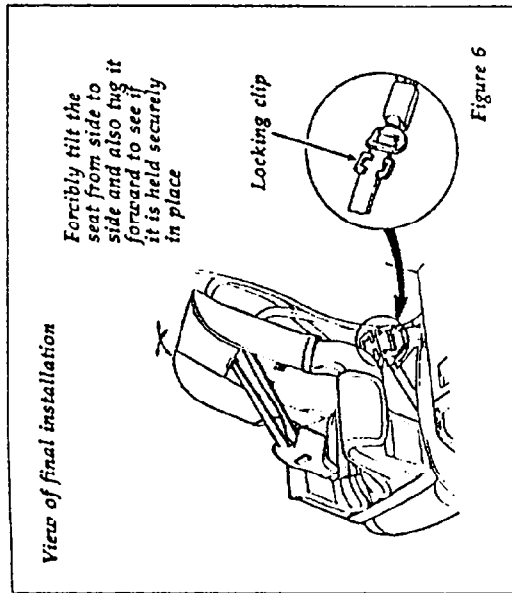

7. Re-buckle belt. Forcibly tilt the child seat from side to side and also tug it forward to see if it is held securely in place, FIGURE 6. If excessive movement occurs, repeat steps 2 through 7 or properly install child seat in a different seating position in the vehicle.

Warning: Once you have attached the safety seat, test the seat before you place the child in it. Tilt the seat from side to side. Also try to tug the seat forward. Check to see if the belt holds the seat in place. If the lap belt is too loose, tighten it by moving the locking clip, or put the safety seat in another seat and test it again. If the safety seat is not anchored properly, the risk of a child being injured in a collision or sudden stop greatly increases. Reclining seatbacks should be in the most upright position for use with child safety seats.

Attaching Safety Seats With Tether Straps **General Instructions**

Some manufacturers make safety seats with a tether strap that goes over the back of the vehicle seat and attaches to an anchoring point behind the vehicle seat.

You can attach a tether strap anchor bracket to the cab inner back panel by using a tether anchor kit (613D74) available at no charge from any Ford dealer.

Read and follow the instructions provided with the kit carefully for installation of the child tether strap anchor.

Follow the child seat manufacturer's instructions to attach the tether strap to the tether bracket.

Warning: Use only the tether attachment hole locations shown in the instructions. The tether anchorage may not perform properly if the wrong mounting location is used.

Warning: Failure to follow these precautions could increase the chance and/or severity of injury in an accident.

Warning: In Super Cabs equipped with Center Facing Jump Seats, the tether strap anchor bracket should be installed only at the center of the cab's back panel with the child seat in the front center seating position. Installing an anchor bracket at the right rear of the cab may increase risk of injury to an occupant of the right rear center facing jump seat in the event of a collision or sudden stop. If a tethered child seat is installed in the right front seating position, secure the tether strap to the webbing of the buckled right rear lap belt. Do not install a child seat in a center facing jump seat. Safety seats for children are not intended for use in center facing seats.

APPENDIX E
INSTRUMENTATION AND CALIBRATION DATA

THIS PAGE INTENTIONALLY LEFT BLANK

CALIBRATION DATA FOR INSTRUMENTATION USED IN ATD CALIBRATION

DUMMY INSTRUMENTS	MANUFACTURER	MODEL	SERIAL No.	CAL DATE	DUE DATE
CHEST DEFLECTION POT	BECKMAN	5311	N/A	EACH USE	EACH USE
CHEST IMPACTOR ACCELEROMETER	ENTRAN	EGV-1	14N3N-V13-1	09/14/92	03/14/93
NECK PENDULUM ACCELEROMETER	ENTRAN	EGV-1	14N3N-V13-1	09/14/92	03/14/93
NECK ROTATION NO. 2	BECKMAN	5311	N/A	EACH USE	EACH USE
NECK ROTATION NO. 1	BECKMAN	5311	N/A	EACH USE	EACH USE
NECK EXTENSION POT	BOURNS	80294-20518-1840202	1684-067	EACH USE	EACH USE
ABDOMINAL COMPRESSION LOAD	LEBOW/EATON	3167	1573	09/14/92	03/14/93
LUMBAR FLEXION LOAD	LEBOW/EATON	3167	1573	09/14/92	03/14/93
LUMBAR ROTATION	BOURNS	3590S-2-102	N/A	EACH USE	EACH USE
ABDOMINAL DISPLACEMENT	CELESCO	PT-101-15B	0786551	EACH USE	EACH USE
TIMER	MSE	MSE TIM	1	08/17/92	02/17/93
TIME TRAP	MSE	1 in.	1	08/17/92	02/17/93