



DOT 4634

National
Technical
Systems

Scientific
Services
Group

Testing Division
1536 East Valencia Drive
Fullerton, California 92631-4797
Tel: 714 879 6110

REPORT NO. 301-NTW-83-001-271-6096-1

"COMPOSITE FY83"
FMVSS 301-75
VEHICLE SAFETY COMPLIANCE TESTING
FOR
FUEL SYSTEM INTEGRITY

FORD MOTOR COMPANY
1983 FORD RANGER 4X4 STYLESIDE - PICKUP
NHTSA CD0614

NATIONAL TECHNICAL SYSTEMS
1536 EAST VALENCIA DRIVE
FULLERTON, CALIFORNIA 92631-4797



APPROVED: *[Signature]*
TOM GRUBBS
CONTRACT TECHNICAL MANAGER
FMVSS 204/208/212/301
DATE: DEC 08 1983

NOVEMBER 1983

FINAL REPORT

PREPARED FOR

U. S. DEPARTMENT OF TRANSPORTATION
NATIONAL HIGHWAY TRAFFIC SAFETY ADMINISTRATION
- ENFORCEMENT -
OFFICE OF VEHICLE SAFETY COMPLIANCE
400 SEVENTH STREET S. W.
WASHINGTON, D. C. 20590



Prepared for the Department of Transportation, National Highway Traffic Safety Administration under Contract No. DTNH22-82-D-31140. This document is disseminated under the sponsorship of the Department of Transportation in the interest of information exchange. The United States Government assumes no liability for its contents or use thereof.

Prepared by D. H. Hand

Approved by G. J. Valenzuela

Date 11/2/83

Report Accepted by:

TOM GRUBBS

Contract Technical Manager
Office of Vehicle Safety Compliance

DEC 08 1983

Date

1. Report No. 301-NTW-83-001	2. Government Accession No.	3. Recipient's Catalog No.	
4. Title and Subtitle Final Report of FMVSS 301-75 Vehicle Safety Compliance Testing for Fuel System Integrity on a 1983 Ford Ranger 4x4 Styleside - Pickup - NHTSA CD0614		5. Report Date 11 November 1983	
		6. Performing Organization Code	
7. Author(s) Don Hand - Project Engineer		8. Performing Organization Report No. 271-6096-1	
9. Performing Organization Name and Address National Technical Systems 1536 East Valencia Drive Fullerton, California 92631 Phone No.: (714) 879-6110		10. Work Unit. No.	
		11. Contract or Grant No. DTNH22-82-D-31140	
12. Sponsoring Agency Name and Address U. S. Department of Transportation National Highway Traffic Safety Admin. Enforcement Office of Vehicle Safety Compliance 400 Seventh Street S. W. Washington, D. C. 20590		13. Type of Report and Period Covered Final Report January 14 - February 23, 1983	
		14. Sponsoring Agency Code	
15. Supplementary Notes			
16. Abstract FMVSS 301-75 Vehicle Safety Compliance Testing on a 1983 Ford Ranger 4x4 Styleside - Pickup, NHTSA CD0614, VIN-1FTCR11A4DUB35433 was conducted at National Technical Systems test facility in Fullerton, California, to determine compliance with the requirements of FMVSS 301-75. The average moving barrier impact speed was 29.49 mph in the rear (180°) mode. Test date was February 23, 1983, and the ambient temperature was 61°F. The subject test vehicle appears to comply with all the requirements of FMVSS 301-75.			
17. Key Words FMVSS 301-75, "Fuel System Integrity"		18. Distribution Statement	
19. Security Class. (of this report) Unclassified	20. Security Class. (of this page) Unclassified	21. No. of Pages 85	22. Price

METRIC CONVERSION FACTORS

Approximate Conversions to Metric Measures

Symbol	When You Know	Multiply by	To Find	Symbol
LENGTH				
in	inches	2.5	centimeters	cm
ft	feet	30	centimeters	cm
yd	yards	0.9	meters	m
mi	miles	1.6	kilometers	km
AREA				
in ²	square inches	6.5	square centimeters	cm ²
ft ²	square feet	0.09	square meters	m ²
yd ²	square yards	0.8	square meters	m ²
mi ²	square miles	2.6	square kilometers	km ²
	acres	0.4	hectares	ha
MASS (weight)				
oz	ounces	28	grams	g
lb	pounds	0.45	kilograms	kg
	short tons	0.9	tonnes	t
			(2000 lb)	
VOLUME				
tsp	teaspoons	5	milliliters	ml
tblsp	tablespoons	15	milliliters	ml
fl oz	fluid ounces	30	milliliters	ml
c	cups	0.24	liters	l
pt	pints	0.47	liters	l
qt	quarts	0.95	liters	l
gal	gallons	3.8	liters	l
ft ³	cubic feet	0.03	cubic meters	m ³
yd ³	cubic yards	0.76	cubic meters	m ³
TEMPERATURE (exact)				
°F	Fahrenheit temperature	5/9 (after subtracting 32)	Celsius temperature	°C

Approximate Conversions from Metric Measures

Symbol	When You Know	Multiply by	To Find	Symbol
LENGTH				
mm	millimeters	0.04	inches	in
cm	centimeters	0.4	inches	in
m	meters	3.3	feet	ft
m	meters	1.1	yards	yd
km	kilometers	0.6	miles	mi
AREA				
cm ²	square centimeters	0.16	square inches	in ²
m ²	square meters	1.2	square yards	yd ²
km ²	square kilometers	0.4	square miles	mi ²
ha	hectares (10,000 m ²)	2.5	acres	ac
MASS (weight)				
g	grams	0.035	ounces	oz
kg	kilograms	2.2	pounds	lb
t	tonnes (1000 kg)	1.1	short tons	st
VOLUME				
ml	milliliters	0.03	fluid ounces	fl oz
l	liters	2.1	pints	pt
l	liters	1.06	quarts	qt
l	liters	0.26	gallons	gal
m ³	cubic meters	35	cubic feet	ft ³
m ³	cubic meters	1.3	cubic yards	yd ³
TEMPERATURE (exact)				
°C	Celsius temperature	9/5 (then add 32)	Fahrenheit temperature	°F

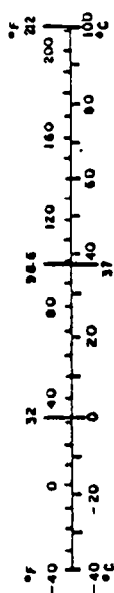

* 1 in = 2.54 cm (exact). For other exact conversions and more detailed tables, see NBS Special Publication 220, Units of Weights and Measures, Price \$1.25, SD Catalog No. C13 10-236.



TABLE OF CONTENTS

<u>Section</u>	<u>Paragraph</u>	<u>Description</u>	<u>Page</u>
1	1.0	Introduction	1
	1.1	Administrative Data	2
2	2.0	Compliance Test Data	4
	2.1	General Test Information	14
	2.2	Test Results	15
3	3.0	Vehicle Collision and Damage Data	32
4	4.0	Test Facilities and Equipment	47
	4.1	Frontal Collision Barrier	47
	4.2	Oblique Angle Collision Barrier	49
	4.3	Moving Collision Barrier	50
	4.4	Vehicle Static Rollover Machine	51
	4.5	Impact Velocity Measurement	51
	4.6	Photograph Coverage	53
	4.7	Data Acquisition and Reduction	56
	4.8	Frontal Fixed Barrier Impact Delta Velocity Calculation	63
	4.9	Rear Moving Barrier Impact Delta Velocity Calculation	71



TABLES

<u>Table</u>	<u>Description</u>	<u>Page</u>
I	Summary of Test Conditions	5
III	Post-Impact Summary	8
VI	Post-Impact Summary - FMVSS 301-75	9
VII	Fuel System Integrity - Static Rollover	10
VIII	Fuel System Integrity - Static Rollover	11
IX	Fuel System Integrity - Static Rollover	12
X	Fuel System Integrity - Static Rollover	13
3-1	Summary of Staged Collision and Damage Data	35
3-2	Vehicle Structural Data	36
3-3	Pre-Test, Vehicle Measurement Data	44
3-4	Post-Test, Vehicle Measurement Data	45
3-5	Summary of Vehicle Measurement Data	46
4-1	Instrumentation for Crash Test	61
4-2	Data Acquisition and Reduction Process	62

<u>Figure</u>	<u>Description</u>	<u>Page</u>
2-1	Pre-Test, Left Side View	16
2-2	Pre-Test, Full Rear View	18
2-3	Pre-Test, Right Side View	20
2-4	Post-Impact, Left Side View	22
2-5	Post-Impact, Full Rear View	24
2-6	Post-Impact, Right Side View	26
2-7	Post-Impact, Rollover Test, 90° Increment	28
2-8	Post-Impact, Rollover Test, 270° Increment	30
3-1	Example: Damage Dimensions - Frontal	33
3-2	Example: Damage Dimensions - Rear	34
4-1	Vehicle and Occupant Crash Impact Data Acquisition System	59
4-2	Comparison Plot of SAE Filters	60
4-3	Example: Original Vehicle CG Acceleration	66
4-4	Example: Unbiased Vehicle CG Acceleration	67
4-5	Example: Integrated Vehicle CG Acceleration	68
4-6	Example: Calibration Vehicle CG Acceleration	69
4-7	Example: Delta Vehicle CG Acceleration	70
4-8	Example: Original Barrier CG Acceleration	75
4-9	Example: Original Vehicle CG Acceleration	76
4-10	Example: Unbiased Barrier CG Acceleration	77



ILLUSTRATIONS
(continued)

<u>Figure</u>	<u>Description</u>	
4-11	Example: Unbiased Vehicle CG Acceleration	78
4-12	Example: Integrated Barrier CG Acceleration	79
4-13	Example: Integrated Vehicle CG Acceleration	80
4-14	Example: Calibration Barrier CG Acceleration	81
4-15	Example: Barrier Velocity - Acceleration	82
4-16	Example: Vehicle Velocity - Acceleration	83
4-17	Example: Delta Barrier/Vehicle CG Acceleration	84



SECTION 1

1.0 INTRODUCTION

This report contains information regarding the preparation for and the conduct of a "Composite FY83" vehicle Fuel System Integrity Test relative to Federal Motor Vehicle Safety Standard (FMVSS) No. 301-75. The test was performed under Contract Number DTNH22-82-D-31140 by National Technical Systems, 1536 East Valencia Drive, Fullerton, California, in accordance with the Office of Vehicle Safety Compliance (OVSC) Laboratory Procedures (TP219-02).

The specific purpose of this test was to check the performance of a 1983 Ford Ranger 4x4 Styleside - Pickup to the requirements of FMVSS 301-75, along with vehicle crush and delta -V measurement data relative to accident reconstruction.

Section 2 contains all compliance related data, while Section 3 contains vehicle damage summary data, along with delta -V measurement data. Section 4 discusses NTS's test facilities and data acquisition and reduction system.



SECTION 1

1.1 ADMINISTRATIVE DATA

A. References

1. Federal Motor Vehicle Safety Standard 301-75 -
"Fuel System Integrity," as published in the
Federal Register, Volume 40, No. 48352, dated
15 October 1975.

2. National Highway Traffic Safety Administration,
Office of Vehicle Safety Compliance Laboratory
Procedures "Windshield Mounting" FMVSS 212 -
"Windshield Zone Intrusion" FMVSS 219 - "Fuel
System Integrity" FMVSS 301-75, TP219-02, dated
9 January 1979.



SECTION 1

B. Description of Test Vehicle

1. 1983 Ford Ranger 4x4 Styleside - Pickup
2. Vehicle Identification No. 1FTCR11A4DUB35433
3. NHTSA No.: CD0614
4. Manufactured Date: October 1982
5. GVWR: 4,460 pounds

C. Dates

1. Vehicle Received: November 9, 1982
2. Start of Test: January 14, 1983
3. Completion of Test: February 23, 1983



SECTION 2

2.0 COMPLIANCE TEST DATA

The 1983 Ford Ranger 4x4 Styleside - Pickup was subjected to a rear moving barrier impact and a static rollover maneuver as required by Federal Motor Vehicle Safety Standard (FMVSS) 301-75.

Color motion picture coverage of the impact, along with the static rollover test are considered part of the accumulated pertinent data. Where applicable, still photographs are presented in this report; while the motion picture coverage is submitted separately.

TABLE I

SUMMARY OF TEST CONDITIONS

TEST VEHICLE INFORMATION:

Manufacturer: Ford Motor Company
Make/Model: Ford Ranger 4x4 Styleside
Body Style: Pickup Model Year: 1983
VIN: 1FTCR11A4DUB35433 Build Date: October 1982
NHTSA No.: CD0614 Color: Red
Engine Date: Four (4) Cylinders; 2.3 Liters
Transmission Data: Four (4) Speed (X) Manual () Automatic
Major Options: Power Steering

VEHICLE ATTITUDE:

Delivered Attitude: LF 31.8 in.; RF 31.6 in.; LR 32.3 in.; RR 32.9 in.
LF 31.0 in.; RF 31.1 in.; LR 30.8 in.; RR 31.0 in.

VEHICLE TIRE DATA:

Recommended Cold Tire Pressure: Front = 35 psi
(Up to Vehicle Load Capacity) Rear = 35 psi
Recommended Tire Size: P195/75R15 Load Range: 1477 @ 35 psi
Tires of Vehicle: P195/75R15 - General
Spare Tire: X Yes; No; Space Saver: Yes; X No

TABLE Ia

SUMMARY OF TEST CONDITIONS (Cont'd)

TEST CONDITIONS:

Date of Test: February 23, 1983 Time of Test: 0945

Ambient Temperature: 61 °F at Impact Area

VEHICLE CAPACITY:

Type of Seats: X Bench; Bucket; Split Bench

Designated Seating Capacity: Front 3
 Center 0
 Rear 0
 Total 3

Cargo: unknown lbs.

Total unknown lbs. (Vehicle Capacity Weight)

GVWR: 4,460 lbs. (Taken From Certification Label)

GAWR: Front 2,220 lbs.; Rear 2,598 lbs.

VEHICLE DELIVERED WEIGHT: (Fuel - 93% of NFC)

Left Front 860 lbs. Left Rear 644 lbs.
Right Front 859 lbs. Right Rear 592 lbs.
Total Front Weight 1,719 lbs. (58.2 % of Total Vehicle Weight)
Total Rear Weight 1,236 lbs. (41.8 % of Total Vehicle Weight)
Total Delivered Weight 2,955 lbs.

CALCULATED VEHICLE TEST WEIGHT: 3,583 lbs.
(With Required Dummies and 300 lbs. Cargo)

ACTUAL VEHICLE TEST WEIGHT:

Left Front 940 lbs. Left Rear 868 lbs.
Right Front 939 lbs. Right Rear 826 lbs.
Total Front Weight 1,879 lbs. (52.6 % of Total Vehicle Weight)
Total Rear Weight 1,694 lbs. (47.4 % of Total Vehicle Weight)
Total Test Weight 3,573 lbs.

TABLE Ib

SUMMARY OF TEST CONDITIONS (Cont'd)

TEST FLUID DATA:

Test Fluid Type: Red Stoddard Solvent ; Specific Gravity: 0.764

Kinematic Viscosity: 1.31

Nominal Fuel Capacity: 15.20 gals. (NFC)

Test Volume: 14.14 gals. (92-94% of NFC)

Fuel System Capacity: 15.20 gals.
(Data from Owner's Manual)

Electric Fuel Pump: Yes; No; Fuel Injection: Yes; No

Does Electric Fuel Pump Operate with Ignition Switch "On"

And the Engine Not Operating: Yes; No; N/A

Details of Fuel System: Fuel filler located on left rear cargo box side
wall forward of wheel opening recessed behind a hinged door, fuel tank
located longitudinally inside left frame rail under cab and cargo box
floor pans.

VEHICLE TEST CONDITIONS:

Temperature in Occupant Compartment: N/A °F

Temperature of Windshield Glazing/Moulding: N/A °F

VEHICLE CRUSH AND REBOUND:

Overall Length of Test Vehicle: Pre-Test - Left 178.1 in.; Right 178.0 in.

Post-Test - Left 168.3 in.; Right 169.4 in.

Crush: Left 9.8 in.; Right 8.6 in.

Rebound (From Rigid Barrier Only): N/A in.

POST IMPACT SUMMARY

Vehicle 1983 Ford Ranger

NHTSA No. CD0614 Test Date February 23, 1983

TYPE OF TEST: 0° Frontal Impact
 30° Oblique Impact (Driver/Passenger) Side
 Rear Impact

REQUIRED IMPACT VELOCITY RANGE: 28.9 to 29.9 mph

IMPACT VELOCITY: (Traps within 5 feet of impact event)

Trap 1 = 29.49 mph

Trap 2 = N/R mph

Average 29.49 mph

Actual distance from vehicle rear bumper to barrier face when entering timing trap 56.0 in.

Actual distance from vehicle rear bumper to barrier face when exiting timing trap 32.0 in.

VEHICLE STATIC CRUSH: Driver's Side = 9.8 inches

Passenger's Side = 8.6 inches

Average = 9.2 inches

Crush Details: Cargo box impacted cab, both frame rails buckled over axel, cab rear window shattered, and both cab doors were jammed.

VEHICLE REBOUND: (From rigid barrier only)

Driver's Side = N/A inches

Passenger's Side = N/A inches

Average = N/A inches

TABLE VI

POST IMPACT SUMMARY

FUEL SYSTEM INTEGRITY - FMVSS 301-75

Vehicle 1983 Ford Ranger

NHTSA No. CD0614 Test Date February 23, 1983

	Actual	Max. Allow.
Fuel spillage from impact until vehicle motion ceases.	- 0 -	1 ounce
Fuel spillage for 5 minute period following cessation of vehicle motion after impact.	- 0 -	5 ounces
Fuel spillage for next 25 minute period.	- 0 -	1 ounce/ 1 minute
Time duration from impact until start of rollover test periods.	21 minutes	30 minutes

Fuel Spillage Location: Not Applicable

TABLE VII

FUEL SYSTEM INTEGRITY - FMVSS 301-75

STATIC ROLLOVER

Vehicle 1983 Ford Ranger

NHTSA No. CD0614

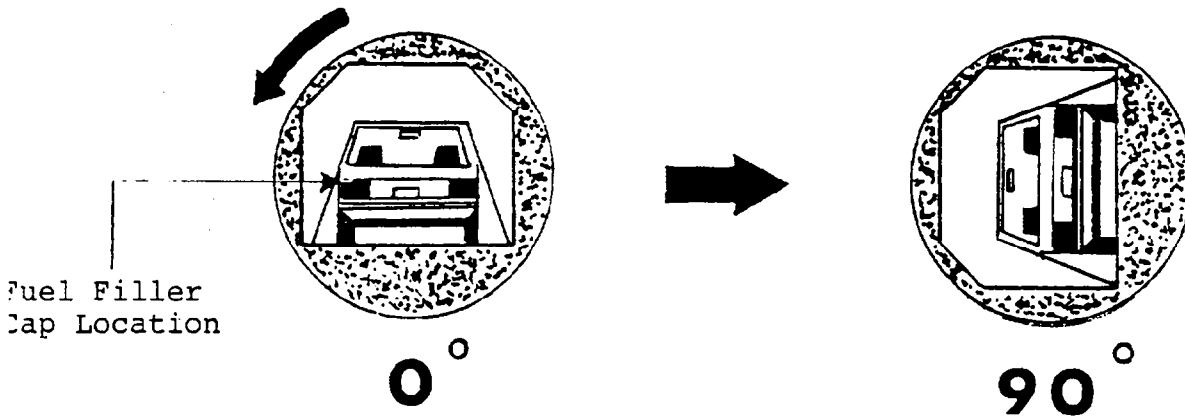

	Actual	Max. Allowed
Rollover fixture 90° rotation time	2 min. 13 sec.	1 to 3 Minutes
Fuel spillage during 5 minute period from onset of rotation	- 0 -	5 ounces
Fuel spillage during 6th minute period from onset of rotation	- 0 -	1 ounce
Fuel spillage during 7th minute period from onset of rotation	- 0 -	1 ounce

Fuel Spillage Location: Not Applicable

TABLE VIII

FUEL SYSTEM INTEGRITY - FMVSS 301-75

STATIC ROLLOVER

Vehicle 1983 Ford Ranger NHTSA No. CD0614

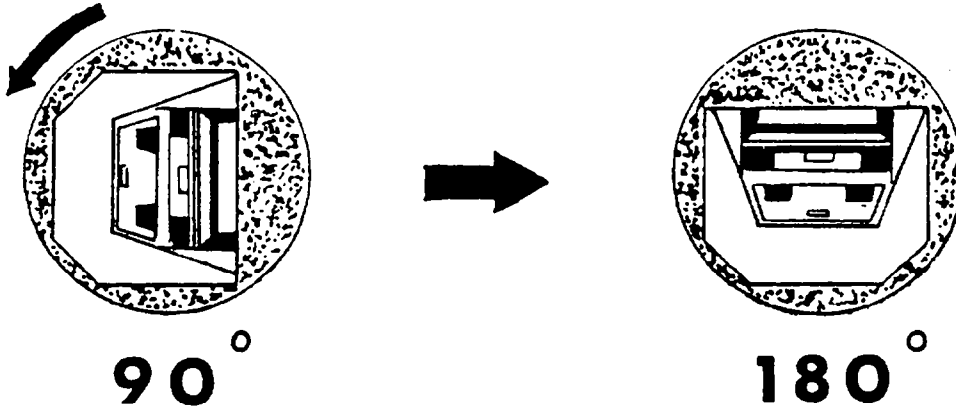

	Actual	Max. Allowed
Rollover fixture 90° rotation time	2 min. 17 sec.	1 to 3 Minutes
Fuel spillage during 5 minute period from onset of rotation	- 0 -	5 ounces
Fuel spillage during 6th minute period from onset of rotation	- 0 -	1 ounce
Fuel spillage during 7th minute period from onset of rotation	- 0 -	1 ounce

Fuel Spillage Location: Not Applicable

TABLE IX

FUEL SYSTEM INTEGRITY - FMVSS 301-75

STATIC ROLLOVER

Vehicle 1983 Ford Ranger

NHTSA No. CD0614

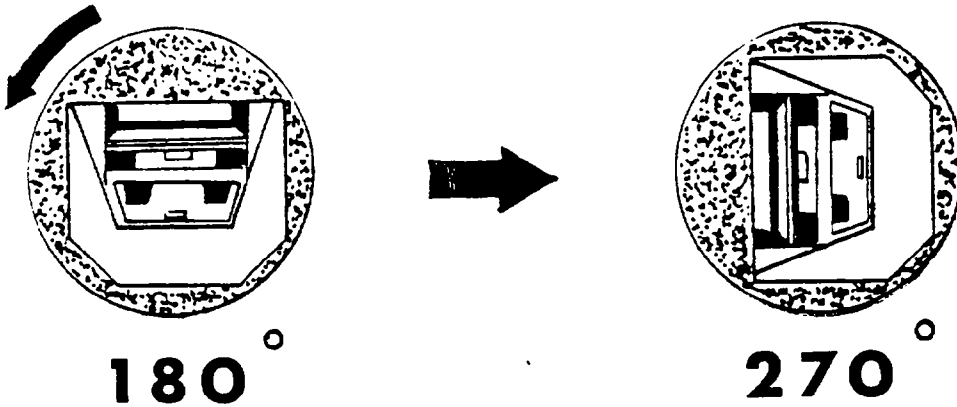

	Actual	Max. Allowed
Rollover fixture 90° rotation time	2 min. 15 sec.	1 to 3 Minutes
Fuel spillage during 5 minute period from onset of rotation	- 0 -	5 ounces
Fuel spillage during 6th minute period from onset of rotation	- 0 -	1 ounce
Fuel spillage during 7th minute period from onset of rotation	- 0 -	1 ounce

Fuel Spillage Location: Not Applicable

TABLE X
FUEL SYSTEM INTEGRITY - FMVSS 301-75
STATIC ROLLOVER

Vehicle 1983 Ford Ranger NHTSA No. CD0614

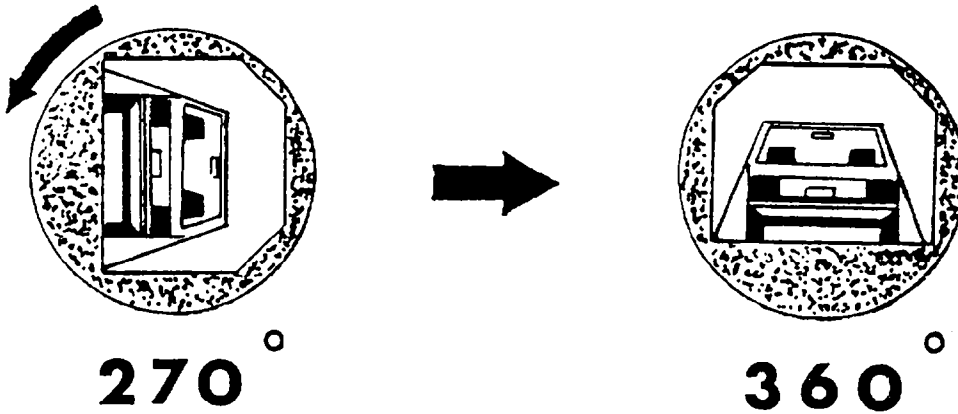

	Actual	Max. Allowed
Rollover fixture 90° rotation time	2 min. 11 sec.	1 to 3 Minutes
Fuel spillage during 5 minute period from onset of rotation	- 0 -	5 ounces
Fuel spillage during 6th minute period from onset of rotation	- 0 -	1 ounce
Fuel spillage during 7th minute period from onset of rotation	- 0 -	1 ounce

Fuel Spillage Location: Not Applicable



SECTION 2

2.1 GENERAL TEST INFORMATION

The 1983 Ford Ranger 4x4 Styleside - Pickup was subjected to a rear moving barrier impact along with a static roll-over test in accordance with the procedures referenced in Section 1 of this report under Administrative Data. The results presented here relate specifically to vehicle performance under Federal Motor Vehicle Safety Standard (FMVSS) 301-75 - "Fuel System Integrity".

The test was conducted essentially in accordance with NHTSA Office of Vehicle Safety Compliance Laboratory Procedures. The critical parameters were impact velocity and the fuel spillage criteria defined in FMVSS 301-75, paragraphs S5.5 and S5.6.

Impact velocity for the moving collision barrier impact was regulated by the fixed tow propulsion system and certified by the redundant timing traps described in Section 4.

The test vehicle "rated cargo and luggage weight" (RCLW) was not used as calculated, in lieu, the 300 pound (lesser) cargo ballast was utilized in determining the ultimate calculated vehicle test weight.



SECTION 2

2.2 TEST RESULTS

Post-impact inspection of the test vehicle revealed almost all crush occurred rearward of the cab doors. The left and right frame rail buckled over the rear axle. The cargo box impacted the cab deforming both the left and right "B" post and both cab doors were jammed. The seat back and cab wall were deformed and the cab rear window shattered. The spare tire (under cargo floor) remained inflated.

No fuel spillage was recorded following the test vehicle impact, nor during the time period before the start of the rollover test. No fuel spillage was recorded during the rollover test increment time periods.

The 1983 Ford Ranger 4x4 Styleside - Pickup test vehicle appears to comply with all the requirements of FMVSS 301-75.

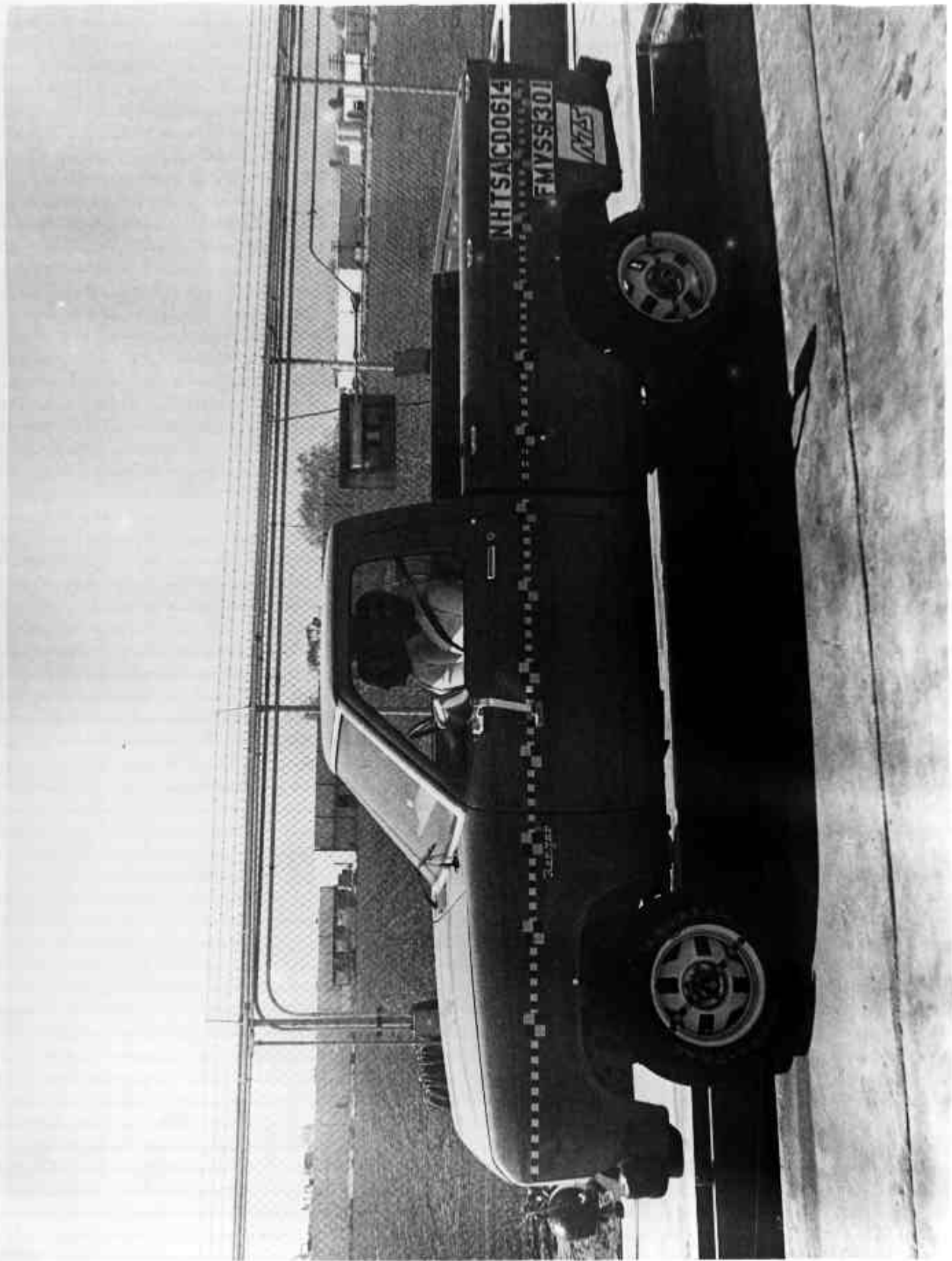

Figure 2-1

1983 Ford Ranger 4x4 - Styleside - Pickup

NHTSA CD0614

Pre-Test, Left Side View



NTS

Figure 2-2
1983 Ford Ranger 4x4 Styleside - Pickup
NHTSA CD0614
Pre-Test, Full Rear View



NHTSA

Figure 2-3
1983 Ford Ranger 4x4 Styleside - Pickup
NHTSA CD0614
Pre-Test, Right Side View

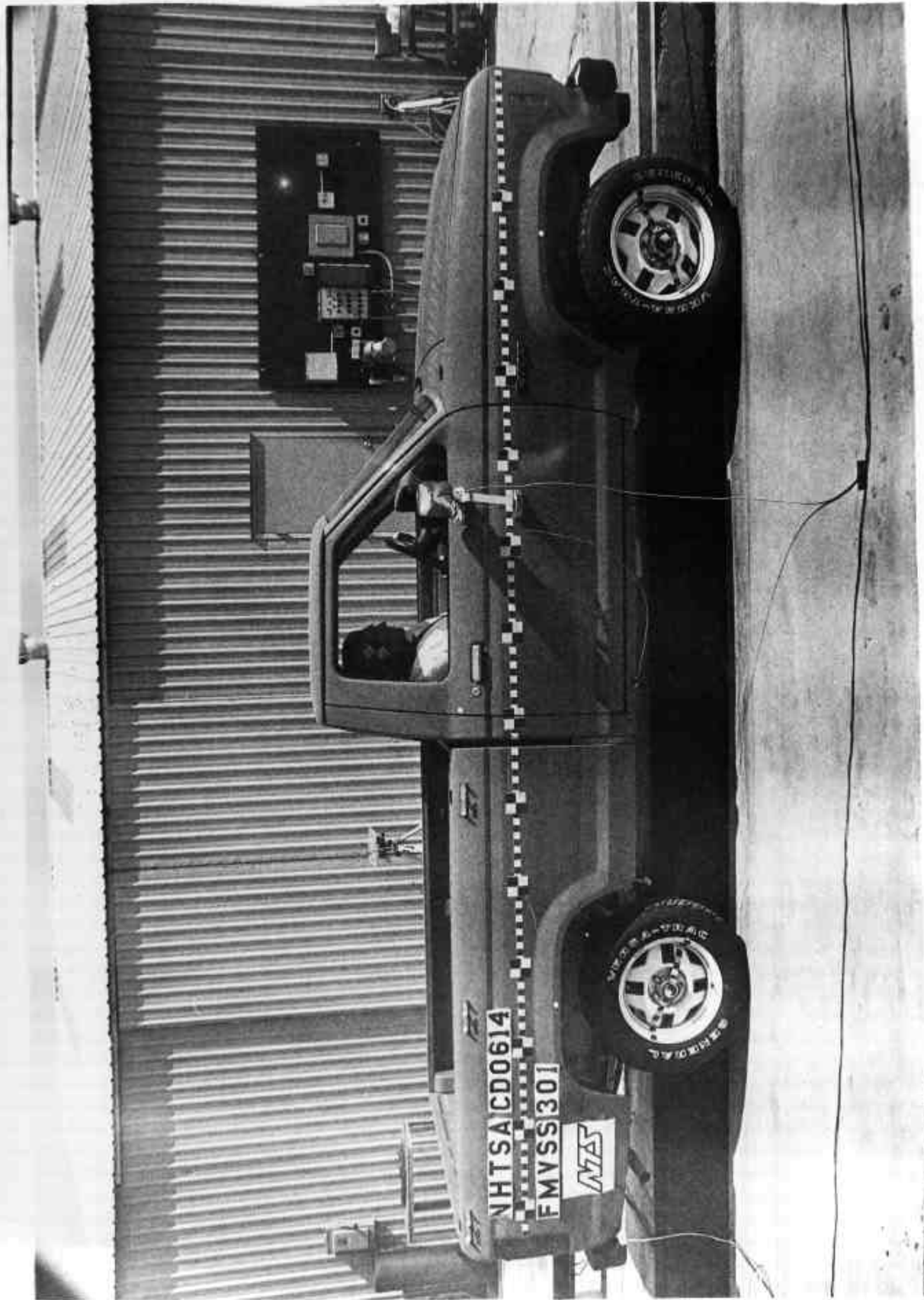

NTS

Figure 2-4

1983 Ford Ranger 4x4 Styleside - Pickup

NHTSA CD0614

Post-Impact, Left Side View



NHTSA

Figure 2-5

1983 Ford Ranger 4x4 Styleside - Pickup

NHTSA CD0614

Post-Impact, Full Rear View

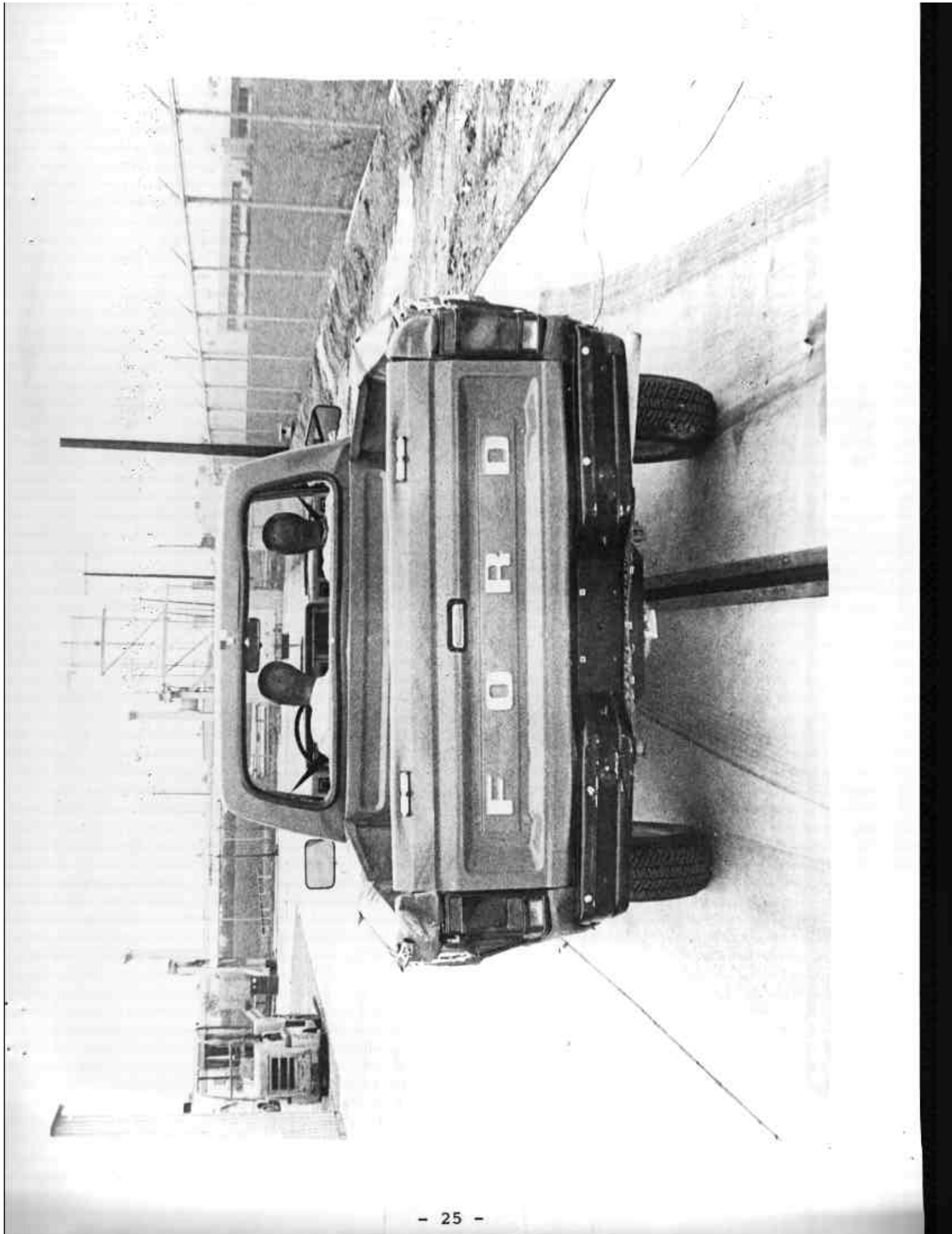

NTS

Figure 2-6

1983 Ford Ranger 4x4 Styleside - Pickup

NHTSA CD0614

Post-Impact, Right Side View

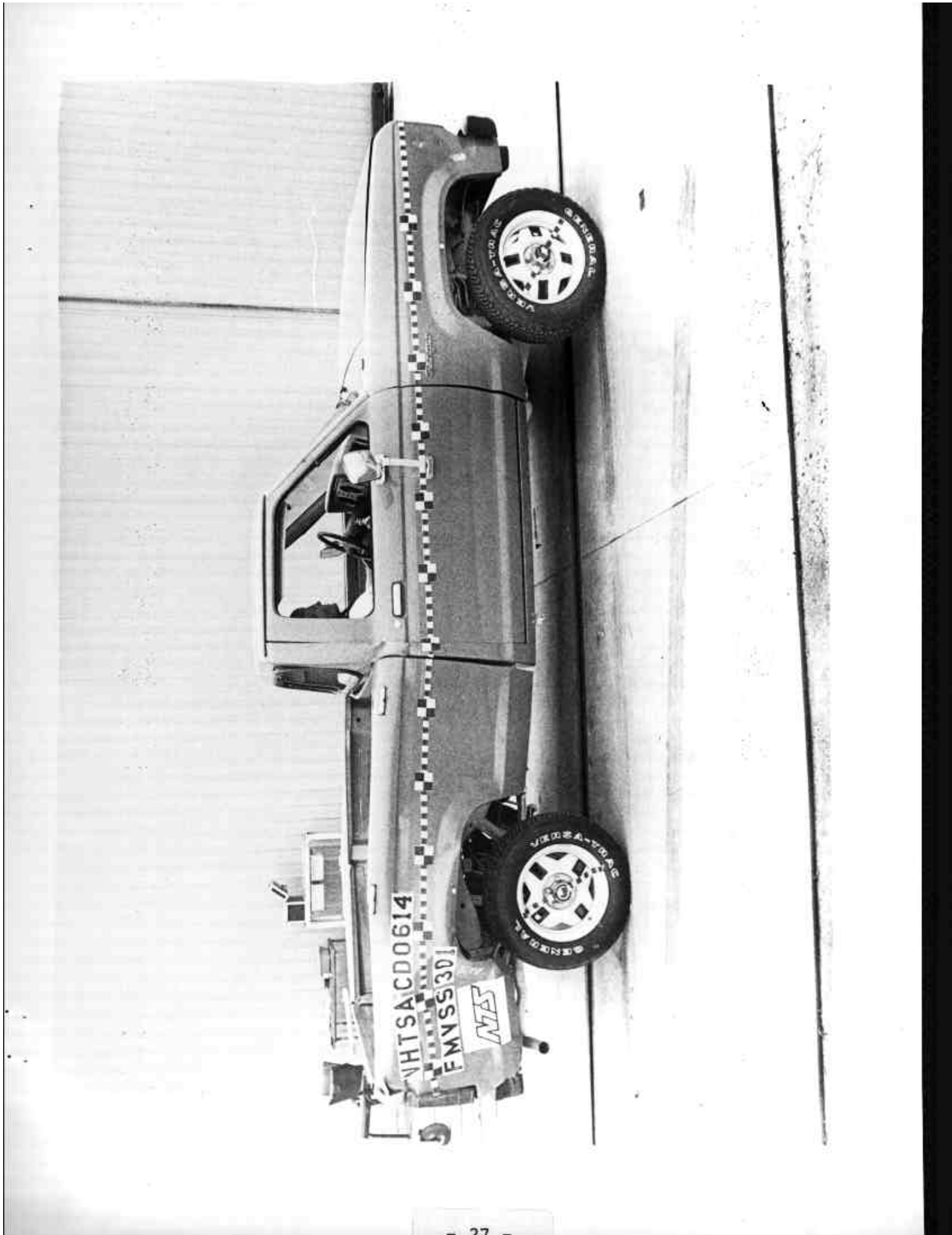

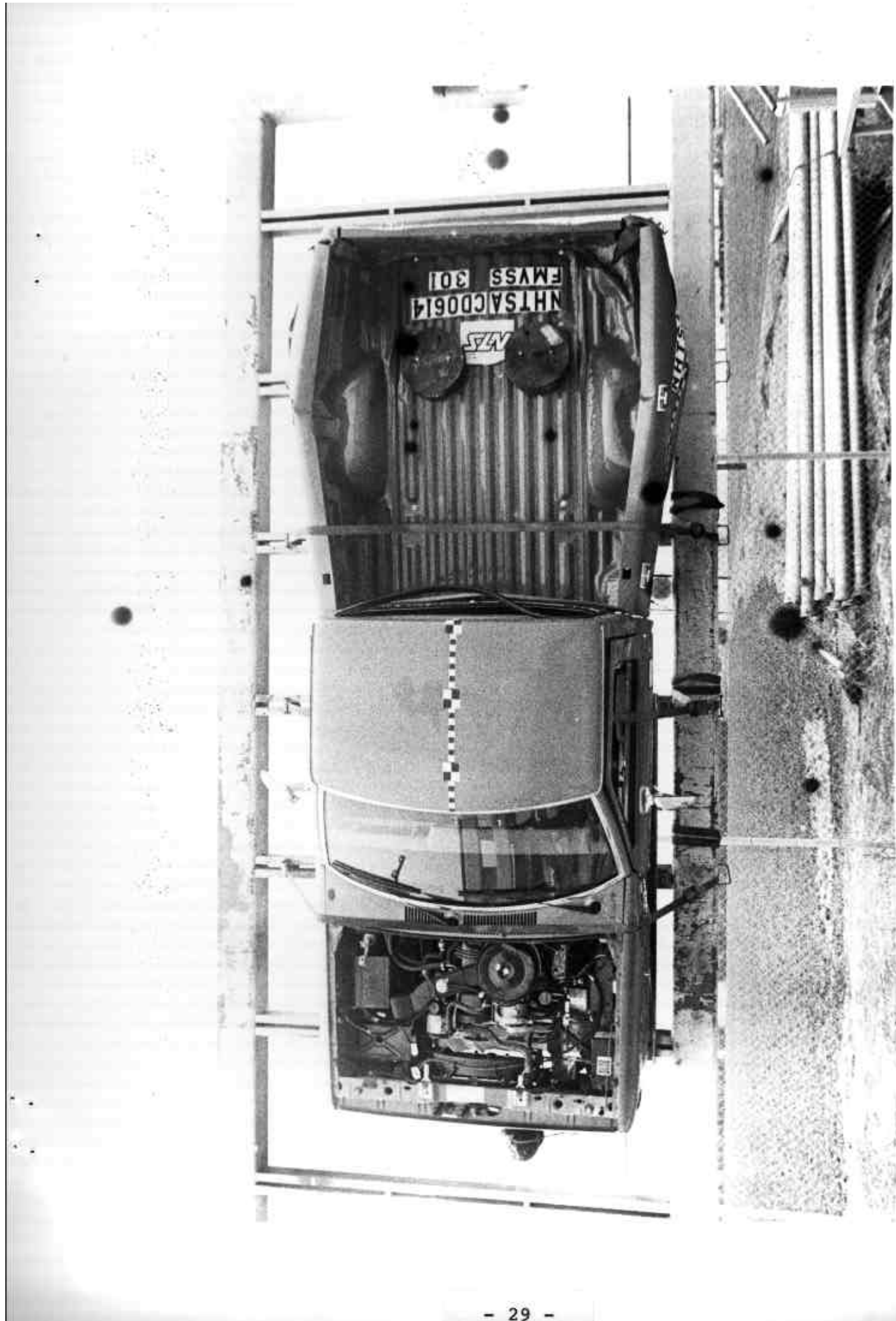

Figure 2-7

1983 Ford Ranger 4x4 Styleside - Pickup

NHTSA CD0614

Post-Impact, Rollover Test, 90° Increment



NTS

Figure 2-8

1983 Ford Ranger 4x4 Styleside - Pickup

NHTSA CD0614

Post-Impact, Rollover Test, 270° Increment

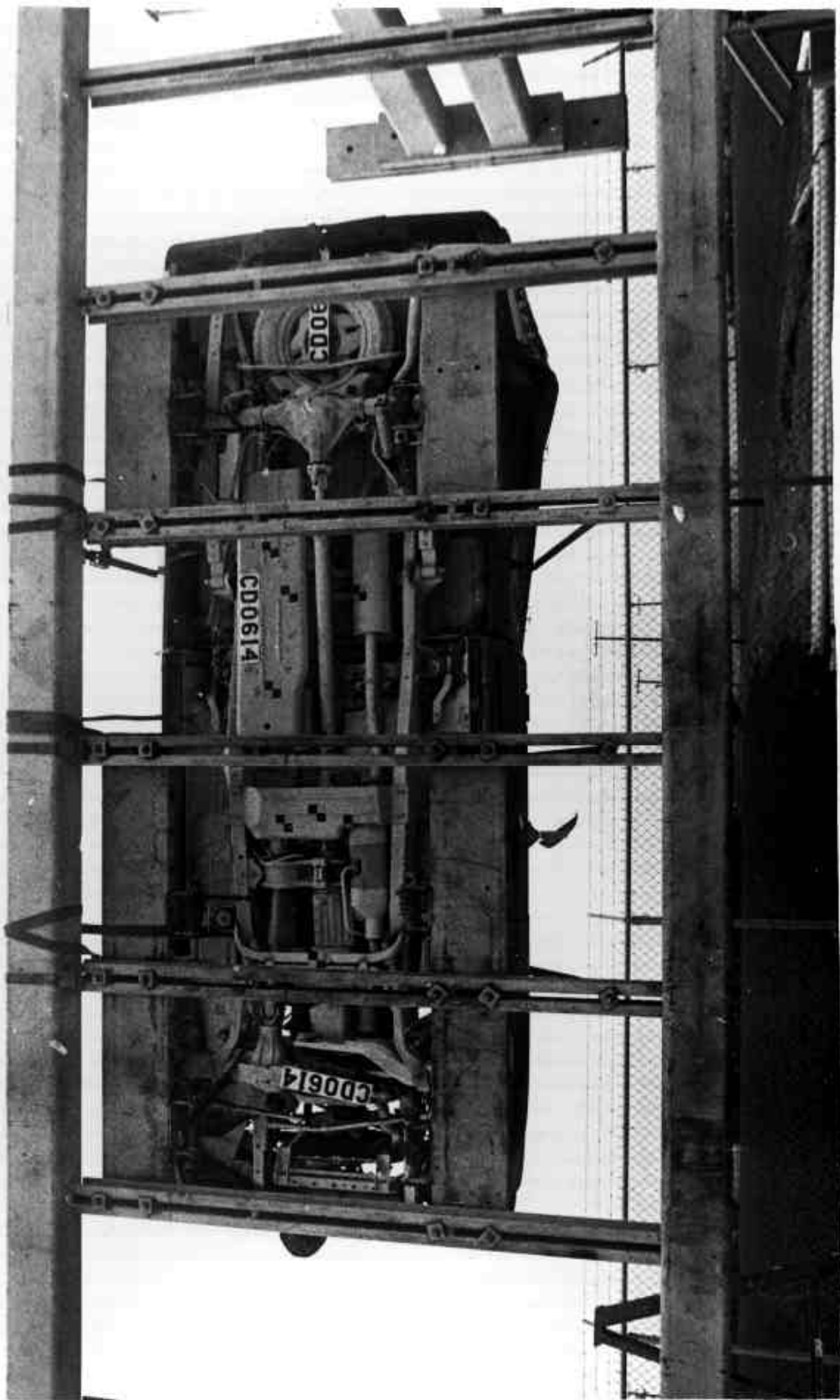



SECTION 3

3.0 VEHICLE COLLISION AND DAMAGE DATA

This section contains residual crush and delta -V's along with other related data.

The following damage dimensions examples depict locations used to generate end damage depth profiles as defined in CRASH 2 User's Manual and are presented on the Staged Collision and Damage Data Sheet under Damage Profile: (Bumper/Frame Level) measurements. This desired measurement is the deflection (inches) into the test vehicle interior from the original, undeformed end dimension.



FIGURE 3-1
EXAMPLE
OF
DAMAGE DIMENSIONS
FRONTAL IMPACT

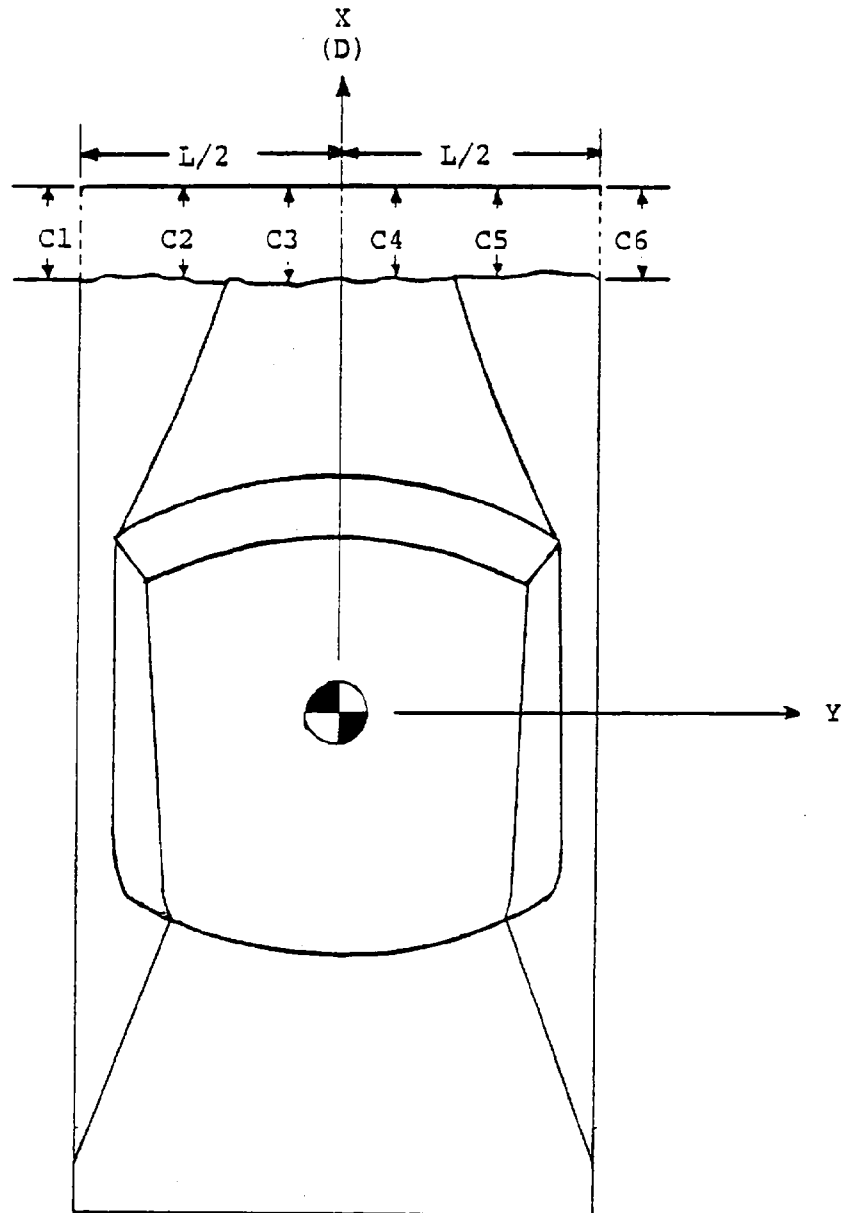

NOTE: D = distance between mid-point of L and X axis.



FIGURE 3-2
EXAMPLE
OF
DAMAGE DIMENSIONS
REAR IMPACT

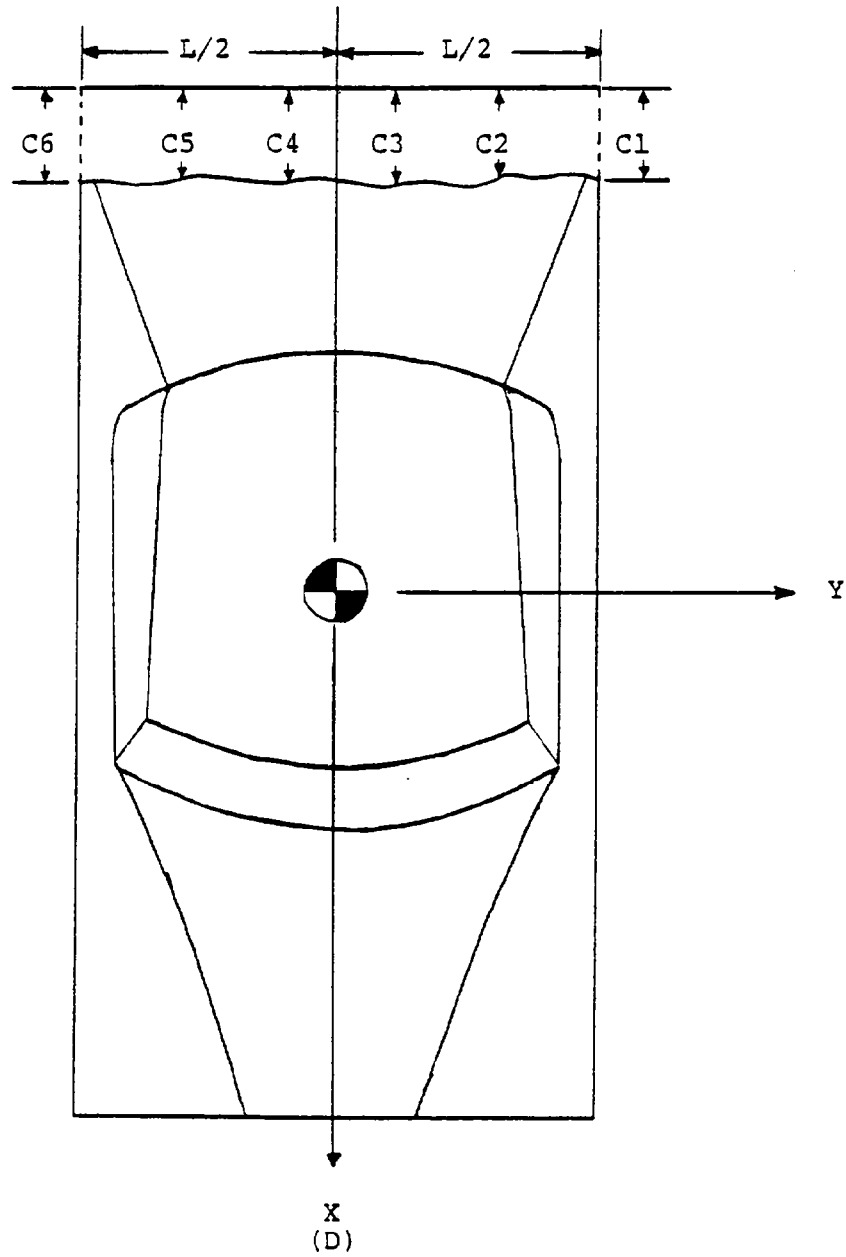

NOTE: D = distance between mid-point of L and X axis.

TABLE 3-1

TEST SUMMARY

STAGED COLLISION AND DAMAGE DATA

Impact Configuration Moving Barrier Into Vehicle

Vehicle Model Year 1983

Vehicle Make Ford

Vehicle Model Ranger 4x4 Styleside - Pickup

Vehicle Size Category Light Truck

Vehicle Test Weight 3,573 lbs.

Impact Speed 00.00 mph

Speed Change 15.80 mph

Principal Direction of Force 180 deg.

Initial Contact Rear Bumper

Damage Profile: (Bumper/Frame Level)

Vehicle Information:

L = 66.6 in.

Width 68.6 in.

D = - 0 - in.

Wheelbase 108.5 in.

C1 = 9.8 in.

Overhang-Front 28.2 in.

C2 = 9.8 in.

Overhang-Rear 42.8 in.

C3 = 9.6 in.

C4 = 9.3 in.

C5 = 9.0 in.

C6 = 8.6 in.

Collision Deformation Classification 06BDEW2

Center of Gravity (Accel.) Location E 53.6" Behind Front Axle

Moving Barrier Model FMVSS 208

Moving Barrier Weight 3,987 lbs.

Impact Speed 29.49 mph

Speed Change 15.65 mph

Center of Gravity (Accel.) Location E 16.0" Front of Front Axle

Test Track Dry Concrete

TABLE 3-2

VEHICLE STRUCTURAL DATA

VEHICLE 1983 Ford Ranger

NHTSA NO. CD0614

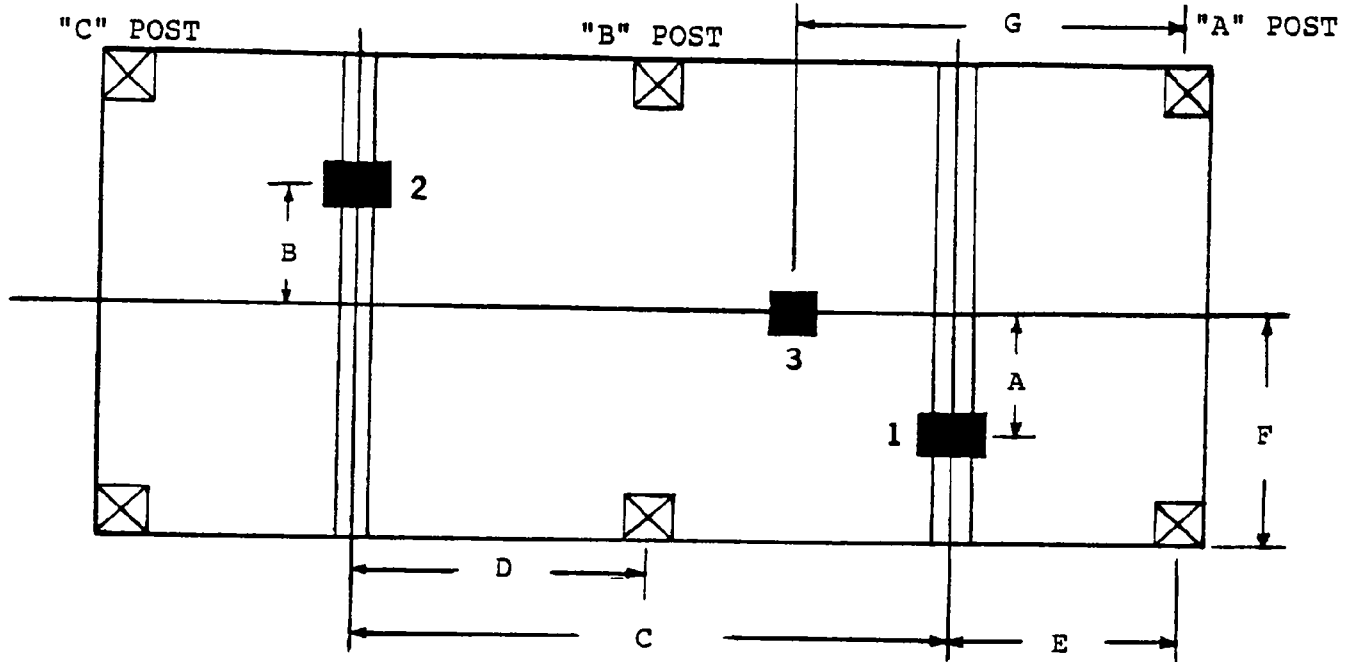

DIMENSIONS			
LOCATION	MEASUREMENT (IN.)	LOCATION	MEASUREMENT (IN.)
A	N/A	E	N/A
B	N/A	F	34.3
C	N/A	G	28.2
D	N/A		

ACCELERATION PEAKS				
ACCELEROMETER LOCATION	POSITIVE* DIRECTION		NEGATIVE* DIRECTION	
	PEAK "G"	TIME (MSEC)	PEAK "G"	TIME (MSEC)
NO. 1 LONGITUDINAL	N/A	N/A	N/A	N/A
NO. 2 LONGITUDINAL	N/A	N/A	N/A	N/A
NO. 3 LONGITUDINAL	37.2	17.0	11.3	47.0

*POSITIVE - LONGITUDINAL: FORWARD DIRECTION

*NEGATIVE - LONGITUDINAL: REARWARD DIRECTION

DOT CRASH PROGRAM APPROVED ENGINEERING TEST LABS

VEHICLE: FORD RANGER 4WD P/U
VEHICLE ID: NHTSA.CD0614
TEST FILE NO: 21 29.49 MPH
DATE: FEBRUARY 22, 1983 REAR

IMPACT SPEEDS

VEHICLE: 00.00 MPH
BARRIER: 29.49 MPH

DELTA VELOCITIES (AT TIME OF VEHICLE/BARRIER SEPARATION)

BARRIER LONGITUDINAL: 15.65 MPH

VEH. CG LONGITUDINAL: 15.80 MPH
LR FLOORPAN LONG: MPH
RF FLOORPAN LONG: MPH

PLOT DATA

IMPACT OCCURED AT: 129 MS
SEPARATION OCCURED AT: 259 MS

DOT CRASH PROGRAM

VEHICLE: FORD RANGER 4WD P/U
VEHICLE ID: NHTSA.CD0614
TEST FILE NO: 21 29.49 MPH
DATE: FEBRUARY 22, 1983 REAR

MJO NO: 271-6096-1
FILTER: CLASS 60

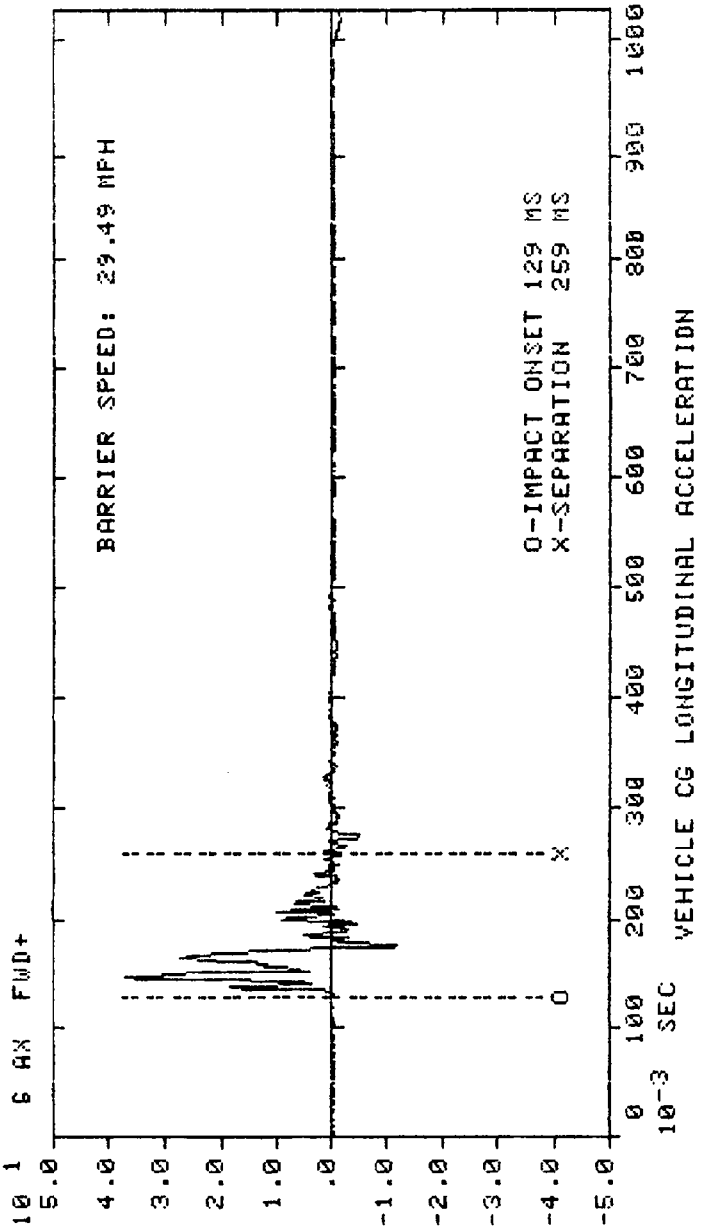

DOT CRASH PROGRAM
 NTS STRUCTURAL DYNAMICS LABORATORY
 MJO NO: 271-6096-1
 FILTER: CLASS 190
 VEHICLE: FORD RANGER 4WD P/U
 VEHICLE ID: NHTSA.CD0614
 TEST FILE NO: 21 29.49 MPH
 DATE: FEBRUARY 22, 1983 REAR

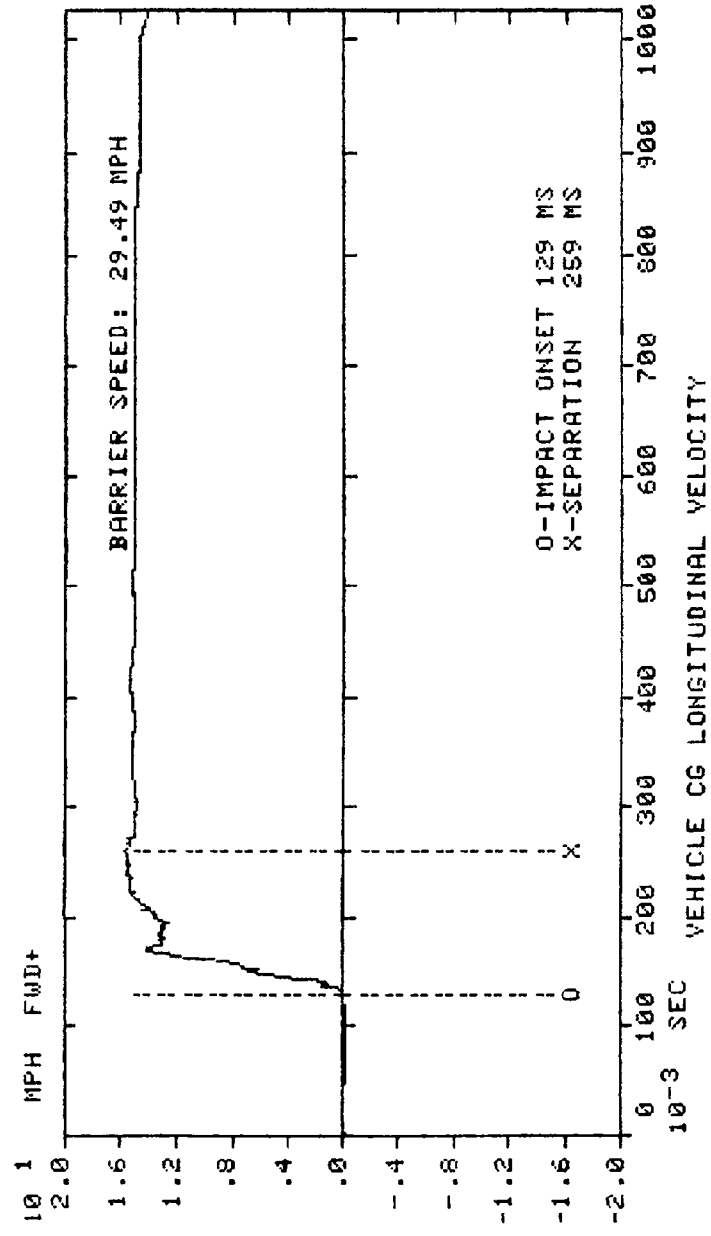

DOT CRASH PROGRAM

VEHICLE: FORD RANGER 4WD P/U
VEHICLE ID: NHTSA.CD0614
TEST FILE NO: 21 29.49 MPH
DATE: FEBRUARY 22, 1983 REAR

NTS STRUCTURAL DYNAMICS LABORATORY
MJO NO: 271-6096-1
FILTER: CLASS 180

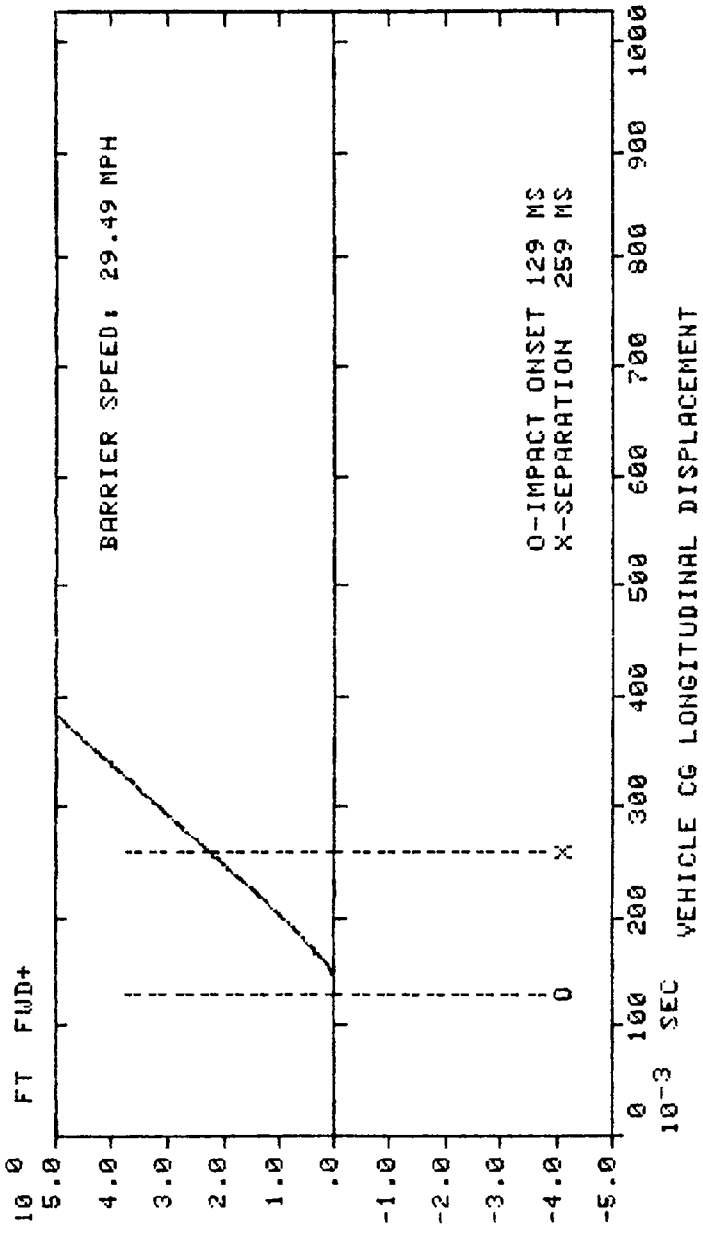

DOT CRASH PROGRAM

VEHICLE: FORD RANGER 4WD P/U
VEHICLE ID: NHTSA.CD0614
TEST FILE NO: 21 29.49 MPH
DATE: FEBRUARY 22, 1983 REAR

10 1 6 AX FWD+

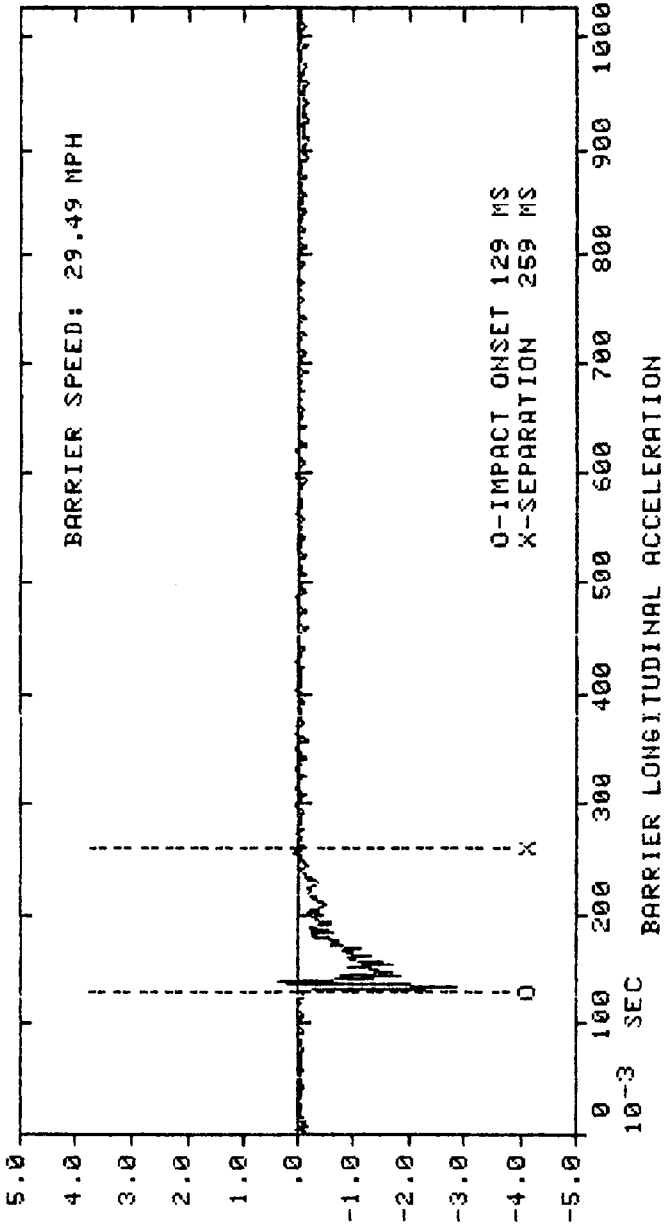

NTS STRUCTURAL DYNAMICS LABORATORY
MJO NO: 271-6096-1
FILTER: CLASS 60

DOT CRASH PROGRAM

VEHICLE: FORD RANGER 4WD P/U
VEHICLE ID: NHTSA.CD0614
TEST FILE NO: 21 29.49 MPH
DATE: FEBRUARY 22, 1983 REAR

NTS STRUCTURAL DYNAMICS LABORATORY
MJO NO: 271-6096-1
FILTER: CLASS 180

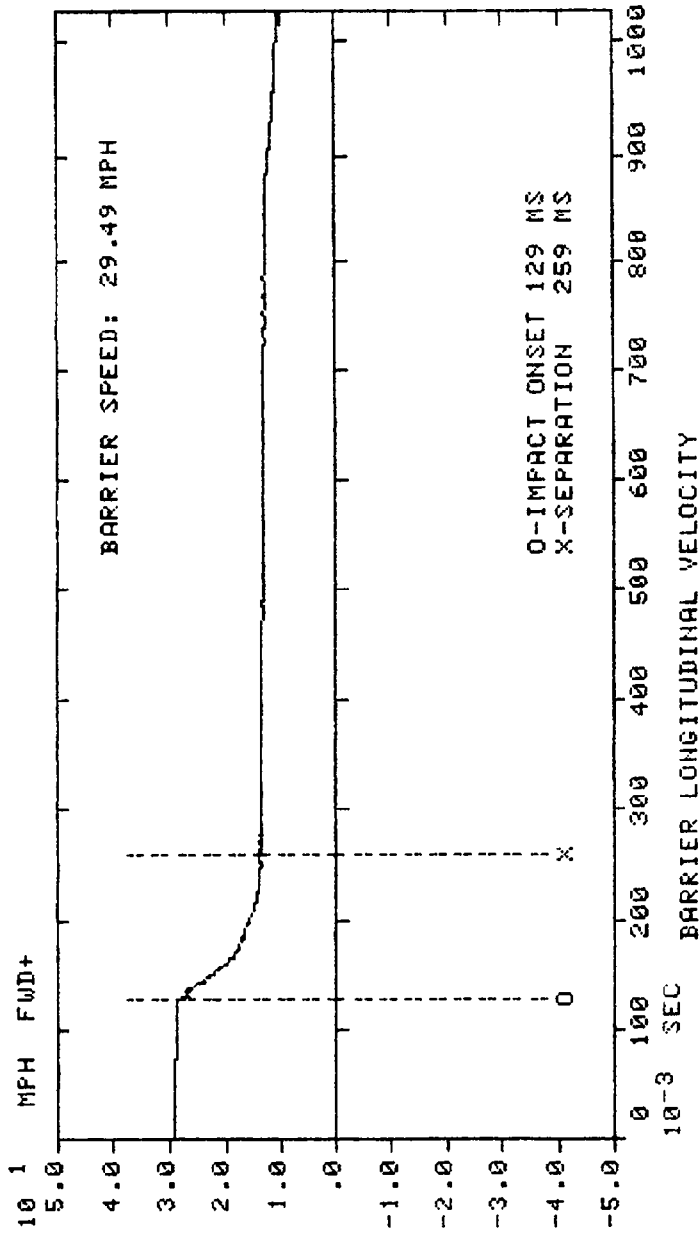

DOT CRASH PROGRAM
 NTS STRUCTURAL DYNAMICS LABORATORY

VEHICLE: FORD RANGER 4WD P/U
 VEHICLE ID: NHTSA.CD0614
 TEST FILE NO: 21 29.49 MPH
 DATE: FEBRUARY 22, 1983 REAR

MJO NO: 271-6096-1
 FILTER: CLASS 180

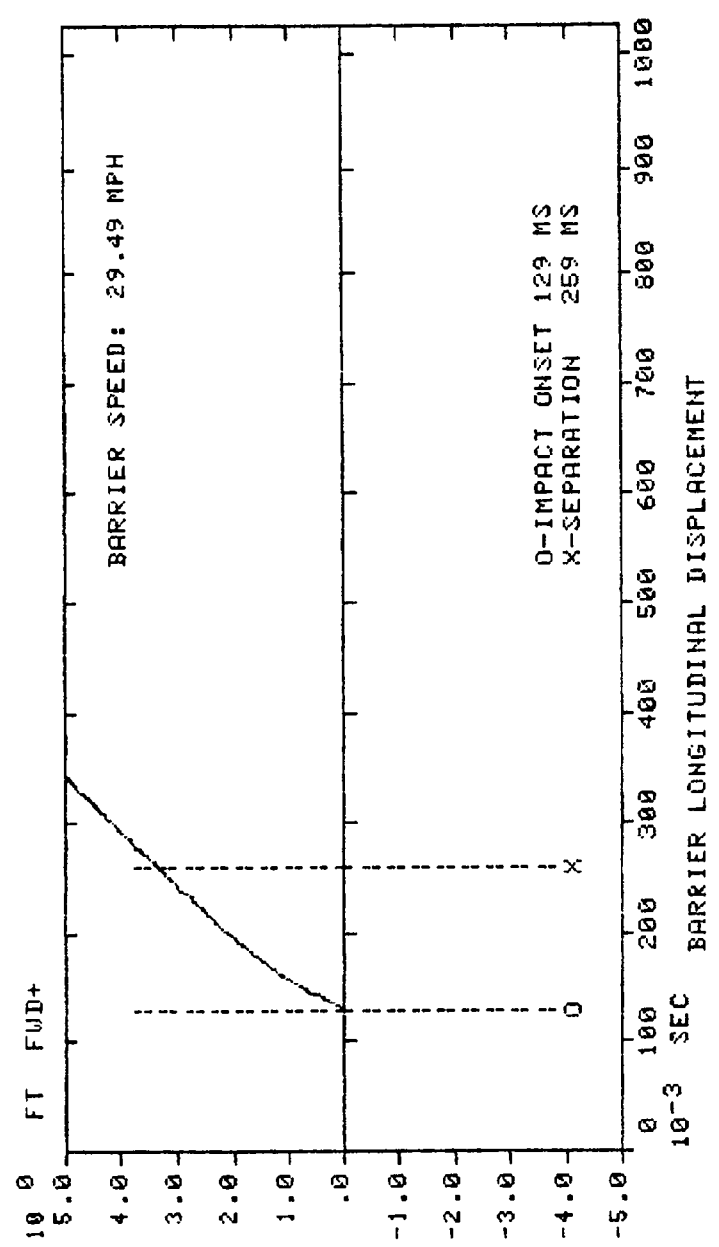

TABLE 3-3
PRE-TEST
VEHICLE MEASUREMENT DATA

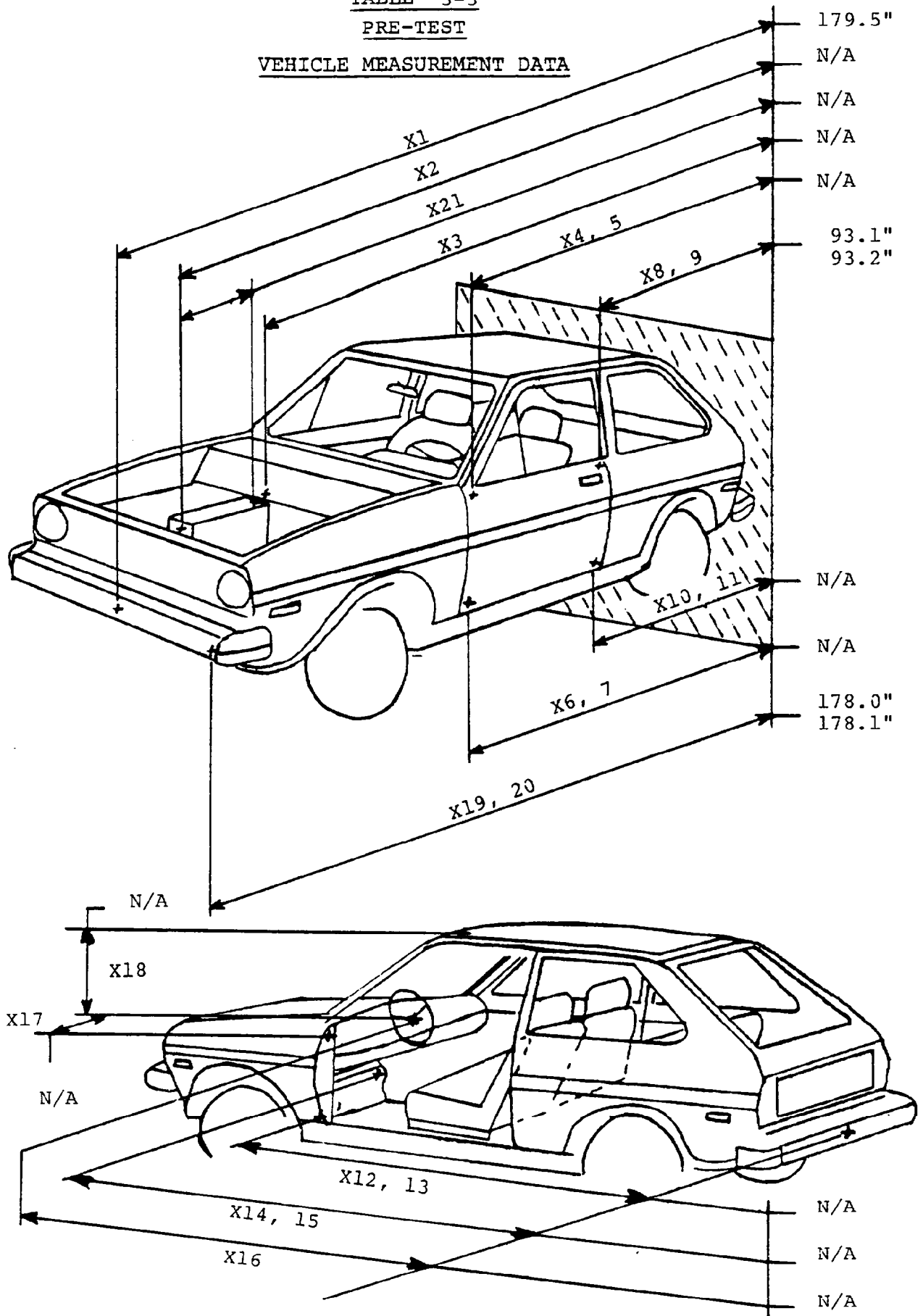

TABLE 3-4
POST-TEST
VEHICLE MEASUREMENT DATA

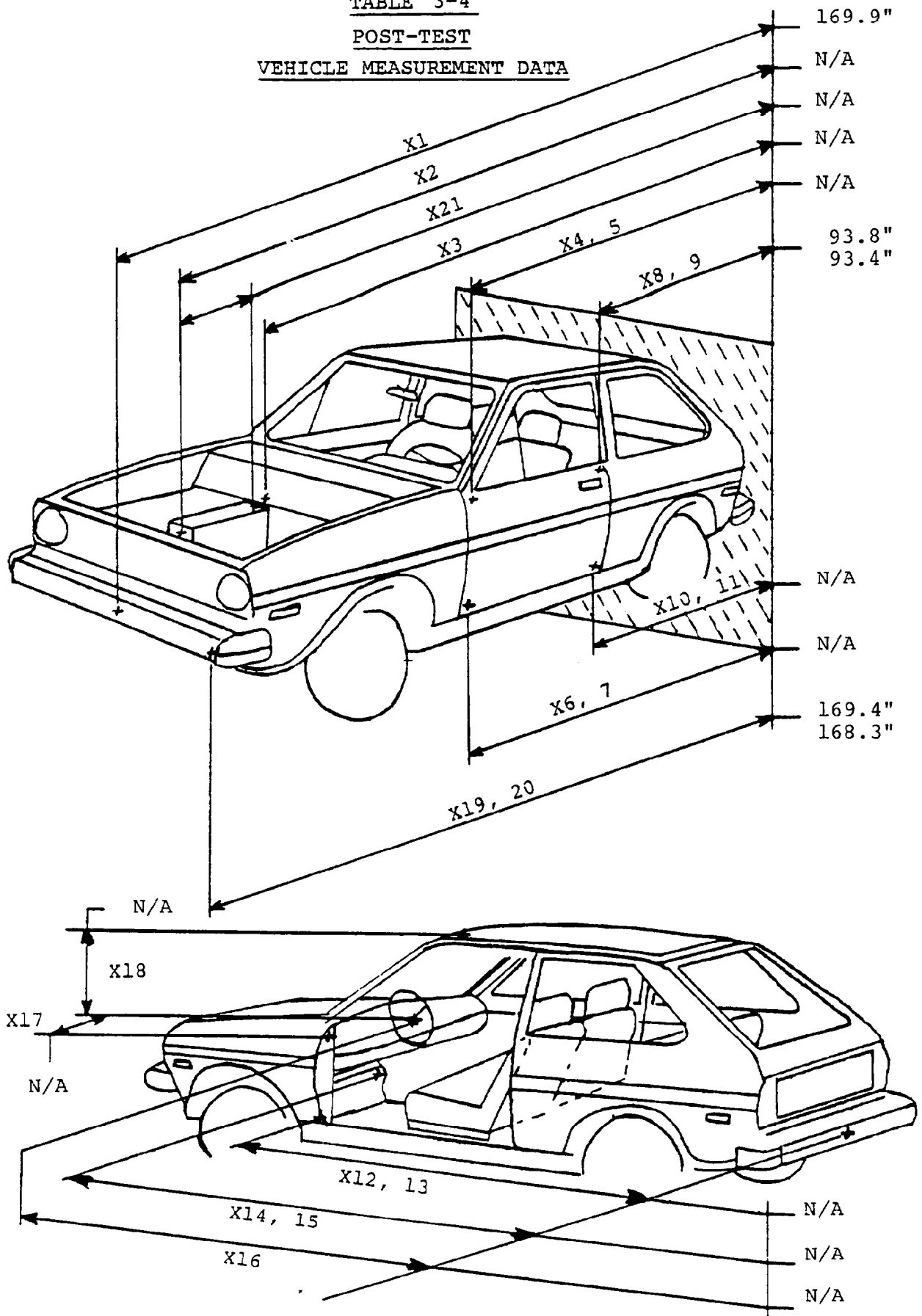



TABLE 3-5

SUMMARY

VEHICLE MEASUREMENT DATA

<u>Measurement Point</u>	<u>Pre-Test</u>	<u>Post-Test</u>	<u>Difference</u>
X1	179.5"	169.9"	9.6"
X8	93.1"	93.8"	+0.7"
X9	93.2"	93.4"	+0.2"
X19	178.0"	169.4"	8.6"
X20	178.1"	168.3"	9.8"



SECTION 4

4.0 TEST FACILITIES AND EQUIPMENT

National Technical Systems (NTS) collision barriers and vehicle static rollover machine test facilities are located at the Fullerton, California Division.

This section discusses these specialized facilities, along with associated equipment and instrumentation required for the performance of this test.

4.1 FRONTAL COLLISION BARRIER

4.1.1 The frontal (fixed) collision barrier conforms to the requirements as set by the NHTSA Office of Vehicle Safety Compliance (OVSC) and as defined in the Laboratory Procedures for FMVSS 212/219/301-75, TP219-02, dated January 9, 1979, with the following special characteristics.

4.1.2 The fixed collision barrier is a steel clad, steel reinforced concrete block with a 6'4" X 12' face. The face is 1" steel plate faced with 3/4 inch plywood. The total mass of the structure is approximately 200,000 pounds, with a substantial portion below ground to provide resistance against sliding or tipping of the barrier during impact.



SECTION 4

4.1.3 The facility consists of a 500 foot concrete paved runway, with a steel monorail embedded in the approach surface. Two camera pits are provided to allow photographing the test vehicle at impact. One pit is located immediately in front of the fixed collision barrier and is 36 inches wide (expandable to 48 inches), 7 feet deep, and 23 feet long (3 feet of the pit length extends under the barrier face). The second (mid) pit with removable monorail section is located approximately 160 feet from the fixed collision barrier and is 43 inches wide, 7 feet deep, and 23 feet long.

4.1.4 Tow propulsion is provided by a fixed prime mover and continuous cable drive system located near the mid camera pit position. The power plant for the tow cable system is a 200 h.p. synchronous electric motor, coupled to an electronically controlled Eddy Current Clutch and a 4:1 gear reduction transfer assembly.

The endless 1/2 inch diameter steel tow cable is wrapped around the drive pulley and is tensioned by a pneumatic loaded idler wheel. The tow cable passes through the fixed collision barrier and around fixed idler pulleys to complete the loop. The test vehicle or moving collision barrier is towed by a dolly assembly attached to the vehicle



SECTION 4

or moving collision barrier by a shear pin release mechanism. For a fixed collision barrier test, the test vehicle is towed within 20 feet of the fixed barrier, at which point the towing dolly assembly is disconnected from the test vehicle and the test vehicle proceeds under its own momentum for the final 20 feet to impact. For a moving collision barrier test, the moving collision barrier is towed within 5 feet of the test vehicle, at which point the towing dolly is disconnected from the moving collision barrier and the moving collision barrier proceeds under its own momentum for the final 5 feet to impact. Heavy steel stops actuate the tow cable release mechanism and prevent the towing dolly from continuing past the point of impact. The towing dolly is designed to fit inside the monorail such that it is constrained in the vertical and lateral directions, and capable of sliding freely along the monorail.

4.2 OBLIQUE ANGLE COLLISION BARRIER

- 4.2.1 The oblique angle collision barrier conforms to the requirements as set by NHTSA Office of Vehicle Safety Compliance (OVSC) Laboratory Procedures TP219-02, with the following special characteristics.



SECTION 4

4.2.2 The oblique angle collision barrier is constructed of a flat 1 1/2 inch steel plate faced with 3/4 inch plywood. The barrier face is 6' X 12' and is adjustable for left or right angle impacts by means of seven tubular gussets that attach to the standard fixed frontal collision barrier to form a rigid buttress structure.

4.3 MOVING COLLISION BARRIER

4.3.1 The moving collision barrier conforms to the requirements as set by Federal Motor Vehicle Safety Standard No. 208, Paragraph S8.2 with the following special characteristics.

4.3.2 The chassis is constructed of 12 inch steel channel with tubular frame gussets. The flat impacting face plate is 1/2 inch steel plate faced with 3/4 inch plywood. The face plate is reinforced with 6 inch steel channel horizontally welded to the chassis to form a rigid symmetrical structure. A camera boom extends above the barrier face plane to provide a view of barrier to vehicle impact. The barrier assembly weighs 3,987 pounds and has a four wheel electric brake system.



SECTION 4

4.4 VEHICLE STATIC ROLLOVER MACHINE

4.4.1 The vehicle static rollover machine conforms to the requirements as set by the NHTSA Office of Vehicle Safety Compliance (OVSC) Laboratory Procedures TP219-02 with the following special characteristics.

4.4.2 The vehicle static rollover machine is constructed of 10 inch square tube with adjustable wheelbase and tread width platforms to accommodate the various test vehicles. The total usable platform area is 8 feet wide and 25 feet long with special design feature to accomodate vehicles with a gross vehicle weight rating (GVWR) of 10,000 pounds or less with various body configuration heights to 12 feet. The test vehicle can be rotated left or right and can turn each 90° rotational increment in approximately two (2) minutes.

4.5 IMPACT VELOCITY MEASUREMENT

The test vehicle impact velocity is measured by two (2) separate certification timing trap systems located within five (5) feet of the vehicle to fixed collision barrier face and to one side on the approach apron. Each timing



SECTION 4

trap system contains two (2) optical beams, mounted twenty four (24) inches apart, in a mechanical housing assembly providing a start-stop signal to a digital display counter. As the test vehicle traverses the impact apron, a blade attached to the test vehicle rear fender interrupts each optical beam providing the precise measurement of time interval for the test vehicle to advance the known distance between the optical beams. Each interval of time measurement is stored in the digital display counter and photographically recorded.

The moving collision barrier impact velocity is measured by two (2) separate certification timing trap systems located within five (5) feet of the moving collision barrier to vehicle impact location and to one side on the approach apron. Each timing trap system contains two (2) optical beams, mounted twenty-four (24) inches apart, in a mechanical housing assembly providing a start-stop signal to a digital display counter. As the moving barrier traverses the impact apron, a blade attached to the moving barrier side interrupts each optical beam providing the precise measurement of time interval for the moving barrier to advance the known distance between the optical beams. Each interval of time measurement is stored in the digital display counter and photographically recorded.



SECTION 4

4.6 PHOTOGRAPH COVERAGE

4.6.1 Because FMVSS 212/219/301-75 may be a combined test, it is necessary that all photographic coverage of the test vehicle be done at one time with specific photographs to document the areas for Vehicle Safety Compliance consideration; windshield area and the fuel system. Each report will utilize only those photographs pertaining to the Vehicle Safety Compliance Test being reported.

4.6.2 FIXED BARRIER IMPACT TEST

Motion picture coverage of the event employs five (5) 16mm 1B Photo-Sonics cameras and two (2) 16mm 51 Redlake Locam cameras using color film at 500 frames per second (fps). Also a 16mm Canon Scoopic 24 frames per second (fps) camera with color film is used to record vehicle pre-test condition, vehicle in-run, impact, and post-impact vehicle conditions including the rollover increments for documentary purposes. The seven (7) high speed cameras are located at stationary positions near the point of impact. One is an overhead camera mounted on a tower above the fixed barrier face on centerline of the test vehicle at impact. Its field of view includes the barrier face and the front of the vehicle to a point about one foot aft of the windshield. A second and third camera is mounted on top of the fixed barrier with



SECTION 4

their field of view concentrating on the windshield area (FMVSS 212/219). The fourth and fifth camera each have a side view of the test vehicle at impact. The sixth and seventh camera are located in the pit and positioned to photograph the underside of the engine compartment and fuel tank area.

4.6.3 MOVING BARRIER IMPACT TEST

Motion picture coverage of the event employs three (3) 16mm 1B Photo Sonics cameras and two (2) 16mm 51 Redlake Locam cameras using color film at 500 frame per second (fps). Also a 16mm Canon Scoopic 24 frames per second (fps) camera with color film is used to record vehicle pre-test condition, barrier in-run, impact, and post-impact vehicle conditions including the rollover increments for documentary purposes. Four (4) of the high speed cameras are located at stationary positions near the point of impact. Two (2) cameras are located in the pit and positioned to photograph the underside of the engine compartment, with overlapping field of views, aft to the fuel tank area. The third and fourth camera each have a side view of the test vehicle at impact.



SECTION 4

The fifth camera is attached to the moving collision barrier to photograph the contact between the barrier and the test vehicle.

4.6.4 TIME PULSE GENERATOR

Time data from two (2) sources are contained in the high speed film coverage. The first is a time reference of 100 pulse per second (pps) light emitting diode event mark along the film edge. This pulse is generated by the time pulse generator and fed to all high speed cameras. Thus, it is possible to relate film data to a real time base. The second time record is an indication of time zero (moment of impact). This is accomplished by a trip switch and event mark system. The trip switch is positioned at the impact point so that it triggers the light emitting diode event mark along the film edge at the moment of bumper-barrier contact. Thus, the particular film frame corresponding to the point of impact is clearly indicated on all the high speed film.



SECTION 4

4.7 DATA ACQUISITION AND REDUCTION

The data acquisition and analysis system used for acquiring barrier and vehicle accelerations is shown schematically in Figure 4-1. A complete list of instrumentation is shown in Table 4-1. An itemized procedure for acquiring data is provided in Table 4-2.

Prior to the vehicle impact test, onboard instrumentation is installed and a calibration and null reference check is performed to check out all data analog devices including FM magnetic tape recorders. Immediately following vehicle impact a post-impact calibration and null reference check is performed.

Analog data is replayed and digitized using a Hewlett Packard Digital Fourier Analyzer (DFA). The data is digitized three channels at a time and placed into permanent storage on magnetic disc. The only modifications to the data at the time of permanent storage are: the application of a 250 Hz predigitizing analog filter (60 db/octave rolloff), the filtering and digitizing



SECTION 4

process of the FM tape recorder (2500 Hz) and the DFA (1000 Hz sampling for a 1 second window), and the application of the appropriate calibration scale factors.

As the data is recalled for integration or plotting, the appropriate SAE filter is applied. These filters are in accordance with SAE J211a, Instrumentation for Impact Tests. Acceleration data is plotted after the application of an SAE class 60 filter. Velocity and displacement data is plotted after the application of an SAE class 180 filter. The filters are shown in Figure 4-2.

Before plotting, the test engineer determines vehicle onset and vehicle separation times. This is done by looking for characteristics contained in both the vehicle and barrier acceleration signals which indicate when these events occurred. Impact onset is verified with the trigger signal. When a velocity, or displacement trace is to be plotted, integration of the appropriate acceleration signal is performed digitally in the DFA.



SECTION 4

All impact data is presented in computer plots of a 1 second time window. Impact onset and vehicle separation times are shown, as well as appropriate labels defining the test vehicle, filter class and data plotted. The descriptions on the plots are self explanatory.

In addition to the data plots, a table listing the barrier closing speed, impact and vehicle separation times and delta velocities is given. Delta velocity is taken as the difference between the velocity at the moment of impact and the velocity at the moment of separation for the barrier or vehicle.

The aforesaid process from digitizing data through plotting data is controlled with standard Hewlett Packard Fourier software in conjunction with NTS designed software written specifically for crash data reduction.

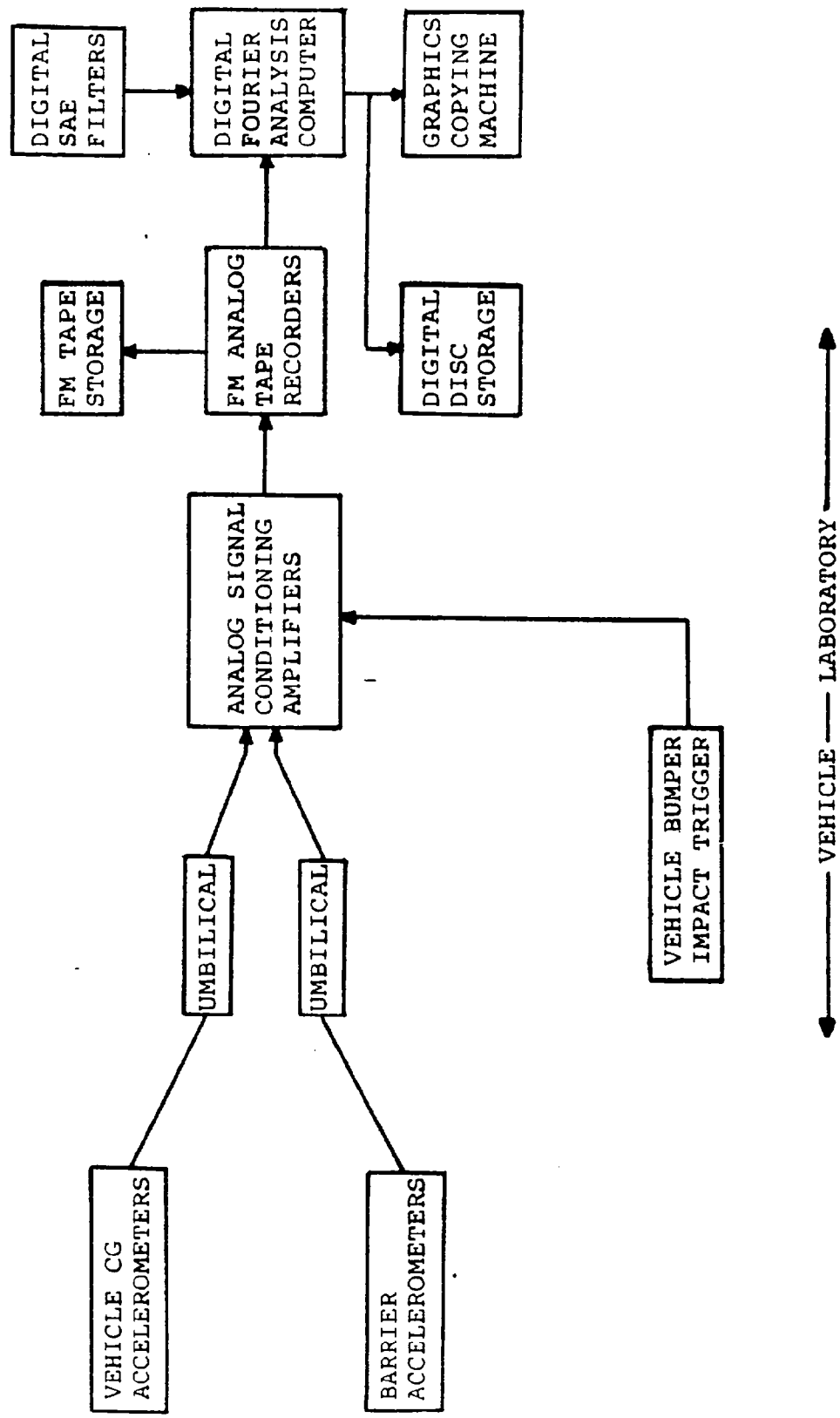

VEHICLE AND OCCUPANT CRASH IMPACT DATA ACQUISITION SYSTEM
 FIGURE 4-1

HP 5451 DATA PLOT

NATIONAL TECHNICAL SYSTEMS

COMPARISON PLOT OF SAE CLASS 60, 180, 600, 1000 FILTERS AND THE DATA ANALYSIS 1250 HZ PREDIGITIZING ANALOG FILTER.

SAE FILTERS ROLL OFF IS 12DB/OCT, ANALOG FILTER ROLL OFF IS 60DB/OCT

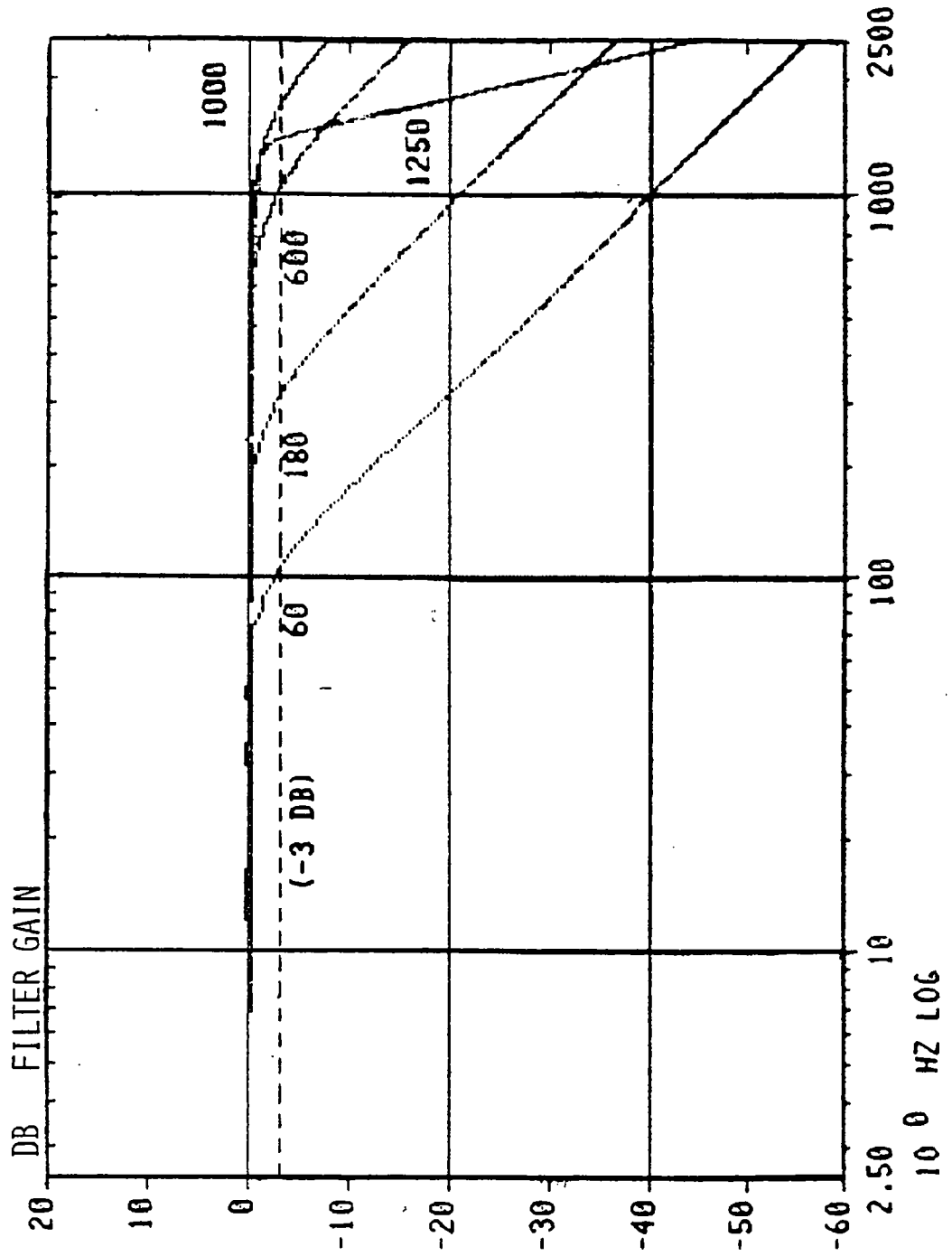

FIGURE 4-2

TABLE 4-1
INSTRUMENTATION FOR CRASH TEST

<u>Instrument</u>	<u>Manufacturer</u>	<u>Model No.</u>	<u>Full Scale</u>	<u>Accuracy</u>	<u>Freq. Max.</u>
Accelerometers, Vehicle, Barrier	Endevco	2262C-200	200g	±1%	3600 Hz.
Contact Switch, Impact	NTS	-	2 V	-	<200 us rise time
FM Tape Recorder	Bell & Howell	4020	±2.8V	47 db SNR	2500 Hz WB
Programmable Filter, All Data	Hewlett Packard	54440A	-	0.5%	1250 Hz, 60 db/oct
Analog-Digital Converter, All Data	Hewlett Packard	5466B	-	0.5%	200 us sampling
Analysis Computer, All Analysis	Hewlett Packard	2100S	32 K Words	16 Bit Word	-
Disc Drive	Hewlett Packard	7900A	5 Meg Words	-	-

TABLE 4-2

DATA ACQUISITION AND REDUCTION PROCESS

<u>STEP</u>	<u>DESCRIPTION</u>
1	DA System Installation
2	DA System Pre-Impact Calibration
3	Impact Trigger Checkout
4	Vehicle Impact Performed
5	DA System Post-Impact Calibration
6	Data Reproduced From FM Tape Into Computer a) Data analog filtered at 250 Hz b) Data digitized at 100 ms sample rate c) Data sychronized by impact trigger signal
7	Digitized Data Examined
8	Data Transferred Permanent Disc Storage
9	Appropriate SAE Filters Are Applied
10	Each Data Signal Plotted With Labels



SECTION 4

4.8 FRONTAL FIXED BARRIER IMPACT DELTA VELOCITY CALCULATION

The data acquisition and reduction process for a frontal fixed barrier impact delta velocity calculation is outlined in the step by step discussion which follows. Figures 4-3 through 4-7 illustrate each step in the process. Reflected in the processed data is:

- 1) Relying on the optical speed trap data as the most accurate source of the test vehicle impact speed, the calibration factor, which converts the vehicle longitudinal acceleration signal from volts to g's, is forced to produce a velocity consistent with the optical speed trap data.

Step 1: Acquire a two (2) second time history of the test vehicle longitudinal acceleration signal at a sample rate and with a pre-digitizing filter that is in accordance with the guideline established by SAE J211b. (Figure 4-3)



SECTION 4

Step 2: Remove bias from the longitudinal acceleration signal. Bias removal is based on the assumption that the test vehicle comes to rest at some point in time prior to the end of the two (2) second time history window. From this point in time through the end of the two (2) second window, the acceleration signal should be at zero, and the velocity trace should exhibit no change (flat). (Figure 4-4 and 4-5)

Step 3: Calculate the test vehicle longitudinal acceleration calibration factor. The optical speed trap reading is used in this step, along with the knowledge that the test vehicle comes to rest, i.e. a known delta velocity from impact to rest. (Figure 4-6)

Step 4: Calculate the delta velocity at the time of test vehicle and barrier separation. The time of separation is determined by examining the test vehicle longitudinal acceleration signal and velocity trace while noting that:



SECTION 4

- 1) Since any external force acting to decelerate the test vehicle in the positive forward direction become zero upon separation, the vehicle should reach its maximum negative velocity (rebound velocity) immediately prior to separation and should exhibit no further deceleration in the positive forward direction after this time.

- 2) After separation, the vehicle is slowed from its rebound velocity to a stop by the friction forces. The vehicle velocity trace should exhibit a slight positive slope (max 1 G) immediately after separation until the vehicle comes to rest. (Figure 4-7)

NATIONAL TECHNICAL SYSTEMS

VEHICLE: EXAMPLE
TEST FILE: FRONTAL IMPACT
DATE: JANUARY 1981

SAMPLING: 1000 HZ
FILTER: CLASS 100

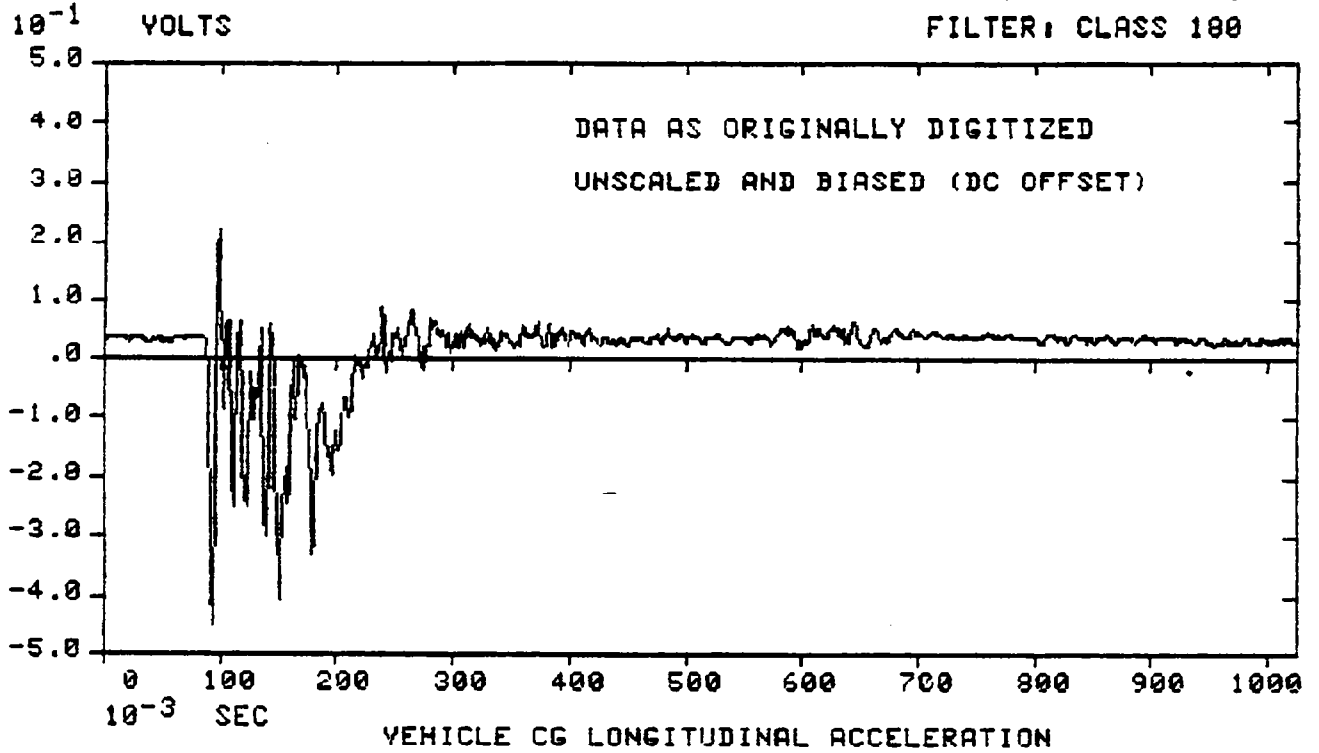

FIGURE 4-3

NATIONAL TECHNICAL SYSTEMS

VEHICLE: EXAMPLE
TEST FILE: FRONTAL IMPACT
DATE: JANUARY 1981

SAMPLING: 1000 HZ
FILTER: CLASS 180

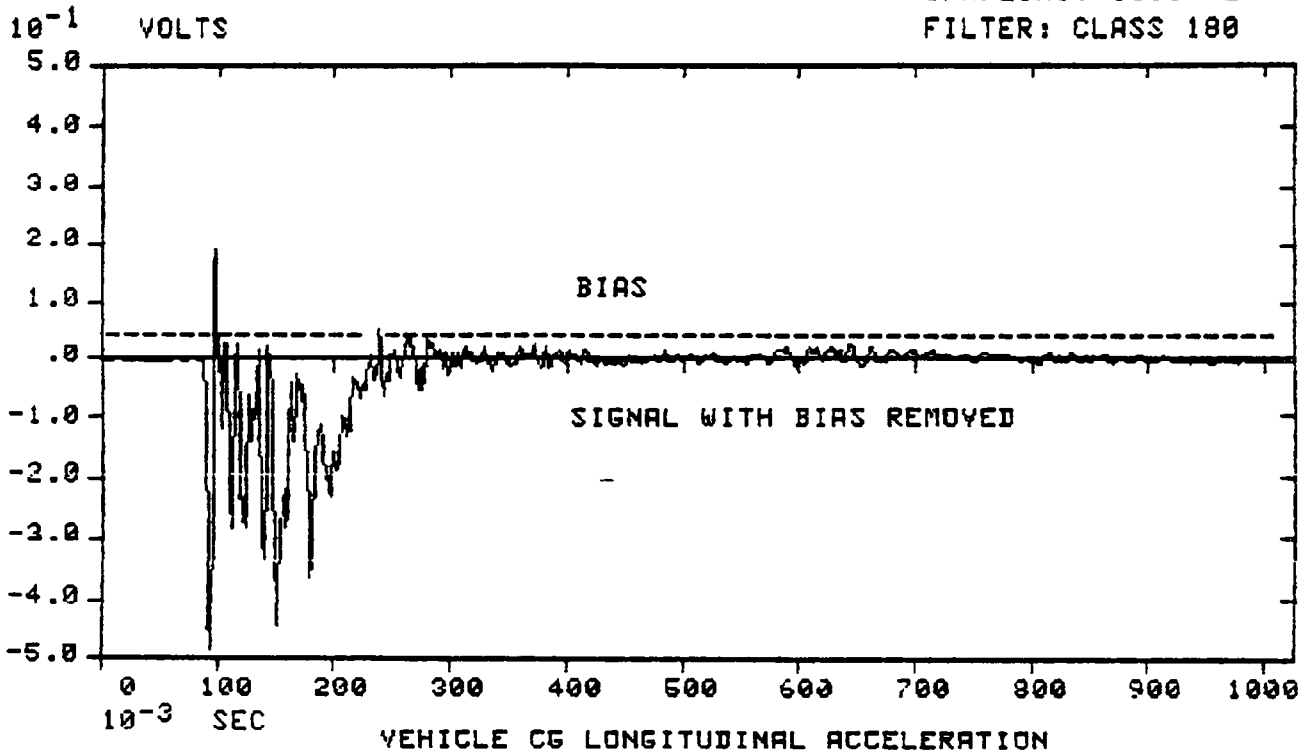

FIGURE 4-4

NATIONAL TECHNICAL SYSTEMS

VEHICLE: EXAMPLE
TEST FILE: FRONTAL IMPACT
DATE: JANUARY 1981

SAMPLING: 1000 HZ
FILTER: CLASS 180

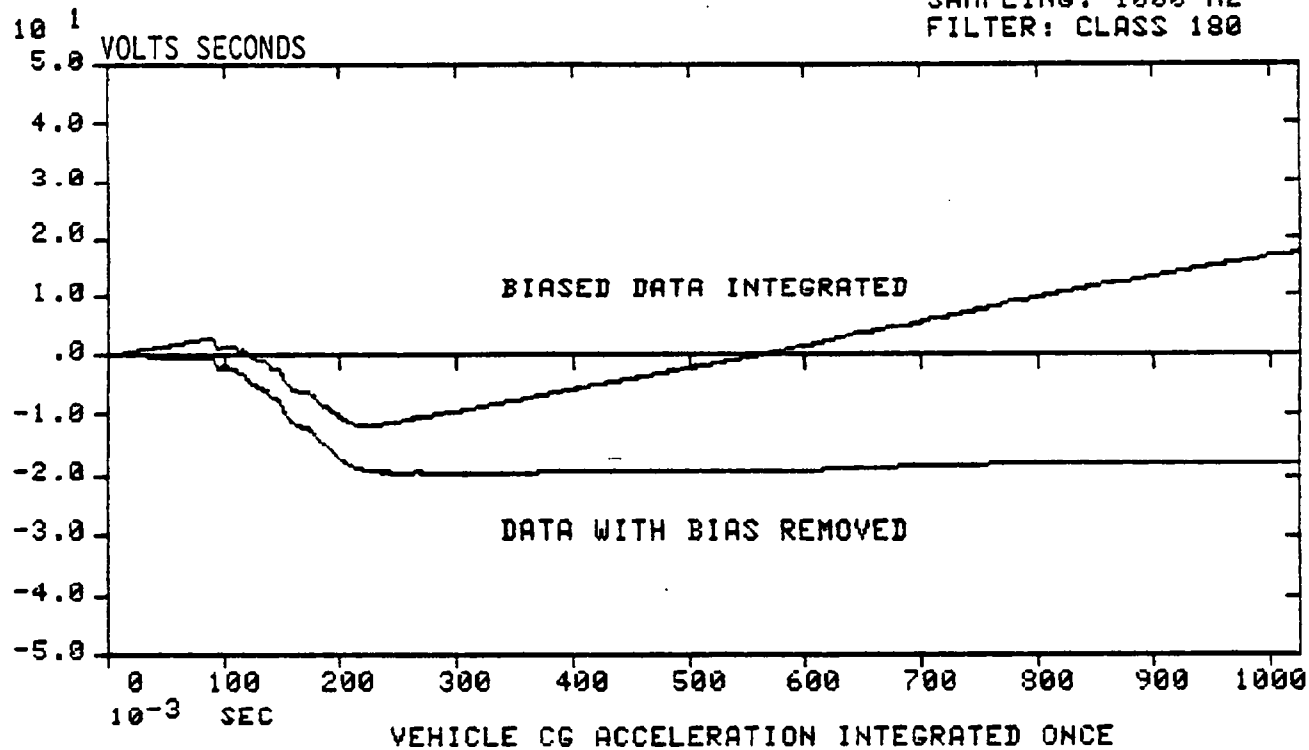

FIGURE 4-5

NATIONAL TECHNICAL SYSTEMS

VEHICLE: EXAMPLE
TEST FILE: FRONTAL IMPACT
DATE: JANUARY 1981

SAMPLING: 1000 HZ
FILTER: CLASS 180

10^0 MPH-VOLTS/G

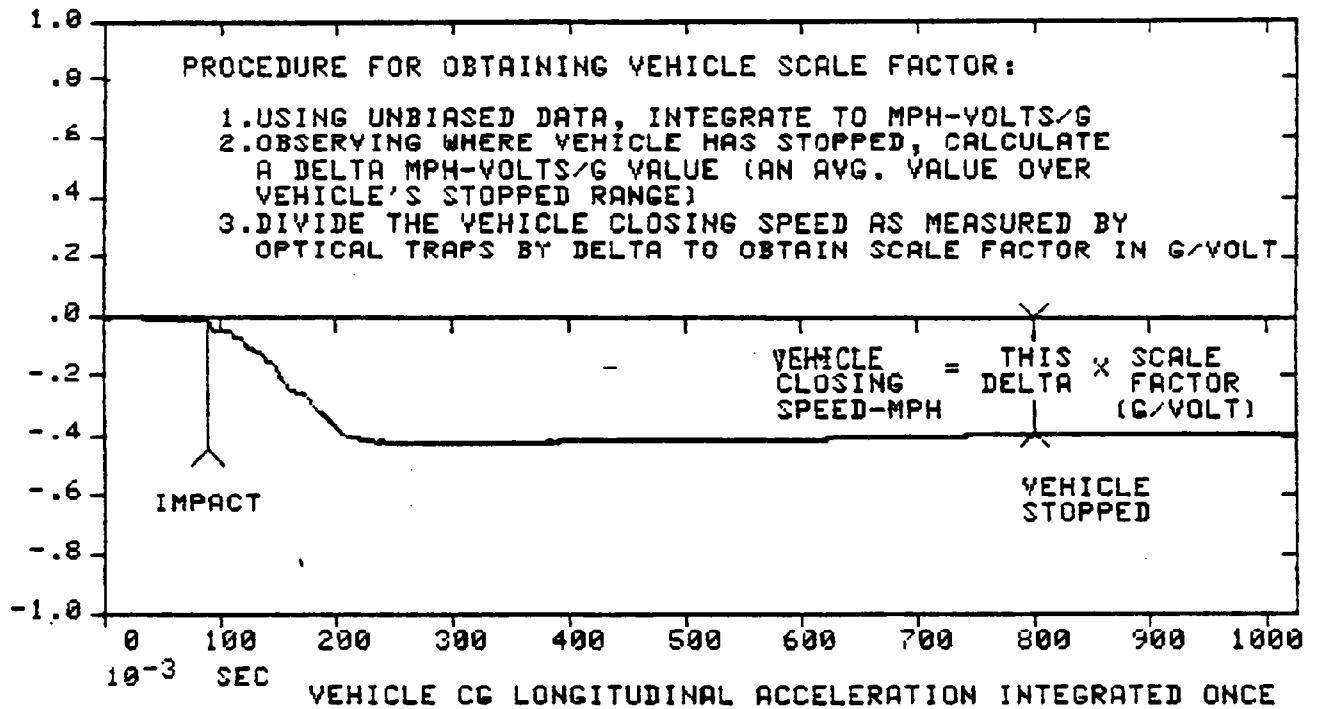
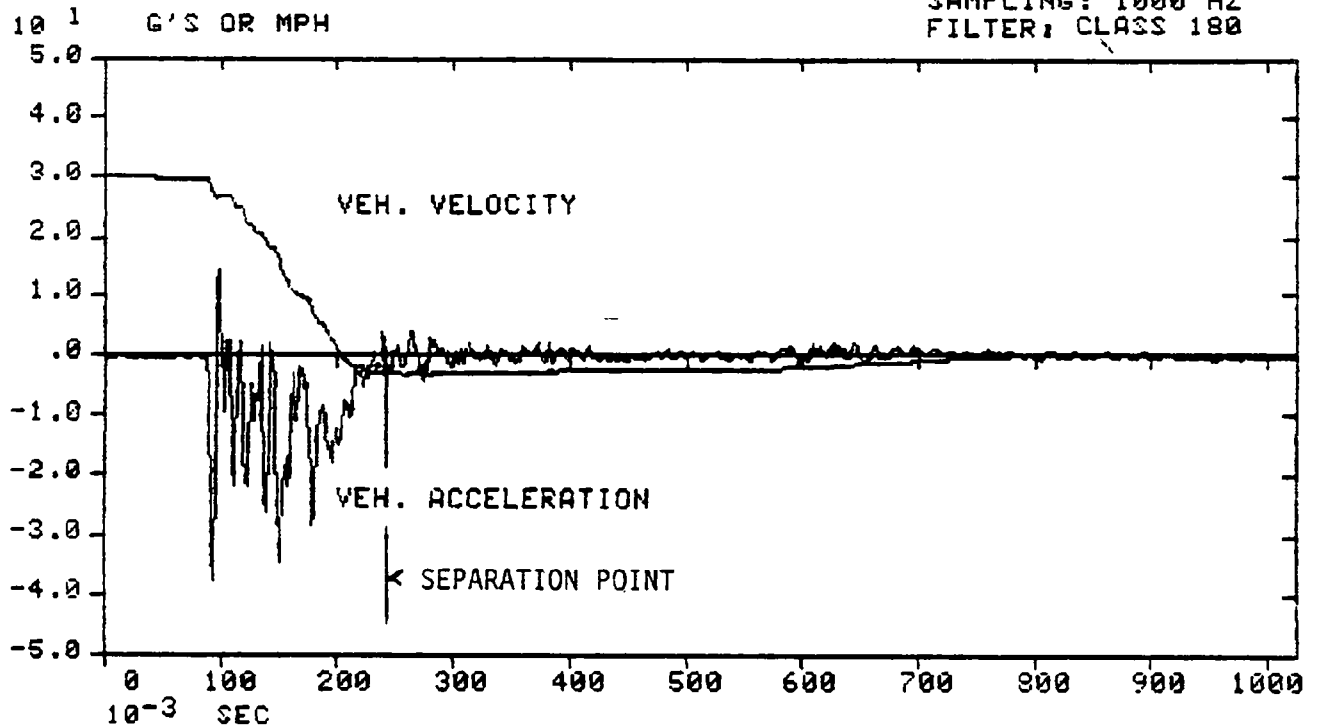

FIGURE 4-6

NATIONAL TECHNICAL SYSTEMS

VEHICLE: EXAMPLE
TEST FILE: FRONTAL IMPACT
DATE: JANUARY 1981

SAMPLING: 1000 HZ
FILTER: CLASS 180



VEHICLE CG LONG. VELOCITY AND ACCELERATION

FIGURE 4-7



SECTION 4

4.9 REAR MOVING BARRIER IMPACT DELTA VELOCITY CALCULATION

The data acquisition and reduction process for a rear moving barrier impact delta velocity calculation is outlined in the step by step discussion which follows. Figure 4-8 through 4-17 illustrate each step in the process. Reflected in the processed data is:

- 1) Relying on the optical speed trap data as the most accurate source of the moving barrier impact speed, the calibration factor, which converts the moving barrier longitudinal acceleration signal from volts to g's, is forced to produce a velocity consistent with the optical speed trap data.

- 2) Since there is no comparable method of forcing a calibration factor on the test vehicle longitudinal acceleration signal, calibration factor for the test vehicle data are the result of the pre-test accelerometer calibration.



SECTION 4

Step 1: Acquire a five (5) second time history of the moving barrier longitudinal and test vehicle longitudinal acceleration signal. (Figure 4-8 and 4-9)

Step 2: Remove bias from the longitudinal acceleration signals. Bias removal is based on the assumption that once the moving barrier and test vehicle come to rest, the acceleration trace should remain at zero and the velocity trace should exhibit no change (flat) from the "stop" time through the remainder of the five (5) second time history window. (Figure 4-10 through 4-13) The five (5) second time history was selected to allow sufficient time for both the moving barrier and the test vehicle to come completely to rest.

Step 3: Calculate the moving barrier longitudinal acceleration calibration factor. The optical speed trap reading is used in this step, along with the knowledge that the moving barrier comes to rest, i.e. a known delta velocity from impact to rest. (Figure 4-14).



SECTION 4

Step 4: Acquire a one (1) second time history of the moving barrier longitudinal and test vehicle longitudinal acceleration signal at a sample rate and with a pre-digitizing filter that is in accordance with the guideline established by SAE J211b. Remove bias and apply calibration factor calculated from the five (5) second time history data. (Figure 4-15 and 4-16)

Step 5: Calculate the delta velocity at the time of moving barrier/test vehicle separation. The time of separation is determined by examining the moving barrier and test vehicle longitudinal acceleration signal and velocity traces while noting that:

- 1) The moving barrier exhibits no appreciable deceleration from the time of separation until the moment the moving barrier brakes are applied, i.e. a period of constant velocity should be exhibited by the moving barrier immediately following barrier/test vehicle separation.



SECTION 4

- 2) Since any external force acting to accelerate the test vehicle in the positive forward direction becomes zero at separation, the test vehicle should exhibit maximum velocity immediately prior to separation and only deceleration due to friction forces thereafter. (Figure 4-17)

NATIONAL TECHNICAL SYSTEMS

VEHICLE: EXAMPLE
TEST FILE: REAR IMPACT
DATE: JANUARY 1981

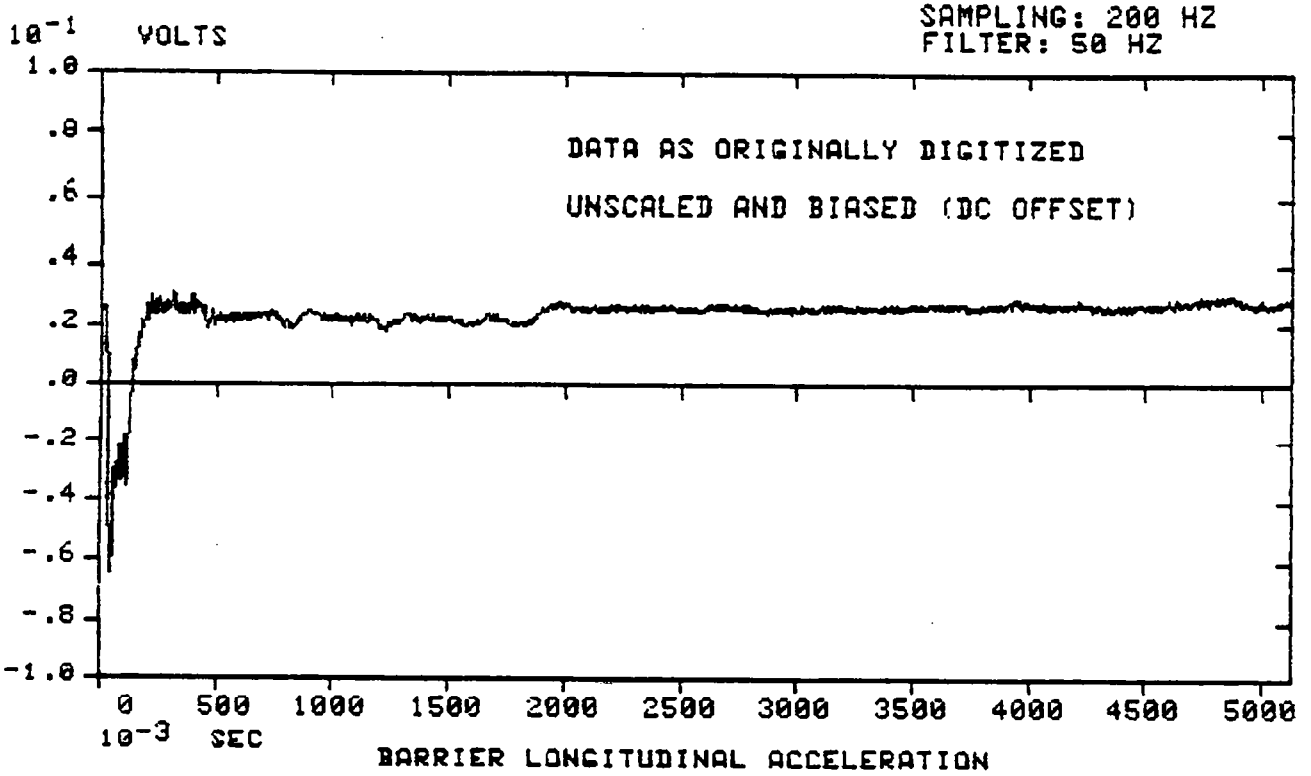

FIGURE 4-8

NATIONAL TECHNICAL SYSTEMS

VEHICLE: EXAMPLE
TEST FILE: REAR IMPACT
DATE: JANUARY 1981

SAMPLING: 200 HZ
FILTER: 50 HZ

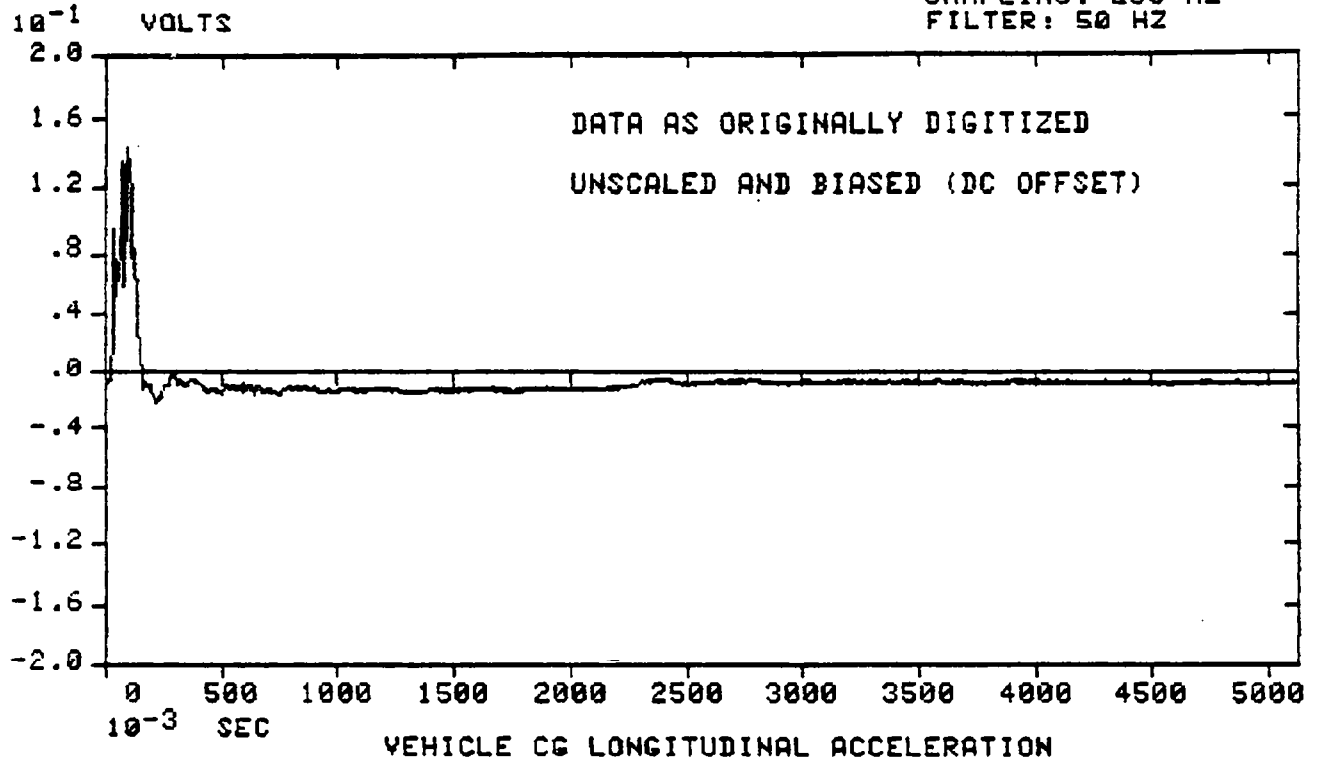

FIGURE 4-9

NATIONAL TECHNICAL SYSTEMS

VEHICLE: EXAMPLE
TEST FILE: REAR IMPACT
DATE: JANUARY 1981

SAMPLING: 200 HZ
FILTER: 50 HZ

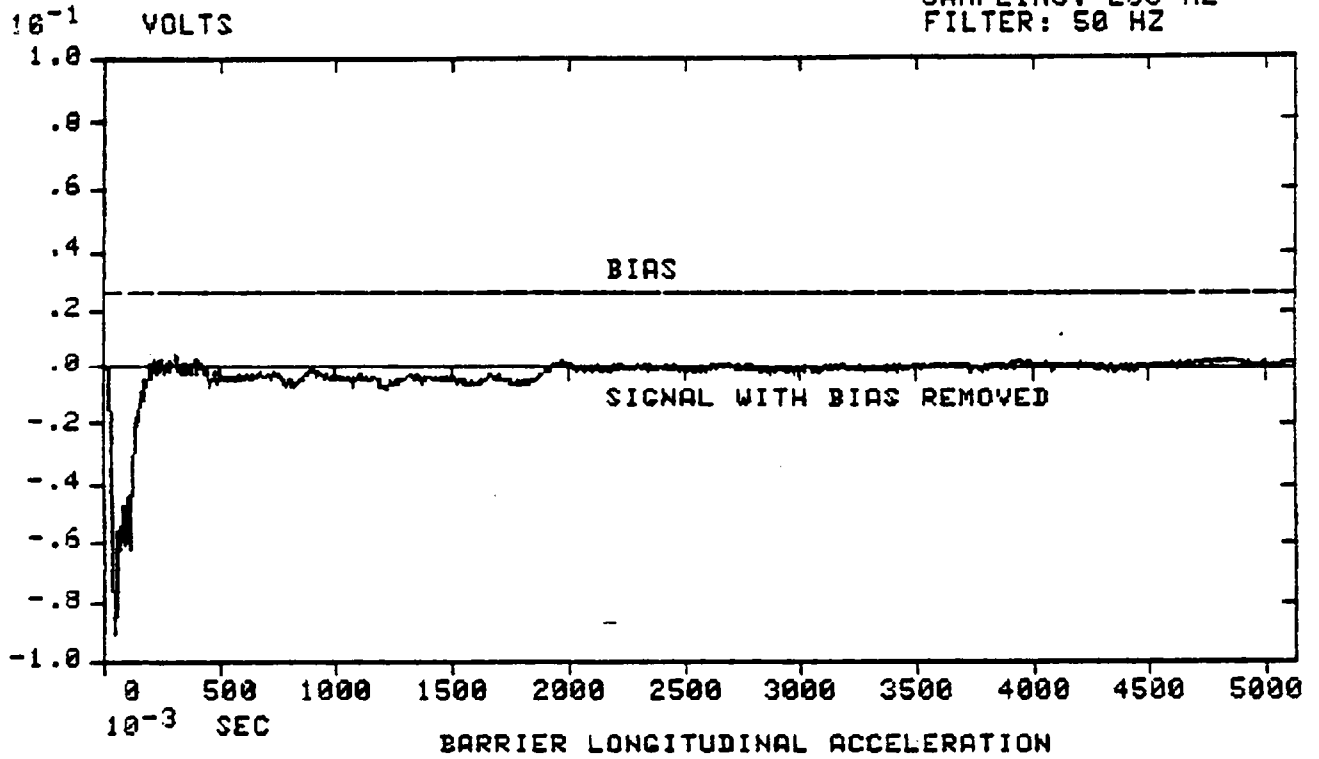

FIGURE 4-10

NATIONAL TECHNICAL SYSTEMS

VEHICLE: EXAMPLE
TEST FILE: REAR IMPACT
DATE: JANUARY 1981

SAMPLING: 200 HZ
FILTER: 50 HZ

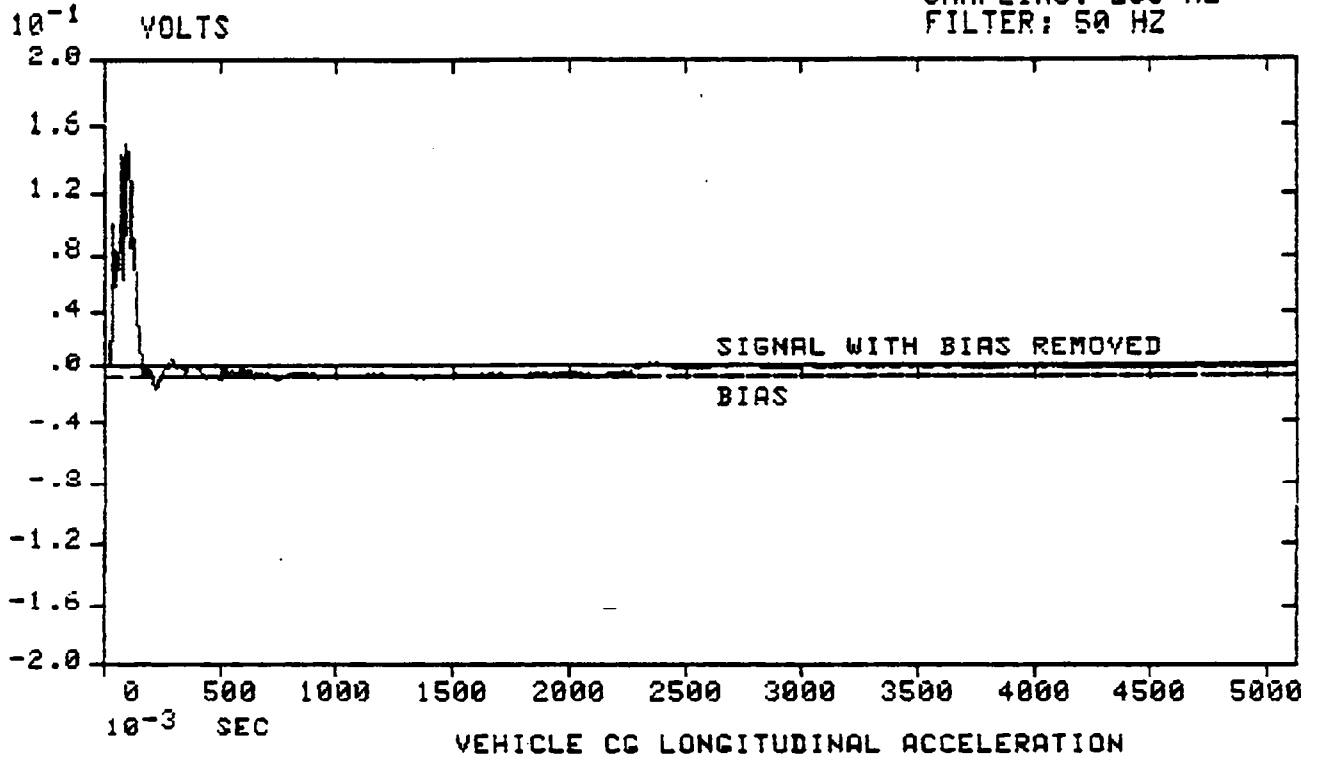

FIGURE 4-11

NATIONAL TECHNICAL SYSTEMS

VEHICLE: EXAMPLE
TEST FILE: REAR IMPACT
DATE: JANUARY 1981

SAMPLING: 200 HZ
FILTER: 50 HZ

10⁰ VOLTS SECONDS

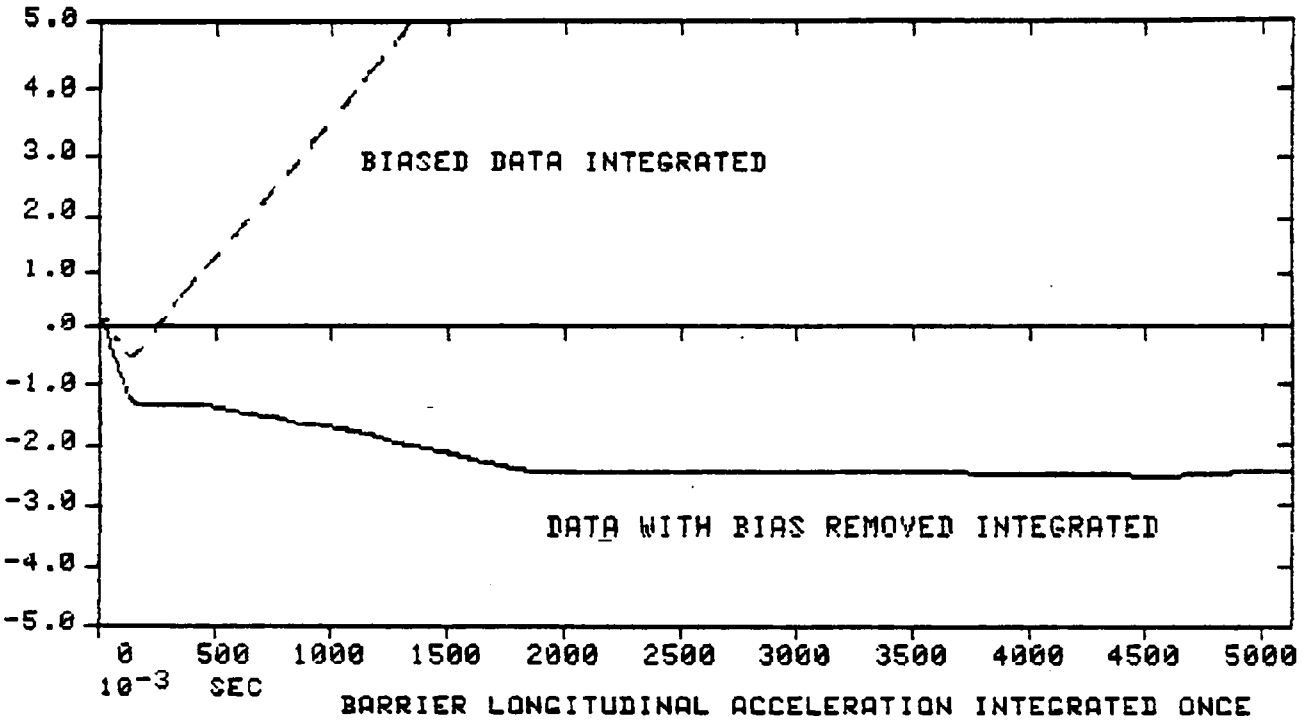

FIGURE 4-12

NATIONAL TECHNICAL SYSTEMS

VEHICLE: EXAMPLE
TEST FILE: REAR IMPACT
DATE: JANUARY 1981

SAMPLING: 200 HZ
FILTER: 50 HZ

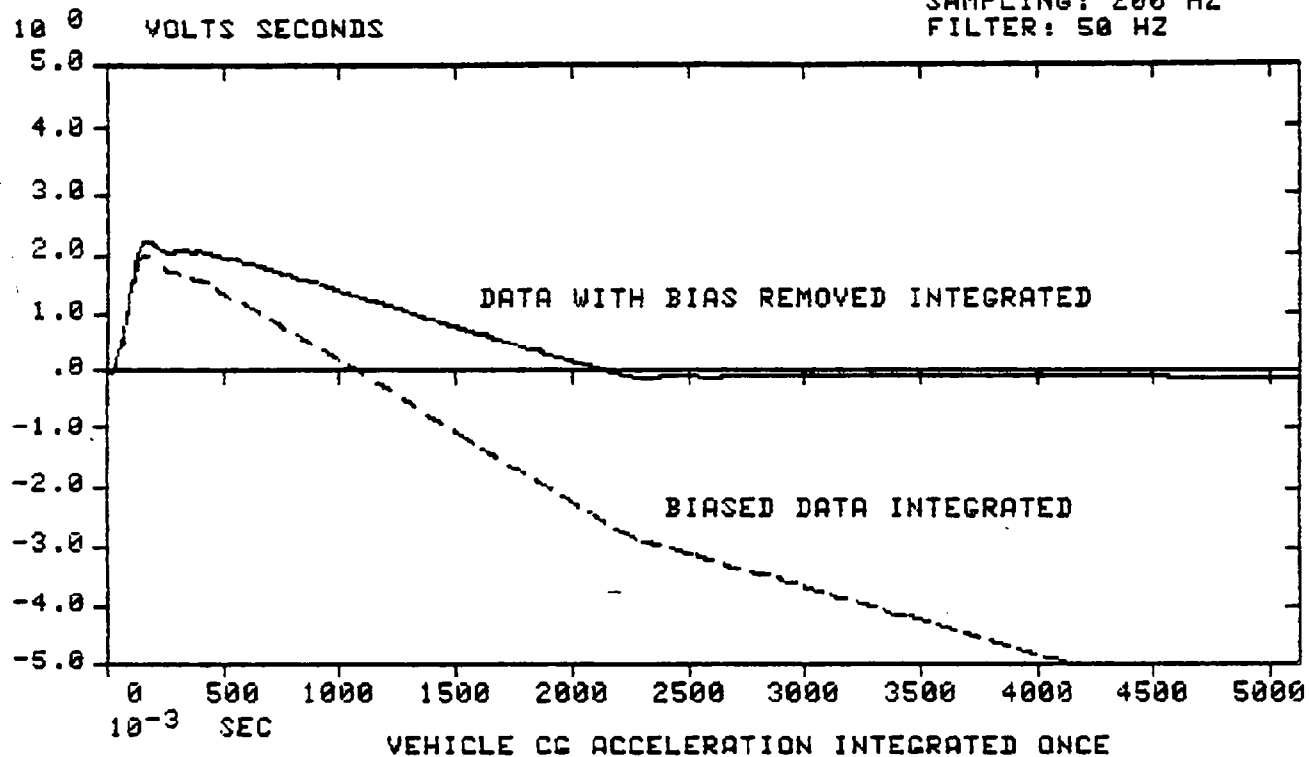

FIGURE 4-13

NATIONAL TECHNICAL SYSTEMS

VEHICLE: EXAMPLE
TEST FILE: REAR IMPACT
DATE: JANUARY 1981

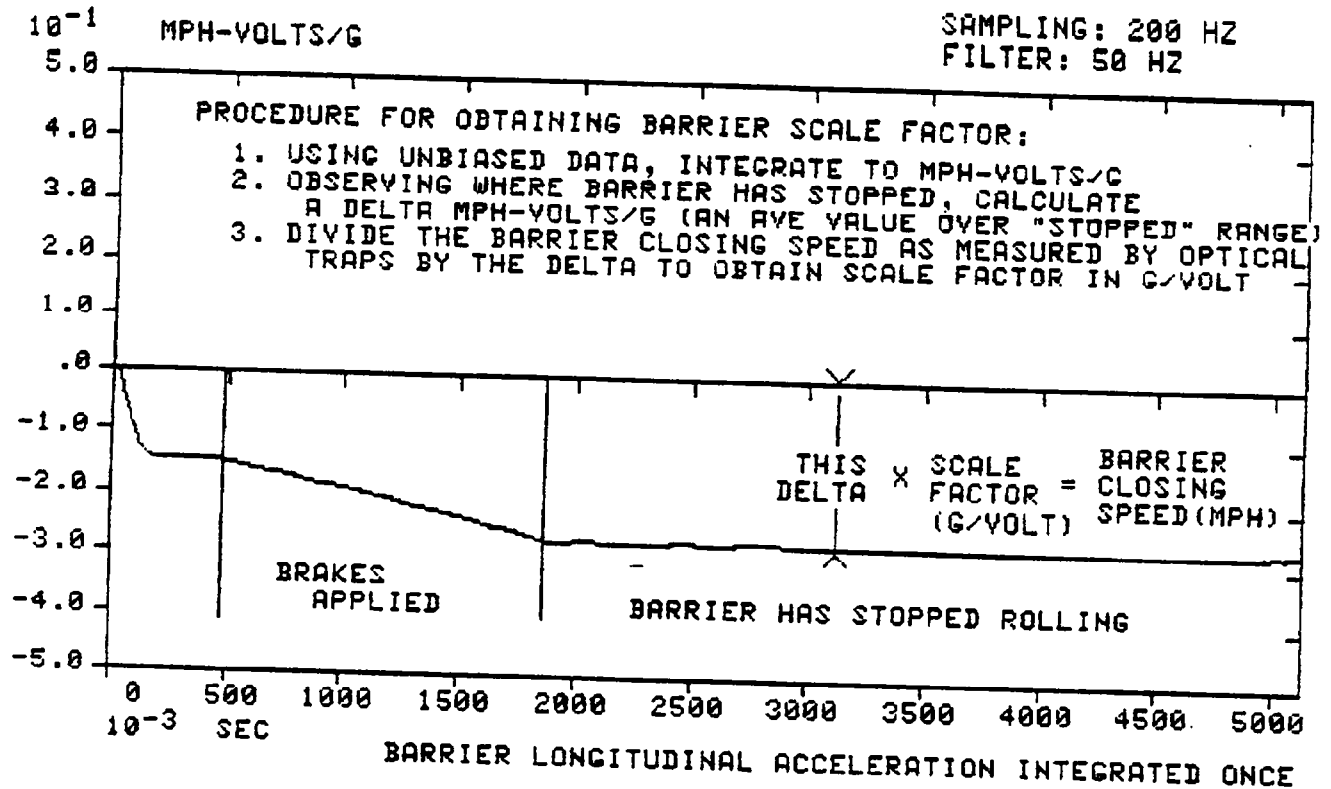

FIGURE 4-14

NATIONAL TECHNICAL SYSTEMS

VEHICLE: EXAMPLE
TEST FILE: REAR IMPACT
DATE: JANUARY 1981

SAMPLING: 1000 HZ
FILTER: CLASS 180

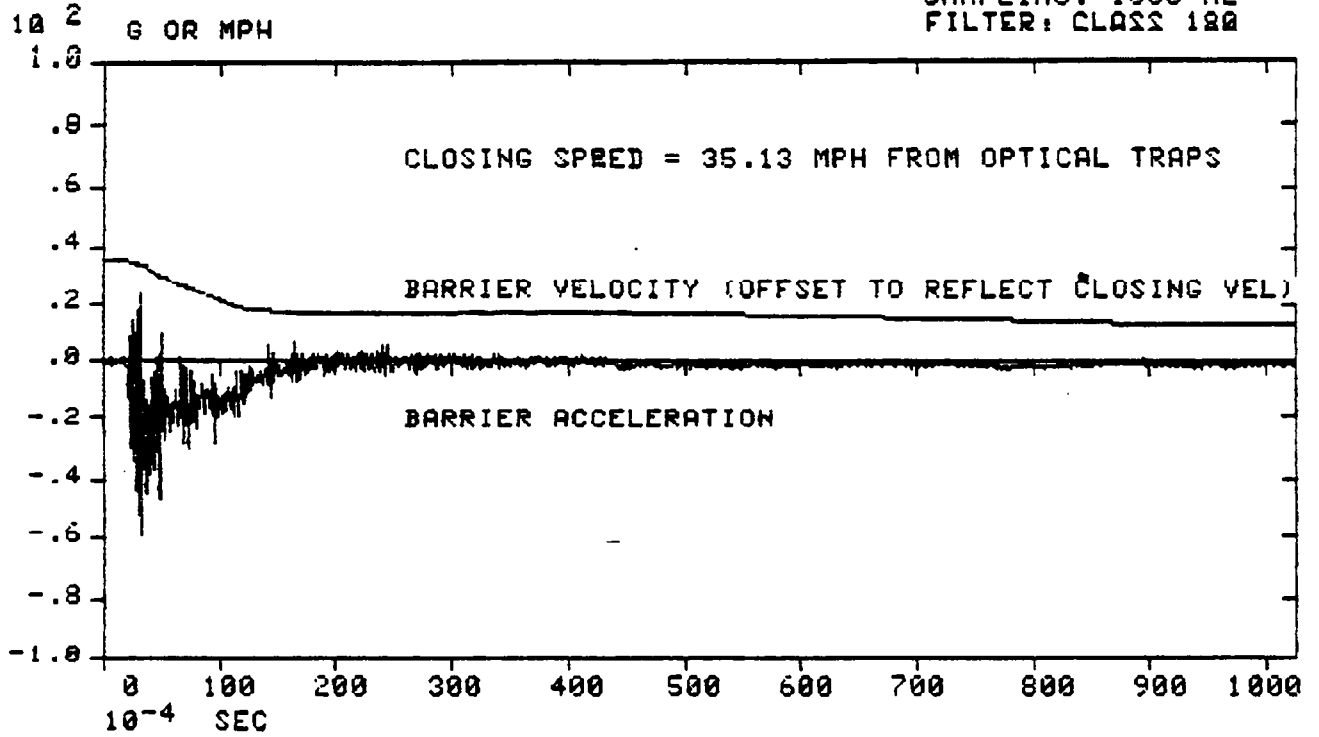

FIGURE 4-15

NATIONAL TECHNICAL SYSTEMS

VEHICLE: EXAMPLE
TEST FILE: REAR IMPACT
DATE: JANUARY 1981

SAMPLING: 1000 HZ
FILTER: CLASS 180

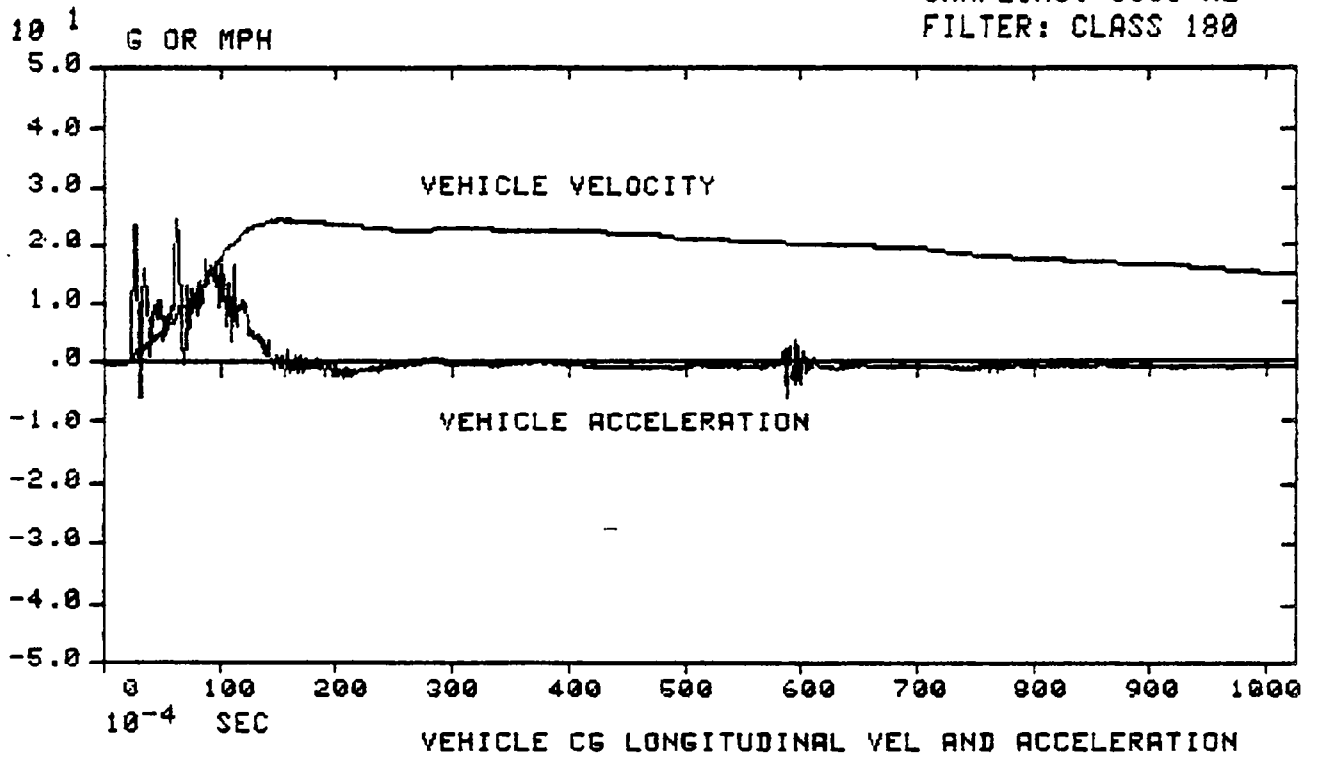

FIGURE 4-16

NATIONAL TECHNICAL SYSTEMS

VEHICLE: EXAMPLE
TEST FILE: REAR IMPACT
DATE: JANUARY 1981

SAMPLING: 1000 HZ
FILTER: CLASS 180

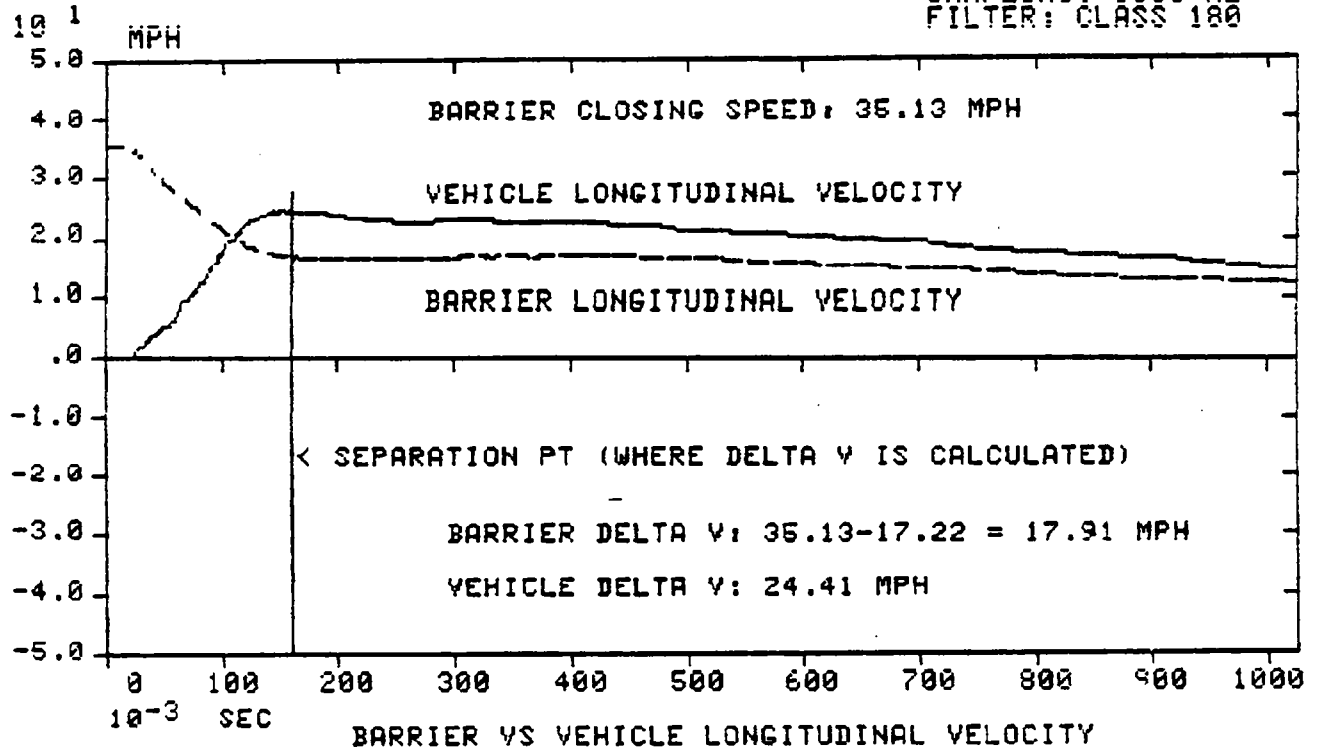

FIGURE 4-17



SERVICE FOR:

U. S. Department of Transportation
National Highway Traffic Safety Administration
Enforcement
Office of Vehicle Safety Compliance
400 Seventh Street S. W.
Washington, D. C. 20590

CONTRACT NUMBER:

DTNH22-82-D-31140

I hereby certify that the preceding report is true and correct to the best of my knowledge.

NATIONAL TECHNICAL SYSTEMS



G. D. Matteson, P.E.,
Division Manager



D. H. Hand, Project Engineer



Jeff Kogen, Dynamics Engineer

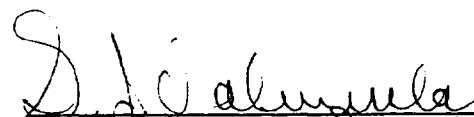

G. J. Valenzuela, Mechanical
Department Supervisor

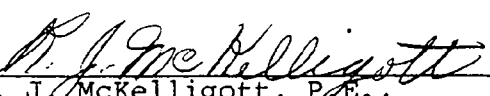

R. J. McKelligott, P.E.,
Quality Assurance Manager

rmh

